

1939 EDITION

RADIO AMATEUR COURSE

By
G.W. Shuart
"W2AMN"

**SHORT
WAVE
and
TELEVISION**

PRICE
50¢

An illustration of a two-story house with a red roof and a chimney. A tall radio tower stands next to the house, with a ladder leaning against it. The scene is set against a dark blue background with stylized trees and a path leading to the house.

PUBLISHED BY
RADIO and TELEVISION MAGAZINE, NEW YORK

THORDARSON

Amateur Specials



DESIGNED
FOR
AMATEUR
USE



PLATE TRANSFORMERS

Shielded cases — Tapped Primaries
Air Cooled Construction — High
Tension Porcelain Terminals — 115
Volt 60 Cycle Primaries.

- T-16P00 D. C. volts 650 or 500 @ 200
M. A.
Amateur Net Price \$3.96
- T-16P01 D. C. volts 1250 or 1000 @
300 M. A.
Amateur Net Price \$7.80
- T-16P02 D. C. volts 1250 or 1000 @
500 M. A.
Amateur Net Price \$12.60
- T-16P03 D. C. volts 1800 or 1450 @
300 M. A.
Amateur Net Price \$11.40
- T-16P04 D. C. volts 2500 or 2000 @
300 M. A.
Amateur Net Price \$13.95

Your parts distributor is now stocking
Thordarson Amateur Specials. Investi-
gate these stupendous values backed
by the Thordarson guarantee of satis-
faction. Bulletin 50-28a now at your
parts distributor or direct from factory.

FILAMENT TRANSFORMERS

Open style sub or top panel mount-
ing — 115 volt, 60 cycle primaries.

- T-16F08 2.5 volts C. T. @ 5.25 Amps.
Insulation volts 2,000
Amateur Net Price 90c
- T-16F09 2.5 volts C. T. @ 10 Amps.
Insulation volts 2,000
Amateur Net Price \$1.05
- T-16F10 2.5 volts C. T. @ 10 Amps.
Insulation volts 7,500
Amateur Net Price \$1.65
- T-16F11 5.25 volts C. T. @ 4 Amps.
Insulation volts 2,000
Amateur Net Price \$1.20
- T-16F12 5.25 volts C. T. @ 13 Amps.
Insulation volts 2,000
Amateur Net Price \$2.10
- T-16F17 6.3 volts C. T. @ 3 Amps.
Insulation volts 2,000
Amateur Net Price \$1.05
- T-16F13 7.5 volts C. T. @ 4 Amps.
Insulation volts 2,000
Amateur Net Price \$1.20
- T-16F14 7.5 volts C. T. @ 8 Amps.
Insulation volts 2,000
Amateur Net Price \$1.95
- T-16F15 10 volts C. T. @ 4 Amps.
Insulation volts 2,000
Amateur Net Price \$1.80
- T-16F16 10 volts C. T. @ 8 Amps.
Insulation volts 2,000
Amateur Net Price \$2.40

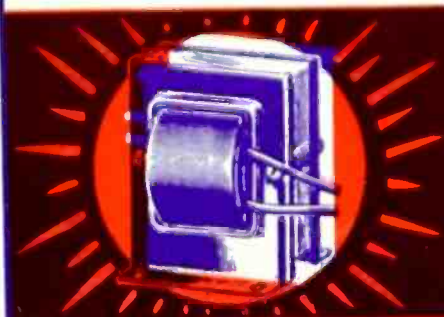

CHOKES INPUT

- T-16C20 5-20h — 200 ma — 2000 v Ins.
Amateur Net Price \$2.25
- T-16C21 5-20h — 300 ma — 3000 v Ins.
Amateur Net Price \$3.00
- T-16C22 5-20h — 500 ma — 3000 v Ins.
Amateur Net Price \$5.40
- T-16C25 12h — 200 ma — 2000 v Ins.
Amateur Net Price \$2.25
- T-16C26 12h — 300 ma — 3000 v Ins.
Amateur Net Price \$3.00
- T-16C27 12h — 500 ma — 3000 v Ins.
Amateur Net Price \$5.40

SMOOTHING

★ THORDARSON BRANDED
★ THORDARSON QUALITY
★ THORDARSON GUARANTEED

THORDARSON ELECTRIC MFG. CO.

500 W. HURON ST., CHICAGO, ILL.

Demand "Power by Thordarson"

RADIO AMATEUR COURSE

— *Including* —

**Constructional Articles on Transmitters and Receivers
for HAM use.**

— *Also* —

**Extracts from the Communications Act of 1934, as
pertaining to Amateur Radio.**

By

George W. Shuart, W2AMN

Published by SHORT WAVE & TELEVISION

99 HUDSON ST.

NEW YORK CITY

If this were to take place in a period of one second it would be said to have a frequency of two cycles. Hence, the term 60 cycle A.C. which is commonly used for des-

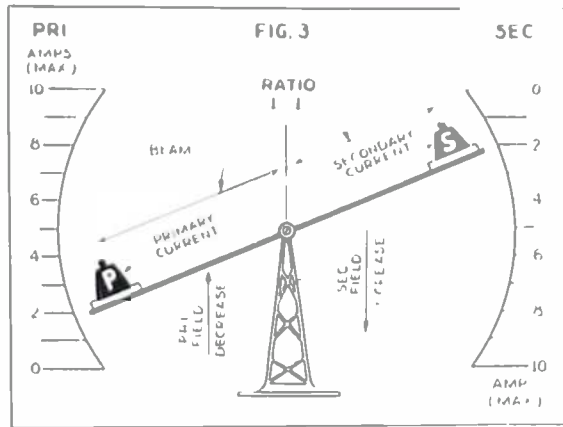

Fig. 3. Mechanical analogy of the action taking place in an A.C. transformer. As the secondary current represented by the weight "S" increases the primary current also increases.

ignating the type of electricity used in home service, means 60 complete cycles or 120 alternations per second. The frequency of alternating current is the number of times a complete cycle takes place in a period of one second.

To obtain a clear picture of the operation previously described let us refer to Fig. 1-B, which shows the hydraulic analogy. We have a cylinder pump with a complete loop through which a liquid can be pushed. The piston of this pump is driven by a motor or else by hand. If the drive wheel "A" is turned to the left the piston moves to the left, forcing the liquid through the tube "L," in one direction and causing the indicator at the top of the loop to indicate that pressure is being exerted upon it. When the piston is to the extreme left and the motor-driven disc has rotated through 180 degrees, the flow stops, allowing the indicator hand to return to zero, due to the two centering springs which are attached to it. This indicates half a cycle.

Then, as the motor is rotated through the remaining 180 degrees, the opposite of the previously mentioned action takes place, causing the vane or indicator to register a maximum in the opposite direction, and then return to zero after the half of the cycle is completed.

Associated with alternating current we also have voltage or pressure, termed E.M.F.

or electromotive force. This voltage is alternating in the same manner as the current and at the same frequency.

The chief value of alternating current lies in the fact that it can be transmitted over long distances at high voltages and low currents, permitting the use of small wire and greater saving in cost and at intervals stepped down to lower voltages with high currents through the medium of the *transformer*. The action of the transformer, briefly explained, is to step the imposed voltage up or down depending upon what the case may require.

If we connect a coil of wire such as shown in Fig. 2A, preferably one that has an iron core, to a 110-volt 60-cycle A.C. source, or any A.C. generator for that matter, we find that the continuously alternating current flow through the coil induces a magnetic field (radiated lines of force) about the coil, see Fig. 2A. This field builds up and collapses twice for every cycle of the imposed alternating current.

Now, if we were to place another coil in close proximity to this coil and one of similar design, we would find that the fluctuating magnetic field in the one coil would induce an E.M.F. or voltage in the added coil; this is known as induction. The entire theory of a transformer is based upon this fact and operates on a plan or principle of mutual induction.

If the two coils shown in Fig. 2B have the same number of turns and we impose a potential of 110 volts upon the primary, then theoretically we will have 110 volts across the two terminals of the secondary. No current will flow in this secondary until it is either short-circuited wholly or in part, either by connecting the two terminals together or by inserting between the two terminals a resistor. The current which will then flow depends upon the resistance of the short circuit.

This resistor is known as the *load* circuit. If the load circuit is purely resistive, that is noninductive and non-capacitive, Ohm's Law can be applied in the same manner as when solving direct current problems. If no load is connected across the secondary terminals of the transformer, the only current which will be flowing in the primary will be that amount which is necessary to energize the primary circuit and is usually termed the *magnetization current*. But, just as soon as we impose a load upon the secondary and cause a current to flow in this circuit, which incidentally flows in a direc-

tion *opposite* to the current flow in the primary, we have an increase in the primary current.

In order to obtain a clearer picture of just what happens in the primary and secondary of a transformer we offer the mechanical analogy shown in Fig. 3. The two outer scales marked from 0 to 10 in steps of two units, represent the amount of current in either primary or secondary that would be shown on an ammeter.

The horizontal or tilting beam represents the fields of the primary and secondary moving in the opposite direction. The ratio of the transformer is 1:1. The field of any coil is analogous to the current flowing through it.

Weight "S" represents the secondary current: weight "P" represents the primary current. As weight "S" moves down the scale it increases the field or lines of force of the secondary which, because they are analogous to the current therein, are in opposition to the field already in the core and tend to decrease it, thus raising weight "P," which is the primary current, upward until the platform becomes horizontal, indicating the same amount of primary current as secondary current.

When the weight "S" is opposite one zero mark, weight "P" in this analogy, will also be opposite the other zero mark. However, as previously mentioned, there is always a slight amount of current flowing in the primary circuit in order that it may be energized.

Always remember that the current in the primary and secondary of the transformer are opposite and that the fields are also opposite.

In all cases, though, it is important to remember that the frequency of the alternating current in the secondary is absolutely the same as the frequency in the primary circuit.

So far as we have considered the two coils, the primary and secondary windings are identical and therefore the voltage in the secondary circuit will be the same as the voltage impressed upon the primary. However, if the number of turns in the secondary coil is one half the number of turns in the primary coil, the voltage will also be one half of the primary voltage. As an example: in transformer design, if we have a primary consisting of 550 turns and we impose a potential of 110 volts upon it, we find by dividing the number of turns by the imposed voltage we have five turns per volt.

In designing the secondary then all we have to remember is that for every volt required in the secondary circuit we should have five turns. Space and time do not permit the complete technical discussion of transformer design and we suggest that the readers refer to some of the excellent books which have been published covering this subject."

If one would like to obtain a visual picture of the field and action of alternating current when applied to a solenoid a simple experiment can be made by constructing the apparatus shown in Fig. 2C. This consists of a coil having an iron core and beside this core a thin piece of steel is mounted. By fastening a piece of pencil lead to this piece of steel and placing under it a piece of paper, so that the lead comes in contact with the paper as it is moved along, the electrical action can be transferred to the paper by applying 110-volts 60-cycle A.C. to the coil, when the thin strip of steel will vibrate back and forth rapidly.

Now as we pull the paper forward at the rate of 1 foot per second we will have approximately 60 complete cycles drawn on the paper, very much similar to these shown in Fig. 1A.

A hydraulic analogy of the action of a transformer is illustrated in Fig. 2D, in the form of a hydraulic jack. We have a small pump to the left, which pumps liquid into a large cylinder, forcing the piston of this cylinder upward.

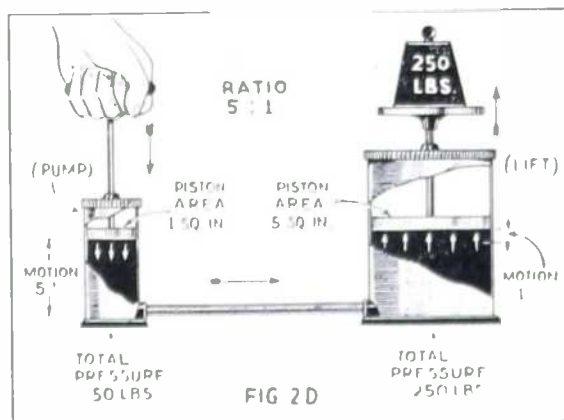
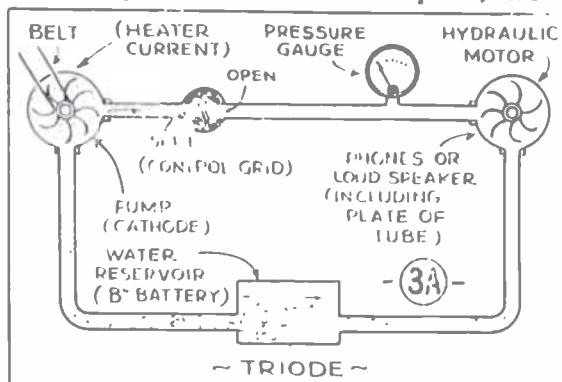

Fig. 2D above shows a very interesting analogy for the A.C. transformer, in which the voltage applied to the primary may be changed to a higher or lower voltage in the secondary. In the hydraulic press shown above, a pressure of 50 pounds exerted by the small downward moving piston at the left, is eventually transformed into an increased pressure of 250 pounds in the large cylinder at the right.

material, and charge it positively, we can draw or attract the electrons to it.

In Fig. 3 we show the action which takes place in a tube having a cathode and a plate or *anode*, as the plate is technically termed. By connecting a battery between the anode and cathode with the positive terminals of the battery connected to the *plate*, we at-



Simple hydraulic analogy to illustrate how the grid in an electron tube acts like a valve to regulate or control the amount of current (water) passing between the plate (motor) and the cathode (pump). The water reservoir in the analog diagram corresponds to the "B" battery or power supply unit in a radio circuit.

tract electrons to this plate or anode. Current will then flow between cathode and anode, remembering always that the current flow is analogous to the electron flow.

If we insert a meter in series with the circuit we will find that it will show the amount of current flowing in the circuit. This tube, as shown in Fig. 3, is known as the *diode* or one having *two elements*. If we remove the battery from the circuit and connect the negative side of the battery to the plate and the positive side to the cathode, no current will flow, because the negatively charged plate will reject the electrons.

Effect of A.C. on Tube

So far, we have considered a constant polarity of voltage applied between the cathode and anode. Now, if we were to apply an alternating voltage between these two elements (see explanations of alternating current electricity), the plate will be alternately charged *positive* and *negative*, which means that current will only flow through the circuit during the period when a positive voltage is applied to the anode. When the anode side of the circuit becomes negative, *current does not flow*. In Fig. 4 we illustrate what is termed *rectification*.

The input circuit is indicated as alternating current while the output circuit shows

current flowing in only *one direction* during half of the time of the input cycle. We have flowing in the output circuit then, an interrupted direct current or what would otherwise be termed *half-wave* rectification. All tubes of the diode type are therefore termed half-wave rectifiers. The 81 is an example of this type of tube.

By using two anodes we can obtain *full-wave* rectification. This is shown in Fig. 4A. A rectifier of this type is termed a full-wave rectifier and an example is the 80 tube.

Returning to Fig. 3 we can readily understand that as we change the degree of positive potential (voltage) applied to the plate, we will change the volume of electrons which are attracted to it. A low potential of electrons will attract a small amount of electrons, while a high potential or high voltage will attract a greater number of electrons. An important point to bear in mind is that a negative potential repels electrons, while a positive potential attracts them. (Unlike charges attract and vice versa.)

How the "Grid" Works

To have a better control over the amount of current flow in the plate circuit of the vacuum tube, we may insert a third element known as the *grid*. Tubes having three elements are termed *triodes* the prefix "tri" meaning three. This grid consists of a form of screen between the anode and cathode through which electrons must pass in order to reach the plate.

This grid being located nearer to the cathode or source of electrons, will have a greater effect upon the electron stream when it is charged either positively or negatively. In Fig. 5, we have the same circuit as in Fig. 3, excepting for the addition of the grid. Because of the great effect this grid has upon the electron flow, it is called the *control grid*.

We may now apply either a positive or a negative potential to this grid and obtain a change in plate current or a change in the number of electrons reaching the plate, because if the grid is charged negatively, it will tend to repel or retard the flow of electrons between the cathode and the plate. This grid can be made so negative (biased) that it will entirely cut off the flow of electrons, reducing the plate current to zero.

As the grid becomes more *positively* charged, an *increase* in the flow of electrons to the plate will take place. That is, providing the potential (voltage) of the grid is not

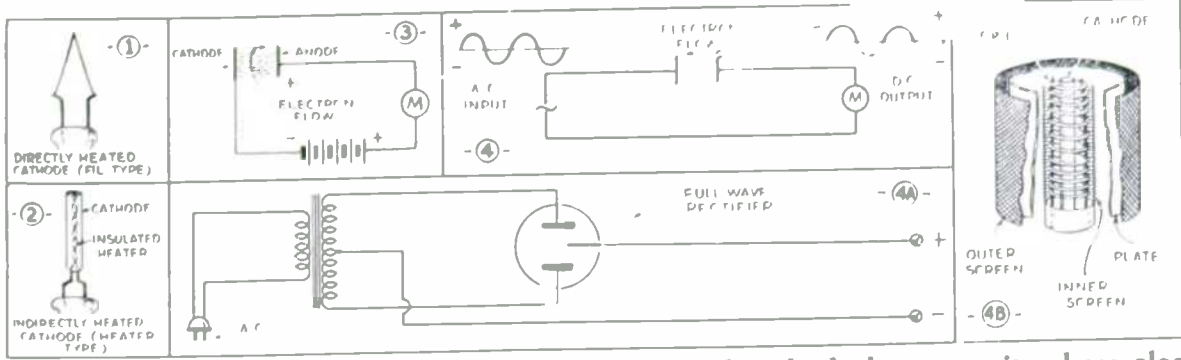

Diagrams above—Figs. 1 to 4A, show filament and cathode heater units; how electrons flow from cathode to anode (3); rectification of A. C. passing through an electron tube (4); hook-up of full-wave rectifier tube (4A); detail of tube element (4B).

as great as that of the plate. As this grid becomes entirely positive, relative to the cathode, it will then collect a certain amount of electrons from the stream and return them to the cathode, causing current to flow in the grid circuit.

In receiving circuits the output of the vacuum tube depends upon the plate current change, that is, the increase and decrease in amplitude or, more simply stated, the magnitude of the change. So, we can readily see that by using this control grid, which is located close to the filament, we can effect great changes in the current flowing in the plate circuit of the vacuum tube with relatively small changes in the potential of the grid and thus obtain considerable amplification in radio circuits.

In Fig. 5a, we show what happens when A.C. is applied to the input circuit of a triode, biased (bias usually means applying a fixed negative or positive charge, independent of the signal voltage, to the grid of the tube) so that the plate current is of fairly low value, but nowhere near the cut-off point. We show the input signal to the grid as alternating current, where it rises above

and falls below the zero mark. As the input signal swings the grid more positive, or better stated—less negative—the plate current begins to rise above what is commonly termed the "no-signal" (static) plate current value; that is, the normal value of plate current with no applied signal.

This constitutes one-half of the cycle of the input signals. On the other half of the input-signal cycle, the grid becomes more negative, causing the plate current to fall below its normal no-signal value. (See previous explanation under "How the Grid Works.") Now, in the plate circuit, we have apparently the same wave form as the input signal. The input signal was A.C.; however, A.C. does not flow in the plate circuit of the tube. This fluctuating replica of the input signal is termed the *alternating component* of the plate current. ("Plate current" is the current flowing through the circuit from cathode to plate, or anode, when the electron stream is established by heating the filament.)

If we were to connect earphones in series with the plate circuit, we would be able to hear the incoming signal reproduced and

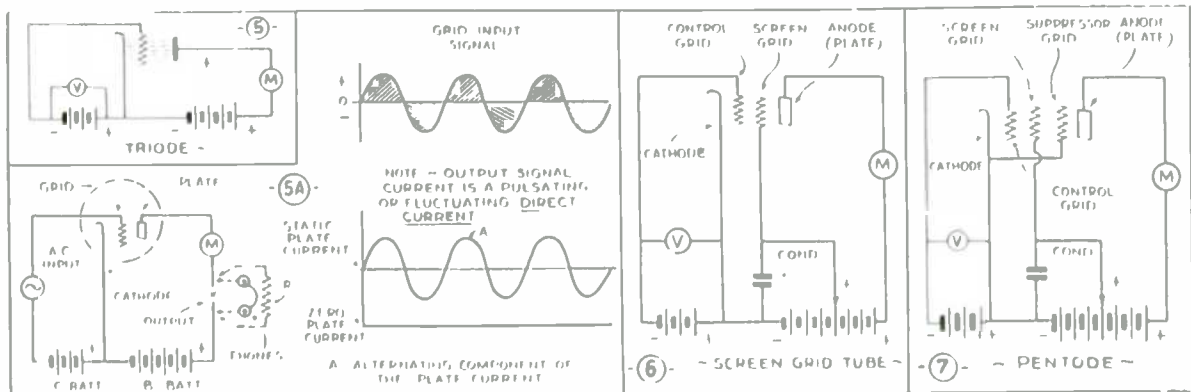
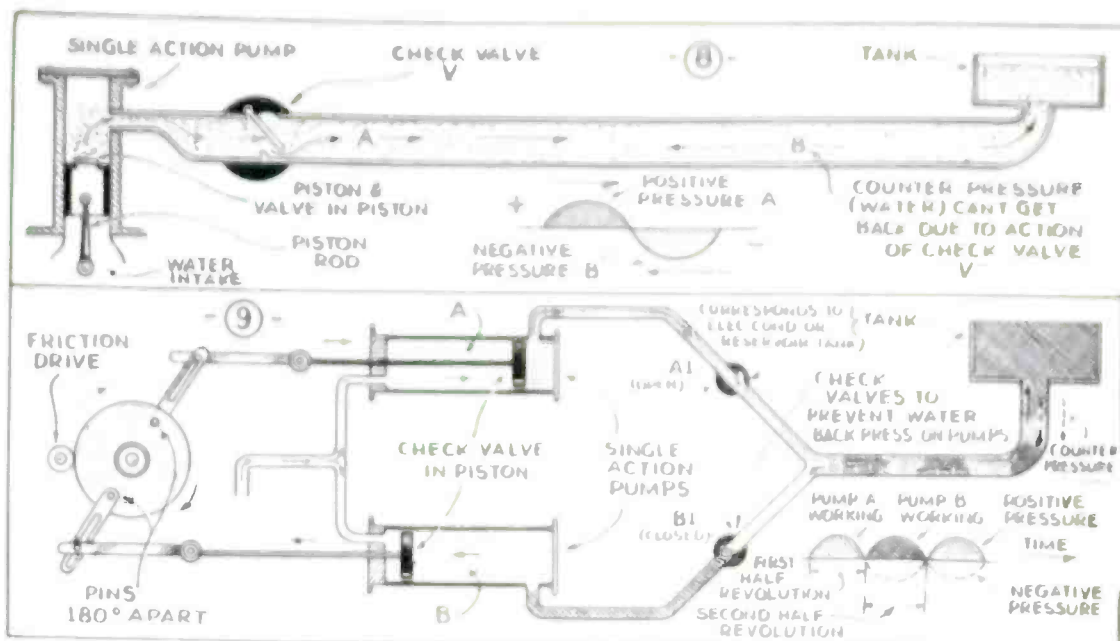

Fig. 5 shows action of triode tube; 5A, how A.C. input is changed into a rectified pulsating direct current by an electron tube; 6, arrangement of the elements in a screen-grid tube; how elements are arranged in a pentode at Fig. 7.



Hydraulic analogs showing action of half- and also full-wave rectifiers, the detector tube in a receiving circuit acting as a rectifier. The first diagram shows how a single-action pump and a check valve permits water to pass through the pipe up into the tank on each half stroke, while any counter water pressure is prevented from passing back into the pump by the check-valve. The second diagram shows how two half-wave rectifiers (pumps), with the aid of two check-valves cause a "full-wave" pressure to be developed in the main water line. When one is not working, the other is.

amplified in the plate circuit, that is if it was of low enough frequency to come within the range of the human ear.

The fluctuating plate current or the alternating component of the plate current would cause the diaphragm of the earphone to vibrate due to the varying current flowing through the phones and the change in the magnetic pull on the diaphragm.

So long as the voltage of the incoming signal does not exceed the value of the bias battery, there will be no grid current flowing through the phones and the change in the magnetic pull on the diaphragm.

So long as the voltage of the incoming signal does not exceed the value of the bias battery, there will be no grid current flowing, because the grid will never go completely positive. On the positive half of the input signal the grid, in reality, becomes just *less negative*.

If we were to insert a resistor (R) in series with the plate circuit, the fluctuating current flowing through the resistor would cause a voltage drop across the resistor, varying directly with the plate current. The ratio of this *varying* voltage drop to the input signal voltage, is known as the *gain* of the tube or the *voltage amplification*.

Tubes Have Capacity Between Elements

In all types of vacuum tubes, we have in reality a number of small condensers in that

there is a definite electrical capacity, for instance, between the plate and the grid, between the grid and cathode, and also between the plate and cathode, for the simple reason that each of these elements can be likened to the plates of a small condenser (current absorber). The grid to cathode capacitance is termed the *input capacitance*. The *output capacitance* is the capacity between the plate and cathode. In many very "high-gain" circuits, it is necessary to neutralize the plate to grid capacity in order that energy will not be fed back from the plate circuit to the grid circuit.

The Screen-Grid

This can be accomplished either by external methods of *neutralizing*, which will be explained later, or by inserting a shield or a screen between the plate of the tube and the grid. This is commonly termed the *screen-grid* and tubes having a control grid and a *screen-grid*, together with the anode and cathode, are termed *tetrodes*.

This screen-grid is so designed that it will effectively shield the plate from the grid. While the plate to grid capacity of a triode may be as great as 8 mmf., the plate to grid capacitance of a screen-grid tube may be reduced to a value as low as .007 mmf. This screen must be constructed so that it will not materially obstruct the flow of electrons between the cathode and plate;

therefore, it is made in the form of wire mesh.

It also must not be negatively charged because the flow of electrons would also be impeded. Therefore, a positive potential is in most cases applied to the screen-grid in order to accelerate the flow of electrons to the plate. This screen being an electrostatic shield must be by-passed with a condenser to the cathode in order to be *grounded*, in so far as high frequency currents are concerned.

The voltage applied to the screen is usually lower than the plate voltage. The stream of electrons going to the plate being greatly accelerated by the screen-grid, may strike the plate at such a terrific speed that they will dislodge other electrons, which may be attracted to the screen, which is the nearest positively charged element. This is known as *secondary emission* and limits the output capabilities of the tube. This condition can be overcome by inserting between the screen and the plate another element which will not obstruct the flow of electrons to the plate but prevent them from returning to the screen.

In order to accomplish this, the third grid or *suppressor* is usually connected directly to the cathode in order that electrons dislodged from the plate may continue back via the suppressor to the cathode.

In some tubes such as the type 34 and 39 this suppressor is connected directly to the cathode of the tube internally. However, tubes such as types 57 and 58 have a separate pin on the base for this suppressor grid, in order that in special circuits a *positive* or a *negative* voltage may be applied to it. The values, of course, will be dependent upon the circuit requirements. In large transmitting tubes of the *pentode* type (pentode is a name given to all tubes having 5 elements), this suppressor is positively charged to the order of 30 or 40 volts.*

*Some excellent books covering the electron theory and the operation of electron tubes are:

"Electrons at Work," by Charles D. Underhill.

"Radio Receiving Tubes," by Moyer & Wostrel. The RCA Tube Manual also contains a wealth of information covering the operation of various types of vacuum tubes.

"Principles of Radio Communication," Prof. John H. Morecroft.

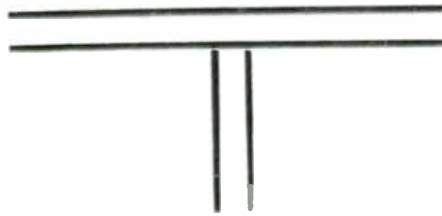

CHAPTER 3



RESISTANCE, INDUCTANCE and CAPACITY

● **RESISTANCE** capacity and inductance, in order to understand how a vacuum tube oscillates, how tuned circuits work, and the function of a tuning condenser, it is necessary to become familiar with these three very important subjects.

Resistance

When electrical current flows through a wire or some other conducting medium it encounters resistance or opposition, the same as the flow of material substances. For instance, a certain amount of water, can be forced through a length of one inch pipe with a definite pressure. In other words, the size of the pipe offers resistance to the flow. The larger the pipe becomes, the greater amount of water can be forced through it at a definite pressure, or the larger the pipe becomes, the less its resistance will be.

This holds true in conductance of electricity inasmuch as a fine wire or conductor offers a greater amount of resistance than a heavy conductor. The resistance of a conductor is inversely proportional to its cross sectional area and with some materials, in fact most of them, the resistance also increases as the temperature rises.

In dealing with resistance in electrical circuits, we have what is known as Ohm's Law. In Ohm's Law, we have to consider three things: First, the flow of electricity, which is current; second, the force or pressure, which is voltage; and third, the resistance which the flow of electricity encounters. Three letters are assigned to the above, and they are:

- I = Current
- E = Voltage (EMF)
- R = Resistance

The formulas for finding the resistance, voltage, or current, where either two of the three are known are as follows:

$$R = \frac{E}{I}$$

$$E = I \times R$$

$$I = \frac{E}{R}$$

When two or more resistors are connected in series the total value of the resistance is the *sum* of all the resistors. In other words, three 5 ohm resistors in series would have a total resistance of 15 ohms.

However, when resistors are connected in parallel the method of calculation is a bit more complicated. For instance, if we have three resistors connected in parallel, one has the resistance of 5 ohms, another of 10, and another of 20. The formula for expressing this is:

$$\frac{1}{R} = \frac{1}{R_1} + \frac{1}{R_2} + \frac{1}{R_3}$$

$$\frac{1}{R} = \frac{1}{5} + \frac{1}{10} + \frac{1}{20}$$

$$\frac{1}{R} = \frac{4}{20} + \frac{2}{20} + \frac{1}{20}$$

$$\frac{1}{R} = \frac{7}{20}$$

$$R = \frac{20}{7} \text{ or } R = 2.857 \text{ ohms}$$

Capacity

Most of us are familiar with the now well-known condenser which is an instrument capable of storing up a certain amount of electricity and consists of two or more plates placed adjacent to each other, with insulation of either air or some other insulating medium. When a constant direct voltage is applied between the plates of a condenser, current will flow into the condenser, until the condenser becomes

charged to its maximum capacity. The current then ceases to flow and the condenser is charged. Then, after the source of electricity (battery for example) is removed from the circuit, the condenser will hold its charge until, due to its inherent (conductivity of dielectric) resistance, the power is dissipated.

If the insulation is mica or parafined (waxed) paper, the condenser will hold its charge for a considerable length of time. In large condensers of one or two microfarads the charge may remain in the condenser for several hours. This can be proved by short-circuiting the two terminals of the condenser and noting the spark, or an ammeter could be connected

of the charging source stored up as electrostatic energy in the dielectric.

A simple analogy for the action of an electrical condenser is a sponge, which absorbs water when placed in a cupful of it, for example, and afterwards its pressure is exerted on the sponge, then it gives up the water stored in it. It requires 1 coulomb (ampere-second) to charge a condenser of 1 farad to a potential of 1 volt. A condenser having a capacity of 1 mf. (1 mf.=1 millionth of 1 farad) requires a charge of 1 millionth of 1 coulomb to charge it to a potential of 1 volt.

Inductance

The coils used in radio circuits are called *inductances* or *inductors*. In the drawings we

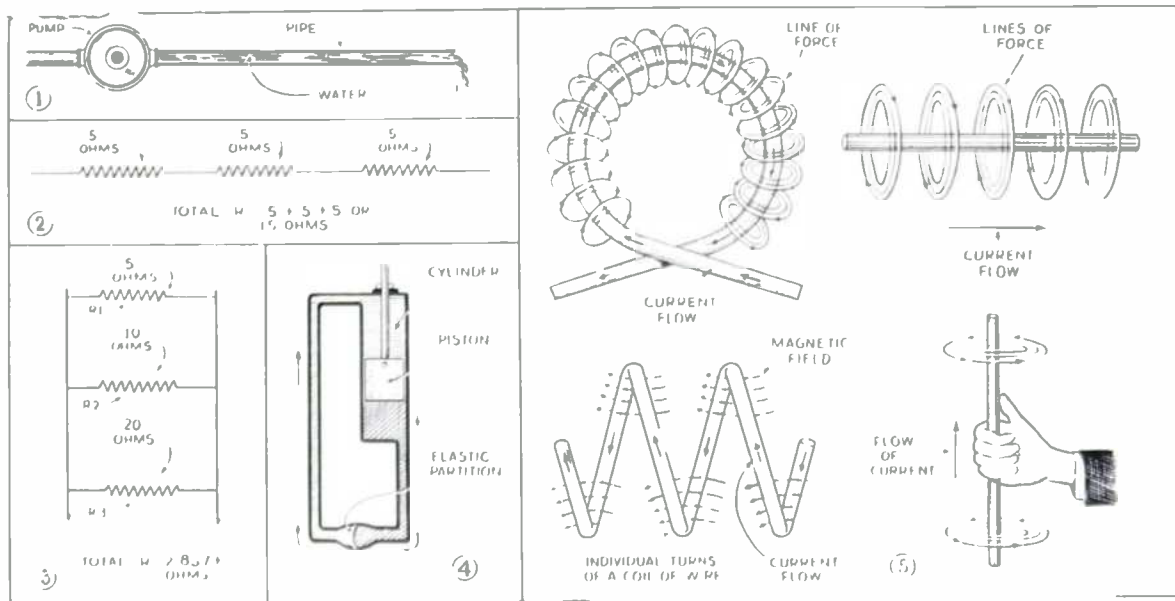

In Fig. 1 we have a diagram showing how the size of a pipe governs the amount that can be forced through it. In Fig. 2 we have resistors connected in series; in Fig. 3 they are connected in parallel; the formulae are given in the text. In Fig. 4 is the hydraulic analogy for the action of a condenser when alternating current is applied to it. Fig. 5 shows the magnetic fields and direction of current flow in straight wires and coils; also the right-hand rule is given, where, if the thumb points in the direction of the current flow, the four fingers will curve around the conductor in the direction of the magnetic field

across the condenser and it would indicate the current flowing until the condenser was completely discharged and the power dissipated. The unit of capacity is a *farad*; however, in radio work, we use considerably smaller units in our condensers.

A *microfarad* is one millionth of a farad, and one *micro-micro-farad* is one millionth of a microfarad. The most vital part of a condenser is the dielectric or insulating material because, contrary to popular belief, it is in the dielectric that the charge resides. When a condenser is charged, the dielectric opposes the setting up of an electric displacement of an electric field in the dielectric and the charge is said to be the energy

see how an electro-magnetic field may be produced around the wire when a current is passed through it. If the flow of current through a conductor is constant (D.C.) a *steady* electro-magnetic field is produced around the conductor. However, when alternating current (abbreviated A.C.) flows through a conductor, the current flow is constantly changing and likewise the field is changing.

When current begins to flow through a wire the circular electro-magnetic field originates at the center of the conductor and travels outwardly away from the center in constantly increasing diameters and of course, extends into the space surrounding

the wire. Until this field becomes of larger diameter than the wire, it causes a second current to flow in opposition to the main current.

When the current flow through the wire decreases or stops, the circular fields collapse and are then said to cut the wire in ever-diminishing diameters. This induces a current in the opposite direction to the field but in the same direction as the original (exciting) applied current, tending to prolong the flow of the exciting current.

This property of a coil or conductor to act upon itself or another inductor in close proximity to it, is called *inductance*. The unit of inductance is the henry and in most

less inductance than one of the same length which was coiled.

Induction subdivides into two branches—*self and mutual induction*. If the current passing through a coil, for example, is rising from zero to maximum value, such as when the circuit is closed from a battery, (or the first half of an alternation of an alternating current) the magnetic field around the wire is expanding and while this is taking place there is induced in the conductor a counter-current (and counter e.m.f. or voltage) which tends to buck or oppose the current (and voltage) which is producing the field.

As one of the diagrams shows there is electrical energy stored up in an inductive

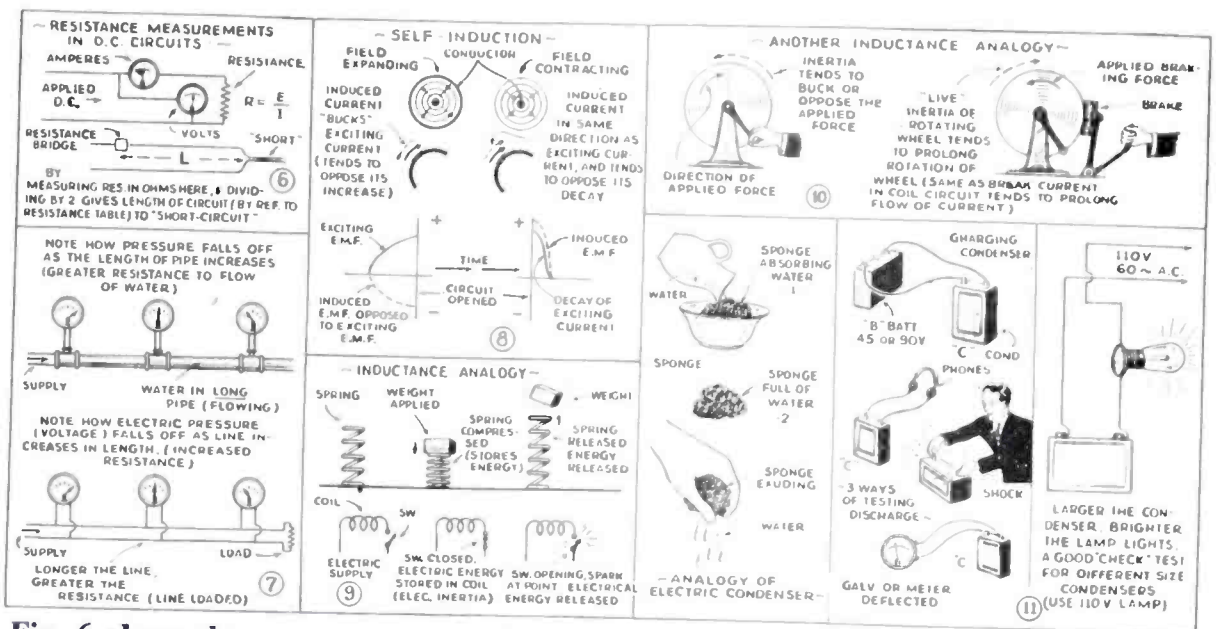

Fig. 6 above shows measurement of resistance. Fig. 7 shows how pressure or voltage decreases with increase in resistance to flow of water or electric current. Fig. 8 shows action of expanding and contracting magnetic fields. Fig. 9 shows mechanical "spring" analogy for inductance; Fig. 10—Fly wheel analogy of inductance. Fig. 11—Analogies for condenser.

formulas it is usually designated by the symbol "L." A *henry* is the inductance of a circuit in which the induced E.M.F. is one volt, when the (varying) current travels at the rate of one ampere in one second. Usually in radio circuits, inductance values are indicated as one thousandth of a henry or one *milli-henry*; a millionth of a henry is known as a *micro-henry*. The physical dimensions and form of a circuit, determine the amount of inductance and it is for this reason that our radio circuits consists of coils rather than straight wire, because a greater amount of inductance can be obtained by coiling the wire, also allowing considerably less D.C. resistance because less wire is used. A straight wire, of course, would have

circuit, just as if you had compressed a spring. The opening of the circuit, and spark at the switch, corresponds to releasing the compressed spring and heaving off the weight.

Another analogy is the flywheel. The inertia of the wheel opposes any force to set it in motion; once in motion, the energy tied up in the wheels tends to keep it going, if any effort is made to stop it.

Let us consider for a moment now the next phase of the action taking place when the circuit is opened or when the *second half* of the alternation of an applied A.C. is taking place. Now the magnetic field around the wire or turns of wire comprising the coil is contracting and while this occurs,

lines of magnetic force are cutting the wire in the opposite direction and a current of opposite sign is induced in the wire, this current being in the same direction as the applied (exciting) current which is flowing around the wire and creating the magnetic field.

In other words, the self-induced e.m.f. is in the opposite direction, while the field is *expanding* about the wire, and tends to oppose it while the opposite is the case when the field is *contracting* and the current is then in the same direction or aids the inducing current and acts to prevent its decay.

It will be apparent, of course, that while the current is varying in strength or let us say increasing, the field about the coil is expanding, and the lines of magnetic force extending out from the coil composed of a number of turns, will induce a current by *induction* in a second coil, placed near or adjacent to the first or exciting coil.

We term the exciting coil No. 1, and the adjacent *unconnected* coil as No. 2, coil 2 is said to have a current induced in it by *electro-magnetic induction*. As the magnetic field in coil No. 1 subsides, the magnetic force of force surrounding coil No. 2 also subsides. At the same time these lines of force are cut across the turns in coil No. 1 and induce therein an e.m.f. or voltage (also a current) and thus we have a third e.m.f. set up by induction.

To begin with, we have the original exciting e.m.f. in coil 1; secondly we find an induced e.m.f. in coil 2; and thirdly, there is *reinduced* e.m.f. in coil 1, due to the reaction of the magnetic field surrounding

coil 2, and this effect is what is known as *mutual induction*.

The usual radio tuned circuit consists of a coil and a condenser, namely: *inductance and capacity*. Coils or inductances have what is known as inductive reactance. When the capacity reactance minus the inductive reactance equals zero, at some certain frequency, the circuit is said to be in *resonance*.

When the condition known as *Resonance* has been established in any given circuit, whether a series or parallel type circuit, then we know that the inductive and capacitive reactance are equal, and that they balance each other. When this condition has been achieved their reactive effect upon the circuit is zero. Under these conditions, or when the circuit has been made resonant, (by the proper adjustment of the capacity and the inductance of the circuit) any current flowing in the circuit due to an applied e.m.f. will be that due simply to the ohmic or direct current resistance in the circuit. Expressed another way, the current passing through such a resonant circuit will be given by the expression: $I = E \div R$.

The difference between the capacitive and inductive reactance of a circuit at some frequency is called the impedance. However, at resonance, this is always zero, and the losses in the circuit are due only to the usual D.C. resistance of the circuit, through which the currents are flowing.

In Fig. 4 we see a hydraulic analogy of current flowing into a condenser. When the piston is moved forward, the elastic partition will bend or become curved but will not allow the liquid to be transferred from one side to the other.

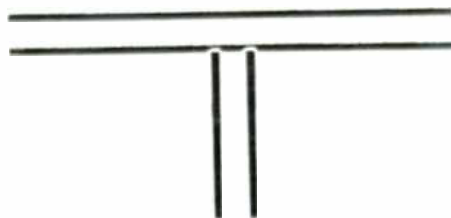

CHAPTER 3



RESISTANCE, INDUCTANCE and CAPACITY

● RESISTANCE, capacity and inductance, in order to understand how a vacuum tube oscillates, how tuned circuits work, and the function of a tuning condenser, it is necessary to become familiar with these three very important subjects.

Resistance

When electrical current flows through a wire or some other conducting medium it encounters resistance or opposition, the same as the flow of material substances. For instance, a certain amount of water, can be forced through a length of one inch pipe with a definite pressure. In other words, the size of the pipe offers resistance to the flow. The larger the pipe becomes, the greater amount of water can be forced through it at a definite pressure, or the larger the pipe becomes, the less its resistance will be.

This holds true in conductance of electricity inasmuch as a fine wire or conductor offers a greater amount of resistance than a heavy conductor. The resistance of a conductor is inversely proportional to its cross sectional area and with some materials, in fact most of them, the resistance also increases as the temperature rises.

In dealing with resistance in electrical circuits, we have what is known as Ohm's Law. In Ohm's Law, we have to consider three things: First, the flow of electricity, which is current; second, the force or pressure, which is voltage; and third, the resistance which the flow of electricity encounters. Three letters are assigned to the above, and they are:

- I = Current
- E = Voltage (EMF)
- R = Resistance

The formulas for finding the resistance, voltage, or current, where either two of the three are known are as follows:

$$I = \frac{E}{R}$$

$$E = IR$$

$$R = \frac{E}{I}$$

When two or more resistors are connected in series the total value of the resistance is the *sum* of all the resistors. In other words, three 5 ohm resistors in series would have a total resistance of 15 ohms.

However, when resistors are connected in parallel the method of calculation is a bit more complicated. For instance, if we have three resistors connected in parallel, one has the resistance of 5 ohms, another of 10 and another of 20. The formula for expressing this is:

$$\frac{1}{R} = \frac{1}{R_1} + \frac{1}{R_2} + \frac{1}{R_3} + \dots$$

$$\frac{1}{R} = \frac{1}{5} + \frac{1}{10} + \frac{1}{20}$$

$$\frac{1}{R} = \frac{4}{20} + \frac{2}{20} + \frac{1}{20}$$

$$\frac{1}{R} = \frac{7}{20}$$

$$R = \frac{20}{7} \text{ or } R = 2.857 \text{ ohms}$$

Capacity

Most of us are familiar with the now well-known condenser which is an instrument capable of storing up a certain amount of electricity and consists of two or more plates placed adjacent to each other, with insulation of either air or some other insulating medium. When a constant direct voltage is applied between the plates of a condenser, current will flow into the condenser, until the condenser becomes

charged to its maximum capacity. The current then ceases to flow and the condenser is charged. Then, after the source of electricity (battery for example) is removed from the circuit, the condenser will hold its charge until, due to its inherent (conductivity of dielectric) resistance, the power is dissipated.

If the insulation is mica or parafined (waxed) paper, the condenser will hold its charge for a considerable length of time. In large condensers of one or two microfarads the charge may remain in the condenser for several hours. This can be proved by short-circuiting the two terminals of the condenser and noting the spark, or an ammeter could be connected

of the charging source stored up as electrostatic energy in the dielectric.

A simple analogy for the action of an electrical condenser is a sponge, which absorbs water when placed in a cupful of it, for example, and afterwards is pressure is exerted on the sponge, then it gives up the water stored in it. It requires 1 coulomb (ampere-second) to charge a condenser of 1 farad to a potential of 1 volt. A condenser having a capacity of 1 mf. (1 mf.=1 millionth of 1 farad) requires a charge of 1 millionth of 1 coulomb to charge it to a potential of 1 volt.

Inductance

The coils used in radio circuits are called *inductances* or *inductors*. In the drawings we

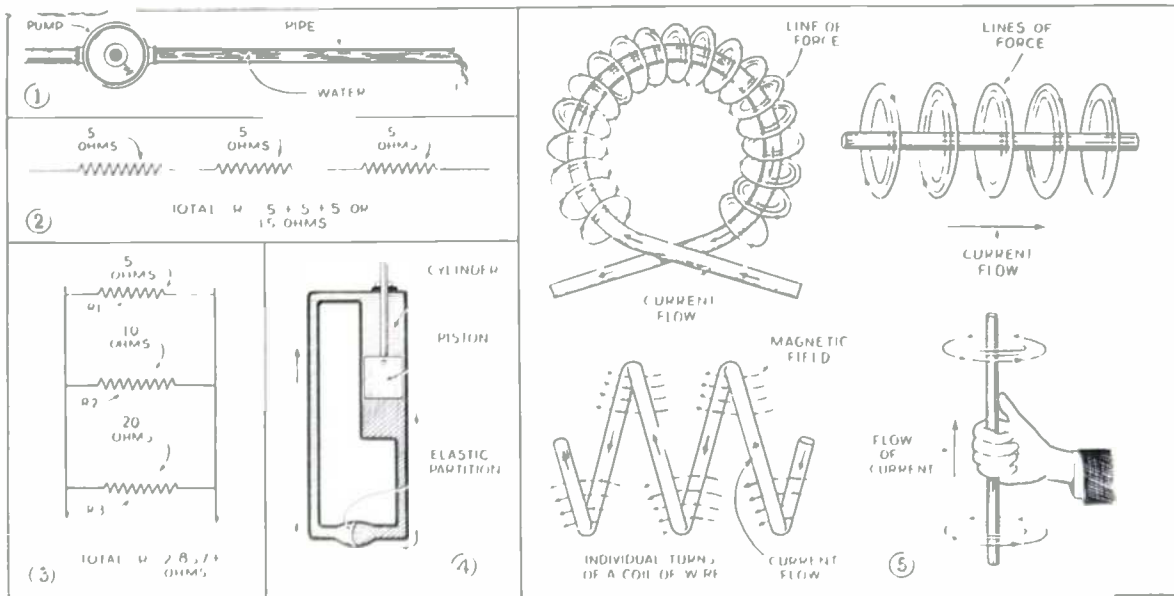

In Fig. 1 we have a diagram showing how the size of a pipe governs the amount that can be forced through it. In Fig. 2 we have resistors connected in series; in Fig. 3 they are connected in parallel; the formulæ are given in the text. In Fig. 4 is the hydraulic analogy for the action of a condenser when alternating current is applied to it. Fig. 5 shows the magnetic fields and direction of current flow in straight wires and coils; also the right-hand rule is given, where, if the thumb points in the direction of the current flow, the four fingers will curve around the conductor in the direction of the magnetic field

across the condenser and it would indicate the current flowing until the condenser was completely discharged and the power dissipated. The unit of capacity is a *farad*; however, in radio work, we use considerably smaller units in our condensers.

A *microfarad* is one millionth of a farad, and one *micro-micro-farad* is one millionth of a microfarad. The most vital part of a condenser is the dielectric or insulating material because, contrary to popular belief, it is in the dielectric that the charge resides. When a condenser is charged, the dielectric opposes the setting up of an electric displacement of an electric field in the dielectric and the charge is said to be the energy

see how an electro-magnetic field may be produced around the wire when a current is passed through it. If the flow of current through a conductor is constant (D.C.) a *steady* electro-magnetic field is produced around the conductor. However, when alternating current (abbreviated A.C.) flows through a conductor, the current flow is constantly changing and likewise the field is changing.

When current begins to flow through a wire the circular electro-magnetic field originates at the center of the conductor and travels outwardly away from the center in constantly increasing diameters and of course, extends into the space surrounding

the wire. Until this field becomes of larger diameter than the wire, it causes a second current to flow in opposition to the main current.

When the current flow through the wire decreases or stops, the circular fields collapse and are then said to cut the wire in ever-diminishing diameters. This induces a current in the opposite direction to the field but in the same direction as the original (exciting) applied current, tending to prolong the flow of the exciting current.

This property of a coil or conductor to act upon itself or another inductor in close proximity to it, is called *inductance*. The unit of inductance is the henry and in most

less inductance than one of the same length which was coiled.

Induction subdivides into two branches—*self and mutual induction*. If the current passing through a coil, for example, is rising from zero to maximum value, such as when the circuit is closed from a battery, (or the first half of an alternation of an alternating current) the magnetic field around the wire is expanding and while this is taking place there is induced in the conductor a counter-current (and counter e.m.f. or voltage) which tends to buck or oppose the current (and voltage) which is producing the field.

As one of the diagrams shows there is electrical energy stored up in an inductive

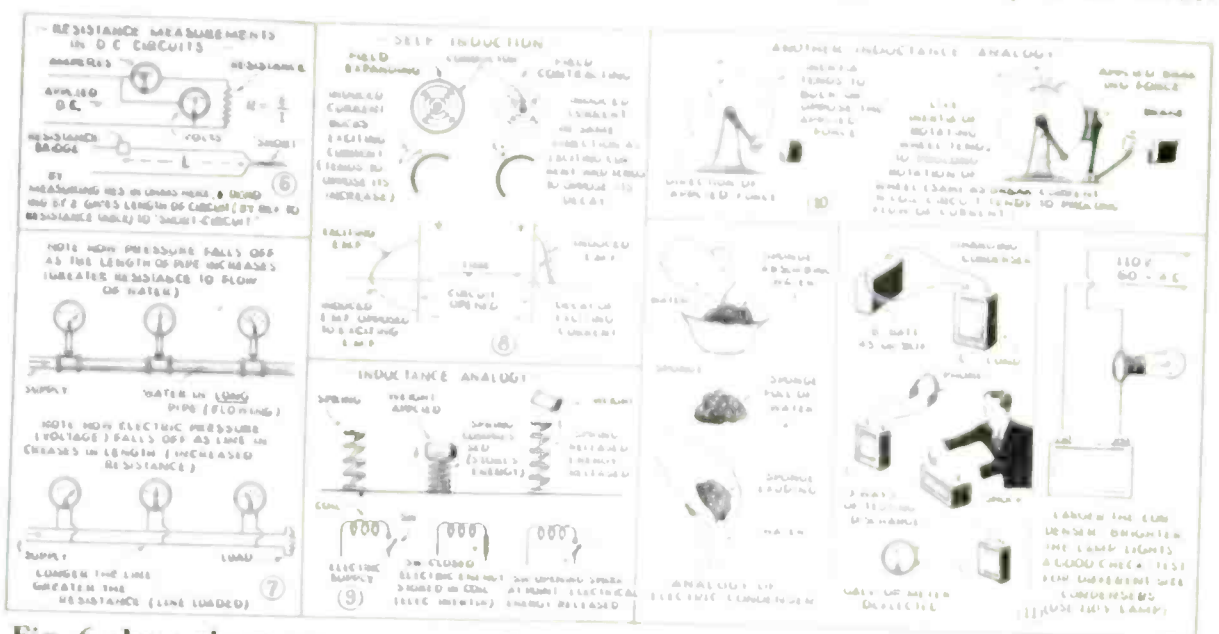

Fig. 6 above shows measurement of resistance. Fig. 7 shows how pressure or voltage decreases with increase in resistance to flow of water or electric current. Fig. 7 shows how pressure or voltage decreases with increase in resistance to flow of water or electric current. Fig. 8 shows action of expanding and contracting magnetic fields. Fig. 9 shows mechanical "spring" analogy for inductance; Fig. 10—Fly wheel analogy of inductance. Fig. 11—Analogies for condenser.

formulas it is usually designated by the symbol "L." A *henry* is the inductance of a circuit in which the induced E.M.F. is one volt, when the (varying) current travels at the rate of one ampere in one second. Usually in radio circuits, inductance values are indicated as one thousandth of a henry or one *milli-henry*; a millionth of a henry is known as a *micro-henry*. The physical dimensions and form of a circuit, determine the amount of inductance and it is for this reason that our radio circuits consists of coils rather than straight wire, because a greater amount of inductance can be obtained by coiling the wire, also allowing considerably less D.C. resistance because less wire is used. A straight wire, of course, would have

circuit, just as if you had compressed a spring. The opening of the circuit, and spark at the switch, corresponds to releasing the compressed spring and heaving off the weight.

Another analogy is the flywheel. The inertia of the wheel opposes any force to set it in motion; once in motion, the energy tied up in the wheels tends to keep it going, if any effort is made to stop it.

Let us consider for a moment now the next phase of the action taking place when the circuit is opened or when the *second half* of the alternation of an applied A.C. is taking place. Now the magnetic field around the wire or turns of wire comprising the coil is contracting and while this occurs.

the lines of magnetic force are cutting the wire in the opposite direction and a current of opposite sign is induced in the wire, this current being in the same direction as the applied (exciting) current which is flowing around the wire and creating the magnetic field.

In other words, the self-induced e.m.f. is in the opposite direction, while the field is *expanding* about the wire, and tends to oppose it while the opposite is the case when the field is *contracting* and the current is then in the same direction or aids the inducing current and acts to prevent its decay.

It will be apparent, of course, that while the current is varying in strength or let us say increasing, the field about the coil is expanding, and the lines of magnetic force expanding out from the coil composed of a number of turns, will induce a current by *induction* in a second coil, placed near or adjacent to the first or exciting coil.

If we term the exciting coil No. 1, and the adjacent *unconnected* coil as No. 2, coil 2 is said to have a current induced in it by *electro-magnetic induction*. As the magnetic field in coil No. 1 subsides, the magnetic lines of force surrounding coil No. 2 also subsides. At the same time these lines of force cut across the turns in coil No. 1 and induce therein an e.m.f. or voltage (also a current) and thus we have a third e.m.f. set up by induction.

To begin with, we have the original exciting e.m.f. in coil 1; secondly we find an induced e.m.f. in coil 2; and thirdly, there is a *reinduced* e.m.f. in coil 1, due to the reaction of the magnetic field surrounding

coil 2, and this effect is what is known as *mutual induction*.

The usual radio tuned circuit consists of a coil and a condenser, namely: *inductance and capacity*. Coils or inductances have what is known as inductive reactance. When the capacity reactance minus the inductive reactance equals zero, at some certain frequency, the circuit is said to be in *resonance*.

When the condition known as *Resonance* has been established in any given circuit, whether a series or parallel type circuit, then we know that the inductive and capacitive reactance are equal, and that they balance each other. When this condition has been achieved their reactive effect upon the circuit is zero. Under these conditions, or when the circuit has been made resonant, (by the proper adjustment of the capacity and the inductance of the circuit) any current flowing in the circuit due to an applied e.m.f. will be that due simply to the ohmic or direct current resistance in the circuit. Expressed another way, the current passing through such a resonant circuit will be given by the expression: $I = E \div R$.

The difference between the capacitive and inductive reactance of a circuit at some frequency is called the impedance. However, at resonance, this is always zero, and the losses in the circuit are due only to the usual D.C. resistance of the circuit, through which the currents are flowing.

In Fig. 4 we see a hydraulic analogy of current flowing into a condenser. When the piston is moved forward, the elastic partition will bend or become curved but will not allow the liquid to be transferred from one side to the other.

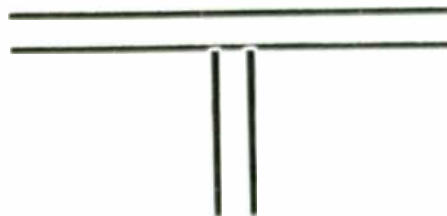

CHAPTER 3



RESISTANCE, INDUCTANCE and CAPACITY

● RESISTANCE, capacity and inductance, in order to understand how a vacuum tube oscillates, how tuned circuits work, and the function of a tuning condenser, it is necessary to become familiar with these three very important subjects.

Resistance

When electrical current flows through a wire or some other conducting medium it encounters resistance or opposition, the same as the flow of material substances. For instance, a certain amount of water can be forced through a length of one inch pipe with a definite pressure. In other words, the size of the pipe offers resistance to the flow. The larger the pipe becomes, the greater amount of water can be forced through it at a definite pressure, or the larger the pipe becomes, the less its resistance will be.

This holds true in conductance of electricity inasmuch as a fine wire or conductor offers a greater amount of resistance than a heavy conductor. The resistance of a conductor is inversely proportional to its cross sectional area and with some materials, in fact most of them, the resistance also increases as the temperature rises.

In dealing with resistance in electrical circuits, we have what is known as Ohm's Law. In Ohm's Law, we have to consider three things: First, the flow of electricity, which is current; second, the force or pressure, which is voltage; and third, the resistance which the flow of electricity encounters. Three letters are assigned to the above, and they are:

- I = Current
- E = Voltage (EMF)
- R = Resistance

The formulas for finding the resistance, voltage, or current, where either two of the three are known are as follows:

$$I = \frac{E}{R}$$

$$E = IR$$

$$R = \frac{E}{I}$$

$$E = I \times R \times 1.08$$

When two or more resistors are connected in series the total value of the resistance is the *sum* of all the resistors. In other words, three 5 ohm resistors in series would have a total resistance of 15 ohms.

However, when resistors are connected in parallel the method of calculation is a bit more complicated. For instance, if we have three resistors connected in parallel, one has the resistance of 5 ohms, another of 10 and another of 20. The formula for expressing this is:

$$\frac{1}{R} = \frac{1}{R_1} + \frac{1}{R_2} + \frac{1}{R_3}$$

$$\frac{1}{R} = \frac{1}{5} + \frac{1}{10} + \frac{1}{20}$$

$$\frac{1}{R} = \frac{2}{10} + \frac{1}{10} + \frac{1}{20}$$

$$\frac{1}{R} = \frac{3}{10} + \frac{1}{20} = \frac{6}{20} + \frac{1}{20} = \frac{7}{20}$$

Capacity

Most of us are familiar with the now well-known condenser which is an instrument capable of storing up a certain amount of electricity and consists of two or more plates placed adjacent to each other, with insulation of either air or some other insulating medium. When a constant direct voltage is applied between the plates of a condenser, current will flow into the condenser, until the condenser becomes

charged to its maximum capacity. The current then ceases to flow and the condenser is charged. Then, after the source of electricity (battery for example) is removed from the circuit, the condenser will hold its charge until, due to its inherent (conductivity of dielectric) resistance, the power is dissipated.

If the insulation is mica or parafined (waxed) paper, the condenser will hold its charge for a considerable length of time. In large condensers of one or two microfarads the charge may remain in the condenser for several hours. This can be proved by short-circuiting the two terminals of the condenser and noting the spark, or an ammeter could be connected

of the charging source stored up as electrostatic energy in the dielectric.

A simple analogy for the action of an electrical condenser is a sponge, which absorbs water when placed in a cupful of it, for example, and afterwards if pressure is exerted on the sponge, then it gives up the water stored in it. It requires 1 coulomb (ampere-second) to charge a condenser of 1 farad to a potential of 1 volt. A condenser having a capacity of 1 mf. (1 mf.=1 millionth of 1 farad) requires a charge of 1 millionth of 1 coulomb to charge it to a potential of 1 volt.

Inductance

The coils used in radio circuits are called *inductances* or *inductors*. In the drawings we

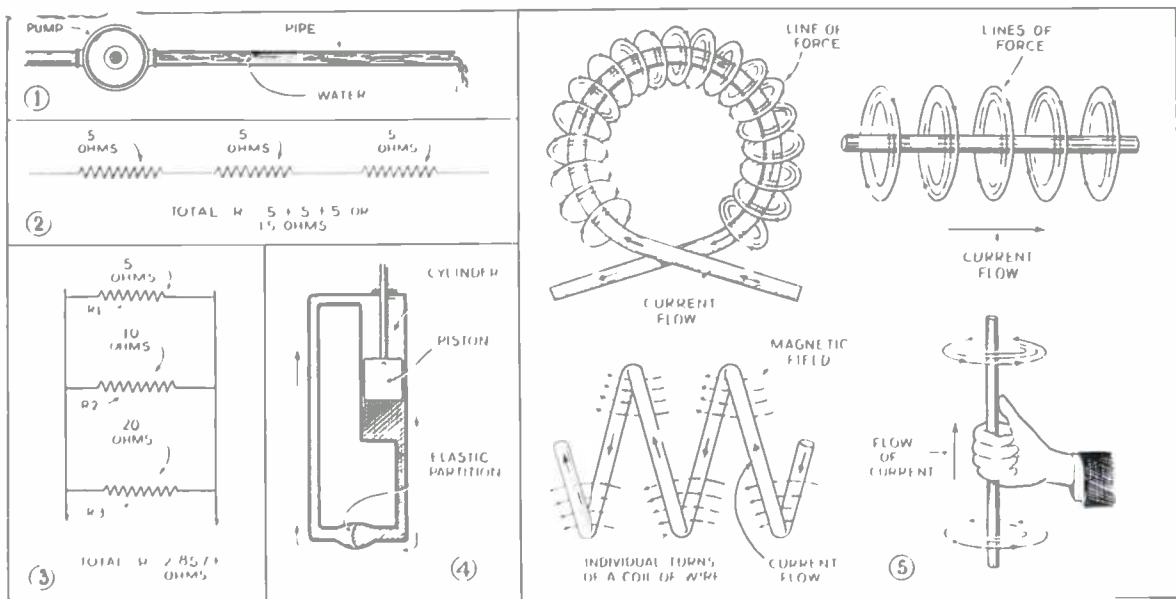

In Fig. 1 we have a diagram showing how the size of a pipe governs the amount that can be forced through it. In Fig. 2 we have resistors connected in series; in Fig. 3 they are connected in parallel; the formulae are given in the text. In Fig. 4 is the hydraulic analogy for the action of a condenser when alternating current is applied to it. Fig. 5 shows the magnetic fields and direction of current flow in straight wires and coils; also the right-hand rule is given, where, if the thumb points in the direction of the current flow, the four fingers will curve around the conductor in the direction of the magnetic field

across the condenser and it would indicate the current flowing until the condenser was completely discharged and the power dissipated. The unit of capacity is a *farad*; however, in radio work, we use considerably smaller units in our condensers.

A *microfarad* is one millionth of a farad, and one *micro-micro-farad* is one millionth of a microfarad. The most vital part of a condenser is the dielectric or insulating material because, contrary to popular belief, it is in the dielectric that the charge resides. When a condenser is charged, the dielectric opposes the setting up of an electric displacement of an electric field in the dielectric and the charge is said to be the energy

see how an electro-magnetic field may be produced around the wire when a current is passed through it. If the flow of current through a conductor is constant (D.C.) a *steady* electro-magnetic field is produced around the conductor. However, when alternating current (abbreviated A.C.) flows through a conductor, the current flow is constantly changing and likewise the field is changing.

When current begins to flow through a wire the circular electro-magnetic field originates at the center of the conductor and travels outwardly away from the center in constantly increasing diameters and of course, extends into the space surrounding

CHAPTER 3



RESISTANCE, INDUCTANCE and CAPACITY

● **RESISTANCE**, capacity and inductance, in order to understand how a vacuum tube oscillates, how tuned circuits work, and the function of a tuning condenser, it is necessary to become familiar with these three very important subjects

Resistance

When electrical current flows through a wire or some other conducting medium it encounters resistance or opposition, the same as the flow of material substances. For instance, a certain amount of water, can be forced through a length of one inch pipe with a definite pressure. In other words, the size of the pipe offers resistance to the flow. The larger the pipe becomes, the greater amount of water can be forced through it at a definite pressure, or the larger the pipe becomes, the less its resistance will be.

This holds true in conductance of electricity inasmuch as a fine wire or conductor offers a greater amount of resistance than a heavy conductor. The resistance of a conductor is inversely proportional to its cross sectional area and with some materials, in fact most of them, the resistance also increases as the temperature rises.

In dealing with resistance in electrical circuits, we have what is known as Ohm's Law. In Ohm's Law, we have to consider three things: First, the flow of electricity, which is current; second, the force or pressure, which is voltage; and third, the resistance which the flow of electricity encounters. Three letters are assigned to the above, and they are:

- I = Current
- E = Voltage (EMF)
- R = Resistance

The formulas for finding the resistance, voltage, or current, where either two of the three are known are as follows:

$$I = \frac{E}{R} \times 1000$$

$$E = I \times R$$

$$R = \frac{E}{I} \times 1000$$

When two or more resistors are connected in series the total value of the resistance is the *sum* of all the resistors. In other words, three 5-ohm resistors in series would have a total resistance of 15 ohms.

However, when resistors are connected in parallel the method of calculation is a bit more complicated. For instance, if we have three resistors connected in parallel, one has the resistance of 5 ohms, another of 10 and another of 20. The formula for expressing this is

$$\frac{1}{R} = \frac{1}{R_1} + \frac{1}{R_2} + \frac{1}{R_3}$$

$$\frac{1}{R} = \frac{1}{5} + \frac{1}{10} + \frac{1}{20}$$

$$\frac{1}{R} = \frac{4}{20} + \frac{2}{20} + \frac{1}{20}$$

$$\frac{1}{R} = \frac{7}{20}$$

$$R = \frac{20}{7} \text{ or } R = 2.857 \times 1000$$

$$R = 2857 \text{ ohms}$$

Capacity

Most of us are familiar with the now well-known condenser which is an instrument capable of storing up a certain amount of electricity and consists of two or more plates placed adjacent to each other, with insulation of either air or some other insulating medium. When a constant direct voltage is applied between the plates of a condenser, current will flow into the condenser, until the condenser becomes

charged to its maximum capacity. The current then ceases to flow and the condenser is charged. Then, after the source of electricity (battery for example) is removed from the circuit, the condenser will hold its charge until, due to its inherent (conductivity of dielectric) resistance, the power is dissipated.

If the insulation is mica or parafined (waxed) paper, the condenser will hold its charge for a considerable length of time. In large condensers of one or two microfarads the charge may remain in the condenser for several hours. This can be proved by short-circuiting the two terminals of the condenser and noting the spark, or an ammeter could be connected

of the charging source stored up as electrostatic energy in the dielectric.

A simple analogy for the action of an electrical condenser is a sponge, which absorbs water when placed in a cupful of it, for example, and afterwards is pressure is exerted on the sponge, then it gives up the water stored in it. It requires 1 coulomb (ampere-second) to charge a condenser of 1 farad to a potential of 1 volt. A condenser having a capacity of 1 mf. (1 mf.=1 millionth of 1 farad) requires a charge of 1 millionth of 1 coulomb to charge it to a potential of 1 volt.

Inductance

The coils used in radio circuits are called *inductances* or *inductors*. In the drawings we

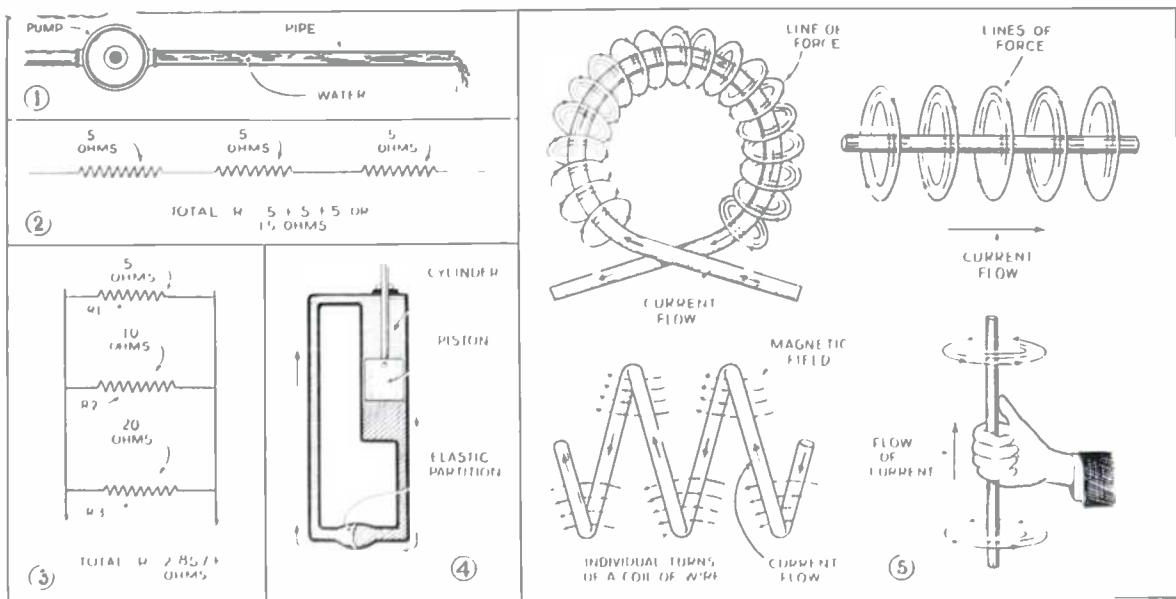

In Fig. 1 we have a diagram showing how the size of a pipe governs the amount that can be forced through it. In Fig. 2 we have resistors connected in series; in Fig. 3 they are connected in parallel; the formulae are given in the text. In Fig. 4 is the hydraulic analogy for the action of a condenser when alternating current is applied to it. Fig. 5 shows the magnetic fields and direction of current flow in straight wires and coils; also the right-hand rule is given, where, if the thumb points in the direction of the current flow, the four fingers will curve around the conductor in the direction of the magnetic field

across the condenser and it would indicate the current flowing until the condenser was completely discharged and the power dissipated. The unit of capacity is a *farad*; however, in radio work, we use considerably smaller units in our condensers.

A *microfarad* is one millionth of a farad, and one *micro-micro-farad* is one millionth of a microfarad. The most vital part of a condenser is the dielectric or insulating material because, contrary to popular belief, it is in the dielectric that the charge resides. When a condenser is charged, the dielectric opposes the setting up of an electric displacement of an electric field in the dielectric and the charge is said to be the energy

see how an electro-magnetic field may be produced around the wire when a current is passed through it. If the flow of current through a conductor is constant (D.C.) a *steady* electro-magnetic field is produced around the conductor. However, when alternating current (abbreviated A.C.) flows through a conductor, the current flow is constantly changing and likewise the field is changing.

When current begins to flow through a wire the circular electro-magnetic field originates at the center of the conductor and travels outwardly away from the center in constantly increasing diameters and of course, extends into the space surrounding

CHAPTER 3



RESISTANCE, INDUCTANCE and CAPACITY

● **RESISTANCE**, capacity and inductance, in order to understand how a vacuum tube oscillates, how tuned circuits work, and the function of a tuning condenser, it is necessary to become familiar with these three very important subjects.

Resistance

When electrical current flows through a wire or some other conducting medium it encounters resistance or opposition, the same as the flow of material substances. For instance, a certain amount of water, can be forced through a length of one inch pipe with a definite pressure. In other words, the size of the pipe offers resistance to the flow. The larger the pipe becomes, the greater amount of water can be forced through it at a definite pressure, or the larger the pipe becomes, the less its resistance will be.

This holds true in conductance of electricity inasmuch as a fine wire or conductor offers a greater amount of resistance than a heavy conductor. The resistance of a conductor is inversely proportional to its cross sectional area and with some materials, in fact most of them, the resistance also increases as the temperature rises.

In dealing with resistance in electrical circuits, we have what is known as Ohm's Law. In Ohm's Law, we have to consider three things: First, the flow of electricity, which is current; second, the force or pressure, which is voltage; and third, the resistance which the flow of electricity encounters. Three letters are assigned to the above, and they are:

- I = Current
- E = Voltage (EMF)
- R = Resistance

The formulas for finding the resistance, voltage, or current, where either two of the three are known are as follows:

$$I = \frac{E}{R \times L}$$

When two or more resistors are connected in series the total value of the resistance is the *sum* of all the resistors. In other words, three 5-ohm resistors in series would have a total resistance of 15 ohms.

However, when resistors are connected in parallel the method of calculation is a bit more complicated. For instance, if we have three resistors connected in parallel, one has the resistance of 5 ohms, another of 10 and another of 20. The formula for expressing this is:

$$R = \frac{1}{\frac{1}{R_1} + \frac{1}{R_2} + \frac{1}{R_3}}$$

$$R = \frac{1}{.2 + .1 + .05}$$

$$R = \frac{1}{.35} \text{ or } R = 2.857 \text{ ohms}$$

Capacity

Most of us are familiar with the now well-known condenser which is an instrument capable of storing up a certain amount of electricity and consists of two or more plates placed adjacent to each other, with insulation of either air or some other insulating medium. When a constant direct voltage is applied between the plates of a condenser, current will flow into the condenser, until the condenser becomes

charged to its maximum capacity. The current then ceases to flow and the condenser is charged. Then, after the source of electricity (battery for example) is removed from the circuit, the condenser will hold its charge until, due to its inherent (conductivity of dielectric) resistance, the power is dissipated.

If the insulation is mica or paraffined (waxed) paper, the condenser will hold its charge for a considerable length of time. In large condensers of one or two microfarads the charge may remain in the condenser for several hours. This can be proved by short-circuiting the two terminals of the condenser and noting the spark, or an ammeter could be connected

of the charging source stored up as electrostatic energy in the dielectric.

A simple analogy for the action of an electrical condenser is a sponge, which absorbs water when placed in a cupful of it, for example, and afterwards if a pressure is exerted on the sponge, then it gives up the water stored in it. It requires 1 coulomb (ampere-second) to charge a condenser of 1 farad to a potential of 1 volt. A condenser having a capacity of 1 mf. (1 mf.=1 millionth of 1 farad) requires a charge of 1 millionth of 1 coulomb to charge it to a potential of 1 volt.

Inductance

The coils used in radio circuits are called *inductances* or *inductors*. In the drawings we

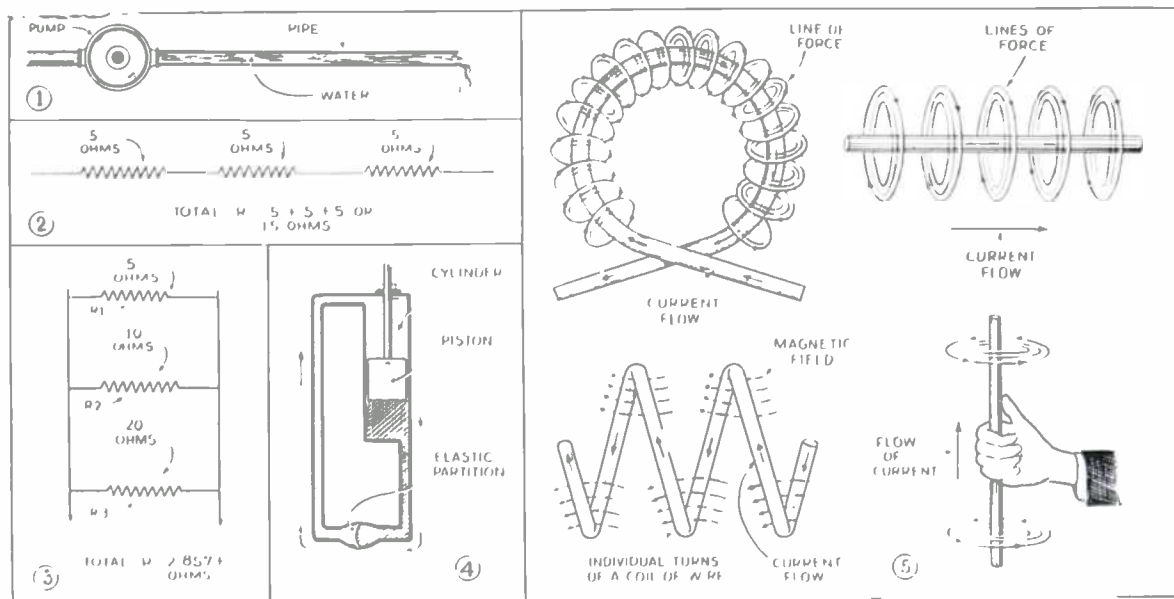

In Fig. 1 we have a diagram showing how the size of a pipe governs the amount that can be forced through it. In Fig. 2 we have resistors connected in series; in Fig. 3 they are connected in parallel; the formulae are given in the text. In Fig. 4 is the hydraulic analogy for the action of a condenser when alternating current is applied to it. Fig. 5 shows the magnetic fields and direction of current flow in straight wires and coils; also the right-hand rule is given, where, if the thumb points in the direction of the current flow, the four fingers will curve around the conductor in the direction of the magnetic field

across the condenser and it would indicate the current flowing until the condenser was completely discharged and the power dissipated. The unit of capacity is a *farad*; however, in radio work, we use considerably smaller units in our condensers.

A *microfarad* is one millionth of a farad, and one *micro-micro-farad* is one millionth of a microfarad. The most vital part of a condenser is the dielectric or insulating material because, contrary to popular belief, it is in the dielectric that the charge resides. When a condenser is charged, the dielectric opposes the setting up of an electric displacement of an electric field in the dielectric and the charge is said to be the energy

see how an electro-magnetic field may be produced around the wire when a current is passed through it. If the flow of current through a conductor is constant (D.C.) a *steady* electro-magnetic field is produced around the conductor. However, when alternating current (abbreviated A.C.) flows through a conductor, the current flow is constantly changing and likewise the field is changing.

When current begins to flow through a wire the circular electro-magnetic field originates at the center of the conductor and travels outwardly away from the center in constantly increasing diameters and of course, extends into the space surrounding

CHAPTER 3



RESISTANCE, INDUCTANCE and CAPACITY

● **RESISTANCE**—capacity and inductance, in order to understand how a vacuum tube oscillates, how tuned circuits work, and the function of a tuning condenser, it is necessary to become familiar with these three very important subjects.

Resistance

When electrical current flows through a wire or some other conducting medium it encounters resistance or opposition, the same as the flow of material substances. For instance, a certain amount of water, can be forced through a length of one inch pipe with a definite pressure. In other words, the size of the pipe offers resistance to the flow. The larger the pipe becomes, the greater amount of water can be forced through it at a definite pressure, or the larger the pipe becomes, the less its resistance will be.

This holds true in conductance of electricity inasmuch as a fine wire or conductor offers a greater amount of resistance than a heavy conductor. The resistance of a conductor is inversely proportional to its cross sectional area and with some materials, in fact most of them, the resistance also increases as the temperature rises.

In dealing with resistance in electrical circuits, we have what is known as Ohm's Law. In Ohm's Law, we have to consider three things: First, the flow of electricity, which is current; second, the force or pressure, which is voltage; and third, the resistance which the flow of electricity encounters. Three letters are assigned to the above, and they are:

- I = Current
- E = Voltage (EMF)
- R = Resistance

The formulas for finding the resistance, voltage, or current, where either two of the three are known are as follows:

$$E = IR$$

$$I = \frac{E}{R}$$

$$R = \frac{E}{I}$$

$$E = IR$$

$$I = \frac{E}{R}$$

$$R = \frac{E}{I}$$

$$E = IR$$

$$I = \frac{E}{R}$$

$$R = \frac{E}{I}$$

When two or more resistors are connected in series the total value of the resistance is the *sum* of all the resistors. In other words, three 5 ohm resistors in series would have a total resistance of 15 ohms.

However, when resistors are connected in parallel the method of calculation is a bit more complicated. For instance, if we have three resistors connected in parallel, one has the resistance of 5 ohms, another of 10 and another of 20. The formula for expressing this is

$$\frac{1}{R} = \frac{1}{R_1} + \frac{1}{R_2} + \frac{1}{R_3}$$

$$\frac{1}{R} = \frac{1}{5} + \frac{1}{10} + \frac{1}{20}$$

$$\frac{1}{R} = \frac{2}{10} + \frac{1}{10} + \frac{0.5}{10}$$

$$\frac{1}{R} = \frac{3.5}{10} \text{ or } R = \frac{10}{3.5} = 2.857 \text{ ohms}$$

Capacity

Most of us are familiar with the now well-known condenser which is an instrument capable of storing up a certain amount of electricity and consists of two or more plates placed adjacent to each other, with insulation of either air or some other insulating medium. When a constant direct voltage is applied between the plates of a condenser, current will flow into the condenser, until the condenser becomes

charged to its maximum capacity. The current then ceases to flow and the condenser is charged. Then, after the source of electricity (battery for example) is removed from the circuit, the condenser will hold its charge until, due to its inherent (conductivity of dielectric) resistance, the power is dissipated.

If the insulation is mica or paraffined (waxed) paper, the condenser will hold its charge for a considerable length of time. In large condensers of one or two microfarads the charge may remain in the condenser for several hours. This can be proved by short-circuiting the two terminals of the condenser and noting the spark, or an ammeter could be connected

of the charging source stored up as electrostatic energy in the dielectric.

A simple analogy for the action of an electrical condenser is a sponge, which absorbs water when placed in a cupful of it, for example, and afterwards is pressure is exerted on the sponge, then it gives up the water stored in it. It requires 1 coulomb (ampere-second) to charge a condenser of 1 farad to a potential of 1 volt. A condenser having a capacity of 1 mf. (1 mf.=1 millionth of 1 farad) requires a charge of 1 millionth of 1 coulomb to charge it to a potential of 1 volt.

Inductance

The coils used in radio circuits are called *inductances* or *inductors*. In the drawings we

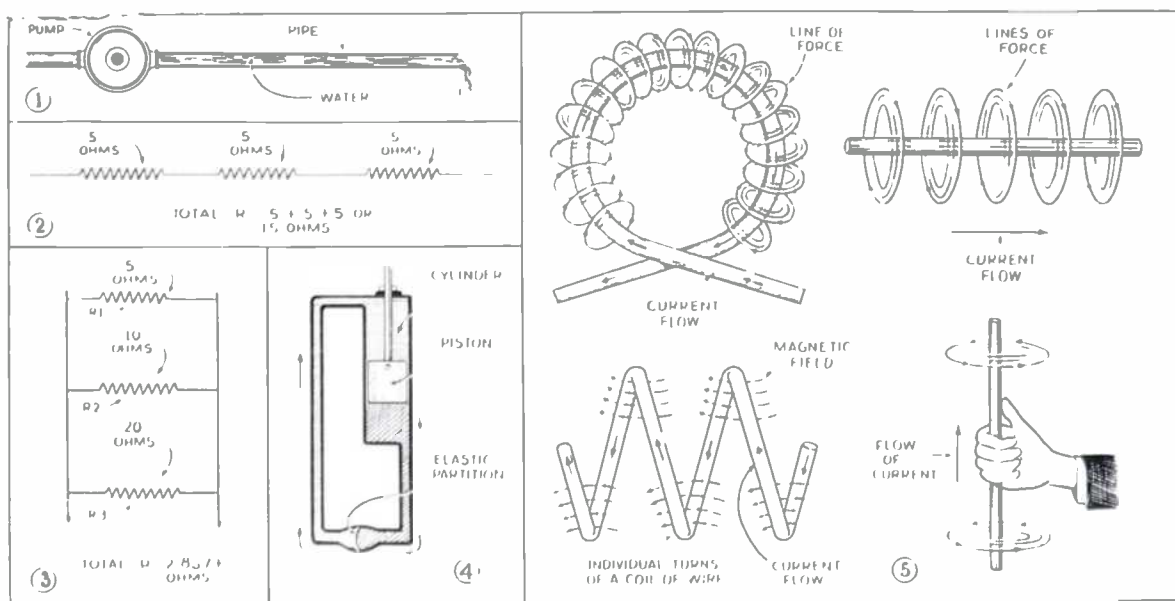

In Fig. 1 we have a diagram showing how the size of a pipe governs the amount that can be forced through it. In Fig. 2 we have resistors connected in series; in Fig. 3 they are connected in parallel; the formulae are given in the text. In Fig. 4 is the hydraulic analogy for the action of a condenser when alternating current is applied to it. Fig. 5 shows the magnetic fields and direction of current flow in straight wires and coils; also the right-hand rule is given, where, if the thumb points in the direction of the current flow, the four fingers will curve around the conductor in the direction of the magnetic field

across the condenser and it would indicate the current flowing until the condenser was completely discharged and the power dissipated. The unit of capacity is a *farad*; however, in radio work, we use considerably smaller units in our condensers.

A *microfarad* is one millionth of a farad, and one *micro-micro-farad* is one millionth of a microfarad. The most vital part of a condenser is the dielectric or insulating material because, contrary to popular belief, it is in the dielectric that the charge resides. When a condenser is charged, the dielectric opposes the setting up of an electric displacement of an electric field in the dielectric and the charge is said to be the energy

see how an electro-magnetic field may be produced around the wire when a current is passed through it. If the flow of current through a conductor is constant (D.C.) a *steady* electro-magnetic field is produced around the conductor. However, when alternating current (abbreviated A.C.) flows through a conductor, the current flow is constantly changing and likewise the field is changing.

When current begins to flow through a wire the circular electro-magnetic field originates at the center of the conductor and travels outwardly away from the center in constantly increasing diameters and of course, extends into the space surrounding

the wire. Until this field becomes of larger diameter than the wire, it causes a second current to flow in opposition to the main current.

When the current flow through the wire decreases or stops, the circular fields collapse and are then said to cut the wire in ever-diminishing diameters. This induces a current in the opposite direction to the field but in the same direction as the original (exciting) applied current, tending to prolong the flow of the exciting current.

This property of a coil or conductor to act upon itself or another inductor in close proximity to it, is called *inductance*. The unit of inductance is the henry and in most

less inductance than one of the same length which was coiled.

Induction subdivides into two branches—*self and mutual induction*. If the current passing through a coil, for example, is rising from zero to maximum value, such as when the circuit is closed from a battery, (or the first half of an alternation of an alternating current) the magnetic field around the wire is expanding and while this is taking place there is induced in the conductor a counter-current (and counter e.m.f. or voltage) which tends to buck or oppose the current (and voltage) which is producing the field.

As one of the diagrams shows there is electrical energy stored up in an inductive

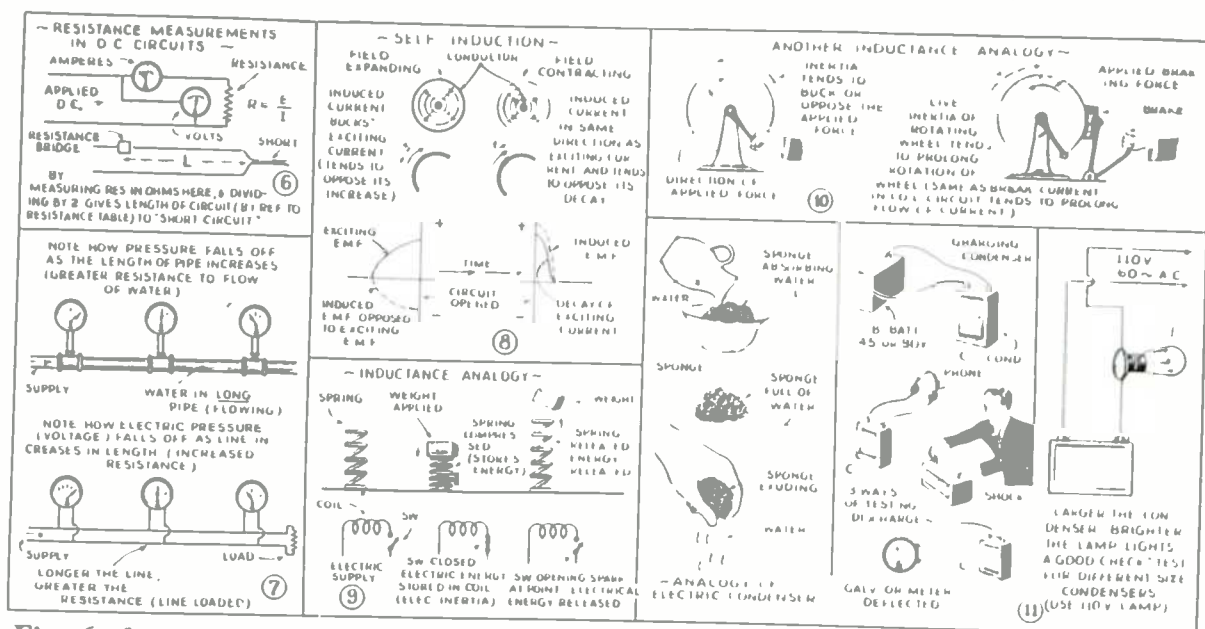

Fig. 6 above shows measurement of resistance. Fig. 7 shows how pressure or voltage decreases with increase in resistance to flow of water or electric current. Fig. 7 shows how pressure or voltage decreases with increase in resistance to flow of water or electric current. Fig. 8 shows action of expanding and contracting magnetic fields. Fig. 9 shows mechanical "spring" analogy for inductance; Fig. 10—Fly wheel analogy of inductance. Fig. 11—Analogies for condenser.

formulas it is usually designated by the symbol "L." A *henry* is the inductance of a circuit in which the induced E.M.F. is one volt, when the (varying) current travels at the rate of one ampere in one second. Usually in radio circuits, inductance values are indicated as one thousandth of a henry or one *milli-henry*; a millionth of a henry is known as a *micro-henry*. The physical dimensions and form of a circuit, determine the amount of inductance and it is for this reason that our radio circuits consists of coils rather than straight wire, because a greater amount of inductance can be obtained by coiling the wire, also allowing considerably less D.C. resistance because less wire is used. A straight wire, of course, would have

circuit, just as if you had compressed a spring. The opening of the circuit, and spark at the switch, corresponds to releasing the compressed spring and heaving off the weight.

Another analogy is the flywheel. The inertia of the wheel opposes any force to set it in motion; once in motion, the energy tied up in the wheels tends to keep it going, if any effort is made to stop it.

Let us consider for a moment now the next phase of the action taking place when the circuit is opened or when the *second half* of the alternation of an applied A.C. is taking place. Now the magnetic field around the wire or turns of wire comprising the coil is contracting and while this occurs,

the lines of magnetic force are cutting the wire in the opposite direction and a current of opposite sign is induced in the wire, this current being in the same direction as the applied (exciting) current which is flowing around the wire and creating the magnetic field.

In other words, the self-induced e.m.f. is in the opposite direction, while the field is *expanding* about the wire, and tends to oppose it while the opposite is the case when the field is *contracting* and the current is then in the same direction or aids the inducing current and acts to prevent its decay.

It will be apparent, of course, that while the current is varying in strength or let us say increasing, the field about the coil is expanding, and the lines of magnetic force expanding out from the coil composed of a number of turns, will induce a current by *induction* in a second coil, placed near or adjacent to the first or exciting coil.

If we term the exciting coil No. 1, and the adjacent *unconnected* coil as No. 2, coil 2 is said to have a current induced in it by *electro-magnetic induction*. As the magnetic field in coil No. 1 subsides, the magnetic lines of force surrounding coil No. 2 also subsides. At the same time these lines of force cut across the turns in coil No. 1 and induce therein an e.m.f. or voltage (also a current) and thus we have a third e.m.f. set up by induction.

To begin with, we have the original exciting e.m.f. in coil 1; secondly we find an induced e.m.f. in coil 2; and thirdly, there is a *reinduced* e.m.f. in coil 1, due to the reaction of the magnetic field surrounding

coil 2, and this effect is what is known as *mutual induction*.

The usual radio tuned circuit consists of a coil and a condenser, namely: *inductance and capacity*. Coils or inductances have what is known as inductive reactance. When the capacity reactance minus the inductive reactance equals zero, at some certain frequency, the circuit is said to be in *resonance*.

When the condition known as *Resonance* has been established in any given circuit, whether a series or parallel type circuit, then we know that the inductive and capacitive reactance are equal, and that they balance each other. When this condition has been achieved their reactive effect upon the circuit is zero. Under these conditions, or when the circuit has been made resonant, (by the proper adjustment of the capacity and the inductance of the circuit) any current flowing in the circuit due to an applied e.m.f. will be that due simply to the ohmic or direct current resistance in the circuit. Expressed another way, the current passing through such a resonant circuit will be given by the expression: $I = E \div R$.

The difference between the capacitive and inductive reactance of a circuit at some frequency is called the impedance. However, at resonance, this is always zero, and the losses in the circuit are due only to the usual D.C. resistance of the circuit, through which the currents are flowing.

In Fig. 4 we see a hydraulic analogy of current flowing into a condenser. When the piston is moved forward, the elastic partition will bend or become curved but will not allow the liquid to be transferred from one side to the other.

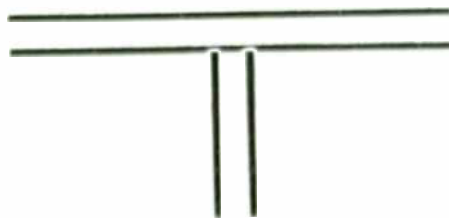

CHAPTER 4

• • •

VACUUM TUBE AS A REGENERATOR AND OSCILLATOR

● TO the average short wave "fan" or an experienced amateur, the two words *regeneration* and *oscillation* are very mystifying, insofar as the technicalities of them are concerned. In Webster's Unabridged Dictionary, the word *oscillation* is defined as follows: "To move backward and forward; to vibrate like a pendulum, to vary or fluctuate between fixed limits." The word *regenerate* in the same dictionary is defined as follows: "Reborn, reformed or created again."

In the chapter covering *alternating current*, we find the current starting at a zero point, building up to a maximum, decreasing again to zero, then building up in the opposite direction, and finally falling to zero, thus completing one cycle or one oscillation. An oscillating vacuum tube is a *generator of alternating current*, but has the advantage over the usual generator employed in generating our house current, in that it can be made to generate electricity of a frequency as high as five hundred million cycles. Before oscillation takes place in a vacuum tube, connected as shown in the accompanying drawings, we must have regeneration. This regeneration represents power taken from the output of the tube and fed back into the input circuit, amplified through the tube and taken out of the plate circuit again. In Figure 1 we have a simple circuit using a triode, which is capable of regenerating and oscillating. If we were to impose a signal voltage on the grid of this tube at the point marked X1, this signal would be carried through the tube and amplified; then by placing coil L1 in inductive relation to coil L2, this signal would be fed back from Coil L1 to L2 and reamplified. This process continues over and over again. That is why our regenerative circuits are so very sensitive.

How Oscillations Are Set Up

The circuit in Fig. 1 shows Coil L1 and L2 very close together. Suppose the filament is lighted and the switch marked "SW" is open; no current will be flowing in the plate circuit. Now if we close the switch, current will immediately start to flow through L1, through R1C and thence back to the filament.

Current flowing through L1 induces a field about the coil. This field is termed magnetic lines of force. As these lines of force thread through the turns of L2, a weak oscillating current is built up in the circuit composing L1 and C1; these weak oscillations are transmitted to the grid and amplified by the tube. If so happens that these oscillations (fed back) are of the proper phase, so that one aids the other, and as the feed back process continues, the oscillations build up in amplitude, as shown in Figure 2 (also Fig. 8). This build up in plate current would continue indefinitely if it were not for the automatic regulation which takes place due to the grid leak R. The grid current increases the same as the plate current increases, and this current flowing in the grid circuit causes a voltage drop across the resistor "R," and this drop is used to bias the tube, so that the plate current cannot rise above a certain fixed maximum. The "B" battery connected in the plate circuit, supplies the necessary power to perpetuate oscillations. In other words, there is no "perpetual motion" in the oscillator, as some people might be led to believe. In our previous chapter on vacuum tubes, we learned that a positive charge on the grid would cause an increase in plate current flow, while a negative charge would cause a decrease in current flow. Assuming that the induced EMF first

found in the circuit L2 applied a positive voltage to the grid, the plate current would rise *above its normal value*. This rise in current would strengthen the field around L1 and continue to increase the EMF induced in L2, and so the plate current would continue rising, remember that the energy used to cause the plate current to rise was taken from the plate circuit. This is the *feed-back* action. Due, as we said before, to the action of the grid-leak, this increase cannot continue indefinitely. When the plate current will then tend to decrease toward its normal resting value, and as it decreases, the magnetic field around L1 will begin to collapse or recede and thus move inward towards its center. The magnetic lines of force of this *decreasing* field now thread through the grid coil in a direction opposite to the movement when they were expanding; that is, when the plate current was rising. This induces an EMF in the grid circuit, but of the opposite polarity. Now, we assumed that the first impulse was *positive* to the grid; this one will then be *negative*, causing the plate current to continue to fall. This will cause a field to again cut the coil L2, causing a positive voltage, the same as the original impulse to be applied to the grid. This action will be reciprocated, and will continue indefinitely, and is termed *sustained oscillation*, just as we show in Figure 2.

The Hartley Oscillator

So far, we have considered an oscillating circuit of the *tickler* feed-back variety commonly used as *detectors* in short wave receivers. There are many varieties of this circuit. In Figures 3 and 4, we have the *Hartley* circuits. The one in Figure 3 has its plate voltage fed through the section of the coil marked L1, while the plate voltage of

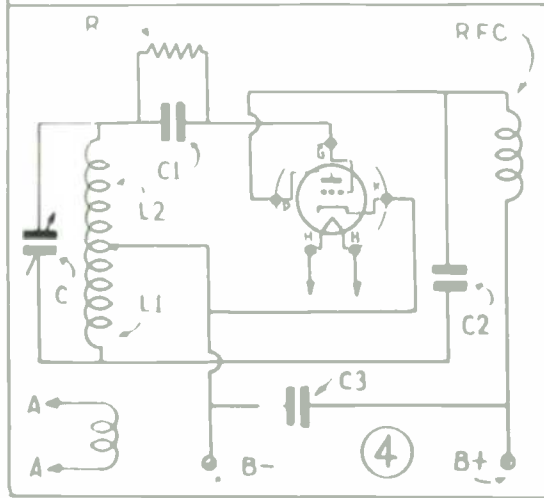
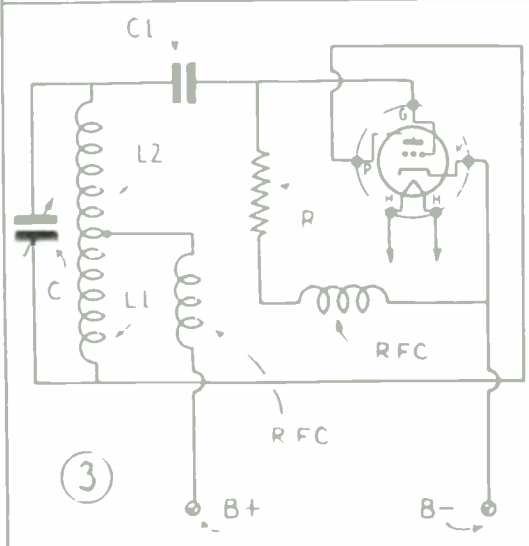
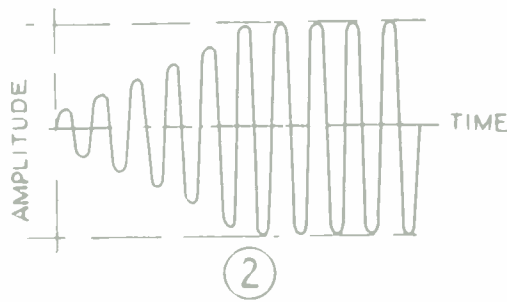
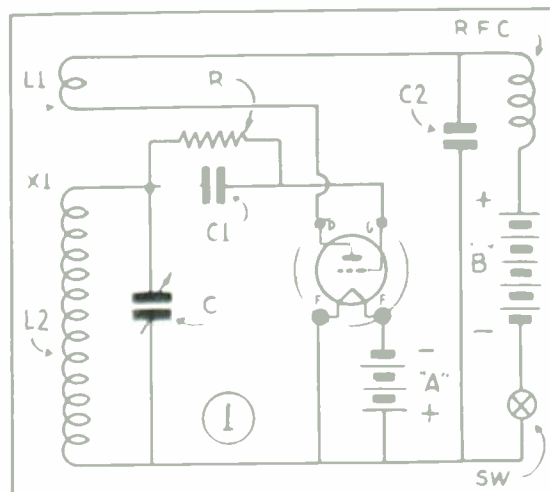

Fig. 1—The usual regenerative oscillating circuit used for receiving. Fig. 2 —The build-up of oscillations start feebly and are gradually increased in amplitude due to "regeneration" or "feed-back." Figs. 3-4—Series and shunt-fed transmitting circuits.

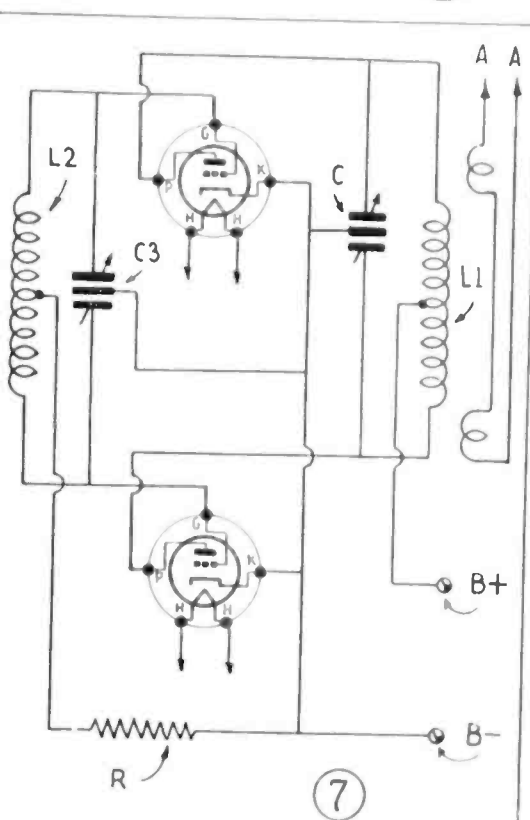
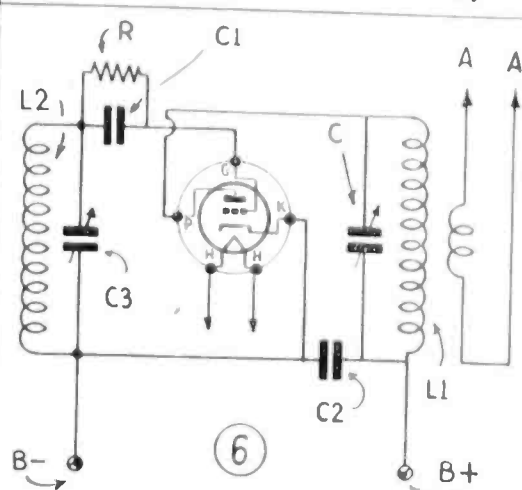
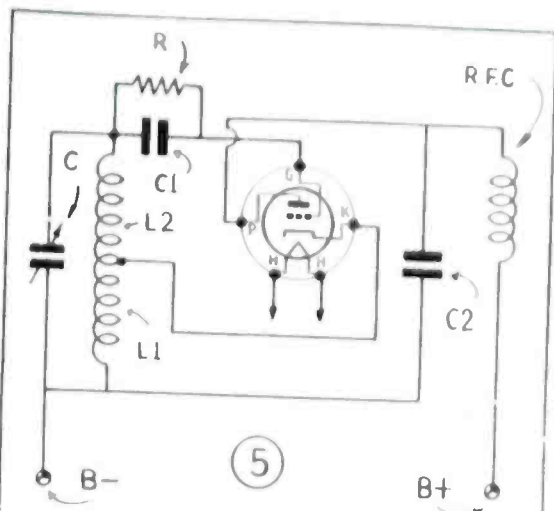

Figure 4 is fed directly to the plate of the tube through an R.F. choke. Figure 3 is known, as *series feed*, while Figure 4 is termed *parallel* or *shunt feed*. In both cases, we really have a tickler and grid coil as indicated by the letters L1 and L2. In present-day receiver circuits, and in some *transmitting* circuits, the cathode of the tube is connected to the coil in order to obtain feedback, and the plate is *apparently* not used. This may be quite mystifying to the average person, not technically inclined, but when comparing Figure 5, which has its cathode connected to the coil, with the diagram in Figure 4, we find there is really no difference in the circuit. All we have done is disconnect the "B" negative from the cathode and connected it to the bottom of L1, causing the "B" current to flow through the coil. By comparing and studying these two circuits, the cathode tap arrangement should not be the least bit confusing.

In all the diagrams and circuits so far, we have considered *magnetic* feed-back that is, energy fed from plate to grid by magnetically or inductively coupling the two coils together. In Figure 6, we show an oscillating circuit which does not have mag-

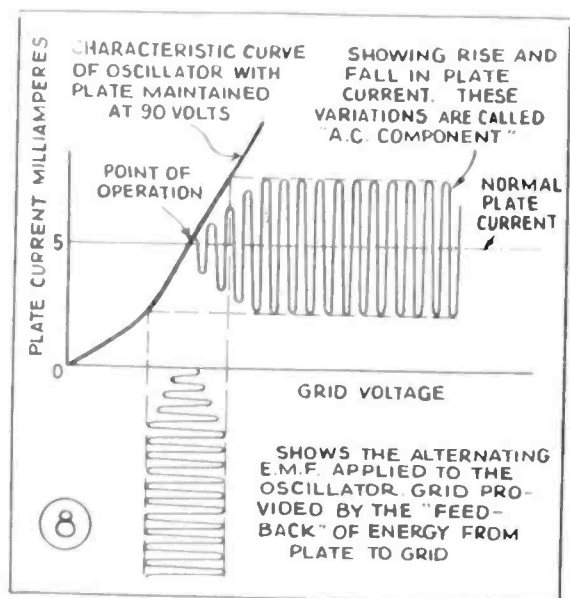

Fig. 5—Shows the cathode tap method of feed-back. Fig. 6—The tuned-plate tuned-grid oscillating circuit used for transmitting. Fig. 7—This circuit is the same as No. 6, except that two tubes are used in push-pull.

netic or inductive coupling. The feed-back in this case is due to the plate-to-grid-capacity within the tube. In triodes, this capacity may be anywhere from 3 to 10 mmf. In this circuit, the grid and plate circuits must closely approach resonance with the same frequency, because the feed-back is not as strong or as great as in the other circuits. This is the tuned-plate tuned-grid circuit. Screen-grid tubes will not oscillate in a circuit of this type, because the plate-to-grid capacity, as pointed out in a previous chapter, is too low to effect sufficient feed-back to cause oscillation.

That is why, in the I.F. amplifiers of our superhets, the plate and grid circuits are tuned to the same frequency, allowing extremely high gain with no feed-back. However, if there were coupling directly between L1 and L2 of this circuit, even though it used a screen-grid tube, oscillations would occur. In Figure 7, we have the same type of circuit—tuned-plate, tuned-grid, except that two tubes are used in push-pull, that is, each tube operates on alternate half-cycles. These circuits shown in Figures 3, 4, 6 and 7, can be and are used for *transmitting*.

How can we take R.F. power from such an oscillator and feed it into an antenna? The answer is quite simple, if you will bear in mind what we have said about the inductive relation between coils in a transformer. In figures 4, 6 and 7, we have additional coils coupled to L1. The high frequency alternating current in the tuned circuit, consisting of L1 and C, will

induce similar currents in the coil coupled to it. This coil is then connected to the antenna, and the power from our oscillator, or a goodly part of it, is radiated.

What Determines Frequency of the Oscillator

The frequency of the oscillator is largely determined by the tuned circuit L1 and C, that is, in all diagrams except the first. In this circuit the frequency is controlled by L2 and C.

It takes a certain length of time for an oscillation or one complete cycle (reversal of current) to take place in any circuit, which consists of inductance and capacity, due to the electrical inertia of the circuit itself. This inertia or lag is readily apparent when we consider what has been studied previously regarding inductances. When a current is passed through a coil, it sets up a field within the wire which, starting at the center of the wire itself, expands outward in ever increasing diameters. These lines of force not only cut the wire going outward, but cut adjacent wires. This cutting induces a current in the conductor or inductance in the opposite direction to the original current, tending to oppose the increase in current flow, thus prolonging the length of time, between the application of current and the time when the current is flowing at maximum amplitude. Now, if we decrease the current flow, the lines of force contract to flow in an *opposite direction to the field*, but in the *same direction as the original receding current*; thus tending to prolong the current flow and preventing its decay.



CHAPTER 5



CLASS A, B and C AMPLIFIERS

● In this chapter of our *Radio Amateur Course*, we will deal with *radio and audio frequency*, class "A" "B" and "C" amplifiers, together with frequency multipliers. The first type of amplifier that the average radio experimenter comes in contact with is the well-known *Class "A" audio amplifier*. In a previous chapter discussing the vacuum tube action, we clearly explained the functions of the cathode grid and plate, also just how the changes in grid potential effect changes in plate current, thus amplifying the signal.

Before reading the following descriptions of amplifiers, it is well to review the previously described actions of the various elements in tubes because these will not be taken up again in detail, and a perusal of the chapter on tubes will greatly aid in obtaining a clear mental picture of various types of amplifiers.

In Figure 1-A, the tube is operated under conditions so that the *output* is an exact replica of the *input* signal. It can, therefore, be said that the tube is operated on the flat portion of its grid-voltage plate-current curve. By examining the drawing at Figure 1-A, we see that the grid never goes suffi-

ciently negative to reduce the plate current to zero, and it is also not allowed to go positive, if it were the grid would draw current on the positive peaks, and this is not desirable in the usual Class "A" amplifier.

Class "A" Amplifiers

Class "A" amplifiers are capable of really faithful amplification, but are quite inefficient, insofar as power conversion is concerned. Usually these amplifiers are much less than 50 per cent efficient. In Figure 2-A we have a 1 tube audio frequency Class "A" amplifier circuit. In figure 2-B we have an amplifier of the push-pull variety wherein two tubes are used, each operating on alternate half cycles of the input signal. In Figure 1-B we have a diagram of the characteristics of a Class "B" radio frequency amplifier. The operating characteristics are essentially the same as a Class "B" audio amplifier, only in the R.F. amplifier, as indicated, the frequency is constant and the amplitude of it is varied by modulation. This is said to be a *Linear* amplifier.

In a Class "B" audio amplifier, the frequency would vary. However, the essential functions are the same. We find that the bias is such that it allows the grid to be

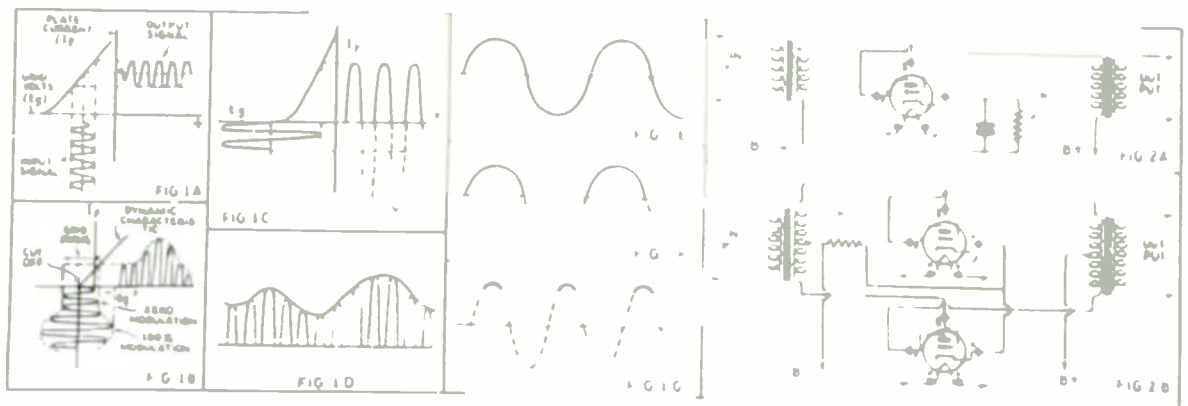

The above drawings show characteristics of Class "A," "B," and "C" amplifiers, together with amplifier diagrams.

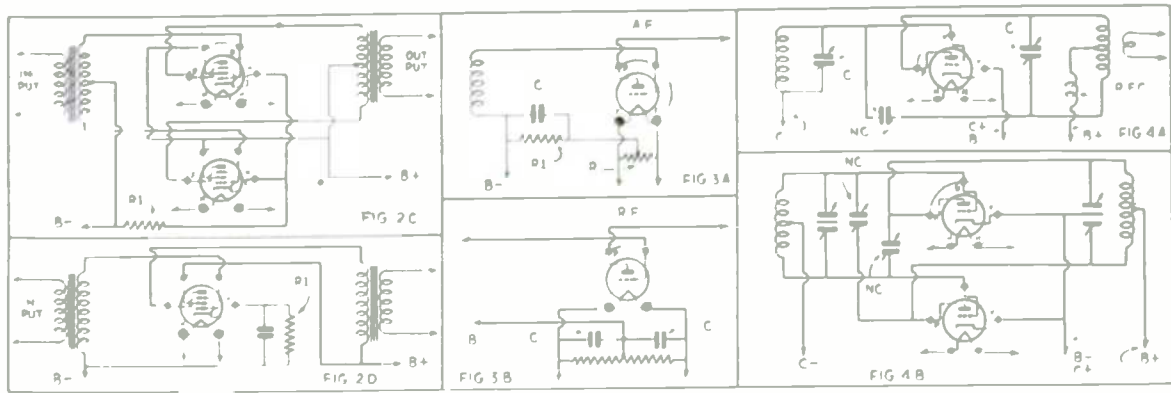

Diagrams of pentode A.F. amplifiers, single and push-pull, together with neutralizing single and push-pull R.F. amplifiers.

come positive on one-half of the incoming signal, running the plate current way up. On the negative half of the cycle in the R.F. amplifier, we find that the plate current is zero and remains zero through the entire 180 degrees of the negative grid swing, and then it begins to rise as the grid goes positive. It can thus be seen that plate current flows over the 360 degrees of the grid swing in Class "A" amplifier, and only 180 degrees of the grid swing in a Class "B" amplifier. Now, in an audio system, it is essential that we reproduce an exact replica of the incoming signal; that is why in Class "B" amplifiers intended for audio frequency use, we use push-pull in order to reproduce *both halves* of the incoming signal.

Class "B" Amplifiers

In R.F. amplifiers wherein the variations in amplitude of a constant frequency carrier constitutes our audio frequency signal, we do not need push-pull, because if we refer to Figure 1-D, we will see that complete A.F. variation is present on the one-half, although two tubes are often used in the Class "B" R.F. amplifier. This is only done to increase the power output. We can very easily see why only one-half of the modulated R.F. signal is needed; because of the action of our detector, really only one-half of it is used anyway. In Class "B" amplifiers of all descriptions, the grid-bias is adjusted so that the plate current is zero or nearly zero with no signal present in the grid circuit. In the now popular Class "AB" or "A" prime, audio frequency amplifiers, plate current flows throughout more than 180 degrees of the input cycle but less than 360. This means that the plate current may fall to zero and remain zero for just a small portion of the input cycle. In Figures 1-E, F and G, we clearly show how in the Class

"A" amplifier, the plate current is continually flowing, and in the Class "B" amplifier, is only flows through 180 degrees of the input cycle, while on Class "C" amplifier, which is next to be discussed, on less than 180 degrees of the input cycle.

Class "C" Amplifiers

Class "C" amplifiers are usually used only for *radio frequency* amplification because of the tremendous amount of distortion which is present in the output wave. In Class "C" amplifiers, the bias is increased to about two times the value necessary to bring the plate current to zero. This means that a greater amount of excitation is required in order to make the plate current flow. This requires of course, that the grid be driven considerably *positive*. Vacuum tubes operated in the Class "C" category are capable of tremendous power output as compared to a Class "A" or "B" amplifier, and are usually quite a bit more efficient, insofar as plate-power conversion is concerned. Efficiencies as high as 85 per cent are quite easily obtained. Of course, the ratio of power amplification is reduced considerably in a Class "C" amplifier, because of the fact that plate current only flows on a small portion of the input cycle and because a Class "C" amplifier requires a good deal more excitation.

A class "C" amplifier in a radio frequency phone transmitter is modulated directly, i.e., a powerful modulator is used to vary the plate input to the tube at audio frequencies, while a Class "B" amplifier used in a phone transmitter is not modulated directly, but a low-power, class "C" amplifier which is modulated at voice frequencies, is used to drive the Class "B" linear R.F. amplifier. While the Class "B" amplifier is not as efficient as the Class "C" amplifier, it introduces a considerable saving in the cost of

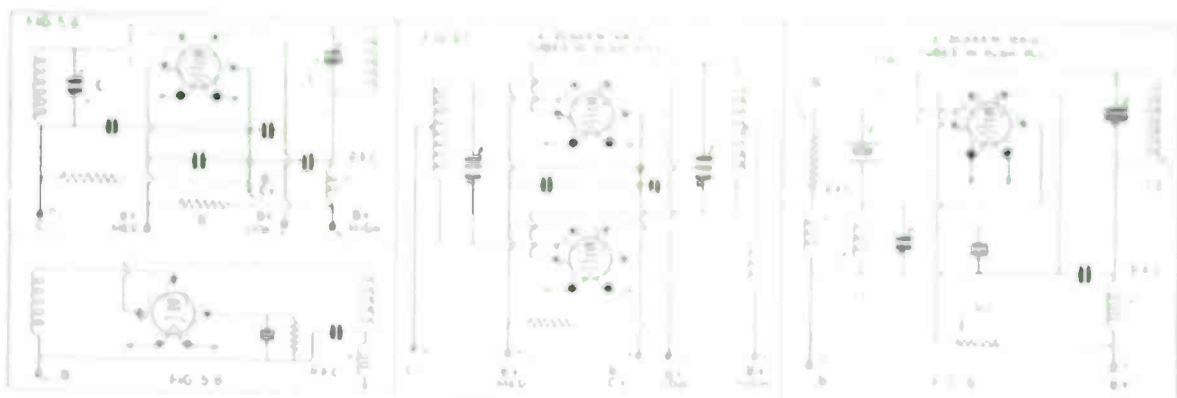

Pentode single and push-pull R.F. amplifiers and crystal oscillator-frequency multiplier diagrams.

modulator equipment, because a fairly low-power stage is modulated, and the Class "B" amplifier is merely used to amplify the modulated output of this low-power stage.

Efficiency in Power Output

Efficiencies of around 70 per cent may be secured from a Class "B" amplifier with 100 per cent modulation on the driver stage, although an unmodulated Class "B" amplifier would be only about 35 per cent efficient. Speaking of plate efficiency or power conversion in the plate circuit of the vacuum tube, we mean the "power" *output* divided by the power *input*, times 100. For instance, if we have an amplifier with a power input of 100 watts and an output of 75 watts, we would have an amplifier which was 75 per cent efficient, the output being 75 per cent of the total plate input.

In figures 1-C and 1-G, we have illustrations of the operation of a Class "C" amplifier. To the lay reader, Figure 1-G would probably be the clearest, because herein we find a clearer picture, showing that the plate current flows on a very small portion of the *input* cycle. In Figures 2-C and 2-D, we have *pentodes* used as *audio frequency* amplifiers. Bias for these is obtained by inserting the resistor in series with the cathode, or if it is a filament type tube, a center-tap resistor is needed, as shown in Figures 2-A and 3-A. In an R.F. amplifier, usually the center-tapped resistor is *by-passed* with two condensers, as in Figure 3-B. Resistors "R" in Figure 2-C, 2-D, and 3-A, are the *self-biasing* resistors.

Neutralizing

With a *triode* used as a radio frequency amplifier and where the input and output circuits are tuned to the same frequency, a method of overcoming *self-oscillation* is required. This is accomplished by *neutralizing* as shown in Figure 4-A. What we have

done here is to center-tap the plate coil, making the two ends *out of phase 180 degrees*. Then a small condenser is connected between the grid of the tube and the end of the coil which is not connected to the plate. The condenser "NC," which is the neutralizing condenser, is then adjusted to feed an amount of R.F. from the plate circuit back to the grid, equal to the amount of R.F. fed from grid to plate, due to the internal capacity of the tube. This external method of feeding back R.F. 180 degrees out of phase, cancels the plate to grid feed-back within the tube.

Push-Pull With Triodes

In figure 4-B, we have *push-pull* amplification, using triodes, each operating 180 degrees out of phase, making neutralizing possible by just connecting small, variable condensers between the plate of one tube and the grid of the other. In other words, one tube furnishes the neutralizing voltage for the other.

In Figures 5-A and 5-B, we have R.F. amplifiers using screen grid tubes which *require no neutralizing*. One is a *push-pull* circuit, and the other is a *single-ended* affair. As we said before, in Class "B" and "C" amplifiers, both *audio* and *radio* frequency, grid current flows during either a portion or all the positive half-cycle of the exciting voltage. Now, this grid current can be utilized for biasing R. F. amplifiers by inserting a resistor in series with the grid return, the same as we have in an oscillator where bias is obtained with a grid leak. We can also obtain bias by the cathode method as shown in Figure 5-B. Grid-leak is never used in audio frequency. Class "B" amplifiers. Screen-grid voltage in amplifiers, such as shown in Figures 5-D and 5-C, can either be obtained directly from a separate power supply or obtained through a voltage-drop-

ping resistor, thus lowering the plate voltage to a sufficient value for the screen.

Frequency Multipliers

Radio frequency amplifiers can be used for *frequency multiplication*. For instance, we can feed a 3500 kc. signal into the grid of any one of the "single-ended," Class "B" or "C" R. F. amplifiers shown in the various diagrams; then by tuning the plate circuit to 7,000 kc. and taking power out of this circuit, we have doubled the frequency of the original exciting signal. Class "B" amplifiers are not well suited for frequency doubling, because there is less second harmonic present in the output circuit. A Class "C" amplifier is a very fine *frequency multiplier* where the even order of harmonics are to be obtained. A *push-pull* amplifier does not make a good second harmonic amplifier or frequency doubler because the push-pull output circuit tends to cancel out the even order of harmonics. The push-pull multi-

plier can be used as a frequency multiplier where the odd order of harmonics are desired. For instance, the 3rd, 5th, etc.

Push-pull amplifiers are generally used where *frequency tripling* is required. Through the use of the new pentode tubes, such as the 2A5, 42, 802, and 23, an oscillator and frequency multiplier can be combined within a single tube. In Figure 6, we have a pentode oscillator and multiplier. The crystal is connected between the cathode and the grid. A tuned circuit is inserted between the cathode and the "B" negative and is tuned to a frequency about midway between the crystal frequency and its second harmonic. This will cause the crystal to oscillate; then the plate circuit can be tuned to twice or even three times the crystal frequency, with a fair amount of power output. It can also be tuned to four times the crystal frequency, but the power output and plate efficiency are very much lower.

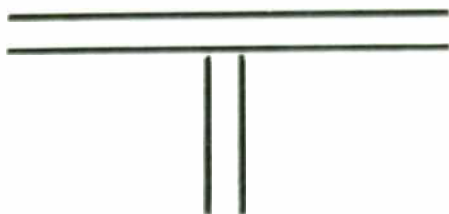

CHAPTER 6



M. O. P. A. — MASTER OSCILLATOR — POWER AMPLIFIER

● THIS chapter of our Amateur Radio Course will cover the M.O.P.A. (master oscillator-power amplifier) transmitter using crystal-control, frequency-multiplication buffers, etc.

Amateur Radio has advanced to the point where multi-tube transmitters are almost a necessity, although single-tube crystal-controlled transmitters are usually very efficient insofar as *stability* and *power output* are concerned. On the other hand, for greatest flexibility and efficiency, an M.O.P.A., comprising at least three stages, is necessary if real efficiency is desired along with three or four band operation.

Today, the Ham does not need to spend a fortune in constructing a modern multi-stage transmitter with a fairly respectable power output, because in nearly all cases, receiving tubes may be used.

In Figure 1, we have a crystal-controlled transmitter built entirely around 2A5 tubes. Although few Hams realize it, this tube is ideally suited to low-power transmitters or in the oscillator, buffer and frequency multiplier stages. In this transmitter, we use a 2A5 connected as a pentode crystal oscillator, another 2A5 as a neutralized amplifier or frequency doubler, and in the third stage, 2—2A5's in push-pull, as amplifiers. When using the 2A5 as an amplifier or doubler, the control grid and screen grid should be tied together.

Pentode Oscillator

In the *pentode-oscillator* circuit of Figure 1, we have condenser coupling to the first amplifier. Experience has proven that the excitation tap on the plate coil should be connected between one-half and three quarters the length of the entire coil, from the

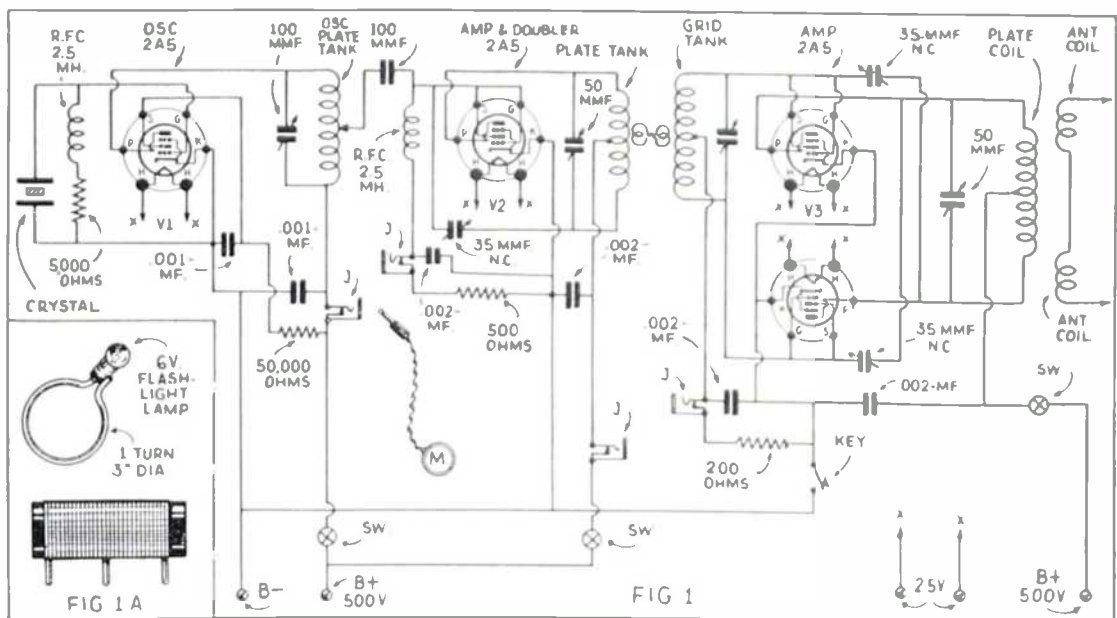

Complete diagram of 3-stage crystal-controlled M.O.P.A. (Master Oscillator Power Amplifier) transmitter with details of the tuning light and plug-in coil suggestion (1A).

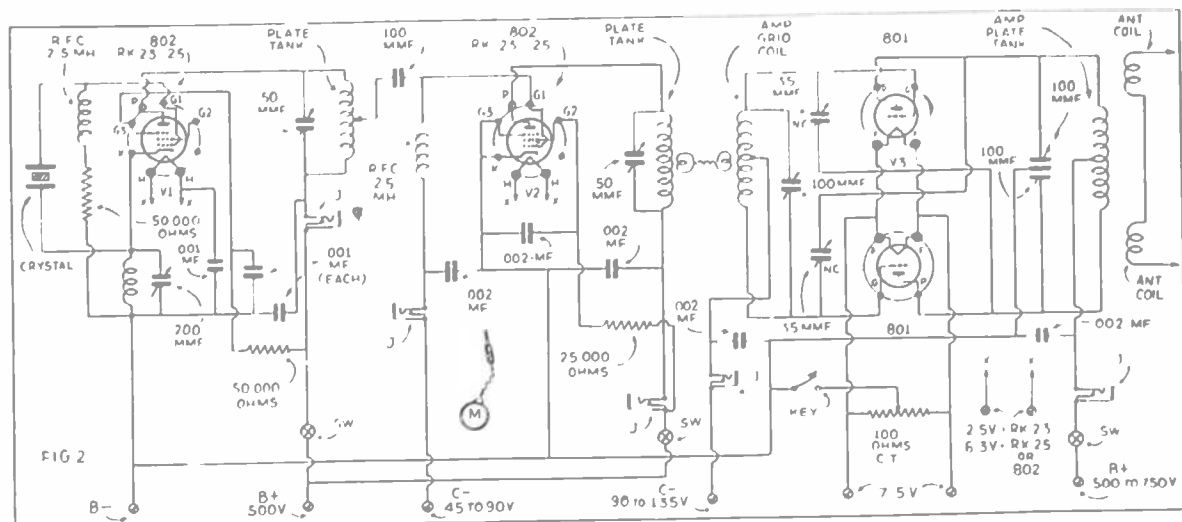

3-stage M.O.P.A. transmitter using pentode oscillator-doubler and pentode-buffer doubler.

B plus side. If this tap were connected directly to the plate end of the coil, considerable instability in the oscillator circuit would result, and in many cases, the oscillator may fail to start oscillating when the transmitter is turned on.

With the two grids of the 2A5 connected together, this tube represents a high- μ triode similar to the 46, and no separate bias is necessary, although a small resistor, around 500 ohms, in series with the grid return, increases the second harmonic output when doubling. Many who have used the 46 will recall that the plate current tends to *creep up* if the circuit is detuned or if too much excitation is applied. This trouble is entirely eliminated in the 2A5 no doubt due to the suppressor which is connected directly to the cathode inside the tube. We might also mention here that those having trouble with the 46 will do well to change to the 47, because this tube exhibits the same characteristics as the 2A5, and requires no change in circuits formerly using the 46, other than a reduction in the value of the grid bias resistor; 500 ohms seems to be the optimum value.

Advantages of Link Coupling

The final amplifier or push-pull stage of this transmitter (Fig. 1, is *link-coupled* to the first amplifier. Experiments have long ago proven where a "single-ended" driver is used in conjunction with a push-pull stage, that inductive coupling is far more efficient than any other method of coupling. Each coil of this link circuit should consist of two turns, coupled fairly close to the center of both the first amplifier plate coil and the push-pull amplifier grid coil. Both grid and plate circuits of the push-pull

amplifier are tuned to the same frequency, and, therefore, neutralization is necessary. For a more thorough discussion of neutralized amplifiers, we refer you to the fifth chapter.

All values of resistors and condensers are given. However, coil data is omitted because this will depend upon the particular band in which the transmitter is to be operated. A transmitter of this type should have an output of from 30 to 40 watts on 80 and 40 meters, and slightly less on 20.

Tuning Procedure

The tuning procedure for this transmitter is as follows: With all the B-plus voltages disconnected, the filaments or heaters allowed to heat up for at least two or three minutes. Then the plate and screen voltages should be applied to the oscillator with the excitation tap of the first amplifier removed from the oscillator plate coil. Then with a flash-light bulb connected to a single turn of wire, coupled rather closely to the plate coil in the oscillator, swing the plate condenser back and forth until a point is reached where the light glows the brightest. Back the pick-up coil away from the plate coil, and retune for a peak in brilliancy of the lamp. The excitation tap should now be connected to the oscillator somewhere around two-thirds the distance from the B-plus end of the coil. The plate milliammeter could have been used for tuning the oscillator. However, the maximum output does not come about with either a maximum or minimum reading on this plate meter but somewhere between the two. Now when the excitation tap is connected to the oscillator plate coil, the plate current will increase, as shown on the

meter. With the neutralized condenser "nc" set at zero capacity, and the flashlight bulb coupled to the first amplifier (V2) plate coil, swing the plate condenser of this stage back and forth until the bulb lights. Now, if we are operating this amplifier at the same frequency as the oscillator, it must be neutralized. Increasing the capacity of the neutralized condenser gradually, and swinging the plate condenser back and forth through resonance, will eventually result in a setting of the neutralizing condenser where the flashlight bulb will not glow. A more

accurate method of neutralizing can be used by plugging a zero to 50 ma. meter in the grid circuit of the amplifier. You will notice that rectified grid current will be present even though no plate voltage is applied to the tube. As the plate condenser is swung back and forth, you will also notice, if the amplifier is not perfectly neutralized, a slight "bump" in the grid current when the amplifier condenser swings through the resonant point. A further adjustment of the neutralizing condenser will eliminate this. After this stage is thoroughly neutralized, the plate voltage can be applied.

The grid coil of the amplifier and tune the grid condenser for maximum brilliancy. The neutralizing condensers of this stage should be at minimum capacity; then couple the flash-light bulb to the plate coil of the push-pull amplifier, and adjust the plate condenser for maximum brilliancy of the bulb. This stage is then neutralized the same as the first amplifier, except that both neutralizing condensers are adjusted simultaneously, and a point will be reached in the setting of these condensers where the flash-light bulb will not glow, and the grid current meter when plugged into this circuit will not change.

A word of warning about push-pull amplifiers—unless a push-pull amplifier is perfectly symmetrical, i.e., the two grid leads of identical length, and the tap on the grid coil in the exact electrical center; the plate leads identical, and the B-plus tap on the plate coil in the exact electrical center, it cannot be neutralized. Also, identical makes of tubes should be used. In a perfectly symmetrical amplifier, the neutralizing condensers will be set at exactly the same capacity. The leads to these condensers should also be symmetrical; they should be mounted so that the grid leads to them are identical, and the plate leads both of the same dimensions. Many experimenters have given up push-pull amplification because they could not neutralize the amplifier, and this, undoubtedly, was due to *lack of symmetry*. If plug-in coils are used in the push-pull amplifier, do not use the usual plug-in receiver type coil with the pins in the base. The coils should be of the flat mounting type, such as shown in the drawing 1A. The other type of plug-in coil form will make the leads uneven in length.

The push-pull amplifier in this transmitter is keyed in the cathode circuit, and the biasing resistor should be 200 ohms or larger. In the plate and grid circuits of the push-pull amplifier and the plate circuit of the first amplifier, single section condensers are used. This makes both ends of the condenser "hot" and an insulating shaft should be used for coupling to the knob or dial. For those who have split-stator condensers, or can afford their usage, they are highly recommended. This transmitter when used with an 80-meter crystal, can be used on the 80 and 40 meter bands. For 80 meters, all three stages are tuned to the crystal frequency; on 40 meters, the first amplifier (V2) is a doubler, and the second amplifier tuned to 40 meters. With a 40 meter crys-

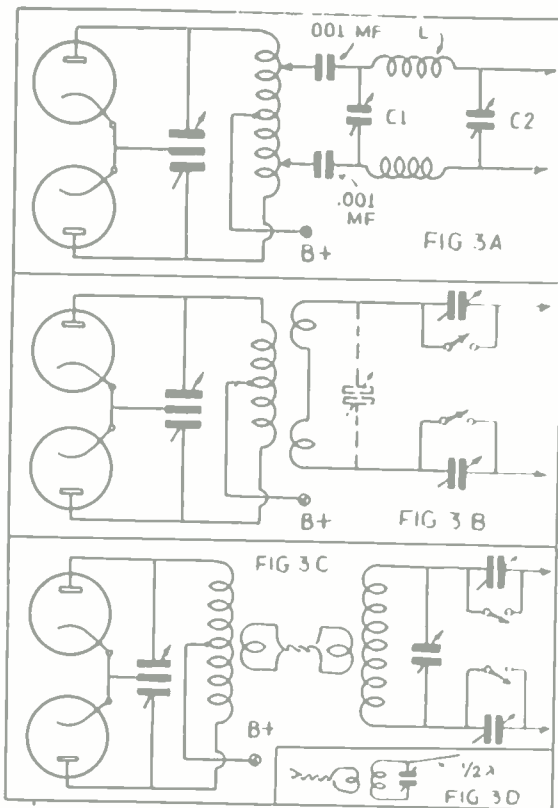

Various methods of coupling antennas to a push-pull amplifier.

accurate method of neutralizing can be used by plugging a zero to 50 ma. meter in the grid circuit of the amplifier. You will notice that rectified grid current will be present even though no plate voltage is applied to the tube. As the plate condenser is swung back and forth, you will also notice, if the amplifier is not perfectly neutralized, a slight "bump" in the grid current when the amplifier condenser swings through the resonant point. A further adjustment of the neutralizing condenser will eliminate this. After this stage is thoroughly neutralized, the plate voltage can be applied.

Tuning of the Push-Pull Amplifier

Our next job is to "tune up" the push-pull amplifier. Couple the flashlight bulb to

tal, all three stages can be tuned to 40, or we can operate on 20 by tuning the first amplifier (V2) and final (V3) to that band. All the power amplifier circuits are tuned the same whether they are frequency multiplier stages or not. After they have been neutralized, that is, if they require it, the plate voltage should be applied and the plate tuning condenser *immediately* adjusted for minimum reading on the plate milliammeter—this always indicates resonance.

Three-Stage Transmitter Using 2 S. G. Tubes

In Fig. 2, we have another 3-stage transmitter using two screen-grid tubes and two 801's in the final amplifier. Tuning the first amplifier and the final amplifier will be identical to the transmitter shown in Figure 1, except that the first amplifier (V2) need not be neutralized because a screen-grid tube is used. The oscillator here is quite different. Because we are using a screen-grid tube which will serve not only as an *oscillator*, but as a *frequency-multiplier*. With this transmitter and an 80-meter crystal, we can work on either 80, 40 or 20 meters without changing crystals. This is the well-known *Tritet* oscillator circuit, where a cathode coil is used to bring about oscillation of the crystal independent of the plate tuning circuit. This plate circuit can be tuned to either 80 or 40 meters. When operating on 80 meters all circuits will be tuned to that band. On 40 meters, the plate circuit of the oscillator, as well as other two stages, will be tuned to 40 meters. For 20-meter operation, we have the plate circuit of the oscillator tuned to 40, the first amplifier, V2, tuned to 20, and the final amplifier, V3, tuned to 20 meters. In this transmitter, external bias is needed for the amplifier stages. This can be

supplied by conventional B batteries or off an especially designed low-voltage power supply.

Method of Coupling Antenna

In Figure 3, we have shown the various methods of coupling an antenna to a push-pull amplifier. In Figure 3A, we have the *impedance-matching* network used with two-wire feed systems. In adjusting this type, the amplifier plate circuit is adjusted for minimum plate current without the network attached to the amplifier coil; then the two feed wires are attached to the plate tank coil and Condenser C1 *immediately* adjusted for a minimum plate current in the amplifier. If a dip in the plate current cannot be obtained, C2 should be changed from minimum to maximum, or vice versa. If a minimum setting of C2 will not allow a dip in plate current when C1 is adjusted, then the maximum setting will. C1 and C2 should then be adjusted until the plate current of the amplifier rises to normal value for *full-load* conditions, always setting C1 to a point giving *minimum plate-current*. The plate tuning condenser should never be touched after it first has been adjusted without the feeders connected. In Figure 3B, we have the usual inductive coupling where either series or parallel tuning of the feeder system is employed. *Link-coupling* can also be used between the final amplifier and the antenna circuit, as shown in Figure 3C. In Figure 3D, we have *link-coupling* to a single wire antenna with a tuned circuit connected to one end of the antenna. In this case, the total antenna length from the tuned circuit to its farthest end should be slightly less than one-half wavelength.

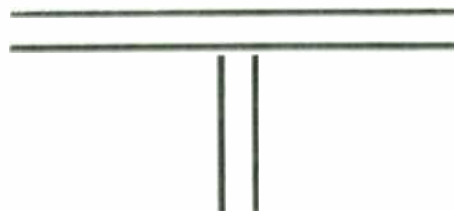

CHAPTER 7

• • •

ANTENNAS and FEEDERS for AMATEUR STATIONS

● ONE of the most important parts of any short-wave station, transmitting or receiving, is the *antenna*. We will endeavor to point out in simple English the nature of each type of antenna and its various uses.

The "Half-Wave" Antenna

It is an established fact that a wire will resonate at a wave-length twice as great as the actual length of the antenna in meters. This is called in radio circles a *half-wave* antenna. On the other hand, certain antennas, which are apparently one-quarter wave-length long, may be used when operating against *ground* (Earth.) This is shown in Figure 1A. The current and voltage distribution along an antenna of this type, which is commonly called the *Marconi antenna*, is shown by the curves I and E. We notice that the point of maximum voltage is at the *ungrounded* end, while the point of maximum current is at the *grounded* end. In Figure B and C, we show how this type of antenna may be tuned and coupled to a transmitter or receiver. In Figure D, we show a method of operating a Marconi antenna with an *untuned* transmission line. This transmission line is connected to the antenna a short distance from the grounded end. Usually, this distance should be equal to 28% of the length of the antenna which as stated before, is one-quarter of a wave-length. In Figure 2A, we have the well-known *one-half wave* antenna. The length of this antenna in feet for any given frequency is expressed by the following formula:

$$L = \frac{492,000}{F} \times K = \text{feet}$$

Where L is the length of the antenna in feet, and F is the frequency in KC., and K is the correction factor. Below 3,000 kc., K=.96. From 3,000 to 28,000 kc., K=.95, and above 28,000, K=.94.

Points of Maximum Voltage and Current

In Figure 2A, we find that the point of *maximum current* is in the *center* of the antenna, and the point of *maximum voltage* is at the *ends* of the antenna. This *half-wave* antenna is undoubtedly the most popular of all types.

In Figure AA, we find the entire current distribution group for an antenna a half wavelength long, one wavelength long, 1½ wavelengths long, and two wavelengths long. This corresponds to a single antenna operated on any one of three amateur bands. If it were cut to operate as a half-wave antenna on 80 meters, for instance, it would be a full wave antenna on 40 meters, and the current distribution would be shown by curve B. It would then be said that the antenna was operating on the second harmonic, as a full-wave antenna. If the same antenna were operated on the 20-meter band, the curve D, indicates that it is operated on its fourth harmonic, and the antenna would be two wavelengths long. Now, curve C shows the current distribution when the antenna is operated on its third harmonic, or when there are three half waves standing on the antenna. For instance, if we wish to construct an antenna operated on its third harmonic in the 40-meter band, the antenna would have a length of three half waves or 60 meters. Third harmonic antennas are not very popular because the average Ham desires an antenna as short as possible. Antennas are usually fed or excited at either point of high current, or a point of maximum voltage when tuned feed lines are used. For instance, in the Zeppelin type antenna where the feeders are connected to the end of the antenna for a point of high voltage, the antenna is said to be voltage-fed. In the

doublet type, where the feeders are connected to the center of the antenna, i.e., a half-wave antenna, it is said to be current-fed. Antennas fed at the center are only current-fed when they are a half wavelength long. This is clearly shown by the curves A and C in Figure AA. If an antenna had a current distribution as shown by Fig. B or D and was fed in the center, it would be said to be voltage-fed. Another method of exciting an antenna, which will be described later, is by an untuned transmission line matched in impedance to the antenna at any point which may provide the necessary impedance match. In Fig. 2—B, C and D, we have this sort of an antenna.

of the feeder systems, in this case, is quite important because they form part of the antenna, although they do not radiate because the fields about the two wires cancel.

In Figure 2B, we have what is known as the *single wire matched-impedance* feed system which consists of a single wire attached to the flat-top *slightly off center*. The distance (A) between the center of the antenna and the point where the feeder is attached, is equal to 14% of the total length of the antenna flat top. With this type of antenna, the feeder should be run at right-angles to the flat-top for a distance of at least 30% of the length of the antenna. In Figure 2C, we have the two-wire feed matched impedance antenna, using a 600 ohm transmission line. The dimensions are:

$$A = \frac{492,000}{F} \times K^1$$

$$B = \frac{147,600}{F}$$

$$C = 75 \times D$$

and $C = 75 \times D$. $K = .25$ for frequencies below 3,000 kc., $.24$ from 3,000 to 28,000 kc. and $.23$ for all frequencies above 28,000 kc., and D is the diameter of the wire. In other words, the spacing between the two feeders should be equal to 75 times the diameter of the wire. This antenna should also have its feeder system running at right angle to the flat top for a considerable distance. Tests have proven that when a halfwave antenna is split in the center (Fig. 2D) it represents an impedance of 70 ohms at this point. Recently, various cables have been introduced on the market having a characteristic impedance of 70 ohms. This type of cable can be connected directly to the center of a half-wave antenna.

In Figure 2E, we have the very popular *half-wave Zepp* antenna which is voltage fed by a pair of "folded-up" feeders. The length

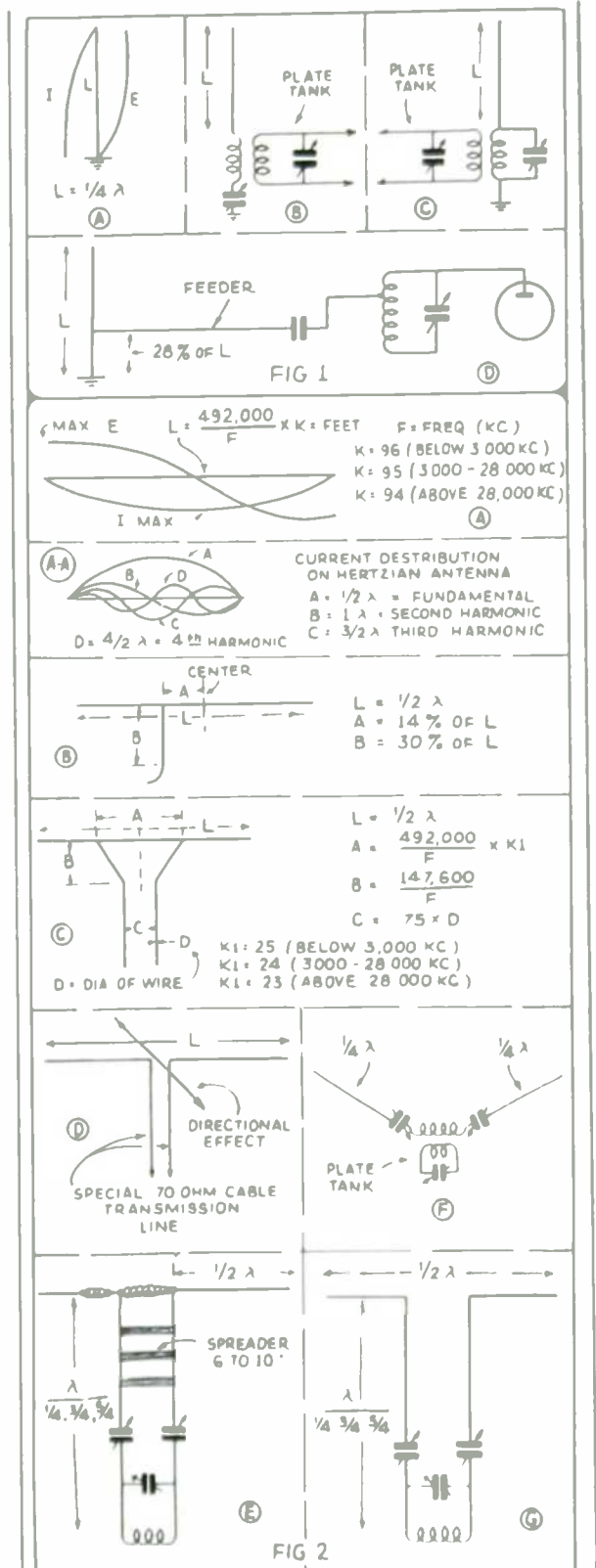

Details of the Marconi and Hertzian type antennas showing the voltage and current distribution.

being 180 degrees out of phase. In Figure 2F, we have the half-wave antenna *current-fed* (meaning the antenna is fed at a point

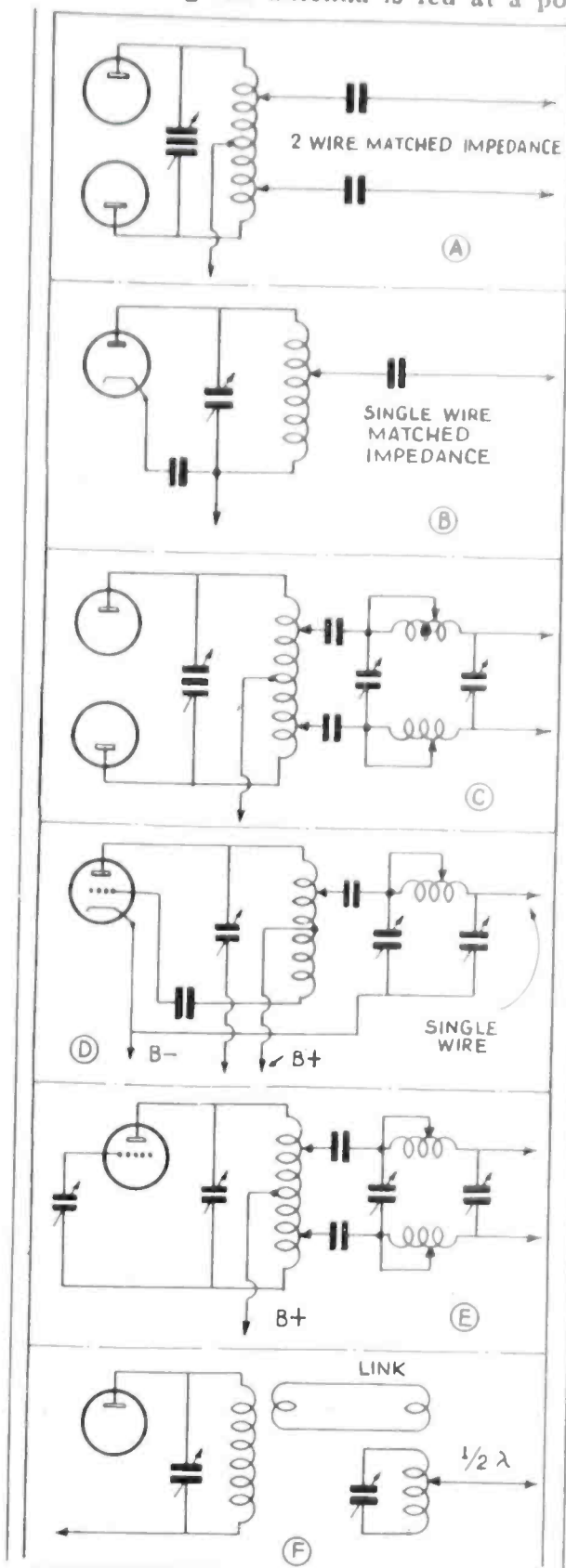

Methods of tuning and coupling antennas to the final amplifier of your transmitter; also "impedance-matching" networks which provide a great increase in the efficiency of the antenna system.

of maximum current) in the center with a coil and two tuning condensers used for tuning the antenna to exact resonance with the transmitter frequency. The disadvantage of this type antenna, of course, is that the *radiating* portion of the antenna is usually brought directly into the transmitter room.

In Figure 2G, we have the half-wave antenna with a tuned feeder system connected to its center. This is also a *current-fed* antenna system when the total flat top length is equal to one-half wavelength. The feeders of this system will have approximately the same dimensions as those for the Zepelin antenna, i. e., they can be $1/4$, $3/4$, $5/4$, etc., any odd number of quarter waves in length. All of these half-wave Hertzian antennas are quite directional in directions at right angles with the plane of the antenna; in other words, should an antenna point north and south, it would be directional east and west.

Aerial Constructional Details

The most important elements of any antenna systems are its height and insulation. The Hertzian antennas, regardless of the type or how it is energized, should be as high as possible. The average height above ground for best results should be at least $1/4$ wavelength. Insulation, wherever used, should be glass or preferably glazed, porcelain or isolantite, and the insulation at the ends of the antenna should be from 8 to 12 inches. In draping the feeders about the "shack," all sharp bends should be avoided. Wherever a bend is necessary, it should be well rounded out rather than making a sharp angle. Another important part of an antenna system is the method of coupling to the transmitter. In Figure 3A, we have the usual connections for the two wire-matched impedance antenna. In Figure 3B, we have the *single-wire* antenna connected to a single-ended power amplifier. Both of these antennas should be connected through condensers in order to keep D. C. plate voltages out of the antenna system. In Figure 3C, we have the well-known *impedance-matching* network, wherein two variable condensers and two coils are used for tuning and matching a two-wire feed system to the transmitter. With a tuning device of this type, and the correct impedance match which it provides between the antenna feeders and the amplifier have proven to be very efficient, and many times increase the effective radiated power of the transmitter a goodly percentage.

In Figure 3D, we have the same type of antenna-matching device except that only a single feed system is used. This is for coupling a single feed system or a single wire of any convenient length to a single-ended amplifier. The two-wire feeder system can be coupled to the single-ended amplifier merely by making both ends of the tank coil *hot*. This is done by feeding the B plus or the low R.F. potential portion to the center of the coil. This is clearly illustrated in Figure 3E. Many amateurs have reported excellent results with a well-known German antenna wherein a separate tuned circuit is used to couple the antenna to the transmitter. In Figure 3F, we show the Fuchs antenna link-coupled to the plate coil of the amplifier. With this type of antenna a very loose coupling is needed, otherwise it would be almost impossible to get the antenna into resonance with the transmitter frequency. In Figure 3G, we have the usual inductive coupling where the antenna coil is coupled to the low potential end of the plate coil and the transmitter. Coupling is varied by changing the distance between the two coils. This type of feeder system may also be link-coupled to the amplifier, as shown in Figure 3H.

All types of tuned coupling, except impedance-matching networks, should be

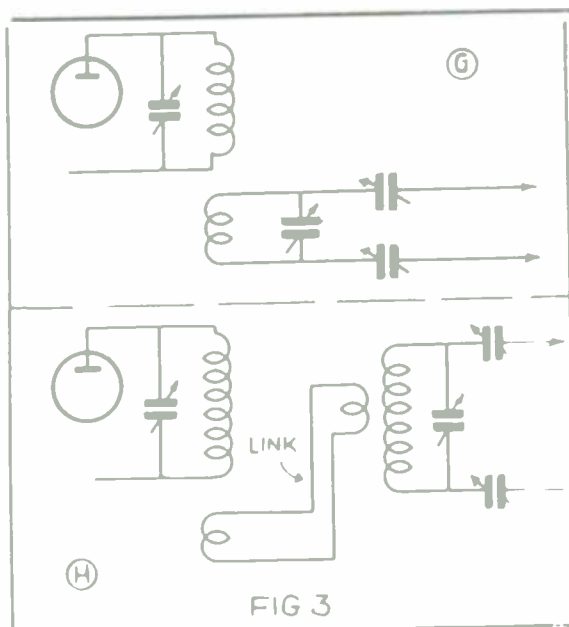

tuned to exact resonance and the coupling made loose rather than close coupling with a detuned antenna. This takes in the usual systems used with the Zepp and the doublet type antennas, which are tuned with a coil and condenser combination.

The plate circuit of the amplifier should also be reset to resonance after each antenna adjustment, except where the matching network is used.

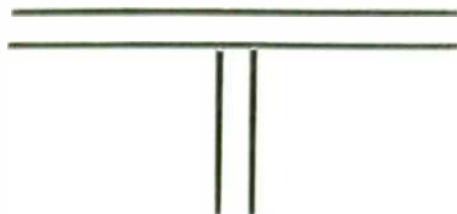

CHAPTER 8

SELECTION OF TUBES FOR LOW-POWER EXCITER STAGES

● THE choice of tubes for the *oscillator*, *buffer*, or *multiplier* stages of a transmitter is always quite a problem to the amateur. Also the circuits to use are numerous, especially with the recent tube developments. In Fig. 1, we have the conventional triode *crystal oscillator* circuit; with this tube the crystal is used in the grid circuit and oscillation is brought about when the plate circuit is tuned to approximately the crystal frequency. This circuit was the first to be used among amateurs when crystals were still a *luxury*. Either series or parallel plate feed may be used in this circuit. Fig. 1 shows the *series* method, while Fig. 2 is the same set-up but with *parallel* feed. Number 2 allows the rotor plate tuning condenser to be independent of the high voltage, and it can be mounted on a metal panel or chassis with no insulation.

The next popular crystal circuit was that using the 47 pentode; this was a considerable improvement over the former circuits. In Fig. 3, we find the conventional 47 pentode, which proved to be an excellent

crystal controlled oscillator and allowed less R.F. crystal current; thus lightening the load on the crystal. In Fig. 4 we have the same circuit except that the heater-cathode type tube is used; such as the 59, 2A5, etc. There is little advantage in this circuit over the 47 aside from the fact that the heater is separate and no filament bypass condensers are necessary.

Tritet Oscillator

Later developments in pentode circuits brought forth the well-known Tritet oscillator as shown; this is a modification of the Dow oscillator. In this circuit we can multiply the crystal frequency in the plate tuned circuit, independent of the crystal oscillatory circuit. However, the plate circuit can not be tuned to the crystal frequency because of insufficient internal shielding in the tube. This circuit is shown in Fig. 5, and a number of different type of tubes may be used as is indicated. A more flexible adaptation of this same circuit is shown in Fig. 6 where the screen grid pentode tubes are used, the shielding in these

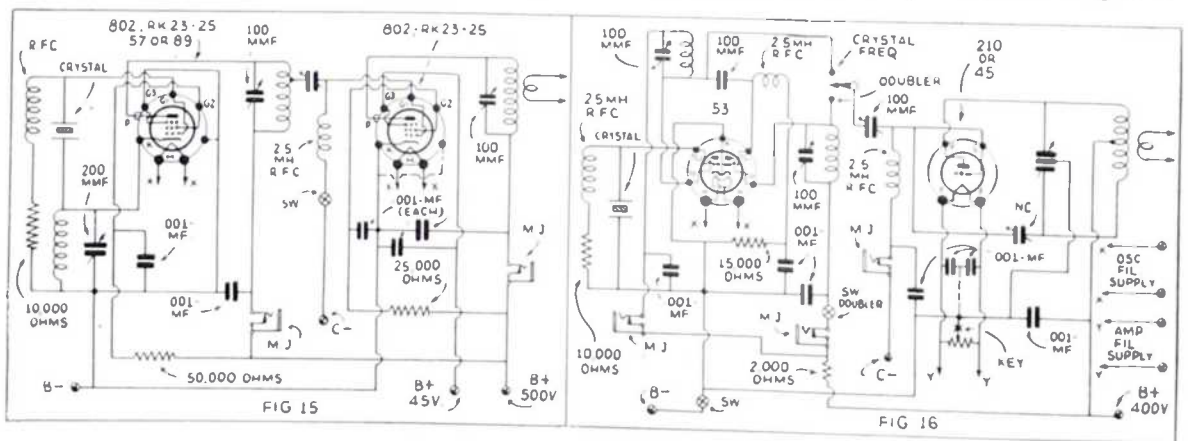

The dual pentode exciter unit, which will operate on any one of three bands, with one crystal and drive the average medium-power amplifier.

Fig. 16: The 53 twin triode is used as an oscillator and multiplier. This will also excite the average medium-power "final" amplifier.

tubes is sufficient to allow plate circuit to be tuned to the crystal frequency or an harmonic of it. Here the power pentodes such as the 802, RK23, 807 or RK39, etc., may be used, or the pentode receiving type tubes where only low-power stages are required. Where a number of multiplications are necessary, the *receiving type* tubes, such as the 57 and 59, are recommended, because of their low cost, and very respectable power "out-put." In the receiving type tubes though there seems to be little advantage in applying a positive potential to the suppressor, while in the power-type tubes this does increase the out-put appreciably.

Neutralization

So much for the oscillator circuits. We now consider Fig. 7 in which an amplifier tube is added to the oscillator. Here we have a triode neutralized amplifier when operating on a crystal frequency. For a frequency multiplication *neutralization* is not absolutely necessary, although the neutralizing condenser and the tapped coil arrangement should be employed, because a certain amount of regeneration may be obtained by the proper adjustment of this condenser N.C. and thus increase the harmonic out-put considerably. Those who have not tried this method of *frequency doubling* will be well rewarded with a considerable increase in "output," through the use of the neutralizing condenser, which then becomes merely a *feed-back control*. The coupling between the two stages in this instance is *capacitive*.

Link Coupling

In Fig. 8 we have both the grid and plate circuits of the amplifier tuned and link coupled to the preceding stage. This *link coupling* may consist of one or two turns connected with a twisted pair of insulated wires coupled to both tank circuits. This is a recommended method where the extra coil and condenser can be incorporated conveniently in the set-up, although where a great many multiple stages are used, as pointed out previously, employing receiving type tubes, this method would be entirely too complicated and the advantages would probably be slight. It is only in the last *buffer* or between the last *buffer* and the *final amplifier* stages where this method is really a distinct advantage.

In Fig. 9 we have the same circuit except that we use two tubes in *push-pull*. In this case one link coil is coupled to the B plus end of the driver tube, and the other coupled to the center of the grid tuned circuit,

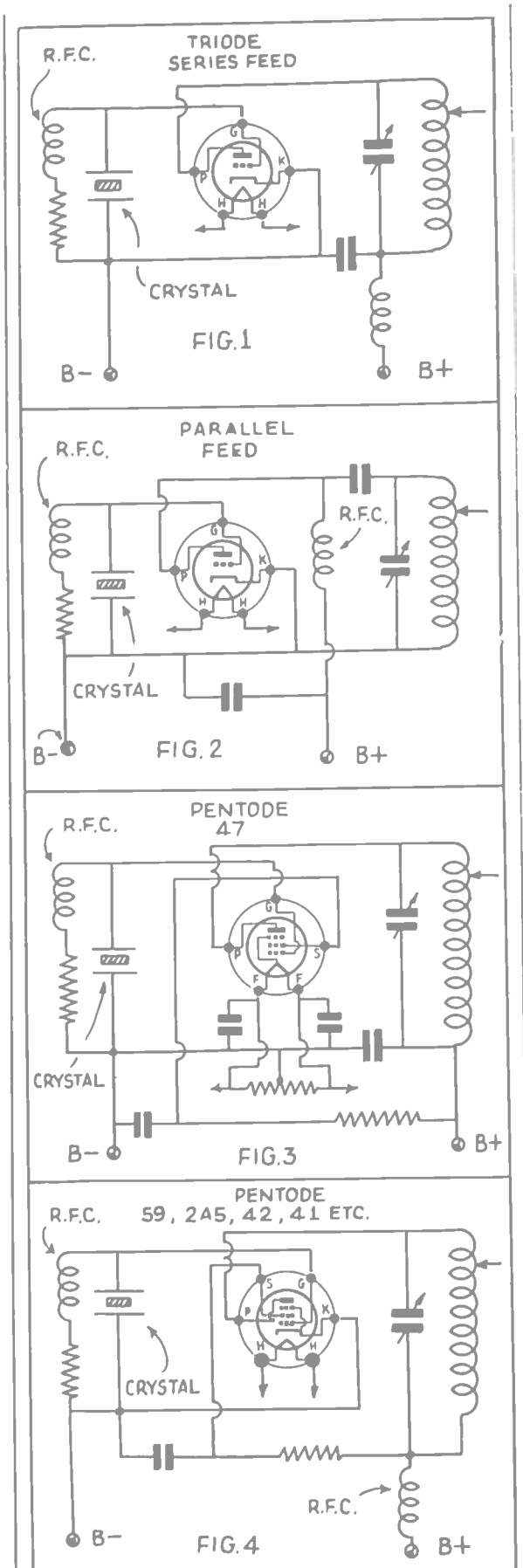

Above we have the triode and pentode crystal oscillator, using conventional circuits.

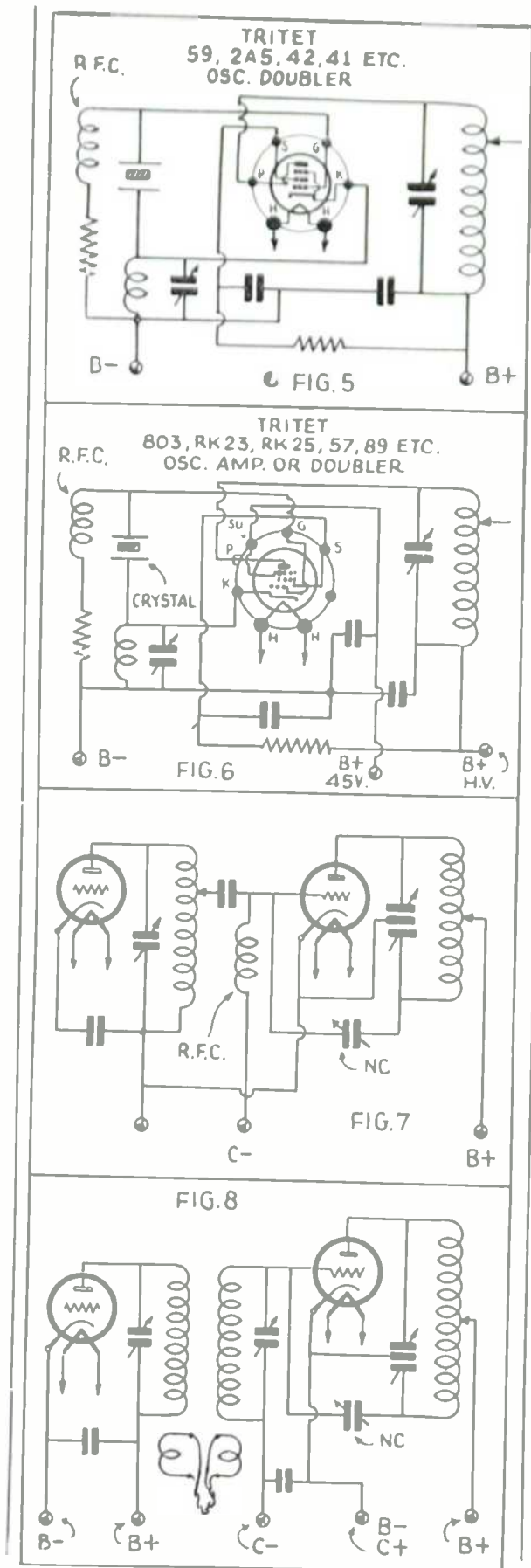

Here we have the oscillator—multiplier—and also neutralized amplifier and doubler.

while in Fig. 8, both coupling coils were coupled to the low potential end of the tuned circuits. The push-pull circuit, of course, is not suited for *frequency doubling* although it is recommended for *tripling*. However, *frequency tripling* is not commonly used in the amateur bands.

We can also obtain frequency multiplication with a single tube in another manner as shown in Fig. 10. This is the twin triode type, such as the 53 and the 6A6, where one section is used as a plate-tuned *crystal oscillator* and the other triode section capacitively coupled to it, is used as a *harmonic amplifier*. Choosing the proper method of neutralizing amplifiers is another problem which very often confronts the amateur. Either *grid neutralization*, as shown in Fig. 11, or *plate neutralization* (Hazeltine) may be used. There is really no difference in the two circuits where adequate driving power is employed. However, in some instances the plate neutralization method may be slightly superior. In both of these circuits, we have used a center-tapped coil, with the tuning capacity shunted across the entire inductance. Another method of accomplishing this is shown in Fig. 12A, where the tuning condenser is only shunted across the plate section of the coil. If the plate coils are well constructed and tapped in the *exact electrical center*, the methods shown in Figs. 11 and 12 are more convenient, because coils may be changed without requiring a *resetting* of the neutralizing condenser. Neutralization voltage may be also obtained as shown in Fig. 13; that is, directly from the driver-stage tank coil.

If push-pull circuits are to be used for frequency doubling, then the connections, as shown in Fig. 14, must be employed. In this case, the grids are connected in the usual push-pull manner, while the plates are connected in parallel. This is a very efficient *frequency doubler* although it employs two tubes instead of one, and unless the increased power obtained in this manner is really necessary, the complication does not warrant the use of this type of multiplier. The most versatile and efficient oscillator and multiplier circuits where low-powered exciters with an out-put of around 10 or 15 watts is required, are shown in Fig. 15 and 16. In 15 we have the pentode *Tritet* "*oscillator buffer*" or *multiplier*, which in turn drives another screen-grid tube. This arrangement will provide 10 to 15 watts out-put used as amplifier and not a multiplier, and around 5 to 10 watts when *doubling*

takes place in the plate circuit of the amplifier.

In Fig. 16 we have used the combination oscillator and multiplier with the 53 tube.

using a two-point switch for operation either at the crystal frequencies or the second harmonic of it, and a 210 or type 45 tube is used as an amplifier.

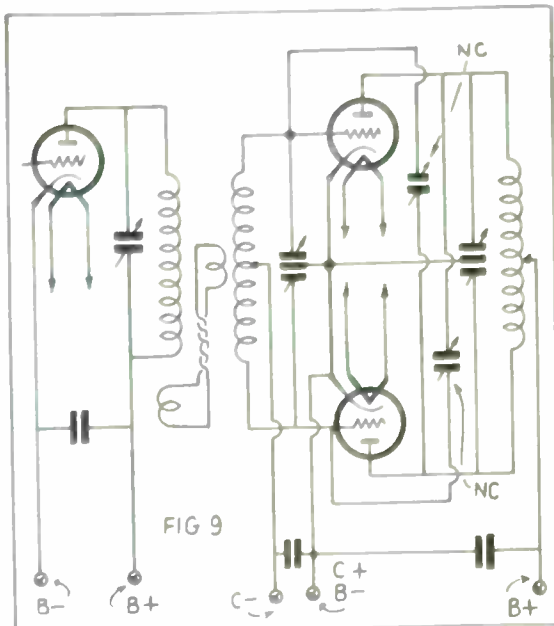

OSC-MULTIPLIER

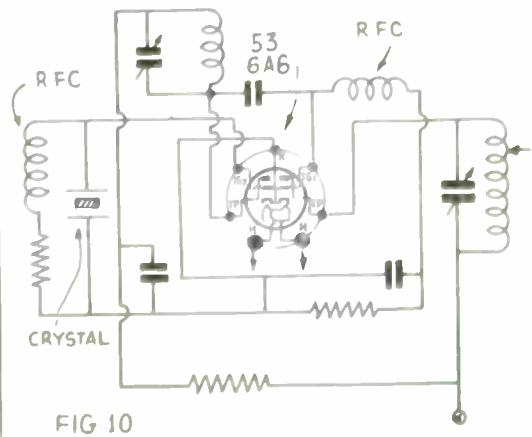

FIG 10

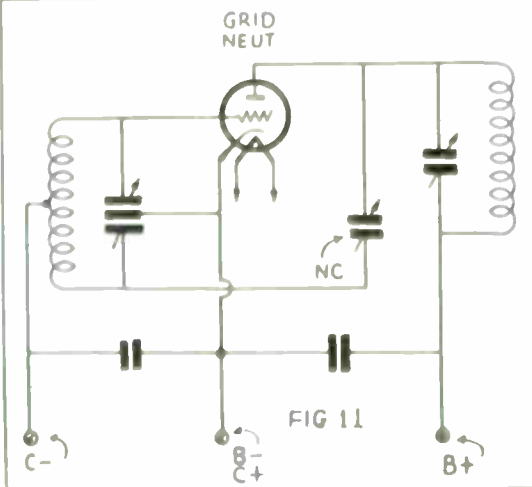

FIG 11

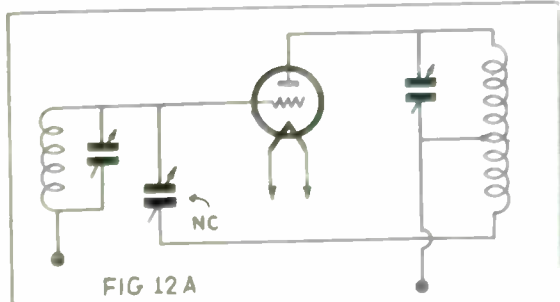

FIG 12A

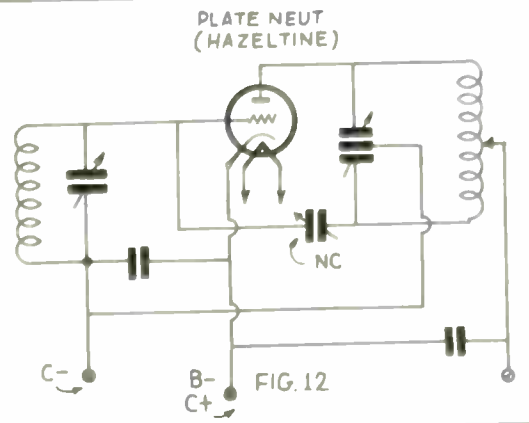

FIG. 12

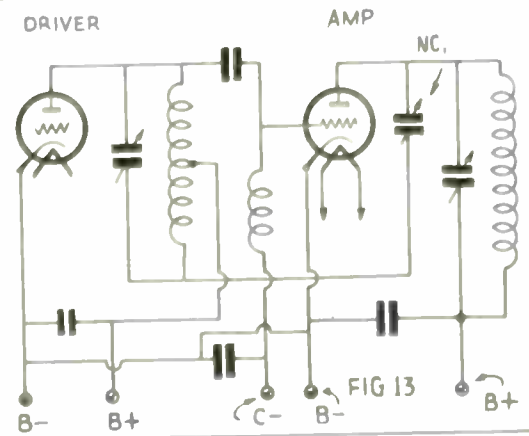

FIG 13

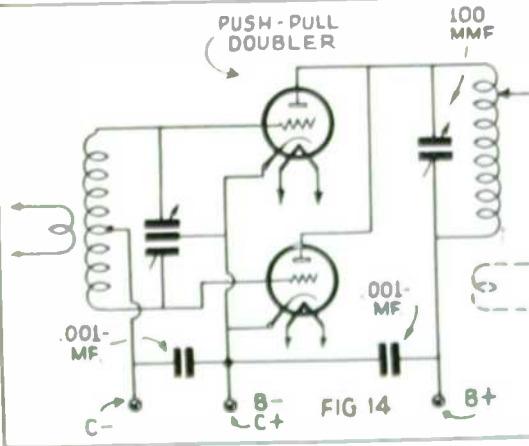

FIG 14

Here we have various types of multiplier and buffer stages.

Different methods of neutralizing and also push-pull doubler.

CHAPTER 9

THE FUNDAMENTALS OF AMPLITUDE MODULATION

● THE term modulation alone might scare the uninitiated, but, really, the radio transmission of voice and music is not in the least complicated if a few of the basic principles are clearly understood. An ordinary continuous wave or CW transmitter emits a wave of constant power or amplitude when the key is held down. Theoretically when transmitting code signals, the

question were to press his foot down, shutting off half the water flow, he would then by moving his foot up and down be able to either increase or decrease the flow of water. The degree by which he may increase or decrease the water would be analogous to the volume of the imposed voice signal, and the rapidity with which he may repeat this motion would be analogous to the

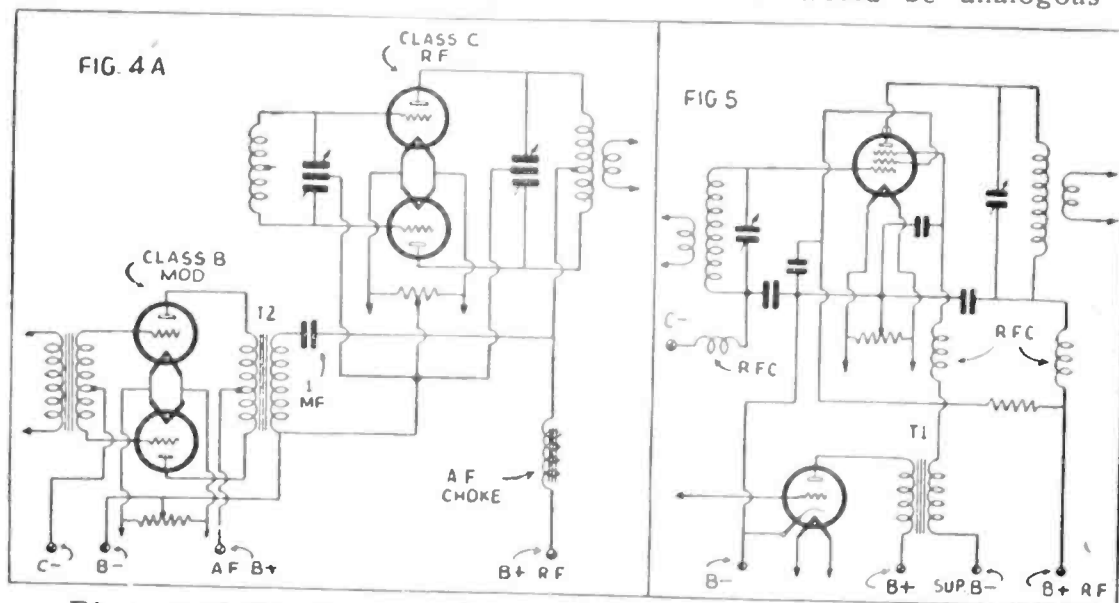
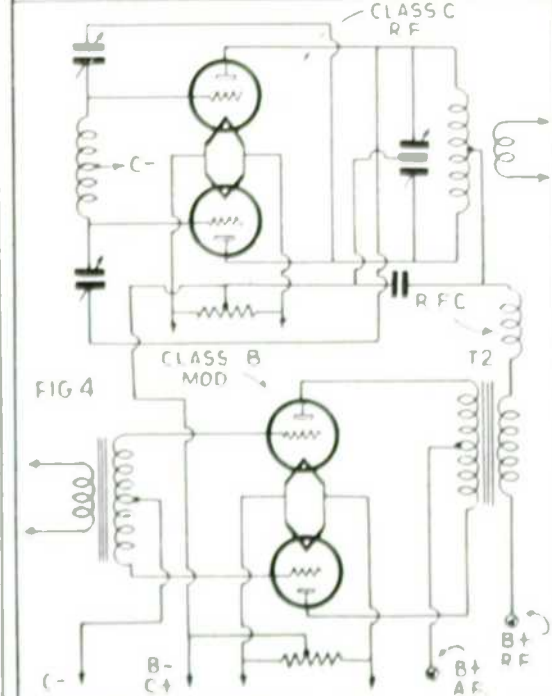
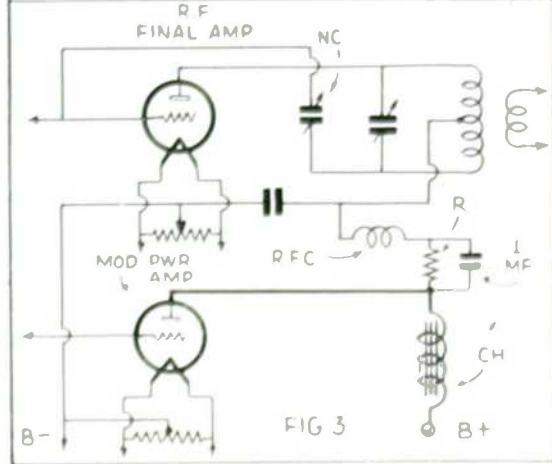
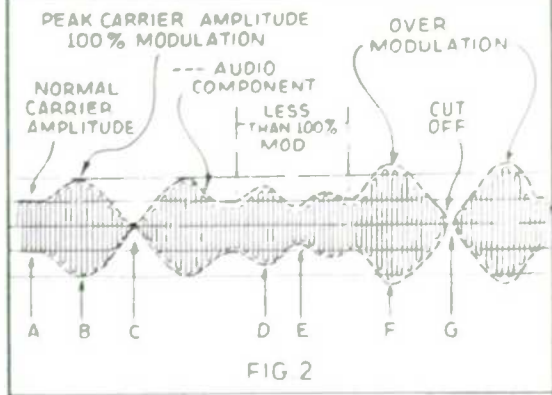
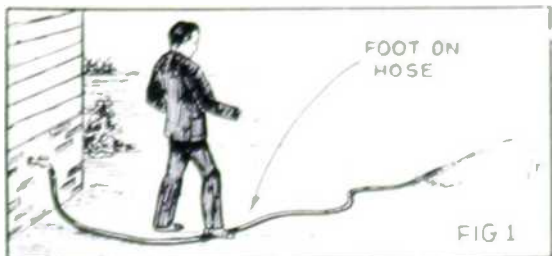

Diagram of Class "B" modulator and also suppressor grid modulation.

transmitter is modulated in the form of dots and dashes. In this case, however, the wave is cut off abruptly to form the characters. In the case of radio telephony, the audio frequency modulation varies the power output of the transmitter in accordance with the intensity of the audio frequency variation imposed upon the microphone.

The analogue shown in the drawing Fig. 1, where we have a person standing on a hose indicates a hydraulic analogy of modulation. For instance, if the gentleman in

voice frequency. In other words, modulation does nothing more or less than vary the output of the transmitter at voice or audible frequencies. The degree of variation is the percentage of modulation, and the number of times it makes a complete change is the frequency of the audio component. In diagram 2 we have graphically illustrated how modulation affects the transmitted wave. In the beginning at "A" we have the normal carrier amplitude. Now if we increase this 75%, for example, on one-half of the audio cycle it would naturally be followed by a similar decrease below



Methods of coupling modulator to R.F. amplifier.

normal, during the opposite half of the audio cycle.

Therefore, it can be seen by referring to the diagram, that we have limits to the increase and decrease. This limit is commonly termed 100% modulation. At point "B" we find the carrier has been doubled in amplitude, then this is followed by the reverse of this action and the carrier is reduced to zero at point "C." If we only modulated the carrier slightly or some amount less than 100%, it does not cut off completely, and neither does it increase to double the amplitude. This is shown in points "D" and "E." We may, however, modulate the transmitter more than 100% as shown in points "F" and "G." The peaks here are well over twice the normal carrier and while the transmitter output can be reduced no further than zero, distortion comes about due to the fact that the output remains zero for the same length of time that it was greater than twice the amplitude. This causes considerable distortion and interference and should be avoided in all cases.

Thoroughly studying the hydraulic analogue, together with the graphic illustration in Fig. 2, should provide anyone with the necessary knowledge of how modulation is accomplished.

Modulation of a transmitter may be accomplished electrically in a number of ways. The plate voltage to the final amplifier of a transmitter may be varied as shown in Fig. 3 or 4, or by other well-known methods.

In Fig. 3 the modulator merely changes the plate power input to the rf. amplifier at voice frequencies. By connecting the output circuits of the modulator and rf. amplifier in parallel and feeding the D.C. voltage to the two tubes through the audio frequency choke CH, the audio voltage is developed across the choke and either adds to the effective plate voltage applied to the amplifier or cancels it. If we were to develop 300 volts of audio frequency across the choke and the voltage applied to the rf. amplifier without modulation was 300 volts, we would find that on the plus half of the AF cycle we would have 600 volts applied to the rf. amplifier. This would be the 300 original volts and the 300 volts developed on the modulator. Now on the negative half of the cycle we have 300 volts minus which actually nullifies the original 300 volts applied to the rf. amplifier, resulting in zero plate voltage. The rf. amplifier

in this case is operated *class C*, as described in a previous chapter, where the changes in power output is directly proportional to changes in the power input. Therefore, when plate voltage is redoubled the amplitude of the carrier is doubled and when the plate voltage is reduced to zero, of course the output is also zero. In Fig. 4 we have other methods of accomplishing the same conditions through the use of push-pull modulators coupled to the amplifier through transformers.

Another method of varying the output of the transmitter is shown in Fig. 5. This is the recently introduced suppressor modulation, where changes in suppressor voltage have direct control over the output of the amplifier. These tubes are pentodes such as the 802, 803, RK20, and many others. In this case, however, the audio power requirements are not as severe as when plate modulation is used. For in plate modulation if we have 50 watts input to the R.F. amplifier, that is D.C. plate voltage times D.C. plate current, we need at least 25 watts of audio power. In other words, for plate modulation the audio requirements are just 50% of the power input to the modulated amplifier for 100% modulation. In figure 5, the audio requirements are, of course, much less. Usually 5 or 6 watts of audio is more than sufficient to modulate even the largest of pentodes. The adjustment of a suppressor modulated amplifier is quite simple. The suppressor voltage is adjusted until the output of the amplifiers is reduced to about 25%. This is accomplished by running the suppressor *negative*. The audio voltage is then coupled to the suppressor through a suitable transformer, and in this manner will increase and decrease the suppressor voltage, thus causing an increase and decrease in the power output of the tube.

In Fig. 6, we have grid modulation. This is accomplished by adjusting the RF. amplifier so that the variation in output is directly in proportion to the changes in grid voltage. Here, too, only a low-powered modulator is required. The output of a grid modulator may even be less than that required for suppressor modulation.

In Fig. 7, we have a diagram of a complete modulator with an output of around 25 watts. We have two stages of speech amplification using type 56 tubes, coupled to a 46 connected as a triode driver for the class B 46's. The output transformer should be of proper design to match the output of

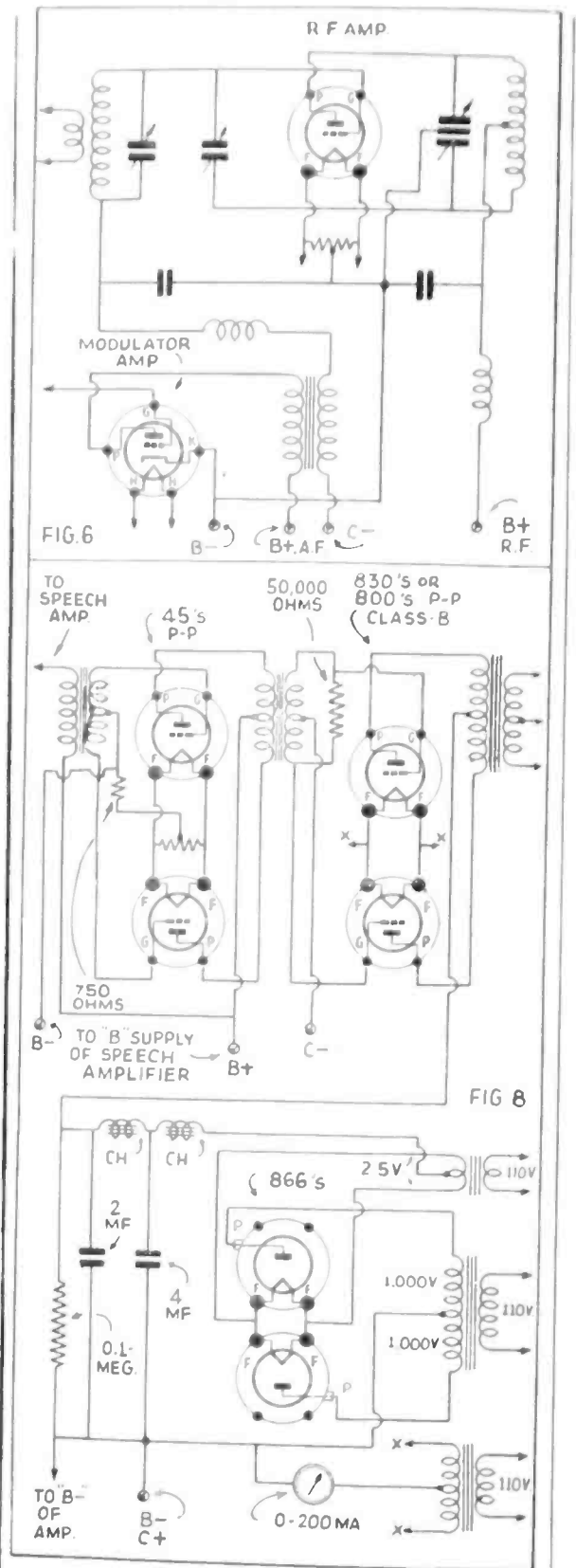

Method of modulating the control-grid also diagram of high-power modulator and power-supply.

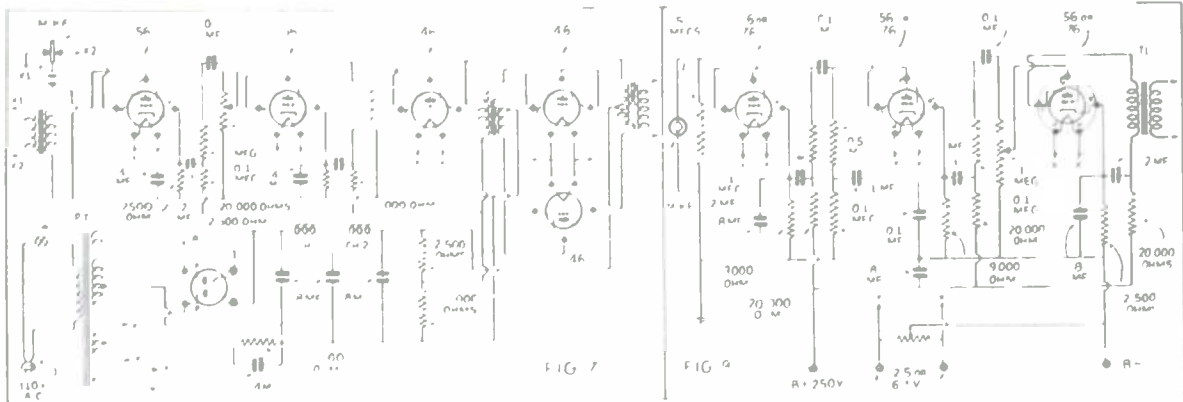

Complete 25-watt modulator and speech amplifier diagram together with a speech amplifier for a "low-level" microphone.

the modulator to the input circuit of the modulated amplifier. Such a modulator will modulate any transmitter having a plate input of 50 watts. For higher power inputs, naturally greater modulator power is necessary.

In Fig. 8 we have the type 830B's or 800's as class "B" modulators with type 45's as *drivers*. These tubes will modulate up to a 200-watt power input. The output of such an amplifier is around 100 watts. The speech amplifier in Figure 7 will serve for the average double-button carbon microphone or a crystal microphone. For lower-level microphones, naturally greater amplification is necessary, and in Fig. 9 we have shown three stages of resistance coupled triodes.

In dealing with high-gain speech ampli-

fiers of this sort, sufficient circuit isolation or de-coupling must be employed in order to eliminate feed-back and audio frequency oscillation.

T1 in diagram 9 should be coupled to the driver stage of any modulator. For instance, it would be coupled to the 45's in push-pull of figure 8.

Below is a list of modulators which may be used with various types of power amplifiers. These are all, of course, for plate modulation.

R.F. Amp. Tubes	Input R.F. Amp.	Modulation Tubes	Mod Out put
46's, 10, single	50W	46's Class B	25W
push-pull or par.			
801's in push-pull	100W	10's in Class B	50-60W
800's in push-pull	150W	800's in Class B	100W
211-03A-838-830B			
up to 200W		800's in Class B	100W
For inputs exceeding	200W	use 838's or 203A's Class B	200 to 260W

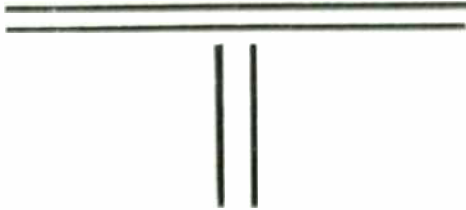

CHAPTER 10

• • •

POWER SUPPLIES FOR AMATEUR SETS

● THE most important part of a transmitter, or any piece of radio apparatus, is the source of power or the *power supply unit*. In nearly all cases the power for operating radio transmitters and receivers is taken directly from the alternating current power mains. In Fig. 1, we have the various types of rectifier units for operation directly from alternating current. Principles of alternating current and the action taking place in rectifier circuits have been clearly defined in previous lessons of this course. In Fig. 1A, we find a representative drawing of alternating current with each half of the cycle numbered starting with 1.

The Half-Wave Rectifier

In Fig. 1B, we have the well-known half-wave rectifier with its pulsating D.C. output also illustrated. We find that the first impulse is transmitted to the output of the rectifier system. The second impulse though, as shown by the dotted line is not transmitted, and then No. 3 which is in the same direction as No. 1 is also transmitted, and so on to No. 5. Here we find a considerable space in between each impulse which is received at the output terminals of the rectifier system. This is characteristic of all half-wave systems, and it will be seen that this is much harder to filter or *smooth out*, due to the great time space occurring between the direct impulses.

Full-Wave Rectifier

However, we can utilize the other half of this A.C. input cycle, by what is known as the *full-wave* rectifier system, diagrammed in Fig. C. In this case we have no particular time space between the impulses as shown in the drawing accompanying Fig. C. This current, of course, is much easier to filter because of the relative *smoothness* compared with the output of the rectifier in Fig. B. In Fig. C, we utilize a center-tapped

transformer, where the output voltage of the rectifier is approximately equal to $\frac{1}{2}$ of the entire secondary voltage, or approximately equal to the voltage existing on either side of the center tap.

Voltage Either Side of Center Tap

This transformer, for instance, may deliver 500 volts at the output terminals of the rectifying system. This would require that each side of the center tap deliver 500 volts, making a total secondary voltage of 1,000. This same transformer can be made to deliver 1,000 volts at the output terminals of the rectifying system if the entire secondary is used in a *half-wave* system, as shown in Fig. B. On the other hand, this would be difficult to filter. With a suitable rectifying system, we can obtain full-wave rectification and have the entire secondary voltage appear at the output terminals of the rectifier.

The Bridge Rectifier

In Fig. D we have the bridge rectifier system which requires four $\frac{1}{2}$ -wave rectifiers. Here the output is just as smooth as that shown in Fig. C, and the voltage is *twice as great!*

When selecting the power transformer, there are many things to consider besides the voltage rating. Of course, the primary of the transformer must be designed to operate at the voltage of the power mains. 110-volt mains require a transformer with a 110-volt primary, and if the power mains deliver 220 volts, then of course a like primary would be needed. We also have to consider the frequency of the A.C. service. The average of course is 60 cycles. However, in different parts of the United States, and in various foreign countries, the frequency may be anywhere from 25 to 60 cycles. The average 60-cycle power transformer will operate satisfactory on either 50 or 60 cycles. However, where 25 or 30 cycle

power is available, a transformer designed especially to operate at that frequency will be required.

Power Rating of Transformer

The *power rating* of the secondary of the average transformer is given in volts and milliamperes. The voltage rating is determined entirely by the rating of the vacuum tube for which the transformer is intended to furnish power. For instance, the average 50-watt tube operates at around 1,000 volts, therefore, a transformer delivering from 1,000 to 1,250 volts will be required. Usually, the voltage rating of the transformer is slightly greater than the tube rating, in

vacuum rectifier in former years was so designed that there was a considerable drop in voltage through the tube. Then to overcome this mercury was added to the tube and the ionization thus coming about during operation, lowered the resistance to a negligible amount, and, therefore, the voltage drop was practically eliminated. The rated voltage drop of the average *mercury vapor tube* is 15 volts.

For power supplies up to 300 volts the type 80 tube is recommended. For power supplies delivering in the neighborhood of 500 volts, the type 5Z3 is suitable. For good regulation in the 500-volt category, either

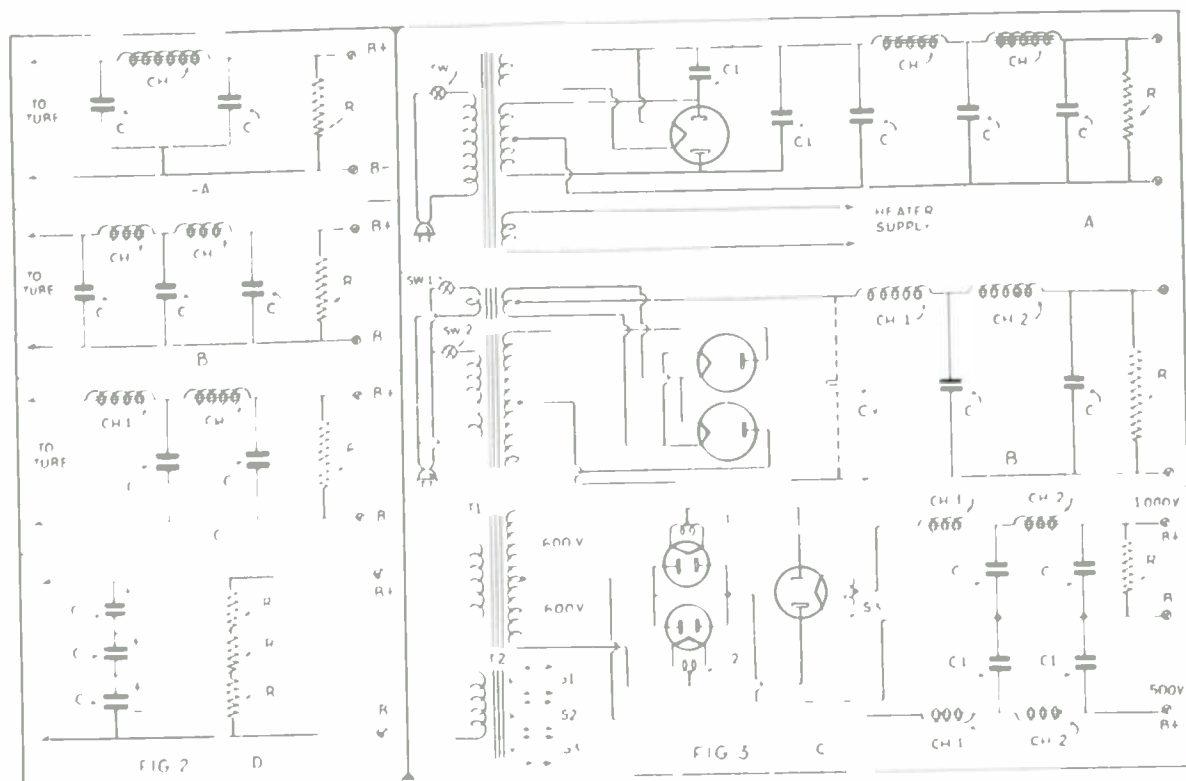

In Figs. 2, A, B, C, and D, we have various types of filter networks together with a method of connecting condensers in series. In Figs. 3, A, B, and C, we have the three fundamental power supply systems. The receiving type, the low-powered transmitting type, and finally the dual power-supply, using the "bridge" rectifier system.

order to allow for a voltage drop in the filtering system. If the total load on the power supply, for instance, is to be 250 ma. (milliamperes), the current rating of the transformer will have to be 250 ma., plus the current drawn by the bleeder resistor. The bleeder will be covered later on in this chapter.

Choice of Rectifier Tube

The *choice of the rectifier tubes* is quite an important one. There are two types of rectifiers generally used among amateurs and experimenters. These are of the *high vacuum* type and the *mercury vapor* type. The high

the mercury vapor tube may be used or the new high vacuum "83V". The "83V" provides excellent regulation and has an extremely low voltage drop, due to the very close spacing of the elements. For the average power supply delivering in the neighborhood of 1,000 volts, with a center-tapped transformer, the type "866" which is a one-half wave mercury vapor rectifier or the high vacuum type 836 are recommended. In fact, both of these tubes work well in power supplies delivering as high as 2,000 volts. The "866" may be used on voltages well above this figure.

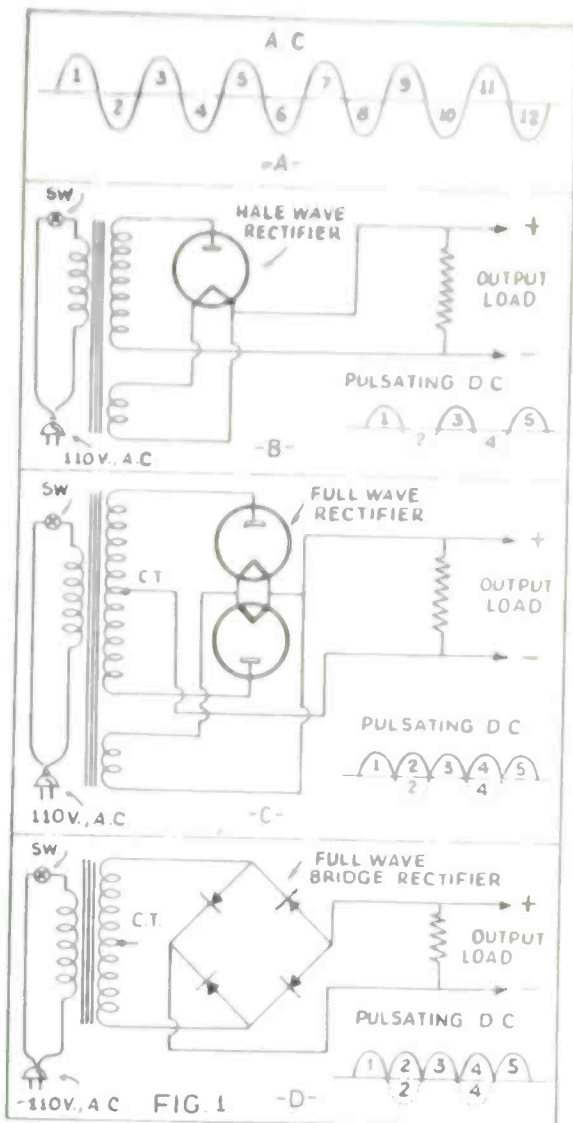

In Fig. 1, A, B, C, and D, we have various types of rectifying circuits, including the half-wave, full-wave with center-tapped transformer, and the full-wave "Bridge" circuit.

The Filter Circuit

After the alternating current has been rectified, we have to use some sort of *smoothing* or *filtering* circuit in order to deliver pure D.C. to the transmitting vacuum tubes. In Fig. 2, we show various filter systems. In 2A, we have the so-called "brute force" filter, wherein a single choke and two condensers are used. The current carrying capacity of the choke should be identical to the transformer rating. The inductance of the choke for low-voltage filters should be around 30 henries, and is not at all critical. In Fig. 2B, we have the double-section filter using two chokes and three condensers. This provides greater smoothing than the one shown in Fig. A. Both of these are known as the *condenser input* types. Either of these filter systems work

very well with the average 500-volt transformer, when the capacities of the condensers are at least 2 mf. each and the inductance of the choke CH is 30 henries each. For voltages below 500, the electrolytic condenser may be used to an advantage because of its low cost. The usual capacity of the electrolytic condenser is 8 mf. There are two types of these condensers; one is the wet, where the electrolyte is in the form of a liquid, and the other is the so-called *dry*, where the electrolyte is in the form of a paste. The advantage of the wet condenser is in that it may be overloaded and not damaged because of the *self-healing* effect which normally comes about in this type of condenser. The dry type, when punctured, usually has to be replaced.

For voltages over 500, of course the paper type condenser is really the best, and this should be of the *oil-impregnated* type. The voltage ratings of the condensers are given in peak voltage and D.C. working voltage. The D.C. *working voltage* (W.V.) should be slightly higher than the average voltage output of the power supply. For instance, a 1,000-volt power supply would require condensers having a W.V. rating of from 1,200 to 1,500 volts. In Fig. 2, we have the conventional filter arrangement used in the power supplies that develop 1,000 volts or over. In this case, we have *choke input*, meaning that there is no condenser across the input to the filter.

Filter Chokes

The regulation of a power supply of this type, regulation pertaining to the difference in output voltage during changes from minimum to maximum load, is better than the condenser input system. The input chokes CH1 should be of the *swinging* type. The second choke CH2 can be of the usual 30-henry type; or, in fact, anything from 15 to 30 henries seems to work well, where the input power is obtained from a 60-cycle source. When the power supply is to be operated from a 25-cycle source, the choke inductance and capacities of the condensers should be increased approximately 2.5 times to obtain the same amount of filtering at the output of each one of the filter systems shown.

In Figs. 2 A, B, and C, we must employ a so-called *bleeder resistor* or what might be called a "buffer load." The amount of power consumed by the bleeder resistor bears a definite relation to the variation of the power taken from the filter. However, values which give satisfactory results under

known conditions are as follows: for 300 volts a 15,000-ohm, 25 to 35-watt resistor; 500 volts 20,000 ohms, 50 watts; for 1,000 volts, 25,000 ohms, 100 watts; 1,500 volts 35,000 ohms, 150 watts; 2,000 volts, 100,000 ohms, 200 watts. In some cases, the amateur may find that he has, for instance, two 1,000-volt condensers and desires to employ them in a filter circuit of 2,000-volt power supply.

In Fig. 2 D, we have shown a method of connecting condensers in series and in order to obtain equal voltage across each one of these condensers a voltage divider must be connected across the condensers, as shown in 2 Fig. D. This is also necessary if electrolytic condensers are used in series and the polarity has been indicated. The value of R is not critical, and may be anywhere from 150,000 to 500,000 ohms each. This parallel resistor reduces the effective filtering capacity of the condenser slightly, but can be ignored for all general purposes.

3 Power Supply Line-Ups

In Fig. 3, we have three complete power supplies. Fig. 3A, shows the receiving type power supply using the type 80 tube. This circuit is satisfactory for voltages up to around 400. The two condensers marked C1 are used solely to reduce *tunable hums*, and the capacity is not critical. Something in the order of .002 to .006 mf. seems to work satisfactory. The ratings of the chokes depend upon the amount of current taken from the power supply, and also the current drawn by the bleeder R. The inductance, however, should be 30 henries, and the capacity of the condensers C should be 8 mf., electrolytics being the most economical.

In Fig. 3B, we have a full-wave power supply, using separate half-wave rectifiers. If the type 81 vacuum type tubes are used, condensers CX may be employed: that is, *condenser input* may be used to the filter, 1 to 2 mf. being the proper capacity of this condenser. For the mercury vapor type tubes, condenser CX should be eliminated. CH1 should be a *swinging choke* having an inductance of approximately 20 to 100 henries. CH2 may be in the order of 15 to 30 henries. Separate transformers are used for the high-voltage and filament supplies. In all cases, the filaments of the tubes should be switched on several minutes before the switch SW2 is closed.

In Fig. 3C we have the Bridge rectifier circuit used in a power supply capable of delivering two voltages; this is really two

power supplies in one. Here we have utilized a center-tap transformer giving approximately 600 volts each side of the center tap. This delivers 1,000 volts through the filter on one side of the B negative, and 500 volts on the other side of B negative. A filament transformer having three separate filament windings is required. The tubes used are three types "83" mercury vapor rectifiers. CH1 in both cases should be *swinging chokes* and CH2 may be from 15 to 30 henries, the same as in 3B. The condensers C, of course, will have to have a rating high enough to safely stand the 1,000 volts, but condensers C1 will require only one-half this rating. If the power transformer, T1, is capable of supplying 300 to 400 ma., this power supply makes an excellent combination to run an entire transmitter, including the low-power stages as well as the final amplifier.

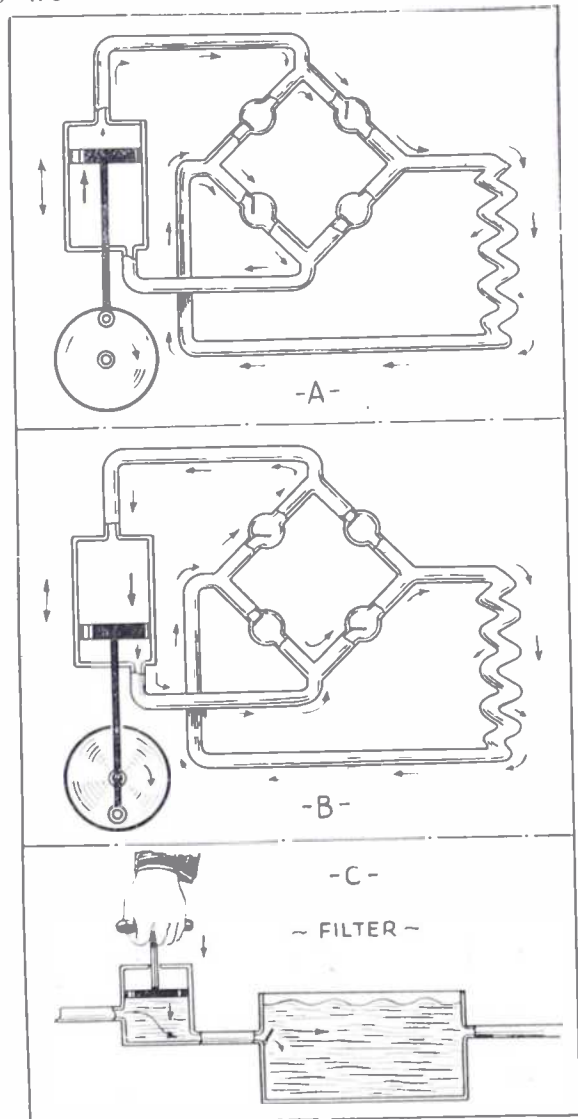

Here we have analogies of the "bridge" rectifier circuit in hydraulic form, and also an hydraulic analogy of the "filter network."

CHAPTER 11

S-W RECEIVERS . . BANDSPREAD . . REGENERATION . . COUPLING METHODS . . .

● THIS chapter will be devoted entirely to a discussion of *simple receiver* circuits, in so far as various types of feed-backs, regeneration controls, and many other minor details are concerned. The theory of the circuits will not be discussed, because this was given in previous chapters.

The most important consideration in simple regenerative detectors is the method by which *regeneration* is obtained. This may be done in a number of ways. The two most prominent are the *plate feed-back* method, as shown in Fig. 1, and the *cathode* method, shown in Fig. 2.

Controlling the regeneration of any receiver may be accomplished by a *variation in voltage* of one of the elements of the tube or by *varying the degree of feed-back coupling*. In Fig. 1, we show both the throttle condenser control of regeneration which is indicated by condenser "C", or the variation of plate voltage by the potentiometer "R". For any detector circuit using a triode there is an optimum range of plate voltage within which the detector operates most efficiently and smoothly. It is strongly advised that both the resistor "R" and condenser "C" be employed to obtain best results. Resistor "R" may be a part of the power supply, and when once adjusted regeneration may be further controlled with the throttle condenser "C". The *number of tickler turns* is also very important. No definite rule can be given for the number of tickler turns which will work satisfactorily for all conditions. If the throttle condenser "C" has a maximum capacity of 140 mmf. the tickler turns should be adjusted simultaneously with the plate voltage for maximum sensitivity, with the plates of your condenser "C" about $\frac{3}{4}$ meshed. This will allow smooth control of regeneration with the remaining 25 per cent of the capacity of the condenser.

An example of what might happen and a situation which in many cases has prevented the experimenter from obtaining a high degree of sensitivity in the receiver follows: For instance, suppose the tickler turns were considered greater than the number necessary to bring about oscillation with a plate voltage of say 45. This would mean that the voltage on the plate would have to be reduced considerably below this value in order to stop oscillation, thus resulting in operation of the tube at a plate voltage which does not permit maximum sensitivity. This holds true with the screen-grid detector as shown in Fig. 2. In this case, the screen voltage is the critical potential. The diagram shown employs the cathode tap, or so-called *electron-coupled* arrangement. This tap should be varied exactly the same as suggested for the tickler turns in diagram 1.

In Fig. 3, we endeavor to show the proper connections for plate and cathode feed-back where separate coils are used. For instance; starting at the top of the coil form, and providing the two windings are both wound in the *same direction*, we have the terminal going to the grid or grid-condenser and grid-leak. This is the grid coil, the lower terminal of which connects to the "B" negative.

Feed-back Connections Important

Now for *plate feed-back*, the B plus connects to the top of the tickler and the plate of the tube to the bottom. If we are using *cathode feed-back* with this coil, the top connection of the tickler will go to the cathode, and the bottom connection will go to the B negative.

We trust that the reader will familiarize himself with the above statements regarding coil connections. It is surprising the number of mistakes made in the connection of the coils.

Going back to Figs. 1 and 2, we find that the grid-leak is shown both across the condenser and directly from grid to "B" negative; each has its advantage. The grid-leak being across the condenser is not a

dous howl or hum will result. Connecting the grid-leak directly from grid to the "B" negative side of the circuit, instead of across the grid condenser, eliminates this irritating occurrence of noise. Practically, there

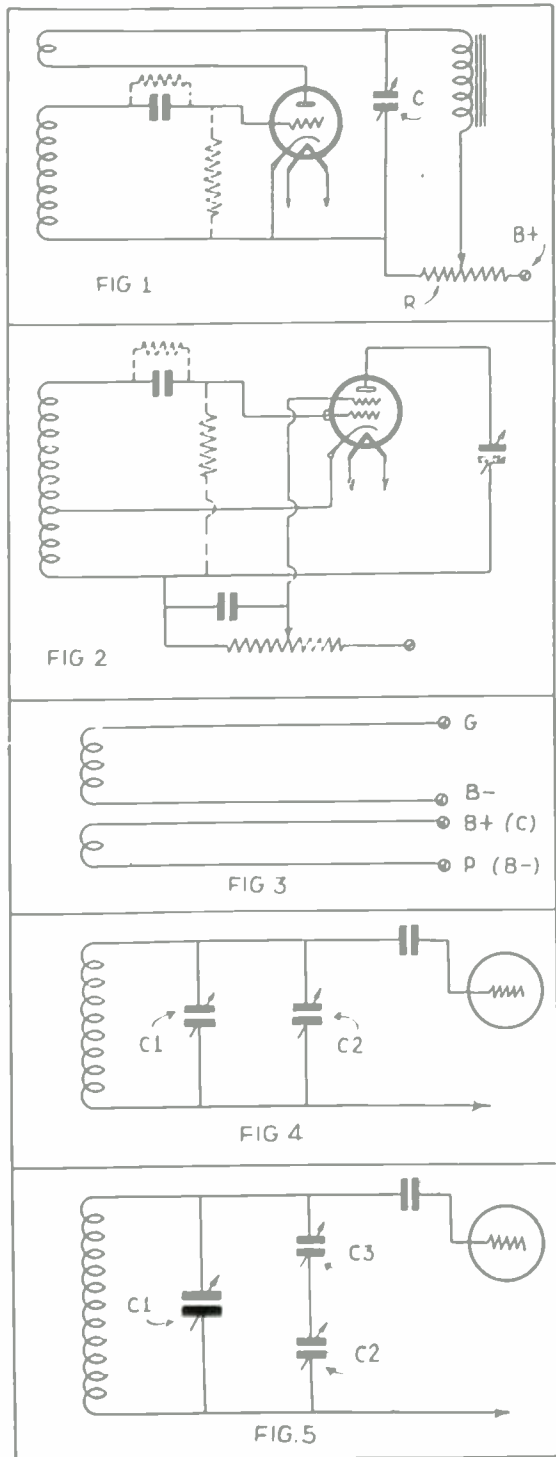

In the above drawing we show various methods of obtaining regeneration and band-spread tuning.

parallel shunt to the tuned circuit and introduces no losses. However, it can easily be seen, and many will recall, that when the plug-in coil is removed the grid circuit is open and in nearly all cases a tremen-

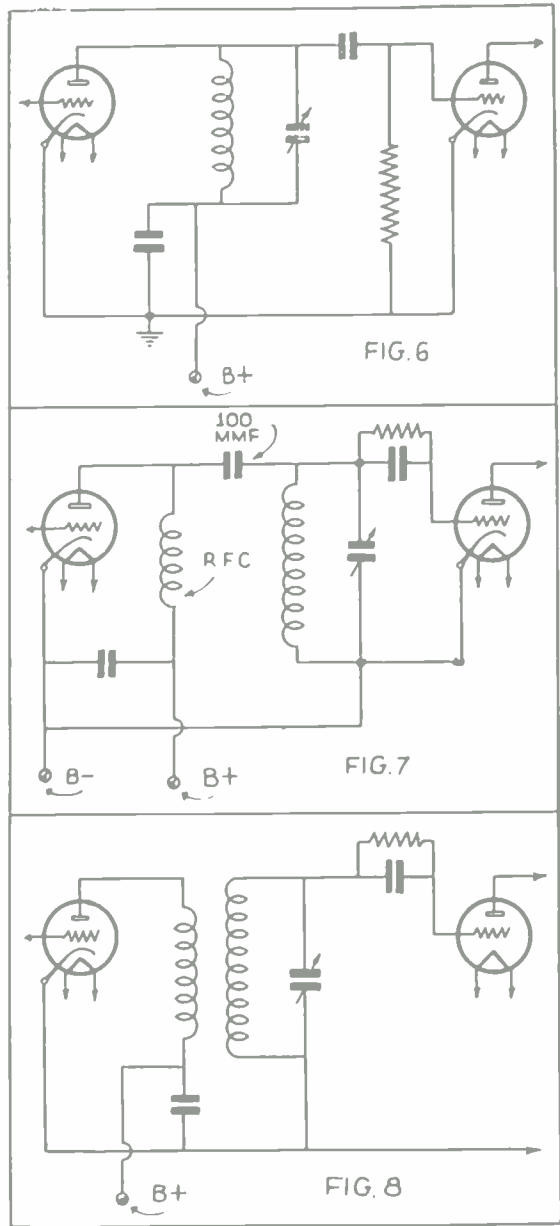

Various types of coupling between two stages of a receiver are illustrated above.

will be no noticeable decrease in efficiency of the detector because the resistance is so high it offers extremely small losses in the tuned circuit. Therefore, the writer believes that it is the most logical connection.

Band-spread Problem

Band-spread has always been a considerable problem and dozens of methods have been put forward. In Fig. 4, we have the parallel condenser arrangement which consists of a fairly large tuning capacity "C1" which is used for setting the range of the smaller condensers "C2". For a fair degree

of band-spread when "C1" is 140 mmf., "C2" should be around 20 to 35 mmf. However, with this arrangement the degree of band-spread is not the same for different settings of "C1". In other words, the band-spread is considerably greater when "C1" (the *band-setting* condenser) is at maximum capacity than it is when "C1" is at minimum. This can be overcome with the arrangement shown in Fig. 5. Here we have "C1" the regular *band-setting* control and "C2" the band-spread unit, with another large condenser similar to "C1" in series with it. This condenser is "C3". By proper adjustment of "C3" and "C1", exactly the same amount of *band-spread* may be obtained at any point of the entire tuning range of the circuit. For great band-spread, "C3" will have a small amount of capacity and for a small amount of band-spread, "C3" will be increased in capacity. This undoubtedly is the most satisfactory method of the two, if a *constant* band-spread ratio is to be maintained.

tween the two tubes, and is usually fairly broad in response when the detector is in the non-oscillating condition. In this case, the tuning condenser rotor and stator both have high voltage applied to them and must be insulated from the metal panel, should one be used. In Fig. 7, we have another variety of the same idea. However, in this case, we have incorporated the tuning condenser and coil in the grid circuit in the usual manner, and the plate of the R.F. tube is coupled through a condenser directly to the grid of the detector. Voltage is fed to the plate through an R.F. choke coil. For general short wave reception, this usually consists of the conventional $2\frac{1}{2}$ mh choke.

In Fig. 8, we have the latest and most popular and, undoubtedly, the most efficient method of coupling an R.F. stage to the detector or to provide coupling, for that matter, between any two tubes. Here we have the plate coil usually interwound with the grid coil and the inductance of the plate coil is usually proportioned to provide max-

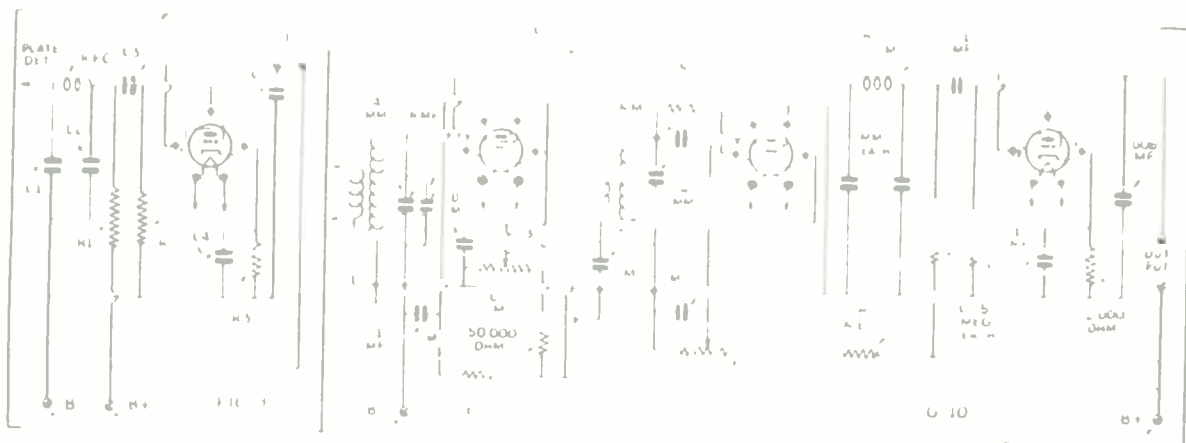

Above—we have the audio coupling arrangement used in the average short-wave receiver, together with a complete working model diagram, embodying the various features discussed in this lesson.

Coupling R. F. Stage to Detector

Coupling the R. F. stage to the detector also provides a number of problems. Undoubtedly the most satisfactory for general use is the *inductive* method. However, each will be discussed so that the reader has a clear picture of just what they consist of.

In Fig. 6, we have the original method which was used many years ago; the so-called *tuned impedance coupling*. The tuned circuit between the detector and R.F. stage is connected in the plate circuit of the R.F. stage. And in this case, the grid-leak *must* be connected between the grid and the "B" negative for best results. This method, of course, does not provide a good match be-

tween the two tubes, and is usually fairly broad in response when the detector is in the non-oscillating condition. In this case, the tuning condenser rotor and stator both have high voltage applied to them and must be insulated from the metal panel, should one be used. In Fig. 7, we have another variety of the same idea. However, in this case, we have incorporated the tuning condenser and coil in the grid circuit in the usual manner, and the plate of the R.F. tube is coupled through a condenser directly to the grid of the detector. Voltage is fed to the plate through an R.F. choke coil. For general short wave reception, this usually consists of the conventional $2\frac{1}{2}$ mh choke.

In Fig. 8, we have the latest and most popular and, undoubtedly, the most efficient method of coupling an R.F. stage to the detector or to provide coupling, for that matter, between any two tubes. Here we have the plate coil usually interwound with the grid coil and the inductance of the plate coil is usually proportioned to provide max-

Coupling Detector to Audio Stage

Coupling the plate circuit of the detector for an audio stage may be done either with a transformer or through the use of resistance and condensers. In Fig. 9, we have

the resistance-capacity coupling, which is usually employed with pentodes. For triodes, such as the 56 for example, or some battery-operated triode, then resistor "R1" and "R2" would be replaced respectively by the primary and secondary of a transformer and condenser "C3" would be eliminated. In many cases where additional audio amplification may be desirable with pentodes, resistor "R1" may be replaced by a high-impedance choke coil; one having an inductance from 300 to 700 henries is entirely satisfactory. It may also be found necessary to connect a $\frac{1}{4}$ meg. resistor across the A.F. choke in order to stabilize the circuit.

Resistance coupling, as shown in Fig. 9, may be used for triodes as well as pentodes. In this case, "R1" would be anywhere from 50,000 to 100,000 ohms. 250,000 ohms is the proper value for screen-grid pentode tubes such as the 57 and 58.

The audio amplification of a simple receiver offers no problem whatsoever. Here an indirectly heated cathode type tube is used. Bias is usually obtained by inserting a resistor in series with the cathode, bypassing it with a high capacity low voltage condenser; in the diagram these are indicated at "C4" and "R3." The resistor, "R3,"

will depend in size upon the type tube used. Condenser "C4" should have a capacity of from 5 to 25 mf. Electrolytics having a working voltage of around 50 volts are entirely satisfactory.

The R.F. filter circuit shown in Fig. 9, consisting of R.F.C., C1, and C2, is really necessary for stable operation. The capacity of "C1" should be about 0001 mf., while that of "C2" is about 0005 mf., for the general short-wave bands from 45 to 200 meters.

In Fig. 10, we have endeavored to incorporate all the various features mentioned in this discussion into a 3-tube receiver, consisting of a pentode, R.F. amplifier, pentode detector, and triode audio amplifier. In tuned R.F. circuits of this type, shielding is necessary as indicated in the diagram. This should separate the two stages completely.

The input to the R.F. stage is also inductive and when a doublet is used the dotted connection between the antenna coupling coil and the ground or "B" negative is not made. This connection is only made when an antenna and ground combination such as the Marconi antenna is used.

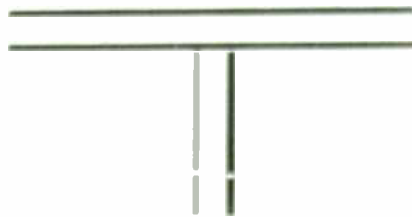

CHAPTER 12

POPULAR SUPERHETERODYNE CIRCUITS

● IN this chapter we will continue the receiver discussion. In our last chapter we took into consideration the simple receivers such as the *regenerative* detector, with and without the R.F. (radio frequency) stage. In this lesson we will cover some of the important points concerning *superheterodynes*. Of course, there is no end to the technicalities involved in designing superheterodynes. However, the average short wave "Fan" and amateur is not interested in detailed technicalities. For instance, the average amateur or "Fan" would not be interested in the technicalities of the converter diagram shown in Fig. 1. It will do him very little good to know the ratios of oscillator output voltage to grid bias and signal in the detector circuit, when in nine cases out of ten he would not be equipped to make the delicate measurements necessary. Therefore, we will cover the standard methods of frequency conversion in so far as practical tube combinations and circuit values are concerned.

Pentode Power-Detector and Electron-Coupled Oscillator

In Fig. 1, we have the pentode *power-detector* and the pentode *electron-coupled oscillator*. In this circuit the output of the oscillator is coupled to the suppressor grid of the detector. This is known as *suppressor grid injection*. This arrangement works out remarkably well because the tuned circuits are entirely independent of the coupling arrangement. Isolation is accomplished by the *screening* (shielding) of the two tubes. It is in this circuit combination that a minimum of pulling takes place. For instance, the strength of the incoming signals and the adjustment of the detector circuit will have practically no effect upon the oscillator tuning which, of course, results in excellent *stability*. If regeneration is to be used in the first detector circuit in order to improve

the *sensitivity* and *selectivity* without adding R.F. preamplifiers, this coupling is the one to use. Of course, without regeneration it would be advisable to employ at least one and preferably two tuned R.F. stages ahead of the pentode detector in order to bring up the sensitivity and reduce image response.

Adding R.F. stages to the front end of a superheterodyne also results in lower-overall set noises, and generally provides a better signal-to-outside noise ratio.

Getting the Circuits to "Track"

One of the most difficult problems in a superhet construction is getting the two tuned circuits to track. The oscillator is tuned to a frequency equal to the I.F. frequency higher than the first detector. This means that if we use 465 kc. as the *intermediate frequency* the oscillator will be tuned 465 kc. higher than the frequency of the first detector, which is the signal frequency. This can be accomplished by the use of properly proportioned inductances and the use of padding condensers. In the diagrams we have shown a condenser in series with the oscillator tuning condenser. This condenser is marked "X." Also, we have a condenser across the entire coil. In the diagram 1, this is marked "T," and there is one in the detector circuit also. For general use in short-wave receivers where trimmers ("T" 140 mmf. bandsetters are used and mounted on the panel, condenser "X" should have a capacity of between .001 and .002 mf. By properly adjusting the coils of the oscillator circuit nearly perfect tracking may be maintained between the two stages. We are considering, of course, that the two tuning condensers "C" (usually 35 mmf.) are small in capacity and the two trimmers "T" are fairly large, the usual band-spread and band-setting condenser combination.

The high frequency coils, for instance, tuning around 14 to 15 megacycles will be identical in construction. The padding condenser "X" will easily take care of the difference. However, in coils tuning around 7 megacycles it will be necessary to use slightly less turns on the oscillator coil; of course, if we go lower in frequency or around 3.5 mc., it will be necessary to have a greater difference between the number of turns in the oscillator and detector coils.

Use of "Dual Purpose" Tube for Detector and Oscillator

In Fig. 1 we have used two separate tubes for converting the frequency. In Fig. 2 we have the 6A7 or 2A7 pentagrid converter. This tube was designed to function both as the first detector and oscillator. Mixing is accomplished electronically within the tube. Although this arrangement is as sensitive as that shown in Fig. 1, experiences have shown that there is considerable reaction between the tuned circuits. Tuning the detector circuit has a noticeable effect upon the oscillator.

The main advantage, of course, is the elimination of the extra tube. However, considering performances, especially on the short waves, one prefers the additional tube.

A New "Mixer" Tube for Superhets

Tube engineers have been working to improve the conversion efficiency of the superheterodyne, and the result has been the introduction of the new 6L7, which is especially designed for use as a mixer tube. Here we have a tube provided with an extra grid solely for the purpose of introducing the oscillator signal into the detector stage. This tube may also be used in a number of other circuit arrangements, but so far it proved the most satisfactory as shown in Fig. 3. This tube provides remarkable efficiency, especially at the higher frequencies and reaction between the two stages has been reduced considerably over other circuits. Of course, both of the diagrams in Fig. 2 and 3, as well as in Fig. 1, require the addition of R.F. stages ahead of the detector, *regeneration* may be introduced conveniently in the detector circuit to partly offset the need of tuned R.F. stages.

The intermediate frequency amplifier of the superhet presents no problem at all if care is used in the layout of parts. Most experimenters who have encountered trouble such as due to feedback or regeneration in I.F. amplifiers can blame it, in

nearly all cases, to crowding, improper use of by-pass condensers, or carelessness in

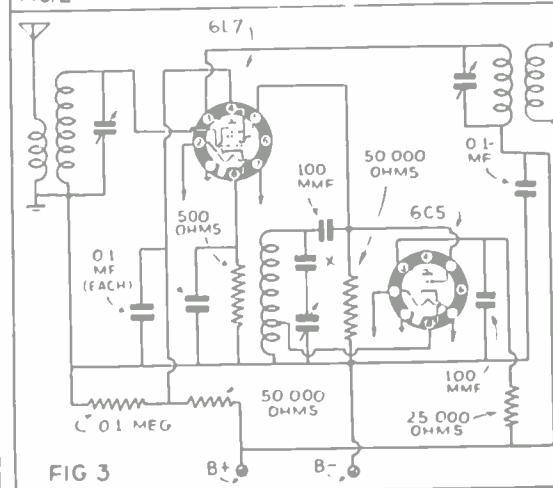
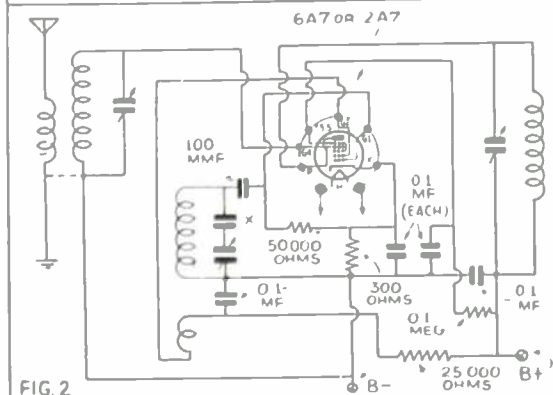
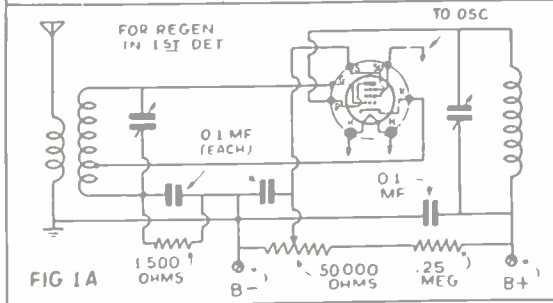
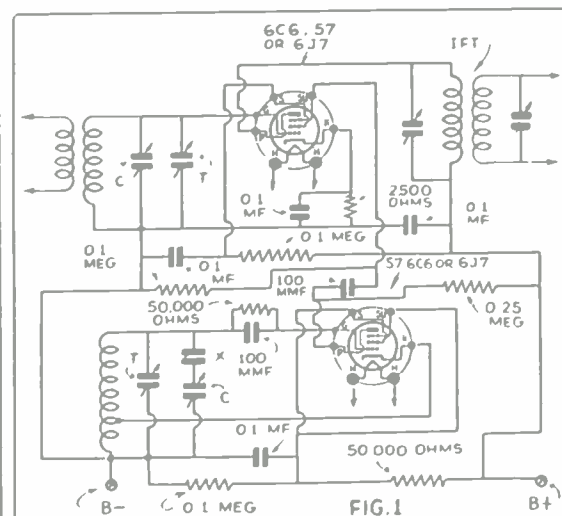

Converter diagrams of the most commonly used types used for superheterodynes.

of band-spread when "C1" is 140 mmf., "C2" should be around 20 to 35 mmf. However, with this arrangement the degree of band-spread is not the same for different settings of "C1". In other words, the band-spread is considerably greater when "C1" (the *band-setting* condenser) is at maximum capacity than it is when "C-1" is at minimum. This can be overcome with the arrangement shown in Fig. 5. Here we have "C-1" the regular *band-setting* control, and "C2" the band-spread unit, with another large condenser similar to "C1" in series with it. This condenser is "C-3". By proper adjustment of "C3" and "C1", exactly the same amount of *band-spread* may be obtained at any point of the entire tuning range of the circuit. For great band-spread, "C3" will have a small amount of capacity and for a small amount of band-spread, "C3" will be increased in capacity. This undoubtedly is the most satisfactory method of the two, if a *constant* band-spread ratio is to be maintained.

tween the two tubes, and is usually fairly broad in response when the detector is in the non-oscillating condition. In this case, the tuning condenser rotor and stator both have high-voltage applied to them and must be insulated from the metal panel, should one be used. In Fig. 7, we have another variety of the same idea. However, in this case, we have incorporated the tuning condenser and coil in the grid circuit in the usual manner, and the plate of the R.F. tube is coupled through a condenser directly to the grid of the detector. Voltage is fed to the plate through an R.F. choke coil. For general short-wave reception, this usually consists of the conventional $2\frac{1}{2}$ mh. choke.

In Fig. 8, we have the latest and most popular and, undoubtedly, the most efficient method of coupling an R.F. stage to the detector or to provide coupling, for that matter, between any two tubes. Here we have the plate coil usually interwound with the grid coil and the inductance of the plate coil is usually proportioned to provide max-

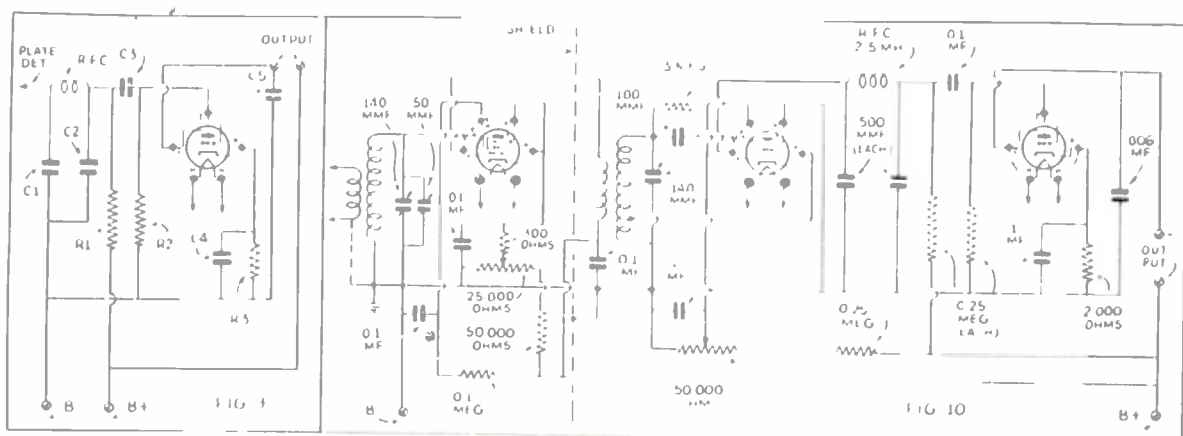

Above—we have the audio coupling arrangement used in the average short-wave receiver, together with a complete working model diagram, embodying the various features discussed in this lesson.

Coupling R. F. Stage to Detector

Coupling the R. F. stage to the detector also provides a number of problems. Undoubtedly the most satisfactory for general use is the *inductive* method. However, each will be discussed so that the reader has a clear picture of just what they consist of.

In Fig. 6, we have the original method which was used many years ago; the so-called *tuned impedance coupling*. The tuned circuit between the detector and R.F. stage is connected in the plate circuit of the R.F. stage. And in this case, the grid-leak *must* be connected between the grid and the "B" negative for best results. This method, of course, does not provide a good match be-

imum efficiency over the entire tuning range of that particular grid coil. The connections of a coil of this type, having three windings, all wound in the same direction, will be identical to those shown in Fig. 3, with the addition of the connection for the plate coil, which are exactly as indicated in the diagram. The *top* of this coil is connected to the *plate*, i.e., the terminal nearest the grid end of the grid coil, and the other terminal of the plate coil is connected to the "B" plus.

Coupling Detector to Audio Stage

Coupling the plate circuit of the detector for an audio stage may be done either with a transformer or through the use of resistance and condensers. In Fig. 9, we have

the resistance-capacity coupling, which is usually employed with pentodes. For triodes, such as the 56 for example, or some battery-operated triode, then resistor "R1" and "R2" would be replaced respectively by the primary and secondary of a transformer and condenser "C3" would be eliminated. In many cases where additional audio amplification may be desirable with pentodes, resistor "R1" may be replaced by a high-impedance choke coil; one having an inductance from 300 to 700 henries is entirely satisfactory. It may also be found necessary to connect a $\frac{1}{4}$ meg. resistor across the A F choke in order to stabilize the circuit.

Resistance coupling as shown in Fig. 9, may be used for triodes as well as pentodes. In this case, "R1" would be anywhere from 50,000 to 100,000 ohms. 250,000 ohms is the proper value for screen-grid pentode tubes such as the 57 and 58.

The audio amplification of a simple receiver offers no problem whatsoever. Here an indirectly heated cathode type tube is used. Bias is usually obtained by inserting a resistor in series with the cathode, bypassing it with a high capacity low voltage condenser, in the diagram these are indicated at "C1" and "R3." The resistor, "R3,"

will depend in size upon the type tube used. Condenser "C1" should have a capacity of from 5 to 25 mf. Electrolytics having a working voltage of around 50 volts are entirely satisfactory.

The R F filter circuit shown in Fig. 9 consisting of R F C, C1, and C2, is really necessary for stable operation. The capacity of "C1" should be about 0001 mf., while that of "C2" is about 0005 mf., for the general short-wave bands from 45 to 200 meters.

In Fig. 10 we have endeavored to incorporate all the various features mentioned in this discussion into a 3-tube receiver consisting of a pentode, R F amplifier, pentode detector, and triode audio amplifier. In tuned R F circuits of this type shielding is necessary as indicated in the diagram. This should separate the two stages completely.

The input to the R F stage is also inductive and when a doublet is used the dotted connection between the antenna coupling coil and the ground or "B" negative is not made. This connection is only made when an antenna and ground combination such as the Marconi antenna is used.

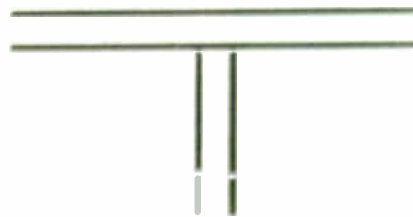

CHAPTER 12

• • •

POPULAR SUPERHETERODYNE CIRCUITS

● IN this chapter we will continue the receiver discussion. In our last chapter we took into consideration the simple receivers such as the *regenerative* detector, with and without the R.F. (radio frequency) stage. In this lesson we will cover some of the important points concerning *superheterodynes*. Of course, there is no end to the technicalities involved in designing superheterodynes. However, the average short wave "Fan" and amateur is not interested in detailed technicalities. For instance, the average amateur or "Fan" would not be interested in the technicalities of the converter diagram shown in Fig. 1. It will do him very little good to know the ratios of oscillator output voltage to grid bias and signal in the detector circuit, when in nine cases out of ten he would not be equipped to make the delicate measurements necessary. Therefore, we will cover the standard methods of frequency conversion in so far as practical tube combinations and circuit values are concerned.

Pentode Power-Detector and Electron-Coupled Oscillator

In Fig. 1, we have the pentode *power-detector* and the pentode *electron-coupled oscillator*. In this circuit the output of the oscillator is coupled to the suppressor grid of the detector. This is known as *suppressor grid injection*. This arrangement works out remarkably well because the tuned circuits are entirely independent of the coupling arrangement. Isolation is accomplished by the *screening* (shielding) of the two tubes. It is in this circuit combination that a minimum of pulling takes place. For instance, the strength of the incoming signals and the adjustment of the detector circuit will have practically no effect upon the oscillator tuning which, of course, results in excellent *stability*. If regeneration is to be used in the first detector circuit in order to improve

the *sensitivity* and *selectivity* without adding R.F. preamplifiers, this coupling is the one to use. Of course, without regeneration it would be advisable to employ at least one and preferably two tuned R.F. stages ahead of the pentode detector in order to bring up the sensitivity and reduce image response.

Adding R.F. stages to the front end of a superheterodyne also results in lower-overall set noises, and generally provides a better signal-to-outside noise ratio.

Getting the Circuits to "Track"

One of the most difficult problems in a superhet construction is getting the two tuned circuits to track. The oscillator is tuned to a frequency equal to the I.F. frequency higher than the first detector. This means that if we use 465 kc. as the *intermediate frequency* the oscillator will be tuned 465 kc. higher than the frequency of the first detector, which is the signal frequency. This can be accomplished by the use of properly proportioned inductances and the use of padding condensers. In the diagrams we have shown a condenser in series with the oscillator tuning condenser. This condenser is marked "X." Also, we have a condenser across the entire coil. In the diagram 1, this is marked "T," and there is one in the detector circuit also. For general use in short-wave receivers where trimmers ("T" 140 mmf. bandsetters are used and mounted on the panel, condenser "X" should have a capacity of between .001 and .002 mf. By properly adjusting the coils of the oscillator circuit nearly perfect tracking may be maintained between the two stages. We are considering, of course, that the two tuning condensers "C" (usually 35 mmf.) are small in capacity and the two trimmers "T" are fairly large, the usual band-spread and band-setting condenser combination.

The high frequency coils, for instance, tuning around 14 to 15 megacycles will be identical in construction. The padding condenser "X" will easily take care of the difference. However, in coils tuning around 7 megacycles it will be necessary to use slightly less turns on the oscillator coil; of course, if we go lower in frequency or around 3.5 mc., it will be necessary to have a greater difference between the number of turns in the oscillator and detector coils.

Use of "Dual Purpose" Tube for Detector and Oscillator

In Fig. 1 we have used two separate tubes for converting the frequency. In Fig. 2 we have the 6A7 or 2A7 pentagrid converter. This tube was designed to function both as the first detector and oscillator. Mixing is accomplished electronically within the tube. Although this arrangement is as sensitive as that shown in Fig. 1, experiences have shown that there is considerable reaction between the tuned circuits. Tuning the detector circuit has a noticeable effect upon the oscillator.

The main advantage, of course, is the elimination of the extra tube. However, considering performances, especially on the short waves, one prefers the additional tube.

A New "Mixer" Tube for Superhets

Tube engineers have been working to improve the conversion efficiency of the superheterodyne, and the result has been the introduction of the new 6L7, which is especially designed for use as a mixer tube. Here we have a tube provided with an extra grid solely for the purpose of introducing the oscillator signal into the detector stage. This tube may also be used in a number of other circuit arrangements, but so far it proved the most satisfactory as shown in Fig. 3. This tube provides remarkable efficiency, especially at the higher frequencies and reaction between the two stages has been reduced considerably over other circuits. Of course, both of the diagrams in Fig. 2 and 3, as well as in Fig. 1, require the addition of R.F. stages ahead of the detector although, as we said before in Fig. 1, *regeneration* may be introduced conveniently in the detector circuit to partly offset the need of tuned R.F. stages.

The intermediate frequency amplifier of the superhet presents no problem at all if care is used in the layout of parts. Most experimenters who have encountered trouble such as due to feedback or regeneration in I.F. amplifiers can blame it, in

nearly all cases, to crowding, improper use of by-pass condensers, or carelessness in

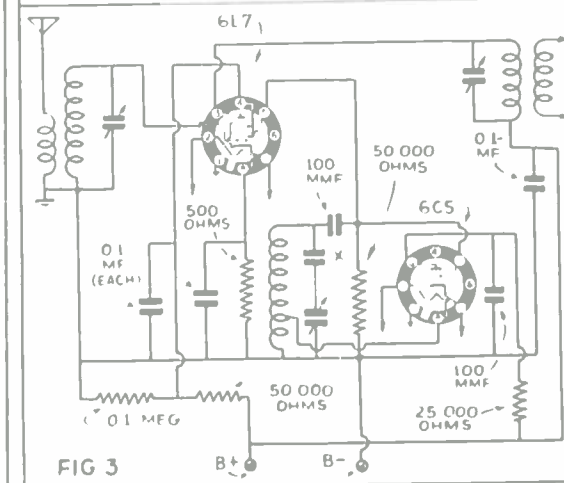
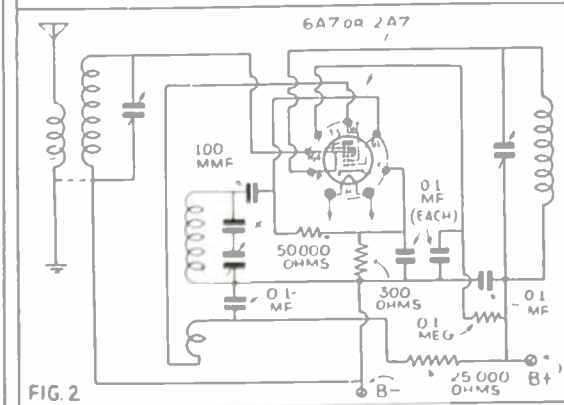
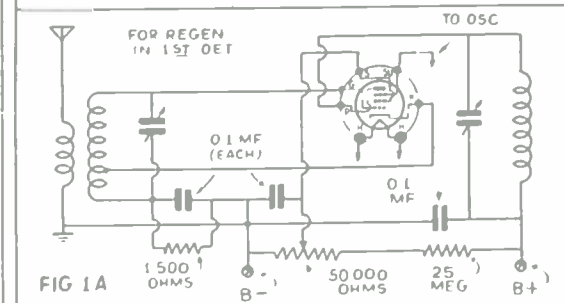
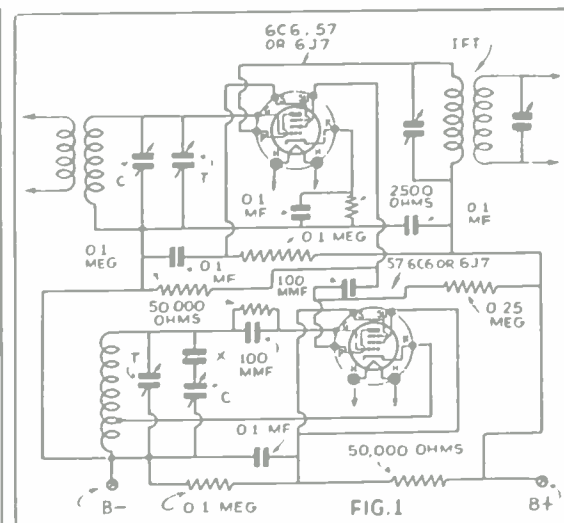

Converter diagrams of the most commonly used types used for superheterodynes.

CHAPTER 12

• • •

POPULAR SUPERHETERODYNE CIRCUITS

● IN this chapter we will continue the receiver discussion. In our last chapter we took into consideration the simple receivers such as the *regenerative* detector, with and without the R.F. (radio frequency) stage. In this lesson we will cover some of the important points concerning *superheterodynes*. Of course, there is no end to the technicalities involved in designing superheterodynes. However, the average short wave "Fan" and amateur is not interested in detailed technicalities. For instance, the average amateur or "Fan" would not be interested in the technicalities of the converter diagram shown in Fig. 1. It will do him very little good to know the ratios of oscillator output voltage to grid bias and signal in the detector circuit, when in nine cases out of ten he would not be equipped to make the delicate measurements necessary. Therefore, we will cover the standard methods of frequency conversion in so far as practical tube combinations and circuit values are concerned.

Pentode Power-Detector and Electron-Coupled Oscillator

In Fig. 1, we have the pentode *power-detector* and the pentode *electron-coupled oscillator*. In this circuit the output of the oscillator is coupled to the suppressor grid of the detector. This is known as *suppressor grid injection*. This arrangement works out remarkably well because the tuned circuits are entirely independent of the coupling arrangement. Isolation is accomplished by the *screening* (shielding) of the two tubes. It is in this circuit combination that a minimum of pulling takes place. For instance, the strength of the incoming signals and the adjustment of the detector circuit will have practically no effect upon the oscillator tuning which, of course, results in excellent *stability*. If regeneration is to be used in the first detector circuit in order to improve

the *sensitivity* and *selectivity* without adding R.F. preamplifiers, this coupling is the one to use. Of course, without regeneration it would be advisable to employ at least one and preferably two tuned R.F. stages ahead of the pentode detector in order to bring up the sensitivity and reduce image response.

Adding R.F. stages to the front end of a superheterodyne also results in lower-overall set noises, and generally provides a better signal-to-outside noise ratio.

Getting the Circuits to "Track"

One of the most difficult problems in a superhet construction is getting the two tuned circuits to track. The oscillator is tuned to a frequency equal to the I.F. frequency higher than the first detector. This means that if we use 465 kc. as the *intermediate frequency* the oscillator will be tuned 465 kc. higher than the frequency of the first detector, which is the signal frequency. This can be accomplished by the use of properly proportioned inductances and the use of padding condensers. In the diagrams we have shown a condenser in series with the oscillator tuning condenser. This condenser is marked "X." Also, we have a condenser across the entire coil. In the diagram 1, this is marked "T," and there is one in the detector circuit also. For general use in short-wave receivers where trimmers ("T" 140 mmf. bandsetters are used and mounted on the panel, condenser "X" should have a capacity of between .001 and .002 mfd. By properly adjusting the coils of the oscillator circuit nearly perfect tracking may be maintained between the two stages. We are considering, of course, that the two tuning condensers "C" (usually 35 mmf.) are small in capacity and the two trimmers "T" are fairly large, the usual band-spread and band-setting condenser combination.

The high frequency coils, for instance, tuning around 14 to 15 megacycles will be identical in construction. The padding condenser "X" will easily take care of the difference. However, in coils tuning around 7 megacycles it will be necessary to use slightly less turns on the oscillator coil; of course, if we go lower in frequency or around 3.5 mc., it will be necessary to have a greater difference between the number of turns in the oscillator and detector coils.

Use of "Dual Purpose" Tube for Detector and Oscillator

In Fig. 1 we have used two separate tubes for converting the frequency. In Fig. 2 we have the 6A7 or 2A7 pentagrid converter. This tube was designed to function both as the first detector and oscillator. Mixing is accomplished electronically within the tube. Although this arrangement is as sensitive as that shown in Fig. 1, experiences have shown that there is considerable reaction between the tuned circuits. Tuning the detector circuit has a noticeable effect upon the oscillator.

The main advantage, of course, is the elimination of the extra tube. However, considering performances, especially on the short waves, one prefers the additional tube.

A New "Mixer" Tube for Superhets

Tube engineers have been working to improve the conversion efficiency of the superheterodyne, and the result has been the introduction of the new 6L7, which is especially designed for use as a mixer tube. Here we have a tube provided with an extra grid solely for the purpose of introducing the oscillator signal into the detector stage. This tube may also be used in a number of other circuit arrangements, but so far it proved the most satisfactory as shown in Fig. 3. This tube provides remarkable efficiency, especially at the higher frequencies and reaction between the two stages has been reduced considerably over other circuits. Of course, both of the diagrams in Fig. 2 and 3, as well as in Fig. 1, require the addition of R.F. stages ahead of the detector although, as we said before in Fig. 1, *regeneration* may be introduced conveniently in the detector circuit to partly offset the need of tuned R.F. stages.

The intermediate frequency amplifier of the superhet presents no problem at all if care is used in the layout of parts. Most experimenters who have encountered trouble such as due to feedback or regeneration in I.F. amplifiers can blame it, in

nearly all cases, to crowding, improper use of by-pass condensers, or carelessness in

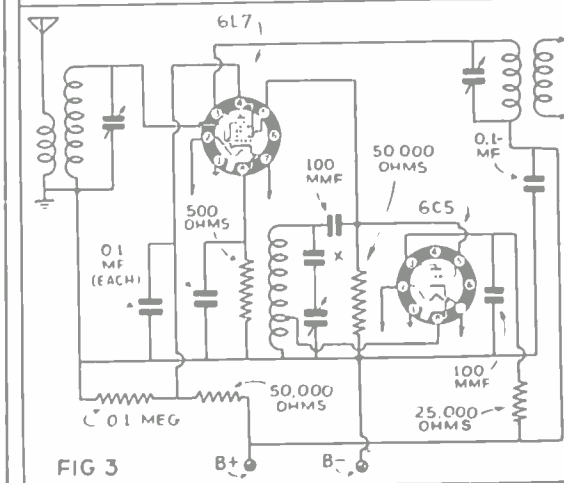
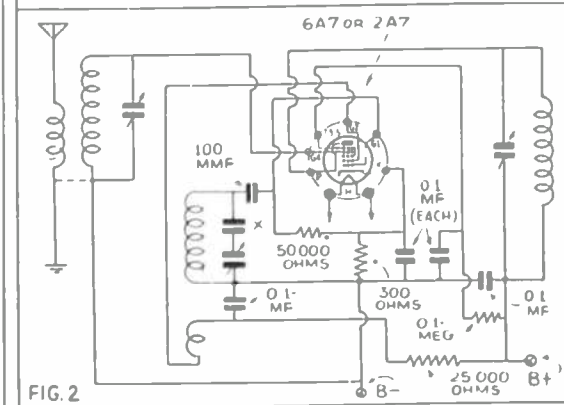
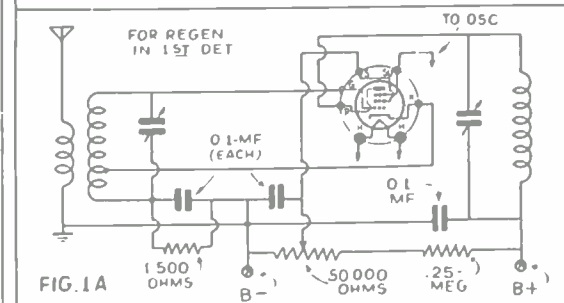
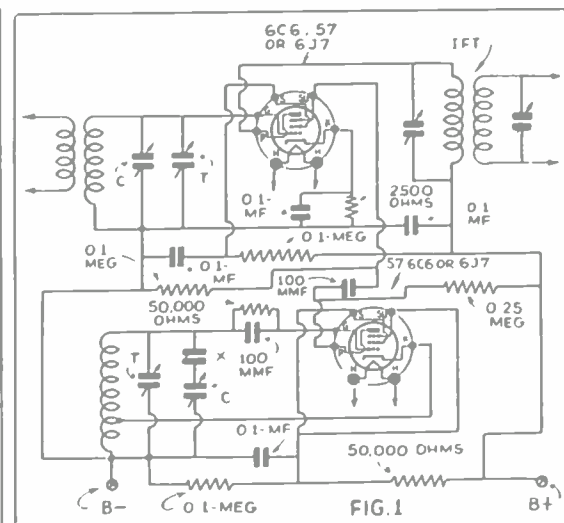

Converter diagrams of the most commonly used types used for superheterodynes.

CHAPTER 13

ULTRA-HIGH FREQUENCY RECEIVERS

—FOR 5 METER AMATEUR BAND

● THERE is probably nothing so fascinating in the radio field as experimenting on the *ultra high frequencies*. In this field lies the future of radio and a great opportunity for all ambitious experimenters. In this lesson we will deal with the more or less standard super-regenerative receivers, which have become the most important part of ultra high frequency reception. The super-regenerator is capable of excellent *sensitivity* and is probably, without doubt, the most sensitive *simple* receiver which ever was or will be devised. This does not

In this unstable condition a fairly weak signal will cause the detector to commence oscillating, and these will continue to build up to an amplitude permitted by the tube constants. However, the receiver cannot reproduce the signal because after the oscillations once start they would not cease. Therefore the *interruption frequency* oscillator is employed to stop the detector from oscillating at intervals, which depend upon the frequency of this interrupting oscillator. It is assumed that on the upward swing a signal is built up along with oscillations,

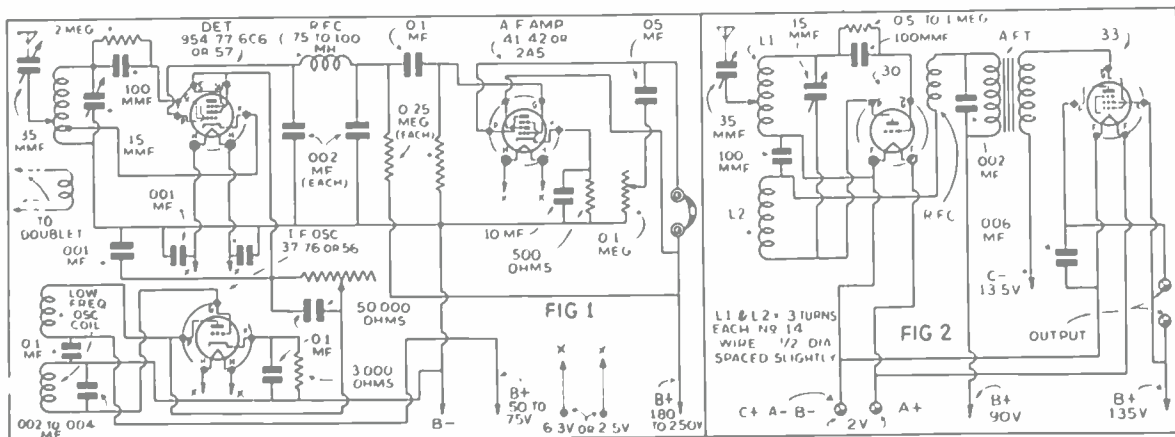

Super-regenerator using a separate quenching oscillator, together with diagram of a battery operated 5-meter receiver.

mean, though, that time will not change the method of reception of ultra high frequency signals, but for the time being the most interesting and most popular receiver is the *super-regenerator*.

Reviewing what we have already learned about *regenerative detectors* and bearing this in mind, we may easily understand the simple functions of the super-regenerator. A regenerative detector is one wherein a signal is built up by regeneration to a point, where, if we employ further regeneration—the tube will break into sustained operation oscillation.

but this procedure is halted before the self-oscillations reach a value comparable with the signal.

This same action can also be obtained without the use of the low frequency oscillator. The single tube can be made to oscillate at two frequencies; one the signal frequency, and the other of super-audible frequency in the neighborhood of 15 to 50 kc. The best all-around frequency for the quenching oscillation has been found to be from 15 to 25 kc.

The selectivity of the super-regenerator is also governed by the interruption fre-

quency. As the interruption frequency becomes higher, the receiver becomes broader or more unselective. Therefore, the lowest possible frequency commensurate with good quality reproduction is desirable.

In Fig. 1 we have either a tetrode or pentode detector. In the case of the pentode the suppressor is connected to the screen-grid; either will give the same results. However, the 954 Acorn tube, especially designed for ultra high frequencies, is preferable when operating the receiver at frequencies higher than 60 meg. At 5 meters or 56 megs. it is difficult to notice the difference between the signal sensitivity of the 954 and the usual tetrode or pentode. It will be noticed, though, that the conventional receiving tubes such as the 6C6 or the 57 will give greater volume, and in this respect, it may be somewhat superior inasmuch as less audio frequency amplification is needed. Of course, this is only true in cases of a super-regenerator detector. In an R.F. amplifier circuit the 954 would be far superior to the other tubes. In the circuit in Fig. 1, the screen is modulated by connecting it in parallel with the plate circuit of the interruption frequency oscillator. The voltage to the screen is variable through the use of a variable resistor, independent of the oscillator plate voltage. It is advisable to also adjust the voltage applied to the oscillator plate for maximum sensitivity and best super-regeneration action of the detector.

It will be found that the voltage fed to the I.F. oscillator is quite critical inasmuch as with high voltage on the oscillator we will have tremendous distortion in the signal and with very low voltage on the oscillator we are liable to have *repeat* spots, that is, the station may appear at several points on the dial very close together. As we said before, there is just one value of plate voltage which gives the cleanest regenerative action in the detector circuit. We should also make sure that the detector is not *super-regenerating* by itself, that is, that it is not *self-quenching* along with the applied voltage of the I.F. oscillator. This can be determined by noting the smoothness of the regeneration control in the detector screen circuit. This should be very smooth in operation and the hiss of the detector should appear gradually as the resistance in the control is decreased. It should not *plop* into oscillation.

One cause of poor operation in a super-regenerator circuit of the type shown in

Fig. 1 may be found in the I.F. oscillator circuit. Usually the detector, if the tube is o.k., will function properly. There are two types of I.F. or low frequency oscillator coils available on the market; one is the shielded and the other is the unshielded type. It has been found that some of the shielded type introduces a loss in the oscillator circuit, sufficient to cause the necessity of high plate voltage in order to make the oscillator function. In turn, this raises the voltage to the screen above the point where there is not enough resistance in the 50,000-ohm control to bring the detector out of oscillation. The unshielded low frequency coils, however, work perfectly. Regardless of the type of oscillator coil used, make sure that it is possible to bring the detector out of oscillation *smoothly* with the regeneration control "R."

Low-Frequency Oscillator Coils

There seems to be no set standard for the value of inductance used in the low-frequency oscillator coils. Therefore, we have shown a capacity of .002 to .004 mf. in the grid circuit across the grid coil. This condenser is used to lower the frequency of the I.F. oscillator and its capacity will depend upon the original design of the coil. In any event, place sufficient capacity across this to bring the I.F. oscillations down to around 20 kc. A good method to follow is to connect a number of .001 mf. condensers across this secondary, bringing the oscillator into the audible range, so that a very high pitched whistle is heard; then remove one condenser at a time, until this whistle becomes inaudible to the ear. Adjusting the low frequency oscillator and its plate voltage is quite important, contrary to popular belief. With excessive voltage on the plate of the oscillator, it may take on "R8" signal to make a "sizeable" dent in the rush of the super-regenerator, where with the proper value, that is a voltage just in excess of the amount that causes repeat spots to appear, will permit even a very weak signal to cause an appreciable "dent" in the characteristic rushing sound of the super-regenerator. In the output circuit of the super-regenerative detector, we find indicated a 75 to 100 mh. R.F. choke bypassed with two .002 mf. condensers. Theoretically, this choke should be relatively large. However, actual practice has proven that the usual 2½ mh. R.F. choke is entirely satisfactory. The idea of this filter is to keep the low frequency oscillations out of the A.F. amplifier grid circuit.

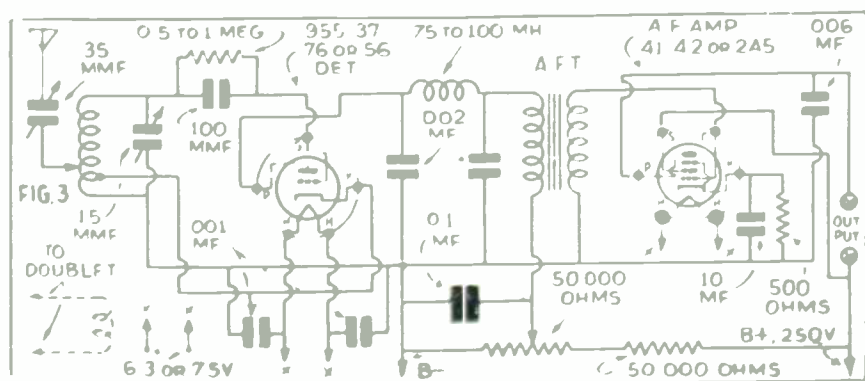

Battery-type Receiver

In Fig. 2, we find a *self-quenching* battery-type, 5-meter receiver, which is generally accepted as a good design for portable equipment. This uses a split-coil circuit and sufficient feed-back is employed to cause *self-quenching* in the detector circuit. The frequency of this "quench" is governed largely by the amount of feed-back, the size of the grid-leak, and the size of the grid condenser. The values given in the diagram are generally found satisfactory.

In Fig. 3 we have what is probably the most "popular" of all super-regenerative receivers. This is a self-quenching triode-detector with the pentode audio amplifier. This was originally introduced in the November, 1934, issue of *Short Wave Craft* and from it sprung a great number of receivers of the self-quenching variety. When first introduced, this receiver caused many unfavorable comments. The "old guard" experts frowned unfavorably upon this method, but gradually conceded that it is the best simple arrangement after all. It possesses many desirable qualities inasmuch as it is entirely self-regulating and when adjusted for the proper amount of feed back, it is an extremely sensitive affair; undoubtedly more sensitive than the usual run of the older type separately quenched detectors. We here have used the cathode as an active R.F. element by connecting it two or three turns from the low potential end of the grid coil. In adjusting this type of detector, starting off with no plate voltage and raising it gradually, we find that at one point the detector will click into oscillation. And as the regeneration control is advanced further, raising the plate voltage, the detector will click again—this time into *super-regeneration*. It is just at the point beyond the second state of oscillation, where the detector is the most sensitive. Here too the 955 ultra high frequency tube may be used, but in 5 meters the conventional type,

such as the 37, 76, 6J5-G, or 56 will provide a much stronger audio signal. With the 955 two stages of audio frequency amplification would be necessary.

Tuned R. F. Stage Ahead of Detector

In Fig. 4 we have a more advanced receiver, employing a tuned R.F. stage ahead of the super-regenerative detector. The main advantage in this case is in the elimination of undesirable radiation of the detector. Super-regenerative detectors emit a strong squealing or modulated signal, which will interfere with other receivers located nearby, where only a detector is used without R.F. ahead of it, the antenna coupling should be *loose*; and also the tubes should be operated with as low plate voltage as possible in order to limit this interference. Aside from overcoming this evil, the tuned R.F. stage provides an appreciable gain in sensitivity and makes the super-regenerative detector more easy to handle and smoother in operation. In the diagram in Fig. 4 we show a pentode in the R.F. stage which may be of the conventional glass type, or of the newer metal type tubes, or the Acorn 954 pentode. The 954 in this case is decidedly better than the others, in so far as *gain* is concerned. The detector and A.F. portions of this receiver are identical to the one shown in Fig. 3. Inductive coupling is preferable between the R.F. and detector stages. However, in Fig. 4A, we show a method of coupling through a capacity with shunt voltage feed to the plate of the R.F. amplifier. In this case the most effective coupling is brought about by tapping on to the detector coil at about the mid-point.

In each of the circuits we have shown the antenna either tapped on to the grid coil of the input stage, or through a coupling coil. However, if a doublet antenna is used the coupling coil of course, is recommended. However, for a single-wire an-

The most popular of all 5-meter receivers — a self-quenched triode. with a pentode audio amplifier.

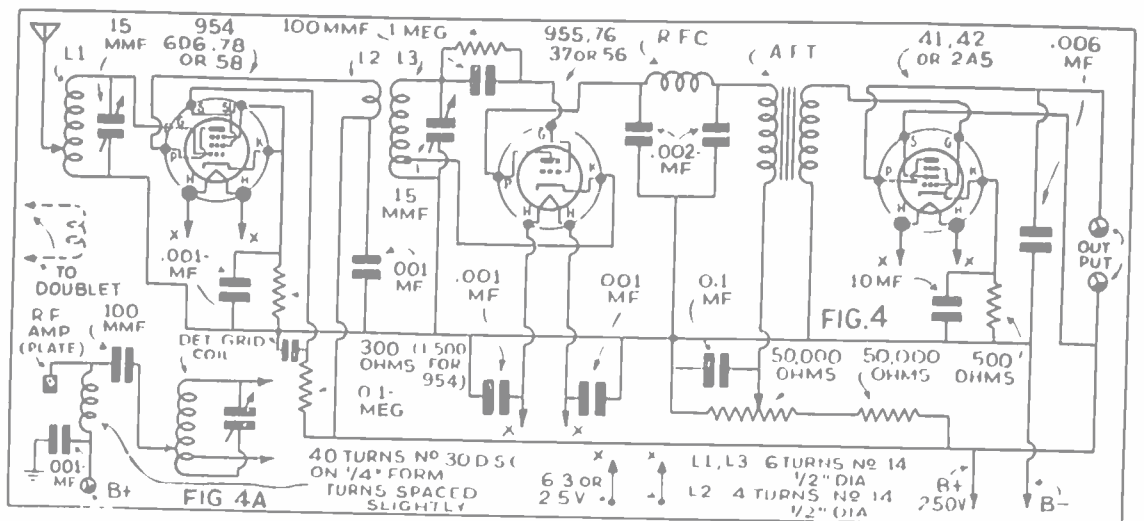

A tuned R.F. stage added to the popular 5-meter receiver, thus increasing sensitivity and eliminating radiation. Fig. 4.

tenna or one having a single-lead, tapping the antenna on to the grid coil, near the low potential end, is preferable to the older method of tapping it directly on to the grid side of the coil. The method shown in the diagrams permits a greater variation in the degree of coupling, without appreciably affecting the calibration of the grid tuning condenser. Tuning of the R.F. stage is similar to all other receivers, as the R.F. stages comes into resonance with the detector stage, there will be a slight *dip* or decrease in the rushing sound and it will be necessary to advance the regeneration control for proper results.

Type of Antenna

Nearly any type of antenna will work with the 5-meter receiver. Aside from the doublet, the most effective antenna has been found to be a single eight foot wire with a lead-in tapped directly on the top. The lead-in should come directly

from the top of the antenna, at an angle of approximately 45 degrees, and should be no closer than this to the antenna proper. The length of lead-in does not seem to be important and tests have proven that stations which could not be heard on many other antennas came in at an R5 and 6 strength with the one shown.

In the tuned circuits of each receiver we have shown a 15 mmf. condenser and have given the sizes of the inductances. This does not provide an appreciable amount of band-spread and to increase this, remove one or two plates from the 15 mmf. condenser and add turns to the coil. The Acorn tubes will require a greater number of metal tubes. In each case the coil may be adjusted by spreading or collapsing the turns, in order to place the band well within the range of the dial. This same method is used for tracking the R.F. and detector stages.



CHAPTER 14

ADVANCED ULTRA-HIGH FREQUENCY RECEIVERS

● Previously we considered the use of the super-regenerative receiver for ultra high frequency reception. While, as previously explained, the superheterodyne has qualities not found in any other set, it also has certain disadvantages which may be rather important under certain conditions. Eventually, the superheterodyne will be perfected for ultra high frequency use because of its controllable selectivity and exceptional sensitivity.

In the early days of ultra high frequency experiments, the broad super-generator was desirable because of the type of transmitting apparatus employed, such as modulated oscillators. As time goes on, these modulated oscillators will be dispensed with, and the more stable MOPAs, with and without *crystal-control*, will be used. There are two good reasons why the transmitter will change and is changing—and they are: first—the ever-increasing number of amateur stations operating in the metropolitan areas, and the desire for better quality signals. The average modulated oscillator occupies a band width in the ultra high frequency region of from 50 to 100 kc., and in many cases a considerably wider

band where the equipment is none too carefully constructed and operated.

The super-regenerator in most cases has about the same band-width as the modulated oscillator. Therefore, as the transmitters are stabilized and held down to a band of from 10 to 15 kc., immediately we need a more selective receiver if we are to cope with the ever-increasing number of stations. The answer to this, of course is the *super-heterodyne*. The most popular super-heterodyne for ultra high frequency reception at this writing is the well-known *resistance-coupled* design in which the I. F. stages are resistance-coupled and the values are chosen to permit a band width of from 10 to 100 kc. In time, even this receiver will not be selective enough, although it can be made considerably more selective than the super-regenerator.

Resistance-Coupled Superhet

In Fig. 1, we have the resistance-coupled I.F. superheterodyne, employing a stage of tuned radio frequency, an autodyne first detector, two stages of I. F. amplification, a second detector, and a pentode audio amplifier. Conversion in this receiver is accomplished by slightly de-tuning the detector

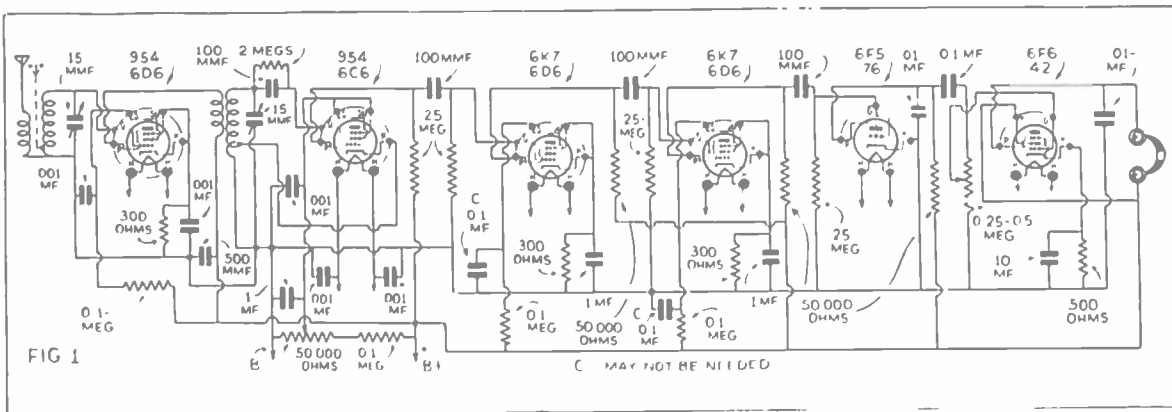

A complete resistance-coupled ultra high frequency superheterodyne, suitable for "Ham" reception.

from the signal frequency. Thus, if we were to assume that the I.F. was 50 kc., the first detector would be detuned 50 kc. from the signal frequency. This means that 50 kc. either side of the resonant point will receive the station. We then have to allow a band width of over 100 kc. for that station because directly between the two beats we hear the "carrier" of the station, the same as you would on an oscillating detector. This carrier whistle is heard because the amplifier stages, as well as the second detector and audio stages, are operating as straight audio frequency amplifier. The R.F. stage is not entirely necessary and may be dispensed with and the antenna connected to the cathode tap on the coil through a 15 mmf. variable condenser. The R.F. stage helps somewhat in working *duplex* and also increases the *sensitivity* slightly when the regular glass type tubes are used, and a considerable increase in sensitivity is brought about through the use of the Acorn pentode 954. The best arrangement, of course, would be to use 954's or 956's in both the R.F. and detector stages.

The "Converter"

With the increasing number of stabilized transmitters, one's thought naturally turns to the *converter*, which may be connected before the regular superheterodyne receiver. This makes an excellent combination when a sensitive receiver and converter are employed. Of course, the sensitivity of such a combination is far beyond the amount which can be used, because of the relatively high background noise in the average metropolitan location. A converter combination which works out very nicely

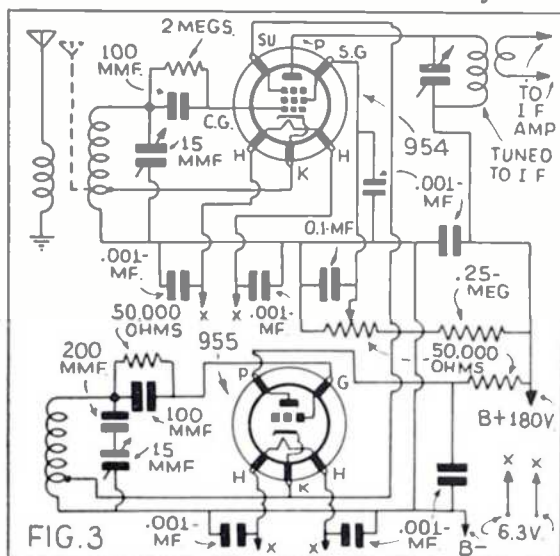

FIG. 3 Converter diagram employing the Acorn tubes, 954 and 955.

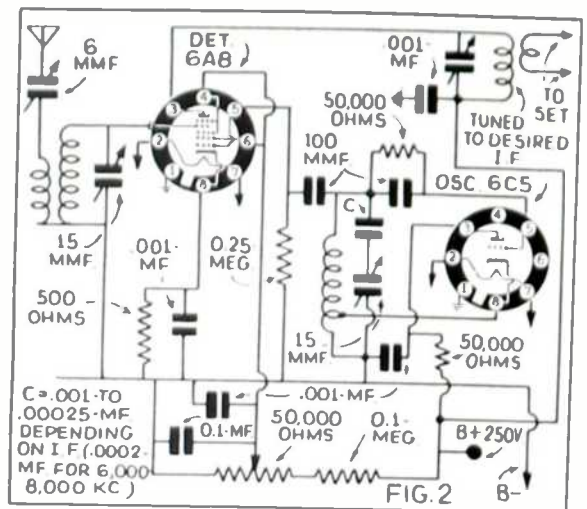

FIG. 2 A converter circuit for ultra high frequency reception, using metal tubes.

is shown in Fig. 2 and consists of a 6A8 metal tube pentagrid and a 6C5 triode. The 6A8 is used as the first detector and grid number 1 is used for injecting the oscillator voltage supplied by the 6C5 oscillator. It has been found that by applying the proper screen voltage to the 6A8 and using very loose antenna coupling, considerable regeneration will come about in this circuit and for this reason we have shown a potentiometer for controlling the screen-grid voltage. This converter works best with a receiver tuned to a frequency of at least 2000 kc., and preferably higher. In choosing this intermediate frequency, we have to bear in mind harmonics of the oscillator in the superhet receiver with which the converter is being used. The receiver should be adjusted so that any harmonics would fall out of the range desired to be covered with a converter. Also, keeping the high I.F. frequency makes images a considerable distance apart and less bothersome. This particular converter in conjunction with an I.F. amplifier tuned to 8000 kc. gave marvelous results, and no image interference was experienced because of the high selectivity of the regenerative detector stage and the wide separation in frequency of the images.

Acorn Tube Converter for High Frequencies

In Fig. 3, we have a similar *converter*, except that here the Acorn tubes are employed. The detector is a 954 Acorn triode. Here regeneration is also employed to further the degree sensitivity. The advantage of the converter using the Acorn tubes, of course, is that it may be operated at a much higher frequency than the one using the metal tubes. These two converters are shown for operation directly from the an-

CHAPTER 15

U. H. F. TRANSMITTERS

● IN this chapter of the *Course* we will consider various types of ultra high frequency transmitters, not including, of course, the well-known *transceiver*. Fundamental circuits of the more important and efficient transmitters are shown and will be discussed.

In Fig. 1, we have the unity-coupled circuit using two triodes in push-pull. Either two separate tubes may be employed or the dual triode tubes, such as the 53, 6A6, and others. For those desiring a compact oscillator circuit of simplicity this one is recommended. Its inherent stability is no

the center of the copper tubing opposite to the tubes the grid return lead is brought out. In a sketch in Fig. 1 we have shown just how this coil is constructed.

The antenna may be coupled to the plate coil at points "A", that is on either side of the "B" plus lead, or another single-turn "loop" the same as the plate coil may be employed for antenna coupling.

In Fig. 2, we have the very popular *long-line* oscillator, sometimes called a linear oscillator. Here we have extended the tuned circuits by employing two heavy copper

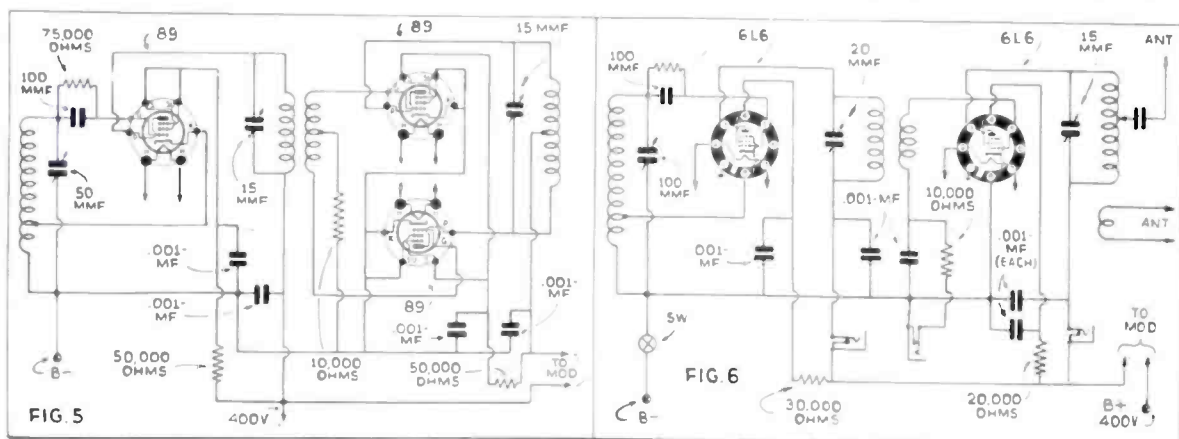

Two very popular 5-meter MOPA's; one uses type 89's while the other uses type 6L6's

better than the usual tuned oscillator, although it is more easily controlled and usually better results are obtained because no critical adjustment of grid circuit tuning is necessary.

The inductance consists of a fairly heavy piece of copper tubing, through which a finer insulated wire is run. The inside wire is the grid coil, while the copper tubing is in the plate circuit. It will be noticed that the grid of one triode enters the copper tubing at the plate end of the other triode. This is necessary to obtain a *feed-back*. In

rods or pipes in each circuit. The tuning is accomplished by sliding the bars marked "S" either toward or away from the tubes, making the circuits shorter or longer. As they become shorter of course, they resonate at a higher frequency. Theoretically, these lines should be approximately $\frac{1}{4}$ wavelength long, but due to the internal capacities of the tubes and the inductance of the tube leads and connecting leads from the copper pipes to the tubes, the length of the line will be somewhat shorter than $\frac{1}{4}$ wavelength.

For the special ultra high frequency tube, such as the 800 or 304A and 304B, the lines will be longer than if 210's or 801's are employed. A good length would be somewhere around 46 inches. This would serve for any type of tube in the 5-meter band. Best results have been obtained when the spacing between the two rods is equal to the diameter of one of the rods. In other words, if 1/2 inch rods are used the spacing between them would be 1/2 inch. Complete information on this is shown in Fig. 2. When operating on wavelengths shorter than 5 meters the lines of this system become uncomfortably short. In Fig. 3, we show the *open-end* line which theoretically at resonance would be 1/2 wavelength long used in conjunction with a single tube. Here, also, the line will be somewhat shorter than 1/2 wavelength because of the losses introduced by the tube. The "B" plus and the grid lead are tapped on to the rods 1/4 wavelength from the open end or the end opposite to the tube. This is the point marked "X" in the diagram and at which no R.F. voltage will appear. This system works exceptionally well on wavelengths as low as 1 1/2 meters and exceptionally well on 2 1/2 meters with the average present-day tube.

Special tubes, such as the new WE-316A will give more satisfactory results, of course, and may be employed in the *push-pull* arrangement of the same circuit shown in Fig. 4. While the oscillator circuits, already explained and shown in the diagram, are efficient and have served the purpose for the past four or five years, during which the ultra high frequency region has been most popular, they eventually will have to be dispensed with and replaced by the more modern type of transmitter, such as used on the lower frequency amateur band.

The master-oscillator, power-amplifier (MOPA), is unquestionably the most satisfactory on frequencies as high as 60 megacycles. However, as we approach higher frequencies, the circuit become more unwieldy and very difficult to manage. On the 5-meter (56 to 60 mc.) band, the MOPA should be adopted by every "Ham" who is seriously interested in the betterment of conditions now existing.

In Fig. 5, we have shown the MOPA which uses the type 89 receiving tubes. One is used as an oscillator in the *triot* circuit with its grid circuit tuned to 10 meters and the plate circuit to 5. This is followed by two 89's employed as screen-grid amplifiers in push-pull. This is very much superior to

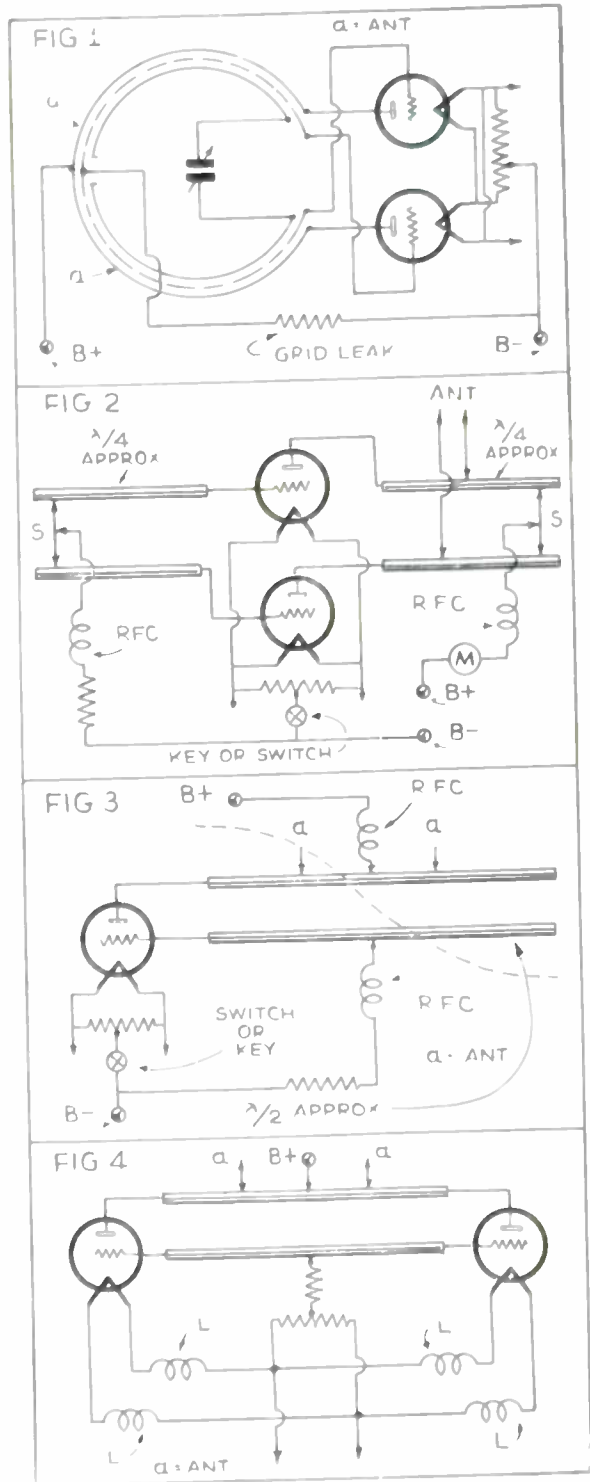

The simplest of all ultra-high frequency transmitters is shown in Fig. 1. Figs. 2, 3 and 4 show "long lines" or linear oscillator.

the previously described circuits inasmuch while the amplifier is being modulated there is no appreciable frequency shift, due to the fact that there is considerable isolation between the actual signal generator and the modulated amplifier. The amplifier being removed by 30 megacycles from the frequency

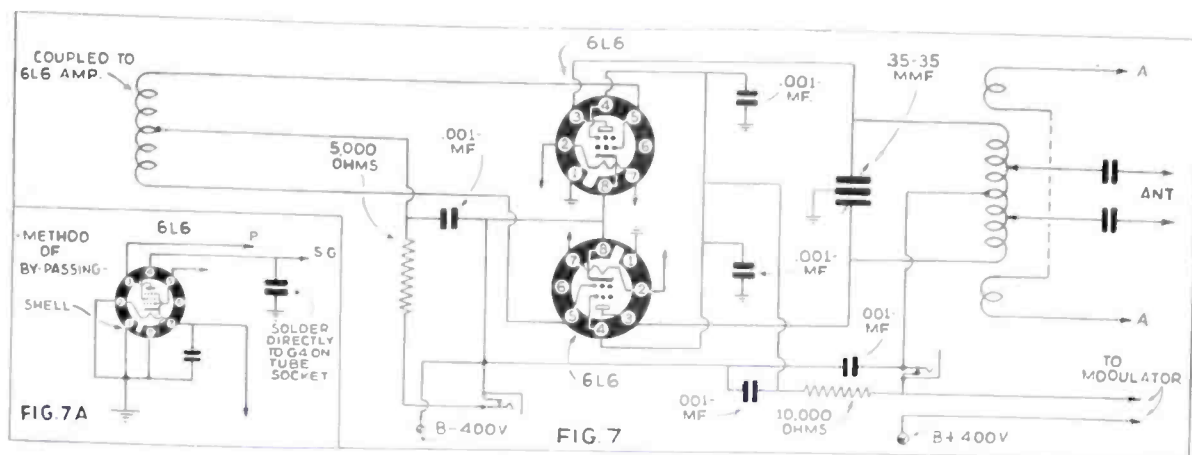

A push-pull amplifier using 6L6's for the 2-tube 6L6 MOPA.

of the oscillator accounts for its excellent stability during modulation. While in the previously explained circuit the oscillator will change frequency as much as 100 kc. during modulation.

In Fig. 6 we have the 6L6 Beam tube used in the MOPA circuit. This is unquestionably the most superior arrangement up to the time of this writing. Due to the construction of the tube excellent efficiency may be obtained in the 5-meter band even with a single-ended-amplifier. The circuit lineup is essentially the same as the 89 transmitter shown in Fig. 5. The oscillator is tuned to 10 meters and "doubling" takes place in the plate circuit, while the second 6L6 operates as a screen-grid amplifier. With 400 volts on the plate, it is possible to obtain 20 watts of R.F. output from the 6L6 amplifier. It may be advisable to include a word of warning at this point that the 6L6's are made in two types; one with a glass envelope and another with a metal envelope. For 5 meters, the metal tube is recommended, inasmuch as a number of extensive tests have proven that it is more stable and far superior in operation, requiring no *neutralizing* while the excitation voltage is being applied. No intricate shielding was found necessary with these tubes while

the glass tubes required considerable shielding together with neutralizing and were no more efficient.

If one is not satisfied with the 20 watts output from the circuit shown in Fig. 6, two 6L6 amplifiers may be added and the diagram is shown in Fig. 7. The amplifier in Fig. 7 added to the two tube transmitter in Fig. 6 will provide some 50 watts output. Here also the *metal* tubes should be used. For best results with the 6L6, bypassing should be done *right at the tube socket!* In Fig. 7A we have shown how the metal shell, the cathode, and one side of the heater are all connected right at the socket and grounded to the metal chassis. (a metal chassis is recommended in all cases for ultra-high frequency circuits of this type), the other side of the heater is by-passed immediately at the tube socket. The same is true of the screen grid. While in the diagram Fig. 7 we show a single by-pass condenser with the two screen-grids connected together, it is advisable to employ two condensers—one for each grid. Various methods of coupling the antenna to these circuits have been shown and will depend entirely upon the antenna and feeder system employed in the transmitting station.



CHAPTER 16

RELAYS SIMPLIFY
OPERATION OF STATION

● UNQUESTIONABLY the up-to-date amateur station should be relay operated. The use of relays in connection with radio and electrical apparatus not only provides a very desirable convenience but in many cases safeguards the apparatus and the operator against damage or injury.

The first application of a relay in an amateur station is for keying the transmitter. There are a number of reasons why this works out most effectively, and they are: It removes high voltage from the metal parts of the key and permits uniform characters to be transmitted, especially when a "bug" is employed. The connections for this relay are shown in Fig. 1. The next application is for turning the transmitter on and off. In cases of low power, where filaments and plate voltage may be applied to the rectifier at the same time in the power supply, only one relay is required, as shown in Fig. 2. When using this particular method, it is advisable to have a switch in the B negative or B plus supply of the transmitter power supply, so that the plate voltage will not be applied to the tubes before the filaments are thoroughly heated.

By employing the system shown in Fig. 3 in conjunction with Fig. 2, we have a very satisfactory arrangement. This should be used as we said before where a low voltage power supply is employed so that there is no danger of damaging the rectifier tubes. The circuit in Fig. 3 primarily opens the B negative circuit right at the power transformer secondary. In addition, we have shown how the receiver may be operated in conjunction with this arrangement to permit *stand-by* for *rapid change-over* during communication. Two relays are employed here—one to disconnect the B minus center tap of the high-voltage secondary, thus turning off the power to all

stages in the transmitter, and another relay to turn the receiver on by connecting the center tap in the high voltage secondary of the receiver power transformer; this is for *standing-by*. In order to transmit, merely make contact with the *stand-by* switch; this turns the high voltage on to all tubes in the transmitter and at the same time turns the receiver off.

Where higher power is used it is neces-

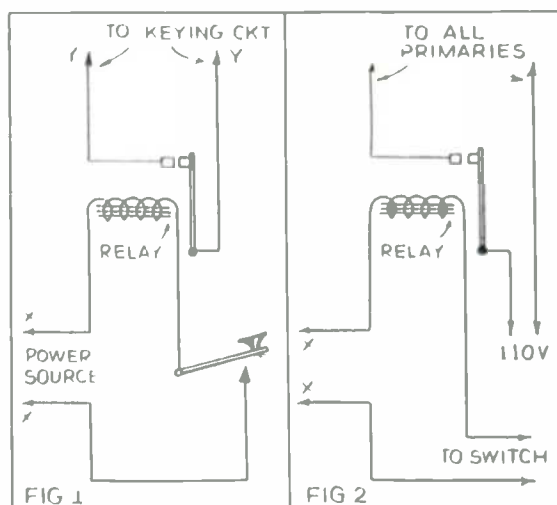

Fig. 1—Keying relay. Fig. 2—Simple circuit for turning transmitter "on" and "off."

sary to heat the filaments for a period of at least 15 or 20 seconds and in some cases a few minutes before plate voltage is applied. This may be accomplished with *time-delay* relays or more simply and more economically by the system shown in Fig. 4. Here a single double-pole, single-throw relay is used to turn on the filament transformers. The other pair of contacts on this relay complete the circuit for the high-voltage relay. Thus, when the plate switch makes contact the primaries of the high-voltage transformers are thrown on and we are ready for operation. If the plate switch

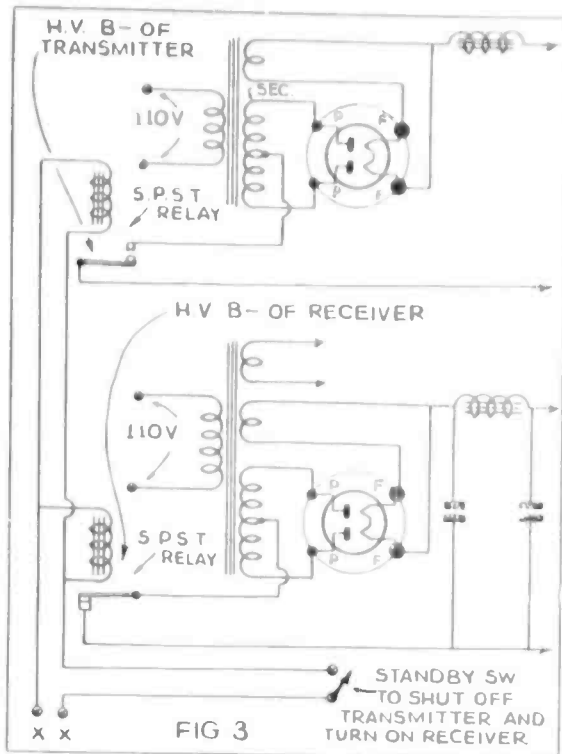

Fig. 3—This system provides rapid change-over from transmit to receive and speeds up operation.

is pulled open, only the filaments remain on; while if the filament switch is pulled open while the plate switch is closed, they all go off at the same time, which is a reasonable measure of safety. The only danger is in throwing the filament switch on when the plate switch is already closed. The operator should make sure that *this is never done!*

The entire group shown in the four different diagrams represent a complete installation. A combination for relatively high voltage would be Fig. 4 for starting the station. In the case of Fig. 4 for relatively high voltage power supplies, where

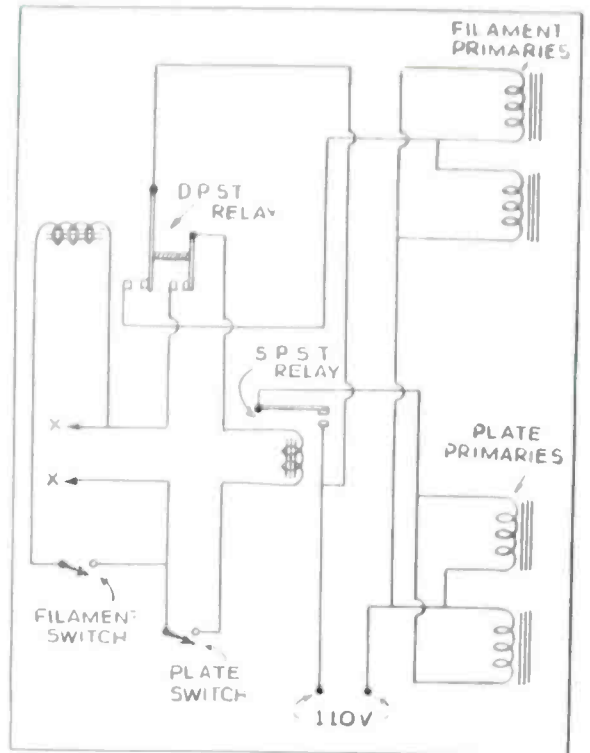
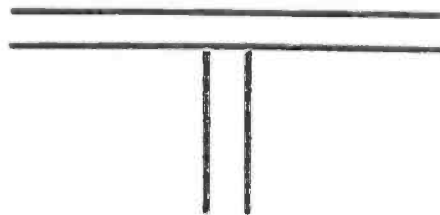
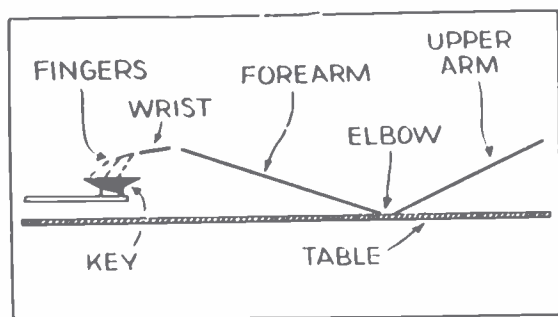

Fig. 4—How two relays are employed in a high-voltage power-supply, using separate transformers for plates and filaments.

separate filament and plate transformers are employed, *break-in* can be accomplished with the plate switch, merely by disconnecting the high voltage primary. In this case, the field of the relay operating the receiver would be connected in parallel with the field of the plate relay. Of course, if a number of separate power supplies are employed, then the number of relays will have to be increased. This will depend upon the particular station layout. If relays are installed, there is no doubt that they will prove the most valuable accessory the operator ever employed.



LEARNING THE CODE



Correct arm position

● Before one may operate an amateur station one must learn the code and be able to send and receive it at the rate of 13 words per minute, (5 letters to the word). The code test is the first part of the examination given, if this is failed, the applicant must wait 3 months before taking another examination.

Our suggestion would be that anyone applying for a license should be able to copy code at least 15 words per minute. Undoubtedly, the reader has heard many arguments pro and con as to the methods of teaching and learning code, and also has heard much about certain people not being able to learn code at all.

There is considerable latitude regarding one point. All the various methods available for learning code are good, but there is no such thing as "can't" in learning the code. The most important of all is PRACTICE. The radio code symbols are known as dots and dashes, but in practice sounds are called, dits and dahs.

The relative lengths of the dots and dashes and spaces between them are as follows; A dash is equal to three dots, the space between parts of one letter, or between dots and dashes of one letter is equal to one dot, and the space between 2 letters should equal three dots; and the

space between two words should be equal to approximately five dots.

Various code teachers prefer different methods for learning the alphabet. Some prefer learning all the dot groups and dash groups separately. However, since they all must be learned, there would seem to be no better method than learning them in mixed groups or choosing letters at random. In fact, learning them in alphabetical order provides a well mixed formation.

Listening to commercial transmitters sending press and various secret codes will provide the student with the sound of the various characters. Most important is the proper formation of the characters composing a single letter, for instance, A in the chart is shown as one dot and one dash. To obtain an idea as to how this would sound, the dot and dash should be pronounced dit and dah as stated before, and as rapidly as possible leaving almost no space between the two. In other words, the dash should be pronounced or sent as soon as possible after the completion of the dots. (ditdah).

After this is done several times, the letter will have a certain rhythm, and, it is this rhythm, and the proper recognition of it, that makes a successful telegrapher.

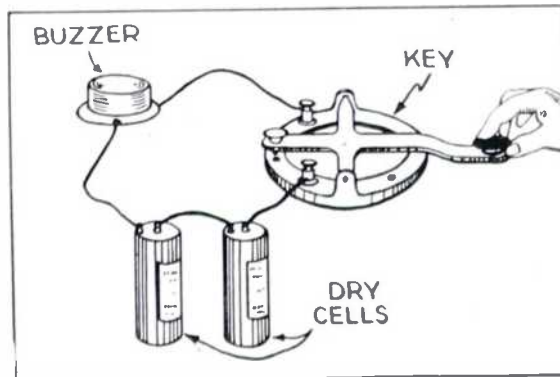

Code set using buzzer

For the beginner we would suggest forming the letter just after it is sent, and form it slowly, then he will find that the next letter is being sent before the letter which is being written down is completed. This method serves for slow speeds from 5 to 10 words a minute. Above this speed he should copy further behind.

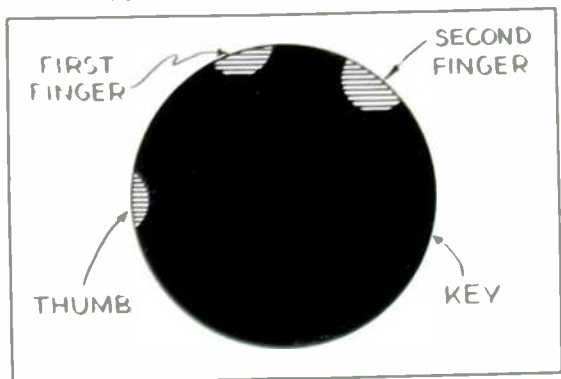

How to grip the key.

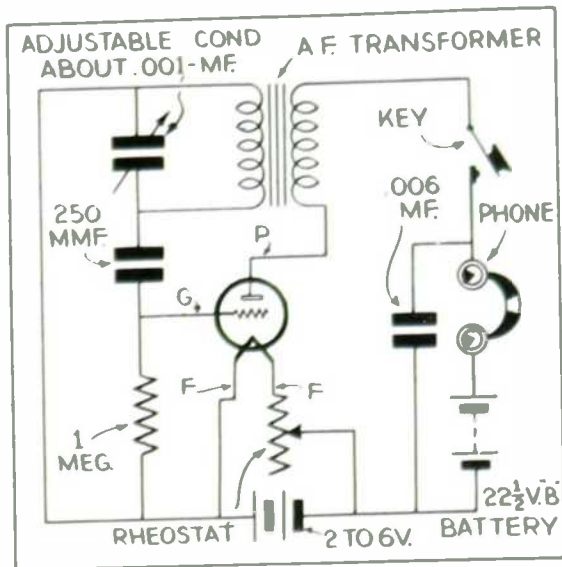

Simple audio oscillator for code practice

PRACTICE EXERCISE 1. This practice exercise contains the all-dash letters listed in memorizing group 1: dah; M dah dah; O dah dah dah.

Two-Letter Code Groups

TT MM OO MO OM TT MM MT MO TM
TO MO TM OT MT OM TM TO OT OM

Three-letter Code Groups

TOM MOO OTO TOM OMO MOO
TTM OMO MMT MMT OTM TMO
TOO MTM MOM TOM TMO MTM
MOT TMT OTM TOO OMT OOM
TMT TOT OOM OOT MTO TOM

Four-letter Code Groups

TOMO TMTM OTOT MMOT MOTO
MTMT MOMO TMOM MOTT OTOM
TMTO MTTM MTMO TMOT TOTO
OTMO MTOM TOTM OMTM TOOM
MOTO OMTT TOMT OTMT MOTM
OMOT TOTO TOMO MOOT OTTO

Five-letter Code Groups

TOTOM MTMOT TOTTO OTTOM
MOTMT MMOOT MTMOT TOMOT
OOMTT TOMTO MTOTM MTOMO
MOTTO MTOTM OTOMO OMTTO
TOTMO OMMOT TOMOT TMOTO
MOTOT OTMTO MOTTO MTOMT
TMOTT TMOTM TOTOO TOMMT
OTMOT OTTOM TOTOO MOMOT
TOMOT TOTOO MOTOM MOMOT
MOTTM TOTOM OMOTT OMOTO

Watch your spacing in the above groups, both between letters and between groups. Notice that these groups can be sent from left to right, or backwards from right to left; also both up and down.

PRACTICE EXERCISE 2: Next send dots and letters such as I, IS, E, EH, HI, HS, SI, and SE. Write up a drill exercise similar to the one which follows. As you write down the letters in the drill exercise say them mentally to yourself, using "dit" and "dah" instead of dot and dash (letter E is dit, I is dit dit, S, dit dit dit, etc.)

This exercise is for sending and receiving the all-dot letters listed in memorizing group 2.

E I S H

Two-Letter Code Groups

EI EH SH SI IH
SS II HI HS EH
ES IS SE IE IE
HH EE HE EI ES

Three-letter Code Groups

SIS SIE ISI ESH HII ESI
ESE EIE ESE ISH HIS SEI
HSI IEI ISI EIE SIH
HEH ISE IHI SHE EIS
EHE HSH ESI EHS ISE

Four-letter Code Groups

SISE ISIS HSEI SEIS EHS
ESHE SHEE HIHI EHIE HSIE
ISHE HISE SEHS SISI
HESE ESHI SIES HISH
HISE EIEI SEHI ISHE
ISES HISH HEHE SHEI
SHIS SHIE ISHE ISHI

A SIMPLE ROTARY

5 - METER BEAM

ANTENNA

● **SOMEWHAT** more than fifteen years ago we secured a piece of well seasoned lumber three inches square and twenty feet long. The edges were trimmed off and the top was tapered so that it would not appear too unsightly and then the stick was given several coats of paint. It has been fastened to one of the studs on the side wall of the house in a corner besides the

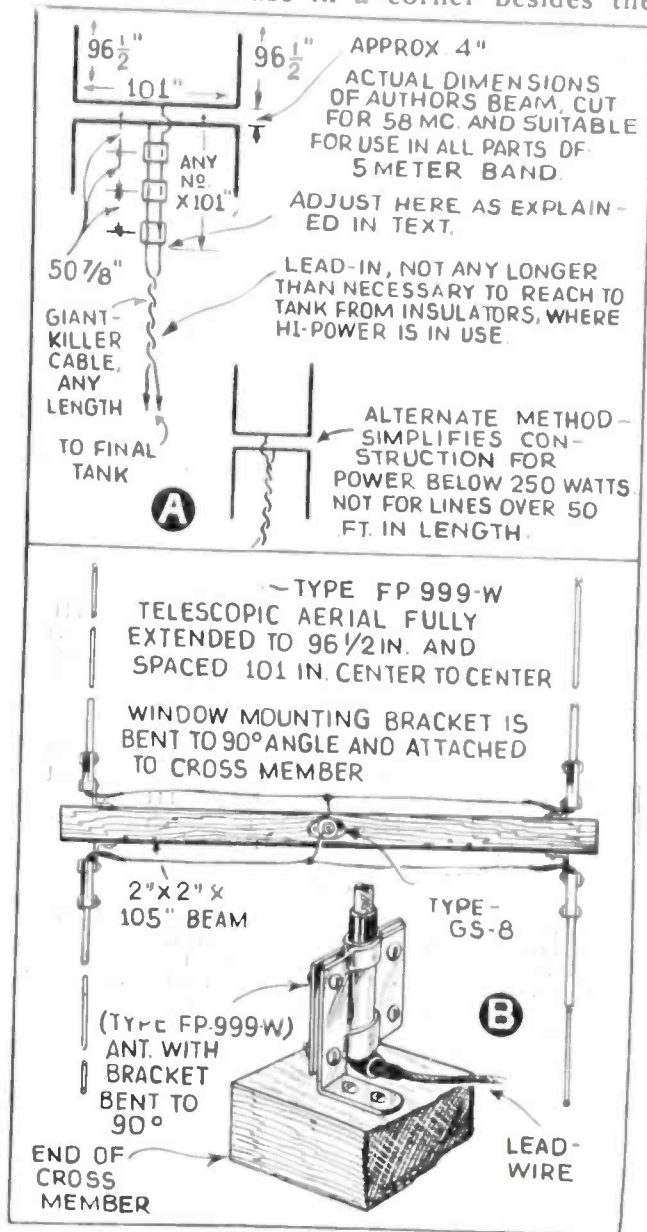

Diagram and side view of 5-meter rotary beam antenna

chimney, by four rather large lag bolts. Telescopic Fishpole antennas, designed for mounting on automobile bumpers and apartment house windows gave us the notion, stated Arthur H. Lynch, W2DKJ, that they could be used very satisfactorily in connection with the building of multi-element ultra hi-frequency antenna systems.

The type FP-999-W broadcast antenna poles are provided with a mounting bracket which is bent to an angle of forty-five degrees. We bent this bracket to an angle of ninety degrees and it formed an ideal support for the antenna itself.

It happens that our crystal has been cut to oscillate on a frequency of 7,245 kilocycles and by suitable doubling, we came to an ultimate frequency in the final stage of 57,960 kilocycles. Extending the telescopic fishpoles to their limit produces rods which are 96 1/2" long and that is just about correct for the frequency on which we are transmitting. Such poles can be used satisfactorily from the middle to the high frequency end of the five meter band but they are not satisfactory for frequencies below 58 megacycles.

The crossarm that we use, states Mr. Lynch, is made of a piece of well seasoned pine two inches square and one-hundred and five inches long. Two radiators are mounted on the lower side. A piece of heavy, insulated wire is provided with this type of fishpole and by joining these lead wires from the two upper radiators at the center and following the same procedure with the two lower radiators we have an "H" beam which might very well be fed by a low impedance transmission line.

In our case, however, we preferred to use an open line for a part of the run to the shack and a junction to the open line is made, without introducing any serious difficulties by sliding the ends of the low impedance twisted pair up and down the last foot or so of the open line until the best point is found, in the usual way. A satisfactory point for starting to locate the op-

imum junction between the open line and the low impedance twisted pair is to make the open line any number of half wavelengths long.

A Simple Spaced Pair

A few years ago we designed a special type of transmission block, for use in connection with the making of noise-reducing antenna. These blocks provide one of the simplest methods of making open transmission line because they keep the wires separated the correct distance, they can be inserted in the line without any tie-wires and any time that it is found desirable to insert additional spreaders these transposition blocks can be used very satisfactorily. When a transmission line of this type is made it should be borne in mind that the wires are NOT transposed. The wire we used is approximately the equivalent of No. 14 solid and, as it becomes automatically spaced with the use of these transposition blocks, we provide ourselves with a line having an impedance of approximately 450 ohms. The losses in a line of this kind are negligible, even at five meters. This is not true of any twisted pair nor is it true of any type of coaxial conductor. So, wherever an open spaced pair can be used, particularly on the ultra hi-frequencies, it should be used and the use of nothing but the best twisted pair should be used in conjunction with it.

Making the Beam Rotate

The simplest method for mounting the 2 x 2 inch cross-member on the top of our 3 x 3 mast would be to drill a reasonably small hole through the 2 x 2 and run a fairly long lag screw into the top of the mast, placing a metal washer between the head of the lag screw and the top of the cross member and another one between the bottom of the cross-member and the top of the mast. Such an arrangement is all right for a temporary affair but it is certainly not workmanlike and we believe that the arrangement that we have used will be welcomed by those amateurs who contemplate making their rotary beams more substantial. The arrangement that we have used is a very simple but very effective one.

We secured a copper contact, of the type which is used on large elevator controls. The contact had an outside diameter of $2\frac{1}{4}$ " The base is $\frac{3}{8}$ " thick, the pin is $2\frac{1}{8}$ " long and the diameter of the pin is $\frac{1}{2}$ ". We drilled three holes through the base and

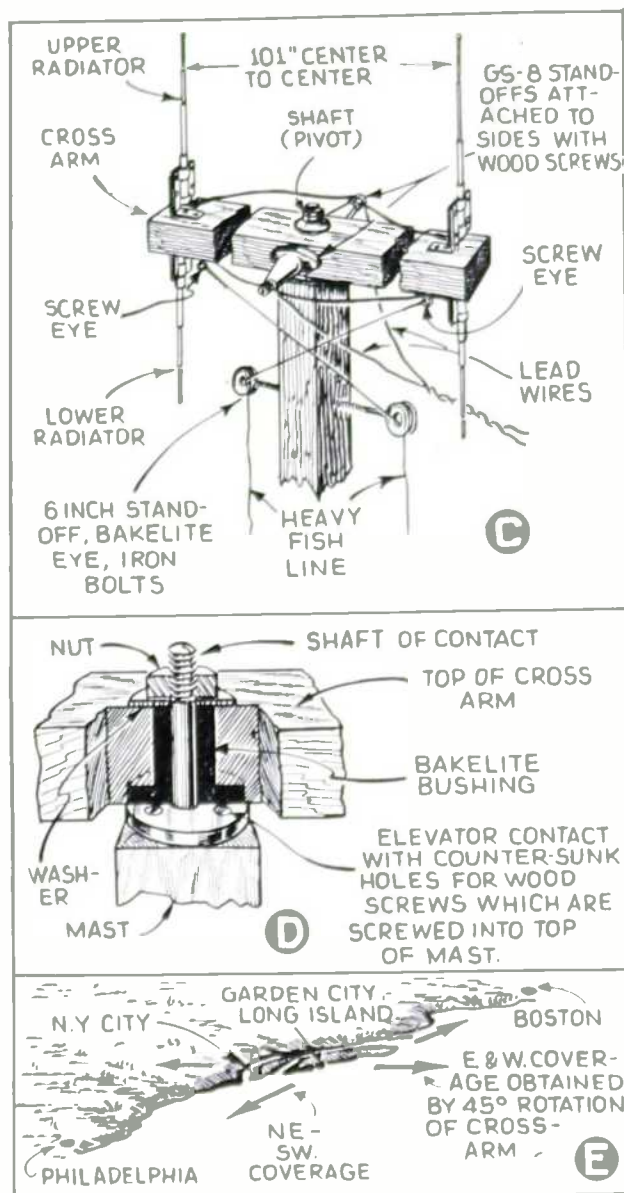

Details of suspension of rotary beam antenna are shown above.

then counter-sunk the holes so that the contact itself could be fastened to the top of the mast with three wood screws. Insulating bushings for these copper contacts are stock items and they are made of molded bakelite. They have a bottom surface which is equivalent to the surface of the base of the copper contact. We drilled a hole through the cross-member and sunk the bakelite bushing into the hole and that gave us a very satisfactory bearing and prevented any side swaying of the cross-member. Plenty of vaseline was applied to the upper surface of the copper contact and the lower surface of the bakelite bushing. The complete antenna can be rotated so easily that it turns as though it was mounted on ball bearings.

806 "ALL-BAND" TRANSMITTER DELIVERS 400 WATTS

● THE main purpose in the design of this transmitter was flexibility and simplicity. It is an easy matter to make an *all-band* transmitter employing a large number of stages. On the other hand, if proper tubes and circuit arrangements are employed, the problem is not quite so complicated as it may seem.

In transmitters having fairly high-power

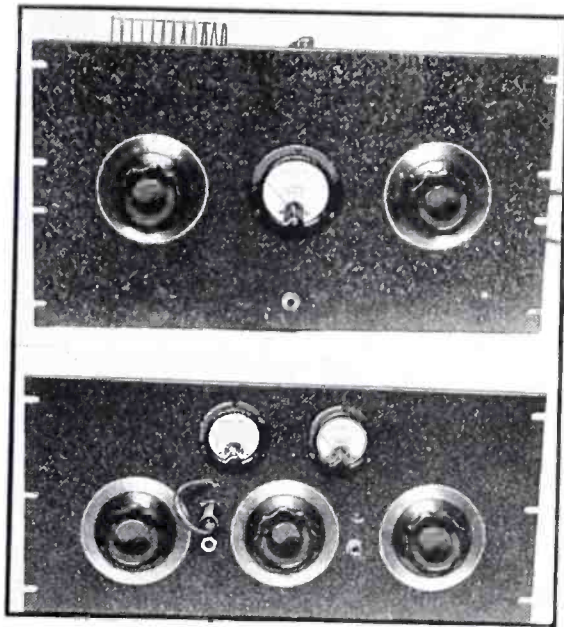

Front view of the complete transmitter. The "exciter" and "driver" stages are built on the lower panel and sub-base; the 806 "final-amplifier" and control panel being the top one.

amplifier stages, that is somewhere around $\frac{1}{2}$ kw., (500 watts) the *driver stage* should receive greatest care in the choice of components. The tube used as the driver determines whether or not the transmitter must be complicated. If the tube used in

this position requires only a few watts excitation, then we can produce all-band operation with a single crystal. With this transmitter we have chosen the 804, which works exceptionally well down to 10 meters. The excitation requirements of this tube are extremely modest, less than 1 watt being sufficient for maximum output.

"Pen-tet" Exciter Employed

In order to obtain the utmost in flexibility, we resorted to the "Pen-tet" exciter. This unit consists of nothing more than 6P6 pentode crystal-oscillator, followed by a 6L6 multiplier. This arrangement makes it possible to quadruple the crystal frequency with excellent efficiency. With 400 volts on the plates of the oscillator and multiplier, the output of the fourth harmonic and 80 meter crystal is more than sufficient to drive the 804 driver and it is necessary to adjust the coupling in order not to overdrive the large pentode. The 804 pentode seems to be the ideal driver for the 806 final amplifier used in this transmitter, as its output ranges from 50 to 80 watts, depending upon the circuit connections and the voltages applied to the tube.

50 Watts From Driver

In our case we used the tetrode connection and applied 1,000 volts to the plate of the tube. The output with this arrangement was approximately 50 watts with an excitation requirement of only .65 watt. This output, of course, is slightly greater than the 25 to 30 watts required for the 806, when operated as a plate-modulated class C amplifier. However, the driver stage, especially in a phone transmitter should have *good regulation* and a *fair surplus of power*; proper excitation being obtained by *varying the coupling* between the driver and the final stage.

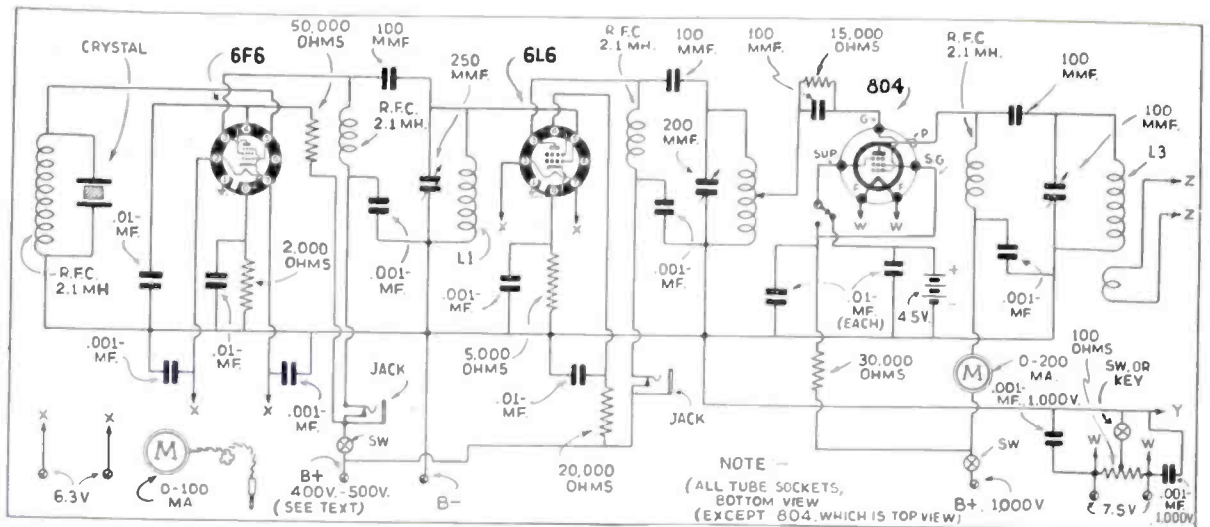

Complete Exciter Unit 50-to-90 watts; for operation of the exciter alone, the switch in the suppressor-grid circuit should be in the position which puts 45 volts on the suppressor.

suppressor of the 804, we have a 90 watt transmitter which should be thoroughly capable of meeting all requirements on the 80 meter band. In fact, this is the way the original transmitter was operated.

The high power final stage is only used on 40, 20 and 10 meters. The grid tuning condenser for the final amplifier stage appears to be a split-stator condenser of quite large dimensions. This was used in the first arrangement of the transmitter in an endeavor to employ a single-section plate condenser by the simple expedient of *grid neutralization*. However, satisfactory results can be more easily obtained with the split-stator condenser in the plate circuit, and a single condenser in the grid circuit. When using *grid neutralization*, the output of the driver stage, operated as shown in the diagram, would not provide sufficient excitation for efficient phone operation on the higher frequencies. Plate neutralization is shown in the diagram and eliminates this problem.

The complete transmitter as described, provides one of the smoothest operating "rigs" ever tried. Its excellent output of 400 watts on *all* bands provides an impressive signal.

Coil Data

80 and 40 meter oscillator 17 turns; 6L6 multiplier, 18 turns. 20 meter multiplier coil, 8 turns. These coils are wound on a 1½" isolantite form with the winding spaced to a length of 1½ inches.

Data for the amplifier is as follows: 80 meters—22 turns, No. 12, 2½" diameter; for 40 meters 14 turns, No. 12, 2½" diameter; 20 meter, 6 turns No. 12, 2½" diameter; 10 meter, 4 turns No. 12, 1¾" diameter. These coils are of the self-supporting type with a length of 4". The 806 grid coils are wound on 1¾" dia. isolantite forms. The coils are wound to a length of 3" with No. 18 tinned wire. The turns are as follows: 22 turns for 40 meters; 12 turns, for 20 meter; and 5 turns for 10 meters.

The 806 plate coils are of the same construction as the 804 plate coils, however, they are wound to a length of 5" and have a diameter of 2½". The 40 meter coil has 26 turns; 20 meter coil has 12 turns. The 10 meter coil has 4 turns of the same diameter but is only spaced to a length of 4".

The self-supporting coils are constructed with No. 12 tinned copper wire of the soft-drawn variety. The supporting strips are made of 1/16" celluloid strips ¼" wide.



LESSON NO. 1 FOR RADIO AMATEURS. SET BUILDERS. EXPERIMENTERS.

MAKE ALLIED'S CATALOG YOUR RADIO BUYING GUIDE!

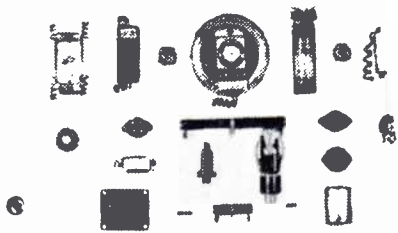
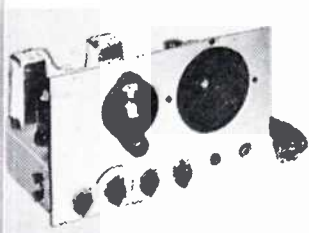

32 NEWEST KITS

In the great section of Build-Your-Own kits of every type, in a Beginners' 1 Tube set to a 14 Tube All-Wave Super. These kits have been built thousands with perfect results. Complete, easy-to-read wiring diagrams are supplied with ALLIED kit.

12,000 PARTS

In ONE book—more than 12,000 exact duplicate and replacement parts for every radio need. No matter whether it's "hard-to-get" or everyday, it's in the ALLIED Catalog! See the complete listings of EVERY part required to build any type of set.



BEST TRANSMITTERS

The finest selection of Amateur Equipment ever assembled in one great book. The Utah Add-A-Unit Amateur transmitter—designed so you can build the 80 watt CW unit and add other units at any time! You have a complete 400 watt CW-Phone rig.

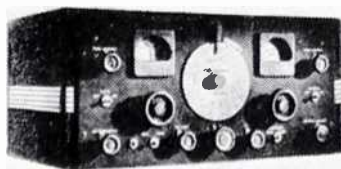

26 HAM RECEIVERS

The finest, most complete array of Amateur Receivers you've ever seen. New RCA 111, new Hallicrafters models—and every other modern communications type set built by the leading manufacturers—as well as the newest Ham equipment in kit form.

FREE PARTS LISTS FOR RADIO BUILDERS

There's an EXCLUSIVE ALLIED service! We can supply matched kits of parts for building any circuit described in any radio publication. We'll be glad to send you—FREE—our complete approved parts lists for any set featured in construction articles in the RADIO AMATEUR COURSE. ALLIED'S parts lists make your radio building easier.

ALLIED RADIO CORP.
833 W. JACKSON BLVD., CHICAGO, ILLINOIS



EVERYTHING IN RADIO IN ONE BIG BOOK

Get off to a head start in your radio work by making the ALLIED Catalog your Complete Buying Guide. Here in one great book you'll find listed every item you need. There are big sections devoted exclusively to Amateur and Set Builder gear, Service equipment and test instruments, Radio Sets, Sound equipment. ALLIED is Headquarters for Radio Builders everywhere and saves you time and money on every order. That's why we say: For Radio Amateurs, Set Builders, and Experimenters—Lesson No. 1 is "Make ALLIED'S Catalog Your Radio Buying Guide."

COMPLETE STOCKS — FASTEST SERVICE — LOWEST PRICES

Under one roof we have gathered together the choicest, most complete stocks in Radio. Every item is approved by ALLIED engineers for performance and value. Everything you need is ready to be shipped instantly from ALLIED'S tremendous stocks. ALLIED buys in huge quantities and shares the savings with you. That's why ALLIED'S prices are always lowest. Your FREE copy of the ALLIED Catalog—Radio's Leading Supply Guide—is ready for you now. Write for it today!
Dept. 3-X.

**MAIL
Coupon**

FREE

ALLIED RADIO CORP.
Dept. 3-X
833 W. JACKSON BLVD.
CHICAGO, ILL.

- Send me your FREE ALLIED Catalog.
 Send me FREE parts lists for:

Name
Address
City State

ONE METER WAVES

FOR

“SHORT-HAUL” QSOs

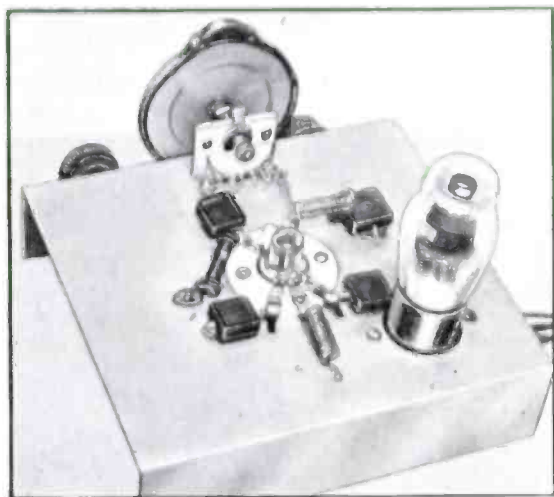

Top view of 1-meter receiver.

● THE amateur has done little experimenting on the real ultra-high frequencies for the simple reason that proper equipment has only recently become available. It is a well-known fact that it is almost impossible to get any appreciable power from the conventional type of vacuum tube at wave-lengths as short as 1 meter.

With the advent of the new Western Electric 316A tube, there is no reason why the amateur who can afford it should not carry on experiments in the $\frac{1}{2}$ to $1\frac{1}{2}$ -meter regions. This new tube can be operated at fairly high efficiency at $\frac{1}{2}$ -meter, and has a power output of from five to eight watts. There are many advantages in working on frequencies in the neighborhood of 300 megacycles or higher; principally the entire lack of *outside interference*.

No Interference Noticed

For instance, during the several months of experimental work, we did not hear a single automobile ignition system, or for that matter, any other type of electrical

disturbance; in fact we heard nothing *save our own signals* and we believe that this real ultra-high frequency business offers the amateur an excellent opportunity for *short range direct communication*. We further believe that a successful amateur band could be organized in these regions, and probably produce more interesting results than the present 5-meter band. Of course, the transmission range is more limited as the frequency increases and the higher we go, the more it seems to take on the *optical effect*.

In other words, in wavelengths around 1-meter, distances of around 25 miles would seem to be “DX,” unless we experience some unusual conditions similar to those now current on the five meter band, where atmospheric conditions play a prominent part. Before any definite opinions can be reached, it will be necessary for the amateurs to occupy these high frequency regions in large numbers and thereby prove whether or not present theories and findings are definitely correct. In any event, we believe it affords an excellent opportunity for *intra-city communication*.

The transmitter employed during our ex-



The 400-volt power-supply used with the oscillator.

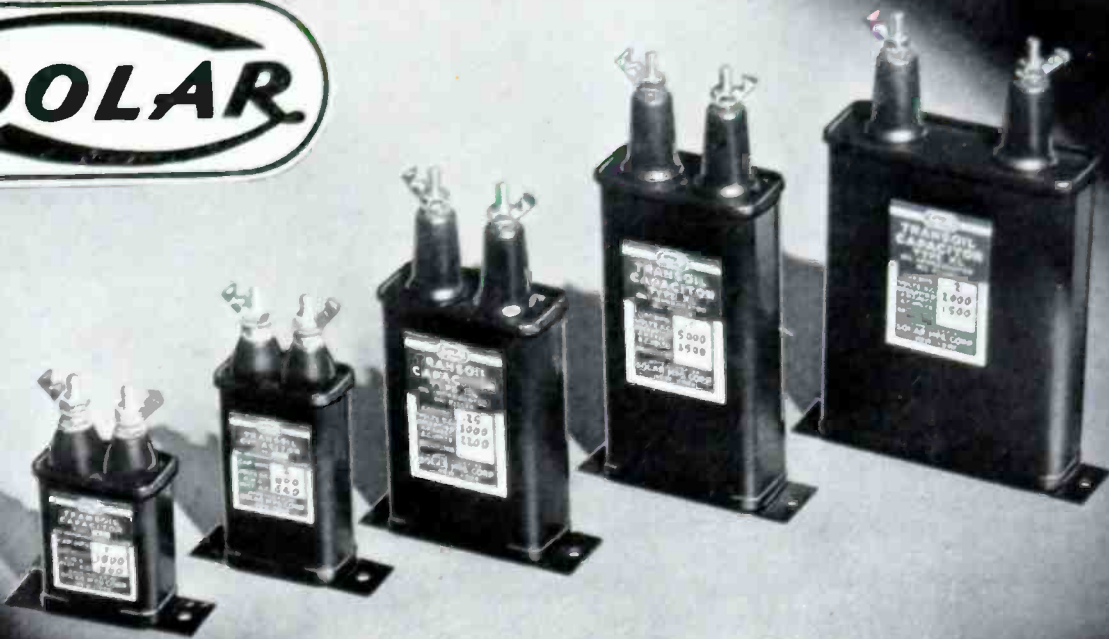

TRANSMITTING CAPACITORS

A COMPLETE LINE OF OIL-PAPER AND MICA TYPES, BUILT TO HIGHEST STANDARDS OF *QUALITY ABOVE ALL.*



TRANSOIL CAPACITORS

—oil impregnated—oil filled.
Type XL—Rectangular cans.
Type XD—Small drawn-shell cans.
Type XT—Metal tubulars.
Type XC—Round cans—
stud mounting.

SOLAREX CAPACITORS

—oil impregnated—wax filled.
Type X—Rectangular cans.

DOMINO CAPACITORS

—Paper molded in Bakelite.

TRANSMICA CAPACITORS

—Mica dielectric.
Type XA—Ceramic cases.

TRANSMICA CAPACITORS

—Mica dielectric.
Type XM—Bakelite molded.

Complete Catalog on Request

SOLAR MANUFACTURING CORP.

99-601 Broadway, New York, N. Y.

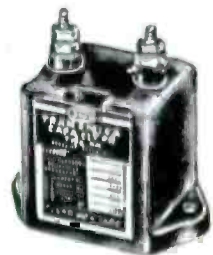

periments was a single 316A, plate-modulated with about 400-volts on the plate. In the photographs you see the actual transmitter that operated in the neighborhood of 275 megacycles. The circuit is exactly the same as that described by the author in the November 1934 issue of *Short Wave Craft*, and this circuit seems to be the only logical one at the present time for 1-meter operation.

Constructional Details

The general constructional details can be learned by referring to the photograph. Here we see that the tube is fastened to the ends of a pair of copper tubes. These tubes are $\frac{1}{4}$ -in. in diameter, and the spacing between them is slightly over a $\frac{1}{4}$ -inch. The spacing in fact is identical to the spacing of the plate and grid prongs of the tube. The length of these copper rods of course, depends upon the frequency at which you wish to transmit. The over-all length

the grid and plate connections on the copper rods, and this is done with the aid of a small neon bulb, after the transmitter is operating and the two clips connected to about the mid-point of the copper-rods until a point is reached where no glow is apparent. This is the point where the two clips should be attached.

The antenna used in our experiments consisted of a single copper rod one-half wavelength long. Its length was determined by the standing wave on the linear circuit of the oscillator. The distance from the free end of the copper tubes to the point where the neon bulb went out may be roughly considered as $\frac{1}{4}$ -wave, and the length of the half-wave antenna will be twice this length. The antenna feeder consisted of a single wire, tapped on to the antenna a short distance from the center. This distance is equal to approximately 14% of the total length of the antenna.

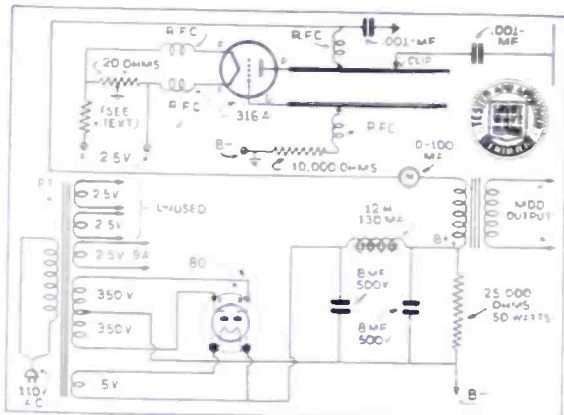

Diagram showing the transmitter connections.

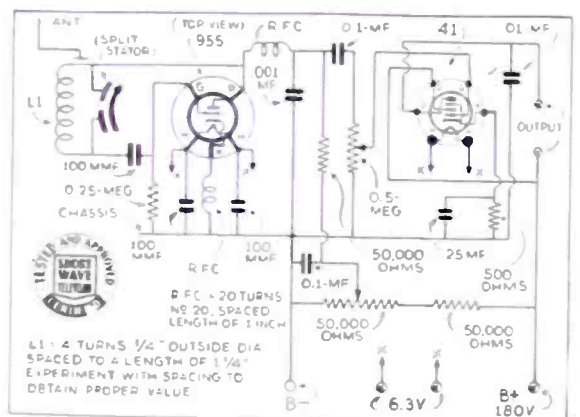

Diagram of the 1-meter experimental receiver.

of the external circuit from the tube to the far end of the copper tubing is $15\frac{1}{2}$ -inches, and the frequency of oscillation is approximately 275 megacycles. The frequency may be increased by shortening the length of the two copper electrodes. The plate and grid re-turn leads are taken from a point of zero R.F. voltage on this oscillatory line. R.F. chokes are used at this point and they consist of 20 turns of No. 18 or 20 wire, wound on $\frac{1}{4}$ -inch dowel stick. After the winding form is removed the turns are spaced so that the over-all length is approximately 2-inches. Similar chokes are also used in series with each leg of the filament.

If the directions given are followed the oscillator will work the first try and no tricky adjustments will be necessary. The one and only adjustment is the placing of

1-Meter Receiver

No directional antennas were tried because the receiver was most of the time located in a moving automobile and therefore a directional antenna would not have served our purpose. The receiver employed is also shown in the photograph, and consisted of an acorn 955 triode, and a 41 audio amplifier. The tuning condenser was a two-plate Trim-air with the stator plate split in the center. Complete data is also given in the diagram covering the construction of the choke coils and the inductance for the grid circuit.

The *power supply* for the transmitter was a very simple affair and the diagram explains it in detail. As $2\frac{1}{2}$ volt windings are the nearest obtainable, in the average power transformer, a resistance is necessary in order to reduce it to 2 volts for the filament.

RAYTHEON *RK* AMATEUR TUBES



The Finest Quality "HAM" Tubes Made!

Raytheon—the first tube manufacturer to build a tube designed for radio amateurs. First to build an Amateur triode . . . first to build an Amateur pentode . . . and the first to build a zero bias Class B modulator. Always—Raytheon led the way.

To the experienced radio amateur, Raytheon R K tubes mean the "tops" in quality amateur tubes. Tubes made from the finest materials in the world—Tanta-

lum plates, Nonex hard glass bulbs, Isolantite bases, etc. Tubes that will stand up under the most adverse conditions—and give the greatest output per dollar over the longest period of time.

Specify Raytheon R K Amateur Tubes. They cost you no more than ordinary tubes—yet you get the finest quality "ham" tubes made. Sold by leading parts jobbers. Write for details.

TWO NEW BEAM POWER TUBES — Just out of the Laboratory!

RK-47	Beam Power Tetrode, 1.0 Watts Driving Power	\$17.50	120 W
RK-48	Beam Power Tetrode, 1.2 Watts Driving Power	27.50	250 W

TYPE No.	DESCRIPTION	PRICE	OUTPUT	TYPE No.	DESCRIPTION	PRICE	OUTPUT
RK-10	Triode Power Amplifier Oscillator	\$3.50	25 W*	RK-30	Triode Power Amplifier	10.00	65 W
RK-18	Triode Oscillator R.F. Amplifier Class B Modulator	10.00	50 W 100 W*	RK-31	Zero Bias Class B Modulator	10.00	140 W*
RK-19	Full-Wave High Vacuum Rectifier 7.5 V. Heater, Peak Current	7.50	600 Ma	RK-32	Triode Power Amplifier	12.00	65 W
RK-20A	R. F. Pentode Oscillator R. F. Amplifier Oscillator R. F. Amplifier Suppressor Modulated Phone Hard Glass Bulb	15.00	80 W 64 W 80 W 18 W	RK-34	Dual Triode Power Amplifier	3.50	14 W
RK-21	Half-Wave Rectifier 2.5V Heater, Peak Current	5.00	600 Ma	RK-35	Triode (for Ultra High Frequencies)	8.00	75 W
RK-22	Full-Wave Rectifier 2.5V Heater, Peak Current	7.50	600 Ma	RK-36	High Output Triode	14.50	200 W
RK-23	R. F. Pentode Oscillator R. F. Amplifier Oscillator R. F. Amplifier Suppressor Modulated Phone 2.5V Heater	4.50	18 W 24 W 5.5 W	RK-37	High Mu Triode	8.00	80 W
RK-24	Triode Power Amplifier (5 Meter Oscillator)	2.25	1.2 W	RK-38	High Mu Triode	14.50	225 W
RK-25	R. F. Pentode Characteristics same as RK-23 except 6.3 volt heater	4.50		RK-39	Beam Power Tetrode 6.3 V. H't'r	3.50	35 W
RK-25B	R. F. Pentode Oscillator R. F. Amplifier Characteristics same as RK-25 (Bakelite Base) Oscillator R. F. Amplifier Suppressor Modulated Amplifier	3.90	18 W 24 W 5.5 W	RK-41	Beam Power Tetrode 2.5 V. H't'r	3.50	35 W
RK-28	R. F. Pentode Oscillator—R. F. Amplifier Oscillator—R. F. Amplifier Suppressor Modulated Phone	34.50	160 W 200 W 60 W	RK-42	Triode Amplifier	1.10	
				RK-43	Twin Triode Amplifier	1.50	
				RK-44	Coated Cathode Type Amateur Pentode with Ceramic Base 12.6 V. Heater	8.50	28 W
				RK-45	Coated Cathode Type Pentode Suppressor grid brought out to a separate base pin 12.6 V. Heater	5.65	24 W
				RK-46	Thoriated Filament Type Pentode Suppressor grid brought out to a base pin 12.6 V. Fil.	21.75	80 W
				RK-49	Beam Power Type Tetrode with standard 6-prong Isolantite base (Similar in characteristics to 6L6G)	2.10	25 W
				P41	Triode R. F. Amplifier	3.25	14 W
				842	Triode Audio Modulator	3.25	3 W
				866	Half Wave Mercury Vapor	1.50	
				866A	Half-Wave Rectifier Mercury Vapor Peak Current	4.00	600 Ma
				872A	Half-Wave Rectifier Mercury Vapor Peak Current	16.50	2.5 Amp.

* Indicates value for two tubes.

RAYTHEON IS THE MOST COMPLETE LINE—ALL TYPES OF GLASS, OCTAL BASE, METAL, RESISTANCE AND AMATEUR TUBES

RAYTHEON PRODUCTION CORP.

445 Lake Shore Drive, Chicago, Illinois
555 Howard Street, San Francisco, Cal.

420 Lexington Ave., New York, N. Y.
55 Chapel Street, Newton, Mass.

415 Peachtree Street, N. E., Atlanta, Ga.

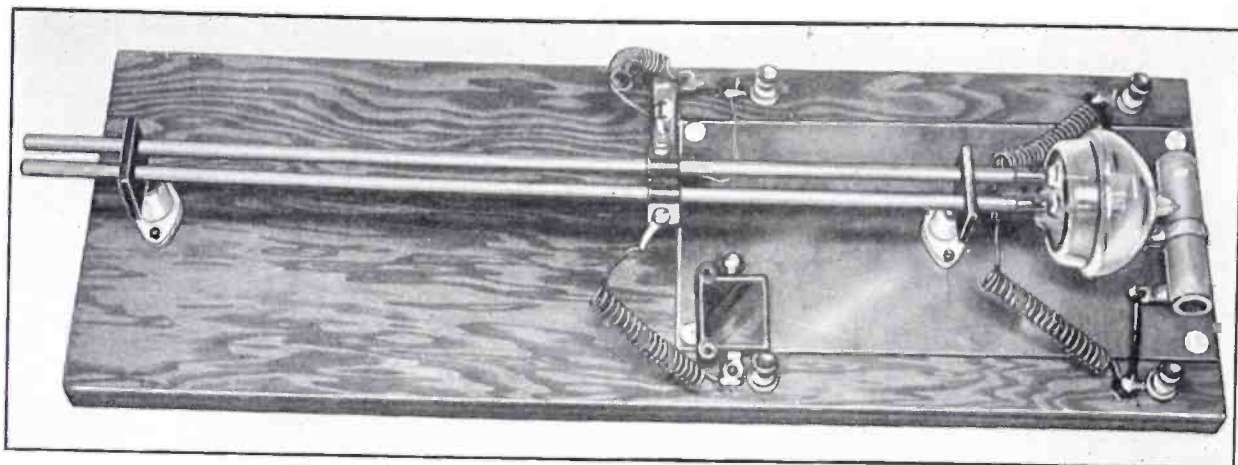

Complete 1-meter oscillator.

This resistance can be a short length of resistance wire, the proper length determined with the use of a voltmeter, the exact resistance should be 1369 ohms.

The modulator used in the transmitter, but not shown in the photographs, consisted of a pair of 2A5's in class A,B. However, any audio unit with about 15-watts output will be entirely sufficient.

In the test conducted all known rules on ultra-high frequency transmission were found to be predominant. In other words, the higher the antenna, whether it is for receiving or transmitting, the better the signal strength; also hills have an appreciable effect on the signal, when either the transmitter or receiver are located close to the base of the hill. The ill-effects of the hills becoming less noticeable as the transmitter or receiver is moved farther away from it.

All in all, our tests proved that the amateur can occupy the ultra high frequency region with just as much satisfaction as he now can obtain from the 5-meter band.

One Meter Set—Parts List

OSCILLATOR

- 1—WE-316A tube
- 2—.001 mf. 1,000 volt condensers
- 1—10,000 10-watt resistor
- 1—100 ohm center tapped resistor
- 1—power transformer; see diagram for ratings
- 1—12 H. 130 ma. filter choke
- 2—8 mf. 500 V. electrolytic condensers
- 1—25,000 ohm 50 watt resistor
- 1—type 80 tube
- 1— $\frac{1}{4}$ meg. resistor $\frac{1}{2}$ -watt
- 1—50,000 ohm resistor $\frac{1}{2}$ -watt
- 1—500 ohm resistor 1-watt
- 1—50,000 ohm resistor 1-watt
- 1—50,000 ohm potentiometer
- 1— $\frac{1}{2}$ -meg. potentiometer
- 3—.0001 mf. mica condensers
- 1—.001 mica condenser
- 2—.1 mf. paper condensers
- 1—.01 mf. paper condenser
- 1—25 mf. electrolytic condenser
- 1—Trim-Air 2-plate condenser with split stator (XV-5-TS)
- 1—Acorn tube socket
- 1—6-prong wafer socket
- 1—955 Acorn tube
- 1—41 tube





They were once

beginners too

MOST of the successful radio engineers of 1937 were, like yourself, experimenters in 1921 when WHOLESALE RADIO SERVICE CO. was founded. They grew up with WHOLESALE. The parts and tubes—the “rigs” and “bugs” which they used then were purchased at WHOLESALE. They leaned on WHOLESALE during those days when their radio technique was in the making. And WHOLESALE never let them down.

TODAY, the number of prominent engineers who still depend on WHOLESALE RADIO SERVICE CO. as their source of supply for anything and everything in radio is up in the hundreds. Follow the example of these successful radio men who have grown up with us. Learn to depend on WHOLESALE for YOUR radio requirements. No order is too small to receive prompt attention. No radio problem, simple or complicated, is overlooked when you bring it to WHOLESALE. You'll find everyone in our organization always ready and willing to help. You'll enjoy consulting with the “hams” on our splendid staff especially trained to assist you. WHOLESALE RADIO SERVICE CO. with its seven branches strategically situated to serve you best, offers you swift service, lowest prices, highest quality.

★ **WHOLESALE issues GREAT CATALOGS**

One of the services which WHOLESALE renders is the fine catalogs which are mailed to you FREE upon request. They cannot be duplicated—only WHOLESALE RADIO SERVICE CO., with its tremendous buying power can offer you such radio “buys.” The new 180-page book full of real values in everything you will ever require for your radio experiments. The merest “gadget” — the most elaborate “rig” are all listed and illustrated. TEN THOUSAND bargains to help you make a success of your radio career. Send for this FREE catalog TODAY. Ask for Catalog No. 69-18.

They're
FREE



WHOLESALE RADIO SERVICE CO. INC.
NEW YORK, N.Y. CHICAGO, ILL. ATLANTA, GA.
 100 SIXTH AVENUE 901 W. JACKSON BLVD. 430 W. PEACHTREE ST., N.W.
BOSTON, MASS. BRONX, N.Y. NEWARK, N.J. JAMAICA, L. I.
 10 FEDERAL STREET 542 E. FORDHAM RD. 219 CENTRAL AVENUE 90-08 • 166th STREET

THE

6L6 MODULATOR

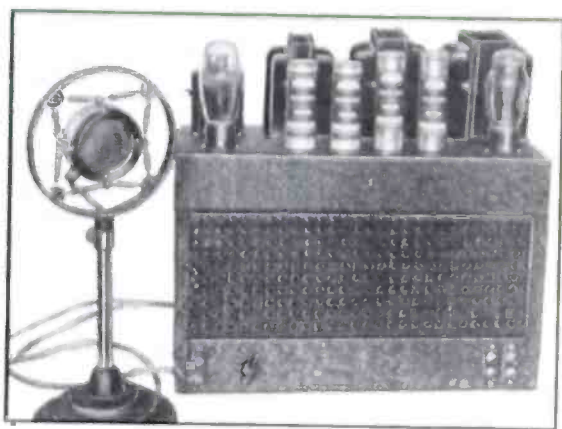

Complete modulator, including the crystal microphone.

● THE famous 6L6 tube, although not very old, has become one of the most popular of all tubes manufactured and is to say the least, the most interesting. Previous articles have shown its adaptability to transmitting apparatus in the R.F. portion and in this article we will describe a *modulator* using them in the output stage.

Two of these tubes in Class A-B in this modulator will deliver over 50 watts of audio and are capable of modulating an R.F. amplifier with inputs up to 100 watts. This modulator is designed to work in conjunction with a crystal microphone and uses metal tubes throughout, except in the *power-supply*. The diagram reveals that we start out with a hi-mu triode, as the first stage of speech amplification, a low-mu triode in the second stage of speech, two in push-pull as drivers for the push-pull 6L6's. Resistance coupling is used in the first two stages which employ a 6F5 and a 6C5. The speech amplifier is "transformer-coupled" to the *driver* stages which, in turn, make use of special transformers for the input and output circuits.

The output transformer is designed for 2500, 5000, and 7000 ohm loads, and is capable of carrying the plate current of the modulated amplifier. The entire audio portion is built on a 7 x 17 inch, crackle-finished chassis, 2 inches deep, and has a metal cane style cover. The power supplies—there are two of them, one for the power stage and another for the three amplifier stages—are mounted on a similar chassis. A cage was not employed here, but would undoubtedly improve its appearance.

Separate Power-Supplies Used

The photographs show the complete unit ready to couple to the R.F. amplifier with the power supply sitting on the top of the speech equipment. The other two photographs show close-ups of both the speech and the power-supply portions. Due to the rather heavy current requirements of the power-stage and extra good regulation being necessary, separate power-supplies were used. The one delivers 400 volts at 250 mills (ma.) and has only to serve the plates of the 6L6's. Another power-supply, delivering 250 volts, supplies the plate voltages for the three low-power stages and screen-voltage for the 6L6's. The screen voltage was taken from the low voltage power-supply in order to obtain perfect regulation and maintain the screen voltage constant during current swings of the power stage.

The transformers available would not permit a single 6.3 volt winding to feed all of the heaters and, therefore, as the diagram shows, the heaters were split up, some being run off the low-voltage power-supply, and some from the high-voltage power-supply. This is not at all inconvenient because the windings are already present on the transformer and are taken care of in the plug arrangement. In the rear

It isn't what you put in
that counts—

It's what you get Out

Use RCA Tubes to be sure of better performance at high frequencies

It seems to us that much emphasis has been placed on tube input ratings with little regard to tube and circuit efficiencies and the resulting output. After all, the other fellow only hears what you put into the antenna—not what you put into the final stage. Why gamble, therefore, with the operation of your transmitter? Give it a good start by designing it around RCA tubes. There are many types to choose from which will give you long, reliable service at high efficiencies.

High plate efficiencies in many tubes are obtainable only at very high plate voltages. This means costly power-supply equipment. RCA offers you a line of tubes designed to give high efficiencies at reasonable plate voltages, thus permitting you to save money on your power supply equipment. The money saved can be used to improve other portions of your transmitter.

Efficiency at ultra-high frequencies is an important matter. Naturally, overall circuit efficiency is lower. Don't let the tubes be the weak link in the system—use RCA ultra-high-frequency types which have been carefully designed and rigidly tested to assure good ultra-high-frequency performance.

*For full information on any RCA type,
see your supplier, or write to*



RCA 801



RCA 802



RCA 803



RCA 805



RCA 807



RCA 808



RCA 834



RCA 866



for Amateur Radio

AMATEUR RADIO SECTION

RCA Manufacturing Co., Inc., Camden, N. J. • A Service of the Radio Corporation of America

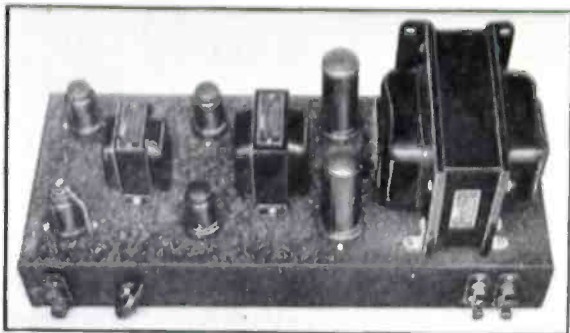

The speech or audio part of the equipment.

of the speech unit we have two sockets which are receptacles for the power-supply leads and from the power-supply unit there are two cables with plugs attached to fit the sockets. In the high-voltage supply, we used an 83 rectifier and an 80 in the low-voltage power-supply. If the 83 causes a *hash* in the receiver, merely substitute it with an 83V which is a special vacuum tube, with regulation nearly as good as the 83. The 83 provided slightly better results.

"Gain-Control" and Bias Arrangements

Good equipment must be used in the construction of the power-supply and the modulator, because poor regulation can *not* be tolerated, otherwise you will have serious distortion and low-power output. The *gain-control* is incorporated in the grid circuit of the second speech amplifier. This is a 500,000 ohm potentiometer and usually has to be turned on about 60 per cent for comfortable speaking into the microphone.

Plenty of circuit-isolating resistors and condensers are incorporated in the speech amplifiers and are absolutely necessary wherever shown in order to obtain maximum stability.

The 6L6 stage may be operated with automatic bias or fixed bias. The battery bias, or fixed bias arrangement, permits slightly greater power output. Although this grid voltage might have been obtained from the low-voltage power-supply, a separate battery was used. The small variety work well because of the low voltage requirements and also due to the very slight amount of grid current that flows during peak power-outputs, which has very little effect upon a good battery. Automatic bias is used throughout the rest of the modulator in the conventional manner.

Both the grid leads of the two speech-amplifier tubes are *shielded* with regular shielding braid. This was found necessary in order to reduce hum pickup and also possible feed-back. Under operating con-

ditions, the amplifier, as we said before, gave over 50 watts audio, and the *quality* is extremely good. In fact, many who have heard it "over the air" claim that it sounds as good as anything they have ever heard and equivalent to "broadcast" quality.

There is absolutely no noise in the amplifier itself when using a crystal microphone, and not the slightest trace of hum—which also makes for better quality.

There are two types of output transformers available for the 6L6's. One is shown in this particular modulator, and another which has low-impedance outputs ranging up to 500 ohms. It has been found desirable in many cases to use an "out-put" transformer with a 500-ohm output secondary and coupled to the modulated amplifier through a 500-ohm transmission line. Although this requires another transformer for matching the 500-ohm line into the modulated amplifier, it eliminates "feed-back" difficulties in that the modulator may be operated at quite a distance from the R. F. amplifier, and thus there will be little chance of R.F. getting into the modulating equipment. Of course, if care is used in setting up the apparatus, no R. F. should be present in the audio system. But one of the best ways of getting around this possible evil is to use the above method and employ a 500-ohm line between the modulator and the modulated amplifier.

Parts List for Modulator

- 1—5 meg. resistor
- 1—3500 ohm resistor
- 1—50,000 ohm resistor
- 1—200,000 ohm resistor
- 1—200,000 ohm resistor
- 1—2,500 ohm resistor
- (The above resistors are all ½ watt)
- 1—20,000 ohm voltage divider
- 1—15,000 ohm voltage divider
- 1—.5 meg. potentiometer
- 2—4 mf. condensers, 100 volt
- 2—2 mf. condensers, 400 volt
- 5—8 mf. condensers, 600 volt
- 1—.1 mf. by-pass condenser
- 1—10,000 ohm resistor
- 1—500 ohm resistor

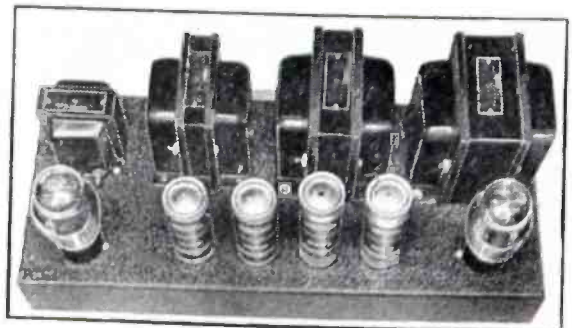

The two power-supplies combined in one unit, which are used for the 6L6 modulator.

FM LIDS TO OT'S— ZL to TF!

HARRISON serves 'em all!

Since 1925 "Harrison" has been the "buy-word" of discriminating Amateurs everywhere! Throughout the years an ever increasing number of Hams, beginners and old-timers alike, have come to consider Harrison as the one really dependable Amateur supply company. There must be a reason—and there is! In fact, there are several.

- Prompt, intelligent SERVICE that makes mail order buying a pleasure!
- Prices that actually mean more watts per dollar!
- Enormous stock enabling immediate shipment without substitution!
- Unconditional guarantee of complete satisfaction with every transaction!

In addition to world famous "Specials" Harrison stocks the products of all leading manufacturers. As an **AUTHORIZED DISTRIBUTOR** maximum discounts are extended to all Amateurs.

SEND YOUR NEXT ORDER TO HARRISON

WE FEATURE—

Aladdin	Clough Brengle	Hickock	Ohmite	Sylvania
American	Communication	Hoyt Meters	Patterson	Taylor
Microphones	Products	ICA	Pioneer	Temco
Amperex	Cornell-Dubilier	I. R. C.	PR Crystals	Thordarson
Amperite	Coto-Coil	Janette	Pyrex	Trimm Phones
Amperite	Deagan Chimes	Jefferson	Paytheon RK	Triplet
Microphones	Dunco Relays	Jensen	Readrite	Tungsol
Amphenol	Eby	E. F. Johnson Co.	RCA—DeForest	Turner
Astatic	Eimac	Kenco Keys	Tubes	Universal
B & W Inductors	Esico Irons	Kester	RCA Transmitters	Utah
Beede Meters	Frost	Krauter Tools	RIDER	U. T. C.
Birnback	General Electric	Leichner	RME-69	Valpey
Bliley	General	Littlefuse	Rola	Ward-Leonard
Breting	Transformer	Lynch	R.T.L.	Weston
Brush	Guardian Relays	Mac-Key	Sangamo	Westinghouse
Bud	Hallicrafters	Magnavox	Sargent	Instruments
Burgess	Hammarlund	Mallory	Shure	Wright-DeCoster
Cardwell	Harvey	Mueller Clips	Signal	Yaxley
Centralab	Heintz & Kaufman	National	Simpson	

● **RECEIVERS** ●

**HALLICRAFTERS
HAMMARLUND
RME RCA
SARGENT
PATTERSON
BRETING
NATIONAL
TIME PAYMENTS
TRADE-INS**

**Come to "The
Friendly
Place"**

Between Vesey, Barclay and
Greenwich Streets.

**EXPORT DEPARTMENT
CABLE "HARRISORAD"**

**MAIL
COUPON
TODAY**

and all other lines of proven **QUALITY!**

For MORE WATTS PER DOLLAR!

Bill Harrison (W2AVA) RAC
12 West Broadway, N. Y. C.
Sa, OM!

I am really interested in getting more real value
for every dollar I spend!

Pse put mi name on ur mailing list for ur Free
Ham Bulletins.

Also send me, without charge, the following manu-
facturers' catalogs es ur money saving discounts:

(Continue list on a separate sheet, if necessary)

Tnx es CUL.

Name

QRA

(A crd or ltr wl do, if u prefer)

**HARRISON RADIO
COMPANY**
12 WEST BROADWAY • NEW YORK CITY

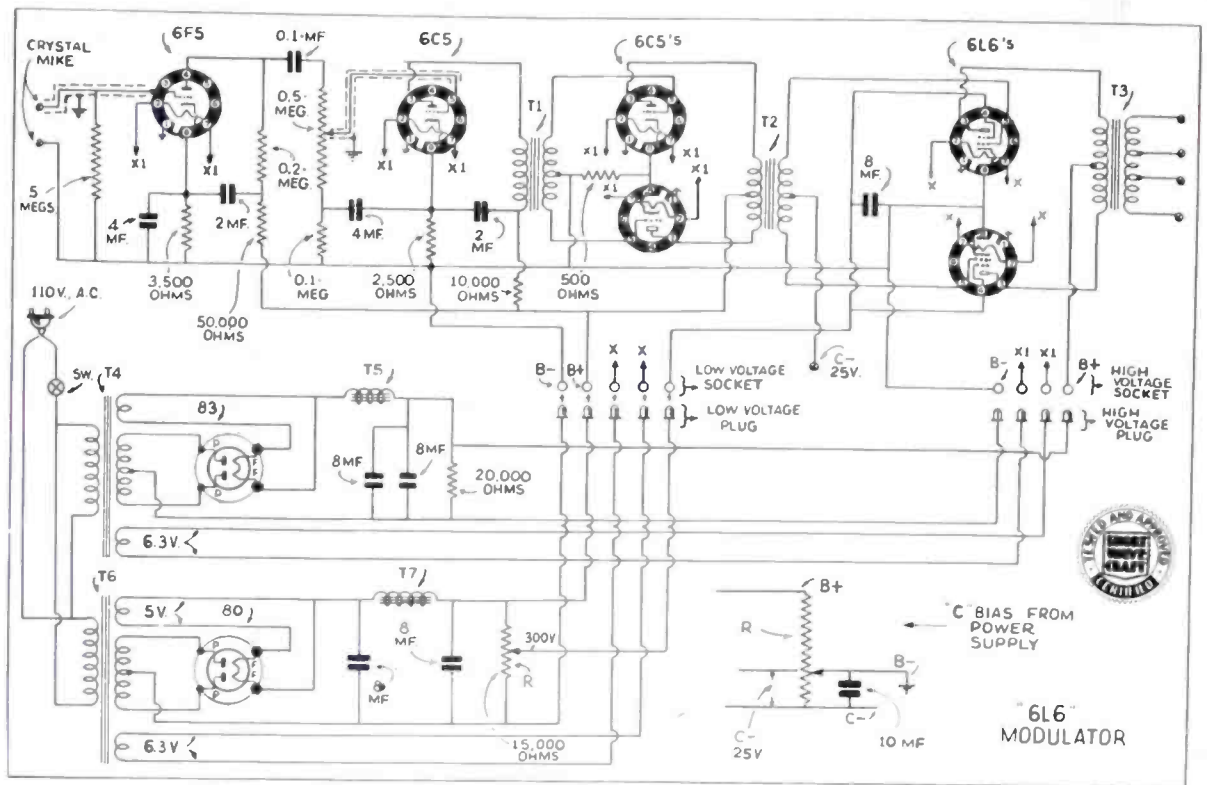

Diagram of the complete modulator and power supplies

2—7 x 17 x 2½ inch chassis, with bottom plates and one cane type cage, black crackle finish
 6—Bakelite wafer sockets, octal
 1—6F5 tube 3—6C5 tubes

2—6L6 tubes
 1—83 tube
 1—80 tube
 1—crystal microphone

UNIVERSAL POWER SUPPLY

FOR THE HAM

● THE problem of supplying voltages to a transmitter is constantly confronting the average amateur.

In most cases two separate power-supplies were used; one furnishing low voltage, that is around 500; another supplying the high voltage, usually around 1,000 to 1,500 volts. It is also possible to obtain the same results with a single power-supply by using a tapped voltage divider. However, this latter method is electrically unsound because of the poor regulation afforded and power wasted. The low-power stages suffer when the high-voltage amplifier is keyed.

The new special triple-winding transformer which is described in this article, and shown in the photographs, permits the

entire problem to be solved economically and in an electrically sound manner.

In most of the amateur stations where the

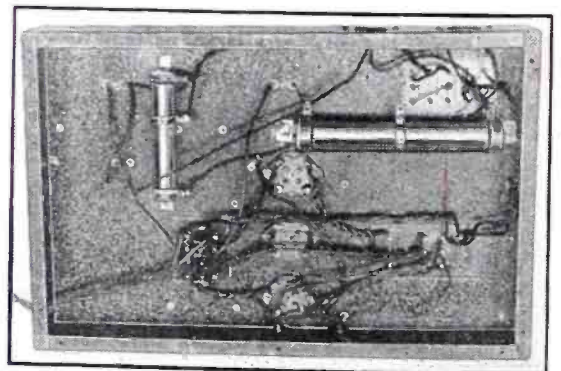

Bottom view showing the wiring.

Begin Right with CORNELL-DUBILIER CAPACITORS



Dykanol Transmitting Capacitors—Type TJ

Moulded Mica Transmitting Capacitors Type 9

Mica Transmitting Capacitors—Type 86

Mica Transmitting Capacitors—Type 86

Dykanol Filter Capacitors Type TL

Paper Filter Capacitors Type PE

Dry Electrolytic Capacitors—Type JR

Paper Tubulars Type DT

CAPACITORS
DYKANOL
DRY ELECTROLYTICS

You're just starting out in this fascinating field called radio. A lot of thrills lie ahead for you . . . and possibly a good many disappointments. One of the most important component parts utilized in any radio circuit is the condenser. Disappointments due to condenser failure have been avoided by those "who know their way about in radio" by standardizing on Cornell-Dubilier Capacitors.

There are a lot of sound technical reasons why C-D Capacitors are "Tops", but what could be more convincing than this: Engineers the world-over specify C-D.

DYKANOL TRANSMITTING CAPACITORS—TYPE TJ

Of proven dependability, these hermetically sealed capacitors are Dykanol impregnated and filled. Universal mounting bracket permits either inverted or upright mounting. Available in a complete capacity range up to 25,000 volts, D.C.

MOLDED MICA CAPACITORS TYPES 9 & 4

Constructed of the finest select India mica. Special Bakelite composition molded under pressure hermetically seals condenser section.

MICA TRANSMITTING CAPACITORS—TYPE 86

Hermetically sealed in glazed, non-hygroscopic ceramic containers. Available from 2,000 to 12,500 volts.

DYKANOL FILTER CAPACITORS—TYPE TL

Hermetically encased in round aluminum containers. Oil impregnated and filled.

PAPER FILTER CAPACITORS TYPE PE

Paper dielectric capacitors with a high degree of safety margin against voltage breakdown.

DRY ELECTROLYTIC CAPACITORS—TYPE JR

The latest etched foil development in the industry. Small, compact, triply sealed in silvered containers.

PAPER TUBULARS TYPE DT

Long recognized as the finest in the field, the DT Tubulars are extensively utilized by leading set manufacturers.

CORNELL-DUBILIER
Electric
CORPORATION
South Plainfield, N. J.

Whether radio is going to be "Just A Hobby" with you, or your life's work, begin right . . . insist on Cornell-Dubilier Capacitors for Quality, Performance, Dependability.

For listing of the entire C-D line of Capacitors write for Cat. No. 151-A, free on request. C-D capacitors are available at all Cornell-Dubilier authorized distributors.

THE WORLD'S LARGEST AND OLDEST EXCLUSIVE MANUFACTURERS OF CAPACITORS

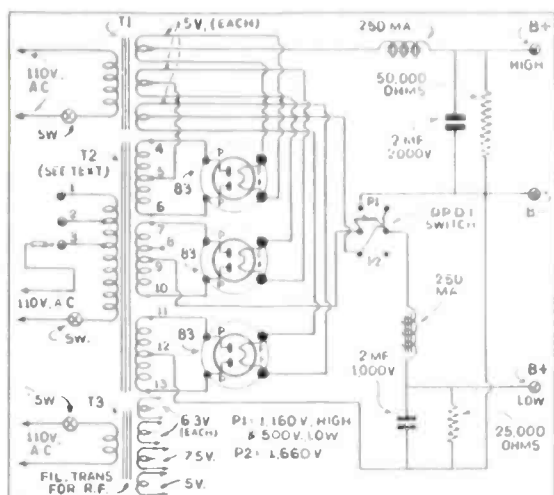

Circuit diagram showing the various connections.

average power output is around 100 to 250 watts, two voltages are required, 500 and 1,000. The 500 volt potential is usually applied to the oscillator and buffer stages, while the 1,000 volt supply furnishes power for the final amplifier alone, and it was for this particular purpose and arrangement that this power-supply was designed.

Here we have in effect, two power-supplies employing only one transformer for the high voltages and using three type 83 rectifiers. A switch is also provided so that a single output of some 1,600 volts may be obtained if needed; however, this does away with the low voltage supply. Elsewhere in this book we describe a transmitter which can satisfactorily employ this particular power-supply. The transformer which supplies the various filament voltages contains two 6.3, 7.5 and a 5-volt winding. One 6.3 and the 7.5 windings are both employed.

By employing a rather long filament cable, the voltage is dropped to around $10\frac{1}{4}$ volts which is entirely satisfactory. The remaining 6.3 volt winding is employed for the low-power stages. Each output section of the power supply will provide the voltages indicated in the diagram at 250 milliamperes, this is entirely satisfactory for almost any medium power amateur transmitter.

Numerous other combinations may be employed aside from those shown in the diagram. The only variations we found necessary were the double-throw switch for

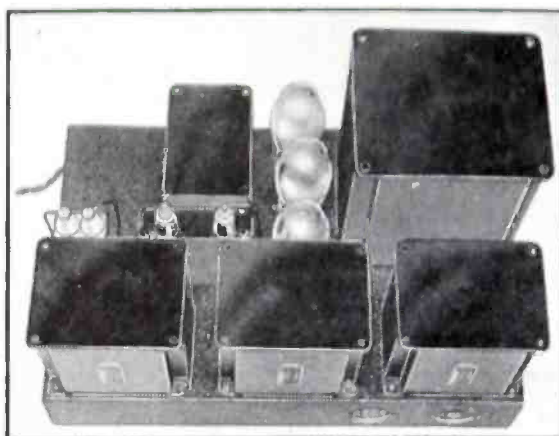

Top view of the Multi-purpose power-supply.

switching from one single output, at 1,600 volts, to two delivering 500 and 1,100 volts, together with three taps on the primary. The voltages shown in the diagram are obtained by employing tap No. *three* on the primary. Taps *one* and *two* will give correspondingly lower voltages.

T-1 in the diagram is a triple-winding, 5-volt filament transformer, and permits the many combination hook-ups with this power-supply. The filter section of the supply may seem rather meager; however, careful examination has shown that a single choke and condenser is entirely sufficient to provide an absolutely *pure note* from an efficiently designed transmitter.

Of course, the *crystal* when used in the oscillator circuit goes a long way toward ironing out any ripple that might be caused by the power-supply.

Tests on the air with a number of transmitters proved that this power-supply gives a perfect note, and one need not incorporate additional chokes or condensers in the filter section.

Parts List—Power Supply

- 1—Triple winding transformer (250 ma.)
- 1—4-winding filament transformer, see text
- 1—3-winding filament transformer
- 2—14 henry—250 ma. filter chokes
- 1—50,000 ohm—50 watt resistor
- 1—25,000 ohm—50 watt resistor
- 1—2 mt. 2,000 volt filter condenser
- 1—2 mt. 1,000 volt filter condenser
- 1—17 by 12 by 3 inch crackle finished chassis
- 3—4-prong wafer sockets





'SWK' COIL



'MCD-X'
DOUBLE-SPACED
SPLIT-STATOR
CONDENSER



'APC' IN
S W F
FORM

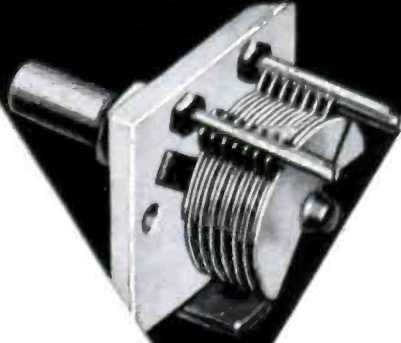

'HF' MICRO CONDENSER

For Dependable Service

WITH Hammarlund precision products in your receiver or transmitter, you are thoroughly assured of dependable service for superior results! Since 1911—when Hammarlund products were introduced—engineers, professionals, amateurs, set builders, and experimenters in every corner of the world have developed and built their equipment exclusively with Hammarlund products—products that insure smooth sailing performance!

Hammarlund, today, manufactures over 500 precision products among which are standard, midget and micro variable condensers; trimming and padding condensers; plug-in coils; coil forms; Isolantite sockets; I.F. transformers; R.F. Chokes; couplings; shields; professional "Super-Pro" and "Comet Pro" receivers, and special laboratory equipment for ultra-high frequency and high frequency receiving and transmitting. Above are illustrated the famous coil forms (SWK and SWF) using the special low loss natural colored XP-53 dielectric with its unusually low power factor, rugged structure and ex-

treme durability. The "MC" condensers use Isolantite insulation, noiseless silver plated Beryllium wiping contact, wide split type rear bearing, cadmium plated soldered brass plates, etc. The "HF" micro condensers, ideal for tuning or trimming high frequency circuits, also use cadmium plated soldered brass plates, Isolantite insulation, wide front bearing, etc.

For best results use Hammarlund, and to be sure you get a genuine Hammarlund product, look for the name HAMMARLUND stamped on every product! Mail coupon below for new catalog with complete details on all Hammarlund products.

If you do not wish to cut this page,
COPY the coupon below

HAMMARLUND MFG. CO., Inc.
424-438 West 33rd St., N. Y. C.

Please send "37" catalog

Name

Address

City

State

RAC-38



HAMMARLUND

AN EFFICIENT

125-WATT MODULATOR

USING 35T's

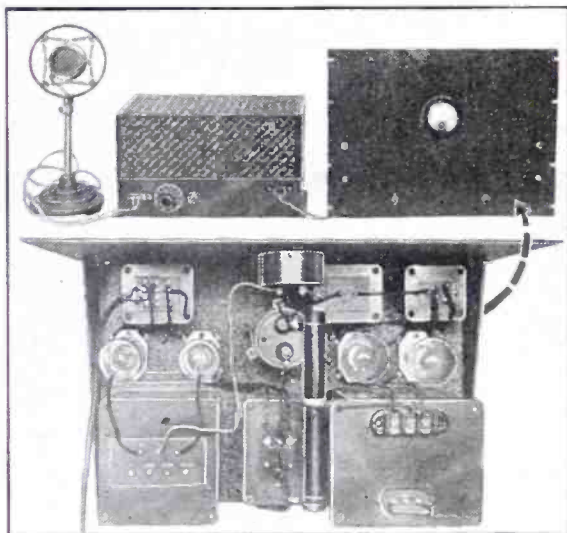

Complete view of modulator and speech equipment, together with an "inside shot" of the high-power stage and its power-supply

● IN previous articles we have described transmitters ranging from 100 to 300 and 400 watts input, and all of these transmitters are capable of *phone* operation. The *modulator* described in this article is a fitting addition to any one of the previously described transmitters.

The modulator consists of two units; one is a combination *speech amplifier* and *driver*, consisting of three 56's and two 2A5's connected in push-pull class A. The class B power stage employs two Eimac 35-T's, with from 1,000 to 1,100 volts on the plates and is capable of an output of over 125 watts.

Referring to the diagram, we find that we start out with a crystal microphone and three stages of triode amplification. Resistance coupling is used to permit good quality, and if the values given in the diagram are followed carefully, there will be no danger of instability or feedback. The

plate circuit of each of the amplifier tubes contains a resistor, condenser and filter. The third triode is transformer coupled to the 2A5's. Transformer coupling is used in this position to simplify construction and design. The 2A5's in push-pull serve as a driver stage for the 35-T's. The 2A5's with from 250 to 300 volts on the plates are entirely adequate for driving the final class B stage. Slightly better quality would be possible with a pair of 2A3's or 45's in class A. However, the combination shown in the diagram provides excellent quality, that is as good as can be found on the amateur bands, and we must agree that there are many fine phone stations now in operation. The output transformer of the 2A5's is a universal affair, designed to match the 2A5's into various loads from 500 ohms downward. Therefore, the input transformer on

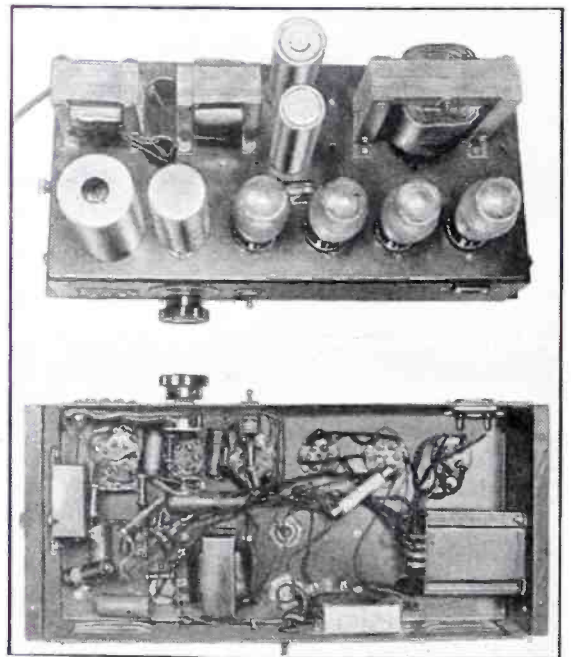

Top and bottom view of the "speech amplifier" and "driver" unit.



The ONE
Complete
LINE



Condensers and Resistors for every radio need—PLUS that extra measure of quality essential to long and dependable service. That's the AEROVOX story.

Our latest 32-page catalog, obtainable at your local supplier or from us direct, gives all the details.

AEROVOX
CORPORATION
70 Washington St. : : Brooklyn, N. Y.

the class B stage is designed to couple a low-impedance line to the 35-T's. The 500 ohm line was chosen and provides the best all-around results. The turn ratio of the input transformer should be 2.8 to 1 step up from the 500 ohm line.

In a good many cases the driving stage and even the voice amplifier stages are included in the same unit with the high-power class B stage. While this can be done successfully, it is much more advisable to follow the arrangement there described, which permits the modulator stage to be mounted in the rack with the rest of the transmitter and the speech amplifier and driver on the operating desk, well out of the field of the transmitter. In this respect there is less likelihood of it picking up R.F. and, at the same time, the amplifier is located close to the microphone where the gain control is readily accessible.

Referring to the photograph of the *final-amplifier* stage, we find that here too, the power supply is mounted on the same chassis with the amplifier. This power-supply makes use of a transformer which has a high and low primary tap, providing an output of 1,100 volts on one tap, and some 1,400 on the other. Either may be used with the audio transformers listed in the parts list. However, some juggling of the load impedance on the 35-T class B stage will be necessary when the higher voltage is employed. In other words, the 6,000 ohm output tap may have to be used with a load impedance as high as 8,000 ohms in order to reflect the proper load into the 35-T's. However, we recommend adhering to the 1,000 to 1,100 volt supply for best all-around results, unless the input of the modulator amplifier is in excess of 500 watts and cannot be applied to the modulator

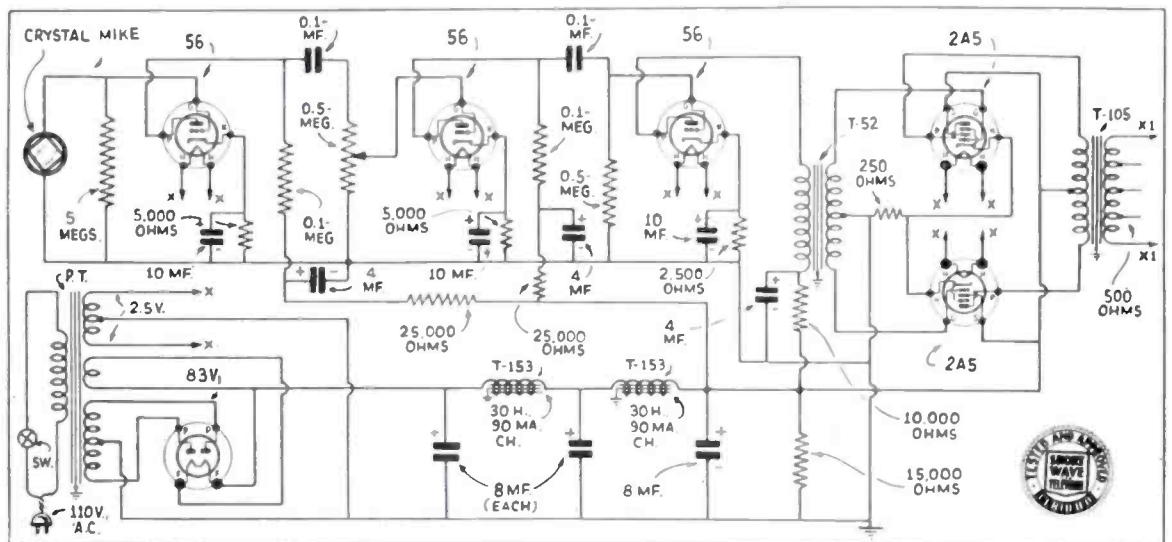

Diagram of the speech amplifier and driver

The power-supply, the speech amplifier and driver stage are all included on the same chassis. Reference to the photograph will show the general construction of this unit. Any fairly high-gain audio amplifier with an output of approximately 7 to 8 watts will drive the 35-T's, and if such an amplifier is readily available completely constructed matters are greatly simplified. There are a number of 6 to 8 watt high-gain amplifiers now being sold by various radio supply houses which can be purchased just as cheaply as they can be constructed, and any of these which have a 500 ohm output winding will work satisfactorily with the class B stage.

tubes. With the plate voltage indicated in the diagram, the plate meter on modulation peaks will show about 180 to 190 milliamperes; higher values than this should not be permitted.

The output transformer employed with these tubes was designed to be used with the type 800 tubes. Since the load impedance of the 35-T's with the voltage specified in this article is slightly less than the value for the 800's, the load impedance represented by the final amplifier input should be slightly less than the values indicated on the output taps of the transformer. For instance, the 6,000 ohm tap should be used for a load of slightly over 5,500 ohms for

LEARN CODE

the way you'll be using it

BY SOUND

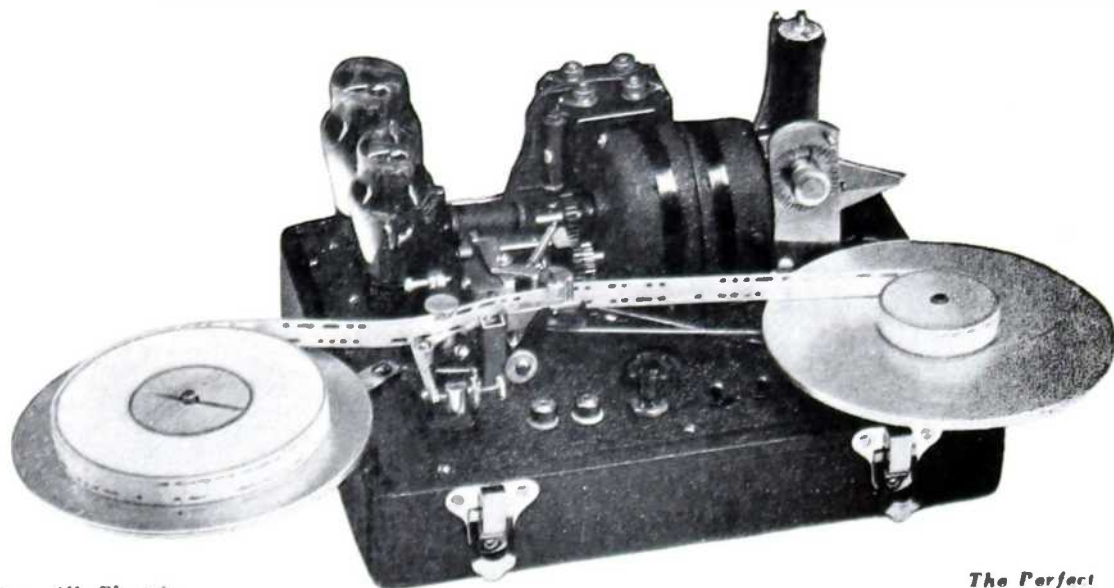

*New All Electric
Master Teleplex*

*The Perfect
Automatic Transmitter*

THERE is only one way to learn to read code and that is by listening to code. There is only one proper way to learn to send code and that is by hearing your own sending repeated back to you. With the Master Teleplex Code Teacher you learn code the natural, easy, fascinating way. Only instrument ever produced which records your sending in visible dots and dashes—then SENDS BACK your own key work at any speed you desire. We furnish complete course, lend you the New All Electric Master Teleplex, give you personal instruction with a MONEY-BACK GUARANTEE—all at a surprisingly low cost per month. Write today for FREE catalog. No obligation.

TELEPLEX CO.

72-76 Cortland Street

Dept. RA

New York, N. Y.

"HAM" SPECIAL STANDARD TELEPLEX

A highly efficient code teacher using heavy specially prepared waxed paper tape, having two rows of perforations. Preferred by



Instrument, with tapes prepared by expert, and complete course of **\$11.95** Without Oscillator

thousands of hams because they receive signals under actual working conditions. Write for Free Folder RAC.

DEALERS—Correspondence invited with dealers for protected territories.

TELEPLEX CO.

Dept. RA, 72-76 Cortlandt St., New York, N. Y.

Please send me Free Catalog about the All Electric Master Teleplex Code Teacher and details of your money-back guarantee.

NAME

STREET

CITY STATE

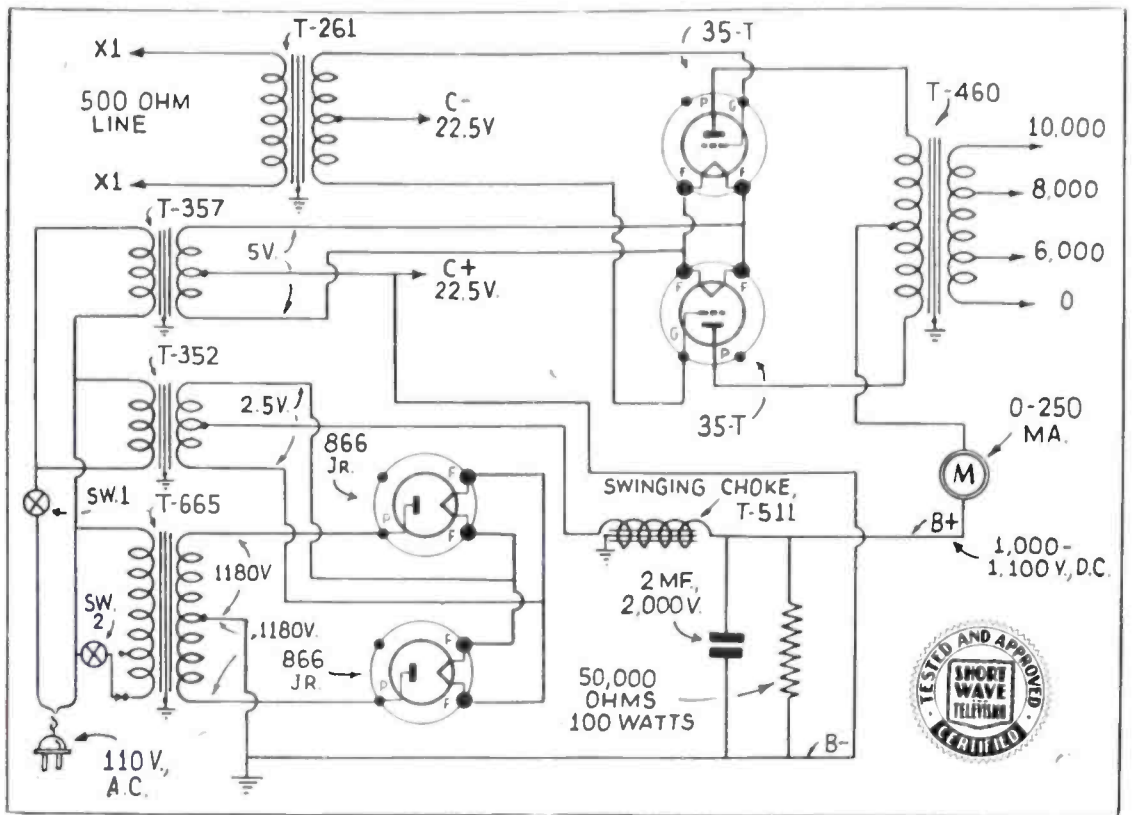

Diagram of the Class "B" stage and its "power supply."

a perfect match. However, such a slight deviation will not impair the quality at voice frequencies, and for all general purposes

the tap may be connected into loads similar to the listings on the transformers.

Parts List for Modulator

Speech Amplifier and Driver.

- 1—5 meg. resistor— $\frac{1}{2}$ -watt.
- 2—5,000 ohm resistors—1-watt.
- 2—100,000 ohm resistors 1-watt.
- 2—25,000 ohm resistors 1-watt.
- 1—5 meg. resistor $\frac{1}{2}$ -watt.
- 1—2,500 ohm resistor 1-watt.
- 1—10,000 ohm resistor 1-watt.
- 1—250 ohm resistor 2-watts.
- 1—5 meg. potentiometer.
- 1—50,000 ohm 50-watt resistor.
- 2—.1 mf. condensers.
- 3—10 mf. electrolytic condensers.
- 3—4 mf. electrolytic condensers.
- 3—8 mf. electrolytic condensers (wet 500 volts).
- 1—push-pull input transformer, T-52.
- 1—push-pull output to low impedance line, T-105.
- 2—30 henry 90 ma. filter chokes, T-153
- 1—power transformer 250 to 300 V., D.C., output, 90 to 100 ma.
- 3—5 prong wafer sockets.
- 2—6 prong wafer sockets.
- 1—4 prong wafer socket.

- 1—D-104 crystal microphone.

- 3—Type 56 tubes.

- 2—2A5 tubes.

- 1—83 V. tube.

- 1—Amplifier foundation unit chassis and cover. Class B power stage.

- 1—Input transformer T-261; variable ratio 500 ohms to class B grids.

- 1—T-460 output transformer with tapped secondary.

- 1—T-357 filament transformer for 35-T's.

- 1—T-352 filament transformer for 866's.

- 1—T-665 plate transformer 1,180 volt output, with primary tap.

- 1—T-511 swinging choke.

- 1—2 mf. 2,000 volt oil condenser.

- 1—50,000 ohm 100-watt resistor.

- 1—0-250-ma. meter, large bakelite case.

- 4—4 prong sockets.

- 1—17 by 3 by 11 inches chassis black crackle finish.

- 1—10 by 10 $\frac{3}{4}$ panel, black crackle finish.

- 2—Eimac 35-T's.

- 2—866 Jrs.



THE**C-O-M 150 WATT****TRANSMITTER**

• • •

● THE trend of late has been toward compact and simplified transmitters. This, of course is due to popular demand but it is only made possible by the increased efficiency of our transmitting tubes. This transmitter is really compact and efficient, and above all is very simple to build and operate. The output consists of a pair of

RK 37's in parallel with an RK 39 driver. The crystal-oscillator circuit is built around the "old-faithful" 6L6. The entire transmitter, exclusive of power-supply of course, is built on a 8 by 17-inch chassis, with a 8 $\frac{3}{4}$ -inch panel 19 inches long. The complete power-supply unit for this transmitter could easily be built on a similar size chassis and panel, making a complete job of small dimensions and capable of putting out a really "husky" signal. The transmitter is simplified and easy to construct and operate.

New Frequency-Doubling Circuit!

From the diagram it would appear that the crystal-oscillator is a conventional tetrode arrangement, however careful examination and operation prove it to be quite the contrary. The plate circuit of the 6L6 oscillator may be tuned to either the crystal frequency *or the second harmonic* (twice the crystal frequency). It will be noticed that the diagram shows a 400 ohm cathode bias resistor with a 140 mmf. variable condenser *connected across it*. This may seem rather unusual, but it is this trick that permits *frequency doubling* in the oscillator with only *one* tuned circuit. With the 140 mmf. set at mid-scale, the crystal will oscillate *regardless of the frequency at which the plate circuit is resonant*. The condenser shunted across the cathode biasing resistor could have been made fixed; however, different crystals require slight changes in this capacity. Also when *doubling* in the plate circuit a slightly different adjustment is required over that which provides stable operation when the plate circuit is tuned to the crystal frequency. This 400 ohm biasing resistor in this particular transmitter is a wire-wound affair, and we also note that the shell of the 6L6 is connected directly to the cathode. These were not according to schedule, for originally the 400 ohm cathode resistor was a metal-

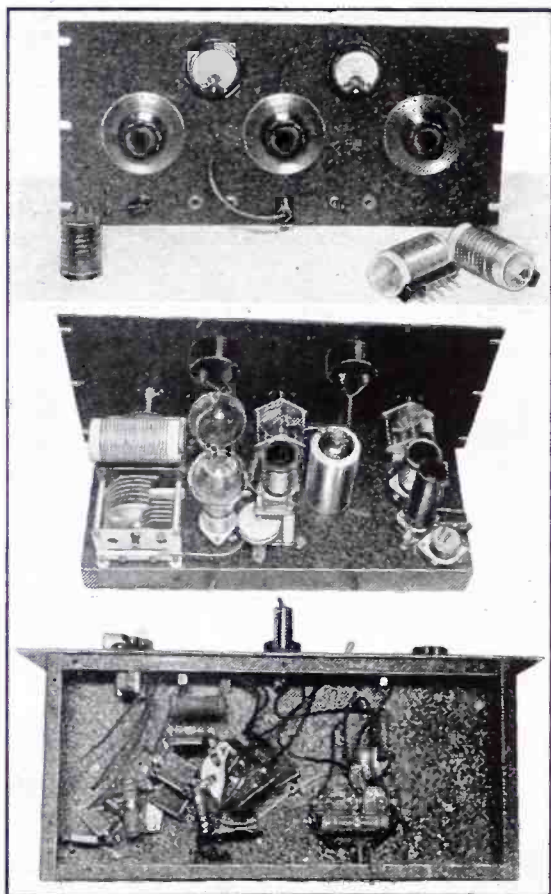

Top: Front view of the complete 150-watt Transmitter. **Center:** A peek at the rear of the 150-watt Transmitter. Note that the final-amplifier plug-in coil is mounted between the two sections of the split-stator condenser. **Lower photo** shows bottom view of Transmitter.

FACTS EVERY AMATEUR SHOULD

OIL

KNOW ABOUT

Nothing is more essential to your Transmitting Condensers than the right oil. On this oil depends their ability to dissipate heat, resist moisture, perform satisfactorily over a long period of time.

Thus, in analyzing oils of many types for Sprague Transmitting Condensers, we paid special attention to the oil used to impregnate the transatlantic cables. Here, there could be no failure. Here, none but the very best would do . . . As a result, we used this same identical oil for our Condensers. We demanded the best—and got it! This Sprague oil has no trick name—but it is the best oil for the purpose BAR NONE.

Use Spragues—and note the difference!

• UNCONDITIONALLY GUARANTEED •

Sprague Transmitting Condensers are oil-filled, oil-impregnated, cylindrically wound and constructed with ample safety factor. They are unconditionally guaranteed against breakdown when used as specified.



SPRAGUE

OIL-IMPREGNATED • OIL-FILLED
TRANSMITTING CONDENSERS

NEW SPRAGUE TRIMMERS



New line of Trimmer Condensers is set an immediate response wherever the call is for extremely stable units with excellent power factor at die frequencies. No possibility of "drifting" capacity ratings.

NEW SPRAGUE fixed MICA CONDENSERS

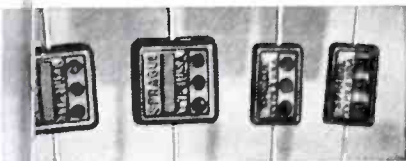

up to 500 working volts. The superior performance of Sprague Micas is due in large part to their remarkably high resistance to moisture. Power Factor is high and stable. Voltage ratings fully guaranteed. The only mica condenser in leads eyeletted to mica—giving secure contact.

NEW THE ONLY FULLY SEALED

UNCASED SECTIONS

Whether you're an amateur interested in Condensers that are unexcelled as low cost transmitting units, or a

hobbyman replacing an old condenser job, you'll be more than pleased with these new and vastly improved uncased sections. Look better—are better!

FREE

If you haven't already received one, we'd like to send you our FREE our new complete catalog. This includes listing of the full Sprague Condenser line for every need PLUS a wealth of valuable condenser facts and information.



SPRAGUE PRODUCTS CO.
North Adams, Mass.

BUILT FOR PERFORMANCE

The KENYON "T" line of audio and power components includes a number of Universal Transformers which entirely eliminate obsolescence. Solves the amateur's problems in an economical manner. Low in price yet built to stand the gaff.



KEN - O - TAP

UNIVERSAL MODULATION TRANSFORMER
The Reliable Solution to the Modulation Problem

KEN - O - DRIVE

UNIVERSAL DRIVER TRANSFORMER
The Modern Answer to Critical Driver Operation

KEN - O - LINE

UNIVERSAL SPEAKER OUTPUT TRANSFORMER
The Precision Method of Matching Output Tubes to Speakers

KEN - O - DYNE

UNIVERSAL LINE TO SPEAKER TRANSFORMER
The Efficient Coupling Device from Universal Line

BEFORE BUYING A PLATE TRANSFORMER GET THE DOPE ON OUR TRIPLE WINDING TRANSFORMERS. THESE NEW UNITS PROVIDE OVER 30 VOLTAGES RANGING FROM 400 TO 3,000 VOLTS.

Beginners and old timers agree that the Kenyon Amateur Transmitter Manual is the most popular manual published to date. Contains design details for the construction of phone and C. W. transmitters. Includes 13 pages of radio data, formulae, conversion tables, inductance calcula-



tions, coil specifications and antenna circuits, etc. 14 additional pages are full page Ken-O-Graphs permitting easy conversions of various units. An excellent reference book for the licensed or prospective amateur. Your net cost 25 cents.

MANY OF THE ARTICLES IN THIS BOOK UTILIZE KENYON COMPONENTS. THEREFORE IN ORDER TO OBTAIN EQUIVALENT RESULTS SPECIFY KENYON.

CATALOG OBTAINABLE FROM YOUR DEALER

OR

Chief Engineer—Amateur Division

KENYON TRANSFORMER CO., Inc.

840 Barry Street, New York, N. Y.

recommend for efficient operation. It is very important that the RK 39 be shielded. The shield should extend up to the top of the tube and should not fit too closely around it. Also it is advisable to have a number of holes around the bottom and top of the shield in order to provide adequate ventilation. The final amplifier is also very simple and conventional. It is capacitively coupled to the driver stage in order to simplify matters.

The two tubes were used in parallel in an effort to further simplify the transmitter, for in push-pull an additional tuned circuit would have been required, and the plate circuit of the driver would also have been more complicated. Down to 10 meters there is apparently no difference in the output of the 2-tubes, whether they are connected in push-pull or parallel. The plug-in coils for the oscillator and buffer-doubler are wound with heavy tinned copper wire on R-39 forms. The plate coil of the final amplifier is wound on the new XR forms and presents a very convenient arrangement, inasmuch as this coil and its mounting can be mounted directly on the tuning condenser.

Plate Current Values

A rough indication of what might be expected in the way of plate currents in the various stages will undoubtedly help the reader in knowing whether or not his transmitter is functioning properly. The oscillator under load should have a plate current from 30 mills when operated at the crystal frequency and 40 to 45 mills when the plate circuit is tuned to the second harmonic of the crystal. The RK 39 plate current will be around 10 mills with the key of the final amplifier open, and when the 39 is used as a straight amplifier, and about 20 milliamperes when it is used as a doubler. With the final amplifier delivering power to the antenna the plate current of the 39 when operated either as a doubler or straight amplifiers will be in the neighborhood of 80 to 90 milliamperes.

The final amplifier with the plate circuit unloaded should show a plate current of around 15 to 20 milliamperes and with 1,000 volts on the plate, under full load the plate current should not exceed 200 milliamperes. With 1,250 volts on the plate of the tubes, 190 ma. will be approximately correct.

There is no fixed bias on the final amplifier, and therefore the key should not be closed unless excitation is being applied to

the grids of the two amplifier tubes. However, if anyone building this transmitter happens to be using the vacuum-tube "keying" arrangement, there will be sufficient automatic bias due to the voltage drop across the keying tubes, to furnish enough grid bias to eliminate all danger, should the excitation fail at any time with the key closed. This is another good feature of the tube keying arrangements.

The final-amplifier can be used as a doubler-stage at considerably reduced power output, but it would be best to always use it as a straight amplifier. If used as a frequency doubler, the grid resistor should be increased from the present 2,000, to 3,000 or 4,000 ohms. Also, the plate current should be kept down to approximately 135 or 140 ma., otherwise the tubes will be dissipating too much power, and "short life" will be the result.

Parts List—150 Watt Transmitter

- 7—.001 mf. mica cond. (1000 V.)
- 2—.01 mf. mica cond. (1000 V.)
- 2—100 mmf. mica cond. (1000 V.)
- 1—.001 mf. mica cond. (5000 V.)
- 1—150 mmf. var. cond.
- 1—100 mmf. var. cond.
- 1—100-100 mmf. var. cond.
- 1—neutralizing cond.
- 1—140 mmf. var. cond.
- 5—5prong coil forms
- 3—coil forms
- 3—plug base
- 3—plug socket
- 4—5 prong sockets
- 1—8 prong socket
- 2—4 prong sockets
- 2—2.5 mh. RF chokes
- 1—1 mh., RF choke
- 1—2000 ohm 10 watt resistor
- 1—400 ohm 10 watt resistor
- 1—50,000 ohm 20 watt resistor
- 1—4,000 ohm 20 watt resistor
- 1—10,000 ohm 20 watt resistor
- 1—400 ohm 20 watt resistor
- 1—20,000 ohm 20 watt resistor
- 1—2000 ohm 20 watt resistor
- 1—100 ohm center-tapped resistor
- 1—0-100 ma. meter (small)
- 1—0-200 ma. meter (small)
- 1—6L6
- 1—RK39
- 2—RK37
- 1—8¼ x 19 inch black crackle panel
- 1—8 x 17 x 2 inch black crackle base
- 1—crystal holder
- 1—60 ma. 2 V. pilot light
- 1—socket for pilot light
- 4—single closed circuit jacks
- 2—phone plugs (for meter and key)

Coil Data for Xmitter

- *Osc and buffer coils
- | Band | Turns | Wire |
|-------|-------|---------------|
| 80 m. | 30 | No. 18 tinned |
| 40 m. | 16 | No. 18 tinned |
| 20 m. | 7½ | No. 16 tinned |
- *Wound full length on R39 form
- * final amp.
- | Band | Turns | Wire |
|-------|-------|---------------|
| 80 m. | 40 | No. 18 tinned |
| 40 m. | 24 | No. 16 tinned |
| 20 m. | 16 | No. 16 tinned |
- *Wound full length on XR13 form

Quod Erat Demonstrandum

as the Latins used to say, means "that which has been proved," and this certainly applies to CENTRALAB. An ever-improving line of radio parts manufactured since 1922 justifies this quotation.

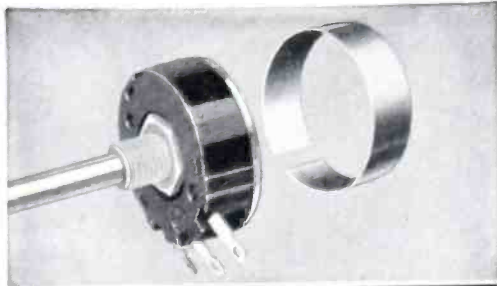

STANDARD RADIOHM

Radiohm

variable resistors for smooth, quiet control of volume, tone, sensitivity, or regeneration. Improve old equipment and insure best performance in new. Available in values from 500 ohms to 3 megohms in six different resistance tapers.

Selector Switches

in assembled or kit form for any normal selector application. Available with bakelite insulation for ordinary requirements and Isolantite insulation for best efficiency at high frequencies. All switches have adjustable stop allowing choice of two to eleven positions. Wide variety of contact arrangement provides correct switching sequence for any application.

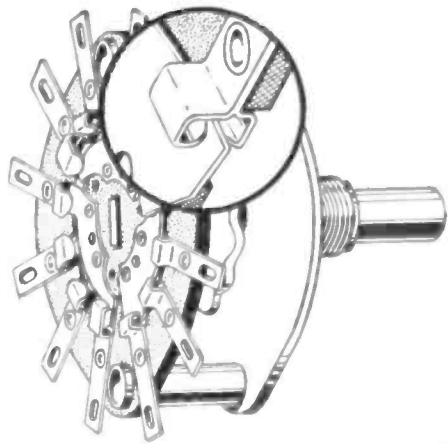

Fixed Resistors

that are "baptized by fire" at 2500° F. in the making. Available in 1½, 1 and ½ watt sizes in all values from fifty ohms to five megohms. The resistor cross section shows the jacket type construction that protects the conducting core against breakage and humidity changes. The small diameter core assures low noise level and constant value over wide ranges of frequency and voltage.

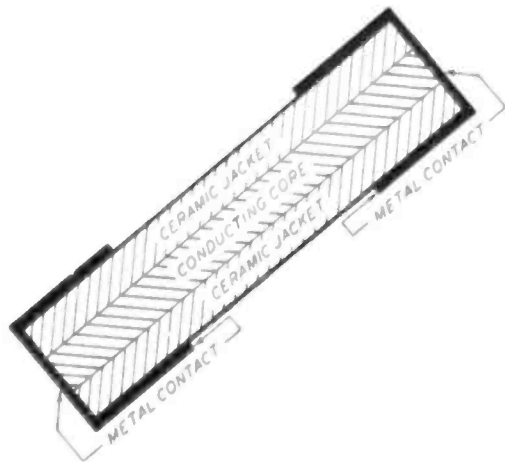

FREE: Your copy of catalog No. 1001, just off the press. Details of these and other Centralab products are included. Send for yours today.

CENTRALAB

900 EAST KEEFE AVENUE
BRITISH CENTRALAB, LTD.
Canterbury Rd., Kilburn
London, N.W.6, England

MILWAUKEE, WISCONSIN
FRENCH CENTRALAB CO.
118 Avenue Ledru-Rollin
Paris XI, France

POWER SUPPLY FOR LOW POWER TRANSMITTERS . . .

● ON the front of the power-supply panel we have two switches and a pilot light. One switch for turning the entire supply on and is connected in the 110 volt line, while the other breaks the center tap of the high-voltage winding on the transformer, allowing the B voltage to be removed for stand-by purposes during communication. The power-supply panel is of the same dimensions as most others being 7x18 inches and is fastened to a 2 inch sub-base. The power transformer is a combination filament and plate transformer. The high-voltage secondary is 625 volts either side of the center tap. There is one 5-volt, 3 ampere winding for the rectifier and two 6.3 volt windings at 3 amperes each.

In this particular unit we used a heavy-duty type 80 tube together with choke input in the filter system, in order to limit the output voltage to a value of around 425 to 450 volts.

An 83 mercury vapor tube may be used to advantage because of the higher voltage it would provide. The two filter choke coils are rated at 11 henries at 300 ma. current carrying capacity. While the transformer is only rated at 250 ma., these chokes were used because they were designed as companion units to the transformer.

For the filter condensers we used 8 mf. electrolytic condenser with a 500 volt peak rating. Two of these were connected in series in each section, resulting in 4 mf. capacity with a working voltage of well over 800, thus allowing a good "safety factor."

With the use of two filter chokes and the condenser arrangement shown in the diagram, absolutely pure D.C. is obtained at 250 mills. The output of the filter system is loaded with a 25,000 ohm, 50-watt wire-wound resistor in order to prevent voltage surges and improve regulation.

Parts List

- 1—power transformer (for rating see text)
- 2—chokes (see text)
- 4—8 mf. 500 volt electrolytic condensers
- 1—25,000, 50-watt wire-wound resistor
- 1—7x19x $\frac{1}{8}$ inch crackle finish steel panel
- 1—2x11x17 inch crackle finish chassis
- 1—26 inch standard relay cabinet, crackle finish
- 2—toggle switches
- 3—4 prong wafer sockets
- 1—type 83-V. or 1 type 80 rectifier tube

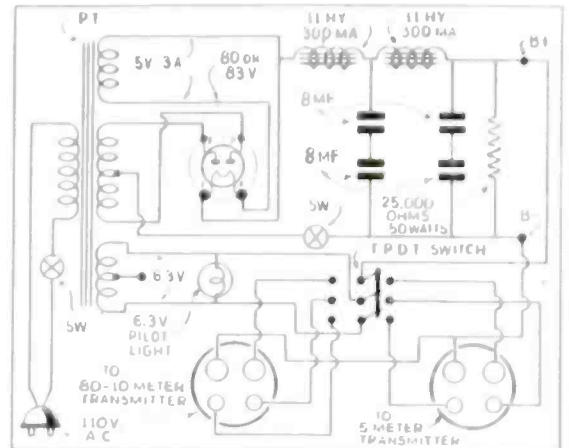
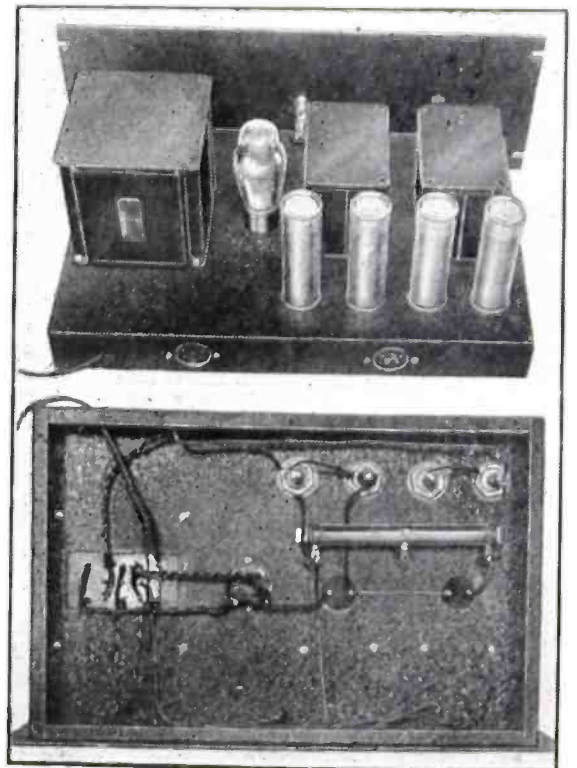
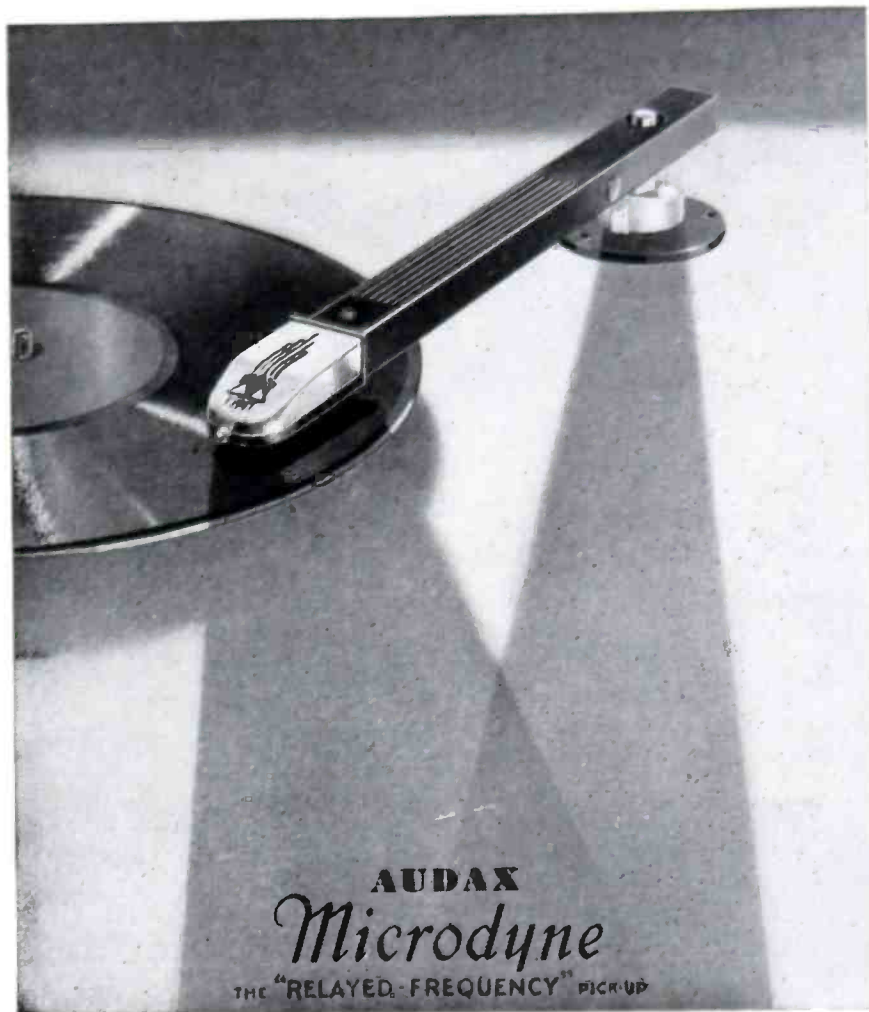

Diagram of power-supply



Top and bottom views of power unit.



"The Standard
by Which
others

Are Judged and Valued"

Every Engineer and Experimenter in any way concerned with pick-ups should choose only after strict comparison . . . and then his choice will naturally be AUDAX. As pioneers in this field and sponsors of many refinements which have become "regulation" with other good manufacturers, we offer you MICRODYNE as the greatest forward stride since the advent of pick-ups in 1926. The astonishing *facsimile* performance of this truly WIDE-RANGE system,—over the full audio range—under all climatic conditions, has won the acclaim of Sound Authorities everywhere. Recording-microphone fidelity at the pick-up! And why should you accept less!

\$7.50 to \$260.00 List A pick-up for your every need, from the humblest portable to the most exacting transcription requirement . . . and each AUDAX model delivers wider range, truer fidelity and greater stability than you can secure elsewhere at any price.

NEW PROFESSIONAL CUTTERS FOR FINE INSTANTANEOUS RECORDING.

Write for your copy of "PICK-UP FACTS"

AUDAX COMPANY

500 Fifth Avenue

New York

"Creators of High Grade Electrical and Acoustical Apparatus since 1915"

THE

“W2AMN”

5-METER

MOPA

● IT is now possible to build a well *stabilized* transmitter with fairly respectable output for as little as a good modulated oscillator of the present-day design would cost. The new 6L6 beam tube which has been featured in other transmitter articles has been found to give excellent per-

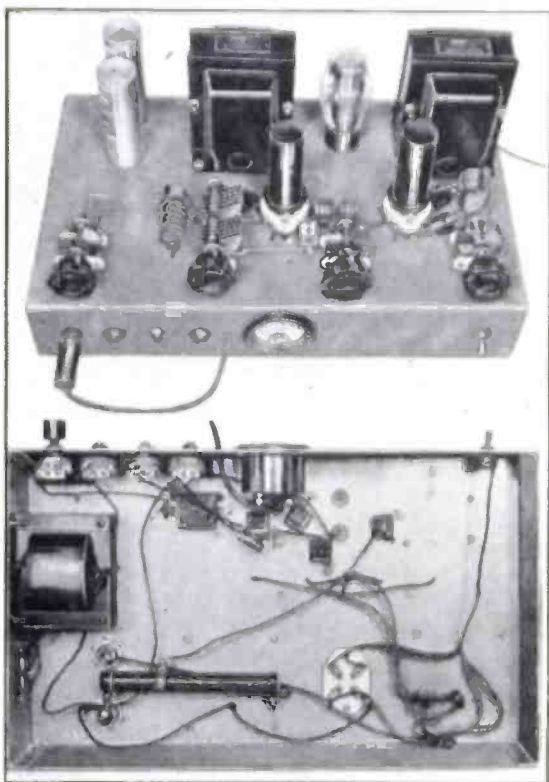

Two photos above show respectively top and bottom views of the 5-meter MOPA, utilizing two of the new 6L6 Beam tubes.

formance on the ultra-high frequencies. In the transmitter shown in the photographs, and outlined in the diagram, we use only two of these tubes—one as an electron-coupled oscillator with the grid circuit tuned to 10 meters and the plate circuit tuned

to 5. This, in turn, drives a 6L6 as a straight amplifier on 5 meters. Both tubes have the same plate voltage applied to them, and run with nearly the same input. The 5-meter output of the oscillator is more than sufficient to drive the 6L6 amplifier and permits an untuned loosely-coupled grid circuit, further isolating the two stages.

As a triode oscillator on 10 meters, the 6L6 exhibits excellent stability characteristics. The oscillator, after the tube has once been heated, does not shift frequency when it is switched on and off. The amount of creeping has been found to be less than a multi-stage transmitter using a low-frequency crystal and operating on 5 meters.

“Crystal-Stability” Reported

A regular “communications” type receiver, operating with a 5-meter converter, proved that this transmitter had no frequency modulation and even when the crystal filter was in the circuit, the thousand-cycle beat note did not vary during complete modulation. With from 400 to 425 volts on the plates of the tubes, the following voltage and current readings are recommended, when the amplifier is delivering power to an antenna 50 ma.; oscillator screen, 250-275 volts; oscillator screen current, 12 ma.; amplifier plate current, 70-80 ma.; screen voltage, 150; amplifier grid current, maximum 10 ma.—minimum 6 ma. It is important that the grid current be held between 6 and 8 milliamperes for maximum efficiency and proper modulation capabilities of the amplifier. The amplifier plate current, when not delivering power to the antenna, will drop to approximately 29 ma. As the grid current is driven higher than 6 or 8 ma. the plate current will swing lower than 20 ma., but the power output will decrease.

Detuning the amplifier circuit will show a rise in plate current up to approximately

WOW!

THAT MUST BE A



UTAH

TRANSMITTER

IT'S EASY TO
OWN A
POWERFUL
MODERN
TRANSMITTER

*if you build
it from the*

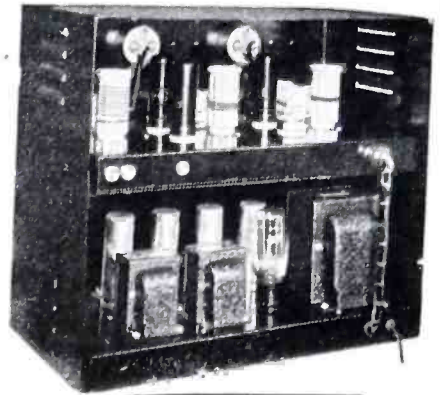

UTAH ADD-A-UNIT TRANSMITTER KIT

ONLY
\$49.75
Less tubes,
meters, crystal

Here's a rig that really packs a wallop! It has twice the power of other similar transmitters—yet costs a third less. It's fun building it yourself. All parts cut and punched to fit. Sensational new circuit. Every part proved and tested by UTAH, so you KNOW it's right. You'll always be glad you started

with this professionally styled transmitter. Later on you can plug in additional UTAH kits and have a complete 400 watt Phone Transmitter! Start *now* and start *right* with this UTAH kit. See your UTAH dealer or write direct to us—TODAY! Address department CB.

- 80 watts input
- Completely self-contained
- 10-20-40-80-160 meter bands
- Sensational new circuit
- Additional units plug in
- Uses standard tubes
- Simply-easily constructed
- Lowest prices

UTAH RADIO PRODUCTS COMPANY
 TORONTO ONTARIO, CANADA CHICAGO, U. S. A. BUENOS AIRES (UCOA RADIO PRODUCTS CO.)
 16 YEARS OF LEADERSHIP

Be a RADIO EXPERT

THE ONE MAN IN 1000 WHO CAN SERVICE MODERN RADIO RECEIVERS

RADIO SERVICE WORK NOW OFFERS GREATEST OPPORTUNITIES SINCE RADIO BEGAN.....

Radical changes have taken place in radio receiver design during the past year. Circuits and construction are very different from the receivers with which the radio receivers with which the radio service industry has had its greatest experience. Even more sensational developments with further complications are coming next season. Who will service these receivers? Certainly not the "old timer" who knows nothing about modern receivers! He can't do it. That is why, right now, there is an urgent demand for reliable service men with up-to-the-minute knowledge of modern radio receivers. Such men can step out and earn up to \$3 an hour doing nothing but pleasant service work in the better homes around town.



Important and far-reaching developments in Radio create sudden demand for specially equipped and specially trained Radio Service Men.



THIS CIRCUIT ANALYZER AND POINT-TO-POINT RESISTANCE TESTER INCLUDED FREE OF EXTRA CHARGE.

Also FOUR LARGE KITS OF HOME PRACTICE EQUIPMENT.....

No Past Experience Needed

Past experience actually counts for little at this time, because the swift changes in receiver construction have made knowledge of old equipment practically useless. Even though you may not know one tube from another today... still, you can take R.T.A. training and make more money servicing modern radios than many of the "old timers" are making. R.T.A. graduates are doing it every day. Many of them are making more money as R.T.A. Certified Radio Technicians than they ever made in their lives before!

Be An R.T.A. Man and You'll Be the One Man in 1000

R.T.A. training will equip you to give fast, complete service to any radio receiver built. The jobs that puzzle and sometimes baffle the usual service man will be simple as "A,B,C." to you... when you become an R.T.A. Certified Radio Technician. It is very possible that you will be the only service man in your locality able to quickly diagnose and quickly repair the new types of radio receivers. Be the one man in 1000! YOU CAN!

Radio Training Association of America
4525 Ravenswood Avenue
CHICAGO, ILLINOIS

IT'S JUST AS SIMPLE AS THIS



R.T.A. Membership Valuable

With your course of training, and as long afterward as you may need help, you always have available, without extra cost, valuable consultation service on any problem that may arise in your radio service work or on any of the newer developments that may appear in new radio receivers from time to time.

To Help You Make Money Quickly

R.T.A. supplies you with an excellent and reliable Circuit Tester and Point-to-Point Resistance Checker as is illustrated above—one of the handiest pieces of portable service equipment. It quickly helps you locate trouble in any type of radio receiver, old or new.

SEND COUPON

A. G. MOHAUPT, Engineer
Radio Training Ass'n. of America
Dept. RAC-38, 4525 Ravenswood Ave., Chicago, Ill.
Dear Mr. Mohaupt: Please send me your free book of facts about radio opportunities and how I can make big money quickly. Also tell me how I can obtain your Circuit Analyzer and four big experimental outfits.
Name _____
Address _____
City _____ State _____

was clipped directly to the plate coil about three turns from the plate side. With this arrangement no coupling coil is necessary. The audio requirement for this transmitter is exceptionally modest. 15 to 18 watts should do very nicely and this is obtainable from a pair of 6L6's or a pair of 2A5's in class A-B.

This transmitter has been in operation for about 2½ months, and every one hearing it, without exception, has expressed the most flattering compliments regarding the *high quality* and *stability* of the signal. Several of these amateurs were using receivers with a selectivity which permitted only the most stable signals to come through. It is now possible to construct a *low-cost stabilized* 5-meter transmitter that can be compared in quality with any other transmitter of amateur design operating on any band. This may seem like a "broad

statement," but it is absolutely true, and we know that if the 5-meter "gang" take heed and construct something of this type, the results will be a much happier 5-meter family, and we will then command the respect of amateurs on the other bands as well as broadcast listeners who are also listening in on the 5 meter band.

Parts List

- 1—100 mmf. tuning condenser
- 1—20 mmf. tuning condenser
- 1—split-stator condenser, 35 mmf. per section
- 1—35 mmf. tuning condenser
- 1—plate and filament transformer (see text)
- 1—250 ma., 19 henry filter choke
- 1—0-100 ma. meter
- 1—20,000 ohm wire wound resistor, 15 watts
- 1—75,000 ohm resistor, 2-watt carbon type
- 6—.001 mf. mica condensers, receiving type, Aerovox
- 1—.001 mf. mica condenser, 1,000-volt Aerovox
- 1—.00025 mf. mica condenser, receiving type
- 2—8 prong isolantite sockets
- 1—10 x 17 x 3 inches electrical alloy chassis
- 2—8 mf. 500-volt wet electrolytic condensers
- 2—6L6 tubes

A FOLDED DOUBLET FOR TRANSMITTING

- THE antenna shown herewith is in use at the writer's station. I thought that it might be of interest to amateurs who desire the directive advantages of an "array" without having the required space. To the best of my knowledge this antenna has not been described in any publication.

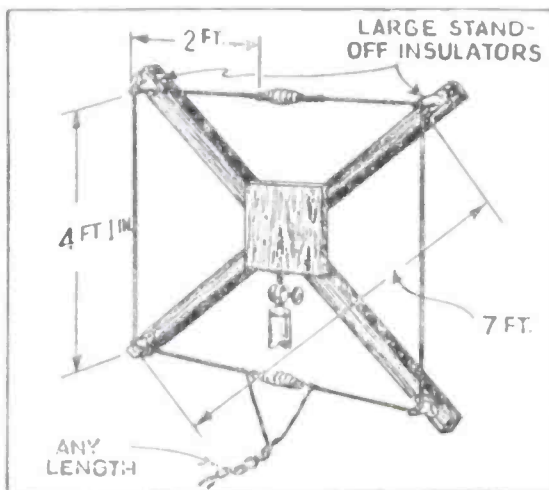

Folded Doublet which has shown fine results.

It is suitable for either 5, 10 or 20 meter operation and even on 20 meters takes up a space only eight feet square.

At this station it is being used for 10 meter operation, and, at present, is installed inside in the attic. The first experiments were highly gratifying as a matter of fact

the first contact made with this antenna was K6MVV in Hawaii, a distance of about 5,000 miles!

At the time this contact was made the antenna was directed broadside W.S.W. We received a report of QSA, R6-7 on this contact with 60 watts input. We next swung the antenna south and worked K4EPO receiving an R8 report in Porto Rico. Tests were made with several other outdoor antennas, namely a half-way vertical and three half-waves horizontal. In all cases and in every direction this simple *loop antenna* provided as good or better reports than could be obtained with any outdoor antenna.

We also tried it for *reception* on 10 meters and found that in many cases an R6 signal could be brought up to R8 by swinging the antenna *broadside* to the incoming signal.

The constructional details are simple; cut a doublet to a half-wave on the desired frequency and bend it back against itself as shown in the diagram. For example, on 10 meters each leg is 8 ft. 3 inches long. The feeders used at this station consist of a length of RCA cable that was originally used for a doublet receiving antenna. I believe that the diagram will be easily understood.

Harold B. Rhodes, W2IKW.

THIRD
EDITION

HAMANUAL

AMATEURS'
TRANSMITTER
CIRCUITS



READY OCTOBER 1ST

GET YOUR COPY FROM YOUR JOBBER

Brand new... from cover to cover! New tubes, new circuits. Full data on the STANCOR LINE, now the most complete line available. 16 NEW TRANSMITTERS with a complete power range from 5 watts to 1 KW. . . . Ask your jobber for your copy. If he cannot supply you, just drop us a post card. We'll send it direct.

STANDARD TRANSFORMER CORPORATION

850 BLACKHAWK STREET CHICAGO

A METAL TUBE

U. H. F. SUPERHET

● MANY of our readers are familiar with the now quite popular resistance-coupled, ultra-high frequency superheterodyne. Many questions have been asked about this type of receiver and among the most prominent, was whether or not *metal* tubes could be used to an advantage. The writer constructed the receiver shown in the photograph for the express purpose of trying out these tubes and comparing it with other receivers. We endeavored to keep this set as simple as possible, not including some of the fancier frills which may be added to almost any receiver.

There is apparently one distinct advantage in the use of *metal* tubes, and that is in the thorough shielding. It is possible, due to their small size and the fact that they require no shields, to make the set very compact and still not crowded to the point where operating efficiency would be sacrificed. Conventional metal tubes were used in the I.F. and A.F. portions. We mention this because in the detector we used one of the newer type which have an Isolantite insulated grid connection; this will be discussed later.

Simplicity and Low Cost

The outstanding advantage of a receiver of this type, of course, is in the simplicity of its construction and its relatively low cost. One building it is almost sure to obtain excellent results, if the few hints given in this article are followed. One need not worry about the delicate task of aligning I. F. transformers or similar adjustments.

The principle of the receiver is one of the oldest; in fact, this was one of the first types of superheterodyne receivers used. The oscillating first detector works on the autodyne principle, with a very low frequency I.F. amplifier, which has a relatively wide band width. The range of the I.F. am-

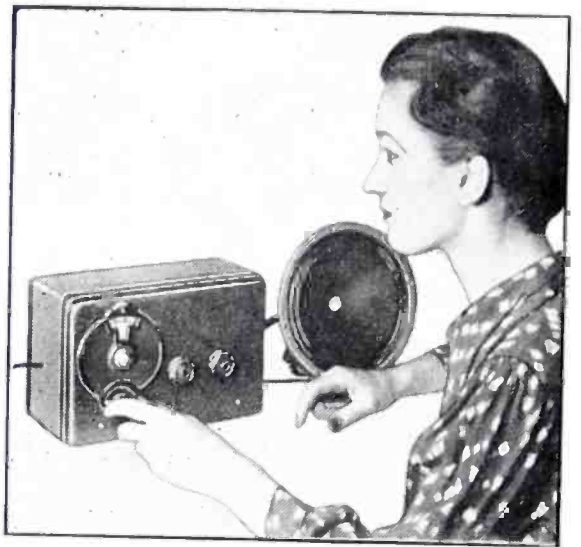

The 5-meter superhet pulling in "Ham" phone stations.

plifier, in the neighborhood of 10 to 100 kc., means that the first detector may be tuned anywhere between 10 and 100 kc. either side of the signal frequency and still permit reception. Or, looking at it from the other side, the incoming signal may swing from 10 to 100 kc. and still come through the I.F. amplifier with relatively good quality. This feature is what has made it exceptionally valuable in the ultra high frequency amateur bands, where modulated oscillators are employed in the transmitters.

Television Reception Possible

A receiver of this type may also serve as a forerunner for any one who is desirous of experimenting with *television reception* now that we have at least two stations in the *ultra-high frequency* region broadcasting television signals. RCA Empire State Transmitter (in New York City) and Don Lee Station in Los Angeles.

Getting back to the *first detector*, we find that when it is tuned approximately to the

CROWE

COMPONENTS FOR AMATEUR EQUIPMENT

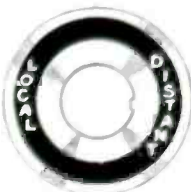

No. 30 "Local-Distant" toggle switch plate.



No. 389 Large Airplane Dial. Two-speed planetary drive.



No. 562 "Send-Rec.-Stand By" 3-point switch plate.



No. 542-A "Chang-O-Name" Dial Plate.



No. 525 "Front-O-Panel" Airplane Dial.



No. 283 Black Bakelite Skirt Knob.



No. 132 Fan-Style Wedge Drive Tuning Unit.



No. 277 "Tone" Dial Plate.

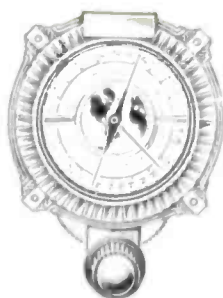

No. 316 Micrometer Band-Spread Unit.



Nos. 587 and 588 New-Style Bar Knobs. Made of black Bakelite. Fit any $\frac{1}{4}$ " shaft.



No. 278 "Off-On" switch plate. Etched Aluminum and black.



No. 564 "1-2-3" switch plate. Etched aluminum and black.

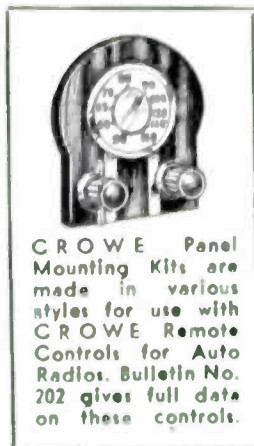

CROWE Panel Mounting Kits are made in various styles for use with CROWE Remote Controls for Auto Radios. Bulletin No. 202 gives full data on these controls.

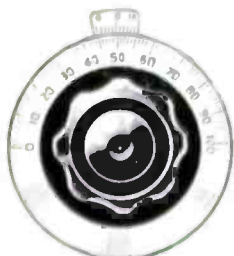

No. 296 Plan-O-Vernier Reduced Speed Dial with Micrometer Marker.

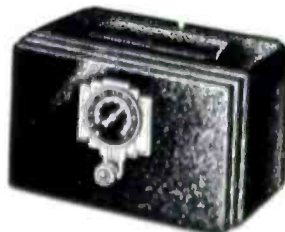

No. 245 Steel Cabinet with black crystalline finish, for receivers, transceivers, pre-selectors, monitors, frequency meters, test equipment, etc.

CROWE manufactures a complete line of components for amateur equipment—Tuning Units, Instrument Dials, Dial and Switch Plates, Knobs, Instrument Controls, and miscellaneous items—for constructing and equipping Receivers, Transmitters, Sound Equipment and for doing Experimental Work.

Representative of the Crowe line for supplying amateurs with their requirements are the items pictured on this page—yet these are only a few of the many quality products Crowe regularly supplies to amateurs the world over.

Ask for Bulletin No. 75

CROWE NAME PLATE & MFG. CO.
1777 GRACE STREET CHICAGO, ILL., U.S.A.

The original receiver, using glass tubes, required higher screen voltage and permitted by-pass condensers at points marked "C" in the diagram. However, when the metal tubes were installed, best results were obtained with $\frac{1}{4}$ meg. resistance in the screen leads and no by-pass condensers. Experiments showed that .001 mf. condensers in position "C" increased the overall volume of the signal, but with it the tube noises also; thus the net result was just about the same as without the condensers.

However, different constructional layouts might prove to demand changes in this



Rear View, showing general construction.

part of the circuit, and we recommend that the builder try condensers up to .1 mf. for *by-passing* screen leads.

The receiver is housed in a $5 \times 9 \frac{1}{2} \times 6$ inch metal cabinet and the chassis is $9 \times 4 \times 1 \frac{1}{2}$. The photos show top and bottom views and indicate how the parts are placed.

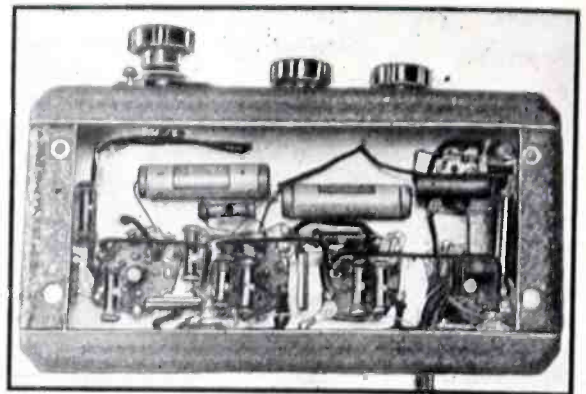

Note the neat wiring and placement of resistors.

Antenna

Best results were obtained with the antenna connected directly on to the grid coil, at about $\frac{1}{2}$ turn from the B negative end. No *dead-spots* were noticed with this rather loose coupling, but should they occur with other types of antennas, it is suggested that a 35 mmf. condenser be connected in series with the antenna.

Parts List

- 1—20 mmf. midget condenser (one plate removed)
- 4—.0001 mf. mica condensers
- 3—5 mf. electrolytic condensers
- 2—.01 mf. condensers
- 2—1 mf. condensers
- 7— $\frac{1}{4}$ meg. $\frac{1}{2}$ watt resistors
- 1—2 meg., $\frac{1}{2}$ watt resistor
- 3—50,000 ohm, $\frac{1}{2}$ watt resistors
- 2—400 ohm resistors
- 1—50,000 ohm potentiometer
- 1—500,000 ohm potentiometer
- 1—vernier dial
- 5—laminated oetal sockets
- 1 set of tubes, see diagram and text

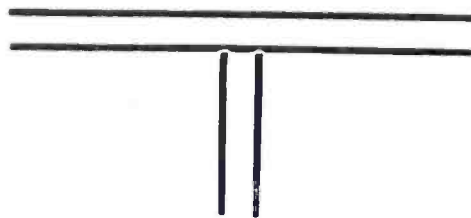

NOW! *The World's Champion* *Telegrapher* -- T. R. McELROY

Offers *YOU* His *Radio Key!*

*For Speedy,
Tireless,*

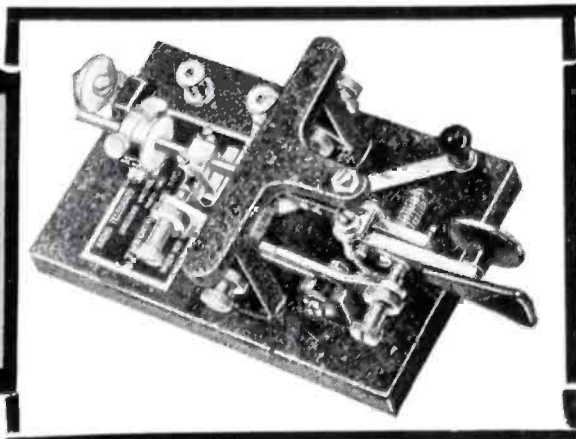

*Rhythmic,
Sending*

NEW 1938 De Luxe Model MAC KEY



T. R. McELROY — The Fastest Radio Operator of all time! His official receiving speed is 69 words per minute. Realizing perhaps more than anyone else the limitations of commercial telegraph keys, McElroy worked for many years on perfecting this important instrument. To McElroy's credit, he refused to market a key until it not only excelled any other, but until it satisfied his own delicate sense of balance and "feel." Every MAC item is designed, built, tested and approved by Champion McElroy himself. Every MAC item is an exclusive opportunity for both the beginner or advanced operator to improve his code technique and efficiency.

Here is the most amazing value in telegraph history. A semi-automatic key so beautifully balanced and designed, that speedy, tireless, rhythmic sending is now easy for any operator. Has a remarkable new dot stabilizer—a specially tensioned Swedish steel main spring—a solid base that really "stays put"—big silver contacts—large adjustment screws—in every detail this key is the finest ever produced! You must see it—at your jobbers. In no time at all you'll be sending out the kind of stuff they love to listen to. Only \$9.50—but don't wait. Get yours now! Also Standard Model. Same construction but with less costly finish, \$7.50.

IF YOU WANT A STRAIGHT KEY—just remember this. ". . . the New 1938 Mac Straight Key is the sweetest ever built." It's beautifully balanced, sturdy, and designed to save your energy and your arm. Priced so that every amateur can have one. Only \$1.50 at your jobber's.

EVERY AMBITIOUS AMATEUR should have a **MAC HUMMER**. This mechanical oscillator gives wonderful performance—yet sells for only \$1.50 to operators. With just a 4½ volt C battery, you can get a 1000 cycle note as clear as a bell.

FOR A REAL PRACTICE SET—be sure you say "MAC" to your jobber. He'll give you the sweetest outfit ever made for this purpose. It's a combination of the New MAC HUMMER and the New MAC STRAIGHT KEY—all on one sturdy base. "It's a honey." And the price? Only \$2.95!

MAC-AUTO—World's finest electrical automatic transmitter—only \$69.

T. R. McELROY

WORLD'S CHAMPION TELEGRAPHER

175 Congress Street,
BOSTON, MASS.

The original receiver, using glass tubes, required higher screen voltage and permitted by-pass condensers at points marked "C" in the diagram. However, when the metal tubes were installed, best results were obtained with $\frac{1}{4}$ meg. resistance in the screen leads and no by-pass condensers. Experiments showed that .001 mf. condensers in position "C" increased the overall volume of the signal, but with it the tube noises also; thus the net result was just about the same as without the condensers.

However, different constructional layouts might prove to demand changes in this



Rear View, showing general construction.

part of the circuit, and we recommend that the builder try condensers up to .1 mf. for *by-passing* screen leads.

The receiver is housed in a $5 \times 9\frac{1}{2} \times 6$ inch metal cabinet and the chassis is $9 \times 4 \times 1\frac{1}{2}$. The photos show top and bottom views and indicate how the parts are placed.

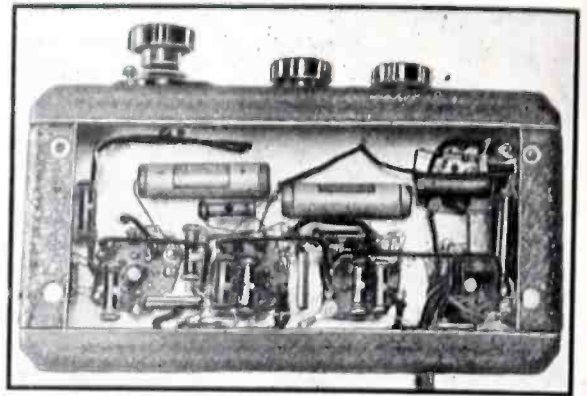

Note the neat wiring and placement of resistors.

Antenna

Best results were obtained with the antenna connected directly on to the grid coil, at about $\frac{1}{2}$ turn from the B negative end. No *dead-spots* were noticed with this rather loose coupling, but should they occur with other types of antennas, it is suggested that a 35 mmf. condenser be connected in series with the antenna.

Parts List

- 1—20 mmf. midget condenser (one plate removed)
- 4—.0001 mf. mica condensers
- 3—5 mf. electrolytic condensers
- 2—.01 mf. condensers
- 2—1 mf. condensers
- 7— $\frac{1}{4}$ meg. $\frac{1}{2}$ watt resistors
- 1—2 meg., $\frac{1}{2}$ watt resistor
- 3—50,000 ohm, $\frac{1}{2}$ watt resistors
- 2—400 ohm resistors
- 1—50,000 ohm potentiometer
- 1—500,000 ohm potentiometer
- 1—vernier dial
- 5—laminated oetal sockets
- 1 set of tubes, see diagram and text



NOW! *The World's Champion* *Telegrapher* -- T. R. McELROY

Offers YOU His Radio Key!

*for Speedy,
Tireless,*

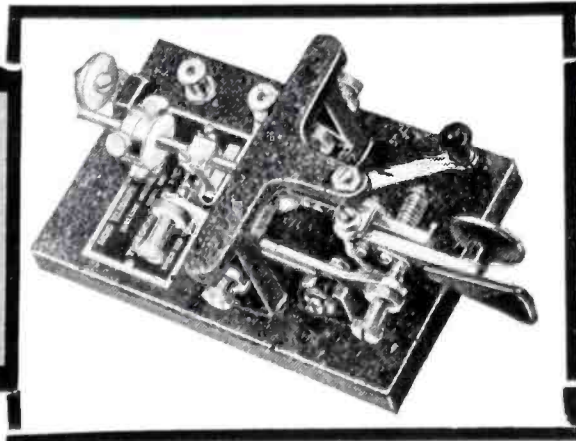

*Rhythmic,
Sending*

NEW 1938 De Luxe Model MAC KEY



T. R. McELROY — The Fastest Radio Operator of all time! His official receiving speed is 69 words per minute. Realizing perhaps more than anyone else the limitations of commercial telegraph keys, McElroy worked for many years on perfecting this important instrument. To McElroy's credit, he refused to market a key until it not only excelled any other, but until it satisfied his own delicate sense of balance and "feel." Every MAC item is designed, built, tested and approved by Champion McElroy himself. Every MAC item is an exclusive opportunity for both the beginner or advanced operator to improve his code technique and efficiency.

Here is the most amazing value in telegraph history. A semi-automatic key so beautifully balanced and designed, that speedy, tireless, rhythmic sending is now easy for any operator. Has a remarkable new dot stabilizer—a specially tensioned Swedish steel main spring—a solid base that really "stays put"—big silver contacts—large adjustment screws—in every detail this key is the finest ever produced! You must see it—at your jobbers. In no time at all you'll be sending out the kind of stuff they love to listen to. Only \$9.50—but don't wait. Get yours now! Also Standard Model. Same construction but with less costly finish, \$7.50.

IF YOU WANT A STRAIGHT KEY—just remember this. ". . . the New 1938 Mac Straight Key is the sweetest ever built." It's beautifully balanced, sturdy, and designed to save your energy and your arm. Priced so that every amateur can have one. Only \$1.50 at your jobber's.

EVERY AMBITIOUS AMATEUR should have a **MAC HUMMER**. This mechanical oscillator gives wonderful performance—yet sells for only \$1.50 to operators. With just a 4½ volt C battery, you can get a 1000 cycle note as clear as a bell.

FOR A REAL PRACTICE SET—be sure you say "MAC" to your jobber. He'll give you the sweetest outfit every made for this purpose. It's a combination of the New **MAC HUMMER** and the New **MAC STRAIGHT KEY**—all on one sturdy base. "It's a honey." And the price? Only \$2.95!

MAC-AUTO—World's finest electrical automatic transmitter—only \$69.

T. R. McELROY

WORLD'S CHAMPION TELEGRAPHER

175 Congress Street,
BOSTON, MASS.

THE "S. W. & T."

COMMUNICATIONS

RECEIVER

• • •

● For really high efficiency we do not believe it is possible for the home constructor to build a coil-switching arrangement which can compare with efficient plug-in coils; therefore, the best compromise is plug-in coils made to plug-in through the front panel, the same as the National-FB-7. In fact, ready-made FB7 coils were employed.

Complete data is given should the reader desire to try his hand at constructing them.

Regen. "Acorn" Detector Stage Solves Many Problems

The next problem how much R.F. to use ahead of the first detector. In order to de-

radio frequency. However, regeneration usually brings about considerable noise. Having recalled the low noise-level of receivers employing acorn tubes, we decided to try a regenerative 954 acorn detector and eliminate all R.F. stages. This yielded remarkable results, the image rejection was as good, if not better than would have been obtained with conventional tubes and one stage of R.F., and the sensitivity was even better. Also the noise generated in the regenerative first detector was practically nil! Using this arrangement eliminated an extra tuning condenser and eliminated one plug-in coil, which is quite a saving inasmuch as the results are as good, if not much superior.

How Good AVC Action was Provided

Next was the problem of I.F. amplification and a method of attaining automatic volume control; immediately we decided that iron core I.F. transformers should be used, and it had been demonstrated long ago that one stage of I.F. was not entirely satisfactory, although very good results can be obtained with that arrangement, so two stages of amplification was decided upon. Efficient AVC meant incorporating at least another tube to get satisfactory results following conventional arrangements. This difficulty was overcome by employing 6L7's in the I.F. stages with grids No. 1 and No. 3 connected in parallel insofar as AVC action is concerned, thus permitting very sharp cut-off, and the voltage developed in the diode second detector proved to be more than sufficient for excellent AVC action. In fact, we have yet to see a set using conventional AVC methods which worked any more satisfactorily than this one. As a means of checking signal strength and aiding tuning we employed a 0 to 5 ma. meter in the plate circuit of the first I.F. tube.

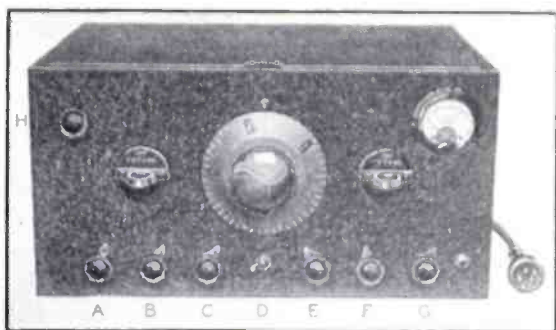

Front view of the receiver, the controls are as follows: A—first detector regeneration, B—Detector trimmer, C—R.F. gain and AVC switch, D—Beat oscillator switch, E—Noise silencer, F—A.F. volume control, G—Tone control, H—Crystal band-width control. The jack in the extreme right-hand corner is for earphone operation.

termine this, considerable experimental work had to be done. We found that to do the job right, two stages of R.F. should be used. One stage would still permit a noticeable amount of image to get through. Then, also, we were sure that regeneration in the first detector would provide at least as much gain as would one stage of tuned

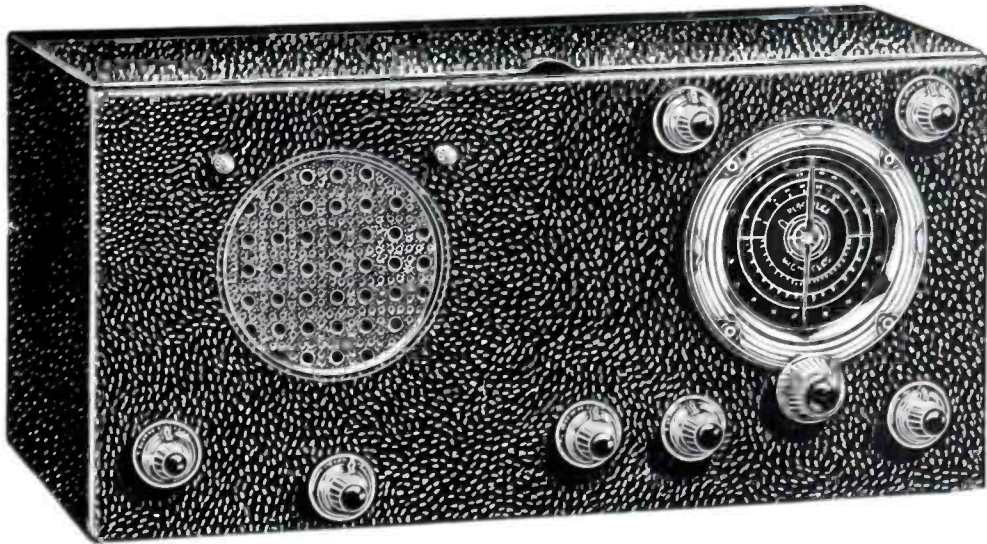

Model D-6 Six-Tube Amateur communications Receiver covers all Ham bands—5-10-20-40-80-160 meters. uses either glass or metal tubes, 6K7G tuned RF, 6K7G tuned electron coupled detector, 6C5G first driver audio stage, 6L6G beam-power audio output amplifier and 6J5G 5 meter detector. Covers 5 to 3000 meters. Amateur model is supplied with special bandspread coils covering only the 20, 40, 80, 160 meter bands plus coils for the regular broadcast band. If general coverage coils covering from 12 to 200 meters are desired they are available at \$2.00 additional.

Complete, ready to use..... **\$25.00**

In Kit form, less tubes and unwired **\$18.50**



HG-35 TRANSMITTER

Powerful and efficient transmitter available for 59 TRI-TET crystal oscillator, 2-46's as a final amplifier of 89 crystal oscillator and 2-6L6G type tubes as a final amplifier.

RG-35 Kit, including all parts, coils for any band, diagram, and simple instructions (completely assembled and ready to wire) **\$21.95**
 Matched Arcturus tubes, 59, 46, 46 **1.95**
 89, 6L6G, 6L6G **3.25**
 Crystals (80-160 meter band) **1.95**
 (40 meter band) **2.75**
 Crystal holder **1.00**
 Coils for additional bands per set..... **1.45**

FREE: New 1937 catalogue

of short wave receivers, transmitters, and 5 meter apparatus. Send stamp to cover mailing costs on YOUR copy.

JUST OFF THE PRESS*

7C 5-Tube

Short Wave Receiver

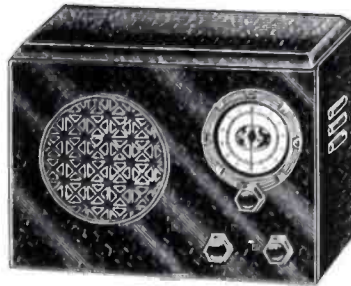

Bigger and More Powerful Than Ever A Giant in Performance

FULL 6 TUBE PERFORMANCE plus **THE NEW K92A SERIES TUBE** makes this an outstanding value. Equipped with a powerful 3 stage audio frequency amplifier.

Uses 6K7G-6F7 (twin 2 in 1 tube)—6C5—K92A-12A7 (twin tube) tubes as RF amplifier, screen grid regenerative detector, powerful 3 stage audio amplifier with pentode output stage, rectifier and complete built-in power supply. Operates entirely from 105 to 130 volt AC or DC light socket.

BAND SPREAD TUNING—smooth regeneration control—built-in high quality loudspeaker—automatic headphone jack—large, illuminated airplane type vernier dial—large 3 electron coupled low-loss inductances. Heavy, black shrivel finish metal chassis and cabinet. Must be seen to be appreciated. Satisfied owners report as high as 35 foreign countries on the loudspeaker with this model. You may do the same under fair conditions. Order **YOURS TODAY! YOU WILL NOT REGRET IT!**

Complete, ready to use, with coils from 9 1/4 to 600 meters **\$15.00**

In kit form, less tubes and unwired, but factory assembled..... **\$10.95**

OSCAR B. KUSTERMAN

**68 BARCLAY ST.
NEW YORK CITY**

Dept. H

The second detector is a 6H6 duo-diode, one section being used for rectification, and the other as a noise-limiter in an effort to reduce ignition interference.

Beat Oscillator—Improved Type

In order to keep the number of tubes down, a twin triode was employed in the first stage of audio amplification, one section is used as an audio amplifier, while the other section is the beat-oscillator. This eliminates the necessity for a beat oscillator tuning control on the front panel; and in the two months during which this receiver has been operating, the beat oscillator adjustment has never been changed; merely set it for the most pleasing tone and forget about it.

The audio amplifier is a conventional 6F6 pentode with a phone jack between the two stages for earphone operation.

Trans-filter Affords Single-Signal Reception

In order to take care of the selectivity problem we employed the new Brush Trans-filter, this permitted excellent selectivity in the phone bands and practical *single-signal* reception on C.W. There is a *control* in the crystal circuit to change the *bandwidth*. However, it is left in the maximum selectivity position because even at this point it is not too selective for fair tone quality on phone signals. For *band-spread* tuning, of course, in a good receiver there is only one solution and that is the use of the National micrometer dial. This is really an excellent device and makes operating a real pleasure. Employing FB-7 *band-spread* coils, the amount of spread obtained with this combination can be gauged by the fact that the 80 meter CW band covers from 135 to 315 on the dial, while the 80 meter phone band takes in that portion between 315 and 390, the entire 40 meter band is spread from 250 to 420, and the 20 meter phone band, as well as the 20 meter CW portion, is also spread out in a similar fashion; one division is approximately $\frac{1}{4}$ inch.

Regeneration

In order to obtain regeneration in the first detector circuit, a small winding must be added to the FB-7 detector coils. If care is exercised in taking the padder out of the coil, the job is really easy and can be done in short order. Merely place a hot soldering iron against the two prongs to be easily removed. This small cathode coil which this padder is connected and it can be wound just below the "B" minus end of the *grid* coil. In some coils there is space enough on the large portion of the form

and on others this regeneration coil will have to be wound in the narrow slot at the bottom of the form. Complete data as to the number of turns is contained in the coil table. This coil should be wound in the direction opposite to that of the grid coil. Fortunately, there was a prong in the FB-7 detector coil, only five prongs were originally used. The blank prong is used for the cathode terminal, the other end of the coil is soldered into the prong used for the "B" negative side of the *grid* coil. An additional hole has to be drilled in the back of the mounting shields, that is, the shield can which supports the coil socket, in order to bring out the cathode lead. There already are five holes in the can corresponding to the five prongs used for the coil.

Naturally, with the extreme selectivity obtained at the regenerative detector stage, a panel trimmer will be needed. This condenser should have a maximum capacity of from 10 to 15 mmf. The lower the capacity used, the better because its adjustment is really critical. A change of two or three degrees will nearly eliminate an R-7 signal. This condenser will require a slight re-adjustment when changing from one end of a given band to the other; however, the circuits "track" excellently, and once an optimum setting is found, it need not be touched unless an extremely weak signal

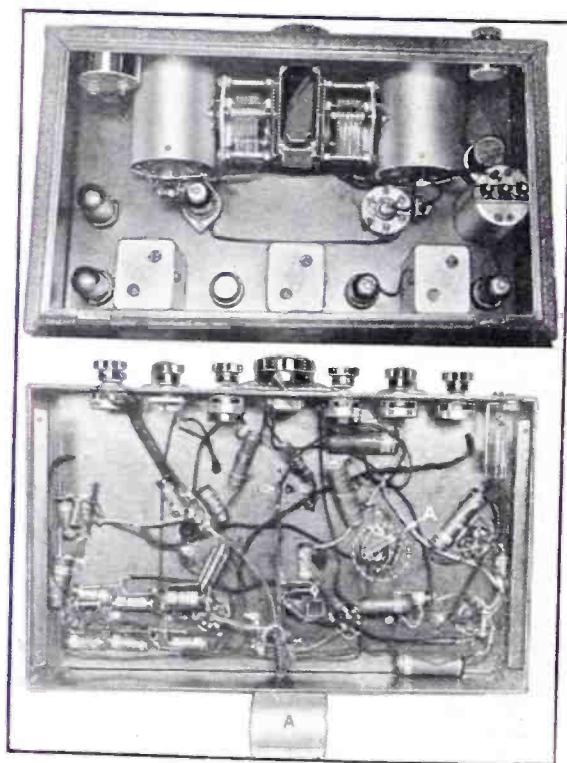

Top and bottom view of receiver showing construction and layout.

ELGIN "AIR ROAMER" III

3-Tube Receiver

Features:

- * A.C. D.C. operation
- * Dynamic Speaker
- * Airplane Tuning Dial
- * Vernier Regeneration Control Kit or Wired Models

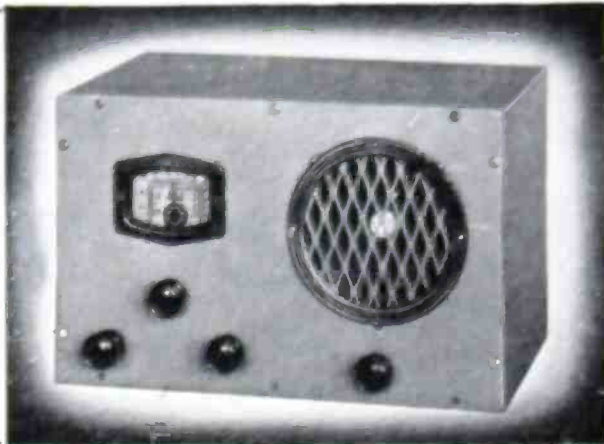

Features:

- * Headphone Jack
- * World Wide Reception
- * Neat Professional Appearance

Completely outclasses any receiver of similar design. Its ability to reach out and pull in signals from all parts of the world has gained it an enviable reputation. Although it was only designed a short time ago it has already caught the fancy of technical and non-technical radiomen as being an outstanding unit. Plug-in coils, the most efficient tuning system in receivers of this design, are employed. Any band from 9 1/2 to 2000 meters may be covered by merely changing the coil. A novel arrangement permits insertion of coils without turning receiver about. Four tube performance is obtained from the three employed, 1-6F7 combination detector and first audio

feeds into a 43 power amplifier. A 25Z5 is used for rectification purposes. The 5" dynamic capably handles the full output.

Elgin Air Roamer three Kit of Parts, with coils tuning from 15 to 550 meters, less tubes, cabinets and extra coils, unwired.

Your Cost	\$8.12
Wiring and testing	1.50
Metal cabinet	1.25
Set of 3 matched tubes	2.08
9 1/2-15 meter coil	.29
200-500 meter coil	.29
550 to 2000 meter coils	.89

ELGIN "AIR ROAMER" IV

4-Tube Receiver



A popular model that persists in being the amateurs' favorite receiver. It has proven itself time and time again to thousands of users.

Requires no plug-in coils. A band switching arrangement permits you to select any band from 15 to 550 meters by a mere twist of the wrist. Band spread tuning of any of the amateur bands enables separation of signals on the overcrowded 20-40-60-80 and 160 meter bands. Four tubes are employed. They include, 2-6J7's, 1-43 and 1-25Z5. The circuit itself has been refined to provide maximum sensitivity and selectivity. It has been designed so that satisfactory selectivity, on the broadcast band, heretofore unobtainable in receivers of this type, is provided.

Available in wired or knocked down form. The kit includes all necessary parts for construction. Base and panel are drilled and punched to eliminate many tedious hours of unnecessary labor.

Complete kit of parts, less tubes, cabinet, unwired.

Amateurs price	\$10.50
Wiring and testing	2.25
Metal crystal finished cabinet	2.25
Set of 4 Matched tubes	2.75

ELGIN "BUDDY TWO"

2-Tube Receiver

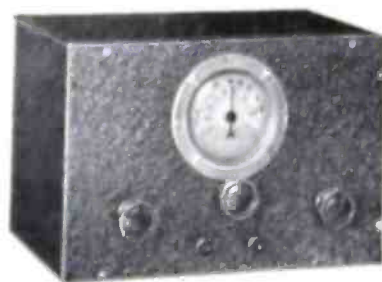

A favorite with beginners and established "hams" alike. Its simple and yet very effective circuit has earned it an enviable reputation. Ideally suited for headphone reception.

Makes use of two high efficiency tubes to provide maximum power output. Although designed to operate with headphones, locals may be heard on loud-speaker. This is primarily due to the use of the 12A7 tube which serves the purpose of a pentode output and combined rectifier. .7 watts output is obtainable. A 6J7 precedes the 12A7 and provides maximum amplification to the power tube. Furnished with four coils to tune from 15 to 200 meters. Additional coils to tune from 9 1/2-15 and 200 to 3000 meters are available.

Complete kit of parts, less tubes, cabinet, extra coils, unwired.

Amateur Price	\$4.95
Set of 2 matched tubes	1.75
Metal crystal cabinet	.95
Wiring and testing	1.25
9 1/2 to 15 meter coil	.29
200 to 550 meter coil	.29
550 to 2000 meter coils	.89

TRY-MO RADIO CO., INC.

85A CORTLANDT ST.

Send For New 1938 Catalog

N. Y. C., N. Y.

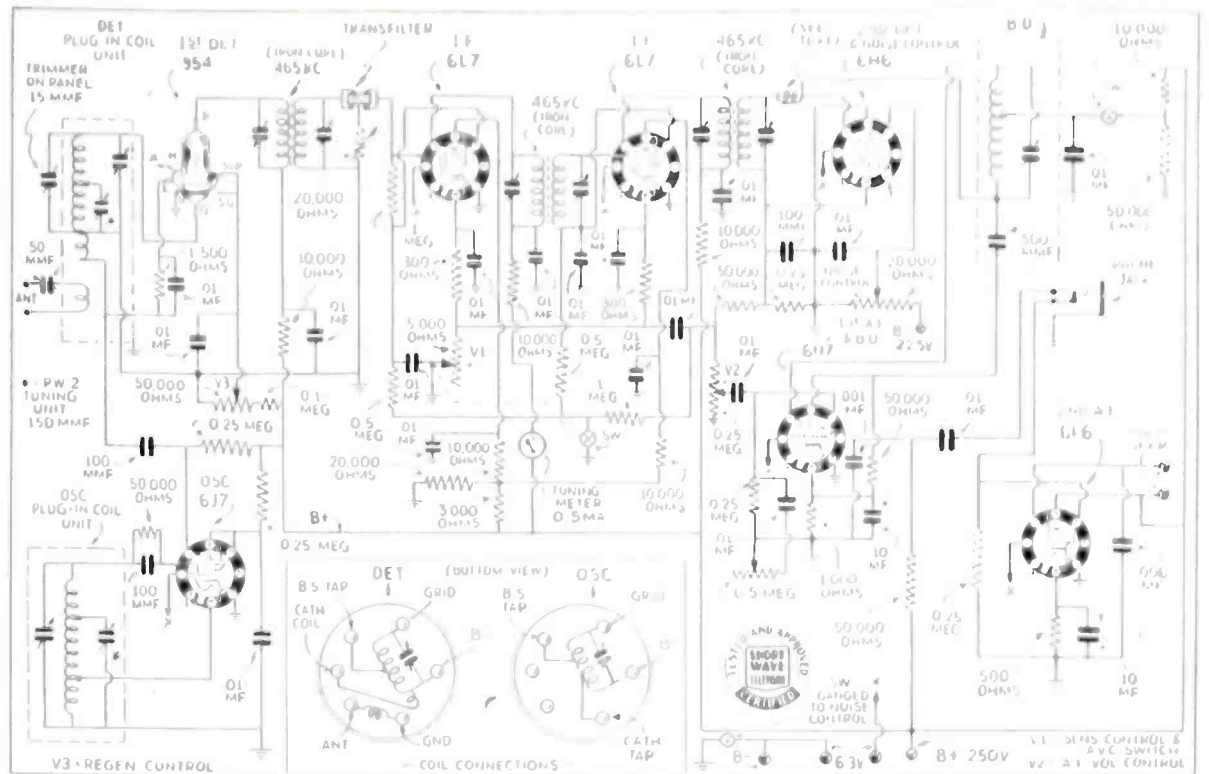

The complete schematic diagram of the "S.W.&T." Communications Receiver.

is being dealt with. Likewise, an optimum setting of the regeneration control for any given band will easily be found and this also will need no adjustment except on extremely weak signals.

The detector coil has a separate antenna winding both terminals of which are available for connection to a doublet. Best results, were obtained with a 50 mmf. condenser in series, with one leg of this coil connected to a single wire antenna with the other side grounded. The antenna which works satisfactorily for all amateur bands is a 66 ft. flat-top, tapped some 9 ft. off center, employing a single-wire feeder.

Of course, the oscillator coil needs no changing. A conventional 6J7 metal tube is used in the oscillator circuit. The use of an *acorn* tube here would not provide a noticeable improvement, inasmuch as the stability of this oscillator, even on 10 meters, is almost perfect. The method of injecting the oscillator voltage into the detector is a result of much experimenting. With the values shown this method provided a lower background level than any other of the several methods tried, with the result that the gain control can be run "wide open" with the receiver remaining *absolutely quiet*, insofar as receiver noise is concerned.

Incidentally, the secret of success in a re-

ceiver of this type is low receiver noise-level, and this receiver really has an *extremely low background noise level*. The urge may be felt to deviate from some of the values shown, and even to employ different tubes and slight modifications of circuits; however, we strongly advise against this, because this receiver is really a perfect working job and we don't recommend changes. That is, if the performance of the original one is to be duplicated. If the builder desires a higher degree of selectivity a conventional quartz crystal of course, may be incorporated.

Reference to the photographs will give an idea of the layout used. In the bottom view you will notice a dotted circle and a shield can at the bottom of the chassis; an explanation may be necessary. After the receiver was finished the I.F. showed a tendency to go into oscillation with the AVC switch in the off position and the sensitivity control *wide open*. This was traced to the H.F. oscillator stage. Due to the wiring arrangement, the by-pass condensers and resistors for the oscillator stage were mounted beneath the chassis directly under the 6J7 tube. It seems that there was sufficient radiation from these parts to throw the I.F. stages into oscillation with the gain control full on. Placing a small shield can over all of these parts, (the by-pass condensers and the plate and screen

Calling all
HAMS

CQ

AMATEUR BAND
RECEIVER FOR
CONSISTENT RE-
CEPTION ON
THE LOUD
PEAKER
5-10 Meters

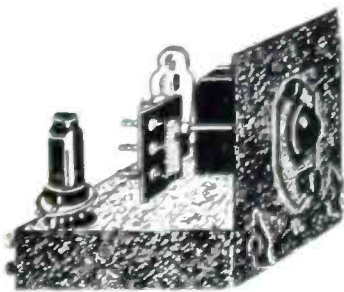

Eagle Minuteman

The classic standby for the "Ham"

MINUTE MAN KIT	\$4.75	FOR A. C. OPERATION 1-Tube	POWER SUPPLY	\$2.95
5 tubes, power sup- ply, speaker, unwired			less tube, speaker, unwired	
TUBES 6S & 42	\$1.50	50 RECTIFIER TUBE 30c EXTRA	5-in. loud speaker	\$1.19
WIRING CHARGE (Optional)	\$1.25	Power Supply	Wired	50c

Just the receiver for duplex work. The most sensitive and selective super regenerator receiver known, uses metal and glass tubes. The last word in performance and simplicity of design. The 1st 2 1/2 to 10 meter receiver ever offered to the amateur at such ridiculously low price. No license necessary to operate it.

The exceptionally fine quality of the Eagle speech amplifier and modulator coupled with the fact that it may be used as a powerful public address system with no changes except the shunting of two regular speakers across the output transformer, make it the ideal unit for the ham who would like to improve the quality of his signal or the fellow who likes to make a little money on the side renting it out. Some of the features of this unit are: Input for all types of microphones; power sufficient to modulate 50-60 watts input to any class "C" stage; overall gain of approximately 90 db and low hum level. Uses 6N7, 2-6L6 and 6L5 in a phase inverter circuit, class AB.

EAGLE MODULATOR KIT	\$10.95
The kit includes heavy duty Kenyon mod. trans. to 2,500 ohm load, also rack panel with brackets.	
Multi-match Thordarson trans to match any tubes up to 50 watts optional	\$2.00

Acclaimed by HAMS! EAGLE 6L6 MODULATOR AND SPEECH AMPLIFIER



Set of 4 guaranteed Tubes	\$3.95
Triplet 0-200 Mil. Meter	\$2.94
Modulator wired and tested additional	\$3.00

MORE BANDS PER CRYSTAL—IT'S BI-PUSH.

Bi-Push All Band Exciter or Transmitter 45—50 Watt

This new development in exciters, recently described in "RADIO", by W. W. Smith W6BCX, has met with wide approval. The BI-PUSH is the most advanced design in really flexible band switching. The change from one band to another can be made in thirty seconds. Output sufficient for moderate dx and exceptionally good ten meter performance, with only an inexpensive power supply required. With our excellent design and careful choice of parts, peak efficiency on all bands is assured.



Work 3 bands on one crystal with only three coils. Your choice of 10-20-40 meters, or, 40-80-160 meters. A combination of all 5 bands can be obtained with the complete set of coils. Complete kit of high quality parts includes: — drilled chassis and rack panel; fully constructed coils for 3 bands; Bi-Push uses two 6A6's and two 6L6's with isolantite base (RK49's).

Complete Kit less crystal	\$18.95
Set of 4 RCA or Raytheon Tubes	\$4.80

And NOW . . . Go on "5" with the EAGLE FB2 6L6-6A6 PHONE TRANSMITTER

Stable 8 Watt Complete
Carrier Kit

100% Modulated **\$6.95**
Less Tubes

A highly efficient 5 meter Transmitter for portable or home use. The EAGLE FB2 Transmitter is a worthy companion to the famous MINUTE-MAN RECEIVER. The combination will give you a powerful 5 Meter Station at the lowest price obtainable.



EAGLE FB2 Transmitter Kit	\$6.95	Wiring Charge (optional) EAGLE FB2	\$2.00
Two Tubes, 6L6, 6A6	\$1.95	Wiring Charge (optional) FB2 Power Supply	75c
Heavy Duty Power Supply Kit with sufficient output to operate Transmitter and Receiver	\$3.95	Black Cracked Metal Cab- inet 8 1/2 x 8 x 6 for either Transmitter or Receiver	50c
523 Tube for Power Supply	59c	Extra Large Black Cracked Cabinet for Transmitter and Power Supply or Receiver and Power Supply	\$2.50

Mail Your Orders Promptly—FREE Circuits and Details on Request

EAGLE RADIO CO.,

84 CORTLANDT STREET
Dept. C. NEW YORK CITY

resistors) cured the trouble. Then there was absolutely no sign of instability at maximum gain setting. With a slightly different arrangement in wiring employed in a duplicate of this receiver, of course, the results would be entirely different and there may be no tendency toward feedback. However, we mention this to show what a slight amount of oscillator radiation can do to a very high gain I.F. amplifier. In an effort to eliminate R.F. in the filament circuit one side of each heater in the tube is connected to ground, and this proved to be entirely adequate. However, in some cases it may be found necessary to by-pass the other leg of the heater circuit right at the first detector and oscillator sockets.

So far as stability in the *high-frequency* portion is concerned, this set leaves practically nothing to be desired. The regeneration control in the first detector circuit does *not affect* the tuning, of either the oscillator or first detector. Also the detector trimmer does *not* pull the oscillator. The entire high frequency portion is absolutely stable in all respects.

As for the sensitivity of the receiver, no measurements were taken and we will not attempt to estimate its sensitivity in microvolts. We will say this—from actual experience and comparison with other sets, it is not found wanting. During its operation we have not found a single signal that could not be brought up to an R-7 value, and we experienced no cases where we could hear signals but too weak to be copied. This is undoubtedly due to the low noise-level of the receiver for anyone experienced with receivers will recall hearing stations, and many at that, which are too weak to be brought in. We found that if they can be heard at all on this receiver, they can be copied solid, providing there is no QRN or QRM.

Aside from being an efficient receiver, its appearance is also modern and business-like, especially with the crackle finished cabinet.

Coil Data for "S.W.&T." Receiver

Band	Use Coils		Length Winding	Wire
	Grid Turns	Cath Tap		
80	34	7	1 1/2"	No 24 enam
40	9	3	1 1/2"	No 24 enam
20	4	2	1 1/2"	No 24 enam
10	2 1/2	1 1/2	1 1/2" space between turns	No 22 enam

Band	Det. Coils		Length	Wire
	Grid Turns	Cath Tap		
80	35	1 1/2	7 1 1/2"	No 24 enam
40	17	1	4 1/2"	No 24 enam
20	8	1	1 1/2"	No 24 enam
10	2 1/2	1 series cond used (35 mf)	1 1/2" space between turns	No 22 enam

*Interwound with B—end of grid coil No 30 d.c.c. wire

+Wound in opposite direction to grid coil at B—end No 30 d.c.c. wire

The 10 meter detector coil is not tapped for bandspread, a 35 mmf. padder is connected in series with tuning condenser, this padder is also inside of coil form as well as the 50 mmf. parallel padder. The small padder (35 mmf.) is mounted with stiff wire so that it can be adjusted through hole in bottom of coil form.

The padders in the coils are 50 mmf.

Parts List

- 18—01 mf. high frequency condensers
- 3—.0001 mf. mica condensers
- 1—.005 mf. mica condenser
- 1—.006 mica condenser
- 2—10 mf. low voltage electrolytics
- 4—50,000 ohm 1/2-watt resistors
- 5—10,000 ohm 1/2-watt resistors
- 2—300 ohm 1/2 watt resistors
- 1—1,000 ohm 1/2 watt resistor
- 5—1/3 meg. ohm 1/2 watt resistors
- 1—.1 meg. ohm 1/2 watt resistors
- 2—1 meg. ohm 1/2 watt resistors
- 1—500 ohm 1 watt resistor
- 1—10,000 ohm 10-watt resistor
- 1—50,000 ohm 10-watt resistor
- 1—3,000 ohm 20 watt resistor
- 1—20,000 ohm 20 watt resistor
- 2—20,000 ohm potentiometers (one with switch)
- 1—5,000 ohm potentiometer (with switch)
- 1—50,000 ohm potentiometer
- 1—250,000 ohm potentiometer
- 1—500,000 ohm potentiometer
- 1—PW-2 150 mmf. tuning assembly, with micrometer dial
- 1—set each 80, 40, 20 and 10 meter FB 7 coils
- 2—Octal tube sockets
- 1—Acorn tube socket
- 2—shield and socket assemblies for plug-in coils
- 3—465 kc. iron core I.F. transformers
- 1—beat oscillator assembly 465 kc.
- 1—HRO cabinet
- 1—15 mmf. midget trimmer
- 1—50 mmf. midget trimmer
- 1—254 acorn tube
- 1—6J7 tube (isolantite)
- 2—6L7 tubes (isolantite)
- 1—6H6
- 1—6N7
- 1—6F6
- 1—Transfilter 465 kc.
- 1—small bakelite case meter 0-5 ma.
- 5—Octal sockets (one hole mounting type)
- 1—toggle switch

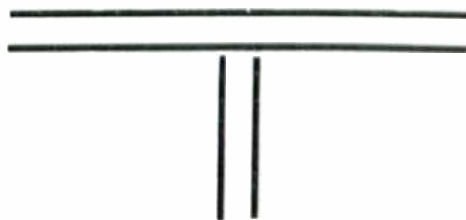

SHORT-WAVE BOOKS WITH A WORLD-WIDE REPUTATION

You must go a long way to buy better books on short waves than you find on this page. Each book has been written by a well-known authority on short waves . . . each book carefully illustrated with photographs and diagrams to make this field of radio simpler. The volumes are the finest books on short-waves today. Order one or more copies . . . find out for yourself how instructive they are. Prices are postpaid.

101 SHORT-WAVE HOOKUPS

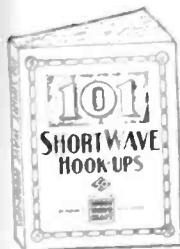

Each diagram illustrated is accompanied by a thorough text explanation. What parts are required, coil-winding information, values of resistors, etc., in fact, everything needed to build the set or look up the data required.

All the important sets which have appeared in print during the past few years are in this book. Sets such as the Doerle, Dinsmore, the "19" Twinplex, Oscillodyne, Denton "Stand-by," Megadyne Triple X 2, "Globe-Trotter," 2-Tube Superhet, Minidyne, "Loop" Receiver, 100 Illustrations, 72 Pages, Stiff, flexible covers.

"Doerle" 2-tube Battery, "Doerle 3-tube Battery, "Doerle" 2-tube A.C., "Doerle" 3-tube A.C., Doerle "Signal Gripper," Duo R.F. 4-tube Receiver, The Sargent 9-33 Tapped Coil Receiver, Globe-Girdler 7, The 2-Tube "Champ"—2 Tubes Equal 3, Ham-Band "2-Tube Pee-Wee" Wyeth All Way 6, Denton Economy 3, 2-Tube "Regenerative-Oscillodyne" will be found here, with full descriptions. In many cases, we have included a picture hook-up in addition to the regular symbolic hook-up.

50c

How to Build and Operate Short-Wave Receivers

This is the most up-to-date book on the subject. It has been prepared by the editors of SHORT WAVE CRAFT, and contains a wealth of material on the building and operation, not only of typical short-wave receivers, but short-wave converters as well. Dozens of short-wave sets are found in this book, which contains hundreds of illustrations; actual photographs of sets built, hookups and diagrams galore.

50 Illustrations, 2 Pages, Stiff, flexible covers.

50c

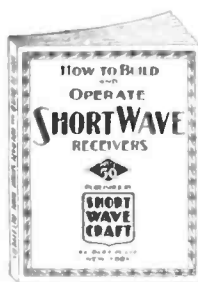

How to Get Best Short-Wave Reception

The author, a professional radio listener for many years, gives you his long experience in radio reception and all that goes with it.

Why is one radio listener enabled to pull in stations from all over the globe, even small 100 watters, 10,000 miles away, and why is it that the next fellow, with much better and more expensive equipment, can only pull in powerful stations?

The reason is intimate knowledge of short waves and how they behave.

40 Illustrations, 72 Pages, Stiff, flexible covers.

50c



HOW TO BECOME AN AMATEUR RADIO OPERATOR PARTIAL LIST OF CONTENTS



We chose Lieut. Myron F. Eddy to write this book because his experience in the amateur field has made him preeminent in this line. He is a member of the I.R.E. (Institute of Radio Engineers), also the Veteran Wireless Operators' Association. If you intend to become a licensed code operator, if you wish to take up phone work eventually—this is the book you must get.

Ways of learning the code. A system of sending, receiving with necessary drill words. Concise definitions of radio terms, units, laws, descriptions of commonly used radio equipment. Symbols used to indicate various parts of radio circuits. General radio theory as it applies to beginners. Electron theory is briefly given, waves—their creation, propagation, reception. Fundamental laws of electric circuits, particularly for radio. Descriptions of modern receivers used with success by amateurs. How to build and operate these sets. Amateur transmitters. Diagrams with specifications. Power equipment used with transmitters and receivers, rectifiers, filters, batteries, etc. Regulations that apply to amateur operators. International "Q" signals, conversion tables for reference purposes.

150 Illustrations, 72 Pages, Stiff, flexible covers.

50c

The Short-Wave Beginner's Book

Here is a book that solves short wave problems. It is the only low-priced reference book on short waves for the beginner.

The book is profusely illustrated—it is not "technical." It has no mathematics and no technical jargon.

It also gives you a tremendous amount of important information, such as time conversion tables, all about aeriels, noise elimination, all about radio tubes, data on coil winding and other subjects.

75 Illustrations, 40 Pages, Stiff, flexible covers.

25c

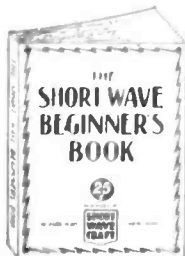

Ten Most Popular Short-Wave Receivers

How To Make And Work Them

SHORT WAVE CRAFT Editors have selected ten outstanding short-wave receivers and these are described in the new volume. Each receiver is fully illustrated. Photographs of the set complete, hookups and all worth-while specifications. Everything from the simplest one-tube set to a 5-tube T. R. F. receiver is presented. Complete lists of parts make each set complete.

75 Illustrations, 40 Pages, Stiff, flexible covers.

25c

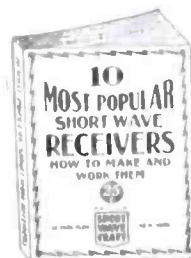

OVERSEAS READERS!—These books can be obtained from the following houses:
 GREAT BRITAIN—Gorrings, 9a, Green Street, Leicester Square, London, England; FRANCE: Editions Radio, 42 Rue Jacob, Paris; AUSTRALIA—McGill's, 183-195, 218 Elizabeth St., Melbourne, C. I.
ORDER TODAY! Send remittance in form of check or money order. If letter contains cash or unused U. S. Postage Stamps, register it.

SHORT WAVE & TELEVISION, 99-RA Hudson Street, New York City

RADIO LAWS

. . .

PERTAINING TO**AMATEURS**

- The amateur and the prospective amateur should be thoroughly familiar with the extracts of the Rules and Regulations of the F.C.C. for amateur stations which follow. Although it is not necessary to know the exact wording it is again stressed that the amateur be thoroughly familiar with them as half of the examination is devoted to the topics of Laws, Regulations and Penalties.

**Extracts from the Communications Act
of 1934**

Section 1. For the purpose of regulating interstate and foreign commerce in communication by wire and radio so as to make available, so far as possible, to all the people of the United States a rapid, efficient, Nation-wide, and world-wide wire and radio communication service with adequate facilities at reasonable charges, for the purpose of national defense, and for the purpose of securing a more effective execution of this policy by centralizing authority heretofore granted by law to several agencies and by granting additional authority with respect to interstate and foreign commerce in wire and radio communication, there is hereby created a commission to be known as the "Federal Communications Commission," which shall be constituted as hereinafter provided, and which shall execute and enforce the provisions of this Act.

Sec. 2. (a) The provisions of this Act shall apply to all interstate and foreign communication by wire or radio and all interstate and foreign transmission of energy by radio, which originates and/or is received within the United States, and to all persons engaged within the United States in such communication or such transmission of energy by radio, and to the licensing and regulating of all radio stations as hereinafter provided; but it shall not apply to persons engaged in wire or radio communication or transmission in the Philip-

pine Islands or the Canal Zone, or to wire or radio communication or transmission wholly within the Philippine Islands or the Canal Zone.

Sec. 4. (a) The Federal Communications Commission (in this Act referred to as the "Commission") shall be composed of seven commissioners appointed by the President, by and with the advice and consent of the Senate, one of whom the President shall designate as chairman.

Section 301. It is the purpose of this Act, among other things to maintain the control of the United States over all the channels of interstate and foreign radio transmission; and to provide for the use of such channels, but not the ownership thereof, by persons for limited periods of time, under licenses granted by Federal authority, and no such license shall be construed to create any right, beyond the terms, conditions, and periods of the license. No person shall use or operate any apparatus for the transmission of energy or communications or signals by radio (a) from one place in any Territory or possession of the United States or in the District of Columbia to another place in the same Territory, possession, or District; or (b) from any State, Territory, or possession of the United States, or from the District of Columbia to any other State, Territory, or possession of the United States; or (c) from any place in any State, Territory, or possession of the United States, or in the District of Columbia, to any place in any foreign country or to any vessel; or (d) within any State when the effects of such use extend beyond the borders of said State, or when interference is caused by such use or operation with the transmission of such energy, communications, or signals from within said State to any place beyond its borders, or from any place beyond its borders to any place within said State, or with the transmission or

ACE HIGH

*with
Amateurs*

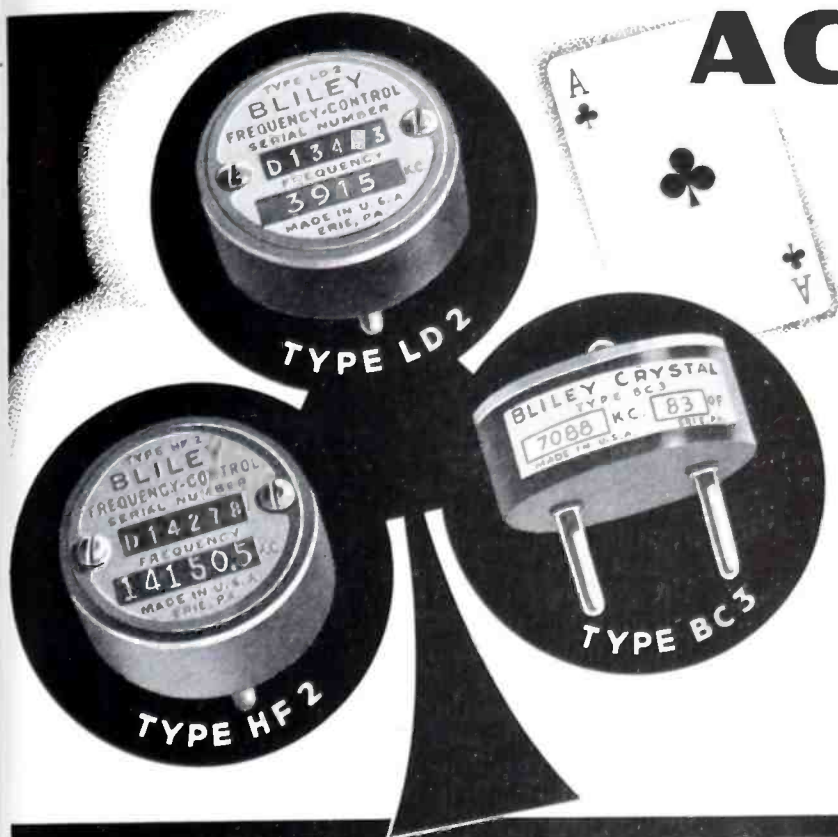

It's not by chance that thousands of amateurs all over the world use Bliley Crystal Units for dependable, accurate frequency control.

Operating experience has shown that these units are always thoroughly reliable, instantly snap into oscillation, key readily and give excellent power output.

Whether you choose the LD2 low-drift crystal unit, the HF2 unit for twenty meters, or the economically priced BC3 X-cut mounted crystal for your transmitter, you will make a grand slam in frequency control.

See your dealer about these popular crystal units and ask for your copy of the Bliley 1938 Technical Catalog. Bliley Electric Co., Erie, Pa.

BLILEY CRYSTAL UNITS

VAN SICKLE

RADIO INC., Distributors

of all leading lines of Transmitting Equipment

EXCLUSIVE CENTRAL INDIANA DISTRIBUTORS OF

R.M.E. - National - Hammarlund - Bliley Taylor - Hallicrafter

W9KJF—W9TKB—W9NNA—W9OHM—W9NNB

34 West Ohio Street

Indianapolis, Indiana

- ★ Indiana's only complete Amateur Supply House.
- ★ We have no affiliation with any other supply house.
- ★ All popular Amateur receivers sold on E-Z payment plan.
- ★ For quick personal service with full discounts allowed send your orders, direct to us.

reception of such energy, communications, or signals from and/or to places beyond the borders of said State; or (e) upon any vessel or aircraft of the United States; or (f) upon any other mobile stations within the jurisdiction of the United States, except under and in accordance with this Act and with a license in that behalf granted under the provisions of this Act.

Sec. 303. Except as otherwise provided in this Act, the Commission from time to time, as public convenience, interest, or necessity requires, shall—

- (a) Classify radio stations;
- (b) Prescribe the nature of the service to be rendered by each class of licensed stations and each station within any class;
- (c) Assign bands of frequencies to the various classes of stations, and assign frequencies for each individual station and determine the power which each station shall use and the time during which it may operate;
- (d) Determine the location of classes of stations or individual stations;
- (e) Regulate the kind of apparatus to be used with respect to its external effects and the purity and sharpness of the emissions from each station and from the apparatus therein;
- (f) Make such regulations not inconsistent with law as it may deem necessary to prevent interference between stations and to carry out the provisions of this Act: **Provided, however,** That changes in the frequencies, authorized power, or in the times of operation of any station, shall not be made without the consent of the station licensee unless, after a public hearing, the Commission shall determine that such changes will promote public convenience or interest or will serve public necessity, or the provisions of this Act will be more fully complied with;
- (g) Study new uses for radio, provide for experimental uses of frequencies, and generally encourage the larger and more effective use of radio in the public interest.
- (j) Have authority to make general rules and regulations requiring stations to keep such records of programs, transmissions of energy, communications, or signals as it may deem desirable;
- (1) Have authority to prescribe the qualifications of station operators, to classify them according to the duties to be performed, to fix the forms of such licenses, and to issue them to such citizens of the United States as the Commission finds qualified;
- (m) Have authority to suspend the license of any operator for a period not exceeding two years upon proof sufficient to satisfy the Commission that the licensee (1) has violated any provision of any Act or treaty binding on the United States

which the Commission is authorized by this Act to administer or any regulation made by the Commission under any such Act or treaty; or (2) has failed to carry out the lawful orders of the master of the vessel on which he is employed; or (3) has wilfully damaged or permitted radio apparatus to be damaged; or (4) has transmitted superfluous radio communications or signals or radio communications containing profane or obscene words or language; or (5) has wilfully or maliciously interfered with any other radio communications or signals;

(n) Have authority to inspect all transmitting apparatus to ascertain whether in construction and operation it conforms to the requirements of this Act, the rules and regulations of the Commission, and the license under which it is constructed or operated;

(o) Have authority to designate call letters of all stations;

(p) Have authority to cause to be published such call letters and such other announcements and data as in the judgment of the Commission may be required for the efficient operation of radio stations subject to the jurisdiction of the United States and for the proper enforcement of this Act;

Sec. 309. (a) (If upon examination of any application for a station license or for the renewal or modification of a station license the Commission shall determine that public interest, convenience, or necessity would be served by the granting thereof, it shall authorize the issuance, renewal, or modification thereof in accordance with said finding. In the event the Commission upon examination of any such application does not reach such decision with respect thereto, it shall notify the applicant thereof, shall fix and give notice of a time and place for hearing thereon, and shall afford such applicant an opportunity to be heard under such rules and regulations as it may prescribe.

Sec. 318 The actual operation of all transmitting apparatus in any radio station for which a station license is required by this Act shall be carried on only by a person holding an operator's license issued hereunder. No person shall operate any such apparatus in such station except under and in accordance with such operator's license issued to him by the Commission.

Sec. 321. (B) All radio stations, including Government stations on board foreign vessels when within the territorial waters of the United States, shall give absolute priority to radio communications or signals relating to ships in distress; shall cease all sending on frequencies which will interfere with hearing a radio communication or signal of distress, and, except when engaged in answering or aiding the ship in distress, shall refrain from sending any radio communications or signals until there is as-

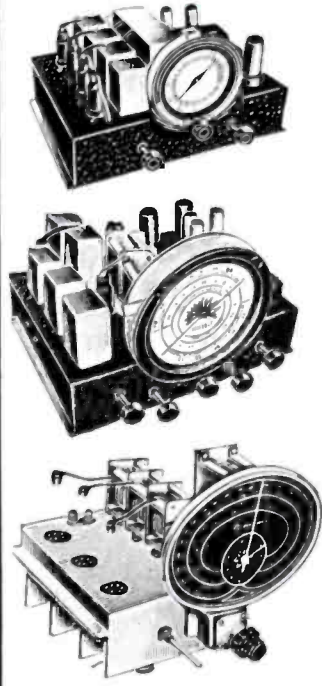

Start Right - Insist On

Meissner

World's Largest Coil Manufacturers

Antenna Coils
R. F. Coils
Oscillator Coils
I. F. Coils
Plug-in Coils
Beat. Osc. Coils
Noise Silver Coils
Complete Coil Kits

R. F. Chokes
Transmitting Chokes
Crystal Filter Coils
Exact Replacements
Trimming Condensers
Padding Condensers
Wave Traps
4 to 14 tube receivers

FREE OFFER—Just mention this book and we will send you absolutely free our complete 32 page Coil and Coil Kit Catalog.

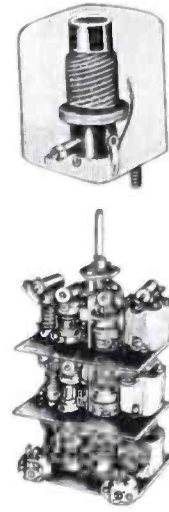

MEISSNER MFG. CO., Mt. Carmel, Ill.



Aladdin
REG. U. S. PAT. OFF.

THE COMPLETE LINE OF POLYIRON INDUCTANCES
One of the most widely used intermediate frequency transformers, type "A" illustrated.
ADJUSTABLE COUPLING — MICA TUNED

Type	Frequency Range, kc	Factory Selling	Gain	Band Width			Between	Use	List Price
				2x	10x	100x			
A101	440-480	465 ke	50	24	82	6A7-6D6	Converter	\$3.00
A101M	440-480	465 ke	48	16	56	6A8-6K7	Converter	3.00
A100	440-480	465 ke	250	19	66	6D6-6D6	Interstage	3.00
A201	440-480	465 ke	110	13	31	6D6-75	Diode	3.00
A200M	440-480	465 ke	113	19	51	6K7-6H6	Diode	3.00
A100C	440-480	465 ke	-XTAL	XTAL Inp.	4.00
A200C	440-480	465 ke	6D6-75	F. W. Diode	4.00
A125	360-380	370 ke	49	16	53	6A7-6D6	Converter	3.00
A125	360-380	370 ke	220	15	47	6D6-6D6	Interstage	3.00
A225	360-380	370 ke	110	12	31	6D6-75	Diode	3.00
A150	250-270	260 ke	62	15	54	6A7-6D6	Converter	3.00
A150	250-270	260 ke	330	13	41	6D6-6D6	Interstage	3.00
A250	250-270	260 ke	120	11	31	6D6-75	Diode	3.00
A175	165-185	175 ke	54	11	50	6A7-6D6	Converter	3.00
A175	165-185	175 kr	300	9	30	6D6-6D6	Interstage	3.00
A275	165-185	175 ke	135	8	24	6D6-75	Diode	3.00
A185	105-125	115 ke	81	10	34	6A7-6D6	Converter	3.00
A185	105-125	115 ke	370	9	28	6D6-6D6	Interstage	3.00
A285	105-125	115 ke	145	6	18	6D6-75	Diode	3.00

Aluminum Shields 1 1/2" D. x 3 1/2" high, 1 13/32" Mtg. Centers

Write for catalog showing complete line.

ALADDIN RADIO INDUSTRIES, INC.,

466 sw WEST SUPERIOR STREET

CHICAGO, ILLINOIS

Licensee of Johnson Laboratories, Inc.

These devices manufactured under one or more of the following U. S. Letters Patents:

1,887,380	1,978,599	1,982,690	2,005,203	2,032,580	2,082,587	2,082,589
1,940,228	1,978,600	1,997,453	2,018,626	2,032,914	2,051,012	2,082,590
1,978,568	1,982,689	2,002,500	2,028,534	2,035,439	2,059,393	2,082,595

Other patents pending

urance that no interference will be caused with the radio communications or signals relating thereto, and shall assist the vessel in distress, so far as possible, by complying with its instructions.

Sec. 324. In all circumstances, except in case of radio communications or signals relating to vessels in distress, all radio stations, including those owned and operated by the United States, shall use the minimum amount of power necessary to carry out the communication desired.

Sec. 325. (a) No person within the jurisdiction of the United States shall knowingly utter or transmit, or cause to be uttered or transmitted, any false or fraudulent signal of distress, or communication relating thereto, nor shall any broadcasting station rebroadcast the program or any part thereof of another broadcasting station without the express authority of the originating station.

Sec. 326. Nothing in this Act shall be understood or construed to give the Commission the power of censorship over the radio communications or signals transmitted by any radio station, and no regulation or condition shall be promulgated or fixed by the Commission which shall interfere with the right of free speech by means of radio communication. No person within the jurisdiction of the United States shall utter any obscene, indecent, or profane language by means of radio communication.

Sec. 501. Any person who wilfully and knowingly does or causes or suffers to be done any act, matter, or thing, in this Act prohibited or declared to be unlawful, or who wilfully and knowingly omits or fails to do any act, matter, or thing in this Act required to be done, or wilfully and knowingly causes or suffers such omission or failure, shall, upon conviction thereof, be punished for such offense, for which no penalty (other than a forfeiture) is provided herein, by a fine of not more than \$10,000 or by imprisonment for a term of not more than two years, or both.

Sec. 502. Any person who wilfully and knowingly violates any rule, regulation, restriction, or condition made or imposed by the Commission under authority of this Act, or any rule, regulation, restriction, or condition made or imposed by any international radio or wire communications treaty or convention, or regulations annexed thereto, to which the United States is or may hereafter become a party, shall, in addition to any other penalties provided by law, be punished, upon conviction thereof, by a fine of not more than \$500 for each and every day during which such offense occurs.

Sec. 605. No person receiving or assisting in receiving, or transmitting, or assist-

ing in transmitting, any interstate or foreign communication by wire or radio shall divulge or publish the existence, contents, substance, purport, effect, or meaning thereof, except through authorized channels of transmission or reception, to any person other than the addressee, his agent, or attorney, or to a person employed or authorized to forward such communication to its destination, or to proper accounting or distributing officers of the various communicating centers over which the communication may be passed, or to the master of a ship under whom he is serving, or in response to a subpoena issued by a court of competent jurisdiction, or on demand of other lawful authority; and no person not being authorized by the sender shall intercept any communication and divulge or publish the existence, contents, substance, purport, effect, or meaning of such intercepted communication to any person; and no person not being entitled thereto shall receive or assist in receiving any interstate or foreign communication by wire or radio and use the same or any information therein contained for his own benefit or for the benefit of another not entitled thereto; and no person having received such intercepted communication or having become acquainted with the contents, substance, purport, effect, or meaning of the same or any part thereof, knowing that such information was so obtained, shall divulge or publish the existence, contents, substance, purport, effect, or meaning of the same or any part thereof, or use the same or any information therein contained for his own benefit or for the benefit of another not entitled thereto: **Provided**, that this section shall not apply to the receiving, divulging, publishing, or utilizing the contents of any radio communication broadcast, or transmitted by amateurs or others for the use of the general public, or relating to ships in distress.

Sec. 606. (c) Upon proclamation by the President that there exists war or a threat of war or a state of public peril or disaster or other national emergency, or in order to preserve the neutrality of the United States, the President may suspend or amend, for such time as he may see fit, the rules and regulations applicable to any or all stations within the jurisdiction of the United States as prescribed by the Commission, and may cause the closing of any station for radio communication and the removal therefrom of its apparatus and equipment, or he may authorize the use or control of any such station and or its apparatus and equipment by any department of the Government under such regulations as he may prescribe, upon just compensation to the owners.

23 INSTRUMENTS IN ONE, \$10.40 AND THE PRICE IS ONLY

See What Far-Reaching Services Our ALLMETER Performs! Instead of being just a volt-ohm-ammeter, it is such an instrument plus a.c. readings for voltages and currents, also accurately measuring very low resistance, from below one ohm, also capacity, and henries and decibels, comprising twenty-three instruments in one.

0-15-150-750 volts d.c.	3
0-15-150-750 volts a.c.	3
0-15-150-750 ma d.c.	3
0-15-150-750 ma a.c.	3
0-1 ma d.c.	1
-12 to 30 decibels (2 ranges)	2
.03-500 ohms	1
500 ohms to 500,000 ohms	1
5-1,000 henries	1
.01-50 mfd.	1
Condenser short tester	1
0-15-150-750 volts, vacuum tube voltmeter	3



The sensitivity on all voltages ranges is 1,000 ohms per volt and the Superior meter has a precision d.ironval movement and measures 4.5 inches overall. The eight scales are direct-reading. The a.c. service is substantially non-reactive to deep into the megacycle range, unlike other instruments that utterly lose accuracy long before even high audio frequencies are reached. This is because we use an electric rectifier.

You must have one of these instruments because it does twenty things and does them well. You can greatly improve the value of your services and perform work more quickly and accurately with an ALLMETER. Order an ALLMETER today (Code AMR). Cabinet 10.6.5x5.25 inches. Shipping weight 6 lbs. Complete with test leads.

THE ALLMETER

COSTS LESS — DOES MORE!

Send for our Catalogue PV in colors. It's Free!

SUPERIOR INSTRUMENTS CO.
Dept. HB 136 Liberty St., N. Y. City

Double Your Power!

At The Useful Voice Frequencies

Cut through QRM with a voice that can be understood. You don't need a tricky high gain amplifier with this tremendous efficient voice microphone—eliminates all RF feedback problems with its "air tight" shielding. Cuts out your hum problems too. You will get more satisfaction out of dollars spent for a VT-73.



MODEL VT-73

THE TURNER CO.

CEDAR RAPIDS, IOWA

Licensed under patents of the Brush Development Co.

LIST
COMPLETE
MIKE
AND
STAND-HANDLE

\$25.25

RADIO IN IT'S ENTIRETY!

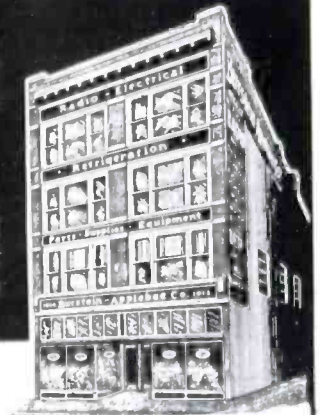

COMPLETE STOCKS --- READY FOR YOU

"B-A" serves the trade with every need in radio. Complete 160-page catalog of radio receivers, public address systems, parts, supplies and equipment is now available. You will find your favorite nationally known lines represented in this big book. "B-A" prompt service will please you—orders shipped same day they are received.

BURSTEIN-APPLEBEE CO.

1012-14 MCGEE ST. -- KANSAS CITY, MO.

**UP-TO-DATE CATALOG
NOW AVAILABLE**

Extracts from the Rules and Regulations of the F.C.C. for Amateur Stations

1. **Prescribed application forms.**—Each application for an instrument of authorization shall be made in writing on the appropriate form prescribed by the Commission for the purpose. Separate application shall be filed for each instrument of authorization. The required forms except as provided in paragraph 408 for amateur applicants, may be obtained from the Commission or from the office of any inspector. For a list of such offices and related geographical districts, see paragraph 30.

2. Filing of application.—

h. Each application for amateur facilities shall be filed in accordance with the following instructions:

(1) Applications for amateur station and/or operators' licenses from applicants residing within 125 miles of Washington, D. C., a radio district office of the Commission, or an examining city (see par. 30).

(2) Applications for amateur station and/or operators' licenses from applicants residing more than 125 miles from Washington, D. C., a radio district office of the Commission, or an examining city (see par. 30).

1 copy to the inspector in charge of the radio district in which the applicant resides

1 copy direct to the Federal Communications Commission, Washington, D. C., in accordance with the instructions specifically set forth on the application form

14. **License where construction permit is not required.**—Each application for new license, where a construction permit is not prerequisite thereto, shall be filed at least 60 days prior to the contemplated operation of the station.

16. **Renewal of license.**—Unless otherwise directed by the Commission, each application for renewal of license shall be filed at least 60 days prior to the expiration date of the license sought to be renewed.

20. **Penalty for transfer of license without the consent of Commission.**—The transfer of a radio station license, or the rights granted thereunder, without consent of the Commission shall be sufficient ground for the revocation of such license or denial of any application for its renewal. Amateur station licenses and call signals are not transferable.

22. **Special authorizations.**—The Commission may grant special authority to the licensee of an existing station authorizing the operation of such station for a limited time in a manner, to an extent or for a service other or beyond that authorized in the license.

24. **Answering notice of violation.**—Any licensee receiving official notice of a viola-

tion of Federal laws, the Commission's rules and regulations, or the terms and conditions of a license shall, within 3 days from such receipt, send a written reply direct to the Federal Communications Commission at Washington, D. C. The answer to each notice shall be complete in itself and shall not be abbreviated by reference to other communications or answers to other notices. If the notice relates to some violation that may be due to the physical or electrical characteristics of the transmitting apparatus, the answer shall state fully what steps, if any, are taken to prevent future violations, and if any new apparatus is to be installed, the date such apparatus was ordered, the name of the manufacturer, and promised date of delivery.

26. If the notice of violation relates to some lack of attention or improper operation of the transmitter, the name and license number of the operator in charge shall be given.

27. **Normal license periods.**—All station licenses will be issued so as to expire at the hour of 3 A. M. Eastern standard time.

e. The licenses for amateur stations will be issued for a normal license period of 3 years from the date of expiration of old license or the date of granting a new license or modification of a license.

28. **Designation of call signals.**—Insofar as practicable, call signals of radio stations will be designated in alphabetical order from groups available for assignment, depending upon the class of station to be licensed. Because of the large number of amateur radio stations, calls will be assigned thereto in regular order and requests for particular calls will not be considered.

29. **Deletion of call signals.**—Call signals of stations will be deleted in each of the following cases:

a. Where an existing instrument of authorization has expired and no application for renewal or extension thereof has been filed.

b. Where a license has been revoked.

c. Where a license is surrendered or canceled.

d. Other cause, such as death, loss of citizenship, or adjudged insanity of the station licensee. Such occurrences coming to notice should be reported to the Commission, preferably accompanied by the station license for cancellation, if available.

30. **Radio districts.**—The following list of the radio districts gives the address of each field office of the Federal Communications Commission and the territory embraced in each district:

FROM ANY ANGLE

Johnson Products Are Tops!

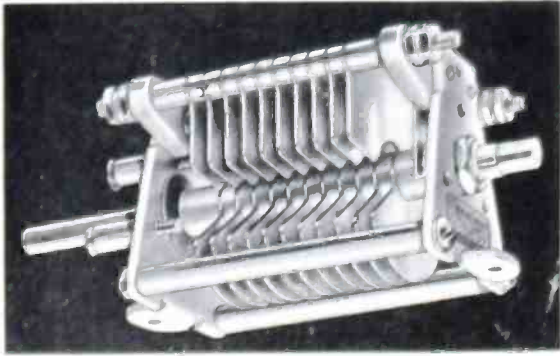

The Johnson type "F" transmitting condenser shown above is one of several NEW types, small in size but big in performance. Consider these features:

- Alsimag 196 insulation, having 1/3 the loss factor of other similar materials.
- Stator mounted above, permitting short leads and resulting in lower minimum capacity.
- Large cadmium plated bronze spring contacts.
- Voltage ratings up to 4500V.

There are other Johnson condensers with ratings up to 13,000 volts.

To complete the condenser-coil combination—

NEW "Hi-Q" INDUCTORS

- Low-loss ceramic skeleton forms.
- Variable coupling by means of rotating coupling coil.
- 10 to 160 meters with a condenser of 100 mmf. maximum.
- 50, 250 and 1000 watt sizes for all bands, 10 to 160.

And for the Antenna— The JOHNSON "Q"

- 95 to 98% transfer of energy from transmitter to antenna.
- Easily installed and adjusted.
- May be located several hundred feet from transmitter.
- The cheapest way to increase effective power.

Available at leading Jobbers everywhere

IF THE LABEL SAYS

"JOHNSON"—IT'S GOOD!

E·F·JOHNSON·COMPANY 
MANUFACTURERS OF *Radio Transmitting Equipment*
WASECA MINNESOTA U.S.A.

Export Office: 25 Warren St., New York. Cable: "SIMONTRICE"

BRUSH

CRYSTAL DEVICES

for Amateurs



- Wide Range Selectivity is possible with the Brush "Transfilter"—for receivers with 165KC I. F. amplifier.

- Brush Crystal Headphones with a fre-



quency response of from 60 to 10,000 cycles and extreme sensitivity will improve your "DX" record.

Detailed Information on Request

The BRUSH

Development Company

3327 PERKINS AVE.
CLEVELAND OHIO

Radio district	Address of the inspector in charge	Territory within district	
		States	Counties
1	Customhouse, Boston, Mass.	Connecticut..... Maine..... Massachusetts..... New Hampshire..... Rhode Island..... Vermont.....	All Counties. Do. Do. Do. Do. Do.
2	United States Subtreasury Building, New York, N. Y.	New York..... New Jersey.....	Albany, Bronx, Columbia, Delaware, Dutchess, Greene, Kings, Nassau, New York, Orange, Putnam, Queens, Rensselaer, Richmond, Rockland, Schenectady, Suffolk, Sullivan, Ulster and Westchester. Bergen, Essex, Hudson, Hunterdon, Mercer, Middlesex, Monmouth, Morris, Passaic, Somerset, Sussex, Union and Warren.
3	Gimbel Building, 35 South Ninth Street, Philadelphia, Pa.	Pennsylvania..... New Jersey.....	Adams, Berks, Bucks, Carbon, Chester, Cumberland, Dauphin, Delaware, Lancaster, Lebanon, Lehigh, Monroe, Montgomery, Northampton, Perry, Philadelphia, Schuylkill, and York. Atlantic, Burlington, Camden, Cape May, Cumberland, Gloucester, Ocean and Salem.
4	Fort McHenry, Baltimore, Md.	Delaware..... Maryland..... District of Columbia Virginia.....	Newcastle. All Counties. Do. Arlington, Clark, Fairfax, Fauquier, Frederick, Loudoun, Page, Prince William, Rappahannock, Shenandoah, and Warren.
5	Customhouse, Norfolk, Va.	Delaware..... Virginia..... North Carolina.....	Kent and Sussex. All except district 4. All except district 6.
6	411 New P. O. Bldg., Atlanta, Ga.	Alabama..... Georgia..... South Carolina..... Tennessee..... North Carolina.....	All Counties. Do. Do. Do. Ashe, Avery, Buncombe, Burke, Caldwell, Cherokee, Clay, Cleveland, Graham, Haywood, Henderson, Jackson, McDowell, Macon, Madison, Mitchell, Polk, Rutherford, Swain, Transylvania, Watauga, and Yancey.
7	P. O. Box 150, Miami, Fla.	Florida..... Puerto Rico..... Virgin Islands.....	All Counties. Do. Do.
8	Customhouse, New Orleans, La.	Arkansas..... Louisiana..... Mississippi..... Texas.....	Do. Do. Do. Do. City of Texarkana only.

MICROPHONE FOR AMATEURS

Inexpensive - Efficient

The Wright-DeCoster Model TBC1000 makes an excellent dynamic microphone for amateur use. The unit is so ruggedly constructed that it will stand much hard usage and it does not become noisy with age.

Because of the high sensitivity of this microphone little preamplification is required.

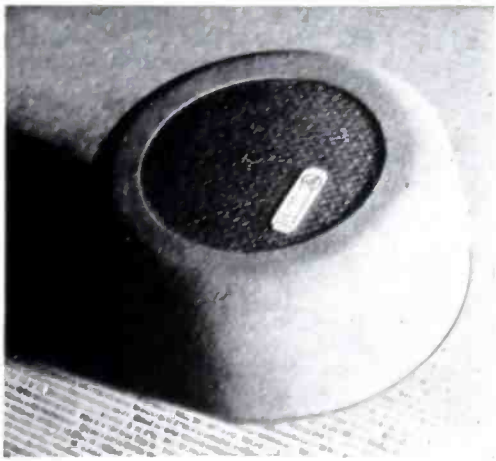

TBC1000

The cabinet is only 6½" in diameter and is finished in soft suede which lends a distinctive appearance and makes the unit an attractive addition to any amateur station. The unit may be mounted on the wall or laid flat on the operator's desk. The soft finish protects the finest furniture.

Besides being an excellent microphone the TBC-1000 is a very efficient speaker which has exceptional quality on voice reproduction. When used with a double-pole, double-throw switch this unit may be operated as a microphone when transmitting and as a speaker when receiving.

Write for literature and name of our nearest distributor.

Wright-De Coster Distributors are always anxious to cooperate.

Wright-DeCoster, Inc.

269 University Ave. Saint Paul, Minn.

Export Department:

The M. SIMONS & SON CO., New York
Cable Address: "Simontrica"

Eastern Canada:

WILLIAM F. KELLY CO. TAYLOR & PEARSON, Inc.
1207 Bay Street
Toronto, Ont., Canada

Western Canada:

Edmonton, Alberta,
Canada



I'LL SEND YOU A RADIO LESSON

and my
BOOK

FREE!



*Make \$15, \$20, \$25 a Week Spare Time,
Then \$35 to \$60 a Week Full Time*

ILL show you right away how I train men at home to make good money in Radio: I'll send you my famous book "More Money in Radio", and one of my unique "Business Builder" Lessons that show where the jobs are, how to get them, and how to handle them.



\$175 A Month
Meet my student Joseph Arizabalo who says: "Now I'm in charge of the repair department of a big distributor—a permanent job. Thanks to your course, which was interesting and easy to understand. I'm making \$175 a month."

No Experience Needed

Don't let lack of experience either in Radio or in Business Methods keep you from getting a start! I have started hundreds of men on the road to better pay by showing them how to pick up spare-time cash while learning, and then step into good-pay jobs when they are trained. Radio needs trained men! Radio needs YOU!

Professional Equipment Sent

As I train you, I send you full professional Radio equipment: Big Tool Kit. Genuine Triplett Tester. Complete Set of Rider Manuals. Repair and Replacement Parts—practically a complete Radio shop!



Special Course for Servicemen

If you are already in the Radio Service business, I have what you need to get the better jobs: A new 45-lesson practical course in Radio repair work that puts you ahead of your competitors. Men taking this course report greatly increased income. You can have it on terms **AS LOW AS \$3 PER MONTH.**



Get complete facts about both courses in my free book "More Money in Radio"—see how I train you from the free lesson also sent. Write to me for complete facts and free books TODAY. P. L. Sprayberry, President, Sprayberry Academy of Radio.

SPRAYBERRY ACADEMY OF RADIO

60 UNIVERSITY PLACE, N. W. WASH., D. C.

Radio district	Address of the Inspector in charge	Territory within district	
		States	Counties
9	209 Prudential Building, Galveston, Tex.	Texas.....	Aransas, Brazoria, Brooks, Calhoun, Cameron, Chambers, Fort Bend, Galveston, Goliad, Harris, Hidalgo, Jackson, Jefferson, Jim Wells, Kennedy, Kleberg, Matagorda, Nueces, Refugio, San Patricio, Victoria, Wharton, and Willacy.
10	164 Federal Building, Dallas, Tex.	Texas.....	All except district 9 and the city of Texarkana.
11	1105 Rives-Strong Building, Los Angeles, Calif.	Oklahoma..... New Mexico..... Arizona..... Nevada..... California.....	All Counties. Do. Do. Clarke. Imperial, Kern, Kings, Los Angeles, Monterey, Orange, Riverside, San Bernardino, San Diego, San Luis Obispo, Santa Barbara, Tulare, and Ventura.
12	Customhouse, San Francisco, Cal.	California..... Nevada..... Hawaiian Islands..... Guam..... American Samoa..... Oregon.....	All except district 11. All except Clarke All Counties. Do. Do. Do.
13	207 New U. S. Court House Bldg., Portland, Ore.	Idaho.....	All except district 14.
14	808 Federal Office Building, Seattle, Wash.	Alaska..... Washington..... Idaho..... Montana.....	All Counties. Do. Benewah, Bonner, Boundary, Clearwater, Idaho, Kootenai, Latah, Lewis, Nez Perce and Shoshone. Beaverhead, Broadwater, Cascade, Deerlodge, Flathead, Gallatin, Glacier, Granite, Jefferson, Lake, Lewis and Clark, Lincoln, Madison, Meagher, Mineral, Missoula, Pondera, Powell, Ravalli, Sanders, Silver Bow, Teton, and Toole.
15	538 Customhouse, Denver, Colo.	Colorado..... Utah..... Wyoming..... Montana.....	All Counties. Do. Do. Except district 14.
16	Room 927, New P. O. Bldg., St. Paul, Minn.	North Dakota..... South Dakota..... Minnesota..... Michigan.....	All Counties. Do. Do. Alger, Baraga, Chippewa, Delta, Dickinson, Gogebic, Houghton, Iron, Keweenaw, Luce, Mackinac, Marquette, Menominee, Antonagon, and Schoolcraft.
17	410 Federal Bldg., Kansas City, Mo.	Wisconsin..... Nebraska..... Kansas..... Missouri.....	All except district 18. All Counties. Do. Do.
18	2022 Engineering Building, Chicago, Ill.	Iowa..... Indiana..... Illinois..... Iowa.....	All except district 18. All Counties. Do. Allamakee, Buchanan, Cedar, Clayton, Clinton, Delaware,

NEW SQUARE METERS
ESPECIALLY ADAPTED
TO AMATEUR USE

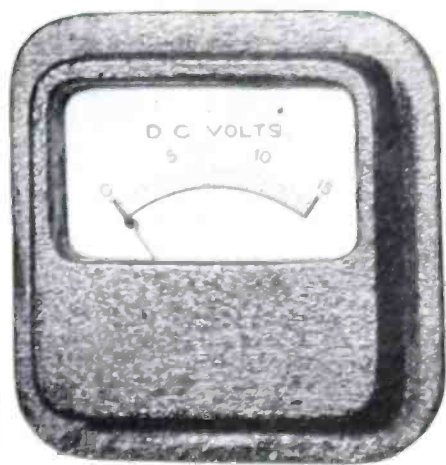

MODEL
95

Case Size: 2-9/16 x 2-5/8"
3/8" in Front of Panel
7/16" Back of Panel

Voltmeters, ammeters, milliammeters, in all popular ranges — A. C. and D. C.

Inexpensive instruments, thoroughly reliable for many applications in the amateur radio field.

RUGGEDLY CONSTRUCTED—DEPENDABLE—LOW COST
For more information and prices See Your Jobber or write

READRITE METER WORKS

738 College Dr., Bluffton, Ohio

ELECTRO-VOICE

MICROPHONES

- Hum Free
- Shock Proofed
- Streamlined
- High Fidelity
- Precision Built



NOTICE

Every Electro-Voice "mike" carries an unlimited guarantee. At Your Favorite Supplier.

FREE Send Today For **FREE** Catalog No. 20

ELECTRO-VOICE MFG. CO., INC.
300 E. Colfax Ave., South Bend, Ind.
Export Office: 100 Varick St., New York, N. Y.

Get a whole shelf-full
of **RADIO BOOKS**

IN ONE
BIG
VOLUME

\$4-



RADIO PHYSICS COURSE

- CLEAR
- COMPLETE
- UP-TO-DATE
- ECONOMICAL

GHIRARDI

The *COMPLETE Ghirardi*
RADIO PHYSICS COURSE

**ONE BIG BOOK
NOW TAKES THE PLACE OF 36 !**

Ghirardi's best-selling **RADIO PHYSICS COURSE** compresses the world's knowledge of radio, electricity and sound between the covers of this great 172-page volume. Don't be satisfied with the dribs and drabs you get when you buy a lot of "little" books. Ever figured up how much they cost you all together? Get "Ghirardi" and get it all—a whole library in 1 big book—for only \$4! The ideal way to learn radio and hit yourself for a better job. You don't have to "study"—just read, and the whole subject is made so plain and easy you can't ever forget it. Hundreds of illustrations make it quick to grasp. Schools and students all over the globe use it more than any other radio text. You, too, should be using Ghirardi. Clip the coupon and get it now! It's guaranteed.

What You Will Learn From This Book

- Sound, Speech and Music . . . Electrons
- Electric Current . . . Electric Units and Circuits
- Resistance . . . Ohm's Law . . . Batteries
- Magnetism . . . Electromagnetism
- Transformers . . . Inductance . . . Condensers
- Alternating Current Circuits . . . Filters . . .
- Electrical Measuring Instruments . . . Radio
- Waves and Radiations . . . Broadcast Stations
- Receiving Equipment . . . Vacuum Tubes
- Radio and Audio Frequency Amplification
- Superheterodynes . . . Loud Speakers
- Battery Operated Receivers . . . Power Supply
- Units . . . Electric Receivers . . . Automobile
- and Aircraft Receivers . . . Phonograph Pickups
- P. A. Systems . . . Short-Wave Receivers
- Photoelectric Cells . . . Television
- Antennas and Grounds . . . Testing and Servicing
- Receivers . . . Sound Motion Pictures
- Appendixes . . . 856 Review Questions for Self-Study . . . AND LOTS MORE!

TEAR OFF — FILL OUT — AND MAIL!

RADIO & TECHNICAL PUBLISHING CO.
45 Astor Place, New York, Dept. G-2
 Encl. and \$4. Send my **RADIO PHYSICS COURSE** postpaid. (Foreign \$4.50).
 Send me a free circular describing this book.
Name _____
Address _____

MONEY-BACK GUARANTEE

			Des Moines, Dubuque, Fayette Henry, Jackson, Johnson Jones, Lee, Linn, Louisa, Muscatine, Scott, Washington, and Winneshiek.
		Wisconsin.....	Columbia, Crawford, Dane, Dodge, Grant, Green, Iowa, Jefferson, Kenosha, Lafayette, Milwaukee, Ozaukee, Racine, Richmond, Rock, Sauk, Walworth, Washington, and Waukesha.
19	1025 New Federal Bldg., Detroit, Michigan	Michigan.....	All except district 16.
		Ohio.....	All Counties.
		Kentucky.....	Do.
		West Virginia.....	Do.
20	514 Federal Building, Buffalo, N. Y.	New York.....	All except district 2.
		Pennsylvania.....	All except district 3.

30a. Examining Cities—Examinations for all classes of radio operator licenses will be given frequently at Washington, D. C., and the District Offices of the Commission in accordance with announced schedules.

(1) Such examinations will be held quarterly at:

Schenectady, N. Y.
 Winston-Salem, N. C.
 Nashville, Tenn.
 San Antonio, Tex.
 Oklahoma City, Okla.
 Des Moines, Iowa
 St. Louis, Mo.
 Pittsburgh, Pa.
 Cleveland, Ohio
 Cincinnati, Ohio
 Columbus, Ohio

(2) Examinations will be held not more than twice annually at:

Albuquerque, N. Mex.
 Billings, Montana
 Bismark, N. Dakota
 Boise, Idaho
 Butte, Montana
 Jacksonville, Fla.
 Little Rock, Ark.
 Phoenix, Ariz.
 Salt Lake City, Utah
 Spokane, Washington

188. Station.—The term "station" means all of the radio-transmitting apparatus used at a particular location for one class of service and operated under a single instrument of authorization. In the case of every station other than broadcast, the location of the station shall be considered as that of the radiating antenna.

192. Portable station.—The term "portable station" means a station so constructed that it may conveniently be moved about from place to place for communication and that is in fact so moved about from time to time, but not used while in motion.

a. Portable-mobile station.—The term "portable-mobile station" means a station

so constructed that it may conveniently be moved from one mobile unit to another for communication, and that is, in fact, so moved about from time to time and ordinarily used while in motion.

204. Allocation of bands of frequencies to services.—Allocations of bands of frequencies to services, such as mobile, fixed, broadcast, amateur, etc., are set forth in article 5 of the General Regulations annexed to the International Radiotelegraph Convention and in the North American Radio Agreement. These allocations will be adhered to in all assignment to stations capable of causing international interference.

207—Interference, prevention of.—Licensees shall use radio transmitters, the emissions of which do not cause interference, outside the authorized band, that is detrimental to traffic and programs of other authorized stations.

210.....Distress messages.—Radio communications or signals relating to ships or aircraft in distress shall be given absolute priority. Upon notice from any station, Government or commercial, all other transmission shall cease on such frequencies and for such time as may, in any way, interfere with the reception of distress signals or related traffic.

213. Operators.—One or more licensed operators, of the grade specified by these regulations shall be on duty at the place where the transmitting apparatus of each station is located and whenever it is being operated; provided, however, that for a station licensed for service other than broadcasting, and remote control is used, the Commission may modify the foregoing requirements, upon proper application and showing being made, so that such operator or operators may be on duty at the control station in lieu of the place where the transmitting apparatus is located. Such modification shall be subject to the following conditions:

ASTATIC

MODEL T-3 MICROPHONE PRAISED for FLEXIBILITY



Unique tilting mount permits directional or non-directional pickup without disturbing frequency response. No yoke and no annoying cable entanglements or breakage. Diaphragm type for high class public address, broadcast, recording or amateur use. Acoustic feedback definitely reduced. Attractively shaped. Beautiful polished chromium finish. Complete with Astatic exclusive interchangeable plug and socket cable connector, cable and spring cable protector. Fully guaranteed.

LIST PRICE \$25.00

SEND FOR LITERATURE on other new Astatic Microphones including unique "GRIP-TO-TALK" Model CD-104, for air-way ground stations, inter-office, inter-factory, amateur and other similar communicating systems.

Licensed under Brush Development Co. Patents
Astatic Microphone Laboratory, Inc.
DEPT. C-2, YOUNGSTOWN, OHIO, U. S. A.
Pioneer Manufacturers of Quality Crystal Devices

The BEGINNERS' FRIEND!

The Newcomer to Amateur radio knows well enough that there are times when he really needs a friend. Sun Radio Company, too, knows that these Beginners require Special Cooperation in the matter of selective buying.

Here at Sun Radio we invite inquiries and orders from Beginners. We are especially equipped to serve intelligently and honestly and to render advice on "tough" problems as they arise.

We carry all nationally advertised lines of Amateur Radio Supplies, Receivers, Parts, Tubes and Accessories. Send us your want list or better still visit us, for special quotations. Experienced hands always on hand to help you. Address Dept. GHB.

SUN RADIO CO.
227 Fulton Street, New York, N. Y.
Cable Address: SUNRADIO NEW YORK

Open or Shielded COIL FORMS

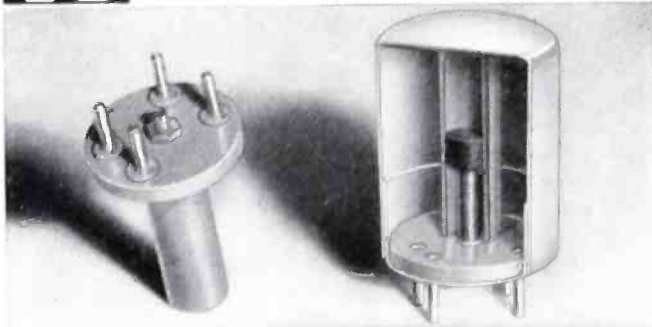

- Use for RF coils, RF filters, or hi-frequency RF chokes.
- May be used for universal, single layer solenoid, or bank type windings.
- .093" base pins removable for permanent mounting.
- High dielectric strength - uniform operation.

AMATEURS

You can now safely build R. F. coils—filters and hi-frequency R. F. chokes. These coil forms, made by the world's finest builders of radio testing equipment, are your guarantee of efficient receiver and transmitter operation. Power factor at 1,000,000 cycles per second is .007. Water absorption gain .07%. Adjustable iron core for changing coil inductance. Clear lacquered Eraydo metal shield. See your favorite parts dealer or write factory today.

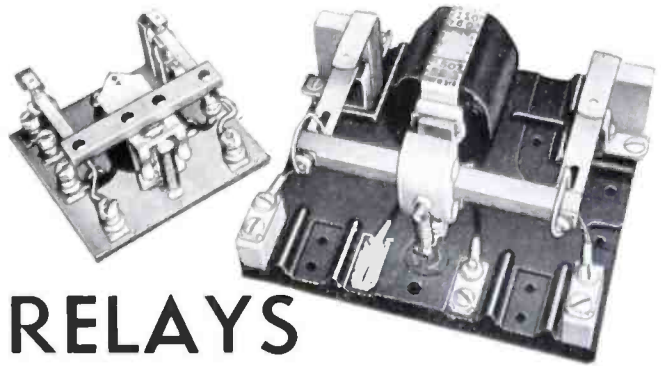

RELAYS for Antenna Changeover

You need one of these relays to change automatically from sending to receiving. You will find these Relays described on pages 5 and 6 of bulletin 507B. Send for a copy.

WARD LEONARD RADIO SPECIALTIES

WARD LEONARD ELECTRIC COMPANY
South Street, Mount Vernon, New York

Name.....
Street.....
City and State.....
Call SignalSW

The CLOUGH-BREngle CO.

2813-Z W. 19th St.

Chicago, Ill.

a. The transmitter shall be capable of operation and shall be operated in accordance with the terms of the station license.

b. The transmitter shall be monitored from the control station with apparatus that will permit placing the transmitter in an inoperative condition in the event there is a deviation from the terms of the license, in which case the radiation of the transmitter shall be suspended immediately until corrective measures are effectively applied to place the transmitter in proper condition for operation in accordance with the terms of the station license.

c. The transmitter shall be so located or housed that it is not accessible to other than duly authorized persons.

214. **Licensed operator required.**—Only an operator holding radiotelegraph class of operators' license may manipulate the transmitting key of a manually operated coastal telegraph or mobile telegraph station in the international service; and only a licensed amateur operator may manipulate the transmitting key at a manually operated amateur station. The licenses of other stations operated under the constant supervision of duly licensed operators may permit any persons whether licensed or not, to transmit by voice or otherwise, in accordance with the types of emission specified by the respective licenses.

220. **Maintenance tests.**—Licenses of stations other than broadcast stations are authorized to carry on such routine tests as may be required for the proper maintenance of the stations: Provided, however, that these tests shall be so conducted as not to cause interference with the service of other stations.

221. **Licenses, posting of.**—The original of each station license, except amateur, portable and portable-mobile stations shall be posted by the licensee in a conspicuous place in the room in which the transmitter is located. In the case of amateur, portable, and portable-mobile stations the original license, or a photostat copy thereof, shall be similarly posted or kept in the personal possession of the operator on duty.

a. The original license of each station operator, except amateur and aircraft radio station operators of portable and portable-mobile stations, shall be posted in a conspicuous place in the room occupied by such operator while on duty. In the case of an amateur or aircraft radio operator, and operators of portable or portable-mobile stations, the original operator's license shall be similarly posted or kept in his personal possession and available for inspection at all times while the operator is on duty.

(b) When an operator's license cannot be posted because it has been mailed to an office of the Federal Communications Commission for endorsement or other change, such operator may continue to operate sta-

tions in accordance with the class of license held, for a period not to exceed 30 days, but in no case beyond the date of operation of the license.

361. **Definitions, amateur service.**—The term "amateur service" means a radio service carried on by amateur stations.

362. **Definition, amateur station.**—The term "amateur station" means a station used by an "amateur," that is, a duly authorized person interested in radio technique solely with a personal aim and without pecuniary interest.

364. **Definition amateur operator.**—The term "amateur radio operator" means a person holding a valid license issued by the Federal Radio Commission who is authorized under the regulations to operate amateur radio stations.

365. **Definition, amateur radio communication.**—The term "amateur radio communication" means radio-communication between amateur radio stations solely with a personal aim and without pecuniary interest.

366. **Station licenses.**—An amateur station license may be issued only to a licensed amateur radio operator who has made a satisfactory showing of ownership or control of proper transmitting apparatus: Provided, however, that in the case of a military or naval reserve radio station located in approved public quarters and established for training purposes, but not operated by the United States Government, a station license may be issued to the person in charge of such a station who may not possess an amateur operator's license.

(a.) **Operator's license.**—An amateur operator's license may be granted to a person who does not desire an amateur station license, provided such applicant waives his right to apply for an amateur station license for 90 days subsequent to the date of application for operator's license.

367. **Eligibility for license.**—Amateur radio station licenses shall not be issued to corporation, associations, or other organizations; Provided, however, that in the case of a bona fide amateur radio society station license may be issued to a licensed amateur radio operator as trustee for such society.

368. **Mobile stations.**—Licenses for mobile stations and portable mobile stations will not be granted to amateurs for operation on frequencies below 28,000 kc. However, the licensee of a fixed amateur station may operate portable amateur stations (Rule 192) in accordance with the provisions of Rules 384, 386, and 387; and also portable and portable-mobile amateur stations (Rules 192 and 192a) on authorized amateur frequencies above 28,000 kc. in accordance with Rules 384 and 386, but without regard to Rule 387.

370. **Points of communication.**—Amateur stations shall be used only for amateur

the **AMPERITE** **VELOCITY** with **NEW DESK STAND**

NAME



Ideal for desk, pulpit, footlights, banquets. Leaf spring suspension acts as shock absorber. **STAND ONLY** ... LIST \$4.00 **NAME PLATE** with call letters ... LIST \$2.00

MICROPHONES: Model RBHn (High Imped.); or RBMn (200 ohms) with cable connector & switch ... LIST \$42.00 Models RBSn, RSHn, with switch only ... LIST \$32.00

NEW "HAM MIKE"

No Peaks! No Splashing! Real Broadcast Quality! RF Choke Circuit Included in microphone. Output, -68 db. Operates directly into grid. **MODEL HAM** (High Imped.) or **MODEL HAL** (200 ohms) ... Gun-metal. LIST \$22.00. Chrome LIST \$23.00. Price includes Ham Desk Stand, Call Letters, and 6 feet of cable.

Ask
Your
Jobber!

FREE: Window Decal
& Window Display

AMPERITE Co. 561 BROADWAY, N. Y.

AMPERITE Velocity **MICROPHONE**

PAR-METAL RACKS-PANELS-CABINETS



PAR-METAL offers you a uniform line of standardized metal products that enables you to quickly build up a job that is professional both in construction and appearance.

All of the parts shown are available in various standard sizes—a complete line that will meet almost every requirement.

Write for copy of our new catalog number 38
PAR-METAL PRODUCTS CORPN.
35-27 41st ST., LONG ISLAND CITY, N. Y.

35 years of Reliable Merchandising

DISTRIBUTORS OF:

NATIONAL

HAMMARLUND

THORDARSON

HALLICRAFTERS

RAYTHEON

CARDWELL

TRIPLETT

TAYLOR TUBES

KENYON

EIMAC

RCA

RME

"HAM HEADQUARTERS"

W3AGV-W3BES-W3DMQ-W3GML-W3UT
M. & H. SPORTING GOODS COMPANY

512 Market St.
Phila., Pa.

1709 Atlantic Ave.
Atlantic City, N. J.

Press Lever- SEMI-AUTOMATIC KEY DOES THE REST

IMPROVES
SENDING

Cuts
Effort
In Half

Genuine Martin
VIBROPLEX
Semi-Automatic Key

JUNIOR

ONLY
\$12.50

Small and more compact. Large contact points. Black japanned base. A low priced key with world famous Vibroplex Quality. Other models, \$17 and \$19.

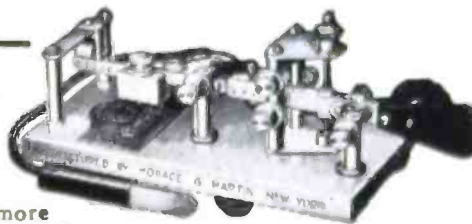

Every code sender wants to be a **GOOD, CLEAR, FAST** sender — **YOU** can be with a New Genuine Martin Vibroplex semi-automatic key. Over 100,000 operators have found sending with a Vibroplex the easiest, fastest and best way to send. Faster than the fastest; hand sender—less than half the effort. Easy to learn, Easy to use. Easy to own. Order to-day! Insist on the Genuine Martin Vibroplex key. Accept no substitute. Your old Vibroplex accepted as part payment. Money order or registered mail. Write for **FREE** illustrated catalog.

Free
Illustrated
Catalog

THE VIBROPLEX CO.

832 Broadway

New York, N. Y.

service, except that in emergencies or for testing purposes they may be used also for communication with commercial or Government radio stations. In addition, amateur stations may communicate with any mobile radio station which is licensed by the Commission to communicate with amateur stations, and with stations of expeditions which may also be authorized to communicate with amateur stations.

371. Amateur stations not to be used for broadcasting.—Amateur stations shall not be used for broadcasting any form of entertainment, nor for the simultaneous retransmission by automatic means of programs or signals emanating from any class of station other than amateur.

372. Radiotelephone tests.—Amateur stations may be used for the transmission of music for test purposes of short duration in connection with the development of experimental radiotelephone equipment.

373. Amateur stations not for hire.—Amateur radio stations shall not be used to transmit or receive messages for hire, nor for communication for material compensation, direct or indirect, paid or promised.

374. Frequency bands assigned.—The following bands of frequencies are allocated exclusively for use by amateur stations:

1,715 to 2,000 kilocycles
 3,500 to 4,000 kilocycles
 7,000 to 7,300 kilocycles
 14,000 to 14,400 kilocycles
 28,000 to 30,000 kilocycles
 56,000 to 60,000 kilocycles
 400,000 to 401,000 kilocycles

374a. The licensee of an amateur station may, subject to change upon further order, operate amateur stations on any frequency above 110,000 kilocycles, without separate license therefor, provided:

(1) That such operation in every respect complies with the Commission's rules governing the operation of amateur stations in the amateur service.

(2) That records are maintained of all transmissions in accordance with the provisions of Rule 386.

375. Types of emission.—All bands of frequencies so assigned may be used for radio telegraphy, type A-1 emission. Type A-2 emission may be used in the following bands of frequencies only:

28,000 to 30,000 kilocycles
 56,000 to 60,000 kilocycles
 400,000 to 401,000 kilocycles

376. Frequency bands for telephony. The following bands of frequencies are allocated for use by amateur stations using radiotelephony, type A-3 emission:

1,800 to 2,000 kilocycles
 28,000 to 29,000 kilocycles
 56,000 to 60,000 kilocycles
 400,000 to 401,000 kilocycles

377. Additional bands for telephony.—Provided the station shall be operated by a person who holds an amateur operator's license endorsed for class A privileges, an amateur radio station may use radiotelephony, type A-3 emission, in the following additional bands of frequencies:

3,900 to 4,000 kilocycles
 14,150 to 14,250 kilocycles

378. Amateur television, facsimile, and picture transmission.—The following bands of frequencies are allocated for use by amateur stations for television, facsimile, and picture transmission.

1,715 to 2,000 kilocycles
 56,000 to 60,000 kilocycles

379. Licenses will not specify individual frequencies.—Transmissions by an amateur station may be on any frequency within an amateur band above assigned.

380. Aliens.—An amateur radio station shall not be located upon premises controlled by an alien.

381. Prevention of interference.—Spurious radiations from an amateur transmitter operating on a frequency below 30,000 kilocycles shall be reduced or eliminated in accordance with good engineering practice and shall not be of sufficient intensity to cause interference on receiving sets of modern design which are tuned outside the frequency band of emission normally required for the type of emission employed. In the case of A-3 emission, the transmitter shall not be modulated in excess of its modulation capability to the extent that interfering spurious radiations occur, and in no case shall the emitted carrier be amplitude-modulated in excess of 100 per cent. Means shall be employed to insure that the transmitter is not modulated in excess of its modulation capability. A spurious radiation is any radiation from a transmitter which is outside the frequency band of emission normal for the type of transmission employed, including any component whose frequency is an integral multiple or submultiple of the carrier frequency (harmonics and subharmonics), spurious modulation products, key clicks and other transient effects, and parasitic oscillations.

381. Waiver of Rule 381.—The following order was adopted by the Telegraph Division on August 1, 1934:

"Until further notice, the provisions of Rule 381 shall not be construed to apply to amateur operation on frequencies above 56,000 kilocycles."

382. Power supply to transmitter.—Licensees of amateur stations using frequencies below 30,000 kilocycles, shall use adequately filtered direct-current power supply for the transmitting equipment, to minimize frequency modulation and to prevent the emission of broad signals.

RCA INSTITUTES

A RADIO CORPORATION OF AMERICA SERVICE

Thorough Training Courses
In All Technical Phases Of

RADIO

RESIDENT SCHOOLS IN
NEW YORK and CHICAGO

Day and Evening Classes
Weekly Tuition Rates

EXTENSION COURSES
FOR HOME STUDY

Catalog Sent on Request
Address Dept. RA-37

RCA INSTITUTES, Inc.

75 VARICK ST. 1154 MERCHANDISE MART
NEW YORK CHICAGO

Recognized Standard in Radio Instruction Since 1909

AMATEUR RADIO SPECIALISTS HEADQUARTERS IN WESTERN NEW YORK

Representing the best in amateur parts. We stock quality merchandise of leading manufacturers. Aladdin Products; Amphenol sockets; Centralab; Cornell Dubilier; Cardwell condensers; Coto coils; Eby products; General transformers; Gordon Specialties; Hammarlund Products; Hallicrafters; Insuline Products; I.R.C. resistors; Johnson Products; Meissner Products; National Union Tubes; Ohmite Resistors; Radio Mfg. Engineers; R.M.E.; Raytheon Transmitting tubes; Speedex Keys; Sprague; Taylor tubes; Thordarson Transformers; and many other items. Mail orders promptly filled.

RADIO PARTS & EQUIPMENT CO.
244 CLINTON AVENUE NORTH
ROCHESTER, N. Y.

"SERVICE WITH EVERY SALE"

VELOTRON

MODEL
S P



Small enough to be used for detective and contact pick-up, or as a lapel microphone! Incorporates all the outstanding features of the famous Velotron! Output and quality high enough for general microphone requirements.

SPECIFICATIONS

Output	55 lb.
Impedance	to grid
Freq. response	Adjustable (30 to 14,000) C.P.S.
Pol. voltage	150 to 350 volts
Size	2 1/8 x 2 3/4 x 1/2"
MODEL	YOUR COST
SP (gunmetal finish)	\$7.94
SP-C (chromium finish)	8.54

For better results insist on "BRUNO"

BRUNO LABORATORIES, Inc.
30 WEST 15 ST., N. Y. C.

"JUST LISTEN" LEARN WITH THE AUTOMATIC CODE Omnigraph

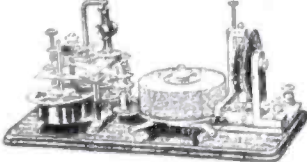
Metal		Easy
Dials		Quick
Changed		Cheap
FREE		Expert

OMNIGRAPH TRAINING HAS HELPED THOUSANDS

to secure ideal positions. You can get "places" too. Started over 37 years ago when Radio was in its infancy, the Omnigraph has proven its worth by actual use. Beginners, Amateurs and Operators agree the Omnigraph is the best for Code. Sends thousands of message combinations. Automatically changed without stop. Practical and foolproof. LIKE LEARNING FROM AN EXPERT. Omnigraph owners for over 30 years still write us. Your first cost, the last expense. Priced right and everlasting.

When you buy the Omnigraph, you buy "STANDARD QUALITY" and excellence.

Write for booklet M

The Omnigraph Co.
810 EAST 39th ST. BROOKLYN, N. Y.

383. **Authorized power.**—Licensees of amateur stations are authorized to use a maximum of power input of 1 kilowatt to the plate circuit of the final amplifier stage of an oscillator-amplifier transmitter or to the plate circuit of an oscillator transmitter.

384. **Transmission of call.**—An operator of an amateur station shall transmit its assigned call at least once during each 15 minutes of operation and at the end of each transmission. In addition, an operator of an amateur portable, or portable-mobile radiotelegraph station shall transmit immediately after the call of the station, the break sign (*BT*) followed by the number of the amateur call area in which the portable or portable-mobile amateur station is then operating, as for example:

Example 1. Portable or portable-mobile amateur station operating in the third amateur call area calls a fixed amateur station: W1ABC W1ABC W1ABC DE W2DEF, *BT*3 W2DEF *BT*3 W2DEF *BT*3 *AR*

Example 2. Fixed amateur station answers the portable or portable-mobile amateur station: W2DEF W2DEF W2DEF DE W1ABC W1ABC W1ABC *K*

Example 3. Portable or portable-mobile amateur station calls a portable or portable-mobile amateur station: W3GHI W3GHI W3GHI DE W4JKL *BT*4 W4JKL *BT*4 W4JKL *BT*4 *AR*

If telephony is used, the call sign of the station shall be followed by an announcement of the amateur call area in which the portable or portable-mobile station is operating.

384a. In the case of an amateur licensee whose station is licensed to a regularly commissioned or enlisted member of the United States Naval Reserve, the Commandant of the naval district in which such reservist resides may authorize in his discretion the use of the call letter prefix "N," in lieu of the prefix "W" or "K" assigned in the license issued by the Commission, provided that such "N" prefix shall be used only when operating in the frequency bands 1715-2000 kilocycles, 3500-4000 kilocycles, 56,000 to 60,000 kilocycles and 400,000 to 401,000 kilocycles in accordance with instructions to be issued by the Navy Department.

385. **Quiet hours.**—In the event that the operation of an amateur radio station causes general interference to the reception of broadcast programs with receivers of modern design, that amateur station shall not operate during the hours from 8 o'clock p.m. to 10:30 p.m., local time, and on Sun-

day from 10:30 a.m., until 1 p.m., local time, upon such frequencies as cause such interference.

386. **Logs.**—Each licensee of an amateur station shall keep an accurate log of station operation to be made available upon request by authorized Government representatives, as follows:

a. The date and time of each transmission. The date need only be entered once for each day's operation. The expression "time of each transmission" means the time of making a call and need not be repeated during the sequence of communication immediately follows; however, an entry shall be made in the log when "signing off" so as to show the period during which communication was carried on.)

b. The name of the person manipulating the transmitting key of a radiotelegraph transmitter or the name of the person operating a transmitter of any other type (type A13 or A14 emission) with statement as to type of emission. (The name need only be entered once in the log provided the log contains a statement that all transmissions were made by the person named except where otherwise stated. The name of any other person who operates the station shall be entered in the proper space for his transmissions.)

c. Call letters of the station called. (This entry need not be repeated for calls made to the same station during any sequence of communication provided the time of "signing off" is given.)

d. The input power to the oscillator, or to the final amplifier stage where an oscillator amplifier transmitter is employed. (This need be entered only once providing the input power is not changed.)

e. The frequency band used. (This information need be entered only once in the log for all transmissions until there is a change in the frequency to another amateur band.)

f. The location of a portable or portable-mobile station at the time of each transmission. This need be entered only once, provided the location of the station is not changed. However, suitable entry shall be made in the log upon changing location, showing the type of vehicle or mobile unit in which the station is operated, and the approximate geographical location of the station at the time of operation.)

g. The message traffic handled. (If record communications are handled in regular message form, a copy of each message sent and received shall be entered in the log or retained on file for at least one year.)

387. **Portable stations.**—Advance notice of all locations in which portable amateur stations will be operated shall be given by the licensee to the inspector in charge of

American **DYNAMIC**

- Exceptionally Rugged
- High Output, Low or High Impedance
- Minimum Feedback
- Immune to Temperature Changes
- Excellent Frequency Response



**Multi-Purpose
Modern Design
Low Price**

Approaches the ideal for general use due to its versatility and dependability

The D-5 10,000 Ohms. Imp.
List Price \$32.50

The D-5-T 50 Ohms Imp.
List Price \$27.50

(Both include 25' cable and plug)

Write Today for Free Catalogue on DYNAMIC, CRYSTAL, CARBON and CONDENSER MICROPHONES, STANDS and ACCESSORIES.

**AMERICAN MICROPHONE CO.
INC., LTD.**
1915 S. Western Ave. Los Angeles, Cal.

THREE TUBE A. C.—D.C. **\$3 20** ALL WAVE AIR SCOUT **WITH** PHONE

Model 3A-E

Less Tubes, Unwired

A powerful sensitive all-wave set. Wonderful record for foreign reception. Brings in police calls, amateur, code, Transatlantic phone and broadcast entertainment. Excellent volume. Works from any A. C. or D. C. house current. Employs newest metal ballast tube as one of the tubes. Speaker mounts on panel. Range 9½ to 1500 meters. Kit includes: Earphone, broadcast coil, 70 to 200 meter coil. Panel, Chassis, High Grade Variable Condenser. Potentiometer, Antenna Trimmer, Dial, Sockets, Knobs, Wire, Resistors, etc.



Model 3A-E
Pat. No. 2,086,256

TWO-TUBE BATTERY SET — Model 2B. Complete kit including all parts listed above plus parts for extra stage **\$2.95** With Tube and including power tube... & Phone (unwired)

THREE-TUBE DE LUXE BATTERY SET — Model 3B. Complete kit including all parts in the 1-tube model plus parts for two extra audio stages including two 30-type tubes and **\$3.45** With Two Tubes 33 power output tube. & Phone (unwired)

Following auxiliary parts are available: 9½ to 20 meter coil 25c; 15 to 45 meter coil (foreign) 25c; 40 to 80 meter coil (foreign) 25c; 22½ volt "B" battery 75c; Two flashlight "A" batteries 10c each; 5" Find-All Loud Speaker \$1; Complete Antenna Kit 50c; Wood Screw Kit 10c. Tubes for Model 3A-E. each 45c. Long Wave Unit and coil for any model \$1. Double Earphones \$1.30. Bandsread attachment 75c. Any model wired extra 75c.

NOTE: If you already have earphones, two extra foreign coils may be substituted in any model.

H. G. CISH, Chief Eng., ALLIED ENG. INSTITUTE
98 Park Place Dept. RA New York, N. Y.

SINCE 1923

BLAN

has helped thousands to get more enjoyment out of

RADIO

as a hobby by supplying almost everything for almost every new circuit or article in most of the radio publications.

PLEASE

Do not confuse us with those mail order houses, who sell Radio parts as a side line.

5000

square feet, 3 floors crammed full of

RADIO PARTS

BLAN, THE RADIO MAN, Inc.
64 DEY STREET NEW YORK, N. Y.

LIFETIME

AMERICA'S OUTSTANDING VALUES!



Model 90
Velocity Mike
LIST \$35.00

Net to
Amateurs
\$17.45

Lifetime offers to the Ham and Public Address Man a complete line of microphones—unexcelled in quality and unbeatable in price. For years Lifetime has been acclaimed for its outstanding values in microphones and Sound Equipment.

A complete line of carbon, condenser, dynamic and Velocity microphones is shown in our attractively illustrated catalog.

Write for it — and get our amazingly attractive prices.

**THE LIFETIME
CORPORATION**

1010-1012 Madison Ave.
Toledo, O.

the district in which the station is to be operated. Such notices shall be made by letter or other means prior to any operation contemplated and shall state the station call, name of licensee, the date of proposed operation and the approximate locations, as by city, town or county. An amateur station operating under this rule shall not be operated during any period exceeding 30 days without giving further notice to the inspector in charge of the radio inspection district in which the station will be operated. This rule does not apply to the operation of portable or portable-mobile amateur stations on frequencies above 28,000 kc. authorized by amateur stations. (See Rule 368)

400. Only amateur operators may operate amateur stations.—An amateur station may be operated only by a person holding a valid amateur operator's license, and then only to the extent provided for by the class of privileges for which the operator's license is endorsed.

401. Validity of operator's license.—Amateur operator's licenses are valid only for the operation of licensed amateur stations, provided, however, any person holding a valid radio operator's license of any class may operate stations in the experimental service licensed for, and operating on, frequencies above 30,000 kilocycles.

402. Proof of use.—Amateur station licenses and or amateur operator licenses may, upon proper application, be renewed provided: (1) the applicant has used his station to communicate by radio with at least three other amateur stations during the 3-month period prior to the date of submitting the application, or (2) in the case of an applicant possessing only an operator's license, that he has similarly communicated with amateur stations during the same period. Proof of such communication must be included in the application by stating the call letters of the station with which communication was carried on and the time and date of each communication. Lacking such proof, the applicant will be ineligible for a license for a period of 90 days.

This rule shall not prevent renewal of an amateur station license to an applicant who has recently qualified for license as an amateur operator.

403. Class of operator and privileges.—There shall be but one main class of amateur operator's license, to be known as "amateur class," but each such license shall be limited in scope by the signature of the examining officer opposite the particular class or classes of privileges which apply, as follows:

Class A.—Unlimited privileges.

Class B.—Unlimited radiotelegraph privileges. Limited in the operation of ra-

diotelephone amateur stations to the following bands of frequencies: 1,800 to 2,000 kilocycles; 28,000 to 29,000 kilocycles; 56,000 to 60,000 kilocycles; 400,000 to 401,000 kilocycles.

Class C.—Same as class B privileges, except that the Commission may require the licensee to appear at an examining point for a supervisory written examination and practical code test during the license term. Failing to appear for examination when directed to do so, or failing to pass the supervisory examination, the license held will be canceled and the holder thereof will not be issued another license for the class C privileges.

404. Scope and places of examinations.—The scope of examinations for amateur operators' licenses shall be based on the class of privileges the applicant desires, as follows:

Class A.—To be eligible for examination for the class A amateur operator's privileges the applicant must have been a licensed amateur operator for at least 1 year and must personally appear at one of the Commission's examining offices, and take the supervisory written examination and code test. See pars. 2h (1), 30, and 408.) Examinations will be conducted at Washington, D. C. on Thursday of each week, and at each radio district office of the Commission on the days designated by the inspector in charge of such office. In addition, examinations will be held quarterly in the examining cities listed in paragraph 30 on the dates to be designated by the inspector in charge of the radio district in which the examining city is situated. The examination will include the following:

a. Applicant's ability to send and receive in plain language messages in the Continental Morse Code (5 character to the word) at a speed of not less than 13 words per minute.

b. Technical knowledge of amateur radio apparatus, both telegraph and telephone.

c. Knowledge of the provisions of the Communications Act of 1934, subsequent acts, treaties, and rules and regulations of the Federal Communications Commission, affecting amateur licensees.

Class B.—The requirements for class B amateur operators' privileges are similar to those for the class A, except that no experience is required and the questions on radiotelephone apparatus are not so comprehensive in scope.

Class C.—The requirements for class C amateur operators' privileges shall be the same as for the class B except the examination will be given by mail. Applicants for class C privileges must reside more than 125 miles air line from the nearest examining point for class B privileges, or in a camp of the Civilian Conservation Corps.

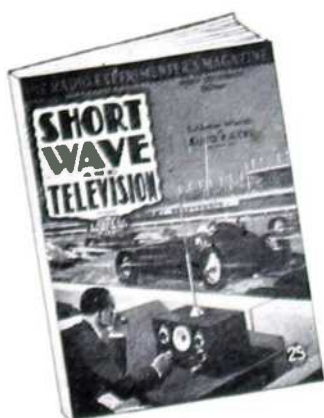

LEADS in EVERY ACTIVITY

of interest to
**EXPERIMENTERS
HAMS and FANS**

The EXPERIMENTER'S MAGAZINE

These Departments, with many other popular features, appear in every issue.

"GUEST EDITORIALS"
THE RADIO AMATEUR
SHORT WAVE SCOUTS
WORLD "SHORT-WAVE
STATION" LIST
LET'S "LISTEN IN"
WITH JOE MILLER
SHORT-WAVE "FAN AND
SET-BUILDER"
SHORT WAVE SET
CONSTRUCTION
TELEVISION
SHORT-WAVE "KINKS"
INTERVIEWS AND
PERSONALITIES
SHORT-WAVE "QUESTION
BOX"
BOOK REVIEWS
WHEN TO LISTEN IN
SHORT-WAVE "LISTENING
POST" REPORTS
"C. Q." COLUMN
NEW APPARATUS FOR THE
"HAM"
SHORT WAVE LEAGUE
SHORT WAVES AND
LONG WAVES
WORLD-WIDE SHORT-WAVE
REVIEW

*Sold on over 25,000 newsstands
and book stores all over the world.*

The only magazine in the world that offers a monthly trophy *absolutely free* to encourage Short Wave DX-ing.

This beautiful Trophy, standing 22½ inches high and designed by one of New York's leading silversmiths, is offered each month to the "short-wave listener" who sends in the longest list of short-wave stations heard and "verified". Fifty per cent of the list of stations must be "foreign". The base of the Trophy is made of handsome black bakelite and the Trophy is quadruple silverplated.



ANYONE may enter the contest. No dues—no fees—no obligation. Read the rules of the contest that appear in every issue.

Sample copy sent free.

SHORT WAVE & TELEVISION
99 HUDSON STREET, Dept. R, NEW YORK CITY

or be in the regular military or naval service of the United States at a military post or naval station; or be shown by physician's certificate to be unable to appear for examination due to protracted disability.

405. **Recognition of other classes of licenses.**—An applicant for any class of amateur operator's privileges who has held a radiotelephone second-class operator's license or higher, or an equivalent commercial grade license, or who has been accorded unlimited amateur radiotelephone privileges, within 5 years of the date of application may only be required to submit additional proof as to code ability and/or knowledge of the laws, treaties, and regulations affecting amateur licensees.

406. An applicant for the class B or C amateur operator's privileges who has held a radiotelegraph third-class operators' license or higher, or an equivalent commercial grade license, or who has held an amateur extra first-class license within 5 years of the date of application may be accorded a license by passing an examination in laws, treaties, and regulations affecting amateur licensees.

407. **Code ability to be certified by licensed operator.**—An applicant for the class C amateur operator's privileges must have his application signed in the presence of a person authorized to administer oaths by (1) a licensed radiotelegraph operator other than an amateur operator possessing only the class C privileges or former temporary amateur class license, or (2) by a person who can show evidence of employment as a radiotelegraph operator in the government service of the United States. In either case the radio telegraph code examiner shall attest to the applicant's ability to send and receive messages in plain language in the continental Morse code (5 characters to the word) at a speed of not less than 13 words per minute. The code certification may be omitted if the applicant can show proof of code ability in accordance with the preceding rule.

408. **Applications.**—Each application for an instrument of authorization shall be made in writing, under oath of the applicant, on a form prescribed and furnished by the Commission. Separate application shall be filed for each instrument of authorization requested.

The required forms may be obtained from the Commission or from any of its field offices.

409. **Grading of examinations.**—The percentage that must be obtained as a passing mark in each examination is 75 out of a possible 100. No credit will be given in the grading of papers for experience or knowledge of the code. If an applicant answers only the questions relating to laws, treaties, and regulations by reason of his right to submit other subjects because of having held a recognized class of license, a percentage of 75 out of a possible 100 must be obtained on the questions answered.

410. **Operator's and station licenses to run concurrently.**—An amateur station license shall be issued so as to run concurrently with the amateur operator's license and both licenses shall run for 3 years from the date of issuance. If either the station license or the operator's license is modified during the license term, both licenses shall be reissued for the full 3-year term: Provided, however, if an operator's license is modified only with respect to the class of operator's privileges, the old license may be endorsed, in which case the expiration date will not change.

411. **Eligibility for reexamination.**—No applicant who fails to qualify for an operator's license will be reexamined within 90 days from the date of previous examination.

412. **Penalty.**—Any attempt to obtain an operator's license by fraudulent means, or by attempting to impersonate another, or copying or divulging questions used in examinations, or, if found unqualified or unfit, will constitute a violation of the regulations for which the licensee may suffer suspension of license or be refused a license and/or debarment from further examination for a period not exceeding 2 years at the discretion of the licensing authority.

413. **Duplicate licenses.**—Any licensee applying for a duplicate license to replace an original which has been lost, mutilated, or destroyed, shall submit an affidavit to the Commission attesting to the facts regarding the manner in which the original was lost. Duplicates will be issued in exact conformity with the original and will be marked "duplicate" on the face of the license.

414. **Oath of secrecy.**—Licenses are not valid until the oath of secrecy has been executed and the signature of the licensee affixed thereto.

415. **Examination to be written in long-hand.**—All examinations including the code test, must be written in longhand by the applicant.

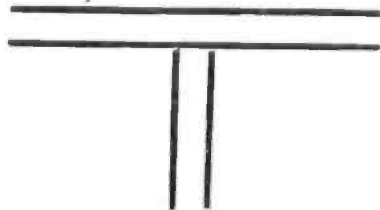

INDEX TO ADVERTISERS

A		N	
Aerovox Corporation.....	87	National Company, Inc.	Inside Back Cover
Aladdin Radio Industries, Inc.....	123	National Radio Institute	144
Allied Engineering Institute.....	139	O	
Allied Radio Corporation.....	71	Omnigraph Co., The	137
American Microphone Co., Inc., Ltd.	139	P	
Amperite Co.	135	Par-Metal Products Corpn.	135
Astatic Microphone Laboratory, Inc.	133	R	
Audak Company	99	Radio & Technical Publishing Co.	131
B		Radio Parts & Equipment Co.	137
Blan, the Radio Man, Inc.	139	Radio Training Assn. of America	103
Bliley Electric Co.	121	Raytheon Production Corp.	75
Bruno Laboratories, Inc.	137	RCA Institutes, Inc.	137
Brush Development Company, The	127	RCA Manufacturing Co., Inc.	79
Burstein-Applebee Co.	125	Readrite Meter Works	131
C		S	
Candler System Co.	109	Solar Manufacturing Corp.	73
Centralab	97	Sprague Products Co.	93
Clough-Brengle Co., The	133	Sprayberry Academy of Radio	129
Cornell-Dubilier Electric Corporation	83	Standard Transformer Corporation	105
Crowe Nameplate & Mfg. Co.	107	Sun Radio Co.	133
E		Superior Instruments Co.	125
Eagle Radio Co.	117	T	
Electro-Voice Mfg. Co., Inc.	131	Taylor Tubes, Inc.	Back Cover
H		Teleplex Co.	89
Hammarlund Mfg. Co., Inc.	85	Thordarson Electric Mfg. Co.	Inside Front Cover
Harrison Radio Company	81	Try-Mo Radio Co., Inc.	115
J		Turner Co., The	125
Johnson, E. F., Company	127	U	
K		Ultra High Frequency Products Co.	91
Kenyon Transformer Co., Inc.	95	Utah Radio Products Company	101
Kusterman, Oscar B.	113	V	
L		Van Sickle Radio, Inc.	121
Lifetime Corporation, The	139	Vibroplex Co., The	135
M		W	
McElroy, T. R.	111	Ward Leonard Electric Company	133
M. & H. Sporting Goods Company	135	Wholesale Radio Service Co., Inc.	77
Meissner Mfg. Co.	123	Wright-De Coster, Inc.	129

I'LL SEND MY FIRST LESSON FREE

*It Shows How I Train You
at Home in Your Spare Time for a*

GOOD JOB IN RADIO



J. E. SMITH, President,
National Radio Institute
Established 1914.

The man who has directed the home study training of more men for the Radio industry than any other man in America.

Here's Proof



Service Manager for Four Stores

"I was working in a garage when I enrolled with N. R. I. In a few months I made enough to pay for the course three or four times. I am now Radio service manager for the M— Furniture Co., for their four stores."—**JAMES E. RYAN, 1535 Slade St., Fall River, Mass.**

\$10 Week in Spare Time



"My work has consisted of Radio set servicing, with some Public Address Systems work—all in my spare time. My earnings in Radio amount to about \$10 a week."—**WILLIAM MEYER, 705 Ridge Road, Hobart, Ind.**



Earnings Tripled by N. R. I. Training

"I have been doing nicely, thanks to N. R. I. Training. My present earnings are about three times what they were before I took the Course. I consider N. R. I. Training the finest in the world."—**BERNARD COSTA, 201 Kent St., Brooklyn, N. Y.**

Clip the coupon and mail it. I will prove I can train you at home in your spare time to be a **RADIO EXPERT**. I will send you my first lesson **FREE**. Examine it, read it, see how clear and easy it is to understand—how practical I make learning Radio at home. Men without Radio or electrical experience become Radio Experts—earn more money than ever as a result of my Training.

Many Radio Experts Make \$30, \$50, \$75 a Week

Radio broadcasting stations employ engineers, operators, station managers, and pay up to \$5,000 a year. Spare time Radio set servicing pays as much as \$200 to \$500 a year—full time jobs with Radio jobbers, manufacturers, dealers as much as \$30, \$50, \$75 a week. Many Radio Experts operate their own full time or part time Radio sales and service businesses. Radio manufacturers and jobbers employ testers, inspectors, foremen, engineers, servicemen, paying up to \$6,000 a year. Radio operators on ships get good pay, see the world besides. Automobile, police, aviation, commercial Radio, loud speaker systems are newer fields offering good opportunities now and for the future. Television promises to open many good jobs soon. Men I have trained are holding good jobs in these branches of Radio. Read their statements. Mail the coupon.

There's a Real Future in Radio for Well Trained Men

Radio already gives good jobs to more than 300,000 people. And in 1938, Radio enjoyed one of its most prosperous years. More than \$500,000,000 worth of sets, tubes, and parts were sold—an increase of more than 60% over 1935. Over a million Auto Radios were sold, a big increase over 1935. 24,000,000 homes now have one or more Radio sets, and more millions of these sets go out of date and are replaced with newer models. More millions need servicing, new tubes, repairs, etc. A few hundred \$30, \$50, \$75 a week jobs have grown to thousands in 20 years. And Radio is still a new industry—growing fast!

Many Make \$5, \$10, \$15 a Week Extra in Spare Time While Learning

Almost every neighborhood needs a good spare time serviceman. The day you enroll I start sending you Extra Money Job Sheets. They show you how to do Radio repair jobs; how to cash in quickly. Throughout your training I send you plans that made good spare time money—\$200 to \$500 a year—for hundreds of fellows. My Training is famous as "the Course that pays for itself."

I Give You Practical Experience

My course is not all book training. I send you special Radio equipment, show you how to conduct experiments, build circuits illustrating important principles used in modern Radio receivers, broadcast



stations, loud speaker installations. I show you how to build testing apparatus for use in spare time servicing from this equipment. Read about this 50-50 method of training—how it makes learning at home interesting, quick, fascinating, practical. Mail coupon.

Money Back Agreement Protects You

I am sure I can train you successfully. I agree in writing to refund every penny you pay me if you are not satisfied with my Lessons and Instruction Service when you finish. I'll send you a copy of this agreement with my Free Book.

Find Out What Radio Offers You

Mail coupon for sample lesson and 64-page book. Both are free to anyone over 16 years old. My book points out Radio's spare time and full time opportunities and those coming in Television; tells about my training in Radio and Television; shows you letters from men I trained, telling what they are doing, earning. Find out what Radio offers YOU! MAIL COUPON in an envelope, or paste it on a penny postcard—NOW!

J. E. SMITH, President, Dept. 71X4
National Radio Institute, Washington, D. C.

MAIL COUPON NOW!



GOOD FOR BOTH 64 PAGE BOOK FREE SAMPLE LESSON FREE

J. E. SMITH, President, Dept. 71X4

National Radio Institute, Washington, D. C.

Dear Mr. Smith: Without obligating me, send the sample lesson and your book which tells about the spare time and full time opportunities in Radio and explains your 50-50 method of training men at home in spare time to become Radio Experts. (Please write plainly.)

NAME.....AGE.....
ADDRESS.....
CITY.....STATE..... 14X-1

The Tested WAY to BETTER PAY

Behind the panels of famous amateur transmitters National Parts will be found. Good transmitters become BETTER transmitters when National Parts are used.

PARTS

NATIONAL

MALDEN, MASS., U. S. A.



RADIO PRODUCTS



NATIONAL
CUTTING
SERIES

YOURS For The Asking

NEW TAYLOR MANUAL

Brand New! 44 pages — each one is chockful of modern, up-to-the-minute transmitter data. Here are a few of the many features contained in this new Taylor Manual. Photos of chassis layouts, circuit diagrams by the score—new, complete L/C charts — tube characteristics—Class B audio data. Full operating information on the New Taylor Zero Bias Tubes TZ-20 and 203Z. It's the most important amateur handbook of 1937. Get your copy NOW from your favorite parts jobber or write to Taylor Tubes direct. The Taylor Manual is well worth a real price tag but it is **FREE**—so don't delay.

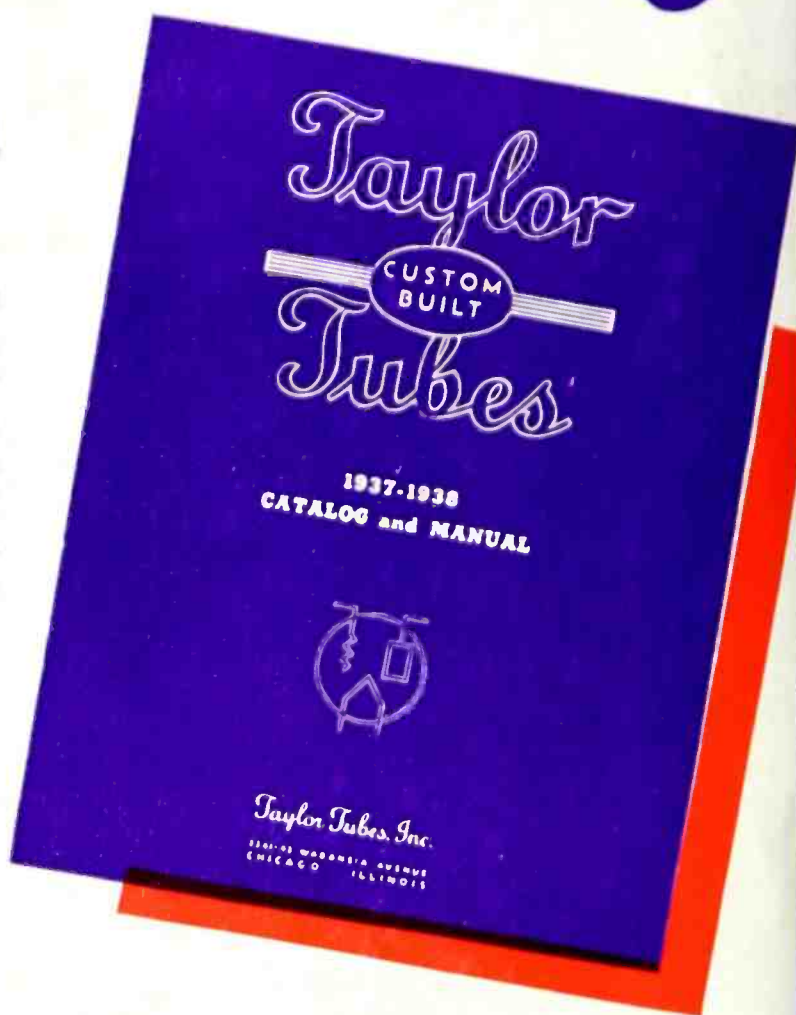

"More Watts Per Dollar"

Taylor HEAVY **CUSTOM BUILT** DUTY **Tubes**

TAYLOR TUBES, INC., 2341 WABANSIA AVE., CHICAGO, ILLINOIS