

RADIO & TELEVISION

FORMERLY
S SHORT WAVE & TELEVISION



**NEW 2½ METER TRANSCEIVER
TALKS 2 WAYS**
SEE PAGE 226

In This Issue —

- Latest Television News
- World-Wide Radio Review
- Television Antennas
- Amateur Frequency Meter
- 2-Band "Portable" Loop Receiver
- 6-Tube Super for "Ham" or "Fan"
- Acorn Transceiver for 2½ Meters
- World S-W Station List

**HUGO
GERNSBACK**
EDITOR

**RADIO EXPERIMENTING
AMATEUR RADIO**

25¢
IN U.S. AND
CANADA

**AUG.
1939**

1939 Edition Just Off the Press!

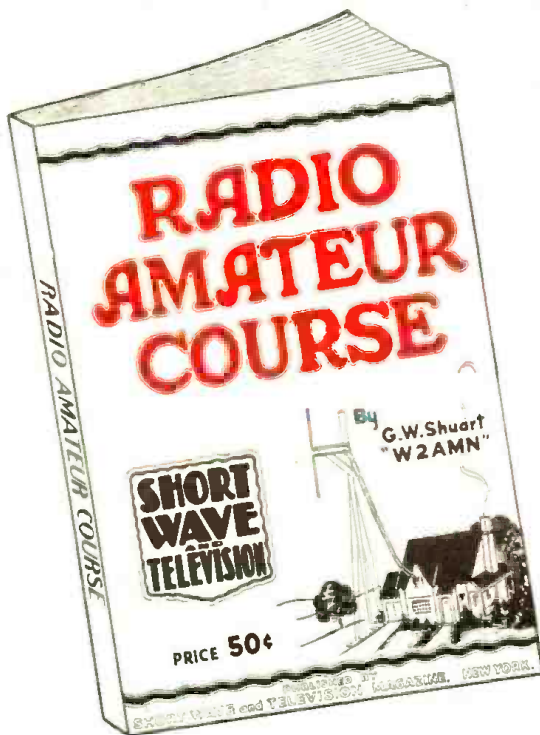

Your Money Back —

IF THE **RADIO AMATEUR COURSE** DOES NOT REPRESENT THE GREATEST BOOK VALUE EVER OFFERED TO THE RADIO "FANS" FOR **50c**

TO convince you that there isn't a better book buy today, the publishers of the **RADIO AMATEUR COURSE** make the sensational offer of a money-back guarantee on such a low-priced book. Stop in at any of the many dealers listed at the right and examine this volume. See for yourself if the **RADIO AMATEUR COURSE** isn't just the book you've always wanted.

Printed on the finest coated paper—well illustrated attractive 4-color cover—complete with radio information you must have. It contains a step-by-step program for obtaining a short-wave radio education.

Written by **George W. Shuart, W2AMN**,
foremost short-wave authority

148 PAGES

6¼ x 9½ INCHES

OVER 150 RADIO DIAGRAMS
and **TECHNICAL PHOTOGRAPHS**

RADIO AND TELEVISION
99 Hudson Street, New York, N. Y.

All Prominent **RADIO DEALERS**
Ready to Show You This Big Book!

- ARIZONA**
Sam's Cigar Store,
127 N. First Ave., Phoenix.
- CALIFORNIA**
Scott Wholesale Radio Co.,
334 E. Fourth Street, Long Beach.
Offenbach Electric Co., Ltd.,
1352 Market Street, San Francisco.
Zack Radio Supply Co.,
1426 Market Street, San Francisco.
- COLORADO**
Auto Equipment Co.,
44th at Lawrence, Denver.
- CONNECTICUT**
Radio Inspection Service Co.,
227 Asylum Street, Hartford.
Stern Wholesale Parts, Inc.,
210 Chapel St., Hartford.
- GEORGIA**
Wholesale Radio Service Co., Inc.,
430 W. Peachtree St., N. W., Atlanta.
- ILLINOIS**
Allied Radio Corporation,
623 West Jackson Blvd., Chicago.
Newark Electric Company,
226 W. Madison Street, Chicago.
Wholesale Radio Service Co., Inc.,
901 W. Jackson Blvd., Chicago.
- INDIANA**
Van Stekle Radio, Inc.,
31 West Ohio Street, Indianapolis.
- MASSACHUSETTS**
Greater Boston Distributors,
40 Waltham St., Boston.
H. Jappe Co., 46 Cornhill, Boston.
Wholesale Radio Service Co., Inc.,
110 Federal Street, Boston.
Springfield Radio Co.,
397 Dwight Street, Springfield.
H. Jappe Co.,
37 Mechanic Street, Worcester.
- MICHIGAN**
Rissi Brothers, Inc.,
5027 Hamilton Ave., Detroit.
Rissi Brothers, Inc.,
443 S. Division St., Detroit.
- MISSOURI**
Modern Radio Company,
409 No. Third Street, Hannibal.
Harstein-Appleebe Co.,
1012-14 McGee Street, Kansas City.
Van Stekle Radio Co.,
1113 Pine Street, St. Louis.
- NEBRASKA**
Radio Accessories Company,
2566 Farnam Street, Omaha.
- NEW JERSEY**
Arco Radio Co.,
227 Central Avenue, Newark.
Wholesale Radio Service Co., Inc.,
219 Central Avenue, Newark.
- NEW YORK**
Wholesale Radio Service Co., Inc.,
542 E. Fordham Rd., Bronx.
Wholesale Radio Service Co., Inc.,
90-08 166th Street, Jamaica, L. I.
Elan, The Radio Man, Inc.,
64 Dey Street, New York City.
Eagle Radio Co.,
84 Cortlandt Street, New York City.
Federated Purchaser, Inc.,
25 Park Place, New York City.
Harrison Radio Co.,
12 West Broadway, New York City.
Sun Radio Co.,
212 Fulton Street, New York City.
Terminal Radio Corp.,
80 Cortlandt Street, New York City.
Thor Radio Corp.,
60 Dey St., New York City.
Try-Go Radio Co., Inc.,
85 Cortlandt Street, New York City.
Wholesale Radio Service Co., Inc.,
100 Sixth Avenue, New York City.
- NEW YORK**
Radio Parts & Equipment Co.,
244 Clinton Avenue No., Rochester.
M. Schwartz & Son,
710-712 Broadway, Schenectady.
- NEW HAMPSHIRE**
Radio Service Laboratory,
1187 Elm Street, Manchester.
- OHIO**
News Exchange,
51 So. Main Street, Akron.
Canton Radio & Supply Co.,
1140 Tuscarawas Street, W., Canton.
United Radio, Inc.,
1103 Vine Street, Cincinnati.
The Hughes-Peters Electric Corp.,
178-180 N. Third Street, Columbus.
Standard Radio Parts Co.,
155 East Second Street, Dayton.
- OREGON**
Portland Radio Supply Co.,
1300 W. Burnside Street, Portland.
- PENNSYLVANIA**
Radio Distributing Co.,
1124-26 Market Street, Harrisburg.
M. & H. Sporting Goods Co.,
512 Market Street, Philadelphia.
Camera-Lo Co.,
963 Liberty Ave., Pittsburgh.
- RHODE ISLAND**
W. H. Edwards Co.,
32 Broadway, Providence, R. I.
- TEXAS**
Amarillo Electric Co.,
111 East 8th Avenue, Amarillo.
- UTAH**
O'Loughlin's Wholesale Radio Supply,
315 South Main Street, Salt Lake City.
Radio Supply, Inc.,
46 Exchange Place, Salt Lake City.
- WASHINGTON**
Spokane Radio Co., Inc.,
611 First Avenue, Spokane.
- WISCONSIN**
Radio Parts Co., Inc.,
536-538 W. State Street, Milwaukee.
- AUSTRALIA**
McGill's Agency,
183-184 Elizabeth Street, Melbourne.
- CANADA**
The T. Eaton Co., Ltd.,
Winnipeg, Manitoba.
Canadian Electrical Supply Co., Limited,
285 Craig Street W., Montreal, Que.
Metropolitan News Agency,
1248 Peel Street, Montreal, Que.
- CUBA**
The Diamond News Co.,
Palacio Asturiano, P.º San Jose,
Habana.
- ENGLAND**
Gorrings's American News Agency,
9a, Green Street, Leicester Square,
London, W.C.2.
- HOLLAND**
Radio Peeters, Van Wovstraat, Amsterdam, Z.
- INDIA**
Empire Book Mart,
Box 631, Bombay.
- MEXICO**
American Book Store, S. A.,
Avenida Madero 25, Mexico City.
Central De Publicaciones,
Avenida Juarez, 4, Apartado 2430,
Mexico, D. F.
- NEW ZEALAND**
Te Aro Book Depot, Ltd.,
64 Courtenay Place, Wellington.
- SOUTH AFRICA**
Technical Book Co.,
5, Strand Street, Cape Town.

If this book is not at your dealer's, send your order directly to us. We will credit your dealer with the sale of this book. To order your copy of **RADIO AMATEUR COURSE**, fill in coupon below and mail.

RADIO AND TELEVISION, 99 Hudson St., New York, N. Y.
Gentlemen: I enclose herewith my remittance of Fifty Cents (50c) for which please send me **POSTPAID**, my copy of the **RADIO AMATEUR COURSE**. (Remit by check or money order; register letter if you send cash or unused U. S. Postage Stamps.)

Name

Address

City State R&T-8-39

A FREE LESSON SHOWED BILL HOW HE COULD MAKE GOOD PAY IN RADIO

BILL, YOU'RE ALWAYS FOOLING WITH RADIO -- OUR SET WON'T WORK -- WILL YOU FIX IT?

I'LL TRY, MARY, I'LL TAKE IT HOME TONIGHT

I CAN'T FIND OUT WHAT'S WRONG -- GUESS I'LL MAKE A FOOL OF MYSELF WITH MARY

HELLO, BILL -- GOT A TOUGH ONE TO FIX? LET ME HELP YOU

HELLO JOE -- WHERE'VE YOU BEEN LATELY -- AND WHERE DID YOU LEARN ANYTHING ABOUT RADIO?

I'VE BEEN STUDYING RADIO AT HOME, BILL, WITH THE NATIONAL RADIO INSTITUTE. YOU OUGHT TO TAKE THEIR COURSE. I'VE GOT A GOOD RADIO JOB NOW. LET'S MAKE A CIRCUIT DISTURBANCE TEST -- STARTING WITH THE AUDIO OUTPUT STAGE AND TESTING EVERY STAGE RIGHT BACK TO THE ANTENNA. LISTEN FOR THE CLICKS WHEN I TAP THE GRID LEADS

SAY -- WHERE DID YOU LEARN THAT TEST? IT'S A GOOD ONE

HERE'S THE TROUBLE, BILL, IN THE FIRST I.E. AMPLIFICATION STAGE. I LEARNED THAT TEST EVEN BEFORE I STARTED TAKING THE COURSE, BILL. IT'S DESCRIBED IN A FREE LESSON WHICH THE NATIONAL RADIO INSTITUTE SENDS YOU WHEN YOU MAIL A COUPON FROM ONE OF THEIR ADS

I'VE SEEN THEIR ADS BUT I NEVER THOUGHT I COULD LEARN RADIO AT HOME -- I'LL MAIL THEIR COUPON RIGHT AWAY

I'M CONVINCED NOW THAT THIS COURSE IS PRACTICAL AND COMPLETE. I'LL ENROLL NOW

AND THEN I CAN MAKE REAL MONEY FIXING RADIO SETS

OR INSTALL AND SERVICE LOUD SPEAKER SYSTEMS

OR GET A JOB WITH A RADIO BROADCASTING OR TRANSMITTING STATION

AVIATION RADIO, POLICE RADIO, TELEVISION, ELECTRONIC CONTROLS -- RADIO IS SURELY GOING PLACES. AND THE NATIONAL RADIO INSTITUTE HAS TRAINED HUNDREDS OF MEN FOR JOBS IN RADIO

I will send you a Lesson on Radio Servicing Tips FREE TO SHOW HOW PRACTICAL IT IS TO TRAIN AT HOME FOR GOOD JOBS IN RADIO

Clip the coupon and mail it. I will prove I can train you at home in your spare time to be a RADIO EXPERT. I will send you a sample lesson FREE. Examine it, read it, see how clear and easy it is to understand -- how practical I make learning Radio at home. Men without Radio or electrical knowledge become Radio Experts, earn more money than ever as a result of my training.

Why Many Radio Experts Make \$30, \$50, \$75 a Week

Radio broadcasting stations employ engineers, operators, station managers and pay well for trained men. Fixing Radio sets in spare time pays many \$200 to \$500 a year -- full time jobs with Radio jobbers, manufacturers and dealers as much as \$30, \$50, \$75 a week. Many Radio Experts open full or part time Radio sales and repair businesses. Radio manufacturers and jobbers employ testers, inspectors, foremen, engineers, servicemen, in good-paying jobs with opportunities for advancement. Automobile, police, aviation, commercial Radio, loud speaker systems are newer fields offering good opportunities now and for the future. Television promises to open many good jobs soon. Men I trained have good jobs in these branches of Radio. Read how they got their jobs. Mail coupon.

Many Make \$5, \$10, \$15 a Week Extra in Spare Time While Learning

The day you enroll I start sending Extra Money Job Sheets; show you how to do Radio repair jobs. Throughout your training I send plans and directions that made good spare time money -- \$200 to \$500 -- for hundreds, while learning. I send you special Radio equipment to conduct experiments and

build circuits. This 50-50 method of training makes learning at home interesting, fascinating, practical. I devote more than 10 Lesson Texts exclusively to Television methods and applications, and cover Television fundamentals thoroughly in my Course.



I Also Give You This Professional Servicing Instrument as Part of My Training

Here is the instrument every Radio expert needs and wants -- an All-Ware, All-Purpose, Set Servicing Instrument. It contains everything necessary to measure A.C. and D.C. voltages and current; to test tubes, resistance; adjust and align any set, old or new. It satisfies your needs for professional servicing after you graduate -- can help you make extra money fixing sets while training.

Get Sample Lesson and 64 page Book FREE -- Mail Coupon

In addition to my Sample Lesson, I will send you my 64-page book, "Rich Rewards in Radio." Both are FREE to anyone over 16 years old. My book points out Radio's spare time and full time opportunities and those coming in Television; tells about my training in Radio and Television; shows you letters from men I trained, telling what they are doing and earning; shows my Money Back Agreement. MAIL THE COUPON in an envelope, or paste it on a penny postcard.

J. E. SMITH, Pres., National Radio Institute, Dept. 9HB3, Washington, D.C.



J. E. SMITH President National Radio Institute Established 25 years
He has directed the training of more men for the Radio Industry than anyone else.



YOU CERTAINLY KNOW RADIO SOUNDS AS GOOD AS THE DAY I BOUGHT IT.



THANKS! IT CERTAINLY IS EASY TO LEARN RADIO THE N.R.I. WAY. I STARTED ONLY A FEW MONTHS AGO, AND I'M ALREADY MAKING GOOD MONEY. THIS SPARE TIME WORK IS GREAT FUN AND PRETTY SOON I'LL BE READY FOR A FULL TIME JOB

OH BILL -- I'M SO GLAD I ASKED YOU TO FIX OUR RADIO. IT GOT YOU STARTED THINKING ABOUT RADIO AS A CAREER, AND NOW YOU'RE GOING AHEAD SO FAST

OUR WORRIES ARE OVER. I HAVE A GOOD JOB NOW, AND THERE'S A BIG FUTURE AHEAD FOR US IN RADIO



J. E. SMITH, PRESIDENT, DEPT. 9HB3
NATIONAL RADIO INSTITUTE, WASHINGTON, D. C.

Dear Mr. Smith: Without obligation, send me a sample lesson and your free book which points out spare time and full time radio opportunities, and shows how I can train for them at home in spare time -- about the N.R.I. Set Servicing Instrument you give. (Please write plainly.)

Name Age

Address

City State

14X-1

RADIO & TELEVISION

The Popular Radio Magazine

August — 1939
Vol. X No. 4

HUGO GERNSBACK, Editor
H. WINFIELD SECOR, Manag. Editor
ROBERT EICHBERG, Assoc. Editor

How to Build the
LT-6 "Loktal"
All-Wave Receiver

See Page 222

In This Issue

GENERAL FEATURES

Beyond the Last Wave Bands—Dr. D. L. Webster	197
Television Brings Sports to Your Home	198
Television Programs Received at 22 Miles on "Home-Made" Set—R. W. Emery	199
World-Wide Radio Digest	200
International Radio Review	202
Radio Test-Quiz	205
Television Antennas—W. Hollander Bohlke	206

CONDENSED FEATURES

Apartment House Television	200
All-Electronic Band	200
New Electrical Piano	200
Field Intensity Meter	200
Television Film Scanner	201
Machine Recreates Speech	201
Television Studio Lighting	201
Newspaper Via Facsimile	201
Supersonic Light Relay	202
Radio Typewriter	202
D.C. Receiver	203
Antenna Coupling	203
Explaining "Q"	203
Loud Speaker Improvement	204
Light-Storage in Television Transmitters	204

INSTRUCTION

Radio Test-Quiz	205
The Radio Beginner—Audio Frequency Amplifiers—Martin Clifford, W2CDV	207
Antennas for the Ham	212
Question Box	228

TELEVISION

Televising Sports	198
Television Programs Received 22 Miles on Home-Made Set	199
Apartment House Television	200

Cover composition by H. Gernsback and Thomas D. Pentz. Staff photos show various applications of 2½ Meter Transceiver, the construction of which is described and illustrated on page 226.

RADIO & TELEVISION—Published monthly on the tenth of the month. Entered as second-class matter Feb. 15, 1938, at the post office at Springfield, Mass., under the act of March 3, 1879. Trademarks and copyrights by permission of H. Gernsback. Text and illustrations are copyright and may not be reproduced without permission. Subscription price \$2.50 a year in the United States and possessions and Canada, \$3.00 in foreign countries. Make all subscription checks payable to Popular Book Corporation.

Published by Popular Book Corporation, Publication Office—29 Worthington St., Springfield, Mass. Editorial and Executive Offices—99 Hudson St., New York, N.Y. HUGO GERNSBACK, President; H. W. SECOR, Vice-President; EMIL GROSSMAN, Director of Advertising, European Agents: Atlas Publishing and Distributing Co., Ltd., 18 Bride Lane, Fleet St., London, England; Brentano's—London and Paris. Australian Agents: McGill's Agency, 179 Elizabeth St., Melbourne.

Copyright 1939 by H. Gernsback

CONSTRUCTION

1-Tube Television Sound Converter—Herman Yellin, W2AJL	210
Building and Using a Wheatstone Bridge	211
How to Build Your Own "Mike"—Arthur Robbins	212
Amateur Frequency Meter with Crystal	213
LT-6 "Loktal" Receiver for Ham or Fan—Harry D. Hooton, W8KPX	222
2-Band Vacation Portable Receiver—C. W. Palmer, E.E.	224
2½ Meter ACORN Transceiver—Howard G. McEntee, W2FHP	226

Field Intensity Meter	200
Television Studio Lighting	201
2-Way Television	202
Supersonic Light Relay	202
Metal Rectifiers in Television	204
Double Beam Cathode-Ray Tube	204
Light Storage in Television Transmitters	204
Television Antennas	206
1-Tube Television Sound Converter	210

MISCELLANEOUS

Radio Test-Quiz	205
14th Silver Trophy Award for Best "Ham" Station Photo	208
Radio Kinks	209
World Short Wave Station "Directory"	214
Let's Listen In with Joe Miller	215
A DX Aerial for Short Wave Fans and U. H. F. Doublets	217
"DX" on the HAM Bands—Elmer R. Fuller	219
What Do YOU Think?	221
Question Box	228
Transmitter-Receiver for the Ham Beginner—D. L. Warner, W9IBC	230
New HAM Licenses	231
Newest Radio Apparatus	232
Book Reviews	242
I Cover the Pacific Coast!—L. M. Nelson	250

In the September Issue

"Looking Ahead in Radio!"—J. R. Poppele, Chief Engineer, Station WOR, Newark, N. J.

A Switch-Type "Ham" Transmitter for All Bands—Herman Yellin, W2AJL

2-Band Portable A.C.-D.C. Receiver: Uses New Single-Ended Metal Tubes and Reverse Feed-Back—M. Harvey Gernsback

A 1-Tube "All-Wave" Pre-Selector—Harry D. Hooton, W8KPX

Building a "Low-Cost" Television Receiver with Small C-R Tube

A Transmitter-Receiver for 2½ Meters

Television Power Supplies—How to Design for High Voltage—F. L. Sprayberry

Getting Started in Amateur Radio—C. W. Palmer, E.E.

Certified Circuits



When you see this seal on a set it is a guarantee that it has been tested and certified in our laboratories, as well as privately in different parts of the country. Only constructional—experimental sets are certified.

You need not hesitate to spend money on parts because the set and circuit are bona fide.

This is the only magazine that renders such a service.

U.S. Sees "Screen Size" Television

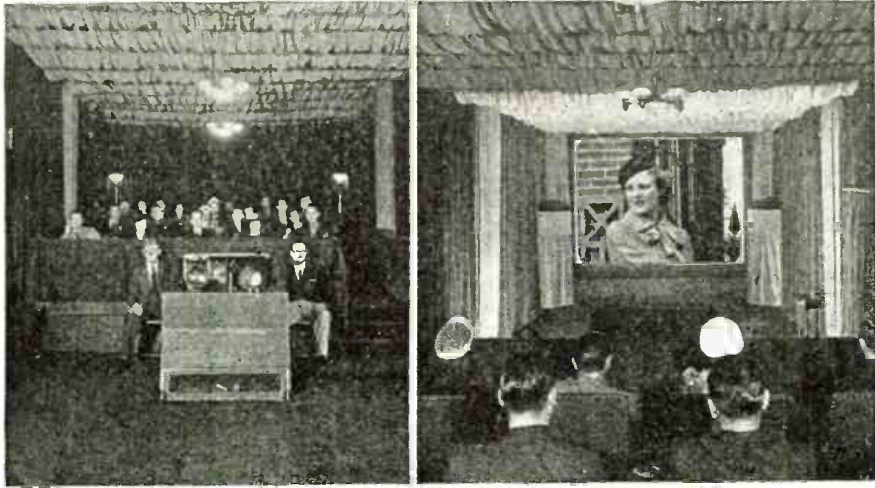

The Baird television system, used for the past few years in London theaters, has been demonstrated in the United States. The apparatus shown above projects a television image on a 9 x 12 foot screen with motion picture brilliance. The projector, with spare channel, is placed about 25 feet from the screen. The audience sees a picture which has remarkable fidelity and detail.

Inside 10 K.W. Television Station



It is planned to broadcast motion picture films as a considerable portion of the Schenectady station's programs. Below—J. W. Downie is seen inserting movie film into the film television projector. Sound films, of course, will be used for these transmissions.



Programs from here will be transmitted through the General Electric's television studio in Schenectady, new G. E. Station in the Helderberg Hills. Below—Main control board of the 10 kw. Helderberg television transmitter, located at Indian Ladder, 12 miles from Schenectady.

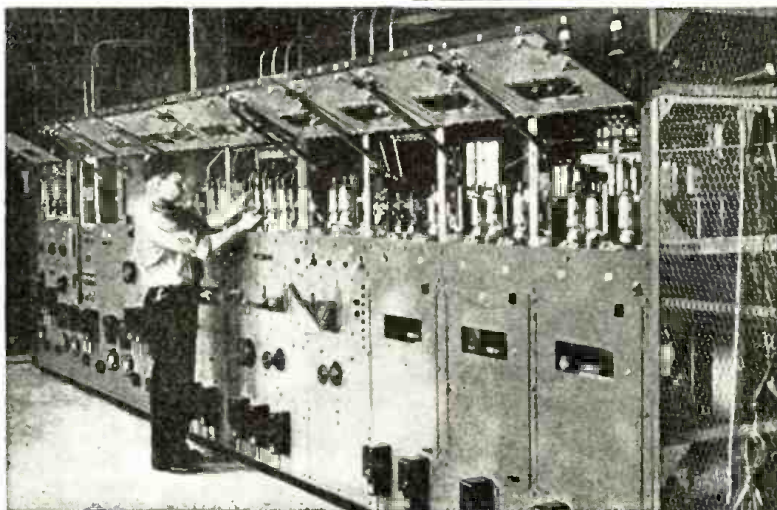

Please say you saw it in RADIO & TELEVISION

QUICKER, EASIER WAY

To TRAIN FOR ELECTRICITY
12 Weeks Practical WORK IN MY CHICAGO SHOPS

WANT TO EARN MORE MONEY?



Don't be discouraged if you never had a chance to get much schooling. Don't think for a minute that you have to be a poorly paid, unskilled workman the rest of your life. You don't need a lot of book learning to have trained hands. Many of my most successful graduates never even finished Grammar School.

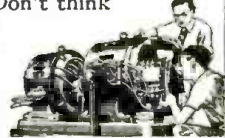

FIRST—You are told and shown how to do it.

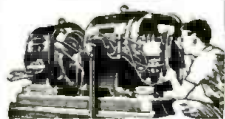

THEN—You do the job yourself.

This same training is open to you—12 weeks of actual shop training in **ELECTRICITY**. Yes, shop training—real shop training. Instead of reading how to do things, you do them—right here in my Chicago Shops. You do real work on real generators, motors and dynamos. You do house wiring and wind armatures. You work in many other branches of electricity. And right now I'm including an extra 4 weeks **Radio Course** and valuable instruction in Diesel, Electric Refrigeration and Air Conditioning—all at no extra tuition cost.

AN EXTRA 4 WEEKS COURSE IN RADIO INCLUDED

I'LL FINANCE YOUR TRAINING

Don't let lack of money stop you! I have a plan that makes it easy for you to get this training, and you don't have to begin paying for the greater part of your tuition until 60 days after your 12 weeks training period is over. And then you have 12 months to complete your payments.

If you need a part-time job to help pay living expenses while you train, my employment department will assist you. After you graduate, this department will also give you lifetime employment service. Mail the coupon and I'll send you my big free book that's filled with interesting facts and shows dozens of pictures of students at work—doing the same things you will do. Fill in and mail the coupon today.

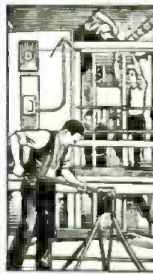

HOUSE WIRING only one of the many branches you "Learn By Doing"



Coyne has first class instructors to teach you the simplest things to start with and they have the equipment to show you these things as you advance... Ben Rickman, S. Car.

H. C. LEWIS, President
COYNE ELECTRICAL SCHOOL
 500 South Paulina St. Chicago Illinois



MAIL THIS COUPON NOW

H. C. LEWIS, President
 COYNE ELECTRICAL SCHOOL
 500 S. Paulina St., Dept. C9-81, Chicago, Ill.
 Please send me free your big catalog and full particulars of your "Pay After Graduation Plan"—also other facts including offer of extra 4 weeks Radio Course at no extra tuition cost.

NAME.....
 ADDRESS.....
 CITY.....STATE.....

... THESE OUTSTANDING SHORT WAVE BOOKS ARE Now Available AT YOUR DEALER!

YOU buy parts, tubes, kits, accessories from your local radio dealer—that's what countless thousands of short-wave fans do. Now through a nation-wide distribution service our numerous books are available at your favorite radio dealer—right where you buy other radio equipment. It's more convenient, saves time and you can inspect the books before you buy. Ask your dealer to show you all the books advertised on this page—they're always in stock.

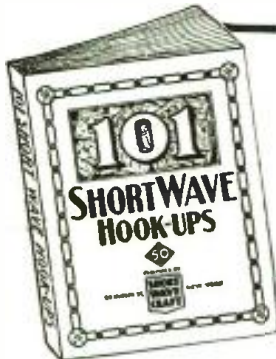

101 SHORT WAVE HOOK-UPS

Compiled by the Editors of RADIO & TELEVISION

Here is a worthwhile book that every short wave listener, every short wave fan, and every short wave amateur has wanted for a long time. It gives you the 101 best short wave hook-ups which have appeared heretofore.

100 Illustrations 72 Pages 50c

HOW TO BUILD AND OPERATE SHORT WAVE RECEIVERS

This is the best and most up-to-date book on the subject. It is edited and prepared by the editors of RADIO & TELEVISION and contains a wealth of material on the building and operation, not only of typical short wave receivers, but short wave converters as well.

150 Illustrations 78 Pages 50c



TEN MOST POPULAR SHORT WAVE RECEIVERS

HOW TO MAKE AND WORK THEM

The editors of RADIO & TELEVISION have selected ten outstanding short wave receivers and these are described in the new volume. Each receiver is fully illustrated with a complete layout, pictorial representation, photographs of the set complete, hook-up and all worthwhile specifications.

75 Illustrations 40 Pages 25c

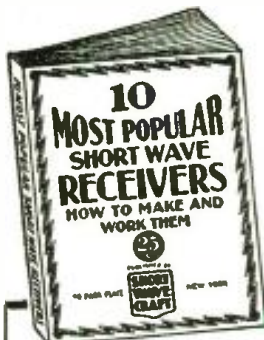

HOW TO GET BEST SHORT WAVE RECEPTION

M. HARVEY GERNSBACK tells you everything you have ever wanted to know about short wave reception. The author, a professional radio listener and radio fan for many years, gives you his long experience in radio reception and all that goes with it.

40 Illustrations 72 Pages 50c

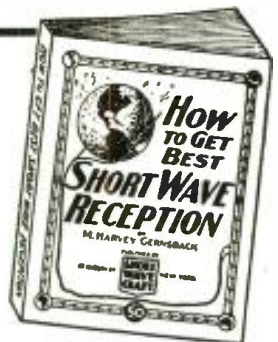

HOW TO BECOME AN AMATEUR RADIO OPERATOR

By Lieut. Myron F. Eddy, whose experience in the amateur field has made him pre-eminent in this line.

If you intend to become a licensed code operator, if you wish to take up phone work eventually—this is the book you must get.

150 Illustrations 72 Pages 50c



THE SHORT WAVE BEGINNER'S BOOK

Here is a book that solves your short wave problems—leading you in easy stages from the simplest fundamentals to the present stage of the art as it is known today. It is the only low-priced reference book on short waves for the beginner.

75 Illustrations 40 Pages 25c

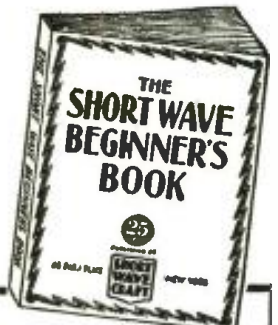

LOOK FOR YOUR NEAREST DEALER

For convenience the publishers list below dealers in all parts of the world where our books are available. On your next shopping trip be certain to examine these volumes. You're sure to want them for your technical library.

ALABAMA
Walther Bros., Montgomery

ARIZONA
Sam's Cigar Store, Phoenix

CALIFORNIA
Electric Supply Co., Oakland
Radio Supply Company, Los Angeles
Radio Television Supply Co., Los Angeles
Pacific Radio Exchange, Inc., Los Angeles
Western Auto Supply, Los Angeles
Zack Radio Supply Co., Los Angeles
Womans' Book Store, Pasadena
Western Radio & Elec. Co., San Diego
Offenbach Electric Co., San Francisco
Technical Book Co., San Francisco
Zack Radio Supply Co., San Francisco
Radio Specialties Co., San Jose

COLORADO
Auto Equipment Co., Denver
Interstate Radio Supply, Denver

CONNECTICUT
The Edward P. Judd Co., New Haven

DELAWARE
Wilmington Elec. Spec. Co., Inc., Wilmington

FLORIDA
Radio Accessories Co., Orlando

GEORGIA
Wholesale Radio Service Co., Inc., Atlanta

ILLINOIS
Allied Radio Corporation, Chicago
Walter C. Braun, Inc., Chicago
Chicago Radio Apparatus Co., Chicago
A. C. McClurg & Co., Chicago
Midwest Radio, Chicago
Newark Electric Co., Chicago
Sears, Roebuck & Co., Chicago
Max Stein & Co., Chicago
Montgomery Ward & Co., Chicago
Wholesale Radio Service Co., Inc., Chicago

INDIANA
Van Sickle Radio, Indianapolis

MASSACHUSETTS
DeWolfe & Piske Co., Boston
The Personal Book Shop, Boston
Wholesale Radio Service Co., Inc., Boston

MICHIGAN
Library Book House, Springfield
Tremont Elec. Supply Co., Boston

MINNESOTA
Riszi Brothers, Detroit
St. Paul Book & Stat. Co., St. Paul

MISSOURI
Burstein-Applebee Co., Kansas City
Radio Labs., Kansas City
Walker Ashe Radio Co., St. Louis
Van Sickle Radio Co., St. Louis

NEW JERSEY
Radio Apparatus Co., Newark
United Radio Co., Newark
Wholesale Radio Service Co., Inc., Newark

NEW YORK
Fort Orange Radio Dist. Co., Albany
Wholesale Radio Service Co., Inc., Bronx
Wholesale Radio Service Co., Inc., City
Harrison Radio Co., New York City
Jamaica, L. I.
American News Co., New York City
Baker & Taylor Co., New York City
Blair, the Radio Man, New York City
David Bogen & Co., New York City
Federated Purchaser, Inc., New York City
Van Riemstdek Book Stores, New York City
The Steiger Co., New York City
Thor Radio Corp., New York City
Try-Mo Radio Co., New York City
Wholesale Radio Service Co., Inc., New York City

NEW YORK (cont.)
H. W. Wilson Co., New York City
Radio Parts & Equipment Co., Rochester
M. Schwartz & Son, Schenectady

OHIO
College Book Exchange, Toledo

OREGON
J. K. Gill Co., Portland

PENNSYLVANIA
Radio Electric Service Co., Philadelphia
Cameradio Co., Pittsburgh

WASHINGTON
Seattle Radio Supply Co., Seattle
Wedel Co., Inc., Seattle
Spokane Radio Co., Spokane

WISCONSIN
Radio Parts Co., Milwaukee

ARGENTINA
Radio Revista, Buenos Aires

AUSTRALIA
McGill's Authorized Agency, Melbourne

BRUSSELS
Emil Arens, Brussels

CANADA
T. Eaton & Co., Winnipeg, Man.
Electrical Supplies, Ltd., Winnipeg, Man.
Wholesale Radio Supply, Winnipeg, Man.
Canadian Electrical Supply Co., Ltd., Toronto, Ont.
Radio Trade Supply Co., Ltd., Toronto, Ont.
Canadian Electrical Supply Co., Ltd., Montreal, P. Q.

BRAZIL
Agencia Soave, Sao Paulo

CHINA
China News Co., Shanghai
International Booksellers, Ltd., Shanghai

CUBA
Diamond News Co., Havana

ENGLAND
Gorrings' Amer. News Agency, London

FRANCE
Toute La Radio, Paris

GERMANY
Rehr G.M.B.H. SW15, Berlin NW No. 7

HOLLAND
Radio Peeters, Amsterdam, Z.

INDIA
Empire Book Mart, Bombay

MEXICO
American Book Store, Mexico, D. F.
Central De Publicaciones, S. A., Mexico, D. F.
Jaques Salvo, Mexico, D. F.

NEW ZEALAND
Johns, Ltd., Auckland
James Johnston, Ltd., Dunedin
Te Aro Book Depot, Ltd., Wellington

SOUTH AFRICA
Technical Book Co., Cape Town
Central News Agency, Johannesburg
International House, Johannesburg
South African Radio Publications, Johannesburg

IF YOUR DEALER DOES NOT CARRY THESE BOOKS, ORDER DIRECT FROM US. FILL OUT COUPON BELOW. SHIPMENT WILL BE MADE IMMEDIATELY.

POPULAR BOOK CORP. R&T-8-39
99 Hudson Street, New York City.

Gentlemen: I enclose herewith my remittance for _____ for which please send me the following books:

.....

Name

Address

City

State

(Send remittance in form of check or money order. If letter contains cash or unused U. S. postage stamps, register it.)

POPULAR BOOK CORPORATION • Publishers • 99 HUDSON STREET • NEW YORK, N. Y.

HUGO GERNSBACK, EDITOR

H. WINFIELD SECOR, MANAGING EDITOR

Beyond the Last Wave Bands

D. L. Webster,
Professor of Physics, Stanford University

Dr. David L. Webster,
*Professor of Physics,
Stanford University,
California.*



● SUPPOSE a radio broadcasting station were remodeled, and your receiver also were remodeled to go with it, so that instead of transmitting and receiving radio waves in the ordinary broadcast range they operated with much shorter waves, even shorter than what are now listed as short-wave bands. What would we find? Would the transmitting station and the receiver then work as well as they do now? Or, perhaps, would they work even better? Or would we find them neither better nor worse, but different? And how could such a change be made? Would it be effected by the new tube called the *Klystron*, of which you may have read? These are the questions I propose to answer briefly.

In the ordinary short-wave bands, we hear of such spectacular distances covered with very moderate power, as to raise hopes of still longer distances at still shorter wavelengths. A definite limit to such hopes can be seen, however, when we recall that radio waves belong to a general class which also includes light. In fact, *light may be regarded as simply radio waves of extremely short wave length*, far shorter than any waves we usually think of under the name of radio. For light, our eyes are very sensitive receivers; but, if the station substituted light for its radio waves, it would be lost to all who are beyond its horizon. Somewhere in the spectrum, therefore, between these radio waves and light, long-distance transmission must cease.

There is room for many changes, between the last wave bands now in use and light. The last wave band listed in my morning newspaper has a frequency of nearly 18 megacycles, which implies a wavelength of 17 meters, or 55 feet. Light, however, has wavelengths shorter than a thousandth part of a millimeter, which is about one twenty-five thousandth of an inch. From shortwave radio to light, therefore, the wavelength is reduced and the fre-

quency is increased by a factor of more than a million. Considering these frequencies on a scale like that of a piano, *this is a jump of more than 20 octaves*—an interval about twice as long as from the lowest audible frequency to the highest.

The loss of long-distance transmission must occur somewhere in this long interval; and it does occur very near the beginning of the interval, just beyond the present short-wave bands. Long distance transmission depends on the presence of ions, or electrically charged atoms, in the rarified air 100 or 200 miles above the earth, where the sunlight still contains its ionizing rays. This layer of ionized air, called the *ionosphere*, acts on radio waves almost like a great spherical mirror surrounding the whole earth. Waves that start from a broadcasting station and go horizontally or at a low angle eventually reach this mirror-like layer and are reflected back to the earth, usually somewhere beyond the horizon. Then they may be reflected by the ground and make a second trip to the ionosphere and then come down again still farther away.

All this, however, depends on the ability of the waves, when they reach the ionosphere, to shake the ions up and down and make them send out the new waves which we call reflections. When the frequency is raised too high, the ions refuse to be shaken far enough to make strong reflected waves, and it is then that long-distance transmission ceases. The exact limit at which this occurs is very changeable with the conditions of the atmosphere, but is usually at a wavelength of 10 or 20 meters, just at the end of the short-wave broadcast bands now in use.

Why, then, do we want *shorter waves*? For at least two reasons. *One is for tele-*

vision. Any broadcasting station must send out waves of more than just one frequency. Station KGO, for example, is now sending waves of its listed frequency, 790 kilocycles, and also waves of frequencies higher and lower, differing from it by amounts equal to the frequencies of the sounds in the program being transmitted. Since these sound frequencies are all less than a very few kilocycles, the frequencies of the radio waves are all within a band less than ten kilocycles wide.

For television, on the other hand, we need a band having a width of *at least* a thousand kilocycles, or a whole megacycle. For technical reasons it would not be fair to ask any transmitter or receiver to work well at all the frequencies between one and two megacycles at once, nor even on all between two and three. But if it runs at 50 megacycles, for example, it may well handle the whole range from 50 to 51 at once. So it is to such frequencies that we must resort for *television*. And a 50-megacycle frequency makes the wavelength only 6 meters—shorter than the wavelength at which the ionosphere stops reflecting.

Television, therefore, does not now promise long-distance transmission. Instead, when you see by television, you see no farther than by direct vision with a telescope. The differences between television and vision with a telescope are not in the distance attained, but rather those which result from the difference in wavelength between the 5- or 10-meter waves of television and the microscopic waves of light.

The most obvious of these differences concerns the manner in which the waves are used. Less obvious, but equally important, is the fact that light usually travels in straight rays, while radio waves can easily spread around obstacles, such as houses and hills. The very short waves used for tele-

(Continued on page 229)

*Thirtieth of a series of
"Guest" Editorials*

Now
 Television Brings
Sports
 To Your Home



▲ Television camera (arrow, above) normally focused on the home-plate during this college baseball game—the first ball game to be visually aired in America. Although the movement of the ball was sometimes visible, the camera was too far from the field and the players were excessively small.

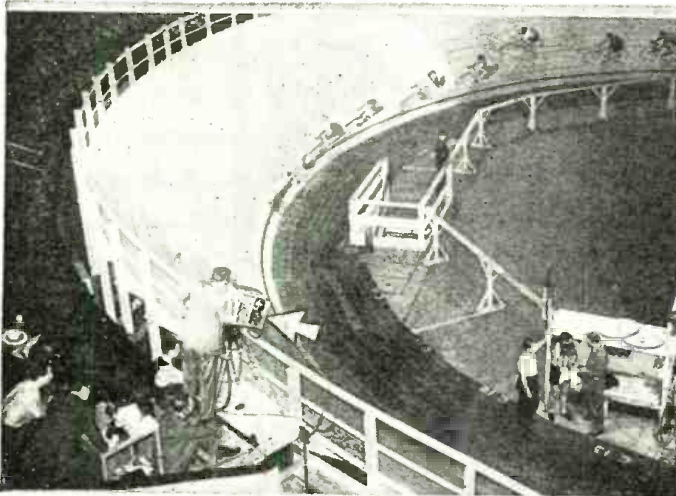

American viewers got their first glimpse of a 6-day bicycle race when the NBC television camera (arrow, above) was placed beside the track in Madison Square Garden, New York. This was the history-making telecast in which standard telephone lines linked the television truck in the Garden basement to the transmitter about a mile away.

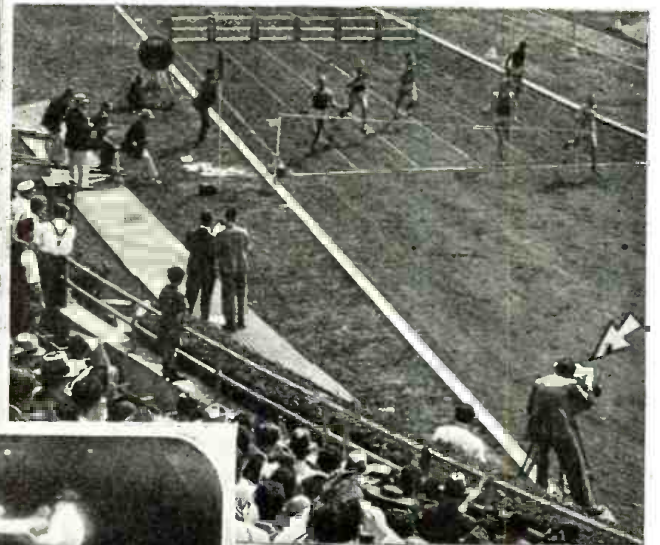

▲ Above—The first telecast of a field meet. The foot races were picked up by the NBC-RCA television camera, shown by the arrow above.

At the right is reproduced exactly what television fight fans saw during the Baer-Nova fight. This is reproduced from a photograph taken of the image appearing on a 12" cathode-ray tube.

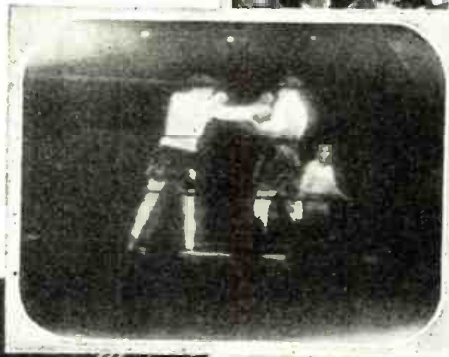

Below is the set-up at the ringside. The arrow points to the television "camera." It could not be placed in a more advantageous position as the management insisted that it be set up where it could not block any spectator's view of the ring.

Below is a group of televiewers in a dealer's store watching the image of the Baer-Nova fight. Note intense interest.

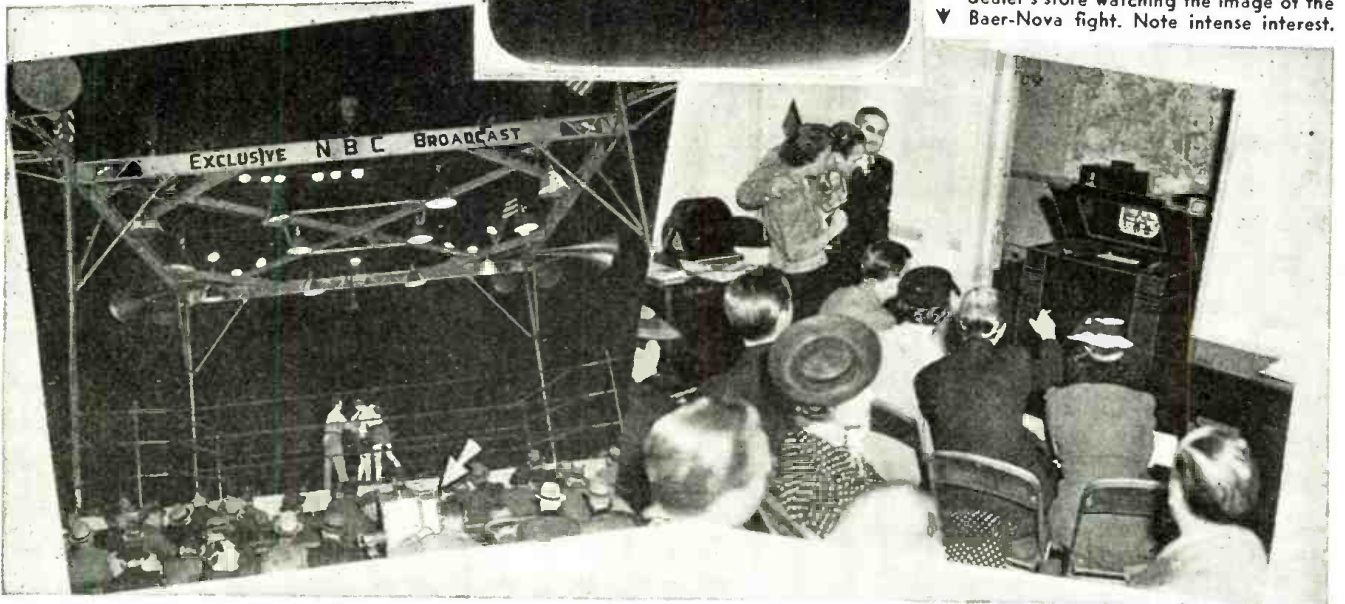

Television Programs Received at 22 Miles on Home-Made Set

Richard W. Emery

California experimenter picks
up telecasts regularly in home

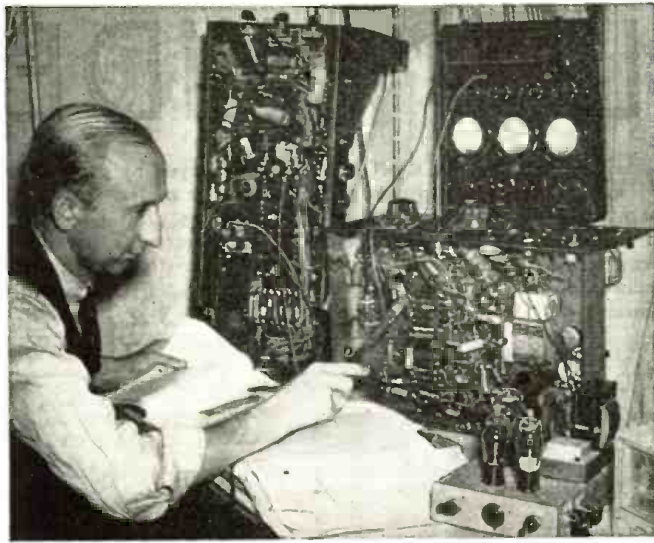

Roger A. Howell, of Long Beach, Calif., who for several years was the only amateur "looker-in" of the Don Lee Los Angeles television station, W6XAO. He has been honored for his work in television by the Hollywood Television Society.



At 22 miles, this is a fair sample of what the more distant television fans in the Los Angeles area are able to pick up from W6XAO.

FOR seven years the Don Lee Broadcasting System has been operating its experimental television station, W6XAO, in Los Angeles. Meanwhile, San Francisco has done comparatively little to prepare for television broadcasts, although San Francisco's several precipitous hills give her the advantage of natural high elevations for transmitters.

Away back in the early days of these experimental television broadcasts at Los Angeles, there were no amateur lookers-in. Now there are a considerable number—but just how many, the station itself would like to know. Amateurs are enthusiastic over results they have seen. The number of lookers-in is rapidly increasing. Los Angeles and other cities within a 25-mile radius offer a population of some 3,000,000 potential television fans.

The necessity of building a set especially to receive the Los Angeles station's broadcasts has discouraged a great many interested spectators. With the expected adoption of RMA standards by Don Lee, no doubt the amateurs will spring up like "mushrooms" after a Spring shower.

Station W6XAO has been transmitting its visual program on 45,000 kilocycles and its audio program on 49,750. The station is on the air every night from Tuesday through Friday with an hour's show, from 7:30 to 8:30 o'clock; and from 7:00 to 8:00 o'clock on Mondays and Saturdays with movie films. Lookers-in find an interesting and entertaining assortment of live camera pick-ups made in the studio. There are world news reports, sport casts, a continued serial play, musical entertainers, tap dancers, lecturers on television and a great many other features.

Because of the experimental factors involved, the station has welcomed all comments by amateurs who have tuned in and watched the programs. The first amateur television experimenter to tune in regularly was Roger A. Howell, Long Beach radio service specialist, who built a set six years ago and gave Don Lee the good news that the telecasts were coming in at Long Beach, 22 air miles from the transmitter. Howell has continually changed his equipment, improving it

as television progressed, and has kept the station advised of reception in Long Beach. For several years he was the only outside looker-in on the Los Angeles television broadcasts.

Gradually, through interest of the Hollywood Television Society, additional sets were built and put in operation. The society meets regularly. It has recognized Howell's contribution to television by giving him its first citation to honorary membership, an honor later awarded to Dr. Lee de Forest of Los Angeles, Dr. R. D. Lemert of Hollywood and Harry R. Lubcke, director of television for the Don Lee Broadcasting System.

Howell has been operating his receiving set at his home in Long Beach, and his nightly guest-list attests the great interest

which the public now has in television. He has had as many as thirty visitors in one evening, to see one of the television programs. In his set a nine-inch tube is used in the receiver, which gives a picture $6\frac{1}{2}$ by $7\frac{1}{2}$ inches when masked down.

The principal problem in television in the Los Angeles area at present is that of power. The television broadcasts are made on 1000 watts and, around the outskirts of the metropolitan

(Continued on page 234)

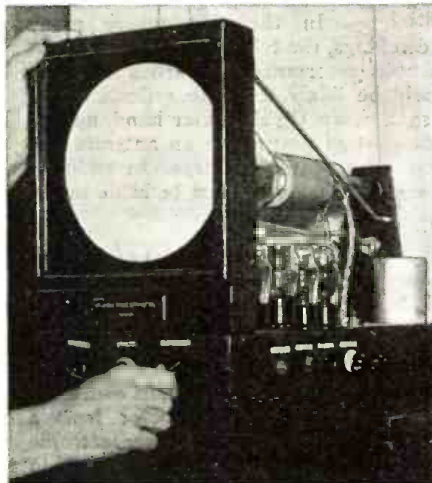

Mr. Howell's home-built television receiver. The nine-inch field is cut to about $6\frac{1}{2}$ inches by $7\frac{1}{2}$ inches when masked down.

Left—Mr. Howell's dipole antenna rises 70 ft. above the ground.

Below: 10-second exposure, at 3 feet of W6XAO announcer, made at distance of 22 miles, on Roger Howell's receiver.



WORLD WIDE

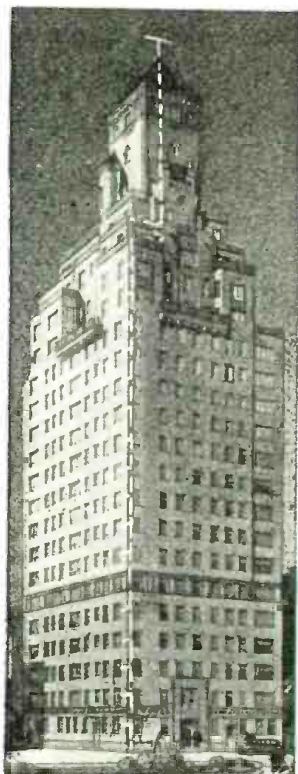

TELEVISION OUTLETS are to be installed in every apartment of a new building being erected at 20 Park Avenue, New York City, according to the builder's plans. A modification of the RCA multi-wave antenna system (the antennaplex) is being considered.

The basic system has been used for several years in many locations, including Rockefeller Center, but this will be the first time that the television adaptations have been actually tested in the field.

At the left is the artist's conception of how the wiring system will be arranged to supply programs throughout the building, which will be the first apartment house in the United States to be wired for television programs.

In the city, where many families live in multiple dwellings, the television antenna problem has been of considerable importance. Numerous antennas erected on the roof would be likely to cause reflections, or other interference with each other. On the other hand, no one tenant wishes to bear the cost of putting up an antenna and then permit others to tap off it without charge. In addition, as high level signals are essential, tap-offs must be made in the most efficient manner possible.

A FLUORESCENT SCREEN on the dashboard of a motor car will show a panoramic view of the road ahead, according to Courtney Atwood, New Zealand insurance official. Mr. Atwood states that about a mile of the road will be visible, says a report by *United Press*.

16 ALL-ELECTRONIC instruments, each with its own loud-speaker and all controlled by the conductor from a central control panel, make up the Cracraft All-Electronic band illustrated below. This is the first band of its type in America. The 16 illuminated controls are divided into four groups, each under the supervision of a group master control.



A separate master control regulates the volume of the entire orchestra. The conductor can set the volume of each instrument individually, highlighting, at will, soloists and individual band sections. The apparatus used in the smaller instruments is a 10-watt Clarion amplifier with a 10-inch permanent magnet speaker. Larger units use a 20-watt amplifier with a 12-inch speaker. Each amplifier has a special remote control circuit connected to the conductor's board.

TELEVISION'S SERVICE range is surveyed by use of the new ultra-high frequency field intensity meter. This apparatus, which is used on signals from all stations operating in the band from 20 to 125 mc. (15 to 2.4 meters) not only provides accurate indications of signal strength but enables records to be made automatically, and provides data on the amount of interference, as well.

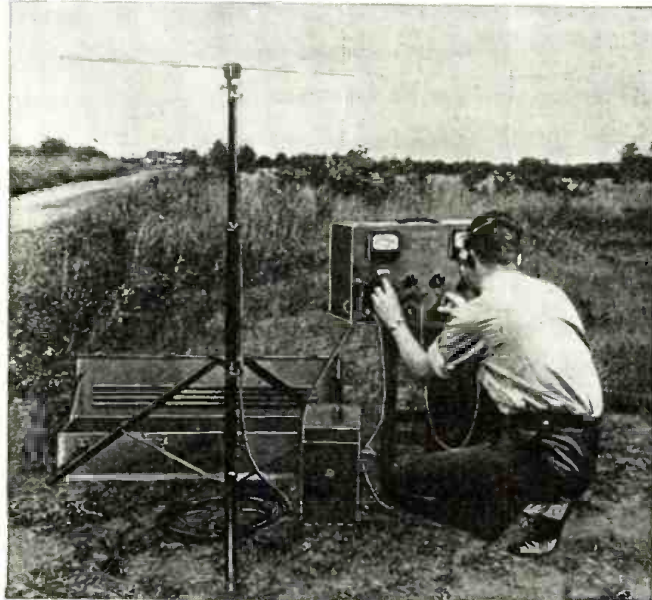

Shown below, this new RCA instrument is portable and can be carried to any location. It is believed that it will increase knowledge about service from high frequency stations as well as aiding in the selection of suitable sites for television and other ultra short wave antennas.

A N ELECTRICAL PIANO, which also receives radio programs and plays phonograph records, has been developed by the engineers of RCA and the Story & Clark Piano Company. This instrument—the Storytone—can have its volume stepped up at least equal to that of the largest concert grand piano, but when stepped down, it gives a harpsichord effect. In addition to the usual "damper" and "soft" pedals, it is equipped with a "swell" pedal to produce organ effects. A special piano bench contains a radio set in one of the sliding

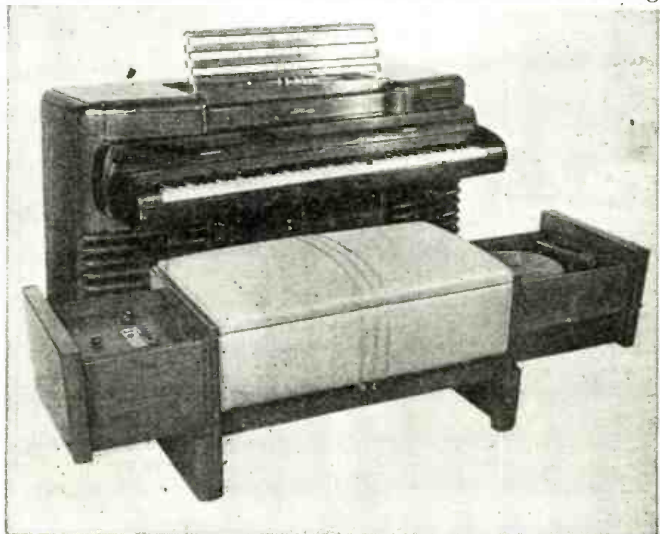

drawers, and a phonograph in the other. The piano may be played as an accompaniment to either of these.

The mechanical vibrations of the piano strings induce electrical vibrations in magnetic pick-ups, and these are amplified.

RADIO DIGEST

FILM SCANNING at first provided 90% of the program material being radiated by the National Broadcasting Company. Experimental television programs there were of two

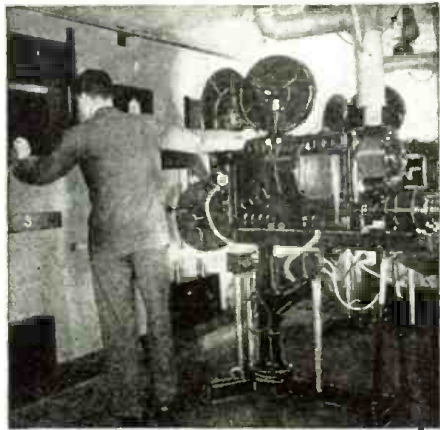

types — studio pick-ups (with live talent) and motion picture film. The accompanying picture is concerned with the latter. Film is placed in the projection machine (right) and run off exactly as it might be in any motion picture theatre. However, instead of showing up as an enlarged image, the film is

focused on the mosaic screen of an Iconoscope "camera." Opposite the projection machine, on the other side of the wall and unseen in this photograph, is the Iconoscope "camera." Virtually identical with those used in the television studio, it picks up the optical picture and transforms it to electrical impulses.

In effect, the motion picture projection machine functions in television exactly as a studio. Television transmission, from the moment the image is picked up in the Iconoscope tube, is the same for both live talent and "canned."

STUDIO LIGHTING has been revolutionized by engineers working under William C. Eddy, staff television expert, according to O. B. Hanson, Vice-President and Chief Engineer of NBC. Shown at the left is a lighting system which was used in early NBC television broadcasts. At the top of the picture are the "broads" and "scoops"; at the left, "suns"; and at the right, "rifles" and "spots." These are types of light sources long used in theatrical and motion picture work.

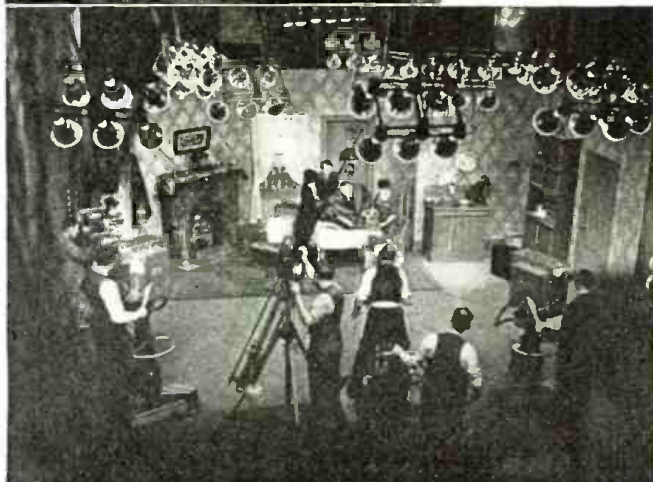
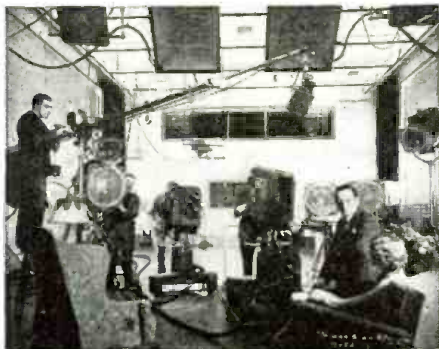

TABLOID SIZE newspaper pages are received on the new Finch equipment, which has a speed of 20 square inches per minute or 8 full pages an hour, according to Fred Ehlert, Information Chief of the Finch organization. Specifications of the apparatus, the receiver of which is

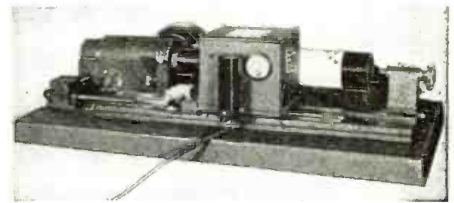

shown at top right with the transmitter below, are as follows: Number of lines per inch, 100; width of useful copy, 10 inches; number of lines per minute, 200; length of page, maximum, 17 inches; continuous feed of paper, 200 feet.

This apparatus utilizes the triple-scanning system described in a previous issue of RADIO & TELEVISION.

One of these new units is now shown in the All-America Cables, Inc., exhibit at the New York World's Fair. Black on white copy is produced by means of an electro-mechanical process on dry paper. It reproduces type and illustrations alike.

BALLS OF FIRE float in a cloud of royal purple gas in the sodium fountain shown below. William A. Gluesing is demonstrating how this apparatus operates in the "House of Magic" auditorium in the General Electric Building at the New York World's Fair. The capacity of the human body, brought near the electrodes of the tube, causes an electronic discharge which is manifested by a brilliant display of miniature "fireworks" within the glass envelope. The use of different gases will provide various other color effects.



RE-CREATED SPEECH is produced by the apparatus shown in the photograph below. This machine analyzes human speech and breaks it into its essential parts—the buzz and the hiss—each of which has ten ranges
(Continued on page 234)

The new lighting units, shown in the lower picture were designed for television studio use. They give better illumination with less heat and greater economy of current, and they can be remotely controlled. In addition to the big ceiling lights, which may be swung to a wide variety of positions, are lightweight "dollies," each of which bears several lamps to furnish the "modeling" illumination. Less than two feet high, these "dolly" lights may be placed in front of the television camera, where they will not be picked up by its lens.

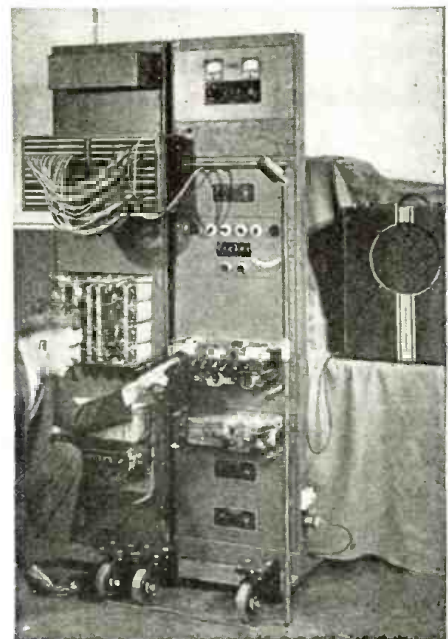



INTERNATIONAL

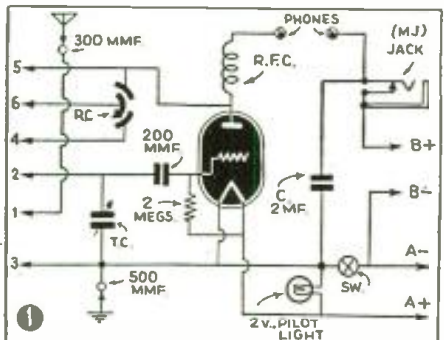

Coil Tester

1 A HANDY tester for checking homemade coils under actual working conditions is described in *Practical and Amateur Wireless* of England. The circuit of this apparatus is shown in Fig. 1.

As the diagram shows, the unit consists of a grid-leak detector having all points which were normally connected to a tuning coil, running instead to a series of separate leads brought out at the back of the cabinet, each of which has an alligator clip at its end. The numerical designations may be marked on the panel at the individual grommet holes through which the leads are taken. The tube used may be any of the standard detectors, but preferably of the high impedance type, and for most requirements should have a plate voltage of approximately 75. The meter jack, MJ, is a refinement which may be omitted if desired. However, if a meter is used, a visual indication may be had, as the plate current will fall when the tube oscillates.

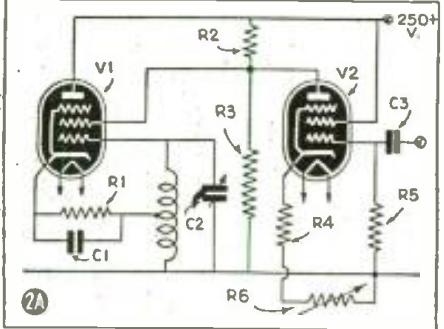

Supersonic Light Relay

2 FIG. 2A, derived from *Television and Short Wave World* of England, shows the diagram of a modulated oscillator for use with a supersonic light relay. Designed originally for use in mechanical scanning television, it has several other applications.

All values of parts shown in Fig. 2A are given in the following table:
RESISTORS: R1—1,000 ohms, 1 watt; R2—15,000 ohms, 3 watt (or two 30,000

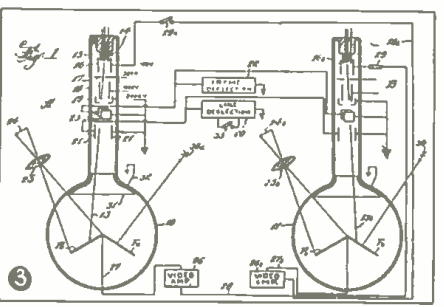
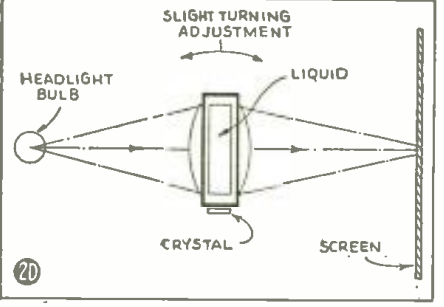
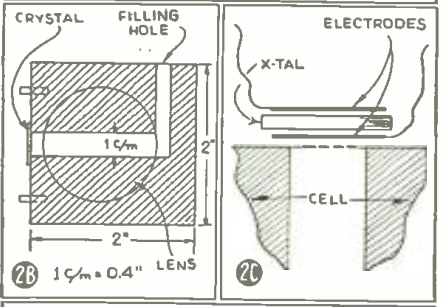

ohms, 1 watt in parallel); R3—30,000 ohms, 1 watt; R4—250 ohms, 1 watt; R5—250,000 ohms, 1 watt; R6—5,000 ohms, W.W. volume control.

CONDENSERS: C1—.0003 mf. tubular; C2—midget variable; C3—0.1 mf. tubular; 10 turn C-T coil; 2—5-prong ceramic tube holders; 2—A.C. (Pen 5-pin Mazda or Premier) tubes.

Shown in Figs. 2B-C are plans of a supersonic cell to be used with this modulated oscillator. Fig. 2D shows how a light source may be assembled with the cell to produce a modulated light beam on a viewing screen. The crystal used in the light cell is specially cut for supersonic work and has a frequency of about 10 mc., though accuracy is not essential.

Two-Way Television

3 A NEW PATENT, granted to the Allen B. DuMont Laboratories of Upper Montclair, N. J., makes telephone television a step nearer, though it is still many years away. Mr. DuMont's invention provides a single cathode-ray tube at each station, for his new tube can be used both as pick-up and viewing device. A single beam of electrons in the tube can be caused to scan either a photosensitive or a fluorescent screen, depending upon whether the user wishes to transmit or receive an image.

One type of circuit is shown in Fig. 3. Modifications of this permit placement of the two plates side by side in a rectangular bulb, and in various other positions.

Radio Typewriter

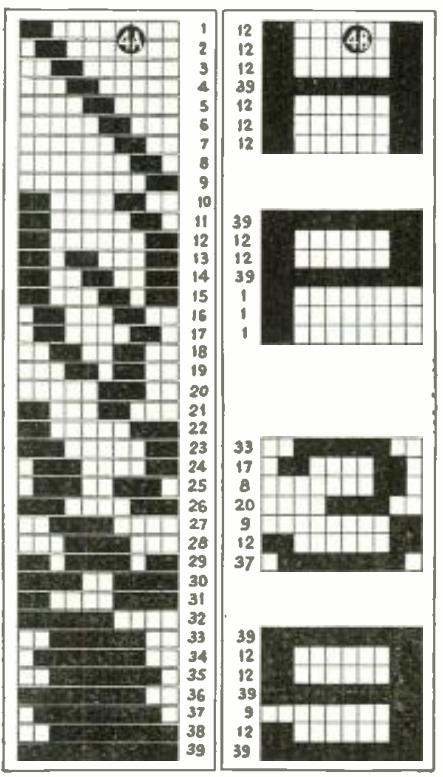

4 FIGS. 4A and 4B, taken from *Le Haut Parleur* of France, show an ingenious system utilized in a teletypewriter. As Fig. 4A shows, there are 39 types of codings and each letter of the alphabet or numeral is made of a combination of seven of these assorted symbols. Fig. 4B illustrates that the letter "H," for example, is made of three Type 12 symbols, a Type 39 symbol, and three more Type 12 symbols. Letter "I," for example, would be made of seven Type 5 symbols.

Radio can be used for this transmission very easily. The transmitter, modulated with seven frequency bands, will actuate a series of relays, causing a key to make an impression wherever the modulating frequencies are suppressed. Suppression is automatic, as the typewriting machine at the transmitter perforates the tape which runs between seven pairs of points, each of which controls one of the bands. When the contacts close through a perforation, the frequency they regulate is suppressed.

New "Footless" Tube

5 IN AMERICA we have our metal tubes, glass tubes, metal-glass tubes, loktals and acorns, but now Great Britain comes out with something new — the Tungram "Footless" Valve. As shown in Fig. 5A, the tube has a locating stem similar to our metal and M-G tubes. However, the positioning of pins on the 8-prong



base is somewhat different from that utilized over here. Also, the heater is mounted horizontally and the grids and plates surround it. Connections are brought out near the edge of the tube and are so spaced as to provide minimum capacity. The sub-base is provided with shields for the plate and grid leads, and the whole tube plugs into a special tube base. The conventional glass foot has been completely eliminated, and surface leakage across the pins has also been reduced to, it is claimed, 1/10 to 1/15 of that of the usual tube. Both *Television and Short Wave World* and *Wireless World* of Britain have detailed descriptions of the new tube, and our Fig. 5B from the latter publication, shows the tube's use.

D.C. Receiver

6 AN INTERESTING D.C. receiver, which incorporates a noise limiter and a regenerative R.F. stage, was recently described by R. G. Drewery, G6OY, in Britain's *T. & R. Bulletin*. As D.C. receivers, even without these features, are none too common in America, a complete diagram is reprinted in Fig. 6A. The values of the parts used are shown in the diagram. Fig. 6B shows an alternative noise eliminator circuit. The tubes used were of British make, but their American equivalents will doubtless suffice. The R.F. stage uses a Ferranti VPTS variable mu pentode; the detector, an ordinary 6K7; and the output stage, an Osram H30 hi-mu triode with plate impedance of 14,500 ohms.

Antenna Coupling

7 O. J. RUSSELL, B. Sc., writing in the *Short-Wave Magazine* of England, brings solace to the owner of a small set which is deficient in selectivity. He tells how to couple and match aerials so that real DX may be pulled in through QRM. Mr. Russell's first suggestion is that the antenna circuit be tuned as shown in Fig. 7A. The coil and condenser values will vary for different bands if an all-wave set is being used. As a suggestion, standard short-wave R.F. plug-in coils with their associated variable condenser are a convenience. Fig. 7B shows an arrangement when coupling a tubular or balanced feeder system to a receiver having only the usual antenna and ground posts. Another matching system for coupling balanced feeders to a set designed for doublet operation, is shown in Fig. 7C. The coils and condensers used in Figs. 7B and 7C are best determined by experiment.

Marine Receiver

8 READERS who are boating enthusiasts will be particularly interested in the 15 to 1600 meter set, designed and built by VK2MZ, for it is particularly designed for marine work. The circuit diagram in Fig. 8, taken from *Australasian Radio World*, shows all values and the tubes are available in the United States. All coils are wound on 1 1/2" forms, spaced over 1 1/2", except oscillator, which is spaced over 1 1/4". Bandsread tap

is from bottom end. Coils with no bandsread tap should have a jumper from B.S. tap pin to top of grid winding pin.

All coils are wound with 24-gauge enamel wire except broadcast coils, which are wound with 30-gauge enamel. Aerial and regeneration coils are spaced 1/4" from cold end of grid windings. Top of grid winding should go to grid, bottom to ground. Then the beginning of regeneration winding goes to "B+"; other end to plate of oscillator. Coil data follows:

Band	Grid	B.S.	Tic.	Acc.
160 m.	27	11	7	5
80 m.	13	4	4	4
40 m.	8	1 1/2	3	3
20 m.	4	1	1 1/2	2

Explaining "Q"

9 AN EXPLANATION of what "Q" really is, is given by an author who signs himself "Engineer" in *Australasian Radio World*. The article uses many analogies, most of which are too simple for the readers of *RADIO & TELEVISION*. However, its illustrations should be of extreme interest.

Fig. 9A shows how "Q" affects the decay of free oscillations in the tuned circuit shown at the lower part of the figure. The upper graph illustrates high "Q" and the lower one low "Q". Fig. 9B is a graph showing the velocity of a pendulum. The kick given by the spring begins at "X" and vanishes at "Y." In Fig. 9C we see how the plate current gives similar kicks in an os-

(Turn the page, please)

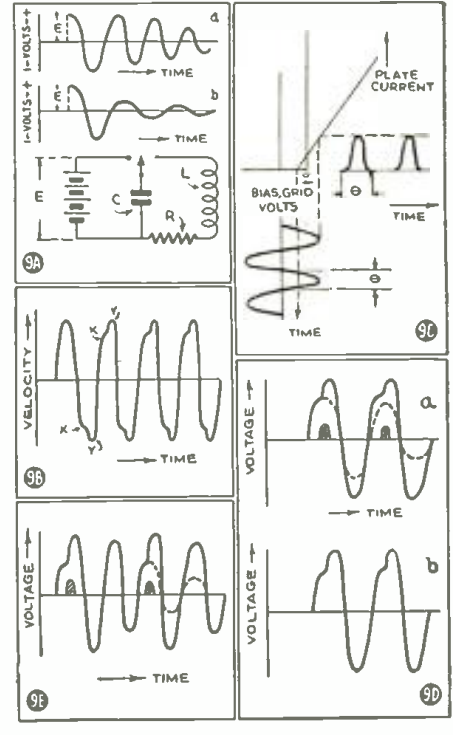
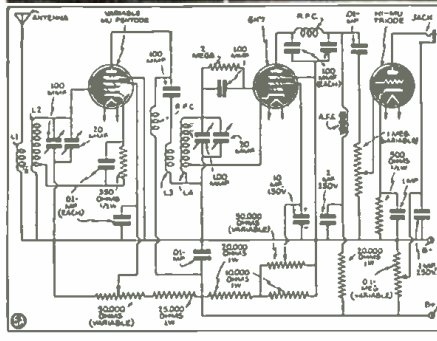
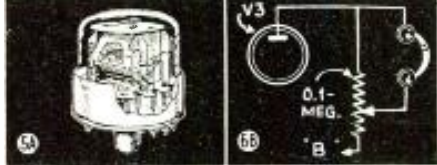
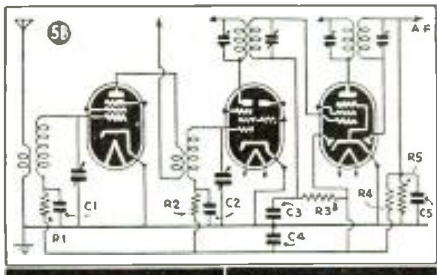
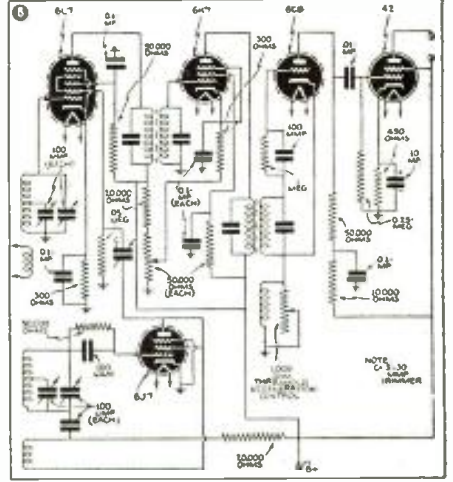
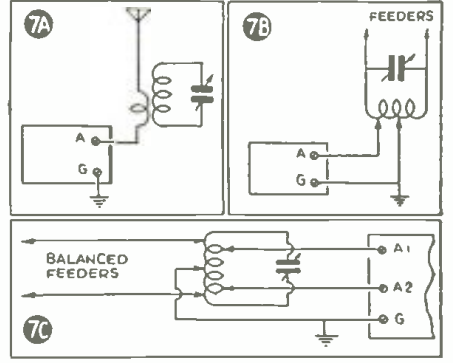

INTERNATIONAL RADIO REVIEW

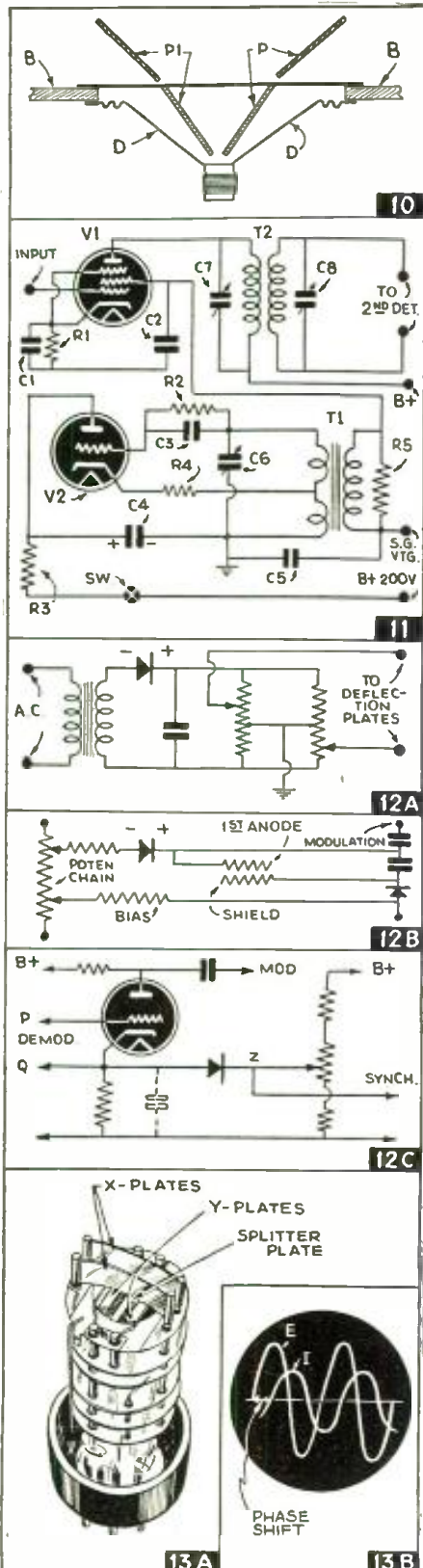

(Continued from preceding page)

oscillator or power (R.F.) amplifier, while in Fig. 9D, we see how the "Q" factor of the tank circuit affects the operation of the stage. The shaded parts in the upper graph are the current kicks. The dotted line shows how the oscillation would decay and how the kick prevents this. The high "Q" circuit (above) in Fig. 9D, permits less harmonics than the lower one, and with lower "Q." Frequency doubling is shown in Fig. 9E, where the kick occurs every fourth half cycle and the "Q" must be fairly high to keep the amplitude (peaks) reasonably constant.

Loud Speaker Improvement

10 A PAIR of diverging partitions, which extend inside and beyond the usual diaphragm, will improve the quality of reproduction from a loud speaker, according to *Wireless World* of England. As Fig. 10 shows, the partitions, P and P1, are hinged near the baffle board, B, to which the edge of the diaphragm is attached in the usual way. The partitions break up or separate the radiations from the parts of the diaphragm which may be vibrating out of phase, especially at high frequencies, and increase the high-note content of the reproduction, radiating a flat beam of sound with a large angular spread. N. V. Philips of Holland, the patentee, has suggested that more than one pair of baffles may be used.

Heterotone Reception

11 AN audio oscillator suitable for heterotone reception is described in *Television and Short-Wave World* of Great Britain. The circuit shown in Fig. 11 will give an apparent gain in signal strength by modulating the screen of the i.f. amplifier. The circuit uses a single tube oscillator, with the secondary of an output transformer connected in series with the grid of the i.f. amplifier. B.F.O. is retained in the succeeding stage. V2 is 6J5, and C6 may be a variable condenser or a bank of fixed condensers. Transformer T1 is a standard push-pull input unit. Other values are as follows: R1—100 ohms; R2, R3, R5—100,000 ohms each; R4—20,000 ohms; C1 and C2—.01 mf. each; C3—.002 mf.; C4 and C5—1 mf. each; C6—.0005 mf.

Metal Rectifiers in Television

12 AN article in *Television and Short-Wave World* discusses the use of metal rectifiers in television receivers. Fig. 12A shows the use of a half-wave rectifier for a picture shift circuit. Fig. 12B shows the use of two rectifiers as a d.c. restorer, and Fig. 12C illustrates the use of a rectifier in a synchronizing filter circuit. A suitable rectifier for use with a 70 to 80 ma. 230-240 volt full-wave power supply is a Westinghouse type HT-17, employed in conjunction with 8 mf. condensers. Type HT-16 may be used if the voltage input is 200 at 170 ma.; in this case 4 mf. condensers are used. Where the output is 3000 to 4000 volts at .75 ma., two rectifiers are used. A number of other rectifier specifications for use with other voltages and currents are also given in the original article.

Double-Beam Cathode-Ray Tube

13 AN interesting inside view of the Cosor double-beam cathode-ray tube is given in England's *Wireless World*. Shown at Fig. 13A, the tube includes one extra plate located between the first pair of deflectors. This single plate splits the cathode beam in half so that the two resulting beams may be employed to show both current and voltage waves, or to bring out any other two characteristics that may be of interest. Fig. 13B shows how phase difference between current and voltage or between two voltages may be observed.

Light-Storage in Television Transmitters

14 THE general arrangement of a system in which the cathode-ray tube becomes a form of light valve instead of a light source, is shown in Fig. 14A. In this arrangement, the screen consists of a mosaic of insulated elements (marked "raster elements" in Fig. 14A) is used. A screen of fine mesh wire is placed inside and is scanned by the modulated electron beam. This beam charges the raster elements, building up a picture in variations of potentials. The discharge process begins immediately after the charge. The graph at the right of Fig. 14A shows the charging and discharging of the elements.

An improved system is shown in Fig. 14B in which the graph shows that the elements remain charged for nearly the whole frame period and are then rapidly discharged. This is done by using a double-beam c-r tube, one beam of which is modulated and charges the raster elements as described. Its scan is preceded by that of the other beam, which discharges the elements.

A means of converting such charge variations to light is shown in Fig. 14C, where

(Continued on page 246)

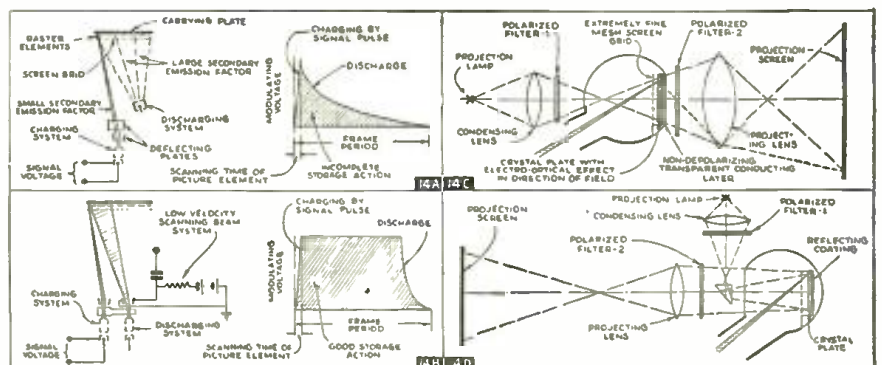

The Radio Beginner

Lesson 8 — Audio Frequency Amplifiers

Martin Clifford, W2CDV

● WE have already seen that waves may vary in their *frequency* or in the number of cycles per second. Since the frequency of waves gives rise to certain identifying characteristics, we may use these characteristics for grouping waves under headings, the headings being somewhat indicative of the nature of the waves. Thus, waves that vary from about twenty-five cycles to approximately fifteen thousand cycles are called *audio-frequency*, for the very simple reason that the human ear will respond to waves within that group of frequencies.

The output from the detector tube of a receiver is audio frequency in nature and can be heard through the proper use of ear-phones. However, group listening has compelled the development of apparatus to build up the *signal following* the detector. Since the signal at that point is in the *audible* stage, we place such apparatus in the category of *audio frequency amplifiers*. Such amplifiers may be built in a number of ways, some of the most widely used being resistance-coupled amplification, impedance coupled, push-pull or power amplification, and simple transformer coupled amplifiers.

Transformer Coupling

In Fig. 1 we see a representative diagram of a *transformer coupled* amplifier, triodes (3-electrode tubes) being used for the sake of simplicity. The audio amplifier tube is connected to the output of the detector by means of an *audio frequency transformer*. Such a transformer consists of two coils wound on a soft iron laminated core, one of the coils being called the *primary* and the other the *secondary*. We recall that an alternating current passing through a coil builds up a magnetic field around that coil, and through magnetic induction can cause a voltage to be impressed on another coil placed near it. The use of the soft iron core is to allow the maximum transfer of the magnetic lines of force, since these lines of force pass much more easily through iron than through air. The current variations of the detector output circuit are applied across the primary of the transformer. These variations of current in the primary produce a corresponding electromotive force (E.M.F.) across the secondary. Since the secondary is connected to the tube's grid, the voltage variations will be impressed on that grid. Thus we see that

the audio transformer is an electrical link between two vacuum tubes. The audio frequency current output of the detector tube, passing through the primary of the audio transformer, produces a magnetic field which in turn induces an alternating voltage across the secondary coil, and hence on the grid of the following tube (first audio tube). Audio transformers may act not only as a link, but as a very practical device for securing an increase in signal strength. This is done by designing them as *step-up transformers*.

Effect of Increasing Turns Ratios

Step-up transformers are so built that the secondaries have more turns of wire than the primary. Transformers may have ratios of two, three, five (or any other figure) to one, that is, the secondary may have two, three or five times as many turns as the primary, etc. Amplification is also secured in the tubes themselves, since it requires only a small voltage on the grid of the tube to secure a large change in the output (or plate) circuit. It might be thought that all that would be required in a transformer-coupled audio frequency amplifier would be a very high ratio of secondary to primary turns in the transformer, in order to secure a very high step-up and maximum amplification. However, as the ratio is increased, the problem of avoiding *distortion* and maintaining fidelity of signal becomes increasingly difficult. In a number of instances, audio transformers have a one to one ratio, that is, the same number of turns in both primary and secondary, in such cases their function is that of a coupling device between the tubes.

It should be observed that one end of the primary of the audio transformer is connected to the plate of the detector tube, and the other end of the primary to the positive potential of the B battery (or power supply). The currents flowing through the primary of the transformer may be resolved into two components; first, the direct current between plate and battery and, second, the audio frequency current. Since there is no physical connection between the primary and secondary, the positive plate voltage of the first tube is electrically insulated from the grid of the following tube. The direct current of the detector, flowing through the primary, creates a permanent magnetic field of a certain minimum strength. Since it is

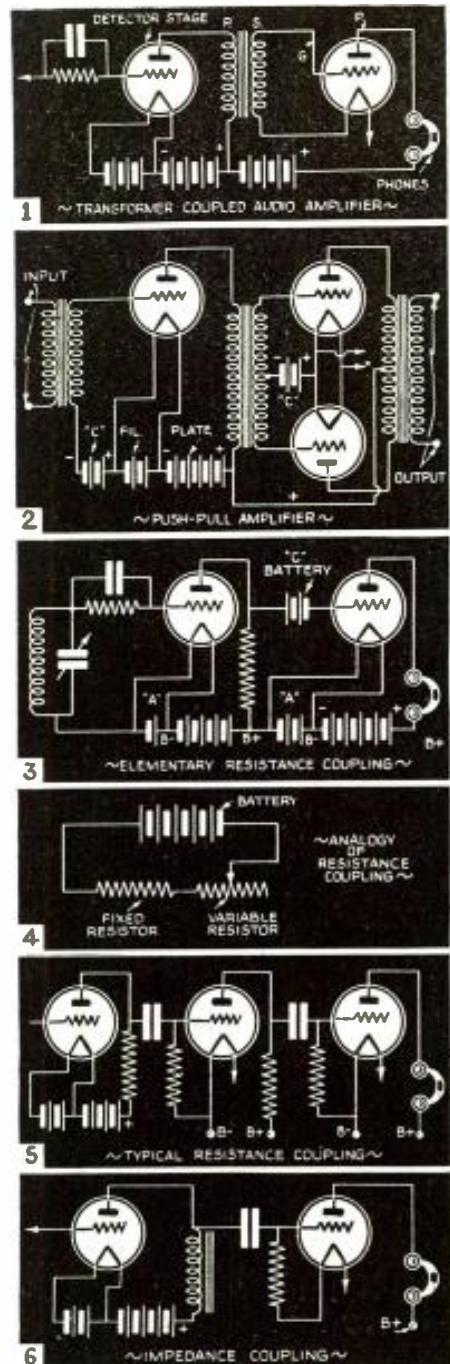

Diagrams above show, top to bottom:—Transformer coupled audio amplifier; push-pull; simple direct-coupling; typical resistance coupling, and impedance type coupling.

desired to transmit only the *audio frequency variations* this direct current (necessary to maintain the plate at a positive potential) may cause distortion. This is especially true in audio transformers having a very small iron core, such that the direct current causes it to become *saturated* by the magnetic field. The use of a larger core will reduce the amount of distortion, but may cause certain losses.

Push-Pull Amplification

In order to secure greater efficiency and at the same time greater amplification, use is made of *back to back* or *push-pull* amplification. See Fig. 2. Note that, in this type of amplifier, the transformers are the

(Continued on page 248)

14th Silver Trophy AWARD

For Best HAM Station of the Month

Awarded to

Dr. Philip Weintraub, W9SZW-W9TMQ
3860 Harrison Street, Chicago, Ill.

Description of Dr. Weintraub's Ham Shack

● "EVERYTHING in my shack is home-made (including the face masks of the XYL and myself) but excluding, of course, the receiver which is a Hallicrafter Superskyrider SX17," says Dr. Philip Weintraub. "The room is completely soundproof to avoid awakening the XYL and two junior Ops on late QSO's."

The station, W9SZW, is located in a penthouse and consequently the antennas are about 110 feet above ground. They are a Johnson 10 meter "Q" and a 132 foot flat-top against a 132 foot counterpoise.

The 160 meter rig consists of a 47 crystal oscillator, 59 buffer and a pair of T20's final amplifier. The speech is a 56, 56, 59 driver into a pair of 59's Class B. The microphones are a 387W and Shure crystal. The same microphones and speech amplifier are also used for the 28 and 56 megacycle transmitters.

The 5 and 10 meter xmitters consist of a 6J5 G crystal operating with a 20 meter "rock," 616 buffer and an 809 final at 38 watts input. All districts have been worked and 14 countries.

"The 10 meter rig is used chiefly to keep in personal contact with the XYL's folks in Beverly Hills, California," says Dr. Weintraub, who adds, "It may interest the editors to know that an article on ham radio has been written for *Oral Hygiene* and accepted and will reach the offices of some 75,000 dentists throughout the world. Naturally, the Bibliography gives special credit to RADIO & TELEVISION."



Ham Station of Dr. Philip Weintraub.

This beautiful silver trophy stands 11 $\frac{3}{4}$ " high and one is awarded monthly by RADIO & TELEVISION magazine for the best photo of a Ham station. The silver statue stands on a handsome bakelite base on which is a silver plate. The name of the winner will be engraved on this plate before the trophy is sent to him.



Rules for Trophy Contestants

● SIMPLY send the Editors a good, clear photograph of your Ham station. If your station photo is selected as the best of those submitted each month, you will be awarded one of these handsome silver trophies with your name engraved on it.

The trophy stands nearly 12" high and is a fine example of the silversmith's art. It represents the spirit of victory and was designed by one of the leading silversmiths. The name of the winner each month will be engraved on a silver plate mounted on the black bakelite pedestal before the trophy is sent to the successful contestant.

The winner of each month's trophy award will be announced in the second succeeding issue, and the closing date for that contest is the end of the current month.

The judges of the contest will be the Editors of RADIO & TELEVISION. In the event of a tie, duplicate prizes shall be awarded to the contestants so tying.

(Continued on page 250)

First Prize Winner Aligning I. F.

I recently built a crystal filter into my Ham receiver, and after completing it, was stuck for a way to align the I.F. system. I was far away from my shop with all its "spare parts," and so I couldn't set up a crystal oscil-

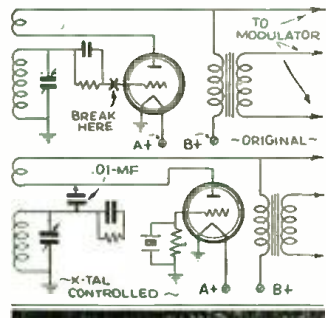

lator. I finally looked into my Triplett No. 1201 signal generator and found a simple way to make a change and make it crystal-controlled. The change is shown herewith. Simply connect a .01 mf. condenser to couple the tuned circuit to the plate, and clip on the crystal unit slanted by a 1 megohm resistor. One thing more had to be done before oscillation could be obtained. An external 45-volt "B" battery was connected in place of the self-contained 22½ volt block, and a milliammeter put in series to indicate oscillation. The signal generator was then employed in the usual manner.—William "Bill" Locke, W9QVT.

Coil Turn Counter

I have used the winder illustrated for several years, during which time I have rewound power and other transformers with success. The winder is made of 7/8" board, and the two shafts shown are 1/4". "A" is a wooden block, of the size and shape to suit the transformer core. "B," flexible shaft coupling, is to hold the block fixed on winding shaft and is attached to both by screws. A speed indicator "C" is attached to end of winding shaft by "D," a shaft coupling. The other shaft is to carry the spool of wire.—E. H. Barrow.

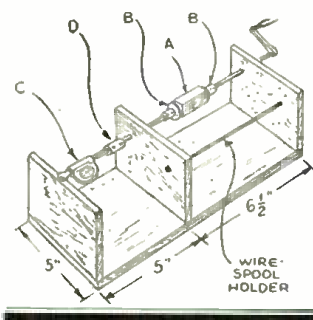

R. F. Indicator

It is often an awkward job to take an R.F. indication on an enclosed 5-meter rig. I have overcome the difficulty, as shown in the accompanying sketch, and now an R.F. indication can be viewed by means of a pilot light, at the turn of a knob.

Radio Kinks

Each month the Editor will award a 2 years' subscription for the best kink submitted. All other kinks published will be awarded eight months' subscriptions to RADIO & TELEVISION. Read these kinks; they will be of real use to you, besides indicating what is wanted. Send a typewritten or ink description with sketch of your favorite to the Kink Editor

The basis of the unit is an old rheostat with the back taken off. A piece of No. 12 or No. 14 enameled wire, bent as shown, with a loop to mesh with the coil, is soldered to the arm of the rheostat. A pair of flexible wires is soldered across the loop on the pilot light which is mounted on the panel. A stop makes it easy to bring the turn into the correct position.—Les. Jones, W4YK.

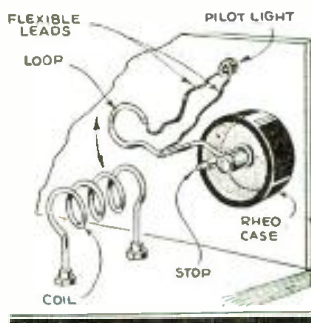

Hot Wire Ammeter

A very simple hot wire R.F. ammeter may be made from five inches of No. 36 resistance wire with a resistance of approximately 100 ohms per foot. The wire should be strung as shown in the accompanying illustration, tightly enough to eliminate sag.

It is supported from a bakelite panel by two stand-off insulators, and a thin aluminum pointer is pivoted on a third stand-off insulator loosely enough so that it moves freely. A small wire hook and a silk thread attach the pointer to the center of the wire. When the wire is heated, it stretches, allowing the pointer to sag and thus indicate the current on the scale attached to the panel.—Billy Savarts.

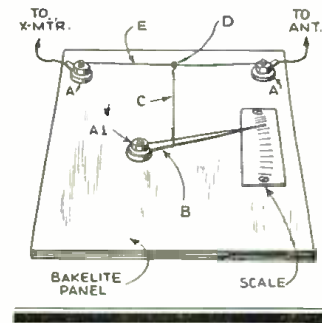

Simple Tube Adapter for Emergency Use

I had an H4G tube burn out. The 30 type is the equivalent but it just won't fit in the octal socket. It meant two to three days to get another and I wanted to use the set at once. With an octal testing adapter (for testing tubes without breaking carton) and four pieces of No. 14 wire and five minutes' time, I had the set operating, using a 30 tube.

Bend the wire over at one end about three-eighths of an inch; this end then makes a snug fit in the adapter. Select two nails, drill bits, or any straight round metal object slightly smaller than the prongs of the 30 tube, and wind the remainder of the wire in the form of a spring, thus completing the second operation. When you have made the four attachments, slip one over each of the prongs on the 30 tube. Spread coiled parts so that they reach the full length

of prong, and insert doubled end in the proper place in adapter. Using a 30 tube to replace an H4G, the two filament prongs of the 30 slip into Nos. 2 and 7 of the octal, the others into Nos.

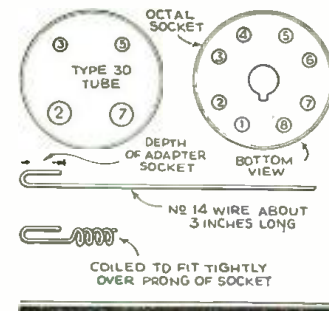

3 and 5. If the fan has no adapter, he can use the base of the burned out tube, but this means a soldering job, which can be done without much trouble.—Herbert S. Rutherford.

Double Doublet

I am using the double doublet illustrated herewith for both transmission and reception. The lead-in is 4-conductor color coded twisted pair cable boiled in paraffin with 25% beeswax. The ends terminate in banana jacks. Two jacks on flexible

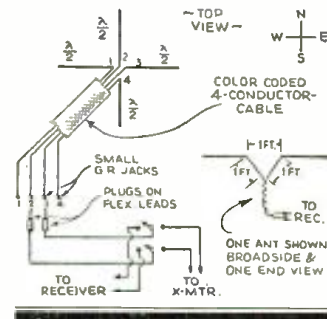

leads go to the blades of a D.P.D.T. knife switch. This changes any antenna you may select from transmitter to receiving position. The N-S antenna has 12" spacing in center. Leads are fanned out to form a 12" equilateral triangle. This is also true of the East-West antenna. With the table below, directional properties are very pronounced.

Jacks	Direction
1-2	Northwest
1-3	North and South
1-4	Southwest
3-2	Northeast
3-4	Southeast
4-2	East and West

By proper selection, QRM may be greatly reduced and a signal gain of 6-8 db. on a RME has been noted when using the V antennas for transmitting.—Robert F. Scott, W4FSI.

Headphone Connection

It is very simple to connect a pair of phones to a radio set, even if there are no phone jacks provided. You do not need to have any direct physical connection between the phones and the output of the receiver. In addition, it is possible to vary the volume heard in the phones without using any of the conventional controls.

All you need to do is short circuit the voice coil on the dynamic loud speaker. The signal can then be picked up by connecting a pair of phones to a high inductance winding placed near the output transformer of the receiver. The winding which I used is a secondary coil removed from an old transformer.

Volume of sound heard in the phones may be diminished by moving this "pick-up" coil to a greater distance from the set's output transformer.—Joseph C. Lipo, W2HTD.

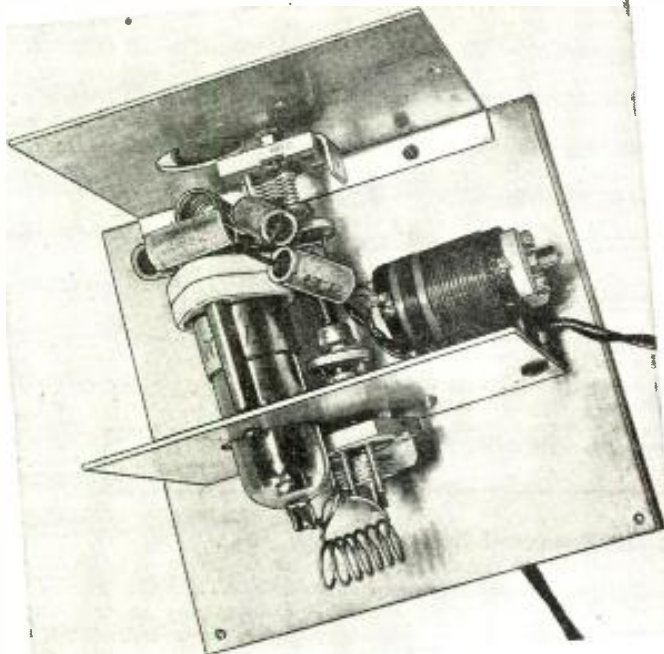

Top view of the 1-tube Television Sound Converter.

1-Tube TELEVISION



Sound Converter

Herman Yellin, W2AJL

Works on any receiver tuning
to 1600 kc. (187 meters.)

● AFTER many false starts, television has at long last arrived—and it's here to stay! The glamour of actually seeing moving images transmitted by radio is enough to fire the imagination of even the most blasé.

Many enthusiasts cannot afford to purchase a complete video and sound receiver; many will wish to build their own. As a modest beginning, a simple *converter* for reception of the *sound* channel is in order. Construction of the simpler sound section will afford some experience in construction, invaluable in the later and more difficult job of building the video section. Too, listening to the sound accompaniment of the images will make one all the more eager to participate in receiving the complete television program.

Only 1 Tube Used

Probably the simplest highly effective system would be to use a single multi-element tube as a *first detector-oscillator*, capable of feeding into the listener's regular radio set, thereby making full use of the *home receiver* with its potentially excellent audio response. In order to accommodate receivers tuning in only the broadcast band, this converter has been built to operate with an intermediate frequency as low as 1600 kc. (187 meters). Where a receiver tuning to a higher frequency of about 2500 kc. (119.9 meters) is available, it is recommended that this higher i.f. be used.

Use of the 6K8GT, one of the new "bantam" tubes approaching the metal-clad variety in size, results in quite compact design. At *six meters* these tubes have quite a high conversion gain, so that in combination with one's regular receiver, a good signal will be available from the loud-speaker.

Wiring Requires About An Hour

There are so few parts in this converter that wiring should be the work of less than an hour. As the photos show, a small 6¾"

x 6½" chassis supports two 5" x 5" aluminum shields. The front shield, upon which is mounted the oscillator tuning condenser and dial, can readily be replaced with the panel of a small cabinet. In fact, it is recommended that a cabinet be used, not only for its shielding effect, but for protection against dust. The detector tuning condenser is mounted on the rear side of the back shield,

with the detector coil soldered directly to the condenser terminals. Two 1¾" brass rods, tapped at the ends for 6/32 screws, serve to support the tube socket away from the shield, so that the control grid of the tube will project outside the shield partition and be close to the stator terminal of the detector tuning condenser.

(Continued on page 245)

Wiring diagram of converter to provide Television Sound on your present Receiver.

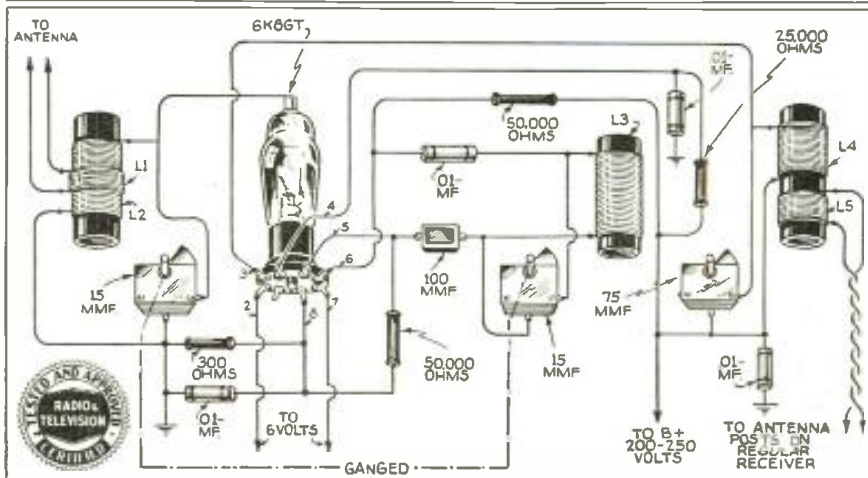
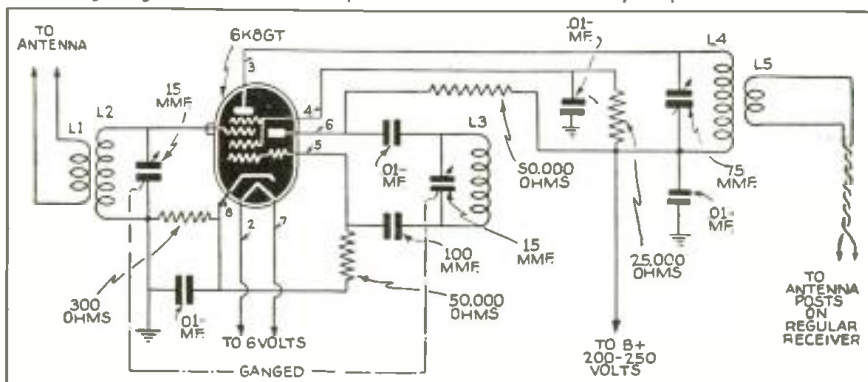

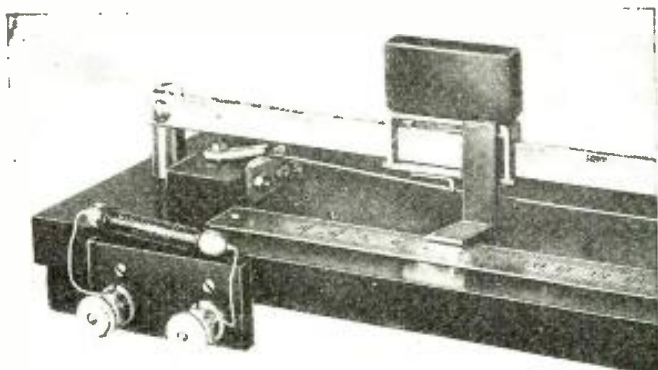

Close-up view of slider and scale on Wheatstone bridge.

Building and Using a Wheatstone Bridge

● THE Wheatstone bridge is a very handy instrument for measuring resistances, capacities and inductances.

Its construction is really simple, practical and inexpensive. We shall see that the Wheatstone bridge replaces a certain number of pieces of special and costly apparatus, and that its results are always of remarkable precision.

The Wheatstone bridge is nothing but a simplified modification of a potentiometer consisting of a resistance wire fastened and stretched between two fixed points (see Fig. 1). Let us suppose that a potential E is applied at the ends of the wire A and B and that the resistance has a value R .

A current $i = E/R$ will flow along the wire and a drop of potential will be linearly distributed along the wire and in proportion to its length, the potential measured increasing gradually from A towards B until the total value of E is reached at point B . We may then say that the total voltage drop occurs between ends of that wire. (See Fig. 2.)

The wire should be, of course, perfectly homogeneous in such a way that its specific resistance and its cross-section be exactly the same for each unit area anywhere along its length.

Referring to Fig. 2, the drop produced will be $e = E \frac{a}{l}$ where $l =$ total length

of the wire in centimeters; $a =$ the part of the wire over which the drop is calculated.

From this we deduce that

$$e^1 = E \frac{xy}{l}$$

for the calculation of the potential between points x and y . Thus the total voltage is divided by point P into two parts, e and $E - e$, the relation being $e/E - e = a/l - a = r/R - r$ (if R is the total resistance of the wire and r is the resistance between points A and P).

Following these fundamentals, we shall become acquainted with the principle of the bridge itself.

Supposing that four resistances R_1, R_2, R_3, R_4 are connected according to Fig. 3. Applying Ohm's Law, we see that the voltage in circuit I divides itself into two particular voltages, e_1 and e_2 the sum of which is equal to E and that e_1/e_2 is equal to the relation of resistances R_1/R_2 .

Diagrams mentioned in text giving explanation of the bridge.

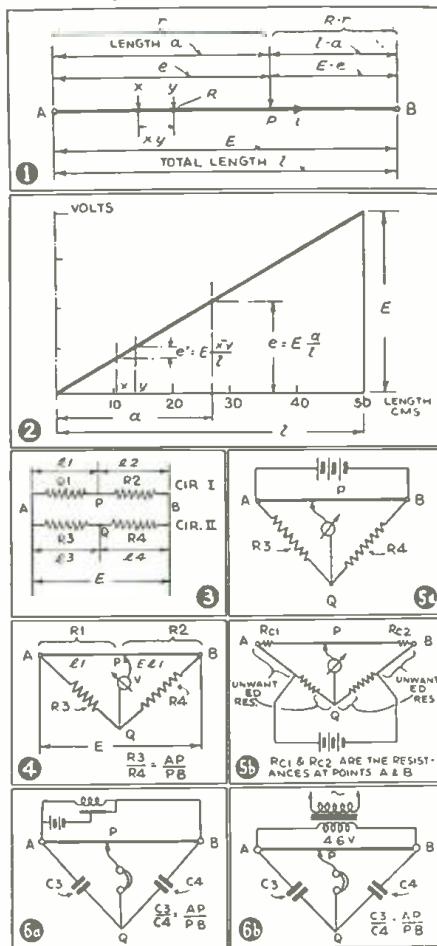

Including Inductance and Capacity Measurements

$$e_1 + e_2 = E; \frac{e_1}{e_2} = \frac{R_1}{R_2}$$

and it follows that in circuit 2,

$$e_3 + e_4 = E; \frac{e_3}{e_4} = \frac{R_3}{R_4}$$

If the drop e_1 has the same value as the drop e_3 ; that is, if points P and Q have the same potential relative to A , no voltage shall be obtainable between P and Q . The bridge being balanced we may then write:

$$\frac{e_1}{E - e_1} = \frac{e_3}{E - e_3} \text{ or } \frac{R_1}{R_2} = \frac{R_3}{R_4}$$

Replacing resistances R_1 and R_2 by the wire potentiometer we mentioned before, we derive a schematic illustration of the principle of the Wheatstone bridge as shown in Fig. 4.

Sliding contact P over the stretched resistance wire, it is possible to change the relation of R_1/R_2 and to find a neutral point, where a sensitive voltmeter connected between P and Q will indicate zero potential.

The balance or equilibrium of the bridge is then perfect. It is not necessary to know the values of R_1 and R_2 ; it suffices to know the value of their relation. Noting that this relation is equal to that of $e_1/E - e_1$, and to that of lengths AP/PB , to obtain a balance we must write $R_3/R_4 = AP/PB$.

When a resistance R_1 is unknown, and the value of a calibrated resistance

(Continued on page 238)

Appearance of complete slide-wire bridge.

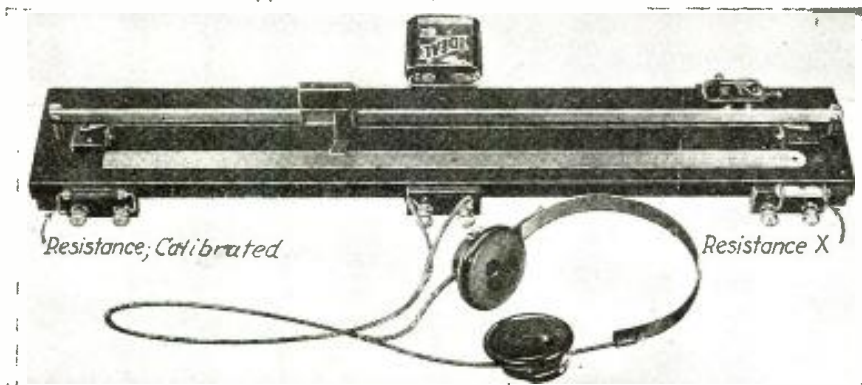

Antennas for the HAM

Half-Wave Radiator—
Twisted Pair Transmission Line

Herman Yellin, W2AJL

● HALF-WAVE radiators can be fed by different types of transmission lines or feeders. In recent years, more and more amateurs, and "commercials," too, have installed *untuned* transmission lines. One of the easiest and perhaps most economical to construct is the *twisted pair* line.

When a transmission line is terminated at the antenna by an impedance equal to the line's surge impedance, there will not be any standing waves on that line. Standing waves on a line result when the radio wave, traveling along the line and striking the radiator, is reflected back along the line. These reflections occur when the transmission line surge impedance is *not* equal to the impedance of the antenna (or radiator) at their *junction* point. At the

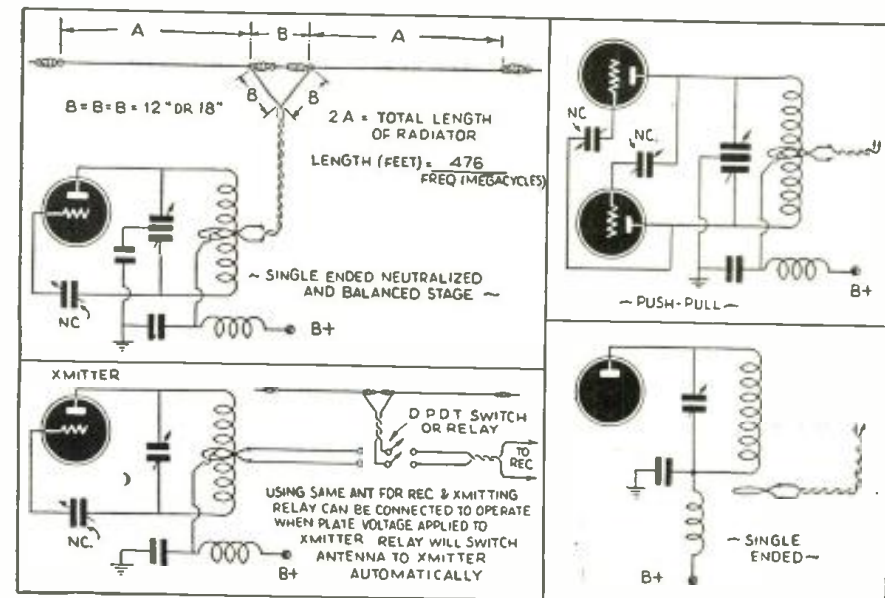

The "half-wave" radiator—an efficient HAM antenna.

center of a half-wave antenna, the impedance is approximately 70 ohms. Now it has been found that the surge impedance of a pair of No. 14 weather-proof wires twisted together is also approximately 70 ohms. This, therefore, is a perfect match and provides a simple means of feeding the antenna. Fanning out the ends of the line at the antenna for a distance of about 12 to 18 inches will result in a much better impedance match.

Up to about 14 megacycles (21.3 meters) losses are negligible for lines up to a couple of hundred feet long. The antenna should not be operated on a harmonic because of the danger of standing waves raising the normally low R.F. voltage between the feeders and breaking down the insulation. The feeders should be made from the best weather-proof lead-in wire obtainable, otherwise the line losses will increase
(Continued on page 251)

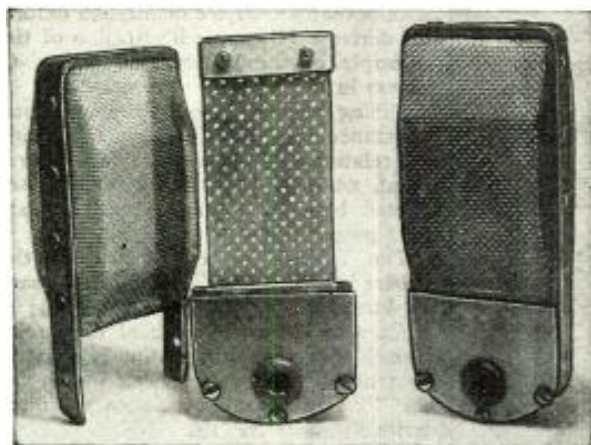

These photos show "professional" appearance of the mike.

Your "Mike" Problem Solved

How to make one suitable for Ham and P.A. work.

Arthur Roberts

- 2 pieces of sheet mica 2" x 1/2"
- 2 pieces of 16 gauge aluminum or brass 2" x 1/2"

The detailed measurements for the backplate are shown on the diagram. Accuracy in perforating the backplate is not essential but it makes a neater job if the holes are drilled as shown. The small holes should be 1/16" diam., and when they are drilled they should be reamed out to remove any burr around the edges. This can be done by twisting a larger drill in the hole, between the fingers.

Now with a 1/4" drill bore the four larger holes (Fig. 1) which are for the ribbon clamps at each end of the plate. The front side of the plate should be selected now and given several coats of model airplane glue,
(Continued on page 247)

● ONE of the most prevalent problems of "hams" and radio experimenters who have a limited income is the microphone. Frequently it is necessary to put up with an inferior model, with either fair or "hashy" quality, until sufficient cash has been collected to purchase something better.

As the crystal is the heart of the C.W. station, so the "mike" is the heart of the *phone* station. And compelling other amateurs to listen to tinny or distorted speech due to a poor microphone is detrimental to the advancement of amateur radio.

It is for the purpose of solving this problem that this "mike" is described. Besides being suitable for "ham" work, it has been used with excellent results both for recording and P.A. work.

Construction of Unit

The actual unit of the "mike" consists of a perforated metal backplate over which is stretched a row of corrugated foil ribbons. These are insulated from the backplate as described later.

The following list of materials is for the unit alone:

- 1 piece 1/8" aluminum or brass 2" x 4 1/4"
- 2 pieces of bakelite panel 2" x 1/2"

Diagrams below show simple construction of the "mike."

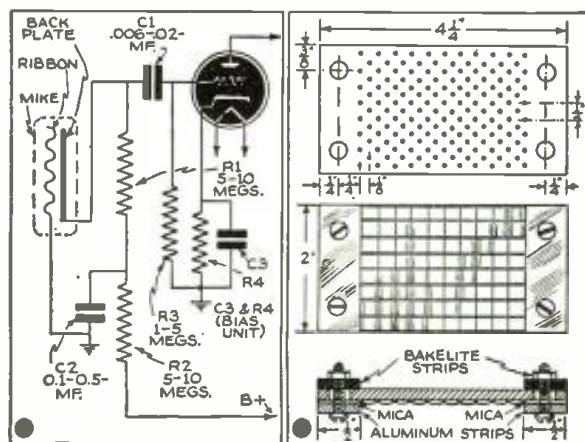

Adding Crystal Control to the *Amateur Frequency Meter*

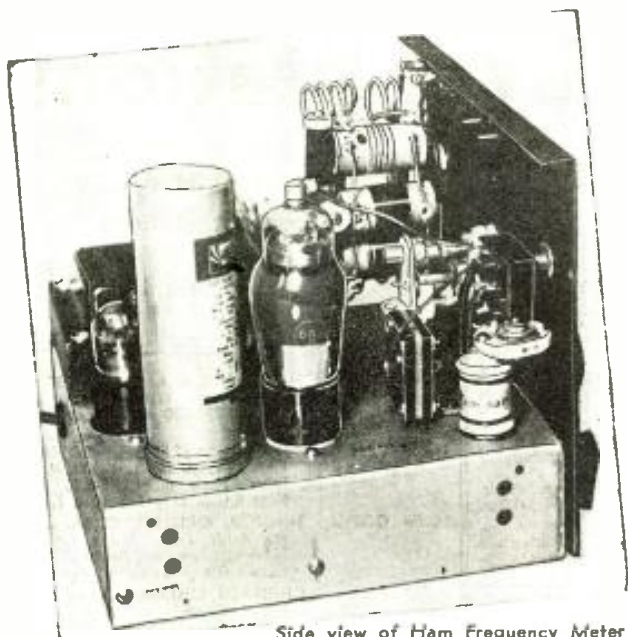

Side view of Ham Frequency Meter with Crystal Control added.

● IN the March issue the writer described a frequency meter suitable for amateur use. Consisting of a 100-1000 kc. electron-coupled oscillator with a 10 kc. multivibrator and harmonic amplifier, the unit was an accurate and extremely useful adjunct to the amateur station. Recently we substituted a 100-1000 kc. crystal unit for the variable frequency oscillator. A crystal-controlled oscillator has its advantages; it is no longer necessary to use signals from a broadcast station or WWV to set the oscillator on 100 or 1000 kc. For ordinary work not requiring extreme accuracy, the oscillator frequency is sufficiently near its rated value to be used without further adjustment.

The SMC-100 crystal unit is an "X" cut bar that can be excited along its length to oscillate at 100 kc. and through its thickness for 1000 kc. For extreme accuracy, it is desirable to use a small variable capacity shunted across the crystal to vary the frequency in order to allow for circuit variations and temperature changes. Increasing the shunt capacity decreases the frequency of oscillation. Also, increasing the crystal temperature lowers the frequency. The crystals are ground so that they can be adjusted to exactly 100 kc. with a 20 or 25 mmf. condenser. However, when operating the crystal through its thickness for 1000 kc., the condenser must be disconnected since its use results in crystal sluggishness. This is not disadvantageous since the 1000 kc. or multiple thereof can be used for locating a particular section of the frequency spectrum, and then the highly accurate 100 kc. frequency can be used for more accurate work.

As in all crystal oscillators, the output circuit must be tuned to the crystal frequency. This is taken care of by two coils, either of which may be selected by means of a D.P.D.T. toggle switch, which also disconnects the crystal shunt condenser for 1000 kc. operation. The 100 kc. coil is an 8 mh. r.f. choke. This 8 mh. choke has just the right inductance and distributed capacity to resonate near 100 kc., so no tuning

Those who built the Frequency Meter described in the March issue by Mr. Yellin, will appreciate this precision attachment — a crystal-controlled oscillator.

small. When the crystal gets warm, thereby resulting in a decrease in frequency, the circuit capacity will not cause the frequency to decrease so much that you will be unable to bring it back to 100 kc. As a check, the completed unit was run continuously for 15 hours without the crystal getting hot enough to prevent the frequency being brought back to exactly 100 kc.

The completed crystal oscillator-multi-

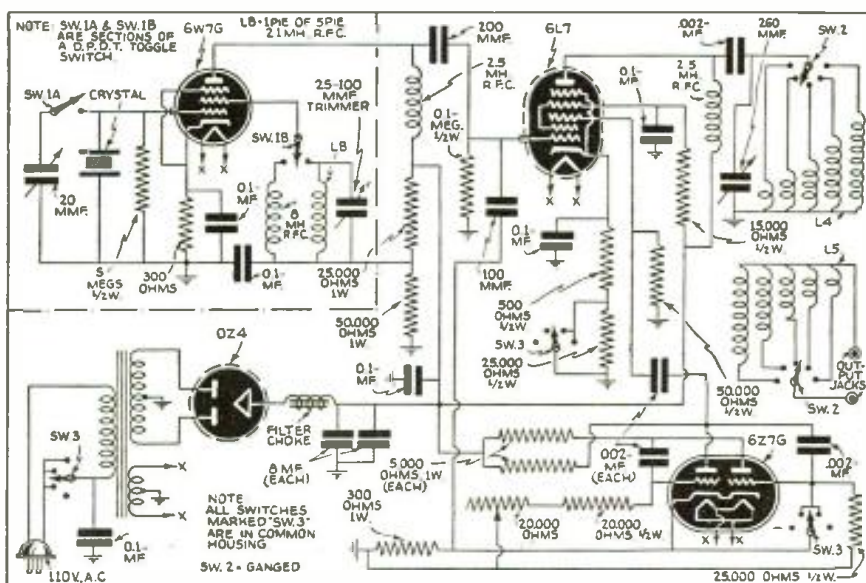

Diagram showing how crystal control was added to the frequency meter circuit.

will be necessary. For 1000 kc. operation, the coil used is a single section of 2.1 mh. 5-pie choke coil tuned by a 100 mmf. mica trimmer condenser. This trimmer should be adjusted for maximum oscillator output by listening to one of the harmonics, or the fundamental itself, on a receiver.

In wiring in the crystal, make the leads short and keep the leads from the crystal to switch and variable condenser as short as possible, in order to keep the minimum capacity of the condenser and its leads

vibrator-amplifier is used in the same manner as the original electron-coupled oscillator model. Detailed methods of use were described in the preceding article. (See page 674, March issue.)

However, one item was eliminated in the crystal-controlled model. In the original unit, one of the oscillator grid coils permitted the generation of the band of frequencies commonly used in i.f. amplifiers. This was left out in order not to unduly complicate. (Continued on page 251)

World Short Wave Stations

Revised Monthly

Complete List of SW
Broadcast Stations

Reports on station changes are appreciated.

Mc.	Call	Mc.	Call
31.600	W1XKA	BOSTON, MASS., 9.494 m., Addr. Westinghouse Co. Daily 6 am.-1 am., Sun. 8 am.-1 am. Relays WBZ.	
31.600	W1XKB	SPRINGFIELD, MASS., 9.494 m., Addr. Westinghouse Co. Daily 5 am.-12 m., Sun. 7 am.-12 m. Relays WBZ.	
31.600	W3XEY	BALTIMORE, MD., 9.494 m., Relays WFBR 4 pm.-12 m.	
31.600	W2XDY	NEW YORK CITY, 9.494 m., Addr. Col. Broad. System, 485 Madison Ave. Daily 5-10 pm.; Sat. and Sun. 12:30-5, 6-9 pm.	
31.600	W9XHW	MINNEAPOLIS, MINN., 9.494 m. Relays WCCO 9 am.-12:30 am.	
31.600	W3XKA	PHILADELPHIA, PA., 9.494 m., Addr. NBC. Relays KYW 8 am.-9 pm.	
31.600	W5XAU	OKLAHOMA CITY, 9.494 m., Sun. 12 n.-1 pm., 6-7 pm. Irregular other times.	
31.600	W9XUY	OMAHA, NEBR., 9.494 m. No sked. known.	
31.600	W4XCA	MEMPHIS, TENN., 9.494 m. Addr. Memphis Commercial Appeal. Relays WMC. 10 am.-6 pm.	
31.600	W8XAI	ROCHESTER, N. Y., 9.494 m., Addr. Stromberg Carlson Co. Relays WHAM 7:30-12:05 am.	
31.600	W8XWJ	DETROIT, MICH., 9.494 m., Addr. Evening News Ass'n. Relays WWJ 5 am.-11:30 pm. Sun. 7 am.-11 pm.	
31.600	W9XPD	ST. LOUIS, MO., 9.494 m., Addr. Pulitzer Pub. Co. Relays KSD.	
31.600	W5XD	DALLAS, TEXAS, 9.494 m., 11.30 am.-1:30 pm. Ex. Sat.-Sun.	
26.550	W2XGU	NEW YORK CITY, 11.3 m. Relays WMCA.	
26.550	W2XQO	NEW YORK CITY, N. Y. 11.3 m. Noon-9 pm.	
26.500	W9XTA	HARRISBURG, ILL., 11.32 m. 1-4 pm.	
26.450	W9XA	KANSAS CITY, MO., 11.33 m., Addr. Commercial Radio Eqpt. Co. 10 am.-1 pm., 3-7 pm.	
26.400	W9XAZ	MILWAUKEE, WIS., 11.36 m., Addr. The Journal Co. Relays WTMJ from 1 pm. to midnite.	
26.300	W2XJI	NEW YORK, N. Y., 11.4 m., Addr. Bamberger Broad. Service, 1440 Broadway. Relays WOR 12 n.-6 pm.	
26.150	W9XUP	ST. PAUL, MINN. 11.47 m. Rel. KSTP 8 am.-1 am.	
26.100	W9XJL	SUPERIOR, WIS., 11.49 m. Relays WEBC daily. 10 am.-8 pm.	
26.050	W9XTC	MINNEAPOLIS, MINN., 11.51 m. Relays WCTN 10 am.-9 pm.	
26.050	W9XH	SOUTH BEND, IND., 11.51 m. Addr. South Bend Tribune. Relays WSBT-WFAM 2:30-6:30 pm., exc. Sat. and Sun.	
25.950	W6XKG	LOS ANGELES, CAL., 11.56 m., Addr. B. S. McGlashan. Wash. Blvd. at Oak St. Relays KGFJ 24 hours daily. DX tips Mon., Wed. and Fri. 2:15 pm.	
25.950	W8XNU	CINCINNATI, OHIO, 11.56 m., 7 am.-1 am. Sun. 8 am.-1 am.	
21.640	GRZ	DAVENTRY, ENG., 13.86 m. Addr. B.B.C., London. Unused at present.	
21.630	W3XAL	BOUND BROOK, N. J., 13.8 m. Addr. N.B.C., N. Y. C. 8 am.-4 pm.	
21.570	W2XE	NEW YORK CITY, 13.91 m. Addr. CBS, 485 Madison Ave. Irregular.	
21.565	DJJ	BERLIN, GERMANY, 13.92 m., Addr. Broadcasting House. Irreg.	

Mc.	Call	Mc.	Call
21.550	GST	DAVENTRY, ENG., 13.92 m., Addr. (B.B.C., London) Irregular at present.	
21.540	W8XK	PITTSBURGH, PA., 13.93 m., Addr. Grant Bldg. Relays KDKA 5:30-8 am.	
21.530	GSJ	DAVENTRY, ENG., 13.93 m., Addr. (See 21.550 mc.) 5.45 am.-12 n.	
21.520	W3XAU	PHILA., PA., 13.94 m., Addr. Col. Broad. Syst., 485 Madison Ave., N. Y. C. Irregular.	
21.500	W2XAD	SCHENECTADY, N. Y., 13.95 m., General Electric Co., 7-10 am.	
21.480	PHI3	HUIZEN, HOLLAND, 13.96 m. Addr. N. Y. Philips, Hilversum. Irregular, 6:10-9:35 am.	
21.470	GSH	DAVENTRY, ENG., 13.97 m. (See 21.550 mc.), 5.45 am.-12 noon. To Africa.	
21.460	W1XAL	BOSTON, MASS., 13.98 m. Addr. University Club. Sun. 9-11:30 am., Tues. 10-11 am.	
21.450	DJS	BERLIN, GERMANY, 13.99 m., Addr., Broadcasting House. 12:05-7:50 am.	
19.020	HS6PJ	BANGKOK, SIAM, 15.77 m. Mondays 8-10 am. See 15.23 mc.	
18.480	HBH	GENEVA, SWITZERLAND, 16.23 m., Addr. Radio Nations. Sun., 10:45-11:30 am.	

16 Met. Broadcast Band

17.850	TPB3	PARIS, FRANCE, 16.8 m. Addr. (See 15.245 mc.) 5:30-10 am.
17.845	DJH	BERLIN, GERMANY, 16.81 m., 12:05-7:50, 8-9, 9:15-11 am.
17.840	HVJ	VATICAN CITY, 16.82 m. Heard 12 n. on Wednesday.
17.840	—	MOYDRUM, ATHLONE, EIRE, 16.82 m. Addr. Radio Eireann. 8:30-10 am. 12:30-4:30 pm. irreg.
17.830	W2XE	NEW YORK CITY, 16.83 m. Addr. CBS, 485 Madison Ave., N. Y. C. Daily 6:30-9 am., 12 n.-5 pm. Sat., Sun. 7-11 am., 11:30 am.-5 pm.
17.820	2RO8	ROME, ITALY, 16.84 m., Addr. (See 2RO, 11.81 mc.) 5-8:45 am., 6-9 pm.
17.810	GSV	DAVENTRY, ENGLAND, 16.84 m., 5.45-11 am. to Far East.
17.800	OIH	LAHTI, FINLAND, 16.85 meters, 4-9 am.
17.800	XGOX	CHUNGKING CHINA, 16.85 m., 9:30-11:30 pm. Mar. 21-Sept. 21 to No. America.
17.790	GSG	DAVENTRY, ENG., 16.86 m., Addr. B.B.C., London. 5.45 am.-12 n., 12:25-1:35, 1:40-4 pm.
17.785	JZL	TOKYO, JAPAN, 16.86 m., 4:30-5:30 pm. to S.A., 8-8:30 pm. to Eastern U. S.
17.780	W3XL	BOUND BROOK, N. J., 16.87 m., Addr. Natl. Broad. Co., 8 am.-5 pm. to Europe, 5-9 pm. to So. Amer.
17.770	PHI2	HUIZEN, HOLLAND, 16.88 m., Addr. (See PHI, 11.730 mc.) Daily 7:10-8:15 am. Mon. & Thurs. 7:10-8:30 am. Sun. 6:10-9:35 am.
17.760	DJE	BERLIN, GERMANY, 16.89 m., Addr. Broadcasting House. 12:05-11 am., 4:50-9 pm. Also Sun. 11-10 am.-12:25 pm.
17.755	ZBWS	HONGKONG, CHINA, 16.9 m., Addr. P.O. Box 200. Dly. 11:30 pm.-1:15 am., 5-10 am., Sat. 9 pm.-1:30 am., Sun. 5-9:30 am. Operates irreg.

End of Broadcast Band

Mc.	Call	Mc.	Call
17.310	W2XGB	HICKSVILLE, L. I., N. Y., 17.33 m., Addr. Press Wireless, Box 296. Tests 9:30-11:30 am. except Sat. and Sun.	
17.280	FZEB	DJIBOUTI, FRENCH SOMALILAND, 17.36 m. Test XMSN 1st Thurs. each month 8-8:30 am. Next B.C.S. May 4 & June 1.	
15.550	CO9XX	TUINICU, ORIENTE, CUBA, 19.29 m., Addr. Frank Jones, Central Tuinicu, Tuinicu, Santa Clara. Broadcasts irregularly evenings.	
15.510	XOZ	CHENG TU, CHINA, 19.34 m. Daily 9.45-10:30 am.	
15.370	HAS3	BUDAPEST, HUNGARY, 19.52 m., Addr. Radiolabor, Gyali Ut 22. Sun. 9-10 am. Daily 8-9 pm.	
15.360	DZG	ZEESEN, GERMANY, 19.53 m., Addr. Reichspostzentralamt. Tests irregularly.	
15.360	—	BERNE, SWITZERLAND, 19.53 m. Irreg. 6.45-7.45 pm.	

19 Met. Broadcast Band

15.340	DJR	BERLIN, GERMANY, 19.56 m., Addr. Broadcast'g House, 4:50-10:50 pm. to C.A.
15.330	W2XAD	SCHENECTADY, N. Y., 19.56 m., Addr. General Electric Co. Relays WGY, 10:15 am.-5 pm.
15.330	W6XBE	SAN FRANCISCO, CALIF., 19.56 m., Addr. General Electric Co., 6:30-11:15 pm. to So. America.
15.320	OZH	SKAMLEBAK, DENMARK, 19.58 m., Sun. 8 am.-1:30 pm.
15.310	GSP	DAVENTRY, ENG., 19.6 m., Addr. (See 17.79 mc.) 12:25-4, 4:20-6, 6:20-9:15 pm.
15.300	YDB	SOERABAJA, JAVA, N. E. I. 19.61 m. Addr. NIROM. 10:30 pm.-2 am., Sat. 7:30 pm.-2 am.
15.300	XE8M	MAZATLAN, SIN., MEX., 19.61 m., Addr. Box 78. "El Pregonero del Pacifico." Irregularly 9-10 am., 1-2, 8-10 pm.
15.300	2RO6	ROME, ITALY, 19.61 m., Addr. (See 2RO, 11.81 mc.) 4:15-4:55, 10 am.-12:04 pm., 3-5:30, 6-9 pm.
15.290	VUD3	DELHI, INDIA, 19.62 m. Addr. All India Radio, 9:30-11:30 pm., 1:30-3:30 am., 7:30 am.-12:30 pm.
15.290	LRU	BUENOS AIRES, ARG., 19.62 m., Addr. El Mundo. Relays LRI, 7-9 am.
15.280	DJQ	BERLIN, GERMANY, 19.63 m., Addr. Broadcasting House. 12:05-11 am., 4:50-10:50 pm.
15.270	H13X	CIUDAD TRUJILLO, D. R., 19.65 m. Relays HIX Sun. 7:40-9:40 am. Tues. and Fri. 8:10-10:10 pm.
15.270	W3XAU	PHILA., PA., 19.65 m. (Addr. See 21.52 mc.) Dly. 10:45-11:45 am., 12:30-5:15 pm. Sat. Noon-5:15 pm. Sun. Noon-5 pm.
15.270	W2XE	NEW YORK CITY, 19.65 m., Addr. (See 21.570 mc.) 5:30-7:30 pm.
15.260	GSI	DAVENTRY, ENG., 19.66 m., Addr. (See 17.79 mc.) Mid. to 2.15 am. to Oceania. 12:25-1:45, 9:40-11:30 pm.
15.250	W1XAL	BOSTON, MASS., 19.67 m., Addr. University Club. 2-3:30, or 4 pm, ex. Sat. and Sun.
15.245	TPA2	PARIS, FRANCE, 19.68 m., Addr. 98 Bis. Blvd. Haussmann. "Paris Mondial" 5-10 am. to Asia.
15.240	2RO	ROME, ITALY, 19.68 m. Irregular 3-9 pm.
15.240	CR7BB	LOURENCO MARQUES, MOZAMBIQUE, 19.68 m. Testing 1-4 pm. Irreg.

(Continued on page 216)

All Schedules Eastern Standard Time

Let's Listen In with

Joe Miller

"DX" Editor

600 KC
11910 KC



500 M
25.19 M

"The call of the Orient"

This station's broadcast on April 9, 1939
is received by you is hereby verified.

E. L. Healey
445 Race Course Rd.
Shanghai, China

XMHA

XMHA—CHINA: This buff card is enhanced considerably by the amusing Oriental swingsters.

● DURING the past month, DX news of interest to the "dyed-in-the-wool" distance tuners has been hard to find. Summer usually brings a let-down in conditions along with a paucity of interesting DX items, so we hope you'll bear with us till the time when things again start "popping."

Regarding summer conditions, OMs, please keep in mind that it is an established fact that Asiatic stations, on the higher frequencies from 9 mc. upwards, actually are heard with better signal strength than in the cool months, so don't forget to give your dials a few twirls weekly during the summer, as the Javanese, Japs, Chinese and other

Rules for VAC Certificates

● RADIO & TELEVISION Magazine has prepared a handsome VAC (Verified All Continents) certificate which will be issued to all short-wave listeners submitting adequate proof of verification from all continents. To secure a VAC certificate the listener must send in a verification card from each of the continents. The VAC certificate will only be issued for verifications of radio-telephone stations, not C.W. stations. The certificates will be signed by the DX Editor, and Hugo Gernsback, Editor-in-Chief of RADIO & TELEVISION.

It is advisable that the cards be sent in a neat package and insured for safe delivery. All cards submitted will be returned. The listener should enclose return postage.

A nominal charge of twenty-five cents (25c) will be made for the certificate to cover the cost of handling and printing.

The DX Editor will be the judge as to whether the verifications submitted are bona fide.

A special notation will be made on the certificate in the event that a listener has more than one complete set of verifications from all continents. All entries should be made to the VAC Editor, RADIO & TELEVISION, 99 Hudson Street, New York, N. Y.

PK6CI—DUTCH NEW GUINEA: This unusual card with drawing in dark green, red call, would stand out on any DX shack's walls.

ZL3IF—NEW ZEALAND: A handsome card with green call and red streak running through call.

Oriental Short Wave Broadcasters may easily be logged and verified. Don't put it off, feeling that it is better to wait till the fall or winter. Go through the station list, jotting down each Asiatic broadcaster and their freq. and sked, and, every a.m. you tune, try for some of them, and, by systematizing your DX-ing, you'll make good headway towards a higher VAC rating, which is certainly the DXer's pedigree.

Regarding DX news:

CHINA

XMHA, lately moved to 11,855 mc., Shanghai, China, sends us the card illustrated, and also a 2 page letter which, signed by Mr. E. L. Healey, station mgr., is very interesting, as evidenced by following extracts from letter. XMHA is a commercial broadcasting station, both short and long wave, and affiliated with RCA Victor and RCA Communications.

XMHA is also the largest station in all China, second in power only to the 35 kw. National station at Chungking. The staff consists of Americans, English, Poles, Russians, Germans and Chinese. Most programs are in English, but Chinese and German programs are also used, the latter for the benefit of the thousands of Jewish refugees at present in Shanghai.

Though commercial in its operation, this station is on call to serve in all emergencies, for the benefit of the U. S. Gov't. and the people of Shanghai, as, during the first days of the war, XMHA was the only means of communication with the outside world, sending out 15,000 messages free of charge! Still of service to all, XMHA has recently sent out many official messages for Americans and Britons stranded in the interior.

QRA E. R. ILLING AMBON D.E.L.

PK6 CI

TO RADIO SWL
J. H. MILLER
WYD U AT
QSA QRK
QRI QRG
WX

XMTR COPA
INP to WAITS
ANT
REC
REMARKS
GD LUCK EST EST 73



PSR QALL

P.O. BOX 39 GREYMOUTH, N.Z.

To Joe Miller
Radio Confirming QSO of Feb 19 1939 at m. N.Z.M.T.

Conditions

ZL3IF

XMTR: 6L6m—6L6g—6L6g—P.P.809 P.P.HK54
CLASS B MODULATED.
RCVR: R.M.E. 69. HUGK E. HIGGINS.

79 es dx de

Listeners throughout Asia, the Indies, and the Antipodes are greatly interested in the broadcasts, and, in many cities and villages in the interior of China, local newspapers are published from the daily transmissions. This news, being uncensored, and being the only source, is all the more appreciated.

Mr. Healey adds as a last word that we request listeners to be sure to send a reply coupon when requesting verifications, as postage over there is 25 cents, and, Mr. Healey adds, "there are too many listeners in the U. S. and Canada," which, however, is not meant as a complaint!

Murray Buitekant, W2, also has a card from XMHA, FB!

XMHA is on daily from 11 p.m.-1 a.m., and from 5-11 a.m., and on Suns., 10 p.m.-11 a.m. QRA (address) is: 445 Race Course Road, Shanghai.

OM Gus Gallagher, our ol' faithful in W6, reports XGOX, 17.80 mc. on daily skeds, 9:30-11:30 p.m., weak, and XGOY, 11.90 mc., both in Chungking, 1:15-2:30 p.m., audible only on West Coast, and in a.m., strong from 6:30-8:30 a.m., sometimes using the call letters, XGOA.

XRVG, 11.38 mc., also at Chungking, verified through Mr. Tseng, of the China Information Committee, P.O. Box 107, to Gail T. Beyer, W9, by air mail, costing XRVG, reported previously as XGRV, \$1.45—certainly nice of Mr. Tseng. However, the letter contains the bad news that XRVG is no longer on the air.

JAVA

YBG, 10.43 mc., at Medan, Sumatra, an old standby, was recently logged with excellent strength while working PLV, 9.415 mc., at Bandoeng, which latter station always hits at least an R7-8 way out here in little ol' New York! Don't forget PLV, 11.00 mc., and PMN, 10.26 mc., both also at Bandoeng, which are "DX cinches" during the hot months, in the a.m.'s! Watch also for PLO, 10.69 mc., which often works YBG, too, during the usual Javanese skeds, 5:30 a.m. to 7 a.m., and sometimes later, but usually near 5:30 a.m. PLE, 18.83 mc., reported by Gus Gallagher at 1 a.m.

JAPAN

JVA, 18.90 mc., Nazaki, heard phoning between 5 p.m. and 1 a.m., frequently, by Gus Gallagher, W6, also JVH, 14.60 mc., transmitting a baseball game once, at midnight. Gus also reports JFO, also known by its BCB call, JFAK, on 9.61 mc., heard outside of sked, at 4 a.m., this station in Formosa, as is also JIB, 10.53 mc., reported several times phoning at 1 a.m.

JFHA has two new relays, another old-timer DX (Continued on page 254)

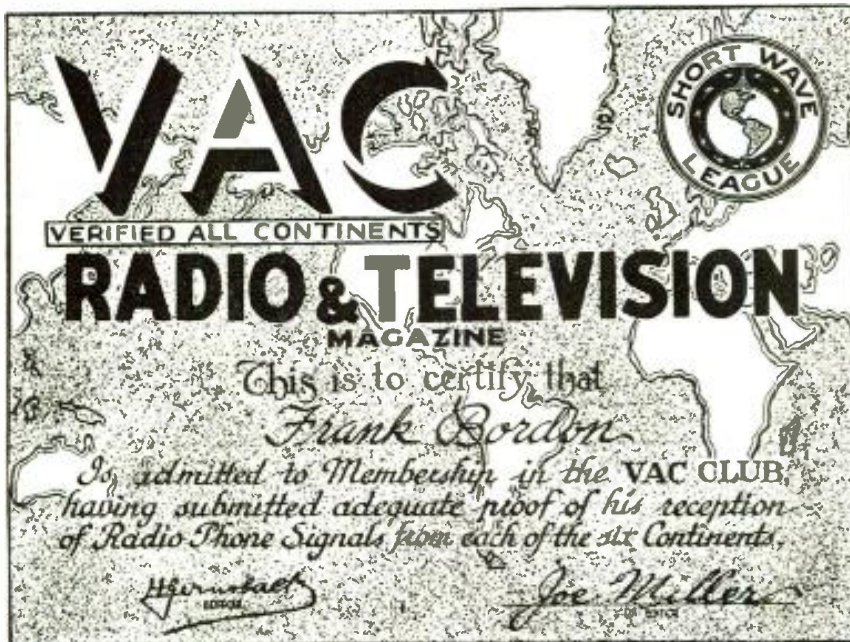

VAC
VERIFIED ALL CONTINENTS

RADIO & TELEVISION
MAGAZINE

This is to certify that
Frank Gordon
is admitted to Membership in the VAC CLUB,
having submitted adequate proof of his reception
of Radio Phone Signals from each of the six Continents.

H. Gernsback
Joe Miller

Mc.	Call	Mc.	Call
15.230	HS6PJ	BANGKOK, SIAM, 19.7 m. Irregularly Mon. 8-10 am.	
15.230	OLR5A	PRAGUE, BOHEMIA, 19.7 m. Addr. (See OLR4A, 11.84) Daily 4:55-8:15 am., 6:55-10:20 pm.	
15.220	PCJ2	HUIZEN, HOLLAND, 19.71 m., Addr. N. V. Philips' Radio Hilversum, Wed. 9:30-11:30 am. Sun. 6:10-9:35 am. Daily 7:10-8:15 am. Mon., Thurs. 7:10-8:30 am.	
15.210	W8XK	PITTSBURGH, PA., 19.72 m., Addr. (See 21.540 mc.) 8 am-1 pm.	
15.200	DJB	BERLIN, GERMANY, 19.74 m., Addr. (See 15.280 mc.) 12:05-11 am., 4:50-10:50 pm. Also Sun. 11:10 am.-12:25 pm.	
15.195	TAQ	ANKARA, TURKEY, 19.74 m., 5:30-7 am.	
15.190	OIE	LAHTI, FINLAND, 19.75 m. Addr. (See OFD, 9.5 mc.), 1:05-4 am, 9 am.-5 pm.	
15.190	ZBW4	HONGKONG, CHINA, 19.75 m., Addr. P. O. Box 200. Irregular. 11:30 pm. to 1.15 am., 3-10 am.	
15.180	GSO	DAVENTRY, ENG., 19.76 m., Addr. (See 17.79 mc.) 4:20-6, 6:25-9:20 pm.	
15.180	RW96	MOSCOW, U.S.S.R., 19.76 m., Daily 1-2, 3-4 am. Mon., Wed., Thurs. 7-9:15 pm.	
15.170	TGWA	GUATEMALA CITY, GUAT., 19.77 m., Addr. Ministere de Fomento. Daily 12:45-1:45 pm.; Sun. 12:45-5:15 pm.	
15.166	LKY	OSLO, NORWAY, 19.78 m. 6:40-10 am.	
15.160	JZK	TOKYO, JAPAN, 19.79 m. 12:30-1:30 am. to Canada & Hawaii, and Pacific U.S. 7-7:30 am. to Eastern U.S. 8-9:30 am. to China and 2:30-4 pm. to Europe.	
15.160	XEWW	MEXICO CITY, MEXICO, 19.79 m., 12 n.-12 m., irregular.	
15.155	SM5SX	STOCKHOLM, SWEDEN, 19.79 m., Daily 11 am.-5 pm., Sun. 9 am.-5 pm.	
15.150	YDC	BANDOENG, JAVA, 19.8 m., Addr. N. I. R. O. M. 6-7:30 pm., 10:30 pm.-2 am., Sat. 7:30 pm.-2 am., daily 4:30-10:30 am.	
15.140	GSF	DAVENTRY, ENG., 19.82 m., Addr. (See 17.79 mc.) 5:45 am.-12 n. 4:20-6, 6:20-9:15 pm.	
15.135	JLU3	TOKYO, JAPAN, 19.82 m., 8-9:30 am. to China.	
15.130	TPB6	PARIS, FRANCE, 19.83 m., Addr. "Paris Mondial," 98 Bis Blvd. Haussmann, 1-4 am.	
15.130	WIXAR	BOSTON, MASS., 19.83 m., Addr. World-Wide B'cast'g Foundation, University Club, 2:30-5:30, 9-10 pm. ex. Wed., Sat., Sun. 2:30-3 pm.	
15.120	SP19	WARSAW, POLAND, 19.84 m., 6-9 pm.	
15.120	HVJ	VATICAN CITY, 19.84 m., 10:30-10:45 am., Tues., Sun. 1-1:30 pm.	
15.120	CSW4	LISBON, PORTUGAL, 19.84 m., 6-8 am., irreg.	
15.110	DJL	BERLIN, GERMANY, 19.85 m., Addr. (See 15.280 mc.) 12:10-2, 8-9 am., 10:40 am.-4:25 pm.	
15.100	CB1510	VALPARAISO, CHILE, 19.87 m. Testing near 7:30 am.	
15.100	2RO12	ROME, ITALY, 19.87 m. Testing irreg.	
15.080	RK1	MOSCOW, U.S.S.R., 19.95 m. Works Tashkent near 7 am. Broadcasts Sun. 12:15-2:30 pm, Daily 7-9:15 pm.	

End of Broadcast Band

14.960	RZZ	MOSCOW, U.S.S.R., 20.05 m., Thurs. 6 pm. Dutch program.
14.930	PSE	RIO DE JANEIRO, BRAZIL, 20.09 m., Broadcasts 6-7 pm., Wed. 4-4:10 pm., Thurs. 3-3:30 pm.
14.920	KQH	KAHUKU, HAWAII, 20.11 m. Sats. 1-1:30 am., 11-11:30 pm, Fri. 9-10 pm.
14.795	IQA	ROME, ITALY, 20.28 m. 4:30-5 am. In Arabic.
14.600	JVH	NAZAKI, JAPAN, 20.55 m. Works Europe 4-8 am. Rel. JOAK Irr. after midnight.
14.535	H8J	GENEVA, SWITZERLAND, 20.64 m. Addr. Radio Nations. Broadcasts Sun. 10:45-11:30 am., Mon. 4-4:15 am., 6:45-8:15 pm.

Mc.	Call	Mc.	Call
14.440	—	RADIO MALAGA, SPAIN, 20.78 m. Relays Salamanca 5:45-7:30 pm. Sometimes 2-4 pm.	
14.420	HC1JB	QUITO, ECUADOR, 20.80 m. 7-8:15, 11:30 am.-2:30, 4:45 pm.-10:15 pm. Exc. Mon.	
14.166	PI1J	DORDRECHT, HOLLAND, 21.15 m., Addr. (See 7.088 mc.) Sat. 12 n.-12:30 pm.	
13.997	EA9AH	TETUAN, SPANISH MOROCCO, 21.43 m. Apartado 124. 5:15-6:15 pm., 6:30-7:30 pm., 9-10 pm. Relays Salamanca from 5:40 pm.	
13.635	SPW	WARSAW, POLAND, 22 m. Daily 6-8 pm. Sat. & Sun. 6-9 pm.	
12.862	W9XDH	ELGIN, ILL., 23:32 m. Press Wire- less, Tests 2-5 pm.	
12.486	HIIN	TRUJILLO CITY, DOM. REP., 24.03 m. 6:40-10:40 am., 5:10-10:10 pm.	
12.460	HC2JB	QUITO, ECUADOR, 24.08 m. Daily exc. Mon. 7-8:15, 11:30 am.-2:30, 4:45-10:15 pm.	
12.310	VOFB	ST. JOHNS, NEWFOUNDLAND, 24.37 m. 5:30-7:30 pm.	
12.235	TFJ	REYKJAVIK, ICELAND, 24.52 m. Works Europe mornings. Broadcasts Sun. 1:40-2:30 pm.	
12.230	COCE	HAVANA, CUBA, 24.53 m.-8 am.-11:30 pm. Sun. noon-11:30 pm.	
12.200	—	TRUJILLO, PERU, 24.59 m., "Rancho Grande," Address Hacienda Chiclin. Irregular.	
12.000	RNE	MOSCOW, U.S.S.R., 25 m. 6-6:30, 10-10:30 am., 1-1:30, 3-5:30, 8:30-10 pm., Sun. 6-10 am., 1-6, 9-10 pm.	
11.970	CB1180	SANTIAGO, CHILE, 25.06 m. 7-11 pm.	
11.970	H12X	CIUDAD TRUJILLO, D. R., 25.07 m., Addr. La Voz de Hispaniola. Relays HIX Tue. and Fri. 8:10-10:10 pm. Sun. 7:40-9:40 am.	

25 Met. Broadcast Band

11.940	T12XD	SAN JOSE, COSTA RICA, 25.13 m. La Voz del Pilot. Apartado 1729. 7:30 am.-noon, 4-10 pm.
11.940	XMHA	SHANGHAI, CHINA, 25.13 m. 5-11 am.
11.910	CD1190	VALDIVIA, CHILE, 25.19 m., P. O. Box 642. Relays CB69 10 am.-1 pm., 3-6, 7-10 pm.
11.910	—	HANOI, FRENCH INDO-CHINA, 25.19 m. "Radio Hanoi", Addr. Radio Club de l'Indochine, 3:45-4:15 am., 7-9:30 am., 150 watts.
11.900	XEW1	MEXICO CITY, MEXICO, 25.21 m., Addr. P. O. Box 2874. Mon.-Wed., Fri. 3-4 pm., 9 pm.-12 m. Tues. and Thur. 7:30 pm.-12 m. Sat. 9 pm.-12 m., Sun. 12:30-2 pm.
11.900	XGOY	CHUNGKING, CHINA, 25.21 m., 5:30-7:10 am. to North Asia, 7:15-7:55 am. to Japan, 8:10-30 am. to South Asia. 11-11:45 am. to U.S.S.R. 4-6:30 pm. to Europe. Mar. 21-Sept. 21-35 kw.
11.895	2RO13	ROME, ITALY, 25.23 m. Irregular 6-9 pm.
11.885	TPA3	PARIS, FRANCE, 25.24 m., 10:15 am.-5 pm. 1-4 am.
11.885	TPB7	PARIS, FRANCE, 25.24 m. (See 15.245 mc.) 6-8:15, 8:30-11 pm.
11.880	VLR3	MELBOURNE, AUST., 25.25 m., 3:30-7:15 pm., 9 pm.-3 am. week-days. Sun. mid.-3 am. Irregular.
11.870	W8XK	PITTSBURGH, PA., 25.26 m., Addr. (See 21.540 mc.) 1-10 pm.
11.870	VUM2	MADRAS, INDIA, 25.26 m. M.W.F. 3:30-4 am. Irregular.
11.865	—	BERNE, SWITZERLAND, 25.28 m. Irreg. 8-9 pm. to No. Amer.
11.860	GSE	DAVENTRY, ENG., 25.30 m., Addr. (See 11.75 mc.) Irregular.
11.855	DJP	BERLIN, GERMANY, 25.31 m., Addr. (See 15.280 mc.) Irregular.
11.850	CB1185	SANTIAGO, CHILE, 25.32 m. Sat. 6-11 pm. and irreg.
11.850	OAX2A	TRUJILLO, PERU, 25.32 m. Testing on this freq. (See 12.200).
11.840	KZRM	MANILA, P. I., 25.35 m. Addr. Erlanger & Gallinger, Box 283. 9 pm.-10 am. Irregular.
11.840	CSW	LISBON, PORT., 25.35 m. Nat'l Broad. Station. 11:30 am.-1:30 pm. Irregular.

Mc.	Call	Mc.	Call
11.840	OLR4A	PRAGUE, BOHEMIA, 25.35 m., Addr. Czech Shortwave Sta., Praha XII, Fochova 16. Daily 6:45-9 pm.	
11.830	W9XAA	CHICAGO, ILL., 25.36 m., Addr. Chicago Federation of Labor. Irregular 7 am.-6 pm.	
11.830	W2XE	NEW YORK CITY, 25.36 m., Addr. Col. Broad. System, 485 Madison Av., N.Y.C. 8-10:30 pm.	
11.826	XEBR	HERMOSILLA, SON., MEX., 25.37 m., Addr. Box 68. Relays XEBH. 9:30-11 am., 1-4 pm., 9 pm.-12 m.	
11.810	2RO4	ROME, ITALY, 25.4 m., Addr. E.I.A.R., Via Montello 5. Daily 4:30-8:45 am., 10 am.-2:30 pm., 6-9 pm.	
11.805	OZG	SKAMLEBAK, DENMARK, 25.41 m. Addr. Statsradiofonien. Irreg.	
11.801	DJZ	BERLIN, GERMANY, 25.42 m. Addr. See 15.280 mc. Irreg.	
11.800	COGF	MATANZAS, CUBA, 25.42 m., Addr. Gen. Betancourt 51. Relays CMGF, 2-3, 4-5, 6 pm.-Mid.	
11.800	JZJ	TOKYO, JAPAN, 25.42 m., Addr. Broadcasting Co. of Japan, Overseas Division 7-7:30, 8-9:30 am. Irreg.	
11.795	DJO	BERLIN, GERMANY, 25.42 m. Addr. (See 15.280 mc.) Irreg.	
11.790	WIXAL	BOSTON, MASS., 25.45 m., Addr. (See 15.250 mc.) 2:30-5:30 pm. Sat., 2-6:30 pm.	
11.780	HP5G	PANAMA CITY, PAN., 25.47 m., Addr. Box 1121. Noon-1 pm., 6-10 pm.	
11.780	OFE	LAHTI, FINLAND, 25.47 m. Addr. (See OFD, 9.5 mc.) 1:05-3 am., 5-6:20, 10 am.-12:30 pm.	
11.770	DJD	BERLIN, GERMANY, 25.49 m., Addr. (See 15.280 mc.) 11:30 am.-4:25 pm., 4:50-10:50 pm.	
11.760	TGWA	GUATEMALA CITY, GUAT., 25.51 m. (See 17.8 mc.) Irregular 10-11:30 pm. Sun. 6-11:30 pm., irregular.	
11.760	XETA	MONTEREY, MEX., 25.51 m., Addr. Box 203. Relays XET, n.-3:30 pm. and evenings.	
11.760	OLR4B	PRAGUE, BOHEMIA, 25.51 m. Addr. (See 11.840 mc.) Daily exc. Sun. 8:25-10:05 am.	
11.750	GSD	DAVENTRY, ENG., 25.53 m., Addr. B.B.C., London, 12:2-15 am., 12:25-4, 4:20-6, 6:20-9:15, 9:40-11:30 pm.	
11.740	SP25	WARSAW, POLAND, 25.55 m., 6-9 pm.	
11.740	HVJ	VATICAN CITY, 25.55 m. Tues. 8:30-9 am.	
11.740	CR6RC	LOANDA, ANGOLA, 25.55 m., Tues., Thurs., Sat. 2-3:30 pm.	
11.735	COCX	HAVANA, CUBA, 25.57 m. P. O. Box 32. Daily 8 am.-1 am. Sun. 8 am.-1 am. Relays CMX.	
11.735	LKQ	OSLO, NORWAY, 25.57 m. 2-6:40, 10 am.-3 pm.	
11.730	PHI	HUIZEN, HOLLAND, 25.57 m., Addr. N. V. Philips' Radio.	
11.730	WIXAR	BOSTON, MASS., 25.58 m., Addr. World-Wide B'cast'g Foundation, University Club. Daily 7 or 7:30-9, 9:15-11 pm. Sat.-Sun. 2:30-5 pm.	
11.720	CJRX	WINNIPEG, CANADA, 25.6 m., Addr. James Richardson & Sons, Ltd. Daily 6 pm.-12 m., Sat. 6 pm.-Sun, 4 am.	
11.720	ZPI4	VILLARICA, PARAGUAY, 25.60 m. 5:30-7:55 pm. irreg.	
11.718	CR7BH	LAURENCO MARQUES, PORTUGUESE E. AFRICA, 25.6 m. Daily 12:05-1, 4:30-6:30, 9:30-11 am., 12:05-4 pm., Sun. 5-7 am., 10 am.-2 pm.	
11.715	TPA4	PARIS, FRANCE, 25.61 m., (See 15.245 mc.) 6-8:15, 8:30-11 pm. to No. America.	
11.710	YSM	SAN SALVADOR, EL SALVADOR, 25.62 m., Addr. (See 7.894 mc.) 1-2:30 pm.	
11.710	—	SAIGON, FRENCH INDO-CHINA, 25.62 m., Addr. Boy-Landry, 17 Place A. Foray. 7:30-9:15 am.	
11.705	JLG3	TOKYO, JAPAN, 25.63 m. 2:30-4 pm.—Irreg. 4:30-5:30 pm.	
11.705	SBP	MOTALA, SWEDEN, 25.63 m., 1-4:15 pm. Sun. 3 am.-4:15 pm. Wed and Sat. 8-9 pm.	

(Continued on page 218)

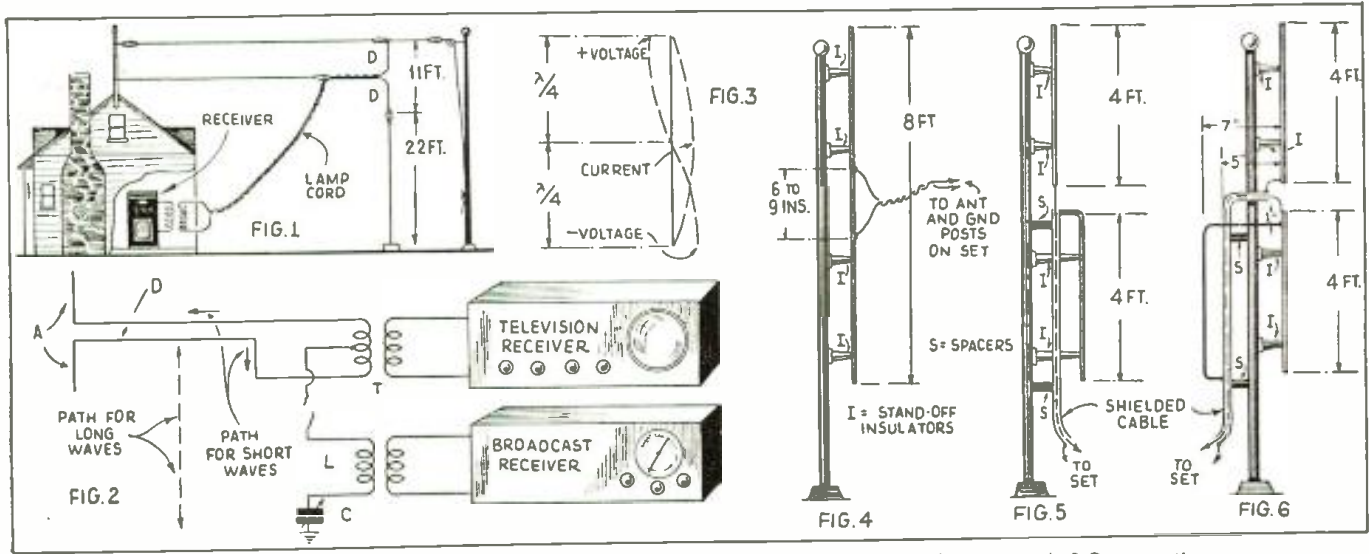

Various types of ultra-high frequency doublets. One at left is suitable for television and B.C. reception.

● WITH the advent of television and facsimile, and the resultant resurgence of interest in ultra-high frequency reception, the use of highly efficient antennas again becomes extremely important.

While almost any piece of wire will serve for broadcast reception, a thoroughly engineered antenna is needed to keep the signal up and the interference down when the very short waves are being received.

Although the antenna is tuned by means of inductance and/or capacity for broadcast reception, this is not so desirable when

Efficient U.H.F. Doublets

working with television, for it results in too sharp a resonance peak. For this reason, the untuned antenna is highly preferable. Antennas whose natural period of oscillation

is $\frac{1}{4}$ or $\frac{1}{2}$ or 1 wavelength afford most efficient results. Therefore a doublet having a total length of approximately 11 feet works out well for 7-meter reception. This is, likewise, a convenient size to handle.

The antenna works most effectively when mounted vertically, with the lower end of the bottom half at least 10 feet above the ground—and higher, if possible. As shown in Fig. 1, each half of the doublet is about 5 feet 3 inches, with a 6-inch separation between them. Exact dimensions for any

(Continued on page 246)

A "DX" Aerial for Short Wave Fans

● HERE is a short wave antenna that has helped me very much in my SWL work. I believe it is an original idea, for I have never seen nor heard of one like it. It occurred to me when I was trying to figure out a way to have good directional antenna (all directions) without having to have a separate antenna for each direction. It has worked wonderfully well for the past six

months, so I thought that others interested in the same field might like to try it.

To begin with, it takes four masts or other elevated objects to anchor the antenna to. At present I am using three 40 foot pipes and a 26 foot wooden pole fastened on the side of the house. All of these are well braced and are on a lot 65 by 175 ft. Two of the masts are at the extreme ends of the

length of the lot. (A and B.) The other two are approximately in the center or half-way between the north and south masts. The enameled wire is of the seven strand type and can be lowered by pulleys on all masts except mast C to the east. By taking the leads on the west side of this rhombic first, we have the best and most important

(Continued on page 246)

This aerial may be made "directional" to any point of the compass—all by switches.

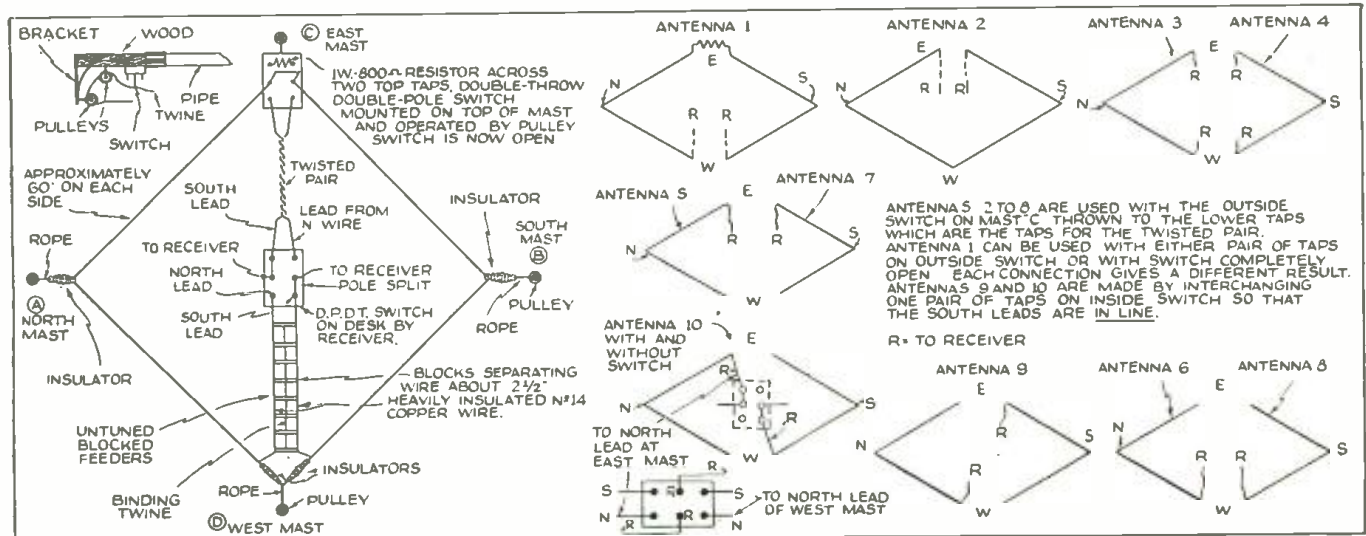

Mc. Call
11.700 HP5A PANAMA CITY, PAN., 25.64 m. Addr. Radio Teatro, Apartado 954. 10 am.-1 pm., 5-10 pm. Sun. 6-10 pm. 7-8:30 am.
11.700 CB1170 SANTIAGO, CHILE, 25.65 m. Addr. P.O. Box 706. Relays CB89 10 am.-2 pm., 3:30-11 pm.

End of Broadcast Band

11.676 IQY ROME, ITALY, 25.7 m. 5:20-5:40 am. ex. Sun., Daily 12:07-12:56, 1:50-2:30 pm.
11.535 SPD WARSAW, POLAND, 26.01 m., Addr. 5 Mazowiecka St. 6-9 pm.
11.402 HBO GENEVA, SWITZERLAND, 26.31 m., Addr. Radio Nations. Sun. 7-7:45, 8-8:45 pm. 1:45-2:30 pm. Mon. 6:45-8:15 pm.
11.380 XGRV CHUNGKING, CHINA, 26.36 m. 1-1:35, 8-8:35 am.
11.040 CSWS LISBON, PORTUGAL, 27.17 m., Addr. Nat. Broad. Sta. 11 am.-4:30 pm. Sun. 10 am.-4:30 pm.
11.000 PLP BANDOENG, JAVA, 27.27 m. Relays YDB. 6-7:30 pm., 10:30 pm.-2 am., 4:30-10:30 or 11 am. Sat. until 11:30 am.
10.950 — TANANARIVE, MADAGASCAR, 27.40 m., Addr. (See 9.38 mc.) 12:30-4:5, 10-11 am., 2:30-4 am.,
10.670 CEC SANTIAGO, CHILE, 28.12 m. Irregular.
10.660 JVN NAZAKI, JAPAN, 28.14 m. Broadcasts daily 1:50-7:40 am. Works Europe irregularly at other times.
10.535 JIB TAIHOKU, TAIWAN, 28.48 m. Works Japan around 6:25 am. Broadcasts, relaying JFAK 9-9:55 am., 1-2:30 am. Sun. to 10:15 am.
10.400 YSP SAN SALVADOR, EL SALVADOR, 28.85 m., 1-3, 6:30-11 pm.
10.360 EAJ43 TENERIFE, CANARY ISL., 28.96 m., 3-4:30, 5-7, 7:45-8:45, 9-10 pm.
10.350 LSX BUENOS AIRES, ARG., 28.98 m., Addr. Transradio International. Tests irregularly.
10.330 ORK RUYSELEDE, BELGIUM, 29.04 m. Broadcasts 12:30-2 pm. Works OPM 1-3 am., 3-5 pm.
10.260 PMN BANDOENG, JAVA, 29.24 m. Relays YDB 6-7:30 pm., 10:30 pm.-2 am., 4:30-10:30 or 11 am., Sat. to 11:30 am.
10.220 PSH RIO DE JANEIRO, BRAZIL, 29.35 m., Addr. Box 709. Broadcasts 6-7 pm., Mon. 8-8:30 pm., Fri. 7-7:30 pm.
10.100 — DEUTSCHE FREIHEITS SENDER, 29.70 m., loc. in Germany, under-cover. 4-5 pm.
10.050 TIEMT SAN JOSE, COSTA RICA, 29.85 m., 4:30-8 pm.
10.050 DZC ZEESEN, GERMANY, 29.16 m., Addr. (See 15.360 mc.) Irregular.
10.042 DZB ZEESEN, GERMANY, 29.87 m., Addr. Reichspostzentramt. Irregular.
9.995 COBC HAVANA, CUBA, 30.02 m., Addr. P. O. Box 132. Relays CMBC 6:55 am.-1 am.
9.920 JDY DAIREN, MANCHUKUO, 30.24 m. Relays JQAK daily 7-8 am. Works Tokyo occasionally in early am.
9.892 CPI SUCRE, BOLIVIA, 30.33 m., 11 am.-n., 7-9 pm.
9.855 EAQ MADRID, SPAIN, 30.45 m., Addr. P. O. Box 951. 7:30-8, 8:40-9 pm. 3:45-4:05, 4:45-5:05 am., also.
9.830 IRF ROME, ITALY, 30.52 m. Works Egypt afternoons. Relays ZRO, 12-12:25 pm. Thurs. Daily 12:40-1, 1:37-3:35, 6-9 pm.
9.815 COCM HAVANA, CUBA, 30.57 m. Addr. Transradio Columbia, P. O. Box 33. 8-1 am. Relays CCMC.
9.785 HH3W PORT-AU-PRINCE, HAITI, 30.66 m. Addr. P. O. Box A117. 1-2, 7-9:15 pm.
9.753 ZRO DURBAN, SOUTH AFRICA, 30.75 m. Addr. S. A. Broadcasting Corp., P. O. Box 4559, Johannesburg. Daily exc. Sat. 11:45 pm.-12:50 am. Daily exc. Sun. 3:30-7:30, 9 am.-12:30 pm., Sun. 5:30-7, 9 am.-12:30 pm., also 4-5 am. on 3rd Sun. of month.
9.735 CSW7 LISBON, PORTUGAL, 30.82 m. Addr. Nat. Broad. Sta. n-2 pm., 6-9 pm. for No. Amer.

Mc. Call
9.730 CB970 VALPARAISO, CHILE, 30.83 m., 6:30-11:30 pm., or mid.
9.708 COCQ HAVANA, CUBA, 30.90 m. Addr. 25 No. 445, Vedado, Havana, 7-1 am. Sun. 6:55 am.-1 am.

31 Met. Broadcast Band

9.705 — FORT DE FRANCE, MARTINIQUE, 30.92 m., Addr. P. O. Box 136. 6-8:10 pm. Irr. to 9:30 pm.
9.700 — SAIGON, INDO-CHINA, 30.93 m., Addr. 17, Place A. Forsy, "Radio Boy-Landry." 7:30-9:45 am. Irreg.
9.700 HNF BAGHDAD, IRAQ, 30.93 m., 10 am.-3 pm. S.O. before or after 3 pm.
9.690 T14NRH HEREDIA, COSTA RICA, 30.96 m., Addr. Amando C. Marin, Apartado 40. Sun. 7-8 am., Tues., Thurs., Sat. 9-10 pm.
9.690 LRA1 BUENOS AIRES, ARG., 30.96 m., 6-9 pm. Mon-Thur., 4-9 pm. Fri., 7-9 pm. Sat.
9.690 — TANANARIVE, MADAGASCAR, 30.96 m., 12:30-12:45, 3:30-4:30, 10-11 am., Sun. 2:30-4 am.
9.690 ZHP SINGAPORE, MALAYA, 30.96 m. Sun. 5:40-9:40 am., Wed. 12:40-1:40 am., Mon.-Fri. 4:40-9:40 am., Sat. 12:25-1:40 am., 4:40-9:40 am., 10:40 pm.-1:10 am. (Sun.)
9.690 GRX DAVENTRY, ENGLAND, 30.96 m., Addr. See GSC, 9.58 mc., 5:45 am.-12 n., 12:25-6 pm.
9.685 TGWA GUATEMALA CITY, GUAT., 30.96 m. Daily 10-11:30 pm.; Sun. 7-10:45 pm.
9.680 JFO TAIHOKU, TAIWAN, 30.99 m. Relays JFAK irreg. 4-10:30 am.
9.675 DJX BERLIN, GERMANY, 31.01 m., Addr. (DJD. 11.77 mc.) 11:30 am.-4:25 pm. To Africa.
9.670 W3XAL SOUND BROOK, N. J., 31.03 m. Addr. NBC, N. Y. C. 5 pm.-12 m.
9.665 ZRO9 ROME, ITALY, 31.04 m. 12:40-1, 1:37-5:30 pm., 6-6:30 pm.
9.660 LRX BUENOS AIRES, ARG., 31.06 m., Addr. El Mundo. Relays LRI, 6-6:45 am.-9:15 am.-10 pm.
9.660 HVJ VATICAN CITY, 31.06 m. Sun. 5-5:30 am.
9.650 W2XE NEW YORK CITY, 31.09 m. (See 21.570 mc. for addr.) Irregular.
9.650 CS2WA LISBON, PORTUGAL, 31.09 m., Addr. Radio Colonial. Tues., Thurs. and Sat. 4-7 pm.
9.650 IABA ADDIS ABABA, ETHIOPIA, 31.09 m., 3:55-4:05, 4:15-4:45, 11 am.-noon, 1-3 pm. Sun. 3:30-3:55 am.
9.645 JLT2 TOKYO, JAPAN, 31.10 m., 2:30-4 pm. to Europe.
9.640 CXA8 COLONIA, URUGUAY, 31.12 m., Addr. Belgrano 1841, Buenos Aires, Argentina; Relays LR3 Buenos Aires 5 am.-10:45 pm. Sat. to 1 am.
9.635 ZRO3 ROME, ITALY, 31.13 m., Addr. (See 11.810 mc.) 12:07-3 pm., 5:30-9 pm., also Mon. 3:50-4:05 pm., Fri. and Sat. 4-4:20 pm.
9.620 CXA6 MONTEVIDEO, URUGUAY, 31.19 m., Rel. CX 6 to 9 pm.
9.618 HJ1ABP CARTAGENA, COL., 31.20 m., Addr. P. O. Box 37. Daily 9 am.-1:30 pm., 7-10:15 pm., Sun. 4:30-9 pm.
9.610 LLG OSLO, NORWAY, 31.22 m., 3-6, 8-9, 11 pm.-mid.
9.606 ZRL KLIPHEUVAL, SOUTH AFRICA, 31.23 m., Addr. P. O. Box 4559, Johannesburg. Daily, exc. Sat. 11:45 pm.-12:50 am. Daily exc. Sun. 3:20-7:20, 9-11:45 am., Sun. 3:30-4:30 or 4-5, 5:30-7, 9-11:45 am.
9.600 RAL MOSCOW, U.S.S.R., 31.25 m. Daily exc. Sun. 6-10 pm. Sun. 6-7, 9:15-10 pm.
9.600 CB960 SANTIAGO, CHILE, 31.25 m., 8-11:30 pm.
9.600 GRY DAVENTRY, ENG., 31.25 m., Addr. See GSC, 9.58 mc., Irreg. 12:25-6 pm.
9.595 — MOYDRUM, ATHLONE, EIRE, 31.27 m., Radio Eireann. 12:30-4:30 pm. Irreg.

Mc. Call
9.595 HBL GENEVA, SWITZERLAND, 31.27 m., Addr. Radio Nations. Irregular.
9.590 HP5J PANAMA CITY, PANAMA, 31.28 m. Addr. Apartado 867. 12 n. to 1:30 pm., 6-10:30 pm.
9.590 VUD2 DELHI, INDIA, 31.28 m. Addr. All India Radio, 1:30-3:30 am.-7:30 am.-12:30 pm., 8:30-10:30 pm.
9.590 PCJ HUIZEN, HOLLAND, 31.28 m., Addr. (See 15.220 mc.) Sun. 2-3, 7:15-9:25 pm. Tues. 1:45-3:30, 7-8:30, 8:45-10:15 pm., Wed. 7:15-8:40 pm., Fri. 8-9 pm.
9.590 VK6ME PERTH, W. AUSTRALIA, 31.28 m., Addr. Amalgamated Wireless of Australasia, Ltd. 6-8 am. exc. Sun.
9.590 YK2ME SYDNEY, AUSTRALIA, 31.28 m., Addr. Amalgamated Wireless of Australasia, Ltd., 47 York St., Sun. 1-3 am.; 5-9, 10:30 am.-12:30 pm.
9.590 W3XAU PHILADELPHIA, PA., 31.28 m. (Addr. See 21.52 mc.) Mon. & Thurs. 5:30-6:15, 6:30-10:30 pm., 11 pm.-Mid. Sat. 5:30-6, 6:30-10:30 pm.
9.580 GSC DAVENTRY, ENGLAND, 31.32 m., Addr. B. B. C., Portland Pl., London W. 1., 12:25-4, 4:20-6, 6:25-9:20 pm.
9.580 VLR MELBOURNE, AUSTRALIA, 31.32 m. Addr. Box 1686, G. P. O. Daily exc. Sat. 3:30-7:15 pm., Sat. 5-10:30 pm. Daily exc. Fri., Sat. 9 pm.-8:30 am., Fri. 9 pm.-9 am. (Sat.), Sat. 12 m.-7:30 am. (Sun.)
9.570 KZRM MANILA, P. I., 31.35 m., Addr. Erlanger & Galingher, Box 283. Wkdays. 4:30-6 pm. m. tof. 5-9 am., Sat. 5-10 am., Sun. 4-10 am.
9.570 WIXK BOSTON, MASS., 31.35 m., Addr. Westinghouse Electric & Mfg. Co. 6 am.-12 m. Sun. 7 am.-12 m.
9.566 OAX4T LIMA, PERU, 31.37 m., 7-8, 11:30 am.-1:30 pm.
9.560 XGAP PEKING, CHINA, 31.38 m. Addr. S. Yoshimura, Dir. Peking Central Sta., Hsi-chen-an-chieh, Peking. 4-9 am.
9.560 DJA BERLIN, GERMANY, 31.38 m., Addr. Broadcasting House. 6:30-10:50 pm.
9.550 HVJ VATICAN CITY, 31.41 m., Sun. 5-5:30 am., Wed. 2:30-3 pm.
9.550 TPB11 PARIS, FRANCE, 31.41 m. Addr. (See 15.245 mc.) 11:15 am.-7 pm., 9:30 pm.-mid. Irreg.
9.550 W2XAD SCHENECTADY, N. Y., 31.41 m., General Electric Co., 5:15-8:15 pm. to So. Amer.
9.550 OLR3A PRAGUE, BOHEMIA, 31.41 m. (See 11.840 mc.) Irreg. 4:40-5:10 pm.
9.550 XEFT VERA CRUZ, MEX., 31.41 m. 10:30 am.-4:30 pm., 10:30 pm.-12:30 am.
9.550 YDB SOERABAJA, JAVA, 31.41 m., Addr. N.I.R.O.M. Daily exc. Sat. 6:30 pm., 10:30 pm.-2 am.-4:30-10:30 am. Sat. 7 pm.-2 am.
9.550 VU82 BOMBAY, INDIA, 31.41 m., Addr. All India Radio. 9:30-10:30 pm., 1-3:30 am. 5-6 am. also.
9.540 DJN BERLIN, GERMANY, 31.45 m., Addr. (See 9.560 mc.) 12:05-2:30, 9:30-11 am., 4:50-10:50 pm. to So. Amer.
9.538 VPD2 SUVA, FIJI ISLANDS, 31.46 m., Addr. Amalgamated Wireless of Australasia, Ltd. 5:30-7 am., exc. Sun.
9.535 — SCHWARZENBURG, SWITZERLAND, 31.46 m., 1-2 pm. 6:45-7:45, 8-9 pm.
9.530 W6XBE SAN FRANCISCO, CAL., 31.48 m., Addr. Gen. Elec. Co., 12 m.-3 am., 7 am.-12 n. to Asia.
9.530 W2XAF SCHENECTADY, N. Y., 31.48 m., Addr. General Electric Co. 3-11 pm.
9.530 VUC2 CALCUTTA, INDIA, 31.48 m. Addr. All India Radio. 2:06-4:06 am. 10 pm.-2 am.
9.526 XEDQ GUADALAJARA, GAL., MEXICO, 31.49 m., N.-4:30 pm., 7 pm.-midnight.
9.526 ZBW3 HONGKONG, CHINA, 31.49 m., Addr. P. O. Box 200. 5-10 am., 11:30 pm.-1:15 am. Sun. 5-9:30 am.
9.525 LKC JELOY, NORWAY, 31.49 m., 4:30-10:30 am., Sun. 2:30-10:30 am.
(Continued on page 220)

All Schedules Eastern Standard Time

● WELL, here we are with another month of reports, and they look very good. Our new plan seems to be working out *fine business*, and every one of the observers co-operated with us 100% in getting it started. There was lots of competition for the first place in the Best DX box, and it turned out to be a tie between Lendzioszek of Massachusetts and Mannheim of Iowa. Both sent in very good reports, and some swell DX for this time of the year.

Conditions on the twenty-meter band have been very erratic, and nothing can be depended upon to produce any good DX. It is there one time and gone a short time later. However, the Aussies are now being heard regularly as well as the New Zealanders. Ten meters is producing some results but nothing like it was a few months ago.

A few special observers for five meters have been appointed, and it is hoped to have some reports on five-meter DX during the coming months. Last summer saw some very fine results, and it is hoped that this year it will even be better.

John Fitzpatrick reports hearing the following in New Jersey:—

W9ZHB	Zearing, Ill.	5	8
W9GGH	Kenosha, Wis.	4	7
W9RGH	Peoria, Ill.	4	8

Todd Storz of Omaha, Nebraska, reports:—
 W8NOR Tonawanda, N. Y. 5 9
 W8SFF Calver, Pa. 5 8-9
 W8RV Buffalo, N. Y. 5 8-9
 W3RL Washington, D. C. 5 9

Laurence Weber of East Orange, New Jersey, reports the following on five meters:—
 W9ZHB Zearing, Ill. W9LYK
 W9GGH Kenosha, Wis. W8CVQ Kalamazoo, Mich.
 W9ARN Bartinville, Ill. W8NZ Bat'e Crk., W9VIH Glenview, Ill. W8NZ Bat'e Crk., Mich.
 W9RGI Peoria, Ill.

This is the first month that we have had any good DX on five meters reported since last fall, and we hope that it continues to come in.

Name	Call	Freq.	R	S	Distance
Lendzioszek	K1ER	14.25	4	7	11,700 miles
Mannheimer	PK2AY	14.05	5	5	11,700 miles
Fleming	PK2AY	14.05	4	8	11,600 miles
Hegler	PK4KS	14.06	4	6-7	11,600 miles
Mannheimer	PK3WI	14.045	5	6	11,400 miles
Slaughter	PK1YY	14.35	5	7	11,200 miles
Hegler	PK2LZ	14.04	4	5-6	11,100 miles
Rush	ZK5Q	14.08	5	9	11,000 miles
Clarke	PK6XX	14.01	5	7	11,000 miles
Lendzioszek	PK6XX	14.095	5	8	10,900 miles

Call	Freq.	R	S	Where Heard	Call	Freq.	R	S	Where Heard
EK1AF	14.12	4-5	7-9	Conn., N. Y., Quebec	W31E	14.25	5	8	England
FA8CF	14.06	5	8	Ala.	W3CBV	14.22	5	7	England
SU1MW	14.14	5	9	Mich.	W3EMM	14.5	4	4	South Africa
SU1JM	14.38	5	7	Ala.	W3EOZ	14.5	8	8	South Africa
SU1MN	14.35	4	7	Mass.	W4CDG	14.19	5	9	England
SU1SG	14.4	5	8	Quebec	W4DCR	14.25	5	8-9	England
VQ2PL	14.0	3	5	Mass.	W4EEV	14.2	4-5	7-8	England, New Zealand
ZS2AF	14.09	5	7	Tex.	W5VU	14.2	5	8-9	England, South Africa
ZS2BJ	14.01	5	7	Tex.	W5FAB	14.21	5	7	England
ZS4H	14.05	4	6	Calif.	W5VV	14.23	5	8	England
ZS5AW	14.1	5	6	Calif., Tex., Kans.	W5GFF	14.2	3	5	England
ZS5Q	14.07	5	9	Ia., Calif., Nebr.	W5HEK	14.19	5	9	England
ZS5T	14.06	5	7	Tex.	W5ATW	14.19	5	8	England
ZS6DY	14.005	5	7	Ia., Calif.	W5ADO	14.21	5	6	England
ZS6AJ	14.1	5	6	Calif.	W5BEV	14.22	3	5	England
ZS6BB	14.06	5	7	Calif.	W5FIJ	14.225	5	8	England
ZS6DV	14.06	5	7-8	Tex., Kans.	W5BGW	14.26	5	7	England
CO6CM	14.498	5	8	S. Dak.	W5YF	14.5	5	6	South Africa
K4FKC	14.1	5	7	Ore.	W5FNH	14.19	3-5	5-6	South Africa, P. I.
K4FAY	14.32	3	8	S. Dak.	W5HDK	14.5	5	9	New Zealand
K4EJT	14.45	3	7	S. Dak.	W5JB	14.5	9	9	New Zealand
					W5ZS	14.5	9	9	New Zealand
					W5FAM	14.2	5	6	P. I.

NORTH AMERICANS

The Short Wave League

DX on the Ham Bands



(with the "Listening Post" Observers)

Edited by Elmer R. Fuller

HONORARY MEMBERS

- Dr. Lee de Forest
 D. E. Replogle
 John L. Reirartz
 Hugo Gernsback, Executive Secretary
 Max von Ardenne
 E. T. Somerset
 Hollis Baird

A few of our observers report stations on twenty meters which were less than two thousand miles from their listening post. These cannot be used, and are not considered good DX by this department. Reports for May were received from the following observers:—
 Alabama Jack Wells
 Arizona Lester Fuller
 California Richard Rush
 Connecticut Howard G. Kemp
 Florida Major Lester
 Iowa Dick Mannheim
 Kansas Burns E. Hegler
 Maryland Cecil Wilkes
 Massachusetts Edward Lendzioszek
 Michigan Vernon Gabriel
 Missouri R. B. Fleming
 Nebraska William Dean Noyes
 New Jersey John Fitzpatrick
 New York Charles H. Fuller
 W. F. Herzog

Oregon Elwood C. Trueman
 Pennsylvania Tom Jordan
 South Carolina Ray Halliday
 South Dakota Robert Hutchinson
 Texas Edward C. Slaughter
 Washington Ernest Lang
 Quebec Stanley Clarke
 England Kenneth Spencer
 South Africa Morris Wasserzug
 New Zealand H. Vernon Wheatley
 Philippine Islands J. M. Ruiz

Only a few Asiatics were reported last month.

Call	Freq.	R	S	Where Heard
VS2AK	14.035	3	5	Wash.
VU2AY	14.105	5	7	Mass.
XU6KA	14.025	4	6	Wash.
XU6TL	14.06	3-4	5-6	Mo.
XU8RB	14.09	4	6	Wash.
XZ2EX	14.065	4	7	Wash.

AFRICANS

CN8M1	14.26	5	6	Ala.
CN8BA	14.075	3	5	Conn.
CN8AU	14.055	2	5-6	Mass.
CN8AM	14.025	4	7	N. J.
CT2BP	14.17	5	6-7	Mich., Ala., Quebec
EK1AS	14.12	5	9	Mich.

K5AS	14.21	5	5	N. Y.
K5AA	28.	5	6	Ore.
NY3AD	14.23	5	7	Ore.
TG5JG	14.08	5	5	N. Y.
TG9AA	14.12	5	4	N. Y.
T12AV	14.005	5	8	Md.
VE1ET	14.15	5	8	England
VE1CK	14.09	5	8-9	England
VE1CR	14.10	5	9	England
VE2EW	14.125	4	1	South Africa
VE3WV	14.13	4	5	South Africa
VE3GK	14.1	4	8	New Zealand
VE4SS	14.12	5	6	South Africa
VE4ACP	14.12	5	5	South Africa
VE5EF	14.12	5	7	England
VE5OT	14.13	5	5-9	England, New Zealand
VE5VP	14.12	5	5-7	England
VE5VO	14.085	5	6	South Africa
VP6YB	28.	5	7	Ore.
VP6FO	14.075	5	8	N. J.
W1ABM	14.17	5	7-8	England
W1JFG	14.2	5	9	England
W1JCN	14.35	3	5	England
W1BLO	14.19	5	9	England
W1DHS	14.18	5	8	England
W1AIG	14.28	5	7	England
W1JLQ	14.2	5	7	England
W1AJZ	14.2	5	8-9	England
W1ADM	14.22	5	9	England
W1WE	14.22	5	7	England
W1MW	14.26	5	6	England
W1CND	14.	5	6	South Africa
W1XKK	14.	4	7	New Zealand
W2JKO	14.19	5	9	England
W2CTF	14.2	5	8	England
W2IKV	14.18	5	8	England
W2HWS	14.32	5	7	England
W21XV	14.25	5	9	England
W2GIZ	14.25	5	7-9	England, South Africa
W2EV1	14.	5	8	New Zealand
W2ZC	14.	5	8	New Zealand
W2AEB	14.16	5	8	P. I.
W2AZ	14.2	5	5	P. I.
W3BRX	14.19	5	8	England
W3FJU	14.26	5	7-8	England
W3ASG	14.2	5	8	England
W3GOG	14.22	5	7	England
W3ECF	14.23	5	9	England
W3BFY	14.21	5	6	England
W3DEK	14.16	5	5	England

W6USA	14	5	9	New Zealand
W6RZ	14.21	5	6	England
W61KQ	14.26	4	7	England
W6AH	14.2	4	4	England, New Zealand
W6TDV	14	5	5	South Africa
W6PMB	28	5	7	New Zealand
W6ATH	28	5	7	New Zealand
W6POV	28.	4	6	New Zealand
W6RR	28.	3	5-6	New Zealand
W6GZZ	28.	4	8	New Zealand
W6MW	14.25	3	6	P. I.
W6OSV	14.	4	5-7	New Zealand
W6MBS	14	5	9	New Zealand
W6EJC	14.	5	7	New Zealand
W6BUY	14	5	8	New Zealand
W6GR	14.	5	8	New Zealand
W6MY	14.	5	9	New Zealand
W6GR1	14.	4	6	New Zealand
W6OCU	14.	5	8	New Zealand
W6MYO	14.	5	5	New Zealand
W6MIE	14.2	5	6	P. I.
W6RX	14.2	5	7	P. I.
W6IDY	14.19	5	7	P. I.
W6CC	14.2	5	8	P. I.
W6LYC	14.34	5	6	P. I.
W6OI	14.2	5	7	P. I.
W6GHI	14.35	5	4	P. I.
W7KS	28.	5	5	New Zealand
W7DC	14.	5	9	New Zealand
W7GAE	14.	5	9	New Zealand
W7BCU	14.2	5	6	P. I.
W8RL	14.	5	5	South Africa
W8VNK	14.2	4	5	P. I.
W9CI	14.15	5	7	England
W9MGT	14.19	5	8-9	England
W9RUK	14.22	5	6	England
W9PTY	14.	5	5	South Africa
W9SZY	14.	5	6	South Africa
W9MCI	14.	5	5	South Africa
W9ARA	14.	4	6	New Zealand
W9CVM	14.	5	9	New Zealand
W9AOM	14.2	5	6	P. I.
XE1MD	14.01	5	7	Md.
XE1CO	14.18	5	5	N. Y.
CE1AS	14.137	5	5	N. Y.
CE1AM	14.0	5	5	Penna., Quebec
CE2PO	14.482	5	8	S. Dak.
CE3AA	14.07	3	4	Conn.
CE3AC	13.9	4	6	Penna.
CE3AG	13.995	5	8	Penna.

(Continued on page 252)

Mc.	Call	
9.523	ZRG	ROBERTS HEIGHTS, S. AFRICA. 31.5 m., Addr. (See ZRK, 9.606 mc.) Daily exc. Sun. 5-7.30 am.; Sun. 5.30-7 am.
9.520	OZF	SKAMLEBOAEK, DENMARK, 31.51 m., Addr. Statsradiofonien, Heibergsgade 7, Copenhagen, 8-9.30, 9.30-11 pm. to No. Amer.
9.520	YSH	SAN SALVADOR, EL SALVADOR 31.51 m., Addr. (See 7.894 mc.) Irregular 6-10 pm.
9.520	RV96	MOSCOW, U.S.S.R. 31.51 m., 1-3, 4-7 pm. and irr.
9.510	GSB	DAVENTRY, ENGLAND, 31.55 m., Addr. (See 9.580 mc.—G5C) 12 m.-2.15 am., 6.20-9.15, 9.40-11.30 pm.
9.510	HJU	BUENAVENTURA, COLOMBIA. 31.55 m., Addr. National Railways. Mon., Wed. and Fri. 8-11 pm.
9.510	—	TANANARIVE, MADAGASCAR, 31.55 m. Addr. Le Directeur des PTT, Radio Tananarive, Administration PTT. 12.30-12.45, 10-11 am., 2.30-4 am.
9.510	HS8PJ	BANGKOK, SIAM, 31.55 m. Thursday, 8-10 am.
9.510	—	HANOI, FRENCH INDO-CHINA. 31.55 m. "Radio Hanoi", Addr. Radio Club de L'Indochine. 12 m.-2 am., 6-10 am. 15 watts.
9.503	XEWV	MEXICO CITY, MEX., 31.57 m. Addr. Apart. 2516. Relays XEW. 7.45 am.-12.30 am.
9.501	PRF5	RIO DE JANEIRO, BRAZIL, 31.58 m., 4.45-5.55 pm. Ex. Suns.
9.500	YK3ME	MELBOURNE, AUSTRALIA, 31.58 m., Addr. Amalgamated Wireless of Australasia, 167 Queen St. Daily except Sun. 4-7 am.
9.500	OFD	LAHTI, FINLAND, 31.58 m., Addr. Finnish Brctst. Co., Helsinki. 12.15-5 pm.
9.497	KZ1B	MANILA PHIL. ISL., 31.59 m., 6-9.05 am.
9.488	EAR	MADRID, SPAIN, 31.6 m., Addr. (See 9.860 mc.) Irreg.

==== *End of Broadcast Band* =====

9.465	TAP	ANKARA, TURKEY, 31.70 m., 11.30 am.-5 pm.
9.445	HCODA	GUAYAQUIL, ECUADOR, 31.77 m., 8.15-10.15 pm., exc. Sun.
9.437	COCH	HAVANA, CUBA, 31.8 m., Addr. 2 B St., Vedado. 8 am.-9.30 pm. Sun. 8 am.-12 m.
9.390	OAXSC	ICA, PERU, 31.95 m., Radio Universal, 7-11.30 pm.
9.370	XOY	CHENG TU, CHINA, 32.02 m., 9.45-10.30 am.
9.355	HC1ETC	QUITO, ECUADOR, 32.05 m., Addr. Teatro Bolivar, Thurs. until 9.30 pm. 8-11 pm. Sats.
9.350	COCB	HAVANA, CUBA, 32.08 m., Addr. Box 2294, P.O. Box CMCD 10 am.-11.30 pm. Sun. 10 am.-9 pm.
9.345	HBL	GENEVA, SWITZERLAND, 32.11 m., Addr. Radio Nations. Sun. 7-7.45, 8-8.45 pm. Mon. 6.50-8.15 pm.
9.340	OAX4J	LIMA, PERU, 32.12 m., Addr. Box 1166, "Radio Universal." 12 n.-3 pm., 5 pm.-1 am.
9.295	HI2G	CIUDAD TRUJILLO, D. R., 32.28 m. 6.40-8.40 am., 11.40 am.-2.10 pm., 3.40-4.40 pm.
9.280	LYR	KAUNAS, LITHUANIA, 32.33 m., 11 am.-1.25 pm. and Irreg.
9.200	ZMEF	SUNDAY ISLAND, 32.61 m., Conts. ZIL5, N.Z. 1.45-2.15 am. Irreg.
9.200	COBX	HAVANA, CUBA, 32.61 m. Addr. San Miguel 194, Altos. Relays CM8X 8 am.-11.30 pm.
9.188	HC2AB	ECUADOR, 32.65 m., nightly to 10 pm.
9.170	HC1GQ	QUITO, ECUADOR, 32.72 m., Mon., Wed., Sat. 9-9.55 pm.
9.125	HAT4	BUDAPEST, HUNGARY, 32.88 m., Addr. "Radiolabor, Gyali-ut. 22. Daily 7-8 pm., Sat., 6-7 pm.
9.124	HC2CW	GUAYAQUIL, ECUADOR, 32.88 m., 11 am.-1, 7-11 pm.
9.100	COCA	HAVANA, CUBA, 32.61 m. Addr. Galiano No. 102. Relays CMCA Noon-1.15 am. Irreg. to 3 am.
9.091	PJCI	CURACAO, D. W. INDIES, 33 m., 6.36-8.36 pm., Sun. 10.36 am.-12.36 pm.

Mc.	Call	
9.030	COBZ	HAVANA, CUBA, 33.32 m., Radio Salas Addr. P. O. Box 866. 7.45 am.-1.15 am. Sun. 7.45 am.-12 m. Relays CMBZ.
8.965	COKE	SANTIAGO, CUBA, 33.44 m. Addr. Box 137. 9-10 am., 11.30 am.-1.30 pm., 3-4.30, 5-6, 10-11 pm., 12 m.-2 am.
8.841	HCJB	QUITO, ECUADOR, 33.5 m. 7-8.30 am., 11.45 am.-2.30 pm., 5-10 pm., except Mon. Sun. 12 n.-1.30 pm., 5.30-10 pm.
8.830	COCQ	HAVANA, CUBA, 33.98 m., 6.55 am.-1 am.
8.700	HKV	BOGOTA, COLOMBIA, 34.46 m. Tues. and Fri. 7-7.20 pm.
8.665	COJK	CAMAGUEY, CUBA, 34.64 m., Addr. Finlay No. 3 Altos. 11.30 am.-12.30 pm., 3.30-6, 8-9 pm.
8.665	W2XGB	HICKSVILLE, N. Y., 34.64 m., Addr. Press Wireless, Mon. to Fri. News at 9 am. and 5 pm.
8.652	HJ4DAU	MEDELLIN, COLOMBIA, 34.67 m.,
8.580	YNPR	MANAGUA, NICARAGUA, 34.92 m. Radiodifusora Pilot. 12.45-2.15, 6.45-10.15 pm.
8.572	—	BUCHAREST, ROUMANIA, 35.02 m., 8.15-10.30 am., 4-7 pm.
7.894	YSD	SAN SALVADOR, EL SALVADOR, 37.99 m., Addr. Dir. Genl. Tel. & Tel. 7-10.30 pm.
7.870	HCIRB	QUITO, ECUADOR, 38.1 m. La Voz de Quito. 8.30-11.30 pm.
7.854	HC2JSB	GUAYAQUIL, ECUADOR, 38.2 m. 11 am.-2, 4-11 pm.
7.797	HBP	GENEVA, SWITZERLAND, 38.48 m., Addr. Radio-Nations.
7.614	CR6AA	LOBITO, ANGOLA, 39.39 m., Mon., Wed., Sats. 2.30-4.30 pm. Also 7.177 mc.
7.520	KKH	KAHUKU, HAWAII, 39.89 m., Fri. 9-10 pm., Sat. 1-1.30 am., 9.30-10 pm.
7.490	EAJ43	TENERIFE, CANARY ISL., 40.05 m., 8-9.30 pm. and Irreg.
7.450	T12RS	SAN JOSE, COSTA RICA. 40.27 m. "Radioemisora Athena". 7-11 pm.
7.440	FG8AH	POINT-A-PITRE GUADELOUPE, F.W.I., 40.32 m., 6-7.10 pm., also 9-10.30 pm. Irreg. P. O. Box 125.
7.410	HCJB4	QUITO, ECUADOR, 40.46 m., 7-9.30 pm. irregularly.
7.380	XECR	MEXICO CITY, MEX., 40.65 m., Addr. Foreign Office. Sun. 6-7 pm.
7.310	VIG	PORT MORESBY, PAPUA, 41.01 m., June 10 & 24, 3-5 am.
7.280	TPB12	PARIS, FRANCE, 41.21 m., 10.15 am.-5.15 pm., 8.30-11 pm.
7.260	CSW8	LISBON, PORTUGAL, 41.32 m., addr. Emisora Nacional de Radiodifusao, rua do Quelhas. Tue., Thur., Sat. 4.05-5 pm.
7.250	YDA	TANDJONGPRIOK, JAWA, 41.38 m., Addr. N.I.R.O.M., Batavia, 10.30 pm.-2 am.; Sat. 7.30 pm.-2 am.
7.220	HKE	BOGOTA, COL., S. A., 41.55 m. Tues. and Sat. 8-9 pm. Mon. and Thurs. 6.30-7 pm.
7.220	YDX	MEDAN, SUMATRA, N. E. I., 41.55 m. Daily exc. Sat., 10.30 pm.-2 am. Sat. 7.30 pm.-1.30 am. Irreg. to 9 am.
7.200	Y15KG	BAGHDAD, IRAQ, 41.67 m., 7.30 am.-4 pm.
7.200	YNAM	MANAGUA, NICARAGUA, 41.67 m. Irregular at 9 pm.
7.177	CR6AA	LOBITA, ANGOLA, PORT. WEST AFRICA. 41.75 m., Mon., Wed., and Sats. 2.45-4.30 pm. Also see 7.614 mc.
7.128	YN3DG	LEON, NICARAGUA, 42.09 m., 2-2.30, 8.30-9.30 pm., ex. Suns.
7.100	F08AA	PAPEETE, TAHITI, 42.25 m., Addr. Radio Club Océanien. Tues. and Fri. 11 pm.-12.30 am.
7.088	PI1J	DORDRECHT, HOLLAND, 42.3 m., Addr. Dr. M. Hellinman, Technical College. Sat. 11.10-11.50 am.
7.010	XGSA	KWEIYANG, CHINA, 42.80 m., 5.30, or 6-11 am.
6.990	XEME	MERIDA, YUCATAN, 42.89 m., Addr. Calle 59, No. 517, "La Voz de Yucatan desde Merida." Irregular.

Mc.	Call	
6.977	XBA	TACUBAYA, D. F., MEX., 43 m. 9.30 am.-1 pm., 7-8.30 pm.
6.960	2ZB	WELLINGTON, N. Z., 43.10 m., Mid-7 am.
6.880	XOJD	HANKOW, CHINA, 43.60 m., 6-8.30 am.
6.805	HI7P	CIUDAD TRUJILLO, DOM. REP., 44.06 m., Addr. Emisora Diaria de Comercio. Daily exc. Sat. and Sun. 12.40-1.40, 6.40-8.40 pm. Sat. 12.40-1.40 pm. Sun. 10.40 am.-11.40 am.
6.790	PZH	PARAMIRABO, SURINAM. 44.16 m., Addr. P. O. Box 18. Sun. 8.40-10.40 am. Tues. & Fri. 5.40-8.40 pm. 1st & 3rd Thurs. monthly 6.40-8.40 pm.
6.775	HIH	SAN PEDRO DE MACORIS, DOM. REP., 44.26 m. 7-9.40 pm. Sun. 5.20-6.40 pm.
6.730	HI3C	LA ROMANA, DOM. REP., 44.58 m., Addr. "La Voz de la Feria." 12.30-2 pm., 5-6 pm.
6.720	PMH	BANDOENG, JAVA, 44.64 m. Relays N.I.R.O.M. programs. 4.30-11 or 11.30 am. Also Sat. 9.30 pm.-1.30 am.
6.690	TIEP	SAN JOSE, COSTA RICA, 44.82 m., Addr. Apartado 257, La Voz del Tropico. Daily 7-11 pm.
6.675	HBQ	GENEVA, SWITZERLAND, 44.94 m. Addr. Radio-Nations. Sun. 1.45-2.45 pm.
6.660	HI5G	TRUJILLO CITY, D. R., 45.05 m., to 8.40 pm.
6.635	HC2RL	GUAYAQUIL, ECUADOR, 45.18 m., Addr. P. O. Box 759. Sun. 5.45-7.45 pm., Tues. 9.15-11.15 pm.
6.630	HIT	CIUDAD TRUJILLO, D. R., 45.25 m., Addr. "La Voz de la RCA Victor." Apartado 1105. Daily exc. Sun. 12.10-1.40 pm., 5.40-8.40 pm.; also Sat. 10.40 pm.-12.40 am.
6.625	PRADO	RIOBAMBA, ECUADOR, 45.28 m. Thurs. 9-11.45 pm.
6.610	YNLG	MANAGUA, NICARAGUA, 45.39 m. Emisora Ruben Dario. 1.30-2.30, 6-10.15 pm.
6.600	HI6H	TRUJILLO CITY, D. R., 45.45 m., 7.40-8.40 pm.
6.565	HI5P	PUERTO PLATA, D. R., 45.70 m., 5.40-7.40, 9.40-11.40 pm.
6.558	HI4D	CIUDAD TRUJILLO, D. R., 45.74 m., Addr. Apartado 623. 12.30-2, 6-8 or 9 pm. Except Suns.
6.550	XBC	VERA CRUZ, MEX., 45.8 m. 8.15-9 am.
6.550	TIRCC	SAN JOSE, COSTA RICA, 45.8 m., Addr. Radioemisora Catolica Costarricense. Sun. 11 am.-2 pm., 6-7, 8-9 pm. Daily 12 n.-2 pm., 6-7 pm., Thurs. 6-11 pm.
6.540	YNIGG	MANAGUA, NICARAGUA, 45.87 m., Addr. "La Voz de las Lagos." 1-2.30, 8-10 pm. Except Sundays.
6.490	TGWB	GUATEMALA CITY, GUAT., 46.2 m. La Voz de Guatemala. Daily 7.45-9 am. 12.45-3.45 pm., 7.30 pm.-12.15 am., Sun. 10.30 am.-5.15 pm., 7 pm.-12 m.
6.480	HI1L	SANTIAGO DE LOS CABALLEROS, D. R., 46.28 m., Addr. Box 356. 9.40-11.40 am., 7.40-9.40 pm.
6.470	YNLAT	GRANADA, NICARAGUA, 46.36 m., Addr. Leonidas Tenorio, "La Voz del Mombacho." Irregular.
6.455	HI4V	SAN FRANCISCO DE MACORIS, D. R., 46.44 m., 11.40 am.-1.40 pm., 5.10-9.40 pm.
6.420	HIIS	SANTIAGO, D. R., 46.73 m., 5.40-7.35 pm. Ex. Suns.
6.400	TGQA	QUEZALTENANGO, GUATEMALA, 46.88 m., Mon.-Fri. 9-11 pm. Sat. 10 pm.-1 am. Sun. 1-3 pm.
6.388	HI9B	SANTIAGO, D. R., 46.95 m., Mon. 6-6.45, 8-8.45 pm.
6.384	ZIZ	BASSETERRE, ST. KITTS, W. INDIES, 46.99 m. 4-4.45 pm., Wed. 7-7.30 pm.
6.357	HRPI	SAN PEDRO SULA, HONDURAS, 47.20 m., 6-7.30 am., 2-4 pm. & Irreg. to 10 pm.
6.340	HIIX	CIUDAD TRUJILLO, D. R., 47.32 m., Sun. 7.40-10.40 am., daily 12.10-1.10 pm., Tues. and Fri. 8.10-10.10 pm.
6.335	OAXIA	ICA, PERU, 47.33 m., Addr. La Voz de Chiclayo, Casilla No. 9. 8-11 pm.

(Continued on page 253)

All Schedules Eastern Standard Time

What Do YOU Think?

Two New Ideas

Editor,

I have just had a couple of brainstormings so I thought I'd write to you and if you wish, you might print them in "What Do YOU Think?"

Nobody knows all of the languages used by radio stations of foreign countries when they announce. Now after spoken announcements, why couldn't these stations send their call letters, and perhaps location, in International Morse code, such as WWV does? This would greatly simplify logging and add new joy to S.W. listening. It could be easily done with a code oscillator or other suitable means.

My other idea is: It would be a great help if RADIO & TELEVISION Magazine would list the power of stations in the S.W. station list.

I listen regularly to the short waves on my 5-tube home-made receiver and I-tube super-regenerative set for U.H.F. I've heard 34 countries!

I subscribe to "R. & T." and belong to the *Short Wave League*. I'm studying up for a Ham license and hope to have one soon.

Good luck to your very F.B. (Fine Business) magazine and 73.

ERNEST EMMONS,
DuBois, Pa.

News from India!

D. R. D. Wadia of Bombay, India, well known in Amateur Radio since 1921, tuning in on the latest 1939 II-tube All-Wave super. "DIARDI" has verified over 300 stations and his rating in the "Heard All Continents" Club is fifth in the world or first among non-American SWL's. The picture below shows a few of his "veris." He is vice-president of the All-India Radio Merchants' Association, president of the Indian Radio Amateurs' League, life member Society of Wireless Pioneers, one of the oldest Indian members of the International Short Wave Club, International DXers' Alliance, R9 Listeners' League, etc., etc. The cup in the photograph is for a golf championship. He is a keen big game shikari, having bagged seven panthers, five bison, three elephants, the last being a record for India, 10 feet, 9 inches high with 60-inch circumference of the front feet and five-feet, four-inch tusks.



This Month's Prize Winner

Photo at right shows Elmer R. Walker and his daughter in their short-wave listening shack at Spokane, Wash. His address is W. 2501 College Ave. Mr. Walker is a member of the I.D.A. He has just built a new room measuring 12 x 20 feet. He says that "he sure looks forward each month to R. & T." (This month's prize winner—one year's subscription to "R. & T.")



A Good Idea

Editor,

I have been reading RADIO & TELEVISION Magazine since it was first published and believe it to be the best radio publication.

As an experimenter and SWL I wish to urge all SWL's to be sure and include postage and give accurate reports to amateurs, so that our hobby will not soon be blacklisted by the Hams. Commercial stations (Continued on page 237)



Above—the smiling face of Bake Young—"the sage from the sagebrush." Bake aspires to become a licensed Ham. Bake has over 400 verifications from S-W broadcast stations and a few of his veri cards are here exhibited on the walls of his shack.

But Will We Get It?

Editor,

Since my stack of R. & T. is beginning to look like something, I guess it's about time I tossed in my two pins' worth.

I find most interesting the articles on construction of receivers, etc. For financial reasons, I am unable to try out many of them but they all go down in my notebook. I also find the "World Wide Radio Digest" and "International Radio Review" very

valuable! Keep up the television and facsimile articles. One punk stated that, as most of the readers were unable to do the actual experiments because of lack of funds, the television articles should be left out! Say, if that was the way I felt, I'd cut out all the "something free for nothing" ads and use the rest to light the fire with.

The "Radio Test Quiz" is OK in a way, but why not stick to the technical end of it?

Let's have a little more about the Frequency Modulation System. The "What Do YOU Think?" page is very good also, and when, I mean if, I learn something, I might send in something for it. I could also send a picture of my listening post; it should prove unusual, and I might get the handle "King of Junk."

The "Radio Beginner's Course" is OK but didn't have to begin so near the beginning. The "Television Course" is just what the doctor ordered! You must have heard me getting all set to kick up a yowl for just such a course.

Your list of *World Short Wave Stations* is very useful and well set up. I have one or two items for your FB "Radio Kinks" page and will send them in shortly, and may also make use of your "Question Box" department.

"Barter and Exchange" is a swell idea! I have already used this and I got what I wanted, and also an interesting and helpful correspondent. On the last pages I find another good idea, the listing of free catalogs and index to all advertisers.

There you are—my criticism and stuff. If you have read this through without skipping, you deserve a raise!

THOMAS D. GRANT,
Lunby, B. C., Canada.

CWL's Can Help

Editor,

In the June RADIO & TELEVISION appeared a letter from Jack Gant, W5EGR, who, in my opinion, very capably answered "SWL Punk's" letter of the February issue.

To begin with, I am not yet a licensed amateur but am working to attain that rating. I do spend considerable time on the C.W. Ham bands, receiving answers from a little better than 50% of the cards written—a better average perhaps than most phone SWL's can boast of. I have written to only one station I haven't copied code from, and that was a phone several hun- (Continued on page 237)



The LT-6 "loktal" receiver provides good all-around reception.

Harry D. Hooton, W8KPX

BUILD the LT-6

● THE new type of construction embodied in the recently released "loktal" tubes makes them especially interesting to the ham or short wave experimenter. It consists of an all-glass tube without the familiar bakelite base. The contact pins are sealed in the glass bottom, thus eliminating soldered connections. The "loktal" arrangement provides compactness, suitable shielding and a lock-in feature as well as the single-ended type of construction which eliminates the top grid cap. The lower portion of the tube is fitted with a metal shell and guide pin. This unit acts

as a shield and makes possible the lock-in feature by employing a groove around the bottom of the locating pin which fits into a catch on the socket. The locking arrangement holds the tube tightly in the socket, assuring good contact at all times. The tubes cannot be removed by a direct, upward pull. By using a slight off side pressure, the socket lock releases and the tube is easily removed.

Six Loktal Tubes Used

The superheterodyne receiver to be described in this article uses six of the new "loktals" and is designed especially for these tubes. As shown in Fig. 1, the line-up is as follows: A 7A8 semi-regenerative mixer, a 7B7 high-frequency oscillator, a 7B7 460 kc. I.F. amplifier, a 7C6 detector, A.V.C. and first A.F. amplifier, a 7B5 output and a 7B7 beat frequency oscillator. The electrical characteristics of these tubes are similar to the older types 6D8G, 6S7G, 75 and 41 but are considerably more efficient.

As the photographs show, the receiver is constructed around the National PW-2 tuning unit and iron-core, air-trimmed I.F. transformers. The plug-in coils are wound on one-inch isolantite forms for the 10, 20 and 40 meter bands and all losses have been reduced as much as possible. The mixer circuit is made semi-regenerative, just enough feedback being used to boost the sensitivity and the image selectivity. The resistor "R" across the 7A8 cathode coil is used to level out the regenerative effect over the entire tuning range of each set of coils. It is placed inside the mixer coil forms down close to the cathode pins. The exact value depends somewhat upon the frequency band in use and the number of turns in the feedback coil, and may vary from 1,000 to 5,000 ohms; usually, however, a value of about 2,000 ohms will be satisfactory for all bands.

"Unusual Band-Spread" Provided

It is interesting to note the amount of band-spread that can be obtained with the National dial and the 50 mmf. double-spaced tuning condensers. The dial which is of the micrometric type reads direct to one part in 500. The division lines are approximately 1/4-inch apart. The dial revolves ten times in covering the tuning range, and the numbers visible through the small windows change every revolution to give consecutive numbering by tens from 0 to 500. The tuning condensers used in this particular unit are of special construction, 50 mmf. per section and double spaced. The spread on the 14 and 28 megacycle bands is about seventy-five degrees; on the lower frequencies the amount of spreading increases until almost two hundred degrees is obtained on the 80 and 160 meter bands.

The actual construction of the receiver is not at all difficult. Lay out the panel and chassis as shown in Fig. 2, making certain that the dimensions are exactly as indicated. The tuning unit is mounted first, with the mixer and oscillator tube sockets next in order. The sockets should be placed in the position which will permit short, direct wiring between the various parts of the R.F. circuit. The R.F. and I.F. bypass condensers and the fixed resistors are mounted either on the parts themselves or on small insulated mounting lugs, as close as possible to their respective circuits.

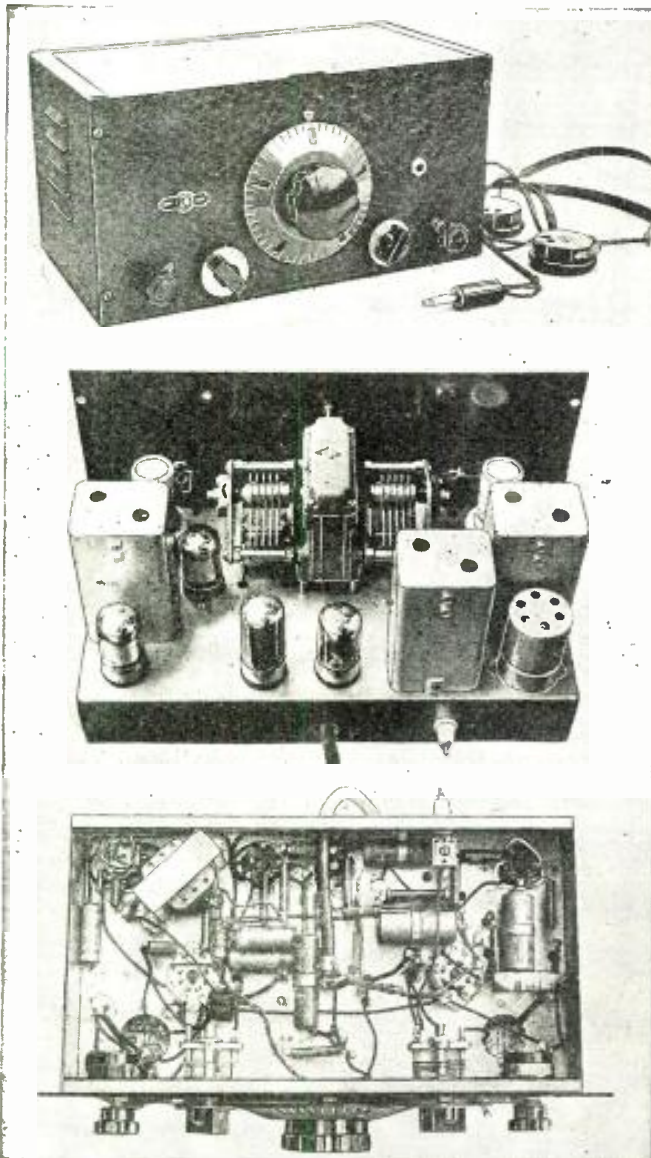

The three photos at the left show front, rear and bottom views of the LT-6 receiver. This set will be found very useful by both Hams and Fans, plenty of bandsread being provided by the National dial and tuning unit.



This interesting superhet receiver uses six of the new "loktal" tubes, and among the features incorporated are a semi-regenerative mixer and a beat-frequency oscillator. Coil data is given for the following bands: 10, 20, 40, 80 and 160 meters.

"Loktal" Receiver

for the

HAM OR FAN

Keep the wiring, especially the "hot" I.F. and R.F. grid and plate leads, as short and direct as possible. It may be necessary to shield some or all of the I.F. leads, as indicated by the dotted lines in Fig. 1, in order to prevent oscillation at this level. Due to the extremely high gain of the National iron-core I.F. transformers, a high noise level may be encountered when the trimmers are "peaked" for the maximum signal output. In most cases this condition can be entirely eliminated by careful shielding, without affecting the gain in any way.

Aligning I.F. Stages

If possible, use a good test oscillator for the alignment of the I.F. circuits. The procedure is quite simple: Disconnect the grid

lead from the 7A8 mixer by removing the plug-in coil and turning the tuning condenser plates all the way out. Feed the 460 kc. test signal to the mixer input by making a connection to the fixed plates of the mixer tuning condenser. If the signal can be heard in the speaker or headphones, adjust each I.F. trimmer for the maximum signal output. If the signal becomes very strong, adjust the attenuator of the test oscillator for a weak signal. The weakest signal that can be heard in the phones or shown on an output meter will give the most accurate alignment.

In lieu of a test oscillator and output meter, the following alignment procedure may be used: Place a set of coils in their sockets, preferably those covering the 40 meter amateur band.

(Continued on page 243)

Fig. 1. Complete schematic and pictorial wiring diagrams for the LT-6 receiver are given below.

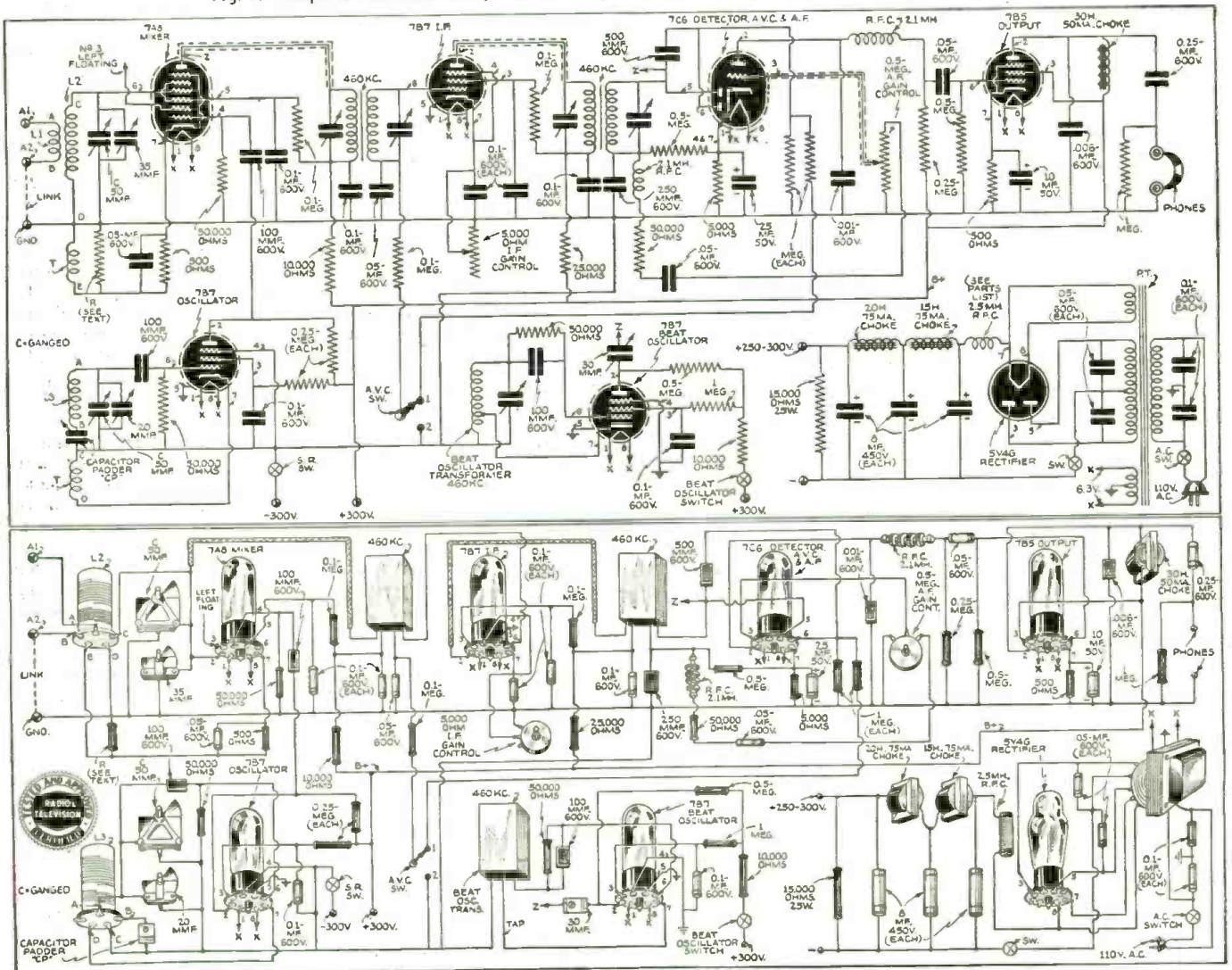

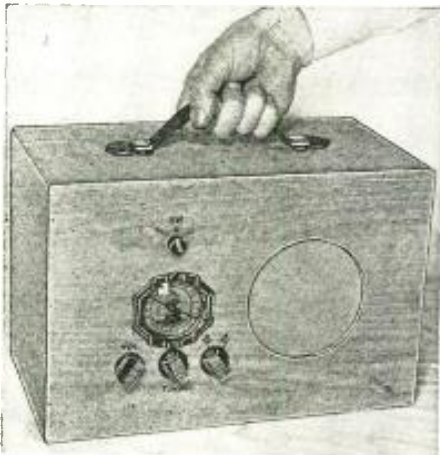

Front view of the set that gives you radio wherever you go.

You Can Easily Build This 2-Band Vacation

No plug-in, no aerial, no ground needed in this 4-tube light-weight set, which pulls in stations from 67 to 550 meters.

● AT the "old ball game"—at the summer camp—on the lawn on summer evenings—and as a second set which can be used anywhere (and I do mean *anywhere*) this little set offers an attraction to radio fans that has not been met before in portables.

In size, the set is no larger than many of the A.C.-D.C. midgets, being only 13½ x 8½ x 7½ inches over-all. It has an enclosed loop so that no trailing wires are needed, except where the set is used at locations where the nearest broadcast station is several hundred miles away. The complete set with batteries weighs less than 16 pounds.

Short Waves, Too! And as an attraction to the short-wave fan, it has a *short-wave* band in addition to the regular broadcast

coverage of 550 to 1500 kc. The short-wave band covers 1500 to 4480 kc. (200 to 67 meters).

Four Tubes Used: Four tubes of the new 1.4 volt, low filament current series are used. The first is a 1A7G which operates as first-detector and oscillator. The second, a 1N5G, is the I.F. amplifier. The third is a 1H5G diode-triode which fills the three functions of second-detector, A.V.C. and A.F. amplifier, while the fourth is a 1C5G pentode output tube.

The I.F. coils are iron-core units with air-condenser trimmers to give the best possible gain. They are Meissner type 16-6643 input which produces a gain of 77, and a type 16-6645 output, rated at a gain of 105. The oscillator coil is a Meissner type 14-7475, which has the required 2 wavebands.

Before beginning assembly, lay out all parts in the order in which they will be used.

Construction Details

The set is built on an aluminum chassis 6 x 7 x 1¼ in. deep. Positions of the parts can be seen in the photos. In order that the dial may be centered on the front of the case, the variable condenser is mounted on a small "U" shaped aluminum bracket which raises it to the desired height. The wave-change switch and the volume control are mounted on another bracket which puts the tuning, volume and wavechange knobs all in line.

Mount the sockets, coils, variable condenser, dial, padding condenser, volume control and waveband switch in place. When this has been done, the wiring can be started. Leave lead wires projecting for the loop aerial and the batteries. Note that the "A" plus and the "B" plus leads are opened by the switch, so that when the set is turned off, both battery circuits are broken. The

Schematic diagram of the battery portable, which uses standard parts throughout.

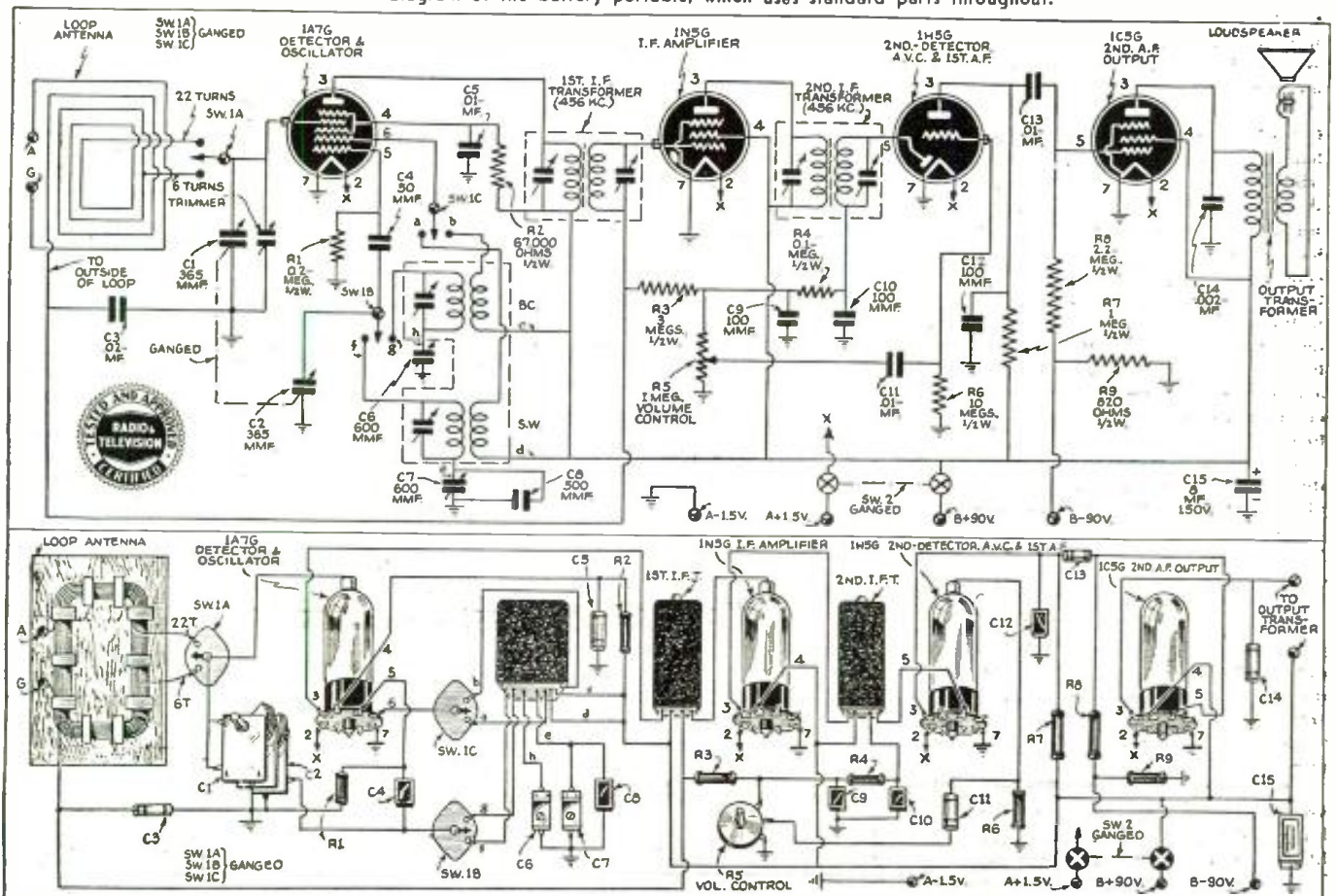

Self-Powered

Portable



C. W. Palmer, E.E.

Set with cabinet back removed, showing loop antenna.

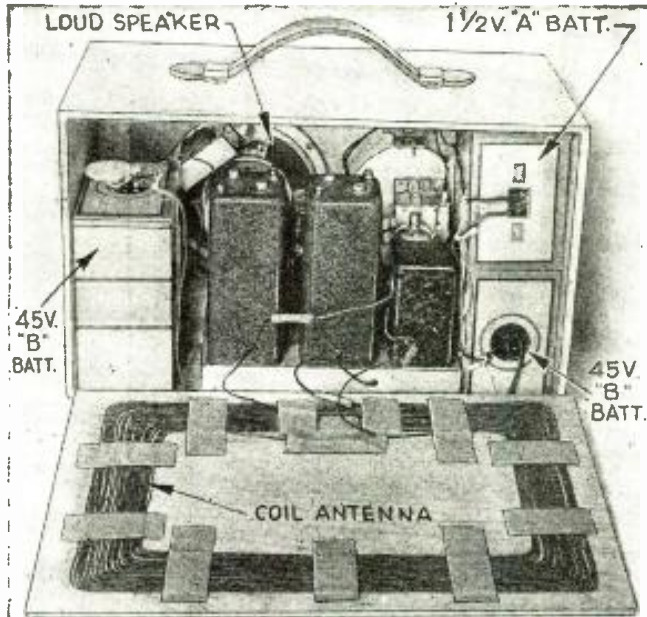

bias for the pentode output tube is obtained through the voltage drop in the 820 ohm resistance in the "B" minus circuit. This eliminates the need for "C" batteries.

Loop Aerial: The loop aerial consists of .22 turns of special flexible loop wire wound on the inside of the back of the wooden case. The wire is formed into an oblong shape, starting at 12 x 7 1/2 inches and decreasing to 9 x 5 for the innermost turn. Small brads hammered into the board will hold the wires while winding—they can be removed later. A tap is made at 6 turns from the outside for the *short-wave* band. The outside of the loop is connected to the a.v.c. line. Duco cement and strips of masking tape, or adhesive tape, will serve to secure the loop to the case. When the turns are all in place, one additional turn on the inside is wound to serve as a coupling coil for an outside aerial if one is desired. Two binding posts on the back make contact with this single turn.

The case is constructed of wood 1/4 inch thick. This is fastened together with good glue and thin headless finishing nails. The positions of the holes in the front for the 5-inch permanent magnet speaker and the dial and knobs are shown in the detail drawings. A suitable leather carrying handle can be purchased from a hardware or leather-goods shop, or one can be taken from an old traveling case. The latter procedure was used by the writer. The case can be covered with airplane cloth, imitation leather or stained and varnished to suit individual preference.

When the wiring is completed, it is advisable to check all connections thoroughly, because if the "B" voltage is applied to the filament circuit, the tubes will burn out. Try connecting the "A" battery—with all other batteries disconnected—to "B" plus

and chassis and look at the tube filaments in a darkened room and note if the filaments light. If they do, when the "on-off" switch is turned on, there is a short-circuit between the "B" and "A" leads and this *short* should be removed before the "B" batteries are connected to the set.

Adjustments

Alignment of the set can best be done with a service oscillator. If one is available, tune it to 456 kc. and align the i.f. trimmers for greatest volume or widest swing on an

Inside the set. Note compact arrangement of components.

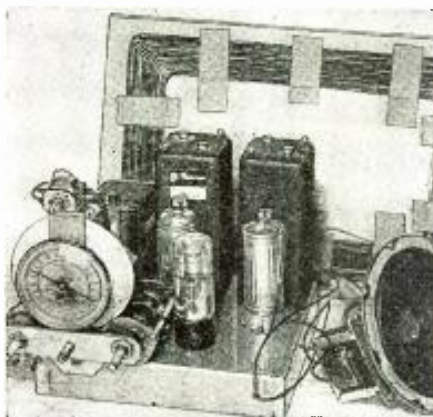

LIST OF PARTS

RCA

- 1—Type 1A7G tube
- 1—Type 1N5G tube
- 1—Type 1H5G tube
- 1—Type 1C5G tube

I.R.C.

- 1—1-Megohm volume control
- 1—0.2 meg., 1/2 watt resistance
- 1—67,000 ohm, 1/2 watt resistance
- 1—3 meg., 1/2 watt resistance
- 1—0.1 meg., 1/2 watt resistance
- 1—10 meg., 1/2 watt resistance
- 1—1 meg., 1/2 watt resistance
- 1—2.2 meg., 1/2 watt resistance
- 1—820 ohm, 1/2 watt resistance

SPRAGUE

- 1—8 mf., 150 volt electrolytic condenser
- 3—.01 mf., 600 volt paper condensers
- 1—.02 mf., 600 volt paper condenser
- 3—100 mmf. mica condensers
- 1—50 mmf. mica condenser
- 1—.002 mf. mica condenser
- 1—500 mmf. mica condenser

PAR-METAL PRODUCTS

- 1—Aluminum chassis 7 x 6 x 1 1/4 inch deep

MEISSNER

- 1—Type 14-7475 oscillator coil
- 1—Type 16-6643 i.f. 456 kc. iron core transformer
- 1—Type 16-6645 i.f. 456 kc. iron core output transformer
- 1—Type 22-5211 600 mmf. dual padder
- 1—Type 21-5214 2-section 365 mmf. tuning condenser
- 1—Type 24-8265 band switch (one section removed)
- 3—Type 25-8221 knobs

CINAUDAGRAPH

- 1—5-inch permanent-magnet speaker, Type CA-5-9 with C53 transformer

CROWE

- 1—Type 380 dial and scale with Type 13312 escutcheon for condenser, with 1/4-inch shaft and clockwise rotation for maximum capacity

NATIONAL CARBON CO.

- 1—"Eveready" Type 741 battery, 1 1/2 volt
- 2—"Eveready" Type 762 battery, 45 volt

CINCH MFG. CO.

- 4—Wafer sockets for octal tubes

EBY

- 2—Binding posts
- 3—Grid clips

HART & HAGEMAN

- 1—2 pole, single-throw rotary panel switch

GOAT RADIO TUBE PARTS, INC.

- 3—Type G1222B tube shields
- 3—Type G1202 shield bases

CORNISH WIRE CO.

- 1—Roll No. 18 push-back wire
- 1—1/4-lb. spool special silk-covered loop wire

MISCELLANEOUS

- Wood for box, carrying handle, aluminum for brackets, screws, nails, glue, etc.

output indicator. Connect the output of the oscillator to the grid cap of the 1A7G, leaving all connections in place. Next, with the switch in the *broadcast* position, connect the oscillator to the aerial terminal on the back of the loop. Tune the oscillator to 550 kc. and turn the dial to this same point. Then, with the volume control on full, adjust the broadcast padding condenser to the point giving the strongest signal. Finally turn the oscillator and dial to 1400 kc. Then adjust the broadcast trimmer condenser (the lower one) in the oscillator coil can and the trimmer on the tuning condenser to give greatest volume (turn the aerial section only, leave the oscillator trimmer at the lowest capacity position).

This will complete the trimming of the *broadcast* band. Repeat the above to be sure all trimmers are peaked correctly.

Trimming on the *short-wave* band consists of adjusting the padding condenser for this band at about 1700 kc., using a signal
(Continued on page 240)



Extremely neat and highly efficient, this portable phone Transceiver will make many friends.

● NOW that amateurs have been forced off five meters with simple equipment by the new F.C.C. regulations, the only band where conventional circuits may be used in highly compact and lightweight *transceivers* is two and a half meters. At higher frequencies it becomes practically imperative to use linear oscillators and unusual circuits, but on 2½ meters the normal circuits such as were used on 5 meters are still workable and practical.

HAMS, Build This 2½ Meter Acorn Every Amateur Will Find

With two of these highly efficient Transceivers, 2-way phone contact can be established over distances of 5 to 15 miles. Construction cost moderate — wiring very simple — parts few in number.

New Acorn Tubes Used

The recent development of a line of battery-operated *acorn tubes* should give a tremendous boost to all portable ultra-high frequency work. Although this line includes two triodes and a pentode, it is only the former that are of use in the equipment to be described. These tubes operate on 1.5 volts with a filament current of 50 ma. and 100 ma. for the 957 and 958 respectively. Like all acorn tubes they oscillate beautifully at the ultra high frequencies and are not at all fussy to get going.

The use of *acorn tubes* is practically a necessity. With ordinary tubes it is quite possible to get good results with relatively high plate voltages, but with only a limited plate supply and the cramped layout required in a portable rig, the very best possible

The front panel swings forward on hinges to permit adjusting the coils, etc. The batteries are in the case.



Diagram of connections for the 2½ meter Transceiver. A single 4-pole double-throw switch converts the circuit from "Talk" to "Listen."

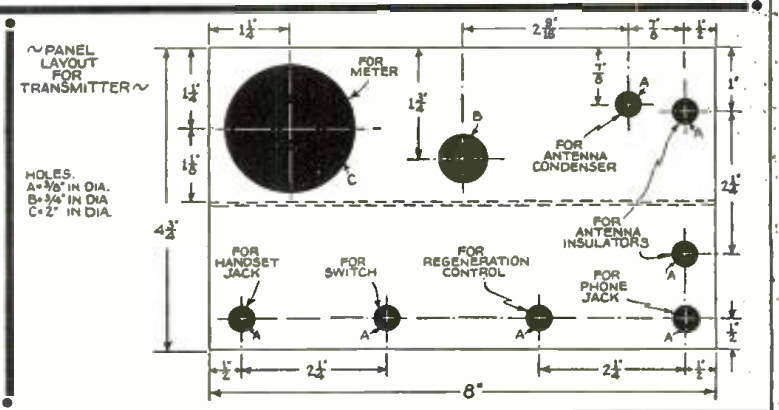
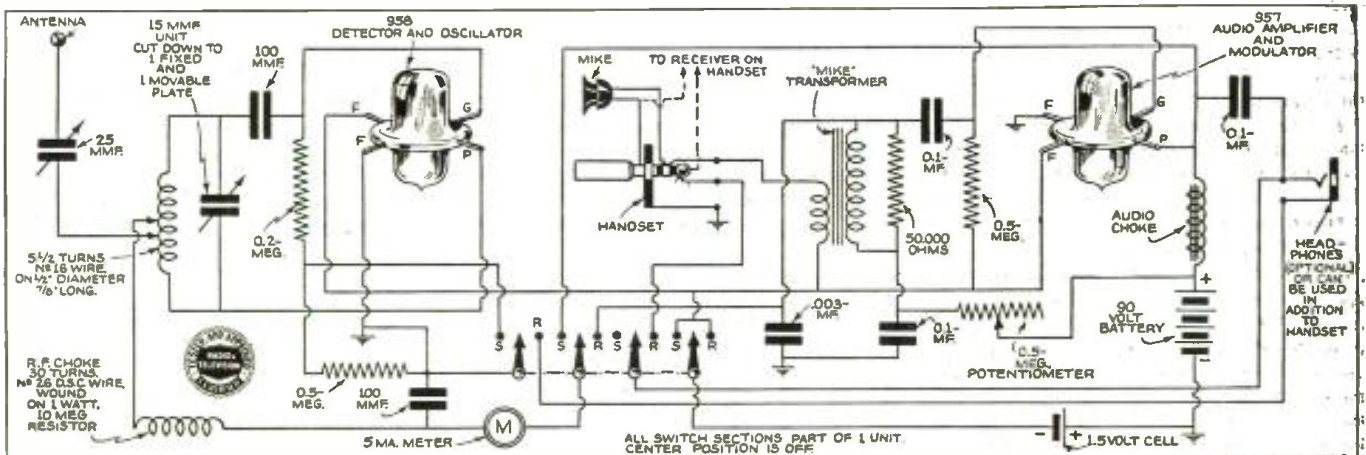

High-Quality

Transceiver

Dozens of Uses For It

Howard G. McEntee, W2FHP



Rear view of the Acorn 2 1/2-meter Transceiver. The batteries are sufficiently large to provide worthwhile service.

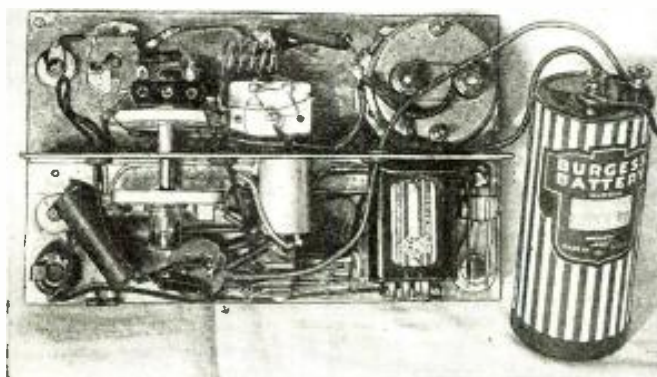

sible tubes for the purpose are necessary.

In the *transceiver* to be described, a 958 is used as the detector and oscillator and a 957 as audio amplifier and modulator. The oscillator is a simple single-coil type, while the audio system is one which was quite popular in 5-meter transceiver work, and is particularly interesting since an ordinary mike transformer and audio choke are used, eliminating the need for the usual three-winding coupling transformer.

A single four-pole double-throw switch takes care of all change-over operations, and also acts as an ON-OFF switch.

Handset or Pair of Phones Can Be Used

A close study of the circuit will show that either a handset or a pair of headphones may be used for receiving, or *both* may be used together if desired. When the switch is in "SEND" position, both phone circuits are opened to conserve audio power. Even though these circuits are opened, however, the voice may still be heard well enough for monitoring purposes, due to stray circuit capacities.

The handset uses a three circuit plug; one lead of the receiver and one of the microphone are common. If another microphone with the ordinary two-circuit plug is to be used, the plug is inserted in the handset jack so that only the first spring of the latter is contacted.

The smallest possible parts are used throughout to conserve space. The batteries are not the smallest available, but are very compact and give surprisingly long service.

Details of Home-Made Case

The case is made entirely of 3/16" tempered pressed-wood which is fastened at

the corners with duco cement and small wood screws carefully tapped in place. The screws serve mainly to hold the parts in place while the cement is drying.

The back is removable to facilitate battery changes, and the front panel is hinged at the bottom so that the coil and antenna tap may be easily reached. Two thumb-screws at the top corners of the panel are removed to allow the latter to swing outward.

After the case has been made and all sides sanded, it is given two coats of clear lacquer with a sanding between. The surface is rubbed with powdered pumice after the second coat and then given a good rub-down with furniture wax. This gives a very tough, smooth surface.

In addition to those on the panel, many of the parts are mounted on a sub-base or chassis of aluminum. This is mounted just high enough so that the lugs of the audio choke do not touch the inside of the case.

The tuning condenser is fastened to the chassis by means of a small bracket and the two tube sockets are both mounted with a single pair of long screws which pass through the chassis.

Placement of other parts may be seen from the photos. If any parts of different make are substituted for those listed, it may be necessary to alter the layout or change the size of the case. Should such alteration be made, be sure all parts will go in the space allowed before constructing the case.

The coil is wound as specified on the circuit, while the R.F. choke is made by winding 30 turns of No. 26 D.S.C. wire on a one-watt insulated resistor. It is supported by pigtails.

The antenna usually employed with the
(Continued on page 244)

They Stay QUIET!

Three great engineering features make IRC Controls PERMANENTLY QUIET, DEPENDABLE, RUGGED. All three were pioneered and perfected by IRC. They are available ONLY in IRC Type CS Volume and Tone Controls. Each one involves more painstaking, more costly manufacture . . . yet you buy IRC Controls at ordinary control prices.

FREE: If you haven't already received your copy of the NEW IRC GUIDE (Edition No. 2) ask your jobber today. The finest, most complete GUIDE ever published. Includes the new IRC Wire Wound Controls, the new IRC Midget Controls and the new IRC universal shafts that save you time and money. Don't miss it!

METALLIZED RESISTANCE ELEMENT

The ideal surface for amazingly quiet contact. You can actually feel the difference when you turn the knob.

SILENT SPIRAL (POSITIVE) CONNECTOR

Metal-to-metal, sliding contact between rotor arm and end terminal is eliminated. Noise hasn't a chance.

5-FINGER "KNEE-ACTION" CONTACT

Each contactor acts independently. Each tracks smoothly and in perfect unison with a cushioned "knee action" effect.

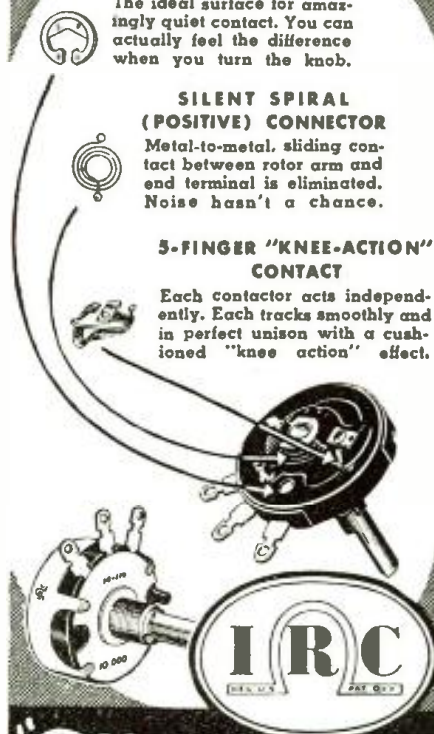

IRC
INTERNATIONAL RESISTANCE CO
401 N. Broad St., Phila., Pa.

"Metallized" CONTROLS

Question Box

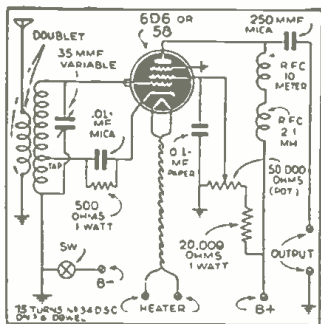

Hook-up of 1 tube Pre-Selector Circuit; Plug-in coils cover all bands. No. 1190.

bands as requested. The unit makes use of a 6D6 tube or one similar, with cathode regeneration and screen grid voltage control of regeneration. The grid is tuned to the desired signal and a slight amount of regeneration is introduced by tapping the cathode $\frac{1}{4}$ to $\frac{3}{4}$ of a turn from the grounded end of the coil in the tuned circuit. A potentiometer varies the screen voltage from zero to approximately 100 volts, thus smooth control of regeneration and volume is available. A very important feature of this unit is the variable antenna coupling system which can be adjusted to suit various conditions and receiving antennas. Should a strong signal be bothersome, a mere turn of the antenna coupling primary coil will bring in the desired weak signal.

The coils are wound on 4-prong plug-in coil forms. The grid end is at the bottom and the ground end at the top. This method minimizes capacity coupling to the grid of the R.F. tube.

For 160 meters	80 turns No. 30 enameled wire close-wound with tap $\frac{3}{4}$ of a turn from ground end.
For 80 meters	40 turns No. 24 DSC wire close-wound with tap at $\frac{1}{2}$ turn.
For 40 meters	23 turns No. 18 DSC wire close-wound with tap at $\frac{1}{4}$ or $\frac{1}{2}$ turn.
For 20 meters	12 turns No. 18 DSC space wound to cover $1\frac{1}{4}$ inches of winding length with cathode tap at $\frac{1}{4}$ turn.
For 10 meters	5 turns No. 18 DSC space-wound to cover 1 inch with tap at $\frac{1}{4}$ turn.

With loose antenna coupling the R.F. pre-selector should oscillate when the regeneration control is turned toward the higher screen voltage.

2½ Meter Transceiver

? I intend to construct a 2½ meter transceiver, battery operated for use in our summer camp. If possible, could you supply a diagram with the needed data for its construction? K. L. Peters, Nyack, N. Y.

A. In the July "Question Box" is shown a diagram with complete data for just such a unit. Write to our circulation department for a copy of that issue. Also see page 226 this issue.

Data on U.H.F. Transmitters

? Being a recent owner of an ultra-high frequency receiver, I heard two stations, the location of which I would like to know. They are W2XUP and W2XDV. C. M. Belittle, Brooklyn, N. Y.

A fee of 25c (stamps, coin or money order) is charged for letters that are answered by mail. This fee includes only hand-drawn schematics. We cannot furnish full-size working drawings or picture layouts. Letters not accompanied by 25c will be answered on this page. Questions involving considerable research will be quoted upon request. Names and addresses should be clearly printed on each letter.

Data on Pre-Selector

? I would like to construct a regenerative pre-selector to be used with my present receiver and one which would take in the 160, 80, 40, 20 and 10 meter bands. Can you publish a diagram of such a unit with complete constructional data?—L. K. Kelly, San Francisco, Cal.

A. Here is a diagram with complete technical data on an R.F. regenerative pre-selector designed to cover most of the

A. W2XUP is the experimental facsimile transmitter of WOR located atop 1440 Broadway in N. Y. City. It operates on a frequency of 25.7 megacycles and is on the air with daily transmissions from 4 to 6 p.m. W2XDV is a general experimental station and is located atop 485 Madison Ave. It broadcasts CBS network programs from 5 to 9 p.m. daily and operates on a frequency of 31.6 megacycles.

Principle of Facsimile

? Can you advise one of your ardent readers what the principles of facsimile broadcasting are and can a recorder be had to operate from the D.C. lines?—Larry Hamsley, New York City.

A. The principle of facsimile broadcasting is briefly as follows: The material to be transmitted is "scanned" much as the human eye scans a page of reading matter, at a rate of 100 lines to an inch, and one inch per minute, by a minute spot of light, which registers light, dark or medium impulses upon a photo-electric cell. These impulses are transmitted by radio to this "printer-receiver." Here an arm, exactly synchronized with the scanner and equipped with a stylus, moves over a special paper. A dark impulse will press down the stylus, bringing through a black impression, a light impulse will leave the paper its natural color, and the medium impulses will bring out varying shades of grey. In this way, an exact facsimile of the original transmitted material is built up line by line. Listeners operating from farm lighting plants or batteries or direct current may receive copy with equal facility as their city cousins.

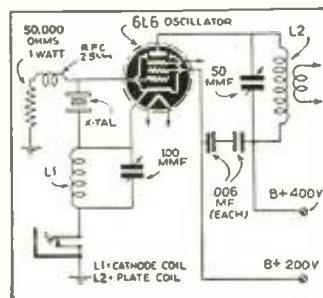

A crystal-controlled 6L6 oscillator circuit for Transmitter. No. 1191.

6L6 Oscillator

? I plan to rebuild my transmitter and, in place of using a 42 or 59, intend using the 6L6. Can you show by diagram a circuit for such a tube when used as an oscillator? K. Kitey, Detroit, Mich.

A. The 6L6 makes a far more effective oscillator than either the 42 or 59 type tubes. The actual cathode tuning capacity should be at least 100 mmf. for high output and moderate crystal current. Too

low capacity in this circuit will often result in fractured crystals.

The cathode circuit is tuned to a frequency about 50% higher than that of the crystal in the triode section and the system oscillates at the crystal frequency. The large tuning condenser in the cathode provides a cathode by-pass condenser for the second harmonic to which the plate circuit is correctly tuned with low C-to-L ratio in its tuned circuit.

6L6 Coil Data

All coils wound on 1½-inch diameter forms.

	L2	L1	Crystal
80 meters	38 turns No. 18 enam. close wound	25 turns No. 22 DSC 1½ inches long	160 meters
40 meters	20 turns No. 18 enam. 1½ inches long	12 turns No. 18 enam. 1½ inches long	80 meters
20 meters	9 turns No. 18 enam. 1¼ inches long	7 turns No. 18 enam. same	40 meters

Adding Switch

? Would you recommend the use of a switch in my television so that I could receive the sound program only when I am not interested in the vision end of it?—Jack MacGregor, Tulsa, Okla.

A. Yes this can be done very easily and economically. However, if one is not familiar with television receivers it would be best to have a serviceman do the job. Such a switch should be placed in the part of the 110 volt line leading to the primary of the high voltage transformer. Or just turn "brightness control" down.

Beyond the Last Wave Bands

Dr. D. L. Webster

(Continued from page 197)

vision also spread around obstacles to some extent, though not so well around big ones.

Even light, in fact, spreads around obstacles if they are small enough; but exactly as with radio waves, the size of the obstacle must not be too great in comparison with the wavelength. This sort of spreading of light waves is indeed the evidence from which we calculate their wavelengths; but we do not notice the spreading unless we look for it very carefully or with nearly microscopic obstacles.

For our present purpose, however, it means this: *The shorter you make the wavelength, the less the waves will spread around any given obstacle.*

At first sight, this fact might look like an argument against using very short waves. And it is, indeed, a definite reason for not using them for ordinary broadcasting, where most of us are so located that the only waves we can receive are those which have spread around hills or houses. But for other uses, very short waves are exactly what we want.

One such use, in which these waves have just recently been tested for the first time, is for *landing airplanes in a fog*. When the pilot of an airplane can see the ground, light waves received by his own eyes are his best guides into the airport. But when the fog rolls in, the next best guides are the radio waves that most closely resemble light and yet penetrate fog. Fortunately, radio waves do penetrate fog and rain when they have any wavelength down to about 5 centimeters, or 2 inches. The shortest of these fog-penetrating waves are still quite different from light, but their wavelength is short enough so that they go almost as straight past some obstacles just not too big to handle. Such waves, therefore, can be sent out almost like the light from a searchlight. In this way they can mark out a straight line inclined slightly upward from the airport, and a pilot receiving these waves can use this line to steer his plane home through any fog.

Receiving these waves! That is good—but possible only when there are such waves to be received, and practical only when the messages carried by these waves can be understood quickly. Strange to say, the means for quick understanding was invented before the means for sending and receiving the waves.

Irving R. Metcalf, of the Civil Aeronautics Authority, a few years ago, realized that such waves would be the only solution of the problem of *blind landing*, and felt sure that somebody would invent means for sending and receiving them; but he also realized that if the pilot had to read several instruments at once, and translate their figures into knowledge of his position, it would be very difficult for him to act quickly enough for safety when close to the ground. It would be much better, Metcalf thought, if we could have the radio waves make the instruments project a sort of moving picture of the airport, so that the pilot could watch the picture and imagine himself looking right through the fog at the airport itself. So Metcalf devised a very ingenious arrangement of lights on the field, to be represented in such a movie; and research workers at Massachusetts Institute of Technology, led by Professor E. L. Bowles, discovered a way to make the instruments really show the movie—provided they had the ultra-short radio waves to tell the instruments what to show. All was ready but the waves.

Other aviators also had faith in ultra-

HELP! YOU HAVE SWAMPED US

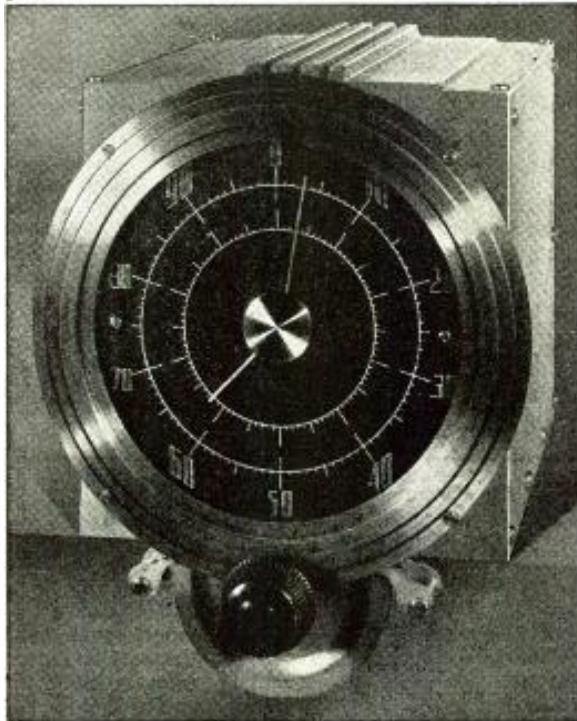

MODEL RX-18—ALL WAVE TUNING ASSEMBLY
NO GANGSWITCH—NO PADDING CONDENSERS
PLUG-IN COIL EFFICIENCY—PATENT PENDING

U. S. RADIO PRODUCTS, INC.

16710 NINE MILE ROAD

Not so long ago, we announced an ALL-WAVE TUNING ASSEMBLY completely eliminating the gang-switch.

We had expected this to make a stir, but we were not prepared for the volume of orders and inquiries that poured into our hands.

At present, we are engaged with the designing and engineering of several types of gang-switchless tuners and other new inventions which will be manufactured by our organization.

As soon as our new and enlarged production facilities are completed, we will, through the medium of the popular radio publications, announce for sale and have available for immediate delivery a complete line of our new products.

We thank you for the tremendous response and interest you have shown us, which was little less than spectacular.

Cordially yours,

Pierre P. Pattyn, Pres.

short waves, among them Captain Sigurd F. Varian of Pan-American Airways. Looking for a source of such waves, he inquired of his brother, Russell H. Varian, a television engineer and a graduate of Stanford University.

Meanwhile, at Stanford University, Professor William W. Hansen had been interested in a wholly different problem, that of smashing atoms by extremely high voltages, as a purely scientific research, with no idea of direct application. In this research, a part of his apparatus was an electrical resonant circuit of a new type, having an unprecedentedly high efficiency, which he had discovered and had named the *Rhumbatron*. The Varian brothers, hearing of Hansen's Rhumbatron, saw in it a prospect for the solution of their problem. There was as yet no means of using the Rhumbatron at the ultra-high frequencies required for ultra-short waves, but it looked hopeful. So they came to Stanford.

At Stanford, Russell Varian made a brilliant invention. He put to use a pair of little Rhumbatrons and some accessories in a new device which he called a "Klystron." This was first put into practical form by Sigurd Varian, and then it was developed further by the Varians and other research workers at Stanford. Coming to the attention of Metcalf and the research workers at Massachusetts Institute of Technology, the Klystron proved to be exactly what they wanted.

As a result of cordial cooperation in this research, at last a radio searchlight shot its invisible beam on an upward slope from a runway at Boston Airport, and an airplane far away picked up the beam and flew in on a straight line marked out by it.

Beyond the last wave bands, then, what we shall find is a different kind of radio, enabling us to do what could not be done before.

NOW READY!

Includes up to date technical information and illustrations on

TELEVISION



FOR HOME STUDY

TO WHAT EVERY RADIOMAN SHOULD KNOW

JUST PUBLISHED—1939

—All the latest information on the new developments in Radio & Television. Explains Repairs, Servicing & Building of Sets for pleasure or profit

—Easy to read & understand. Gives all the important phases of Modern Radio, Electricity & Sound. Handy reference guide. A Real Helpful, Easy Way to secure authentic data on Radio Troubles—Static Elimination—Broadcasting—Antennas—Electronic Television—Repairs—Service—Short Wave

—Auto Radio—Including Questions and Answers—34 chapters—72 Pages. Over 400 Diagrams & Illustrations, Handy Size, Sturdy Flexible Binding. A Good Investment for Servicemen—Experimenters—Electronic Television Students

—Aviation & Marine Radio Operators and all others. Get this practical information in handy form for yourself. Fill in and mail coupon today.

4 COMPLETE • PAY ONLY \$1 A MO.

THEO. AUDEL & CO., 49 West 23rd Street, New York
Mail AUDELS NEW RADIOMANS GUIDE for free examination. If O. K., I will send you \$1 in 7 days; then remit \$1 monthly until price of \$4 is paid. Otherwise, I will return it.

Name _____
Address _____
Occupation _____
Reference _____

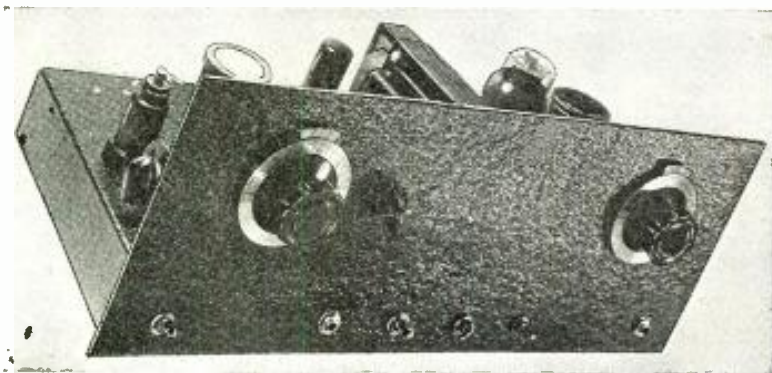

The beginner in Amateur Radio will find many good features in this 25-watt crystal-controlled CW Transmitter and 2-tube regenerative receiver. It is available in kit form and is simple to assemble.

Front view of Transmitter-Receiver, which will interest every beginner in the Amateur Radio Game.

D. L. Warner
W9IBC

Xmitter-Receiver for the HAM Beginner

● THIS kit has been designed to provide the Ham beginner with one complete unit consisting of a two-tube Autodyne regenerative receiver, a 25-watt crystal-controlled CW transmitter, and one power-supply which will operate either the receiver or transmitter unit. All three sections are built on one metal chassis and panel, providing a compact unit which is, in itself, a complete amateur station, requiring no accessories other than an antenna, a pair of headphones, and a transmitting key.

In assembling the various parts on the chassis and panel, it is important that you follow a definite method of assembly in order to secure the best operating performance from the completed unit. First mount the front panel on the chassis by inserting the various switches and jacks through the proper

holes in the chassis and through the front panel. When these units are tight in place, they will securely hold the front panel to the chassis.

The next operation is to mount all tube sockets on the metal chassis, and then, turning the unit right side up, mount the various receiver parts such as the tuning condenser, etc., on the top of the metal chassis and on the front panel. Then mount the power transformer and filter choke for the power supply section on top of the metal chassis in their proper positions, and follow that by mounting the tuning condenser for the transmitter section on the front panel in its proper place.

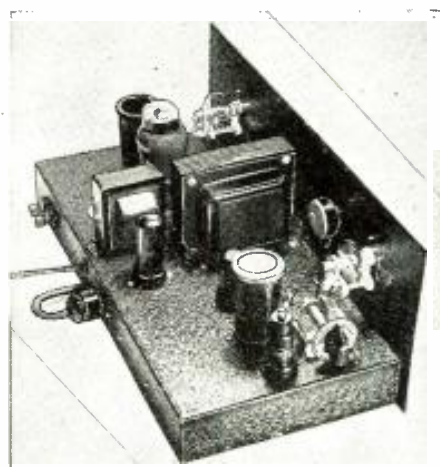

Rear view of Transmitter-Receiver.

Hook-up of Beginner's Transmitter-Receiver.

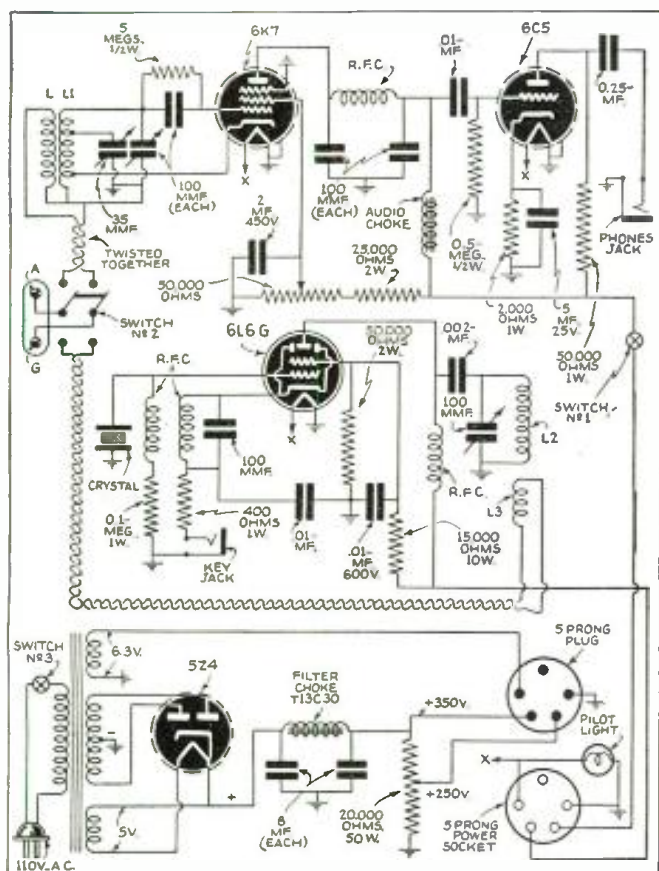

After all large parts have been mounted, you are ready to start the actual wiring. Refer to the photograph of the bottom of the unit, and carefully follow the placement of parts. You will find that many of the smaller parts may be mounted directly in position by means of their own wire pigtail leads. In wiring both receiver and transmitter sections keep all leads as short as possible, making all connections from point to point.

The *band-setting* condenser on the left end of the chassis just behind the front panel should be mounted by means of two of the small isolantite stand-off insulators which are supplied with the tube sockets. The small 2" bronze dial plate mounts directly on this band-setting condenser by means of the lock nut, which would ordinarily hold this condenser to the panel. This dial provides a convenient reference point when changing the receiver from one frequency band to another.

Note that all leads from the power-supply section go through the short piece of five-conductor cable and terminate in the five prong plug. This plug should then be inserted in the five prong socket at the rear of the chassis; filament and plate voltage leads for the receiver and transmitter circuit all come from this power socket.

If it is ever desired to operate this unit at points remote from the regular 110-volt A.C. power lines, the power cable plug can be pulled out of the power socket.

(Continued on page 241)

New HAM Licenses

COMPILED FROM THE LATEST RECORDS OF THE FEDERAL COMMUNICATIONS COMMISSION

THERE are now approximately 50,000 licensed radio amateurs in this country. And dozens of new amateurs are being licensed every month.

Heretofore no publication has listed the names and addresses of the new licensees as issued. RADIO & TELEVISION Magazine now provides this unique service, and publishes a list of newcomers in every issue. Check the names carefully so that you will be able to get in touch, not only with amateurs in your neighborhood and vicinity, but also with those distant amateurs whom you wish to contact either by mail or by radio.

This list contains 266 names of newly licensed amateurs. YLs' names appear in blackface type.

- | | | | |
|-------|--|-------|--|
| K6HOT | James E. Keefer, 475 Lau Kapu, Hilo, T. H. | W2NHA | Arthur M. Peterson, 167 Midland Ave., Grant, N. Y. |
| K6RNX | Teruo H. Arakaki, 1030 Akapahulu, Honolulu, T. H. | W2MHB | Everett J. Althoff, 98 22d St., Kenilworth, N. J. |
| K6RNZ | Kenneth N. Hanks, Waimanalo, Oahu, T. H. | W2MHC | Vincent S. Dembowske, 420 42d St., Brooklyn, N. Y. |
| K7HPL | Irene Schaeffer Smith, Tanana, Alaska. | W2MHD | Vester H. Thurmond, 320 W. 96th St., New York, N. Y. |
| W1AUE | Harry Olin Groves, 32 Hope Ave., Concord, N. H. | W2MHE | Frank V. Pacier, 140-54 Queens Blvd., Jamaica, L. I., N. Y. |
| W1BGF | Robert W. Kingman, Purchase St., S. Easton, Mass. | W2MHG | Herman W. Grissler, 64 Morgan Place, North Arlington, N. J. |
| W1MBI | Walter Wm. Knowles, Jr., 11 Pearl, Liverpool Falls, Me. | W2MHH | Joseph J. Jeransky, 72 Hallock, Farmingdale, L. I., N. Y. |
| W1MBS | Stanley F. Brigham, 63 Oriole, West Roxbury, Mass. | W2MHI | Gerald O'Brien, 71 Bayview Ave., Jersey City, N. J. |
| W1MBT | Eugene E. Camerlin, 50 Linden, Chicopee Falls, Mass. | W2MHJ | John R. Nelson, 6 Burnet, Maplewood, N. J. |
| W1MBU | Anthony Henry Cipolle, 2 McTurs Court, West Warwick, R. I. | W2MHK | Samuel G. Nelson, 6 Burnet, Maplewood, N. J. |
| W1MBV | Julian Hamilton, 245 Cabot St., Beverly, Mass. | W3DUG | William H. Guerrant, 927 Tazewell Ave., Roanoke, Va. |
| W1MBW | Donald A. Sturgeon, 59 Summer St., Bristol, Conn. | W3HY | John Nathan Boland, Mews Ferry, Va. |
| W1MEX | Francis E. Berry, 71 Aldie St., Boston, Mass. | W3IFB | Lawrence W. Bullock, Washington Blvd., Halethorpe, Md. |
| W1MBZ | William Henry Draidmond, Jr., 68 Eleanor, Chelsea, Mass. | W3IFD | John Jasper Kimball, 319 Tennessee Ave., Washington, D. C. |
| W1MCA | William O. Hamlin, 194 Plymouth, Stratford, Conn. | W3IFF | Marion Paschal Shorb, 319 13th St., S. E., Washington, D. C. |
| W1MCB | Harry H. Handfield, 13 Norton, Nashua, N. H. | W3IFI | Rudolph F. Brandt, 2913 Diamond St., Philadelphia, Pa. |
| W1MCC | William G. Knonos, 28 Eden, Salem, Mass. | W3IFJ | Robert W. Vernon, 1120-26th St., Newport News, Va. |
| W1MCD | Michael A. Limanni, 115 Garden, Lawrence, Mass. | W3IFK | Alvan S. Goodman, 1610 N. Payson St., Baltimore, Md. |
| W1MCE | Paul M. Erdson, M.I.T. Dormitories, Cambridge, Mass. | W3IFL | Jiles W. Collins, Main St., Marion, Va. |
| W1MCF | Albert H. LaFleur, Camp S-82, W. Townsend, Mass. | W3ZZZ | Roland O. S. Akre, Saxis, Va. |
| W1MCG | Edward R. Potacchiola, 5 Elston, Somerville, Mass. | W4BLV | John J. Ross, 201 Green, Robersonville, N. C. |
| W1MCI | Frank G. Boston, 211 Roslindale Ave., Roslindale, Mass. | W4GCQ | Robert Boyd Wilds, 605 E. Walnut St., Decatur, Ala. |
| W1MCJ | Robert E. Prigger, 277 Pine St., South Weymouth, Mass. | W4GCU | Richard Gould Bullock, 118 Turtle Ave., Bennington, Ala. |
| W1MCK | James E. Farley, 39 Plummer Ave., Lowell, Mass. | W4GCV | Julius T. Weidlich, 1936 North 10th Ave., Pensacola, Fla. |
| W1MCL | Edward J. Rice, 19 Willow, Whitinsville, Mass. | W4GCW | Newell E. McCombs, New Airlaid Mt., 1 mile N. of Easley, S. C. |
| W1MCM | Forrest J. Rye, 8 1/2 Stark Ave., Dover, N. H. | W4GCX | Howard H. Rowe, 315 S. E. 5th Ave., Ft. Lauderdale, Fla. |
| W1MCN | Robert W. Greene, 110 Laura, Providence, R. I. | W4GCV | Leslie E. Thompson, 17 S. Catherine St., Mobile, Ala. |
| W1MCO | Douglas H. Hickox, 189 W. Center, Manchester, Conn. | W4GCZ | George E. Myrick, 1461 Brown St., Mobile, Ala. |
| W2BKO | Emil J. Sibi, 265 New York Ave., Union City, N. J. | W4GDD | Samuel T. Davenport, 800-17th, Phenix City, Ala. |
| W2LEX | Willard I. Rogers, 137 Kensington Ave., Jersey City, N. J. | W4GDC | Earl C. Pritchard, 303 Woodland Ave., Homewood, Ala. |
| W2IYX | Fred John Kienzle, 15 Ridgewood Place, Brooklyn, N. Y. | W4GDF | Heber R. Adams, 14th and Glen Arthur, Greenville, N. C. |
| W2MGF | Richard Allen Jensen, 69 Kempton Place, Metuchen, N. J. | W4GDI | Lawrence E. Victor, 1320 S. Oak, Memphis, Tenn. |
| W2MGI | Edward M. Coan, 76 Elm St., Montclair, N. J. | W4GDH | Robert W. Townsley, 324 N. Willett, Memphis, Tenn. |
| W2MGJ | Rudolph John Brossmann, 291 Wardwell Ave., Westerleigh, L. I., N. Y. | W4GDJ | John W. Goodwin, 404 N. Appletree, Dothan, Ala. |
| W2MGK | Paul Joseph Barczik, 769 Park Ave., Brooklyn, N. Y. | W4GDK | James R. Garner, 407 W. Washington, Dothan, Ala. |
| W2MGL | Milton J. Schreiber, 806 Pennington St., Elizabeth, N. J. | W4GDL | Stanley D. Stearns, 77 N. W. 48th St., Miami, Fla. |
| W2MGM | Robert E. Lee, 640 W. 139th St., New York, N. Y. | W4GDM | Donald H. Drennan, 828 Forrest Rd., Columbus, Ga. |
| W2MGN | Charles Spreman, 9430 54th Ave., Elmhurst, L. I., N. Y. | W4GDN | Johnnie R. Edmondson, Robersonville, N. C. |
| W2MGO | Victor F. Suel, 401 E. 71st, New York, N. Y. | W4GDO | James C. Handey, 410 LeBron Ave., Montgomery, Ala. |
| W2MGP | George Shaler, 2332 E. 19th St., Brooklyn, N. Y. | W4GDP | William H. Small, 190 N. Oak, Bartow, Fla. |
| W2MGS | Andrew Mehalko, Oceanport Ave., Oceanport, N. J. | W4GDQ | Alvin F. Badgett, 1820 Highland, Knoxville, Tenn. |
| W2MGT | Leo P. George, 1717 78th St., Brooklyn, N. Y. | W4GDR | Claude V. Holland, Teachey's, N. C. |
| W2MGU | Douglas J. Johnson, 526 W. 133d St., New York, N. Y. | W4GDS | Samuel F. Hubbard, 2269 York St., Memphis, Tenn. |
| W2MGV | Charles P. Stenger, 116 Gotham Ave., Brooklyn, N. Y. | W4GDT | Joseph W. LeFrangé, 2780 Mt. Brook Parkway, Birmingham, Ala. |
| W2MGW | John F. Ulfet, 25 Elizabeth Ave., Cranford, N. J. | W5AAZ | John G. Clark, 126 Main, Uvalde, Tex. |
| W2MGX | Louis Weber, 256 Snediker Ave., Brooklyn, N. Y. | W5BCZ | Jewel Lee Sikes, R. F. D. No. 3, Little Rock, Ark. |
| W2MGZ | Kenneth Everhart, 3613 Ave. D, Brooklyn, N. Y. | | |

(Continued on page 233)

NEW



all
about

Television

Set Builders, Experimenters, Students, Service Men—here is a book as new as the transmitter on the Chrysler Building in New York. EVERYTHING YOU WANT TO KNOW in one handy book. Hot off the press. Contains latest developments in television. Written by M. B. Sleeper, active in television since the industry started. DON'T MISS THIS BOOK.

Transmitting, Building Installing, Servicing

Inside information by an insider. Clear, understandable. Unusual photographs, 5 BIG Diagrams of set assembly stages. Step-by-step instructions. A complete "dictionary" of television terms. 7 Sections cover Development of Television, Transmission, How and Why of Receivers, Building a Receiver, Erecting Antenna, Operation and Installation, Trouble Shooting.

More Than 100 Special Illustrations

"Action" photographs that show you how and why. Printed on special paper for clarity. Instructions you can follow. Plain enough for the beginner—accurate enough for the expert. If Television interests you—get this book. Special circular sent on request.

Get Your Copy NOW Send NO Money

Now—this second—order your copy. It will be sent prepaid on receipt of your dollar. Or, address a penny post card saying "send Look and Listen C.O.D." Your copy will go forward at once. Satisfaction guaranteed. This book may be worth hundreds of dollars to you. Yet it costs you only one dollar and you needn't even send this now. Don't wait. Don't put it off. Get your postcard or letter with your dollar mailed TODAY to NORMAN R. HENLEY PUBLISHING COMPANY, 2 West 45th Street, New York, N. Y.

only
1.00

BUILD A LOW COST STANDARD

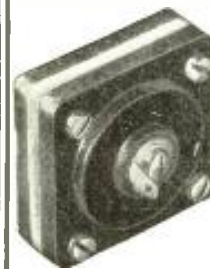

With a Biley SMC-100 Dual Frequency Crystal Unit you can easily build an accurate frequency standard for performing frequency measurements and aligning radio receivers. Bulletin E7 (free) gives full details. Write for copy.

**BILEY
ELECTRIC CO.
ERIE, PA.**

SEE PAGES 242 AND 249 FOR
SPECIAL SUBSCRIPTION OFFERS!

NEWEST RADIO APPARATUS

Receiver with B.C. and 13 to 49 Meter S-W Range

● AVAILABLE in two models, the new RCA Victor de luxe table model radios housed in an ultra-modern style molded plastic cabinet and provides domestic, foreign, police, aviation, and amateur reception. Incorporating radically new circuit design, this powerful instrument has exceptionally high sensitivity and combines outstanding performance with distinctive appearance. Other features include 5" high-sensitivity electro-dynamic



loudspeaker; vernier tuning; edge-lighted, angle-vision, straight-line dial. Tuning range is 540-1720, 2300-7000, 7000-22,000 kcs., providing domestic broadcasts and foreign short-wave reception on the 49-, 40-, 31-, 25-, 19-, 16- and 13-meter bands, plus police, aviation and amateur calls. This set is available in two colors—mottled brown and ivory.

Paper-Wound Replacements for Electrolytics

● TO meet the occasional demand for paper-wound replacements for metal-can and cardboard-case dry electrolytics, two new condensers have been announced by Aerovox Corporation. The PWC series, matching in size and shape the dry electrolytic metal-can condensers, is available

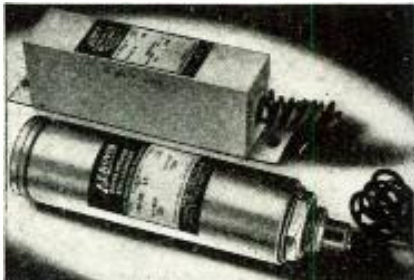

in three types replacing the 4-600, 8-600 and 8-8-600 electrolytics, with actual capacities of 2.0, 2.75, and 1.75-1.75 mf., respectively. The PWP series matches the cardboard-case dry electrolytics of 4-600, 8-600 and 8-8-600, with actual capacities of 2.0, 3.0, and 2.75-2.75 mf. These paper replacement units have extremely low power factor and leakage. No polarity need be observed.

Visual Freq. Meter

● AN amateur Visual Frequency monitor and deviation meter has been recently announced by the Browning Laboratories. It is so designed that amateur bands are spread over approximately 240 degrees on a 5 1/2" laboratory type dial calibrated in megacycles. The circuit devised makes it possible to check various points in each amateur band against WWV's frequency. An electric eye is used as an accurate zero beat indicator. This frequency monitor can be set to a precision of at least two parts in 70,000.



Records Sound on Film

● AN ideal device for the man who wishes to keep a permanent record of all DX work or QSO's, is the model BBA Filmgraph. This ingenious apparatus records sound on 16 mm. motion picture film. The film may be old exposed film, or any other inexpensive film, as the recording is done by engraving the sound track into the film mechanically, rather than by optical means. As the impressions are made on the side of the groove, several hundred playbacks may be had with each recording.

The sturdily constructed recording head makes use of a sapphire stylus, the same head and stylus being used for both recording and playback. The head has an impedance of 500 ohms and can be matched to any radio receiver by using a standard adapter. A special adapter is available to permit wireless linkage between the filmgraph and the receiver. The magazine is provided with feeding and take-up arms to accommodate all sizes of reels up to 2000 feet of film. Twenty-eight sound tracks may be indented across the width of 16 mm. film and each track will take four minutes of recording and playback on 100 feet of film. In other words, a 100-foot length of film will provide 112 minutes (or about 1 3/4 hours) of recording and playback. As no dark room or processing is required, playback may be immediate. Model BBA includes amplifier, speaker and microphone.

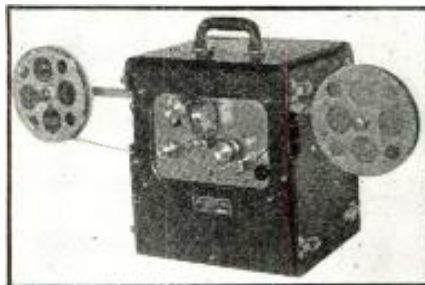

Latest "Filmgraph" recorder.

There are also various other models for both 16 mm. and 8 mm. film. The model BBA illustrated and described here has a sprocketless drive to insure flutterless operation. In fact, film without sprocket holes may be used in this machine.

Paper Replacements for Dry Electrolytics

● TO meet the demand for paper condensers of the same sizes and shapes as dry electrolytics, Simon Products Company has introduced Type DR canners, can type units, and Type RP rectangular cardboard container condensers. Actual capacities are from one-third to one-half those of dry electrolytics in the same size container. Leakage and power factor are extremely low, and no polarity has to be observed. Thus, the new paper units are unexcelled as dry electrolytic replacements in high voltage P.A. systems, power amplifiers, high voltage filter circuits, etc.

Types DR (inverted can types) are available in four capacities, 4, 8, dual 4-4 and dual 8-8 mf. Cardboard Type RP is supplied in two capacities, 8 mfd. and 8-8 mf. All are conservatively rated at 600 volts, working voltage.



Television Dipole

● A NEW dipole type television antenna has just been announced by Consolidated Wire & Associated Corps. It has two telescoping brass rods (shown in the closed position) which allow for adjustment to the exact frequency to be picked up by the television receiver. An especially designed,

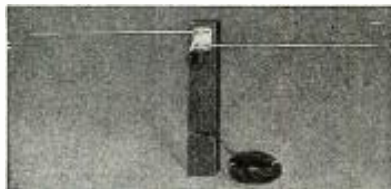

low loss, transmission line is used, the impedance of which will match the input of every television receiver (approximately 100 ohms). The unit comes with 75 feet of transmission line.

New Midget Controls Have Universal Shafts

● MIDGET Controls with metallized type resistance elements and exclusive construction features heretofore available only in the larger Standard Controls have been announced by the International Resistance Co. Known as IRC Type D Midgets, the new controls are designed to accommodate two types of plug-in shafts.

Among the exclusive features included in Type D Controls are the spiral spring connector which

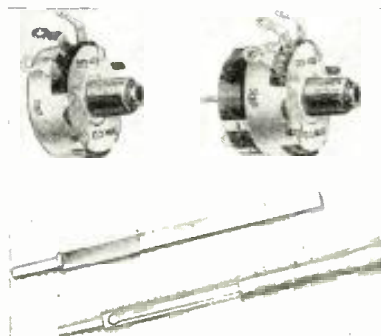

eliminates wiping, metal-to-metal contact between rotor arm and center terminal; the 5-finger "knee action" silent element contactor and a special steel coil spring on the shaft used as a thrust washer to eliminate end-play.

Plug-in Shaft "A", which is packed with each Type D control is designed for use where definite flat location is necessary. Shaft "B", which must be ordered separately, is for use where either a slotted or tongued shaft is required.

New All-Purpose Tester

● THE new Simpson "Hammer" measures only 5 1/2" x 2 1/4" x 1 3/4" and weighs but 20 ounces. A 3,000 volt self-contained unit using no external multipliers, it is completely encased in bakelite and its test cables are insulated for 5,000 volts which makes it safe to use on amateur apparatus, transmitters and television sets. The ranges provided by the instrument are: 0-15 - 150 - 750 - 3000 volts, A.C.; 0-15-75-300 - 750 - 3000 volts, D.C.; 0-15 - 150 - 750 ma. D.C.; and 0-3000 - 300,000 ohms. The resistance of the meter is 1000 ohms per volt for both the A.C. and D.C. scales—a valuable feature when testing circuits where but little current is drawn. The meter used is a Simpson D'Arsonval movement with bridge type construction and soft iron pole-pieces. A copper oxide rectifier is built into the meter for A.C. voltage ranges and a battery is provided for both ohmmeter scales. The unit may be used as an output meter if an external condenser is used in series with the A.C. voltage ranges.



New Xmtr Coils

● BUD RADIO, Inc., is producing a new small air-wound coil for use in transmitters. This oscillator and buffer coil is designed for all sets with inputs of 50 watts or less, from 5 to 160 meters. The ceramic base is highly glazed and is designed to keep the coil a reasonable distance from the chassis. Coil spacing is maintained permanently accurate by means of acetate locking strips. These coils are available in center-linked and tapped models and end-linked untapped models.



(Continued on page 249)

New HAM Licenses

(Continued from page 231)

W5FO Fred W. Harris, 44 E. Main, West Point, Miss.	W6RNV George J. Rogers, 1244 Calif. St., San Francisco, Calif.
W5IDC Robert R. Brown, 301 Virginia Ave., McComb, Miss.	W6RNW Robert E. Alleman, 1904 Newport Blvd., Costa Mesa, Calif.
W5IDE John E. W. Spencer, 1733 N. 11th St., Abilene, Tex.	W6ROA Charles J. Leipert, 912 Kacawa St., Pacific Palisades, Calif.
W5IDF Anne S. Duthie, 211 Upson Ave., El Paso, Tex.	W6ROB Albert W. Morris, 560 N. State St., Sandy, Utah.
W5IDG John S. Hollis, 611 College Ave., Lafayette, La.	W7EDJ Casper Joe Trescl, 109 5th West St., Roundup, Mont.
W5IDI Ernest C. Cline, 4767 Tulsa Ave., Shreveport, La.	W7FMC Spencer D. Collins, Room 418, Y.M.C.A., Spokane, Wash.
W5IDJ William F. Knebel, 932 Esplanade Ave., New Orleans, La.	W7HOZ Earl M. Wilton, 116 N. 36th St., Billings, Mont.
W5IDK Jesse M. Hilton, Rt. 1, Jonesboro Rd., West Monroe, La.	W7HPI William E. Clyne, 3815 S. E. 28th Ave., Portland, Ore.
W5IDL Julian Gilliam, Highway No. 1, North Forrest City, Ark.	W7HPJ Allon H. Walsh, Race Lowrey St., Port Angeles, Wash.
W5IDM William V. Taylor, 216 E. "J," Russellville, Ark.	W7HPK Harley A. Payne, 1202 N. 42d St., Seattle, Wash.
W5IDN Robert S. Bond, 1745 N. 5th, Abilene, Tex.	W7HPM Dale G. Buffington, 634 S. 1st, Douglas, Wyo.
W5IDO Joseph Caltagirone, 1222 Garland, Texarkana, Ark.	W7HPM James R. Carper, 524 S. Ferrall St., Spokane, Wash.
W5IDQ Raymond L. Stinnett, 1221 Commerce, Little Rock, Ark.	W7HPO Robert D. Church, 1713 2nd Ave., Orchard Ave., Spokane, Wash.
W5IDR Owen B. Harvey, 2207-10th, Lubbock, Tex.	W7HPP George R. Dickinson, 3044 Dillon Ave., Cheyenne, Wyo.
W5IDX James D. Horney, 2601 County Ave., Texarkana, Ark.	W7HPQ Roger O. Loken, 903 W. 62d, Seattle, Wash.
W5IDT Madison K. Kuykendall, Crockett Rd., Harlingen, Tex.	W7HPR Eldred K. Reid, 1101 State, Chehalis, Wash.
W5IDU Reb M. Scoggins, Jr., 208 N. Vale, Jefferson, Tex.	W7HPT John R. Hall, 7923 N. E. Glisan, Portland, Ore.
W5IDV Jack S. Smith, Marks, Miss.	W7HPU Harold L. Kiesel, 1721 S. 54th, Tacoma, Wash.
W5IDX Cleotis L. Carwile, 3522 Clifton St., El Paso, Tex.	W7HRH Robert A. Gregory, R. F. D. 2, Emmet, Idaho.
W5IDY Charles D. Catt, 3016 Wheeling, El Paso, Tex.	W8AUK Charles M. Kugel, 2422 E. 74th St., Chicago, Ill.
W5IDZ Cecil Miller, 1012 C. St., S. E., Ardmore, Okla.	WBCRY George Roger Gardner, 1474 Wagar Ave., Lakewood, O.
W6BFD James H. Haughawout, 2229 N. Laurel Ave., Phoenix, Ariz.	W8DFC Owens A. Hutcheson, 902 Straley Ave., Princeton, W. Va.
W6BXN Ernest Howard Hale, Trustee, Turlock Amateur Radio Club, Radio Ave., 200 ft. off West Main, Turlock, Calif.	W8GKA Robert Henry Geresiman, Montville, O.
W6ET Alan N. Cormack, 5461 Encino Ave., Encino, Calif.	W8KJD George J. Klettke, 4319 Archwood Ave., Cleveland, O.
W6HJM Mike Milkis, 2710 Pomeroy Ave., Los Angeles, Calif.	W8KW Edwin C. Miller, 236 Boston, Buffalo, N. Y.
W6QAL James F. C. Robertson, 636 Bush St., San Francisco, Calif.	W8NZA John C. Mundorff, 248 Donner Rd., North Canton, O.
W6RKZ Byron L. Hatherell, 6178 Rockridge Blvd. S., Oakland, Calif.	W8PHS Virgil M. Brotton, 309 Dorceter, Ashland, O.
W6RMC Bruce Raymond Hansen, 1305 Arthur, Fresno, Calif.	W8TLO Harold Marshall Gruener, 2099 Martindale Rd., Cleveland Heights, O.
W6RMD Warren Pinkney Henderson, Jr., 670 Pettis Ave., Mountain View, Calif.	W8TLP John Havula, 3583 E. 105, Cleveland, O.
W6RML Julius Aluisi, 707 Pottle, Fresno, Calif.	W8TMC John Bretelson, 3113 W. 92nd St., Cleveland, O.
W6RMM Ronald Louis Bothna, 738 Richmond St., El Centro, Calif.	W8TMD Hal F. Foyer, 1645 Robinwood Ave., Lakewood, O.
W6RMN Howard M. Beck, 4434 Lockwood Ave., Los Angeles, Calif.	W8TME Harry B. Gerts, 3306 Bosworth Rd., Cleveland, O.
W6RMO Robert C. Brain, 1328-18th St., San Francisco, Calif.	W8TMF Albert Chester Bassett, 1058 Lima Drive, Cleveland, O.
W6RMP Richard William Graham, 1117 33d St., Sacramento, Calif.	W8TMG Fred Wayne Bratten, 612-4th S. W., Canton, O.
W6RMS Richard L. Hayes, 6300 1/2 Pasadena Ave., Los Angeles, Calif.	W8TMH Thomas Charles Groat, 1670 Chandler, Lincoln Park, Mich.
W6RMU Harold C. Lakes, 1517 1/2 11th St., Santa Monica, Calif.	W8TMK Thomas Burns, 215 Perry Pl., Wyandotte, Mich.
W6RMW Lloyd L. Roe, 5720 S. Manhattan Pl., Los Angeles, Calif.	W8TML Cleo Allen Briley, 820 Lansing, Detroit, Mich.
W6RMX Verdis J. Deacon, 2028 Bancroft Way, Berkeley, Calif.	W8TMM Earl Carter, 12216 Taft Ave., Cleveland, O.
W6RMY Truman O. Lamb, 755 Patterson Ave., Glendale, Calif.	W8TMN Bernard D. Fellows, 1836 Pine Crest Drive, Ferndale, Mich.
W6RMZ Clair L. McHolland, 6123 Fountain Ave., Hollywood, Calif.	W8TMO James A. Stepro, 206 Raleigh St., Beckley, W. Va.
W6RNA John J. Schodron, Providence, Utah.	W8TMP Sherwood Glenn Espenschied, West Maysle, Hartville, O.
W6RNB Kenneth R. Greenwood, 1616 E. 6th, Tucson, Ariz.	W8TMQ Richard P. Burson, 453 Vinewood, Wyandotte, Mich.
W6RNC Carroll C. Howlett, 1346 Piamo, San Luis Obispo, Calif.	W8TMR Wilbur W. Claypoole, 22604 W. McNichols Rd., Detroit, Mich.
W6RND John P. Johnson, 1045 2nd St., Delta, Utah.	W8TMS Arthur L. Iverson, 2916 Rochester Rd., Royal Oak, Mich.
W6RNH Lorren Millhollin, 1119A Washington Blvd., Venice, Calif.	W8TMT Peter F. Kantor, 1713 St. Elmo Ave., Canton, O.
W6RNI William F. Craggs, 1023 Washington Blvd., Venice, Calif.	W8TMU James C. Randall, R. F. D. Star Rt., Stony Creek, N. Y.
W6RNJ Randsli E. Sorenson, Smitheld, Utah.	W8TMW John W. Mills, 312 Arthur Ave., Endicott, N. Y.
W6RNK Lawrence E. Tollnson, 107 S. Gramercy Pl., Los Angeles, Calif.	W8TMY Stuart J. Tuma, 10 National, N. W., Grand Rapids, Mich.
W6RNM Gareth C. Garner, 1265 Harrison Ave., Salt Lake City, Utah.	W8TNB Philip G. Dilorio, 1000 Evangeling Rd., Cleveland, O.
W6RNR Stuart F. Walmsley, 3948 Dalton Ave., Los Angeles, Calif.	W8TND Robert J. Lieber, 606 Shorb Ave., N. W., Canton, O.
W6RNO John W. Wardell, 131A W. Garfield Ave., Glendale, Calif.	W8TNE Carl F. Lusic, 1120 Parkdale Drive, Akron, O.
W6RNP James H. Watson, 1711 Robbins St., Santa Barbara, Calif.	W8TNF Howard O. McCall, 1207 3rd S. E., Canton, O.
W6RNQ Ronald J. Forestal, 1349 W. 59th St., Los Angeles, Calif.	W8TNG Robert D. McCartney, 247 S. Oakland Ave., Sharon, Pa.
W6RNR Thomas W. Haislip, 320 E. Fern Ave., Redlands, Calif.	W8TNH Robert L. Mills, 1335 California, Ave., Akron, O.
W6RNW Dwaine R. Henderson, 214 W. 60th, Los Angeles, Calif.	W8TNI Clifford Morrow, 801-5th N. W., Canton, O.
W6RNT Jack A. Paisley, 1511 E. Monroe St., Phoenix, Ariz.	W8TNJ Howard R. Munding, 2632 Norwalk, Toledo, O.
W6RNU Thomas F. Pollock, 1010 5th, Coronado, Calif.	W8TNK Ronald G. Potts, 967 Locust St., Williamsport, Pa.

(Continued on page 234)



HQ-120-X for
HIGH SENSITIVITY
and
LOW NOISE LEVEL

HIGH SENSITIVITY and low noise level have made the "HQ-120-X" radio's outstanding low priced receiver. The variable selectivity feature permits the operator to tune out strong stations and pull in the weak distant stations that would normally be buried in QRM. Remember, the weak stations are there, but it requires a sensitive and selective receiver to get them. If you want the best in high frequency performance, use an "HQ-120-X." Send for booklet!

HAMMARLUND MFG. CO., INC.
424-438 W. 33 St., N. Y. City RT-8

Please send 16-page booklet.

Name

Address

City State



HAMMARLUND

Canadian Office: 41 West Ave. No., Hamilton, Ontario

BRUSH HIGH LEVELER SERIES MICROPHONES



Range in price from \$22.50 to \$32.50

NEW BRUSH HEADPHONES

Write for your Brush catalog today.

THE BRUSH DEVELOPMENT CO.

3326 PERKINS AVE. CLEVELAND, OHIO

SOLAR

quality above all

**ALL TYPES OF
FIXED CAPACITORS
FOR RADIO AND
TELEVISION . . .**

Catalog on Request

SOLAR MFG. CORP. Bayonne, N. J.

It Will Pay You!

When you need amateur equipment it will pay you to write me. I make it my business to be able to supply all amateur receivers, transmitters, kits, antennas, and parts at the lowest net prices in any catalog or advertisement. I try to be the first to supply the newest equipment. I will help you get the best equipment for your use. All equipment is available on W9ARA's 6% terms financed by myself so you can buy with less cost and more convenience.

You get personal attention you can't get elsewhere; fair trade-in value for your receiver and equipment; ten day trial of all receivers; and my cooperation in every way to see that you are 100% satisfied. No wonder W9ARA's customers are boosters. You will be too.

Your inquiries and orders invited. You can reach me by letter, telegram, phone, or visit nearly 24 hours a day, 365 days a year. Foreign orders solicited too. Write for full information.

Bob Henry
W9ARA

BUTLER, MISSOURI

DETROLA
CANDID CAMERA
With Fast F-4.5 Lens



AMERICA'S GREATEST CAMERA VALUE AT

\$9.95

EASY TERMS ARRANGED

A really fast miniature candid camera with shutter speeds to 1/200, optical view finder and variable focusing f4.5 lens, fully corrected.

DETROLA CORP.
DETROIT, MICHIGAN

THE WORLD FAMOUS SUPER CLIPPER. Thousands sold at \$29.75. Now offered at the phenomenally low price of \$23.75 each. Seven tubes, built-in signal booster, 3-550 meters. Band-switching, of course, with three stages of radio frequency amplification, the Super Clipper is our most powerful and sensitive receiver. Due to over-production, we are disposing of a limited number at this unheard of price. Act Now! First come, first served. Fully guaranteed for one year.

RADIO CONSTRUCTORS LABS.
136 LIBERTY ST., NEW YORK, N. Y.

W8TNL Charles W. Pilius, 712 Warren Ave., Youngstown, O.
W8TNM Paul J. Reynolds, 1812 18th, Nitro, W. Va.
W8TNN Kenneth E. Robinson, 1414 Webster, Bay City, Mich.
W8TNO Leon M. See, 3405 Mill, Auburn Heights, Mich.
W8TNP Wayland L. Shepard, 557 Thompson St., Elmira, N. Y.
W8TNQ Howard C. Hendrickson, 117 Wescott, Jamestown, N. Y.
W8TNR Vincent C. Henophy, 119 Garfield, Rochester, N. Y.
W9ARO Orville L. Hilligoss, 3621 St. Charles, Anderson, Ind.
W9ARY Arlo Almeron Kirkpatrick, 2826 S. Hackett, Muncie, Ind.
W9ASA Charley R. Leigh, 3933 Charlotte St., Kansas City, Mo.
W9ASB Leonard V. Anderson, 1216 5th St., Rockford, Ill.
W9ASI Ira R. Bourland, 4023 N. Osceola, Chicago, Ill.
W9AST Ernest M. Patchman, 4835 Euclid Ave., East Chicago, Ind.
W9ASU Charles J. Smalley, 1342 N. Dearborn St., Chicago, Ill.
W9ATA Lyle E. Cook, 1202 Charles St., Streator, Ill.
W9ATW Donald E. Laughlin, New Providence, Ia.
W9AAU Russell W. Hammer, R. R. 3, Polo, Ill.
W9AVA William B. Harris, 6516 S. May, Chicago, Ill.
W9AVD Richard R. Hawk, 6533 S. Sangamon, Chicago, Ill.
W9AVE William A. Karraker, 5815 Drexel Ave., Chicago, Ill.
W9AVK August H. Krivitz, 2024 West Pierce St., Milwaukee, Wisc.
W9AVR Richard P. Mates, 4302 N. Kildare Ave., Chicago, Ill.
W9AVY Joseph P. Nakutis, 2511 W. 46th St., Chicago, Ill.
W9AWD Edmund A. Parsons, High School Bldg., Pierce, Colo.
W9AWK George A. Alley, 129 W. Monroe, Villa Park, Ill.
W9AWW George S. Porter, 3131 Harlem Ave., Berwyn, Ill.
W9AXE James M. Gerrits, 517 N. Durkee, Appleton, Wisc.
W9AXG Elroy V. Friberg, R. F. D. 1, Boyd, Minn.
W9AXU Hoyt I. Peterson, 128 S. Ash, Yuma, Colo.

W9AXX Stanley A. Nelson, 312 Dodge, Janesville, Wisc.
W9AYK Fred E. Hempt, 1111 Niagara, Denver, Colo.
W9AYV Frank W. Kullman, 4307 Winona St., Denver, Colo.
W9AZO Charles L. Yeager, 315 4th Ave., S. W., Rochester, Minn.
W9AZS Wesley C. Brase, Radcliffe, Ky.
W9BAJ Frederick W. Thorp, 129 S. Oakland, Green Bay, Wisc.
W9BAK Leslie D. Gilliland, 941 Vermont, Lawrence, Kans.
W9BAN Leonard M. Frederick, 716 Wesley Ave., Oak Park, Ill.
W9BAR Robert G. Fallis, Shell Lake, Wisc.
W9BAT Frank L. Doner, Shell Lake, Wisc.
W9BAX Alfred C. Dille, 66th & Glenwood, Overland Park, Kans.
W9BAY Roy C. Stegemiller, 49 McEldowney Pl., Chicago Heights, Ill.
W9BBD Clarence A. Holritz, 1233 11 1/2 St., N. Fargo, N. D.
W9BBO John H. Mullaney, 235 1st Ave. E, Dickinson, N. D.
W9BBT Claude B. Harman, 1404 E. 8th St., Pueblo, Colo.
W9BBV Charles F. Patton, 271 W. 3d St., Paintsville, Ky.
W9BBY Ernest R. Piercy, 122 Pine Ave., Flaxton, N. D.
W9BCZ Wesley N. Richardson, 118 E. Kellogg, Wichita, Kans.
W9BDJ Billy E. Swarts, N. 2nd, Natoma, Kans.
W9BDN Peter A. Simich, 13240 Burley Ave., Chicago, Ill.
W9BDQ Richard H. Barthuly, 904 W. Q., Lincoln, Nebr.
W9BDZ Walter B. Bills, Rt. 2, Eaton, Colo.
W9BER Edward B. Russell, 3543 Fremont, Chicago, Ill.
W9BEY Stanley J. Kucinski, Hq. Trp. 13th Cavalry, Ft. Knox, Ky.
W9BEY Mae Hirt, Deerbrook, Wisc.
W9BFF Henry Y. Hoskin, Burlington, Colo.
W9BFG Horace S. Shaw, 204 E. St. Clair St., Indianapolis, Ind.
W9NYN Albert Bradt, 1211 8th, Greeley, Colo.
W9UDC Michael W. Healy, 7139 Woodlawn, Chicago, Ill.
W9USH Robert M. Mattison, 1025 5th St., Brookings, S. D.

Television—22 Miles

(Continued from page 199)

area, even slight interference causes distortion or interruption. Diathermy machines and automobile ignition systems are the worst offenders in this regard. Howell believes that if the power were stepped up to 10,000 watts, reception would be tremendously improved. Within five miles of the station, however, little interference is now being experienced by lookers-in.

Howell has found that a vertical dipole antenna with a parasitic reflector, 70 feet above the ground, helps greatly to overcome the lack of power in signals received. Images on his set are sufficiently bright to permit excellent photographs to be taken of them, with fast film and ten-second exposure.

Keen interest of the California television fans shows itself at the meetings of the Hollywood Television Society. Recently, at one of the society's gatherings, 100 spectators watched a program being received on a nine-inch tube. Most of those 100, as should be expected, went away even more keenly interested in television.

Frank Andrews, "Around the World" commentator on W6XAO, planned and executed recently a program believed to be the world's first attempt at visual education in the public schools by television. Members of the Hollywood Television Society installed receivers in public school in Los Angeles and Long Beach, the University of Southern California, Pomona College and other schools, for reception of a telecast dramatization of the crossing of the Pacific by Pan-American Airways clipper. The Los Angeles Board of Education and the Pan-American company cooperated in the venture, which was outstandingly successful.

World Wide Radio Digest

(Continued from page 201)

of overtones. Thus the machine splits the voice into twenty parts and uses them in varying proportions in remaking speech, according to a writer in the *New York Times*. A sentence uttered in a normal way may be reproduced exactly as the speaker has said it, as a monotone chant, or in various other ways. The voice of a man may be made to sound like that of a woman and vice-versa, and voices which are not musical may be improved. The machine may permit multiple conversations over standard phone wires.

August, 1939 RADIO-CRAFT

How to Make a "B"-Batteryless Radio Set
"Wireless" Phono Unit

Emergency Servicing Without Meters
(by Charles R. Leutz)

Obscure Sources of Hum in High-Gain Amplifiers

Test Your Radio Knowledge

Circuit of RCA Teleceiver

Servicing Television Receiver Faults

—Now on newsstands—

Television Antennas

(Continued from page 206)

matter of interest, the horizontal scanning speed of the electron beam in this particular case is about 8,500 miles per hour in traveling from left to right. In the illustration of Fig. 1, the reflected wave is delayed a difference of 1/93,000 second from the direct wave because its transmission path is two miles longer. It should be apparent then that the reflected signal will cause a second image displaced 93,000/150,000 of an inch, or about 5/8-inch to the right of the primary or wanted image.

New York City. This particular illustration is an unretouched photograph of an image obtained from a signal that contained no reflections or "ghosts" due to multipath reception.

Figure 3, on the other hand, shows the same test pattern seriously impaired by a reflected signal. Needless to say, a televised program would be likewise impaired and would be unsatisfactory to the owner of a television receiver. Reflections of much less intensity and negligible delay to be

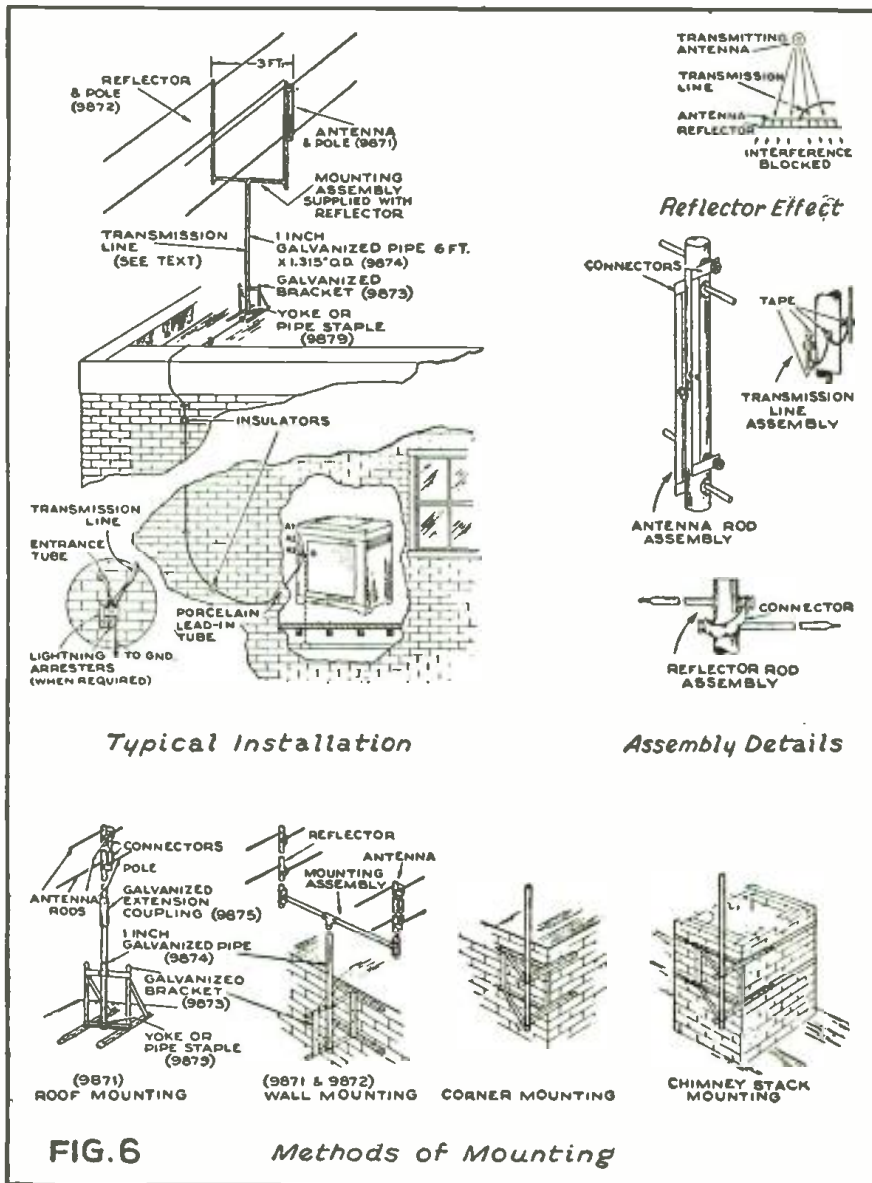

Fig. 6. Typical installation details of RCA Double Di-pole reflector antennas.

The reflected signal image may be white or black, depending on its polarity. Its intensity may vary from almost as intense as the primary image to a point where it is just noticeable. Any difference in relative intensities is due to the attenuation the reflected waves may encounter in their transmission path.

Ghost Images

In Fig. 2 is shown the test pattern which the National Broadcasting Company transmits at periodic intervals from its transmitter W2XBS, Empire State Building,

hardly noticeable in themselves will cause the wanted image to appear fuzzy with consequent loss of observable detail of the finer portions of the received picture.

If the receiving antenna of Fig. 1 could be designed to reduce pick-up of the reflected wave signal, or signals, then the impairing of the received image may often be reduced or entirely eliminated.

Engineers studied the problem as based on seven years of RCA-NBC field test experience of television reception in the New York City area. Development work (Continued on following page)

FREE!

and it saves you
**TIME,
TROUBLE,
MONEY**



This FREE catalog is your dish. Has everything in Radio — thousands of parts, tubes, Test Instruments, Sound Systems, Receivers, build it yourself kits, etc. Every item nationally advertised, arranged for quick, easy reference. Order at home. Save time and trouble. And take advantage of real money saving prices. Not just on some items. There's value after value right through this book's 188 pages. You save on everything you buy! Send at once for your copy. Remember, it's FREE! Just tear out and mail the coupon NOW.

LAFAYETTE
RADIO CORPORATION
WHOLESALE RADIO SERVICE CO., INC.

Rush New FREE Catalog No. 76

NAME _____ PLEASE PRINT
ADDRESS _____

CITY _____ STATE _____
LAFAYETTE RADIO CORPORATION
Dept. 4H9 — 100 Sixth Ave., New York, N. Y.

PASTE COUPON ON PENNY POSTCARD

Now!
BALLAST REPLACEMENT
made
AMAZINGLY SIMPLE!
Only 4 standard types of Amperite AC-DC Regulators will replace 90% (over 100 types) of AC-DC Ballast Tubes now in use!
WRITE FOR CHART A.R.
New Low Price \$1.00 List
AMPERITE AUTOMATIC REGULATORS
561 BROADWAY, N. Y.

FILM GRAPH
Newly patented "FILMGRAPH"—instantaneous SOUND-ON-FILM RECORDER and REPRODUCER. No dark room nor processing is required. Special models to make "TALKIES" in conjunction with camera or silent (as well as sound) projectors. Also models for use with or without pictures. 2 hours of recording (without pictures) may be had on a 100 feet of 16 mm. film costing only 85 cents. Permanent PLAYBACK. Moderate initial cost of FILMGRAPH—only expense for putting SOUND-ON-FILM. MILES REPRODUCER CO., INC., 812-RT BROADWAY, NEW YORK.

MAKE YOUR OWN "TALKIES"!
HAMS, EXPERIMENTERS!
FREE punched and drilled chassis supplied with kits of parts for any apparatus described in Radio and Television, QST, the Handbook or other publications. We design and build amateur and communications equipment to meet the most exacting specifications. Write for our low prices.
SIGMON RADIO SUPPLY COMPANY
"Custom-Built Radio Headquarters"
104 Washington St., East Charleston, W. Va.

Get 5 and 10 ON YOUR AUTO RADIO



Easily installed between antenna and your present auto radio, the new GUTHMAN U-39 converter brings you the 5 and 10 meter amateur bands well spread out over its dial, and with all the tuning stability needed to hold signals on these bands after you've tuned them in.

This new 5-10 meter converter—and the new U-36, 6 band mobile phone c.w. transmitter-permanent station exciter—were definite hits at the trade show. See them at any up-to-the-minute jobber's—or write for GUTHMAN catalog of these and many other "hot" items.



AIR-CONDITIONED CABINET
Saves Your Batteries!

DETROLA
BATTERY Life Saver
Portable RADIO

5-TUBE SUPER BATTERIES for use in the wide open spaces. AC current for use in the home. DC current in hotels, offices or traveling.



MODEL NO. 299-A

\$24.95

See It and Believe It!

DETROLA CORP.
DETROIT, MICHIGAN

**Greatest Slide Rule VALUES
ever offered!**



8 inch slide rule in case 25c

Eight inch, white wood, accurate slide rule with A, B, C, D, G1 and K Scales, a 20-page Book of Instructions, How to Use a Slide Rule, a 30-page Book of 300 Examples and Answers, a two-toned "Facsimile of the Declaration of Independence," suitable for framing, and an 8-page catalog illustrating and describing indoor games and many unusual items. All five prepaid anywhere in the United States and Canada for **50c**

10 inch enameled slide rule, only 35c

10 inch enameled slide rule, made of kiln dried genuine mahogany wood, has auxiliary removable magnifier with pins to fit (cursor) runner. This rule has inch, millimeter, pint, log and tangent scales. Packed in individual carrying case. This rule is equal in performance to a \$10.00 rule. **\$1.00**

Our special price, P.P. Prepaid anywhere

GOLD SHIELD PRODUCTS
Dept. RT-89 350 Greenwich St. New York

indicated that the ordinary di-pole could be made more directive by the addition of a parasitic reflector spaced about $\frac{1}{4}$ to $\frac{1}{10}$ wavelength behind the antenna proper. This materially reduced pick-up from the direction opposite to the transmitter location. However, this occurred at a sacrifice in frequency response. It must be remembered that a television channel for high definition television occupies 6 mc. of which over 4 mc. is necessary for the picture modulation. Even the ordinary di-pole alone was found to have insufficient frequency response, particularly for the contemplated use of the television spectrum. It was early recognized that in suburban areas reflection phenomena were not usually present so little need for a di-pole reflector assembly would be expected.

Double Di-pole Television Antenna

The outcome of the development was the design of the Double Di-pole Television Antenna, which could also be used as part of a special di-pole-reflector assembly. The Double Di-pole Television Antenna Assembly is shown in Fig. 4. The double di-poles used improve the frequency response to cover the contemplated use of the television spectrum. This antenna is recommended for suburban locations or any location where reflection phenomena are not present. Its sturdy construction and corrosive protection of its metal parts provide added safety when installed in high locations. The use of a round pole for support readily adapts the assembly for rotating the antenna so it will be broadside to the transmitter location for maximum signal pick-up. A compromise from the broadside position may at times be necessary so advantage of the null plane of reception can be taken to minimize local interference.

Double "V" Wire Antenna: A similar antenna of lower cost and requiring two supports, is available as the Double "V" Wire Television Antenna illustrated in Fig. 5.

For more efficient operation on the higher television bands the lengths of the antenna rods or wires should be changed in accordance with the instructions accompanying the antennas.

For congested city areas the combination of Double Di-pole and Reflector is recommended. Multi-path reception (causing "ghost" images) due to reflections can often be reduced materially or entirely eliminated with such an antenna installation. Reflections coming from such a direction as to form a broad angle with respect to the direction of the direct wave will usually be attenuated due to this antenna having a comparatively narrow zone of reception. The directional feature is obtained at negligible sacrifice of frequency response band and is a function of its unique design. The installation of the Double Di-pole and Reflector, as well as the use of other accessories are shown in Fig. 6.

The Double Di-pole and Reflector, while reducing pick-up from the direction opposite to the transmitter also increases the signal pick-up from the transmitter. Compared to a simple di-pole, the gain in signal strength is about 1.5 times. Reception from the transmitter location to that from the opposite location is in the ratio of about 3 to 1. Where low signal strengths are liable to be received due to distance or shielding effects, the installation of the Double Di-pole and Reflector will give an improved signal-to-noise ratio that may be sufficient to obtain satisfactory results. In some locations, sufficient signal strength may be available to permit rotating the antenna from the normal broadside position so advantage of the antenna's direc-

tional characteristic can be taken to minimize any serious noise interference.

Two New Types of Transmission Line

For maximum efficiency the RCA Television Antennas should be used with corresponding type Transmission Lines of which there are two types. The type 9882 (1000 ft. roll) is a special low-loss weather-proofed line having only 4 db. loss at 50 mc. per 100 feet. The standard weather-proofed line, No. 9881 (1000 ft. spool) has a loss of 8 db. at 50 mc. per 100 feet. Interior finish lines of the proper surge impedance are also available in brown and white colors. Use of improper lines may result in excessive loss or may lead to line reflections. Use of the RCA Television Antennas and Transmission Lines with balanced input receivers, such as the RCA Victor Television Receivers, provides reduction of noise picked up on the transmission line.

For transmission line runs excessively long, such as over 200 feet, or where the receiver is located in an area of weak field strength, the low-loss line, type 9882, is to be recommended. For the average residential installation, the standard line, type 9881, is suggested.

Notes on Installing the Antenna

The primary requisite for the antenna location is to place it in a "line of sight," or as near a "line of sight" as possible and broadside position to the transmitting antenna. This usually means that the antenna should be placed near, or on, or above the roof of the residence or apartment house. The location on a suburban dwelling may usually be decided upon from the standpoint of roof accessibility, availability of support, and shortest possible transmission line run. Reflection phenomena are not often present in the suburbs, so it is not likely that the antenna location need be changed once it is decided upon.

Obviously, as the horizon distance from the transmitter is approached, many objects may intervene to destroy the "line of sight." Usually, the higher the antenna is erected under such conditions the greater will be the received signal. The actual received signal intensity under any conditions is a function of the receiving antenna height. The antenna should be placed as high as possible and as far removed from highways, hospitals, doctors' offices, etc., to reduce effects of auto ignition and diathermy interference. Such locating of the antenna may be offset by the added line losses and consideration must be given to the type line used.

In the congested city areas, the antenna should be installed permanently on the apartment or residence roof only after actually observing results on the television receiver. A temporary transmission line can be run between receiver and the antenna allowing sufficient slack to permit rotating or moving the antenna. Then with a portable telephone system connecting an observer at the receiver and an assistant on the roof at the proposed antenna location, the antenna can be positioned to give the most satisfactory results. A shift of only a few feet in antenna position may effect a tremendous difference in picture reception.

The only positive check of television receiver operation is to use the test pattern signal from the television transmitter. Field strength and interference conditions will be different at every location. Even though the antenna and receiver installation might be tested with a local R-F oscillator, there is no assurance that the antenna and receiver location will be satisfactory until the received test pattern is actually observed on the receiver's Kinescope.

(Continued on page 237)

In mounting any antenna, care must be taken to keep the antenna rods or pick-up wires at least 1/4 wave length (at least 6 feet) away from other antennas, metal objects, such as, metal roofs and gutters, etc. Local fire regulations may require a certain distance between antenna and roof.

Under certain unusual conditions, it may be possible to rotate or position the antenna so it receives the cleanest picture over a reflected path. If such is the case, the antenna should be so positioned. However, such a position may give variable result with the weather, as a wet surface has been known to have different reflecting characteristics than a dry surface.

In short, a television receiving antenna and its installation must conform to much higher standards than an antenna for reception of International Short Wave and Standard Broadcast signals because:

(1) Intervening obstacles have a pronounced shielding effect on the ultra high frequency waves producing low intensity signals. Severe trouble with multi-path reception may often be experienced, especially in congested city areas.

(2) The picture signal is comprised of a very wide band or range of frequencies, all of which must be received with good efficiency.

(3) It must be continually remembered that the discernment of the eye is much more critical than that of the ear. More than ever, it can be said—"The finest television receiver built may be only as good as the antenna design and installation."

Hints on Installing Transmission Lines

After the antenna and receiver locations have been decided upon, the residence or

apartment should be carefully surveyed to determine the best method of running the transmission line. The most important consideration is to keep the run as short as possible consistent with other factors such as appearance and availability or accessibility of support.

The transmission line should be supported on outside runs every 8 to 12 feet. Telephone bridle rings are a convenient and inexpensive means of line support. Number 14 Rawl or similar plugs should be used for support of the rings when masonry is encountered. Clearing obstructions, such as rain gutters, may be readily done by using 6 inch or 12 inch screw-eye insulators. The line should be secured to avoid vibration. Slack in the line should be taken up wherever a turn is made by appropriate taping. Use of 1/2 inch loom will provide protection to the line where abrasion might occur.

Entrance to the receiver location in a suburban residence may be neatly made by passing the line through a porcelain tube installed in a basement window and running the line in the basement to a location below the receiver, where a small hole may be drilled in the floor with the owner's permission. In order to maintain proper impedance relations, the free ends of the transmission line should never be fanned apart. *At the conclusion of the line installation it should always be checked for continuity and short circuit.*

It is extremely important that a good GROUND connection be provided for the television receiver. This is necessary to protect the user in case of a primary to secondary breakdown of the high voltage transformer.

What Do YOU Think?

(Continued from page 221)

A Good Idea

(Continued)

tions appreciate reports, so why not concentrate on them for verifications?

My best DX for 1939 is as follows: PK6XX, VLR, JZJ, JZK, VR6AY, TAP, EA9AH, ZRK, VUI12. These were all received on an RCA 1938 Superhet and a peak preselector using a 40-meter half-wave doublet.

Please devote more space to *What Do You Think?* and why not ask readers to vote on the subjects that they desire most to be published. I will be pleased to hear from all SWL's and Hams and will send my card, pictures and correspond 100%, so what say OM's and YL's?

ERNEST PAVLIDIS,
139 W. 7th Avenue,
Conshohocken, Penna.

CWL's Can Help

(Continued)

dred miles away with a loud second harmonic.

Mr. Gant's statement was well put, that amateurs don't need SWL cards because they can get all the reports they need from the stations worked. Although I attempt to give as complete a report as possible, I know that even those are not much help to the Hams. But can any one blame the boys for not answering SWL's when they get reports such as "u were R.S.T. 5-8-7x hr in West Wixtree, Ohio" or "ur sigs R.S.T. 5-9-9—on all five bands"? And I know plenty of C.W. operators who have gotten phone reports with no evidence that their calls were being bootlegged. SWL's who want cards, whether they deserve them or not, have gotten the entire fraternity into

disrepute by their acts, and as long as a person is willing to remain in their ranks, he might as well become resigned to the fact that he is going to send out a lot more cards than he receives.

Some phone listeners only rarely become licensed. How can amateurs be expected to spend time and enough money in a year or two to buy them a nice piece of apparatus when for all their trouble they are really doing nothing to further the art?

I would like to see RADIO & TELEVISION publish, as received, the calls of those C.W. operators who would volunteer to answer verifications of their signals. I know their QSL's would be encouraging and would help many beginners to know that they are copying code correctly and at about what approximate speed.

ALLAN MURPHY,
107 South 21st Street,
Paducah, Ky.

What He Likes

Editor,

After reading your magazine for five years, I think it is about time for me to tell you what I think of it.

There are some extra good points in your magazine. The "Kinks" department, the "Question & Answer" department, "World Wide Radio Review" (I like this very much) and Joe Miller's "Let's Listen In" column. "On the Ham Bands" is also okay with me, but I think it would be better if it was in paragraph form instead of column form.

Mr. Hooton is my favorite author in your magazine.

JOHN MOSKAL,
85 Gardner Ave.,
So. Attleboro, Mass.

Radio's Biggest P. A. VALUES!

18 WATT AMPLIFIER

\$19.95



GET ALLIED'S SUMMER CATALOG!

Amazing values now in ALLIED'S Free 164-page Summer catalog! New Sound Systems for every purpose, 8-65 watts. Over 14,000 parts; radio's biggest line of Record Players, Phonographs, Recorders; latest Test Equipment; new Amateur gear; dozens of Kits; books, tools, etc.—and 82 new "KNIGHT" Sets, as low as \$5.95—all types, new 3-in-1 Portables, etc. Everything in radio at lowest prices. In ALLIED'S catalog. FREE—send coupon!

RADIO BUILDERS' P. A. MENU!

"Radio-Builder's Handbook"—For beginners, tells how to select circuits, read diagrams, make chassis, etc.—only 10c!

"Essentials of Recording"—Complete facts, tips on making records, re-producing, etc.—only 10c. send coupon.

ALLIED BOOKS 10c

FREE CATALOG

ALLIED Radio Corp., Dept. 3-H-9
833 Jackson Blvd., Chicago

Send your Free Radio Catalog.
 10c Enclosed—Send Builder's Handbook.
 10c Enclosed—Send book on Recording.

Name _____

Address _____

Just Published . . . a NEW RADIO AND ELECTRONIC DICTIONARY Containing 3,800 Definitions



RADIO AND ELECTRONIC DICTIONARY
MANLY

THIS RADIO AND ELECTRONIC DICTIONARY, written by Harold P. Manly, explains the meaning of 3,800 words used in radio, electronics and other closely allied fields. It includes new terms used in radio transmission, sound pictures, television, public address, aviation radio, navigation and industrial control, photo-electricity, photocell application, telephotography, etc. This dictionary permits learning every new expression whether you hear it or read it. Alphabetically arranged for quick reference. 350 illustrations augment definitions in the text.

The book is recommended for students, instructors, engineers, service men, experimenters, salesmen and everyone in any way associated with radio. ONLY BOOK OF ITS KIND—HANDY—EASY TO USE—AND TIMELY.

The RADIO AND ELECTRONIC DICTIONARY is new, authentic and printed in a single volume of 300 pages, size 6 x 9 inches. The book weighs two pounds, and bound in durable cloth. SHIPPED ANYWHERE \$2.50 IN U. S. A. POSTPAID . . . price

Mail remittance by check or money order to RADIO PUBLICATIONS
88 HUDSON STREET NEW YORK, N. Y.

HANDEE

Tool of 101 Uses

A WHOLE TOOL SHOP IN YOUR HAND

Smooth, steady power at your finger tips. Uses 300 accessories to grind, drill, polish, rout, cut, carve, sand, saw, sharpen, engrave, etc. Plugs in any AC or DC socket, 18,000 r.p.m. 16 oz.

Get A Demonstration at Hardware, Tool or Dept. Stores, or order on 10-Days Money-Back Trial. \$10.75 postpaid with 3 Accessories . . . De Luxe Model, 25,000 r.p.m. 12 oz. \$18.50 with 6 Accessories.

Chicago Wheel & Mfg. Co., 1101 W. Monroe St., Dept. RT, Chicago, Ill.

Save Hours of Hand Work

FREE 64-PAGE CATALOG

Complete information on Handee Products and their application in crafts work and industry all over the world.

FAST CODE doesn't scare the CANDLER TRAINED OPERATOR!



When you have received your training from Candler, fast code can't stump you—you have learned sound consciousness, so that you are reading whole letters and words—copying several with no more strain or effort than is required to read a newspaper.

And you learn code quickly with the Candler system, a few weeks with Candler will bring you more progress than months of undirected practice, because Candler teaches the correct fundamentals.

Read the FREE "Book of Facts." Learn how champion operators got their training, how commercial operators won their positions and promotion through Candler Training! Send for your FREE copy today!

CANDLER SYSTEM CO.

Dept. S-8, Box 331, Asheville, No. Carolina
British Address: Room 56, Craven House
121 Kingsway, London, W.C.2.

READ AND SEND CODE

Learn Easily at Home This Quicker Way

No experience needed. Beginners read code quickly, copy accurately. If already an op, speed up your wpm with this approved amazing all Electric Master Teleplex Code Teacher. Only instrument which records your sending in visible dots and dashes on specially prepared paper tape—then sends back your own key work at any speed you wish. Fascinating, foolproof—gets results because you learn by HEARING as well as SEEING. That is why thousands agree this method is surest and quickest. While not designated standard equipment, Teleplex is used at many U. S. Army Posts, Naval Training Stations. We furnish Complete Course, lend you the New All Electric Master Teleplex, and personal instruction with a MONEY-BACK GUARANTEE. Low cost, easy terms. Write today for folder 88, no obligation.



TELEPLEX CO., 67-69 Park Place, New York
In Canada write: CANADIAN ELECTRONIC INST., TORONTO, ONT.

RADIO ENGINEERING - DEGREE IN 2 YEARS

Complete Radio Engineering Course in 96 weeks. Bachelor of Science Degree. Radio (television, talking pictures and the vast electronic field) offers unusual opportunities for trained radio engineers. Courses also in Civil, Electrical, Mechanical, Chemical, Aeronautical Engineering, Business Administration and Accounting. Tuition, living costs low. World famous for technical two-year courses. Special preparatory department for those who lack required high school work. Students from all parts of the world. Enter September, January, March, June. Write for catalog. 2489 COLLEGE AVE. ANGOLA, IND.

TRI-STATE COLLEGE

AMATEUR RADIO LICENSES

Day and evening classes in code and theory
Home Study Courses

Hundreds of students now on the air. Results guaranteed. Reasonable, efficient and thorough.

AMERICAN RADIO INSTITUTE
1123 BROADWAY NEW YORK, N. Y.

Building and Using a Wheatstone Bridge

(Continued from page 211)

R_3 is known, the value of R_4 is found through the equation $R_4 = R_3 + PB/AP$.

To measure a resistance with a Wheatstone bridge, it is necessary to have a known resistance and to find the relation of PB/AP for which a balanced condition is obtained. This will be found, as we said before, by sliding the contact P until the voltmeter reads zero between points P and Q .

flows through the voltmeter and therefore any value of resistance may be measured without any possibility of errors which might be caused by voltage drops within this measuring instrument.

Great care must be taken to secure firm and clean contacts at points A and B (see Fig. 5B), as otherwise any contact resistance added at these points would interfere with the proper operation of

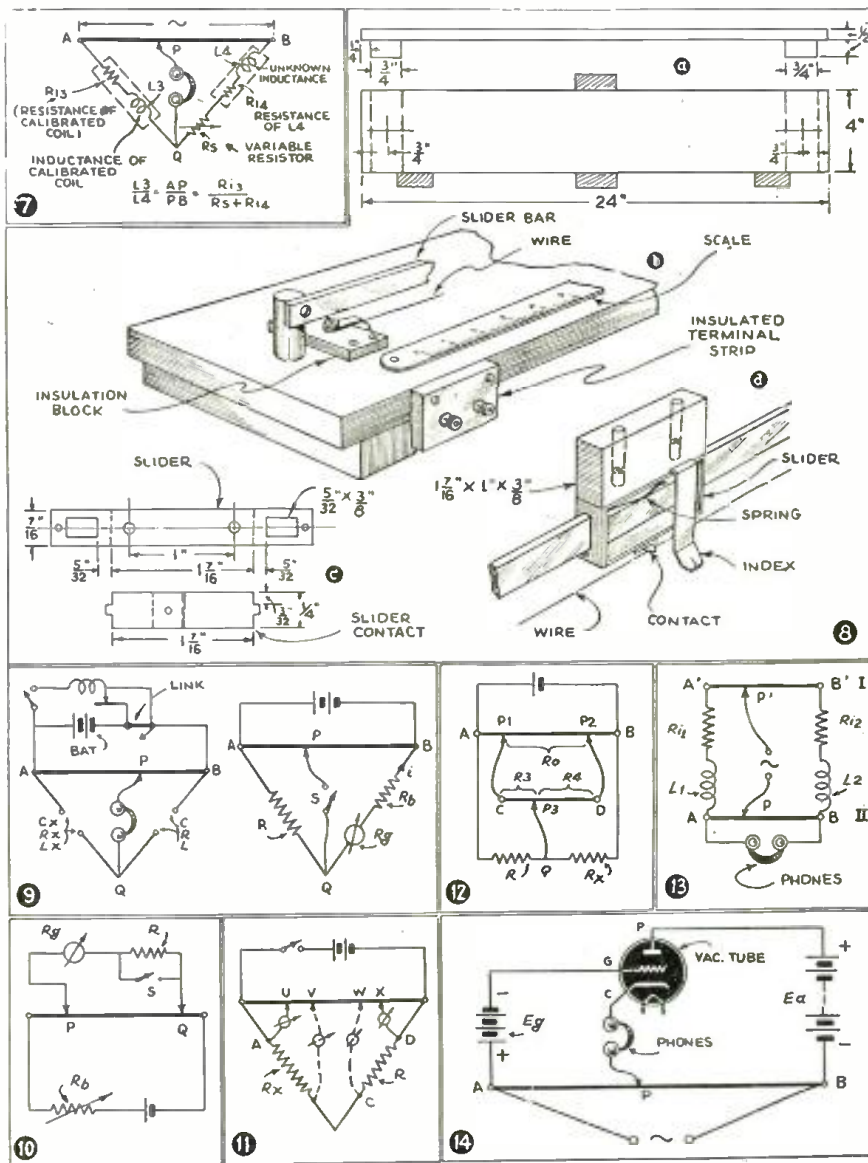

It is preferable to use a double swing voltmeter, one having its zero setting in the middle of the scale, because before balance is reached, the voltmeter needle may swing either to the right or to the left, according to the position of contact P over the length of the potentiometer wire.

Assembly and Method of Operation

In order to avoid certain defects, a very strong wire having a high resistance must be used.

Heating of the wire must be as low as possible to prevent its deterioration and therefore a source of low potential is more practical. Similarly, a very sensitive voltmeter is needed, more so for the measurement of very high resistances.

When the balance is perfect, no current

the bridge to obtain exact measurements. We have explained that the mechanical resistance of the wire must be high, but we must add that the total electrical resistance of this length of wire is only a few ohms.

It is evident that whenever the contact resistances are higher than the resistance of the wire, the distributed resistance of the latter would not be proportional to its length.

It will be found useful to also eliminate as much as possible the resistance of connecting wires and other points of contact.

For the resistance wire of the potentiometer, we must select a non-oxidizable metal such as chromium-nickel or nichrome.

When the bridge is supplied by a

source of alternating current, the voltmeter may be replaced by a pair of headphones.

Measurement of Inductances and Capacities

The source of voltage which up to now has been a small 4 to 8 volt storage cell, is replaced by a buzzer or a transformer.

The neutral point-indicating balance, or matching of values, is found when the buzzer sound of the A.C. hum has been completely eliminated by displacing the contact P.

This method is much more satisfactory than the voltmeter and may be used for measurements of resistances, capacities, inductances, or combinations thereof as long as the corresponding calibrated units are available.

We know that a capacity has an impedance which is its resistance in an alternating current circuit, and that its value may be calculated in the following manner:

$$R_c = \frac{1}{2\pi f C}$$

or

$$\pi = 3.1416$$

R_c = Resistance of capacity in ohms

f = Frequency of the alternating current flowing through the condenser, in cycles per second.

C = Capacity of the condenser in farads.

When we assume that the internal ohmic resistance of the dielectric is negligible, the balance of the bridge may be represented by the following equation:

$$\frac{C_3}{C_1} = \frac{AP}{BP}$$

Therefore the unknown capacity C_3 , corresponding to resistance R_1 (Fig. 4), will be

$$C_3 = C_1 \times \frac{PB}{AP}$$

C_1 being a calibrated capacity.

For measuring a larger capacity, a 1 mf. condenser for example, a frequency of 60 cycles supplied by the secondary of a small transformer, is enough to produce an audible sound in the headphone receiver.

However, if the capacity to be measured is small, its capacitive resistance becomes too high for the sensitivity of the receiver and a higher frequency must be used, such as 600 cycles, which may be supplied by an oscillator or a buzzer.

Due to the increase in frequency, the capacitive resistance decreases as is shown by the equation, and the sensitivity of the receiver will be satisfactory even for very small values of capacities. On the other hand, the use of a buzzer requires a high resistance for the measuring (potentiometer wire), as otherwise the buzzer might stop.

Measuring Inductances

This is more difficult because an inductance consists of two or three components. Ordinarily, only the inductive and the ohmic components are considered. An ideal case is represented by the equation

$$R_L = 2\pi f L$$

$$\pi = 3.1416$$

R_L = Inductance (inductive resistance in ohms)

L = Coefficient of self-induction in Henrys.

f = Frequency of alternating current passing through the coil

This equation is correct if the ohmic resistance of the coil and its capacitive resistance are negligible, compared to its inductive resistance.

In a general manner, the ohmic resist-

ance must not be ignored completely, as a neutral point of balance cannot be found on the bridge without compensating for the ohmic resistance of the coil.

The equation for an inductance is:

$$R_2 = \sqrt{R^2 \times (2\pi f L)^2}$$

R = ohmic resistance of the wire forming the coil (in ohms).

Remember also that the total resistance depends upon the ohmic resistance component and that the square root of the equation indicates that there will be *dephasing* between the voltage and the current. In order to balance the bridge, it is then necessary to equalize dephasing not only by balancing the absolute values of resistances and inductions, but also by aligning the relation between ohmic resistance and self-induction.

We must not forget that the relation of the lengths of the wire has ohmic resistance characteristics and that it is impossible to attempt a comparison between two circuits when they are out of phase.

When dephasing is equal in both circuits, the relation is independent of the phase and it depends only upon the absolute values.

To match an inductance, it is first of all necessary to measure the ohmic resistance of the calibrated inductance and that of the unknown inductance to be measured. For this purpose, the bridge shall be supplied by direct current, and after this preliminary test, it will be supplied by alternating current.

When measuring a large iron core inductance, it is preferable to use the transformer, but for a small inductance without iron core, the buzzer will do.

In order to obtain rapidly a balanced condition on the bridge, it is recommended to always use a calibrated inductance not differing too much in value from the inductance to be measured.

Whenever the ohmic resistances differ greatly, they must be equalized approximately by adding a variable ohmic resistance in series with the inductance having the lowest resistance. During the balance of the bridge, it will be noticed that the sound in the receiver does not disappear entirely; this is because the dephasing is not complete.

By varying the additional series resistance together with the contact on the bridge, a neutral point of complete silence will be found.

We can now determine the inductance:

$$\frac{L_3}{L_1} = \frac{AP}{AB}$$

The resistances are related as follows:

$$\frac{R_{13} + R_{15}}{L_1} = \frac{L_3}{L_1} = \frac{AP}{PB}$$

Construction of the Bridge

Knowing the theory, we shall now proceed with the construction of the bridge with all the necessary precautions for obtaining perfect results.

Fig. 8 shows all the parts separated, several of them can be home-made. The approximate dimensions of the parts are shown in this illustration. The bridge, consisting of a stretched resistance wire, a sliding contact and a ruler or scale, may be assembled as shown without difficulty.

We shall not recommend any method of construction, as the reader may use his own ideas or ingenuity to assemble the parts. The main precautions are neatness, solid construction, and a firm clean contact.

(Continued on following page)

RADIO INSTRUCTION

RADIO made EASY

with Ghirardi's Home-Training Course COMPLETE IN 7 BIG BOOKS



only \$4

Fit yourself at home, in spare time, for a good-paying radio job. You'll learn all that's really essential in Ghirardi's world-famous self-training course complete in this big 972-page volume including Television sound, Cathode-Ray Tubes, as well as Radio and Electricity. All the basic theory is here, carefully explained, fully illustrated, easy to grasp!

Quick Way to Learn!

Ghirardi's simplified method is the quickest way to get your radio education. No "background" study—no math—no "headaches." Easy as A.B.C.

36 Volumes in 1—972 pp.—508 illus.

1. Radio Broadcasting System. 2. Sound. 3. Music. 4. Electron Theory. 5. Elec. Current. 6. Elec. Units. 7. Ohm's Law. 8. Resistance. 9. Elec. Circuits. 10. Batteries. 11. Magnetism. 12. Electro-magnetism. 13. Electromagnetic Induction. 14. Inductance. 15. Capacitance. 16. Condensers. 17. A.C. Circuits. 18. Filters. 19. Measuring Instruments. 20. Radio Waves. 21. Broadcasting. 22. Receiving. 23. Vacuum Tube Principles. 24. Vacuum Tube Characteristics. 25. Vacuum Tube Construction. 26. Vacuum Tube Detector and Amplifier Action. 27. Radio Frequency Amplification. 28. "Superhets." 29. R.F. Amplifiers. 30. Tuning Coils. 31. Audio Amplifiers. 32. Battery Operated Receivers. 33. Power-Supply Units. 34. Elec. Receivers. 35. Automobile and Aircraft Radio. 36. Phono Pickups. 37. Sound Systems. 38. Short-Wave. 39. Photoelectric Cells. 40. Cathode-Ray Tubes. 41. Television. 42. Antennas and Grounds. 43. Testing; Servicing. 44. Sound Pictures. 45. Review Questions.

USE IT 5 DAYS—OUR RISK!

Get it!—Read it!—Use it! If not completely satisfied, return the book within 5 days and get your money back. You risk nothing—but you lose your great opportunity, unless you TRY IT!

MAIL COUPON TODAY!

Radio & Technical Publishing Co.,
45 Astor Place, New York, Dept. R&T-89

Here is my \$4. Please send RADIO PHYSICS COURSE postpaid, with money-back guarantee.

NAME

ADDRESS

CITY

Send free descriptive literature.

YOU CAN BECOME A MONEY-MAKING RADIO EXPERT

WITH THE **NEW SPRAYBERRY**

Personalized HOME TRAINING in **RADIO** and TELEVISION



You Learn Easily in Your Spare Hours ... By Doing Many Experiments with Up-To-Date Equipment

Here's a really fine, up-to-the-minute Radio and Television Training that's specially designed to give you quick results. TRAINING PREPARES YOU FOR GOOD RADIO JOBS ... AT EXCELLENT PAY. My training starts right at the beginning of Radio and unfolds each subject in a simplified, logical, understandable style. You easily learn Television, Electronics, Facsimile Radio, Radio Set Repair and Installation Work, etc.

NO PREVIOUS EXPERIENCE NEEDED

It makes no difference what your education has been. I can fit you for a good-paying Radio job. Your success is my full responsibility.

YOU GET PROFESSIONAL TEST EQUIPMENT PLUS EXPERIMENTAL OUTFITS

... Includes 146 Radio Parts (to build complete Receiver), Tools, All-Wave, All-Purpose Analyzer, and Experimental Outfits for conducting actual experiments with your own hands.

EARN WHILE YOU LEARN

My BUSINESS BUILDERS show you how to put your Equipment to practical use in handling actual money-making Radio service jobs shortly after you begin training.

SERVICEMEN

I offer Advanced Training for those already in Radio. Get complete details in my FREE 28-page Book. The Sprayberry Course is Sold Under a Money-back Agreement

RUSH COUPON FOR BIG FREE BOOK

SPRAYBERRY ACADEMY OF RADIO
F. L. Sprayberry, Pres.
245-H University Place, N.W.
Washington, D. C.

Please send me FREE copy of "HOW TO MAKE MONEY IN RADIO."

Name

Address

City

Tear off this coupon, mail in envelope or paste on penny postcard. Servicemen—Check here

RADIO INSTRUCTION

RADIO plus TELEVISION

mastered by pre-tested Training

No matter where you are or what you do, National has a complete training plan for you—to fit your circumstances. National's plan is for those seeking immediate shop-training as well as for those who cannot give up present employment and income. Mail coupon below.

NATIONAL SCHOOLS

NATIONAL SCHOOLS, Dept. 8-RT
4600 So. Figueroa St., Los Angeles, Calif.

Please send free Radio and Television Booklet.

NAME _____ AGE _____
ADDRESS _____
CITY _____ STATE _____

EASY TO LEARN CODE

It is easy and pleasant work to learn the modern way—with an INSTRUCTOGRAPH CODE TEACHER, ideal for the beginner or advanced student. Many tapes available ranging from alphabet for beginners to typical messages on all subjects. Speed range 5 to 40 WPM. Always ready, no QRM, beats having someone send to you.

FOR SALE OR RENT

STANDARD with 10 tapes and book of instructions\$20.25
JUNIOR with 5 tapes and book of instructions (not rented)\$12.00
RENTAL Standard with 10 tapes and book of instructions \$3.00 first month, \$2.25 each additional month.
All rental payments may be applied on the purchase price should you decide to buy the equipment.

Write for details today

INSTRUCTOGRAPH COMPANY

Dept. SW, 912 Lakeside Place, Chicago, Ill.
Representatives for Canada:
Radio College of Canada, 863 Bay St., Toronto

RADIO ENGINEERING

RCA Institutes offer an intensive course of high standard embracing all Phases of Radio and Television. Practical training with modern equipment at New York and Chicago schools. Also specialized courses and Home Study Courses under "No obligation" plan. Catalog Dept. SW-39.

RCA INSTITUTES, Inc.

A Radio Corporation of America Service
75 Varick St., New York, 1154 Merchandise Mart, Chicago

LEARN RADIO TELEVISION

600 LICENSED graduates placed in past 7 years in shipping, broadcasting, aviation, police, etc.; we also teach radio servicing and repairing; new beginners' class now forming; 60-page catalog free; oldest, largest and best equipped.

MASS. RADIO SCHOOL

18 BOYLSTON ST., BOSTON Est. 1896

BE A RADIO SERVICE EXPERT

Modern receivers require men with modern training for service work

LEARN AT HOME

Our home instruction method and service equipment offer starts your earning money almost at once. Up to \$5 an hour easy in a short time. Write for free book.

Radio Training Ass'n of America
Dept. RT-89
4525 Ravenswood Ave., Chicago

RADIO COURSES

New Fall Classes Start in September
RADIO OPERATING—BROADCASTING

- RADIO SERVICING — a practical course
- RADIO AMATEUR CODE ● TELEVISION
- ELECTRONICS—1 yr. day course 2 yrs. eve.

Day and Evening Classes. Booklet Upon Request.

New York Y.M.C.A. Schools
6 W. 64th Street New York City

RADIO ENGINEERING

broadcasting, aviation and police radio, servicing, marine radio telegraphy and telephony, Morse telegraphy and railway accounting taught thoroughly. 48 weeks' Engineering course equivalent to 3 years of college radio work. All expenses low. Catalog free. School established 1874. Dodge's Institute, Turner St., Valparaiso, Ind.

2-Band Vacation Portable Receiver

(Continued from page 225)

from the service oscillator and then adjusting the oscillator trimmer in the oscillator coil can (the upper one) at about 3500 kc. Do not attempt to trim the aerial circuit as this will throw the broadcast band out of adjustment. If further trimming of the short-wave band is desired, a sewing needle and a short length of wire stuck into the loop at several points and used as the "grid" connection in place of the 6-turn tap will indicate the point of greatest signal strength, from a 3500 kc. oscillator signal. However, this will not be necessary in most cases.

If a service oscillator is not available, tune in broadcast signals at the top end and bottom end of the broadcast band for padding and trimming adjustments turning I.F. and tuning condensers to maximum signal.

On the short-wave band, adjust for greatest signal strength, using the dial only as an approximation, unless a station on a known frequency can be picked up, then this can be used to align the dial at this one point.

With the alignment completed, the set can be installed in the case. The batteries are placed on either side of the chassis, one "B" battery on the speaker side and two on the opposite side—to keep the weight balanced. The "Loop" back can then be screwed in place, using small screws. It is well to pack corrugated cardboard around the batteries, or fasten them to the inside of the case to prevent them from shifting in transit.

This completes the construction of the receiver—the parts used in the original model are listed below, for the convenience of the builder.

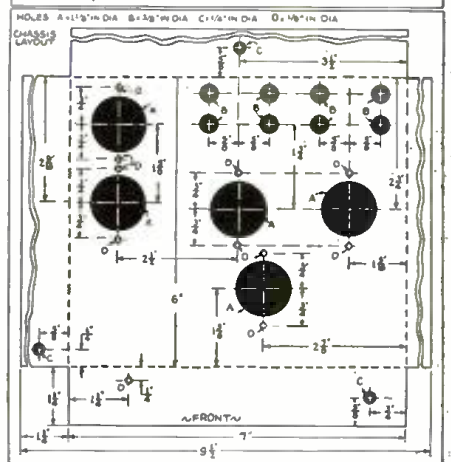
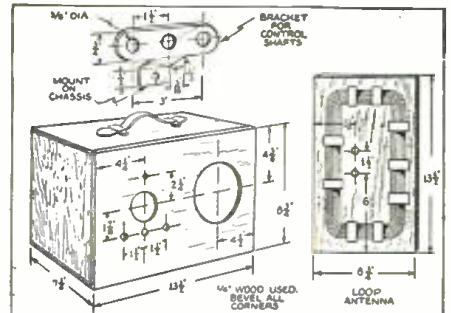

Details of chassis and cabinet.

Building and Using a Wheatstone Bridge

(Continued from preceding page)

Measuring the Resistance of a Measuring Instrument

$$R_{ap} = R_{ab} \frac{AP}{AB}$$

and $R_{pb} = R_{ab} \frac{PB}{AB}$

Between P and Q, we now add an interrupter; a balance is obtained when the deflection of the instrument is the same for an open circuit as for a closed circuit. We calculate the resistance as follows.

$$R_x = R \frac{PB}{AP} - R_0$$

For very sensitive instruments, a double bridge circuit may be used, as shown in Fig. 11. The formula is:

$$R_x = R \times \frac{a_2}{a_2 - a_1}$$

In this case, the bridge being a plain potentiometer, the resistance of the wire must be very small compared to the resistance of the instrument measured. The unknown resistance will be:

$$R_x = R \times \frac{UV}{WX}$$

The Thomson bridge is especially practical for extremely small values of resistances (see Fig. 12). The formula is:

$$R_x = \frac{R(P_2B + CP_1)^2}{AP_1 + P_2D^2}$$

In Fig. 13, two single bridges are used for very accurate measurements of inductances or capacities. The formula is:

$$I_1 = I_2 \frac{R_{11} + R_{1p}}{R_{12} + R_{1b}}$$

R_{1p} and R_{1b} are the two resistances of the wires between AP or PB, which is calculated by

Measuring Amplification Factor of a Tube

The circuit is shown in Fig. 14. The bridge is fed by alternating current, one part to the control grid, another to the plate circuit. When the sound in the receiver disappears, the amplification factor is:

$$\mu = \frac{PB}{AP}$$

(J. Fasal; courtesy "Radio-Constructeur," Paris, France.)

Correction

RADIO & TELEVISION is glad to publish this letter from Mr. Selde to correct a statement attributed to him last month.

Editor, RADIO & TELEVISION:

I did not say that the Government "should make some funds available" for television. I never discussed the finances of television, which are totally outside my department.

I did say that I have heard people talk about the Government making some kind of investment in television, but it would be totally impossible for me to make the specific statements that are attributed to me in your July issue.

Faithfully yours,

Gilbert Selde,

Director of Television Programs,
Columbia Broadcasting System, Inc.

Xmitter- Receiver for the Ham Beginner

(Continued from page 230)

A 6-volt storage battery can be connected to this power socket in place of the two filament leads from the A.C. power-supply. A number of 45-volt "B" batteries, or a genemotor or vibro-pack type of power-supply can then be connected to the positive and negative terminals of this power socket corresponding to the positive and negative terminals of the A.C. power supply which is built in the station. It will be necessary for any battery type source of power supply (such as "B" batteries or a genemotor) to provide at least 350 volts at 100 milliamperes for efficient operation of the transmitter, although the receiver itself may be operated with plate supply voltages as low as 250 volts.

Assuming that you have completely assembled and wired the Knight Junior Amateur station, and that you have wound the receiver and transmitter coils according to the coil data given later, the next step will be to put up an antenna.

The Antenna

This antenna should be of the doublet type, consisting of a straight wire 132 feet in length. Cut this length of wire in the exact center and insert a 3- or 4-inch antenna insulator. Then attach a length of twisted pair transmission line to the antenna, connecting one side of the transmission line to one-half of the antenna at the center insulator, and the other wire of the transmission line to the half of the antenna which is fastened to the other end of the center insulator.

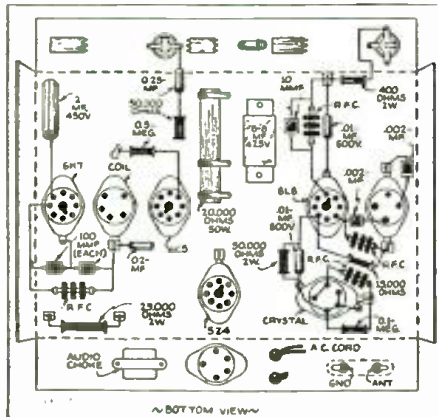

Plan view of set.

In order to transmit, the antenna switch must first be placed in the position which connects the transmitting antenna to the transmitter portion of the station unit. Now obtain a small six volt pilot light bulb such as is used in most radio sets, and a piece of wire about 6" long. Make a loop of this wire and solder one end to the shell of the pilot light bulb, and the opposite end to the center connection of the pilot light bulb. Now suspend this loop around the coil in the transmitter, press the key and rotate the tuning dial to the spot where the light bulb lights up. You will find that perhaps it is easier to get the bulb to light if the antenna is disconnected from the transmitter (that is, turned over to the receiving position) before you tune the transmitter to the point where the pilot bulb lights up. This lighting up of the pilot bulb indicates that the transmitter is oscillating properly. Then by flipping the antenna switch back to the transmitting position, the pilot light bulb should dim considerably. This indicates that the an-

tenna is drawing power from the transmitter. In order to be sure that the transmitter is operating properly however, you should slightly re-tune the transmitter by moving the tuning dial a very slight amount in order to find the point where the pilot light bulb will be the brightest.

The transmitting key should never be pressed while you are listening to the receiver. If the transmitting key were pressed while the receiver were in operation, the radio frequency field set up by the transmitter would "block" the receiver, entirely preventing any signals from being heard. Likewise when the antenna has been connected by means of the change over switch to the transmitter, and while keying the transmitter, a series of rapid clicks or thumps will be heard in the headphones. This condition can be eliminated by always turning the regeneration control back to the zero position while transmitting, and this control can be advanced to the proper position as soon as transmission has stopped.

Essential Coil Data—Transmitter

The coil for the transmitter section should be made on a 4-prong coil form, by winding on 38 turns of No. 22 double silk covered wire. At a distance of 1/4" from the bottom of this winding, wind on 3 turns of wire which will be the link coupling circuit for connection to the antenna.

By using separate crystals and coils of the proper type, this transmitter may also be operated on the amateur 160 meter, 40 meter and 20 meter bands. A 160 meter crystal can be used with the same coil which is used for 80 meters. However, for operation on 40 meters, the coil should consist of 20 turns of No. 22 double silk covered wire and should have only a 2 turn link. The 20 meter coil requires only 10 turns of No. 18 double cotton covered wire spaced out to cover 1 3/16" on the coil form, and a separate 2 turn link winding.

Coil Data—Receiver

The primary winding of the 80 meter coil for the receiver should have 10 turns of No. 24 D.S.C. wire. This antenna winding should be spaced approximately 1/8" below the main or secondary winding. The secondary winding should have a total of 27 turns of wire, with the cathode tap 1 1/4" turns up from the bottom or ground side on the secondary winding. The band-spread tap or the tap on the coil where the band-spread condenser connects to the coil will be 2 turns from the top of the secondary winding.

(This article prepared from data supplied by Allied Radio Corporation.)

JUNIOR AMATEUR STATION

Receiver Section

- (All parts numbers are Knight catalog numbers)
- 2—Octal sockets—E1520
 - 1—5-prong socket—E1516
 - 1—Hammarlund MC-35-S—E5301
 - 1—Hammarlund MC-140-S—E5299
 - 3—.0001 mf. mica condensers—E7830
 - 1—2 mf. 450 volt condenser—E3777
 - 1—5 mf. 25 volt condenser—E3790
 - 1—5 meg., 1/2 watt resistor—E5008
 - 1—500,000 ohm, 1/2 watt resistor—E4947
 - 1—2,000 ohm, 1 watt resistor—E5067
 - 1—25,000 ohm, 2 watt resistor—E5185
 - 1—50,000 ohm potentiometer—E3043
 - 1—R.P. choke—E2163
 - 1—Single-circuit jack—E8982
 - 1—Audio choke—E11654
 - 1—S.P.S.T. toggle switch—E5450
 - 2—Bar knobs—E3760
 - 1—Dial plate—E5677
 - 1—Dial—E5734
 - 1—Twin binding post—E4058
 - 1—Grid clip—E6335

AN ULTRA COMPACT CAPACITOR BRIDGE For Servicemen and Technicians

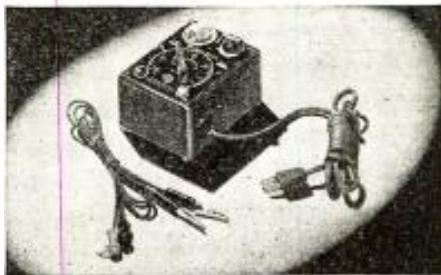

Built in an attractive walnut Bakelite case this Capacitor Bridge is the most compact useful instrument of its type ever offered to the service field. No serviceman can afford to be without one of these useful, economical instruments. Check these outstanding features found only in the C-D Capacitor Bridge.

Measures Capacity . . . of all type capacitors between limits of .00001 mfd. to 50 mfd.

Detects Defective Capacitors . . . will check for opens, shorts, high and low capacity, and high power-factor.

Checks Circuit Continuity . . . may be used as continuity meter.

Employs Wien Bridge . . . accuracy independent of line voltage variations.

Visual Eye Bridge Balance . . . dual type visual bridge balance for accurate measurements facilitates quick tests on service jobs.

Direct Reading Scale . . . direct reading ranges with all scale markings directly in microfarads.

Economical . . . List price, less tubes, \$16.50. Dealer's Net \$9.90.

Other features of this outstanding C-D Capacitor Bridge described in Catalog No. 167-A free on request.



ALL NEW TUBES FOR THE TRANSMITTING RADIO AMATEUR

**RCA—RAYTHEON
TAYLOR—EIMAC
GAMMATRON**

ALL TYPES IN STOCK FOR RUSH SHIPMENT

CAMERADIO

963 LIBERTY AVE. • 30 TWELFTH ST.,
PITTSBURGH, PA. • WHEELING, W. VA.

Established 1919

TELEVISION

Experimenters and Servicemen!

Check your television receiver installations with this beautiful French compass.



Accurately indicates the Earth's magnetic field, thus permitting the television or short wave aerial to be quickly positioned in the home, office, store or factory.
P.P. prepaid in U.S. and Canada
\$1.50

\$1.50

GOLD SHIELD PRODUCTS

Dept. RT-8 350 Greenwich St. New York

EVERYTHING IN RADIO!

A COMPLETE SOURCE FOR YOUR RADIO NEEDS
Our immense stock of radio sets, parts and supplies enables you to purchase your radio needs on one order. You will find all your Nationally Known Favorites in this big book which is FREE for the asking. Practically every order is shipped the same day it is received.
WRITE FOR BIG NEW CATALOG

BURSTEIN-APPLEBEE CO.
1012-14 McGee St. • Kansas City, Mo.

- 1—Metal tube cap—E5290
- 1—8" x 17" x 12" chassis base—E12441
- 1—7" x 18" panel—E9756
- 1—6K7 tube—E1071
- 1—6C5 tube—E1066
- 1—.01 mf. 400 volt tubular condenser—E7921
- 1—.25 mf. 400 volt tubular condenser—E7928
- 1—50,000 ohm. 1 watt resistor—E5088

Transmitter Section

- 1—100,000 ohm, 1 watt resistor—E5091
- 1—400 ohm, 2 watt resistor—E5156
- 1—15,000 ohm, 10 watt resistor—E8292
- 1—50,000 ohm, 2 watt resistor—E5188
- 1—.0001 mf. mica condenser—E7830
- 1—Hammarlund MC-100-S—E6305
- 2—.01 mf. 600 volt tubular condensers—E7937
- 1—.002 mf. mica condenser—E7839
- 1—Octal socket—E1520
- 1—4-prong socket—E1515
- 1—5-prong socket—E1516
- 1—4-prong coil form—E5371
- 3—R.F. chokes—E2163
- 1—Dial—E5734
- 1—Key jack—E8983
- 1—Crystal holder—E2533
- 1—80-meter crystal—E2511
- 1—6L6G tube—E237

Power-Supply Section

- 1—A.C. line cord—E2447
- 1—T13R15 transformer—E11252
- 1—T13C30 choke—E12761
- 1—Octal socket—E4511
- 1—8.8 mf. condenser—E3819
- 1—20,000 ohm, 50 watt resistor—E4767
- 1—S.P.S.T. toggle switch—E5450
- 1—Pilot light bracket—E6388
- 1—6.3 volt bulb—E1256
- 1—5-prong plug—E1631
- 1—Ft. 5 conductor cable—E3503
- 1—5-prong socket—E4507
- 1—D.P.D.T. toggle switch—E5459
- 1—5Z4 tube—E1063

Hardware

- 3—Dozen 1/2" 6/32 machine screws—E7012
- 3—Dozen 6/32 nuts—E7005
- 12—Insulated tie lugs—E6513
- 4—2-lug terminal strips—E6305
- 1—25-ft. roll No. 18 hookup wire—E3394
- 1—Length spaghetti—E2895
- 1—Spool No. 24 D.S.C. wire—E2775
- 1—Spool No. 22 D.S.C. wire—E2774
- 1—Complete kit, including all parts for receiver, power supply, transmitter, and accessories—E9537

BOOK REVIEW

TELEVISION CYCLOPEDIA, 64 pages, size 5 1/2" x 8 1/4", illustrated. Published by Supreme Publications, Chicago.

M. N. Beitman, the author of this book, is Radio Instructor in Englewood High School, Consulting Engineer of Allied Radio Corporation, and B.S. in Mathematics of the Lewis Institute.

In addition to definitions of television terms from "Aberration" to "Work Function" there are numerous illustrations of television sets and circuits with graphs to illustrate special points. The latter portion of the book gives an explanation of the principles of television, and the articles throughout go far enough beyond mere definitions to make the name "Cyclopedia" truly appropriate.

AUDEL'S NEW RADIOMANS GUIDE, published by Theo. Audel & Co., New York, N. Y. This book consists of 34 chapters; 750 pages, size 4 3/4" x 6 1/2"; 400 diagrams, charts and photos.

The author is E. P. Anderson, the well known electrical engineer. The contents are progressively arranged, beginning with the basic fundamentals of radio explained through numerous analogies, and ranging all the way through aircraft radio, automatic radio alarms, short-wave receivers, 47 pages are devoted to Television alone with up to the minute technical information and illustrations. Several sections are devoted to trouble shooting, antenna systems, vacuum tubes, electrical measuring instruments, phonograph pick-ups, etc.

The book will form a handy reference volume, particularly for the experimenter and others who wish to get a broad background of radio. Detailed index is supplied.

LOOK AND LISTEN (The Television Handbook), published by Norman W. Henley Publishing Company, New York, N. Y. Contains 96 pages, 6 1/2" x 9", illustrated.

M. B. Sleeper, the author of this book is a member of the Institute of Radio Engineers and is, at present, actively engaged in the television business. He is certainly an authority on the subject and fitted to write upon it, if anyone is. This opinion is proven by an inspection of his book which is practical, understandable and handsomely illustrated.

The first book on television published since American television left its experimental stage to become a regular service, its contents are up to the minute. They give the reader a thorough picture of just what has been done in television and of the steps which will doubtless follow. The operation of receivers and transmitters is explained clearly and simply, and detailed instructions are given for assembling the Andrea KTE-5 television kit. Other

chapters deal with the erection of a television antenna, installation and operation of a completed receiver, "trouble shooting" when things go wrong, and a television dictionary. In fact, any one who is interested in television either from the academic end or for practical purposes cannot be without Mr. Sleeper's book.

TELEVISION, published by Radio Corporation of America, 18 pages, size 8 1/4" x 3 3/4".

This little book has a foreword generally explanatory of the television situation in New York and of RCA's part in providing visual entertainment. The section following answers thirteen general questions pertaining to television; next comes a section of twenty-three questions and answers on television receivers. Six answers to questions on television transmitters follow, after which come four questions, together with answers, regarding television programs. A glossary of television terms, a chronological outline of the early activities leading to television, and a summary of RCA television contributions complete the book, which is profusely illustrated.

THE RADIO MANUAL, 3rd edition, by George E. Sterling, 1107 pages, plus index, size 5 3/4" x 8". Published by D. Van Nostrand Co., Inc., New York City.

First published in October, 1928, this volume has now reached its third edition and already the first and second printings have been run off. The author, who is Assistant Chief of the Field Section for the Engineering Department of the Federal Communications Commission, and a member of the Institute of Radio Engineers, commences his book with elementary electricity and magnetism, explaining the fundamentals of radio operation.

In extremely well-organized style, he follows, with motors, generators, storage batteries, vacuum tubes and their uses, modulation systems, etc., and devotes large sections to broadcasting apparatus and operating technique, antenna design, modern aircraft and police radio, etc. He not only describes apparatus but gives data as to procedure. Appendices give further information on the examination for aeronautical operators (a field which is daily growing in importance), U. S. Coast Guard distress instructions, and medical aid to radio vessels at sea. The index occupies 11 pages and is arranged so that one may quickly find any subject on which information is desired. The book is illustrated with photographs, diagrams and graphs. It is a volume which should be on every radio experimenter's book-shelf.

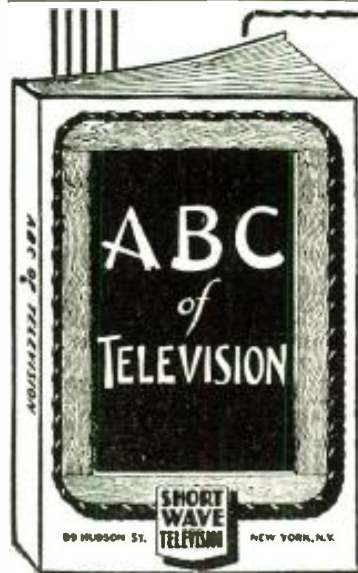

TELEVISION'S Stride Today Makes It Essential for You to Read—"ABC of TELEVISION"—

WITH important progress being made in Television every day—and with developments satisfactory to Television engineers that consistent programs will be broadcast shortly, it is important that principles be understood quite thoroughly.

The publishers of RADIO AND TELEVISION give you the opportunity to add "ABC OF TELEVISION" or two other books to your technical library. They make the offer even more attractive by giving these books to you absolutely FREE. A subscription to RADIO AND TELEVISION for seven months at the cost of One Dollar gives you a choice of either of the three books shown in this advertisement. For Two Dollars you receive RADIO AND TELEVISION for fourteen months and you receive any two books of your choice absolutely FREE. To get all three books FREE, enter your subscription for twenty-one months for only Three Dollars. ANOTHER SAVING FOR YOU—THE PUBLISHERS PAY POSTAGE ON THE BOOK OR BOOKS YOU CHOOSE.

Partial Contents of ABC of Television

- CHAPTER 1—The simplest television receiver: how the eye sees; its likeness to television equipment.
- CHAPTER 2—Theory of scanning; the Nipkow disc and its relation to television; the photo-electric cell; neon lamps; brief description of several modern mechanical systems.
- CHAPTER 3—Need for a large number of picture elements; need for broad channel width in transmission of high-fidelity television signals.
- CHAPTER 4—The use of the cathode ray tube in television receivers; necessary associated equipment used in cathode-ray systems.
- CHAPTER 5—How a television station looks and how the various parts are operated.

- CHAPTER 6—The Iconoscope as used for television transmission in the RCA system.
- CHAPTER 7—The Farnsworth system of television transmission.
- CHAPTER 8—The future of television; probable cost of receivers; some expressions of opinion by prominent men; list of present television transmitters.

64 PAGES—100 ILLUSTRATIONS
Stiff, Flexible Covers, 5 1/4 x 8 3/4 INCHES

FREE!!

Get One or All of These Books

SHORT WAVE GUIDE



Covers hundreds of short-wave questions and answers; illustrates popular short-wave kinks; gives explicit instructions for building simple short-wave receivers; instruction on the best type of antenna installation; diagram and construction details for building transmitters.

S. W. RADIO QUIZ BOOK

This book covers questions and answers on transmitters, short-wave receivers, ultra short-wave receivers; practical converters, noise silencers, power supplies, modulators, beat oscillators, antennas, pre-selectors and 5-meter receivers.



RADIO AND TELEVISION, 99 Hudson Street, New York, N. Y. R&T-8-39

Gentlemen: Enclosed you will find my remittance of \$..... for which enter my subscription to RADIO AND TELEVISION as checked below; also send me, postpaid, the book or books which I have marked below.

- ABC OF TELEVISION
- S. W. RADIO QUIZ BOOK AND KINKS
- SHORT WAVE GUIDE

- 7 months—\$1.00—choice of any one of three (3) books. (Canadian and foreign—\$1.30)
- 14 months—\$2.00—choice of any two (2) of the three (3) books. (Canadian and foreign—\$2.60)
- 21 months—\$3.00—all three books. (Canadian and foreign—\$3.90)

If you are a subscriber now, we will extend your present subscription.
 New subscriber Old subscriber

Name..... Address.....

City..... State.....

Send your remittance by check or money order. If you send cash or unused U.S. postage stamps, please be sure to register your letter for your own protection.

The LT-6 Loktal Superhet

(Continued from page 223)

and try to tune-in a fairly strong signal. Rotate the R.F. trimmer condenser for best reception and carefully "peak" each I.F. trimmer for the loudest signal. Do not, under any circumstances, turn either the dial or the gain controls during the I.F. adjustments. Always have a good reliable signal tuned in before making any adjustment of the trimmers; otherwise, the I.F. circuits may be thrown so far out of alignment that it will be impossible to hear a signal no matter how strong it may be.

R.F. Circuit Adjustments

The alignment of the R.F. circuit is extremely simple. The oscillator padding condenser, "CP," is used on the 40, 80 and 160 meter coils only; the tuning circuits track quite evenly over the 10 and 20 meter ranges, so the use of padding condensers in this region is not necessary. The padder values listed with the oscillator coil data are not at all critical and the same size, 500 mmf., may be used on all three of the low-frequency bands if desired. Tune-in the test signal, "rock" the tuning dial back and forth and at the same time adjust the padding condenser for greatest sensitivity.

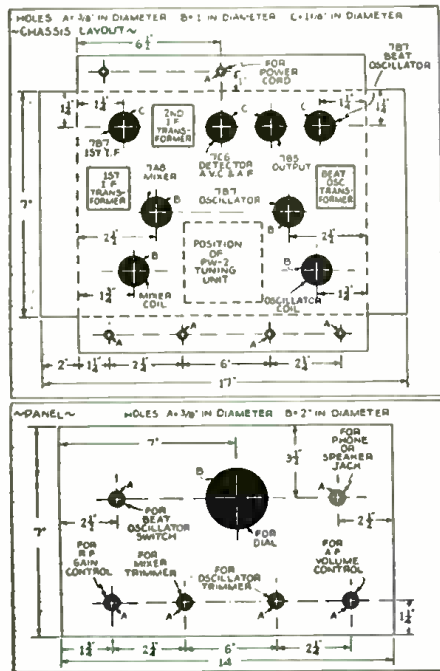

Repeat the process on each of the three low-frequency bands. Alignment of the mixer circuit is not required as the 35 mmf. trimmer takes care of any small difference which may exist during tuning.

The power supply is built on a separate chassis and is not shown in the photographs. The R.F. choke in the positive "B" circuit, and the bypass condensers across the primary and the high voltage secondary windings of the power transformer, help to eliminate noises.

Either a single-wire or a doublet antenna may be used with this receiver. For best results the antenna should be erected well in the clear and at least 25 to 50 feet in length. If a doublet antenna is used, open the link, which is indicated by the dotted line in series with the antenna coil in Fig. 1, and attach the two wires of the twisted pair to the free ends of the coil. A good ground is connected to the chassis in the usual manner.

Parts List—"LT-6" Ham Receiver

NATIONAL CO.

- 1—PW-2 Tuning Unit, 50 mmf., double-spaced condensers
- 2—Iron-core I.F. transformers, 450-550 kc., Type IFC
- 1—Air-core Beat Oscillator transformer, 450-550 kc., Type IFCO
- 6—Isolantite "lokta" sockets (recommended)
- 2—Isolantite sockets, 4 prongs (for coils, see text)
- 1—Set XR-1, 4-prong coil forms (two for each band desired)
- 1—Mica trimmer condensers, Type M30
- 2—"HRO" type dials

HAMMARLUND MFG. CO.

- 1—"MC" Tuning condenser, 35 mmf.
- 1—"MC" Tuning condenser, 20 mmf.
- 2—"CHX" R.F. chokes, 2.1 mh.
- 1—"TS-50" tube shield (see text)

I.R.C. (Resistors)

- 3—250,000 ohm resistors, 1 watt
- 3—100,000 ohm resistors, 1 watt
- 4—50,000 ohm resistors, 1/2 watt
- 3—500,000 ohm resistors, 1/2 watt
- 2—10,000 ohm resistors, 1 watt
- 1—25,000 ohm resistor, 1 watt
- 4—1 megohm resistors, 1/2 watt
- 1—500 ohm resistor, 1 watt
- 1—300 ohm resistor, 1 watt
- 1—5,000 ohm resistor, 1 watt
- 1—500 ohm resistor, wire-wound, 10 watts
- 1—5,000 ohm volume control, with S.P.D.T. switch
- 1—500,000 ohm volume control, with S.P.S.T. switch

CORNELL-DUBILIER (Condensers)

- 3—.0001 mf. mica condensers, Type 1W
- 1—.006 mf. mica condenser, Type 3L
- 1—.00025 mf. mica condenser, Type 3L
- 1—.0005 mf. mica condenser, Type 1W
- 1—.001 mf. mica condenser, Type 3L
- 7—.01 mf., 600 volts D.C. working volts, paper, Type SM
- 4—.05 mf., 600 volts D.C. working volts, paper, Type SM
- 1—10 mf., 50 D.C. working volts, electrolytic, Type JR
- 1—.25 mf., 25 D.C. working volts, electrolytic, Type JR

NATIONAL UNION (Tubes)

- 3—Type 7B7 "lokta" tubes
- 1—Type 7A8 "lokta" tubes
- 1—Type 7C6 "lokta" tubes
- 1—Type 7B5 "lokta" tubes

BRUSH DEVELOPMENT CO.

- 1—Pair Brush crystal headphones

WRIGHT DECOSTER

- 1—Model 682 "Nokoil" P.M. dynamic speaker, 8" suede finish case

MISCELLANEOUS

- 2—Notched knobs
- 1—Steel cabinet and panel, 7 x 14 inches
- 1—Steel chassis, 7 x 13 x 2 inches
- 1—S.P.S.T. toggle switch and plate
- 1—Output choke, 30 henries, 75 ma.

POWER-SUPPLY UNIT (Halldorson Transformers)

- 1—Power transformer, 275 volts D.C., 70 ma. after filter, Type 67
- 2—Filter chokes, 30 henries, 80 ma. Type C4-967
- 1—R.F. choke (75 turns of No. 30 enameled on a 1/2" form)
- 3—8 mf., 450 volts D.C. electrolytic condensers
- 2—0.1 mf., 600 volt paper condensers, tubular
- 2—0.05 mf., 600 volt paper condensers, tubular
- 1—15,000 ohm, 25 watt fixed resistor, wire-wound
- 1—Chassis, 7 x 16 x 2 inches
- 1—5Y4G tube (National Union)

COIL DATA

Mixer Coils

L2	Spacing	Tickler	L1	Wire	Dia.	Band
4 t.	1"	3 t.	3 t.	20 E.	1"	10 m.
12 t.	1"	4 t.	3 t.	20 E.	1"	20 m.
17 t.	1 1/4"	6 t.	4 t.	22 E.	1 1/2"	40 m.
37 t.	1 1/4"	9 t.	7 t.	22 E.	1 1/2"	80 m.
58 t.	1 1/4"	14 t.	10 t.	28 E.	1 1/2"	160 m.

L1 can be wound over center of L2 (grid coil) for Ant. & Gnd. or near "cold" end of L2 for "doublet."

Oscillator Coils

L3	Spacing	Tickler	Wire	Dia.	Band	"CP"
4 t.	1"	3 t.	20 E.	1"	10 m.	None
12 t.	1"	4 t.	20 E.	1"	20 m.	None
15 t.	1 1/4"	6 t.	22 E.	1 1/4"	40 m.	.001 mf.
32 t.	1 1/4"	9 t.	22 E.	1 1/4"	80 m.	.0007 mf.
52 t.	1 1/4"	16 t.	28 E.	1 1/2"	160 m.	.0004 mf.

The mixer coils are wound on four- or five-prong forms; the oscillator coils are wound on four-prong forms. All ticklers are wound on "cold" or ground end of form.

Make MORE EFFICIENT use of your STATION POWER

with NEW



TRIPLET

Model 1696 Dealer Net \$33.00

MODULATION MONITOR

★ USABLE ON ALL AMATEUR BANDS

★ PERMITS COMPLIANCE WITH FEDERAL REGULATIONS

- 110 Volt AC 60 Cycle Operation.
- Two meters—one for carrier, one for % Modulation.
- Neon Light for Instantaneous Flash.
- Tip Jacks for Phone Connection.
- Uses Vacuum Tube Rectification.

FREE TECHNICAL DATA ON REQUEST

Write Section 288 Harmon Ave.

TRIPLET ELECTRICAL INSTRUMENT CO. Bluffton, Ohio

PYRO PANTAGRAPH



Size of Box: 12 1/2 x 8 1/2 inches

\$2.75

Shipping weight, 3 lbs.

THIS electrical outfit is especially designed for burning designs permanently on materials such as Leather, Wood, Cork, Bakelite, etc. Plug the Pyro-electric pencil in any 110 volt AC or DC outlet and it is ready to be used. Plug and cord furnished.

By the use of the Pantagraph included in the outfit, any design may be reproduced either in original, reduced or enlarged form.

Outfit consists of: one Pyro-electric Pencil; one Pantagraph; three hardwood plaques; one bottle of Varnish; one Brush; one tracing tip and four-page instruction sheet.

Size of box: 12 1/2 x 8 1/2 inches.

Outfit will be forwarded by Express Collect if not sufficient postage included with your order.

WELLWORTH TRADING CO.

1915 S. State St., Dept. RT-839 Chicago, Ill.

8 GREAT 10 CENT RADIO BOOKS

RADIO FANS EVERYWHERE—these fine ten cent text books give you an excellent foundation for the study of radio. They are clearly written, profusely illustrated and contain over 15,000 words in each book. You'll be amazed at the wealth of information these books have. Handy for review or reference. Your money back if you are not pleased!



NO. 1—HOW TO MAKE FOUR DOERLE SHORT WAVE SETS

Literally thousands of radio fans have built the famous DOERLE Short Wave Radio Receivers. No insistent has been the demand for these receivers, as well as construction details, that this book has been specially published. Thousands of copies of this book have been bought by short-wave fans. Contains EVERYTHING that has ever been printed on these famous receivers. These are the famous sets that appeared in the following issues of SHORT WAVE CRAFT: "A 2-Tube Receiver that Reaches the 12,500 Mile Mark," by Walter C. Doerle, "A 3-Tube 'Signal Gripper,'" by Walter C. Doerle, "Doerle '2-Tube' Adapted to A.C. Operation," "The Doerle 3-Tube 'Signal Gripper' Electrified," and "The Doerle Goes 'Band-Spread'".



NO. 2—HOW TO MAKE THE MOST POPULAR ALL-WAVE 1- and 2-TUBE RECEIVERS

This book contains a number of excellent sets, some of which have appeared in past issues of RADIO-CRAFT. These sets have been carefully engineered. They are not experiments. To mention only a few of the sets the following will give you an idea: "The Megadyne 1-Tube Pentode Loudspeaker Set," by Hugo Gernsback, "Electrifying The Megadyne," "How To Make a 1-Tube Loud Speaker Set," by W. H. Cheney, "How To Make a 2-Tube 1-Tube All-Wave Electric Set," by F. W. Hart, "How To Build A Four-In-Two All-Wave Electric Set," by J. T. Bernaley, and many others.



NO. 3—ALTERNATING CURRENT FOR BEGINNERS

This book gives the beginner a foothold in electricity and radio. Electric circuits are explained. Ohm's Law, one of the fundamental laws of radio, is explained; the generation of alternating currents, sine waves; the units—volts, amperes, and watts are explained. Condensers, transformers, A.C. instruments, motors and generators. Here are some practical experiments to perform at home. Simple tests for differentiating between alternating and direct current; how to light a lamp by induction; making a simple electric horn; demagnetizing a watch; testing motor armatures; charging storage batteries from A.C. outlet; testing condensers with A.C.; making A.C. electro magnets; frying eggs on a cake of ice; making simple A.C. motors; many others.



NO. 4—ALL ABOUT AERIALS

This book explains the theory underlying the various types of aerials: the inverted "L," the Doublet, the Doublet, etc. It explains noise-free reception, how low-impedance transmission lines work; why transposed leads are used. It gives in detail the construction of aerials suitable for long-wave broadcast receivers, for short-wave receivers and for all-wave receivers. Various types of aerials for the amateur transmitting station are explained. It eliminates, once and for all confusion about the type of aerial to choose for best broadcast and short-wave reception. For the thousands of radio fans who wish to know just what type of antenna they should use and why, this book has been published. Experts in radio have found valuable information in this book.



NO. 5—BEGINNERS' RADIO DICTIONARY

Are you puzzled by radio language? Can you define Frequency? Kilocycles? Text-books? Triodes? Bass? Anode? Triode? Ionization? Joule's Law? Harmonic Gravity? Call? If you understand these very common radio words and dozens of others, more technical terms used in all radio magazines and instruction books, you need this book in your library. It's as modern as tomorrow—right up to the minute. It tells you in simple language just what the words that puzzle you really mean. You cannot fully understand the articles you read unless you know what radio terms mean. This is the book that explains the meanings to you. Can you afford to be without it, even one day longer?



NO. 6—HOW TO HAVE FUN WITH RADIO

Stunts for parties, practical jokes, scientific experiments and other amusements which can be done with your radio set are explained in this fascinating volume. It tells how to make a newspaper talk—how to produce silent music for dances—how to make visible music—how to make a "silent radio" unit, usable by the deafened—how to make toys which dance to radio music—sixteen clever and amusing stunts in all. Any of these can be done by the novice, and most of them require no more equipment than can be found in the average home. Endless hours of added entertainment will be yours if you follow the instructions given in this lavishly illustrated book. Get a copy today by using the coupon below—mail it today.



NO. 7—HOW TO READ RADIO DIAGRAMS

All of the symbols commonly used in radio diagrams are presented in this book, together with pictures of the apparatus they represent and explanations giving an easy method to memorize them. This book, by Robert Eichberg, the well-known radio writer and member of the editorial staff of RADIO-CRAFT magazine, also contains two dozen picture wiring diagrams of simple radio sets that you can build. Every diagram is completely explained in language which is easily understood by the radio beginner. More advanced radio men will be interested in learning the derivation of diagrams, and the many other interesting facts which this book contains. It is also helpful in solving many of the problems of servicemen.



NO. 8—RADIO FOR BEGINNERS

Hugo Gernsback, the internationally famous radio pioneer, author and editor, whose famous magazines, RADIO AND TELEVISION and RADIO-CRAFT are read by millions, scores another triumph with this new book. Any beginner who reads it will get a thorough ground work in radio theory, clearly explained in simple language, and also the use of many illustrations. Analogies are used to make the mysteries of radio as clear as "2+2 is 4." It also contains diagrams and instructions for building simple radio sets, suitable for the novice. If you want to know how transmitters and receivers work, how radio waves traverse space, and other interesting facts about this modern means of communication, this is the book for you!

2 1/2 Meter Acorn Transceiver

(Continued from page 227)

set is a half-wave vertical, and was made from a cut down 5-meter unit. It fastens onto the panel insulators with wing nuts and should be adjustable from 2.5 to 4 feet in height.

How to Operate the Set

Operation of the rig is quite simple. The receiving side should be tried first. With no antenna connected, advance the regeneration control towards maximum till a hissing is heard. The hiss should be smooth but quite loud and the plate meter should register not more than 1/2 ma. or so. Then install the antenna and put the coupling clip from the antenna condenser one turn away from the RFC clip. The latter, by the way, is not very critical, but seems best near the center of the coil. It should be tried in different positions before soldering fast. It will be found that oscillation can be controlled by the setting of the antenna condenser as well as by the regeneration control. A point will usually be found for best adjustment of these two to give loudest and clearest signals.

On the transmitter side, the plate meter will indicate about 1.5 ma. with no antenna and when the antenna is coupled, it may be run up to 3 ma. but not much over. A point of maximum plate current for each length of antenna around 3.5 feet will be found, and the rig should always be operated at this point for best efficiency. The same point will hold for reception and will give greatest signal strength.

An accurately calibrated absorption type wavemeter may be used to set the rig to the proper frequency. A wide band may be covered by spreading or crowding the turns of the coil until the desired frequency range is covered.

List of Parts

- HAMMARLUND**
 1—25 mmf. trimmer condenser, APC25
 1—15 mmf. trimmer condenser, HF15
 2—Isolantite octal sockets, S9

- RCA**
 1—Acorn tube, No. 958
 1—Acorn tube, No. 957

- I.R.C.**
 1—10 megohm insulated resistor, BT1
 1—2 megohm insulated resistor, BT½
 2—5 megohm insulated resistors, BT½
 1—50,000 ohm insulated resistor, BT½

- CORNELL-DUBILIER**
 2—100 mmf. bakelite condensers
 1—.003 mf. bakelite condenser
 3—.1 mf. 400 volt paper condensers

- TRIPLETT**
 1—Metal case milliammeter, 2" size, 0.5 ma. range, No. 223

- UNIVERSAL MICROPHONE COMPANY**
 1—Handset with S.B. carbon mike and 2000 ohm phone

- BURGESS**
 2—45 volt B batteries, No. X30BP
 1—1.5 midget dry cell, No. 4

- UNITED TRANSFORMER COMPANY**
 1—Mike transformer, No. 0-14
 1—A.F. choke, No. A30

- UTAH**
 1—.5 meg. variable resistor, No. JP500 M
 1—3 circuit plug, No. 6
 1—3 circuit jack, No. 502 B
 1—Single-circuit jack, No. 1
 1—4-pole, double-throw switch, No. 312 B

- MISCELLANEOUS**
 1—NATIONAL vernier dial
 1—AMERICAN RADIO HARDWARE 5 meter, 3 section antenna, No. 279-1
 2—Small knobs
 4—Butt-in insulators
 Case material and hardware

BOOKS ARE ALL UNIFORM

Every book in the GERNSBACH EDUCATIONAL LIBRARY has 32 pages—with illustrations varying from 30 to 66 in number. Each title volume contains over 15,000 words. Positively radio's greatest book buys! If you do not think these books worth the price asked, return them in 24 hours and your money will be instantly refunded.

RADIO PUBLICATIONS • 101 HUDSON STREET • NEW YORK, N. Y.

RADIO PUBLICATIONS, Dept. RT-839
 101 HUDSON STREET, NEW YORK, N. Y.
 Gentlemen: Please send immediately, POSTPAID, the book numbers circled below, I am enclosing cents—each book being 10c.

Send FREE listing of 48 new 10c publications.

Name

Address

City

State

Remit by check or money order—register letter if you send cash or unused U. S. postage stamps.

MAIL COUPON TODAY!

1-Tube Television Converter

(Continued from page 210)

All resistors and condensers are grouped around the socket, making for extremely short leads. All grounds are brought to the No. 1 terminal of the socket, and this in turn is grounded through the upper brass stand-off to the shield.

The oscillator tuning condenser must be insulated from ground. Using the new Bud Tiny-Mite condensers, this is greatly simplified because they have a pair of tapped metal stand-offs fastened to the Aismag insulating plate. The condenser is therefore mounted on the shield by means of these small stand-offs, making certain that the hole in the front shield is large enough to clear the condenser shaft without shorting. Two flexible shaft couplings and a short length of bakelite rod are used to couple the two tuning condensers.

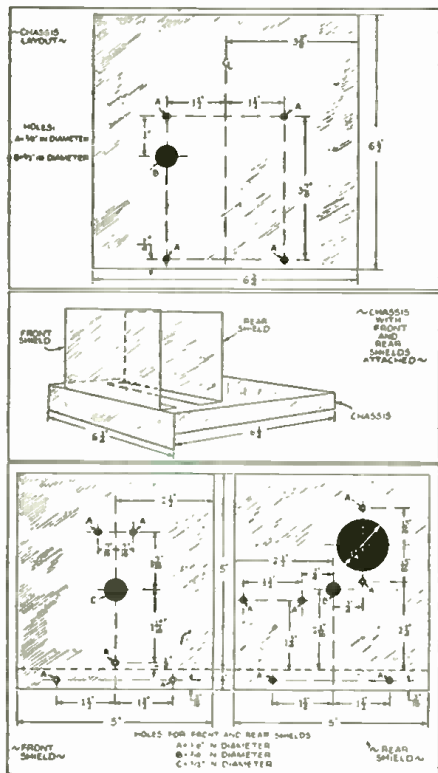

The output coil L4-L5 is unshielded. It might be preferable to shield this coil if a metal cabinet is not used. Mounted inside the 1 1/4" diameter coil form is a 75 mmf. condenser for adjusting to the I.F. frequency.

Power Supply for the Converter

The converter derives its power from the receiver with which it is used. Practically any receiver can supply the additional current necessary for its operation. However, if the receiver is of the a.c.-d.c. type where all the filaments are in series, it will be necessary to rewire the receiver filament circuit so that the converter tube filament can be placed in series with the receiver tube filaments. Alternatively, a separate power-supply can be built for the converter. The B plus lead from the converter should preferably be connected to about 200-250 volts, although lower voltage will suffice where necessary. If, in the receiver, one side of the filaments is grounded (instead of the center tap of the filament winding being grounded), then one side of the 6K8GT filament can be grounded at the tube socket, thus allowing the use of only three wires for power connection.

A pair of twisted wires should be used for connecting the output of the converter from L5 to the antenna terminals of the regular receiver. These leads should be shielded in order to prevent pickup of stations operating on the I.F. frequency. If, with the antenna disconnected from the receiver, stations can still be heard, a different intermediate frequency (that is, receiver frequency) should be carefully chosen so that no station can be heard with receiver r.f. gain wide open.

An effective antenna with a single wire lead-in can be clipped onto the detector grid coil L2. An antenna with a two-wire lead-in will require an antenna coupling coil. The writer didn't mount this coil on the chassis because it is intended to place the converter in a cabinet and the antenna coil will be supported from a pair of binding posts. This coil may consist of about 4 or 5 turns of hook-up wire wound inside the grid coil.

With the converter hooked up to the regular receiver, and the receiver tuned to a frequency between 1600 and 2500 kc., vary the condenser across L4 until the noise output from the receiver peaks up, indicating that the condenser-coil is tuned to the receiver frequency. Now uncouple the detector tuning condenser from the oscillator tuning condenser, and with the detector condenser set at about 2/3 its maximum capacity, vary the oscillator condenser until the noise output of the receiver once more peaks up. Two peaks will be heard. Referring only to the peak at the higher oscillator condenser capacity, note whether there is any great difference in oscillator and detector condensers. If there is, then vary the inductance of the detector coil by spreading apart or squeezing together the turns. If the detector capacity is higher than the oscillator capacity, decrease the detector inductance, while if the detector capacity is lower than the oscillator capacity, increase the detector inductance. This will require a little experimenting until the coils are so adjusted that the two tuning condensers will have the same capacity, when the frequency difference between the two circuits is equal to the intermediate frequency. This done, tuning for the desired stations can be accomplished.

At the lower capacity settings of the tuning condensers, amateur stations on the 5 meter band will be heard. So, if the television station is off the air, the converter can be tried out by tuning in this "ham" band. Incidentally, this converter makes an excellent unit for amateur use. For this purpose it might be well to use 15 mmf. tuning condensers for greater band-spread.

Television Sound Converter—Parts List

BUD RADIO

- 1—No. 524 chassis
- 2—1642 Tiny-Mite condensers, 25 mmf.
- 1—75 mmf. Tiny-Mite air padder, No. 1683
- 1—Isolantite octal socket, No. 959
- 2—Ceramic flexible couplings, No. 795

I.R.C.

- 2—50,000 ohms; 1—25,000 ohms; 1—300 ohms; 1/2 watt (BT)

SOLAR

- 4—.01 mfd. paper condensers, type SO-221
- 1—.0001 mfd. mica, type MT-1316

HYTRON

- 1—Type 6K8GT bantam tube

Coil Data

- L1—3 or 4 turns hook-up wire wound inside L2
- L2—7 turns No. 14 wound 9/16" diameter, 1" long (approximate)
- L3—7 turns No. 14 wound 9/16" diameter, 7/8" long (approximate)
- L4—88 turns No. 30 D.S.C. wound on 1 1/4" diameter form
- L5—5-10 turns No. 30 D.S.C. wound at one end of L4

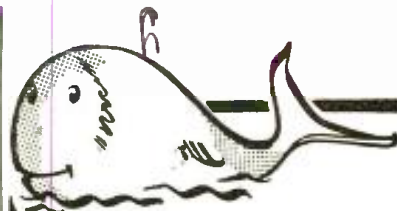

MIDGET CONDENSERS That Do a WHALE of a BIG JOB!

Want to save money on many of your condenser replacements? Want really good midget dry electrolytics—in really small sizes—at really rock-bottom prices? Then get next to Sprague ATOMS today. The fastest selling midgets on the market because they're the most reliable. Ask your jobber.

- ★ DUAL COMBINATIONS OR SINGLES
- ★ ALL WORKING VOLTAGES
- ★ UNCONDITIONALLY GUARANTEED AGAINST BLOW-UPS
- ★ LOW LEAKAGE
- ★ QUICK BUILD-UP
- ★ HIGH SURGE VOLTAGE

Sprague Products Co., North Adams, Mass.



SPRAGUE ATOMS

SAVE TIME - MONEY - SPACE

OUR STOCK OF U.S. ARMY SIGNAL CORPS LAMPS IS RAPIDLY DEPLETING. EVEN AT \$3.95. COMPLETE WITH FITTINGS AND PACKED IN A WOODEN CARRYING CASE, THE SAVING IS NEARLY 90% FROM THE GOVERNMENT COST.



U. S. ARMY SIGNAL CORPS LAMPS

The lamp of 100 uses

- Scout Signalling
- Night Bowling Alleys
- Trailer Lamp
- Night Motor Boat Races
- Auto, Truck and Trailer Lamps
- Tractor Light
- Camp Light
- Barnyard Lighting
- Night Fishing
- Radio Shacks
- Bungalows
- Picnics, etc.



Scouts Signalling

Large size—1 1/4" wide, 5 3/4" deep, 1 1/2" high including socket, fitted with 10" silver plated reflector (no glass, nothing to break). Packed in portable wooden carrying case, with hinged cover, haap and handles. Every case contains weatherproof extension cord and plus 2 extra bulbs, telegraph signalling key and 16 page U.S. Army Instruction Manual. Shipping weight 18 lbs. Price

\$3.95
F.O.B. N. Y.

Same size lamp without wooden case or extra fittings \$2.00
Small lamps, 6" \$1.00
Send for catalog containing full descriptions of this and many other interesting items.

GOLD SHIELD PRODUCTS

Dept. RT-8-9 350 Greenwich St. New York

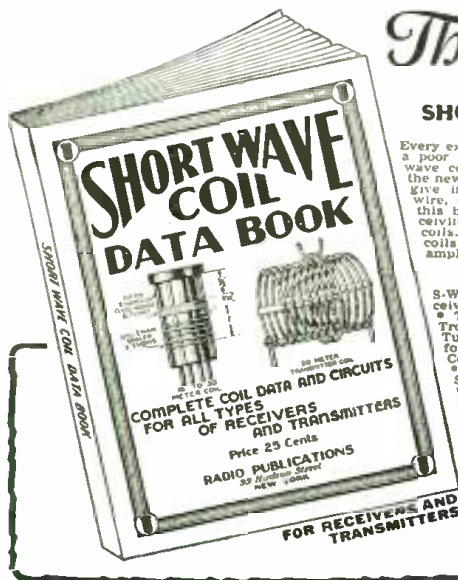

The 1 and ONLY

SHORT WAVE COIL DATA BOOK

Every experimenter knows that the difference between a good and a poor radio set is usually found in the construction of short-wave coils. Coil winding information is vitally important and in the new coil book all "dope" appears. There're illustrations which give instructions on how to wind coils, dimensions, sizes of wire, curves and how to plot them. Every experimenter needs this book—it also contains complete data on all types of receiving coils, together with many suitable circuits using these coils. Also complete data on various types of transmitting coils with many transmitting circuits such as exciters and amplifiers using the various coils described.

Contents Briefly Outlined

S-W Tuning Inductance Charts * Coil Data for T. R. F. Receivers * One Tube Oscillodyne * Two Tube Bandspreaders * The Mono-Coil * 2-Tube Old Reliable * 2-Tube Globe Trotter * 2 Winding Coils—10-500 Meters * Double 3-Tube "Signal Gripper" Electrified * 3-Tube Bandspreaders for the Ham * General Covered Coils on Ribbed Forms * Coil Data for Superhet or S-W Converter * Ultra S-W Coils * Switch Coils for S-W Superhets * Experimental Coils * S-W Antenna Tuner * Most Popular S-W Tuning Circuits * Self-Supporting Transmitting Circuits Employing Coils Described * All Band Antenna Tuner for Transmitters * Plug-in Coils for Parilla Frequency-Wavelength Conversion Chart.

PRICE 25c PREPAID

For a copy of this handy book, send 25c in U.S. Coin or stamps to

RADIO PUBLICATIONS
97 HUDSON STREET NEW YORK, N. Y.

ceiver, as pointed out in *Wireless Retailer and Broadcaster*, London. The primary tap on this transformer makes the doublet act as an ordinary "T" type antenna, as far as the broadcast receiver is concerned, while it retains its doublet characteristics for the other set, for the tuned coupler acts as a choke, blocking the 7-meter waves. Fig. 3 shows the doublet's cycle in free oscillation, with the current reaching its maximum in the center, and the voltage variation greatest at both ends.

In working with 5 meters, two 4-foot lengths of duralumin tubing or, as a substitute, number 12 copper wire, may be mounted on a mast with stand-off insulators, in the position previously described. A variation of this method calls for the use of a single 8-foot length of wire or tubing, with the ends of the twisted pair connected across the center, as shown in Fig. 4, the distance between them being from 6 to 9 inches.

Even more efficient is the antenna shown in Fig. 5. The upper end of the doublet is connected to the center wire of a shielded conductor, the lower end to the shield, as indicated. The shielded lead is run parallel to the lower branch, at a distance of 3 inches from it. Instead of 4 feet, each arm of this doublet should be 37 inches, for 5 meter reception.

Fig. 6 illustrates another variation. In this installation, the arms of the doublet are each 4 feet long; the shielded lead is kept 5 inches from the lower arm which is connected to the center wire, the upper arm being connected to the shield.

A piece of number 12 copper wire is connected 1 inch from the upper end of the lower arm, and at right angles to it. At 7 inches from this joint the wire is bent, and is continued parallel to the lower arm of the doublet for 47 inches. It is then bent at right angles again and soldered to the shield of the cable, which is led to the set.

Efficient U.H.F. Doublets

(Continued from page 217)

particular wave are best found by calculation—followed by experimentation.

The transmission line is ordinary twisted pair lamp cord, run at right angles to the antenna for at least ten feet, in order to avoid capacity effect to the lower half. This affords a good match to the doublet, and must be used with a correctly designed coupling transformer to feed the set.

Note in Fig. 2 how a coupling transformer may be applied directly to the doublet, in order to feed a standard broadcast receiver as well as the television re-

A "DX" Aerial for S-W Fans

(Continued from page 217)

feeders. The two joints and, in fact, all splices are well soldered and in some instances also taped. The leads are of heavily insulated (*Bare wire should serve just as well*—EDITOR.) number 14 copper wire, spaced about every 12 inches by flat simple little porcelain insulators with the nails taken out. In this way you get two spreaders from one insulator. The leads are run through the nail holes and drop as far as possible straight down and then run to the window. These spreaders are held in place by binding twine, which is tied around each spreader and drawn tight at the bottom of the drop. The spreaders are allowed to slide on the wire and are held in place only by the twine. This proves much more effective if the feeders are allowed to swing freely. At the end of the lead-in, a D.P.D.T. switch is connected with the antenna leads from the receiver soldered to the center taps on the switch. The antenna feeders are then soldered to one of the two pairs of outside jaws on the switch. Thus far you have one complete rhombic antenna with feeders to the west.

Now for the switch at the top of the east mast. (c). Another D.P.D.T. switch is screwed to the top of mast C, as indicated in the diagram. The antenna is "broken" and the loose ends are soldered onto the center taps of the switch. An 800-ohm 1-watt resistor is soldered across the top taps. This is optional, but does help a lot in getting rid of QRM. Another pair of feeders is soldered to the lower taps and brought down to the switch at the receiver. Be sure that when you fix this second pair to the open taps on the inside switch, that

you do not fix the north wires parallel on the switch, as shown in the drawing. In this way you have two end-fed V antennas. I have never seen an end-fed V yet, but these two work very well and seem rather *directional*. The outside switch on mast C is worked by a system of pulleys with a double length of twine dropping to the bottom of the mast. A bracket is placed on the top of the mast and the switch far enough below it so that there is sufficient leverage to work the blade of the switch both ways. By splitting the blades of the switch at the receiver and using the lineup I have just given, you have eight different antennas; 2 V's fed from the ends; 4 straight wires, end-fed, which really are V's also; and 2 rhombics, each fed from a different direction. By interchanging one pair of wires on the inside switch, you have two other antennas.

Light-Storage in Television Transmitters

(Continued from page 204)

the raster element is built up of transparent insulated crystal layers having an electro-optical effect in the direction of the field. This element is at an angle to the electron beam, and polarized light is passed through it, as shown.

An improved method is seen in Fig. 14D where the metallic coating of the raster screen is made reflecting and the light is passed twice through the crystal layer. This achieves a double polarizing effect with a corresponding decrease in operating voltage.



DATAPRINTS SHOW YOU HOW!

20c Each in Order for 10

TESLA-ODDIN HI-FREQ. COILS

(Data and Drawings only)

- 36" Sp'k Tesla-Oudin Coil.....40c (1 K.W. Exc. Trf. Data, included FREE!)
- 8" Sp'k Tesla-Oudin Coil.....40c (1/4 K.W. Exc. Trf. Data included FREE!)
- 5" Sp'k Oudin; 110 Vt. "Kick Coil" type.....40c
- 3" Sp'k Tesla Works on Ford Sp'k Coil.....40c
- 1" Sp'k Violetta Hi-Freq. Coil.....40c

FREE with order for \$1.00 or more—"20 Tricks with Hi-Freq. Coils" (40c separate)

Television Hook-ups "Sight & Sound" . . . 40c

20 ELECTRIC PARTY AND LODGE TRICKS! Loads of Fun!

How to Shock 'em!.....40c

Order with other prints; see special price below and save.

Solenoid & Magnet Data—Get Our List!

20 Telephone Hook-ups—Build Your Own . . . 40c

RADIO CONTROL FOR MODEL BOATS, PLANES, ETC.

(Circuit data40c)

S-W DIATHERMY (Artificial Fever)

DataPrint giving Constructional data for Small, Medium and Large size APP. (All 3)...40c

Induction PIPE & ORE LOCATOR

Construction Data40c

You NEED these DATAPRINTS!! 40c Each.

- 20 A.C. Problems and their Solutions.
- 1/2 Meter Transm. & Rec. Hook-ups.
- 5 Meter Superhet.
- 100 Mechanical Movements.
- 20 Motor Hook-ups.
- 20 Simple Bell Circuits.
- Welding Trans. 2 K.W.
- Rewinding Armatures.
- Eindhoven String Galv.
- Wheatstone Bridge.
- Model Ships—get list.

Special Prices: 4 prints \$1.00; 10 for \$2.00; 40c each, single orders.

The DATAPRINT Co.

Lock Box 322A

RAMSEY, N. J.

Your "Mike" Problem Solved

(Continued from page 212)

which acts as a dielectric between the ribbons and plate. To make this glue, dissolve a quantity of celluloid shavings in acetone, which can be purchased at the druggist's. Make sure it is not too thick as it may cause lumps on the surface or clog up the holes.

When the glue has thoroughly dried (it takes about five or ten minutes to dry) take the two strips of mica and punch two $\frac{1}{8}$ " holes in each strip corresponding to the two larger holes at each end of the plate. Glue one strip across each end of the plate so that the holes in the mica coincide with the centers of the larger holes in the brass. The four strips of bakelite and aluminum must be drilled similarly so that two 6-32 screws will slip into place right through the various strips at each end without touching the brass backplate. (Figs. 2 and 3.)

The unit is now ready for the ribbons to be assembled. These are corrugated after they are put on. By experimenting with common metal foils the writer had best results from that obtained from an old paper condenser, but whatever is used make sure it is not lead foil or the "mike" will be dead.

Cut a piece of the smooth aluminum foil, about $\frac{1}{8}$ " narrower than the plate for clearance on both sides and from $3\frac{3}{4}$ " to 4" long.

Instead of cutting each ribbon separately it is by far the easiest plan to leave all the ribbons in one piece by cutting out slots down the length of the foil, thus forming a row of ribbons all joined together at both ends. With this prepared, cut out a piece of fairly smooth resilient paper the same width as the backplate and 3" long. Newspaper can be used but when it is being withdrawn from under the ribbons the rough surface tends to pull them. Place this paper rectangle on the face of the plate between the two strips of mica and lay the ribbons over it so that about $\frac{1}{4}$ " of foil overlaps both pieces of mica as indicated by the dotted line in Fig. 2. The foil should be glued to the mica right across, sufficiently to hold the ribbons in place while the clamps are screwed down at each end. There must be a certain amount of slack in the ribbons and to insure this you can place a match or something of similar proportions across the middle of the plate and glue the ribbons down over it. Then remove the match gently without dragging or tearing any of the ribbons and the most ticklish part of the job is over.

Next come the clamps. Take one of the aluminum strips, place it over one of the pieces of mica and on the opposite side of the plate place the corresponding strip of bakelite. If the holes were correctly drilled you can drop a $\frac{1}{2}$ " 6-32 screw in each hole and tighten them up, thus clamping them down at one end permanently. These two bolts must not touch the brass backplate or the "mike" will be shorted out, so be sure to center the bolts in the large holes (Fig. 1). The other end is done exactly the same way only $\frac{3}{4}$ " bolts are used instead. When fastening down this end place a soldering lug on the head end of one of the bolts, and place a narrow strip ($\frac{1}{4}$ " wide) of copper weather stripping between the backplate and the bakelite. These are the two "mike" connections, one for the ribbons and one for the plate. Finally tighten up the bolts and the unit is finished except for corrugating the ribbons.

To do this, taking for granted that the rectangle of newspaper is still under the ribbons, place the unit on a firm horizontal surface with the ribbons upward. Next take a steel ruler and press it across the center of the ribbons. Press down firmly, but not hard enough to cut through the foil or bend the backplate and don't let the edge of the ruler

slide or the ribbons will tear. Do this again at each end, subdividing the ribbons until each one is divided into eight loops. When this is finished, carefully remove the piece of paper underneath and the job is complete.

The nodes should touch the surface of the backplate so if it is not well insulated with the glue, the mike will "leak," causing a sound much like a carbon hiss.

Casing the "Mike"

The only remaining part of the construction is the case, which is $2\frac{1}{2}$ " wide and $6\frac{3}{4}$ " high overall. It is built in two sections, the bottom section to which the unit is bolted, and the top section or screening which fits over the unit as a protector.

The bottom section is built around a piece of copper rod $\frac{1}{4}$ " x $\frac{3}{4}$ " and about $5\frac{1}{4}$ " long, which is bent into a U $2\frac{1}{2}$ " across. Two brass plates are made the same shape as the copper horseshoe and fit over each side forming a small U-shaped box. These brass plates extend about $\frac{1}{4}$ " above the prongs of the horseshoe. To fit them on, holes must be drilled through each plate into the copper which is tapped for 6-32 bolts. The unit is bolted to one of these plates so that it comes exactly half way between the two. A hole is drilled in the other plate and a rubber grommet is inserted to protect the "mike" cable. In the bottom or bent part of the copper U another hole is drilled so a "mike" stand adapter can be bolted on. If a stand is handy the adapter can be screwed into it. If not, a length of aluminum tubing threaded to fit the adapter and provided with a heavy base does a good job. On the outer side of each leg of the U, a slot is filed $\frac{1}{8}$ " deep and $\frac{5}{8}$ " wide to accommodate the two ends of the metal band over the screening.

For the screening section of the case a strip of copper rod $\frac{1}{8}$ " x $\frac{5}{8}$ " and 14" long is bent to form three sides of a rectangle. The two legs should be $5\frac{3}{4}$ " long and $2\frac{1}{2}$ " apart, being sure to make the corners as square as possible. Two holes are drilled $1\frac{1}{2}$ " apart in the top or short side of this frame and four holes are drilled down each leg. The first one is $\frac{1}{2}$ " from the top, the rest are 1" apart. Next a piece of fairly heavy brass screening $3\frac{3}{4}$ " x $9\frac{3}{4}$ " must be procured. In the middle of this screening on each side a square $\frac{1}{2}$ " wide by $\frac{7}{8}$ " deep is cut out, thus allowing it to fit between the prongs of the copper frame. To make the rest easier the screening can be bolted at the top and by bending the two flaps of screening down on each side and folding the edges in, the job begins to take shape. A certain amount of clipping and shaping is necessary still, but if the model illustrated is followed a fairly nice looking "mike" should be the result. When the side flaps have been fitted, clipped and bent they can be tucked inside the copper legs and clamped there by the nuts. The screening should only extend down 4" from the top, thus leaving $1\frac{1}{2}$ " of bare copper prong on each side at the bottom. These fit into the slots cut in the sides of the bottom section of the case.

Assemble the whole microphone now and connect a length of shielded rubber cable to it. It will be found that the ribbons are grounded to the frame of the "mike," so connect the shielding conductor to the frame and the wire to the backplate. Incidentally, the photographic illustrations were taken with no ribbons on the unit in order to give a clear idea of the plate.

If the bass response is preferred, for close speaking, the polarizing voltage should be low (from 50 to 150 volts). This bass may become exaggerated. When the polarizing voltage is increased the ribbons are attracted to the plate thus breaking them into sections and so reducing the bass frequencies. This also has the effect of increasing the output of the microphone up to 200, 300 and even 400 volts.

HYVOL HIGH-VOLTAGE CAPACITORS



For X-mitter or P-A amplifier power supply assemblies, you'll want these compact oil-filled capacitors. Inverted screw mounting. No larger than usual electrolytics—and just as easy to install. Insulated washer insulates grounded can from metal chassis, when desired.

Compactness due to new and exclusive Hyvol super-dielectric oil. .5 to 4 mfd. 600, 1000 and 1500 v. D.C. working. Cool operation. Long life. And quite inexpensive.

Ask...

Your local jobber can show you these handy, inexpensive units. Ask for our latest catalog—or write us direct.



Westinghouse Power Generator

Manufactured for U. S. Signal Corps
200 Watt. 110 V. AC



A. C. ELECTRICAL POWER

from a Windmill, from available Waterpower, from your Automobile, from your Motorcycle, from your Bicycle, Foot-pedals or Handcrank (for transportable Radio Transmitters, Strong Floodlights, Advertising Signs); do you want to operate AC Radio sets from 32 V. DC farm light systems; operate two generators in series to get 200 V. AC; obtain two phase and three phase AC, etc., etc.

There Are Over 25 Applications Some of which are:

A.C. Dynamo lighting from eight to ten 20 Watt 110 Volt lamps. Short Wave Transmitter supplying 110 Volts AC for operating "Ham" transmitter. Operating 110 V. AC 60 Cycle Radio Receiver in DC districts. Motor Generator. Public Address Systems. Electric Sirens on motor boats, yachts, etc. Camp Lighting. Short Wave artificial "feet" apparatus. Television. Pelton Waterwheel for lighting or other purposes. Airplane for lighting strong searchlights or electric signs. Laboratory work, etc., etc. $\frac{1}{4}$ to $\frac{1}{2}$ H.P. needed to run generator.

BLUE-PRINT 22 x 28 in. and Four-Page
8 $\frac{1}{2}$ x 12 in. INSTRUCTION SHEETS
FREE with Generator.

Generator, as described, including Blue-print and instructions **\$790**
Send \$2.00 deposit, balance C.O.D.
Shipping weight 18 lbs.
MONEY-BACK GUARANTEE

WELLWORTH TRADING COMPANY
1915 S. State Street, Dept. RT-839, Chicago, Ill.



HEY FELLOWS! 6 BACK NUMBERS OF SHORT WAVE AND TELEVISION SENT ANYWHERE IN U.S. FOR 70¢

For a limited time only, and as long as they last, we will send you six back numbers of **SHORT WAVE & TELEVISION** assorted, your choice, for 70 cents.

The usual price for six copies would be \$1.50, and most publishers charge a higher price for back numbers over one year old.

We can supply only the following back numbers: Dec., 1930; Feb., April, June, Sept., Oct., 1931; July, Oct., 1932; Jan., April, Oct., Nov., 1933; Jan., Feb., Mar., May, June, July, Aug., Sept., 1934; and 1935—all issues except January, February and March; 1936, 1937, 1938—all issues; 1939—all issues to date.

If you do not specify copies, we will send assorted numbers to fill your order. Note, we cannot exchange the copies for ones that have been sent to you.

Every copy of **SHORT WAVE & TELEVISION**

contains information which you should have. Here is a chance to get those copies.

As only a small supply of back numbers on hand, this offer will be withdrawn as soon as they have been sold.

We accept U. S. stamps, U. S. coin, or money order. Rush your order today.

RADIO & TELEVISION 8-39

99-101 Hudson Street, New York, N. Y.

Gentlemen: I enclose herewith 70¢, for which you are to send me six back number copies of **SHORT**

WAVE & TELEVISION as follows:.....

Name

Address

City State

Radio Men Find This Book Handy

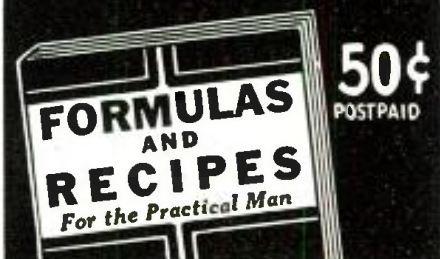

Here Is the Contents of the Book

- 1 Adhesives: Glues, Cements, Gums, Mucicages, Lubricants
- 2 Cleansing: Stain Removers, Paint Removers, Bleaches, Cleaning Fluids
- 3 Metal Craft: Coloring, Oxidizing, Plating, Repairing, Welding, Polishes, Alloys, Solders, Amalgams.
- 4 Paints: Colors, Stains, Varnishes, Enamels, Luminous Paint, Washable Paint; Paint-Removing, Waterproofing, Fireproofing.
- 5 Glass-Working: Cutting, Drilling, Borik, Bending, Blowing, Etching, Engraving, Frosting, Silver-ink, etc.
- 6 Wood-craft: Fillers, Fireproofing, Acid-Proofing, Waterproofing, Furniture Polishes, Finishes, etc.
- 7 Ink Recipes, Eradicators, Ink Stain Removers, Special Inks, Colored, Insoluble, Sympathetic, Invisible, Hectograph.
- 8 Photography: Developers, Emulsions, Fixers, Sensitizing, Toning, Printing, Photographic Paper, Blueprint Paper
- 9 Antidotes for Poisons, Remedies for Burns and Scalds, Disinfectants, First-Aid in Accidents, Emergency Remedies, Home Remedies, 10, Preparation, Manipulation, Handling, Mixing, Measuring, Weighing, Filtering, Straining Solutions; List of Technical Substances; Emulsifying; Use of Hydrometer, Use of Thermometer; Tables of Weights and Measures, Decimal Systems. Useful Tables.

TECHNIFAX, Division RT-839
1915 So. State Street, Chicago, Illinois

TECHNIFAX, Division RT-839
1915 So. State Street, Chicago, Illinois

Gentlemen: Enclosed please find 50¢ (check, money order, coin or unused U.S. stamps accepted) for which send me **POSTAGE PREPAID**, One Copy of **FORMULAS AND RECIPES For the Practical Man**.

Name

Address

City State



"JIFFY" Magazine Binders

Sturdily built and covered with black fabricoid. Has two stamped metal ends with 12 spring wire separators. Magazines can be inserted and removed in a jiffy. No fuss—no lost time—no labor.

- No. 1, 12 3/4" x 9 1/2", with 2-inch back for R.&T., Radio-Craft, Radio News, etc. **\$1.00**
- No. 2, 10 1/2" x 7 1/2", with 3-inch back for QST, Radio, Popular Mechanics, etc. **\$1.00**
- No. 3, 8 1/2" x 6 1/4", with 3-inch back for Reader's Digest, etc. **\$1.00**

P.P. Prepaid in U.S. and Canada. Send for catalog containing full descriptions of many other interesting items.

GOLD SHIELD PRODUCTS
Dept. RT-8-9 350 Greenwich St. New York

Short-Wave fans need this WORLD-TIME CLOCK

The Only Clock for Universal Use Throughout the Entire World!

A REGULAR CLOCK with A.M. and P.M. divided dial

A WORLD-TIME CLOCK Instantly Indicating Time in all 24 zones

INTERNATIONAL CLOCK with A.M. and P.M. 24 hour dial



Here is really the first new clock advancement in 200 years—three clocks in one, a world-time clock. It is revolutionary! It is years ahead! The Sky Pilot **WORLD-TIME CLOCK** is the only clock designed for use anywhere in the world. For short-wave fans this clock offers great convenience—it is educational and at the same time indicates world time differences. In a few seconds you can determine the correct time in London, Moscow, Hawaii, Tokyo, Buenos Aires, Halifax—anywhere. American made—it is exceptionally easy to operate. It carries a guarantee of ninety days against defects in material or workmanship. In modernistic design, it is made of brushed brass—measures 5 1/4" high by 4 3/4" wide—and has convex crystal. Spring driven model **\$4.95**

Electric driven (for A. C. 110-120 volts, 60 cycles) **\$5.95**

Remit by check or money order; register letter if you send cash or unused U.S. postage stamps. Add 25¢ to cover postage and insurance in U.S.A., Canadian and foreign add 35¢.

RADIO AND TELEVISION Magazine

99-T HUDSON STREET NEW YORK, N. Y.

The Radio Beginner

(Continued from page 207)

same as those shown in Fig. 1, except that there is a mid-tap on the secondary of the input transformer and on the primary of the output transformer.

The voltage impressed on the primary is the same as the voltage on a regular audio transformer, but since the secondary is tapped in the center, the voltage placed on the grid of each of the two tubes in push-pull, is only half of the voltage which would be impressed on the single tube of an ordinary audio amplifier. For this reason we must impress upon the primary of such a transformer twice the voltage that we would impress on the regular audio transformer. The divided voltage is united again in the output transformer. In such a system of amplification we get a balancing effect between the two tubes which permits us to work the tubes at a higher output without distortion than the same tubes in a straight audio amplifier.

Resistance-Coupled Circuits

The transformer coupled amplifier is very efficient, but is not always the most satisfactory where a very high degree of quality is desired; the range of audio frequencies is quite broad, and a transformer must be very well designed in order to pass every audio frequency with equal fidelity. In order to avoid this difficulty, a system of *resistance-coupled* audio frequency amplification may be used. This type of amplifier, as shown in Fig. 3, takes advantage of voltage drops across resistances. In order to understand more completely how this amplifier functions, let us examine the circuit in Fig. 4. Here we have two resistors, one variable, and the other fixed, in series with each other, and the two resistors thus connected, placed across a small battery. Let us assume for the moment that the two resistors have the same value; then the voltage drop across each will be the same, the sum of these voltage drops being equal to the voltage of the battery. Now let us decrease the value of the variable resistor. This will mean that there will be less of a voltage drop across the variable, and consequently a greater drop across the fixed resistor. If we were to reverse the procedure and increase the value of the variable resistor, there would be a greater voltage drop across it, and a smaller drop across the fixed resistor. We have an analogous situation in Fig. 5, simply by substituting a vacuum tube in place of the variable resistor. Because the resistance of the space between the filament and plate will vary depending upon the voltage on the grid, the voltage drop across the fixed resistor will vary.

It will be noted that the plate of the detector tube in Fig. 3 is connected to the positive side of the "B" battery, through a fixed resistor. It is essential to keep this voltage from reaching the grid of the next tube, but at the same time the alternating audio frequency currents must be allowed to pass. This may be accomplished by placing a "C" battery in series with the grid, in such a manner that it places a small negative charge on the grid, while the positive side opposes the positive potential of the "B" battery. The varying voltages from the preceding tube will either add to or subtract from the fixed grid voltage, making the grid alternately more or less negative, and in this fashion regulating the electron flow in the second tube.

While the circuit showing the resistance-coupled amplifier using the "C" battery is fundamentally sound, yet the awkwardness of using the battery and other undesirable factors may be overcome by using the circuit shown in Fig. 5. The small condenser allows alternating audio currents to pass to the grid of the tube, but prevents the positive plate potential of the first tube from passing. The second resistor connected to the grid of the tube at one end, and the negative side of the battery at the other end, places a small negative charge on the grid, thus eliminating the battery.

Impedance Coupling

One of the disadvantages of the resistance-coupled amplifier lies in the fact that rather high values of plate potential are required. In order to overcome this difficulty, a type of amplifier known as *impedance coupled* is sometimes used. This is shown in Fig. 6. The circuit is very similar to that of the resistance-coupled type, the only change being the insertion of an impedance in place of the plate resistance. This impedance is simply a coil of wire wound over a laminated iron core, and closely resembles the primary of an audio transformer.

Newest Radio Apparatus

(Continued from page 232)

New Relays

● A RECENT bulletin issued by the Guardian Electric Manufacturing Company shows many new types of relays. Among the most interesting is model A-100, an antenna relay designed for the amateur who wants compact, convenient change-over control, with large contact points of silver, to insure long life even under heavy overload. The insulation is low-loss AlSiMag 196, and the design of the instrument is such that there is low capacity between the switch points. This relay will control up to one kilowatt in either A.F. or R.F. circuits, and all frequencies up to and including 28 mc. The coils used to actuate the contacts operate on 110 volt 50-60 cycle A.C., but coils for other voltages and currents may be had at a slight increase in price. At the standard voltage and frequency ratings, however, the current consumption is approximately 7 watts.



A-100 TYPE

The models U-100 and U-200 are adjustable underload relays, sensitive, precise, and well constructed. Each is enclosed in a black metal container to protect it from dust, dirt, and accidental misadjustment. The contact points are of silver and oversized to take care of overloads. The insulation is bakelite and the switches are single-pole, single-throw, normally open. These units will control the A.C. primary of any power supply delivering up to and including 500 watts. The standard coil operates over an adjustable range of 100 to 200 mils D.C. on the U-100 model, and from 200 to 400 mils on the U-200. The release current value is 75% of the attract current value. The latter is obtained by a screw adjustment of the spring tension. At these ratings, the voltage drop through the small model is 10.5 volts; and through the larger, 9 volts.

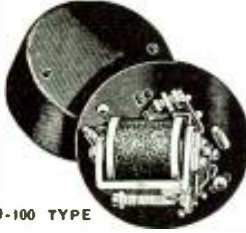

U-100 TYPE

The New RCA Tubes

RCA-1624 Transmitting Beam Power Amplifier. Filament voltage, A.C. or D.C., 2.5; filament current, 2 amps.; transconductance (for plate current of 50 ma.) 4000 micromhos; direct inter-electrode capacitances, grid-plate (with external shielding) .25 mmf., input, 11 mmf.; output, 7.5 mmf. Uses: As push-pull Class AB₂ audio amplifier—D.C. plate voltage 600; max. signal D.C. plate current 90 ma.; plate dissipation 25 watts. As grid-modulated R.F. power amplifier, Class C telephony—plate voltage, same; plate current 75 ma.; plate dissipation, same. As plate-modulated R.F. power amplifier, Class C telephony—D.C. plate voltage 500; D.C. plate current, same; plate dissipation 16.5 watts. As R.F. power amplifier and oscillator, Class C telephony—D.C. plate voltage 600; D.C. plate current 90 ma.; plate dissipation 25 watts. Note: In this case, modulation essentially negative may be used if the positive peak of the audio-frequency envelope does not exceed 115% of the carrier conditions.

Types 2050 and 2051 Hot-Cathode Gas Tetrodes are sensitive, gas-filled tetrodes of the indirectly heated, hot-cathode type, designed for grid-controlled rectifier service. The tubes are highly sensitive and may be operated directly from a vacuum-type phototube. Heater voltage A.C. or D.C., 6.3; heater current .6 amp.; grid-anode capacitance 2 mmf. The following are the characteristics for the type 2050: peak forward anode voltage 650 max.; peak inverse anode voltage 1300 max.; shield grid (grid No. 2) voltage, 0; peak anode current 500 ma. max.; average anode current 100 ma. max. (averaged over a period of not more than 30 seconds); tube voltage drop (approx.) 8; grid resistor .01 meg. min., 10 meg. max.

The following are the characteristics for the type 2051: peak forward anode voltage 350 max.; peak inverse anode voltage 700 max.; shield grid (grid No. 2) voltage, 0; peak anode current 375 ma. max.; average anode current 75 ma. max. (averaged over a period of not more than 30 seconds); tube voltage drop (approx.) 14; grid resistor .01 meg. min., 10 meg. max.

Several new 1.4 volt tubes have just been announced. These include the 1A7-GT Pentagrid Converter, the 1H5-GT Diode High-Mu Triode, the 1N5-GT R.F. Amplifier Pentode, all of which operate on .05 amp. filament current, and the 1Q5-GT which requires 1 amp.

The triode unit of the 1H5-GT is for use as a Class A₁ amplifier; the diode is independent of the triode except for the common filament, which is located at the negative end of the filament. The 1N5-GT is likewise for use in a Class A₁ amplifier, but the 1Q5-GT is to be used in a Class A amplifier.

A 50-volt filament Beam Power Amplifier is the 50L6-GT. Its heater current is .15 amp. and its plate may be operated on 110 volts maximum. The maximum power output of this tube is 2.2 watts.

The 6AG7 Video Beam Power Amplifier is a heater-cathode type of metal tube intended for use primarily in the output stage of the video amplifier of television receivers. It may also be used advantageously in television transmitters as a coupling device between video-frequency stages and transmission lines.



The design of the 6AG7 features not only an exceedingly high value of transconductance but also high plate-current capability. As a result, a large voltage for modulating a Kinescope can be built up across the relatively low load resistance required for coupling the 6AG7 to the Kinescope.

New National Products

● IN the National Company's new radio bulletin No. 291-L are described many of this well-known manufacturer's products. Among the interesting items, in addition to receivers featured in this catalog, are a safety meter panel to make it safe and easy to connect meters into high-voltage leads rather than into ground leads. It is available either blank or punched with 2, 3 or 4 holes for 2" meters. End screw slots are included.

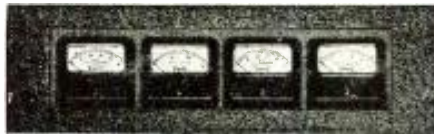

Rugged cast aluminum shields are also featured in the catalog. These, though particularly designed for use as stage shields in high-gain equipment, may also be used as cases for small wavemeters and the like. They are available in three sizes, from 5" x 3" x 3" to 6 3/4" x 6" x 6".

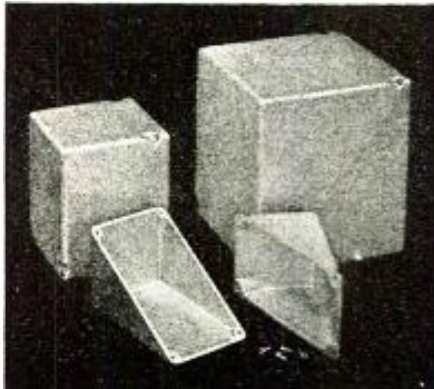

FREE - REAL ELECTROPLATING OUTFIT



Now You Can ELECTROPLATE Easily with a BRUSH!

SOMETHING new for amateurs, fans, set builders—something which gives you the opportunity with which to experiment. Here's an ELECTROPLATING KIT amazingly simple to operate—you just Electroplate with a Brush! Requires only one single dry cell.

NOT A TOY

You can electroplate for profit, hundreds of things in the household—ashtrays, fixtures, water faucets, worn brackets, door knobs, musical instruments, jewelry and silverware and other articles. It's an indispensable piece of equipment to you for plating articles in hotels, apartments, office buildings, medical and dental offices, factories, schools, laboratories, etc. Exactly the same outfit (but larger) is used professionally by electricians, radio service men, automobile repair shops, etc. And for radio work you can electroplate tarnished receiver parts, chassis, contacts, worn radio parts and accessories.

Put this REAL ELECTROPLATING KIT to use immediately—make it the most useful article in your lab or work bench. And you can get it absolutely FREE (except for slight mailing cost).

Send your subscription today to RADIO AND TELEVISION for One Year (12 issues) and receive absolutely FREE one of these REAL ELECTROPLATING KITS—New subscribers are accepted or you may extend your present subscription another twelve months under this offer. Mail your remittance of \$2.50 (Plus 10c for shipping charges on kit) to the publishers of RADIO AND TELEVISION. (Canada and foreign \$2.85.) You will promptly receive your FREE REAL ELECTROPLATING OUTFIT by return mail. Use the coupon below to order your subscription.

RADIO AND TELEVISION

99 Hudson Street New York, N. Y.

RADIO AND TELEVISION

99 HUDSON STREET, NEW YORK, N. Y.

Gentlemen: Enclosed you will find my remittance of \$2.50 for which enter my subscription to RADIO AND TELEVISION for One Year (12 issues). Send me promptly my FREE REAL ELECTROPLATING OUTFIT. (Canada and foreign \$2.85.) In U.S. add 10c additional to cover shipping charges on kit.

() NEW SUBSCRIBER
() EXTEND PRESENT SUBSCRIPTION

Name

Address

City State

(Send remittance by check, money order or unused U. S. Postage stamps. Register letter if you send cash or stamps.)

RT-8-39

RADIO'S MANY NEW BOOKS HAVE BEEN ADDED TO MOST COMPLETE LOW-PRICED TECHNICAL LIBRARY



THE RADIO-CRAFT LIBRARY SERIES (each volume fifty cents)—a most complete and authentic set of Volumes—treats individually, important divisions of radio, refrigeration and air conditioning. Each book has been designed to give you the opportunity to learn one or more branches of the fields mentioned. The authors of the books are well-known to everyone. Each is an expert—an authority on the subject—each is thoroughly familiar with the field which he represents.

ALL BOOKS ARE UNIFORM—The volumes in the RADIO-CRAFT LIBRARY SERIES measure 6 x 9 inches. Each book contains on an average of 50 to 120 illustrations. The books are printed on an excellent grade of paper which makes the type easy reading.

Here Are the Titles - - -

- | | | |
|--|---|--|
| No. 2. MODERN VACUUM TUBES | No. 12. PUBLIC ADDRESS INSTALLATION AND SERVICE | No. 17. SERVICING WITH SET ANALYZERS |
| No. 3. THE SUPER-HETERODYNE BOOK | No. 13. ABC OF AIR CONDITIONING | No. 18. POINT-TO-POINT RESISTANCE ANALYSIS |
| No. 6. BRINGING ELECTRIC SETS UP-TO-DATE | No. 14. POCKET RADIO GUIDE | No. 20. THE CATHODE-RAY OSCILLOSCOPE |
| No. 9. AUTOMOBILE RADIO AND SERVICING | No. 15. ABC OF REFRIGERATION | No. 21. BREAKING INTO RADIO SERVICING |
| No. 10. HOME RECORDING AND ALL ABOUT IT | No. 16. PRACTICAL RADIO CIRCUITS | |

RADIO PUBLICATIONS • R&T 8-39 • 99T Hudson Street, • New York, N. Y.

I have circled below the numbers of books in the RADIO-CRAFT LIBRARY SERIES which you are to send me. I have included my remittance in full, at the price of 50¢ each. (Stamps, checks or money orders accepted).

2 3 6 9 10 12 13 14 15 16 17 18 20 21

Name Address

City State

All books are sent postage prepaid

NEW!

A NEW GERNSBACK PUBLICATION
The Constructive Photo Magazine



ON ALL NEWSSTANDS

FOR serious-minded amateur photographers, here's a photo magazine, FOTO-CRAFT, really different from any you've read. It tells you how and why to do things—it's a constructive publication which shows what can be done with the equipment you have, and how to make handy photographic accessories. FOTO-CRAFT, with its broad editorial features, covers such important branches of photo: ready-to-use Scientific Researches; Developing; Fixing; Enlarging; Duplicating; Cropping; Photo-micrography; Color Photography; Amateur Movies; How to Make It Items.

A Few of the Articles in the Current Issue

By such authorities as Herbert C. McKay; Mabel and Mario Scacheri; Dr. E. Bade; Leonard Hyams; Carl Dial, etc., the titles include: Plenty to Photograph Right Under Your Nose—Soup is Soup—It's All Greek; Alpha, Beta, Gamma, Delta—Photographic Designs without a Camera—Noodle Titles—The Simplest Synchronizer Tester—Microscopic Table Top—Home-made Synchronizing Flashcubes—Super Cabinet for Enlarging—Tomorrow's Photography—International Photo Digest—Table Top—Watch the Birdie, Modern Style—Elegant Photographs—Bag Reliefs Made by Treating Photographs—Movie Trick and Action Titles—Paper Negative Technique—Print It Yourself—Photo Hints and Kinks—What's New? Questions and Answers—Photo Quiz, etc.

BIG OPPORTUNITY!! Get a FOTO-CRAFT Press Card today—with it you can get permission to take photos which might be difficult to obtain. PRESS CARDS are sent FREE to subscribers of FOTO-CRAFT. Enter your subscription for Seven Months for \$1.00—and get your PRESS CARD immediately.

FOTO-CRAFT

99-T HUDSON STREET NEW YORK, N. Y.

EXTRA MONEY FOR YOU

MAIL ORDER PLANS TESTED MONEYMAKERS BUSINESS SECRETS SUCCESS SCHEMES

68 PAGES

300 WAYS TO MAKE MONEY

25 CENTS

A MARVEL BOOK 40,000 WORDS in TEXT! In "CASH IN" you get ALL the real money-makers—dozens of profitable tested mail order plans, confidential business secrets, dozens of practical tested formulas, successful tested schemes—actual experiences of men who have started on a shoestring—with less than \$10 capital. Money-Back Guarantee. "CASH IN" contains only tested ideas covering every type of full- or spare-time enterprise—it's a "masterpiece" in business ventures. 10 CENTS per copy. Sent POSTPAID anywhere upon receipt of 10 cents U.S. stamps or coin.

NATIONAL PLANS INSTITUTE
246-T FIFTH AVENUE NEW YORK, N. Y.

Silver Trophy Award

(Continued from page 208)

Note These Important Rules

The photos must be sharp and clear and preferably not less than 5" x 7".

The pictures will be judged for the general layout of the station, the quality of workmanship exhibited, and the appearance of the photograph itself. The judges will also consider neatness as an important point.

When you submit the photograph of your Ham station, send along a brief description not longer than 300 words, describing the general line-up of the apparatus employed, the size, type and number of tubes, the type of circuit used, name of commercial transmitter (if not home-made), watts rating of the station, whether for c.w., or phone, or both, etc., and give the name of receiver.

State briefly the number of continents worked, the total number of stations logged or contacted, and any other features regarding the station which you think will be of general interest. Mention the type of aerial system used, especially any unique or new features about it, and which type of aerial

you use for transmitting and receiving; also what type of break-in relay system, if any, is used. Include a photo of yourself.

Address all photos and station descriptions to Editor, Ham Station Trophy Contest, c/o RADIO & TELEVISION, 99 Hudson Street, New York, N. Y.

I Cover the Pacific Coast!

By Lyle M. Nelson

(All time is in P.S.T.)

● DAYTIME reception of the more powerful European short wave stations has showed marked improvement during the past month here on the Pacific Coast. Programs from Berlin, London, Rome, Paris, Moscow and many other cities are now booming through with excellent volume! Perhaps the most noticeable improvement has been from the Moscow stations. As reported in this column last month, a new station announcing as RAL is heard daily on 15.18 megacycles. In addition to this station, Soviet authorities are using RKI on 15.08 mc. and RAL on 9.6 mc. during the program for North America from 4 to 6:15 p.m. daily.

A trio of Guatemalan stations continues to hold forth with excellent signal on Saturday nights from 9 to 11:30 p.m. TGW on 15.20 mc., TGWA on 9.87 mc. and TGWB on 6.49 mc. are heard with the regular Saturday night broadcasts advertising Guatemala coffee.

The Kanimba's floating broadcaster 9MI has shifted frequency from 9.82 megs. (where it was heard last winter) to 6.06 mc., according to word from New Zealand. The new frequency will make it difficult for Pacific Coast listeners to receive 9MI.

Typical South Sea Island music with all the romance that singing guitars and native voices can give it can be enjoyed by Pacific Coast listeners every Tuesday and Friday night by tuning to Tahiti's popular short-waver, FO8AA on 7.10 megs. FO8AA has been reported by several listeners as broadcasting from 8 to 9:30 p.m. Occasionally code interference blots out reception from this station.

Kendall Walker of Yamhill calls our attention to the fact that neither JVN on 10.66 nor JWV3 on 11.73 is carrying the Saturday night baseball games from Tokyo as reported in this column in the June issue. Mr. Walker is right, the ball games have been shifted to JVH on 14.60 mc. He also reports an unidentified station on 11.53 mc. announcing its location as the Philippine Islands. Heard daily near 6 a.m., he says.

JFO of Taihoku, Taiwan, has moved higher in the 31 meter band and is now heard on 9.68 mc., according to George Goehring of Oakland. Japanese war news is given at 6 a.m. daily.

Two other changes on the 31 meter band have been the appearance of Costa Rica's TIPG on 9.61 mc. and the disappearance of Colombia's popular HPIABP from that frequency. A short time ago TIPG appeared on this frequency broadcasting from 4 to 7 each night, relaying the broadcasts of long wave station TIX. It was not long after that HPIABP disappeared from the band. HPIABP was heard to announce that they were shifting to 4.92 mc. Jack McCliment of Portland reports.

In addition to regular North American programs from 1:50 to 7:50 p.m. each night, the German short wave stations are heard here with excellent volume on the program for Australia and the Far East, from 9:05 p.m. to midnight. Both DJB on 15.20 and DJN on 9.54 mc. carry the program.

London's GSD on 11.77 mc. continues to boom forth daily with the program for western America from 6:20 to 8:30 each night. This station is also on the air from 9 to 11:15 p.m. with fair volume. Mr. McCliment writes, GSP on 15.31 mc. was heard with good volume from 9:25 to 10:15 a.m. by T. S. Hite of Los Angeles.

ROUND 'N' ABOUT—From listener's reports.

New station HNF on 9.70 mc. in Baghdad, Iran, heard once near 6 a.m. Signal was weak. Iran is almost on the other side of the world from the Pacific Coast. Java stations PMN on 10.26, PIP on 11.00 and YDB on 9.54 coming in well from 3 to 7 or 8 a.m. daily. COCQ is back on 8.85, but continues to shift frequency. "Radio Hanoi" on 11.90 mc. heard irregularly near 5 a.m. on 11.90 mc. CB970 of Valparaiso, Chile, heard broadcasting as late as 9 p.m. on 9.70 mc. Good reception.

"Hawaii Calls" program now being relayed by KKP on 16.03 mc. from 2:30 to 3 p.m. on Sunday. HP5J heard on 9.59 mc. near sign-off at 7:30 p.m. SP25 of Warsaw, Poland, breaks through to coast irregularly on 11.74 mc. near 6 p.m. with weak volume. VFB of Colombo, Ceylon, is no longer broadcasting on 6.13 mc. Has changed this station over to code. HS8PJ heard here Mondays from 5 to 7 a.m. on 19.02 mc. with weak volume. HS8PJ on 9.51 mc. very irregular from 5 to 7 a.m. daily except Monday.

Antennas for the HAM

(Continued from page 212)

rapidly after being out in the open for a little while. If it is at all possible, the writer would even advise the amateur to cover the entire line with one or two layers of rubber and friction tape. The better the insulation between the wires and the better the protection against the elements, the longer will the line remain without increasing losses.

Recently there has been placed on the market a commercial brand of twisted pair called EO-1, which has much better insulation than the home-made line described above.

A feature of twisted pair lines is the ease with which it can be run around corners. Sharp bends have no ill effects on operation. Coupling these lines to the transmitter is done merely by connecting the line to a one-to-three turn loop and coupling this coil to the ground end of the final tank coil. Vary the coupling between the coils until the final amplifier draws its rated plate current. Coupling can be varied either by varying the number of turns in the link coil, or preferably by changing the distance between the two coils. If the antenna is cut for the center of the amateur band on which it is desired to operate, there will be practically no loss in efficiency when operating at the edges of the band.

This type of antenna makes an ideal system for receiving because of the inability of the transmission line to pick up any signals, thereby discriminating against noise, most of which is generally picked up by the lead-in. A double-pole, double-throw switch will enable the operator to use the same antenna for transmitting and receiving. Although it works best at the approximate frequency for which it has been cut, this antenna can also be used for receiving on other bands as well. If used exclusively for receiving, it should preferably be cut for the lowest frequency band to be employed.

The writer would be interested in hearing from readers as to the types of antennas they would like to see described in this series. A postcard will do.

Amateur Frequency Meter

(Continued from page 213)

cate the revised model of this instrument. All in all, the addition of the crystal greatly adds to the convenience and accuracy of the frequency measurements.

Additional Parts Required for the Added Crystal Control

BLILEY ELECTRIC CO.
1—SMC-100 100-1000 kc. crystal

HAMMARLUND
1—8 mh. A.F. choke coil, No. CH-8
1—25-100 mmf. trimmer condenser, No. CTS-85
1—20 mmf. tuning condenser, No. MC-20S

CORNELL-DUBILIER
1—1 mf. 400 v. condens-cr. No. DT-4P1

New DX'ers League

Editor,
The American League of Negro DXers is now having a membership campaign. We are asking all colored SWLs and Amateurs, who wish to join our organization, to send for application blanks. There is no joining fee, we only request a 3c stamp for return mail.

James W. Cheek, Director,
William Lewis, Ass't. Dir.
2047 Llewellyn Ave.,
Baltimore, Md.

For August, 1939

STOP—LOOK and BUY

Rockbottom Prices on All Our Merchandise

When prices are low we buy! They're low now—LOWER THAN THEY EVER WILL BE—hence this sale. 100% satisfaction on each transaction or your money refunded. ORDER FROM THIS PAGE. Use the convenient coupon below. Be sure to include sufficient extra remittance for parcel post charges, else the order will be shipped express, charges collect. Any excess will be refunded. C.O.D. shipments require a 20% deposit. If full remittance accompanies order deduct 2% discount. Send money order—certified check—new U. S. stamps. No C.O.D. to foreign countries.

ORDER TODAY QUANTITIES LIMITED QUICK SHIPMENTS ASSURED

VARIABLE SPEED UNIVERSAL MOTOR

FOR 110 VOLTS, A.C. OR D.C.

Made for Dictaphone machines by American Gramophone Co. Used, but in excellent condition. Special lever control permits variable speeds up to 3000 r.p.m. 1/2" shaft extends from both sides of motor. Measures 7 1/2" diam. overall. Shp. Wt. 6 3/4 lbs.

ITEM No. 11 Your Price \$2.55

WELDING! BRAZING! SOLDERING! 3-IN-1 PORTABLE ELECTRIC TORCH

WORKS FROM 110 VOLTS A.C. OR D.C. LINE

This electric torch is not a gadget or toy but a sturdily built outfit using the finest materials. With it you are able to do professional type of welding, brazing and soldering work, regardless of whether or not you've had previous experience. It will do a thousand and one jobs: fender welding, auto body repairs, bumpers, cylinders, tanks and industrial repairs—ideal for steel fitters, plumbers, sheet metal jobs, engineers, maintenance men, radio and bicycle repair men, etc. Works on aluminum, brass, copper, iron, steel and other metals.

The 3-in-1 electric torch is so simply constructed that even a boy can operate it after reading the simple and concise instructions furnished with the unit. Not necessary to know how to strike an arc! All you do is plug the torch into the light socket, adjust the carbons per instructions, and presto—you have an intense, blazing flame, ready for work. The outfit comes complete with power unit, electric cord, electrode holder, carbons, welding rods, blazing rods, solder flux, goggles, and instructions.

Save money! Do your own repairing. Earn money by doing repairing for others. Simple, practical, durable and safe to handle—that's why the price is amazingly low. Don't delay—order one today. Shp. Wt. 8 lbs.

ITEM No. 50 Your Price \$6.95

POWER JIG SAW

A trouble-proof powerful tool with self-contained power unit. Cuts 7200 strokes per minute, leaving smooth edges. An ideal machine for wood-crafters, model makers, handy-men, etc. Has 10" square table and gray iron frame mounted on rubber to absorb vibration. Arm blade depth 13 1/2". Designed for 110-120 V. AC use. Measures 9 1/4" x 19 1/2". Adjustable guide and stroke. Sold complete with 8 ft. approved cord and plug, ready to use. Shp. Wt. 12 lbs.

ITEM No. 45 Your Price \$9.96

COMPLETE ELECTRIC SPRAYER OUTFIT

Consists of a sturdy compressor 110 V. 1/4 HP, 1750 RPM Motor, 10 ft. hose, efficient spraying gun and all necessary mounting accessories. Costs only 2 cents per hour to operate. Delivers considerable air pressure. Possibly will not pump oil. Few working parts to wear. Sprays practically anything. Shp. Wt. 40 lbs.

ITEM No. 46 Kit less motor, but with gun Your Price \$6.36

ITEM No. 47 The complete kit including 1/4 HP motor Your Price \$14.53

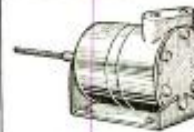

NEW FUEL PUMPS

Brown & Sharpe pumps. Brand new; never been used. Can be used for gasoline, oil, kerosene, and other fuels. Not good for water. Takes standard sized 1/4" input and output pipes. Has 1/4" drive shaft. Measures 4 x 3 3/4 x 3 1/4" diam.

overall. Shp. Wt. 8 1/2 lbs. ITEM No. 24 Your Price \$4.45

SPERRY GYROSCOPE LIQUID COMPASS

Made for U.S. Signal Corps; sensitive and accurate. Quick readings easily made from top; accurate readings of graduations through focusing magnifying lens on side of instrument. Complete with level sight and ratchet leather carrying case. Excellent for boats, boy scouts, campers, hikers, etc. A few turns of wire around the case makes it usable as a galvanometer. Shp. Wt. 3 lbs.



ITEM No. 12 Your Price \$1.85

1/75 HP AC MOTOR

Develops 1/75 HP at 3000 RPM. The entire motor is only 3 3/4 inches in diameter. 7/32" shaft. Inducor type motor with shaded pole for self starting. Speed can be varied with suitable rheostat. Complete with cord, plug and base, but less pulley. For use on 110 V. 60 cycle AC line. Shp. Wt. 8 lbs.



ITEM No. 44 Your Price \$1.75

20,000 RPM HAND GRINDER

Save 50% on a tough little hand grinder that is extremely useful to radio servicemen, experimenters, jewelers, dental mechanics etc. Develops 20,000 RPM. Fits solidly in the palm of the hand. Operates on 110 V. AC or DC, 25 or 60 cycles. Its features are: high torque, oilless bearings, sturdy thrust, cool running, handy switch, collet chuck, for 1/4" and 3/32" wheels, finger support for Precision work. SHIP. Wt. 6 lbs.



ITEM No. 48 Your Price \$7.62

VENTILATION FAN

Handy for eliminating kitchen odors. Installs on either window or flue on chimney. Can also be used as radiator fan for room circulation. Induction motor. Operates on 110 volts, 60 cycles A.C. only.

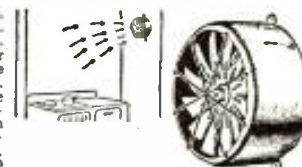

ITEM No. 49 Your Price \$4.50

WE HAVE NO CATALOG. ORDER DIRECT FROM THIS PAGE.

HUDSON SPECIALTIES - 40-T West B'way - N.Y.C.

IT'S EASY TO ORDER—CLIP COUPON—MAIL NOW

HUDSON SPECIALTIES CO., 40-T West Broadway, New York, N.Y. RT-839

I have circled below the numbers of the items I'm ordering. My full remittance of \$..... (include shipping charges) is enclosed.

OR my deposit of \$..... is enclosed (20% required), ship order C.O.D. for balance. (New U.S. stamps, check or money order accepted.)

(Circle Item No. wanted: 11 12 24 44 45 46 47 48 49 50)

Name Address

City State

Send remittance by check, stamps or money order; register letter if you send cash or stamps.

Please say you saw it in RADIO & TELEVISION

COMMERCIAL ADVERTISEMENTS 10¢ A WORD

Under this heading only advertisements of a commercial nature are accepted. Remittance of 10¢ per word should accompany all orders. Copy should reach us not later than the 10th of the month for the second following month's issue.

AGENTS WANTED

300% PROFIT SELLING GOLD Leaf Letters for Store Windows; Free samples. Metallic Co., 446 North Clark, Chicago.

CORRESPONDENCE COURSES

CORRESPONDENCE COURSES and educational books, slightly used. Sold. Rented. Exchanged. All subjects. Satisfaction guaranteed. Cash paid for used courses. Complete details and bargain catalog Free. Send name. Nelson Company, H-210 Manhattan Building, Chicago.

INSTRUCTION

ALGEBRA PROBLEMS SIMPLIFIED \$1.30; Low Voltage Transformer Construction \$0.60; Data on 500 to 20,000 Volt Step-up Transformer Construction \$1.35 (Prepaid). H. Ackerson, Box 322-D, Ramsey, N. J.

METAL LOCATORS

RADIO METAL LOCATOR (TREASURE FINDER) custom-built to order. Guaranteed sensitivity of 10-foot penetration. More efficient, less expensive than many commercial instruments. Write for details and special offer. Not obligated to buy. A. Stuart, 1015 Wilson Ave., Teaneck, N. J.

PATENT ATTORNEYS

INVENTORS — PROTECT YOUR rights before disclosing your invention to anyone. Form "Evidence of Conception"; "Schedule of Government and Attorneys' Fees" and instructions sent free. Lancaster, Allwine & Rommel, 456 Bowen Building, Washington D. C.

QSL-CARDS-SWL

100 NEAT SWL CARDS PRINTED with your name and address sent postpaid for \$1. Hunch of samples and

RST Chart for five cents in stamps. W1BFF, 16 Stockbridge Ave., Lowell, Mass.
SWL'S QSL'S, 150 FOR 75¢ OR \$1.00. Any 2 colors, free samples. W3DFE, Maple Shade, N. J.

SHORT WAVE

1½ AND 2½ METER RECEIVERS and transmitters constructed and for sale. For information U.H.F. Service, 64 Zeilner Street, Roxbury, Mass.

SPECIAL EQUIPMENT

CALL LETTERS, 2½ IN. POLISHED aluminum mounted for studio or license plate \$1.00 each, per pair \$1.50, add 10 cts. per plate for red edging. Money back if not satisfied. E. Bailey, West Newton, Pa.

MOUNT THOSE UNATTACHED meters in M.E. portable mounts, standard type with closed sides, crackle finish, binding posts. 90¢ postpaid in U.S. Markit Engineering, Annapolis, Md.

DX on the Ham Bands

(Continued from page 219)

Call	Freq.	R	S	Where Heard
CP2BP	14.16	5	6	Mich.
HC1AZ	14.035	3	3	Conn.
LU2HF	14.3	5	6	Penna.
LUSAG	14.1	5	7	Penna.
LUSAN	14.302	5	7	Penna.
LUBAB	14.15	5	7	N. Y., Penna.
LU9BV	14.18	5	8	Fla.
PV2AC	14.24	5	7	Ore.
PY7EI	14.26	4	5	Conn.
VP3CO	14.065	5	8	Quebec
YV1AQ	14.115	5	7	N. J.

EUROPEANS

CT1PK	14.26	5	8	Conn.
CT1CK	14.25	5	8	N. Y.
EA7BA	14.295	4-5	7-9	Mich., Penna., N. J., Quebec
EA9AH	14.03	5	7	N. Y.
E12L	14.005	5	7-8	Md.
F30S	14.2	5	7	N. Y.
F8VP	14.01	5	5	N. Y.
F8LX	14.1	4	7	N. J.
F8NT	14.035	4-5	7	Ariz., Nebr.
G2PU	14.02	4-5	8-9	Md., Nebr., Fla.
G2UT	14.035	4	7	Wash.
G5ML	14.115	5	7-8	Mich.
G5LU	14.05	5	6-7	Md., Kans.
G5JO	14.01	5	4	N. Y.
G5BJ	14.19	5	7	Fla.
G6VX	14.32	4	7	Fla.
G6LK	14.12	5	8	Wash.
G6PC	14.1	5	8	Md.
G8TX	14.07	4	6	Md.
G81L	14.1	5	6-7	Kans.
G81G	14.13	4	6	Ariz.
G15ZY	14.06	5	7	Quebec
GM2UJ	14.07	3	7	Wash.
GM3OL	14.116	3	6	Nebr.
GM6MN	14.07	5	7	Kans.
GM6RG	14.2	5	7	Md.
GM8MN	14.095	5	7-8	Md., N. Y.
GW3KY	14.038	5	6	Nebr.
HA1K	14.26	5	7	Ala.
11MP	14.08	5	7	N. Y.
I1TKM	14.04	5	5	Ala.
LA8C	14.13	5	6-7	Ala., N. Y.
LX1AI	14.03	5	6	Quebec
ON4HS	14.08	5	8-9	Mich.
ON4TO	14.05	4	7	Fla.
PA0EH	14.1	5	7-9	N. Y., Quebec
SM6WE	14.27	5	5	Ala.
SV1KE	14.02	4-5	6-9	N. Y., Mass., Mo.

OCEANICS

K6NBY	14.2	5	7	Conn.
K6NVD	14.26	5	7	Penna.
K6BNR	14.162	5	8	Penna.
K6OKH	14.298	5	4-8	S. Dak.
K6PPR	14.42	4	5-7	S. Dak.
K6NYD	14.49	5	7	S. Dak.
K6OJL	14.488	4	7	S. Dak.
K6OJR	14.315	4	8	N. J.
K4IER	14.25	4	7	Mass., Nebr.
K4JME	14.205	3-5	5-8	Mass., Mo., Nebr.
K4IJM	14.24	5	7	Ore.
K4IAF	14.245	5	6	Ore.
K4IAF	14.14	4	7	Ariz.
K4IAF	14.145	5	8	Ariz.
K4IHS	14.26	5	8	Ariz., Nebr.
KA2OV	14.255	5	8	Ariz.
KA41H	14.12	5	9	Wash.
KA7EF	14.12	5	8	Ala., Mo., Nebr.
K47HB	14.27	4-5	5-8	Wash., Kans.
PK1VU	14.35	5	7	Tex.
PK2AY	14.03	4-5	5-8	la., Wash., Mo.
PK2TZ	14.04	4	5-6	Kans.
PK3A	14.3	4	6	Tex.
PK3WI	14.045	5	4-6	la., Tex., Ala.
PK4KS	14.06	4	6-7	Kans.
PK6XX	14.095	4-5	6-9	Mass., Ia., Mich., Mo., Wash., Conn., Quebec
VK2ADE	14.005	5	7	Ia.
VK2ADU	14.035	5	6-7	Ia., Quebec
VK2AGH	14.06	4-5	6	Ore., Ariz.
VK2UC	14.05	4	7	Mo.
VK4AB	14.01	5	7	Ia.
VK4MW	14.0	5	6-7	Ia., Tex.
VK4KH	14.03	4	7	S. C.
VK4KO	14.04	5	7	Mo.
VK4JP	14.	5	7	Ore.
VK4HG	14.1	5	7-8	Ariz.
VK5CS	14.075	4-5	6-8	Ia., Tex.
VK5VF	14.18	5	9	Mo.
VK5QR	14.045	4	7	Nebr.
VK5GM	14.155	4	7	Mass.
VK6MW	14.11	5	7	Kans.
VK7AB	13.996	5	6	Mich.
ZL1HY	28.2	5	6	Calif.
ZL1AM	28.2	4	6	Ariz.
ZL2BE	14.09	4	7	Mo.
ZL2BE	28.42	5	7	Calif., Ariz.
ZL3BV	28.17	3	4	Calif.
ZL3KZ	28.3	5	7-8	Kans.
ZL4BK	28.25	4	5	Calif.

FOR SALE (NON COMMERCIAL) 3¢ A WORD

Under this heading we accept advertisements only when goods are offered for sale without profit. Remittance of 3¢ per word should accompany all orders. Copy should reach us not later than the 10th of the month for the second following month's issue.

FOR SALE! RIDER MANUALS—Vols. 1, 2, 3 and 4. New in original cartons—\$6.00 each. F.O.B. Colorado City—cash or money order. H. E. Manias, Colorado City, Texas.

HAVE TEST EQUIPMENT: LATEST SW-3; 4 tube PA system; and other apparatus for sale only; all letters answered. Write John Womack, Box 89, Dimmitt, Texas.

FOUR TUBE FIVE METER SUPER-REGENERATIVE RECEIVER, complete with power supply and speaker in cabinet, \$7.50. Hansen, 826 S. 4th St., Aurora, Ill.

EXCELLENT 50T \$8.00 POSTPAID. Insured. W9WJB, Verona, Wisconsin.

RME-69 \$89.00. PR-15M \$79.00. SX-16 \$79.00. NC100 \$69.00. NC80X \$69.00. Breting 14 \$69.00. Breting 12 \$49.00. Sky Champion \$39.00. Sky Chief \$24.00. Howard 430 \$19.00. FB7 \$19.00. Sky Buddy \$15.00. SW3 \$9.00. Practically all other models of receivers. All sets shipped on ten day trial. List free. Terms. W9ARA, Butler, Missouri.

FOR SALE: ULTRA STRATOSPHERE 10 transmitting receiver \$18.00.

Atwater Kent superhet 9 tubes with cabinet \$12.00. Gross 3 tube short wave battery receiver usink 3 volt tubes \$15.00. Riders Manuals 4-5-6 also Riders Resistance Measuring, also Ghirardi's Modern Radio Servicing and Field Service, also 20 Radio & Television mags., Radio Call Book, also many other radio books. Sell all books \$15.00. 2-B eliminators, Majestic and All American \$6.00. Jensen, 211 East 200 St., Bronx, N. Y.

SKY-BUDDY, PERFECT CONDITION, about 150 including tubes. Edward Bird, 4340—6th Avenue N.E., Seattle.

BARTER AND EXCHANGE — FREE!

NO ADVERTISEMENT TO EXCEED 35 WORDS, INCLUDING NAME AND ADDRESS

Space in this department is not sold. It is intended solely for the benefit of our readers, who wish to buy or exchange anything in the Radio and Television fields for Radio and other merchandise. As we receive no money for these announcements, we cannot accept responsibility for any statements made by the readers. Use these columns freely. Only one advertisement can be copy should reach us not later than the 10th of

accepted from any reader in any one issue. All dealings MUST be above board. Remember you are using the U. S. mail in all these transactions and therefore you are bound by the U. S. Postal Laws. Describe anything you offer accurately and without exaggeration. Treat your fellow men the way you wish to be treated. We welcome suggestions that will help to make this department interesting and helpful to our readers. Copy should reach us not later than the 10th of

accepted from any reader in any one issue. All dealings MUST be above board. Remember you are using the U. S. mail in all these transactions and therefore you are bound by the U. S. Postal Laws. Describe anything you offer accurately and without exaggeration. Treat your fellow men the way you wish to be treated. We welcome suggestions that will help to make this department interesting and helpful to our readers. Copy should reach us not later than the 10th of

HAVE 410 AND 16 GAUGE SHOTGUNS, also other guns. Deep sight, pump. Vank Sky Buddy, Guthman UT, 16 gauge Ithaca pump shotgun, Savage 410 single shotgun. R. Wolker, 406 No. Harvey, Oak Park, Ill.

HAVE 6L6 XTAL CONTROLLED transmitter with built-in power supply. Mounted on metal chassis, complete with meter, tubes, xtal and coils. Swap for good Sky Buddy receiver, typewriter or fast camera. Beacon Radio, Saugus, Calif.

WILL SWAP ONE PHILCO 7 TUBE battery receiver in good condition, with A Battery, for wireless record player, or P. A. equipment or what-have-you. Joseph S. Dawson, Kenbridge, Virginia.

HAVE ALL KINDS XMITTING parts, Teleplex, Moritz coil winder, signal gen. Swap for T53, T220, T240, 7.5V-6.5 amp. RL former, xtal mike. 0-10000 200 mill 2" Triplet M. A. What have you? Wm. A. Hoelker, W9ZHO, Oldensberg, Ind.

HAVE GENERAL ELECTRIC CARBON mike, also have 350 volt, 75 mill power supply. Would like to trade for good fast camera or electric phono motor with table and pick-up. E. E. Bateman, Saugus, Calif.

WANTED—PLATE CAMERA. BUG or typewriter. Have 28 ft. shielded rubber covered mike cable, speakers, B eliminators, meters and new tubes including 6L6, 83, 2A3, 59 etc. Send or complete list. W9POC, Beecher, Ill.

TO SWAP—ONE COMPLETE TRIPLET Mastor 4 unit test lab. in carrying case. Will swap complete or any part, make trade offer. R. I. Gardner, 2639 L St., San Diego, Calif.

SWL CARD COLLECTORS! SEND me ten used U.S.A. commemorative postage stamps, or fifty used U.S.A. common postage stamps, and receive fifty PB foreign QRA's by return mail. Frank Tooker, 1929 Albany Street, Schenectady, N. Y.

TO SWAP—18 COPIES QST—DEC. 1937—May 1939. 15 copies Radio—Dec. 1937—Apr. 1939. Want photography textbooks and equipment. J. R. Hanson, Box 550, Rome, N. Y.

WANTED A McMURDO SILVER Masterpiece V or VI. State price. J. C. Fury, 807 Reed St., Olean, N. Y.

TRADE 7-TUBE SINGLE-SIGNAL superhet, just built for 35 mm. enlarger, developing equipment, or Univer 8 mm. motion camera and projector. All replies answered. Edward Wooten, Varita Court, Apt. L, Wilson, N. C.

HAVE 5-TUBE SUPER, 4 ELECTRIC motors, speakers and radio parts, assortment of ferrite and xmittr tubes, 2 carbon new. Want used motor, cycle or what have you? Gilbert Hannon, 1000 Main St., Green Bay, Wis.

WANTED—U.S. AND FOREIGN stamps. Will swap midget radio, power transformer, condensers, resistors, meters, service manuals, B eliminator etc. David Rudolph, 84 West 188 Street, Bronx, New York City, N. Y.

SWAP JEWELRY VOLT-METER FOR volt meter kit reads 0-7-0-150 V. D.C. Meter is jewelled movement. Want 82 type tube and 3 (8m) 450V. condensers. Ship prepaid. W9MIO, 919 W. 4th St., Mount Carmel, Ill.

HAVE \$95 DEVRV 16-MM. MOVIE outfit, \$125.00 Arca-Anso \$65.00 camera, with \$20.00 case. Will exchange for modern radio tester or what have you? Walter Wiesneki, E. Grove St., Nanticoke, Pa.

WANTED: ANY TRANS, HIGH pwr. parts or bug or what have you. Will swap a 6' cabinet, standard, finished in gray and black. Cabinet is of masonite. Peter Benicini, 1359 Alorton Avenue, Bronx, N. Y.

HAVE HUNDREDS OF RADIO parts, tubes, eliminators, maxazines, cameras, golf clubs, tools, etc. Send your list. Describe fully. I will send mine. G. F. Roby, 6303 Kenwood Ave., Chicago, Ill.

EXCHANGE FEDERAL ENLARGER, or Argus focus camera, developing tank, and Schick razor (electric) or complete Sears-Roebuck spraying outfit. Value \$40 for 1939-9 commercial ham receiver that includes 10 meters. Howard or Hallcraft prepaid. I. Brody, W2JAP, 1163 Wheeler Ave., Bronx, N. Y.

WANTED: 40 METER BILEY xtal. 4 Bronz Isolantite sockets. NC300, two Triplet 301 M.A. 0-100 or 0-300, 100-100 mmf cond. rev. type. Trade: 80 meter xtal. B.F.O. tubes, new radio bug, Dawson, 1306 E. The Dalles, Oregon.

SWAP 10 POWER TELESCOPE, code oscillator. Atwater Kent battery speaker, postmarks and stamps. Trade for old coils. Barrett, P.O. Box 186, Jeannette, Pa.

WANT VIBRAPHONE DELIVERS about 200 volts or 5 meter crystal, any kind of 5 meter parts. Johnson Q5 meter antenna. Have swap list. Swap 200 tubes, speakers, A. Branzanskas, 105 Elizabeth St., Athol, Mass.

HAVE S.V. AND B.C. RADIO parts, meters and tubes all types, tools and radio magazines. What am I offered in exchange. Answer all, Ruby Rodman, 605 Woodland Park, Chicago, Ill.

WANTED — "ULTRA STRATOSPHERE 10" in A-1 condition, complete with all coils. Address—Charles Burwell, Magnolia D-X (Club, Magnolia, Ohio.

HAVE WESTINGHOUSE LIGHT meter—like new—lists at \$35.00. Want good microscope—please give complete descriptive details in first letter. Jack Potter, 14 Lincoln Pl., Haleswood, N. J.

HAVE A FEW RADIO PARTS TO trade for Precancelos, or will trade Precans. U.S. commemoratives for others especially Presidentials. A. Eldschun, 455 Summit Ave., Carlstadt, N. J.

WANTED: MEISSNER TUNING unit #7512 in exchange for an RCA piezo-electric calibrator. Joseph Jordan, 907 N. State St., Chicago, Ill.

HAVE MIDGET EMERSON RADIO parts, 2 speakers, 12 tubes, violin with case bow and 4 books. All used. What have you? J. Doroshenko, 483 Cleveland St., Brooklyn, N. Y.

WANTED: INFORMATION AND diagrams on buried treasures and treasure locators. Have radios and parts. John Haynes, Doe Run, Missouri.

(Continued on opposite page)

World S-W Stations

(Continued from page 220)

- 6.324 **COCW** HAYANA, CUBA, 47.4 m., Addr. La Voz del Radio Philco, P. O. Box 130, 6:55 am.-12 m, Sun. 9:55 am.-10 pm.
- 6.310 **HIZ** CIUDAD TRUJILLO, D. R., 47.52 m. Daily except Sat. and Sun. 11.10 am.-2.25 pm., 5.10-8.40 pm. Sat. 5.10-11.10 pm. Sun. 11.40 am.-1.40 pm.
- 6.295 **OAX46** LIMA, PERU, 47.63 m., Addr. Apartado 1242. Daily 7-10.30 pm.
- 6.280 **HIIG** TRUJILLO CITY, D. R., 47.77 m. 7.10-9.40 am., 11.40 am.-2.10 pm., 3.40-9.40 pm.
- 6.243 **HIIN** CIUDAD TRUJILLO, D. R., 48 m., Addr. "La Voz del Partido Dominicano." 12 n.-2 pm., 6-10 pm.
- 6.236 **HRD** LA CEIBA, HONDURAS, 48.12 m., Addr. "La Voz de Atlantida." 8-11 pm.; Sat. 8 pm.-1 am.; Sun. 4-6 pm.
- 6.210 **—** SAIGON, INDO-CHINA, 48.28 m., Addr. Radio Boy-Landry, 17 Place A. Foray, 4.30 or 5.30-9.15 am. 11.45 pm.-1 am.
- 6.200 **H10Q** CIUDAD TRUJILLO, D. R., 48.36 m. Irregular.
- 6.190 **JLK** TOKYO, JAPAN, 48.47 m. 8-9.30 am.
- 6.190 **HVJ** VATICAN CITY, 48.47 m. Mon., Wed., Thur., Sat. 2-3.30 pm., Tues., Fri. 2-3 pm. Thur. also 3-3.30 pm.
- 6.190 **T02** GUATEMALA CITY, GUAT., 48.47 m., Addr. Dir. Genl. of Electr. Commun. Relays TGI Mon-Fri. 6-11 pm., Sat. 6 pm.-3 am. Sun. 7-11 am., 3-8 pm.
- 6.185 **HIIA** SANTIAGO, D. R., 48.5 m., Addr. P. O. Box 423, 7 am.-5 pm.

49 Met. Broadcast Band

- 6.170 **W2XE** NEW YORK CITY, 48.62 m., Addr. Col. B'cast System, 485 Madison Ave., 11 pm.-12 m. Sat. & Sun. 10.30 pm.-Mid.
- 6.183 **H1EN** MOCA CITY, D. R., 48.75 m. 6.40-9.10 pm.
- 6.150 **HJ4DAE** MEDELLIN, COLOMBIA, 48.78 m., 9.30 am.-1 pm., 5-11.30 pm.
- 6.150 **VP8** COLOMBO, CEYLON, 48.78 m., 7-11 am.
- 6.180 **CJRO** WINNIPEG, MAN., CANADA, 48.78 m., Addr. (See 11.720 mc.) Daily 6 pm.-12 m., Sun. 5-10 pm.
- 6.180 **ZP14** VILLARRICA, PARAGUAY, 48.78 m. 4-6 pm.
- 6.148 **ZTD** DURBAN, SOUTH AFRICA, 48.8 m., Addr. (See ZRO, 9.753 mc.) Daily 12.40-3.45 pm., Sat. till 4 pm., Sun. till 3.20 pm.
- 6.147 **ZBB** BULAWAYO, RHODESIA, S. AFRICA, 48.8 m. Mon., Wed., and Fri. 1.15-3.15 pm.; Tues. 11 am.-12 n.; Thurs. 10 am.-12 n. Sun. 3.30-5 am.
- 6.140 **W8XK** PITTSBURGH, PA., 48.83 m., Addr. Westinghouse Electric & Mfg. Co. Relays KDKA 10 pm.-12 m.
- 6.140 **LEOPOLDVILLE**, BELGIAN CONGO, 48.83 m. Sun. 5.35-7 am.
- 6.140 **SP48** WARSAW, POLAND, 48.83 m., 3-5.30 pm.
- 6.187 **CR7AA** LAURENCO MARQUES, PORT. E. AFRICA, 48.87 m. Daily 12.05-1, 4.30-6.30, 9.30-11 am., 12.05-4 pm., Sun. 5-7 am., 10 am.-2 pm.
- 6.180 **XEXA** MEXICO CITY, MEX., 48.93 m., Addr. Dept. of Education. Daily 8-11 am., 2.30-4 pm., 7.30 pm.-12.45 am. Sun. 1.30 pm.-12.45 am.
- 6.180 **VP886** GEORGETOWN, BRIT. GUIANA, 48.94 m. 9-10 am., 2.15-6.30 pm., Sun. 5.30-11.30 am., 3-5 pm.
- 6.130 **T1EM** SAN JOSE COSTA RICA, 48.94 m. "El Mundo." Apartado 1049. 11 am.-11 pm., Sun. 10 am.-6 pm.
- 6.130 **CHNX** HALIFAX, N. S., CAN., 48.94 m., Addr. P. O. Box 998, 7 am.-11.15 pm. Sat. 8 am.-11.30 pm. Sun., Noon-11.15 pm. Relays CHNS.
- 6.130 **LKJ** JELOY, NORWAY, 48.94 m. Noon-6 pm.
- 6.128 **CXA4** MONTEVIDEO, URUGUAY, 48.98 m., Addr. Radio Electrico de Montevideo, Mercedes 823. 8 am.-Noon. 2-10 pm.
- 6.122 **HP8H** PANAMA CITY, PAN., 49 m., Addr. Box 1045. 10 am.-1 pm., 5-11 pm.

BARTER and EXCHANGE FREE ADS (continued)

- WANTED RADIO TEST EQUIPMENT** meters and supplies, or testers manuals vol. 1 to 9. Will swap or pay cash. Send for list. S. J. Batorty, 35 Potter Place, North Adams, Mass.
- HAVE AMPERITE MIKE**, P. A. Amplifier, phono pickup, phono radio combination, violin, thousand books, sporting goods, etc. Want recorder or swap lists. M. Epstein, 2953 Ituckle, Indianapolis, Ind.
- HAVE PAIR SCIENTIFIC PHONES**, straight radio telephone key, 3 vernier dials, trade for 6L6 or 6L6G tube and socket and 100 mnif transmitting condenser. Write: Len Fitchett, 637 Pine St., Victoria, B. C., Canada.
- WANTED A 1/2 OR 3/4 HP** All cooled gas motor. Trade a Keystone projector for what have you. Also unmounted 3904 Key xtal, also want a D.B. mike. J. O. S. Hunter, Box 165, Kensington, P.E.I.
- WHO HAS A TRANSCIEVER** to trade for a new Lionel remote control whistling streamliner. Old Bing Harvarian typewriter, 1/75 h.p. motor A.C. roll up track, O' gauge, wipers, etc. Donald Nelson, 138 Johnson Ave., Dumont, N. J.
- EXCHANGE ALMOST NEW DOUBLE** button mike in Rud ring with cable and plug, for TZ 40 HK 53 or what have you? QSL cards 100% answered. W. J. Weightman, 132 N. 5th St., Middletown, Indiana.
- HAVE NATIONAL PW-2 UNIT**, tubes 6" speaker 25-60 cycle power, filament transformers IPT's variable, fixed condensers, potentiometers, resistors, key mazines, etc. Need 5-10 meter receiver, xmitter, Charles M. Edwards, 1108 Douglall Ave., Windsor, Ont., Canada.
- CANADIANS—HAVE RADIO** parts, tubes, radio books, camera, rock samples. Will exchange parts. For wanted: receiver, test equipment, radio books or transmitter. (Send your list.) Steve S. Boychuk, 64 George St., Sault Ste. Marie, Ontario, Canada.
- SWAP—GREBE (R-9 BATTERY RE-** ceiver—150-2000 meters. Class "B" 48's transformers (new). 47-210 CV xmitter. Need watchmaking tools, photographic supplies, printing press, adjustable film tank, or? Stanley, 2738 Meade St., Detroit, Mich.
- WANT BATTERY OPERATED 3 TO 5** tube short wave radio receiver, good condition. Trade \$63.00 N.R.I. Radio and Television course in good shape for same. Will answer all mail. J. K. King, Jr., R.F.D. 3, Mendenhall, Miss.
- WANTED: RADIO AMATEUR** Hand book and SW radio plans, trade or buy. Have field glasses and radio parts. Answer all letters. Bob McNellie, Moorefield, W. Va.
- HAVE RIDERS MANUALS 1 TO 4**, W.E. 242A, socket, double button carbon mike, 80-160 trans. choke. Want —communications receiver with R meter, 10-550 meter 40 meter crystal. Grover S. Dale, W9RFD, Linton, Ind.
- 20 WATT WRIGHT-DECASTER** Auditorium dynamic speaker A-1 condition, 1000 ohm field. What have you? Want T30's, Herbert Fisher, R.11, Box 1760, Houston, Texas.
- BEST TRADE OFFER TAKES 150** watt phone or cv transmitter complete, 160 to 10 meters, send for full particulars. Columbus Emma, 6539 Gavista Ave., Van Nuss, Calif.
- WANTED: CODE PRACTICE** Machine, with tapes, for cash. Give full description. Arnold Badt, 169 Britain Ave., Benton Harbor, Mich.
- HAVE 8 SHOT CLIP 22 REPEAT-** ing rifle with telescope sights. Would like Lafayette 6 volt transistor or transistor, with tubes. Roy Woodin, 522 Bliddle St., Kane, Penna.
- HAVE NO. 7 1/4 GILBERT** ERECTOR set, 250 v. factory-built power supply. 38 ARRL handbook, electric train, civil war muzzle-loader rifle, complete size 17 scout uniform. What have you? H. Patchen, 23 Grand St., Sidney, N. Y.
- HAVE 8 ERECTOR; BACK COPIES** Stamps and Associations Magazines; 2 100 ft. 16 mm films. Cost \$30. Want Readrite Ranker free point test model 640 in excellent condition. Benson, 737 Rekester Avenue, Baltimore, Md.
- HAVE ELECTRO-VOICE III-Z** Velocity mike, cost \$149.00, perfect condition; also N.R.I. course less apparatus; other radio parts; tubes; want crystal mike, what have you? William Lock, 222 N. 8th St., Spearfish, So. Dak.
- HAVE 110 VOLT 60 CYCLE** 150 watt power-AC fan belt generator, portable-mobile 10-160 meter (one xmitr, 160 meter portable, fone xmitr, and parts. Trade for? Radio or camera line preferred. Wilbur Golsion, % WJRO, Baton Rouge, La.
- WANTED A USED SET OF "MAR-** con Victor Wireless Records" in good condition. Will buy used coils, condensers, resistors, etc. Send list. QRA, Jose E. Mesonara, 82 W. De Diego St., Aguadilla, Puerto Rico.
- SWAP: HAVE MANY TRANSMIT-** ting and SW receiving parts (new and used). Would like to swap for crystals, condensers or other radio parts that I don't have. E. W. Earps, 1316 E. Hope St., Pensacola, Fla.
- WANT "NATIONAL SW-3"** 2 VOLT 250 model only. New Fairbanks-Morse 4 tube 2-6 volt battery superb, over 40 broadcast stations received on loudspeaker. Latest tubes and circuit. Alexander Podolsky, 211 Pine St., Phila., Penna.
- WILL TRADE NEW SHURE** CRYSTAL pickup model 99 black, used for high fidelity equipment, with powerful motor, 10" turntable, swing recordings. Want typewriter or test equipment. Irving Goldstone, 332 Alabama Ave., Brooklyn, N. Y.
- WILL TRADE 200 WATT 16MM** movie projector 400 ft. capacity with 1000 ft. film and other items, for television set or complete kit, such as Radio, J. Winkler, 82 Bergen Ave., Clifton, N. J.
- SWAP HAM STATION** RACK transmitter, 80 watts input, cover supplies, GE 8 tube superb, key, Triplet meter for 1931 Ford or Chevrolet roadster, good condition. W2LHC, George Fogarty, 407 W. 56 St., New York City.
- WANTED — "CLASSICAL"** PHONO-graph records. Electric recorded, new channels, such as pick-ups, books, etc. Joseph Monahan, Old Frankfort Pike, Lexington, Ky.
- MULTIMETER AND OSCILLATOR** in case, tube tester, condenser tester, tubes, condensers and resistors. P.A. outfit, phono pickup, mike, speakers and other parts. Will trade for what have you. J. R. Reed, 2178 West 3d St., Durango, Colorado.
- SWAP NAMES OF 50 ENERGETIC** swappers, Sylvania 53 tube (unused), old fundamental radio course, "Increasing Farm Profit", 100 valuable formulas, signal corps fundamental radio book, SWL cards appreciated. Bill Schroeder, 803 Wisconsin, Peoria, Illinois.
- SWAP FOR WHAT HAVE YOU?** Complete shortwave receiver—9 to 1000 meters. "Leutz" 9 tube \$325 SW-LW receiver, speakers, phones and radio parts. List. J. Wm. Anderson, M.W.D. Eagle Mt. Plant, Desert Center, Calif.
- WILL SWAP—COOKE'S "ELECTRI-** cal Course" (62 lessons). Will send titles of lessons if requested. Want—Sky Buddy or similar receiver, radio or servicing course or what have you? Robert Jones, 201 Walnut St., West-empert, Md.
- HAVE COMPLETE SET POWERED** wood working tools for home workshop. Oil paintings, tent for camping. Interested in complete ham radio rig, phone, CW. All communications answered. C. D. Journell, 8726 Morehead Ave., El Paso, Texas.
- WANTED GAS ENGINE FOR MOD-** el airplane, good camera and photographic equipment. Have radio parts, tubes, mags., S.W. converter, 8.W. receiver, etc. Write for details to: Anthony Conlin, 83 Westfield Rd., Holyoke, Mass.
- WANT SMALL PLATE CAMERA,** exposure meter, developing tanks, binoculars, portable typewriter, Riders, Ghirsa manuals. Have RCA and radio, 1/4 H.P. A.C. motor, revr. parts, books, coils, cash. W. J. Closson, 295 8th St., Troy, N. Y.
- WANTED: RECEIVER AND TRAN-** smitter in good condition provided the price is right. Will pay cash for best offer. John Enkratt, 31 Chiduan St., Waterbury, Conn.
- MOVIE PROJECTOR 8MM** WANTED or other photo apparatus. Have Super Allmeter 1150-S and S tube tester 1140-S. What have you? F. W. Johnson, Antwerp, O.
- BEGINNER IN RADIO WILL BUY** or swap N.W. parts, circuit diagrams, etc., and would like to correspond with other beginners. Alfred J. Badker, 21 Leavett Place, Lynn, Mass.
- WANTED—HALLICRAFTERS 5-10** or other commercial receiver. Trade—modulator, P. P. 6L6, modulator transformer, 1000 volt power supply with meter, or cash. Value \$95. Write—James Wood, 1224 Kunkle Ave., N.S. Pittsburgh, Penna.
- HAVE 5 TUBE EMERSON, 4 PUS-** h-buttons, almost new; exchange for factory built preselector. Would like to correspond with SWL's having Sky Buddy, S19-R, SWL's, exchanged. Mail answered 100%. Daniel Platt, 225 Division Avenue, Brooklyn, N. Y.
- WANTED: ANY KIND OF A** transmitter or what have you. Have 1917 model one tube radio slightly used, also a 36, 37, 38 and 39 tube. All letters ans. Adrian Bernakozzi, Coneague, I. I., N. Y.
- WANT LOW POWER SW TRAN-** smitter. Will trade typewriter, binoculars, books and postage stamps. Gall Harry Moreland, 326 North Walnut, Wichita, Kansas.
- SWAP RME 510X EXPANDER** FOR DB20 preselector. Or what? William Quigley, 102 Ave. S., Brooklyn, N. Y.
- HAVE AC, 119 TRANC. VOLT-** age, mill meter, 2 stage preselector code oscillator, couple single mic. Send your list for mine. What have you to swap? Steve Varco, Jr., 2338 Riverview, Dayton, Ohio.
- WANTED: SKY BUDDY** OR A good S.W. receiver. Have phonograph equipment or practically anything in radio parts or receivers. I would prefer to trade. Stanley Bartleman, Box 27, Graettinger, Iowa.
- CANADIANS—WANT SKY BUDDY** fairly new. Have new 6L6 20 watt, 80 meter xmitter less power supply, new \$30 Spanish guitar key and \$500 cash. Write J. Davis, 27 Vernon St., Halifax, N. S., Canada.
- HAVE STROMBERG CARLSON** RADIO 8 tube separate speaker, good condition, also 64 chromatic harmonica with case new. Swap for bicycle or what have you. Russell B. Turney, Jr., Box 81, Salem Depot, N. H.
- WANTED—SCOTT RECEIVER 23 OR** 30 tube model, state price and describe completely. Swap—Hallicrafter communication receiver, Kenometer, RCA auto radio M34, oil condensers high voltage, parts. Oliver F. Klein, 2235-N. 39 st., Milwaukee, Wis.
- WANT USED** EILLEN, Deutsches or Do-All Deluxe or similar set either A.C. or battery. Have an Upco magnetic phono pickup, list of parts and cash. Write now. SWL? Don Yocum, Bettvsville, Ohio.
- 5 TUBE AC SET AND PARTS** TO exchange for stamps, coins. Will trade ten unused three cent stamps for duck stamps (no torn). Merlyn Reynolds, Dept. RT, Jefferson, Maine.
- WANTED OLD TRANSMITTER** AND receivers, mikes and bugs, no parts accepted. Also swap SWL's. QRA Mitchell Miller, Randolph St., Vandallia, Ill.
- WILL PAY CASH FOR UTAH KIT** No. 2 in good condition. All letters answered. B. E. Hecker, 310 N. "A" St., Arkansas City, Kansas.
- HAVE WESTON PHOTONIC PRO-** cess, rail revolution counter, laboratory equipment, books, magazines, linoleum cutters, mikes and dials. Want meters, multimeter or receiver. Will exchange lists. George Friedl, 1764 Weeks Ave., N.Y.C.
- HAVE—HOWARD MODEL 450** communication receiver, separate speaker, crystal filter, etc. Set cost \$109, last year. Want Sky-Champion A-1 shape, jumbo meter and what have you. E. Rusconi, 6942 Ave. K., Houston, Tex.
- HAVE 9 FT. GASOLINE MODEL** airplane with Syncro ac motor. Valued at \$30.00. Want fone transmitter, Halliferafter receiver or what have you? Your description for mine. Answer all letters. Nelson Harrill, Eilenboro, N. C.
- HAVE 10" UTAH SPEAKER, 5"** RCA with output transformers. Also a two tube regenerative receiver of A.H.I. in 1935. What have you? Robert C. Dole, 10 Chilton Ave., Rutland, Vermont.
- WILL TRADE 2-47 TUBES AND** 1-30 or 1-47, 1-2525, 1-31 for 1-58 and 1-56. Want a 40 meter crystal also. Write: Dick Conrad, Saco, Mont.
- SWAP—SILVERTONE HOWARD** 12 tube communications set with crystal and speaker 1938 model for moving picture machine 16 mm or what? H. Davis, Oconomowoc, Wis.
- WANTED FOR CASH—LOOSE CO-** mpleters, tuners, 23, 43 plate table mounting variable condensers, spark coils, spark gaps. Give condition, particulars. George C. Starry, 210 N. Ligonier St., Latrobe, Pa.
- HAVE UNUSED AND USED** stamps, wood block clarinet, Euphonor saxophone (gold lacquer) and radio parts. Will trade for unused U. S. stamps or? All letters answered. Huddleston, 918 South 25th Street, Temple, Texas.
- WANTED: MIDGET OR AUTO** RADIO, binoculars, sleeping bag, 22 rifle; have fishing tackle, Taylor barometer and outdoor equipment. Waltz, 121 Transverse, Carrick, Pittsburgh, Pa.
- HAVE SIGNAL PRACTISE KEY;** License Manual; How to Become a Radio Amateur; Radio Amateur Course; How to Draw by Murray; 175 viewcards. Want stamps, books, etc. Robert J. Grzeskowiak, 302 Adams Street, Albena, Michigan.
- SWAP—0-1 M.A. TUBESTER** Meter, Hickock made; eleven assorted metal receiving tubes; 3-50; 2-81 tubes slightly used; Mafestic G-10-B dynamic speaker with output transformer—for what have you. Albert Buckner, Charleston, Mo.
- 1939 HALLICRAFTERS SX-17** Complete with speaker and xtal. Purchased 3-11-39 and in excellent condition and covered by original guarantee. Need modern B.C. console. P. O. Box 104, Tamaqua, Pa.

(Continued on following page)

BARTER and EXCHANGE FREE ADS (continued)

WANT LARGE LENS FROM OLD Jenkins or Baird television set, or similar. Give diameter and tell you wants in reply. Robert Eichberger, 782 West End Ave., New York, N. Y.

WANTED P.M. DYNAMIC SPEAKERS any size. Have power transformers, input and output transformers and other miscellaneous parts. Hyron St. Clair, 54 Selwyn Rd., Belmont, Mass.

WANTED—TYPEWRITER—GOOD make in good condition. Have brand new Spanton wireless record player with microphone attachments. Value twenty-five dollars. Julius Unger, 1349—50 St., Brooklyn, N. Y.

HAVE WEBSTER TELE-TALK INTERCOMMUNICATION SYSTEM. 5 tubes, 2 speakers and main station; open for ten speakers. A.C. or D.C. Cost \$79.50. Want amateur transmitting, receiving or transceiver, or what? R. B. Gurney, Rt. 1, Box 81, Salers Depot, N. H.

MOTOR GENERATOR HAS OUTPUT OF 450 volts at 10 amps., also 1.5 and 7 volts to be traded for condenser tester or other test equipment. H. Malik, Statesan, Wis.

WANTED—USED 8MM MOVIE films and 8MM accessories, telescopes, rifles, binoculars, cameras, auto radio, world war relics. Will pay cash or trade. Send for my list. Floyd Miller, 217 N. Main St., Towanda, Pa.

WANT ELECTRIC GUITAR. SMALL gas driven 110 volt 50-60 cycle charging plant, or converter for 6 volts dc to 110 volts ac. Also could use combination 6 volts dc and 110 ac amplifier. Orville Price, Hillsboro, Ill.

WANT 5 OR 6 TUBE SUPHERET. Have 160 meter xtal xmitter, Hawkins Elec. Guide, vols. 2-10, 6V vibrator pack, 250 V. tra. converters, etc. All letters ans. Garth Henry, 911 Evans, Cheyenne, Wyo.

WILL SWAP RADIO PARTS FOR four midget wheels and tires. Also have battery charger and stamps. Terrence Genes, Fort Lawn, S. C.

NO. 7 1/2 DIRECTOR SET AND NO. 4 Chemcraft set, also 1 television book, slightly used. Want Sky Buddy or other short wave receiver. Floyd Schuler, 2410 Cudaback Ave., Niagara Falls, N. Y.

HAVE JEWELL 3/4" 0-5 MILLIAMPERE meter. Weston 1-140 V. D.C. (301), Hoyt 0-200 A.C. meter, 5 mfk. manuals, Crosley, G.E.—AK—Strom. Sky Buddy or similar receiver. Robert Newman, 1700 E. 15th St., Brooklyn, N. Y.

TRADE 150 WATT PHONE AND CW transmitter. All band operation. Need T230s, high voltage transformers, choke, condensers, etc. What have you? H. G. Gwinn, 935 W. 21, Anderson, Ind.

HAVE COMPLETE N.R.I. RADIO and television course and 1939 Sky Buddy. Want 16mm Keystone camera and projector in A1 condition. Exchange SWL cards. 1 QSL 100%. John Basta, 31 Lake Street, Brooklyn, N. Y.

HAVE N. W. SCH. OF TAXIDERMISTRY course (worth \$20) or cash for good A1 superhet, Sky Buddy or SW3. QRA: Bob Bennett, 618 Berkley Ave., Elmhurst, Ill.

WANT SKY BUDDY OR HOWARD 430 in good condition. Will trade excellent collection 1430 different stamps. (135 countries) mounted in swell album. Some of U.S. collection 70 years old. John Creamer, 423 Third, Chillicothe, Missouri.

WANTED—PARTS FOR 25 WATT c.w. transmitter. Trade new complete photo electric relay circuit with GM photo cell and high resistance relay. Also have Nokoli 6" PM speaker. All inquiries answered. Charles Schaeble, Canute, Okla.

HAVE N.R.I. COURSE. GOOD. Will trade for A1 300 volt vibrator pack, Billey crystals, buk key, or crystal mike. Phillip H. Barnhart, WTHPB, Valley Route, Cody, Wyo.

WANTED—ONE OR TWO METER Aneco Memo 35 mm camera, F6.3 lens. D.C. H. A. Keys, W5WN, Kinder, La.

I HAVE A 600 POWER THREE stage microscope. dissection instruments both in a wood case. I want Riders Manual number four or new tubes in sealed cartons. M. Rosen, 496 Stone Ave., Brooklyn, N. Y.

EXCHANGE 5 AUDIO TRANSFORMERS, six inch dynamic speaker, 3 pair earphones, 13 note accordion, 1775 H.P. motor A.C., 3 power binoculars with compass, Lionel remote whistle train set new. Want anything radio. Nelson, 138 Johnson Ave., Dumont, N. J.

HAVE MIDGET CAMERA. SMALL 5 tube S.W. radio and phone trans. parts. Want movie camera, prof. films or 22 cal. rifle. A. Razzando, R.D. 1, Fayette City, Pa.

HAVE WESTON ANALYZER 660. Brownie No. 2 folding camera. Hammarlund dual 00014 cond., small amplifier 57-56-2A5-2A5-80 8 tube super (communications). Swap for Sky Buddy, accordion, etc. Stanley Garner, 29 W. Chestnut St., Norristown, Pa.

HAVE HIGH AND LOW POWER xmitting tubes to swap. Pair 805, 838, 807, one 803 and a new RCA 833. Want receiver, high voltage transformers, 250 watt class B equipment. W3HJR, 4500 Frederik Ave., Baltimore, Md.

HAVE OXFORD 8 INCH DYNAMIC speaker, amplifier, Weston model 506 voltmeter, Readrite 0-20-100 ma. and 30 adventure books. Want old model Itaco Clipper. State age. H. Hale, Jr., 1756 Wallen Ave., Chicago.

6 TUBE THORDARSON OSCILLOSCOPE, 1 inch tube with 2 inch lens. Like new. Internal sweep, 12 controls, all variable. Want good camera or good shotgun. Eric Pohle, 151 Mahar Ave., Milton, N. J.

HAVE LOADS OF POPULAR SCIENCE magazines, other magazines, telegraph set, pocket radio, etc. Want Argus camera, bicycle, United States stamps, watch in good condition, etc. Send list. L. Bernstein, 1071 Elder Ave., Bronx, N. Y.

HAVE BRAND NEW INBOARD marine engine, radios, parts. Want radio tools, art photo collection, SWR radio, records, amplifiers, or make your own offer. J. Kubik, 37 Pine St., St. Rarrington, Mass.

WILL SWAP 2 TUBE AC BROADCAST receiver (Peerless) parts alone worth approximately \$25, for a Hallcraft receiver or what have you in radio apparatus. QSL and SWL cards answered 100%. A. E. Perry, Eddyville, Iowa.

FOUR-BAND A.C.-D.C. short-wave receiver. Swap for automatic 4-jaw chuck for "AA" brand lathe; or power tools and machines. Write for list of other radio stuff. A. Stuart, 1015 Wilson Ave., Teaneck, N. J.

WANT A SHORT WAVE RECEIVER. Will give 154 stamps. C. I. Johnson, 116 West 2nd St., Jamestown, N. Dak.

HAVE NEW PING PONG SET. 13 magazines for boys, 8 Geographic Magazines and about 1,000 stamps. Want good radio parts, old radios, or books on radio? All letters ans. Ross Manning, Millington, Tenn.

WANTED—8" DYNAMIC 2,500 OHM field. Have power transformers, bell transformer condensers, tubes, etc. Send your list for mine. Louis Mazzagetti, Crabtree, Penna.

TRADE RADIO PARTS. MIMF-TRAC amplifier, 110 volt DC to AC converter, 35mm motion picture projectors. Want—RCA 15mm sound camera, 16mm projector or what? Wm. Hansen, Niles, Mich.

HAVE 616-807 TRANSMITTER, 35 watts output C.W. including tubes, power supply. Less crystal. Swap for good 10 meter receiver or crystal mike. Have transmitting tubes, 211, 242. Leonard Wright, 59 Creighton St., N. Cambridge, Mass.

HAVE FIVE DOLLARS AND AN Aneco Memo 35 mm camera, F6.3 lens. What testing equipment can you offer? Tom Martinek, Co. 375 C.C. Lewistown, Montana.

HAVE INSTRUCTOGRAPH SR. 10 tapes, also many books on radio. What have you? All letters answered. Jack Butler, 508 Whitley Ave., Joliet, Ill.

WANT CODE INSTRUCTOR OR low powered transceiver. Have books on all subjects, radio, science, etc. Also stamp collection and coins. All offers considered. Write to Sidney Novorodsky, 90 Orange Street, Chelsea, Mass.

SWL EXCHANGE

UNITED STATES
JOHN A. B. WERTZ, WGAR, Co. 4468, C.C. Barnwell, So. Car.
MAURICE WYNNE, 210 Hector Ave., Metairie, Louisiana.
EDWIN NELSON, 1417 Monroe Ave., Racine, Wisconsin.
BOB HANSEN, 1414 Grove Avenue, Racine, Wisconsin.
T. P. SWOL, 30 Mill St., Middletown, Conn.
J. A. AUGHT, P. O. Box 1424, New J. Orleans, La.
JOHN HALLIN, W40H56, 40 East 66 St., New York, N. Y.
WM. C. PALMER, R#2, Brunswick, Ohio.

MRS. ALDEA BEACHEMPTIN, 231 Henry St., Manhattan, N. Y.
JOSEPH WASTAK, JR., 1748 W. 18th St., Chicago, Ill.
HARRIET KNIGHT, 1428 E. Jefferson St., Fort Worth, Texas.
JOHN HASTA, 31 Lake St., Brooklyn, N. Y.
G. T. HARRON, 1517 Ruan St., Ft'd., Phila., Penna.
BOB HIASE, 80 Greyrock Place, Stamford, Conn.

BOB JOHNSON, P. O. Box 146, Logan, West Virginia.
JAMES CRUM, Box 223, North Ridgerville, Ohio.
HAROLD BEICHEL, Highland, Ill.
LEO PRZENITZKI, JR., Box 146, North Ridgerville, Ohio.
V. Y. FIELD, Center Moriches, N. Y.
OLIVER ROBERTS, 7 Fairmount Avenue, Wakefield, Mass.

LOUIS H. JASON, JR., 55 Cleveland Street, Arlington, Mass.
PAUL HOPFARTH, Orange, Texas.
N. E. WHITTON, 76 Green St., Greenwood, Mass.
JAMES COLE, 1321 No. Irving St., Arlington, Va.
WILLIAM LEWIS, 2047 Llewellyn Ave., Baltimore, Md.

FRANKLIN PEASE, 3160 Dodge, Omaha, Nebraska.
HENRY HECKERT, 910 Coolbaugh Street, Red Oak, Iowa.
WALTER McMAHAN, 320 Hunstock Ave., San Antonio, Texas.
DONALD HOCKEY, V.P., Plymouth Radio Club, North 4th St., Plymouth, Ind.

CANADA
CHARLES TAYLOR, 4 Water St., St. Catharines, Ont.
CUBA
HELIO LOPEZ R. ECAY, P. O. Box 2325, Havana.

ENGLAND
ROY BROMELL, 303 Warwick Road, Solihull, Birmingham.
DENY'S CRAMPTON, 35 York Road, Bingley, Southport, Lancashire.
WILFRED TARBOTTON, BSW1909, 28 Curzon Rd., Bradford Moor, Bradford, Yorkshire.
R. PITTILO, BSWL776, Queen Margaret St., Kinross, Scotland.
ANDY ROBERTSON, 5 York Rd., Southport.

EDDIE STROWBRIDGE, 11 Leigh Gardens, Kensal Rise, London.
RON JOHNSON, 11 Perry Mansions, Catford Hill, S. E. 6, London.

MALAY
TANBIN HUSSAIN, Municipal, Ipoh, Perak, F.M.S.

SWEDEN
GUNNAR SANDBERG, Drottninggatan 102, 111, o.g.o., Stockholm.

Mc.	Call	
6.122	FK8AA	NOUMEA, NEW CALEDONIA, 49.00 m., Radio Noumea, Addr. Charles Gaveau, 44 Rue de l'Alma., Wed. & Sats. 2.30-3.30 am.
6.120	W2XE	NEW YORK CITY, 49.01 m., Addr. See 6.170 mc., 11 pm.-12 m., Sat. & Sun. 10.30 pm.-12 m.
6.117	KEUZ	MEXICO CITY, MEX., 49.03 m., Addr. 5 de Mayo 21. Relays XEFO 9 am.-1 pm., 7 pm.-12 m.
6.116	—	SAIGON, FR. INDO-CHINA, 49.05 m., 6 or 7 to 9.30 am., 11-11.30 pm.
6.115	OLR2C	PRAGUE, BOHEMIA, 49.05 m. (See 11.40 mc.)
6.110	XEGW	MEXICO CITY, MEX., 49.1 m., Addr. La Voz de Aguila Azteca desde Mex., Apartado 8403. Relays XEJW 11 pm.-1 am.
6.105	HJ6FAB	MANIZALES, COL., 49.14 m., Addr. P. O. Box 175, Dly. 5.30-10 pm. Sat. to 11 pm. Sun. 2.30-5 pm.
6.100	YUA	BELGRADE, JUGOSLAVIA, 49.18 m. 1-3, 6.30-8.30 am., Noon-6.30 pm.
6.100	W9XF	CHICAGO, ILL., 49.18 m., 4-6.50 pm. (Sat. to 5.30 pm.) 1-2 am.
6.100	W3XL	BOUND BROOK, N. J., 49.18 m., Addr. Natl. Broad. Co. 9 pm.-12 m.
6.097	ZRK	KLIPPEUVEL, S. AFRICA, 49.2 m., Addr. S. African Broad. Co., Johannesburg. Daily 12 n.-4 pm. Sun. 12 n.-3.20 pm.
6.097	ZRJ	JOHANNESBURG, S. AFRICA, 49.2 m., Addr. S. African Broad. Co. Daily exc. Sat. 11.45 pm.-12.50 am.; Daily exc. Sun. 3.15-7.30, 9-11.30 am. (Sat. 8.30-11.30 am.) Sun. 3.30-4.30 or 4-5 am., 5.30-7, 9-11.30 am.
6.095	JZH	TOKYO, JAPAN, 49.22 m., Addr. (See 11.800 mc., JZJ.) Irregular.
6.090	ZNS	NASSAU, BAHAMAS, 49.26 m., Addr. Dir. of Tel. East St., Nassau. 1.30-2, 8-9 pm.
6.090	CRXC	TORONTO, CAN., 49.26 m., Addr. Can. Broadcasting Corp. Daily 6.45 am.-4 pm., Sun. 9.30 am.-11 pm.
6.090	ZBW2	HONGKONG, CHINA, 49.26 m., Addr. P. O. Box 200. Irregular.
6.083	VQ7LO	NAIROBI, KENYA, AFRICA, 49.31 m., Addr. Cable and Wireless, Ltd. Mon., Fri. 5.30-6 am., 11.15 am.-2.15 pm., also Tues. and Thurs. 8.15-9.15 am.; Sat. 11.15 am.-3.15 pm.; Sun. 10.45 am.-1.45 pm.
6.080	W9XAA	CHICAGO, ILL., 49.34 m., Addr. Chicago Fed. of Labor. Relays WCFL irregular.
6.080	CRY9	MACAO, MACAO, 49.34 m., Tues. 8.30-10 am.
6.080	HP5F	COLON, PAN., 49.34 m., Addr. Carlton Hotel. 7-9 pm.
6.079	DJM	BERLIN, GERMANY, 49.34 m., Addr. Broadcasting House. Irregular.
6.077	OAX4Z	LIMA, PERU, 49.35 m. Radio National 7 pm.-1.30 am. Except Sun.
6.075	VP3MR	GEORGETOWN, BRI. GUIANA, 49.35 m. Sun. 7.45-10.15 am.; Daily 4.45-8.45 pm.
6.070	CFRX	TORONTO, CAN., 49.42 m. Relays CFRB 6.30 am.-11 pm., Sun. 9 am.-11 pm.
6.070	VE9CS	VANCOUVER, B. C., CAN., 49.42 m. Sun. 1.45-9 pm., 10.30 pm.-1 am.; Tues. 6-7.30 pm., 11.30 pm.-1.30 am. Daily 6-7.30 pm.
6.069	—	TANANARIVE, MADAGASCAR, 49.42 m., Addr. (See 9.51 mc.) 12.30-12.45, 3.30-4.30, 10-11 am., Sun 2.30-4.30 am.
6.065	SBO	MOTALA, SWEDEN, 49.46 m. Relays Stockholm 4.15-5 pm.
6.060	—	TANANARIVE, MADAGASCAR, 49.5 m., 12.30-12.45, 3.30-4.30, 10-11 am.
6.060	YDD	BANDONG, JAVA, 49.5 m., 5.30 am. on.
6.060	W8XAL	CINCINNATI, OHIO, 49.5 m., Addr. Crosley Radio Corp. Relays WLW Sun. 7 am.-6.30 pm., Mon., Tues., Thur. 5.45-11 pm., Sat. to 10 pm. Other days to 10.30 pm.
6.060	W3XAU	PHILADELPHIA, PA., 49.5 m. Tues., Wed., Fri. 5.30-6.15, 6.30-11 pm. Sat. 11 pm.-1 am. Sun. 6.30-11 pm.
6.057	ZHJ	PENANG, FED. MALAY STATES, 49.53 m. 6.40-8.40 am., except Sun., also Sat. 11 pm.-1 am.

Let's Listen In with Joe Miller

(Continued from page 215)

reporter from the West Coast, adds that it has added 2 new relays, one on 9.69 mc., and another on a frequency varying from 7.30-7.34 mc. The latter is heard daily, 8-10:15 a.m., but the former is used only irregularly.

Radio Saigon, which operates on 6.116 mc., has added another frequency, 9.49 mc., adding another signal to the growing number emanating from this far-away land. Ashley Walcott also adds that often another frequency, 11.78 mc., is used after 8:30 a.m., taking over the program of the 6 mc. transmitter, which is scheduled from 6-8:30 a.m. daily. The 11 mc. transmitter carries on 'til 9:30 a.m. The 9.49 mc. signal operates simultaneously with the one on 6 mc. QRA is P.O. Box 412, Saigon.

MTCY, Hsingking, Manchukuo, was heard by Ashley Walcott, W6, on 2 occasions from 4-5 a.m., on 13.635 and 15.200 mc., simultaneously.

JVW, 7.257 mc.; JVW2, 9.675 mc.; JVW3, 11.725 mc.; JVW4, 15.235 mc.; and JVW5, 17.825

mc., will now relay JOAK programs to Manchukuo. At present, JVW3 broadcasts irreg. 4-7:30 a.m., and also, with JVH, 14.60 mc.

TPZ2, 8.96 mc., Alger, Algeria, often heard phoning Paris using side-band secrecy in mid-afternoon, now may be heard regularly, in clear speech, relaying a CB program of Radio-Alger to Tunisia and the Near East, on Tuesday from 12:30-1:30 p.m.

KAX, 19.98 mc., Manila, Philippines, heard by Gus Gallagher, W6, transmitting a program to the NBC at 7 p.m.

HNF, Baghdad, Iraq, formerly on 9.83 mc., now is being heard on 9.685 mc., with a daily schedule of 10 a.m.-3 p.m.

XGOK, 11.81 mc., Canton, is the latest addition to the Chinese stations, and is apparently being operated by the Japanese, who have occupied Canton. Schedule is at present 5:30-8:40 a.m., with English used after 8 and news at 8:20 a.m., with English programs announced by a woman. Ashley Walcott sends this data, and reports XGOY, 11.90 mc., being nearer 11.89 mc., with a very strong signal.

Mc.	Call	
6.050	GSA	DAVENTRY, ENGLAND, 49.59 m., 12.25-6 pm.
6.045	XETW	TAMPICO, MEXICO, 49.6 m. Irregular 7-11 pm.
6.040	W4XB	MIAMI BEACH, FLA., 49.65 m. 1-3 pm., 9 pm.-2 am., Sun. 4-6 pm. Relays WIOD.
6.040	WIXAL	BOSTON, MASS., 49.65 m., Addr. University Club. 7-9 pm. exc. Sat. & Sun. Sun. 2.30-6 pm.
6.033	HP58	PANAMA CITY, PAN., 49.75 m., Addr. P. O. Box 910. 10.30 am.-2, 6-10 pm.
6.030	CFVP	CALGARY, ALTA, CAN., 49.75 m. Thur. 9 am.-1 am.; Sun. 12 n.-12 m.
6.030	RW96	MOSCOW, U.S.S.R., 49.75 m. 1-3, 4-7 pm.
6.030	OLR2B	PRAGUE, BOHEMIA, 49.75 m. (See 11.875 mc.) Off the air at present.
6.023	XEUW	VERA CRUZ, MEX., 49.82 m., Addr. Av. Independencia 98. 10 pm.-1 am.
6.020	DJC	BERLIN, GERMANY, 49.83 m., Addr. (See 6.079 mc.) 11.30 am.-4.30 pm.
6.020	HJ3CAX	BOGOTA, COL., 49.83 m., Addr. Apartado 26-65. 12 n.-2 pm., 5.30-11 pm., Sun. 6-11 pm.
6.017	H13U	SANTIAGO DE LOS CABALLEROS D. R., 49.84 m. 7.30-9 am., 12 n.-2 pm., 5-7 pm., 8-9.30 pm.; Sun. 12.30-2, 5-6 pm.
6.015	PRA8	PERNAMBUCO, BRAZIL, 49.85 m., Radio Club of Pernambuco, 4-9 pm.
6.010	OLR2A	PRAGUE, BOHEMIA, 49.92 m. Addr. (See OLR, 11.84 mc.) Irreg.
6.010	COCO	HAVANA, CUBA, 49.92 m. Addr. P. O. Box 98. Daily 7.55 am.-12 m., Sun. until 11 pm.
6.010	YK9MI	S. S. KANIMBLA, 49.92 m. (Travels between Australia and New Zealand). Sun., Wed., Thurs. 6.30-7.30 am.
6.010	CJCX	SYDNEY, NOVA SCOTIA, 49.92 m. Relays CJCX 7 am., 1.30, 4-8.30 pm.
6.007	XYZ	RANGOON, BURMA, 49.94 m., 6.30-10 am., 9-11 pm., Sat. 9.30-11 pm.
6.007	ZRH	ROBERTS HEIGHTS, S. AFRICA, 49.94 m., Addr. (See ZRK, 9.606 mc.) Daily exc. Sun. 9.30 am.-3.30 pm.; Sun. 9 am.-12 n., 12.15-3.15 pm. Daily exc. Sat. 11.45 pm.-12.50 am.
6.005	HP5K	COLON, PAN., 49.96 m., Addr. Box 33, La Voz de la Victor. 7-9 am., 10.30 am.-1 pm., 5-11 pm.
6.005	CFCX	MONTREAL, CAN., 49.96 m. Can. Marconi Co. Relays CFCF 6.45 am.-12 m.; Sun. 8 am.-10.15 pm.
6.005	VE9DN	DRUMMONDVILLE, QUE., CAN., 49.96 m., Addr. Canadian Marconi Co.
6.002	CXA2	MONTEVIDEO, URUGUAY, 49.98 m. Addr. Rio Negro 1631. Relays LS2, Radio Prieto, Buenos Aires. 5.30-10.30 pm.
6.000	XEBT	MEXICO CITY, MEX., 50 m., Addr. P. O. Box 79.44. 10 am.-1.45 am.
5.990	ZEA	SALISBURY, RHODESIA, S. AFRICA, 50.08 m. (See 6.147 mc., ZEB.) Also Sun. 3.30-5 am.

End of Broadcast Band

5.977	CS2WD	LISBON, PORTUGAL, 50.15 m., Addr. Rua Capelo 5. 3.30-6 pm.
5.975	OAX4P	HUANCAYO, PERU, 50.16 m. La Voz del Centro del Peru. 9-11 pm.
5.968	HVJ	VATICAN CITY, 50.27 m. Off the air at present.
5.950	HH2S	PORT-AU-PRINCE, HAITI, 50.37 m., Addr. P. O. Box A103. 7-9.45 pm.
5.940	OAX2A	TRUJILLO, PERU, 50.51 m., Tue., Thu., Sat., Sun. 7-10 pm.
5.900	ZNB	MAFEKING, BRI, BECHUANALAND S. AFRICA, 50.84 m. Addr. The Govt. Engineer, P. O. Box 106. 6-7 am. 1-2.30 pm. Ex. Suns.
5.900	TILS	SAN JOSE, COSTA RICA, 50.85 m. 6-10 pm.
5.885	H19B	SANTIAGO, D. R., 50.95 m. Irregular 6-11 pm.
5.875	HRN	TEGUCIGALPA, HONDURAS, 51.06 m. 1.15-2.16, 8.30-10 pm.; Sun. 3.30-5.30, 8.30-9.30 pm.
5.855	H11J	SAN PEDRO DE MACORIS, D. R., 51.25 m., Addr. Box 204. 11:40 am.-1.40 pm., 6.10-8.40 pm.

FREE CATALOGS and INFORMATION

By carefully reading the advertising columns, you will find many offers to furnish literature containing valuable technical information that will help you in your work. Use this list freely.

Firm	Business	Offer	No.	Cost	Ado. Page
Aerovox Corporation	Parts Mfr.	Catalog		Free	247
Allied Radio Corp.	Mail Order	Radio Catalog		Free	237
		Builder's Handbook		10c	
		Recording Book		10c	
American Radio Institute	Radio School	Booklet		Free	238
Amperite Co.	Parts Mfr.	Chart	AR	Free	235
Audel, Theo., & Co.	Book Publisher	Information		Free	229
Bliley Electric Co.	Parts Mfr.	Engineering Bulletin	E-6	10c	231
		Circular	A-6	Free	
		Bulletin	E-7	Free	
Brush Development Co.	Parts Mfr.	Catalog		Free	233
Burstein-Applebee Co.	Mail Order	Catalog		Free	241
Cameradio Co.	Mail Order	1939 Catalog		Free	241
Candler System Co.	Code Course	Book of Facts		Free	238
Chicago Wheel & Mfg. Co.	Manufacturer	64-page Catalog		Free	237
Cornell-Dubilier Elec. Corp.	Parts Mfr.	Catalog	165-A	Free	241
		Catalog	166-A	Free	
		Catalog	167-A	Free	
		House Organ		Free	
Coyne Electrical School	Trade School	Electrical Catalog		Free	195
		Radio Catalog		Free	
		Literature		Free	234,236
Detrola Corporation	Radio & Camera Mfr.	Catalog		Free	240
Dodge's Institute	Radio School	Catalog		Free	236,241
Gold Shield Products	Mail Order	Catalog		Free	245,248
Guthman, Edwin I., & Co.	Set & Parts Mfr.	Catalog		Free	236
Hammarlund Mfg. Co.	Set & Parts Mfr.	1939 Catalog		Free	233
		16 page Booklet		Free	
		Circular		Free	231
Henley, Norman R., Publ. Co.	Book Publisher	Information		Free	234
Henry, Bob	Mail Order	Information		Free	240
Instructograph Company	Code Machine	IRC Guide		Free	227
International Resistance Co.	Parts Mfr.	Catalog	76	Free	235
Lafayette Radio Corp.	Set Mfr.	60-page Catalog		Free	240
Mass. Radio School	Radio School	Bulletins		Free	235
Miles Reproducer Co.	Recording Equip.	Receiver Group Booklets		Free	I.B.C.
National Company, Inc.	Set & Parts Mfr.	64-page Book		Free	193
National Radio Institute	Radio School	Radio & Television Bklt.		Free	240
National Schools	Radio School	Booklet		Free	240
New York Y.M.C.A. Schools	Trade School	Circulars on each Book		Free	239
Radio & Technical Publ. Co.	Radio Textbooks	Catalog		Free	234
Radio Constructors Labs.	Set & Kit Mfr.	Literature		Free	B.C.
Radio Corp. of America	Radio & Television	Book		Free	240
Radio Train. Assn. of Amer.	Radio School	Catalog		Free	240
RCA Institutes, Inc.	Radio School	Catalog		Free	256
Remington Rand, Inc.	Typewriter Mfr.	Blue Prints & Diagrams		Free	235
Sigmon Radio Supply	Set Mfr.	General Parts Catalog	9S	Free	233
Solar Mfg. Corp.	Parts Mfr.	Transmitting Catalog	2X	Free	
		Condenser Testers Cat.	CBCC-1	Free	
		Condenser Catalog		Free	245
Sprague Products Co.	Parts Mfr.	52-page Book		Free	239
Sprayberry Acad. of Radio	Radio School	Booklet	S-8	Free	238
Teleplex Co.	Code Machine	Technical Data		Free	243
Triplett Electrical Inst. Co.	Parts Mfr.	Catalog		Free	238
Tri-State College	Radio School	Information		Free	229
U. S. Radio Products, Inc.	Parts Mfr.	Catalog	76	Free	235
Wholesale Radio Service Co.	Mail Order				

GREATEST BARGAIN in 10 years



as little as

**10¢
A
DAY**

Remington NOISELESS Portable NOW AS LITTLE AS 10¢ a day

Imagine a typewriter that speaks in a whisper. You can write in a library, a sick room, a Pullman berth, without disturbing others. And superb performance that literally makes words flow from the machine. The Remington Noiseless Portable is equipped with all attachments that make for complete writing equipment—it manifolds and cuts stencils perfectly. Furnished in black with chromium fittings.

SPECIFICATIONS

Standard keyboard. Takes paper 9.5 inches wide. Standard size, 12 yard ribbon. Makes up to 7 legible carbons. Back spacer. Paper fingers. Roller type. Black key cards with white letters. Double shift key and shift lock. Right and left carriage release. Right and left cylinder knobs. Large cushion rubber feet. Single or double space adjustment. A brand new NOISELESS typewriter, right off the assembly line.

10-DAY FREE TRIAL

For the first time in history you can own a genuine Remington Noiseless Portable for as little as 10¢ a day or \$3.00 a month. Think of it! The finest Remington Portable ever built at the lowest terms we have ever offered.

And you don't risk a penny! We will send this brand new Remington Noiseless Portable for a **TEN DAYS' FREE TRIAL!** If you are not satisfied, send it back. We pay all shipping charges.

FREE TYPING COURSE

With your Remington Noiseless Portable—absolutely free—a 19-page course in typing teaching you the Touch System, always used by experts. With the help of this course you will find typing the most enjoyable way you ever wrote.



SPECIAL CARRYING CASE

Carrying Case, handsomely covered in DuPont fabric is included with your purchase. The case makes it easy to take your machine anywhere. You can use it on trains, or on your knees at home. Don't delay. Mail the coupon.



MAIL NOW

Remington Rand Inc. Dept. 300-8
465 Washington St., Buffalo, N. Y.

Tell me, without obligation, how to get a Free Trial of a new Remington Noiseless Portable, including Carrying Case and Free Typing Course for as little as 10¢ a day. Send Catalog.

Name.....
Address.....
City..... State.....

Mc.	Call	
5.825	TI6PH	SAN JOSE, COSTA RICA, 51.5 m., Addr. Alma Tica, Apartado 800. 11 am.-1 pm., 6-10 pm. Relays TIX 9-10 pm.
5.813	TI6PH2	SAN JOSE, COSTA RICA, 51.59 m., Addr. Senor Gonzalo Pinto, H.
5.770	T6S	GUATEMALA CITY, GUAT., 51.75 m. Casa Preidencial, Senor J. M. Caballero. Irregular.
5.735	HCIPM	QUITO, ECUADOR, 52.28 m. Ir- regular 10 pm.-12 m.
5.460	YNOP	MANAGUA, NICARAGUA, 52.40 m., 8.30-9.30 pm. Sun. 2-3 pm.
5.300	ZIK3	BELIZE, BRIT. HONDURAS, 56.6 m., Tue., Thurs., Sat. 1.30-2, 8.30- 9 pm.
5.145	OKIMPT	PRAGUE, BOHEMIA, 58.31 m., Addr. (See OLR, 11.84 mc.) Irregular.
5.145	PMY	BANDOENG, JAVA, 58.31 m. 5.30- 11 am.
5.040	YV5RN	CARACAS, VENEZUELA, 59.52 m., 4-11.30 pm., Sun. 8.30-11.30 am., 3.30-10 pm.
5.020	YV4RQ	PUERTO CABELLO, VENEZ., 59.76 m., testing nightly. Off 9.20 pm.
5.010	YV5RM	CARACAS, VENEZ., 59.88 m., 3.30- 10 pm., Sun. 8 am.-10.30 pm.
4.990	YV3RX	BARQUISIMETO, VENEZ., 60.12 m., 10 am.-11 pm.
4.970	YVIRJ	CORO, VENEZ., 60.36 m., Irreg.
4.960	VUD2	DELHI, INDIA, 60.48 m., Addr. All India Radio. 7.30 am.-12.35 pm.
4.960	YV5RS	CARACAS, VENEZ., 60.48 m., Irreg.
4.950	YV4RO	VALENCIA, VENEZ., 60.61 m., Noon-1, 8-10 pm.
4.940	YV5RO	CARACAS, VENEZ., 60.73 m.
4.930	YV4RP	VALENCIA, VENEZ., 60.85 m. Irreg.
4.920	YV5RU	CARACAS, VENEZ., 60.98 m., 6.30- 7.30, 10.30 am.-1, 3.30-10 pm.
4.920	VUM2	MADRAS, INDIA, 60.98 m. Addr. All India Radio. 6.30 am.-12.10 pm.
4.910	YVIRY	CORO, VENEZ., 61.10 m., 6.30-9.30 pm., ex. Sundays.
4.905	HJ1ABG	BARRANQUILLA, COLOM., 61.16 m., 11 am.-11 pm., Sun. 11 am.-8 pm.
4.900	YV6RT	BOLIVAR, VENEZ., 61.22 m., Signs- off at 9.30 pm.
4.900	HJ3CAH	BOGOTA, COLOM., 61.22 m., 11.30 am.-2, 6-11 pm.
4.890	YVIRX	MARACAIBO, VENEZ., 61.35 m., 10.30 am.-1.30, 4.30-10.30 pm.
4.890	HJ7GAD	BUCARAMANGA, COL., 61.35 m., 5.45-6.30, 11.30 am.-1 pm., 6-11 pm.
4.885	HJ4DAP	MEDELLIN, COLOM., 61.42 m., 8 am.-2, 6-11 pm.
4.880	VUB2	BOMBAY, INDIA, 61.48 m. Addr. All India Radio, 7.30 am.-12.30 pm.
4.880	YV6RU	BOLIVAR, VENEZ., 61.48 m., 6.30- 9.30 pm. except. Sundays.
4.875	HJ6FAH	ARMENIA, COLOM., 61.54 m., 8- 11 am., 6-10 pm.
4.865	HJ2BAJ	SANTA MARTA, COLOM., 61.67 m., 5.30-10.30 pm.
4.860	YVIRL	MARACAIBO, VENEZ., 61.73 m., 11 am.-1 pm., 4.30-10.30 pm.
4.855	HJ3CAF	BOGOTA, COLOM., 61.80 m., 7 pm.-mid. ex. Sundays.
4.850	YVIRZ	VALERA, VENEZ., 61.88 m., 11.30 am.-1, 5.45-8.45 pm.
4.845	HJ3CAD	BOGOTA, COLOM., 61.92 m., 6- 11.30 pm.
4.840	VUC2	CALCUTTA, INDIA, 61.98 m. Addr. All India Radio, 6.30 am.-12 n.
4.840	YV4RX	MARACAY, VENEZ., 61.98 m., 6-11 pm. ex. Sundays.
4.835	HJ1ABE	CARTAGENA, COLOM., 62.05 m., 7 am.-6, 7-11 pm.
4.830	YV5RH	CARACAS, VENEZ., 62.11 m., 5-9.30 pm. (Sun. to 10.30 pm.)
4.825	HJ5EAD	CALI, COLOM., 62.17 m., 7-11 pm. ex. Sundays.
4.820	YV3RN	BARQUISIMETO, VENEZ., 62.24 m., 11.30 am.-1.30, 5.30-9.30 pm.
4.815	HJ2BAC	CUCUTA, COLOMBIA, 62.31 m.
4.810	YVIRU	MARACAIBO, VENEZ., 62.38 m., 10.45 am.-12.45 pm., 4.30-10.30 pm.
4.800	YVIRV	MARACAIBO, VENEZ., 62.50 m., 10.45 am.-12.45 pm., 4.30-10.30 pm.
4.795	HJ6FAC	PEREIRA, COLOM., 62.57 m., 9 am.-noon, 6.30-10.30 pm. ex. Sun.
4.790	YV5RY	CARACAS, VENEZUELA, 62.63 m., 5.30-8 pm.
4.785	HJ1ABB	BARRANQUILLA, COLOM., 62.69 m., 4.30-10.30 pm. ex. Sundays.
4.772	HJ7GAB	BUCARAMANGA, COLOM., 62.87 m., Nightly to 10.45 or 11 pm.
4.560	HC2ET	GUAYAQUIL, ECUADOR, 65.79 m., Wed. & Sat. 8-10 pm.

Index to Advertisers

A	
Aerovox Corporation	247
Allied Radio Corporation	237
American Radio Institute	238
Amperite Co.	235
Audel, Theo., & Co.	229
B	
Barter & Exchange Free Ads	252-254
Bliley Electric Co.	231
Brush Development Co., The	233
Burstein-Applebee Co.	241
C	
Cameradio Co.	241
Candler System Co.	238
Chicago Wheel & Mfg. Co.	237
Commercial Notices	252
Cornell-Dubilier Electric Corp.	241
Coyne Electrical School	195
D	
Dataprint Company	246
Detrola Corporation	234, 236
Dodge's Institute	240
F	
For Sale Ads	252
Foto-Craft	250
G	
Gold Shield Products	236, 241, 245, 248
Guthman, Edwin I., & Co., Inc.	236
H	
Hammarlund Manufacturing Co., Inc.	233
Henley, Norman R., Publishing Co.	231
Henry, Bob	234
Hudson Specialties Company	251
I	
Instructograph Company	240
International Resistance Co.	227
L	
Lafayette Radio Corp.	235
M	
Mass. Radio School	240
Miles Reproducer Co.	235
N	
National Company, Inc. Inside Back Cover	
National Plans Institute	250
National Radio Institute	193
National Schools	240
New York Y.M.C.A. Schools	240
R	
Radio Amateur Course Inside Front Cover	
Radio & Technical Publ. Co.	239
Radio Constructors Labs.	234
Radio Corporation of America	246, 247
Radio Publications	237, 244, 246, 250
Radio Training Assn. of America	240
RCA Institutes, Inc.	240
Remington Rand, Inc.	256
S	
Simmon Radio Supply	235
Solar Mfg. Corp.	231
Sprague Products Co.	245
Sprayberry Academy of Radio	239
T	
Technifax	248
Telex Co.	238
Triplett Electrical Instrument Co.	243
Tri-State College	238
U	
U. S. Radio Products, Inc.	229
W	
Wellworth Trading Company	243, 247
Wholesale Radio Service Co., Inc.	235

(While every precaution is taken to insure accuracy, we cannot guarantee against the possibility of an occasional change or omission in the preparation of this index.)



The
NC-100XA
RECEIVER

HIGH PERFORMANCE

National Receivers are designed with the single aim of producing maximum performance, long life, and rugged dependability. You will find them wherever maintenance of communication is vital, and wherever fine receivers are appreciated.

The receiver illustrated above, the Type NC-100XA, is representative. Its design includes a number of unique details, among them a range changing system in which the required coils are moved into position adjacent to the coils and the condensers, and there connected into the circuit. Such a mechanism, with its heavy cast aluminum coil shield sliding on a smoothly fitted track by rack and pinion drive, is far more machinery than one usually finds in a radio receiver. But its use permits short, direct wiring, ample space for the coils in use, and complete circuit shielding. The gain in performance is unmistakable. This is but one of the refinements that make the NC-100XA so outstanding.

A set of free booklets describing the NC-100XA and other National receivers will be mailed free on request. Though primarily instruction booklets, they contain a wealth of general information on receiver design and operation that will be of real value to anyone interested in fine instruments. Just ask for "Receiver Group Booklets." They will be mailed promptly, postpaid.



National builds a complete line of communication receivers, ranging from the Type HRO, in which cost is a secondary consideration, to the Type NC-44, designed for the lowest price which good performance permits.

NATIONAL COMPANY, INC., MALDEN, MASS.

In New York Rises Radio City—Lofty Symbol of RCA World-wide Service!

**The home of
Radio Corporation of America
—the headquarters of the only
organization engaged in
every phase of radio**

SET IN THE HEART OF NEW YORK is a city within a city. It is Radio City. Its "city hall" is the seventy-two story RCA Building. From here are directed all of the manifold services of RCA.

Basis of all is RCA Laboratories. In them vital research is carried on in radio and television. Great universities are usually thought of as the homes of research. The fact is that in RCA Laboratories there is now a group of research men who probably exceed in number and can certainly match in ability, those engaged in any one phase of research, in any university in the world.

RCA Services In Every Field of Radio

RCA serves the listening public through the Red and Blue Networks of the National Broadcasting Company. In the home, RCA Victor Radios, RCA Victrolas, and Victor and Bluebird Records afford the finest in radio and records. Now RCA Victor Television Receivers are bringing the thrills of television to families in the New York Metropolitan Area. And, added to these services for the home are those rendered in manufacturing a complete variety of radio equipment, sound equipment, and motion picture equipment such as RCA Photophone, the Magic Voice of the Screen.

Through R. C. A. Communications, world-wide communication service is provided to and from 43 foreign countries, and among leading cities in the United States.

Radiomarine, another of the RCA family, offers communication service to ships at sea. It also builds radio devices for safeguarding lives and property on ships.

Because of this background of experience in every field of radio, RCA keeps ahead, offering dealers an ever better and ever increasing opportunity to make more money by going "RCA All the Way."

**See Radio's World of
Tomorrow at New York
World's Fair**

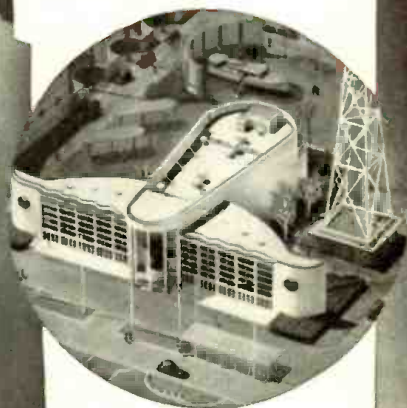

Great crowds of visitors are enjoying the exhibits at the RCA Building at the New York World's Fair. And, across the country, many thousands are being thrilled by similar RCA exhibits at the San Francisco Exposition. Chief attraction is the demonstration of television which offers many visitors their first opportunity to see how television pictures appear on the screen of a television receiving instrument.

As you look at the complete exhibit of everything RCA does . . . you will understand more clearly why RCA offers you the greatest opportunity for profits.

*Trademarks "RCA Victor,"
"Victrola" and "Victor"
Reg. U. S. Pat. Off. by
RCA Mfg. Co., Inc.*



Radio Corporation of America

RADIO CITY, N. Y.

RCA Manufacturing Company, Inc.
RCA Laboratories

National Broadcasting Company
R. C. A. Communications, Inc.

Radiomarine Corporation of America
RCA Institutes, Inc.