



Sept.

SHORT WAVE CRAFT

Edited by
HUGO GERNSBACK

NOW
25¢

BUILD THE
DENTON 2-TUBE
ALL-WAVE Receiver
See Page 272

IN THIS ISSUE

- ANTENNAS AND HOW TO COUPLE THEM
By A. R. HAIDELL
- I-TUBE MASTER OSCILLATOR - POWER AMPLIFIER TRANSMITTER
By A. J. SPRIGGS, W3GJ
- WHAT "IF" FREQUENCY FOR S.W. SUPERS?
By EDGAR MESSING
- LOUIS MARTIN'S IDEA OF A GOOD S.W. RECEIVER



SEPTEMBER SPECIALS!!

EVERY month we list on this page certain **STAR** ★ items, which are NOT LISTED IN OUR CATALOG. These are all specials of which the quantities on hand are not sufficient to catalog them. Once sold out, no more can be had. First come, first served. Save yourself disappointment by ordering NOW.

STOP SHOPPING. The lowest prices are right on this page. No one undersells us. We meet any price on ANY NEW Merchandise. Order direct from this page and save money. 100% satisfaction on every transaction. Take advantage of these special offers. **ORDER NOW, TODAY.**

IMPROVED READRITE MODEL 700 ANALYZER

EIGHT METER SCALES AVAILABLE

The "Model 700" is an extremely compact device. The outside dimensions of the carrying case are only 10 3/4" by 7 3/4" by 3 3/4" inches. The analyzer contains a D.C. voltmeter, an A.C. voltmeter and a milliammeter. The D.C. voltmeter has three ranges: 0 to 60; 0 to 200; and 0 to 600 volts. The A.C. voltmeter has also three ranges: 0 to 10; 0 to 140; and 0 to 700 volts. The milliammeter has two ranges; one for 20-mill. reading and the other for 100-mill. This variety of ranges makes it possible to test every conceivable radio circuit; high voltage secondaries of power transformers, current drain of all radio tubes, including the high power 250 and 210 tubes, etc.

CONVENIENT SELECTOR SWITCH

The instrument is equipped with a six-position bi-polar selector switch; by means of which readings may be obtained of "C" volts, "C" volts reversed, "K" volts, "K" volts reversed, plate voltage, and screen-grid voltage. A 4 1/2-volt battery is supplied with the analyzer, to provide "C" bias, for grid tests, continuity tests, etc.

TESTS PENTODES—"MULTI-MUS"

'57's and '58's—and '80 RECTIFIERS There are two sockets on the panel of the analyzer, one for four-prong tubes and the other for five-prong tubes. There is a "grid-test" push-button. Pin jacks are available for the individual use of all meters, externally, in every range. There is a screen-grid pin jack, and there are two pin jacks for connecting the external battery. A two-way toggle switch controls the testing circuit for either regular or pentode tube.

Tests Latest Type '57 and '58 6-Prong Tubes



Model 700 Analyzer. List Price \$35.00.
Your Price **\$14.70**

Both plates of the '80-type rectifier may be tested by use of a special adapter furnished. Charts are provided for measuring resistances and capacities.

FREE

We take pleasure in offering with the purchase of each analyzer—**ABSOLUTELY FREE OF CHARGE**—the latest radio publication to come off the press.

"Radio Set Analyzers" Contains detailed descriptions, photographs and circuit diagrams of all commercial set analyzers and testers.—**A Real Book.**

The Analyzer is furnished complete with test leads, connecting cables, Burgess 4 1/2-volt battery, several battery leads, UY to UX adapter, '80 rectifier, adapter and resistance and capacity charts. Shipping weight, 8 lbs.

"MEGADYNE" ONE-TUBE PENTODE LOUDSPEAKER RECEIVER KIT

In the front part of our catalog—get your FREE copy now—there is presented a thoroughly illustrated discussion on the construction and operation of the MEGADYNE Receiver

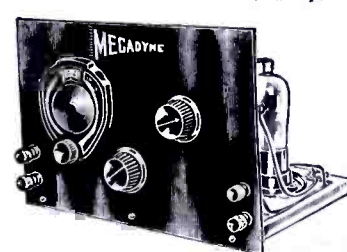

by Hugo Gernsback, editor. This ingenious circuit was originally described in the July issue of the RADIO CRAFT Magazine, FREE copy of which will be given with each purchase. This receiver is indeed one of the most outstanding

developments in the radio industry. It is the first real one-tube receiver which will actually operate a loudspeaker. Thousands of experimenters and radio fans will want to build this remarkable receiver. For their convenience, we have compiled a complete list of parts required for its construction. These parts are of the highest quality and are exactly as specified by the author. The following parts comprise the complete kit.

1 B.M.S. Fixed Crystal Detector; 1 6-ohm Filament Rheostat; 1 3-circuit tuner for used with a .0005 mf. tuning condenser; 1 Na-ald type 481 UY 5-prong socket; 1 Hammarlund type ML-23 Variable Condenser; 2 sets of Cinch double binding posts; 1 Polymet .00025 mf. fixed condenser; 1 X-L Variocoupler; 1 Polymet .00025 mf. fixed condenser, or 1 Polymet .0005 mf. fixed condenser (NOTE: Only one of the latter two condensers is actually employed in the circuit); 5 Fahnestock binding posts; 1 25-ft. roll of hook-up wire; 2 black Bakelite 1 1/2" knobs; 1 Kurz-Kasch vernier dial with 0 to 100 scale reading clockwise; 1 type '38 pentode tube, "Triad" or "Speed"; 1 Bakelite Panel already drilled with all holes, size 7 x 10 x 3/16 inch; 1 hardware assortment.

The wooden base is not included.
No. 2545—Megadyne Receiver Kit. Your Price **\$10.25**

WORLD-WIDE SHORT-WAVE SET



Range 18 to 200 meters. Employs low current drain 230 tube. Requires but 1 1/2 volt "B" battery, 2 No. 6 drycells and earphones to operate. No. 1666—S.W. Set Your Price **6.25**

R.C.A.-VICTOR HAND "MIKE"



Designed especially for home recording and personal entertainment. Requires but a 2 1/2 volt battery to operate. Easily connected to any radio or amplifier in a few minutes. Responds indiscriminately to all speech and music frequencies. Sold complete with 6 ft. cable. Shipping weight 2 lbs. No. SP9064. RCA-Victor Hand "Mike." Your Price **2.75**

★ METALLIZED PIGTAIL RESISTORS AT ROCK BOTTOM PRICES

A very fortunate purchase enables us to offer these fine resistors at prices which surprise even ourselves—prices more than three times lower than in our own catalog. Resistors are guaranteed to maintain their ohmage under even adverse operating conditions. The resistance element is based on the famous metallized principle which has proven its superiority wherever accuracy and uniformity are paramount requisites. The special ceramic casing of these resistors is of sturdy construction and affords maximum heat dissipation. A feature of these resistors is their molded end-caps, tapered so they can be mounted in all standard resistor mounts. By means of their pigtails, they may also be soldered in any convenient position. Available in the following sizes—all rated at one watt: 300, 450, 600, 8,000, 10,000, 12,000, 350,000. Act fast to take advantage of this offer, as the supply is limited. Sold only in lots of six or more.



Values Clearly Marked on Each Unit
No. SP2226. Metallized Resistors. NOW YOUR PRICE **6c** EACH
12 for 60c.

AUTOMATIC BLOW TORCH



Heat intensity over 1200° Fahr. Requires no mouth-blowing. Entirely automatic. Used for heavy duty soldering, aluminum soldering, metal tempering, etc. Ship. wt. 1 lb. No. K1006—Torch. Your Price **\$0.60**

★ 8 MF. ELECTROLYTIC CONDENSERS



These guaranteed units will perform miracles in eliminating objectionable A. C. hum from A. F. and filter circuits. Easily mounted through use of bayonet socket. Shipping weight 1 lb. No. SP 9054. Condenser. Your Price **\$0.49**



A.C. SUPERHET S.W. CONVERTER
Converts any broadcast receiver into a full-featured superhet S.W. Receiver. Range 20 to 115 meters. Requires no plug-in coils. Has built-in filament transformer for 110 volts 60 cycles A.C. Employs 3 227 tubes. Single dial control. Instructions included. Shipping wt. 8 lbs. No. 1614—Converter. Your Price **NOW \$7.50**

FREE RADIO AND SHORT WAVE TREATISE



The new and enlarged Summer edition of our Radio and Short Wave Treatise, No. 26, has just come off the press—100 solid pages of useful information, radio items, diagrams and illustrations. Positively the greatest book in print—NOT JUST ANOTHER CATALOG. Contains a large editorial section with valuable information not found anywhere else. Considerable space is devoted to a TREATISE ON SHORT WAVES for both beginners and regular "hams." Among the new technical information listed are the following: Modernizing old radio sets—repairing speakers and headsets—making superhets out of old sets—data on constructing two-volt battery and automobile receivers—circuit of the famous Gernsback Megadyne One-Tube Loudspeaker Set—short wave coil winding data—discussion on S.W. adapters, converters and receivers, etc., etc.

100 New Hook-Ups, Etc. 1000 Illustrations. WRITE TODAY. Enclose 4 cents for postage. Treatise sent by return mail.



MICROPHONE & PRE-AMPLIFIER OUTFIT

Excellent suited for P. A. work, inter-communication systems, etc. Comprises sensitive single-button microphone, microphone coupling transformer and battery, cut-off switch, gain control and output terminals. Put up in neat black crackle-finished metal case, equipped with convenient carrying handle. Measures 5" x 6 1/2" x 6 3/4". Will correctly match the input impedance of practically all type amplifiers. Easily connected to the broadcast receiver for home recording. Ship. wt. 10 lbs. No. 1654—Pre-Amplifier. Your Price **\$8.25**

★ ELECTRIC CLOCK

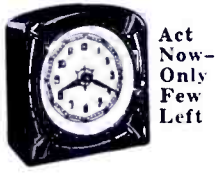

Act Now—Only Few Left
Naval observatory time right from your light socket! No spring to wind, no batteries. Never out of order. For 110 volts 60 cycle A.C. operation only. No. 1689—Clock. Your Price **\$1.00**

★ UTAH A.C. DYNAMIC SPEAKER

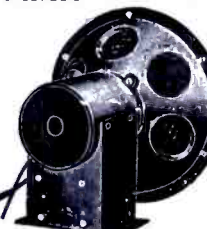

Operates from 110 volt 60 cycle A.C. line. 9" high by 9 1/4" wide by 7 1/2" deep. Ship. wt. 19 lbs. No. 1506—Speaker. Your Price **\$7.45**

RADIO MIRROR PENLIGHT



A clever device for looking around corners or other inaccessible spots on the radio chassis. Comprises pen flashlight and magnifying mirror. Complete with battery and bulb. No. 1695—Penlight. Your Price **\$0.85**

NEW PENTODE ADAPTER



A new and simple device for replacing the old '45 type power tube with the latest super-power pentode. Remove the '45, insert adapter in vacated socket and then place a pentode tube in the socket of the adapter. Gives added life and power to old receivers and amplifiers. Shipping weight 1/2 lb. No. 1873. Adapter. Your Price **65c**

★ MIDGET MICROPHONE

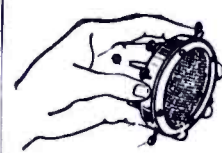

A real microphone of single button type. Extremely sensitive. Excellent for P.A. work, etc. Standard resistance of 100 ohms. Responds up to 2500 cycles. Ship. wt. 1 lb. No. 1655—Mike. Your Price **\$2.25**

MIDGET DYNAMIC SPEAKER

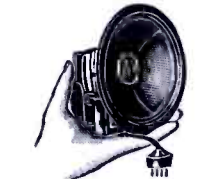

A real dynamic speaker with surprising volume and tone. 6 1/4" overall, 1 1/2" diaphragm. Standard 2500 ohm field coil. Output transformer to match all type output tubes. Wt. 5 lbs. No. 1549—Speaker. Your Price **\$2.50**

SPEED "295" TRIPLE-TUBE

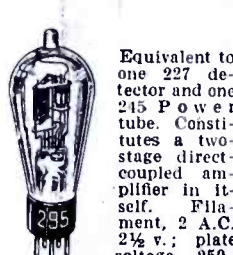

Equivalent to one 227 detector and one 215 Power tube. Constitutes a two-stage direct-coupled amplifier in itself. Filament, 2 A.C. 2 1/2 v.; plate voltage 250. Large undistorted output. Ship. wt. 12 oz. No. S699. Tube. Your Price **\$1.85**

WE ARE A WHOLESALE HOUSE AND CANNOT ACCEPT ORDERS FOR LESS THAN \$3.00. If C. O. D. shipment is desired, please remit 20% remittance, which must accompany all orders. If full cash accompanies order, deduct 2% discount. Send money order—certified check—U. S. stamps.

Radio Trading Co.
25A West Broadway
New York, N. Y.

ORDER FROM THIS PAGE. You will find special prices from time to time in this magazine. Get our big FREE catalog for the greatest Radio Bargains. Should you wish goods shipped by parcel post, be sure to include sufficient extra remittance for same. Any excess will be refunded.

265 268 270 271 272 275 276 279 280 281 282 283 290 293
300 301 304 305



J. E. Smith, President, National Radio Institute, the man who has directed the Home-Study training of more men for the Radio Industry than any other man in America.

BE A RADIO EXPERT

Many Make \$50 to \$100 a Week

I'll Train You at Home in Your Spare Time for RADIO · TELEVISION · TALKING MOVIES

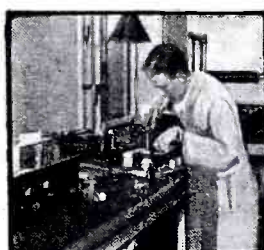

Set Servicing
Spare-time set servicing pays many N.R.I. men \$200 to \$1,000 a year. Full-time men make as much as \$65, \$75 and \$100 a week.

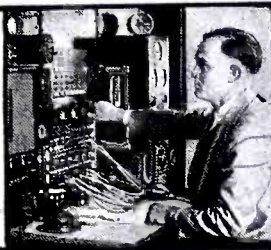

Broadcasting Stations
Employ trained men continually for jobs paying up to \$5,000 a year.



Ship Operating
Radio operators on ships see the world free and get good pay plus expenses. Here's one enjoying shore leave.

Aircraft Radio

Aviation is needing more and more trained Radio men. Operators employed through Civil Service Commission earn \$1,620 to \$2,800 a year.



Talking Movies

An invention made possible by Radio. Employs many well trained Radio men for jobs paying \$75 to \$200 a week.



Television

The coming field of many great opportunities is covered by my course.

If you are dissatisfied with your present job, if you are struggling along in a rut with little or no prospect of anything better than a skinny pay envelope—clip the coupon NOW. Get my big FREE book on the opportunities in Radio. Read how quickly you can learn at home in your spare time to be a Radio Expert—what good jobs my graduates have been getting—real jobs with real futures.

Many Radio Experts Make \$50 to \$100 a Week

In about ten years the Radio Industry has grown from \$2,000,000 to hundreds of millions of dollars. Over 300,000 jobs have been created by this growth, and thousands more will be created by its continued development. Many men and young men with the right training—the kind of training I give you in the N.R.I. course—have stepped into Radio at two and three times their former salaries.

Get Ready Now for Jobs Like These

Broadcasting stations use engineers, operators, station managers, and pay up to \$5,000 a year. Manufacturers continually employ testers, inspectors, foremen, engineers, service men, buyers, for jobs paying up to \$6,000 a year. Radio Operators on ships enjoy life, see the world, with board and lodging free, and get good pay besides. Dealers and jobbers employ service men, salesmen, buyers, managers, and pay up to \$100 a week. My book tells you about these and many other kinds of interesting Radio jobs.

Many Make \$5, \$10, \$15 a Week Extra in Spare Time, Almost at Once

The day you enroll with me I send you material which you should master quickly for doing 28 jobs common in most every neighborhood, for spare-time money. Through-

out your course I send you information on servicing popular makes of sets! I give you the plans and ideas that have made \$200 to \$1,000 a year for N.R.I. men in their spare time. My course is famous as the course that pays for itself.

Talking Movies, Television, Aircraft Radio—I Give You Money-Back Agreement

Special training in Talking Movies, Television, and Home Television experiments. Radio's use in Aviation, Servicing and Merchandising Sets. Broadcasting, Commercial and Ship Stations are included. I am so sure that N.R.I. can train you satisfactorily that I will agree in writing to refund every penny of your tuition if you are not satisfied with my Lesson and Instruction Service upon completion.

64-Page Book of Information FREE

Get your copy today. It's free to all residents of the United States and Canada over 15 years old. It tells you where Radio's good jobs are, what they pay, tells you about my course, what others who have taken it are doing and making. Find out what Radio offers you without the slightest obligation. ACT NOW!

J. E. SMITH, President
National Radio Institute
Dept. 2JB3
Washington, D. C.



Special Free Offer

In addition to my big free book, "Rich Rewards in Radio," I'll send you my valuable manual, "28 Tested Methods for Making Extra Money." Never before available except to Students. Now, for a limited time, it is free to readers of this magazine. How to make a good baffle for cone speakers, how to reduce hum in externally fed dynamic speakers, how to operate 25 cycle apparatus on 60 cycle current, how to operate 110 v. A. C. receivers on D. C., how to shield sets from local interference are five of the subjects covered. There are 23 others. Get this valuable book by mailing the coupon.

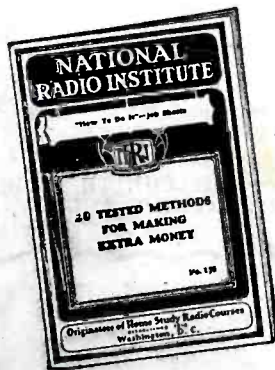

THIS COUPON IS GOOD for
One FREE COPY OF MY BOOK *mail it now*

J. E. SMITH, President
National Radio Institute, Dept. 2JB3
Washington, D. C.

Dear Mr. Smith: I want to take advantage of your Special Offer. Send me your two books, "Twenty-Eight Tested Methods for Making Extra Money" and "Rich Rewards in Radio." I understand this does not obligate me.

Name.....

Address.....

City..... State..... "J"

IN THIS ISSUE: PROMINENT SHORT WAVE AUTHORS
Reinartz • Martin • Denton • Smith • Messing • Spriggs • Tanner • Palmer



HUGO GERNSBACK
Editor

H. WINFIELD SECOR
Managing Editor

CONTENTS FOR SEPTEMBER, 1932

FEATURES:

Editorial—Short Wave Noise Elimination, by Hugo Gernsback 265

Crack Amateur Station, W2PF, by Robert Hertzberg 267

Louis Martin's Idea of a Good Short Wave Receiver.. 268

New National Ultra Short Wave Receiver..... 270

The Denton 2-Tube "All-Wave" Receiver, by Clifford E. Denton 272

Good Antenna Design, by Arthur H. Lynch..... 275

Static Omission in New Receivers, by W. A. Smith, Chief Engineer, Midwest Radio Corp..... 276

Micro-Rays—Quasi-Optical Waves, by H. A. Pelton.. 278

A Capacity and Inductance Bridge..... 279

How to Become a Radio Amateur, Part 3—Vacuum Tube Curves, by John L. Reinartz..... 280

What "I.F." Frequency? by Edgar Messing..... 281

8-Tube Portable "All-Wave" Superhet, Part 2, Conclusion, by Clifford E. Denton..... 282

Hammarlund Comet "Pro" 285

Winners in the Second Set-Builder's Contest..... 286

SHORT WAVE LEAGUE—A Real "Live" Club..... 288

New Receiving Tubes, by Louis Martin..... 290

A 1-Tube Master Oscillator - Power Amplifier Transmitter, by A. J. Spriggs, W3GJ..... 292

THE SHORT WAVE BEGINNER, No. 3, Receiving Aerials, by C. W. Palmer 295

SHORT WAVES FOR THE BROADCAST LISTENER:

The Denton 2-Tube "All-Wave" Receiver..... 272

Good Receiving Aerial Construction..... 275

The Midwest All-Wave Receiver with Static Omitter. 276

8-Tube Portable Short and Broadcast Wave Superhet, by Clifford E. Denton..... 282

SHORT WAVE RECEIVERS:

Louis Martin's Idea of a Good Short Wave Receiver.. 268

New National 5-Meter Receiver..... 270

The Denton 2-Tube All-Wave Receiver (cover feature) 272

Static Omission in New Midwest All-Wave Receivers. 276

8-Tube Portable Short and Broadcast Wave Receiver. 282

Hammarlund Comet "Pro" Receiver..... 285

Prize-Winning Receivers in SHORT WAVE CRAFT \$500 Contest 286

Which Regeneration Scheme? by M. Harvey Gernsback 300

\$5.00 for Best Short Wave Kink, Monthly Prize..... 301

SHORT WAVE TRANSMITTERS:

Barkhausen-Kurz Ultra Short Wave Oscillator..... 278

A 1-Tube Master Oscillator - Power Amplifier Transmitter, by A. J. Spriggs, W3GJ..... 292

Transmitting Antennas—How to Couple Them, by A. R. Haidell..... 302

MISCELLANEOUS:

Oddities in Short Wave News..... 266

Crack Amateur Station, W2PF..... 267

How to Make a "Noise-Free" Antenna..... 275

Capacity and Inductance Bridge..... 279

How to Become a Radio Amateur..... 280

Winners in the Second Set-Builder's Contest..... 286

SHORT WAVE LEAGUE 288

FEATURES IN NEXT ISSUE

Latest Super-regenerative Receivers—both European and American Sets illustrated and described,
 Short Wave "Pentode Four."
 A "DX" Superhet Portable—Short Wave and Broadcast Range—works on 110 volts A.C. or D.C., by H. G. Cisin, M.E.
 A Receiver "That Laughs At Static," by John L. Reinartz.
 Mysteries of the 5 Meter Band, by C. H. West.
 Crystal Oscillators and Crystal Control, by A. Binneweg, Jr.
 A "Free-Wheeling" Receiver for Beginners, by R. W. Vosburgh.
 The Horizontal Diamond-Shaped Antenna.
 A New Ultra Short Wave Converter, by James Millen, M.E.
 Band-Spreading—How and Why.

CONTENTS FOR SEPTEMBER—Continued

Short Wave Events of the Month..... 285

When to Listen In..... 289

The Short Wave Beginner..... 295

Short Wave Stations of the World..... 296

Television Stations 298

Police Radio Stations 298

Letters from S-W Fans..... 299

\$5.00 for Best Short Wave Kink..... 301

\$500.00 Short Wave Builder's Prize Contest—Rules.. 304

Short Wave Question Box..... 305

Amateurs Who Made Good..... 306

OUR COVER

The Denton 2-Tube All-Wave Receiver is fully described in text and illustration on page..... 272

SHORT WAVE CRAFT—Monthly. Entered as second class matter May 7, 1930, at the post office at Mount Morris, Illinois, under the act of March 3, 1879. Trademarks and copyrights by permission of H. Gernsback, 98 Park Place, N. Y. C. Text and illustrations of this magazine are copyrighted and must not be reproduced without permission. SHORT WAVE CRAFT is published on the 15th of every month. Twelve numbers per year. Subscription price is \$2.50 a year in the United States and possessions. Canada and foreign countries, \$3.00 a year. Single copies 25c. Address all contributions for publication to Editor, SHORT WAVE CRAFT, 96-98 Park Place, New York, N. Y. Publishers are not responsible for lost manuscripts. Contributions cannot be returned unless authors remit full postage. SHORT WAVE CRAFT is for sale at all principal newsstands in the United States and Canada. European agents: Brentano's, London and Paris. Printed in U. S. A. Make all subscription checks payable to Popular Book Corporation.

COPYRIGHT, 1932, BY H. GERNSBACK

Published by POPULAR BOOK CORPORATION

HUGO GERNSBACK, President - H. W. SECOR, Vice-President
 EMIL GROSSMAN - - - - - Director of Advertising
 Chicago Adv. Office - - - L. F. McCLURE, 737 No. Michigan Blvd.
 Publication Office - - - 404 N. Wesley Avenue, Mount Morris, Ill.
 Editorial and General Offices - 96-98 Park Place, New York, N. Y.
 London Agent: HACHETTE & CIE., 16-17 King William St. Charing Cross, W.C.2

Paris Agent: HACHETTE & CIE., 111 Rue Reaumur
 Australian Agents: MCGILL'S AGENCY, 179 Elizabeth St., Melbourne

OPPORTUNITIES *are many* for the Radio Trained Man

Don't spend your life slaving away in some dull, hopeless job! Don't be satisfied to work for a mere \$20 or \$30 a week. Let me show you how to get your start in Radio—the fastest-growing, biggest money-making game on earth.

Jobs Leading to Salaries of \$50 a Week and Up
Prepare for jobs as Designer, Inspector and Tester—as Radio Salesman and in Service and Installation Work—as Operator or Manager of a Broadcasting Station—as Wireless Operator on a Ship or Airplane, or in Talking Picture or Sound Work—HUNDREDS of OPPORTUNITIES for a real future in Radio!

Ten Weeks of Shop Training

We don't teach by book study. We train you on a great outlay of Radio, Television and Sound equipment—on scores of modern Radio Receivers, huge Broadcasting equipment, the very latest and newest Television apparatus, Talking Picture and Sound Reproduction equipment, Code Practice equipment, etc. You don't need advanced education or previous experience. We give you—**RIGHT HERE IN THE COYNE SHOPS**—the actual practice and experience you'll need for your start in this great field. And because we cut out all useless theory and only give that which is necessary you get a practical training in 10 weeks.

TELEVISION *and* TALKING PICTURES

And Television is already here! Soon there'll be a demand for THOUSANDS of TELEVISION EXPERTS! The man who learns Television now can have a great future in this great new field. Get in on the ground-floor of this amazing new Radio development! Come to COYNE and learn Television on the very latest, new-

est Television equipment. Talking Picture and Public Address Systems offer opportunities to the Trained Radio Man. Here is a great new Radio field just beginning to grow! Prepare NOW for these wonderful opportunities! Learn Radio Sound Work at COYNE on actual Talking Picture and Sound Reproduction equipment.

All Practical Work At COYNE In Chicago

ALL ACTUAL, PRACTICAL WORK. You build radio sets, install and service them. You actually operate great Broadcasting equipment. You construct Television Receiving Sets and actually transmit your own Television programs over our modern Television equipment. You work on real Talking Picture machines and Sound equipment. You learn Wireless Operating on actual Code Practice apparatus. We don't waste time on useless theory. We give you the practical training you'll need—in 10 short, pleasant weeks.

Mail Coupon Today for All the Facts

H. C. LEWIS, President

Radio Division, Coyne Electrical School
500 S. Paulina St., Dept. 62-2K Chicago, Ill.

Dear Mr. Lewis:— Send me your Big Free Radio Book, and all details of your Special Offer.

Name

Address

City.....State.....



Many Earn While Learning

You get Free Employment Service for Life. And don't let lack of money stop you. Many of our students make all or a good part of their living expenses while going to school and if you should need this help just write to me. Coyne is 32 years old! Coyne Training is tested—proven beyond all doubt. You can find out everything absolutely free. Just mail coupon for my big free book!

H. C. Lewis, Pres. RADIO DIVISION Founded 1899

COYNE Electrical School

500 S. Paulina St., Dept. 62-2K Chicago, Ill.

Again Midwest Offers the Season's Greatest Radio Sensation!

World-Wide Reception

Just a few excerpts from letters written by delighted Midwest owners. We have thousands of them on file. Mail coupon or write for new catalog and we'll send you ample PROOF of Midwest World-Wide reception.

Clarity! Selectivity Volume! Distance!

"To try and express our joy over the set we purchased from you would be a problem, but with the deepest sincerity we will defy anyone to pry it away from us.

"Clarity! Selectivity! Volume! Distance! Anything and everything one would care for in a radio. It surely is a beauty! Having visited your plant, I am at liberty to say I found it just like the radio. 'Ship-Shape'.

"May you enjoy many more years of success as I know you will with your 'direct from factory' prices."

P. G. Kurth, 2211 N. Booth Ave., Milwaukee, Wis.

France, England, Spain, Cuba, Hawaii

"We have always thought that our nine-tube radio was quite superior to most, but now that we have tried out the Midwest All-World, All-Wave, we are all for your set. There is nothing to equal its clear, life-like tone, selectivity and power to bring in distant stations as clearly as locals.

"Regarding the Short Wave, it comes way above our expectations. Police stations, testing stations, airports and amateur operators come in clearly at almost any time. We also get stations in France, England, Spain, Cuba and Hawaii."

D. M. Fish, R. F. D. No. 4, Ithaca, N. Y.

Germany, Italy, South America

"Have received the set and so far am very pleased with it. On broadcast it is exceptionally sharp. I live in the heart of the city with 42 broadcasting stations within 10 miles and the Midwest is surely giving results. KMOX comes in like a local.

"As for short waves, received Germany last Sunday afternoon. Italy has also been heard and several South American Stations."

E. Joyce, 756 Home St., Bronx, New York City.

Likes Midwest Automatic Tone Control

"Reception on the regular broadcast set, in my opinion, is very hard to equal and I dare say impossible to beat on any set costing twice the amount of the Midwest. It is very sensitive and so selective that barely a touch of the dial knob and you have another station coming in clear and without interference. The automatic tone control is great. I am now able to hold many stations which before would fade out right in the best part of the program. I have not done very much 'fishing' with the short wave as yet, although I have listened to Bound Brook, N. J., Schenectady and Australia and a few others."

Archie J. Goss, 6th South 3rd West, Brigham City, Utah.

W8XK—W3XAL—WIXAZ
—W2XAF

"I am very much satisfied in every way with my Midwest radio. I heard Sydney, Sunday 3:00 A. M. Also W8XK, W3XAL, WIXAZ, W2XAF, in the evening. On the regular band have some 55 stations so far."

Aug. Balbi, 1427 Myra Ave., Los Angeles, Calif.

All-Wave

Regular Broadcasts-- Foreign Broadcasts--Police--Amateur--Ships at Sea--All With One Dial!

WHAT a radio! One complete 16-tube chassis with one DUAL-RATIO DIAL—new Super-Heterodyne circuit with a range of 15 to 500 METERS. . . . No plug-in coils—No Trimmers . . . and with the new STAT-OMIT tuning silencer you get in-between-station silence and perfect tuning without Neon lights, meters or buttons which were formerly necessary without this latest tuning circuit. . . . Large acoustically matched DUAL SPEAKERS. . . . New CLASS "B" PUSH-PUSH Super Power Amplifier with six times the power of ordinary tubes. . . . Full band AUTOMATIC VOLUME CONTROL. . . . COLORLITE Multi-Wave Band Selector giving instant choice of four distinct wave bands, regular broadcasts, foreign broadcasts, police and amateur. . . . FULL-FLOATING VARIABLE CONDENSER. . . . Complete Scientific Shielding. . . . Absolute tone fidelity. . . . Image Frequency Suppressor. . . . Fractional Microvolt Sensitivity. . . . 18 TUNED CIRCUITS. . . . NEW TYPE TUBES, 29, 56, 57, 58, 42, 46 and 82 tubes. . . . SUPER TRIODES, DUAL AND TRIPLE GRIDS, Two Full Wave Rectifiers including the new Mercury type. DUAL POWERED, two separate power transformers. A bigger, better, more powerful, more selective, finer toned radio than you've ever seen before . . . offered at an amazingly low price direct from the big Midwest factory. Midwest engineers have far outdistanced all past performances in perfecting this new set.

DEAL DIRECT with FACTORY! Save the Middlemen's Profits



Complete Line of Beautiful New Consoles

The big new Midwest catalog shows gorgeous line of artistic consoles in the new six-leg designs. Mail the coupon or write us a postal. Get all the facts. Learn how you can save 30 percent to 50 percent on a big powerful radio by ordering direct from factory.

Midwest methods of production effect large economies and give radio fans bigger and better radios for less money. And when you get this big, powerful Midwest 16-TUBE set you get ALL that the radio world can offer you—great range, perfect tone, amazing selectivity, tremendous reserve power, sensationally low cost of operation. Don't be satisfied with less than a Midwest 16-tube all-electric set. Broadcast listeners are coming to realize that a receiver covering only the regular broadcast waves is *only half a set*. This amazing new Midwest gives you regular, foreign, police and amateur broadcasts in one single dial set. No converter or any extra units required. Improvements in short-wave receivers and programs have made ordinary broadcast sets obsolete. In selecting a set, choose one that is not only good today but will be in step with tomorrow.

PAY As You PLAY!

Remember, you buy DIRECT FROM THE MAKERS. No middlemen's profits to pay. You get an absolute guarantee of satisfaction or money back. You try any Midwest 30 DAYS before you decide to keep it. Then, if you wish, you can pay for your set in easy monthly amounts that you'll scarcely miss. Besides, you can make easy EXTRA money as our USER AGENT. Coupon brings full details—mail it NOW!

TERMS
as low as
\$5.00
DOWN

Mail the Coupon!

Investigate! Mail the coupon. Get the Midwest catalog. Learn the facts about Midwest 9, 12 and 16-tube ALL-WAVE sets. Learn about our sensationally low factory prices, easy payment plan and positive guarantee of satisfaction or money back. Save up to 50 percent on your new radio!

MIDWEST RADIO

16-Tube ^{Only} \$39.95

Completely Assembled with Large DUAL SPEAKERS

Save UP TO 50%



New 1933 Features

New Class "B" Push-Push Power Amplifier. . . . Stat-Omit Tuning Silencer. . . . Color-Lite Tuning. . . . Full band automatic Volume Control. . . . Triplex Duo-Diode Detection. . . . Dual-Ratio Single Dial. . . . No Trimmers, No Plug-in Coils, No tuning meter or Neon light required. . . . Fractional Microvolt Sensitivity. . . . Dual Powered (2 separate Power Transformers). . . . Absolute Tone (30 to 5200 cycles). . . . 18 Tuned Circuits. . . . New Mercury Rectifier. . . . Full-Floating Variable Condenser. . . . Low Operating Cost. The new Midwest 16-tube set actually uses less current than previous sets of 8 and 10 tubes. . . . Uses the new type tubes, 29, 56, 57, 58, 42, 46, 82. . . .

Every Improvement That Makes for Better Reception

BATTERY RADIOS

Using the New AIR CELL BATTERY

Two sensational values: a 6-tube super-het for standard-wave reception and a 9-tube ALL-WAVE, both using the new AIR CELL "A" battery that never needs recharging. Low factory prices. Coupon brings details. Mail it NOW!

Nothing has been overlooked and nothing important omitted in the new Midwest 9, 12 and 16-tube ALL-WAVE A.C. sets. You'll be amazed and delighted with the volume, the ease of control, the amazing clarity of reproduction and the absence of frying and cracking noises. Such radio reception has never before been known. Don't buy a set of any kind until you get the big new Midwest catalog. Mail the coupon now. Learn how you can save 30 percent to 50 percent direct from the factory—and buy on easy terms to suit your convenience.

Get All the Facts NOW

30 DAYS FREE TRIAL

Remember, every Midwest set is backed by a positive guarantee of satisfaction or your money back. 30 DAYS' FREE TRIAL in your own home makes you the sole judge. Midwest, now in its twelfth successful year, offers bigger, better, more powerful, more sensitive radios at lower prices than ever before. The coupon or a postal card brings you big new information and complete information. Mail it NOW!

RUSH THIS COUPON FOR AMAZING FREE TRIAL OFFER AND BIG BEAUTIFUL CATALOG

USER AGENTS Big money in spare time. Check here for details.

Midwest Radio Corp., Dept. 113, Cincinnati, Ohio. Gentlemen: Please rush my copy of your big, beautiful, new catalog and complete details about the powerful, new 9, 12, and 16-Tube ALL-WAVE super-heterodyne outfits. I am not obligated.

Name Street Town State

CORP. Dept. 113 CINCINNATI, O.

50¢
The Copy

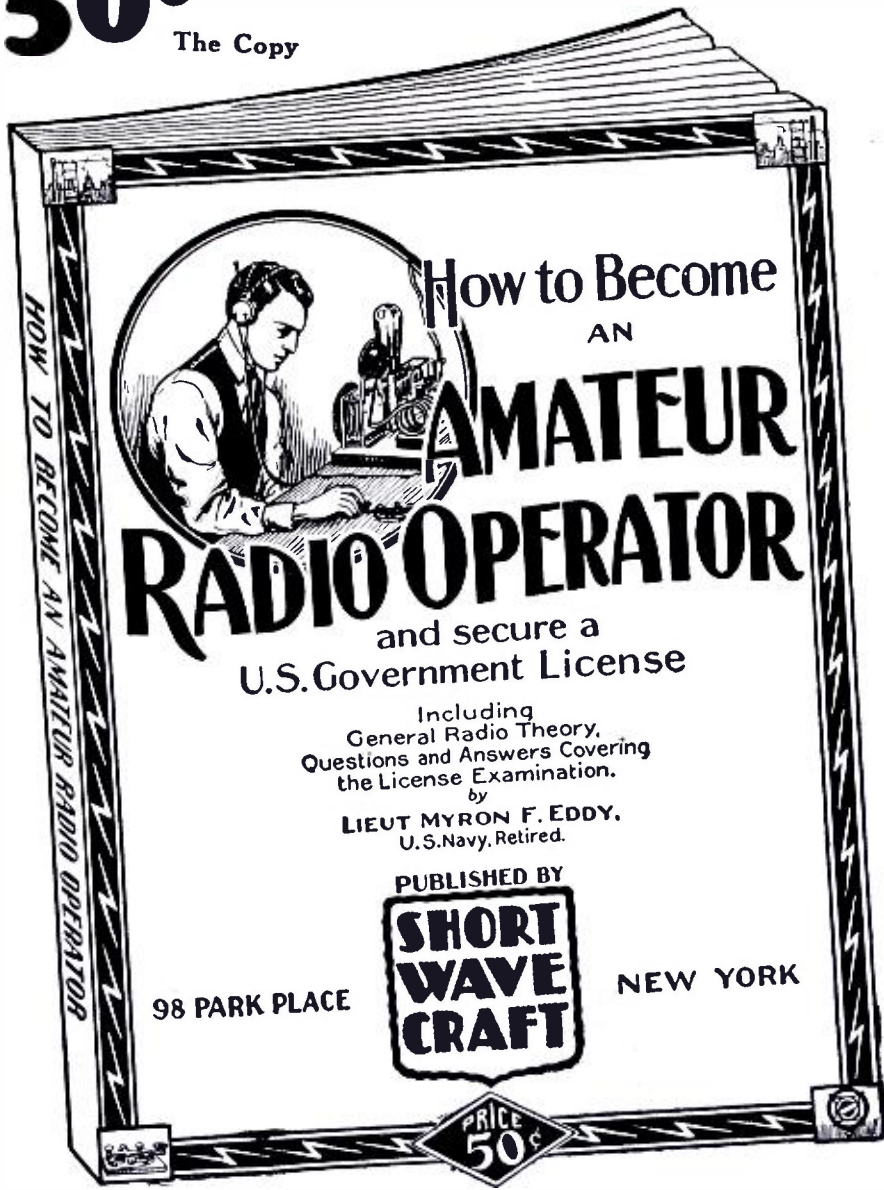

Announcing-

THERE are at the present time, in this country alone, about 25,000 licensed radio amateurs. For the past several years we have been bombarded with requests from radio readers for a reasonably priced book to cover the subject on "How to Become a Radio Amateur and Obtain a Government License."

While there have been some books of this type on the market before, most of them are either obsolete and of little use to the newcomer or otherwise are so high in price that the average man cannot afford them.

We therefore commissioned Lieut. Myron P. Eddy, U. S. Navy, Retired, to write a book on this subject that would answer EVERY possible question on the subject in such a way as has never been done before. We chose Lieut. Eddy for this difficult task because his long years of experience in the amateur field have made him pre-eminent in this line. For many years he was an instructor of radio telegraphy at the R.C.A. Institutes, and in this capacity he obtained a vast knowledge and insight on the subject such as is had by few men. He is a member of the I.R.E. (Institute of Radio Engineers), also the Veteran Wireless Operators' Association.

The Book You Have Been Waiting For

If you intend to become a licensed code operator, if you wish to take up phone work eventually, if you wish to prepare yourself for this important subject—this is the book you must get.

Every Short-Wave Enthusiast Should Have a Copy of This Book

This book covers literally everything from "soup to nuts" on the subject, in such a clear and lucid manner that it will be of great value to every student.

Only Brand New Material . . . No Reprints Of Any Kind In This Book

This book contains only brand new material that has not been published before and gives entirely new slants on the entire matter of amateur radio. It is replete with many illustrations, and contains everything that is to be known on the subject. Dozens of illustrations, photographs, hook-ups and diagrams in great profusion are included.

In general get-up this book is a companion volume to our first book, "How to Build and Operate Short Wave Receivers." It comes with a heavy colored cover, and is printed throughout on fine bond paper. No expense has been spared to make this the outstanding volume of its kind. The book measures about 7½ x 10 inches.

72 PAGES—OVER 150 ILLUSTRATIONS

PARTIAL LIST OF CONTENTS

CHAPTER 1 is devoted to ways and means of learning the code. A system of sending and receiving with necessary drill words is supplied so that you may go right to work on approved methods.

CHAPTER 2 contains concise, authoritative definitions of radio terms, units and laws, as well as brief descriptions of the most commonly used pieces of radio equipment. This chapter supplies you with the working terminology of the radio operator so that the chapters to follow may be readily assimilated and yet free from exhaustive explanations of the phrases used. All graphic symbols used to indicate the various parts of radio circuits are shown so that they may be readily recognized when studied in the following chapters.

CHAPTER 3 takes up general radio theory particularly as it applies to the beginner. The electron theory is briefly given, then waves—their creation, propagation and reception. Fundamental

laws of electric circuits, particularly those used in radio, are explained next and typical basic circuits are analyzed.

CHAPTER 4 contains descriptions of receivers that are being used with success by amateurs at this time. You are told how to build and operate these sets, and are told how they work.

CHAPTER 5 takes up transmitters of interest to amateurs. Diagrams with specifications are furnished so that their construction is made easy. Operating instructions are also furnished.

CHAPTER 6 describes the power equipment that may be used with transmitters and receivers, rectifiers, filters, batteries, etc.

CHAPTER 7 includes all of the regulations that apply to amateur operators.

CHAPTER 8 is the appendix, which contains the international "Q" signals, conversion tables for reference purposes, etc.

This book is published by the publishers of SHORT WAVE CRAFT Magazine. This alone will be your guarantee that it is a really worthwhile publication.

If you are at all interested in amateur radio and all that goes with it, you certainly do not wish to do without this valuable book. It is the most important and timely book of its kind ever published.

THIS BOOK IS NOT SOLD ON THE NEWSSTANDS

CLIP AND MAIL COUPON TODAY!

OTHER IMPORTANT DATA

The Amateur Self-Examiner. Something radically new—every amateur has been looking for it.

Over 300 Questions and Answers on radio subjects of interest to amateurs.

Latest Changes in Radio Law, rules and regulations, including the new license requirements issued July, 1932.

All Information contained in this book which you need to become a licensed radio amateur—and more! It tells you how to build and operate an amateur radio station.

WRITTEN FOR THE AMATEUR

USE COUPON BELOW

SHORT WAVE CRAFT,
98 Park Place, New York City.

SW-3-5

Gentlemen:
I enclose herewith 50c for which please send me prepaid, a copy of your new book, "How to Become a Radio Amateur and Secure a U. S. Government License," the book to be sent to me immediately upon publication. (Send Money Order, Check, Cash or new U. S. Stamps. Register letter if it contains currency or stamps.)

Name

Address

City..... State.....

Announcing a New receiver

POSITIVELY Guaranteed TO RECEIVE
REGULARLY, WITH LOUD SPEAKER
VOLUME, FOREIGN STATIONS ♦ ♦
10,000 MILES OR MORE DISTANT

THE SCOTT ALLWAVE DELUXE

Eleven new and sensational developments enable this receiver to completely shatter all previous known standards of radio performance



No Plug-In Coils or Tapped Coils—New system actually MORE efficient than Plug-In Coils.

Single Dial tunes BOTH R. F. and oscillator circuits from 15 to 550 meters, perfectly and *automatically* WITHOUT TRIMMERS, by newly developed method protected by patents pending.

4/1000ths Microvolt Sensitivity—This truly tremendous power brings in stations 10,000 miles distant with volume of a local station.

New Selectivity Masters Every Channel—Laboratory curves prove DELUXE MODEL most selective receiver ever built. Absolute 10 KC separation at 200 times signal ratio.

New Class "A" Linear Amplifier—Gives perfectly uniform response to all frequencies from 30 to 8,000 cycles—Provides perfect reproduction and linear output at LOW as well as HIGH volume.

New Twin Speakers—Laboratory-matched to give richness and thrilling realism and to eliminate all trace of speaker distortion or blasting at high volume.

New Tonal Realism—The perfectly engineered combination of CLASS "A" Amplifier, laboratory-matched twin speakers—and receiver—gives to the tone of the SCOTT ALLWAVE DELUXE the fourth dimension lacking in all ordinary reproduction.

New Type Tubes Used in highly developed circuits secure amplification never before attained in a radio receiver.

Static Suppressor reduces atmospheric noises to minimum, permitting practical use of our extreme sensitivity on far distant stations.

100% Shielding—Makes possible full use of tremendous sensitivity without slightest trace of oscillation.

New Scott Slow Motion Drum Dial—No cords or cables to get out of adjustment—Positive drive without back lash.

Guaranteed Daily World Wide Reception in your own home—any day of the month—any month of the year.



Send for Technical Details, Laboratory Information and Proof of the above statements. Use the coupon. Mail it today to

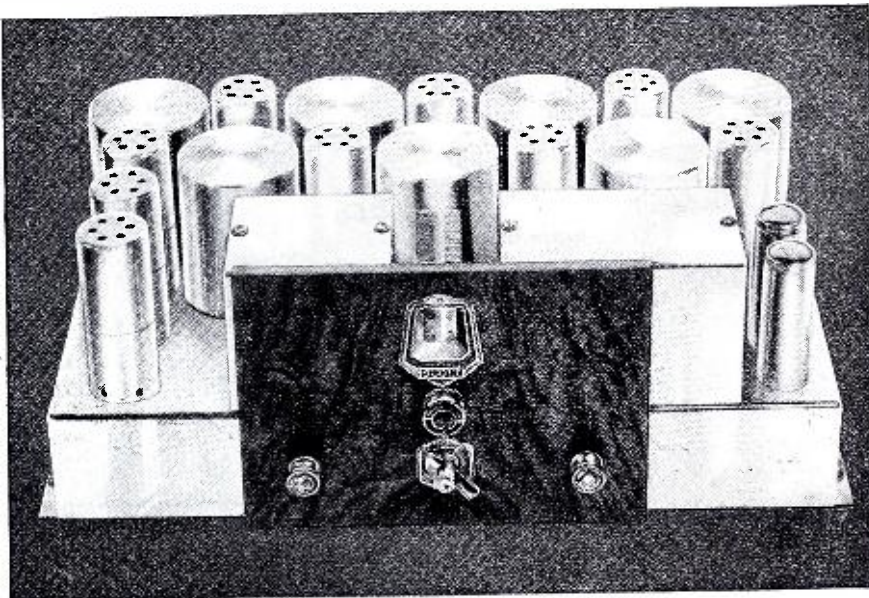

Our Challenge to the Radio World

Our tests show the performance of no other receiver even approaches that of the new SCOTT ALLWAVE DELUXE—A fact confirmed by laboratory measurements made by *independent* testing laboratories. Here's our Challenge—

1. Over eight years ago a SCOTT SUPER EIGHT brought in 119 programs from 19 different broadcasting stations, all 6,000 miles or more distant, and had all reception fully verified—**Who Can Equal THIS Record?**

2. Over 16,000 detailed logs of foreign station reception have been received from owners of SCOTT SETS since January 1st, 1932 from 257 different foreign stations in 43 foreign countries (Canada and Mexico logs not counted). **Who Can Equal THIS Record?**

3. Every regular program from station VK2ME, Sydney, Australia, 9,500 miles distant, has been logged and reception recorded for twelve consecutive months on a SCOTT ALLWAVE RECEIVER located in Chicago. **Who Can Equal THIS Record?**

4. Finally—What manufacturer claiming "record breaking performance" is willing to place his receiver alongside the new SCOTT ALLWAVE DELUXE for a competitive test on distant stations from 15 to 550 meters—the results of this test to be published in THIS magazine—Reception results to be judged by three or more leading Radio Engineers or Radio Editors—After reception tests, both receivers to be subject to tone test—Results to be judged by three or more well known musical authorities. **Who Will Accept THIS Challenge?**

THE E. H. SCOTT RADIO LABORATORIES, INC.
4450 Ravenswood Ave., Dept. SW 92, Chicago
Send me full particulars of the new SCOTT ALLWAVE deluxe.

Name

Street

Town State

THE E. H. SCOTT RADIO LABORATORIES, INC.
4450 Ravenswood Avenue, Department SW-92, Chicago

WHAT ARE YOU DOING IN RADIO IN THESE DAYS OF KEEN COMPETITION AND SCARCITY OF JOBS AND POSITIONS?

It is always the well-trained man who wins out over the horde of thousands of superficially trained and incompetent men. You are reading this magazine because you are interested in radio. Sooner or later, the time big and vital question will be, "How well equipped am I to fill the job?" You are in radio because you like it. You also realize that, at the present time, there are many branches of the radio art which you do not know as thoroughly as you should. Knowledge, these days, can be gotten cheaper than ever before. It isn't necessary for you to go to college to become proficient in radio. Start today, to build a REAL radio library and become acquainted with all branches of this great and growing art. In this page are listed the world's best radio books. We have combed the market for the really important books in radio; so that, no matter what branch you are interested in, you can pick out the best books that are now printed. Start, today, to build a complete radio library. You do not have to get all the books at once, but make up your mind to get one book a month; so that, when your chance comes, you will be fully equipped to win out over the others not so well equipped.

WE herewith present the most complete collection of recent important radio books. We have, after an exhaustive study, selected these volumes because they represent the foremost radio books of their kind in print today. There is such a great variety that we are sure it will satisfy any taste as well as any requirement that the student of radio might have. We publish no catalogue and ask you to be kind enough to order direct from this page. Prompt shipments will be made to you direct from the publishers. We merely act as a clearing house for a number of radio publishers and OUR PRICES ARE AS LOW OR LOWER THAN WILL BE FOUND ANYWHERE. Remit by money order or certified check. If you send cash, be sure to register it.

IMPORTANT.—This list is changed every month to include the latest books. Note also new low prices.

THE RADIO HANDBOOK, by James A. Moyer and John F. Wostrel. Flexible covers, size 5½x8", 886 pages, 650 illustrations. Price **\$5.00**

Comprehensive data on short-wave apparatus, vacuum tubes, modern radio receivers and transmitters, photoelectric cells, television, sound motion pictures, tables, graphs, diagrams, etc. No radio man should miss it.

RADIO FREQUENCY ELECTRICAL REQUIREMENTS, by Hugh A. Brown. Cloth covers, size 6x9", 386 pages, 235 illustrations. Price **\$4.00**

One of the few great books on this important subject. Everything from thermionic-tube coefficients to piezoelectric measurements.

PRACTICAL TELEVISION, by E. T. Lerner. Cloth covers, size 5½x8", 223 pages, 127 illustrations. Price **\$3.75**

This book explains television in full, including elementary principles, photo-electric cells, and all important types of television sets as well as basic principles of optics, images, mirrors, lenses, etc.

TELEVISION. Its Methods and Uses, by Edgar H. Felix. Cloth covers, size 5½x7¾", 272 pages, 73 illustrations. Price **\$2.50**

A practical complete cross-section of television today. One of the very best books on this important art in print.

MAGNETIC PHENOMENA, by Samuel Robinson Williams. Cloth covers, size 6x9", 230 pages, 150 illustrations, and numerous tables. Price..... **\$3.00**

All electric motors, coupling coils, magnetic and dynamic loud-speakers, transformers, choke coils, etc., are dependent on magnetic phenomena. This fine book is complete on the subject.

HOW TO BUILD AND OPERATE SHORT-WAVE RECEIVERS, by the Editors of SHORT WAVE CRAFT. Stiff Paper covers, size 7½x9¾", 76 pages, 250 illustrations. Price prepaid..... **40c**

The greatest book on building and operating short wave sets and converters in print today. No better book printed.

CINEMATOGRAPHY, by James R. Cameron. Stiff covers, size 7½x5", 240 pages, 150 illustrations. Price **\$3.50**

Everything on the subject from "silent" and "talkie" 16 mm. film to its manufacture and to the final projection is in this marvelous volume.

QUESTIONS AND ANSWERS—Sound Motion Pictures, by James R. Cameron. Cloth covers, size 7½x5", 250 pages. Price **\$3.50**

The most important book on the technical subject of "Talkies."

AUDEL'S RADIOMAN'S GUIDE, by Frank D. Graham. Cloth covers (flexible), size 5x6¾", 220 pages, 300 illustrations. Price **\$1.00**

A practical, concise book presenting the theoretical and practical information for the proper operation, maintenance and service as applied to modern radio practice.

THE RADIO AMATEUR'S HANDBOOK (New Revised Edition), by A. Frederick Collins. Cloth covers, size 5½x7¾", 394 pages, 116 illustrations. Price.. **\$2.00**

If you wish to become a radio amateur (radio ham) this book tells you how. Everything in receiving and transmitter sets and how to build them.

RADIO SET ANALYZERS AND HOW TO USE THEM, by L. Van der Mel. Stiff Paper covers, size 6x9", 68 pages, 45 illustrations. Price prepaid **40c**

The first book giving the fundamentals of radio servicing design in a manner which is clear even to the tyro. No service man can be without it.

RADIO AND ELECTRONIC DICTIONARY, by Harold P. Manley. Cloth covers, size 6x9", 300 pages, 550 illustrations. Price prepaid **\$2.50**

A fully-indexed volume, which places at your finger-tips definitions of 3,800 radio words and phrases; of inestimable value.

FOUNDATIONS OF RADIO, by Rudolph L. Duncan. Cloth covers, size 5½x8", 246 pages, 145 illustrations. Numerous tables. Price **\$2.50**

This textbook gives you the fundamentals of electricity as applied to radio. It equips you for further study in the field of radio.

EXPERIMENTAL RADIO ENGINEERING, by John H. Morecroft. Cloth covers, size 6x9", 346 pages, 250 illustrations. Price **\$3.50**

A student's book; devoted to the principles of radio apparatus; intended to accompany a course in electricity. The best of its kind.

TALKING PICTURES, by Bernard Brown. Cloth covers, size 5½x8½", 327 pages, 161 illustrations. Price **\$3.00**

The non-technical man reading this book feels that he has been transported to a wonderland; technicians refer to it time after time.

RADIO THEORY AND OPERATING, by M. T. Loomis. 5th revised Edition. Cloth-bound; size 5½"x8"x1½" thick; 1,000 pages; over 800 illus.; 450 review questions and answers. Price **\$4.50**

Written in textbook style, a tremendous amount of useful information has been crammed into this thin-paper, compact reference work. Radio transmission and reception have been covered, "from soup to nuts." A truly great book.

THE RADIO MANUAL, by George E. Sterling and Robt S. Kruse, E.E. 2nd enlarged edition. Flexible fabrikoid covers. Size 5½x3", 805 pages, 348 illustrations. Price **\$6.00**

A complete Radio Course for the operator, the technician, the amateur, the student and experimenter. Everything imaginable in the whole radio art is covered in this great book—the "radio bible" of the amateur. DON'T MISS THIS.

RADIO AND ITS FUTURE, by Martin Codel. Cloth covers, size 6x9", 349 pages, 8 plates. Price **\$4.00**

Vivid chronicles of radio broadcasting, communications, industry, regulations, etc. If you are in radio you MUST have this book

SHORT WAVES, by C. R. Leutz and R. B. Gable. Stiff Covers. Size 6x9", 384 pages, 258 illustrations. Price, prepaid.. **\$3.00**

The biggest and most complete book on short waves. Covers every imaginable phase, including S.W. Superheterodynes. The authors are famous S.W. authorities.

RADIO FREQUENCY MEASUREMENTS, by E. B. Moullin. Cloth covers, size 6x9", 487 pages, 289 illustrations. Price prepaid **\$12.50**

This large volume answers all questions which arise in the design and construction of R.F. circuits of every possible type. The greatest and most authoritative book of its kind in print for radio students and engineers.

RADIO MOVIES AND TELEVISION, by C. Francis Jenkins. Cloth covers, size 9½x6", 144 pages, profusely illustrated. Price **\$1.00**

A complete volume by the master of television, giving everything in television, including constructional details for building your own television sets.

RADIO VISION, by C. Francis Jenkins. Cloth covers, size 9½x6", 144 pages, profusely illustrated. Price prepaid..... **90c**

An excellent book. The Jenkins television system, as well as many other modern television systems fully described.

A POPULAR GUIDE TO RADIO, by B. Francis Dashiell. Cloth covers, size 5½x8½", 286 pages, profusely illustrated. Price prepaid **\$3.50**

The fundamental principles of radio. From crystal rectifiers to the latest electron tube amplification, etc.

How to order
We cannot ship C.O.D. Our prices are net, as shown. Some of the books include postage. Those that do not will be shipped by express collect if sufficient postage is not included by you.

RIDING THE AIR WAVES, by Eric Palmer, Jr. Cloth covers, size 7½x5½", 328 pages. Price **\$2.00**

No radio amateur or "ham" can afford to be without this book, written by the author of "Around the World with 5 Watts."

SOUND PICTURES AND TROUBLE SHOOTERS MANUAL, by Cameron and Rider. Cloth cover, size 8x5½". 1120 pages, profusely illustrated. Price **\$7.50**

The standby of every operator. It is the most thorough book on the subject.

TELEVISION TODAY AND TOMORROW, by S. A. Moseley and H. J. B. Chapple. Cloth covers, size 8x5½", 130 pages, profusely illustrated. Price prepaid **\$2.50**

A most up-to-date work on television describing in detail the apparatus used by Baird.

S. GERNSBACK'S RADIO ENCYCLOPEDIA (Second Edition). Red Morocco Flexible Binder, 352 pages, 2201 radio definitions, 1253 illustrations, 34 tables. Price **\$3.25**

The most comprehensive encyclopedia of its kind in print. Remarkably up-to-date in every way, with marvelous illustrations.

DRAKE'S CYCLOPEDIA OF RADIO AND ELECTRONICS, by H. P. Manly. Cloth covers, size 8x9", 1050 pages, 1080 illustrations. New 1932 Edition. Price **\$6.00**

The largest work of its kind ever put between two covers. New and up-to-date; a standby for every radio man.

RADIO TROUBLE SHOOTING, by Ennor R. Haan, E.E. Flexible covers, size 6x9", 323 pages, 257 illustrations. Price... **\$3.00**

An intensely practical handbook for all radio service men and operators. Up-to-date in every respect.

FUNDAMENTALS OF RADIO, by R. R. Ramsey, Professor of Physics, Indiana University. Cloth covers, size 9½x6", 372 pages, illustrated. Price, prepaid. **\$3.50**

The backbone of the radio art. This book gives you the foundation on radio from A to Z.

OFFICIAL RADIO SERVICE MANUAL, Volume I, by Hugo Gernsback and Clyde Fitch. Flexible loose-leaf binder, size 9x12", over 2,000 illustrations, 650 pages. COMPLETE WITH SIX SUPPLEMENTS. Price prepaid **\$4.50**

The Service Man's Bible. Greatest book ever published on the subject. Contains all old circuits of every imaginable commercial radio set up to 1931.

OFFICIAL RADIO SERVICE MANUAL, Volume II, by Hugo Gernsback, C. E. Denton and C. H. W. Nason, with 1932 Free Supplements, 1000 pages, 2000 illustrations. Flexible Loose-leaf Binder, size 9x12". Price, prepaid **\$4.00**

The talk of the radio industry. This marvelous volume contains everything in radio, circuits, and radio developments, for 1932. Not a line of duplication between 1931 and 1932 volumes. (Vol. I and Vol. 2.)

ELEMENTS OF RADIO COMMUNICATION, by Professor John H. Morecroft. Cloth covers, size 9x6", 270 pages, 170 illustrations. Price **\$3.00**

An authoritative volume embracing every imaginable phase in radio communication.

RADIO SERVICE MAN'S HANDY BOOK WITH ADDENDA DATA SHEETS. Flexible covers, size 9x12", 200 pages, 400 illustrations. Price prepaid.. **\$1.49**

The Service Man's standby. Contains the latest practical information on radio servicing.

RADIO TELEGRAPHY AND TELEPHONY, by R. L. Duncan and C. E. Drew. (New Edition.) Cloth covers, size 9½x6", 950 pages, 468 illustrations. Price **\$7.50**

Everything from Ohms Law to vacuum tubes and detectors, to oscillographs and radio compasses thoroughly treated in this great book.

PRACTICAL RADIO CONSTRUCTION AND REPAIRING, by J. A. Moyer, S.B., A.M. and J. F. Wostrel. Cloth covers, size 8x5", 354 pages, 163 illustrations. Price **\$2.50**

A handbook that every radio set tester and general student must have. The diagrams alone are worth the price of the book.

PRACTICAL RADIO—INCLUDING THE TESTING OF RADIO RECEIVING SETS, by James A. Moyer, S.B., A.M. and John F. Wostrel. Cloth covers, size 8x5", 378 pages, 223 illustrations. Price **\$2.50**

The title gives the story. Everything from crystal sets to the latest multi-tube receiver, and how they work.

RADIO RECEIVING TUBES, by Moyer and Wostrel. Cloth covers, size 7½x5½", 298 pages, 181 illustrations. Price... **\$2.50**

One of the finest books on vacuum tubes. Everything worthwhile on the subject treated in a masterful manner.

HOW TO PASS U. S. GOVERNMENT RADIO LICENSE EXAMINATIONS, by R. L. Duncan and C. E. Drew. Flexible covers, size 9½x7", 170 pages, 92 illustrations, appendix. Price. **\$2.00**

The most important book on the subject ever published. Gives every conceivable angle which will help you to pass a radio license examination successfully.

PRINCIPLES OF RADIO, by Keith Henney, M.A. Cloth covers, size 8x5½", 478 pages, 306 illustrations. Price **\$3.50**

A marvelously written textbook with the latest radio principles, including screen grid and pentode, amplifiers, etc.

PHOTOELECTRIC PHENOMENA, by Arthur Llewelyn Hughes and Lee Alvin Dubridge. Cloth covers, size 6"x9¾", 531 pages, 202 illus. Price..... **\$5.00**

A critical survey of the whole field of photoelectric phenomena, intended as a reference book for research workers, students and teachers. The most complete work in print.

RADIO TRAFFIC MANUAL AND OPERATING REGULATIONS, by R. L. Duncan and C. E. Drew. Flexible covers, size 9x6", 186 pages. Price..... **\$2.00**

A live wire book for all radio amateurs, including how to learn code, abbreviations, International Radiograph Convention, Radio Act of 1927, etc.

PRINCIPLES OF RADIO COMMUNICATION, by J. H. Morecroft, Prof. of Electrical Engineering, Columbia University. Cloth covers, size 9½x6", 988 pages, profusely illustrated. Price.. **\$7.50**

THE radio classic, by the dean of radio. Covers entire radio art as does no other book.

EXPERIMENTAL RADIO, by R. R. Ramsey, Prof. of Physics, Indiana University. Cloth covers, size 7½x5½", 256 pages, 168 illustrations. Price, postpaid **\$2.75**

A marvelous book for the experimenter. Experiments galore in easy comprehensible language.

FUNDAMENTAL PRINCIPLES OF RADIO, by Louis Martin, B.S. Stiff Paper covers, size 6x9". 68 pages, 85 illustrations. Price, prepaid **40c**

Just what the title says, but it gives you the HOW and WHY of radio in plain English. THE book for beginners.

MODERN VACUUM TUBES and How They Work, by "Bob" Hertzberg. Stiff Paper covers, size 6x9", 68 pages, 150 illustrations. Price, prepaid..... **40c**

Just published, this important book covers the art as does no other book. Describes all the latest tubes, including the "Triple Twin".

ORDER DIRECT FROM THIS PAGE

ORDER DIRECT FROM THIS PAGE
RADIO PUBLICATIONS • • • **245-S GREENWICH STREET**
NEW YORK, N. Y.



Short Wave Noise Elimination

An Editorial by HUGO GERNSBACK

● WHEN broadcast receivers first took to the loud speaker the public was very often annoyed and sometimes disgusted by the extraordinary amount of noise that issued from this instrument.

It was soon found in broadcast practice that one of the best ways to eliminate noise was to increase the power of the set itself. By this I mean that engineers built up the radio signal to such an extent that it would *over-ride* the natural noise level. In this they were partially successful, although the remedy is still a make-shift. We have not as yet been able to eliminate all noises in broadcast reception, but inasmuch as we have succeeded in amplifying the signal to a very large degree, most receivers operate with the volume control only half in use. It is only seldom that we cut out *all* the resistance from the volume control and let the receiver go at full blast; therefore, on moderate strength reception the noise level is not objectionable in most cases.

On the short waves we have the same conditions except that they are very much worse. When a person first listens to short-wave stations a good distance away, as a rule he invariably remarks about the unaccustomed noise which often might be described better by the word "racket." The reasons for this extraordinary amount of noise which we have to contend with at the present time are manifold.

In the first place, we usually use too much amplification. When we operate a converter in conjunction with a regular broadcast set, it means that we immediately add from three to five tubes to the latter, and often the combination exceeds twelve or fourteen tubes.

If there were no outside man-made static, and if the receiver was entirely shielded, we would still have a great amount of noise. This is produced first by the tubes themselves. Engineers as yet have not devoted themselves sufficiently to the problem of eliminating *tube noises*. It seems futile to do anything until engineers have overcome this objection.

Some progress has been made along this line, but not enough attention has been paid to it of late, and there is room for a tremendous amount of improvement. Of course, natural static has not been considered as yet. Sometimes it is almost impossible to receive short-wave signals due to the "grinders" and other crackling noises produced by atmospheric disturbances. The best solution at the present time for this problem is a short aerial, but this is only a make-shift remedy. In time, the static problem will no doubt be solved.

When it comes to man-made static the situation is wholly different, because here we really can do something about it. It is distinctly worthwhile to use an entirely shielded lead-in, which should be grounded. Such aerials are on the market now. They consist of a central wire over which an enameled wire is wound helically. There is another type in which we have the identical inside insulated wire, shielded on the outside by a woven metal sleeve.

THE IMPORTANT POINT ABOUT THE SHIELDED LEAD-IN IS THAT IT WILL DO YOU NO GOOD UNLESS IT GOES TO THE VERY ANTENNA BINDING POST OF

YOUR SET, OR NOT MORE THAN A QUARTER OF AN INCH FROM THE POST. THE OUTSIDE SHIELD IS THEN GROUNDED. EVEN AN INCH EXPOSURE BRINGS IN ENOUGH NOISE TO DEFEAT THE PURPOSE OF THE SHIELDED LEAD-IN. SUCH SHIELDED LEAD-INS WILL BECOME MORE POPULAR AS TIME GOES ON AND WHEN THE PUBLIC BEGINS TO REALIZE THEIR IMPORTANCE.

When it comes to the short-wave set itself, I might say that altogether too little attention is paid to the mechanical end. It may be superfluous to state that a really good short-wave receiver must be completely shielded with metal. When you have only a two- or three-tube set, you need not worry, but when you have a multi-tube set, with high amplification, then the matter of shielding becomes of paramount importance. Some years ago French engineers demonstrated that they could put a radio set into a steel safe, with walls two inches thick, and still get reception inside the safe through minute cracks caused by the door not being perfectly closed. Once the safe was tightly shut, with its metallic faces making continuous contact with each other, no reception was had.

I cite this example to show how important good shielding is on short waves, because we want to shield the set to keep out *all* extraneous interference, which in turn produces objectionable noises. Just screwing together a few aluminum sheets will not do. For a perfect job, we should use nothing but tight fitting shields that slide into grooves. If you want to make a really perfect job, then the entire seams should be soldered. Just placing a loose top on the receiver is bad engineering, and here is where most sins are committed. Extra tight fittings should be used on the top as well. Some manufacturers are beginning to realize this and are using shield covers of the refrigerator door type.

Wherever lead wires come from the set, these should be shielded too, and grounded. Even a half-inch hole is sufficient to let stray waves pass into the set. As most sets today are shielded with aluminum, and as there are excellent aluminum solders available on the market, the job of hermetically sealing short-wave receivers is not very troublesome these days. For maximum results, solder up your shield cans!

Then there is the elimination of stray radio-frequency currents in the power line. This can be done by the use of filters now on the market, or filters which can be constructed by the experimenter himself. A good test for such a filter is to switch off and on electric lights in the same or an adjoining room. If the filter is perfect, no click will be heard, if the set is turned on with the volume control all the way up. If a click is heard, the filter is poor or inefficient, or the set has not been shielded properly, or the lead-in is still picking up energy.

Of course, these conditions are aggravated in the city. They are not quite as bad in the country, so for city use the short-wave set should be shielded all the better and nothing overlooked.

We shall be pleased to hear from readers on new ideas or methods of *noise elimination* on short waves, and shall be glad to publish such hints for the benefit of all our readers.

SHORT WAVE CRAFT IS PUBLISHED ON THE 15th OF EVERY MONTH

This is the September, 1932, Issue - Vol. III, No. 5. The Next Issue Comes Out September 15th

Editorial and Advertising Offices, 96-98 Park Place, New York City

Oddities in Short Wave News

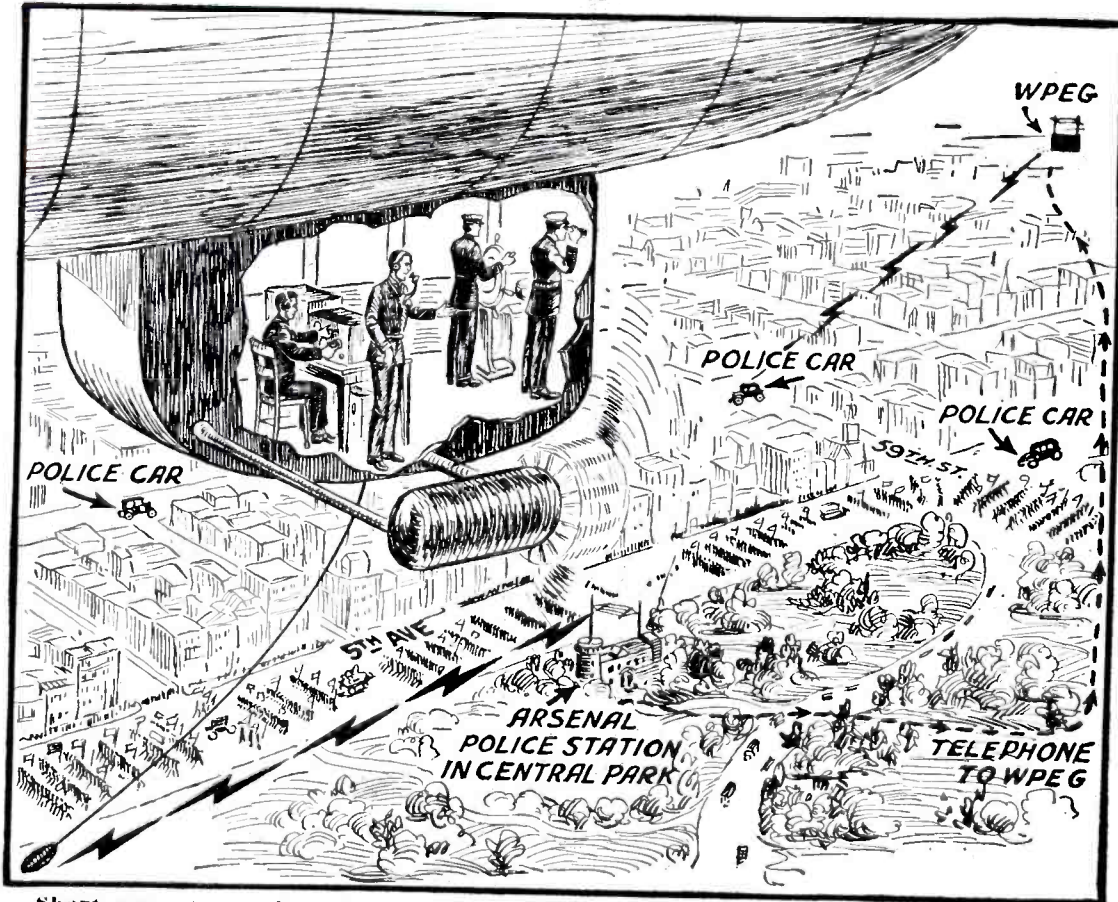

Short-wave transmitter located in a blimp sent traffic dispatches to police headquarters during the recent "beer parade" in New York City.

15 KW. USW Transmitter

● THE photo below shows one of the most powerful, if indeed it is not the strongest, ultra-short-wave transmitter in the world. This unusual transmitter, designed and built by the famous German radio firm of Telefunken, has an output up to 15 kilowatts or more in the antenna, which has already been obtained in tests, on waves as low as 6 to 8 meters! This transmitter is notable also from the fact that waves of 6 to 8 meters can be adjusted or tuned for without any change in the coils or condensers. The transmitter includes instruments for indicating the output, suitable control apparatus with "listening in" circuit, and also an R.F. amplifier and modulator for short-wave phone or code, as well as television.

The newly developed Telefunken ultra-short-wave transmitting tubes are used, the last stage containing two of these tubes, which are of a special water-cooled type, and each tube has an electron emission of 10 amperes. They are operated with a D.C. potential of 6,000 volts. In spite of the great size of these tubes, it was found possible to operate them on waves as short as 6 meters by suitably "scattering" the electrical capacities within the tube and by careful avoidance of any undue lengths of conductors.

Short Waves Direct Traffic

● DURING the recent "beer parade" in New York City, short waves played an interesting and very important role. A short-wave transmitter and receiver was installed on a blimp and as the airship sailed slowly along over the line of march, instructions and reports as to where traffic jams were occurring were radioed to Police Headquarters. The short-wave messages from the blimp were picked up at a receiving station located at the Arsenal Police Station at Central Park, then telephoned to the police radio station WPEG and short-waved to police cars.

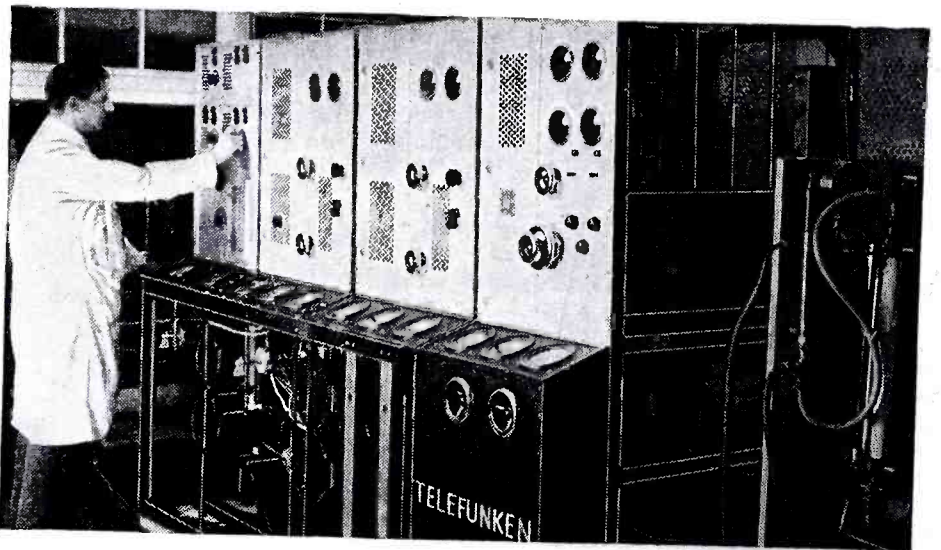

Powerful ultra-short-wave transmitter in Berlin, with an output of 15 kw. on waves as low as 7 meters.

Bootlegger's Set in Car

● ALL sorts of ingenuity has been manifested by bootleggers when it comes to radio. The accompanying photos at the left show how an elaborate short-wave transmitting station was built into an automobile, the controls for the station being placed on the instrument board and steering column of the car. This elaborate transmitting and receiving set was found in an automobile in a private garage in Rockaway by the "radio detectives" of the U. S. Department of Justice. The transmitting apparatus, batteries, etc., were mounted in a trunk concealed at the rear of the car. It is believed that this transmitter could send signals as far as 2,000 miles to rum-running ships, or to other radio-equipped automobiles belonging to the gang. The value of such a mobile transmitting set is, of course, that it is far more difficult to locate than a stationary one. The metal framework of the car, including the engine, was used as a counterpoise and a piece of metal netting in the roof of the car served as an antenna.

At left—Complete short-wave sending and receiving set found built into an automobile. Apparently it was used by rum-runners for communicating with their ships.

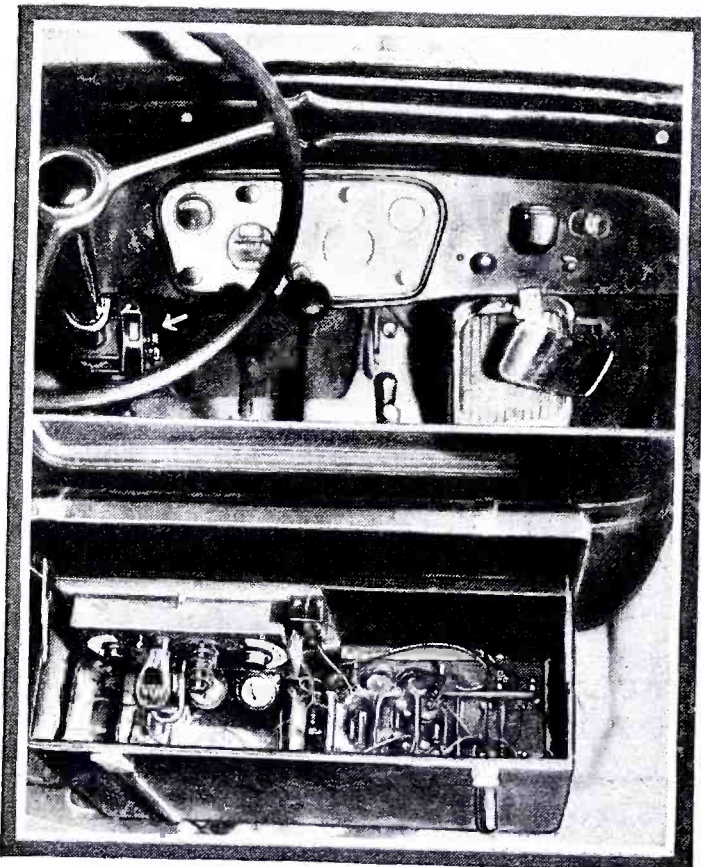

Crack Amateur Station W2PF

Part of Army-Amateur Net

By **ROBERT HERTZBERG**

This inspiring story shows what perseverance plus a knowledge of short waves really does; David Talley has received special recognition from Uncle Sam.

● STATION W2PF, built, owned and operated by David Talley, of 2222 Avenue O, Brooklyn, N. Y., is generally regarded as one of the "crack" amateur stations of the very active second district, which comprises metropolitan New York, Long Island, the upper part of New Jersey, and the Hudson Valley section of New York State. Some idea of its importance in the eyes of the government may be obtained from the fact that it is one of the very few amateur stations in the United States that has an official U. S. Army call, in addition to its regular amateur letters. When it operates as the alternate net control station of the Second Corps Area in the Army-Amateur net, it uses the call letters WLN-1, and transmits on the special

frequency of 6,990 kilocycles, which is outside of the regular "80-meter" ham channel.

In recognition of his efforts in helping the organization of the Army-Amateur radio net, Talley was commissioned as a First Lieutenant in the Signal Corps Reserve of the U. S. Army in September, 1926, and has been unceasingly active in building up this wholly voluntary and highly successful body. In October of 1930 he was promoted to a Captaincy. He is now radio aide to the Signal Officer of the Second Corps Area, the headquarters of which are located on Governors Island, in New York Harbor.

In 1926, Talley designed a short-wave

transmitter for W2SC, an amateur station operated by Signal Corps personnel at Fort Wood, Bedloes Island, the site of the Statue of Liberty. Functioning as net control station for the busy Second Corps Area, W2SC has established a wonderful reputation for consistent DX, and its signals are known to amateur operators everywhere.

A "ham" since 1915, Talley has gone
(Continued on page 311)



David Talley of Brooklyn, New York, and his crack amateur transmitter, W2PF.

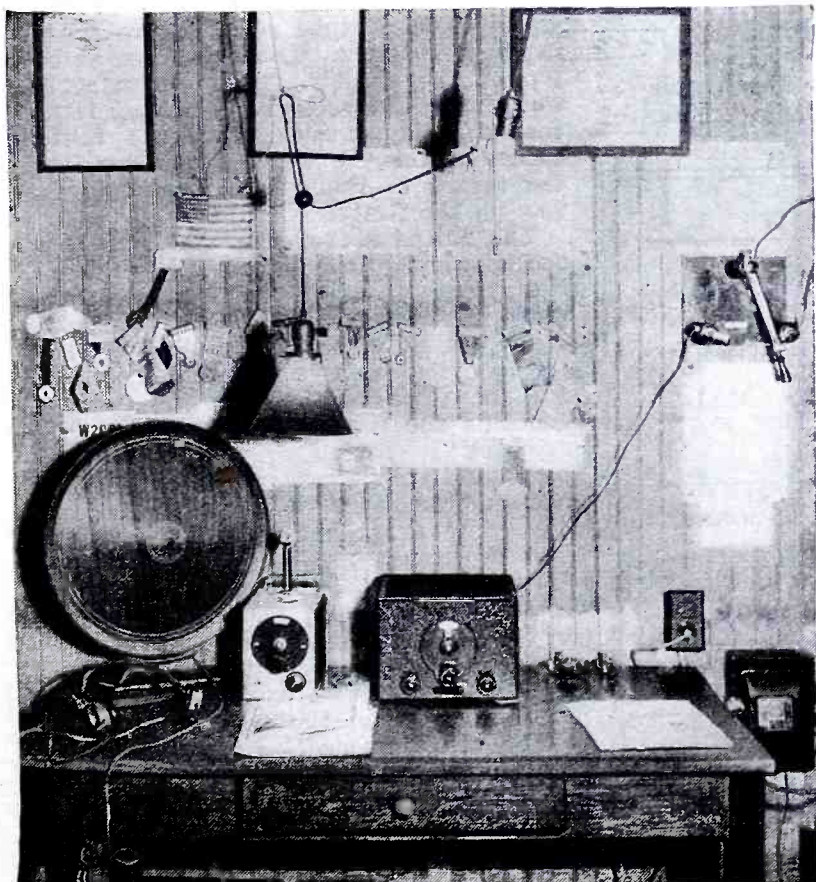

Short-wave receiving apparatus in David Talley's station W2PF.

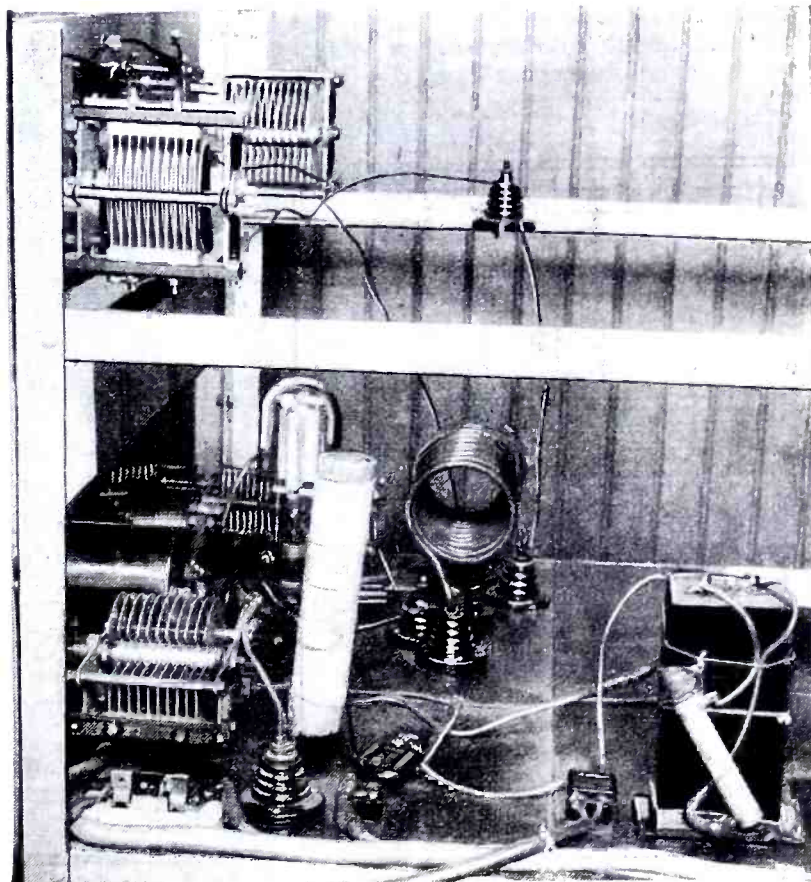

Here we see a rear view of W2PF's transmitter.

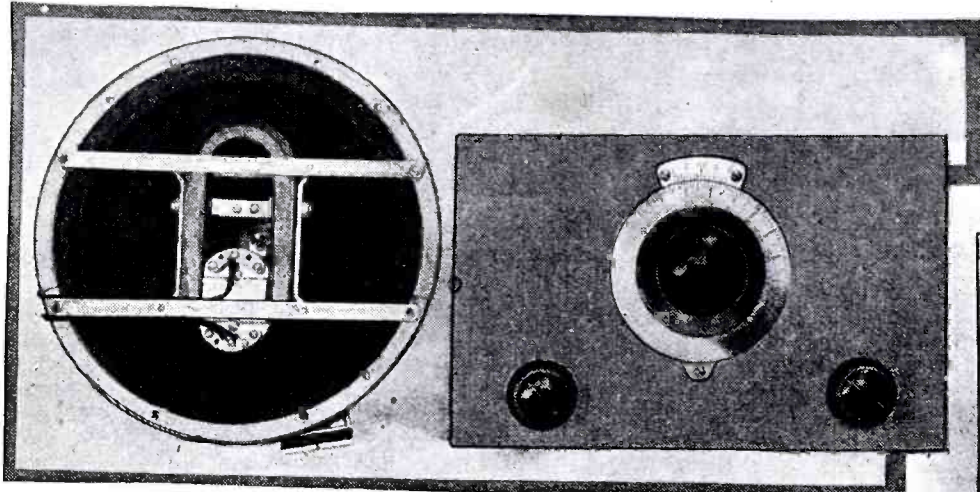

At the left and below we have the front and rear views of Mr. Martin's ideal short-wave receiver, which uses three of the latest tubes—57, 58 and '47. Yes—it operates a loud speaker.

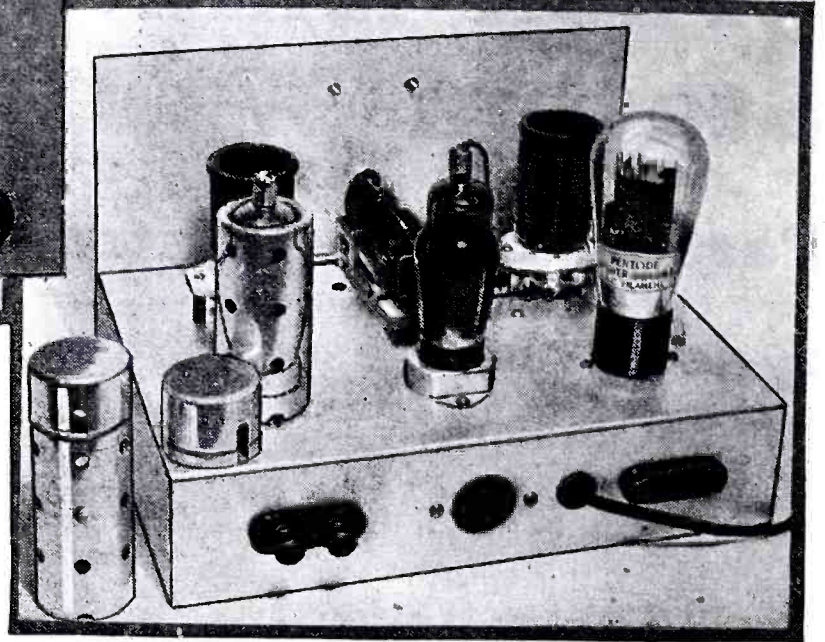

Mr. Martin has built and tested this exceedingly well-designed three-tube receiver, which permits accurate "logging" of stations. Why? Because the regeneration control he employs does not change the tuning dial index—a common failure of the average short-wave receiver. Oh, yes! It uses the latest tubes, 57, 58 and '47, and it operates a loud speaker.

Louis Martin's Idea of a Good S-W Receiver

• IN the July issue of this publication the author discussed the characteristics of the new tubes and predicted that they would be used in practically all new model short-wave receivers. In the article, special emphasis was placed on the desirability of using tubes with low input capacity in order to reduce such undesirable effects as normal oscillation, parasitic oscillation, etc. In order to convince himself that the theoretical considerations outlined in the article would result in a practical increase in efficiency, the author set about to construct a short-wave receiver incorporating the new tubes.

General Considerations

It seems to the writer that a short-wave receiver using more than three or four tubes is entirely unwarranted. Although it is true that the over-all gain of a receiver increases as the number of tubes—although not in direct proportion—the complexity of construction becomes so undesirable that the ordinary home builder would secure far better results from an *efficient* 3-tube set than from complicated 8- or 9-tube affairs, which require the use of oscillators, output meters, etc., if proper operation is to be obtained.

A very highly sensitive short-wave receiver becomes an excellent "locator of

automobiles" unless the receiver is shielded so thoroughly that absolutely no outside pick-up is tolerated. Tube noises, especially in the first few R.F. stages, cannot be tolerated and extreme care must be exercised in the choice of tubes.

For the above reasons, the writer believes that a moderately sensitive receiver, efficiently constructed, is to be more desired than an 8- or 9-tube monstrosity.

General Description of Receiver

Photographs of the front and rear views of the 3-tube receiver are shown in Figs. 1 and 2. Looking down at the top of the chassis, from left to right, there are three sockets. The first is for the '47, the output tube; the center socket is for the 57, the detector, and the socket to the extreme right is for the 58, the first R.F. tube.

The raised socket near the panel, at the left, houses the second R.F. coil, and the raised socket at the right, near the panel, is for the antenna coil. The two-gang tuning unit is at the center, and the grid leak and grid condenser alongside it. The underside of the chassis contains the filament transformer (the set uses "B" batteries for the plate supply) and miscellaneous apparatus as chokes, resistors, by-pass condensers, etc. The exact location of the miscellaneous apparatus is unimportant; the only condition that must be maintained is that they should be placed as close to the point of connection as possible.

The front panel contains the single tuning dial and two controls. The knob at the left is for the combination *off-on* switch and *regeneration control*, and the one at the right is for the volume control. A precision-type tuning dial is recommended for the simple reason that if an actual vernier dial reading is possible, a station, once logged, may be received again by merely setting the dial to the desired point. With the dial used,

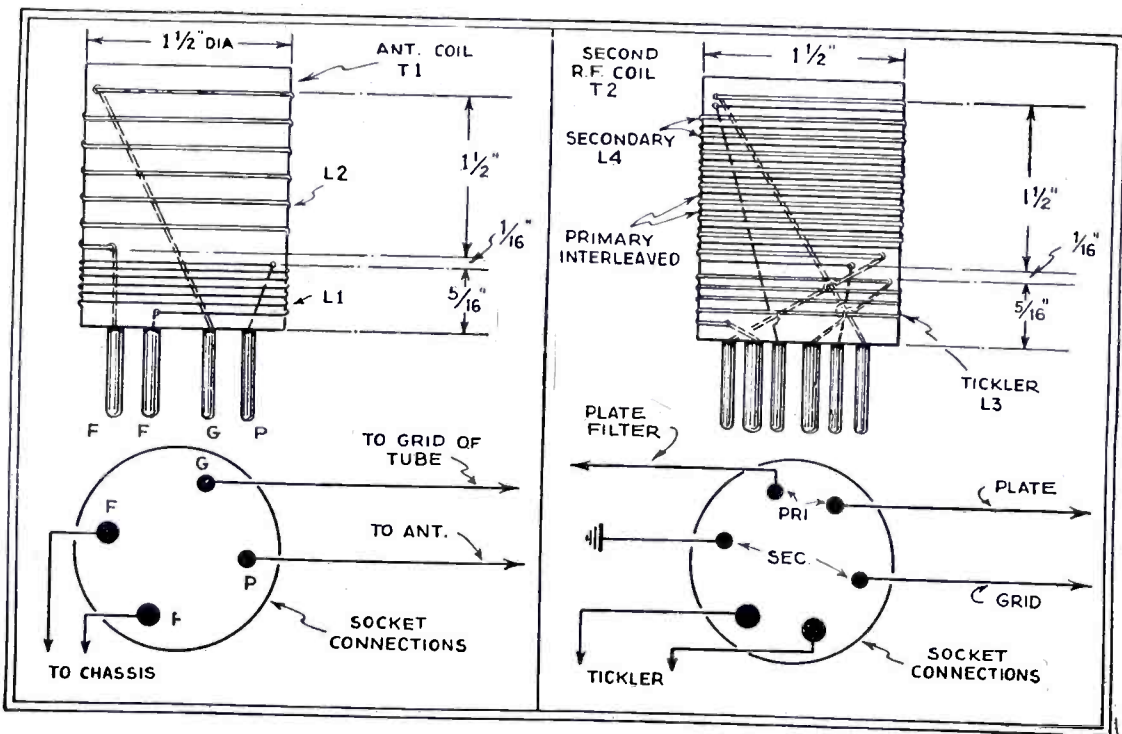

The drawing above shows constructional details of the short-wave plug-in coils used in Mr. Martin's short-wave receiver.

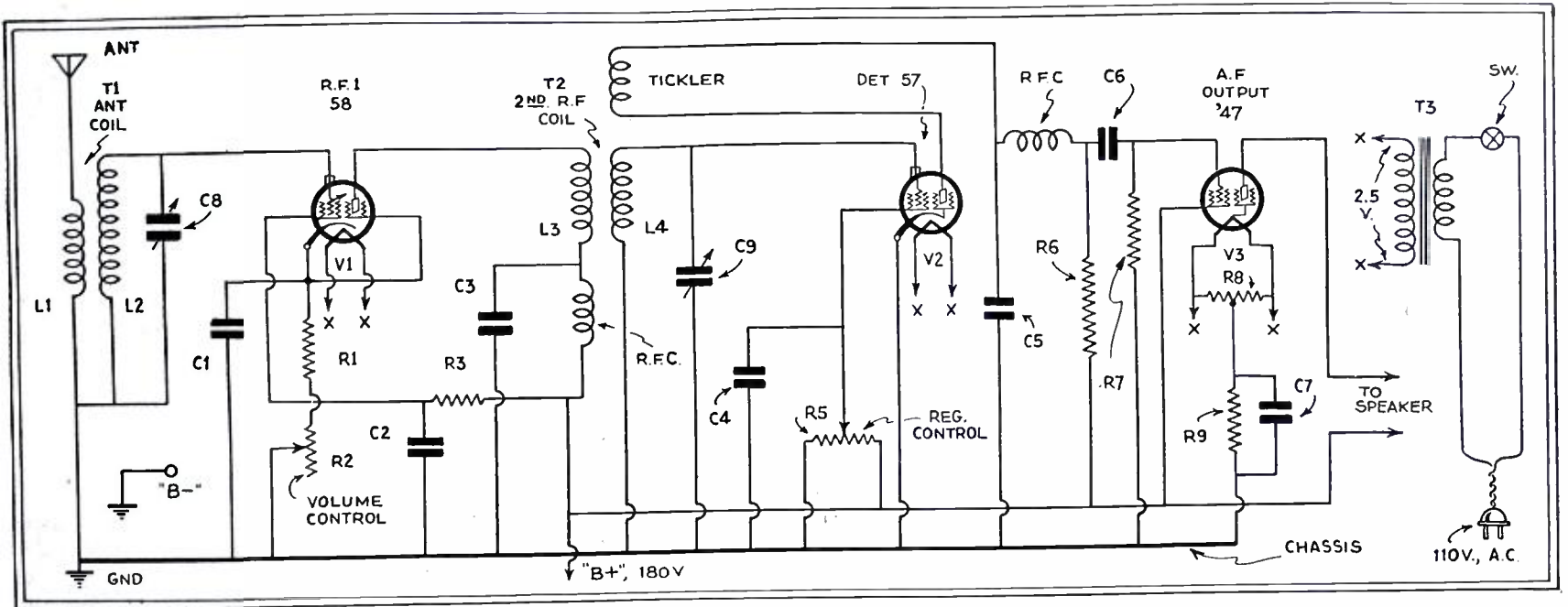

Simple layout of parts used in building the Martin receiver. R4 is in series with and just ahead of the arm (arrow head) on R5.

one-tenth of a division may be accurately determined.

Technical Considerations

The diagram of the completed receiver is shown in Fig. 3. The high efficiency of the receiver is secured, aside from the use of efficient tubes, by the judicious use of filters in the plate and screen-grid circuits. In constructing this receiver, the builder should adhere rigidly to the values of parts given at the end of this article.

The first R.F. tube contains the volume control in the cathode circuit (R2). The resistor R1 is used to secure a minimum bias and the condenser C1 is a by-pass condenser. The screen-grid lead contains a resistor-capacitor filter R3, C2; the plate circuit also has a filter circuit consisting of C3 and an R.F. choke. A resistor-capacitor filter C5 and R.F.C. in the detector plate is very important. The screen-grid lead in this tube also has a resistor-capacitor filter C4, R4, and connects to the regeneration control R5. R4 is in series with shield grid and R5.

An interesting feature of this regeneration control is the fact that as regeneration is advanced or retarded, the tuning of the receiver *does not change an appreciable extent*. This is one of the most important factors that must be considered in the design of a good short-wave receiver. The author has spent considerable time in the design of different systems that would minimize the detuning effect caused by regeneration, and has reached the conclusion that the system as used in this receiver results in the least amount of detuning and at the same time holding the efficiency of the system at a maximum.

The Coils

The coils used are of standard construction and require but little comment. L1 is the antenna coil, and the data are given below for the various bands used. The second R.F. coil, T2, is standard only insofar as the secondary and tickler turns are concerned; the primary turns vary as the type of tubes used varies. All of the coils are wound on bakelite

or isolantite tubing, 1½ inches in diameter.

For the 16 to 31 meter band: Coil L1 has 3 turns jumble wound over the filament end of the secondary, the latter consisting of 6½ turns of No. 18 enameled wire, space wound to cover a length of 1½ inches. The second R.F. coil contains 6½ turns of No. 18 enameled wire on the secondary, space wound to cover a length of 1½ inches. Interleaved between the secondary turns are the primary turns which consist, also, of 6½ turns of No. 30 D.S.C. wire. The tickler coil is jumbled at one end of the secondary, having for the 16 to 31 meter band 3 turns of No. 30 D.S.C. wire. Diagrams of the antenna and R.F. coils are given in Fig. 4.

For the 31 to 55 meter band: The primary of T1 consists of 7 turns of No. 30 D.S.C. wire, and the secondary, 11¾ turns of No. 18 enameled wire wound as shown in the sketches of Fig. 4. It might be pointed out that the spacing for the coils given in the sketch of Fig. 4

are valid for all the coils in any of the bands. The tickler consists of 6 turns of No. 30 D.S.C. wire, and the primary 11¾ turns of No. 30 D.S.C. wire interleaved with the secondary as indicated in Fig. 4.

For the 55 to 104 meter band: The primary of T1 consists of 13 turns of No. 30 D.S.C. wire; the secondary, 25½ turns of No. 18 enameled wire. For the second R.F. coil the primary consists of 25½ turns of No. 30 D.S.C. wire interleaved with the secondary of a like number of turns of No. 18 enameled wire. The tickler consists of about 9 turns of No. 30 wire, wound as explained above.

List of Parts

- 1 Set of antenna coils as described.
- 1 Filament transformer, 2½ inches high, with a 2.5-volt secondary, T3.
- 1 5,000-ohm volume control, R2.
- 1 Frost 100,000-ohm potentiometer, R5.
- 2 Acra-test 600-ohm resistors, 1-watt, R1, R9.
- 1 I. R. C. .1-meg. resistors, 1-watt, R3, R4, R6.
- 1 I. R. C. .5-meg. resistor, 1-watt, R7.

(Continued on page 317)

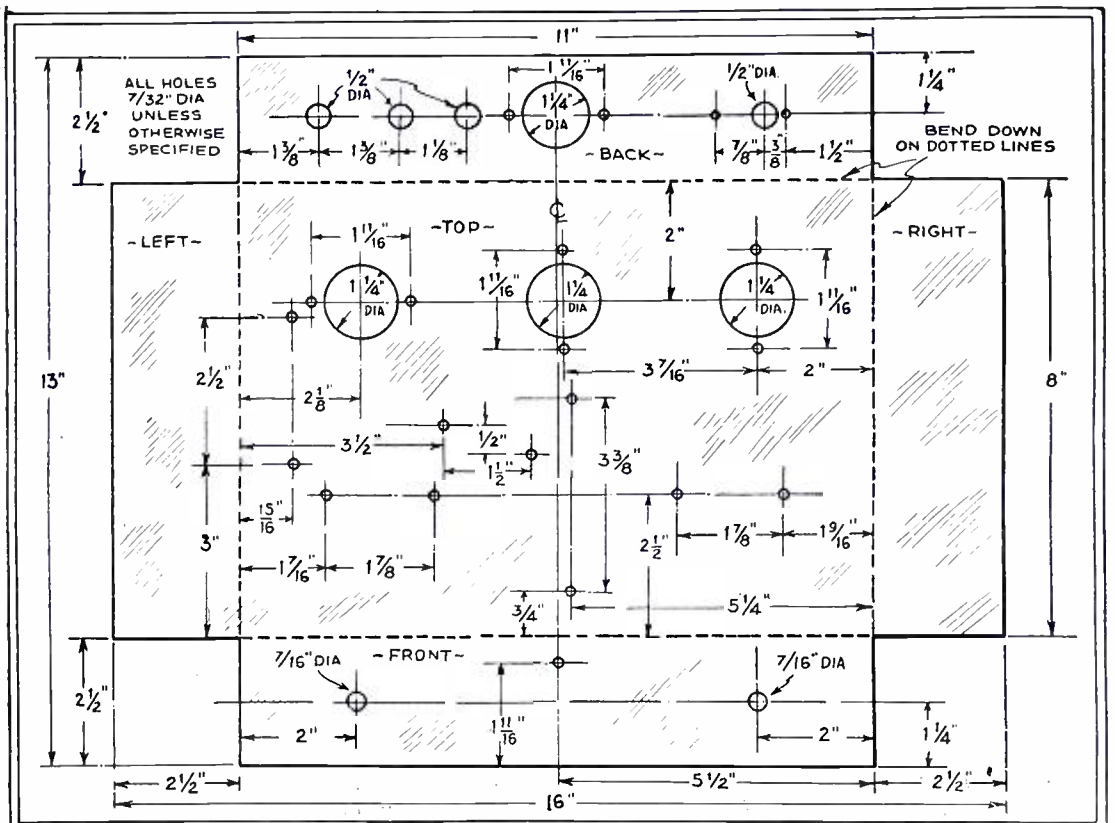

The dimensions for laying out and drilling the aluminum subpanel for the 3-tube receiver are given above.

New Ultra

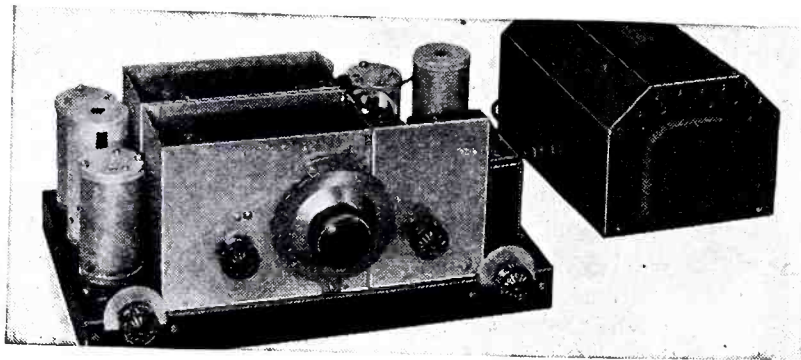

Front view of new 4 to 7½ meter ultra-short-wave receiver.

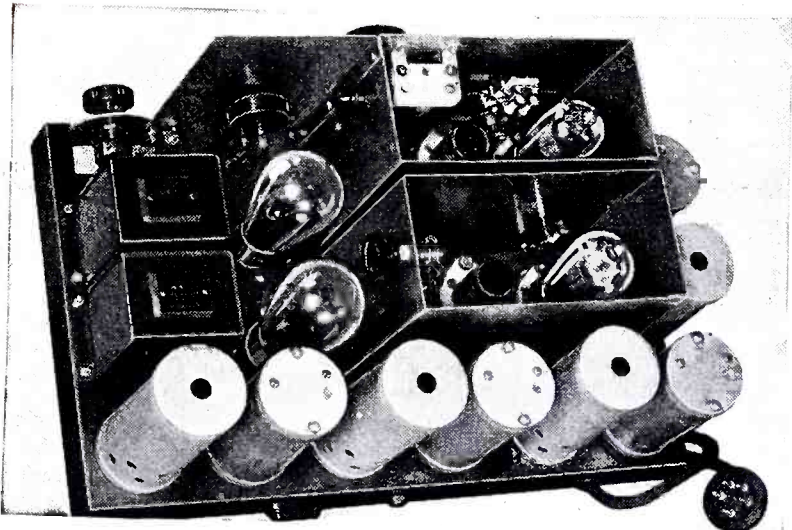

Rear view of receiver having a range of 75 to 40 megacycles.

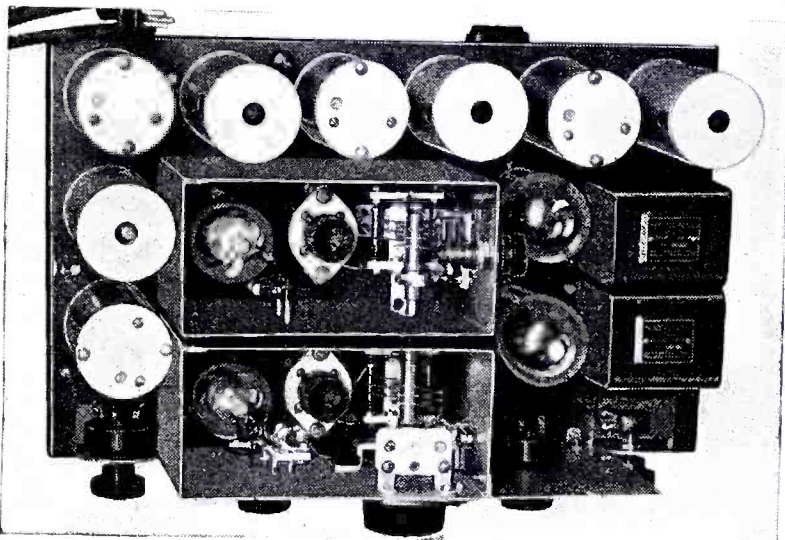

Top view of the U.S.W. receiver, showing tuning condensers.

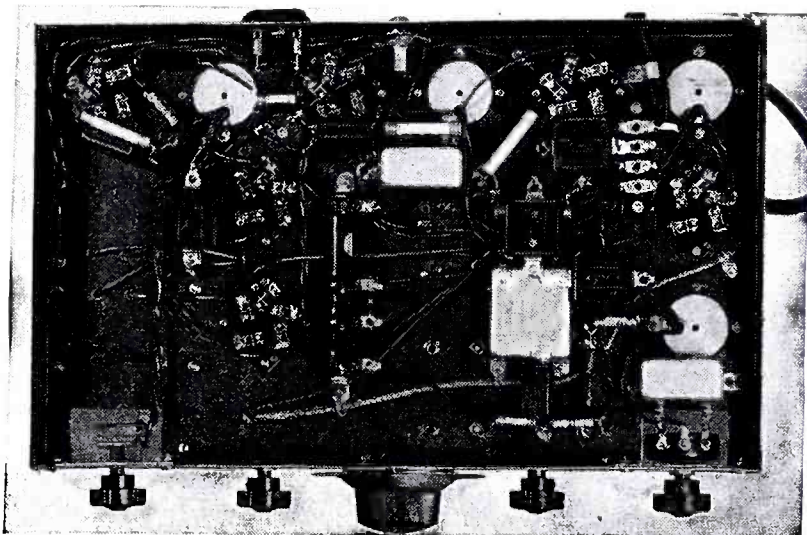

Bottom view of the new 4 to 7½ meter receiver.

● AS a result of the rapid developments in the field "Below Ten Meters," it was felt that there was a real need for a carefully engineered and commercially available ultra-short-wave receiver. As a result, the new National Type HFR, covering the frequency range of from 75 to 40 megacycles (4 to 7½ meters), has just made its appearance on the market.

Among the outstanding features is the use of "electron coupling" between all of the different ultra-high-frequency circuits. By means of this type of coupling, it is possible to secure stable operation with high signal-to-noise ratio over the enormously wide frequency band being covered.

In addition, the inductances, variable condensers, tube sockets and all other components employed in the ultra-high-frequency parts of the circuit are especially designed for this particular service. Some of these new component parts are here illustrated.

Nine tubes are employed in the following manner:

Two type '24—First detector and high frequency oscillator.

Two type 35—First and second I.F. amplifier.

Two type 27—Second detector and I.F. beat oscillator.

Two type 47—Push-pull output amplifier.

One type 80 Power pack.

Type '35 tubes may be substituted for the two '24s if desired. A certain amount of care must be exercised in the selection of tubes or trouble will be experienced from microphonics or noise resulting from leakage between heater and cathode. This latter trouble appears as a loud grating or scratchy hum. As a general rule, tubes of recognized quality having standard characteristics will prove entirely satisfactory. No special matching is required, since ample provision for balancing tube capacities, etc., is incorporated in the various circuits. Trouble from poor tubes becomes increasingly noticeable as the high frequency limit of the receiver is approached. In fact, some tubes that are quite satisfactory between 5 and 6 meters, for instance, may give poor performance at 4 meters. These remarks apply particularly to the first detector and high frequency oscillator circuits.

Antenna

The antenna requirements are not in any way critical, although as a general rule a single wire as high as possible will give best results. The directional effects of various types of antenna are often very pronounced at high frequencies, so that the use of a vertical antenna located well away from any surrounding objects is usually preferable. The length may be between 5 and 50 feet over-all. A longer wire is not recommended, as it tends to increase the noise-to-signal ratio.

Power Supply

The power supply designed for use with this receiver is the National type 3258 AB. This unit will supply correct voltages for all heater, plate and bias circuits. Since this power supply unit is of special design, having R.F. filters for removal of line noises, as well as provision for biasing the pentodes, and a separate filter section for the high frequency circuits, the receiver will not operate satisfactorily when any other type of unit is employed.

Loud Speaker

Any loud speaker of good quality having an input impedance between 2,000 and 10,000 ohms will give good results, the choice depending largely upon the individual preference of the operator. Probably the most satisfactory type from the standpoint of convenience and best all-around performance is the permanent magnet dynamic speaker. If the conventional type of dynamic reproducer is employed, suitable provision must be made for the field excitation, since this power cannot be obtained from the set or power supply. The dynamic speakers must also employ a coupling transformer as supplied by the manufacturer, having an input impedance within the range specified above.

Installation

Installation of this receiver is extremely simple, since it is only necessary to connect the antenna, ground, power supply unit and loud speaker. If trouble is experienced from microphonic tubes, it is advisable to place the loud speaker a few feet from the receiver so that acoustical feed-back will not be bothersome. If headphones are used, the output tubes should not be removed from their sockets. The 3258 power unit should not be turned on unless all the tubes are in the set and the set

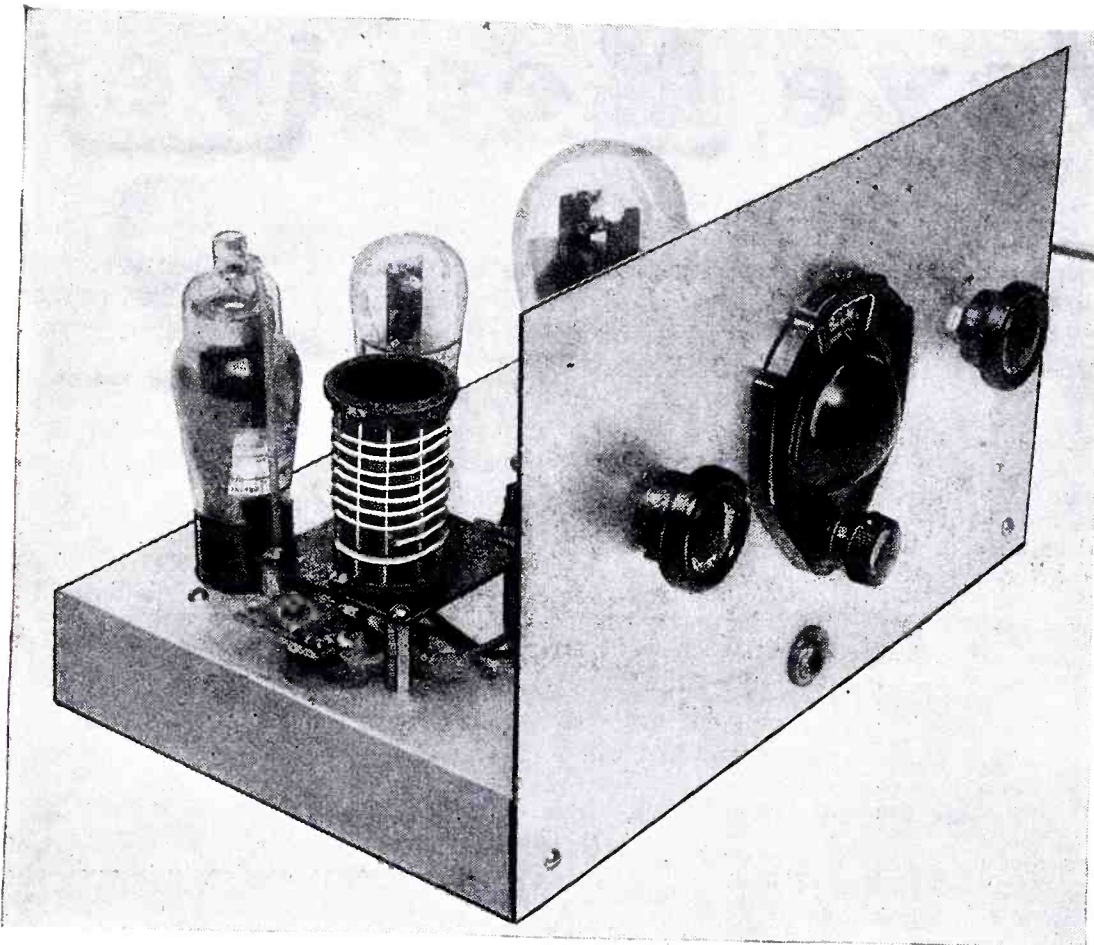

Our front cover illustrates Mr. Denton's latest creation—his 2-tube all-wave receiver for use with phones or as a "tuning unit" for a power amplifier. One of the main features of this receiver is that it employs two of the latest tubes, the '56 and the '57. Regeneration is employed to provide maximum results.

Note the handsome appearance as well as the extreme simplicity of Mr. Denton's latest "brain-child"—the 2-tube all-wave receiver—which employs two of the newest tubes introduced to the short-wave fraternity, viz., the '56 and the '57. It's just the receiver you have been looking for.

The DENTON 2-Tube ALL-WAVE Receiver

• THE average short-wave enthusiast is constantly building new sets, always hoping that the new one will be superior to the old one. Sadly enough, new sets cost money and most of us have little money to devote to radio sets at this time.

Many years ago the step-by-step or add-a-unit type of radio receiver was introduced and for a while this stunt worked out well. The idea was this: if

you had money enough to buy parts for the radio-frequency end of a receiver, you bought it. When you had more money you bought the audio amplifier parts, and so on. Now, with conditions as they are today, let's go back and try that stunt again.

The short-wave set can be considered in two distinct sections: the radio frequency and the audio frequency, with their associated power supply equipment.

The first set to be described is a simple two-tube job incorporating two new tubes, namely the '56 and the '57. The circuit is simple and the cost low, even though the power supply is *built in*.

The circuit is a modification of the now-famous "Standby," which is enjoying such widespread builder interest.

Many folks interested in building short-wave receivers have *audio amplifiers* which they would like to use with

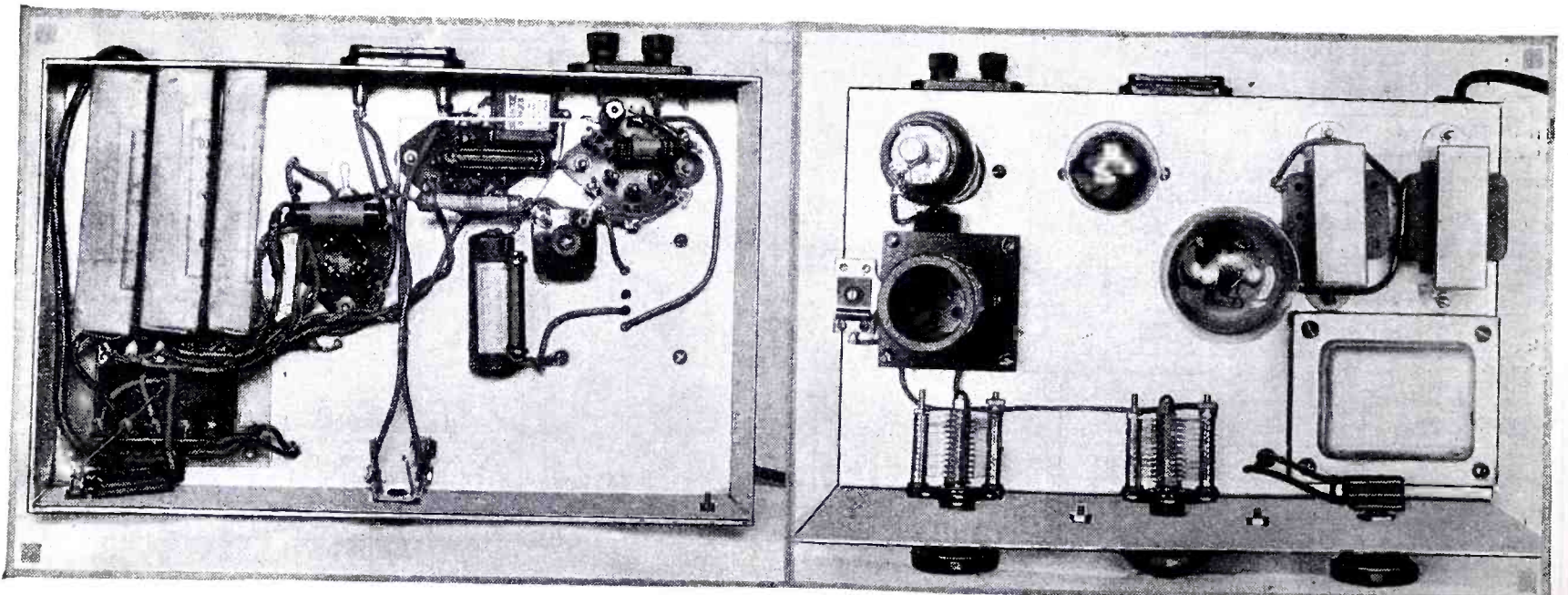

Bottom view showing simple wiring of the 2-Tube All-Wave Receiver.

Simplicity and neatness distinguish this newest of Mr. Denton's receivers.

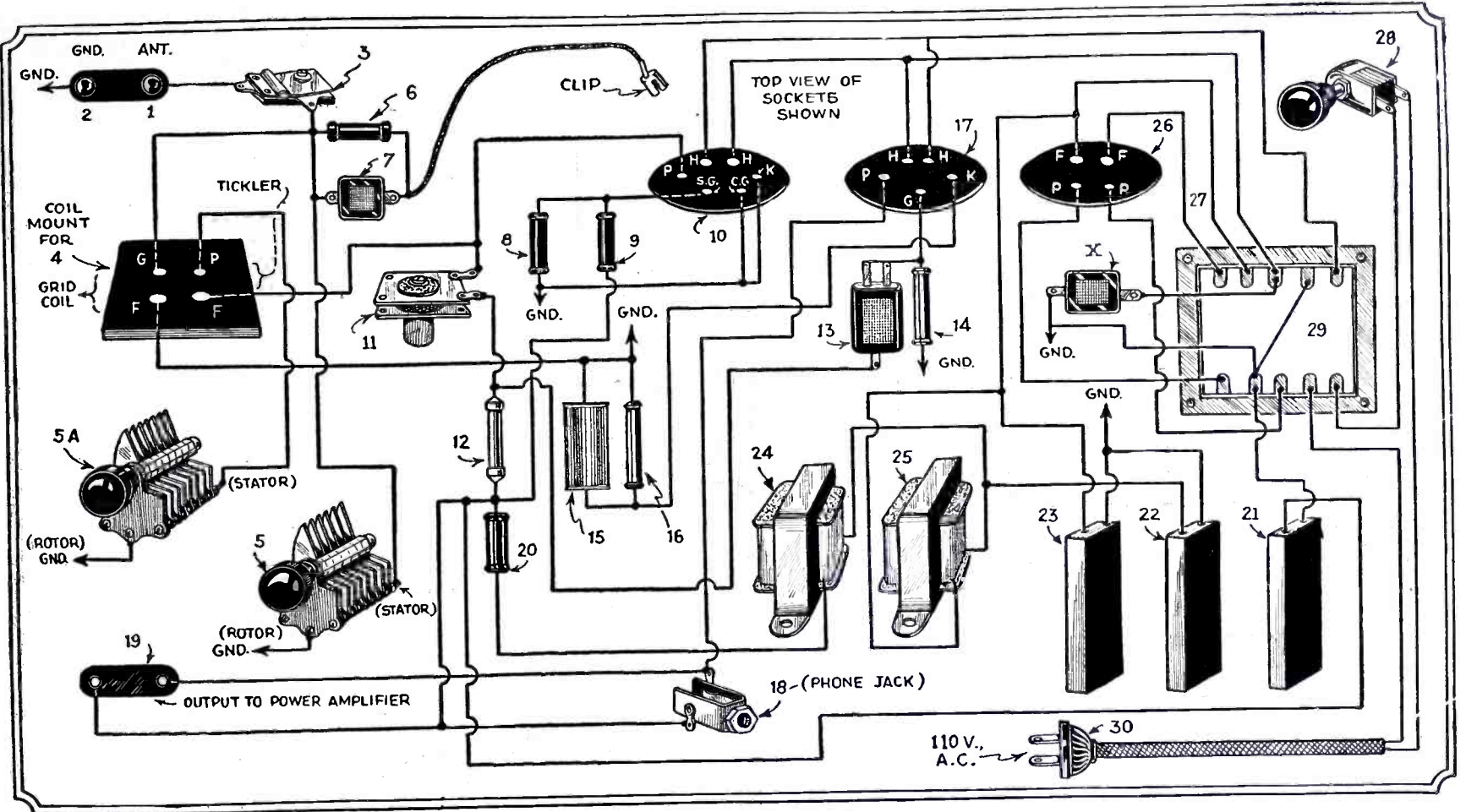

Physical wiring diagram for the Denton 2-Tube All-Wave Receiver—this diagram should prove far clearer to the lay reader than any blue-print.

a radio tuner. To those with good audio amplifiers this R.F. section offers a neat and sure-fire design.

RCA-56 TUBE

- For Use as a Detector, Amplifier or Oscillator
- Heater Voltage2.5 volts
- Heater Current1.0 ampere
- Control Grid-Plate Capacity3.2 micromicrofarads
- Control Grid-Cathode Capacity3.2 micromicrofarads
- Plate-Cathode Capacity 2.2 micromicrofarads
- BulbS-12
- BaseSmall 5 pin

For Use as Class "A" Amplifier

- Plate Voltage250 volts
- Control Grid Voltage.....-13.5 volts
- Plate Current5.0 milliamperes
- Plate Resistance9,500 ohms
- Amplification Factor13.8
- Mutual Conductance1,450 micro-mhos

RCA-57 TUBE

- Heater Voltage2.5 volts
- Heater Current1.0 ampere
- Control Grid-Plate Capacity 0.01 micromicrofarad
- Input Capacity5.2 micromicrofarads
- Output Capacity6.8 micromicrofarads
- BulbST-12 with small metal cap
- Base*610—6 prongs

For Use as a Class "A" Amplifier

- Plate Voltage250 volts
- Screen Grid Voltage.....100 volts
- Control Grid Voltage.....-3 volts
- Plate Current2.0 milliamperes
- Screen Grid Current.....1.0 milliamperes
- Amplification FactorGreater than 1,500
- Plate ResistanceGreater than 1,500,000 ohms
- Mutual Conductance1,225 micro-mhos
- Plate Current Cut-off at Eg-7 volts

The Screen Grid, Plate, 2 Heater leads, Cathode and Suppressor Grid leads are connected to the 6 prongs in anti-clockwise sequence when looking at bottom of base. The Control Grid is connected to the metal cap on bulb.

These tubes are not interchangeable with older models and should be used only in circuits designed for their use. The writer sees several indications of

the further use of tuned radio frequency amplifiers in short-wave receivers. This was anticipated by the design of the T.R.F. short-wave receiver which was described in SHORT WAVE CRAFT for April, 1932.

The circuit of this simple receiver uses two tubes, the first being a 57 used as a grid-leak detector with regeneration. The output is resistance-capacity coupled.

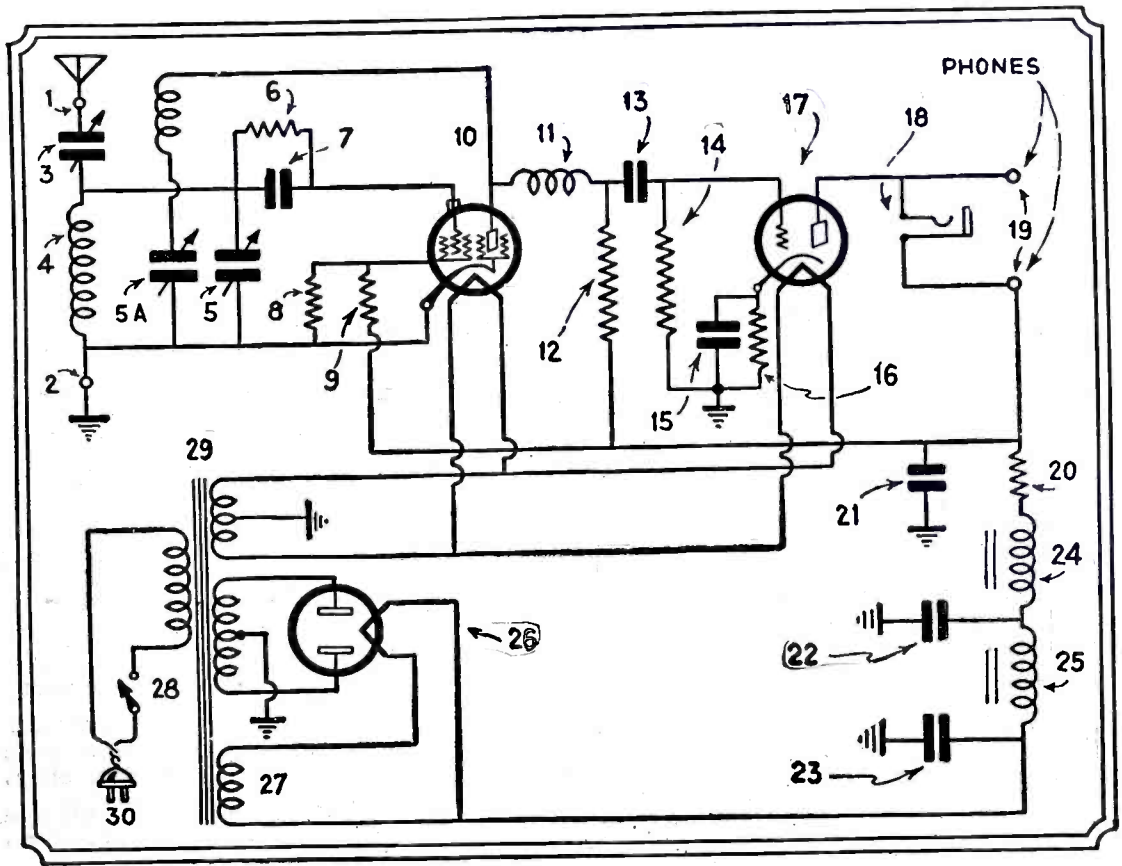

Schematic wiring diagram of Mr. Denton's short-wave receiver—the 2-Tube All-Wave model.

* No. 610 base has all 6 prongs equally spaced 60 degrees apart with 2 "Heater" prongs 0.156 inch diam., and all others 0.125 inch diam.

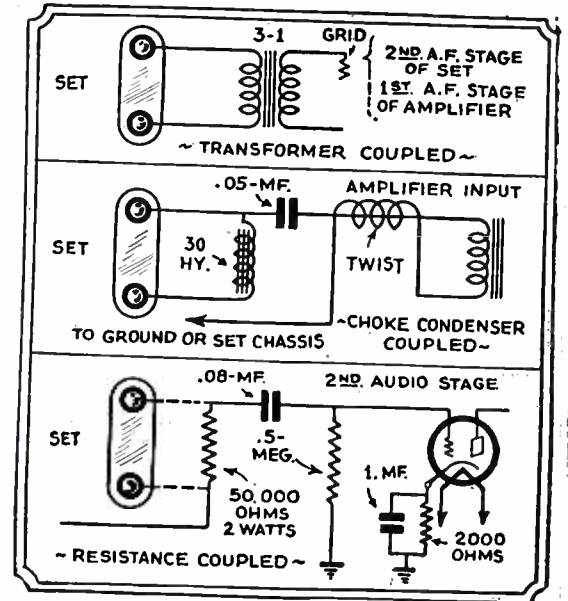
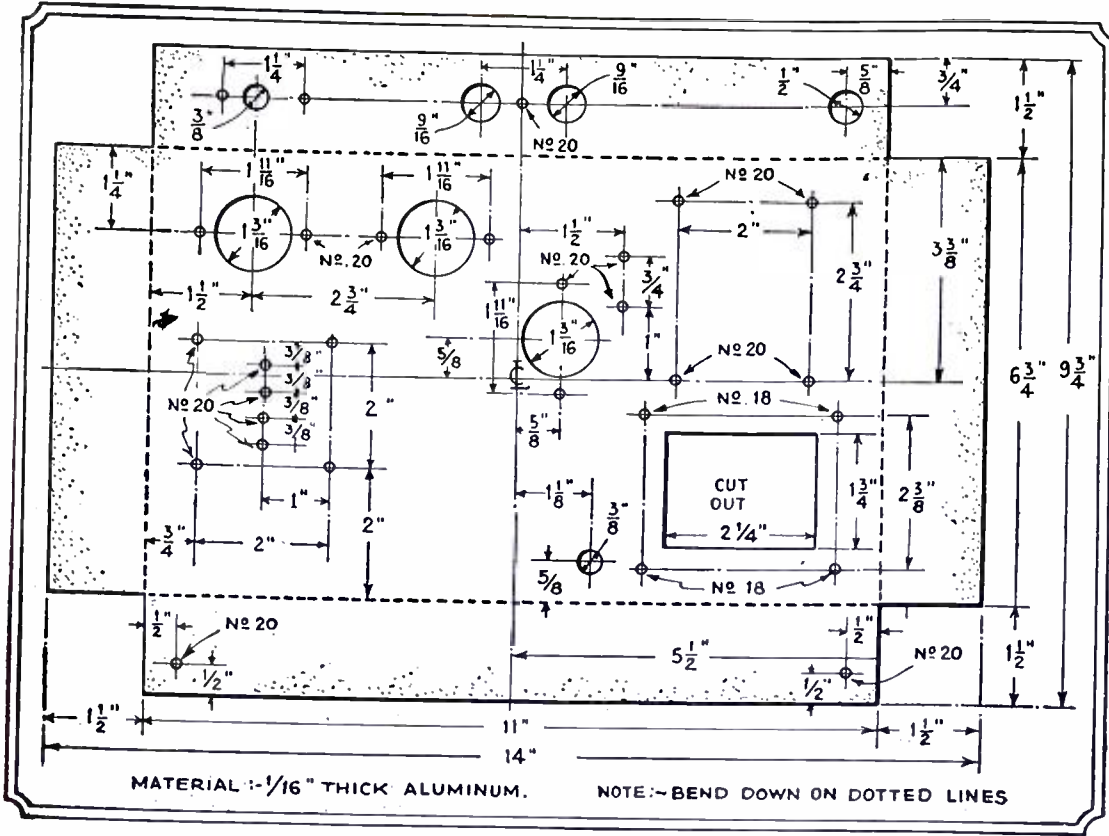

Above—Several different forms of "out-put" circuits for the all-wave 2-tube receiver, including transformer coupling, choke condenser coupling and resistance coupling.

Left—Showing the dimensions for laying out aluminum subpanel for the Denton 2-Tube All-Wave Receiver.

The output circuit can be arranged in many ways to suit the circumstances under which the set is to be used. Several circuits are shown in the sketches covering the output connection possibilities of the receiver.

The reason for the choice of the 56 type tube, with its comparatively low output impedance, was a simple one. It is easy to match a low impedance tube, as suitable transformers are at hand or can be had readily. While it would be possible to obtain more amplification from a screen grid or pentode tube, it is almost impossible to find suitable audio transformers to use with them.

The power supply unit consists of the conventional power transformer with windings for the filaments of the 56 and 57 tubes. The particular transformer used in the model had a single winding for both the 56 and 57 tubes.

Two small 30-henry chokes with 20 mf. of filter condenser complete the power supply circuit. The small .005 mf mica condenser is connected from the ground to one side of the 2 1/2-volt secondary winding heating the 56 and 57 tubes. This condenser tends to prevent resonance in the secondary winding of the transformer at very short wavelengths.

This resonating effect results in *tunable hums* at various portions of the tuning dial, which are hardly pleasant to the ear.

Construction

The chassis can be obtained drilled and folded to size, or the builder can lay out and drill the holes from the mechanical drawings shown.

Mount the tuning condenser on the front panel, in the center. The tuning dial can be mounted on the condenser at this time. The power switch may be mounted on the panel to the left of the tuning unit and the regeneration condenser placed to the left as shown in the photographs.

The units on the chassis should be placed in position before the front panel is fastened into place.

Mount the three sockets, two chokes, power transformer and coil mounting assembly on the top of the chassis. The rest of the small parts are mounted on the under part of the chassis.

Note that the antenna coupling condenser is mounted on the coil mounting assembly. The grid condenser and the grid leak is mounted under the coil socket for convenience. This makes short leads for the control grid connections.

The antenna and ground posts are mounted on the rear of the chassis. A small rubber bushing should be used where the power supply cable runs into the chassis.

The choke in the plate circuit of the detector tube is fastened into place by a 6-32 bolt through one of the mounting studs of the coil assembly under the chassis. The .005 mf. mica condenser is fastened into place when the front panel is put on. All the other resistors and condensers are held in place by the wiring, so do a good soldering job.

How to Wire the Set

The set is simple to wire, but do not make a poor job of the soldering. In many instances the lack of good connections through poorly soldered joints means a poor receiver.

Wire four leads to the four terminals on the coil socket, making them about 6 inches long. Wire the grid condenser and leak into the grid circuit by twisting the wire leads of the condenser and the resistor together and soldering one of the resulting wires to the grid terminal of the coil socket. The other end of this unit has a 4-inch piece of flexible wire (Continued on page 318)

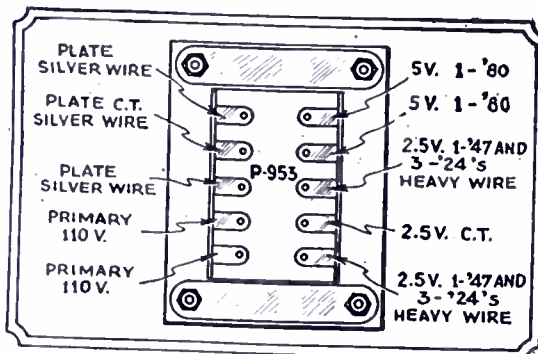
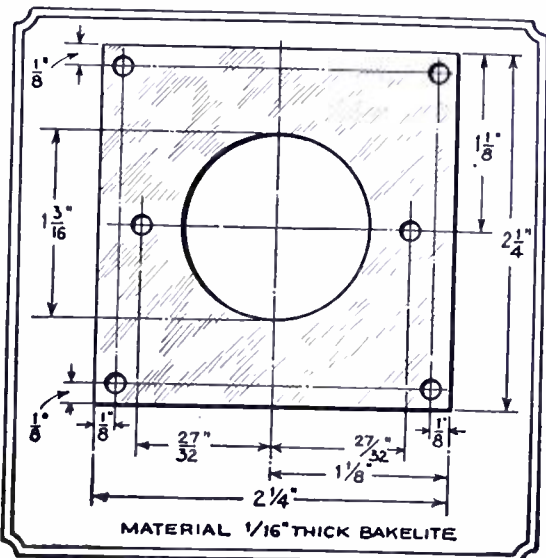

Above—Power transformer connections used in building the All-Wave Receiver.

Left—Bakelite support base for plug-in inductances used with the 2-tube receiver.

Right—Output hook-ups for long lines between set and amplifier and also Loftin-White set-up.

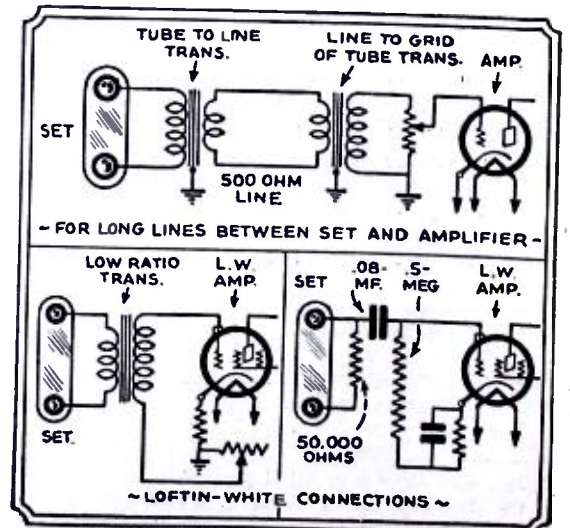

Good Antenna Design

By ARTHUR H. LYNCH

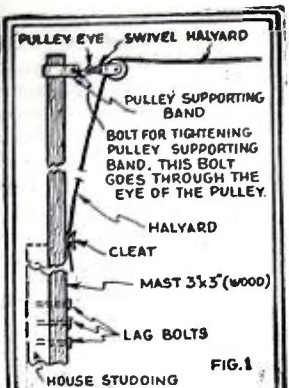

Fig. 1—Type of mast used by the author for ten years. 3"x3" wood, painted every three years with gray marine paint as a protection against the weather. Mast can be held against the house by lag screws into studs or ordinary bolts may be used. Mast can be 15 to 20 ft. high.

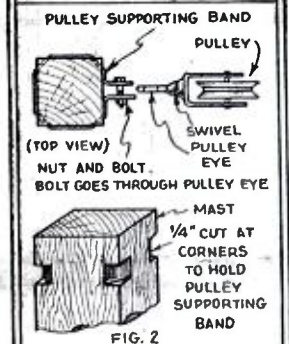

Fig. 2—Enlarged view of the section shown at Fig. 1, showing corners of mast cut to hold pulley wire or rope. Commercial type hooks are available in the chain stores very cheaply; see figures below. Iron parts are best painted to give weather protection. A piece of galvanized iron wire may be used to hold the pulley instead of a ground clamp.

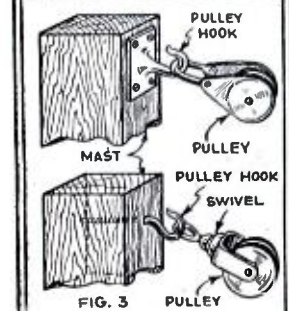

Fig. 3—Top view of the mast pulley-hook and assembly. A good pulley supporting band can be made from a regular ground clamp. Slip the pulley eye over the bolt used to hold it before the bolt is put through the band itself. It is usually best to mount the pulley and halyard on the pole before erecting it.

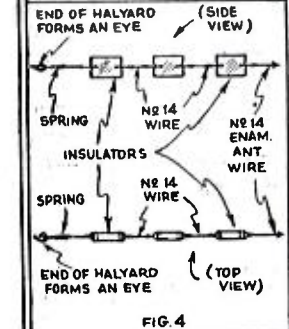

Fig. 4—Two views of the "free end" of antenna system. The insulators are especially thin, for short-wave requirements. No. 14 copper wire ties the insulators together. The wire is coiled on itself and soldered. Tie wires should not be longer than 6". A tie wire links the antenna to an "eye" in the rope halyard.

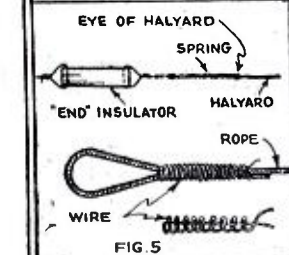

Fig. 5—Assembly at the extreme end of the antenna. We see the last of the three insulators, the tie wire connecting it to the spring and the tie wire joining the spring with the eye of the halyard.

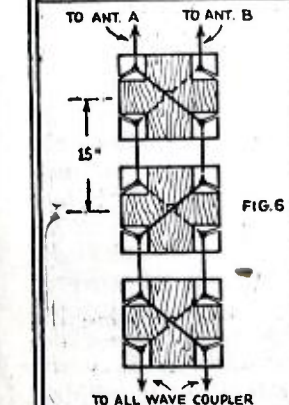

Fig. 6—Note carefully how transposed antenna leads are run to the receiver; leads pass through transposition blocks as shown to prevent twisting. "A" enters the block at the upper rear, while "B" enters the block from the upper front side. The lead-in should be kept rather taut.

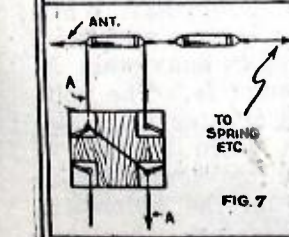

Fig. 7—Simple single wire antenna with transposed lead-in taken from one end. "A" passes through the TRP block and joins directly to the flat-top. "B" ends at the lower TRP block and "B" then goes to the receiver.

SOMEONE has said that a good antenna is as good as a stage of radio frequency amplification. I do not remember who made the remark, but I do know that it was intended to refer to broadcast reception. It is even more apropos of short waves and it is still more desirable where television reception is desired. It is to be regretted that most manufacturers and practically all experimenters have not given this important subject the attention it deserves. Perhaps, to paraphrase the older quotation, we might say that a good antenna is the best and cheapest form of amplification.

In general, a good antenna for broadcast reception may not prove very satisfactory for either short waves or television. On the other hand, an antenna which is suitable for short wave reception is also suitable for broadcast reception. We will, therefore, consider the entire proposition from the short wave point of view.

Regardless of the particular type of antenna we are to construct—and there are a great many varieties, all of which have some desirable characteristics, many of them having been described in SHORT WAVE CRAFT, for August—it should be remembered that it will give the best results if it is as high and as long and as free from surrounding objects as possible.

Another important consideration of the antenna system, is that it should be as thoroughly insulated as possible. The insulators chosen for this important part of the receiving system should be as free from high-frequency losses as possible and should be designed to avoid the accumulation of moisture. It is sometimes thought that glazing of insulators accomplishes this purpose. This is true, to an extent, but it is equally true that very satisfactory insulating materials have their resistivity reduced in direct proportion to the amount of glazing applied to them. It should also be remembered that, though some special glass makes highly desirable insulating material, it is not cheap. When glass insulators may be had for a few cents, it may generally be assumed that they are made of a quality of glass which is not desirable for short wave use. Some cheap glass contains lead and it may be realized that its resistivity is not very high. Insulators made of cheap glass and porcelain will work fairly well on the broadcast wavelengths, but they are not suitable for use where the best results are desired on the short waves.

Considering, therefore, that we have determined upon the type of antenna which we are to use and that we have found a suitable place to install it as high and as free from all surrounding

* President, Lynch Manufacturing Co
(Continued on page 309)

Fig. 8—Shows the "cage" type of antenna. It has great "pick-up" range without being directional. Total length about 75 ft., using several insulator spreaders as shown. Weights keep the antenna from swaying and twisting. Several weights may be placed along the cage.

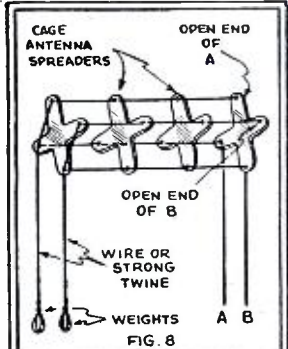

Fig. 9—Method of connecting extreme "cage" spreader to the regular aerial insulating system. Note that two tie wires are run in the form of a bridle, from the grooves on the spreader to the first antenna insulator. The distance from the center of the terminal cage-antenna spreader to the first antenna insulator should not be more than 9" or less than 6".

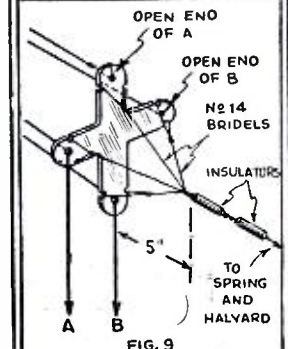

Fig. 10—Absorption is prevented by keeping the transposed lead-in well away from the building. Two insulators are secured to the end of a 1 1/2" x 1 1/2" pine stick 3 to 4 ft. long, supported by a shelf-bracket. Tie wires will hold the lead-in wires in the grooves.

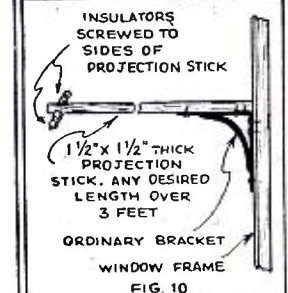

Fig. 11—Typical arrangement of dipole antenna with transposed "noise-eliminating" lead-in. It is almost useless to employ one of the newest "anti-static" shielded receivers, unless you also use one of these new transposed lead-in arrangements. The parts required are of nominal cost and the construction is simple.

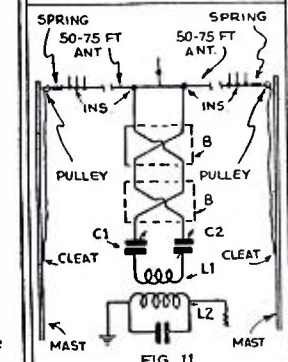

Fig. 12—The Lynch "All Wave" Automatic Antenna Coupler, which couples any of the new antenna systems with transposed lead-ins, to any receiver. Variations in wavelength are compensated for by changing the position of the Lynch coupler inside the first RF coil of the receiving set.

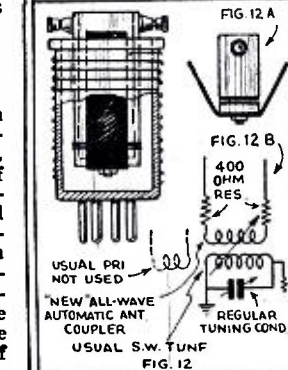

Fig. 13—This picture shows how the author mounted an aerial mast on his house, the mast being well painted and lag-screwed to the stud or bolts may be used.

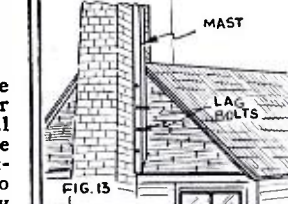

Fig. 14—A very good design for a lead-in board, which may be made in two halves, is here shown. The lightning arrester can be bought or made. Two holes may be drilled through the window glass if desired.

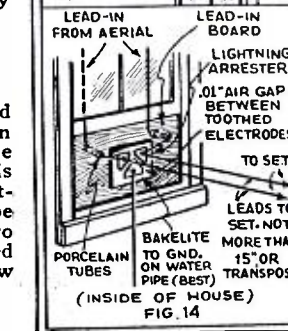

Photo at right—the newest Midwest 16-tube “short” and “long” wave receiver. The dial is lighted by different colored bulbs for each band, to aid in tuning. All parts of the set are very thoroughly shielded to prevent pick-up of external currents.

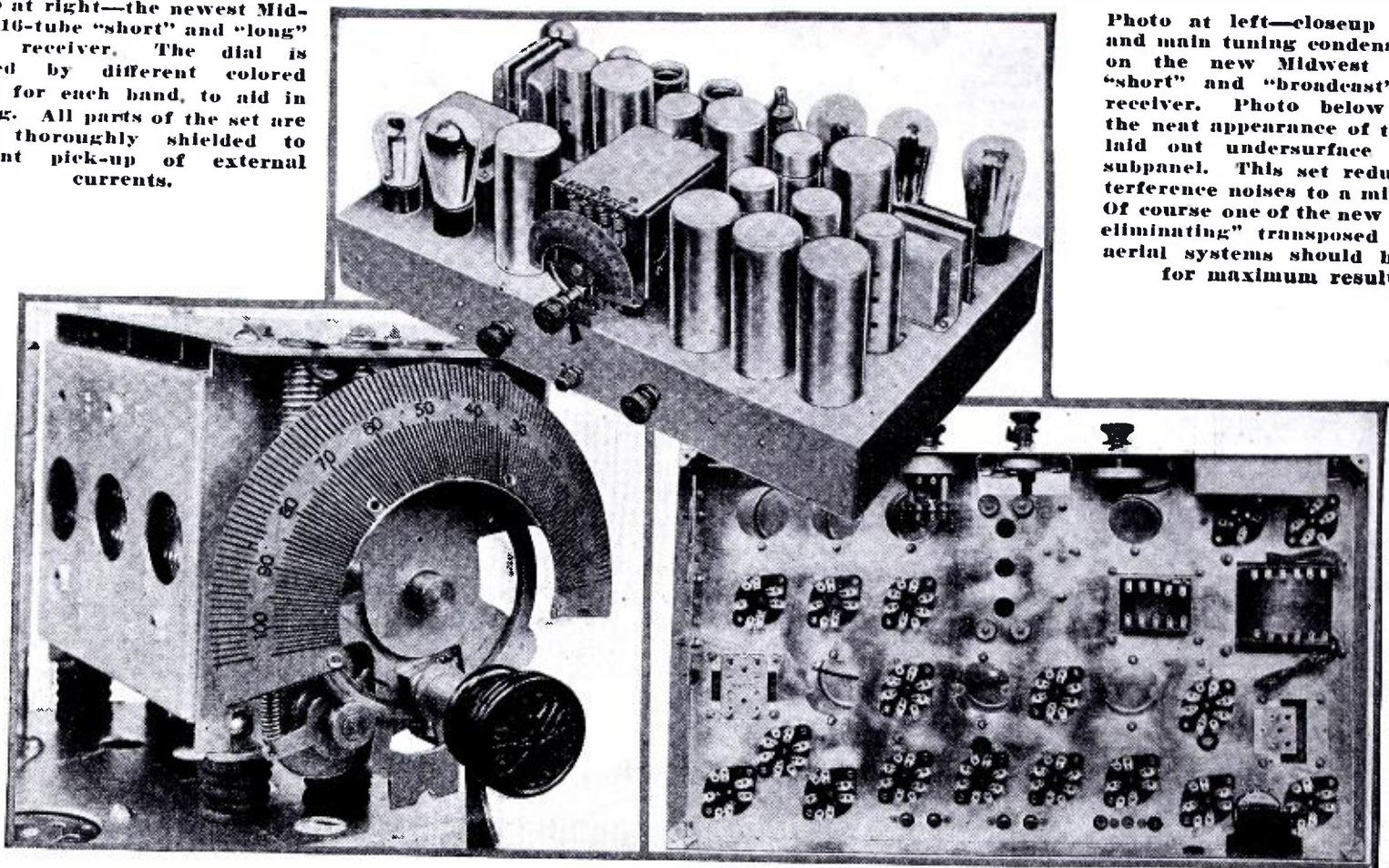

Photo at left—closeup of dial and main tuning condenser unit on the new Midwest 16-tube “short” and “broadcast” wave receiver. Photo below shows the neat appearance of the well laid out undersurface of the subpanel. This set reduces interference noises to a minimum. Of course one of the new “noise-eliminating” transposed lead-in aerial systems should be used for maximum results.

Static Omission in New Receivers

By W. A. SMITH*

● HAVE you ever noticed in tuning a radio set that static is most noticeable between stations and that when you tune in a good strong signal, the static disappears entirely and fades out on any signal even if it is weak? Wouldn't it be nice if we could go from station to station without having any static between stations? Wouldn't it be even better if one could omit all of those signals which are chopped up with static and bring in only those signals which are strong enough to over-ride and blanket out the static, leaving only enjoyable music? This is exactly what is being done this year.

The energy in a radio wave, being continuous, actually contains more energy than the intermittent bursts of static. This fact is the basis of the modern radio that omits static between stations.

The energy in the radio wave is amplified through the radio frequency end of the set and impressed upon the detector. At the time that it is stripped of its audio frequency component, the radio frequency component is rectified and used to provide an automatic volume control bias voltage. This voltage is applied to the radio frequency amplifier so as to maintain a constant volume. This same voltage is utilized in operating a relay to silence the set between stations by controlling the audio amplifier in the radio set in such a way that the audio

amplifier is blocked or killed except when a signal is tuned in.

A mechanical relay might be operated in the plate circuit of a tube controlled by this automatic volume control bias voltage by causing it to short circuit some portion of the audio frequency amplifier, but such a relay would necessarily be delicate and subject to mechanical troubles such as bad contact, chattering and sluggish action during cold weather, and would also cost much more than the scheme finally adopted.

In general, the outline of the scheme is such that this automatic volume control bias voltage is amplified and applied to the grid return of one of the audio tubes in such a way as to completely block passage of any current. Further, the action is such that the effect is accumulative; that is, the energizing voltage applied to the amplifier tube is aided by the effect it causes. This insures that the action, once started, will carry through to completion without any possibility of lag or motorboating. The effect is one of complete and instantaneous cutoff.

The simplified circuit is shown in Fig. 1. The automatic volume control bias voltage is represented by a battery and potentiometer between ground and grid of the statomit. When this voltage is zero and no signal is coming in, the grid is at such a voltage as to permit con-

siderable current to flow from the plate of this tube through Rx, producing a voltage across Rx. This voltage is applied to the grid of the first audio tube and is sufficient to completely block this tube so that no static can come through.

If a signal is tuned in and a negative voltage generated by the rectifier, this negative voltage is applied to the grid “Statomit” tube, completely blocking it, and the voltage across Rx falls to zero unblocking the audio tube and permitting it to amplify and pass the signal through to the loud speaker.

This action is accumulative and self-locking in such a way that when once started it carries itself through. This is accomplished in the following manner:

The voltage E_t on the grid of the “Statomit” tube is composed of the drop across R_y , plus the automatic volume-control bias voltage. These voltages are in series and equals about 80 volts. The voltage across R_y is produced by the total current composed of several constant currents plus the variable currents I_s and I_a . When the set is blocked, I_s is at a maximum and I_a is zero; therefore, only I_s is effective in helping to produce the voltage across R_y . When the set is operative I_s is zero and I_a is at a maximum; therefore maximum I_a is greater than maximum I_s . The voltage across R_y will be greater when the set is operative than when the set is blocked. Now the voltage across R_y is aiding the voltage from the automatic volume control tube; therefore, when this

* Chief Engineer, Midwest Radio Corporation.

● IN the new receivers here described the effects of static have been reduced to a minimum, so far as the set itself is concerned, by a very clever design of the automatic control circuit. The sensitivity control of the receiver may be set so that it is absolutely quiet except when stations of predetermined strength are tuned in; the sensitivity may be increased however at the desire of the operator.

automatic volume control bias voltage builds up to the point where it operates to unblocking the audio system, it is locked in this position by this aiding voltage.

This locking section is illustrated in curve shown in Fig. 2. Assume that the automatic volume control bias voltage is zero and the set is operative. Assume the automatic volume control bias to increase until it reaches the point marked L; its effect is to produce a drop in voltage across R_x , permitting passage of a small current to the audio tube, so that I_s is decreasing and I_a is increasing. As soon as I_a increases greater than I_s , the locking action takes place and instantly the curve shifts to point N. This action is controllable by condensers to prevent clicks and surges but without such condensers the action is quite violent. Any further increase in the automatic volume control bias can produce no further effect on I_a because I_s is already zero.

If the automatic volume control bias is decreased because of lower signal volt-

age, it is necessary that it decrease to the point P before any effect is noted on I_a . It is necessary that I_s increase above I_a before the decrease in the voltage across R_y is effective. Instantly that this point is noted, the current in I_a drops to Q zero and the set is completely blocked.

The distance between N and P may be adjusted by means of resistor R_x , R_y and R_z . It is adjusted to the point where fading of signals does not produce blocking of the set unless the fading is sufficient to produce the signal below the static level. This insures that when a signal is once tuned in it will remain until such times as it is useless for entertainment purposes.

The circuit action used is shown in Fig. 3. The tubes selected as shown in this circuit were more positive in their action than the triode shown in Fig. 1. The cutoff points are very definite in the 57 type tube, the screen grid currents further aiding in the action described previously.

(Continued on page 317)

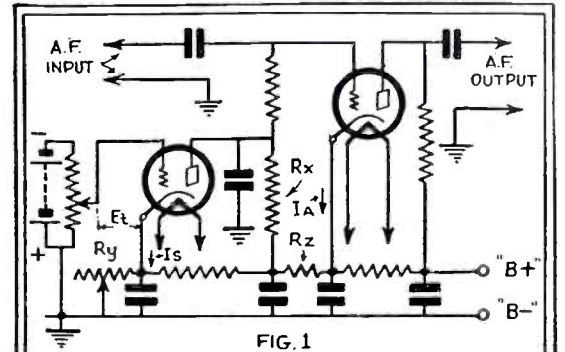

FIG. 1

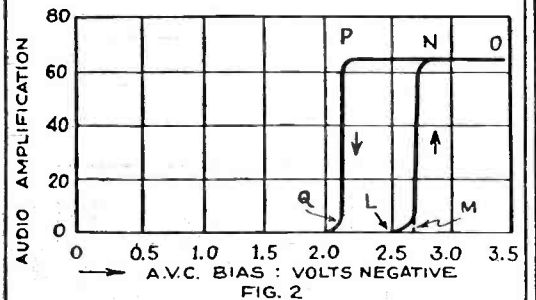

FIG. 2

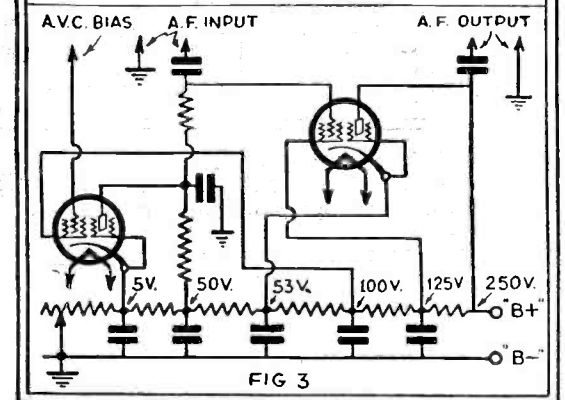
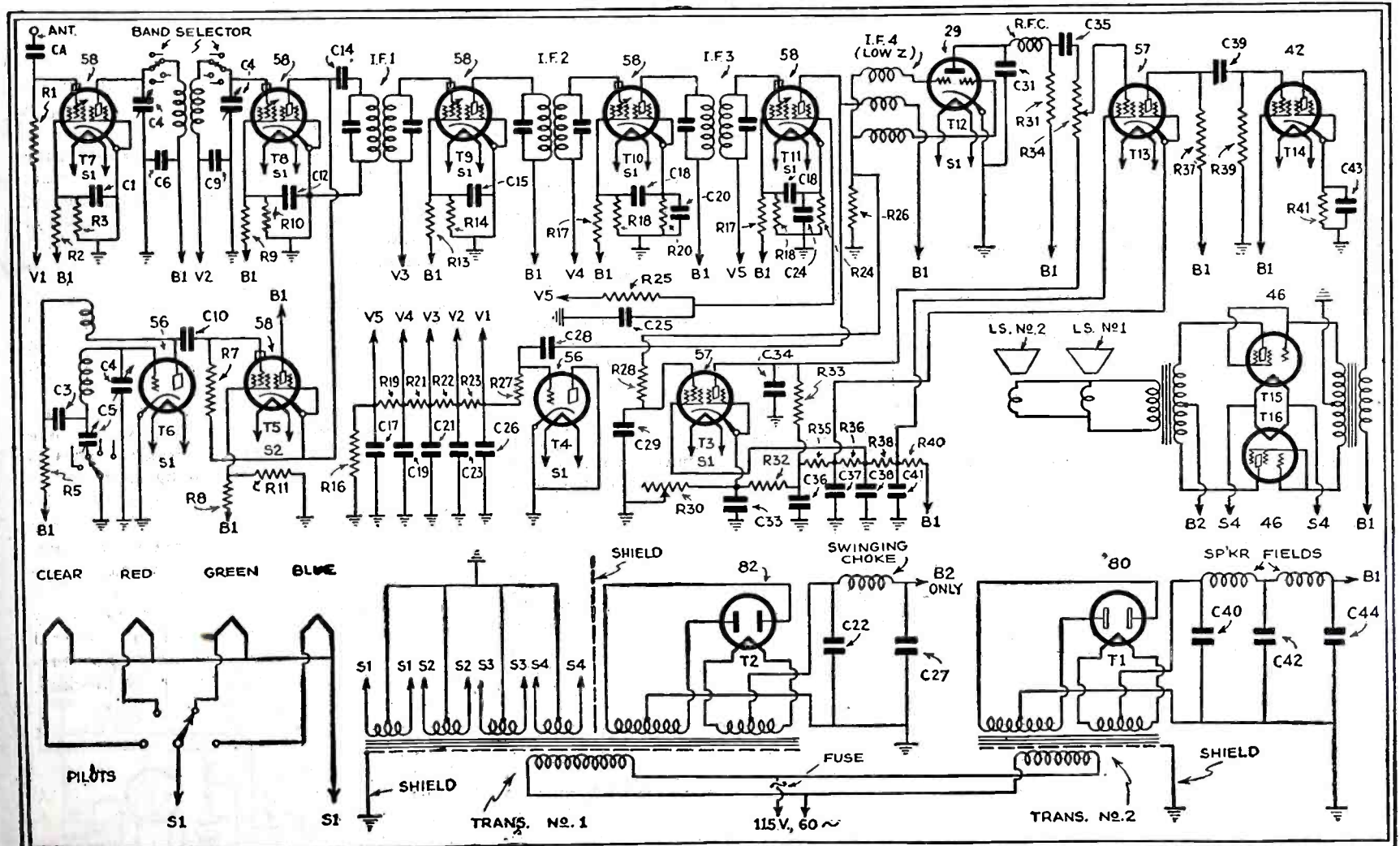

FIG. 3

Various diagrams of the automatic volume control.



Wiring diagram of the newest Midwest creation—the 16-tube short and long wave receiver. A superheterodyne with special automatic volume control system, which enables the operator to adjust the sensitivity to high or low degree. With the sensitivity adjusted "low," reception with a minimum of static and other interference is obtained.

MICRO RAYS

This interesting discussion on the production and application of ultra-high frequency waves, or "micro rays," by Mr. Pelton should prove of more than passing interest to every student of short-wave phenomena, as very little has been published in American radio journals on these rays. Mr. Pelton describes how and why these ultra-short waves are produced by the action occurring within a vacuum tube and how their length is determined. The effect of tuning and other conditions affecting the electron generator are explained.

By H. A. Pelton

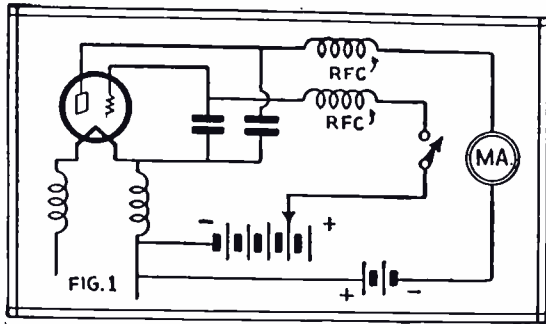

Fig. 1—Barkhausen-Kurz oscillator in which ultra-short waves having a length of but a few centimeters in some cases are generated. Note that negative charge is placed on the plate.

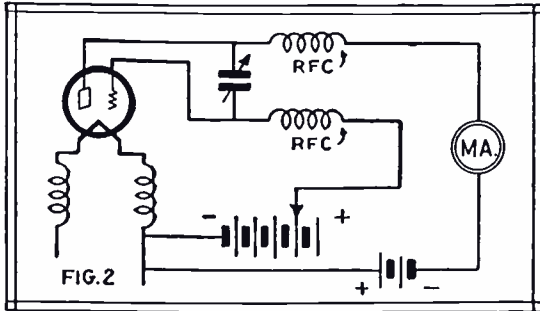

Fig. 2—Micro ray generator known as the Gill-Morrell oscillator. Plate gets a negative charge and grid a positive charge.

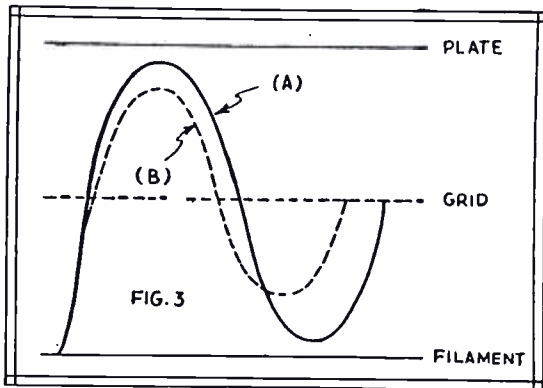

Fig. 3—Curves showing path taken by an electron in oscillating about the grid. Curve A, path taken under the influence of the steady grid voltage only, while curve B shows how this path changes when an alternating voltage is superimposed on the steady voltage.

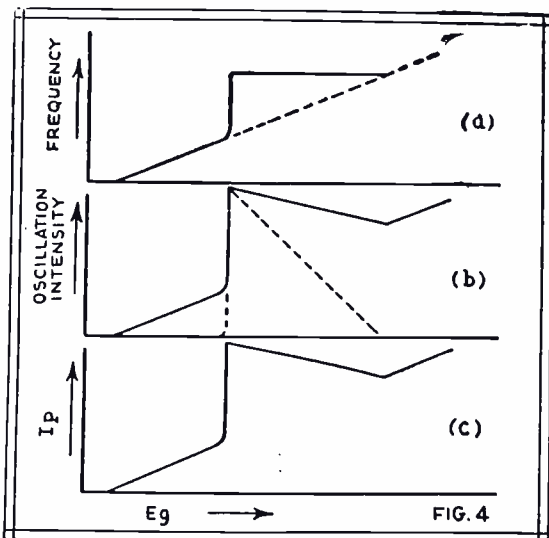

Fig. 4—Curves of frequency, oscillation intensity, and plate current plotted against grid voltage. In (a) dotted portion indicates how frequency would vary if external circuit were not present. In (b) solid curve indicates oscillation intensity within tube, while dotted curve shows oscillation intensity in external circuit.

• THE recent success by a group of engineers in communicating across the English Channel on a wavelength of a few centimeters (1 cm. equals .39 inch) has served to focus attention on these ultra-high frequencies, or "micro rays," as they have been termed. In all fairness it must be admitted that comparable distances had been covered using similar frequencies as early as 1929, but the recent test marks the first attempt to commercialize the apparatus.

While little other information is available, it is known that the apparatus used in this latest test is based upon the *electron cloud oscillations* within a three-element vacuum tube as first reported in 1920 by Barkhausen and Kurz. Since little information on such apparatus has been published for the amateur experimenter, the following discussion is offered.

Early in 1920 Barkhausen and Kurz reported the production of stable oscillations within a conventional three-element vacuum tube operated with a highly positive grid and a negative plate. The frequency of these oscillations was extremely high and was determined solely by the construction of the tube and the potentials used on the elements.

A Simple Generator of Electron Oscillations

A simple generator of such electron oscillations is shown in Fig. 1. It will be noted that both the plate and grid are effectively by-passed to the filament at the tube terminals, so that the frequency of the external circuit is far removed from the frequency of the oscillations to be produced within the tube.

If the switch in the grid circuit is closed, a cloud of electrons will be attracted from the vicinity of the filament and will pass rapidly towards the grid and continue on toward the plate, which is maintained at a slight negative poten-

tial and which repels them back toward the grid and the filament. While portions of the electron cloud are near the plate the space in its vicinity carries a higher negative charge than usual, which discourages further electron movement in that direction. As the space charge disappears, due to the repulsion of the cloud by the plate, another electron movement takes place, and so on. The *oscillating movement of the electron cloud* constitutes an oscillating current whose frequency is determined by the distance through which the electrons move and their velocity. The velocity is in turn governed by the potentials applied to the tube elements, an increase in grid potential causing a greater electron velocity. The starting of the Barkhausen and Kurz oscillations is indicated by a flow of plate current even though the plate is at a negative potential with respect to the filament.

Tuned Circuit Added to Tube

In an attempt to make the oscillations available outside the tube, an oscillating circuit was added as shown in Fig. 2. This circuit usually takes the form of a series tuned combination, containing *inductance* in the form of two straight wires, a rather large external *variable capacity* and the *grid-to-plate capacity* of the tube itself. The large external capacity serves primarily as a blocking condenser, since the much smaller capacity within the tube controls, almost exclusively, the total capacity and frequency of the circuit. The blocking condenser may be varied to effect small changes in frequency, but must always have a capacity large in comparison to the grid-plate capacity, in order that the alternating voltage between those elements be as great as possible. Large changes in circuit frequency are usually made by varying the length of the parallel inductance wires.

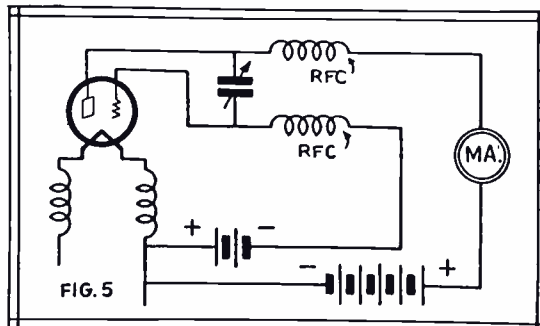
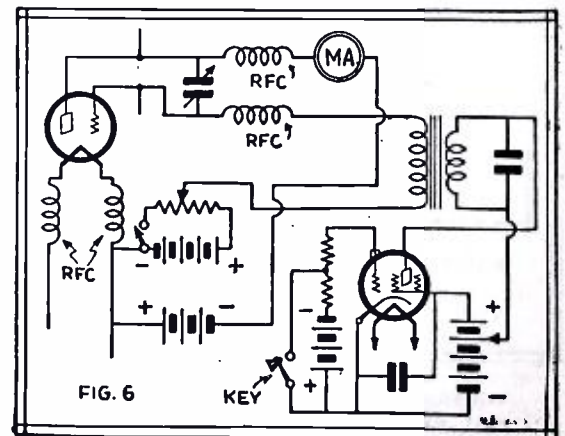

Fig. 5—Circuit of the famous ultra-audion oscillator. Fig. 6 (right)—Tone modulated micro ray transmitter.



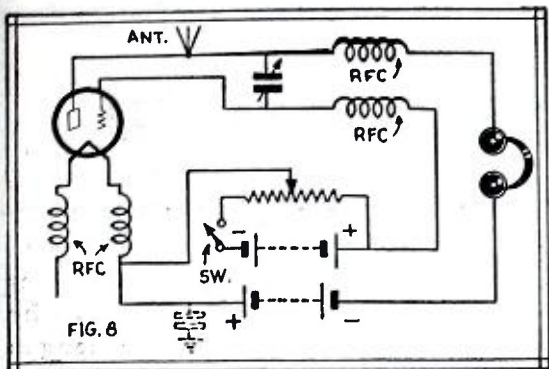

Fig. 8—Regenerative receiver used to pick up ultra-short waves from transmitters of the Gill-Morrell type.

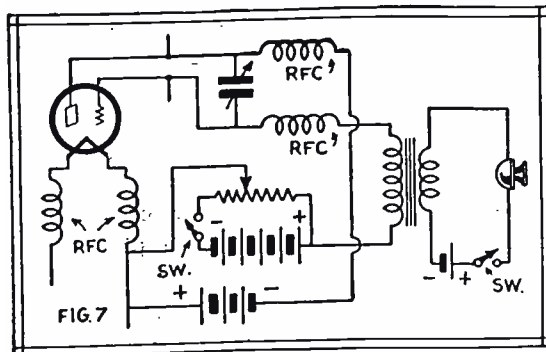

Fig. 7—Here we have the circuit for a voice-modulated transmitter of the Gill-Morrell type. It will be noted that grid voltage modulation is used. Note use of R.F. chokes in grid and plate circuits, also in filament circuit.

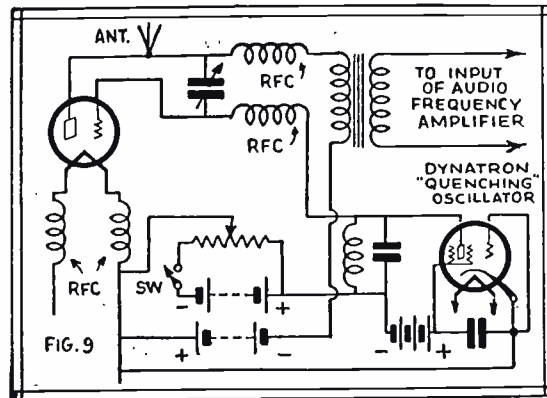

Fig. 9—Excellent receiver for intercepting signals from the Gill-Morrell transmitter—the super-regenerative circuit.

Gill and Morrell Make New Discovery

It was soon discovered by several investigators, particularly Gill and Morrell, that a new type of oscillation having a higher intensity and a higher frequency could be obtained under certain circuit conditions. It was also discovered that the frequency and intensity of oscillation under these conditions was governed almost entirely by the external oscillating circuit.

If the external oscillating circuit is adjusted to a frequency slightly higher than the frequency of the electron cloud oscillations within the tube, an alternating potential is set up across the oscillating circuit in phase with the potential caused by the electron cloud. This in-

crease in potential decreases the time required for an electron cloud oscillation, as shown in Fig. 3, and pulls the electron cloud oscillations into step with the oscillations in the external circuit. The Gill-Morrell oscillations are far more intense than the Barkhausen-Kurz oscillations and cause a much greater flow of plate current.

Interesting Conditions Affect Oscillations

A thorough knowledge of the conditions surrounding the transition from one type of oscillation to the other is essential to an understanding of the modern apparatus, so it will be discussed in detail.

Assume that the external circuit fre-

quency is fixed and that the steady grid voltage is varied from a low to a higher value. At first, the frequency of the electron cloud oscillation is below the frequency of the external circuit; hence the alternating potential across the terminals of the circuit will be small and practically pure Barkhausen-Kurz oscillations exist. As the grid potential is increased the frequency of the electron cloud oscillation is increased and the alternating potential across the terminals of the tuned circuit increases, since the circuit is now excited at a frequency closer to its own resonant frequency. The alternating field superposed upon the steady field between the tube elements

(Continued on page 312)

A Capacity and Inductance Bridge

● MOST experimenters lack the wherewithal for purchasing accurate laboratory instruments, but the two units to be described may both be made for somewhat less than one dollar and with reasonable care in construction and operation will give surprisingly accurate results. They are capacity and inductance bridges, the principle being the same as the famous Wheatstone Bridge. The hook-up for the capacity bridge is given in Fig. 1, and is almost self-explanatory:

- T is a set of headphones.
- Z, a buzzer or "works" of an electric door-bell.
- B, three or four dry cells.
- Cx, the unknown capacity.
- Cs, the standard capacity, of which more later.

The slide wire as used by the writer consists of a base of 2 x 1 inch pine 44

inches long, on which is fastened a meter stick after cutting small pieces off the latter to bring the zero and 100 centimeter graduations flush with the ends. The resistance wire is No. 24 nichrome, though any other of approximately the same resistance and strength may be used. The wire is stretched tightly over the meter stick and through slots in angles of spring brass or phosphor bronze of the shape shown in Figs. 5a and 5b. This gives an effective length to the wire of 100 centimeters (39 inches). De-

tails of the slider are given in Figs. 2 and 3. It is cut from a rectangular cube of wood 2 x 1 1/2 x 1 inch. The dimensions of the contact strip, also of spring brass or phosphor bronze, are shown in Fig. 4. The "button" consists of a 3/4-inch length of bakelite rod 1/4-inch in diameter.

Operation

The apparatus is connected as shown in Fig. 1. The standard capacity may be an ordinary condenser of known value although special ones may be obtained for precise work. Its value should be more or less near that of the unknown capacity. That is, in measuring the capacity of a variable condenser use, say, a .00015 mf. standard, and for testing power unit blocks, say, a 4 mf. standard. The operation is extremely simple. The slider is moved back and forth on the

(Continued on page 311)

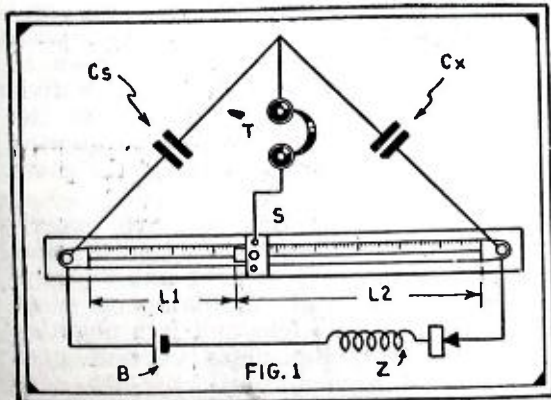

Bridge circuit for determining capacity of a condenser connected at Cx.

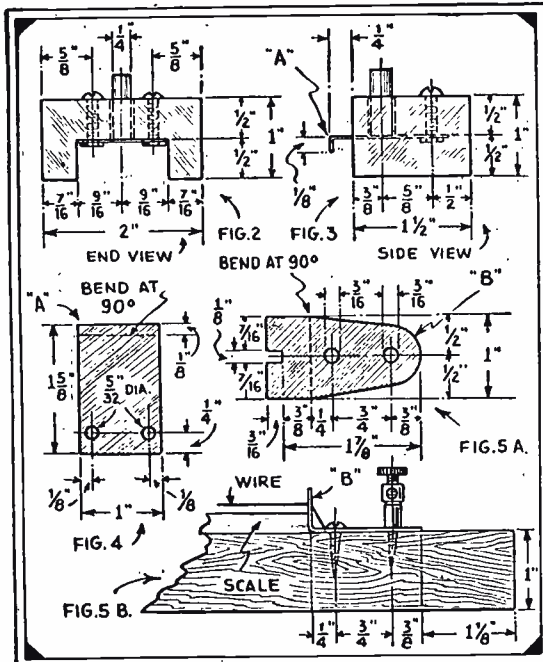

Details of slider and wire support used in building the measuring bridge.

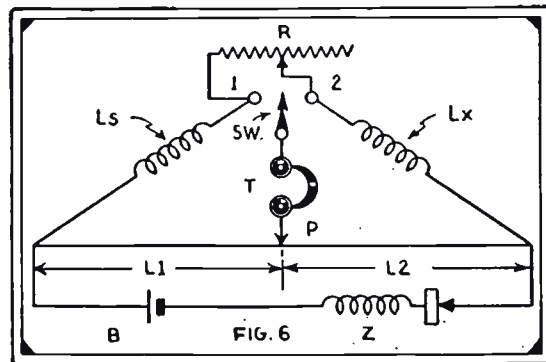

Bridge circuit set up to measure inductance of a coil connected at Lx.

How to Become a Radio Amateur

By JOHN L. REINARTZ

Plotting Curves for Vacuum Tubes

No. 3 of a Series

● DR. LEE DE FOREST really originated the vacuum tube as we know it today. Before him Edison had noticed that even though no metallic connection existed between a filament and some other wire, when both had been enclosed in an evacuated tube, he could, upon heating the filament, cause current to flow between the filament and the other metallic wire or plate. Others played with the Edison effect, notably Fleming; however, he used only the two elements that Edison had used. Then de Forest came along and inserted a third element, or *grid*, interposed between the filament and the plate, and this invention on his part is directly responsible for the state of the radio art today.

Let us take a look at this wonderful device called the *vacuum tube* and see what it is like. Suppose we select one that has gone bad and take it apart. We find that enclosed in the glass bulb are three elements; that is, if we have picked a tube called a *triode*, we find that it has a *filament*, a *grid*, and a *plate*. The filament is in the center, the grid surrounds it, and the plate surrounds the grid, the whole being placed in the glass bulb in such a manner that they are rigidly supported. Connecting leads to each of the three elements are brought out through the stem and base to the pin type terminals, with which connections are made in the socket. After the elements are placed in the glass bulb the air it contains is pumped out until the tube represents a high vacuum; to help the pump along the elements are bombarded with high-frequency current, which heats the elements to incandescence. This process gets rid of some of the gases that are contained in the elements, which would cause trouble later if they were heated in regular use. The tube is then sealed off at the tip and when the base is cemented on, it is ready to be used in someone's radio set.

Now that we have the tube, let's see what it can do. We place it in a socket and connect to the filament terminals what is normally called the "A" or filament battery. Different tubes have different filaments and they therefore need different voltages applied to their filaments. We have one that requires five volts, so we take four dry cells and connect a rheostat in series with them to the filament connections at the socket; as the four batteries connected in series develop six volts, we have to use the rheostat to absorb the remaining volt, which it does by virtue of its resistance, the voltage drop being the result of the current flowing through it multiplied by the resistance of the rheostat.

As the filament is heated by the electric current flowing through it from the "A" battery, it gives off electrons. These

electrons are minute particles of negative electricity and are shot off from the filament in all directions, pretty much as the energy from our sun is shot out into space. We know the sun shoots out energy because we can see the light and feel its effects as heat. We do not see the filament in our tube shoot out these electrons, but we have means of telling that it does take place.

As the electrons leave the filament they collide with each other and also hit the grid. Some get through the spacing of the grid wires and find that a plate has been put in the tube. Lots of them fall back on to the filament and are again shot off into the interior of the tube a little later. So far they haven't been doing any work for us, so we connect a battery from the filament to the grid in such a manner that by the use of a potentiometer we can supply the grid with either *negative* or *positive* potential and also connect between the filament and the plate a battery in such a manner that the plate will have the positive connection. In this battery line to the plate we also connect a milliammeter of ten milliamperes range. The meter will indicate to us that which we cannot see happen inside the tube. The grid potential battery we will make of two 4½-volt "C" batteries and the plate potential will be supplied by two 45-volt "B" batteries. The "C" batteries will be so connected that the wire from the filament will go to the connection between the two "C" batteries; this will give us 4½ volts positive one direction from the mid-connection on the two "C" batteries, and also 4½ volts negative from the mid-connection of the two "C" batteries. Across the two "C" batteries we connect the potentiometer and the potentiometer slide we connect to the grid of the tube. By this arrangement we can at will supply the grid with either negative or positive potential, keeping the plate at a positive potential all the time.

Before we try to find out what the tube actually does, we supply ourselves with some cross-section paper to plot the results of our experiment on. From the graph so plotted we shall be able to tell what the vacuum tube does, even though we cannot see it. Laying out our cross-section paper so that the Y-ordinate represents the plate current and the X-ordinate the grid voltage, with the zero grid voltage in the center of the X-ordinate as shown, each small division to represent one-tenth volt in the case of the grid voltage and two-tenths of a milliampere in the case of the plate current.

The '01-A type tube we are experimenting with has a curve (Fig. 2) that for 4½ volts negative grid and 90 volts plate starts off at 1.8 milliamperes plate current; as we go less and less negative for the grid, the plate current goes higher and higher, until, for the zero grid voltage, the plate current has gone to 4.8 milliamperes. As we proceed to

(Continued on page 313)

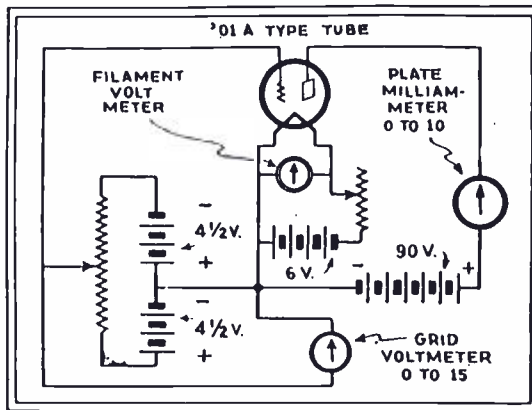

Fig. 1—Showing how to connect voltmeter and milliammeter in vacuum tube circuit.

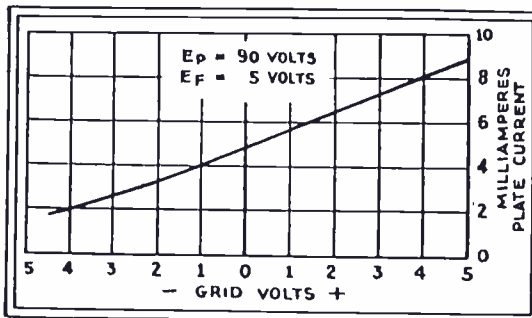

Fig. 2—Curve above shows change in plate current with variation in grid voltage.

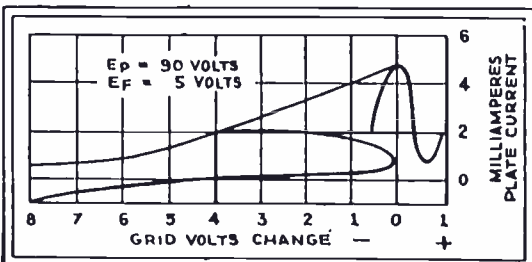

Fig. 3—Curves plotted to show the effect of change in grid voltage with respect to variation in plate current.

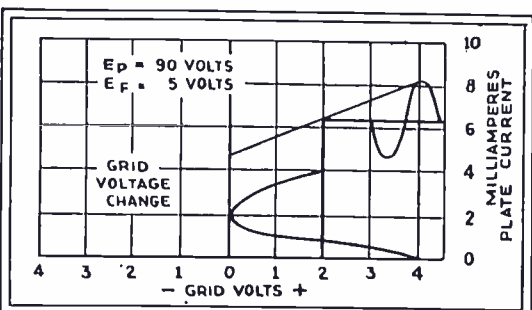

Fig. 4—Here's what happens when the original grid potential is 4 volts negative and the alternating voltage added is 4 volts, making it swing from 0 to 4 volts negative and then 4 volts positive. Adding the 4 volts negative to the already 4 volts minus grid bias makes 8 volts negative for the swing in that direction. Adding 4 volts plus to 4 volts minus results in 0 grid voltage on the positive swing.

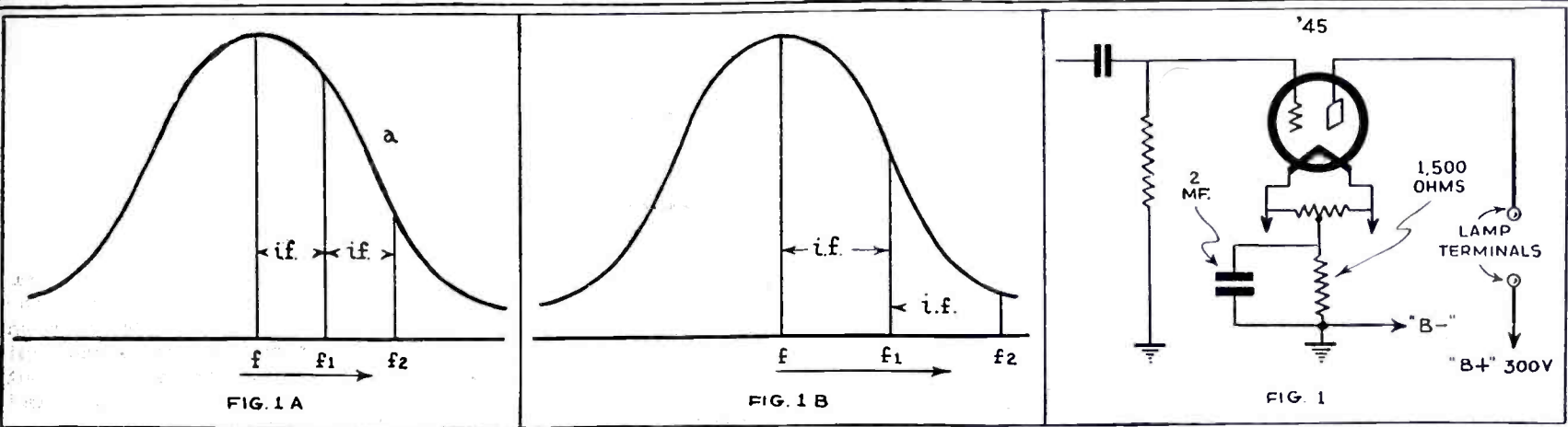

Fig. 1A shows the effect of the I.F. on image frequency selectivity; the degree of image is directly proportional to the height of the line f2. Fig. 1B shows the same conditions for the case where a higher I.F. is used, which causes f2 to shift further toward the right, with greater reduction in image signal. Diagram at right shows typical "output" stage.

What "I. F." Frequency?

By EDGAR MESSING

● One of the very first questions that the designer of a short-wave superhet, whether the set be for commercial production or for one's own shack, must answer is: What intermediate frequency (I.F.) shall I use? And the question becomes a bit more complicated if the set is to cover the broadcast band as well as the shorter wavelengths.

Today there is a distinct understanding of the I.F.'s importance. Fortunately, there is a distinct trend toward certain values and it will be noticed that most 15 to 550 meter sets have an I.F. between 400 and 520 kc.

"Gain" Considerations

From the standpoint of *gain* there is little or no limitation—amplifiers can be constructed for either high or low frequencies (within the range 10 to 550 kc.) to have the same gain, though the lower frequency amplifier will tend to cause less trouble and will be more stable. But with careful design, which simply means more attention to detail, the higher frequency amplifier can be made to be satisfactory and reliable. The field is still quite open, then, so far as the question of *sensitivity* is concerned. One small vote, then, for a relatively high I.F.

Selectivity versus I.F. Value

Selectivity.—Under this heading we can group the major arguments controlling the I.F. choice.

Adjacent channel selectivity—the ability to separate stations whose signals differ by 10 or 15 kc.—may be first considered. In general, attempts to get the same gain at a higher frequency as at a lower frequency will mean that the lower frequency amplifier will be sharper. This selectivity is, of course, highly desirable, especially on the broadcast band. But if the amplifier is composed of two stages or more with tuned grid and plate circuits, any I.F. value below 500 kc. can be made to give satisfactory adjacent channel selectivity.

Just as important as this type of selectivity is what we have come to call "image" or "double-spot" selectivity—the measure of the set's ability to reject signals differing from the oscillator by the I.F. value but *higher* in frequency.

Lack of this selectivity may be apparent in two ways—stations may be picked up at two dial settings, and stations may interfere with others differing widely from them in frequency. As an example of the second type, one commercial receiver now on the market with an I.F. of 500 kc. has its 120 meter police band rendered useless by artificial interference from the 80 meter amateur stations. While this selectivity is primarily a function of the signal frequency tuning circuits, it is largely dependent on the value of I.F.

Effect of I.F. on Selectivity

Figure 1A will help show the effect of the I.F. on image frequency selectivity. Curve "a" represents the response of the signal frequency tuning circuit; this, for the frequencies we are considering, will be quite broad. The circuit is assumed to be tuned to the signal "f". The oscillator in the superhet will be tuned to a higher frequency, f1. The amount of image signal, f2, that will be passed on to the I.F. amplifier depends on the amount reaching the first detector grid, which in turn depends upon the rejectivity of the tuned circuit. The amount of image, then, is directly proportional to the height of line f2 from the base to curve "a".

Figure 1B shows the same conditions for the case where a higher intermediate frequency is used. It is apparent that the effect of using the higher I.F. is to move f2 further from the peak of the tuning curve and thereby lessen its height. The image signal is correspondingly reduced. From this viewpoint as high an I.F. as possible is desirable.

This is the first distinct advantage of a high I.F. that we have met and it is a very important one. It is the primary reason for the comparatively high values now in use.

There are several other elements to consider before making a final decision.

1. **Direct Pick-up.**—The I.F. should be such that the amplifier will not directly pick up a strong signal. The proper choice of frequency, good R.F. selectivity,

and close shielding of the amplifier will answer this problem.

2. **Harmonics.**—The harmonics of the oscillator frequency can beat with signals to cause unforeseen reception and interference. A low oscillator frequency means a large number of harmonics within any range compared to a higher oscillator frequency. Since a high I.F. means a high oscillator frequency, the higher the intermediate frequency, the fewer the harmonics within the receivable range.

3. **Oscillator Range.**—The frequency limits which the oscillator should cover on any band should have as low a ratio as possible. This is desirable in the interests of oscillator stability and input. If an I.F. of 100 kc. were used with a signal range of 1500 to 3000, the oscillator range ratio would be 3100:1600. If 500 kc. were the I.F. the oscillator range ratio would be 3500:2000—a much lower figure. The higher I.F. is thus desirable.

4. **Tracking.**—The ability of oscillator and detector to keep in step. With a low I.F. the oscillator frequency and signal circuit frequency do not differ much comparatively and little correction is necessary. A higher I.F. will mean greater difference between oscillator and detector circuits and therefore more correction to secure accurate tracking. The use of a trimmer condenser will, however, compensate for unavoidable tracking differences. One small vote for a low I.F.

5. **Frequency Range and "Wobblation."**—This point has not seen much light as yet but will come into more prominence shortly. At the higher frequencies, say, 12 meters and below, the transmitting station's frequency may wobble noticeably, unless the station is *crystal-controlled*. For 10-meter reception the I.F. can very well be in the neighborhood of 5000 kc.

Our arguments seemed to have summed up in favor of a high I.F. or maybe the author was somewhat prejudiced at the start. Experience has shown that for reasons considered briefly above, the value should not be too close to the broadcast band. A good compromise value and one that has been adopted for many commercial sets is 465 kc. This does not mean 465.00; any value in that neighborhood may be used.



H. W. Secor is here shown trying out the 8-Tube Portable "All-Wave" Superhet designed by Mr. Denton.

8-Tube Portable "All Wave" Super-Het

By **CLIFFORD E. DENTON**

● MORE detailed information covering the connections of the detector and oscillator systems would not be amiss at this point, as this is generally a stumbling block for the average constructor.

A detail drawing of the circuit incorporated in the receiver covers this point clearly. By referring to the coil specifications as printed in the August issue of *SHORT WAVE CRAFT*, one will note that a winding is specified as the "coupling winding" and for every band there is a different number of turns. Do not confuse the circuit of page 207 with the circuit as shown in this section of the article.

In the original circuit the only coupling between the oscillator and first detector was the inductive effect between the two coils located two inches between centers. The reason underlying the use of the inductive coupling was that it offered the easy way out of a hard problem. It is a simple matter to couple circuits when the tubes are of the cathode type. But with the two-volt type there are no cathodes.

If the set is to be built using the two-volt tubes, use the circuit as shown in the August issue; if six-volt tubes are used, then the circuit shown here can be followed.

Last month Mr. Denton described the general line-up and circuit of his latest 2-volt "portable" 8-tube superhet. This super is a real job and will appeal to hundreds of people who want a good portable receiver using high-gain tubes, and a set, moreover, which can be carried easily. Diagram and data are here given for building this super also with the new 6-volt automobile tubes. This set works a loud speaker on either 2-volt or 6-volt tubes. Regeneration is used to provide maximum "pick-up" range.

Do not wind the pick-up coils on the oscillator coil forms and subtract these turns from the total number of turns wound on the secondary of the first detector coil. These additional turns are for the purpose of coupling only, and actually add but little to the inductance of the detector secondary.

If the coupling is too great between the oscillator and the detector, then a small aluminum shield should be placed between the coils, so that the greatest coupling takes place through the coupling coil winding on the oscillator.

This small shield should be placed in the center of the small coil mounting platform. The physical details are given in the sketch.

Changes for Six-Volt Operation

There are many builders who would like to use the six-volt tubes in place

of the two-volt type, especially for service in the automobile or the motor boat.

A complete circuit is given with the necessary changes for operation with these cathode type tubes.

It will be necessary to change over the four-prong sockets to the five-prong type. There will be eight fives instead of six four-prong sockets in the parts list.

The following changes in the parts list will also have to be made.

25 becomes 15,000-ohm, 2-watt resistor (International Resistance Co.).

27 becomes Acra-test by-pass condenser, .02 mf., 200 volts, No. 2817.

26 becomes Frost potentiometer, 0-10,000 ohms, No. 6188.

18 becomes 500-ohm, .5-watt resistor (International Resistance Co.).

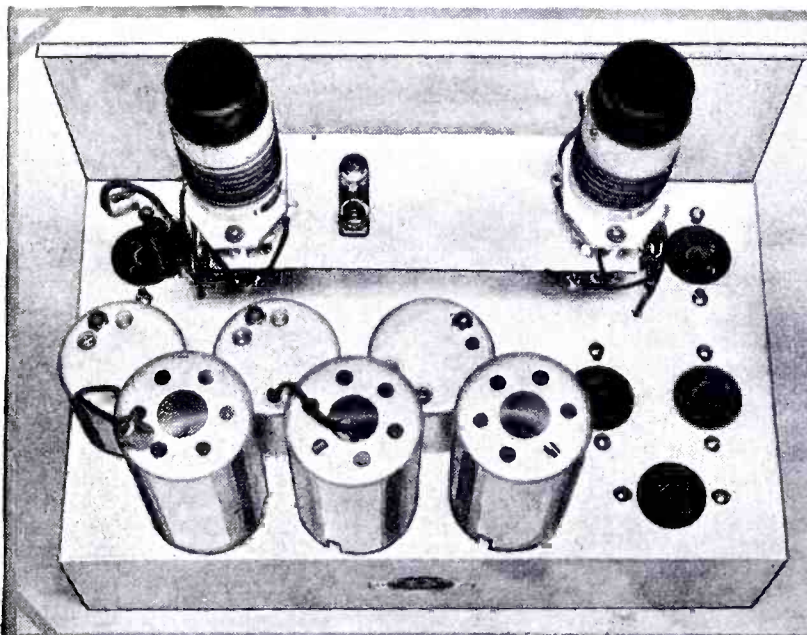

Rear view of the new Denton Portable Superhet.

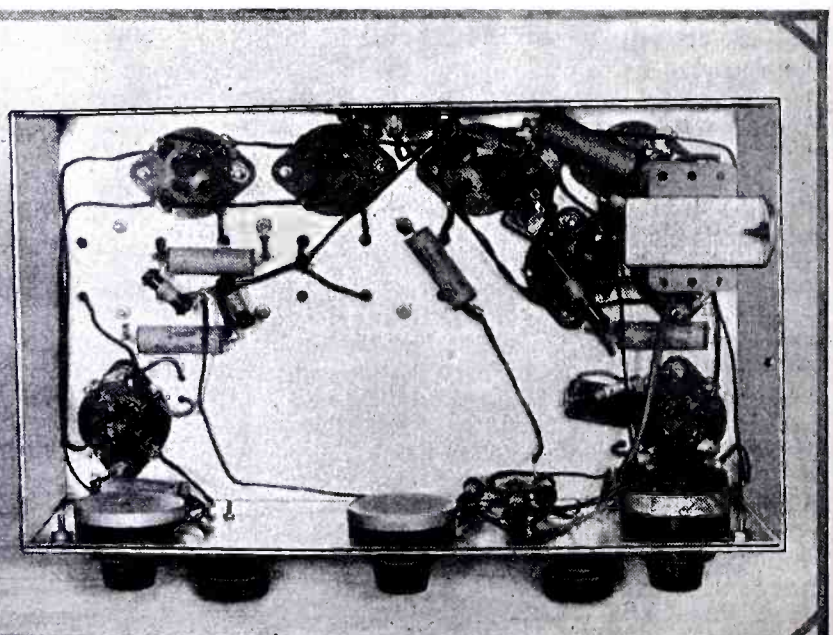

A view of the superhet "looking up from under."

22 becomes 500-ohm, .5-watt resistor (International Resistance Co.).
 39A is a 2,500-ohm, 1-watt resistor (International Resistance Co.).
 40A is a 700-ohm, 1-watt resistor (International Resistance Co.).

The speaker should be wound with a winding suitable for operation with the 38 type power pentodes connected in push-pull. If such a speaker cannot be obtained, then an output transformer should be used to match the output of the tubes to the speaker to be used. It is important to use the proper output matching transformer, if the maximum efficiency is to be obtained from the set. Proper matching will permit the builder to obtain the same quality of reproduction which is to be had with the parts as specified in Part 1.

It is amazing that 1.2 watt connected to a good speaker in a proper manner should give such satisfactory reproduction. For example, signals from a sta-

If the reader cannot build the chassis, due to lack of equipment, the author will be glad to advise where the completed chassis can be obtained.

Mount the tuning condensers on the front panel. After the condensers are mounted the small coil platform should be bolted down on the condensers. Mount the coil sockets; that is all the work that should be done on the front panel at this time.

The first detector socket should be mounted on the right-hand front of the chassis. Then, running along the back, place the first, second intermediate frequency amplifier tubes, and the second detector. The oscillator tube is mounted on the left and near the front of the chassis, this socket being backed up to the rear by the sockets of the output pentodes and the first audio tube. The first audio tube is mounted in line with the second detector.

A six-prong wafer socket is mounted

der one of the wafer socket mounting bolts and solder the small end of the lug to one of the socket filament connectors. The A-plus connection is then run and it is the one wire common to all sockets.

Wire all grid leads. Run the grid leads in the shortest possible manner. Be sure and mount the intermediate frequency transformers so that the grid and plate leads furnished with these parts are run in the shortest possible manner to their respective socket terminals.

Wire in all of the grid returns. Included under this section there are the by-pass condensers and the isolating resistors. As these parts are self-mounted, care must be used in soldering. At this time complete all grid and grid return connections. This holds true for both the audio and the radio sections of the receiver.

Wire in all plate leads. This is the

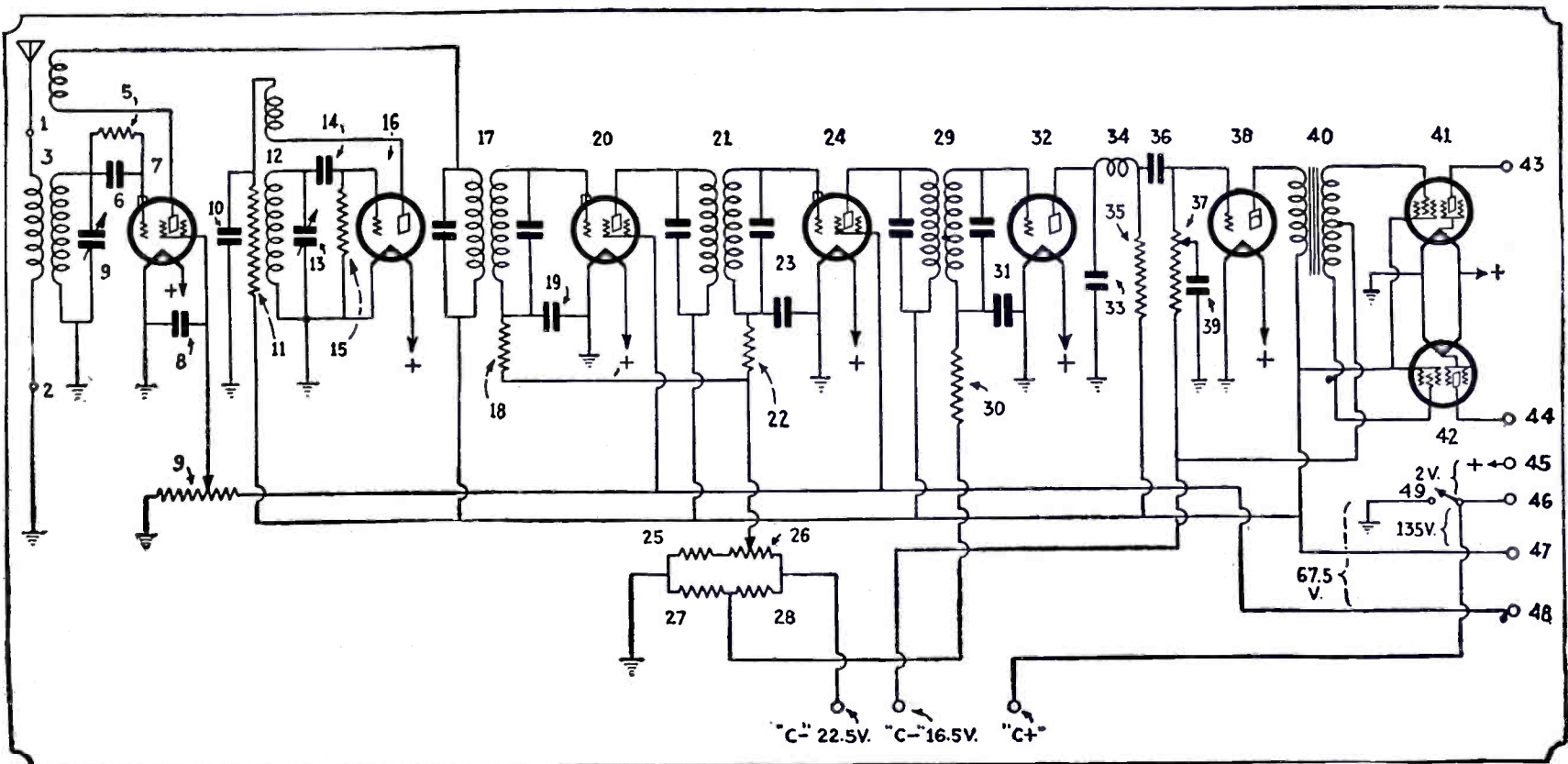

Wiring diagram of Mr. Denton's 8-tube portable superhet which utilizes 2-volt tubes.

tion over four thousand miles away come in loud enough to be heard all over the house. One would believe that the signals were from some broadcast receiver tuned to a station located within four or five hundred miles.

Short-wave reception is erratic at best, compared with reception on the broadcast band, but the "kick" of good loud speaker reception from stations more than 5,000 miles away is worth while. Reception from stations on the conventional broadcast band are tuned in a manner that would give due credit to any good broadcast receiver. For complete broadcast band coverage one must use two sets of coils, as the size of the tuning condensers will not provide the correct capacity ratio to cover the entire band.

Construction

The first thing to do is to lay out the front panel and the chassis. This should be done in accordance with the drawings accompanying this article. Use half-hard sheet aluminum about 1/16 inch thick.

on the back of the chassis, so that connections can be made to the battery-speaker case through the six-wire cable. The "C" battery is carried in the space under the receiver chassis, thus insuring short leads and reducing the number of wires running in the cable.

Mount the push-pull transformer underneath the chassis as shown in the photographs. The rest of the small parts, such as the resistors and the filtering or isolating condensers, are held in place by the wiring.

Wiring Details

The proper wiring of any radio set is half the battle on the road to a real radio receiver. Use a clean iron and heat the joint being soldered well. See that all surfaces are clean!

A receiver which is to be used as a portable needs particular care when it comes to wiring. Every connection should be good mechanically before it is soldered.

Wire all filaments. This is easy in the two-volt model. Use soldering lugs un-

last thing to be done under the chassis and nothing more need be said on this point.

Solder in three pieces of stranded, insulated wire to be used as "C" battery connections. The "C" battery lies in the open space to the rear of the sensitivity control. Have these leads about six inches long for convenience sake. There is plenty of space to place a standard 22-volt "C" battery in this space.

This completes the wiring of the chassis and the front panel can be mounted in place. This panel is held in position by the three variable resistors and the two lower holding screws of the National dial.

Testing

Of course, the first thing to do is tune the intermediate frequency amplifier to 465 kc. The method by which this is done will depend upon the equipment on hand which can be used for this purpose.

DO NOT USE A METAL SCREWDRIVER FOR TUNING OR ADJUSTING I.F. TRANSFORMERS WHEN THE BATTERIES ARE CONNECTED!

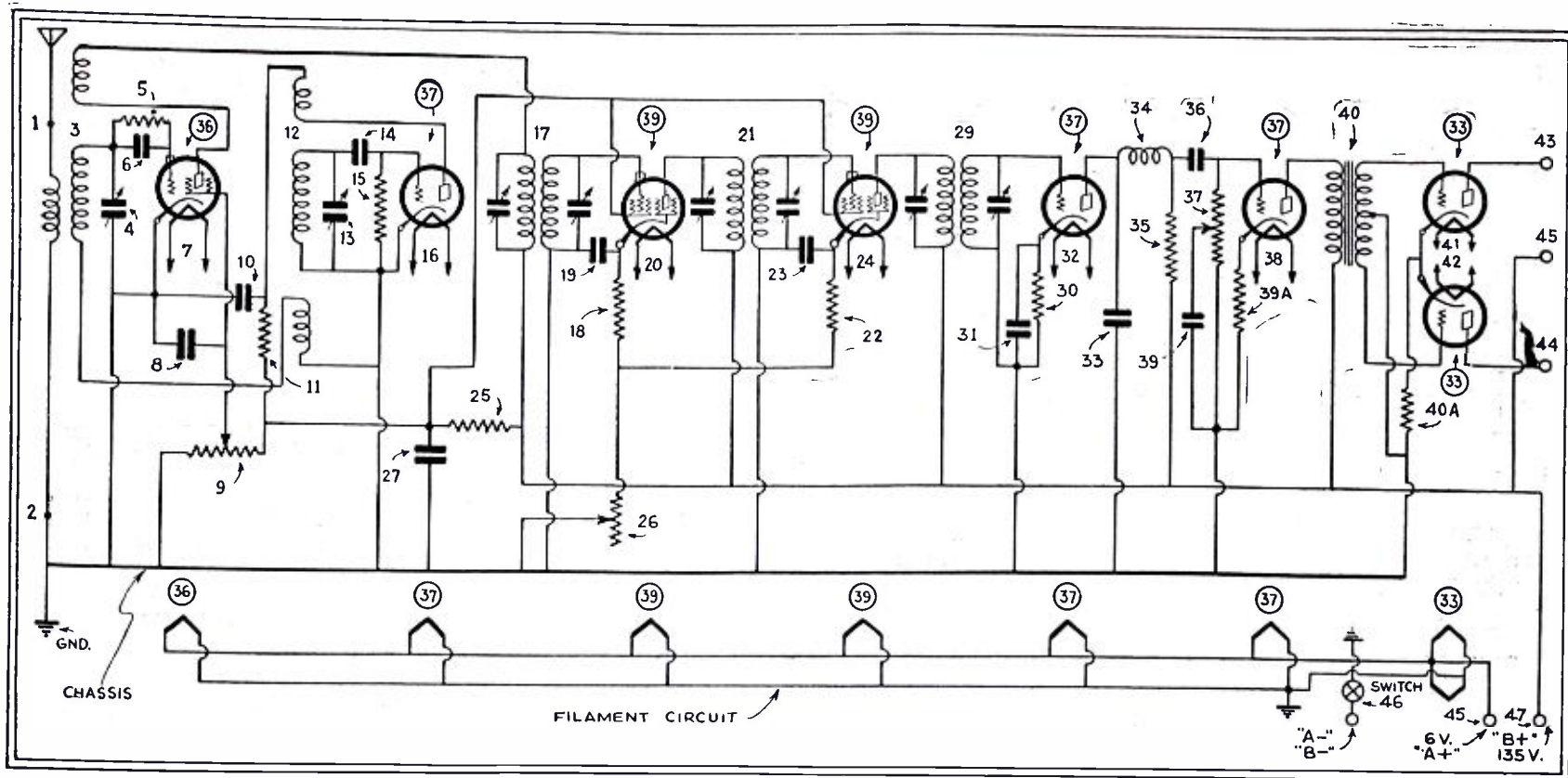

Six-volt automobile tube wiring diagram for Mr. Denton's S-Tube Portable "All-Wave" Superheterodyne receiver.

The above statement is very important! The use of the metal screwdriver must be avoided; when one is adjusting the set screws on the tops of the shielded cans and the screwdriver slips, bang goes all of the tubes, unless a small fuse is included in the plate circuit. Fuses such as the Little fuse should be used for safety any way.

After the set has been adjusted, check the battery voltages, and if the filament voltage is too high on the tubes, place a small resistor or rheostat in series with the filament line and carry this resistor in the battery-speaker case.

Connect the set to an antenna and ground, tune in a signal and adjust the regeneration control below the point of *spilling over*.

Set the tone control for the required pitch and see if the action of the sensitivity control is smooth over the entire range. If this control is not smooth in action, then vary the "C" bias voltage at the battery to some lower value, although experience proves that the best action will be obtained from the 22.5-volt connection.

The wavelength ranges of the five sets of coils and the number of turns required are as follows:

14 TO 30 METERS

Detector

- Primary..... 4 turns No. 30 D.S.C.
- Secondary..... 7 turns No. 20 Enam.
- Regeneration.. 5 turns No. 30 D.S.C.

Oscillator

- Plate..... 4 turns No. 30 D.S.C.
- Secondary..... 6 turns No. 20 Enam.
- Coupling..... 1 turn No. 20 Enam.

Detector secondary is space wound 6 turns to the inch with a winding length of 1 1/8 inches scant.

Oscillator secondary is space wound six turns to the inch with a winding length of 1 inch.

28 TO 60 METERS—Detector

- Primary..... 4 turns No. 30 D.S.C.
- Secondary..... 14 turns No. 20 Enam.
- Regeneration.. 6 turns No. 30 D.S.C.

Oscillator

- Plate..... 4 turns No. 30 D.S.C.
- Secondary..... 12 turns No. 20 Enam.
- Coupling..... 2 turns No. 20 Enam.

Detector secondary is space wound 12 turns to the inch with a winding length of 1 1/8 inches scant.

The oscillator secondary is space wound 12 turns to the inch with a winding length of 1 inch.

55 TO 125 METERS—Detector

- Primary..... 5 turns No. 30 D.S.C.
- Secondary..... 33 turns No. 20 Enam.
- Regeneration.. 16 turns No. 30 D.S.C.

Oscillator

- Plate..... 5 turns No. 30 D.S.C.
- Secondary..... 24 turns No. 20 Enam.
- Coupling..... 3 turns No. 20 Enam.

The detector secondary is space wound 24 turns to the inch with a winding length of 1 1/8 inches.

The oscillator secondary is space wound 24 turns to the inch; length of 1 inch.

120 TO 300 METERS—Detector

- Primary..... 6 turns No. 30 D.S.C.
- Secondary..... 78 turns No. 30 D.S.C.
- Regeneration.. 30 turns No. 30 D.S.C.

Oscillator

- Plate..... 14 turns No. 30 D.S.C.
- Secondary..... 44 turns No. 28 D.S.C.
- Coupling..... 5 turns No. 30 D.S.C.

The detector secondary is space wound 56 turns to the inch with a winding length of 1 3/8 inches.

The oscillator secondary is space wound 56 turns to the inch; length of over 3/4 inch.

240 TO 550 METERS—Detector

- Primary..... 10 turns No. 30 D.S.C.
- Secondary..... 114 turns No. 30 D.S.C.
- Regeneration.. 48 turns No. 30 D.S.C.

Oscillator

- Plate..... 30 turns No. 30 D.S.C.
- Secondary..... 70 turns No. 28 D.S.C.
- Coupling..... 8 turns No. 30 D.S.C.

Parts List

- 1, 2—Alden antenna-ground assembly.
- 3, 12—Hammarlund S6 Isolantite sockets.
- 4, 13—National 150-mmf. tuning condensers ST-150.
- 2 National type "B" dials VB-D.
- 5—International resistor, 1 meg., 1 watt.
- 6, 14—Illini mica condenser, .000125-mf.
- 7, 16, 20, 24, 32, 35—4-prong Eby sockets.
- 8, 10, 19, 23, 31, 39—Acratest by-pass condensers; No. 2817, capacity .02-mf.
- 9—Frost 250,000-ohm potentiometer No. 6189.
- 11—Micamold resistor, 30,000 ohms, 1 watt.
- 15—International resistor, .1 meg., .5 watt.
- 17, 21, 29—Acratest 465 kc. transformers.
- 18, 22, 30—Acratest resistors, 50,000 ohms, .5 watt.
- 25—Acratest resistor, 15,000 ohms, .5 watt.
- 26—Frost potentiometer, 100,000 ohms, No. 6188.
- 27—Acratest resistor, 30,000 ohms, .5 watt.
- 28—Acratest resistor, 60,000 ohms, .5 watt.
- 33—Micamold condenser, .001-mf.
- 34—Acratest I.F. choke No. 2871.
- 35—Acratest resistor, 150,000 ohms, 1 watt.
- 36—Acratest coupling condenser, .075-mf.
- 37—Frost potentiometer, 500,000 ohms.
- 40—Acratest push-pull input transformer No. 5834.
- 41, 42—Eby 5-prong sockets.
- 43, 44, 45, 46, 47, 48—Pins of Eby 6-prong socket.
- 49—Power switch mounted on (37).
- Special drilled and folded panel and chassis, Blan, the Radio Man.
- 3 Hammarlund tube shields, type TS.

(Continued on page 308)

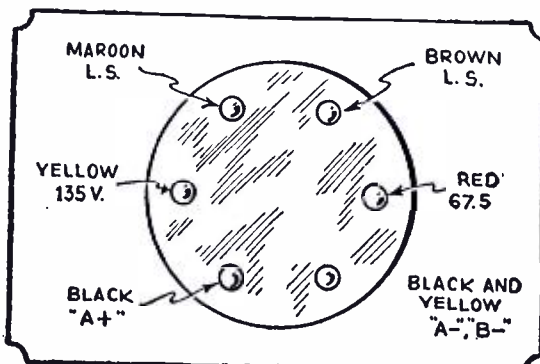
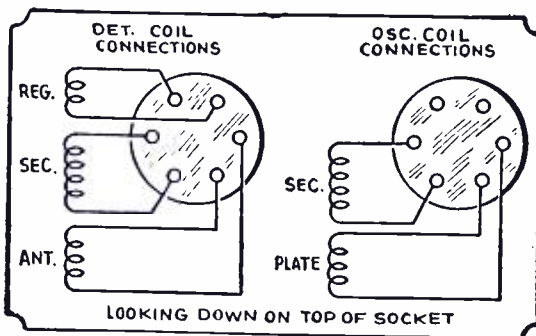
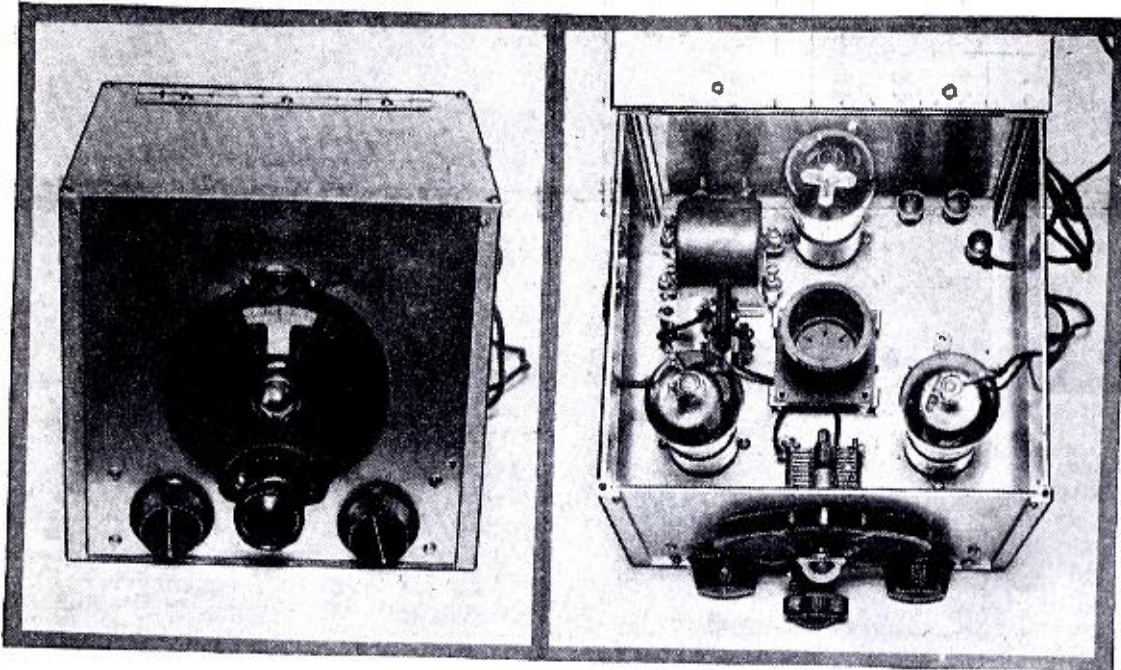

Diagram above shows the connections of detector and oscillator coils to 6-pin forms, and lower diagram shows the line-up of battery cable plug terminals.

Winners in the Second Set Builders' Contest

FIRST PRIZE—\$50.00

Won by EDWARD G. INGRAM



Mr. Ingram's De Luxe Short-Wave Receiver.

Edward G. Ingram, of New York City, walks off with the "first prize" honors in the JUNE contest, with his well designed and beautifully built short-wave receiver illustrated above. There were only four entries for June and each has been awarded a prize. Come on, boys, send us some more sets!

also provided with a screen-grid tube. This stage supplies some additional gain in amplification, eliminates "dead spots" in the tuning range, and permits either a long or short antenna to be used without affecting dial settings and smooth regeneration.

The A.C. tubes used are a type '35 in the R.F. stage, a '34 or '24 in the detector stage, and a '27 in the audio stage. For automobile service it is merely necessary to use the 6.3-volt automotive tubes and take the filament supply from the car battery and the plate supply from dry batteries.

Knowing that the successful performance of a short-wave receiver depends to a considerable extent upon the design of the A.F. stage into which the detector works, considerable thought was put into this end of the receiver. Owing to the high A.C. plate resistance of the screen-grid detector, transformer coupling is unsuitable, at least with the transformers now available. With resistance coupling the I.R. drop in the plate resistor seriously reduces the voltage available on the plate of the detector, unless a voltage supply greater than 180 is obtainable.

It was well known that provision of a choke in the plate circuit in place of the resistor would be a solution to the difficulty, but the problem was to find a choke of the necessary high impedance which would fit into the small space available in this little receiver.

In a recent issue of SHORT WAVE CRAFT, Robert Hertzberg pointed out that the secondary of an audio transformer sometimes could be used to fulfill the purpose of a series plate choke. Experiments showed that some of the large type transformers worked very nicely in this way, but these also were too large for the set. At last an old type Patent No. 26 audioformer was found, having very small dimensions and shielded with a white metal cover which harmonized with the aluminum chassis and box. Tests showed that the secondary of this transformer functioned nicely as a high impedance choke, and it fitted easily into the set. With this transformer and proper by-passing of the R.F. current, the set was found to regenerate smoothly on all short-wave bands when the plate voltage was 180.

While primarily designed for earphone reception, it was found that this little receiver would operate a loud speaker with good volume on many local and distant stations. The first evening the perfected receiver was put in operation, the following stations were received within a short period: VE9GW, Bowmanville, Canada; EAQ, Madrid; FYA, Pontoise

(Continued on page 315)

● COMPACTNESS combined with sensitivity sufficient to receive short-wave stations throughout the world was the primary consideration in the development of the short-wave receiver submitted for this contest. It was not the intention to build a minute receiver on the order of the coat-pocket or cigar box type, because greater sensitivity was required than could be obtained from a receiver of this size, but rather to produce one small enough to be placed by a bed for convenient use day or night.

While A.C. operation was a requirement for home use, it was thought desirable to build a receiver which easily could be changed for battery operation

so that it could be carried in an automobile at times to test reception conditions in other localities. This does not mean that operation with the car in motion was intended.

Space limitations called for a receiver having linear dimensions of approximately 7 1/4 x 7 1/2 x 7 1/2 inches. This made impracticable the use of a tuned R.F. stage, which would call for two coils in separate shielded compartments. To obtain the necessary sensitivity without a tuned R.F. stage, a screen-grid detector is used. This will bring in signals which would be inaudible with a three-element tube. The detector is supported by an untuned R.F. stage, choke-coupled, and

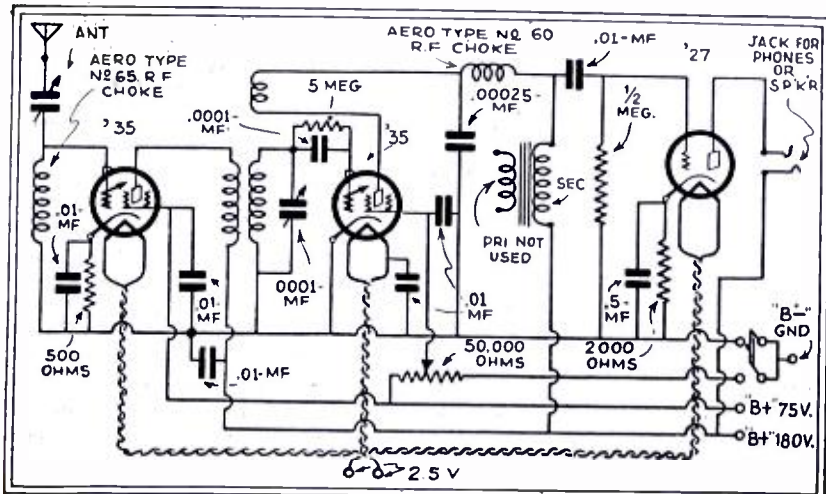

Wiring diagram worked out by Mr. Ingram and which provides a very efficient, selective and powerful short-wave receiver. The set works very smoothly indeed.

SECOND PRIZE—\$25.00

Won by PAUL V. PRICE

Short-Wave Portable.

Photos at left and below show the "second prize" winner—a "Hiker's" S. W. portable receiver, built by Mr. Price. The watch is shown for comparison.

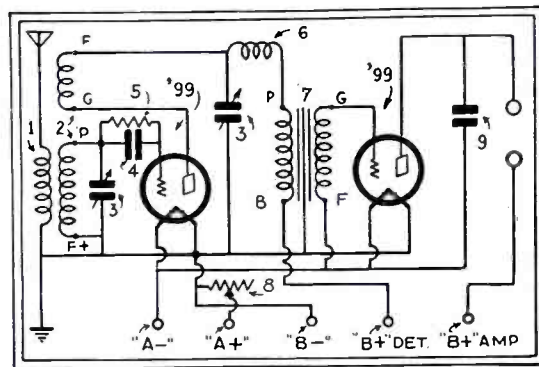
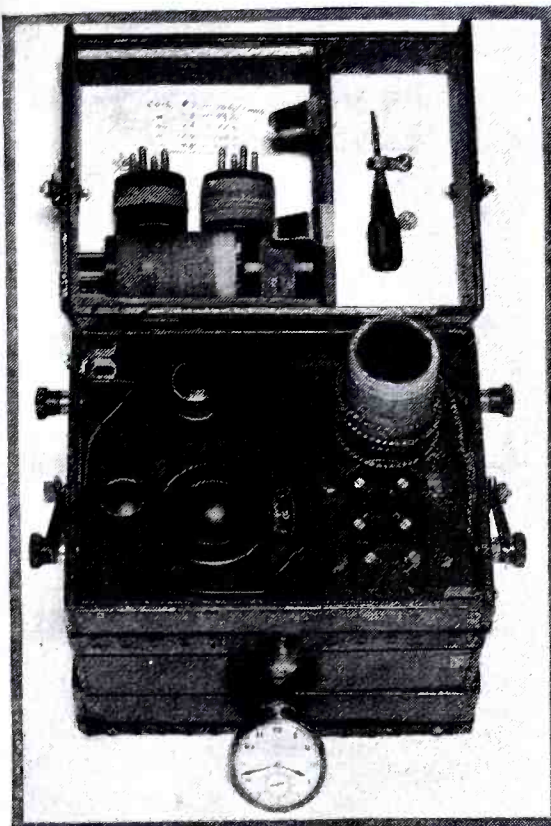

Wiring hook-up used by Mr. Price in building the "Hiker's" short-wave portable receiver, which is designed for use with phones.

● PERHAPS the most difficult part of the building of this "HIKER'S SHORT WAVE PORTABLE" is the construction of the container or carrying case. Secure cigar boxes of the following sizes or cut down larger sized ones to fit the requirements:

- 1 box 5½ x 7½ x 2½ inches—Bottom of container.
 - 2 boxes 5½ x 7½ x 2½ inches—middle of container.
 - 1 box 5½ x 7½ x 2¼ inches—Top of container.
- Make sure that all parts of the boxes

are of wood and not cardboard. Remove the paper on the box by placing it in warm water for a few seconds. Allow it to dry, and sandpaper it with fine sandpaper. Remove the tops and bottoms from the two "middle" boxes so that only the frames remain. From another cigar box cut two pieces of wood 2 x 6¾ inches or just the length necessary to fit inside the frames. Put one frame on top of the other and hold them permanently together by nailing the strips on the inside of the frames, so that they are 1¼ inches from the bottom edge of the double frame and 1 inch from the top edge. The "top" part of the strips supports the panel and a board can be placed on the other edge to separate the set from the batteries, if de-

(Continued on page 314)

THIRD PRIZE—\$12.50

Won by SAMUEL RUBIN

● FRANKLY, I have been dabbling with radio receivers for about five years. Most of the sets I have used have been standard commercial short-wave receivers and converters, but lately the building itch got me. I wonder how many of you short-wave enthusiasts have had the extreme pleasure of building your own? You that have will know just how it feels to complete a new receiver of more or less your own design, hook it up and thrill at the first reception.

The amateur builder is always looking for a circuit which is particularly acceptable to his pocketbook as well as his ability. My problems were just this. Batteries are a nuisance and bulky and

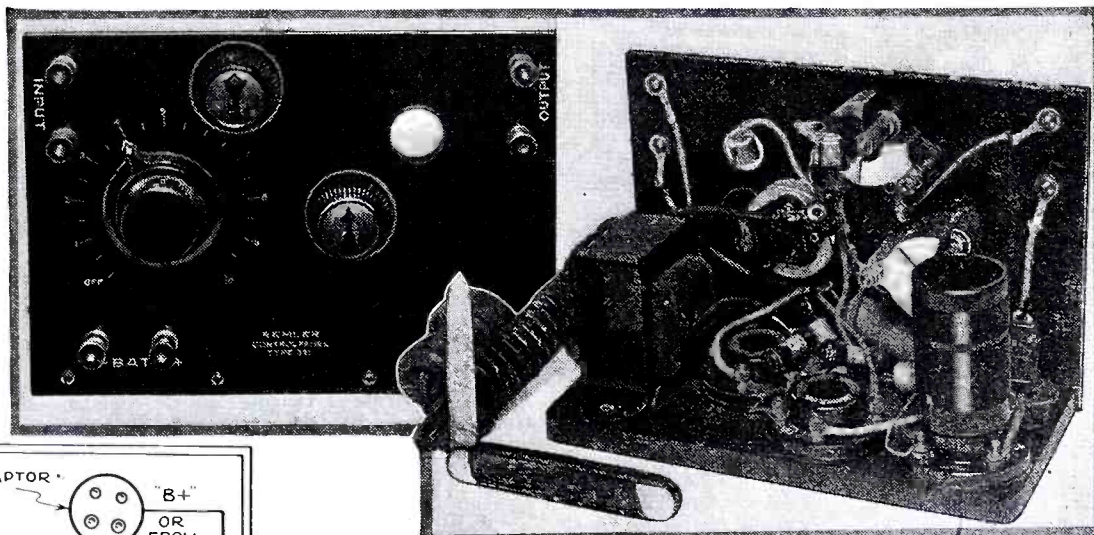

Miniature S-W Receiver.

Mr. Rubin built one of the smallest, efficient short-wave receivers that we have seen; note the comparative size of jack-knife. Diagram for Mr. Rubin's set is given at the left.

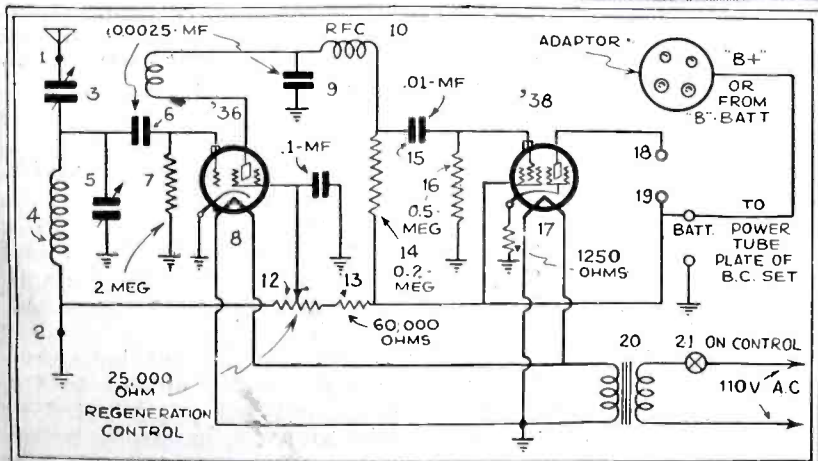

therefore out of the question. Then my set must be A.C. operated. To build a "B" power supply is costly, and greatly increases the size of the set. Why not utilize a supply already available in my broadcast receiver? Well, why not? And I did! I had heard that the new automobile tubes were excellent for short-wave reception and because of their being exceptionally small in size were particularly desirable. Secondly,

(Continued on page 314)

SHORT WAVE LEAGUE



HONORARY MEMBERS

Dr. Lee de Forest
 John L. Reinartz
 D. E. Replogle
 Hollis Baird
 E. T. Somerset
 Baron Manfred von Ardenne
 Hugo Gernsback
Executive Secretary

A Real Live Club

By **ROBERT HERTZBERG, W2DJJ**

• WHAT holds a successful radio club together? A club station, comfortable meeting quarters, good technical talks, an energetic president, code lessons? All these factors are undoubtedly important, but there is still another—diversification of interest. Or in less high brow language: don't talk radio all the time, but change the subject occasionally.

Too much of a good thing is never too good. Even the most enthusiastic radio nut's interest will wane just a little if he is fed oscillating circuits, directional antennas and screen-grid tubes every meeting. The man who is interested in radio is invariably also interested in scientific things in general, for a man cannot know something about radio without also knowing something about the related arts of physics, chemistry, optics, etc. Some member who is only a beginner at radio may be an accomplished expert at back-yard astron-

omy, and may be able to deliver an altogether impromptu but highly interesting talk on home-made telescopes. Another may have had practical experience with X-ray tubes, and can tell some of the extraordinary work being done with them.

One of the best examples of a radio club that has followed and encouraged this policy of diversification is the Bronx Radio Club, located in the borough of the Bronx in the City of New York. Started in 1922, it is still running strong and shows no sign of letting up. Its membership list has included and still includes some very well known radio personages, who find relaxation and enjoyment in the weekly meetings. These are held in the cellar of the home of Frank Frimmerman, W2FZ, one of the pioneer short-wave amateur phone operators of the East. This meeting place is no ordinary dusty cellar, but a fully finished

slides. The walls are decorated with handsomely framed pictures of famous radio stations, conventions, deceased members, etc.

The meetings are generally characterized by their informality and total disregard of parliamentary procedure. If no definite talk is scheduled, the chatter of the thirty or so men present will range all the way from tire trouble to the correct method of neutralizing a 500-watt power amplifier. However, let one unusual idea or suggestion pop up, and immediately a round table discussion will take place. Everyone is encouraged to talk; sometimes a sixteen-year-old high school sophomore is able to explain something that has stumped another man old enough to be his grandfather.

The best talks and lectures seem to be the extemporaneous ones. The club's star performer is S. Young White, internationally famous for his work on the various Loftin-White contributions to the radio art, whose versatility and ready wit are the marvel of his listeners. A radio engineer of long experience, he is also a flier of no mean ability, and during an involved description of a combination one-tube oscillator-modulator circuit he is quite likely to digress into the tricks of getting out of a tailspin or on how to unwrap yourself from a balky parachute.

Although radio has been and always will be the main topic of conversation, a list of the other subjects that have been discussed expertly and at great lengths reads like the table of contents of the Encyclopedia Britannica. Let's see: astronomy, photography, aviation, life saving, boating, automobiling, mathematics, optics, the theatre, amateur and professional movie making, target shooting, medicine, psychology, politics, jewelry, and matrimony (and how!) Very frequently a member will walk in with a movie projector under his arm, and entertain with films of his own making.

It isn't safe for anyone to "pull a boner" in geography, for many of the members are or have been ship operators and are as familiar with rick-shaws and camels as they are with the nearby subway. Radio operators do see the world, you know!

The Bronx Radio Club has long been active in amateur radio affairs in the Second District and has participated in many activities and won handsome prizes in competitions. An accompanying pic-

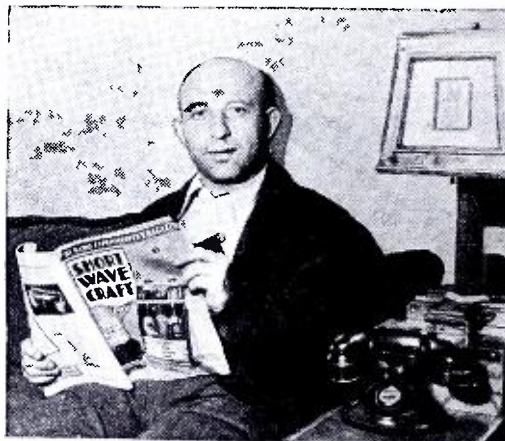

Above—Frank Frimmerman, who took time to pose for us although highly absorbed in reading an article in *SHORT WAVE CRAFT*. Mr. Frimmerman is a very active member of the Bronx Radio Club and he built the beautiful transmitting and receiving station shown in the photo at the top of the next page. The club makes its headquarters at his home, where the station is located. Some of the trophy cups won by this club are shown in the bookcase at the left.

room about 30 x 15 feet, equipped with an illuminated blackboard, a code practice table and a closet for books and apparatus. Over the blackboard is a large window shade which makes an excellent screen for motion pictures and lantern

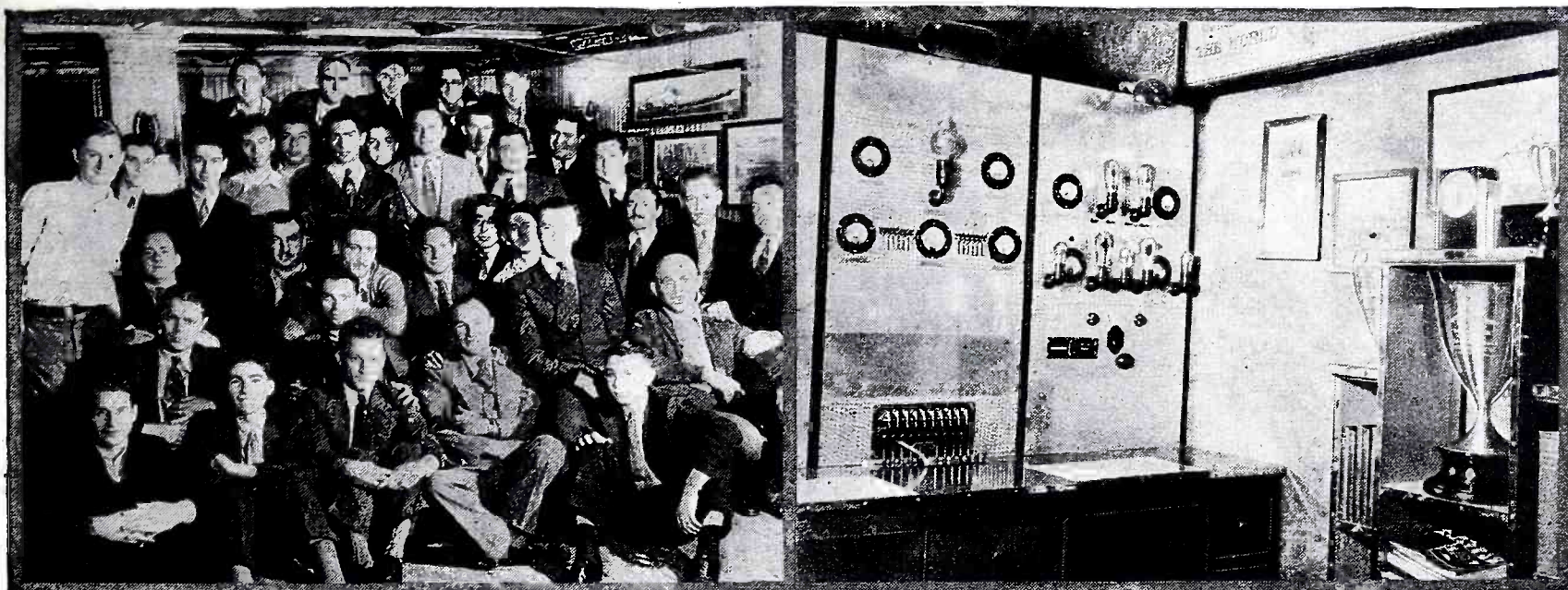

A Short-Wave Radio Club what am! Here's what the editors like to see and we hope that this will be the start of an avalanche of photos of SHORT WAVE LEAGUE clubs all over the country—we shall use all we can.

Oh Boy! What a Station! Mr. Frimmerman, whose likeness is shown on the opposite page, is the genius who designed and built this elaborate amateur transmitting and receiving station.

ture shows some of the trophies mounted in a modernistic cabinet that adorns Frimmerman's station upstairs.

The Bronx Radio Club does not have a club station, as such, but since W2FZ is only ten feet upstairs, this station receives numerous visitors on Friday nights, when the meetings are held. The equipment, which is now being rebuilt to accommodate the latest ideas in amateur practice, is pictured herewith. Everything is mounted on or behind vertical aluminum panels, which are machine finished. When the outfit is finished, there will be two independent short-wave receivers, a broadcast receiver, power amplifiers for all three, a television unit, and a complete 250-watt phone transmitter. Everything is being made by Frimmerman himself, who is not a radio engineer, as his apparatus would indicate, but a furrier!

Except for special holidays, the club has not skipped a Friday night meeting for more than ten years, summer or win-

Get Your Button!

The illustration herewith shows the beautiful design of the "Official" Short Wave League button, which is available to everyone who becomes a member of the Short Wave League.

The requirements for joining the League were explained in the May issue; copies of rules will be mailed upon request. The button measures $\frac{3}{4}$ inch in diameter and is inlaid in enamel—3 colors—red, white, and blue.



Please note that you can order your button AT ONCE — SHORT WAVE LEAGUE supplies it at cost, the price, including the mailing, being 35 cents. A solid gold button is furnished for \$2.00 prepaid. Address all communications to SHORT WAVE LEAGUE, 96-98 Park Place, New York.

ter, rain or shine. This is truly a record of which to be proud! Many of the charter members, men who now have families or perhaps other hobbies, still attend. The membership is by no means limited to the Bronx; men come from Long Island, Westchester and New Jersey. Members who have not been around in four, five or eight years may drop in unexpectedly from California, South America, Europe or Japan, to find a hearty welcome and an enjoyable meeting.

The club has a treasurer, but he isn't too persistent. If money is needed, say, for one of the occasional "hot dog" parties or for an exhibit at some convention, it appears mysteriously out of some place. The word is simply passed around—not the hat—and everyone contributes, perhaps a dime, perhaps ten dollars.

The meetings are always open. All a visitor need do is identify himself as a radio man and he is welcome to a seat—if he can find an empty one!

When to Listen in By Robert Hertzberg

Verifications from G5SW

"World Radio" is the official organ of the British Broadcasting Corporation. Therefore, the following letter and its accompanying instructions may be read with profit by all short-wave listeners:

WORLD-RADIO

Savoy Hill, London W.C.2

DEAR SIR:

Owing to the large number of requests for the confirmation of reported reception of our experimental short-wave station, G5SW, it has been decided to include such questions among those which this journal answers in the course of its service known as "Which Station Was That?" The conditions under which these questions are answered will be found in the accompanying leaflet to which special attention is directed.

For experimental purposes G5SW radiates the London programme, at the following times: 12:30 p. m., 1:30 p. m., 7:00 p. m., midnight. Except on Saturdays and Sundays.

In the meantime, we are glad to be able to confirm that according to the particulars you furnish, you received G5SW on September 1st, 1931.

Yours faithfully,

EDITOR.

American Stations

Station W9XAA, Chicago, is now using 11,830 kc., or 25.36 meters.

W2XNE, formerly located in Jamaica, Long Island, has been moved to Wayne, N. J., where the 50-kw. transmitter of WARC, key station of the Columbia network, is located. It has also been licensed to use 11,830 kc., or 25.36 meters, and 15,270 kc., or 19.65 meters.

A Good Suggestion

J. M. Covington, Corregidor, Cavite, Philippine Islands, writes:

"It is suggested that the 'star' United States short-wave broadcasting stations be added to your list of 'star' short-wave broadcasting stations published in SHORT WAVE CRAFT. Accurate schedules of the most powerful U. S. stations will save your foreign readers a lot of sleep.

"Among the most important short-wave stations that I have received with good clarity on the loud speaker are the following:

W8XK, Pittsburgh, 25.24 meters.

W2XAF, Schenectady, 31.48 meters.

FYA, France, 19.68 and 25.63 meters.

I2RO, Rome, 25.42 meters.

I3RO, Rome, 80 meters.

G5SW, England, 25.53 meters.

Konigs-Wusterhausen, Germany, 31.38 meters.

VK2ME, Australia, 31.28 meters.

VK3ME, Australia, 31.38 meters.

F3ICD, Saigon, Indo-China, 49.1 meters.

RV15, Khavarovsk, Siberia, 70.2 meters.

HSP2, Bangkok, Siam, 41 meters.

VQ7LO, Africa, 49.5 meters.

Moscow, 50 meters.

PLV, Java, 31.86 meters.

Rabat, Morocco, 23.38 meters."

Your suggestion is a good one, Mr. Covington, and we will feature the American stations as well as the foreign ones in the next issue. As a matter of fact, we intend to revise the whole list completely, as there have been many changes between issues.

Schedule of Rome

From A. N. Lump, 4413 North 7th Street, Philadelphia, Pa.:

"On a card received from I2RO they state that they broadcast on 25.4 and 80 meters from 1700 to 1830 and 2030 to 2330 Central European Time, or 11 a. m. to 12:30 p. m. and 2:30 to 5:30 p. m., E. S. T. I also wish to state that after trying about eight other short-wave logs and magazines, I find yours the best in every respect. Your log and time table are great."

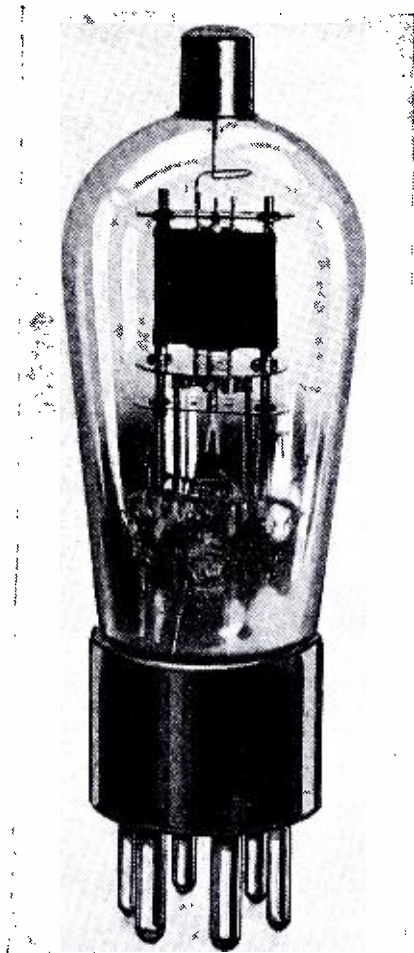

Fig. 5 (left). Photo of the Duplex - Diode Triode—otherwise known as the 55. The type 85 is identical, with exception of the filament rating. It is 6.3 volts for the 85 and 2.5 for the 55.

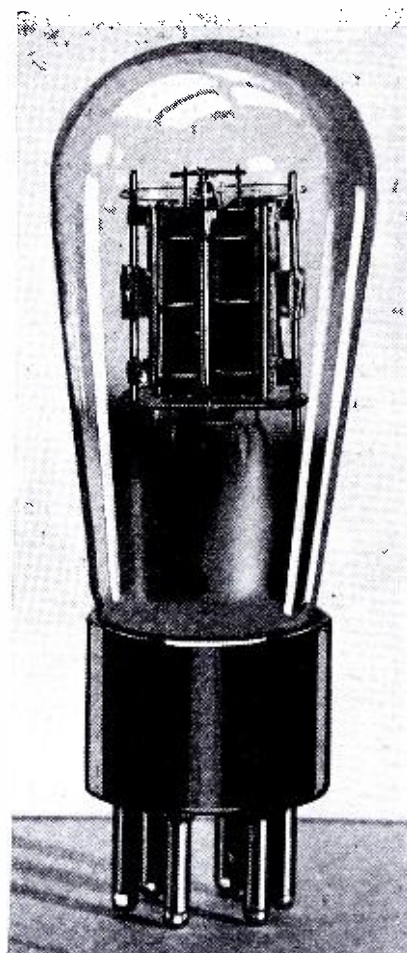
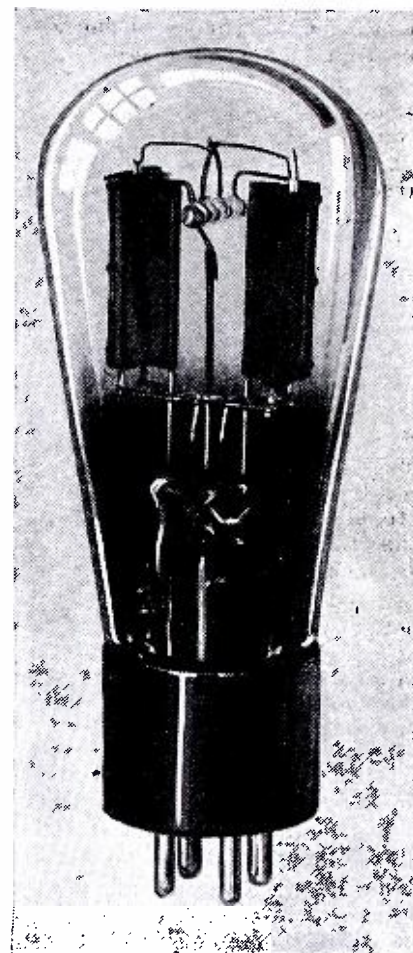

Fig. 9 (left). This is the new high-voltage rectifier capable of delivering 250 ma. Fig. 7, right, the new 29 and 69 special detector having two separate cathodes and grids.



New Receiving Tubes— Detectors and Rectifiers

By LOUIS MARTIN

● SINCE the days of the crystal receiver, old-timers have been seeking means whereby the quality secured from the crystal detector may be obtained from vacuum tube detectors. Not many years ago, sensitivity and volume were the main requisites of a good receiver, but today, with 1-microvolt sets in common use, engineers have been turning their attention toward quality.

Some remarkable strides have been made in this direction already, and the rather recent announcement of the return of the old diode (two-element) detector marks another milestone in the march toward quality.

Ten years ago audio transformers were peaked at 1,000 cycles so that the response of the audio amplifier would be a maximum at that frequency; today, such transformers are nearly obsolete because they introduce distortion. All of these advances affect short-wave reception to a far greater extent than broadcast reception. Why? Because the selectivity of the average broadcast receiver is so much less than any short-wave receiver that, to obtain good quality at the shorter wavelengths, every possible means must be used to retain whatever quality is received at the antenna.

It will be but a short time before the following tubes will be used in every receiver, both long and short wave.

The 55 and 85—Duplex-Diode Triode

The original Fleming valve, used as the first vacuum detector, was of the diode or two-element type. The insertion of the third element—the grid—by De Forest, created a sensation and the triode (three-element) completely overshadowed its predecessor, the diode, until about a year ago, when the diode returned incognito.

To properly rectify strong signals and at the same time retain an output which resembles the original input to some extent, requires a low impedance tube. The diode admirably serves this purpose. The circuit of a simple diode rectifier, shown in Fig. 1, is simplicity itself. The secondary of the detector or R.F. transformer connects to the plate and filament of the tube through the resistor, R1. During the time that the plate is positive, due to a signal, current flows through the resistor; during the alternate half-cycles when the plate is negative, no current flows. Thus the device becomes a half-wave rectifier of the type used in "B" power units. Note the fact that there is no external "B" voltage applied to the plate of the tube.

Since current only flows during half the cycle, the device is not as efficient as it might be, and so another plate may be inserted as shown in Fig. 2. Here it may be seen that current flows through the resistor during both halves of the

cycle, in a manner similar to the usual full-wave "B" power unit. Now we have a very simple means of rectifying the incoming signal, but since no plate voltage is applied, the input signal must be fairly strong if an appreciable amount of current is to flow. Another important point is that the D.C. component of the plate current also flows through R1, so that we may say in conclusion that the voltage across R1 consists of a D.C. part which must be removed from the grid of the succeeding tube, and an A.C. component—the actual signal. The use of the A.C. part is clear, but the manner in which the D.C. component is used (if at all) needs some explanation, which will be given shortly.

It seems reasonable that if a grid and another plate be placed in the same envelope as the double diode of Fig. 2, triode amplification could be secured in addition to the diode detection. This idea is depicted in Fig. 3.

The conditions are exactly the same as for Fig. 2, with the exception that the voltage developed across R1 is connected to the grid of the triode which is now an integral part of the tube itself. The D.C. voltage across the resistor R1 now provides the proper bias for the triode part of the tube. Thus, in a single envelope (glass tube), there is a double-diode and a triode—hence the name.

Fig. 3 is the fundamental circuit of

the 55 and 85 tubes. (The 85 is exactly the same as the 55, with the exception of the filament rating.) The commercial 55 has an additional unique feature of construction. A single cathode, exactly as in the 27, surrounds the heater. Surrounding the cathode at one end is the two diode plates. Surrounding the cathode at its other end is the triode grid and plate. The two sets of elements are separated by a mica disc as shown in Fig. 4A, the socket connections being given in Fig. 4B. The location of the diode plates with respect to the other elements is clearly shown in the photograph of Fig. 5.

Figure 6 is a list of the commercial circuits in which the tube may be used. Note that at A of the figure, an additional resistor, R2, and condenser, C3, are used. These are merely for automatic volume control purposes (A.V.C.). If only diode rectification is desired, the two plates, P1 and P2, may be connected together as shown in C and D of the same figure.

Note that in B of the figure the triode grid return is connected to the "C" battery through resistor R4; hence the bias on this tube is fixed and is not dependent upon the voltage across R1, and hence the signal. The description of the remainder of the circuits are given in the diagram.

For the benefit of those desiring to try the tube, the following constants are recommended for the circuit of Fig. 6. Resistor R1, .5-meg.; R2, 2 meg.; R3, .1-meg.; R4, .5-meg. Condenser C1, .00015 mf. for T.R.F. receivers, and .0006 mf. for second detectors in superheterodynes; C2, C3, C6, .01-mf.; C4, C5, 5-mf.; C7, .05-mf.

The characteristics of the triode section of the tube is as follows: Heater voltage, 2.5 volts (6.3 volts for the 85); heater current, 1. ampere (.3-ampere for the 85); plate voltage, 250; grid voltage, -20; amplification factor, 8.3; plate resistance, 7,500 ohms; mutual conductance, 1,100 micro-mhos; plate current, 8 milliamperes; load resistance, 20,000 ohms; undistorted power output, 200 milliwatts.

The 29 and 69—Special Detector

Another type of detector, known as the 29 and 69. (both tubes are identical except for the filament rating) is now available to users. This tube, having a very low input impedance is specially adaptable for second detectors in superheterodynes. Its general appearance is shown in Fig. 7 and its internal construction in Fig. 8.

As may be seen by reference to the figure, it consists of two separate cathodes, each of which has its own grid. Surrounding the entire structure is a single plate. The tube is connected like a push-pull amplifier, each of the grids tying to one end of the input transformer secondary. The center tap of the input transformer then becomes the grid return. The theory of operation is very simple. While one grid is positive, plate current flows; during this time the second grid is negative and no plate current flows, due to this grid. The process reverses during the second half of the cycle, and thus the tube becomes a full-wave rectifier.

As far as short-wave work is concerned, the low input capacitance of this tube is especially desirable. The D.C.

component obtainable may be used for A.V.C. work and the author predicts its ultimate use in short-wave receivers, when real quality must be had.

To utilize the 29 or 69 for A.V.C. work in addition to its duty as a detector, the grids of the R. F. tubes must be removed from a D.C. ground connection. That is, tuning must be accomplished through a .05 tuning condenser. The noise level in the receiver will probably be high unless the antenna coil is grounded directly. The plate circuit will require some filtering and the usual .001-mf. condenser will be found insufficient. A 10,000-ohm resistor in series with the plate or the addition of an R.F. choke will be found helpful.

The following characteristics obtain: Heater voltage, 2.5 for the 29 (6.3 for the 69); heater current, 1. ampere (.3-ampere for the 69); plate voltage, 180; grid bias, -3 volts; amplification factor, 30; plate resistance, 20,700 ohms; mutual conductance, 1,450 micromhos; plate current, 4.5 ma.

The 83—Full-Wave Mercury Vapor Rectifier

The use of Class B tubes in broadcast receivers is rapidly increasing. To supply the increasing demands of such receivers, the 83, a mercury vapor rectifier, has been designed and is now offered to the public.

In size and physical appearance, it resembles the 280, but in electrical characteristics it differs radically. One of the most important characteristics of this tube is the practically constant 15-volt internal drop from no load to full load. To appreciate what this means, it may be pointed out that the additional voltage secured by using an 83 over a 280 is nearly 100 volts!

It becomes at once evident that if the full possibilities of this tube are to be realized, a practically constant voltage power transformer must be employed.

In all respects, the connections of this tube (illustrated in Fig. 9) is identical to the 280. The following ratings should be followed: Filament voltage, 5 volts; filament current, 3 amperes; maximum A.C. voltage per plate, 500 volts (R. M. S.); maximum peak inverse voltage, 1,400 volts; maximum D.C. output current, 250 milliamperes; maximum peak plate current, 800 milliamperes; tube voltage drop, 15 volts.

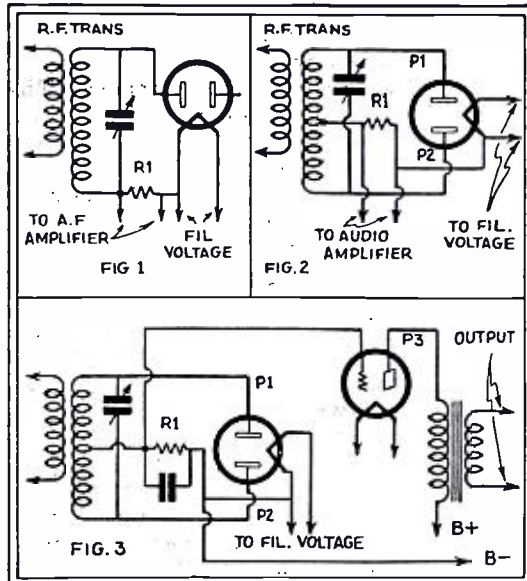

Figs. 1, 2 and 3—Fundamental circuits of diode rectifiers.

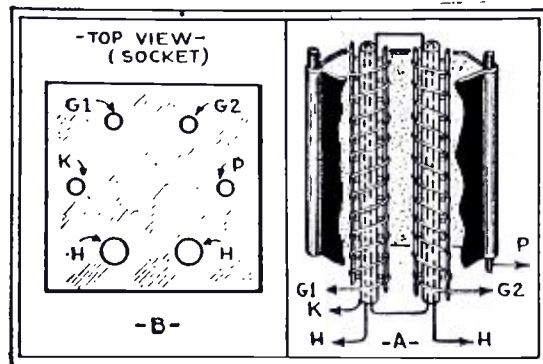

Fig. 8—Left, socket connections; right, internal construction of the new 29 and 69 detectors. Note the use of a double heater, cathode and grid; only one plate is necessary.

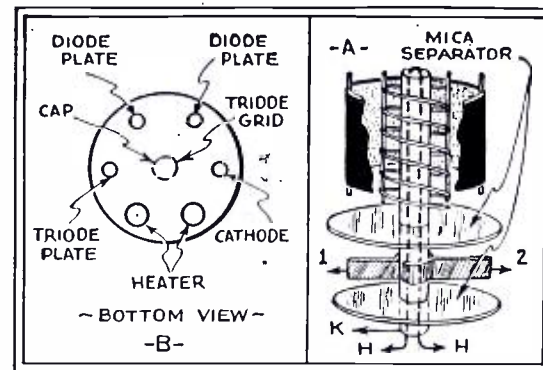

Fig. 4—At the left, socket connections; at the right, internal view of the elements in the new Duplex-Diode Triode. Contrast this internal arrangement with Fig. 8, above.

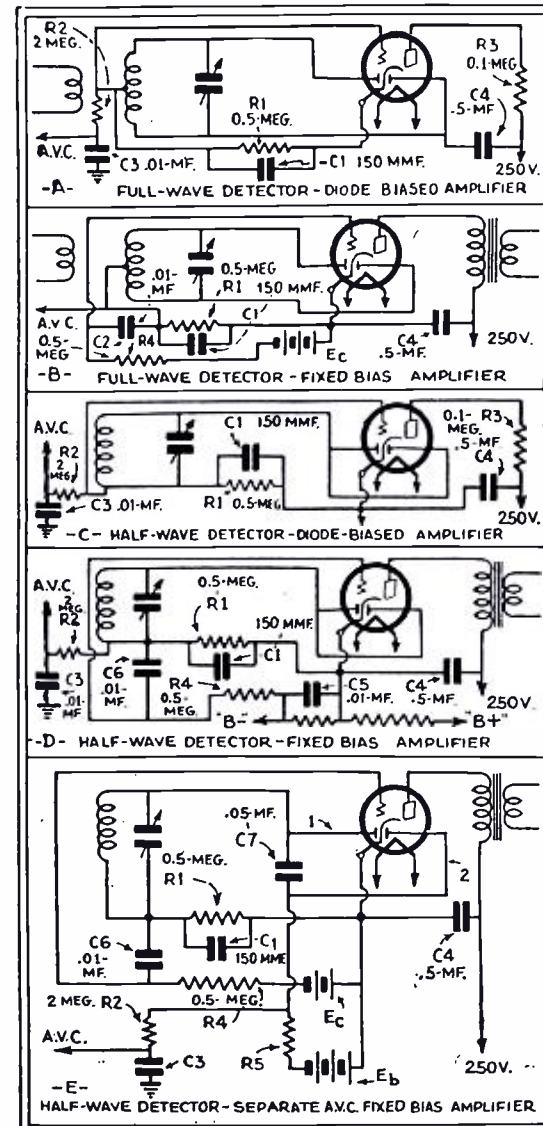
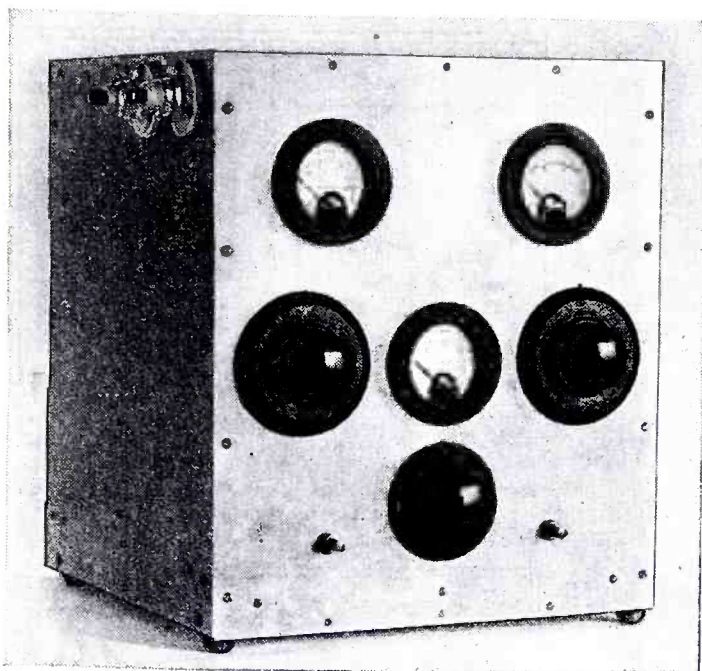

Fig. 6—Commercial circuits using the 55 or 85 tubes.



Front panel appearance of the extremely well designed 1-tube master oscillator-power amplifier transmitter, using a single UX-860 tube.

A ONE-TUBE Master Oscillator Power Amplifier TRANSMITTER

By A. J. SPRIGGS, W3GJ

● IN the December issue of the *Proceedings of the Institute of Radio Engineers*, Mr. J. B. Dow, in an article entitled "A Recent Development in Vacuum Tube Oscillator Circuits," described a new type of oscillator circuit based upon the use of a four-element tube.

The original basic circuit is shown in Fig. 1. The filament, control grid, and screen grid of the tube are so connected as to form, with the associated apparatus, an oscillating circuit similar to the conventional Colpitts circuit. (The use of the Colpitts type of circuit is not strictly essential, however, as any of several standard oscillator circuits may be used.) The constants of the elements of this circuit determine the frequency generated, except for slight variations which may be caused by effects external to this circuit. The output or load circuit is connected between the plate and filament of the tube, and is carefully shielded to prevent electromagnetic or electrostatic coupling between the plate or output circuit and the frequency determining circuit. The purpose of the balancing condenser C is to permit neutralization of the small electrostatic coupling between the output

Mr. Spriggs, who holds an engineering position with Uncle Sam, here presents a fresh new design of improved transmitter for the short-wave experimenter. This transmitter, here illustrated in photograph and diagram, is an experimental type suited to amateur frequencies and based upon the use of a UX-860 tube with the Dow circuit. A frequency determining circuit is provided.

circuit and the frequency determining portion of the circuit, which would otherwise exist due to the effect of capacity between the shield grid and the plate of the tube.

Since there is no electromagnetic or electrostatic coupling between the frequency determining portion of the circuit and the output circuit, it is apparent that the radio frequency power developed in the output circuit is due to the production of pulses of the plate current corresponding to the variations of potential developed on the control and screen grids by oscillations in the frequency determining circuit. The means by which the oscillations in the frequency determining circuit result in the production of radio frequency power in the plate or output circuit has been called "electron coupling." The

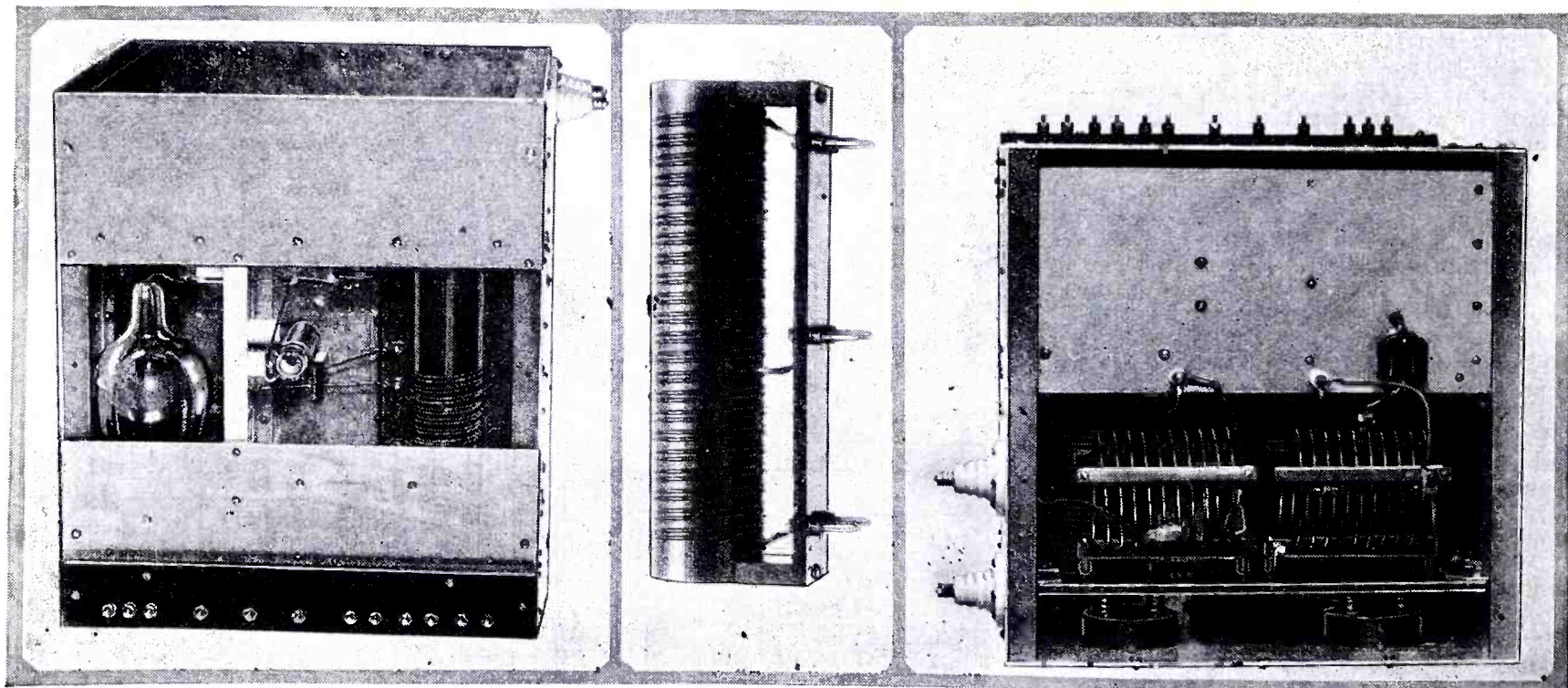

Fig. 7 (left) shows rear view of Mr. Spriggs' MOPA transmitter; Fig. 10 (center) shows one of the plug-in inductances, and Fig. 6 (right) shows top view of transmitter.

over-all effect is similar to the action in a master oscillator-power amplifier transmitter, the action of the frequency determining portion of the circuit and the filament, control grid and screen grid of the tube being similar to the action of the master oscillator, and the action of the screen grid, plate, and output circuit being similar to the action of a power amplifier stage.

In Fig. 2 is shown a somewhat different circuit arrangement in which the necessity for the use of the balancing condenser shown in Fig. 1 is eliminated by making use of the shielding properties of the shield grid. In this arrangement the shield grid is kept at zero radio frequency potential, with respect to ground, and serves as an electrostatic shield between the plate and the frequency determining circuit. This arrangement necessitates the use of chokes in the filament leads, since the filament of the tube is at radio frequency potential with respect to ground. The basic principles of operation of this circuit are identical with the principles involved in the circuit of Fig. 1.

Frequency versus Voltage Changes

In connection with various tests which have been made of the operating characteristics of the circuit shown on Fig. 2, it has been found that under certain conditions variations of the screen and plate potentials have effects upon the generated frequency of opposite sign. By suitable choice of the operating voltages a condition can be established under which, with the screen and plate voltages supplied from a common source or from the same line, practically no change in frequency will result from variations of line voltage of as much as 25 per cent. The curves shown in Fig. 3 show the effects upon frequency of variations in screen and plate voltages using a UX-860 shield grid tube, in a circuit similar to that shown in Fig. 2. By choice of operating voltages for the screen and plate corresponding to points on the curves where the slopes are equal and opposite, it is apparent that variations of line supply voltage will necessarily have minimum effect upon the generated frequency.

In addition to the very desirable characteristics of the circuit arrangement of Fig. 2 as regards frequency stability under varying line supply variations, this type of circuit has other advantages as regards frequency stability. Tests show that with this circuit, changes in the output circuit or loading have only slight reaction upon the frequency as compared with standard types of circuits. The small magnitude of this reaction is to be expected, due to the fact that there is little or no electromagnetic or electrostatic coupling between the output circuit and the frequency determining circuit. The effect of tuning of the output circuit upon the generated frequency can be reduced to a practically negligible value, only a few cycles per million, by tuning the output circuit to the second harmonic of the frequency generated in the frequency determining circuit. When operating in this manner, the amount of power obtainable in the output circuit has been 25 to 50 per cent of the power obtained when working straight through on the fundamental. Changes in the ambient temperature cause variations in frequency of about the same magnitude as with conventional oscillator circuits. Changes of filament voltage cause little change in frequency, provided the filament emission is sufficient to produce saturation at the plate voltage used. In general, variations of filament voltage of 5 to 8 per cent above or below normal operating values will have negligible effect on the frequency generated.

Special Switches for Mercury Vapor Rectifiers

The circuit diagram of Fig. 4 and the photographs and sketches shown in Figs. 5 to 11, inclusive, show various features of an experimental transmitter for *amateur frequencies* based upon the use of a UX-860 tube with the Dow circuit. The general arrangement of parts and details of assembly are shown in the photographs of Figs. 5, 6 and 7, and the sketches of Figs. 8 and 9. The frame is constructed of sheet aluminum and angle brass, well bolted and banded together.

Particular attention is invited to the circuit arrangement of the two switches on the front of the transmitter panel (S1 and S2 of Fig. 4). In order to provide for necessary time delay in application of plate voltage to the mercury vapor rectifier tubes, the switches are so wired that the left-hand switch lights the filaments of the oscillator and rectifier tubes and the right-hand switch applies the plate voltage. The plate voltage cannot be applied unless the filaments are lighted. The necessity of providing a 15 to 30 second delay in applying voltage to the rectifier tubes after their filaments are lighted is a responsibility of the operator in manipulating the two switches. Between transmissions the plate voltage can be removed by operating the right-hand switch to provide a stand-by condition. Retaining the oscillator in a lighted condition results in less drift of frequency when keying is again resumed.

The inductance system used in the frequency determining circuit utilizes a novel method of providing for operation of the filament of

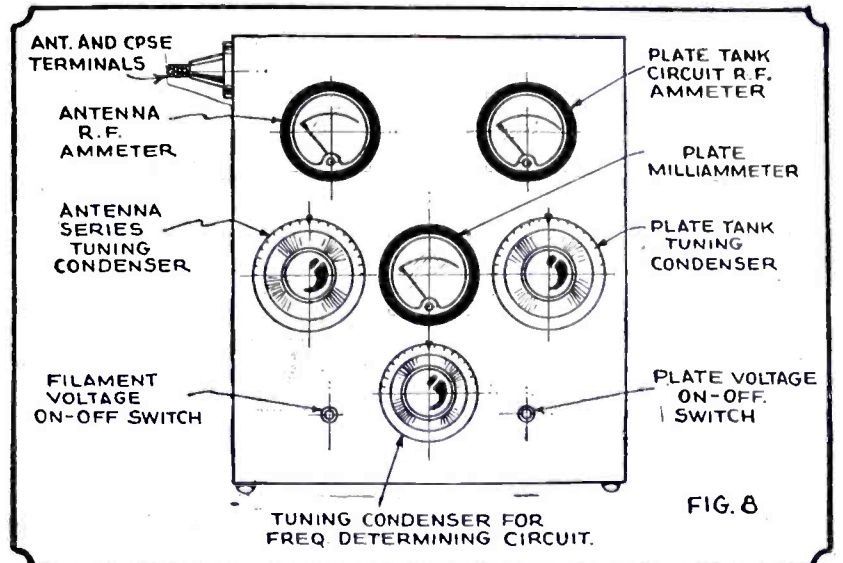

Fig. 8—Drawing above shows front view of Mr. Spriggs' single tube transmitter, which utilizes the famous Dow circuit. The names of the control dials and meters are given above.

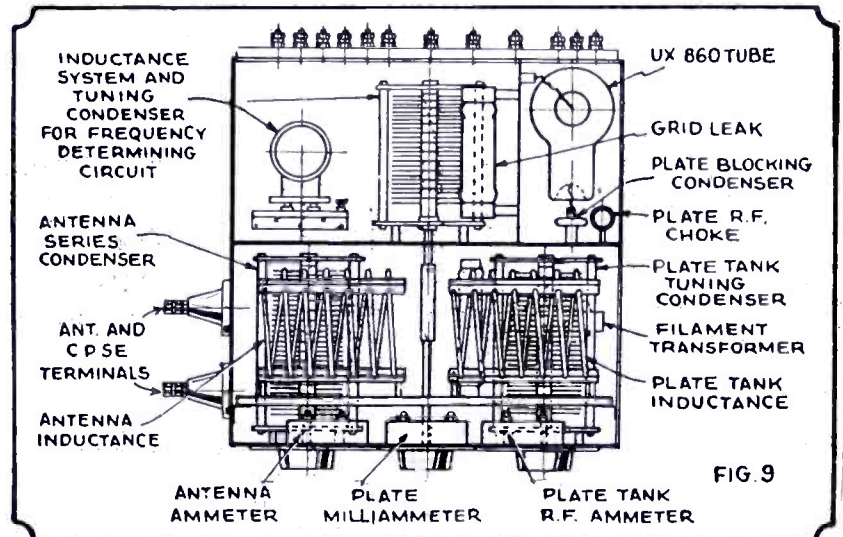

Fig. 9—Top view of the transmitter, showing position of UX-860 transmitter tube, together with location of various inductances and condensers.

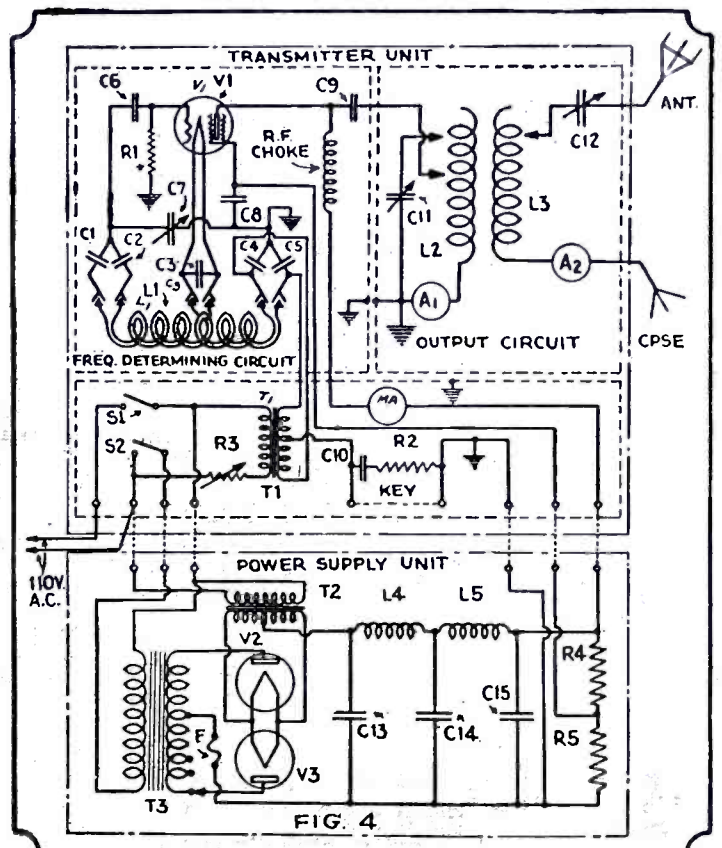
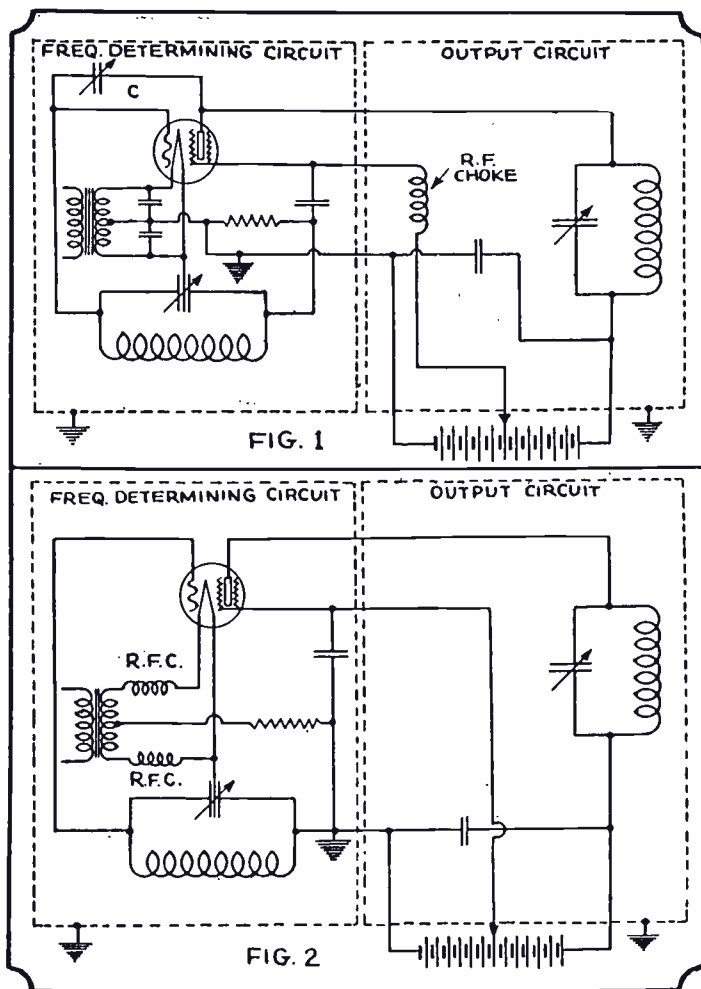

Fig. 4—Diagram above shows complete circuit of Mr. Spriggs' one-tube master oscillator - power amplifier transmitter, together with diagram of power supply unit. Dotted lines show shielding compartments.



Left—Fig. 1 shows the original Dow circuit based upon the use of a four-element tube. The filament, control grid, and screen grid tube are so connected as to form, with the associated apparatus, an oscillating circuit similar to the Colpitts circuit.

Fig. 2, below at left, shows a somewhat different circuit from Fig. 1, and which eliminates the necessity for the balancing condenser by utilizing the shielding properties of the shield grid.

Fig. 11, at right, shows details of plug-in inductances.

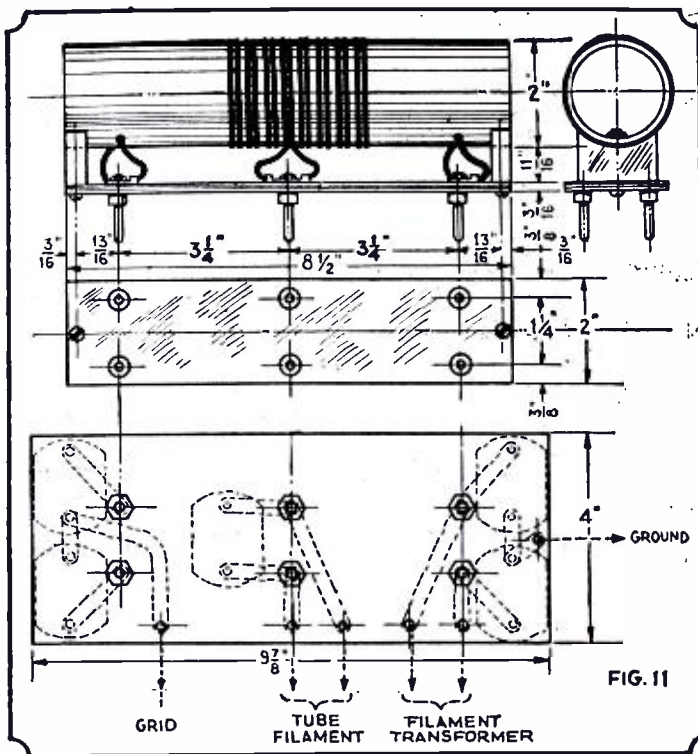

Fig. 3, at left—The curves here reproduced show the effects upon the frequency of variations in screen and plate voltages, using a UX-860 shield-grid tube, in a circuit similar to that shown in Fig. 2, above at left.

the tube at a radio frequency potential above ground potential, without the necessity of using radio frequency chokes in the filament leads by an arrangement similar to that shown in Fig. 2. Each coil is wound with two separate No. 14 enameled wires, wound side by side on a bakelite tube and arranged for plug-in connection in such a manner that the low voltage A.C. filament supply is fed through the two wires from the low potential end of the coil and taken off to the filament from the center of the coil. The two wires of the coil are by-passed at each end and in the middle in such a manner that, as regards radio frequency, the two wires are in parallel and equivalent in radio frequency effect to a single wire winding. The construction details of the coils and coil mounting are shown in Figs. 10 and 11. It has been found possible to cover the amateur 3.5, 7, and 14 megacycle bands by the use of only two coils for the frequency determining circuit, one of 22 turns tapped at the ninth turn, and one of 7 turns tapped at the third turn. For the lower frequencies, however, I recommend a coil of 19 turns tapped at the eighth turn instead of the 22-turn coil.

The radio frequency choke used in the plate circuit consists of a winding of No. 30 double-silk-covered magnet wire 4 3/4 inches long on a Victron tube 5 3/4 inches long and 3/4 inch in diameter. No choke was found to be necessary in the grid leak circuit because of the high resistance of the leak itself, i.e., 20,000 ohms.

It will be noted that the tube is located in a separate compartment, shielded from both the frequency determining and the output circuit. This additional shielding is highly desirable to reduce to a minimum the possibility of electrostatic coupling between the plate or output circuit and the frequency determining circuit. Additional shielding to close completely the tube compartment or the frequency determining circuit compartment was found to be unnecessary.

Since the filament leads between the tube and the associated coil system are at radio frequency potential, it is desirable that there be wide separation between these leads and the shielding, that the length of the leads be as short as possible, and that the leads be rigidly supported. The filament leads in the set are of No. 10 solid enamel wire and are rigidly supported about 1 inch apart, well clear of all shielding on bakelite pedestals made for the purpose. The isolantite tube socket is mounted in such a manner as to provide about 1 1/2

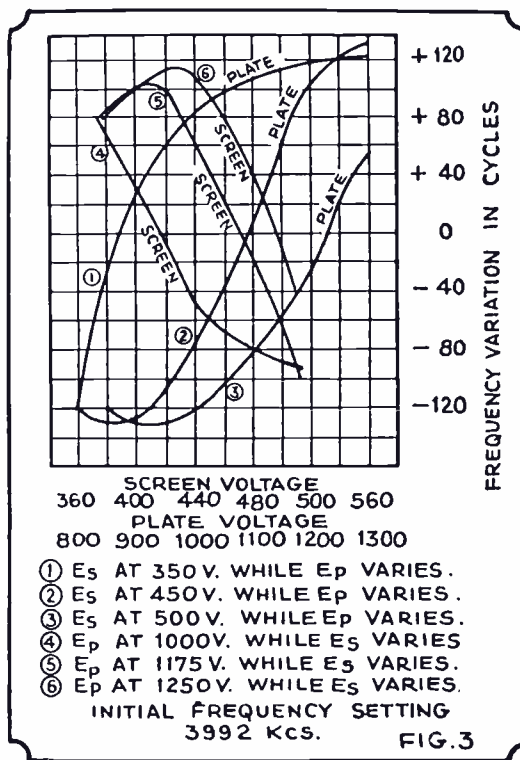

inches spacing between the base of the tube and the nearest shielding.

The filament transformer is located in the front compartment directly under the plate tank tuning condenser. The secondary leads run directly to the lower or grid end of the frequency determining coil system. In series with the primary of the filament are two resistors, one fixed and one variable. The fixed resistor is located in the front compartment just to the left of the filament transformer. (See Fig. 9.) The variable resistor is mounted on the underside of the subpanel and is not shown in any of the figures. The operating procedure includes an

initial adjustment of the variable rheostat to obtain correct filament voltage, after which no further adjustments are undertaken except for excessive variations of line supply voltage. The differences in voltage drop resulting from changing of coils in the frequency determining circuit has been found to be so slight that no readjustments of the filament circuit have been considered.

The plate tank and antenna coupling coils are of conventional design, 3 1/4 inches in diameter, each of 10 turns, and wound of No. 8 solid wire with bakelite supporting strips. The antenna coil is arranged to slide back and forth to provide variable coupling. The antenna series tuning condenser is completely insulated from the shielding. By suitable shifting of the taps on these coils it has been found possible to operate satisfactorily on all three of the 3.5, 7 and 14 megacycle band. By operating the frequency determining circuit on 14 megacycles and tuning the output to the 28 megacycle band with a smaller output coil, good output can be obtained at 28 megacycles.

The variable condensers used are Cardwell .00045 mf., 3,000-volt transmitting condensers, and the condenser dials are Velvet Verniers. A condenser of somewhat larger spacing would be preferable for use in the plate tank circuit, as the condenser shown has a tendency to spark over on high power in the 3,500 kc. band, and also in the 7,000 kc. band if the

(Continued on page 307)

THE SHORT WAVE BEGINNER

By C. W. PALMER

Receiving Aerials

No. 3 of a Series

● IT MAY seem to some of our readers that we jumped rather suddenly, last month, from our discussion of electric currents to the construction of a short-wave set. However, those of us who are interested in learning more about short waves are naturally impatient to get started, and even though the theory of radio reception is important, the reception of those elusive distant stations is more important.

Those who made the set last month may be a little disappointed that it will not operate a loud speaker. We must remember that just as a building must be started from the foundation up, so our receiver must be started small and be improved as we gain more knowledge and experience. Later, we will make the set larger so that more volume can be obtained.

Why the Aerial Is Used

At the broadcasting station the antenna system (aerial and ground) is used to create the electromagnetic radiations that we commonly call "radio waves," which travel out into space. For this reason, transmitting aerials are designed so that a maximum amount of power is radiated. At the receiving set, on the other hand, the function of the antenna is to act as a circuit in which the passing waves from the broadcasting station may be picked up (induced) in a manner very much the same as the example given in Fig. 10 of the first article of this series, in which a current was induced in the second coil when the switch was closed. (Refer to page 176 of the July, 1932, issue.) The waves that make up the signals from the transmitting station cause corresponding high frequency alternating currents to flow up and down through the circuit between the aerial and ground, which really forms the plates of a large condenser (like the plates of a variable condenser in our set). This effect is shown in Fig. 1.

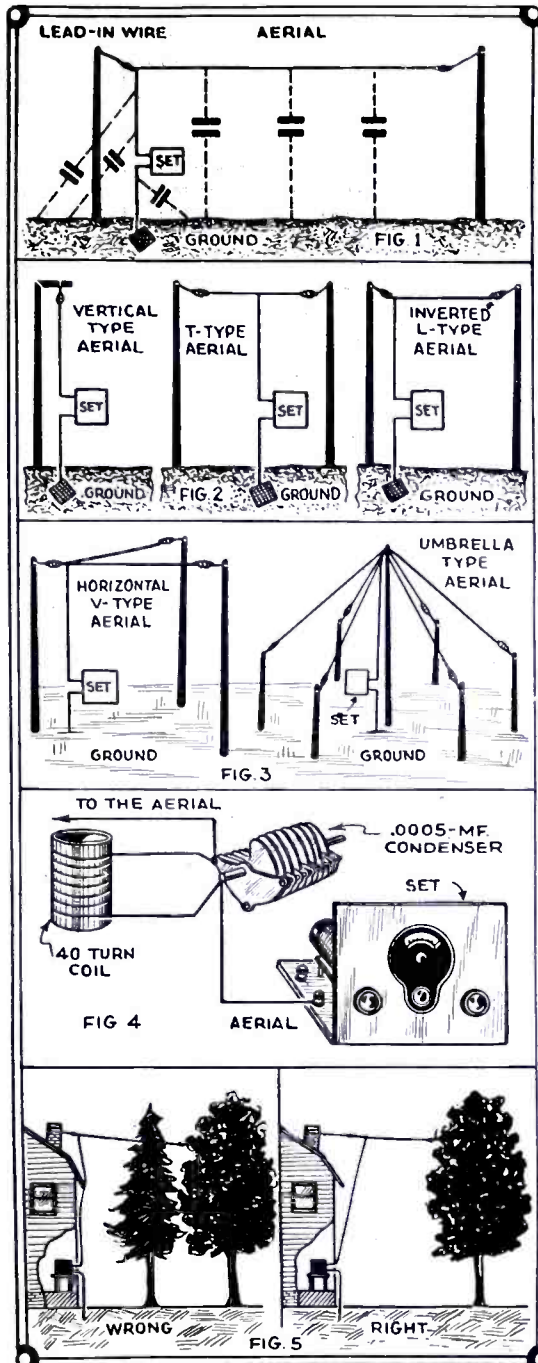

Illustrating various simple types of short-wave aerials suitable for receiving purposes.

Types of Antennas

A number of forms of antennas have been devised for transmitting and receiving, some of which are generally useful and others which have special characteristics that adapt them to a particular use. However, we are not particularly interested in the latter now, and we will consider only those of general use for short-wave reception.

Figure 2 shows three simple forms of antennas. At the left is the vertical type, consisting of a single wire suspended vertically in the air. This type of aerial receives equally well in all directions. At the center of the illustration is the T-type aerial, consisting of a wire suspended horizontally with a vertical connecting wire (called the lead-in) at the central point. Antennas of this type receive best from the two directions of the ends of the horizontal wire. At the right of Fig. 2 is the inverted L-type aerial, commonly used because of the convenience of erecting it. It receives best from the direction of the lead-in. For most wavelengths, the directional effects of these three aerials are not very pronounced; however, on certain wavelengths, especially on certain very short ones, the directional effect of the inverted L is quite marked.

In Fig. 3 are shown two other less common types of aerials. The left one is the horizontal V-type, which receives best from the direction of the lead-in. The other is known as the umbrella type because of its resemblance to the ribs of an umbrella. This type is much less common than the others because of its complicated structure. It is used more frequently for transmitting, because of its complicated structure. It is used more frequently for transmitting, because of its low resistance and also because it sends equally well in all directions.

The Antenna Installation

Any attempt to set down rules for making an aerial of definite dimensions would be foolish, as we can all see. Every antenna installation presents different conditions; thus it is

(Continued on page 316)

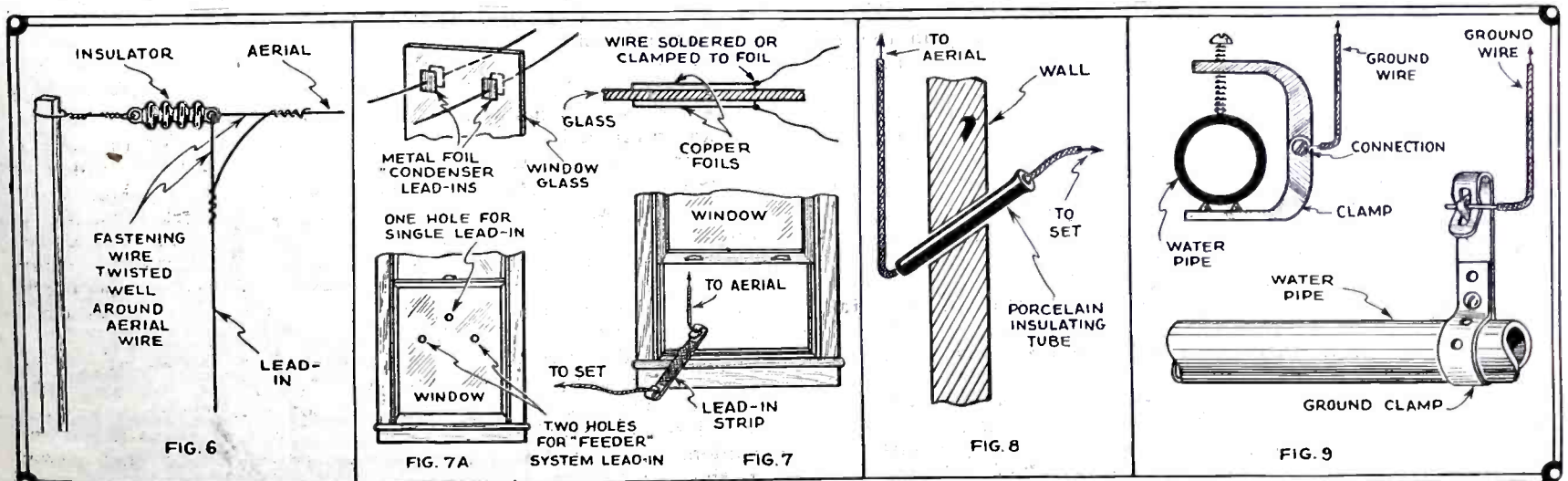

Various details worth while watching out for in constructing short-wave receiving antennas.

SHORT WAVE STATIONS OF THE WORLD

ALL SCHEDULES EASTERN STANDARD TIME: ADD 5 HOURS FOR GREENWICH MEAN TIME

Wavelength (Meters)	Frequency (Kilocycles)	Call Letters	Address and Schedule	Wavelength (Meters)	Frequency (Kilocycles)	Call Letters	Address and Schedule	Wavelength (Meters)	Frequency (Kilocycles)	Call Letters	Address and Schedule
19.56	15,330	W2XAD	General Electric Co., Schenectady, N. Y. Broadcasts 3-6 p.m. daily; 1-6 p.m. Sat. and Sunday.	31.49	9,520	OXY	Skamleboek, Denmark. 2-7 p.m. daily.	48.99	6,120	F3ICD	106 Boulevard Charner, Chi-Hoa (Saigon), Indo-China. 6:30-10:30 a.m.
19.68	15,240		Pontoise (Paris), France. 9:30-12:30 a.m. Service de la Radiodiffusion. 103 Rue de Grenelle, Paris.	31.55	9,510	VK3ME	Amalgamated Wireless, Ltd., 47 York St., Melbourne, Australia. Wed. and Sat., 5-6:30 a.m.	48.99	6,120	W2XE	Columbia Broadcasting System, 485 Madison Avenue, New York, N. Y., 7:00 a.m. to midnight.
19.72	15,210	W8XK	Westinghouse Electric & Mfg. Co., Saxonburg, Pa. Tues., Thurs., Sat., Sun., 8 a.m. to noon.	31.70	9,460	Radio Club of Buenos Aires, Argentina.	FL	Eiffel Tower, Paris. 5:30-5:45 a.m., 5:45-12:30, 4:15-4:45 p.m.
19.83	15,120	DJB	For address, see listing for DJA, Mondays, 10-11 p.m.	32.00	9,375	EH90C	Berne, Switzerland. 3-5:30 p.m.	49.10	6,110	VE9CG	Calgary, Alta., Canada.
19.99	15,000	HVJ	Vatican City (Rome, Italy) Daily, 5:00 to 5:15 a.m.	32.26	9,290	Rabat, Morocco. 3-5 p.m. Sunday, and irregularly weekdays.	49.15	6,100	W3XAL	National Broadcasting Company, Bound Brook, N.J., Irregular.
20.50	14,620	XDA	Trens-News Agency, Mexico City, 2:30-3 p.m.	35.00	8,570	RV15	Far East Radio Station, Khabarovsk, Siberia. 5-7:30 a.m.	VE9CF	Halifax, N. S., Canada. 6-10 p.m. Tu., Thu., Fri.
20.95	14,310	G2NM	Gerald Marcuse, Sonning-on-Thames, England. Sundays, 1:30 p.m.	38.6	7,790	HBP	League of Nations, Geneva, Switzerland. 3-8 p.m., Irregular.	49.17	6,095	VE9GW	Bowmanville, Ontario, Canada. Irregular.
21.50	13,940	University of Bucharest, Bucharest, Roumania, 2-5 p.m. Wed., Sat.	39.80	7,530	"El Prado," Riobamba, Ecuador. Thurs., 9-11 p.m.	49.31	6,080	W9XAA	Chicago Federation of Labor, Chicago, Ill. 6-7 a.m., 7-8 p.m., 9:30-10:15, 11-12 p.m. Int. S.-W. Club programs. From 10 p.m. Saturday to 6 a.m. Sunday.
23.35	12,850	W2XO	General Electric Co., Schenectady, N. Y. Antipodal program 9 p.m. Mon. to 3 a.m. Tues. Noon to 5 p.m. on Tues, Thurs. and Sat.	40.00	7,500	"Radio-Touraine," France. Lyons, France. Daily except Sun., 10:30 to 1:30 a.m.	49.40	6,070	VE9CS	Vancouver, B. C., Canada. Fridays before 1:30 a.m. Sundays, 2 and 10:30 p.m.
23.38	12,820	Director General, Telegraph and Telephone Stations, Rabat, Morocco. Sun., 7:30-9 a.m. Daily 5-7 a.m. Telephony.	40.20	7,460	YR	Lyons, France. Daily except Sun., 10:30 to 1:30 a.m.	49.46	6,065	SAJ	Motala, Sweden. 6:30-7 a.m., 11 a.m. to 4:30 p.m.
25.16	11,920	FYA	Pontoise, France. 1-3 p.m. daily.	40.50	7,410	Eberswalde, Germany. Mon., Thurs., 1-2 p.m.	49.50	6,060	W8XAL	Crosley Radio Corp., Cincinnati, O. Relays 6:30-10 a.m., 1-3 p.m., 6 p.m. to 2 a.m. daily. Sunday after 1 p.m.
25.24	11,880	W8XK	Westinghouse Electric & Mfg. Co., Saxonburg, Pa. Tues., Thurs., Sat., Sun., 11 a.m.-4 p.m.	40.70	7,370	X26A	Nuevo Laredo, Mexico. 9-10 a.m.; 11 a.m.-noon; 1-2; 4-5; 7-8 p.m. Tests after midnight. I.S.W.C. programs 11 p.m. Wed. A.P. 31.	49.55	6,050	W3XAU	Byberry, Pa. Relays WCAU.
25.26	11,870	VUC	Calcutta, India. 9:45-10:45 p.m.; 8-9 a.m.	41.46	7,230	DOA	Johannesburg, So. Africa. 9:30 a.m.-2:30 p.m.	49.59	6,050	VE9CF	Halifax, N. S., Canada. 11 a.m.-noon, 5-6 p.m. On Wed., 8-9; Sun., 6:30-8:15 p.m.
25.34	11,840	W2XE	Columbia Broadcasting System, 485 Madison Ave., N. Y., Jamaica, New York. 7:30 a.m. through to 2 a.m. Sundays 8 a.m. to midnight.	41.50	7,220	HB9D	Zurich, Switzerland. 1st and 3rd Sundays at 7 a.m., 2 p.m.	49.67	6,040	HKD	Barranquilla, Columbia.
25.42	11,800	VE9GW	W. A. Shane, Chief Engineer, Bowmanville, Canada. Daily, 1 p.m.-10 p.m.	42.00	7,140	HKX	Budapest, Hungary. 2:30-3:10 a.m., Tu., Thurs., Sat. Budapest Technical School, M.R.C., Budapest. Muegyetem.	49.75	6,030	VE9CA	Calgary, Alta., Canada.
25.47	11,780	VE9DR	Drummondville, Quebec, Canada. Irregular.	42.70	7,020	EAR125	Singapore, S. S. Mon., Wed. and Fri., 9:30-11 a.m.	49.80	6,020	W9XF	National Broadcasting Co., Downers Grove (Chicago), Ill.
25.50	11,760	XDA	Trens-News Agency, Mexico City. 3-4 p.m.	42.90	6,990	CTIAA	Bogota, Colombia. Madrid, Spain. 6-7 p.m. Lisbon, Portugal. Fridays, 5-7 p.m.	49.96	6,005	VE9DR	Canadian Marconi Co., Drummondville, Quebec.
25.53	11,750	G5SW	British Broadcasting Corporation, Chelmsford, England. Mon. to Sat., 1:45-7 p.m.	43.00	6,980	EAR110	Madrid, Spain. Tues. and Sat., 5:30 to 7 p.m.; Fri., 7 to 8 p.m.	49.97	6,000	YV2BC	Caracas, Venezuela. 7:45-11 p.m. daily ex. Mon.
29.30	10,250	T14	Winnipeg, Canada. Weekdays, 5:30-7:30 p.m.	46.40	6,875	F8MC	Casablanca, Morocco. Sun., Tues., Wed., Sat.	50.26	5,970	HVJ	Vatican City (Rome). 2-2:15 p.m., daily. Sun., 5:53 a.m.
30.3	9,890	EAQ	Transradio Espanola, Alcala, 43-Madrid, P.O. Box 951, Spain. Daily for America, 0030-0200 G.M.T.; for Europe and Canaries, on Saturdays only, 1800-2000 G.M.T.	46.60	6,480	TGW	Guatemala City, Guat. 8-10 p.m.	50.80	5,900	HKO	Medellin, Colombia. 8-11 p.m., except Sunday.
31.10	9,640	HSP2	Broadcasting Service, Post and Telegraph Department, Bangkok, Siam. 9-11 a.m. daily.	46.70	6,425	W9XL	Anoka, Minn.	51.40	5,835	HKD	Barranquilla, Columbia. 7:45-10:30 p.m. Mon., Wed. 8-10:30 p.m.; Sunday 7:45-8:30 p.m. Elias J. Pellet.
31.28	9,590	VK2ME	Amalgamated Wireless, Ltd., 47 York St., Sydney, Australia. Sun., 1-3 a.m. 5-9 a.m., 9:30-11:30 a.m. daily.	46.70	6,425	W3XL	National Broadcasting Co., Bound Brook, N. J. Relays WJZ, irregular.	52.50	5,710	VE9CL	Winnipeg, Canada.
31.30	9,580	W3XAU	Byberry, Pa., relays WCAU daily.	47.00	6,380	RV62	Minsk, U.S.S.R. Irregular.	54.02	5,550	W8XJ	Columbus, Ohio.
31.33	9,570	WIXAZ	Westinghouse Electric & Mfg. Co., Springfield, Mass. 6 a.m.-10 p.m. daily.	47.35	6,335	VE9AP	Quito, Ecuador. 8-11 p.m.	58.00	5,170	OKIMPT	Prague, Czechoslovakia. 1-3:30 p.m., Tues. and Fri.
31.38	9,560	DJA	Rachspostzentralamt, 11-15 Schoenberge Strasse (Berlin), Konigswusterhausen, Germanv. Daily, 8 a.m.-7:30 p.m.	47.35	6,335	CN8MC	Casablanca, Morocco. Mon. 3-4 p.m., Tues. 7-8 a.m., 3-4 p.m. Relays Rabat.	60.30	4,975	PMY	Bandoeng, Java.
31.48	9,530	W2XAF	General Electric Co., Schenectady, N. Y., 5-11 p.m.	47.81	6,270	HKC	Bogota, Colombia. 8:30-11:30 p.m.	62.56	4,795	PMB	Sourabaya, Java.
		SRI	Poznan, Poland. Tues. 1:45-4:45 p.m., Thurs. 1:30-8 p.m.	48.00	6,250	HKA	Barranquilla, Colombia. 8-10 p.m. ex. Mo., Wed., Fri.	67.65	4,430	W2XV	Radio Engineering Laboratories, Inc., Long Island City, N. Y. Irregular.
		DJA	Rachspostzentralamt, 11-15 Schoenberge Strasse (Berlin), Konigswusterhausen, Germanv. Daily, 8 a.m.-7:30 p.m.	48.62	6,170	HRB	Tegucigalpa, Honduras. Monday, Wednesday, Friday, Saturday 5-6 p.m. and 9-12 p.m.	70.00	4,280	W9XAM	Elgin, Ill. (Time signals.)
		W2XAF	General Electric Co., Schenectady, N. Y., 5-11 p.m.	48.83	6,140	W8XK	Westinghouse Electric and Mfg. Co., Saxonburg, Pa. Tues., Thurs., Sat., Sun., 5 p.m. to midnight.	70.20	4,273	W3XZ	Washington, D. C., Chicago, Ill.
		W2XAF	General Electric Co., Schenectady, N. Y., 5-11 p.m.	48.99	6,120	Motala, Sweden. "Rundradio," 6:30-7 a.m., 11-4:30 p.m. Holidays, 5 a.m. to 5 p.m.			W9XL	Chicago, Ill.
		W2XAF	General Electric Co., Schenectady, N. Y., 5-11 p.m.						DOA	Doberitz, Germany. 6-7 p.m., 2-3 p.m., Mon., Wed., Fri.
		W2XAF	General Electric Co., Schenectady, N. Y., 5-11 p.m.						OHK2	Vienna, Austria. Sun., first 15 minutes of hour from 1 to 7 p.m.
		W2XAF	General Electric Co., Schenectady, N. Y., 5-11 p.m.						RV15	Far East Radio Station, Khabarovsk, Siberia. Daily, 3-9 a.m.

(NOTE: This list is compiled from many sources, all of which are not in agreement, and which show greater or less discrepancies; in view of the fact that most schedules and many wavelengths are still in an experimental stage; and that wavelengths are calculated differently in many schedules. In addition to this, one experimental station may operate on any of several wavelengths which are assigned to a group of stations in common. We shall be glad to receive later and more accurate information from broadcasters and other transmitting organizations, and from listeners who have authentic information as to calls, exact wavelengths and schedules. We cannot undertake to answer readers who inquire as to the identity of unknown stations heard, as that is a matter of guesswork; in addition to this, the harmonics of many local long-wave stations can be heard in a short-wave receiver.—EDITOR.)

(Continued on opposite page)

SHORT WAVE STATIONS OF THE WORLD

(Continued from opposite page)

Short Wave Broadcasting Stations

80.00	3,750	F8KR	Constantine, Tunis, Africa. Mon. and Fri.	82.90	3,620	DOA	Doerberitz, Germany.	128.09	2,342	W7XAW	Fisher's Blend, Inc., Fourth Ave. and University St., Seattle, Washington.
		13RO	Prato Smeraldo, Rome, Italy. Daily, 3-5 p.m.	81.24	3,560	OZ7RL	Copenhagen, Denmark. Tues. and Fri. after 6 p.m.				

Experimental and Commercial Radio-Telephone Stations

Wavelength (Meters)	Frequency (Kilocycles)	Call Letters	Address and Schedule	Wavelength (Meters)	Frequency (Kilocycles)	Call Letters	Address and Schedule	Wavelength (Meters)	Frequency (Kilocycles)	Call Letters	Address and Schedule
5.83	51,400	W2XBC	New Brunswick, N. J.	16.80	17,850	PLF	Bandoeng, Java ("Radio Malabar").	26.44	11,340	DAN	Nordeich, Germany. Time signals, 7 a.m., 7 p.m. Deutsche Seewarte, Ham- burg.
7.05	42,530	Berlin, Germany. Tues. and Thurs., 11:30-1:30 p.m. Telefunken Co.	16.82	17,830	W2XAO PCV	New Brunswick, N. J. Kootwijk, Holland. 9:40 a.m. Sat.	27.30	10,980	ZLW	Wellington, N. Z. Tests 3- 8 a.m.
8.67	34,600	W2XBC	New Brunswick, N. J.	16.87	17,780	W8XK	Westinghouse Electric and Mfg. Co., Saxonburg, Pa.	28.20	10,630	PLR	Bandoeng, Java. Works with Holland and France weekdays from 7 a.m.; sometimes after 9:30.
9.68	31,000	W8XI	Pittsburgh, Pa.	17.00	17,640	Ship, Phones to Shore:	WBSN, "Levia- thian"; GFWV, "Majestic"; GLSQ, "Olympic"; GDLJ, "Homerio"; GMJQ, "Belgenland"; work on this and higher channels.	28.44	10,540	WLO VLK	Lawrence, N. J. Sydney, Australia. 1-7 a.m.
10.79	27,800	W6XD	Palo Alto, Calif. M. R. T. Co.	17.25	17,380	JIAA	Tokio, Japan.	28.80	10,410	PDK KEZ LSY	Kootwijk, Holland. Bolin, Calif. Buenos Aires, Argentina.
11.55	25,960	G5SW	Chelmsford, England. Ex- perimental.	17.34	17,300	W2XK	Schenectady, N. Y. Tues., Thurs., Sat. 12 to 5 p.m. General Electric Co.	28.86	10,390	GBX	Rugby, England.
11.67	25,700	W2XBC	New Brunswick, N. J.			W8XL W6XAJ W2XCU W9XL	Dayton, Ohio. Oakland, Calif. Ampere, N. J. Anoka, Minn., and other experimental stations.	29.54	10,150	DIS	Nauen, Germany. Press (code) daily; 6 p.m., Spanish; 7 p.m., Eng- lish; 7:50 p.m., German; 2:30 p.m., English; 5 p.m., German. Sundays: 6 p.m., Spanish; 7:50 p.m., German; 9:30 p.m., Spanish.
12.48	24,000	W6XQ	San Mateo, Calif. (Several experimental sta- tions are authorized to operate on non-exclusive waves of a series, both above this and down to 4 meters.)	17.52	17,110	W00	Deal, N. J.	30.15	9,950	GBU	Rugby, England.
			Vienna, Austria, Mon., Wed., Sat.	17.55	17,080	W2XDO	And other experimental sta- tions.	30.30	9,890	LSN	Buenos Aires, phone to Europe.
13.92	21,540	W8XK	Saxonburg, Pa.	18.40	16,300	GBC PCL	American Telephone & Tele- graph Co., Lawrence, N. J., transatlantic phone.	30.64	9,790	LSA GBW	Buenos Aires. Rugby, England.
14.00	21,420	W2XDJ	Deal, N. J.	18.50	16,200	WLO	Monte Grande, Argentina. (Hurlingham), Buenos Aires, Argentina.	30.75	9,750	Rugby, England. Agen, France. Tues. and Fri., 3 to 4:15 p.m.
14.01	21,400	WLO	And other experimental sta- tions.	18.56	16,150	GBX	Monte Grande, Argentina. Telephone.	30.90	9,700	WNC	Deal, N. J.
14.15	21,130	LSM		18.68	16,060	NAA	Monte Grande, Argentina, after 10:30 p.m. Tele- phony with Europe.	30.93	9,600	LQA	Buenos Aires.
14.27	21,020	LSN		18.80	15,950	PLG	Paris-Saigon phone.	31.23	9,600	LGN	Bergen, Norway.
14.28	21,000	OKI		18.90	15,860	FTK	Bandoeng, Java. After 4 a.m.	32.13	9,330	CGA	Drummondville, Canada.
14.47	20,710	LSY		18.93	15,760	JIAA	Chicago, Ill.	32.21	9,310	GBC	Rugby, England. Sundays 2:30-5 p.m.
14.50	20,680	LSN		19.60	15,300	OXY	Nauen, Germany. Tests 10 a.m.-3 p.m.	32.40	9,250	GBK	Bodmin, England.
		LSX		20.65	14,530	W6XAL	Monte Grande, Argentina. From 7 a.m. to 1 p.m. Telephony to Paris and Nauen (Berlin).	32.50	9,230	FL	Paris, France (Eiffel Tow- er). Time signals 4:56 a.m. and 4:56 p.m.
14.54	20,620	FSR PMB		20.70	14,480	LSA W8XK GBW	Paris-Saigon phone. Bandoeng, Java. After 4 a.m.	32.59	9,200	GBS	Rugby, England. Transat- lantic phone.
14.62	20,500	W9XF		20.80	14,420	WNC	Deal, N. J.	33.26	9,010	GBS	Rugby, England.
14.89	20,140	DWG		21.17	14,150	VPD	Nauen, Germany.	33.81	8,872	NPO	Cavite (Manila), Philip- pine Islands. Time sig- nals 9:55-10 p.m.
15.03	19,950	LSG		22.38	13,400	KKZ WND	Monte Grande, Argentina. 8-10 a.m.			NAA	Arlington, Va. Time sig- nals 9:57-10 p.m., 2:57- 3 p.m.
15.07	19,906	DIH LSG		23.46	12,780	GBC	Deal, N. J.	33.98	8,810	WSBN	S.S. "Leviathan."
15.10	19,850	WMI		24.41	12,290	GBU	Suva, Fiji Islands.	34.50	8,690	W2XAC	Schenectady, New York.
15.12	19,830	FTD		24.46	12,250	FTN	Bolinas, Calif.	34.68	8,650	W2XCU W9XL W3XE	Ampere, N. J. Chicago. Baltimore, Md. 12:15-1:15 p.m., 10:15-11:15 p.m. Radio Engineering Lab., Long Island City, N. Y.
15.45	19,400	FRO, FRE		24.68	12,150	GBS PLM GBS	Deal Bench, N. J. Trans- atlantic telephony.	34.74	8,630	W00 W2XDD W00 PRAG	Deal, N. J. Ocean Gate, N. J. Ocean Gate, N. J. Porto Alegre, Brazil, 8:30- 9:00 a.m.
15.50	19,350	FTM		24.89	12,045	NAA	Rugby, England.	35.02	8,550	W00	
15.55	19,300	FTM		24.98	12,000	FZG	Rugby, England.	35.50	8,450	PRAG	
15.58	19,240	DFA		25.10	11,945	KKQ	St. Assise (Paris), France. Works Buenos Aires, In- do-China and Java. On 9 a.m. to 1 p.m. and other hours.	36.92	8,120	PLW	Bandoeng, Java.
15.60	19,220	WNC		25.05	11,680	YVQ	St. Assise, France.	37.02	8,100	EATH	Vienna, Austria. Mon. and Thurs., 5:30 to 7 p.m.
15.94	18,820	PLE		25.68	11,670	KIO	Tokio, Japan. 5-8 a.m.			JIAA	Tokyo, Japan. Tests 5-8 a.m.
		GBJ		25.68	11,670	KIO	Arlington, Va. Time sig- nals, 11:57 to noon.	37.80	7,930	DOA	Doerberitz, Germany. 1 to 3 p.m. Reichpostzentra- lamt, Berlin.
16.10	18,620	GBJ		25.68	11,670	KIO	Arlington, Va. Time sig- nals, 11:57 to noon.				
16.11	18,620	GBU		25.68	11,670	KIO	Arlington, Va. Time sig- nals, 11:57 to noon.				
16.33	18,370	PMC		25.68	11,670	KIO	Arlington, Va. Time sig- nals, 11:57 to noon.				
16.35	18,350	WND		25.68	11,670	KIO	Arlington, Va. Time sig- nals, 11:57 to noon.				
16.38	18,310	GBS		25.68	11,670	KIO	Arlington, Va. Time sig- nals, 11:57 to noon.				
		FZS		25.68	11,670	KIO	Arlington, Va. Time sig- nals, 11:57 to noon.				
16.44	18,240	FRO, FRE		25.68	11,670	KIO	Arlington, Va. Time sig- nals, 11:57 to noon.				
16.50	18,170	CGA		25.68	11,670	KIO	Arlington, Va. Time sig- nals, 11:57 to noon.				
16.57	18,100	GBK W9XAA		25.68	11,670	KIO	Arlington, Va. Time sig- nals, 11:57 to noon.				
16.61	18,050	KQJ		25.68	11,670	KIO	Arlington, Va. Time sig- nals, 11:57 to noon.				

(Continued on next page)

"STAR" SHORT WAVE BROADCASTING STATIONS

The following stations are reported regularly by many listeners, and are known to be on the air during the hours stated. Conditions permitting, you should be able to hear them on your own short-wave receiver. All times E.S.T.

G5SW, Chelmsford, England. 25.53 meters. Monday to Saturday 1:45 p.m. to 7 p.m. Signs off with the midnight chimes of Big Ben in London.

HVJ, Vatican City. Daily 5 to 5:15 a.m. on 19.83 meters; 2 to 2:15 p.m. on 50.26 meters; Sunday 5 to 5:30 a.m. on 50.26 meters.

VK2ME, Sydney, Australia. 31.28 meters. Sunday morning from 1 to 3 a.m.; 5 to 9 a.m.; and 9:30 to 11:30 a.m.

VK3ME, Melbourne, Australia. 31.55 meters. Wednesday and Saturday, 5 to 6:30 a.m.

Pointoise, France. On 19.68 meters, 9:30 a.m. to 12:30 p.m.; on 25.16 meters, from 1 to 3 p.m.; and on 25.63 meters from 4 to 6 p.m.

Konigs-Wusterhausen, Germany. On 31.38 meters daily from 8 a.m. to 7:30 p.m.

HKD, Barranquilla, Colombia. On 51.4 meters, Monday, Wednesday and Friday, 8 to 10:30 p.m.; Sunday, 7:45 to 8:30 p.m.

VE9GW, Bowmanville, Ontario, Canada. 25.42 meters, from 1 to 10 p.m.

HRB, Tegucigalpa, Honduras. 48.62 meters. Monday, Wednesday, Friday and Saturday, 5 to 6 and 9 to 12 p.m.

T14, Heredia, Costa Rica, Central America. 29.3 meters. Monday and Wednesday, 7:30 to 8:30 p.m.; Thursday and Saturday, 9 to 10 p.m.

XDA, Mexico City. 25.5 meters. Daily, 3 to 4 p.m.

F3ICD, Chi-Hoa, French Indo-China. 49.1 meters. Daily from 6:30 to 10:30 a.m.

RV15, Khabarovsk, Siberia. 70.2 meters. Daily from 2 to 9 a.m.

SHORT WAVE STATIONS OF THE WORLD

(Continued from preceding page)

Experimental and Commercial Radio-Telephone Stations

Wavelength (Meters)	Frequency (Kilocycles)	Call Letters	Address and Schedule	Wavelength (Meters)	Frequency (Kilocycles)	Call Letters	Address and Schedule	Wavelength (Meters)	Frequency (Kilocycles)	Call Letters	Address and Schedule
38.00	7,890	VPD	Suva, Fiji Islands.	43.70	6,860	KEL	Bollnas, Calif.	63.00	4,760	Radio LL	Paris, France.
		JIAA	Tokio, Japan (Testing).			Radio Vitus	Paris, France. 4-11 a.m., 3 p.m.	63.13	4,750	W00	Ocean Gate, N. J.
38.30	7,830	PDV	Kootwijk, Holland, after 9 a.m.	43.80	6,840	CFA	Drummondville, Canada.	63.79	4,700	WIXAB	Portland, Me.
				44.40	6,753	WND	Deal, N. J.	72.87	4,116	W00	Deal, N. J.
38.60	7,770	FTF	Ste. Assise, France.	44.99	6,660	F8KR	Constantine, Algeria, Mon., Fri., 5 p.m.	74.72	4,105	NAA	Arlington, Va. Time signals, 9:57-10 pm., 11:57 a.m. to noon.
		PCK	Kootwijk, Holland, 9 a.m. to 7 p.m.			HKM	Bogota, Colombia. 9-11 p.m.	92.50	3,256	W9XL	Chicago, Ill.
39.15	7,660	FTL	Ste. Assise.	45.50	6,560	RFN	Moscow, U.S.S.R. (Russia) 2 a.m.-4 p.m.	95.00	3,150	PK2AG	Samarang, Java.
39.40	7,610	HKF	Bogota, Colombia. 8-10 p.m.	46.05	6,515	W00	Deal, N. J.	96.03	3,124	W00	Deal, N. J.
				62.80	4,770	ZL2XX	Wellington, New Zealand.	97.53	3,076	W9XL	Chicago, Ill.
39.74	7,520	CGE	Calgary, Canada, Testing, Tues., Thurs.								Motala, Sweden. 11:30 a.m.-noon, 4-10 p.m.

Airport Stations

98.95	3,030	VE9AR	Saskatoon, Sask., Canada.			KRF	Lincoln, Neb.			WAEC	Pittsburgh, Pa.
53.25	5,630	WQDP	Atlanta, Ga.			KMR	North Platte, Neb.			WAEB	Columbus, Ohio.
86.00	3,490	WSDE	Tuscaloosa, Ala.			KQE	Cheyenne, Wyo.			WAEA	Indianapolis, Ind.
		WSDB	Jackson, Miss.			KQC	Rock Springs, Wyo.			KGTR	St. Louis, Mo.
		KGUK	Shreveport, La.			KQD	Salt Lake City, Utah.			KSY	Tulsa, Okla.
		KGUF	Dallas, Tex.			KKO	Elko, Nevada.			KSW	Amarilla, Tex.
		KGUC	Fort Worth, Tex.			KJE	Reno, Nevada.			KSX	Albuquerque, N. M.
		KGUL	Abilene, Tex.			KFO	Oakland, Calif.			KGPL	Kingman, Ariz.
		KGUG	Big Springs, Tex.			KRA	Boise, Idaho.			KG TJ	Las Vegas, Nev.
		KGUA	El Paso, Tex. (Southern Air Transport Lines.)			KDD	Pasco, Wash. (Boeing Air Lines).			KSI	Los Angeles, Calif.
53.53	5,600	WQDU	Aurora, Ill.	54.00	5,560	WAEF	Newark, N. J.			KGTD	Wichita, Kan.
94.52	3,170	KQQ	Iowa City, Iowa.	96.77	3,100	WAEI	Camden, N. J.			KST	Kansas City, Mo. (Transcontinental Air Transport).
		KQM	Des Moines, Iowa.			WAED	Harrisburg, Pa.				
		KMP	Omaha, Neb.								

Television Stations

3.75 to 5 meters—60 to 80 megacycles.	105.9	2,833	W6XAN	Los Angeles, Calif.			W3XAD	R. C. A.-Victor Co., Inc., Camden, N. J.
5.96 to 6.18 meters—48.5 to 50.3 megacycles.			W7XAB	Spokane, Wash.			W2XCW	Schenectady, N. Y.
6.52 to 7.14 meters—42 to 46 megacycles.	105.3 to 109.1 meters—2,750 to 2,850 kc.		W2XAB	Columbia Broadcasting System, 485 Madison Ave., N. Y. 8:00-10:00 p.m.			W8XAV	Pittsburgh, Pa. 1,200 R. P.M., 60 holes, 1:30-2:30 p.m., Mon., Wed., Fri.
			W8XF	The Goodwill Station, Pontiac, Mich.			W9XAP	Chicago, Ill.
			W8XL	WGAR Broadcasting Co., Cleveland Ohio.			W2XAP	Kansas State Agricultural College, Manhattan, Kans.
6.89	43,500	W9XD	Milwaukee Journal, Milwaukee, Wis.			W2XCR	Jersey City, N. J.	
		W3XAD	Camden, N. J. (Other experimental television permits: 48,500 to 50,300 k.c., 43,000-46,000 k.c.).			W3XK	Jersey City, N. J. 3-5, 6-9 p.m. ex. Sun.	
101.7 to 105.3 meters—2,850 to 2,950 kc.	108.8	2,758	VE9CI	London, Ont., Canada.			W2XCD	Wheaton, Maryland, 10:30 p.m.-midnight ex. Sun.
	136.4 to 142.9 meters—2,100 to 2,200 kc.		W2XBS	National Broadcasting Co., New York, N. Y. 1,200 R.P.M., 60 lines deep, 72 wide. 2-5 p.m., 7-10 p.m. ex. Sundays.			W8XF	Passaic, N. J. 2-3 p.m. Tues., Thurs., Sat.
			W2XR	Radio Pictures, Inc., Long Island City, N. Y. 48 and 60 line. 5-7 p.m.			W9XAA	The Goodwill Station, Pontiac, Mich.
							W9XAA	Chicago, Ill.
							W9XAA	Chicago, Ill.

Police Radio Stations

Wave-length (Meters)	Frequency (Kilocycles)	Call Letters	Location	Wave-length (Meters)	Frequency (Kilocycles)	Call Letters	Location	Wave-length (Meters)	Frequency (Kilocycles)	Call Letters	Location
121.5	2,470	KGOZ	Cedar Rapids, Ia.	122.8	2,442	KGPX	Denver, Col.	124.2	2,414	WMO	Highland Park, Mich.
		KGPN	Davenport, Ia.			WPDF	Flint, Mich.			KGPA	Seattle, Wash.
		WPDZ	Fort Wayne, Ind.			WPBE	Gr'd Rapids, Mich.			WPDA	Tulare, Cal.
		WPDT	Kokomo, Ind.			WMDZ	Indianapolis, Ind.	175.15	1,712	KG PJ	Beaumont, Tex.
		WPEC	Memphis, Tenn.			WPDL	Lansing, Mich.			WPDB	Chicago, Ill.
		KGPI	Omaha, Neb.			WPDE	Louisville, Ky.			WPDC	Chicago, Ill.
		WPDP	Philadelphia, Pa.			KGPP	Portland, Ore.			WPDD	Chicago, Ill.
		KGPD	San Francisco, Cal.			WPDH	Richmond, Ind.			WKDU	Cincinnati, Ohio
		KGPM	San Jose, Cal.	123.4	2,430	WPDI	Columbus, Ohio			KVP	Dallas, Tex.
		WRDQ	Toledo, Ohio	123.8	2,422	KSW	Berkeley, Cal.			KGPL	Los Angeles, Cal.
122.0	2,458	WPDO	Akron, Ohio			WMJ	Buffalo, N. Y.			KGJX	Pasadena, Cal.
		WPDN	Auburn, N. Y.			KGPE	Kansas City, Mo.			WPDU	Pittsburgh, Pa.
		WPDV	Charlotte, N. C.			KGPG	Vallejo, Cal.			KGPC	St. Louis, Mo.
		WRDH	Cleveland, Ohio	124.1	2,416	WPDW	Washington, D. C.			WRDS	E. Lansing, Mich.
		WPDR	Rochester, N. Y.	124.2	2,414	WPDY	St. Paul, Minn.			WMP	Fram'gham, Mass.
		WPEA	Syracuse, N. Y.			KGPS	Atlanta, Ga.			KG PY	Shreveport, La.
122.4	2,450	WPKD	Milwaukee, Wis.			WCK	Bakersfield, Cal.	1123	257	WBR	Butler, Pa.
		WPEE	New York, N. Y.			WPDX	Belle Island, Mich.			WJL	Greensburg, Pa.
		WPEF	New York, N. Y.			WRDR	Detroit, Mich.			WBA	Harrisburg, Pa.
		WPEG	New York, N. Y.				Grosse Point Village, Mich.			WMB	W. Reading, Pa.
		KGPH	Okla. City, Okla.							WDX	Wyoming, Pa.
		KGPO	Tulsa, Okla.								
		KG PZ	Wichita, Kans.								

Marine Fire Stations

187.81	1,596	WRDU	Brooklyn, N. Y.	192.4	1,558	WEY	Boston, Mass.
		WKDT	Detroit, Mich.			KGPD	San Francisco, Cal.
		WCF	New York, N. Y.				

LETTERS FROM S-W FANS

THRILLS FROM THRILL-BOX

Editor, SHORT WAVE CRAFT:

With each issue of your magazine, SHORT WAVE CRAFT gets better and more interesting; in other words, it's a magazine with "no comparison." I have been reading your magazine since it was first issued. I have had four years' experience in short wave, and I think it is the most interesting hobby there is. I'm the owner of a National Thrill Box A.C. 45. It's a set that can't be beat.

Here is some information for Thrill Box owners who would like to know where to find certain stations:

	Meters	Dial No.
CEC—Santiago, Chile	15.2	63
HJY—Bogata, Colombia	16.2	80
KKJ—Kauhuka, Hawaii	18.7	110
KKZ—Bolinus, Calif.	21.9	136
GBS—Rugby, England	24.6	40
I2RO—Rome, Italy	25.4	56
G5SW—Chelmsford, England	25.5	57 1/2
FYA—Pontoise, France	25.63	60
XAM—Merida, Yucatan	26.0	65
VRT—Hamilton, Bermuda	29.8	98
LSN—Buenos Aires	30.3	101
EAM—Madrid, Spain	30.47	103
VK2ME—Sydney, Australia	31.28	86
UKD—Barranquilla, Col.	50.5	95
CMCI—Havana, Cuba	49.9	104
VE9DR—Drummondville, Que.	49.8	100
XDA—Mexico City, Mexico	51.0	96
GBC—Rugby, England	60.2	132

I have verifications from all except CMCI. Havana, Cuba. I'm a member of the International Short Wave Club, of Klondyke, Ohio. Well, keep up the good work.

Yours truly,

Charles Guadagnino,
15226 Mack Ave.,
Grosse Pointe Park, Mich.

(An excellent record, Charlie, and we know for a sure thing that the "Thrill Box" is pulling 'em in right along, although you are doing exceptionally well.—Editor.)

A GOOD JUNK SET

Editor, SHORT WAVE CRAFT:

I have been a subscriber to your magazine since its publication. Every copy is kept on file, for the information contained in each is worth its weight in gold. I recommend as a good course in short wave radio a complete file of SHORT WAVE CRAFT! I can't think of any criticism as yet to make, but would like to encourage this copy-a-month idea.

The tubes used in my present set are a '24 detector, '27 (resistance-coupled) and two '01A audio-transformer-coupled amplifier, with good results. I hear all the higher powered stations in the U. S. with loud-speaker reception.

Wishing you success with your magazine, with this letter finding its way in a complete file.

Yours truly,

Emil Voigt,
489 E. Holman St.,
Portland, Oregon.

(Not bad for a "junk set," Emil, and we hope this letter encourages others to use the "ash can" and automobile "junk heap" from which to construct new and useful "junk box" sets.—Editor.)

HEY, YOU SWAPPERS!

Editor, SHORT WAVE CRAFT:

There is nothing I can say that can praise your wonderful magazine too highly. You certainly know what we want.

There is only one thing I wish to reproach the magazine about. What the heck's the matter with those "swappers"? Out of the many letters I have sent them I have received dis-

couragingly few replies. I cannot understand why they do not answer me, if they are real "hams." Maybe it's because I am only fifteen years old and they are more experienced than I. I don't know.

Well, that's the only "brickbat" against our magazine (to me, anyhow).

I would be greatly pleased to see my letter published, and will look for the next issue.

Yours very sincerely,

Carl Penk,
693 Washington St.,
Bedford, Ohio.

MORE "DOERLE" SUCCESS

Editor, SHORT WAVE CRAFT:

When distant stations are received on costly superhets, a person has no reason to boast about it, but when I receive far-away stations on a home-made "two-tube," then that IS something to brag about. My set is the "Doerle" job, described in the Dec. '31-Jan. '32 issue of SHORT WAVE CRAFT.

Today is my third day for working the set, and to date I have received over fifty stations. Some of the more distant ones I shall list. From my home in Maplewood, N. J., I received the following: WVR, Atlanta, Ga.; WGK, Ohio; W9BHM, Ft. Wayne, Ind.; W9AYS, Elgin, Ill.; W8ERK, Girard, Ohio; and, best of all, XDA, Mexico; PZA, Surinam, South America; TIR, Cartago, Costa Rica; G2WM, Leicester, England. I have also received stations WDC and PJQ, which I have not found listed in the call book. Will someone please tell me where these stations are located?

That's not a bad record for three days on a two-tube job, is it? Hope to see some more fans make the Doerle set. I will answer any questions concerning the Doerle set.

Sincerely yours,

JACK PRIOR,

9 Mosswood Terrace,
Maplewood, New Jersey.

(Row-dy-dow! Great work, and FB for three days' work on a new two tube receiver. If we receive many more letters from the boys who complain of a pain in their cardrums from listening to the daily tid-bits from the King of Siam's realm, we shall have to see if we cannot intercede for Mr. Doerle and get him a well-earned niche in the Hall of Fame and also a D. S. M. (Doerle Service Medal). Let us hear some more from you, especially if you build and try out some of the other receivers described in recent numbers of SHORT WAVE CRAFT, and tell us how you like them.—Editor.)

P.S.—Will answer all letters. Would like to hear from boys of fifteen.

(Honest, Carl, this is the first intimation that we had that the Swappers were laying down on the job. This certainly is getting serious and we are going to send immediately a circular letter to the swapper advertisers and find out what is wrong. It's the first letter we have received; and it must be that the depression has struck their pocket-books and that mayhap they no longer can afford to buy postage stamps.—Editor.)

GOOD STUFF

Editor, SHORT WAVE CRAFT:

I have been purchasing copies of your great magazine since early this summer. It sure is a great radio magazine. I enjoy the page of "hams." I have a home-made two-tube short wave set using plug-in coils. I have received the following stations: G5SW, I2RO, FYA, PCJ, VE9CL, VE9GW, VK2ME, VK3ME, HRB, WSNB, GDLJ, WOO and the stations at Rugby,

England; VRC, St. Georges, Bermuda; CMF, at Tamaray, Cuba, and fifteen amateur stations on the 20-meter wave length. I have had W5ABO at Oklahoma City and W9CJJ at Denver, Colorado. Through the summer months I heard VK3ME twice a week and usually on the loud-speaker! I get G5SW on the loud-speaker as well as FYA at France, I2RO at Rome, besides the Canadian and American stations. Hoping to hear from other "hams," to whose letters I will reply, I am,

Le Briton Fader,
125 Henry St.,
Halifax, N. S., Canada.

(Not bad at all, "Le," for a two-tube set; just think what you could do in your location with a "real" set, and here's hoping that the "hams" will snow you under.—Editor.)

NOT A FLOP!

Editor, SHORT WAVE CRAFT:

I have been a reader of your magazine since you started to publish it and think it is the best out for short wave fans. I have seen only two letters in your magazine relating to the "Sun" Short Wave Tuner described in your Aug.-Sept., 1930, issue. In the Feb.-Mar., 1932, issue Albert Bates says it is "a flop." But I do not agree with him. I built this tuner in 1930 and still have it in use with a two-stage A.F. amplifier and would not change it for the world. I have heard nearly all the countries of importance and can go down to 15 meters on it. My set is not shielded, but I set all three condensers on extension rods and this does away with hand capacity. I wound my own coils on two-inch tubing, using the coil data given.

Yours truly,

Ross Adair,
RR4, London, Ontario,
Canada.

(Thanks a lot, Ross, for coming to our assistance. If there's anything that peevcs the Editor's bump of conceit, it's when one of you "hams" write in and tell us that one of the sets is a flop. But evidently the "Sun" set was not a 100 per cent flop anyhow, as your letter would seem to prove.—Editor.)

TO ALL "SET-WRECKERS"!

Editor, SHORT WAVE CRAFT:

I would like to put a word in for the "Doerle" 12,500-mile receiver described in your December and January issue. I recommend this set to all "set wreckers" in a big way! Thanks to SHORT WAVE CRAFT and to our good friend, the Editor, for making this a monthly magazine. I would like to see data for coil winding 125-600 meters as W.C.A.O. will cheer anyone. Hoping that this set "perks" for all "hams" in a big way.

Yours truly,

H. J. Keilholtz,
1508 Belt St.,
Baltimore, Maryland.

(Well, "H. J. K." here's the dope on the coil winding data. We are publishing some of it right along.

A coil to cover the 100 to 200 meter band may be wound on a tube 1 5/8 inches outside diameter with a tuned grid coil of about 55 turns of No. 24 enameled wire, space wound, in a length of about 1 1/2 inches. 1/2 inch beyond the grid coil a tickler coil is wound, comprising 20 turns of No. 24 enameled wire, close wound. To cover the broadcast band from 200 to approximately 500 meters, you will need in the grid coil on a similar size tube, about 135 turns of No. 28 enameled magnet wire, close wound. 1/8 inch beyond the grid coil a tickler is wound with 28 turns of about No. 34 enameled wire, close wound.—Editor.)

Which Regeneration Scheme?

Regeneration control is always an interesting problem in the mind of the short-wave experimenter. Mr. Gernsback here presents an excellent resume of all the well-known methods.

By M. HARVEY GERNSBACK

● ONE of the most important factors in short-wave receiver design is *regeneration control*. Unless a set has an efficient method for controlling regeneration it is well nigh useless. A discussion of various methods of control and their advantages and disadvantages will be undertaken in this article.

Detector systems using three-element tubes such as types '99, '01A, '30, '36, '27 and the new '56 will first be discussed. For simplicity, all diagrams will show grid returns to cathode, which is equivalent to A-minus filament in battery sets. Figure 1 shows the simplest system of control, by mechanical movement of the tickler coil with respect to the grid coil. This method is now obsolete, as it is very critical in adjustment and causes quite a noticeable *detuning* effect on the detector tuning control. Figure 2 shows a method that was once considered the best possible for short-wave work. It is used but little at present, as it also is fairly critical in adjustment and causes detuning. It is simply a parallel plate feed system, similar in principle to the method of isolating the plate current from an A.F. transformer primary in audio amplifiers.

The control shown in Fig. 3 merely varies the voltage applied to the detector plate by means of a variable resistor. This control is likely to be very noisy and in addition it gives only rough control, together with detuning effects, all of which makes it unsatisfactory for high efficiency. In Fig. 4 is shown a method which, although it has negligible detuning effects, is not very satisfactory because of its critical and not always noiseless operation. Figure 5 illustrates what is probably the most generally used form of control. If carefully designed it will usually prove a very quiet and smooth form of control. Noisy variable condensers cause trouble frequently and in addition there is a pronounced detuning effect.

Figures 6 and 7 illustrate two entirely different methods of control. The exponents of the scheme shown in Fig. 6 claim that it is free from detuning effects, is very quiet in operation and gives a very smooth control of regeneration. This system was originally described in the first issue of SHORT WAVE CRAFT. The method of control illustrated in Fig. 7 also gives very satisfactory results, according to reports. We have not yet experimented with it, however, so we are not able to give definite statements as to its merits, but it is certainly worth a trial. (Mr. Secor tried this circuit and reports it is very good.)

Recently quite a number of set builders have advocated the use of screen-grid and R.F. pentodes in the detector stage. These tubes, when properly used, give much stronger signals than triodes and offer much more efficient methods of controlling regeneration. All of the methods of control discussed under three-elements tubes may be used with these tubes and will give much stronger signals. There is a much better system of control for these tubes, by varying the potential applied to the screen-grid. This method gives very fine control with none of the objectionable features of the methods of control described above. Figure 8 shows how the screen

(Continued on page 318)

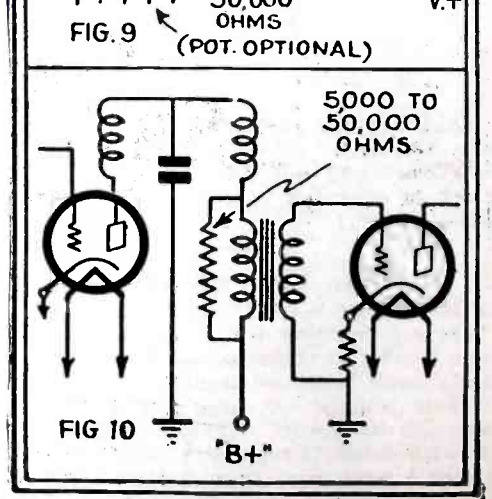
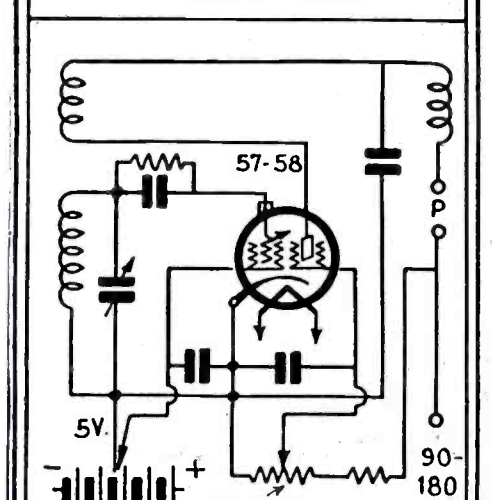
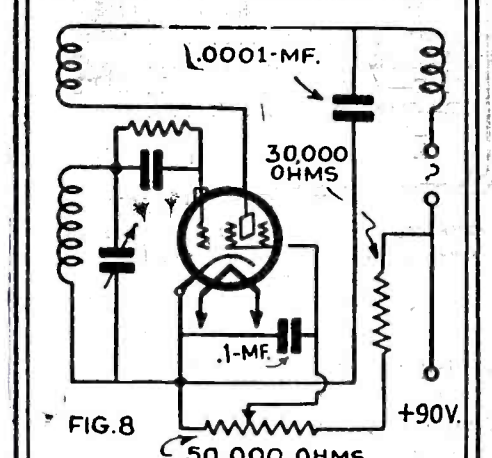
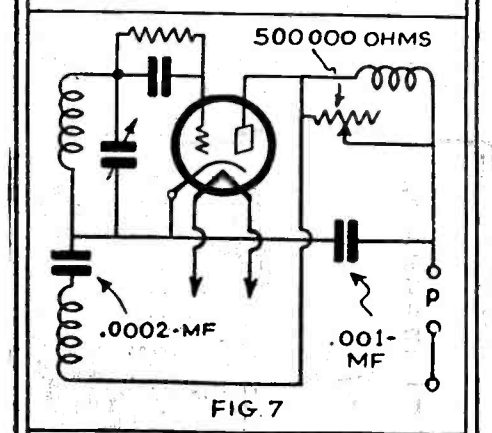
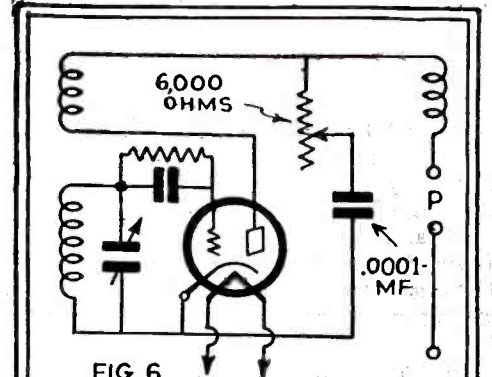
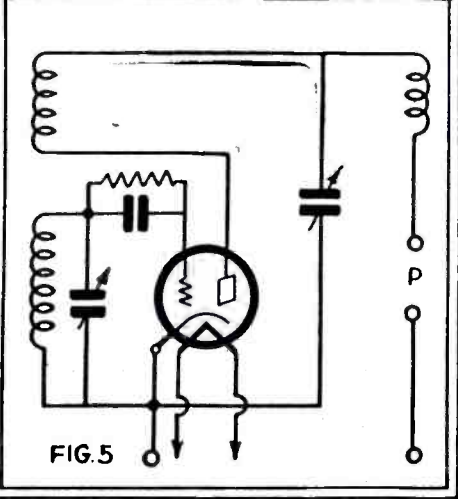
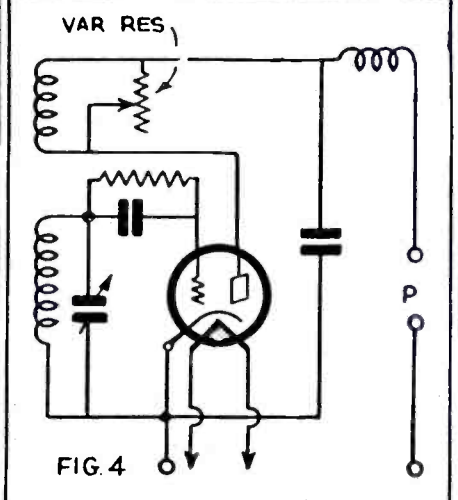
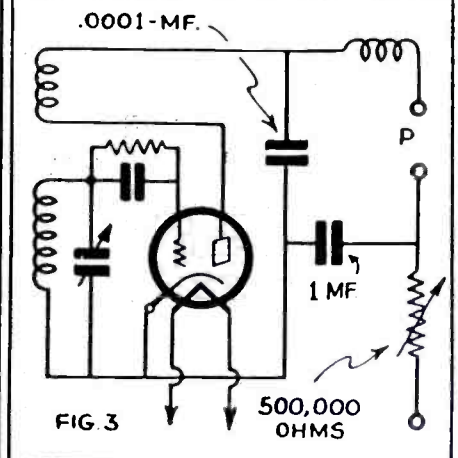
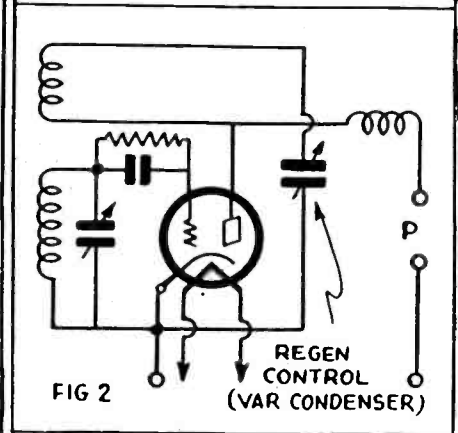
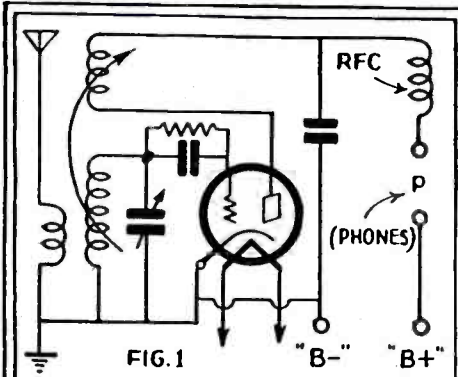

\$5.00 Prize

Plug-in Coil Hint

● I HAD trouble getting a S-W plug-in coil using 12-gauge wire to work properly caused by the loose wire moving together and touching.

Measure your wire exactly, leaving from 1/4 to 1/2 inch on each end to run through the tubing. Then have your garageman thread both ends. Find nuts to fit.

Wind coil and pull up slack with nuts, solder flexible leads to the ends and connect to base prongs. The turns will be tight and can be spaced with some precision.—L. S. Tou Velle.

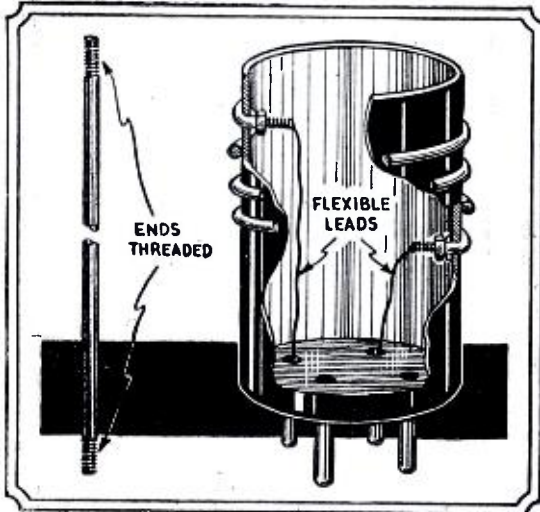

Effective way in which to hold heavy wire in place—thread the ends and put nuts on them.

Drilling Tube Bases

● HEREWITH is a sketch and description of a coil jig devised by myself. The device illustrated is used for holding tube bases while drilling them for making S-W coils. All that is needed is an empty thread spool, a dime store "C" clamp and a small vise, just large enough to grip the "C" clamp firmly. There is nothing to make. The tube base is held rigidly and can be rotated by loosening the clamp. There is no danger of the base breaking as the holding force is applied to the flat bottom and not the curved shell.—W. J. Francey.

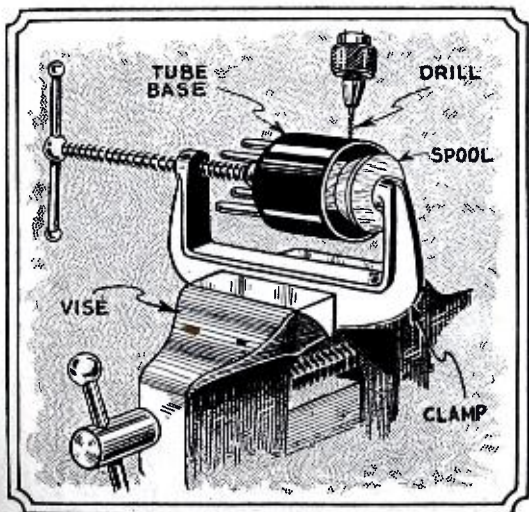

How a spool serves to hold tube base while drilling it.

Band-Spreading Idea

● I HAVE a three tube short wave receiver. I wanted to spread the amateur band. Also to be able to hear com-

\$5

FOR BEST SHORT WAVE KINK

Beginning with the July issue of SHORT WAVE CRAFT, the editor will award a five dollar prize each month for the best short-wave kink submitted by our readers. Look over these "kinks" and they will give you some idea of what the editors are looking for. Send a typewritten or ink description, with sketch, of your favorite short-wave kink to the "Kink" Editor, SHORT WAVE CRAFT.

mercial stations easily. I tried different ways of band spreading, but I could not get a circuit that would spread the amateur band and also be able to get commercial stations easily.

I had a 23 plate Pilot midget condenser so I put it in series. I started taking plates off until I got the proper spread of the amateur code signals on the 80 meter band. I also noticed that I

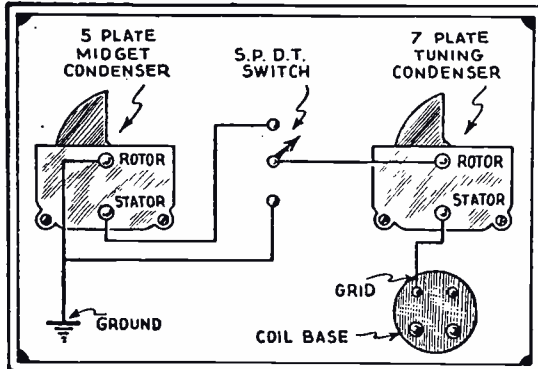

How Mr. Klimas uses switch and two condensers for band spreading.

got enough spread on the 40 meter band. By using a 7 plate tuning condenser, which was cut down from a 17 plate condenser, and by putting a five plate midget condenser in series I had a lot of hand capacity.

I got myself a bakelite condenser shaft putting it in the tuning condenser. That helped to reduce the hand capacity until you could hardly notice it.

I could spread the band all right but I could not get commercial stations, so I put a S P D T Sw. (a midget type S W that I bought for 15 cents from the Kresge 25 cent store) across the two condensers.

When you throw the switch to ground, and the rotor of the tuning condenser, you get all of the commercial stations easily, but when you throw the switch

putting the midget condenser in series, you get all the band-spreading on the amateur band that is wanted. Have the tuning condenser insulated from all parts that are grounded, or it will not work.—Edmund Klimas.

"Converter" Switch

● HEREWITH is a sketch of a switch I have used in connection with several short-wave converters, to change from broadcast to short wave or the reverse.

This switch can be attached to the panel of the short-wave unit and the switching done within the unit.

The average broadcast listener will not take the time to connect up a unit every-time they want to tune in a short-wave program. By the use of this switch short waves come in a few seconds after the switch position is changed.

I hope this will help other short-wave converter set builders to put out a flexible unit that can be attached to any good radio in a few minutes.

All the converters I build have a filament heating transformer built in and it has a grounded center tap—to reduce hiss when the set is operating.—K. A. Staats.

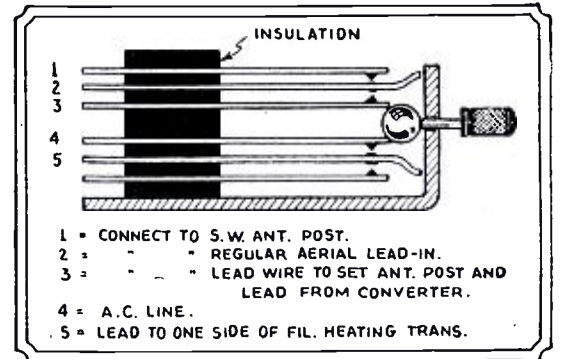

A very handy switch to throw over from broadcast to short-wave converter, or vice versa, in a jiffy.

"Freak Aerial" the Berries

● I AM sending in a diagram of my short wave aerial which enables me to get good overseas reception in answer to your query for short-wave aerials. I recommend it to anyone who would enjoy overseas reception. I have an outdoor aerial fifty feet in length, also fifty feet of bell wire wound under the dining room carpet (as illustrated) and besides that I have thirty feet of bell wire strung up behind the picture moulding in the adjoining room. These with the use of two midget condensers receive the D.X.—Joseph Sziemiata.

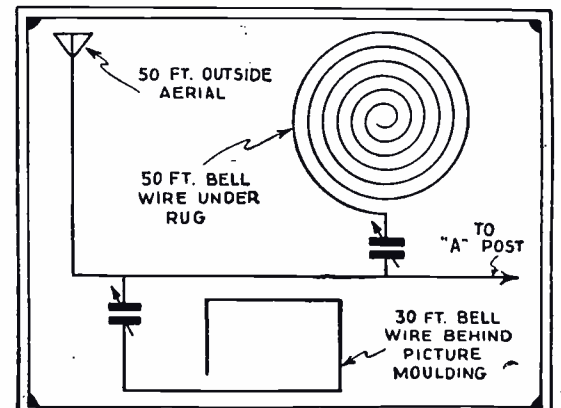

A freak receiving aerial that "brings 'em in."

Transmitting Antennas — How to Couple Them

By A. R. HAIDELL

This article deals with both the theory and practice of transmitting antennas. The subjects covered include the "Zep" antenna; tuning each section; how to determine length for given wavelength; conditions for maximum efficiency; how to couple transmitter to aerial, etc.

Good example of aerial mast construction, showing guy cables "sectionalized."

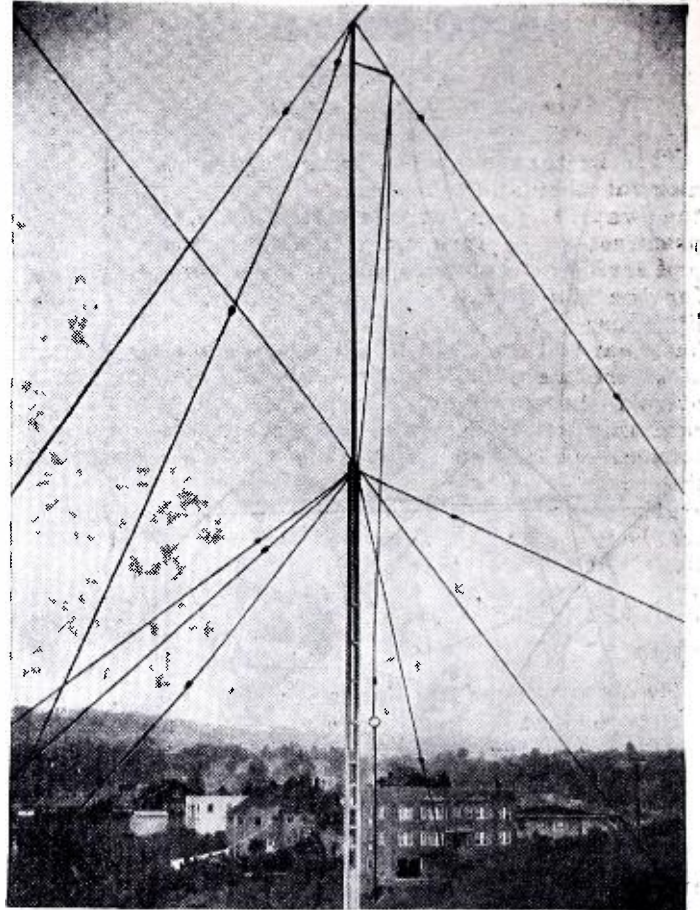

● THIS article considers some important facts about transmitting-antenna design and construction, methods of coupling the oscillator to the antenna and adjustment and operation of common antenna types. The amateur usually constructs a transmitter, perhaps mounts it in a panel and then runs out, just before the rain, to hang up an "antenna," which may or may not hold up under the first blast, and seldom holds up longer than the second. The antenna construction is, in general, flimsy and the wire waves in the breeze like a string and takes the frequency with it, because of the poor relation between antenna and oscillator coils; the coupling value between antenna coils and oscillator coils is very important.

No amateur is entirely free from these things (especially those who try to tell others—Hi!); it seems to be contagious. Anyway, lend an ear; it took years to learn these things by experience, but it only takes a few minutes to tell.

Let's start with popular antennas.

The "Zeppelin" Type Antenna

Perhaps the most popular antenna in use in American amateur stations is the "Zeppelin" type shown in Fig. 1. (This type of antenna was first used on Zeppelins, hence the name.) The method of coupling it to the oscillator is shown in Fig. 1 also. The voltage distribution on an antenna must be such that a voltage "loop" (maximum) occurs at the end of both feeders (the two parallel wires are the feeders in the "zep") and also at the end of the antenna. If a Zeppelin antenna is operated at double the frequency for which it is designed, the voltage distribution will be as suggested by the dotted lines in Fig. 1. This means that it cannot be used at the second harmonic with good results, even if everything else is properly adjusted, since the voltage is not distributed properly. It can be used at the 3rd, 5th (odd) har-

monics but not at even harmonics of its fundamental frequency.

We hear someone say, "Yes, but mine works fine at the second harmonic." The writer has operated such an antenna at its second harmonic and actually worked stations at a considerable distance with it, but a little investigation with a neon bulb, when using a high-power oscillator, showed that it was not operating as an ordinary Zeppelin type. Often touching the coils together (thus changing from inductive to direct coupling) will give better results when the second harmonic frequency is being used.

Figure 1 is a more or less theoretical arrangement, not convenient for a practical installation. In order to make an antenna like this work right, it has to be designed for a single frequency, and the wires carefully cut to get the exact lengths for optimum results. Obviously, this is a decided disadvantage because the average amateur wants flexibility and convenience, so the wavelength can be changed away from interference. It is therefore necessary to arrange for tuning each wire to the proper length to compensate for unseen factors which have relatively large effects on the location of the voltage loops and nodes on the feeder and the "radiator" proper.

Each Section Must Be Tuned

It is necessary to tune each wire so that the voltage loops and nodes occur at the most favorable positions on the wires. This is done by connecting in series with each wire a variable condenser of the proper value so that tuning of each wire can easily be accomplished over the width of the desired band. Figure 2 gives all the necessary construction data for 40-meter work; all constants are given. To calculate antenna sizes for other wavebands, use the general method suggested there for the design of a 40-meter antenna. Although a meter is somewhat larger than a yard, the amateur can, for approximate values,

assume a meter as equal to an even 3 feet in preliminary calculations for approximate wire lengths. For exact values the following table can be used as described below.

Meters	Feet	Meters	Feet
1	3.28	20	65.6
2	6.56	25	82.0
3	9.84	30	98.4
4	13.1	35	114.8
5	16.4	40	131.0
10	32.8	45	147.6
15	49.2	50	164.0

Suppose that an antenna for 41.6 meters is desired. Since it is better to operate an antenna above its fundamental, one can call this 42 meters, since the series condensers will reduce the wave to the proper value anyway. An antenna must be one-half wavelength long, consequently it is 42 divided by 2 or 21 meters long. Twenty meters from the table above is 65.6 feet; 1 meter is 3.28, also from the table; the sum of these two values is 68.88 feet. This is total length of wire to use. Usually the value so obtained is slightly too long because of the additional loading of the coupling coil. The series condenser compensates, however, so these values can be used in the preliminary design. In extreme cases, where the wires must be near the earth, it is necessary to cut a few feet from the length of each wire to neutralize the effect of the added capacity.

S-W Aerials Comparatively Simple

Short-wave antennas are very simple compared with the elaborate arrangements used at longer wavelengths. Even the old 200-meter amateur transmitting aerials are elaborate compared with a 20- or even a 40-meter one. But short-wave antennas are not a new type of aerial; they have simply been evolved, step by step, from the more elaborate systems used at higher wavelengths. It

is interesting to trace the development of a short-wave antenna because of the practical considerations involved, useful in similar work and necessary in the construction of single antennas which can be used in more than one band.

The writer's 200-meter antenna had a natural period of 200 meters. This, by the way, was an exceptional antenna; practically all amateurs in those days preferred to operate above 200 meters, for the lower waves were considered of little use for communication. Everyone has heard of the wonderful development of short waves by "hams," which disproved this theory. By using a small coupling coil in a 200-meter antenna it is possible to operate at 40 meters easily; this is the 5th harmonic. Harmonic operation is interesting for the experimenter because of the distance and directional effects of such antennas, but is otherwise usually more difficult, so that a majority of amateurs use the simpler systems.

Maximum Efficiency for An Antenna

Another antenna arrangement is shown in Fig. 3. The type of antenna to be used depends upon the location of the station and the space available, so various types will be discussed. The amateur can thus select the type suited to his own particular needs. In Fig. 3, the idea is to place the clip at a point of high voltage on the inductance, thus exciting the electrons in the antenna system; maximum effect is produced when the entire inductance and capacity of the whole antenna system is such that the natural frequency is equal to the frequency supplied by the oscillator. The oscillator must be tuned to the antenna.

If the exciting tap is connected directly to the plate, the output will be so great, due to the high voltage applied to the system, that the oscillator will stop oscillating; if connection is made to the filament clip, no energy will be radiated. An intermediate position must be selected for proper operation and stability. This point is perhaps three-fourths the way from filament end to plate end of the oscillator inductance.

In general, the length of the feeder has very little effect on the natural frequency of the antenna system itself unless it happens to tune it to a harmonic of the operating frequency. The size of wire used in the feeder also has little

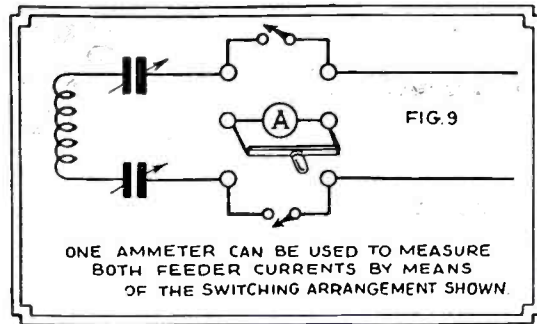

Diagram above shows how to use one meter to measure radiation in both sections of an aerial.

At right—Obtaining curve and method of connecting two radiation meters.

effect; the currents are small, consequently any resistance has little effect. The antenna arrangement of Fig. 3 has many advantages, but cannot be used in some locations.

If a pair of poles is available, the antenna can be stretched out into a single-wire affair, as shown in Fig. 4. It is advantageous to have an antenna as well in the clear as possible so that a pole is an advantage, since the antenna is raised above its surroundings. Great height, however, is not necessary if the antenna is well in the clear.

Where poles are available, a single wire stretched taut, in the clear, is quite convenient. For 40-meter work, a single wire having a natural period near 40 meters can be used. The terms "antenna" and "counterpoise" are meaningless for such a single-wire aerial. The counterpoise is at one end and the antenna at the other, strictly speaking, but, for simplicity, let's call the whole thing the antenna, and use the term "counterpoise" for systems in which it can readily be distinguished separately.

40-Meter Antenna

A 40-meter antenna should be about 65 feet in total over-all length. Towel (glass) bars are perhaps the best insulators for the price. Figure 4 shows the method for connecting the feeder to the antenna. The end of the feeder is adjusted on the antenna, as well as the clip on the oscillator inductance, as shown, until the lamp glows the brightest, consistent with oscillator stability and constant frequency. If a small flashlight bulb is used, and the oscillator is

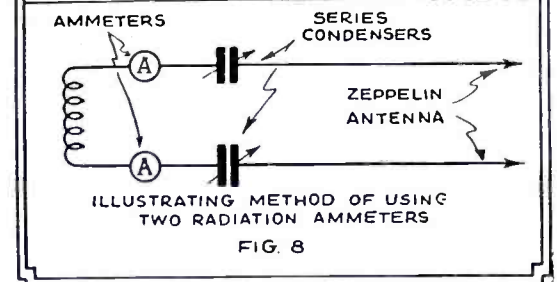
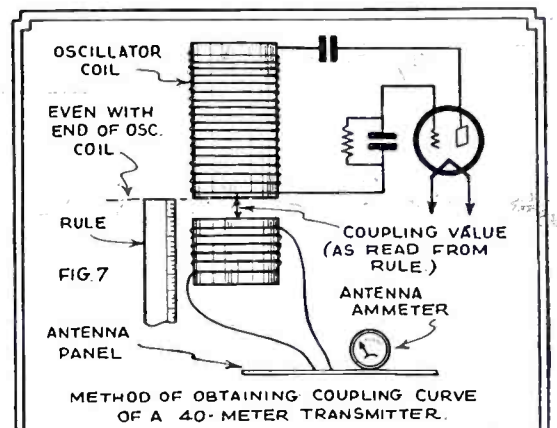

of 50 watts power, a shunt of about 4 inches of No. 14 wire will be necessary for the radiation indicator. Smaller oscillators will require more resistance in the shunt, or none at all.

If the wire is close to the ground, it should be made somewhat shorter because of the added capacity effect. It is not necessary to support an antenna high above the earth so long as it is in the clear and the waves have a chance to "get a good start." This, by the way, is important. The antenna is the connecting-link between the oscillator and outside world; if the antenna is poor, results will always be correspondingly poor. A good antenna is very important, we repeat.

If this type of antenna is close to the ground, it can be adjusted easily for excellent efficiency, since it can be reached for adjustment. Distance work is only accomplished by the radiated energy which is refracted down from ionized layers in the upper atmosphere, so that the height of the antenna above ground is usually not so important.

It is wise to warn the neighbors if a bulb is used permanently in the middle of the antenna; otherwise they may think

(Continued on page 319)

<p>Diagram showing the "Zeppelin" antenna with an oscillator and coupling coil. It illustrates the voltage distribution and second harmonic distribution. The caption states: "THE 'ZEPPELIN' ANTENNA. THE METHOD OF COUPLING IT TO THE OSCILLATOR, INDUCTIVELY, IS SHOWN."</p>	<p>Diagram showing antenna dimensions L1 and L2, and feeder connections C1 and C2. The caption states: "FIG. 2. L2 = 5 TURNS 2 INCHES IN DIAMETER (COPPER TUBING). L1 = 1/4 WAVELENGTH = 10 METERS = 30 FT. APPROX. L2 = 3/4 WAVELENGTH (1/2 + 1/4) = 30 METERS = 95 FT. APPROX. NOTE: SEE DESIGN TABLE IN TEXT. C1 & C2 = ABOUT 200 MMF EACH - NOT CRITICAL."</p>	<p>Diagram showing a Hartley oscillator connected to an antenna system. The caption states: "ONE METHOD OF FEEDING AN ANT. SYSTEM. THE AMMETER IS OPTIONAL. A CONDENSER IN THE FEED-LINE IS SOMETIMES USED, ALTHOUGH NOT NECESSARY."</p>
<p>Diagram showing a simple antenna system with a shunted flashlight lamp and an oscillator. The caption states: "SIMPLE ANTENNA SYSTEM WHICH CAN BE USED IN SOME LOCATIONS. IF CLOSE TO THE GROUND, IT IS EASILY ADJUSTED."</p>	<p>Diagram showing an antenna for crowded locations with a voltage distribution indicator, wires, and a 5-turn coupling coil. The caption states: "A GOOD ANTENNA FOR CROWDED LOCATIONS. IT IS ADJUSTED WITH ONLY ONE VARIABLE CONDENSER."</p>	<p>Graph showing the typical curve obtained from a short-wave oscillator showing the relation between antenna current and coupling value. The x-axis is labeled "COUPLING IN INCHES" and the y-axis is "ANTENNA CURRENT".</p>

Various methods of arranging and calibrating short-wave antennas as explicitly described by the author in accompanying article.

\$500.00 Short Wave Builder's Prize Contest

\$100 In Monthly Prizes For Best Models

In the May number of SHORT WAVE CRAFT, we announced, in considerable detail, this new contest and the rules for those desiring to enter sets in the contest. For the benefit of those who did not read the original announcement in the May number, we mention here some of the more important points that you should bear in mind.

The closing date for the August contest is given below. The keynote of this contest is expressed by the single word—SIMPLEST.

Short wave set builders may submit any one of the following apparatus:

- SHORT WAVE SET
- SHORT WAVE ADAPTER
- SHORT WAVE CONVERTER

You will please note that the set must be BUILT BY YOU and furthermore THE SETS THEMSELVES must be sent, PREPAID, preferably by express, to the editorial offices of SHORT WAVE CRAFT. Remember that WORKMANSHIP will be one of the strong factors that the judges will have in mind in awarding prizes. Sets may be sent with or without phones or loud-speaker. Data is given below on the length of descriptive article, diagrams and other information required by the judges. Have your article typewritten, if at all possible; diagrams need not be finished mechanical drawings, as our draughtsmen will re-draw diagrams for publication, but make neat sketches in ink. All coil and condenser data must be given; also all resistor and speaker (or phones) ohmic or impedance values.

FIRST PRIZE	\$50.00
SECOND PRIZE	25.00
THIRD PRIZE	12.50
FOURTH PRIZE	7.50
FIFTH PRIZE	5.00

RULES FOR \$500.00 SHORT WAVE BUILDER'S CONTEST

During the contest period, SHORT WAVE CRAFT will award a total of \$500.00 in prizes in an important new contest. You are asked to build a home-made short wave set which should fill one or more of the following requirements: 1, Simplicity; 2, Compactness; 3, Ingenuity; 4, Novelty of Circuit Used; 5, Portability; 6, Workmanship.

Read carefully the text of the adjoining article, and observe the following simple rules:

- 1.—Short wave sets submitted may be in either of the following classes:
"Straight" S-W Receiving Set (battery operated or A.C. operated).
Short Wave Converter.
Short Wave Adapter.
- 2.—Sets must be home-made and built by contestants themselves. Manufactured sets are absolutely excluded from this contest.
- 3.—Sets submitted may be for ONE, TWO, THREE and NOT MORE THAN FIVE TUBES. Any type of tube as selected by the builder can be used. Crystal operation or crystal-tube combinations allowable, at the option of builder. Sets may be of any size or shape, at the option of the builder.

4.—In order to win a prize, it is necessary that the set itself be submitted to the editors. The five best models submitted each month will be awarded the prizes as scheduled here.

5.—All sets submitted to SHORT WAVE CRAFT Magazine will be returned to their owners after they have been judged and described for the benefit of SHORT WAVE CRAFT readers in the magazine.

6.—This is a monthly contest, which began May 1st, 1932, and will last for five months. Each monthly contest closes on the 1st of the following month. Thus the contest for August closes Midnight September 1st, 1932, at which time all entries for this month must be in the editorial offices of SHORT WAVE CRAFT. The third prize-winning announcements will be made in the October, 1932, issue of SHORT WAVE CRAFT.

7.—Every set must be accompanied by an article written by the builder, and contain not more than 2,000 words, giving minute instructions with wiring (schematic) diagram, list of parts with values of all resistors, condensers, coil data, including number of turns, etc., how the set was built, its operating characteristics, what stations have been

received with it, and other information considered important by the builder. Such article should be typewritten or written in ink, and should be sent separately by mail, and should not be included with the set itself!

8.—All sets must be shipped in strong wooden boxes, NEVER in cardboard boxes. All sets must be sent "prepaid"! Sets sent "charges collect" will be refused. SHORT WAVE CRAFT Magazine cannot be held responsible for breakage in transit due to improper packing of sets. Before packing the set, be sure to affix tag with string giving your name and address to the set itself. IN ADDITION, PUT YOUR NAME AND ADDRESS ON THE OUTSIDE OF THE WRAPPER OF THE PACKAGE.

9.—Employees and their families of SHORT WAVE CRAFT are excluded.

10.—The judges will be the Editors of SHORT WAVE CRAFT Magazine, and the following short wave experts: Robert Hertzberg, Clifford E. Denton. Their findings will be final.

11.—Address all letters, packages, etc., to Editor, SHORT WAVE BUILDER'S CONTEST, care SHORT WAVE CRAFT Magazine, 96-98 Park Place, New York.

A Few Facts About Short Wave Coils

• RADIO experimenters who build their own short-wave receivers, particularly those experimenters who are new to the game, are at a loss to know exactly how to make short-wave coils having the lowest possible losses. A large number of the short-wave receivers in use contain a relatively small number of tubes, so that there is considerable advantage in using low-loss coils. The amplification-per-tube is also relatively small at short waves, so it becomes apparent that coils giving greater amplification from existing sets are desirable.

Short-wave coil design is quite a study

in itself. Much valuable information can, of course, be gathered by "try it again" methods; but, as in any line, the experiments must be directed by a certain knowledge of theory. Theoretical studies are very valuable to any experimenter, since theoretical knowledge serves to guide one, saving considerable time, and aiding in an interpretation of the results discovered. This article deals with some of the simple theories underlying short-wave coil design. Common methods used to construct short-wave coils will also be considered in detail.

Short-wave coils are "good" or "bad,"

depending upon the losses within them. In some uses for coils, the losses within them are not of importance, since the loss factor does not enter. However, the most important use for coils, to the short-wave fan at least, is in tuned circuits. In such circuits, especially where high amplification is essential, the losses within the windings of the coils, and the forms upon which they are wound, are of considerable importance. In any tuned circuit, the loss in the variable condenser is usually relatively unimportant but the losses in the coil are large in comparison.

(Continued on page 310)



Above—Different forms of short-wave coils. At right—Diagrams explaining action about short-wave coil conductors. A simple yet effective design for a short-wave plug-in coil is shown at the extreme right.

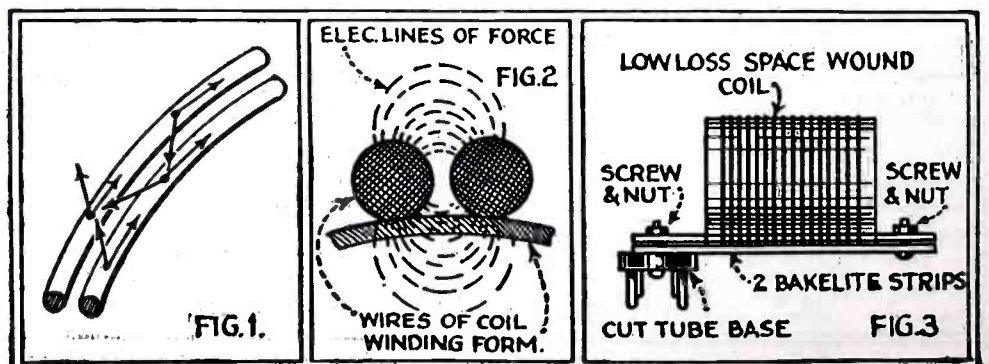

SHORT WAVE QUESTION BOX

Edited by R. WILLIAM TANNER

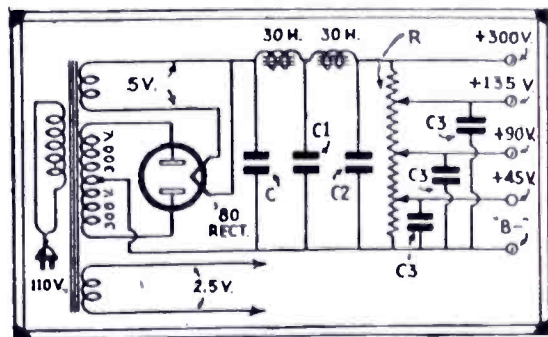
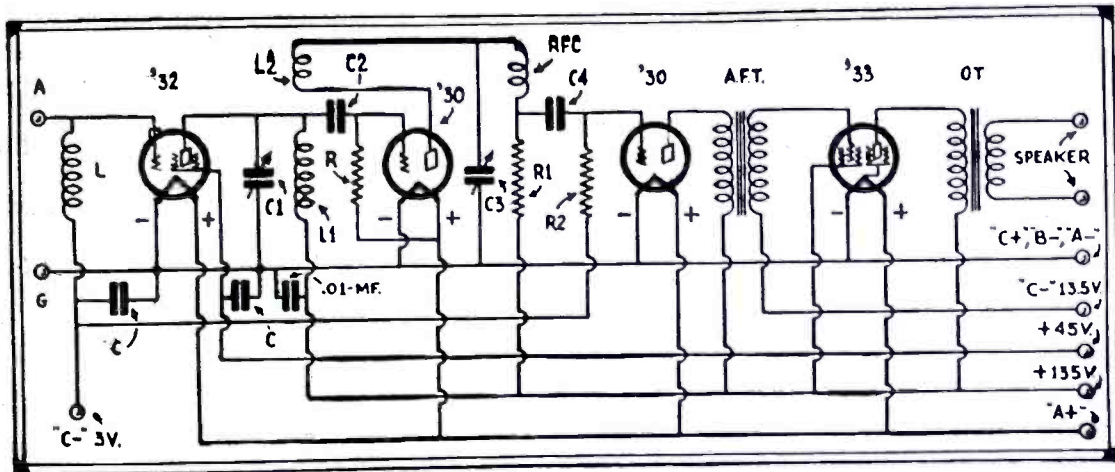

Above—"B" eliminator hook-up for use with D.C. tube receivers. The eliminator is to be used on 110 volts, 60-cycle A.C., of course.

Diagram at left—Hook-up for a good 4-tube short-wave receiver.

FOUR-TUBE RECEIVER HOOK-UP

H. Wertz, York, Pa., asks:
Q. For a circuit using a stage of R.F., detector and three stages of A.F. for two-volt tubes.

A. The circuit will be found in these columns. Three A.F. stages would be too complicated for a beginner and would require special means for the prevention of motor-boating. Two stages, with one a pentode power stage, is an ideal arrangement.

Q. I have built the "Doerle" receiver and it works fine but cannot get distance on it. What is the trouble?

A. The fact that it works at all indicates that you have no real trouble. You are probably located in a section where "DX" (long distance reception) is impossible.

Q. What type is the "Doerle" circuit?

A. This is not a "Doerle" circuit any more than it is an Abie Goldstein circuit. It could be named after thousands of different builders, since amateurs have used the same arrangement for many years. The circuit itself is merely a two-tube regenerative one with a single audio frequency amplifier stage.

PEAKING SUPERHET COILS

Irving Adams, Philadelphia, Pa., writes:

Q. I have some Sickles 1.2 mh. coils which are supposed to peak at 450 kc. when used in a superhet. What capacity condensers should be used?

A. Condensers of semi-variable type having a capacity range of .00007 to .00014 mf. should be employed.

Q. Could I use the same value coils for R.F. chokes?

A. Yes, but not at 450 kc. Such chokes would be OK for short waves, such as an antenna coupling choke or chokes in screen grid and plate leads, but not in detector plate circuit.

Q. Will you show by diagram how to use two of these coils in a band-pass filter?

A. The circuit is shown in these columns.

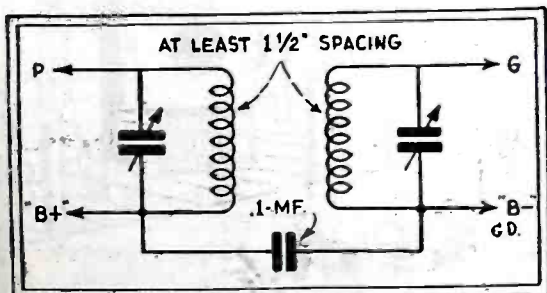

Circuit for condenser and coil arrangement in band-pass filter.

CONDENSER SPECIFICATIONS

Willard Zethmayr, Congress Park, Ill., asks:

Q. How many plates are employed in the tuning condenser used in the *Portable Short Wave Receiver*, page 390, April issue?

A. The number of plates is of no importance; the value in Mf. is all that you need to know. The diagram shows this condenser to be .00014 mf.

Q. How many turns on the R.F. choke?

A. As this article described a manufactured set, this information is not available. However, any choke of 20 to 90 mh. will do.

WHAT SIZE CHOKE?

Roy Birren, Chicago, Ill., writes:

Q. In the receiver described on page 17, May issue, is the R.F. choke an 80 henry or 80 mh.?

A. 80 mh.

CRYSTAL RECEIVER

F. E. Allen, Ft. Wayne, Ind., writes this department:

Q. I have built a crystal receiver with two stages of tuned R.F. All coils and tubes are completely shielded and "B" leads properly filtered with R.F. chokes and by-pass condensers. The amplifier oscillates excessively. Can you give me any idea on how to cure this trouble?

A. Your feed-back troubles are probably due to insufficient filtering in the output of the crystal detector. Generally when the crystal is transformer-coupled to the A.F. amplifier, a choke of 20 to 90 mh. and one or two .0001 mf. by-pass condensers are sufficient to shunt the R.F. currents to ground. With a coupling transformer having a high impedance primary or with resistance coupling, this filter is too small. A choke of 200 to 250 mh. and one .001 mf. by-pass condenser will probably cure your feed-back.

Q. I have been using a De-Tec-Tone crystal detector which was taken from an old reflex broadcast receiver. Would a D.C. bias of a few volts improve operation?

A. No, not with this crystal.

COIL DATA

E. Rider, Dayton, Ohio, writes:

Q. How many turns for 100-200 meter coil for circuit on page 258, Dec.-Jan. issue?

A. Using a tube base with a 1 1/2-inch bakelite tube (1/16-inch wall) slipped over to increase diameter and length, wind on 45 turns of No. 24 S.C.C. wire for grid coil and 15 turns same wire for tickler.

"B" ELIMINATOR FOR D.C. SETS

Robert Haus, Ft. Thomas, Ky., and eight others want:

Q. A simple "B" eliminator circuit for use

with D.C. tube receivers described in *SHORT WAVE CRAFT*.

A. The circuit appears in these columns. The chokes should have a current carrying capacity of 85 ma. or more. The first filter condenser C should be 2 mf., 450 volt; C1, 4 mf., 450 volt; C2, 4 mf., 450 volt. By-pass condensers C3 are each 1 mf., 300 volt units. The voltage divider R is preferably an Electrad Truvolt 25,000-ohm, 75-watt resistor provided with the correct number of taps, which slide along the resistor, making exact voltages possible.

D.C. POTENTIAL FOR CRYSTAL DETECTOR

H. D. Barton, Bolton, N. Y., asks:

Q. For data on applying a D.C. potential to a carborundum crystal detector used in an A.C. short-wave superheterodyne.

A. The circuit for this is shown in these columns. A 10,000-ohm potentiometer is connected from "B" negative to 45 or 75 volts positive with the lever connecting to the low side of the transformer primary. In this case, the crystal cup MUST go to the tuned circuit and the contact towards the transformer primary. When adjusting the bias, tune in with volume control set so that a signal is barely audible. Then adjust potentiometer for maximum sensitivity and best tone quality. This is rather critical.

Q. I am having some trouble in this super due to oscillation in the I.F. amplifier, although all coils and tubes are shielded and all leads are provided with filters. By detuning one of the I.F. stages or shunting the first A.F. grid with a 50,000-ohm resistor, it is possible to eliminate the trouble. Can you give me any data as to a cure?

A. A crystal rectifier is NOT a perfect rectifier; therefore the output circuit will have considerable R.F. current flowing. The only cure in a VERY large R.F. choke and larger by-pass condensers than are usually employed. A 250-mh. choke and a 1,000-mmf. condenser will generally suffice.

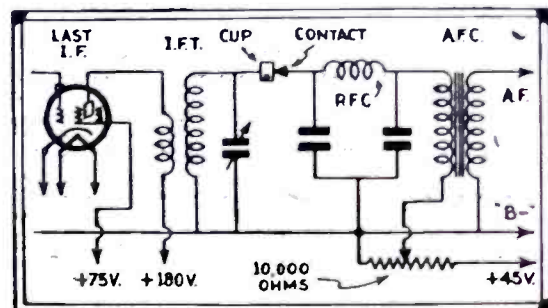

How to accurately adjust voltage applied to crystal detector when used in an A.C. short-wave superheterodyne.

Amateurs who made good

WILLIAM HENRY HOLLISTER



William H. Hollister, President of Lincoln Radio Co. and well-known to the amateur short-wave fraternity throughout the country, built amateur transmitting and receiving apparatus at a very early date and experimented with all kinds of receivers including superhets.

MR. HOLLISTER built one of the earliest successful transmitting and receiving capable of transmitting fifty feet. From 1902 to 1907, he held the position of Assistant Electrical Engineer for the Pacific Electric Interurban System, having charge of all tests of power plant and line transmission. Mr. Hollister experimented with modulated carrier waves, sending signals three miles from Pico Heights to Boyle Heights in the city of Los Angeles; also experimented with receiving equipment through the early "one-tube" days and built many of the earliest models of the superhetero-

dyne circuit. In 1928, he purchased the Lincoln Radio Corporation and developed the first "one-spot" superheterodyne receiver, using screen grid tubes. Active as President of the Lincoln Radio Corporation, developing Laboratory Constructed superheterodyne receivers.

Mr. Hollister's experience in radio dates back to the earliest days before Marconi spanned the ocean. His chief ambition has been to produce radio performance by new methods, and his only aim is "Better reception and farther distance-getting ability."

The value of Mr. Hollister's work is indicated in the success of the "Donald B. MacMillan Expedition" into the Arctic, where for the first time daily contact with civilization was maintained, also for the first time enabling an explorer to make accurate surveys by checking standard time with Station NAA, Arlington, Virginia.

NORMAN R. HOOD, W8FDN

NORMAN R. HOOD tinkered with radio as a hobby from 1911 to 1920 and thus did not start in as a "rank beginner" when he took a course with the National Radio Institute. After seven years as a commercial operator he saw the need for more details and advanced training. Mr. Hood took up the course because he figured it would organize the work, starting with the simple and proceeding to the more complex, in logical sequence. Since graduation he has worked as Radio Operator for the Firestone Tire and Rubber Company on their short-wave circuit to Liberia, West Africa. He completely redesigned and rebuilt a broadcast station in North Dakota, leaving there to come to Akron, Ohio, to supervise the installation of the Police Radio Alarm System. At present Mr. Hood is acting as Chief Operator of the Police Radio System.

Before the days of amateur call letters Mr. Hood operated a "ham station" in Burlington,



Norman R. Hood started in as a radio amateur in 1911 and he has had an interesting and varied experience in radio. He designed and built a broadcasting station and has recently supervised the installation of the police radio system in Akron, O. His amateur call is W8FDN.

Iowa. Following is a list of his amateur calls from 1912 to date:

- 1912 to 1913—9JZ
- 1913 to 1917—9XL
- 1920 to 1929—7Z0
- 1929 to Date—W8FDN

IN NEXT ISSUE:

MYSTERIES
of the
5-METER BAND
By C. H. West - W2AIU

A "FREE-WHEELING"
RECEIVER FOR
BEGINNERS
By R. W. Vosburgh

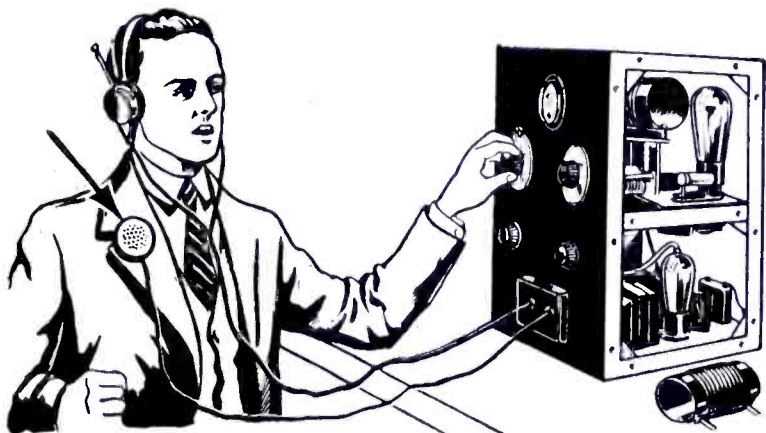

... ARE YOU "MIKE-ANNOYED"?

Many amateurs tell us that in phone transmitting they sometimes have to move around to make certain adjustments or they have to look for important papers. This means moving the mike around with them and they find it annoying to do so.

FOR PUBLIC ADDRESS WORK

It is here that the Micromike is very effectively used, as it enables the speaker to move fifteen feet in any direction. The volume can be controlled with the use of the Mikontrol which lists for \$3.00.

The New Powerizer Micromike solves the problem. This mike can be attached to any part of the clothing by the use of a fountain pen clip placed in the rear. The Micromike is about the size of a quarter and comes with fifteen feet of cord—enabling the speaker to move about and transmit at the same time. Monitoring does not become necessary, as the slight variation from the speaker's mouth to the microphone affects the volume but slightly.

The regular price of the Micromike is \$12.50 but we want to introduce this indispensable microphone to Short Wave fans and so our offer to you is.....

\$10.00

RADIO RECEPTOR CO., Inc.
106 SEVENTH AVENUE
NEW YORK, N. Y.

Write for our pamphlet entitled "Whisper and the World Hears," which tells more about our microphones and public address systems . . . Dept. SW.

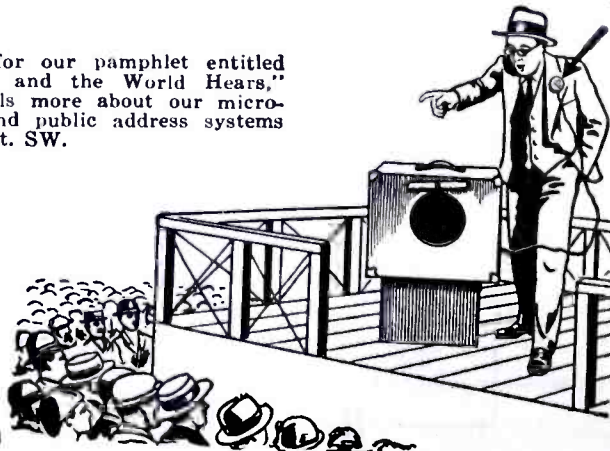

A 1-Tube MOPA

(Continued from page 294)

antenna circuit happens to become detuned. The meters I used are Westons. The 1.5-ampere antenna ammeter is not of sufficient capacity for use with a reasonable low resistance antenna. A 2.0 or 2.5 ampere meter would be preferable. The 15-ampere plate tank meter is adequate unless the tank circuit losses are substantially less than in the transmitter described. This meter can be dispensed with by using the dip of the plate milliammeter for tuning. The plate milliammeter is an 0-200 ma. Weston.

For normal operation with maximum output, the coil for the frequency determining circuit should be plugged in with the section of the coil with the larger number of turns in the grid circuit. Reversing this coil will reduce the input and output by a large percentage. No exact determination of the best ratio of turns in the grid to turns in shield grid section of this coil has been made, but it appears that about a 60-40 percentage is satisfactory.

The plate blocking condenser "C," Fig. 4, has a capacity of .000067 mf.

When first placing the equipment in operation the plate voltage applied should be not over about 1,500 volts. The tap on the voltage divider system which supplies voltage to the shield grid should be placed one-third to one-half the way from the low end; that is, the shield grid voltage should be somewhat less than half of the plate voltage. The plate current with the plate circuit out of tune is considerably greater than when it is in tune, although not high enough to be dangerous to the tube. The frequency determining circuit oscillates at practically the same frequency, regardless of the tuning of the plate circuit.

List of Parts

- A1—Weston R.F. ammeter, 0-15 amps.
- A2—Weston R.F. ammeter, 0-1.5 amps.
- C1, C2, C3, C4, C5—.01 mf., 2,500-volt Sangamo fixed condensers.
- C6—.0002 mf., 5,000-volt Sangamo fixed condenser.
- C7—.00045 mf., 3,000-volt Cardwell variable condenser.
- C8—.002 mf., 5,000-volt Sangamo fixed condenser.
- C9—Two 5,000-volt Sangamo fixed condensers in series, .0001 and .0002 mf., respectively; net total capacity, .000067 mf.
- C10—½ mf., 1,500-volt G. E. Co. fixed condenser.
- C11, C12—Same as C7.
- C13, C14—1 mf., 3,500 Potter filter condensers.
- C15—2 mf., 3,500 Potter filter condenser.
- F—High voltage fuse rated at 2,000 volts, .75 amps.
- L1—Frequency determining coil system.
- L2—Plate tank circuit inductance.
- L3—Antenna coupling inductance.
- MA—Weston D.C. milliammeter, 0-200 milliamperes.
- R1—Grid leak Ward Leonard resistor, 60-watt, 20,000 ohms.
- R2—Ward Leonard 60-watt, 100-ohm resistor.
- R3—Variable resistor, fixed Ward Leonard 60-watt, 300-ohm resistor in series with 20-ohm, 60-watt porcelain base variable resistor.
- R4—Ward Leonard 200-watt, 14,000-ohm fixed resistor.
- R5—Ward Leonard 200-watt, 11,000-ohm fixed resistor.
- S1—Filament switch, Cutler Hammer.
- S2—Plate power switch, Cutler Hammer.
- T1—Thordarson 80 va., 12-volt filament transformer.
- T2—Thordarson rectifier filament transformer for UX-866 tubes.
- T3—Special home-made plate transformer, 0-1500-2000-2500 each side of center tap, 1,000 va.
- V1—UX-860 screen grid, 75-watt transmitting tube.
- V2, V3—UX-866 mercury vapor rectifier tubes.

Looking for a GOOD Short Wave Receiver ?

READ THIS BUY THIS

Short wave receivers come and go, but the ROYAL Model RP has passed the severe test of time with flying colors. It has been accepted by the Short Wave fraternity as the *outstanding value* today. Its performance closely approaches that of sets and converters selling for four to five times as much. It completely overshadows any other sets in the low priced field. Considering results obtained it is the most economical. Every day it piles up new records for distance, volume, and ease of operation. Remember! The final proof of superiority of the ROYAL lies in verification by owners of repeated, consistent reception of French, Italian, New Zealand, African, Asian, South American, and many other stations. *No idle boasting on our part!* World-wide reception guaranteed or your money back!!



ROYAL MODEL RP

Sturdily constructed on a heavy metal chassis and enclosed in a neat crackle finished cabinet, this remarkable two-tube receiver presents an attractive, efficient appearance. A full vision dial and a smooth acting regeneration control makes tuning remarkably easy. This set tunes from 14 to 550 meters. A special "Ham" model is available with the amateur bands of 20, 40, 80 and 160 meters widely spread. (State your choice.) The use of a UX-232 screen-grid detector and a 233 power pentode amplifier gives extreme sensitivity and tremendous volume.

Kit WITH INSTRUCTIONS \$10.95

● 13⁹⁵

Set of MATCHED RCA Licensed Tubes \$2.55

Set of BURGESS Batteries (including three full sized 45 volt "B"s) \$5.45

SET COMPLETE \$20.95

It pays to buy the best!

SPECIAL !!

Brunswick Two Tube Short Wave Tuners

THE USES OF THIS UNIT ARE ALMOST UNLIMITED! Consists of a stage of untuned Screen-Grid RF Amplification and a sensitive detector. Tunes from 12 to 120 meters using three plug-in coils. It may be used as an earphone S.W. Receiver on batteries, power pack, or on a 2½ volt filament transformer and B batteries. One or two stages of audio amplification may be added, making it a regular three or four tube set with a wallop! By means of a plug supplied with each tuner, all voltages necessary may be obtained from your screen-grid broadcast receiver. The output may be fed through the audio amplifier of the set for real loud speaker volume! The satin finished metal cabinet measures only 8"x5"x6". Tubes needed are a 224 and a 227. These tuners are all new and are guaranteed to be genuine Brunswick apparatus. ORDER ONE NOW and you will agree with us that the parts alone are worth much more than our sensational price for the complete tuner!

\$6.95

Brunswick Short Wave Converters

Only through our tremendous cash buying power are we enabled to make this sensational offering of latest model, genuine Brunswick Short Wave Converters. Makes your broadcast receiver a short wave superheterodyne with a wavelength range of 20 to 60 and 120 to 200 meters with coil switch. Can be attached by anyone in five minutes. Once connected, a throw of a switch automatically changes from short wave to broadcast reception. For use with any receivers using 247 or PZ pentode tubes. (Adapter for 245 tube sets \$1.00 extra.) Complete in original factory sealed cartons with two Brunswick 224 tubes.

\$10.95

POWER SUPPLIES

MODEL PB—For any transmitter using 245 tubes. Delivers 2½ volts and 350 volts at 100 mills. By using a voltage divider this pack can be used to furnish power to an AC broadcast receiver. Built on cadmium plated metal chassis. SPECIAL, \$9.95 KIT, \$7.95

MODEL PE—Uses two 281 tubes. Output is 650 volts DC at 170 mills and 7½ volts c.t. at 3 amps. For any transmitter using up to three 210's. \$17.95. KIT, \$12.95

TUBES

Genuine RCA licensed tubes. Fully guaranteed against any defect for three months. These are good tubes!

112A	\$.075	238	\$.140
201A	.35	247	.80
224	.75	281	1.35
230	.80	282	.75
233	1.45	199	1.30
237	.90	222	1.50
245	.55	227	.50
280	.50	232	1.25
239	1.40	236	1.40
171A	.45	240	1.60
210	1.45	250	1.95
225	.40	234	1.45
231	.80	246	.90
235	.84		

ACCESSORIES

Shielded Filament Transformers. All windings center tapped. Good regulation.

2½ volts at 4 amps\$1.25
2½ volts at 10 amps\$1.75
6.3 volts at 4 amps\$1.45
7½ volts at 4 amps\$1.45
10 volts at 4 amps\$2.25
2½ volts at 10 amps. and 2½ at 4 amps\$1.95

BURGESS BATTERIES

Dry Cells, 40c; 4½ volt C, 31c; 22½ volt C, 95c; Standard 45 volt B Battery, \$1.35; Heavy duty, \$2.00; Transmitting Key, \$1.25; Signal Brass Base Key, \$2.25.

ORDER NOW!

All above prices include Government TAX
20% DEPOSIT REQUIRED WITH ALL ORDERS
Money Back If You Are Not Entirely Satisfied

OUR PRICES ARE LOWEST

We can supply your entire radio needs at lowest wholesale prices. Just send us your whole order mentioning catalog and page number wherein you find our competitors' lowest prices. We will promptly fill your order at those prices or lower. Besides saving you extra transportation expense you receive the advantages of our intelligent, experienced service.

Harrison Radio Co. 142 LIBERTY ST., Dept. C-11
NEW YORK CITY

Train Now for New RADIO Opportunities



Get Into a Line Where There's Action — Every Day — And a Payday Every Week—You Be the Boss!

YOURS Without Extra Cost

This excellent set analyzer and trouble shooter included with our course of training.

Right now while hundreds are looking for work where there isn't any, the radio service field can use trained men. With the proper training and the necessary equipment, you can enter this field and make a comfortable living. We include with our course this modern set analyzer and trouble shooter without any extra charge. This piece of equipment has proved to be a valuable help to our members. After a brief period of training, you can take the set analyzer out on service calls and really compete with "old timers." We show you how to wire rooms for radio—install auto sets—build and install short-wave receivers—analyze and repair all types of radio sets—and many other profitable jobs can be yours.

Teaching you this interesting work is our business and we have provided ourselves with every facility to help you learn quickly yet thoroughly. If you possess average intelligence and the desire to make real progress on your own merits, you will be interested.

ACT NOW — MAIL COUPON

Start this very minute! Send for full details of our plan and free booklet that explains how easily you can now cash in on radio quickly. Don't put it off. Write today! **Send Now!**

RADIO TRAINING ASSN. OF AMERICA.

Dept. SWC-9, 4513 Ravenswood Av., Chicago, Ill. Gentlemen: Send me details of your Enrollment Plan and information on how to learn to make real money in radio quick.

Name

Address

City..... State.....



You Can Become a Fast, Capable RADIO OPERATOR at Home

WITH THE FAMOUS CANDLER Scientific System

Fine opportunities for trained operators! Copy px easily from CANDLER trained operators sending out of WNU, KUP, WPN, KAA, WGG, WHD, NAA, NSS and others. FREE Px Schedule and other valuable information. Make reputation in Amateur field.

"Passed amateur exam. with 3rd lesson." — E. Miller, Toledo, Ill. "Studied 11 hours, can copy 8 wpm." — E. J. Yarris, Chicago, T. R. McElroy, Boston. Retired World's Champion Radio Operator, is Candler trained.

Amazing results in short time. If "stuck," write Candler. No obligation. Learn about Junior Course for beginners, Advanced Course for operators with speed of 10 wpm or over who want to get in 45 wpm class and copy behind, also Radio Mill Course. Save Time and Money by sending for FREE BOOK today.

CANDLER SYSTEM Co., Dept. 26
6343 S. Kedzie Ave., Chicago



World's Only Code Specialist

8-Tube Portable "Super-het"

(Continued from page 284)

PARTS LIST FOR BATTERY AND SPEAKER CASE

- 1 "Best" 9-inch magnetic speaker, with special winding for push-pull pentodes, 7,000 ohms per side.
- 3 45-volt "B" batteries.
- 2 No. 6 dry cells.
- 1 Eby 6-prong socket.
- Connecting wire, etc.
- 1 small case, 8.5 x 12.5 x 10.5 inches.
- 2 Alden 106 plugs.
- 3-foot 6-wire cable.

The coils are tuned by individual tuning condensers so that the maximum resonance peaks can be easily tuned in. Individual control of the oscillator and detector tuning dials is very handy in tuning in weak or fading signals. Dial calibration can be accurately accomplished when two dials are used, doing

away with the error in logging caused by the use of a large antenna compensating condenser.

Little need be said in regards to the wiring, as the various leads are run in a straightforward manner. There is one little kink which should be watched closely. It will be seen that there is a network of resistors shunted across the "C" battery and whether the set is in operation or not the "C" battery will discharge through the network unless the circuit is opened when the receiver is not in operation. The drain through these resistors is low enough so that it equals the drain of the receiver on the "B" batteries. Thus when a set of "B" batteries is worn down to the point of replacement it is time to replace the "C" battery. This has the effect of properly proportioning the voltage applied to the grid of the second detector to its plate voltage. In

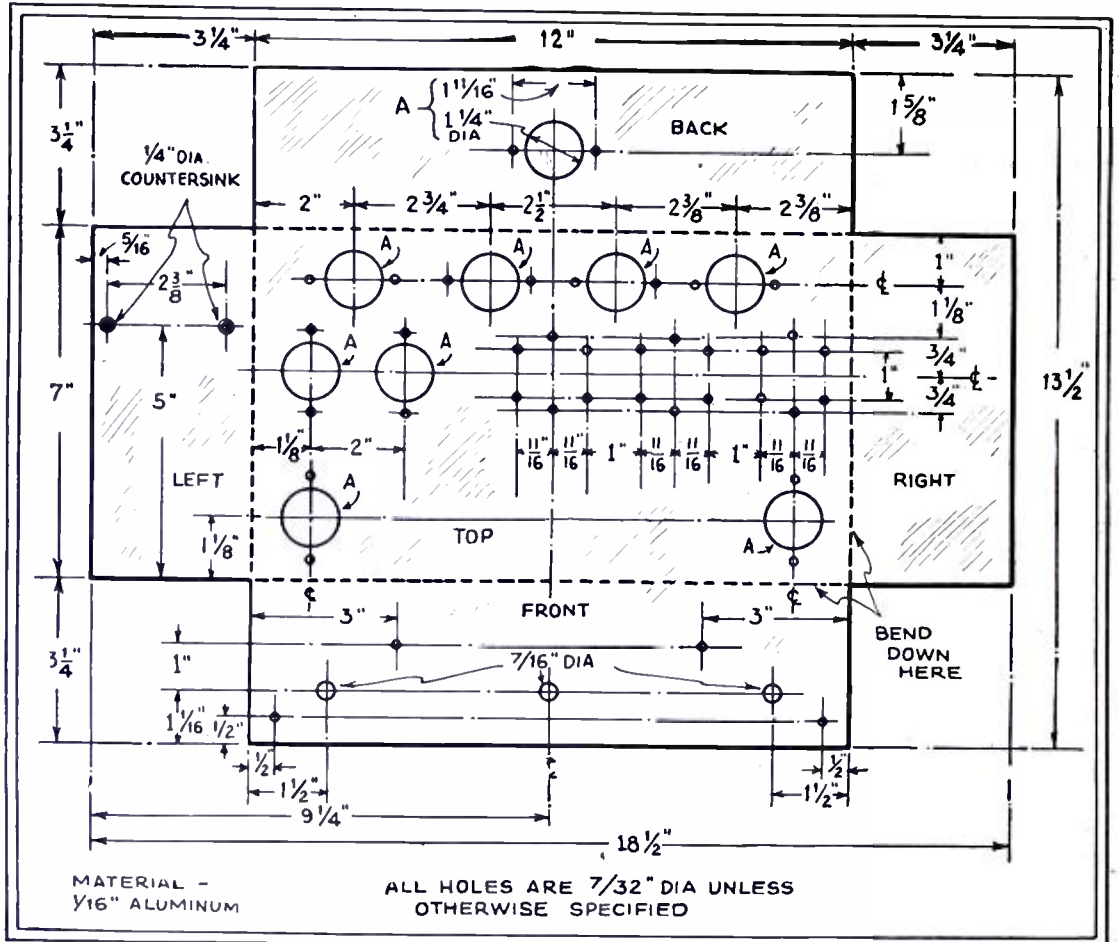

Subpanel layout for the S-tube super.

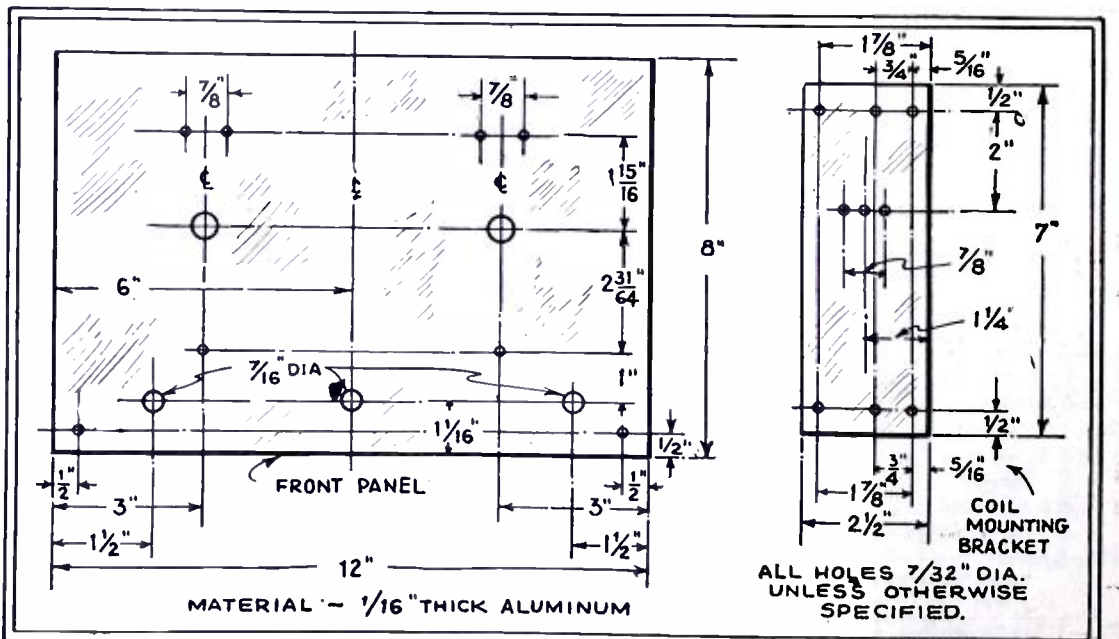

Layout of aluminum front panel for the Denton 8-Tube Super.

Both SHORT WAVE CRAFT and RADIO CRAFT may now be had for \$2.00 for the next eight months. Send your subscription to SHORT WAVE CRAFT, 100 Park Place, New York, N. Y.

other words the normal drop in the output voltage of the "B" supply is proportionate to the drop through the "C" battery. This limits the distortion introduced into the detector circuit by the ageing of the power supply batteries.

Both of the carrying cases are of the same size and are not awkward to carry. Although the battery case is by far the heavier, weighing about 12 pounds fully loaded, it can be readily carried.

Connections between the two cases are made by means of a six-wire cable. This includes all of the connections necessary between the two units. The length of the six-wire cable can be anything within reason. Be sure that the wire which goes to make up the cable is large enough so that there is no loss of voltage along the line.

There is room enough in the case to carry more "B" batteries, if desired, or extra "A" battery units as spares.

If only 135 volts of "B" is used there is plenty of room to carry all of the coils in the detector and oscillator sockets, as well as the battery-speaker cable.

If it is desired—and the writer does it—coil up about 75 feet of enamel covered wire with a couple of insulators for a semi-portable antenna, with a 20-foot length of wire with a clip to ground to some convenient water pipe. All of these things can be carried without any trouble in the battery compartment. Thus the set is complete for use anywhere.

One may gather the impression from the above that a long antenna is necessary for this set. Short-wave stations in Venezuela were received on an antenna 30 feet long. This was at loud speaker volume and one did not have to put his head in the speaker to hear it.

New S-W Receiver

(Continued from page 271)

COIL NUMBER	1		2		3		4	
	DET.	OSC.	DET.	OSC.	DET.	OSC.	DET.	OSC.
TOTAL TURNS	3 7/8	2 3/4	2 3/8	2 1/8	1 7/8	1 5/8	1 1/4	1 1/8
FRACTIONAL TURN BETWEEN TOP AND BOTTOM OF COIL	2/3	2/3	3/8	3/8	1/3	1/3	1/4	1/4
RANGE MC	40 TO 46		46 TO 53 1/2		53 1/2 TO 62 1/2		62 1/2 TO 75	

TUNING CONDENSER, CAP. (DET. AND OSC.) = 18 MMF EACH. (TYPE, NEW 270° STRAIGHT FREQUENCY LINE)

I. F. COIL DATA :-
 FORM 1 1/4" DIA 2 1/2" LONG
 PRI = 50 TURNS NO. 32 D.S
 SEC. = 100 TURNS NO. 28 ENAM
 (SAME DIRECTION)

64 TURNS PER INCH
 TUNED WITH A 4-70 MMF COMPRESSION TYPE I.F. TUNING CONDENSER



I.F. TRAP Ckt TUNED TO 1550 KC.
 COIL L2 = 100T 10-68 LITZ WIRE ON A 5/8" FORM.
 CAP C2 = 4-70 MMF

In the Ring!

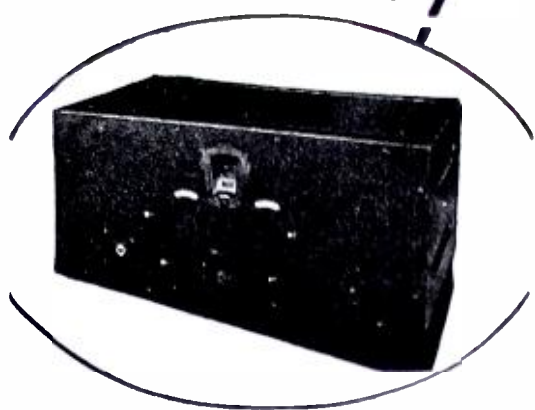

THE PROFESSIONAL SHORT-WAVE RECEIVER THAT CHALLENGES ALL COMERS

Now, you can span the oceans, the continents—travel the world over, any day or night, any time—with the short-wave superheterodyne, specially designed for professional and advanced amateur use, but so easy to tune that even the inexperienced fan gets professional results.

SELECTIVITY never before attained by any receiver. Band-spread tuning. Special long-wave oscillator for clear C. W. code and locating weak distant stations. Low noise level. Eight-tube superheterodyne circuit. Phone and speaker connections.

WHAT AN EXPERT SAYS:

"As a result of the test of the Comet "Pro" Superheterodyne, in which I participated with you, and subsequent tests which I conducted myself, I find that this short-wave receiver meets the combined requirements of the commercial operator, the amateur and the short-wave broadcast listener better than any receiver that I have heretofore operated. Its sensitivity, selectivity and low noise level make it an outstanding receiver in any of the three fields, while its extremely simple band-spread tuning represents, in my estimation, the foremost advance in short-wave tuning since the advent of single control."

S. GORDON TAYLOR,
 Technical Editor, Radio News.

For police, ships, airports, broadcasting stations and other professional use, the COMET "PRO" is the most reliable and efficient receiving instrument ever devised.

The Mail coupon TODAY for 16-page illustrated folder giving all details.

COMET Custom-Built "PRO" by HAMMARLUND

HAMMARLUND-ROBERTS, INC.,
 424 W. 33rd St., New York

Please send me 16-page illustrated folder, describing the COMET "PRO" Short-Wave Superheterodyne.

Name

.....

..... SW-9

tion control it will be found that as the padding condenser is rotated, the background noise will sharply increase at two points. At these points the oscillator is aligned with the detector, the lower capacity setting of the padding condenser being the correct adjustment, since the oscillator is designed to work on the high frequency side of the detector. In other words, while there are two points where the oscillator and detector may be aligned (when the oscillator is tuned either above or below the detector by the amount of the intermediate frequency), the correct setting of the oscillator is equal to the detector frequency plus the intermediate frequency.

Good Antennas

(Continued from page 275)

objects as possible, we are confronted with the problem of getting all the energy from the antenna to the receiver itself, without permitting the lead-in to pick up any interference. This is accomplished very easily by the use of a transposed lead-in. The accompanying illustrations give all the details. Keep the transposed lead-in three or more feet from the building, by means of the projection insulators, shown in Fig. 10.

It is highly desirable, therefore, to have the leads from the place where entrance to the room is made to the contact with the receiver just as short as possible. If it is impossible to keep these leads very short, they should be transposed, in just the same fashion as the outside portion of the lead-in. In fact, more interference is picked up inside of apartment houses than is picked up outside.

We now come to the important matter of connecting the transposed lead-in to the receiver itself. A very ingenious scheme has been developed for doing this job. It is the result of the combination of several coupling systems which have been in use at several of the important commercial receiving stations for some time. The coupler itself is shown in Fig. 12. It is nothing more than a suitable moulding which acts as the housing for the antenna coupling coil and the balancing resistance units which make up the coupler proper. It will slide right into almost any regular coil form and it requires no adjustment for changes from one wave band to another. The two legs of the antenna are automatically balanced by the action of the metallized resistors, while the shift from one wave band to another is accomplished by securing the correct degree of coupling.

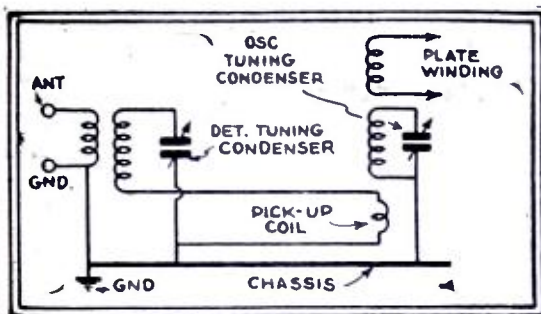

Simplified diagram showing "pick-up coil" linking detector and oscillator.

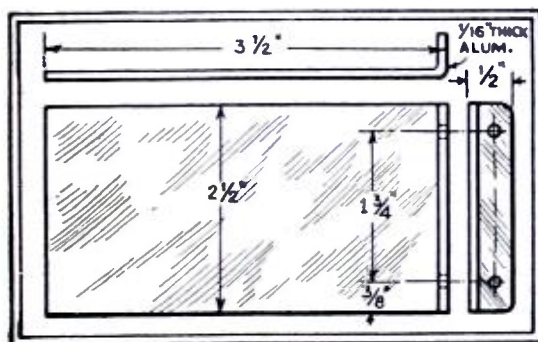

Aluminum shield or partition for the Denton super.

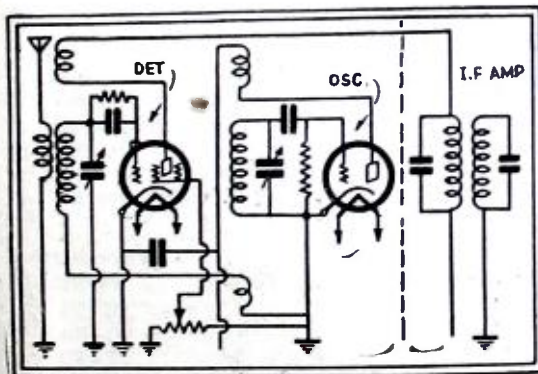

Circuit of detector and oscillator for Denton super-hot showing coupling coil.

Here's a Real Catalog of SHORT WAVE EQUIPMENT



12,500 MILES on a 2-Tube Set Costing only \$4.95

The above price includes ALL PARTS necessary to build this remarkable set. Aluminum chassis and panel, 3 plug-in coils covering 10 to 100 meters. Complete, simple instructions and Blueprint free with each Kit. This set uses 2-230's, 2 dry cells, and 2 B batteries. Can be supplied for 6 volt AC or DC operation. for AC operation with 2-227's — At NO EXTRA PRICE.

- KIT COMPLETE\$4.95
- Above set wired and tested.....\$9.00
- Assembled but unwired..... 7.00
- Pentode Tube output, 2 tubes makes set three times as loud. Complete Kit 5.00
- Above Kit—All Wired and tested.....10.00
- Assembled but unwired..... 7.50
- 3 Tube Kit 5.95
- 4 Tube Kit—1 stage RF, 2 Audio..... 6.95

SHORT WAVE PARTS OUR SPECIALTY

UNITED RADIOBUILDERS
SHORT WAVE HEADQUARTERS
1234-36 SPRINGFIELD AVE., IRVINGTON, NEW JERSEY

LEARN BY LISTENING **Telegraphy**
Morse or Continental

TELEPLEX is more than a machine—it is a SYSTEM. It teaches you expert sending and receiving, Morse or Continental Code—for amateur work or a good-pay position.

TELEPLEX is used by the U. S. Army and Navy and leading radio and telegraph schools.

Write for Folder SW9

Teleplex Co.

76 Cortlandt St., New York



The coupon on page 262 will bring you an interesting and informative book.

UNIVERSAL MODEL "BB"
1932 VALUE—NEW DESIGN

No other 2-Button microphone can give such superlative value for such a low price. Extra large size. Extra rugged construction. Extra excellence of performance. Built especially for voice pick-up public address work and amateur broadcasts. 24 kt. Pure Gold Spot Centers. Duralumin Diaphragm. Frequency range to WELL over 4000 cycles. **Guaranteed Performance at Rock Bottom Price**

LIST PRICE \$25.00

Universal Microphone Co., Ltd.
424 Warren Lane,
Inglewood, Cal., U.S.A.

Facts About S-W Coils

(Continued from page 304)

One worries about the losses in short-wave coils because the amplification usually depends upon the coils. When good coils are used, the amplification is high. If a set is insensitive, such as one discovers at frequencies in the neighborhood of five meters, the chances are that the coils are bad! A little simple theory will show why such losses exist.

One loss in short-wave coils, perhaps the most familiar one, is that due to so-called "skin effect." Radio frequency currents tend to flow on the surface of a wire. The effective cross-section of the wire is reduced, and the resistance of the wire therefore increases. The current flows on the surface of the wire because the inductance is less at the wire surface and therefore the reactance (engineer's term for "resistance to flow of alternating currents"; it is like ordinary "resistance" in direct current circuits) is less, the current preferring the path of least resistance. Of course, the action in a coil is considerably more complicated than the action within a simple straight wire. Nevertheless, the effect is similar, giving an increase in resistance as the frequency is increased. That is one source of loss in short-wave coils.

Another source of loss is that due to eddy currents. Eddy currents are currents which flow in every direction in general and no direction in particular, being due simply to the nature of the peculiar electrical "breeze" associated with coils in which a high-frequency current is flowing. Any electrical current consists of a stream of billions upon billions of electrons. Each electron has associated with it an electro-static field which acts across space. These fields are capable of exerting forces on neighboring electrons, causing them to move in the direction of the strongest field. Since these fields perform the wierdest acrobatics under the influence of the high-frequency alternations, it is clear that all sorts of electrical breezes proceed in different directions inside and around short-wave coils. It is as if each electron was supplied with a tiny electric fan; obviously, with the electrons proceeding in various directions, the electrical breezes within short-wave coils are something complicated! It is no wonder that a great number of electrons are blown in the wrong direction!

It must be remembered that any flow of electrons constitutes an electric current. So, if some electrons are caused to move in the "wrong" direction, interference is caused with the "main" current flow and an effective resistance is created. If all the electrons within a coil behaved absolutely alike, a much greater effective current would result, which is an apparent reduction in the resistance of the coil itself.

In Fig. 1, a greatly enlarged portion of a section of a radio coil is shown. This illustration shows, by arrows, that electrons flowing in adjacent wires exert forces on each other, causing complicated electrical phenomena. No extraordinary results would be obtained if the flow of electrons in all turns of a coil was constant; however, difficulties arise because high-frequency currents constantly reverse their direction, speeding up and slowing down, or accelerating and decelerating. Such changing currents cause induced currents in adjacent wires which tend to flow oppositely. In Fig. 1, only two wires are shown; in an actual coil, one can imagine how complicated these electron fields become! Eddy currents, then, are random currents which may aid the main current flow, but generally hinder it, causing an apparent increase in resistance within the wire constituting the coil's winding.

Another important source of loss at high radio frequencies is dielectric loss. The form upon which a coil is wound has an effect on the coil's losses because the electric lines of force find it easier to proceed through a solid dielectric than they do through air. Because of the higher dielectric constant of solid dielectrics, the capacity between the turns of a coil is increased. This effect would not be

particularly troublesome if the dielectric used as a winding form were perfect; and at short waves, however, solid dielectrics are far from perfect.

The effect of an imperfect dielectric is to cause a heat loss. The dielectric is subjected to strains at a radio-frequency rate, since the current direction is constantly changing; at one instant the dielectric is strained in one direction (see Fig. 2), and, after a lapse of time (dependent upon the frequency), the strain is reversed. This effect causes a loss within the form itself. Dielectric loss can be overcome by winding the turns of a coil further apart (so that the field-strength in the dielectric is reduced), winding the coil on a thinner material, or selecting a special dielectric which has low losses at high frequencies. The "perfect" coil would be air supported, that is, "wound on air"; obviously this is impossible. However, space-wound coils are popular for short-wave work because of their low losses.

From the foregoing it is apparent that the wire in a coil must be of a certain size; if it is too large, the eddy current loss will be increased; if it is too small, the resistance will increase. For every coil diameter there is a best size, and the larger the diameter, the larger one may make the wire size for the same amount of loss.

For all-around short-wave use, two inches is a good diameter to use. Coils should be space wound for lowest losses.

For two-inch coils, No. 20 wire is a good size; the coils when wound are also then quite sturdy.

Needless to say, it takes considerable work to test all kinds of short-wave coils, especially when they are wound by hand. Several kinds of coils are shown in the photograph herewith. It will save the constructor considerable time if he will construct coils like the one shown at the extreme right in the picture. This is a space-wound solenoidal coil made of No. 20 wire. It is wound on a thin celluloid frame, two inches in diameter. This type of winding is popular for short-wave use, as it consists of the usual primary, secondary and tickler windings. Other interesting kinds of coils (not so effective for short-wave, however) are also shown in the photo. Note the large basket-weave coils; these were quite popular for short-wave use several years ago.

The construction of the space-wound coils is not difficult. A collapsible form is constructed of a wooden cylinder about two inches in diameter. The celluloid sheet is wound on the form, cemented into a cylinder and the wire is wound on and spaced. The wire is then given a thin coating of a low-loss cement such as collodion. This holds the wire securely in place. The form can then be removed and the coil remains self-supporting. Those wishing to construct such coils can purchase coil kits. Others may desire to construct their own winding forms.

If one must use the above coils for plug-in, a simple mounting arrangement is shown in Fig. 3. Two strips of bakelite, arranged as a clamp, are mounted on a tube base. This base may be either a 4- or 5-prong. For only primary and secondary coils, the 4-prong base will serve, while a 5-prong base is needed for primary, secondary and tickler connections.

Using a .0001-mf. condenser, the specifications of two-inch diameter coils of No. 20 wire (with a space between turns equal to the wire diameter, except the largest coils) are as follows:

Primary	Secondary	Tickler	Wavelength Range
5	3	4	16-26
5	6	5	23-39
7	13	5	37-80
9	36	5	76-160

Differences in construction will influence the ranges of individual coils somewhat.—A. Binneweg, Jr.

Capacity Bridge

(Continued from page 279)

wire until a minimum or no sound is heard in the phones. At that point

$$C_x = C_s \times \frac{L_1}{L_2} \text{ or } = C_s \frac{L_1}{100-L_1}$$

If you buy a new buzzer obtain one with variable tone, as this helps greatly in obtaining a fine adjustment. Notice that C_x will be in the same units as C_s ; thus, if C_s is in microfarads, C_x will be in microfarads; if C_s is in micro-microfarads, C_x will be in micro-microfarads.

Inductance Measurement

The inductance bridge (Fig. 6) must have the addition of a 30-ohm non-inductive rheostat and the S. P. D. T. switch Sw. Otherwise it is the same as the capacity bridge. The standard inductance is any good R.F. choke. The writer used a Hammarlund, of known inductance.

Operation is somewhat more complicated with the inductance bridge, but after a little practice it presents little difficulty. With the rheostat at its point of least resistance and Sw on either contact 1 or 2, give P a trial setting for least sound. With P in this position the rheostat is given some resistance, which, when Sw is on either 1 or 2, gives a further reduction in sound. Thus the adjustment of P and R is continued alternately until minimum sound is heard in the phones. Then:

$$L_x = L_s \times \frac{L_2}{L_1} \text{ or } = L_s \times \frac{100-L_1}{L_1}$$

Note that in this case the ratio is $\frac{L_2}{L_1}$;

that is, the reciprocal of that in the case of capacity, also that if L_s is in millihenries L_x will be in millihenries; if L_s is in henries L_x will likewise be in henries.

Many uses for these instruments will at once suggest themselves to the reader. The writer has used them for a rough alignment of gang condensers and condensers in intermediate transformers, determination of unknown capacities in power packs, by-pass condensers, etc., and in finding the inductance of all kinds of short-wave and other coils, etc. They may also be used for determining the approximate frequency of a coil and condenser combination for

$$F = \frac{159,200}{\sqrt{L \times C}}$$

Where F is the frequency in kilocycles, C the capacity in microfarads, L the inductance, in microhenries, that is millihenries $\times 1,000$ or henries $\times 1,000,000$.

Crack Station W2PF

By ROBERT HERTZBERG

(Continued from page 267)

through all the phases of amateur radio activity. He started with a crystal receiver and a spark coil transmitter, and made considerable noise in the local ether with the self-assigned call, "DT." After the War, when the emergency restrictions on amateur radio were lifted (in 1919), he was among the first New York experimenters to obtain a license. He has used the call 2PF and then W2PF for a variety of transmitters ranging from rotary spark-gap outfits to his present neat 50-watt C.W. job. As shown in the accompanying illustration, this is built up on a vertical rack in one corner of the room. It uses the very stable and efficient MOPA (master-oscillator-power-amplifier) circuit, with a crystal controlled '10 feeding a '10 intermediate amplifier, this in turn working into a '03A final amplifier. The antenna is a simple 66-foot voltage fed Hertz between the back porch and the garage.

Explore the New Radio Trails! with this NATIONAL

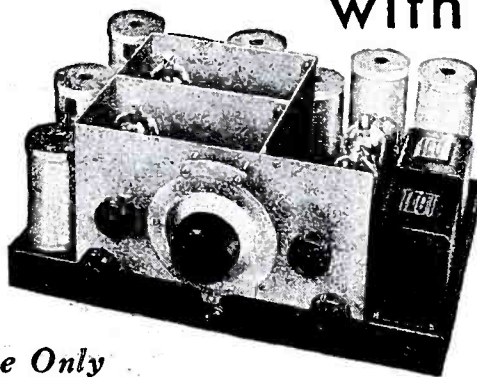

5-METER RECEIVER ULTRA SHORT WAVES

Here are some of the New Ultra S.W. Parts used in the National 5-Meter Set.



SPECIAL ULTRA SHORT WAVE TYPE SEU CONDENSER

Insantite insulation, extra-heavy 270° plates, double spaced. Insulated front bearing, constant low impedance. For ultra short-wave tuning.

Insantite insulation, extra-heavy 270° plates, double spaced. Insulated front bearing, standard size 25 mmf.



NATIONAL ISOLANTITE SOCKETS

Reduce losses to a minimum—suitable for either standard or sub-panel mounting. Made in standard 4, 5 and 6-prong styles as well as in special 6-prong for National Standard, R-39 coils.



MIDGET R-39 COIL FORMS

Give stability, maintain calibration and insure maximum efficiency and flexibility in ultra-short wave circuits.

Send in this COUPON today!

NATIONAL COMPANY, INC.
61 Sherman St., Malden, Mass.
Gentlemen:
Please send me..... full description and prices of your new 5-Meter Receiver.
Please send me a copy of your Ultra Short-Wave Manual No. 3, "Below 10 Meters" for which I enclose 50c (stamps, coin or money order).
Name.....
Address..... SW 9-32

The Only Standard Receiver Available Designed and Made for Ultra Short Waves

Receiving range 7 1/4 to 3 1/4 meters (40-80 megacycles). Special coils can be furnished for use on amateur 20 and 80 meter phone bands. Receives ultra short-wave transmissions now on air such as television programs experimental airplane beacon signal (U. S. Navy), Amateur phone transmitters.

HIGH SIGNAL TO NOISE RATIO

The National Receiver is especially noteworthy for its high signal to noise ratio. This is the direct result of a long period of development from which radically different circuits were evolved.

"ELECTRON-COUPLED" CIRCUITS

A high degree of stability results from the "Electron-coupled" circuits used in this receiver.

GENERAL CHARACTERISTICS

Single control tuning. Equipped with volume control, sensitivity control, special shielding, push-pull Pentode power-output for loud speaker operation. Employs the new NATIONAL Isolantite coil and tube sockets—midget coil forms made of improved R-39, the wonderful non-hygroscopic material especially developed for National Company Short Wave Receivers in the Radio Frequency Laboratories.

MADE FOR FULL AC OPERATION

The National Five Meter Receiver is made to operate with Standard AC Tubes on full AC power supply with special National Power Pack, R.C.A. Licensed.

AN ULTRA-MODERN RECEIVER FOR ULTRA SHORT WAVES

For prices and complete information write National Co., Inc., 61 Sherman Street, Malden, Massachusetts.

NATIONAL ULTRA SHORT WAVE APPARATUS



Aero Short Wave Receiver... \$ 6.45
Aero Auto Radio, Complete... 39.50
Aero Short Wave Converter... 12.50

Send for Complete Catalog

CHAS. HOODWIN CO.

Dept. S17 4240 Lincoln Ave. Chicago, Ill.

PATENT Z. H. POLACHEK
YOUR IDEAS REGISTER YOUR TRADE-MARK BY 1234 BROADWAY 31st NEW YORK DO IT NOW

REG. PATENT ATTORNEY PROF. ENGINEER
WHAT IS YOUR INVENTION?

Send me a simple sketch or model for CONFIDENTIAL ADVICE

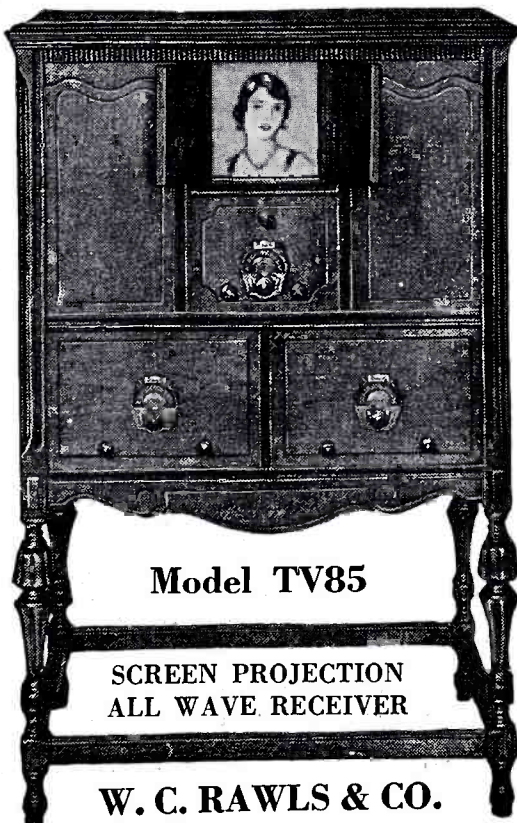

Model TV85

SCREEN PROJECTION
ALL WAVE RECEIVER

W. C. RAWLS & CO.

SW Bankers Trust Bldg., - NORFOLK, VA.

Rawls

TELEVISION with Synchronized Sound

LIST PRICE \$295.00

A Message to Moneymakers

And by moneymakers we mean dealers who are alive to new developments—dealers who are quick to appreciate the tremendous selling possibilities to the public of a Television set that provides real home entertainment. If you are interested drop us a line on your firm letterhead and we will be glad to send you full details.

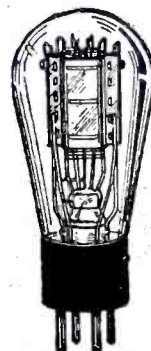

Originators of "Rawls Yellow Base Tubes"

—building, testing and repairing all kinds of radio receivers!

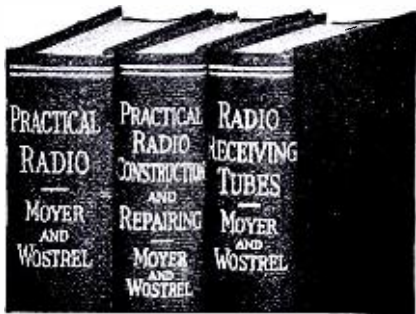

THE three volumes of this Library cover the entire field of building, repairing and "trouble-shooting" on modern radio receivers. The Library is up-to-the-minute in every respect and is based on the very latest developments in the design and manufacture of equipment. The rapidly-growing interest in short-wave and television reception is thoroughly covered in a complete section which deals with the construction of this type of apparatus.

Radio Construction Library

INCLUDING CONSTRUCTION
OF SHORT-WAVE AND
TELEVISION RECEIVERS

By JAMES A. MOYER and
JOHN F. WOSTREL

Faculty, University Extension, Massachusetts Department
of Education

Three Volumes — 1087 Pages, 6x9
605 Illustrations

VOLUME I: presents the fundamental principles of radio so clearly and simply that anyone of average training will be able to read, understand and apply them. It gives actual working drawings and lists of materials for the construction of many typical sets.

VOLUME II: fully discusses all of the elementary principles of radio construction and repair. An explanation of the necessary steps for "trouble-shooting," repairing, servicing and constructing radio sets successfully. Practical data is also given on antenna systems, battery eliminators, loud speakers, chargers, etc. This volume includes complete instructions for the construction and operation of short-wave and television receivers.

VOLUME III: covers the essential principles underlying the operation of vacuum tubes in as non-technical a manner as is consistent with accuracy. It discusses the construction, action, reactivation, testing and use of vacuum tubes; and an interesting section is devoted to remote control of industrial processes; and precision measurements.

EXAMINE these books for 10 days FREE

This Library is not only a thorough home-study course, but a handy means of reference for the more experienced radio experimenter, repair man, and radio shop-owner. To these men, as well as to those who desire to advance in the radio profession, this offer of a 10 days' Free Examination is made.

Simply clip, fill in, and mail this coupon

McGRAW-HILL

FREE EXAMINATION COUPON

McGRAW-HILL BOOK COMPANY, INC.
370 Seventh Avenue, New York.

Gentlemen:—Send me the new RADIO CONSTRUCTION LIBRARY, all charges prepaid, for 10 days' Free Examination. If satisfactory I will send \$1.50 in 10 days, and \$2.00 a month until \$7.50 has been paid. If not wanted I will return the set at your expense.

Name

Home Address

City and State

Position

Name of Company.....SWC-9-32

(WRITE PLAINLY AND FILL IN ALL LINES)

Micro Rays — (Continued from page 279)

causes a shortening of the exciting wave (electron cloud oscillation), so that the attainment of resonance is accelerated. The result is an additional strengthening of the alternating field, and so on. That is, a building up process takes place which rapidly affects both the alternating potential and frequency. The final stable state is reached when the frequency of the electron cloud oscillation coincides with the frequency of the tuned circuit, for an increase in electron cloud frequency above resonance would cause a weakening of the alternating field.

In order to have self-sustained Gill-Morrell oscillations it is necessary that enough energy be supplied to the tuned circuit to overcome all losses, and this energy must be supplied in phase with the oscillations already existing.

If the steady grid potential is increased to a value slightly higher than that at which resonance was obtained, it is found that the frequency no longer increases. This is due to the fact that the accelerating and retarding fields, in the Gill-Morrell oscillator, have two components—the steady component and an alternating component. Due to the increased steady grid potential the electron cloud oscillation frequency tends to increase, but such an increase would reduce the alternating component of the inter-electrode field with a corresponding reduction in frequency. The result is that the frequency remains constant at the frequency of the external circuit and is not affected by small changes in steady grid potential. This indicates that the oscillations are now of the Gill-Morrell type.

If the steady grid potential is increased still more, the alternating potential across the tuned circuit decreases slowly to a negligible value and the steady voltage again takes control. Increasing this potential now causes increases in electron cloud oscillation frequency, indicating that Barkhausen-Kurz oscillations again exist. The curves in Fig. 4 show how the frequency, oscillation intensity, and plate current vary as the steady grid potential is increased.

It is interesting to note that, although the Gill-Morrell oscillator bears a striking circuit resemblance to the familiar old ultra-audion oscillator, the operation of the two circuits is very different. In the ultra-audion circuit the plate is given a positive potential and the grid a zero or negative potential. Under these conditions the Barkhausen-Kurz electron cloud oscillations cannot exist, since, without the external circuit, any electrons passing through the grid would be attracted to the plate and result in a steady flow of plate current. When the external circuit is attached as shown in Fig. 5, oscillations may be generated at the frequency of the external circuit. The method of building up of these oscillations is well understood—some change in a circuit constant causing a change in plate current which in turn causes a change in the potential between plate and filament, thus setting the tuned circuit into oscillation and causing variations in grid voltage in the proper phase relationship to sustain oscillation. The frequency of the ultra-audion oscillator is governed entirely by the tuned circuit and oscillations may build up regardless of the frequency to which that circuit is adjusted. The intensity of oscillation is controlled by the tube and potentials used. In the Gill-Morrell oscillator the alternating potential across the tuned circuit is created by the electron cloud oscillation, so the frequencies at which this circuit will oscillate are those slightly higher than the frequency of the electron cloud oscillation with the external circuit removed. The intensity of oscillation cannot be adjusted as easily as in the more common oscillators, since any change in the operating potentials will cause a large variation in the frequency of the electron cloud oscillations.

Utilizing the Gill-Morrell Oscillator As a Transmitter

In order to utilize the Gill-Morrell oscillator as a transmitter it is only necessary to add a modulating or keying system. Since the frequency stability of such a transmitter is far from perfect, it has been found advisable, thus far, to use either tone or voice modulation rather than pure C.W.

A tone modulated transmitter is shown in Fig. 6 and a voice modulated transmitter in Fig. 7. It will be noted that grid voltage modulation is used. In order to secure undistorted modulation, i.e., pure amplitude modulation, the grid voltage is chosen so that the intensity of oscillation varies in a linear fashion throughout the range of the modulating voltage. By choosing a value of grid voltage approximately half way between the voltage at which external circuit oscillations appear and that at which they become negligibly weak again (in the center of the Gill-Morrell "band"), the modulating voltage superposed upon the radio frequency grid voltage causes changes in oscillation intensity and plate current without greatly affecting the frequency. Plate voltage rather than grid voltage modulation is frequently used in order to reduce the losses caused by the comparatively large grid current flowing through the windings of the modulation transformer, but a larger modulating voltage is required in order to secure the same degree of modulation.

The transmitters shown in Figs. 6 and 7 have simple Hertzian doublet antennas, although other types of radiators may be used with excellent results.

Action of Electron Oscillator as Detector

A careful analysis of the curves shown in Fig. 4 indicates that the electron oscillator may be used as a detector of ultra-high-frequency oscillators, and that it may possess regenerative or even super-regenerative properties as well.

In Fig. 8 it is evident that any signal voltage picked up by the antenna will create an alternating field between grid and filament. This field superposed on the already existing field tends to increase the frequency and intensity of electron cloud oscillation. Assume that the external circuit has been tuned to the frequency of the incoming signal and that the steady grid voltage is adjusted so that the frequency of the electron cloud oscillation is lower than the frequency of the tuned circuit. Under these conditions a small alternating voltage will be created across the tuned circuit by the electron cloud oscillation, but will not cause variations in grid voltage sufficiently large to sustain oscillation. Now the addition of the signal voltage increases the frequency of the electron cloud oscillation and this causes a greater alternating potential across the external circuit. If the signal voltage is large enough, the electron cloud frequency will be increased to the point where the alternating potential across the circuit becomes great enough to sustain Gill-Morrell oscillations.

These oscillations will continue only so long as the signal voltage is supplied and will be rapidly damped out between wave trains. The "point of critical regeneration" is the point at which the voltage across the external circuit is just great enough to sustain the Gill-Morrell oscillations after the signal voltage is removed. It is, of course, impossible to operate the circuit at this point, since oscillations, once started, would be maintained, thus decreasing the sensitivity greatly. By choosing the steady grid voltage so that the signal voltage "triggers" the circuit into oscillations which are damped out as soon as the signal voltage ceases, we obtain maximum sensitivity.

If it were possible to increase the damping of the oscillation circuit after each wave train, so that all Gill-Morrell oscillations were damped out prior to the arrival of the next signal impulse, it would be possible to work the circuit at or even beyond the point of critical regeneration and obtain a still greater sensi-

tivity. It was previously shown that the amount of energy supplied to the external circuit (or the alternating potential across it) could be controlled by varying the frequency of the electron cloud oscillation through a variation of the steady grid voltage. To secure the maximum sensitivity, then, it will only be necessary to arrange an auxiliary oscillator in such a manner that the grid voltage will be varied rapidly. Under such conditions the circuit would alternately work in a highly regenerative condition and then, after the signal voltage had triggered it into Gill-Morrell oscillations and these oscillations have had time to build up to their maximum, in a non-regenerative condition to damp out the oscillations and return the circuit to its previous sensitive condition prior to the arrival of the next wave train. Such a circuit is shown in Fig. 9. This is nothing but the conventional super-regenerative circuit, modified to fit the Gill-Morrell detector.

How Super-Regeneration Fits In

Super-regeneration fits in extremely well at these super-high frequencies. It has been estimated that the amplification obtainable varies approximately as the square of the difference between the signal and "quenching" frequencies, provided that the quenching action takes place before the amplitude of the oscillations has become constant. This means that, in the case of the Gill-Morrell receiver, the quenching frequency may be made high enough to be entirely inaudible and yet, since the signal frequency is so high, provide amplification far in excess of anything previously obtained at these frequencies.

The receiving antenna may be a doublet, but, since such an antenna would be difficult to adjust over a wide band of frequencies, it is usually more satisfactory to use a simple combination of several elevated wires of different lengths, coupled loosely through a capacity to the grid circuit. Several wires are used so that at least one may have the proper electrical length to oscillate under the influence of a signal of any frequency within the ultra-high-frequency band.

The practical receiver may use one or two stages of audio frequency amplification, by substituting the primary of an audio frequency transformer for the telephones in the simple circuit.

Plotting Curves

(Continued from page 280)

the positive grid voltage side, it continues to rise to 8.5 milliamperes at 4.5 volts positive for the grid. We see that there is a slight slope at the bottom or start of the curve and that it starts to go fairly straight from the 1-volt negative grid portion on; this is the part of the curve that is most useful to us later on in the application of the tube to radio circuits, as that is the portion where little or no distortion occurs when we impress alternating voltages on the grid of the tube.

To illustrate this we will plot the effects of our last curve in a different form; we will keep the grid voltage between the points zero and 4 volts positive and the plate current then will be between the points 4.8 and 8.1 milliamperes. As we continually change this grid voltage between zero and 4 volts positive, periodically, the plate current changes accordingly; the effect is the same as if we had a normal 2-volt positive potential applied to the grid and then added an alternating voltage which had a maximum swing of two volts from zero to negative and to positive. The resultant curve as shown is symmetrical and shows no distortion. (Fig. 3.)

In the next graph, Fig. 4, we show what happens when the original grid voltage is at 4 volts negative and the alternating voltage that is added is made greater than before, to the extent of 4 volts, making it swing from zero to 4 volts negative and then 4 volts positive. Adding the 4 volts negative to the already 4 volts negative grid bias makes 8 volts



*What
Wouldn't
You Do
for Them*

YET you may be overlooking the most vital thing of all for their future security and happiness—MONEY.

If you were taken away tomorrow, what would they have to live on? Could the children go on through school? Could mother earn enough for them?

Life insurance is now sold by mail at so small a cost **NO ONE** need be without its splendid protection. We now offer a special old line, legal reserve life policy for as low as \$4.13 at age 35 (other ages in proportion)—a policy paying you \$1,000, with an additional \$5,000 special travel accident benefit; disability benefits, loan values, and other advantages. Think of it! No family can afford to be without such protection, at so trifling a cost.

We sell entirely by mail, hence these savings—no agents' commissions, no medical fees, no extras, no red tape. **YOU** save the difference.

Mail the coupon below. We will send you a free sample policy which you can judge for yourself. If you like it, keep it. If you don't, there's not a cent of cost or obligation.

For your own peace of mind, for the security of those you love, get this low-cost protection while you CAN. Mail the coupon now.

FREE! Mail this coupon TODAY for sample policy and complete details.

Union Mutual Life Company of Iowa, (Box 214)
Des Moines, Iowa.

Send me above described Free sample policy and complete details—this is not to obligate me in any way.

Name _____

Address _____

Age _____ Occupation _____

negative for the swing in that direction, and adding 4 volts positive to the original 4 volts negative brings it to zero grid voltage on the swing in the positive direction. The resultant plate current curve as can be seen is now not symmetrical in its values, the negative swing bringing the plate current down to .6 milliamperes and the positive swing bringing it up to 4.8 milliamperes. As this alternating grid voltage averages 4 volts negative, the mean plate current centers at 2 milliamperes and the swing is then from 2 milliamperes down to .6 milliamperes and from 2 milliamperes up to 4.8 milliamperes, making a swing downward of 1.4 milliamperes and a swing upward of 2.8 milliamperes, the upward swing being twice as great and of course not symmetrical. This is what causes distortion, but for some purposes this form of curve is necessary, as when we wish to obtain rectification, as in detection; we then go even farther with our bias voltage to the grid, nearly to the point where for a given plate voltage no plate current flows.

(Don't miss the next article of Mr. Reinart's series.)

**Reduce Interference
on
SHORT WAVES**

Latest engineering achievement eliminates most of the disagreeable interference on short wave broadcast, television and amateur bands.

LYNCH

Antenna Transposition Blocks

were designed after long tests and are put up in handy kit form with full instructions.

Complete kit of 10 LYNCH Transposition Blocks **\$2.50**

Send order today to

LYNCH MFG. CO., Inc.

1775SW Broadway, New York City

DATAPRINTS

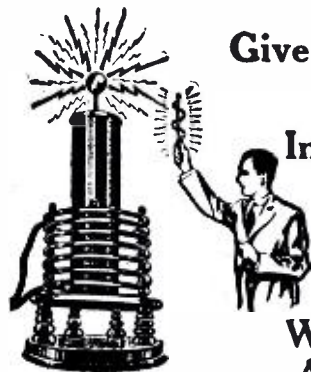

Give
Technical
Information
on the
Building
of
Worthwhile
Apparatus

Dataprint containing data for constructing this 3 ft. spark Oudin-Tesla coil.

\$.75

Includes condenser data.

OTHER "DATAPRINTS"

MOTOR—1/16 H.P., 110 volt A.C., 60 cycle (suitable for television, driving 12" fan or light apparatus), constructional data.....**\$.75**

PHONIC WHEELS—How to Build Instructions—1200 cycle (including field winding data)... 0.50
60 cycle (including field winding data).... 0.50

MAGNET COIL DATA

Powerful battery electro-magnet; lifts 40 lbs..**\$.50**
110 volt D.C. magnet to lift 25 lbs..... 0.50
110 Volt D.C. solenoid; lifts 2 lb. through 1 inch. 0.50
110 Volt D.C. solenoid, lifts 6 lb. through 1 inch. 0.50
12 Volt D.C. solenoid, lifts 2 lb. through 1 inch. 0.50

TESLA OR OUDIN COILS

36 inch spark, data for building, including condenser data**\$.75**
8 inch spark, data for building, including condenser data 0.75
Violet type, high frequency coil data; 110 volt A.C. or D.C. type; 1" spark; used for giving "violet ray" treatments..... 0.75
How to operate oudin coil from a vacuum tube oscillator 0.75

TRANSFORMER DATA

Any size, 200 to 5000 watts, (1 primary and 1 secondary voltage data supplied—specify watts and voltage desired).....**\$.100**
Book—"How to Make High Pressure Transformers" 1.25
Book—"How to Make Low Pressure Transformers" 0.40
(Postage 10 cents extra on books.)

DATA BOOKS—Engineering for the Layman—

Induction Coils—How to Make.....**\$.100**
Preliminary Mathematics..... 1.20
Battery Engineering..... 1.25
Fundamentals of Direct Current Machines..... 2.50
Examples in Alternating Currents..... 1.00
Examples and Problems in Magnetism..... 1.10
(Postage 10 cents extra on books.)

REFRIGERATION MACHINE — Dataprint —

How to Make Data..... 1.00

TELEGRAPHONE — Records Voice or "Code" signals on steel wire by magnetism. Code can be recorded "fast" and translated "slow". Constructional data (special).....**\$.50**

TELEVISION—10 practical hints; including lens disc and crater tubes; receiver diagrams, etc.**\$.75**

SHORT WAVES—10 practical circuit kinks... **0.75**

CLOCKS—Electric chime ringer. How to make one to fit on any ordinary clock..... **0.50**

MISCELLANEOUS DATAPRINTS—

Electric Ice Skates—How to make..... **0.50**
How to Thaw Pipes by Electricity..... **0.75**
20 motor circuits—hook-ups..... **0.75**
20 practical telephone hook-ups..... **0.50**

SLIDE RULES—Specially Selected

Students' 10-inch wood slide rule, accurately engraved (prepaid)**\$.110**
ELECTRICAL Slide Rule, 10 inch size, with special electrical law ratios and indexes, wood with white ivorine scales (prepaid)..... **5.75**
5" "Pocket" slide rule..... **4.00**
"Circular Pocket" slide rule. Fits vest pocket, 2½" diameter, leather case..... **4.00**
(Postage 10 cents extra on last two slide rules.)

The DATAPRINT COMPANY
Lock Box 322 RAMSEY, N. J.

Second Prize Winner

(Continued from page 287)

sired. Care should be taken that the wood doesn't split when nailing.

The top of the box is separated into two compartments by placing a strip (5¼ x 2½ inches) 2½ inches from one end of the lid. A board 4½ x 5¼ inches is made in the form of a small door to cover the larger of the two compartments, which is used to house the plug-in coils, phones, etc. The other is occupied by the tubes when the lid is closed.

The Plug-in Coils

Old tube bases are used for the coils and four holes are drilled to receive the leads from the two coils. As shown in the diagram, the bottom of the tickler coil goes to the "G" prong of the base while the top goes to the F-minus prong. The F-plus prong is for the bottom of the grid coil and the "I" prong for the top of the grid coil.

Before the coils are wound, the pin at the side of the tube is filed off. For the higher wavelength a cardboard or bakelite extension will be necessary to accommodate the necessary number of turns of wire. When no extension is used, it is necessary to remove the solder from the prongs, as the leads can be run down into them and held in place with a large size carpet tack. After they have been checked and found OK, sealing wax poured into the base will hold the connections secure. This saves time and energy and makes a much neater job.

Where extensions are made the tickler coil is wound double to save space. In this case only one hole is necessary for the ends of the coil. The coils are made so that they will give good results on various bands. Thus,

though they may overlap, coil 1 is for the 31-meter band, coil 2 is for the 49-meter band, coil 3 for 75-meter amateur band, coil 4 for 120-meter police calls, coil 5 for 170-meter police and 160-meter phones.

Two of the '99 type tubes are used. One 4½-volt "C" battery furnishes "A" supply for filaments of the tubes. The "B" current is obtained from two of the small sized (2½ x 4 x 2½ inches) 22½-volt batteries. A pair of the Trimm 4-oz. type (featherweight) headphones is recommended for use with this set.

Coil Data

	Grid Winding	Tickler Winding	Wire
Coil 1	6½ turns	12 turns	No. 28 D.C.C.
Coil 2	15 "	16 "	No. 28 D.C.C.
Coil 3	24½ "	14½ "	No. 28 D.C.C.
Coil 4	50 "	32 "	No. 24 D.C.C.
Coil 5	74 "	44 "	No. 28 D.C.C.

List of Parts Used

- 1 Antenna coil, 5 turns bell wire on tube socket.
- 2 Plug-in coils.
- 3 Two 15-plate De Jur midget condensers.
- 4 .00025-mf. grid (fixed condenser).
- 5 7-megohm grid leak.
- 6 Choke coil.
- 7 Hedgehog transformer, ratio 1:5.
- 8 25-ohm rheostat.
- 9 .001-mf. fixed condenser.

Also: A Panel "X" and aluminum shield "X", two wafer (UX) and one UX tube sockets, four binding posts, two bushings and quantity of machine screws.

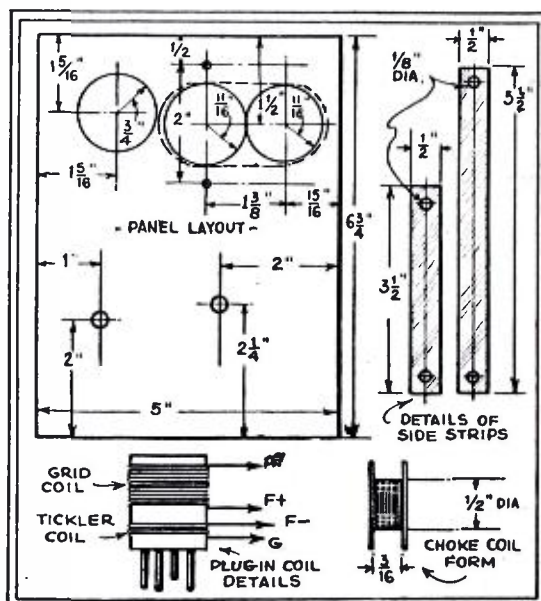
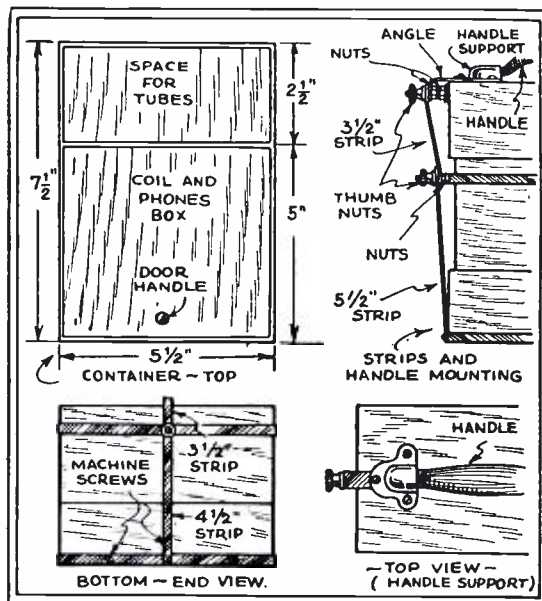

Third Prize Winner

(Continued from page 287)

the automobile output tube, the '38 pentode, would give a great deal of amplification with a small amount of input. The '38 also won because its low plate current allowed the use of earphones. The problem of filament supply was soon settled when I learned of the fact that the auto tubes were designed for use on from 5 to 8 volts of filament safely, enabling the use of a 7½-volt transformer, which is available at any dealer. The receiver was limited to two tubes, firstly because of a lax pocketbook, secondly because it could be gotten down to a small size, and lastly for simplicity of construction. More than two tubes were unnecessary, as fairly good loud speaker reception was had from stations up to more than 2,000 miles away.

For the "B" supply I fashioned a simple adapter which fit under the '45 output tube of my broadcast receiver and made contact with its plate prong. The "B" negative was taken from the chassis of this set.

Parts List

- 1—Antenna binding post.
- 2—Ground binding post.
- 3—.0005 mf. De Jur condenser.
- 4—One set Genwin or Na-ald short-wave coils.
- 5—.0001 mf. De Jur tuning condenser.
- 6, 9—.00025 Micamold mica grid condenser.
- 7—2 meg. Aeratest half-watt grid resistor.
- 8, 17—5-prong socket.
- 10—R.F. choke.
- 11—.1 mf., 200-volt by-pass condenser.
- 12—Frost 25,000-ohm with power switch (21).
- 13—60,000-ohm half-watt Aeratest resistor.
- 14—200,000-ohm 1-watt resistor.
- 15—.01 mf Micamold tubular condenser.
- 16—500,000-ohm half-watt resistor.
- 18-19—Speaker or phone posts.
- 20—7½-volt filament transformer, Acme.

First Prize Winner

(Continued from page 286)

(Paris); LSY, Buenos Aires; W2XAF, Schenectady; W8XK, Pittsburgh. Bowmanville could be heard all over the house and overloaded the '27 audio tube at maximum volume. Buenos Aires, 5,000 miles away, came through with fair loud speaker volume. Later, G5SW (Chelmsford), DJB (Berlin), I2RO (Rome) and Paris, on 19.68 meters, were heard on the speaker, but some rather weakly. Many stations on the 80-meter amateur band came through with great volume.

Good performance was obtained with aerials from 6 to 115 feet long, the latter size giving somewhat stronger signals. The set will operate with or without a ground.

Selectivity proved better than expected and no doubt this is partly due to the provision of an R.F. transformer in preference to tuned impedance coupling. National type SW5 coils, which are wound on a special dielectric, are used. The number of turns on these coils was published in the April issue of SHORT WAVE CRAFT.

The design of the chassis and layout of the parts is such as to provide extremely short leads. The National type C illuminated dial is placed exactly in the center of the 7 x 7 inch aluminum panel. This panel is bolted to the base, which consists of a 6 1/2 x 9 inch sheet of aluminum with the ends bent down. The height of the base is 2 inches, which places the coil socket terminals about level with the tuning condenser, so that the stator lead is less than 1 1/2 inches long. The chassis is enclosed in an aluminum box with grooved corners.

The location of the three tubes can be seen in the illustration, the R.F. being at the right, detector at left and audio in rear.

FOURTH PRIZE — \$7.50

Won by HAROLD JOHNSON

Description will appear in next issue, due to lack of space in present one.

Both the main and antenna tuning condensers are .0001 mf. Pilot midgets, and because of the single bearing design, operate without noise. While not designed for the purpose, the set will operate on the broadcast band and the antenna condenser is chiefly used to aid tuning in this field.

To dispose of the by-pass condensers, R.F. chokes and resistors under the base of the little set, considerable ingenuity was required. All condensers are bolted firmly to the base, three being placed on top of each other in one case. Non-inductive mica condensers are used in the R.F. and detector circuits. The binding posts and antenna condenser are insulated from the chassis with bakelite bushings. Smooth control of regeneration is obtained by regulating the voltage on the screen-grid of the detector with a 50,000-ohm Frost roller type potentiometer. A little two-pole switch under the tuning dial knob provides means for cutting off the "B" supply when desired.

List of Parts

- 3 Pilot tube sockets.
- 2 Pilot midget variable condensers, .0001 mf.
- 1 Aero R.F. choke No. 65 (antenna choke).
- 1 Aero R.F. choke No. 60 (detector plate lead choke).
- 1 Pacent No. 26 Audioformer. (See text.)
- 1 Set of National SW5 inductances.
- 1 50,000-ohm Frost roller type potentiometer.
- 6 Fixed condensers, .01 mf., Aerovox and Pilot.
- 1 .0001 mf. grid condenser.
- 1 .00025 mf. fixed condenser, Micamold.
- 1 .5 mf. fixed condenser, Aerovox.
- 1 5-megohm grid leak, Lynch.
- 1 500-ohm, 1-watt resistor, Lynch.
- 1 2,000-ohm, 1-watt resistor, Lynch.
- 1 1/2-megohm, 1-watt resistor, Pilot.
- 1 Carter midget jack (two-prong).
- 2 K-K knobs.
- 6 Eby binding posts with bakelite bushings and washers.
- 1 Two-pole, single-throw switch.
- 1 National type C dial with light.
- Aluminum chassis and box.



...An Announcement That Created Favorable Comment

The May issue of SHORT WAVE CRAFT carried an article of tremendous importance to every Short Wave enthusiast. Hugo Gernsback, editor of SHORT WAVE CRAFT announced to many thousands of fans that an organization was to bring closer those who were interested in this comparatively new branch of radio. The announcement of a SHORT WAVE LEAGUE took the Short Wave world by storm. Thousands of letters and applications poured in and well known figures in the radio field congratulated the magazine on the great work it was doing. Such men as Lee de Forest, D. E. Replogle, Hollis Baird, Baron Manfred von Ardenne pledged their whole-hearted support in this wonderful movement.

SHORT WAVE LEAGUE PLATFORM

- To help popularize short waves among the public.
- To assist authorities in the apprehension of criminals and in general crime prevention through the instrumentality of short waves.
- To demand enactment of new regulations enabling operators of phone transmitters to be licensed without code requirements, below 6 meters.
- To bring together short wave enthusiasts by promoting comradeship among them.
- To eliminate man-made static, the greatest enemy of short waves.

If you are interested in Short Waves you should join the SHORT WAVE LEAGUE and benefit from the advantages that will accrue as a result of the League's platform. The SHORT WAVE LEAGUE can only realize certain measures if it gets YOUR support. If you are interested, kindly mail the coupon at the right.

You may order at once the insignia of the League. This beautiful button measures 3/4" in diameter and is inlaid in enamel—3 colors—red, white and blue. The price is only 35c. A special reprint of the announcement of the SHORT WAVE LEAGUE which appeared in the May issue, will be sent to anyone interested, upon receipt of 15c to cover necessary mailing charges.



SHORT WAVE LEAGUE
98 Park Place,
New York, N. Y.

Gentlemen:—
I enclose herewith —c. for which please send me:—

- Reprint of May Article explaining all details.
- SHORT WAVE LEAGUE Button.

Name

Address

City..... State.....



WHAT THE WELL VERSED SHORT WAVE FAN IS READING THESE DAYS !

- Partial List of Contents**
- The "S. W. C." Two Tube Portable Works "Speaker"—Clyde Fitch.
 - How to Operate a Short Wave Receiver
 - Two-Volt Tube Receiver
 - A "Plug-less" S. W. Receiver—John M. Avery
 - "My Favorite" Short Wave Receiver—F. H. Schnell
 - The HY-7B Super-Het for A. C. Operation—L. W. Hatry
 - The "Expert" SWS-9 Super-Het—How to Make It—Joseph I. Heller
 - A Super Sensitive Short Wave Receiver—Thomas A. Marshall
 - A S. W. Power Amplifier—H. Winfield Secor

**72 Pages
100 Illustrations**

Mail Coupon Now !

If you have a library of Short Wave books, your collection is incomplete without this instructive text. If you haven't a library as yet, let HOW TO BUILD AND OPERATE SHORT WAVE RECEIVERS be the forerunner of a group of ready references. Our "Partial List of Contents" is just an idea of the topics that this book covers, and of the experts that have written for it. You should own a copy if you want to be well versed in the art of Short Waves.

SHORT WAVE CRAFT SW-3-5
96-98 Park Place, New York City.

Gentlemen:—
I enclose herewith fifty (50c) cents for which please send me a copy of your new book, HOW TO BUILD AND OPERATE SHORT WAVE RECEIVERS. (Send money order, check, cash, or new U. S. Stamps. Register letter if it contains currency or stamps.)

Name

Address

City and State.....

RADIO+

A Host of Other Interesting Scientific Subjects—

- | | |
|-------------|--------------------|
| TELEVISION | CONSTRUCTION |
| ELECTRICITY | METAL WORKING |
| PHOTOGRAPHY | PHYSICS |
| AVIATION | ENGINEERING |
| WOODWORKING | METALLURGY |
| AUTOMOBILES | PUBLIC ADDRESS AND |
| PATENTS AND | SOUND EQUIPMENT |
| INVENTIONS | HOUSEHOLD AND |
| NEW DEVICES | SHOP HINTS |
| | AND OTHERS |



25c
The Copy

MR. HUGO GERNSBACK'S latest magazine contains the most important and recent developments in Science, Mechanics, Radio, Television, Aviation and Chemistry. For everyone, regardless of age, EVERYDAY SCIENCE AND MECHANICS will be found to be useful and instructive. Thoroughly illustrated with scientific events from all parts of the world, and helpful to thousands of high school, university students and instructors who wish to advance their scientific knowledge.

Many excellent pages for the home workshop man who finds pleasure in building things; experiments in electricity, chemistry and formulas of all kinds.

SPECIAL OFFER!

8 Months for \$1.00

Clip Coupon Now and Mail!

EVERYDAY SCIENCE MECHANICS
100 Park Place, New York, N. Y. SW-3-5

I enclose herewith One Dollar for which you are to enter my subscription to EVERYDAY SCIENCE AND MECHANICS for the next Eight Months.

Name

Address

City..... State.....

Canadian and Foreign Subscriptions Not Accepted

The Short Wave Beginner

(Continued from page 295)

perfectly easy to say that the ideal aerial for general short-wave reception is one 50 feet long and 100 feet high, but it may not be practical to follow these instructions because of the surrounding layout of buildings, etc. In crowded locations, such as city apartment houses where one encounters difficulties because of the presence of other aerials and finds no convenient support for the contemplated one, the best judgment must be exercised.

The writer has found that the horizontal type of antennas are preferable to the vertical types. In one particular case, it was found that a horizontal 30-foot wire of the T type would bring in stations 200 miles away with several times the intensity possible with a vertical wire of the same dimensions.

In building an aerial for our *Beginner's Short-Wave Set*, it may be found that greater signal strength is obtained if we use a short aerial of about 25 or 30 feet total length for the two smallest tuning coils. A few of us may also be unfortunate enough to have trouble in getting the set to oscillate on certain parts of the dial with one or more of the tuning coils. In this case, if the length of the aerial is changed slightly, this trouble will disappear. The difficulty is due to the natural wavelength of the antenna being tuned to one of the wavelengths at which we desire to receive a station. In this case, the aerial absorbs so much energy from the set that it cannot oscillate.

While we are talking about trouble with our receiver, a few of us may be unfortunately located quite near a large broadcast station operating on the broadcast band and may have difficulty in tuning it out. A simple but effective cure for this interference is a wave trap. The trap is simply a coil and a variable condenser which will tune to the wavelength of the broadcast station. It is connected in the aerial lead-in wire. A suitable coil which will tune over the entire broadcast wave band consists of 40 turns of No. 22 wire wound on a coil three inches in diameter. The condenser may be any variable condenser of about .0005 mf. (23 plates). Figure 4 shows how the wave trap is made and connected in the aerial lead-in. All that is necessary is to tune the condenser slowly while listening to the receiver. At one point the broadcast station will either disappear entirely, or nearly so. So much for the trouble in our set.

To return to the construction of antenna systems, in Fig. 5 we find two illustrations of a typical aerial installation. At the left is shown how NOT to do it and at the right is illustrated the correct way. It will be noticed that the correct aerial is kept clear of all obstructions and that the lead-in is removed from the building. The aerial wire should be suspended as far away from nearby electric light and power wires as possible. If it is practical, the wire should be run in a direction at right angles to such wires, also those of trolley lines, electric railways, etc., from which electrical disturbances might be picked up. In this case the lead-in should be taken off the end furthest from the source of the disturbance.

We must also be careful to keep the aerial away from metal roofs, gutters, leaders, steel framework, etc., since these grounded objects absorb the radio energy and leave very little for the antenna.

The Lead-In

As we explained in Fig. 5, the lead-in wire should be kept some distance from the wall of the building. It must never be allowed to touch the metal cornice or leader at the edge of the roof, for these are grounded. It is a good plan to bring the aerial wire directly into the set. In this way, no difficulty is encountered with connections becoming loose or corroded. Figure 6 shows a method of bringing the wire down at the lead-in end without making a joint.

Two systems for bringing the lead-in wire

into the building are commonly employed. The simplest way is to bring it through the nearest window, using a special insulated lead-in strip which is sold for the purpose. These strips consist of a flat conductor about 1/2 inch wide covered with a flexible insulating covering. The strip is placed under the window so that it will close. The end of the lead-in is connected to the outside terminal and a wire is connected to the inside terminal for the purpose of connecting to the set. It is well to solder the two wires to this strip to prevent corrosion from increasing the resistance of the aerial. This method is illustrated in Fig. 7.

The other method that is used to carry the lead-in into the building consists of a hollow porcelain bushing similar to those used for certain types of electrical wiring. A hole is drilled through the wall, slanting down to the outside, as we can see by referring to Fig. 8. The purpose of this down slant is to prevent rain water from entering the tube. The lead-in wire is passed through this tube and is connected directly to the set. Of course, in brick buildings the latter method is rather difficult, so the window strip is more commonly used. Another method is that described in last month's editorial by Mr. H. Gernsback, which involves the use of two small copper foil leaves glued opposite each other on the window glass.

The Ground Connection

For both the aerial wire and the ground lead, a wire of not less than No. 14 should be used. In order to get good results, we must keep the resistance of the antenna system as low as possible. It is a good plan to use enameled wire so that the wire will not become corroded, as this would cause an increase in the resistance.

The ground connection should provide an electrical connection of as low a resistance as possible to the earth, since the earth acts as one of the large plates formed by the antenna system. We can easily understand that if the ground is not good, the aerial is not good either. The importance of a good ground connection cannot be too strongly emphasized.

A water pipe which forms part of a water supply system installed in the ground usually makes an excellent ground, since the pipe makes a direct contact with the earth for a long distance. It is well to note that the water pipe grounds are approved by the Board of Fire Underwriters, as they are usually more efficient than the average artificial or home-made variety of ground connections.

In making the connection between the ground wire and the pipe, it is advisable to use a ground clamp, as a wire wrapped around the pipe may become corroded and a poor connection will result. A ground wire connected to a simple strap-type ground clamp is shown at the left of Fig. 9. In order that we may be sure of a good connection, it is necessary to file or sandpaper any paint or rust from the pipe. Another type of clamp that is tightened by a screw to the pipe is shown at the right of the illustration.

When it is not possible to use the water pipe, in places where the water is not piped to the house, a copper plate, a bucket or other large metal object may be sunk in a well or cistern.

Another way is to bury a copper plate about two feet square in moist earth. In general, the greater the number of well grounded objects that we can connect to the ground lead, the better will be the reception, especially on the very short waves. This difference may not be noticed particularly on the nearby stations, but it will certainly be noticed in the reception of distant stations.

A suitable approved lightning arrester should always be used with any aerial, as the Underwriters' rules require it.

(The fourth installment will appear in the next issue.)

Louis Martin's Set

(Continued from page 269)

- 1 20-ohm center-tapped resistor, R8.
- 1 Acratest .006-mf. condenser, C1.
- 1 Acratest .02-mf. condenser, C2.
- 1 Acratest .1-mf. condenser, C3.
- 1 Acratest .1-mf. condenser, C4.
- 1 Micamold .001-mf. condenser, C5.
- 1 Sprague .03-mf. condenser, C6.
- 1 Acratest 25-mf. dry electrolytic condenser, C7.
- 1 Hammarlund two-gang "tuning" condenser, type MCD-140M, 140-mmf., C8, C9.
- 2 R.F. chokes, 100 turns No. 38 enameled wire on a spool 1/4-inch in diameter and 1/4-inch long.
- 1 Special panel and chassis by Blan-the-radio-Man.
- 2 Special tube shields by Blan-the-Radio-Man.
- 1 Eby antenna and ground strip.
- 1 Eby loud speaker strip.
- 2 Eby 6-prong sockets.
- 1 Eby 5-prong socket.
- 1 Eby 4-prong socket.
- 1 Hammarlund 4-prong isolantite socket, type S-4, for T1.
- 1 Hammarlund 6-prong isolantite socket, type S-6, for T2.
- 1 Three-wire cable.
- 1 Power cable with plug.
- 1 National type N, 0-100 vernial dial.
- 1 Best or Magnavox "magnetic" loud speaker.

Static Omission

(Continued from page 277)

The area L M N P L may be shifted along the abscissae by adjusting R_y. With the larger R_y aiding the automatic volume control bias voltage, the operative point of the set is lowered to a most sensitive point, so that fainter signals may be heard. The value of R_y may be increased to a point where the set is never blocked, even with the antenna "shorted." This insures that even the faintest signals may be tuned in. The value of R_y may be decreased to the point where exceedingly strong signals are required to produce sufficient automatic volume control bias voltage to unlock the set.

Midwest Data

R1—.5 meg 0.5 W. (watt); CA—.01 mf. 200 V. (volts); R2—30,000 ohms 1 W.; R3—50,000 ohms 0.5 W. C1—.05 mf. 200 V.; R5—30,000 ohms 1 W. C3—.0005 mf. Mica; C4—.00036 mf. 3 gang; C5—.001 mf. (Mica) Pad 4 gang; C6—.05 mf. 400 V.; R6—700 ohms flex.; C8—.05 mf.; C9—.05 mf. 400 V. 200 V.; C10 20, mmf. Trim.; R7—200,000 ohms 0.5W.; R8—30,000 ohms 1 W.; R9—30,000 ohms 1 W.; C12—.05 mf. 200 V.; R10—50,000 ohms .05W.; R11—50,000 ohms .05W.; C14—.05 mf. 400 V.; R13—30,000 ohms 1 W.; R14—50,000 ohms 0.5 W.; C15—.05 mf. 2000 V.; R15—275 ohms flex.; C16—.05 mf. 200 V.; R16—200,000 ohms 0.5 W.; R17—30,000 ohms 1 W.; C17—.01 mf. 200 V.; R18—50,000 ohms 0.5 W.; R19—200,000 ohms 0.5 W.; C18—.05 mf. 200 V.; R20—275 ohms flex.; C19—.01 mf. 200 V.; C 20—.1 mf. 200 V.; R21—200,000 ohms 0.5 W.; C21—.01 mf. 200 V.; R22—200,000 ohms 0.5 W.; C22—4 mf. spec.; C23—.05 mf. 200 V.; R23—200,000 ohms 0.5 W.; C24—.05 mf. 200 V.; C25—.05 mf. 200 V.; C26—.05 mf. 200 V.; R24—275 ohms flex.; R25—200,000 ohms 0.5 W.; C27—2 mf. 500 V. ELEC.; R26—5 meg. 0.5 W.; R 27—2,500 ohms 5 W.; C28—20 mmf. Trim.; R28—.5 meg. 0.5 W.; C29—.05 mf. 200 V.; C30—.05 mf. 200 V.; R30—1,000 ohms 0.5 W.; C31—.001 mf. 400 V.; C33—.1 mf. 200 V.; R31—100,000 ohms .05 W.; R32—10,000 ohms 0.5 W.; C35—.05 mf. Spec.; C36—.05 mf. 200 V.; R33—200,000 ohms 0.5 W.; R34—.5 meg. Pot.—A.C. Switch Spec.; R35—600 ohms ± 5% flex.; C37—.05 mf. 200 V.; R36—12,000 ohms 0.5 W.; R37—.5 meg. 0.5 W.; C38—.05 mf. 200 V.; C39—.05 mf. spec.; R38—12,000 ohms 0.5 W.; R39—100,000 ohms 0.5 W.; C40—8 mf. 450 V. Elec.; C41—.05 mf. 400 V.; R40—25,000 ohms 0.5 W.; R41—410 ohms flex. 0.6 W.; C42—4 mf. 450 V. Elec.; C43—1 mf. 400 V. Elec.; C44—8 mf. 450 V. Elec.

SEND 15c
FOR SAMPLE
COPY
(See Coupon)

The Television Trend...

Timely developments in radio's latest wonder, Television, are published in every issue of TELEVISION NEWS—Mr. Hugo Gernsback's latest magazine. Rapid advancement in this art today is becoming a repetition of the radio cycle of years ago. Daily broadcasts are becoming more numerous and experimenters are following in quick order in building television sets for experimental purposes. Foresight of its development can be seen by the pioneers of radio—they are equipping themselves now with television experience.

The articles published in TELEVISION NEWS are of primary importance to experimenters—they are simple in construction, understandable and replete with diagrams, photographs and illustrations.



A Few of the Interesting Articles

- Sight and Sound on the Same Wavelength
- Televising the English Derby
- Television Without Modulated Light
- Pointers in Lens Disc Design
- How to Use Crater Lamps
- A Simple Television Mirror Drum Scanner
- Amplification in Television
- Television by the Line Control Method
- Controlling Light With Metal Films
- Automatic Synchronization
- Ultra High Frequency Receiver Development
- Television Disc Speed Indicator
- Viso-Telephony in France

Television News,
98 Park Place, New York, N. Y.

SWC-5

Mark X in square which offer desired:

- As per your Special Offer, I enclose \$1.25 (Canada and Foreign \$1.50), for which enter my subscription to TELEVISION NEWS for one year.
- Send me a sample copy of TELEVISION NEWS for which I enclose 15c (U. S. Stamps or coin accepted).

Name

Address

City..... State.....



RACODE

CODE TEACHER

You can learn the Radio Code at home with the help of the RACODE record.

The RACODE record will send to you as slow as two (2) words per minute or as quickly as you desire.

Only \$1.25

Send Order Today

RACODE COMPANY

2406 Kenley St. Fort Worth, Tex.

"HAM" ADS

Advertisements in this section are inserted at 4c per word to strictly amateurs, or 8c a word (8 words to the line) to manufacturers or dealers for each insertion. Name, initial and address each count as one word. Cash should accompany all "Ham" advertisements. No less than 10 words are accepted. Advertising for the October issue should reach us not later than August 20.

SHORT WAVE LOG BOOK—Separate log for every day of the week. Tells at a glance what stations are broadcasting any hour of day or night. Price 75 cents, money order or draft. V. A. Stein, 1315 Woodrow, Wichita, Kansas.

GUARANTEED MICROPHONE REPAIRS—Any make or model—24 hour service. Stretched diaphragm double button repairs, \$7.50. Others \$3.00. Single button repairs, \$1.50. Write for 1932 Catalog with diagrams. Universal Microphone Co., Ltd., Inglewood, Calif.

35 LESSON National Radio Institute Course. Good condition. \$10 cash. W7CGI, Kelso, Wash.

FOR SALE OR TRADE—Condenser microphone complete with 2-stage amplifier. Frequency response 30 to 8,000. Only \$20. 211E's, new, \$5. 205D's \$2.50. Stamp for list. W9ER, Timken, Kansas.

SHORT WAVE LISTENERS CARDS—We print just the type of card you need for reporting the stations you hear. Write for free samples today. W1BEF, 16 Stockbridge Ave., Lowell, Mass.

YOU can rely on Precision Power Crystals for frequency stability and maximum output. X cut, one inch square, carefully ground to your approximate specified frequency. 0.1% calibration. 1750 and 3500 kc. bands—\$4.50. 7000 kc.—\$8. Plug-in, dustproof holder—\$2.25. Mercury vapor 280M—\$1. 866's—\$2.25 each. Type 210, 15-watt rating—\$1.25. 866 filament transformer—\$2.25. 50-watt sockets—\$1. Please include postage. Precision Piezo Service, 427 Asia St., Baton Rouge, La.

BEST APPROVALS for stamp collectors, 15c per sheet. Two-tube short-wave all-electric radio \$9.50 (kit form). Blueprint 25c. David Kennedy, R-6, Chambersburg, Pa.

TRADE—Complete parts for phone transmitter, 700 v. power, three 171A, one 210 tubes. For portable regular receiver complete. 507 Des Moines St., Keokuk, Iowa.

Denton 2-Tube

(Continued from page 274)

soldered to it, with a screen-grid clip on the free end.

Complete the soldering of the wires from the coil socket to their proper terminals under the chassis. The wires running to the tuning and regeneration condensers should be soldered after the front panel has been mounted.

Wire in the filament lines to the rectifier socket and the plates lines from the power transformer. Wire in the filament lines for the detector and the audio tubes. Run leads from the chokes down through the holes in the chassis drilled for that purpose. Wire the various resistors in place along with their associated condensers, thus completing the connections for the set portion of the receiver.

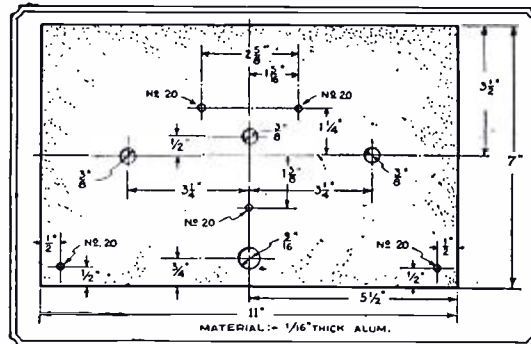

Panel layout.

Some may question the use of the separate power supply unit for the receiver, but it is the best method, as it does away with undesired coupling effects which are present when the same power supply is used for both units.

(This article is the first of a series devoted to the design and construction of audio systems and short-wave tuners, each to be described with full constructional details and data.)

Parts List

- 1 Eby antenna-ground strip (1, 2).
- 1 Hammarlund equalizing condenser (3).
- 1 set Octo-Coils (4). (Ranges: 16-30, 29-58, 54-105, 100-200, 200-510 meters. See April, 1932, issue for coil winding data; the broadcast coil has a secondary of 126 turns of No. 28 enameled wire on a 1 1/2-inch diameter tube. The tickler has 28 turns No. 34 enameled wire.)
- 2 Pilot midget condensers, .00015 mf. each (5A, 5).
- 1 Acratist .5-watt, 3-meg. resistor (6).
- 1 Micamold mica condenser, .00015 mf. (7).
- 1 Acratist resistor, 7,500 ohms, .5 watt (8).
- 1 Acratist resistor, 500,000 ohms, .5 watt (9).
- 1 Eby 6-prong tube socket (10).
- 1 Blan short-wave R.F. choke (11).
- 1 International resistor, 200,000 ohms, 1 watt (12).
- 1 Sprague condenser, .075 mf. (13).
- 1 International resistor, 1 meg., 1 watt (14).
- 1 Acratist dry electrolytic condenser, 1 mf., 200 volts, No. 6662 (15).
- 1 International resistor, 1 watt, 2,500 ohms (16).
- 1 Eby 5-prong socket (17).
- 1 Frost short jack (18).
- 1 Eby phone jack (19).
- 1 Acratist resistor, 5 watt, 25,000 ohms (20).
- 3 Acratist electrolytic condensers, one 4 mf. and two 8 mf., No. 6493 and 6495 (21, 22, 23).
- 2 Acratist chokes, 30-henry, No. 2505 (24, 25).
- 1 Eby 4-prong socket, marked 280 (26).
- 1 Acratist power transformer, No. 6027 (27).
- 1 H. & H. filament switch, No. 4122 (28).
- 1 G. E. power cable and plug (30).
- 1 Micamold condenser, .005 mf. (29).
- 1 Blan aluminum chassis, folded and drilled.
- 1 K. K. port dial.
- 1 National screen-grid clip.

Tubes Required

- 1 Eveready-Raytheon '80.
- 1 Eveready-Raytheon '56.
- 1 Eveready-Raytheon '57.

Which Regeneration Scheme?

(Continued from page 300)

voltage is varied by a potentiometer. A variable-mu tube used as detector in this circuit will give even better control than an ordinary screen-grid or pentode tube.

The use of the R.F. pentode as detector has only recently been considered, because of lack of R.F. pentodes in the open market. This tube should prove even more efficient as a detector than the screen-grid tube, especially when provision is made for varying the potential on the suppressor grid, as well as on the screen grid. The suppressor grid potential should be adjustable so that positive as well as negative potential may be applied. This control need only be adjusted when first operating a receiver, as once the best point is found there is no further need of adjustment unless tubes or the circuit is changed. We would like to hear from experimenters as to what results they have had using these new tubes. (See Fig. 9.)

One of the most troublesome things in a regenerative detector system is *threshold howl*—a strong audio frequency howl which occurs just before the receiver goes into oscillation. As the period just before oscillation is the most sensitive point of operation, *threshold howl* effectively ruins a receiver's efficiency. The reasons for *threshold howl* are not very well understood, but there are several methods of eliminating it. Figures 10 and 11 illustrate methods of curing this condition when a transformer is used for coupling to the audio amplifier. Both of these methods result in reduction of volume, but they are necessary if the receiver is to function properly.

If resistance or impedance coupling is used between detector and audio system, *threshold howl* is not present. This is the most satisfactory method, as the systems illustrated in Figs. 10 and 11 affect the audio response. Figure 12 shows a *resistance* coupling system. It is necessary to apply at least 180 volts to the plate of the detector, due to the drop in the resistance. Figure 13 is a form of *impedance* coupling. This is the best method for all-around use, as the voltage drop through the plate impedance is very slight and a fairly low plate voltage may be applied to the detector. When using a screen-grid or pentode tube as detector, it is almost imperative to use the impedance method, due to the high plate impedance of these tubes. By connecting the primary and secondary of an A.F. transformer in series as shown in Fig. 14, a satisfactory plate impedance may be secured. It may be necessary to shunt this impedance with a resistance in series with condenser, as shown by the dotted lines in Fig. 13. This is to cut the high note response. It is also possible to use a high impedance choke coil in place of the audio transformer.

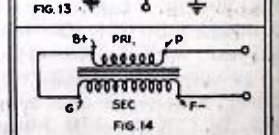
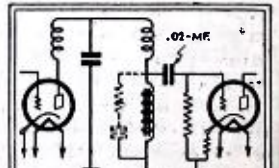
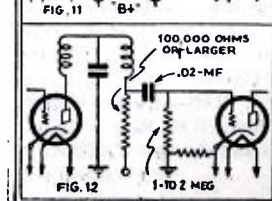
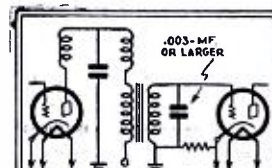

Four regeneration hook-ups described by Mr. Gernsback.

Transmitting Antennas

(Continued from page 303)

there is a "fire." One neighbor to a radio amateur once turned the hose on the aerial to put out the "sparks coming from the heated wire."

A Popular Style of Antenna

Another popular type of antenna is shown in Fig. 5. It requires the usual length of wire and coupling coil, but requires only one variable condenser for adjustment. This type of antenna is used by many amateurs who have limited space and where no high poles are available. The two wires are simply strung in two opposite directions (and fastened rigidly): the coupling coil (about 5 turns 2 inches in diameter for 40-meter work) and series condenser (a 23-plate size will serve) are connected in series and the coupling between antenna and oscillator coils is adjusted (as described later). The antenna is tuned into resonance by means of the series condenser; resonance is indicated by maximum antenna current for the coupling value used.

Proper Coupling Is Important

The average amateur is very little concerned with the coupling value used between oscillator primary and antenna coils. This, however, is of extreme importance if a good constant-frequency signal is desired. The swinging of an antenna system in the wind (this, of course, cannot be entirely eliminated) has a considerable effect when the coupling is too close. The narrow bands require a very constant frequency for best results. Receivers are so selective now (those with "peaked" audio amplifiers) that poor signals are often completely lost among the background noises.

If the coupling is close, two frequencies are radiated and there is unnecessary interference in the narrow bands. If loose coupling is used, the emitted frequency is considerably more constant and transmission is on but a single frequency.

The antenna and plate coils should be coupled very close together at first, and the antenna tuned into resonance by means of the antenna series condensers. A certain maximum current will be obtained. The coupling should then be reduced, by separating the coils, until the antenna current has dropped to about 85 per cent of the maximum value first obtained. The antenna should be maintained in resonance with the oscillator frequency, as the coils are separated. Separating the coils causes a slight change in frequency, and a reduction in antenna current due to detuning as well as to the decrease in the coupling.

The signal should be carefully studied in a shielded nearby receiver and while the antenna series condenser is passed through the point at which the antenna and oscillator are at resonance. It will be noted that the signal is better on one side of resonance than in the other. The antenna is then detuned to the side which gives the best "note," and by an amount such that the final antenna current is 75 per cent of the value first obtained.

Making a Study of Antenna Coupling

The curve of Fig. 6 is very interesting. It shows the relation between antenna current (actual antenna ammeter readings) plotted against the distance between the antenna and oscillator coils (for coils about 2 inches in diameter). Note that the radiation actually falls off for very close coupling. The maximum value of antenna current is not desirable because there are other factors not shown by such a curve, such as change in frequency at the distant station, when the antenna sways, and other effects. When the antenna current is reduced to 75 per cent of its maximum value, the signal is actually louder at the distant station, in some cases; it is always easier to read because of the improved note and lack of frequency change.

Any amateur can spend an enjoyable evening taking a curve like Fig. 6 for his own transmitter. Curves like this should be taken for different sizes of antenna coils. For example,

in one transmitter it was found that the 5-turn coil could be replaced by a 3-turn size and still have the desired radiation. The difficulty with coils having a large number of turns is that the antenna is loaded up unnecessarily; if an extremely large coil were used, the "external" part of the aerial would have to be reduced greatly and consequently the radiation efficiency would be reduced. It is much better to use more wire in the aerial itself.

If curves for different coil sizes are "run" or made, it will be found that for proper coupling the large coils must be set at a considerable distance from the oscillator coil, thus utilizing unnecessary table space and detracting from the appearance of the set. It is better to use a smaller size so that the coils can be placed closer together for a given coupling value.

At this point it is wise to mention that very large diameter coils are not to be recommended. A large coil has a "field" of considerable extent; this causes unnecessary loss and also gives the set the appearance of being an old model. Use small coils about 2 inches in diameter for 40-meter work, wound with about 1/4-inch copper tubing.

To take a curve like that shown in Fig. 6, proceed as follows. First place the coils in line so that one of them can be moved to vary the coupling value. Place the end of a common rule even with the end of the oscillator inductance as suggested in Fig. 7. With the oscillator operating at normal input, select different values of "coupling" (as read on the rule) and note corresponding values of antenna current.

Be careful to tune the antenna to resonance with the oscillator each time; simply moving the coils apart changes the wavelength. Small wave changes are not important. With the particular antenna and oscillator coils used in your set, a particular type of curve will be obtained. The final graph can be placed near the set and proper coupling values easily selected in the future without any measurements if the rule is left in place or is always handy. The amateur who selects the coupling value in a scientific way will find such scientific ways will become contagious, resulting in improved all-around efficiency and results.

It is quite a problem for most amateurs to obtain a suitable indicator to indicate resonance between the antenna and the oscillator. For low-power transmitters, a 0/1-ampere thermocouple or hot-wire (cheaper) can be used, as already explained; by using shunts, a variety of ranges can be obtained. The actual value of antenna current in amperes is of no consequence. In some interesting tests carried out by the writer with and at W6EJ, the signals were actually louder when a smaller antenna current was obtained on a different antenna. Whatever the coupling used, simply tune the antenna for maximum current and leave it go at that; for your antenna, it's the best that can be done.

In a Zeppelin antenna some amateurs use two radiation meters as suggested in Fig. 8. The idea is to obtain equal readings in both meters. Needless to state, two meters certainly increase the cost greatly. If one meter is available, it is possible to use a simple switching arrangement for reading both feeder currents, as shown in Fig. 9. A D.P.D.T. switch and two S.P.S.T. switches are required. These can be obtained at the five and ten-cent store for a small sum. The ammeter is connected to the double-throw switch as shown. When it is connected in one of the feeder wires, the single-throw switch in this wire is opened. The other single-throw switch is closed so as to complete the feeder wire. Thus the current in either wire can be measured conveniently during adjustment. When adjustments have been completed, the small switches can be closed and the meter used for other work, external to the set, since it is removed from the circuit by the double-throw switch. Result: price of one meter in pocket for a while.



Stoppani Belgian Compass

Being a precision instrument, the Stoppani Compass lends itself admirably for use in the Radio Experimenter's test laboratory. It affords an ideal means of determining the polarity of magnets, electro-magnets and solenoids carrying current. Since the compass needle is itself a magnet, having a North-seeking pole (which is actually the South pole) and South-seeking pole (which is actually the North pole); and since, as we all know, like poles repel each other and unlike poles attract each other, it is merely necessary to bring the compass in the vicinity of the magnet under test. The North pole of the compass needle will then point to the North pole of the magnet under test or the South pole of the needle will point to the South pole of the magnet depending, of course, upon their relative positions.

May Be Used As a Galvanometer

Because of its uniform magnetic properties, high sensitivity, and delicate frictionless bearings, the Stoppani compass may be utilized to advantage as a highly precise galvanometer for detecting electric currents in experimental or conventional radio circuits. The Compass is easily and readily converted into said galvanometer by merely winding several turns of ordinary radio wire completely around the face and lower case of the compass; leaving small spaces between turns to observe the movements of the needle. The ends of the wire are brought out as test leads to be inserted in series in circuits under test. A deflection of the compass needle in either direction indicates the presence of an electric current. Incidentally the intensity of the current may be closely approximated since the force with which the needle gyrates is proportional to the intensity of the current flowing through the wire.

Stoppani Compass is an ideal SURVEYORS instrument with elevated sights. It is made of Solid Bronze, Parkersized, non-rusting, graduated in 1/10, Ruby Jewelled, 4 inches square. Fitted in a hardwood case, with set screw in corner to hold needle rigid when not in use. The United States Government paid more than \$30.00 for this precision instrument.

Our Price \$4.50

Gold Shield Products Company

102 Chambers Street SWC New York, N. Y.

NA-ALD

Precision Wound Coil Forms

wound on the new material, molded Makalot. Set of four—with brilliantly colored code rings—red, green, yellow and blue. Range 15 to 200 meters, \$2.00 a set. Two additional bank wound coils for broadcast band, 75c a pair. Forms without winding, four, five or six prongs, 25c each. Send for new Na-ald price sheets. Adapters for testing all the new tubes—connecting converters and every purpose.

ALDEN MFG. CO.

Dept. W

Brockton, Mass.

ORDER DIRECT FROM THIS PAGE

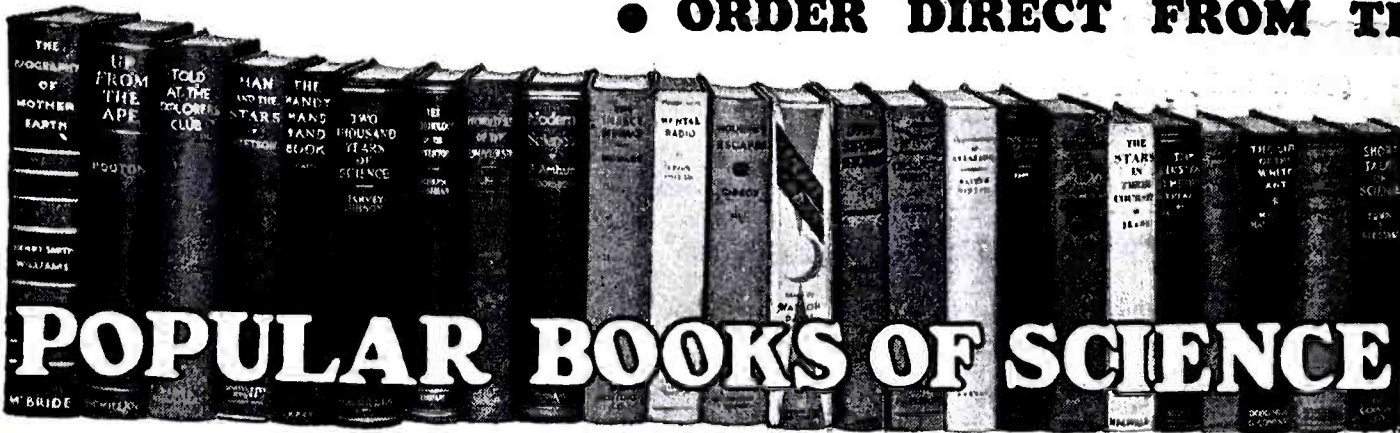

POPULAR BOOKS OF SCIENCE

WE herewith present the most complete collection of recent important popular Science books. We have, after an exhaustive study, selected these volumes because they represent the foremost books of their kind in print today. There is such a great variety that we are sure it will satisfy any taste as well as any requirement of the student of science.

We publish no catalogue and ask you to be kind enough to order direct from this page. Prompt shipments will be made to you direct from the publishers. We merely act as a clearing house for a number of publishers and OUR PRICES ARE AS LOW OR LOWER THAN WILL BE FOUND ANYWHERE. Remit by money order or certified check. If you send cash, be sure to register it.

ASTRONOMY

MAN AND THE STARS. by Harlan T. Stetson. Cloth covers, size 5 1/2 x 8, 221 pages, illustrated. Price \$2.50

DREAMS OF AN ASTRONOMER. by Camillo Flammarion. Cloth covers, size 5 1/2 x 8 1/2, 223 pages. Price \$2.50

THE UNIVERSE AROUND US. by Sir James Jeans. Cloth covers, size 5 1/2 x 8 1/2, 351 pages, 24 illustrations. Price \$4.50

SIGNALS FROM THE STARS. George Ellery Hale. Cloth covers, size 5 x 8, 138 pages, 56 illustrations. Price \$2.00

THE STARS IN THEIR COURSES. by Sir James Jeans. Cloth covers, size 6 x 8 1/2, 172 pages, 50 illustrations and maps. Price \$2.50

POPULAR ASTRONOMY. by Camille Flammarion. Cloth covers, size 6 1/4 x 9 1/4, 696 pages, 291 illustrations. Price \$6.00

AVIATION

WINGS OF TOMORROW. by de la Cierva. Cloth covers, size 8 1/2 x 5 1/4, 284 pages, 31 illustrations. Price \$2.50

OPPORTUNITIES IN AVIATION. by Walter Hinton. Cloth covers, size 5 1/2 x 8 1/2, 255 pages, 14 illustrations, map and charts. Price \$3.00

AVIATION AND ALL ABOUT IT. by A. Frederick Collins. Cloth covers, size 5 1/2 x 7 1/2, 260 pages, 134 illustrations. Price \$2.00

CHEMISTRY

THE AMATEUR CHEMIST. by A. Frederick Collins. Cloth covers, size 5 x 8 1/4, 210 pages, 77 illustrations. Price \$1.50

EXPERIMENTAL CHEMISTRY. by A. Fred Collins. Cloth covers, size 5 x 7 1/2, 276 pages, 108 illustrations. Price \$2.00

THE MAKING OF CHEMISTRY. by Benjamin Harrow. Cloth covers, size 5 1/2 x 7 1/2. Price \$2.00

EXPLORATION

TOLD AT THE EXPLORERS CLUB. by Vilhjalmur Stefansson, Sir Hubert Wilkins, Col. Chas. A. Lindbergh, Capt. Felix Riesenbergh, Dr. Roy Chapman Andrews and others. Edited by Frederick A. Blossom. Ph.D. Cloth cover, size 6 x 9, 425 pages, 34 illustrations. Price \$3.50

GENERAL SCIENCE

TWO THOUSAND YEARS OF SCIENCE. by R. J. Harvey-Gibson. Cloth covers, size 5 1/2 x 8 1/4, 522 pages, fully illustrated. Price \$3.50

UP FROM THE APE. by Earnest A. Hooton. Cloth covers, size 6 1/2 x 9 1/4, 605 pages, 86 illustrations. Price \$5.00

EVOLUTION. by Vernon Kellogg. Cloth covers, size 5 1/2 x 8 1/4, 291 pages. Price \$1.75

EXPERIMENTAL SCIENCE. by A. Frederick Collins. Cloth covers, size 5 x 7 1/2, 280 pages, 152 illustrations. Price \$2.00

SCIENCE TODAY. by Watson Davis. Cloth cover, size 5 1/2 x 8 1/4, 310 pages. Price \$2.50

SHORT TALKS ON SCIENCE. by Edwin E. Slosson. Cloth covers, size 5 x 7 1/2, 281 pages, 20 illustrations. Price \$2.00

WONDERFUL STORY OF SCIENCE. by I. McFee. Cloth covers, size 5 1/2 x 8, 400 pages, 125 illustrations. Price \$2.50

MASTERS OF SCIENCE AND INVENTION. by Floyd Darrow. Cloth covers, size 5 x 8, 352 pages, illustrated. Price \$2.25

HEALTH. HOW TO LIVE LONGER. by Robt. B. Ludy, M.D., and John C. Frank. Cloth covers, size 5 x 7 1/2, 146 pages, 40 illustrations. Price \$1.50

INVENTION. THE PSYCHOLOGY OF THE INVENTOR. by Joseph Rossman, Ph.D. Cloth covers, size 5 1/2 x 8 1/2, 252 pages, 13 illustrations. Price \$3.00

MECHANICS. EXPERIMENTAL MECHANICS. by A. Frederick Collins. Cloth covers, size 5 x 7 1/2, 302 pages, 167 illustrations. Price \$2.00

THE HANDY MAN'S BOOK. by C. T. Schaefer, M.E. Cloth covers, size 6 x 9 1/2, 341 pages, 14 illustrations and diagrams. Price \$4.00

THIS MECHANICAL WORLD. by Morton Mott-Smith, Ph.D. Cloth covers, size 5 x 7 1/2, 293 pages, 45 illustrations. Price \$2.00

How to order

We cannot ship C.O.D. Our prices are net, as shown. Please include sufficient postage, for Parcel Post, otherwise books must be shipped by express collect.

MICROSCOPY AND PHOTOGRAPHY

SCIENCE AND PRACTICE OF PHOTOGRAPHY. by John R. Roebuck. Cloth covers, size 5 1/2 x 8 1/2, 298 pages, 52 illustrations. Price \$2.50

THE BOOK OF THE MICROSCOPE. by A. Frederick Collins. Cloth covers, size 5 x 7 1/2, 245 pages, 71 illustrations. Price \$1.50

MISCELLANEOUS. HOUDINI'S ESCAPES. by Walter Gibson. Cloth covers, size 6 x 8, 315 pages, illustrated. Price \$2.00

THE AQUARIUM BOOK. by Bouleenger. Cloth covers, size 5 1/2 x 8 1/2, 208 pages, 57 illustrations. Price \$3.50

MOTION PICTURES. THE TALKIES. by Arthur Edwin Knows. Cloth covers, size 5 x 7 1/2, numerous illustrations, 245 pages. Price \$2.00

THE ART OF SOUND PICTURES. by W. Pitkin and W. Marston. Cloth covers, size 5 1/2 x 8, 287 pages, 15 illustrations. Price \$2.50

PHYSICS. FOUNDATIONS OF THE UNIVERSE. by M. Luckesh. Cloth covers, size 5 1/2 x 8 1/2, 253 pages, diagrams and tables. Price \$3.00

THE NATURE OF THE PHYSICAL WORLD. by A. S. Eddington. Cloth covers, size 5 1/2 x 8, 353 pages, charts. Price \$3.75

THE MYSTERIOUS UNIVERSE. by Sir James Jeans. Cloth covers, size 5 1/2 x 9, 190 pages, 2 plates. Price \$1.00

THE EINSTEIN THEORY. by Samuel H. Guggenheimer. Cloth covers, size 5 1/2 x 7 1/2, 200 pages, illustrated. Price \$2.50

THE UNIVERSE. by Frank Allen. Cloth covers, size 5 1/2 x 7 1/2, 145 pages, 31 illustrations. Price \$2.00

SEXOLOGY. THE SEXUAL SIDE OF MARRIAGE. by M. J. Exner, M.D. Cloth covers, size 5 x 7 1/2, 252 pages, illustrated. Price \$2.50

SEXUAL IMPOTENCE. by Dr. Wm. J. Robinson. Cloth covers, size 5 1/2 x 8 1/4, 502 pages, 18 illustrations. Price \$3.00

COMPLETE BOOK OF SEX KNOWLEDGE. by Dr. Bernard Bernard. Cloth covers, size 7 1/2 x 5, 331 pages. Price \$2.75

SEX CONDUCT IN MARRIAGE. by Dr. Bernard Bernard. Cloth covers, size 7 1/2 x 5 1/4, 218 pages. Price \$1.75

WOMEN, HER SEX AND LOVE LIFE. by Dr. William J. Robinson. Cloth covers, size 5 1/2 x 8 1/4, 411 pages, numerous anatomical illustrations. Price \$3.00

ZOOLOGY. INSECT STORIES. by Vernon Kellogg. Cloth covers, size 5 x 7 1/2, 298 pages. Price \$2.00

LIFE OF THE WHITE ANT. by Maurice Maeterlinck. Cloth covers, size 5 1/2 x 7 1/2, 238 pages. Price \$2.50

There is a

"CERTIFIED"

TRIAD TUBE

For every SHORT WAVE requirement

— HERE ARE A FEW —

T-866

A mercury vapor rectifier tube that will give a uniform voltage output regardless of the current drain up to the maximum peak plate current of the tube.

Fil. Volts—2.5.
Fil. Current—5.0 Amp.
Max. Peak Inverse Volt.—7,500.
Max. Peak Plate Cur.—0.60 Amp.
Approx. Voltage Drop—11 volts.

List \$7.50

T 10-S

This new type of 210 tube for amateur transmitters, which is known as the Triad 210-Special, incorporates a number of improvements which make it possible to use this tube in circuits which, up to now, were a practical impossibility. For instance, the type 210-Special is conservatively rated to carry a maximum of 800 volts on the plate, as compared to the present rating of 425 volts.

List \$8.00

T-82

Mercury Vapor Full Wave Rectifier. (Not interchangeable with Type T-80.)

Fil. Volts—2.5.
Fil. Current—3.0.
A.C. Volts per plate—400 max.
D.C. Output — 125 mls.

List \$1.25

T-34

Super Control R.F. Amplifier Pentode Radio Frequency Intermediate Frequency of 1st Detector (battery operated) Receiver.

Fil. Volts—2.0 D.C.
Fil. Current—.060 amps.
Plate Voltage—180 max.
Screen—67.5 max.
Grid, -3 min.
Plate Current—2.8 mil.
Screen Current—1.0 mil.

List \$2.75



What
"CERTIFIED"
Means

CERTIFIED TRIAD TUBES are the result of many years' experience. All the guesswork has been eliminated. They are designed, manufactured and tested by the most modern machinery. They are produced by skilled operators. No better tubes can be bought.

If your local dealer cannot supply you with these special tubes you may order them direct from the factory by using the attached coupon accompanied by your money order or check.

The TRIAD LINE is complete. It includes all types of standard Tubes as well as Photo-Electric Cells and Television tubes. CERTIFIED TRIAD TUBES are licensed by RCA, and are sold at the same list prices.

T-205D

Special power amplifier. For use in special amplifiers and sound moving picture equipment.

Fil. Volts—4.5 volts.
Fil. Current—1.90 amps.
Plate Voltage—350.0 volts.
Grid Voltage, -15.0 volts.

List \$7.50

T-46

Class "B" Amplifier.

Fil. Volts—2.5.
Fil. Current—1.75.
Plate Volts—400 max.

List \$1.50



"BUILT"

TRIAD MANUFACTURING CO. SWC-3-5
Pawtucket, R. I.

Gentlemen:
Please send me.....of the types.....Certified
cash
Triad Tubes for which my money order \$.....
check
is enclosed.

Name

Address

City..... State.....

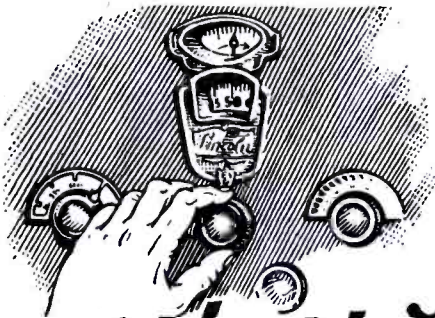

Tune the **NEW** way for World-Wide Reception with the **LINCOLN DE-LUXE-SW-33**

SILENT TUNING...

The weakest carrier wave is registered on the signal indicator and can be tuned with precision and perfect silence without disturbing atmospheric noises.

SIGNAL INDICATOR

A meter directly above the dial indicates, not only the weakest signal, but allows the operator to tune into a signal perfectly. Guess work is entirely eliminated. Comparative signal strength is indicated.

UNDISTORTED HIGH AMPLIFICATION

Three stages of push pull with new system of twin-grid detection allows tremendous undistorted amplification of the high gain I. F. amplifier. The handling power of this system seems to be unlimited and tremendous volume on weak signals can be had if desired.

AUTOMATIC VOLUME CONTROL.....

There are two paramount advantages in good automatic volume level. First, in tuning from weak to strong signals; and secondly, in holding a steady volume level on fading stations which is so common in short wave reception. The effect of this new Lincoln feature is so efficient that a near-by stroke of lightning registers only a muffled sound in the speaker; it has the same effect on all sharp electrical interference.

NEW FIDELITY

Twin-grid detection preceded by push pull input I. F. transformers and followed by two stages of transformer coupled push pull stages, produces an undistorted register of a wide band of frequencies, giving a perfectly balanced output with realism hard to associate with radio.

All of the new reactions in the SW-33 model are what we all have wanted for years,—they are here for you today—thanks to Lincoln's foresight in radio possibilities.

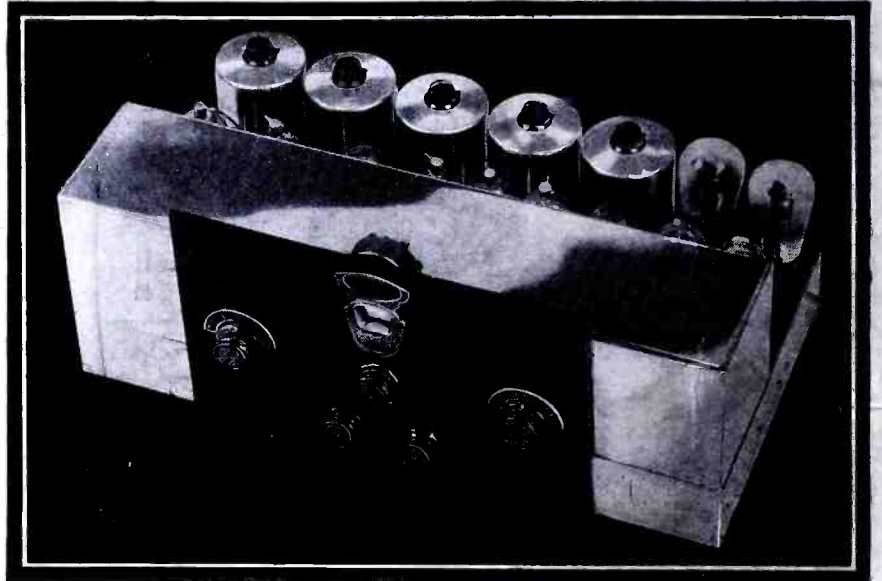

THE NEW DEVELOPMENTS

have made the new DeLuxe SW-33 just about as ideal a receiver as one could hope to own. The use of five variable mu tubes controlled by the new twin grid second detector and followed by two transformer coupled push pull stages has opened the gates to new ideas of enjoyable distant reception.

The signal indicator locates carrier waves which are difficult to hear; many times the carrier is not being used or modulated as is the case in transatlantic phone. The signal indicator registers these silent carriers and enables you to be accurately tuned, ready for the voice to be heard.

WHEN THIS CARRIER IS TUNED, ATMOSPHERIC NOISES ARE REDUCED TO A MINIMUM, AUTOMATICALLY.

Distant stations can be tuned silently, and volume then brought up to desired strength (volume control does not affect sensitivity). Perfect volume level on short wave stations is another great asset in the new Lincoln. If you have ever tuned in a foreign short wave station, or even many of our short wave stations in the U.S.A., you will appreciate the great value of uniform volume level.

The performance of Lincoln equipment has been known the world over for years. Its use by Polar Expeditions, broadcasting stations, both domestic and abroad, U. S. Naval Station operators, and hundreds of super critical DX fans, has proved Lincoln's exceptional merit.

Complete equipment consists of chassis, power equipment, auditorium type speaker and complete set of laboratory tested tubes. Chassis is finished in highly polished nickel over copper and presents a handsome appearance. Precision laboratory construction is employed throughout, and every receiver is tested on distance before shipment.

Write for description of new developments and new sales plan which overcome the present defects in the present custom built radio merchandising.

LINCOLN
DeLuxe Receivers

LINCOLN RADIO CORPORATION

Dept. SWC-11, 329 S. Wood St., Chicago, Ill.

Please send information on A.C. D.C. receivers.

Name

Address

City State

Print name and address plainly