

SHORT WAVE CRAFT

Edited by
HUGO GERNSBACH

ARTICLES BY

R. William Tanner W8AD
 Dr. Fritz Schroter L. B. Robbins
 C. H. W. Nason H. G. Cisin, M. E.
 A. Binneweg, Jr. Prof. Esau
 Clifford E. Denton Dr. Fritz Noack

October 2, 1931
 NOVEMBER

IN THIS ISSUE:

- ULTRA SHORT WAVES — APPARATUS, RESULTS, MEDICAL ASPECTS
- A GERMAN ALL-ELECTRIC S-W ONE-DIAL RECEIVER
- TUBE PORTABLE THAT WORKS LOUD-SPEAKER
- THE SUPER-REGENODE S-W RECEIVER
- SHORT WAVES AND DIVINATION
- A "LONG WAVE" RECEIVER
- WHEN TO LISTEN FOR SHORT WAVE PHONE STATIONS
- NEW SILVER-MARSHALL ALL-WAVE "SUPER"
- HERTZIAN AND INFRARED RAYS
- HOW TO NEUTRALIZE TRANSMITTING AMPLIFIERS
- PUSH-PULL TRANSMITTER CIRCUITS — GOOD OR BAD?
- PRACTICAL HINTS AND HOOK-UPS
 150 ILLUSTRATIONS
 75 HOOK-UPS

page 203

NEW ULTRA
 SHORT WAVE
 MEDICAL APPARATUS



Baird

Now you can have a SHORTWAVE RECEIVER

(Formerly \$95.10)

or a

TELEVISION RECEIVER

(Formerly \$88.39)

FOR

Pick up Programs from all parts of the
World with Loud Speaker Reception

\$39.50
IN KIT
FORM

Do you know that stations all over the world are broadcasting interesting programs at all hours of the day and night? Do you know that with the BAIRD SHORTWAVE KIT you can pick up these programs easily with loud speaker reception? Would you like to tune in Rome on the loud speaker and listen to opera 4,000 miles away — *and in the day time*? And have a perfect Shortwave Receiver for Television? You will be amazed at the ease and consistency with which this can be done — with a BAIRD SHORTWAVE KIT. European stations in the evening, Australia in the wee sma' hours. Something, somewhere at all hours of the day and night.

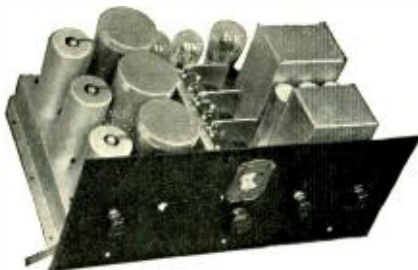

Front view of the assembled chassis,
Baird Shortwave Receiver Kit

Simple to build. Easy to tune, with single dial control. Operates dynamic or magnetic speaker. A.C. operated, but with no A.C. hum interference, especially below 50 meters. Ear phone jack. Phonograph pickup. All aluminum chassis. Coils and screen grid tubes individually shielded. Carefully shielded variable condensers. Two shielded stages of screen grid radio frequency. Shielded screen grid detector. Uses famous OCTOCOILS. Highest quality resistance coupled amplification. 245 power tube. Wavelength range 15 to 520 meters. Complete with blueprints and instructions for assembly.

Television Signals are Buzzing in the Air All Around You . . .

There are nearly twenty stations in this country transmitting Television pictures every day on regular schedules, most of them with synchronized sound. Television



THE COMPLETED
TELEVISION UNIT
This "X-Ray" picture
shows the complete
assembly in the
cabinet, as if you
were looking thru
the Scanning Spider.

actually going to waste. Join the thousands of fans already eagerly looking-in on Television. Get the amazing experience of actually seeing transmitted Television pictures. Make your home or your experimental quarters the center of interest for Television reception in your locality.

The BAIRD TELEVISION KIT is simple to build (taking an hour to assemble completely) and is no more difficult to operate than an ordinary radio set. The BAIRD TELEVISION RECEIVER works in conjunction with the BAIRD SHORT WAVE RECEIVER just by making a simple plug-in connection between the two. Tune in your Television signal on the Shortwave Receiver through the loud speaker—throw a switch and the picture appears.

The complete Baird Television Kit contains everything necessary for the construction of this Receiver, including a cabinet and large and easily read blue prints. No mechanical or electrical ability required. It is also furnished in units X, Y, and Z so as to allow you to spend a minimum amount of money and yet get best results.



Shortwave & Television Corporation

70 Brookline Avenue, Dept. SW-1, Boston, Mass.

Owners and Operators of Television and Sound Stations WIXAV and WIXAU

or

Buy them in units on
the
Three Payment Plan

SHORTWAVE SET
The Shortwave Set can be bought
in Units A, B and C at \$13.95 each
Buy Unit A and begin the assembly of your Baird Shortwave kit. When you have assembled all these parts, send for Unit B and when B has been mounted with Unit A then send for Unit C and you will have your complete kit.

TELEVISION SET
The Television Set can be bought
in Units X, Y and Z.
Buy Unit X for \$13.50 and assemble the parts. Then buy Unit Y for \$15.50 and continue the assembly. Then buy Unit Z for \$13.50 and complete the Kit and you have your complete job ready to operate.

SHORT WAVE Specialists!

Also MANUFACTURERS of RECEIVERS and TRANSMITTING APPARATUS

As specialists in the manufacturing of short wave radio apparatus, we have, during the past few years, developed receivers which are used in all parts of the world. These Short Wave Sets have given thousands of fans world-wide reception . . . their prices are extremely low and the materials included in the sets are high-grade and fully guaranteed.

AERO WORLD WIDE—1 TUBE SHORT WAVE RECEIVER

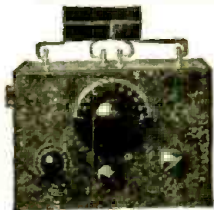

\$6.45

Police Calls, Television Amateur and Commercial Bands. Also your regular Broadcast Band.

Span the World with this Set!

WORLD-WIDE RECEIVER gets 14 to 550 meter stations with surprising clarity. New thrills for you when you listen to London, Paris, Buenos Aires and other far-away stations. Completely assembled in attractive cabinet, with six coils. Equipped with UX socket and suitable for operation with either a UX-200A, UX-201A or UX-112A tube, using a 6-volt "A" battery. The UX100 tube may be used with 4½-volt "C" battery, or two dry cells as an "A" battery; the new type 230 tube requires two dry cells for "A" supply. The "B" power may be 45 to 90 volts.

Head phones extra . . . \$1.75
Adapter cable with socket for DC sets. . . .95

AERO WORLD WIDE—2 TUBE SHORT WAVE RECEIVER

\$11.95

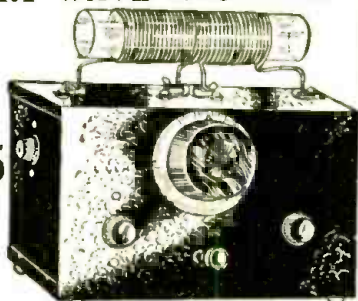

An all around set which gives loudspeaker volume; in metal shield-cabinet. Six coils included; covers wave band from 15 to 550 meters.

AERO C. W. TRANSMITTER

Complete Phone and Transmitter in beautiful cabinet



\$39.50

15 to 30 watts. Including tuned plate, tuned grid oscillator with provision for crystal control. Wired for one or two UX210 tubes, one or two 250's as modulators, and two stages of speech amplification; 8 coils included. Mounted in walnut cabinet. Price includes Stromberg-Carlson Microphone. Ample space for our A.C. power supply.
Power Supply Unit for 15 to 30 watt Transmitter. \$19.75
Will deliver 150 milliamperes at 600 volts for plate current. Has filament for types 281, 210, 250, 226 and 227 tubes.

NEW AERO MIDGET



\$17.75

Due to the use of the Latest Pentode tube this set is equal in performance to many 8 tube sets.

Using the latest type Pentode and Multi-Mu Tubes. This Midget performs an distance and has tone qualities like a large expensive set. Wonderful selectivity. Full dynamic speaker, full vision dial, beautiful walnut finish cabinet. This is a 5-tube set. Price 60 cycle A.C. **\$17.75**
110 Volt
Price for set of 5 tubes, \$6.00. Available in 110 to 220 Volts, 25 to 60 Cycle AC and DC \$2.50 extra.

AERO SHORT WAVE CONVERTER

15 to 200 Meters

Police Calls, Television Amateur and Commercial Bands.

\$12.50



Convert your AC or DC radio set into a short-wave Super-heterodyne. With this converter on your regular set you will be able to tune in short-wave stations from many different parts of the world. The Aero Converter contains its own filament supply. B voltage can easily be obtained from your regular set, or you may use a single 45-volt B battery. No plug-in coils. Single tuning dial. Very easy to tune. No whistles or squeals. Uses two UX227 tubes, one as oscillator and one as mixer. Price. **\$12.50**
AC model, less tubes, ready for operation

DC model for battery-operated sets. \$11.50. Two matched UX227 Tubes at 75c each. \$1.50; one 45-volt battery, \$1.45.

AERO PENTODE AUTO RADIO



\$20.00

This is the latest model 6-Tube Aero Pentode Auto Radio. Due to the use of the latest Pentode tubes, this set is equal in performance to many 8 tube receiving sets. The circuit used is one which will be embodied in most of the expensive 1932 model auto radios. The complete set can be clamped on the steering post of your car, or can be operated by remote control from the dashboard. Price of **\$20.00** set only

This set complete with tubes, batteries, dynamic speaker, antenna equipment and noise suppressors. \$39.50.

SHORT WAVE—LOW POWER AERO TRANSMITTER

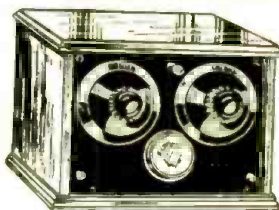

\$14.45

Simple one-tube, low power transmitter with plug-in coils. Ideal for beginners. Can be used for code or phone, also on

broadcast band for set testing, etc. Used with our ABC Power Pack, with 171A or 112A tube as an oscillator and 226 speech amplifier; 245 tube for modulator. To increase power, use transmitter as master oscillator feeding into stage of push-pull I.F. amplification.

Transmitter completely assembled in beautiful cabinet, with one set of plug-in coils and plate milliammeter, instructions included \$14.75
Our ABC Power Supply for this Transmitter. 8.75
Speech Amplifier and Modulator (uses A.C. or battery tubes) 11.95

IMPERIAL CONCERT GRANDE DYNAMIC SPEAKER

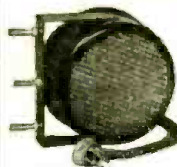

6 VOLT D.C. \$5.75
Noted for marvelous rich tone quality. In a beautiful compact case considered one of the best Auto Radio Speakers made.
Imperial D.C. Dynamic Speaker Chassis \$3.75
An ideal speaker for your A.C. set. State capacity of field when ordering.

OTHER RADIO BARGAINS

| | |
|--|--------------------|
| B Eliminator, 180 volt bond dry (including a 280 tube) | \$6.75 |
| A.B.C. A.C. Power Packs. | 8.75 |
| Nathaniel H. Hoodwin Speaker Units for Auto Radio. Phonograph, Portable or Horn Speakers. | .50 |
| Microphone on desk stand, single button. | 2.75 |
| International Microphone, 2 button. | 9.75 |
| Audio Transformer, any ratio. | .75 |
| Microphone Transformers, single button. | .95 |
| ABC Transformers, 300 volts each side, A.C. filament, 5, 1½ and 2½ volts. | 1.95 |
| Output Push-Pull Transformers, with voice coil secondary. | 1.40 |
| Output Push-Pull Transformers, with voice coil secondary, pentode type. | 1.70 |
| Filament Transformers, 2½ volt, 10 amperes. | 1.50 |
| Chokes, 30 Henry, 60 mil. | .75 |
| Mershon Electrolytic Condenser, 8 MFD, 500 volt (Inverted or upright, can be mounted in any type of set) | .95 |
| Temple Condenser, 10 1/10 MFD, 1000 volts, A.C. test, ratings 4, 2, 2, 1, 1, and 1/10. | 1.95 |
| Western Electric Condenser Blocks, 2 MFD, 500 volts. | .45 |
| Ward Leonard 1800-ohm Voltage Dividers, for any type A.C. set, or B Eliminator. | .65 |
| Aero Escutcheon Plates, with full vision dial, complete. | .90 |
| R.C.A. Radiotron 210 Tubes. | 2.75 |
| Tung-Sol Tubes, Guaranteed first grade, 30-day replacement: | |
| 235 \$1.35 | 224 \$1.25 |
| 236 1.60 | 24585 |
| 238 1.60 | 271A75 |
| 217 1.25 | 22660 |
| | 281 \$2.35 |
| | 28075 |
| | 200A75 |
| | 250 2.35 |
| | 201A60 |
| | UX19995 |

OUR TERMS

All prices quoted are net. We require a deposit of at least 20% on C. O. D. shipments. 3% discount if full remittance is sent with order. All shipments are made F. O. B. Chicago. All our merchandise is guaranteed to be as represented.

FREE CATALOG

The Chas. Hoodwin Company

4240 Lincoln Avenue

Dept. K17

Chicago, Illinois

Please mention SHORT WAVE CRAFT when writing to advertisers

HUGO GERNSBACK, Editor

H. WINFIELD SECOR, Managing Editor

CONTENTS

OCT.-NOV., 1931

*In This Issue: Prominent Short Wave Authors***Esau - Schroter - Nason - Binneweg - Denton - Noack - Tanner****FEATURES:**

| | |
|---|-----|
| Editorial—Short Waves and Crime, by Hugo Gernsback | 167 |
| What Short Waves Mean to the Lindberghs, by Lieut. Myron Eddy, U. S. Navy, Retired.... | 168 |
| This Short Wave Station "Walks"!..... | 170 |
| Beelitz—Where Transatlantic "Sigs" Are Received in Germany..... | 171 |
| Short Waves Highly Important to the New U. S. Navy Dirigible | 172 |
| Subsea "Rescue" Short Waved..... | 173 |
| Ultra Short Waves in Medicine, by Dr. Fritz Noack | 175 |
| The "S. W. C." Two-Tube Portable Works "Speaker," by Clyde Fitch..... | 176 |
| What I Think of Ultra Short Waves, by Guglielmo Marconi | 181 |
| Short Wave Sky Signals Direct Plane and Auto, by Olen W. Clements..... | 182 |
| Hertzian and Infra-Red Rays as Means of Communication, by Dr. Fritz Schroter..... | 184 |
| "Long Wave" Receiver Easy to Build, by L. B. Robbins | 188 |
| New Features of the 1931-32 National Thrill Box, by J. J. Freeley..... | 190 |
| New All-Wave Super, by McMurdo Silver..... | 192 |
| New S-W Superregenode, by Clifford E. Denton.. | 194 |
| What Can We Do With the Ultra-Short Waves? The work of Prof. Esau described by L. Rohde (his assistant) and N. C. von Halem.. | 198 |
| All-Electric, Single-Dial Tuning, S-W Super-Het, by K. König..... | 208 |
| How Research and Industry Depend on Vibration, by Dr. Willis R. Whitney..... | 220 |

SHORT WAVES FOR THE BROADCAST LISTENER:

| | |
|--|-----|
| The Hoodwin Short Wave Converter—Permits Reception of Short Waves on Your "Broadcast" Receiver | 179 |
| New All-Wave "Super"—Range 15 to 550 Meters | 192 |

| | |
|---|-----|
| Short Wave Stations of the World—Operating time-table | 212 |
| "When To Listen In." by Robert Hertzberg..... | 235 |
| The "Gem" Short Wave Adapter..... | 232 |

SHORT WAVE RECEIVERS:

| | |
|--|-----|
| The "S. W. C." Two-Tube "Portable," That Works a Loud Speaker..... | 176 |
| The "Vari-Coil" S. W. Tuner..... | 181 |
| An A.C.-D.C. Dynatron Oscillator, by H. G. Cisin, M. E. | 187 |
| New Features of the 1931-32 National Thrill Box | 190 |
| New All-Wave "Super"..... | 192 |
| New Short Wave Superregenode..... | 194 |
| The "V-T" Voltmeter, by C. H. W. Nason..... | 203 |
| Combination Long and Short Wave Receiver.... | 203 |
| Benefits I Derive from a Separate Regeneration Tube, by E. T. Somerset, G2DT..... | 205 |
| All Electric, Single Dial Tuning Super-het (German design, with full details)..... | 208 |

SHORT WAVE TRANSMITTERS:

| | |
|---|-----|
| Ultra-Short Wave Transmitters—Esau type.... | 198 |
| Getting Started on $\frac{3}{4}$ Meter, by A. Binneweg, Jr. | 200 |
| How to Neutralize Transmitting Amplifiers..... | 204 |
| Push-Pull Transmitting Circuits, by C. H. W. Nason | 206 |

MISCELLANEOUS:

| | |
|--|-----|
| Cathode Ray Tube Analyzes Oscillating Currents | 174 |
| An A.C.-D.C. Dynatron Oscillator..... | 187 |
| Long Wave Receiver—How to Build..... | 188 |
| The "V. T." Voltmeter..... | 203 |
| Short Wave Stations of the World—Directory.... | 212 |
| Among the "Hams"—Letters from Readers..... | 214 |
| Short Wave "Question Box," Edited by R. Wm. Tanner, W8AD | 216 |
| New Short Wave Transmitters, Receivers, and Kits | 233 |
| "When To Listen In"..... | 235 |

OUR COVER —

Shows patient receiving electro-medical treatment from newest German ultra-short wave generator described by Dr. Fritz Noack, on....Page 175

SHORT WAVE CRAFT—Bi-monthly. Entered as second class matter May 7, 1930, at the post office at Mount Morris, Illinois, under the act of March 3, 1879. Trademarks and copyrights by permission of H. Gernsback, 98 Park Place, N. Y. C. Text and illustrations of this magazine are copyright and must not be reproduced without permission. SHORT WAVE CRAFT is published on the 15th of every other month. Six numbers per year. Subscription price is \$3.00 a year in the United States and possessions. Canada and foreign countries, \$3.50

a year. Single copies 50c. Address all contributions for publication to Editor, SHORT WAVE CRAFT, 96-98 Park Place, New York, N. Y. Publishers are not responsible for lost manuscripts. Contributions cannot be returned unless authors remit full postage. SHORT WAVE CRAFT is for sale at all principal newsstands in the United States and Canada. European agents: Brentano's, London and Paris. Printed in U. S. A. Make all subscription checks payable to Popular Book Corporation.

COPYRIGHT, 1931, BY H. GERNSBACK

Published by **POPULAR BOOK CORPORATION**

H. GERNSBACK, President - H. W. SECOR, Vice-President

Publication Office, 404 N. Wesley Avenue, Mount Morris, Ill.
Editorial and General Offices, 96-98 Park Place, New York, N. Y.

BIG PAY JOBS

open

for the Radio Trained Man

Scores of jobs are open to the Trained Man—jobs as Designer, Inspector and Tester—as Radio Salesman and in Service and Installation work—as Operator, Mechanic or Manager of a Broadcasting station—as Wireless Operator on a Ship or Airplane—jobs with Talking Picture Theatres and Manufacturers of Sound Equipment—with Television Laboratories and Studios—fascinating jobs, offering unlimited opportunities to the Trained Man.

Ten Weeks of Shop Training

Come to Coyne in Chicago and prepare for these jobs the QUICK and PRACTICAL way — BY ACTUAL SHOP WORK ON ACTUAL RADIO EQUIPMENT. Some students finish the entire course in 8 weeks. The average time is only 10 weeks. But you can stay as long as you please, at no extra cost to you. No previous experience necessary.

TELEVISION *and* TALKING PICTURES

In addition to the most modern Radio equipment, we have installed in our shops a complete model Broadcasting Station, with sound-proof Studio and modern Transmitter with 1,000 watt tubes—the Jenkins Television Transmitter with dozens of home-type Tele-

vision receiving sets—and a complete Talking Picture installation for both “sound on film” and “sound on disk.” We have spared no expense in our effort to make your training as COMPLETE and PRACTICAL as possible.

FREE Employment Service to Students

After you have finished the course, we will do all we can to help you find the job you want. We employ three men on a full time basis whose sole job is to help our students in finding positions. And should you be a little short of funds, we'll gladly help you in finding part-time work while at school. Some of our students pay a large part of their living expenses in this way. Mail the coupon below!



COYNE IS 32 YEARS OLD

Coyne has been located right here in Chicago since 1899. Coyne Training is tested—proven by hundreds of successful graduates. You can get all the facts—FREE. JUST MAIL THE COUPON FOR A FREE COPY OF OUR BIG RADIO AND TELEVISION BOOK, telling all about jobs . . . salaries . . . opportunities. This does not obligate you. JUST MAIL THE COUPON!

RADIO DIVISION COYNE ELECTRICAL SCHOOL
H. C. LEWIS, President Founded 1899
500 S. Paulina St., Dept. 71-2K, Chicago, Ill.

H. C. LEWIS, *President*

Radio Division, Coyne Electrical School
500 S. Paulina St., Dept. 71-2K, Chicago, Ill.

Send me your Big Free Radio and Television Book. This does not obligate me in any way.

Name

Address

City..... State.....

Please mention SHORT WAVE CRAFT when writing to advertisers



Broadcasting Stations offer fascinating jobs paying from \$1,200 to \$5,000 a year.



Police Departments are finding Radio a great aid in their work. Many good jobs have been made in this new field.

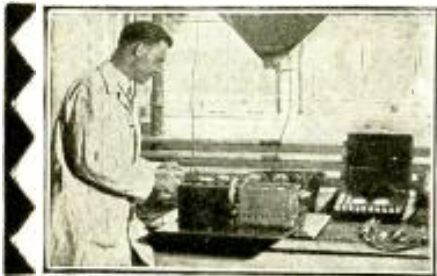

Spare time set servicing is paying N. R. I. men \$200 to \$1,000 a year. Full time men are making as much as \$65, \$75, \$100 a week.



Talking Movies—an invention made possible only by radio—offers many fine jobs to trained radio men, paying \$75 to \$200 a week.



Television—the coming field of many great opportunities—is covered by my course.

You're Wanted

Take your pick of these fine Big Pay Radio Jobs

YOU have seen how the men and young men who got into the automobile, motion picture and other industries when they were started had the first chance at the key jobs—are now the \$5,000, \$10,000 and \$15,000 a year men. Radio offers you the same chance that made men rich in those businesses. Its growth has already made men independent and will make many more wealthy in the future. Its amazing growth can put you ahead, too. Don't pass up this opportunity for a good job and future financial independence.

Many Fine, \$50 to \$100 a Week Jobs Opening Every Year

Radio needs more trained men badly. Why slave your life away for \$25 to \$40 a week in a no-future job when you can get ready in a short time for Radio where the good jobs pay \$50, \$60, \$75 and \$100 a week? And many of these jobs can quickly lead to \$150 to \$200 a week. Many fine jobs are opening every year for men with the right training—the kind of training I'll give you.

I am Doubling and Tripling Salaries

Where you find big growth you always find many big opportunities. I am doubling and tripling the salaries of many men every year. After training with me only a short time they are able to make \$1,000 to \$3,000 a year more than they were getting before. Figure out for yourself what an increase like this would mean to you—the many things that mean so much in happiness and comfort that you could buy with an additional \$1,000 to \$3,000 a year.

Many Make \$10 to \$25 a Week Extra Almost at Once

The day you start I'll show you how to do twenty-eight jobs common in most every neighborhood that you can do in your spare time. I'll show you how to repair and service all makes of sets and do many other jobs all through my course. I'll give you the plans and ideas that are making \$200 to \$1,000 for my students while they are taking my course. G. W. Page, 133 Pine Street, McKenzie, Tenn., writes: "I made \$935 in my spare time while taking your course."

You Have Many Jobs to Choose From

Broadcasting stations use engineers, operators, station managers. Radio manufacturers continually need testers, inspectors, foremen, engineers, service men, buyers and managers. Shipping companies, Police departments, commercial land stations, aircraft companies, offer good operators jobs from time to time. There are hundreds of opportunities for you to have a spare time or full time Radio business of your own. I'll show you how to start one with practically no capital. My book tells you of other opportunities. Be sure to get it at once.



\$400 a Month

"I spent fifteen years as traveling salesman and was making good money but could see the opportunities in Radio. Believe me I am not sorry, for I have made more money than ever before. I have made more than \$400 each month and it really was your course that brought me to this. I can't say too much for your school." J. G. Dahlstead, Radio Station KYA, San Francisco, Cal.



\$800 in Spare Time

"Money could not pay for what I got out of your course. I did not know a single thing about Radio before I enrolled but I have made \$800 in my spare time although my work keeps me away from home from 6:00 A. M. to 7:00 P. M. Every word I ever read about your course I have found true." Milton I. Leiby, Jr., Topton, Pennsylvania.



Seldom Under \$100 a Week

"My earnings in Radio are many times greater than I ever expected them to be. In November I made \$577, December \$645, January \$465. My earnings seldom fall under \$100 a week. I'll say the N. R. I. course is thorough and complete. You give a man more for his money than anybody else." E. E. Winborne, 1267 W. 48th St., Norfolk, Va.

Please mention SHORT WAVE CRAFT when writing to advertisers

for a **Big Pay** Radio Job



I will train you AT HOME free book gives facts and proof

I Will Train You at Home In Your Spare Time

Hold your job. There is no need for you to leave home. I will train you quickly and inexpensively during your spare time. You don't have to be a high school graduate. My course is written in a clear, interesting style that most anyone can grasp. I'll give you practical experience under my 50-50 method of training — one-half from lesson books and one-half from practical experiments. When you graduate you won't have to take any kind of a job to get experience—you will be trained and experienced ready to take a responsible job in the radio field of your choice.

Television and Talking

Movies Included

My course not only gives you a thorough training in Radio—all you need to know to get and hold a good job—but also your choice, without extra charge, of any one of my special advanced courses: (1) Television, (2) Aircraft Radio, (3) Broadcasting, Commercial and Ship Radio Stations, (4) Sound Pictures and Public Address Systems, and (5) Advanced Radio Servicing and Merchandising. You won't be a "one job" man when you finish my course. You'll know how to handle a job in any one of Radio's 20 different branches of opportunity.

Lifetime Employment Service to All Graduates

When you finish my course you won't be turned loose to shift for yourself. Then is when I will step in to help you find a job through my Employment Department. This Employment Service is free of extra charge both to you and the employer.

Your Money Back If Not Satisfied

You do not risk a penny when you enroll with me. I will give you an agreement in writing, legal and binding upon the Institute, to refund every penny of your money if, upon completing my course you are not satisfied with my Lessons and Instruction Service. The resources of the N. R. I. Pioneer and Largest Home-Study Radio training organization, stands back of this agreement.

Find Out What Radio Offers You—Get My Book at Once

One copy of my valuable book, "Rich Rewards in Radio," is free to anyone interested in making more money. It tells you where the good jobs are, what they pay, how you can quickly and easily fit yourself to get one. The coupon below will bring you a copy. Send it at once. Your request does not obligate you in any way. Act NOW.

I give You 8 Big Outfits of Radioparts for Extensive Practical Experiments

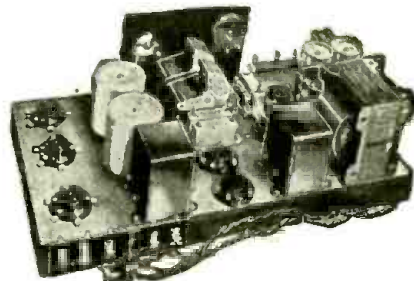

Seven tube screen grid tuned radio frequency receiver.

You can build over 100 circuits with the outfits I give you. You learn from actual experience about A. C., Screen Grid Circuits, push-pull amplification and the other features in modern sets. Shown here are two of the outfits you build. You work out with your hands the principles, diagrams and circuits you learn from my lesson books. You get as much practical experience under this unequaled method of home training, in a few months, as the average fellow gets in two to four years in the field.

Public Address Audio System

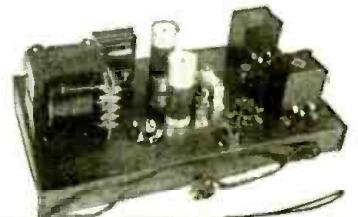

J. E. SMITH, President
NATIONAL RADIO INSTITUTE
Dept. 1 K B 3, WASHINGTON, D. C.



Salary Three Times Larger

"Before I completed your course I went to work for a Radio dealer. Now I am Assistant Service Manager of the Sparks-Withington Company. My salary is three times what it was before taking your course. I could not have obtained this position without it. I owe my success to N. R. I. training." H. A. Wilmoth, Sparks-Withington Co., Jackson, Mich.



Clip and mail NOW for FREE INFORMATION

J. E. Smith, President,
National Radio Institute, Dept. 1 K B 3,
16th and U Sts., N. W., Washington, D. C.

Dear Mr. Smith: Send me "Rich Rewards in Radio." Tell me more about Radio's opportunities for good jobs and quick promotion; also about your practical method of Home Training. I understand this request does not obligate me and that no agent will call on me.

Name
Address Age.....
City State.....

Please mention *SHORT WAVE CRAFT* when writing to advertisers

KEEP STEP WITH RADIO PROGRESS!

RADIO is one of the real marvels of this modern age. Its development has been phenomenal. It is growing, changing, evolving new principles which require constant study. The demand is for technically trained men—men who keep pace with the unfolding revelations of this mighty and promising industry.

The International Correspondence Schools Course in Radio, prepared and constantly supplemented by outstanding authorities in the field, is specifically designed to meet the requirements of the radio industry for technically trained radio men. The manufacturer, the distributor, the dealer, Communication and Steamship Companies, the U. S. Government, all insist upon up-to-date, expert training. Recognized for its completeness and practicability, an I. C. S. Radio Course provides this training.

Authorities responsible for the preparation of the I. C. S. Radio Course include: H. H. Beverage, Radio Corporation of America; George C. Crom, American Transformer Company; Keith Henney, author of "Principles of Radio"; Malcom

E. Gager, Instructor at the Massachusetts Institute of Technology; E. V. Amy, consulting radio engineer, formerly with R. C. A.; H. F. Dart, authority on radio tubes; Julius C. Aceves, consulting radio engineer, formerly of Columbia University, and others.

The I. C. S. Radio Course is complete, from the foundational principles of radio to the most advanced stages, thoroughly and scientifically covering every department of this vast industry. It is a modern education in radio, a valuable guide of advancement for men engaged professionally in the radio business. Experimenters will find the I. C. S. Radio Course extremely useful. A thorough understanding of the principles underlying radio communication as presented in the Course will lead to more intelligent undertakings, more systematic work, and more fruitful results. Ample material for experimentations is now available in the ultra-high frequency field and in television.

Mark and mail the coupon. We will send you all details. This act may be the real beginning of your career in radio!

INTERNATIONAL CORRESPONDENCE SCHOOLS,
Box 2881, Scranton, Penna.

Without cost or obligation, please tell me all about the
COMPLETE RADIO COURSE

Name
Street Address
City State.....

If you reside in Canada, send this coupon to the International Correspondence Schools Canadian, Ltd., Montreal, Canada.

HUGO GERNSBACK

EDITOR

OCT.-NOV.,

1931



H. WINFIELD SECOR

MANAGING EDITOR

VOLUME II

NUMBER 3

Short Waves and Crime

By HUGO GERNSBACK

IT seems that during the past year, the Police Departments of the various cities and municipalities all over the world have found out, almost simultaneously, that *short waves* are one of the most important weapons in the combating of crime.

Not only are Police cars being equipped rapidly with short wave apparatus, whereby central police headquarters can get into instant communication with the cars, but policemen themselves are being equipped with portable short wave sets, which provides instantaneous communication with the policeman on the beat as well.

While the art of short waves as applied to police work is, as yet, in its infancy, a tremendous amount of good work has already been accomplished, and thousands of actual arrests have been accomplished through the instrumentality of short waves.

Short Wave Phone Preferred

Some years ago, code messages were used, which, however, proved to be of little use, because the transmission of important instructions was not rapid enough; but during the past two years, and particularly during the past twelve months, radio telephony on short waves has been used and is now being used almost exclusively. There is, of course, one drawback to the system, and this is that the up-to-date criminal naturally knows about police activities and may be "listening in" on a short wave set himself, which, therefore, counteracts the police activities to some extent.

When Criminals "Listen In"

If criminals can tune in on messages sent to police cars, there would, therefore, seem to be little use in sending out the information. In order to circumvent this phase, Michigan has passed a law which *forbids the installation of short wave receivers in any private cars; only police cars can be equipped with short wave sets.* This seems a particularly foolish idea, because criminals will install sets whether it is legal or not! There are, however, other ways to get the desired information to the proper officer, without any difficulty whatsoever. Some of the police departments are already installing a so-called "scrambling device" which is now used with excellent results on Transatlantic phone circuits. This scrambling makes the message unintelligible except to those having the correct filtering apparatus, but even this will not remain a complete success for any length of time, because criminals can easily obtain the correct circuits

for "unscrambling" the messages, and once they are in possession of this information, they can, of course, "listen in" the same as before.

The Author's "Secrecy" Scheme

To me, the most successful secrecy scheme that can be devised would appear to be a code system. If you listen in on your short wave set almost any night, you can hear plenty of police activity going on. It usually has to do with police headquarters giving the license number of a car and the road on which the car is travelling. Proper secrecy can easily be had by using a code. Instead of giving the numbers of the car, letters can be given. These code letters can be changed every day, and should be changed in such a manner that only the policeman on the beat has the proper "key." He will be handed a small printed card on which the key is given, and if police headquarters on a Thursday morning mention that car No. 1 BBAKLS is desired, the proper policeman would immediately translate this into the correct number, without the listening criminal being any wiser. The same key should be given to streets, so that for example, if a police car is to go to 650 Market Street, the information would be given as 1946 Street. This key can always be changed every day and unless a crooked policeman gives this "key" to the criminal, it would seem to be fairly safe, at least for a little while. By continuing to change the key a reasonable amount of times, secrecy should be assured.

Mulrooney Stirred to Action

Police Commissioner E. P. Mulrooney of New York City has been so well impressed by results obtained in other cities, that short wave radio will be installed soon in a number of cruising cars in New York City.

William J. Quinn, Chief of Police of San Francisco, reports that short wave radio has been a great success in San Francisco and resulted in greater efficiency during the past years.

2,260 Arrests in 6 Months

Michael F. Morrissey, Chief of Police of Indianapolis, reports very satisfactory results. There are 43 cars short wave equipped, as well as six county sheriff's cars. In the first six months of this year there were 2,260 arrests directly traceable to short waves. Among them 111 were for assault with intent to kill, 245 drunken drivers, 101 auto bandits, 125 burglars, 86 robbers and 36 hit-and-run drivers.

SHORT WAVE CRAFT IS PUBLISHED ON THE 15th OF EVERY OTHER MONTH

THE NEXT ISSUE COMES OUT NOVEMBER 15th



What SHORT

Short waves today, more than ever before, are a distinct asset to Col. Lindbergh and his wife, as they are to all other fliers on long distance trips. Valuable weather reports can be picked up regularly on short waves from many different points, and also radio compass bearings can be taken by short waves. Lieut. Eddy, who prepared the accompanying article, is a friend of the "Flying" Colonel and piloted a ship in the U. S. Naval Service for over eleven years.

Col. and Mrs. Lindbergh standing in front of their plane before "taking off" on their hazardous flight across Canada on their way to Japan.

crowd of admirers are waiting. The morale of both will be immeasurably improved by this ability to "pick the landing spot" by radio. It will also be nice to be able to send private messages. For instance these flying parents can be notified hourly, if they wish, as to their son. The knowledge that this could be done must have made it easier for the mother in Mrs. Lindbergh to join her husband on this flight away from her baby.

WHEN Colonel Lindbergh took off on his hop to the Orient and return, he had with him two invaluable allies—Mrs. Lindbergh, a licensed aircraft radio operator, and a complete "short-wave" radio set. Short waves as a means of communication therefore mean a great deal to him; by their means he will be in communication with the ground, somewhere, all throughout this long and perilous flight. What a difference this will make to Mrs. Lindbergh on the trip!

Having decided to land at one place for gas or tea, the radio set will permit Mrs. Lindbergh to exercise the feminine prerogative of changing her mind and ordering tea, gas, or "what have you," at any landing field sighted from the air.

This ability to change scheduled stops will appeal to them both; for they do not like to disappoint waiting crowds, and yet Colonel Lindbergh will not wish to fly into a rainy, foggy airport with Mrs. Lindbergh aboard, just because a

Short Waves Tell of Weather Ahead

Besides messages to airports, and private messages, a complete and up-to-the-minute "weather report" and "forecast" will be sent by radio to the Lindbergh plane, as it flies its eastward course across the United States. After leaving Alaska, on the outward bound trip, spec-

All undue landing hazards will be eliminated; because every airport superintendent will advise her before the approach of the plane, as to the condition of various parts of the field. Remember, Mrs. Lindbergh has had one bad landing with the Colonel, when he lost a wheel from his plane. Should this, or any similar mishap, by chance occur again, she can radio to the ground crew to send a plane into the air with any replacement parts needed and a mechanic, if necessary; for in several instances in the Army, wheels and such parts have been replaced in the air when ordered by radio.

It is not probable that the radio will be needed for this, however; but it will be used before each landing to inquire which run-way is soft and which is not; whether there is a fog or mist at the airport, and if so, what nearby field it will be best to use.

"Picking the Landing Spot" by Radio

Long before each airport is reached, during their leisurely return trip, the Lindberghs will, in this manner, be enabled to decide whether to proceed to that airport for an over-night stay, or land at some nearer, safer landing place.

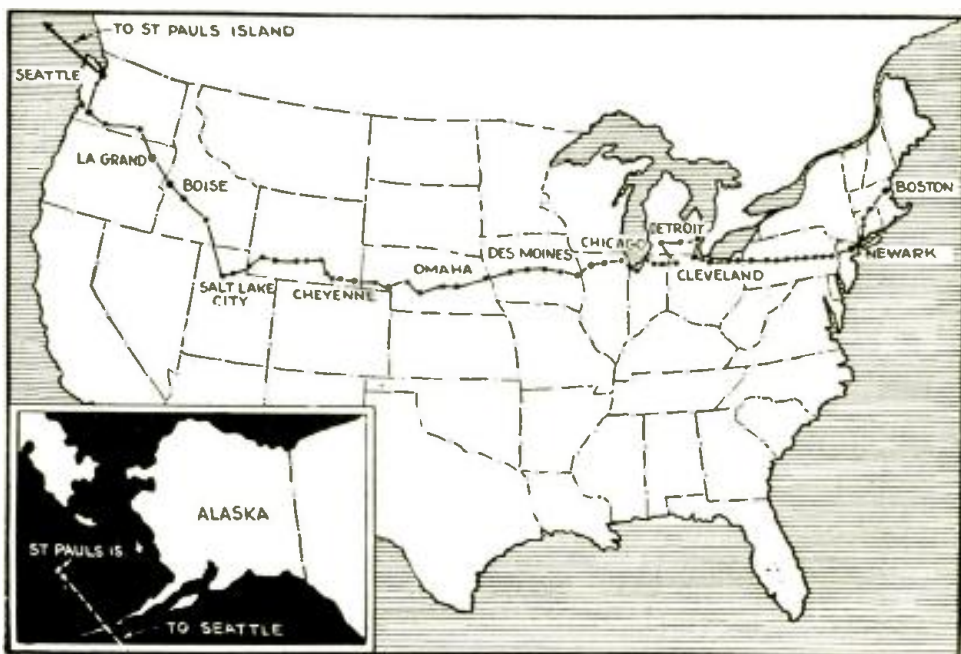

Map above shows northern chain of short wave airport stations from which fliers, including Col. Lindbergh and his wife, could receive weather reports regularly. A radio station at St. Paul's Island served to supply radio compass bearings and weather reports to the Colonel and Mrs. Lindbergh.

WAVES Mean to the LINDBERGH'S

By MYRON F. EDDY*

(Lieut. U. S. Navy, Retired)

ial reports were broadcast to the Lindberghs of the *weather ahead of them*; the Colonel never had to fly blind through stormy weather. *Short Waves* kept the wings of the Lindbergh plane dry; for, being warned by radio of existing and impending unfavorable weather, the flyers have been able to avoid all storms so far. Having this menace to safe flying removed, by the same radio that assures safe landings, makes that radio of double safety valuable. And this safety idea is the thing of greatest importance.

The Lindbergh plane carries, as a flight crew, two of the most important and beloved of our young people. It is being guarded in its flight by an *international network* of *short-wave* stations: Every amateur in the world wants to tune in on Lindbergh's wave length. Every airport passed will wish to "stand by" to render any assistance desired. It is not probable that any assistance will be needed while returning across the United States, because "forewarned is forearmed" and Lindbergh will be forewarned of every possible danger that besets the flyer on land.

After leaving Alaska in the flight from island to island in the Aleutian chain, ground facilities for radio communications with aircraft are not so plentiful, as Gatty and Post recently discovered. The Navy radio stations on these islands are prepared to guard the flight for several hundred miles beyond their farthest shore, and every ship along the flight course will tune down to the Lindbergh short-wave set.

How Ships Assist Fliers

These ships can assist Colonel Lindbergh in his navigation problems by stating their position when sighted. If unable to reply direct to Lindbergh's inquiry, they will be able to do so through several short-wave stations in Japan and Alaska. Such ships may furnish a "fix" indirectly, by merely reporting sighting the Lindbergh plane at such and such a time, in a certain latitude and longitude. These messages, relayed to Lindbergh, will enable him to check his navigation and plot a line of "positions" or "fixes" as he flies across open water on the last and more dangerous leg of his flight.

There is another way by which the short-wave transmitter will assist in the navigation of this aircraft. Radio-compass stations, aboard vessels at sea, and at shore stations along both the Northern Pacific coast and the China coast, will be able to take bearings of the plane in

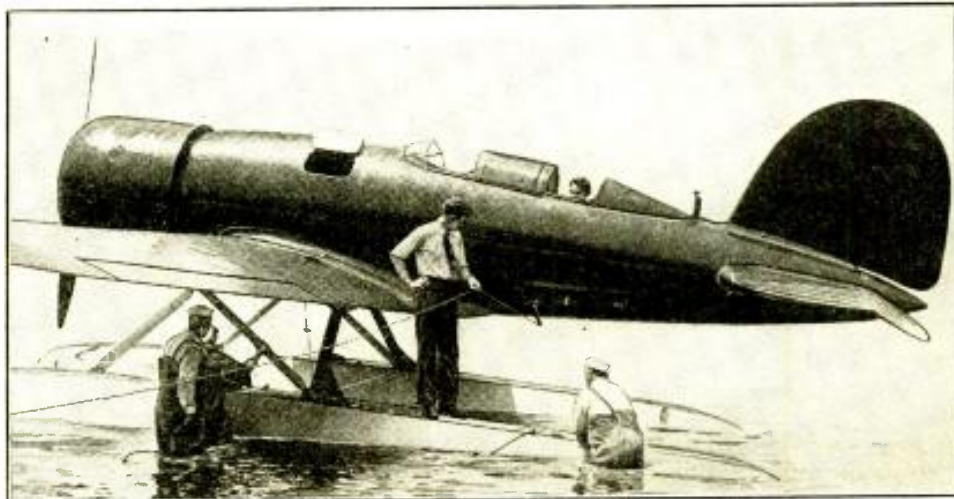

Col. Lindbergh is seen standing on one of the pontoons of his plane (Mrs. Lindbergh seated in the rear cockpit) and he is examining the trailing antenna wire, which is reeled up of course when "taking off." Mrs. Lindbergh operated the radio transmitter and receiver.

flight, during general or special transmission periods. The range of the Lindbergh transmitter will enable a number of stations to take simultaneous bearings and these, plotted so as to intersect reasonably close together, will constitute another series of invaluable "fixes" on the chart aboard the plane.

Lindbergh has paid considerable attention to navigation since his epochal flight across the Atlantic; at one time studying this subject with Commander Weems, an air navigation specialist of the Navy. Lindbergh, as well as Byrd, Gatty and other famous airmen, has commented most favorably on the fact that the Weems system of navigation made full use of radio as an aid to navigation; so that Lindbergh is very well informed as to these possibilities. As Mrs. Lindbergh will be able to devote her time without interruption to radio operating, the set will yield wonderful assistance to her pilot-husband's navigation.

Undoubtedly, as an aid to navigation short waves mean much to Colonel Lindbergh and his radio-operator-wife; if assistance is needed, they will mean *everything*. If an "SOS" ever comes from the Lindbergh plane, the whole world will respond; for the *short waves* will carry it east and west and south to thousands of short-wave enthusiasts. If they are forced down at sea, communication can still be maintained with some short-wave station, until help is guided to the plane; which will float and drift many days on its pontoons. The ability to radio new "position reports" from a drifting seaplane has many times facilitated its rescue.

Col. and Mrs. Lindbergh Both Licensed Operators

Colonel Lindbergh and Mrs. Lindbergh have recently obtained Federal licenses as Third Class Commercial Radio Operators. Study was necessary to pass the required examination for this license, which license entitles the holder thereof to operate any licensed aircraft radio station.

Details of Lindbergh Plane Radio

The call letters of the Lindbergh plane, KHCAL, were published before its departure, so that all might listen for this station throughout the entire flight. Many amateurs have already reported hearing it; some have even "worked" the plane.

The transmitter is designed to normally operate on the following frequencies (in kilocycles), 333, 500, 3130, 5615, 8450 and 13240 (25 to 900 meters). The frequency to be used for emergency messages is 8015 kc. The circuit is of the typical master-oscillator, power-amplifier type. It is rated as a 12-watt set, and its range may prove to be several thousand miles. Power is obtained from a 12-volt storage battery driving a dynamotor. A trailing wire antenna is used.

The receiver is a 4-tube set, designed to cover a frequency band of from 17 to 1200 meters. It should pick up signals from distances up to several thousand miles. The total weight of the radio equipment is about 100 pounds.

Radio Beacon Guides

When flying the U. S. airways, with decreased visibility, the Colonel can lis-

(Continued on page 232)

* Author of text-book "Aircraft Radio".

THIS SHORT WAVE STATION "WALKS"

How Columbia Broadcasting System covers special events with a "portable" short wave transmitter, strapped on the back of an announcer.



Operator tuning "pack-on-back" short wave transmitter.

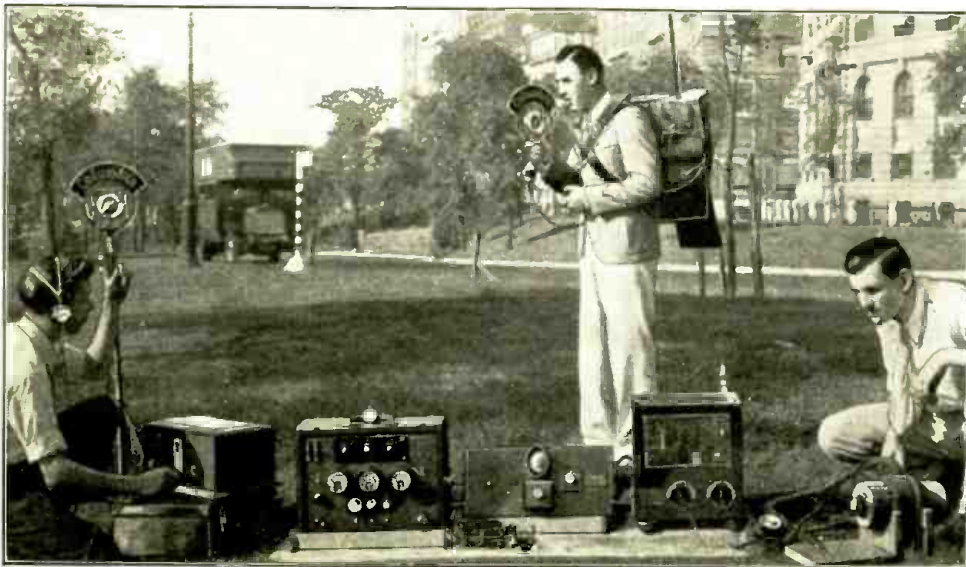

might at first imagine. Signals have been picked up clearly over a distance of as great as one mile, but ordinarily it is not necessary to pick up the short wave voice signals from the "walking" short wave transmitter, being carried around on the back of the announcer, for distances greater than one-quarter of a mile. A new form of aerial, comprising a rod a few feet in length and noticeable in the photographs, is used with the portable "pack-on-back" short wave transmitter. The transmitter here shown has been operated on a wavelength of about 120 meters. The voice signals from the battery-operated portable transmitter are picked up by the receiving set shown at left of large photo; the voice currents thus picked up from the "walking broadcast station" are then considerably amplified by a multi-stage vacuum tube amplifier; next they are

(Continued on page 225)

ACTION—with a capital "A", is the key-note in the daily life of the "special events" announcer, on the staff of any modern broadcasting organization. For instance, look at the pack-on-back portable set used by the Columbia Broadcasting System, whose equipment is here illustrated. In the June-July number of *SHORT WAVE CRAFT* a feature article illustrated and explained how "N. B. C." covers special events, such as athletic games, parachute jumps, and other exciting and unusual happenings where it is necessary to broadcast the voice of the announcer in action. One of Germany's outstanding broadcast announcers is Hellmut H. Hellmut, who recently broadcast some "thrilling moments" while on a visit to this country, which included a (N.B.C.) broadcast from the top of the Statue of Liberty and other unusual points.

It may be surprising to many of our readers, but the portable short wave transmitter carried on the back of the announcer, as here shown, possesses a considerably greater range than one

Above: Columbia Broadcasting System "Portable" short wave transmitter in action. Harry Von Zell, announcer, has "mike" and one-watt short wave transmitter on his back. Other equipment includes audio frequency amplifier, 50-watt short wave transmitter, and dynamotor.

Right: Mr. Harry Von Zell at the "mike" of the special "pack on back" short wave transmitter, seen at left of picture. At right, portable audio frequency amplifier used for transmitting programs over broadcast telephone circuits.



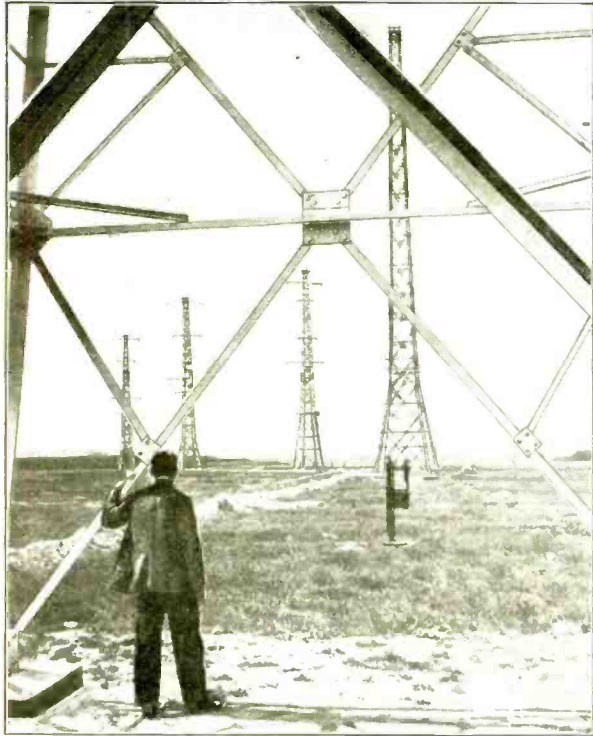

B E E L I T Z -

Where the
Trans-atlantic
Signals
are Received
in Germany

Practically, the last word in short wave, receiving station design, is to be seen by those fortunate enough to visit the town of Beelitz, a suburb of Berlin, Germany, where the Telefunken Company has built an ultra-modern central radio station. Here transatlantic radio and telephone calls are received and distributed.

Modern receiving aerials in use at "Beelitz".

BEELITZ—a word to conjure with, when it comes to short wave wonders in Germany. In the town of Beelitz, a suburb of Berlin, there has been built a great radio central station, designed by the engineers of the famous Telefunken Company. Here at Beelitz, the transatlantic radio and television signals are picked up and distributed to various land wires, radiating to various cities. One of the accompanying photographs shows the huge metal aerial masts which support "wave form" receiving aerials of the very latest design and directional efficiency. As the photo below shows the dynamos, driven by oil engines, are surprisingly large in size for a receiving station, but it has to be remembered that there are many

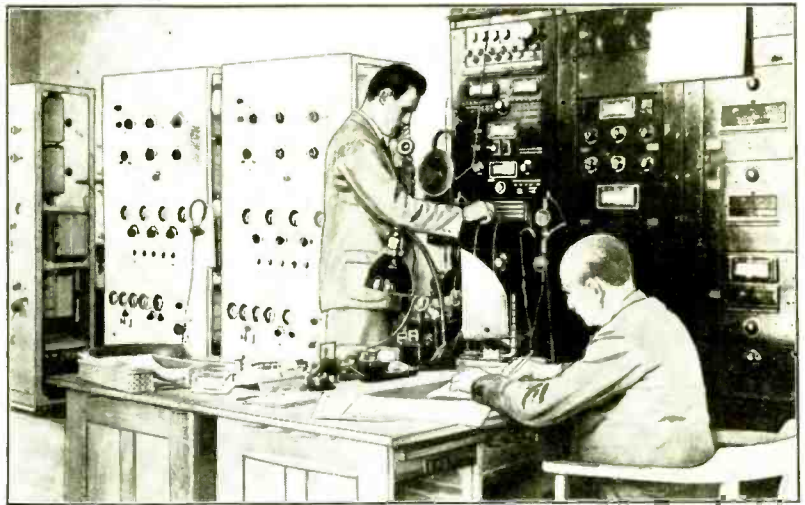

A glimpse of the main receiving "laboratory" of the Telefunken station at Beelitz. The operator is putting through a call for Buenos Aires, Argentina.

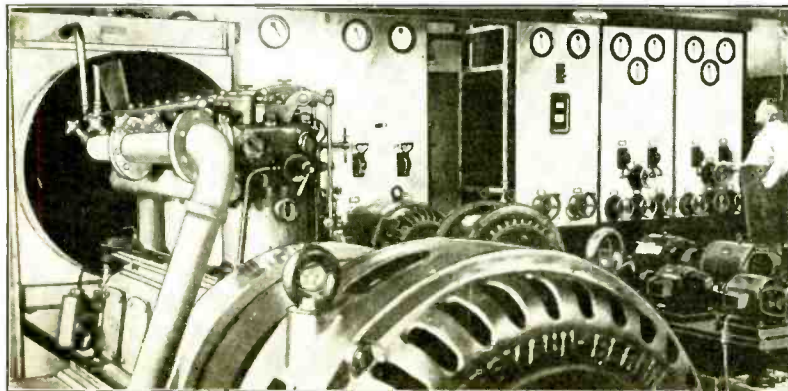

different forms of amplifiers used at such a giant station as this one erected by Telefunken at Beelitz.

Short wave signals are used principally today for transatlantic reception of telephone messages, as many amateurs who have listened in in the neighborhood of 20 to 30 meters, know.

Photo at left shows the powerful oil-engine driven generators, which provide the current for the reception of transatlantic calls.

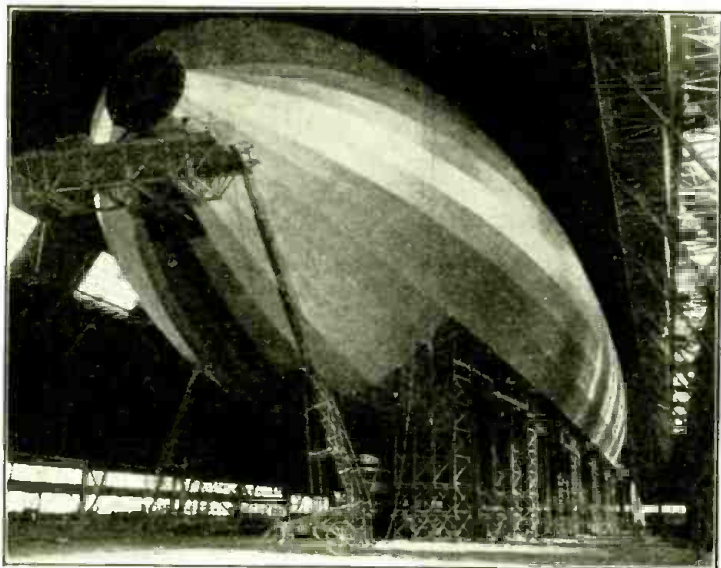

The U. S. Navy's new dirigible, "Akron," which will soon take the air.

THE new giant U. S. Navy dirigible, the "Akron", will soon leave the manufacturer's construction dock to sail the skies. The airship will be made far safer than ever before, by the constant reception of "short wave" messages, giving the very latest meteorological reports. The general appearance of the short wave radio equipment will be gleaned from a study of the accompanying photograph, which shows the apparatus installed aboard the "Los Angeles". The apparatus carried by the "Akron" will include facsimile transmitting and receiving equipment. There will be three receiving sets; one for reception of short waves, another for intermediate wavelengths, and one for the reception of long wavelengths; including a direction-finder with loop aerial. The radio cabin is directly over the control car.

Short wave equipment aboard the dirigible "Los Angeles," which is similar to that which will be installed on the new Navy dirigible, "Akron".

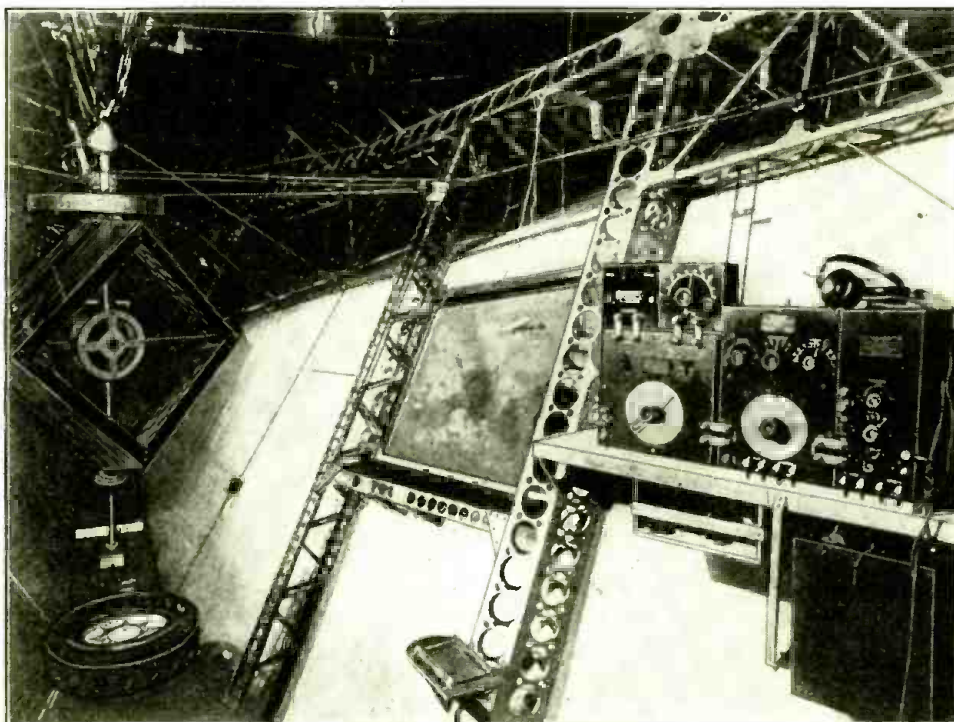

(Official U. S. Navy Photographs)

SHORT WAVES Highly Important to NEW U. S. NAVY DIRIGIBLE

Uncle Sam's newest airship, the "Akron", will carry extensive short wave equipment. Apparatus will also be carried for the transmission and reception of facsimile pictures.

Don't's for Short Wave Listeners

- Don't pass up any weak signals. Often a weak program can be brought out plainly by careful tuning.
- Don't tune haphazardly. Learn where stations should be found on the dials of your particular receiver.
- Don't expect wonderful results with a poor receiver. A good receiver is necessary for good results.
- Don't tune above 33 metres for distant stations in daylight.
- Don't tune below 25 metres for distant stations after dark.
- Don't expect to hear many distant stations above 50 metres.
- Don't expect the best reception only at night. Short waves offer twenty-four hours of entertainment each day.
- Don't say "I heard your station", when writing for verifications. Tell what you heard and how you heard it.
- Don't forget to tell others about this organization.

- Don't expect to find stations on all parts of the dials. Short-wave stations are widely separated except in a very few places.
 - Don't expect stations to tune broadly. Most distant stations tune very sharp.
 - Don't expect to hear the world the first day you tune. It requires some knowledge of tuning to get excellent results.
 - There are many distant stations to be heard when you have learned to tune.
 - Don't expect to hear a station simply because it is on the air. Many things govern short-wave reception.
 - Don't get discouraged. If reception is poor one day, it may be fine the next.
 - Don't skim over the dials. Tune slowly.
 - Don't tune in without referring to the stations others are hearing in our news sections.
 - Don't tune for stations at random. They may not be on the air. Consult a S-W station list.
- Courtesy Philips Radio, operators of
"P.C.J."—Holland.

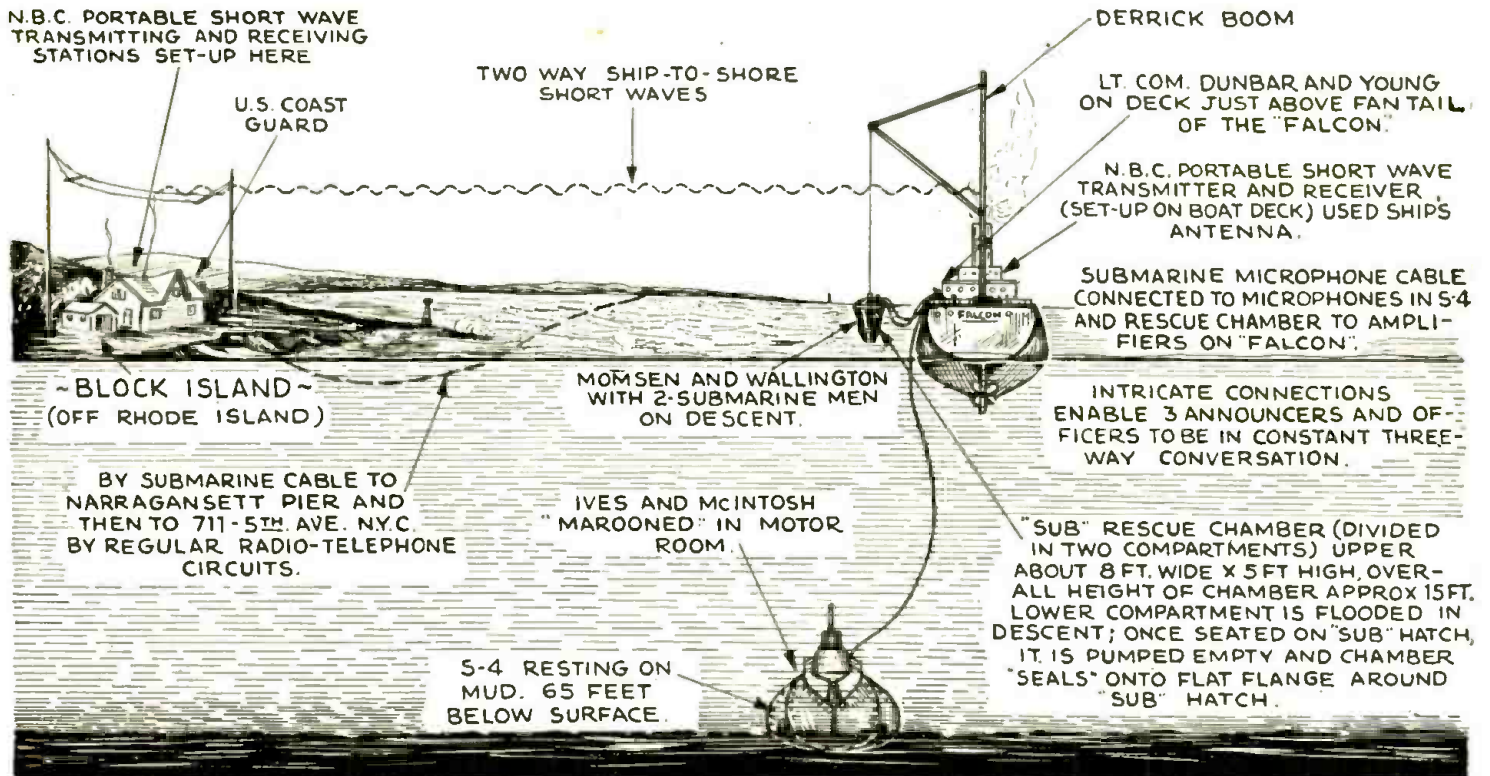

Subsea "Rescue" Short Waved



As shown above and in photos herewith National Broadcasting Co. recently broadcast over a nation-wide chain of stations, the "rescue" of two men from a submarine resting on the mud, 65 ft. below the surface of Great Salt Pond in Long Island Sound, off Block Island. Short waves "did their bit" as usual.

Photo (left) shows James Wallington, N.B.C. announcer, in the hatch of the diving bell, just before it submerged. (Right) U. S. Navy man entering the diving bell. (Below) "Sub" S-4 diving.

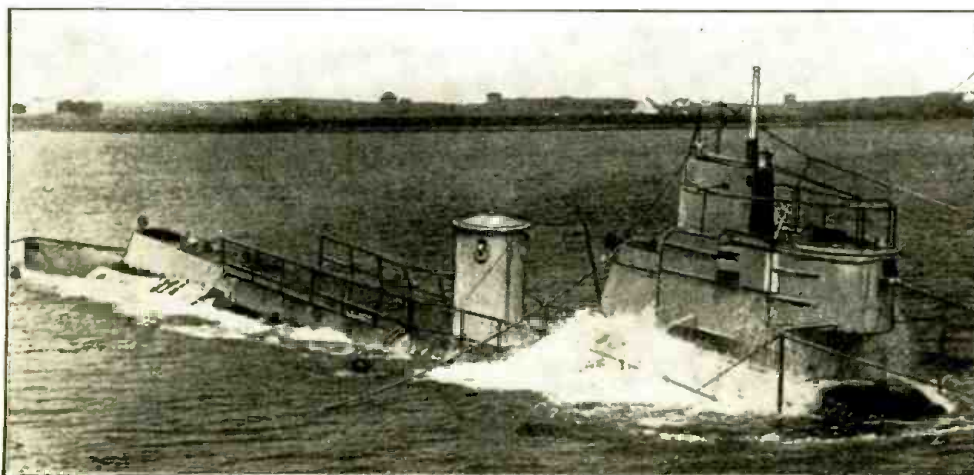
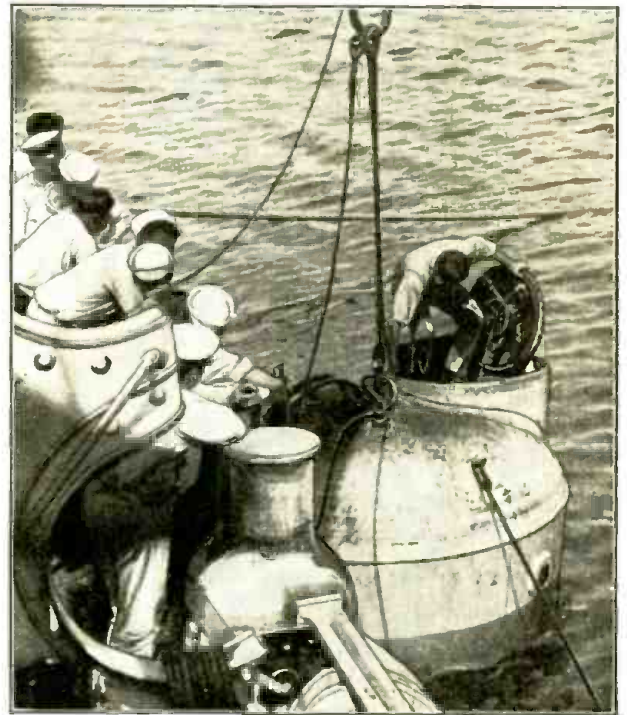

THE pictures herewith portray one of the greatest stunts ever broadcast, that of the "rescue" of two men from a "sunken" submarine off the coast of Long Island. A new eight-ton diving bell was demonstrated by the Navy Department, this device being intended for rescuing the crew of a submarine trapped on the sea-bottom. Lieut. N. S. Ives, U. S. Navy, and announcer Ezra MacIntosh, were in the "sub" on the bottom; announcer James Wallington was in the diving bell, with Lieut. Chas. B. Momsen, inventor of the Momsen "lung" for submarine rescue work, and Edward Kalinowski, one of the Navy's best divers. The broadcast was effected with the aid of a short wave transmitter installed on the tender "Falcon".

Cathode ray tube analyzes oscillating currents

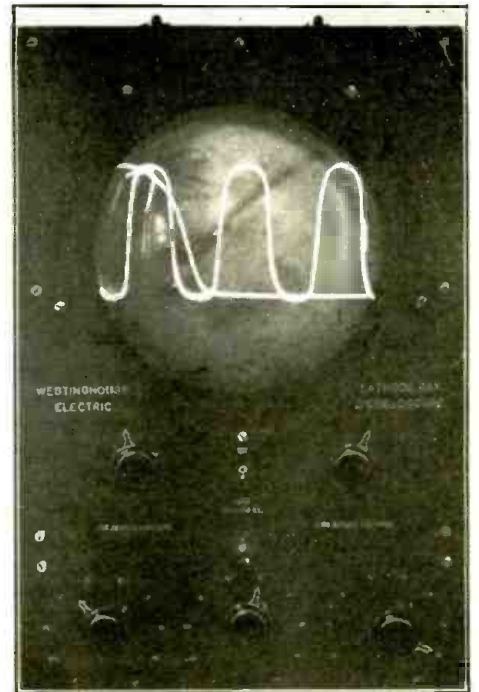
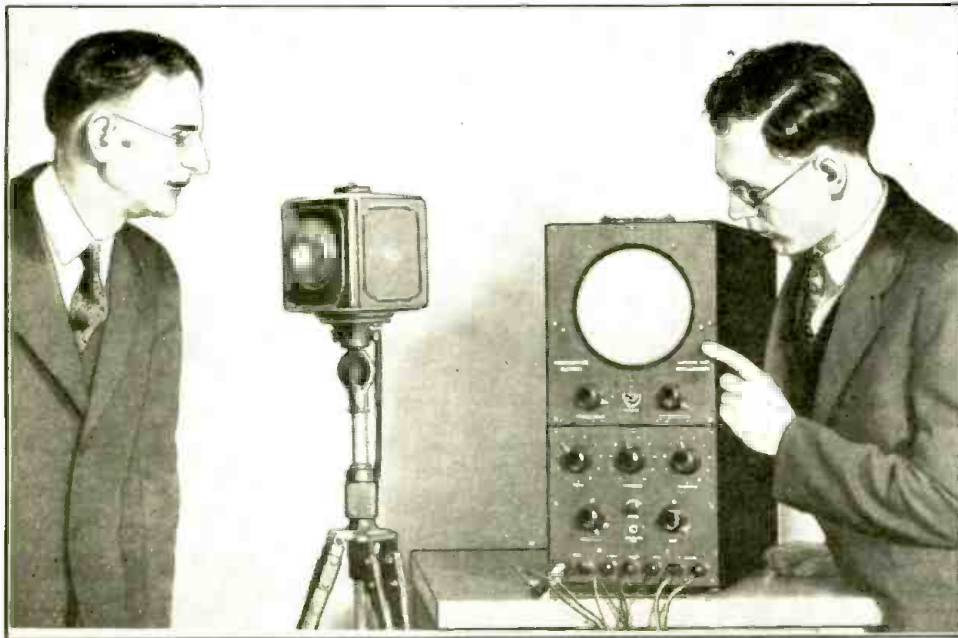

One of the useful applications of the Westinghouse cathode ray tube oscilloscope is that of analyzing various spoken sounds, particularly in the study of languages.

WHEN a person speaks into a microphone the corresponding voice pattern is observed at the large end of the oscilloscope tube, to which the man at

the right of the photo is pointing. A typical "wave form" is painted by the cathode ray on the end of the tube, in the photo at the extreme right. An

"electron gun" shoots a narrow beam of electrons toward a screen; the voice currents deflect the beam of electrons and create changing patterns.

Ultra S-W Transmitter

AT the right—one of the newest apparatus perfected for the transmission of ultra-short waves and built at the famous Heinrich Hertz Institute in Germany. This apparatus generates ultra-short waves, having a length of but a few centimeters (or a couple of inches). These waves have almost the qualities of light and by means of metal-mirrors they can be focussed in certain directions, the same as the light waves.

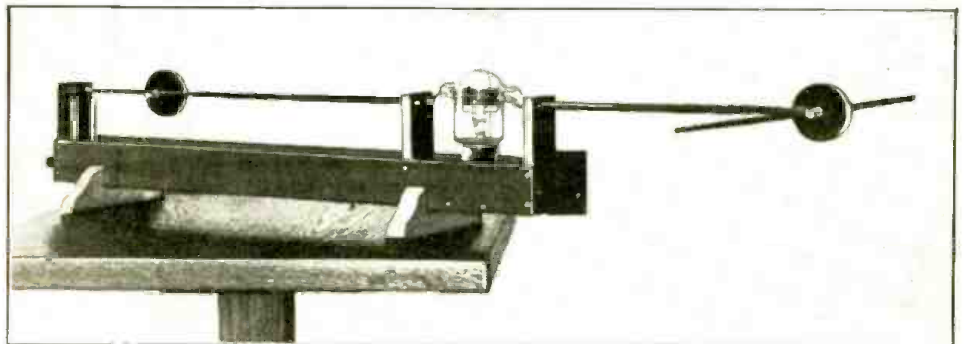

New Short Wave Aircraft Transmitter and Receiver

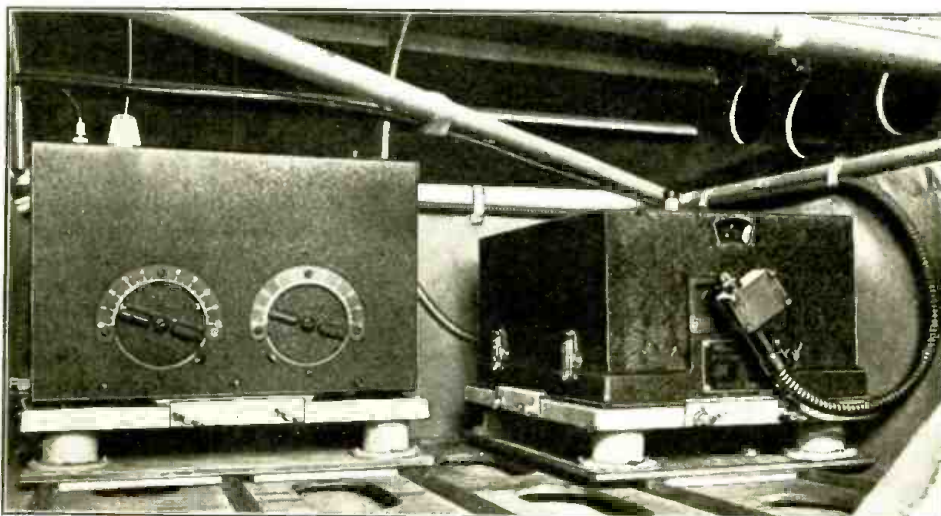

Appearance of new Western Electric short wave aircraft transmitter and receiver, which weighs but 18 pounds; transmitter at the left and receiver at the right.

ASHORT WAVE transmitter, weighing only 18 pounds, has been evolved for use in airplanes. It is part of a system for two-way communication that is specially adapted for the needs of the private flier. Associated with the lightweight transmitter is a long wave receiver. These, together with the auxiliary equipment which forms the complete system, weigh 80 pounds, about half the normal weight of a passenger.

The transmitter and receiver, designed by the Bell Telephone Laboratories for the Western Electric Company, are shown in the accompanying photograph. Despite its light weight, the transmitter is rugged in construction. It is controlled by the quartz crystal oscillator method. This eliminates the necessity for tuning and automatically holds it to the prescribed frequency. It also embodies high percentage modulation.

ULTRA SHORT WAVES IN MEDICINE

By DR. FRITZ NOACK
(Berlin)

New apparatus recently constructed in Europe is suitable for the treatment of various human ailments by the application of ultra-short waves.

(Cover Feature)

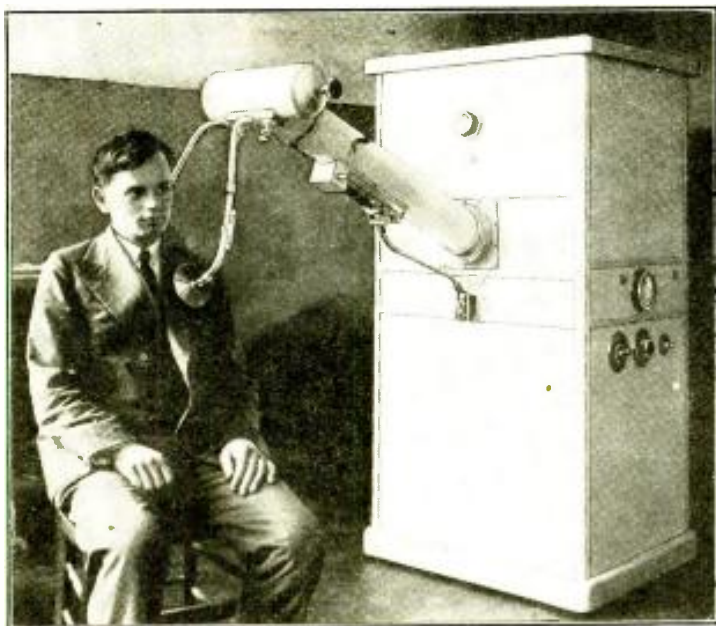

PROFESSOR ESAU, of the University of Jena, the well-known pioneer in the field of ultra short waves, was the one who nearly two years ago pointed out that very evidently the ultra short wave exercised beneficial medicinal effects. It was also very peculiar, according to Prof. Esau's article, how the effect was discovered. Those working near an ultra short wave transmitter noticed a feeling of warmth, as soon as they came very close to the transmitter.

For further investigation of this effect, small mice were put between the condenser plates of the sender; and Lo! after some time the mice fell victims to a sort of tetanus, which eventually led to death. The result of this fact was that Prof. Esau resolved to commission a physician to make a further study of the physiological effect of these ultra short waves. Naturally the serious investigation of medicinal effects requires experience in physical measurements, likewise an apparatus operating in a constant and easily controlled manner.

Siemens and Halske Interested

It is gratifying that a manufacturer which already possesses very great experience in constructing electro-medical apparatus and which also has the requisite experience in physical measurements, the prominent firms of Siemens and Halske took up the matter. Now this company has manufactured a first ultra-short wave radiation apparatus and recently exhibited it to a picked group of scientists and to the press.

The pictures show the new set which, of course, has to be considered as the first of an evolutionary series. There will still be necessary all sorts of experiments to produce the set in such form that it will correspond to all the needs of the medical profession. The present set will, for the time being, be used for the further study of the physiological effect of ultra short waves. It will be the problem of the doctors to

New ultra - short wave generator with its movable electrode-arm adjusted to give a treatment through the chest of the patient. When properly adjusted a glow appears in a neon tube.



One of the "fair sex" receiving a treatment through the knee by ultra-short waves. Several treatments are given for the average ailment.

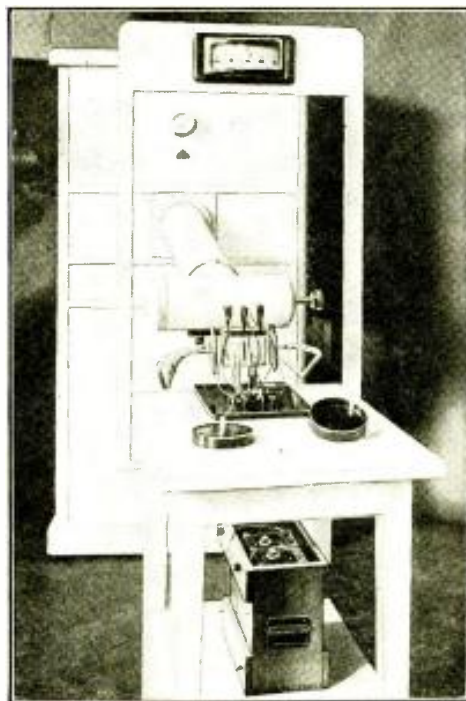
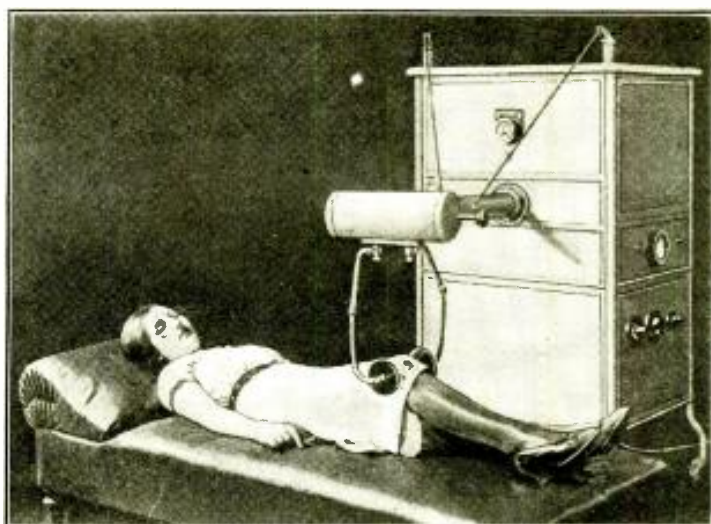

The ultra-short wave medical apparatus with its electrode arm adjusted to permit the waves passing through a solution for experiment.

investigate the fields of use and the conditions under which the set may be used.

Arrangement of U. S. W. Generator

In the large shielded box are the real ultra short wave generator—(actually resembling a radio transmitter) and the parts needed for its operation. The generator can work on two waves, four and eight meters. The wavelength is adjusted by inserting the proper tuning coils. The arm which projects out of the apparatus has inside it two lead wires which convey the oscillations outward; they are led to the two electrodes, which are placed at the ends of the two visible supports.

In the cross-beam at the end of the arm is a "tuning" device, which tunes the electrode oscillatory circuit exactly to the wavelength of the generator. The exact tuning can be read on a meter, which is above the arm on the box; this shows the direct plate current of the transmitter, which, with correct tuning of the electrode circuit, adjusts to a minimum; the value then indicated by the meter gives, after calibration of the set, a value for the electrode energy.

To be able to adjust the electrodes, as is necessary from one case to another

(Continued on page 227)

The Short Wave Beginner



The "S.W.C." specially designed "short wave" portable in operation in the Editor's office. Works loud speaker on two tubes, battery operated, no plug-in coils, light in weight, and other features.

The "S. W. C." Two Tube PORTABLE Works "Speaker"

By CLYDE FITCH

Two tubes, a screen grid and a pentode, working on batteries, give surprising loud-speaker volume on this portable. No plug-in coils are used, but a clever switching scheme instead.

WEIGHING but twelve pounds, and measuring only 6½" by 8½" by 11", this complete, self-contained, battery-type short wave portable receiver gave such remarkable results in sensitivity and volume on the short-wave stations, that it amazed all who had the pleasure of operating and listening to it. It seemed incredible that such enormous volume could be obtained from two tubes—a screen-grid type '32 and a pentode type '33—both battery-operated. Tuning from 15 to 250 meters (with the particular short-wave coils employed) it brought in some of the lower-wave broadcast stations with volume comparable to that of many of the best commercial five and six tube sets. This particular combination, fully shown in the circuit diagram, is recommended for all who contemplate building a short-wave receiver—portable or otherwise. It will out-perform many of the best "multi-tubers." Of course, the new dry-cell pentode makes this possible, giving great power in conjunction with the screen-grid's sensitivity.

No Plug-In Coils

Plug-in coils were considered a nuisance in a portable and therefore were eliminated in the design of this receiver; in spite of the fact that they are generally considered to be the most efficient.

This point of superiority of the plug-ins is still questionable; many authorities have obtained some remarkable results without them. But the writer will not attempt to settle this question here; it is sufficient to say that, for convenience in handling and operating this set, a switching arrangement is employed—and it has given much better results than were originally anticipated.

The coils are of the Pilot type, only four being employed; the largest or "broadcast" coil of the usual set was not used. Of course, if the constructor desires to tune in the long-wave broadcast stations also, a broadcast (200-550 meter) coil may be substituted for one of the short-wave ones, but there is room for only four coils in this particular carrying case.

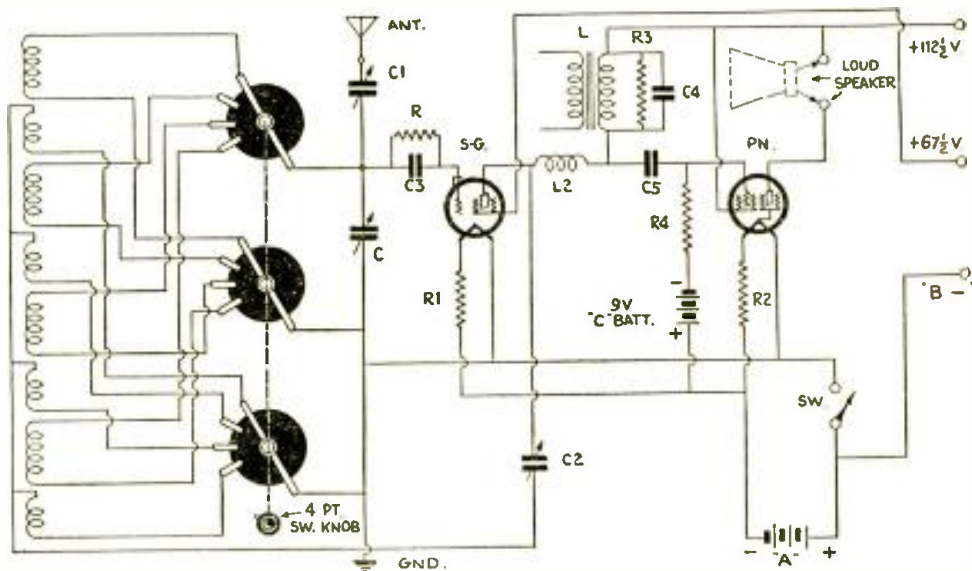

Hook-up of "S.W.C." short wave portable.



Chassis and battery compartment of "S.W.C." portable.

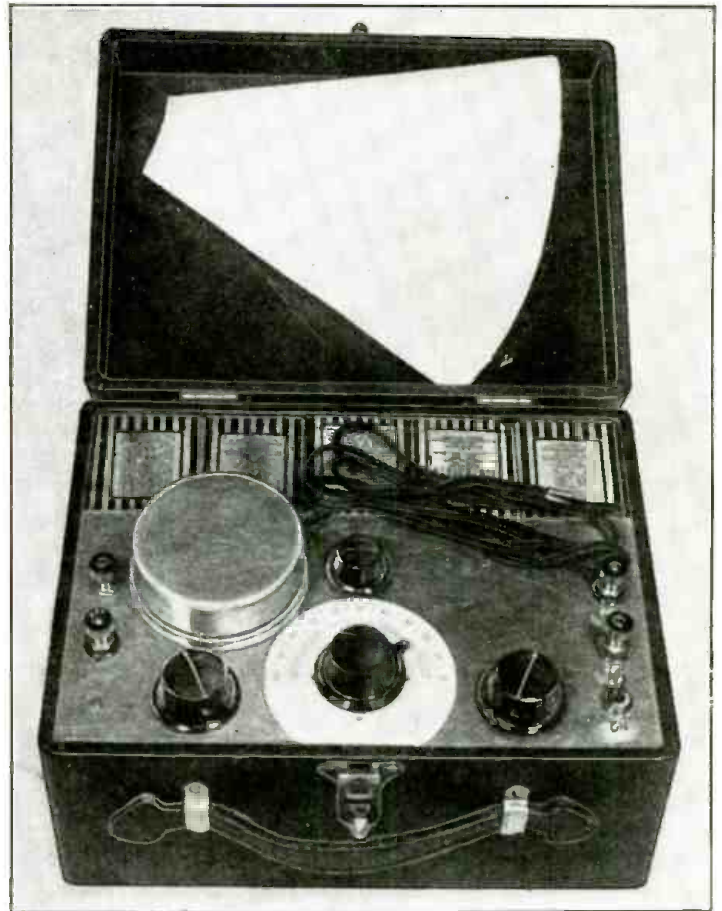

Tuning and control panel of portable short wave set.

The terminals and metal prongs were first detached from the coils; this had the effect of increasing their efficiency, since considerable metal was removed from the field of the coils and the leads were also made much shorter. The four coils are connected into the circuit, one at a time, by means of a "Best" three-pole, four-throw rotary switch.

Power Supply

The power supply consists of five of the very smallest 22½ volt "B" batteries

for the plate supply and eight large-size flashlight cells for the "A" or filament current. Two 4½-volt flashlight batteries supply the 9-volt "C" bias for the pentode power tube.

The "B" batteries are all connected in series, giving a total of 112½ volts. A tap is taken from the third battery, at 67½ volts, for the detector's screen voltage. The cells of the "A" battery are connected in series-parallel (four cells in parallel and two in series) giving a total of three volts. Since the total cur-

rent drawn by the two tubes is only 0.32 ampere, the battery will last a long time—sufficient for any vacation needs.

The Circuit

The circuit is conventional. There is nothing new in it, and it has no trick connections. The results obtained are due entirely to correct design and taking full advantage of the amplification factors of the tubes. Fig. 1 gives the complete circuit, except for the batteries. The aerial is connected directly to the grid side of the grid coil, as shown, a small .000125-mf. series condenser, C1, being used. Regeneration is controlled by a throttle condenser, C2, of the same size. The switch and coil connections are clearly shown in the diagram. The tuning condenser, C, is of the Hammarlund midget type and has a capacity of .00035-mf. C4 is a fixed bypass condenser of .00025-mf. capacity. Grid leak and condenser detection is employed, by means of a .00025-mf. grid condenser, C3, and a 2-megohm grid leak, R.

The output of the screen-grid detector is coupled to the input of the pentode by means of an audio-frequency choke, L, shunted by a ¼-megohm resistor, R3. By this method the detector plate current is not limited, as it would be if straight resistance coupling were used; and the use of the shunt resistor flattens the characteristic curve, resulting in better tone quality on the phone stations. An .01-mf. coupling condenser, C5, and

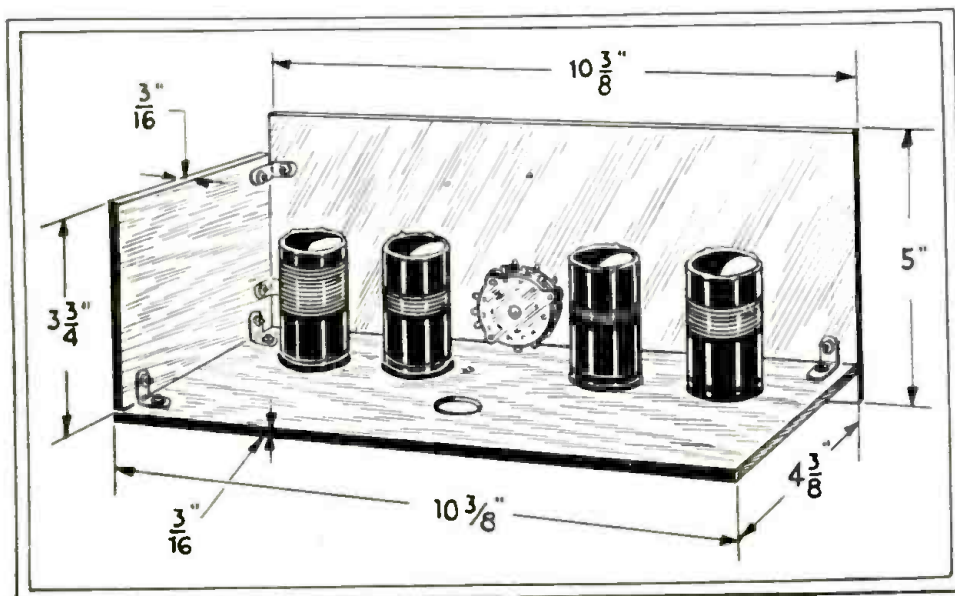

How short wave coils are mounted.

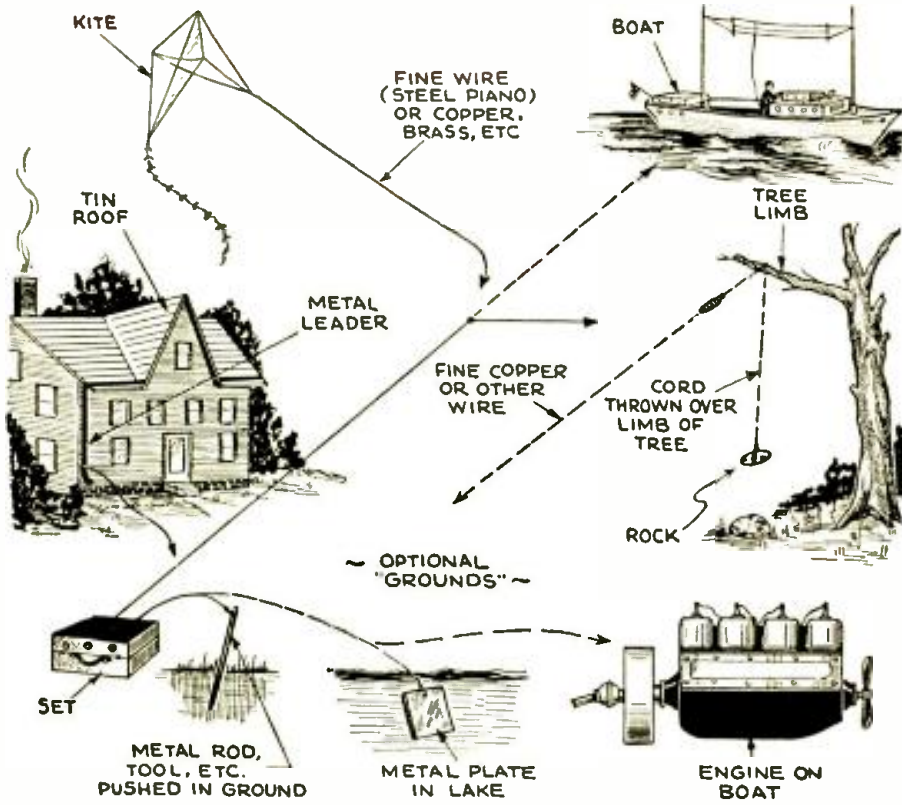

Various forms of antennas and grounds.

obtain or build a case of the exact size specified, for the parts may be arranged differently to fit some other case. The inside dimensions of the case are 10 $\frac{3}{8}$ x 7 $\frac{1}{2}$ x 6 inches. It is an "Insuline" case, as used in this company's portable Companion receiver, and was found ideal for the purpose because the batteries and other parts just fit, as the reproduced photographs show.

The photographs illustrate practically everything but the coils and switch, as these are concealed by the other apparatus; for this reason, they are shown in detail in one of the illustrations. This sketch gives also the dimensions of the aluminum panel, end piece and sub-base. The set proper was assembled on the base and panel and later fitted into the carrying case. This construction was found necessary to facilitate the wiring. The coils are first mounted on the base, as shown, and then connected to the rotary switch, which is mounted on the panel. Note that the leads to the coils are very short. From the diagram (Fig. 1), you will also note that the secondary of each coil is completely disconnected from the circuit by the switch when it is not in use; whereas only one side of the primary is disconnected.

After the coils and switch are mounted and wired, the other parts may be mounted and connected, as shown. When finished, there will be four long leads for connection to the batteries: the "A-";

a $\frac{1}{2}$ -megohm grid leak, R4, are employed.

Fixed resistors are used in the filament circuits, since they are operated from a 3-volt battery. For the screen-grid tube the resistor R1 has a value of 15 ohms and, for the pentode, R2 has a value of 4 ohms.

Note that the coupling choke, L, is actually the secondary of an audio transformer, the primary of which is not used; it is shown disconnected in the diagram.

L2 is an R.F. choke of 80 millihenries, used for the purpose of obtaining regeneration through the throttle condenser C2.

Constructional Details

The first thing necessary, before construction can be started, is to procure

a suitable carrying case; for the parts must fit within the case without too much crowding. It is not necessary to

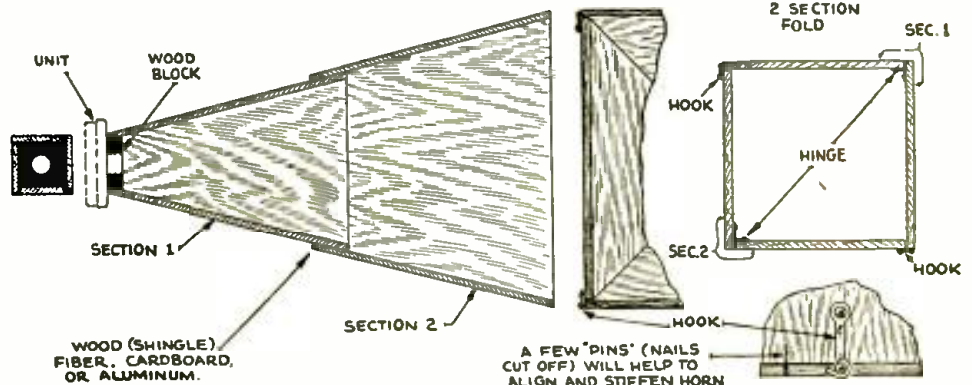

One form of folding horn for loud speaker.

"A+" and "B-" (common); "B+67 $\frac{1}{2}$ "; and "B+112 $\frac{1}{2}$." The batteries can then be inserted in the case and these leads connected; and the chassis is next inserted. The assembly is then ready for use, with the exception of the speaker, which will be described later.

The list of parts gives the values and makes of the components used in this particular set; others of equally good design may be substituted, if desired. Note that the panel contains the three variable condensers, rotary switch, filament switch, and four binding posts (two for the aerial and ground and two for the loud speaker).

The ground post is connected directly to the grounded metal panel, from which aerial post is insulated by means of rubber washers; the loud speaker posts

(Continued on page 225)

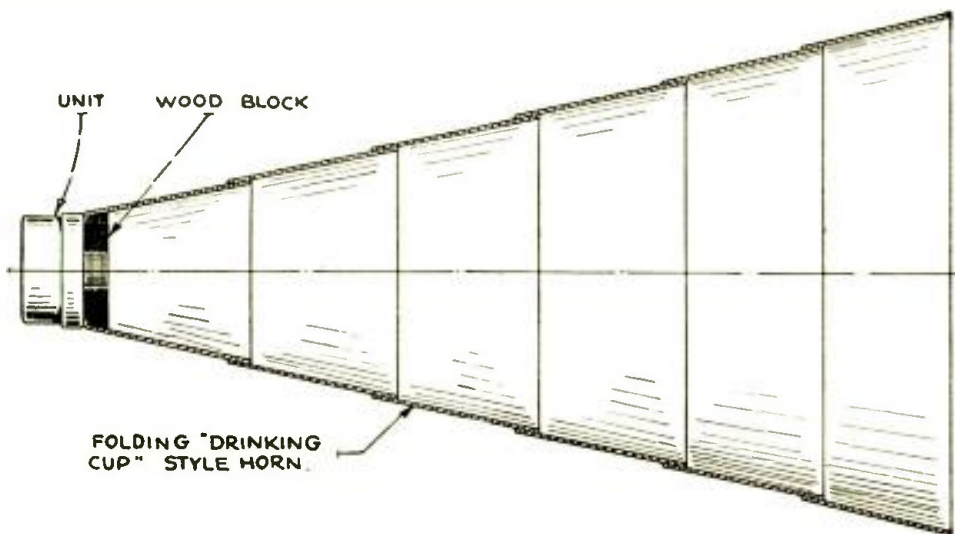

Folding "drinking cup" design of loud speaker horn.

Short Waves for the Broadcast Listener

The HOODWIN S-W CONVERTER

By ARVID FRANKE*

A new converter that makes a short wave super-heterodyne out of your broadcast receiver; no plug-in-coils are used.

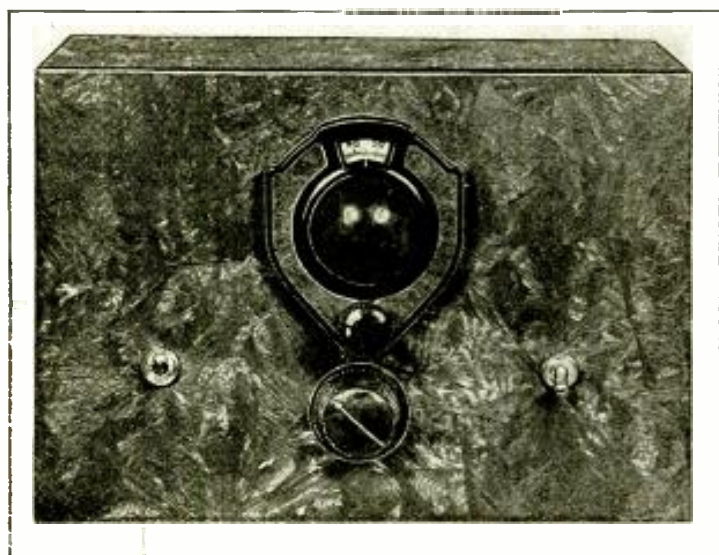

Appearance of front panel of the Hoodwin short wave converter, which when used with the present broadcast receiver, provides a super-heterodyne for short wave reception.

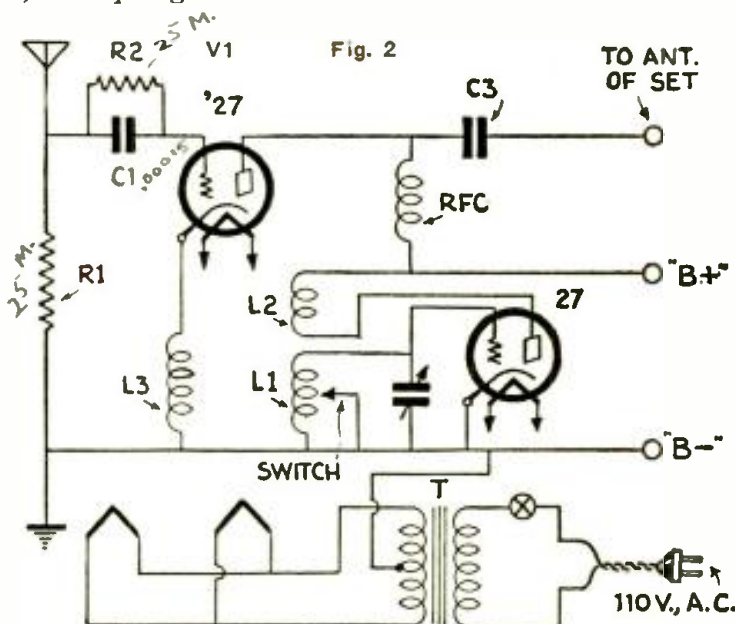

Circuit diagram of the Hoodwin short wave converter, showing the detector tube at left and oscillator tube at right. Plate supply may be obtained from a "B" battery.

ANY superheterodyne receiver can be divided into at least four separate and distinct parts. In Fig. 1, the mixing tube, or first detector, is indicated at A; B represents the oscillator; C the intermediate-frequency amplifier and D the second detector, with audio-frequency equipment. Signals entering the antenna are selected by the tuning circuit of the first detector, or mixing tube. In the mixing tube the selected signal is combined, or mixed with a signal from the oscillator, and two new frequencies are found in the plate circuit of the mixing tube. If for example, the incoming signal in the antenna circuit has a frequency of 700 kilocycles, and the oscillator a frequency of 875 kilocycles, the two frequencies in the plate circuit, or output circuit of the mixing tube would be: $(875-700=175)$ and $875+700=1575$.

If the plate circuit of the mixing tube is coupled to a radio-frequency amplifier which is tuned to either 175 or 1575 Kc., the signal can be amplified, detected, and then amplified as an audio-frequency signal.

One may well ask, "Why not amplify the signal at 875 kc., instead of shifting it to some other frequency and then

amplifying it?" The advantage of changing the signal frequency to some predetermined lower frequency, and then amplifying it, is well founded. By designing an amplifier for one particular frequency, it is possible to utilize all parts of the circuit to their fullest advantage; whereas this cannot be done in an amplifier designed to cover a broad band of frequencies. It is also possible to simplify greatly the construction of a receiving set in which it is desired to cover the short wavelengths; as only the oscillator and the grid circuit of the mixing tube must work at the high frequencies found in the shorter wavelengths. The intermediate-frequency amplifier can be adjusted to some frequency which is comparatively easy to handle while, and at the same time yielding large amplification.

Diagram showing process in super-heterodyne reception of short wave signals; oscillator "B" working into first detector "A", then through intermediate amplifier "C" and second detector "D".

How To Hear Short Waves on Broadcast Receiver

If we have a good broadcast receiver of modern design, the only parts needed to convert this into a short wave super-heterodyne receiver are a mixing tube and an oscillator. The addition of these two units to a good six- or seven-tube broadcast receiver would provide a short-wave receiving set which will out-perform most any four- or five-tube, tuned-radio-frequency, short-wave set. The average owner of a radio receiver would like to tune in foreign broadcast stations, provided that it could be done without purchasing an expensive short-wave set (which would duplicate in some parts his present receiver) and also without requiring the bothersome plug-in coils. The logical solution to this problem is the superheterodyne converter unit, which can be connected

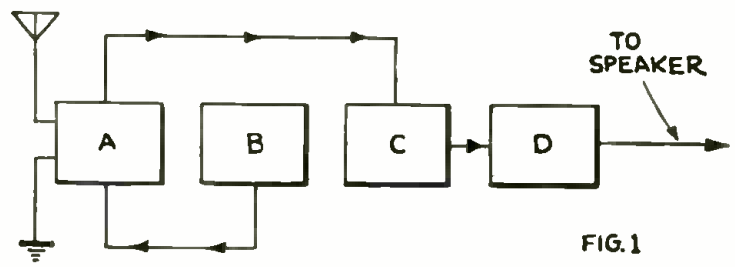

* Chief Engineer, The Chas. Hoodwin Company, Chicago, Ill.

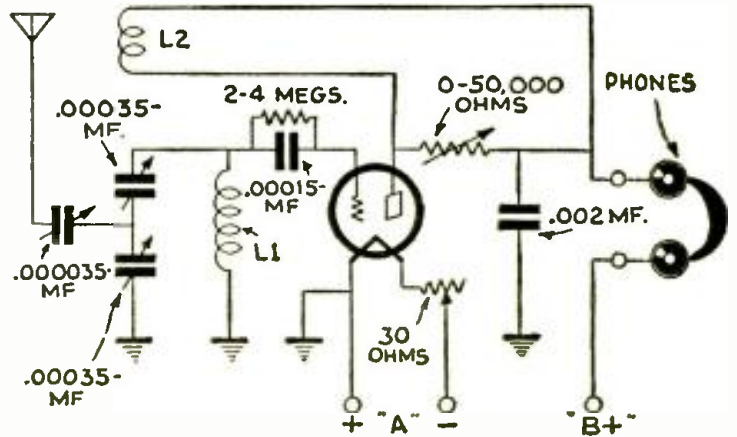
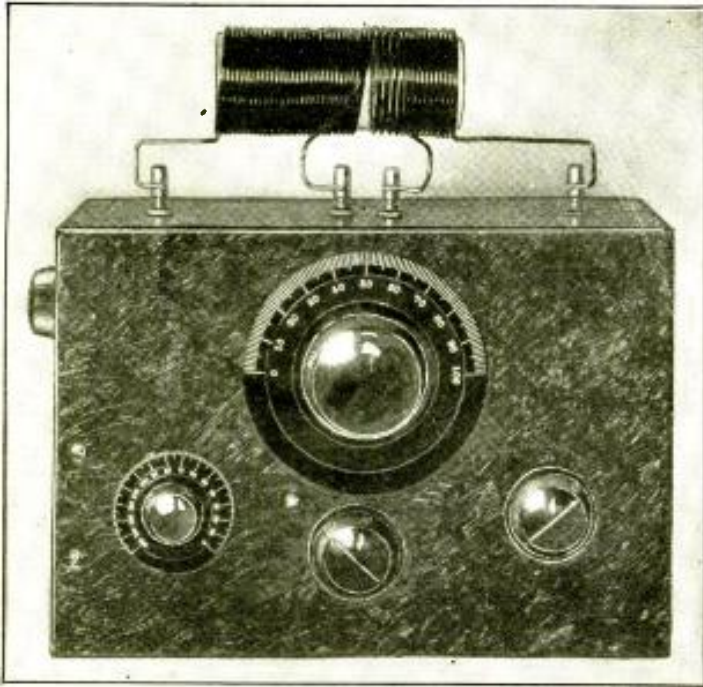

Hook-up of the Hoodwin "one tube" short wave receiver, of similar construction to the converter shown elsewhere. Six plug-in coils are furnished with the one tube receiver. Fig. 3.

Left—New Hoodwin short wave receiver of the one tube type. The signals can be listened to by connecting a pair of phones to the output terminals, or the output may be connected to a suitable A.F. amplifier.

quickly to the average broadcast receiver and which will give splendid results, is simple to tune and does not use plug-in coils.

Simplified Tuning

If we design a short-wave converter unit for use in conjunction with a modern broadcast receiver, the selectivity of the mixing tube grid circuit, or input circuit, can be neglected; for the tuned R. F. circuits in the broadcast receiver will act as the intermediate frequency amplifier and be sufficiently selective. The intermediate frequency can be so chosen that the possibilities of "image" interference are greatly reduced, or entirely eliminated. Hence, it is perfectly feasible to design a converter unit employing an untuned mixing tube, and to tune only the oscillator coil.

To eliminate plug-in coils we may tap the oscillator coil and provide a switch, so that the oscillator will cover the necessary frequency range.

The S.W. Converter Circuit

Fig. 2 shows the converter circuit in which V1 is the mixing tube, which receives from the antenna all signals the antenna picks up, and is coupled to the oscillator by L3, which is connected into the cathode circuit of V1. The plate circuit of V1, is connected to the antenna lead, on the broadcast set, through the coupling condenser C3. The plate power for V1, is supplied through the radio-frequency choke R.F.C., which is so designed that it blocks the passage of any frequency in the broadcast band; thus assuring that all low frequencies are passed to the broadcast receiving set.

Assume that the broadcast receiver is adjusted to 1500 kc.; if a signal of 4000 kc. is present in the antenna circuit of the converter, it is naturally passed to the mixing tube. If the oscillator be adjusted to differ by 1500 kc. from the 4000 kc. signal (at either 2500 kc. or 5500 kc.) the two signals will mix in the

mixing tube, and be present in the plate circuit of the mixing tube as a 1500 kc. signal. As the plate signal of the mixing tube is coupled to the broadcast receiver, this 1500 kc. signal will be passed into the broadcast receiver where it will be amplified and detected.

Changing Range Without Plug-in Coils

Referring again to Fig. 2, it will be seen that the oscillator inductance contains three windings. The first is the secondary winding, which is provided with a tap so that a few turns may be "shorted out" to give the necessary frequency range. This secondary inductance is tuned by a .00035-mf variable condenser. Shunted across the main tuning condenser is a small 7-plate mid-gate condenser to provide easier tuning. The second winding L2 is the tickler or feed-back coil, which causes the oscillator tube to oscillate or generate a radio-frequency voltage, which is fed to the

mixing tube by L3, which is really a continuation of L1.

R1 and R2 are 25,000-ohm resistors; R1 creates a voltage drop, across the antenna circuit, which supplies the signal voltage to the tube V1. R2, in conjunction with condenser C1, provides the proper time constant so that V1 will function as a mixing tube, or detector. C1 has a capacity of .00015-mf. The converter uses two '27 tubes, whose filaments or heater circuits are wired in parallel and receive two and one-half volts A. C. from the small filament transformer T. The center tap on this transformer is connected to the ground or "B—" lead of the converter.

In Fig. 3 is shown a complete converter which can be connected to any broadcast receiving set, thus converting it into a short wave superheterodyne. Fig. 4 shows the converter chassis unit which can be built into a broadcast re-

(Continued on page 226)

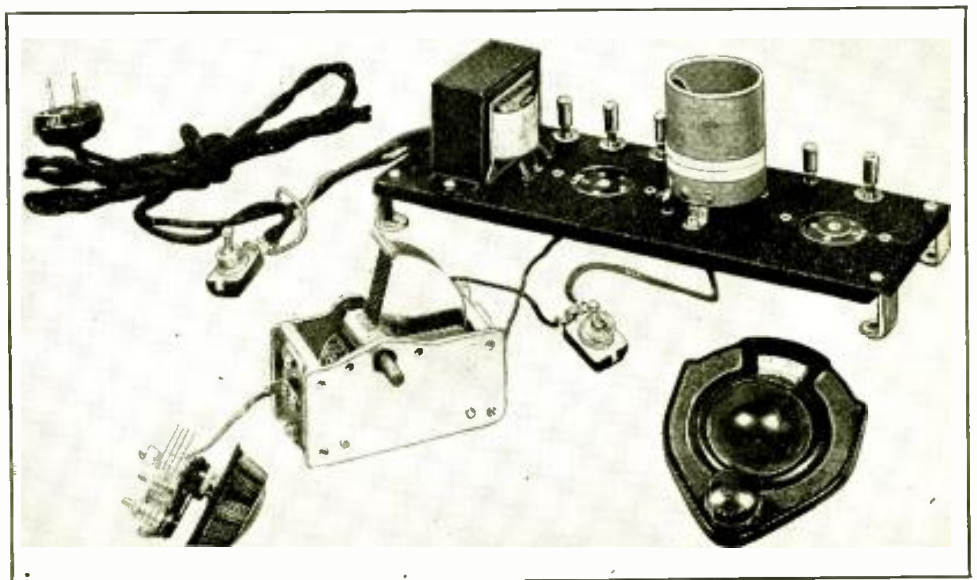

Here we see the parts used in making the Hoodwin short wave converter.

The VARI-COIL S-W TUNER

Plug-in coils, eliminated by device that "winds" inductance to suit wavelength desired; it tunes condenser at same time, all with one dial.

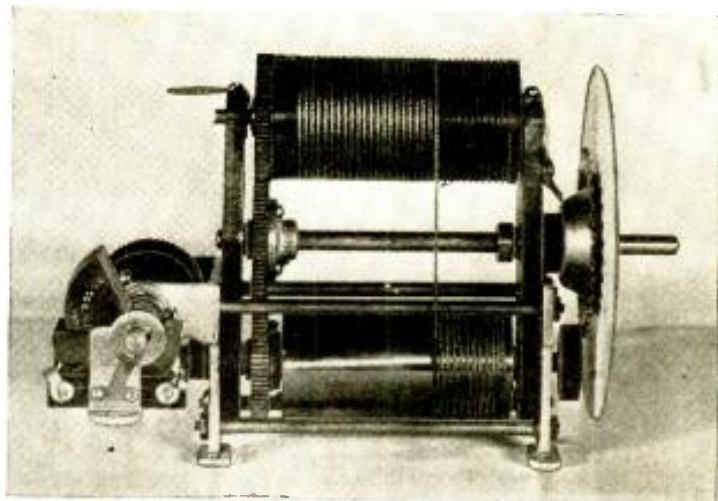

Side view of Vari-Coil tuner, with variable condenser at left end.

A BRAND new flexible means for tuning a receiver to the short-wave channels. This device employs a sound basic principle—a variable turn solenoid coil and correct L-C ratio throughout the range of the tuner. It's makers guarantee perfect regeneration with no "dead spots". An average of 3½ meters per turn of coil is provided, which insures against critical tuning; it is adaptable to all manner of circuits. The vari-coil has no metal to metal contacts but fibre to metal throughout. Two stages of tuned R.F., may be used with two vari-coils.

Operation.—A special bare flexible copper stranded wire is wound on or off the top bakelite tube from a bare brass cylin-

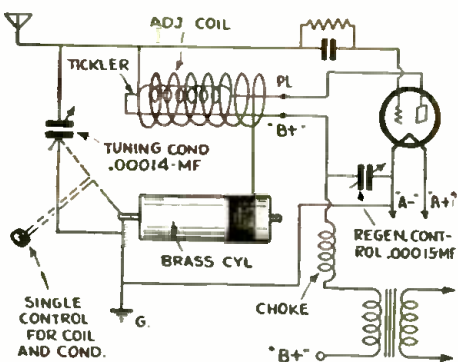

Simple detector hook-up using new Vari-Coil, which has tickler coil inside it.

der. The wire is held taut on the brass drum by a spring take-up mounted inside the brass drum. As wire is added to the coil or turns increased, capacity is added by a .00014 m.f., S.L.F. condenser. The condenser is driven by means of a worm and gear, so that a turn of the coil moves the condenser 12 degrees, keeping the correct L-C ratio at all times. If a throttle

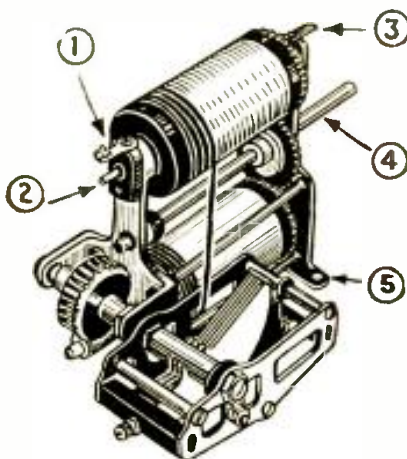

1, 2 and 3 represents circuit terminals of Vari-Coil, as well as 5 (ground) and dial shaft 4.

condenser is used for controlling regeneration, very little movement of this condenser is needed to keep the set in oscil-

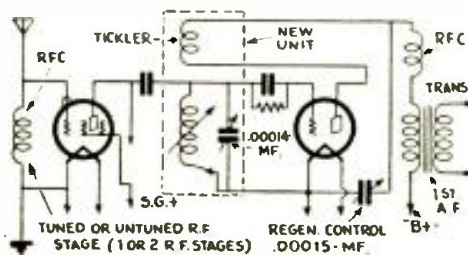

How new Vari-Coil can be used with R.F. stage and detector.

lation. A small condenser of .00015 m.f. capacity is large enough to give extremely smooth control of regeneration.

Band-spreading.—When the vari-coil is used for tuning only, and the condenser drive gear is not used, the condenser being set by separate control to the desired band, exceptional "band spreading" may be obtained. For instance, there are about 550 degrees of dial movement in the 7-meg. amateur band. Most condensers can only spread the band over 180 degrees. No vernier control is needed with the vari-coil.

When used in two stage R.F. jobs with the above arrangement, no trouble is experienced with the coils not tracking, as is the case with condenser arrangements. The vari-coil will oscillate, and regeneration is smooth down to two turns of the coil. The coil when used in a tuner does not seem to favor any frequency as regards signal strength.

The parts used in the vari-coil are moulded bakelite, the grooves for the wire being machined. Some may think that the wire might cause noise; on the contrary, it is very quiet in operation.

The tuning range with Cardwell tapered plate .00014 m.f., variable condenser is as follows:

| | |
|---------------------------|------------|
| 33 turns of Vari-coil.... | 100 meters |
| 25 " " " " " " " " | 66 " " |
| 20 " " " " " " " " | 49 " " |
| 15 " " " " " " " " | 35 " " |
| 10 " " " " " " " " | 22½ " " |
| 5 " " " " " " " " | 12 " " |
| 3 " " " " " " " " | 10 " " |

What I Think of Ultra-Short Waves—Guglielmo Marconi

The Marchese Marconi in a recent interview discussed the research into short-wave radio which brought him to England and which he intends to investigate on his yacht *Elettra*.

"The short wave is the most important thing in radio," he said. "It has revolutionized everything. If we can probe the secrets of the ultra-short waves the possibilities will be extremely interesting. But we have not done so yet.

"I have been experimenting with them more than thirty years. I applied my attention to them at the outset and some

years ago went back to them with fresh vigor. The beam system that has been developed over great distances is an indication of the importance of short-wave transmission; but if we can use still shorter waves the beam will be narrower and therefore more exclusive and secret, with all the advantages that implies.

"Unfortunately, when you work on less than six meters, the signal travels only a limited distance, which does not extend beyond the horizon and maybe less. The signals are restricted to places practically in sight of one another; and

if a big hill or obstacle is in the way there is trouble. The signal cannot get around.

"From some points of view this may be useful. In war, for instance, instead of broadcasting a message you desire to restrict to your own army you might find this screening of greatest utility. But for long-distance messages the barrier is serious. The trouble arises because unlike what happens in regard to all other transmissions, the ray does not shoot up to the Heaviside layer above

(Continued on page 234)

Robert F. Autrey, radio wizard, recently demonstrated his short wave control apparatus for directing airplanes and automobiles. Mr. Autrey tapped out the control signals on his 30 watt, short wave transmitter; the receiver has 16 different selective controls. In some tests an automobile was controlled from a plane flying overhead.

Short Wave Sky Signals Direct PLANE and AUTO

By OLEN W. CLEMENTS

SKIMMING through the ether at an altitude of 3,000 feet, a radio-controlled plane thrilled 5,000 spectators at the municipal airport at Houston, Texas, recently, when Robert E. Autrey, holder of three government patents on the device, staged the initial public demonstration of the radio-controlled plane.

The big monoplane used for the exhibition circled the airport, banking, dipping and turning at will, while Autrey in another ship with his finger on the master key, kept the ship under control.

The demonstration ship was constructed with dual controls, with Whitney Owen, transport pilot, seated in the rear cockpit to satisfy government inspectors that the ship at all times would be under control.

Shortly after taking off from the flying field, Owen plugged in a switch which put the ship in the control of Autrey, flying in another plane.

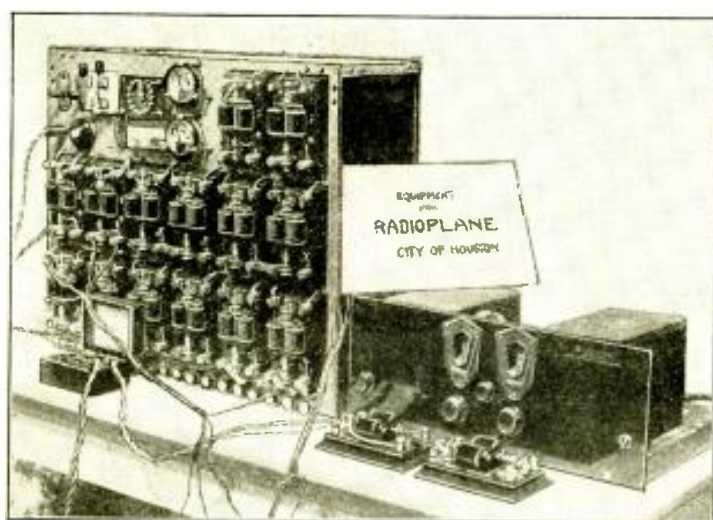

The two ships soared heavenward, and nestled down to a cruising speed of 85 miles an hour when they reached an altitude of 3,000 feet. Autrey kept the radioship under his control for approxi-

mately fifteen minutes, circling the flying field several times.

Only once during the fifteen-minute period did the monoplane get out of the control of the pilot in the other plane.

The radio ship, "City of Houston", which was successfully flown and "radio-directed" at the Houston (Texas) municipal airport. Whitney Owen, transport pilot, who went aloft in the plane during the demonstration, is standing in front of the monoplane. The ship remained under the control of a short wave transmitter in the hands of Robert E. Autrey, who manipulated the controls by short wave radio.

The short wave receiving set installed on the master control panel of the radio plane, "City of Houston", at its trial flight at Houston, Texas.

The planes became separated by more than half a mile and Autrey for a split second lost control of the ship.

Owen disconnected the radio switch, righted the plane and then plugged the radio current back in as the two planes were brought nearer together.

During the experiment the ships maintained an altitude ranging from one thousand to three thousand feet.

When the two ships were brought back to earth, Owen said that he took control when Autrey "over controlled" the plane. He explained that an aviator was guided largely by a sense of touch in operating a plane and that Autrey had only his eyes to guide him in determining whether he was banking too sharply.

"I became frightened when Autrey banked too quickly and was afraid of a tailspin," Owen said, "I grabbed the switch and cut out the current. As soon as I righted the ship I pushed the switch; turning it back over to Autrey, who resumed the experiment with radio."

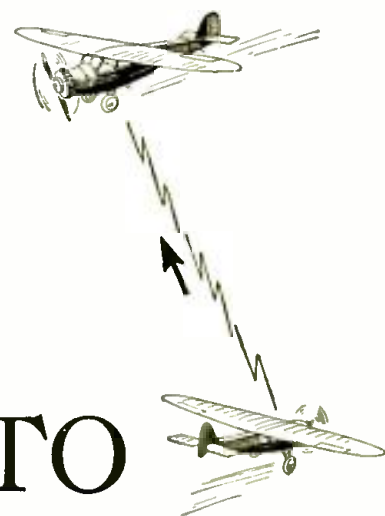

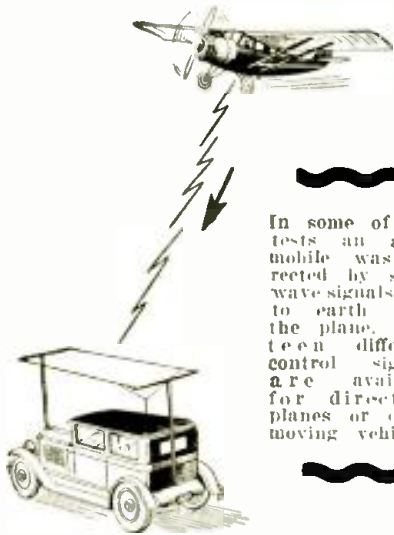

In some of the tests an automobile was directed by short wave signals sent to earth from the plane. Sixteen different control signals are available for directing planes or other moving vehicles.

(Right) — The "radio-controlled" car demonstrated at the flying field. This automobile was driven by radio from a plane soaring above and also from a truck parked in the center of the landing field. Mr. Autrey is the operator standing in the rear of the photo with the headphones and cap on.



(Below) — The short wave transmitter stored in the control ship from which Mr. Autrey tapped out code signals to the "pilot-less plane" as it skimmed across the heavens at the municipal airport at Houston, Texas.

Autrey explained that the principle of a radioplane was designed seven years ago, and that many private experiments had been made before he ventured into the public's eye with his new device.

In operating the radio plane, Autrey sat in the guiding plane tapping out signals on his thirty-watt, short-wave transmitter, which is operated entirely by battery.

Radiated from the aerial of the control plane, the code signals shot through intervening space and were picked up by a short-wave receiver on the radioplane's master control panel. Through the intervention of the relays, six-volt electric motors turned the gears operating the airplane's control rods. Each control is provided with a friction

different controls, which are operated by the coded radio signals. Two and a half seconds is the maximum time needed to operate any control.

The equipment aboard the radioplane is so compact that it weighs only 315 pounds.

Double tube installations are used, in both transmitter and receiver, assuring the radioplane security in the event one tube burns out. The radio apparatus can be altered to different frequencies in flight, to avoid interference from local radio stations.

The experiment on May 29 also included driving an automobile by radio with the controls in a plane flying overhead and in a truck stationed on the field.

The automobile, a Ford, was driven across the landing field several times, the horn blown, the lights turned on and off and the machine stopped and started frequently.

The automobile controlled by radio has been exhibited throughout the United States numerous times by Mr. Autrey, who first launched this system of radio control about seven years ago.

As a finale to the exhibition the radio genius froze water by radio, lighted a Texaco gasoline pump, and drove a fleet of automobiles.

Mr. Autrey is a resident of Los Angeles and New York, dividing his time between the two cities.

He has been experimenting with radio since 1911 and is familiar with both domestic and foreign radio apparatus. In recent years he has been engaged in commercial radio work; was formerly a radio instructor in the United States

It was Owen's first time to go aloft in a radio-controlled plane.

Autrey explained that the principle of radio control, which he has perfected, holds unlimited possibilities in time of war. One man could easily control by radio a dozen planes in flight. If they were filled with explosives and sent over the enemy's lines, havoc could be wrought.

At the conclusion of the test flight the two planes were packed away and shipped to San Antonio, Texas, where the second flight was made.

Following their exhibition in the Alamo City, Autrey began a tour of Texas, Oklahoma, Arkansas and other states as he wended his way toward New York.

The tour, sponsored by three nationally known companies, will be conducted throughout the summer, during which time the radioplane will visit every state in the Union.

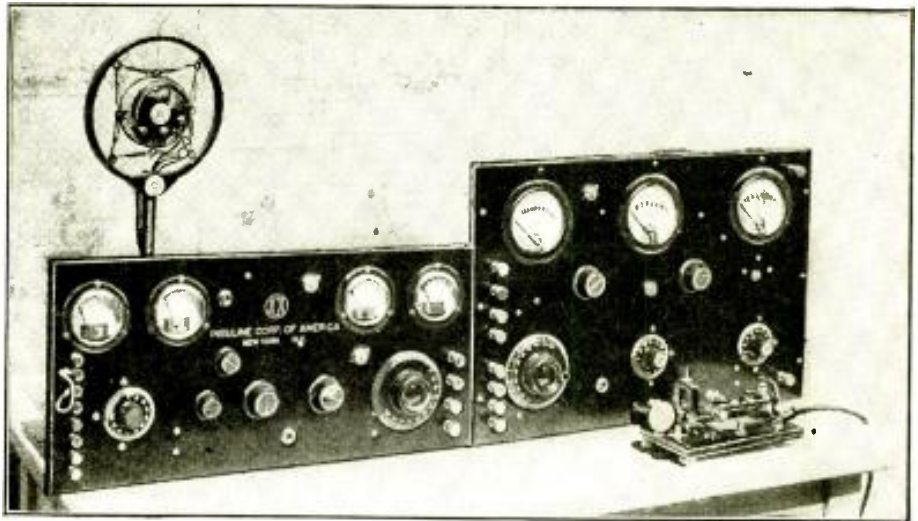

brake, so that it will stay where the motor leaves it.

There are, on the radioship, sixteen

Shipping Board Service and at one time inspector of the United States Signal Corps radio equipment.



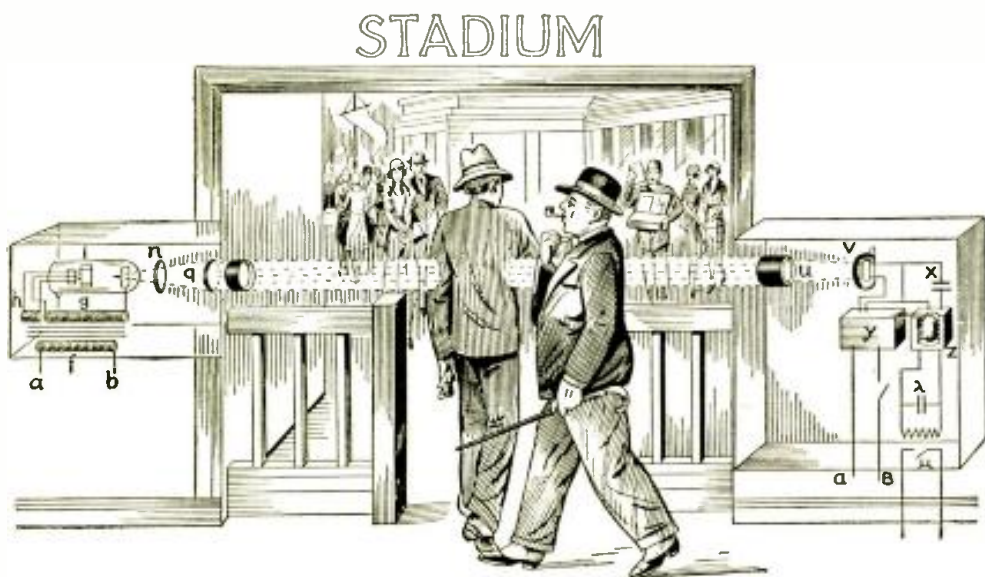

Dr. Schroter, one of Europe's leading investigators of ultra-short-wave phenomena, here presents some very interesting information on the production and utilization of ultra-short waves—including the infra-red rays.

Fig. 9—At left, shows how invisible infra-red rays can be utilized to count the number of visitors to a stadium or other public place. Every time a person's body blocks the path of the infra-red rays, passing from the helium-filled glow-lamp generator (i), the infra-red detector (v) opens the measuring or recording circuit (u). As long as the infra-red rays fall on the cell (v) the indicating circuit (u) is kept closed.

HERTZIAN and Infra-Red Rays

Shall We Use Them As A Means Of Communication?

By DR. FRITZ SCHROTER

THE Hertzian waves, while gliding along the curved conductive surface of the earth, undergo increasing damping; in fact, the damping increases as the wavelength becomes shorter. Their distant reception, at a wavelength of 1,000 meters (3,280 feet) depends solely on the conduction along the earth. For the short waves, between 8 meters and about 100 meters (26 to 328 feet) a totally different phenomenon appears. Here the energy of the wave is consumed by damping, along the surface of the earth, at relatively short distances.

The surprising ranges of short waves which, in the past few years have produced a rapid revolution in transoceanic radio-communication channels are dependent entirely on the space radiation (sky-wave) which makes itself more and more noticeable, even from the 1,000-

meter wavelength downward. In fact, the waves are propagated around the earth in a highly-conductive ionic stratum of the atmosphere (the "Heaviside Layer") which is located high up; and they can even encircle the earth several

of Mesny with 3-meter (9.8 ft.) waves between France and Algiers, and by the Marconi Co., with 6-meter (19.68 ft.) waves between Italy and Sardinia). In this case the wave is evidently able to follow the curved, conductive surface of

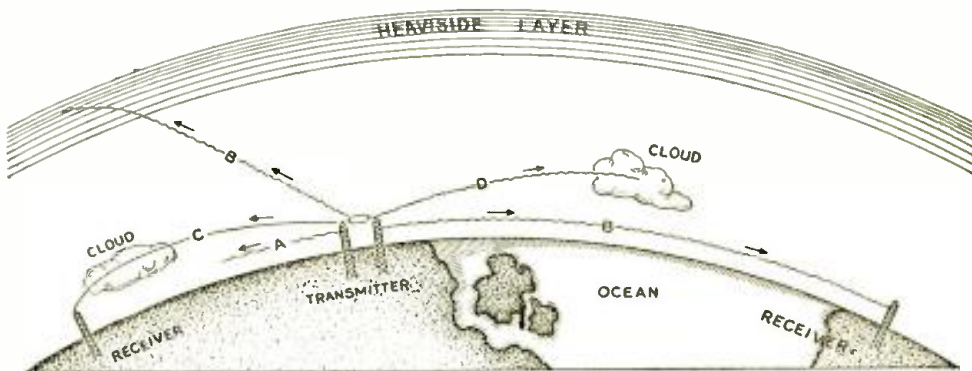

Fig. 2—Ultra-short (9.8 to 26 ft.) waves are quickly damped above the dry land (A); over the sea water (B) they follow the curved water surface and keep their intensity. The ultra-short waves (B) directed toward the Heaviside layer are not sent back. Ultra-short waves from (26 ft.) down to (4 inches) and infra-red waves of 2.5 microns down to .75 micron wavelength (C) pass through water vapor. Waves of (4 inches) and less (D) are quickly absorbed in fog.



Fig. 1—Short waves are reflected out of the Heaviside layer, 100 km. (56 miles) above the earth, and can thus encircle the earth several times.

times; while retaining a great deal of their energy (Fig. 1). Their return to the surface of the earth depends on a sort of reflection downward from the Heaviside Layer.

Below about the 8-meter (26 ft.), wavelength, this peculiar space radiation ceases. We have reached the so-called "ultra-short" or "quasi-optical" waves; reception of which at great distances through the higher strata of air is impossible. But, likewise the utilization of the ground wave is possible only in special cases with the ultra-short waves; i.e., over sea water, as in the experiments

of the sea water and, because of the lessened damping (which is perhaps to be ascribed to a special behavior of the ions in the salt solution) it is able to retain sufficient intensity. Over the land, however, the surface wave is quickly absorbed. The rays leaving the antenna in a straight line, which do not touch the earth, may indeed, with sufficient power, even reach the Heaviside layer; but they are not reflected downward again by it. For communication, or sending signals, therefore only such ultra-short waves can be used as leave the antenna, which is placed as high as possible above the



Fig. 3—Spark sender with mirror for decimeter (tenth of a meter) waves.

earth, and reach a receiver located within the *visible horizon*. Accordingly, the range of such transmission is similar to that of light, which goes from its source in straight lines in all directions; hence the term "quasi-optical waves". They can be used only for nearby communication.

Quasi-optical waves of 8 (26 ft.) meters to about 10 cm. (4 inches) in length penetrate mist or fog well; though, indeed, absorption and dispersion increase fairly rapidly below the half-meter wavelength. From 10 cm. (4 inches) downward, all the way to the infra-red rays, the weakening caused by the water-vapor and ionized-gas content of the atmosphere, is too great to permit their technical use. (Fig. 2.)

In the lower range of the infra-red waveband, however, the water vapor becomes again permeable. Here the damping of the rays takes place through *refraction* by the floating particles of water of the fog. To be sure, this dis-

with a few watts of pencilled (focussed) radiation, it has been possible to span some 20 kilometers (12 miles), if transmitter and receiver were placed sufficiently high above their surroundings (to overcome the curvature of the earth). The natural limitation of the horizon of the ultra-short-wave radiation, and the sharply directional transmission, make it possible to operate without interference many systems (*i.e.*, each composed of a transmitter and a receiver) side by side on the same wavelength (in similar fashion to light rays). The signals can be amplified, and thus utilize the full ranges, with little expenditure of energy by the transmitter.

Production of Extremely Short Waves

Undamped *quasi-optical* waves can be produced by electron tubes. The efficiency of these for waves of less than half a meter is too slight, however, for technical purposes. Decimeter (4-inch) waves of greater energy can be produced by the old spark method; to be sure, it generates strongly damped waves, but this disadvantage is not fatal. The radiator and the spark gap are, as formerly in the classic experiments of Heinrich Hertz, combined and placed in the focal point of the mirror. Fig. 3 shows such an arrangement: on an insulated bracket are placed the two strip-like halves of the radiator, between whose disc-shaped electrodes the spark passes. W. Ludenia, who was assisted by the Telefunken Co., has devised such a sender, which makes possible telephonic transmission.

Fig. 4 shows the Ludenia transmitter

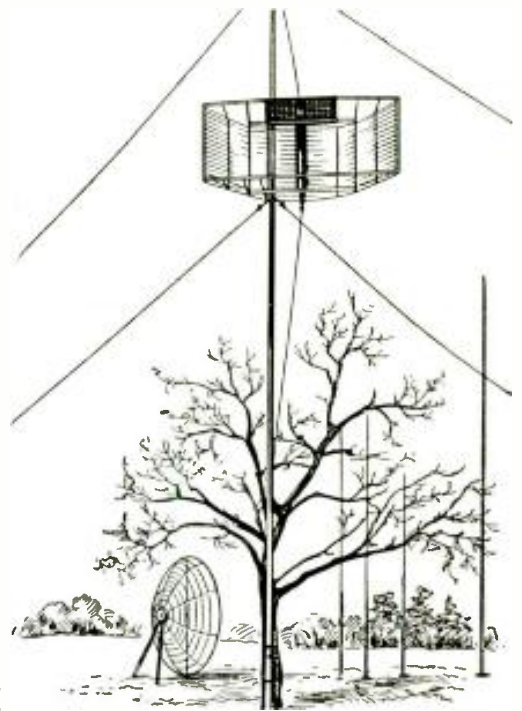

Fig. 4—Ludenia sender for decimeter (4 inch) waves, hung on a mast.

parabolically curved reflecting sheet of metal.

With the generators previously described, the wave range from 8 meters (26 ft.) down to 10 cm. (4 inches), can be covered. The centimeter and millimeter waves (0.4 to .04-inch), which have thus far found no technical use, can only be produced by creating sparks between microscopically small metallic oscillators (the "filings radiator" or "mass radiator" of A. Glagoleva-Arkadieva). It is interesting, from the viewpoint of physics, to note that the harmonics of these spark waves reach into the upper range of the infra-red spectrum, in which lie also the heat-produced radiations, like those of the highly-charged mercury vapor lamp and the Auer burner. The spectrum has been thereby completely bridged, between the *Hertzian* or radio waves and the *heat waves*.

For the infra-red communication radiators there are practicable as generators only the glow lamp, arc lamp, gas flame, and the Geissler tube; the latter chiefly filled with electrically stimulated helium, which demonstrates an intensive radiation at 1 micron (.00004-inch). The nitrogen-filled lamp (absolute temperature 2,400 degrees) gives off 22%, and the pure-carbon arc lamp (absolute temperature 4,200 degrees) about 36% of its total transmission, in wavelengths between 1.1 microns and .7-micron (.000044- and .00003-inch). This is a relatively high degree of efficiency, compared with that for light (a tungsten lamp converts only 4% of the energy conducted to it into light).

For receiving, there is used a detector, sensitive to infra-red radiations, and placed in a collecting reflector. For this purpose, the writer and F. Michelssen constructed a selenium cell with about 10% tellurium added, the coating being

| Wavelengths | Mode of Production | Method of Detection |
|--|---|--|
| 8 m. to 3.5 cm. (26 feet to 1.4 inches) | (a) Spark gaps (b) Electron tubes | Standing waves Resonance of dipole antennas |
| 3.5 cm. to 1.8 mm. (1.4 inches to 0.7-inch) | Basic waves of spark oscillator | Heat effect |
| 1.8 mm. to 30 microns (.07- to .0012-inch) | Harmonics of spark oscillator separated out by prismatic screen | Heat effect |
| 400 microns to .7 microns (.016- to .000028-inch) | Long-wave radiation of heat radiators Mercury-vapor quartz lamp Auer Lamp | (a) As above (b) By photo-electric effect (selenium, molybdenite, etc.) |

persion is less marked than that of visible light. These are the reasons why the entire range of the quasi-optical waves, bordering on the visible-light spectrum, cannot be used for sending out signals; only the two bands between 8 meters and 10 cm. (down to 4 inches), and between 2.5 microns and 0.75-micron (1/10,000 to 1/33,000 of an inch) wavelength can be used. (See the appended table.)

Spectrum of the Quasi-Optical Waves

The short length of the quasi-optical waves permits their being focused into searchlight-like cones, to obtain directional transmission of communications or signals. For this purpose there are preferably used metal mirrors, with the source of the transmitted oscillations located in the focal point or focal line. By means of suitable apparatus, using 40 cm. (16 inch) damped spark waves,

for decimeter waves, suspended on a supporting mast. The radiator is enclosed and made watertight; and behind it is a



Fig. 5—Schröter-Michelssen selenium cell in a protective case.

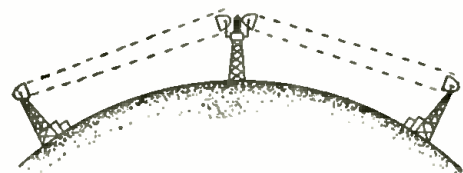

Fig. 6 (top diagram)—Straight line communication by quasi-optical waves. Fig. 7 (below)—Shows a pair of straight line connections effected by a relay station.

very thin. (See Fig. 5.) Similarly-made thallium-sulphide cells can also be used. These elements, deposited in a thin layer, to give them their slight inertia, reproduce modulations up to several thousand cycles per second, and can therefore also be used for receiving speech.

Fog-Piercing Radiation

The field of application of the infra-red rays is not yet entirely clear. We first think of replacing optical waves for signalling in foggy weather. Below are given the distances, for various wavelengths within which (L. P. Granath and E. H. Bulbert—*Physical Review*, Vol. 34, p. 140, 1928) the intensity of the received ray falls to 1/100 when a strong fog prevails.

| Wavelength | | Distance Penetrated | |
|------------|---------|---------------------|--------|
| Microns | (Inch.) | Meters | (Feet) |
| 0.4 | .000016 | 710 | 2330 |
| 0.5 | .000020 | 843 | 2765 |
| 0.6 | .000024 | 910 | 2985 |
| 1.0 | .000039 | 970 | 3180 |
| 2.0 | .000079 | 980 | 3220 |
| 3.0 | .000119 | 980 | 3220 |

One recognizes the superior range of the infra-red radiation, even if a moderate one, from 1 micron upward, compared with the spectrum between 0.4-micron and 0.6-micron, which is perceptible to the eye. Since our eye is an extremely delicate indicator for light, it first seems natural to give the preference to visible light. But the sensitivity of the eye, greatest in darkness, is not so great by day in the diffused light of fog; in such a case an infra-red cell, in combination with a good amplifier, is far more sensitive. Furthermore, the eye, because of its inertia, could not perceive the modulation of the transmitted radiation. One is therefore directly led to the idea of communication by an organ free from inertia.

If we consider, at the same time, the far greater production of the infra-red radiation, in proportion to that of light, then the infra-red rays, even with only slightly better power of penetrating fog and mist, come seriously into consideration as a supplement to luminous sea beacons and position lights for planes, etc.

Fig. 8 exhibits such an infra-red "lighthouse" for guiding the course of ships entering port. Present experiments on

their range are being made to develop these possibilities for use. The basic principle is the possibility of sharply directing the radiation and of concentrating it within a definitely determined angle (on which principle, of course, likewise depends the use of optical pencils of rays for lighting up coast waters and lines of travel).

The Invisible Watchman

Aside from this communication by infra-red rays, instead of light, is interesting on account of the invisibility of the rays. This is true, not only for the bridging of considerable stretches of land (say, for secret military communications), but also for the use of very short pencils of rays as an auxiliary of burglar alarms. The invisible pencil of rays falls on a receiving cell; if it is cut off by a human body (all unconsciously, of course), say by a thief, then the normal current is interrupted and an indicating apparatus is actuated and starts to work. Similar devices serve for secret counting of passers-by, for watching over passages or entrances, etc. (See Fig. 9.)

Invisible Rays Count People

At the left of the gate in the illustration there is shown a generator, at the right a receiver, for invisible infra-red

SINGLE SIDE BAND SYSTEM
for
SHORT WAVES
By **A. H. REEVES**
The Subject Every One
Is Talking About
See Next Issue

rays, both built in. The passage of the rays is broken by each person entering, and registers the visitor. From the connections *a* and *b* of an A.C. power supply, a wire leads to the primary winding of a transformer (*f*). Of the latter's two secondary windings *g* and *h*, the former furnishes the intermittent discharge current of a helium-filled glow lamp (*i*); while the latter (*h*) serves to heat the glowing cathode. The rays produced are directed into a filter *n*, which absorbs all visible light and only passes the infra-red rays between .75 microns and about 1.1 microns. The glass lens *q* directs the rays in a parallel beam, and they reach the collecting lens *u* of the receiver. The infra-red radiation, falling on the infra-red detector cell *v*, causes an alternating current to flow; this acts, via a condenser *x*, on an audio-frequency amplifier *z*. Here *y* represents a power-supply connection, which is fed by connections *a* and *B* of the A.C. light-line. The amplified A.C. energy, obtained at the output of amplifier *z* is conducted to condenser *λ*. As

long as the cell *v* is illuminated, the condenser *λ* will also always be charged with a uniform potential; so that a relay keeps the circuit closed by means of an armature *μ*.

If a person going through the gate breaks the pencil of rays, then the A.C. potential is cut off; the condenser discharges, the relay armature is released, and a signal device, or a counter, operating in a D.C. circuit, begins to work.

The quasi-optical waves between 1 m. and 10 cm. can be used where there is no desire for exact limitation of the beam of rays, but only secrecy or the least possible expenditure of energy; as in portable sets for short-distance communication. Also, the idea is created, of fixed lines of radiation, made by mirror transmitters and mirror receivers, which are erected on high masts or mountains in direct line of vision with one another, which would permit direct covering of distances up to say 50 k.m. (30 miles). (Fig. 6.) Such pairs can be combined in relay fashion for covering greater distances (Fig. 7).

To be sure, because of the curvature of the earth, the required heights of the masts or towers increases as the square of the desired distance. Therefore, one soon reaches the practical limit of expense, on account of the rapidly increasing costs. Here the relay connection offers a way out. By such sets, which might fairly soon be manufactured, signals up to a very high number of alternations (say, as for television or multiple telegraphy), could be transmitted free from distortion to over 100 km., (60 miles); this could only be attained by wire lines at a most uneconomical expense.

Besides the above-described uses of waves between 1 m. (3.28 ft.) and 10 cm. (4 inches), there is possible also their use in special systems to replace optical beacons in fog. Such processes, devised and worked out by W. Ludenia, might attain importance in navigation; since with the decimeter (4-inch) waves, greater ranges can be obtained than with infra-red radiation, and in fact with considerably less power in the transmitter.

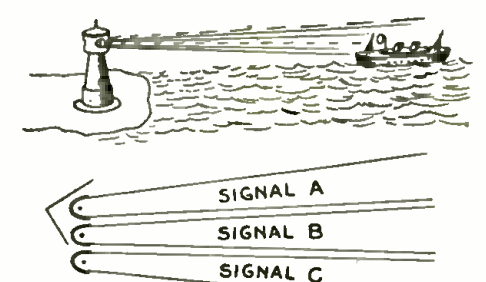

Fig. 8—Infra-red beacon for safeguarding the course of ships entering a port.

Waves between 8 m. (26 ft.) and 3 m. (9.8 ft.) might be suitable, not only for movable field stations and airplane communication, but also for local radio through municipal "central station" transmitters; that is, if we can succeed
(Continued on page 234)

AN A.C.-D.C. Dynatron Oscillator

By H. G. CISIN, M.E.

A useful testing instrument for experimenters and radio service men.

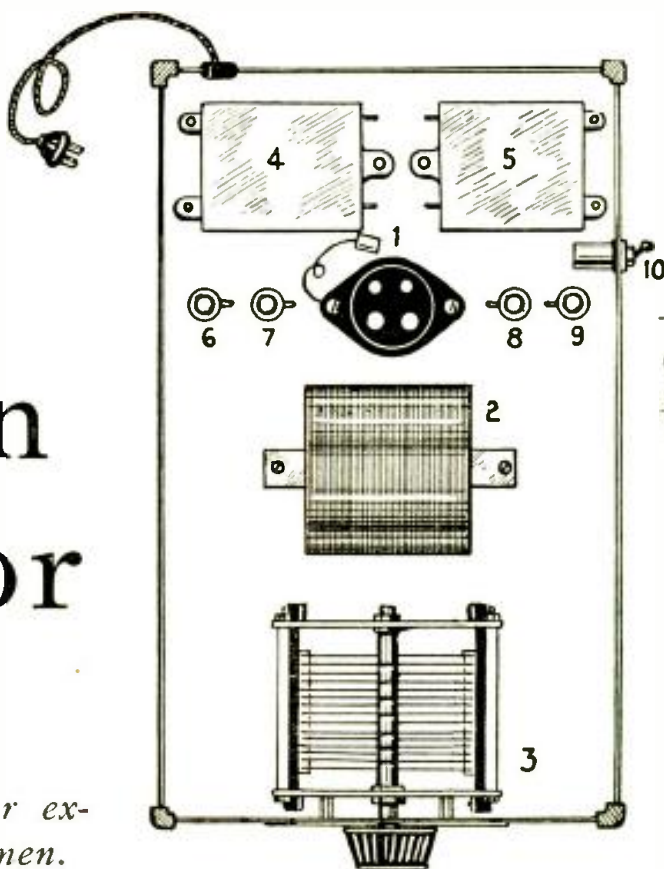

Neat design of a Dynatron Oscillator, here described by Mr. Cisin. The apparatus is of standard make and the parts are best mounted in an aluminum "shield can" as shown.

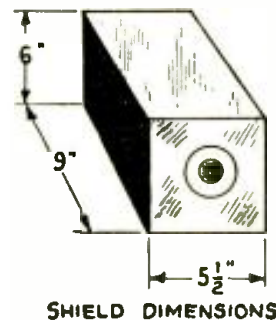

A SIMPLE A.C.-D.C. DYNATRON OSCILLATOR

THE application of the dynatron circuit, to an oscillator, produces a testing instrument of great value to radio service men; the dynatron oscillator is versatile, stable and efficient. Provided that it is properly constructed, using good coils and high-grade components, it can be calibrated accurately, so that it will perform the functions of an expensive laboratory instrument. Moreover, it will maintain its accuracy indefinitely.

The dynatron oscillator, in addition to its many other advantages, is very easy to construct, since it consists only of nine or ten parts. Hence its cost is

negligible. The entire instrument may be assembled within a small aluminum box shield as shown. The circuit has a number of interesting features. First of all, no batteries are required, and the oscillator can be used on either A.C. or D.C. When used on direct current, modulation is obtained by means of the commutator ripple. On D.C., the positive terminal of the plug must go to the end of resistor (9); and the negative to switch (10), and then directly to the filament. The polarity may be determined by trial, simply reversing the plug if incorrectly connected at first.

The dynatron oscillator uses an

Arcturus 122 screen-grid tube, operated at such voltages that oscillations are produced when the tuned circuit is connected in series with the plate. This type of oscillator requires only a single coil; thus simplifying the circuit and permitting rapid changes of range, through the use of plug-in coils.

The tuned circuit consists of a plug-in coil, shunted by a Cardwell "Midway" variable condenser. The necessity for an accurate condenser and coil cannot be emphasized too strongly. In order to cover the range from 14 to 205 meters, five Hammarlund short-wave plug-in inductor coils are specified. These coils are highly efficient and therefore will be certain to give the desired accurate results. To cover the range from 205 to 550 meters, a special coil must be wound. Directions for making this coil will be given in later paragraphs. In order to keep the special coil small and compact, the coil is calculated with an inductance of 560 microhenries; so that it covers a band of from 300 to 550 meters, when tuned with a 150-mmf. condenser. By taking advantage of the second and third harmonics, it is possible to tune the circuit to any desired point between 200 and 300 meters; for example, the second harmonic of 400 is 200, etc.

When the oscillator is to be used for long waves, as in superheterodyne testing, a honeycomb coil may be substituted at (2). This oscillator may even be used to generate audio frequencies, by connecting the primary of an audio

(Continued on page 223)

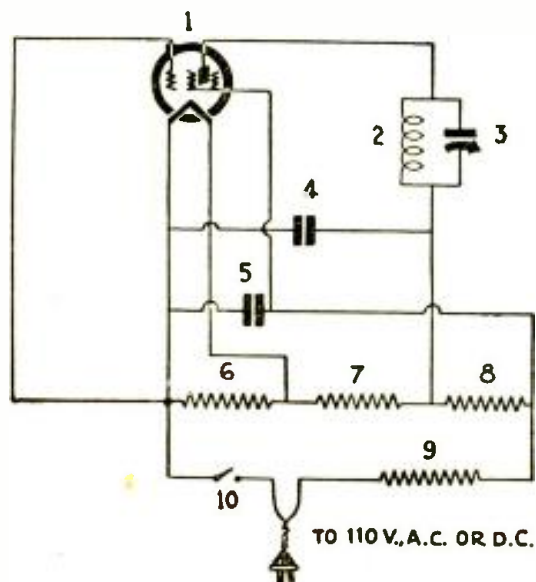

DIAGRAM OF SIMPLE DYNATRON OSCILLATOR

Circuit of the A.C.-D.C. Dynatron Oscillator which is readily constructed at a small cost from standard parts. The oscillator can be used as the source of R.F. energy for matching coils; as a check against the oscillator stage in super-heterodynes, etc.; and it can also be used for checking "short wave" receivers, adapters and television sets.

LONG WAVE RECEIVER EASY TO BUILD

By L. B. ROBBINS

"Listen In," Fellows, on Waves from 600 to 1500 meters, with this set. There's a lot of high-powered stations transmitting in this region, such as Warsaw on 1411 meters; Oslo on 1071 meters; Moscow on 1304, etc.



Front panel appearance of Mr. Robbins' "long wave" receiver for listening in above 600 meters. Code as well as European broadcast may be heard.

THERE are always many who desire to learn the code as well as to listen to commercial, Army and Navy traffic. For them a long-wave receiver is ideal; because radio stations working on commercial frequencies are usually operated by expert operators whose sending is ideal to copy. Then again some of these stations send along, hour after hour, slow enough for the beginner to read; and such practice makes for good copying and rapid learning of the code.

"Odd Parts" Do the Job

The receiver shown in these photos and sketches was built by the writer just for this code practice purpose, and entirely from "junk" or unused apparatus lying about the laboratory. It works nicely and with good readable volume. The only tricky part of it is the coil but, by following the diagrams and specifications closely, no trouble should be anticipated. The coil described will tune from approximately 600 to 1500 meters; but similar and larger coils can be constructed to reach much higher wavelengths.

Condenser Varies Regeneration

The top-view photo shows the general layout of parts. Of the two variable condensers, both .0005-mf. capacity, the one at the right is for tuning and the left one is for regeneration—C1 and C2 respectively. These can be mounted on any suitable panel; the writer used the cover of an especially long cigar box for

this purpose. The paper was peeled off, and the wood given a couple of coats of shellac on each side. This panel was then mounted vertically on the edge of a suitable baseboard.

Back of the regeneration dial (C2) was mounted a UX socket for the audio tube, and behind that the audio transformer; in this case a 5-to-1 ratio, to

gain volume. A phone jack was mounted on the panel below this condenser dial.

The detector tube socket was placed between C1 and C2; behind it the grid leak R1, the 10,000 resistor R3. Back of C1 is the rheostat R2. The space at the rear right hand corner is taken up by the coils—L1, L2 and L3. The several clips in front of the coil are used for spring clips for connecting coil ends, etc., but can be dispensed with if desired. A switch has also been added, for filament lighting, under the dial of C1. The panel view photograph shows the panel and parts clearly.

Coils Are Home-Made

Coils L1 and L2 are wound on one form, as shown in the illustrations; this consists of a piece of heavy mailing tube 4 inches long by 2 inches in diameter. Cut out two coil-end supports of heavy cardboard, as shown in sketch, and glue one to each end of the tube. A backstop for coil L2 should also be cut from heavy cardboard, in the shape of a washer, and glued to the tube 1 inch back from the left end, as shown.

Wind L1 with 100 turns of No. 24 D.C.C. wire, winding the 3-inch space

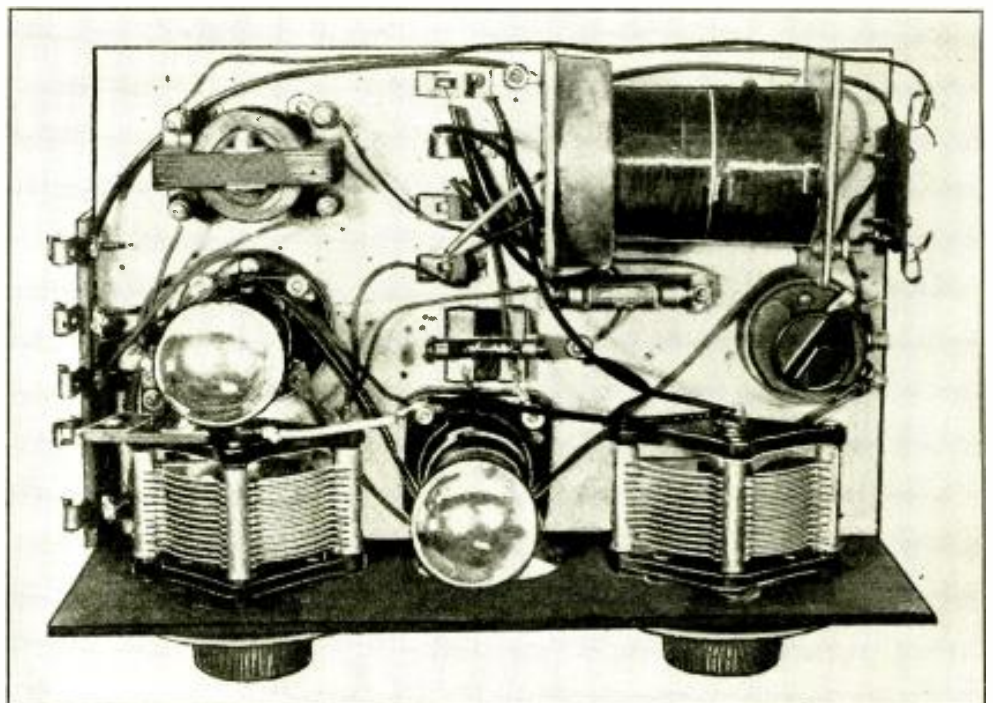

Looking down on the chassis of the Robbins' "long wave" receiver.

full, and then returning in the opposite direction until the required number of turns are on. Fasten the outer end to a binding post for the antenna, and then connect the inner end to the end of the wire to be used for L2; this latter is wound in the space provided between the end support and backstop. This lead connects to rotors of C1 and C2 as diagramed. Wind on for L2 260 turns of No. 24 D.C.C. wire, which will make a solid bank-wound coil of many layers. Connect the outer end to a binding post which is used to connect to C1 stator and grid leak.

The Tickler Winding

Now wind the tickler L3 on a 2-inch length of tubing 1½ inches in diameter. Wind on about 60 turns of No. 24 D.C.C. wire, and leave several inches of leads for connections. This tickler is

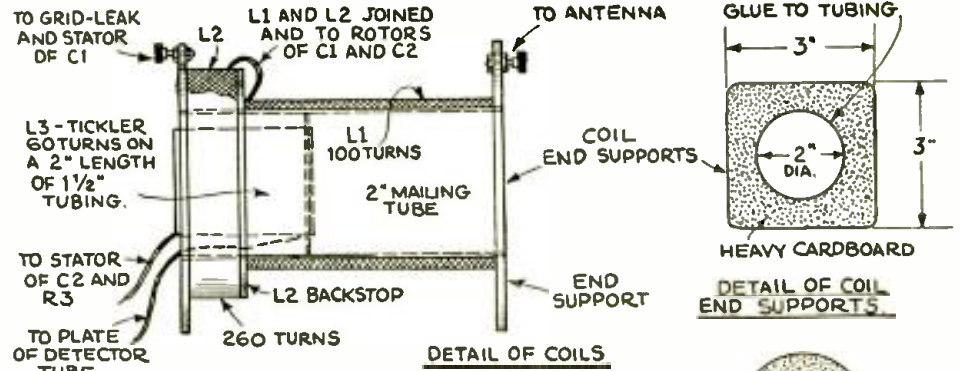

- C1 = .0005-MF. VARIABLE CONDENSER.
- C2 = " " " "
- C3 = .00025-MF. GRID CONDENSER.
- C4 = .002-MF. FIXED CONDENSER.
- R1 = 6-8 MEGS. GRID-LEAK.
- R2 = 10 OHMS RHEOSTAT.
- R3 = 10,000 OHM RESISTOR.
- J = SINGLE CIRCUIT CLOSED JACK.
- T = 5-1 AUDIO TRANSFORMER.



Construction of "long wave" tuning inductance, including the tickler.

Wiring diagram of Mr. Robbins' "long wave" receiver. Regeneration is controlled by the throttle condenser C2.

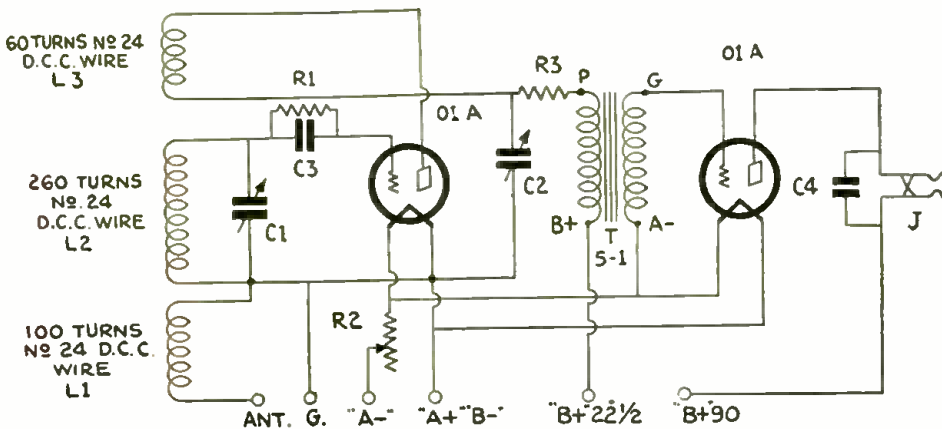

When the receiver is turned on for the first time, it may not oscillate. This may be due to too high resistance in the grid leak, (R1) or the resistance of R3 may not be suitable; for the latter try a 7,500- or 15,000-ohm resistor. If you have a suitable variable resistor for R3, it may prove best for that purpose.

placed inside L2 and supported midway between the sides, by any convenient means. One end connects to the stator of C2 and to R3 while the other leads to the plate of the detector tube. When completed, the entire coil assembly can be mounted to the baseboard with a pair of little angle braces.

Arrange a suitable strip of binding posts or connecting clips at one end of the baseboard and then proceed to wire up exactly as in the schematic diagram, using the constants shown in the table. Use rubber-covered hookup wire, and

carefully solder all necessary connections.

Tubes to Use

Two '01 A tubes were used in the original, but '30 type (2-volt) tubes or '99s can be used. For the latter a 4-volt battery supply is necessary; for the '01As use a six-volt supply. A 90-volt to 135-volt B battery or eliminator can be used for plate power, and from 22½ to 45 volts will be necessary for the plate potential to the detector.

Long Aerial Best, with Good Ground
Use a long antenna and a good ground. To reduce possible coupling between phone cords, it may be necessary to shunt the phone jack with a fixed condenser, C4. Oscillation should go in and out smoothly. If it does not do this, reduce the detector "B" voltage, or substitute different grid leaks until the smoothest regeneration possible is secured.

With good parts and careful construction this will prove a valuable receiver for the code fan, and it is well worth the building.

English "Series Gap" Condenser Ideal for Short Waves

THE Cyldon "Series Gap" Condenser consists actually of two variable condensers with a common spindle connected in series. There are thus two sets of fixed vanes which are insulated from each other, and two sets of moving vanes in series between them.

It is thus unnecessary to take any connection from the moving vanes, for the two sets of fixed vanes represent the two elements of the condenser. The moving vanes and spindle are, therefore, entirely insulated from the rest of the condenser, and no lead should be taken to them.

It is this form of construction that makes the series gap condenser so excellent for short wave work.

(Continued on page 225)

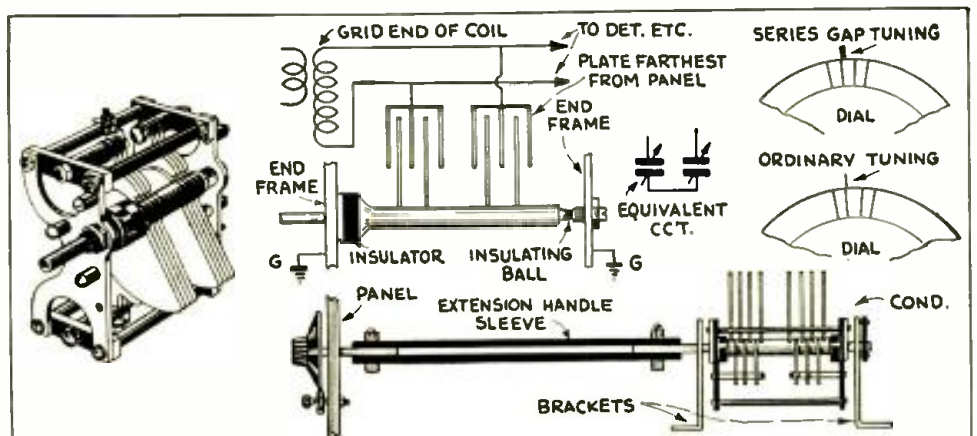

At left—Appearance of English built receiving condenser for S-W work, having series gap created by having two variable condensers in series. The two rotors are mounted on insulating shaft.

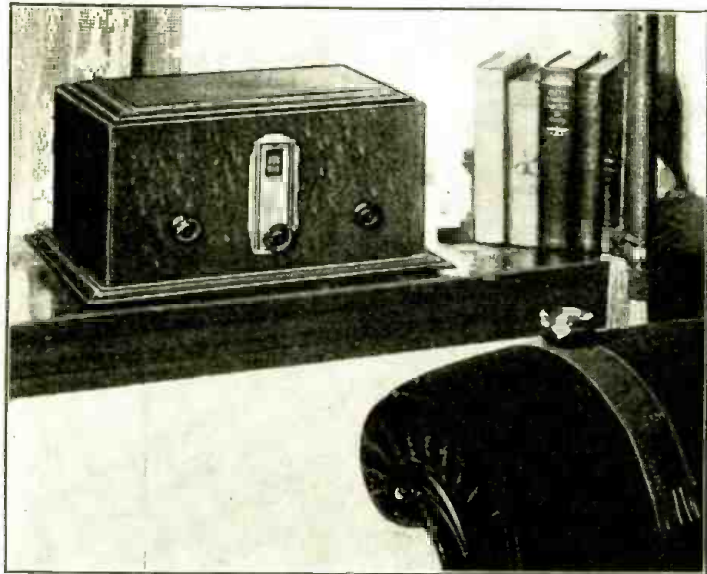

Fig. 1—Neat appearance of new National receiver.

New Features of the 1931-32 NATIONAL Thrill Box

J. J. FREELEY

New vari-mu tube used for R.F. and detector stages, after careful research. Power tubes in output stage; also two-volt tube model available for "Air Cell" battery operation.

THE new 1931-32 models of the "SW5 Thrill Box" are practically the same as the previous designs, which made such fine reputations for themselves during the past year. Generally speaking, the electrical and mechanical arrangement is unchanged, although some important refinements of detail have been made.

The new "Thrill Boxes" take full advantage of the progress of the radio art during the past year. New tubes, new materials, and new data have become available; and the "Thrill Boxes" show these new developments in their electrical design.

The following paragraphs describe the most important changes.

The Variable MU Detector

While designed primarily for use in R.F. amplifiers in order to eliminate cross talk due to undesired rectification, it has been found that the '35 variable mu tube makes an ideal regenerative short-wave detector. True enough, the data sheets supplied with the tubes of this type state that they are unsatisfac-

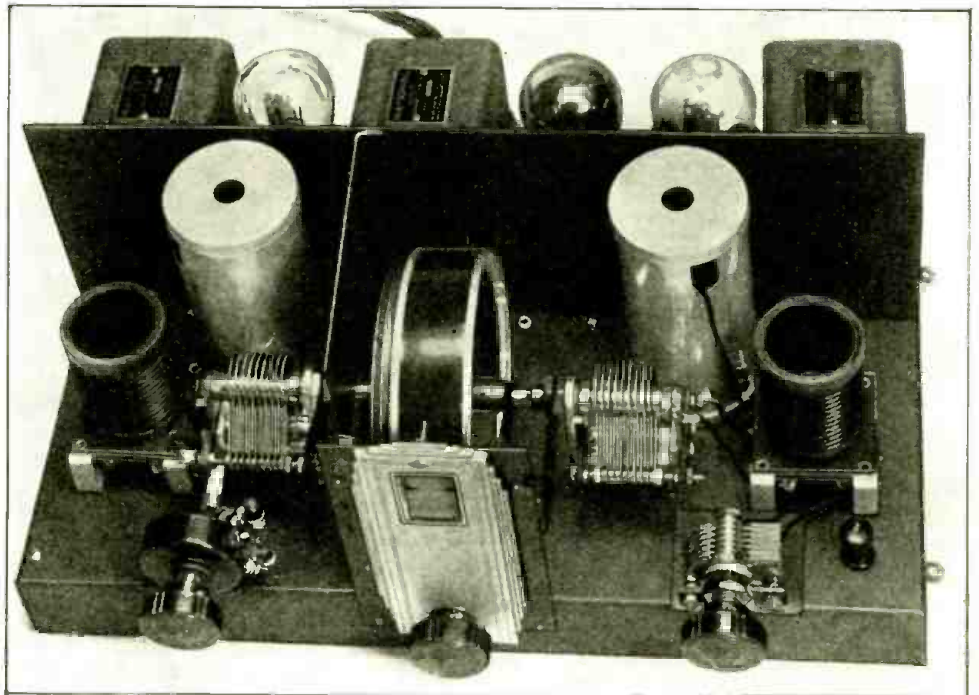

Fig. 2—Chassis of improved National "Thrill Box."

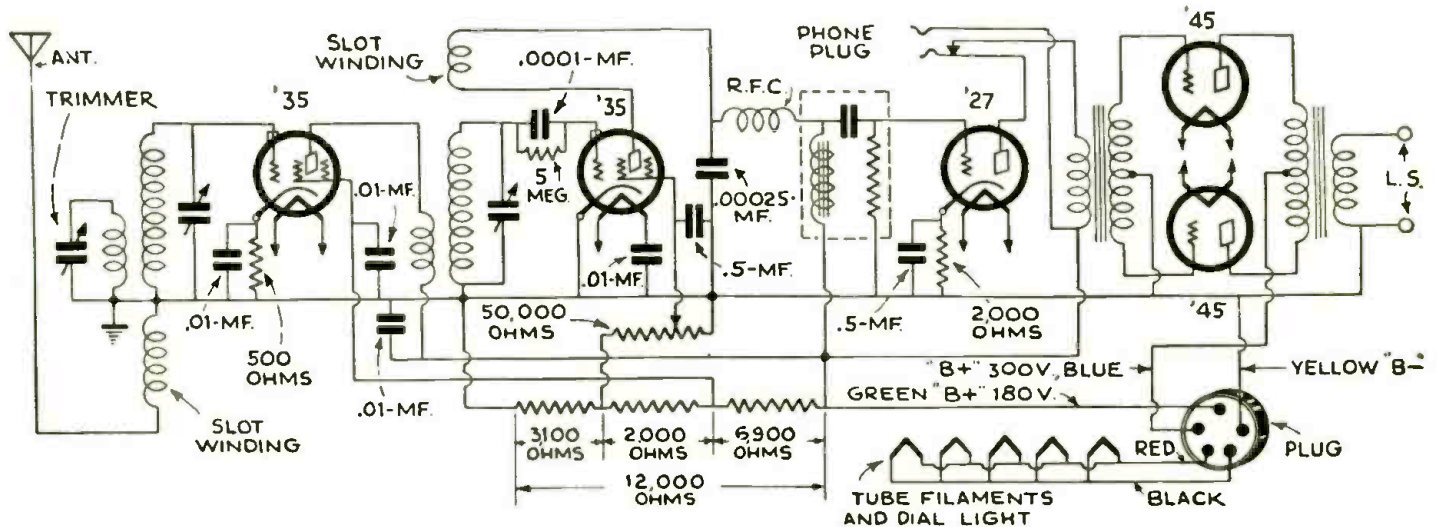

Fig. 6—Wiring diagram of improved "Thrill Box" with provision for new vari-mu '35 tubes in the R.F. and detector stages; also '45 tubes in second audio stage.

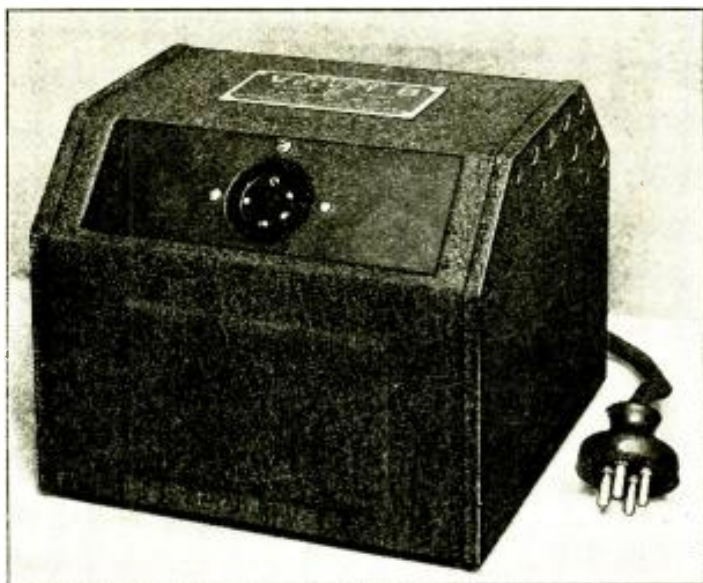

Fig. 3—Appearance of improved "power pack" for operating the National "Thrill Box" of the A.C. type. This cabinet contains the filament and heater transformer; also plate supply and filter apparatus, including chokes, condensers, etc.

tory as detectors; this reference, however, is to their use as plate rectifiers in broadcast receivers. As a grid-leak condenser regenerative detector, especially at the higher frequencies, numerous investigations made in the "National" laboratories during recent months have shown quite the reverse to be the case.

From past experience in designing high-frequency receivers employing the '24 type of screen-grid tube as a grid leak-condenser regenerative detector, it had been found that the most satisfactory of the various methods of regeneration control was the variation of screen voltage by means of a potentiometer. How would the action of the '35 tube as a grid leak-condenser regenerative detector differ from that of the '24 when its screen voltage was shifted? For some unknown reason, the tube manufacturers in their data sheets and their so-called engineering and specification reports, as supplied to the radio set manufacturers, seem to be surprisingly consistent in at least one respect; namely, the complete omission of any curves that might throw some light on the subject.

It was soon found, however, that this relation is of an *inverse exponential* nature. Thus, when the screen voltage of the '35 is increased, the tube rapidly approaches an oscillating condition. The nearer the tube approaches the "spill over" point, however, the less effect the increasing of screen voltage has upon its tendency to oscillate. Consequently, this affords a regeneration control that permits of readily obtaining and maintaining a higher degree of regeneration, with the attendant smooth sliding into oscillation so much sought after in S.W. receivers of the past—and obtained in them to only a fair degree by the careful selection of tubes and the juggling of grid leak and condenser values.

This same characteristic of the '35, that permits of this higher order of regeneration, also results in a more stable condition with regard to the holding of the regeneration adjustment when one

set. There seems to be entirely lacking that tendency, of regenerative detector tubes of the past, to "pop" suddenly into oscillation on the slightest provocation.

Of course the '35 tube is also used in place of the original '24 in the specific manner for which the '35 was developed; so that anyone having one of the original "SW5" models, who wishes to use the variable mu tube in the R.F. and detector circuits, will find that but one change is necessary: namely, the substitution of a 500-ohm R.F. biasing resistor for the 350-ohm value employed in the former set. No change in the detector circuit is required.

Short-Wave Broadcast Reception

As the original receiver was designed primarily for experimental and communication work which required an extremely low "hum level," at the sacrifice of audio power output, the undistorted output on short-wave broadcast reception was rather limited. Nevertheless these receivers found wide accept-

type, it results in very fine tone quality and large volume on foreign broadcast reception.

The only physical difference in the receiver itself is that the broadcast model varies from the original in the use of four-prong sockets in the push-pull output stage, and the omission of the 1000-ohm biasing resistor.

The "power pack," however, as will be seen from Fig. 3, is quite a bit larger, to supply the additional power and much higher voltage required for operating the power output tubes at full rating. As this broadcast model is primarily for use in foreign countries, to receive American short-wave programs, there is considerable call for power packs designed for 25-40 cycles; as well as for 230 volts, in addition to the standard 110-115 volt, 50-60 cycle unit.

The R.F. Transformers

Considerable progress has been made during the past year in chemical research laboratories, working on syn-



Fig. 5—"Band spreader" coil and condenser for use in "Thrill Box" receiver; makes for easier tuning.

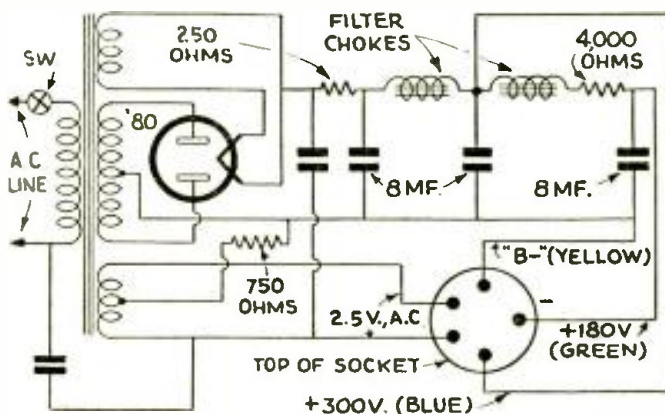

Fig. 7—Hook-up of apparatus comprising the "Thrill Box" power pack; including heater—filament transformer winding, also high voltage plate supply winding; filter condensers, choke coils and necessary resistances.

ance, especially in foreign countries, for short-wave broadcast reception; and consequently a special model has now been designed to employ '45 power output tubes in place of the '27s. While such a receiver is naturally not as well suited for communication work as the original

thetic insulation material for ultra-high-frequency work; and advantage has been taken of some of the developments in this field to change slightly the formula for the National "R-39" molding material for coil forms; which played such
(Continued on page 221)

Tune 15 to 550 Meters, Without Plug-in Coils, on This NEW ALL-WAVE SUPER

By McMURDO SILVER*

No plug-in coils, simply a switch on the front panel of this newest All-Wave superheterodyne, enables the operator to tune in wavelengths from 15 to 550 meters. A new feature—"double suping"—is utilized for the short-wave reception, 10 to 200 meters. Multi-mu and pentode tubes are featured.

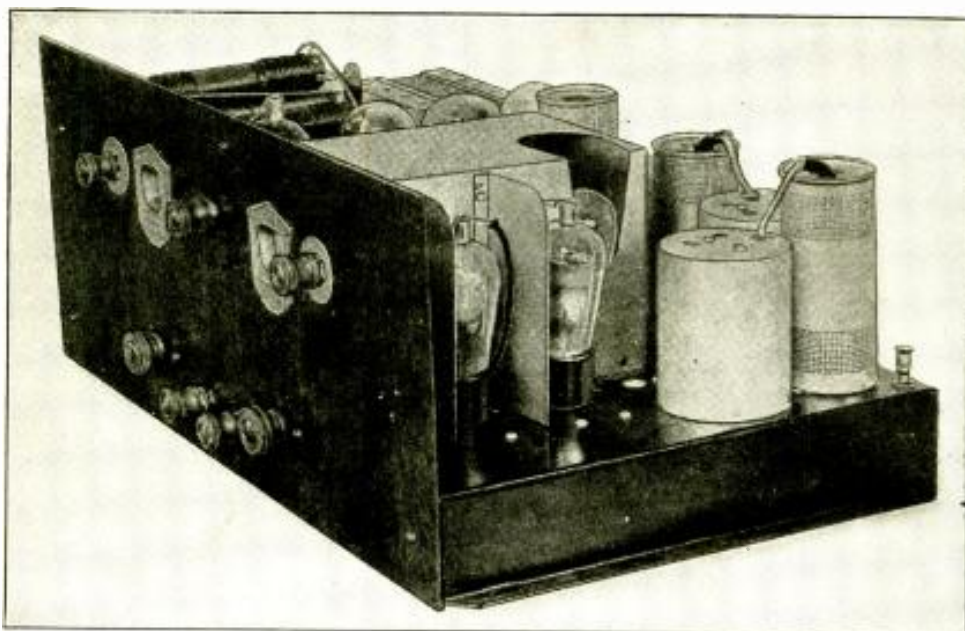

General appearance of latest Silver-Marshall "All-Wave" Super-Het. Various wave bands are tuned in by means of a simple switch on the front panel. Range 15 to 550 meters; 2 oscillators and 3 detectors are used for short waves.

WHEN short-wave reception first began to become popular, it was almost entirely so among the amateur operators and, even after short-wave broadcast stations were installed, broadcast listeners as a whole did not go in extensively for short-wave reception because of the relatively limited availability of programs and the uncertainty of short-wave reception.

The number and availability of programs, both domestic and foreign, has been vastly increased and it may be said that the coming season will see a very rapid increase in broadcast listeners' use of short-wave receivers; both because of real interest in the now very excellent short-wave programs, as well as their distance and "foreign variety" appeal, and because design technique has now developed to a point where short-wave receivers may be built and offered that really will make available, to the average American home, foreign and far-distant domestic programs with a very high order of regularity.

The first short-wave receivers were nothing more than antiquated and obsolete broadcast receivers; such as three-tube regenerators, or at best, three-tube regenerators with a stage of untuned or tuned R.F. amplification ahead of the detector. The second disadvantage of commercial short-wave receiver design has been the necessity of plug-in coils to cover the required frequency range; with consequent frequent prying into the set to pull out and put in coils, often located inside the shielding—for even greater inaccessibility, it undoubtedly seemed to the user.

In addition to this problem, there was the further fact, that attempting to combine into one single receiver unit both a broadcast and a short-wave receiver, usually meant that something had to be sacrificed in one section, and sometimes quite a bit in both. Consider, for instance, who would today use a two-tuned circuit, four-tube set for good broadcast reception?

Super-het the Solution of S-W Receiver Problem

The superheterodyne receiver was obviously the solution of the short-wave receiver problem; but even here a number of problems thrust up their ugly heads. For instance, the intermediate-amplification frequency commonly employed for the broadcast band is 175 kc., but this is an unsatisfactory I.F. (intermediate frequency) for operation in the range of 1500 to 30,000 kc. How was this to be compromised, and how was a simple, permanent design to be developed that would be at once a fine broadcast receiver, and at the same time a short-wave set that would really show what modern broadcast design technique applied to short-waves would do?

The new Silver-Marshall "726 SW" All-Wave Superheterodyne, which covers a range of from 10 to 550 meters, or 550 to 30,000 kilocycles (so that it will tune in the frequencies of all American broadcast as well as American and foreign short-wave stations) seems to answer the short-wave receiver problem. As a broadcast receiver it shows exactly the same operating characteristics and curves as the "S-M 726" superheterodyne. As a short-wave receiver, it is the dream of old come to life—a double superheterodyne using two intermediate amplification frequencies.

Results Achieved With New Set

Some idea of the set's actual performance may well be presented before considering design problems and features of the receiver. Located in Chicago, with a ten-foot aerial, broadcast stations all over the country can be tuned in on almost any spring evening. Noise level is extremely low for such a sensitive receiver, and may be further reduced by means of the tone control—no small advantage in summer when static is quite heavy.

On the short-wave bands, practically every American short-wave broadcast can be tuned in with excellent volume; and with surprisingly good tone quality, due to the nearly rectangular response-curve of the entire receiver, from antenna to ear. It is not at all difficult to get G5SW in England, every afternoon, with far more than the volume ordi-

*President, Silver-Marshall, Inc.

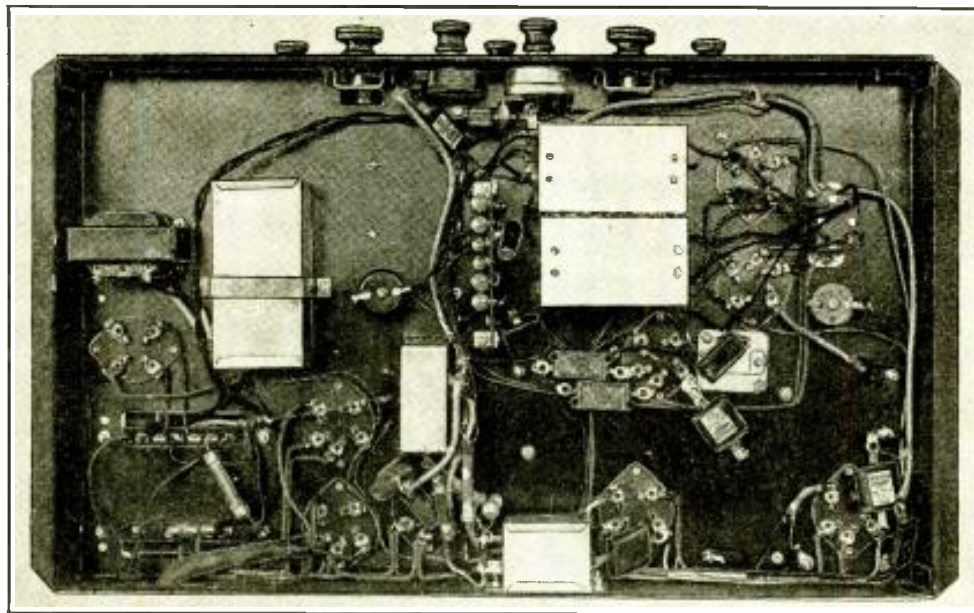

Bottom view of new "S-M" All-Wave Superheterodyne. "Double-super" is employed for the short wave reception.

band of 1,500 to 30,000 kc. Neglecting maximum gain possibilities entirely in selecting the intermediate frequency for the broadcast band (since adequately high amplification may be obtained at any frequency from 1,500 kc. down today) the choice of the intermediate frequency becomes almost entirely a matter of selectivity in terms of "image-frequency" or "repeat-point" interference. If a low intermediate frequency is used, the second station which may be heterodyned by a given setting of the oscillator will be so close to the wanted signal that, unless a very high order of pre-selection is employed, the unwanted signal will get through, along with the wanted signal. This requirement suggested the use of a reasonably high intermediate frequency (say in the order of 300 to 400 kc.), but this in turn has its disadvantages; the simplest among which is the fact that the second harmonic of such a high frequency falls directly in the broadcast band. This is extremely disadvantageous; since in a high-gain receiver the harmonics of the intermediate carrier frequency necessarily generated by the second detector, in performing its rectifying function, may "feed back" into the first detector or R.F. circuit and cause serious trouble. This has been gone into by the writer in several articles.

narily required in the home; while at night foreign broadcasters are received with almost the same ease as the American short-wave stations.

Since the broadcast band portion of the "726 SW" receiver is well-known, there is little point in reviewing it here.

The Chassis

The receiver chassis is illustrated by the photograph, and a schematic diagram appears herewith also. The housing at the right front center contains the broadcast-band "gang" condenser, oscillator coil and oscillator tube. To the right of this housing is the R.F. tube and the first detector, with (just behind it and to the right of the oscillator tube) the low-frequency broadcast-band "trin-

ming condenser" C4. The I.F. amplifier is laid out along the back of the chassis, with the two '47 pentode output tubes between the power transformer and the shielded '27 second detector. The '80 rectifier is at the left front of the power transformer which, in turn, is seen at the left rear corner of the chassis. The balance of the equipment visible on the chassis is the short-wave portion of the receiver.

Choosing the Intermediate Frequency

As was previously mentioned, the ideal intermediate amplification frequency for operation on the broadcast band of 550 to 1,500 kc. differs considerably from the ideal intermediate amplification frequency for operation in the short-wave

The frequency of 175 kc. is high enough so that, for a given oscillator setting, the second station which may be heterodyned, in addition to the wanted signal will be 350 kc. away from the wanted signal—sufficiently far away so that no excessive precautions of pre-selection at the signal frequency are required to keep out this unwanted signal; two tuned circuits utilized with the new multi- μ tubes being adequate. More-

(Continued on page 228)

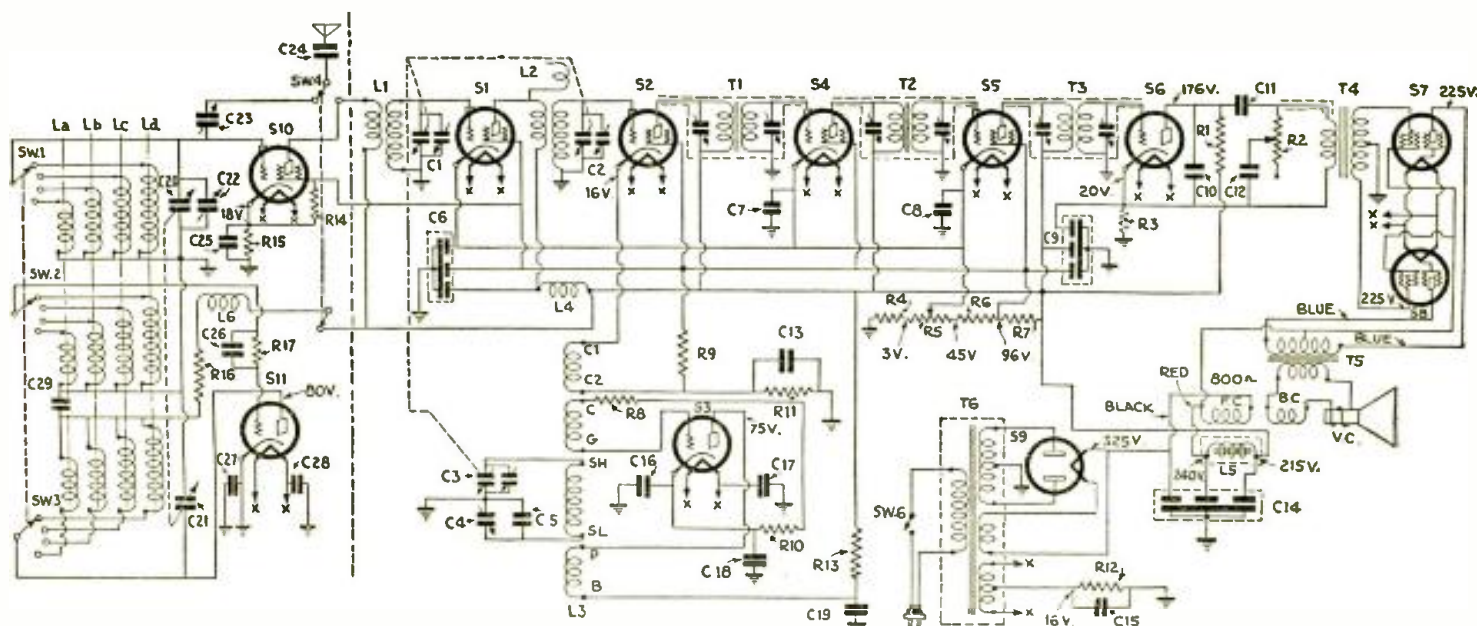

Wiring diagram for the latest "S-M"—726 SW., "All-Wave" Super-het. For short wave reception the aerial feeds into a S-W detector S-10 and oscillator S-11; in all 2 oscillators and 3 detectors are used. Tubes—S2, S-10—'24's; S3, S6, S11—'27's; S7, S8—'47's; S1, S4, S5—'51's (R. C. A. 235); S9—'80 rectifier. This set is a combination of a 9 tube vari- μ pentode broadcast super-het, and an 11 tube short wave super, using switches instead of plug-in coils. Pentodes are used at S7 and S8.

NEW—SHORT WAVE

By CLIFFORD E. DENTON

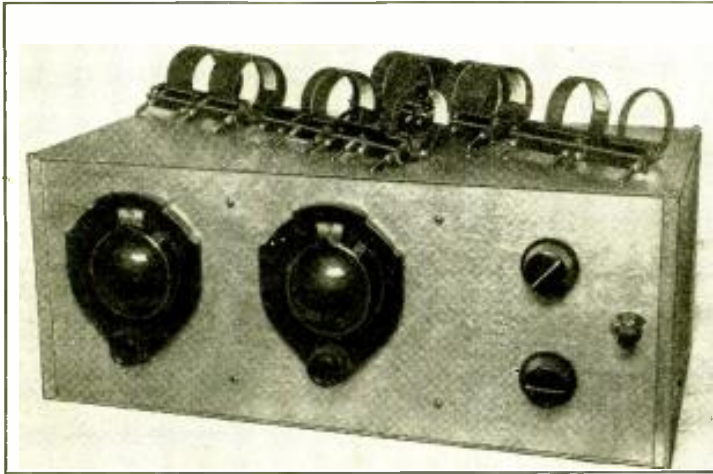

A NEW super-regenerative circuit, with screen-grid detection and pentode output—sensitive and powerful.

Fig. A — The 14-110 - meter Superregenode with its plug-in coils. The lid lifts.

RECENT issues of SHORT WAVE CRAFT have contained interesting details of new devices and circuits that enable the technician to obtain the last bit of efficiency from them. Not the least of these is the Pentode power tube with its possibilities for exceptionally high audio-frequency amplification.

And speaking of things to become *la mode*, the author harks back to the time when E. H. Armstrong told of a new receiver the like of which had never before been seen, with a response far greater than could be obtained from even his famous regenerative circuit. The main idea in a radio man's life then was: "What's the circuit? How does it work?" The conniving and detective work to obtain the inside "dope" and be first to build it—oh, boy!

Superregeneration has been with us for nine years, but little of what has been done toward refining the circuit has so far reached print. Experimenters have from time to time brought forth receivers based on the standard circuit as originally designed; but short-wave sets using this principle of operation have not reached the pinnacle of performance which a theoretical consideration of the exceptional efficiency of this circuit, at the very shortest wavelengths, would seem to indicate is readily obtainable.

The Superregenode, however, incorporates the very latest advances in tube and circuit design for effective operation at wavelengths between 14 and 110 meters, including as it does screen-grid and pentode tubes in a superregenerative connection; and tube-for-tube, it far outstrips in performance any other radio set ever before offered to the short-wave fraternity. It opens up an entirely new playground for the short-wave enthusiast.

The Hows and Whys

A simple explanation of the principle underlying the operation of a superregenerative receiver will be of interest alike to the old-timer "gone rusty," and to the novice.

The circuit shown in Fig. 1 is the familiar "3-circuit regenerative," wherein R.F. energy in the plate circuit is fed back to the grid circuit, through the inductive coupling between coils L1 and L2. By increasing this, additional energy may be fed into the grid circuit to

augment by regeneration the strength of the incoming signal. Turning the regeneration control beyond the point of maximum regeneration will result in circuit oscillation; the tube then "plops over," and the signal disappears. In this condition, the circuit is useful for "C.W." or continuous-wave code reception; but it is quite unsuited for phone or broadcast reception. The most desirable adjustment point, for sensitivity, is just a hair's breadth below oscillation.

In the simplest terms, it may be said that the principle of the superregenerative circuit is to carry the regenerative action of the detector tube quite up to the point of oscillation; but to hold it under control by the periodical application of a *suppressor* voltage which checks the tendency to oscillate as soon as it sets in. This voltage may be applied in either the grid or the plate circuit or, in a four-element tube, to the screen-grid circuit, as shown here. (Fig. 2.)

The uniformity of this *periodical* application is obtained by the action of a local oscillator, the frequency of which determines the length of time during which a tube can approach the condition of oscillation without its being checked.

THE SUPERREGENODE RECEIVER

Puts Short-Wave Radio on the Map, and Solves Many of Its Reception Difficulties

WITH this story by the well-known radio engineer, Mr. Clifford E. Denton, we present to the radio world the most perfected short-wave receiver ever developed!

We challenge any radio constructor to equal its effectiveness, with any previously-known circuit, tube-for-tube.

On its "shake down" test in New York City, before a group of hard-boiled short-wave experimenters "from Missouri," distant short-wave 'phone stations were heard at loud-speaker volume throughout the largest room, there being sufficient power output from the battery-model SUPERREGENODE to drive a standard dynamic reproducer.

Its ramifications are legion: high-power portable loop sets; automatic-volume-control short-wave sets; short-wave adapters; Police radio sets; television receivers; interference locators; super-quality designs incorporating direct-coupled audio amplifiers with single and push-pull pentode output; combination transmitter-receivers; quasi-optical frequency receivers; prospecting equipment, etc.

The astounding efficiency, which goes UP as the wavelength goes DOWN, of this ultra-new factor in short-wave reception, the "Superregen(-ative Pent-)ode," is due to the use of a superregenerative circuit and three new 2-volt tubes—the general-purpose '30, screen-grid '32, and pentode '33—in the battery model; or the standard '27, screen-grid '24, and pentode '47, in the high-power or A.C. model.

The battery model is conveniently powered from any available current supply; and is as compact as good efficiency will permit.

Watch for the construction details of the "Big Bertha"—the high-power 3-tube A.C. model Superregenode, complete with power pack, which will appear in the next article.

SUPERREGENODE

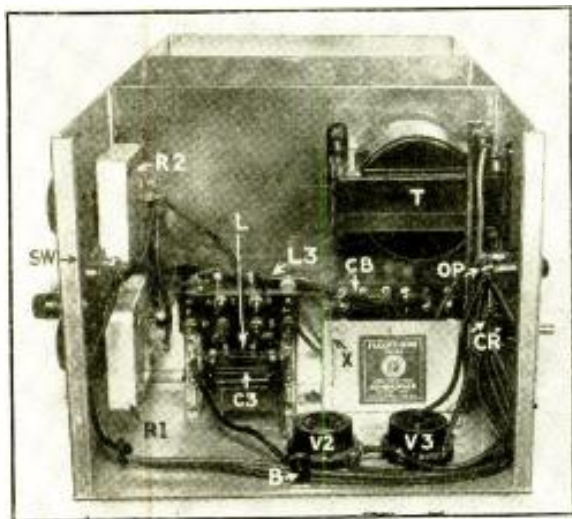

Fig. C—OP, output terminals 10-11; CR, battery-cable receptacle; CB, condenser bank; X, bare-wire "A—" common lead.

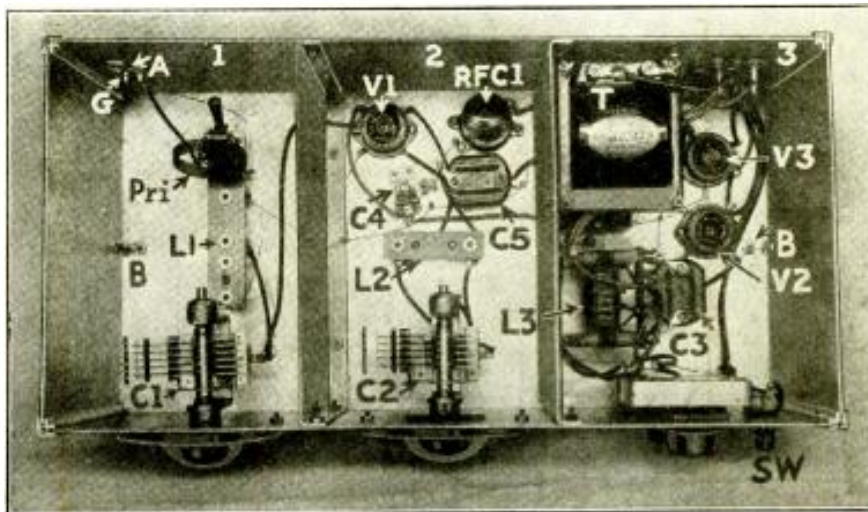

Fig. B—Bolts B hold the heavy aluminum case rigidly. The primary of L1 is hinged to the coil receptacles. L3, 30-kc. transformer; L, its 150-turn added winding.

For instance, if the local oscillator has a frequency of 10,000 cycles, every 1/10,000 of a second it will apply to the detector tube a negative voltage which damps the oscillation of the latter; and then remove this potential, applying a positive voltage which increases sensitivity.

Thus the action of the local oscillator enables us to push the detector further into that state of sensitivity in which oscillation takes place in a normal regenerative detector. It is apparent that more signal energy thus reaches the plate circuit, and more will be fed back to the grid, before the tube can spill over. The result is tremendous gain in volume; and the effectiveness of this circuit increases greatly as the frequency of the incoming signal increases—that is, as the wavelength shortens.

Addressing the Institute of Radio Engineers, in June, 1922, Major Armstrong pointed out that the superregenerative principle is that "if a periodic variation be introduced in the relation between the negative and the positive resistances of a circuit containing inductance and capacity, in such manner that the negative resistance is alternately greater and less than the positive resistance, but the average value of resistance is positive, then the circuit will not of itself produce oscillation; but, during those intervals when the negative resistance is greater than the positive, it will produce great amplification of an impressed E.M.F."

The Superregenode Circuit

The latest laboratory development of this circuit is shown here for the first

time in Fig. 3. It comprises a screen-grid detector or mixing tube V1; a suppressor - frequency "general-purpose" tube V2 which is coupled to V1 and working at a frequency which results in the desired blocking action; and a pentode power audio amplifier V3, which handles the audio output of the detector. (Hence the name, "Superregen[eration and pent-]ode.")

In Fig. 2 it will be noted, the tuning circuit is of the "tuned-grid tuned-plate" type; and, as the inductances L1, L2 are in separate shield cans, the only existing place for feed-back is through the ex-

tremely low internal capacity of the screen-grid tube. At resonance, however, this tube will spill over into oscillation, if the screen-grid potential is correctly adjusted. Because both the grid and plate circuits are tuned, selectivity is exceptionally good; and every care must be taken to lay out, wire, and shield the receiver properly to keep circuit oscillation under control. Smooth action in this portion of the circuit was obtained through the use of a "Supertontrol" variable resistor for R1, which controls the energy fed into the detector.

Optimum Suppressor Frequency

Tests of frequencies between 4,000 and 30,000 cycles show that the maximum gain is obtained in the Superregenode when the oscillator develops a suppressor-frequency between 4,000 and 8,000 cycles. Extremely interesting results were obtained with a fixed oscillator working at a frequency of 6,000 cycles.

In consideration of the pleasure that may be derived from experiments in unbeaten paths, two variations in oscillator design are shown in Figs. 4 and 5; the latter, as worked out by the writer, includes Pacent "honeycomb" coils.

In Fig. 4 is shown an unusual arrangement for obtaining low-frequency oscillations, without the detriment of excessive bulk. A push-pull A.F. transformer and a 30-henry choke coil are used to generate the desired frequency; without condenser C1, the circuit will oscillate at its natural frequency, approximately 6,000 cycles. The output of the oscillator is fed to the screen-grid tube through one half of the

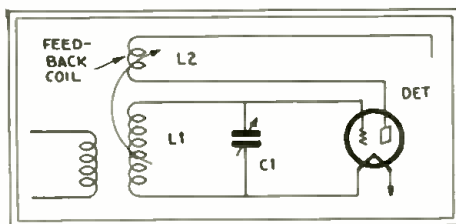

Fig. 1—The regenerative detector is extremely sensitive, but oscillation limits its effectiveness.

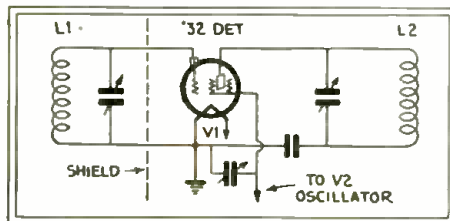

Fig. 2—Varying the screen-grid voltage prevents oscillation from feedback through the tube.

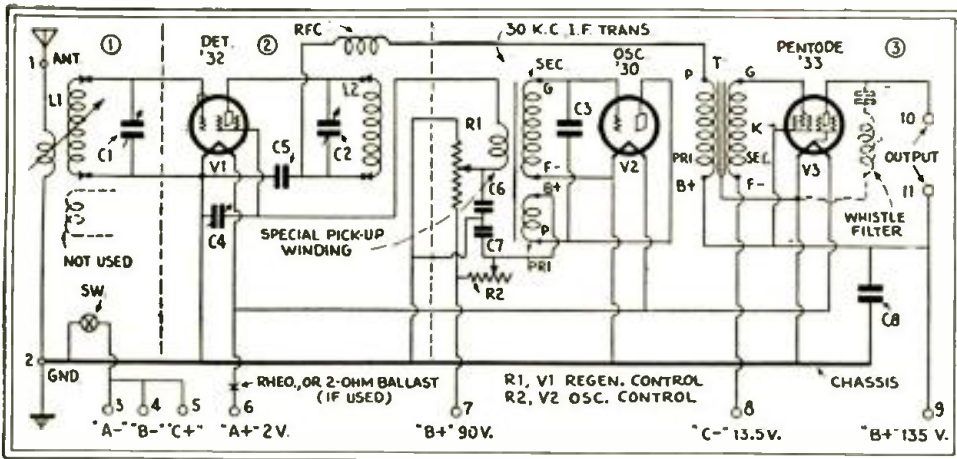

Fig. 3—The Superregenerative circuit for battery operation; see Fig. 11 for the detail of the "whistle filter." A push-pull output transformer for '45s is a good match for the '33 pentode.

secondary. Resistor R1 functions as a means of throwing the modulated tube circuit into and out of oscillation; and R2 controls the power output of the local oscillator.

The circuit shown in Fig. 5 is conventional; it includes a 50,000-ohm grid leak and a .00025-mf. grid condenser. Tuning condenser C1 has the large capacity of .001-mf. An optional method of tuning is to place the variable condenser as shown in dotted lines.

Any one of these oscillator circuits is sure-fire and, by substituting different values of capacity, the frequency of oscillation may be raised or lowered; the latter effect resulting when the capacity is increased.

Some explanation is necessary, of the extremely novel, effective and compact oscillator inductance design which has been selected as the best—that illustrated in the photographs.

An old Acme 30-kc. superheterodyne I.F. transformer (appropriately enough) had its outer protective metal covering removed; and over the outside of the exposed winding (the original primary-secondary combination) was wound a third or tertiary pick-up coil L of 150 turns of No. 28 enamelled wire, random-wound. Condenser C3, .001-mf., tunes the oscillator circuit.

This happy artifice worked right off the bat, and oscillated to beat the band; functioning exactly right for the particular receiver shown in the photographs.

Construction and Wiring

The first part of the construction job is to drill the holes in the aluminum box as indicated in the drawings; which give the dimensions of the set illustrated.

If the constructor wishes to be certain that the parts will mount correctly the first time, he must use the components specified.

If substitution is made, it will change the drilling specifications.

Having drilled all the holes, the next step is to mount the antenna and ground binding posts on the rear panel (Fig. 6); making certain that the antenna post does not short to the panel. The male

member of the 7-wire cable and the speaker's dual terminal are mounted at the opposite end. This completes the assembly.

Next let us mount the instruments that appear on the front panel (Fig. 7). At the right-hand side is placed the filament switch, and next to it the two 50,000-ohm "Tonatrols" R1 and R2, which are insulated by washers. The

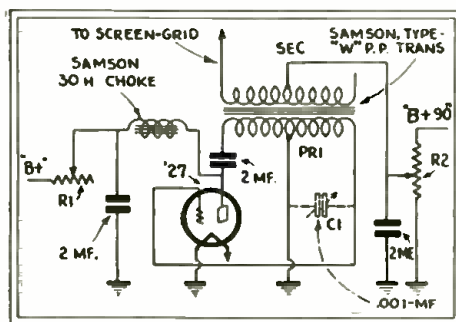

Fig. 4—One of the oscillators used experimentally to generate the suppressor-frequency.

plate circuit's tuning condenser C2 also must be insulated. There are numerous ways in which this may be accomplished, and it is a little problem for the ingenuity of the constructor. The grid tuning condenser C1 is the last item to mount on the aluminum panel.

On the base (Fig. 8) are to be fastened the coil mountings.

Wire in the antenna and ground connections, control-grid lead, and the leads of the tuning condenser. Place in position the first of two compartment inter-stage shields (Fig. 9) and lock it tightly. (In short-wave receivers, loose shielding is the source of great noise.)

In the second compartment, place the four-prong socket for the type '32 tube; the 80 mmf. equalizing condenser C4; and the 250-millihenry choke coil RFC1. The .001-mf. fixed condenser C5 is grounded to the chassis.

However, do not depend upon the chassis for connections, but run a wire to every point shown as grounded. This

eliminates what would otherwise be a source of inter-unit connection, causing undesired effects.

Wire up all of the parts which so far have been assembled, and drill four small holes at the bottom of the second partition. One is for the plate lead to the A.F. transformer, one is an oscillator pick-up connection; another for the "A+" line; and the fourth for the "A—" lead and ground, a wire which should be bare. Pull these wires through the holes provided for them, after tightly bolting the second partition (also Fig. 9) in place.

Solder flexible leads to the filter block and fasten it in place. In this bank there are five one-microfarad condenser sections; one section bypasses the "B+135" lead; two more in parallel, the 50,000-ohm resistor R1; and the two remaining, also in parallel, at the moving arm of R2 bypass the plate supply of V2.

The sockets of V2 and V3 and the 30-kc. transformer L3, with its added winding, are mounted in position and wired.

To prevent the resistor R1 from shorting the plate supply when the receiver is not in use, and thus slowly draining the "B" batteries, "B—" and "C+" are connected to separate leads, which return to the chassis only through the filament switch.

Now fit the end shields (Fig. 10) into place.

Operation of the Receiver

Insert in their respective receptacles the requisite two coils for a given tuning range and turn the receiver's control switch to the "on" position. If the receiver is working, a thin high-pitched whistle will be heard in the background.

If this whistle is not evident, it is an indication that the oscillator is not functioning; and the first step is to reverse the leads to either the primary or secondary winding of the 30-kc. transformer (or the honeycomb coils, if used). This should correct the condition.

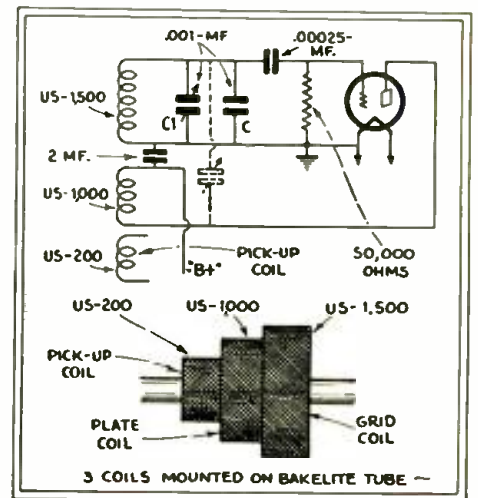
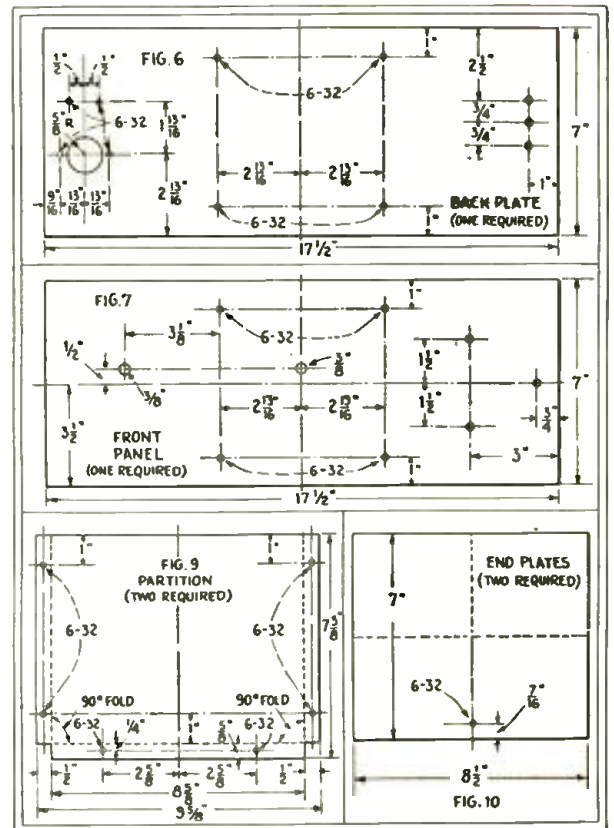
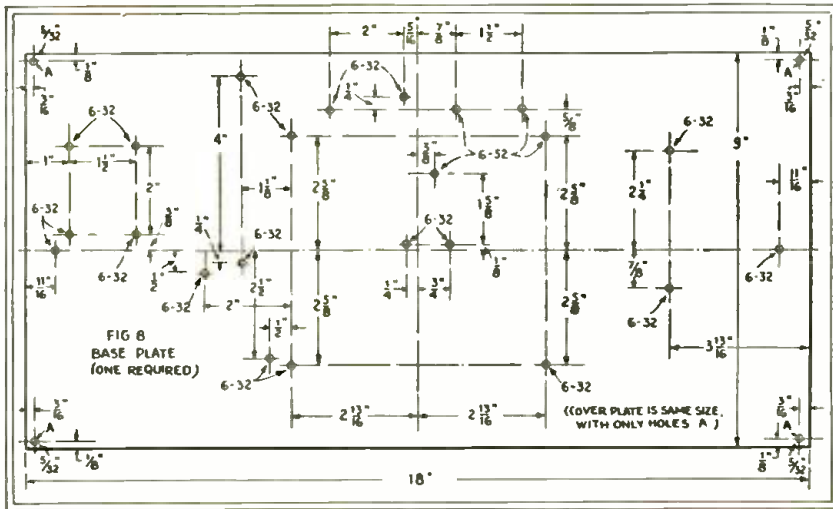

Fig. 5—A less compact oscillator design, using duo-lateral ("honeycomb") coils. This was tried experimentally, but is difficult to shield.



Vary the resistor R2; when volume of the whistle should change. Rotate the tuning control until a signal is heard; and, for 'phone reception, vary the voltage on the screen-grid of V1 until the circuit is just under the point of plop-over. For C.W. signals, let it plop. Simple?

Every short-wave receiver must be nursed along until the operator becomes conversant with its eccentricities; although it must be said that the Superregenerative handles very well; since once the setting for maximum volume has been determined the set may be tuned from one end of the range to the other, in either the oscillating (C.W.) or non-oscillating ('phone) condition.

When searching for 'phone signals tune by the chirps and then lower the screen voltage by means of the potentiometer R1.

The action of the battery and A.C. models is the same in tuning, but the R.F. gain and power output of the A.C. job is far greater. It is interesting to note that the voltage gain in the audio-frequency end of the battery-type Superregenerative receiver has a figure of about 34; while that of the A.C. model is about 49.

For maximum efficiency, the load impedance in the plate circuit of the pentode in either case should be between 7000 and 8000 ohms at 60 cycles. Where headphones or a dynamic reproducer are used, a matching transformer of suitable design must be employed.

Trapping the Suppressor-Frequency

If, for reasons not evident in the receiver constructed by the writer, the high-pitched whistle is considered objectionable, it may be expedient to have recourse to the circuit arrangement shown in Fig. 11; the tone filter shown in this diagram consists of a coil and condenser in series, connected across the output; that is between pentode plate and ground. If the oscillator's output frequency is known, the values required for L and C may be determined in a minute from the following formula:

$$L \times C = 259,300 \div f^2$$

Here L is in henries, C in microfarads, and f is in cycles.

In Figs. 6 to 10, at right and above, the drilling measurements of the shields are indicated, for the receiver illustrated. They must be altered if necessary to suit the components selected by the constructor.

For example, if the oscillator frequency is 6,000 cycles, a result is obtained as follows:

$$LC = \frac{259,300}{6,000 \times 6,000} = \frac{259,300}{36,000,000} = .00721$$

Since .0072 is the product of the value of the inductance and capacity, if we are using a 30-henry audio choke, we divide this L x C product by 30, as follows:

$$\frac{.0072}{30} = .00024\text{-mf.}$$

The nearest commercial condenser value is .00025—quite close enough for our purpose; for it will tune the circuit very close to 6,000 cycles and, acting as an acceptor-trap, it by-passes to ground the 6,000-cycle suppressor frequency

but obtaining this result at excellent loudspeaker volume, with low current consumption and extreme circuit simplicity, is something further. The beauty of the design is that much may be learned through working with it; extraordinary loud-speaker results may be gained; and in the A.C. model, the Superregenerative does not present the complications that exist in even the ordinary regenerative short-wave A.C. receiver.

Variations and Applications

Countless ideas can be developed by the fellow with a little inventive ability and the initiative to push them through. For instance, there is before us the use of variable-mu tubes in place of the more standard screen-grid type. Again, it is possible to modulate the screen-grid circuit with the output of a microphone amplifier and "mike"; when you will have a low-power speech transmitter!

Indeed, by suitable switching arrangement and parts selection it is possible to build up a portable combination transmitter and receiver with very great range for the tubes used and power expended; something in the order of 5 miles as a transmitter, and thousands as a receiver.

Instead of speech transmission, code may be sent by breaking with a key the detector circuit when adjusted for oscillation. The local oscillator, instead, may be keyed, if desired; and thus modulation of the oscillating detector's output signal may be obtained and varied by adjustment of the local oscillator.

Acknowledgement is here made of the courtesy of York Engineering Service for the use of their equipment and labo-

(Continued on page 231)

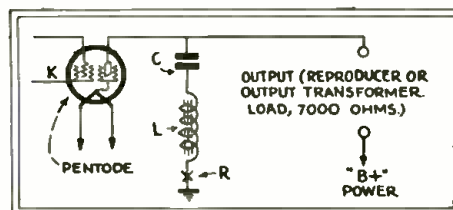

Fig. 11—The "whistle filter," or trap for the audible suppressor frequency. Values are suggested in the text, for 6000-cycle suppressor frequency.

that has served its usefulness in the receiver. If it is desired to broaden slightly the tuning of our acceptor-trap, a 5,000- to 10,000-ohm variable resistor R (Fig. 11) may also be connected in series at X and adjusted for best effect.

The thrill of working great distances is not a new one for the short-wave fan;

WHAT CAN WE DO WITH ULTRA SHORT WAVES?

The latest researches of Prof. Esau at the Jena Technical-Physical Institute. By L. Rohde, assistant to Prof. Esau, and N. C. von Halem.

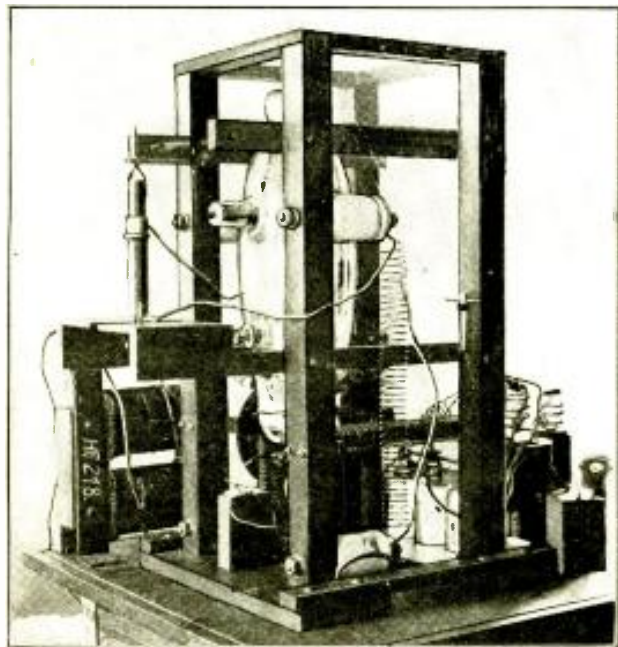

Fig. 1—Above shows high power transmitter tube for three meter waves, this transmitter being capable of delivering 800 watts of R.F. energy for either broadcast or medical purposes.

THE designation "ultra-short" takes in all waves of less than 10 meters length. This limit has not been arbitrarily selected—it has, in fact, been determined that all ultra-short waves possess properties, dependent on their length, which make them suitable for special purposes of communication technique.

While all longer waves are reflected from the Heaviside layer, the ultra-short waves do not come back to earth again. The short-wave amateurs, who have been able to achieve such remarkable success, especially in America, have also made the important observation in this field: that, with 10-meter waves, one can nevertheless bridge distances of several thousand kilometers (1 kilometer = 0.62-mile). If one shortens the wavelength only one meter, then it is no longer possible.

Because of this peculiarity, the ultra-short waves can be used for a number of very definite purposes. Extensive experiments have shown also that the ultra-short waves vary greatly from one an-

The accompanying article was prepared by Mr. Rohde and Mr. von Halem, in answer to our request for an article on the latest activities in the field of ultra-short waves by Prof. Esau in Europe. The laboratory of Prof. Esau is the focal-point of major activities in ultra-short waves in Europe, and we are sure that our readers will be glad to read this latest report from such an important source.

other in applicability, according to their length. Therefore, in the following discussion they are arranged in various groups; which is the best way to show their practical significance.

Waves from 9 to 6 Meters

Since the ultra-short waves cannot bridge great distances, they are naturally of value where one wishes to cover only small areas by radio. For example, the purpose, in the case of the so-called "local radio," is only that of providing a single city with broadcast service. In this case, there is no value in having a great range; since even a large city district rarely has a radius of more than 20 km. (12 miles). For this local radio, the waves from 9 to 6 meters (1 meter = 3.2-ft.) are especially suitable. They are

absorbed neither by houses nor by slight elevations. Still shorter waves adhere so strongly to optical laws that, in their transmission, "shadow" effects are produced by houses and buildings. But, with wavelengths from 9 to 6 meters, there is sufficient bending of the waves, so that reception is still possible behind small mountains and even behind great masses of metal. The range of a transmitter of this kind is about 40 km. (25 miles). Accordingly, the local stations of two cities can use the same wavelength without interference, provided they are at least 80 km. (50 miles) apart. The shortage of radio broadcast channels, already very evident in Europe, will not extend to local radio using ultra-short waves.

The short range is a consequence of the curvature of the earth. It can be influenced only very little by the increase of the transmitter's power. On the other hand, the location of the sender or transmitter is of greater importance. From a plane, or from the peaks of a high mountain, much greater ranges can be attained than from a transmitter set up on a plain.

Time and Weather Have No Effect

The various times of day, and the weather, have no effect on the ultra-short

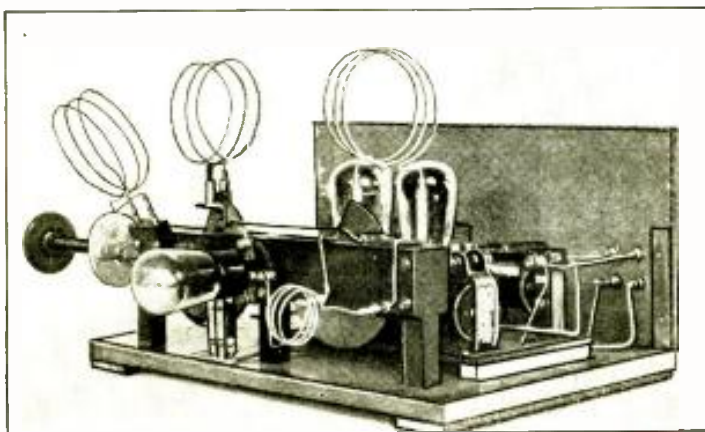

Fig. 2 (Left)—Ultra short wave receiver for intercepting three meter waves. This receiver employs super-regeneration so as to make it ultra-sensitive.

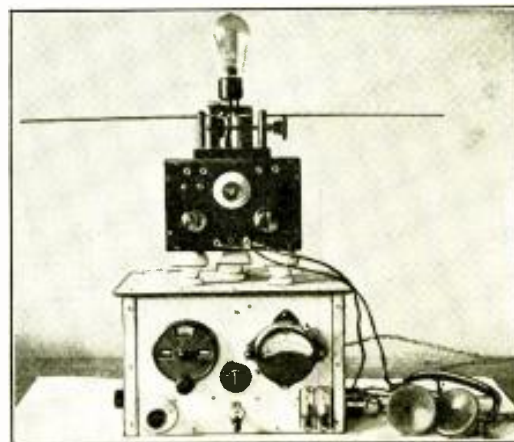

Fig. 4—Here we have a one meter transmitter and receiver as used in the laboratory of Prof. Esau.

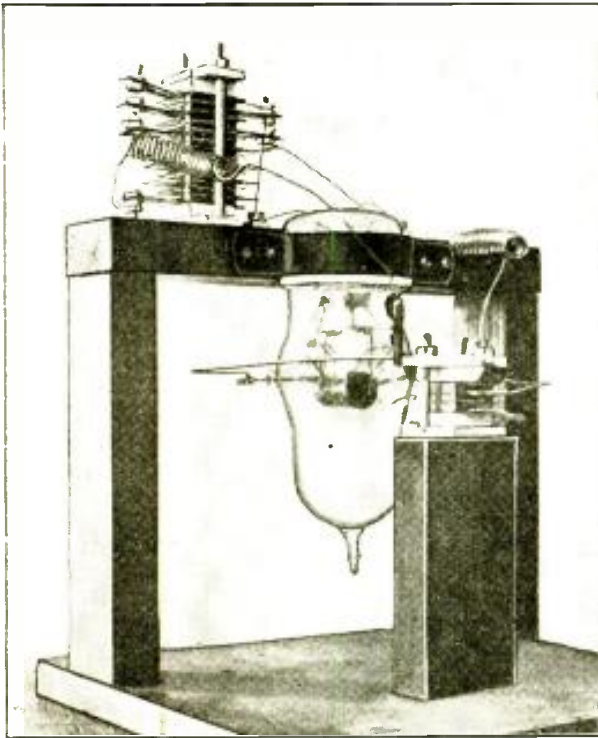

Fig. 3 (Left)—This tube has been used for two meter wavelength experiments and it yields 30 watts of R.F. power at two meters.



Fig. 5 (Right)—One of Prof. Esau's experimental ultra short wave reflectors for projecting a 16 centimeter (6.4 inches) wave, and producing a narrow beam only four degrees in width.



waves. It is, however, a still more important fact that they show only a very slight sensitivity to "static" of any kind; above all, there is a complete absence of those disturbances which are produced by electric phenomena in the atmosphere. Only the ignition systems of automobiles cause a disturbance, if they are close to the receiver; and even here matters may be mended by putting protective devices on the autos.

Because of their high frequency, the waves from nine to six meters have also opened up for us new possibilities in the solution of television problems. With their aid, one can transmit a much higher number of pictorial elements. As is well known, the introduction of high-quality television has so far always failed, on account of the relatively low number of pictorial elements which have been practical by the use of longer waves.

Waves of 6 to 3 Meters Manifest Unusual Effects

This wave range is suited for bridging small distances up to 20 km. (12 miles), where there is *partial (optical) vision*, and where portable stations are to be used.

Their chief field of use might perhaps be communication from ship to ship, in port and on the high seas. In war these waves in particular will be used for military purposes. Wireless telephony in the air has already made great progress by their help.

Moreover, the science of medicine has made use of research concerning ultra-short waves. It has appeared that irradiation with such waves kills numerous bacteria in the human body.

Produce Heat Inside Body

But the greatest medicinal significance of these waves appears to be due to their

production of heat inside the parts of the body; since, in contrast to the diathermy hitherto used, they attain great penetrative effects. Very lately, there have been used for investigations in this field, not the electromagnetic waves produced by radiation from antennas, but instead (as proposed by Prof. Esau) the electric field between the plates of a condenser.

In the wave range from six to three meters, one must use special tubes and transmitting circuits, to produce the requisite energy. Fig. 1 shows a 3-meter (10-foot) transmitter, which has a high-frequency output of 800 watts. By connecting two such generators together, it has been possible to generate 1.5 kilowatts (1500 watts) at the frequency of these waves. Previously, such a result had probably never been attained.

Fig. 2 shows a *receiver* for 3-meter (10-foot) waves; it has to be very highly developed, to possess sufficient sensitivity. A striking point is the small number of turns used on the coils.

3 to 1 Meter Waves—Actual Results

While, with the waves hitherto discussed (those of greater length) the use of mirrors still encounters considerable difficulties, for waves from 3 to 1 meter (118 to 39 inches), handy reflectors can be constructed.

By using mirrors and small antennas, one can make the waves of this field serviceable for the same purposes as the 6-to-3 meter waves.

It is only with difficulty that fairly great power can be produced, in the form of waves of less than 3 meters. This requires special tubes, and the dissipation of the resulting heat causes especially great difficulties.

Fig. 3 shows a transmitter tube which, on 2 meters (78 inches) can produce a radio-frequency energy of 30 watts. With this energy great ranges are possible, but only up to the limit of optical

vision; since the similarity of the waves to light rays has become very great.

On the One Meter Wave

Waves of 1 meter (39 inches) permit only a few watts to be used; but this energy is fully sufficient for ranges corresponding to the range of vision.

The quality of the focusing (of the radiation) is very greatly dependent on the ratio between the dimensions of reflector and the wavelength. The mirror should have an opening at least four times the wavelength; of course it need not consist of solid metal for a system of individual wires is sufficient. Such a reflector can be made fairly easily.

Fig. 4 shows a receiver and its transmitter for 1-meter (39-inch) waves. The convenience of this apparatus is a recommendation for its use; especially for transportable stations. With these sets, numerous experiments and tests have already been performed; in some of which tests the sets were placed in moving automobiles, airplanes and other conveyances. To be sure, uninterrupted vision between transmitter and receiver is a prerequisite for reception. Yet, with half a watt, it is easy to send 15 kilometers (9 miles). This distance can even be doubled, if the transmitter is provided with a reflector.

Although in producing such short waves one is forced to use a method which *necessarily* prevents the use of high power still these waves can be used practically. For, with proper reflectors, one can get so concentrated a beam that—as with a searchlight—no energy is lost. Fig. 5 shows a reflector for a 16-cm. (6.3-inch) wave, which has a dispersion of only 4 degrees.

These ultra-short electric waves can, be employed where it has been necessary to use long-wave (infra-red) light. But the

(Continued on page 234)

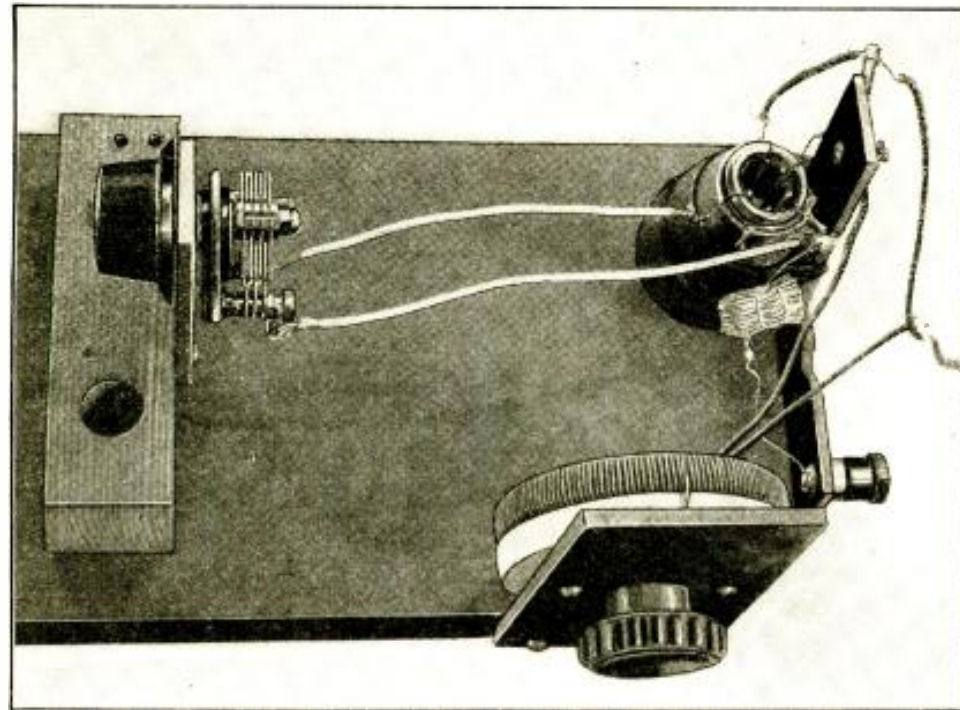

Fig. A—The author's 1 1/2 meter short wave oscillator.

Getting Started on 3/4 METER

By A. BINNEWEG, JR.

How to experiment with inexpensive apparatus; also how to measure ultra short waves; kind of tubes to use, etc.

WAVELENGTHS below one meter offer an interesting field for experimentation, because the apparatus required is exceptionally inexpensive and easily procured. With a few small power tubes, rheostats, small condensers and an ordinary "B" eliminator, some very interesting experiments can be carried out. No license is necessary for such experiments if one does not actually transmit signals. If transmission experiments are desired, an ordinary amateur license is all that is required; because the amateurs were given a waveband at 3/4-meter (400 megacycles or 400,000 K.C.) which has not received the attention lately that it should. Some amateurs hardly realize that this band is open for experimental purposes.

The purpose of this article is to give the results of some interesting tests, together with circuit diagrams of the apparatus used. An interesting photo of a 1 1/2-meter oscillator is shown in Fig. A.

Of course, the first requirement for any experimental work of this nature is a wavemeter. But some very interesting tests can be performed at these frequencies before the wavemeter is constructed and calibrated; because no operation "on the air" is desired until the

oscillators are carefully adjusted to the correct frequencies.

Let's assume that a type '10 tube is available for the experiments. Any small tube will serve; but for good strength and ease in noting the various

base is removed by holding it over a gas flame while rotating the tube. The solder at the ends of the tube-pins soon softens and falls out: somewhat longer heating will loosen the base,—which can then be turned or twisted off with a

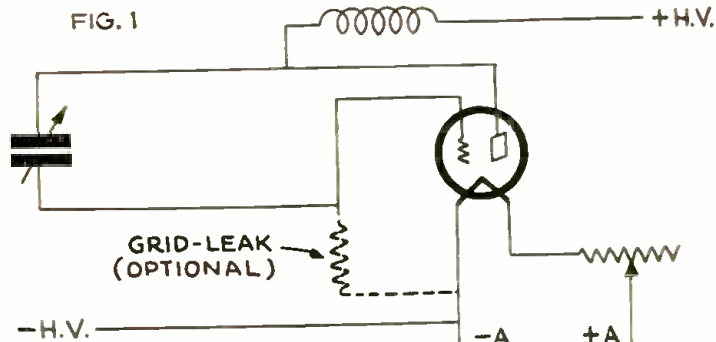

Fig. 1—Here is the circuit diagram for the oscillator illustrated at Fig. A, at top of page. The tube base is removed for experiments below 5 meters.

interesting effects, a type '10 tube should be used. This tube will give a sufficient output, at these frequencies, so that the effects can easily be noted.

Removing Tube Base for Ultra-Short Wave Work

Although at a wavelength of about 5 meters, it is not absolutely necessary to remove the base of the tube, for experiments in the vicinity of one meter, this is a practical necessity. The usual tube-

piece of cloth, to protect the hand. One must be very careful in removing the base; because otherwise the small length of glass tubing which protrudes from the bottom of the glass bulb will be broken off, destroying the vacuum. The cement should be thoroughly softened before attempting to remove the base. Care should also be taken to see that the solder has softened and flowed out; otherwise, when force is applied to the base, the connecting wires may be broken off right at the glass.

Arranging Leads on De-based Tube

If the base of a '10 type tube is removed, it will be noticed that the plate lead comes out separately, somewhat nearer the base and at one side of the bulb. The leads should all be carefully separated and bent around the tube, and a length of string run around the base to hold the leads securely and thus prevent "shorts" in the base. If the string is looped around each wire, there will be no possibility of the leads acci-

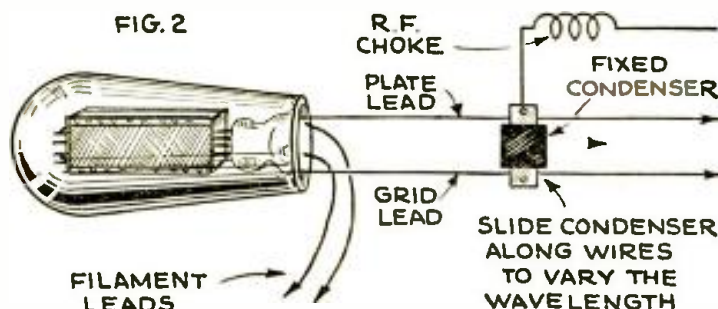

Fig. 2—Diagram at left shows how condenser is slid back and forth on wires to adjust the wavelength of the master oscillator.

dentally coming together. If desired, short lengths of small-diameter glass tubing can be slipped over the leads, to prevent any contacts.

The tendency for most experimenters at these frequencies (the number of these experimenters, by the way, can probably be counted on the fingers of one hand—pioneers!) is to try immediately to build up a sort of permanent set, which they expect to operate promptly with no difficulties at all. Forget it!

If the writer's experience with hundreds of such oscillators and receivers is any indication, the set will not work at first! But that's all the fun—cutting and trying until it *does* work! In other words, this ultra-high-frequency experimentation is a sort of an informal affair—no "tux" is required! Simply follow some simple arrangement, as shown in Fig. A, apply the proper voltages, and—experiment!

the best way is to include a low-range milliammeter of the usual size in the plate circuit of the tube. If such a milliammeter is used, simply bringing the hand near the oscillating circuit will cause a slight change in the deflection. Obviously no change in plate current occurs unless the set is oscillating; unless, of course, one touches the grid terminal of the tube. This effect can also be noticed at lower frequencies; but such small inductance and capacity values are not as easily noticed at the lower frequencies. For proper oscillations, somewhat higher plate voltages are necessary than the lowest value required for oscillations at lower frequencies.

Value of Variable Condenser to Use

Each time the value of the inductance in the oscillating circuit is changed the small variable condenser (a 100-mm. size will be better, especially for frequencies lower than 2 meters) should be

lating circuit will restore the circuit to an oscillating condition, since the R.F. voltage is usually lower at the condenser.

Use of Different Types of Tube

Trying different tubes, or even tubes which are apparently the same (same type) will reveal some interesting things. The wavelength of the oscillation will shift all around, for the same constants, when different tubes are tried, because of the exaggerated effects of small changes. Some tubes won't oscillate at all, no matter how favorable the conditions. Tubes having the leads in the "mesh" farthest apart are usually the best, although there are many exceptions.

The lower limits of an ordinary small power tube is in the neighborhood of one meter, but usually between 1.2 and 1.4 meters. Cutting and trying will usually reduce the wave from the lower practi-

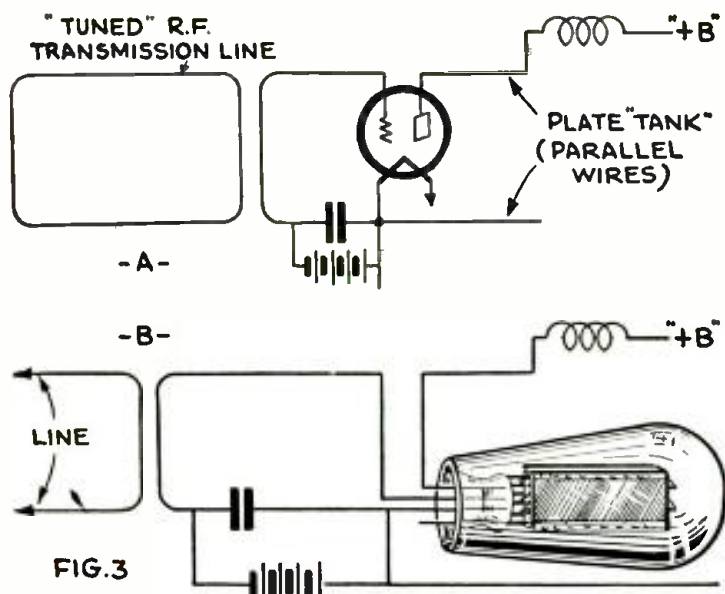

Fig. 3 (above)—Shows circuit diagram of three-quarter meter amplifier. B—Set-up of tube and tuned circuits.

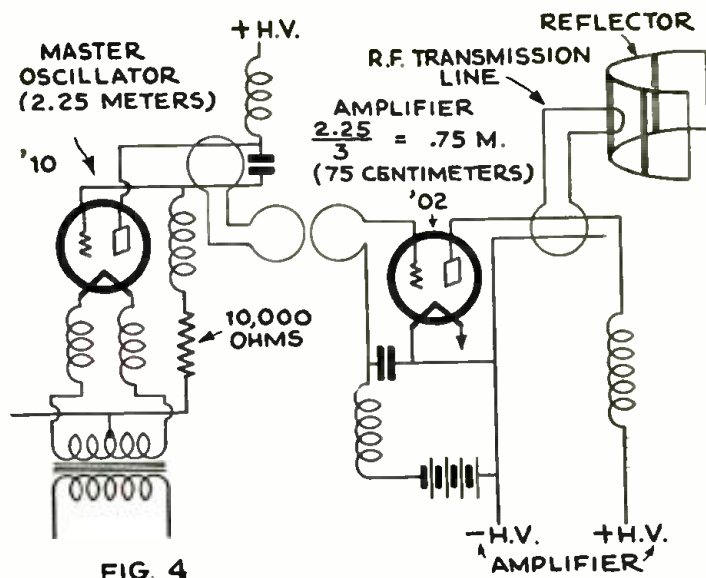

Fig. 4—Here's circuit arrangement of master oscillator—power amplifier used for three-quarter meter transmission; note reflector.

Getting Started

This is approximately how the experiments will proceed. The two parallel pieces of No. 12 wire used in the oscillating circuit shown in Fig. A (circuit diagram in Fig. 1) are the final "inductances." However, if two 3-turn, 2-inch diameter coils are substituted for these two wires at first, one can gradually reduce the turns until he is operating near one meter. If the set is built up directly as shown in Fig. A, the chances are that it won't work at first; since the higher frequencies are more particular as the losses are greater. The grid leak (10,000 ohms) shown dotted in Fig. 1 may not be required, but it is best to try operating both with and without it, to determine which gives the strongest oscillations.

Test for Oscillations

One naturally wonders how to tell when such a set is oscillating. Perhaps

readjusted for best oscillation. Since the external shunt condenser and the tube capacity itself are in series in the oscillating circuit, a series-condenser effect is produced. Beyond a certain minimum value of capacity, the external shunt condenser has relatively little effect on the frequency; so that the leads to the tube must be changed in order to change the wavelength of operation. Correct filament voltage is important. There will be, for each length of plate and grid leads, a definite value of shunt capacity for best operation, normally.

As the wavelength is gradually reduced, it becomes increasingly difficult to maintain oscillations against the increasing circuit losses. Possibly a higher plate voltage, or a slightly different arrangement of the oscillating circuit, will give better results. Perhaps the R.F. choke needs attention. Often, moving the choke to the end of the wires (near the condenser) in the oscil-

cal limit a tenth of a meter or so. The oscillations, however, become less stable, so that this is hardly worth while. It is therefore obvious that some other method must be employed for operation at 3/4-meter, if ordinary small power tubes of American manufacture are to be successfully employed.

One naturally thinks of the master oscillator-power amplifier arrangement. This system consists in amplifying either the fundamental or a harmonic of the oscillator frequency. Although it is impossible to make certain tubes oscillate directly at 3/4-meter, one can amplify a harmonic and thus secure an amplified signal for feeding a reflecting system. The necessary constants required do not allow an oscillator to operate directly at this extreme frequency; but a tube can be used as an amplifier for such a frequency quite satisfactorily, although the amplification is, of course, rather low.

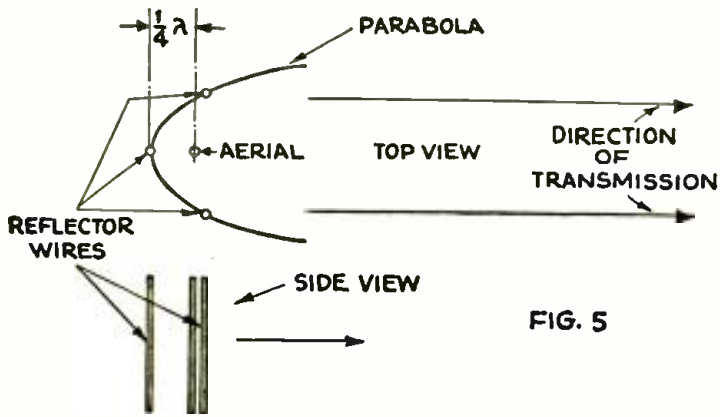

FIG. 5

Fig. 5—Set-up of wires for $\frac{3}{4}$ meter parabolic reflector. Some very interesting experiments are possible at these extreme frequencies.

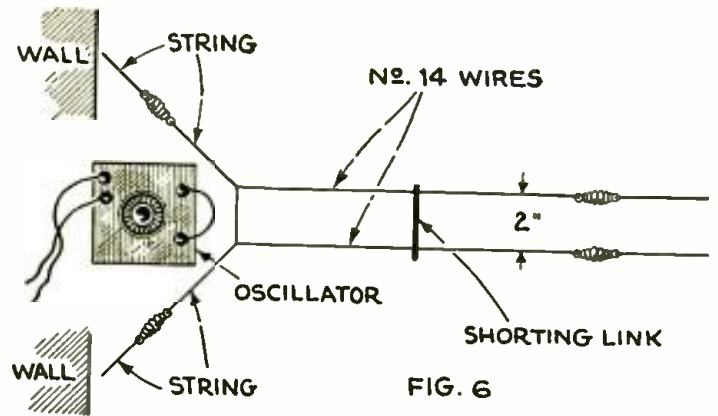

FIG. 6

Fig. 6—How to measure the length of ultra-short waves—that's the problem! Here's simple apparatus described by the author in the text.

The Master Oscillator-Power Amplifier

One can thus operate the oscillator at some multiple of $\frac{3}{4}$ -meter, and amplify the $\frac{3}{4}$ -meter harmonic for transmission. Either $1\frac{1}{2}$ meters or $2\frac{1}{4}$ meters can be used as the fundamental wavelength. The oscillator of Fig. A operates satisfactorily at $1\frac{1}{2}$ meters, but employs a tube not readily available to every experimenter. A type '10 tube will give better results if operated at $2\frac{1}{4}$ meters. This wavelength will allow constants large enough to furnish a good, steady oscillating frequency.

Fig. 2 shows how the oscillator wavelength is adjusted to the desired value. The leads to the tube may consist of two No. 14 wires soldered to the tube's leads. The actual length of wire required in the oscillating circuit depends, of course, upon the wavelength at which it is desired to operate the oscillator. The particular tube employed influences to a considerable extent the required values. However, if a '10-type tube is operated at 2.25 meters, and a .00025-mf. condenser is used across the wires, the No. 14 bare wires will be about 6 inches long, external to the tube. The best way to tune the oscillator is to solder the condenser in position; measure the wavelength (as described later); more wire included in the oscillating circuit gives a higher wavelength, less a lower wave.

Constructing a $\frac{3}{4}$ -Meter Amplifier

After the wavelength is adjusted to 2.25 meters, an amplifier can be constructed. The amplifier is very simple indeed in its circuit arrangement, but considerable experimentation will be required to amplify the $\frac{3}{4}$ -meter wave effectively. The circuit of the amplifier is shown in Fig. 3. The input circuit to the amplifier is simply a loop which is coupled to the transmission line. The transmission line consists of a pair of

parallel wires, spaced about 2 inches apart, and closed upon itself at each end. In order to furnish a strong $\frac{3}{4}$ -meter harmonic, the plate voltage on the oscillator should be raised above normal. Naturally, unless special precautions are taken, the amplifier will amplify other harmonics than the $\frac{3}{4}$ -meter one. The transmission line should first be tuned to the oscillator by carefully adjusting its length and the loops at its ends, until a maximum plate current results in the oscillator plate circuit. The amplifier is then loosely coupled to the transmission line, and the grid loop adjusted until the plate current in the oscillator increases still more. If the oscillation stops, the coupling should be reduced between the transmission line and the oscillator, between the amplifier and transmission line, or both.

Fig. 3 shows also the general amplifier arrangement to be employed with a type 202 tube; other tubes can also be employed, but in the writer's tests this type gave good results. The plate "tank" of the amplifier consists of two parallel wires about one foot in length, when a type 202 is employed.

All the circuit constants, however, are influenced greatly by factors of construction and apparatus employed. The by-pass condensers, and other apparatus, usually assumed to be all right, at lower frequencies, may vary in their distributed capacity and inductance values, changing the required constants.

The Complete $\frac{3}{4}$ -Meter Transmitter

The complete master oscillator-power amplifier, $\frac{3}{4}$ -meter transmitter is shown in Fig. 4. All chokes in the oscillator consist of about 20 spaced turns on a
(Continued on page 231)

**WHAT YOU DON'T SEE
—ASK FOR!**

If there is some S-W set or subject you wish to see an article on—

TELL THE EDITOR

parallel wires, spaced about 2 inches apart, and closed upon itself at each end.

In order to furnish a strong $\frac{3}{4}$ -meter harmonic, the plate voltage on the oscillator should be raised above normal. Naturally, unless special precautions are taken, the amplifier will amplify other harmonics than the $\frac{3}{4}$ -meter one. The transmission line should first be tuned

In Our Next Issue

SUPER-MIDGET S-W TRANSMITTER FLIES WITH WEATHER BALLOONS. By Capt. James A. Code, Jr., U. S. Signal Corps.

SINGLE SIDE-BAND SYSTEM APPLIED TO SHORT WAVELENGTHS. By A. H. Reeves.

DIRECT-READING INDUCTANCE CHARTS—Enable You to Read the Inductance in Microhenrys of a Coil Easily.

THE PROPAGATION OF SHORT WAVES. By Robert Meyer (Germany).

NOVEL PLUG-IN-COIL CONSTRUCTION.

A NEW TRANSMITTER HOOK-UP FOR ULTRA SHORT WAVES.

ECONOMICAL MODULATORS FOR AMATEUR PHONE TRANSMITTERS. By C. H. W. Nason.

A SIGNAL FREQUENCY AMPLIFIER FOR S. W. CONVERTERS.

CHECKING THE SHORT WAVE TRANSMITTER, Including Instructions for Building a Wavemeter and Also a Monitor. By H. Harrison.

INTERESTING EXPERIMENTS WITH AN OSCILLOGRAPH. By Jess M. Reed.

EXPERIMENTING WITH RADIO "PROSPECTING" APPARATUS. By A. Binneweg, Jr.

The V-T V VOLTMMETER

THE writer is not going to insist upon the above sub-title, if it's going to cause any protracted argument—but as an engineer he feels that there is little doubt that the award may be given to the *vacuum-tube voltmeter* of E. B. Moullin. This instrument operates by virtue of the fact that the thermionic vacuum tube will act as a rectifier of alternating currents when correctly biased. Since the vacuum tube depends solely upon the *voltage* developed across its input for operation, little or no current is drawn from the circuit across which it is connected and, except at radio frequencies, it may be connected across any circuit without making any correction whatever for its presence. For this reason the device may be employed in measurements in amplifier circuits where any other available instrument would so upset the circuit structure as to render the readings valueless.

In constructing a tube voltmeter, the grid of the tube is so biased that, with no input signal, little or no plate current will flow. If a slight deflection of the plate current meter exists, it may be compensated by shifting the zero adjustment (with which all good meters are provided until with no signal input the indicating needle is exactly at zero on the scale. When a signal is now introduced across the grid of the tube a pulsating direct current, varying at the frequency of the input will result; the meter will indicate a *mean* value for this pulsating current. Calibration of the instrument may be made by the use of a small A.C. voltage, such as is available from a transformer, with input values varied by means of a potentiometer and measured by means of a good A.C. voltmeter of any type. The set-up of the apparatus for this purpose is as shown in the figure.

The simplest tube voltmeter, which the writer has used for many purposes in late years, employs a '20 tube with a

Radio's most useful instrument.

By C. H. W. NASON

This instrument is widely used for radio measurements and the author here describes how to make and use one. This meter draws practically no current from the circuit across which it is connected, and thus is invaluable for all radio measurements.

0-1.5-ma. meter in its plate circuit; it has a range from zero to 12.5 volts. This meter may be used with a tapped voltage divider for extending the range; that is to say, if a resistance across the circuit to be measured has a value of 1 megohm, and the meter is connected across one-fifth of the total resistance (across a 200,000-ohm section) the meter readings should be multiplied by 5 to obtain the true voltage. Thus the meter range has been extended to 62.5 volts. A voltage divider having ten 100,000-ohm sections will permit of a range up to 125 volts.

As An Output Meter

In using the tube voltmeter as an output meter it may be connected either across a speaker winding or across a resistance having a value fairly near the impedance of the speaker it simulates. Remembering Ohms' law ($I = E/R$), it is a simple matter to obtain the current through the resistance or through a speaker of known impedance. The power output may then be determined by multiplying the voltage by the current.

With a '20 type tube, applying a plate voltage of 22.5, a grid bias of 7.5 volts negative, and a filament voltage adjusted to 3 volts by means of a rheostat, the calibration of the meter will be approximately as shown in the curve. This may be taken as a true calibration of your meter if the results are not to be extremely accurate. If accuracy is desired, it will be necessary to take a new calibration by the method shown.

The calibration is in R.M.S. volts, which are but .707 of the peak values. In taking measurements on A.F. amplifiers it should be remembered that it is the peak voltage which determines when the D.C. bias of the amplifier tube will be overcome; so that a tube biased to ten volts, D.C., will accept a signal of but 7 volts, R.M.S., without swinging positive.

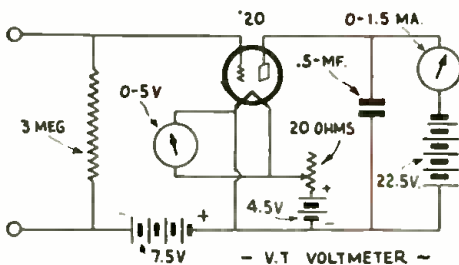

Hook-up of vacuum tube voltmeter.

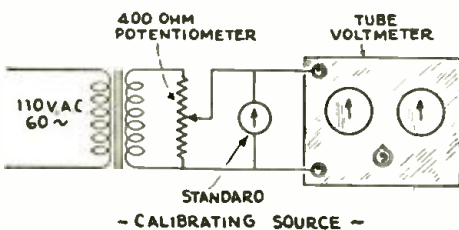

Calibrating source for V.T. voltmeter.

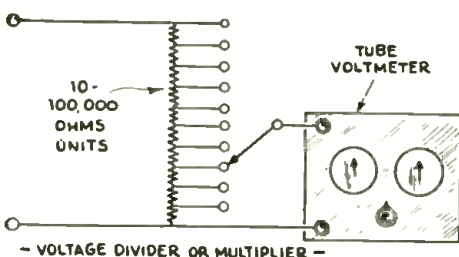

Voltage divider or multiplier for V.T. voltmeter.

Combination Long and Short Wave Receiver

I GIVE herewith a diagram of a combination Short and Broadcast Wave receiving set that really works. Although only one tube is shown, I use three (detector and two stages of audio). The switch connecting to the .00035 condenser (C2) cuts the C2 condenser out of the circuit, when working the short waves. When using the broadcast coil, the .000015 condenser (C3) is used as a vernier, while condenser C4 controls the regeneration.

The 500,000 ohm resistance (Frost type) is used in the first audio stage to control volume and cut out any howling that might be present.

The broadcast coil is made on a tube base, that has a four inch (length) card-

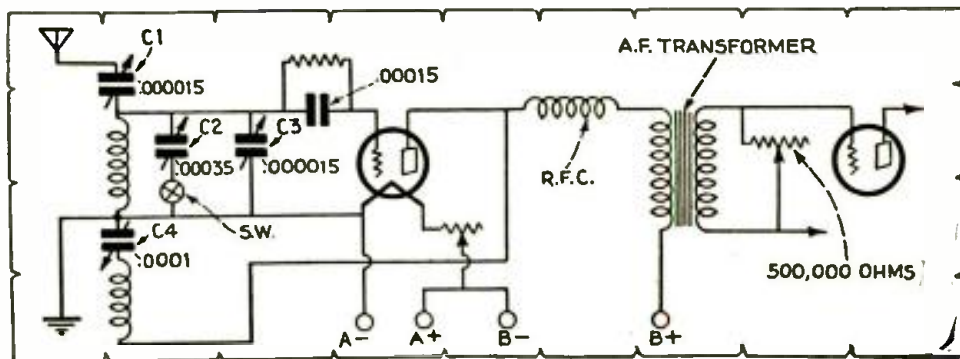

board tube. This can be made by using two or three turns of heavy wrapping paper, using radio cement to give it

strength. I have found that the four connections, with the help of a little
(Continued on page 232)

HOW TO NEUTRALIZE *Transmitting Amplifiers*

IN triodes used as R.F. (radio-frequency) power amplifiers, the tendency toward self-oscillation is quite as great as in tuned R.F. circuits in receivers. Simple and inexpensive neutralization methods involving the use of

The author explains in a clear manner how to neutralize radio frequency power amplifiers, with the aid of a few midget variable condensers.

from grid to plate of the opposed tubes. Viewed from the standpoint of equivalence (Fig. 2 B) we find a capacity

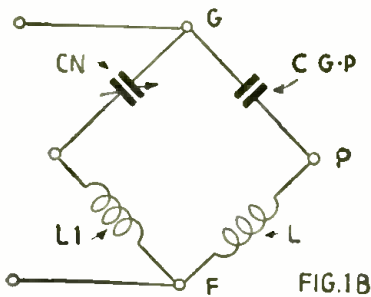

Fig. 1B illustrates equivalent bridge circuit of the neutralized stage in Fig. 1A below.

a few midget condensers are described in the following paragraphs. For this service, the straight-line capacity type with semi-circular plates should be used; the recently announced Hammarlund line of midget condensers is ideal for this service in low-powered transmitters. These condensers are provided with set screws for locking them in permanent adjustment, making it unnecessary to readjust unless prearranged circuit changes make it necessary to reneutralize the stage. In as much as the neutralizing circuits contribute to the losses in the circuit (unless they consist of pure reactances) the new low-loss insulating material employed in the construction of these condensers adds to their general adaptability for this service.

The system of neutralization to be employed with single tubes is known as the *Roberts* circuit, from its inventor, W. Van B. Roberts, whose name has been connected with so many receivers well known to the radio fan. Fig. 1 A shows a stage of amplification neutralized by this means; the winding in series with the neutralizing condenser should be a continuation of the plate tuning inductance.

The equivalent bridge circuit of such a stage is shown graphically in Fig. 1 B. It may readily be seen that, if L and L¹

and C_{g-p} and C_n are equal, the two arms of the bridge shown will balance. If, however, it is inconvenient to have the inductance L¹ equal to L then fewer turns may be used in the neutralizing winding, and a larger capacity should be employed. It should be remembered in this connection that the inductance of a

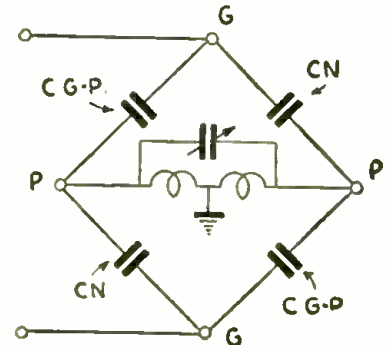

FIG. 2 B

Fig. 2B, equivalent bridge circuit of neutralized push-pull stage illustrated in Fig. 2A below.

**"CHECKING THE
SHORT WAVE TRANSMITTER"**

By H. HARRISON

Includes instructions for building a wave-meter and also a monitor. In Next Issue.

winding varies as the *square* of the number of turns employed. For this reason the equation

$$C_n = a^2 \times C_{g-p}$$

should be borne in mind in designing neutralizing circuits. In this equation "a" represents the ratio between the number of turns comprising L and those in L¹.

In a stage employing a 211 tube (C_{g-p} = 15 mmf.) with half the number of turns in the coupling inductance that appear in the main tuning inductance, the capacity of the neutralizing condenser should be 30 mmf. The maximum capacity of the condenser chosen should be at least a small percentage higher than this value, to allow for ease of adjustment. (The MC-S 49.2 mmf. type is ideal.)

In transmission circuits where push-pull connections are employed neutralization is highly simplified. In Fig. 2 A is shown a stage of push-pull, with neutralizing condensers at C_n.

bridge of rare simplicity. The values for balancing the bridge require that the condensers (C_n) be equal in value to C_{g-p}. This necessitates in most cases, a condenser having an extremely low minimum value (the MC-S 19.2 mmf. model for example) if ease of adjustment is to be obtained.

The process of neutralization is quite simple. With the grid and filament voltages applied, but with the *plate voltage off*, start up the oscillator in order to apply a signal of the desired frequency to the amplifier input. Now couple a few turns of wire, connected to a small neon lamp or flashlight bulb, to the high-potential end of the plate tuning coil of the amplifier stage being neutralized; and tune the plate circuit to the signal frequency. The search lamp will indicate where a voltage transfer through the tube exists. Rotate the neutralizing condenser slowly, until no signal is present in the amplifier output. The stage is now completely neutralized, and plate voltage may be applied. Starting with the first amplifier stage, this same process is continued until the successive stages of a multi-stage amplifier system have been neutralized.

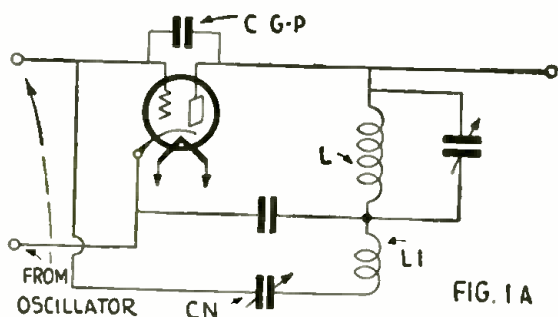

FIG. 1 A

Fig. 1A at left, shows a stage of amplification neutralized by a midget variable condenser CN. Coil L1 is a continuation of winding L.

Fig. 2A shows a stage of push-pull, with neutralizing condensers at CN.

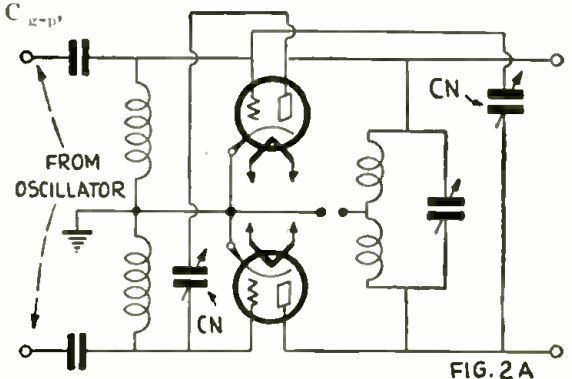

FIG. 2 A

Benefits I Derive From — A SEPARATE REGENERATION TUBE

IT is common knowledge that the ordinary autodyne (regenerative) detector used in all short wave receivers is hard put to it, to efficiently carry out the dual functions of *rectification* and *regeneration*; and it is the purpose of this article briefly to describe a tuned radio-frequency receiver, in which the function of regeneration is allotted to a separate tube, called the "reactor." This tube need not be chosen with an eye to its ability to rectify, but rather to oscillate smoothly and easily; and here is advantage number one. The mean grid voltage of the reactor will not be

By E. T. SOMERSET
G2DT, Assoc. Member I. R. E.

Probably no one thing has caused as much trouble as the regeneration control in the average set. Mr. Somerset here explains how he uses a separate "reactor" tube, which at last provides a smooth and reliable regeneration control.

except that the familiar hiss of the detector has vanished and the trials and tribulations of getting the correct ratio of screen-grid volts to plate volts for an autodyne S.G. detector becomes quite a simple job. It will be found in operation that, when a separate reactor is used, a quite considerable increase in tank capacity is needed, as against the autodyne (usual tickler feed-back) arrangement.

As a guide to efficient operation it may be well to mention that readings on the oscillator and detector meters of 0.4 to

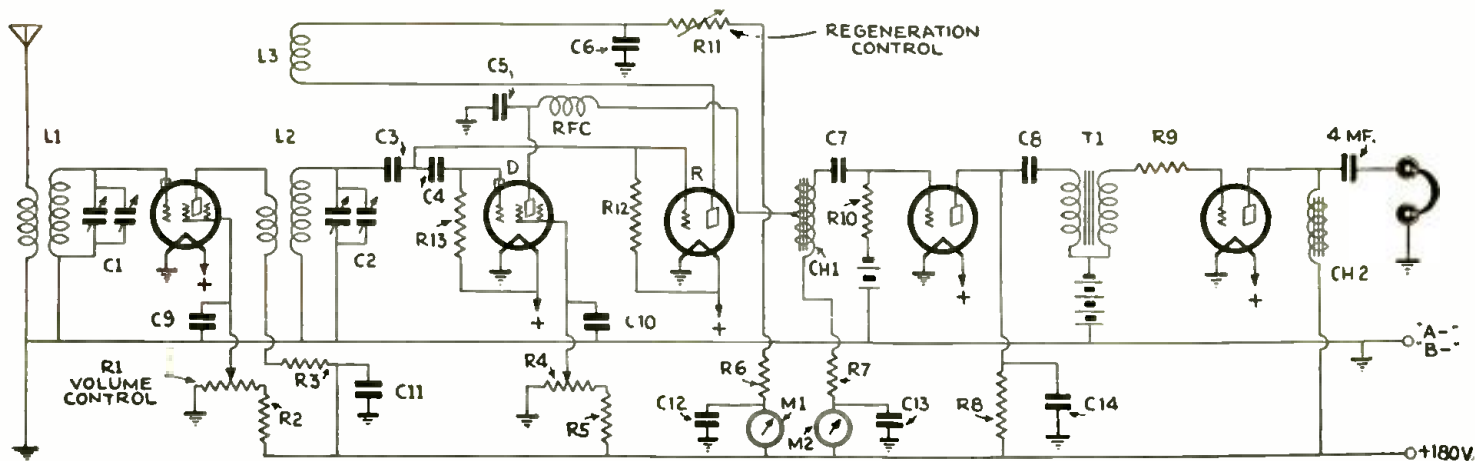

Complete hook-up of the Somerset short wave receiver, with separate reactor tube "R," used solely to provide smooth and reliable regeneration control. The regeneration is regulated by the variable resistance R11. Detector tube "D," is impedance-coupled to the first audio stage.

affected by the change in the steady grid voltage of the rectifier (detector), so that the fall of grid voltage due to the rectification of the carrier does not have to be arranged for—and this is advantage number two. Lastly, we have the greatest advantage in being able to make our detector, whether it be a triode or a screen-grid, operate at optimum and thus achieve maximum efficiency in rectification.

Simple to Construct

From the circuit diagram it will be apparent that no difficulties in construction will be encountered by the beginner—in fact, a Pilot Super-Wasp can readily be altered to take the "separate reactor" tube. The question of coupling between the detector and the first audio tubes arises and, while the author has found resistance-capacity coupling to be preferable in the case of the autodyne detector, it is possible here to use choke-coil coupling (which gives greater amplification) without fear of encountering "threshold howl." The only shielding used is a cylindrical cover for the R.F. tube, and an electro-

static shield of 14 gauge aluminum between C1 and C2—and the receiver is perfectly stable; this being due, in no small measure, to the adoption of the Ferranti plate-feed scheme, as shown by the liberal use of resistors, which serve the dual purpose of decoupling and voltage dropping and save the necessity of battery tapping points for varying potentials required.

Ease of Operation

In operation the receiver is very much the same as the customary autodyne;

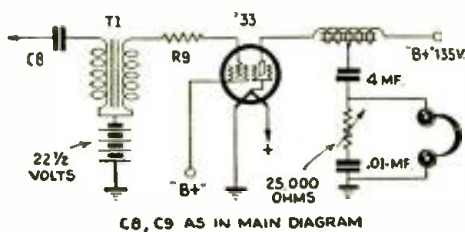

C8, C9 AS IN MAIN DIAGRAM

Mr. Somerset's improved regenerative short wave receiver, may have a Pentode power tube added to the output stage, as shown in the diagram above.

0.5 ma. and 0.8 to 1.1 ma., respectively, should be aimed at.

Winding data are given for the coils which are wound on R. E. L.* forms; although a Pilot form may be used for L1 to advantage, as it occupies far less room. For non-amateur use it will be advisable to substitute ordinary Pilot 100 mmf. variable condensers for the tank-verniers used by the author.

Use of a Pentode

In this case it is also worth considering the use of a pentode tube in the second audio stage and a diagram for this is appended. The important thing of note after the tone control (of which more anon) is the negative bias of 22 1/2 volts, which is recommended to limit the flow of plate current through the phones to reasonable proportions. For loud-speaker work reduce this bias to about 10 volts.

As regards telegraphy, we can pass over the pentode but it is the reception of telephony which causes us to halt and

*Radio Engineering Laboratories, L. I. City, N. Y.

(Continued on page 219)

PUSH-PULL TRANSMITTER CIRCUITS—

A Frank Discussion of Their Merits and Demerits

By C. H. W. NASON

ONE of the virtues of the push-pull circuit is the fact that the signal voltages automatically stay put. High frequencies have a way of sliding through one's fingers in a weird, eel-like fashion and getting in

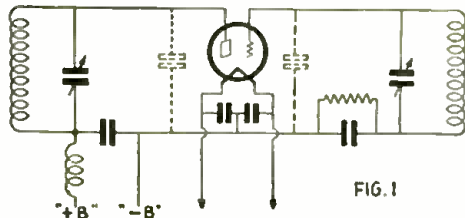

Fig. 1—The tuned-grid, tuned-plate oscillator.

where they can pop condensers in circuits never meant to carry them. Condensers and chokes have a way of reversing their purposes in the extreme short-wave ranges; the condenser you thought so well of turns out to be a first-class inductance in its ultimate effect, while the R.F. choke you wound so carefully has a complete change of heart and behaves as no self-respecting inductance should—exactly like a condenser.

Push-Pull Amplifiers

Push-pull amplifiers are readily neutralized by a simple arrangement of two midget condensers; and stray admittances, due to the internal capacitance of the tubes, have a nice way of appearing in series across the tuned circuits so that they are but half as effective in decreasing the efficiency of the circuit. Tube variations, due to changing voltages or heating effects, operate amongst themselves so that the effects are greatly reduced. On top of this, amplifiers in 'phone transmitters can be operated at greatly increased efficiency without incurring undue distortion. Now let us see just how all these wonders come about.

Tuned Grid—Tuned Plate Oscillator

Fig. 1 shows a circuit arrangement for a tuned grid—tuned plate oscillator of rather ordinary characteristics. The grid-filament capacities are shown directly across the tuned circuit in one case, and the plate-filament capacity is across the capacity in the other. Besides this there are various chokes, etc., which may or may not act as specified when operating at high frequencies. At any rate, it is rather a certainty that the chokes will not act properly without a great deal of experiment if we are to use the set in several of the transmission bands assigned for amateur operation. This means that we will have to shift when changing our operating bands—an awkward procedure, to say the least.

Why is a push-pull circuit superior to a single tube for transmitters? What is the Mesny oscillator? What is a self-rectifying transmitter? These and other questions are answered by the author.

In Fig. 2 we have the same circuit rearranged for push-pull operation. Here we have gained one thing—the tube capacities are in series, and their total effect across the tuned circuit is just half that found in the single-tube circuit. But wait—aren't there still a few things left undone? Look at those condensers—neither side is at ground potential! Are you certain that the by-pass condensers are in their proper place—that is, that they are not effective as inductances at the frequencies you expect to operate at? In fact, are you certain that your circuit does not look like Fig. 3?

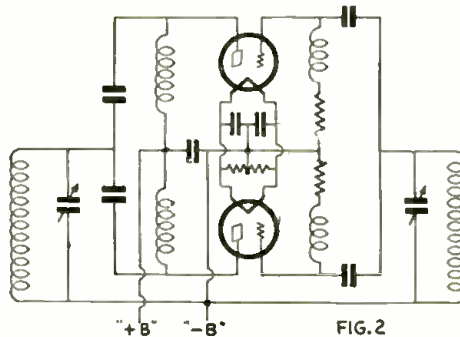
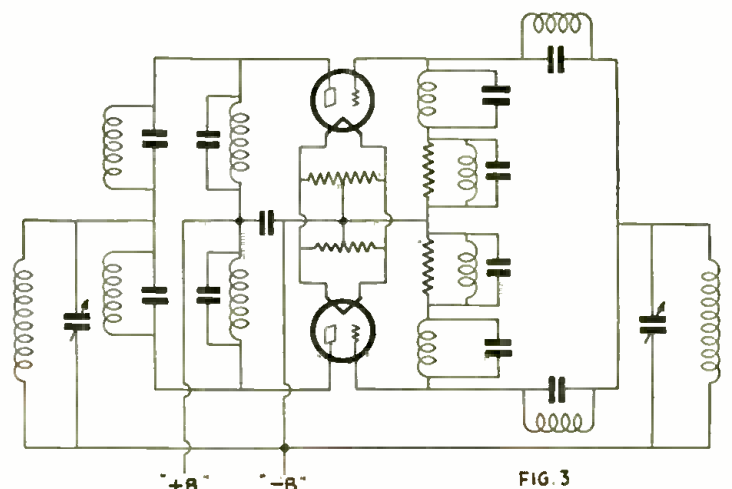

Fig. 2—Push-pull form of tuned-grid, tuned-plate oscillator.

Simplifying the Circuit With Advantage

It is a fact that the most of the "junk" shown in the circuit can be thrown overboard in the push-pull circuit, with good advantage as to ultimate operating efficiency. There is no voltage of the signal frequency present in the common circuits—that is the "B," "C" or "A" cir-

Fig. 3—After studying the diagram of the push-pull transmitter shown above in Fig. 2, are you sure that this circuit does not resemble Fig. 3.



cuits. The circuit arrangement shown in Fig. 4 is far more efficient in operation, and far less liable to trouble by breakdown from stray R.F. energy, than the previous design where such elaborate precautions were taken—and where these very precautions defeated their own purpose.

The condensers shown may be .0005-mf. receiving condensers, where low power operation is involved, and they are each composed of two such units ganged. The total capacity of the two units in series is half the maximum of one alone, or 250-mf. There is a certain amount of second-harmonic voltage flowing in the common circuits and for this reason, the one R.F. choke in the plate supply lead is left in the circuit. Note that all other by-passing and choking devices have been completely thrown out.

This makes things look more interesting; as it appears that such a low power push-pull job can be constructed for less money than was the case with the single-tube arrangement.

Advantages of Push-Pull Amplifiers

The advantages possible with push-pull audio amplifiers, as compared with single-tube units in broadcast receivers, obtain in transmission circuits also. In a previous article, the writer made lengthy comment on the different classes of amplifier operation. It makes little difference how much distortion occurs in the amplifier stages of a code transmitter; for the use of circuits in which the capacity is predominant results in a short-circuiting of the harmonics produced. Indeed, in the "frequency-doublers" used in some systems, we deliberately produce distortion in order to obtain a large harmonic content. Push-pull amplifiers do not provide for frequency doubling, unless special connections are made in the circuit elements. If the direction of winding of one of the plate

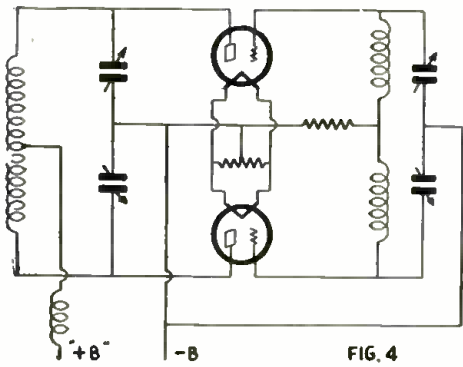

Fig. 4—Shows an efficient push-pull transmitter circuit, which has a number of advantages, as pointed out by the author.

coils is reversed, however, the entire output will be of the second harmonic or double the frequency of the input. By their proper connection, an amount of third harmonic is obtainable.

We noted, in the previous article mentioned above, that with push-pull amplifiers it is possible to employ Class "B" amplifiers in the stages succeeding modulation, in order to secure the added efficiency possible. Class "B" amplifiers, used with a single tube to amplify a modulated signal, produce, not only harmonics of the carrier frequency, but also harmonics of the modulation with resulting distortion. The second harmonic being the strongest, the use of push-pull leaves only the odd harmonics in the output. These are never very strong and, unless the modulation percentage is excessively high, no distortion will result from using push-pull amplifiers as Class "B" stages following the modulated amplifier.

Neutralization Is Simple

Neutralization of the push-pull stage is simplicity itself. It is merely necessary to "cross-neutralize" from alternate grid to plate as shown in the figure. The procedure has been described so often as to make the repetition needless.

Note that in the push-pull amplifiers, it is possible to provide a perfectly bal-

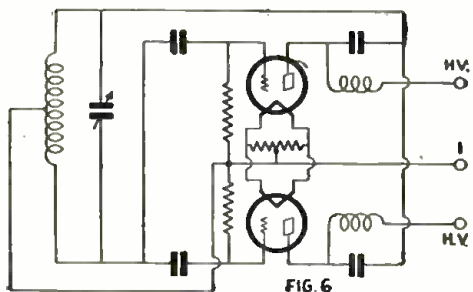

Fig. 6—Shows an oscillator circuit of the simple Hartley type, redesigned for use with raw A.C. on its plates.

anced feed to the antenna, since neither end of the coupling coil is at ground potential. This makes a perfect arrangement for use with directive antennas, such as will be described elsewhere.

Self-Rectifying Hook-up

Some "old-timer" made the crack that "all that glistens is not gold"; and, similarly, be certain to note that all is not

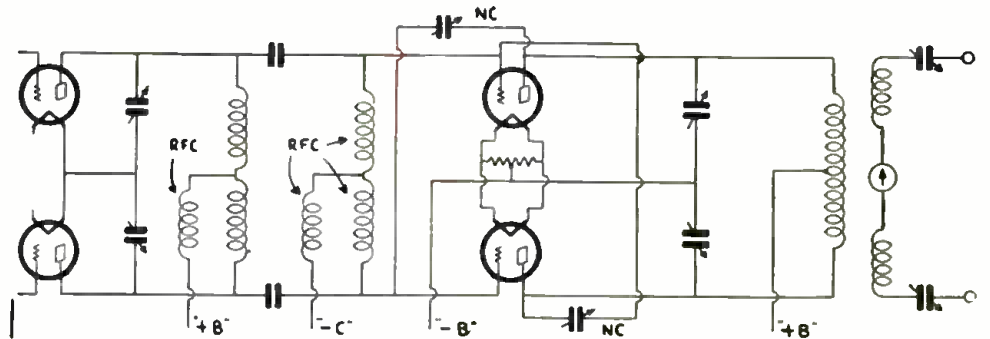

Fig. 5—Shows cross-neutralization in a push-pull transmitter circuit. It is merely necessary to cross-neutralize from alternate grid to plate as shown.

"push-pull" that uses two tubes in a peculiar arrangement! The oscillator circuit shown in Fig. 6 is a simple Hartley oscillator, redesigned for use with raw A.C. on its plates; the arrangement is such that one tube operates during each half of the A.C. cycle. This type of operation is not permissible in modern transmitters; but it is possible to employ self-rectifying circuits as R.F. power amplifiers, provided the preliminary stages

must balance and tubes must be identical, if the pure note put into the amplifier by the preceding D.C. stages is to come out "sweet" instead of "sour"!

Tubes are so connected that they are in parallel, so far as the plate supply is concerned, but in push-pull with regard to the radio-frequency circuit arrangement. Tubes alternate in operation, so that one tube in each side of the circuit will be in oscillation at all times. The terminals HV go to the outer ends of the power transformer, while the terminal CT goes to the transformer center tap and ground.

The Mesny Oscillator

To go from such a complex arrangement to the simple one shown in Fig. 8 seems ridiculous, only if we have forgotten that the reduction in the capacity across the tuned circuit, obtained through the use of the push-pull connection, will assist us in operating at the ultra high frequencies. The circuit shown is that of the well-known Mesny oscillator, probably the first push-pull transmitting arrangement to gain any particular note; it will oscillate with ease at the highest frequencies.

The circuit arrangement shows the oscillator coupled to a half wave an-

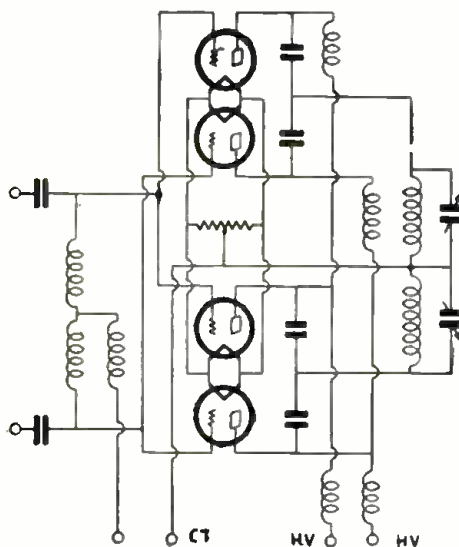

Fig. 7—Here we have a method for operating an R.F. power amplifier with "self-rectifying" connection.

are fed with D.C. It is possible to effect great economies in this fashion, if reasonable care is taken in the balancing of the circuits.

In Fig. 7 is shown a method for operating an R.F. power amplifier with a self-rectifying connection. It is essential that all possible symmetry be obtained if the desired results are to be obtained—chokes

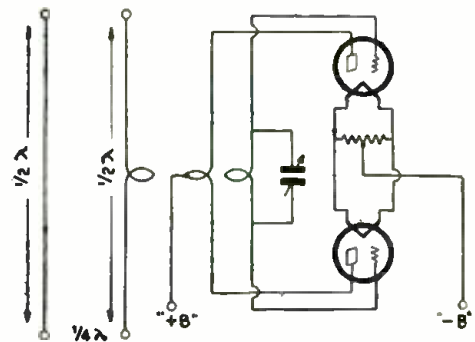

Fig. 8—The Mesny oscillator circuit, using tubes connected in push-pull, arranged to be tuned to any particular note.

**How to
EXPERIMENT
with
"ORE LOCATING"
Short Wave Apparatus**

By A. BINNEWEG, Jr.

In Next Issue

tenna. Directive action may be secured by putting a second half-wave antenna at a quarter-wavelength away from the radiator; the directivity will then be away from the reflector, in the plane of the antennas. Operation on the extremely high frequencies is quasi-optical in effect; in making tests have the two stations within sight of one another.

All-Electric, Single Dial Tuning SHORT WAVE SUPER-HET

PROBABLY the majority of all short-wave sets today use a regenerative detector, with an audio frequency amplifier. Even if it is possible to receive far-distant stations with such a set, still it must not be forgotten that the tuning of such a short-wave receiver is essentially harder than that of an ordinary radio receiving set.

The receiver described here avoids the critical tuning difficulty just mentioned. In the present design are united high sensitivity and ease of adjustment; for the difficult regeneration control is done away with, and the tuning is accomplished by merely operating a single variable condenser. Therefore this set has *single-dial operation*, and is accordingly just as easy to tune as an ordinary radio receiver.

By K. KÖNIG

Description of the prize-winning set in this year's competition of the Reichs-Rundfunk-Gesellschaft.

amplifying effect of regeneration, it is necessary to introduce an efficient stage of R.F. amplification ahead of the detector. Because the efficiency of direct radio-frequency amplification strongly decreases with increasing frequency, we cannot use the direct radio frequency amplification of the short waves. We therefore use, as is evident from Fig. 1, the *superheterodyne principle*, by which the short waves are changed into long ones; which can then be subjected to R.F. amplification with a high degree of efficiency.

The antenna is, as made clear from Fig. 1, coupled with a screen grid tube, a method which has proved efficient for more sensitive short-wave receivers and has already become a standard hook-up. The input circuit is not tuned but is kept fully aperiodic by the resistor R1, of 10,000 to 30,000 ohms. In spite of the lack of tuning this input hook-up gives a certain R.F. amplification and,

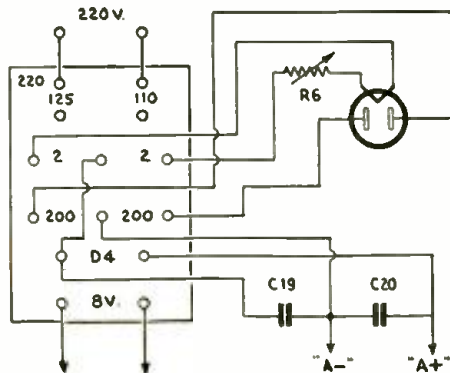

Fig. 2—Terminals and hook-up of the A.C. power transformer with choke.

The Hook-up

Since we do not make use of the

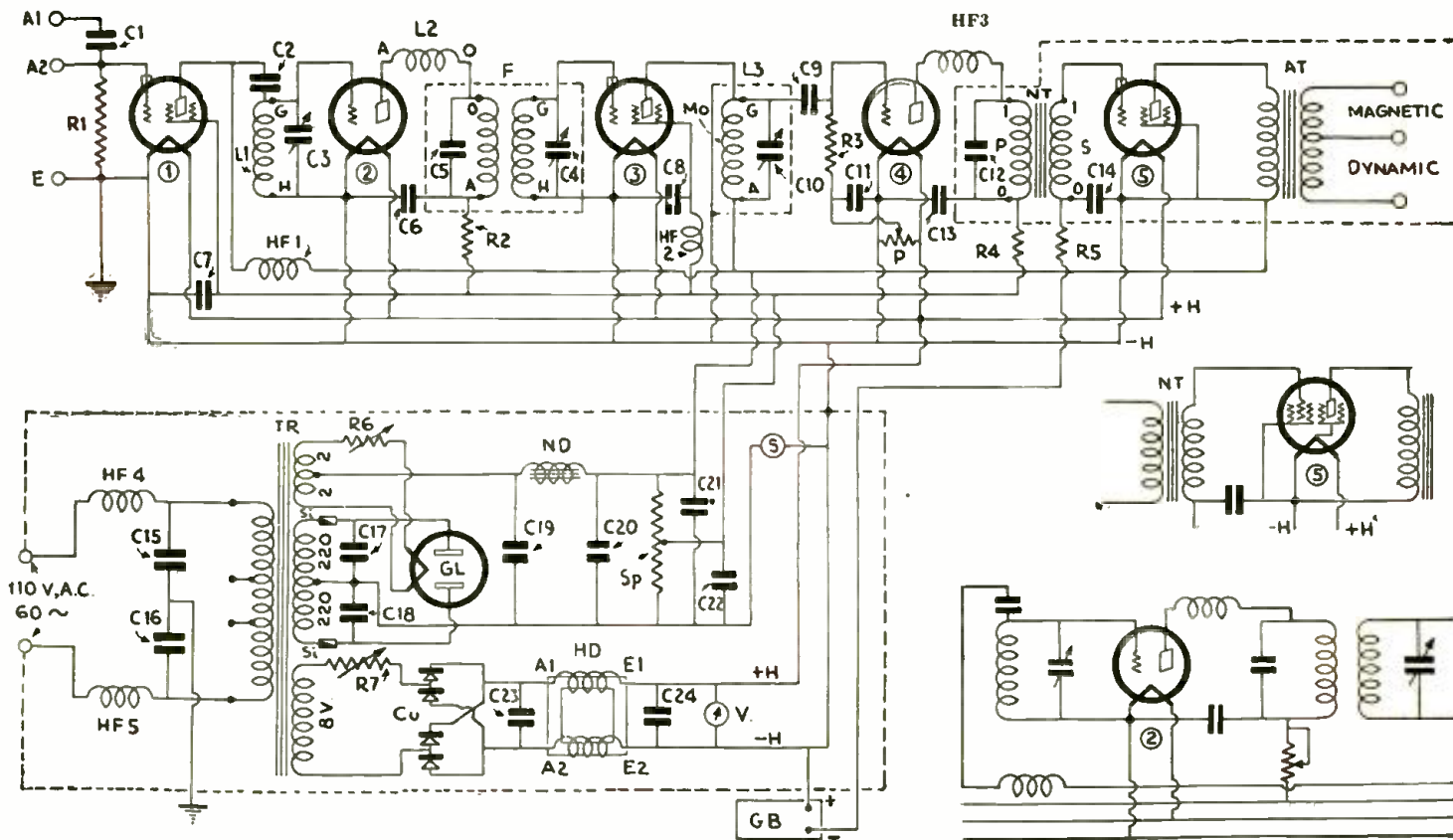

Fig. 1—Hook-up of the All-Electric Super-Heterodyne: L1, L2, oscillator coil; F, filter; primary 300, secondary 600 turns; C5 1250 mmf.; C4 500 mmf.; L3 1200 turns, C10 300 mmf.; C1, 25 mmf.; C2 15 mmf.; C3, 100 mmf.; C6, C7, C12, each 2000 mmf.; C9, 250 mmf.; C8, C11, C13, C14, C15, C16, each 1 mf.; C17, C18, each 1 mf.; C19, 10 mf.; C20, 8 mf.; C21, C22, each 2 mf.; C23, C24, each 2500 mf.; HF1, HF2, HF3, HF4, HF5, radio frequency chokes; R1, R2, each 10,000 ohms; R3, 2 megohms; R4, .02 megohm; R5, .1 megohm; R6, 5 ohms (2.2 amp.); R7, 20 ohms (1.6 amp.); P, 1000 ohms; Sp, 15,000 ohms; NT, 1:4 ratio transformer; AT, 1:1; TR, power transformer; ND, filter choke; HD, heater filter choke; GL, rectifier tube; Cu, copper oxide (dry rectifier plate) system, 1 amp.; V, voltmeter, 0-6 volts; Si, delicate safety devices, .125 amp.; S, tube fuse. Center diagram at right is hook-up for pentode, if used in output stage; lower right diagram shows use of potentiometer in oscillator plate lead.

thereby, an increase in the sensitivity of the set. Compared with sets with tuned input circuits, however, this arrangement has the advantage that one is independent of the antenna conditions, so that different types or sizes of antennas do not influence the tuning.

The receiver therefore becomes very stable and capable of exact calibration; which is especially favorable for easy tuning of the set described here, since only the 100 m.m.f. rotary condenser C₃ is used for tuning. Smaller antennas are connected at A2, directly to the grid of the input tube; larger ones at A1 over the 25 m.m.f. "shortening" aerial condenser C1. At the ends of the resistor R1 (which should be as free as possible from induction and capacity) are produced the necessary A.C. grid potentials which, after being amplified by the input tube, pass over the 15 m.m.f. coupling condenser C2 to the grid of tube 2, which is an oscillator. In the plate lead of the input tube is inserted a special, short-wave, R.F. choke HF1, which will be more exactly described later.

The tuned grid circuit L1-C3 of the second tube is made to oscillate by the feed-back coil L2. Besides this natural (local) frequency, the signal frequency also, as already shown, passes from the input tube through the coupling condenser C2, to the grid of the oscillator tube; so that both frequencies appear, amplified, in the plate circuit of the tube. Now the natural (local) frequency of the oscillator circuit, caused by the grid current flowing during the positive half period, results in a weakening of the signal frequencies; and thereby makes possible the rectification of both frequencies. There is thus produced a kind of rectification like that in the so-called *Strobodine* receiver.

The oscillator tube gets its most favorable plate potential through resistor R2, which at the same time, in connection with the bypass condenser C6 (2,000 mmf.) prevents reverse action of the oscillator currents on the other tubes, via the battery leads. To get the best conditions for operating the oscillator tube, one must in some cases exchange resistor R2 (Fig. 1) for another size. Whoever does not have different values of resistors on hand, can make the adjustment easier by building in a potentiometer, instead of the resistance, as in Fig. 1 at the right. Parallel to the primary side of filter F, lies a 1,250 mmf. block; the secondary side can be equalized by the rotary condenser C4 (500 mmf.). To prevent mutual coupling of filter and blocking circuit (L3, C10), both are completely screened.

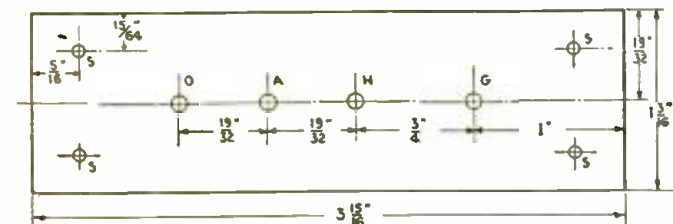
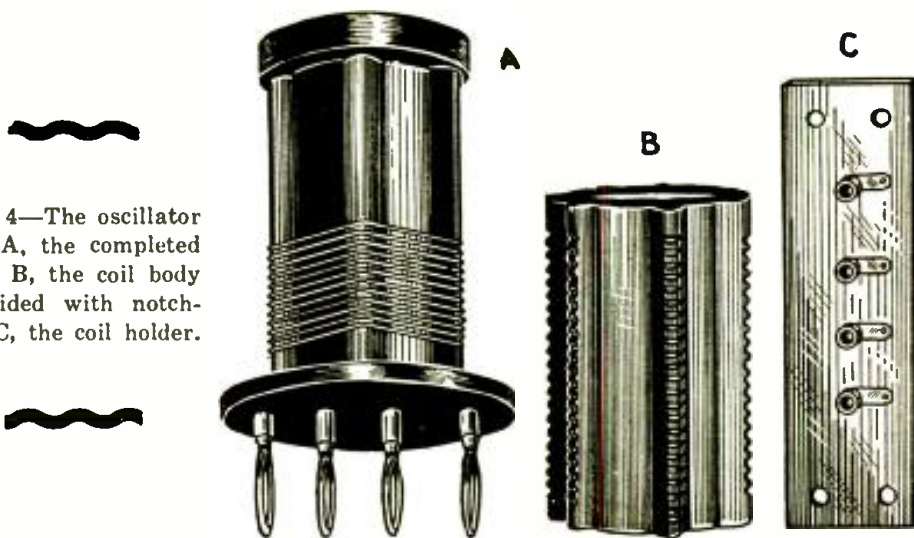

Fig. 5—Diagram for drilling coil holder.

Fig. 4—The oscillator coil A, the completed coil; B, the coil body provided with notches; C, the coil holder.



It was possible to limit the intermediate-frequency amplification to a single stage by putting in a screen-grid tube

(3). Since the long waves are especially favorable for radio-frequency amplification, the high degree of amplification of the screen-grid tube is well utilized. In the plate potential lead lies a blocking choke HF2, which is bridged by a 1-microfarad bypass condenser C8. The choke consists of a hard rubber form 1 inch in diameter, with six slits each .08 inch wide and 1/4 inch deep. The slits are wound in series with enamelled resistance wire. No. 36 B. & S. gauge magnet wire. There are 15 turns per slit; the D.C. resistance amounts to about 500 ohms. In the plate circuit of the intermediate-frequency tube, lies the coupling circuit L3, C10, tunable by the 300 mmf. rotary condenser C10; the grid of the detector tube 4 being connected to this circuit.

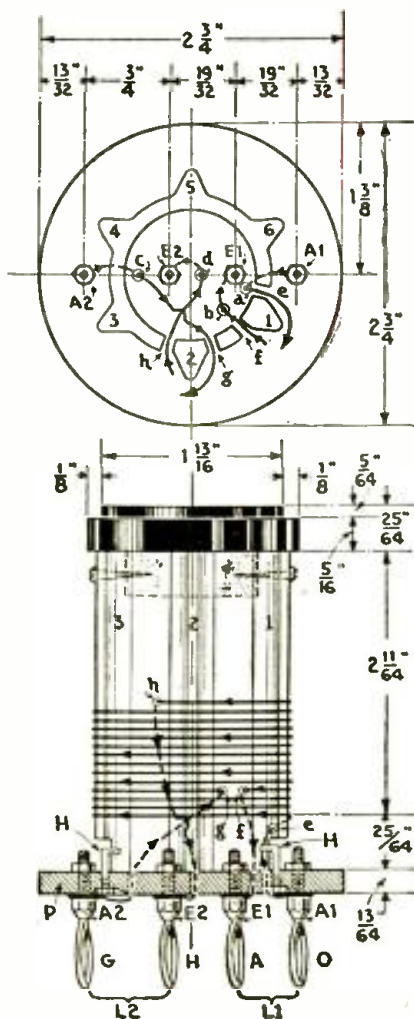

Fig. 3—Construction diagram for the oscillator coils.

The detector stage has the usual hook-up. C9 and R3 therefore have the usual values of .00025-mm.f. and 2 megohms. The grid return is not joined to the heater lead but to the arm of the 1,000-ohm potentiometer P; with which one can adjust to the most favorable operating point of the tube. The arm is shunted by a 1-mf. bypass condenser C11. For keeping the radio-frequency currents out of the audio-frequency amplifier, ordinary commercial radio-frequency chokes HF3 are utilized, and the .002-mf. bypass condenser C12.

The single stage of audio-frequency amplification, with a screen-grid tube, is likewise shielded with sheet aluminum. The resistors R4 and R5 serve in combination with the bypass condensers C13 and C14 (1 mf. each) as filters. The loud speaker is connected to an output transformer AT, which makes possible the use of either a magnetic or a dynamic loud speaker.

The Power Unit

Since short-wave receivers are especially sensitive to A.C. line disturbances, no indirectly-heated tubes have been used but, on the contrary, ordinary battery tubes, whose heater current is provided by a dry rectifier. The A.C. transformer TR has for this purpose a special heater winding (8V) for producing a low A.C. potential, which is

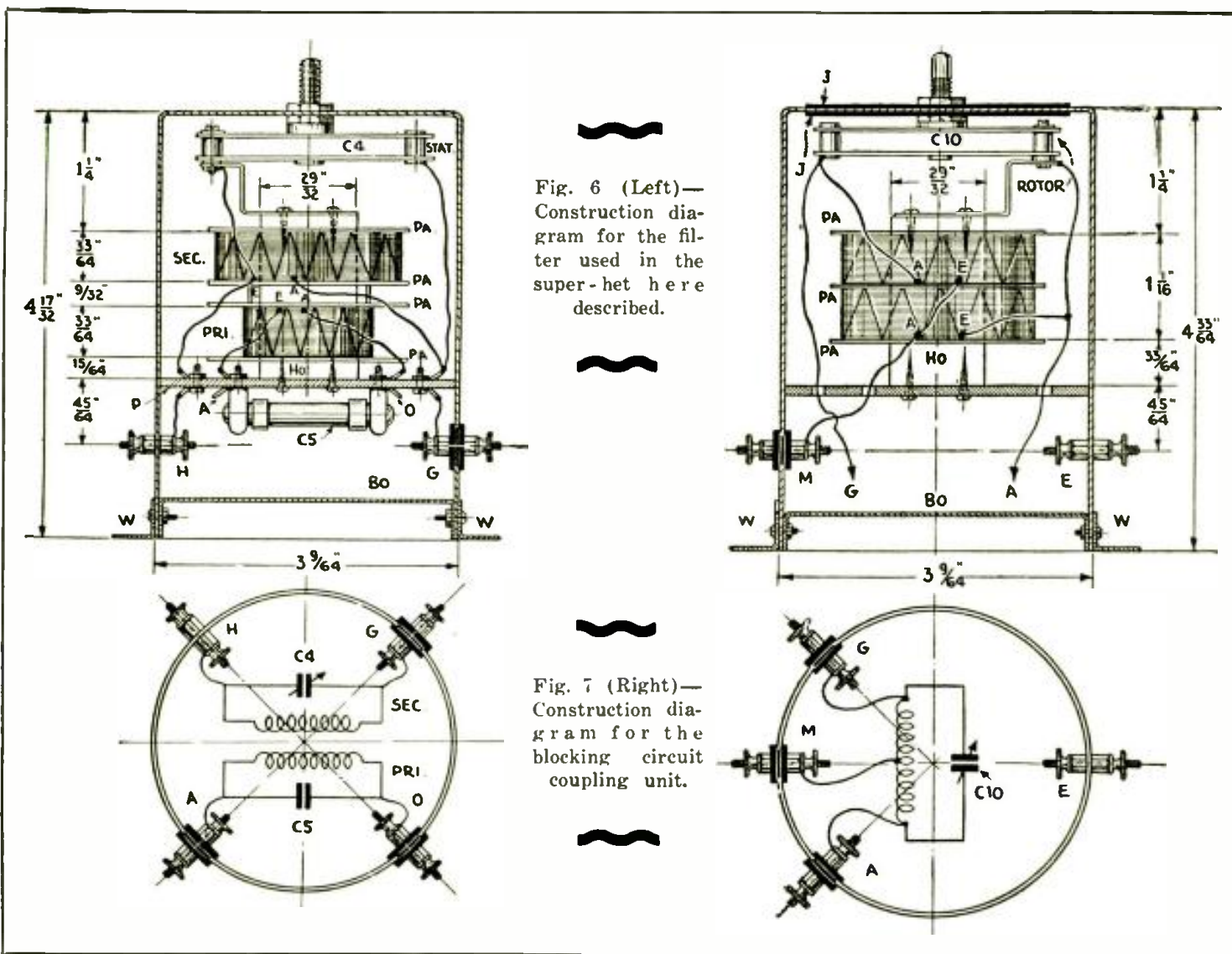

Fig. 6 (Left)—
Construction diagram for the filter used in the super-het here described.

Fig. 7 (Right)—
Construction diagram for the blocking circuit coupling unit.

rectified by the copper oxide system "Cu." Naturally, this system must be of such dimensions that the heater current obtained suffices for the number of tubes. The system employed has a heater current output of 1 ampere. The pulsating direct current furnished by the copper oxide system, is smoothed out by the double choke HD, in combination with the two electrolytic condensers C23 and C24 (each 2500 mf.). For regulating the heater potential at 4 volts, there is used the 20-ohm resistor R7, in combination with the voltmeter V (0-6 volts: a soft iron instrument). The two resistors R6 (5 ohms) and R7 must be of wattages suited to the loads present (so-called "high-amperage resistors").

The power transformer TR and the choke ND are sealed up together in an iron case and in this form represent an especially practical component. The terminal connection and the hookup of the power unit are shown in Fig. 2. In every plate lead of the rectifying tube G1, lies a special delicate safety device S1 of 0.125 ampere. As a further safety device, a plate ballast lamp S prevents the burning out of the filaments of the receiver tubes. To prevent any disturbances of a high-frequency nature from running over the A.C. system, there

have been built into the A.C. supply wires the R.F. chokes HF4 and HF5 (described in detail later) and the condensers C15 and C16 (1 mf. each). The iron cores of the power transformer TR and of the chokes ND and HD, as well as the cans of all the block (bypass) condensers, are, as will be shown later, grounded in a simple manner.

Individual Parts: The Oscillator Coils

Grid circuit coil and feed-back coil are on the same coil body; the tickler coil L2 is below the grid coil L1 above. Both have the same direction of winding (see Fig. 3). For the wave range, about 10 to 200 meters, six coils are used, which cover approximately the following bands: Coil 1, 10-23 m.; coil 2, 18-32 m.; coil 3, 28-52 m.; coil 4, 50-72 m.; coil 5, 70-125 m.; coil 6, 110-200 m. The windings of the coils 1 to 4 consist of No. 18 enamelled copper wire, spaced twice their thickness. For coils 5 and 6 the windings lie side by side without any spaces. In the two feed-back coils the winding consists of No. 20 D. S. C. copper wire. The grid circuit coils are of 30 x No. 40 Litz wire. The coil form is a hard-rubber ribbed tube of 1.9 inch external diameter.

First the coil form must be provided with the necessary notches for fasten-

ing the windings (Fig. 4, B); they begin .4 inch above the lower edge. After the point of notching is marked with a colored crayon, it is given a small incision with a fine saw (fretsaw or, better still, a small hack saw); this then being enlarged with a sharp-edged file. In this way the distance between turns is kept more exact than if one goes to work with the file without preliminary sawing; since the file slips easily from the point of marking. The bottom plate P with the prongs consists of 0.2-inch bakelite.

The arrangement of the prongs is evident from Figs. 3, 4, and 5. The coil form is fastened to the bottom plate P at ribs 1, 3, and 5 by three small prongs having nuts on them (H, in Fig. 3), and thereby results a very stable construction. From the designated ribs there is first removed with a file, so much material that the vertical part of the prong no longer projects beyond the edge of the rib. Two-tenths inch above the lower edge of the coil body, there is made a hole (.08 inch in diameter) for the horizontal part of the hook. The vertical part has a thread for receiving a nut, which (as is evident from Fig. 3) is countersunk in the bottom plate P. According to Fig. 3 the hooks seem to be

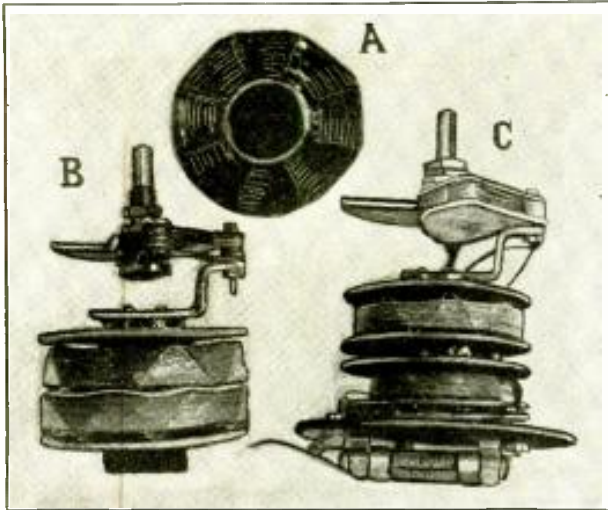

Fig. 8—Blocking circuit and filter before being built in. A, an individual coil; B, blocking circuit; C, filter.

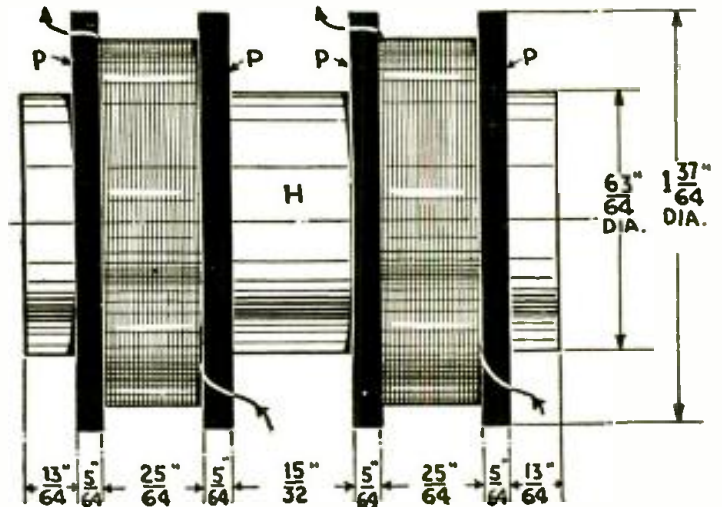

Fig. 10—The R.F. (radio frequency) chokes HF4, HF5.

located directly beside the prongs; which, however, is not actually the case. Fig. 3 was purposely drawn somewhat out of alignment, to show as many details as possible of the coil,

In making the windings we put the beginning of the tickler coil A1, under prong O, pass the wire at "a" through the bottom plate, at "e" on the right-hand side of rib "1" through the wall of the coil form to the outside; now wind on the prescribed number of turns (see below). From end "E" of the winding, we go at the left-hand side of the same rib "1" at "f," through the wall of the coil body inward; at "b" through the bottom plate; and put the end under prong "A." The beginning A2 of the grid coil, we put under prong "G"; pass at "c" through the bottom plate; pass at "g" on the right-hand side of rib "2" through the coil body outwards; and, after ending the winding at the left-hand side of the same rib "2," pass at "h" inward through the wall of the coil body; at "d" through the base plate; and then to prong "H." The two windings are therefore no specified distance apart.

At the upper end of the coil body we screw the cover "D," turned out of hardwood on a lathe. This makes possible more convenient handling when changing coils (also in the case of accidental disconnections). The number of windings are as follows, "a" being for the regeneration coil and "b" for the grid circuit coil in each case: 1, a, 1½; b, 3; 2, a, 2; b, 5; 3, a, 3; b, 10; 4, a, 5; b, 20; 5, a, 10; b, 30; 6, a, 18; b, 50.

The construction of the coil holder is shown in Fig. 4C and Fig. 5. The bakelite plate contains four sockets for the four coil prongs and four holes "S" for fastening to the mounting board of the receiver.

The Filter

The filter is, as appears from Fig. 6,

completely shielded. The upper illustration shows the construction; the lower one the arrangement of the terminals. For shielding there is used a regular commercial shield can, whose bottom "Bo" is taken from the coil fastening belonging to the can, and is at the same time screwed on the shielding cup by the angle pieces "W" made of sheet aluminum. The coils are made without bodies (so-called "lattice coils") and represent a special type obtainable commercially. The primary coil has 300 turns, the secondary coil 600; made of No. 30 silk-covered copper wire. The beginning and end of the coils are indicated by "A" and "E" in Fig. 6.

The coils are fastened with some glue in the position indicated in Fig. 6 on a round hardwood form Ho, ¾-inch in diameter and 1.8 inches long, For further securing the coils in position, there are used the cardboard discs "Pa," likewise glued to the hardwood body. After mounting both coils we fasten at the

upper end of the wooden body, by means of an angle, the variable condenser C4 (500 mmf., with solid dielectric). Then we screw on the lower end an insulating plate P 2 to 0.12-inch thick, with mountings for the fixed condenser C5 (1250 mmf.) and the lugs for connecting the coils and the terminals H, G, A, O. After the connections have been made between the coils and lugs, we screw condenser C4, with the coils hanging to it, to the upper face of the shield can, without insulating the condenser from the can. After the terminals H, G, A, and O are put in the can, we connect the lugs lying on the under side of the plate P to the terminals, and can now finally screw bottom "Bo" and the angle fasteners W to the shield can. The terminals G, A, and O must be carefully insulated from the shielding; which affords no trouble with the very practical commercial insulation terminals used here. The shielding is at the same time grounded by terminal H.

The Blocking Circuit

The external construction, as is clear from Figs. 7 and 8, corresponds to that of the filter. The variable condenser C10 (300 mmf., solid dielectric) is here however insulated from the shielding by the two insulating plates J, which are best fastened to the upper surface of the shielding hood by special screws. The insulation plate P is here not provided with lugs. On the contrary, the coils are directly attached to terminals G, M, and A, which likewise have to be put through insulated. The uninsulated terminal E serves for grounding the shielding. The two coils of 600 turns each (the same construction as in the filter) are connected in series, and the center is led to terminal M; so that it is also possible to connect terminal M instead of G (in Fig. 1) to the plate of the screen-grid tube 3.

(Continued on page 224)

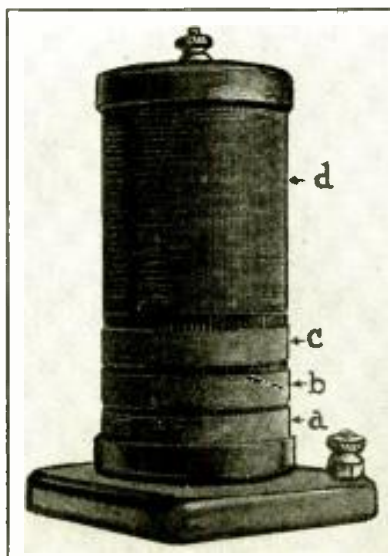

Fig. 9—The short-wave choke HF1.

Short-Wave Stations of the World

Table of short-wave stations listing frequency, power, and location. Includes stations like W10XAY, W2XBC, W9XD, etc.

All Schedules Eastern Standard Time: Add 5 Hours for Greenwich Mean Time.

Table of short-wave stations listing frequency, power, and location. Includes stations like GBC, VLK, PCL, etc.

Table of short-wave stations listing frequency, power, and location. Includes stations like W8XK, UORZ, W2XE, etc.

(NOTE: This list is compiled from many sources, all of which are not in agreement, and which show greater or less discrepancies...

Table of short-wave stations listing frequency, power, and location. Includes stations like KZKZ, Buharest, etc.

(Continued on opposite page)

Getting Started on 3/4 Meter

By A. BINNEWEG, Jr.

(Continued from page 202)

one-inch diameter form.

The correct procedure in coupling the amplifier to a 3/4-meter reflector is also shown in Fig. 4. Another R.F. line, like the one between the oscillator and amplifier, is used between the amplifier and the reflector.

Fig. 5 shows the details of a parabolic reflector which can be used for transmitting at 3/4-meter. The wires of the reflector proper are arranged around a parabola with the main transmitting aerial at the focus. The distance between the aerial and the wire at the vertex of the parabola should be a quarter of the wavelength.

In calibrating wavemeters the oscillator is operated at the desired wavelength and coupled to the end of the "line" which consists of two parallel No. 14 wires, about 2 inches apart. The line should be very well insulated; otherwise the indications will be very broad and the accuracy poor. The oscillator includes a plate milliammeter in its circuit for indicating resonances with the wires.

With the oscillator in operation, the shorting link (a length of No. 14 bare wire), or bridge is moved along the wires and the flicks of the plate meter are noted. These abrupt changes in plate current are exactly one-half wavelength apart; so that it is necessary only to measure the distances between two such positions on the wires, and multiply the resulting value in meters (a meter stick can be used) by 2 to obtain the correct wavelength (in meters).

A wavemeter (constructed of a small two-plate midget and a small loop of wire for 3/4-meter use) is then tuned

into resonance with the oscillator; and the value just obtained by measurement is then marked on the wavemeter scale.

S-W Stations of the World

(Continued from page 213)

- Lansing, Mich. —W3XB, Portable.
- 123.9 2.122—WMJ, Buffalo, N. Y. —KGPE, Kansas City, Mo. (Mo. State).
- 124.2 2.416—WPDJ, Columbus, O. —WPDE, Louisville, Kentucky. —KGPB, Minneapolis, Minn. —WPDJ, Passaic, N. J. —WPDS, St. Paul, Minn. —WPDA, Tulare, Calif.
- 124.5 2.410—WCK, WRDR, WMO, Detroit (Belle Isle, Grosse Pointe, Highland Park, Mich. —WPDW, Washington, D. C. —KGPD, San Francisco, Calif. —KGGP, Vallejo, Calif. Police Dept. —W3XAG, Baltimore, Md. Police Dept.
- 125.1 2.338—W9XL, Chicago, Ill.—W2XCU, Amberg, N. J.—And other experimental stations. —W2XAD, W2XAF, Schenectady. —WPDJ, Kokomo, Ind. Police Dept.
- 125.4 2.392—W10XAL and W10XAO, Portable. National Broadcasting Co.—W2XCZ, Portable. N.B.C.
- 128.0-129.0 —Aircraft.
- 129.0 2.325—W10XZ, Airplane Television.
- 130.0 2.306—DDD, S.S. "Bremen" and "Europa" testing.
- 135.0 2.220—Stockholm, Sweden. —Oslo, Norway.
- 136.4 to 142.9 meters—2,100 to 2,200 kc. Television. —W2XBS, New York, N. Y., 1,200 R.P.M., 60 lines deep, 72 wide, 2-5 p.m., 7-10 p.m. ex. Sundays, National Broadcasting Co. —W2XR, Long Island City, N. Y. 48 and 60 line, 5-7 p.m. Radio Pictures, Inc. —W3XAD, Camden, N. J. (60 lines). —W2XCW, Schenectady, N. Y. —W3XAK, Bound Brook, N. J. (Portable, 60 lines). —W8XAV, Pittsburgh, Pa., 1,200 R.P.M., 60 holes, 1:30-2:30 p.m., Mon., Wed., Fri. —W9XAP, Chicago, Ill. (15 lines). —W8XS, Gardena, Calif. Don Lee, Inc., Los Angeles.
- 142.9 to 150 meters—2,000 to 2,100 kc. Television. —W2XAP, Jersey City, N. J. —W2XCR, Jersey City, N. J. 3-5, 6-9 p.m. ex. Sun. —W3XK, Wheaton, Maryland, 10:30 p.m.-midnight ex. Sun. Works with W3XL. —W2XBU, No. Beacon, N. Y. (1-2 p.m.). —W2XCD, Passaic, N. J. 2-3 p.m. Tu., Thur., Sat. —W9XAO, Chicago, Ill. (45 lines). —W10XG, portable, De Forest Radio Co. —VE9AU, London, Ont., Canada. —VE9RM, Toronto, Ont., Canada. —RA7Z, Smolensk, USSR.
- 149.9-171.8—2,000-1,715—Amateur Telephony and Television. —Cuxhaven, Germany, Elbe-Weser Radio. —W110, Wellington, New Zealand.
- 155 1.715—W9XAN, Elgin, Ill.
- 156X, Los Angeles, Calif. And other experimental stations.
- 153.2 1.712—Municipal, Police and Fire. —KGMK, Beaumont, Texas. —WKDT, Detroit, Mich. —WEY, Boston, Mass. —WPDG, WPDG, WPDG, Chicago, Ill. —WKDU, Cincinnati, O. —KSW, Berkeley, Calif. —WKDU, Cincinnati, Ohio. —KUP, Dallas, Texas. —WMDZ, Indianapolis, Ind. —KGPC, St. Louis, Mo. —KGOY, San Antonio, Texas. —KGIJ—Pasadena, Calif. (Police Dept.). —St. Quentin, France. —BBFY, Cannes, France. 5 p.m. Wed.; 1 a.m. Sunday.
- 176.5 1.700—Orly, France.
- 178.1 1.681—WKDX, New York, N. Y., Dept. Plant & Structures. —KDX, Honolulu, T. H. Mutual Telephone Company.
- 180.0 1.662—WMP, Framingham, Mass. (State Police). —WRDS, Lansing, Mich. (State Police).
- 186.6 1.608—W9XAL, Chicago, Ill. (WMAAC) and Aircraft Television. —W2XY, Newark, N. J. —W2XCU, Wired Radio, Amberg, N. J. —W2XCD, DeForest Radio Co., Passaic, N. J. 8-10 p.m., synchronized with television broadcasts. —W1XAU, Boston, Mass. —W3XJ, Wheaton, Md. —W2XAD—W2XAF, Schenectady. —W9XX, Cartersville, Mo. —W5XN, Dallas, Texas. —W2XDD, Portable. —And other experimental stations. —Ornskoldsvik, Sweden.
- 187.9 1.596—WCF, New York, N. Y. (Fire Dept.) —WKDT, Detroit, Mich. (Fire Dept.) —KGMK, Beaumont, Texas. —KGA, Seattle, Wash. Fire & Police Dept.
- 189.4 1.584—W10XAL, W10XAO, Portable (N. B. C.)
- 192.3 1.560—Scheveningen, Holland.
- 194.3 1.544—W2XDA, New York.
- 196 1.530—Karlskrona, Sweden.

Gem Short Wave Unit for Local and Long Distance SHORTWAVE BROADCAST

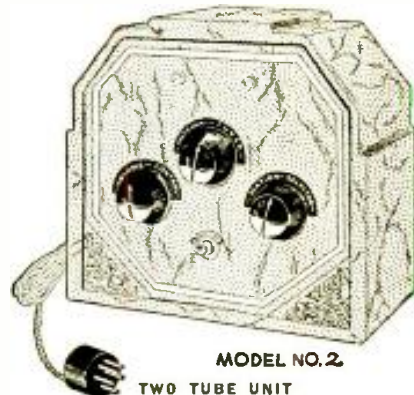

This unit including with plug-in coils ranging from forty to two hundred meters. The Short Wave Unit is universal, either for No. 227 or No. 224 Detector Tubes. Once this unit is attached to your radio, it can always remain. A switch on this unit is to cut on and off your regular broadcast reception. We guarantee Short Wave Broadcast in the United States and Canadian Stations. For foreign stations, if all is favorable, this unit will receive them with great clarity and volume. Extra coils as low as seven meters can be obtained from us at a price of 60 cents each. Regular price of this unit is \$15.00, special for this issue only \$9.00 with money order accompanying coupon, 20 cents extra for postage anywhere in the U. S. A. and Canada.

NAME

ADDRESS

CITY

Essenbee Radio Devices Co.
732 Mather St. Chicago, Ill.
ERC

Aluminum Box Shields

Beautiful Silver Dip Finish

5 x 5 x 5 Knocked-down Coil Shield (like pictured on right) 1.00

5 x 9 x 6.....\$1.87

6 x 10 x 7 Monitor Size... 3.25



We make any size to order.
Alcoa Shield Plate, 25c; 7x16 Aluminum Panel, 75c



"BUDDY" Test Prod

Always sharp pointed, using phonograph needles, 4 ft. wires, spade or phone tips. Colored nipples identify each lead.

75c each. \$1.50 per pair.

WE SPECIALIZE IN RADIO PARTS EXCLUSIVELY—parts furnished for any kit in any magazine.

- .00035, Midget Cond...\$1.75
 - 80 Millihenry Choke... .59
 - Pilot Coil Forms..... .35
 - 3 Gang, 4 Point Switch 2.25
 - 2 Gang, 4 Point Switch 1.65
 - Sponge Rubber Phone Cushions50c pair
- Short wave coils, \$1.75
- Please include sufficient postage

BLAN, The RADIO MAN, Inc.
Dept. SWC 1031
89 CORTLANDT ST. NEW YORK, N. Y.

In the Next Issue—
Short Wave Midget Transmitter Flies With Weather Balloons
By Capt. James A. Code, Jr.

New—The Short Wave Superregenode

By CLIFFORD E. DENTON

(Continued from page 197)

ratory facilities for the construction and testing of this interesting receiver.

If any of the readers of SHORT WAVE CRAFT wish to write to obtain any assistance in the construction of the Superregenode, the writer will be glad to oblige if a stamped and return-addressed envelope is enclosed with the inquiries. It is hoped that constructors will not deviate too greatly from the parts recommended and constructional data just completed, in their choice of apparatus, and the individual arrangement of the chassis. Nevertheless the ramifications of the Superregenode are legion, and the writer expects to receive some mighty interesting comments on the results obtained by some of the more advanced technicians.

List of Parts—Battery Model

Two Hammarlund "MLW-125" 125 mmf.

(Continued on page 238)

Please mention SHORT WAVE CRAFT when writing to advertisers

This Offer Saves You \$2.00

Until the 31st of October this opportunity is yours—this chance to read radio's two great magazines, **SHORT WAVE CRAFT** and **RADIO-CRAFT**, at a saving of \$2.00.

Regularly the rate for one year's subscription to **SHORT WAVE CRAFT** is \$3.00 and for eight months of **RADIO-CRAFT**—\$2.00. For a brief period only, our readers can enter their subscription to receive both magazines for \$3.00. This is a reduction of 40% and represents a saving of \$2.00.

SHORT WAVE CRAFT you have read, and it is needless for us to say that you are well pleased and want to read every issue. It is the "Town Crier" of new developments in the short wave field.

And **RADIO-CRAFT**, also edited by Hugo Gernsback, is the radio magazine selected by the greatest number of service men, dealers and radiotricians. Of course, thousands of amateurs read **RADIO-CRAFT**, too. Each month, men of outstanding prominence in the radio field contribute articles of real interest to all. Here is a summary of articles usually found in each issue: Service Men's Department—Radio Service Data Sheets—New Developments—Radio Construction and Theory—Kinks and Information Bureau—Tubes and Their New Design—etc.

Clip the coupon NOW and mail with your remittance, check or money order will do. Postage stamps accepted in small denominations if more convenient.



Mail Coupon TODAY!

SHORT WAVE CRAFT 100 Park Place, New York, N. Y. **SWC-2-3**

As per your special offer, I enclose \$3.00, for which you are to enter my subscription to **SHORT WAVE CRAFT** for one year and to **RADIO-CRAFT** for the next eight months.

Name

Address

City..... State.....

The "Gem" Short Wave Adapter

THE accompanying illustration shows the latest model No. 2 "Gem" Short Wave Unit Adapter, which will enable one to hear local as well as distant short wave stations, including police calls and all other short wave broadcast events, when using this adapter in conjunction with their regular radio broadcast receiver.

This particular adapter sells for the nominal list price of \$15.00 and is a two tube unit, available for plugging in on broadcast receivers using either a '27 or else a '24 screen grid detector tube.

The front panel of the "Gem" short wave adapter contains an "on" and "off" switch, three control knobs—one for "volume control", a second for "antenna tuning", the third knob being the "station selector" or tuner. — *Illustration Courtesy of Essenbee Radio Devices Co.*



Comb. Long and Short Wave Receiver

(Continued from page 203)

radio cement around the bottom of the coil, will keep the coil form quite firm and ready for rough handling.

Since this set is easy to build and covers at the same time both the short and long waves, I feel that it would prove worth while indeed to the radio fan.—*Contributed by Morris Dorsey.*

What Short Waves Mean to the Lindberghs

By **LT. MYRON F. EDDY**

(Continued from page 169)

ten to the familiar "A," "T," or "N" of the "radio-beacon"; telling him that he is flying "left of course," "on course" or "right of course," respectively. He is used to this as a mail pilot. Mrs. Lindbergh can hear this and also the government weather reports on this receiver, at regular intervals. She will be able to work the transmitter as she wishes; between these weather broadcasts, when visibility is good and the radio-beacon course signals are therefore not needed.

By the use of short waves a constant exchange of messages can be accomplished during the entire flight between the plane and a ground or ship station, thus providing maximum safety.

Please mention **SHORT WAVE CRAFT** when writing to advertisers

Amateurs— Experimenters

If you are interested in Commercial Radio Work You should read

CQ

The only magazine devoted exclusively to the interests of

Commercial Radio Men

Read *Dr. Lee de Forest's* account of the first American commercial stations and operators, appearing serially in *CQ*. Many other interesting departments and features.

— Send 15c for a Copy of *CQ* —

**CQ, 1725 Bedford Road
San Marino, Calif.**

FREE!

SHORT-WAVE TIME TABLE

The important short-wave program stations of the world are listed in our table "SWC" in chronological order. Call, location, frequency and wavelength given. Ask for Table "SWC". No charge.

ROLAND RADIO COMPANY
27 to 35 Hooper St.
Brooklyn, N. Y.

CLAROSTAT

REPLACEMENT LINE BALLASTS and VOLTAGE REGULATORS

When replacing voltage regulators install a real, long-lived, guaranteed **CLAROSTAT LINE BALLAST** and insure against voltage troubles. A better unit... for less money. Specified by leading set manufacturers. **WRITE** for list of receivers and the proper Ballast or Regulator required.

CLAROSTAT MFG. CO., Inc.
285 N. 6th St. Brooklyn, N. Y.

There's good news on page 234—it tells how to read *Television's* greatest magazine at a reduced subscription price. Turn the page NOW to that announcement.

New Transmitters and Receivers

EVERY day more and more persons are bitten by the short wave "bug". All of them would like to explore the realm below 200 meters, receive foreign broadcasts, listen to ship and airplane conversations, hear police transmissions, and even enjoy the greatest thrill of all



New Harrison Short Wave Receiver.

—that of operating their own transmitter! But many have been restrained from doing so by their unfamiliarity with short wave parts, the high cost of those parts, and lack of time in which to figure out their order and purchases.

All these difficulties have been solved by a New York City pioneer short wave concern, who have just introduced the latest additions to the well-known Royal line of quality apparatus. These new items are complete kits containing every part necessary to build a modern design receiver, short wave transmitter, or power supply, of extremely high efficiency. The different models are also offered completely assembled, wired, and tested, all ready to operate.

These kits are designed by Government licensed operators, with broad experience in the short wave field, and they combine careful engineering, simplicity of construction and operation, and the use of high grade parts, with amazingly low prices.

The model TP transmitter illustrated, employs the popular tuned-plate, tuned-grid circuit. All the transmitter kits are so designed that one can start using the set with only a receiving tube and batteries or an inexpensive eliminator. Later, the power output may be increased without buying new parts, merely by using a larger tube and higher voltage supply. To insure absolute steadiness of the emitted wave the inductance coils are of heavy copper tubing rigidly mounted on large porcelain insulators, every part is solidly secured to the base board, and the set is wired with heavy solid wire.

Sensitive receivers with a world-wide range are available in one, two, and



New power supply unit for S-W transmitters.

three tube models; special refinements ensure extraordinary results. The wavelength range is from 14 to 550 meters, and provision is made for even higher wavelengths.

Five different models of transmitting power supply units, reasonably priced, round out this interesting new line of kits. The use of one of these units gives the transmitter a D.C. note with a real "wallop" behind it. The one illustrated is the model PC which supplies up to 700 volts D.C. for plate current and filament voltage for the oscillator.

Mr. William E. Harrison (W2AVA—amateur license), manager of the concern bearing his name, says, "The day is past when an amateur station took up a whole room and needed a power house to run it. Amateur radio in its infancy was limited to those with a well-stuffed wallet. 200 miles was considered quite a respectable distance to be heard. Today that is all changed. These new kits enable anyone to be the proud possessor of a real "Ham" outfit at a low



The Harrison tuned plate, tuned grid transmitter.

cost. A complete station with receiver, transmitter, power supply and all accessories will fit on a small table and costs as little as \$22.00! Careful adjustment and operation of the station can result in international contacts, even with very low power."

These new kits are the ideal thing for those who want to become a short-wave fan with the least expenditure of time, labor and money.—Illustrations courtesy Harrison Radio Company.

New Mercury Vapor Rectifier Gives Minimum Ripple

THE Odeon Lo-Ripple mercury vapor rectifiers are said by the manufacturers to have been the first rectifier tubes containing mercury to be placed on the market.

The originator and maker of these tubes guarantees them to produce a lower alternating current ripple than has been attained heretofore. These rectifier tubes have, according to the statement of the manufacturer, an operating life in excess of 1,000 hours. For amateur short wave work, both transmitting and receiving, a very enthusiastic reception has been accorded them. Lo-Ripple rectifier tubes have found great favor among S-W amateurs and clubs, owing to the superior performance of these tubes and the consequent smooth current in the rectifier output circuit.



PRESTON DYNATRON OSCILLATOR

RADIO frequency circuits in both Tuned Radio Frequency and Superheterodyne sets must be adjusted to greater accuracy than is possible by the use of the broadcast wave. The Preston test oscillator covers the broadcast band from 550 to 1500 K.C. and instructions are supplied for testing and adjusting superheterodynes. The operation is very simple, and a calibration chart and wiring diagram is fastened in the cover of carrying case. Two tubes are used of the new '32 type. One acts as a radio frequency oscillator and the second tube is used to audibly modulate the radio frequency current generated by the first tube. Dry cells supply the current and a 5-prong plug and cable is furnished. The whole device is very simple and easy to operate. A valuable instrument for experimenters and custom set builders.

List Price\$20.00
SPECIAL TO EXPERIMENTERS.....\$16.75

Preston Output Meter for use with test oscillator. Used for trimming condensers, checking tubes by substitution, adjusting detector voltages and other adjustments.
List Price\$7.50
SPECIAL TO EXPERIMENTERS \$5.50
Mail Remittance Directly to



THE **B E E D E**
ELECTRICAL INSTRUMENT CORP.
Penacook, New Hampshire

Everything You Need to Become an Expert

WIRELESS OR WIRE OPERATOR
Instructograph
Code Transmitter
Ten Rolls of Tape
Complete Instructions
ONLY \$24.50



The unit illustrated includes INSTRUCTOGRAPH, ten rolls of double perforated tapes (approximately 2,000 feet of characters), a comprehensive and thorough course of instructions for study and practice with INSTRUCTOGRAPH and interpretation of the tape matter, and complete directions for the care and operation of INSTRUCTOGRAPH. Also, complete directions for building and installing an oscillator unit. We supply a "tuzzer" or oscillator if desired, at a reasonable price, but you can easily build your own by following our directions. Write for information regarding our "CQ" call tapes. Extra tapes either code, \$1.00 each.

INSTRUCTOGRAPH COMPANY
815 LELAND AVE., CHICAGO, ILLINOIS
Dept. S.W.-1

The Voltage 'POLICEMAN' in Your RADIO

AMPERITE Self-Adjusting Line Voltage Control prevents noisy voltage fluctuations in electric radios. Saves tubes—improves tone. Demand AMPERITE when you buy a radio, include it when you build. For Free Bulletin Write Dept. SW-10



AMPERITE Corporation
501 BROADWAY, NEW YORK
AMPERITE
Self-Adjusting
LINE VOLTAGE CONTROL

-- no greater magazine published on the development of TELEVISION --

4-Color Cover 9 x 12 in.



On All Newsstands

A Brief Summary of Contents

Prominent Television Authorities

SARNOFF — DU MONT — DR. IVES — CISIN — FITCH — NASON — REPLOGLE

FEATURES:

- How Jenkins Televises With New Lighting Scheme, by D. E. Replogle.
- Television—Today and Tomorrow, by David Sarnoff, President of the Radio Corp. of America.
- What Television Inventors Are Doing.
- Columbia Is Telecasting!
- How I Produce 6 1/2 Foot Images, by Ulysses A. Sanabria, As Told to H. Winfield Secor.
- Some Interesting Optical Features in Two-Way Television, by Dr. Herbert E. Ives, of the Bell Telephone Labs.
- How We Staged the World's First Television Plays, by William J. Toneski.
- The "Find-All" Television Receiver, by H. G. Clsin, M. E.
- How We Received W3XK Images in Kansas, by C. Bradner Brown.
- New Helical Mirror for Television Scanning.
- Synchronous Images With a Home-Built Motor, by Clyde J. Fitch.
- The New Baird Television and S-W Receiver, by Joseph Calcesterri.
- Thrill of a Televised Derby.
- A Short Course in Television, Lesson 1—Elementary Television Optics, by C. H. W. Nason.
- The Practical Operation of a Complete Television System, by Allen B. Du Mont.
- How to Make a Synchronous Motor, by R. Stair and S. R. Winters.

Timely developments in radio's latest wonder, Television, are published in every issue of TELEVISION NEWS—Mr. Hugo Gernsback's latest magazine. Rapid advancement in this art today is becoming a repetition of the radio cycle of years ago. Daily broadcasts are becoming more numerous and experimenters are following in quick order in building television sets for experimental purposes. Foresight of its development can be seen by the pioneers of radio—they are equipping themselves now with television experience.

The articles published in TELEVISION NEWS are of primary importance to experimenters—they are simple in construction, understandable and replete with diagrams, photographs and illustrations.

A New Test Oscillator

A NEW TEST oscillator known as the Preston, has recently been brought out by the concern who makes the well-known Beede meters. This oscillator utilizes two tubes of the '32 type, one acting as a radio frequency oscillator and the second tube is utilized to audibly modulate the R.F. current generated by the first tube. The current for operating the oscillator is supplied by dry-cells; a five-prong plug and cable comes with the outfit. This oscillator is very useful in checking R.F. circuits in T. R. F. and super-het receivers. A special output meter for use with the test oscillator is furnished at a slight extra cost.

What Can We Do With Ultra Short Waves?

By L. Rohde and N. von Halem
(Continued from page 199)

possibilities for the use of these waves are by no means exhausted with this application. Investigations in this field are at present being carried on with great zeal in Germany and other countries.

The illustrations shown here were all taken in the Technical-Physical Institute of the University of Jena, where for six years the investigation of ultra-short waves has been going on under the direction of Prof. Esau.

What I Think of Ultra Short Waves

By GUGLIELMO MARCONI
(Continued from page 181)

the earth, to be reflected to earth again. "On the beam system to India we use a wavelength of fifteen meters and to Australia twenty-six meters; but the shortest commercial wave length in use is from Italy to Sardinia, nine and a half meters. Below that wavelength you may not be able to transmit over twenty, thirty or forty miles, and the final limitation that arise from the earth's curvature. How to overcome this disadvantage is the problem I am at present studying. —New York Times.

Hertzian and Infra-Red Rays

By DR. FRITZ SCHROTER
(Continued from page 186)

in making the high sensitivity of an existing receiver circuit serviceable for this purpose by eliminating the disturbing noise. Experience has shown that these ultra-short waves can penetrate the stone houses of our (German) cities, even though greatly weakened. Since the radiation of the elevated transmitter cannot go beyond the geometrical (visible) horizon, it is possible to use the same carrier wave in as many centers of such radio operation as may be desired. Stations of this kind will be useful for improving the direct-wave radio.—(Die Umschau.)

COMPLETE COURSE IN TELEVISION

Over 200 Illustrations, Diagrams, Circuits and Photographs — Actual Photographs of Television Transmitters and Receivers.

Rush Coupon TODAY!

Special Offer

VOID AFTER OCTOBER 31st

TELEVISION NEWS SWC-2-3
98 Park Place, New York, N. Y.
As per your special offer, I enclose herewith \$2.00 (Canadian and foreign \$2.50) for which enter my subscription to TELEVISION NEWS for One Year.

Name

Address

City..... State.....

The regular price of TELEVISION NEWS is \$3.00 a year (Canada and foreign, \$3.50). Up to October 31st, if you use the coupon at the left, we will accept \$2.00 (Canada and foreign, \$2.50) for a full year's subscription. THIS OFFER WILL NOT BE MADE AGAIN.

Published Every Other Month

Please mention SHORT WAVE CRAFT when writing to advertisers



MILES
Miles Heavy Duty
Concert Model
Two-Button
Microphone
Carbon Type

Net weight 2 lbs.
O. D. 4x3 1/2" thick.
Extra fine carbon
polished special
granules used.
Uniform frequency
response 30 to
8500 cycles. For
speech and music.
An instrument of
highest precision
within .001" accuracy. Smooth and uniform finish.
Consumes 5-8 mills at 3 volts, 8-15 mills at 6 volts.
Balanced most accurately on both sides. Code Word:
VOCAL. List Price, \$75.00

Type No. M303

Also complete line of single and double
button microphones from \$15 up; variable
input transformers, amplifiers, exponential
horns, trumpets, and dynamic horn units
and complete public address systems. Mer-
chandise of the finest quality—exception-
ally low priced.

Write for free catalog A.



PUBLIC ADDRESS EQUIPMENT
MILES REPRODUCER CO.
26 E. 22ND ST. NEW YORK CITY



**THE SUPERLATIVE
BROADCAST
MICROPHONE**
Extra Heavy Type
Two Button

Model "B R"
List Price \$25.00
Microphone Only.

Outstanding beauty of work-
manship and finish. True,
Natural Tone. Tremendous
Volume. Scientifically Damped.
Extra Heavy 24-Karat Pure Gold Centers.
Duralumin diaphragms. Accurately Machined.
Three Degrees of Sensitivity.
Other Models from \$5.00 up.

UNIVERSAL MICROPHONE CO., Ltd.
1163 Hyde Park Blvd.
INGLEWOOD, CALIF., U. S. A.

**FOR REAL
SATISFACTION**



**SIEMENS &
HALSKE
CONDENSERS
RESISTORS
MICROPHONES
MORRILL
CONDENSERS**

Write for Circular 82
MORRILL & MORRILL
Sole U. S. A. Distributors
30 Church St. New York City

REVOLUTIONARY
That describes this ultra modern
short wave tuner—

The VARI-COIL

Gives you single dial control over a range
16 to 100 meters with perfect regeneration
over entire scale. It uses the best of
materials with sound engineering princi-
ples.

Write for information.
ARTHUR J. HURT & CO.
550 Clayton St., Denver, Colo.

WHEN TO LISTEN
By **ROBERT HERTZBERG**

Guatemala

EVIDENTLY spurred by the success of
T14NRH, and other well-known Cen-
tral American stations, the government
of Guatemala is sponsoring an experimental
short-wave broadcasting station in the capital
city. This has the call letters TGW and is
known as "Radiodifusora Nacional." It is the
property of the government and was construct-
ed by Senor Julio Caballeros.

At present a frequency of 6,675 kilocycles is
being used with a power of 100 watts. This
doesn't sound like much, but remember that
T14NRH achieved international renown with
only 7 1/2 watts. The schedule on this fre-
quency is from 8.00 to 10.30 p.m. Centrai
Standard Time. A frequency of 10,715 kilo-
cycles will be used for daylight work, but no
definite schedule for this short wave has been
adopted.

TGW has already been received in Mexico
and parts of the United States, and reports
from listeners are invited. These should be
addressed as follows: Telegrafos y Telefonos
Nacionales, Seccion de Radio, Guatemala City,
Guatemala, Central America.

A second station in Guatemala City is
TGCA, in the Hotel Rex, working on 13,040
kilocycles between 9.00 and 11.00 p.m. (Central
Standard Time), with a power of about 80
watts. This is a rather short wavelength for
night time transmission, but the short waves
are full of surprises, and, as previously re-
marked in this department, most anything
is likely to happen. Address your QSL cards
to Senor Guillermo Andreu y Enrique Castillo,
Hotel Rex, Guatemala City.

Still a third outfit will soon be on the air
to acquaint short-wave listeners with Guate-
mala City. This will be located in the Hotel
Palace, and will use 25 watts of power on
9.375 kilocycles. The call letters are TGX, the
owner and operator Senor Miguel Angel Mejli-
cano Novales. The station is altogether ex-
perimental, but has been heard between 9.00
and 11.00 Central Standard Time.

Pacific Coast

The *S.S. Malala*, a well-known Pacific liner,
is the latest passenger vessel to be equiped
with ship-to-shore radiophone. Using the call
letters W10XAI, it is testing on 31.48 meters
with Punta Reyes, California, and has been
heard around 2.00 in the morning (Pacific
time). This testing is done in the clear, but
the ship will undoubtedly use a "scrambler"
when regular toll service begins.

Speaking of this radiophone stuff prompts
me to warn new listeners against using their
imagination too freely when they pick up the
transoceanic telephones. The unholy gibberish
that comes out of the loud speaker, from the
scrambled transmissions, can readily be in-
terpreted as any foreign language you like.
Don't tell your friends you have tuned in
Japan or Turkey until you've waited patiently
for the end of the conversation and then heard
the technical operators say "Hello London"
or "Hello New York" in perfectly clear Eng-
lish.

The North Pole Again

Sir Hubert Wilkins' polar submarine *Nau-
tilus* experienced considerable misfortune in
the rough Atlantic after her start from the
United States; but the indomitable Sir Hubert
is on his way again. There is still a possi-
bility that the short-wave phone transmitter
will broadcast from the North Pole, when and
if the submarine gets there. The transmitter
carries the appropriate call letters WSEA. The
broadcast chains are anxiously awaiting word
from Sir Hubert; as a broadcast from the
North Pole would undoubtedly be one of the
greatest radio stunts ever accomplished.

Madeira

The home of a famous wine is now also the
home of a new short-wave station, CT3AQ. It
is working on 24 meters, on an irregular
schedule.

(Continued on page 237)

Please mention **SHORT WAVE CRAFT** when writing to advertisers

**YOU
MAY THINK THAT**
any variable condenser is good
enough, so long as it's a condenser.
Well, mebbe so—mebbe so; opin-
ions differ.

BUT—
Westinghouse
General Electric
Western Electric
Radio Corp. of America
Bell Telephone Labs.
and many others supreme in the
radio engineering field, use

**CARDWELL
CONDENSERS**
when the going is tough, when the job
must be right and the best is none too good.

GET THE IDEA?
Send for Literature
The Allen D. Cardwell Mfg. Corp.
85 Prospect Street, Brooklyn, N. Y.

**BECOME A
RADIO OPERATOR**
QUICKLY AT HOME
BY
**CANDLER
SCIENTIFIC
SOUND
METHOD**



TELEPLEX and 10
Scientifically Prepared
Tapes that go with
our Course, furnished
at Wholesale to our
Students. If you have
an automatic machine
you can use our tapes.

We teach you CODE IN
less than half the usual
time. We've taught thou-
sands in past twenty years,
including former champion
McElroy, whose speed was
56 1/2 wpm. Our methods
originated by world's fore-
most CODE SPECIALIST,
who instructs you person-
ally. Endorsed by officials and 45,000 Morse and
Radio operators. Take up this interesting profession.
We help you get your "ticket" quickly and inex-
pensively. Make a start TODAY! Send for FREE
Brochure.

THE CANDLER SYSTEM CO., Dept. SW-3
6343 So. Kedzie Ave., Chicago, Ill.

**Ideal for
Short-Wave
RADIO**



requiring midget con-
densers of finest qual-
ity. Hammarlund
Condensers, Chokes
and Coils are backed
by 30 years of engi-
neering experience.

**HAMMARLUND
MFG. CO.**
Write Dept. SIV-10 424-438 W. 33rd St.
for Data. New York

For Better Radio
Hammarlund
PRECISION
PRODUCTS

PATENT
YOUR IDEAS
REGISTER YOUR
TRADE-MARK BY

Z. H. POLACHEK
1234 BROADWAY
31st. NEW YORK

**DO
IT
NOW**

REG. PATENT ATTORNEY, PROF. ENGINEER
WHAT IS YOUR INVENTION?
Send me a simple sketch or model for
CONFIDENTIAL ADVICE

STRATFORD - SUPER - POWERED DUAL "250" Push-Pull AMPLIFIER DYNAMIC PERFORMANCE — DYNAMIC VALUE!!

FACTORY BUILT—WIRED—AND GUARANTEED! "STRATFORD"

THREE STAGE
DOUBLE PUSH PULL
"250" AMPLIFIER

For auditorium, public address, theatre,
or home use.

A remarkable radio, phonograph and
microphone amplifier.

Super power and extraordinary fidelity of repro-
duction are only a few of the superior accom-
plishments, resulting from this dual 250 push
pull amplifier.

This unique amplifier incorporates all the latest
and original laboratory developments to produce
a perfect mechanical and electrical instrument
built like a battleship—offering dependable and
superior performance for the first time at

UNHEARD OF VALUE!

A dual power transformer is employed, mechani-
cally assembled, so that the cores are incorporated
and parallel to the pressed steel metal base, elec-
trically designed to supply the high voltages to
the new mercury vapor 588 full wave rectifier for
ideal rectification.

The new mercury vapor 588 full wave rectifier is a
remarkable new accomplishment in tube develop-
ment, permitting improved and perfected single
tube full wave rectification, thus eliminating the possibility of introducing
hum caused by unevenly matched half wave rectifiers.

A single 588 mercury vapor tube has the same conversion qualities as two
281 half wave rectifiers at $\frac{1}{4}$ of the cost.

This means of rectification together with the balanced filter circuit, con-
sisting of 1000 volt surge-proof condensers, and the new type hum bucking
choke, brings the hum level far below the commercial tolerances, being
almost inaudible to the human ear.

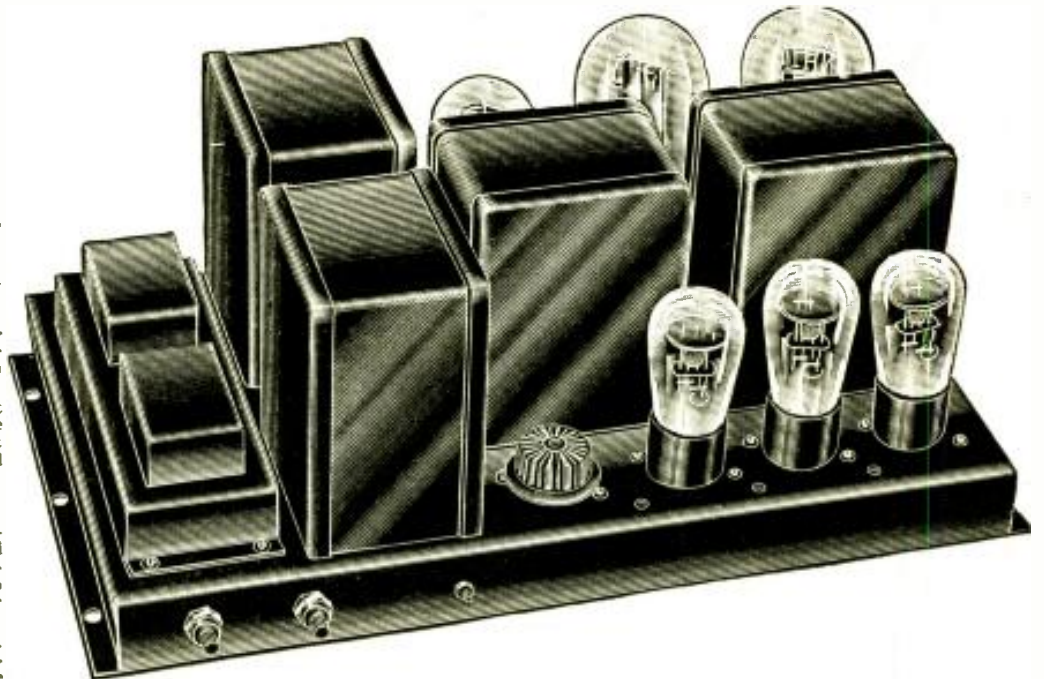

A new standard of mechanical design is revealed in this new shielded and
sealed unit assembly of component parts placed to produce the best electri-
cal results, together with mechanical rigidity having all the desirable
electromagnetic and electrostatic shielding qualities.

Every possible precaution has been taken to seal the units in special heat
resisting compounds which permits us to guarantee this amplifier uncondi-
tionally against breakdown!

Each audio transformer unit assembly is so arranged to permit maximum gain; no feedback; being placed to produce its mag-
netic flux in a plane at right angles to the others.

All grid and plate leads of the amplifier circuit are resistance capacity filtered to eliminate any possibility of motor-boating
and insure even gain over the entire frequency band from 40 to 8000 cycles.

The first audio transformer has a very low ratio, which allows the use of a very large primary and thus gives sufficient induc-
tance to maintain a constant amplification factor over the entire musical scale.

The push pull interstage has a maximum undistorted power output of 450 milliwatts which swings the grids of the two 250's to
produce an output of 12.9 watts rated by Western Electric Standards, enough to flood a 2000 seat theatre or auditorium with
sound.

The life of the 250 tubes is prolonged, being operated at half their maximum rating.

Automatic grid biasing compensates for commercial variation in power tubes and
automatically produces a bias proportional to the plate current, thereby eliminating
the necessity of matching tubes.

Terminals are provided for energizing the field of as many as four D.C. dynamic
speakers at no additional cost.

The refinements of the amplifier are shown by the fact that this is only one of
many added features.

This superbly finished super powered dual 250 push pull amplifier is furnished com-
pletely assembled and wired and equipped with gain control and one 14-inch Oxford
D.C. dynamic speaker, presenting a regular \$275.00 value in appearance and per-
formance.

Size, 10 $\frac{1}{4}$ x 18 x 8 inches. Tubes required—three 27's, two 50's, one M-588.

\$ 37⁵⁰

COMPLETE WITH 14"
D.C. OXFORD DYNAMIC
SPEAKER—LESS TUBES

Complete kit of Licensed, Matched, Guaranteed Tubes \$8.22

STRATFORD SUPER POWERED DUAL 250 PUSH PULL AMPLIFIER

This amplifier is the same as the one listed
and described above excepting that 2-281 half
wave rectifiers are employed in place of the
single 588 Mercury Vapor full wave rectifier.
This amplifier does not include a gain control.

PRICE \$39.50

complete with 14-inch dynamic speaker.
Less tubes.

A complete kit of licensed guaranteed matched
tubes.

PRICE \$11.59

LOFTIN-WHITE DIRECT COUPLED 245 AMPLIFIER For Home and Auditorium

Reproduces with enormous volume maintaining ultra superior quality. Tubes employed
are 221 screen grid first audio, 215 output tube and a 280 full wave rectifier. Com-
pletely wired, ready for use, simplicity of connections, beautifully finished in brown
lacquer—power supplied for any tuner—sturdy oversized parts—no possibility of break-
down and volume plus having an undistorted power output of 1600 milliwatts for
110-120 volts, 50-60 cycles.

SPECIALY PRICED!

A complete kit of licensed guaranteed matched tubes.

PRICE \$2.16

PRICE \$9.95

NEW PENTODE LOFTIN-WHITE DIRECT COUPLED AMPLIFIER

The Pentode amplifier tube, is the newest development in radio design, having an
undistorted power output of 2500 milliwatts and a power sensitivity four times as great
as that of a 215 tube. Ideal for home, dance halls, auditoriums and other large
public assemblies. For 110-120 volts, 50-60 cycle.

PRICE \$12.95

A complete kit of licensed guaranteed matched tubes.

PRICE \$2.48

TELEVISION AMPLIFIER SCREEN GRID-PENTODE POWER AMPLIFIER

This specially designed amplifier employs a
221 screen grid tube in the first stage, which
is resistance capacity coupled to the 247
Pentode power output tube. A unit that will
supply "A" and "B" supply for any tuner,
making an ideal combination television ampli-
fier and power supply. For 110-120 volts,
50-60 cycle.

PRICE \$15.90

A complete kit of licensed guaranteed
matched tubes.

PRICE \$2.48

TERMS

20% with order, balance
C. O. D. 2% discount
allowed for full remit-
tance with order only.

BALTIMORE
RADIO CORPORATION
S-725 BROADWAY
NEW YORK CITY

Order From This Page
DEALERS!
SERVICEMEN!
AGENTS!
SET BUILDERS!
Order From This Page
Send for Our Newest Catalog

When to Listen

(Continued from page 235)

Poland

A one-kilowatt station in Poznan is operating on 31.35 meters, crystal controlled, on Tuesdays from 2.45 p.m. to 5.45 p.m., and on Thursdays from 2.30 p.m. to 9.00 p.m., Eastern Standard Time.

Colombia

Has any one heard a station purported to be located in the city of Medellin, in Colombia? The wavelength is said to be 50.6 meters. Reports on this outfit will be appreciated.

Madagascar

The French authorities have erected a short-wave station on the island of Madagascar, off the east coast of Africa. The announcer identifies the station as "Radio Tananarive." It transmits daily on 50 meters from 1.00 to 3.00 p.m. (Eastern Standard Time) and on Saturdays from 2.00 to 6.00 p.m. Not much chance of hearing this outfit in the United States at these hours; but of course there's no telling.

Holland

Not to be outdone by the Germans, whose experiments on waves below 10 meters have been described in this magazine, the Dutch are conducting a series of tests on 7.85 meters every Saturday from 4.40 p.m. to 7.40 p.m. (Eastern Standard Time). Dance music from the Carlton Hotel, in Amsterdam, is broadcast. This work is mentioned as a matter of interest, and indicates the trend in short-wave development.

Vatican City

A British reader has sent me a clipping to the effect that the Pontifical Academy of Science broadcasts the "Giornale Radiofonico" twice daily: 5.00 a.m. (Eastern Standard Time) on 19.84 meters and 2.00 p.m. (Eastern Standard Time) on 50.26 meters. The station is the famous H.V.I. The Academy receives correspondence from all parts of the world on scientific questions.

Spain

A mild controversy has arisen out of my remarks in past issues about an alleged phone station in Madrid. Station EAQ, using radio telegraph transmission, is known to every amateur who can read the code, but it also uses voice on occasions, which is news to me. The following letter from Mr. Arthur C. Pfister, of Fairfield, Ohio, may throw some light on the subject:

"—you asked about telephone transmission from EAQ. The reception I was referring to was on the date of the inauguration of the President of Spain. The services were being transmitted by several GB-stations also, but I had them on EAQ before any of the English phones were on the air. The time was about 5.00 p.m. (Eastern Standard Time). I also had EAQ for about a week before, when they were testing with New York in preparation for the services. The wavelength used was 30.40 meters. Time was always about 5.00 p.m. Lately I haven't heard them."

A Hint

Rome and Chelmsford are only a fraction of a meter apart. You can always distinguish between them because Rome has a woman announcer who clearly says "Radio Roma Napoli," pronouncing the word "radio" like "rah-dio."

Costa Rica

T14NRH, on 29.3 meters, has changed his schedule slightly. He broadcasts on Monday, Tuesday and Wednesday from 6.30 to 7.30 p.m. (Central Standard Time), and on other week days from 8.00 to 9.00 p.m.

Mexico

Station NDA, which makes such a big hole in the ether with its modulated telegraph signals, has become articulate and is now using voice as well as I.C.W. The following dispatch speaks for itself:

"Will you please tune in every night at eight o'clock (Central Standard Time), on station XDA, Mexico City, Mexico, and hear the regular spot news report of the Trens Mexican News Agency, which goes out in English on a 51.1-meter short-wave, for half an hour?"

AUTOMATIC VOLUME CONTROL

Is obtainable in the HY-7 Short-Wave Superheterodyne. With or without A. V. C., as you wish. Write now.

National, Aerovox, Flechtheim, Pilot, Electrad, International, Centralab, Polymet, Sprague, Cardwell, Insuline, Frost, Tobe, Siemens-Halske, Clarostat, etc. 24 HOUR MAIL-ORDER SERVICE.

Write now, inclose 4c, for volume-control booklet. Helps on all repair and replacement problems. Simplifies every volume-control job.

Hatry & Young

119 Ann St.

Phone 5-2733

HARTFORD, CONN., U. S. A.

NEW ACSW-5 by National

Uses '45 and '35 Tubes—in Stock

Kit price\$46.74
 Factory wiring..... 5.88
 Power-pack 23.24
 Standard SW-5, '35 and '27 tubes.
 Kit price\$46.74
 Factory wiring 5.88
 Power-pack 20.57
 SW-3—Wired 32.34
 D.C. 2 volt models at comparable prices.
 Act now, offer good for 30 days.
 Full stock National Parts.

"The report is a good will report pure and simple. Its primary purpose is to carry into the homes of foreign peoples, and especially of the people of the United States of America, a picture of the Mexico of to-day, from the political, economic, financial, commercial and business points of view; to the end that the listeners-in may be brought to a better and more sympathetic understanding of Mexico, the people who inhabit it, and what they are doing in the world of affairs.

"The report, so we learn from innumerable messages we have already received, is being heard with the greatest possible clarity in many parts of the United States. We should appreciate a card from you, at our address, Colon Street 43, Mexico City, telling us how you, yourself, are receiving the broadcast, which, by reason of its entire impartiality and reliability, has aroused sympathetic understanding in all parts of your country.

"Also copy code press report, English, at 10.00 a.m. (Central Standard Time), on 20.5 meters, for five minutes."

Canada

The Calgary *Herald*, station CKS, broadcasts every afternoon from 3.30 to 4.30 p.m.; on Tuesday evenings from 9.00 to 10.30 p.m.; and on Thursday evenings from 7.30 to 10.30 p.m., (Mountain Standard Time), on 7.550 kilocycles.

New Stations in Venezuela

In the event that it can be any use to you, I give herewith a list of some Short-Wave Broadcast Stations, that are broadcasting regularly in this city. They're as follows: YV2BC—6000 Kc. "La Voz del Avila" every day except Monday from 7.45 p.m. till 11 p.m.

YV8BC—9550 Kc. "Broadcasting Nacional" every day except Monday from 12 m. till 1 p.m. and from 8 p.m. till 11 p.m.

YV10BC—11780 Kc. Every day except Sunday the same schedule that AVOHE.

I give you also some authentic details about the Paris Station, received directly from the "Ministère de Postes Télégraphes et Téléphones, Service de la Radiodiffusion, Paris, République Française" 103 Rue de Grenelle. They're broadcasting with a power in antenna of 12 Kw. as follows:

From 14.30 to 17.30 G.M.T. on 19.68 meters, in the East-West Antenna, especially for Asia.

From 18.30 to 20.30 G.M.T. on 25.20 meters, in the North-South Antenna, especially for Africa.

From 21 to 23 G. M. T. in 25.32 meters in the East-West Antenna especially for America and Oceania.

P. AGUIRRE H.,
 Este 3 No. 75,
 Caracas, Venezuela, S. A.

ODEON LO-RIPPLE Mercury Vapor Rectifiers

| Type | Volts | Fil. Amperes | Plate Inc. Volts | Peak Amps | Price |
|------|-------|--------------|------------------|-----------|--------|
| 80 | 2 | 2 | 2000 | .3 | \$2.25 |
| 866 | 2.5 | 5 | 7500 | .6 | \$3.50 |
| 866B | 5 | 5 | 7500 | 1.2 | \$8.00 |

We also make the following Rectifying-Charger Bulbs:

2 Amp. New or Old Type...\$2.25
 5-6 Amp.\$3.35

ODEON MERCURY VAPOR RECTIFIERS ARE GUARANTEED TO REPRODUCE A LOWER AC RIPPLE THAN ANY OTHER MERCURY VAPOR RECTIFIER IN THE PRESENT MARKET, AND TO HAVE AN OPERATING LIFE IN EXCESS OF 1000 HOURS.

20% With Order—Balance Shipped C. O. D. Include Postage

Mail Orders to:

ODEON MANUFACTURING CO.
 30 CLINTON STREET
 NEWARK N. J. U. S. A.

LEARN BY LISTENING

Telegraphy

Morse or Continental

TELEPLEX is more than a machine—it is a SYSTEM. It teaches you expert sending and receiving Morse or Continental Code—for amateur work or a good-pay position. TELEPLEX is used by the U. S. Army and Navy and leading radio and telegraph schools.

Write for Folder SW-5
Teleplex Co.
 76 Cortlandt St., New York

Please mention SHORT WAVE CRAFT when writing to advertisers

A real Short Wave Set at a BARGAIN PRICE



The Aero Standard Short Wave Converter for A.C. or D.C. receivers can be assembled in a few minutes and can be plugged into the detector or sometimes in the first R.F. socket of any receiver, utilizing the same tube which has been removed from the socket in which the converter is plugged. The layout and general appearance are the same as the "International" Short Wave Converter, except that the shield grid amplifier has been removed. This is the simplest converter to build and the easiest to assemble and is adapted to any receiver, regardless of type.

No. 144—Complete "Standard" Kit for A.C. Tubes. List Price \$32.00. YOUR PRICE..... **\$5.95**

RADIO TRADING CO.
25-A WEST BROADWAY NEW YORK, N. Y.

HERE is a famous short wave set manufactured by Aero Products, Inc., famous throughout the world. We have a small quantity of these sets on hand, and they will be sold as long as the supply lasts. After they are gone, there will be no more.

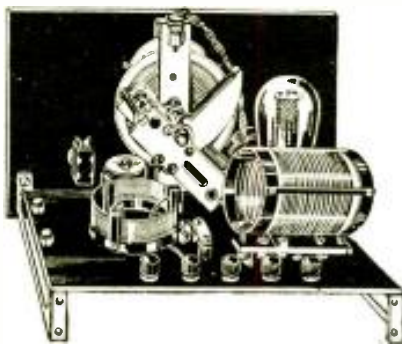

SWAPPERS

SWAPPERS are swappers of correspondence. During the past few years we have noted that Short-Wave enthusiasts love to get acquainted with each other by mail in order to swap experiences.

That's the reason we have opened a department for them under the above heading, in which we will print the names and addresses of all those who wish to correspond with others. As we know we will be deluged with requests, please be sure to follow these simple rules: Use a postcard only. Never write a letter. Address postcard as follows:

SWAPPERS
c/o SHORT WAVE CRAFT
96-98 PARK PLACE
NEW YORK, N. Y.

On the blank side of the postal PRINT clearly your name, address, city and State. Don't write anything else on card. We will then understand that this is your request to publish your name and address and that you wish to enter into correspondence with other short-wave readers. There is no charge for this service.

—EDITOR.

- CHARLES BUTCHER
117 Lakeview Ave., Cambridge, Mass.
- EARLE COMBELLACK
12 So. Chestnut St., Augusta, Maine
- B. COSTIN (BRS-233).
"Westlea", Billericay, Essex, England
- JOHN DELEGAN
1131 - 167th St., Hammond, Ind.
- RUDOLPH DOSTAL
5241 W. 25th St., Cicero, Illinois
- ERNEST ERWIN
2424 Pinkney St., Omaha, Nebr.
- FRED D. FISHER
1627 So. McClure St., Marion, Ind., U. S. A.
- THOMAS FLANIGAN
7224 Jonathan St., Pittsburgh, Pa.
- J. P. FRANK, Jr.
226 North 2nd St., Danville, Ky.
- HERBERT J. GLEED, Jr.
1721 Ohio St., Lawrence, Kansas
- HAROLD HARDING
48 Fourth Ave., Auburn, Maine
- ROGER S. HOLDEN
R. F. D. No. 1, Box 85, Bath, Maine
- W. WINSTON HUNT
35 Madison St., Malden, Mass.
- MURREL J. KELLEY, W8DWH
721 Madison St., Conneaut, Ohio
- B. J. KOZACK
149 Smith St., Fall River, Mass.
- EDWARD MARHETTE
La Belle, Florida
- LEON MARTIN
113 - 4th St., Bluefield, W. Va.
- EDGAR MCKEE
1622 Jackson Ave., Wichita, Kansas
- C. W. MEARES
No. 68, Clarkton, N. C.
- LEOPOLDO MENDEZ M.
Telegrafos Nacionales, Panama, R. de P.
- E. C. MILLER, W8EYD
16 1/2 N. Main St., Three Rivers, Michigan
- W. F. MORRIS
23 Monmouth Road, London, W2, England.
- JOHN NEVA
246 West 67th St., N. Y. City
- ED. PALGUTA, W8BJR
328 M. Walt St., Youngstown, Ohio
- C. HADDON PERDEW
Box 461, Henry, Ill.
- A. PAUL RABITO
Care Radio WSHR—3511.4 kc.
2655 Canal St., New Orleans, La.
- JOHN REEDER
145 West 45th St., New York, N. Y.
- ALBERT C. SMITH, W9HDZ
Box 404, Middlesboro, Ky.
- CLYDE DE VON SMITH, W9DFD, W9GIZ
West Fargo, N. Dak.
- PAUL R. SMITH
Box 91, Bradner, Ohio
- ALBERT SOBEL
8428 - 115th St., Richmond Hill, L. I., N. Y.
- LEON B. STROIK
Care of Pioneer Radio Laboratories, Inc.
Second and Ward Streets, Chester, Pa.
- EDWARD J. TRELIA
Care of Trella Radio Service
547 Broad St., Meriden, Conn.
- JOHN VINCENT
3479 East 104th St., Cleveland, Ohio

"HAM" ADS

Advertisements in this section are inserted at the cost of two cents per word for each insertion—name, initial and address each count as one word. Cash should accompany all "Ham" advertisements. No less than ten words are accepted. Advertising for the December-January issue should be received not later than October 10th.

WILL sacrifice my entire stock of radio parts, worth about \$75, some used, but perfect. Ideal for beginners. Amazing low prices. Write for price list, or send \$3.00 or more and tell me your needs and I will try to include what you need in a box of parts of my own selection, which I'm sure will please you. E. W. Clark, Rutland, Ohio.

TRANSMITTING and receiving tubes—brand new, and guaranteed. 210, 95c; 250, 80c; 245, 45c; 224, 60c; 171A, 35c; 280, 40c. L. W. Robson, WACKU, Heron Lake, Minn.

THOUSANDS of used radio parts at unheard of prices. Guaranteed A1 condition. Send stamp for list. Arno Wilkens, 241 South 11th Street, Reading, Pa.

SELLING Master-Oscillator Power-Amplifier portable 15-watt station at 50% off list price of parts. No junk. All AC operation. Four Weston meters. 20-40-80 meter coils. Pone or C.W. Also Teleplex with oscillator. Miscellaneous parts. What do you need? List free—Fotos 10c. Hurley, W6CKN, San Fernando, Calif.

TRADE double detector short-wave receiver and cabinet for good microscope, binoculars, or?—Sell for \$5.00 with tubes. Frank Matyae, 248 Jackson Street, Columbus, Ohio.

SHIELDED Audio transformers, standard ratios, 65c each; Western Electric hand microphone, \$6.50; 4-gang variable condenser, .00035 mfd., \$1.50; Loftin-White direct coupled amplifier employs 1 224, 280, 245 tubes, with tubes, \$13.50; also a large variety of new and used transmitting and receiving condensers, resistors, power packs, meters, coils, etc., etc. Write for prices and descriptions. Julius Skinder, Box 54, Universal, Ind.

SLIGHTLY Used Bosch \$20 phonograph pickup to trade for good short wave converter. Harold Geer, 200 Broadway, Salem, N. J.

PILOT SUPER WASP (verified by PCT) with good tubes, \$20.00; 2 German sets (resistance coupled) with tubes 3NF and 211E, two reserve tubes, \$30.00; Imported magnetic speaker, \$3.00; Willard B eliminator, \$6.00. Dr. Richard Hirsch, 881 Brooklyn Ave., Brooklyn, N. Y.

SWAP \$60 Gibson guitar and case for W.B. 212D or C.V. 201A, Nichols (W4AJP), 2213 North 16th Street, Birmingham, Ala.

The S-W Superregenode

(Continued from page 231)

Short Wave condensers, C1, C2, and two Kurz-Kasch vernier dials;

One Hammarlund 14-to-110 meter

"Model LWT-4" short-wave kit, L1;

One Hammarlund 14-to-110 meter

"Mode LWC1" short-wave kit, L2;

One Hammarlund "Type RFC 250" 250-

mh. R.F. choke, RFC1;

One Hammarlund "Type EC 80" 80

mmf. equalizing condenser, C4;

One Flechtheim filter block (five 1-mf.

units), C6, C7 (2 mf.), C8 (1 mf.);

One Ferranti "Type AF-5," 3.75-to-1

ratio audio transformer, T;

Two Sangamo .001-mf. fixed condensers,

C3, C5;

Two Electrad 50,000-ohm "Super-Tona-

trols," R1, R2;

One Acme 30-kc. I.F. transformer, L3

(see text);

One Yaxley 7-wire cable, 3 to 9;

Two Eby lettered binding posts, 1 and 2;

One output connection block, 10-11;

Two Pilot 4-prong UX sockets, V1, V2;

One Pilot 5-prong UY socket, V3;

One aluminum cabinet 7 x 9 x 3 1/2-

in. thick;

Two aluminum sheets (partitions), 7 1/2 x

9 1/2 x 3/32 in. thick;

Miscellaneous hardware (screws, nuts,

lock-washers, wire, etc.).

The kit of coils designated as LWC1

consists of single windings with the

same number of turns as the secondary

in the Type LWT4 kit. Data on the

latter are as follows:

| Meter Range | Sec. Turns |
|-------------|------------|
| 14-24 | 3 |
| 22-40 | 7 |
| 36-65 | 15 |
| 60-110 | 24 |

The first two coils are wound with No. 16 D.S.C. wire, 11 turns to the inch; the last two coils, No. 18 D.S.C., 17 turns to

the inch; all on forms two inches in diameter. The adjustable antenna primary has 6 turns of No. 28 D.S.C. wire on a two-inch tube.

Please mention SHORT WAVE CRAFT when writing to advertisers

Whatever your **HOB**BY-

you'll find it in



MR. HUGO GERNSBACK'S latest magazine, contains the most important and recent developments in Science, Mechanics, Radio, Television, Aviation and Chemistry. For everyone, regardless of age, EVERYDAY SCIENCE AND MECHANICS will be found to be useful and instructive. Thoroughly illustrated with scientific events from all parts of the world, and helpful to thousands of high school, university students and instructors who wish to advance their scientific knowledge.

Many excellent pages for the home workshop man who finds pleasure in building things; experiments in electricity, chemistry and formulas of all kinds.

Just to Mention a Few Departments

- LATEST INVENTIONS
- AERO-MECHANICS
- SHOP KINKS
- TELEVISION
- EXPERIMENTS
- FORMULAS
- CHEMISTRY
- WOOD AND METAL CRAFTS
- RADIO KINKS
- AND OTHERS

SPECIAL OFFER!

8 Months \$1.00

On All Newsstands OCTOBER 1st

:: MAIL COUPON TODAY FOR SUBSCRIPTION ::

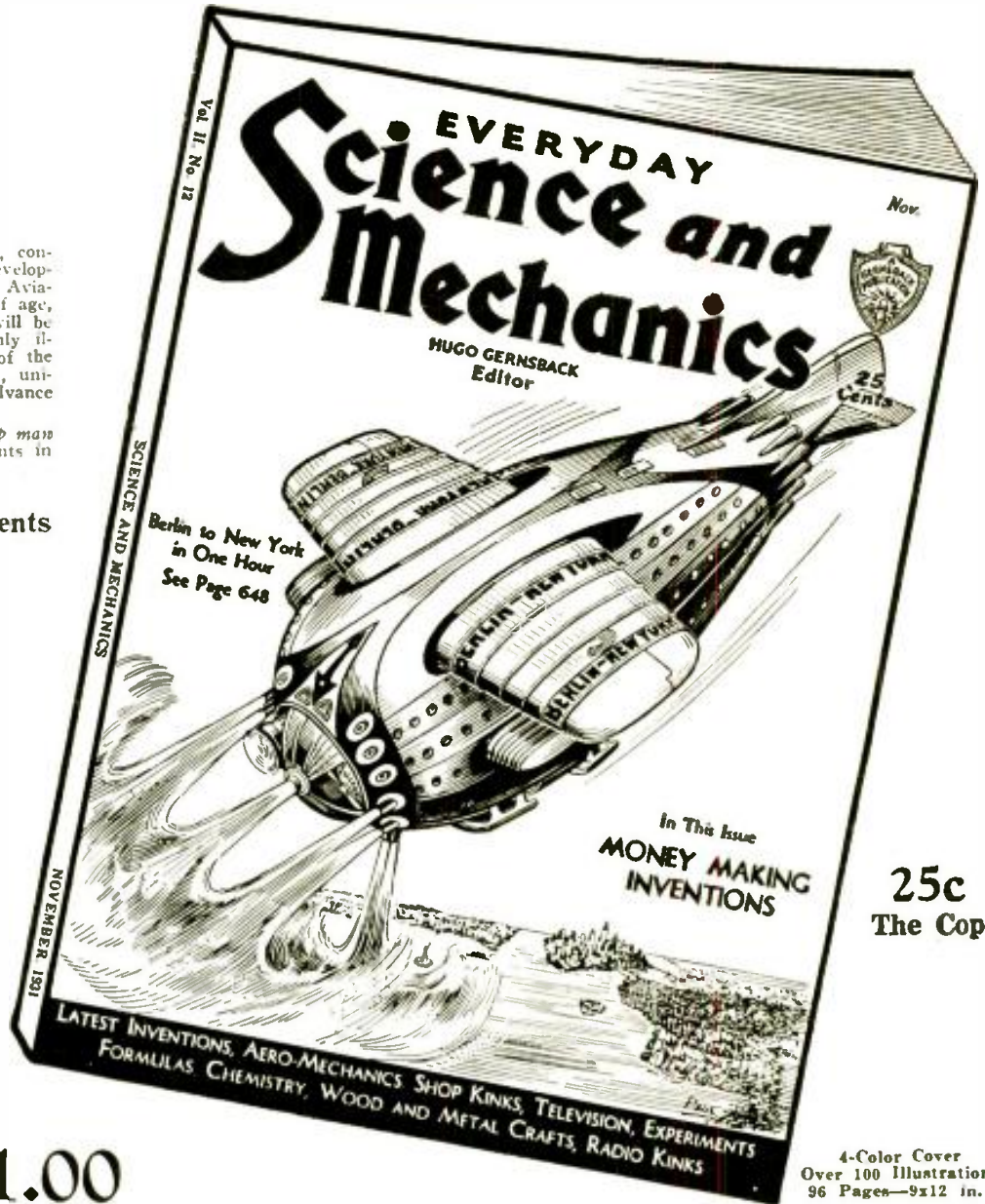

25c
The Copy

4-Color Cover
Over 100 Illustrations
96 Pages—9x12 in.

EVERYDAY SCIENCE AND MECHANICS
98 Park Place, New York, N. Y. SWC-10
I enclose herewith One Dollar for which you are to enter my subscription to EVERYDAY SCIENCE AND MECHANICS for the next Eight Months.

Name

Address

City State.....

(Canadian subscriptions not accepted at this price.)

Please mention SHORT WAVE CRAFT when writing to advertisers

STOP SHOPPING!!

HERE'S a NEW plan, which saves you money. Stop shopping—the lowest prices are right on this page. Yes, lower than in our own catalog. Why? Because no house can get out a new catalog every month, but by advertising in this magazine we can bring

you the latest and lowest prices up to the time this ad is printed. We watch our competitors and do not allow anyone to undersell us. We meet ANY price on NEW merchandise. Order direct from this page and save money. 100% satisfaction on every transaction.

Patent "250" Power Auditorium Amplifier

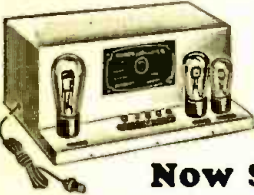

One of the Most Powerful Super Power Amplifiers ever made.

Now \$8.75

CONTAINS 2 STAGES SUPER POWER A.F. AMPLIFICATION

This famous amplifier is provided with input and output transformers for working from a phonograph pick-up into a 2000-ohm transmission line or into the counting transformer furnished with most dynamic reproducers. The tubes required are one '28, one '50 and one '81 rectifier. Where maximum output is not required a '10 may be substituted for the '50 in the output. Automatic adjustment takes care of the discrepancy in voltages. The undistorted power output is 2.5 watts—enough for four small dynamic reproducers. This degree of power output provides satisfactory coverage for auditoriums having a volume of 25,000 cubic feet. The input voltage necessary to provide maximum output is but .025 volts.

Ideal for theatres seating approximately 3,000 people, dance halls, schools, lectures, hospitals, auditoriums, outdoor gatherings, etc., etc. The gigantic power is at all times within control—for that matter, it can be used in any home, as the volume can be regulated down to a whisper!

A PHONOGRAPH AMPLIFIER—PUBLIC ADDRESS AMPLIFIER SYSTEM, ETC.

Use of the '26 tube in the input stage makes the long "warming up" period unnecessary. Shipping weight, 30 lbs. Overall size, 16 x 8 1/2 x 6 1/2" high. List Price, \$90.00.

No. 1925—Patent Model 250 Power Amplifier (less tubes). Your Price \$8.75

BRAND NEW! RADIO MIRROR PENLITE



The Latest and Cleverest Tool for Radio Servicemen. The only device that enables you to LOOK AROUND CORNERS or UNDERNEATH inaccessible spots. Your vision is ONLY in a straight line, but with the Mirror-Penlite you can look around a 45 degree angle. You can now look under the whole chassis and see every nut, every wire, every socket, behind condensers, transformers, etc. This is made possible by the powerful pocket flashlight to which is attached a GENUINE DENTAL MAGNIFYING MIRROR. Mirror clips on or off so flashlight can be used alone if desired. The cleverest device yet. Complete with battery and bulb. Shipping weight 8 ozs. No. 1695—Mirror-Penlite. List Price \$2.50. YOUR PRICE 85c

Earl Power Transformers

Make money revamping the old battery set. This power transformer used in Earl Model 22 receiver supplies "A," "B," and "C" potentials for: two '27's (or screen-grid '21's), three '26's, two '71A's and one '80 rectifier; total current output of high-voltage winding at maximum output (about 300 volts) is 80 ma. High-voltage secondary filament winding for '27's and for '71A's are center-tapped. Size, 3 1/4 x 3 x 2 1/4 inches. 16 long leads and full wiring directions. Shipping weight 5 lbs. List Price, \$7.50.

No. 1410—Earl Transformer (with brackets). YOUR PRICE \$1.73

No. 1411—Earl Transformer, the same but with mounting brackets... \$1.98

SPECIAL!

Baldwin RIVAL Speaker Unit

A loud speaker unit bearing the world famous Baldwin mark. Designed for use with horn type speakers or with old style phonographs. Complete with cord. Shipping weight 1 lb. POSITIVELY LOWEST PRICE THIS UNIT HAS EVER BEEN SOLD. No. 1520—Baldwin "Rival" Unit. YOUR PRICE 45c

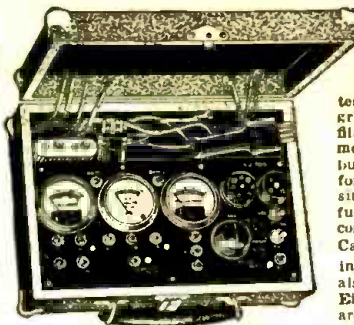

NEW READRITE Analyzer

This three-meter analyzer has selector switch for checking all parts of tube circuits by connecting to the set sockets. Selection for testing voltages of plate, grid, cathode and screen-grid done quickly and accurately. Plate current, filament volts, line and power supply volts are measured. Grid swing test for tubes used. Just push one button for screen-grid and other button for other tubes. Makes testing of all type tubes simple and thorough. 4 1/2-volt grid battery is furnished. Battery is used for grid test and continuity testing of transformers, chokes, etc. Capacity and resistance charts furnished showing use of instruments for testing condensers. Also measuring resistances up to 100,000 ohms. Eight scale readings of meters may be used separately with the jack terminals provided. Scale readings are 0-60-300-600 I.C. volts, 0-10-100, readings are 0-60-300-600 I.C. volts, 0-10-100, readings are 0-60-300-600 I.C. volts, 0-10-100, readings are 0-60-300-600 I.C. volts, 0-10-100, readings are 0-60-300-600 I.C. volts. A.C. and D.C. filament voltages are accurately measured on the one meter. Strong case with leatherette covering. Attractive. Compact. Size 10 1/2 x 3 1/2 x 8 inches. Shipping weight 15 lbs. List Price \$25.00. No. 700—READRITE ANALYZER. YOUR PRICE \$14.70

THORDARSON

"245" Power Transformer

A Miniature Power Plant — Supplies All ABC Voltages — 60 Watts

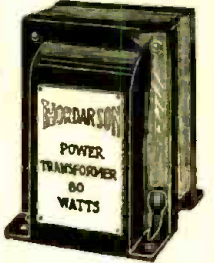

In addition to supplying a full 250 volts to the plates and 50 volts to the grids of two type '45 tubes in push-pull, this transformer may be used to light the filaments of seven or eight 2.5-volt filament tubes; and by connecting in series two of the three 2.5-volt filament secondaries it is possible to light 5-volt filament tubes too. Five secondaries: S1—5 V., 2 Amp.; S2—340 V. Cent. T.; S3—2 1/2 V., 3 Amp. Cent. T.; S4—2 1/2 V., 10 1/2 Amp.; S5—2 1/2 V., 3 Amp. Cent. T. Just the power transformer for building up a high-grade public address amplifier to use a screen-grid A.F. amplifier to boost the output of a microphone or phonograph pick-up; following this with two stages of push-pull amplification consisting of two '27's in the first stage and two '45's in the second. Bottom of transformer has bakelite panel on which are mounted all taps. It outperforms ANY similar transformer. Many Service Men keep this model transformer on hand for emergency replacements in hundreds of makes of radio sets. For 110-120 volts, 50-60 cycles. Size: 5 in. high x 4 x 3 1/4 in. Shipping weight, 8 lbs. List Price, \$15.00.

No. 1450—Thordarson Power Transformer. YOUR PRICE \$3.84

New 36 page Summer Edition No. 23



The new Summer Edition of our greatly enlarged RADIO SERVICE TREATISE has just come off the press. If you liked the Winter Issue, you will like this one a hundred-fold. It contains some 75 new hook-ups, circuit diagrams; and some 350 illustrations. POSITIVELY THE GREATEST BOOK EVER PUT OUT BY ANYONE. Among the new matters listed are:

VACUUM TUBE TREATISE, with many illustrations; full page Vacuum Tube Average Characteristic Chart; How to Take Care of Your Tubes; How to Connect Phonograph Pick-ups; Improving the Tone Quality of Old Sets; Connecting Additional Loud Speakers; all fully illustrated with diagrams.

Other articles: Modernizing Old Radio Sets; How to Convert Battery to Power Sets; Selection of Tubes; Push-Pull Amplifiers; Replacing Audio Transformers; Phono Attachments; How to Choose Power Transformers; Voltage Dividers; Wabage of Power Transformers; Selecting and Installing Replacement Parts in Radio Sets; Filter Condensers; Repairing Eliminators.

WRITE TODAY. Enclose 2 cents for postage. Treatise sent by return mail.

75 New Hook-Ups, etc. 350 Illustrations.

NEW! NEW!!

Superheterodyne S-W Converter

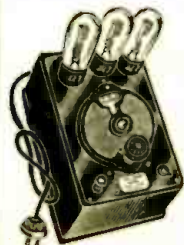

At last a short-wave converter that converts any broadcast set into a superheterodyne short-wave receiver. Employs three '27 tubes and covers from 20 to 115 meters. No plug-in coils! Coil switch is used to cover all wavelengths. Single dial control, no body capacity, no squeals. This converter has built-in filament transformer to heat the three '27's.

All you need to obtain from your receiver is a positive B voltage anywhere from 45 to 180 volts. Voltage is not critical; no modulation of the receiver. So simple a child can operate it. Size 7 x 10 x 5 inches. Shipping weight, 8 lbs. List Price \$25.00.

No. 1614—Super Converter (less tubes). YOUR PRICE \$14.69

World-Wide Short-Wave Set NOT A CONVERTER

A perfect radio short-wave receiver for use between 17 and 81 meters. To put into operation, connect antenna, ground 45-volt "B," and 6-volt "A" batteries, and headphones to the posts provided, plug in a type '01A tube, and tune in! An ingenious circuit makes possible a 4-coil single-winding plug-in design. This little instrument has the same sensitivity as many big, shielded short-wave receivers costing ten times as much. A power amplifier may be added for any degree of volume. Complete with 1 plug-in coil. Has the vernier dial for precision tuning. Never has a first class short-wave set sold for so little money. This short-wave set measures 5 1/4 x 7 x 1 1/2 in. high, over all. Ship. weight, 3 lbs. List price, \$12.50.

No. 1666—World-Wide S.-W. Set. \$6.25 Your price.....

6 MONTHS GUARANTEED NEONTRON TUBES

Sold on a 6 MONTHS FREE REPLACEMENT GUARANTEE BASIS. PROVIDING TUBE LIGHTS! All tubes are carefully meter-tested before shipment, and carefully packed. Do not confuse these HIGH QUALITY tubes with any other "low priced" tubes—our low prices are possible because we do a VOLUME business!

| NEW | | | | | |
|---------|-----------|---------|----------|----------|----------|
| Choice | Choice of | Choice | Choice | Choice | Choice |
| 226 | 112A | 245 | 222 | 230 | 235 |
| 227 | 200A-109X | 280 | 210 | 231 | 247 |
| 171A | 100TV-120 | 171 | 250 | 232 | |
| 201A | 224 | | 281 | | |
| 63c ea. | 69c ea. | 79c ea. | 1.58 ea. | 1.08 ea. | 1.50 ea. |

R.C.A. LICENSED TRIAD AND PERRYMAN TUBES

These nationally advertised tubes are guaranteed UNCONDITIONALLY for six months. The prices are slightly higher than our NEONTRONS because these tubes are of much better quality. See listing above for tube numbers.

| Choice Price | Choice Price | Choice Price | Choice Price | Choice Price | Choice Price |
|--------------|--------------|--------------|--------------|--------------|--------------|
| 76c | 96c | 86c | \$1.76 | \$1.46 | \$2.09 |

Flewelling-Dayton SW Adapter

This wonderful instrument connects to any A.C. radio set by plugging into tube socket in place of the tube (which must be a type '27, or "heater" tube) the plug which is on the end of its 2-ft. cable; then put tube into tube-socket of adapter. Remove aerial from broadcast set and connect to antenna post on adapter. Special plug-in coil No. 1 covers a wavelength band of 17 to 29 meters; coil No. 2, 27-28 meters; coil No. 3, 47-84 meters. Plug-in coil inductances come with the adapter. 5 1/2 x 7 1/4" high, overall. Ship. weight 4 lbs.

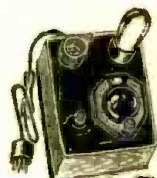

No. 1613—Dayton Flewelling Short-Wave Adapter. List Price, \$15.00. YOUR PRICE (without tube).... \$4.93

Short-Wave Converter

Build a short wave converter at lowest price on record, but with which excellent results are obtainable nevertheless. The voltage for the three '27 tubes used may be obtained from an external filament transformer or from a secondary winding of 2 1/2 volts in a power pack. Wavelength from 30 to 110 meters. No plug-in coils; coil switch is used to cover wave band. Single dial tuning to grunting, no body capacity, no squeals. Leak-condenser modulation. Converter consisting of all parts (less filament transformer) including cabinet, label, diagram and 4-page instruction sheet (less tubes). \$4.85

No. 1619—YOUR PRICE \$4.85

No. 1615—6-Volt Battery Model, same price.

We guarantee these condensers unconditionally. They are ideal for general replacement purposes and can be installed in any new power-pack. All condensers are furnished with 8-inch lengths of tinned "push-back" wire.

| 600 VOLTS | | | 800 VOLTS | | |
|-----------|-------------|------------|-----------|-------------|------------|
| Cat. No. | Mid. Capac. | Your Price | Cat. No. | Mid. Capac. | Your Price |
| 1702 | 1/2 | \$0.25 | 1706 | 1 | \$0.40 |
| 1703 | 1 | .30 | 1707 | 2 | .70 |
| 1704 | 2 | .40 | 1708 | 4 | 1.05 |
| 1705 | 4 | .60 | | | |

WE ARE A WHOLESALE HOUSE AND CANNOT ACCEPT ORDERS FOR LESS THAN \$3.00.

If C. O. D. shipment is desired, please remit 20% remittance, which must accompany all orders.

If full cash accompanies order, deduct 2% discount. Send money order—certified check—U. S. stamps.

Radio Trading Co.
25A West Broadway
New York, N. Y.

ORDER FROM THIS PAGE. You will find special prices from time to time in this magazine. Get our big FREE catalog for the greatest Radio Bargains.

Should you wish goods shipped by parcel post, be sure to include sufficient extra remittance for same. Any excess will be refunded.

NOW You Can Do It!

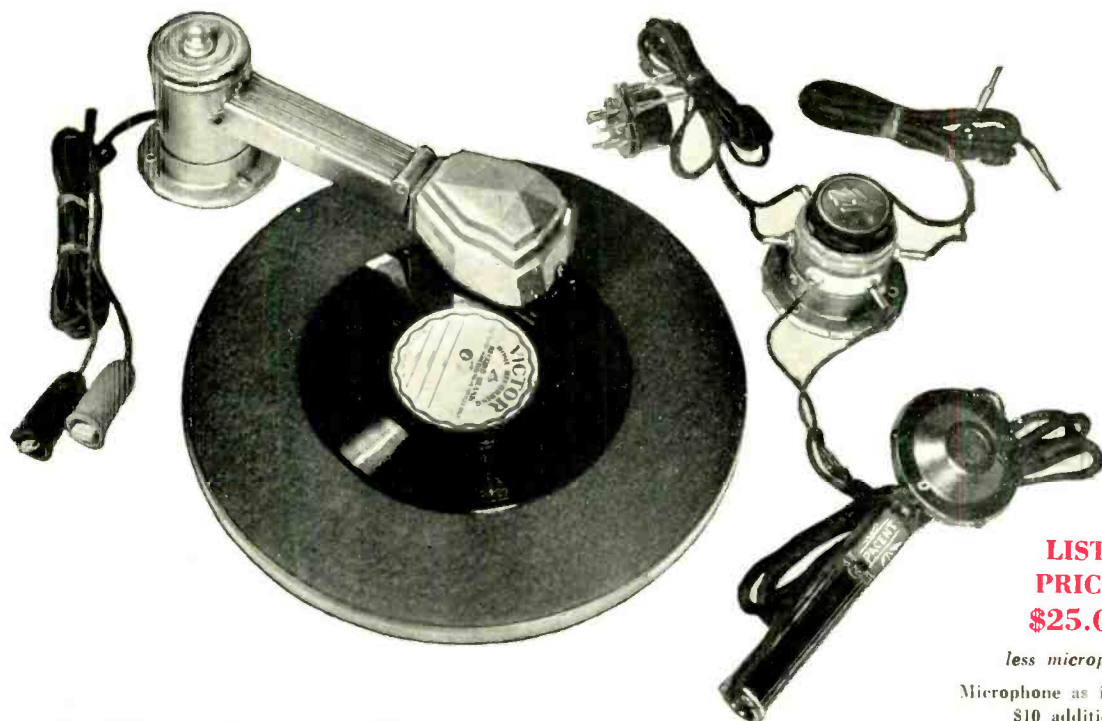

**LIST
PRICE
\$25.00**

less microphone

Microphone as illustrated,
\$10 additional

AT LAST it has become possible for every Short Wave enthusiast to actually record his messages be they code or phone.

How often have you boasted that you have received a far distant phone station, 12,000 miles away, so loud that it "rattled the gaskets of your loud speaker." But frequently your friends were highly skeptical.

Now with the PACENT RECORDOVOX, recording of any foreign program becomes child's play. And, of course, the RECORDOVOX is supreme as well for home recording, because it faithfully records and keeps for posterity the voices of the entire family.

The special blank records cost only a few cents and can be secured anywhere.

Electrically and mechanically, the PACENT RECORDOVOX is as fine an instrument as you could find even in the professional recording laboratories.

Every possible angle has been taken into consideration in the design of the RECORDOVOX. Supplied with 3 adjustable weights, it can be used with motors that lack sufficient torque to operate the turntable when the head is fully weighted. Like the well-known PHONOVOX, the RECORDOVOX, as the result of careful design, possesses excellent frequency characteristics.

Designed for pre-grooved type of records only. List Price \$25.00. Microphone \$10.00 list extra.

*Write for information on special types and models
to meet your specifications*

Manufacturers

PACENT ELECTRIC CO., INC., 158 W. 16TH ST., NEW YORK, N. Y.
Pioneers in Radio and Electric Reproduction for Over 20 Years. Licensee for Canada: White Radio, Ltd., Hamilton, Ont.



Electric Phonograph Motor, Catalog No. 140

Meets every requirement of radio-phonograph use. Has sufficient torque to cut even 10" records.

List Price \$25.00

P A C E N T

THE LINE OF RADIO PARTS YOU CAN *finish* WITH AS WELL AS *Start* WITH



KITS • PARTS • ACCESSORIES

Now occupying the largest factory in the world owned and operated by a radio manufacturer, **Pilot Radio & Tube Corporation** offers the service man, custom set builder and amateur set builder assurance of a future supply and service on every item necessary for replacement for years to come. • Pilot Super-Wasp Kits are the best known short wave apparatus throughout the world. Pilot power supply units, transformers, fixed condensers, resistances, and other accessories are only second to the Super-Wasp in international fame.

• Pilot Broadcast Receiver Parts, coils, variable condensers, shields, etc., are in use in more home and custom built receivers than any other brand. • Pilotron Radio Tubes are depended on in more different countries for constant radio contact over immense distance than any other tubes.

Pilotrons are the only radio tubes all of which give as good results in short wave work as on broadcast wavelength.

Pilot short wave experience has taught Pilot tube engineers the value of manufacturing practices not yet generally known, with the result that Pilotrons are unexcelled in uniformity of design and consistency of operation.



TUBES

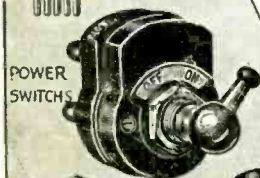

POWER SWITCHES

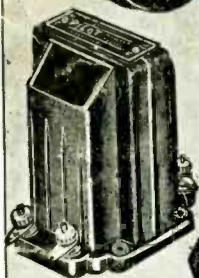

TRANSFORMERS AND CHOKES



COILS



JACKS



REOSTATS

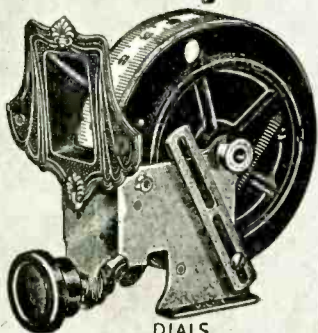

DIALS



FIXED CONDENSERS



PILOT RADIO & TUBE CORP.

Chicago Office 234 S. Wells Street LAWRENCE, MASS. San Francisco Office 1278 Mission Street
New York Office—525 Broadway

OFFICES IN PRINCIPAL COUNTRIES OF THE WORLD

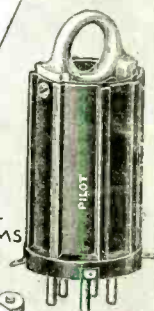

COIL FORMS

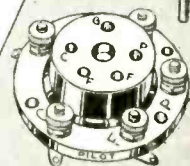

TUBE SOCKETS



"VAULTTYPE" VARIABLE CONDENSERS



BINDING POSTS



POWER PACKS

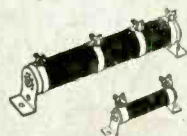

FIXED RESISTORS



KITS