

TAPE EQUIPMENT

# SERVICE

THE TECHNICAL JOURNAL OF THE TELEVISION-RADIO TRADE

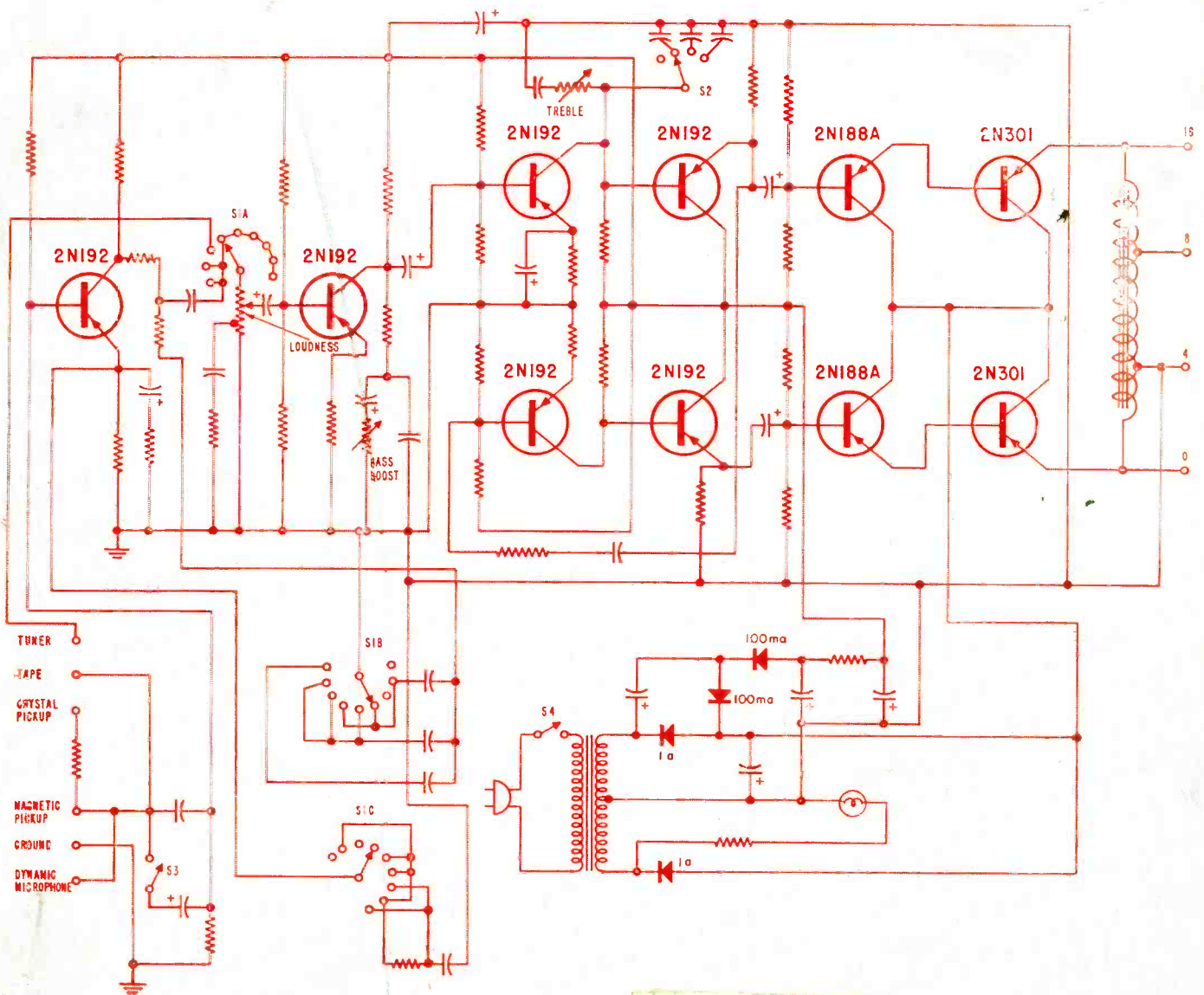

Ten-transistor audio amplifier with inputs for tuner, tape, magnetic or crystal pickups and dynamic microphone, which can deliver 20 watts to speaker load.

See circuit analysis, this issue

35 SAR 10-1-57  
 CHICAGO 12, ILL  
 2123 W SUPERIOR ST  
 WM HORETAKO  
 2-63

**MODEL 280SW** (shown right)

- Double stacked array PLUS high frequency elements.
- All Aluminum Construction.
- Mounts on any mast up to 1 3/4".
- QUICK-RIG design for speedy one man installation.
- Complete with stacking bars.

**MODEL 180SW** . . . . same as 280SW only not double stacked.

**MODEL 180** . . . . QUICK-RIG 8 element "Lazy-X" Conical.

**MODEL 280** . . . . QUICK-RIG double stacked "Lazy-X" Conical.

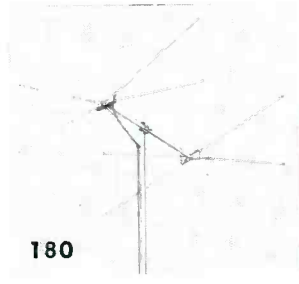

180

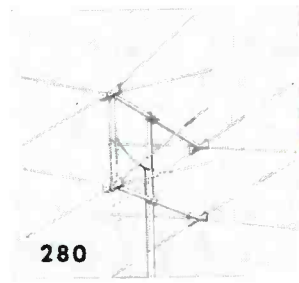

280

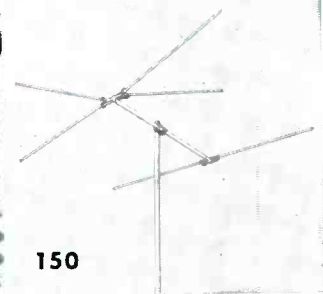

150

# TV ANTENNAS

Proven Unquestionably . . .  
the best performing at  
the lowest possible price!

RADIART . . . the name you can depend upon for QUALITY and VALUE . . . offers a COMPLETE . . . and NEWLY ENGINEERED line of superbly performing TV antennas at an economy price. Carefully tested under all conditions . . . each of these new models is guaranteed to be the best performing at the lowest possible price.

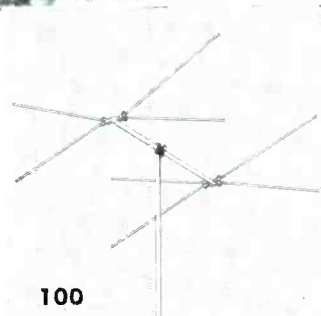

100

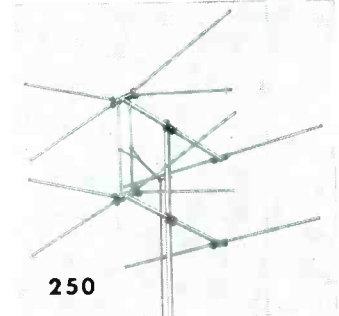

250

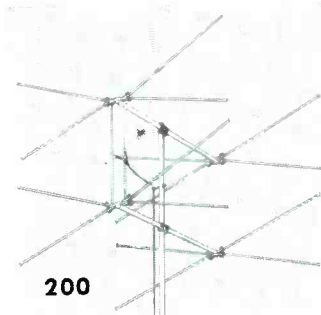

200

- LZX 100 single array
- LZX 101 single array, unassembled
- LZX 200 8 element conical completely assembled, stacked array
- LZX 201 8 element conical unassembled, stacked array
- LZX 150 single array
- LZX 151 single array, unassembled
- LZX 250 6 element conical assembled, stacked array
- LZX 251 6 element conical unassembled, stacked array



SUBSIDIARY OF



THE RADIART CORPORATION / CLEVELAND 13, OHIO



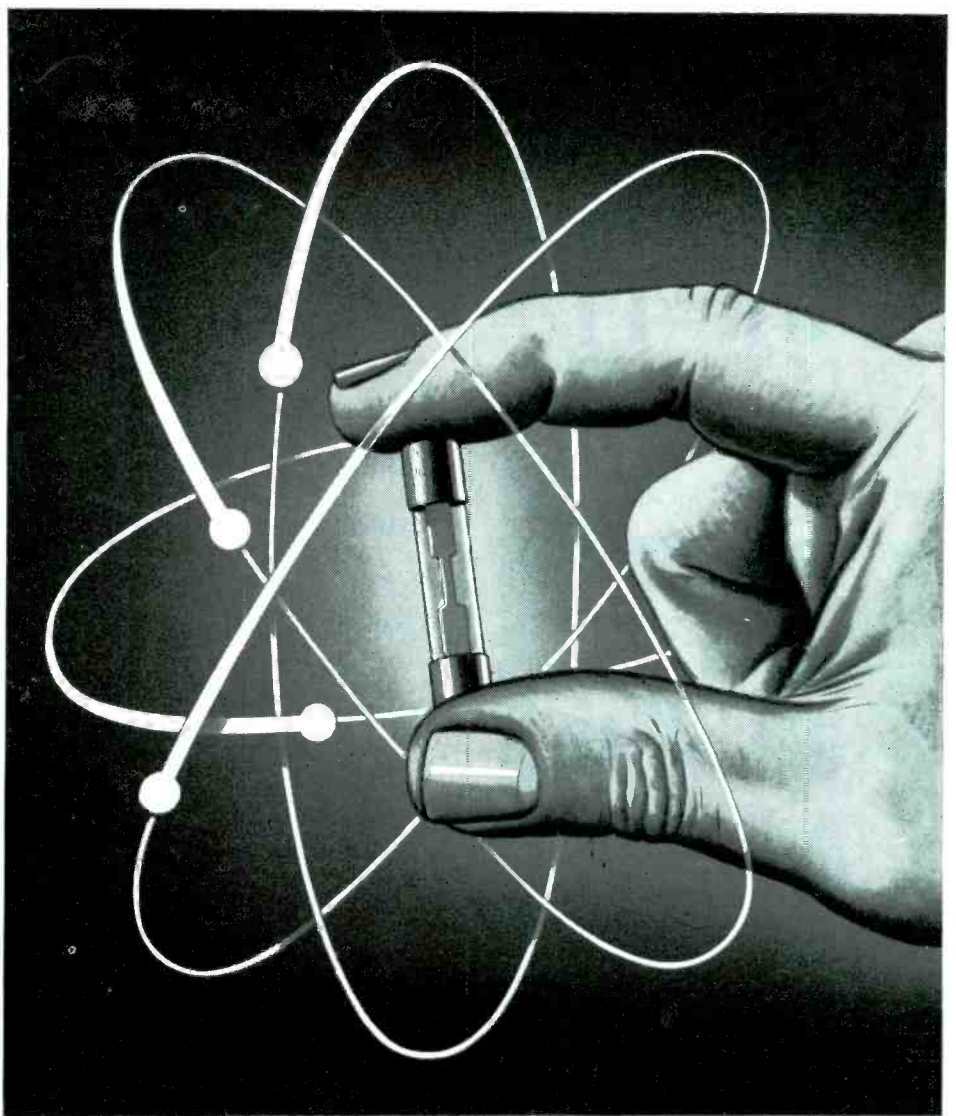

## ELECTRONICALLY TESTED BUSS FUSES *can help safeguard you against troubles and complaints*

With BUSS fuses, dependable electrical protection is not left to chance. Every BUSS fuse is tested in a sensitive electronic device that automatically rejects any fuse not correctly calibrated, properly constructed and right in all physical dimensions.

As a result, when you sell or install BUSS fuses you are sure the fuses will operate properly under all service conditions. You avoid 'kicks' or complaints from customers about faulty

fuses failing to protect or causing needless shutdowns.

By their unfailing dependability, BUSS fuses can help you safeguard your reputation for quality and service.

### **BUSS fuses have ready customer acceptance**

The universal acceptance of BUSS fuses is based on the millions upon millions of BUSS fuses used in homes on farms and in industry over the past

43 years. This means sales are easier to make because BUSS quality is never questioned.

For more information on BUSS and FUSETRON Small Dimension fuses and fuseholders . . . Write for bulletin SFB. Bussmann Mfg. Division McGraw-Edison Co., University at Jefferson, St. Louis 7, Mo.

***BUSS fuses are made to protect - not to blow, needlessly***

S-1257



MAKERS OF A COMPLETE LINE OF FUSES FOR HOME, FARM, COMMERCIAL, ELECTRONIC, AUTOMOTIVE AND INDUSTRIAL USE.

SERVICE DECEMBER, 1957 • 1

ANOTHER **Snyder** PHILADELPHIA

**SALES-MAKER**

**TUK-IT**  
HIDE AWAY

INDOOR TV ANTENNA  
FOR BACK MOUNT

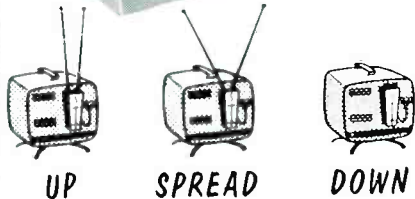

**SNYDER**  
**MANUFACTURING CO.**  
PHILADELPHIA • TORONTO  
EXPORT: ROBURN AGENCIES, N.Y.  
WAREHOUSES: LOS ANGELES, SEATTLE, DALLAS



**SERVICE**

THE TECHNICAL JOURNAL OF THE TELEVISION-RADIO TRADE  
Including RADIO MERCHANDISING and TELEVISION MERCHANDISING  
Registered U. S. Patent Office

**COVER CIRCUIT**

Transistorized 20-Watt Amplifier (Vico 77) ..... 10

**FEATURES**

Editorial ..... 9

9-Transistor 20-Watt AF Amplifier (Cover: With Complete Circuit)  
George Young ..... 10

This Month in SERVICE ..... 12

New Trends in Power Transformers for TV Chassis ..... J. C. Spindler ..... 14

Troubleshooting Dual-Diode Horizontal AFC Circuits ..... Jesse Dines ..... 17

A Field Progress Report on Latest Tape-Equipment Developments:  
Monaural Tape Recorder-Stereotape Player ..... Sam F. Pusey ..... 18

Troubleshooting Tape Equipment ..... 20

Glossary of Monaural-Stereo Tape Recording-Playback Terms ..... 22

Troubleshooting AF-FM Tuners . . . Fuse-Resistor Replacements ..... 24

Annual Index for 1957 ..... 28

A Report on a TV-Antenna Replacement-Market Study ..... 32

Tube Report: TV Tubes for Wide-Angle Chassis . . . Color-BW  
Replacements . . . Hi-Fi Audio Tubes ..... 36

Semiconductor Developments ..... 37

Servicing Carrier-Current Wireless Intercoms ..... 42

**CIRCUIT DIAGRAMS**

Vico 77 All-Transistor Amp (Cover; With Complete Circuit) ..... 11	RCA STR-6/8 Stereo-Monaural Tape Player Recorder ..... 19
Crosley 393-394 Horiz-Sync ..... 17	Crescent Tape Amp for TR-773 A/B and 774 A/B ..... 21
Admiral 22E2 Horiz-Sync ..... 17	Westinghouse AM/FM Tuner ..... 25
Basic Stereo Playback-Monaural Record-Playback Circuits ..... 18	Bennett 100 Wireless Intercom ..... 42

**DEPARTMENTS**

Transistor-Radio Service Notes ..... 10	Radio-TV Components ..... 35
Audio Installation and Service ..... 20	Tube News ..... 36
Catalogs and Books ..... 26	Semiconductor Developments ..... 37
Association News ..... 27	Test Instruments ..... 38
Ten Years Ago in SERVICE ..... 27	Service Engineering ..... 42
TV Antenna Digest ..... 32	Bench-Field Tools ..... 47
Accessories ..... 34	Personnel ..... 48

Index to Advertisers ..... 47

© 1957 by Bryan Davis Publishing Co., Inc. All rights reserved.

Second-Class mail privileges authorized at New York, N. Y.; additional entry at the Post Office, Norwalk, Conn. . . . Subscription price: \$2.00 per year (\$5.00 for 3 years) in the U.S.A. and Canada; 25 cents per copy. \$3.00 per year in foreign countries; 35 cents per copy.





**EDITOR and PUBLICATION DIRECTOR**

**Lewis Winner**

- Associate Editor: **David E. Pearsall II**
- Assistant Editor: **Robert D. Wengenroth**
- Editorial Assistant: **Arnold Gewirtz**
- Editorial Assistant: **Howard Jennings**
- Field Editor (Mid-West):  
**Rudolph T. Plemich**
- Art Director: **Anthony R. Aliffi**
- Supervisor, Circuit Diagrams:  
**Michael D. Bellezza**
- Editorial Production: **Astrid Kelly**

**CIRCULATION DEPARTMENT**

- Circulation Manager: **A. Goebel**
- Ass't Circulation Mgr.: **A. Kiernan**

**ADVERTISING DEPARTMENT**

- Advertising Mgr.: **Aaron L. Lafer**
- Pacific Coast: **Leo Sands, Dist. Mgr.**  
535 Ramona St.  
Palo Alto, Calif.:  
Tel.: DAVenport 5-3716

Published Monthly by  
**Bryan Davis Publishing Company, Inc.**  
 52 Vanderbilt Ave., New York 17, N. Y.  
 Tel.: MURray Hill 4-0170  
 B. S. Davis, Pres. Lewis Winner, Vice-Pres.

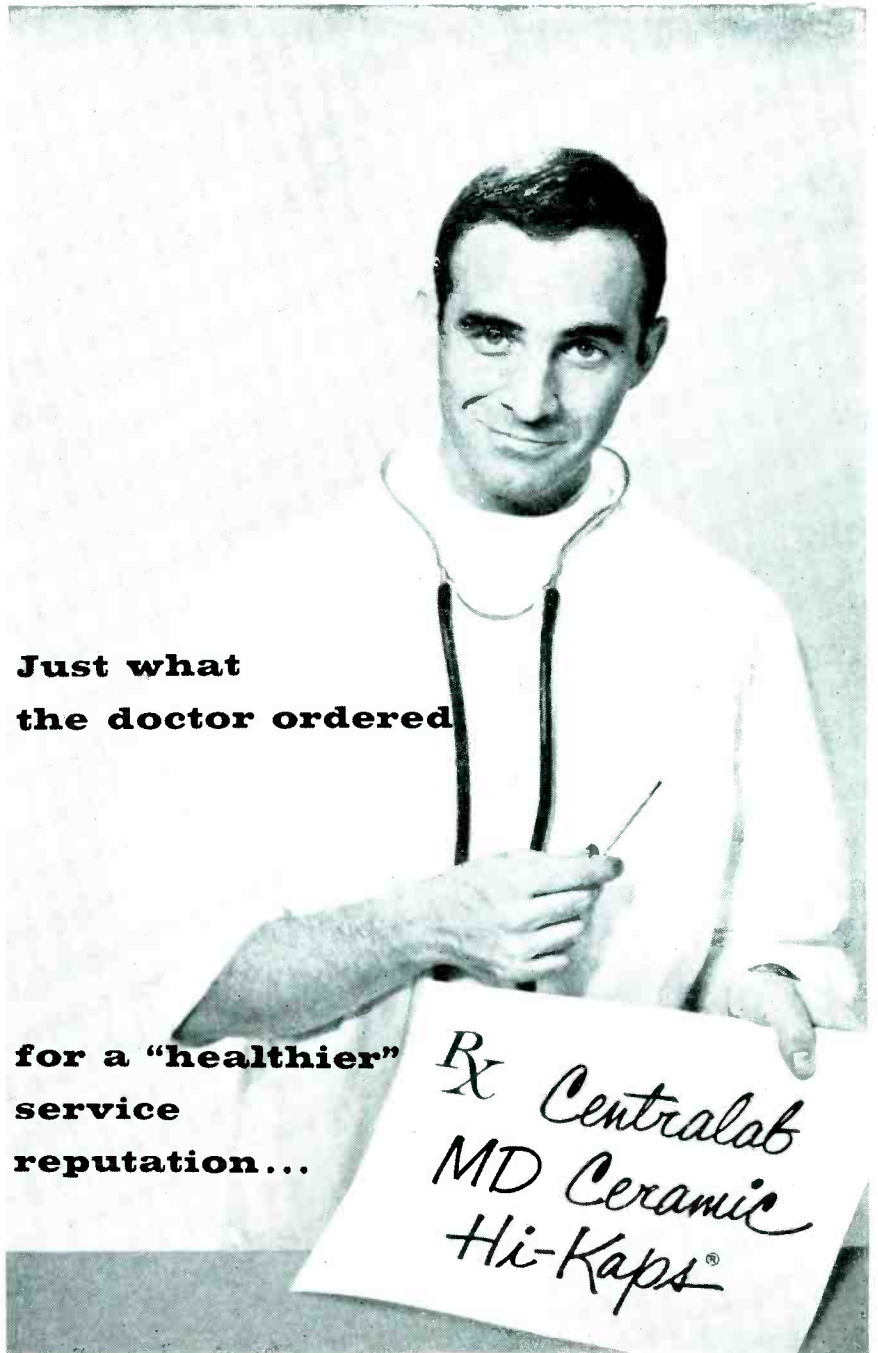

**Just what  
the doctor ordered**

**for a "healthier"  
service  
reputation...**

Check these "undoctored" facts yourself to learn why CRL MD (molded disc) ceramic capacitors outlast and outperform conventional "mud" discs—yet cost the same. You'll find that CRL molded discs give you:

1. *Three times* the voltage breakdown — 3000 V.D.C. breakdown to ground.
2. *Eight times* the lead strength—greater than the breaking strength of the No. 22 tinned-copper wire itself.
3. *Ten times* the humidity resistance — .005% or less moisture absorption by the molded casing.
4. *Many times* the resistance of ordinary discs to physical shock and vibration.

The results: more satisfied customers . . . more business for you . . . and a self-assurance that you gave the best.

Pick them up at your CRL distributor who handles these and thousands of other quality components described in Centralab Catalog 30, which is available on request.



**Centralab**

® Centralab Trademark

A DIVISION OF GLOBE-UNION INC.  
934-L EAST KEEFE AVENUE • MILWAUKEE 1, WISCONSIN  
IN CANADA: 804 MT. PLEASANT ROAD • TORONTO, ONTARIO

D-1756

**A** merely insert card in slot

**B** flip power lever to "power-on" position

**C** press calibrate lever and adjust calibration control

simple as **A-B-C...**

# NEW RCA WT-110A AUTOMATIC TUBE-TESTER

means more service profits!

Dollar for dollar, feature for feature, you'll find RCA's WT-110A the fastest, most accurate automatic punched-card tester you can buy today. It's a virtually *obsolescence-proof design* ... from the exclusive RCA 700-card capacity magazine file that always keeps the pre-punched cards in type number sequence, to the fully automatic circuit setup (including *all* operating voltages) and the easy, do-it-yourself punch card accessories available to keep the tube-card file up-to-date!

See and test the WT-110A at your local RCA Distributor. Prove to yourself what a boost in business, prestige, profits the RCA-WT-110A can mean!



**TEST EQUIPMENT**  
**RADIO CORPORATION OF AMERICA**  
Electron Tube Division, Harrison, N. J.

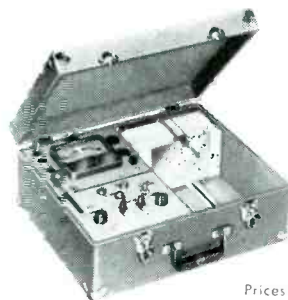

All this for  
**\$199.50**

USER PRICE (Optional)  
Prices higher in Hawaii and Alaska

- automatically sets up socket connections, and all operating voltages such as heater, signal, plate and screen voltages, and bias (both fixed and cathode).
- checks tubes for transconductance, gas, shorts, and leakage between elements.
- automatically selects correct conditions from 220 possible combinations of heater voltage (from 0.1 volt to 120 volts) at currents up to 4 amps., 10 bias voltages and 11 values of cathode resistors.
- tubes, such as rectifiers, tested under heavy load currents up to 140 ma per plate.
- high-and-low sensitivity ranges for leakage tests.
- 12-volt plate and screen supply for testing new auto-radio tubes.
- meter protected against burnout.
- test card provided for checking instrument.
- 239 pre-punched cards supplied with instrument cover 95% of currently active TV tubes. Pre-punched accessory cards available.
- active card magazine capacity—350; storage capacity—350...a total capacity of 700 cards.



**G-C-TELCO**

# **GOLDEN INVADER**

## The Antenna That Beats Them All!

**TRY TELCO'S NEW GOLDEN INVADER,** the powerful antenna for VHF fringe areas and UHF primary areas. Extensive tests prove its uni-plane design can pull in stations from as far as 200 miles away. Ghosts and co-channel interference are eliminated. The **GOLDEN INVADER**, for color or black-and-white TV, comes pre-assembled with the new Snap-Lock construction that makes it easier to handle, easier to install. Available in single bay (illustrated), two-bay or four-bay models.

- SUPER SHARP DIRECTIVITY
- BEAUTIFUL GOLD ANODIZING
- NEW SNAP-LOCK DESIGN
- RECEPTION UP TO 200 MILES AWAY

**No. A-8121 Single Bay..... List \$29.95**  
**A-8122 Two-Bay..... 59.95**

### **VALUABLE BONUS FOR YOU!**

Enclosed with each TELCO GOLDEN INVADER is a special Golden Bonus Certificate. Look for these Certificates . . . save them. They're valuable to you!

### **UNCONDITIONAL GUARANTY...**

A Telco Exclusive! TELCO guarantees the GOLDEN INVADER and all Telco Antennas to be free from defects in materials and workmanship. This guarantee on the Golden Invader is for *three* years. All other antennas are guaranteed for one year.

**G-C-TELCO**

**TELCO ELECTRONICS MFG. CO.**

Division of G-C - Textron Inc. • Los Angeles 18, Cal. • Rockford, Ill., U.S.A.

### **THE COMPLETE LINE OF TELCO POWER PACKED ANTENNAS**

CONICALS

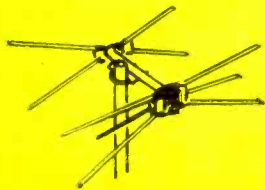

YAGIS

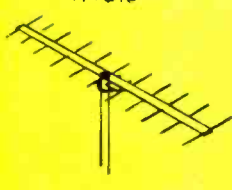

INLINES

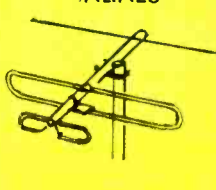

BOW TIES

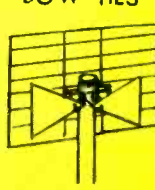

INDOORS

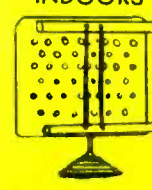

ANTENNA KITS



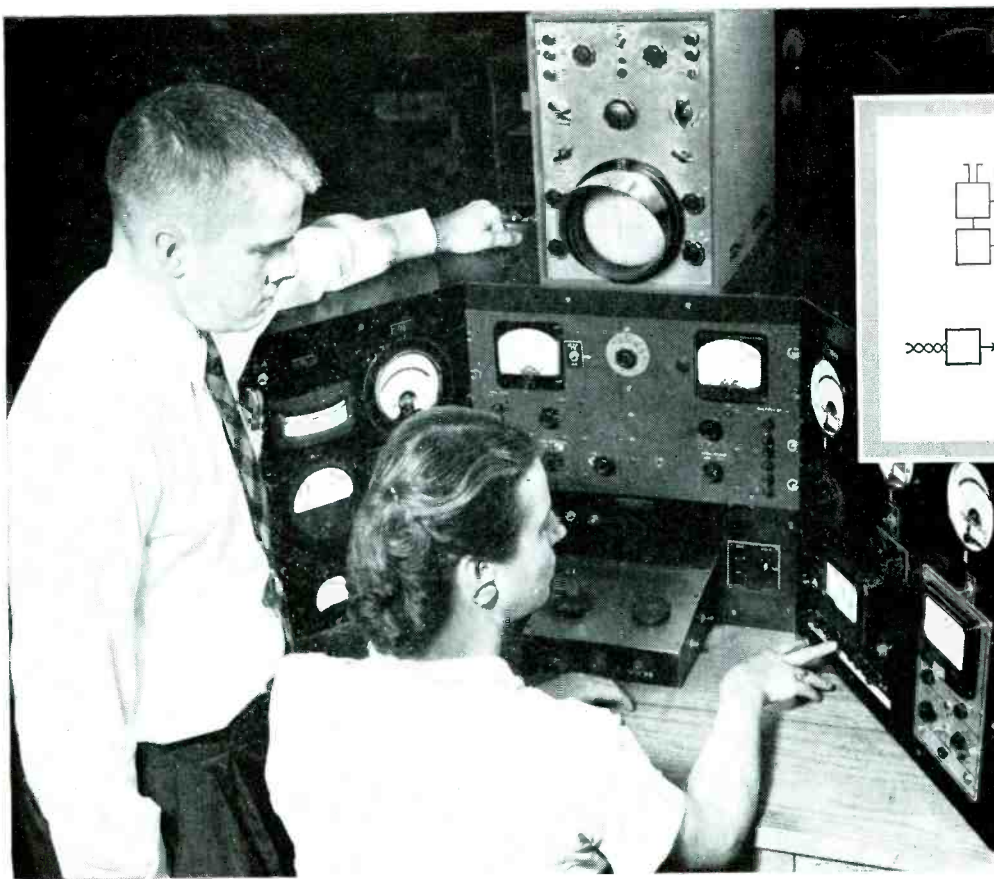

◀ **G-E PROCESS ENGINEER J. N. Holeman** studies the dial reading of a 6BN6 being checked for AM rejection. When taken at intervals from their life-test racks, these G-E audio tubes must continue to show an AM rejection figure that, under standard operating conditions, is at least  $-25$  decibels.

## Guard customers' sets from hum and sync buzz! Install G-E high-quality TV audio tubes!

Once you have adjusted the buzz control on a customer's TV set for noise-free audio, it is annoying . . . and costly in working time . . . to be summoned back later because the buzz has recurred.

Change in the AM-rejection characteristics of an audio tube may produce this result. In order to keep down service callbacks needed to remove buzz and hum, General Electric tests 6BN6's, 3AL5's, 5T8's, and other audio detector types under conditions which closely parallel actual operation—and over periods of time that give ample opportunity for any change in characteristics to develop.

This testing for stability of characteristics throughout tube life, supplements G-E manufacture that employs fully every modern method for building superior performance into the finished product.

A pace-setter in designing and applying audio types, General Electric brings you tubes for replacement that add real listening pleasure to customers' visual enjoyment. Install audio-tube quality you can back up . . . and which will back up *your* service reputation! Phone your G-E tube distributor! *Distributor Sales, Electronic Components Division, General Electric Company, Owensboro, Kentucky.*

*Progress Is Our Most Important Product*

**GENERAL**  **ELECTRIC**

161-1A12



# No Grass Grows Here!



The 1958 IRE Convention and Show will be the source of new ideas for more than 50,000 radio engineers.

Be sure you are there.

**MARCH 24-27**

## THE IRE NATIONAL CONVENTION

Waldorf-Astoria Hotel  
and The Radio Engineering Show  
Coliseum  
New York City

REGISTRATION: IRE Members \$1.00  
Non-members \$3.00



THE INSTITUTE OF RADIO ENGINEERS 1 East 79th Street, New York 21, N. Y.

SERVICE, DECEMBER, 1957 • 7

*another first*

*for*

**RAYTHEON  
BONDED  
ELECTRONIC  
TECHNICIANS**



*Now eligible for*

# **GROUP LIFE INSURANCE**

*from* **RAYTHEON**

## **SPONSORING BONDED PROGRAM DISTRIBUTORS**

*at no added cost.....*

Registered Bonded Dealers who by preference use Raytheon Receiving Tubes are now eligible for valuable life insurance coverage through their sponsoring distributors. It is obtainable without the necessity of a physical examination.

This Group Life Insurance Plan for Raytheon Bonded Electronic Technicians is underwritten by one of America's leading insurance companies for the exclusive use of sponsoring distributors of the Bonded Dealer Program.

Any Sponsoring Bonded Distributor who meets the necessary requirements for setting up a Group Life

Insurance Plan for Bonded Dealers may help them obtain this important protection.

Check with your Raytheon Sponsoring Distributor and see if he has available to you this automatic way to gain personal security for you and your family. If you're not already a Raytheon Bonded Dealer, here's another wonderful reason why you should call your distributor and see if you can qualify. Being a Raytheon Bonded Dealer makes you stand out from the crowd. And using finest quality Raytheon Receiving Tubes for replacement work makes you the fair-haired boy with your customers, too.



<b>RAYTHEON MANUFACTURING COMPANY</b>			
Receiving and Cathode Ray Tube Operations			
<b>NEWTON 58, MASS.</b> 55 Chapel Street	<b>CHICAGO, ILL.</b> 9501 Grand Ave. (Franklin Park)	<b>ATLANTA 6, GA.</b> 1150 Zonolite Rd. N.E.	<b>LOS ANGELES 7, CALIF.</b> 2419 So. Grand Ave.
Raytheon makes all these		} Receiving and Picture Tubes, Reliable Subminiature and Miniature Tubes, Semiconductor Diodes and Transistors, Nucleonic Tubes, Microwave Tubes.	

  
*Excellence in Electronics*



## 1957 In Review

ANOTHER BRILLIANT CHAPTER in the dynamic history of our industry was written during 1957. Sweeping changes were recorded everywhere—in radio, TV, audio, electronics.

The TV market, in the doldrums a year ago, forged ahead, sparked by the hardy impact of new developments in portables, picture tubes, sound systems and color.

Improvements in picture tubes played an important role in the progress parade. Designers found practical ways to handle deflection and resolution requirements of the short-neck 110° wide-angle tubes. And then went on to shorten the length of 21-inch and 24-inch 90° tubes by several inches, using new-type guns and novel circuitry. The new guns—of the straight type which eliminate the need for ion-trap magnets—have been found capable of delivering more than twice the beam current for the modulating voltage used in standard 90° chassis, providing better highlight and contrast control.

BASIC CIRCUIT MODIFICATIONS, elsewhere, also contributed to more efficient chassis. More stabilization and gain has been achieved by the use of quadrature-grid detectors; the -BN6 and -DT6 types. Also because of their increased sensitivity characteristics, neutrode and tetrode tuners were specified for a growing number of receivers, replacing the cascode tuners—long a favorite.

THE REDUCED-SIZE RECEIVER trend created a need for new approaches to chassis structure. Answers were found in stacked printed-wiring boards, miniature components and semiconductors.

A large number of sets now use selenium and germanium diodes in *afc* nets to develop voltage for multivibrator-type horizontal oscillators.

SEMICONDUCTORS not only became a factor in TV during '57, but in radio—for home and auto—as well as in audio and test equipment.

The bulk of home radios—and a quantity of auto sets, too—produced during the year, feature the use of transistors and diodes, and the audio sections of many TV models include all-transistor amplifiers.

<sup>1</sup>An exclusive progress report on tape-equipment developments in 1957 appears in this issue, pages 18 to 23.

TO FACILITATE COMPACT-CHASSIS TROUBLESHOOTING test-gear manufacturers developed a wide assortment of analyzers to localize quickly problems in tight areas. Even tube testers underwent a radical design change during the year. Here, too, the essential factor—speed—received prime consideration through the use of isolation-type quick-check circuits and the development of automated code-card systems.

AUDIO SCORED a huge success during '57. In packaged phonos, and in combinations featuring radio and TV, the accent was on sound quality. Practically every package or combination made—portable or console—used multiple speakers, high-output amplifiers and three or four-speed changers. And FM—the forgotten medium—received a tremendous boost, thanks to audio's growth. It became a must in most tuners used in radio-phonos because of its wide-band noise-free features.

TAPE also found itself in the spotlight in '57, thanks not only to equipment improvements,<sup>1</sup> but the extensive libraries of prerecorded tapes produced for both monaural and stereo playing.

COLOR-TV also made excellent progress during 1957. The introduction of all-glass picture tubes with graded-hole shadow masks, coupled with streamlined circuitry, added a new dimension to the color receiver. Picture brightness was increased to a point where daylight viewing is now possible; color adjustment controls—only two are required now—were brought up front; and convergence and purity problems were minimized through the use of the new tube and neutralizing component improvements.

INDUSTRIAL ELECTRONIC expansion was outstanding, too, during the year. System packages were produced for the longest list of services ever booked, which included two-way, closed-circuit TV, control and computer networks, plant, office and hotel-motel sound, and commercial-TV links using hilltop *uhf* and *chf* boosters and translators.

IN EVERY FIELD, solid growth and progress were recorded during 1957—a record spelling broadening opportunities for the progressive Service Man in the year ahead—in installation, service and maintenance.

# THIS MONTH IN SERVICE

CONSUMER PROGRAM DRAMATIZING SERVICE PROBLEMS ANNOUNCED BY MANUFACTURER-- A concerted effort--in the form of a build-confidence program--to bring into focus the problems of the modern radio and TV service shop has been announced by Westinghouse. . . . Key to the campaign is a pamphlet titled--This is the Story of a TV Set--bringing some of the little known facts of servicing to the consumer, such as the basic costs that go into a service call, and underscoring the fact that consumers really get a buy in service today. . . . Pamphlets are being supplied free together with window displays and streamers.

PROPOSED SERVICE LAW IN DES MOINES TABLED--The City Council in Des Moines, Iowa, recently voted to shelve an ordinance calling for the licensing of TV Service Men. . . . The legislators noted that the public had not complained about service conditions in the city; they did not come in and ask for any controls, and accordingly it was felt there was no need for a bill. . . . The measure, which would have made it illegal to service TV sets without having a city license, would have been issued on passing an examination conducted by a five-member board selected by the City Council. . . . The ordinance had been proposed in the Spring of '57 by the Television Service Association of Des Moines, but opposed by another association--the Association of Independent Television Servicemen.

TRANSISTORIZED MICROAMMETER DESIGNED BY BUREAU OF STANDARDS--A portable, battery-powered 50-cps to 100-kc transistorized microammeter (with a 200-microamp full-scale) has been developed in Washington by the Bureau of Standards. . . . Current pickup is a miniature split-core transformer that can be clamped onto a wire; thus it is unnecessary to open the circuit to make a measurement. Output of a transformer using .014" silicon-steel laminations is fed into a preamp consisting of two transistors and a feedback network. . . . Gain is provided by two intermediate stages, each using a pair of transistors, with direct coupling from the first transistor to the next. A feedback network, from the emitter of the second transistor to the base input of the first, stabilizes the dc operating point for each pair and reduces the overall current gain of each stage to about 20. The ac feedback factor at low frequency for each stage is about 100; the low-frequency current gain is thus stabilized against transistor and battery aging, and the frequency range for constant response is extended beyond that available without feedback.

STANDARDIZATION OF TUBES SOUGHT--A drive to standardize tube types and halt the increasing number now being made was suggested recently by Donald W. Gunn of Sylvania during a talk before the Joint Electron Tube Engineering Council. . . . Pointing out that the variations of existing types, often dreamed up by design engineers, are hamstringing everyone--from manufacturers to Service Men--Gunn said that the galaxy of tube duplications represents endless loss of time and money. . . . He noted that the replacement market currently handles a total of 735 different types of receiving tubes and only 95 of this total represents 80 per cent of all of the sales. The remaining 640 slow-moving types are carried through all of the distribution system to the shop's shelf at considerable inconvenience and cost, Gunn added. . . . The sensible solution to this situation, it was emphasized, would be for tube manufacturers to adopt the best design and eliminate others, in instances where several tubes represent solutions to the same problem.

SEMICONDUCTORS DEVELOPED TO REPLACE RELAYS--A silicon-controlled rectifier which will replace relays and certain industrial power tubes has been designed by General Electric. . . . Applications for the new device were said to include electronic devices for the shop and home, such as weather-conditioning equipment and light control panels.





# New Trends In Power

ALMOST EVERYONE has seen large industrial or public utility power distribution transformers with oil-filled corrugated metal containers. In these units the heat of the windings is carried by the oil to the outer metal cases, the extended surface of which helps dissipate the heat into the surrounding air. This construction serves the two-fold purpose of permitting a more economical use of copper and iron in the transformer itself and (what is probably even more important) eliminates *hot spots* in the winding, thereby significantly increasing the reliability and probable life of the unit. Thermodynamic principles are involved here. In the cooling system of an automobile engine they are more commonly and forcefully encountered. Here, the localized heat in the cylinder walls is quickly conducted to a coolant (water) which is circulated by a pump to a very large extended surface (the radiator) in contact with air, into which the heat is dissipated. A fan forces air past the radiator to increase further the rate of heat transfer when the car is standing still or moving slowly. To do the job effectively, each step in the procedure must be done efficiently, and everyone is aware that clogging of the circulation by rust scale, failure of the water pump or radiator fan, clogging of the radiator openings by insects, or use of an inefficient coolant (alcohol instead of water on a hot day) result in overheating and possible damage to the engine itself. An engine could be designed that did not require this

cooling equipment, but it would be larger, heavier, and much more expensive.

## Heat Transfer

The basic principles involved (for either the engine or the transformer) for getting rid of the unwanted heat generated as a by-product of the useful function are:

- (1) Transfer the heat from the source to the *sink* quickly by means of an efficient intermediate material.
- (2) Get a large contact surface with the *sink*.

Until recently there were two major obstacles to the use of these principles in small power transformers.

- (1) There was no really efficient intermediate material. Liquids (such as oil) are confined to such small spaces that the transfer of heat by convection would be virtually nil, and their conductivity alone is too poor to do the job. Solids (such as waxes and pitch) do not have sufficiently good conductivity and become soft at operating temperatures, thus presenting a potential leak or drip problem, which in addition to being messy, would result in overheating and failure of the transformer after enough of the compound has leaked out.
- (2) No economical way had been found to provide sufficiently effective extended surfaces to dissipate heat into the air fast enough to justify their use.

## Impregnation

Varnish impregnating serves several purposes:

- (1) It acts as an adhesive to hold the windings together more securely.
- (2) It sticks the laminations together and prevents *buzzing*.
- (3) It offers some protection against humidity getting into the winding.
- (4) It fills *some* of the air spaces between the winding wires with varnish.

The effectiveness of varnish in removing heat is relatively small. Varnish being thin, it runs out on removal of the unit from the tank, leaving small air pockets throughout the wind-

ing. Thus the thermal conductivity within the winding is variable and in operation there will be *hot spots*. These hot spots become potential sources of voltage break-down and hence of transformer failure, because the electric insulating properties of varnish and tapes deteriorate rapidly at elevated temperatures.

## Other Heat Problems

The transfer of heat from the windings themselves to the outer air is very inefficient because:

- (1) There are also dead air spaces between the laminations and the outer winding layer.
- (2) There are large air pockets between the outer winding layer and the transformer end shells, which (to draw a parallel) act like the storm windows on a house, impeding the rate at which heat is *lost* from the inside to the outside.

Since the losses in the transformer iron also generate heat, the innermost winding is in the unfortunate predicament of being entirely surrounded by materials which are in themselves sources of heat. These materials cannot efficiently draw heat from the innermost winding, unless their own heat is dissipated into the surroundings rapidly, which however is not the case. The situation is like trying to cool a hot brick which is wrapped in an electric heating pad and then put into a picnic jug.

This problem results in the innermost winding being the hottest

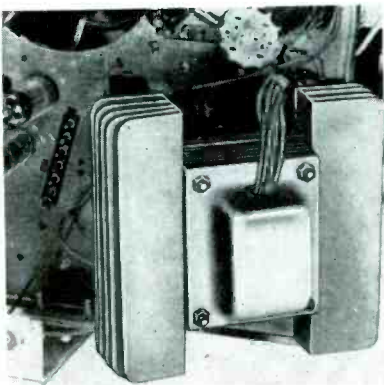

FIG. 1: VERTICAL CHASSIS mounting of recently-designed fin-cooled power transformer which simplifies chassis layout and removes heat problems.

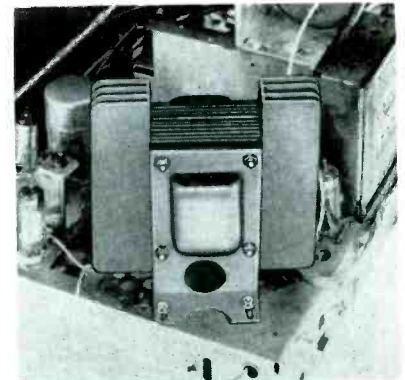

FIG. 2: ORIGINAL HORIZONTAL chassis mounting, where fin assembly had to be placed above the chassis. This mounting has been modified as illustrated in Fig. 3.



# Transformers For TV Chassis

portion of the transformer by a considerable margin, and therefore this winding becomes the governing factor in the thermodynamic design of the entire unit. Consequently, the transformer becomes larger, heavier, more expensive, and less reliable than would be the case if the means of dissipating the winding heat were more effective.

## Filling Compounds

There are now available special filling compounds with improved thermal conductivity and good electrical insulating properties, which do not soften at operating temperatures. One of these is based on a liquid called Permafil<sup>1</sup>, to which is added finely ground slate powder and a catalyst. At room temperature, the resulting mixture is very fluid. When the transformer is assembled, a sealing compound is inserted between the end shells and the lamination surfaces. The assembly is then baked at 290°F for one hour, which sets the sealer, thus leaving only the transformer lead hole as access to the inside of the transformer. The filled transformer is baked and cured at 275°F for five hours, at the end of which the entire assembly has become one solid rock-like unit.

The benefits obtained from the Permafil process are:

- (1) The physical protection to the winding against shock and vibration are at a maximum. There is no possibility of winding shifting.
- (2) There is no deterioration of the insulating properties of the compound at temperatures considerably in excess of those that would represent a serious problem with varnish. Since temperature limits specified by Underwriters' Laboratories are still based on varnish impregnated construction, the insulating ability of the compound should last indefinitely.
- (3) A much heavier barrier against the penetration of humidity has been provided.
- (4) There is now a continuous thermally conductive path throughout the entire assembly. This eliminates the *hot spots* and greatly increases the rate at which heat

by J. C. SPINDLER

Engineering Department, Zenith Radio Corporation

can be removed from the critical innermost winding.

- (5) The greatly improved cooling of the inner winding permits a redesign of the transformer to use less iron and copper. Reduction in the copper wire size increases the copper losses, which however are now more rapidly dissipated. Since in transformer design the iron is kept at a constant flux density, the total iron loss is directly proportional to the weight of iron, and hence less pounds of iron result in less total watts of iron loss, thereby offsetting a part of the increased copper loss.

Having provided the means of getting heat more quickly from the inside to the outside of the transformer, it now becomes necessary to transfer the heat more efficiently to the surrounding air. To do this both effectively and economically the following factors must be considered:

- (1) The transformer iron is in closest thermal contact with the inner surface of the innermost winding.
- (2) While the transformer iron is a source of heat itself, it is also an excellent thermal conductor.

Made by G. E.

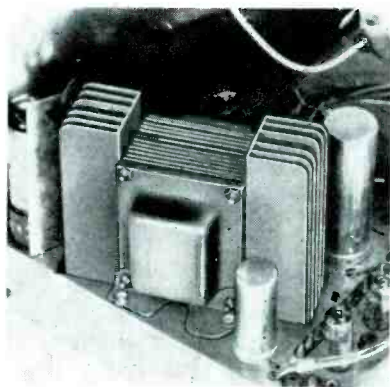

**FIG. 3: PRESENT MOUNTING** on a horizontal chassis where short brackets are used and the fins protrude through holes in the chassis to take advantage of the cooler air available from openings in the cabinet bottom.

- (3) The transformer iron is in close thermal contact with about 70% of the outer and inner surfaces of the complete winding assembly.
- (4) The transformer iron outer surface is flat and represents over 50% of the entire outer surface of the transformer.

In the structure finally evolved by engineering nested U-shaped pieces of .025" aluminum were clamped to the longer sides created by the lamination edges by means of two long studs. Nested U pieces have been found to be not only more economical, but provide additional strength to the final assembly.

This structure was found to provide the following advantages:

- (1) The innermost winding still being the hottest, the means chosen are as directly effective on it as possible.
- (2) Extension of the outer surface in this manner does not increase the internal volume of the transformer body, and therefore the amount of Permafil required is not increased. Additional Permafil would not only be costly and increase weight, but by being in series with the thermal circuit would actually slow down the overall rate of heat transfer.
- (3) Extension of the outer surface with this construction provides the maximum increased surface in contact with the air and the minimum of material and complexity of parts.
- (4) The increased surfaces are vertical and therefore take full advantage of the natural convection (chimney effect) set up when air is heated.
- (5) Maximum access is provided for entry of cool air at the bottom of the extended surface and easy exit is provided for the warm air at the top.

On a vertical chassis the transformer is mounted by means of a

(Continued on page 41)

**NEW**

# "Super Showman"

A **More Powerful** version of the world's most beautiful indoor antenna

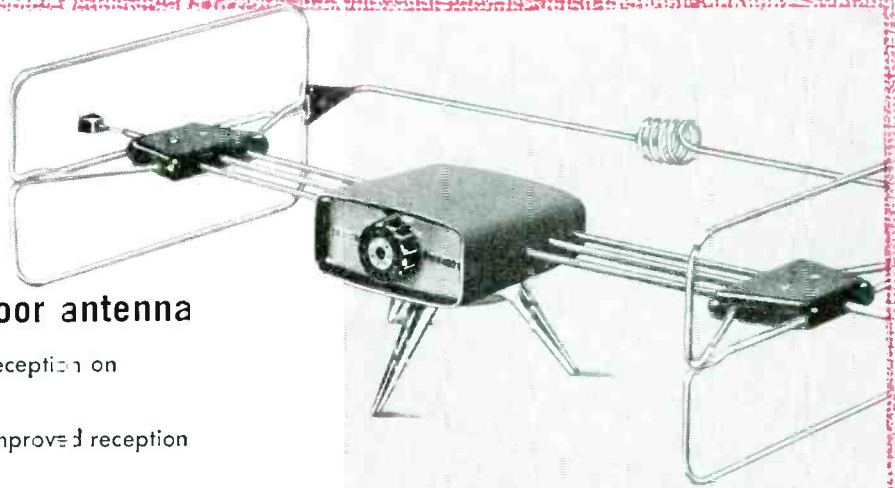

- **New Disappearing Dipoles** for improved reception on Channels 2-6.
- **New Compressed Parasitic Reflector** for improved reception on Channels 7-13.
- **Metro-Dyne Electronic Tuning** reduces "ghosts" ... rejects unwanted signals ... filters out electrical interference on ALL CHANNELS.

Available in stunning Mahogany and Gold or Blond and Gold **\$18<sup>95</sup>** list



**CHANNEL MASTER**  
Shower of Prizes

for the whole family

## CHANNEL MASTER

brings you new **P**RODUCTS  
... bigger **P**ROFITS  
... quality **P**REMIUMS

You get valuable coupons redeemable for distinctive and useful gifts with every order for the new Super Showman or T-W kit.

Pick from more than 135 FREE premiums ... featuring America's best known name brands.

Your Channel Master Distributor has your FREE 16-page catalog. Call him now.

"INSTALL-IT-YOURSELF"

### T-W ANTENNA KIT

An entirely new type of City and Suburban antenna

- Powerful 2-element T-W antenna outperforms a stacked conical.
- Fully Super-Sembled — elements pop out in seconds.

A Complete Antenna Installation in Attractive 3-Color Carton — to help you crack the BIG-PROFIT "Do-It-Yourself" market.

Promotionally Priced at

**\$29<sup>95</sup>** list



Including: 2-element T-W combination aluminum mast and tripod mount, wire, and hardware.



**CHANNEL MASTER CORP.**

ELLENVILLE, N. Y.

copyright 1957 Channel Master, Inc.



# Troubleshooting Dual-Diode Horizontal AFC Circuits

by JESSE DINES

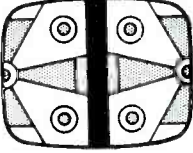
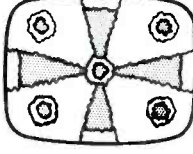
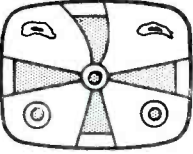
Trouble	Picture Indication	Cause	Remedy
Loss of horizontal sync	 <p>(A)</p>	<p>The following components may have to be replaced: C<sub>136</sub> or C<sub>137</sub> (.001 mfd), R<sub>146</sub> or R<sub>147</sub> (100,000 ohms) (faulty); R<sub>110</sub> (4.7 megohms) open; C<sub>141</sub> (.01 mfd) leaky; C<sub>138</sub> (.006 mfd) shorted; R<sub>151</sub> (33,000 ohms) or C<sub>140</sub> (.001 mfd) open; R<sub>150</sub> (4.7 megohms) faulty. —See circles 1, 2, 3, 4, 5 and 7 in Fig. 1.</p> <p>The following components may also be defective: C<sub>142</sub> or C<sub>143</sub> (.001 mfd), R<sub>426</sub> or R<sub>427</sub> (100,000 ohms), R<sub>128</sub> (470,000 ohms), C<sub>140</sub> (.047 mfd), C<sub>147</sub> (.01 mfd), R<sub>130</sub> (12,000 ohms), and R<sub>420</sub> (4.7 megohms). —See circles 1, 2, 3, 4, 5 and 7 in Fig. 2.</p>	Replace or repair defective component.
Vertical blanking bar; split picture.	 <p>(B)</p>	<p>C<sub>138</sub> (.006 mfd) may be leaky, or R<sub>151</sub> (33,000 ohms) increases in value. —See circles 4 and 5 in Fig. 2.</p> <p>C<sub>147</sub> (.01 mfd) and R<sub>430</sub> (12,000 ohms) should also be checked for possible defects. —See circles 4 and 5 in Fig. 2.</p>	Replace or repair defective component.
Piecrust or geartooth pattern.	 <p>(C)</p>	<p>The following components may be faulty: R<sub>149</sub> (4.7 megohms), C<sub>141</sub> (.01 mfd), C<sub>139</sub> (.003 mfd) or R<sub>150</sub> (4.7 megohms). The .003-mfd capacitor may be open. —See circles 2, 3, 6 and 7 in Fig. 1.</p> <p>Also check R<sub>128</sub> (.0047 mfd), C<sub>416</sub> (.047 mfd), C<sub>415</sub> (.0047 mfd) and R<sub>420</sub> (4.7 megohms). —See circles 2, 3, 6 and 7 in Fig. 2.</p>	Replace or repair defective component.
Picture hook.	 <p>(D)</p>	<p>The following components may change in value: C<sub>138</sub> (.006 mfd), C<sub>139</sub> (.003 mfd), C<sub>140</sub> (.001 mfd), C<sub>141</sub> (.01 mfd), R<sub>148</sub> (22,000 ohms), R<sub>149</sub> and R<sub>150</sub> (4.7 megohms), and R<sub>151</sub> (33,000 ohms). —See circles 2, 3, 4, 5, 6, 7 and 8 in Fig. 1.</p> <p>Also check C<sub>115</sub> (.0047 mfd), C<sub>416</sub> (.047 mfd), C<sub>417</sub> (.01 mfd), R<sub>420</sub> and R<sub>428</sub> (470,000 ohms), and R<sub>420</sub> (12,000 ohms). —See circles 2, 3, 4, 5, 6 and 7 in Fig. 2.</p>	Replace or repair defective component.

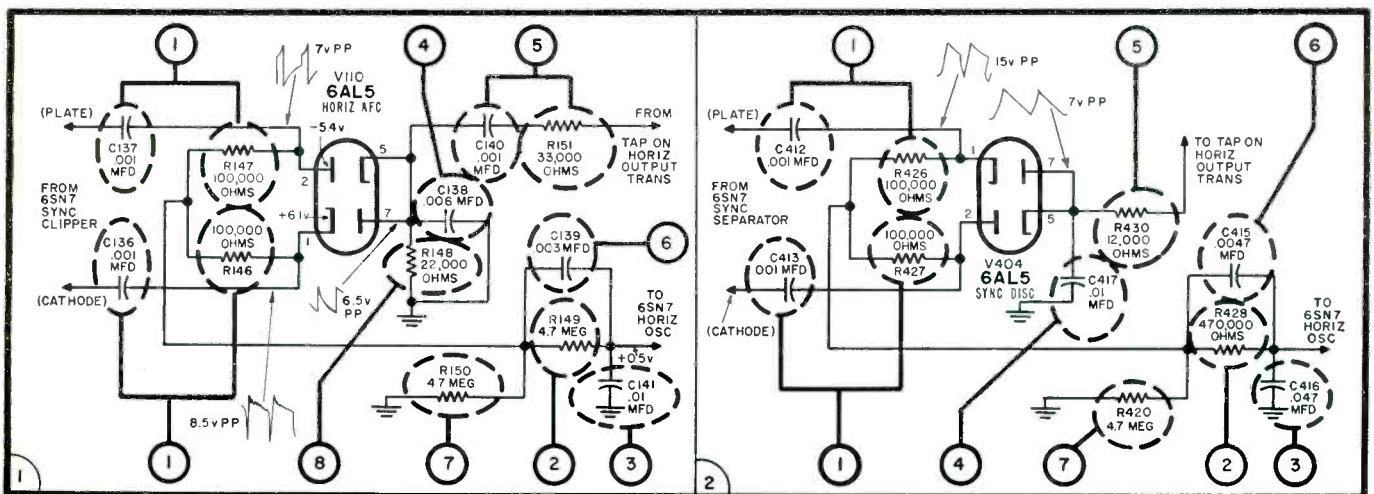

FIGS. 1-2: The Fig. 1 diagram is the horizontal-sync circuit used in the Crosley 393-394. Fig. 2 is the horizontal-sync circuit used in the Admiral 22E2 chassis.

# Monaural Tape Recorder-

## Dual-Purpose Unit Features 2-Speed Operation



FIG. 1: CONSOLE stereo tape player.

THE RAPIDLY increasing use of tape equipment in the home is being reflected by the steady rise in the production of prerecorded tapes, not only for monaural, but stereophonic reproduction. For stereo (1/4" in-line), as well as standard (half or full-track) play, tape machines<sup>1</sup> of the type illustrated in Fig. 1 have been developed.

Although the stereotape players were designed for use in conjunction with companion speaker units for stereophonic sound reproduction, the stereotape players can be used alone for monaural reproduction.

The tape transport mechanism in these models has four pushbuttons and a stop bar for controlling tape motion, and two pair of pushbuttons for selection of stereophonic or monaural playback amplification and for modification of recording characteristic. Knob-type controls are used to select operating speed, loudness, tone and type of external speaker system.

An in-line stereo record/playback head and a separate erase head are

used. To thread, the tape is placed in a slot and secured to the takeup reel. A tape holdout lever holds the tape away from the heads during fast-forward and rewind; this prevents irritating squeaks and squawks when rewinding.

Other features of the tape transport mechanism are: Heavy balanced flywheel, flat linen take-up belt, shock-absorbent mounting and *ac* erase. The recording level can be set without the tape being in motion.

The tape-amplifier chassis<sup>2</sup> and a separate power-supply chassis<sup>3</sup> are both attached to the tape transport mechanism to make a single unit.

The amplifier has four dual amplifier tubes and two power output tubes: 12AX7 (two-stage preamp—left channel); 12AX7 (two-stage preamp—right channel); 12AX7 (two-channel *af* ampl—playback or *af* ampl and neon ampl—record); 12AU7 (two-stage recording ampl); 6AQ5 (left-channel output—playback or 60-kc oscillator—record), and a 6AQ5 (right channel output—playback or neon amplifier—record).

The power unit has a 5Y3GT rectifier for *B* supply and a selenium rectifier for *dc* supply to the heaters of the preamp tubes.

Power output for each channel is 3 watts (undistorted) and 4.5 watts maximum.

Three speakers are used. In the console are one 8" and two 3 1/2" pm

units; the portable has one 6 1/2" and two 3 1/2" pm speakers.

### Circuit Description

The amplifier has been designed with two channels, each channel having four stages of playback amplification. Switching is provided in the third stage to permit full power output with either stereophonic or conventional tapes.

The type of playback operation to be used can be selected by two pushbuttons. When the buttons are in the *stereo* position, each channel is fed through separate preamps from the in-line stereo playback head. With the *single* pushbutton depressed, the input circuits of the 12AX7 left and right audio-amp channels ( $V_{5A}$  and  $V_{5B}$ ) are paralleled and fed from the output of the 12AX7 left channel preamp ( $V_{1B}$ ).

A dual loudness and a dual tone control are used to provide equal playback amplification and tone in both channels. An adjustable gain control in the right-channel amplifier permits equalization of the gain of the two channels.

Monaural recordings can be made from a microphone or from another source or mixed if the input to the *radio-phono* jack is from a high-impedance source.

On *record* operation one stage ( $V_{1B}$ ) of microphone preamplification

FIGS. 3, 4 and 5: BLOCK DIAGRAMS of stereo playback and monaural record-playback systems used in RCA STR-6/8 tape machines.

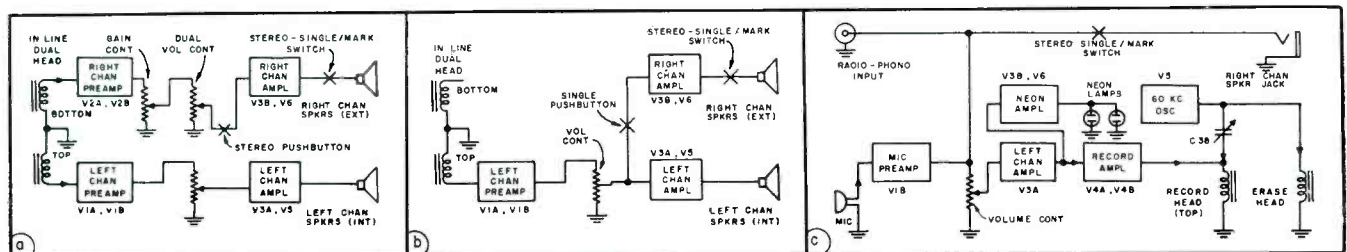



# Stereotape Player

## and 3-Speaker System

is used ahead of the *radio-phono* input (top of volume control). Three subsequent stages (12AX7 and 12AU7;  $V_{3A}$ ,  $V_{4A}$  and  $V_{4B}$ ) of audio amplification are used for recording. Inverse feedback is provided between the plate of  $V_{4B}$  and the cathode of  $V_{4A}$ .

A 6AQ5 ( $V_5$ ) serves two functions: On *playback* it is the left-channel output and on *record* it is a 60-kc oscillator. A switch ( $S_5$  front) selects the input (audio or oscillator) to the grid of  $V_5$ ; the rear of this switch selects the load (output transformer or oscillator coil) connected to the plate of  $V_5$ . In *record* operation the cathode of  $V_5$  is connected directly to ground, and self-bias is provided by a 47,000-ohm resistor in the grid osc coil circuit. The oscillator output is used for both erase and bias. The bias signal is mixed with the audio signal at the output of  $V_{4B}$  and then applied to the upper record/playback head through the rear of another switch ( $S_1$ ). The oscillator output is applied directly to the erase head.

Recording level is indicated by the flashing of two neon indicator lamps. The signal to the indicator lamps is supplied from the plate circuit of a 6AQ5;  $V_5$ . This signal is audio only and not a mixture of audio and bias.

Tape motion is controlled by three pushbuttons and a *stop* bar. A fourth pushbutton (*monitor*) of this group actuates the record-playback switch ( $S_1$  and  $S_2$ ) only. When the *monitor* pushbutton is depressed, the record-

(Continued on page 40)

<sup>1</sup>RCA STR-6 and STR-8.

<sup>2</sup>RS-166. <sup>3</sup>RS-167.

(Right)

FIG. 6: COMPLETE CIRCUIT of RCA STR-6/8 stereo-monoaural tape player-recorder.

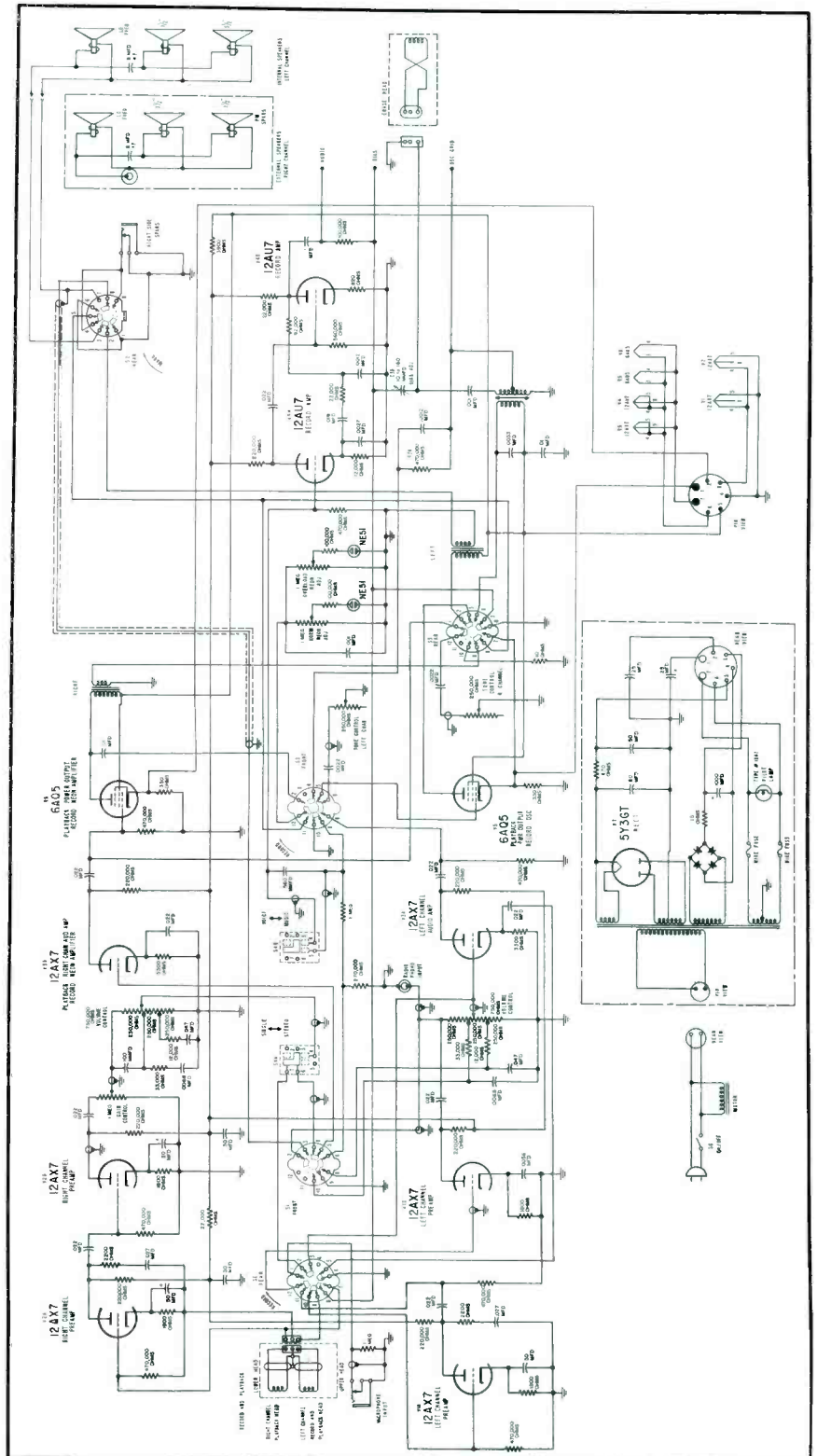



**Alignment and Test Procedures for Oscillator Coils in Tape Recorders<sup>1</sup> . . . Troubleshooting Tape Equipment‡ . . . Tools Required for Tape Repairs‡**

IN ALIGNING oscillator coils in Crescent, Silvertone and Columbia tape recorders one must first determine if the oscillator is operating at its assigned frequency of 52.5 kc. This can be determined by employing a coil<sup>2</sup> preset to 52.5 kc.

The coil can be placed in any convenient sized can. The tap on the primary should be grounded to the coil can. A clip of some kind should be fastened to the outside of the can to permit connection to chassis of the unit under test. The other three leads should be unshielded and not over one-foot long.

Since the coil is set at the factory in open air, placing it in a can may affect its resonant point. As a result, it may be necessary to reset the coil by peaking against a known value

coil as in a new tape recorder in good operating condition.

The frequency check should be made by clipping the coil case to the chassis of the unit under test. Blue lead should go to the output of oscillator coil; this is the orange lead running from oscillator coil to erase head. Red and black leads should go to any *vtvm* set on 50-v ac scale.

The powdered iron slug in the oscillator coil of the unit under test is then rotated to the point where maximum voltage reading is obtained on the *vtvm*. At this point a definite dipping of the meter should be noticed if the slug is turned in either direction.

A similar procedure can be followed for setting the 52.5-kc trap; all units do not contain a trap. Basically the same hookup is used, with the

blue lead in this case connecting to the 12AX7 side of the trap. The trap is tuned by dipping meter to minimum rather than maximum voltage. (All readings should be taken in record position on a *vtvm*.)

After the frequency of the coil has been set, it should be determined if the erase and bias voltage are correct. On units using a 6V6 as oscillator, the erase voltage at 52.5 kc should be approximately 70 v, with bias about 22 v. Readings are taken at the head socket in record position, with no signal input, using a *vtvm*.

On many units the erase voltage will run considerably higher. This is a normal condition, since an increase in erase voltage is not detrimental, but a decrease (below 65 v) will cause incomplete erase and distortion. On units containing a 12AU7 as the oscillator, the erase voltage reading should be 100 v minimum, and bias voltage 50 v minimum.

**Remedies for Other Tape Problems**

IF THE ERASE voltage is proper, but bias voltage is not, value of capacitor feeding the erase voltage to the record head must be checked; also one should check for open or shorted record head.

For low erase voltage the 6V6 or 12AU7 oscillator should be checked; also values of feedback network consisting of resistor to ground and capacitor to grid of 6V6 or 12AU7. Erase head may be partially shorted; erase head should measure about 10 ohms.

One should also make a resistance check of the oscillator coil. The oscillator coil can be checked in the circuit if the head is removed from socket, and unit is in record position. Readings on units containing a 6V6 as oscillator should be as follows: Across full primary, 14 ohms; lesser part of primary, approximately 3 ohms; and greater part, approximately 11 ohms. Secondary should measure approximately 12 ohms. Readings on units containing a 12AU7 as oscillator should be approximately 16 ohms across full winding; 3.5 ohms across lesser part, and 12.5 ohms across greater part of winding. On units using a 6V6 as an oscillator, capacitor across primary of output transformer should be checked. And on units using a 12AU7 as an oscillator, capacitor

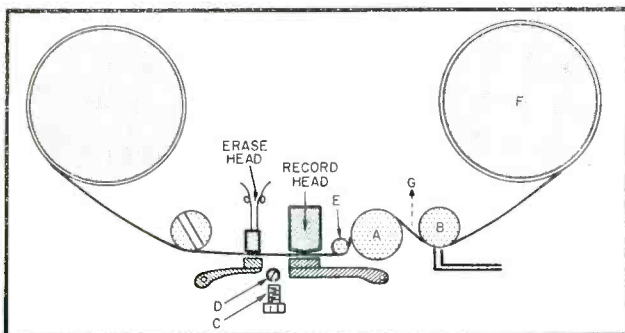

**TAPE COMPONENTS** in Ampro equipment which require adjustments to cure pinch rollersqueek: A—pinch roller, B—guide, C—set screw, D—adjusting cam screw, E—capstan, and F—takeup reel. G represents direction tape should be pushed.

<sup>‡</sup>Based on service notes for Ampro tape recorders.



coupling plate of 12AU7 to erase circuit should be checked.

If there is no erase voltage, one should check coil windings for continuity; erase head for shorts; change-over switch to see if movement is sufficient to allow switch to go fully into record position; 6V6 or 12AU7; open capacitor, shorted resistor, or open leads in feedback network to grid of 6V6 or 12AU7. On units using a 6V6 as an oscillator, capacitor across primary of output transformer should be tested, and on units using a 12AU7 as an oscillator, capacitor coupling plate of 12AU7 to erase circuit should be checked.

### Pinch Roller Squeek Cures†

PINCH ROLLER SQUEEK in a tape recorder is a small constant noise, variously described as *monkey chatter*, *hiss*, *squeal* or *creaking*.

To diagnose this trouble one can apply a pencil or other small smooth object, pressing back on tape between the pinch roller and guide if the noise disappears it is pinch roller squeek. The trouble is caused by too much tension on the tape between the pinch roller and capstan.

To correct this condition, the control panel should be removed, tape put on machine, set screw loosened and *play* key depressed. With tape recorder running, adjusting cam screw should be turned (either way; it controls an eccentric) slowly until tension on tape between capstan and pinch roller is decreased sufficiently to eliminate noise.

One should test for sufficient tension by holding takeup reel from turning. Tape should continue to move smoothly between capstan and pinch roller.

Tools required are a small Philips head screwdriver, a standard blade type screwdriver, a jeweler's screwdriver and a 5/16 spintite.

### Removing Takeup Reel Scrape‡

TAKEUP REEL SCRAPE is a small intermittent scraping, not unlike the sound made by sandpaper on wood, sometimes higher pitched.

Two methods can be used to determine the source of this trouble. In the first approach, with tape running, supply and takeup reels should be checked for evenness and freedom

(Continued on page 44)

†Crescent, Silvertone and Columbia tape recorders.

‡Crescent Products part No. 700080.

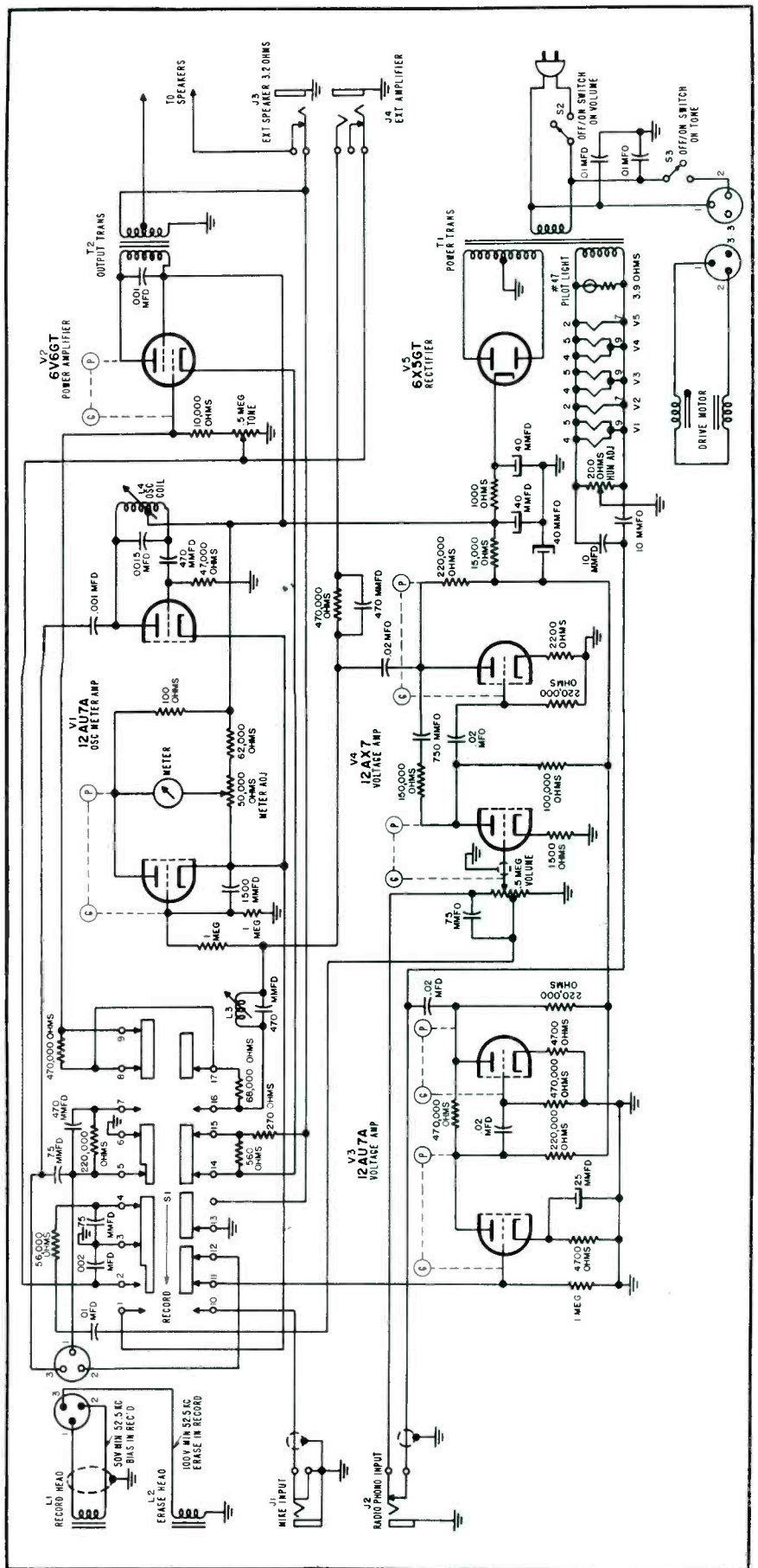

SCHEMATIC of amplifier used in Crescent tape recorder models TR-773, 773A, 773B, 774, 774A and B.

# Glossary of Monaural-Stereo

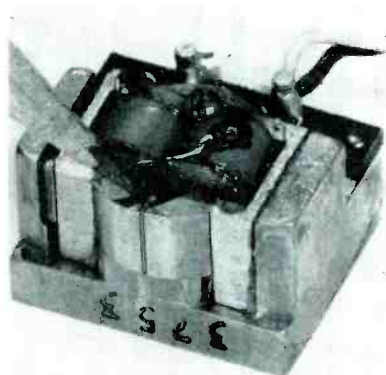

**ERASE HEAD** which removes recorded sound from the tape automatically just before the tape reaches the record head.

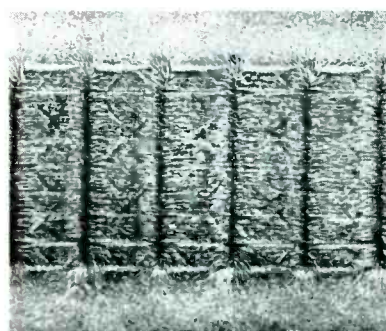

**PHOTOMICROGRAPH** showing lineup of iron-oxide particles in magnetic field. This is an actual section of magnetic recording tape with a signal on it made visible by a special process.

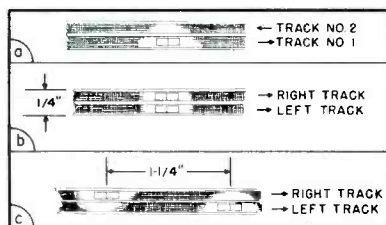

**STEREOPHONIC SOUND** showing the difference in head arrangement of (a) dual track monaural recording, (b) stereo or binaural recording (in-line heads), (c) stereo or binaural recording (staggered heads).

**TAPE RECORDING** has given new meaning to many words in the English language. Numerous terms long used in the field of sound have become important to the tape recorder user.

Here are definitions of some of the most common tape recording terms.

**A Wind:** Magnetic tape wound on the reel with the dull, oxide-coated side of the tape toward the inside; the wind almost universally used today. Recorder design determines whether A or B wind tape is required.

**Bias:** A high-frequency alternating current fed into the recording circuit to eliminate distortion.

**Binaural Recorder:** A tape recorder which employs two separate recording channels or systems, each with its own microphone, amplifier, recording and playback heads and earphones. Recordings using both systems are made simultaneously on a single magnetic tape on two parallel tracks. Use of headphones for listening is necessary for true binaural effect.

**Capstan:** The spindle or shaft—often the motor shaft itself—which rotates against the tape, pulling it along at a constant speed on recording and playback.

## Microphones and Networks

**Ceramic Microphone:** Piezoelectric type microphone supplied with many tape recorders which employs a ceramic element to generate voltages. Extremely rugged, it requires more gain than does a crystal microphone.

**Crossover Network:** Filter circuits for a multiple loudspeaker system which separates highs and lows and feeds each to the particular speaker designed to handle them.

°Based on data prepared by Minnesota Mining and Manufacturing Co.

**Crystal Microphone:** Piezoelectric type microphone supplied with many tape recorders which employs a natural crystal—usually Rochelle salt—as its element. As the diaphragm moves, it causes the crystal to generate electrical voltages. Should be handled with care, however, and never exposed to heat. Provides best quality of all inexpensive microphones.

**Dual-Track Recorder:** Usually a tape recorder with a recording head which covers half of the tape width, making it possible to record one track on the tape, then turn the reels over and record a second track in the opposite direction. Sometimes called a half-track recorder.

**Dynamic Microphone:** Electromagnetic type microphone which employs a moving coil in a magnetic field to produce varying voltages.

**Electromagnetic Type Microphone:** Microphone using an electromagnet to produce varying voltages; includes ribbon or velocity microphones, dynamic or moving coil type, and reluctance, or moving vane type.

**Equalization:** Either boosting or decreasing the intensity of the low, middle or high tones of a recording during recording or playback or both. This compensation serves to correct any deficiencies in the recording system and to increase the signal-to-noise ratio.

**Gap:** The tiny distance between the poles of the recording head, measured in mils. The head gap of most home recorders may range from 1 mil down to 1/4 mil. The smaller the gap, the higher the frequency range of the tape recorder.

## Heads—Alignment

**Head Alignment:** Positioning of the record-playback head on a tape recorder so that its gap is exactly perpendicular to the path of travel of the tape. Head misalignment would cause loss of high frequencies upon playback. Special head alignment testing tapes are available.

°°Such as Scotch timing tape 43P.



# Tape Recording-Playback Terms

**Head Demagnetizer:** Device to eliminate any magnetism built up and retained in a recording head. Some tape recorders feature automatic head demagnetization.

**In-Line Heads:** Arrangement of stereophonic heads on a tape recorder so that gaps are directly in line. One head is mounted directly above the other; also called *stacked* heads.

## Leader-Timing Tapes

**Leader and Timing Tape:** Tough, non-magnetic tape which can be spliced to either end of a tape to prevent damage or breaking off of the magnetic tape ends and possible loss of part of the recorded material. White in color, it usually features a one-inch plaid marker every 7½ inches.\*\* Used as timing tape, it can be spliced between musical selections on a tape providing a pause of a given number of seconds, depending on the tape speed.

**Monaural Recorder:** Standard type tape recorder which uses a single-channel system consisting of one microphone, amplifier and recording head (as opposed to a binaural or stereophonic recorder).

**Motor Board:** Also called tape transport mechanism. The platform, or assembly, of a tape recorder on which the motor (or motors), the reels, the heads and the controls are mounted. It includes those parts of the recorder other than the amplifier, preamplifier, loudspeaker and case.

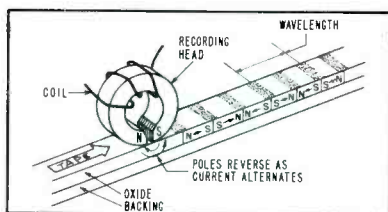

**RECORDING HEAD** (ring-shaped electromagnet) which magnetizes oxide coating of tape in series of magnetic fields corresponding to the frequency of the sound being recorded.

**NARTB Curve:** Standard playback equalization curve set by National Association of Radio and Television Broadcasters.

**Oxide:** Microscopically small particles of ferric oxide dispersed in a liquid binder and coated on a tape backing. Red oxide used on some magnetic tape<sup>1</sup> is most common; high-output magnetic tapes<sup>2</sup> employ a dark green oxide. These oxides are magnetically hard; that is, once magnetized, they remain magnetized permanently, unless they are demagnetized by exposure to a strong magnetic field.

## Tape and Equipment Definitions

**Polyester Backing:** Plastic film backing for magnetic tape used for special purposes where strength and resistance to humidity change are important.

**Pressure Pads:** Felt pads mounted on spring-brass arms which hold the magnetic tape in close contact with the heads on some machines.

**Pressure Roller:** Also called *capstan idler* or *puck*. A rubber-tired roller which holds the magnetic tape tight against the capstan by means of spring pressure to insure constant tape speed and prevent slippage.

**Print Through:** Transfer of the magnetic field from layer to layer of tape on the reel.

## Performance Terms

**Signal-to-Noise Ratio:** The ratio between the loudest, undistorted tone recorded and reproduced by a recorder and the noise induced by the recording system itself. Normally measured in *db's*.

<sup>1</sup>Such as Scotch 111.

<sup>2</sup>Such as Scotch 120.

**Single-Track Recorder:** A tape recorder which records only one track on the tape. Usually a full-track recording head is used which covers the full width of the ¼-inch tape although some machines use a narrower, half-track recording head which records a single track down the middle of the tape. Output of a full-track recording is theoretically double that of a half-track recording, although actually the output is only slightly greater because of improved half-track head design.

**Stacked Heads:** Arrangement of recording heads used for stereophonic sound where the two heads are located directly in line, one above the other.

**Staggered Heads:** Arrangement of recording heads used for stereophonic sound where the heads are located 1 7/32" apart. Stereo tapes recorded using staggered heads cannot be played on recorders using stacked heads, or vice versa.

**Tape Speed:** Speed at which tape moves past the recording head. Standard tape speeds for home use are 3¾ and 7½ ips. Faster speeds are 15 and 30 ips. Slower speeds sometimes used are 1¼ and 15/16 ips. Faster speed makes possible improved high-frequency response, while slower speed means greater tape economy. If a tape is recorded at 3¾ ips, then played back at 7½ ips, all sound will be raised one octave in pitch. Cutting the speed in half lowers a tone one octave.

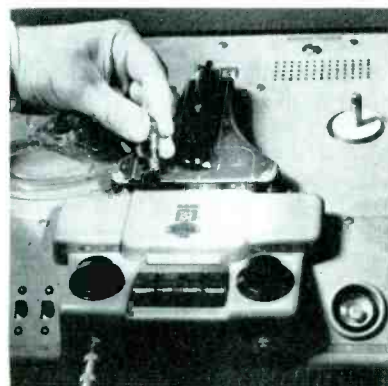

**CAPSTAN**—the spindle or shaft (often the motor shaft itself) which rotates against the tape, pulling it along at a constant speed on recording and playback. Interchangeable capstan shown here is used to alter the speed of the recorder.

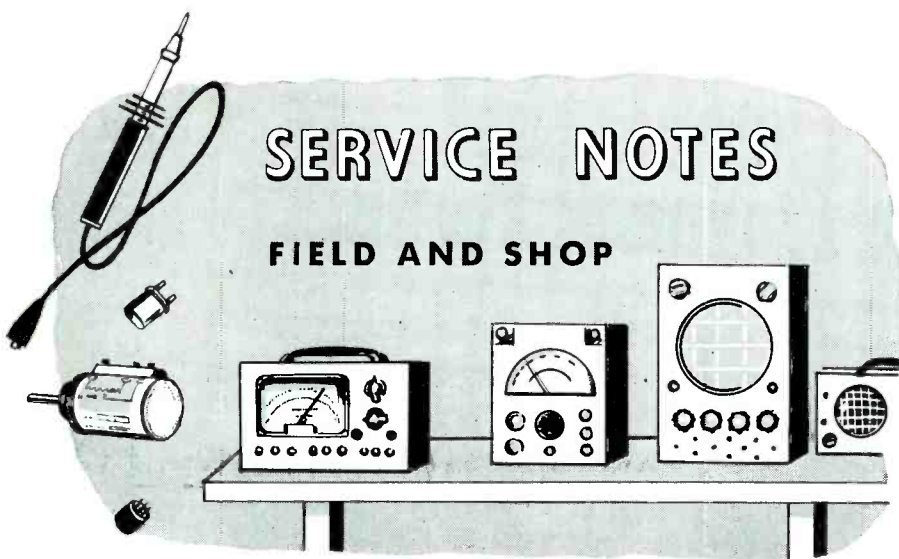

# SERVICE NOTES

## FIELD AND SHOP

Troubleshooting AM-FM Tuners† . . . TV Tuner Detent Spring Lubrication . . . Fuse-Resistor Replacements . . . Ringing Cures

WITH THE ADVENT of high-fidelity, the AM-FM tuner has found a permanent place for itself, in view of the performance features of FM—extended audio range and greater interference rejection characteristics required for high-fidelity sound.

In FM operation, tuners (Fig. 1) use the following stages; an *rf* amplifier, mixer, local oscillator, two *if* amplifiers, a ratio detector, tuning-eye indicator and audio amplifier.

A 300 ohm, built-in antenna is coupled to the grid of the pentode *rf* amplifier through an impedance-matching network. This network matches the antenna impedance to the input impedance of the tube, at the FM frequencies, to permit maximum transfer of energy. Capacitor  $C_2$  and resistor  $R_1$  provide the necessary grid bias. The resistor-capacitor networks in the screen and plate circuits of the 6BJ6 *rf* amplifier are for decoupling; to prevent unwanted regenerative coupling between the *rf* and *if*-amplifier stages of the tuner.

One half of a 12AT7 dual-triode tube is employed as a local oscillator and the other half as a mixer. Permeability tuning is used to vary the oscillator frequency and tune the *rf* coupling transformer between the *rf* amplifier and mixer stages;  $C_5$  and  $R_4$  develop the grid-leak bias for the oscillator tube. Capacitor  $C_6$  is a negative-coefficient type and compensates for oscillator drift during warmup time.

The oscillator signal, taken from the grid of the oscillator tube, is fed

to the grid of the mixer through a capacitor,  $C_8$ . The *rf* signal is coupled from the secondary of the coupling transformer to the mixer grid through capacitor  $C_9$ . The gain of the mixer stage is controlled by the *avc* control voltage applied to the grid of the mixer tube through  $R_3$ .

### Mixer *IF* Output Coupling

The mixer *if* output is coupled to the first *if* amplifier by transformer  $T_1$ . Two stages of *if* amplification are used to provide increased receiver selectivity and sensitivity. The second *if* amplifier stage is not operated as a limiter because the ratio detector does its own limiting.  $C_{13}$  prevents the *avc* control voltage from being shorted to ground and couples the *if* signal from the transformer to the *if* amplifier grid.  $R_8$  and  $R_{11}$  drop the *avc* voltage to the *if* amplifier grids. Cathode bias for the first and second *if* stages is provided by a pair of resistors,  $R_9$  and  $R_{15}$ . Possible *if* regeneration is prevented by not bypassing these resistors, thus creating degeneration for both stages.

An unbalanced ratio detector is used to develop the audio signal. Limiting is accomplished by the stabilizing voltage developed across  $R_{10}$ - $C_{20}$ ; this voltage compensates for changes in the carrier amplitude. This voltage is also used to drive a tuning indicator, and serves as the *avc* con-

†Based on a report prepared by Sol Libes, editor of the *Westinghouse Technical News*.

trol voltage for the mixer, first and second *if* amplifier stages.  $R_{17}$ - $C_{23}$  form a load for the detector diodes. The audio voltage appearing across capacitor  $C_{23}$  is coupled to the audio amplifier through a deemphasis network.

An *if* amplifier is common to both AM and FM operation. Separate *if* transformers, one for AM and the other for FM, are connected in series. Because the AM coils operate at 455 kc and the FM coils at 10.7 mc, the AM coils have many more turns and a higher inductance than the FM coils. As a result, when operating on AM, the AM signal at 455 kc has little impedance from the small FM coil; the signal acts as though the FM coil is shorted out. When operating on FM, the capacitor across the AM coils offers virtually no impedance to the FM signal at 10.7 mc, and thus shorts out the AM coils. The *if* transformers, therefore, do not affect each other and may be connected together.

### Troubleshooting the Tuner

If the AM section is found to be in good operation, FM can be checked by first feeding an AM modulated signal at 10.7 mc to the last *if* amplifier grid. The generator should be adjusted for full output and the frequency control wobbled to each side of 10.7 mc. If the *if* amplifier and ratio detector are operating properly, a modulation note will be heard. As the frequency control is rotated away from 10.7 mc the note will be fairly loud. As 10.7 mc is approached and reached, the note will dip sharply in loudness. As the frequency control is moved off frequency to the other side, the note will rise to its previous loudness. This procedure should be performed slowly to hear the sharp dip in loudness.

This procedure should be repeated, loosely coupling the signal to the grid of the first *if* amplifier. Absence of the note indicates that this stage is not functioning. If this stage is operating properly, you should move to the mixer grid and repeat this procedure.

To check the FM oscillator, a modulated signal should be fed, at an *rf* frequency, to the mixer grid to observe mixing action. If your generator does not reach these frequencies but does reach, say, 15 mc, the harmonics of the generator signal can be used. For example, the 11th, 12th and 13th harmonics of 8 mc are 88, 96 and 104 mc, respectively, and can be used to check oscillator operation, since these frequencies are within the FM band. The *rf* generator should be tuned to 8 mc and the output connected to the mixer grid. The tuning dial should then be turned to 88, 96



and 104 mc. If the oscillator is working, the modulation note will be heard at each of these positions, when the generator is wobbled. If the note is not heard, a defective oscillator may be the cause.

A negative *dc* voltage measured with a *vom* at the oscillator grid is another indication that the oscillator is not operating.

The *rf* amplifier can be checked in the same manner as the oscillator, except that the 8-mc signal must be fed to the grid of the *rf* amplifier. This same procedure can be used to check the antenna.

### Solving Ringing Problems

INDICATIONS of ringing are either a ripple or wave in the scanning lines on the left side of the picture or white vertical lines in the same location, or both. The location of this trouble is usually in the horizontal winding of the deflection yoke.

The high pulse of voltage appearing in the horizontal-output circuit during horizontal retrace, tends to produce a shock-excited oscillation in the circuit. As a result of the high harmonic content of the pulse, a few cycles of damped oscillation can be produced at a harmonic frequency, if the circuit components resonate at that frequency. This effect sometimes occurs when the horizontal winding of the deflection yoke or, in some instances, the linearity coil, resonates with the distributed capacity at the fourth harmonic (roughly 70 kc) of the pulse frequency. When this ringing occurs, the linearity at the left of the raster is effected.

### Ringling Replacement Parts

To minimize ringing effects, a 51 or 43-mmfd capacitor should be connected in parallel with one-half of the horizontal winding of the deflection yoke. The capacitor serves to make the reactances of the two sections of the horizontal winding equal and opposite at the ringing frequency, so that the ringing effect is cancelled. If ringing occurs, it may be due to an open capacitor which was the cause of this trouble, or the capacitor may be of the wrong value for the particular yoke. If so, different values of capacitance should be tried. Suggested trial values are 33, 43, 47, 51, 56 or 68 mmfd.

In some cases it may be necessary to replace the deflection yoke to cure ringing symptoms. This represents a last resort, however, and the measures

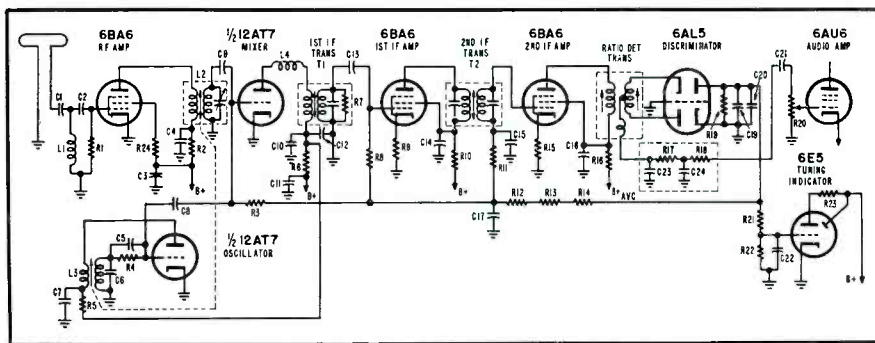

FIG. 1: CIRCUIT of FM section of AM-FM tuner used in Westinghouse chassis.

previously mentioned should be tried first.

### Tuner Detent Spring Lubrication

THE DETENT SPRING life in Magnavox 700584 and 700587 tuners can be extended by applying *lubriplate* 105 at the point of contact between the detent gear and spring. This lubricant should be applied generously.

### Fuse-Resistor and Ballast Replacements†

ALTHOUGH THERE are hundreds of thousands of fuse-resistors and line-voltage ballasts in radio-TV sets, some misunderstanding as to their purpose still exists.

Occasionally fuse-resistors, are claimed to fail as replacements. In checking returned units, it has been found that they have functioned as originally intended; that is, burned out when overloaded. The difficulty has been found to lie in the individual application.

The fuse-resistor serves a dual purpose in its application:

- (1) Manufacturers of certain types of rectifiers specify that a dropping resistor of from 5 to 15 ohms be used in series with their rectifiers to absorb peak surges that may be present in the line-voltage.
- (2) Underwriters recommend that these circuits be fused to eliminate the possibility of fire occurring in the set when surges occur at a higher level than the resistor will reduce to safe value.

The fuse-resistor is designed to function for both of these conditions. Causes for failure or blowing may be

†Based on a report by Fran J. Chamberlain, Clarostat Manufacturing Co., Inc.

attributed to two commonly-known factors:

- (1) The line-voltage source, having fluctuations reaching a high peak value and remaining there long enough to cause the fuse-resistor to burn out. Or . . .
- (2) Through aging of parts in the set, causing an increase in the load. Such increase will increase the current through the fuse-resistor. If this current reaches or exceeds the rating of the fuse-resistor for over the time limit rating, it will burn out.

A simple remedy for the first condition is the use of external dropping resistors or a regulator. Line-voltage regulators will perform this function satisfactorily and are available in several sizes for various load wattages. For the second condition, they will function as a temporary remedy; but eventually, parts causing added load will need to be replaced while the regulator can still be used against future conditions of this nature.

It must be remembered that the fuse-resistor is an expendable item designed to burn out in protecting expensive components of a set. Amperage in excess of normal operating current is responsible for fuse burn-outs. Fuse after fuse could be installed and each one would perform as expected, namely, burn out. Using a higher rating fuse-resistor would be

(Continued on page 41)

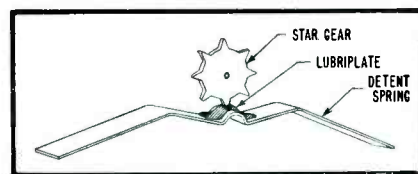

FIG. 2: POINT of lubrication in tuner detent spring. Both sides of the point of contact on the detent spring, as well as the point of contact, should be well lubricated.

# FOR A Brighter TV picture



Rely on the tube that has always been specified by leading independent set makers.

*Blue Chip Quality*  
**TUNG-SOL**<sup>®</sup>  
 Magic Mirror Aluminized  
**PICTURE TUBES**

TUNG-SOL ELECTRIC INC., Newark 4, N. J. Sales Offices: Atlanta, Ga.; Columbus, Ohio; Culver City, Calif.; Dallas, Tex.; Denver, Colo.; Detroit, Mich.; Irvington, N. J.; Melrose Park, Ill.; Newark, N. J.; Seattle, Wash.

## CATALOGS—BOOKS

JFD ELECTRONICS, INC., 6101 16th Ave., Brooklyn 4, N. Y., has published two brochures to stimulate indoor antenna and TV accessory business. The indoor-antenna brochure (6 pages), which describes and illustrates JFD indoor antennas now in use, from the deluxe Magic Genie to the Venus table-top rabbit ear model, can be used as a streamer or reference to the line covering applications and specifications of the various models. . . . The second circular describes outdoor and indoor set couplers, outdoor-indoor antenna couplers, wave traps, baluns, impedance matching transformers, antenna isolators, attenuators and switches. [SERVICE]

THE HOWARD W. SAMS & Co., Inc., 2201 E. 46th St., Indianapolis 5, Ind., has issued volume 7 of the *Tube Location Guide* series, which show chassis layout of TV receivers, types of tubes used, and function of each tube. Also included is a *tube failure check chart* which lists the tubes which are to be suspected when the indicated trouble is experienced. . . . Volume 7 covers 160 chassis (approximately 500 models) of TV receivers produced in '56 and '57, including three color-TV chassis. . . . Contains 204 pages; priced at \$2.00. [SERVICE]

THE RADIO-ELECTRONIC MASTER, 60 Madison Avenue, Hempstead, N. Y., has compiled a chart on panel and flashlight lamps. Chart is a composite listing, arranged numerically, of panel and flashlight lamps manufactured by Chicago Miniature, G. E., National Carbon (Eveready), RCA, Raytheon, Tung-Sol and Westinghouse. [SERVICE]

CLEVELAND INSTITUTE OF RADIO ELECTRONICS, 4900 Euclid Ave., Cleveland 3, O., has issued a 24-page booklet, *Opportunities in Electronics for You*, designed to provide pictorial coverage of opportunities in electronics, plus thumbnail descriptions of many of the available employment opportunities. [SERVICE]

UNIVERSITY LOUDSPEAKER, INC., 80 S. Kensico Avenue, White Plains, N. Y., has published a 12-page illustrated catalog covering high fidelity speakers, systems and enclosures, and do-it-yourself enclosure kits. Also detailed are paging and talk-back speakers, heavy duty trumpets and driver units, submergence-proof speakers, portable soundcasting systems, and super-power projectors. [SERVICE]

THE 1958 POCKET-SIZE EDITION of the *RCA Reference Book* is now available through RCA distributors. Contains 216 pages of information on RCA tubes, test equipment, batteries, transistors, and semiconductor diodes. Includes a *Quick Selection Guide* of RCA power tubes, crt, phototubes, special tubes, and semiconductor devices, as well as 50 pages of receiving tube characteristics, with base and envelope diagrams. Picture tube characteristics and socket diagrams occupy 13 pages. Also has *Interchangeability Directories* for tubes, transistors, and batteries, a daily reminder calendar, and 16 pages of world maps in color. [SERVICE]

THE HICKOK ELECTRICAL INSTRUMENT Co., 10521 Dupont Ave., Cleveland 8, O., has prepared an 8-page composite test equipment catalog, *form SM-31*. Compilation lists 24 instruments including color generators and the *Cardmatic* automatic tube tester. [SERVICE]

BUSSMANN MANUFACTURING Co., University at Jefferson, St. Louis 7, Mo., has issued a 52-page TV fuse chart booklet which shows proper fuses to use for TV, as well as auto-radios and Christmas-tree light sets. Detailed also are fuse mounts and information on circuits fuse protects. [SERVICE]

MERIT COIL AND TRANSFORMER CORP., 4427 N. Clark St., Chicago 40, Ill., has released a wall-chart-type exact replacement guide for transformers, flybacks, yokes and coils. [SERVICE]



# ASSOCIATIONS

## TEA, Fort Worth, Texas

THE FIRST ISSUE of the *TEA Times* has been published by the Texas Electronics Association, Inc.

Contents include an editorial by TEA president *W. J. Inman, Sr.*, stressing the need for strong business and technical educational programs and unified participation among Service Men and associations; also local association news, technical service tips, and minutes of recent meetings. The journal also contains an announcement that the fifth annual clinic will be held in Dallas, Texas, at the Baker Hotel on August 1, 2 and 3, 1958. Chairman of the convention is *Tillman Babb*.

## RTTA, California

HENRY C. LEVECK has been elected president of the Radio-Television Technicians Association of Orange County, Calif.

Others named include *George Morgan*, vice president; *Gordon Maurer*, treasurer, and *Francis Rice*, secretary.

## IRTSA, Wis.

AT A RECENT MEETING of the Indianhead Radio-TV Servicemen's Association, Wis., *Len Rubbert*, an instructor at Northwest Radio and Television Schools, Minneapolis, Minn., appeared as a guest speaker and covered *the proper method of obtaining an overall response curve and proper TV alignment procedures*, explaining an alignment process on a mis-adjusted set and showing the differences in alignment for fringe areas and local reception.

## NATESA

THE CURRENT ISSUE of the NATESA Scope features a letter from FCC chairman *John C. Doerfer*, thanking members of the association for their cooperation in filling out and returning the industry questionnaires on TV reception conditions submitted by the Television Allocations Study Organization in Washington.

## TEN YEARS AGO IN SERVICE

THE ROCHESTER CHAPTER of the Radio Technicians Guild held a two-day technical-business session. Plans were made to form ten state guilds which would become members of a Radio Technicians Guild of New York State. *Bertram L. Lewis* was named chairman of a ten-man guild committee. *William Brewerton* was named to assist Lewis. *David Boyce*, president of RTG, said the federation would help exchange information on trade techniques, provide for standardization of servicing procedures and establish codes which would promote good will and better business. Among those at the meeting were *Ben DeYoung*, president of the Ithaca chapter, Technicians Guild; *E. M. Howland*, who represented the Hudson Valley Radio Servicemen's Association; *Leo N. Burt* of the Jamestown Radio Men's Association, and *Ted Telaak*, president of The Buffalo Servicemen's Association. . . . One of the guest speakers at the meeting, *Dave Krantz*, described the operation of the Federation of Radio Servicemen's Associations of Pennsylvania, of which he was chairman. Other speakers at the sessions were *A. C. W. Saunders* and *B. V. French*. . . . The Whaling City Chapter of the Radio Technicians Guild in New Bedford, Mass., was reorganized and *Al Wobecky* elected president. *John Santos*, *Harry Wood* and *Albert Gagnon* were appointed as a committee to study revision of the bylaws. . . . The first annual convention of the Federation of Radio Servicemen's Associations of Pennsylvania was announced for January 11-13, 1948, at the Bellevue-Stratford hotel in Philadelphia. The Philadelphia Radio Service Men's Association was named convention host. . . . Scheduled as a feature of the convention was the Town Meeting of Radio Technicians, a joint undertaking of RMA, the Sales Managers' Club, NEDA, EPEM and the Mid-Atlantic Chapter of The Representatives, with the assistance and cooperation of FRSA and PRSMA.

# FOR A brighter

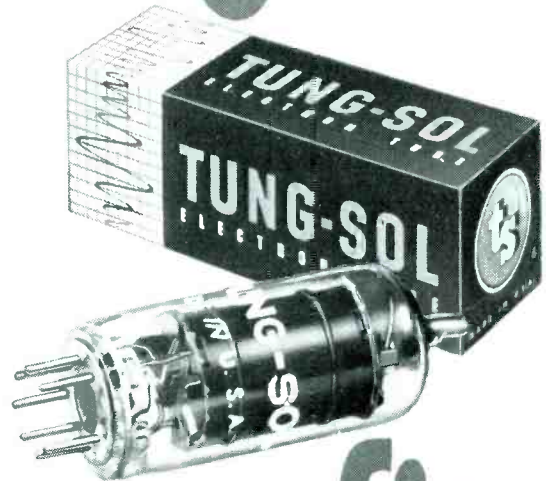

# profit picture

Rely on the tube that has always been a favorite with leading independent service dealers.

*Blue Chip Quality*  
**ts TUNG-SOL<sup>®</sup>**  
**RECEIVING TUBES**

TUNG-SOL makes All-Glass Sealed Beam Lamps, Miniature Lamps, Signal Flashers, Picture Tubes, Radio, TV and Special Purpose Electron Tubes and Semiconductor Products.

# ANNUAL INDEX

January-December, 1957

## ANTENNAS (TV—Two-Way)

A Report on a TV-Antenna Replacement Market Study ..... Dec.

All-Band VHF-Antenna Fringe-Area Installations; *Jack Darr* ..... Feb.

Analysis of an Indoor TV Antenna Using Single Vertical-Element Rod for Pickup; *Matthew Mandl* ..... May

Color-TV Transmission-Line Checks With TV Alignment Equipment; *Robert Kerzman* ..... Apr.

Community-TV Long Transmission Lines; *Jack Darr* ..... June

Design-Application Analysis of a Diplexer 2-Set Coupler; *Harold Harris* ..... Aug.

Design-Application Report on a Variable Control PW-Tuning-Element Indoor Dipole ..... Mar.

How to Develop an Antenna-Replacement Program ..... Nov.

Latest Two-Way Developments: Short Antennas; *Leo Sauts* ..... June

Line-Loss Equalization in Low-High-Band TV Systems ..... Apr.

Repeaters, Antennas, Test Equipment for Two-Way ..... Oct.

Rooftop TV Antenna Mast Multiple-Set-Coupler Installations ..... Jan.

TV-Antenna Replacement Field-Investigation Report ..... July

TV-Antenna Replacement With All-Channel Types ..... Oct.

TV-Antenna Tower Installation ..... Sept.

## AUDIO (Commercial Sound—Radio-Phono—Tape)

A Guide to the Selection of Phono Replacement Cartridges; *G. A. Morrell, Jr.* ..... Nov.

A Packaged 4-Speaker Hi-Fi Radio-Phono; *Roy S. Fine* ..... Nov.

A Report on the Useful Life of Hi-Fi Components and Accessories ..... Jan.

Alignment and Test Procedures for Oscillator Coils in Tape Recorders ..... Dec.

Troubleshooting Tape Equipment Tools Required for Tape Repairs ..... Dec.

AM-FM-Phono With Push-Button Loudness Control in Preamp; *Harry Schmidt* ..... Aug.

AM-FM Radio-Phono With Mood-Music Control; *C. C. Kayhart* ..... May

Amplifiers for Outdoor Commercial Sound Systems; *Norman Crowhurst* ..... June

Changing Needles in Phonos ..... Mechanical-Feedback Vibration-Distortion Cures ..... Crystal-Ceramic Pickup Replacement With Magnetic Types ..... July

Commercial Sound Cables; *Frank Timmons* ..... Feb.

Cures for Hum in Amplifiers and Preamplifiers ..... Sept.

Diamonds Are a Record's Best Friend; *Robert G. Walcutt* ..... Nov.

Dropout and Modulation-Noise Problems in Tape ..... Oct.

Eliminating Distortion in Transistor-Radio Audio ..... Sept.

Features of New Types of Tone Arms and Pickups ..... Nov.

Field-Bench Facilities of Shop Specializing in Commercial Sound; *Kenneth Sonnenberg* ..... May

Glossary of Tape Recording-Playback Terms ..... Dec.

Manual Tape Recorder-Stereotape Player; *Sam F. Pusey* ..... Dec.

Motel Sound-System Installation; *L. A. Randall* ..... Oct.

9-Transistor 20-Watt AF Amplifier; *George Young* ..... Dec.

Outdoor Amplifiers for Commercial Sound; *Norman Crowhurst* ..... July

Outdoor Transformer Replacements LF Instability Cures ..... Square-Wave Testing ..... June

Output-Transformer Replacement ..... May

Phono Pickup Tests Before Installation to Insure Best Results ..... Aug.

Portable-Phono Transistor-Amp Servicing; *Norman Crowhurst* ..... Apr.

Regulated Power Supplies ..... Sept.

Remedies for Phono Motor Noise, Grille Static Charges ..... Sept.

Replacement of Pickups, Stylis and Phono Motors in Portable Phonos ..... Apr.

Round and Wide-Angle Horns; *Lawrence J. Epstein* ..... May

Servicing Carrier-Current Wireless Intercoms ..... Dec.

Servicing Commercial and Home Hi-Fi Systems; *Ernest A. Dahl* ..... Nov.

Servicing Transistor Portables and Audio Circuits ..... Mar.

Small Store-Office Announce-Music Sound System Installation-Repair; *Jack Darr* ..... Mar.

Sound Is King; *Maurice E. Swift* ..... Nov.

Transistor-Amp Portable-Phono Circuitry Tape-Recording Repair Tips ..... Feb.

4-Speed Player Servicing ..... Feb.

Troubleshooting AM-FM Tuners ..... Dec.

## CIRCUIT DIAGRAMS

AC Wattmeter ..... May

Admiral Color-TV Chrominance Channel ..... May

Admiral 8F1 Remote-Control Amplifier (Complete Circuit) ..... Nov.

Admiral 14UY3B Portable-TV Horiz-Sync ..... Apr.

Admiral 22E2 Horiz-Sync ..... Dec.

Admiral 42SB Audio Amp With Remote Control ..... Nov.

Admiral 94E119-1 Portable-TV Tuner (Complete Circuit) ..... Apr.

Admiral Pentode Disc-Type VHF Tuner RF-Mixer (Cover) ..... Apr.

Admiral Remote Circuitry for Power, Phono, Radio, Amplifier and TV ..... Nov.

Admiral Resonator Remote-Control Functional Schematic ..... Nov.

Admiral 20T1-20V1 Isolation Transformer Circuit ..... May

Admiral 23A1 Horiz Sync ..... Nov.

Aerovox AF-Module Preamp ..... Apr.

Aerovox Module Preamp-Mixer ..... Apr.

AF Circuits Modified to Prevent LF Instability and Blocking ..... June

Alignment Test Setups ..... July

AM-FM Phono Power Amp-Preamp With Push-Button Loudness Control (Cover) ..... Aug.

Amp Automatic Bias ..... June

Amp Separate Resistor Biasing ..... June

Amp Test Setup ..... May

Antenna Matching Networks ..... Oct.

Auto-Radio Electro-Tuning ..... Apr.

Auto-Radio PNP Transistor Diagrams ..... Apr.

Auto-Radio Transistor Circuits ..... Apr.

Autotransformer HV TV System ..... May

B&K Flying Spot Scanner Video Generator ..... Mar.

Basic Colpitts, Ultraudion and Push-Pull Oscillators ..... July

Basic Microwave System ..... Mar.

Battery-Set Power Supply ..... May

Bennett 100 Wireless Intercom ..... Dec.

Biilar Elevator Coupler ..... Aug.

Blocking TV Oscillators ..... Jan.

Cartridge Checker With Low-Level Input Standard ..... Aug.

Cathode-Bypass Capacitor Test Circuit ..... Mar.

Color-TV Dynamic Convergence Circuit for Glass Picture Tube (Cover) ..... Oct.

Color-TV Shading Control ..... Mar.

Color-TV Switching Circuits for Gun Biasing ..... Oct.

Commercial-Sound Amp Power Supply ..... June

Commercial-Sound Mike-Speaker Amp Rack ..... June

Computer Control Trans Multivibrator (Cover) ..... Sept.

Computer Control Tube Dual-Cathode Follower (Cover) ..... Sept.

Coupling-Capacitor Insulation Test ..... Mar.

Crescent Tape Amp for TR-773 A/B and 774 A/B ..... Dec.

CRL 4-Stage Trans Amp ..... Sept.

Crosley 393-394 Horiz-Sync ..... Dec.

Crosley 431 Autotransformer Circuit ..... May

Crosley 9-408 Synch-lock ..... Sept.

Crosley 10-428MX Synchroguide ..... June

Delco Transistor (1N278 PNP) Radio Output ..... Feb.

Direct-Drive IIV TV System ..... May

Du Mont RA-372-3 Component Changes to Eliminate Vertical Jitter ..... Aug.

Du Mont RA-380/381 Component Changes. Sept.

Electric Coffee Percolator Test Board ..... May

Emerson Chassis Change to Improve AGC. June

Emerson 867B RF-AP Modules ..... May

Emerson 1258-59-68-69 Revised to Eliminate Ringing ..... June

Engineered Electronics Crystal Osc (Cover) ..... Sept.

Engineered Electronics Phase-Shift Osc. Sept.

Engineered Electronics P-P Volt Amp. Sept.

Engineered Electronics Squaring Amp. Sept.

Engineered Electronics Tube Dual-Cathode Follower ..... Sept.

Engineered Electronics Tube Multivibrator. Sept.

Expanded Microwave Network ..... Mar.

5U4-6N4 Test Circuit ..... June

Four-Channel Ultrasonic Remote Control Amplifier (Cover) ..... Nov.

Gaseous Voltage-Regulator Test Circuit. June

G.E. 17TO25 Portable-TV Sync Separator. Apr.

G.E. 805-6-7-9 Gruen Horiz AFC. Aug.

Germanium Rectifier Circuitry ..... Apr.

G-M 13-Transistor Auto Radio (Complete Circuit) ..... May

Grounded-Grid RF Stage ..... Aug.

Heater-Circuit Change to Limit Hum ..... Jan.

HF-Rolloff Improvement ..... May

Hoffman Solaradio 411 (Complete Circuit). June

IF Loading Circuitry ..... Nov.

In-Circuit Horizontal-System Short Test Circuit ..... Jan.

Indoor-Antenna PW-Assembly Equivalent Circuit ..... Mar.

Infinite-Gain Stage Amp ..... June

Instantaneous Screen-Voltage Regulator. June

Intermittent Electrolytic Test Setup ..... Feb.

Internal-Outdoor Speaker Output Circuit. Mar.

IQ Color-TV Receiving System ..... May

Isolation-Transformer HV TV System. May

Knee-GM Test ..... June

Magnavox CT/CU/CM4401B Sweep ..... Feb.

Magnavox HV-Transformer Circuit Modified for AGC-Keying Pulse ..... Oct.

Magnavox 25-Watt Power Amp ..... May

Magnavox 295C AM-FM Phono (Complete Circuit) ..... May

Magnavox Mood-Music Control for AM-FM Radio-Phono (Cover) ..... May

Marker Adder-Scope for Alignment ..... Mar.

Miniaturized Circuitry (Cover) ..... Sept.

Mobile 2-Way as Paging System ..... June

Motorola AM-FM-Phono Radio (Complete Circuit) ..... Aug.

Motorola Auto-Radio AF Output ..... Apr.

Motorola Auto-Radio RF With Limiter ..... Apr.

Motorola Auto-Radio Transistor AF ..... Apr.

Motorola Auto-Radio 12-V Supply ..... Apr.

Motorola Auto-Radio Vibrator Power Supply ..... Apr.

Motorola 918-919 Circuit Revised to Minimize Motor Noise ..... Oct.

Motorola Preamp With Loudness Control. Aug.

Motorola TS-9 Pulse-Width ..... June

Motorola TS-422A-00 Cascade Pentode Tuners ..... Feb.

Motorola TS-422A-00 (Complete Circuit). Feb.

Motorola TS-422A-00 PW Chassis Power Supply ..... Feb.

Motorola TS-422A-00 TV Horiz/Osc/HV Rectifier Section of PW Packaged-Assembly Chassis (Cover) ..... Feb.

Motorola 25-Watt Power Amp ..... Aug.

Multiple Cartridge Checker ..... Aug.

Olympic CT Portable-TV LV Supply ..... Apr.

1B3-1X2 Test Circuit ..... June

110° 21-Inch Horizontal-Vertical Deflection Circuitry (Cover) ..... July

Output Transformer Tapping ..... July

Padding to Eliminate Amp Hum ..... Sept.

Pentodes as Triodes in AF Output ..... May

Pentode-Tuner RF Amp ..... Oct.

Philco 8H25 Contrast Control ..... Sept.

Philco Transistor Auto-Radio With Feedback ..... Apr.

Picture Blanking During Retrace ..... Sept.

Picture-Tube Flux Cancellation ..... July

PNP Transistor Audio Stage ..... Apr.

Portable-TV Doubler Circuitry ..... Apr.

Power Supply Filter-Test Circuit ..... Mar.

Preamp for High and Low-Level Pickup Checking ..... Aug.

Printed-Wiring Indoor-Antenna Tuning Element ..... Mar.

Radio-Phono Amplifier ..... Mar.

RCA 8/9BT-9 Conv-IF-Det Transistor Stages ..... July

RCA CTC7 (800 Series) Color-TV Block Diagram ..... Oct.

RCA 800 Series Color-TV Chassis (Complete Circuit) ..... Oct.

RCA 800 Series Color-TV VHF-UHF Tuner ..... Nov.

RCA 800 Color-TV Dynamic Convergence and Power ..... Oct.

RCA 800 Color-TV Sound ..... Oct.

RCA KCS-61 Direct-Drive Circuit ..... May

RCA KCS-81E Horizontal Sweep ..... Feb.

RCA KCS-94 Miniaturized Horiz Osc. Sept.

RCA Mark IVD AM-FM Tuner ..... Nov.

RCA 648PV Synchrolock ..... Sept.

RCA 16-Watt Amplifier for Mark IVD Radio-Phono ..... Nov.

RCA STR-6/8 Stereo-Monaural Tape Player-Recorder ..... Dec.

RCA 21-T-197DE Synchroguide ..... June

RCA 2-Way Fil-String Modification ..... Sept.

RCA WR-46A Color-TV Video Generator Pattern Output Amp (Cover) ..... Jan.

RCA WR-46A Video Generator Block Diagram ..... Jan.

RCA WR-46A Video Generator (Complete Circuit) ..... Jan.

RCA WR-70A Marker-Adder ..... July

Regulated Power Supply for Amp. Sept.

Resistor-Type 2-Set Coupler ..... Aug.

RF-IF Alignment Setup With Marker-Adder ..... July

RF-Output Convergence Generator ..... Jan.

(R-Y) (G-Y) Color Demodulators ..... May

'Scope Modified to Increase Gain ..... Jan.

'Scope Amp Three-Step Attenuator ..... Jan.

Seeley 30-50 MC FM Chassis (Complete Circuit) ..... July

Series-Fed Cascade ..... Aug.

Signal-Seeking Lucite-Tab System ..... Apr.

Signal-Seeking Trigger ..... Apr.

Signal-Seeking Tube Starter ..... Apr.

Signal-Test-Source Coupling ..... Nov.

Simpson 382 In-Circuit Horizontal-System Analyzer ..... Jan.

Single-Gun Color-TV Circuitry ..... May

6AF4 Test Oscillator ..... Mar.

6AL5-6AV6 Test Circuit ..... June

6W4-6AX4 Test Circuit ..... June

Snyder Vertical-Antenna Circuit ..... May

Snyder Vertical-Antenna Selector-Switch. May

Solar Transistor-Radio Converter-IF Detector Stages (Cover) ..... June

(Continued on page 30)



how long would it take you to solve this service problem?

# PHOTOFACT

helps you lick problems

like this in just minutes

for only \*  $2\frac{1}{2}\text{¢}$  per model!

## SYMPTOM:

Horizontal Foldover affecting the right side of the screen, accompanied by an overall reduction in width

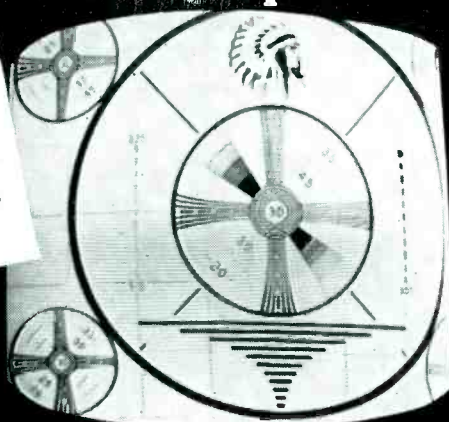

Let's look at this problem: When the foldover occurs at the right side of the picture, the trouble usually originates in the horizontal discharge or output circuits. Look for the following possible causes:

1. Defective tube in the flyback circuit
2. Leaky coupling capacitor (C74)
3. Misadjusted or defective drive control
4. Open or leaky capacitor (C76) in the cathode of the output stage
5. Incorrect value of the grid resistor (R93) in the horizontal output stage
6. Open or leaky screen bypass capacitor (C75) in the output stage
7. Incorrect value of the cathode resistor (R94) in horizontal output stage
8. Incorrect value of the screen resistor (R96) in horizontal output stage
9. Defective yoke or flyback transformer

With the applicable PHOTOFACT Folder at your fingertips, you'll trouble-shoot and solve this problem in just seconds. Here's-how:

Using the Tube Placement Chart (you'll find it in every PHOTOFACT TV Folder) you'll quickly locate and check the tubes in the Flyback Circuit. Tubes okay?—then: A waveform analysis of the signal in the sweep section is perhaps

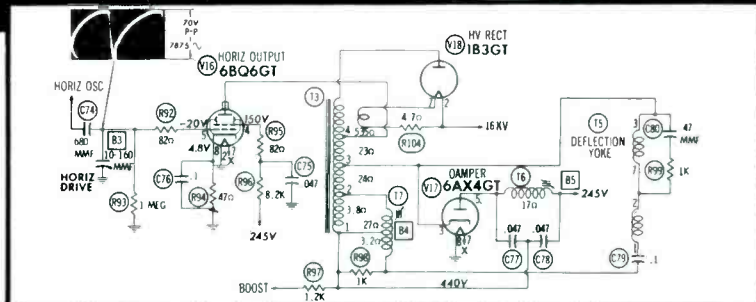

(Based on an actual case history taken from the Howard W. Sams book "TV Servicing Guide")

the quickest procedure you can use to localize the trouble. Check the waveform at the junction of the two capacitors, B3 and C74. The correct waveform and peak-to-peak voltages are shown right on the PHOTOFACT Standard Notation Schematic. Waveform incorrect?—Then, using the easy-to-read resistance chart and the correct voltages shown on the schematic, check for proper resistance and voltage values to determine which part is defective. The exclusive PHOTOFACT chassis photos with "call-outs" keyed to the schematic help you locate the faulty part quickly. Important! Horizontal Foldover may result from improperly matched components in this circuit. It is imperative that all parts replaced duplicate the originals. You'll find the proper replacement parts for all components listed in the complete PHOTOFACT parts list.

Remember, whatever the trouble may be, you'll locate it faster and solve it easier and more profitably with a PHOTOFACT Folder by your side.

Use the servicing method you prefer—checking of waveform, voltage or resistance—you'll find all the information you need at your finger-tips in PHOTOFACT.

For only \* $2\frac{1}{2}\text{¢}$  per model, PHOTOFACT helps you solve your service problems in just minutes—helps you service more sets and earn more daily!

\*Based on the average number of models covered in a single set of PHOTOFACT Folders.

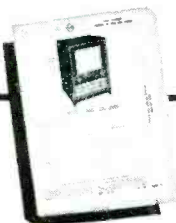

## MONEY BACK GUARANTEE!

Got a tough repair? Try this—at Howard W. Sams' own risk: see your Parts Distributor and buy the proper PHOTOFACT Folder Set covering the receiver. Then use it on the actual repair. If PHOTOFACT doesn't save you time, doesn't make the job easier and more profitable for you, Howard W. Sams wants you to return the complete Folder Set direct to him and he'll refund your purchase price promptly. GET THE PROOF FOR YOURSELF—TRY PHOTOFACT NOW!

FREE



## FOR SERVICE TECHNICIANS ONLY

Fill out and mail coupon today for Free subscription to the Sams Photofact Index — your up-to-date guide to virtually any receiver model ever to come into your shop. Send coupon now.

## HOWARD W. SAMS & CO., INC.

Howard W. Sams & Co., Inc.  
2207 E. 46th St., Indianapolis 5, Ind.

Put me on your mailing list to receive the Sams Photofact Index and Supplements. My (letterhead) (business card) is attached.

I'm a Service Technician:  full time;  part time

My Distributor is: \_\_\_\_\_

Shop Name \_\_\_\_\_

Attn: \_\_\_\_\_

Address: \_\_\_\_\_

City \_\_\_\_\_ Zone \_\_\_\_\_ State \_\_\_\_\_

# ANNUAL INDEX

## CIRCUIT DIAGRAMS

(Continued from page 28)

Spartan 24U213 Sweep System	Feb.
Speaker Network in Small Building	Mar.
Stromberg-Carlson Amp for Motel Sound System	Oct.
Superhet Frequency Conversion Equivalent Circuit	Jan.
Sweep-Generator/Marker-Adler Alignment	Mar.
Sylvania Trans-Radio Diode Detector, Audio Driver, P-P Output (Cover)	Mar.
Sylvania S-110 21-Inch Set (Complete Circuit)	July
Sylvania S-110 Vertical Scan	July
Sylvania Thunderbird (Complete Circuit)	Mar.
Sylvania Trans DC Gating	Sept.
Sylvania Trans Diode Gate	Sept.
Sylvania Trans Flip-Flop	Sept.
Sylvania Trans Gated-Pulse Amp	Sept.
Sylvania Trans Pulse Amp	Sept.
Telematic Adjustable TV Bias Supply	Jan.
Test Equalization Setup for Tuners	Nov.
Tests for Triodes-Pentodes	June
35W4-35Z5 Test Circuit	June
Tone-Squelch System	June
Transformer Circuit Capacitor Check	Mar.
Transistor Phono Amp	Apr.
Transistor Radio Socketry	Mar.
Transistor Resistance-Test Setup	Apr.
Transistor Vertical Deflection Circuit for 90° 21-Inch Tubes	Aug.
Transistor Video Amplifiers	Aug.
Transmission-Line Low Bypass Filter	Apr.
Transmitter 6-12 V Fil String Modification	Sept.
Tuned Cascade-Triode	Aug.
Tuner Couplings	July
TV-Antenna 2-Set Feed Network	Aug.
TV Horizontal Output Showing Current Flow	July
Twin-T Feedback Slot Amplifier Circuit	July
VHF-Tuner Pentode-Mixer Stage	Jan.
VHF-Tuner Triode-Mixer Stage	Jan.
Vico 77 All-Transistor 20-Watt Amp (Cover: Complete Circuit)	Dec.
Video-Output Convergence Generator	Jan.
Voltage Boost for CRT Cathods	Jan.
Westinghouse AM-FM Tuner	Dec.
Westinghouse Horizontal Sweep	Oct.
Westinghouse Transistor-Radio AF	Apr.
Westinghouse V-2346 Gated-Beam Detector	Nov.
Zenith 7NT40 Transistor Radio AGC	Mar.
Zenith 20H20 Gruen Horiz AFC	Aug.
Zenith 27F20	Sept.

## MINIATURIZATION

### (Circuitry—Components—Equipment—Servicing)

A Field Report on Miniaturized Circuitry	Sept.
A Field Report on the Repair of Printed-Wiring Circuit Boards; Russell D. Gagne	Apr.
A Six-Transistor Portable With Solar-Pack Power Supply; R. L. Jablonski	June
Eliminating Distortion in Transistor-Radio Audio	Sept.
Transistor Radio Repair Tips	Oct.
Latest 2-Way Developments: Selective-Calling Systems—Short Antennas	June
Transistor Chassis; Leo Sands	June
Miniaturized Signal-Seeking Tuners; W. C. Caldwell	June
Miniaturized Component Developments	Aug.
Modulized Circuitry	Apr.
9-Transistor 20-Watt AF Amplifier; George Yonno	Dec.
Packaged Electronic Circuit Printed-Wiring TV Chassis; Bernard Schlaeter	Feb.
Portable-Phono Transistor-Amp Servicing; Norman Crowhurst	Apr.
P-W Board Chassis Repair Using Latest Type Soldering Irons and Guns	Aug.
Semiconductor Circuit Developments; Allan Lytel	Apr.
Servicing Transistor Portables, AGC and Audio Circuits	Mar.
Servicing Transistor Radios	July
Seven-Transistor Printed-Wiring Portable; Thomas Vanacore	Mar.
The Chicago Electronic Parts Show	June
13-Transistor Signal-Seeking Auto Radio; W. C. Caldwell	May
Transistor-Amp Portable-Phono Circuitry	Feb.
Tape-Recording Repair Tips	Feb.
Transistor Chassis Repair	Feb.
Transistor Radio AF-RE Repair Tips	Aug.
Transistor-Radio Test-Equipment Application Tips—Modulized Chassis Repair	May
Transistor-TV Auto-Radio Repair Tips	Apr.
Troubleshooting P-W Boards	June
Troubleshooting Tube-Transistor Auto Radios; Howard Jennings	Apr.
TV Circuits Suitable for Transistors and Diodes	Aug.

## PRINTED WIRING

### (Circuitry—Servicing)

A Field Report on the Repair of Printed-Wiring Circuit Boards; Russell D. Gagne	Apr.
Packaged Electronic Circuit Printed-Wiring TV Chassis; Bernard Schlaeter	Feb.
P-W Board Chassis Repair Using Latest Type Soldering Irons and Guns	Aug.
Solar-Transistor Radio With P-W Boards	June
Seven-Transistor Printed-Wiring Portable; Thomas Vanacore	Mar.
Troubleshooting P-W Boards	June
Design-Application Report on a Variable Control PW Tuning-Element Indoor Dipole	Mar.

## RADIO

### (Home-Auto)

A Packaged 4-Speaker Hi-Fi Radio-Phono; Roy S. Finck	Nov.
A Six-Transistor Portable With Solar-Pack Power Supply; R. L. Jablonski	June
AM-FM Phono With Push-Button Loudness Control in Preamp; Harry Schmidt	Aug.
AM-FM Radio-Phono With Mood-Music Control; C. C. Kayhart	May
Eliminating Distortion in Transistor-Radio Audio	Sept.
History of the Signal-Seeking Auto-Radio Tuner; W. C. Caldwell	Apr.
Improper Damping Cures—Checks for Multirange Ohmmeter Accuracy	Oct.
Transistor Radio Repair Tips	Oct.
Miniaturized Signal-Seeking Tuner; W. C. Caldwell	June
Semiconductor Circuit Developments; Allan Lytel	Apr.
Servicing Transistor Portables, AGC and Audio Circuits	Mar.
Servicing Transistor Radios	July
Seven-Transistor Printed-Wiring Portable; Thomas Vanacore	Mar.
13-Transistor Signal-Seeking Auto Radio; W. C. Caldwell	May
Transistor Chassis Repair—Auto-Radio Intermittent Electrolytic Tests—Radio IF Replacements	Feb.
Tracing Receiver Troubles With Input Power Tests; Jack Darr	May
Transistor Radio AF-RE Repair Tips	Aug.
Transistor-Radio Test-Equipment Application Tips—Modulized Chassis Repair	May
Transistor-TV Auto Radio Repair Tips	Apr.
Troubleshooting AM-FM Tuners	Dec.
Troubleshooting Tube-Transistor Auto Radios; Howard Jennings	Apr.
Ultrasonic Remote Control for TV-AM-FM Phono Chassis; Perry Sheneman	Nov.

## SEMICONDUCTORS

### (Transistors . . . Diodes)

A Field Report on Miniaturized Circuitry	Sept.
Auto Radio PNP Transistors	Apr.
Color-TV Semiconductor Dynamic Convergence	Oct.
Color-TV Tube and Semiconductor Developments	Aug.
Conv-IF-Det Transistor Stages	July
Four-Stage Transistor Amplifier	Sept.
Latest Developments in Semiconductors, FM Tubes and Wide-Angle Picture Tubes	Oct.
9-Transistor 20-Watt AF Amplifier; George Yonno	Dec.
PNP Audio Transistor	Apr.
Semiconductor Developments	Sept.
Semiconductor Developments	Dec.
Semiconductor Circuit Developments; Allan Lytel	Apr.
Solar Transistor Radio	June
13-Transistor Auto Radio	May
Transistor (IN278 PNP) Auto Radio Output	Feb.
Transistor Auto Radio With Feedback	Apr.
Transistor Multivibrators	Sept.
Transistor Radio Audio Driver—P/P Output	Mar.
Transistor Radio Diode Detectors	Mar.
Transistor DC Gating	Sept.
Transistor-Diode Gates	Sept.
Transistor Flip-Flop	Sept.
Transistor Gated-Pulse Amplifier	Sept.
Transistor Phono Amplifier	Apr.
Transistor Pulse Amplifier	Sept.
Transistor Radio AGC	Mar.
Transistor TV Vertical Deflector	Aug.
Tube-Transistor News: Semiconductor Power Rectifiers	June
TV Circuits Suitable for Transistors and Diodes	Aug.

## SERVICE ENGINEERING

### (Commercial Sound—Two-Way Communications)

Field-Bench Facilities of Shop Specializing in Commercial Sound; Kenneth Sonnenberg	May
Floating Service Shop for Marine Radio Repair; Harold Spoelstra	Apr.
Latest 2-Way Developments: Selective-Calling Systems—Short Antennas	June
Transistor Chassis; Leo Sands	June

Maintenance of Communications Equipment in Santa Clara County, Calif.; Robert A. Mason	Jan.
Marine-Mobile Radio Installation-Servicing in San Pedro, Calif.	July
Microwave System Field Servicing by Independent Service Engineers; George Vass	Feb.
Repeaters, Antennas, Test Equipment for Two-Way	Oct.
Service Engineering the Microwave Network; George Vass	Mar.
Servicing Carrier-Current Wireless Intercoms	Dec.
Servicing Commercial and Home Hi-Fi Systems; Ernest A. Dahl	Nov.
Servicing the Microwave System; Leo Jochimsen	Aug.
Test Instruments Required for Two-Way	Sept.

## SERVICING REPORTS

### (Procedures—Charts—Installation—Repair Notes)

A Field Report on the Repair of Printed-Wiring Circuit Boards; Russell D. Gagne	Apr.
Adjustable Bias Supplies—Scope Modifications for TV-Set Alignment	Jan.
Alignment and Test Procedures for Oscillator Coils in Tape Recorders	Dec.
Troubleshooting Tape Equipment	Dec.
Tools Required for Tape Repairs	Dec.
Alignment of TV Chassis Using Marker-Adler Techniques; Rhys Samuel	July
Changing Needles in Phonos—Mechanical-Feedback Vibration Distortion Cures	July
Crystal-Ceramic Pickup Replacement With Magnetic Types	July
Color-TV Convergence-Alignment Adjustments With a Flying Spot Scanner Test-Pattern Generator; Ralph G. Peters	Mar.
Color-TV Picture-Tube Adjustments; John T. Jans	Jan.
Color-TV Transmission-Line Checks With TV Alignment Equipment; Robert Kertzman	Apr.
Color-TV Video Generator for Convergence Adjustments; Rhys Samuel	Jan.
Converting Six-Volt Two-Way Mobile Systems for Twelve-Volt Operation; Jack Darr	Sept.
Cures for Hum in Amplifiers and Pre-amplifiers	Sept.
Dropout and Modulation Noise Problems in Tape	Oct.
Eliminating Distortion in Transistor Radio Audio	Sept.
Field Service Experiences With Color-TV Receivers; W. H. Powell, R. Scattergood and J. H. Mills	Nov.
Horizontal AFC Troubleshooting Chart for Pulse-Width or Synchroguide Circuits; Jesse Dines	June
Improper Damping Cures—Checks for Multirange Ohmmeter Accuracy	Oct.
Transistor Radio Repair Tips	Oct.
In-Circuit Horizontal System Analyzer to Check Flybacks; Robert G. Middleton	Jan.
Installation Checks for Latest Color-TV Chassis; J. R. Meagher	Oct.
Line-Loss Equalization in Low-High-Band TV Systems	Apr.
Localizing Capacitor Troubles With In-Circuit Checks; R. D. Wengenoth	Mar.
Output-Transformer Replacement—IF Instability Cures—Square-Wave Testing	June
Phono Pickup Tests Before Installation to In-sure Best Results	Aug.
Portable-Phono Transistor-Amp Servicing; Norman Crowhurst	Apr.
P-W Board Chassis Repair Using Latest Type Soldering Irons and Guns	Aug.
Remedies for Intermittent Hum and Sound in Picture—Troubleshooting Tips for TV Tuners, Gated-Beam Detectors and Transistor Squelching	Nov.
Remedies for Picture Streaking, Phono Motor Noise, Grille Static Charges	Sept.
Replacement of Pickups, Stylis and Phono Motors in Portable Phonos	Apr.
Resistive Line-Voltage Regulators; Glenn Hall	Jan.
Servicing Carrier-Current Wireless Intercoms	Dec.
Servicing the Microwave System; Leo Jochimsen	Aug.
Servicing Transistor Portables, AGC and Audio Circuits	Mar.
Servicing Transistor Radios	July
The Installation of Color-TV Receivers; Robert G. Middleton	Mar.
The Modern Trend in TV Alignment; Norman Crowhurst	Mar.
Tracing Receiver Troubles With Input-Power Tests; Jack Darr	May
Traffic Appliance Servicing: Repair of Automatic Coffee Percolators; Sol Wallach	May
Transistor-Amp Portable-Phono Circuitry	Feb.
Tape-Recording Repair Tips	4.
Speed Player Servicing	Feb.



Transistor Chassis Repair . . . Auto-Radio	
Intermittent Electrolytic Tests . . . Radio	
IF Replacements . . .	Feb.
Transistor Radio AF-RF Repair Tips . . .	Aug.
Transistor-Radio Test-Equipment Application	
Tips . . . Modulized Chassis Repair	
Transistor-TV Auto-Radio Repair Tips . . .	May
Troubleshooting AM-FM Tuners . . . TV	
Tuner Detent Spring Lubrication . . .	
Fuse-Resistor Replacements . . . Ringing	
Cures . . .	Dec.
Troubleshooting Arcing and Corona; Jesse	
Dines . . .	Mar.
Troubleshooting Chart for Sound No.	
Raster . . .	May
Troubleshooting Color-TV, P-W Boards, Pic-	
ture-Tube and AGC Circuits . . .	June
Troubleshooting Dual-Diode Horizontal	
AFC Circuits; Jesse Dines . . .	Dec.
Troubleshooting Du Mont TV Chassis . . .	Aug.
Troubleshooting Horizontal AFC Gruen Cir-	
cuits; Jesse Dines . . .	Aug.
Troubleshooting Horizontal AFC Synchro-	
lock Circuits; Jesse Dines . . .	Sept.
Troubleshooting Horizontal-Output HV-Rec-	
tifier Circuits in the Horizontal Sweep	
System; Jesse Dines . . .	Feb.
Troubleshooting Multivibrator Horizontal	
Oscillators; Jesse Dines . . .	Nov.
Troubleshooting Tube-Transistor Auto	
Radios; Howard Jennings . . .	Apr.
TV Horizontal Retrace: Problems and So-	
lutions; S. Wlasuk . . .	Sept.
TV-Portable Circuit Troubleshooting; Jesse	
Dines . . .	Apr.
VOM Design and Operation . . .	June

### SERVICE SHOPS

#### (Operation—Equipment—Tools)

An Industry Report on Test Equipment . . .	Mar.
Caddies—Special Tools . . .	Aug.
Field-Bench Facilities of Shop Specializing in	
Commercial Sound; Kenneth Sonnenberg . . .	May
Field Service Experiences With Color-TV	
Receivers; W. H. Powell, R. Scattergood	
and J. W. Mills . . .	Nov.
Floating Service Shop for Marine Radio	
Repair; Harold Spoelstra . . .	Apr.
Latest Specialty-Type Tools and Kits . . .	Aug.
Maintenance of Communications Equipment	
in Santa Clara County, Calif.; Robert A.	
Mason . . .	Jan.
Marine-Mobile Radio Installation-Servicing	
in San Pedro, Calif. . . .	July
Outdoor-Installation Equipment . . .	Aug.
Radio—B-W Color-TV Servicing in Oak-	
land, Calif.; Ernest Copley . . .	Feb.
Servicing Commercial and Home Hi-Fi	
Systems; Ernest A. Dahl . . .	Nov.
Storage Bins—Dollies—Pickup Trucks . . .	Aug.
Tight-Spot Tools . . .	Aug.
TV Service Shop With Overhead Test-	
Equipment Rack and Mobile Benches;	
Al Reyenga . . .	Mar.
Why the Television Service Man Should	
Be a Color-TV Booster; C. E. Walter . . .	Oct.

### TELEVISION

#### (Black-and-White)

Adjustable Bias Supplies . . . Scope Modi-	
fications for TV-Set Alignment . . .	Jan.
Alignment of TV Chassis Using Marker-	
Adder Techniques; Rhyss Samuel . . .	July
B-W Color-TV VHF Tuner Mixers and	
Local Oscillators; Wayne S. Rial . . .	Jan.
B-W/Color-TV VHF Tuner Mixers-Oscil-	
lators; Wayne S. Rial . . .	July
Circuitry and Tube Requirements in VHF	
Tuner RF Amplifiers; Wayne S. Rial . . .	Aug.
Disc-Type Pentode-Tuner for Portable-TV;	
Ove E. Petersen . . .	Apr.
Horizontal AFC Troubleshooting Chart for	
Pulse-Width or Synchroguide Circuits;	
Jesse Dines . . .	June
In-Circuit Horizontal System Analyzer to	
Check Flybacks; Robert G. Middleton . . .	Jan.
Instruments-Procedures Used in Plants to	
Check TV Tubes; Earl G. Bond . . .	Jan.
New Trends in Power Transformers for	
TV Chassis; J. C. Spindler . . .	Dec.
Packaged Electronic Circuit Printed-Wiring	
TV Chassis; Bernard Schluter . . .	Feb.
Remedies for Picture Streaking . . .	Sept.
RF Amplifier Stages for VHF Tuners;	
Wayne S. Rial . . .	Oct.
Semiconductor Circuit Developments; Allan	
Lytel . . .	Apr.
The Modern Trend in TV Alignment;	
Norman Crowhurst . . .	Mar.
Tracing Receiver Troubles With Input-	
Power Tests; Jack Darr . . .	May
Troubleshooting AM-FM Tuners . . . TV	
Tuner Detent Spring Lubrication . . .	
Fuse-Resistor Replacements . . . Ringing	
Cures . . .	Dec.
Troubleshooting Arcing and Corona; Jesse	
Dines . . .	Mar.
Troubleshooting Chart for Sound No.	
Raster . . .	May
Troubleshooting Dual-Diode Horizontal	
AFC Circuits; Jesse Dines . . .	Dec.

Troubleshooting Du Mont TV Chassis . . .	Aug.
Troubleshooting Color-TV Picture-Tube and	
AGC Circuits . . .	June
Troubleshooting Horizontal AFC Gruen Cir-	
cuits; Jesse Dines . . .	Aug.
Troubleshooting Horizontal AFC Synchro-	
lock Circuits; Jesse Dines . . .	Sept.
Troubleshooting Horizontal-Output HV-Rec-	
tifier Circuits in the Horizontal Sweep	
System; Jesse Dines . . .	Feb.
TV Circuits Suitable for Transistors and	
Diodes . . .	Aug.
TV Horizontal Retrace: Problems and So-	
lutions; S. Wlasuk . . .	Sept.
TV-Portable Circuit Troubleshooting; Jesse	
Dines . . .	Apr.
21-Inch TV Chassis Using 110° Picture	
Tube; Don Winters . . .	July
UHF Oscillator Tubes; J. W. Rush . . .	Mar.
Ultrasonic Remote Control for TV-AM-FM-	
Phono Chassis; Perry Sheneman . . .	Nov.
Wide-Angle 17-Inch Portable Circuitry;	
Ernest C. Freeland . . .	Sept.

### TELEVISION

#### (Color)

B-W/Color-TV VHF Tuner Mixers and	
Local Oscillators; Wayne S. Rial . . .	Jan.
B-W/Color-TV VHF Tuner Mixers-Oscil-	
lators; Wayne S. Rial . . .	July
Circuitry Report on 21-Inch Color-TV	
Chassis Using Glass Picture Tube; J. A.	
May . . .	Oct.
Color-TV Convergence-Alignment Adjust-	
ments With a Flying Spot Scanner Test-	
Pattern Generator; Ralph G. Peters . . .	Mar.
Color-TV Picture-Tube Adjustments; John	
T. Jans . . .	Jan.
Color-TV Video Generator for Convergence	
Adjustments; Rhyss Samuel . . .	Jan.
Field Service Experiences With Color-TV	
Receivers; W. H. Powell, R. Scattergood	
and J. W. Mills . . .	Nov.
Glass-Envelope 21-Inch Picture Tube for	
Color-TV; L. B. Hadrick . . .	Oct.
How the 3-Gun Color-TV Tube Operates;	
Ken Kicidon . . .	Feb.
Installation Checks for Latest Color-TV	
Chassis; J. R. Meagher . . .	Oct.
The Installation of Color-TV Receivers;	
Robert G. Middleton . . .	Mar.
Trends in Circuits for Color-TV Receivers;	
Robert G. Middleton . . .	May
Troubleshooting Color-TV, P-W Boards,	
Picture-Tube and AGC Circuits . . .	June
Why the Television Service Man Should	
Be a Color-TV Booster; C. E. Walter . . .	Oct.

### TEST EQUIPMENT—PROCEDURES

Adjustable Bias Supplies . . . Scope Modi-	
fications for TV-Set Alignment . . .	Jan.
Alignment of TV Chassis Using Marker-	
Adder Techniques; Rhyss Samuel . . .	July
An Industry Progress Report on Test	
Equipment . . .	Mar.
Color-TV Convergence-Alignment Adjust-	
ments With a Flying Spot Scanner Test-	
Pattern Generator; Ralph G. Peters . . .	Mar.
Color-TV Transmission-Line Checks With	
TV Alignment Equipment; Robert Kers-	
man . . .	Apr.
Color-TV Video Generator for Convergence	
Adjustments; Rhyss Samuel . . .	Jan.
Improper Damping Cures . . . Checks for	
Multirange Ohmmeter Accuracy . . .	Oct.
In-Circuit Horizontal System Analyzer to	
Check Flybacks; Robert G. Middleton . . .	Jan.
Installation Checks for Latest Color-TV	
Chassis; J. R. Meagher . . .	Oct.
Instruments-Procedures Used in Plants to	
Check TV Tubes; Earl G. Bond . . .	Jan.
Localizing Capacitor Troubles With In-	
Circuit Checks; R. D. Wengeroth . . .	Mar.
Phono Pickup Tests Before Installation to	
Insure Best Results . . .	Aug.
Test Equipment for Two-Way . . .	Oct.
Resistive Line-Voltage Regulators; Glenn	
Hall . . .	Jan.
Test Instruments Required for Two-Way	
Sept. . . .	Sept.
The Installation of Color-TV Receivers;	
Robert G. Middleton . . .	Mar.
The Modern Trend in TV Alignment;	
Norman Crowhurst . . .	Mar.
Tracing Receiver Troubles With Input-	
Power Tests; Jack Darr . . .	May
Auto-Radio Intermittent Electrolytic Tests	
Feb. . . .	Feb.
Transistor-Radio Test-Equipment Applica-	
tion Tips . . .	May
Tube Testing With Coded Cards; Robert D.	
Wengeroth . . .	June
VOM Design and Operation . . .	June

### TRANSISTORS—TRANSISTORIZED EQUIPMENT

A Field Report on Miniaturized Circuitry	
Sept. . . .	Sept.
A Six-Transistor Portable With Solar-Pack	
Power Supply; R. L. Jablonski . . .	June
Eliminating Distortion in Transistor-Radio	
Audio . . .	Sept.
Transistor Radio Repair Tips . . .	Oct.

Latest Application Information on Transis-	
tors for UHF, VHF, and AM Receivers. Nov.	
Latest Developments in Audio Transistors	
Feb. . . .	Feb.
Latest 2-Way Developments: Transistor	
Chassis; Leo Sands . . .	June
9-Transistor 20-Watt AF Amplifier; George	
Young . . .	Dec.
Portable-Phono Transistor-Amp Servicing;	
Norman Crowhurst . . .	Apr.
Remedies for Transistor Squeaking . . .	Nov.
Semiconductor Circuit Developments;	
Allan Lytel . . .	Apr.
Semiconductor Developments . . .	Sept.
Semiconductor Developments . . .	Dec.
Servicing Transistor Portables, AGC and	
Audio Circuits . . .	Mar.
Servicing Transistor Radios . . .	July
Seven-Transistor Printed-Wiring Portable;	
Thomas Vanacore . . .	Mar.
13-Transistor Signal-Seeking Auto Radio;	
W. C. Caldwell . . .	May
Transistor-Amp Portable-Phono Circuitry . . .	Feb.
Transistor Chassis Repair . . .	Feb.
Transistor Radio AF-RF Repair Tips . . .	Aug.
Transistor-Radio Test-Equipment Applica-	
tion Tips . . . Modulized Chassis Repair	
May . . .	May
Transistor-TV Auto-Radio Repair Tips . . .	Aug.
Troubleshooting Tube-Transistor Auto	
Radios; Howard Jennings . . .	Apr.
Tube-Transistor News: Transistors for	
Apr. . . .	Apr.
Tube-Transistor News: Transistors for	
High-Power AF, TV and 2-Way . . .	May
Tube-Transistor News: Semiconductor	
Power Rectifiers . . .	June
TV Circuits Suitable for Transistors and	
Diodes . . .	Aug.

### TUBES

A Field Report on Miniaturized Circuitry	
Sept. . . .	Sept.
A Report on TV Tubes Designed for Wide-	
Angle Chassis Replacements for Wide-	
Angle Color and B-W TV Receivers . . .	Hi-Fi
Audio Tubes . . .	Auto-Radio 12-V
Tubes . . .	Dec.
B-W/Color-TV VHF Tuner Mixers and	
Local Oscillators; Wayne S. Rial . . .	Jan.
B-W/Color-TV VHF Tuner Mixers-Oscil-	
lators; Wayne S. Rial . . .	July
Circuitry and Tube Requirements in VHF	
Tuner RF Amplifiers; Wayne S. Rial . . .	Aug.
Color-TV Picture-Tube Adjustments; John	
T. Jans . . .	Jan.
Color-TV Tube Developments . . .	Aug.
Glass-Envelope 21-Inch Picture Tube for	
Color-TV; L. B. Hadrick . . .	Oct.
How the 3-Gun Color-TV Tube Operates;	
Ken Kicidon . . .	Feb.
Instruments-Procedures Used in Plants to	
Check TV Tubes; Earl G. Bond . . .	Jan.
Latest Application Information on Auto-	
Radio and Audio Power Tubes . . .	Nov.
Latest Developments in Color-TV/B-W TV	
Picture Tubes and Miniatures . . .	Feb.
Latest Developments in FM Tubes and	
Wide-Angle Picture Tubes . . .	Oct.
Replacement Tubes for 110° Chassis . . .	Audio, FM, Auto Radio Tube Develop-
ments . . .	Sept.
RF Amplifier Stages for VHF Tuners;	
Wayne S. Rial . . .	Oct.
Trends in Circuits for Color-TV Receivers;	
Robert G. Middleton . . .	May
Troubleshooting Color-TV, P-W Boards,	
Picture-Tube and AGC Circuits . . .	June
Troubleshooting Tube-Transistor Auto	
Radios; Howard Jennings . . .	Apr.
Tube Testing With Coded Cards; Robert D.	
Wengeroth . . .	June
Tube-Transistor News . . .	Apr.
Tube-Transistor News: Beam Power AF	
Tubes . . .	May
Tube-Transistor News: Wide-Angle Picture	
Tube Replacements . . . 12-V Auto	
Tubes . . .	June
UHF Oscillator Tubes; J. W. Rush . . .	Mar.

### TWO-WAY COMMUNICATIONS

Converting Six-Volt Two-Way Mobile Sys-	
tems for Twelve-Volt Operation; Jack	
Darr . . .	Sept.
Fixed-Frequency Low-Band FM Mobile	
Receiver; Warren M. Seeley . . .	July
Floating Service Shop for Marine Radio	
Repair; Harold Spoelstra . . .	Apr.
Latest 2-Way Developments: Selective-	
Calling Systems . . . Short Antennas . . .	June
Transistor Chassis; Leo Sands . . .	June
Maintenance of Communications Equipment	
in Santa Clara County, Calif.; Robert A.	
Mason . . .	Jan.
Marine-Mobile Radio Installation-Servicing	
in San Pedro, Calif. . . .	July
Microwave System Field Servicing by In-	
dependent Service Engineers; George	
Vass . . .	Feb.
Repeaters, Antennas, Test Equipment for	
Two-Way . . .	Oct.
Service Engineering the Microwave Net-	
work; George Vass . . .	Mar.
Servicing the Microwave System; Leo	
Joergensen . . .	Aug.
Test Instruments Required for Two-Way . . .	Sept.

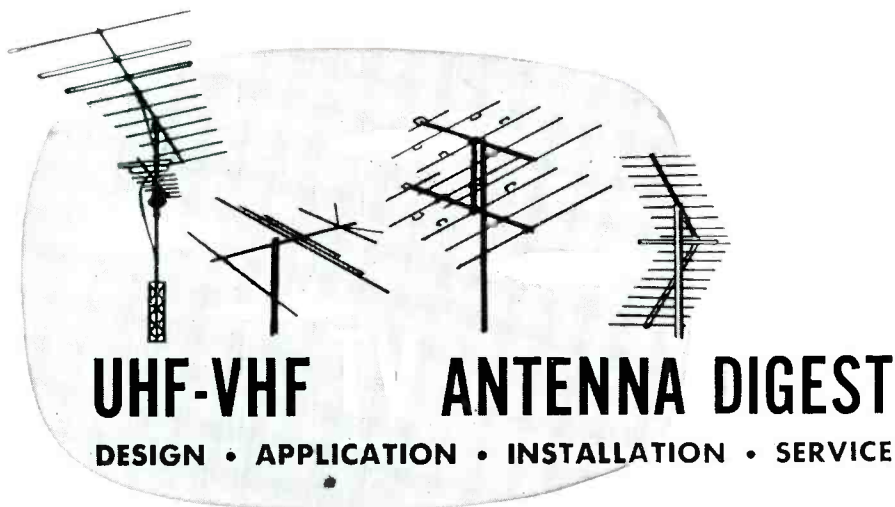

# UHF-VHF ANTENNA DIGEST

DESIGN • APPLICATION • INSTALLATION • SERVICE

## A Report on a Recent Nationwide Investigation Which Reveals Existence of a Large Market for TV Antennas Among Those Who Still Use Weird Inefficient Home-Made Setups\*

EVEN IN THIS modern day and age—with many homes enjoying the use of two and even three television receivers—a vast army of set owners are still resorting to the most primitive methods for manufacturing home-produced antennas. In fact, many set owners have never used either an indoor or an outdoor antenna.

But, it is these self-same, self-made, do-it-yourselfers who plague the lives of the Service Man because reception is not of the finest.

Even in some rural areas set owners have been depending upon so-called

built-in antennas to bring in pictures which are shaky, snowy, blurred and almost illegible.

The biggest violators of good reception appear to be in the south and the southwest, where normally an antenna of the finest make, designed for fringe reception, has trouble bringing any picture due to distance.

Research finds that set owners resort to some unique approaches to

*\*Based on a national study by Snyder Manufacturing Co. through the company's distributors and field men and coordinated by national sales manager Dick Morris.*

producing their own antennas—often defying the poor Service Man to discover why reception is poor when the set is in perfect working order.

One woman, for example, found some bailing wire somewhere, managed miraculously to attach it to the antenna leadin and then tossed the end of the wire out of the nearest window after running it under a rug.

Some owners—believed to run in the five figures—use the same bailing wire without tossing the end out of the window and then complain the loudest because the Service Man cannot discover the reason for snow or flurring.

Probably the most popular indoor antenna in the southwest appears to be rebent coat hangers. Simply, rabbit ears are made out of coat hangers, some plain wire is attached, and the reshaped coat hanger is connected to the leadin and all hope for the best. Naturally, the best is not forthcoming.

Thousands of set owners are particular. They go to a supply house and buy twin leadin. They do the attaching to the set and then (having read something somewhere that bed springs are exceptionally good receiving antennas) attach the other end to the nearest bed or sofa spring or even to a radiator or just throw them out of a window, since a window can be shut tightly over them.

Even though the 98-cent rabbit-ear antenna is rapidly going out of business, many set owners were still using them and still complaining loudly.<sup>1</sup>

The biggest puzzler for the Service Man is the set owner who insists upon

(Continued on page 41)

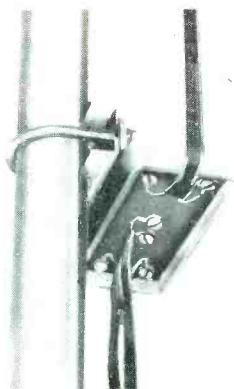

**OUTDOOR TV RECEIVER** coupler which can be installed on mast by means of a U-bolt assembly. Device is encapsulated in colplast. Insertion loss is claimed to be reduced by utilization of distributed-line-parameter network of bifilar coils and location of components; design also provides increased isolation between receivers.—Types AC-40, AC-60, AC-70; JFD Manufacturing Co., Inc., 6101 Sixteenth Ave., Brooklyn 4, N. Y. [SERVICE]

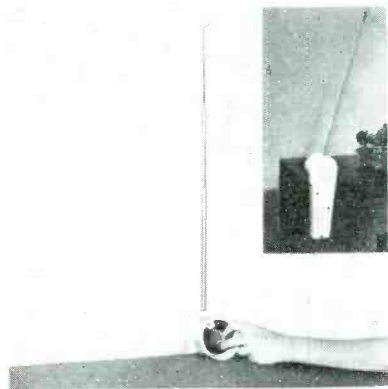

**SINGLE-STAFF 4-SECTION GOLD-TONE** indoor antenna designed for mounting on back of set. Features tuned vertical polarization. Mast can be rotated. Has a directronic switch.—Wun/Rod 9-D; Snyder Mfg. Co., 22nd and Ontario, Philadelphia, Pa. [SERVICE]



**FM ANTENNA**, of turnstile design, which features a self-supporting base. Available as a kit with 3/8" aluminum elements and 60' transmission line.—Telco FM Antenna Kit (A-124); Telco Electronics Mfg. Co. (a division of General Cement-Textron), 400 S. Wyman St., Rockford, Ill. [SERVICE]



# ASTRON "Staminized" CAPACITORS HAVE . . .

## long life

**NO CALL-BACK CONSTRUCTION  
ASSURED BY 10 INDIVIDUAL  
PRODUCTION TESTS**  
*plus* **100% FINAL INSPECTION**

Long life in capacitors is important to you as a serviceman. Complete confidence in the components you use is a necessity, because your business is built on reputation.

Astron considers the serviceman's reputation to be prime importance. That is why each capacitor is manufactured under Astron's "Staminized" system.

Astron's "Selected Purchasing" guarantees that only the very finest of raw materials are chosen. Astron's special production techniques are supplemented by continuous inspection under strict quality controls. Production tests are made right on the production line . . . 10 separate tests in all. A 100% final inspection is made before any capacitor can be shipped.

You can put your trust in Astron . . . your assurance of top performance . . . every time.

There is an Astron "Staminized" Capacitor built especially to fill the specific, exacting replacement requirements of any job you tackle.

Remember, your reputation is our business, too. Build it, guard it, protect it . . . Buy Astron!

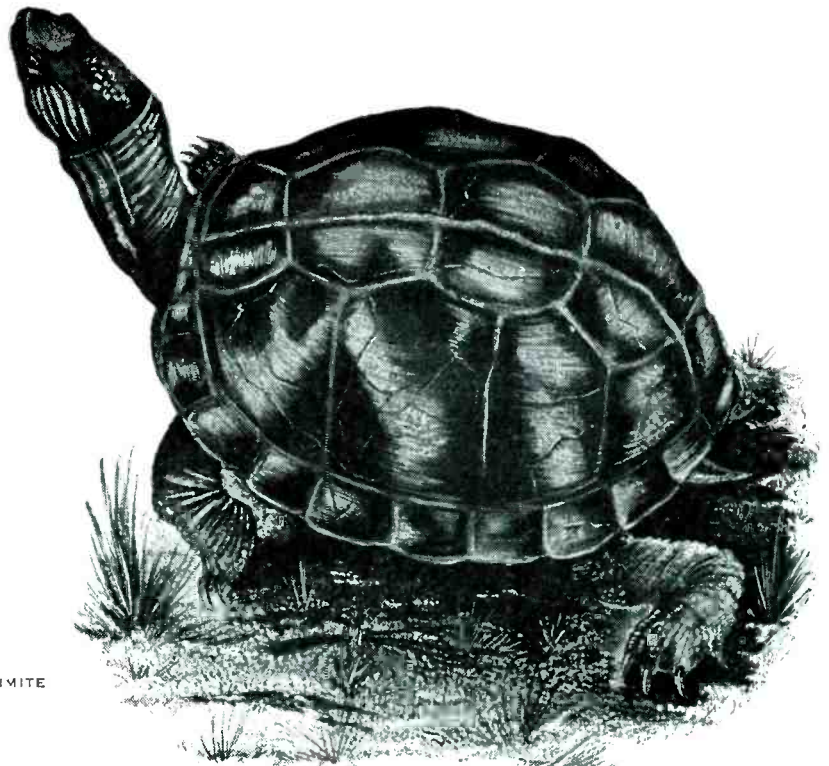

\*Trade-Mark



SAFETY MARGIN "SM" MINIMIZE

BLUE-POINT <sup>®</sup> MOLDED  
PLASTIC PAPER TUBULAR



Free Servicing Aid . . .

Save time, use handy Astron pocket-sized Replacement Catalog and Pricing Guide (AC-4D) . . . Write today!

**ASTRON**  
CORPORATION  
255 GRANT AVENUE EAST NEWARK, N. J.

Export Division: Rocke International Corp., 13 East 40th St., N. Y., N. Y. In Canada: Charles W. Pointon, 6 Alcina Ave., Toronto 10, Ontario



only  
\$3.50  
at your distributor

...it's  
here!

# 1958 RADIO-ELECTRONIC MASTER (22nd edition)

biggest, most authoritative buying guide ever published

## TV - RADIO - AUDIO - ELECTRONICS

Completely catalogs over 150,000 standard electronic parts and equipment necessary to radio-TV-audio and industrial servicing. It places the entire electronic industry at your fingertips!

1584 pages  
The world's largest and most referred to electronic buying guide contains...

direct-from-the-factory product information covering 150,000 items produced by 350 manufacturers

- ★ complete descriptions
- ★ specifications
- ★ prices
- ★ 11,500 illustrations

**When you BUY and SELL  
You can immediately find out**

- What product best fills your needs?
- How does it compare with other makes?
- What does it look like?
- What does it cost?

...because the MASTER is systematically arranged in 18 product sections with all similar products grouped together.

**You operate more efficiently,  
more profitably with  
The MASTER**

The MASTER describes, illustrates, lists specs of all items necessary to radio-TV servicing. What's more - it offers thousands of additional products that can lead to extra income in Hi-Fi, sound and industrial servicing. You can buy, sell and bill direct from The MASTER. It shows list prices! It's invaluable at the bench, over-the-counter or in the field.

Remember, no matter what product or component you require... **YOU FIND IT FASTER IN THE MASTER!**

Act now - the supply is limited

Get your 1958 MASTER today at local parts distributor or write for list.

**THE RADIO-ELECTRONIC MASTER** 60 Madison Avenue, Hempstead, N. Y.

## ACCESSORIES

### PIX TUBE BASE ADAPTER

A 110° PICTURE TUBE base adapter, D1 Adapt-It, for converting RCA 110° picture-tube bases to duo-decal type for test purposes, has been announced by Workman TV, Inc., 309 Queen Anne Rd., Teaneck, N. J.

### PIX TUBE REJUVENATOR

A TV PICTURE-TUBE rejuvenator, Kure-all, for use with parallel or series wired circuits, has been introduced by Anchor Products Co., 2712 W. Montrose Ave., Chicago 18, Ill.

Device is said to cure open cathodes, heater-cathode shorts, open-cathode grids, control-grid shorts, slow heating, low emission or any combination of these.

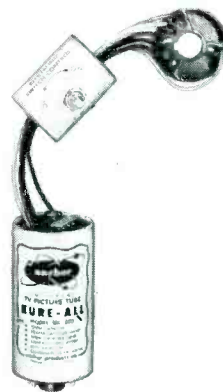

### MARINE-RADIO LOOP EXTENSION KIT

A THROUGH-THE-DECK loop extension kit, 8230, for use on boats with space and heavy metal-work interference problems, has been developed by Kaar Engineering Corp., Middlefield Rd., Palo Alto, Calif.

Kit permits mounting of direction-finder receiver against the overhead and extension of the loop through the cabin on a 14" support column, putting top of the loop 32" from the bottom of the receiver cabinet.

### Self-Service Capacitor Display Rack

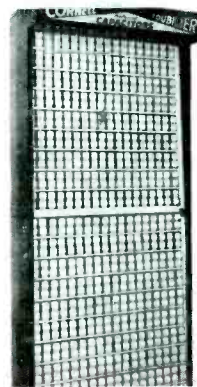

**FLOOR RACK** for C-D preferred-type list of twist-prong electrolytics. Each single-section rack with canopy holds 360 cartons, or 720 cartons for the dual-section unit. Units are available in single or multiple sections, with or without canopy display.—Cornell-Dubilier Electric Corp., South Plainfield, N. J. [SERVICE]



# COMPONENTS

## MINIATURE WIRE TANTALUM CAPACITORS

MINIATURE WIRE TANTALUM capacitors, WT, for low-voltage *dc* applications, such as transistor audio amplifiers, have been developed by Aerovox Corp., New Bedford, Mass.

Operating temperature range is from  $-20^{\circ}\text{C}$  to  $+50^{\circ}\text{C}$ . Of polar construction, capacitor case and attached lead form the cathode terminal and are available in insulated or non-insulated construction. Anode tantalum wire extends through teflon bushing to which a solder lead is attached. Welded connection is encapsulated in a thermosetting resin. Units are color-coded to indicate capacitance and voltage ratings. [SERVICE]

## PLUG-SCREW MOUNT SILICON RECTIFIER

A SILICON RECTIFIER that may be screwed onto the chassis or plugged into a holder has been introduced by the rectifier division of Audio Devices, Inc., 620 E. Dyer Rd., Santa Ana, Calif.

Hermetically-sealed, unit is rated at 750 *ma* at 400 *v*. [SERVICE]

## PUSH-PULL SWITCH VOLUME CONTROL

AN AC LINE switch, with push-pull action, is now available on volume controls manufactured by P. R. Mallory and Co. Inc., 3029 E. Washington Street, Indianapolis 6, Ind.

The line circuit closes when the control shaft is pulled out, opens when the shaft is pushed in. Volume, it is said, always remains at proper level because the set is turned on at the same volume at which it is turned off.

The push-pull switch uses a *floating ring* contact action that gives protection against overloads. It is available on single and dual Mallory controls in ratings to match original controls in popular radio and TV sets.

## Capacitor Contest Winners



**GRAND PRIZE WINNERS** in Pyramid's Serviceman's twist-mount capacitor contest who won a weekend in New York plus a cash award. Left to right: Mr. and Mrs. Sidney White, Cross Island Electronics, Bellrose, N. Y., and Mr. and Mrs. R. Berthold, Springfield Gardens, N. Y. Berthold won the grand prize. As Berthold's distributor, White, manager of Cross Island Electronics, received a duplicate grand prize. [SERVICE]

# NEW improved model Simpson 260!

TRADEMARK

**RUGGED  
PRINTED  
CIRCUIT!**

still  
only  
**\$43<sup>95</sup>**  
Complete with leads and  
Operator's Manual.  
Also available in  
Roll-Top model at  
only . . . \$49.95

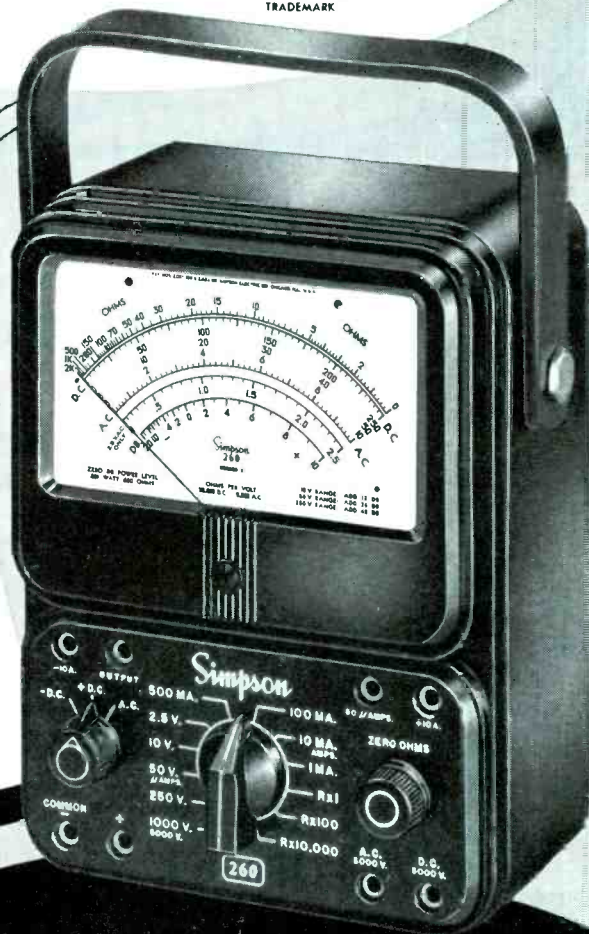

**...the VOM that outsells  
all others combined**

## MANY NEW FEATURES MAKE THE 260 MORE VALUABLE THAN EVER!

- POLARITY REVERSING SWITCH
- 50 MICROAMPERE—250 MILLIVOLT RANGE
- EASIER-TO-READ SCALES
- LESS CIRCUIT LOADING
- POPULAR DBM RANGES
- FULL-WAVE BRIDGE RECTIFIER SYSTEM
- RUGGED PRINTED CIRCUIT
- ALL COMPONENTS EASILY ACCESSIBLE
- IMPROVED FREQUENCY RESPONSE IN A. C. MEASUREMENTS

See it at your Distributor, or write

## SIMPSON ELECTRIC COMPANY

5200 West Kinzie Street, Chicago 44, Illinois

Phone: EStbrook 9-1121

In Canada: Bach-Simpson Ltd., London, Ontario

WORLD'S LARGEST MANUFACTURER OF ELECTRONIC TEST EQUIPMENT





## A Report on TV Tubes Designed for Wide-Angle Chassis . . . Replacements for Color and B-W TV Receivers . . . Hi-Fi Audio Tubes . . . Auto-Radio 12-V Tubes

THREE NEW-TYPE tubes<sup>1</sup> have been developed for wide-angle TV receivers.

One, an octal-based T-9 high permeance, low- $\mu$  triode (6CK4) has been designed for use as a vertical deflection amplifier.

The tube features a maximum plate dissipation of 12 watts and an average cathode current of 100 *ma*.

Intended for receivers with high accelerating potentials, the 6CK4 is said to incorporate a plate capable of conservative operation at rated dissipation. At the same time, the base pin has been isolated electrically to withstand high pulse plate voltages.

The others are 9-pin (T-6½) miniature beam power pentodes (6DW5 and 12DW5), also for use in vertical-deflection amplifiers.

Both tubes, capable of operation at relatively low *B* supply voltages, are characterized by high zero-bias plate current. Double base pins for the number-1 grid permit cooler operation. An electrically isolated plate pin is said to help each tube withstand high pulse plate voltages.

Type 12DW5 features controlled heater warmup time for operation in receivers utilizing a 600-*ma* series heater string; the 6DW5 has been designed for operation in conventional transformer sets.

### B-W/Color-TV Replacements

TWO TUBES, the 6BJ8 and 5V3, are now available as replacements for b-w and color-TV chassis.<sup>2</sup>

The 6BJ8 is a heater-cathode type medium- $\mu$  triode and double diode

miniature designed for use as a phase splitter, phase comparator and horizontal-deflection oscillator. It has a 600-*ma* heater rating.

The 5V3 is a filament type, high-vacuum, double diode. Its principal application is as a full-wave rectifier in the power supply of color-TV receivers and in other equipment of high current requirements.

### Sharp-Cutoff Twin Pentodes

SHARP-CUTOFF TWIN pentodes of the 9-pin miniature type (3BU8 and 6BU8), intended for use in sync circuits and automatic-gain-controlled amplifier circuits of TV receivers, have been announced.<sup>3</sup>

In such receivers, one pentode unit performs the function of combined

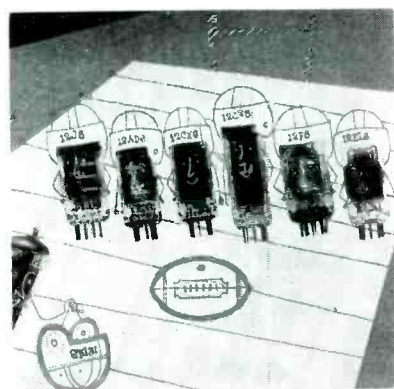

**TWELVE-VOLT** miniatures designed to operate directly from an automobile's battery-generator supply (left to right): 12J8, a 9-pin audio driver; 12AD6, a 7-pin pentagrid converter; 12CX6, a 7-pin rf pentode; 12CNS, a 7-pin if amplifier; 12F8, a 9-pin double diode pentode audio driver, and 12EL6, a 7-pin double diode triode audio amplifier—Sylvania. [SERVICE].

sync separator and sync clipper; the other pentode unit serves as an automatic-gain-controlled amplifier.

Each utilize a common cathode, grid 1 and 2. In addition, grid 1 and 3 of each type have a separate base-pin terminal and may be used independently as a control electrode.

The 3BU8 has been designed for use in receivers employing series heater-string arrangements and is like the 6BU8 except that it has a 3.15-*v/6-a* heater.

### Miniature Beam Power Tube

A BEAM-POWER tube (6973) of the 9-pin miniature type (6.3 *v* at 450 *ma*), for use as an output tube in high-fidelity audio equipment, is now available.<sup>3</sup>

Design is said to feature linear operation over a wide range of power, high power sensitivity and stability.

### 20-Watt Output

In push-pull class AB<sub>1</sub> audio service, two 6973's, operating at a plate voltage of 350, grid-2 voltage of 280, and fixed grid-1 voltage of -22, can deliver, it is claimed, a maximum-signal power output of 20 *w* with a total harmonic distortion of 1.5 per cent.

Tube has double base-pin connections for both grid 1 and 2 to provide cool operation of these grids and to minimize grid emission. Cool operation of both grids also permits use of relatively high values of grid-circuit resistance to reduce driving power.

### 12 Volt Auto-Radio Tube

A MINIATURE 9-PIN combined twin diode and space-grid tetrode (12DL8) with independent unipotential cathodes, has been announced for auto radios.<sup>1</sup>

### Detector-Amp Application

The diode section is intended for use as a detector, while the tetrode section, a power amplifier, has been designed to drive transistor audio output stages. All tube elements, including the heater, operate at a potential of 12 *v*, obtained directly from the automobile battery.

### Miniature Audio Pentode

Also recently announced for audio is a 6BQ5 miniature pentode.<sup>1</sup>

<sup>1</sup>Sylvania.

<sup>2</sup>Raytheon.

<sup>3</sup>RCA.



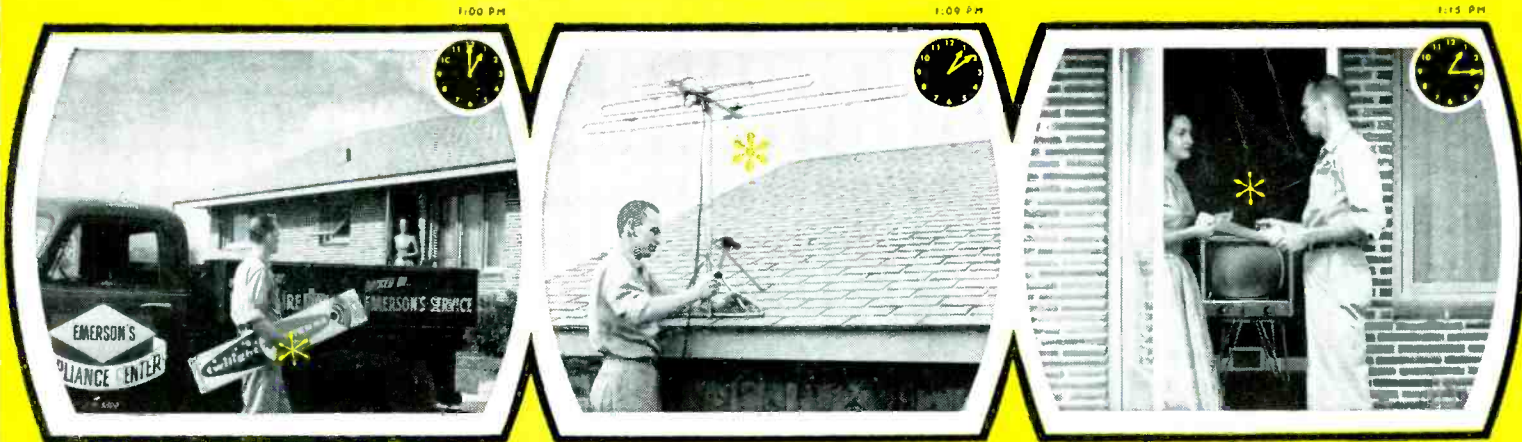

**Picture of a smart TV technician making a dollar a minute on his way back from lunch**

\*  
 "Naturally... it's the  
**GOLD Twilight Antenna**  
 by **Winegard Co.** Dept. E-12  
**BURLINGTON, IOWA"**

## Semiconductor Developments

**Latest Information on New Types of Transistors and Diodes**

A PNP GERMANIUM-ALLOY high-voltage power transistor has been added to the renewal line of Sylvania Electric Products Inc.

The transistor, type 2N296, has been designed for high-voltage power amplifier and switching applications in which 25 to 60-v supply voltage is required.

Features welded hermetic seal construction and has a collector current of two *a*.

### **Junction IF Amp Transistors†**

GERMANIUM-ALLOY junction transistors of the *pn*p type (2N409 and flexible-lead version, 2N410) have been designed for 455-kc *if* amplifier applications in transistorized portable radios.

Both are said to feature a power gain of 31.2 db in a common-emitter type of fixed circuit that sacrifices gain to provide stability and interchangeability. The neutralizing network of this circuit is fixed. The amount of gain sacrificed is minimized by manufacturing controls on the transistor parameters, particularly the para-

eters responsible for system feedback.

These transistors are hermetically sealed and utilize a metal case.

### **Junction Transistors for Converters‡**

TO MEET THE REQUIREMENTS of converter and mixer-oscillator applications in the AM broadcast band, *pn*p junction transistors (2N411 and flexible-lead type 2N412) have been developed.

In a common-emitter type of fixed circuit, these transistors are claimed to have a conversion power gain of 32 db at 1 mc.

These transistors are also hermetically sealed in a metal case.

### **HF Drift Transistors‡**

DRIFT TRANSISTORS (2N370, 2N371, and 2N372) of the germanium *pn*p type are now available for all-wave battery-portables. The 2N370 is intended for *rf* amplifier service, the 2N371 for oscillator service, and the 2N372 as a mixer.

The 2N370, 2N371, and 2N372 look alike. They are hermetically sealed in metal cases, have a diameter of .360" a body height of .375" and

four flexible leads. One of the leads provides shielding to minimize inter-lead capacitance and to minimize coupling to adjacent circuit components, of primary importance in *hf* applications.

### **Silicon Rectifiers**

A LINE of diffused silicon rectifiers (M14) has been announced by Motorola.

The rectifiers are available in peak inverse ratings of 100 through 600 v with average forward currents of 500 *ma*, and with the case common to either cathode or anode.

Three silicon rectifiers have also been announced by Sarkes-Tarzian.

Two are high-current types, rated at 150 and 200 amperes (types X and W) and the third type is a high-voltage half-wave rectifier (S-5033) that can be used as a direct replacement for several octal based rectifier tubes.

### **Silicon Junction Diodes**

A SUBMINIATURE SILICON JUNCTION diode, 1N658, has been brought out by General Instrument Corp.'s semiconductor division through its Radio Receptor subsidiary. The new diode has been designed for computer, communications and general circuit requirements.

The 1N658 features a forward voltage drop under 1 at 100 *ma*, with a .3-usec reverse recovery. Peak inverse voltage is 120, with a reverse leakage of .05 *ua* at -50 v.

†RCA.

## TEST INSTRUMENTS

### TRANSISTOR CHECKER

A TRANSISTOR CHECKER, TRC4, which also tests crystal diodes and selenium rectifiers, has been developed by Service Instruments Corp., 171 Official Rd., Addison, Ill.

Tests for opens, shorts, current gain and leakage on transistors and forward-to-reverse currents on crystal diodes and rectifiers. [SERVICE]

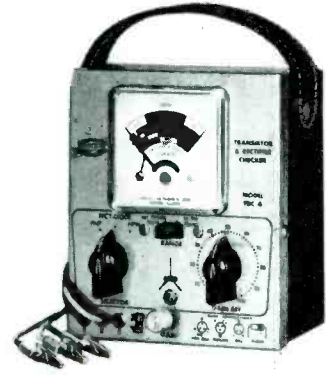

### STABILIZED VTVM WIDE-BAND VIDEO AMP

A STABILIZED VTVM, *Microleter*, without feedback, said to afford wide-band accuracy to 50 *mc*, has been announced by Kay Electric Co., Maple Ave., Pine Brook, N. J.

Unit permits measurement of low-level *rf* signals down to 250 *uv*. Has a 7-position switch which provides full-scale steps of 1, .3, .1, .03, .01, .003 and .001 *v*. Instrument can also serve as a wide-band video amplifier with a maximum output of approximately .25 *v* at 75 ohms and gains of up to 40 db. Input capacitance is 5 mmfd. [SERVICE]

### MULTI-PURPOSE TEST SET

A TRANSISTORIZED MULTI-PURPOSE portable test set, TU546, to facilitate aligning and testing of mobile and base-station transmitters and receivers, has been announced by Motorola Communications and Electronics, Inc., 4501 W. Augusta Blvd., Chicago 51, Ill.

Unit includes a built-in PM speaker for audio reception. An audio-frequency electronic voltmeter permits measurement of *ac* voltages below 2 *v*. An *if* oscillator circuit provides crystal-controlled *if* frequencies between 280 *kc* and 13 *mc*. A 455-*kc* crystal is included for alignment of the last *if* and discriminator stages.

Can be used to measure A+ and B+ in both receivers and transmitters, grid and plate current in the transmitter, relative field strength of radiated signals, transmitter power output and receiver quieting sensitivity. A transistorized *rf* peaking generator, available as an accessory, provides crystal-controlled *rf* output for *rf* peaking of 25-54, 144-174, 450-470, and 890-960 *mc* receivers. [SERVICE]

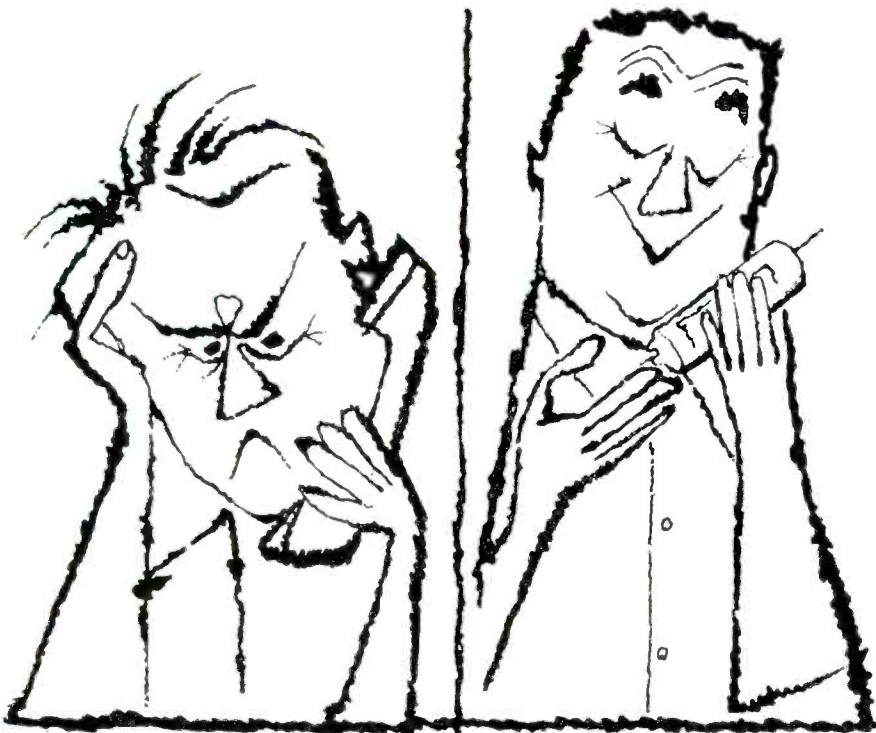

## STOP CB\* WITH C-D

\*CALL BACKS ARE COSTLY. Cornell-Dubilier are specialists in ELECTROLYTICS for replacement service. The familiar C-D Trademark has been the mark of outstandingly superior quality for over 47 years. Every style, size, rating and characteristic of electrolytic capacitor is produced in C-D's own network of plants. From the tiny "finger-nail" size "ELECTOMITE",<sup>®</sup> to the compact "BLUE BEAVER",<sup>®</sup> to the long-life "UP" C-D ELECTROLYTICS have earned their great popularity because they are consistently MADE BETTER to LAST. Say C-D when you buy ELECTROLYTICS—be particular. Write for Catalog 200D-3E to Dept. S-12.

Electric Corp., South Plainfield, New Jersey.

stop call backs...insist on

### CORNELL-DUBILIER CAPACITORS

SOUTH PLAINFIELD, N. J.; NEW BEDFORD, WORCESTER & CAMBRIDGE, MASS.; PROVIDENCE & HOPE VALLEY, R. I.; INDIANAPOLIS, IND.; SANFORD, FUGUAY SPRINGS & VARINA, N. C.; VENICE, CALIF.; & SUB.; THE RADIART CORP., CLEVELAND, OHIO. CORNELL-DUBILIER ELECTRIC INTERNATIONAL, N. Y.

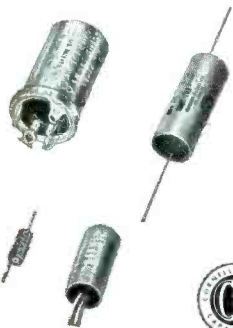

### GRID CIRCUIT TUBE TESTER

A GRID CIRCUIT tube tester, GCT-8, for checking critical-control grid condition of tubes, has been introduced by the Seco Manufacturing Co., 5015 Penn Ave. S., Minneapolis, Minn.

Said to provide as many as 11 simultaneous tests on a typical pentode such as the 6AU6. Presence of any one or a combination of the following faults, it is claimed, will register as *bad* on an electron-eye indicator: control grid emission, grid-to-cathode shorts, gaseous condition, cathode-to-heater shorts, grid-to-heater shorts, grid-to-plate shorts, plate-to-heater shorts, grid-to-screen shorts, screen-to-heater shorts, heater-to-suppressor shorts and grid-to-suppressor shorts. [SERVICE]





### PORTABLE VOM

AN IMPROVED model of vom 260 (series III), featuring a polarity-reversing switch, spread scales and a printed circuit, has been introduced by Simpson Electric Co., 5200 W. Kinzie St., Chicago 44, Ill.

Unit provides a 50  $\mu$ a-250  $m$ v current range for coverage in six steps; dbm ranges from -20 to +50, 1  $m$ v in 600 ohms; ac sensitivity of 5000 ohms/volt; and frequency response of 5 to 500,000 cps. A full-wave bridge rectifier system is used. [SERVICE]

• • •

### TWO-SETTING TUBE TESTER

A TUBE TESTER, Fast-Check FC-1, has been announced by Century Electronics Co., Inc., 111 Roosevelt Ave., Mineola, N. Y.

Two settings on panel board are said to check for quality, shorts and life expectancy of more than 600 tube types, including series-string TV tubes, auto-battery type 12 plate-volt tubes, OZ4's, magic-eye tubes and gas regulators. Tester has 41 sockets to accommodate present and future types. A D'Arsonval-type meter with multi-color scales is used. Twelve filament voltages are provided and unit is line isolated to eliminate shock or short hazards. Seven and nine pin straighteners are mounted on the panel. Reference charts showing instant setting for more than 600 tube-types are included. A picture tube adapter, AD-1, said to check all picture tubes, including short-neck 110° types, is available. [SERVICE]

• • •

### FIELD STRENGTH METER

A BATTERY-OPERATED vhf field-strength meter, FSM-1, tuning continuously from 54 to 216  $m$ c, has been developed by Blonder-Tongue Laboratories, Inc., 9-25 Alling St., Newark 2, N. J.

Unit covers vhf TV, FM, aircraft, mobile, amateur and special service bands. Addition of a ulf converter expands signal readings to complete ulf TV range. Exact signal strengths can be read from 10  $\mu$ v to 3 v. Meter includes a phone jack, front-panel attenuator switches, db and percentage AM modulation scales, and balun to handle 300-ohm inputs. [SERVICE]



look what \$24<sup>50</sup> buys  
in test equipment!

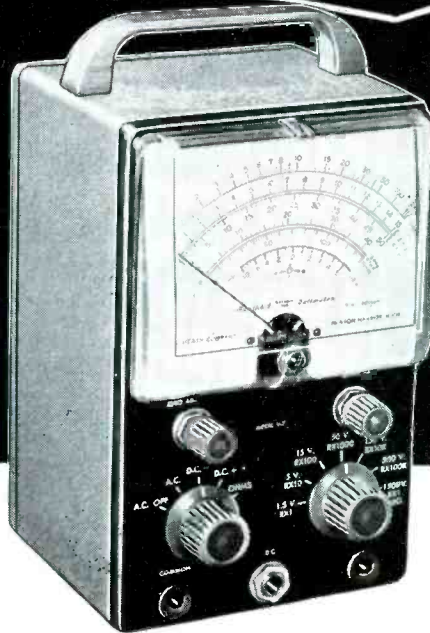

**HEATHKITS  
GIVE YOU  
TWICE AS MUCH  
equipment for  
every dollar  
invested**

The famous model V-7A Vacuum-Tube-Voltmeter is a perfect example of the high-quality instruments available from Heath at 1/2 the price you would expect to pay! Complete, only \$24<sup>50</sup>

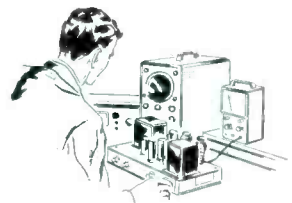

Get the most out of your test equipment budget by utilizing HEATHKIT instruments in your laboratory or on your production line. Get high quality equipment, without paying the usual premium price, by dealing directly with the manufacturer, and by letting engineers or technicians assemble Heathkits between rush periods. Comprehensive instructions insure minimum construction time. You'll get more equipment for the same investment, and be able to fill your needs by choosing from the more than 100 different electronic kits by Heath. These are the most popular "do-it-yourself" kits in the world, so why not investigate their possibilities in your particular area of activity! Write for the free Heathkit catalog now!



Contains detailed descriptions of Heathkit models available, including VTVM's, scopes, generators, testers, bridges, power supplies, etc.



Also describes Heathkit ham gear and hi-fi equipment in kit form. 100 interesting and profitable "do-it-yourself" projects!

**FREE catalog**

Mail coupon below for your copy—Now!

**HEATH COMPANY**  
A SUBSIDIARY OF DAYSTROM, INC.,  
BENTON HARBOR 11, MICHIGAN

Name \_\_\_\_\_

Address \_\_\_\_\_

City & Zone \_\_\_\_\_

State \_\_\_\_\_

... another  
**MALLORY**  
 service-engineered  
 product

*Months under Water...*

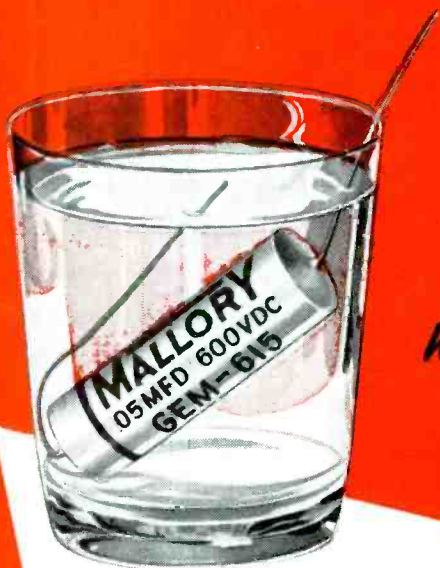

prove  
**MALLORY**  
 "GEMS"

*moisture proof*

To demonstrate how well Mallory "Gem" tubular capacitors resist moisture, we put some in plastic tubes filled with water. Months later, their internal resistance remains unchanged... proving there has been no moisture absorption.

Sure, you don't expect to submerge the capacitors you install. But when you're looking for top performance, even under the toughest humidity—always ask for Mallory "Gems."

Get your stock today from your Mallory distributor. He carries them in all popular ratings for by-pass and coupling applications.

P. R. MALLORY & CO. Inc.  
**MALLORY**

P. R. MALLORY & CO. Inc., INDIANAPOLIS 6, INDIANA

- Capacitors
- Vibrators
- Resistors
- Power Supplies
- Mercury and Zinc-Carbon Batteries
- Controls
- Switches
- Rectifiers
- Filters

## Tape Recorder-Playback

(Continued from page 19)

ing level may be set before the tape is set into motion. To record, it is necessary to depress and latch both the *monitor* and *play* pushbuttons simultaneously. This avoids erasure of prerecorded tapes if one pushbutton were accidentally depressed.

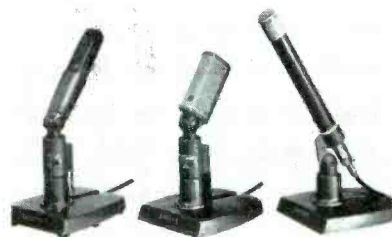

**THREE BASIC TYPES** of microphones (l to r) bidirectional, unidirectional, and omnidirectional, which can be used for tape recording. All three can be mounted on table stands as pictured, or placed on floor stands. The omnidirectional unit is particularly suited for use as a hand-carried unit and can be worn as a lavalier microphone.—Shure Brothers, Inc., 222 Hartrey Ave., Evanston, Ill. [SERVICE].

**POLYSTYRENE** container for tape which can be stacked or hung on a wall by means of a dovetail slot in the back and a fitted strip. Package also includes a tape-time ruler to permit accurate measurement of elapsed and remaining time.—Ferrodynamics Corp., Lodi, N. J. [SERVICE].

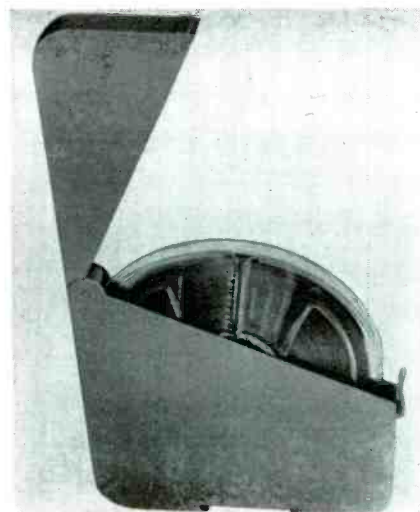



## TV Power Transformers

(Continued from page 15)

steel plate welded to one end shell (Fig. 1—p. 14), and on a horizontal chassis it uses two mounting brackets similar to those used for other transformers. In the original horizontal mounting these mounting brackets were larger than usual and were provided with vent holes because the entire fin assembly was above chassis. The present horizontal mounting (Fig. 3—p. 15) uses short brackets and the fins protrude through holes in the chassis to take advantage of the cooler air available from openings in the cabinet bottom.

## Service Notes

(Continued from page 25)

dangerous, because while it would not burn out, the entire set would be exposed to overloads.

Such burnouts indicate excessive line-voltage-surge conditions that must be compensated for if components are to operate within their rating. In such instances there's need for a line-voltage regulator or ballast that can be installed in conjunction with the replacement. The ballast actually compensates for line-voltage variations over a considerable range, thereby providing extra protection.

## TV Antennas

(Continued from page 32)

using a cheap rabbit-ear antenna and attaching two receivers to one antenna.

What is the answer to all of this?

The Service Man is the answer. He has to do a selling job. He has to educate the set owner into a top quality installation of top quality antennas. If he doesn't, the primitive do-it-yourselfer will continue to be the bane of his existence.

*A previous Snyder investigation found that the average set owner purchased up to four dollar-type antennas within two years because of dissatisfaction with reception.*

**Join the  
MARCH OF DIMES**

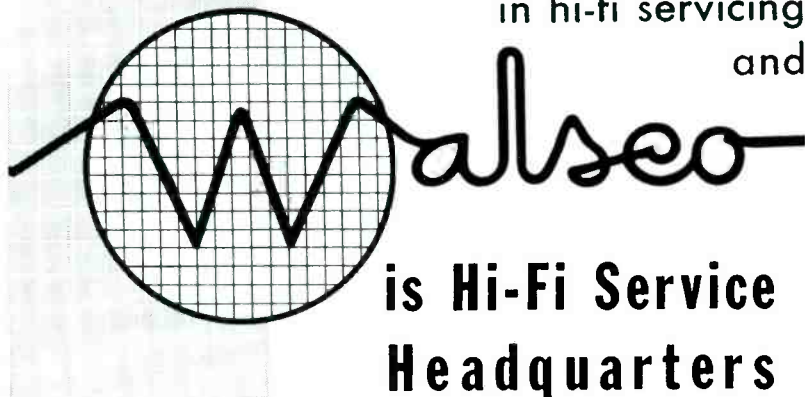

new profits available  
in hi-fi servicing  
and

## is Hi-Fi Service Headquarters

Hi-Fi servicing is a booming new profit source for you, and WALSCO—always your completely dependable supplier for radio-tv service products—is ready with all the things you need to tap this growing field.

### MOLDED-ON CABLES AND CONNECTORS



Look for this WALSCO display at your distributor. A complete assortment for your every need. Dozens of tenite shielded cables with phono pin plugs, jacks, phone plugs and alligator clips in a wide variety of combinations—in lengths up to 72".

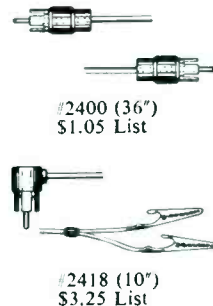

#2400 (36")  
\$1.05 List

#2418 (10")  
\$3.25 List

### PHONO-RECORDER BELTS AND DRIVES



Webcor Drive Wheel  
#1463—\$2.50 List



RCA Idler Wheel  
#1432—\$1.00 List

A complete replacement source for Ampro, Collaro, Crescent, Garrard, Pentron, Revere, RCA, VM, Webcor and every other standard changer and recorder.

### HI-FI CHEMICALS



"No-Slip" for cords  
and pulley belts  
#260-01—60c List



RH Recording  
Head Cleaner  
#93-01—95c List

A full line of special chemicals for Hi-Fi servicing—to make your job easier and faster.

*free!*  
The latest  
WALSCO cata-  
log . . . from  
your distribu-  
tor, or write for  
it today.

WALSCO ELECTRONICS MFG. CO.

A division of Textron, Inc.  
108 west green street  
rockford, illinois

# service engineering

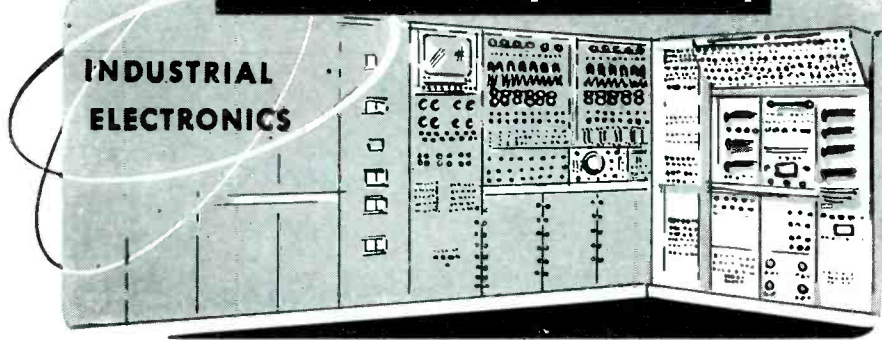

## Servicing Carrier-Current Wireless Intercoms

WIRELESS INTERCOM systems consist of two or more fixed two-way units which operate at low radio frequencies, with signals being conveyed over the power lines via a *carrier current*. Each unit consists of a simple radio receiver and radio transmitter. As in wired-intercom systems, the loudspeaker serves both as a loudspeaker and microphone.

Installation is simple. Wires for conveying audio signals from one unit to another are not required. Instead, the audio signal is used to modulate a radio transmitter. The *rf* signal is fed over the power lines and the receiver in the second intercom unit demodulates the *rf* signal. When more than two intercom units are used, party-line communication results. In other words, speech and sounds picked up by unit A, for example, are picked up by units B, C, and D. Likewise, when unit B is set to the *talk* position, units A, C, and D intercept signals being transmitted by unit B.

In wired systems, of course, it is possible for a person at unit A, if it is a master unit, to select individually

units B, C, and D. In wireless systems which operate on one frequency, all intercom units are called simultaneously. Of course, it would be possible to provide selective calling of slave units from a master unit by providing the master unit with a means for changing the transmitter frequency and by tuning each of the slave units to an individual frequency. However, this is seldom done and therefore most wireless intercom systems operate on a party-line basis.

While, theoretically, all that is required to install a wireless-intercom system is to plug into the line, trouble may be encountered due to losses in the power lines. Some equipment is provided with an extra terminal which is connected to ground or directly between units, as illustrated in Fig. 1. A wire may be connected to the terminal on each unit so that all units in a system are directly connected by the wire and indirectly through the power line. Optionally, but with somewhat more transmission loss, the terminal of each unit may be grounded to the screw that holds the

cover plate on the power receptacle or to some other ground.

In one type of wireless intercom (Fig. 2), the direct-wire or ground terminal leads to a tap on the receiver tuning coil. A switch is provided for selection of either the two-wire or three-wire transmission arrangement. When installing wireless-intercom equipment, regardless of whether the two-wire or three-wire hookup is used, the power plug at each unit should be plugged in one way and then reversed to determine which will provide the most satisfactory results.

The Fig. 2 wireless-intercom circuit features a grid-leak type detector tuned to 175 kc and a two-stage audio amplifier. A 12AX7 dual triode is used as the detector and first audio stage. And a 50C5 audio power amplifier functions as the *rf* oscillator or transmitter, also tuned to 175 kc.

A unique feature of the intercom shown in Fig. 2 is the squelch circuit which silences the receiver until an *rf* signal is picked up from another unit. A part of the intercepted *rf* signal is fed through an *rc* filter network to a 1N51 diode. In the presence of an *rf* signal of sufficient amplitude, a positive voltage is built up across the diode which reduces the bias in the first audio stage permitting it to amplify incoming signals. When no signal or a very weak signal is present, the first audio stage is cut off by the biasing action of the cathode-resistor network. Bias is reduced when the unit is set to *send* so that the first audio stage will amplify. In *send* position, the stage referred to as the first audio stage actually becomes the second stage which grid modulates the 50C5 oscillator stage.

While the procedure for aligning wireless intercom units may differ among various makes, the general principles described here are applicable. To align the receiver an *rf* signal generator tunable to 175 kc is

(Continued on page 45)

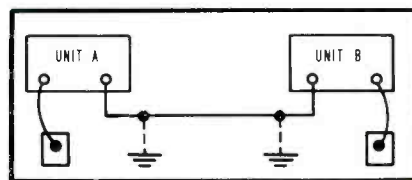
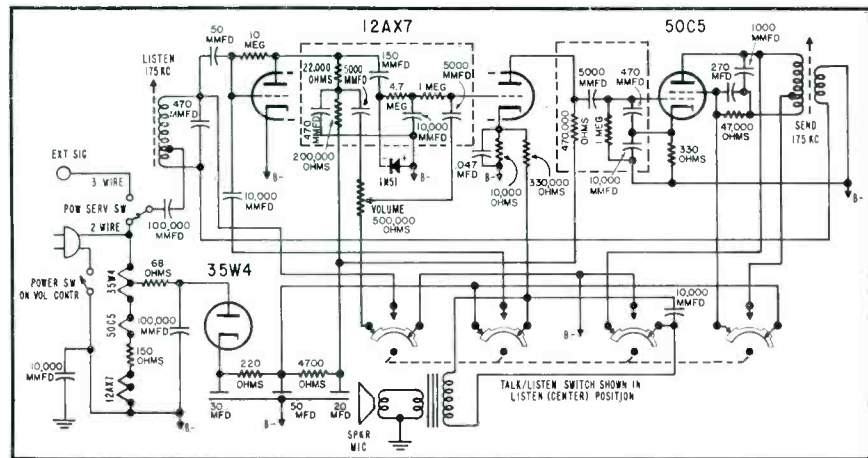

(Above)

FIG. 1: BLOCK DRAWING of a typical link between intercom units.

(Left)

FIG. 2: SCHEMATIC of Bennett model 100 wireless intercom.

<sup>1</sup>Bennett Laboratories, Inc., Redwood City, Calif.



The foremost name in automotive loudspeakers!



Three-way universal terminal-lead arrangement is especially convenient. Tip jacks fit Ford-Lincoln-Mercury rear seat pin terminals; twin lead for splicing to front seat plug cable; solder lugs for general use.



BURTON BROWNE ADVERTISING

PROVED IN **10,000,000** CARS AND TRUCKS!

**Jensen** WORLD'S MOST RUGGED AUTOMOTIVE SPEAKERS

## CONCERT SPECIAL OVAL GROUP

Jensen designed this extra ruggedized Special Oval Group at the request of one of the largest automobile manufacturers. Millions of units with years of service in truck and passenger vehicles have established the complete dependability of these speakers for use as replacements wherever 6 x 9 and 5 x 7 units are required. Not to be compared with conventional ovals, they are up to 3 times as resistant to housing distortion due to mounting strains and vehicle vibration, maintain alignment indefinitely in specially oversized gaps, withstand severe overloads, are immune to weather and temperature changes. Efficient magnetic structure design, using DP-Alnico 5 magnets, has made possible shallow construction, virtually universal in complying with crowded installation conditions.

*New high fidelity models* will give superior wide range performance and added power handling capacity for a noticeable improvement in auto radio sound quality.

## VIKING

For lowest cost, combined with rugged compactness, Jensen VIKING Series ovals fill the bill in automotive and other replacement services. Features include a completely enclosed magnetic structure, with precision locked-in alignment and new high efficiency DP-Alnico-5 magnet. Heavy gauge rigid housing. Solder lug terminals. One model in each 5" x 7" and 6" x 9" sizes handles 90% of your oval speaker requirements.

### CONCERT SERIES—SPECIAL OVAL GROUP

Nominal Size Inches	Model No.	Magnet Weight* Ounces	Voice Coil			Dimensions, Inches			List Price
			Imped. Ohms	Power Watts	Dia. Inches	H. & W.	Depth	Baffle Opening	
5 x 7	P57-U	1.73†	3.2	8.0	1	5 x 7¼	2½	4¼ x 6½	\$7.20
5 x 7	P57-TX§	2.5‡	3.2	9.0	1	5 x 7¼	2½	4¼ x 6½	8.35
6 x 9	P69-U	1.73†	3.2	9.0	1	6⅝ x 9⅝	3⅝	5¼ x 8⅝	7.80
6 x 9	P69-T	2.5‡	3.2	10.0	1	6⅝ x 9⅝	3⅝	5¼ x 8⅝	8.65
6 x 9	P69-TX§	2.5‡	3.2	10.0	1	6⅝ x 9⅝	3⅝	5¼ x 8⅝	8.95
<b>VIKING SERIES</b>									
5 x 7	57-J9	1.47	3.2	6.0	¾	5 x 7¼	2⅝	4¼ x 6¼	5.85
6 x 9	69-J9	1.47	3.2	7.5	¾	6⅝ x 9⅝	2⅝	5¼ x 8⅝	6.50

§High Fidelity Model. \*All Magnets DP Alnico 5.

†Performance Equivalent to RETMA 2.15 oz. ‡Performance Equivalent to RETMA 3.16 oz.



Send for your free copy of Data Sheet 167.

**Jensen** MANUFACTURING COMPANY  
6601 South Laramie Ave., Chicago 38, Illinois

Division of The Muter Co. In Canada: J. R. Longstaffe Co., Ltd., Toronto  
In Mexico: Radios Y Television, S.A., Mexico D.F.

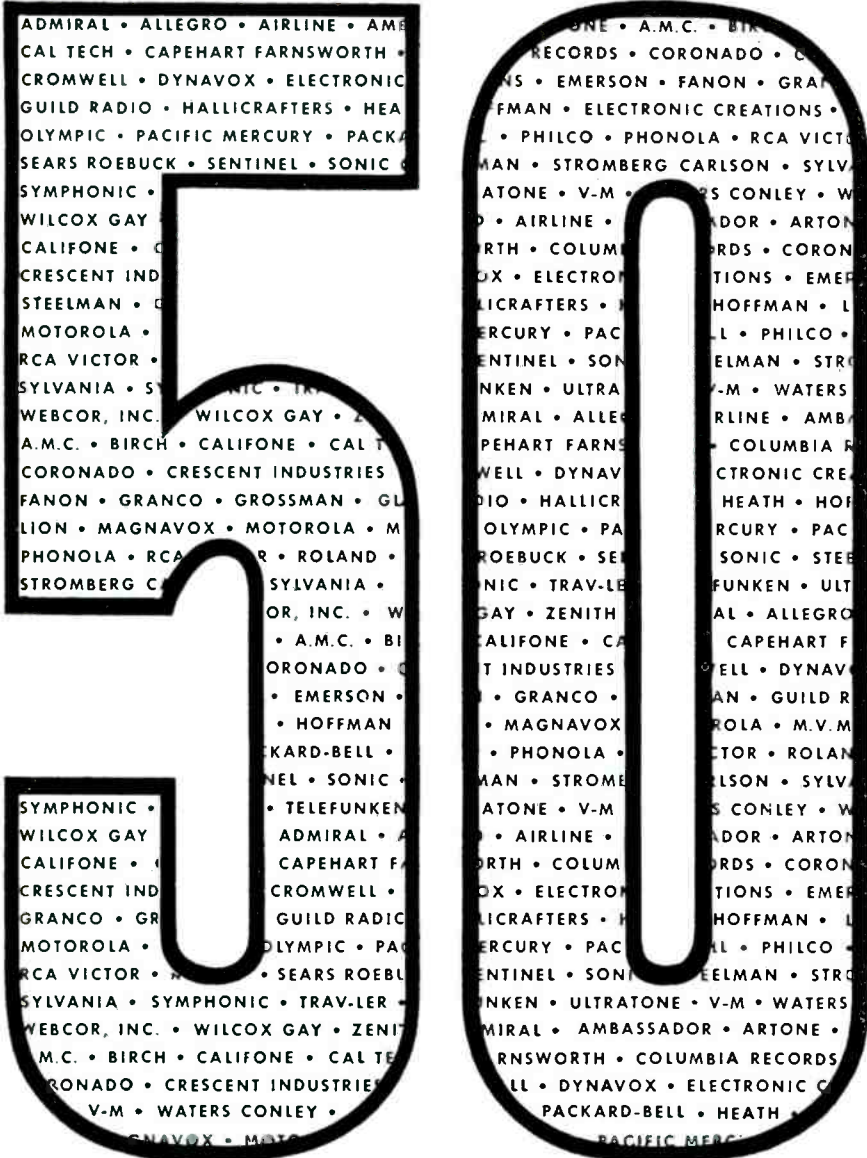

**MANUFACTURERS HAVE  
SPECIFIED SONOTONE  
CERAMIC CARTRIDGES  
FOR ORIGINAL EQUIPMENT**

Make the industry's choice your choice, Mr. Serviceman.  
Replace with Sonotone Ceramic Cartridges for these good reasons:

1. You give your customer's phonograph "original-equipment" brilliance in sound—adding to your reputation.
2. You work with the standard cartridge of the industry—so you finish jobs easier and faster.
3. Sonotone Ceramics fill over 90% of your quality replacement needs—less cartridges for you to handle.

For list of manufacturers' set models using Sonotone Cartridges, write:

Electronic Applications Division  
**SONOTONE** CORPORATION  
ELMSFORD, N. Y.

IN CANADA, CONTACT ATLAS RADIO CORPORATION, LTD., 50 WINGOLD AVE., TORONTO

**Audio**

(Continued from page 21)

from wobble. If tape hits reel intermittently coincident with noise, noise is probably caused by warped condition of the tape reels.

To correct, the warped reel should be replaced. Care should be used in storing reels to prevent future warpage; however plastic reels should be considered expendable.

In the second analysis of the problem, if the reel is not warped, but wobble is noted, the probable cause is a high spot on one side of the reel spindle casting. This can be corrected by wrapping spindle with a cloth to prevent filings falling into the mechanism. High spot should be filed or sandpapered; to remove excess material retouch with lacquer.

Tools required are a file, piece of 00 sandpaper, small amount of lacquer, and a brush.

*Amplifier Hiss†*

A SMALL CONSTANT hiss is often emitted from an amplifier when the tone control is on full treble and volume is at maximum. This is most apparent when no recorded sound is on tape.

This can be detected by depressing stop key, turning volume control up full and turning tone control to full treble; a low hiss may be heard.

Actually, this is not a defect. Any amplifier system capable of reproducing a full range of tones will have a small amount of hiss most noticeable in the higher frequency range. The presence of a certain amount of amplifier hiss is actually one of the criteria of a playback music system capable of high-fidelity response.

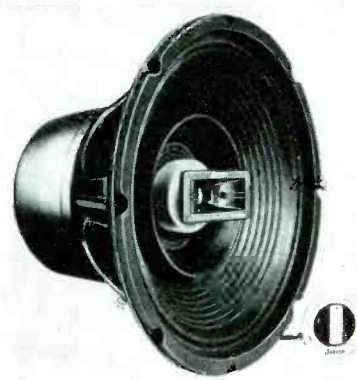

**COAXIAL THREE-ELEMENT** speaker available in both 12" and 15" sizes. In these units, a dual diaphragm affords lf and mid-range performance, while a compression driver supertweeter covers the higher frequency range.—Type CX; Jensen Mfg. Co., 6601 S. Laramie Ave., Chicago 38, Ill. [SERVICE].



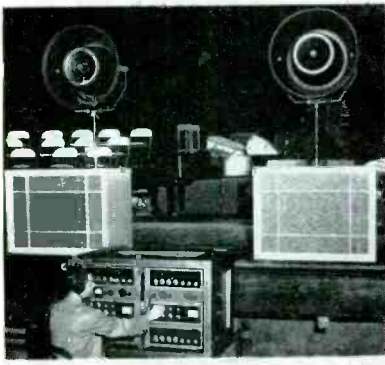

**VIEW OF FRONT center stage before a performance of Fred Waring's Hi-Fi Holiday, currently touring the nation and featuring a sound reinforcement system to preserve musical balance and perspective, regardless of acoustical properties of the theater. Electronic conductor, in pit at master amplifier controls, tests speakers prior to their being placed around the theater.**—System developed by University Loudspeakers, Inc., 80 S. Kensico Ave., White Plains, N. Y., uses Classic consoles and WLC Hi-Fi Speakers. [SERVICE].



**SHIELDED TENITE cables with molded-on connectors for use with hi-fi systems and sound equipment. Supplied in lengths from 10" to 72", with various combinations of phono pin plugs and jacks, alligator clamps, spade lugs and phone jacks.**—Walseco Electronics Manufacturing Co., 100 W. Green St., Rockford, Ill. [SERVICE].

## Service Engineering

(Continued from page 42)

required as the signal source. A *dc vtvm* is needed as an output indicator.

The hot output lead of the signal generator is connected to the external signal (or ground) terminal and the ground lead of the signal generator is brought to the chassis of the intercom unit. The hot lead of the *vtvm* is connected to the minus terminal of the 1N51 diode and the ground lead to the other side of the diode. The three-wire two-wire switch is set to the three-wire position.

The signal generator is adjusted to 175 kc and with the *vtvm* set to the 3-volt scale an unmodulated signal is applied. The signal generator output control should be set so that only a small deviation of the *vtvm* is noted. The receiver-coil tuning slug should be adjusted for maximum reading on the *vtvm*, reducing signal generator output to prevent more than 3 v being developed across the diode.

The transmitter is aligned by connecting the *rf* signal generator's hot lead to the external signal (or ground) terminal on the unit and the ground lead of the signal generator to the chassis. An *ac vtvm* or a 'scope is also connected to the external signal terminal and chassis. With the signal generator set to deliver a 1-v signal (unmodulated) the transmitter tuning coil slug should be adjusted, with the intercom unit in *send* position, until the 'scope or the *vtvm* indicate zero beat condition. The point to be remembered is that the transmitter should be adjusted to the same frequency as the receiver (175 kc) as closely as possible. Zero-beat condition may be determined by slight re-tuning of the signal generator to note

(Continued on page 46)



"You're sewing with my JENSEN NEEDLE again, I see."

## HI-FI ACCESSORIES BY

*Dynamic*  
ELECTRONICS

FOR BETTER RESULTS

## RECORD COMPENSATOR

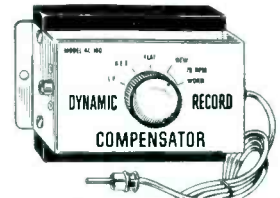

Finest precision accessory to obtain maximum quality from all types of recordings—European—Domestic LP's, old and new 78's, etc. To be used with all types of reluctance cartridges.

- Shielded Lead & Molded Pin Plug
- Pin Jack & Rotary Switch

**Model RC 180 \$9.50 List**

**THERE IS A DYNAMIC ACCESSORY FOR ALMOST EVERY NEED . . . SOLD ON A MONEY BACK GUARANTEE!**

At leading distributors everywhere. Full Line Catalog on Request!

Manufactured By

**DYNAMIC ELECTRONICS-NEW YORK, INC.**  
Forest Hills, Long Island, N. Y.

## SERVICE MEN KNOW THERE IS JUST ONE

### HUSH

Reg. U.S. Pat. Off.

Chemically engineered for tuners and switching mechanism



Hush comes in a 6 oz. pressure can with sufficient pressure to reach all contacts to wash-away that dirt, leaving clean and positive contacts, protected with a lasting lubricant film.

**\$2.25 net**

Hush also available in 2 oz., 8 oz. and 32 oz. containers.

### EVER-QUIET

Reg. U.S. Pat. Off. Pend.

Since 1949 the Original Volume Control and Contact Restorer

EVER-QUIET is a free-flowing liquid that leaves no powder residue. Scientifically designed to seep around the shaft and penetrate the control or potentiometer, cleaning the contacts and leaving a safe protecting film. Harmless to metals, wire or carbon. Will not affect inductance, capacitance or resistance.



6 oz. Spray can **\$1.59**  
2 oz. and 32 oz. sizes available. Net

See your distributor or write to

**CHEMICAL ELECTRONIC ENGINEERING, INC. Matawan, New Jersey**

and NOW a NEW

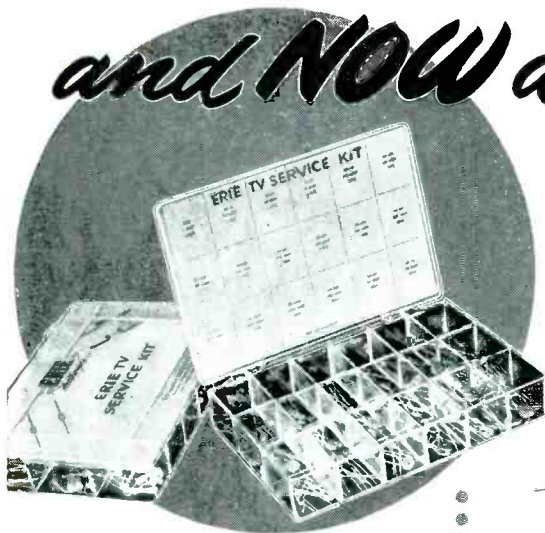

# ERIE CERAMICON<sup>®</sup> TV SERVICE Kit

### HERE'S WHAT YOU GET

- 1 63 High Stability ERIE Disc or Tubular Ceramicon
- 2 18 Popular Values
- 3 Handy, Convenient 18 Section Plastic Storage Case
- 4 Exceptional Value

### HERE'S WHAT YOU SAVE

REGULAR PRICE	
63 Piece ERIE Ceramicon Assortment . . . . .	\$15.00
18 Section Plastic Case . . . . .	1.75
<b>Total Value</b>	<b>\$16.75</b>
<b>YOU PAY</b> . . . . .	<b>\$10.65</b>
<b>YOU SAVE</b> . . . . .	<b>\$ 6.10</b>

**ORDER NOW.**  
From Your  
**ERIE**  
DISTRIBUTOR



## Service Engineering

(Continued from page 45)

the point where the two signals are out of phase with each other and cause a minimum output indication. When a *vtvm* is used, it should be set on the 3-v scale.

The intercom illustrated was designed to produce an *rf* signal of 2 watts; the receiver delivers 2 watts of audio to the speaker with maximum useable signal applied. While it is possible to build wireless intercom systems which transmit a stronger signal and hence would have greater range, there is the possibility that the signal would radiate further from the power lines than now permitted by FCC rules.

Still another adaptation of wireless intercom is a one-way unit; a wireless microphone which is picked up on a standard AM broadcast receiver. This device can be used for monitoring a nursery, serving as an electronic baby sitter. It picks up sounds in the room and transmits them over the power lines. The unit can be tuned to any clear spot within the AM broadcast band between 500 and 800 kc. One chassis<sup>2</sup> recently developed uses three tubes; a 12AU6 as an audio amplifier, a 50C5 as a grid-modulated *rf* oscillator and a 35W4 rectifier.

To align this equipment the transmitter's *rf* coil is tuned to the desired frequency. This is done by setting a radio receiver to a clear spot between 500 and 800 kc and then adjusting the tuning slug for maximum signal.

<sup>2</sup>Bennett model 300.

**FIG. 3: SWITCHING** system in an intercom where speaker functions as a listening and transmitting device.

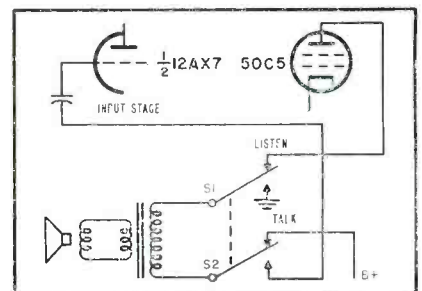

### Noise-Control Displays



**COUNTER DISPLAYS** for Electronic Chemical products. [SERVICE].

# MORE ACTIVE! EFFECTIVE!



**THE BEST FOR TV-RADIO WORK . . . EVERYTHING ELECTRICAL**—Kester "Resin-Five" Core Solder is better and faster than any solder ever developed. It has an activated flux-core that does a perfect job on all metals including zinc and nickel-plate. The flux residue is absolutely non-corrosive and non-conductive.

Available in all practical Tin-Lead Alloys; 40/60, 50/50 and 60/40 in diameters of 3/32", 1/16", 3/64", 1/32" and others.

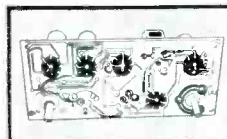

**Printed Circuit Soldering**  
On Copper-etched boards use 60% Tin-40% Lead Alloy . . . for those that are Silver-surfaced use 3% Silver-61 1/2% Tin-35 1/2% Lead

## KESTER SOLDER COMPANY

4248 Wrightwood Avenue, Chicago 39, Illinois • Newark 5, New Jersey, Brantford, Canada



ADVERTISERS IN SERVICE  
DECEMBER, 1957

	Page
Acme Electric Corp.	48
Astron Corp.	33
Bussmann Manufacturing Co.	1
Centralab, A Div. of Globe-Union, Inc.	3
Channel Master Corp.	16
Chemical Electronic Engineering, Inc.	45
Cornell-Dubilier Electric Corp.	38
Inside Front Cover,	38
Coyne Electrical School	47
Dynamic Electronics—New York, Inc.	45
Erie Resistor Corp.	46
General Electric Co., Electronic Components Div.	6
Heath Co.	39
iE Manufacturing Co.	47
The Institute of Radio Engineers	7
Jensen Industries, Inc.	45
Jensen Manufacturing Co.	43
JFD Electronics Corp.	13
Kester Solder Co.	46
P. R. Malory & Co., Inc.	40
The Radiart Corp.	38
Inside Front Cover,	38
Radio Corporation of America, Electron Tube Div.	4, Back Cover
The Radio Electronic Master	34
Raytheon Manufacturing Co.	8
Howard W. Sams and Co., Inc.	29
Service Instruments Corp.	48
Simpson Electric Co.	35
Snyder Manufacturing Co.	2
Sonotone Corp.	44
South River Metal Products Co., Inc.	48
Sprague Products Co.	Inside Back Cover
Telco Electronics Manufacturing Co., A Div. of G-C-Textron, Inc.	5
Tung-Sol Electric, Inc.	26, 27
Waage Manufacturing Co.	47
Walsco Electronics Manufacturing Co.	41
Winegard Co.	37

# BENCH-FIELD TOOLS

## SOLDERING IRON HANDLE

A HEAVY-DUTY SOLDERING-IRON handle, 880, for continuous-use applications, has been announced by the industrial division of Ungar Electric Tools, Inc., 4101 Redwood Ave., Los Angeles 66, Calif. Features include a stainless-steel heat reflector to lower handle temperature; high-temperature insulation for continuous use; flexible 18-gauge (65-strand No. 36 wire) rubber insulated 6' cord with molded protector. [SERVICE]

## WORK BENCH-DESK

A COMBINATION work-bench and desk for repair, test and light assembly jobs has been introduced by the Nebauer Manufacturing Co., 521 Lowry Ave. N. E., Minneapolis 18, Minn. Has metal-edged, masonite top (54" x 25") and two shallow drawers—a narrow one for paper and a wide drawer subdivided into 24 compartments for parts and small tools; also two large file drawers for blue prints, circuit drawings, and instructions manuals, and two open storage shelves for test equipment and extra supplies. Drawers may be inserted from back to reverse knee-hole position. Legs are fitted with adjustable glides. [SERVICE]

## LIGHTWEIGHT SOLDERING PENCIL

A PENCIL-TYPE soldering iron (25), designed for high-temperature use, has been announced by Oryx Co., 9015 Wilshire Blvd., Beverly Hills, Calif. Unit is said to achieve tip temperatures of 1000° F while handle remains cool. Features a 25-w built-in element supplied with replaceable 3/16" nickel-end tip; 1/4" copper-chrome alloy tips are also available. Operates on 12 v, 2 amps, ac or dc. Can be operated from a battery supply or 110 v ac using a step-down transformer. [SERVICE]

## COLOR-TV MICROSCOPE

A 25-POWER microscope, designed for calibration of the mosaic of color-TV tubes, has been introduced by D. P. Bushnell and Co., Inc., 412 Bushnell Bldg., Pasadena, Calif. An extensible foot serves to equalize effect of TV tube curvature and permits focusing to a depth of 70 mm. Interchangeable opaque and transparent bases allow the unit to use either reflected or transmitted light. [SERVICE]

*To Our Many Good Friends  
In the Industry  
Cordial Holiday Greetings  
and Best Wishes  
for the New Year.*

**WAAGE MFG. CO.** 632R N. ALBANY AVE.  
CHICAGO 12, ILL.

"ESTABLISHED QUALITY Since 1909"

**NEW! iE**  
**WOOD PLUS MACHINE**  
**SCREW SCREW**  
**STANDOFF**

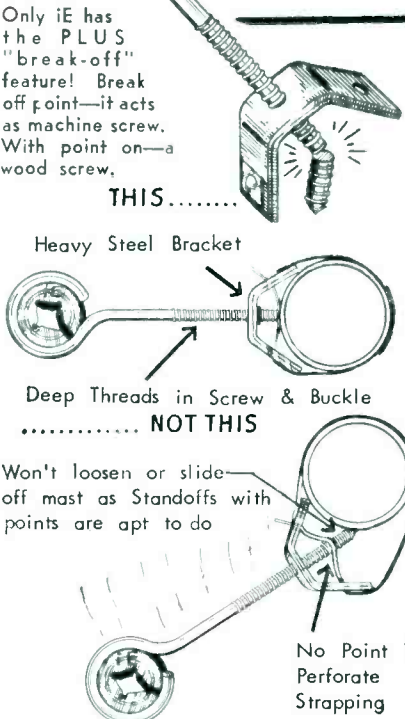

Only iE has the PLUS "break-off" feature! Break off point—it acts as machine screw. With point on—wood screw.

THIS.....

Heavy Steel Bracket

Deep Threads in Screw & Buckle ..... NOT THIS

Won't loosen or slide off mast as Standoffs with points are apt to do

No Point To Perforate Strapping

IN CANADA:  
ATLAS RADIO CORP.  
50 Wingold, Toronto, Ont.  
**325 North Hoyne Ave.  
Chicago 12, Illinois**

**Amazing New Handbook  
Takes The "Headache"  
Out of TV Trouble Shooting**

*Pin Point*  
**TV TROUBLES  
IN  
10 MINUTES**

**SAVES TIME . . . ELIMINATES  
GUESSWORK!**

Now, a simple, practical way to accurately spot the cause of trouble in any TV set. FAST! Quick, easy-to-understand tests tell you in which of 5 TV set sections to find the cause of trouble. Fool-proof Check Charts help you locate the exact trouble spot at once, from as many as 700 possibilities. Book fits easily into your tool kit for handy on-the-job use. Over 300 spiral bound fast reference pages with 50 time-saving Check Charts; dozens of easy-to-understand diagrams and tests; explanations of circuits and designs. The hours and aggravation this amazing handbook can save you on a single servicing job more than pay its low price!

**USE IT ON 7 DAYS' FREE TRIAL!**  
Send no money. Just mail the coupon. We'll rush your copy of "Pin Point TV Troubles" on FREE TRIAL. After 7 days, send only \$3.95 plus postage or return the book and owe nothing. Take advantage of this no-risk offer now. Mail the coupon at once!

**MAIL COUPON NOW!**

Educational Book Publishing Div.  
COYNE ELECTRICAL SCHOOL, Dept. SV-C7  
500 S. Paulina St., Chicago 12, Ill.

Rush TV handbook for 7 days FREE TRIAL per offer.

Name..... Age.....

Address.....

City..... Zone..... State.....

Check here if \$3.95 enclosed. We pay postage. 7-day money-back guarantee.

**WHEN  
PERFORMANCE  
IS  
AFFECTED BY  
LOW VOLTAGE  
CONDITIONS**

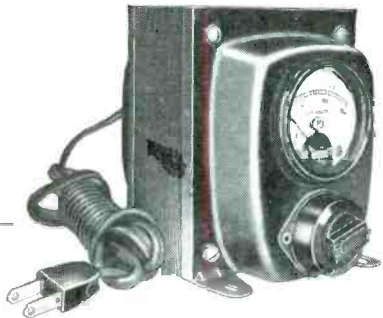

**SELL THIS  
ACME ELECTRIC  
VOLTAGE  
ADJUSTOR**

TV sets are designed to operate best when voltage holds closely to 115-117 volts. Overloaded supply lines (the power industries greatest problem) may result in a voltage drop of 10 to 15% at certain times of day. Usually the TV set will function in a fashion under such low voltage conditions but with a great strain on its components. For example; narrowing of picture, output stage tube life shortened, frequent burn-out of filaments, fuzzy focus have been traced to lack of proper voltage.

These conditions can be corrected with an Acme Electric T-8394M Voltage Adjustor. Simply plug-in to convenient outlet. Plug-in television set cord into female receptacle built into adjustor. Voltmeter indicates output voltage. If voltage is incorrect turn regulating control until proper voltage is reached for best performance. Voltage range 95 to 125 volts. Tell your supply dealer you want the Acme Electric T-8394M. No other so compact, practical, inexpensive.

**ACME ELECTRIC CORPORATION**  
4712 WATER STREET CUBA, NEW YORK



## PERSONNEL

WILLIAM J. NAGY has been appointed general sales manager of the accessory division of Philco Corp., Philadelphia 34, Pa.

THOMAS P. CLEMENTS has been promoted to national service manager of Admiral Corp., 3800 Cortland St., Chicago 47, Ill.

LEE GUNTER, JR., has been promoted to chief development engineer of Shure Brothers, Inc., 222 Hartrey Ave., Evanston, Ill. . . . Robert Troxel is now chief products engineer of the company.



Gunter



Troxel

JACK YOUNT CO., Dallas, Tex., has been appointed representative for Tobe Deutschmann Corp., in Oklahoma, Arkansas, Louisiana and Texas (with the exception of El Paso county).

CLARENCE F. JENSEN has been appointed chief engineer of Jensen Industries, Inc., 7333 W. Harrison, Forest Park, Ill.



Jensen

CRUMP SMITH has been named manager of institutional and export advertising, and coordinator of trade shows and exhibits for U. S. divisions and subsidiaries of International Telephone and Telegraph Corp., 67 Broad St., New York 4, N. Y.

ROBERT W. REDECKER has been named manager, sales and merchandising, consumer products service, RCA Service Co., Inc., Cherry Hill, Delaware Township, Camden 8, N. J.

ROBERT M. STEVENS has joined Zenith Radio Corp., 6001 W. Dickens Ave., Chicago 39, Ill., as advertising manager.

MORTIMER SUMBERG has been named to handle all commercial distributor sales for the Bogen-Presto division of the Siegler Corp., Paramus, N. J. . . . Thomas L. Aye has joined the division as head of professional product sales.

S. K. MAGEE has been promoted to manager, sound merchandising, theatre and industrial products department, RCA, Camden, N. J.

ask the  
"Man-on-the-Roof"  
why he prefers

*South River*



**COMBINATION PEAK  
& FLAT ROOF MOUNT**

MODEL  
PFM-30  
(Fits Masts  
up to 1 1/2")

MODEL  
PFM-30 LM  
(Fits Masts  
up to 2")

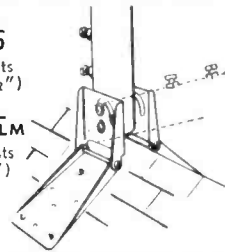

Features the patented South River "Walk-Up" — "Drop-Lock" mast socket for easy installation on either Peak, Flat or Pitched roofs. Heavy gauge pipe mast socket has two heavy duty screws and locknuts to secure mast. Factory assembled and supplied in a heavily plated rust resistant finish. U.S. PAT. #2734708

WRITE FOR NEW 1957 CATALOG

**SOUTH RIVER**  
METAL PRODUCTS CO., INC.  
South River, New Jersey

pioneer &  
outstanding  
producer of  
finest line  
of antenna  
mounts

**SENCORE**  
Handy "36"  
R-C  
Substitution Unit

Another Sencore Time-Saver

"36"  
Most Often Needed Components At YOUR Fingertips!

3 pole, 12 position switch individually selects one of the "36" components for direct substitution.

Contains:

- \* 12—1 watt 10% resistors from 10 ohms to 5600 ohms
- \* 12—1/2 watt 10% resistors from 10K ohms to 5.6 megohms
- \* 10—600 volt capacitors from 100-mmfd. to .5mfd.
- \* 1—10mfd., 450V Electrolytic
- \* 1—40mfd., 450V Electrolytic

★ For Shop, Lab, or outside service AVAILABLE AT ALL PARTS DISTRIBUTORS!

**ONLY \$1275 DEALER NET** Completely isolated

**POPULAR SENCORE PRODUCTS**

- Transistor Tester
- Leakage Checker
- Filament Tester
- Voltage Regulator
- Bias Supply

**SERVICE**  
INSTRUMENTS CORP.  
171 OFFICIAL RD., ADDISON, ILL.

Cut out this ad now for further information.



## Reputation Builder #3: it pays to be neat



- Treat a set-owner's home like a dog house and you're likely soon to be living in one



- BUT . . . treat his possessions as you would your own, and you'll always be an honored guest

## it pays to replace with Sprague Atom<sup>®</sup> Miniature 'Lytics



don't be vague...insist on

- Another way to build and hold a reputation is to insist on top quality replacement parts. Callbacks due to replacement failures not only cost you *money* . . . they also cost you customers! Replace with less than the best and you place your reputation at stake. In capacitors, the best is *Sprague*.

- Take Atom Tubular Electrolytics, for example. The smallest TV 'lytics made, they're the only small ones for 85°C (185°F) up to 450 VDC. Guaranteed for low leakage and long shelf life, they withstand high temperatures, high ripple currents, high surge voltages. From crowded TV chassis to jam-packed portables, Sprague Atoms fit them all.

- Get your copy of Sprague's latest radio and TV service catalog, C-456. Write Sprague Products Co., Distributors' Division of Sprague Electric Company, 61 Marshall Street, North Adams, Mass.

# SPRAGUE<sup>®</sup>

*world's largest capacitor manufacturer*

SPRAGUE RESEARCH IS CONSTANTLY PRODUCING NEW AND BETTER CAPACITORS FOR YOU

# "CHECKUP"

at RCA

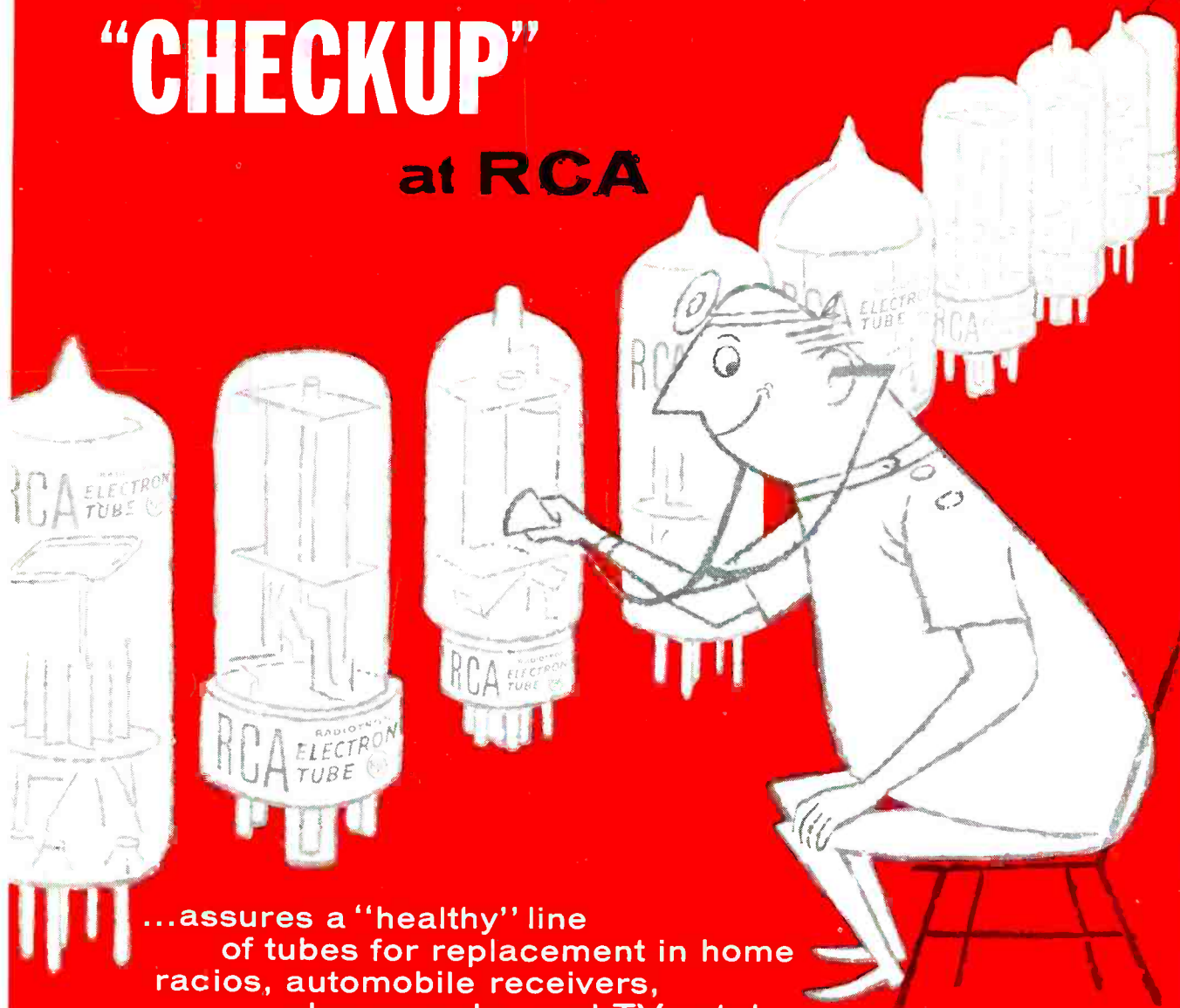

...assures a "healthy" line  
of tubes for replacement in home  
radios, automobile receivers,  
phonographs, and TV sets!

Fast service, efficient service—without time-taking callbacks due to early hour tube failures—are the vitamins, minerals, proteins and plasma of the healthy service business. "Out-of-the-carton" and "right-into-the-set" is the service dealer's dream. And RCA's rigid program of production-line testing and warehouse sampling converts it to reality.

Tests for shorts, heater-cathode leakage, and transconductance help weed-out the weaklings—assure superior-quality tubes. And where low noise and low microphonics are essential to top performance, certain tubes undergo visual and acoustic tests. Before RCA tubes are put into the famous red-and-black RCA carton they are tested all over again at the warehouse for "solid" shorts "flicker" shorts, and continuity. Add to this RCA's quality monitor: microscopic inspection of welds, seals, stems, and electrodes of all popular-types and new-type receiving tubes used in black-and-white and color-TV sets, and automobile receivers...and you have powerful reasons why RCA tubes are preferred by manufacturers of electronic equipment and by you who service it. So, never ask your distributor for "tubes" alone. Always specify: RCA TUBES!

## Your "Profit Builders" Catalog

...now available from your  
RCA TUBE DISTRIBUTOR...  
lists and describes the  
many promotional, busi-  
ness, service, and tech-  
nical aids RCA offers  
to service dealers.  
Get your copy and  
start building  
more profits  
right away.



**RECEIVING TUBES**  
**RADIO CORPORATION OF AMERICA**

Electron Tube Division • Harrison, N. J.