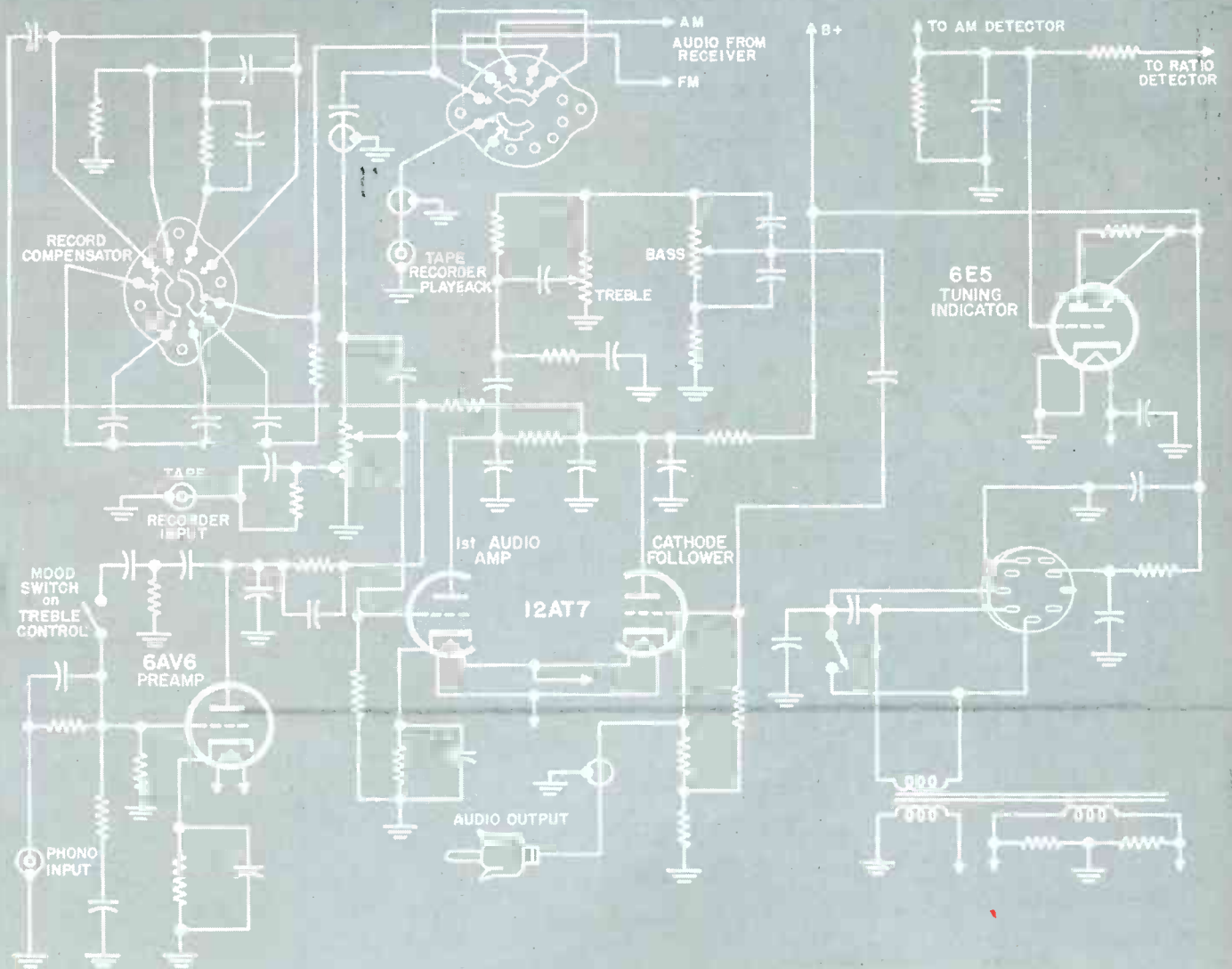


ELECTRONIC  
PARTS  
DISTRIBUTORS  
SHOW  
NUMBER

# SERVICE

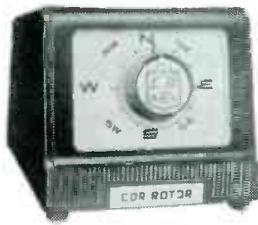
THE TECHNICAL JOURNAL OF THE TELEVISION-RADIO TRADE



Mood-music system on treble control of AM-FM receiver using 25-watt audio amplifier.

See circuit analysis, this issue

25 SAR 6-28-56 MR  
T L DILLON  
814 WATER ST  
MEADVILLE, PA  
2-59



AR-22



TR-2



TR-4



# 5-star feature...

1

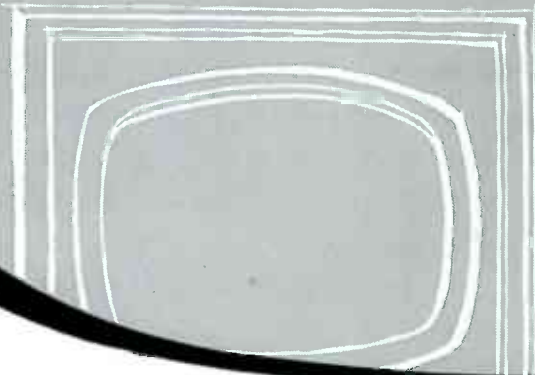
## the best color TV picture

the growth of color TV means an even greater demand for CDR Rotors for pin-point accuracy of antenna direction.

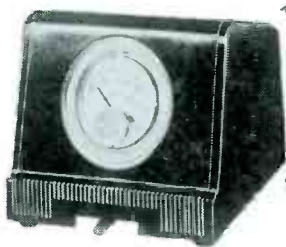
2

## a better picture on more stations

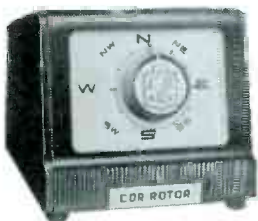
CDR Rotors add to the pleasure of TV viewing because they line up the antenna perfectly with the transmitted TV signal giving a BETTER picture . . . and making it possible to bring in MORE stations.



# CDR ROTORS



TR 11 and 12



AR 1 and 2

3

## tested and proven dependable

thousands and thousands of CDR Rotors have proven their dependability over years of unflinching performance in installations everywhere in the nation. Quality and engineering you know you can count on.

4

## pre-sold to your customers

the greatest coverage and concentration of full minute spot announcements on leading TV stations is working for YOU . . . pre-selling your customers.

5

## the complete line

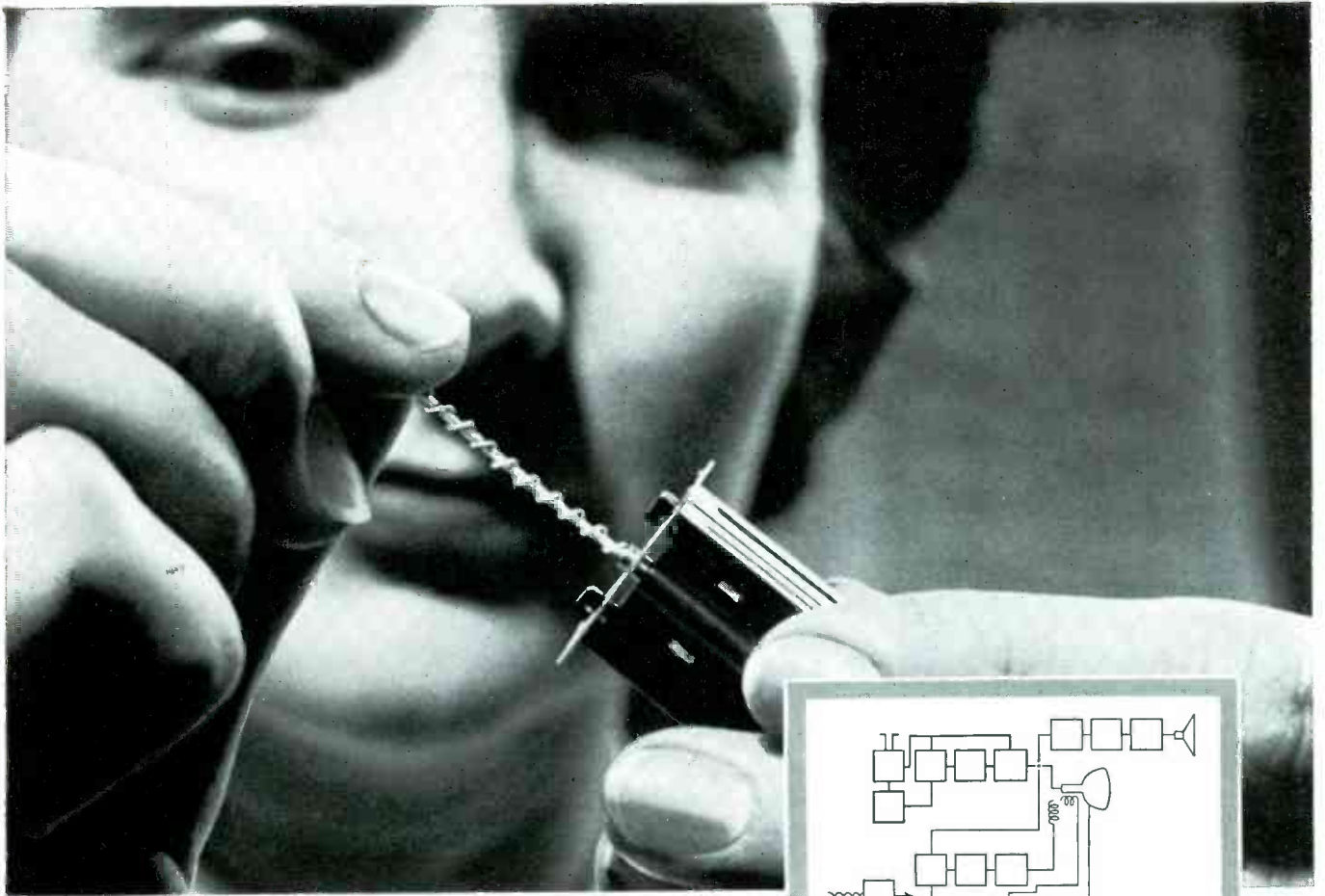
a model for every need . . . for every application. CDR Rotors make it possible for you to give your customer exactly what is needed . . . the right CDR Rotor for the right job.



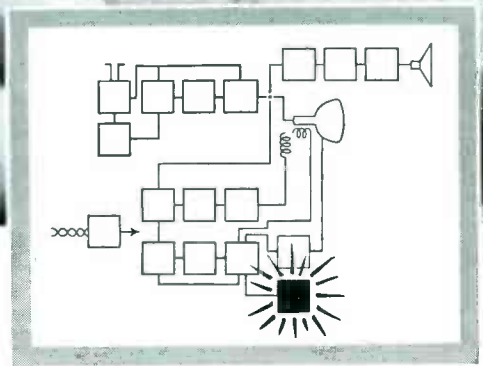
CORNELL-DUBILIER  
SOUTH PLAINFIELD, N. J.



THE RADIART CORP  
CLEVELAND 13, OHIO



● Operator fits heater spacer-coil assembly into the cathode sleeve. This quality feature found in all General Electric horizontal damper types, sharply reduces heater-to-cathode shorts for increased tube life.



## High quality spacer-coil design cuts heater-cathode shorts, reduces G-E horizontal damper tube failures!

IN all General Electric horizontal damper tubes, a spacer coil permanently centers the heater in the cathode sleeve. This increases electrical insulation between heater and cathode and greatly lessens possibility of heater-to-cathode shorts, the largest single cause of horizontal-damper failure.

Other quality features of General Electric horizontal damper tubes further promote long-life, superior service. Micacs are sprayed and slotted to reduce electrical leakage, and improved, highly adhesive cathode coating guards against plate-to-cathode arcs.

Testing is thorough. All General Electric horizontal dampers are flyback tested at maximum rated

voltages. And, to protect full-life performance under extreme current loads, the tubes are life-tested in actual circuits reflecting severe usage.

Always replace with General Electric tubes! Their uniform high quality will build widespread customer goodwill . . . help bring you increased service business. *Distributor Sales, Electronic Components Division, General Electric Company, Schenectady 5, New York.*

*Progress Is Our Most Important Product*

**GENERAL  ELECTRIC**

181-1A5

SERVICE, MAY, 1957 • 1

Made by  
**Plasti-Kote**

ADVERTISED IN  
**LIFE**

**PLASTIC SPRAY**

**\$127**  
Dealer Net  
16 oz. can

The finest acrylic spray you can buy—made by the greatest name in spray paints... Plastic Kote.  
Now sold to the radio technician by the makers of the famous "Tube Caddy." Ask your distributor. \*Reg. T.M.

**Argos**  
PRODUCTS COMPANY  
310 MAIN STREET • GENOA, ILLINOIS

**A SPEAKER IN EVERY ROOM**

**NEW Slanting Corner Baffles**

Double, or triple your Hi-Fi enjoyment! Ideal for Bedroom, Dining Room, Workroom or Porch. Corner location gives excellent Hi-Fi tone because adjacent walls act as extension surfaces. Slanting front aims sound at you.

Extra heavy wood, covered with thick-ribbed fabric... takes paint beautifully if desired. Blonde or Mahogany, Same Price. SCB-8 (8" speaker)... List \$12.35 SCB-12 (12" speaker)... List \$17.05

Ask your Parts Distributor

**Argos**  
PRODUCTS COMPANY  
310 MAIN STREET • GENOA, ILLINOIS

*Craftsmanship in Cabinets*

Vol. 26  
No. 5  
MAY,  
1957

# SERVICE

THE TECHNICAL JOURNAL OF THE TELEVISION-RADIO TRADE  
Including RADIO MERCHANDISING and TELEVISION MERCHANDISING  
Registered U. S. Patent Office

## COVER CIRCUIT

Mood-Music Control System for AM-FM Radio-Phono (Magnavox 295C) . . . 14

## FEATURES

Editorial . . . . .	Lewis Winner	11
Tracing Receiver Troubles With Input-Power Tests . . . . .	Jack Darr	12
AM-FM Radio-Phono With Mood-Music Control (Cover; With Complete Circuit) . . . . .	C. C. Kayhart	14
13-Transistor Signal-Seeking Auto Radio (With Complete Circuit) . . . . .	W. C. Caldwell	18
Trends in Circuits for Color-TV Receivers . . . . .	Robert G. Middleton	20
This Month in SERVICE . . . . .		22
Troubleshooting Chart for Sound No-Raster . . . . .		24
Transistor-Radio Test-Equipment Application Tips . . . . . Repair (Servicing Helps) . . . . .	Modulized Chassis	26
Field-Bench Facilities of Shop Specializing in Commercial Sound Kenneth Sonnenberg		28
Traffic Appliance Servicing: Repair of Automatic Coffee Percolators Sol Wallach		32
Tube-Transistor News: Beam Power AF Tubes . . . . . High-Power AF, TV and 2-Way . . . . .	Transistors For	36
Analysis Of An Indoor-TV Antenna Using Single Vertical-Element Rod For Pickup . . . . .	Matthew Mandl	39
Audio: Round and Wide-Angle Horns . . . . .	Lawrence J. Epstein	43
Audio: Output Transformer Replacement (Test Instruments Required . . . . . Component-Circuit Changes) . . . . .		54

## CIRCUIT DIAGRAMS

AC-Wattmeter Circuitry . . . . .	12	Direct-Drive HV TV System . . . . .	25
Battery-Set Power Supply . . . . .	13	Admiral 20T1-20V1 Isolation-Transformer Circuit . . . . .	25
Magnavox 25-Watt Power Amp . . . . .	15	Crosley 431 Autotransformer Circuit . . . . .	25
Magnavox 295C AM-FM-Phono (Cover; Complete Circuit) . . . . .	16	RCA KCS-61 Direct-Drive Circuit . . . . .	25
G-M 13-Transistor Auto Radio (Complete Circuit) . . . . .	19	Emerson 867B RF-AF Modules . . . . .	26
Admiral Color-TV Chrominance Channel . . . . .	20	Electric Coffee Percolator Test Board . . . . .	32
IQ Color-TV Receiving System . . . . .	20	Snyder Vertical-Antenna Circuit . . . . .	48
(R-Y) (G-Y) Color Demodulators . . . . .	20	Snyder Vertical-Antenna Selector-Switch Circuit . . . . .	48
Single-Gun Color-TV Circuitry . . . . .	21	Pentodes As Triodes in AF Output . . . . .	54
Isolation-Transformer HV TV System . . . . .	25	Amp Test Setup . . . . .	54
Autotransformer HV TV System . . . . .	25	HF-Rolloff Improvement Circuit . . . . .	54

## DEPARTMENTS

Transistor-Radio Service Tips . . . . .	26	Test Instruments . . . . .	53
Service Engineering . . . . .	28	Audio Developments . . . . .	43, 54-60
Catalogs and Books . . . . .	30	Audio Installation and Service . . . . .	54
Association News . . . . .	34	Components . . . . .	62
Ten Years Ago in SERVICE . . . . .	35	TV Parts . . . . . Accessories . . . . .	62
Tube-Transistor News . . . . .	36	Bench-Field Tools . . . . .	63
TV Antenna Digest . . . . .	39	Personnel . . . . .	64

Index to Advertisers . . . . . 63

Entire Contents Copyright 1957, Bryan Davis Publishing Co., Inc.

Second-Class mail privileges authorized at New York, N. Y.; additional entry at the Post Office, Norwalk, Conn. . . . . Subscription price: \$2.00 per year (\$5.00 for 3 years) in the U.S.A. and Canada; 25 cents per copy. \$3.00 per year in foreign countries; 35 cents per copy.



EDITOR and PUBLICATION DIRECTOR

**Lewis Winner**

Associate Editor: **David E. Pearsall II**  
Assistant Editor: **Robert D. Wengenroth**  
Editorial Assistant: **Arnold Gewirtz**  
Editorial Assistant: **Howard Jennings**  
Art Director: **Anthony R. Aliffi**  
Supervisor, Circuit Diagrams:  
**Michael D. Bellezza**  
Editorial Production: **Astrid Kelly**

**CIRCULATION DEPARTMENT**

Circulation Manager: **A. Goebel**  
Ass't Circulation Mgr.: **A. Kiernan**

**ADVERTISING DEPARTMENT**

Advertising Mgr.: **Aaron L. Lcfer**  
Pacific Coast: **Leo Sands**, Dist. Mgr.  
535 Ramona St.  
Palo Alto, Calif.:  
Tel.: DAvenport 5-3716

Published Monthly by  
**Bryan Davis Publishing Company, Inc.**  
52 Vanderbilt Ave., New York 17, N. Y.  
Tel.: MUrray Hill 4-0170  
B. S. Davis, Pres. Lewis Winner, Vice-Pres.



## Versatile as a one-man band

(Our apologies,  
Mr. Petrillo!)



## Centralab Model B Control

Try a Model B just once and you'll see why we blow our horn about this 15/16" control that adapts readily to virtually any application.

Universal, fluted, knurled-type shaft fits all knobs — split knurl, shallow flat, deep flat, half-round, round.

KB-Fastatch switches snap on, to convert control to switch-type unit.

Sound like music to your ears? It does to other servicemen! That's why Centralab distributors are selling Model B's to beat the band. Order your supply now.



**Centralab** A DIVISION OF GLOBE-UNION INC.  
934E EAST KEEFE AVENUE • MILWAUKEE 1, WISCONSIN

# Sylvania IF Amplifier Tubes



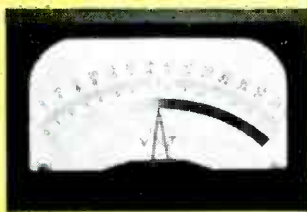
“fixed-bias” tested



Low “fixed bias” point at  
-1 volt (bottom scale)



Mid-range “fixed bias” point at  
-3 volts (top scale)



High “fixed bias” point at  
-7.5 volts (bottom scale)

In determining the plate current ( $I_b$ ) and Transconductance curves, grid bias is fixed at three points. These points, representing conditions of weak, average, and strong signals establish the nature of the plate current characteristic curve. The “fixed bias” points selected vary according to tube type.

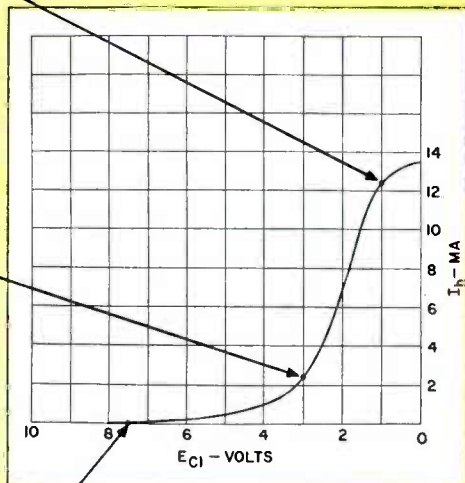


Plate current characteristics, shown on this typical test curve, are carefully controlled by the “fixed bias” test, assuring good performance and stable AGC functioning over a wide range of TV signal conditions.



Dynamic TV set conditions are set up in these test bridges making the “fixed bias” test a true measure of how the tube will perform in TV sets encountered by you in the field.



## for stable performance and service dependability

It has always been Sylvania's policy to search for new and better ways to test tubes under dynamic conditions for closer control over performance. The "fixed bias" test is typical of these techniques. It places a more stringent, realistic measure on the tube's ability to perform under varying circuit conditions.

By controlling the plate current characteristics and transconductance of IF amplifier tubes, the "fixed bias" test gives the serviceman an extra measure of dependability regardless of make, model, or age of the TV set serviced.

The range of stable operation is controlled, too, for smooth AGC action over wide variations in signal strength.

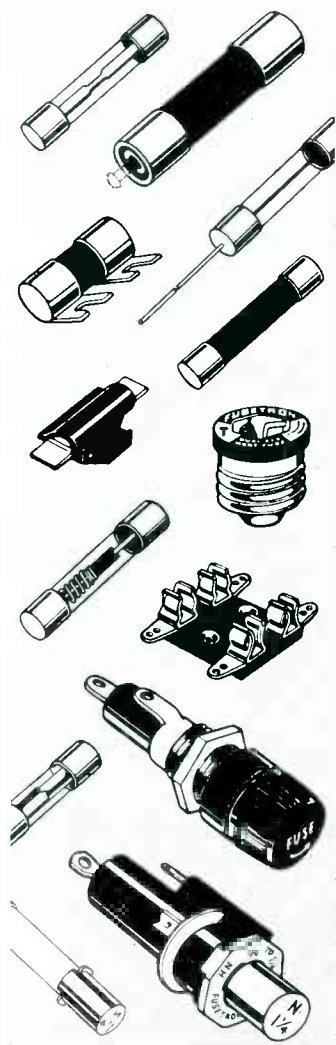
These are the same reasons that Sylvania IF types are the choice of leading TV set manufacturers, attested by the wide assortment of Sylvania original types listed among IF tubes now in popular use.

In addition to the "fixed bias" test many other electrical tests are performed on Sylvania IF amplifier types including stability during life. During life tests, close controls are placed on interelectrode leakage.

In every way, Sylvania IF amplifier types offer you maximum assurance of trouble-free service based on sound, newly developed testing methods. Specify Sylvania IF amplifier tubes in the new yellow and black carton.

 **SYLVANIA**

SYLVANIA ELECTRIC PRODUCTS INC.  
1740 Broadway, New York 17, N. Y.  
In Canada: Sylvania Electric (Canada) Ltd.  
University Tower Bldg., Montreal



**"We find BUSS Fuses provide the dependable electrical protection we must have for our equipment" . . .**

*George Thole*, CHIEF CONTROL DESIGN ENGINEER  
 D. W. ONAN & SONS INC., MINNEAPOLIS, MINNESOTA

"Our automatic line transfer units are used to transfer the electrical load from the normal commercial service to the Onan Standby Generating Set should a power failure occur.

"It is essential that our units operate properly in this emergency otherwise there would be a plant shut-down and the possibility of damaged equipment and property. In some cases human lives would be in danger.

"You can see why all the components used in our equipment must meet the very highest standards for dependability.

"Fuses are an integral part of the battery charging circuit which is incorporated into our line transfer controls.

"In fuses, we have found by experience that BUSS Fuses

can be depended upon to meet the standards of reliability that are required by our stand-by power units."

**In sales and service, you too, can profit by standardizing on BUSS fuses.**

The unfailing dependability of BUSS fuses protects you against 'kicks' and complaints. Whereas faulty fuses might cause needless burnouts or useless shutdowns, — BUSS fuses can be relied on to operate properly under all service conditions.

*Complete Line:* There is a BUSS Fusetron fuse to meet your needs,—plus a companion line of fuse clips, blocks and holders.

For more information on BUSS and FUSETRON Small Dimension fuses and fuseholders . . . Write for bulletin SFB. Bussmann Mfg. Co. (Division of McGraw-Edison Co.) University at Jefferson, St. Louis 7, Mo.

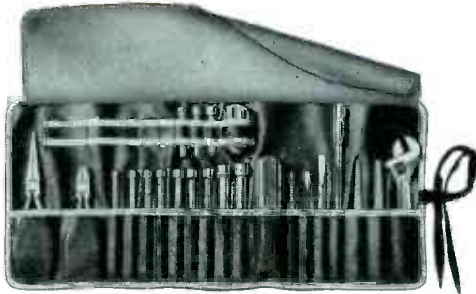
***BUSS fuses are made to protect — not to blow, needlessly***

S-557



Makers of a complete line of fuses for home, farm, commercial, electronic, automotive and industrial use.





### "99" TOOLS

cover the full range of electronic servicing — 3 popular "99" roll kits — the 26 individual "99" tools shown — plus distributor backup stock kits.



No. 99-JR  
Roll Kit  
— 11 Tools



No. 99-PR  
Roll Kit  
— 13 Tools

New! No. 99 S.M. Kit — 21 tools



*Toolmanship...  
Preferred by All Hands!*

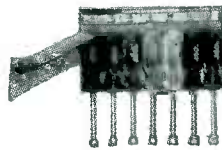
From individual screwdrivers, nut drivers and pliers to the big new No. 99 SM Service Master Kit, there's a bonus of craftsmanship and imagination that makes every XCELITE hand tool "preferred by the experts."

Besides its regular popular line, XCELITE brings you a continual supply of new and original tools — the new No. 99-X10 Snap-in Shaft Extension — reamers with the T-handle leverage feature — pocket clip nut drivers and screwdrivers — adjustable wrenches and "special-purpose" pliers.





























See the latest  
— as well as the  
"tried and true"  
— at the

**PARTS SHOW  
BOOTH 592!**



No. 127  
Lockable Wall Kit  
— 7 Color Coded  
Nutdrivers

### SERIES "99" TOOLS

-  No. 99-1 Handle (Regular) .....
-  No. 99-2 Handle (Junior) .....
-  No. 99-3 Handle (Stubby) .....
-  No. 99-6 3/16" Nut Driver .....
-  No. 99-7 7/32" Nut Driver .....
-  No. 99-8 1/4" Nut Driver .....
-  No. 99-9 9/32" Nut Driver .....
-  No. 99-10 5/16" Nut Driver .....
-  No. 99-11 11/32" Nut Driver .....
-  No. 99-12 3/8" Nut Driver .....
-  No. 99-14 7/16" Nut Driver .....
-  No. 99-16 1/2" Nut Driver .....
-  No. 99-81 3/16" & 9/32" Slotted, Reversible .....
-  No. 99-82 #1 & #2 Phillips, Reversible .....
-  No. 99-83 3/16" & 9/32" Frearson, Reversible .....
-  No. 99-84 3/16" Clutch "G," Reversible .....
-  No. 99-811 3/16" Slotted .....
-  No. 99-812 9/32" Slotted .....
-  No. 99-821 #1 Phillips .....
-  No. 99-822 #2 Phillips .....
-  No. 99-38 Reamer (1/8"-3/8") .....
-  No. 99-39 Reamer (1/4"-1/2") .....
-  No. 99X10 Extension .....
-  No. 99-58 Stubby Nut Drivers
-  No. 99-510
-  No. 99-512

**XCELITE, INCORPORATED**

ORCHARD PARK, NEW YORK

In Canada — Charles W. Pointon Ltd., 6 Alcina Avenue, Toronto, Ontario



**PHILCO MODEL 50**

Five element, all channel VHF antenna. High gain, clean lobes and high front to back ratio. Easy to handle. Reinforcing tube supplied with two bay assembly. Factory preassembled. Two driven elements, high frequency and low frequency aluminum folded dipoles. Aluminum tubing reflectors and director. Cross arm of seamless aluminum tubing. Profile serrated and riveted to cross arm. Molded plastic insulators. For the finest reception on color or black-and-white.



**PHILCO MODEL 100**

Ten element antenna gives high gain and high directivity on all VHF channels. Factory preassembled with all hardware captivated.



**PHILCO MODEL 70**

Seven element, all channel VHF antenna with two driven elements. Riveted construction and factory preassembled. Elements are held in place and reinforced with a newly developed snap lock.



**PHILCO MODEL 30**

Three element all channel VHF antenna for excellent color or black-and-white reception. Completely preassembled. This antenna is ideal for most metropolitan areas.

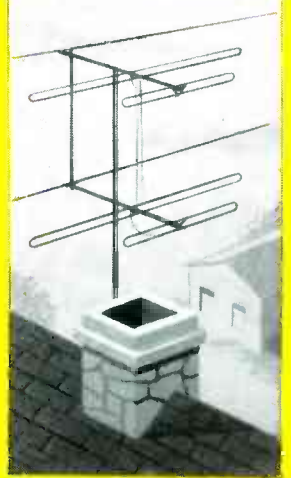


**PHILCO MODEL 262F**

The Philco "Fast Lock" element retainer is featured in this conical antenna. With the "Fast Lock", elements can be installed after the cross arm is mounted.

Mr. Service Dealer

# BIG NEWS from PHILCO!



## Fringe tested, color tested TV Antennas, now at volume prices!

Give picture power equal to antennas priced two to three times higher. Compare! Now, Philco brings you a complete line of quality antennas with a wide range of models to give outstanding performance over the entire VHF range. These antennas were designed and engineered to reproduce the best pictures whether in strong signal areas or far out into the fringe and whether receiving

a picture in color or black and white. In many locations you can give your customers stations they never received before. Field and laboratory comparison tests conducted under the most exacting circumstances on actual on-the-air programs give you the complete insurance that you can always sell Philco antennas with complete confidence in any TV area.

### Philco Super Power TV Antenna ROTORS

color or black-and-white at its best



**P11 CONTROL**  
Manually operated antenna rotor that will easily handle two bays. Designed for years of dependable service. Fits masts up to 1 1/2" diameter.



**P4A CONTROL**  
A heavy duty rotor. Accurate direction control provided by manually operated motor switch and indicator meter. Plastic cabinet of modern design.



**AP22 CONTROL**  
Heavy duty, long-life automatic rotor with new automatic control unit providing dependable and fool proof operation. Also available as AP1.



**P11  
AP1  
Rotor**



**P4A  
AP22  
Rotor**

a complete line, Mr. Service Dealer, for every installation need!

Get the full story on Philco antennas and rotors with more quality and performance for your dollar. See your local Philco distributor or mail this coupon now!

# PHILCO CORPORATION

ACCESSORY DIVISION • PHILA. 34, PA.



Philco Corporation Accessory Division  
"A" Street and Allegheny Ave.  
Philadelphia 34, Pa.

Please send me information on Philco antennas and rotors with more performance per dollar.

NAME \_\_\_\_\_

ADDRESS \_\_\_\_\_

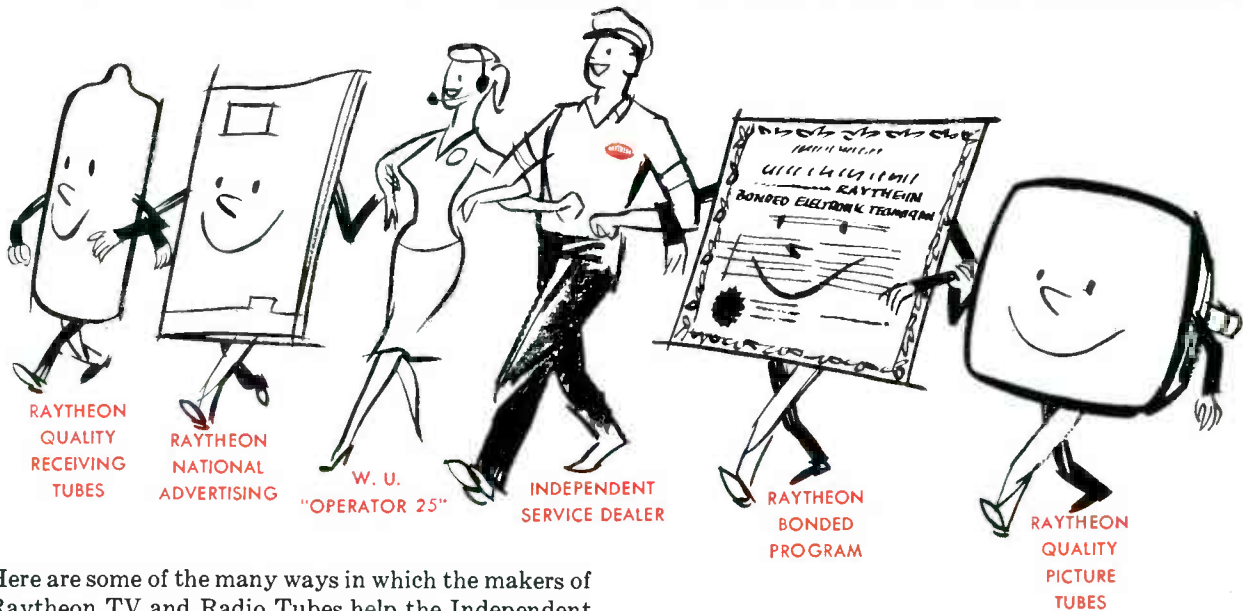
CITY \_\_\_\_\_ ZONE \_\_\_\_\_ STATE \_\_\_\_\_

How



Helps

# Independent Service Dealers with their TV-Radio Service Business



RAYTHEON  
QUALITY  
RECEIVING  
TUBES

RAYTHEON  
NATIONAL  
ADVERTISING

W. U.  
"OPERATOR 25"

INDEPENDENT  
SERVICE DEALER

RAYTHEON  
BONDED  
PROGRAM

RAYTHEON  
QUALITY  
PICTURE  
TUBES

Here are some of the many ways in which the makers of Raytheon TV and Radio Tubes help the Independent Service Dealer with his business.

**1** For nearly 12 years Raytheon has offered the Raytheon Bonded Electronic Technician program to Independent Service Dealers. Dealers who qualify have their service and parts guarantee backed by a bond issued through Continental Casualty Company, one of the country's largest insurance companies. It gives them real prestige in the eyes of the customer.

**2** Raytheon provides "Western Union Operator 25" service for Bonded Dealers in 23,000 cities and towns. In answer to phoned requests for fast, dependable, bonded TV-Radio service, "Operator 25" sends customers to Bonded Dealers.

**3** Raytheon consistently runs national advertising, presenting Independent Service Dealers as the best in the business.

**4** Raytheon has a network of independent distributors with well trained personnel who are eager to help independent dealers.

**5** Raytheon makes a complete line of TV and Radio Tubes that are tops for replacement work — Raytheon All-Set Tubes — designed to help the versatile service dealer who repairs all makes and models.

For the whole Raytheon story, get in touch with your nearest Raytheon Tube Distributor.

**TV-Radio service is your business . . . serving you is ours**



## RAYTHEON MANUFACTURING COMPANY

Receiving and Cathode Ray Tube Operations

Newton, Mass. • Chicago, Ill. • Atlanta, Ga. • Los Angeles, Calif.

Raytheon makes all these { Receiving and Picture Tubes, Reliable Subminiature and Miniature Tubes, Semiconductor Diodes and Transistors, Nucleonic Tubes, Microwave Tubes.



Excellence in Electronics



# SERVICE

THE TECHNICAL JOURNAL OF THE TELEVISION-RADIO TRADE

## Recognition For The Parts Distributor

IN THIS RAPIDLY EXPANDING industry of ours, which has soared into the multi-billion-dollar class, one group merits special commendation for an outstanding job that is contributing much to this growth—the parts distributor.

To the Service Man, these achievements are particularly significant. They spell dynamic vision, so vital to the success of all service shops. It is not only this awareness of the problems of the day, but a willingness and ability to cooperate, that makes the distributor a valued associate and friend of the Service Man. Whether the situation is technical, or one involving merchandising, warehousing, delivery, accounting, credit or public relations, the distributor is usually well equipped to lend a hand.

In this complex technical age, prompt availability of the variety of advanced-designed products—be they components, test equipment or accessories—is extremely important. Distributors are the source of vast stocks of literally thousands of items—available not only in central depots, but in branches strategically located to expedite handling and delivery. Successful, proper and, in most cases, cordial credit arrangements are effected and maintained between the manufacturer upon the one hand and the service shop upon the other.

KNOWING THAT SERVICE MEN are busy people, many distributors send sales crews out to visit shops—trained sales crews who are not only able to discuss new products and check inventory, but to resolve problems involving business trends, displays, advertising and sales promotions, and credit. Like those at the counter, in the stockroom or in the sales office, these field men have been schooled in modern technical and business practices, and are equipped to render sound counsel.

In order to supply professional technical advice on latest developments, a number of distributors maintain carefully supervised laboratories in which new test equipment, tools and components can be thoroughly investigated. Under critical study are the newest types of products, such as semiconductors, packaged electronic assemblies, printed-wiring boards, wide-angle picture tube parts; as well as equipment for color-TV, audio, commercial sound, closed-circuit and community-TV, transistor radios and two-way.

HEADLINED ALSO BY DISTRIBUTORS is an all-out preference for standard-brand merchandise—a refusal to buy and sell unbranded and unknown products—and consistent campaigns to discourage the purchase of any merchandise of doubtful quality or origin. This progressive policy is vital to the Service Man; it not only makes it possible for him to do a better and faster job, because he has a dependable product on hand, but it is insurance against costly callbacks.

Another timely assist offered by distributors, highly prized by Service Men, are the numerous merchandising tips. Many distributors offer special bulletins describing field-tested promotional aids that can be used to develop more business. Covering the subject of advertising, one recent memo to Service Men pointed out that one doesn't necessarily have to advertise in newspapers, or on radio or TV—though depending upon one's market and scope of operation, these media have their place. But, the bulletin emphasized, one should resort to constantly changing displays to attract customers, to mail and to telephone follow-ups. And, the field memo added, the best advertising is word-of-mouth, passed along by satisfied customers who have enjoyed friendly and efficient service.

Also contributing to the progress parade is the active participation by distributors in cooperative educational and promotional drives designed to boost the independent service shop.

EVER ALERT TO THE CHANGING SCENE, the distributors of the nation are constantly on the go, attending industry meetings, conferences and clinics. Once again, this year, they'll travel to the annual parts show in Chicago, the huge market place of ideas, where the latest components for installation, maintenance and repair will be on exhibit. And, as usual, they'll return armed with helpful front-line information for their most important customer—the Service Man.

THE PARTS DISTRIBUTORS certainly deserve recognition for their resourcefulness and their conscientious efforts to help all Service Men.—L. W.

# Tracing Receiver Troubles

How To Use Wattmeter, Ammeter and Milliammeter To Locate Defects In

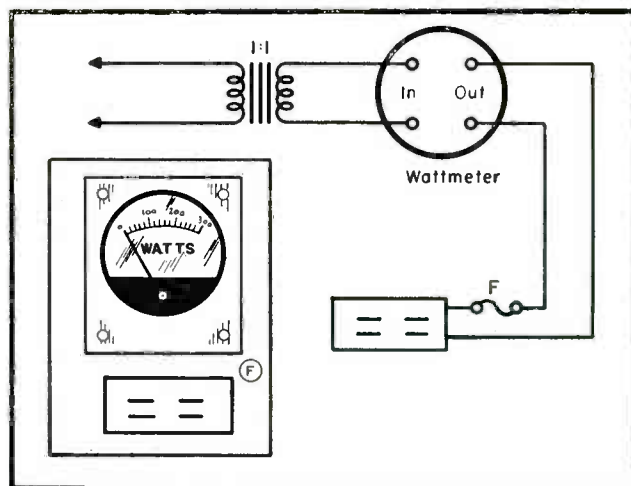
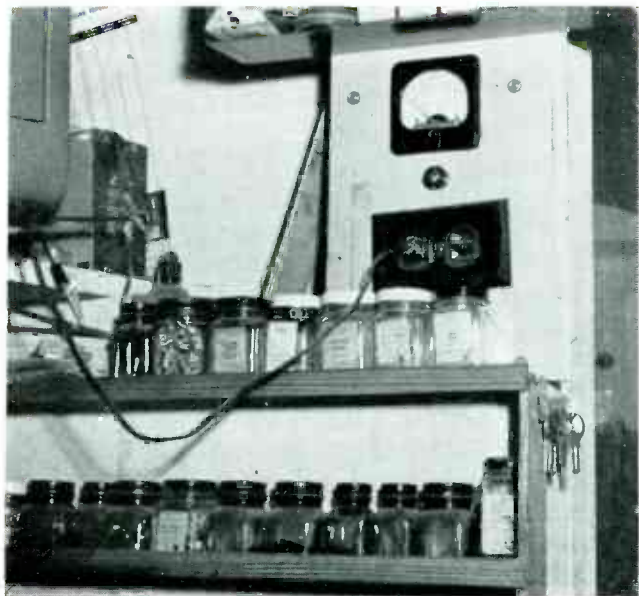


FIG. 1: WATTMETER with outlet mounted on wall of service shop close to TV end of bench; an extension from the outlet is wired to the bench proper, in parallel. Fusepost just below wattmeter holds 5-ampere fast blow fuse for meter protection against overloads.

ONE OF THE MOST USEFUL measurements that can be made in a service shop is that of power input. If the power drawn from a source is excessive, there is trouble ahead, regardless of performance. Overloads, partial shorts and leakages might initially degrade performance only slightly, but eventually contribute to the cause of future troubles, leading to frequent callbacks.

The basic equipment needed for the power checks involves three items: A wattmeter reading up to 300 watts, that will take care of practically all requirements for any *ac/dc* apparatus from the smallest *ac/dc* radio to the largest TV set; an 0-30 *dc* ammeter to service auto radios, mobile amplifiers and even two-way radio sets, and a milliammeter in the bench *vom* to check battery-operated radios of any type.

The smallest, although not necessarily the simplest item that requires power checks, is the transistor portable that should always be tested for excessive battery drain. To perform this test the milliammeter should be connected in series with one of the battery leads and the current measured. In the Regency TR-1 transistor portable the correct battery drain is from 3.5 to 4.6 ma. Any reading above this should be investigated; a leaky filter is the most common cause

by JACK DARR

of trouble here, as low-voltage filters used in transistor sets are subject to leakage problems. Other sets using the same number of transistors will have approximately the same drain.

Battery sets, such as those on farms, must also be checked carefully. Inserting a milliammeter in one of the B-battery leads will provide a quick check on the set's condition. This measurement should be taken often, especially when there are complaints about short battery life.

Many factors can affect current drain in a conventional battery set circuit; leakage in the filter capacitor, or in one of the few bypass capacitors. A more common cause is inter-electrode leakage in the power tube, which uses over 80% of the total current drawn by the whole set. Leakage here upsets the bias, causing the tube to draw heavy currents. A change in the value of the bias resistor, or leakage in the coupling capacitor on the grid, can also upset the bias. Checks should be made with a *vtom*, by measuring the grid voltage on the output tube; readings should always be negative, the actual value depending upon the type of tube used. The common 3Q5 or 3Q4, for instance, uses 4.5 v on the grid. A reading of only 2 volts would

be reason for suspicion of leaky coupling. After servicing, the battery drain should be rechecked. For a four-tube set, readings run from 7-8 ma at normal volume; in a 5-tube set readings might go as high as 10 ma.

Auto-radios, being battery operated, can be easily checked, with an ammeter. Any troubles in the power supply circuits will show up on this test. If a portable ammeter is available many common troubles can be diagnosed, without even removing the set from the car. (A number of *vom*'s provide a 10-ampere range which is just right for this test.) For instance, if a set refuses to operate, even though the vibrator is running, and the ammeter shows a reading of 15-20 amperes, the buffer is almost certain to be the culprit; it's either shorted or leaking badly.

This test will also spot open vibrators. If a reading of about 3-4 amperes is obtained and there is no vibrator sound, but the filaments are lit up, the vibrator is open. The new hybrid sets, using the low-voltage tube types, transistor output and no vibrator warrant careful attention. The 12-volt sets, for instance, draw much less current than the older 6-volt types. To illustrate, a 12-volt set with 8 tubes would draw about 3-5 amperes, as compared to the 6-10 amperes drawn by the same set

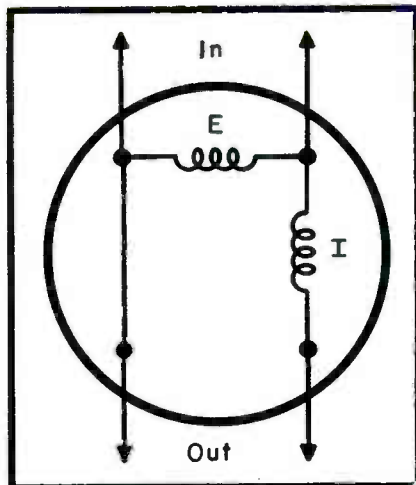
# With Input Power Tests

## Transistor-Tube Home-Auto Radios, TV Chassis, and Mobile Equipment

using 6-volt tubes. Actually, the total wattage is the same, but because the voltage has been doubled, the current drain is halved.

Even the common *ac/dc* radio may be checked quickly using an *ac* wattmeter. This instrument should be installed on the service bench, at an accessible location and connected to a convenient outlet. For quick confirmation of a suspected open filament into the wattmeter outlet; no reading means no continuity. Tubes should also be checked using one of the checkers made for TV tubes. (Incidentally, the order of failures, in almost all cases, seems to be: Rectifier, power tube, second detector, *if* amplifier and mixer-oscillator.)

Replacement of a dead tube should develop a meter reading, indicating immediately that the trouble has been spotted. This report can also be a timesaver in those cases where the filament string is not open. For instance, if a surge resistor has opened and cut off the *B* supply, the meter will reveal only the drain of the filament string. This will average 10 to 12 watts. The normal reading for the common 5-tube *ac/dc* radio without a clock, should be from 28-35 watts. Clock drains are small; 3-5 watts. The low reading assures one that the filament string is complete and that there is trouble elsewhere. The rectifier tube should be checked for an open cathode ribbon; if this shows up, the set should be checked for shorts. (This can be done from the top of the socket by measuring the resistance from the cathode to one side of the line plug.) If nothing shows up, the tube should be re-



**FIG. 2: BASIC CIRCUIT** of *ac*-wattmeter setup. Instrument has four terminals; two input and two output, necessary because of internal circuitry. Wattmeter must combine functions of both a voltmeter and an ammeter. Therefore, a true wattmeter has voltage and current coils, effects of which are combined, so that, in effect, instrument multiplies the voltage across its terminals by the current flowing through them providing the product as a meter reading.

placed. If there still is no sound and the same low drain obtains, checks should be made for open surge or open filter resistors.

Other troubles also show characteristic drains. For instance, normal current with no sound might indicate an open voice coil on the speaker; no sound with a drain of 40-50 watts might be caused by a leaky power tube (50L6 or 50B5), a leaky coupling capacitor, or a shorted plate bypass capacitor on this tube. The resistance of the output-transformer primary winding would prevent the

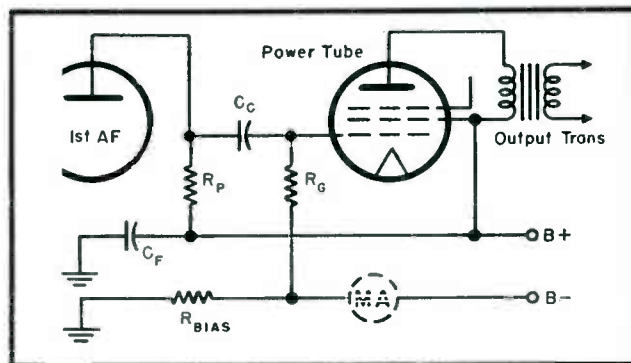
rectifier tube from being blown. Readings of only 3-5 watts below normal, with no sound, might indicate an open output-transformer primary winding.

The *ac*-operated sets may be analyzed in similar fashion. Wattage will be higher due to the added power. Although the rated wattage is or should be shown on the set label, a good approximation can be made by applying a base of 10 watts per tube and 10 for the transformer. Thus, in a 6-tube set, the wattage may be expected to run about 70 watts. Usually, it will run a little less; averaging around 65 watts. In these chassis, as in the *ac/dc* models, lower than normal readings indicate troubles in the power supply, with some stages being cut off completely. A reading of about 50% normal would probably indicate no voltage on the power output tube; a 20% low would indicate no screen voltage in the front end. What is more common and more dangerous, are the higher than normal readings; such readings always indicate trouble. If the reading is 10% to 15% too high, one should look for leaky coupling capacitors in power stages, heater-cathode leakage in power tubes, or filter or bypass capacitor leakage.

Wattage tests can also be used to locate internal shorts in the power transformer. If the transformer shows definite signs of overheating, with wax running out, but all voltages are close to normal, one must determine whether the fault has been caused by an external short circuit or by a breakdown in the transformer itself. With a wattmeter setup, one can

(Continued on page 46)

**FIG. 3: TYPICAL BATTERY-set power supply**, including output stage, where most power troubles occur. By inserting a milliammeter in the *B-* or *B+* leads, one can check battery drain. If the bias resistor ( $R_{BIAS}$ ) is off value, or if the coupling capacitor ( $C_c$ ) is leaky, the power tube will be forced to draw excessive current. If the filter ( $C_F$ ) is leaky, it will cause excessive drain. Normal drain for an average 4-tube set should never be over 8 ma at medium volume.



# AM - FM Radio-Phono With

THE RISING INTEREST in audio has prompted the design of complete radio-phono systems that include high-power amplifiers, multi-speaker setups, AM-FM tuners, plus remote control.

The circuit of a combination radio-phono<sup>1</sup> with the foregoing features and such innovations as a mood-music channel appears in Figs. 1, 2 and on the cover of this issue.

## Remote Speakers

A hi-fi type of listener is often asked why he must use so much volume. The answer is that there is more realism in the music when heard at high levels. It cannot be denied that he is correct, but in the interest of harmony at home, such practice is advisedly limited to rare periods of solitude. One solution would be the use of remote speaker facilities which enable one to shut off the speakers in the cabinet and turn on the remote units installed elsewhere, perhaps in the bookshelf of the den, where one can listen in comfortable isolation.

In the chassis diagrammed, the remote speaker systems were designed to work in conjunction with single or dual-channel amplifiers. The systems consist of bass and treble speakers carefully integrated with acoustically designed enclosures. The speaker cabinet has been dimensioned for convenient placement in standard bookshelves, should this be desirable. A terminal strip on the power amplifier provides for a convenient connection to the remote speaker system.

## The Mood Switch

There are other times when one would like soft background or mood

## Analysis of Chassis That Features A 25-Watt Amplifier — 3-Speaker System, Remote Equipment And A Mood-Music Switch That Provides Wide-Range Reproduction At Low Levels

by C. C. KAYHART, Service Training Director, The Magnavox Company

music for dining, for reading or even conversation. This mode of listening must be done with low output if the music is not to intrude on any basic activity; but it is apparent to anyone who has tried this that something more than just a reduction in loudness is desirable, if the mood music is to add to the activity without being distracting.

To resolve this problem, engineering has devised a mood-music system.

The mood-music feature is placed into operation by a pull switch on the treble control and is performed electrically by a high-pass filter network ( $C_{177}$ ,  $R_{108}$  and  $C_{176}$ ) between the plate and grid circuit of the 6AV6 phono preamplifier. This filter provides feedback of the middle and high frequencies from the plate to the grid circuit. The phasing of the feedback circuit causes degeneration in the grid circuit and reduces the amplification at these frequencies. Since low frequencies are blocked by the high-pass filter circuit, they are not affected and

the net result is an increase in low-frequency response below 800 cycles relative to the response at all higher frequencies. The relative change in response due to the mood-music switch is shown in the response curve; Fig. 1a.

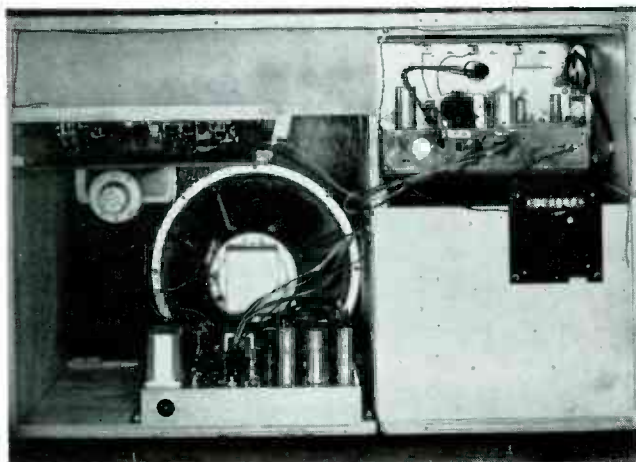
For serious high-fidelity listening at all levels the mood-music switch must be in the open position to restore the response to normal.

## Phono

A 4-speed automatic record changer incorporated in this model was chosen for its low wow, flutter and rumble characteristics which are of essential importance when driving a high-powered, wide-range system. The physical mass of the changer has also been found to be sufficient to allow operation at full output without degrading effects of acoustical feedback from the speakers to the pickup.

The changer is equipped with a pickup having a diamond stylus for microgroove and a sapphire stylus for standard groove records. This pickup contains a ceramic type element. Compliance characteristics provide for excellent tracking throughout the frequency range with a stylus pressure of 7 grams.

The output of the pickup has been compensated to conform with the recording characteristics (RIAA) man-



<sup>1</sup>The Magnavox Continental model 295C

REAR VIEW of radio-phono combination that features a mood-music system.

<sup>2</sup>The power output ratings described in this report refer to rms power outputs at approximately 2% total distortion. Some use peak power figures to rate their amplifiers. To illustrate, 20-watt amplifiers have been rated at 40 watts peak-power output. This figure is arrived at by multiplying the rms power by  $(1.414)^2$ .



# Mood-Music Control

[ See Front Cover and Page 16 for Complete Circuit ]

ufactured into present day records. This compensation is provided by an *rc* network ( $C_{140}$ ,  $R_{139}$ ,  $C_{172}$  and  $R_{170}$ ) located between the phono input receptacle and the 6AV6 phono preamp on the radio chassis. Additional compensation to take care of variations in recording characteristics between various makes of records, is provided by a four-position compensator switch and appropriate *rc* equalizing elements in the plate circuit of the preamp: *RIAA* for most records now made in this country; *LP* for early-type long-playing records; *EUR* for records made in Europe, 78 for most 78 recordings. The 78 position provides a considerable cut in high-frequency response, making it useful for reducing noise from any badly-worn record.

## Radio Chassis

The radio chassis<sup>2</sup> contains the AM-FM tuner, phono preamp, first audio amp, cathode follower and all operating controls. Plate power for the radio chassis is provided from a main power supply contained on the power amplifier chassis. Filament power is obtained from a separate filament transformer mounted on the chassis, which contains two separate heater windings; one winding that supplies the 6AV6 phono preamp and the 12AT7 first audio, and cathode follower is balanced to ground in the interest of hum reduction.

Two separate mixer-oscillator circuits are used to provide stability and low noise level. The FM mixer-oscillator is a 6U8. Its triode section functions as an oscillator whose stability is further enhanced by carefully-controlled thermal compensation. The pentode section provides high gain as a mixer and minimum coupling of the oscillator signal between grid and plate, which minimizes undesirable oscillator radiation from the chassis. Total oscillator radiation is held well under FCC requirements by isolation of the oscillator signal from the antenna circuit.

The AM mixer-oscillator is a 6BE6. Radio-frequency amplification is provided for both FM and AM by a 6BZ6 pentode. A 3-section function switch, controlled from the front panel of the radio chassis, affords switching between AM and FM. All *rf* circuit switching is done at *dc* with the exception of the *rf* grid circuit. This feature permits the *rf* circuits

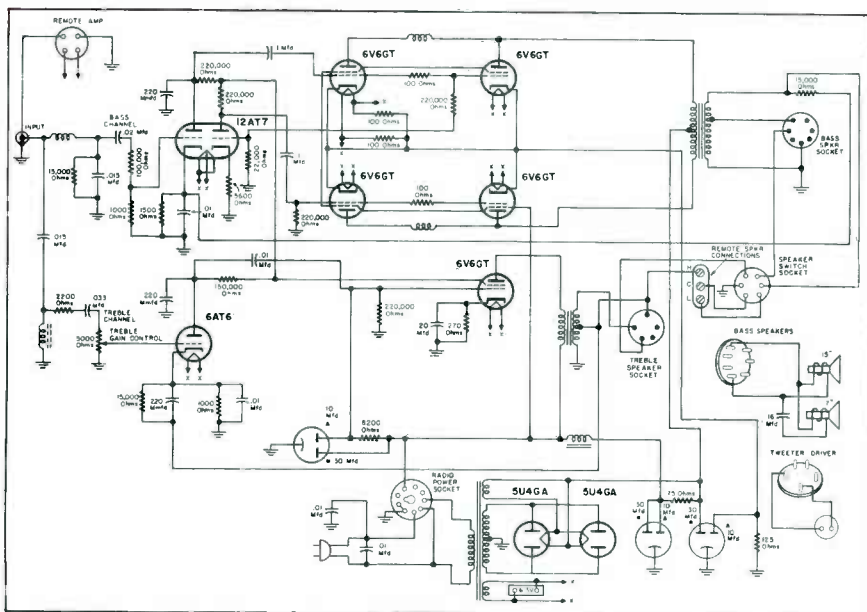


FIG. 1: POWER AMPLIFIER and speaker system for Magnavox mood-music chassis.

to be carefully confined for minimum regeneration, allowing for higher circuit gain, while still maintaining good stability.

## FM IF Amplifiers

Adequate gain and selectivity for FM are provided by a two stage 10.7-mc *if* amplifier driving a ratio detector. The first *if* and FM driver stages use 6BA6s. The ratio detector is a 6AL5 twin diode. Sufficient AM gain and selectivity are provided by a single 455-kc *if* stage driving a IN34A crystal detector. A sharply-tuned high-Q 10-kc filter, following the AM detector, prevents the beat between adjacent AM broadcast stations from appearing in the output.

The quieting sensitivity of the FM tuner is better than 6 microvolts. The sensitivity of the AM tuner is 20 microvolts per meter for 1/2 watt out-

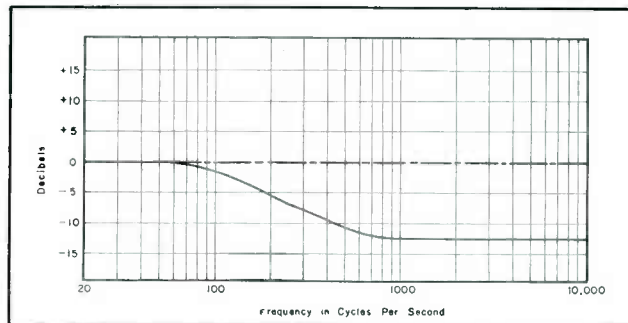
put. Overall response of the instrument to FM is 30-20,000 cycles. Overall response to AM is limited, for all practical purposes, only by the nature of the broadcast signal itself.

A 6E5-type tuning indicator is mounted on the instrument control panel. Since the tuning characteristics of the AM and FM circuits are similar, the indicator serves for both. The indicator control voltage for AM tuning is a portion of the receiver *avc* voltage. The control voltage for FM tuning is taken from the negative side of the ratio-detector balanced load.

Section 1 of the function control switch serves to transfer the audio outputs of the AM or FM detectors across the 1-megohm loudness control ( $R_{147}$ ). A third and fourth position of the function control places the loud-

(Continued on page 50)

FIG. 1a: MOOD-MUSIC response. The dashed line represents the normal instrument response; solid curve illustrates the relative change in response due to the mood-music switch.



<sup>2</sup>Model CR-730BB

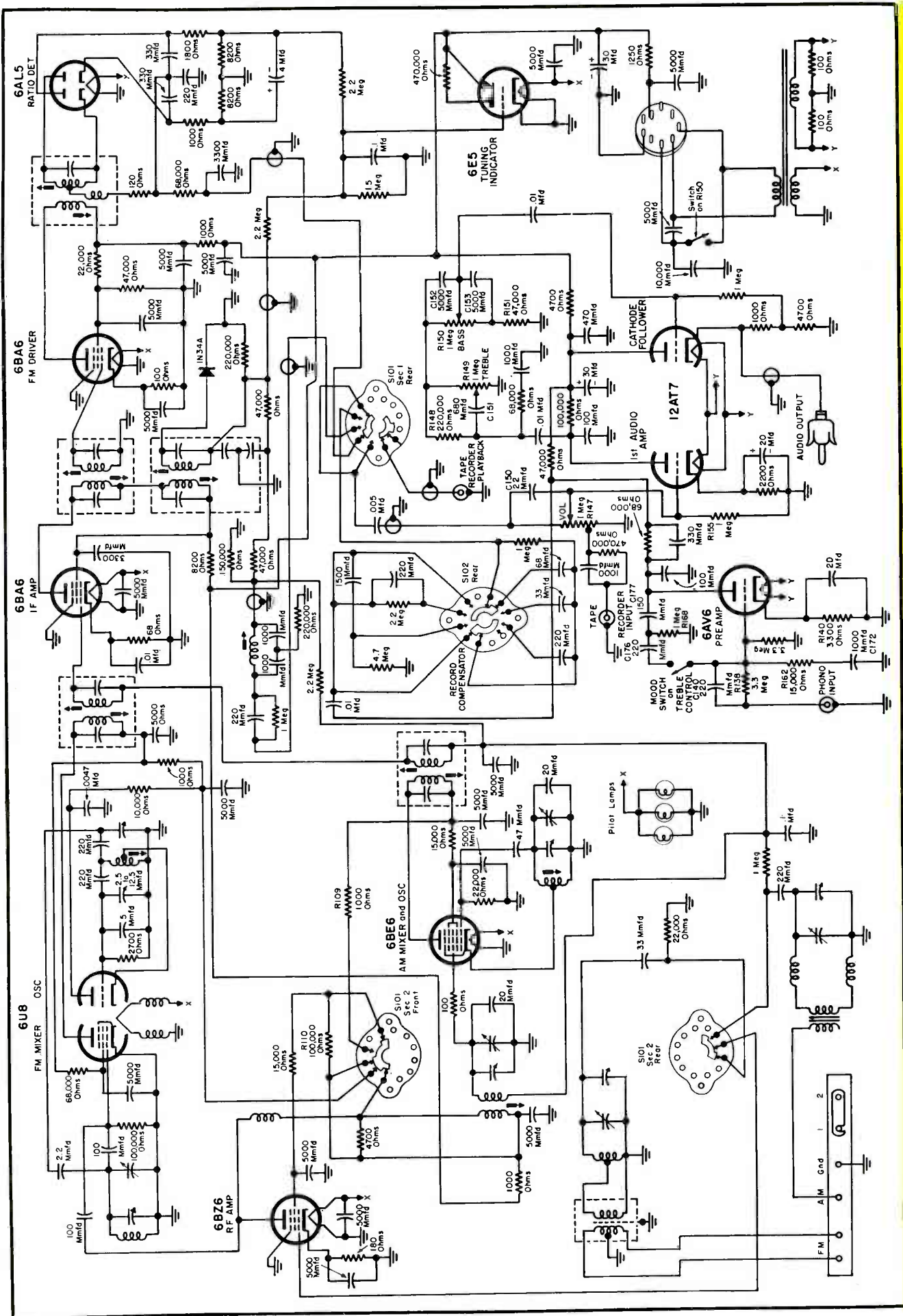
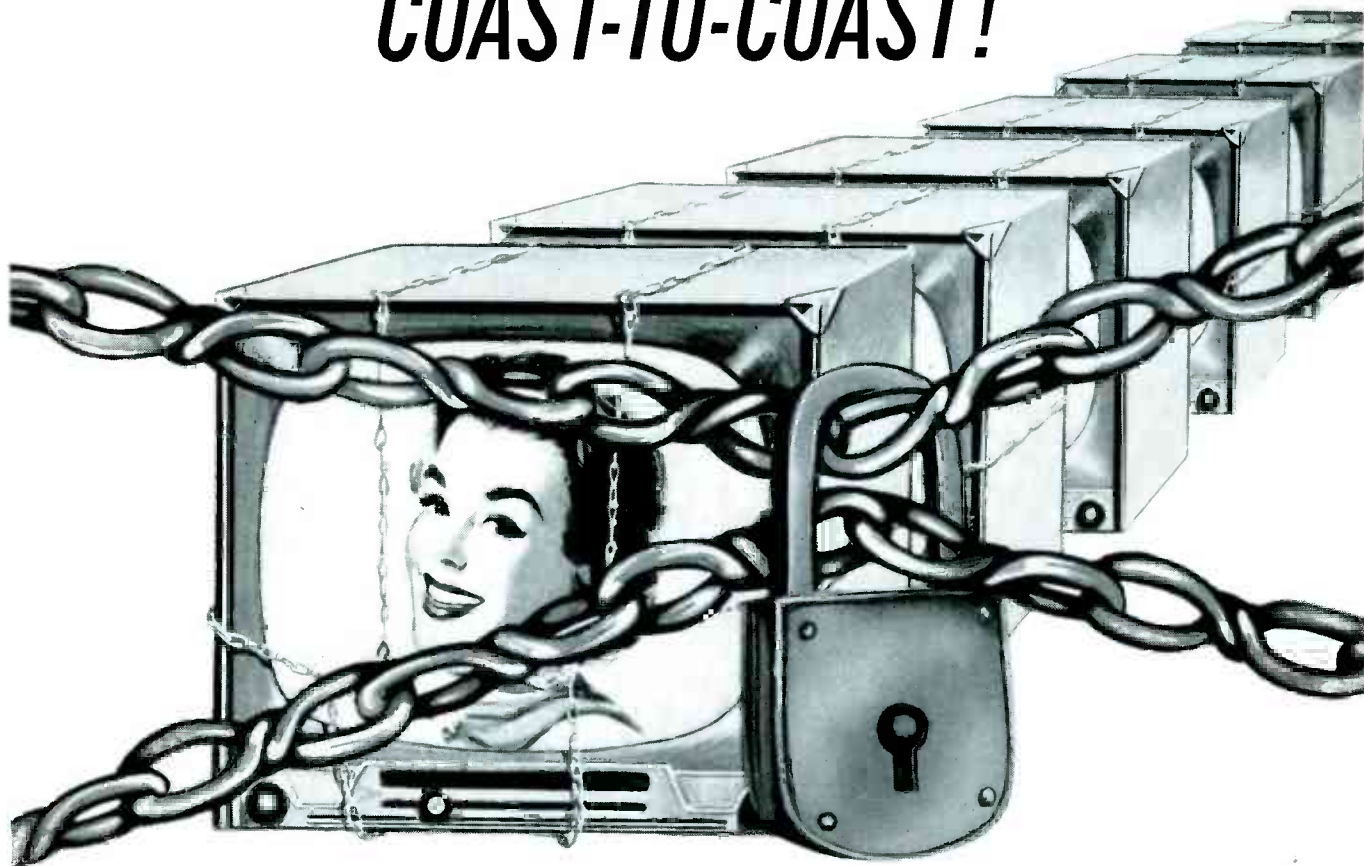


FIG. 2: COMPLETE DIAGRAM of Magnavox AM-FM radio-phonograph which features a 25-watt amplifier—three-speaker system and mood-music control.

# 103 TV TUBE "TORTURE TESTS"

## COAST-TO-COAST!



### "Locked TV" prove WESTINGHOUSE tubes work better, cut call-backs!

**RIGHT NOW** leading Electronic Parts Distributors across the nation are giving Westinghouse RELIATRON® Tubes the most grueling test in TV history!

**RIGHT NOW** 103 standard make TV sets—like those used by your customers—are performing continuously! Every set is locked tight. Every set is 100% equipped with Westinghouse RELIATRON Tubes taken right from regular Distributor stock to prove they outlast, outperform other tube brands—in any make TV!

**RIGHT NOW** these 103 sets are racking up fantastic performance records! For example, one "Locked TV" has run over 17,000 hours . . . more than 11 years' average viewing time!

**SEE THE "LOCKED TV" TEST** right now at *your* Westinghouse Tube Distributor. Find out how it can pay off in profits for *you!*

**Electronic Tube Division • Elmira, New York**

**YOU CAN BE SURE...IF IT'S**

# Westinghouse



# 13-Transistor Signal-Seeking Auto Radio

by W. C. CALDWELL

Service Engineer, Delco Radio Div., General Motors Corp.

W. C. CALDWELL checking all-transistor radio in the lab.



AN ALL TRANSISTOR radio featuring *wonder-bar* tuning and up to 10 watts of *af* output has been designed for the Cadillac Brougham car.

Relatively high-frequency *npn* transistors are employed in all stages except in the audio amplifiers and relay control stages, where *pnp* types are used. All transistors except the power output units plug into small transistor sockets; the power units (Delco 2N278) are insulated by mica and bolted tightly to the chassis for good heat transfer.

In the circuit, a signal is fed to the *rf* stage where it is amplified and then sent into a mixer stage. At this point, the station signal combines with the oscillator signal to form the intermediate frequency of 262 kc. This 262-kc output signal (from the mixer stage) is amplified by three *if* stages. At this point, the signal is sent out in two directions; down to the *agc* detector diode, and into the audio detector where the *if* carrier is removed and the intelligence passed on to the audio driver stage. Having obtained sufficient drive, considerable power is then developed by push-pull

## Complete Description of All-Transistor Chassis That Provides Up To 10-Watts Output

power output transistors and sent to the speaker for reproduction.

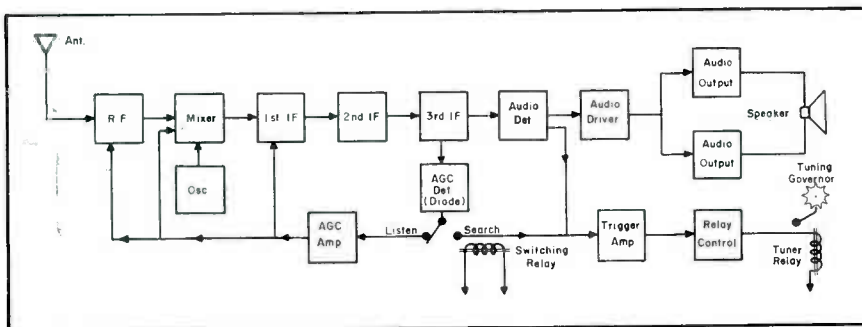
An *agc* detector diode changes the *if* signal to a *dc* voltage which is proportional to the station signal strength being received. A special switching relay then feeds this voltage into the *agc* amplifier during *listen* time, where it is amplified and used to control the gain of the *rf* mixer and first *if* stages. While searching, the *agc*-detector output voltage mixes with the voltage from the audio detector stage to form a uniform trigger voltage for various signals received. This composite voltage is then sent to the trigger amplifier, which turns off the relay control transistor and stops the tuner on stations.

The antenna is tuned by an *lc* input circuit, of which the antenna is a part, and coupled by a step-down transformer into the base circuit of

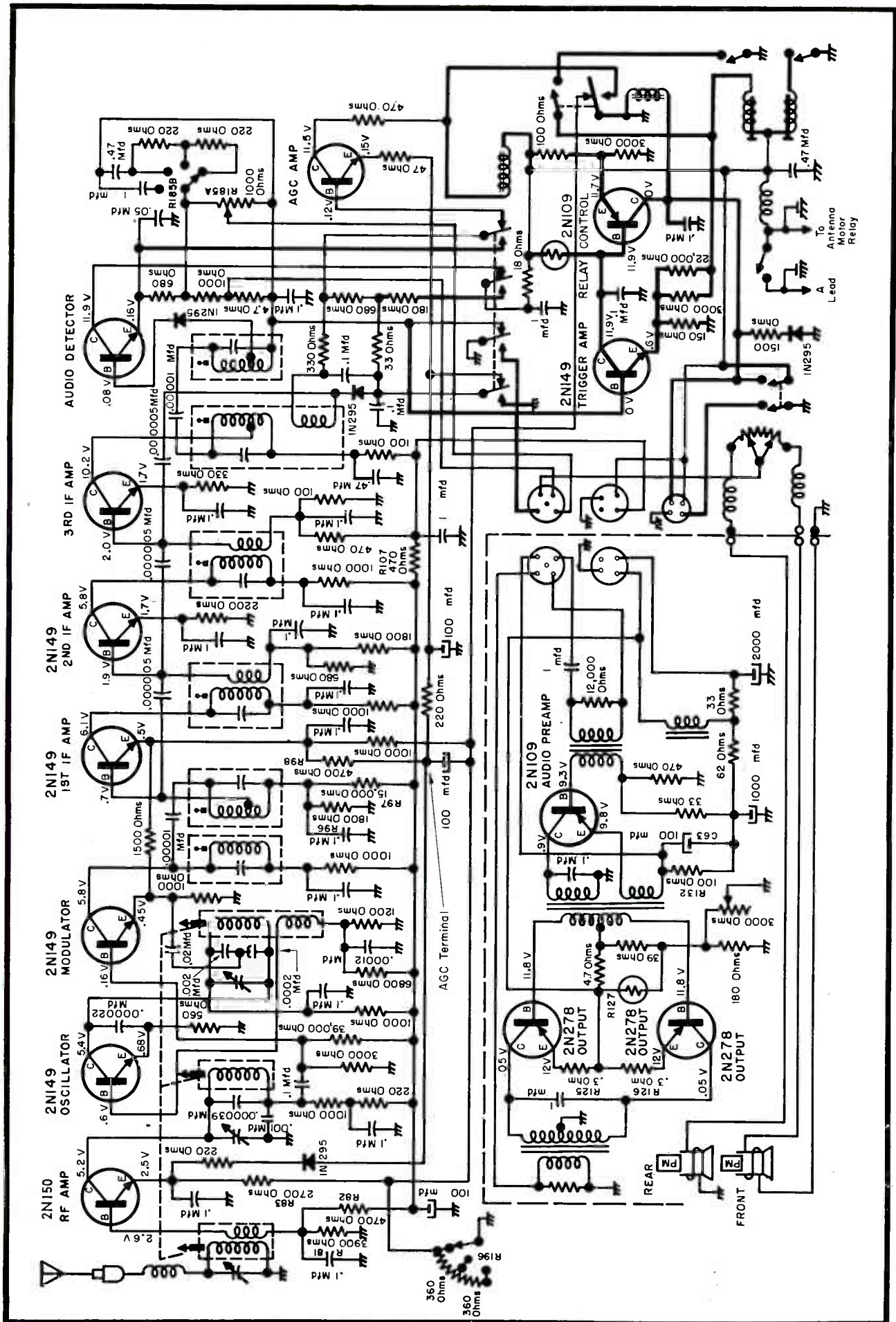
the *rf*-amplifier transistor. This is common practice in transistor circuits, since the input impedance of transistors is generally much lower than the input impedance of vacuum tubes. In this stage, and in all of the signal amplifier stages in this receiver, the popular common-emitter circuit arrangement is used; that is, the signal is applied between base and emitter and taken off between collector and emitter, so that the emitter becomes the common element for the input and output circuits. A *dc* bias voltage is applied to the base of the *rf* (2N150) amplifier. This is obtained from a voltage divider consisting of 3900 and 4700-ohm resistors;  $R_{81}$  and  $R_{82}$ . The bottom of  $R_{82}$  is connected to a 6.5-v line, supplied from the 12-v car battery and dropped by a 470-ohm series resistor ( $R_{107}$ ) in that line. The emitter of the *rf* amplifier stage obtains its voltage by a voltage drop across a 2700-ohm emitter resistor ( $R_{82}$ ) as transistor collector current flows through it. This leaves a difference voltage of .1 between base and emitter for forward bias. Approximate static current drawn by this stage is 1 ma, with no signal applied. This is varied by *agc* voltage applied to the emitter and by a search sensitivity control ( $R_{100}$ ) during the time that the tuner is seeking.

The oscillator (2N149) uses a tuned collector circuit, with an untuned base winding for positive feed-

(Continued on page 49)



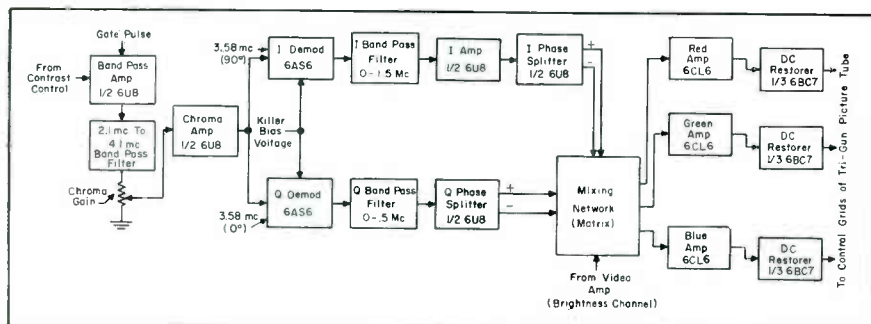
**BLOCK DIAGRAM** of all-transistor auto-radio which features signal-seeking tuning and employs thirteen transistors, two of which are power types in a push-pull audio circuit.



COMPLETE CIRCUIT of the Cadillac all-transistor radio with npn transistors in all stages except the audio and relay-control portion where pnp types are used.

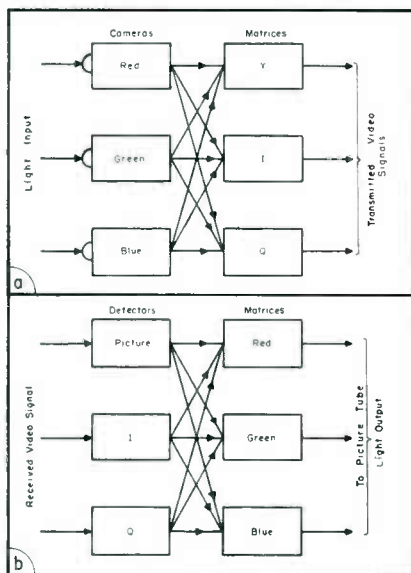
# Trends In Circuitry For

A Report on the Circuits Developed For Early and Present 3-Gun



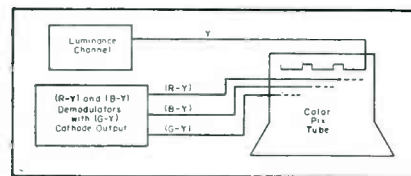
(Above)

FIG. 1: CHROMINANCE channel of an early ceiling-performance color-TV receiver. (Courtesy Admiral Corp.)



(Above)

FIG. 2: THE IQ color-TV receiver system which is the inverse of the color transmission system.



(Above)

FIG. 3: HOW HIGH-LEVEL color detectors drive the color picture tube directly.

(Right)

FIGS. 4a-b: BLOCK diagram in (a) illustrates (R-Y) (G-Y) color demodulation system which provides better utilization of the dynamic ranges of the tubes. Early color-detection system is diagrammed in (b); this circuit operated from the quadrature phases of the subcarrier voltage.

THERE ARE two well-defined trends at present in the development of color-TV circuitry. One concerns simpler and more economical circuit arrangements for the utilization of the three-gun picture tube. The second trend is directed toward the commercialization of one-gun picture tubes such as the *Apple* and *Lawrence* types. The one-gun picture tubes utilize a modified color signal, which has been converted from a simultaneous to a sequential signal.

## Early Model Wide-Band IQ Color-Demodulation

Early color receivers all processed the NTSC signal<sup>1</sup> in a very straightforward manner, as illustrated in Fig. 1. Such receivers can provide ceiling performance in color reproduction, but on the other hand require a relatively large number of tubes and components. The arrangement of an IQ-color receiver, one technique in the early designs, is basically the in-

by ROBERT G. MIDDLETON

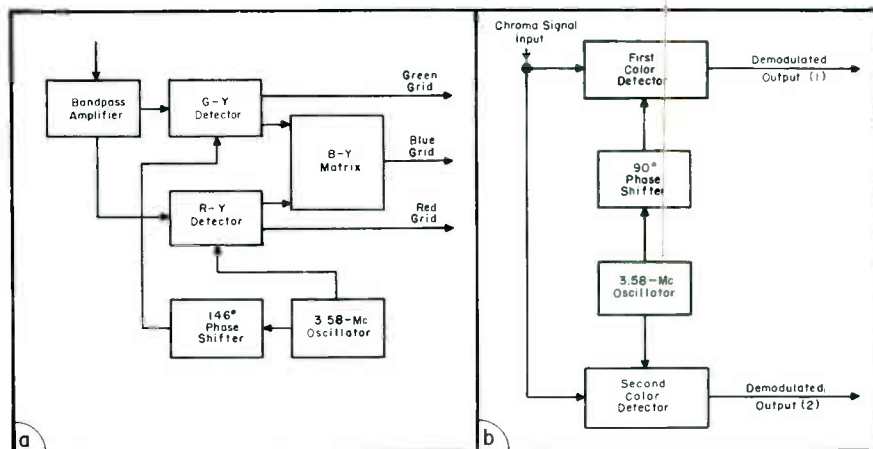
Chief Field Engineer, Simpson Electric Co.

verse of the circuitry of a color transmitter, as illustrated in Fig. 2.

The arrangement shown in Fig. 1 uses what is known as *low-level color demodulation*, since the color detectors are followed by amplifiers. Some more recent receivers utilize *high-level-color demodulation*, in which the detector outputs are applied directly to the grids in the color picture tube.

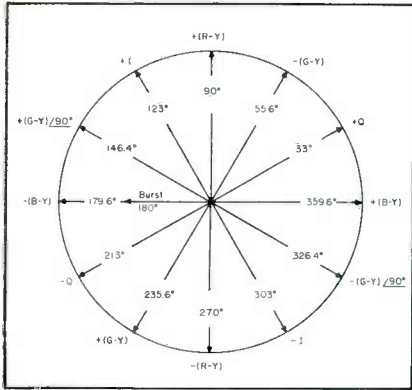
In a typical high-level demodulation system, two triodes are utilized as color detectors and (G-Y) matrix. The output from one triode plate is an (R-Y) signal which is applied to the red grid in the picture tube. The output from the second triode plate is a (B-Y) signal which is applied to

<sup>1</sup>The standard NTSC color signal is remarkable from the standpoint of its compatibility, since the same transmission is utilized directly to energize either a black-and-white receiver, or a color receiver. The NTSC signal utilizes techniques of frequency interleaving and two-phase subcarrier modulation to achieve compatible picture reproduction.



# COLOR-TV Receivers

## Tube Chassis and Systems Projected For 1-Gun Models



**FIG. 5: A CHROMINANCE** phase diagram which shows that I and Q are in quadrature.

the blue grid in the picture tube. A common cathode circuit is used; this develops (G-Y) output which is applied to the green grid in the picture tube. The Y (or luminance) signal is applied to all three cathodes in the color picture tube. Thus, the picture tube serves as the final matrix, as well as a transducer. The principle of this arrangement is shown in Fig. 3.

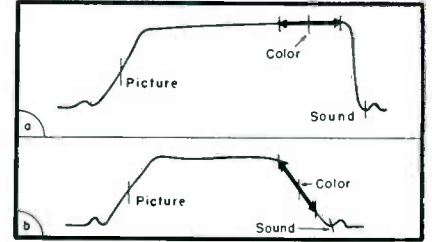
The earlier color-TV receivers, both of the IQ and (R-Y) (B-Y) types, made use of quadrature color detection. That is, the color-subcarrier voltage applied to one color detector was separated 90° in phase from the color-subcarrier voltage applied to the other color detector, as noted in Fig. 4b. Fig. 5 illustrates the point that the I axis is separated from the Q axis by a phase angle of 90° (123°-33°); likewise, the (R-Y) axis is separated from the (B-Y) axis by 90°.

Both IQ and (R-Y) (B-Y) detection systems operate equally well

when energized by the transmitted IQ color signal. Although transmission is made along the IQ axes, demodulation can be accomplished along any pair of axes; however, when demodulation is accomplished along the IQ axes, the I channel is operated at a bandwidth of 1.5 and the Q channel is operated at a bandwidth of .5 mc. This is in contrast to the chroma bandwidths utilized in the (R-Y) (B-Y) detection system, where the bandwidth of the (R-Y) and (B-Y) channels must both be restricted to .5 mc, to avoid color crosstalk. The I signal is transmitted in double-sideband form out to .5 mc, and in single-sideband form from .5 on out to 1.5 mc. The Q signal is transmitted in double-sideband form only out to .5 mc. It is the single-sideband region of the transmitted signal which restricts the bandwidth of (R-Y) (B-Y) demodulators to .5 mc, since the I signal has components along both (R-Y) and (B-Y) axes. Of course, very small areas of color cannot be reproduced in the (R-Y) (B-Y) type of receiver.

### Tube Range in (R-Y) (G-Y) Detection

Since demodulation can be accomplished along any pair of axes, some of the later color-TV receivers operate along the (R-Y) and (G-Y) axes for detection; this approach affords better utilization made of the dynamic ranges of the tubes in the chrominance section. This possibility results from the readjustment of chrominance values made at the transmitter; to avoid overmodulation on highly saturated colors (R-Y) is reduced to 87.7% of its initial value, (B-Y) to



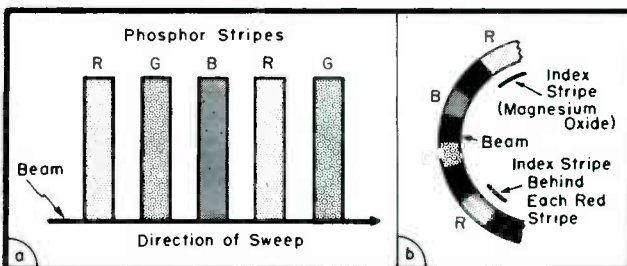
**FIG. 6: COLOR-IF** response curves. Curve in (a) shows result when the color signal is placed on top of the if curve as in the conventional system. The vestigial color-sideband system of reception result is shown in (b); the color signal falls on side of the if curve.

49.3% of its initial value, and (G-Y) is accordingly increased to 143.2% of its initial value.

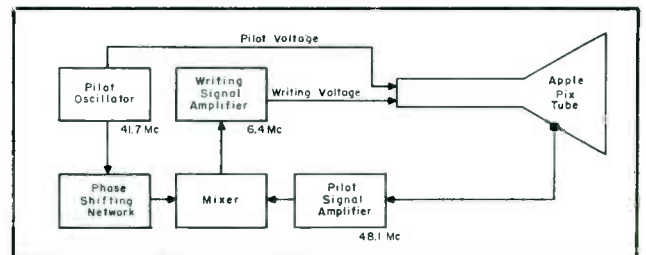
These readjusted chrominance values must be restored to their initial (unadjusted) values in the receiver, by suitable proportioning of gains in the chrominance channels. It is obviously more economical to reduce (G-Y) than to amplify (B-Y). Hence, the (R-Y) (G-Y) detection system depicted in Fig. 4 has made considerable headway. It will be observed from Fig. 5 that (R-Y) and (G-Y) are separated by a phase angle of 146°, and the injected color subcarrier voltages to the detectors accordingly have this phase-angle difference.

Hence, the (R-Y) (G-Y) detection system is not a quadrature system. The circuits have the same bandwidth as the (R-Y) (B-Y) system, and for the same reason. An interesting point to note is that a (G-Y)/90° signal

(Continued on page 52)



**FIG. 7: APPLE-TUBE** design. Illustration (a) shows how the writing beam is modulated by the color signal as it traverses the phosphor stripes of the tube to reproduce the color picture. Thin index stripes that are behind each red phosphor stripe are detailed in (b); these produce secondary emission sync signals when the electron beams pass through the index stripe.



**FIG. 8: BLOCK DIAGRAM** of the circuit functions that produce individual fields on the screen of the apple tube.

The writing signal frequency here is 48.1-41.7 mc, or 6.4 mc.

# THIS MONTH IN SERVICE

SERVICE MEN TO PARTICIPATE IN NATIONAL PROBE OF UHF RECEPTION--For many months a number of plans to resolve the TV-channel situation, that might involve the more active use of the ultrahighs, have been under consideration. In reviewing the proposals, the FCC found that the suggestions were so varied, that it would be difficult to reduce the ideas offered to a concrete plan. It was suggested therefore that industry lend a hand and set up a special research program under the auspices of a study group. All segments of industry concurred and as a result a TV Allocations Study Organization, tagged TASO, was developed. Their job will be to investigate every phase of vhf and uhf reception and broadcasting. . . A highlight feature of the probe will be a critical analysis of uhf receiving conditions, based on experiences of Service Men throughout the country. . . Association members, independent Service Men and technical personnel of distributors who handle service sales will be asked to answer a detailed questionnaire and return to TASO in Washington for a review that will eventually become part of an official report to the Commission.

SERVICE MEN will be queried on such subjects as terrain in their areas: Whether it's flat, hilly, mountainous, heavily built up with high buildings, residential and light commercial not built up, urban or rural. They will also be asked to note the proportion of receiver installations that use indoor and outdoor antennas and the effectiveness of these pickups for uhf and vhf. Antenna location information will also be sought: Service Men will be asked if in fringe or marginal areas they explore the rooftop area for locations of maximum signal intensity, and if so, how such locations are correlated with optimum picture tube results at the receiver. . . TASO will also ask about centralized TV-receiving-system performance on the high and low bands. On tuners, Service Men will be questioned about tuning procedures as the set owners see it; also if there are difficulties in uhf tuning which have been found to prejudice owners against ultrahigh stations. Some of the specific technical questions on tuning that will be posed will revolve about: Oscillator drift, short tube life, self-oscillations, failure of the beating oscillator to cover the range, noise levels, spurious beat notes and oscillator range coverage. . . Other problems that will be listed in the quiz form will be: Man-made interference on uhf and vhf, effectiveness of uhf for color-TV and the types of antennas and accessories found to be best suited for such reception.

MEMBERS OF TASO believe that the field-experience information Service Men will supply in their replies will be extremely helpful to them in determining the steps that both industry and the FCC will have to take in setting up a new long-term allocation policy, in which the ultrahighs could play a vital role.


HEAVY PRODUCTION SLATED FOR FM AUTO SETS--FM auto sets, often described as the ideal car chassis, will soon be a featured item on many receiver lines, according to reports from leading auto-set makers. . . Now being made in small quantities, the early Fall is expected to see a real swing to the noise-free wide-band type of chassis. . . Tube lineup of one model, operating in the 30 to 50-mc range, now being produced on the Pacific coast, is: 6BJ6 rf,  $\frac{1}{2}$  of 6U8 as mixer and  $\frac{1}{2}$  of the tube as an oscillator which also uses a crystal in the circuit, 6BJ6s in two if stages, 6AL5 detector, and 12AX7 audio and squelch.

BROADCASTERS SPENDING MILLIONS FOR COLOR-TV FACILITIES--In preparation for the heavy schedules of color shows this Fall and Winter, huge studios costing millions, with elaborate monitoring, camera, lighting and air-conditioning systems, are now being built by telecasters not only on the West coast, but even in the East. . . In upstate New York, one broadcaster has set aside an entire wing of a building for color. The studios, management says, will be spacious enough to stage the largest type of spectacular presentations, the type they expect to offer within the next few months.

COMMUNITY-TV CONVENTION TO BE HELD IN JUNE--The sixth annual convention and trade show of the National Community TV Association will be held on June 4, 5 and 6 at the Penn-Sheraton Hotel, Pittsburgh, Pa.



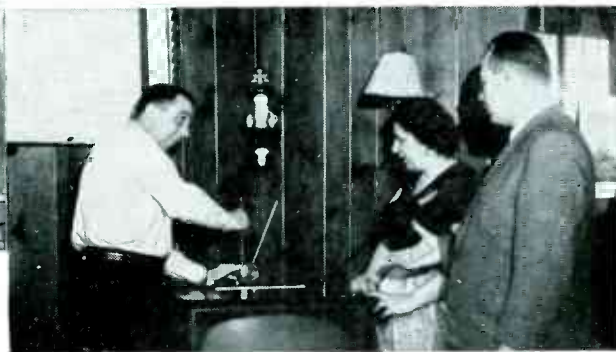
Johnny Lucci of Lucci TV-Appliance Sales,  
Staten Island, N. Y., reports:

“Our Servicemen  
Proved to be the Best  
 *Magic Genie* Salesmen  
We’ve Got!”



Take it from Johnny Lucci,  
important Staten Island TV dealer—

“We expected our showroom  
salesmen to sell JFD Magic Genies  
but not our service department—  
but they did and how.”



“Every time one of our servicemen makes a home  
call, he takes along a Magic Genie for demonstration.  
75% of the time he makes the sale and earns the  
commission.”

THE JFD MAGIC GENIE BELONGS IN YOUR PROFIT PICTURE!



More service-dealers are  
*making more and keeping*  
more with the JFD Magic  
Genie. Dynamic advertising  
in local and national  
media is creating thousands  
of Magic Genie  
ready-to-buy prospects in  
your trading area. Make it  
pay off at *your store* by  
stocking and showing the  
JFD Magic Genie. Now at  
your JFD distributor.



“We make sure no buyer or shopper leaves our store  
without being shown the Magic Genie. Many buy  
them with a new set or to replace their old antenna.”

NATIONALLY ADVERTISED AT \$17.95 promotionally  
priced at \$14.95



**ELECTRONICS, INC.**  
PIONEERS IN ELECTRONICS SINCE 1929

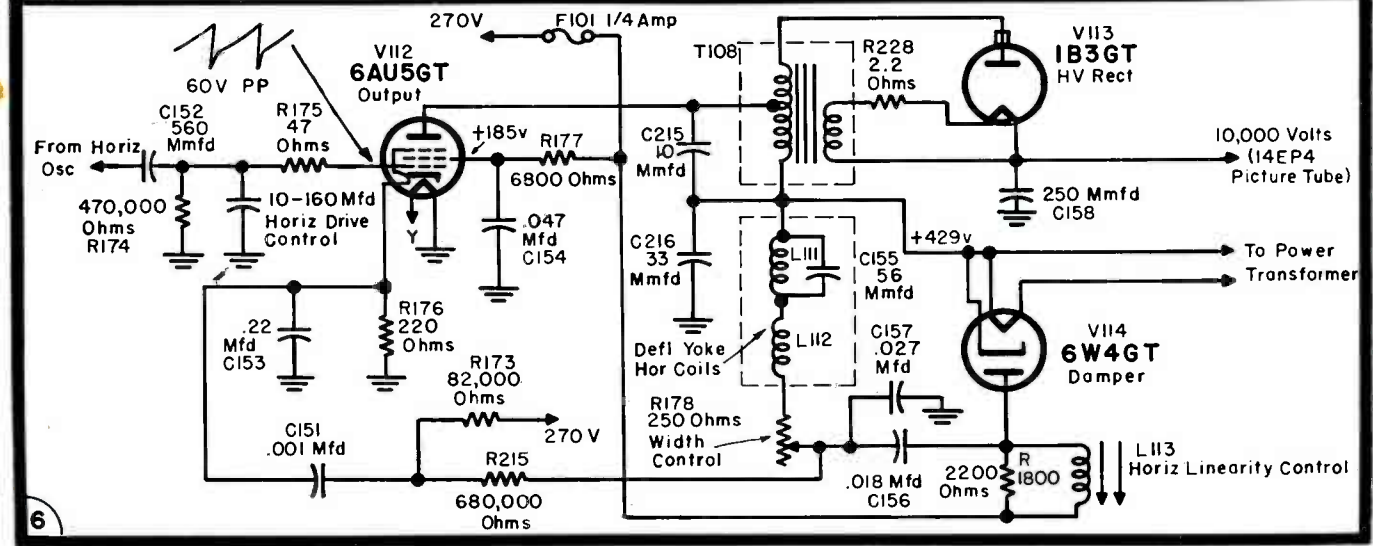
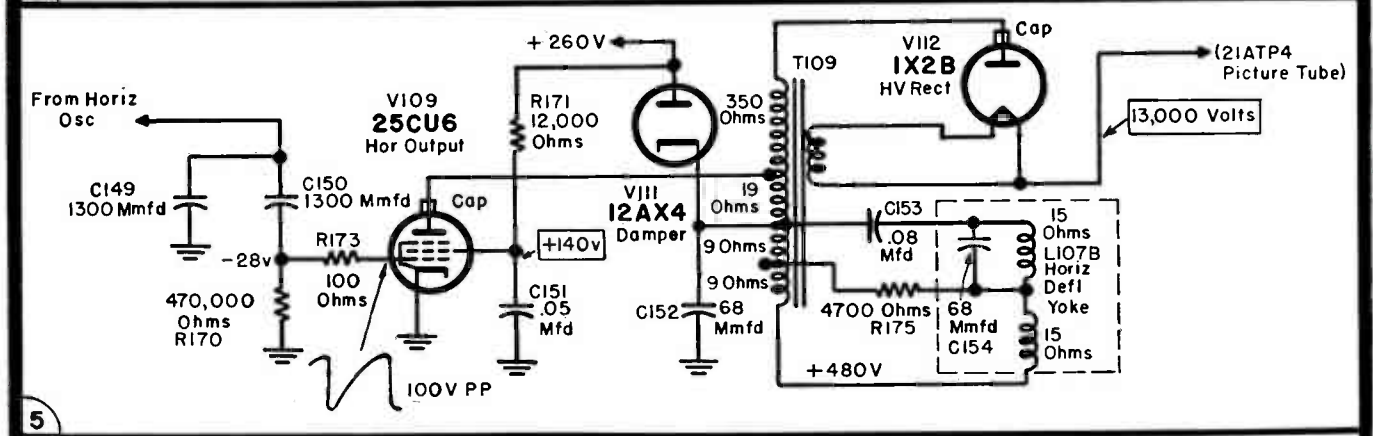
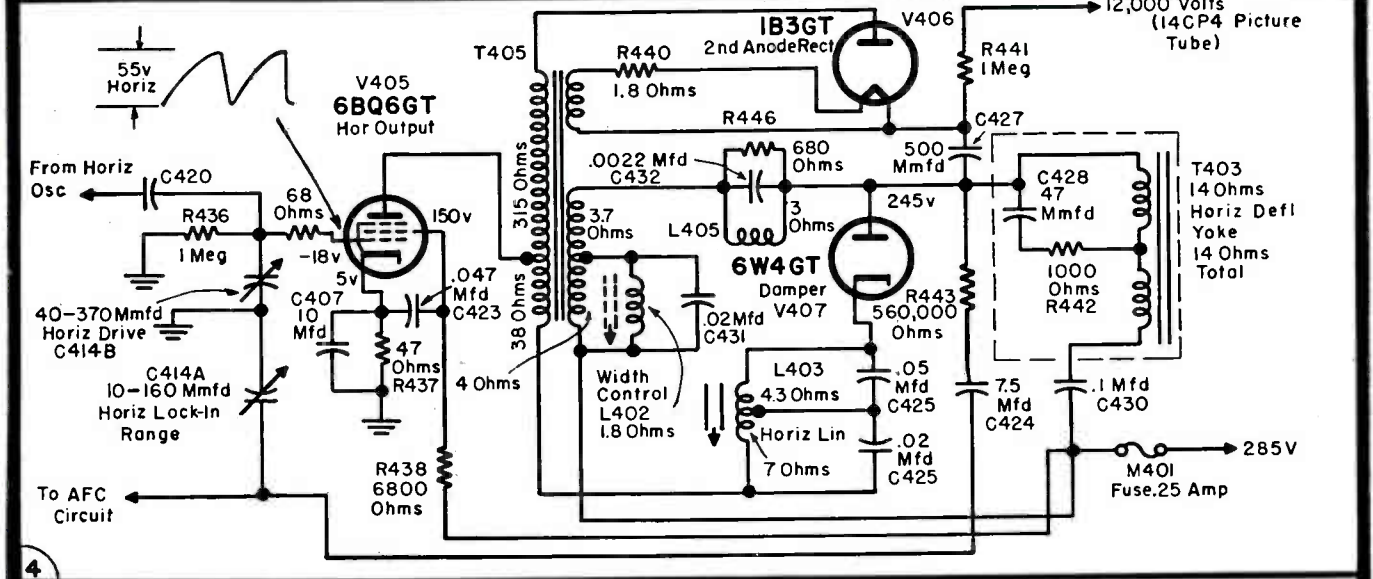
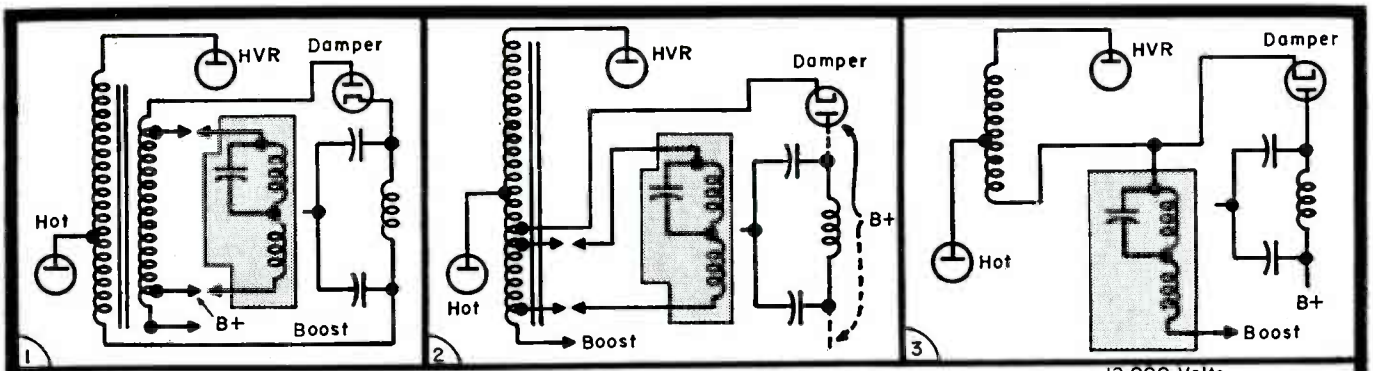
# Sound No-Raster Troubleshooting Chart ‡

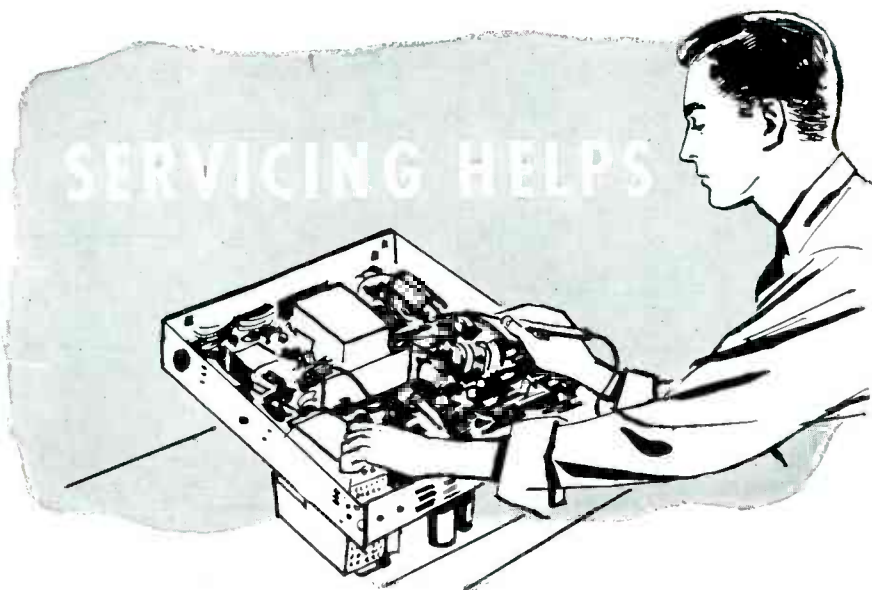
**Preliminary Circuit Checks:** Horizontal oscillator, horizontal output, damper and *hv* rectifier tubes should be substituted. A visual check should be made for burned-out resistors, open fuses, bulging capacitors and broken leads.

Isolation-Transformer (See Fig. 1)			Autotransformer (See Fig. 2)			Direct-Drive (See Fig. 3)		
In the isolation-transformer circuit, B+ is applied directly to the horizontal output transformer, the damper plate is connected to the transformer, and the <i>spike</i> at the cathode is negative.			In the autotransformer circuit, B+ is applied to the damper tube cathode (sometimes through the linearity coil) which connects to the horizontal-output transformer and has a positive <i>spike</i> . The horizontal-yoke windings are connected across two taps of the horizontal output-transformer secondary.			B+ and cathode connections are the same as those of the autotransformer circuit. The horizontal yoke windings are connected in series with the horizontal-output transformer. The transformer core may be either metallic or air; in either case it is circular.		
Check Using	Check or Connection Point	Approximate Measurement	Examples: Isolation-Transformer (See Fig. 4)		Autotransformer (See Fig. 5)		Direct-Drive (See Fig. 6)	
			Actual Measurement	If Abnormal, Check	Actual Measurement	If Abnormal, Check	Actual Measurement	If Abnormal, Check
Voltmeter	B+	10% of low voltage rectifier output	285 v	<i>Lv</i> rectifier and filter circuit, <i>M</i> <sub>401</sub>	260 v	<i>Lv</i> rectifier and filter circuit	270 v	<i>Lv</i> rectifier and filter circuit, <i>F</i> <sub>101</sub>
	Horizontal-output tube ( <i>hot</i> ) screen cathode	60 to 200 v	150 v	<i>R</i> <sub>438</sub> (6800 ohms) and <i>C</i> <sub>428</sub> (.047 mfd)	140 v	<i>C</i> <sub>151</sub> (.05 mfd) and <i>R</i> <sub>171</sub> (12,000 ohms)	185 v	<i>R</i> <sub>177</sub> (6800 ohms) and <i>C</i> <sub>154</sub> (.047 mfd)
	<i>Hot</i> cathode voltage	10 v per 100 ohms of cathode resistance	5 v	<i>C</i> <sub>407C</sub> (10 mfd) and <i>R</i> <sub>107</sub> (47 ohms)	None	.....	18.6 v	<i>C</i> <sub>151</sub> (.001 mfd), <i>C</i> <sub>153</sub> (.22 mfd), <i>R</i> <sub>178</sub> (220 ohms), <i>R</i> <sub>173</sub> (82,000 ohms), and <i>R</i> <sub>215</sub> (680,000 ohms)
	Boost voltage (at damper plate for isolation-transformer and damper cathode for other types)	1½ times greater than B+	400 v	<i>T</i> <sub>105</sub> , <i>L</i> <sub>102</sub> (width control), <i>C</i> <sub>131</sub> (.02 mfd), <i>C</i> <sub>425</sub> (.05 mfd), <i>C</i> <sub>430</sub> (.02 mfd) and <i>L</i> <sub>103</sub> (horizontal linearity)	480 v	<i>T</i> <sub>109</sub> , <i>C</i> <sub>152</sub> (68 mmfd) and <i>L</i> <sub>107B</sub> (horizontal-deflection yoke)	429 v	<i>T</i> <sub>109</sub> , <i>C</i> <sub>215</sub> (10 mmfd), <i>C</i> <sub>210</sub> (33 mmfd), <i>L</i> <sub>111</sub> and <i>L</i> <sub>112</sub> (horizontal-deflection coils), <i>L</i> <sub>113</sub> (horizontal-linearity control), <i>C</i> <sub>156</sub> (.018 mfd), <i>C</i> <sub>157</sub> (.027 mfd) and <i>R</i> <sub>178</sub> (250-ohm width control)
	<i>Hot</i> grid voltage	-10 to -80 v	-18 v	<i>C</i> <sub>420</sub> , <i>C</i> <sub>414A</sub> (10-60 mmfd) and <i>R</i> <sub>435</sub> (68 ohms) and <i>R</i> <sub>430</sub> (1 megohm)	-28 v	Horizontal-oscillator circuit; <i>C</i> <sub>149</sub> and <i>C</i> <sub>150</sub> (1300 mmfd), <i>R</i> <sub>170</sub> (470,000 ohms) and <i>R</i> <sub>173</sub> (100 ohms)	-7.9 v	Horizontal oscillator circuit; <i>C</i> <sub>152</sub> (560 mmfd), <i>C</i> <sub>142B</sub> (10-60 mmfd), <i>R</i> <sub>174</sub> (470,000 ohms) and <i>R</i> <sub>175</sub> (47 ohms)
Scope	<i>Hot</i> grid	50 v <i>p-p</i> (50° yoke) 65 v <i>p-p</i> (70° yoke) 75 v <i>p-p</i> (90° yoke)	55v <i>p-p</i> (70°)	<i>C</i> <sub>420</sub> , <i>C</i> <sub>414A</sub> , <i>R</i> <sub>435</sub> and <i>R</i> <sub>430</sub>	100 v <i>p-p</i> (90°)	100 v <i>p-p</i> (90°)	60 v <i>p-p</i> (70°)	60 v <i>p-p</i> (70°)
Ohmmeter	Plate cathode of damper tube	Greater than 30,000 ohms (disconnect damper tube resistor if used)	Greater than 50,000 ohms	<i>L</i> <sub>103</sub> (horizontal linearity), <i>C</i> <sub>125</sub> (.05 mfd) and <i>C</i> <sub>420</sub> (.02 mfd)	Greater than 50,000 ohms	<i>C</i> <sub>151</sub> (.05 mfd) and <i>C</i> <sub>152</sub> (68 mmfd)	Greater than 50,000 ohms	<i>C</i> <sub>150</sub> (.018 mfd)
Substitute Yoke	An 8-20 <i>mh</i> yoke should be substituted for original yoke; a 20-20 <i>mh</i> yoke can be used for direct drive	If <i>hv</i> returns, original yoke is defective	10 <i>mh</i> (10 ohms)	<i>C</i> <sub>128</sub> (47 mmfd) and <i>R</i> <sub>142</sub> (1000 ohms)	19 <i>mh</i> (21 ohms)	<i>C</i> <sub>151</sub> (68 mmfd) and <i>R</i> <sub>175</sub> (4700 ohms)	30 <i>mh</i> (35 ohms)	<i>C</i> <sub>150</sub> (56 mmfd)

**RIGHT—FIGS. 1, 2, 3: THREE TYPES OF** hy-drive systems; transformer (Fig. 1), autotransformer (Fig. 2) and direct drive (Fig. 3). **FIGS. 4, 5 and 6: ISOLATION-TRANSFORMER** circuit used in Admiral chassis 20T1 and 20V1 is illustrated in Fig. 4. The autotransformer circuit in Crosley 431 TV sets is shown in Fig. 5. A direct-drive system in RCA KCS-61 chassis appears in Fig. 6.

‡Based on PTM-bulletin service-aid data prepared by Irv Tjomsland, service engineer, Triad Transformer Corp.





Transistor-Radio Test-Equipment Application Tips . . . Servicing Modulized Chassis . . . Radio-TV Set Service Notes: Hum Reduction . . . Curbing Regenerative Squeal

IN SERVICING transistor radios, voltage and continuity checks can be particularly revealing. The voltage tests can disclose current-drain problems that could be sources of key troubles.

Since transistors are relatively low-resistance devices and extremely non-linear, the continuity checks must be done carefully. An ohmmeter can give misleading results in continuity checks and can readily burn out a transistor if an excessive or wrong polarity voltage is applied to an element.

If signal-injection checking is used, care must also be taken to avoid damaging of the transistors. Shorting a

transistor base to ground on many sets will cause excessive current drain and transistor failure. A blocking capacitor must be inserted in the signal-generator output lead to prevent loading of biasing circuits.

In many transistor models the same elements in the converter function both as oscillator and mixer. If the signal generator is connected to the converter-transistor terminal base, the local oscillator will be loaded out of oscillation. An *if* signal injected here is amplified properly; but an *rf* signal cannot be heard because the transistor no longer acts as a converter.

To check the converter, the *rf* signal must be injected through a very small capacitor; it is usually more satisfactory to employ a signal tracer to check the input circuit performance and then inject the *rf* signal through loose coupling to the antenna. To check the local oscillator operation, an *rf* voltmeter is required. A typical value of local-oscillator injection to the base is .15 *v rms* at 1400 kc. One must not use the vacuum-tube technique of measuring the *dc* drop across the oscillator grid resistor, because there is no comparable resistor.

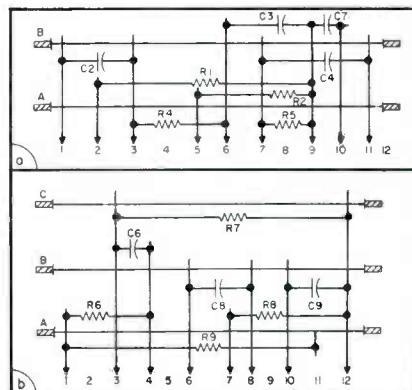
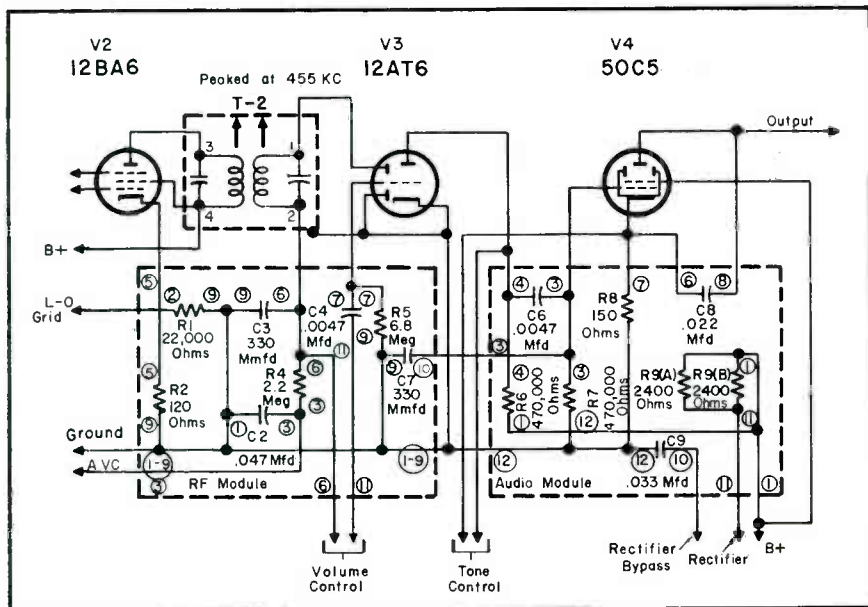
Servicing Modulized Chassis

SERVICING CHASSIS which include components mounted on modules require the use of special techniques. In one chassis, Emerson 120349B, one module includes the *r* and *c* components of the *rf* and *if* section; another mounts the audio resistors and capacitors. When a component failure occurs in one of these modules, the module may be replaced or, often, repaired.

In most modules, as in the two in this receiver, all component terminals are available on the *risers* (wires running from top to bottom of the module); therefore it is possible to reach all terminals of each component. While it may not be possible to eliminate parallel paths to isolate a single component, measurements will usually clearly indicate the particular component at fault.

Repair or replacement is determined by the location of the defective component, and the nature of the defect. If a component can be isolated

(Continued on page 47)



(Left) FIG. 1: RF-AUDIO MODULE circuitry in Emerson 867B.

(Above) FIG. 2: DETAILED SCHEMATIC of RF-AF modules.

# New High Quality Precision Instruments For SERVICE CALLS or SHOP WORK

...From **KAY ELECTRIC**



## **KAY** *Utilator*

Portable, Compact Utility Oscillator

### FEATURES

- AGC'd for Flatness
- Metered Output 0.7 V rms into 75 ohms
- Broad-Band 4.5 to 220 mc
- Direct Reading Dial
- High Quality

A small, compact utility oscillator designed for bench or field service, the new Kay *Utilator* covers the 4.5 to 220 megacycle range. The unit is completely self-contained with attenuators, power supply and output meter. The *Utilator* provides a high level RF output AGC'd for flatness over the range, and a direct-reading frequency dial accurate to  $\pm 1\%$ .

### SPECIFICATIONS

Frequency Range: 4.5 to 220 mc, in six switched bands, fundamental frequency.

RF Output: 0.7 volts rms into nominal 75 ohms, metered; AGC'd.

Flatness:  $\pm 0.5$  db over the range.

Frequency Calibration: Direct reading frequency dial calibrated to within  $\pm 1\%$ .

Attenuators: Switched steps of 20 db, 20 db, 10 db and 6 db, plus continuously variable 6 db.

Dimensions: Width 11", Depth 6½", Height 8½"

Weight: 19 lbs.

Price: \$295.00 F.O.B. Pine Brook, New Jersey



## **KAY** *Transifier*

All-Transistorized, Plug-In Wide-Band  
Video Amplifier

### FEATURES

- Broad-Band Response to 15 mc
- Completely Transistorized — Small, Self-Contained, Compact Portable Unit
- Signal Gain Controlled by Overall Feedback—Built-In Stabilization
- No Hum
- Long Stable Life—Powered by Two Penlight or Mercury Cells
- Units May Be Cascaded to Provide Additional Gain

The Kay *Transifier* is a *true* modular unit, completely transistorized, with built-in feedback circuit for stabilized signal gain. The unit is self-contained in a cast-aluminum housing with standard banana plug input and output.

The *Transifier* may also be used as a low level pulse amplifier or as a pre-amplifier for video and audio instruments, vacuum tube voltmeters, cathode ray oscilloscopes, tape recorders and microphones. Other uses include, use as a humless audio amplifier and as a modular in control circuitry, and all types of audio-video electronic devices.

### SPECIFICATIONS

Frequency Response: 10 db Position: 3 db down at 20 cycles and 15 mc

20 db Position: 3 db down at 20 cycles and 10 mc

Gain: 10 db and 20 db switchable

Input Impedance: Capacitance 15 mmf—Resistive Component—20,000 ohms at 1 mc to 15,000 ohms at 10 mc

Output Impedance: 500 ohms, approximately

Maximum Output Voltage: 0.15 volts 10 db position  
0.30 volts 20 db position

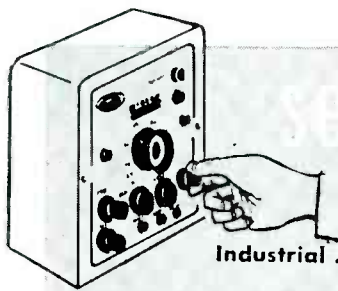
Price: \$85.00 F.O.B. Pine Brook, New Jersey

For Literature on The Complete Line of Kay Transistorized Instruments, Write:

## **KAY ELECTRIC COMPANY**

Dept. S-5, 14 Maple Avenue, Pine Brook, N. J.

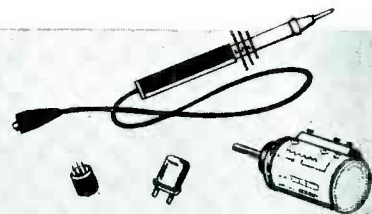
CAldwell 6-4000



## FIELD AND SHOP NOTES

Industrial . . . Commercial . . . Institutional

Communications . . . Audio . . . Television Installation . . . Maintenance . . . Repair



### Field-Bench Facilities of a Resort-Area Service Shop Specializing in Commercial-Sound Installation and Repair

by KENNETH SONNENBERG, BDM Electronic Labs, Inc.

WE HAVE BEEN in the service business for twenty years and now specialize in the installation and repair of commercial sound equipment. We also handle TV and radio repairs.

Our shop, with approximately 1000 square feet of space, is located in Far Rockaway, N. Y., a resort town which with the adjacent area has a population of 60,000. In the summer months, the population swells to 250,000.

The main servicing area in our shop consists of a 20-foot work bench, that is 37 inches high, found to be a good height when standing or when seated on a stool.

The bench has been covered with tempered masonite and edged with aluminum. Along the front of the bench we installed *wiremold*, a continuous line of *ac* sockets each 6" apart. The equipment shelf, which has a depth of 20", enough for the deepest piece of equipment and a library of manuals, runs the full length of the bench. Ladders are kept beneath the work bench and against the wall which is in direct line with the outside door.

On the wall opposite the work bench is our stock of TV antennas,

components, tubes and accessories on a unit of steel shelves 17' long. The receiving tubes are stocked on 5' long shelves spaced 6" high. This space is enough for 1000 receiving tubes. The remaining 12' of shelf space is for larger parts such as transformers, coils, batteries and mikes. Here the shelves are spaced to the height of 12". Small parts are kept in steel cabinets which have 4 drawers with 12 partitions to a drawer. Here such small parts as capacitors, resistors, sockets, plugs and connectors are kept. Hardware is housed in a steel cabinet having 24 plastic drawers each of which has 3 partitions.

Tools are kept on a specially-built two-sided rack, made of masonite with an inside supporting frame of wood, mounted on a wooden dolly with rubber wheels. The tools are held in place by means of friction clips. Empty clips, indicate missing tools.

Antenna masts are stored on cradles beneath the large work bench. This space is in line with the door and is accessible for loading and stocking.

Test cables, wires, and equipment

connectors are kept on a rack to prevent tangling.

For the repair of radios, both home and auto, a smaller version of the main work bench is used. This is 8' long and is enclosed on the bottom by 4 doors. This enclosed area has been found to be ideal for the storage of stationery, bill books, statements, and anything that must be kept dust-free.

Along the back wall of the shop is a finished wooden shelf unit, on which sound equipment is displayed. Since sound equipment sales, service, and rentals represent a large part of our business this display plays an important role in our operation.

#### Service Call Procedure

Service call requests are detailed on a special form which notes customer's name, address, phone, brand of set, model, size of picture and complaint. The form is turned over to the Service Man assigned to the call. An itemized bill is supplied to all of our customers. Duplicates of the paid bills are entered in a daily book which details the work performed and parts sold. The service information is then noted on a card and filed alphabetically in a steel file.

Two days after a service call is completed a special postcard with a prepaid return postcard attached is

(Continued on page 31)



ASSORTMENT of commercial sound-system equipment involved in typical outdoor sound installations made by BDM.



TV REPAIR bench at BDM. Tool rack, at left, is mounted on a dolly for mobility. All tools are held in place by friction clips.



# A NEW FRONTIER FOR TECHNICIANS

RCA offers an opportunity for you to apply your technical skill to its Missile Test Project at Patrick Air Force Base, Florida—"Launching Site of the Satellite."

Here at the world's longest missile testing range, extending from Florida far across the South Atlantic, you can enjoy improved status with the recognized leader in Electronics. Unprecedented growth opportunities are offered in various phases of data acquisition, transmission and processing, including Radar—Communications—Optics—Computers—Timing—Telemetry.

At RCA's Missile Test Project you will enjoy technical advancement

combined with famous Florida living. Your family will appreciate the ideal climate—allowing year 'round outdoor activities—and pleasant social surroundings.

Immediate assignments are available in Florida, the Bahama Islands, and aboard tracking ships in the South Atlantic. Attractive home leave policy and salary differential make the Bahama Islands and tracking ship assignments especially attractive for single men.

Let the Missile Test Project become *your* symbol of the future. Join in our assault on the frontier of space!

For complete information about this new and challenging field, write to:

Personnel Manager, Dept. N-34E  
RCA Service Company, Inc.  
Missile Test Project  
P. O. Box 1226  
Melbourne, Florida



**RADIO CORPORATION of AMERICA**

## CATALOGS—BOOKS

TRU-OHM PRODUCTS, Division of Model Engineering and Manufacturing, Inc., 2800 N. Milwaukee Ave., Chicago 18, Ill. has released a 24-page resistor-rheostat catalog listing information on fixed enameled, adjustable enameled, oval, vitreous axial and printed circular resistors, as well as data on dustproof, caged and 360° rheostats.

\* \* \*

THE HICKOK ELECTRICAL INSTRUMENT Co., 10535 Dupont Ave., Cleveland 8, O., has published an 8-page composite test-equipment catalog listing 25 pieces of test gear, color generators and the *Cardmatic* automatic tube tester.

\* \* \*

HOWARD W. SAMS & Co., Inc., 2201 East 46th Street, Indianapolis, Ind., has announced publication of the first volume of a series of manuals covering instructions for the removal of radios, power supply units and speakers from autos. This initial volume covers 1955 models of American cars. . . . For every auto covered, there is a list of the tools required, a phantom view of the dash panel with the radio in place, and a photo of the radio being removed. . . . Also listed with each model are rear-seat speaker data. This information indicates if there is a cutout provided, the size speaker required, and if control of the speaker must be added or if it is provided on the radio. . . . Priced at \$2.95.

\* \* \*

KINGSTON ELECTRONIC CORP., 17 Tudor St., Cambridge 39, Mass., has prepared a four-page brochure detailing the operation of the Kingston absorption analyzer designed to locate and isolate TV troubles through a waveform analysis.

\* \* \*

SYLVANIA ELECTRIC PRODUCTS, INC., 1740 Broadway, N. Y. 19, has published a 48-page handbook of baseball facts and figures containing complete major and minor league schedules for 1957. Booklet includes a section on basic baseball strategy and plays by the game's top experts. Lists also outstanding major league records for 1956 together with a 1957 outlook for both the American and National leagues.

\* \* \*

SKOTTIE ELECTRONICS, INC., subsidiary of Astron Corp., Peckville, Pa., has issued a six-page catalog describing their complete line of ceramic capacitors. Disk, tubular, and plate types are illustrated with charts and diagrams. Applications for temperature compensation, high voltage, and printed circuitry are discussed.

\* \* \*

THE JAMES VIBRAPOWR COMPANY, 4050 N. Rockwell Street, Chicago 18, Ill., has announced the availability of a four-page technical paper on the measurement of residual noise in chopper circuitry. Article covers the theoretical as well as the practical evaluation of residual noise in a wide variety of chopper circuitry.

\* \* \*

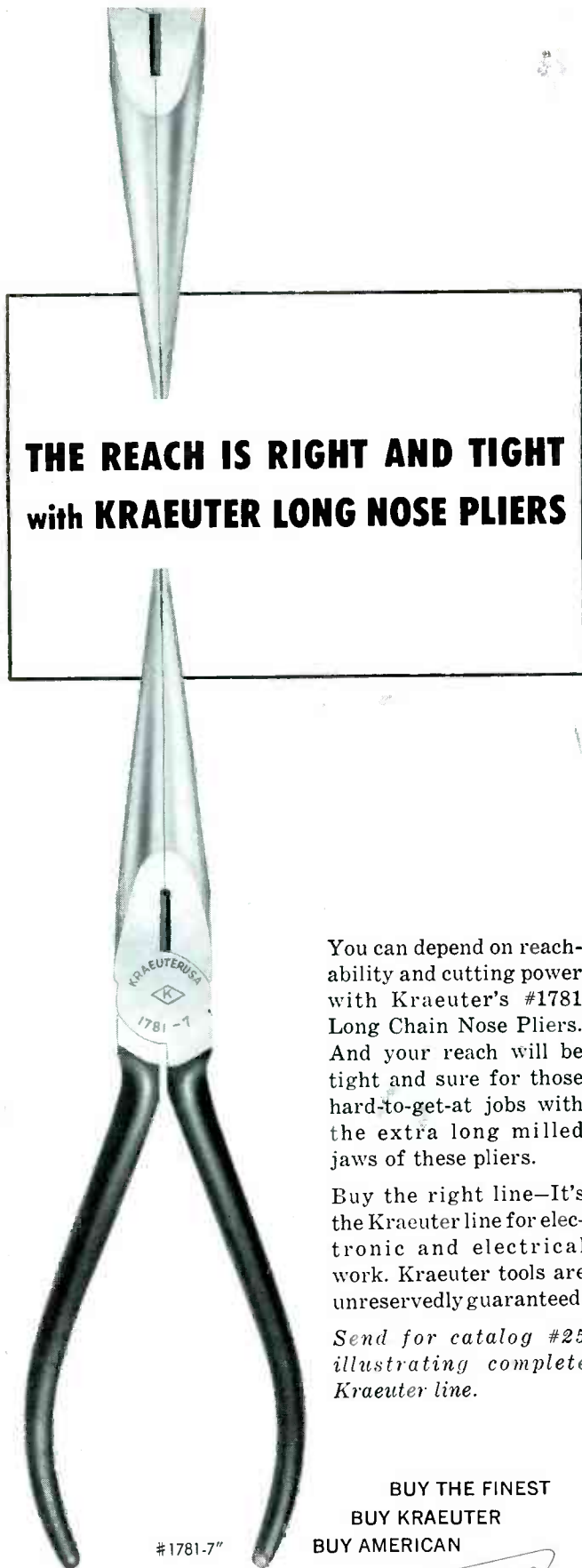
HEATH Co., Benton Harbor, Mich., has released a 16-page booklet describing audio and test instrument kits. . . . Among the test units detailed are audio wattmeters, harmonic distortion meters, audio signal generators and audio analyzers.

\* \* \*

GENERAL ELECTRIC Co., Syracuse, N. Y., has published two booklets on germanium TV rectifiers. One contains general information on the semiconductors; the other is a replacement guide listing a number of TV chassis in which the germanium rectifiers can serve as substitutes for the selenium types originally installed.

\* \* \*

WARREN RADIO Co., 1002 Adams, Toledo, O., has announced release of a 224-page catalog listing components, equipment and other electronic products for industrial and service use.



**THE REACH IS RIGHT AND TIGHT  
with KRAUTER LONG NOSE PLIERS**

You can depend on reachability and cutting power with Krauter's #1781 Long Chain Nose Pliers. And your reach will be tight and sure for those hard-to-get-at jobs with the extra long milled jaws of these pliers.

Buy the right line—It's the Krauter line for electronic and electrical work. Krauter tools are unreservedly guaranteed.

Send for catalog #25 illustrating complete Krauter line.

#1781-7"

BUY THE FINEST  
BUY KRAUTER  
BUY AMERICAN



AS MODERN AS TOMORROW

**krauter & co., inc**

FOR 100 YEARS THE FINEST IN HAND TOOLS 1860-1960 • NEWARK, N. J.



## Service Engineering

(Continued from page 28)



**SECTION OF SHOP** devoted to commercial sound system work. Shown is portion of inventory of equipment and accessories.

mailed out. Information sought covers operation of set, satisfaction with service and general comments. Through this simple medium we have an accurate appraisal of our service. This technique has been found to be a great goodwill builder.

### Field Problems . . . Solutions

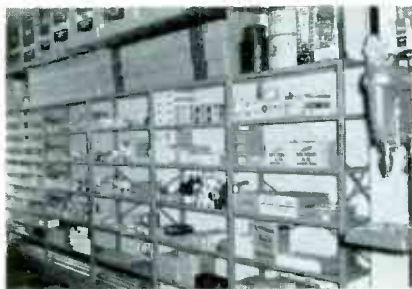
In the summer time, we are quite busy with outdoor sound-system installation and repair work. Because of the salt and sea-spray problems in our area, we often encounter odd problems.

Called on to check up on a paging-system installation we found that the speakers serving the beach front were not developing sufficient output.

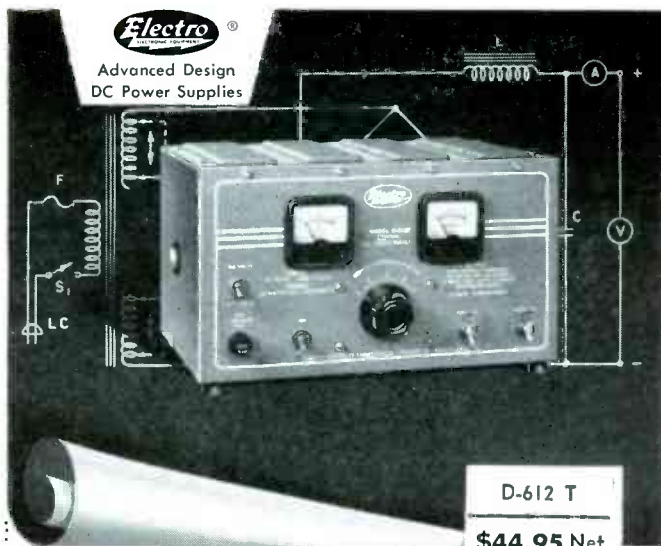
On inspection of the equipment it was found that paper-cone speakers had been installed and though they were enclosed in baffles designed to protect them, time and moisture had taken its toll.

This problem was resolved by installing, in an overlapping pattern, 15-watt wide-angle speakers that are made of fiberglass-resin material and use hermetically-sealed driver units. These speakers enabled us to cover every part of the beach with maximum intelligibility.

All of our crew wear uniforms, which we supply. We've found that the uniform serves to advertise our shop, positively identifies our personnel and particularly affords a neat and business-like appearance reflecting our professional standards of operation.



**ANTENNA, COMPONENTS, TUBE and wire racks. Component-area shelves are 12' long and spaced 6 3/4"; tube shelves are 5' long and with 6" of space between to accommodate 1000 tubes.**



## SPECIALLY DESIGNED to service today's and tomorrow's auto radios

DC Power for TRANSISTOR and Tube Sets  
Modern... Self-Contained...  
and you get these

### 4 big advantages

- 1 **2 Ranges . . .** 0-8 and 0-16 volts, continuously variable.  
10 amperes continuous duty up to 12 volts. 20 amperes intermittent service.
- 2 **Less than 1 1/2% ripple\* output . . .** a must for TRANSISTOR radio operation—perfect for tube sets. Prevents transistor damage, reduces audio hum.
- 3 **Conduction-cooled selenium rectifiers . . .** the entire steel cabinet acts as heat sink—gives over 450 sq. in. of cooling surface. Rectifier life is lengthened . . . normal rating is **doubled**. Patented—an **exclusive** Electro feature!
- 4 **Rugged choke input filter . . .** gives smooth filter action, better regulation, stable output.

\*Up to 5 amps.



More DC Power  
Per Dollar

### ELECTRO PRODUCTS LABORATORIES

4501-T North Ravenswood Ave.  
Chicago 40, Ill.

### Send today for detailed Bulletin

Electro Products Laboratories  
4501-V Ravenswood Ave., Chicago 40, Ill.

Rush descriptive and technical data on  
MODEL D-612T Power Supply,

FIRM NAME \_\_\_\_\_

ADDRESS \_\_\_\_\_

CITY \_\_\_\_\_ ZONE \_\_\_\_\_ STATE \_\_\_\_\_

7077

Canada: Atlas Radio Ltd., Toronto

# Traffic Appliance Servicing

## How Automatic Electric Coffee Percolators Operate and How To Repair Them

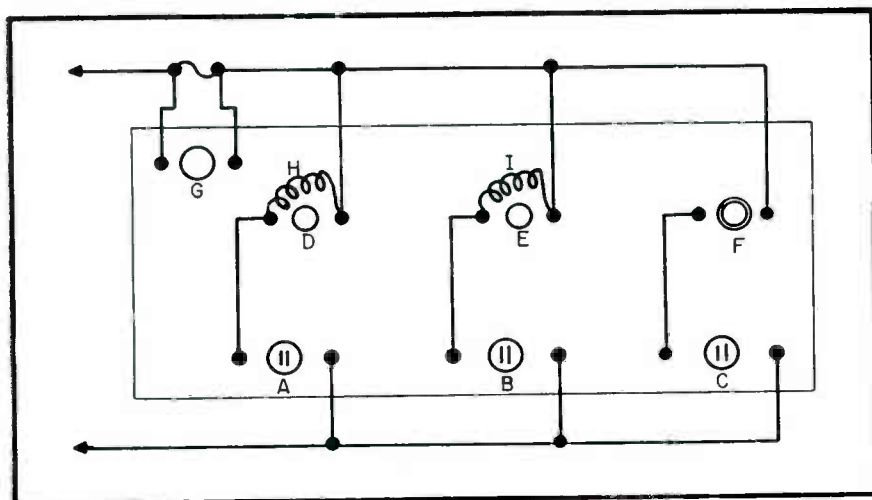
WITHIN THE LAST FEW YEARS the electric automatic coffee percolator has become the third most popular traffic appliance and as a result an expanding need for service has developed.

Basically, all percolators operate in the following way: Cold water must be used in all instances; if not the operation of the entire timing mechanism is affected. Perking action should take place almost immediately and the surrounding liquids should heat up while this perking action continues. This action should stop when the fluid of the vessel is below the boiling point of water. In most makes this condition is indicated by a pilot light that flashes on when the main heating element cuts out. At this point a low-wattage heating element serves to keep the coffee hot (approximately 170°), if, of course, the percolator is connected to the power line.

### Design Variables

In the *Universal* automatic percolator there are two separate heating units; the main heating and the warming units. Used, too, is a bi-metal strip, which upon reaching a maximum temperature point will bend towards switch contacts; on the

**ELECTRIC PERCOLATOR testing board.** A=receptacle for testing 400 to 600-watt percolators; B=receptacle for 1000-watt unit tests; C=receptacle for continuity checks; D—E=receptacle for a 6 to 8-v bulb (such as pilot bulb No. 43); F=oulet for 7-watt 117-v bulb; G=standard fuse receptacle (15 amperes); H=9 turns of a .660-watt coil element and I=9 turns of a 1000-watt coil element.



by SOL WALLACH, Electra-Craft Appliance Company

position known as *strong*, the contacts are forced to open at approximately 204°. At this moment the indicator light will go on and the warming unit will remain in the circuit.

### Calrod-Rod Types

The Westinghouse percolator (model PE-541) has a calrod unit welded to the base of the body to heat the liquid at the same time that another element heats the well where perking action takes place. There are two thermostats on this model; the first one cuts off the calrod unit at 160°-180° and perking action continues until the temperature of 190°-200° is reached in the *strong* position.

In another Westinghouse model (PE-552) there's a preset thermostat that cuts out the main perking unit at 180°-190° and keeps a warming unit on to keep the liquid hot.

### Indicator-Light Models

A fourth type, the *Presto* percolator, has an indicator light that goes on when the appliance is plugged in.

It also has a calrod element welded to the bottom of the body. On the *strong* position, the calrod element should cut out at 190°-194°; perking action will continue for 3 to 5 minutes and then the indicator light will go out.

### Preset Thermostats

Still another percolator, the *Mirro*, has a factory-preset thermostat that will cut out the main combination heating and perking element at approximately 195° and a 30-watt warming element will continue to warm the liquid. This type of preset thermostat is used by many manufacturers and can be easily recognized.

A preset thermostat with only one heating unit is used in the *West-Bend* models; here the thermostat cuts in and out to keep the coffee hot.

### Booster-Perking Elements

A pair of 400-watt elements are used in G.E.'s percolator (model 13P30). One is a booster element for heating the liquid, the other for perking. A low-wattage element is used to keep the coffee hot.

Another G.E. model (P-31) uses a bi-metal blade which opens the control switch at 181° to 195° and throws a *keep-warm* unit in series with the perking element to develop about 50 to 70 watts to keep the coffee hot.

### Service Tools

The tools required for servicing are mostly standard nut drivers, screwdrivers, long-nosed pliers, diagonals and crimping pliers. A suitable thermometer is a must. It must have a range of 60° to 300° F and should be long enough to reach almost the bottom, yet extend up through the top so that it can be easily read.

Special attention should be given to the inset or stem. The valve washer

(Continued on page 61)

*television's most dramatic*

*indoor antenna*

**Snyder**  
PHILADELPHIA

**IMPERIAL**

**Directronic® 10-D**

*the ultimate in beauty  
and performance*

*Handsome cabinet in choice of traditional walnut, contemporary blond or smart ebony tones. Four-section extendable gold tone staff with 360° Roto-Tilt adjustment; the exclusive Snyder 12-position Directronic® Beam Selector For black & white and color, all channels. 10-day money back guarantee. Insured by the world's largest and oldest insurance company.*

*Another Antenn-gineered Original*

by **Snyder**  
MANUFACTURING COMPANY

*Twenty Dollars*



PATENTS  
PENDING

**SNYDER** Manufacturing Company

PHILADELPHIA · LOS ANGELES · TORONTO  
EXPORT: ROBURN, NEW YORK



... another  
**MALLORY**  
service-engineered  
product

for value in  
"wire-wounds"  
make it  
**MALLORY**

Take your choice of these Mallory wire-wound resistors, and you're sure of long service and stability on any replacement job.

Mallory vitreous enamel resistors are protected against moisture and corrosion by a special non-porous, non-alkaline vitrified coating . . . are wound on a high-stability steatite core. In both fixed and adjustable types, 5 to 200 watts.

Mallory axial lead resistors, famous for cool operating and easy mounting, are coated with a dense, non-corrosive cement that keeps moisture out, and assures good heat dissipation. Leads can't pull away from the winding. 4-watt and 7-watt ratings, in a full range of resistance values.

Order now—from your nearby Mallory distributor!

**P. R. MALLORY & CO. Inc.**  
**MALLORY**  
P. R. MALLORY & CO. Inc., INDIANAPOLIS 6, INDIANA

- Capacitors
- Vibrators
- Resistors
- Power Supplies
- Mercury Batteries
- Controls
- Switches
- Rectifiers
- Filters

## ASSOCIATIONS

### IRTSA, Wisconsin

At the annual election of officers of the Indianhead Radio-TV Servicemen's Association, Wisconsin, *Everett Siemond* was elected president; *Clyde Struve* was named vice president; *Richard Presnell*, secretary, and *Vernon Meindel*, treasurer.

*Kenneth Wheeler* was appointed chairman of the program committee, and *C. W. Stiemke* will continue in his post as corresponding secretary.

### TSA, Albany, N. Y.

THE TELEVISION SERVICE ASSOCIATION, Albany, N. Y., has elected *Warren Baker* president.

Other new officers include *Henry T. Sepulski*, vice president; *William Noah*, treasurer, and *William Skilling*, secretary.

### CSEA, California

THE BOARD OF DIRECTORS of the California State Electronics Association, headquartered in Fresno, California, now consists of the following members: *H. Lawrence Schmitt*, president; *Jim Wakefield*, secretary; *Lee Johnson*, vice president; *John Blackwood*, treasurer; and *Art Blumenthal*, *Herb Sulkin*, *George Martin*, *Arnold Meyer*, *Ray Warthen*, *Jack Halloway* and *Ed Mitchell*.

On the board of delegates are: *Ed Mitchell* (TSDA, San Mateo County); *Andy King* (RTA, Vallejo); *Jack Brown* (RTA, San Gabriel Valley); *Morris Bloombaum* (SRTT, San Fernando); *Del Davis* (SRTT, Glendale); *Dick Kelso* (RTA, Santa Clara Valley); *Fred Abrams* (Long Beach RTA); *Lloyd Brown* (RTA, South Bay); *E. E. Harris* and *Jerry Strouse* (San Francisco Technical Guild); *Howard Bogue* (Citrus Belt RTA); *Mel Dumolt* (RTA, Alameda County); *Vernon Steinhauer* (CEA, Fresno); *Vic Bangle* (RTA, San Antonio); *Ben Leff* (RTA, Pasadena); *Walt Rundquist* (RTA, Los Cerritos); *James Brewer* (ARTDA, Sacramento); *Clinton Matthews* (RTA, San Diego County); *Harry Bernstein* (RTA, Santa Monica); *Tom Lawson* (Tri County RTA); *Bob Martin* (San Joaquin RTA); *J. Blackwood* (TV Service Association of Bakersfield); and *G. McGeorge* (RTA, Salinas).

The state association has been set up on a five-section basis covering the following areas: *A*, northern end of the state south to Santa Clara County; *B*, the Fresno region; *C*, the Bakersfield region; *D*, the Los Angeles area; and *E*, the San Diego territory.

Twenty-two local associations are now members of CSEA.

### TSA, Seattle, Wash.

*HAROLD HART* has been elected president of the Television Service Association of King County, Seattle, Washington.

Others named were *Clayton Fuller*, vice-president; and *Ray Murphy*, secretary-treasurer.



**NEW OFFICERS OF ESFETA** (left to right): P. P. Pratt, treasurer; Gordon Vrooman, president; Robert A. Larsen, vice president; and Thomas Salisbury, sergeant-at-arms. George Carlson, secretary, was absent when photo was taken.

**ESFETA, New York**

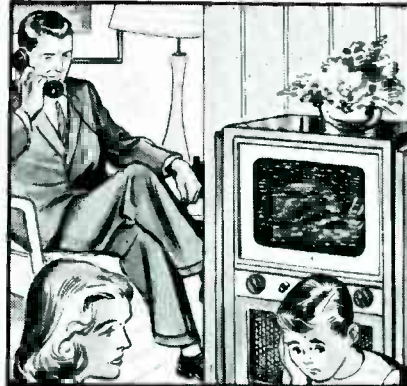
GORDON VROOMAN, of the Syracuse TV Technicians Association, has been re-elected president of the Empire State Federation of Electronic Technicians Associations. Robert Larsen, of the Radio Television Guild of L. I., has been elected vice president; George Carlson, of the Electronic Technicians Association of Jamestown, secretary, and P. P. Pratt, of the Television Electronic Service Association of Western, N. Y., has been renamed treasurer. Thomas Salisbury, of the Mohawk Valley TV Technicians Guild, is now ESFETA sergeant-at-arms.

Four associations have been accepted by ESFETA as member associations: Tri-County Electronic Technicians Association, Olean; Rockland Association of Electronic TV Services, Pearl River; Mohawk Valley TV Technicians Guild, Utica; and Tompkins County TV Dealers Association, Ithaca. There are now eleven associations active in ESFETA. The state body is now said to represent 80% of the organized service associations in New York.

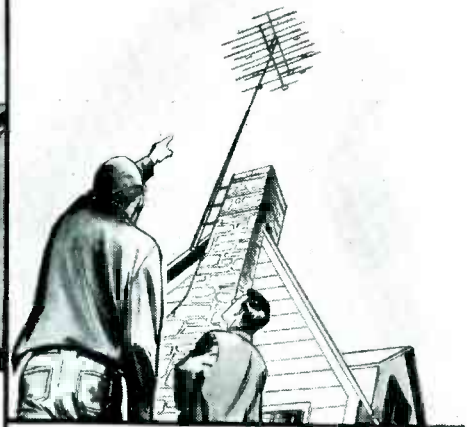
**TEN YEARS AGO IN SERVICE**

COMPONENT, ACCESSORY and test-equipment manufacturers disclosed plans for nationwide clinics, co-sponsored by local distributors and in some instances associations, featuring technical sessions on tube testers, alignment, troubleshooting, emergency repair and antenna installations, with emphasis on TV and FM chassis. . . . A number of associations indicated keen interest in a national service association, patterned like the Institute of Radio Engineers, that would be known as the Society of Service Engineers. . . . The first analyses of mixer-oscillators used in Philco, G.E., RCA, and DuMont TV chassis were published in SERVICE. . . . An exclusive report on the testing and troubleshooting of shaded-pole motors used in small fans, blowers and phono players also appeared. . . . A code-of-ethics program for Service Men was outlined by Herb Clough, chairman of an industry parts coordinating committee, at a meeting attended by Jack Berman, representing EPEM; Harry Walker, RMA; Bob Baggs, Sales Managers Club, and Bill Schoning, NEDA.

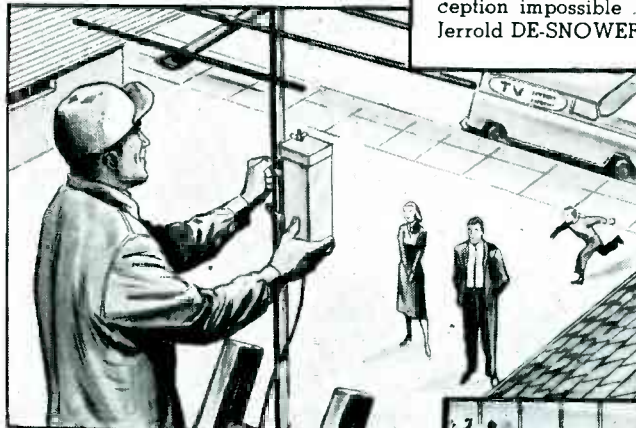
# The Case of The Serviceman WHO KEPT IT CLEAN!



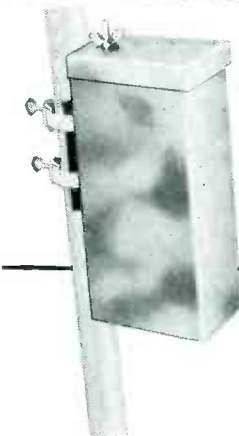
The fringe area Jones family wanted TV entertainment but got "snow". When Junior's favorite show was ruined once too often, the serviceman was called in.



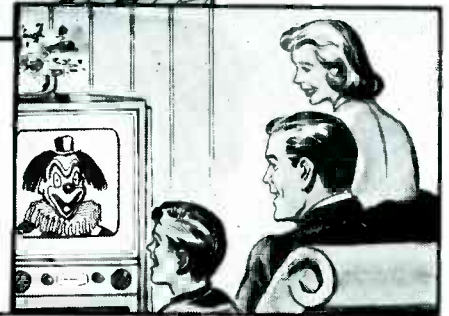
He pointed out that even with a good antenna weak signals are affected by line loss and noise, making good reception impossible . . . recommended a Jerrold DE-SNOWER.



Antenna mounted, the DE-SNOWER captures the signal before loss and noise affect it, delivers it to the set over shielded coax . . . providing snow-free pictures.



Thanks to the serviceman and Jerrold the Joneses get high fidelity color and black and white pictures every time!



## THE JERROLD DE-SNOWER

A high profit pre-amplifier accepted everywhere! Combines 25 db gain with low noise input—only 6 db. No AC outlet or separate wiring on mast.

Available in 3 models—Single Channel; Broadband Chs. 2-6, Broadband Chs. 2-13. Packed complete with remote 24 volt power supply. See the DE-SNOWER line at leading distributors or write direct for illustrated brochure to: Dept. P. D. #5

### JERROLD ELECTRONICS CORPORATION

23rd & Chestnut Sts. Philadelphia 3, Pa.  
LOOK TO JERROLD FOR AIDS TO BETTER TELEVIEWING

# hi-LOW with ATLAS

high quality  
low price



**PAGING & TALK-BACK SPEAKERS**  
6 sizes and types.  
All impedances  
from 4 to 45 ohms.  
From 5 to 15 watts.  
From \$15.00 to \$24.00 NET.



**WEATHERPROOF LINE MATCHING TRANSFORMERS**  
For constant impedance  
or constant voltage systems.  
\$5.00 NET.



**HIGH-POWERED PUBLIC ADDRESS SPEAKERS**  
Four sizes from 2½' to 6' air column.  
From \$10.00 to \$39.00 NET.



**U-I APPROVED EXPLOSION-PROOF SPEAKERS**  
For hazardous applications.  
Several sizes, all classes.  
From \$66.00 to \$75.00 NET.



**SUPER-POWER DRIVER UNITS**  
For all purposes,  
powers, frequencies.  
From \$15.00 to \$30.00 NET.



**MIKE STANDS & ACCESSORIES**  
All sizes and types:  
boom stands, desk stands,  
adapters, fittings, etc.



**NEW! SWITCHBOARD MIKE SUPPORT**  
Adjustable 12" goose  
neck. Use as desk support,  
for dispatcher office,  
dais, table, etc.  
#SB-1 . . . \$7.80 NET.

**New!**



**NEW! "CHESTY" NECK-SUPPORTED MIKE STAND**

Quick, easy 3-way  
adjustment. Lightweight.  
Multiple uses.  
#NS-1 . . . \$3.00 NET.

**New!**

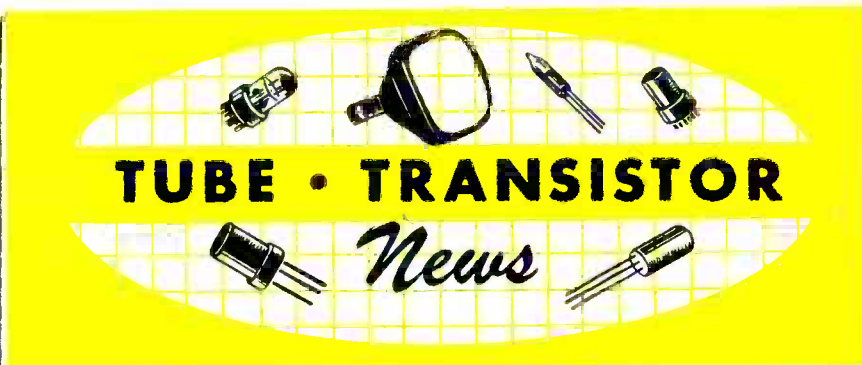


**NEW! MIKE FOOT SWITCH**  
Hand, foot or knee  
operation—shielded,  
grounded, noise-free,  
dependable, damage-proof.  
#FS-1 . . . \$7.20 NET.

SEND FOR COMPLETE  
FREE CATALOG



**ATLAS SOUND CORP.**  
1442 39th St., Brooklyn 18, N. Y.  
In Canada: Atlas Radio Corp.,  
Ltd., Toronto, Ont.



## Design-Application Notes on New Beam-Power AF Tubes . . . Transistors for High-Power AF and TV, and Two-Way-Radio

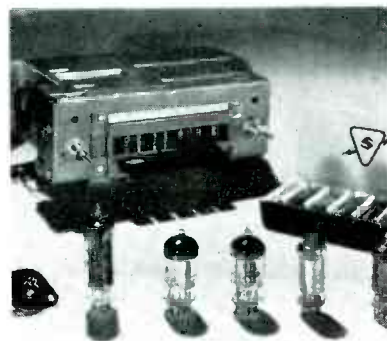
THE ACCELERATED interest in audio has prompted the development of new types of tubes and transistors to provide improved performance. Recently, one manufacturer<sup>1</sup> announced a beam power tube of the 7-pin miniature type for use as a class A amplifier in the audio output stage of TV and radio receivers.

The tube (6DS5), when used in cathode-bias circuits, can deliver a maximum-signal power output of approximately 3.6 watts with a peak *af* grid-1 voltage of 9.2. Cool operation of grid 1 is claimed because of the tube's structural design which minimizes grid emission. In view of this feature, the 6DS5 can be used with cathode bias and a relatively large value of grid-1-circuit resistance. This is a significant feature in TV receivers where the audio output tube is driven directly by the FM detector tube.

### Transistor Developments

IN THE TRANSISTOR FIELD, one company<sup>2</sup> has developed a pair of high-power types, with it is said a significant potential in audio amplifiers.

Designated the MN-24 and MN-25,



RECEIVING TUBES and transistor (foreground), manufactured by Sylvania, presently being used in 12-volt hybrid auto radios.

the transistors can provide 30-35 db gain at less than 5% total harmonic distortion when delivering 4 watts.

These new types were noted as embodying a number of advantages over earlier models: More power, more reliable high-temperature performance, gain maintained at high power, and less distortion.

THREE NEW HIGH-FREQUENCY transistors (germanium tetrodes)<sup>3</sup> have also been announced. Among some of the possible applications of these new semiconductors are TV sets, and two-way radio transmitters and receivers.

One of the transistors has been designed to amplify at 120 mc.

The new tetrodes are produced by the meltback process. In this process layers of *p*-type germanium are produced; these are said to be so thin that twenty such layers would be required to equal the thickness of a single magazine page.

The tetrode transistors are hermetically sealed in an all-metal case of welded construction. The transistor package is designed for use on printed-wiring boards.

The new transistors have been designated 3N29, 3N30, and 3N31. With a common base connection and a bandwidth of 2 mc, they are rated for a minimum of 10 db gain, respectively, at 30 mc, 120 mc and 15 mc.

Maximum collector dissipation for all three units is 50 milliwatts at 25°C. They are rated for operation at a maximum junction temperature of 85°C.

The allowable collector voltage for the three devices is 7.

For receiver local oscillator use, the 3N29 has an oscillating frequency of 50-60 mc; the 3N30 will oscillate at over 200 mc, and the 3N31 at 30 to 40 mc.

<sup>1</sup>RCA    <sup>2</sup>Motorola    <sup>3</sup>G. E.

# You Have More TO SELL WITH A Winegard

The more sound selling facts you can put before a customer, the more chance you have of closing a sale! And the Winegard Color'Ceptor gives you selling points no other antenna can offer . . . exclusive buying appeals that clinch 9 out of 10 sales!

## They See the Gold and They're Sold

The gold-anodized finish of the Color'Ceptor gives it a rich, quality appearance not found in any other antenna. When you show the Color'Ceptor alongside competitive models, the Color'Ceptor is so distinctive, so finished-looking that it is invariably selected by your customers. Gold-anodizing has a practical sales advantage, too. It provides immunity to corrosion—prevents deterioration in performance.

## If the Winegard Color'Ceptor Won't Bring in a Station You Want to See . . . Nothing Will!

Proof of performance was dramatically illustrated when Robert Seybold of Dunkirk, New York—using a Winegard Antenna—broke all long-distance reception records in 1956 (see Radio-Electronics Magazine, Jan., '57). Equipped with optional signal-boosting Power Pack and patented "Electro-Lens"\* focusing, the Color'Ceptor is second to none for long-distance reception and clear, watchable pictures in both black-and-white and color!



## The Sign of Better Business

The Winegard Authorized-Dealer decal (pictured above) is proving a real business-builder for every dealer who displays it. Heavily promoted in Winegard's national advertising, the decal tells the world that "here's the place to buy the gold-anodized Color'Ceptor."

## Want More Details?

Mail coupon below for all the facts on Color'Ceptor's spectacular success story! Winegard gives you everything you need to make antenna sales boom—the product, free display, national advertising, proven sales techniques. Join the swing to Winegard—it's the best move you can make!

 **Winegard company**

Dept. B5, 3000 Scotten Blvd., Burlington, Iowa

Name \_\_\_\_\_

- Please rush me free 4-color descriptive literature on your gold-anodized Color'Ceptor and information on display material.
- I'm interested in the complete line of new 1957 Winegard antennas.

Company \_\_\_\_\_

Address \_\_\_\_\_

City \_\_\_\_\_ State \_\_\_\_\_

# Winegard Color'Ceptor TV Antenna



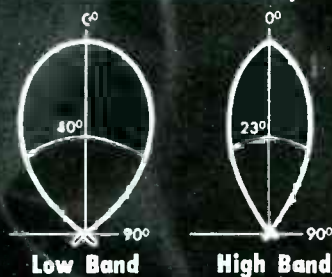
all 12 VHF Channel Reception For Both Black-and-White and Color

*Color so bright they sell on sight!*

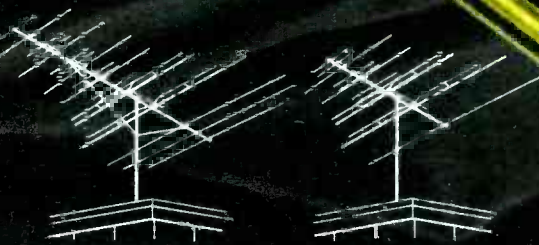
### Notes:

Even gold Color'Ceptor you install helps sell another. Once folks see these bright gold antennas sprouting up in their neighborhood, they won't be satisfied until they own the gold antenna, too!

### Horizontal Directivity



Gain Chart CL-4X with Power-Pack



Color'Ceptor Model CL-4X — \$44.90

Color'Ceptor Model CL-4 — \$29.95

If Color'Ceptor won't bring in a station you want to see . . . nothing will!

### Exclusive Color'Ceptor features

- Completely non corrosive gold-anodized finish.
- Power-Pack—up to 47.1% more sensitivity.
- Pat. "Electro-Lens"\* - clearer pictures at greater distance.

Winegard Color'Ceptors are consistently advertised in leading national magazines your customers read!



 **Winegard Co.**

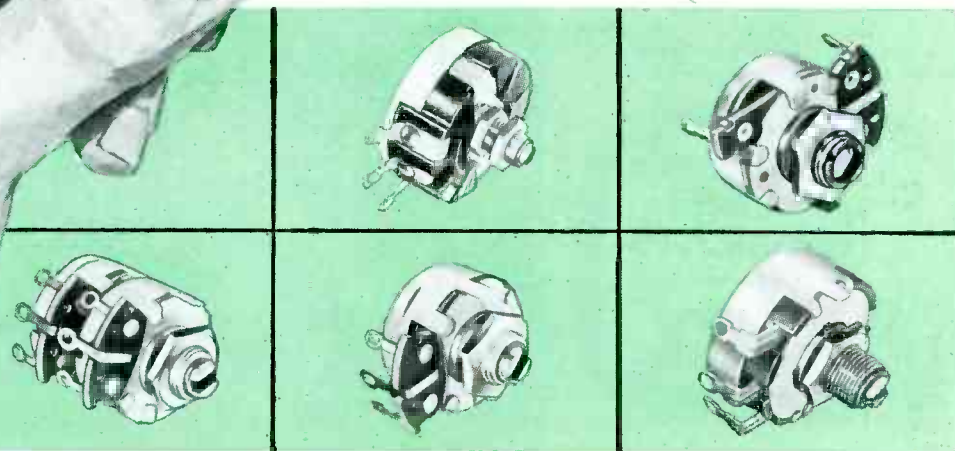
3000 Scotten Blvd., Burlington, Iowa  
Cable Address: Western Union JWCO

\*Pat. No. 2,700,195 Copyright © 1957

Choose the shaft  
**YOU WANT...**



WITH EVERY CLAROSTAT  
 PICK-A-SHAFT\* CONTROL YOU GET YOUR  
 CHOICE OF SHAFT AT NO EXTRA COST!



Select the control you want — ½-watt composition-element, regular, tapped, or dual; 2-watt wire-wound; 3-watt wire-wound; or 4-watt wire-wound. Then choose from any one of 13 different shafts. There's one for every need.

\*Reg. U.S. Pat. Off.

Ask your Clarostat Distributor...



for **P**erformance... **D**ependability... **Q**uality...

*Controls and Resistors*

CLAROSTAT MFG. CO., INC., DOVER, NEW HAMPSHIRE

In Canada: CANADIAN MARCONI CO., LTD., TORONTO 17, ONT.



MULTIPLE REFLECTIONS developed by metallic objects in a room represent one of the major problems in indoor TV reception. Such multiple reflections due to bouncing of horizontally-polarized waves at all angles, make it difficult to orient an indoor antenna properly.

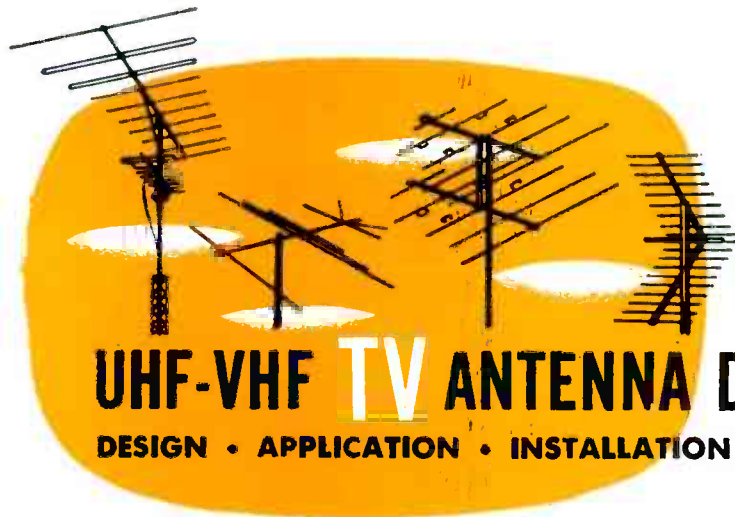
Initially, the picture and sound signal energy is transmitted with horizontal polarization; that is, a horizontal antenna is used and the transmitted wavefront of energy is as indicated in Fig. 2, where the electrostatic lines of force are in a horizontal plane. When high frequency signals travel through space, part of the horizontally polarized waves invert (about 10 to 20 per cent) and actually arrive at the TV antenna vertically polarized; Fig. 3. Thus, since the receiving antenna is horizontal in its position, all the energy is not picked up because horizontal antennas are not sensitive to vertically-polarized waves. Tilting an antenna upward, as is sometimes done with rabbit-ear types, helps; but at an angle between true vertical and true horizontal portions of the vertical and the horizontal signals are lost.

If the rabbit-ear type of indoor antenna is adjusted so that both of the elements are in a vertical plane, the lines of force of each interact and tend to cancel each other, because the two vertical rods act as a transmission line section instead of an antenna.

### Field Investigation

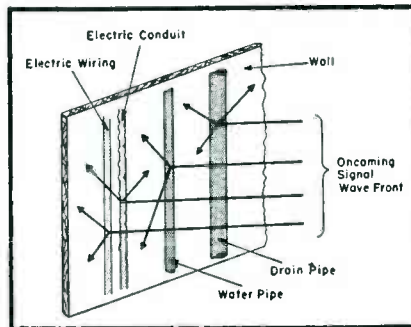
In an investigation of these problems, it was discovered that at low levels in built-up areas, or indoors, over fifty per cent of the signal often was vertically polarized.

Thus, it was felt that the answer to the problem lay in a technique that would permit pickup of the vertical waves, or those near vertical, and this could be accomplished with



## Analysis Of An Indoor TV Antenna Using A Single Vertical-Element Rod For Pickup

by MATTHEW MANDL



**FIG. 1: HOW METAL** in walls can cause reflection of TV waves. Metallic objects in ceilings and floors would add to multiple reflections and re-reflections. Tests have indicated that an almost unmeasurable amount of reflections occur in a typical room, causing points of high gain where in-phase conditions exist, and low gain and interference where out-of-phase points occur.

a single-rod vertical member which could be angled or tilted slightly to

<sup>1</sup>Snyder 10-D.

take advantage of the waves that are slightly off the true vertical plane.

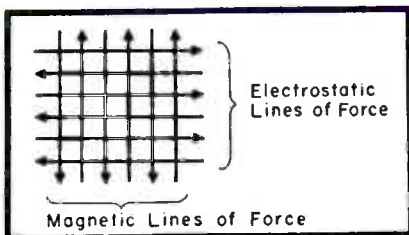
### Vertical Member Design

Experiments with various straight-rod element systems resulted in the design of a model<sup>1</sup> with a single member whose length could be extended substantially to meet receiving conditions in a room. Since the use of a single rod left one side of the transmission line open and unbalanced, it was found necessary to incorporate a bent-rod load (within the housing) to provide system balance.

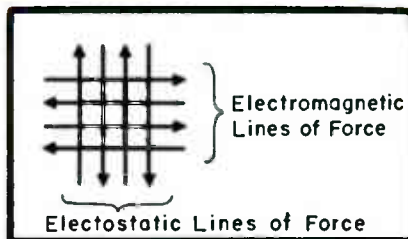
### Phasing Section

A phasing section, harmonically related to the channels, was also included; in addition, a 12-point position selector switch was circuited in the system so that the normally low

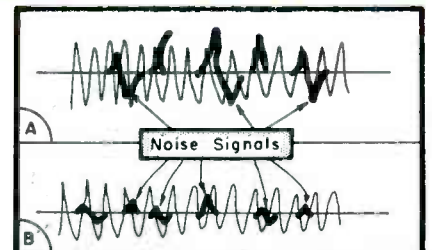
(Continued on page 48)



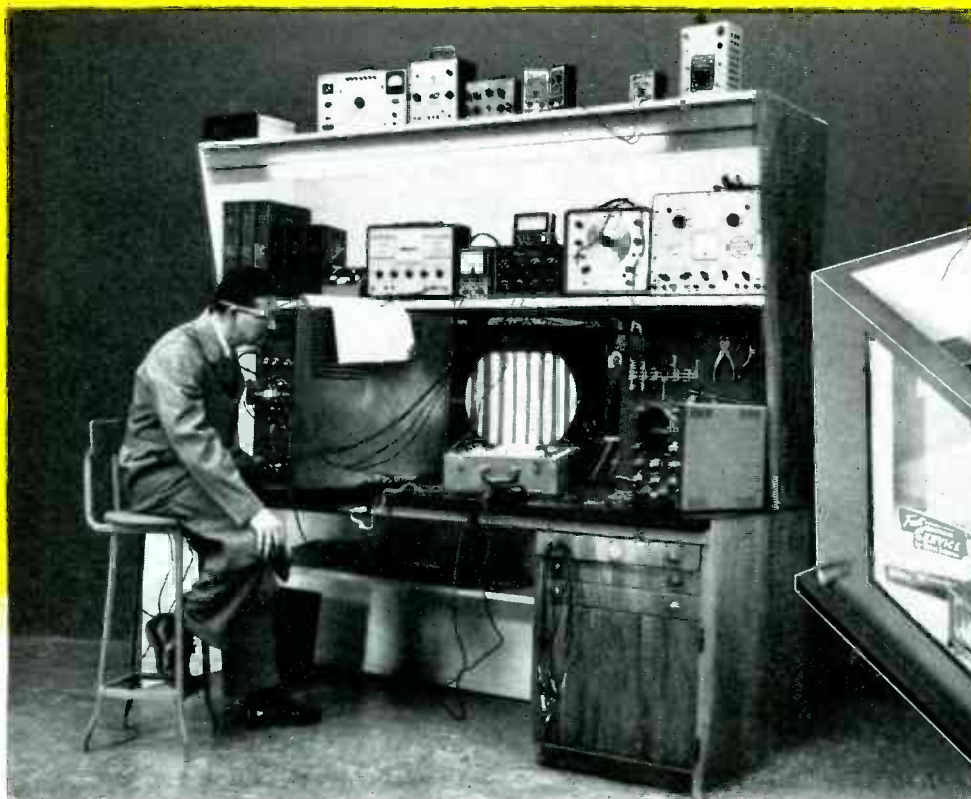
**FIG. 2: SINCE THE** transmitted signal from a TV station is horizontally polarized, the type of wavefront transmitted shown above results; here the electrostatic lines of force are horizontal.



**FIG. 3: AFTER THE TRANSMITTED** energy leaves a TV antenna and travels through space, some of the vhf horizontally polarized energy (about 20%) inverts and becomes vertically polarized, as illustrated here.



**FIG. 4: NOISE SIGNALS** for horizontally-polarized waves that are present during indoor pickup are shown in the (a) traces. The relative noise reduction that occurs when the waves assume vertical polarization is illustrated in (b).



# JOIN THE 50,000 PROGRESSIVE READY TO MODERNIZE WITH NEW

Over 50,000 TV-radio service dealers already have asked for the new General Electric shop plans (above) that were specially developed for the independent technician. Dealers in every part of the country know that today's growing market for service, calls for improved facilities... and that proper planning saves space, costs, time, and labor.

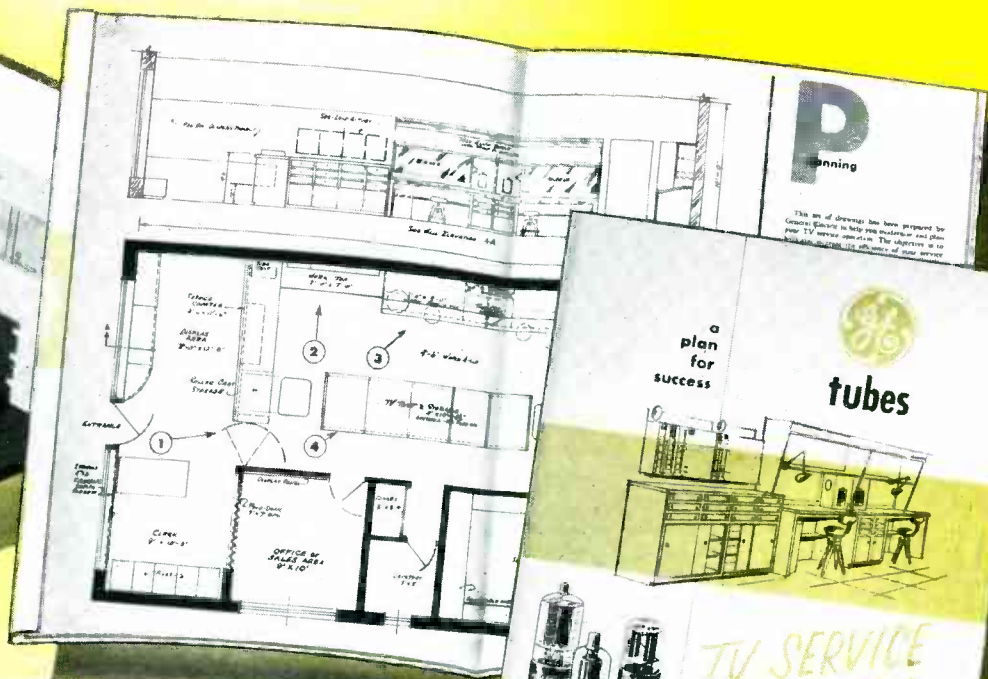
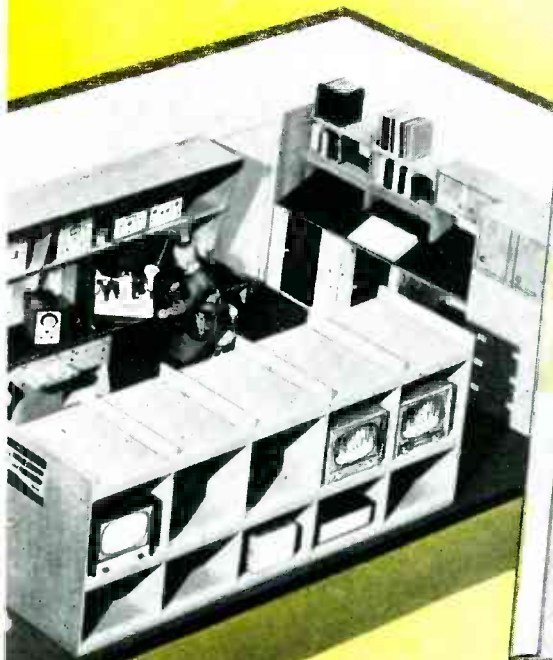
You too can modernize for the in-

creased volume that lies ahead... by following the practice of other progressive technicians, and using General Electric's shop layout to equip your shop for top-efficiency service to more customers. Phone your local General Electric tube distributor for complete plans! They include dimension drawings and material lists, so a carpenter or builder can start work at once.

*Progress Is Our Most Important Product*

**GENERAL**  **ELECTRIC**

161-1A20

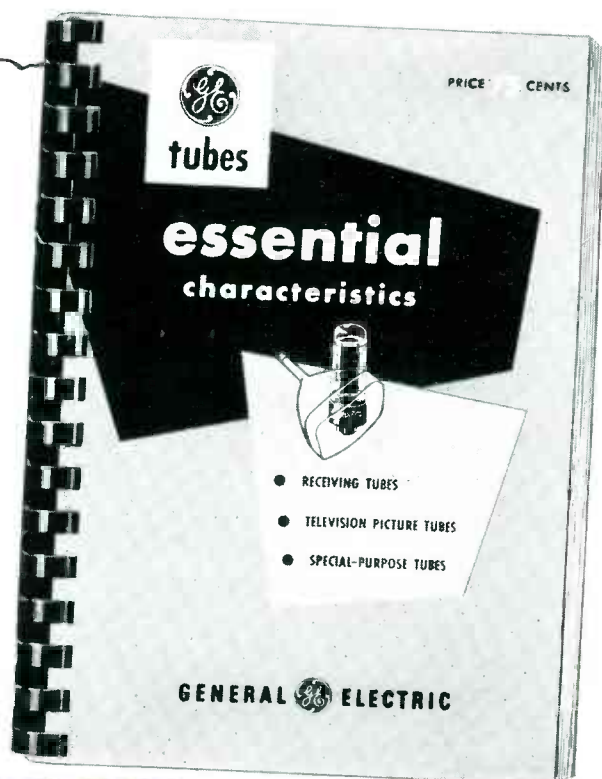


# SERVICE DEALERS GENERAL ELECTRIC SHOP PLANS!

**AND NOW**

**ANOTHER G-E BUSINESS-BUILDING,  
TIME-SAVING AID TO THE  
INDEPENDENT SERVICE TECHNICIAN...**

Most complete tube guide ever published—the new edition of “Essential Characteristics”! Over 1500 types, with descriptions, ratings, and basing diagrams. Pocket size. See your General Electric tube distributor immediately!



**Only one  
Manufacturer  
Specializes  
in TV  
Replacement  
Tuners  
...that is  
STANDARD  
COIL**

See the ultimate in TV tuners  
Standard Coil's new line of APPROVED  
NEUTRODE REPLACEMENT TUNERS  
Booth 691—Room 2405-6 Conrad Hilton  
May Parts Show

*Standard*

**Coil Products Co., Inc.**  
2085 North Hawthorne Avenue · Melrose Park, Ill.  
In Canada: Standard Coil Products Co. Limited, Toronto

Overseas:

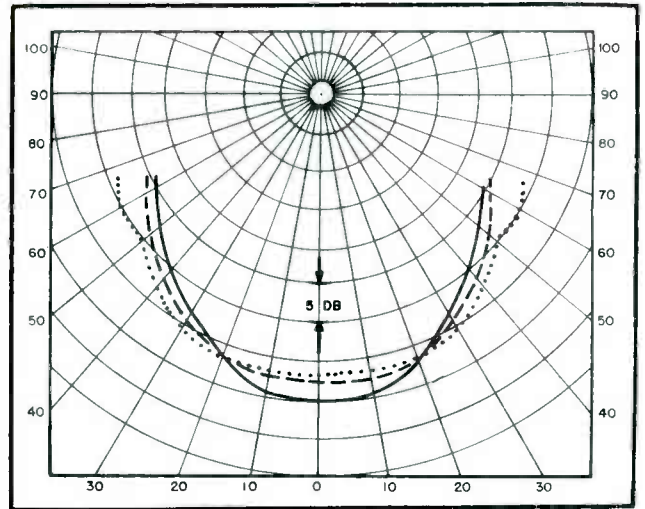
*Scheel*

International, Inc.  
Chicago, Ill.



**ABE COHEN**, engineering manager for University, applying a driver unit into a reflex trumpet preparatory to testing for polar-frequency response. Wide-angle trumpet, on stand, has just been similarly tested.

**FIG. 1: POLAR PATTERNS** at 1000 cps for a 4½' directional horn (solid line), 2½' directional horn (dashed line) and 4½' wide-angle horn (dotted line).



## Round and Wide-Angle Horns

### How To Determine Which Type To Use In A Sound-System Installation

WITH THE ADVENT of *wide-angle* dispersion trumpets in the 40's and the subsequent introduction of a number of variations featuring advanced designs, Service Men often find themselves in a quandary on speaker choice. Factually speaking, while both directional and wide-angle type horns are popularly employed in the field today, the author has come to wonder whether the reasons for selection are equally factual.

If either type is occasionally compromised by improper application or installation, it has not been the fault of the Service Man. Advertising claims are easily misinterpreted, not so much by what is stated as what is *not*. Both type designs have a definite place in modern sound, but truly suc-

by LAWRENCE J. EPSTEIN  
University Loudspeakers, Inc.

cessful utility of the advantages of each is assured if we also appreciate the limitations.

#### Trumpet Characteristics

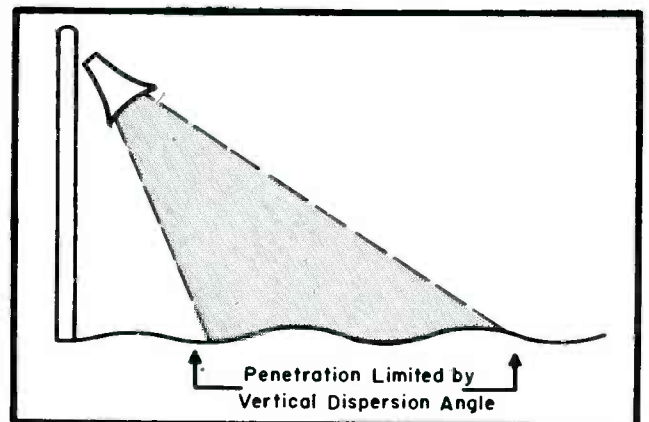
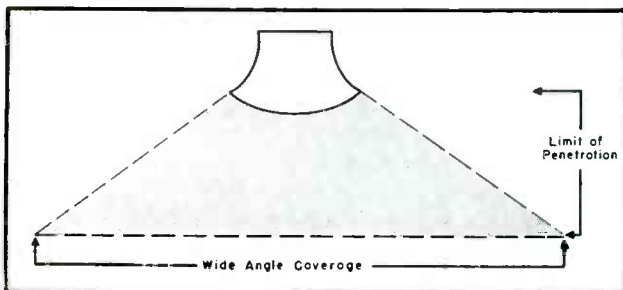
All too often the selection of a loudspeaker is predicated on habit, price, and insufficient understanding of loudspeaker characteristics. The latter is of inestimable value is planning a successful and *economical* system.

For example, it has been common practice to select heavy-duty trumpets primarily on the basis of initial cost, usually with the idea that only low

frequency response is being compromised. A second glance at trumpet specifications will reveal a relationship between trumpet size (air-column length and horn-mouth diameter) and the angle at which the sound is dispersed. Note that the dispersion angle *decreases* as the horn size increases. Thus a gain in fidelity is accompanied by a loss of coverage off the speaker axis. On the other hand, if the sound is required to penetrate to as great a distance as possible, or override high ambient noise, the larger trumpets with their sharper distribution pattern will provide more sound intensity along the speaker axis than the smaller horns. The larger horns, in addition to

(Continued on page 44)

**FIGS. 2a AND b: COVERAGE** of wide areas with little depth that obtains when wide-angle trumpets are used as normally recommended.



## Round and Wide-Angle Horns

(Continued from page 43)

affording greater protection to the driver unit against low-frequency overload, distribute the load on the driver diaphragm more uniformly, thereby producing smoother overall response as well. Obviously, then, there are three essentials to be considered when selecting a trumpet; fidelity, distribution angle and penetration of distance or noise.

Four trumpet sizes are available for applications where directional pro-

jection characteristics are preferred. One type is a reflex trumpet with a 6½' air column having a low frequency cutoff especially suited for reproduction of musical programs. Then there is the 4½' air column trumpet, recommended for general applications requiring good music and speech characteristics. Also available is a 3½' trumpet, with a slightly higher cutoff than that of the 4½' horn, that is suggested where economy is an important factor in the planning of a music and speech system. Finally, we have 2½' trumpets designed primarily for voice reproduction where a heavy-duty speaker

must be relied on for continuous, highly intelligible speech reinforcement. The 2½' and 3½' trumpets will also provide excellent coverage of wide-angled areas. The 4½' and 6½' horns, with their sharper dispersion characteristics, will deliver *more* sound intensity on axis, and may therefore be used to greater advantages in covering longer distances or beaming sound to where it is particularly required. For determining sound-pressure corrections, relative to a given driver unit on a 6½' trumpet, the data in table I (at right) should be used.

Since the advent of *wide-angle* projection, there appears to be considerable misunderstanding in the field

**STOP LOSSES** due to inaccurate instruments

# CHECK AND ADJUST

Your Test Instruments  
with **LABORATORY ACCURACY**



Designed by  
**MILTON S. KIVER**  
Author of the Book  
"Servicing and Calibrating  
Test Equipment."  
Published by  
Howard W. Sams & Co., Inc.

## New 750 **B&K** TEST EQUIPMENT CALIBRATOR

Calibrates VOM, VTVM and other meters, signal, sweep and marker generators and oscilloscopes.



Provides dc and ac voltages for checking voltage ranges of VOM, VTVM and other meters.



Standard resistances from 10 ohms to 10 megohms for checking reliability of each resistance range in VOM and VTVM.



Crystal oscillator generating harmonics over 300 mc for use as marker generator in all receivers, and to calibrate AM signal generator, and to align TV audio I.F. system.



Built-in tone generator for signal tracing amplifiers in all audio equipment. This tone also available at modulated RF.



Oscilloscope voltage calibrator in measuring peak-to-peak voltages of unknown waveforms.



### Voltage Accuracy ±1% or Better

Avoid instrument errors that cause wrong decisions and time-killing rechecks in receiver testing. With the new, low-cost, laboratory-type Model 750 Calibrator you can quickly, easily check test equipment accuracy and make necessary adjustments.

Provides standard of ± 1% or better in all of its voltage sections—enables you to calibrate your test instruments like the labs do, and give better service at lower cost.

### Model 750 Calibrator

Complete with 5 mc crystal. Operates on 110-120 v., 60 c. ac. Sturdy metal case. Size: 8¾ in. high, 8 in. wide, 5½ in. deep. Net wt. 6¾ lbs.

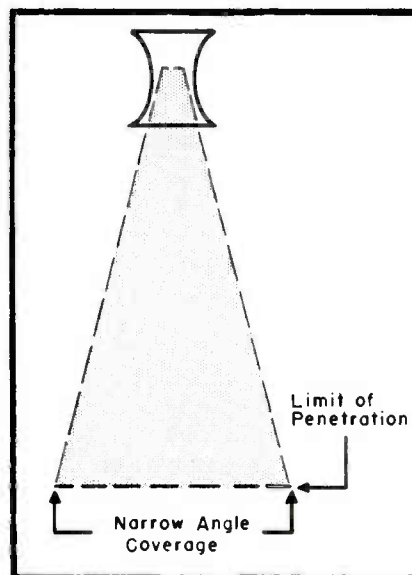
**\$54<sup>95</sup>**  
NET

See Your Distributor or Send For Bulletin 750-S

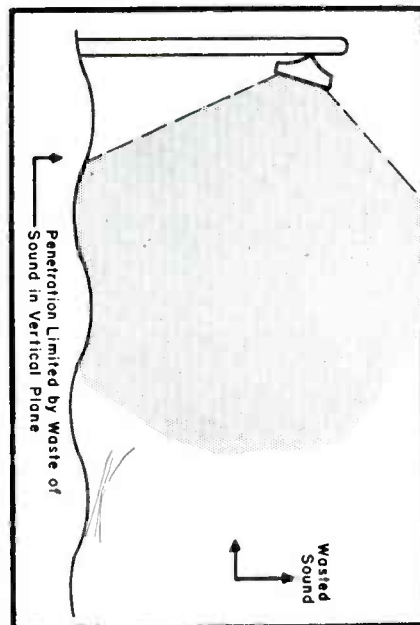
**B & K MANUFACTURING CO.**

3726 N. Southport Ave., Chicago 13, Illinois

Makers of DYNA-QUIK, CRT, DYNA-SCAN and CALIBRATOR



FIGS. 3a and b: **COVERAGE** of very narrow and deep areas that prevails when wide-angle trumpets are used in the reverse plane.



Air-column Length	Deduct
4½'	1 db
3½'	2 db
2½'	3 db

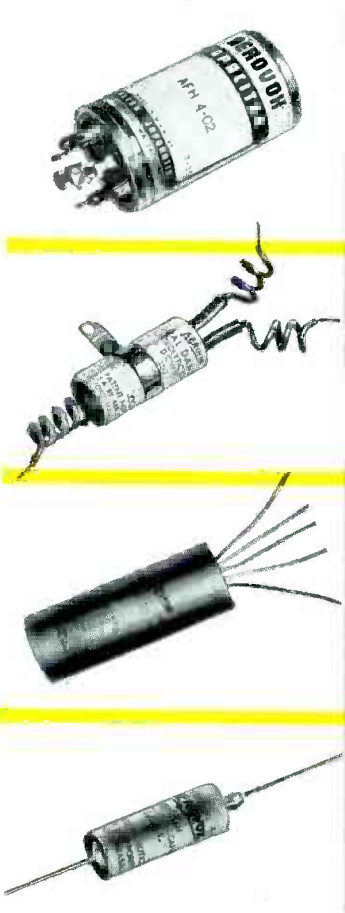
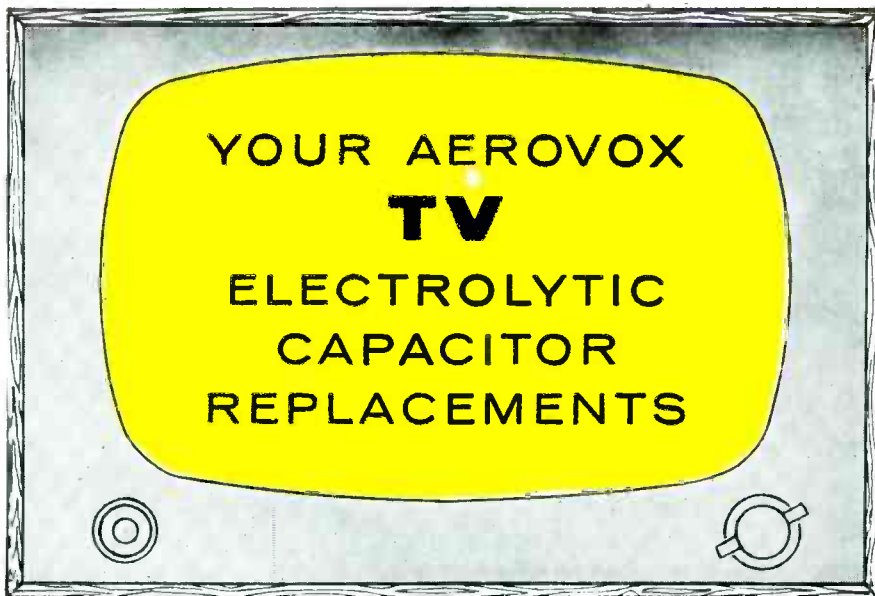
Table 1

regarding the relative merits of directional versus wide-angle horns. Properly applied, a wide-angle horn series is another contribution in solving certain sound problems; but by no means do such horns replace the round *directional* trumpet for general utility and in specific instances. This point is illustrated in Fig. 1 (p. 43), where we have a comparison of the polar patterns (horizontal plane) of a wide-angle 4½' air-column projector and a directional round horn with equivalent 4½' air column (taken at 1000 cps). Response of a round directional trumpet with only a 2½' air column is also included to show what this smaller horn with a wider dispersion than the 4½' directional horn will do. The wide-angle horn provides a much wider pattern than the equivalent round horn but at a *loss* of 3 db in the horn axis region, and a similar *gain* off speaker axis.

If we were to attempt to make up for that loss in order to penetrate to the same *distance* of projection, the power input to the driver on the 4½' air-column wide-angle projector would have to be *doubled*. If it were not a matter of distance, but the need to overcome particularly troublesome noise conditions, again that loss of 3 db could make a big difference in intelligibility. On the other hand, notice how more closely the pattern of the 2½' air-column round directional trumpet follows that of the wider 4½' air-column projector. Though 2 db below that of the 4½' directional horn in the axis region, it is 1 db better than the 4½' wide-angle projector near the axis. Then, it too falls off below the wide-angle projector in the farther off-axis regions. The 2½' round directional trumpet would not, of course, have the low-frequency characteristics of either the 4½' directional horns, due to its shorter air column length.

Clearly, then, what the wide-angle projector has to offer is *uniformity* of wide-angle response, falling off less rapidly, off-speaker axis, than the *equivalent* directional horn. But, does *wide-angle* mean *more coverage*? Not necessarily; it all depends upon the configuration of the area to be covered. If the area is very *wide* but not too deep, the *wide-angle* horn

(Continued on page 56)



**TYPE AFH (85°C) TWIST-PRONG ELECTROLYTICS...**  
the most complete line in the industry, more exact-duplicate replacements than anyone else. All AFH units offer improved hermetic-sealing, sturdy terminals and mounting prongs; hi-purity aluminum foil construction throughout.

**TYPE PRS (85°C) TUBULAR ELECTROLYTICS...**  
compact capacitors in aluminum cans with cardboard insulating sleeves. Available in a complete selection of singles, duals, triples and multiples. Insulated, stranded copper wire leads standard on all units.

**TYPE PR WAX-FILLED TUBULAR ELECTROLYTICS...**  
popular and economical units in cardboard tubes manufactured to the same high standards as more expensive metal-cased types. These are exact-duplicate replacements for TV receivers and antenna rotating devices.

**TYPE SRE "BANTAM" ELECTROLYTICS...**  
small in size but big in performance. Hermetically sealed in aluminum cans and furnished with cardboard insulating sleeves. Perfect for limited space assemblies and miniaturized low voltage circuits.

All these popular Aerovox TV electrolytic capacitors are always carried in stock by your local Aerovox Distributor. Ask him for your free copy of the complete Aerovox Catalog with detailed listings and information on all Aerovox components.



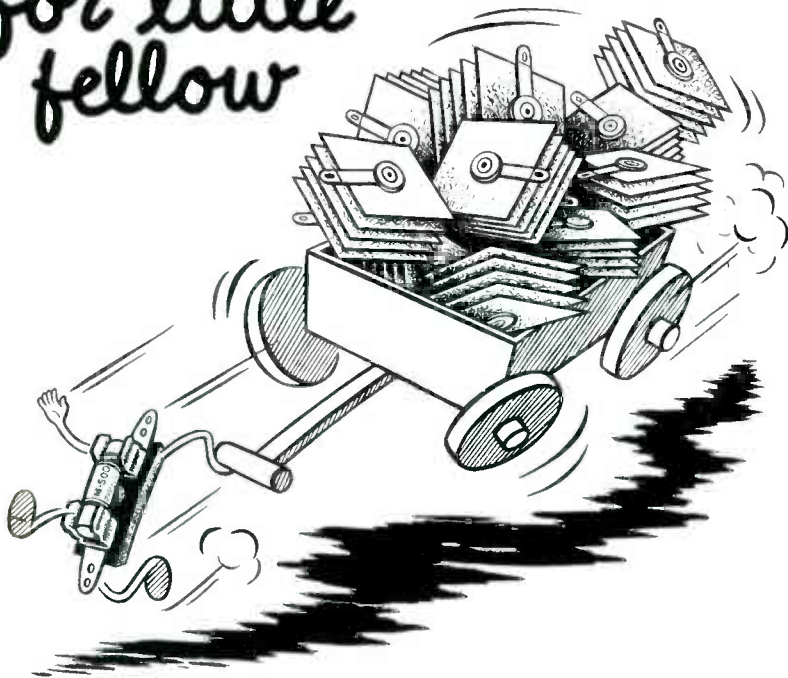
## AEROVOX CORPORATION

**DISTRIBUTOR SALES DIVISION,  
NEW BEDFORD, MASS.**

In Canada: AEROVOX CANADA, LTD., Hamilton, Ont.  
Export: Ad. Auriema., 89 Broad St., New York, N. Y. • Cable: Auriema, N. Y.

# BIG LOAD

for little fellow



.... and away we go!

-----WITH ANOTHER LOAD OF  
SELENIUM RECTIFIERS REPLACED  
BY THE M-500 SILICON RECTIFIER.

MOST SMART SERVICEMEN  
ARE REJUVENATING WEAK TV SETS  
---ARE YOU----- HUH ?

**Sarkes**  
**Tarzian** INC. **RECTIFIER DIVISION**

415 N. College Ave., Bloomington, Indiana  
IN CANADA: 700 WESTON RD., TORONTO 9, TEL. ROGERS 2-7535  
EXPORT: AD AURIEMA, INC., NEW YORK CITY

## Input-Power Tests

(Continued from page 13)

easily locate the problem. First all tubes and pilot lights must be removed; this eliminates the external load from the transformer. Now, the wattmeter test can be made. If the unloaded transformer shows presence of more than a small drain, (never more than 1-1.5 watts) the transformer has an internal short and must be discarded. When making this test, you must be absolutely sure that all external loads have been disconnected from the transformer. In one set, heavy leakage was found through the rectifier socket itself, causing a high-voltage leak to chassis, indicating a short when the transformer was tested. A normal well-designed transformer will show only a small drain with no load; in some cases, only the initial charging surge will be read, the meter dropping back to zero.

Typical indications for the more common defects are about as follows: Shorted turns in high-voltage secondary, 50-100 watts; shorted turns in primary, 50-100 watts; short in heater secondary, 200-300 watts. Dead short in primary or filament windings will be in the fuse-blowing class.

To protect the wattmeter against shorts, it should never be used without fuse protection. If the wattmeter has a 300-watt scale a fuse of not over 3 amperes capacity, (the quick-blow type) must be inserted in series with one of the output leads. One should never use a slow-blow fuse in this circuit; the added current drain may cause meter damage, whereas the quick action of the regular fuse will usually save it.

Television set wattage readings generally run higher than radios, because of the increased number of tubes; power drains run from 125-150 watts for the series-filament sets using dry rectifiers (usually voltage doublers), up to 150-160 watts for sets using filament transformers with dry rectifiers, and on up to 200-225 watts for the larger sets, using full transformer-type power supplies. Color-TV set drains, of course, run even higher, with their larger number of tubes. The rating label on the set should be consulted, if there is any doubt as to the normal wattage. On some of the earlier color sets, with their long strings of tubes, the normal wattage might even go above the 300-watt range of the meter. Circuit refinements are bringing the color-set ratings into the 250-300 watt range.

Wattage-check instruments are available in both panel and portable types. In our shop we use two; one on the radio end of the bench and a wall-mounted duplicate, with fuse and outlet, at the TV end. The latter is fed through an isolation transformer and is used as a combination wattmeter and isolator for the chassis-connected types of TV sets to reduce the shock hazard. Incidentally, we found the transformer in this unit to be too small, with a maximum rating of around 150 watts; it overheated when TV sets had to be cooked for long periods of time. To carry this load continuously a 350-400 watt transformer is being installed.

When intelligently used, the wattmeter technique will prove to be the most useful, and the most used, on your test bench. Its applications are numberless and every day will bring out new uses for it.





**Admiral**

Model TE100

DOT GENERATOR

**Most Reliable  
Most Compact  
Lowest Cost**

- Absolute sync stability—no warm-up time required.
- Simplified operation—only two easy-to-read controls.
- Gives extremely sharp, well defined dots.
- Provides vertical or horizontal lines for linearity adjustments—may be used to adjust black and white as well as color receivers.
- Designed especially for home service as well as convenient shop use.
- Convenient cord storage provided at rear of cabinet.
- Steel cabinet finished in two-tone gray baked-on hammerloid enamel.
- Size: 7" high x 5" wide x 8" deep.
- Weight 6½ lbs. complete with cables.
- Power supply required: 105-125 volts, 50-60 cycles A.C.

**\$79<sup>95</sup>** NET

Price includes cable assemblies for both color and black-and-white



Order from your parts jobber

Manufactured by

**Admiral Corporation**

Special Products Division, Chicago 47, Ill.

## Servicing Helps

(Continued from page 26)

so it does not affect circuit operation, a repair can be made. Open components need not be isolated so long as they do not intermittently restore themselves or short. Others, such as shorted or wrong-value components, must be isolated by cutting the proper risers with a very fine-toothed saw or a 1/32" thick abrasive disk in a hand tool. (Diagonal cutting pliers should not be employed since they are likely to crack a module deck.) Then, a new component can be connected across the proper riser wires, usually on the opposite side of the printed board from the module.

All riser wires must be heated at the same time to insure removal of the module. Two methods are available for this simultaneous heating; One involves heating by a soldering iron with a hollow-square tip; the second requires dipping of the underside (dip-soldered side) of the printed board in one of the small solder pots which are now available. In either case, the holes can be cleaned and the new module inserted and resoldered either by individually soldering each riser, or by dipping in the solder pot.

### Hum Reduction

SEVERAL CASES of hum have been reported in RCA models 8-EY-4DJ and 8-EY-4FK, due to heater-cathode leakage in the 12AX7. This hum usually increases with use and the tube should be replaced.

For reduction of 60-cycle hum at both minimum and maximum positions of the volume control, an insulated wire, 2½" in length, has been added between terminal 4 of the 12AX7 socket and terminal 2 of the tone control. Although both points are at -B potential, the addition of the wire cancels out a hum pickup due to circulating currents.

### Regenerative Squeal Curbs

UNDER HIGH-HUMIDITY conditions an electrolytic action may take place between the chassis mounting spacer (zinc die-casting) (on RCA models 8-BT-9E, 8-BT-9J and 9-BT-9) and two circular contact areas of the printed-wiring board used. The spacer is in direct contact with the two contact areas and provides the electrical circuit between them. An oxidized connection at this point will result in a poor contact which, in turn, may cause regenerative squeal.

To overcome the effects of this electrolytic action, a 3-point wire jumper may be added to interconnect the two contact areas mentioned and the printed-wiring at the third tuning capacitor mounting screw.

### Short Circuit Repair

INSTANCES OF INTERMITTENT short circuit of  $C_{14}$  (100 mfd) on RCA chassis 8-BT and 9-BT series, have been found to result from the chassis mounting spacer short circuiting to the printed wiring underneath the spacer. Any chassis that is removed from its case should be examined and any spacer on which the two mounting bosses are of unequal height should be replaced.

### Critical Vertical Hold Sure

IN SOME MOTOROLA TS-537 chassis, critical vertical hold conditions have appeared; the trouble has been traced to the vertical hold control locking at one end of its range. Replacing resistor  $R_{600}$  (6.8 megohms) with a 5.6-megohm unit will eliminate this problem.

Have the  
satisfactions  
you want  
for your future  
... as an

**RCA**

**FIELD SERVICE**

**ENGINEER—**

**SCATTER**

**COMMUNICATIONS**



You will be responsible for supervising installation, maintenance and operation of scatter communication stations. You must be familiar with recording of measurements such as received-signal level, RF power measurement and noise measurements. You should be familiar with the installation, maintenance and operation of point-to-point radio relay equipment.

For personal interview, please send a complete resume of your education and experience to:

Mr. James Bell  
Employment Manager  
Dept. Y-11E

RCA Service Company, Inc.  
Cherry Hill, Camden 8, N.J.



**RCA SERVICE  
COMPANY, INC.**

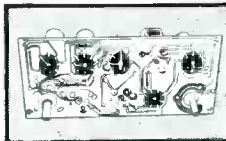
# MORE ACTIVE! EFFECTIVE!

## KESTER "RESIN-FIVE" CORE SOLDER



**THE BEST FOR TV-RADIO WORK . . .  
EVERYTHING ELECTRICAL**—Kester "Resin-Five" Core Solder is better and faster than any solder ever developed. It has an activated flux-core that does a perfect job on all metals including zinc and nickel-plate. The flux residue is absolutely non-corrosive and non-conductive.

Available in all practical Tin-Lead Alloys; 40/60, 50/50 and 60/40 in diameters of  $\frac{3}{32}$ ",  $\frac{1}{8}$ ",  $\frac{3}{16}$ ",  $\frac{1}{4}$ " and others.



**Printed Circuit Soldering**  
On Copper-etched boards use 60% Tin - 40% Lead Alloy . . . for those that are Silver-surfaced use 3% Silver-61½% Tin-35½% Lead

## KESTER SOLDER COMPANY

4248 Wrightwood Avenue, Chicago 39, Illinois • Newark 5, New Jersey, Brantford, Canada

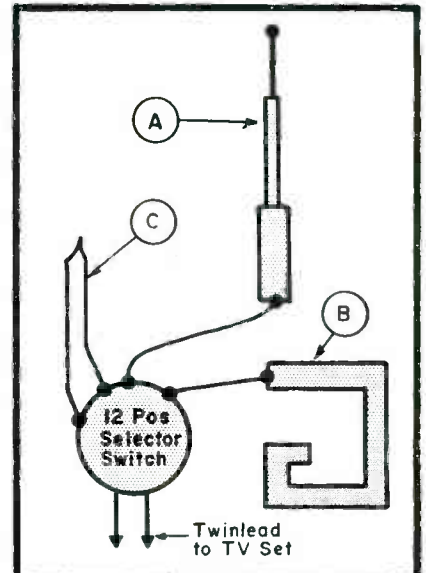
### TV Antennas

(Continued from page 39)

impedance of the dipole could be raised at will to match the impedance of the receiver's input.

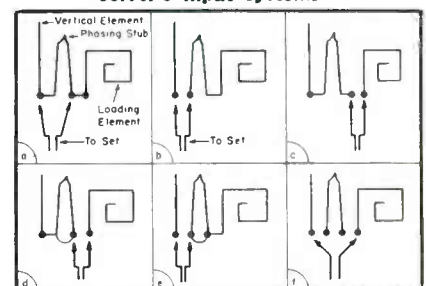
In field tests with the antenna it was found that noise and ghost-type signal-pickup was reduced when vertically-polarized waves were utilized; Fig. 4 (p. 39). The internal circuit of the vertical-rod antenna is shown in Fig. 5. The variety of switching combinations possible appears in Fig. 6.

The antenna is not intended to replace an outdoor type, for the gain, while high, does not equal that of a good outdoor antenna that has been properly installed at the proper height. It does, however, offer an effective compromise when one must use an indoor model due to building and location conditions.

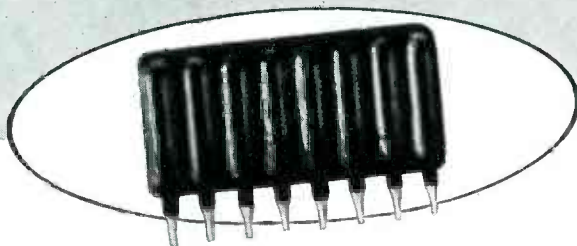


**FIG. 5: BASIC CIRCUITRY** of the vertical antenna\*. The single rod (a) is mounted in a ball socket to permit a slight swivel to take advantage of any near-vertical signal energy. The loading element included in the circuit-selector housing (b) serves to maintain balance in twinlead lines. Also included in assembly is a phasing stub (c) harmonically related to TV channels. (\*Snyder model 10-D; patent pending.)

**FIG. 6: SIX TYPICAL SWITCH** positions available with 12-position selector. In some instances one element is shorted out and used against the other, and in other cases all elements are in active use. It is also possible to omit one element for extreme cases of unbalance in the receiver's input system.



## Your **ERIE** Distributor Has "PAC" Replacement Modules



## for Servicing 1957 Auto Radios

PAC is a group of interconnected capacitors and resistors, combined in a single-insertion unit. Several popular 1957 model automobile and truck radios employ this new concept in component packaging. When servicing these auto radios, a complete PAC (Pre Assembled Circuit) module can be quickly and easily replaced.

Your **ERIE** Distributor has PAC Replacement Modules in stock. See him for complete information and prices.

**ERIE ELECTRONICS DISTRIBUTOR DIVISION**  
ERIE RESISTOR CORPORATION  
Main Offices: ERIE, PA.  
Factories: ERIE, PA. • LONDON, ENGLAND • TRENTON, ONTARIO

## 13-Transistor Auto Radio

(Continued from page 18)

back. The oscillator signal voltage is capacity coupled to the emitter of the 2N149 modulator, or mixer; *agc* is also applied to the modulator emitter and the signal from the *rf* stage is applied to the base. A 262-kc output is developed across the collector transformer of the modulator and coupled to the base winding in the first *if* stage by a .00001-mfd capacitor.

The first *if* stage is *dc* forward biased in the same manner as the *rf* stage. A pair of 1800 and 15,000-ohm voltage divider resistors ( $R_{66}$  and  $R_{67}$ ) obtain a voltage from the 6.5-v line and emitter voltage is obtained from a static collector current of about .5 ma flowing through the transistor's emitter resistors. This current is varied by *agc* action on the emitter circuit applied through a 4700-ohm resistor ( $R_{68}$ ) which raises the emitter voltage as signal is applied. The *dc* biasing circuits in these stages are *ac* bypassed to prevent signal degeneration.

The second and third *if* amplifier stages are very similar to the initial stage, except that *agc* is not applied. Transformer step-down windings are used at the input of each stage for impedance matching.

The primary tickler winding of the transformer in the collector circuit of the third *if* couples a signal to the 1N295 *agc* detector. The secondary winding here supplies signal to an infinite impedance audio detector through a 1N295 isolation diode. This prevents loading of the last *if* transformer, which is necessary to prevent dampening of the signal for signal-seeking purposes. The audio-detector load circuit contains a tone control ( $R_{158B}$ ) and a volume control ( $R_{158A}$ ), from which the audio signal is coupled into a driver transformer in the 2N109 audio preamplifier stage. This is a *pnp* medium-power driver circuit, drawing about 5 ma of *dc*. A 100-ohm stabilizing resistor ( $R_{132}$ ) helps to maintain this operating point for temperature variations.

Automatic station tuning is provided by a miniaturized *wonder-bar* tuner (to be described next month); a trigger control circuit is provided to operate a tuner relay for this system. The complete circuit used to transform the signal voltage into current pulses for the relay appears in heavy lines in the lower right portion of the complete diagram on page 19.

The trigger signal is taken from the audio detector circuit; this actually consists of two separate voltages—one from the *agc* detector and one from the input diode of the audio detector. The audio-detector load voltage is negative and the smaller *agc*-detector voltage is positive. These two combine, and the result is a constant negative trigger voltage applied to the base of the trigger amplifier transistor as signal is received. This cuts off the 2N149 trigger amplifier, which in turn cuts off the 2N109 relay control transistor. The tuner relay in the collector circuit of the relay control stage is then deenergized, causing the tuner to stop automatically on the station being received. A 1N295 diode serves to discharge any excessive *back voltage* kick which may be developed across the relay winding as it is suddenly deenergized. This protects the 2N109 transistor from excessive collector voltages.

# TECHNICIANS

Here's an opportunity for experienced technicians to enter our comprehensive

## TECHNICAL WRITING TRAINING

Electronic technicians with at least three years' practical experience in corrective maintenance of electronic equipment (radar, communications, television, computers, etc.) and an ability to express technical information clearly will be considered for the formal McGraw-Hill Technical Writing Training Program.

Those selected will be paid while training and upon successful completion of the Program will be assigned on a permanent basis in our New York office to the McGraw-Hill Technical Writing Service, a division of the world's largest technical publishing organization. The Technical Writing Service prepares special technical literature for Government and industry.

We want people who have a good understanding of basic electronic theory, have actual equipment maintenance experience, and have a sincere interest in technical writing as a career.

If you are interested in a career in the technical writing field, write and tell us in detail about your experience and education. To help us evaluate your potential, also describe in writing a step-by-step trouble-shooting procedure you have used recently. Make it simple and clear so another person could understand it easily. Please indicate generally your acceptable salary range.

Please give us all the information we have asked for or we may not be able to consider you. Please address replies to Section TP-S1.

### McGraw-Hill Technical Writing Service

330 West 42nd Street

New York 36, New York

*As easy to use as a pencil*



**WALL**  
INDUSTRIAL  
SOLDERING IRONS  
*give you*

More  
BTU's...

Faster  
HEAT...

Higher HEAT  
CONTINUITY

than ANY OTHER  
soldering irons of equal tip size

Proved 4 times faster on the production lines of America's leading electronics firms. Complete range of sizes... *scientifically designed*... *individually tested*... for easier, surer precision work or heavy duty soldering. Operate on 110-120 volts, AC or DC! Model 18T illustrated, \$6.25 list.

Exclusive  
THERMOSTATIC ACTION...

Guaranteed for the life of the iron!  
Prevents excessive tip burning!



Write for FREE Catalog



**WALL** MANUFACTURING CO.  
Grove City, Pennsylvania

OVER 20,000,000 SOLDERING PRODUCTS SINCE 1864



# modern technicians rely on RIDER books, manuals and S D O

... their future depends on electronic know-how

acclaimed by technicians  
throughout the country

## REPAIRING TELEVISION RECEIVERS

by Cyrus Glickstein

The most modern completely practical book, written by an expert with long experience in television receiver repair. Devoted to troubleshooting and repair techniques which are modern, yet down-to-earth. Covers the use of simple as well as elaborate test equipment of all kinds. Profusely illustrated.

This is not a theory book. It is a guide which every practicing TV technician, every student of TV repair and every newcomer to the TV repair business can use to exceptionally good advantage, because it explains step-by-step procedures.

CHAPTERS: Introduction to TV Servicing... Localizing the Defective Section... Localizing the Defective Stage... Localizing the Defective Component... Basic Receiver Types and Trouble Symptoms... Quick Key Checks for Finding the Defective Section and Stage... Video and Sound Circuit Trouble Analyses... Typical Sync and Sweep Troubles... CRT, High- and Low-Voltage Power Supply Troubles... General Operation and Servicing Techniques, Signal Selections and Generator Sections... Correcting Difficult Troubles... Timewasters in TV Servicing. Index.

Soft Cover, 212 pp., 5 1/2 x 8 1/2", illus.  
#191.....Only \$4.40

## TV REPAIR QUESTIONS & ANSWERS

by Sidney Platt

A practical, extremely useful series of question and answer books on the troubles in, and the repair of, TV receivers.

- #173, Front Ends: 128 pp., \$2.10.
- #173-2, Video Circuits: 128 pp., \$2.10.
- #173-3, Sync & Sweep Circuits: 140 pp., \$2.10.
- #173-4, Deflection & H-V Circuits: 128 pp., \$2.10.
- #173-5, Sound & L-V Circuits: 120 pp., \$2.10.

## NEW BOOKS

### A Must For Every Technician TV PICTURE TUBE-CHASSIS GUIDE by Rider Lab Staff

No busy service technician can afford to be without this easy-to-use TV tube location guide. It covers all picture tube types used in TV receiver production from 1946 to February 1957—over 7,000 listings. This reference guide is organized by chassis number, and in some cases, by models so that the technician can immediately locate the correct picture tube type simply by knowing the chassis number. #204.....Only \$1.95

### HOW TO INSTALL & SERVICE INTER-COMMUNICATION SYSTEMS by Jack Darr

The growth of the intercom as a modern tool of business presents an important service and installation opportunity. This book covers completely installation and maintenance of commercial inter-communication equipment. Soft Cover, 152 pp., 5 1/2 x 8 1/2", illus.  
#189.....Only \$3.00

### SERVICING TV AFC SYSTEMS by John Russell, Jr.

This book discusses the trouble, location, and repair of the major types of AFC circuits used today... as well as some of the less common AFC systems the technicians may encounter. Waveforms, components, common faults, and their diagnosis are presented in a manner that affords the reader a thorough understanding of AFC circuits. Supplemented by more than 75 illustrations. Soft Cover, 128 pp., 5 1/2 x 8 1/2", illus.  
#192.....Only \$2.70

## MUST READING FOR TECHNICIANS

### TELEVISION—HOW IT WORKS (2nd Edition) by J. Richard Johnson

The most modern and authoritative text describing the theory of operation of all black-and-white television receivers. Each part of the receiver is explained in thorough detail and in a manner that makes the functioning of the components and the organization of the circuitry completely understandable. Fully illustrated. #101, MARCO cover, 352 pp., \$4.60; #101-H, cloth bound, \$5.50.

### SERVICING TV VERTICAL AND HORIZONTAL OUTPUT SYSTEMS by Harry Thomas

Technicians and students will here find a complete discussion of vertical and horizontal output systems and their operation. #150, Soft cover, 176 pp., illus., \$2.40.

## AM-FM Radio-Phono

(Continued from page 15)

ness control respectively across the output of the phono preamp and an auxiliary receptacle on the rear of the radio chassis. The auxiliary receptacle is suited for the playback of tape recordings or other sound sources. A tap on the loudness control connects to an additional receptacle on the rear of the chassis. This circuit provides a connection to the input of a tape recorder and allows any program material being handled by the radio-phono to be recorded simultaneously. The material being recorded can be monitored by the instrument speakers at any desired level, since the setting of the instrument loudness control does not affect the program level to the recorder.

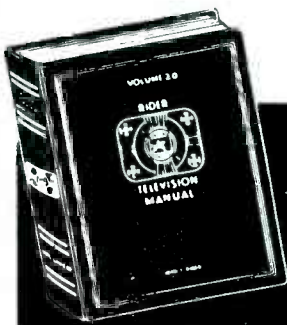
The loudness control is compensated to improve low level high-fidelity listening. This is accomplished by a 22-mmf capacitor ( $C_{150}$ ) connected between the top and the arm of the loudness control which boosts the highs in relation to the mid-range frequencies as the loudness setting is reduced. A 1-megohm resistor ( $R_{155}$ ), connected between the arm of the control and ground, boosts the lows proportionally by virtue of decreased low frequency loading on the signal circuit, as the loudness setting is reduced.

The first audio amplifier, consisting of one section of a 12AT7 dual triode, provides additional voltage gain for the system; however, some of this additional gain is lost to the treble and bass control circuits in the coupling circuit to the next stage.

The treble-control circuit is an  $rc$ -filter network consisting of  $R_{118}$ ,  $C_{151}$  and the treble control ( $R_{110}$ ). The series resistor ( $R_{118}$ ) by itself provides essentially equal attenuation at all frequencies. With the treble control set at the top of its range, high frequencies are shunted around  $R_{118}$  through capacitor  $C_{151}$  to provide a boost in the treble response. A setting of the treble control at the bottom of its range provides a cut in treble response by virtue of the high frequencies being shunted to ground through this capacitor. The treble control provides a total range of 15 db in treble response. Normal treble response results with the control set to approximately 75% of full clockwise position.

The bass-control circuit is another  $rc$ -filter network consisting of a bass control potentiometer ( $R_{150}$ ),  $R_{151}$ , and capacitors  $C_{152}$  and  $C_{153}$ . With the bass control set near the center of its range, capacitors  $C_{152}$  and  $C_{153}$  may be considered as a capacitive-voltage divider, which provides essentially equal attenuation at all frequencies. With the control set to the top (clockwise position), all frequencies are shunted around  $C_{152}$  to the output; however, any increase in high-frequency output at this setting is prevented by the high-frequency shunting effect of  $C_{153}$  through  $R_{151}$  to ground. This results in an overall boost in the low-frequency output. Maximum bass cut results with the control set at the bottom (counter-clockwise position) as both  $C_{152}$  and  $R_{150}$  represent a high impedance to low frequencies. Middle and high frequencies pass readily through  $C_{152}$ ; however, their response is again limited at the circuit output by the voltage dividing action of  $C_{153}$  in series with

## NOW AVAILABLE



### RIDER'S TV 20

The only source of unabridged factory prepared and factory accurate TV receiver servicing information.

#### LIMITED PRINTING

Reserve your copy at your jobber. If your jobber does not handle Rider Manuals, write direct.

### IF YOU WANT THE BEST IN TV SERVICE INFORMATION

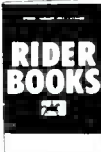
PHILCO GE EMERSON  
ADMIRAL RCA MOTOROLA  
SYLVANIA ZENITH WESTINGHOUSE  
HOFFMAN CROSLLEY PACKARD-BELL

Covers Production 1950-1956

RIDER'S NEW  
**S D O**  
("single diagram only")  
SERVICE

ONLY 50¢ PER CHASSIS  
AT YOUR LOCAL JOBBER

RIDER books, manuals, S D O are available at your Parts Jobber. Look for the RIDER BOOK-SELLER. If these RIDER books are not available, order direct by checking books desired in this ad. FREE! FREE! Handsome genuine leather, gold stamped book-mark — lasts a lifetime — if you write today for FREE 1957 Spring-Summer Catalog S-5 of all RIDER Books.



JOHN F. RIDER PUBLISHER, INC. 116 West 14th Street, New York 11, N. Y.

$R_{151}$ . The bass control has an overall range of 15 db. Normal bass response results with the bass control set to approximately 75% of its full clockwise position. Bass and treble control circuit parameters have been chosen to provide minimum loudness changes with changes in control settings.

The output of the bass and treble control network is capacitively coupled to the grid of a cathode-follower stage. The cathode follower contributes no additional gain; however, it provides for a low-impedance coupling from its cathode circuit to the input of the power amplifier by means of a shielded cable and plug. Since the coupling impedance is low, we have freedom from hum pickup and loss of high-frequency response for any convenient length of cable.

The power amplifier chassis is mounted on a shelf at the bottom of the speaker compartment.

The plate power supply for the entire instrument is contained on the power amplifier chassis and consists of a conventional full-wave rectifier circuit employing two 5U4GAs. Filament voltage for all amplifier tubes in the power amplifier is provided by a single 6.3-volt secondary winding on the power transformer. To minimize 60-cycle hum, the filament winding is balanced by means of two 100-ohm resistors ( $R_{100}$  and  $R_{110}$ ). The junction of the balancing resistors is returned to the common cathode connection of the bass amplifier output tubes. This places a positive bias on the amplifier filaments and removes the possibility of hum amplification in the amplifier resulting from heater-to-cathode emission within the tubes.

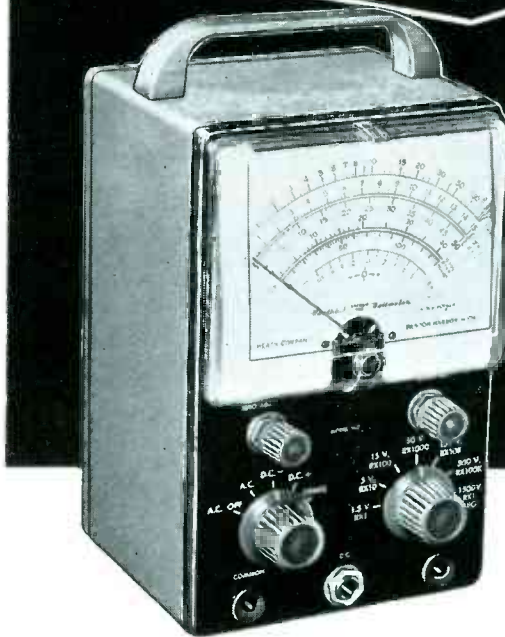
One unique feature of the power-amplifier system is the dual-channel power amplifier system. A crossover filter at the input to the power amplifier presents only frequencies above 2000 cps to the input of the treble channel and only frequencies below 2000 cps to the bass-channel input. Each channel contains inverse feedback from the voice-coil windings of their respective output transformers to the cathodes of their respective driver stages. In spite of the limited range of signal frequencies handled by each channel, the overall response of each channel has been found to be flat over the audio range.

The two-channel system affords low intermodulation distortion by virtue of the isolation between the high and low frequencies in the power output stages.

The bass channel consists of a 12AT7 twin-diode audio amplifier and phase inverter driving a push-pull-parallel power output stage comprising four 6V6GT pentodes. Maximum undistorted average power output of the bass channel is 22 watts.

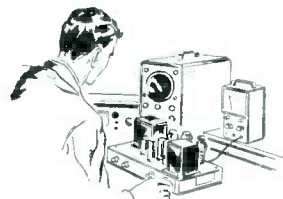
The bass channel drives a two-speaker system designed to provide a balanced response from 20 to 2000 cps. A 15-inch low-range bass speaker connected across the 3.2-ohm secondary of the bass-channel output transformer provides response between 30 and 2000 cps. A 7-inch speaker connected in parallel with the 15-inch speaker that is in series with a 16-mfd crossover capacitor provides reinforcement in the response between 600 and 2000 cps. The 7-inch speaker is mounted within the forward cone space of the 15-inch speaker. This combination, in addition to producing a balanced response, provides fairly constant loading of the bass channel over its frequency range.

look what **\$24<sup>50</sup>** buys  
in test equipment!



**HEATHKITS  
GIVE YOU  
TWICE AS MUCH  
equipment for  
every dollar  
invested**

The famous model V-7A Vacuum-Tube-Voltmeter is a perfect example of the high-quality instruments available from Heath at 1/2 the price you would expect to pay! Complete, only **\$24<sup>50</sup>**



Get the most out of your test equipment budget by utilizing HEATHKIT instruments in your laboratory or on your production line. Get high quality equipment, without paying the usual premium price, by dealing directly with the manufacturer, and by letting engineers or technicians assemble Heathkits between rush periods. Comprehensive instructions insure minimum construction time. You'll get more equipment for the same investment, and be able to fill your needs by choosing from the more than 100 different electronic kits by Heath. These are the most popular "do-it-yourself" kits in the world, so why not investigate their possibilities in your particular area of activity! Write for the free Heathkit catalog now!



Contains detailed descriptions of Heathkit models available, including VTVM's, scopes, generators, testers, bridges, power supplies, etc.



Also describes Heathkit ham gear and hi-fi equipment in kit form. 100 interesting and profitable "do-it-yourself" projects!

**FREE catalog**

Mail coupon below for  
your copy—Now!

**HEATH COMPANY**  
A SUBSIDIARY OF DAYSTROM, INC.,  
BENTON HARBOR 11, MICHIGAN

Name \_\_\_\_\_

Address \_\_\_\_\_

City & Zone \_\_\_\_\_

State \_\_\_\_\_

## Color-TV Circuitry

(Continued from page 21)

has the same relation to (G-Y), as (R-Y) has to (B-Y), or that I has to Q. That is, an I detector nulls on a Q signal, and vice versa; an (R-Y) detector nulls on a (B-Y) signal; a (G-Y) detector nulls on a (G-Y)/90° signal. A (G-Y) detector does not null on an (R-Y) signal; a fact of key importance to the Service Man.

It has been pointed out that the earlier receiver arrangements in-

cluded a *dc* restorer at each grid of the picture tube. The restorers were required because of *ac* coupling utilized in the chrominance channels. However, most present-day receivers make use of *dc*-coupled circuits from the outputs of the color detectors, through the color-difference amplifiers, to the grid of the color picture tube. These *dc*-coupled circuits, of course, retain the *dc* component of the complete color signal, and thereby eliminate three *dc* restorers.

Coincident with this trend to *dc*-coupled chroma circuitry has been the introduction of high-level demodulation, in which the outputs from the color detectors are applied directly to the grids of the color picture tube, thereby eliminating chroma amplifiers. The general arrangement of the high-level system is

seen in Fig. 3 (p. 20). A pair of triodes are commonly used as demodulators, developing (R-Y) and (B-Y) at the plates of the triodes; a common cathode circuit for the triodes develops the (G-Y) signal. This arrangement is commonly referred to as a *bootstrap* demodulator system.

All of the early color-TV receivers utilized a flat-topped *if* response, in which the color signal was located on top of the response curve, as shown in Fig. 6a (p. 21). It is evident that simplified *if* circuitry can be realized by placing the color signal on a sloped curve, as indicated in *b* of Fig. 6.

### The One-Gun Apple Tube

A one-gun color picture tube that has developed substantial interest is the *apple* tube under development by Philco. Basically, in this tube the screen is comprised of alternate stripes of color phosphors, as shown in Fig. 7 (p. 21). The single gun develops two beams, one of which is called the writing beam and the other the pilot beam. The writing beam operates at a relatively high beam current, and produces visible light from the phosphor stripes. The pilot beam is much weaker, and is utilized only to produce a *sync* signal from index strips to key chrominance circuits; the pilot beam is of constant intensity, and travels simultaneously with and slightly below the writing beam.

The writing beam is not of constant intensity, but is modulated by the complete color signal. To illustrate: When a red area is being televised, the beam intensity is brought to peak value as the red stripes are being crossed, while the beam intensity falls to zero as the green and blue stripes are being crossed. To reproduce a black-and-white transmission, the beam maintains its intensity while crossing all three primary color stripes.

The index stripes produce secondary emission when energized by the beams, and to separate the signal from the pilot beam from that of the writing beam, a 41.7-mc pilot oscillator is utilized, as shown in Fig. 8 (p. 21). The pilot signal amplifier is tuned to pass the signal sideband frequency impressed upon the pilot beam due to scanning so that the secondary-emission signal produced by *video modulation* of the writing beam is rejected by the pilot signal amplifier.

The arrangement shown in Fig. 7 (p. 21) produces solid color fields, such as red, or green, or blue, depending upon the setting of the phase-shifting network. This is the basis of operation of the apple-tube circuitry. It is evident that a color picture can then be produced by variation of the phase-shifting network in accordance with hue, varying the voltage from the pilot oscillator in accordance with the saturation of the hue, and varying the voltage on the writing grid in accordance with the luminance.

The Lawrence one-gun tube has also been under development for some time and currently is receiving considerable attention in the Du Mont labs. Up to now, one of the major problems confronting those conducting research on the tube, has been severe radiation generated by the tube's system. It has also been found difficult to provide adequate brightness, particularly on monochrome reproduction; b-w pictures have also been found to suffer from a lack of tonal quality distribution.

# A

Always dependable...

# B

Better quality and design...

# C-D

## VIBRATORS

the complete line...

There is a CORRECT replacement C-D vibrator for every original installation...no guessing...no problems! And every C-D vibrator delivers longer service that is dependable...and quieter in operation! AND...the complete line of COMMUNICATION VIBRATORS answers every replacement problem in this important field!

It's as basic as knowing your A B C D's... that C-D vibrators are your best buys year 'round... day in and day out! Look for the famous C-D seal... it is your guarantee of quality combined with skilled engineering and controlled manufacture!



**CORNELL-DUBILIER**

Plants in South Plainfield, N. J.; New Bedford, Worcester and Cambridge, Mass.; Providence and Hope Valley, R. I.; Indianapolis, Ind.; Sanford, Varina and Fuquay Springs, N. C.; and Venice, California. Subsidiary: The Radiart Corporation, Cleveland, Ohio.



## TEST INSTRUMENTS

### TRANSISTORIZED BROAD-BAND VM

A TRANSISTORIZED broad-band audio-video voltmeter, the *Transvolter*, has been announced by Kay Electric Co., 14 Maple Ave., Pine Brook, N. J.

Instrument, a low-level unit, incorporates a negative-feedback amplifier for stable operation.

Operates on 110 v, with a built-in regulated supply; can also be powered by four mercury-cell batteries for portable operation. Frequency range is 10 cps to 10 mc; direct reading in volts and db. Frequency response of amplifier is said to be flat  $\pm .5$  db over range. Voltage range is 1 millivolt to 1 volt-full scale; 7 ranges will measure to 250 microvolts.

The audio-video amp has a maximum output of .25 volt at 75 ohms; gain up to 40 db.



### AUTOMATIC TUBE TESTER

AN AUTOMATIC TUBE TESTER, *model 123A Cardmatic*, which utilizes a punched card system to set and test automatically, has been announced by the Hickok Electrical Instrument Co., 10521 Dupont Ave., Cleveland 8, O.

Preselected voltages on screen, plate, grid or filament are tabulated on vinyl type cards which are inserted into the machine. These cards trip an automation mechanism to make electrical connections necessary for testing of tube.

Regulated dc-voltages available are: plate, 12 to 160 v; screen, 12 to 160 v. Combined plate and screen currents up to 100 milliamperes. Bias readings of .1 to 100 v can be obtained.

### VACUUM-TUBE PREHEATER

A VACUUM-TUBE PREHEATER, *FP22*, for intermittent troubleshooting has been introduced by Service Instruments Corp., 171 Official Rd., Addison, Ill.

Unit will accommodate up to 20 tubes at one time, including the series-filament types; 7 and 9 pin miniature tube straighteners are included. A *quick heat* switch is provided to increase filament voltages by 10%, which is said to accelerate gassy and intermittent conditions. Suspected tubes can be inserted into preheater and then placed in a tube checker while hot.

## Short description of a Small Efficient TV System...

**1 antenna .. IN**  
**8 set lines .. OUT**  
**10 db signal .. GAIN**

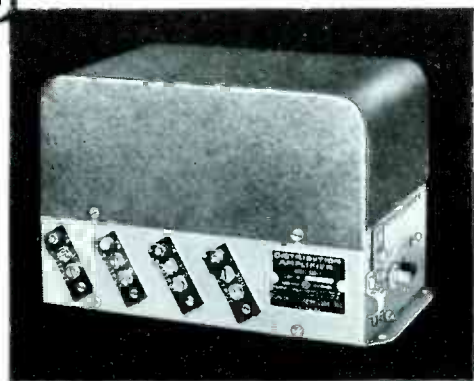
all with  
the



## DISTRIBUTION AMPLIFIER

### model DA8-B

approved  
for  
Color-TV



**\$89<sup>50</sup> List**

Ideal for garden apartments, motels, TV showrooms, deluxe home installations and other small TV systems. The DA8-B is a broadband, all-channel unit that requires no tuning, impedance matching devices, preamps or other special fittings.

### Features and Specifications:

- Low noise all-triode circuit
- More than 10db gain on all VHF Channels
- Inter-set isolation in excess of 22db
- Provision for 75-ohm cable or 300-ohm twin lead
- Prevents overload through 10:1 gain control range
- Built-in power supply
- Designed for continuous duty operation

NOTE: For larger systems, Blonder-Tongue will furnish Free planning service on request.

Sold by Radio-TV Parts Distributors and Jobbers.

Write for Installation Details and FREE Booklet—"TV for 2. or 3. or More"

Dept. S-5

**BLONDER-TONGUE  
LABORATORIES, INC.**  
9-2 Alling St., Newark, N. J.



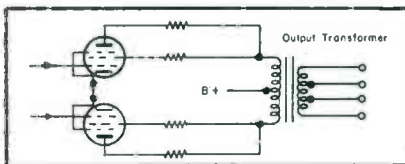
Manufacturers of TV Cameras,  
TV Amplifiers, Boosters, Converters,  
Accessories and Originators of the  
Masterline and 'Add-A-Unit'  
Master TV Systems.



# AUDIO INSTALLATION AND SERVICE

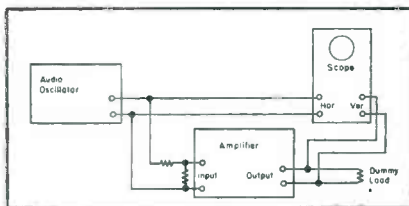
Phono • Tape • PA  
Cartridges • Needles • Amplifiers • Speakers

Output Transformer Replacement: Test Instruments Required . . .  
Components and Circuitry Changes Involved in Amplifiers to  
Match Results Obtained With Original Parts



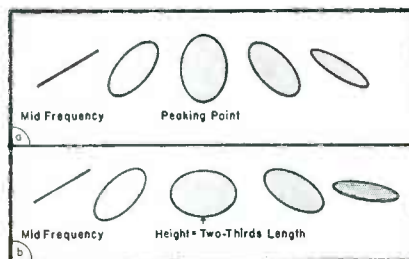
(Above)

**FIG. 1: OUTPUT CIRCUITRY** with pentodes connected as triodes. Screen-grid resistors can have values of 470 to 2200 ohms; plate-resistor values could range from 100 to 470 ohms.



(Above)

**FIG. 2: TEST SETUP** to check amplifier in which replacement output transformer has been installed.



(Above)

**FIG. 3: AUDIO TRACE** variations illustrating (a) peaking with too little margin of stability, and (b) correct rolloff. In the peaking and rolloff sequence, the initial trace shown represents mid-frequency. The center traces cover the peaking point; height of oval trace in (b) equals two-thirds of its length.

BEFORE THE ADVENT of amplifiers featuring substantial negative feedback, output-transformer replacement was a relatively simple matter. If an *exact* replacement was not available, one with the same specifications could be fitted in, making slight mechanical adjustment, if necessary, for the mounting. With modern amplifiers, utilizing a considerable amount of negative feedback, more than mechanical adjustment is often necessary. In fact, there are several amplifiers<sup>1</sup>, which require transformers with special taps and windings, where only an exact replacement will do.

If these special types are not involved, and it is not possible to get an exact replacement, we must then look for a *nominal* replacement that has the same impedance rating from primary to secondary, the same power rating, and, if possible, the same specified frequency response. But, even though the nominal replacement does match the specs, we still may have a few problems to resolve.

As well as making any necessary *mechanical* adjustments, so that the transformer can fit in the chassis physically, it may be necessary to make some *electrical* adjustments so that the transformer *fits* from the performance viewpoint.

If the amplifier uses triode output tubes, or pentodes with the screens strapped to the plate so that they

<sup>1</sup>Such as the unity coupled, ultra-linear or circlotron amplifiers.

operate as triodes (Fig. 1), then a transformer that is a nominal electrical replacement will probably need little if any adjustment. But, if the output tubes operate in any kind of pentode circuit, whether auto or fixed biased, straight-plate coupled or partially-cathode coupled, it is more probable that some electrical adjustment will be needed before the amplifier operates correctly.

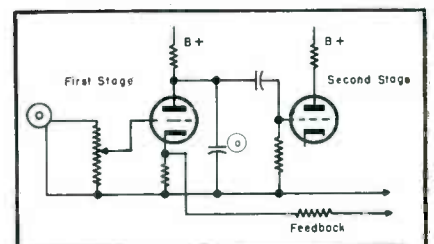
To determine the need for replacement one should initially check the performance of the overall amplifier, using the setup shown in Fig. 2. This test requires an audio oscillator that will provide sine waves from 20 to 20,000 cps and, if possible, up to 100 or even 200 kc, and also a 'scope. The input should be connected not only to the amplifier through suitable resistances, to get the right input voltage, but also to the horizontal deflection of the 'scope. The output of the amplifier, with the transformer fitted, should then be connected to a resistance load and also to the vertical deflection of the 'scope.

If the amplifier does not oscillate (as shown by a vertical deflection from the output) without input from the oscillator, you can proceed to check the frequency response and performance of the amplifier. The frequency should be run up the scale, carried on beyond the audible limit of 20 kc to see whether the response runs into a peak, as shown in (a) of Fig. 3, or rolls off properly as shown in (b).

Since few audio oscillators provide signals below 20 cps, a test for stability at the low-frequency end cannot be performed with the direct aid or the audio oscillator. To perform this check, therefore, one should intermittently short-circuit the output from the audio oscillator, so that the amplifier alternately amplifies almost its full level and then zero.

One must watch to see if the 'scope trace *bounces* vertically when the oscillator short is interrupted, indicating that the kick start given by the signal suddenly being applied produces a low frequency oscillation. Also it is

(Continued on page 59)



**FIG. 4: IMPROVING** high frequency rolloff in a feedback amplifier by adding a capacitor in the plate circuits (a).



*In one complete package University offers everything in loudspeakers for sound reinforcement... and public address—*



REFLEX TRUMPETS



RADIAL PROJECTORS



WIDE-ANGLE HORNS



HIGH EFFICIENCY DRIVER UNITS



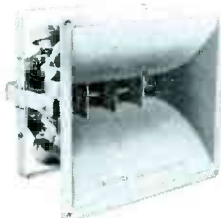
PAGING, TALK-BACK SPEAKERS



OUTDOOR MUSICASTING



EXPLOSION-PROOF SPEAKERS



HIGH POWER SPEAKERS UP TO 720 WATTS



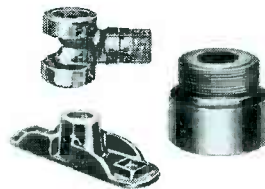
SUBMERGENCE-PROOF SPEAKERS



WIRED MUSIC SYSTEMS



WEATHERPROOF LINE-MATCHING TRANSFORMERS



ADAPTORS FOR DIVERSIFIED APPLICATIONS

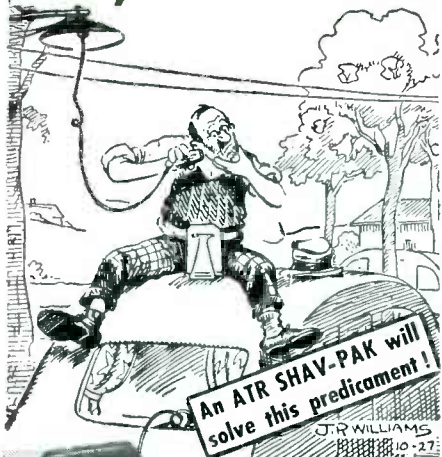
■ People have come to expect the highest standard of quality in a product bearing the University label. ■ This kind of public acceptance is something that University has consistently worked to achieve. First—by making available a complete variety of the finest commercial, industrial and high fidelity speakers and components. Second—by building the kind of quality into them that assures years of efficient, trouble-free service. ■ Find out for yourself why "University sells on sound." ■ For information regarding products or technical data, write Desk W-33, University Loudspeakers, Inc., 80 South Kensico Ave., White Plains, N. Y.



LISTEN... *University sounds better*



# ATR SHAV-PAK NEW, LOW PRICE!



**SHAVE IN THE COMFORT  
OF YOUR CAR,  
Boat or Plane!**

Specially Designed for  
Operating Standard A.C.  
Electric Shavers in  
Automobiles, Buses,  
Trucks, Boats, and  
Planes.

Plugs into  
Cigarette Lighter  
Receptacle on Dash

**\$ 6.63**

DEALER  
PRICE  
List Price  
\$8.95

TYPE	INPUT D.C. VOLTS	A.C. OUTPUT 60 CYCLES	OUTPUT WATTAGE	Dealer Price
6-SPB	6	115 volts	15	\$6.63
12-SPB	12	115	15	\$6.63

## Introducing ATR MIGHTY MIDGET portable INVERTER WITH GREATER OUTPUT

DICTATE REPORTS ACCURATELY-PROMPTLY!

**make your car, boat or plane  
a "rolling office"**

with ATR INVERTERS

for changing your  
storage battery  
current to A. C.

Household  
ELECTRICITY

Anywhere  
in your own car!



Plugs into  
Cigarette Lighter  
Receptacle on Dash

**\$13.30**

and up  
DEALER  
PRICE  
LIST PRICE \$19.95

ATR INVERTERS . . .

especially designed for operating  
standard 110 volt A. C. . .

- DICTATING MACHINES
- TAPE RECORDER
- ELECTRIC RAZORS
- WIRE RECORDERS

TYPE	INPUT D.C. VOLTS	A.C. OUTPUT 60 CYCLES	OUTPUT WATTAGE	DEALER PRICE
12-DME	12	115	30-50	\$13.30
12U-RHG	12	115	150-175	\$9.97

Inverters available for 6, 12, 28, 32, 110 & 220 D.C.  
input operation.

See your jobber or write factory today  
for complete information

**ATR** AMERICAN TELEVISION & RADIO CO.  
Quality Products Since 1931  
SAINT PAUL 1, MINNESOTA - U. S. A.

## Round and Wide-Angle Horns

(Continued from page 45)

with a 120° horizontal x 60° vertical projection pattern would do a good job; see Figs. 2 a and b (p. 43). On the other hand, let us suppose the area to be covered was *very* narrow and *very* deep. In this case, the wide-angle horn could be mounted and used in a manner opposite to normal, with the horizontal dispersion of the horn operating physically in the vertical plane; Figs. 3 a and b (p. 44) show what would happen. Used in this manner, a wide-angle horn is satisfactory, *provided* the distance of depth is not greater than can be penetrated with the resulting sound output of the horn at the listening point. Note how in Fig. 3b much of the sound energy is wasted in upper space. Mounting angles are obviously very important, especially in the applications just discussed.

Now let's take a look at the round *directional* horn. From Fig. 4 a and b we see the area covered by a round horn with a moderate dispersion angle (neither wide nor too narrow). Because the vertical disper-

# You Can't Beat This TECH-MASTER COMBINATION

**60**

## WATTS

undistorted at any audio frequency (20 to 20,000 cps)

**2**

## UNITS

a superlative power amplifier combined with a versatile preamp-control

**1**

## CHASSIS

with low-silhouette beige cabinet and striking black-and-gold panel

**0.25%**

## IM DISTORTION

or less, at all ordinary listening levels (less than 1% at 60 watts)

**\$129.50**

## COMPLETE

for the greatest engineering-per-dollar value in hi-fi history!



## MODEL 19

high-fidelity amplifier-preamp

Now, for the first time, an integrated high-power amplifier package for the budget-minded audio perfectionist—complete with low-distortion preamplifier in a single low-slung unit of strikingly elegant appearance. Only the most advanced high-fidelity circuitry and the finest available components are used in this superb new Tech-Master instrument. Reserve power is great enough to drive, without distortion, the new wide-range electrostatic loudspeakers. The preamplifier provides compensation for all recording characteristics. Regardless of new developments in other hi-fi components, the Model 19 is your gilt-edged insurance against amplifier obsolescence for many years to come.

See it At all leading Radio Parts  
Distributors or write to:

**TECH-MASTER CORPORATION**  
75 Front St., Brooklyn 1, New York  
Makers of Custom-Built TV Chassis



the cartridge that  
scores **100%**



passes all  
tests with  
**FLYING  
COLORS**

## Recoton-Goldring

New MODEL "555 SDM"  
MUMETAL SHIELDED  
MAGNETIC  
TURNOVER CARTRIDGE

Acclaimed the best performer by a national  
independent research organization!

Acclaimed the best by audiophiles everywhere!

Sturdy construction, excellent performance,  
popular price, make it the best bet for bigger  
profits, bigger sales! Write for descriptive  
literature today.

**RECOTON CORPORATION**

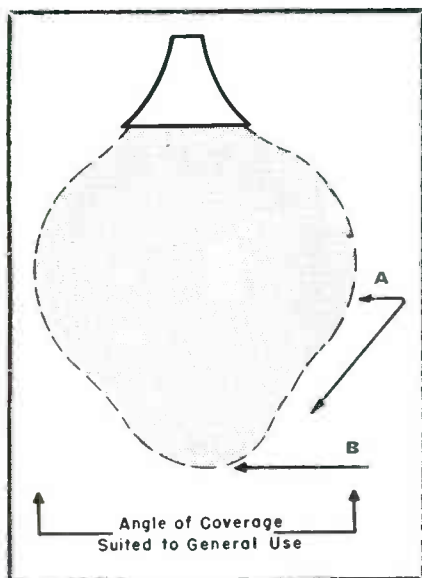
52-35 Barnett Ave. Long Island City 4, N. Y.  
In Canada: Quality Records, Ltd., Toronto

sion and sound energy is the same as that of the horizontal plane, considerable distance of penetration results. The actual configuration of sound on the ground surface would be a circle, becoming more of an ellipse as greater distance penetration is attempted. In fact, the pattern of Fig. 3a can often be duplicated by the round trumpet, angularly mounted for distance projection, without as much loss in sound pressure. Considering the selection of round trumpets available, it is easy to see why the majority of general applications and many special requirements will be satisfactorily met by these *directional* types.

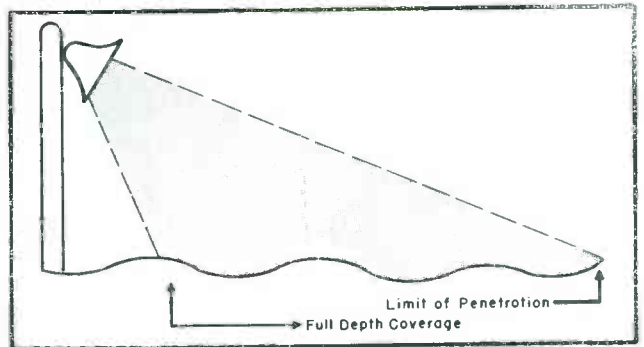
Aside from angle of dispersion, the considerations in selecting *wide-angle* horns are quite the same as with round horns; physical dimensions compatible with application requirements, and air column length to provide desired frequency characteristics. No *one* wide-angle horn should be expected to perform equally well for all applications any more than may be expected for round horns. The level and characteristics of ambient noise, the nature of the installation structural environment and acoustics, and the kind of program material are all important technical factors in determining the selection of the right *size* wide-angle horn. Given a choice of horn sizes (whether round or wide-angle) and a horn design which allows for the selection of driver units, driver and horn characteristics can be blended by the sound specialist to meet both technical and cost requirements.

**How Much Efficiency and Power?**

There are many ways to approach this question of selecting a companion



**FIGS 4a (below) AND b (right): COVERAGE provided by round directional trumpets. At point A in Fig. 4a (below) bonus penetration obtains due to greater on-axis energy. The limit of penetration appears at point B.**



driver unit. We suggest that initially you establish the horn on the basis of function. For example, suppose a

6 1/2" round trumpet is selected on the basis of on-axis sensitivity for greatest (Continued on page 58)

**YOU CAN REALLY**  
*Cash in*  
**ON THE HI-FI BOOM**

**ON THE STEADY PUBLIC ADDRESS MARKET**

with  
**QUAM**  
*Adjust-a-Cone*<sup>®</sup>  
**SPEAKERS**



*Do you have the latest Quam catalogs? Available free from your distributor or by writing direct to us. Catalog 56 lists the entire Quam line. Catalog 69 describes the hi-fi line in detail.*

Extra profits for you when you go after these two hot markets. For small budget hi-fi installations, you can't beat Quam extended range and coaxial speakers, which provide the perfect way to give your customers fine audio reproduction at low cost. And for fine quality public address, Quam is truly the quality line. Special voice coil impedances are available, and Quam makes the only public address speakers on the market featuring the famous patented Adjust-a-Cone Suspension.

*ask for QUAM, the quality line for all your speaker needs*

**QUAM-NICHOLS COMPANY**  
232 E. MARQUETTE RD. • CHICAGO 37, ILLINOIS

Driver	Frequency Response	Round Trumpets†					Wide-Angle Horns	
		6½' 4	4½' 5	3½' 6	2½' 7	2½' 8	4½' 9	
<b>Type A<sup>1</sup></b>								
25 watts	85- 6,500 cps	127 db	126 db	125 db	124 db	122 db	123 db	
50 watts°		130 db	129 db	128 db	127 db	125 db	126 db	
<b>Type B<sup>2</sup></b>								
30 watts	80-10,000 cps	130 db	129 db	128 db	127 db	125 db	126 db	
60 watts°		133 db	132 db	131 db	130 db	128 db	129 db	
<b>Type C<sup>3</sup></b>								
50 watts	70-10,000 cps	134 db	133 db	132 db	131 db	129 db	130 db	
100 watts°		137 db	136 db	135 db	134 db	132 db	133 db	

1-9 University types M.A-25, S.A-11F, P.A-11F, G.H, L.II, P.H, S.M.H, Cobrexflex and C.L.II, respectively.  
 °With proper value capacitor in series with driver. †Air-column lengths of the various horns are indicated.

Chart showing sound pressure of various trumpets with different drivers and input wattages: Sound pressure readings taken at 4'; reduce by 6 db each time distance is doubled and 3 db each time power input is halved.

## Round and Wide-Angle Horns

(Continued from page 57)

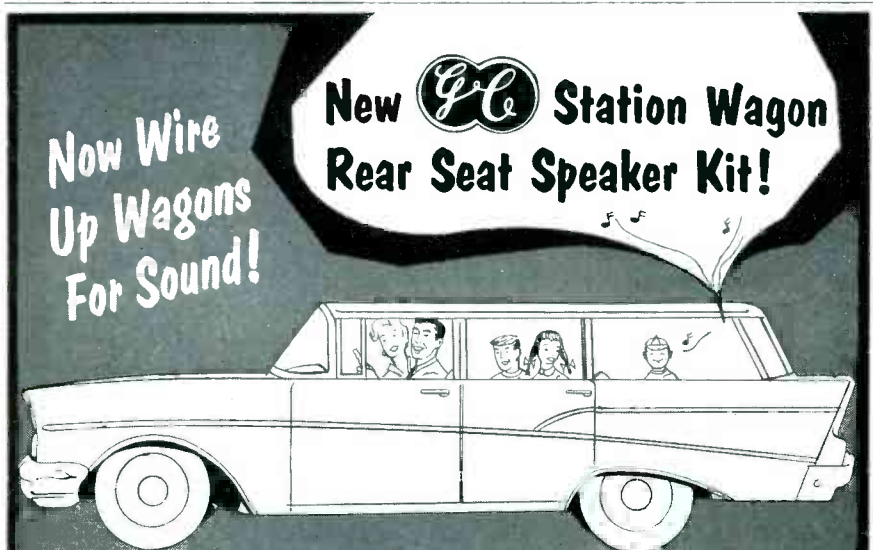
distance coverage. If the program is to consist mostly of speech, a moderately priced driver would be practical, such a unit providing 127 db with 25 watts input: See driver chart at left. Let us suppose, however, that the area to be penetrated is quite noisy. A more efficient driver unit, type B, could provide 130 db at 30 watts. Need more? Heavy-duty, type C, models are available to produce 134 db at 50 watts. The influencing factors determining the selection of the driver, other than sound pressure requirements, are amplifier power available and the cost of more amplifier power.

It's easy to see from the foregoing that on a watts-per-dollar basis, you can get more sound by using a more efficient driver than by pouring on more amplifier watts. For example, let us suppose you had selected a reflex trumpet because it offers the desired dispersion characteristics and meets frequency response requirements. The 25-watt type-A driver will yield 125 db on this trumpet. You need more? You can get a somewhat more expensive 50-watt amplifier instead, and obtain 128 db by using a capacitor of proper value in series with this driver to double power handling capacity. Or, the type-B driver, costing only a few dollars more can be used with a trumpet to provide the same 128 db at only 30 watts. If speech were still the only consideration and high sound pressure desired at a minimum cost, you might even consider the 2½' horn with a type-C driver. That combination will produce 131 db at 50 watts as against 130 db using the 6½' horn-type-A driver combination at the same 50 watts (with a series capacitor).

Obviously, horn-driver combinations can be juggled to yield desired sound pressures. Once the horn has been selected on the basis of dispersion and frequency-response characteristics, the driver should be selected to provide the sound pressure required. Bear in mind that as the smaller horns are used, dispersion increases and the available sound energy is more spread out.

### What Frequency Response?

Naturally, if the program is to be both voice and music, a wide-range driver unit should be used. However, in the event a 2½' trumpet has been selected (say for reasons of dispersion, cost or physical requirements),



- COMPLETE . . . WIRED . . . READY TO INSTALL
- KIT "FITS" EVERY STATION WAGON

**G-C STATION WAGON SPEAKER KIT**—This new Station Wagon Speaker Kit is easily installed right over the rear door of any wagon. Kit contains speaker and speaker baffle box with brackets for easy adjustment . . . plus 3-way switch, knob, plate, wire, terminal, hardware and full instructions. Finished in Spring-time Gray to harmonize with all wagon interiors.

No. 9501 List \$15.95

## GENERAL CEMENT MFG. CO.

Division of Textron Inc., 400 South Wyman Street • Rockford, Illinois



**G-C EXTERNAL SPEAKER CONTROL**—Includes Fader Control and Outlet Panel. Plug in external speaker to use outside car, bring car radio music to picnics. Or plug in ear piece and listen without annoying other passengers or passing cars. Plug shorts out car speakers.

No. 9500 List \$3.50



**G-C REAR SEAT SPEAKER PERSONAL CONTROL**—Now rear seat passengers can control rear speaker volume to suit themselves without affecting front speaker volume.

No. 9504 List \$2.50

LOOK TO G-C FOR ALL AUTOMOTIVE SPEAKER APPLICATIONS!

SEND FOR YOUR FREE CATALOG. NO OBLIGATION . . . DO IT TODAY!



a unit such as the type A driver can be successfully used, since its limited high-frequency response (6500 cps) will balance reasonably well with the high cut-off (200 cps) of the horn. If music is an important consideration, and for other good reasons a 4½" horn or even a 3½" horn is to be used, the type C driver will produce an aurally discernible improvement in low-frequency response over the type B unit because of its greater efficiency. Where the need is for the finest musical reproduction, a 6½" horn with either the types B or C drivers should be used.

It is not a simple thing to plan a good sound installation, nor is it a difficult thing to accomplish, if we make just a small effort to understand the factors involved. It is in seeking a *cure-all* to *do-all* that one flirts with disappointment. Any piece of equipment that makes noise of some kind will be heard somewhere by someone. It is in getting the sound to where we want it, to be heard and understood with the quality we want and with the least possible waste, that makes a *sound specialist* out of a Service Man.

## Audio

(Continued from page 54)

important to notice what happens to the spot when you short-circuit the oscillator terminals. This should not bounce up and down, but should return to the center of the screen quite quickly.

If the trace does not obey this rule, it may be advisable to strap the vertical and horizontal deflection together, as a check on the deflection amplifiers in the 'scope. It may be that the bounce occurs in the 'scope amplifiers and not in the amplifier under test. But most 'scope amplifiers in modern equipment are above reproach in this respect.

If the amplifier exhibits either the bouncing effect at low frequency or the peaking effect at supersonic frequency, some adjustment to improve the margin of stability in the amplifier circuit is indicated. The best procedure is to clip out all of the small phase-correction capacitors.

It is possible that then the amplifier may oscillate, either at supersonic or subsonic frequency. If the oscillation is at supersonic frequency, the best remedy is to apply a suitable capacitor from plate to ground of the first tube; Fig. 4 (p. 54). The value of this plate-to-ground capacitor should be adjusted until the amplifier is not only stable again at supersonic frequency but, when the frequency run is made a smooth rolloff appears, not a peak.

This may require a plate-to-ground capacitor in the first stage, whose value may be as large as .001 mfd. If the response still shows some peaking with so large a capacitor, it may be well to try small values of phase-correction capacitors in the circuit (where they were previously connected) until a suitable rolloff is achieved at the hf end.

# sell

# RECOTON

## REPLACEMENT NEEDLES



Kit #100

### on every job!

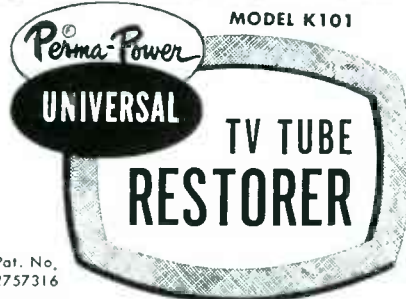
It's easy to sell famous Recoton Replacement Needles on every service call you make! Everyone buys phonograph needles — and Recoton's have 100% consumer acceptance. Easy to carry in Recoton's smart, professional #100 Kit, complete with eye loupe and tools, all Recoton Replacement Needles are easy to find, too, without guessing, and best of all, easy to install.

That's why more service men recommend — and sell — RECOTON Replacement Needles on every job!

### RECOTON CORPORATION

52-35 Barnett Avenue  
Long Island City 4, N. Y.

IN CANADA: QUALITY RECORDS, LTD., TORONTO



Pat. No. 2757316

RESTORES PICTURE TO DEFECTIVE PICTURE TUBE OF ANY TV SET —

Model K-101

**\$550**

List Price



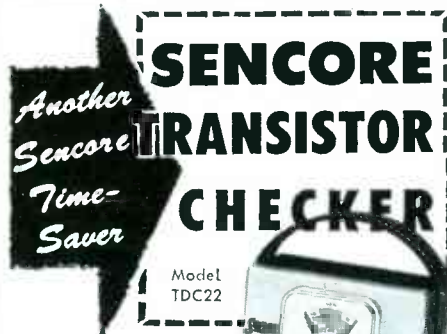
LOCATES AND CORRECTS FOR

- Open Cathode
- Heater-Cathode Short
- Open Control Grid
- Control Grid-Cathode Short
- Low Emission
- Combinations of above

**Perma-Power** COMPANY

3100 N. ELSTON AVE. • CHICAGO 18, ILLINOIS

There's Always Something NEW Being Developed by Perma-Power



## SENCORE TRANSISTOR CHECKER

Model TDC22

NOW WANTED and NEEDED by EVERY SERVICEMAN

Quickly and accurately checks all transistors and crystal diodes.

Provides these 4 important checks on transistors:  
OPEN • SHORT • CURRENT GAIN • LEAKAGE  
Checks forward to backward resistance of diodes.

★ Complete set-up chart and instruction booklet attached to back ★ Will never become obsolete, with test leads, replaceable up-to-date set-up chart and gain control to vary battery voltage ★ Accurate and simple to operate — takes less than 30 seconds to test either TRANSISTORS or crystal diodes  
★ Uses test leads which eliminates need of completely removing transistor from circuit.

At Leading Distributors Everywhere

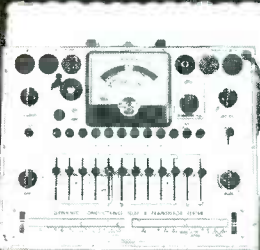
Mfg by **SENCORE SERVICE INSTRUMENTS CORP.**  
171 OFFICIAL RD., ADDISON, ILL.

only **\$15.95** DEALER NET

POPULAR SENCORE PRODUCTS

- Transistor Tester
- Leakage Checker
- Filament Tester
- Voltage Regulator
- Bias Supply

the specs are the proof . . .  
 the BEST BUYS are **EICO**  
 for COLOR & Monochrome TV servicing



**NEW**  
**Dynamic**  
**Conductance**  
**Tube &**  
**Transistor**  
**Tester**  
**#666**  
**WIRED \$109<sup>95</sup>**  
**KIT \$69<sup>95</sup>**

COMPLETE with steel cover and handle.

**SPEED, ease, unexcelled accuracy & thoroughness. Tests all receiving tubes (and picture tubes with adapter). Composite indication of Gm, Gp & peak emission. Simultaneous sel of any 1 of 4 combinations of 3 plate voltages, 3 screen voltages, 3 ranges of continuously variable grid voltage (with 5% accurate pot). New series-string voltages: for 600, 450, 300 ma types. Sensitive 200 ua meter. 5 ranges meter sensitivity (1% shunts & 5% pot). 10 SIX-position lever switches: freepoint connection of each tube pin. 10 pushbuttons: rapid insert of any tube element in leakage test circuit & speedy sel. of individual sections of multi-section tubes in merit tests. Direct-reading of inter-element leakage in ohms. New gear-driven rollechart. Checks n-p-n & p-n-p transistors: separate meter readings of collector leakage current & Beta using internal dc power supply. Deep-etched satin aluminum panel; rugged grey wrinkle steel cabinet. CRA Adapter \$4.50**

See the 50 EICO models of tests instruments and hi-fi equipment IN STOCK at your neighborhood distributor. Write for FREE Catalog S-5

Prices 5% higher on West Coast

**EICO** BROOKLYN 11, N. Y.



## KEEP AHEAD

by keeping informed. CORNELL-DUBILIER'S pocket-size monthly magazine is loaded with technical articles that KEEP you ahead. PLUS a "Sell-Swap and Buy" section for your ad. Mailed FREE to your home every month for the asking.

CORNELL-DUBILIER ELECTRIC CORP.  
 DEPT. S57 SOUTH PLAINFIELD, N. J.

OK! Send me "The Capacitor"—Free

Name \_\_\_\_\_

Please Print!

Address \_\_\_\_\_

City \_\_\_\_\_ Zone \_\_\_\_\_ State \_\_\_\_\_

My occupation or job title is \_\_\_\_\_

## New Audio Developments



**OUTDOOR THEATRE SPEAKER** with a **Humi-Gard** cone said to be resistant to moisture and abrasion. Cone is made of a plastic-impregnated synthetic fabric. (Quam-Nichols Co., 234 E. Marquette Road, Chicago)



**RECORD SPRAY** said to eliminate static buildup and coat record grooves with a lubricating film to reduce coefficient of friction. (Lubri-Stat; Permo, Inc., 6415 N. Ravenswood Ave., Chicago)



**MU-METAL** shielded magnetic turn-over cartridge supplied with sapphire stylus for 78 and diamond stylus for 33 $\frac{1}{3}$  and 45. Features a cantilever - stylus - armature construction. (Recoton-Goldring 555 SDM, Recoton Corp., 52-35 Barnett Ave., L.I.C., N.Y.)



"Gosh, Martha, these records sound so clear with this **JENSEN NEEDLE** that you'd swear those musicians were right here in this very room."

## ALERT SERVICEMAN BECOMES SUCCESSFUL SALESMAN

Direct-from-the-factory product information is the key . . .

he finds it faster in **The MASTER!**

The **MASTER** describes, illustrates, lists specifications of over 125,000 items necessary to radio-TV servicing. What's more—it offers thousands of other products that can lead to extra income in Hi-Fi, sound and industrial servicing. You can buy, sell and bill direct from **The MASTER**. It shows list prices! 1546 pages of current, direct-from-the-factory product information, systematically arranged for quick, easy reference.



1546 pages  
 World's Largest  
 Electronic Parts  
 Catalog

Get the **NEW**

**1957 Radio-Electronic MASTER**

(21st edition)

ONLY **\$2.95**

at your parts distributor—or write for list

**The Radio-Electronic MASTER**  
 60 Madison Avenue, Hempstead, N. Y.

# CSR

Means **SERVICE—plus!**  
Every Coffee Maker Needs  
**MAID-EASY**

## COFFEE STAIN REMOVER (CSR) to eliminate oils and stain that spoil true coffee taste.

**USE CSR** on repairs  
... return a stain  
free coffee maker  
to the customer.

**SELL CSR** over the  
counter ... bring  
a *satisfied* cus-  
tomer back to  
your store time  
and time again.

**SHOW** your customers the need for  
CSR—ordinary cleansers and clean-  
ing methods *will not* do the job.

**OTHER** important uses for CSR make  
it a household **MUST**.

Write for name of nearest supplier. Sample  
furnished if requested on company letter-  
head.



### MAID-EASY

## CLEANSING PRODUCTS CORP.

CSR Division  
25 Elm Ave., Mt. Vernon, N. Y.

**NEW!**



## STEAM IRON REJUVENATOR

- Cleans **INSIDE** steam iron
- Fast, safe, odorless
- Recommended



**EVERY  
STEAM IRON  
OWNER A  
PROSPECT!**

Use it for ser-  
vicing, or sell  
to customers.  
\$1.00 suggested  
resale.

**ORDER TODAY**  
from your jobber or  
write Dept. S for name  
of nearest supplier.

**FREE!**  
Sample upon re-  
quest on company  
letterhead.

**FAST CHEMICAL PRODUCTS CORP.**  
65 Page Avenue Yonkers, N. Y.

## Traffic Appliance Servicing

(Continued from page 32)

must be clean, true and unpitted and free to move. The wells where the inset or stem set must be clean. Valve seats that are stuck (the type that unscrew) can be freed by heating over a hot flame for a minute or so and then immediately dipping in cold water. A stuck stem can be loosened similarly by heating the percolator without water for a few seconds and then with cold water.

Coffee stain removers can be used for cleaning. These removers not only dissolve coffee oils, but have a bleaching action. When this cleaner is used on aluminum bodies it is necessary to flush thoroughly to prevent possible staining.

### PERCOLATOR shut-off data on strong or high position.

Types	Shut-Off Data
Camfield P100	204°
Mirro . . . . .	195°
General 13P30	Booster cuts out at 125°-150°
Electric	Perking unit: 185°-200°
P31	181°-195°
Presto	190°-194°: Continues to perk for 3-5 minutes
Sunbeam . . . . .	202°-Approximately
Universal . . . . .	204°
Westinghouse	155°-180°: First thermostat
	190°-200°: Second thermostat
PE552	180°-190°
PE561	200°-Approximately

### Silver-Anniversary



**AT 25th ANNIVERSARY** celebration of the Precision Apparatus Company, Inc., recently held in Glendale, Long Island. Among the honored guests were (left to right); Mike Wolfe; Sol Weingast, president and co-founder; D. Lou Harris; Morris Zigman; Preston Mack, representing his late father, Pearce W. Mack, the first Precision rep, and Morris F. Taylor.

## SMALL APPLIANCE REPAIRMEN

If you repair small appliances you need a catalog which is a complete manual of parts and service. There are several catalogs available to you. Some list replacement parts. *Our catalog lists the complete original parts of 79 manufacturers.* This means you can get all genuine parts from one source of supply, thus saving clerical work and shipping costs. Deserve your customer's confidence — Order an Electra-Craft genuine parts and service manual today.

**Electra-Craft Appliance Company**  
348 West 42 Street  
New York 36, N. Y.

Please send me a *free* copy of your catalog which you regularly sell for \$1.50. I am enclosing 25¢ to cover the costs of handling. I understand the supply is limited.

Name .....

Company .....

Address .....

City..... Zone... State.....



## SELL-SWAP-BUY

Turn your unneeded equipment into dollars. CORNELL-DUBILIER's pocket-size monthly magazine gives you space for a Sell-Swap & Buy ad. The ad is **FREE**—the magazine is **FREE**. Mailed to your home every month for the asking—use coupon.

CORNELL-DUBILIER ELECTRIC CORP.  
DEPT. S57 SOUTH PLAINFIELD, N. J.  
**OK! Send me "The Capacitor"—Free**

Name.....  
Please Print!

Address.....

City..... Zone..... State.....

My occupation or job title is.....

# SAVE with SECURITY



Because Wright Wire Strand comes to you pre-measured and uncoils without snarling, it gives to you unique economy. Quality wire, perfectly stranded and heavily galvanized, the bright Wright way. SAVE with Wright.

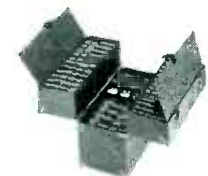


Prompt deliveries from stocks in Worcester, Chicago, Atlanta, New Orleans, Houston, Dallas and Los Angeles.

**G. F. WRIGHT STEEL & WIRE CO.**  
249 Stafford St. • Worcester, Mass.

## NOW-A COMPLETE LINE!

### TOTE MASTRA BOXES



Model 11 "Special"

Choose from this complete selection:

**Model 11 "Special"**  
Holds 135 tubes of all sizes.  
L. 16 1/2"; H. 13 1/2"; W. 8".  
Serviceman's Cost \$11.95.

or from the  
**NEW BLUE LINE:**

**Model 33 "Deluxe"**  
Holds tools, tester, 190 tubes.  
Over 2600 cu. in. usable space.  
L. 22 1/4"; H. 15 1/4"; W. 8".  
Serviceman's Cost \$17.95.  
Complete with removable  
insert tray for tools

**Model XX "Thrill Kit"**  
Most attractive in the low price  
field. Low in price, high in qual-  
ity. L. 16 1/2"; H. 13"; W. 8".  
Serviceman's Cost \$9.95.



Model 33 "Deluxe"

**Model 55 "Custom"**  
Holds complete assortment of  
tools, up to 250 tubes. Over  
2800 cu. in. of usable space.  
L. 19 5/8"; H. 14 1/4"; W. 9 3/8".  
Serviceman's Cost \$22.95.  
Includes removable insert tray  
(not shown) for tools, parts.

**Model 22 "Super"**  
Over 2200 cu. in. of usable  
space. Attractive blue finish.  
Ideal for more extensive tube  
requirements. L. 22 1/4"; H.  
13"; W. 8". Serviceman's Cost  
\$13.95.



Model 55 "Custom"

Now available in a complete line of tote boxes for every re-  
quirement, the TNT Tote Boxes are unequalled in quality, unsur-  
passed in appearance, competitive in price. Also custom boxes  
made to your specifications for specialized purposes.

Write for full line  
catalog No. CX1235

## MASTRA COMPANY

2104 SUPERIOR AVENUE • CLEVELAND 14, OHIO  
CANADIAN DISTRIBUTOR: TENATRONICS LTD., NEW MARKET, ONTARIO

See us in Chicago during the Parts Show—May 20-23

## COMPONENTS

### PW PLASTIC TUBULAR CAPACITOR

A PLASTIC TUBULAR capacitor for print-  
ed-wiring circuits, *BTS*, has been intro-  
duced by Pyramid Electric Co., 1445  
Hudson Blvd., North Bergen, N. J.

Unit has been designed to meet re-  
quirements for minimum board space,  
close mechanical tolerances and opera-  
tion under severe conditions.

### MINIATURE AUDIO TRANSISTOR TRANSFORMERS

MINIATURE AUDIO TRANSFORMERS for  
transistorized-circuit applications have  
been announced by Gramer Halldorson  
Corp., 2734 N. Pulaski Rd., Chicago 39,  
Ill.

A 150-mw series features units 21/32"  
high x 12/16" wide x 3/8" deep with  
mounting tab centers 13/16"; 300-mw  
series units are 13/16" high x 1 1/8" wide  
x 13/16" deep with mounting centers  
1 1/8".

### SURGE-CURRENT LIMITER

A COMBINATION RELAY AND RESISTOR,  
*Surgistor*, for limiting in-rush current un-  
til tube heaters are warmed sufficiently  
to accept full voltage without damage,  
has been developed by Wuerth Tube  
Saver Corp., 9125 Livernois Ave.,  
Detroit 4, Mich.

Unit is said to hold B+ voltages down  
temporarily to prevent cathode *stripping*.

### EXACT FLYBACK REPLACEMENTS

FIVE EXACT REPLACEMENT flybacks for  
Admiral, Magnavox, Philco and Zenith  
chassis have been announced by Chicago  
Standard Transformer Corp., 3501 W.  
Addison St., Chicago 18, Ill.

HO-264 replaces Philco 32-8709-1 in  
one chassis and five separate models;  
HO-265 is used to replace Admiral  
79C70-1 in portable model series T-  
101-N; HO-266 replaces Magnavox  
360659 in portable model and chassis  
series 821; HO-267 replaces Zenith  
S-20099 in two chassis and twenty-four  
models; and HO-268 replaces Zenith  
S-23049 in three chassis and thirty-two  
models.

### PIX TUBE BRIGHTENER

A PICTURE-TUBE BRIGHTENER, Comet  
SP43, for electromagnetic or electrostatic  
focusing tubes has been announced by  
Anchor Products Co., 2712 W. Montrose  
Ave., Chicago 18, Ill.

Unit can be used in either series or  
parallel filament circuits.





## ADVERTISERS IN SERVICE

MAY, 1957

	Page
Admiral Corp., Special Products Div.	47
Aerovox Corp.	45
American Television and Radio Co.	56
Argos Products Co.	2
Atlas Sound Corp.	36
B&K Manufacturing Co.	44
Blonder-Tongue Laboratories, Inc.	53
Bussmann Manufacturing Co.	6
Centralab, A Div. of Globe-Union, Inc.	3
H. G. Cisin	63
Clarostat Manufacturing Co., Inc.	38
Cornell-Dubilier Electric Corp. Inside Front Cover, 52, 60, 61	61
EICO	60
Electra-Craft Appliance Co.	61
Electro Products Laboratories	31
Erie Resistor Corp.	48
Fast Chemical Products Corp.	61
General Cement Manufacturing Co., Div. of Textron, Inc.	58
General Electric Co., Electronic Components Div.	1, 40, 41
Heath Co.	51
International Electronics Corp.	64
Jensen Industries, Inc.	60
Jerrold Electronics Corp.	35
JFD Electronics, Inc.	23
Kay Electric Co.	27
Kester Solder Co.	48
Kraeuter & Co., Inc.	30
Maid Easy Cleansing Products Corp., CSR Div.	61
P. R. Mallory & Co., Inc.	34
The Mastra Co.	62
McGraw-Hill Technical Writing Service	49
Perma-Power Co.	59
Philco Corp., Accessory Div.	8, 9
Quam-Nichols Co.	57
The Radiart Corp. Inside Front Cover, 52, 60, 61	61
Radio Corporation of America, Electron Tube Div.	Back Cover
Raytheon Manufacturing Co.	10
RCA Service Co., Inc.	29, 47
Recoton Corp.	56, 59
John F. Rider, Publisher, Inc.	50
Sarkes Tarzian, Inc., Rectifier Div.	46
Service Instruments Corp.	59
Snyder Manufacturing Co.	33
Standard Coil Products Co., Inc.	42
Sylvania Electric Products, Inc.	4, 5
Tech Master Corp.	56
Trio Manufacturing Co.	64
Triplett Electrical Instrument Co. Inside Back Cover	64
United Catalog Publishers, Inc.	60
University Loudspeakers, Inc.	55
Waage Manufacturing Co.	63
Wall Manufacturing Co.	49
Westinghouse Electric Corp., Electronic Tube Div.	17
Winegard Co.	37
G. F. Wright Steel & Wire Co.	62
Xcelite, Inc.	7

## BENCH-FIELD TOOLS

### CONTROL CLEANER-LUBRICATOR

A SOLVENT, *Kleontrol*, for cleaning and lubricating controls, has been introduced by R-Columbia Products Co., Highwood, Ill.

Solvent which contains no carbon tet, will not harm wood, metal or acetate surfaces.

### TEST PROD KIT

A TEST PROD KIT, 6037, featuring self-holding points, has been made available by General Cement Manufacturing Co., 400 S. Wyman St., Rockford, Ill.

In addition to basic test leads and prods, kit includes five pairs of adapters (banana plugs, alligator clips, etc.).



### SINGLE-POLE SOLDERING GUN

A 250-WATT SOLDERING gun with a single-pole built-in transformer has been announced by Gregg Electric Co., 2 S. Broadway, Lawrence, Mass.

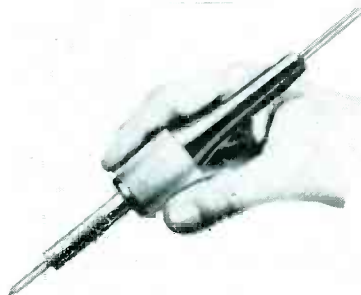
Tips available include pencil (5-inch) and chisel types. Trigger control claimed to be soft-action type.



### 50-WATT SOLDERING PENCIL

A 50-w SOLDERING PENCIL, 24S, with a 1/8" tip, has been developed by Hexacon Electric Co., 594 W. Clay Ave., Roselle Park, N. J.

Unit weighs 2 ounces. Has a stainless steel alloy for element housing. Tip and element are separate parts and replaceable independently.



## NEW SPEED TV SERVICING SYSTEM

### TV TROUBLE TRACER—Vol. 6

Trouble Indicating Tube Location Guides of newest TV PORTABLES from Admiral to Zenith—Also 1957 RCA TV Tube Location Guides incl. portables. Just off the press.  
Vol. 6 (TT6).....Only 50¢

Other TV TROUBLE TRACERS include:

- Vol. 1 (TT1)—Older Models.....50¢
- Vol. 2 (TT2)—1952-3 sets.....50¢
- Vol. 3 (TT3)—1953-4 sets.....50¢
- Vol. 4 (TT4)—1954-5 sets.....50¢
- Vol. 5 (TT5)—1955-6 sets.....50¢

**SPECIAL FEATURE:** Each volume contains 40 illustrations of picture faults caused by defective tubes, plus 40 SYMPTOM-CAUSE-REMEDY instruction charts whereby 70 Common Tube Troubles may be traced to their sources and cured.

**Guaranteed Money Back in 5 Days if not Satisfied!**

**ABSOLUTELY FREE** with each order for six Trouble Tracer volumes: H. G. Cisin's "TV & RADIO TUBE SUBSTITUTION GUIDE" which sells for 50¢. Gives direct replacements of set & pix tubes. Most valuable servicing aid! ACT NOW—get all 7 books postpaid for only \$3.

### RUSH COUPON NOW!

**H. G. CISIN, CONSULTING ENGINEER**  
Amagansett, N. Y. Dept. S-37

Enclosed find \$..... RUSH following:  
 Ship books checked above.  
 Ship all six Vol.'s plus FREE book.

Name .....

Address .....

City..... Zone... State.....

### "ATTENTION REPS"

Valuable territory still open.  
Write or wire for full particulars to  
**H. G. CISIN, Amagansett, N. Y.**

### When . . . You Change Your Address

► Be sure to notify the Subscription Department of SERVICE at 52 Vanderbilt Avenue, New York 17, N. Y., giving the old as well as the new address, enclose address label from your last SERVICE copy, and do this at least four weeks in advance.

► The Post Office Department does not forward magazines unless you pay additional postage, and we cannot duplicate copies mailed to the old address.

► We ask your cooperation.

### OUTSTANDING NATIONAL SERVICE

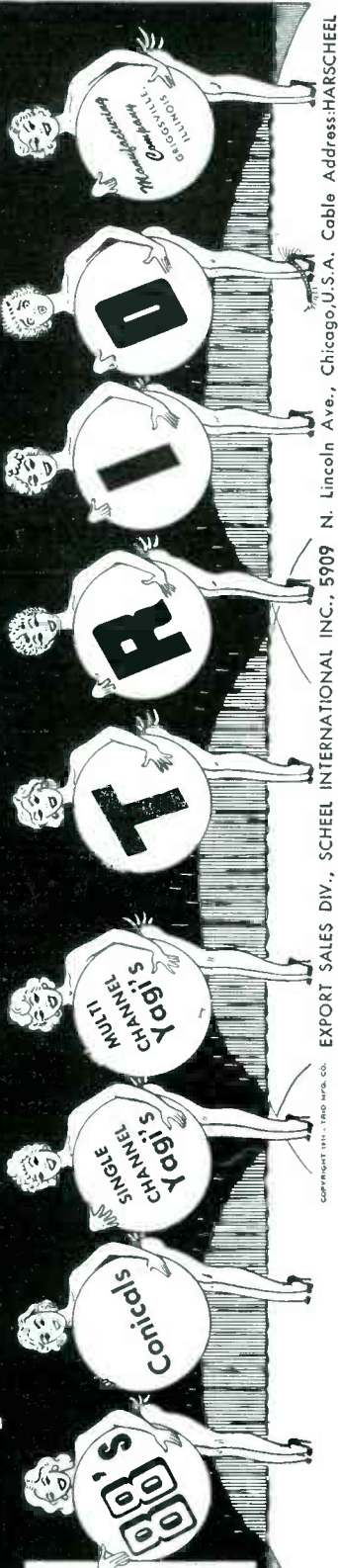
Co-operation with Parts Jobbers makes possible a "ONE STOP" source from nearby stocks, for Appliance and Electronic Repair Parts—Cords and Cord Sleeves, Plugs; Iron, Percolator, Toaster and Water Heater Elements; Cements and Insulators; Special Tools, Switches, Repair Tags; Testing Equipment, includes Tube Testers and Ohmmeters.

New RW58 Catalog available from your parts jobber, or if he cannot supply, write us with name and address of your parts jobber.

**WAAGE MFG. CO.** 632R N. Albany Ave.  
Chicago 12, Ill.

# The Most Popular Line In America!

**TRIO**  
*Sharpshooters*  
TV ANTENNAS



EXPORT SALES DIV., SCHEEL INTERNATIONAL INC., 5909 N. Lincoln Ave., Chicago, U.S.A. Cable Address: HARSHEEL

SEE US AT THE PARTS SHOW — ROOMS 639, 640A AND BOOTH 876

## PERSONNEL

ABE KOSAKOWSKY has been promoted to assistant sales manager, jobber division, Pyramid Electric Co., 1445 Hudson Blvd., North Bergen, N. J. . . . *Eileen Johnson* is now sales correspondent and expeditor for the division.



Kosakowsky



Sundberg

HUGO SUNDBERG has been elected president and member of the board of directors of Oxford Electric Corp., 3911 S. Michigan Avenue, Chicago, Ill. He succeeds *Joseph D. Ceader*, who was elected chairman of the board. Sundberg previously had been vice president and general manager of the firm and its subsidiaries.

ARCH T. HOYNE, formerly in charge of the General Cement Manufacturing Co. division sales, has become eastern sales manager, with headquarters in Rockford. *William H. Dean*, previously G-C Electronics sales chief, is now west coast sales manager for all divisions, with offices at 3225 Exposition Place, Los Angeles, Calif.

JAMES M. IGOE has been promoted to distributor sales coordinator for the operations sales services department of Raytheon Manufacturing Co., 55 Chapel St., Newton 58, Mass. . . . *Robert F. Sim, Jr.*, is now manager of the distributor order service department for receiving and picture tubes.

JAY J. NEWMAN has been promoted to manager, new product and market development, RCA components division, Camden, N. J. . . . *Thornton F. Scott* is now administrator, advertising and sales promotion for the division.

C. E. SEAMAN, formerly phono cartridge product manager, is now eastern regional sales manager for Electro-Voice, Inc., Buchanan, Mich. . . . *Frank Linter*, former assistant distributor sales manager, will handle the central region. . . . *Frank Stroempl*, formerly public-address loud-speaker product manager, becomes western regional sales manager.

JULIAN K. SPRAGUE, president of Sprague Electric Co., North Adams, Mass., has been named president of the board of trustees of the Mark Twain Research Foundation, Inc., Perry, Mo.

RICARDO MUNIZ, formerly division general manager of the television-radio division of Canadian Westinghouse, has been appointed coordinator of manufacturing and engineering for the Magnavox Co., Fort Wayne 4, Ind.

## PROTECT COSTLY HIGH FIDELITY EQUIPMENT



**GZ34**  
Rectifier

**Mullard**  
MADE FOR MUSIC

### CHECK THESE ADVANTAGES

- Better voltage regulation due to lowered power supply impedance.
- Higher output voltage and cooler operation due to lower voltage drop.
- Protection of costly filter condensers and power output tubes due to delayed warm-up and reduced ripple.

The Mullard GZ34 is a low-impedance, indirectly heated, full-wave rectifier. Compactness and unique characteristics make the GZ34 an excellent replacement for high power rectifiers such as the 5U4G, 5U4GA, 5V4G, etc. in most amplifiers.

### OTHER Mullard TUBES designed specifically for High Fidelity:

EL34/6CA7	High-power pentode, 100 W PP
EL37	High-power pentode, 69 W PP
EL84/6BQ5	Miniature output pentode, 20 W PP
EF86/6Z67	Low-noise input pentode
ECC81/12AT7	Low-noise medium $\mu$ dual triode
ECC82/12AU7	Low-noise low $\mu$ dual triode
ECC83/12AX7	Low-noise high $\mu$ dual triode
EZ80/6V4	Miniature rectifier cathode type, 90 ma.
EZ81/6CA4	Miniature rectifier cathode type, 150 ma.

**Mullard**



Available at all leading distributors. For detailed technical data and application information write:

**INTERNATIONAL ELECTRONICS CORP.**  
81 Spring Street, New York 12, N. Y.

World's Most Complete Range of audio tubes

# to do more

## ...today and tomorrow!



The first  
low priced  
tube tester  
to provide  
**DUAL SENSITIVITY  
SHORT TEST**

Triplet Model  
**3413-B Tube Tester**  
\$79.50

BURTON BROWNE ADVERTISING

And here are just 2 answers that tell you why.

**Question:**

Why Will Triplet Model 3413-B "do more" tomorrow?

**Answer:**

Because it will test *any new tube*. Unlike testers with preset panels of test sockets which become obsolete with the release of a new tube, Triplet flexibility of switching allows a set-up to test any new tube.

**Question:**

Why Will Triplet Model 3413-B "do more" today?

**Answer:**

Because it combines provision for conventional short test (0.25 megohms) with high sensitivity leakage test (2.0 megohms)—will test series string tubes without adapter. At only \$79.50 today's and tomorrow's biggest value.



And for the ultimate in laboratory quality testing examine MODEL 3423 MUTUAL CONDUCTANCE TUBE TESTER \$199.50. Proportional Mutual Conductance testing of *all* radio and TV tubes plus selenium rectifiers, crystal diodes, pilot lamps, thyratrons, transistors, etc., by a new patented circuit.

*At leading Parts Distributors everywhere, see the finest and most complete line of test equipment by*

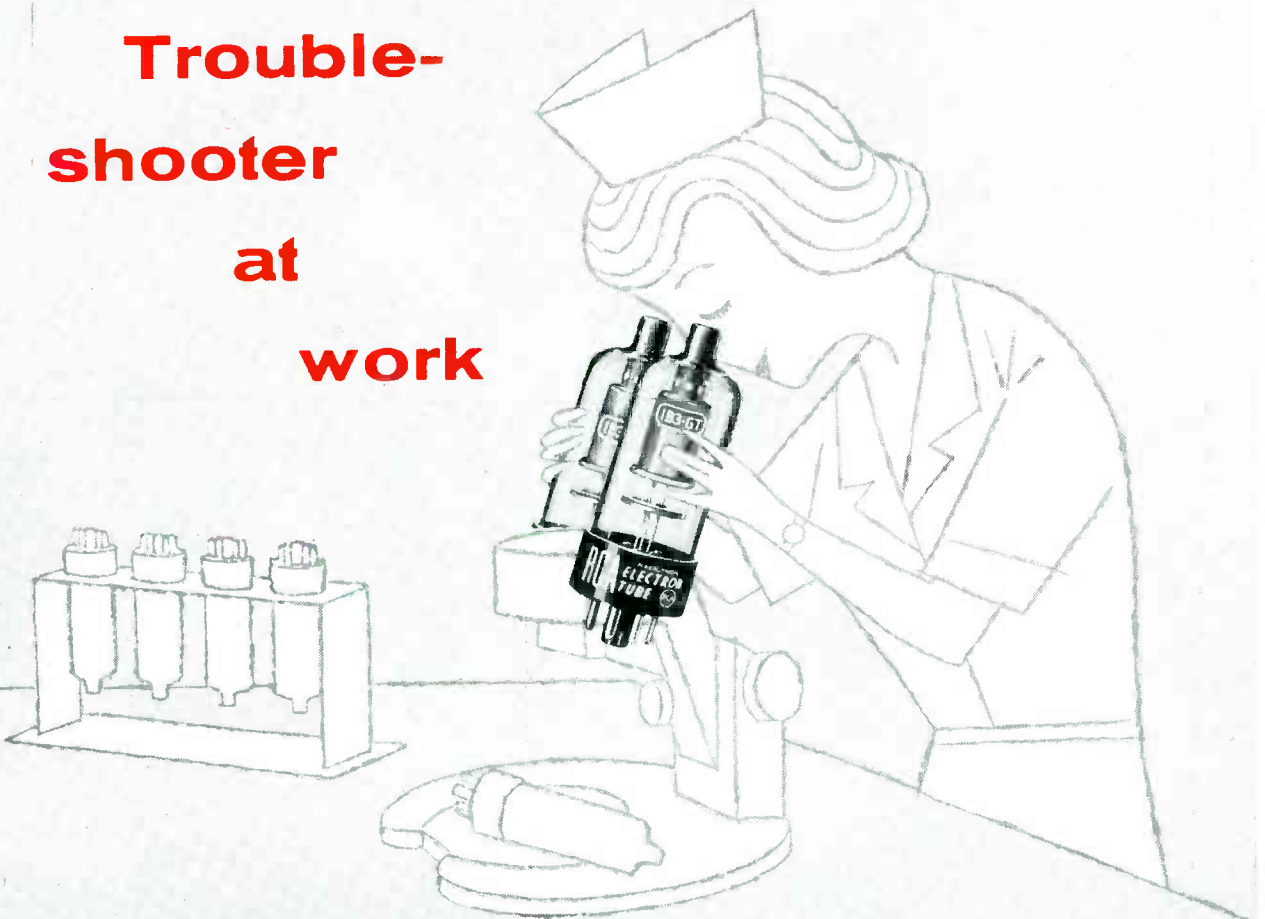
# TRIPLET

Triplet Electrical  
Instrument Company  
Bluffton, Ohio

53 years of experience.

**QUIET**

**Trouble-  
shooter  
at  
work**



**Here's how Microscopic Inspection by RCA helps reduce costly callbacks...**

A bad tube, or a potential trouble-maker—can it get by this gal? Not likely. She's part of the specially trained RCA group of inspectors whose important job it is to find trouble and help prevent it from happening to you.

RCA Quality-Control Procedures include MICROSCOPIC INSPECTION OF POPULAR TV RECEIVING TYPES! These types are closely examined for possible poor welds, weld splatter, bad crimps, damaged stems, improper assembly, and many other factors that can affect top quality, long-term performance. Though the tubes may pass all electrical tests, such defects could slip by and mean the difference between a profitable service call and a costly callback.

You gain valuable assurances from this *extra* care: (1) that popular TV receiving types shipped to RCA Tube Distributors have had the *extra* benefit of the MICROSCOPIC INSPECTION PROGRAM and (2) that you can always service your customers with the confidence that RCA TV Receiving Types are top quality replacement tubes.

When you order—tell your distributor "RCA only" and watch your profits grow.



**RECEIVING TUBES**

RADIO CORPORATION OF AMERICA

Tube Division, Harrison, N. J.