

SERVICE

THE TECHNICAL JOURNAL OF THE TELEVISION-RADIO TRADE

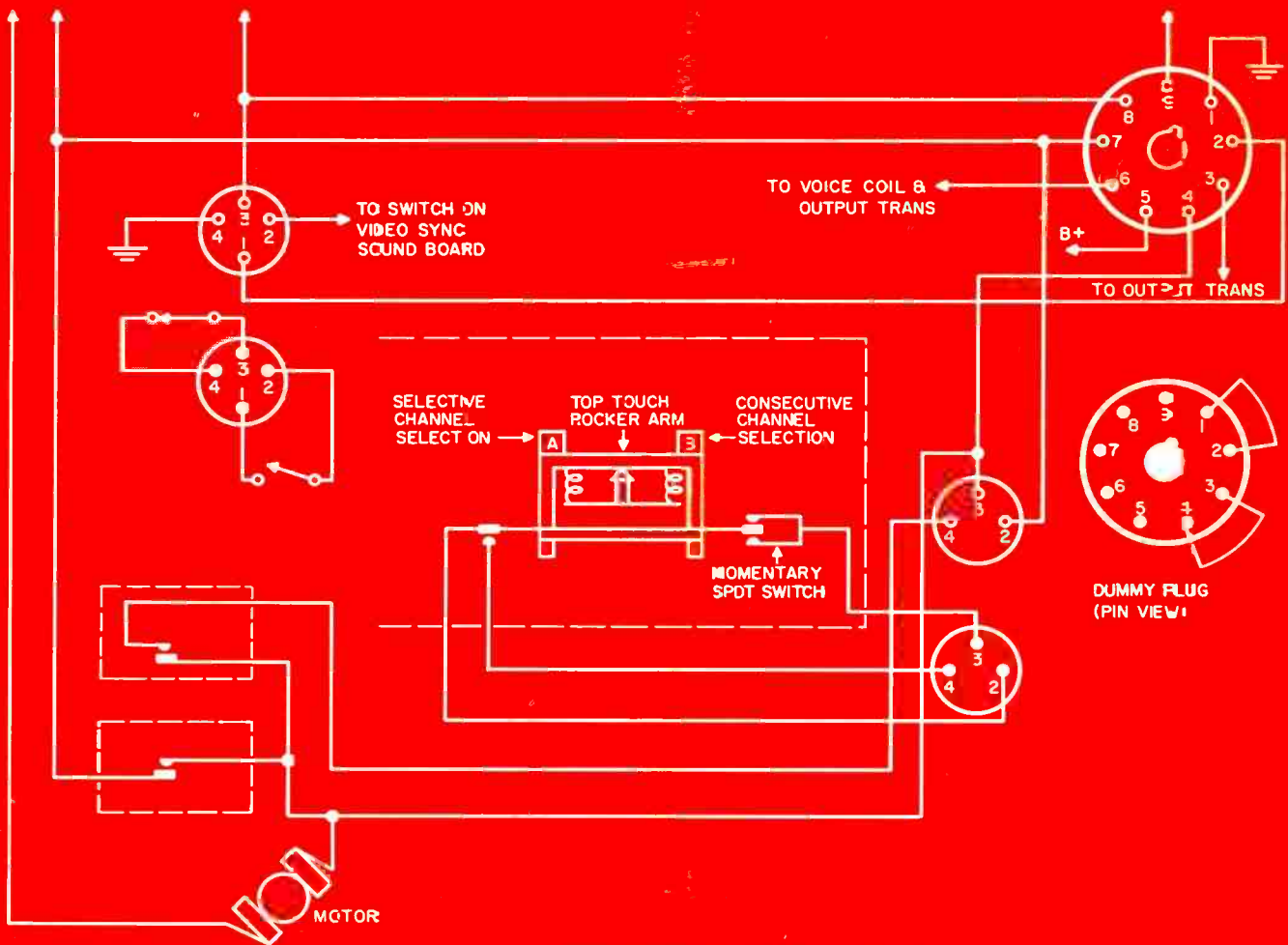

Automatic tuner-bar circuit of TV chassis remote-control system. See circuit analysis, this issue

10-57
R TURSE
CLARKEW LANE
COMPTON LAKES, ILL.
25 SAR 9-6-55

only

C·D·R Rotors

have
the

1

2

punch

1. The Most Complete Line

The CDR Rotor line is COMPLETE to every detail, with a model for every application! A distinct selling advantage because YOU can give your customer EXACTLY what is required! The RIGHT CDR Rotor for the RIGHT job.

2. Pre-SOLD For You on TV

to millions of viewers through an extensive coverage of audiences in every important TV market. Capture this pre-sold market by featuring these nationally advertised CDR ROTORS.



AR-22

Completely AUTOMATIC version of the TR-2 with all the powerful features that made it famous.



AR-1

Completely AUTOMATIC rotor, powerful and dependable. Modern design cabinet. 4 wire cable.

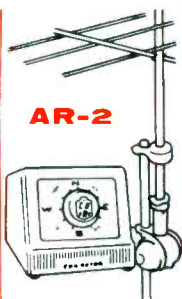

AR-2

Completely AUTOMATIC rotor with thrust bearing. Handsome cabinet. 4 wire cable.

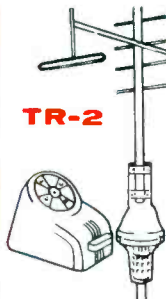

TR-2

Heavy duty rotor with plastic cabinet, "compass control" illuminated perfect pattern dial. 8 wire cable.

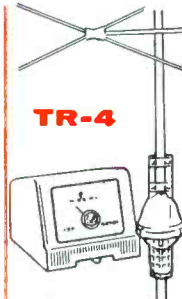

TR-4

Heavy-duty rotor, modern cabinet with METER control dial, 4 wire cable.



TR-12

Combination value complete rotor with thrust bearing. Modern cabinet with meter control dial, uses 4 wire cable.

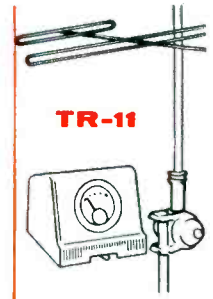

TR-11

Ideal budget all-purpose rotor, new modern cabinet featuring meter control dial, 4 wire cable.



CORNELL-DUBILIER
SOUTH PLAINFIELD, N. J.



THE RADIART CORP.
CLEVELAND 13, OHIO

**"This new Crosley chassis
really saves us time and money!"**

*—reports H. HARRISON NEEL, Owner, Neel Television;
President, TV Service Dealers Assoc., Phila.*

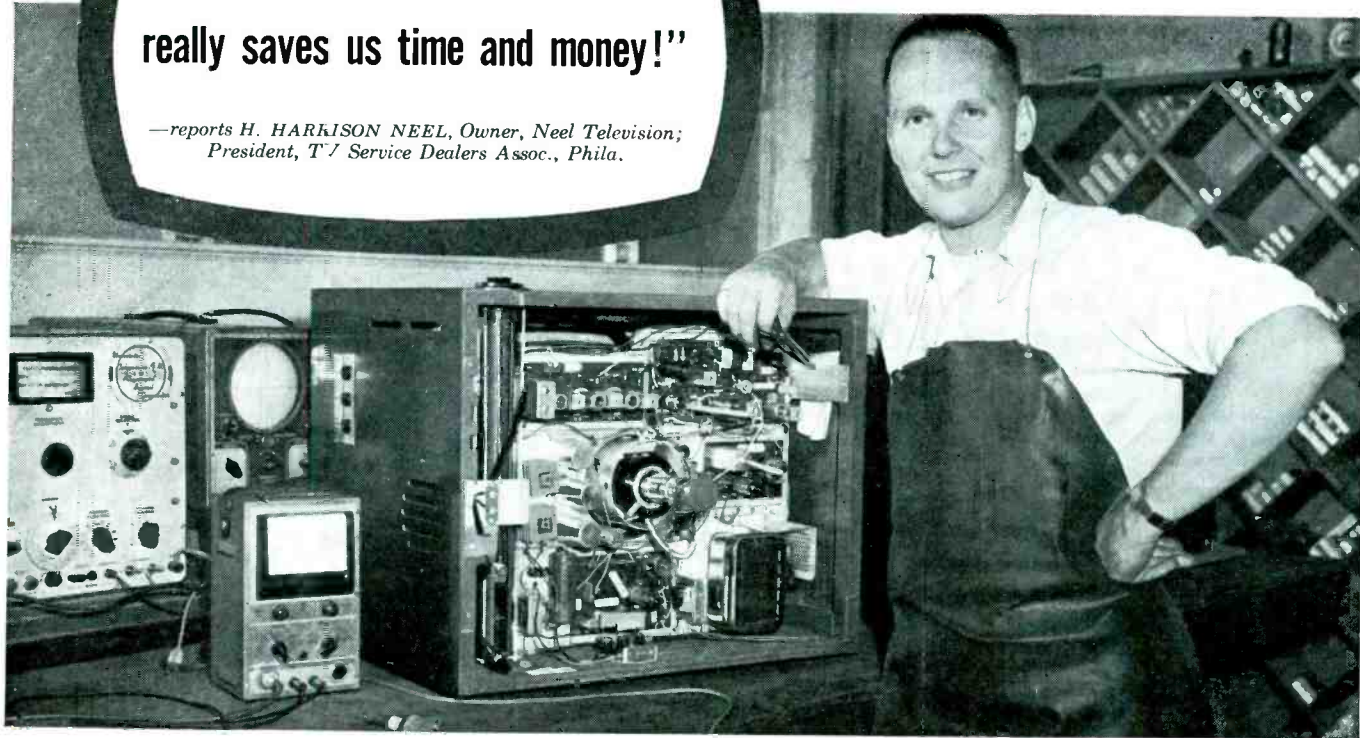

'57 CROSLY EASIEST-TO-SERVICE CHASSIS

Doubles Servicemen's Efficiency—Cuts Call-Backs!

Another great TV advance from Crosley—the chassis designed with the serviceman in mind! "If all sets were made like Crosley, my service efficiency would double . . . because Crosley sets can be serviced in *half the time!*" says Mr. Neel.

"The set's so easy to service that the job is done right the first time—no costly call-backs." Yes, you can build customer satisfaction and build your profits at the same time with Crosley. Many major repairs now can be done in the home. You can drastically reduce repair time—even in the shop! Look at the features described here and you'll see why Crosley is

KNOWN FOR THE NEWEST . . . RESPECTED FOR THE BEST!

Has all the features Servicemen want—AND MORE!

- Printed circuit board is translucent. Just place light behind it to trace circuitry.
- Picture tube is removable from the *front* of set. Loosen four screws and tube slides out.
- Even filter capacitors and selenium rectifiers can be replaced without removing chassis!
- Transformers and chokes are screwed on—not riveted. Easy to service or replace!
- Special Crosley funnel-guide helps find oscillator adjustment. Cuts down probing time!



Test points are labeled and easily available from the rear without removing chassis. Quick circuit analysis and trouble-shooting make for simplified servicing.

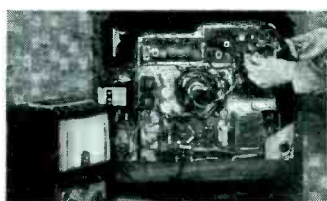

95% of all parts replaced without removing chassis, without touching a chassis bolt. Provision is even made for changing the power supply parts easily.



Find tube blowouts with a screwdriver. Open heater tubes are a cinch to locate with the marked special test points. All receiving tubes easily replaced.



Picture tube comes out with the chassis. The tube mounting is a part of the chassis assembly for quick handling. Replacement and set-up are quicker and easier.

crosley and bendix
HOME APPLIANCES

DIVISIONS OF AVCO MANUFACTURING CORP., CINCINNATI 25, OHIO

SERVICE, OCTOBER, 1956 • 1

HOW TO SELECT THE tube caddy*

BEST FOR YOU



the ORIGINAL
\$14.50
Dlr. Net

TC-1C. Neat appearing, best for tubes. Space inside cover for mirror. Max. cap. 262 tubes. New longer, thinner size 21x15x8 in.



the CARRY-ALL
\$14.50
Dlr. Net

TC-4. Break-away design gives quick access. Takes tubes or tools easily. Max. cap. 262 tubes. Size 21x15x8 in.



the ADD-A-CADDY
\$5.40
Dlr. Net

AC-1. Snaps firmly on bottom of either TC-1C or TC-4. Gives 46% more space, ideal for tools. All hardware included. Size 21x8x6 1/4 in.



the JUNIOR
\$9.50
Dlr. Net

TC-2A. Same popular features as TC-4 only 2/3 as big. Ideal for quick trips. 15 1/4 x 12 1/2 x 8 in.

ASK YOUR PARTS DISTRIBUTOR

*Tube Caddy is the Reg. TM of Argos Products Co. . . . originators and Largest Manufacturer of Tube Carrying Cases for the Electronic Technician

Argos

PRODUCTS COMPANY
GENOA, ILLINOIS

Craftsmanship in Cabinets

SERVICE

The Technical Journal of the Television-Radio Trade

Including RADIO MERCHANDISING and TELEVISION MERCHANDISING.
Registered U. S. Patent Office.

COVER CIRCUIT

Automatic Tuner-Bar Circuitry for TV Remote System (Crosley 493) 19

FEATURES

Editorial	Lewis Winner	11
Transistorized Wireless TV Remote Control (With Complete Circuit)	Drexel Johnson	12
Radio-TV Plus 2-Way/Broadcast Equipment Service Engineering Shop	John T. Wrigley	15
This Month in SERVICE		16
Automatic Tuning Printed-Wiring Board TV Chassis	(Cover: With Complete Circuit) . . . A. W. Kramer	19
Simplified Convergence Adjustment Procedure for Color-TV	Ken Kleidon	22
TV Fuse Installation-Repair	Cyrus Glickstein	24
Commercial Mobile Tape-Phono 2-Way Sound Truck (Service Engineering)		28
Dynamic Diode Discriminator	R. H. Overdeer	30
Apartment House TV-Distribution System for Fringe Areas	Louis E. Raburn	32
21-Inch Color TV Chassis (Circuitry Report)	J. A. May and W. H. Fulroth	34
Keyed AGC Circuitry Used in Old and New TV Chassis	J. M. Sheeha	36
Leakage Control Factors in Bantam Electrolytics for Transistor Amps	(Servicing Helps)	38
Vernon Downs Raceway Sound System	Frederick Hoffman	40
Servicing RCA TV Portables	W. W. Cook	50

CIRCUIT DIAGRAMS

Motorola TV Remote-Control Power System	12	Fused Plug Lines	24
Motorola TK-74 Transistorized Remote Control (Complete Circuit)	13	Philco Dynamic Diode Discriminator	30
Crosley 493 Fil Wiring Remote Motor-Control Circuit	20	Philco Diode System; Simplified Block Drawing	30
Crosley 493 TV Chassis (Complete Circuit)	21	Fringe-Area TV-Antenna Distribution System	33
Sylvania 1-534-1 Color-TV Convergence Circuit	23	RCA 21-Inch Color-TV Power Supply	34
RCA CTC5 Color-TV Convergence Circuit	23	AGC Delay Circuit	36
Westinghouse 2292-1 Color-TV Convergence Circuit	23	Two-Stage Transistorized Audio Amplifier	38
		Hi Fi Bull Horn Raceway Speaker Layout	40
		Amp-Mike-Tape-Turntable-Speaker Setup at Raceway	53

DEPARTMENTS

Catalogs, Leaflets and Books	26	TV Parts Accessories	60
Ten Years Ago in SERVICE	27	Instruments	62
Association News	27	Color-TV Instruments	62
Personnel	49	Bench Field Tools	64
Latest in Audio	53-55	Components	66
		Tube News	68
Index to Advertisers			67

Entire Contents Copyright 1956, Bryan Publishing Co., Inc.

Second-Class mail privileges authorized at New York, N. Y.; additional entry at the Post Office, Norwalk, Conn. Subscription price: \$2.00 per year (\$5.00 for 3 years) in the U.S.A. and Canada; 25 cents per copy. \$3.00 per year in foreign countries; 35 cents per copy.



EDITOR and PUBLICATION DIRECTOR

Lewis Winner

Associate Editor: **David E. Pearsall II**
 Assistant Editor: **Robert D. Wengenroth**
 Editorial Assistant: **Eli Cohen**
 Editorial Assistant: **Howard Jennings**

Art Director: **Anthony R. Aliff**

Supervisor, Circuit Diagrams:
Michael D. Bellezza

Editorial Production: **Astrid Kelly**

CIRCULATION DEPARTMENT

Circulation Manager: **A. Goebel**
 Ass't Circulation Mgr.: **A. Kiernan**

ADVERTISING DEPARTMENT

Advertising Mgr.: **Aaron L. Lafer**

East-Central Rep.: **James C. Munn**
 2253 Delaware Dr.
 Cleveland 6, O.
 Tel.: ERview 1-1726

Pacific Coast: **Leo Sands, Dist. Mgr.**
 535 Ramona St.
 Palto Alto, Calif.
 Tel.: DAvenport 5-3716

Published Monthly by
Bryan Davis Publishing Company, Inc.
 52 Vanderbilt Ave., New York 17, N. Y.
 Tel.: MUrray Hill 4-0170

B. S. Davis, Pres. Lewis Winner, Vice-Pres.

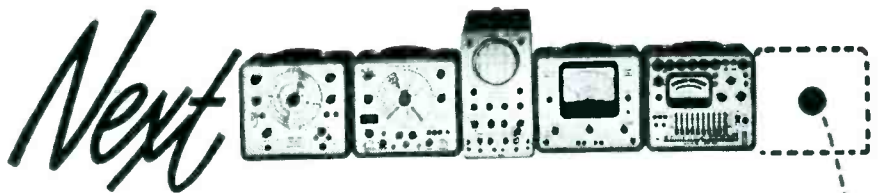

ON YOUR TV SERVICE BENCH...



...the NEW *PRECISION* COLOR BAR GENERATOR

MODEL
E-440

A 'must' for the color TV service bench... indispensable for adjusting color phasing and matrix networks in color TV receivers.

If you now own or have ever worked with a *PRECISION*-equipped service bench, you know that you can confidently expect more engineering-per-dollar from this new *PRECISION* instrument than from any other on the market.

IDEAL COMPANION INSTRUMENT

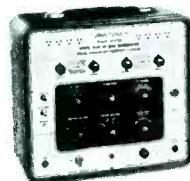

PRECISION
Model E-420
White Dot and
Bar Generator

Compatible for Color and Monochrome TV. A standard for dot convergence and linearity adjustments.

Net Price: . . . \$150.00

- Provides ALL Required Test Signals including RF carrier, color sub-carrier, sound carrier, horizontal sync pulses, luminance, brightness
- Produces 10 Simultaneous Color Bars including all essential signals for R-Y, B-Y, I, Q, etc.
- All Signals Crystal-Controlled for maximum stability and reliability
- Both Video and RF Outputs Available for separate testing of video amplifiers and front ends
- Simple Operation and Easy Application—individual panel controls permit regulation of each element of the composite output signal
- External Meter Jack permits convenient and direct metering of sub-carrier and sync amplitudes.

Model E-440 (Deluxe)

In custom-styled blue-grey, hooded steel cabinet and four-color, satin-brushed aluminum panel with contrasting dark-blue control knobs. Dimensions 13 x 11½ x 6 inches. Shipping Weight: 19 lbs. Complete with tubes, output cables and comprehensive instruction manual.

Net-Price: . . . \$235.00



PRECISION Apparatus Company, Inc.
70-31 84th Street, Glendale 27, L. I., N. Y.

Export Division: Morhan Exporting Corp., 458 Broadway, New York 13, U.S.A.
In Canada: Atlas Radio Corp., Ltd., 50 Wingold Ave., Toronto, Ontario

Bull's-eye every time!

We hit the target again . . .
with this new, modern version of the
most wanted service-test instrument.

Pyramid introduces the CRA-2 Capacitor-Resistor Analyzer, a versatile, up-to-date, moderately priced test instrument. The CRA-2 is the perfect multi-purpose analyzer for the technician, serviceman and engineer, in industrial and military electronics, black and white, and color television, and all related fields.

The guesswork has been removed from circuit trouble shooting. When making leakage-current measurements, the values are read directly from the meter while the rated operating voltage is applied to the capacitor. A vacuum-tube ohmmeter circuit displays accurate insulation-resistance values on the meter for many types of capacitors. The extended range calibrated power factor control permits power factor measurements of electrolytic capacitors rated as low as 6 volts DC working and as high as 600 volts DC working. This special "QUICK CHECK" circuit performs rapid "IN CIRCUIT" test for short, open, intermittent high RF impedance and high power factor without removing or disconnecting the component from its operating circuit.

MODERN DESIGN

VERSATILE

DEPENDABLE

TIME SAVING

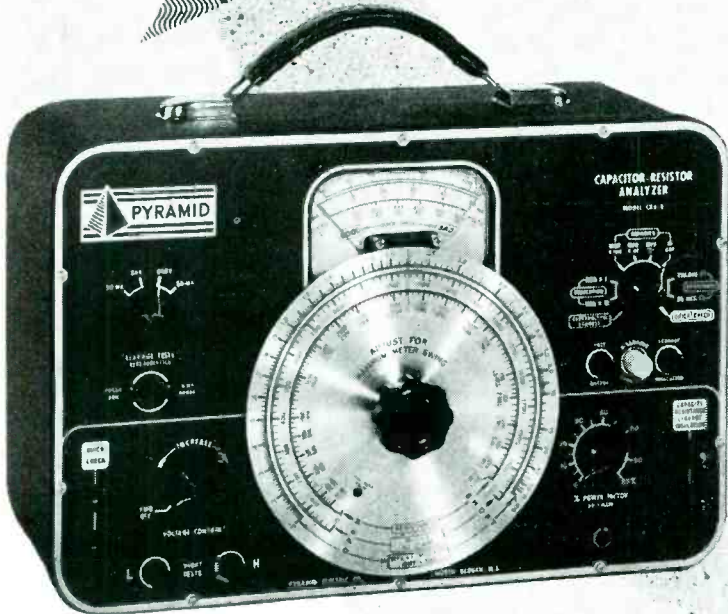

Examine it today

Being introduced by leading Electronic Parts Distributors

FEATURES

- "Quick Check" in circuit test for Open Circuits. Short Circuits. Intermittents. High RF Impedance. High Power Factor.
- Speedily and accurately checks: Capacitance. Power Factor. Resistance. Insulation-Resistance. Leakage Current.
- Precision meter for accurate readings of leakage current, applied voltage and insulation resistance.
- Combination Wien and Wheatstone bridge.
- Accurate vacuum-tube meter circuit.
- Parts of the highest quality are used. Wire and wiring meet military specifications.

PYRAMID ELECTRIC COMPANY

1445 Hudson Blvd., North Bergen, New Jersey



**FOR THE BEST IN COLOR...
VIEWERS INSIST ON
ALLIANCE TENNA-ROTOR**

New decorator colors—Forest Green and Ivory
—for Alliance Tenna-Rotor control cases—are
selected to blend with the major color trends
in contemporary home decorations.

*More than 3,000,000
Alliance Tenna-Rotors are in use*

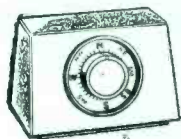
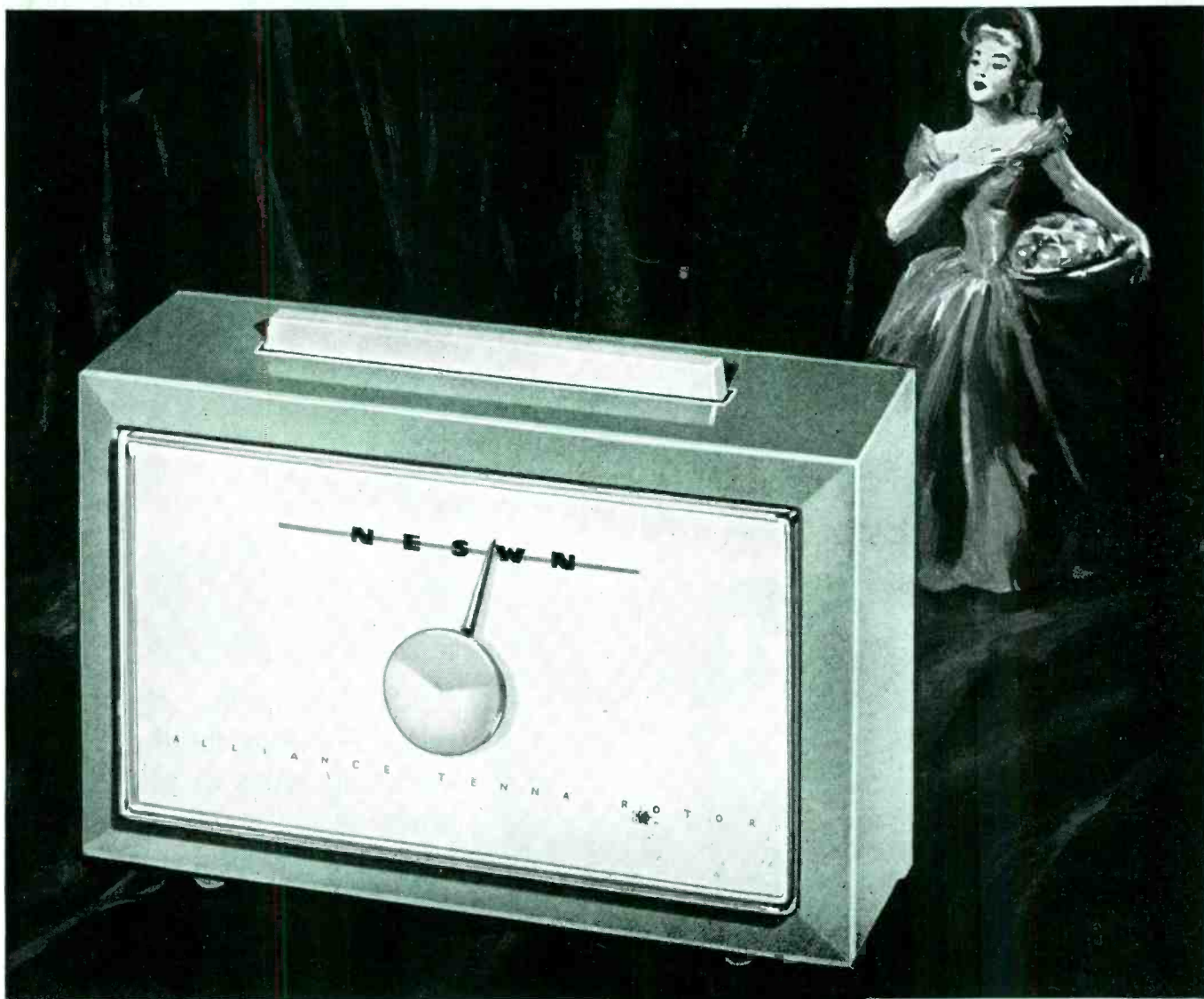

Model T-12-G above—with
famous Tenna-Teller Pointer.

Model U-98-G Left—Deluxe
model—completely automatic.

**Color Set Owners Protect
Their Investment with Alliance Tenna-Rotor!**

Millions of viewers will want color—even if it is more costly
and critical! ALLIANCE TENNA-ROTOR helps to minimize
ghosting—makes for stronger, clearer color definition...
expands color viewing in all markets.

Color can be critical—good color, like good black and
white will improve with a directional antenna which can



be beamed with pin-point accuracy using the famous
ALLIANCE TENNA-ROTOR.

THE ALLIANCE MFG. CO., INC., ALLIANCE, OHIO
(Division of Consolidated Electronics Industries Corp.)

In Canada—ALLIANCE MOTORS, Schell Avenue, Toronto 10

CHANNEL MASTER

PUTS NEW SELL IN

DEALERS HAVE SOLD MORE *CHANNEL MASTER* T-W AND SHOWMAN ANTENNAS DURING THE PAST 30 DAYS THAN ANY OTHER ANTENNA DURING ANY 30 DAY PERIOD IN TV HISTORY!

Isn't it time you called your Channel Master distributor?

- ★ Full-Color Ads
- ★ 2-Page Spreads
- ★ Full-page Ads



Month after month... all thru the prime TV buying months... this continuing series of sales-stimulating ads is creating loads of lively new prospects... right in your own selling area.

55,000,000
ads building new
customers and sales for you!

www.americanactionhistory.com

NATIONAL ADVERTISING TV ANTENNAS!

"Showman" INDOOR ANTENNA

This smartly styled antenna overcomes consumer objection to ugly "rabbit-ear" antennas. Exclusive "Metro-Dyne" electronic tuning brings in pictures sharp and clear on all VHF channels. Tuning knob with channel markings just like a TV set makes channel selection so easy. It's the most powerful indoor antenna ever developed . . . and it's backed with an UNCONDITIONAL MONEY-BACK GUARANTEE. Engineered for Black and White and COLOR.

model no.	description
3900	Mahogany & Gold
3901	Blond & Gold
3902	Ebony & Silver

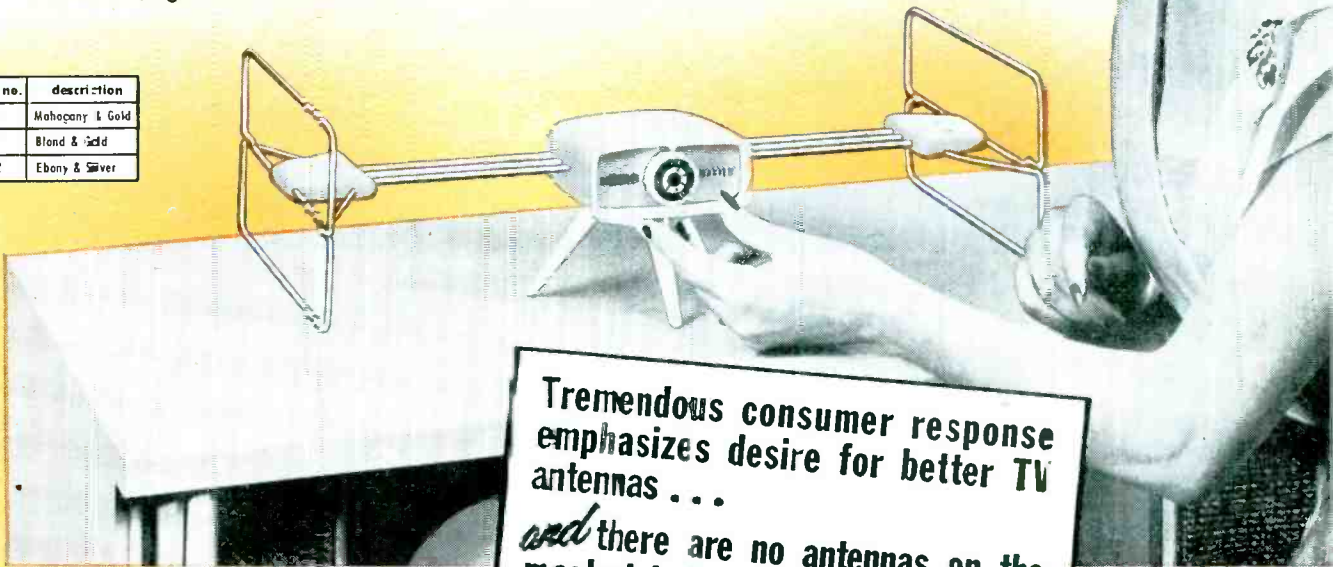

Tremendous consumer response emphasizes desire for better TV antennas . . .
and there are no antennas on the market today that compare with these fabulous new Channel Master models.

T-W OUTDOOR ANTENNA

The revolutionary new T-W is the very first TV antenna to use the "Traveling Wave" principle. This unique design electronically reinforces signals . . . eliminates "ghosts" and "snow" . . . rejects all unwanted signals and interference. In gain, front-to-back ratio, and mechanical strength, the T-W is unequalled by any other Broad Band antenna. Engineered for Black and White and COLOR.

model no.	description
350	2-element
350-2	2-element stacked
351	5-element
351-2	5-element stacked
352	3-element
352-2	3-element stacked



CHANNEL MASTER CORP.

ELLENVILLE, N. Y.

WORLD'S LARGEST MANUFACTURER OF TV ANTENNAS AND ACCESSORIES

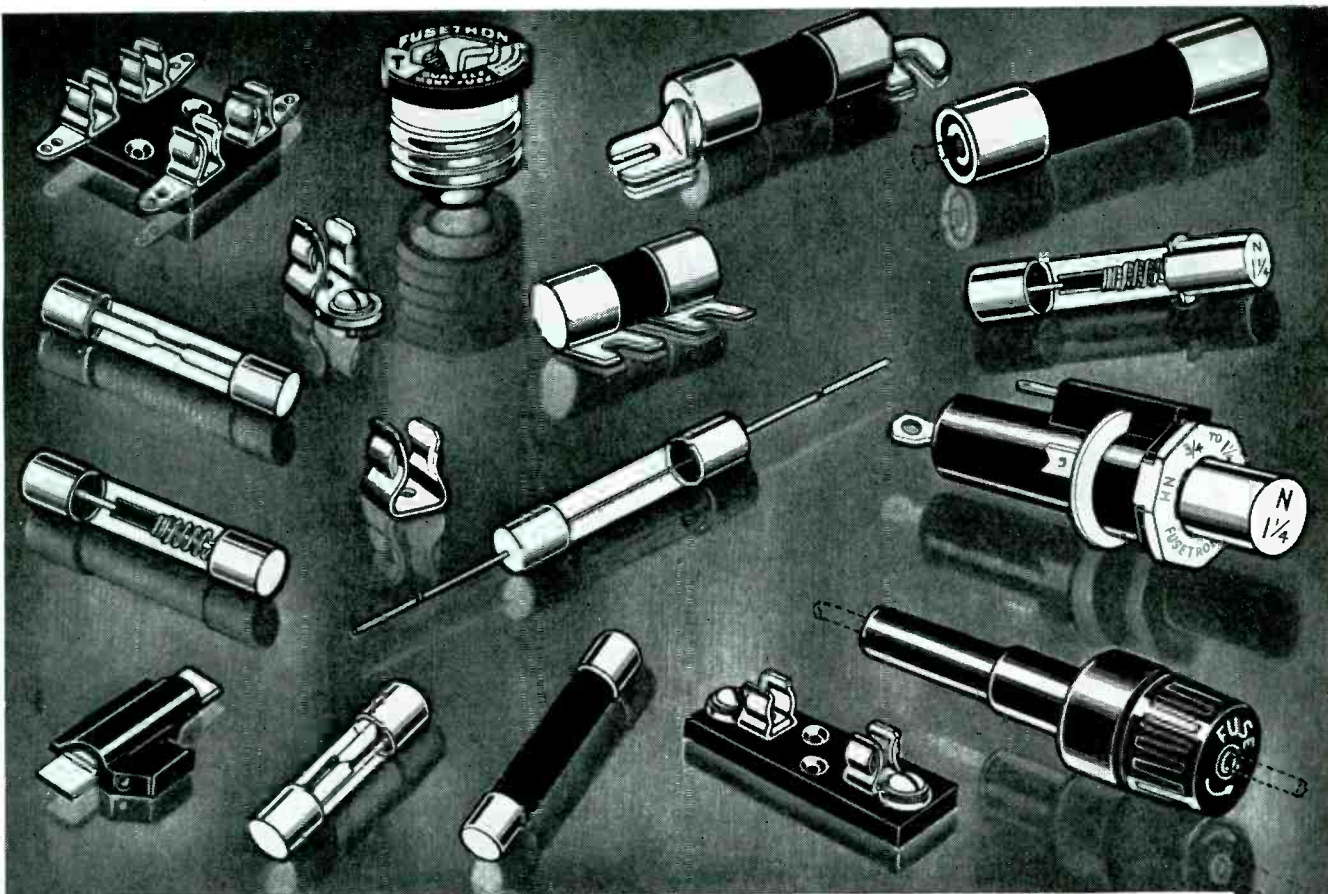

For safe electrical protection — and the elimination of needless blows, rely on BUSS FUSES . . .

When electrical faults occur, BUSS fuses open and clear the circuit. The danger of damage to equipment is reduced to a minimum.



Yet, BUSS fuses are designed and engineered so they won't blow needlessly. When you replace a blown fuse with a Fusetron or BUSS fuse, your customers are protected against useless, irritating shutdowns—and you avoid costly, time-wasting callbacks.



By relying on BUSS for all your fuse needs . . . you can help safeguard against loss of customer good will and costly troubles.

In sales and service, profit by the BUSS trademark

Millions upon millions of BUSS fuses for home, industry and automotive use have firmly established BUSS as the *Known* brand. Handling quality products, like BUSS fuses, help you maintain your reputation for quality and service.

Be sure to get the latest information on BUSS and FUSETRON small dimension fuses and fuseholders . . . Write for bulletin SFB.

BUSSMANN MFG. CO.
(Div. McGraw Electric Co.)
University at Jefferson St. Louis 7, Mo.

Makers of a complete line of fuses for home, farm, commercial, electronic, automotive and industrial use.

S-1056

ASTRON "Staminized" CAPACITORS ARE - -

clearly marked

Astron . . . truly a *quality capacitor* to the last detail.

You, as a specialist in replacement parts, must capture the complete confidence and respect of your customer. Astron takes every step to insure this. Designs are accurately tested, production techniques are carefully inspected, quality controls strictly enforced and protective guards built-in to govern staying power of each capacitor - - - finally clear, easy-to-read markings for quick, positive identification.

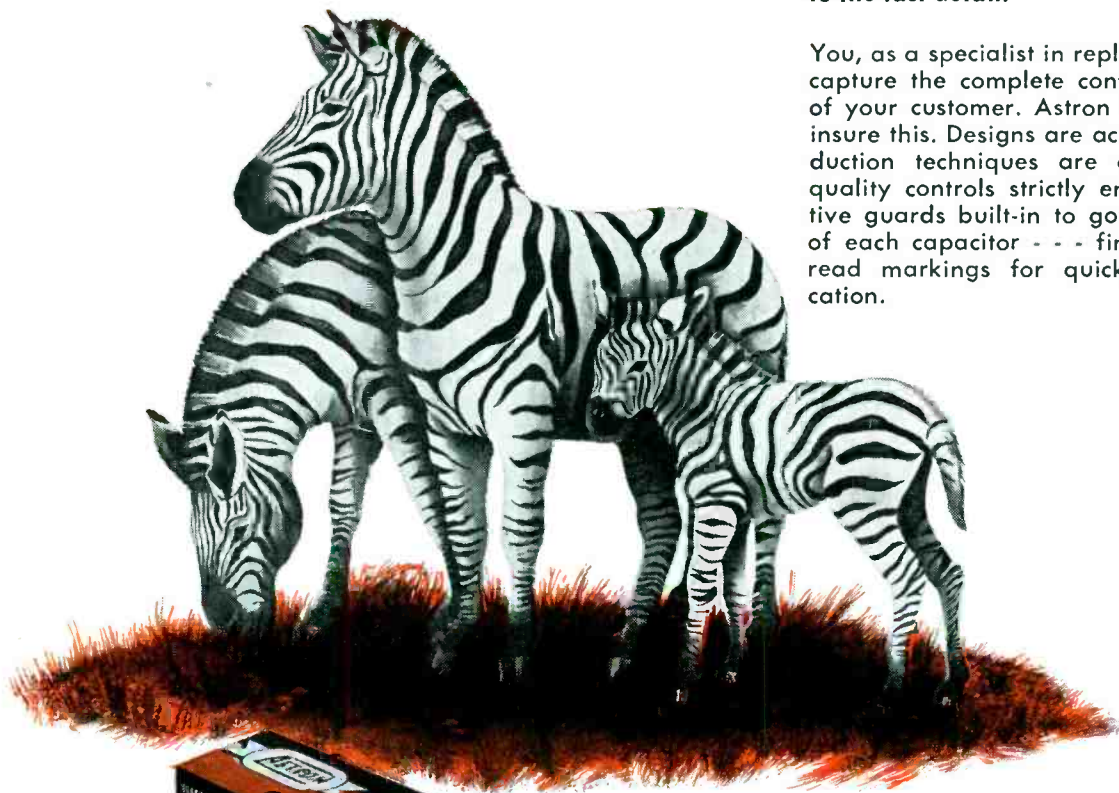

You can put your trust in Astron, for behind each Astron capacitor is the meticulous quality control that insures you of top performance and the elimination of call backs.

Remember, your reputation is our business. Build it, guard it, protect it - - - Buy Astron

**Trademark*



FREE Servicing Aid
Save time, use handy Astron pocket-sized Replacement Catalogue and Pricing Guide (AC-4D) — Write Today!



ASTRON

C O R P O R A T I O N
255 GRANT AVENUE EAST NEWARK, N. J.

Export Division: Rocke International Corp., 13 East 40th St., N. Y., N. Y.

In Canada: Charles W. Pointon, 6 Alcina Ave., Toronto 10, Ontario



IN **23,000** CITIES AND TOWNS



WESTERN UNION
"Operator 25"

is sending customers to

RAYTHEON BONDED DEALERS



Ask your Sponsoring Bonded Raytheon Tube Distributor about "Operator 25" and the many other important advantages of being a Raytheon Bonded Electronic Technician.

RAYTHEON MANUFACTURING COMPANY
 Receiving and Cathode Ray Tube Operations
 Newton, Mass. • Chicago, Ill. • Atlanta, Ga. • Los Angeles, Calif.

Raytheon makes all these { Receiving and Picture Tubes, Reliable Subminiature and Miniature Tubes, Semiconductor Diodes, Power Rectifiers and Transistors, Nucleonic Tubes, Microwave Tubes

Excellence in Electronics

Brand Merchandise — Always The Best Buy

WHEN DESIGN ENGINEERS map their plans for new chassis, whether they are for TV, radio, audio, instruments or special gear, there is one rule that is always followed: All components, accessories and tubes must be ordered from a brand-name source of supply, for only such a supplier can always be depended on not only to meet all specifications, but insure peak results through quality-control inspection before shipping.

Service Men have always found that it is wise to adhere to this sound brand-name policy in purchasing replacements or installation parts, since only such products are always dependable. Nationwide polls among Service Men have also indicated all-out preference for standard-brand components.

The development of the higher gain and better sounding radio and TV chassis, the evolution of wide-range phonos, the arrival of highly-efficient color-TV and improved transistorized models and their complement of new-look parts, many in the bantam family, have accented the importance of the buy-brand-merchandise rule. For only from these depots is it possible to obtain accurately-made replacements that really toe the line on the spec sheets and can produce the top-notch performance built into the original equipment.

TO MAINTAIN PACE with equipment-engineering research and design, extensive lab facilities must be maintained not only by component suppliers, but by those who supply raw materials.

Mounting Activity in Small Appliance Repairs

THE REPAIR of traffic or small electrical appliances, noted a few months ago in these columns as an ideal supplementary service operation with excellent potentials, has already become a specialty of a number of shops across the country.

We're Pledged to Serve and Please

SERVICE, the only technical journal in the radio-TV trade which has maintained *unbroken* membership in the ABC for over twenty years, with a continuing record of the largest audited circulation in the field, is proud once again to pay tribute to the Bureau of Circulations during this, ABC month.

FOR MORE THAN TWO DECADES, the Audit Bureau of Circulations has served the editor and publisher of SERVICE, no less than the advertiser, with a means of helping to keep the contents of the

PICKUPS AND NEEDLES represent an interesting area where exhaustive plant research is so important.

Over the past six years, the tracking force at which top-quality phono pickups operate has gone through something like a 10-fold reduction. At the outset, we had a 10 to 20-gram range; today we have pickups which will track at from 1 to 3 grams. With the reduction in tracking force has come the need for small dynamic mass. A number of pickups have been designed with such low mass,

The effectiveness of these well-designed components can be completely destroyed if ill-fitting styli are used. These can take the form of assemblies that do not match the original cartridge design and additionally use inferior materials. Unfortunately, there are a few bargain-chasing manufacturers, producing non-branded items, who are flooding metropolitan centers with these styli. They are also peddling inferior needles, particularly diamonds, at ridiculously low prices. All of these needles, which do not meet the specs of any of the original cartridge makers, have large mass tips that gouge records, even after a single play.

To stay out of trouble, stay away from these bargains. They will not only develop a call-back epidemic, but alienate those neighborhood contacts, and that loyalty you've built up so carefully will surely go down the drain.

Play safe—buy advertised brand-name merchandise. Not only will you always find these products the best for every need, but your customers will hail your choice, too.

Letters have been pouring in asking for appliance-servicing catalogs and more information on repairs. Because of this mounting interest, we've scheduled additional articles on traffic-appliance repair; the next one will appear in November SERVICE. Watch for it!

printed page responsive to the reader's needs and to the highest standards of publishing ethics. This is done through an independent check that shows how many people get the magazine each month, who they are, where they are, and how well they like the publication, as measured by their renewal of subscriptions as they expire.

Our pledge to our readers has always been that we must devote our best efforts to provide editorial content that will serve them; our readers are the people whose decisions and interests govern the policy of this magazine.—L.W.

TV Remote Control

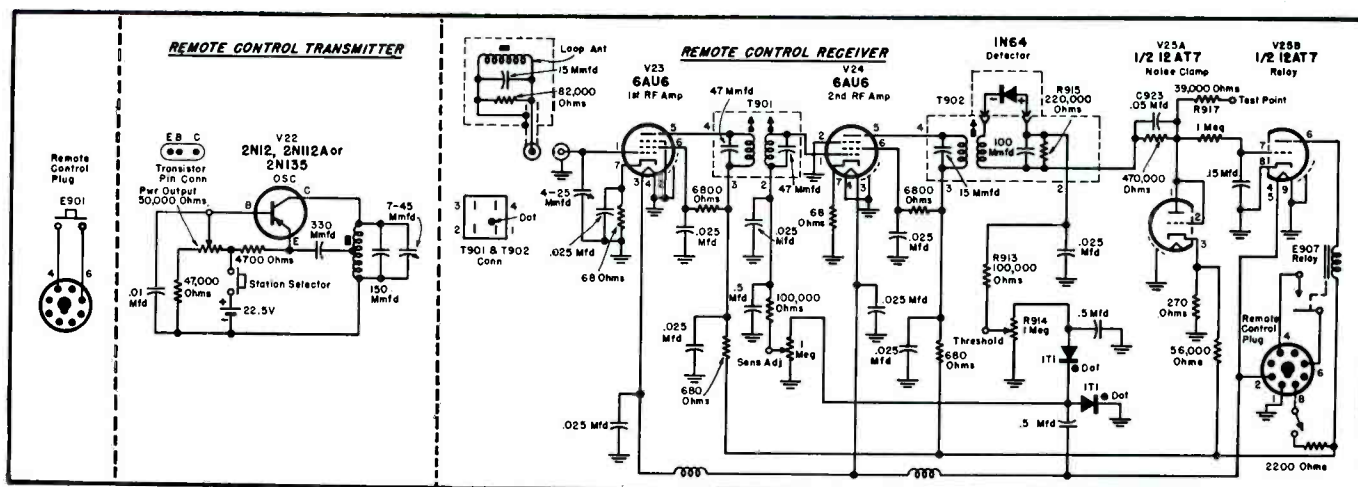

CIRCUITRY of Motorola TK-74 remote-control system with transistorized transmitter and special receiver for TV set.

bias voltage into the grid of the second *rf* amplifier stage.

The *threshold* control determines the detected signal voltage amplitude required to cause the relay tube to close the relay contacts and begin channel selection. This control injects a negative bias voltage into the grid of the relay tube (output stage).

A test jack has been provided for metering the effect of all manual controls, as well as the automatic action of the noise-clamp tube. The test jack, direct-coupled to the control grid of the relay tube, indicates the effect of the overall receiver operation on the relay action.

Operation of the Remote-Control Receiver

In operation, the remote-control receiver's relay tube (1/2 12AT7) drives the contact-closing relay by means of plate current. The relay contacts are electrically in parallel with the TV receiver's front-panel channel-selector pushbutton and when closed initiate the automatic tuner operation.

Upon receipt of a transmitted signal, the crystal detector (1N64) develops a positive rectified voltage across a 220,000-ohm load resistor, R_{915} , which appears at the control grid of the relay tube. This positive voltage increases the conduction of the relay tube, causing the relay to close and the automatic tuner to begin station selection.

Since random pickup of signals from unwanted sources will also produce a positive output at the detector, and fire the relay tube, the *sensitivity*

control must be adjusted to a point where the receiver will be insensitive to such interference. Since such interference will vary from installation to installation, adjustment of the *sensitivity* control is an important part of the installation procedure.

The *threshold* 1-meg control (R_{914}) provides an electrical means of compensating for differences in relay tube conduction characteristics, as well as differences in relay-closing current. This control receives approximately -15 v from the bias supply and any desired value of this negative voltage can be picked off by the arm of the control. This variable bias is coupled to the control grid of the relay tube through a 100,000-ohm resistor (R_{913}), and the crystal detector in parallel with 220,000, 470,000 and 1-meg-ohm resistors (R_{915} , R_{916} and R_{918}). An increase of negative bias at the relay tube's control grid will require a stronger input signal to the receiver (and greater positive output from the detector) to close the relay.

Threshold Control Adjustment

Adjustment of the *threshold* control not only sets the operating bias of the relay tube and the detected output required to close the relay, but also applies a negative voltage to the plate of the noise clamp tube. The noise clamp tube is essentially in parallel with the control grid of the relay tube (isolated only by a 1-megohm resistor, R_{918}) and will conduct on any signals producing a positive detector

output greater than the delay bias provided at its cathode, approximately $.9\text{ v}$. Conduction of the noise-clamp tube will cause a current to flow in the grid-input circuit of the relay tube opposite to that produced by the detector, producing a bias voltage across the parallel combination of R_{916} and C_{923} , a .05-mfd capacitor. This bias voltage, negative on the relay-tube's grid, cancels out any random signal of great enough amplitude to cause station selection. This would be especially important on high amplitude impulse-type interference such as produced by automotive ignition systems, electrical appliances and lightning.

Adjustment of the *threshold* control applies a negative voltage to the plate of the noise clamp tube simultaneously with that being applied to the grid of the relay tube. Thus, the noise clamp is automatically delayed to the extent that it will conduct only after the received signal has reached an amplitude greater than the normal noise level or random signal pickup of the receiver.

Performance Standards

With proper adjustment of the *sensitivity* and *threshold* controls, the receiver: (1) *will not* be operated by random noise and signal pickup; (2) the relay *will* close on a normal strength signal from the remote control transmitter and (3) the receiver *will not* operate on high-impulse signals of greater amplitude than that of the remote control transmitter.

**AS MODERN
AS TOMORROW...**

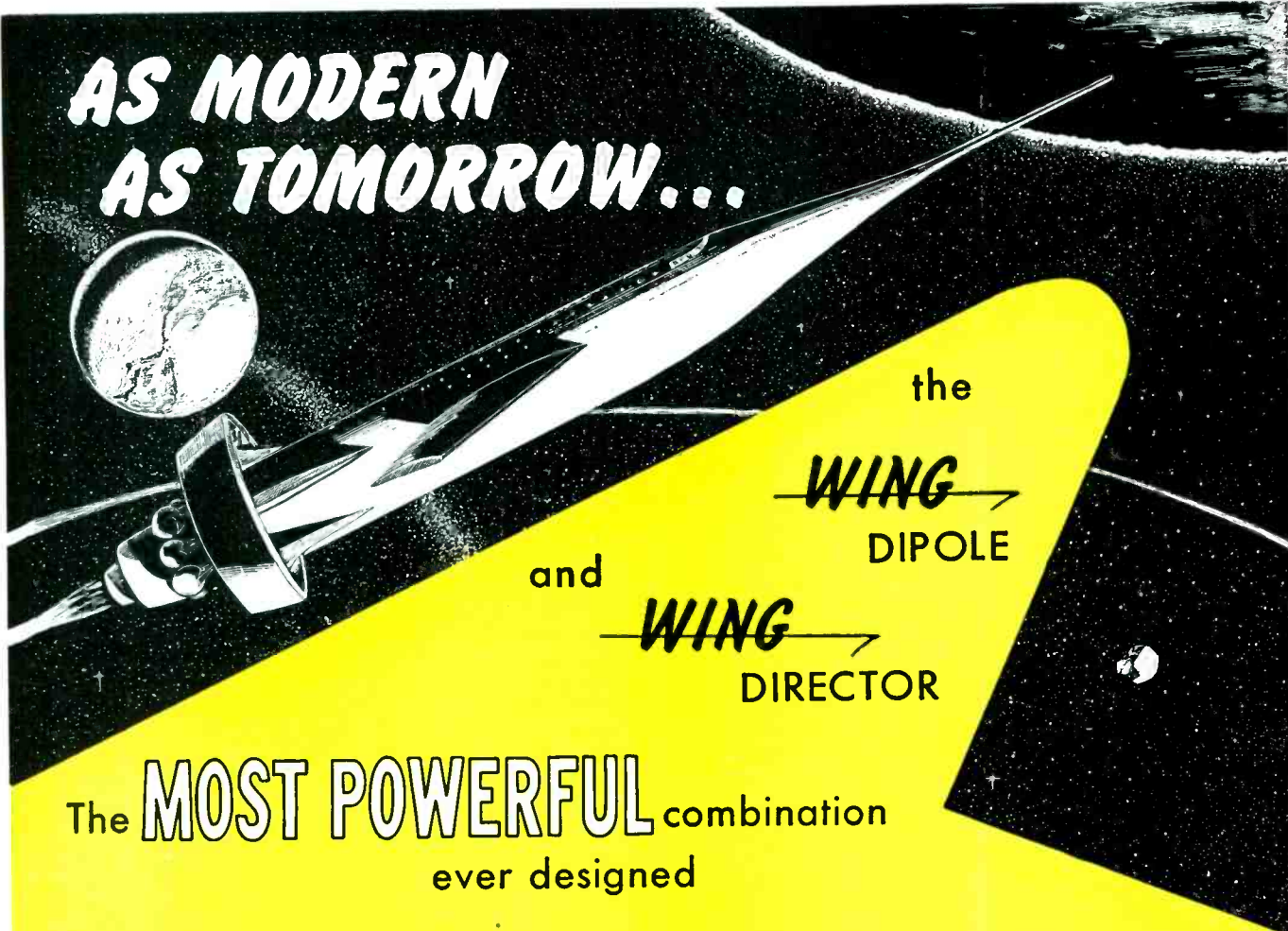

the

WING →
DIPOLE

and

WING →
DIRECTOR

The **MOST POWERFUL** combination
ever designed

FOUND ONLY IN THE TRIO ZEPHYR LINE



POWER PACKED PAIR



FOR DISTANCE

Zephyr

POWER PACKED THREESOME



FOR EXTREME DISTANCE

ZEPHYR ROYAL

POWER PACKED FOURSOME

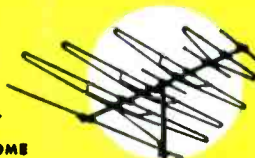

FOR THE MAXIMUM

Trio's Zephyr and Zephyr Royal, the leaders of the 1956 season, are brought to you in the 1957 models improved and perfected, and destined to remain the champions. This famous antenna family is expanded by the Zephyr-Mite, newest addition to the Zephyr family. Trio's Zephyr family features the "Wing" dipole—the composite dipole that brought the power of the Yagi to every channel! Add to this the "Wing" director, the revolutionary new director specifically

designed to enhance the power and sensitivity of the "Wing" dipole—and you have a combination that is unequalled in the TV antenna field today for the maximum in performance. The "Wing" dipole and "Wing" director are exclusive features of the Trio Zephyrs—features that make Trio "the choice antenna line."

Trio's recognized quality construction features the internationally famous Insta-Lok clamps—the clamps that 'protect' the element!

TRIO®

Manufacturing Company
GRIGGSVILLE, ILLINOIS

COPYRIGHT 1956 TRIO MFG. CO. EXPORT SALES DIV., SCHEEL INTERNATIONAL INC., 4237 N. Lincoln Ave., Chicago, U.S.A. Cable Address: HARSHEEL

Radio-TV Plus 2-Way and Broadcast Equipment

Service-Engineering Shop

by JOHN T. WRIGLEY

IN 1942 Dimitri Roulias joined the Navy to become a radio-communications man aboard one of Uncle Sam's destroyers.

Enthusied by the potentials that radio appeared to offer, Roulias decided to carve out a career in the field and as a first step enrolled in a 3-year electronics course at Idaho State College. Upon graduation he went into business for himself and established a service shop in Pocatello.

Prior to December '54, Roulias' repair work dealt strictly with radio. Then a local TV station went on the air and TV became the major shop activity. Because this station broadcast from approximately 2 P.M. until midnight, most of the repair work had to be done in the evening. To complicate matters, a community TV system was installed in Pocatello in the spring of '55. This meant that sets had to be serviced to provide satisfactory reception of both the local station and the three outside channels that had become available through the community-TV system.

Of all the problems created by this situation, one was and still is toughest

SERVICE BENCH in the Roulias' shop showing assortment of test instruments available for installation and repair.

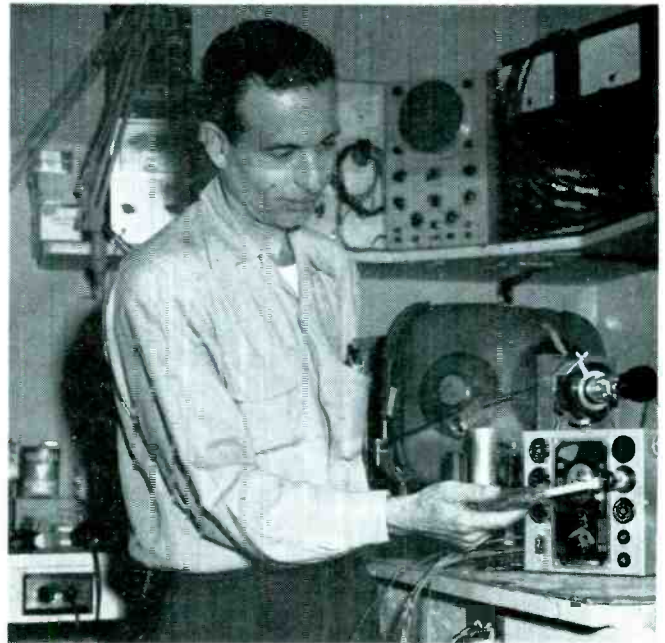

to resolve. One must determine whether the trouble is in the set or in the amplifiers used in the cable system. Often the TV sets are blamed for troubles which are caused by the TV signal pipe line.

Tubes have been found to be a major source of trouble. Often tubes which checked okeh on a good-bad tube tester were found to work in one socket of a set, but not another. To avoid this headache it was decided to purchase tube testers that told a complete story about the tube's condition,

including grid-emission properties. These instruments, it was found, permitted a much quicker analysis of troubles.

Pocatello, the home of Idaho State College and an important junction of the Union Pacific railroad, is the center of a trading area with an estimated population of 50,000. It has been estimated that there are approximately 9000 TV receivers in this area.

The Union Pacific railroad operates a huge hump yard which was among
(Continued on page 65)

BESIDES SERVICING radio and television receivers, and 2-way gear, Roulias maintains broadcast transmitters.

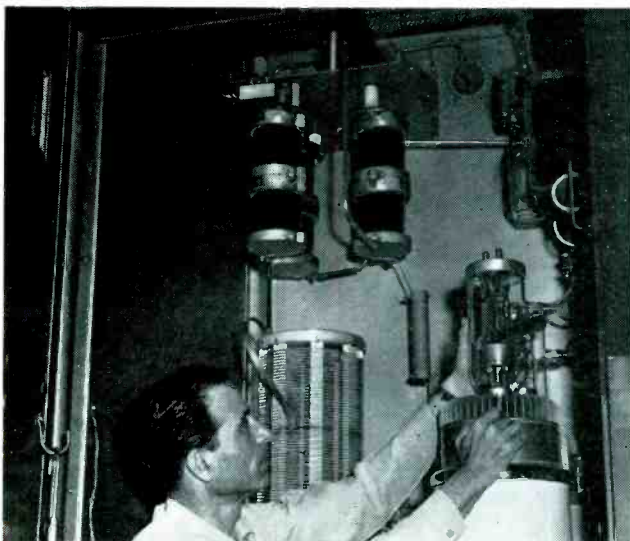

THIS MONTH IN SERVICE

ALL-UHF FCC PLAN CRITICIZED BY INDUSTRY--Briefs filed by industry in Washington have scored the Commission program suggesting the shift of all TV to the ultrahighs. Such a move, it was pointed out, would be disastrous. However, engineers emphasized that uhf does have a very definite place in TV and can perform a real public service, but in specific areas. The Commission was told that it is in this direction that a careful study should be made promptly.

MID-RANGE SPEAKERS CALLED VITAL TO AUDIO SYSTEM--The mid-range speaker, heretofore defined as not too important a factor in the audio chain, was placed in the limelight at the recent audio convention in New York, where the importance of these speakers was stressed. The 500 to 5000-cycle range, it was said, contains most of the qualities which can irritate if exaggerated; it is the range that can actually suffice if a tweeter is lacking. . . . Outlining the reason for this condition, the author of a report on this subject said that undue peaks in the middle range can result in listener fatigue. Distortion is more noticeable here than in the bass range and in quantities apt to be found even more irritating than in the tweeter range. Extensive tests have shown that saddle-shaped response curves in the middle range can cause tubbiness. . . . It is the middle range that has been found all-important in the reproduction of the transients of the piano. Therein, it was emphasized, lies an important secret of sound reproduction; its oversight explains some of the lack in many of the early and even in a number of the present two-way systems.

FABULOUS DEMAND DEVELOPING FOR COLOR-TV, EXPERTS FIND--Color television is really off the ground and a fabulous demand is developing for sets, which will mean a new era for the entire industry: So have prexy's of leading set manufacturers declared at recent meetings. . . . Substantial credit for this progress was attributed to the growing number of progressive Service Men across the nation who have studied hard and are continuing to dig into the subject, so they can do an even better job in installation and service.

SILICON-COATING METHOD DESIGNED TO IMPROVE SOLDERING ON PW SETS--A new method of coating printed-wiring boards with a silicon solution to assure better soldering connections has been developed. . . . The coating is applied by a silk-screen process similar to the one used in transferring printed-circuit patterns to the board. Covering the circuit side of the board, except for the points where component connections are to be soldered, the silicon solution forms a hard heat-repellent film. By repelling the extreme heat of the solder pot into which the board is dipped, the heat-resistant silicon forces the solder toward the component connections. The result, it is said, is selective soldering which concentrates the solder in desired areas to form stronger connections.

NEW TECHNIQUE DEVELOPED TO CURB INTERFERENCE BETWEEN TV STATIONS--A new method, which reduces the alternating light-and-dark bar effect of co-channel interference on TV sets in many areas lying between stations broadcasting on the same channel, was announced recently during a professional group meeting of IRE engineers. . . . The solution, as explained by the inventor of the system, revolves about a method of establishing a fixed relationship between the basic transmitting frequencies of the two stations and then cutting down the fluctuation of frequency at each station to as little as 5 cps. This tight operation has been accomplished through the use of recently improved techniques in frequency control and in the production of crystals which can oscillate steadily at a desired frequency.

HOME RADIOS MORE POPULAR THAN EVER--Home radio interest is booming this year; current sales of table, portable and clock radios are nearly 50% ahead of 1955. . . . Industry reports that it expects to market nearly 8-million units, excluding auto radios, during '56. . . . Transistor radios, it is said, are playing an important role in stimulating the radio business. Complete portability was cited as having pushed these bantam sets to a new high in popularity.



ARE YOU COLOR-BLIND?

NOT IF YOU CAN READ THIS... BUT THE ANTENNAS YOU INSTALL COULD BE...

THE age of color ushers in your greatest challenge as well as your greatest antenna selling opportunity since the advent of television. For even the finest color TV receiver cannot deliver a satisfactory picture if the eye of the receiver—the television antenna—is "color-blind."

Exhaustive tests by leading color receiver manufacturers have proved that an antenna must possess the following electrical characteristics to render true color reception:

1. Sufficiently high gain to override set noise and provide a clear color picture.
2. Flat response. Gain variation of not more than 1 db within 1.5 mc. below and .5 mc. above the color subcarrier.
3. Narrow unidirectional polar pattern.
4. Close impedance match to help effect a low V.S.W.R. to eliminate line reflections.

11 months ago, the JFD engineering staff undertook an intensive antenna research program. Their objective: to develop a select group of antennas that more than satisfied these stringent color requirements. The results: 8 outstanding antennas, so color-perfect in performance, that we have designated them as the NCB* Colortenna line, signifying Non Color Blind performance.

8 COLORTENNA models to choose from assure you of the right antenna answer for every location or reception problem. They spell out a great new profit opportunity for you... in replacement antenna sales... in new set sales, in trade-in sales—black and white, or color. Because now, for the first time, you can guarantee your prospects and customers both the finest black and white TV today, as well as the truest color performance possible in the future when they decide to buy.

Spearheading your antenna sales break-through will be the most spectacular sales promotion in antenna history—the NCB* COLORTENNA Sell-A-Bratton!

Every COLORTENNA you sell earns you merit points for all-expense paid trips to Europe, America or any place you want to go—and a host of free valuable gifts from minks to Chris Craft cruisers. Plus newspaper advertisements, displays, streamers, direct mail, TV-radio spots, and give-aways selling you and your JFD NCB* COLORTENNA performance guarantee.



JOIN THE



COLORTENNA

Non Color-Blind

SELL-A-BRATION!



deep-fringe areas.
SHUT-OUT HELIX
Model SX992-SX996



deep fringe areas.
WONDER-HELIX
Model WX811



fringe areas.
POWER-HELIX
Model PX911



fringe areas.
STAR HELIX
Model SX711

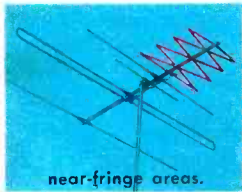

near-fringe areas.
SUPER-HELIX
Model RX511

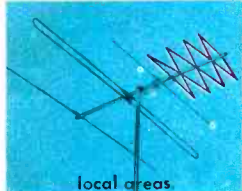

local areas.
JUNIOR HELIX
Model JX311



fringe areas.
UHF 4-BOW HELIX
Model UX211



local UHF areas.
UHF CORNER-HELIX
Model UX411

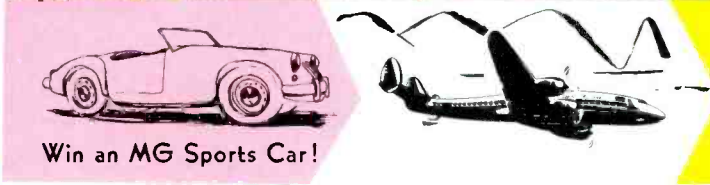

Win an MG Sports Car!

Write your own ticket
to exotic faraway places
... fabulous prizes
... or even both!

JFD is putting its promotion dollars where they count – in *your* pocket – not just for 3 months but for the next 6 months, yes, the *entire* selling season – *longer* than any other similar program. It's our way of saying thanks for every NCB* **COLORTENNA**® you sell. You not only help yourself to fabulous *free* trips and prizes but you cash in on the big *antenna replacement* market that nation-wide **COLORTENNA**® advertising will crack wide open for you.

Every **COLORTENNA**® you sell earns merit points for American Express all-expense paid trips to Paris, Rome, Switzerland, Hawaii, Mexico, Bermuda, Havana, Miami, Las Vegas – or *any* place you name. You go *when* you want to go, *where* you want to go, *how* you want to go or...

If you prefer merchandise prizes, take your pick from over 900 of America's most wanted products – mink coats, MG sports cars, diamond rings, living room suites, Chris Craft cruisers, power mowers, and other wonderful gifts. You can't miss. *Every* point counts. *Everybody* wins.

Your JFD distributor has your NCB* **COLORTENNA SELL-A-BRATION** portfolio waiting for you. It doesn't cost you a cent – no entry blanks – no red tape. Get started *now* and *write your own ticket* in the greatest give-away in antenna history.

SALES PROMOTION EXCITEMENT FOR YOUR STORE!

- window streamers
- newspaper mats
- TV slide commercials
- displays
- TV film commercials
- radio commercials
- cards
- mailers, stickers
- bumper signs

JFD MANUFACTURING COMPANY, INC., BROOKLYN 4, N. Y.

world's largest manufacturer of TV antennas and accessories

International Div.: 15 Moore St., N.Y.C. • Canadian Div.: 51 McCormack St., Toronto 14, Ont.



PARIS



HAWAII



HAVANA



LAS VEGAS



MINK COATS



CHRIS-CRAFT

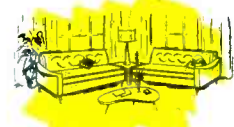

LIVING ROOM SUITES

BELOW: ED HELLER, president of the Master Radio and TV Service Association of Cincinnati, checking Crosley chassis in his shop. Right: Checking tubes in quick-check filament circuit featured in Crosley chassis, by shunting the filament of tubes with a screwdriver put in contact with special filament test points (see inset). Shunting open filaments allows other tubes to light up and serves to identify the tube with burned-out filament.

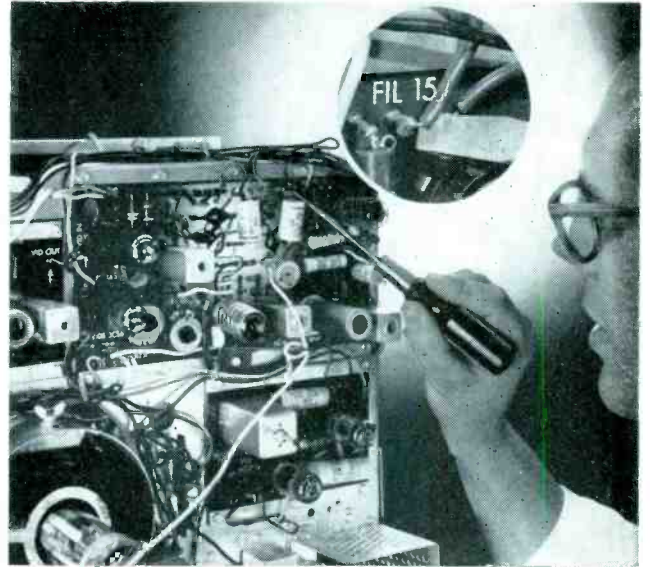
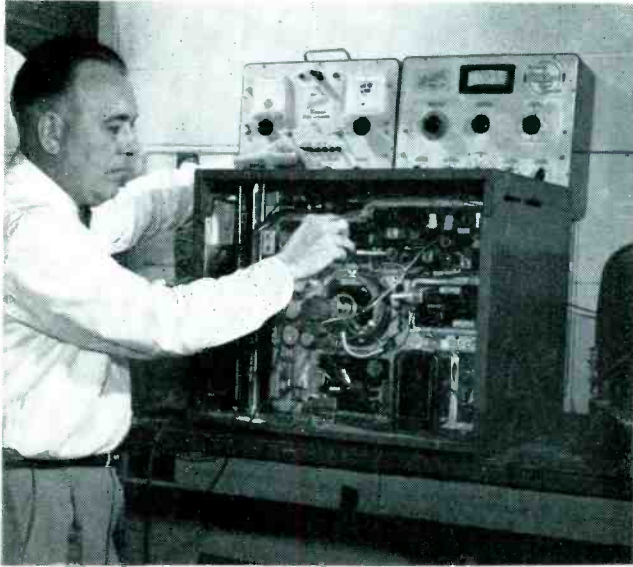

Automatic-Tuning Printed-Wiring Board TV Chassis Designed To Facilitate Servicing

A MAJOR FEATURE of Crosley's new line of receivers¹ is that 90 per cent of the parts that are likely to need replacement during the normal life of the sets can be changed while the chassis is still in the cabinet.

In one series² the tuner is located on the top side of the chassis, making it readily accessible for service. The cover is towards the outside, and once removed the tube sockets and other components are within easy reach. The mounting of the tuner on *uhf* models is such that the *uhf* crystal cover can be removed without trouble, and the crystal changed from the back of the set.

Large openings around the tuner shaft, in both the mask and window, make it possible to adjust the local oscillator from the front, using a long

¹Four groups make up the complete line: *Eldorado*, *Custom*, and *Deluxe*, which have printed circuitry, and *Advance*. Basic automatic features are present in varying degrees in all the sets in the line, with the *Eldorado* and *Custom* groups being designated as fully automatic. For the most part, the basic internal makeup of the *Eldorado*, *Custom*, and *Deluxe* sets is the same; a major difference is in the tuning mechanisms.

²The *DeLuxe* line.

by **A. W. KRAMER**, *Manager, Technical Section, Service Department*

Crosley and Bendix Home Appliances Divisions, Avco Manufacturing Corp.

non-metallic screwdriver, after the knobs are removed. To simplify this operation a funnel-shaped guide around the small opening receives the end of the screwdriver and draws it directly into the oscillator hole in the tuner-mounting bracket.

All of the *if*'s can be aligned in the cabinet. This is possible because test points and other connections have been placed on the boards, facilitating connection of the test equipment. The cores on both windings on the coils can be adjusted from the rear with a standard *hex*-type alignment tool.

The adjustment screw on the horizontal oscillator coil is both the horizontal frequency, and the hold control; there is thus only a single adjustment necessary.

On the end of the focus electrode a small socket pin clip makes it possible to connect it, without soldering,

to any one of four focus potentials (+0, +150, +260, +490 volt) available on a special focus-voltage terminal board.

A similar socket pin on the end of two voice-coil leads from the transformer enables them to be connected or disconnected (without soldering) from the speaker lugs.

Chassis feature vertical design, making it possible to look directly into the socket pin openings of all the tubes except those in the tuner. The vertical chassis is mounted in a box-type framework. Practically all of the circuit components are grouped into seven sections, made up of four printed circuit boards, two sub-chassis panels, and the tuner.

The window and mask, of course, are removable from the front. The picture tube also is removable from
(Continued on page 20)

[See Front Cover and Pages 20-21 for Complete Circuits]

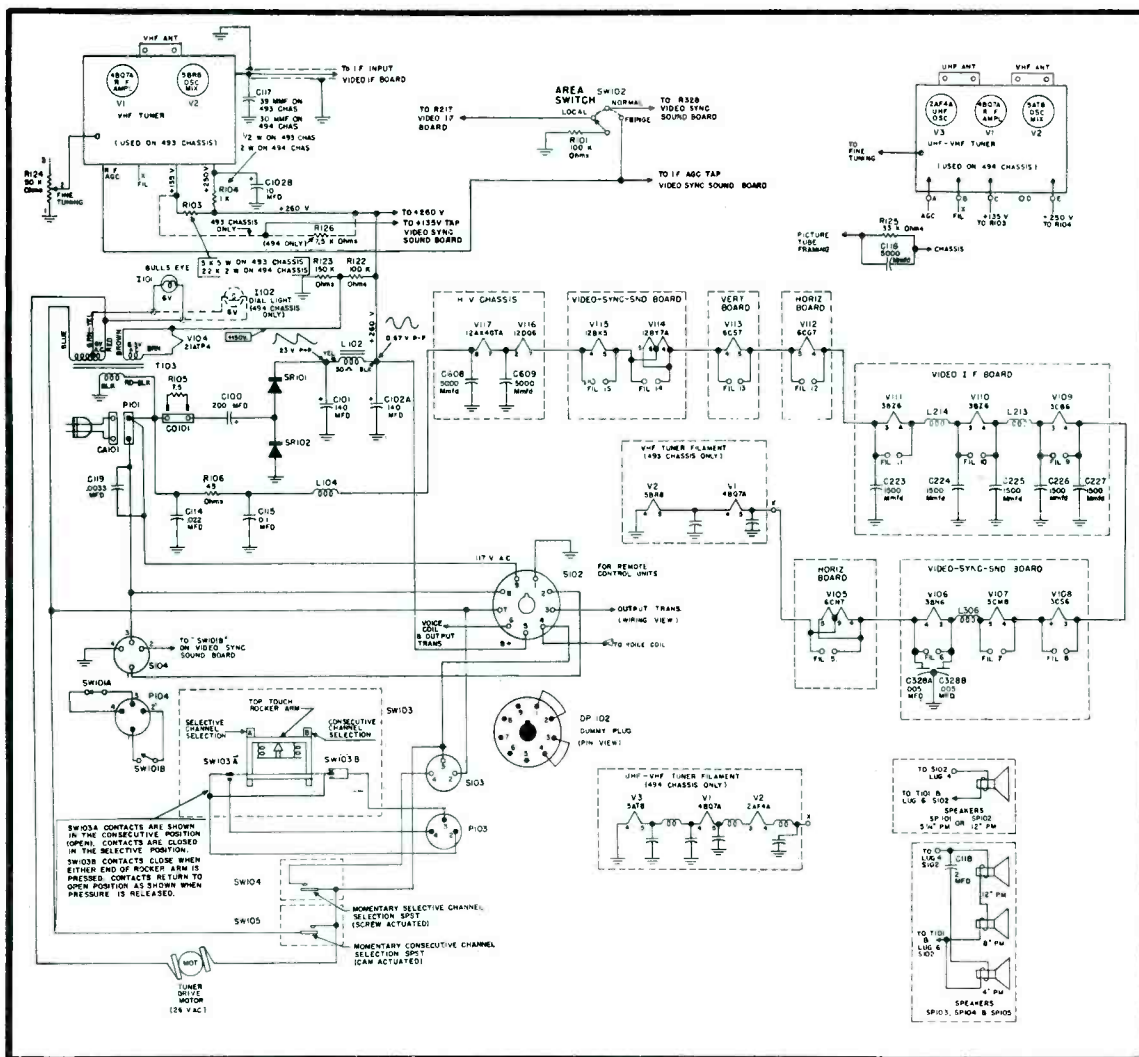

FILAMENT WIRING and motor-control circuit employed in automatic-tuning Crosley TV models.

the front; the only word of caution required is that since the high-voltage lead is short, it should be disconnected before the tube is pulled all the way clear.

The test points, and the type of mounting terminal connections used on the boards, permit checking of nearly all the voltages from the back, except those on the tuner, and a couple on the high-voltage sub-

chassis. Key test points, tube types, and socket numbers are stamped directly on each board to speed servicing.

The boards themselves are translucent. There are no metal chassis or shields over or behind the boards; thus placing a light behind the boards provides a clear tracing of the wiring without removing the chassis. Parts were mounted to the board on the

side opposite the printed circuitry, so that the translucent feature of the boards could be utilized.

All the printed circuit boards are mounted with quarter-inch self-tapping screws. Since all the external leads are soldered at the front, it is not difficult to remove any one of the boards from the chassis, should

(Continued on page 61)

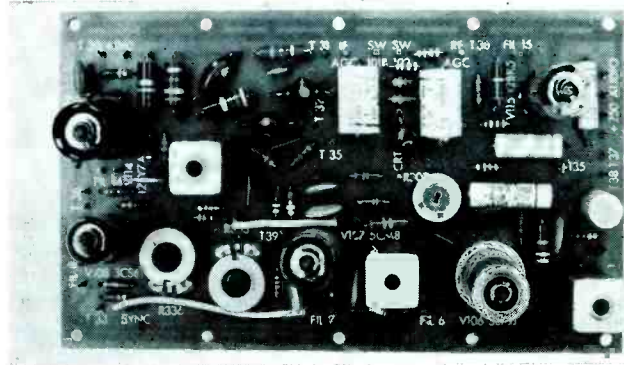
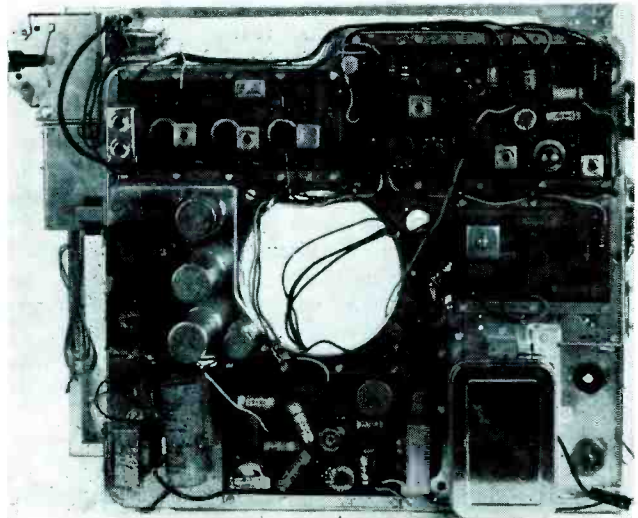

ABOVE: TYPICAL OF THE PRINTED circuitry in Crosley's TV sets is this video-sync-sound board of rigid phenolic laminates. The boards are translucent for easy circuit tracing; copper circuitry is made right on the board. Test points and parts are labeled. Left: Four printed circuit boards, two sub-chassis panels, and tuner in Crosley receiver. Picture tube is removable from front.

Simplified Convergence Adjustment

Step-By-Step Analysis For Static And Dynamic Convergence Control

by **KEN KLEIDON**

*National Color Television Manager
Hycon Electronics, Inc.*

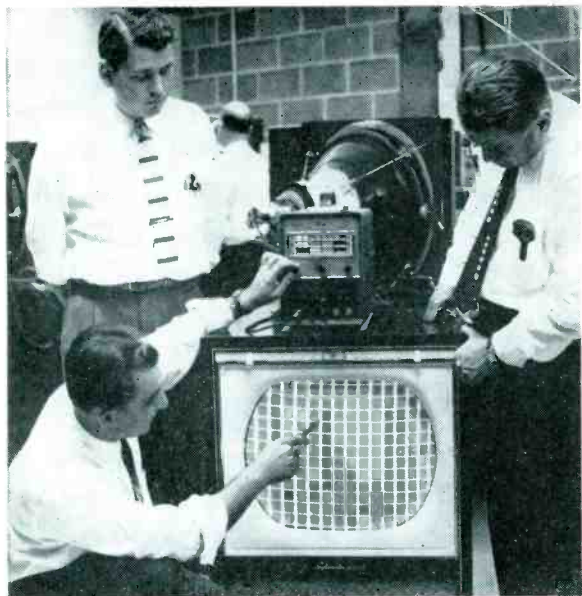

(Left)

FIG. 1: WITH HELP of color bar/dot generator* and Sylvania 21-inch color receiver, author (kneeling) demonstrates convergence procedure to E. W. Merrian, Sylvania service manager (right) and D. Winters, Sylvania color school director (left).

THE MOST difficult task facing Service Men in color-TV installation and service is making the necessary control adjustments to achieve acceptable convergence. Acceptable convergence was almost an impossibility for the early 15 and 19-inch color receivers, and until recent improvements occurred in picture tubes and convergence circuitry, 21-inch color receivers were almost as difficult.

Convergence is so troublesome because perfect convergence can never be achieved, due to component, circuitry and manufacturing tolerances. Another contributing factor is that it is very difficult, until sufficient experience is gained, to determine when an improvement is no longer possible, or when acceptable results have been obtained during a particular step in the adjustment procedure. Even though these conditions exist, present 21-inch color receivers can be adjusted so that the slight amount of misconvergence that is present will be unnoticeable at normal viewing distances, even by the most critical viewers.

Another important consideration concerning convergence adjustments

is the type of convergence generator used. Whether the signal used is *rf* or video, the generator must supply sync which corresponds in frequency to that of a station. The horizontal and vertical scanning frequencies of the receiver must be the same during convergence adjustments as when an air signal is received. If the generator does not correspond, the dynamic convergence waveforms developed will differ and misconvergence will result.

After reviewing the convergence adjustment procedures contained in the service manuals of various color receiver manufacturers, it was found that the procedures varied considerably. The basic method was similar in each procedure, but the approach differed drastically. When examining the convergence circuitry of each receiver, it was found that, except for a few, there were no major differences and the same type controls were employed which affected the electron beam in an identical manner. The convergence circuitry of three color TV manufacturers appears in Fig. 1, 2 and 3. It will be

*Hycon 616

noted that in Figs. 1 and 2, identical controls are used in every case. The *dc* or static convergence controls in one case are permanent magnets and variable controls in the other. The circuit in Fig. 3 employs the same type vertical controls with combination red and green horizontal-convergence controls. In those receivers which were not similar, the differences as far as an overall convergence adjustment procedure is concerned, were found to be only minor. Also, the convergence generator suggested in the instructions varied from that supplying white dots to a cross-hatch pattern to vertical and horizontal lines.

Since such a variation existed, and due to the fact that three-gun color-picture tubes will be in use for a considerable length of time, it was decided to devise a practical convergence adjustment procedure that would apply to the greatest majority of color receivers and that could be used by those who are unfamiliar with convergence procedures. The convergence adjustment procedure that resulted was a combination of existing

(Continued on page 45)

EXTREME RIGHT—COLOR CONVERGENCE PATTERNS (Figs. 5-12): Fig. 5 illustrates patterns obtained when red static convergence control is adjusted properly. Results of red vertical amplitude and red vertical tilt-control adjustments are shown in Fig. 6. It is important to note the unequal separation between red and blue vertical lines at left, center and right sides as illustrated in Fig. 7. The red horizontal amplitude and horizontal tilt (phase control adjustment) must be set so that red vertical lines are equally separated from blue vertical lines across entire face of tube, as shown in Fig. 8. The blue static convergence control adjustments must be carefully made until the blue horizontal line in the center of the picture tube is separated below the green horizontal line by about $\frac{1}{4}$ " as shown in next pattern; Fig. 9. Blue vertical amplitude and blue vertical tilt-control adjustment results are illustrated in Fig. 10. One should note unequal separation between blue and green horizontal lines in center at left, center and right sides, as shown in pattern in Fig. 11. Result of blue horizontal amplitude and blue horizontal tilt-control adjustments are shown in Fig. 12; blue line is parallel to green line in center of tube.

Procedure For COLOR-TV

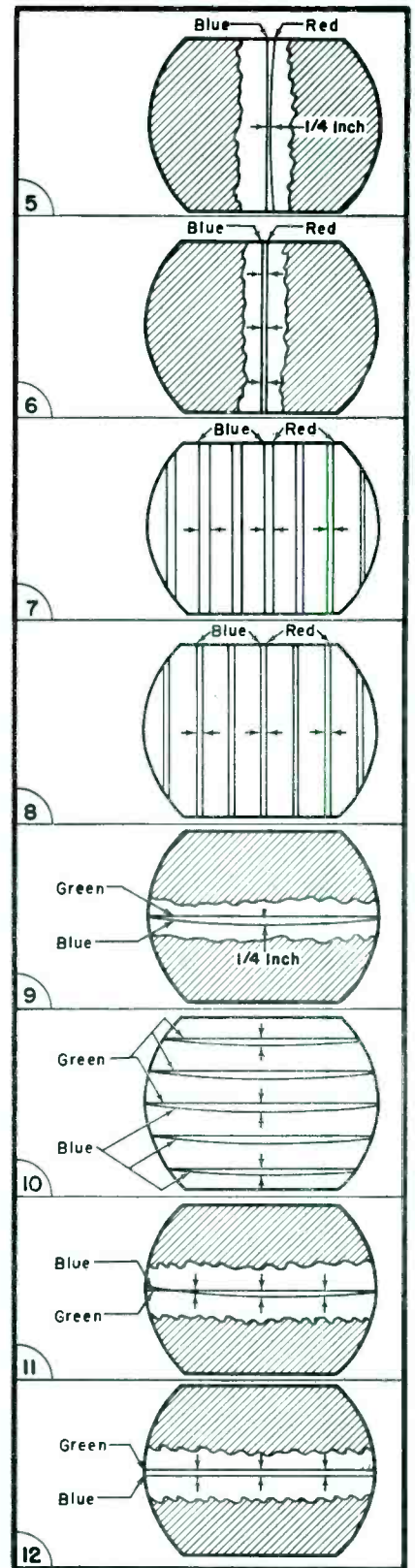
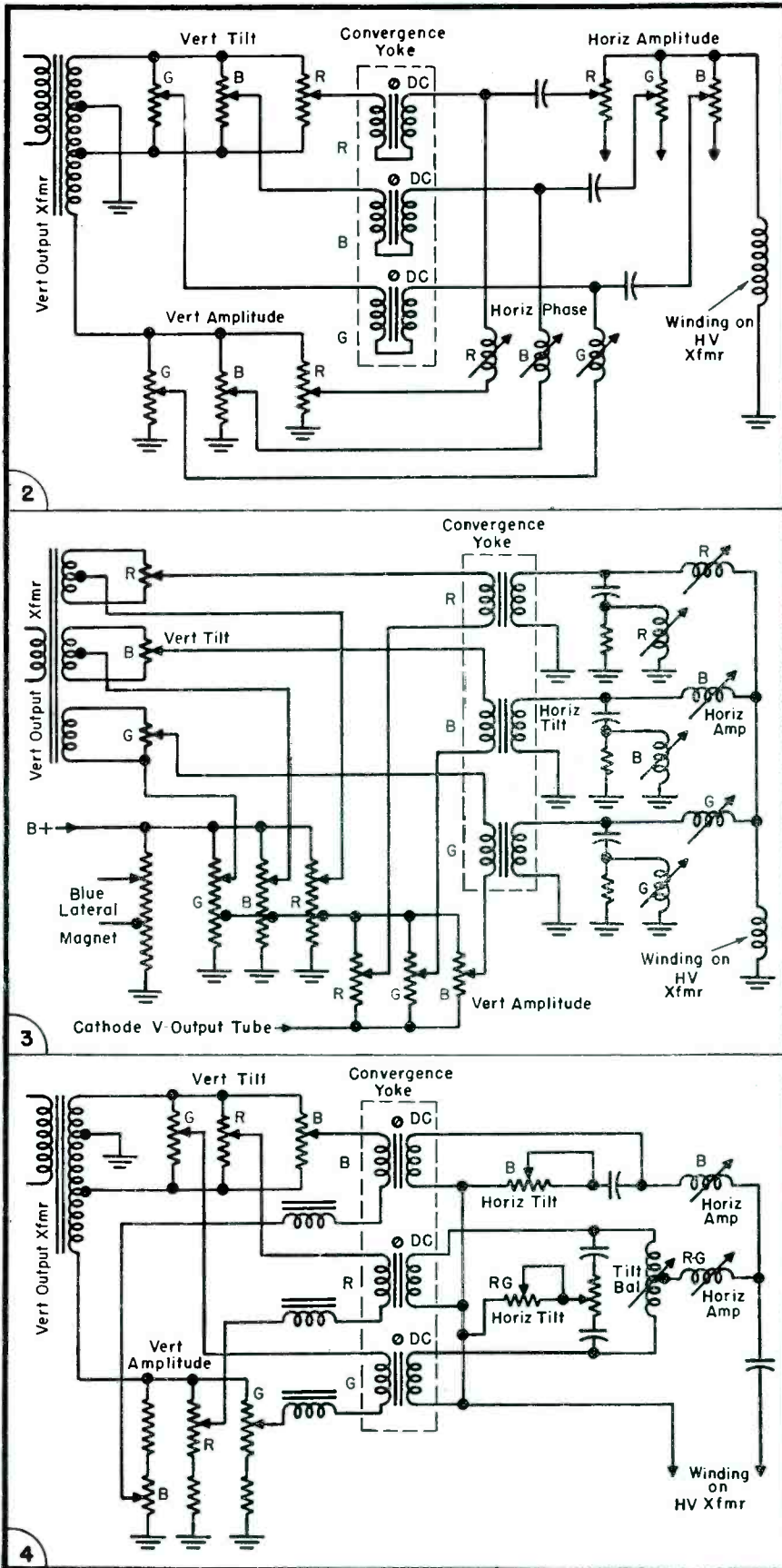

(Left)
FIGS. 2, 3, 4 (TOP TO BOTTOM): Convergence circuitry of Sylvania 1-534-1 (Fig. 2), RCA CTC5 (Fig. 3) and Westinghouse 2292-1 models (Fig. 4).

TV Fuse Installation-Repair

How To Use Fuse Plugs And C (Quick Blow) and N (Slow Blow) Fuses

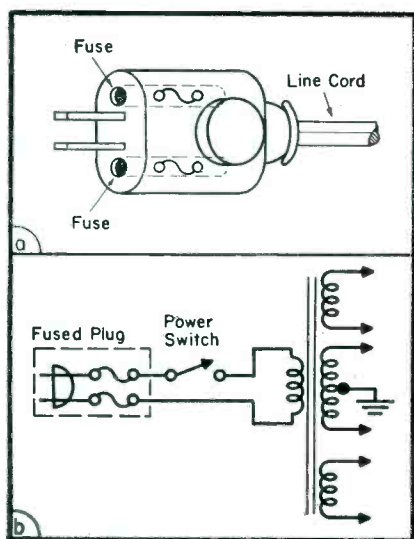

FIG. 1: FUSING SET with fused plug. Cross-sectional view of typical plug is illustrated in (a). How the fused plug is connected in a line is shown in (b).

by **CYRUS GLICKSTEIN***

EXCEPT FOR fusible resistors and lengths of wire used in filament circuits, TV fuses are of the cartridge variety and come in various lengths. Cartridge fuses may have pigtails for soldering in the circuit or come without pigtails for insertion in a fuse clip or fuse holder. Replacement fuses without pigtails must be the same length as the old fuse to fit properly in the fuse clip or fuseholder.

A dual-fuse clip (illustrated in the first installment of this report†, and in Fig. 2 in this report) may be used to replace a blown pigtail fuse without unsoldering the old fuse. One side of each clip is placed on each end of a replacement fuse without pigtails. The other side of the fuse clips is placed on each end of the blown pigtail fuse. In this way, a new fuse can be inserted in the circuit without soldering. No metal parts in the new fuse connection should be close enough to the chassis or other components to cause possibly a short. This

*Author of *Repairing Television Receivers*; John F. Rider Publisher, Inc.

method of replacing a pigtail fuse should be used only if the old fuse is in a chassis area not easily accessible to the set owner.

The simplest method to insert a fuse in a set not having one is to install a fused plug. Fuses commonly used for this purpose are 3.2-amp slow blow. The objection to this type of fusing is its accessibility to the set owner. On occasion, Service Men may want to install a fuse on the chassis.

As a guide to effective fuse-installation procedure, one should follow the requirements set forth by the Underwriters' Laboratories, Inc., for fusing circuits to minimize the danger of shock and fire.

Up to very recently, a serious fuse problem in TV sets has been the complete interchangeability of cartridge fuses, regardless of current rating. As a result, fuses with too high a current rating are often substituted by error or otherwise, especially in sets where the fuses are accessible to the set owner. If the overfusing is great enough, the fuse is obviously

servicing no useful function, and damage to the set or a fire may result. As a result of the initiative of *UL*, fuse companies are now producing fuse holders and associated fuses which safeguard against substituting the wrong size and type of fuse.

Two basic types of fuses are used: *C* (quick blow) and *N* (slow blow). The top cap of each fuse has two flanges, varying in width according to a small amperage range. Slots in the top of the fuseholder are made to match the flanges on the fuses for each specific range. In addition, three fuse lengths are used. Since fuses with higher current ratings have wider flanges, they will not fit into a fuseholder designed for fuses with a substantially lower current rating. In the same way, to avoid blowing caused by using a quick blow fuse where a slow blow one should be used, a type *C* fuse will not fit into a type *N* fuseholder of the same amperage.

A *C* or *N* fuseholder can be installed by inserting the holder in a
(Continued on page 43)

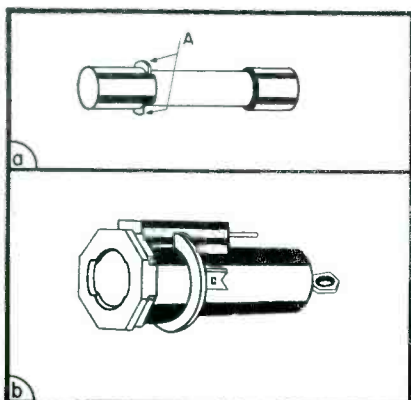

(Right)
FIG. 2: SNAP-ON insulated fuse holder designed for replacement of TV pigtail fuses, which can remain in holder, while snap-type fuse is inserted in other side.

(Left)
FIG. 3: TYPICAL TYPE N fuse (a) and fuseholder (b). Type *C* fuses and holders are similar. The flanges (A) vary in width according to current rating; they match slots in the holder.

[Illustrations courtesy Bussmann and Littelfuse.]

†The first report on TV fuses appeared in the September issue of *SERVICE*.

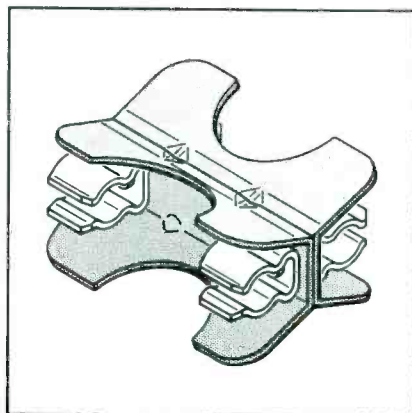

BEST IN



SIGHT

The Tung-Sol Magic Mirror Aluminized Picture Tube captures every tone, every detail brilliantly to bring out the best in every set. It's your best insurance for loyal, satisfied customers. Tell your supplier you'd rather have Tung-Sol tubes.

Blue Chip Quality

ts TUNG-SOL®

Magic Mirror Aluminized
PICTURE TUBES

TUNG-SOL ELECTRIC INC., Newark 4, N. J. Sales Offices: Atlanta, Columbus, Culver City, Dallas, Denver, Detroit, Melrose Park (Ill.), Newark, Seattle.

CATALOGS—LEAFLETS—BOOKS

EAGLE ELECTRIC MANUFACTURING Co., Inc., 23-10 Bridge Plaza South, Long Island City 1, N. Y., has released a 72-page illustrated catalog covering electrical wiring devices, extension and cord sets, fuses, lamps, wall plates, push buttons, flashing devices, lighters and elements, nichrome wire and elements.

ALLIED RADIO CORP., 100 N. Western Ave., Chicago 80, Ill., has published a 356-page catalog, 160, listing more than 27,000 items. Has a special section devoted to high-fidelity equipment. Contains descriptive and technical data on TV chassis, boosters, rotators, *uhf* converters; table model and portable phonos; *pa* amplifiers and systems; industrial *chf* radio and radiotelephone equipment; test equipment; components; hardware; tools and technical publications.

HOWARD W. SAMS AND Co., Inc., 2201 E. 46th St., Indianapolis 5, Ind., has announced publication of *Servicing and Calibrating Test Equipment* by Milton S. Kiver. Chapters cover proper use of test equipment, methods for checking accuracy of instrument, keeping of test equipment operational records, preventive maintenance and servicing. Has 192 pages; priced at \$2.75.

NEWARK ELECTRIC Co., 223 W. Madison St., Chicago 6, Ill., has issued 308-page catalog 65, with descriptive and technical specifications on test equipment, tubes, hardware, capacitors, fuses, tools, audio equipment, resistors, transformers, connectors and relays.

MERIT COIL AND TRANSFORMER CORP., 4427 N. Clark St., Chicago 40, Ill., has published a 128-page *All-Industry Repl Guide*, 409, with coil and transformer replacement information for approximately 20,000 models and chassis. Included is a 6½-page section with flyback schematics.

THE RADIO-ELECTRONIC MASTER, 106 Lafayette St., New York 13, N. Y., has issued an illustrated industry-wide chart on panel and flashlight lamps. Chart lists numerically all panel and flashlight lamps manufactured by General Electric, National Carbon, RCA, Raytheon, Tung-Sol and Westinghouse.

MCGRAW-HILL BOOK Co., Inc., 330 W. 42nd St., New York 36, N. Y., has published an 832-page *Handbook of Semiconductor Electronics*, edited by Lloyd P. Hunter. Appearing are data on transistor action; basic physics of electrical conduction in solids; technological processes used in transistor and diode manufacture; and circuit design and applications for transistors, diodes and photocells, with information on low and high-frequency amplifiers and switching circuits, directly-coupled amplifiers, transistor oscillators and circuits using special semiconductor devices. Priced at \$12.

GENERAL ELECTRIC Co., Tube Department, Schenectady 5, N. Y., has released wall-chart TV-picture tube replacement guide *ETR-702B*, listing 223 types currently available. Chart details both aluminized and non-aluminized replacements, where available, for each type. Tube types are classified by size, base, bulb structure, external coating, anode contact, focus method, deflection angle, overall length, bulb diameter, neck length, anode voltage and type of ion-trap magnet. Color tubes are included. Available from distributors.

JOHN F. RIDER, PUBLISHER, INC., 480 Canal St., New York 13, N. Y., has announced a TV receiver single-diagram-only service, *S-D-O*, consisting of 17" x 22" sheets with schematics, service information, voltage data, tube layouts, alignment information, trimmer locations, adjustments and parts lists. Sheets, which fold for filing, cover RCA, Philco, Admiral, General Electric, Emerson, Motorola, Crosley and Zenith sets produced during the past five years, including present production. Service is available through parts distributors.

Associations



AL HAAS, head of the Television Service Advisory Council, inking joint proclamation between Council and **WHYY-TV**, Philadelphia's channel 35 station, calling for close teamwork adapting area sets so they can pick up uhf signals. Looking on: Paul Blanshard Jr., and Richard Burdick of **WHYY** and **Morrie Green**, local distributor and Council member.

RTTA, Pasadena, Calif.

HARRY COOLIDGE, president of the Radio-Television Technicians Association of Pasadena has been elected delegate to the California State Electronics Association.

According to **Ben Leff**, RTTA publicity chairman, the association has made tentative plans to take a booth at the Pasadena Home Show, Nov. 16-18, 1956. An operating TV chassis, surrounded by scopes and meters, connected to major test points, is expected to be shown.

NATESA, Chicago, Ill.

THE NATIONAL ALLIANCE OF TELEVISION and Electronic Service Associations has named **Frank Moch** to a newly created salaried office of executive director for a two-year period. Moch will also serve as a member of a 12-man executive council which includes: **Robert Hester**, president; **F. B. Koepnick**, secretary general; and **C. Nelson Burns**, treasurer. **Albert C. W. Saunders** has been retained as educational director.

RTG, Long Island, N. Y.

ON SUNDAY, DEC. 9, following the three-day electronics fair of the Radio and Television Guild, Long Island, N. Y., the group will sponsor a national conference of service associations to discuss current industry problems. Arrangements are also being made to have the national service managers from leading manufacturers participate in a panel discussion on "What does the future hold for the independent service business?"

TEN YEARS AGO IN SERVICE

TALKS ON independent servicing and TV installation-repair, featured at the annual conference of the Television Broadcasters Association in New York, stressed overwhelming approval of the independent Service Man and his ability to take care of TV receivers. Manufacturers indicated that they would set up schools to train Service Men and subsequently would authorize those who complete the courses successfully to take care of their servicing work. Associations, it was noted, would be asked to send members in for these special courses. . . . First of a series of exclusive reports on industrial intercom was published in **SERVICE**. . . . **Roy S. Laird**, Ohmite, was elected chairman of the Association of Electronic Parts and Equipment Manufacturers; **Les A. Thayer**, Belden, vice chairman. . . . **Dick Morris** was appointed general sales manager of Snyder. . . . **Charles Golenpaul**, Aerovox, and **Walter Jablon**, Hammarlund, were named directors of the 1947 Radio Parts and Equipment Trade Show. . . . A volume control, said to be smaller than a dime, was announced by Centralab. . . . **Don G. Mitchell**, president of Sylvania, was named to the National Distribution Council.

BEST IN



SOUND

Made to the highest requirements of leading set manufacturers, Tung-Sol Tubes are perfect replacements for all sets. Bank on Tung-Sol's brand of quality—tops in the industry. It's the sure way to avoid callbacks that eat into profits. Tell your supplier you'd rather have Tung-Sol tubes.

Blue Chip Quality

ts TUNG-SOL[®]
RECEIVING TUBES

TUNG-SOL makes All-Glass Sealed Beam Lamps, Miniature Lamps, Signal Flashers, Picture Tubes, Radio, TV and Special Purpose Electron Tubes and Semiconductor Products.

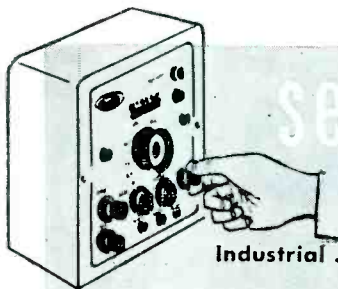

Service Engineering

FIELD AND SHOP NOTES

Industrial . . . Commercial . . . Institutional

Communications . . . Audio . . . Television Installation . . . Maintenance . . . Repair

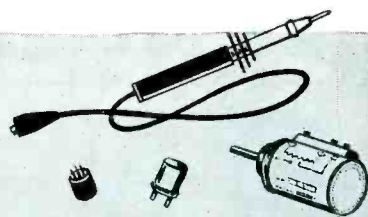

A Report on a Commercial Mobile Tape-Phono Sound Truck With a Two-Way System

LEADING THE MARDI GRAS parade in New Orleans this year was an innovation in mobile public-address service: a complete 2-way high-fidelity unit on wheels.† Housed in a custom-built car, the unit features a tape sound system with a two-way telephone system.

Transmitted over the truck's *pa* system is a tape narration. Operators of the sound truck have reported that the tape has proven most satisfactory in operating in varied climate and weather conditions. The microphone input was altered to a low 50-ohm impedance; input to a phono (also used in the truck) was set at a high impedance. For the reproduction of records, the phono player output can be fed to the phono input of the tape recorder.

Tape Output VC Circuit

While the output of the tape recorder is normally a cathode-follower circuit, a special small volume-control

mixer circuit was built in; two 500,000-ohm gain controls, with 250,000-ohm isolation resistors were used. One gain control was connected to the output of the tape recorder; the other was connected to the grid input of the first audio tube of the car radio. This was found to allow for independent volume control of not only the tape recorder, but a radio chassis over the loudspeaker system. The output of the volume control mixer was connected to the high-gain input of the power amplifier, serving as a bridging circuit.

Ample current to operate the equipment involved was a prime requisite in the sound car, so the standard generator was replaced with a 100-ampere alternator. An output of 18-*v ac* (at motor idling speed the frequency is approximately 45 cycles) is rectified via a three-phase selenium rectifier attached to the fender firewall. The resulting 12-*v dc*

†Owned by the Miller Brewing Co., Milwaukee, Wis.

serves to keep the standard battery fully charged.

An additional 400-ampere hour, 12-*v* battery was placed inside the car and wired with the regular battery, giving approximately 500 ampere battery service without the car motor running. A three-phase, 18-*v* transformer was attached to the output of the alternator. The output of the transformer secondary is rectified to produce 120-*v dc* with 800-watt capacity.

Installation of the public address system and tape recorder required more than five months.

Rack-Mounted Facilities

The magnetic tape recorder can be used while the car is in motion. Mounted in the conventional rack and panel manner, the recorder can be set to tape material from the loudspeaker system, radio or phono. By using intercomponent switches material to

(Continued on page 55)



ABOVE: CUSTOM-BUILT car which features a complete public-address sound and 2-way radio system. At right is sound track tape recorder designed to be used to record voice announcements over the loudspeaker, phono records or radio. The recorder can be used while the car is in motion, and recordings played back directly through the loud speaker. While recording it is not necessary to have the material go through the loudspeaker. (Courtesy Miller Brewing Co.)

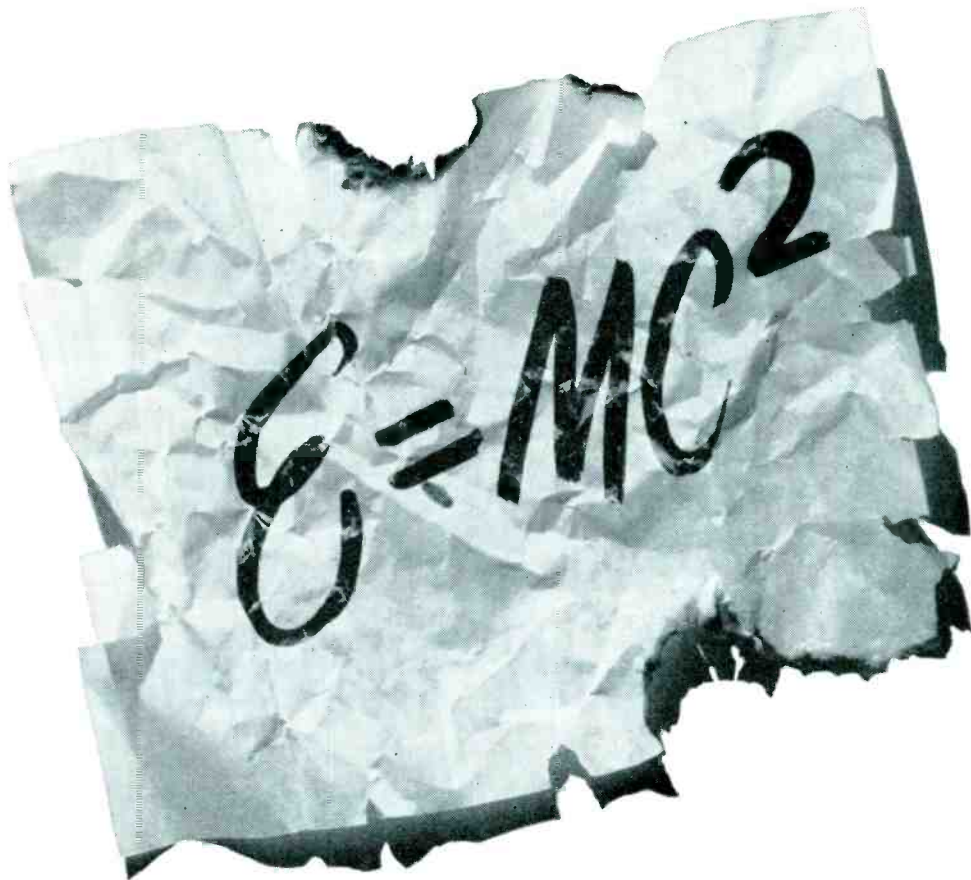

The Equation that Shook the World!

A hasty scrawl on a scrap of paper ushered in the Atomic Age. Through this equation, Dr. Albert Einstein revealed to mankind the awesome secret of atomic fission, with all of its tremendous power for good or evil.

This is the kind of a world we live in . . . a world where knowledge is power in a truer sense than ever before. It is an exciting world.

Univac® has added a new dimension to the world of science, processing data with a speed that crowds many lifetimes of research into a few hours.

Squarely in the midst of this exciting world are the engineers and scientists of Remington Rand Univac. Their potential for growth and achievement (and the rewards that go with them) is unlimited. *You can be one of them.*

Immediate Openings for:

FIELD LOCATION ENGINEERS with a college degree in a scientific or engineering field and experience in electronics. Extensive electronic background may substitute for some college. Many opportunities for rapid advancement.

FIELD LOCATION TECHNICIANS with technical school background and preferably some experience in electronics. These positions can lead to full engineering responsibility.

Send complete resumé to:

Remington Rand Univac

DIVISION OF SPERRY RAND CORPORATION

Mr. Phil Wilson

Dept. SO-28

1902 W. MINNEHAHA AVENUE • ST. PAUL W4, MINNESOTA

SERVICE, OCTOBER, 1956 • 29

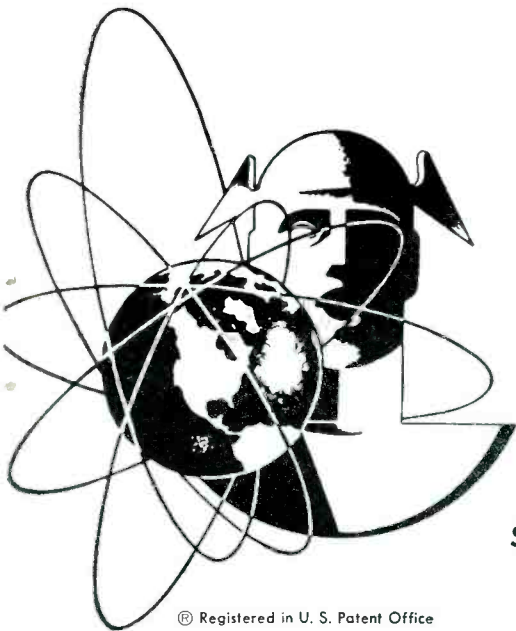

® Registered in U. S. Patent Office

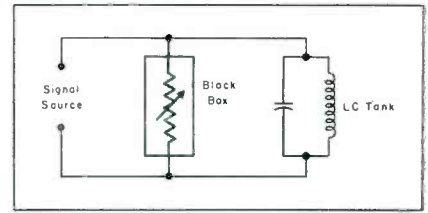
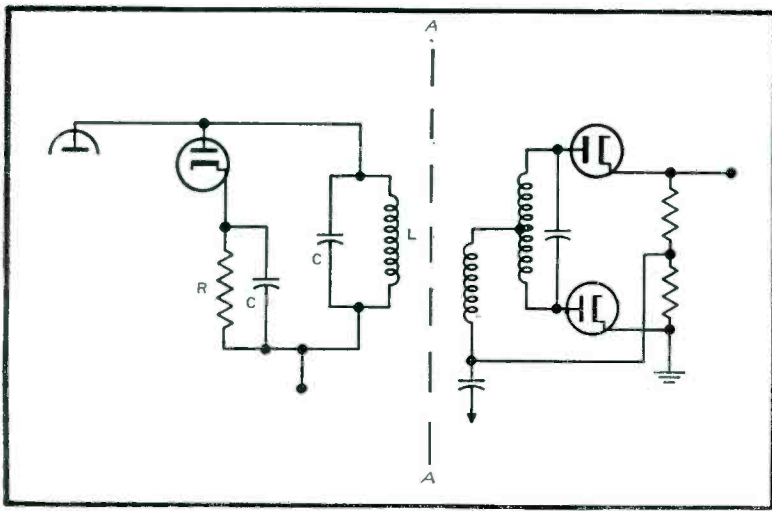

(Left)

FIG. 1: PHILCO dynamic diode discriminator. Circuit at right of AA is the demodulator section; circuit at left is responsible for AM reduction.

(Above)

FIG. 2: BLOCK DIAGRAM of diode system, illustrating overall operation.

Dynamic Diode Discriminator

An Improved System of Sound Detection In TV Chassis

by **R. H. OVERDEER**

Television Section, Engineering Department, Philco Corporation

IN THE IDEAL CASE, the design philosophy of a frequency-modulation demodulator desires that the two functions, amplitude-modulation reduction and frequency-modulation demodulating, be accomplished by different circuits. This is desirable, because in a device which accomplishes both functions with common elements, there will exist a region of operation where the action of AM reduction will also prevent any output of the FM signal. The ratio detector is an example of a system which suffers this drawback. It is also required that the AM reduction action be self adjusting to different levels of input signal.

To meet the ideal conditions, with the added advantage of AM limiting at the highest signal level available and at a relatively high impedance, the circuit shown in Fig. 1 was developed. Termed the *dynamic diode discriminator*, this circuit performs the functions of AM reduction and FM demodulation in two distinct parts of the system.

Demodulation Action

Referring to Fig. 1, the portion of the circuit to the right of AA constitutes the demodulator section. This circuit is a conventional FM discriminator. The only feature here is the addition of the tertiary winding, which provides a *dc* return for the diodes and also a means of adjusting

the primary voltage impressed on the secondary. It is important to realize that the choice of discriminator type is arbitrary and not limited to this particular type.

The circuit to the left of AA is responsible for AM reduction; this is the dynamic diode from which the circuit takes its name.

AM Suppression

To simplify an analysis of the operation of the AM suppression circuit, the block diagram in Fig. 2 has been prepared.

The model shown in Fig. 2 consists of a parallel *lc* circuit with a black box connected across its terminals. Three conditions of operation obtain here: When the signal across the *lc* tank is constant, the box acts as a constant resistive load; when the signal suddenly increases across the *lc* tank, the resistance of the box decreases; conversely when the impressed signal suddenly decreases, the box resistance increases. It can be seen that this action will tend to hold the signal across the tank constant, since the effective *Q* is varied inversely as any short time change in the input signal.

Comparing the relationship of Fig. 2 to Fig. 1, we have the black box

of Fig. 2 representing the diode and its *rc* load in Fig. 1. The *rc* load, which biases the diode to the peak value of the impressed carrier, acts as a level-sensing device and, by controlling the conduction of the diode, varies the resistive load across the *lc* circuit from $R/2$ to a low value determined by the permeance of the diode.

This action serves to remove any upward or downward amplitude modulation which appears on the positive cycle of the carrier. Amplitude modulation occurring on the negative cycle is removed by the filter action of the *lc* circuit. Since it is not loaded during this portion of the cycle by the diode, and the *Q* is high enough only since waves can exist across the tank and the amplitude modulation is removed.

The damping action of the dynamic diode imposes several requirements on the design of the circuit. The *Q* of the primary must be as high as practical for best AM reduction and is limited only by stability requirements. The dynamic diode effectively broadens the bandwidth of the primary and for best thermal-noise performance, the bandwidth of the signal ahead of the dynamic diode discriminator must be limited.

New RCA WR-46A Video Dot/Crosshatch Generator.

Produces stable, sharp patterns at high-level video output for convergence adjustments.

Saves installation time; enables more precise convergence adjustments.

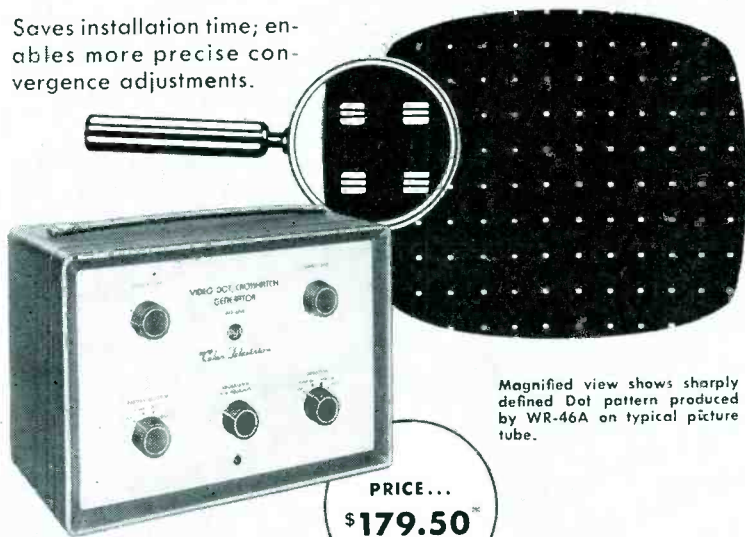

Magnified view shows sharply defined Dot pattern produced by WR-46A on typical picture tube.

PRICE...
\$179.50

- high-level video output permits direct connection to grid or cathode circuits of color picture tubes—eliminates pattern distortion which may be caused when generator signals are fed through rf, if, or vf channels—results in clean, extremely sharp pattern display
- permits simultaneous display of pattern with broadcast picture in background to assure that convergence adjustments are made at correct horizontal and vertical scanning rates
- switch-selection of four types of patterns is provided: "V" bars for vertical dynamic tilt and amplitude convergence adjustments; "H" bars for horizontal dynamic phase and amplitude convergence; Crosshatch for simultaneous check of "V" and "H" convergence adjustments; Dots for center-screen static-convergence adjustments and for "touching up" dynamic convergence
- has Brightness Equalizer Control for "V" and "H" elements in cross-hatch pattern
- vertical sync is frequency-divided from horizontal sync, resulting in interlaced scanning and exceptional freedom from "jitter", "crawl", and "sync-hunting"
- light weight • portable.

Simplify, Speed-up Color TV Servicing!

RCA WR-61B Color-Bar Generator.

Provides crystal-controlled signal source for trouble-shooting, and adjusting color-phasing and matrixing circuits.

WR-61B simplifies the usually complex measurement of the relative gains of the 3 chrominance channels (R-Y, B-Y, G-Y). With the WR-61B the relative gains of these channels can be measured at the output of each demodulator stage. This simplified method of measuring gain is possible because the subcarrier output of the generator is constant for all color-phase angles. Curve A shows WR-61B output as it would appear on a scope. Curve B shows the output signal of one of the demodulators.

Outstanding features of WR-61B: generates signals for producing 10 different color-bars simultaneously—including bars corresponding to R-Y, B-Y, G-Y, I, and Q, signals

- excellent signal source for localizing trouble ahead of or following the 2nd detector
- accepted as a standard for checking accuracy of color-phasing in many TV stations and network operations
- light weight • portable.

*User price (optional)

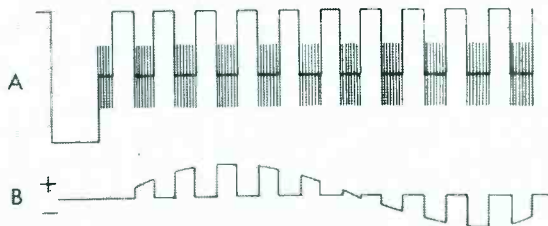

PRICE...
\$259.50*

RCA TEST INSTRUMENTS ARE AVAILABLE THROUGH YOUR RCA DISTRIBUTOR.



TEST EQUIPMENT

RADIO CORPORATION OF AMERICA, HARRISON, N. J.

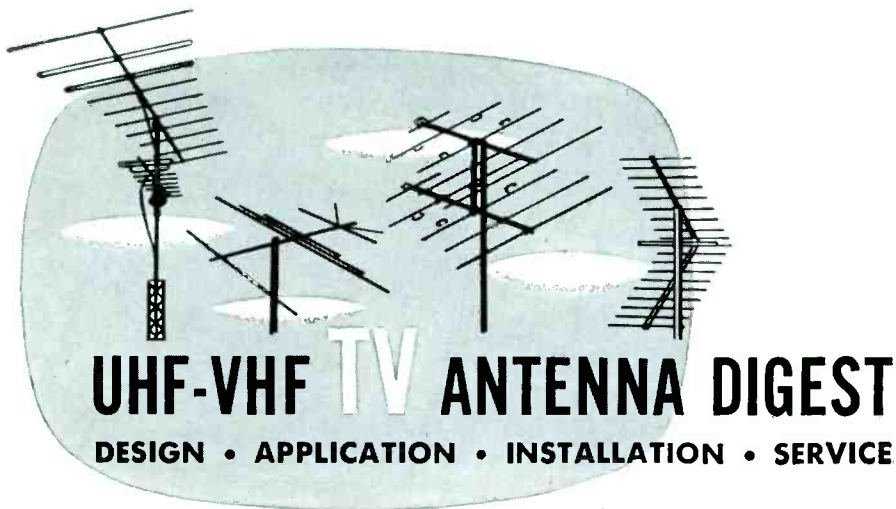

Apartment-House TV-Distribution Systems For Fringe Areas

THERE ARE THREE basic types of TV distribution systems in use today. The first, and by far the most popular, is the local-area, multiple-outlet system used in hotels, large apartment buildings, and in some motels. Next is the city-wide subscription system used in shadow-areas. This type usually depends upon a group of antennas and channel boosters on top of a nearby hill to pick up and amplify signals which are then fed on a cable to subscribers in the town or village in the valley. Both of these systems exist in many forms, and some have developed to a high degree of reliability, fidelity, and relative economy. Several manufacture a complete line of distribution components which are especially engineered for these systems.

The third system is the fringe area, limited outlet type for multiple-dwellings or apartment houses outside the secondary service areas, that has its own set of requirements. Specifically, this fringe area encompasses a distance range of 60 to 100 miles from *vhf* stations. A distribution system is necessary here because satisfactory reception can be obtained only by an installation of large, high-gain antennas on the top of a tall pole or tower. Obviously, the installation of several such antennas and towers is not practicable on the roof of a single apartment building.

The fringe-area distribution system has the following general requirements. It must have a good signal-to-noise ratio on all the promised channels. In most fringe areas, the term *good reception* is rather loosely used, but here the signal-to-noise performance of the distribution system obviously must be as good, and in general

by **LOUIS E. RABURN**

somewhat better than that of residential installations in the same fringe area. The system also must have good reliability; not only so that the service expenses are reasonably low, but also so that subscribers are not often disappointed when they turn on their sets to watch scheduled TV programs. In addition, the cost of installing the system, adding tap-ons, and routine preventive service must all be reasonably low. It has been found desirable to employ an electric-clock timing arrangement to switch the system on only when the stations are on the air. This not only spares the amplifier tubes, but also saves needless power consumption. Finally, it is sometimes necessary to equalize the signal levels in the different channels to avoid overload distortion and inter-channel coupling. There is usually no requirement for special compensation due to the variation of the distribution cable losses with frequency. These cables are not long enough to have appreciable loss at even the highest *vhf* frequency.

Outdoor Components

The most important of the outdoor components is the antenna. It must have high gain throughout its own channel and must be rugged enough to perform in the worst extremes of wind, rain and sleet. Since it is usually convenient to cover the station in each channel with a separate antenna, the yagi-type antenna has been found to be the most suitable; it is generally best to choose one with

at least eight or nine elements and stabilizing angle braces. It may be necessary in some areas to receive two stations in the low band or two stations in the high band. It is then possible to use a single high-gain broad-band antenna quite satisfactorily if low noise preamplifiers, which can cover the required excess bandwidth without degradation in signal-to-noise ratio, are used.

The next important component is the channel preamp which should be located on top of the antenna tower near the feed terminals of the antenna and far from the high-noise area around the apartments. The preamp should have the best possible signal-to-noise ratio, such as that provided by a cascode circuit or some equivalent design.

The leadin from the channel preamp should be shielded to prevent pickup of ignition noise and other extraneous signals by the leadin. Pickup on this leadin is quite possible, even though the preamp may boost the antenna signal on the order of 10 or 20 db; voltage gain of approximately 3 to 10. A variety of suitable leadin cables in single lead coax and balanced two lead twin-ax forms are available for this purpose. The other leadin requirement is that it be designed and installed to provide reliable service without corrosion or increase in attenuation after prolonged exposure to the elements.

The supporting tower for the outdoor components must be stable and reliable. It should have a height of at least 20' to 30' above the apartment house roof. The main reason for this minimum height is not to provide an increase of the received signal but rather to move the antennas out

of the high-noise level environment surrounding the apartment building. Naturally, the tower must also be high enough to place the antennas above nearby buildings and trees.

Indoor Components

The indoor components do not have any reliability problems due to weather conditions. However, distribution amplifiers, which are usually necessary, do require some reliability consideration, since there are a multiplicity of amplifier tubes with increased chances for outage. The amplifier should also provide sufficient branch outputs without appreciable distortion of the signals from the pre-amps. A moderately good input signal-to-noise ratio is required so that the input noise does not degrade the signal-to-noise ratio of the preamps.

The branch distribution cables may be either of the shielded or the unshielded balanced twin-lead type, depending upon the noise conditions near the cable runs of the apartment building. Obviously, if these cables must pass near electrically-controlled signs, furnaces, washing machines, etc., they should be shielded. Also, it is usually found that runs of perhaps more than 150' will be more likely to pickup noise; therefore, as a general precaution, they also should be shielded. There are two reasons for avoiding the use of shielded cables throughout a system: (1) More attenuation loss per foot in the shielded than the unshielded cable, and (2) expense per foot and considerably more installation expense per branch, if it has to be fished past a number of obstructions or partitions.

There are obvious advantages to the use of small coax cable for the

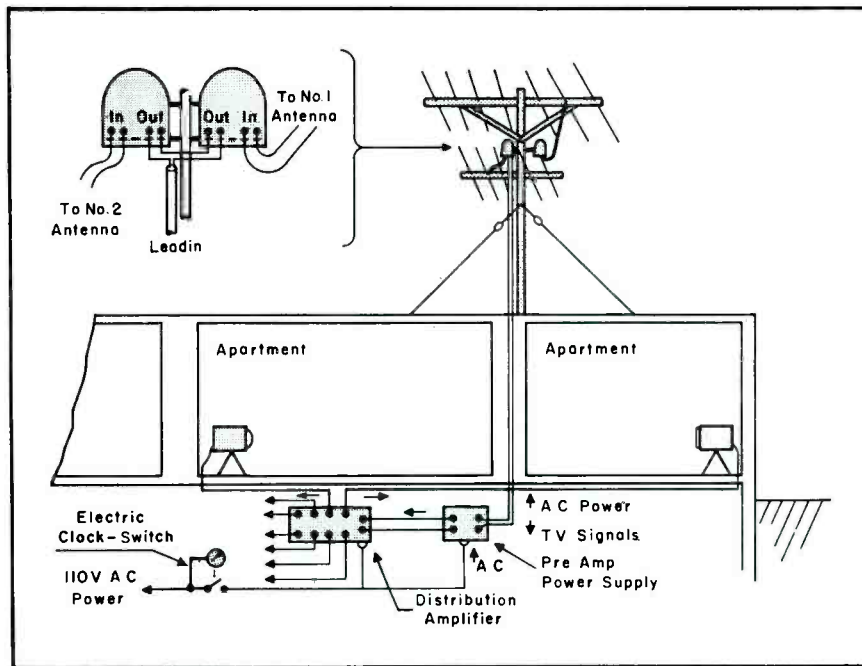

A LOW-COST fringe-area TV-antenna distribution system.

secondary branch lines. However, this cable, while slightly less expensive than shielded twin-ax, is likely to result in a more expensive overall installation when the costs of the matching transformers for feeding the balanced 300-ohm terminals on the set are included.

The distribution setup shown in Fig. 1 illustrates a low-cost (\$300 exclusive of secondary branches) type of system which has been found to provide good performance and acceptable reliability. This system has been used with as many as three yagis, each feeding into a single-channel preamp and then into a multiple-distribution amplifier.

The costs of stringing the secondary branches depends to a great

extent on the type of building and the type of cable that is involved. It has been found that the cost of an average length of secondary branch, including the labor, is in the range of \$20 to \$30. An installation of this type can be profitable if at least five subscribers can be secured at a rate of \$20 a month.

Special Problems

Two basic problems are usually encountered in these installations: A sufficient number of prospective subscribers must be signed up to make the installation profitable; and the apartment house owner must be convinced that this system will satisfy
(Continued on page 67)

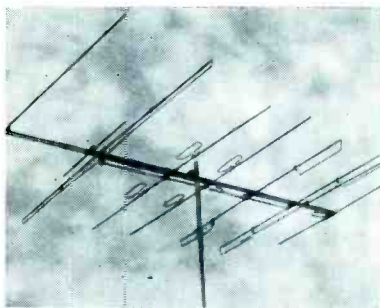

ANTENNA BUILT around an antenna-connecting delay line network said to maintain optimum impedance match to transmission line and a single lobe pattern throughout the vhf band. Line is essentially a balanced T section composed of inductive series elements and a capacitive shunt element. Mechanically, it is made up of the antenna element and four heavy-aluminum coils. (Topliners '40, '50, '60 and '70; Technical Appliance Corporation, Sherburne, N. Y.)

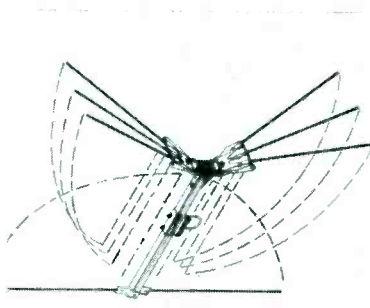

CONICAL-V-BEAM all-aluminum conical designed for the replacement market. Butterfly clamps are all-aluminum, and elements are doweled tubular. Radiator assembly with swing clamp automatically position the elements. Snap-in, positioned-reflector assembly said to provide positive locking. (Quickies Q-2X (single bay), Q-4X (two bay stack) and Q-8X (four bay stack); Telrex Labs., Asbury Park, N. J.)

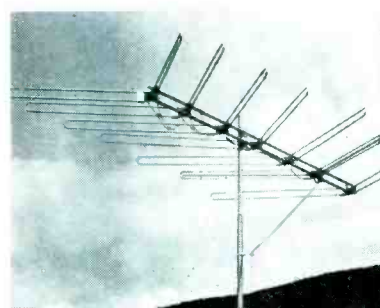

ANTENNA utilizing a traveling-wave principle said to reinforce picture signals electronically by providing for an equal flow of current in every dipole on each of the vhf channels. All but one of the antenna's elements are driven elements. Hairpin or fat dipoles replace conventional folded dipole; all elements are of folded construction, including the reflector. (Channel Master Corp., Ellenville, N. Y.)

Circuitry Report on RCA 21-Inch COLOR-TV Chassis

by J. A. MAY and W. H. FULROTH

Commercial Service, TV Service Clinic, RCA Service Company, Inc.

THE LUMINANCE CHANNEL in the RCA 21-inch color chassis¹, which performs the same functions as the video amplifiers in conventional black-and-white TV receivers, consists of two stages. The first video amplifier uses the pentode section of a 6AW8. The picture second detector output is applied between the grid and cathode of the first video stage. Output from the first video stage is taken from both the cathode and plate circuits. Luminance (the black-and-white signal) is coupled to the second video amplifier grid from the cathode circuit. Sync, *agc* voltage and chrominance information are derived from the plate circuit of this stage. A delay line between the first and second video amplifiers delays the luminance information so that it will arrive at the picture at the same time as the chrominance information. Because of its narrower bandwidth, compared with the luminance signal, the chrominance signal normally would arrive at the picture tube at a later time than the luminance information. If the delay line were not used, the color picture would appear to have fringing or *color ghosts*.

The contrast control in these models is a variable resistor in the cathode circuit of the second video stage. Brightness is varied by chang-

ing the operating level of the second video amplifier with a variable resistor in the grid circuit of the second video amplifier. The plate circuit of the second video stage is coupled to the cathodes of the picture tube. Varying the operating level of the second video amplifier changes the plate voltage, which thus varies the picture-tube bias and consequently, the brightness.

A horizontal-retrace-blanking circuit is provided to prevent the appearance of a vertical yellow stripe in the picture during a color program. This is accomplished by amplifying a horizontal retrace pulse in the horizontal-blanking amplifier and applying the resultant voltage to the screen grid of the second video amplifier. This causes a positive pulse to appear at the picture-tube cathodes and cuts off the picture tube during horizontal-retrace time, preventing burst (which occurs during horizontal retrace) from appearing as a yellow stripe on the picture-tube.

Vertical-retrace blanking is accomplished by applying a voltage from the plate of the vertical output stage to the plate of the second video stage. The result is a positive pulse at the picture-tube cathodes which blanks

the picture-tube during vertical retrace time.

The chrominance channel in the *Special* and *Super* series consists of a bandpass amplifier (the pentode section of a 6AW8) and the demodulators, two type 12AT7 dual triodes.

The bandpass amplifier is tuned to amplify the portion of the composite color-TV signal appearing about the region of the color-subcarrier frequency and receives signal from the plate circuit of the first video amplifier.

Chrominance drive to the demodulators, the burst (the color sync signal) are derived from the plate circuit of the bandpass amplifier.

The signal appearing in the sidebands of the color subcarriers is fed to the grids of the four triodes in the demodulator circuit. A locally-generated 3.58-mc *cw* subcarrier signal is fed to the cathodes of the demodulators from the 3.58-mc *cw*-output transformer. The transformer is tuned so that the *B-Y* demodulator tube is fed a *cw* reference signal differing in phase by 123° from the *cw* reference signal fed to the *G-Y* demodulator. Cancellation of the 3.58-mc *cw* signal takes place in the grid circuit of the demodulators, and output at the plate circuits consists of the color difference signals + (*B-Y*), - (*B-Y*), + (*G-Y*) and - (*G-Y*). The *R-Y* color difference signal is developed by mixing portions of the - (*B-Y*) and - (*G-Y*) signals.

Sufficient output is available from the demodulators to drive the grids of the picture-tube directly. Direct coupling is used to affect *dc* restoration and maintain color balance. Color synchronization is maintained by the burst keyer, burst amplifier,

(Continued on page 56)

¹RCA CTC-5/CTC5N.

†Initial report on these models, with complete circuit of basic chassis, appeared in September, 1956, SERVICE.

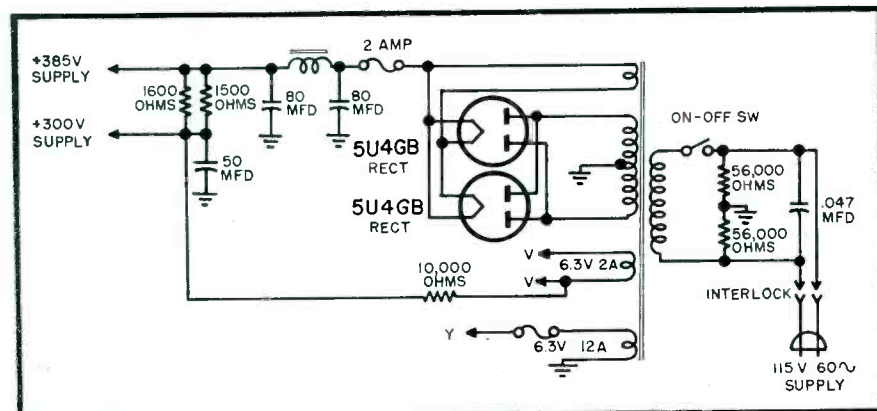

(Left)

LV POWER SUPPLY of 21-inch RCA color-TV models.

Another **Snyder** Antenn-engineered Original
PHILADELPHIA

ATTIC TORQUE-TENNA[®]

with exclusive interceptor discs

An **INDOOR ANTENNA**
with **OUTDOOR**
EFFICIENCY

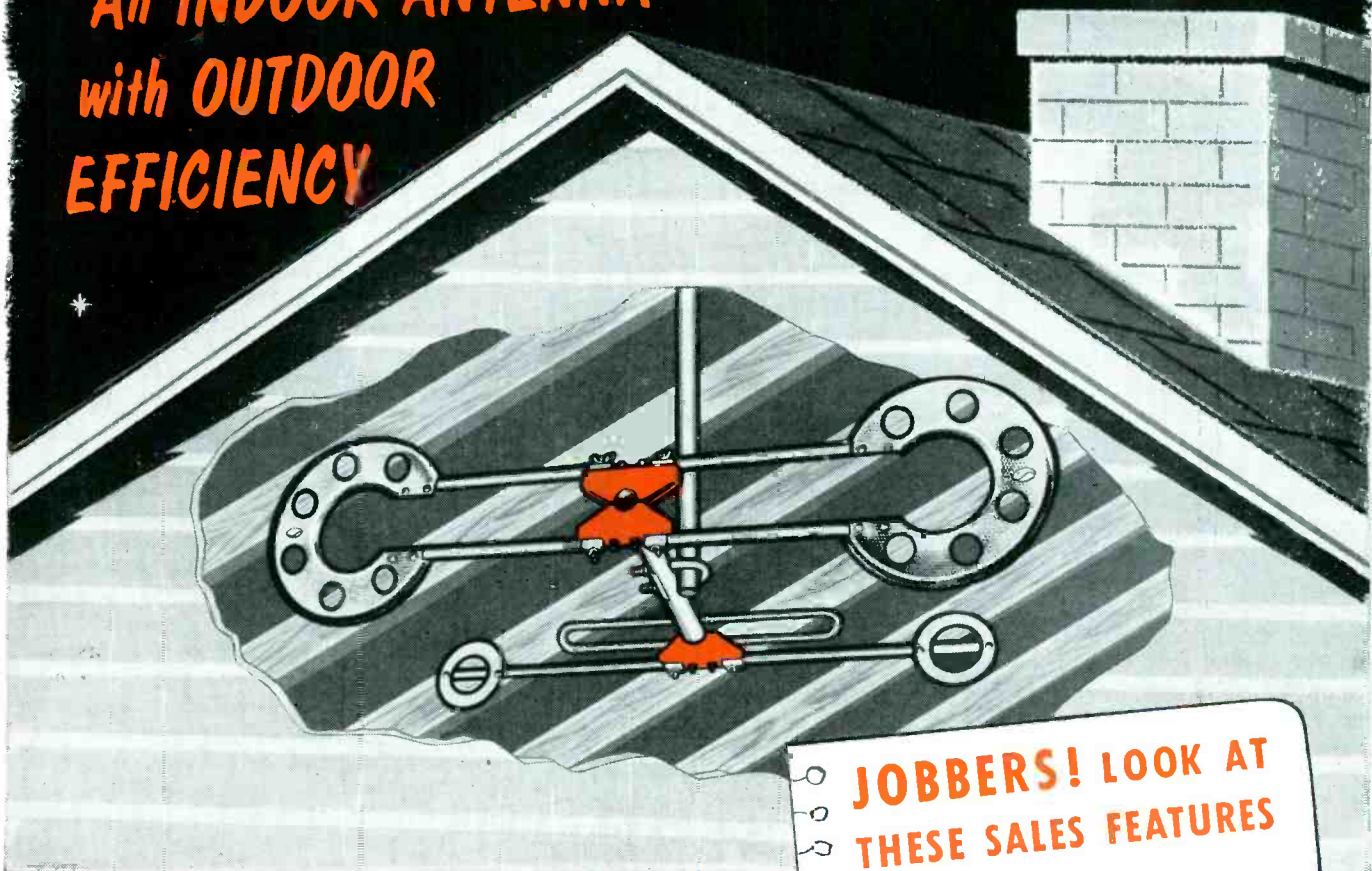

AX-100A COMPLETE KIT **\$995**
Nothing Else to Buy

1 MAST SECTION; 3 WALL STANDOFF INSULATORS
35' TWIN-X CABLE; 1 ADJUSTABLE MOUNTING BASE

ATTENTION TECHNICIANS!

1st time in electronic history a $\frac{1}{2}$ wave length resonant antenna with only a $\frac{1}{4}$ wave length physical dimension.

JOBBERS! LOOK AT THESE SALES FEATURES

- ✓ Makes every building contractor a market for built-in antennas
- ✓ Opens a big replacement market
- ✓ Offers an exclusive "hideaway" installation
- ✓ Handles easily because of light weight and small size
- ✓ Recommended for METROPOLITAN and SUBURBAN areas within 20 miles of television stations

SNYDER

MANUFACTURING CO.
PHILADELPHIA • LOS ANGELES • TORONTO

A Report On Keyed AGC Circuitry Used in Old and New TV Chassis*

by J. M. SHEEHE, Application Engineer, Electronic Tube Division, Westinghouse Electric Corp.

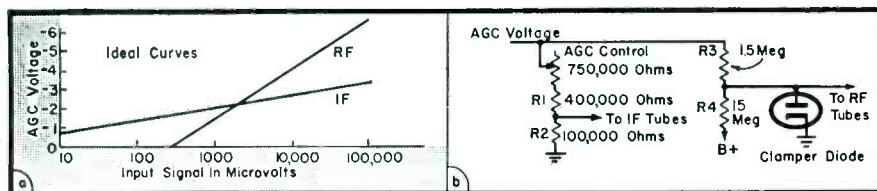

Fig. 1. Ideal curve of agc versus input signal for both the rf and if tubes.

IN KEYED AGC systems, when conductance does take place, the output of the *agc* tube appears across a capacitor which charges up to the full amount of the amplified sync pulse. Phase reversal takes place in the tube, so that the output pulses extend in a negative direction as needed for *agc* voltage. A *rc* network filters the voltage appearing across the *agc* output capacitor so that the filtered *agc* voltage is approximately equal to the peak output pulses. The time constant of the filtering network can be made short, in the order of .01 second, so that the system will have a fast response to rapid fluctuations in the signal strength such as that caused by airplane flutter, noise, etc. Since the system acts only during the time of the horizontal sync pulses, there will be no vertical sync suppression; hence, no need for a long time constant.

Noise immunity is excellent since there is only conduction for 5 per cent of the time. Any noise spikes that occur during the non-conducting portion of the cycle will have no effect upon the *agc* voltage.

A sufficient amount of *agc* voltage is available so that good *agc* action is obtained even with a strong input signal. Considerable amplification is obtained when a pentode tube is used. Another advantage obtained when a pentode is used is that variations in the amplitude of the pulse from the horizontal output transformer will have little effect upon the amplitude of the output waveshape.

Advantages of keyed *agc* are:

- (1) Good noise immunity.
- (2) Fast response to changes in signal strength.

(3) A large amount of *agc* voltage is obtained and it is directly proportional to the peak signal strength.

(4) A flat input signal versus detector output characteristic is obtained for a wide range of input signals.

The high cost of the circuit which uses a pentode and requires an addition to the horizontal output transformer is the only major disadvantage of this system.

Keyed *agc* is the most satisfactory of the various *agc* systems that have commercial usage at the present time, and there has been widespread use of this system during the past few years. However, with the accent upon economy in new chassis designs during the past year, the trend has been away from *keyed agc* systems in favor of the cheaper simple systems.

For any type of *agc* system to operate to its best advantage, the bias applied to the *rf* amplifier should be very low for weak signals; but it should be very high for strong signals. The same *agc* voltages should not be applied to the *if* tubes that are applied to the *rf* amplifier. The ideal curve of the *agc* voltage versus input signal for both the *rf* and *if* tubes is shown in Fig. 1.

It will be noted that the bias applied to the *rf* amplifier is delayed until the input signal has reached a value of around 500 microvolts.

Maximum gain is desired in the *rf* amplifier on weak signals in order that the signal appearing at the grid of the mixer tube be as large as possible. The greatest source of noise in the set is in the mixer stage. To keep the signal-to-noise ratio as high as possible, it is desired that the signal reaching the mixer be as high as possible.

On strong signals, it is also better to have more control on the *rf* amplifier gain, since this stage has the greatest effect on the overall gain of the set.

One Delay Circuit

One method of obtaining this delay is shown in *b* of Fig. 1. A large amount of *agc* voltage is needed, such as is obtainable with a keyed *agc* system. A divider network is used to step down the voltage applied to the *if* stages. The delay voltage is applied to the *rf* amplifier by means of the divider network and clamper diode. The clamper diode will conduct when the positive voltage supplied by the *B+* divider network exceeds the negative *agc* voltage. This will occur with weak signals. The bias supplied to the *rf* amplifier will be zero as long as the diode conducts. The point at which the diode starts to conduct is determined by the proper selection of resistors for the divider network. When the *agc* voltage is increased on stronger signals, the tube will no longer conduct and bias will be applied to the *rf* amplifier.

The clamper diode is seldom used in new designs. The same circuit shown in Fig. 1 *b* can be used without the clamper diode. The grid of the *rf* amplifier tends to go positive causing positive grid current to be drawn. This grid current causes the voltage across the grid resistor to go negative, counteracting the positive *agc* voltage, effectively clamping the grid close to the zero level.

Many sets incorporate controls into the design of the *agc* system to increase the efficiency of the system. A potentiometer of a *local-distance* switch is the common type of control used. The *local-distance* switch usually consists of a switch which shorts part of *agc* voltage to ground on the *distance* position, so that maximum gain

(Continued on page 48)

*Concluding installment; parts I and II were published in the August and September, 1956, issues of SERVICE.

A MUST for Accurate TV Service at a Profit



Model 8500

PHILCO® *Service King*

Pinpoints chassis or picture tube trouble
...without removal from cabinet

At last, a multi-purpose instrument that simplifies service and saves you time and money. Completely eliminates the task of removing chassis or picture tube from the cabinet for trouble shooting. Tells whether trouble is in the chassis or picture tube. Permits checking new CR tubes without removal from original cartons. The Philco "Service King" is available now at your Philco distributor.

- Tests both color and black and white picture tubes and receivers •
- Clears picture tube shorts • Aids in setting up color purity, white balance and matrix circuits •
- Measures DC voltage, anode voltage and resistance.

PHILCO UNIVERSAL COLOR BAR AND DOT BAR GENERATOR

A single, compact instrument that puts you in the color TV service business

New, highly efficient and compact. Designed to provide the widest possible variety of functions. Unmatched for trouble shooting of circuits associated with color reproduction, and making accurate convergence adjustments in any color receiver made. In conjunction with your present monochrome equipment, it gives you complete color service facilities.



Model 7100

Write for FREE brochure on the complete line of Philco test equipment today.

PHILCO TUBES
IMPROVE THE
PERFORMANCE OF
ANY TV OR
RADIO RECEIVER

PHILCO CORPORATION
ACCESSORY DIVISION • PHILADELPHIA 34, PENNA.



Servicing Helps

Leakage Control Factors in Bantam Electrolytics Used in Transistor Amplifiers . . .

IN LOW-FREQUENCY transistor amplifiers bantam electrolytics serve as coupling devices between stages. In tube circuits, a fixed capacitor is the rule for *rc* coupling; in transistorized equipment, the electrolytic is the rule rather than the exception. A transistor amplifier illustrating typical coupling circuits is shown in Fig. 1. Here we find an electrolytic capacitor C_1 coupling a signal into transistor Tr_1 , and another capacitor C_2 feeding the output signal of Tr_1 to the input of Tr_2 .

The circuit in Fig. 1 does not differ appreciably from a conventional tube circuit except for C_1 and C_2 . But the electrolytic is not just plain capacity; it has shunt leakage, as illustrated in

Fig. 2. At left the capacity is shunted by a *leak* resistance; this characteristic must be kept in mind whenever the electrolytic symbol (on right of Fig. 2) appears in the diagram.

Small subminiature electrolytics have the same capacity, power factor, and *dc* leakage qualities. In transistor coupling circuits, leakage may mean far more than capacity in determining the behavior of the circuit. To illustrate, let us take the capacitor C_2 of Fig. 1 and redraw the coupling circuit, as shown in Fig. 3. Now, we have a resistor RC_2 with which to reckon. The collector of transistor Tr_1 will run at nearly the battery potential; the base of transistor Tr_2 will be biased to about 1 volt by the ac-

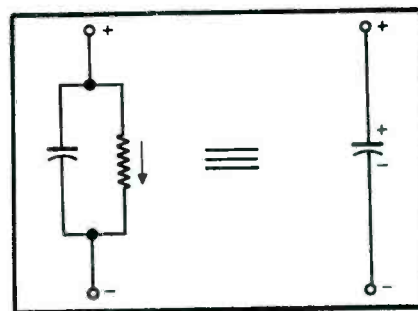

FIG. 2: EQUIVALENT circuit of electrolytic (left) contrasted to schematic symbol (right).

tion of R_1 , primarily. RC_2 will be rather high for a good capacitor, in the vicinity of a megohm.

Now suppose the leakage of RC_2 lowers to around 220,000 ohms. The base of Tr_2 thus has an additional bias path, the bias being about -2v instead of about 1 as intended. The operating load line of the transistor will shift, resulting in distortion or peak clipping; also an increased collector current of Tr_2 obtains, even if distortion does not become disagreeable, and the battery will wear out sooner. The circuit of Fig. 3 redrawn with the interelectrode resistances of the transistors drawn in to illustrate

(Continued on page 42)

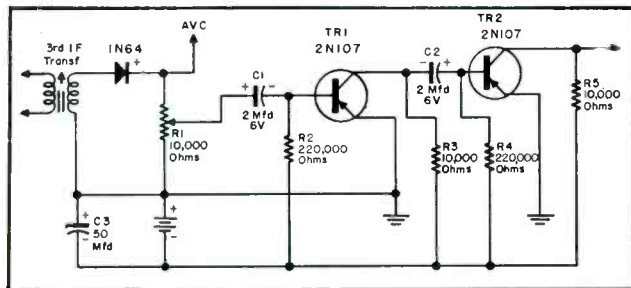
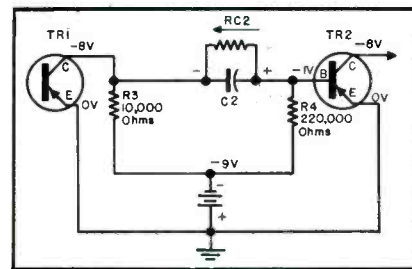

FIG. 1 (LEFT): Typical two-stage transistorized audio amplifier employing electrolytic coupling capacitors.

FIG. 3 (RIGHT): Second stage coupling of Fig. 1 redrawn illustrating the leakage across capacitor C_2 .



IF YOU WANT THE **BEST** IN TV SERVICE INFORMATION

RCA^{ON} GE
 PHILCO CROSLEY
 ADMIRAL MOTOROLA
 EMERSON ZENITH

(other manufacturers later on)

...ASK YOUR JOBBER ABOUT
 RIDER'S NEW
S D O

("single diagram only")

ONLY **50¢** PER CHASSIS!

WIDE

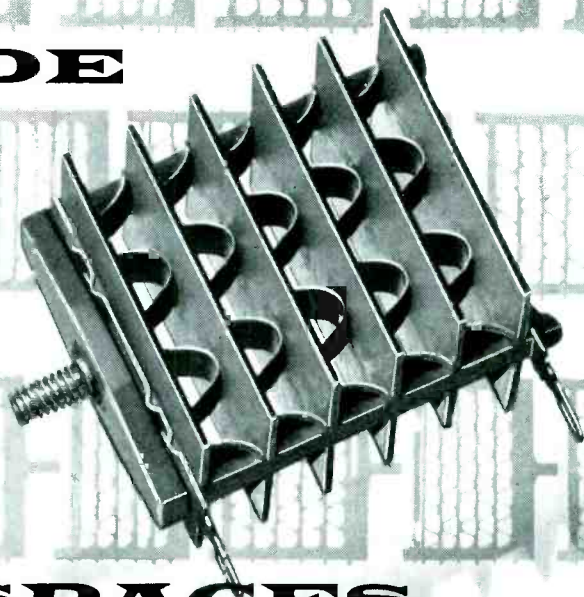

OPEN

SPACES

keep operating temperatures down—dependability up!

RCA SELENIUM RECTIFIERS utilize modern design—*full surface ventilation* with no chance of center-core hot-spots. Note the corrugated spring-steel separators which provide positive multiple-area contacts with each plate. This open construction facilitates free-flow of air and efficient cooling of the plates, and minimizes the possibilities of overheated components in compact TV, radio, and phonograph designs.

The one-piece assembly-yoke with the molded mounting stud prevents *twisting* or *squeezing* the stack during installation. Rigid construction minimizes the possibility of "barrier" breakdowns—*gives greater assurance of dependability in operation.*

So, when you need a replacement selenium rectifier, ask your distributor for a dependable, long life RCA SELENIUM RECTIFIER. Available now in 12 types, ratings from 65 Ma to 500 Ma.



SELENIUM RECTIFIERS

Radio Corporation of America • Harrison, N. J.

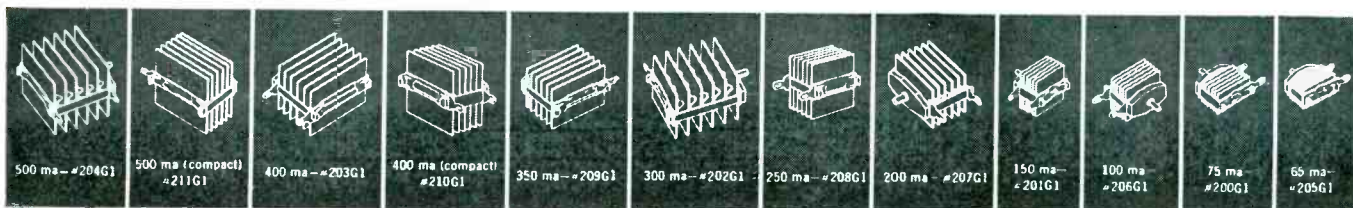

The Vernon Downs Raceway



BUD HEBERT, announcer, in sound-announce booth, located on front end of steel beams which hold stadium overhang.

FRED HOFFMAN at tape recorder controls.



NICK STEMMLER, WRUN radio announcer, at recording equipment used to monitor track commentary for daily broadcasts.



SOUND PLAYS an important role at the three-quarter mile harness-racing oval in Vernon, N. Y., serving not only to supply running information to the fans in the park, interim music and sports news, but intercom contact for management and guests.

The system features four separate telephone circuits, four intercom systems and four independent *pa* systems ranging from a 12-watt mobile unit with one speaker used at the starting gate to 125-watt high-power boosters feeding hi-fidelity horns across the track in the infield.

Main Track Sound System

The main track system is powered by rack-mounted amplifiers¹; a monitoring speaker in the rack assembly enables operator to monitor or check the output of any booster amplifier. Below monitoring panel are two preamplifiers² whose inputs and outputs can be changed with the flip of a switch if one in use fails; pre-amps are self-powered five-channel mixers having low impedance micro-

¹Bogen.

²Bogen LOL; response is 20-15,000 cps \pm 2 db.

³Bogen HO125.

phone inputs; these preamps have level-indicating meters so the level may be kept down to about 0 db. It is possible to mix the outputs of four microphones and a phono pickup in any combination.

In operation the tone control is held to near midposition so that minimum frequency attenuation appears on either end of the audio range; with the system used previously it was necessary to augment the bass response to give the sound *body*.

The rack also contains three booster amplifiers³ each capable of 125 watts output, with a frequency response of 20 to 20,000 cps flat within 1 db. These amplifiers have been found very effective at the track where the background noise level rises as each field of horses drives at the finish line.

Conduit Line Runs

To expedite an efficient transfer of audio power from the amplifiers to the load in the infield, low-impedance twisted-pair lines (No. 12) were run in conduit under the track to terminate at the *tote board*. For impedance matching, constant-voltage outdoor hi-fidelity transformers were installed; their use also simplified load calculations. The highest (16 w) tap was used on

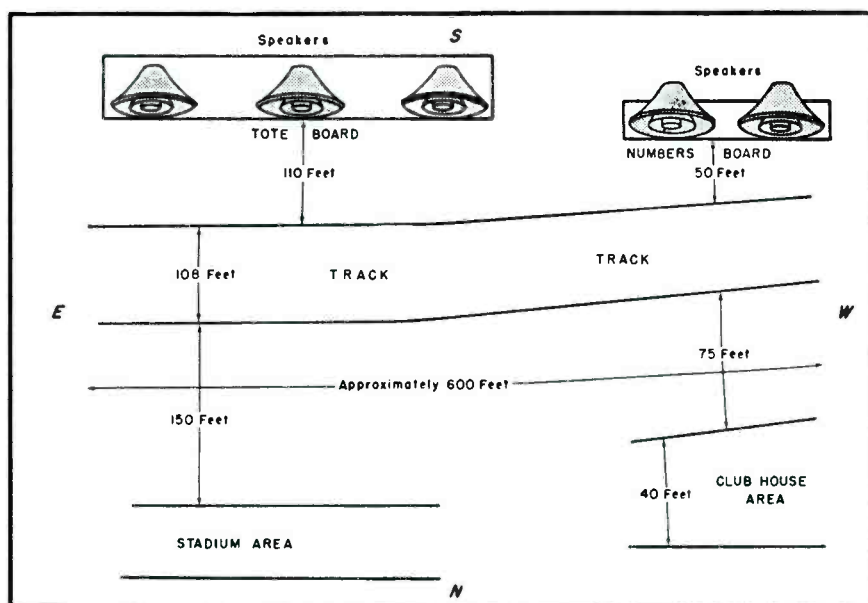

SPEAKER LAYOUT on tote and numbers board at Vernon Downs track.

Features Hi-Fi Announce-Music and Intercom Networks

each transformer. These units have the added feature of taps down to .5 watt; in our case, though, each speaker cluster was set up so it could be independently controlled by its related booster amplifier.

Main Area Speakers

The present speaker setup for the main area covered consists of five folded horns⁴ which have a 1,000-cycle *lc* crossover network. In the process of speaker placement, four of these units were tried on top of the *tote board*, in keeping with the single point source of sound principle; but it was found that even by employing brute force technique the sound arriving at the club house in the sheltered area was pinched and weak. Although these horns are large (33½" diameter) with good directional control, facing them directly at the club house made slight difference; the distance from the speakers was too great to provide adequate coverage.

Tests showed that each time the distance was doubled the pressure of the sound dropped 75% below its previous level. The situation was rectified by placing two speakers near the club house in the infield, behind the numbers board, and another cluster of three-equally spaced on top of the *tote board* for the main stadium; these were connected to another amplifier.

Care had to be taken in phasing and orienting these speakers (even though they were operated on separate amplifiers) to cut down the distortion effect in the fringe area between the club house and main grandstand, where the field of one set of horns was found to overlap the field of the other. A third booster³ was installed to feed speakers near the betting windows under the grand-

stand and other speakers facing the main entrance and parking area to transmit event information to those coming into the park.

Club House Sound

Also on this line are club house dining room speakers, as well as another set which carry event announcements to the paddock where the racetrack Marshall takes his place with a field of horses that enter the track for a parade preceding the race. Another booster is available to switch as a replacement for any defective unit which requires service.

Mike Platform

The announcer has a unique elbow platform (on which is mounted a microphone⁵ from which he can observe the track; he can also swivel this platform at will. At the right of the announcer is a switch mounted so that it can be operated while holding binoculars; this elbow-operated switch is preceded by a switch on the *pa* operator's control panel which is normally *off* for phono use. Another low-impedance microphone cable runs to the winner's circle where another microphone⁵ is used. A relay-operated precedence line runs to a switch at the junction box, so that if the winner's circle *mike* is needed

(Continued on page 53)



AMPLIFIER control panel and phono unit. Additional control equipment was added to rack after this photo was taken.

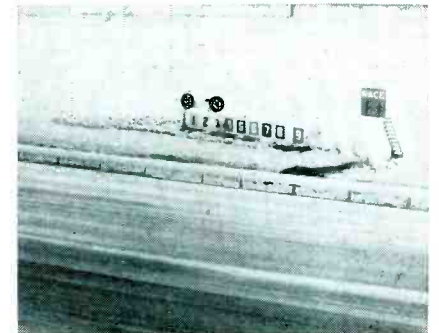

VIEW of two horns on numbers board.

(Below)

TOTE BOARD with three hi-fi bull horns.

¹University WLC.

²Shure 55S Unidyne.

³Bogen RP-1.

⁴University PH.

[All photos by E. L. Bouffier]

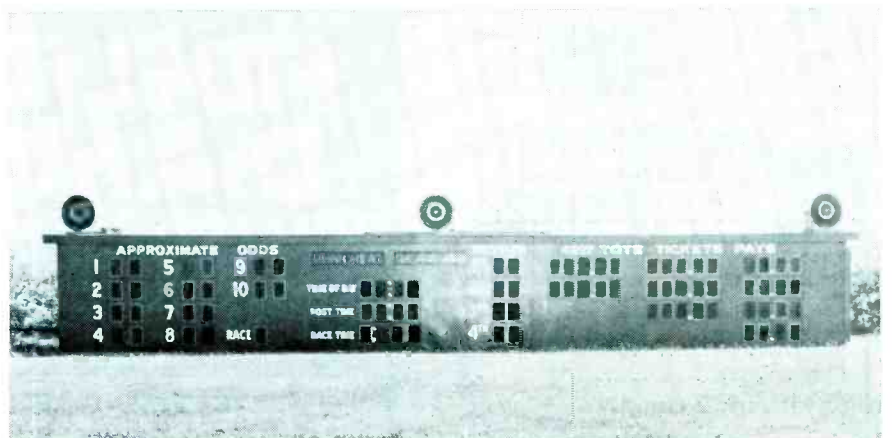

**When . . .
You Change Your Address**

- ▶ Be sure to notify the Subscription Department of SERVICE at 52 Vanderbilt Avenue, New York 17, N. Y., giving the old as well as the new address, enclose address labels from your last SERVICE copy, and do this at least four weeks in advance.
- ▶ The Post Office Department does not forward magazines unless you pay additional postage, and we cannot duplicate copies mailed to the old address.
- ▶ We ask your cooperation.

**HERE'S
ADDED
SERVICE
PROFIT**
at no extra expense



YOU can easily service small appliances as well as TV and radio for extra profits. You're in the home, so no extra call is required. Just inquire if there's an iron, toaster, mixer or other appliance that needs attention. You'll be surprised how many will say "yes" and be glad you mentioned it!

**More Than 5 Million
General Mills Appliances
alone are in Daily Use!**



Yes, aside from other makes, more than 5,000,000 GENERAL MILLS appliances have been sold to American homes. They are famous for their performance and satisfaction, yet through abuse and carelessness thousands of them need repair and service.

You can get that business in your city.

We are exclusive national parts headquarters for all General Mills appliances. We have an attractive profit-proposition for you. Send the coupon today.



APPLIANCE SERVICE CO.

1516 East Lake Street
MINNEAPOLIS 7, MINN.

APPLIANCE SERVICE CO.
1516 E. Lake Street, Minneapolis 7, Minn.

Enclosed is 25 cents to cover cost of printing and mailing complete parts list and detailed instructions for servicing General Mills appliances.

Name.....
Firm.....
Address.....
City..... Zone..... State.....

Servicing Helps

(Continued from page 38)

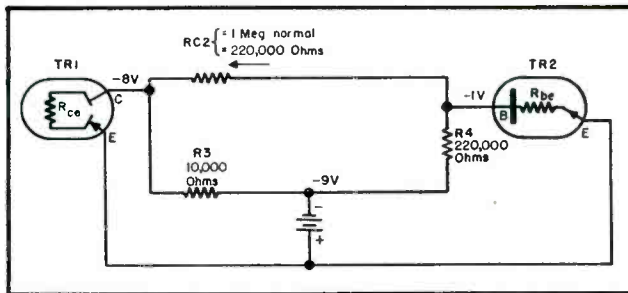

FIG. 4: FIG. 3 redrawn with transistor interelectrode resistance inserted; RCc resistance shown for two values.

the foregoing is shown in Fig. 4. R_{C_c} is represented as having two values: 1 megohm (low leakage) and 220,000 ohms (high leakage).

In Fig. 5 is another version of the first coupling capacitor of Fig. 1. The minus point has been connected to the input of Tr_1 , in contrast to the plus connection of capacitor C_2 to the base of transistor Tr_2 . The arrow indicates the direction of maximum capacitor resistance; note its reversal for C_1 in contrast to C_2 .

If the resistance of C_1 was reduced to a quarter megohm, the bias on the base of Tr_1 would be reduced by about half (to $\frac{1}{2}$ -v negative). Such a change will affect the load line of the transistor and can result in distortion of signals; if used in conjunction with the output of a detector also supplying *avc*, it may upset the normal operation of the *avc* circuit, causing overloading on strong stations.

Now let us review the leakage effects of capacitor C_2 shown in Fig. 1.

Here, leakage does not cause anything except shortened battery life; a 50-mfd, 15-v capacitor can have a leakage of about 4-5 microamps when formed, if good. But if defective, it may be several times this value.

Like their big brothers, bantam capacitors must be formed to produce a film on the electrodes. Such forming should obtain prior to their use in transistor circuits, particularly when used as coupling capacitors. The leakage may be very high (resistance near zero) for the first few seconds of even a low leakage capacitor. The result is a high base bias with high collector current. Even though the capacitor may form rapidly, the transistor may be damaged in this short time by overheating of the metallurgical junctions inside. The net result is a defective transistor with a good capacitor! (The transistor blowup will not become evident until the device fails to work; meanwhile the capacitor has formed perfectly).

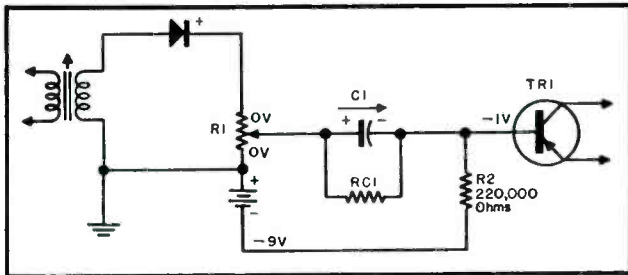

FIG. 5: FIRST stage of Fig. 1 redrawn to emphasize leakage of C_1 as a circuit element; it will decrease the forward bias on the base of Tr_1 as the leakage resistance lowers.

**FIDELTONE
DIAMOND
PHONOGRAPH NEEDLES**

QUALITY and DEPENDABILITY BACKED
by 27 YEARS of DESIGN LEADERSHIP.

PERMO, INC. **Chicago 26**

TV Fuses

(Continued from page 24)

hole of the required size on the chassis inside the cabinet. A special snap-in steel clip on the body of the holder engages the edge of the chassis hole and locks the holder securely in place. These newer types of fuses have already appeared in sets and will become more common in new models.

There are two *UL* regulations concerning fuses which are of particular interest to Service Men. (These are part of a list of specifications which must be followed by manufacturers to secure the *UL* seal of approval for a given model. While these regulations are, of course, not binding on those who install fuses in TV sets, they do serve as a guide to good practice.)

The *UL* regulations state that: (1)—a fuseholder for a type *C* or a type *N* fuse should be mounted so that at least one terminal of the fuseholder remains inaccessible (under the chassis) during servicing (fuse replacement) by the set owner. This is to minimize the possibility of shock. (2)—A fuse other than a type *C* or *N* should be soldered in place and located where it is not readily accessible or perceptible to the set owner (under the chassis, inside the high-voltage compartment, etc.).

It should be noted that the fuseholder is mounted inside the cabinet so that the rear cover must be taken off the set owner to reach the fuse. The interlock therefore opens the *ac* line to the chassis before the fuse can be replaced. This is important to prevent shock. In normal operation, one end of the fuse projects beyond the end of the fuseholder. To remove the fuse, the fuse end must be grasped and twisted so that the fuse flange comes through the slot in the holder.

In many circuits, this fuse end remains *hot*, even though the fuse is blown, if power continues to be applied to the set. For Service Men, this means that caution must be observed in replacing these fuses. *One must never attempt to replace such fuses with the cheater cord connected and the set turned on or serious shock may result when the end of the fuse is touched.* The recommended procedure is to disconnect the cheater cord from the chassis before replacing the fuse. In addition, when servicing any set with a *C* or *N* fuse for troubles other than a blown fuse, care should be exercised to avoid touching the end of the fuse or fuseholder when power is applied to the chassis.

TOPLINER '50
Model 2550

TOPLINER '60
Model 2560

TACO

Topliners
Trade-mark

TOPLINER '70
Model 2570

TOPLINER '40
Model 2540

get more useable power

Each of the four TOPLINER models has the Power Pack, an exclusive feature that delivers more of the signal at the receiver—where you need it, and . . . precision manufacture saves assembly and installation time.

. . . dry cleaning eliminates apologies for your appearance.
. . . streamlining gives the customer a better looking installation.

Dollar-for-dollar, a TOPLINER gives the customer more performance, greater picture clarity for only TOPLINERS have

exclusive built in



Ask For
Your Copy
of the Folder

"Tomorrow's
Antenna Today"

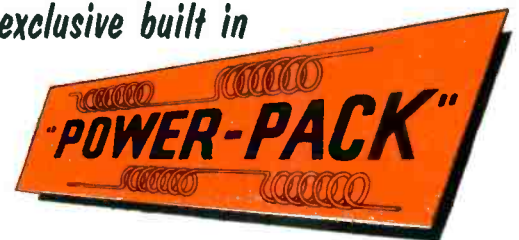

TACO Distributors
Have Full Information
on The Topliner Antennas

TECHNICAL APPLIANCE CORPORATION, SHERBURNE, N. Y.
IN CANADA: Hackbusch Electronics, Ltd., Toronto 4, Ont.

Rohn

only complete line of

TV and COMMUNICATION TOWERS

proven in Profits and Customer Satisfaction

• • • • HIGHLIGHTS OF THE ROHN LINE • • • •

look at these
ROHN exclusives

● HOT DIPPED GALVANIZED

The finest, most durable finish is available for ROHN Towers and accessories... all done entirely on the ROHN premises under careful ROHN supervision.

● UNEQUALLED DESIGN AND ENGINEERING

ROHN is the only design that has stood up over the years. ROHN has been first and foremost... and always the leader in new products to meet the changing demands.

● MASS PRODUCTION FOR LOW COSTS

ROHN was the first to utilize mass production techniques to build a superior tower at the most competitive prices. This means no sacrifice in quality yet far greater profits for you.

● UNIVERSAL CUSTOMER ACCEPTANCE

Thousands and thousands of installations prove the ROHN line first in customer satisfaction.

● PIONEER MANUFACTURERS

Pioneers in tower manufacturing—and today one of the world's largest manufacturers of this type equipment. The ROHN Company was built on satisfaction on the part of distributor, dealer and customer alike.

● COMPLETE LINE

Only ROHN offers a full line—one dependable one-stop source for all TV installation equipment. Save headaches, save shipping costs, save time... use ROHN unequalled service *exclusively*.

ALSO a full line of ROHN ACCESSORIES

Rotor posts, house brackets, eave brackets, peak and flat roof mounts, instant drive-in bases, hinged base sections, telescoping mast bases, guying brackets, UHF antenna mounts, erection fixtures, variety of mounts and supports for masts or tubing,

tower installation accessories, TV service tables, mast and TV hot-dipped galvanized tubing, guy rings, "twister-anchors", rubber tower grommets, insulator sections, hinged rotor platform, accessory shelf and platform and dozens of other items. Get the complete catalog TODAY!

ROHN Manufacturing Company

116 LIMESTONE, BELLEVUE
PEORIA, ILLINOIS



no. 6 tower

"All-Purpose" tower.

Fulfills 75% of your general tower needs—is structurally as sturdy—yet costs less than the well-known Rohn No. 10 Tower. Ideal for home and industrial installations, communication requirements... eliminates stocking many different tower models. *Self-supporting to 50 ft. or guyed to 120 ft.!* Easy to climb for fast, efficient servicing. Utilizes "Magic Triangle" which insures far greater strength and stability. Permanent hot-dipped galvanized coating. Dependability—a feature customers demand—is assured with the Rohn No. 6 Tower... designed to "stand up" for years to the rigors of weather and climatic conditions.

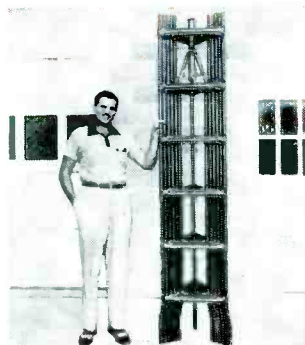

Package Tower*

"Space Saver"—cuts storage space 300% or more!

Popular PT-48 has almost 50' of sturdy tower within a compact 8' x 20" package! "Magic Triangle" design is adapted to a pyramid shape using a wide 19" base with progressively decreasing size upward. Decreases your overhead... easy to transport and assemble—cuts shipping costs. Galvanized throughout. Available in heights of 24, 32, 40, 48, 56 and 64 feet!

COMMUNICATIONS TOWER

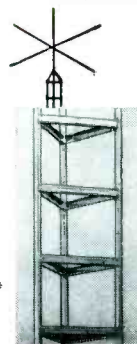

For extreme heights and communication purposes of all kinds, the Rohn No. 40 gives you strength and durability on which you can depend. The time tested and proven

equilateral triangle design using extra heavy duty tubing and corrugated steel cross-bracing is utilized. The No. 40 is structurally sound so you can install it for heights up to 300'; or at lesser heights when considerably greater strength is required because of excessive wind or antenna loading. Use for radio telephone, broadcasting, microwave relay and all other such communication purposes. If a particular job calls for this type tower, save real money by using ROHN towers.

Note: For lesser heights, use the Rohn No. 20 or No. 30 Tower.



Both Towers Feature THE ROHN MAGIC TRIANGLE*

For structural superiority, famed wrap-around "magic triangle" design is featured in these all-steel towers. Towers have full 2 1/2" wide corrugated cross-bracing welded to tubular steel legs. The exclusive design assures dependable strength and permanence.



Telescoping Masts

Heavy-duty hot-dipped galvanized steel tubing and rigid joints give extraordinary strength. *Quick installation*... mast attached to base—antenna fixed, then mast hoisted quickly to desired height. Utilizes special clamp and guy ring arrangement. Flanged interior section; crimped exterior section gives mast stability that can't be beat. Complete with guy rings and necessary erection parts. In 20, 30, 40 and 50 ft. sizes. Bases and ground mounts available.

* pat. pending

ROHN FOLD-OVER TOWERS

These unique fold-over towers are perfect for experimentation. TV service departments, amateur use, and special purposes. Uses regular ROHN tower sections with kit. Now available in standard No. 10 tower to 50', and in ROHN No. 30 & No. 40 towers for heavy-duty use.



MAIL THIS COUPON FOR FREE LITERATURE!

Rohn Manufacturing Company
116 Limestone, Bellevue
Peoria, Illinois

Gentlemen: Please rush me complete details on the full line of Rohn Towers and Accessories.

Firm _____

Name _____ Title _____

Address _____

City _____ State _____

Color-TV Convergence

(Continued from page 22)

procedures as well as the ideas and suggestions of many individuals. On those receivers checked, the procedure proved to be efficient and time saving.

The procedure utilizes a white-dot pattern for static (center-*dc*) convergence and horizontal and vertical bars for dynamic (edge) convergence. A crosshatch pattern is suggested for final touch adjustments. It is recommended that the four convergence patterns provide thin white lines or small white dots on a black background. It is much easier to use these type patterns for convergence adjustments than those with thicker lines or larger dots. The color bar/bar dot generator, shown in Fig. 1,^o is one type test instrument that will produce the dot, horizontal and vertical bar and crosshatch patterns recommended for the convergence adjustment procedure. In addition, this model will also provide an NTSC standard color-bar pattern, found to be a must for color-circuitry alignment and trouble-shooting. The generator produces NTSC sync which is crystal controlled and corresponds to that of a station. The convergence patterns produced can, therefore, be coupled to the antenna terminals or video circuits without locking a station's signal with the convergence pattern.

Before attempting to follow the procedure, it is suggested that the entire plan be reviewed to obtain an overall idea of the adjustments necessary to complete convergence adjustments. It is also suggested that the results outlined in a particular step in the procedure be obtained before proceeding to the next step. This is very important if acceptable convergence is expected after completing the adjustment procedure.

As with any convergence adjustment procedure, the controls associated with the black-and-white circuitry (horizontal and vertical size, linearity, hold, etc.) must be adjusted prior to the convergence controls. Also, the purity controls must be adjusted to achieve acceptable purity and the dynamic convergence controls should be pre-set to mid-range.

Static Convergence

(1) Power should be applied to the generator and color receiver. Then the *power sync switch* should be placed in the standby position and

(Continued on page 46)

^oHycon 616.

MODEL T-801
\$417 LIST

MODEL T-811
\$500 LIST

MODEL T-791
\$444 LIST

BAR X
MODEL T-751
\$556 LIST

BAR X
MODEL T-851
\$472 LIST

MODEL T-741
\$529 LIST

BAR X
MODEL T-781
\$556 LIST

MODEL T-771
\$500 LIST

Tenna
FORMERLY RADELCO

OFFERS YOU FOR THE
COMING SELLING SEASON

America's Finest AND MOST COMPLETE LINE OF Conical Antennas

Nowhere else can you buy such a high quality, full size Antenna with as many practical, useable features at such low, down to earth prices. Here's what you get when you buy Tenna.

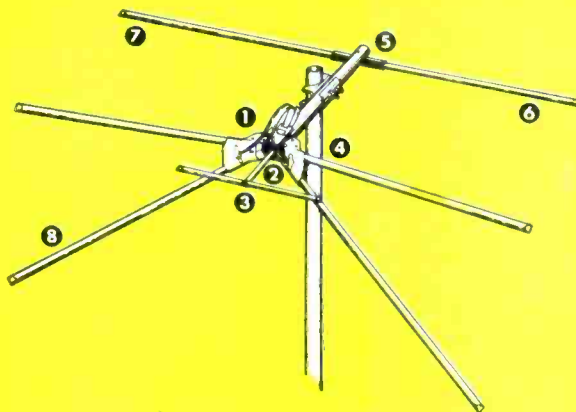

Check these Tenna features, feature by feature, with any or all other makes and you'll quickly agree that Tenna is truly the antenna for you . . . truly the king of all the conicals.

1. Completely pre-assembled. "Presto" Instant Mount Assembly opens as easily, quickly as an umbrella.
2. Now! Polyethylene Cable Anchor takes all tension off of terminals, prevents cable from breaking at terminals.
3. Models T-781, T-851 and T-751 are equipped with famous Tenna Director Bar to improve performance on higher channels.
4. Front Bracket made of heavy spring temper aluminum alloy with High Q molded plastic insulator.
5. Rear Bracket is made of heavy gauge aluminum to assure long life and resist strongest gales and heavy ice.
6. Arrays are full size in every respect and of all aluminum construction.
7. Aluminum elements are doweled to prevent whistling and provide greater strength.
8. Full line to select from; 8 single array antennas, 8 stacked antennas and 8 "Do-It-Yourself" antenna kits.

YOU BUY THE FINEST WHEN YOU BUY TENNA!

The **Tenna** Manufacturing Co.

Cleveland 25, Ohio

SHOW ANY PICTURE or PATTERN

at any time — ON ANY TV SET

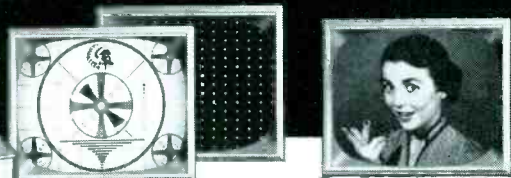
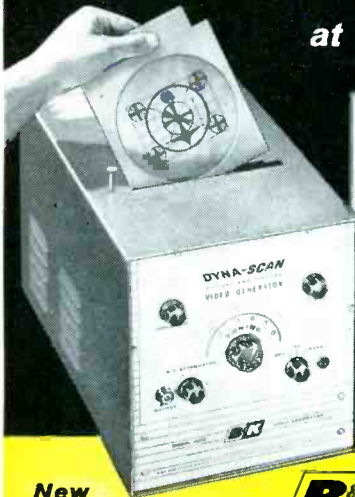

- For Servicing Black & White and Color TV
- For Merchandising and Advertising Promotions
- For Paging, Educational and Industrial Use

New
MODEL 1000

B&K DYNA-SCAN PICTURE AND PATTERN VIDEO-GENERATOR

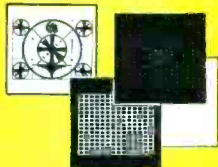

3 SLIDE
TRANSPARENCIES
ARE SUPPLIED

1. Indian Head Pattern
 2. White Dot Pattern
 3. White Line Crosshatch
- Plus One Clear Acetate

These are broadcast quality and assure high-definition TV images. You can also transmit slides of any subject you wish.

Simplify and speed servicing with this unique, new, COMPLETE FLYING SPOT SCANNER. Produces composite video and sync signal that operates any standard VHF black and white or color TV receiver. Easily reproduces standard Indian Head test pattern or any other pattern—in home, shop or store—for proper TV set alignment; enables you to make all color TV static and dynamic convergence adjustments with stable White Dot and White Line patterns. Can be used with one or more standard TV receivers or fed into master antenna system. Reproduces from any film transparency. Transmits messages typed or written on clear acetate. Size: 16½ in. long, 10¾ in. high, 9½ in. wide. Net wt. 28 lbs.

\$199⁹⁵
NET

Model 950 Dyna-Scan Pickup and RF Generator Only

Make your own picture and pattern generator. Just connect Model 950 to any properly modified 10-inch TV set which acts as your external flying spot scanner. Size: 3½ in. high, 10½ in. wide, 5 in. deep. Complete with 3 slide transparencies and 1 clear acetate. Net wt. 5 lbs.

\$69⁹⁵
NET



MODEL 950

See Your Distributor or Send For Bulletin 1000-S

B & K MANUFACTURING CO.

3726 N. Southport Ave. • Chicago 13, Illinois

Makers of DYNA-QUIK, CRT, CALIBRATOR and DYNA-SCAN



RADIOTELEPHONE JOBBER MARKETING PLAN

Plans for marketing radiotelephone products through parts distributors have been announced by Kaar Engineering Corp.

Distributors who do not have their own service departments will be asked to make suitable arrangements with independent Service Men who are equipped and manned to handle maintenance of two-way radio equipment. In some sections of the country, distributors will be serviced by technically trained manufacturer's reps. Reps will also advise how FCC licenses may be obtained and will also assist in the selection of suitable service sub-contractors.

PREFERRED TUBE TYPES PROGRAM ANNOUNCED

A preferred tube type program, encompassing a group of electron tubes having universal application in TV receiver design, has been announced by the RCA Tube Division.

List of preferred tubes includes types for TV receiver applications (such as rf tuners, amplifiers, deflection oscillators, rectifiers, damper circuits and control circuits). Tubes were selected for preferred listing by engineering analysis and customer preference. List contains 18 types designed specifically for AM and FM broadcast receiver applications including rectifiers, diode detectors, amplifiers, oscillators and mixers.

Color-TV Convergence

(Continued from page 47)

blue or green fringing is observed, steps 16, 17, 18, 19 and 20 should be repeated until best compromise is reached.

(21) The selector switch should now be placed in the crosshatch position.

(22) The red screen control should be advanced until a white crosshatch pattern is observed.

(23) Finally one should observe carefully face of picture tube for presence of red, blue or green fringing; step back approximately six feet and again observe fringing. If the face of the picture tube appears as a white crosshatch pattern at a distance of six feet, the convergence adjustment procedure is completed.

If fringing is observed, dynamic convergence controls should be carefully touched up, using blue as a reference for red and green and using either red or green as a reference for blue. It is suggested that only two colors be viewed at one time during the touch-up adjustments to avoid confusion.

For those color receivers which use combination red-green horizontal dynamic convergence controls, the procedure should be modified to the extent that three colors are viewed rather than two during steps 12 and 18 and steps 6 and 7 should be disregarded.

Keyed AGC

(Continued from page 36)

of the *if* strip is realized in fringe areas. The potentiometer is used as a divider network for the *if agc* line. The control is adjusted to the point where, with the strongest signal available, maximum gain without distortion results. This control is needed for *if* strips which use sharp cutoff pentodes such as the 6CB6, and have large amounts of *agc* voltage available so that the *agc* voltage will not bias *if* amplifier tubes beyond cutoff with strong signals.

The trend in recent months has been toward the use of remote cutoff tubes such as the 6BZ6 in the *if* stages that are *agc* controlled. The *agc* pot control can be eliminated when remote cutoff *if* tubes are used, because these tubes will not be cut off completely when large values of *agc* voltages are applied.

An *agc* control is also sometimes used to change the amount of delay voltage delivered to the *rf* amplifier, so that maximum delay is applied with weak signals and no delay with strong signals.

PERSONNEL

EDWARD R. MACDONALD has been appointed components products manager of National Co., Malden, Mass.

EUGENE V. DI SCIULLO has been named eastern district sales manager of Hycon Electronics, Inc. with offices in Plainfield, N. J.

CLARENCE P. BAIRD has been appointed Southwestern field engineer for the Hoffman Radio Division, Hoffman Electronics Corp., with headquarters in Houston, Tex.

JAMES J. LANIGAN has joined Sylvania Electric Products, Inc., 1740 Broadway, New York 19, N. Y., as a public relations project manager. . . . CLYDE W. FOSTER is now a field rep of the company's parts division in the Chicago office. . . . DEAN C. MIDEY has been named supervisor of private-brand sales service of the television tube division, Seneca Falls, N. Y. . . . ROBERT W. PLUNKETT is now supervisor of equipment sales service for the division and EDWARD T. WESTGREN supervisor of renewal picture tube sales service.

HENRY F. DELONG has been promoted to general manager of the cathode-ray tube department of General Electric Co., Electronics Park, Syracuse, N. Y.



DeLong



Schulman

HAROLD J. SCHULMAN has been named assistant to the president of Trav-Ler Radio Corp., 571 W. Jackson Blvd., Chicago 6, Ill.

ROBERT L. BORCHARDT has been promoted to manager of the technical information center of the communications and electronics division of Motorola, Inc. . . . FREDERICK W. ALEXANDER is now ad manager of the division. . . . ROBERT E. NEWLIN has been named product promotion supervisor.

JOHN R. BAKER has been named field engineer by Koessler Sales Co., 6907 Melrose Ave., Los Angeles 38, Calif.

L. F. WAELTERMAN has been appointed regional manager of the midwest region of Jerrold Electronics Corp., with offices in St. Louis, Mo.

RAYMOND B. GEORGE, formerly vice-president merchandising, has been named vice-president sales promotion of Philco Corp., Philadelphia 34, Pa. . . . MAX ENELOW, formerly ad counsel, is now ad manager.

NEAL W. TURNER is now merchandising manager of Heath Co., Benton Harbor, Mich.

HENRY N. MULLER, JR. has been named assistant service manager of the Sentinel Radio Company, at its service department headquarters in Fort Wayne.

BILL ASHBY has been named director of service engineering of the Cornell-Dubilier Electric Corp. . . . Ashby has served as broadcast chief engineer, field and sales-service engineer and chief radio technician for the U. S. Navy.

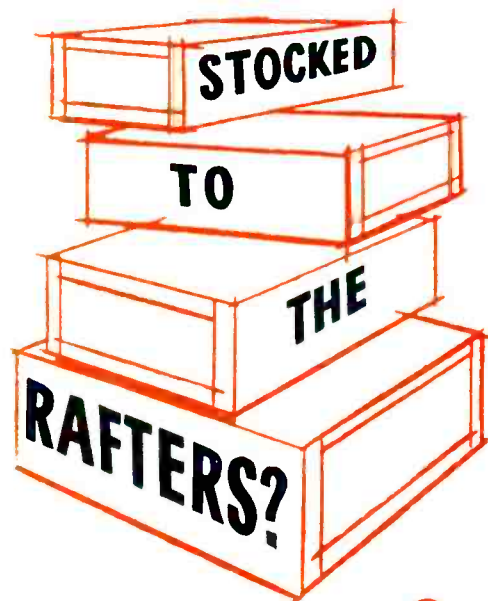

not with **api** !
Trade Mark

API's local service and inventory facilities solve your terminal and tooling stockpiling problems.

API local service and inventory facilities stock a wide variety of A-MP terminals and tools for your service and maintenance requirements. API inventory and service facilities are as near as your telephone. Call API's nearest branch office for service and expert technical assistance.

In addition to branch offices, API maintains a group of local telephone information centers for your convenience.

api **dependability 2 ways**
Trade Mark
The product and the product knowledge of the API man who serves you.

AMERICAN PAMCOR, INC.

Subsidiary of Aircraft-Marine Products, Inc.

181 Hillcrest Ave., Havertown, Pa.

Atlanta, Ga.	Philadelphia, Pa.	*Baltimore, Md.
Boston, Mass.	Pittsburgh, Pa.	*Portland, Oregon
Chicago, Ill.	St. Louis, Mo.	*Dayton, Ohio
Cincinnati, O.	San Francisco, Calif.	*Huntington, W. Va.
Cleveland, O.	*Milwaukee, Wisc.	Washington, D.C.
Dallas, Texas	*Buffalo, N.Y.	*Knoxville, Tenn.
Detroit, Mich.	*Indianapolis, Ind.	*Charlotte, N.C.
Hawthorne, Calif.	*Kansas City, Mo.	*Minneapolis, Minn.
Maplewood, N.J.	*Albany, N.Y.	*Richmond, Va.

*Consult the yellow pages of your local telephone directory under AMERICAN PAMCOR INC. for local telephone center number.

Perma-Power
TV
VOLTAGE
REGULATOR

**10 Volt Line
Adjuster . . .**



At All Distributors

manufactured by
Perma-Power COMPANY
4727 N. Damen Ave., Chicago 25, Ill.
manufacturers of electronic equipment since 1928
Export: SCHEEL INT., Chicago

for SURE profits

*deal yourself
a winning hand*

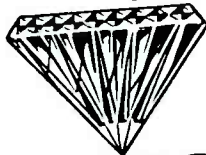

**RECOTON
DIAMOND
NEEDLES**

For repeat sales and higher profits—sell **RECOTON DIAMOND NEEDLES**. Recoton has 100% consumer acceptance, insuring your fast turnover! Stick with the winner—**RECOTON**—famous for quality!

RECOTON CORPORATION
52-35 Barnett Avenue
Long Island City 4, N. Y.

Servicing RCA TV Portables*

How To Remove Chassis and Make Tuner, Control and Picture-Tube Adjustments

by **W. W. COOK**, Technical Training, RCA Service Company, Inc.

To ADJUST PROPERLY the servicing controls in the RCA portable-TV receiver, the chassis must be removed from the cabinet. This is accomplished by removing the standard control knobs and six screws located at points A and B shown in Fig. 1. As the chassis is then slid from the cabinet the antenna and ac interlock will automatically disengage.

The relative position of the deflection yoke, centering magnets and ion trap magnet is illustrated in Fig. 2. The ion trap magnet is positioned on a paper sleeve which extends slightly beyond the yoke hood. The adjustment of the ion trap magnet is accomplished by moving it backward or forward, at the same time rotating it slightly around the neck of the picture tube. To facilitate this adjustment long nose pliers must be used to grasp the paper sleeve. Movement of this sleeve will automatically rotate the ion trap magnet. This adjustment is continued until maximum raster brilliance is obtained.

If yoke adjustment is necessary to correct for raster tilt, the screw at point C in Fig. 2 must be loosened. With the aid of a screwdriver inserted at either points A or B, the yoke may be rotated until the raster is squared

*Complete diagram and circuit analysis appeared in September, 1956, SERVICE.

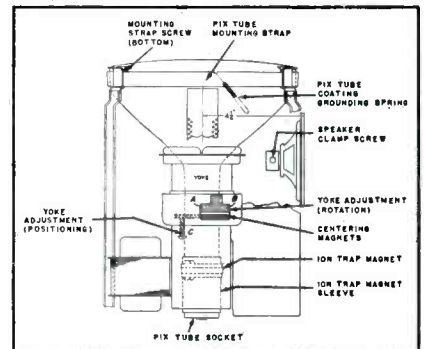

FIG. 2: MAGNET adjustments on portable.

with the picture mask. Following this adjustment the screw at point C must be tightened.

Two disc type centering magnets are mounted directly behind the deflection yoke. Proper raster centering is accomplished by alternately rotating one disc with respect to the other, then rotating the entire assembly around the neck of the picture tube. A small screwdriver is placed in the teeth of these discs to facilitate adjustment.

The width and drive adjustments are similar to other receivers. The picture is overscanned by $\frac{1}{4}$ " at each side by adjustment of the width coil. The drive trimmer is adjusted clockwise until a drive line appears in the picture, then backed off until this line (Continued on page 59)

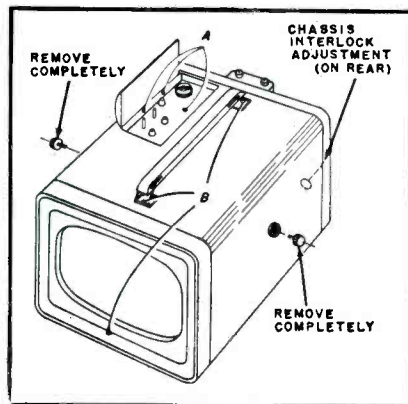

FIG. 1: POINTS ON PORTABLE where cabinet removal screws appear.

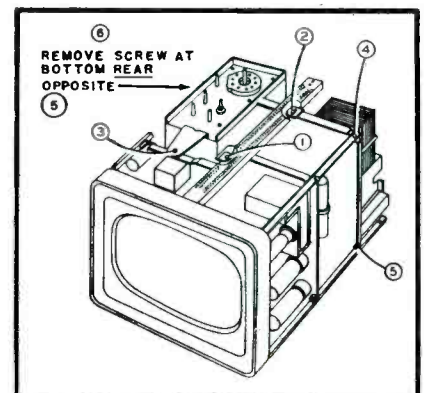

FIG. 3: CHASSIS SEPARATION points on the portable.

Superior's New Streamlined Model TC-55

TUBE TESTER



FOR The Experimenter or Part-time Serviceman, who has delayed purchasing a higher priced Tube Tester.
The Professional Serviceman, who needs an extra Tube Tester for outside calls.
The Busy TV Service Organization, which needs extra Tube Testers for its field men.

CHECKS FOR SHORTS AND LEAKAGES BETWEEN ALL ELEMENTS — Model TC-55 provides a super sensitive method of checking for shorts and leakages up to 5 Megohms between any and all of the terminals. Continuity between various sections is individually indicated. **"FREE-POINT" ELEMENT SWITCHING SYSTEM** — Model TC-55 incorporates a newly designed element selector switch system which reduces the possibility of obsolescence to an absolute minimum. Any pin may be used as a filament pin and the voltage applied between that pin and any other pin, or even the "top-cap." **ELEMENTAL SWITCHES ARE NUMBERED IN STRICT ACCORDANCE WITH R.M.A. SPECIFICATION** — The 4 position fast-action snap switches are all numbered in exact accordance with the standard R.M.A. numbering system. Thus, if the element terminating in pin No. 7 of a tube is under test, button No. 7 is used for that test.

Speedy, yet efficient operation is accomplished by: 1. Simplification of all switching and controls. 2. Elimination of old style sockets used for testing obsolete tubes (26, 27, 57, 59, etc.) and providing sockets and circuits for efficiently testing the new Noval and Sub-Minar types.

Model TC-55 comes complete with operating instructions and charts. Housed in rugged steel cabinet. Use it on the bench — use it for field calls. A streamlined carrying case, included at no extra charge, accommodates the tester and book of instructions.

\$26⁹⁵
NET

Superior's New Model TV-12 **TRANS-CONDUCTANCE**

TUBE TESTER



TESTING TUBES

- ★ Employs improved TRANS-CONDUCTANCE circuit. An in-phase signal is impressed on the input section of a tube and the resultant plate current change is measured. This provides the most suitable method of simulating the manner in which tubes actually operate in Radio & TV receivers, amplifiers and other circuits. Amplification factor, plate resistance and cathode emission are all correlated in one meter reading.
- ★ NEW LINE VOLTAGE ADJUSTING SYSTEM. A tapped transformer makes it possible to compensate for line voltage variations to a tolerance of better than 2%.

ALSO TESTS TRANSISTORS!

- ★ SAFETY BUTTON—protects both the tube under test and the instrument meter against damage due to overload or other form of improper switching.
- ★ NEWLY DESIGNED FIVE POSITION LEVER SWITCH ASSEMBLY. Permits application of separate voltages as required for both plate and grid of tube under test, resulting in improved Trans-Conductance circuit.

TESTING TRANSISTORS

A transistor can be safely and adequately tested only under dynamic conditions. The Model TV-12 will test all transistors in that approved manner, and quality is read directly on a special "transistor only" meter scale.

Model TV-12 housed in handsome rugged portable cabinet sells for only

\$72⁵⁰
NET

Superior's new Model TV-11 STANDARD PROFESSIONAL

TUBE TESTER



- Uses the new self-cleaning Lever Action Switches for individual element testing. Because all elements are numbered according to pin-number in the RMA base numbering system, the user can instantly identify which element is under test. Tubes having tapped filaments and tubes with filaments terminating in more than one pin are truly tested with the Model TV-11 as any of the pins may be placed in the neutral position when necessary. • The Model TV-11 does not use any combination type sockets. Instead individual sockets are used for each type of tube. Thus it is impossible to damage a tube by inserting it in the wrong socket. • Free-moving built-in roll chart provides complete data for all tubes.

• NOISE TEST: Phono-jack on front panel for plugging in either phones or external amplifier will detect microphonic tubes or noise due to faulty elements and loose internal connections.
EXTRA SERVICE — The Model TV-11 may be used as an extremely sensitive Condenser Leakage Checker. A relaxation type oscillator incorporated in this model will detect leakages even when the frequency is one per minute.

The model TV-11 operates on 105-130 Volt 60 Cycles A.C. Comes housed in a beautiful hand-rubbed oak cabinet complete with portable cover

\$47⁵⁰
NET

Superior's New Model TV-40

PICTURE TUBE TESTER



Tests all magnetically deflected tubes . . . In the set . . . out of the set . . . In the carton!!

A complete picture tube tester for little more than the price of a "make-shift" adapter!!

The Model TV-40 is absolutely complete! Self-contained, including built-in power supply, it tests picture tubes in the only practical way to efficiently test such tubes; that is by the use of a separate instrument which is designed exclusively to test the ever increasing number of picture tubes!

SPECIFICATIONS

Tests all magnetically deflected picture tubes from 7 inch to 30 inch types • Tests for quality by the well established emission method. All readings on "Good-Bad" scale • Tests for inter-element shorts and leakages up to 5 megohms • Test for open elements.

Model TV-40 comes absolutely complete — nothing else to buy. Housed in round cornered, molded bakelite case. Only

\$15⁸⁵
NET

SHIPPED ON APPROVAL NO MONEY WITH ORDER—NO C.O.D.

We invite you to try before you buy any of the models described on this and the following page. If after a 10 day trial you are completely satisfied and decide to keep the Tester, you need send us only the down payment and agree to pay the balance due at the monthly indicated rate. (See other side for time-payment schedule details.)

**NO INTEREST
OR FINANCE
CHARGES ADDED!**

If not completely satisfied, you are privileged to return the Tester to us, cancelling any further obligation.

**SEE OTHER
SIDE**

CUT OUT AND MAIL TODAY!

BUSINESS REPLY CARD

No Postage Stamp Necessary if Mailed in the United States

POSTAGE WILL BE PAID BY—

MOSS ELECTRONIC DIST. CO., INC.

3849 TENTH AVENUE

NEW YORK 34, N. Y.

FIRST CLASS
Permit No. 61430
New York, N. Y.

VIA AIR MAIL

The **FIRST POCKET-SIZED**

VOLT-OHM MILLIAMMETER

USING THE NEW "FULL-VIEW" METER.
71% MORE SCALE AREA!!

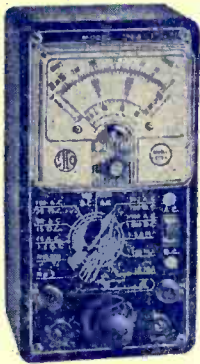

Yes, although our new FULL-VIEW D'Arsonval type meter occupies exactly the same space used by the older standard 2 1/2" Meters, it provides 71% more scale area. As a result, all calibrations are printed in large easy-to-read type and for the first time it is now possible to obtain measurements instead of approximations on a popular priced pocket-sized V.O.M.

SPECIFICATIONS

6 A.C. VOLTAGE RANGES: 0-15/30/150/300/1500/3000 Volts. 6 D.C. VOLTAGE RANGES: 0-7.5/15/75/150/750/1500 Volts. 2 RESISTANCE RANGES: 0-10,000 Ohms, 0-1 Megohm. 3 D.C. CURRENT RANGES: 0-15/150 Ma., 0-1.5 Amps. 3 DECIBEL RANGES: -6 db to +18 db, +14 db to +38 db, +34 db to +58 db.

Compact — 3 1/4" x 5 3/4" x 2 1/4"

\$ 15⁸⁵
NET

The Model 770-A comes complete with self-contained batteries, test leads and all operating instructions.

SUPER METER

A COMBINATION
VOLT-OHM MILLIAMMETER PLUS CAPACITY REACTANCE INDUCTANCE AND DECIBEL MEASUREMENTS

ADDED FEATURE:

Built in ISOLATION TRANSFORMER reduces possibility of burning out meter through misuse.

SPECIFICATIONS

D.C. VOLTS: 0 to 7.5/15/75/150/750/1,500/7,500 Volts
A.C. VOLTS: 0 to 15/30/150/300/1,500/3,000 Volts
OUTPUT VOLTS: 0 to 15/30/150/300/1,500/3,000 Volts
D.C. CURRENT: 0 to 1.5/15/150 Ma. 0 to 1.5/15 Amperes
RESISTANCE: 0 to 1,000/100,000 Ohms 0 to 10 Megohms

CAPACITY: .001 to 1 Mfd. 1 to 50 Mfd. (Good-Bad scale for checking quality of electrolytic condensers.)

REACTANCE: 50 to 2,500 Ohms 2,500 Ohms to 2.5 Megohms

INDUCTANCE: .15 to 7 Henrys 7 Henrys to 7,000 Henrys

DECIBELS: -6 to +18 +14 to +38

+34 to +58

\$ 28⁴⁰
NET

The Model 670-A comes housed, in a rugged crackle-finished steel cabinet complete with test leads and operating instructions.

Superior's New
Model TV-60

20,000 OHMS PER VOLT

ALLMETER

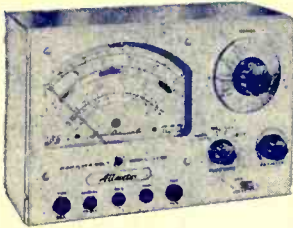

SPECIFICATIONS

8 D.C. VOLTAGE RANGES (At a sensitivity of 20,000 Ohms per Volt) 0 to 15/75/150/300/750/1500/7500/30,000 Volts.

7 A.C. VOLTAGE RANGES: (At a sensitivity of 5,000 Ohms per Volt) 0 to 15/75/150/300/750/1500/7500 Volts.

3 RESISTANCE RANGES: 0 to 2,000/200,000 Ohms, 0-20 Megohms.

2 CAPACITY RANGES: .00025 Mfd. to 30 Mfd.

5 D.C. CURRENT RANGES: 0-75 Microamperes, 0 to 7.5/75/750 Milliampere, 0 to 15 Amperes.

3 DECIBEL RANGES: -6 db to +58 db.

AUDIO SIGNAL TRACER SERVICE: Functions in the same manner as the R.F. Signal Tracing service specified at right except that it is used for the location of cause of trouble in all audio and amplifier systems.

R.F. SIGNAL TRACER SERVICE: Enables following the R.F. signal from the antenna to speaker of any radio or TV receiver and using that signal as a basis of measurement to first isolate the faulty stage and finally the component or circuit condition causing the trouble.

FEATURES

Giant recessed 6 1/2 inch 40 Microampere meter with mirrored scale. Built-in Isolation Transformer. Use of the latest type printed circuit and 1% multipliers assure unchanging accurate readings.

Model TV-60 comes complete with book of instructions; pair of standard test leads; high-voltage probe; detachable line cord; R.F. Signal Tracer Probe and Audio Signal Tracer Probe. Pilot-film bag for all above accessories is also included. Price complete. Nothing else to buy **ONLY**

\$ 52⁵⁰
NET

Superior's New Model TV-50

GENOMETER



A versatile all-inclusive GENERATOR which provides ALL the outputs for servicing A.M. Radio • F.M. Radio • Amplifiers • Black and White TV • Color TV

R. F. SIGNAL GENERATOR: Provides complete coverage for A.M. and F.M. alignment. Generates Radio Frequencies from 100 Kilocycles to 60 Megacycles on fundamentals and from 60 Megacycles to 180 Megacycles on powerful harmonics. • **VARIABLE AUDIO FREQUENCY GENERATOR:** In addition to a fixed 400 cycle sine wave audio, the Genometer provides a variable 300 cycle to 20,000 cycle peaked wave audio signal. • **BAR GENERATOR:** Projects an actual

Bar Pattern on any TV Receiver Screen. Pattern will consist of 4 to 16 horizontal bars or 7 to 20 vertical bars. • **CROSS HATCH GENERATOR:** Genometer will project a cross-hatch pattern on any TV picture tube. The pattern will consist of non-shifting horizontal and vertical lines interlaced to provide a stable cross-hatch effect. • **DOT PATTERN GENERATOR (FOR COLOR TV):** The Dot Pattern projected on any color TV Receiver tube by the Model TV-50 will enable you to adjust for proper color convergence. • **MARKER GENERATOR:** The following markers are provided: 189 Kc., 262.5 Kc., 456 Kc., 600 Kc., 1000 Kc., 1400 Kc., 1600 Kc., 2000 Kc., 2500 Kc., 3579 Kc., 4.5 Mc., 5 Mc., 10.7 Mc., (3579 Kc. is the color burst frequency.)

MODEL TV-50 comes absolutely complete with shielded leads and operating instructions.

\$ 47⁵⁰
Only NET

SHIPPED ON APPROVAL NO MONEY WITH ORDER—NO C.O.D.

MOSS ELECTRONIC DISTRIBUTING CO., INC.
Dept. D-310, 3849 Tenth Avenue, New York 34, N. Y.

Please send me the units checked. I agree to pay down payment within 10 days and to pay the monthly balance as shown. It is understood there will be no finance or interest charges added. It is further understood that should I fail to make payment when due, the full unpaid balance shall become immediately due and payable.

- | | |
|---|--|
| <input type="checkbox"/> Model TC-55..... Total Price \$26.95
\$6.95 within 10 days. Balance \$5.00
monthly for 4 months. | <input type="checkbox"/> Model 770-A..... Total Price \$15.85
\$3.85 within 10 days. Balance \$4.00
monthly for 3 months. |
| <input type="checkbox"/> Model TV-12..... Total Price \$72.50
\$22.50 within 10 days. Balance \$10.00
monthly for 5 months. | <input type="checkbox"/> Model 670-A..... Total Price \$28.40
\$7.40 within 10 days. Balance \$3.50
monthly for 6 months. |
| <input type="checkbox"/> Model TV-11..... Total Price \$47.50
\$11.50 within 10 days. Balance \$6.00
monthly for 6 months. | <input type="checkbox"/> Model TV-60..... Total Price \$52.50
\$12.50 within 10 days. Balance \$8.00
monthly for 5 months. |
| <input type="checkbox"/> Model TV-40..... Total Price \$15.85
\$3.85 within 10 days. Balance \$4.00
monthly for 3 months. | <input type="checkbox"/> Model TV-50..... Total Price \$47.50
\$11.50 within 10 days. Balance \$6.00
monthly for 6 months. |

Name _____

Address _____

City _____ Zone _____ State _____

All prices net, F.O.B., N.Y.C.

We invite you to try before you buy. any of the models described on this and the preceding page. If after a 10 day trial you are completely satisfied and decide to keep the Tester, you need send us only the down payment and agree to pay the balance due at the monthly indicated rate.

**NO INTEREST
OR FINANCE
CHARGES ADDED!**

If not completely satisfied, you are privileged to return the Tester to us, cancelling any further obligation.

**SEE OTHER
SIDE**

CUT OUT AND MAIL TODAY!

Vernon Downs Sound

(Continued from page 41)

it can be fed into the circuit without delay. No feedback problems were encountered at the winner's circle due to the distance factor; being correctly phased and installed the speakers carry a much higher level without feeding back.

Switching System Installed

To permit more flexible music reproduction a two-pole three-throw switch was installed; this made it possible to use one turntable for a bugle-call record and two others to fade from one selection to another as required. A tape recorder, also available, can be switched into the preamps separately.

Barn Area Speakers

In the barn area (carrying announcements pertaining to racing and track personnel) is a preamp⁶ feeding two boosters³ whose inputs and outputs are paralleled. Seventeen trumpets⁷ with drivers provide coverage over an area of about two square miles.

Telephone-Intercom Lines

The main telephone system consists of a seven party line using magneto desk set phones, one each for the patrol judges, the paddock judge, as well as for the presiding judge. Across

(Continued on page 54)

BLOCK DIAGRAM of amp-mike-tape/turntable-speaker setup at Vernon Downs track.

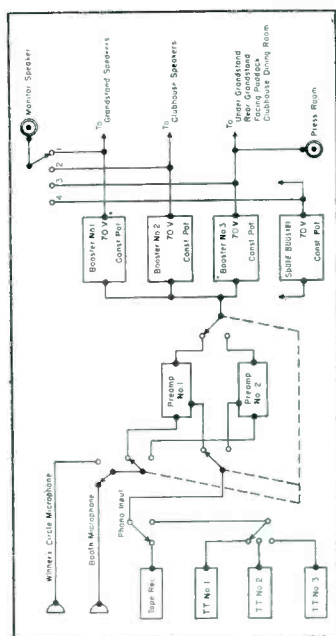

*Used the World Over
more than any other Microphones!*

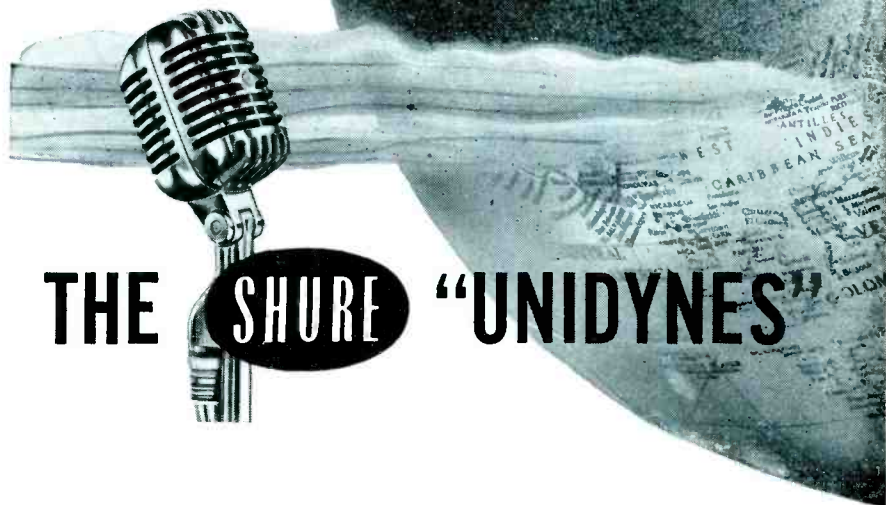

THE SHURE "UNIDYNES"

are the only small size, all-purpose moving coil Dynamic Microphones that reduce the pickup of random noise energy by 67%.

The Unidynes, 55s and 556s, simplify P. A. installation . . . enhance your reputation . . . insure customer satisfaction by eliminating or reducing callbacks due to critical gain control settings—often necessary when conventional microphones have been installed.

No wonder the Unidynes are used the World over—more than any other microphones—for finest quality public address . . . theater stage sound systems . . . professional recording . . . remote broadcasting.

SHURE

SHURE BROTHERS, Inc.

Microphones-Electronic Components

204 Hartrey Avenue, Evanston, Illinois

Cable Address: SHUREMICRO

EICO 84 Withers St., Brooklyn 11, N. Y. S-10

SAVE ME 50% on precision instruments—
send **FREE CATALOG** on EICO's 46 models
in factory-wired and kit form.

My Name.....
Address.....
City..... Zone..... State.....



NEW! COLOR
and Black-&-White
DC to 5 MC LAB & TV
5" OSCILLOSCOPE

#460
Factory-wired
and tested..... \$129.50
Also available as kit \$79.95

• Features DC Amplifiers!

Flat from DC-4.5 mc, usable to 10 mc. **VERT.**
AMPL.: sens. 25 rms mv/in; Z 3 meg; direct-cou-
pled & push-pull thruout; K-follower coupling bet.
stages: 4-step freq-compensated attenuator up to
1000:1. **SWEEP:** perfectly linear 10 cps-100 kc (ext.
cap. for range to 1 cps); pre-set TV V & H positions
(30 & 7875 cps); auto. sync. ampl. & lim. **PLUS:**
direct or cap. coupling; bal. or unbal. inputs; edge-
lit engraved lucite graph screen; dimmer; filter;
bezel fits std photo equip. High intensity trace
CRT. 0.06 usec rise time. Push-pull hor. ampl., flat
to 400 kc, sens. 0.6 rms mv/in. Built-in volt. calib.
Z-axis mod. Sawtooth & 60 cps outputs. Astig. con-
trol. Retrace blanking. Phasing control.

BEFORE you buy ANY instruments—get the
FACTS on the money-saving, high-precision
EICO line. Fill in coupon for **FREE** cata-
log & name of your nearby distributor.

EICO® 84 Withers St., Brooklyn 11, N. Y.
Prices 5% higher on West Coast

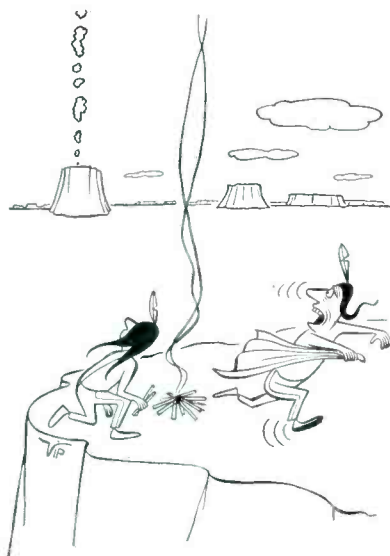

*"By golly, it is an emergency
call . . . they're out of
JENSEN NEEDLES."*

Vernon Downs Sound

(Continued from page 53)

this telephone is a tape recorder
which records all comments of the
judges during each race; these reels
are filed for future reference.



(Above)

**THREE-SPEED phonomotor, supplied
with either a metal or a plastic eight-
inch turntable and dynamically bal-
anced friction drive. For use in port-
able or small size phonos. Has idler
wheel whose outer rim is pierced with
tiny holes. Affixed to rim is a rubber
tire whose upper and lower edges are
vulcanized to each other through the
holes so that tire does not slip on the
wheel's rim. Shock mounted to min-
imize vibration.** (Federal Telephone
and Radio Co., 35 Central Ave., East
Newark, N. J.)

(Below)

**P-M DRIVER (25 watts continuous)
with hermetically-sealed magnetic as-
sembly and inverted dome diaphragm.
Has phase-equalizing plug said to pre-
vent internal phase cancellation or
interference.** (Model PD-5VH; Atlas
Sound Corp., 1449 39th St., Brooklyn
18, N. Y.)



REAR SEAT SPEAKER LINE EXPANSION

Oxford Electric Corp., 556 W. Monroe
St., Chicago 6, has purchased all tools,
dies and inventory of the rear seat
speaker line from Lowell Manufacturing
Company.

MERIT

first in exact replacement

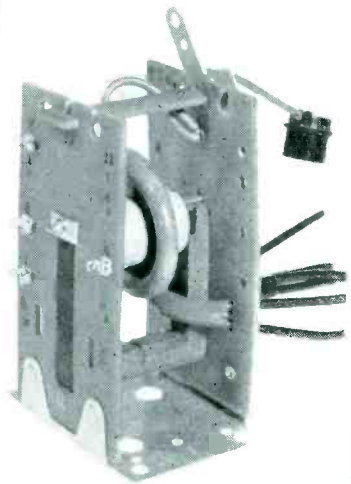

For exact replacement in over 60
G.E. models and chassis. HVO-59
replaces G.E. parts RTO-125, 126,
127. HVO-61 replaces G.E. parts
RTO-129 and 130. Both feature
Merit's **NEW** anti-corona ring plus
exact lead color coding! Another
in Merit's line of exact replace-
ment transformers, yokes and
coils—as always, the most com-
plete in the industry. And Merit
is the only manufacturer of these
products who has complete pro-
duction facilities for all parts sold
under their brand name.

MERIT

MERIT COIL AND TRANSFORMER CORP.
4427 N. CLARK ST., CHICAGO 40, ILLINOIS

Commercial Mobile Sound*

(Continued from page 28)

be recorded need not go through the loudspeaker system. Recordings can be replayed directly through the car's loudspeaker.

One speaker¹ was mounted horizontally on the roof of the car above the front seat; duplex speakers² were mounted on either side of the car at the rear. These speakers served as a bass reflex unit. All speakers were provided with line-matching transformers³. Facilities were also provided for rapid connection of additional speakers if required.

Since the unit finds most of its use in voice announcements, a pair of microphones were included as standard equipment with a power amplifier and microphone preamp. The output has been connected for 70.7 volt circuits. Snap action toggle switches allow for easy connection of one or all speakers. Input plugs for the microphone were located in both front fenders, the dash and the front panel of the equipment. All mike units were paralleled.

The magnetic tape recorder has dual track heads and operates at a single speed of 7½ inches per second. One mm Mylar based tape is used.

When the car is near a commercial source of 110-v ac, a throw-over switch enables tying in to the line. Current to operate the amplifier, tape recorder and phono comes from a 12-v dc to 120-v sixty cycle ac output.

¹E-V.

²Altec-Lansing.

³Sound system was installed by the Milwaukee Sound Service.



TV LISTENING device that attaches to audio system of TV sets via a 15' cord. Supplied with a control unit housing volume controls and on-off switch, cord, two jacks and an earset receiver which plugs into the jacks. (TV Listener; Telex, Telex Park, St. Paul, Minn.)

**you can
hear the
quality of**

QUAM
Adjust-a-Cone[®]
SPEAKER

When you install a Quam speaker, listen to it carefully.

Your ears will tell you why Quam Speakers have earned the reputation of "the Quality Line."

No other replacement speaker offers you all these important quality features: patented Adjust-a-Cone[®] suspension, U-shaped pot, heavier magnetic structures, 4 threaded holes in coil pot, transformer brackets, universal mounting brackets, factory packaging, listing in Howard Sams' Photofacts.

For happier customers,

ask for QUAM, the quality line for all your speaker needs

**QUAM-NICHOLS
COMPANY**

232 East Marquette Road

Chicago 37, Illinois

SERVICE AID COUNTER DISPLAY

LINE OF 60 service aids, accessories, components, hardware and specialty items in self-service display, designed for Dynamic Electronics, 73-39 Woodhaven Boulevard, Forest Hills, Long Island, N. Y. Items in line include assortment of coupler jumper cords and extensions for the coupling of hi-fi amplifiers, phonos, tuners, speakers and recorders, in addition to assortment of radio and TV hardware such as nuts, screws, cotter pins, tinnermans, brackets, rubber bumpers.

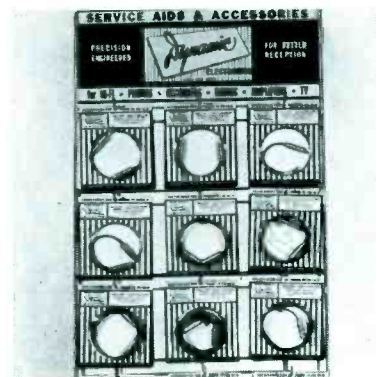

THE GREATEST VALUE IN TEST EQUIPMENT



MODEL
980 VOM

Only \$46⁷⁵/_{LIST}

A real value leader . . . accurate, compact, rugged, and low in cost. Has a combination of 28 functional ranges, simplified by a single dial. Ideal for radio and TV servicing, and for all 'round electronic and electrical measurement needs. At leading distributors, or write for literature. WESTON Electrical Instrument Corporation, Newark 5, N. J. A subsidiary of Daystrom, Inc.

WESTON test equipment
The Quality Line

THIS



PLUS THIS

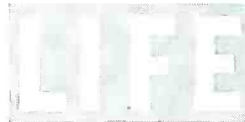

MEANS MORE OF THIS
FOR YOU



DFF—Ductone Fidelity Focus is big—big as Life where it's being advertised in the biggest program of its kind in needle history. For DFF brings music out of the shadows into focus. It's the big needle news. Put it to work for you. It's the perfect door opener. So is the free DFF Needle Test Card. Lets you test customer's needle right in his machine. Then send test card to us (with 25¢ to cover handling); and we will rush you back a complete report on the customer's needle. Gives you chance for second visit—second sale. Ask us about free DFF Needle Test Cards and DFF Program—it's big—



SPECIAL SERVICE MAN'S KIT
The all-in-one needle repair kit with the famous four free extras. Includes free—one 50X microscope to check needle. Jeweler's screwdriver. Professional Tools. Plastic carrying case. 13 of the most used needles. List \$25.00.

DUOTONE TV CLOTH



REMOVES TV SMOG
CLEARS VISIBILITY • BRIGHTENS PICTURE
KEEPS DUST FROM CLINGING
REDUCES REFLECTION GLARE
MADE IN NEWARK, NEW JERSEY

Reduces reflection glare. Keeps dust from clinging. A quick wipe by servicemen inside and outside of protective glass and on picture tube. Sell one for home use to remove fingerprints—keep off dust. \$1.00 list.

DUOTONE T-V CLOTH

An extra on every service call. New especially treated cloth that removes T-V Smog like magic. Gives brighter picture. Reduces reflection glare.

Reduces reflection glare. Keeps dust from clinging. A quick wipe by servicemen inside and outside of protective glass and on picture tube. Sell one for home use to remove fingerprints—keep off dust. \$1.00 list.

THE DUOTONE COMPANY, Newark, New Jersey

21-Inch Color-TV

(Continued from page 34)

3.58-mc *cw* oscillator and the color-killer circuits.

The burst keyer separates burst from the chrominance signal and the burst amplifier provides sufficient signal to injection-lock the 3.58-mc *cw* oscillator in frequency and phase. Hue is controlled by a potentiometer which varies effectively the capacity of the load on the primary of the transformer coupling the burst signal from the keyer to the burst amplifier.

The color killer is held at cutoff during reception of a color program by a bias developed in the 3.58-mc oscillator. During black-and-white picture reception, the killer conducts and applies a bias to the bandpass amplifier which cuts off this stage and prevents high-frequency signal information from appearing as color interference in the picture.

Deflection sync, in the *Special* and *Super* series, is developed from the composite video signal at the plate of the first video amplifier.

The sync stages consist of the triode section of a 6U8, the first sync amplifier, and one triode section of a 6CG7 as the sync separator. Horizontal sync is fed to the synchro-guide horizontal-oscillator and control circuits, and vertical sync is fed to the vertical-oscillator grid from the differentiating and integrating networks in the plate circuit of the sync output stage.

AGC is also derived from the composite video at the plate of the first video amplifier. Fixed bias for the *agc* tube is controlled with a potentiometer in the grid circuit and is fully adjustable to compensate for varying signal conditions.

The 21-inch tricolor tube is operated with a potential of 20,000 volts at the ultor. The necessary high voltage and horizontal-deflection voltages are supplied from the horizontal-sweep output circuit. A 6CB5A is driven by the horizontal oscillator to produce, in the horizontal output transformer; high voltage, drive for the horizontal windings of the deflection yoke, a pulse source for *agc*, focus voltage for the picture-tube, horizontal dynamic convergence voltage, a pulse for the burst keyer and a pulse for the horizontal blanking amplifier.

The complete horizontal output circuit consists of the 6CB5A, horizontal output; 6AU4GTA, damper; a 6BK4 shunt regulator to maintain high volt-

age under varying beam-control conditions; high-voltage rectifier, type 3A3; and focus rectifier, a 1V2.

An unusual feature found in the vertical-deflection circuit in these receivers is the method used to isolate the vertical deflection yoke to minimize and improve overall efficiency.

A vertical-isolation winding is incorporated in the horizontal output transformer. Vertical deflection current, from the vertical output transformer, is fed to the vertical-deflection coils through this winding and the vertical yoke operates at a horizontal pulse potential.

A tubeless, high-sensitivity convergence system is employed to maintain convergence for all three beams of the picture tube.

Static convergence, which controls convergence at the center of the screen, is maintained by applying a *dc* actuated magnetic field to each gun of the picture-tube. This is a departure from previous methods which used rotatable permanent magnets to accomplish this function.

DC for static convergence is obtained from the cathode circuit of the horizontal sweep-output tube and is controllable individually for each gun.

Horizontal - dynamic convergence-control current is obtained from a winding on the horizontal-sweep-output transformer and is controlled in both shape and amplitude by individual slug-tuned inductances.

Vertical dynamic-convergence-control current is obtained from the vertical sweep output circuit and is controlled in amplitude by a variable resistor in the cathode circuit of the vertical sweep-output tube, and in shape (tilt) by a variable resistor across the vertical convergence winding of the vertical-output transformer.

Lateral control of the blue beam in the picture tube is effected by a *pm* magnet located on the neck of the picture tube. A few chassis have been equipped with a *dc*-actuated blue lateral beam positioning magnet. In these chassis the *dc* for this coil is supplied from the cathode of the horizontal sweep-output tube.

In conjunction with mechanical improvements, the *DeLuxe* series receivers incorporate additional features. Circuitwise, these include a noise-cancellation circuit, an additional stage of sound *if* amplification, a tone control, color channels having wider bandwidth, and automatic chroma control in the color synchronization stages.

The noise-cancellation circuit in the

(Continued on page 58)

NEW EDITION!

SONOTONE

PHONOGRAPH MODERNIZATION MANUAL

SECOND EDITION
PRICE 10 CENTS

ELECTRONIC APPLICATIONS DIVISION
SONOTONE CORPORATION
ELMSFORD, N. Y.

PACKED WITH VALUABLE INFORMATION

- Advantages, operation and use of ceramic cartridges
- Replacement data

...and it's yours FREE!

This handy booklet will help you make proper and intelligent use of the amazing new Sonotone Ceramic Cartridges. It will enable you to make profitable replacements, modernizing your customer's phonograph. It will give him extra satisfaction and bring you prestige.

Be sure to get your up-to-date manual.

Just fill in the coupon and mail to Sonotone. Attach to a postcard if you wish.

SONOTONE® Corporation

Department CS-106
Elmsford, N. Y.

Please send me, without cost or obligation, a copy of the newly revised "SONOTONE Phonograph Modernization Manual."

NAME _____

ADDRESS _____

CITY _____ ZONE _____ STATE _____

KESTER

21-Inch Color TV

(Continued from page 57)

KESTER
"RESIN-FIVE"
SOLDER

Absolutely non-corrosive and non-conductive, KESTER "RESIN-FIVE" CORE SOLDER contains an activated type of resin that gives you that fast, positive action on all your jobs . . . including the most difficult.

FASTER ACTING
EASIER TO USE
LONGER LASTING
THE BEST

KESTER SOLDER COMPANY
4248 Wrightwood Avenue • Chicago 39, Illinois
Newark 5, New Jersey • Brantford, Canada

SOLDER

for service and lab. work

Heathkit PRINTED CIRCUIT OSCILLOSCOPE KIT FOR COLOR TVI

① Check the outstanding engineering design of this modern printed circuit Scope. Designed for color TV work, ideal for critical Laboratory applications. Frequency response essentially flat from 5 cycles to 5 Mc down only 1½ db at 3.58 Mc (TV color burst sync frequency). Down only 5 db at 5 Mc. New sweep generator 20-500,000 cycles, 5 times the range usually offered. Will sync wave form display up to 5 Mc and better. Printed circuit boards stabilize performance specifications and cut assembly time in half. Formerly available only in costly Lab type Scope. Features horizontal trace expansion for observation of pulse detail — retrace blanking amplifier — voltage regulated power supply — 3 step frequency compensated vertical input — low capacity nylon bushings on panel terminals — plus a host of other fine features. Combines peak performance and fine engineering features with low kit cost!

MODEL 0-10
\$695.00
Shpg. Wt. 27 lbs.

MODEL TS-4
\$495.00
Shpg. Wt. 16 lbs.

Heathkit TV
SWEEP GENERATOR KIT
ELECTRONIC SWEEP SYSTEM

Heathkit
COMPANY
A SUBSIDIARY OF DAYSTROM, INC.
BENTON HARBOR 11, MICH.

WRITE FOR FREE CATALOG
...COMPLETE INFORMATION

Heathkit TV SWEEP GENERATOR KIT ELECTRONIC SWEEP SYSTEM

② A new Heathkit sweep generator covering all frequencies encountered in TV service work (color or monochrome). FM frequencies too! 4 Mc — 220 Mc on fundamentals, harmonics up to 880 Mc. Smoothly controllable all-electronic sweep system. Nothing mechanical to vibrate or wear out. Crystal controlled 4.5 Mc fixed marker and separate variable marker 19-60 Mc on fundamentals and 57-130 Mc on calibrated harmonics. Plug-in crystal included. Blanking and phasing controls — automatic constant amplitude output circuit — efficient attenuation — maximum RF output well over .1 volt — vastly improved linearity. Easily your best buy in sweep generators.

DeLuxe chassis uses the triode section of 6AW8 first video amplifier.

Composite video signal is coupled from the cathode of the first video stage to the cathode of the noise-inverter tube. The output of the noise inverter is fed to the grid of the first sync amplifier. Composite video is also coupled to the grid of the first sync amplifier through the primary of the chroma takeoff transformer in the plate circuit of the first video amplifier. Thus, by controlling conductivity of the noise-inverter tube with the noise threshold control in its grid circuit, noise appearing at a level higher than tips of sync is cancelled effectively at the grid of the first sync amplifier.

The chrominance stages of the DeLuxe chassis include two bandpass amplifier stages, two 6BY6 demodulators, and a matrix amplifier for each of the R-Y, B-Y and G-Y color difference signals.

The bandpass amplifiers perform the same function as the bandpass stage in the standard chassis. However, the gain of the first bandpass amplifier stage is controlled automatically by a bias developed as a function of burst amplitude. When the amplitude of burst increases, the gain of the stage decreases and conversely, when burst amplitude decreases, the gain of the first bandpass amplifier increases, thus supplying an essentially constant chroma signal to the second bandpass amplifier, and the demodulator and output stages.

Color saturation is controlled by a potentiometer in the grid circuit of the second bandpass amplifier. The horizontal retrace blanking amplifier couples an amplified horizontal pulse from the horizontal output transformer to the cathode of the second bandpass amplifier, applying a positive pulse which cuts off operation of the tube during horizontal retrace.

The color-demodulator stages operate at a phase displacement of 57.5° and are noted as the X and Z demodulators. The chrominance signal from the second bandpass amplifier output is coupled to the No. 1 grids of both demodulator tubes; 3.58-mc cw is applied to the No. 2 input grids of the demodulators, and is displaced by 57.5° at each grid. By the process of sync phase detection, color-difference signals are produced at the plates of the demodulators. The — (B-Y) and — (G-Y) output of

the demodulators is matrixed to produce (R-Y), (B-Y) and (G-Y) are also developed in the demodulators. These signals are then amplified by individual triode stages for each color-difference signal. The three channels, R-Y, B-Y and G-Y are of equal bandwidth; thus no delay lines are required in the chrominance channels. Since the channels are wider in bandwidth than the color channels in the standard chassis, the delay in the luminance channel is less.

The color-sync circuits include the burst amplifier and the 3.58-mc. oscillator. Operation of these circuits is similar to the standard chassis, except that the *cw*-output transformer provides phase displacement of 57.5° instead of 123°. Hue is controlled by a potentiometer and a fixed resistor in the secondary circuit of the *cw* output transformer. The potentiometer varies effectively the load capacity on the secondary of the transformer causing a change in resonance and thus shifting the phase.

A 1N60 crystal-diode in the grid circuit of the 3.58-mc oscillator rectifies and doubles the oscillator-grid voltage developed when burst is present. The resultant rectified voltage is applied as automatic chroma control voltage to the first bandpass amplifier and color killer bias since the voltage varies directly with the burst level in the chrominance signal.

Servicing TV Portables

(Continued from page 50)

just disappears. These adjustments will provide the brightest picture and best picture focus.

The height, vertical linearity and focus controls are adjusted in the normal fashion, after the foregoing adjustments have been made. When the receiver requires troubleshooting or alignment, the two chassis sub-assemblies may be separated by removing five screws, as shown in Fig. 3 (p. 50). The picture tube socket is removed and the rear chassis slid off the yoke hood; the chassis is so placed that the bottom wiring side becomes visible. The picture tube socket may then be dressed through the hole in the chassis and reconnected on the picture tube.

To service the tubes in the tuner requires removal of the speaker. To remove the speaker the clamp screw shown in Fig. 2 (p. 50) must be loosened and the speaker removed from the clamp. When replacing the speaker, care must be taken that the face of the speaker is exactly 4¼" from the center line of the chassis.

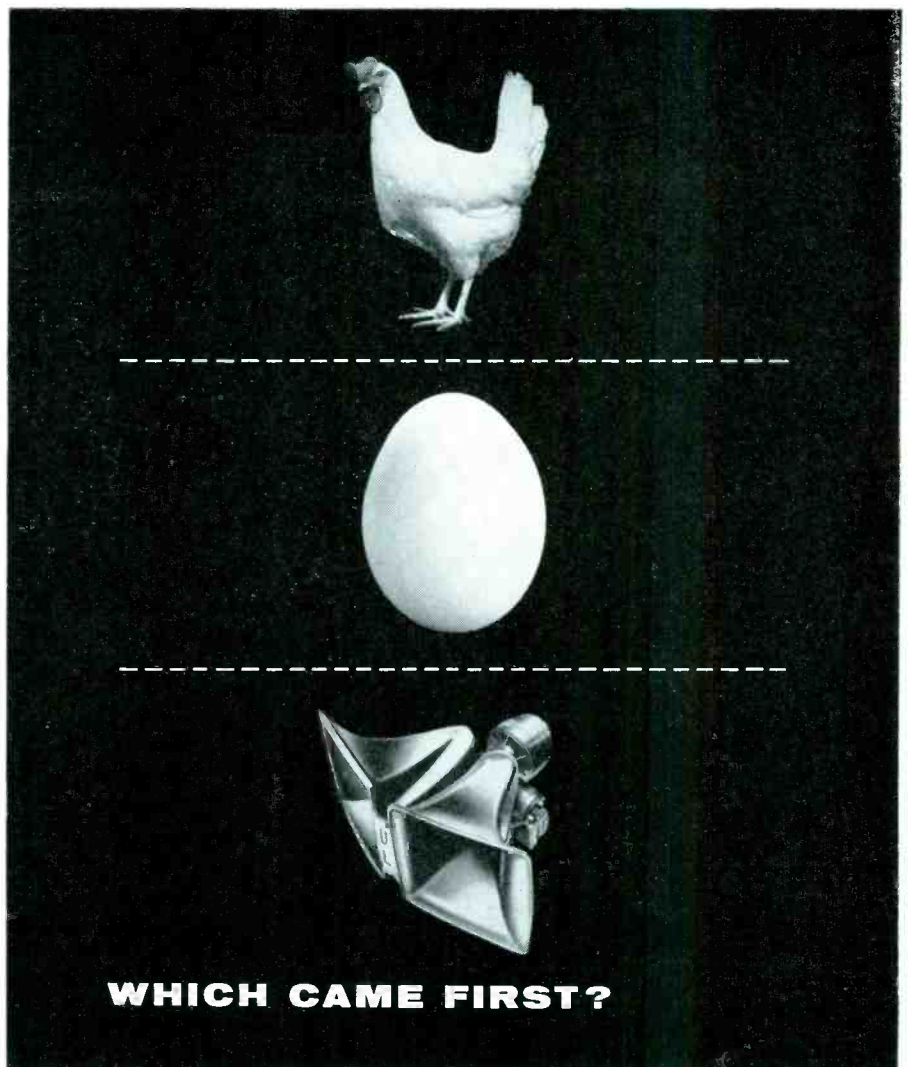

There's a lot of controversy about which came first, the chicken or the egg . . . but there's no question about the fact that University has been first with many of the most sensational developments in the loudspeaker field.

Merely being first is not enough. We, at University, subject every new product to the most rigorous laboratory tests, placing it on the market only when it has been brought to the peak of perfection. (Our customers have felt it was worth waiting for these "proven-firsts").

We've always enjoyed the challenge of finding new answers to old problems as well as exploring entirely new fields in audio engineering. Perhaps that's the reason University has become the leading manufacturer of specialized loudspeakers and components.

For the record—here are some of the "firsts" which we have engineered.

University was the FIRST to . . .

Pioneer high power reflex trumpets . . . now the industry standard

Introduce radial projectors . . . making full coverage still more economical

Achieve the one-piece integrally cast tone arm, reflector and bell Cobreflex—permitting durable construction of intricate designs

Offer wide-range response, breakdown and weatherproof driver units . . . bringing the best in Sound to public address

Devise "rim-centered" diaphragm/voice coil and magnet assemblies . . . eliminating need for shims and guides, ensuring shock and vibration-proof reliability

Depart from obsolete, erratic-performing

multi-cellular and slit type diffraction projectors . . . by introducing the still superior "reciprocating flare" principle for uniform wide-angle dispersion of high frequencies

Make available high efficiency blast and submergence-proof speakers for p.a. and industrial applications . . . opening new markets to Sound installations

Combine driver and multi-match transformer in one unit . . . substantially increasing versatility of application and flexibility of operation

Conceive "progressive speaker expansion" (PSE) . . . together with specially designed components such as adjustable impedance voice coils, adjustable response woofers, adjustable crossover networks

and others too numerous to mention



University sounds better



UNIVERSITY LOUSPEAKERS, INC., 80 SOUTH KENSICO AVENUE, WHITE PLAINS, N. Y.



Easy Does it WITH Winegard

Most Winegard antennas are so easy to install that you can put them up in minutes. Without a helper, too! All of which means more time for you to put in on skilled service instead of on rooftops.

Only Winegard makes a *complete*, factory-assembled antenna installation. You get the whole package—*nothing else to buy!* Not a kit, but a completely assembled unit that opens easily as an umbrella. No loose parts. Nothing to put together. Nothing to attach. Fold it open—nail it up. (Special screw-type nails included!) Clip lead-in to terminals... and you're done!

There's a Winegard model for every area and every customer.

Nationally advertised in SATURDAY EVENING POST and other leading magazines.

"Minute-Mount" Model

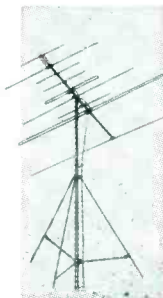

for fringe areas. A high-gain antenna with patented "Electro Lens" focusing and 10' aluminum fold-out tower. Factory-assembled and ready for installation. Complete, including lead-in, insulators, lightning arrester, ground wire and ground rod — \$44.95 retail.



See your Jobber, or write:

Winegard Co.

3000 Scotten Blvd., Burlington, Iowa

*Pat. No. 2700105

TV PARTS... ACCESSORIES

SELENIUM PLUG-IN DUAL DIODE

A subminiature selenium plug-in dual diode, 60-7788, for replacing 6AL5s in TV sync discriminator circuits, has been developed by International Rectifier Corp., El Segundo, Calif.

Unit consists of two 1U1 selenium diodes mounted and soldered to a plug that fits a seven-pin miniature tube socket. Each diode is designed to deliver 20 v dc at 1.5 ma for an rms voltage input of 26 v maximum. Temperature range is from -50° to +100° C. Further information in bulletin SD-1B.

REPLACEMENT FLYBACK TRANSFORMERS

Three replacement flyback transformers for use in General Electric TV sets have been introduced by the Ram Electronics Sales Co., Irvington, N. Y.

One type, X133, delivers 18 kv with a B+ of 300 v and boost voltage of 680; replaces G.E. part numbers RTO-149-1, -150, -151, -151-3, -161, -166 and 166-5. Another, X134, delivers 14 kv with a B+ of 135 v and boost of 300 v; replaces G.E. part numbers RTO 165, -165-1, -173, -175, -175-3 Third, X135, replaces G.E. part numbers RTO-179, -179-4, and -183; delivers 17 kv with B+ of 320 v and boost of 575 v.

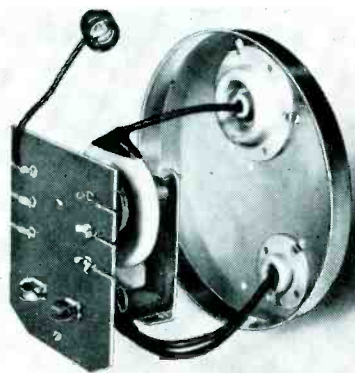

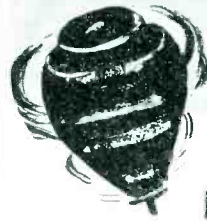

still **TOPS...**
in the
**2-Set
market!**



the
**MOSLEY
Dual-Match
TV Coupler**



tops for...

-  Impedance match
-  Signal transfer
-  2-Set isolation

With the MOSLEY *Dual-Match* TV Coupler "convenience" becomes a byword for the folks who have that *extra* TV for the den or play-room!

The *Dual-Match* Coupler is efficient, solderless, compact and so easily installed on baseboard or set—yet priced so low you are assured complete customer satisfaction.

Available at Radio and Television Parts Distributors, Coast-to-Coast.

MOSLEY 902 List Price **\$2.95**

Mosley Electronics, Inc.

8422 ST. CHARLES ROCK ROAD, ST. LOUIS 14, MISSOURI

SERVICE MEN KNOW THERE IS JUST ONE

HUSH

Reg. U.S. Pat. Off.

Chemically engineered for tuners and switching mechanism



Hush comes in a 6 oz. pressure can with sufficient pressure to reach all contacts to wash-away that dirt, leaving clean and positive contacts, protected with a lasting lubricant film.

\$2.25 net

Hush also available in 2 oz., 8 oz. and 32 oz. containers.

See your distributor or write to

EVER-QUIET

Reg. U.S. Pat. Off. Pend.

Since 1949 the Original Volume Control and Contact Restorer

EVER-QUIET is a free-flowing liquid that leaves no powder residue. Scientifically designed to seep around the shaft and penetrate the control or potentiometer, cleaning the contacts and leaving a safe protecting film. Harmless to metals, wire or carbon. Will not affect inductance, capacitance or resistance.

2-Ounce Bottle with Handy Dispenser (32 oz. sizes available)

only 59c



CHEMICAL ELECTRONIC ENGINEERING, INC. Matawan, New Jersey

(Continued from page 20)

this appear necessary. In some cases, the boards can be detached far enough from the chassis to permit soldering of the connections on the back, without any of the leads being unsoldered.

The high-voltage sub-chassis has been designed so that the high-voltage transformer can be removed and replaced from the rear.

All connections in the deflection yoke come to a terminal board just below the yoke, permitting it, too, to be changed simply from the rear.

The chassis also feature a quick-check filament circuit; special filament test points are arranged to permit the filament of any tube on the board to be shunted with a small screwdriver or metal object. Shunting the open filament allows the other tubes to light up, and thus identifies the tube with a burned-out filament.

There is no increase in *B* load, but the size of the seleniums has been increased to assure longer trouble-free operation.

Circuitry Features

Two new tubes have been included in the receivers; they are in the *vhf* tuner and in the sound *if* and *agc* circuits. A 5BR8 is used in the *vhf* tuner. This is a dual triode used as a combination mixer-oscillator in the tuners. Although similar to the 5AT8, the tuner was designed around the 5BR8, and since this has more gain, a lower internal capacitance, and separate cathodes, it is not directly interchangeable. In the sound *if* and *agc* circuits, a 5CM8 is used.

Picture tube, tuner, and chassis comprise a single unit. The chassis itself mounts to the bottom of the cabinet, and can be slid in and out. It is held in place by seven mounting bolts, three of which are additional shipping bolts which need not be replaced once removed for any reason. One size socket wrench will fit all seven bolts.

The Tuning Mechanism

Automatic tuner-bar controls have been designed for two lines³ in the series.

To obtain the fullest benefits from pushbutton tuning, the receiver's circuitry provides for automatic compen-

³Custom and Eldorado.

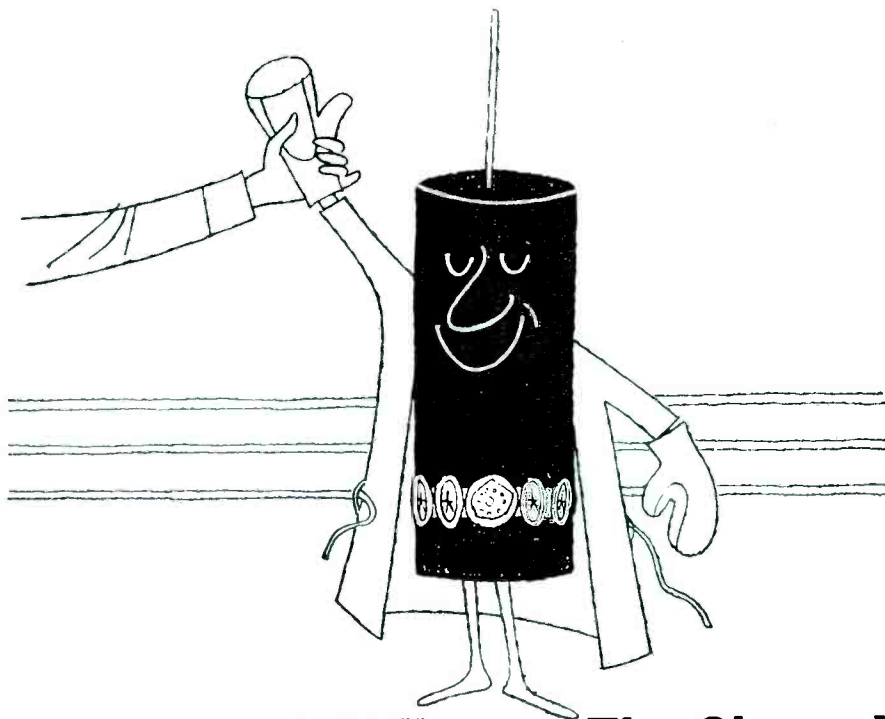

...and Still The Champ! Cornell-Dubilier "CUBS"®

YES, THE "CUB" has come through like a real champ in its battle with—high humidity—sizzling temperatures—shattering vibration—and punishing endurance. In the molded tubular class, THE "CUB" rates second to none. THE "CUB" like the "Blue Beaver" is made exclusively for the service trade—for full profit and customer satisfaction. You can bet your reputation on the C-D "CUB" when it comes to tubulars. Ask your nearby C-D Distributor for catalog or write Cornell-Dubilier Electric Corporation, South Plainfield, N. J.



Cornell-Dubilier capacitors

South Plainfield, N. J.; New Bedford, Worcester & Cambridge, Mass.; Providence & Hope Valley, R. I.; Indianapolis, Ind., Sanford, Fuquay Springs & Varna, N. C.; Venice, Calif., & subsidiary, The Radiart Corporation, Cleveland, Ohio.

sation of changes or variations in the TV signal when the set is tuned from one station to another. The five fully-automatic features are tuner bar, picture monitor, interference guard, sound control, and tube protector.

Add-On Remotes Available

Wireless or other remote controls are available for these sets. They are add-on units designed to plug into the rear of the receiver without removal of the back.

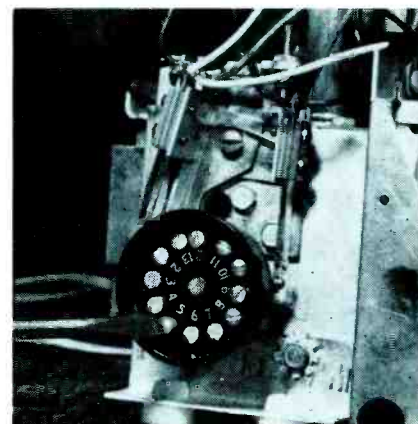

FULLY-AUTOMATIC controls on Crosley's line that permit consecutive or selective tuning, in which a touch on a tuner-bar skip-stops to pre-selected channels. These are set by backing-out the marked channel screws one-quarter inch.

STEAM IRONS NEED CLEANING TOO!

get INSIDE clean for MORE steam

SSS-T! STEAM IRON CLEANER

- EASY TO USE
- ODORLESS
- NON-ACID
- WILL NOT BURN
- ECONOMICAL
- MFGR. RECOMMENDED
- FULL YEAR SUPPLY

Free literature on request. Stores and shops only, for free sample send 25¢ to cover cost of handling and postage.

Choice jobber areas available.

A NATURAL Over-the-Counter Seller!

Used and Sold in Leading Appliance Service Stations Coast-to-Coast!

Order from your JOBBER or write us for name of your nearest supplier.

Fast Chemical Products Corp.

65 Page Avenue
YONKERS 4, N. Y.

Saves Time Servicing



SIGNAL TRACER

For fast, accurate service of AM, FM, TV, Audio and Electronic Equipment. Checks all stages from Antenna to speaker or picture tube. Tests microphones, appliances, pickups, transformers, speakers, resistors, condensers, etc.

Model 202 (with AF Probe)..... Net 37.50
Model A Probe (RF Demodulator)..... Net 4.50
Model B Probe (RF Demodulator, Amplifier)..... Net 7.50
See your dealer . . . if he cannot help you, write

PRECISION ELECTRONICS, INC.

Dept. S-10, 9101 King Ave., Franklin Park, Ill.

Send Full Details

NAME OF DEALER

Send Check Enclosed

Send COD (\$5.00 Enclosed)

Name

Address

City

Zone

State

INSTRUMENTS

FIVE-INCH 'SCOPE FOR COLOR-TV

A 5-inch 'scope, 632, for color TV testing, has been announced by Hycon Electronics, Inc., 2961 E. Colorado St., Pasadena, Calif.

'Scope can be used for testing voltage and waveforms in color-TV and b-w receivers. Units was designed to complement model 616 color bar-dot generator.

TRANSISTOR AND CRYSTAL DIODE CHECKER

A transistor and crystal-diode checker, TDC22, featuring test leads so that transistors and crystal diodes need not be completely removed from the circuit, has been introduced by Service Instruments Co., 171 Official Rd., Addison, Ill.

A gain control is used to vary the 6 v battery voltage for different gain transistors. Setup chart is in a removable booklet. Checks both pnp and npn transistors for current gain, leakage, opens and shorts. Crystal diodes can be checked for forward to backward resistance ratio.

PICTURE AND PATTERN VIDEO GENERATOR

A picture and pattern video generator, Dyna-Scan 1000, for producing a composite video and sync signal that operates any standard b-w or color-TV receiver on any vhf channel, has been developed by B&K Manufacturing Co., 3731 N. Southport Ave., Chicago 13, Ill.

Any picture or pattern placed in front of scanning tube, it is said, can be reproduced with high definition on TV receivers. Can be used with a single monitor on any number of standard TV receivers or fed into a master antenna system. Maximum capability is said to be in excess of 400 lines. Can be used to make color TV static and dynamic convergence adjustments with stable white dot and white line patterns. Provides closed circuit TV system. Rf carrier output is continuously variable from 50,000 microvolts to minimum level for testing fringe area TV receiver sensitivity. Built-in synchronized bars are claimed to make the unit self-calibrating and insure good vertical and horizontal linearity. Can also be used as a square wave generator for video amplifier troubleshooting.



HORIZONTAL SYSTEM ANALYZER/ CAPACITOR CHECKER

An in-circuit horizontal system analyzer and capacitor checker, 382, has been developed by Simpson Electric Co., 5200 W. Kinzie St., Chicago 44, Ill.

Tester is said to enable one to check an entire TV horizontal deflection system (in-circuit), test flyback transformers and deflection yokes for opens and shorts, and measure capacitances from 10 mmfd to .1 mfd by direct reading. Accuracy is claimed to be better than 10%. Unit can also be used as a continuity meter and will compare various flyback transformers and deflection yokes for relative Q by means of a logging scale.

TV CIRCUIT TESTER

A TV circuit tester, Service King 8500, a multi-purpose portable instrument for b-w and color-TV servicing, has been developed by Philco Corp., Philadelphia 34, Pa.

When used for receiver troubleshooting, unit is connected between receiver output cable and pix tube without removing either from the cabinet. Setup is said to permit measurement of video drive, K-G₁ voltage, K-G₂ voltage and cathode current. When used with three gun, shadow-mask type of color receivers, information is available separately on each of the three guns. A feed-through position is provided so that the receiver output can be viewed on cathode-ray tube.

Unit is also claimed to be a complete pix tube tester that checks emission, grid control, gas and leakage. Leakage is read directly in ohms with a 20,000 ohms/volt voltmeter, calibrated 0 to 1 megohm with mid-scale approximately 50,000 ohms. The pix tube test function is performed with voltages derived from the instrument and is useful for checking tubes installed in cabinets as well as tubes in cartons. An additional pix tube test function is available to permit determining cutoff voltage of each gun, measurement of emission and functioning of control grid, while the pix tube is operating with its normal anode voltage. Test prods are provided so that the meter can be used for the measurement of dc voltages up to 1000 and up to 30,000 with high voltage probe supplied, and as an ohmmeter.

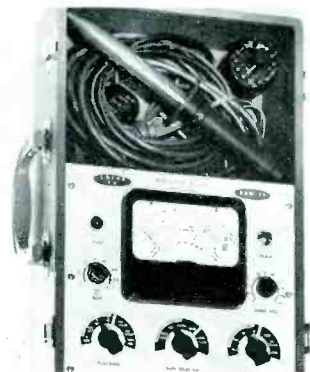

MONEYBACK GUARANTEE ON THE WORLD'S FINEST SERVICE DATA!

Howard W. Sams will prove to you that
PHOTOFACT will help you solve any service problem
FASTER, EASIER, BETTER, MORE PROFITABLY

GET THE PROOF...DO THIS NOW:

1.

Choose a "Tough Nut"

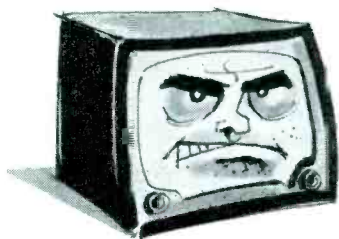

Pick a set that's been giving you plenty of trouble—the tougher the test, the better the proof. Get the make and chassis number of the set . . .

2.

See Your Parts Distributor

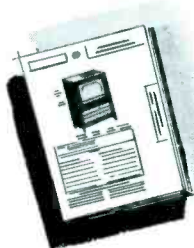

Look up the set in the Sams Index to PHOTOFACT Folders. In just 60 seconds you'll find the applicable Folder Set. Buy it—take it back to your shop . . .

3.

Give PHOTOFACT the "Acid Test"



With the proper PHOTOFACT Folder by your side, start solving your service problem . . .

THEN, YOU BE THE JUDGE:

If PHOTOFACT doesn't save you time, doesn't make the job easier and more profitable for you, Howard W. Sams wants you to return the complete Folder Set direct to him and he'll refund your purchase price promptly.

**TRY THE PHOTOFACT
MONEYBACK OFFER NOW**

**LEARN FOR YOURSELF HOW PHOTOFACT
SAVES YOU TIME ON EVERY SERVICE JOB...
HELPS YOU EARN MORE DAILY**

HOWARD W. SAMS, INC. • 2207 E. 46th ST. • INDIANAPOLIS, IND.

SERVICE, OCTOBER, 1956 • 63

CORNING LOW-POWER RESISTORS

available now through

ERIE
distributors

for Service Replacements

Corning Low-Power Resistors Types LP-4 and LP-5 have been especially designed for radio, TV, and similar applications. They have the highest resistance range of any low-power resistors on the market, and are used by leading manufacturers. They are stable and non-inductive, and impervious to moisture and dirt. Resistance spiralling is automatic and is electronically controlled.

For complete service information and prices . . . see your Erie Distributor.

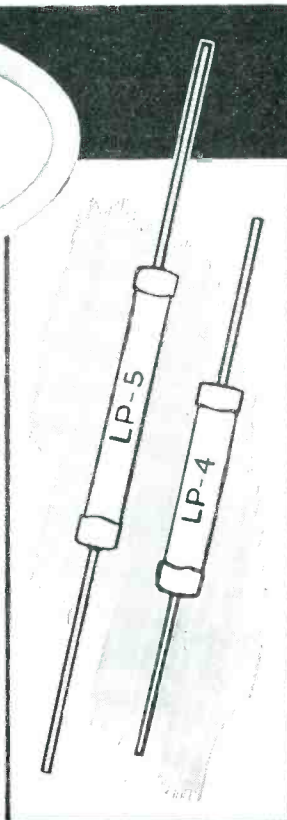

ERIE
electronics

ERIE ELECTRONICS DISTRIBUTOR DIVISION
ERIE RESISTOR CORPORATION
Main Offices: ERIE, PA.
Factories: ERIE, PA. • LONDON, ENGLAND • TRENTON, ONTARIO



BENCH-FIELD TOOLS

SOLDERING TIPS

Soldering tips, *Hexclad*, with a coating of iron alloy over a copper base on all exposed surfaces, have been introduced by Hexacon Electric Co., 594 W. Clay Ave., Roselle Park, N. J.

Units are said not to erode or pit and are available in 40 stock sizes and shapes.

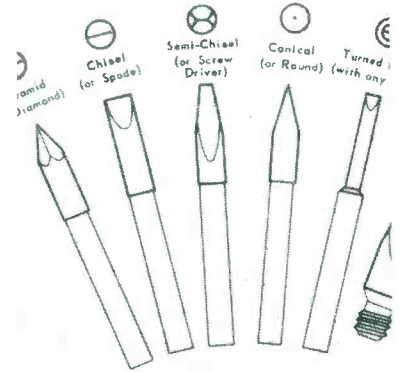

UNMATCHED BIT STRENGTH SCREW DRIVER

A screw-holding unmatched bit screw driver, for driving or loosening tight screws, has been announced by the Speedring Manufacturing Co., 12860 Fisk Ave., East Detroit, Mich.

Driver employs two spring tension bits that are inserted in screw slot to provide positive holding action. Units feature Tenite handles and are available in five models for handling size 4 to 1/4" screws.

FLUSH CUTOFF PLIERS

A transverse cutter (No. 62) for flush cutoff in miniature and subminiature circuits, featuring a small coil return spring, has been announced by Xcelite, Inc., Orchard Park, N. Y. Set into body of plier, near the leverage axis, spring is said to be clear of the handles, permitting use of insulating sleeves.

Plier is *long-nose* type, has small transverse end-cutters hand-honed to a keen edge and induction-hardened.

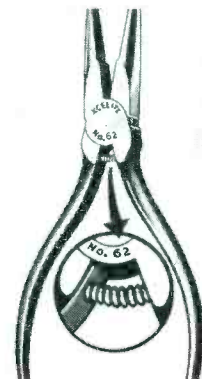

Don't Juggle a Heavy Chassis

WHEN A FINGER TIP WILL DO THE JOB FOR YOU . . .

How many times have you had to lift and turn a big chassis in order to get the light correctly focused so that you could make a solder connection . . . or look for a broken lead? All this extra work can now be eliminated if you put a LUXO LAMP above your bench.

LIGHTWEIGHT AND PORTABLE . . . YET SO STURDY!

The remarkable LUXO LAMP directs *all* the light where you want it. With just the touch of a finger, you can raise, lower, turn or tilt it to any angle . . . get just the desired focus, direction and intensity of light. Comfortable to work under, too, because it eliminates reflections and disturbing shadows . . . and provides glare-free illumination.

INSPECT THE LUXO LAMP AT YOUR JOBBER TODAY!

See for yourself why LUXO is the ideal lamp for your service bench.

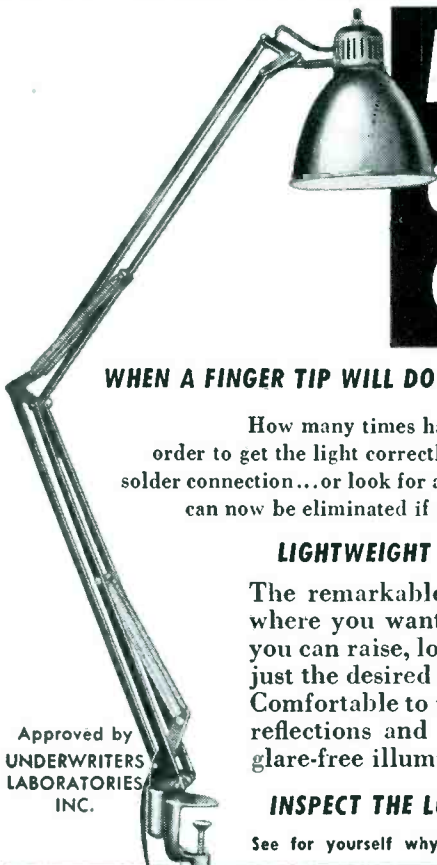

Approved by
UNDERWRITERS
LABORATORIES
INC.

LUXO LAMP CORPORATION • TUCKAHOE, N. Y.
SAN FRANCISCO, CAL. • MONTREAL, QUEBEC

Servicing Engineering Shop

(Continued from page 15)

the first to be equipped with 2-way radio and a talk-back loudspeaker system.

The city has two radio broadcasting stations, KSEI and KWIK. A third recently went off the air. Day-time radio reception from Boise and other Idaho cities is possible, but not entirely satisfactory. Excellent long distance reception at night is experienced because of the lack of numerous local stations. However, tropospheric fading is often severe.

The one local TV station, KID (channel 3) has its transmitter on a mountain about 40 air miles away and because of its location serves the Idaho Falls area as well. Network programs are brought in by microwave.

Television programs from three stations (channels 2, 4 and 5) in Salt Lake City, Utah, 175 miles south are piped to subscribers by the community-television system. The TV signals are picked up at a nearby mountain location and are cabled to approximately 1000 subscribers in town.

Only standard-brand replacement parts are used by Roulias and a substantial stock is always at hand to minimize installation or repair delays.

In addition to the complement of tube testers the shop has a 'scope, a *vtvm*, *rf* and *audio* signal generators, multimeter, plus a healthy assortment of modern tools and accessories.

Because of his extensive experience in servicing and his ham activities which have familiarized him with transmitting gear, Roulias also maintains and services equipment at one of the radio-broadcasting stations, and is also called on to repair the railroad-radio 2-way equipment at the yards and 2-way systems others operate in town.

These professional assignments have boosted the stock of Roulias; he has an outstanding reputation and as a result a booming service business.



HAM EQUIPMENT installed and operated by Service Man Roulias, who is also a member of the Amateur Radio Emergency Corps for Public Service.

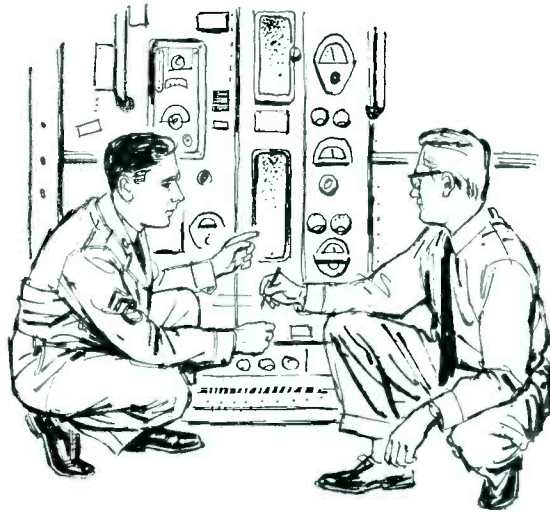

TODAY...

A TECHNICIAN

TOMORROW...

AN RCA FIELD ENGINEER!

HOW ABOUT YOU? Many technicians have the knowledge and experience that can immediately qualify them as Field Engineers with RCA! Now is the time to find out whether you can make the big step up to Field Engineering with RCA.

As an RCA Field Engineer, you'll be responsible to advise and assist the military in the installation, maintenance and use of:

**HEAVY GROUND RADAR
AIRBORNE FIRE CONTROL RADAR
COMMUNICATIONS EQUIPMENT**

You may be assigned to one of many military installations in this country, or overseas. Liberal RCA benefit program adds security . . . a Tuition Refund Plan makes continued education easy . . . relocation assistance, too.

Arrange confidential interview with representative of RCA Engineering Management at a location convenient to you.



Please send complete resume to:

**Mr. James Bell
Employment Manager, Dept. Y-11K
RCA Service Company, Inc.
Cherry Hill, Camden 8, N. J.**

RCA SERVICE COMPANY, INC.

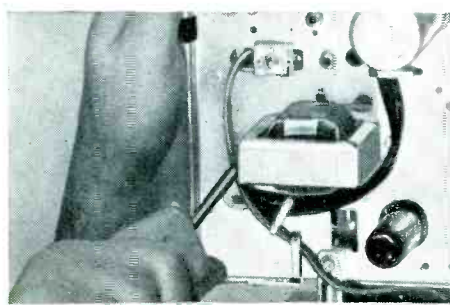
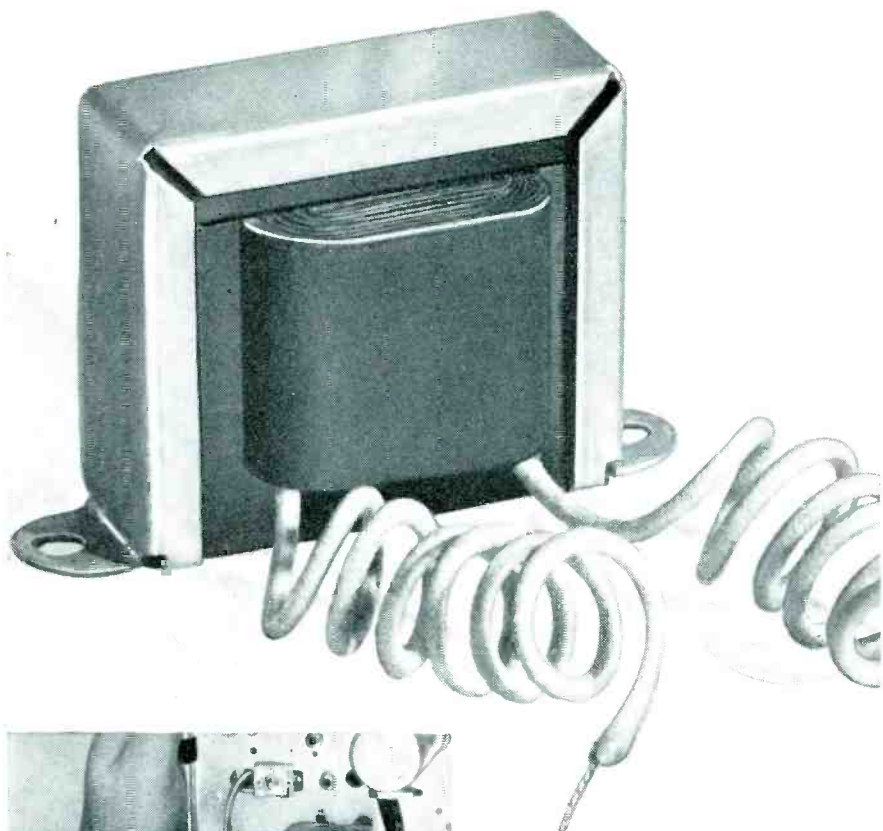

always
replace with

RCA SERVICE PARTS

...your bench-time goes **DOWN!**
...profits go **UP!**

RCA Service Parts are factory-tailored to fit right, install fast. You can depend upon their true-to-the-original design to keep your service calls short, your profits high.

This RCA inductor, for example, has exactly the same inductance and dc resistance values as the part originally built into an RCA Victor television receiver. This means optimum "Q", proper power-supply filter action—correct TV set performance. And, because all RCA Service Parts—like this inductor—install easily, they help cut daily bench-time by hours.

So, keep your servicing on-the-go, profitably. When you need a replacement part for an RCA Victor TV receiver, radio, or "Victrola" phonograph, ask your RCA Distributor for an RCA Service Part.



RCA VICTOR PRODUCTS • RCA SERVICE PARTS—made for each other!

COMPONENTS

FUSE-TYPE SILICON RECTIFIERS

A fuse-type silicon rectifier, M500, for selenium-rectifier replacement has been announced by Sarkes Tarzian, Inc., Rectifier Division, 415 N. College Ave., Bloomington, Ind.

Unit is rated at 400 v back at 500 ma. Dimensions are 3/4" and approximately 1" long; will fit into standard fuse holder.



45-VOLT SELENIUM RECTIFIERS

Forty-five volt selenium rectifiers, said to feature high stability and low reverse or leakage current, have been introduced by the Components Division, Federal Telephone and Radio Co., 100 Kingsland Rd., Clifton, N. J.

Rectifiers are available in standard sizes from 1 1/16" to 2" square, in both commercial and radio-TV types.

RECTANGULAR AC MOTOR CAPACITORS

Rectangular ac motor capacitors, KGN, featuring small case sizes, have been announced by Cornell-Dubilier Electric Corp., South Plainfield, N. J.

Capacitors are available in 236, 330, 440 and 660 v ac ratings and capacitance values from 1 to 60 mfd. Cases are lead coated steel, hermetically sealed at seam and covers to prevent leakage and moisture absorption.

LIME AND SCALE REMOVER

A lime and scale remover for steam irons has been announced by Ion Exchange Products, 9349 S. Cottage Grove Ave., Chicago 19, Ill.

Said to have a special solvent action which dissolves clogging water scale without the use of acids, and without disassembling the iron.



ADVERTISERS IN SERVICE

OCTOBER, 1956

	Page
Alliance Manufacturing Co., Inc.	5
American Pamcor, Inc.	49
Amphenol Electronics Corp.	46
Appliance Service Co.	42
Argos Products Co.	2
Astron Corp.	9
Avco Manufacturing Corp., Electronics Div.	1
B&K Manufacturing Co.	48
Bussmann Manufacturing Co.	8
Channel Master Corp.	6, 7
Chemical Electronic Engineering, Inc.	60
H. G. Cisin	67
Cornell-Dubilier Electric Corp.	Inside Front Cover, 61
Duotone Co., Inc.	56
Dynamic Electronics-New York, Inc.	68
Electronic Instrument Co., Inc.	54
Erie Resistor Corp.	64
Fast Chemical Products Corp.	62
Heath Co.	58
Hickok Electrical Instrument Co.	67
Hotpoint Co.	25
Hycon Electronics, Inc.	47
Jensen Industries, Inc.	54
JFD Manufacturing Co., Inc.	17, 18
Kester Solder Co.	58
Luxo Lamp Corp.	64
P. R. Mallory and Co., Inc.	Inside Back Cover
Merit Coil and Transformer Corp.	54
Mosley Electronics, Inc.	60
Moss Electronic Distributing Co., Inc.	51, 52
Perma-Power Co.	50
Permo, Inc.	42
Philco Corp., Accessory Div.	37
Precision Apparatus Co., Inc.	3
Precision Electronics, Inc.	62
Pyramid Electric Co.	4
Quam-Nichols Co.	55
The Radiart Corp.	Inside Front Cover, 61
Radio Corporation of America, Tube Div.	Back Cover, 31, 39, 66
RCA Service Co., Inc.	65
Raytheon Manufacturing Co.	10
Recoton Corp.	50
Remington Rand Univac, Div. of Sperry-Rand Corp.	29
John F. Rider, Publisher, Inc.	38
Rohn Manufacturing Co.	44
Howard W. Sams and Co., Inc.	63
Shure Brothers, Inc.	53
Simpson Electric Co.	68
Snyder Manufacturing Co.	35
Sonotone Corp.	57
Technical Appliance Corp.	43
Tenna Manufacturing Co.	45
Trio Manufacturing Co.	14
Tung-Sol Electric, Inc.	26, 27
University Loudspeakers, Inc.	59
Weston Electrical Instrument Co., Inc.	56
Winegard Co.	60

TV Antennas

(Continued from page 33)

the legitimate expectations of his tenants. The latter is usually not a difficult job, for the landlords can usually be sold on the idea that a single, well-designed distribution system will provide more reliable television reception at a far less cost than reasonably-priced individual residential installations in the same community. This feature is also a good selling point for landlords in leasing apartments. In many cases, a large proportion of prospective small-town apartment tenants are those who have lived in some large city where they had become accustomed to a steady diet of good television viewing, and are now interested in obtaining TV reception in the fringe-area provided the cost is not excessive.

If a landlord has been plagued with a number of requests for such a system, he may welcome a contract for its installation.

Technical Problems

In one installation we encountered a problem that merits comment. In this particular case, a secondary branch using shielded twin-lead cable had been installed during a hot summer period in a new air-conditioned apartment unit.

When the branch was first installed, it gave perfect performance. However, on the second day, the signal-to-noise ratio appeared somewhat impaired and on the third day the signal had practically disappeared. At first it was thought that the cable had broken or shorted out. The branch cable was checked by open and short circuit tests with an ohmmeter, and the cable checked out all right. After considerable head-scratching, it was decided that the cold air in the apartment had crawled down the air space inside the shielding of the cable and had caused progressive moisture to condense out of the warm air in the low portion of the branch run. This length of condensed water, of course, did not cause a *dc* short circuit or an open circuit, but it caused a severe cable mismatch as well as extremely high *rf* signal attenuation. In this particular case, a satisfactory answer was provided by pulling out the shielded twin-lead and substituting a run of unshielded twin-lead; however, an equally good answer would have been to seal airtight both ends of the branch cable.

SHOOT TV TROUBLE FAST

With H. G. Cisin's Copyrighted RAPID "TV TROUBLE SHOOTING METHOD"

Without experience or knowledge, this guaranteed new method of servicing TV sets, enables you to DIAGNOSE TV troubles as rapidly as an expert. NO THEORY—NO MATH—you can locate all faults in record-breaking time regardless of make or model. "TV TROUBLE SHOOTING METHOD" is the most valuable aid to TV servicing ever written. Be a TV Trouble Diagnostician. Increase your present earnings. Open your own Profitable Business or get a high-paying skilled job.

It's all in this book . . .
Nothing more to Pay—Nothing else to Buy
85 picture troubles, over 58 raster and 17 sound troubles. By this unique copyrighted method you know EXACTLY WHERE the trouble is: plus step-by-step instructions, including 69 RAPID CHECKS, enabling you to find the faulty part.
13 IMPORTANT PRELIMINARY CHECKS NEED NO INSTRUMENTS! Of the 69 Rapid Checks, OVER 63 ALSO REQUIRE NO INSTRUMENTS! Rapid checks include emergency checks for distorted pictures, defective tubes including PIX tube, plus 57 others. ALL EXPLAINED IN SIMPLE LANGUAGE. PERFORMED WITHOUT INSTRUMENTS, MANY CHECKS USE THE PICTURE TUBE AS A GUIDE.
H. G. Cisin, the author, is the inventor of the AO/DC midget radio. He licenses RCA, AT&T, etc. He has also trained thousands of technicians now owning their own prosperous TV service organizations or holding highly paid TV positions. His years of experience are embodied in this remarkable new book. Guaranteed, Money Back in 5 Days if Not Satisfied!

ABSOLUTELY FREE with each order: H. G. Cisin's newest book "TV & RADIO TUBE SUBSTITUTION GUIDE." Gives direct replacements of set and picture tubes. Most valuable servicing aid! ACT NOW—get both books postpaid at cost of only one! **\$1** Postpaid

RUSH COUPON NOW!

H. G. CISIN, CONSULTING ENGINEER,
Amagansett, N. Y. Dept. S-32
Enclosed find \$1. Rush both books.

Name _____
Address _____
City _____ Zone _____ State _____

HICKOK

Model 690



VHF-UHF
Marker Generator

- Crystal controlled frequency coverage from 4.25 to 225 mc on fundamentals — harmonic output on UHF.
- Optically magnified screen permits most accurate marker setting.
- Write for technical details . . .

THE HICKOK ELECTRICAL INSTRUMENT CO.

10521 Dupont Ave., Cleveland, Ohio

BEST BUY IN SCOPES



new!
Simpson
COLORSCOPE
MODEL 458

Compare the new Simpson Colorscope Model 458 with any oscilloscope on the market. It is an advanced, seven-inch, high-gain, wide-band scope especially designed for color-TV service. Ideal for black and white, too.

100% RESPONSE at 3.58 mc color-burst!

DUAL bandwidth—narrow or wide!
FLAT FREQUENCY RESPONSE, within 1 db to 4.5 mc!

RISE TIME less than 0.05 microsecond (wide band)!

FULL RANGE compensated vertical attenuator!

Price with shielded input cable, \$229.95 manual...

Four accessory probes available for extra utility!

See your distributor for details or write—



SIMPSON Electric Company

WORLD'S LARGEST MANUFACTURER
OF ELECTRONIC TEST EQUIPMENT

5200 W. Kinzie St., Chicago 44, Illinois
Phone: EStebrook 9-1121
In Canada: Bach-Simpson Ltd., London, Ont.

Tube News

SIX REPLACEMENT TUBES for TV and auto radio have been announced by Raytheon: 8BA8A, 8CM7, 12AF6, 12CN5, 17AX4GT and 17DQ6.

The 8BA8A, a heater-cathode medium-mu triode and sharp cutoff pentode of miniature construction with its triode section designed for use as a sync separator and the pentode section as a video amplifier, is a 450-ma heater type.

The 8CM7, also a 450-ma type, is a heater-cathode type medium-mu dual triode of miniature construction containing two dissimilar triodes in one envelope, and is designed especially for use as a vertical deflection amplifier.

Horizontal Frequency Damper

The 17AX4GT, also in the 450-ma heater family, is a heater-cathode type diode designed for use in horizontal frequency damper service and is said to be able to withstand high voltage pulses of line frequency between cathode and both heater and plate elements, such as normally encountered in *direct-drive* circuits.

The fourth TV tube, 17DQ6, is a heater-cathode type beam pentode for use as a horizontal deflection amplifier. It is said to have an extremely high perveance for 90° deflection systems. This is also a 450-ma tube.

12-V Auto Tubes

The 12AF6 and 12CN5 are auto-radio tubes, designed to operate with plate and screen voltages supplied directly from a 12-v storage battery. The 12AF6 is a heater-cathode miniature pentode for use as an *rf* or *if* amp.

The 12CN5 is also a heater-cathode miniature pentode, designed for use as an *if* amp.

Series-String Chart

A QUICK SELECTION chart for 600 and 450-ma series-string tubes has been prepared by G. E.

The chart classifies 52 tube types in the 600-ma series and 24 types in the 450-ma series according to elements, typical service, heater voltages, maximum ratings, and gives average characteristics.

The recently-developed 450-ma heater types are intended for use in medium-to-small-size series-string TV receivers, including portable models, where the reduced heater wattage eases ventilation design problems in compact cabinets.

Only the CLEAR PICTURE Comes Thru!



with the
NEW and
AMAZING

Dynamic
**FILTER
TENNA**

with the EXCLUSIVE built-in
HI-PASS FILTER

T. M. Reg. Pat. Pend.
THE FIRST TRULY ELECTRONIC
INDOOR TV ANTENNA TO GIVE
CLEAR FILTERED RECEPTION.



List

\$18.95

SATIN
BRASS,
SATIN
CHROME,
SATIN
COPPER
FINISHES.

Beautiful!

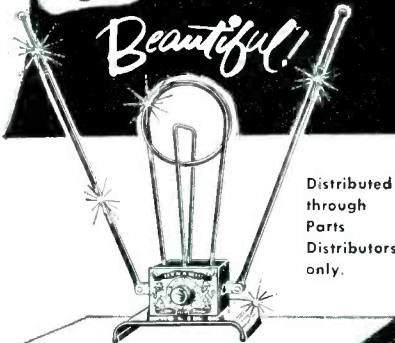

Distributed
through
Parts
Distributors
only.



**THE HI-PASS FILTER
SCREENS OUT!** . . . all electrical disturbances. Field tests prove that this built-in unit rejects all interferences picked up in the antenna circuit . . . only a completely filtered signal comes thru. **GUARANTEED TO OUT-PERFORM ANY INDOOR TV ANTENNA** — in rejecting electrical disturbances—OR YOUR MONEY BACK!

STRONGEST POSSIBLE SIGNAL on any TV.

Powerful high gain phasing elements with adjustable 12 position channel attenuator. Eliminates orientation, ghosts, fuzz, picture tearing, and distortion in practically all locations — on color and black & white TV.

Manufactured By . . .
**DYNAMIC ELECTRONICS -
NEW YORK, INC.**
Forest Hills, Long Island, New York

... another
MALLORY
service-engineered
product

Etched Cathode

prevents
"middle age hum"
in capacitors



Do your capacitors have etched cathodes? If not, chances are they are developing "middle age hum"—may cost you some dissatisfied customers.

All Mallory FP's, and all popular Mallory metal and cardboard tubular electrolytics, have etched cathodes—at no extra cost to you. Ask your Mallory distributor why this is important . . . or write directly to us.

P. R. MALLORY & CO. Inc.
MALLORY

P. R. MALLORY & CO. Inc., INDIANAPOLIS 6, INDIANA

• Capacitors • Vibrators • Resistors • Controls • Switches
• Rectifiers • Power Supplies • Filters • Mercury Batteries

**Show your
customers
what RCA
Silverama
Picture
Tubes
can do for
their old
TV sets**

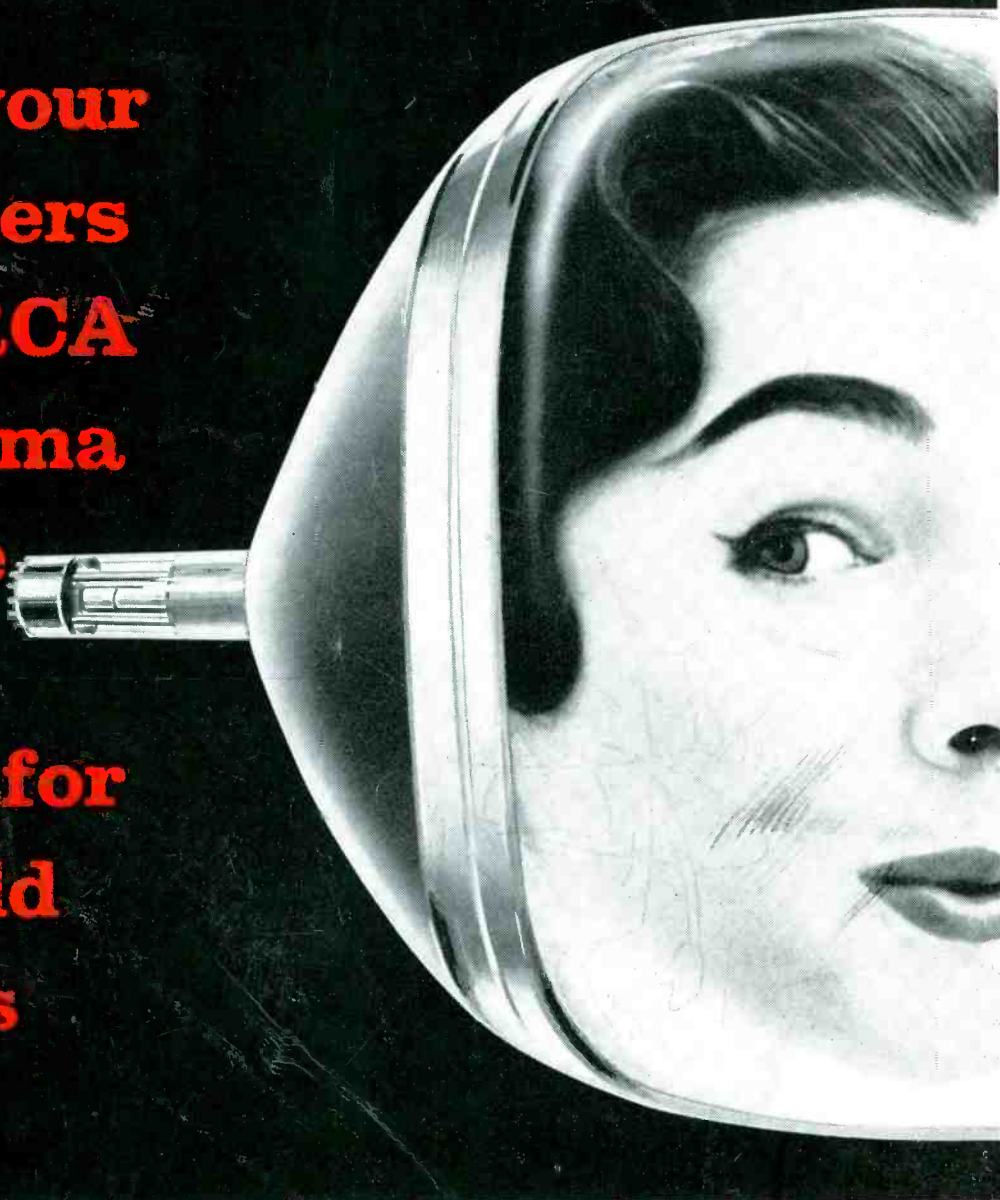

Today, and each succeeding day, too, there is a vast new replacement market opening up for you with RCA SILVERAMA Super-Aluminized Picture Tubes. Many customers are no longer satisfied with dull, dim TV pictures on their present sets—and many are not even waiting until the picture tube is gone entirely. They want the maximum light output and picture clarity their set is capable of giving *right now*.

These potential customers have seen the RCA SILVERAMA TV commercials...they have read about the advantages of RCA SILVERAMA Picture Tubes in Life, Saturday Evening Post, and TV Guide...they are pre-sold on the technical advantages of RCA SILVERAMA Picture Tubes...and they want to see it for themselves.

It's smart business for you to "sell-up" to an RCA SILVERAMA when a replacement picture tube is needed—and your customer benefits, too, in increased viewing pleasure backed by a reliable RCA product. Next time *you're* on a replacement call recommend SILVERAMA and add another satisfied customer to your list.

See Your RCA Distributor for Silverama display material and sales helps.

**The RCA SILVERAMA line
meets virtually every set need
—just 25 types handle over
110 replacements.**



PICTURE TUBES

Radio Corporation of America • Harrison, N. J.