

SERVICE

THE TECHNICAL JOURNAL OF THE TELEVISION-RADIO TRADE

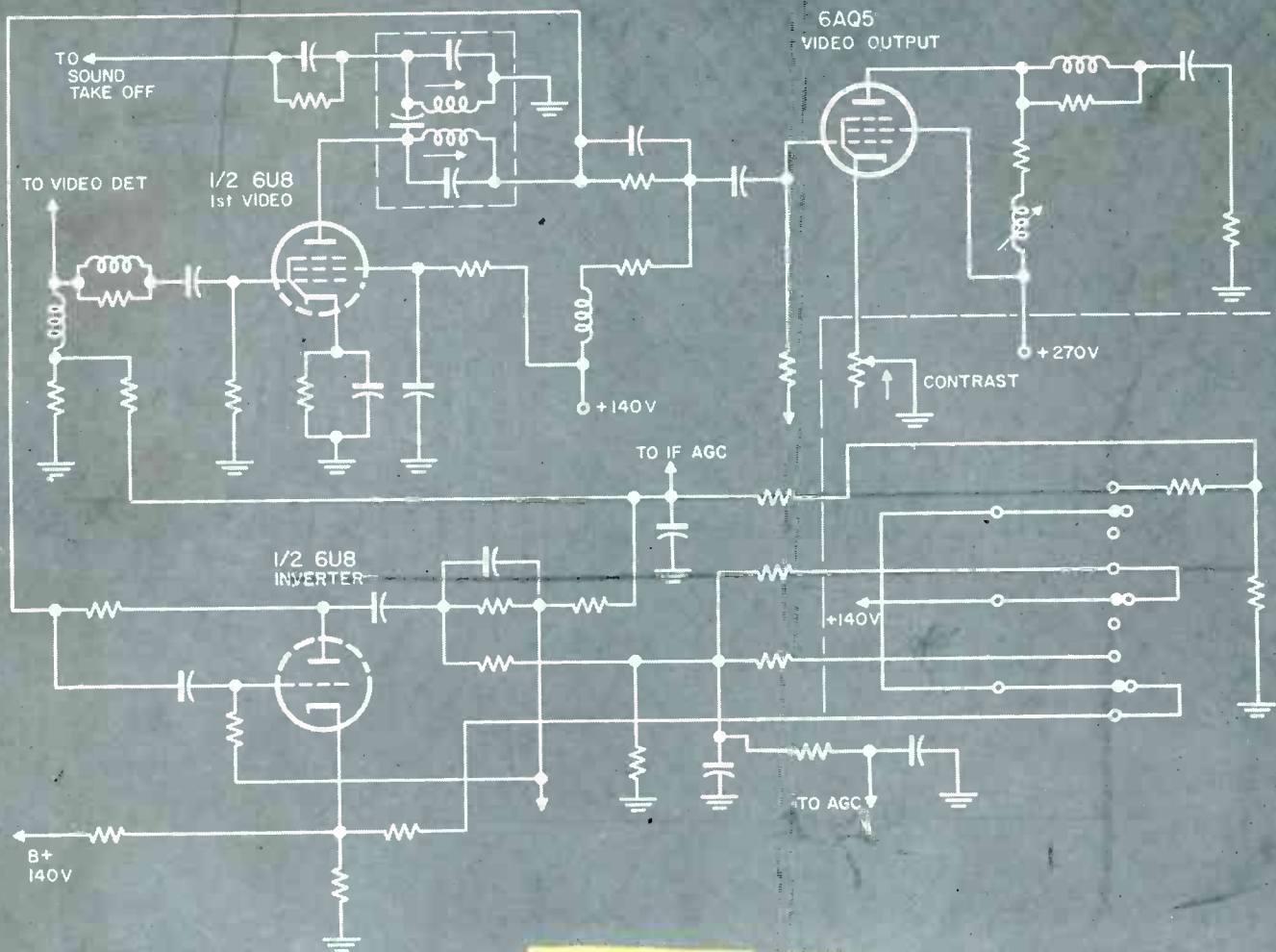

Two-stage video amplifier with a 6AQ5 power pentode in the final stage.
See circuit analysis, this issue

2-59
T L DILLON
914 WATER ST
MEADVILLE, PA
25 SAR 6-28-56 MR

This combination of **CDR ROTORS**
and the **Biggest TV Spot Campaign**

in our history

PRE-SELLING your customers

opens the door

for you to



CORNELL-DUBILIER
SOUTH PLAINFIELD, N. J.



THE RADIART CORP.
CLEVELAND 13, OHIO



There's more in store
for you... when you feature

CDR ROTORS

Proven the popular favorite
the complete line...
a model for every need!



AR-1

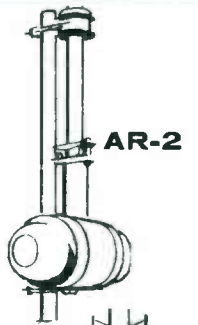

AR-2

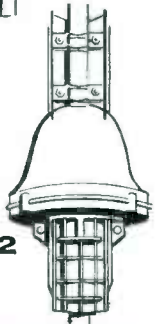

AR-22

featuring

CDR AUTOMATIC Rotors

An outstanding group of rotors... three proven and tested models... ALL 40% SHARPER TUNING than ANY other automatic rotor. Handsome cabinet... dependable performance... proven and tested by thousands and thousands of satisfied users.

TR-12 a special combination value consisting of complete rotor, including thrust bearing. Handsome new modern cabinet with meter control dial, uses 4 wire cable.

TR-11 same as TR-12 without thrust bearing.

TR-4 the heavy duty rotor complete with handsome modern cabinet with METER control dial, uses 4 wire cable.

TR-2 the heavy duty rotor with plastic cabinet featuring "compass control" illuminated perfect pattern dial, uses 8 wire cable.



CORNELL-DUBILIER South Plainfield, N. J.



The **RADIART** Corporation, Cleveland 13, Ohio

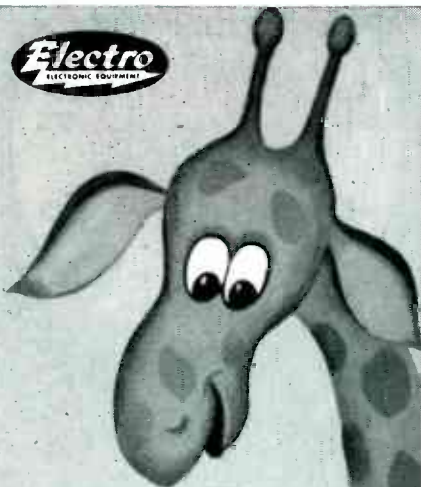

Overlooking
25%
of the profitable
radio repair
business?



Electro

MODEL D-612T

DC POWER SUPPLY

lets you service

TRANSISTOR AUTO RADIOS

(services 6/12V
tube-vibrator radios, too)

* 1 out of 4 radios is an auto set

An Electro exclusive

FOR PRICES AND DATA SEND COUPON TODAY!

Electro Products Laboratories
4501-V N. Ravenswood Ave.,
Chicago 40, Ill.

Rush descriptive and technical data on MODEL
D-612T Power Supply for Transistor Auto
Radios.

Firm name _____

Address _____

City _____ Zone _____ State _____

623 Canada: ATLAS RADIO LTD., Toronto

Vol. 25 No. 9

SERVICE

SEPTEMBER, 1956

The Technical Journal of the Television-Radio Trade

Including SERVICE—A Monthly Digest of Radio and Allied Maintenance: RADIO MERCHANDISING
and TELEVISION MERCHANDISING. Registered U. S. Patent Office.

COVER CIRCUIT

2-Stage Printed-Wiring Decatron Video Circuit (Philco 7L70 Series) 18

FEATURES

Editorial	Lewis Winner	9
Garage Door Opener Installation-Servicing (A Field Report)	John B. Sevec	10
Blown Fuses in TV (How to Track Down Troubles)	Cyrus Glickstein	12
11-Tube 90° 8½" RCA Portable TV (With Complete Circuit)	W. W. Cook	15
2-Stage Printed-Wiring Decatron Video System (Cover; With Complete Circuit)	E. C. Freeland	18
Magnetic Recording (Tape Types—Tape Defect Cures) W. H. Woglom and Lawrence Knees		20
21-Inch Color-TV With Printed-Wiring Boards (With Complete Circuit) J. A. May and W. H. Fulroth		22
This Month in SERVICE		24
2-Way Railroad-Radio Service (Service Engineering)		26
Horizontal-Amplifier Tube Tests in the Plant	Elmer H. Niehaus	28
Design-Application Report on Variable Inductance-Tuned Indoor Antenna		32
Tubes and Circuits in AGC Systems	T. A. Sheehe	34
IF Overloading—Vertical Roll Cures . . . Ion Trap Checks (Servicing Helps)		37
Large Sound-System Installations (Phasing-Mike Wiring-Impedance Runs)		44

CIRCUIT DIAGRAMS

G.E. (TV) 21T26 Fused HV Line	12	RCA 7-TRC-1 Tape Recorder (Complete Circuit)	20
Hallcrafters D1400D Fused B+ Line	12	RCA CTC5 Color Chassis (Complete Circuit)	23
DuMont RA-340/341 Fused B— Lead	12	Railroad-Radio 2-Way Test Setup	26
Sylvania 1-533-1 Fil-Circuit Fusing	12	Capacitive Effects in Ant	32
Motorola TS-533 Fused-Fil Circuit	12	Variable Inductance in Ant Circuit	32
Sentinel 1U-1202 AC-Line Fusing	13	Autotransformer in Ant Circuit	32
Admiral 17XP3 Fusible-Resistor Line	13	Average AGC System	34
Thermal Cutout As Line Fuse	13	Keyed AGC System	34
RCA Portable Tube Complement	15	Level-Control Audio Circuit	44
RCA Portable HF Tuning	15	Remote-Control Mixing	44
RCA 8PT-7030 Portable (Complete Circuit)	16	Two-Channel Mixer	50
Philco Decatron Video Circuit (Cover)	16		

DEPARTMENTS

Catalogs and Books	29	Association News	47
Personnel	30	Instruments	48
Bench Field Tools	31	Color-TV Instruments	48
Parts . . . Accessories	46	Latest in Audio	50-55
Ten Years Ago in SERVICE	46	TV-Auto Radio Tube Developments	64

Index to Advertisers 63

Entire Contents Copyright 1956, Bryan Davis Publishing Co., Inc.

Second-Class mail privileges authorized at New York, N. Y.; additional entry at the
Post Office, Norwalk, Conn. . . . Subscription price: \$2.00 per year (\$5.00 for 3 years)
in the U.S.A. and Canada; 25 cents per copy. \$3.00 per year in foreign countries;
35 cents per copy.



EDITOR and PUBLICATION DIRECTOR

Lewis Winner

Associate Editor: **David E. Pearsall II**
 Assistant Editor: **Robert D. Wengenroth**
 Editorial Assistant: **Eli Cohen**
 Editorial Assistant: **Howard Jennings**

Art Director: **Anthony R. Aliffi**

Supervisor, Circuit Diagrams:
Michael D. Bellezza

Editorial Production: **Astrid Kelly**

CIRCULATION DEPARTMENT

Circulation Manager: **A. Goebel**
 Ass't Circulation Mgr.: **A. Kiernan**

ADVERTISING DEPARTMENT

Advertising Mgr.: **Aaron L. Lafer**

East-Central Rep.: **James C. Munn**
 2253 Delaware Dr.
 Cleveland 6, O.
 Tel.: ERievew 1-1726

Pacific Coast: **Leo Sands, Dist. Mgr.**
 535 Ramona St.
 Palo Alto, Calif.
 Tel.: DAvenport 5-3716

Published Monthly by
Bryan Davis Publishing Company, Inc.
 52 Vanderbilt Ave., New York 17, N. Y.
 Tel.: MURray Hill 4-0170

B. S. Davis, Pres. Lewis Winner, Vice-Pres.



Radio Receptor Rectifiers



Really Reliable Replacements

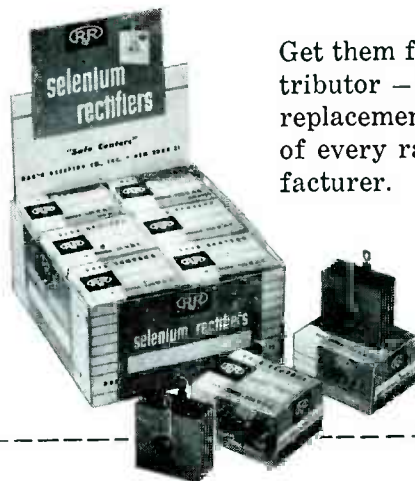

Get them from your parts distributor - There's a standard replacement available for sets of every radio and TV manufacturer.



Semiconductor Division

Radio Receptor Company, Inc.

Radio and Electronic Products Since 1922

240 Wythe Ave., Brooklyn 11, N. Y. • EVergreen 8-6000

1957 CROSLY

TELEVISION'S EASIEST-TO-SERVICE CHASSIS

drastically reduces repair time — even in the shop!

**"This new CROSLY TV
can be serviced in half the
time of ordinary sets!"**

—says **ED HELLER**, Owner,
Heller Radio & Television;
President of Master TV
Servicemen's Assoc., Cincinnati, Ohio



"If my men serviced these new Crosley sets exclusively," says Mr. Heller, "they could increase calls handled in the home by 90%!" Yes, Crosley once again takes TV leadership in producing a chassis that's so easy to service, you'll be recommending it every chance you get. It gives you an opportunity to give better, faster and less expensive service—at greater profit per call! It greatly reduces repair time in the shop.

Many of the major repairs required on a TV set—even the replacement of the picture tube—can now be done in the home while the chassis is in the cabinet. Here's a true "Serviceman's Set," specially designed to make your job easier and much more profitable.

Check the advantages described below, and see for yourself why Crosley is

KNOWN FOR THE NEWEST... RESPECTED FOR THE BEST!

Special Reasons Why You'll Prefer 1957 Crosley TV

- Printed circuit board is translucent! Just place light behind it to trace circuitry.
- Even filter capacitors and selenium rectifiers can be replaced without removing chassis!
- Transformers and chokes are screwed on—not riveted. Easy to service or replace!
- Special Crosley funnel-guide helps find oscillator adjustment. Cuts down probing time!

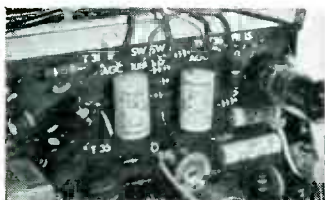

Test points are labeled and easily available from the rear without removing chassis. Quick circuit analysis and trouble-shooting make for simplified servicing.



95% of all parts replaced without removing chassis, without touching a chassis bolt. Provision is even made for changing the power supply parts easily.

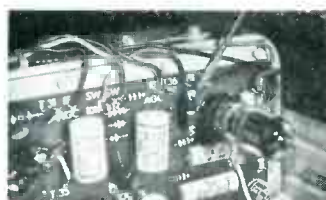

Find tube blowouts with a screwdriver. Open heater tubes are a cinch to locate with the marked special test points. All receiving tubes easily replaced.



Picture tube comes out with the chassis. The tube mounting is a part of the chassis assembly for quick handling. Replacement and set-up are quicker and easier.

Two great brand names from one single source

crosley and bendix
HOME APPLIANCES

DIVISIONS OF **AVCO** MANUFACTURING CORP., CINCINNATI 25, OHIO

CHANNEL MASTER

Explodes a Spectacular Campaign of NATIONAL CONSUMER MAGAZINE ADVERTISING

THE FIRST PROGRAM OF ITS KIND IN TV ANTENNA HISTORY

2-Page Spreads . . . Full-Page Ads . . .
Full-Color Ads . . .

reaching into millions of American homes on
the pages of these outstanding magazines:



CHANNEL MASTER REVOLUTIONIZES ANTENNA MERCHANDISING! With large-scale national advertising and traffic-building local promotions, Channel Master now places TV antennas on the same retail level as traffic appliances. It's actually a NEW WAY for you to sell antennas — and sell more of them. Climb aboard the Channel Master brandwagon and tie in with these profit-making promotions. Get details from your Channel Master distributor.

NEW MARKETS . . . NEW CUSTOMERS . . . FOR THESE 2 GREAT NEW ANTENNAS

CHANNEL MASTER®

T-W

the world's first
"Travelling Wave" antenna

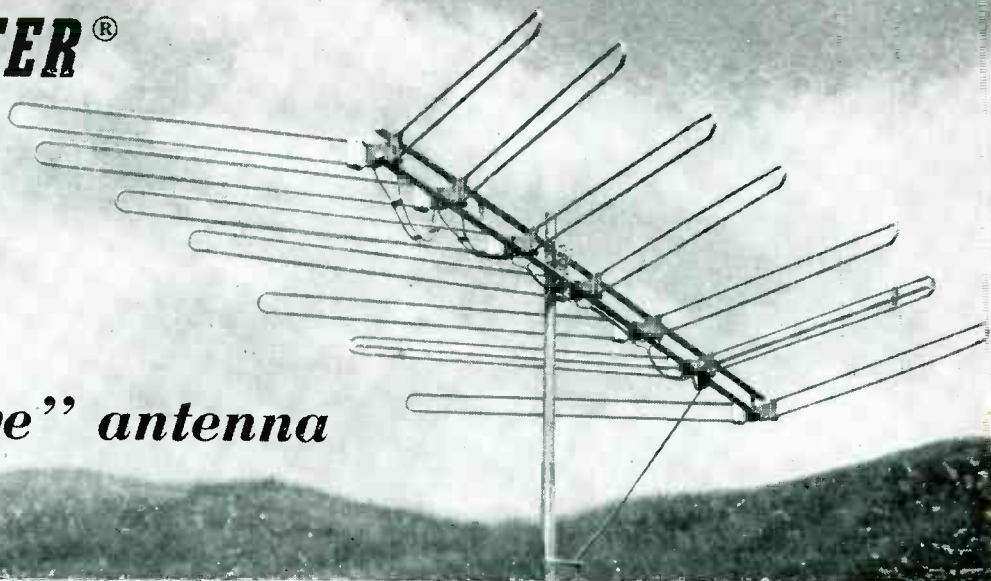

WHAT THE "TRAVELLING WAVE" PRINCIPLE MEANS—

- ideal phase relationships on *all* channels
- optimum impedance matching on *all* channels
- equal flow of current in all dipoles on *all* channels
- fullest use of transmitted energy on *all* channels

IN SHORT — FABULOUS PERFORMANCE
ON ALL CHANNELS

SENSATIONAL 3- AND 5- ELEMENT MODELS!

Amazing T-W performance for sub-urban and near-fringe areas, too! Wonderfully compact and rugged!

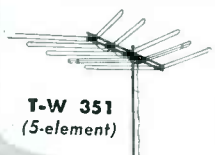

T-W 351
(5-element)



T-W 352
(3-element)

revolutionary new design provides picture quality never before possible

After two years of research—a completely new kind of VHF antenna, operating on revolutionary new electronic principles. The T-W is Channel Master's greatest antenna achievement.

ALL THREE — IN ONE ALL-CHANNEL ANTENNA

1 HIGHEST GAINS

Most powerful all-channel antenna ever developed. A single-bay T-W 350 (7-element) actually **OUTPERFORMS—**



any wide-spaced 5-element Yagi on each low band channel.



any stacked 10-element Yagi on each high band channel.

2 TOP FRONT-TO-BACK RATIOS

Low Band:

Better than 10:1 on every channel. **HIGHER THAN ANY 10-ELEMENT SINGLE CHANNEL YAGI ON ALL CHANNELS!**

High Band:

From 5:1 to 12:1. **HIGHEST RATIOS OF ANY SINGLE ALL CHANNEL ANTENNA.**

3 GREATEST MECHANICAL STRENGTH

The most rugged antenna ever built. "Twin Truss" design amplifies the strength of every component. And new mechanical features add still greater durability . . .

◀ "Twin Booms" . . . Two full-length crossarms—really rugged and rigid.

2 "Super-Nests" One heavy-duty mast clamp on each crossboom .
A TOTAL OF 4 U-BOLTS! Antenna cannot move.

"Line-Lok" Twinlead can't possibly tear away from terminals.

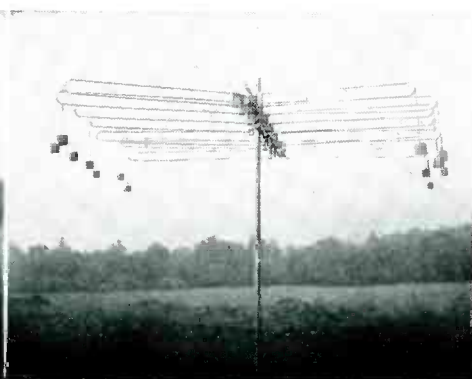
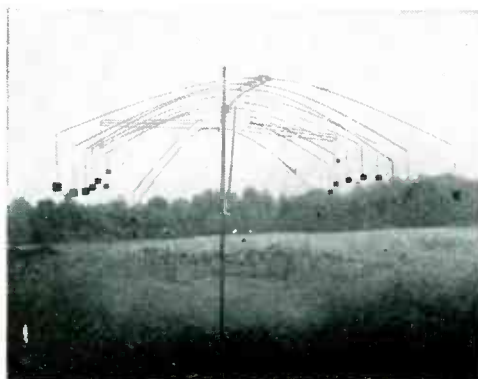
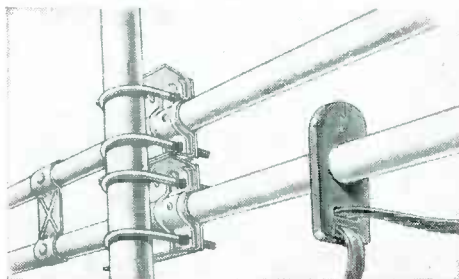

PROOF OF THE SUPERIORITY OF "TWIN-TRUSS" CONSTRUCTION

Look at the dramatic result when equal weights are hung on a T-W and a standard 10-element Yagi!

Write for complete technical literature.

® - Trade Mark Reg. U.S. Pat. Off.

CHANNEL MASTER® "Showman"

new "Metro-Dyne" tuning
obsoletes
"Rabbit-Ears"

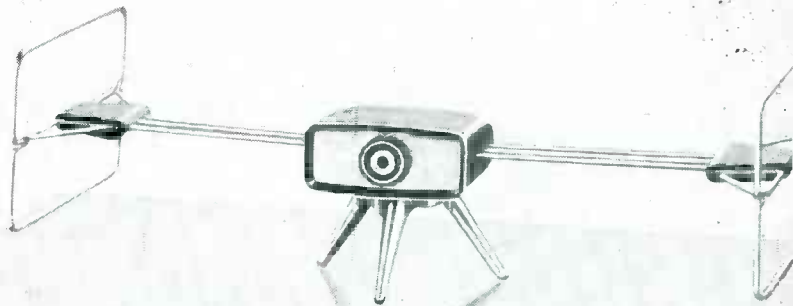

the first basic indoor antenna improvement in over 10 years

Channel Master sets an exciting new trend in TV antennas with the Showman. In appearance (so important in the sale of indoor antennas) the Showman is in a dazzling class by itself. Yet, it's a complex electronic instrument—the most powerful indoor antenna yet developed by modern science!

The SHOWMAN is perfect for color reception, tops for black-and-white. And, it provides excellent FM reception, too!

**ACTUALLY TUNES OUT "GHOSTS" AND "SNOW"!
MORE EFFECTIVE THAN ANY OTHER INDOOR ANTENNA!**



With ordinary
indoor antennas



With the
Showman

Metropolitan areas, where indoor antennas are most frequently used, are often subject to the most severe "ghosting" problems. Only the SHOWMAN, with its sensational new Metro-Dyne tuning, can overcome this difficulty. You'll be amazed at the job it does on all kinds of interference. Test it for yourself! Demonstrate it for your customers!

Channel Master stands squarely behind every SHOWMAN you sell. An unconditional money-back guarantee assures your customer of complete satisfaction.

**UNCONDITIONAL
MONEY-BACK
GUARANTEE**

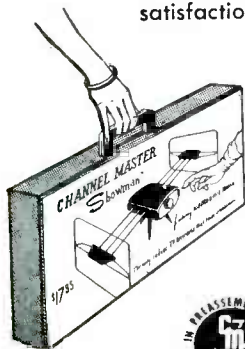

"High fashion"
packaging.
Attractive,
convenient.
Ideal for
display.

Available in three "decor designs"—
to blend with any setting.

Mahogany and Gold	Blond and Gold	Ebony and Silver
model no. 3900	model no. 3901	model no. 3902



CHANNEL MASTER CORP. ELLENVILLE, N. Y.

the world's largest manufacturer of television antennas and accessories

Copyright 1956, Channel Master Corp.

what makes the
"Showman" different?

**FABULOUS
"METRO-DYNE"
TUNING!**

*The Metro-Dyne 12-Channel
"Variable Inductance" Tuner*

Ordinary switch-type antennas work by connecting various elements into different combinations. METRO-DYNE tuning, on the other hand, is "variable inductance" tuning, using the same tuning principles as any TV set. It is the first broad band antenna which can be tuned to a specific channel so that it exhibits the band width characteristics of a single-channel Yagi. This selectivity cuts down tremendously on "electronic noise" and interference. A built-in auto transformer maintains a constant 300 ohm impedance match.

EASY OPERATION: the Showman is calibrated by channels. Just turn it to the same channel number as the TV set. No arms to adjust; no guesswork or error.

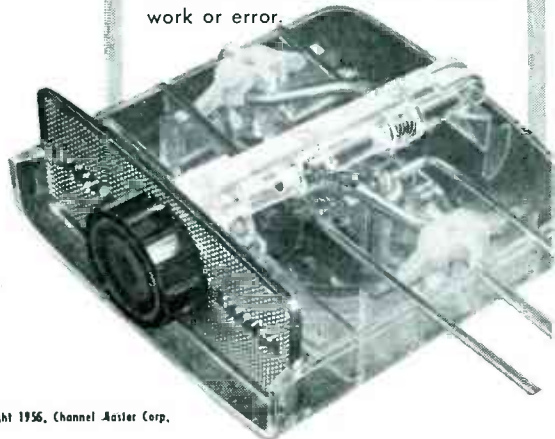



TUBES

are the best you can buy...

HERE'S WHY

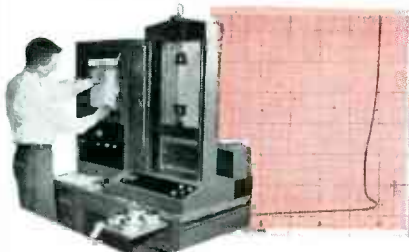

INSTRON WIRE TESTING

Testing of grid lateral and filament wire on the Instron Tester for specified physical properties as tensile strength, yield point, breaking point and proportional limit insures better tube quality and uniformity for Raytheon tubes.

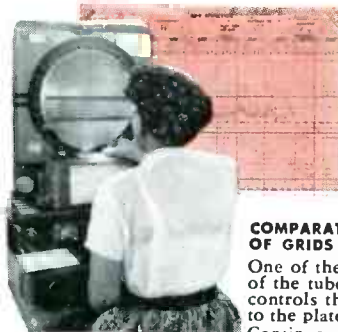

COMPARATOR INSPECTION OF GRIDS

One of the most critical parts of the tube is the grid which controls the flow of electrons to the plate.

Continuous comparator inspection of critical parts such as the above grid (magnified 20x) supplies information for better quality control and guards against deviations from Raytheon's high quality standards.

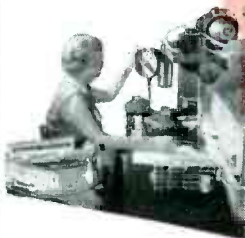

WEIGHING CATHODE COATING

The weight and O. D. of the cathode coating are controlled by periodic measurements with precision instruments. Here, an operator is checking the weight of cathode coating at the operation.

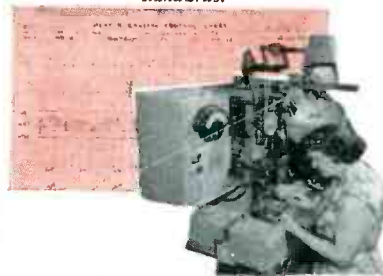

HEATER COATING CHECK

Heater wire must have uniform and closely tolerated coating thickness to insure short and uniform warm-up-time and durability. Raytheon makes continuous inspections of the heater wire coating to make certain of uniformity.

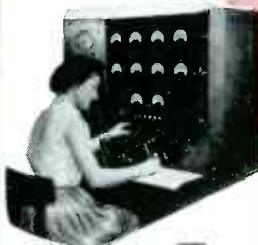

LIFE TESTING

Representative tubes of all tube production lots are put on life test which measures tube performance under simulated actual conditions to ensure original and continuing performance of Raytheon tubes.



1ST FINISHED TUBE TEST

All Raytheon tubes undergo a rigid 100% First Test where they must pass strict requirements on both physical and electrical characteristics.

These girls are testing tubes for excessive noise and microphonics, inoperative tubes, specified electrical characteristics and physical appearance.



ENGINEER CHECKS DESIGN CHARACTERISTICS

Behind all these quality activities stands a large group of experienced, capable engineers whose sole concern is maintaining and developing Raytheon tube quality performance. This engineer is measuring tube design characteristics with the purpose of developing a tube for a customer with special applications.

These and many other vital tests and checks add up to
UNIFORMITY OF CHARACTERISTICS THROUGH RIGID QUALITY CONTROL

RAYTHEON MANUFACTURING COMPANY

Receiving and Cathode Ray Tube Operations

Newton, Mass. • Chicago, Ill. • Atlanta, Ga. • Los Angeles, Calif.

Raytheon makes all these: } Receiving and Picture Tubes, Reliable Subminiature and Miniature Tubes, Semiconductor Diodes and Transistors, Nucleonic Tubes, Microwave Tubes.



SERVICE

The Technical Journal of the Television-Radio Trade

Service Is BIG Business

THE SERVICE BUSINESS is now ringing up cash registers at an estimated rate of well over \$2-billion a year (for labor, parts and accessories), and offering more than 120-million call opportunities to provide service. And the potentials are climbing daily.

Based on the present TV set count of over 40-million in homes, and an average need for servicing of about 1½ calls per year, over 60-million opportunities to repair and install TV replacements, adding up to over a \$1-billion income, are on tap. To these figures nearly another \$1-billion can be added to cover the cost of new and replacement antenna installations, and radio, audio, 2-way and electronic equipment maintenance and repair.

IN THE TV ANTENNA business, sales are soaring up to over \$250-million for over 20-million antennas that have been blown down, become corroded or suffered other damages, and at least 5-million more needed for new chassis.

THE MILLION RECORD player attachments, phonos and phono combinations installed since the beginning of the year, the additional million installations expected before the year is out, plus the 10-million older units in use, represent another husky repair market, totaling at least \$25-million for new and replacement components and accessories.

RECEIVING AND PICTURE TUBE replacement needs are also hitting new highs. According to a study completed only a few weeks ago, the latest yearly national replacement sales estimate for receiving tubes is 170,000,000 and 5,300,000 for picture tubes.

During the next twelve months, a total of nearly 70-million tubes is expected to be sold in New York, Pennsylvania, Illinois, California, New Jersey and Ohio. Over 3-million unit sales are in view for Florida, Georgia, Minnesota, North Carolina and Wisconsin. Substantial replacement sales are also anticipated in the smaller states; well over 1-million unit sales are scheduled for Maine, Mississippi, Colorado, Arkansas, Oregon and West Virginia. And in Montana, Vermont, North and South Dakota, New Mexico, New Hampshire, Idaho, Delaware and Arizona, tube sales of at least a half-million per state are expected.

THE COLOR BREAKTHROUGH the Fall and Winter months will bring, will also contribute healthy sums to the installation-repair package.

In the last two months of '55, more color sets were sold than in the previous 10 months combined. There are now nearly 150,000 color chassis in the field, and another 100,000 are expected to be added before the year is out. This quantity should be *tripled* within the next twelve months, production estimates of leading color set makers indicate.

The growing interest in color has been sparked by the tremendous increase in programming. A 500 per cent boost in color programs is now on the books. In the fourth quarter of this year, nighttime color programming will total between 120 and 130 hours, as against 22½ for the fourth quarter a year ago. Network heads have also announced that the daytime schedules of color shows will be stepped up. In some localities, as in Chicago's WNBQ, the bulk of the TV broadcasts are already in color.

THE COLOR PROSPECTS have given birth to many dynamic educational drives designed to sell color and develop markets for the Service Man.

Make Way For Color, the theme of one drive, features a novel slide film that will be exhibited at meetings from coast to coast. The film, explaining the differences between black and white and color, points out that tube replacements and convergence adjustments will demand most of the Service Man's attention.

In a commentary on the tube-replacement picture in color, the film notes that we can expect to find (as an average) about four tubes burning out yearly in the color set, or twice as many as in the black and white models.

Another vital fact underlined in the color drives is the need for complete sets of instruments that will not only take care of installations, but all repair calls in the field or on the bench.

THE SERVICE BUSINESS has certainly set an extraordinary growth record, and as all statistics show, there's just no ceiling to the expansion possibilities that are ahead.—L.W.

GARAGE-DOOR OPENER

WE SPECIALIZE in the installation, repair and maintenance of radio remote-control systems associated with garage-door operators.

Located in Joliet, Illinois, about 40 miles southwest of Chicago, our shop is housed in a duplex garage facing a street. We chose a garage site for its promotional value and because it makes an ideal arrangement for on-the-spot demonstration of remote-control door operators.

In view of the unusual construction and operation of the door openers, it has been found necessary to develop and build a number of special installation jigs. For operator installation, we use a jig made up of two-by-four in an inverted T arrangement, with another two-by-four slotted to slide up or down on this T. The resultant arrangement allows one man to install an operator-door mechanism. The jig is positioned under the track at the motor end raised and locked into position. This allows freedom of

movement for permanent mounting and simplifies installation.

We have examined and tested many makes of door-operators so that we might know how they work and thus be better able to install and repair them. As a result of these studies, we have learned that in the high-frequency band control type units, the transmitter and receiver are variably tuned. In most cases, the receiver employs a super-regenerative circuit, and a choice of key frequencies is available. Basically, in tuning, a meter is placed in the relay circuit with the receiver tuned to a region of no-meter kicks. Then the transmitter is tuned to the receiver on this spot. Sensitivity of this arrangement is very good. However, because of the super-sensitive inherent characteristic of this type of receiver, various troubles loom.

In a case of two car transmitters operating with one receiver, it is sometimes difficult to achieve equal

Left: Figs. 1-4

1: THE INSTALLATION of the remote-control receiver door-operator in the garage.

2: TEST BENCH in shop specializing in garage-control work. Test equipment employed includes a 'scope, signal generator, capacitor checker, vtvm, tube tester, regulated power input and battery eliminator.

3: ANOTHER VIEW of shop showing inventory of stock required for electronic operator installation and repair: Electric motor belts, drive chain, vibrators, selenium rectifiers, diode detectors, etc. Plug-in channel coils, transmitters, receivers, antennas, operators, not shown.

4: PARTS AND TOOLS carried in car for door-opener jobs: Jig, vise, level, hacksaw, power drill, 25' tape, antenna, lag bolts, spare tubes, transmitter-receiver, operator, ladder on top of wagon on a carrier.



RIGHT: TONE MODULATED transmitter of door-opener remote control with a 12AU7A. A triode section of tube serves as crystal-controlled rf oscillator which is plate modulated by second triode section functioning as a tone oscillator in conjunction with a plug-in tuned circuit. (Perma-Power RC201)

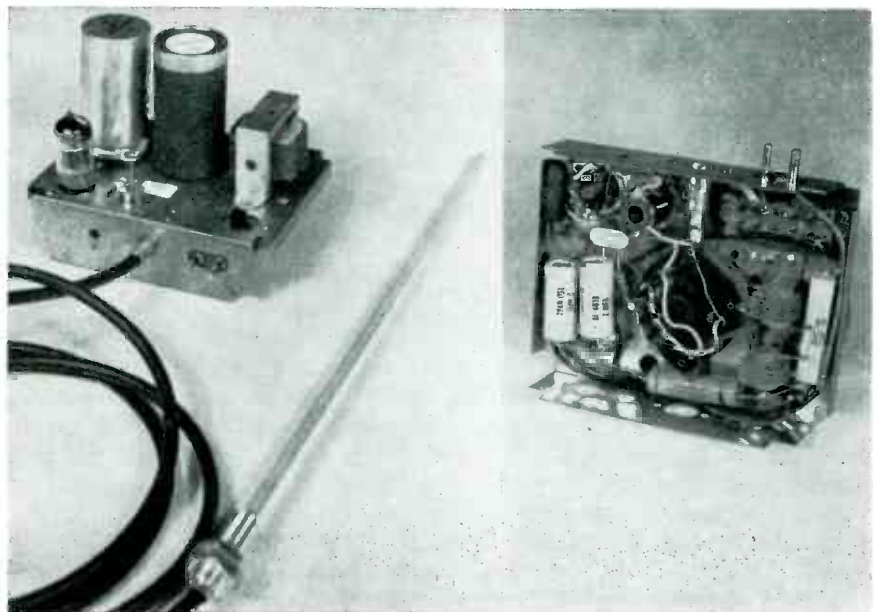

Installation and Servicing

results from both transmitters. Since no crystal control is employed, we have found that after an operation sequence of several weeks, some drift occurs and retuning becomes necessary. Another disadvantage is the radiation caused by the receiver. This results in false openings, especially when other units of the same type are operating in the neighborhood.

We have found these units susceptible to *rf* from planes, amateur radio, atmospheric and man-made noise. The FCC now specifies that receivers in this classification shall be certified with a seal stating in effect that no *rf* radiation obtains. This has been met by some with shielding and the addition of an isolation stage.

Another control device, known as an induction field type, employs a resonant relay, which in turn is used to actuate an auxiliary relay or thyatron. In response to energy at the resonant frequency, the contacts vibrate, closing the controlled circuit.

This system has posed some problems, too; primarily the troubles have been due to mechanical vibration imparted by the operator itself or heavy vehicle rumble in the vicinity causing

by **JOHN B. SEVEC**

John B. Electronics

adverse operation of the door. The units are shock mounted and therefore critical if any departure occurs from its original mount. No field repair should be attempted on this unit.

At present, we are using an operator featuring a transmitter crystal controlled at 27.25 mc, with various plug-in coils allowing ten-channel audio key frequencies.

Since many cars now have a 12-volt system, the hot connection, if made to the coil, must be on the ignition lead side of a dropping resistor which is in series with the coil. If this is overlooked, subnormal input voltage results.

The system we now use employs an antenna mounted beneath the car and behind the bumper. This gives a range of about 6' to 300' with a sensitivity adjustmnet on the receiver.

Where, in some special case, extended range is desired, you may find the geometric placement of the antenna at a disadvantage. In this case,

(Continued on page 56)

Right: Figs. 5-8

5: **TYPICAL GARAGE-door installation** in garage.

6: **JIG IN POSITION** under operator that facilitates installation of ceiling unit.

7: **TEST SETUP** with light which allows operation from transmitting car to be seen at a distance, and enables range of receivers and transmitters to be checked under actual field conditions.

8: **TRANSMITTER INSTALLATION** mounted on car's firewall.

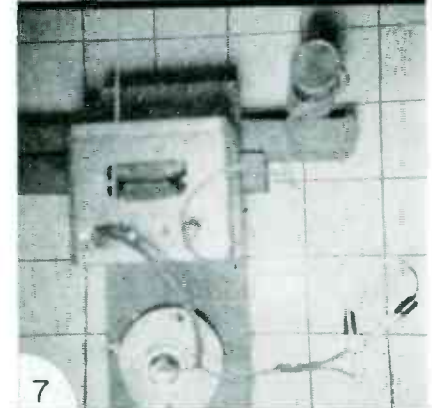
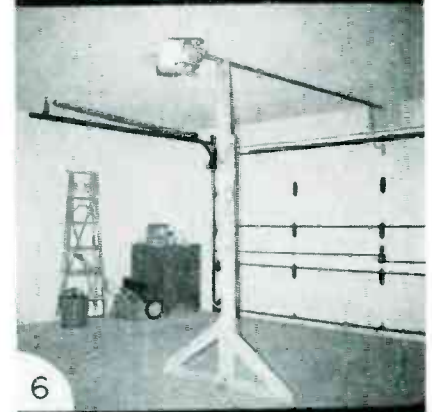
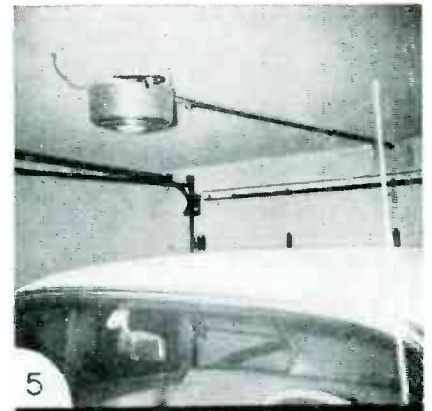
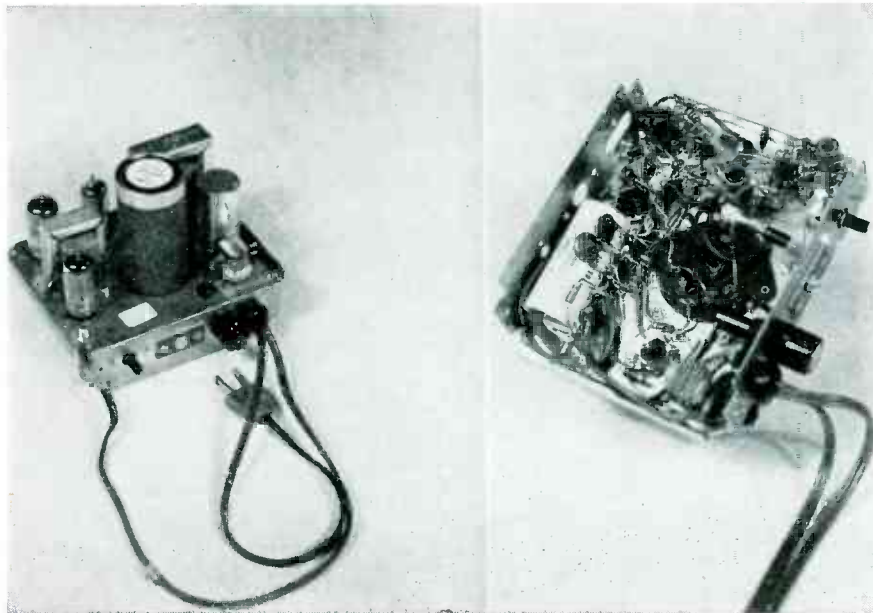

LEFT: REMOTE DOOR-OPENER receiver which uses three tubes (6BA6, 12AU7A and 2D21), germanium diode (1N64) for signal detection, a pair of selenium diodes (1S1) in tone selector network and selenium rectifier (H50B) in power supply.

(Perma-Power RC201)

reset by pushing a button provided for this purpose on the rear apron.

Line fuses are generally found only in transformer-type sets. Filament fuses are used in those chassis that use either a power or a filament transformer. B+ supply and high-voltage fuses are found in either transformer-type or series-filament type sets.

Some models have more than one fuse. Sets with a filament fuse usually have in addition a high-voltage or B+ supply fuse. Other sets may have any two of the four main types. Most sets with fuses, however, have only one. There are a number of receivers that do not carry any fusing.

The symptoms due to a blown fuse vary, depending on the type of fuse which blows. In any of the following cases, one of the first checks should be for a blown fuse: If the symptoms are no raster, no pix and no sound and none of the filaments light up, one should check for an open line or filament fuse. If the symptoms are no raster, no pix and no sound and the filaments light, one should check for an open B+ supply fuse. If the symptoms are blank screen and normal sound, one should check for an open *hv* fuse.

Home Servicing Steps

To save time in home servicing, the following procedure is recommended for all types of blown fuses:

(a) The initial assumption should be that the blown fuse has been caused by a momentary current surge, rather than a component failure, unless some indication of damage is noted, or a breakdown is suspected on the basis of experience or the manufacturer's service bulletins.

(b) With the set off, the fuse should be replaced with another fuse of the same rating. (If the open fuse is a fusible resistor, it will then be necessary to follow other troubleshooting methods; these are explained in another section of this report.

(c) The set should then be turned on.

(1) If the replacement fuse blows immediately, this indicates that there is trouble in the receiver rather than a surge.

(2) If the set operates normally with the replacement fuse, then it is necessary to find out if the fuse has blown previously within a recent period. If so, there may be an intermittent breakdown in the set or the fuse is operating too close to its rating

to take normal current surges. One should note if the old fuse is fast blow or slow blow and the fuse rating should be checked against the range of common values mentioned. If the old fuse was a fast-blow type, it should be replaced with a slow-blow fuse of the same or slightly higher rating. However, unless the old current rating is obviously low, the capacity should not be increased. In any event, the capacity should not be increased by more than 20%, unless the setup is specifically suggested in a manufacturer's field service bulletin for a given model.

(3) If the set operates normally with the replacement fuse, and a slow-blow type with adequate current capacity was used originally, one must then check further for the possibility of an intermittent breakdown. With the set on, the tubes should be tapped (especially the *heavy-duty* low-voltage rectifier, sound output, horizontal output and damper tubes) with an insulated rod. In transformer-type sets, it is important to make a further check for the possible intermittent by removing the sound-output tube; this raises both low-voltage and boosted B+ somewhat. A borderline component will tend to break down because of the higher voltage. (In shop servicing, the same type of test can be performed on a series-filament set by using a *variac* to raise the input voltage to about 125 v.) In any event, the set should be allowed to operate for at least 10-15 minutes before leaving the home to check if the replacement fuse blows.

Blown Fuse Replacements

When a blown fuse is replaced and the replacement fuse blows, the specific procedure to follow next varies, depending on the type of fuse (line, B+ supply, etc.). In making further checks at this stage of troubleshooting, some prefer to pull the chassis and make detailed resistance checks around the circuit before inserting a second replacement fuse. Others find that they can often localize the fault

(Continued on page 40)

(Right)

FIG. 7: METHOD that can be used to replace pigtail fuse, using dual fuse clips and replacement fuse without pigtails. No soldering is required in this operation. The fuse clip is shown in a; installation method in b. The replacement fuse is installed as noted at A; the blown pigtail fuse can remain in the circuit and the open side of the fuse clip clamped over it as shown in B and C.

*Author of *Repairing Television Receivers*; John F. Rider Publisher, Inc.

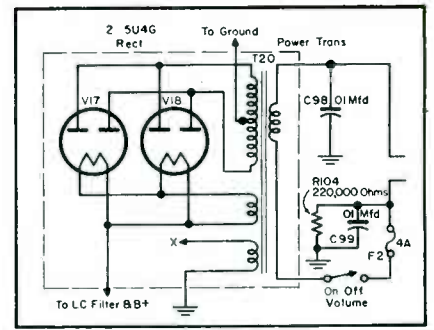

FIG. 4: AN AC-LINE fuse circuit.
(Sentinel 1U-1202)

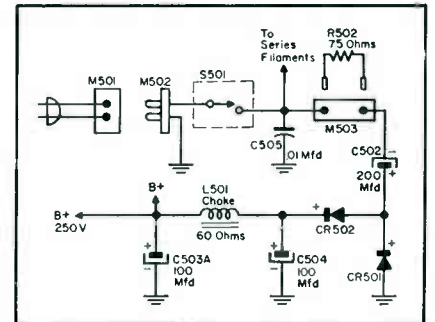

FIG. 5: LV B+ TRANSFORMERLESS supply with selenium rectifiers fused by a fusible resistor; series filaments are not fused by the resistor. (Admiral 17XP3)

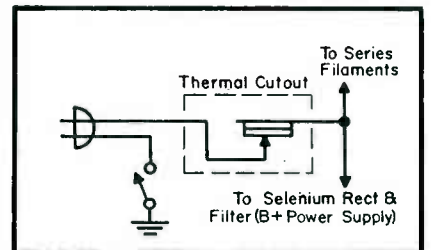
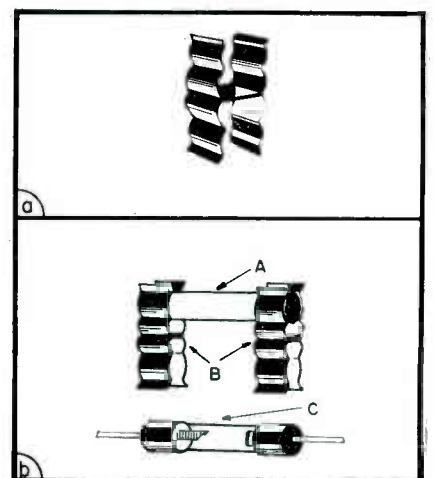

FIG. 6: THERMAL CUTOUT used as a line fuse in a series-filament receiver. Both the B+ supply and series filaments are fused by the cutout protective unit.



n Your Present Set... with a

Announcing

The Most Sensational Advertising Program in TV Antenna History

Winegard

Full color ads—reaching over 30,000,000 prospects across the nation!

**Saturday Evening Post
House Beautiful • Farm Journal
Better Homes & Gardens
Town Journal • Sunset
TV Guide and others**



Write for "Operation Team-Up"—Local Dealer Tie-in Advertising
Winegard Co. 3000 Scotten Blvd., Burlington, Iowa

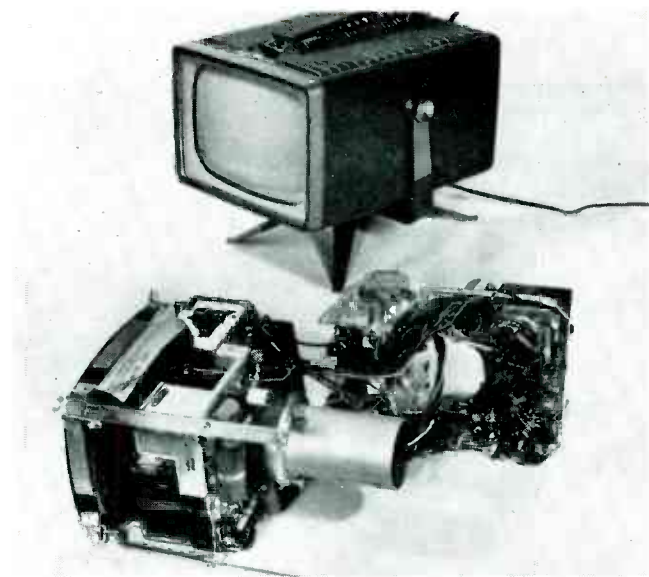
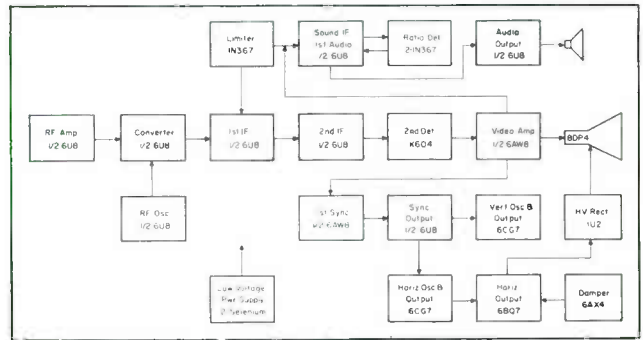

FIG. 1 (left): EXTERNAL AND INTERNAL views of RCA portable (model 8PT7030) which utilizes an 8½ picture tube providing 36 square inches of viewable picture.

FIG. 2: BLOCK DIAGRAM of portable showing tube complement.



11-Tube 90° 8½-Inch RCA Portable TV

THE DEBUT OF THE TV portable, the television counterpart of the personal radio, within the first decade of large scale television broadcasting, is another example of the tremendous pace of television development. Progress which required 20 years in the radio field has been telescoped into 10 years of television.

As in the case of radio, a high standard of performance had to be specified even though the receiver components had to be compacted into a package much smaller than was thought practical or possible just a short time ago. Just how this has been made possible is best understood

by **W. W. COOK**, *Technical Training, RCA Service Company, Inc.*

by considering the technical and constructional features of these unique receivers.

The portable¹, diagrammed in Fig. 4 (p. 16) which features an 8½" (90° with electrostatic focus) rectangular picture tube, is housed in a case that is only 10½" x 9½" x 12½" and weighs approximately 22 pounds without a stand.

The receiver utilizes 11 tubes including a picture tube (8DP4) and four crystal diodes, which serve as second detector, sound *if* limiter and ratio detector. The receiver uses the usual number of tube functions, except in the case of the picture *if*,

where only two pentode tube functions are employed.

Normal *if* gain is present; however, the *if* bandwidth is somewhat narrower. This is allowable since the size of the picture tube is a determining factor on the resolution perceptible by the human eye.

The receiver is constructed on three separate chassis sub-assemblies. Two of the sub-assemblies are vertical chassis, through which the picture tube is inserted. The third assembly is the *rf* tuner.

Circuit Description

An incremental inductance tuner² used in this receiver, has two pentode-triodes (6U8) as *rf* amplifier, converter, *rf* oscillator and first picture *if* amplifier.

The antenna input circuit is conventional and includes an antenna matching transformer, two *if* traps, AM rejection and an FM trap. The output of this circuit feeds the *rf* amplifier which is connected as a grounded-grid amplifier. An *agc* bias voltage is applied to the *rf* grounded grid through a 22,000-ohm decoupling resistor.

The *rf* amplifier plate voltage is obtained from the cathode of the first *if* (Continued on page 16)

¹RCA models 8PT7030/7031/7032 7034. ²KRK 55A.

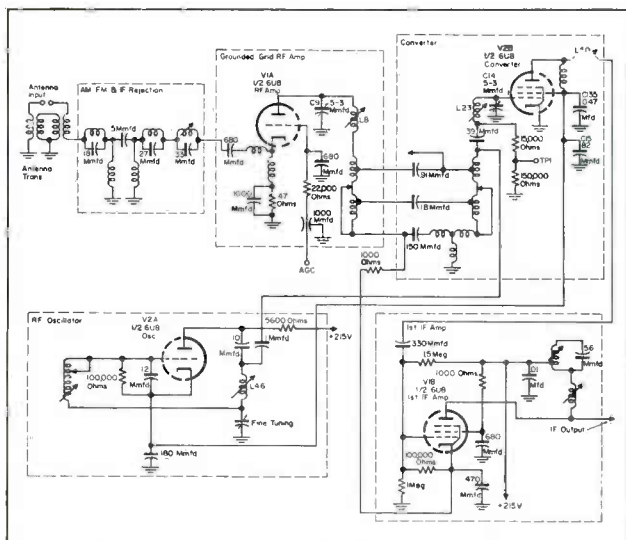
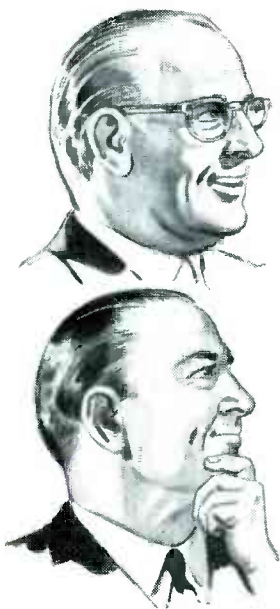

FIG. 3. CIRCUIT (simplified) of the *rf* tuner used in RCA personal portable chassis.

[See Page 16 for Complete Diagram]



**Why you can
rely on BUSS
Fuses . . .
for dependable
electrical
protection!**



Makers of a complete line of fuses for home, farm, commercial, electronic, automotive and industrial use.

To make sure of top quality and proper operation—BUSS fuses are tested in a sensitive electronic device. Any fuse not correctly calibrated, properly constructed and right in all physical dimensions is automatically rejected.

That's why BUSS fuses provide maximum protection to users' equipment against damage due to electrical faults . . . and help safeguard your reputation for quality and service. And just as important, BUSS fuses, by their unfailing dependability, help you avoid costly, time-wasting callbacks by eliminating needless blows.

To meet service needs, a complete line of BUSS fuses is available: standard types, dual-element (slow blowing), renewable and one-time types—in sizes from 1/500 amp. up . . . plus a companion line of fuse clips, blocks and holders.

BUSS fuses have ready customer acceptance . . .

Over the past 41 years, millions upon millions of BUSS fuses have been used in homes, industries and on farms. As a result, BUSS is the known brand of fuses—accepted by the trade and consumer as the finest available. This means sales are easier to make because BUSS quality is never questioned.

BUSSMANN MFG. CO.
(Div. McGraw Electric Co.)
University at Jefferson St. Louis 7, Mo.

S-956

For information on BUSS and Fusetron small dimension fuses and fuseholders . . . Write for bulletin SFB.

[See Front Cover]

2-Stage Printed-Wiring

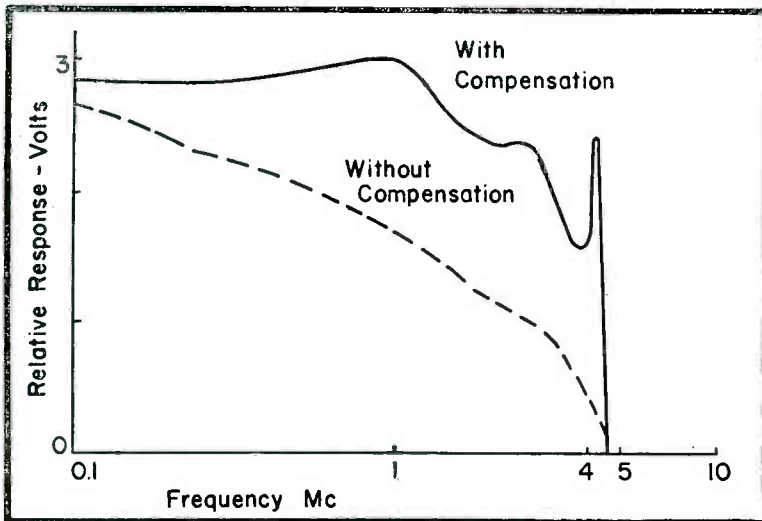

FREQUENCY RESPONSE of first video stage.

IN DESIGNING any receiver, certain performance requirements must be met. The specifications spelled out for the video amplifier¹ of our new line of TV sets² called for a two stage unit that would deliver sufficient drive to get the maximum amount of contrast available in the picture tube with a linear gamma characteristic, and a picture resolution capable of reproducing the detail available in good quality studio transmission. So that the overall gain of the receiver could, in the fringe area, take every advantage of the low noise figure of the tuner used in these models, the amplifier also had to have two to three times the video gain of the average video amplifier.

The highlight brightness obtainable from a picture tube is determined by

the high voltage and beam current available to zero grid bias. However, the beam current available at zero bias is also a function of the screen or first anode voltage of the picture tube. Therefore, by increasing this voltage, it is possible to gain in highlight brightness and at the same time improve the focus quality of the beam. But, increasing the first anode voltage increases the cutoff voltage of the control grid of the picture tube; hence, a proportional increase in drive is required to drive the black level to zero beam current.

The first anode voltage of the picture tube in our chassis³ has been increased by approximately 50% over that of the average set, and the available video drive has been upped by a corresponding percentage.

To obtain the required video drive and maintain good gamma or shading characteristic and high resolution in the picture a 6AQ5 power pentode was chosen for the final stage of the video amplifier. This type tube was chosen for three reasons: (1) The available plate voltage swing between zero bias and grid voltage cutoff is greater than can be obtained in a triode; (2) the grid-to-plate capacity is much lower than a triode; and (3)

a pentode as a power tube has higher G_m than a triode. A power pentode is effective because large excursions of current are required to deliver the required video drive voltage across the relatively low value of plate load.

Low grid-to-plate capacity is more important than a casual observation would indicate. Where the amplifier tube is working into a resistance amplifier, the effective input capacity of the tube is increased by an amount equal to the gain of the stage, multiplied by the grid-to-plate capacity. This capacity could amount to as much as 20 or 30 mmfd in the case of a triode, as compared to 2 or 3 mmfd for a pentode.

A two-stage video amplifier was chosen to provide adequate over-all receiver gain for the fringe area, and sufficient gain to amplify the level at the second detector to that required to deliver the ultimate available contrast at the picture tube. A two-stage amplifier, it was also found, permits placing the contrast control in the cathode of the last video amplifier, where the synchronizing signals and transient response or picture quality are independent of the contrast setting.

Circuitry Analysis

In the special circuit developed, the sync information is taken off at the plate of the first video amplifier ahead of the second video amplifier, where it is unaffected by the contrast control. By using a cathode type of contrast control, a low-impedance control can be used, so that the stray circuit capacities across the control have little or no effect on the transient response. Here the choice of a pentode again plays an important part because the reflected grid-to-plate capacity is very low. Hence, the magnitude of this capacity, which varies with the gain of the stage, as the contrast setting is varied, has little or no effect on the transient response.

The second detector level must be maintained relatively low to prevent overload in the last *if* stage and to permit the use of a high *agc* loop gain that is required to hold constant *if* gain and guard against overload at high signal levels. This means high gain in the first video stage to provide the necessary grid swing for the power stage. A high G_m pentode ($\frac{1}{2}$

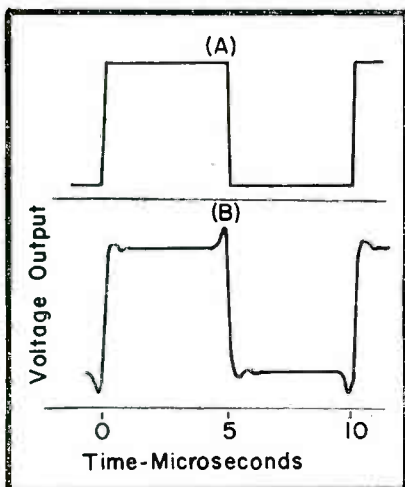

OVERALL TRANSIENT RESPONSE of video-amplifier. Plot in a shows overall transient or square-wave response of modulated antenna signal. In b is illustrated the extended frequency range and sharp corners of the transient response obtained because of the use of lower inductance peaking coils.

¹Using the Decatron circuit.
²Philco 7L70.

Decatron Video System

by E. C. FREELAND
Engineer, Television Division
Philco Corporation

With 6AQ5 Power Pentode In Output and 6U8 as First Video Amplifier and Inverter

6U8) was chosen for this function. The dual tube was selected so that the triode section could be employed as a noise inverter. The noise inverter is closely related with the video amplifier, in that its input energy comes from the video amplifier and its output energy is again fed back into the video amplifier in reverse phase. The use of the 6U8, therefore, makes for a compact layout on a printed-wiring panel (used in this chassis series), which results in low circuit capacities and contributes to the gain bandwidth of the amplifier.

The use of a pentode with high G_m

and low grid-to-plate capacity in the first video stage not only contributes to picture resolution, but also boosts the available sound gain. The low reflected grid-to-plate capacity makes it possible to use a low value of series peaking coil in the grid of this stage, without losing picture resolution. The value of this peaking coil was chosen so as to resonate approximately the input capacity of the tube at 4.5 mc. A high-impedance parallel-resonant trap is used in the plate circuit of this stage; this has been found to be a most effective means of trapping out the 4.5-mc sound beat from the pic-

ture channel and at the same time functions as a part of a broad-band double-tuned sound take-off transformer.

The grid of the second video stage is tapped half way down on the video plate load to provide the proper portioning of the noise inverter and video voltages. The output capacity of the noise inverter and input capacity of the sync separator are in parallel and load the video amplifier through a 15,000-ohm plate load of the noise inverter. This puts a step function in the frequency response, which must

(Continued on page 60)

CIRCUIT DIAGRAM of the Philco decatron video system which features use of a 6AQ5 power pentode in the final video-amplifier stage.

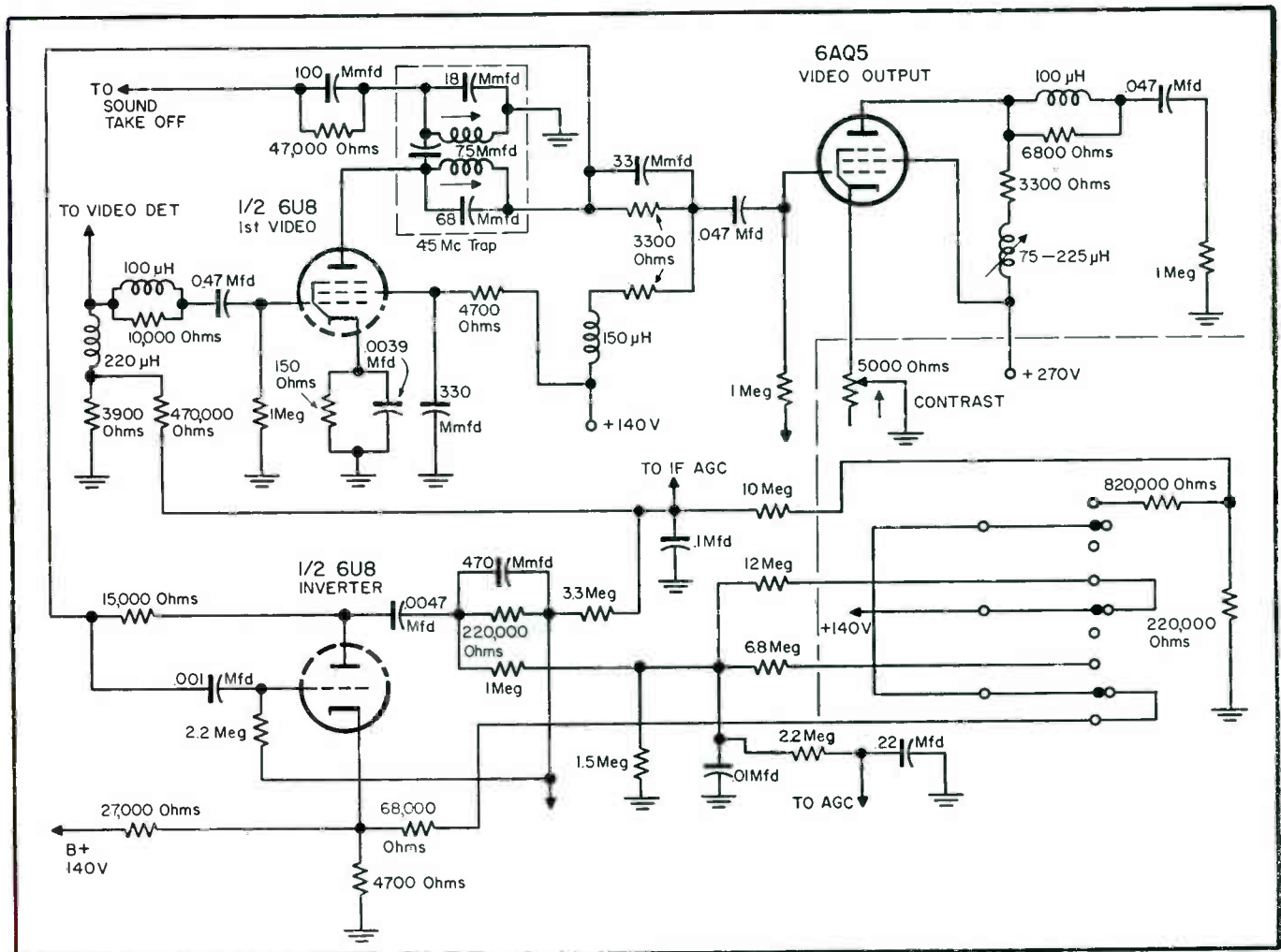

Magnetic Recording

Tape Types . . . Cures for Physical-Electronic Tape Defects

IN SELECTING TAPE for magnetic recorders, it is necessary to consider tape gage.

The thinner gage tapes afford more recording footage per reel, but are not as strong as standard gage. It is therefore important that tensions in a machine using thin gage tape be correctly adjusted, to avoid tape damage.

In recorder repair, Service Men must be alert to various problems in recording and reproduction which are caused by the tape itself, rather than the recorder, to avoid useless work on a recorder which is blameless. If a complaint of either squeal or static is received, the tape should immediately be suspect and before any work is done on the recorder, the tape should be replaced by a roll known to be free of these defects. Although great strides have been made by tape manufacturers to rid their products of these faults, and they are much

by **WILLIAM H. WOGLOM** and **LAWRENCE KNEES**

Quality Control Manager

Service Manager

Reeves Soundcraft Corp.

less common than formerly, it is possible that tape with such defects still exists. Intermittent pops and bangs can also be caused by the tape. Here again, the tape should be replaced with a roll known to be good, before the recorder is worked on.

If a lack of high-frequency response is noted, again it may save the Service Man a good deal of time if he assures himself that the tape is not the cause, before working on the machine. Good high-frequency response is dependent on good head contact. It would be well to check tape adhesion; if it is poor large amounts of oxide could be building up on the heads, causing the tape to

be removed from the heads just enough to lose the highs.

It is also necessary for a tape to be flat, both vertically and longitudinally, if good high-frequency response is to be had. Should a tape not be flat across its width, or *cupped*, either the edges or the middle of the tape will stand away from the head, depending upon which way it is cupped. This will cause a serious loss of high frequencies, especially in half-track recording. This effect will be less noticeable in the thinner base tapes, which generally maintain better head

(Continued on page 61)

COMPLETE CIRCUIT DIAGRAM of RCA 7-TRC-1 tape recorder-playback and remote control system.

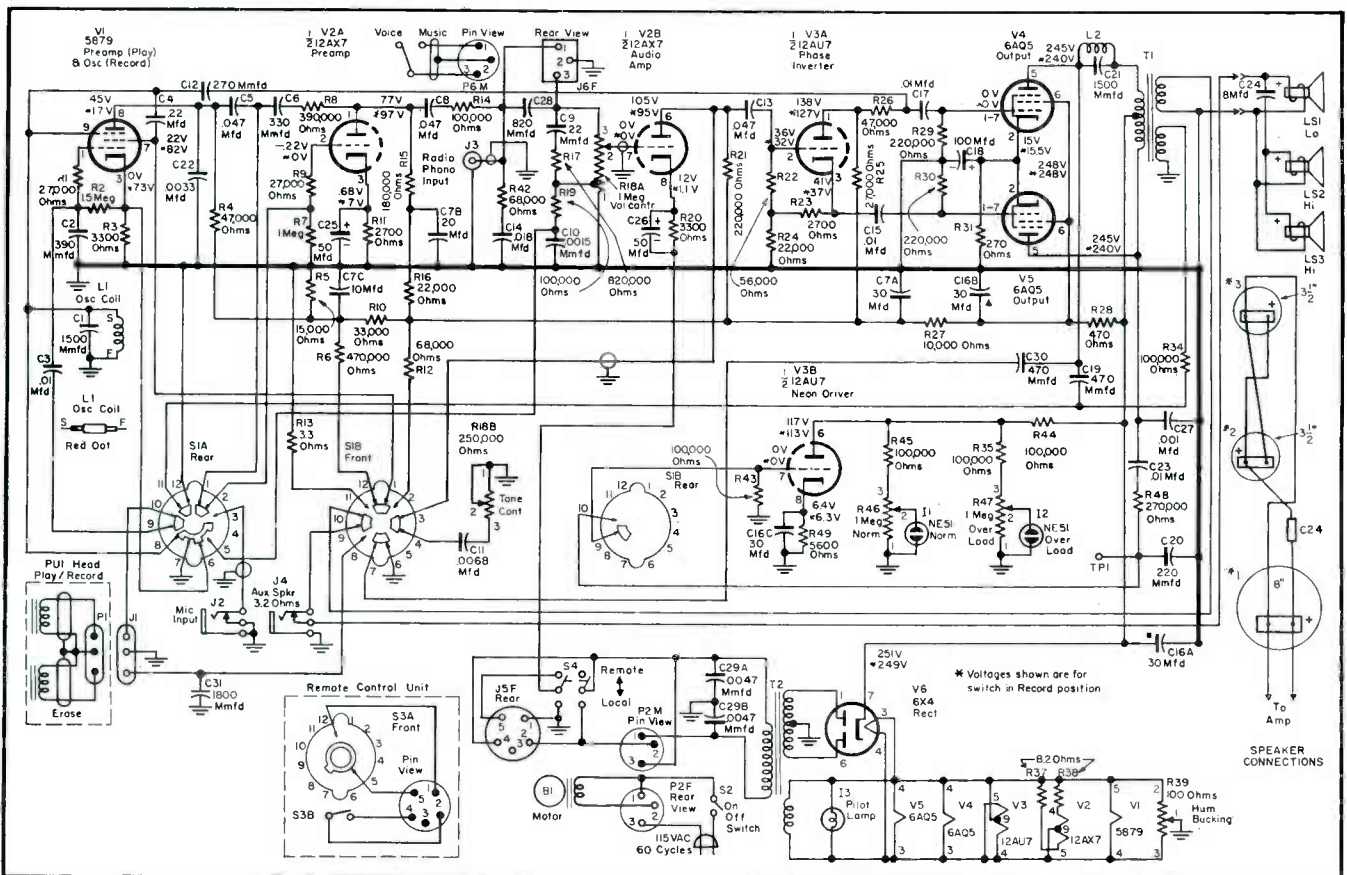

HOTPOINT ENTERS THE TV FIELD

... in a BIG way! Hotpoint, one of the biggest names in Appliances, is now in TV. With 129 of the nation's best distributors, huge production and spectacular advertising, Hotpoint TV will be among the top ten by Christmas. You'll see a lot of Hotpoint TV in days to come. You'll need to know about these sets, and Hotpoint announces this program to make that information easy-to-get.

HOTPOINT TV INFORMATION AND HELPS FOR SERVICEMEN

Hotpoint TV Distributors are your service contacts. They're anxious to help you every way they can. They want your friendship.

Service manuals and supplementary TV service notes are available from your Hotpoint Distributor.

Service training schools will be held for you and your servicemen by the distributor.

Factory specialists will maintain daily contact with distributors. This factory-distributor relationship offers you a factory answer to any problem, usually immediately.

Genuine parts will be available from your Hotpoint TV Distributor.

GET ACQUAINTED NOW!

Send the coupon at right to us and we will pass it along to the Hotpoint TV Distributor in your area. He will contact you and provide you with all the information you will need. There is no obligation, this is simply a good-will service by Hotpoint for TV servicemen. Send now!

Hotpoint

HOTPOINT CO., (A Division of General Electric Co.)
Chicago, Illinois

Hotpoint Co., TV Service Dept.
227 S. Seeley, Chicago 12, Ill.

I'll need Hotpoint TV service information, so please have the distributor in my area contact me.

Name _____

Firm _____

Street Address _____

City _____ State _____

21-Inch COLOR-TV Chassis Featuring Printed-Wiring Boards

by J. A. MAY and W. H. FULROTH
Commercial Service, TV Service Clinic, RCA Service Company, Inc.

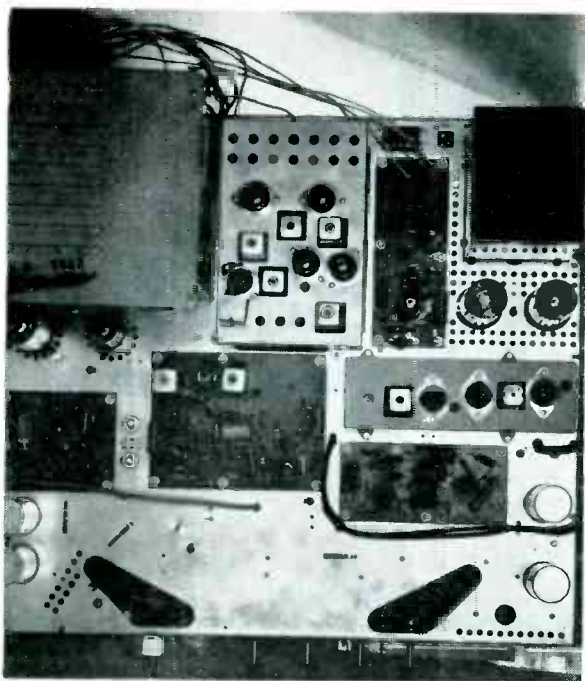

LEFT: TOP CHASSIS view of RCA CTC5 color chassis.

THE RCA 21-inch color-TV line receivers recently introduced incorporates 10 models, equipped for *vhf* reception only, or optionally, for *uhf-vhf*.

In all models the tuner unit is mounted separately from the main receiver chassis. The receiver chassis are mounted horizontally with cables extending to the tuner unit, and the volume and brightness controls. The volume and brightness control unit is attached to the tuner mounting bracket and is removable separately.

For the convenience of the Service Man there is a special bracket, built into the main receiver chassis,

for attachment of the tuner, when both units are removed from the cabinet.

New circuitry in one line of models¹ includes separate second detectors for picture *if* and sound *if*. All models feature the intercarrier-type sound system which places the sound *if* 920 kc from the color subcarrier; sound *if* at 4.5 mc, color subcarrier at 3.58 mc. The use of dual second detectors, it has been found, makes it possible to obtain attenuated sound for application to the output of the picture second detector without impairment of sound gain. This attenuation minimizes the possibility of the

920-kc beat appearing as an interference pattern in the picture when viewing a color picture.

Another advance includes the use of printed-wiring boards that comprise approximately 80% of the circuitry in the receivers.²

Each board is mounted flush with the chassis and has the components and convenient test points located on the top side of the boards.

In the new models the top of the cabinet is not removable as it was in previous RCA color receivers. Because of this, a new feature has been incorporated; all grey scale adjustments and all convergence adjustments except the blue-lateral beam positioning magnet have been made accessible at the front of the receiver when the control box cover is removed. This means that for all normal service adjustments, except during initial purity setup adjustments, where it may be necessary to properly position the deflection yoke, convergence yoke or purity magnet from the rear of the receiver, the rear cover of the receiver need not be removed.

The 21-inch color tube used in these new models has a high-voltage
(Continued on page 62)

MASK, PICTURE TUBE, high-voltage insulator and color picture-tube accessories.

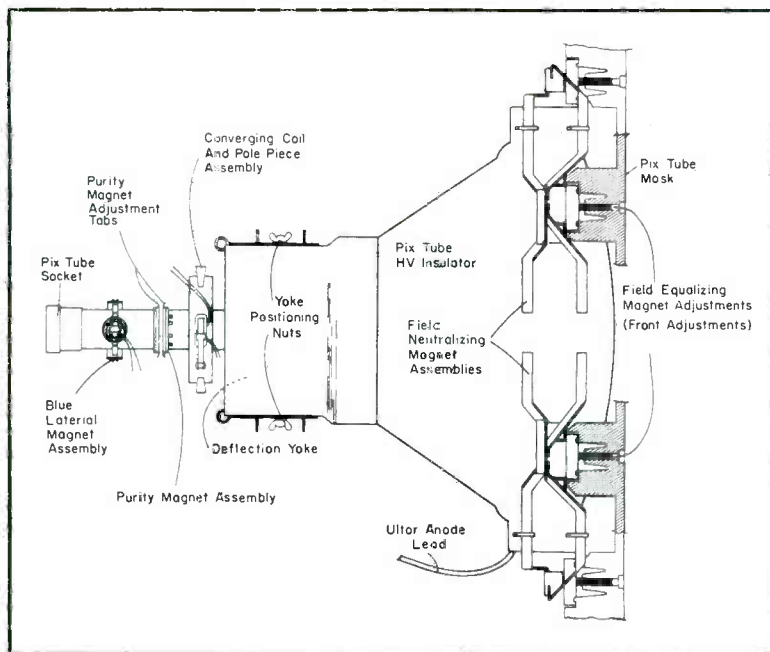

¹The *Special* series.

²In the *Special* and *Super* models (CTC5), there are six boards; in the *DeLuxe* series (CTC5N), there are five boards.

► Right ►

COMPLETE diagram of RCA CTC5 color-TV chassis.

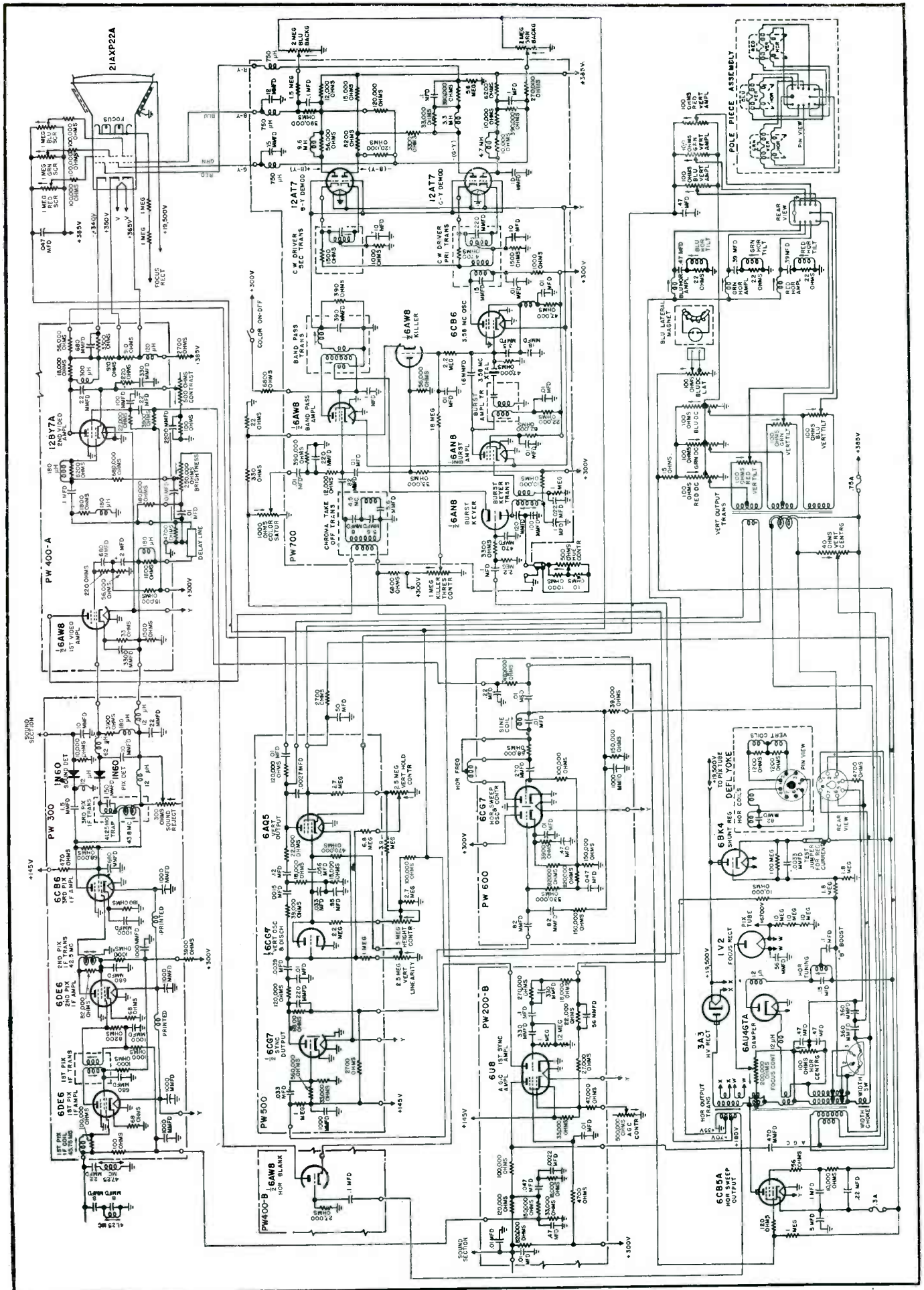

THIS MONTH IN SERVICE

CRASH PROGRAM TO EXPAND UHF UNDER WAY--The first industry conference to develop a high-speed ultrahigh research program that will revitalize the highbands has been called by the FCC. . . . The agenda for this special session calls for the setup of a TV allocation and research committee of industry experts to work closely with the Commission. . . . Basic objectives of this new development group are to determine the feasibility of transferring TV to the ultrahighs, and technical principles and channel allocations involved in any changes. . . . In the proposed probe, receivers will receive headline attention. The committee will evaluate comparative potential performance and costs of veryhigh and ultrahigh black-and-white and color sets; antenna, transmission line and other pickup-accessory low and high-band requirements will also be analyzed. Detailed, too, will be design specifications for circuits and tubes. . . . An intensive field testing study program is also scheduled. Determined will be the uniform methods that will be required to measure field intensity and appraise the quality of TV service on all bands. Measurements and observations are expected to cover reception in canyon type and average type cities, prairie area locations, as well as sites in mountainous terrain.

WIDER ANGLE PIX TUBES AHEAD FOR SMALLER PORTABLES -- The new crop of TV receivers are going to be smaller and yet still offer the same size picture screens prevailing today. This prediction, made recently by the prexy of RETMA, was based on the forthcoming production of picture tubes with angles of 110° (as against 90° tubes now in use), that will shorten the depth of a receiver by four or five inches. Using such a tube, it was said, a 14-inch portable will be about 25% shorter. . . . Others commenting on the trend said that we may even have 120° picture tubes that will reduce further the overall depth of portables. The only disadvantage in the wider-angle tubes, it was pointed out, is increased distortion at the edges. Circuits are now being designed to overcome this objection. . . . Reviewing the growth of the portable market, industry specialists have pointed out that whereas in the first six months of '55 only 50,000 sets in the 15-inch or smaller sizes were made, over 300,000 were produced during the first six months of this year.

ADVANCED COLOR SCHOOL CREATED BY NEW YORK SET MANUFACTURER -- A new school offering a 40-hour tuition-free course in the theory, mathematics and practical aspects of color TV servicing is now in full swing in Syracuse, N. Y., under the sponsorship of a set maker. The school is being operated on a year-round basis. . . . Text books and local transportation to and from the school are also being supplied on a free basis. . . . To gain admission to the school, Service Men are required to apply to their distributors. There is no written entry examination, but students are given a quiz before the actual classes start to determine their familiarity with black and white television. . . . Test questions ask for such information as: The basic principle employed in horizontal automatic-frequency control. . . . Video polarity of signals fed to the picture tube cathodes. . . . If detector diode-video amplifier coupler circuits (showing series and shunt peaking). . . . Differentiator and integrator circuitry characteristics. . . . Nature of the transmitted rf signal envelope. . . . Rf tuner, as well as 45-mc if response.

HUGE FOUR-FLOOR SOUND SYSTEM AT COLISEUM IN NEW YORK -- Four separate sound systems for each of the building's four exhibition floors, that can be used individually or on a building-wide scale, are now in operation in the New York Coliseum. . . . Sixteen microphone circuits and facilities for amplifying four different program sources are provided on each floor. In addition to microphone originations, the program sources include AM and FM radio, a turntable for phono records and a wire line input for remote program pickup. Other features of the sound system include availability of 280 watts of power to each floor, and 60° radial-type horns spaced among 12 and 15-inch loudspeakers.

DO-IT-YOURSELF TUBE TEST WONDER HITS NEW YORK -- A miracle gimmick to check tubes, without even using a tester, has been announced. The designers say that they have found the answer for tube tests with a magic chart equipped with a few simple patterns. It's only necessary to turn a dial, we are told, and a slide rule index pinpoints the tube or tubes that may need replacing. "Replacing a tube is as easy as replacing a light bulb," the official announcement declares. And to rub it in, the manufacturers say that anyone can now do their own troubleshooting easily and quickly without any previous knowledge of electronics or circuitry. Presto!

**ON SEPTEMBER 1ST, JFD
ANNOUNCED TO THEIR
DISTRIBUTORS A
SPECTACULAR NEW
NCB* COLORTENNA[®]
PROFIT-PACKAGE FOR
YOU, THE SERVICE
DEALER.**

This publication went to press before its completion.

The NCB* COLORTENNA[®] PROFIT-PACKAGE is now
available at your JFD antenna distributor.

It will be well worth your while to see it before
stocking up on any antennas.

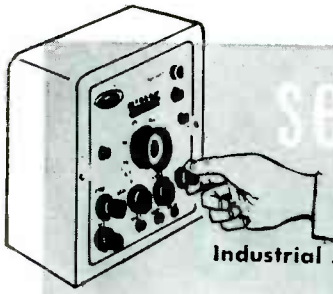

service engineering

FIELD AND SHOP NOTES

Industrial . . . Commercial . . . Institutional

Communications . . . Audio . . . Television Installation . . . Maintenance . . . Repair

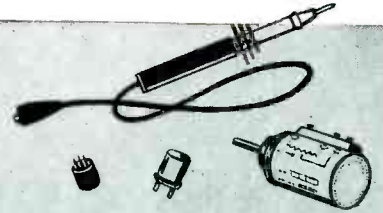

2-Way Railroad-Radio Service: Field-Shop Procedures . . . Test Equipment . . . How To Get Into The Field

by LEO SANDS

THE STEAM LOCOMOTIVE presents many electrical and physical problems in 2-way operations, and as a result most railroads have not installed radio systems on steam engine equipment. Instead, they have waited until the steamers were replaced with diesel power.

The typical iron horse is provided with a steam-turbine driven *dc* generator delivering 32 volts *dc* for

operation of a headlight. When a radio setup is installed, the generator must usually be replaced by a bigger one of adequate capacity.

The radio equipment must be mounted in a weatherproof case generally on the top of the tender. Cables provide connections to the handset, loudspeaker and control box in the cab. The antenna is mounted on the roof of the cab or on the tender near the radio equipment. However, because of vibration, noise, smoke and water, radio installations on steam locomotives leave much to be desired.

Radio on a diesel-electric road engine is an entirely different story. The cab of a modern locomotive is a quiet, comfortable place to ride. Thus the equipment takes less punishment. The handset can be placed within

easy reach of the engineman or the fireman or both. The radio equipment is usually placed in the nose of the locomotive or behind the cab in the engine compartment.

Most diesel-electric locomotives are equipped with 64-volt starting batteries which are also used for powering radio equipment; some have 72 or 110-volt batteries.† In older installations, a *dc* to *ac* inverter is used in conjunction with *ac* operated radio equipment. Some railroads still prefer this method.

Four-unit locomotives usually have two cabs, one at each end. When radio is installed, both cabs can be provided with independent radio systems or only one radio system may be installed which is operable from either cab. The latter requires extensive wiring and multi-conductor connectors between locomotive units. Even though the connectors are husky, they are subject to damage when the locomotive units are separated and someone forgets to disconnect the radio wiring. The main disadvantage of providing only one radio system for each locomotive is that when the engine is separated into two separate two-unit locomotives, one or neither have radio, depending upon the nature of the installation.

The voltage delivered to the radio apparatus or the input of the *dc* to *ac* inverter varies in locomotives, as it does in cabooses and for the same reason; it must if battery charging is to be effected. Thus the variation, if directly affecting the radio equipment, can cause changes in performance. However, in the case of both caboose and locomotive installations, the overall radio communications system must be so designed that with the radio equipment operating at its lowest ebb, communication should be adequate.

If radio is to be of any value to a railroad, it must be dependable and
(Continued on page 57)

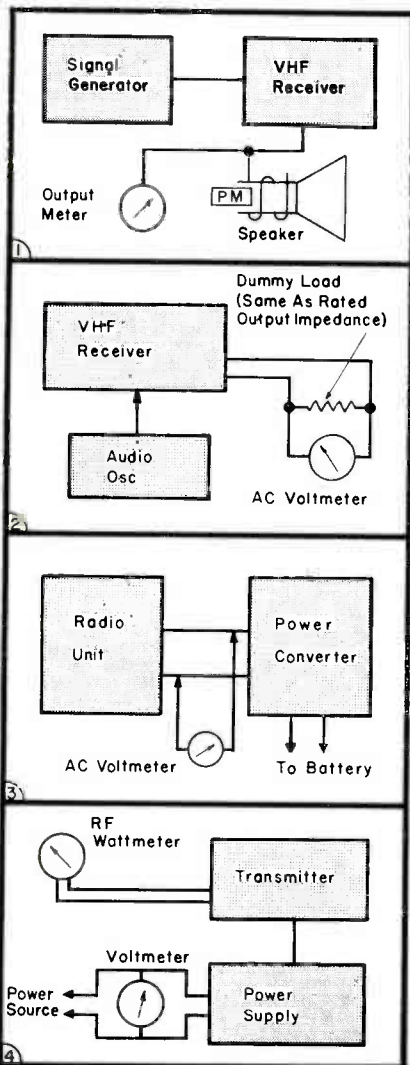

FIGS. 1-4: TEST LAYOUTS for railroad-radio tube, audio, power and transmitter checks. To test tubes, the setup diagrammed in Fig. 1 is used. A low-output (unmodulated) signal from the generator is fed to the receiver; it must be low so that the receiver noise as indicated by the output meter is reduced 20 db, or voltage drops to about 4 one-tenth. By replacing tubes one at a time and repeaking trimmers, improvement will be noted when the signal input can be reduced to maintain 20-db quieting. Fig. 2 illustrates audio-output test technique. Here an audio signal (1000 cps) is applied at the input of the audio amp and output voltage noted: $\text{Watts} = \frac{\text{Voltage}^2}{\text{Impedance}}$. Thus, if the voltmeter reads 5 volts and the load is 8 ohms, a 3.1-watt dissipation would obtain in the resistor shown. A power source check is detailed in Fig. 3. On rolling stock the power source may be checked with an ac voltmeter (when ac is provided with the radio set to receive and then to transmit). Voltage should not exceed 120 or drop below 110 volts. If more variation obtains, converter or battery source must be checked. To check the transmitter output an r-f wattmeter should be used, as indicated in Fig. 4. Input voltage should also be measured, and if possible the input voltage should be varied over the range encountered on trains.

†Bendix and Motorola both provide railroad radio equipment which will operate directly from a 64-volt *dc* source.



The Equation that Shook the World!

A hasty scrawl on a scrap of paper ushered in the Atomic Age. Through this equation, Dr. Albert Einstein revealed to mankind the awesome secret of atomic fission, with all of its tremendous power for good or evil.

This is the kind of a world we live in . . . a world where knowledge is power in a truer sense than ever before. It is an exciting world.

Univac® has added a new dimension to the world of science, processing data with a speed that crowds many lifetimes of research into a few hours.

Squarely in the midst of this exciting world are the engineers and scientists of Remington Rand Univac. Their potential for growth and achievement (and the rewards that go with them) is unlimited. *You can be one of them.*

Immediate Openings for:

ELECTRONIC DESIGN ENGINEERS — Must have degree and be experienced in pulse circuitry, digital computers, or data processing equipment.

ELECTRO-MECHANICAL DESIGN ENGINEERS — Should have bachelor's degree in Engineering. However, extensive mechanical design background may substitute for some college. Men selected will do basic preliminary design and layout of small mechanisms. Requires original ideas and application of logical analysis to design problems.

Send complete resumé to:

Remington Rand Univac

DIVISION OF SPERRY RAND CORPORATION
at any one of these four plant locations

D. A. BOWDOIN
Dept. PS28
2300 W. Allegheny Ave.
Philadelphia, Pa.

FRANK KING
Dept. NS28
Wilson Avenue
South Norwalk, Conn.

J. WOODBURY
Dept. SS28
1902 W. Minnehaha Ave.
St. Paul W4, Minn.

CAL BOSIN
Dept. YS28
315 Fourth Ave.
New York City

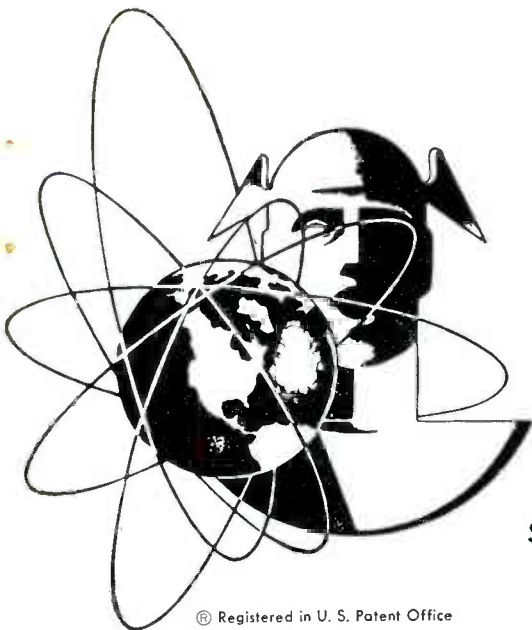

® Registered in U. S. Patent Office

Mr. Electronic
Service
Technician

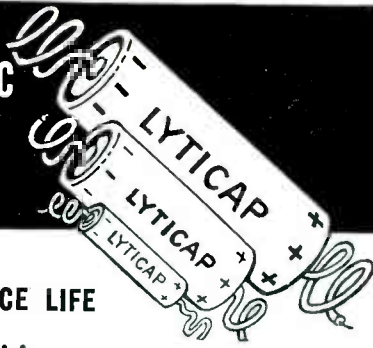

FOR LONGER SERVICE LIFE

you can rely on . . .

LYTICAP* ELECTROLYTIC CAPACITORS

You can recognize PLANET LYTICAPS by their shiny red cardboard jackets and their general neat workmanlike appearance. Available in all frequently used capacities from 3 to 500 volts, they are ideal for all types of service work—radio—television—industrial.

PLANET LYTICAPS are 100% tested for capacity and leakage; they receive a rigid mechanical inspection. Like all Planet products, they are fully guaranteed for one year. No wonder so many set manufacturers use them as original equipment!

Ask for PLANET LYTICAPS by name at your regular parts jobber.

*Registered

PLANET SALES CORP.
BLOOMFIELD, N. J.

XCELITE Hand Tools
PREFERRED BY THE EXPERTS

NOW!

any "99" parts
you need—
IMMEDIATELY!



You can now replace or add any part to your XCELITE 99-PR nut driver, screwdriver and reamer roll kit immediately because your supplier has this No. 699 Replacement Kit! It has backup stock to supply the hundreds of thousands of "99" kits now in use. If you've lost a handle—want that new 1/2" XCELITE 99-39 reamer—need a new plastic roll pocket kit—your distributor can supply you in a hurry. Ask him!

XCELITE, Incorporated
Dept. V
Orchard Park,
N. Y.

For Originality
LOOK TO XCELITE

Horizontal Amplifier Tube Tests in the Plant

by **ELMER H. NIEHAUS**

Standard Products Application Engineering
Receiving Tube Department, General Electric Company

IN MOST RECEIVERS, the cathode of the horizontal amplifier is tied directly to ground. Small amounts of heater to cathode leakage in these receivers would not be noticeable. However, to assure satisfactory operation in all receivers, tubes with excessive heater cathode leakage must be rejected.

To eliminate disturbances in the picture, the horizontal amplifier tube is tested for arcs and for microphonics. The *arc test* is performed with maximum rated voltages on the tube and a sensitive indicator rejects even those tubes with extremely small arcs. An arc in a tube results in the loss of a portion of one or more trace lines, while the effect of microphonics is to cause displacement, to right or left, of one or more trace lines.

The *microphonics test* is performed by connecting the output of the tube to a sensitive amplifier. During the test the tube is tapped by an automatic tube tapper and any output is indicated by a meter at the amplifier output.

Another type of picture disturbance which has been troublesome is called the *snivet*. The *snivet* is actually an *rf* radiation that occurs at the same point or points of each scan line. The radiation is picked up by the tuner and is amplified through the receiver, resulting in one or more black lines of varied widths, usually near the right hand edge of the picture. Frequently, the lines go together, forming oval shaped disturbances due to 60-cycle hum modulation. It has been found that tubes which exhibit a discontinuity in plate current, usually located at a point just below the knee of the zero bias plate current curve, will produce *snivets*. This discontinuity is a place on the curve where there is a change in plate current, with no change in plate voltage. It would be represented on the curve by a vertical slope at some point on the plate current curve. The *snivet* producing discontinuities can be detected by reducing the plate voltage slowly and watching for a sudden drop in plate current.

Tests are also performed for unwanted tube currents, such as gas current, emission current from the control grid, emission current from the screen grid and emission current from the plate. If the level of these currents is too high, tube life is significantly reduced. Each of these tests is performed by different methods with rejection levels consistent with the requirements for efficient tube operation in a receiver.

Tests to Guarantee Satisfactory Tube Life: A sample of tubes from each production lot must pass prescribed life tests before that production lot can be placed in the warehouse for shipment to customers. The regular life test is conducted with the tube operating at maximum conditions of current, voltage and dissipation for a minimum of 500 hours. At the end of the 300 hours the tubes must pass the tests previously described. Another life test is run simultaneously with elevated voltages for a shorter period of time. On this life test particular attention is given to the unwanted emission currents which would shorten tube life.

‡First report on tests performed in the tube factory appeared in August, 1956, issue of SERVICE.

CATALOGS — BOOKS

SPRAGUE PRODUCTS Co., 231 Marshall St., North Adams, Mass., has published a 63-page 5½" x 8½" pocket size *TV Replacement Capacitor Manual* (K-102). Covers 6589 different TV sets made by 88 manufacturers. Tables are broken down into two sections: Electrolytic section, with each manufacturer listed alphabetically, and Sprague replacement capacitors described and cross referenced to original part numbers; and ceramic section which also lists sets alphabetically by make, but Sprague replacements are grouped according to the section in the TV set in which they are used. Copies are available free from Sprague distributors or by mailing 10c direct to Sprague.

HOWARD W. SAMS & Co., Inc., 2201 E. 46 St., Indianapolis 5, Ind., has published a 12-chapter book, *TV Servicing Guide*, by Leslie D. Deane and Calvin C. Young, Jr. Chapters are subdivided according to symptoms that result from failure within that particular section of the receiver. Trouble symptoms are illustrated by photos of picture-tube screen; possible causes for each symptom are listed. In each chapter are troubleshooting procedures and servicing hints. Priced at \$2.00.

AEROVOX CORP., New Bedford, Mass., has prepared a 20-page guide on ceramic plate assemblies, including circuit diagrams, constants, functions and a cross reference section. Also included is a 10-page section of replacement information with manufacturers part numbers and correct Aerovox equivalent.

HARRY G. CISIN, Amagansett, New York, has published bulletin *S-11* describing an assortment of TV and radio service books. Included are books for novices as well as experts, tube location guides, tube substitution guides, color TV, picture guides to TV troubles and rapid diagnosis of TV faults.

PERMA POWER CO., 4727 N. Damen Ave., Chicago, Ill., has released a distributor catalog describing and illustrating TV tube *briteners*, voltage regulators, radio-controlled garage door openers, battery eliminators and a line of electronic accessories.

SHURE BROTHERS, INC., 222 Hartrey Avenue, Evanston, Ill., have published general catalog '56 (with technical data) covering microphones, microphone cartridges, microphone accessories, phono pickup cartridges and magnetic recording heads.

AIRCRAFT-MARINE PRODUCTS, INC., Harrisburg, Pa., has published a booklet, *The Adventures of Grandpa Champ*, which dramatizes some of the dangers in improperly handled electrical wiring around the home.

Simpson...the most Complete Line of VOM's

Select the one that fits your needs!

MODEL
260
world's most popular!

Over half a million Model 260's have been sold to date! 20,000 Ohms per volt. You'll find it wherever quick, accurate, electrical checks are needed. It's so handy, so dependable, so sensibly priced! Ask your jobber. Price, including Adjust-A-Vue Handle, only ...

\$38.95
Carrying Cases from **\$6.75**

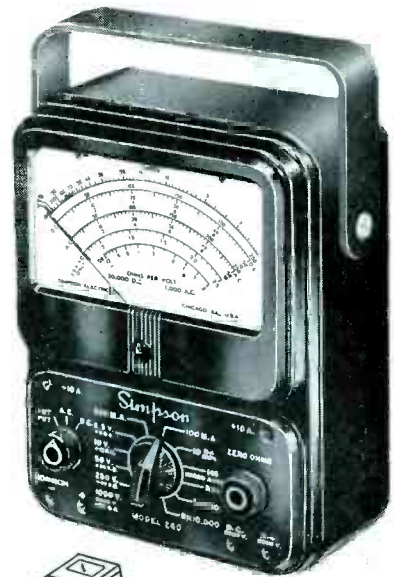

MODEL **262**

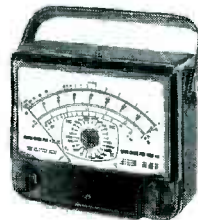

the new VOM with a 7" meter

20,000 Ohms per volt DC and 5,000 Ohms per volt AC sensitivity ... 33 ranges ... compact 7" case with Adjust-A-Vue Handle ...

\$59.50
Carrying Case ... **\$ 9.95**

MODEL **269**

100,000 Ohms per volt!

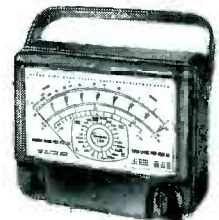

Most sensitive VOM

available! A Volt-Ohm-Microammeter with a big 7" meter in a compact 7" case ... 33 ranges ... Adjust-A-Vue Handle ...

price complete ... **\$88.00**
Carrying Case ... **\$ 9.95**

NEW!

- **MIDGETESTER** Model 355—New shirt-pocket size Volt-Ohmmeter **\$29.95**
- MODEL 240**—Small VOM; 14 ranges; up to 3000 volts AC or DC **\$26.35**
- MODEL 230**—Small VOM; 12 ranges; up to 1000 volts AC or DC **\$24.95**
- ROTO RANGER** Model 221—25 Separate meters at turn of a switch **\$75.00**
- LABORATORY STANDARD**—For instrument calibration. Price on application.

Simpson ELECTRIC COMPANY

World's Largest Manufacturer of Electronic Test Equipment

5200 W. Kinzie St., Chicago 44, Ill. • Estebrook 9-1121
In Canada: Bach-Simpson, Ltd., London, Ontario

**SAVE
with
SECURITY**

Because Wright Wire Strand comes to you pre-measured and uncoils without snarling, it gives to you unique economy. Quality wire, perfectly stranded and heavily galvanized, the bright Wright way. **SAVE** with Wright.

Prompt deliveries from stocks in Worcester, Chicago, Atlanta, New Orleans, Houston, Dallas and Los Angeles.

G. F. WRIGHT STEEL & WIRE CO.
249 Stafford St. • Worcester, Mass.

THE ALL-PURPOSE OSCILLOSCOPE

(MODEL 983)



A high gain, wide band scope which accurately reproduces waveforms comprising a wide band of frequencies.

No scope offers equal versatility and profit-making possibilities. High sensitivity of 15 millivolts per inch RMS makes it ideal for setting resonant traps, signal tracing in low level stages as a general null indicator, phase characteristic measurements, sweep frequency visual analysis. At your distributor, or write for bulletin—F-35-A. WESTON Electrical Instrument Corporation, Newark 5, N. J. A subsidiary of Daystrom, Inc.

WESTON test equipment
The Quality Line

PERSONNEL

MIKE REMUND has been named vice president in charge of sales of Jensen Industries, Inc., 7333 W. Harrison St., Forest Park, Ill.



Remund



Clements

WALTER CLEMENTS has been promoted to the position of jobber sales manager of Littelfuse, Inc., Des Plaines, Ill.

MILTON SCHINDLER, administrative assistant to Ben Snyder, president of Snyder Manufacturing Co., has been promoted to director of west coast sales. He will headquarter at the Snyder west coast offices and warehouse in Los Angeles.



Schindler



McDonald

SAMUEL J. McDONALD has been named eastern regional manager, distributor sales, of the electronic product sales department of Sylvania Electric Products, Inc.

M. P. FIELDMAN is now vice president in charge of sales at Raypar, Inc., 7800 West Addison St., Chicago 34, Ill.



Fieldman



Huser

WILLIAM A. HUSER has been appointed ad manager of Potter and Brumfield, Inc., Princeton, Ind.

KENNETH C. KLEIDON has been named to a newly-created post of national color television manager for Hycon Electronics, Inc., Pasadena, Calif. Kleidon, formerly director of technical publications, color television training and assistant director of sales engineering for the radio and TV division of Raytheon, will conduct color television symposiums in cities across the nation for Hycon.

BENCH-FIELD TOOLS

CIRCULAR SAW

A circular saw, *Arco Hole-Saw*, featuring an automatic slug ejector which pops out sawed discs, has been developed by Arrow Metal Products Co., 140 W. Broadway, New York 13, N. Y.

Saw, powered by any electric drill, drill press, lathe or motor, cuts holes from 1" to 2½" in diameter in wood, wallboard, plastics, and sheet metal. Two models are available: 650 cuts 1", 1¼", 1½", 1¾", 2", 2¼" and 2½" holes through any ⅜" stock; 600 cuts 1", 1½", 2" and 2½" holes. Both models include ¼" drill bit.

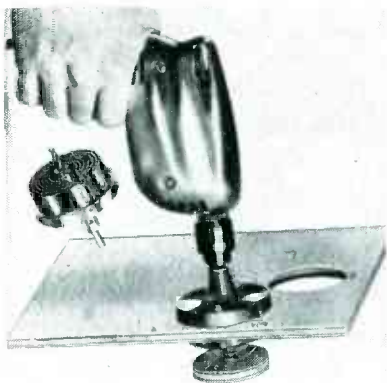

PW SOLDERING IRON

A soldering iron, *Pencil*, for work on printed-wiring circuits and regular radio and TV circuits, has been announced by Wall Manufacturing Co., Grove City, Pa.

Iron weighs 1 ounce, has a ⅛" tip and is 7½" long. Tip temperature is controlled by thermostatic action. Comes with copper or *Walloy* tips; also in ¼" tip size.

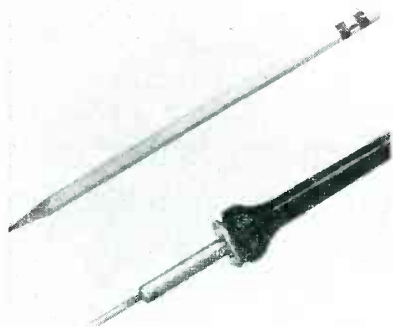

PRINTED WIRING PLIERS

Printed wiring pliers, featuring compound leverage for cutting and one operation cutting and crimping, are being manufactured by Utica Drop Forge and Tool Corp., Utica 4, New York.

Tool crimps as it cuts to prevent the cut wire from sliding back through the hole of the printed wiring board.

an easy out!

for all your transformer
replacement problems



• exact duplicates,
electrically
and physically

• no chassis or circuit alterations

There are over 200 TV transformers listed in the new Stancor TV Replacement Guide... 140 of them are exact replacements. Write now for your FREE copy.

NEW STANCOR EXACT REPLACEMENTS include

- A-8151 Vertical Output
for RCA 972448-1 and 970727-27
- DY-18A Yoke
for Sylvania 100-00C3/5/6/7
- DY-19A Yoke for Sylvania 100-0009
- DY-20A Yoke for Sylvania 100-0004
- A-8283 Flyback
for CBS Columbia 12000841

CHICAGO STANDARD TRANSFORMER CORPORATION

3507 ADDISON STREET • CHICAGO 18, ILLINOIS



Export Sales: Roburn Agencies, Inc.
431 Greenwich St., New York 13, N.Y.

PORTABLE TERMINAL TOOL REPAIR KIT

A portable repair kit, made of crackle-finish lightweight metal, partitioned for A-MP terminals, connectors and the *Champ* or *Super-Champ* tool, has been announced by American Pamcor, Inc., Havertown, Pa. Kit features partition design and terminal tool and connector identification.

Also announced by A-MP is a line of junior *Faston* flag-type terminals with insulation support.

Fastons accommodate wire sizes 22-14; insulated and non-insulated support types accommodating wire sizes 22-14 are also available.



Design-Application Report on Variable-Inductance Tuned Indoor Antenna†

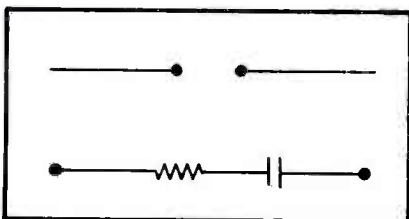
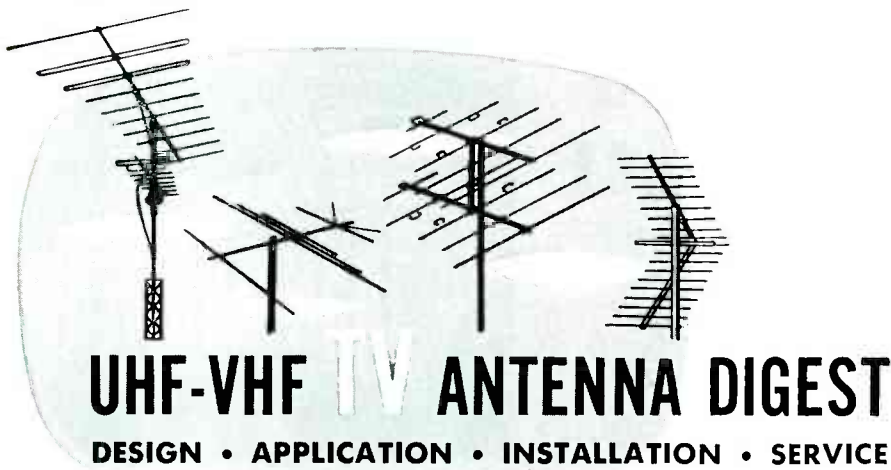
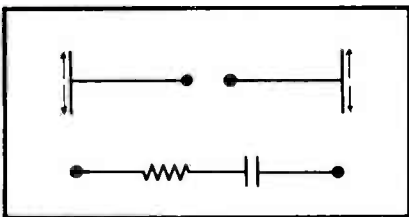

FIG. 1: SHORT low-band dipole (much less than $\frac{1}{2}$ wavelength) which has a radiation resistance of approximately 3 ohms; this appears at feed points as a highly capacitive reactance.

FIG. 2: ELECTRICAL CIRCUIT for capacitive condition in antenna. Current in hats is equal and opposite; therefore, there is no radiation from the hats themselves. Radiation resistance at feed points raised to approximately 30 ohms is still highly capacitive; see p. 49 for detailed analysis.



IN THE EARLY DAYS of TV, indoor antenna models featured half-wave dipole design and were most commonly made with their two halves bent vertically in the shape of the letter V. In use, this type of antenna had to overcome many hurdles. Since the simple half-wave dipole presents only 72 ohms impedance, considerable mismatch obtains when it is connected to a 300-ohm line. Also, for maximum effectiveness, these dipoles should be oriented horizontally; and for the lower channels they must be fully extended. Technically, the lengths of each element should also be adjusted for each channel. It has been found that attempts to adjust the antenna for optimum reception have been hampered by the fact that the ele-

(Continued on page 49)

†Based on field notes prepared by Channel Master engineering department.

FIG. 4 (RIGHT): Use of autotransformer to step up 30-ohm impedance to provide match with 300-ohm transmission line.

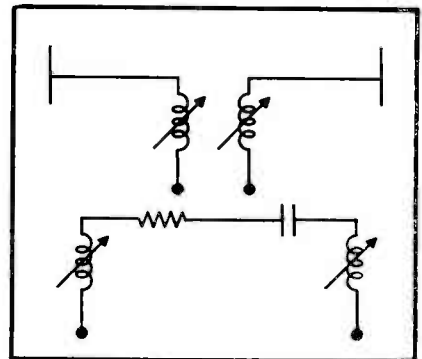
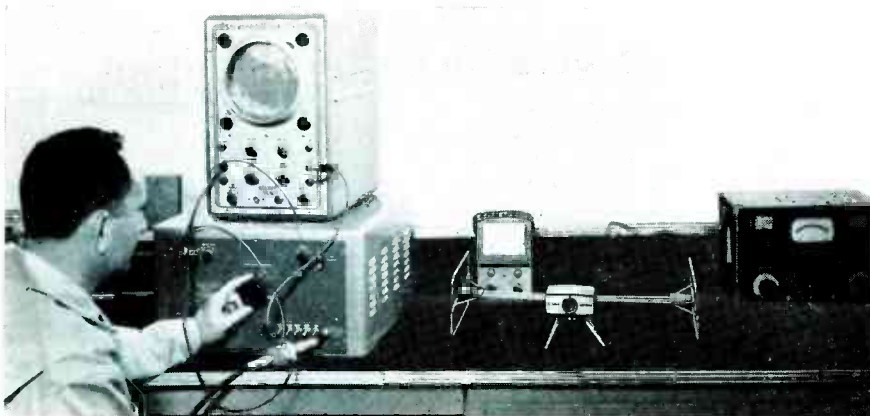
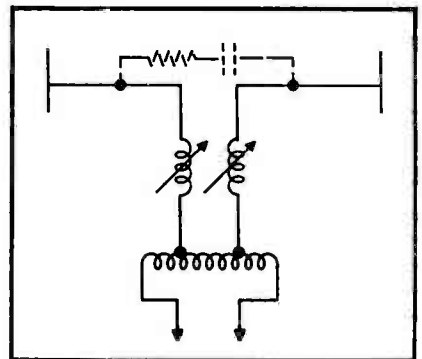
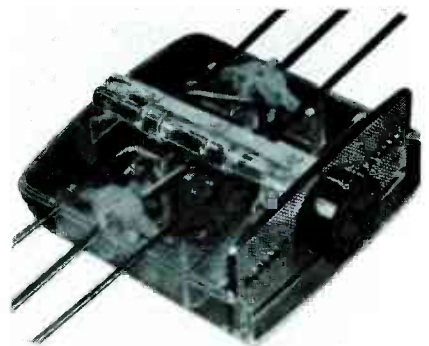

FIG. 3: CIRCUITRY illustrating use of variable series inductances added to feed points for tuning.



PROJECT ENGINEER JULIUS GREEN in Channel Master lab checking tuned indoor antenna at right.



CUTAWAY VIEW of the variable inductance tuner used in the indoor antenna.

TUNG-SOL 1956 TECHNICAL DATA BOOKS

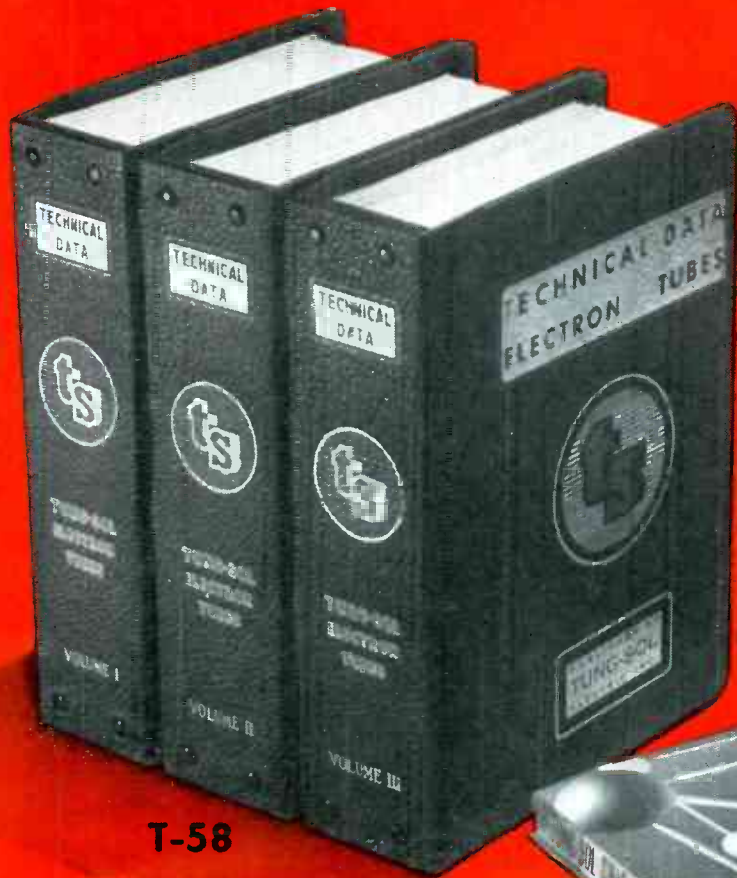

T-58

T-70

The new 1956 Tung-Sol Electron Tube Technical Data books are the most practical set of reference books in the entire industry. They contain all the information you need for everyday use. Clearly indexed and streamlined for fast reading, they open flat for rapid on-the-job reference. Ask your Tung-Sol supplier how you can get your set.

TUNG-SOL ELECTRIC INC.
Newark 4, N. J.

Sales Offices: Atlanta, Columbus, Culver City, Dallas, Denver, Detroit, Melrose Park (Ill.), Newark, Seattle.



T-31



ALL THE INFORMATION... AT YOUR FINGER TIPS!



T-58 1250 pages—1000 tube types.



T-70 More than 250 pages of data on CR tubes, receiving and special purpose tubes and dial lamps.



T-31 Over 350 blueprint base diagrams for 1400 tube types.

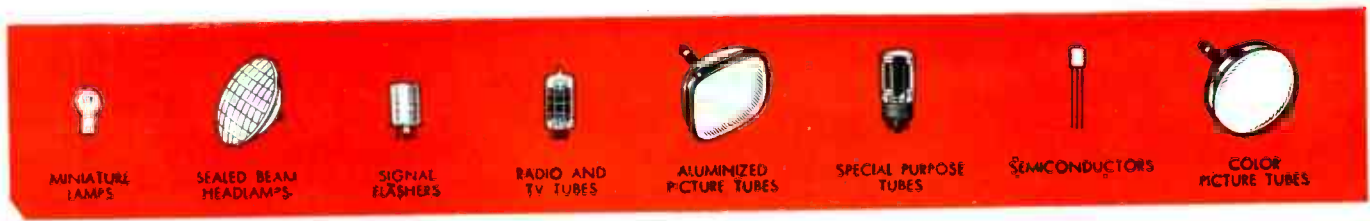

MINIATURE LAMPS

SEALED BEAM HEADLAMPS

SIGNAL FLASHERS

RADIO AND TV TUBES

ALUMINIZED PICTURE TUBES

SPECIAL PURPOSE TUBES

SEMICONDUCTORS

COLOR PICTURE TUBES

ASTRON "Staminized" CAPACITORS ARE moisture proof

Astron's Climatic Protection Processes Insure Real Staying-Power

Service technicians rely on a completely dependable capacitor . . . one which remains the same *after* the installation. And Astron builds them just that way.

Astron's climatic protection processes are many. Each designed to guard the quality of Astron capacitors against environmental and climatic conditions . . . Blue-Point® and Comet* paper capacitors molded in extra-rugged plastic . . . "SM" Minimite electrolytics, hermetically sealed in metal-cased tubulars . . . A wide range of hermetically sealed electrolytics "SM" Twist Prong . . . Hermetically sealed metallized paper, Metalite* Hy-Mets®, positive glass to metal seals.

You can put your trust in Astron, for behind each Astron capacitor is the meticulous quality control that insures you of real staying-power . . . over 10 separate production line tests are performed, plus 100% final inspection before any capacitor is sent out by Astron . . . your guarantee of top performance and call back elimination.

Remember your reputation is our business. Build it, guard it, protect it . . . Buy Astron.

*Trademark

FREE Servicing Aid
Save time, use handy Astron
pocket-sized Replacement
Catalogue and Pricing
Guide (AC-4D)
—Write Today!



Safety Margin
"SM" Minimite*



Safety Margin
"SM" Twist Prong



Safety Margin
"SM" Cardboard Tubular



Blue-Point (R) Molded
Plastic Paper Tubular

ASTRON

C O R P O R A T I O N



255 GRANT AVENUE, E. NEWARK, N. J.

Export Division: Rocke International Corp., 3 East 40th St., N. Y., N. Y.

In Canada: Charles W. Pointon, 6 Alcina Ave., Toronto 10, Ontario

the choice antenna line

TRIO

Sharpshooter

ANTENNAS

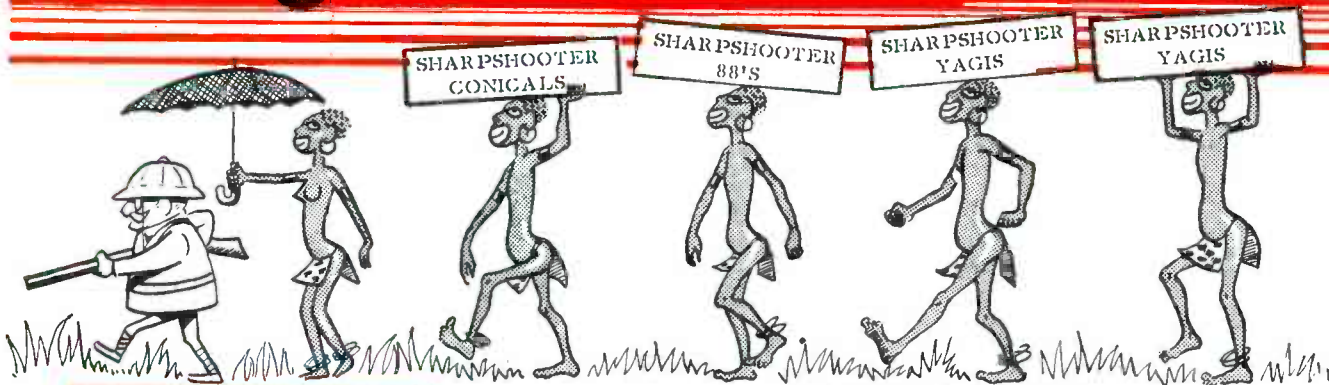

Sharpshooter 88

Completely Pre-assembled

- Ratio Type Dipole
- Insta-Lok Clamps
- Riveted Construction
- Mycastylene Insulators
- Model 88 Single Bay
- Model 88 2/2 Bay with Stacking Bars

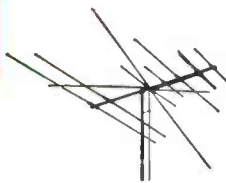

SHARPSHOOTER CONICALS

- 14 Models to Choose from
- Insta-Lok Conical Head
- Insta-Lok Clamps
- Riveted Construction
- Instant Assembly!

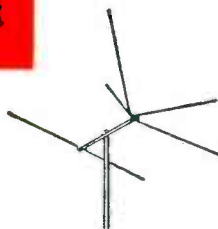

SHARPSHOOTER YAGIS

- Insta-Lok Clamps
- Riveted Construction
- Complete Pre-assembly

Broadband Ch. 7-13 Yagis



Trio 6713



Trio 10713

Use two ratio type dipoles for close match to 300 ohm line for improved performance.

Cut-To-Channel Yagis



A complete line of 5 element and 10 element cut-to-channel Yagis. Use ratio type dipole for necessary impedance step-up to give close match to 300 ohm line.

Install-It-Yourself



TV ANTENNA KITS

TRIO 50

TRIO 50 KIT—Recommended for distances up to 50 miles. Kit contains Trio model 742 Conical with everything needed for a complete installation.

TRIO 70

TRIO 70 KIT—For distances up to 70 miles. Contains single bay Trio model 88 with materials for a complete installation.

TRIO SUPER 70

TRIO SUPER 70 KIT—For distances of over 70 miles. Contains Trio model 88-2 for improved reception. Complete with everything required for the economical "Do-It-Yourself" installation of a stacked array.



EXPORT SALES DIV., SCHEEL INTERNATIONAL INC., 4237 N. Lincoln Ave., Chicago, U.S.A. Cable Address: HARSCHERL

Servicing Helps

Cures for IF Overloading and Vertical Rolling . . .

Checking Magnetic Tools

OVERLOADING of the *if* in the Bendix T14 chassis has been found to be due to the IN60 crystal detector.

Overloading of this type normally takes place when switching from a weaker distant channel to a local strong signal. The crystal does not appear to respond to the sudden strong signal and, consequently, no *agc* is developed through the normal function of the 6AH6 video amplifier and 6AU6 *agc* amplifier. The receiver usually remains in this condition until the signal is disrupted or the set is tuned to another weaker channel. If this condition is encountered the crystal should be replaced.

Curbing Vertical Rolling¹

VERTICAL ROLLING is often found to be an intermittent problem. With a setting of the vertical hold control and the use of a particular 6BL7 good lock may be obtained for a period, and rolling will begin. Re-setting of the hold control may result in again stretching the locked-in period. Tube replacement, because of internal leakage, is generally indicated. Tubes that use gold-plated wire in the grid structures often resolve the problem, the wire reducing the leakage problems which can be a cause of instability.

When tube replacements do not cure the problem, the vertical sync pulses used for locking should be checked. Poor pulse clipping, poor video signal from the tuner or *if*, or a poorly-integrated vertical-sync pulse fed to the oscillator circuit, can cause vertical rolling.

In some instances, an open *agc* filter capacitor can cause loss of vertical sync pulses. Poor tuner or *if* tubes can cause similar trouble.

Tape Recorder Tools—Use Precautions

TOOLS USED in the vicinity of erase, record, and playback heads of tape recorders must not be magnetized.²

If such a tool touches the magnetic structure of the head it can magnetize it. There is then the trouble of demagnetization which must be performed to restore the unit to normal operating condition.

For this reason, it is desirable to have some convenient way of checking all iron and steel tools employed in the vicinity of the heads. A pocket compass can be used as a quick and efficient check on the magnetic condition of all tools and implements. If either end of the compass needle is repelled when the tool is held near it, the tool is magnetized and should not be used in tape repair work.

Photographic Negatives as Shims

OLD PHOTOGRAPHIC negatives can be used to shim up small distances, such as the space between the flat on a shaft and the spring on a knob.

The negs can be cut into small strips and then the strips can be trimmed to length. More than one thickness can be employed if a greater thickness of shim is required.

The celluloid base of photo negatives is far less elastic or springy than paper or match sticks more commonly employed for such shims. It will withstand the pressure of a motor driven device, but is ample in strength for channel selectors and other knobs on TV or radio chassis.

Ion-Trap Setting Checks

In servicing a television receiver for any type defect, it is good practice to check the setting and condition of the ion trap. If one finds that the ion trap no longer fits snug to the neck of the picture tube, a small piece of rubber should be placed under the clamps, or a piece of friction tape should be wrapped around the clamps to prevent the magnet from slipping from its optimum setting.

¹From Motorola service notes.

²Practical Considerations in Magnetic Recording, SERVICE; August, 1956.

SHOOT TV TROUBLE FAST

With H. G. Cisin's Copyrighted
RAPID "TV TROUBLE SHOOTING
METHOD"

Without experience or knowledge, this guaranteed new method of servicing TV sets, enables you to DIAGNOSE TV troubles as rapidly as an expert. NO THEORY—NO MATH—you can locate all faults in record-breaking time regardless of make or model. "TV TROUBLE SHOOTING METHOD" is the most valuable aid to TV servicing ever written. Be a TV Trouble Diagnostician. Increase your present earnings. Open your own Profitable Business or get a high-paying skilled job.

It's all in this book . . .

Nothing more to Pay—Nothing else to Buy
85 picture troubles, over 58 raster and 17 sound troubles. By this unique copyrighted method you know EXACTLY WHERE the trouble is: plus step-by-step instructions, including 69 RAPID CHECKS, enabling you to find the faulty part.

13 IMPORTANT PRELIMINARY CHECKS NEEDED NO INSTRUMENTS! Of the 69 Rapid Checks, OVER 65 ALSO REQUIRE NO INSTRUMENTS! Rapid checks include emergency checks for distorted pictures, defective tubes including PIN tube, plus 57 others. ALL EXPLAINED IN SIMPLE LANGUAGE, PERFORMED WITHOUT INSTRUMENTS, MANY CHECKS USE THE PICTURE TUBE AS A GUIDE.

H. G. Cisin, the author, is the inventor of the AC/DC midjet radio. He licenses RCA, AT&T, etc. He has also trained thousands of technicians now owning their own prosperous TV service organizations or holding highly paid TV positions. His years of experience are embodied in this remarkable new book. Guaranteed, Money Back in 5 Days if Not Satisfied!

ABSOLUTELY FREE with each order: H. G. Cisin's newest book "TV & RADIO TUBE SUBSTITUTION GUIDE." Gives direct replacements of set and picture tubes. Most valuable servicing aid! ACT NOW—get both books postpaid at cost of only one!

\$1

Postpaid

RUSH COUPON NOW!

H. G. CISIN, CONSULTING ENGINEER,
Amagansett, N. Y. Dept. S-31

Enclosed find \$1. Rush both books.

Name _____

Address _____

City _____ Zone _____ State _____

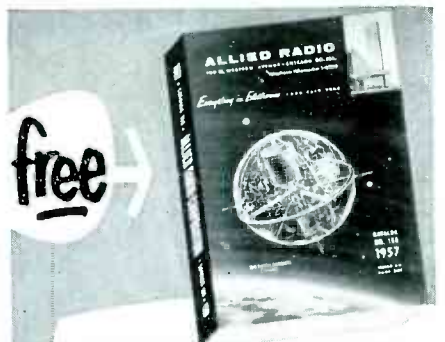

1957 ALLIED ELECTRONIC SUPPLY GUIDE

For Service Technicians and Engineers

Get the up-to-date 1957 ALLIED Catalog. Packed with the world's largest selection of radio parts and accessories, test instruments, famous KNIGHT-KITS, Hi-Fi systems, tubes, tools—everything for service work and industrial electronic application. Save time and money—depend on ALLIED for everything in Electronic Supplies.

Send for 356-Page Catalog Today

FREE

ALLIED RADIO

ALLIED RADIO CORP., Dept. 23-J-6
100 N. Western Ave., Chicago 80, Ill.

our
36th
year

Send FREE 1957 ALLIED Catalog

Name _____

Address _____

City _____ Zone _____ State _____

CATALOG OFFERS AND TV-SERVICE AIDS!

THE "new-look" picture at left shows *your* store with General Electric's eye-catching displays installed! These displays highlight the big G-E catalog of promotional and TV-service aids that is just off the press—help make the book a sure guide to more tube, parts, and service volume.

Included are a dozen signs, decals, and streamers for your store identification alone—among them a brand-new Sign-a-rama that flashes different colors three times every two seconds. There are 18 attractive mailers and postcards to

pull business . . . 19 copy-tested ads in mat form . . . many doorknob hangers, "out" cards, and other sales-builders. The catalog also lists service helps galore, from job tickets to 10 ingenious mechanical aids to faster, more economical service work.

Pick up your copy of the catalog from your G-E tube distributor . . . or, if your location makes this inconvenient, write direct to General Electric. Just clip, fill out, and mail the handy coupon below! *Electronic Components Division, General Electric Company, Schenectady 5, N. Y.*

GENERAL ELECTRIC'S 108 BUSINESS AIDS INCLUDE—

For store identification:

- Multi-color Sign-a-rama
- Projecting outdoor signs
- Window and counter signs
- Clock signs
- Window and truck decals

Window valances & streamers

Direct-mail material

Postcards

Ad mats

TV and radio spots

Public-relations helps:

- Doorknob hangers
- Children's Color Book
- Customer TV service reports
- Giveaway booklets

Business stationery

Business aids

Service aids

TV service clothing

Technical publications

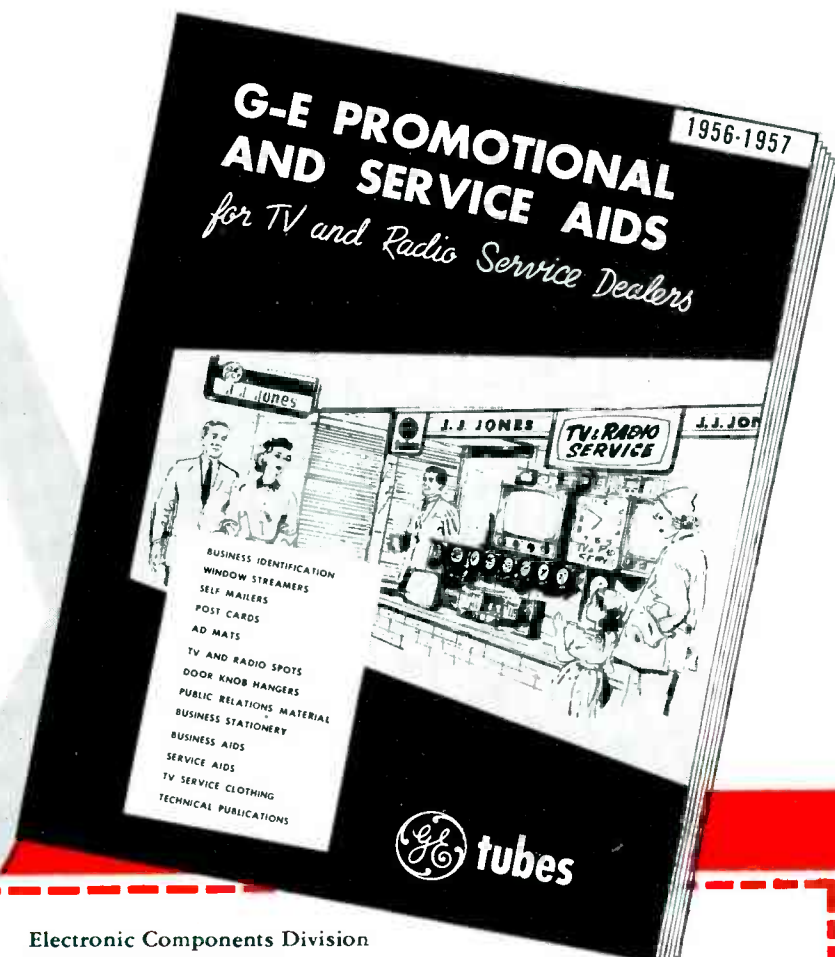

Electronic Components Division
General Electric Company
Bldg. #3—C.A.R.T., Schenectady 5, N. Y.

Please rush your 16-page illustrated catalog of business-promotion and service aids (ETR-589-D) to:

YOUR NAME

STREET ADDRESS

CITY AND ZONESTATE.....

Blown Fuses in TV

(Continued from page 13)

before pulling the chassis, especially if the trouble is a defective tube, by steps which may involve blowing one or two additional fuses. Time can be saved at the expense of the extra fuses. This is a matter of preference which the individual must decide for himself. The following suggested troubleshooting procedures make use of the second method wherever possible.

When a replacement *hv* fuse blows, the most likely possibilities of trouble are the horizontal output and damper

tubes. In sets with power or filament transformers, these two tubes should be removed. Then, without replacing the tubes, the fuse should be replaced and the set turned on. If the fuse blows again, a shorted capacitor on one side of the fuse is indicated (*C₂₈₈*, Fig. 1: p. 12). If the fuse doesn't blow, both of these tubes should be replaced with new tubes and in addition the horizontal oscillator tube should be replaced. If, after replacing the tubes, the fuse doesn't blow, then one of the old tubes is defective. Each old tube can then be put back to determine which is defective. The fuse will open after the bad tube is put back. However, if the new fuse blows with the three new tubes in, then a voltage and resistance check should be made in the horizontal sweep circuit.

In some sets, the *hv* fuse also fuses the vertical oscillator or vertical output stages. In these models, new vertical sweep tubes should be substituted before making further voltage and resistance checks in the horizontal and vertical circuits.

Blown HV Fuse Causes

Common causes for blown *hv* fuses include gassy horizontal output tube; defective damper tube; shorted capacitors in the horizontal output or damper stage; defective horizontal output transformer or arcing in this transformer or its leads; defective yoke; shorted horizontal size or linearity coils (slugs may be turned in too far and possibly shorting one of the coil terminals to ground). In some cases, a defective horizontal-oscillator tube or other defect in the horizontal oscillator stage may cause a *hv* fuse to blow. This results from a lack of drive (horizontal input signal) to the

horizontal output grid, which may cause excessive current through the tube and associated fused circuit.

Troubleshooting Blown B+ Supply Fuses

When a replacement B+ supply fuse blows, one should:

(a) Replace the fuse. (If a fusible resistor is used, see *b.*) Try a new rectifier tube, if a tube is used. If the new fuse does not blow, the original rectifier tube is evidently defective. If the replacement fuse blows with the new rectifier tube in the circuit, make a resistance check for a short in the B+ line.

(b) If a fusible resistor in the B+ line has opened (*R₅₀₂*; Fig. 5: p. 13), one should make a circuit check before replacing the resistor.

One should check to see if the selenium rectifiers appear defective; burn spots, discoloration, characteristic odor.

A resistance check of the selenium rectifiers should be made. Front-to-back resistance should be measured; then the ohmmeter prods should be reversed for a second resistance check. One reading should be considerably higher than the other. Two low resistance readings indicate a shorted rectifier. To get accurate readings, it is advisable to disconnect the wiring from one end of the rectifier.

The resistance of B+ to ground should be checked. A lower-than-normal reading indicates a defective B+ filter capacitor or other short in the B+ line.

If a fusible resistor is not available for replacement, a 7.5-ohm, 5-watt re-

(Continued on page 42)

Coming Event

N. Y. High-Fidelity Show

Institute of High-Fidelity Manufacturers

September 26-30, 1956

New York Trade Show Building, N. Y. C.



"... the hand of the princess in marriage, and half of all the JENSEN NEEDLES in my kingdom."



**CHICAGO STANDARD
TRANSFORMER CORPORATION**

3507 Addison Street • Chicago 18, Illinois

ASK FOR SPRAGUE BY CATALOG NUMBER

Know what you're getting . . . get exactly what you want. Don't be vague . . . insist on Sprague. Use complete radio-TV service catalog C-610. Write Sprague Products Company, 61 Marshall Street, North Adams, Massachusetts.

**DON'T JUST SAY
CAPACITORS
SAY**

SPRAGUE®

WORLD'S LARGEST CAPACITOR MANUFACTURER



LITTELFUSE

Des Plaines, Ill.

electronic specialists to manufacturers of
electronic equipment for almost 30 years

Expendable Littelfuse components have built their own reputation in these famous brand products and many others.

	<i>Bendix</i>	
	SETCHELL-CARLSON	
	<i>Caphart</i>	
	SPARTON	
	Hoffman	<i>ZENITH</i>
STEWART-WARNER	Motorola	
STROMBERG-CARLSON	RADIO	
PHILCO	TELEVISION	SONORA
	Admiral	ETC. ETC.
RAYTHEON	SYLVANIA	Sentinel
	Emerson	Westinghouse
DU MONT		<i>Packard-Bell</i>
RCA	GE	CBS
		Trav-Ler Radio
	hallicrafters	
		CROSLLEY
		Magnavox
		OLYMPIC
		Grommes
	Bell & Howell	<i>Pilot</i>
	harman kardon	
	HEATH COMPANY	
AMPLIFES	AMPEX	ETC.
Magnecord, inc	TUNERS	ESPEY
	NEWCOMB	FISHER
	WEBSTER-CHICAGO	Pacific Mercury
	National	Automatic Radio
		L.I. Scott



famous



AMPHENOL TUBULAR TWIN LEAD*

—now available in 50, 75, 100 ft. coils!

AMPHENOL's patented Air-Core Tubular Twin Lead can now be obtained in pre-cut 50, 75 and 100 foot coils. This job-size packaging makes Air-Core easier to store, easier to handle, easier to install.

Air-Core features the lowest measurable electrical loss (wet or dry) of any twin lead and is unsurpassed for UHF and best for VHF installations. Pure virgin brown polyethylene and pure copper 7/28 conductors assure combined flexibility and strength.

Recommend Air-Core to your customers—use Air-Core in its new convenient packaging.

*U.S. PATENT 2543696



AMPHENOL ELECTRONICS CORPORATION Chicago 50, Illinois



Blown Fuses in TV (Continued from page 40)

sistor, in series with a 1.6 amp, 125-volt fuse, may be substituted.

Common causes for blown B+ supply fuses include leaky or shorted power supply filter capacitors; gassy rectifier tube (or defective selenium rectifier); shorted bypass capacitor in the B+ line; defective yoke; defective tubes causing B+ overload especially sound output, damper, and horizontal output tubes. (Set with B+ supply fuses usually do not have hv fuses.)

When a replacement line fuse blows, the rectifier tube should be removed, the fuse replaced and the set turned on again.

If the fuse blows again with the rectifier tube out, then the trouble is in the power transformer, the power transformer filament line, or between the power transformer primary and the fuse (switch, etc.). To isolate further, it is necessary to make a resistance check of the primary circuit, including the transformer, to determine if there is a short. (In many sets, the resistance of the power transformer primary is normally quite low; about 1 ohm.) If no short is found, one side of the filament line should be detached. With the rectifier tube still out, the fuse should be replaced and the power turned on. A blown fuse now points to a defective power transformer.

If the fuse does not blow with the rectifier tube out, a new rectifier tube should be tried. The old one may be defective (shorted plates). If the fuse blows with a new rectifier tube in the circuit, a defect in the B+ side of the rectifier is indicated. Further resistance checks should then be made in the B+ supply.

The most common causes for a blown-line fuse include a defective rectifier tube; defective power transformer; short in the transformer primary circuit; short in the B+ line; or short in the filament line. In some cases, a short in the B+ line may cause the hv rectifier filament to open before the line fuse is blown.

Troubleshooting Blown Filament Fuses

When a replacement filament fuse blows, the set should be turned off and the fuse replaced. As the first check, the tubes most likely to be defective should be removed before turning the set on again; the rf amplifier (if a cascade rf stage is used), audio output, and damper. These

(Continued on page 61)

ATTENTION ALL SERVICE DEALERS!

Beginning September 1st at your Philco Distributor

SKY'S THE LIMIT for **PRIZES** and **PROFITS** with **PHILCO** **PARTS AND ACCESSORIES**



Your choice of . . . 600 valuable prizes . . . Philco parts . . . accessories . . . test equipment . . . all-expense-paid vacation trips. Yours FREE with purchase of Philco receiving tubes, parts and accessories during this exciting event. Merely register at your Philco Distributor. He'll give you a "Flight Log" in which your prize points will be recorded. Each time you purchase Philco receiving tubes, parts or accessories, he'll enter the points earned by those purchases in this book. You'll be amazed how quickly your points will accumulate . . . and how many prizes you'll earn. Get started today. Concentrate your purchases on Philco and profit two ways.

NOW FOR THE FIRST TIME...

For black and white or color TV...an instrument that pinpoints chassis or picture tube trouble without removing either unit from cabinet

PHILCO *Service King*

Now, at last, a multi-purpose, portable instrument that simplifies service and saves you time and money. Completely eliminates the task of removing chassis or picture tube from the cabinet for trouble shooting. Also permits checking new CR tubes without removal from original cartons. In addition, the new Philco "Service King" is unmatched for features.

Tests both color and black and white picture tubes and receivers • Rejuvenates picture tubes • Clears picture shorts • Aids in setting up color purity, white balance and matrix circuits • Measures DC voltage, anode voltage and resistance • The Philco "Service King" is available now at your Philco Distributor •



Model
8500

PHILCO CORPORATION ACCESSORY DIVISION

PHILADELPHIA 34, PENNSYLVANIA

E. PETERS OF WERK-PETERS Sound Service, Chicago, in his Volkswagen bus sound truck, which uses tape and disc equipment (powered by an inverter), plus three rectangular Hypex projectors*, each driven by drive units** that afford a total power-handling capacity of 90 watts concentrated in an area having a horizontal angle of 170°.



Phasing...Microphone Wiring...Low and Line-Impedance Runs In Large Sound-System Installations

PHASING, as noted in previous reports, is a particularly important factor in the sound-system installation.

Most loudspeaker manufacturers phase their loudspeakers by marking the same terminal consistently positive or negative; thus by connecting all the positives together and all the negatives together, the loudspeakers are automatically in phase. In series connections, of course, a positive should be connected to a negative throughout the chain.

When, however, a 70-volt distribu-

tion system is used, you are not connecting directly to the voice coil and the transformer may well destroy your direct possibility of achieving such convenient phasing. It is a good idea to connect up the loudspeakers beforehand to be sure that all the commons of the primary side are connected together and the remaining side connected to the other terminal of the output. Then, by using a color-coded wiring system, phasing will be as simple an item as the direct voice-coil connection.

A simple check for the phasing of

a pair of speakers is to 1)—Stand them a few feet apart, 2)—connect together, and 3)—listen to program material played over the two loudspeakers, first connected one way and then in reversed position.

When correctly phased, and you are at an equal distance from both of the speakers, the sound should appear to come from a point midway between them; you should have a definite sense of sound source. When incorrectly connected, the sound will become confused; you will get the

(Continued on page 50)

*Jensen RT-20 **Jensen D-30

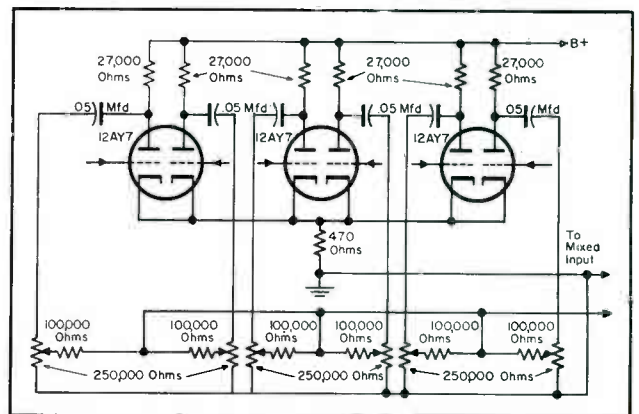
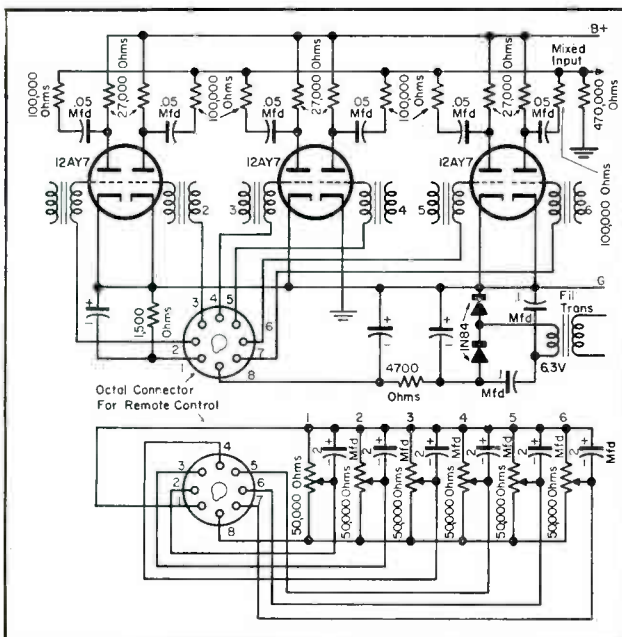

ABOVE: FOR MORE THAN TWO channels, it is necessary to use tubes to maintain level, using circuit illustrated here.

LEFT: IF REMOTE CONTROL OF mixing is desirable, use of dc controls is better than the installation of live audio lines at low level. This circuit shows a simple way of building up such a system. None of the 1 to 8 contacts can be grounded.

the new
Jensen

**PROFESSIONAL
SERIES**

the complete line for
**INDUSTRIAL,
COMMERCIAL
and INSTITUTIONAL**
sound systems

... indoors or out—there is a
JENSEN PROFESSIONAL SERIES
loudspeaker that will do the job
*better, more dependably and
more economically* than ever before.

Here is a *complete* new line of
loudspeakers to meet every sound
system need for both entertainment
and efficient, effective communication.

Catalog 1070 describes all of
these new Jensen products.
Send for your free copy today.

Jensen

**MANUFACTURING
COMPANY**
6601 South Laramie, Chicago 38

Division of The Muter Co. • In Canada: Copper Wire Products, Ltd.

DD-1-30
D-40
D-30

LIFETIME DRIVERS
100 WATT
30 WATT
40 WATT
Lifetime guaranteed against failure!

RT-2C
H-150
H-200
H-240
R-242

HORNS
RECTANGULAR,
ROUND and RADIAL

HF-100
VH-01
VR-11

Complete PROJECTORS
FOR HIGH FIDELITY
and HIGH EFFICIENCY

TRIAxIAL*
High Fidelity 3-way
unitary loudspeaker.
3 coaxial 2-way h-fi
unitary loudspeakers.
*T.M. Registered

**EXTENDED
RANGE**
4" to 15". Qual-
ity performance
in a "one-way"
speaker.

**SPEECH
MASTER**
Highly efficient
PM speakers for
speech repro-
duction.

**TRANS-
FORMERS**
Constant Volt-
age and Imped-
ance Match-
ing types.

Barclay Brown advertising

STOP LOSSES due to inaccurate instruments

CHECK AND ADJUST

Your Test Instruments
with **LABORATORY ACCURACY**



Designed by
MILTON S. KIVER
Author of the Book
"Servicing and Calibrating
Test Equipment."
Published by
Howard W. Sams & Co., Inc.

New 750 **B&K** TEST EQUIPMENT CALIBRATOR

Calibrates VOM, VTVM and other meters, signal, sweep and marker generators and oscilloscopes.

Provides dc and ac voltages for checking voltage ranges of VOM, VTVM and other meters.

Standard resistances from 10 ohms to 10 megohms for checking reliability of each resistance range in VOM and VTVM.

Crystal oscillator generating harmonics over 300 mc for use as marker generator in all receivers, and to calibrate AM signal generator, and to align TV audio I.F. system.

Built-in tone generator for signal tracing amplifiers in all audio equipment. This tone also available at modulated RF.

Oscilloscope voltage calibrator in measuring peak-to-peak voltages of unknown waveforms.



Voltage Accuracy $\pm 1\%$ or Better

Avoid instrument errors that cause wrong decisions and time-killing rechecks in receiver testing. With the new, low-cost, laboratory-type Model 750 Calibrator you can quickly, easily check test equipment accuracy and make necessary adjustments.

Provides standard of $\pm 1\%$ or better in all of its voltage sections—enables you to calibrate your test instruments like the labs do, and give better service at lower cost.

Model 750 Calibrator

Complete with 5 mc crystal. Operates on 110-120 v., 60 c. ac. Sturdy metal case. Size: 8 $\frac{3}{4}$ in. high, 8 in. wide, 5 $\frac{1}{2}$ in. deep. Net wt. 6 $\frac{3}{4}$ lbs.

\$54⁹⁵
NET

See Your Distributor or Send For Bulletin 750-S

B & K MANUFACTURING CO.

3726 N. Southport Ave. • Chicago 13, Illinois

Makers of DYN-A-QUIK, CRT, DYN-A-SCAN and CALIBRATOR



COLOR-TV INTERLOCK CHEATER

A color-TV interlock cheater, 5650, which is plugged into set to permit entry of a high-voltage probe through its shell, has been announced by General Cement Manufacturing Co., 400 S. Wyman St., Rockford, Ill.

Also available from G-C is a pix-tube rejuvenator, Zipt 9264, said to repair grid and cathode shorts without pulling chassis.

TRANSISTORIZED RADIO BATTERIES

Three battery types, VS304, VS305 and VS306, designed for use in transistorized radio receivers have been added to the battery line of the RCA components division.

TV REMOTE CONTROL TUNER

A battery-operated TV remote-control tuner, it, that is attached to the channel selector shaft, has been introduced by Alliance Manufacturing Co. Inc., Lake Park Blvd., Alliance, O.

Unit is powered by a dc reversible motor which turns channel selector in either direction; works up to 20 feet away from set. Features finger-tip pressure controls.



PARTS . . . ACCESSORIES

DC TO AC POWER SUPPLIES

A line of electrical power supplies, *Powercons*, designed to convert the normal 6 or 12-v dc battery power supply to 110 v 60-cycle power, has been announced by the Powercon division, Cornell-Dubilier Electric Corp., South Plainfield, N. J. Can be installed under the dashboard or in a car's trunk compartment; they may then be wired to convenient outlet such as at the cigarette lighter socket. Range in size, weight, and capacity from light 20-watt units for operating electric shavers to 150-watt or 200-watt units for operation of larger devices. Several models have output voltage control built in.

MINIATURE SEALED ALUMINUM ELECTROLYTICS

Small hermetically-sealed aluminum electrolytic capacitors *Littl-Lytics*, have been designed by the Sprague Products Company, 231 Marshall Street, North Adams, Mass.

Tiny capacitors, said to serve as replacements in such equipment as transistor radios, hearing aids, pocket-sized wire recorders, and other miniature electronic units, range in size from 3/16" diameter by 9/16" long to 3/8" diameter by 7/8" long. Values range from 1 to 200 mfd in voltages from 1 to 50 vdc.

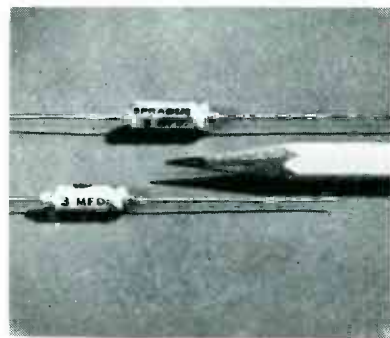

TEN YEARS AGO IN SERVICE

THE FIRST NATIONAL conference on TV servicing, under the direction of *ye ed*, was held at the annual exhibition-meeting of the Television Broadcasters Association at the Waldorf-Astoria Hotel in N. Y. C. . . . Copies of the talks presented at the session were distributed among associations for use at clinics. . . . Two-way FM (*Motorola*) communication systems operating on 152.27 (receiving) and 157.53 mc (transmitting) were installed in Chicago taxis. . . . *Ted Smith* was named general sales manager of the engineering products department of RCA. . . . The first photodiagram report on the installation of selenium disc rectifiers, based on information supplied by FTR, appeared in SERVICE.

Associations

TSDA, San Mateo, Calif.

AT A RECENT meeting of the Television Service Dealers Association of San Mateo County, Calif., Don Johnson of Westinghouse discussed and demonstrated the Westinghouse 22-inch glass rectangular color set, which was originally described in the June issue of SERVICE.

A highlight report of the meeting appeared in TV Service, the official journal of the association.

IRTSA, Wisconsin

A NEW GROUP of officers was elected recently by the Indianhead Radio-TV Servicemen's Association, Inc., Eau St. Clair, Wisc. Earl Kratch was named president; Upton St. Clair, vice prexy; Richard Presnel, secretary; and Vernon Christian, treasurer.

Sherwood Stolp and Earl Struve were elected to the board of directors. C. W. Stiemke remains as corresponding secretary.

RSA, Luzerne County, Pa.

THE TENTH annual clambake of the Radio Servicemen's Association of Luzerne County, Pa., was held a few weeks ago on Sgarlet Lake.

Formerly the meetings were held at Lily Lake.

MTSE, Minneapolis, Minn.

THE FIRST service-engineering conclave of the Minnesota Television Service Engineers, Inc., Minneapolis, at the University of Minnesota, was an outstanding success, according to association prexy John Hemak.

Those at the meeting received certificates of attendance from University president J. F. Morrell.

The group will meet again next year at the University during a 3-day session on May 6, 7, 8.

TVEC, Evansville, Ind.

THE TV ETHICS COMMITTEE of the Evansville (Ind.) Chamber of Commerce recently celebrated its third anniversary at a special meeting in Sterling, Indiana.

The group was praised by many business and professional members of the Chamber of Commerce for its activities in protecting the TV set owners and the self-policing program of the association membership which, it was said, insured honest and competent service and installation.



At third anniversary celebration meeting of TV Ethics Committee: Lee White, secretary, and John Buchman, president.

what's a square foot

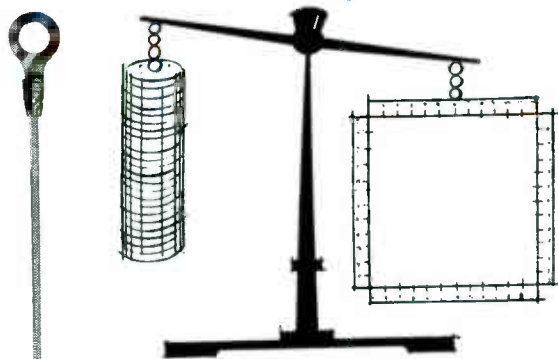

worth to you?

api can increase its
productive value!

API's local inventory and service facilities can help you increase square foot floor space value for productive uses by eliminating heavy warehousing requirements.

At any of API's local inventory and service centers, you will find a wide variety of A-MP® Terminals, Connectors and Tools to meet all your service requirements. Order only the amount to satisfy your service needs. Call API's nearest branch office for inventory, service and technical assistance!

In addition to branch offices, API maintains a group of local telephone information centers for your convenience.

api
Trade Mark

dependability 2 ways

The product and the
product knowledge of
the API man who
serves you.

AMERICAN PAMCOR, INC.

Subsidiary of Aircraft-Marine Products, Inc.
181 Hillcrest Ave., Havertown, Pa.

Hawthorne, Calif.	*Minneapolis, Minn.	*Dayton, O.
San Francisco, Calif.	*Kansas City, Mo.	*Portland, Ore.
*Washington, D.C.	St. Louis, Mo.	Philadelphia, Pa.
Atlanta, Ga.	*Maplewood, N.J.	Pittsburgh, Pa.
Chicago, Ill.	*Albany, N.Y.	*Knoxville, Tenn.
*Indianapolis, Ind.	*Buffalo, N.Y.	Dallas, Tex.
Baltimore, Md.	*Charlotte, N.C.	*Richmond, Va.
Boston, Mass.	Cincinnati, O.	*Huntington, W. Va.
Detroit, Mich.	Cleveland, O.	*Milwaukee, Wis.

*Consult the yellow pages of your local telephone directory under AMERICAN PAMCOR, INC., for local telephone center number.

EICO 84 Withers St., Brooklyn 11, N. Y. S-9

SAVE-ME 50% on precision instruments—
send **FREE CATALOG** on EICO's 46 models
in factory-wired and kit form.

My Name.....
Address.....
City..... Zone..... State.....



NEW! COLOR
and Black-&-White
DC to 5 MC LAB & TV
5" OSCILLOSCOPE

#460
Factory-wired
and tested \$129.50
Also available as kit \$79.95

• Features DC Amplifiers!

Flat from DC-1.5 mc, usable to 10 mc. VERT. AMPL.: sens. 25 rms mv/in; Z 3 meg; direct-coupled & push-pull thruout; K-follower coupling bet. stages; 4-step freq-compensated attenuator up to 1000:1. SWEEP: perfectly linear 10 cps-100 kc (ext. cap. for range to 1 cps); pre-set TV V & H positions (30 & 7875 cps); auto. sync. ampl. & lim. PLUS: direct or cap. coupling; bal. or unbal. inputs; edge-lit engraved lucite graph screen; dimmer; filter; bezel fits std photo equip. High intensity trace CRT. 0.06 usec rise time. Push-pull hor. ampl., flat to 400 kc, sens. 0.6 rms mv/in. Built-in volt. calib. Z-axis mod. Sawtooth & 60 cps outputs. Astig. control. Retrace blanking. Phasing control.

BEFORE you buy ANY instruments—get the FACTS on the money-saving, high-precision EICO line. Fill in coupon for **FREE** catalog & name of your nearby distributor.

EICO 84 Withers St., Brooklyn 11, N. Y.
Prices 5% higher on West Coast

INSTRUMENTS

COLOR-TV VIDEO MULTIMARKER

An absorption-type *video multimarker* (WG-295B), designed especially for use in sweep alignment and troubleshooting of color-TV receivers, has been developed by the RCA components division. The instrument, it was said, provides seven simultaneous reference markers on a sweep-response curve at factory-set frequencies.

Markers at 4.1 and 3 mc provides facilities for checking video-amplifier and bandpass amplifier response curves, are in addition to the markers at .5, 1.5, 2.5, 3.58 and 4.5 mc supplied by the WG-295A. These are frequencies needed for checking Q and I filters, bandpass filter, color subcarrier circuitry and sound trap of color set.

COLOR CONVERGENCE GENERATOR

A color-TV convergence and linearity generator (model 250), that provides white dot pattern, white line crosshatch and horizontal or vertical bars has been developed by Winston Electronics, Inc., 4812 Main St., Philadelphia 27, Pa.

Auto-lock counter chain with *afc* said to provide jitter-free patterns locked to the power line frequency. Standard 15,750-horizontal sync pulse and 60-vertical sync pulse, 30-frame 525-line interlaced raster with blanking of retrace lines makes unit also useful as a test pattern and sync generator.

TEST EQUIPMENT CALIBRATOR

A lab-type *test equipment calibrator* (model 750) with, it is said, accuracy of 1% or better in all of its voltage sections has been announced by the B&K Manufacturing Co., 3731 N. Southport Ave., Chicago 13, Ill.

Calibrator checks test equipment accuracy; reveals how far any instrument may be off.

Supplies 2, 5, 25, 100, and 300 v dc, and 5, 25, 100, and 300 v ac, to check voltage ranges. Provides 10, 100, 1,000, 10,000 and 100,000 ohms and 10 meg-ohms to check resistance ranges. Supplies crystal oscillator capable of generating harmonic frequencies well over 300 mc. Plugging in proper crystal facilitates use as a marker generator in radio and TV receivers; helps to check calibration on AM signal generators, or check and align the audio *if* system of TV receivers.

Serves as a voltage calibrator for scopes in the measurement of peak-to-peak voltages of any unknown waveforms such as are found in TV receivers.



TUBE TESTER

A tube tester (model T72) that provides 72 sockets to check over 300 TV and radio tubes including 600-mil and color tubes without, it is said, roll charts or multiple switching, has been placed on the market by the Anko Manufacturing Co., Inc., 5042 W. State St., Milwaukee 8, Wis.

Tests all sections of multi-section tubes. Dynamic-loaded test supplied by instrument, puts tubes under fully loaded conditions. Checks for shorts from any element to any adjacent element. Also affords special tests for gas, grid emission and grid shorts on one and two-section tubes. Ten spare sockets are provided for new tubes that cannot be tested on presently wired sockets.



When signal conditions demand a TOWER... choose one built by AERMOTOR



AERMOTOR TOWERS have proven their excellence in thousands of installations . . . installations exposed to the most severe weather and wind loading conditions.

AERMOTOR steel antenna towers are self supporting . . . require no cumbersome guy wires. Each part is heavily galvanized *after* fabrication to insure complete protection from exposure.

Towers are shipped knocked down in convenient bundles; well designed parts make section-by-section assembly easy.

AERMOTOR 3-post antenna towers are available in heights of 33, 47, 60, 73, 87 and 100 feet.

WRITE FOR ADDITIONAL INFORMATION ABOUT THE AERMOTOR TOWERS AND A DEALER FRANCHISE IN YOUR TERRITORY.

SINCE 1888, MANUFACTURERS OF QUALITY BUILT TOWERS

• AERMOTOR COMPANY •

2500 W. ROOSEVELT RD. — CHICAGO 8, ILLINOIS U.S.A. DEPT. 14U9

TV Antennas

(Continued from page 32)

ments become loaded as the positions and sleeve lengths are changed.

To overcome these objections antenna manufacturers have designed many innovations in the basic V-shaped dipole configuration.

Recently, the lab of one antenna manufacturer announced the development of an indoor model¹ with a number of unique properties.

A feature of this antenna is its novel shape, with a flat length of twenty inches. This is considerably less than the desired length for a normal halfwave dipole causing its impedance to be almost entirely capacitive and its radiation resistance to be only 3 ohms. An electrical representation of this situation is shown in Fig. 1; p. 32. The electrical length of the antenna can be increased without increasing its physical length by end-loading. The *hats* at the end serve this purpose and increase the radiation resistance to about 30 ohms, but its impedance is still mostly capacitive; this condition is illustrated in Fig. 2; p. 32.

Since capacitive reactance can be tuned out with series inductance, this feature was included in the antenna

¹The Showman, designed by Julius Green, Channel Master project engineer.

²Metro-Dyne tuning

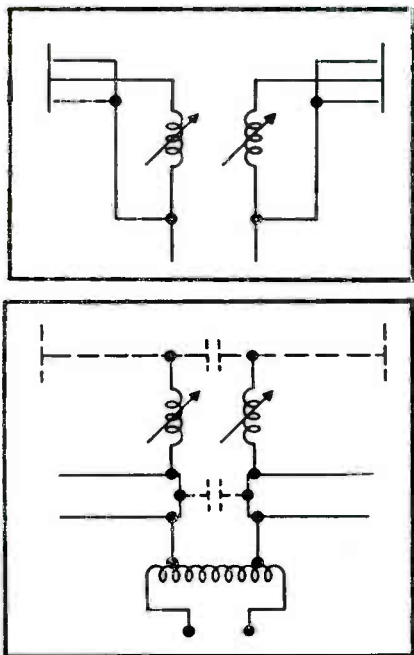

FIG. 5: CIRCUIT (top) illustrating high-band dipole; it is highly capacitive. Equivalent circuit (bottom) shows shunt compensation of high-band dipole; capacitive reactances of both the high and the low-band dipoles (dashed lines) can be tuned out. Impedance can then be stepped up by autotransformer as illustrated.

via a variable inductance² which could be adjusted for each channel; this approach was found to provide a 30-ohm radiation resistance, as noted in Fig. 3; p. 32.

To provide an impedance step-up of 10:1 so that the antenna would appear as a 300-ohm impedance, an auto-transformer was added; Fig. 4; p. 32.

This arrangement served to provide an antenna of short physical length that still could be tuned to even the lowest TV channel.

The use of the end-loading principle to increase the impedance was found to serve more than one useful purpose. It allowed the use of the 10:1 impedance ratio in the auto-transformer instead of a 100:1 ratio; this would have been required if the antenna impedance was left at 3 ohms. End-loading also was found to

control the antenna's Q , affording an increase in bandwidth and corresponding channel coverage.

In planning this indoor for low-band use, the center rod and *hats* at the ends (shown in Fig. 2) served as the basic elements. For high-band use, there were added two outside rods on each part of the antenna to form two *Us* to simulate a *fat* dipole. In view of the limited length of the antenna on the high bands it was found it would appear capacitive with a low impedance, were it not for the introduction of a tuning inductance. Therefore, the tuning mechanism used on the low band (in series) was adapted for the highs, but in shunt, to tune out the capacity. The equivalent circuit for the high band, including the auto-transformer to step up the impedance, is shown in Fig. 5.



"Blue Beaver"® Electrolytics

Cornell-Dubilier's "Blue Beavers" are the serviceman's very own. They're sold only through authorized C-D Distributors. Full profit and complete customer satisfaction comes only with "Blue Beaver" Electrolytics. They are a truly *exclusive* capacitor—exclusive in quality and long life performance—and made only by C-D, *exclusively* for the service trade. Ask your nearby C-D Distributor for catalog or write direct to Cornell-Dubilier Electric Corporation, South Plainfield, N. J.

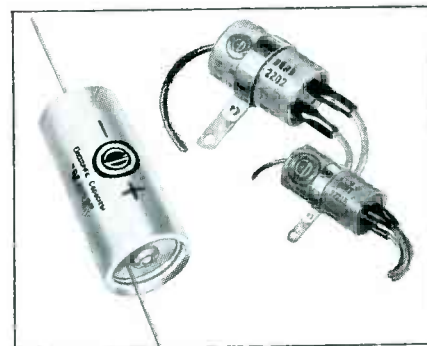

Cornell-Dubilier capacitors

South Plainfield, N. J.; New Bedford, Worcester & Cambridge, Mass.; Providence & Hope Valley, R. I.; Indianapolis, Ind.; Sanford, Fuquay Springs & Varina, N. C.; Venice, Calif., & subsidiary, The Radiart Corporation, Cleveland, Ohio.

Give your customers
fine music reproduction

with their conventional
phonographs by installing the

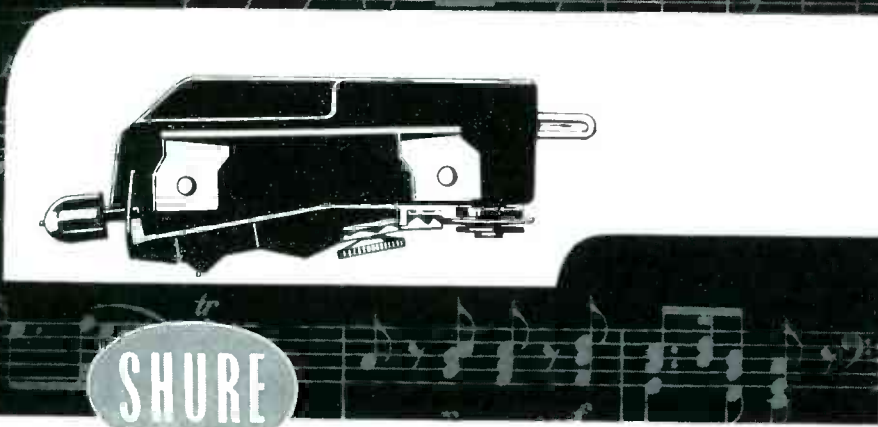

"Twin-Lever"

Ceramic Phono Cartridge

MODEL WC10

List Price \$9.50
with two sapphire needles

MODEL WC10D

List Price \$34.00
with a 1-mil diamond and a
3-mil sapphire needle

The WC10 "Twin-Lever" Improvement Cartridge has a peak-free frequency response from 40 to 12,000 cps. It makes conventional phonographs sound better than new—and its low list price enables you to make a sale every time you suggest a "Twin-Lever" Cartridge.

The "Twin-Lever" replaces and outperforms 157 three-speed, plastic-cased cartridges, crystal or ceramic, turnover or single needle.

It is easily installed in any tone arm with standard 1/2" mounting centers. Needle replacement can be accomplished in seconds—without tools—with the cartridge in the arm.

SHURE

The Mark of Quality

IN ELECTRONICS SINCE 1925

SHURE BROTHERS, INC.

Microphones—Electronic Components

204 HARTREY AVENUE • EVANSTON, ILLINOIS

Audio

(Continued from page 44)

impression that the sound fills the room rather than coming from a definite point.

To phase up a whole batch of loudspeakers, one should be set aside as a reference. Then, each of the remaining loudspeakers can be compared with the original one. If necessary, the voice coils should be reconnected, so that all of them are in phase when the common side of the primary is connected to the same side of the amplifier output.

Having completed this test, and coded black and red, or red and white wire combinations are adopted for the wiring system, it will then be necessary to use only a black or white lead for the common and the red for the *live* side throughout the system, and you will automatically be phased.

If these preparatory steps are not taken you will be faced with the problem of phasing on site. This will mean connecting and disconnecting each loudspeaker in turn and comparing the sound between individual pairs until you have the whole system phased; a very time-consuming process. It is much easier to make the test in the shop, where the speakers can be placed in position quite quickly and phasing checks made in quick succession.

Care should be taken in running the wires to the loudspeakers; they must not project into the audience area to present a safety hazard.

The possibility of sabotage must also be considered. Some people come to meetings just to spoil them in some way. It is much more convenient to cut the loudspeaker wire, if it is accessible, than to interrupt by heckling. So all the loudspeaker wiring should be placed out of harm's way.

In large sound installations, there are a number of special problems that must be resolved.

To illustrate, often the amplifier has to be at a considerable distance from

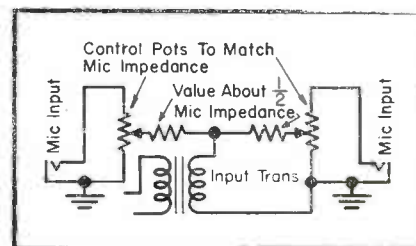

SIMPLE TWO-CHANNEL mixer for two microphones. This arrangement can also be used at high impedance, in which case the input transformer will be unnecessary.

hi-LOW with ATLAS

high quality
low price



PAGING & TALK-BACK SPEAKERS
6 sizes and types.
All impedances
from 4 to 45 ohms.
From 5 to 15 watts.
From \$15.00 to \$24.00 NET.



WEATHERPROOF LINE MATCHING TRANSFORMERS
For constant impedance
or constant voltage systems.
\$5.00 NET.



HIGH-POWERED PUBLIC ADDRESS SPEAKERS
Four sizes from 2 1/2' to 6' air column.
From \$10.00 to \$39.00 NET.

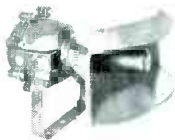

U-L APPROVED EXPLOSION-PROOF SPEAKERS
For hazardous applications.
Several sizes, all classes.
From \$66.00 to \$75.00 NET



SUPER-POWER DRIVER UNITS
For all purposes,
powers, frequencies.
From \$15.00 to \$30.00 NET.



MIKE STANDS & ACCESSORIES
All sizes and types:
boom stands, desk stands,
adapters, fittings, etc.



NEW! SWITCHBOARD MIKE SUPPORT
Adjustable 12" goose neck. Use as desk support, for dispatcher office, dais, table, etc.
#SB-1 ... \$7.80 NET.

New!

NEW! "CHESTY" NECK-SUPPORTED MIKE STAND

Quick, easy 3-way adjustment. Lightweight. Multiple uses.
#NS-1 ... \$3.00 NET.



New!



NEW! MIKE FOOT SWITCH
Hand, foot or knee operation—shielded, grounded, noise-free, dependable, damage-proof.
#FS-1 ... \$7.20 NET.

SEND FOR COMPLETE FREE CATALOG



ATLAS SOUND CORP.
442 39th St., Brooklyn 18, N. Y.
In Canada: Atlas Radio Corp., Ltd., Toronto, Ont.



INVERTER specially designed to operate tape recorders, record players and pa systems from auto dc supply. One model (ATR 6-RHF) operates on 6-v battery and delivers 100 watts continuous (125 watts intermittent). Another model (ATR 12-RHF), operating from 12-v battery, delivers 125 w continuous (150 w intermittent).

the microphone; this means the installation of relatively long lines.

On small installations, it is usually most convenient to use a high-impedance microphone, because this avoids the necessity of an input transformer on the amplifier. But long lengths of shielded cable can lead to excessive high-frequency loss or, if crystal type microphones are used, excessive attenuation of the entire signal.

Two impedances are favored by microphone manufacturers and public address groups. One may be described as a *low impedance* in the region of 25 to 50 ohms; the other is usually called a *line impedance* and may vary from a 150 to 600 ohms. The exact value is not usually very important, but the method of using the two groups does differ.

With low-impedance microphones it is possible to use the standard wiring for the microphone, because the low-impedance circuit is only likely to pick up crosstalk or hum by electro-

magnetic induction. Thus, tightly-twisted pairs can be used, either one side grounded or balanced, usually the former; *but* the leads must be kept reasonably well away from power lines or other sources of interference.

However, when low-impedance circuits are used on very long lines, say a mile or more, losses are often so serious that it becomes necessary to use a booster amplifier at the microphone end.

The 150 to 600-ohm variety of *line impedance* was originally introduced to make it possible to run distances up to a mile or more without serious

(Continued on page 52)

HERE'S ADDED SERVICE PROFIT at no extra expense

YOU can easily service small appliances as well as TV and radio for extra profits. You're in the home, so no extra call is required. Just inquire if there's an iron, toaster, mixer or other appliance that needs attention. You'll be surprised how many will say "yes" and be glad you mentioned it!

More Than 5 Million General Mills Appliances alone are in Daily Use!



Yes, aside from other makes, more than 5,000,000 GENERAL MILLS appliances have been sold to American homes. They are famous for their performance and satisfaction, yet through abuse and carelessness thousands of them need repair and service. You can get that business in your city.

We are exclusive *national* parts headquarters for all General Mills appliances. We have an attractive profit-proposition for you. Send the coupon today.

APPLIANCE SERVICE CO.
1516 East Lake Street
MINNEAPOLIS 7, MINN.

APPLIANCE SERVICE CO.
1516 E. Lake Street, Minneapolis 7, Minn.
Enclosed is 25 cents to cover cost of printing and mailing complete parts list and detailed instructions for servicing General Mills appliances.

Name.....
Firm.....
Address.....
City..... Zone..... State.....

DON'T Just say capacitors

Ask For Sprague By Catalog Number

Know what you're getting... get exactly what you want. Don't be vague... insist on Sprague.

Use complete radio-TV service catalog C-610. Write Sprague Products Company, 61 Marshall Street, North Adams, Massachusetts.

SPRAGUE

WORLD'S LARGEST CAPACITOR MANUFACTURER

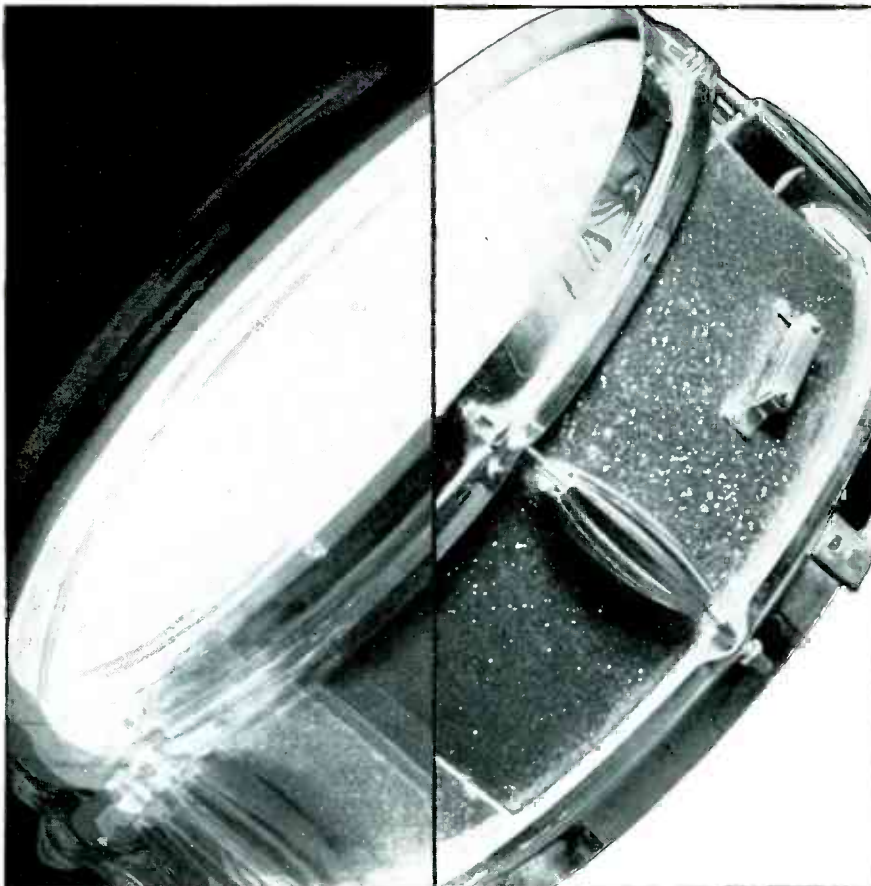

DUOTONE IN LIFE...

The first and only big time door-opener in your field . . .

It's the big news of the trade—for Duotone is the first Company in the history of the needle business—the only Company in the accessory field to launch a full-scale, cross-country promotion in Life Magazine and five other national magazines.

Means you can count on people wanting, knowing, asking for Duotone by brand name. Over 21 million people, to be exact.

Cash in on this—Count on Duotone to help you open the door to new sales on service calls—it's a name people know and want. Open the door with Duotone—and

GET YOUR FOOT IN WITH THESE

The Duotone Company, Inc.

Keyport, N. J.



SPECIAL SERVICE MAN'S KIT
The all-in-one needle repair kit with the famous four free extras. Includes free—one 50X microscope to check needle. Jeweler's screwdriver. Professional Tools. Plastic carrying case. 13 of the most used needles. List \$25.00.



DUOTONE MAGIC RECORD CLOTH
Over 60 million sold so far. The original, popular Magic Record Cloth—removes dust and electrical static. Protects record from damage. An extra safe on every service call.



DUOTONE T-V CLOTH
REMOVES TV SMOG
CLEANS INTERIOR & EXTERIOR SURFACES
REMOVES DIRT FROM GLASS
REMOVES SMOG FROM SCREENS

DUOTONE T-V CLOTH
An extra on every service call. New especially treated cloth that removes T-V Smog like magic. Gives brighter picture. Reduces reflection glare. Keeps dust from clinging. A quick wipe by servicemen inside and outside of protective glass and on picture tube. Sell one for home use to remove fingerprints—keep off dust.



FREE NEEDLE TESTER CARD
Another extra from Duotone. Card is treated with special material. Customer can press needle into card at home—send card to you—and without having to make a special call, you can tell if needle is bad or good. Suggest they check regularly. Let's you know, without visiting them, whether the trouble is with their needle. Tester cards free from Duotone with Serviceman's Kit.

Audio

(Continued from page 51)

loss. This is, in fact, the region of optimum line impedance for audio transmission. However, lines at microphone level must be both balanced and screened for successful transmission over long distances. Thus twin shielded wire must be used with a center-tap input transformer, so that the line can be run balanced, by connecting the center tap to ground. The microphone output should not be grounded on either side; otherwise the balanced arrangement will be shorted out.

100' To 200' Run Requirements

For 100' or 200' runs, the 150-ohm impedance, which is becoming quite popular these days, is sufficiently low to be satisfactory connected single ended. As noted, the twin twisted or single shielded lead can usually be used at this impedance; the single shielded line is somewhat better, because higher impedances are up in the region where electrical pickup can be troublesome.

As all crystal or ceramic microphones are high impedance, these types are *not* recommended where long microphone connections are involved.

Mixing

Another large-installation situation that requires careful consideration is the mike junction point; often a number of microphones, at various points, must be connected into the same amplifier for use at different times during the program. Maybe a number of speakers distributed at different points on a platform have to talk, and instead of bringing each speaker to a central mike a number of mikes are grouped across the platform, so that each speaker can step up to his own microphone.

If all the microphones are connected into the same input, and are on simultaneously, the extraneous-noise pickup will be excessive and affect output. It is very desirable to use only the necessary microphones at one time. This requires some mixing arrangement, so that individual microphones can be faded in as desired.

If only two microphones are used, a parallel mixer can be connected right at the input to the amplifier. But even this will cause a loss of about 6 to 8 db in maximum gain from either individual microphone, so

it will not be successful unless this much spare gain is available in the first place.

Where four or five microphones have to be connected into the same circuit with a mixing arrangement, as much as 15 to 20 db loss can occur on each individual channel. Of course, additional gain can be provided to make up this loss; but, if it is provided after the mixing, the whole input circuit can become much more susceptible to pickup of extraneous signal, crosstalk and hum.

The best arrangement, therefore, is to provide each microphone input with a separate microphone amplifier stage. A 12AY7 amp is excellent for this purpose; it is low noise and has a medium gain. One half of a 12AY7 can be used for each microphone input; this will provide sufficient amplification to mix in the plate circuit of all the 12AY7s.

Six-Input Setup

With three 12AY7s, six inputs are possible. Filament and plate supply for the extra tubes can be obtained from the regular amplifier, after having ascertained that the filament winding is adequate for the purpose. Three 12AY7s connected to a 6.3-volt



LINE FILTER designed for use with tape and wire recorders and phono to eliminate noises picked up through line, caused by motors, ignition, neon, diathermy, lighting and heating equipment, and home appliances. Filter incorporates ferrite wound chokes and noise-rejection filter capacitors. (Model DF-200; Dynamic Electronics-N. Y., Inc., 73-39 Woodhaven Blvd., Forest Hills, L. I., N. Y.)

winding will take an additional .9 amp from the filament transformer.

This mixing circuit is at high impedance, to save stepping down and up again, and should be connected to the amplifier itself. It is not wise to try and make this remote from the amplifier.

If the refinement of a remote control is required, this can be achieved by using a variable bias on each tube; (Continued on page 54)

HICKOK

Model 605A



DYNAMIC MUTUAL CONDUCTANCE

Tube Tester

Handy Size Portable

- Popular—Accurate—Dependable.
- Large 5" easy-to-read meter.
- Accurately tests tubes in micromhos.
- Built-in 20,000 ohms per volt DC multimeter measures capacitance, inductance, volts, current and decibels.
- Write for technical details...

THE HICKOK ELECTRICAL INSTRUMENT CO.

10521 Dupont Ave., Cleveland, Ohio

for SURE profits

Deal yourself a winning hand



RECOTON DIAMOND NEEDLES

For repeat sales and higher profits—sell **RECOTON DIAMOND NEEDLES**. Recoton has 100% consumer acceptance, insuring your fast turnover! Stick with the winner—**RECOTON**—famous for quality!

RECOTON CORPORATION
52-35 Barnett Avenue
Long Island City 4, N. Y.

Let CONALERT* monitor Conelrad for you



For National Defense

Standard broadcast, public service, radio amateur, land transportation and all other radio stations

must monitor Conelrad by JANUARY 2, 1957

Conalert does monitor Conelrad!

*CONALERT is FCDA listed for Federal Matching Funds

Conalert is the simplest, surest, most practical way for you to conform to FCC Conelrad regulations. Conalert features:

- 5 preset channels (3 for key Conelrad stations, one each for 640 and 1240 kc)
- Multiple alarm system
- Fail-safe design
- Silent or audible monitoring with aural and visual warning
- Rack or cabinet models

See the Conalert at your local Kaar dealer, or write for information. (Dealerships for qualified organizations are open in certain areas).

KAAR ENGINEERING CORP.
2996 Middlefield Rd., Palo Alto, Calif.

Please send information concerning

Conalert
Dealership

Name _____

Address _____

City _____ Zone _____

State _____

Little Devil[®] COMPOSITION RESISTORS

Meet all MIL-R-11A requirements. Rated at 70C rather than 40C. Available in 1/2, 1, and 2-watt sizes in all standard RETMA values.

BROWN DEVIL[®] RESISTORS

Vitreous - enameled. In 5, 10, and 20-watt sizes.

TYPE AB POTENTIOMETERS

Resistance material is solid-molded, noise-free. Rated at 2 watts.

FR-7.5 FUSE RESISTOR

For easy replacement in all television receivers. 1 1/2" Tinned wire leads.

WRITE FOR STOCK CATALOG

Be Right with OHMITE[®] DEPENDABLE RESISTANCE UNITS

Eliminate call-backs due to faulty replacements. Use Ohmite components.

AXIAL-LEAD RESISTORS

Vitreous-enameled, power-type units designed to withstand high temperatures.

3 WATT SIZE
9/16" x 1/4"

5 WATT SIZE
1" x 11/32"

10 WATT SIZE
1-3/4" x 13/32"

OHMITE[®]

OHMITE MANUFACTURING CO.
3642 Howard Street, Skokie, Illinois

Audio

(Continued from page 53)



EXPLOSION-PROOF, U-L approved, pa loudspeakers made for paging and talk-back applications. Available with built-in line matching transformers. (Models HLE-1-30 and 1-42; Atlas Sound Corp., 1451 39 Street, Brooklyn 18, N. Y.)

a negative supply can be obtained from a separate filament transformer, using a voltage-doubler circuit to get about 12-volts negative.

DC For Pots

With such a circuit plan, the potentiometers on the remote control unit only have to carry *dc*; the signal circuit goes straight into the amplifier and through the mixing tubes. This arrangement is very convenient where

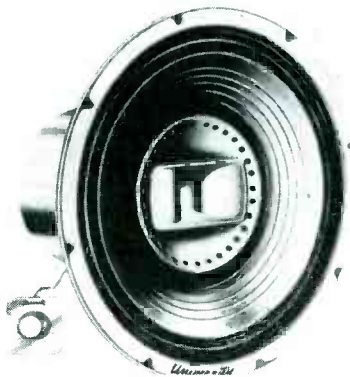

UNITARY TYPE SPEAKER assemblies, containing two or three integrated radiators, for two- or three-way performance. Split range performance of two-way unit is said to be obtained through mechanical parameters designed into woofer and Diffusicone sections to achieve mechano-acoustical crossover characteristics. In three-way unit a top-range compression diver-tweeter coupled to a reciprocating flare horn is added. Wide-angle horn is mounted through center of woofer assembly for exponential expansion. Tweeter is electrically meshed to two-way cone system through a built-in L/C dividing network. (Diffaxial; University Loudspeakers, Inc., 80 S. Kensico Ave., White Plains, N. Y.)

CERAMIC CARTRIDGES



American
"Clearamic"

LOADED with PROFIT

- Lightweight, miniature size, greater compliance
- New mechanical construction gives higher output
- New "throw-away" element
- Simple replacement, snap-in action
- Assorted stock orders totaled for maximum discount
- "Clearamic"—The "new look in good listening"

New Turnover Type



Response . . . 40-12,000 cycles
Output . . . 1-1.2 volts

New Single Needle Type



Response . . . 40-12,000 cycles
Output . . . 1-1.2 volts

Turnover type features "throw-away" element offering snap-in replacement of both element and needle assembly for essentially the price of a good replacement needle. Single needle type features simplified self-locating needle replacement.

Ask for the handy new "dispenser" assortment — meets almost all replacement needs.



ELECTRONICS DIVISION

ELGIN NATIONAL WATCH COMPANY

For Cartridges:
370 South Fair Oaks Avenue
Pasadena 1, California

Sales representatives in principal cities.

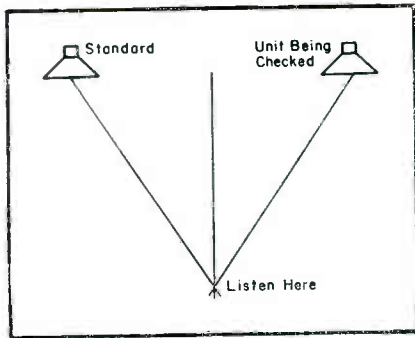

HOW TO LISTEN to two loudspeakers when making phasing checks.

it is desired to use controls remote from either amplifier or microphone.

The remote control can be connected with the amplifier by means of an octal plug and socket, so that the system can be made quite portable.

Tone Controls

A final feature that one should include in a large installation is a comprehensive tone control on the main amplifier. Most modern public-address amplifiers have this feature; but it is much more important in a large installation than a smaller one, because most large buildings have characteristic frequencies at which they reverberate and cause acoustic feedback. By careful adjustment of both high and low frequency tone controls, the best overall response can be obtained in that particular building, compensating to some measure for the peculiarities of the building acoustics.



SWITCH HARNESS kits for auto rear seat speakers; seven models said to fit all cars from '49 through '56. Kits include a 3-position dial-type mounting switch and all necessary leads and instructions. (Rickay Manufacturing Co., 4319 W. 35th St., Cleveland 9, O.)



PROGRESS MAKES WASTE

It takes courage to discard plans and models . . . especially when they involved time and effort. Yet, we at University, do just that!

In our almost fanatic dedication to achieving perfection, we carry the development of new products to the highest degree possible. In this exacting process, things which do not meet our rigid requirements find their way into the waste basket. Actually *this* kind of waste makes *real* progress.

Too often items are rushed onto the market before they are ready. *We* introduce products only when they've conformed to traditionally high University standards (customers have always found them worth waiting for).

This philosophy of business has made us countless friends who look to *University* for the latest developments in loudspeakers. Today—*University* is the leading specialized speaker manufacturer. There are more satisfied users of *University* speakers than of all other speakers combined. *The University label on a speaker is a guarantee of trouble-free operation and performance that conforms to specs.*

That's why *University* "sells on sound." Our engineering department will gladly consult with you on any technical requirement.

UNIVERSITY LOUDSPEAKERS, Inc., 80 So. Kensico Ave., White Plains, N. Y.

LISTEN

University sounds better



**When . . .
You Change Your Address**

▶ Be sure to notify the Subscription Department of SERVICE at 52 Vanderbilt Avenue, New York 17, N. Y., giving the old as well as the new address, enclose address labels from your last SERVICE copy, and do this at least four weeks in advance.

▶ The Post Office Department does not forward magazines unless you pay additional postage, and we cannot duplicate copies mailed to the old address.

▶ We ask your cooperation.

New! POCKET SIZE
Rejuva-Check
TESTS • REPAIRS
REJUVENATES
ALL PICTURE TUBES
right on the job!



REJUVA-CHECK does everything the big instruments do and then some! **TESTS** cathode emission. Indicates leakage between elements. Estimates remaining useful life of CRT. **REPAIRS** by removing cathode surface contamination. Clears inter-element shorts and leakage. **REJUVENATES** and gives new life to weak, dim tubes by restoring emission. Simple and easy-to-use!

SEND
NO
MONEY

FREE
10-DAY
SERVICE
TEST

TRY
BEFORE
YOU
BUY

Mail Coupon Now! No Obligation!

CENTURY ELECTRONICS CO., Inc.
111 Roosevelt Ave., Dept. S-9
Mineola, N. Y.

OK, rush REJUVA-CHECK for FREE 10 day use on my toughest service calls. After 10 days, I will send \$7.95 plus postal charges or return it without obligation.

Name _____

Address _____

City _____ State _____

SAVE POSTAL CHARGES! Enclose \$7.95 with coupon and we pay all postal charges. Same NO-RISK refund privilege.

Garage Door Openers

(Continued from page 11)

a vertical mount on a fender or cowl is more satisfactory. To enable operation of a circuit posing a greater power demand, along with the door operation, an external relay will have to be added to the circuit.

Before an installation is ready, the leads from the receiver control leads must be left detached from the operator and a flashlight with two clip leads (in series with the bulb and batteries) hooked on. With the garage door open, the car's transmitter can be tested by observing the light each time the button is pressed. This will demonstrate range and directivity. The switch can be jumped with a lead (with light out) and the receiver antenna oriented. By placing the antenna in other directions or by adding a quarterwave length to the existing antenna, the light will go on signifying control from the car.

On all of the aforementioned control units, we have found the general type of troubles common to all electronic equipment, such as defects in vibrators, capacitors, resistors, selenium rectifiers and tubes.

It has been found that a tube in cutoff develops what is referred to as cathode-face resistance. This seems to be a function of the type of cathode material used. Consequently, premature failure in the relay circuit of the receiver results. We have met this problem by using premium tubes, specifically designed for computers, which lend themselves well in radio-control circuitry.

Service Call Procedures

On a typical service call over the phone customers are asked if the door operates with the garage button. If the answer is in the affirmative, the radio control is suspected. Our vehicle has a transmitter, and on reaching the customer's home, the key plug-in unit from his transmitter is used. If door operation is still lacking, the receiver is checked. With tubes lit up, fuse okeh, a substitute receiver is mounted; this change requires little time. We have found that this substitution method gives fast field service.

The future of radio control garage door openers is dependent on a design criteria that will overcome some of the shortcomings noted. Remarkable progress has already been made and many more developments will, we are sure, appear soon.



**Series or Parallel
Booster!**



At All
Distributors



manufactured by
Perma-Power COMPANY
4727 N. Dohen Ave., Chicago 25, Ill.
manufacturers of electronic equipment since 1928
Export: SCHEEL INT., Chicago

**STEAM IRONS
NEED CLEANING TOO!**

get **INSIDE** clean for **MORE** steam

**SSS-T! STEAM IRON
CLEANER**

- EASY TO USE
- ODORLESS
- NON-ACID
- WILL NOT BURN
- ECONOMICAL
- MFGR. RECOMMENDED



FULL
YEAR \$100
SUPPLY RETAIL

A NATURAL Over-the-Counter Seller!
Used and Sold in Leading Appliance Service
Stations Coast-to-Coast!

Order from your **JOBBER** or write
us for name of your nearest supplier.

Fast Chemical Products Corp.

65 Page Avenue
YONKERS 4, N. Y.

Service Engineering

(Continued from page 26)

must be *available*. It is not as easy to make a piece of radio equipment which will function without frequent failures when it is subjected to heavy shock, weird types of vibrations, fumes, smoke, gases, and other unusual environmental conditions.

Once the hurdle of obtaining good equipment has been cleared, the railroad must install it properly and then must give it adequate maintenance. Stringent labor regulations on most railroads require that the installation of radio equipment must be performed only by properly classified railroad employees. Some railroads hire their own Service Men to maintain radio equipment. The Northern Pacific, for example, employs 9 people to maintain radio. However, many of the small railroads and a number of the big ones contract with independent service organizations to maintain some of their radio equipment in certain areas. The Walla Walla Valley Railroad and the South Shore Line farm out all of their radio maintenance; the New York Central in certain locations.

Service Men, whether employed by the railroad or outside contractors, seldom service the radio equipment while it is still on board rolling stock. Some roads require removal of the equipment by personnel employed in the railroad mechanical department. In some cases, Service Men are asked to come aboard to remove the set and replace it with a spare; Service Men are also called on to diagnose troubles which may be caused by the power supply, antenna system or control equipment.

Mobile communications units are removed and brought or shipped to a shop, where they are serviced and then stored as spares for later use. How often sets are replaced with spares on a routine basis depends upon the individual railroad. Some follow a 30-day cycle, others do not touch the sets for six months, unless a set fails in service before that time.

When a single unit type set is used, the entire assembly is, of course, exchanged. When three units sets are used, all three are usually replaced; in emergencies, however, when it is known which unit is ailing, only one unit need be replaced.

In the shop, the sets are thoroughly checked electrically and mechanically. Whole sets of tubes are rarely replaced at one time. In the rugged type of rail service to which 2-way

(Continued on page 58)

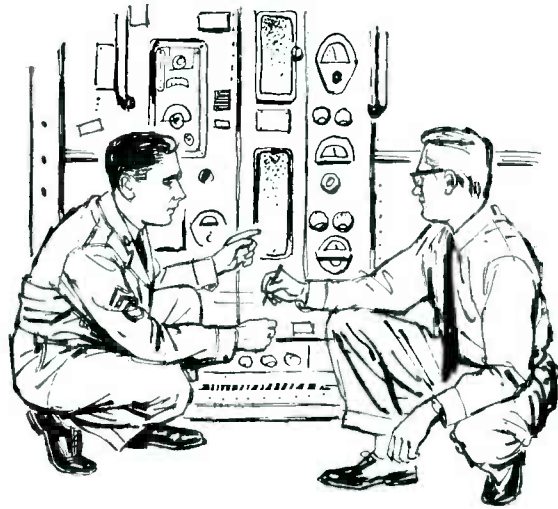

TODAY...

A TECHNICIAN

TOMORROW...

*AN RCA FIELD
ENGINEER!*

HOW ABOUT YOU? Many technicians have the knowledge and experience that can immediately qualify them as Field Engineers with RCA! Now is the time to find out whether you can make the big step up to Field Engineering with RCA.

As an RCA Field Engineer, you'll be responsible to advise and assist the military in the installation, maintenance and use of:

**HEAVY GROUND RADAR
AIRBORNE FIRE CONTROL RADAR
COMMUNICATIONS EQUIPMENT**

You may be assigned to one of many military installations in this country, or overseas. Liberal RCA benefit program adds security . . . a Tuition Refund Plan makes continued education easy . . . relocation assistance, too.

Arrange confidential interview with representative of RCA Engineering Management at a location convenient to you.



Please send complete resume to:

Mr. James Bell

Employment Manager, Dept. Y-11J

RCA Service Company, Inc.

Cherry Hill, Camden 8, N. J.

RCA SERVICE COMPANY, INC.

KESTER

Service Engineering

(Continued from page 57)



Absolutely non-corrosive and non-conductive, KESTER "RESIN-FIVE" CORE SOLDER contains an activated type of resin that gives you that fast, positive action on all your jobs . . . including the most difficult.



KESTER SOLDER COMPANY
4248 Wrightwood Avenue • Chicago 39, Illinois
Newark 5, New Jersey • Brantford, Canada

SOLDER

for service and lab. work

Heathkit PRINTED CIRCUIT OSCILLOSCOPE KIT FOR COLOR TVI

① Check the outstanding engineering design of this modern printed circuit Scope. Designed for color TV work, ideal for critical Laboratory applications. Frequency response essentially flat from 5 cycles to 5 Mc down only 1½ db at 3.58 Mc (TV color burst sync frequency). Down only 5 db at 5 Mc. New sweep generator 20-500,000 cycles, 5 times the range usually offered. Will sync wave form display up to 5 Mc and better. Printed circuit boards stabilize performance specifications and cut assembly time in half. Formerly available only in costly Lab type Scope. Features horizontal trace expansion for observation of pulse detail — retrace blanking amplifier — voltage regulated power supply — 3 step frequency compensated vertical input — low capacity nylon bushings on panel terminals — plus a host of other fine features. Combines peak performance and fine engineering features with low kit cost!



Heathkit TV SWEEP GENERATOR KIT ELECTRONIC SWEEP SYSTEM

② A new Heathkit sweep generator covering all frequencies encountered in TV service work (color or monochrome). FM frequencies too! 4 Mc — 220 Mc on fundamentals, harmonics up to 880 Mc. Smoothly controllable all-electronic sweep system. Nothing mechanical to vibrate or wear out. Crystal controlled 4.5 Mc fixed marker and separate variable marker 19-60 Mc on fundamentals and 57-180 Mc on calibrated harmonics. Plug-in crystal included. Blanking and phasing controls — automatic constant amplitude output circuit — efficient attenuation — maximum RF output well over .1 volt — vastly improved linearity. Easily your best buy in sweep generators.



Heath
COMPANY
A SUBSIDIARY OF DAYSTROM, INC.
BENTON HARBOR 11, MICH.
WRITE FOR FREE CATALOG
...COMPLETE INFORMATION

equipment is subjected, new tubes are more apt to fail than tubes which have been in service; aging racks are often used to permit tubes to be run-in before their installation in mobile units. When tubes are changed, particularly in the *rf* section of a receiver, realignment is generally necessary. If tubes are removed from a set for testing, they should be reinserted in the same sockets.

One large railroad reports that 63% of all radio failures are due to defective tubes and that types 6AK5, 6J6, 6BH6 and 2E26 fail far more frequently than other types. Vibrators have an average life of 21.5 months. Dynamotors have been found to require only routine maintenance.

Exact replacement parts are used for replacement. Wiring and placement of parts must not be altered lest what may be apparent small changes could produce major operating difficulties.

The law requires that all persons who make adjustments to radio transmitters must be properly licensed or must work under the direct supervision of a properly licensed operator. In the railroad radio service, the maintainer must possess either a first or second class radio-telephone operator's license.

Technical knowledge of electrical circuits, transmitters and receivers, plus familiarity with FCC rules and regulations is required. Written tests are administered at FCC regional offices.¹

Test Equipment

Test equipment which has proved adequate for servicing home radio and TV sets may not be satisfactory for servicing railroad radio equipment. For example, an *rf* signal generator may be tunable through the 152-162 mc band, but if its output cannot be attenuated to less than one microvolt, it will not be satisfactory; railroad communications receivers can provide useful output with signals of one microvolt or less. Even if the signal generator-attenuator is calibrated down to one microvolt, the signal leakage around the attenuator and through the case may be far in excess of one microvolt.

Another must in the shop is a frequency and deviation meter.² The frequency meter must be a professional type acceptable to the

¹There is no charge for an FCC license.

FCC. In making frequency measurements periodically, as required by the FCC regulations, the findings must be entered in the log. It is not satisfactory to state that the frequency checked within limits. Instead the exact frequency as indicated by the measuring device, must be recorded. Means must also be provided for checking the accuracy of the calibration of the frequency-measuring instrument. This can be done at a qualified laboratory or by the Service Man by making a comparison with standard frequency signals transmitted by the Bureau of Standards radio station WWV.

Shops should be provided with the proper wiring jigs so that the sets may be operated on a bench. The jig should provide a control system, microphone, loudspeaker and dummy antenna. Power must also be available for operation of mobile units in the shop. What kind of shop power supplies must be provided depends upon the equipment to be serviced; shops equipped to handle all types of railroad radio will need *dc* at 6, 12, 32, 64, 72, and 110 volts *dc* plus the usual *ac* power.

To get 6 or 12 volt power, rectifier power supplies are available. One with excellent regulation characteristics should be selected. A lot of time can be wasted if it is necessary to reset the voltage control every time the set being tested is transferred from *receive* to *transmit* and vice versa. A storage battery with a floating charger is a good reliable power source.

A rectifier power supply for furnishing 64 volts *dc*, the most popular value, is being developed specifically for shop testing of railroad radio units and power converters. Another solution is to use an *ac* to *dc* motor-generator set.

An *rf* wattmeter may be used in lieu of a dummy load. This is an expensive, but very handy instrument to have on hand. With it, the condition of transmitter tubes can be determined quickly. Tuning can be handled more accurately and quickly. Besides, it will often give a more accurate reading of power output, than the rating on the nameplate. This instrument is also valuable for detecting such faults as the decay of transmitting power after a short period of operation.

Getting Into the Field

To get into the railroad-radio servicing business, one should either get a full or part-time job with a railroad or a contract to handle servicing as an outsider. The superintendent of communications[‡] usually makes the final decision in selecting either an employee of this type or an outside contractor. On very large railroads, contact is usually made at a lower echelon of management. The large railroads have regional communications supervisors, who, if they cannot make that type of decision, will know through what channels such inquiries should be routed.

There are 131 major railroads and about 3,000 of all types in the United States, so there are plenty of prospects. In addition, there are many industries which operate their own private railways. Radio maintenance work is generally performed in those areas where railroads have shop or yard facilities and at major terminals.

There is a greater opportunity now for the independent contractor because the rapid adoption of other new electronic devices by the railroads is overloading what technical manpower the railroads have available.

[‡]The name of the superintendent of communications of almost any railroad can be found in the Official Guide of the Railways that is available in almost every railroad ticket office. Such information also is available from either A. H. Grothmann or L. E. Kearny at the offices of the Association of American Railroads, 59 E. Van Buren St., Chicago.

*Several manufacturers including Lampkin, James Knights, Motorola and West Coast Electronics make these instruments.

PHILCO

The World's Largest
Field Service Organization

WANTS

Electronic Engineers, Radar
and Communications Men at
All Levels and In All
Fields of Electronics

YOU FOR IMMEDIATE OPENINGS!



- As the Pioneer in the servicing of electronic equipment, PHILCO has an interesting variety of BOTH Commercial and Government operations to be serviced on a long range basis. To men who possess the ability and/or educational background necessary to Design, Maintain and/or Instruct others in the fields of Communication, Radar and Sonar equipment this combination provides BOTH challenging opportunities and employment security.

What's more . . . in addition to TOP PAY commensurate with your ability to do a better than average job, PHILCO has many valuable company benefits which are acclaimed as "THE BEST IN THE INDUSTRY." But, why not find out for yourself . . . TODAY!

WRITE NOW FOR OUR
NEW 22 PAGE, FULL COLOR BOOKLET
'FIRST In Employment Opportunities . . .'

Dept. 14
PHILCO TECHREP DIV.
22nd & Lehigh Ave.
Philadelphia 32, Pa.

Please send me your booklet, "Philco TechRep Division, FIRST In Employment Opportunities The World Over."

NAME _____

ADDRESS _____

CITY _____

FIELD OF INTEREST _____

PHILCO TECHREP DIV.
22nd & Lehigh Avenue • Phila. 32, Pa.

AT LAST . . . one tester that does the whole job!

Faster—Easier—Better

**NO OTHER
QUICK-TEST
TUBE CHECKER
IS SO
COMPLETE**



The Advanced, Improved,

ANKO

TELETEST

TV and RADIO TUBE CHECKER

with the Exclusive Anko "Grid-Snooper"

that spotlights troubles

**CHECKS MULTI-SECTION TUBES—
UP TO 4 SECTIONS—
ONE SECTION AT A TIME—
WITHOUT ADDITIONAL
SWITCHING!**

A Necessity for Profitable Operation

The Anko-Teletest is so advanced in design that it not only accurately tests over 300 tubes in use today, but also has 10 spare sockets for new tubes that cannot be tested on presently wired sockets, so that it will fill your needs for years to come.

Tells the "inside story" of every set quickly and reliably—speeds bench work, pleases customers on service calls.

Simple to Use

No special skill or experience required—anyone can operate with speed and efficiency. A model of simplicity in spite of its advanced design.

Costs Little More But Worth It

You can own the all-inclusive Anko-Teletest for just a few dollars more than partial, inadequate testers, and have the benefit of top quality, serviceable equipment for years to come.

**Ask Your Jobber for
a Free Bench
Demonstration on
Your Toughest
Problem!**

1. Checks for shorts from any element to any adjacent element—requires no additional set-up. Special tests for gas, grid emission and grid shorts on all one and two section tubes.

2. Quick-test feature eliminates roll chart and multiple switching. Tests an entire set of tubes in minutes.

3. Dynamic loaded test puts tubes under fully loaded conditions.

4. Long life case—so light it can be carried anywhere, easily. Heavy duty wood case is covered with imported fabric that resists scratches and scuffing. Trimmed with genuine leather. Detachable hinged cover with firm holding catch.

**Fully Guaranteed.
90 day warranty on
all defective material
and workmanship.**

**ANKO MANUFACTURING
COMPANY, INC.**

5042 W. State St., Milwaukee 8, Wis.

Decatron Video System

(Continued from page 19)

be corrected for in-phase and amplitude response by the application of networks having the inverse characteristic of the step function.

Since the first stage employs a high G_m pentode, the required compensation can be obtained by using cathode and screen networks having an impedance of the inverse frequency characteristic. These networks have a rising frequency characteristic above the crossover point, and since the crossover point or time constant is the same as the 15,000-ohm load and its associated tube capacities, the result is flat frequency response within the desired pass band. A small part of this correction is also obtained from a 33-mmf capacitor placed across a 3300-ohm resistor in the top half of the plate load of the first video amplifier.

The use of two pentodes has been found to result in lower circuit capacities as well as lower plate loads. This permits the use of lower inductance peaking coils, which in turn extends the frequency range and sharpens the corner of the transient response.

To insure further uniformity, the circuit employs a variable shunt peaking coil in the plate of the second video amplifier. This coil is adjusted on each set by a test operator to give the specified overshoot in the transient response. This slight overshoot sets off the blacks from the whites with a fine line of demarcation which gives depth and crispness to the picture. The low value of series-peaking coils achievable with this circuit has been found to make it possible to obtain this fine line of demarcation, by providing the high-frequency part of the response required to give a sharp corner to the transient response.

By combining a good transient response with high contrast, it has been possible to obtain pictures with extremely great depth and high resolution.

AGC Systems

(Continued from page 34)

horizontal sync pulse is not applied to the grid, or the horizontal pulse from the output transformer is not applied to the plate, the *agc* tube will not conduct. When conductance does take place, the output of the *agc* tube appears across capacitor C_2 , which charges up to the full amount of the amplified sync pulse. Phase reversal takes place in the tube, so that the output pulses extend in a negative direction as needed for *agc* voltage.

[Additional data on *agc* systems will appear in the third and concluding installment of this series, next month.]

Blown Fuses in TV
(Continued from page 42)

tubes have the greatest difference of potential between the filament and cathode, and are the most likely to have a filament-cathode or filament short, causing the filament fuse to open. However, any tube in the set may develop a short across the filament and thereby blow the fuse.

After removing the foregoing tubes the set should be turned on. If the new fuse doesn't blow, the old tubes should be reinstalled one by one until the fuse blows; the last tube put back is the defective one, and should be replaced by a new tube.

In the event the foregoing tubes are removed and the replacement fuse blows immediately, one or more of the remaining tubes is faulty. The rest of the tubes should be removed. The fuse can then be replaced and the tubes returned to their sockets one by one, until the defective tube is found. In rare instances, a shorted filament bypass capacitor or a short in the filament line wiring to the chassis is responsible for the blown fuse.

Types of Fuses

TV cartridge fuses have electrical ratings which refer to the opening time, current-carrying capacity, and voltage-breakdown value. With regard to opening time, fuses are either ordinary (fast blow) or slow blow. Fast-blowing fuses have a single link which opens quickly on overload. The drawback to this type of fuse is that it may open on a momentary surge of current which would not damage the circuit. Slow-blow fuses have two elements: a thermal cutout and a fuse link. These fuses do not open on momentary surges, but do open if the overload is sustained.

Fuse ratings for current-carrying capacity and voltage breakdown can be defined simply. The current rating indicates the maximum current the fuse can carry without opening. The voltage rating refers to the amount of voltage an open fuse can withstand safely without arcing over and breaking down. Most TV fuses are rated at 250 volts, though 125-volt fuses are used in some circuits.

It is important to replace blown fuses with new ones having the same ratings. As mentioned previously, exceptions should be made only when it is clear that the old rating does not allow adequately for current surges.

[A report on the C and N-type fuses, recently introduced, and replacement tips will appear in October, Service.]

Magnetic Recording
(Continued from page 20)

contact than the standard tape, because of their increased pliability.

If one edge of the tape has become stretched, either in manufacture or in subsequent handling, head contact will be poor. If a tape is suspected of stretched edge, about ten feet of the tape should be pulled out and the length of it sighted. If one edge droops below the other, this edge is

longer, and will stand away from the heads. Should this condition exist, it would be well to determine whether the tape was stretched in manufacture, or if the customer's machine is stretching it. Tape can be stretched on a machine by incorrect holdback or takeup tensions, in either forward or rewind modes; a bad capstan bearing, which will cause the tape to run up on capstan thus stretching edge; or an oxide build-up on tape guides, especially on take-up side.

Why "The Man On The Roof"

prefers

South River



for making superior television antenna installations

Take "Snap-In" Type
CHIMNEY MOUNTS and WALL BRACKETS

for instance . . .

Unique U Bolts instead of two screws make for quick, simple, antenna installation. Spring tension on steel mast retainers holds antenna mast while Special U Bolts are inserted and tightened. Saves installer time—permits greater safety. Same features are included in Snap-In Wall Brackets.

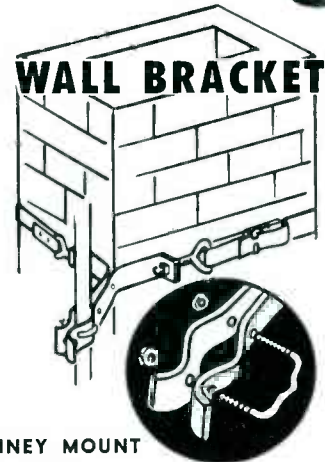

SN-50 CHIMNEY MOUNT
(Two To A Set)

"Special U Bolt is far superior to two screws"

"Hot-Dip Galvanized for rust resistance . . . prevents ugly rust streaking"

"Need only one hand and spintite for securing mast"

"One hand can be used to hold on to the mast, ladder or mounting for greater safety"

"Saves time fumbling with screws and screwdriver. Only one man needed on roof"



Mr. Installer:

DON'T BE SWITCHED—IT'S YOUR TIME AND SAFETY

Your Distributor has these in stock or can order and receive them *immediately*. If your distributor does not handle South River products, please write us on your business letterhead. We'll

see him at once and tell him the story of South River superiority. *Products made better by design — with the installer in mind*
MAKE IT EASY FOR YOURSELF
. . . Better for your Customers

Insist on mountings and accessories made by

South River **METAL PRODUCTS CO., INC.**
South River, New Jersey

PIONEER MANUFACTURER AND OUTSTANDING PRODUCER OF THE FINEST LINE OF ANTENNA MOUNTING ACCESSORIES

WRITE FOR NEW 1956 CATALOG

MERIT, first in exact and universal replacement transformers, yokes, coils—the only manufacturer of transformers, yokes and coils who has complete production facilities for all parts sold under their brand name.

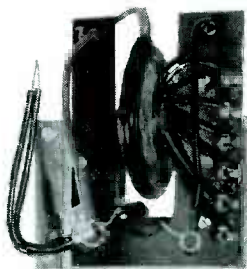

HVO-43 FOR EXACT REPLACEMENT IN AIRLINE, GAMBLE-SKOGMO, MONTGOMERY WARD, HUDSON, TELECRAFT, ARLINGTON, FAIRMONT, TRUETONE, CORONADO, WELLS-GARDNER... USED IN OVER 25 MODELS AND CHASSIS. Another in the complete MERIT line of exact and universal replacements—the only single source for all your transformer and coil requirements.

Merit

COIL AND TRANSFORMER CORP.
4427 North Clark Street
Chicago 40, Illinois



21-Inch Color-TV

(Continued from page 22)

resistor built into the neck portion of the tube. This has been found to permit the use of a conductive coating (applied to the exterior of the high voltage insulating boot) as the high-voltage filter capacitor.

A high-voltage insulating shield serves to support the deflection yoke and also to support the bell portion and the rear of the picture tube. An insert within the deflection yoke centers the neck of the tube in the deflection yoke.

By removal of only four nuts at the picture-tube mask, it is now possible to remove the picture tube, high-voltage insulating shield, deflection yoke, convergence yoke, and the purity magnet and blue lateral beam-positioning magnet as a unit.

As noted previously, two different tuner types are available in all three series of the receivers.

For *vlf* only, a switch-type tuner is used; this features a 6BQ7A dual triode as a driven grounded-grid *rf* amplifier coupled to the mixer, the pentode section of a 6X8. The triode section of the 6X8 is used as the local oscillator; the *if* output of the tuner is in the 41-mc range.

The *uhf-vlf* tuner assembly uses the same tube lineup as the *vlf* unit; however, when switched to the *uhf* position the 6X8 (triode) oscillator is switched off, the 6BQ7A becomes an *if* amplifier at 41 mc, and the pentode section of the 6X8 becomes another stage of 41 mc *if* amplification.

The *uhf* local oscillator uses a 6AF4A triode whose output is coupled, with the *rf* signal from the preselection circuits of the tuner, to a crystal-diode mixer. Output from the mixer feeds into the 6BQ7A which is used on the *vlf* positions as the *rf* amplifier.

In one line of chassis³ the picture *if* amplifier consists of three stages using 6DE6s in the first two stages and a 6CB6 in the third stage.

The luminance channel, which performs the same functions as the video amplifiers in conventional black-and-white TV receivers, consists of two stages. The first video amplifier uses the pentode section of a 6AW8. The picture second detector output is applied between the grid and cathode of the first video stage. Output from the first video stage is taken from both the cathode and plate circuits. Luminance (the black-and-white signal) is coupled to the second video amplifier grid from the cathode circuit. Sync, *agc* voltage and chrominance information are derived from the plate circuit of this stage. A delay line between the first and second video amplifiers delays the luminance information so that it will arrive at the picture at the same time as the chrominance information.

³Special and Super chassis.

[A circuitry report on the remaining portion of the color chassis will appear in next month's issue of SERVICE.]

NEW Senco TRANSISTOR CHECKER

NOW WANTED and
NEEDED by EVERY
SERVICEMAN!

Quickly and
accurately
checks all
transistors and
crystal diodes.

Provides these 4 important
checks on transistors:

OPEN • SHORT
CURRENT GAIN
• LEAKAGE

Checks forward to backward
resistance of diodes

★ Complete set-up chart and instruction
booklet attached to back

★ Will never become obsolete, with test
leads, replaceable up-to-date set-up chart
and gain control to vary battery voltage

★ Accurate and simple to operate—
takes less than 30 seconds to test either
TRANSISTORS or crystal diodes

★ Uses test leads which eliminates need of
completely removing transistor from circuit
At leading distributors everywhere

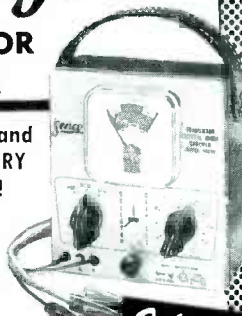

Only
\$15.95

DEALER NET
Approved by leading
manufacturers

**SERVICE INSTRUMENTS
CO.**
171 OFFICIAL RD • ADDISON, ILL.



3 big reasons why QUIETROLE
Reg. U. S. Pat. Off.

is "The Choice of Better Service Dealers Everywhere"

- 1 MERIT
- 2 QUALITY
- 3 RELIABILITY

The original product for quieting noisy controls and switches... the universal lubri-cleaner for TV and radio...

Say "QUIETROLE" to your distributor... be sure you get it.

**NO GUM!
NO GOO!
NO GRIME!**

Carried by recognized jobbers... everywhere!

manufactured by

QUIETROLE

COMPANY INC.
Spartanburg, South Carolina

IN CANADA: Active Radio & TV Distributors
58 Spadina Ave., Toronto 2B, Ont.

ADVERTISERS IN SERVICE
SEPTEMBER, 1956

	Page
Aermotor Co.	43
Allied Radio Corp.	37
American Elite, Inc.	64
American Pamcor, Inc.	47
American Television and Radio Co.	64
Amphenol Electronics Corp.	42
Anko Manufacturing Co.	60
Appliance Service Co.	51
Astron Corp.	35
Atlas Sound Corp.	51
Avco Manufacturing Co., Electronics Div.	4
B & K Manufacturing Co.	46
Bussmann Manufacturing Co.	17
Century Electronics Co.	56
Channel Master Corp.	5, 6, 7
Chicago Standard Transformer Corp.	31, 40
H. G. Cisin	37
Columbia Wire and Supply Co.	63
Cornell-Dubilier Electric Corp. Inside Front Cover, 1,	49
Duotone Co., Inc.	52
Electro Products Laboratories	2
Electronic Instrument Co.	48
Elgin National Watch Co., Electronics Div.	54
Fast Chemical Products Corp.	56
General Electric Co.	38, 39
Heath Co.	58
The Hickok Electrical Instrument Co.	53
Hotpoint Co.	21
Jensen Industries, Inc.	40
Jensen Manufacturing Co.	45
JFD Manufacturing Co., Inc.	25
Kaar Engineering Corp.	53
Kester Solder Co.	58
Littelfuse, Inc.	41
P. R. Mallory and Co., Inc. Inside Back Cover	62
Merit Coil and Transformer Corp.	62
Ghmite Manufacturing Co.	54
Perma-Power Co.	56
Philco Corp., Accessory Div.	43
Philco Techrep Div.	59
Planet Sales Corp.	28
Quietrole Co.	62
The Radiart Corp. Inside Front Cover, 1 Radio Corp. of America, Tube Div. Back Cover	57
RCA Service Co., Inc.	3
Radio Receptor Co., Inc. Semiconductor Div.	8
Raytheon Manufacturing Co.	8
Recoton Corp.	53
Remington Rand, Div. Sperry-Rand Corp.	27
Service Instruments Co.	62
Shure Brothers, Inc.	50
Simpson Electric Co.	29
South River Metal Products Co.	61
Sprague Products Co.	40, 51, 63
Trio Manufacturing Co.	36
Tung-Sol Electric, Inc.	33
University Loudspeakers, Inc.	55
Weston Electrical Instrument Corp.	30
Winegard Co.	14
G. F. Wright Steel and Wire Co.	30
Xcelite, Inc.	28

8½" Portable TV

(Continued from page 16)

the crystal (CR_{501}) second detector. *Agc* is obtained by filtering the rectified *if* signal; the filter components are a 820,000-ohm resistor and a .33-mfd capacitor (R_{120} and C_{117}). This *agc* bias is applied to the combined *if* amplifier and the first *if* amplifier and also to the second picture *if* amplifier.

The bandwidth of the *if* under normal signal conditions is approximately 2.1 mc. However, as the signal strength decreases, *agc* bias changes proportionately and the bandwidth decreases. This is due to the *Miller effect* and provides greater *if* gain for weak picture signals.

A single pentode is utilized as a video amplifier. Its output drives the cathode of the picture tube. The 4.5-mc sound *if* carrier is capacitively coupled to the grid of the sound *if* amplifier from this stage.

The 4.5-mc sound *if* carrier is coupled by means of a 5-nmfd capacitor (C_{101}) to the sound takeoff transformer (T_{101}). The sound *if* amplifier is a reflex circuit, since it serves both as an *if* and audio amplifier.

The ratio detector is comprised of two crystal diodes; CR_{102} and CR_{103} . The detected audio signal is coupled through a .01-mfd capacitor (C_{110}) to the grid of the sound *if* and first audio amplifier, a 6U8. The audio signal is developed across a 33,000-ohm resistor (R_{104}) and is coupled to the volume control by means of a .01-mfd capacitor (C_{105}). A filter network decouples the 4.5-mc signal from the audio prior to the volume control. A triode is used as an audio output stage. This tube function is part of the 6U8 so that the sound *if* and audio uses only one tube and three crystals.

The portable uses a synchroguide circuit with a 6BQ6 as a horizontal output to provide the relatively high deflection (90°) power required by the 8DP4.

Ask For Sprague By
Catalog Number

Know what you're getting . . .
get exactly what you want.
Don't be vague . . . insist on

Sprague. Use complete radio-TV service catalog C-610. Write Sprague Products Company, 61 Marshall Street, No. Adams, Mass.

**DON'T
JUST SAY
CAPACITORS**

SPRAGUE
WORLD'S LARGEST CAPACITOR MANUFACTURER

NEW!

flexlife
PLASTIC INSULATION

makes
ALL
COLUMBIA
Microphone
Cable

more
flexible
more
durable



Our **NEW Flexlife Plastic Insulation** now used in our microphone cables and test lead wire provides flexibility as good as rubber with much neater appearance and far greater life.

Send for your samples today! . . . no cost or obligation.

Available from leading distributors

Columbia
WIRE & SUPPLY CO.

2850 Irving Park Road
Chicago 18, Illinois

EXPAND YOUR PORTABLE TV SALES

WITH

ATR

INVERTERS

for changing your storage battery current to A. C. HOUSEHOLD ELECTRICITY

Anywhere...
in your own car!

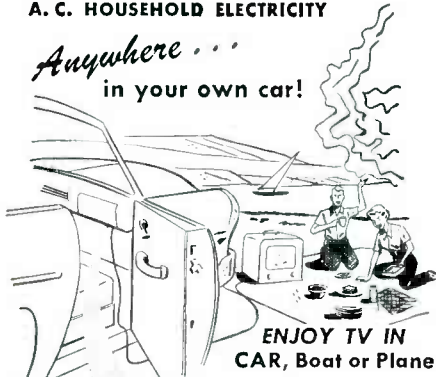

mounted out of sight under dash or in trunk compartment!



EASY TO INSTALL
EASY TO OPERATE

ATR INVERTERS

especially designed for operating standard 110 volt A.C. portable TV sets

also

- TAPE RECORDERS
- WIRE RECORDERS
- DICTATING MACHINES
- ELECTRIC RAZORS

for

- EXECUTIVES
- SALESMEN
- PUBLIC OFFICIALS
- POLICEMEN
- FIREMEN
- OUTDOOR MEN
- REPORTERS
- FIELD INSPECTORS
- DOCTORS
- LAWYERS, ETC.

See your jobber or write factory

✓ NEW MODELS ✓ NEW DESIGNS ✓ NEW LITERATURE
"A" Battery Eliminators, DC-AC Inverters, Auto Radio Vibrators



AMERICAN TELEVISION & RADIO CO.

Quality Products Since 1931
SAINT PAUL 1, MINNESOTA, U. S. A.

TV-AUTO RADIO Tube Developments

PORTABLE-TV tubes for 450-mil series-string applications are now available as replacements.

One line, announced by Sylvania, includes 26 types.†

Auto Radio Types

SEVEN NEW RECEIVING tubes,¹ designed for use in auto receivers in which transistors are used in the output stage and in which voltages for both tubes and transistors are obtained directly from a 12-v storage battery, have been developed for chassis that will be available in many models of '57 automobiles.

One is a pentagrid converter of the 7-pin miniature type (12AD6) intended for use as a combined mixer and oscillator tube. Two others (12AE6 and 12AJ6) are multiunit tubes of the 9-pin miniature type. Each contains two diodes and a medium- μ triode in one envelope, and is intended to perform the combined functions of AM detection, *af* amplification, and automatic volume control. The 12AE6 can also serve as a trigger tube in auto receivers utilizing automatic station-selection circuits.

For use as *rf* or *if* amplifiers, remote-cutoff pentodes (12AF6 and 12BL6) of the miniature type were designed.

For service as a combined AM detector and automatic volume-controlled audio amplifier, the tube engineers designed a 9-pin tube (12F8) containing two diodes and a remote-cutoff pentode in one envelope.

Driver Tubes

For driver applications, to supply high input power at low distortion to the transistor in the output stage, a high perveance 7-pin power tetrode (12K5) has been designed. This tube is also intended for use as the relay tube in receivers utilizing automatic station selector circuits.

†Sylvania 450-mil series string tubes and their prototypes (italicized) are: 3AF4A (6AF4A), 4BC5 (6BC5), 4BN6 (6BN6), 4BU8 (6BU8), 4CB6 (6CB6), 4DT6 (6DT6), 5BQ7A (6BQ7A), 5BZ7 (6BZ7), 6AQ5A (6AQ5), 6BK7B (6BK7A), 6CL8 (6CL8), 6CM8 (6CM8), 6J6A (6J6), 6T8A (6T8), 6U8A (6U8), 8AU8 (6AU8), 8AW8A (6AV8A), 8BA8A (6BA8A), 8BH8 (6BH8), 8CG7 (6CG7), 8CM7 (6CM7), 8CN7 (6CN7), 8CS7 (6CS7), 9AU7 (12AU7), 17AV5GA (6AV5GA), 17AX4GT (6AX4GT), 17CS (50CS), and 17DQ6 (6DQ6).

¹RCA.

Europe's Largest Selling Electronic Tubes Now Available to the discriminating American tube buyer —at standard prices.

- Receiving Tubes
- Special Purpose Tubes



not just a replacement—
but an improvement



TELEFUNKEN

PIONEER IN ELECTRONICS
SINCE 1903

Write for your Telefunken Tube Manual and for the name of your nearest jobber.

Imported exclusively by

AMERICAN
ELITE, INC.

Dept. 8
7 Park Avenue
New York 16, N. Y.

... another
MALLORY
service-engineered
product



You'll go for
MALLORY GEMS
—the new plastic
tubular capacitors

For replacement of paper tubulars,
you can't beat new Mallory
"Gems." Compare these value
features—yours *without* premium
price:

- **Locked-in leads** can't loosen from soldering iron heat or vibration.
- **Real humidity protection**, using a high grade mica-filled bakelite case, ends possibilities of premature shorts.
- **Uniform quality** of each capacitor is assured by true-center construction, which protects the element from damage during assembly.

Try Mallory "Gems"—and you'll never settle for less. Get your stock now, from your local Mallory distributor.



• Capacitors • Vibrators • Resistors • Controls • Switches
• Rectifiers • Power Supplies • Filters • Mercury Batteries



It's a fact...

*9 of the 12 top-selling replacement TV tubes are original RCA designs.** Manufacturers of TV sets have given RCA tube-type leadership by using RCA-designed tubes in their equipment. Experience has shown these manufacturers that RCA-designed tubes are tops in performance. Service dealers know, too, that the company which knows how to design tubes knows how to build them BEST. So follow the lead of smart service technicians everywhere—say “RCA brand, only” on *all* your tube orders and get tubes that are tops in quality and performance.



RECEIVING TUBES
RADIO CORPORATION OF AMERICA, HARRISON, N. J.

*FETMA REPORT for year of 1955