

SERVICE

THE TECHNICAL JOURNAL OF THE TELEVISION-RADIO TRADE

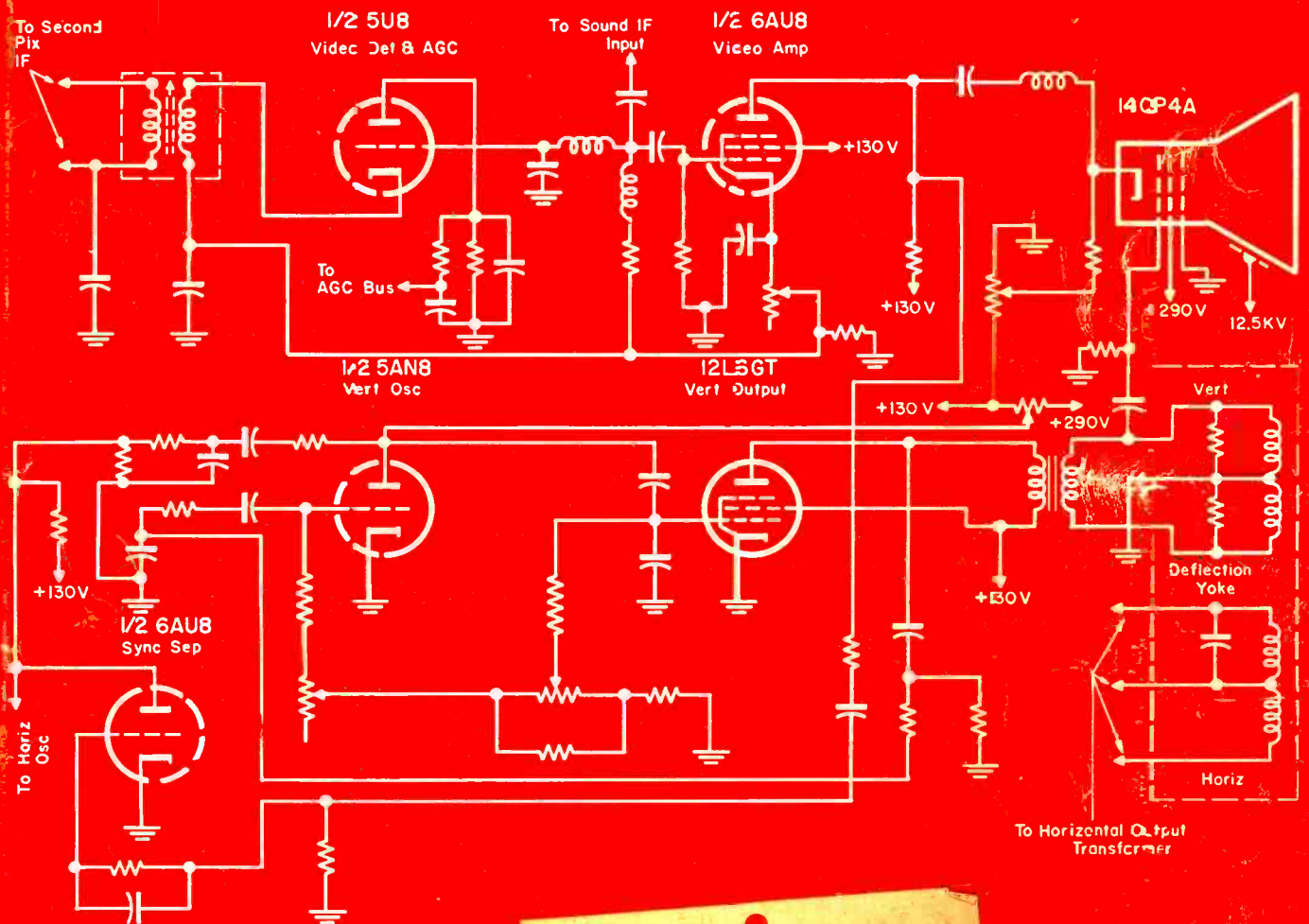

Series-string portable TV receiver with 5U8 detector circuit that provides agc with delay and detection with no delay. See circuit analysis, this issue

AL BROWSE
 1962 90 STEARNS DR
 LOS ANGELES 34, CALIF
 2-59

2S SAR 1-10-56

only

C.D.R. Rotors

have
the

1

2



punch

1. The Most Complete Line

The CDR Rotor line is COMPLETE to every detail, with a model for every application! A distinct selling advantage because YOU can give your customer EXACTLY what is required! The RIGHT CDR Rotor for the RIGHT job.

2. Pre-SOLD For You on TV

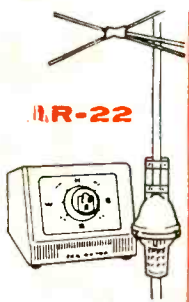
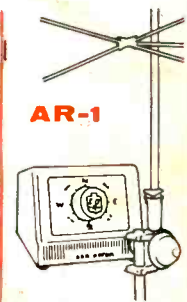
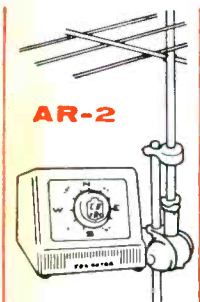
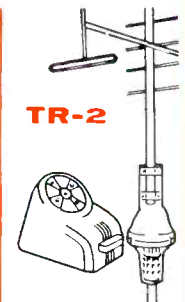
to millions of viewers through an extensive coverage of audiences in every important TV market. Capture this pre-sold market by featuring these nationally advertised CDR ROTORS.

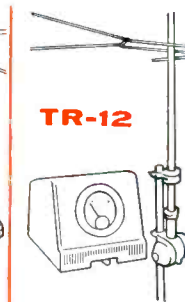
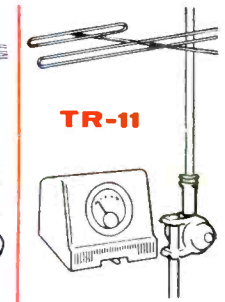
 <p>AR-22</p>	 <p>AR-1</p>	 <p>AR-2</p>	 <p>TR-2</p>	 <p>TR-4</p>	 <p>TR-12</p>	 <p>TR-11</p>
<p>Completely AUTO-MATIC version of the TR-2 with all the powerful features that made it famous.</p>	<p>Completely AUTO-MATIC rotor, powerful and dependable. Modern design cabinet. 4 wire cable.</p>	<p>Completely AUTO-MATIC rotor with thrust bearing. Handsome cabinet. 4 wire cable.</p>	<p>Heavy-duty rotor with plastic cabinet, "compass control" illuminated perfect pattern dial, 8 wire cable.</p>	<p>Heavy-duty rotor, modern cabinet with METER control dial, 4 wire cable.</p>	<p>Combination value complete rotor with thrust bearing. Modern cabinet with meter control dial, uses 4 wire cable.</p>	<p>Ideal budget all-purpose rotor, new modern cabinet featuring meter control dial, 4 wire cable.</p>



CORNELL-DUBILIER
SOUTH PLAINFIELD, N. J.



THE RADIART CORP.
CLEVELAND 13, OHIO

THOUSANDS OF SERVICE DEALERS

SATISFY CUSTOMERS
SAVE REPEAT CALLS

MAKE MONEY EVERY DAY with **B&K**



DYNA-QUIK MODEL 500
DYNAMIC MUTUAL CONDUCTANCE TUBE TESTER

Tests over 95%

OF ALL POPULAR TV TUBES*— IN SECONDS

It's easy and profitable to check all the tubes in a TV set with DYNA-QUIK—on every service call. Cuts servicing time. Creates more on-the-spot tube sales. Saves repeat calls, protects service guarantee.

DYNA-QUIK 500 measures true dynamic mutual conductance, completely checks tubes with laboratory accuracy under actual operating conditions right in the home.

Tests each tube for shorts, grid emission, gas content, leakage, dynamic mutual conductance and life expectancy. One switch tests everything. No roll charts. No multiple switching. Makes complete tube test in as little as 12 seconds. Large 4 1/2-inch plastic meter shows tube condition on "Good-Bad" scale or in micromhos on scales calibrated 0-6,000 and 0-18,000. Used in home or shop, DYNA-QUIK is a proved money-maker!

*Including new 600 mil series tubes.

NET \$109⁹⁵

Dyna-Quik 500. Easily portable in luggage-style carrying case. Size: 15 1/4 x 14 1/2 x 5 1/2 in. Weighs only 12 lbs. Has 7-pin and 9-pin straighteners on panel.

DELUXE—PORTABLE
CRT MODEL 400
Tests and repairs
TV Picture Tubes



NET \$54⁹⁵

Deluxe CRT 400. With 4 1/2-in. plastic meter. Weighs only 5 lbs. Luggage style carrying case. Size: 11 x 7 1/2 x 5".

Also available in economy model CRT 200 with 3-in. meter at \$39.95 net.

Quickly spots and corrects picture tube troubles right in the home, without removing tube from set. Restores emission, stops leakage, repairs interelement shorts and open circuits. Life test checks gas content and predicts remaining useful life. Grid cut-off reading indicates picture quality customer can expect. Eliminates tube transportation, cuts service-operating costs. Also saves money on TV set trade-in reconditioning. Earns dollars in minutes—pays for itself over and over again.

Proved In Use by Servicemen Everywhere.

See your B & K Distributor or send for facts on "Profitable TV Servicing In the Home" and informative Bulletins 500-104-S.



B & K MANUFACTURING CO.
3726 N. Southport Ave. • Chicago 13, Illinois

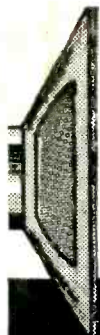

Now... "A SPEAKER

in every
room"

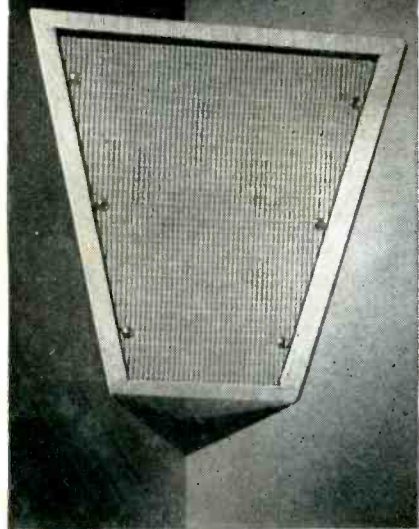

You can have music wherever you go — bedroom, dining room, work-room or porch — at low cost with these new Argos *slanting* corner baffles.

They are the ideal extension speaker for any hi-fi system. Their slanting front aims sound down toward you instead of straight out. They work equally well on floor or ceiling, comfortably filling your room with sound from a most unobtrusive location.

How Do They Sound? Far better than any wall baffle ever built because adjacent walls and ceiling all serve as extension surfaces to produce materially better tone. Bass reflex design helps low notes.

How Are They Made? Heavy wood covered with extra heavy ribbed fabric, mahogany or blonde, same price. They cost no more than regular corner baffles. They hang simply, — take paint beautifully if desired.

Blonde or Mahogany, same price

SCB-8 (8" spkr.) List \$12.35
SCB-12 (12" spkr.) List \$17.05

Ask your Parts Distributor



The Technical Journal of the Television-Radio Trade

Including SERVICE—A Monthly Digest of Radio and Allied Maintenance; RADIO MERCHANDISING and TELEVISION MERCHANDISING. Registered U. S. Patent Office.

COVER CIRCUIT

UHF/VHF 14-Inch Portable TV (Hoffman 1144/1144U) 20

FEATURES

Editorial	Lewis Winner	11
Mid-West Service Shop (A Field Report)	R. O. Walton	12
This Month In SERVICE		14
Color-TV IF Amplifiers (With Complete Circuit of New RCA 21-Inch Color Set)	Steve Wlasuk	17
UHF/VHF 14-Inch Portable TV (Cover; With Complete Circuit)	E. R. Jahns	20
Horizontal Amplifier Tube-Testing Procedures	Elmer E. Niehaus	22
TV Flicker Causes—Cures (Servicing Helps)		24
Railroad-Radio 2-Way Servicing (Servicing Engineering)	Leo Sands	26
6-Tube Modular Portable (With Complete Circuit)	Richard J. Harasek	28
Damper Tube—Linearity Coil Boost Defects—Remedies	Jesse Dines	30
Practical Considerations in Magnetic Recording	William O. Woglom and Lawrence Knees	32
FCC Report on Community-TV Line Radiation Control		34
AGC Systems	J. M. Sheehe	37
A Guide to Basic Tools for Field-Bench Installation-Repair		38
Traffic Appliance Servicing	Milton Wallach	42
Speakers in Large Indoor-Outdoor Areas (How to Place, Feed, Match, Phase)		45

CIRCUIT DIAGRAMS

Video Section of TV Chassis	17	Motorola 66L Modular Portable (Complete Circuit)	29
Color TV IF Chain	17	Horizontal Sweep (RCA 630)	31
IF Test Alignment	18	Westinghouse V2318/2328 Horiz Sweep	31
RCA CT5/A Color TV (Complete Circuit)	19	G.E. Stratopower Horiz Sweep	31
Hoffman 1144/1144U TV Portable (Complete Circuit)	21	Pentron T-90 Tape Recorder	32
TV Horizontal Amp Stage	22	Tape Oscillator For Bias-Erase	33
Grid/Cathode Driven Pix Stage	24	Peak AGC System	37
Decoupling Network	24	Power Requirements For Speakers	46
2-Way Setup on Diesel Locomotive	26	Series—Connected Speaker Line	46
		Series—Parallel Speaker Groupings	51

DEPARTMENTS

TV Antenna-Accessory Developments	34	Instruments	50
Latest in Audio	46	Personnel	62
Association News	48	Catalogs, Bulletin and Books	63
Industry News	49	TV-Tube Developments	64
Ten Years Ago in SERVICE	49		

Index to Advertisers 63

Entire Contents Copyright 1956, Bryan Davis Publishing Co., Inc.

Second-Class mail privileges authorized at New York, N. Y.; additional entry at the Post Office, Norwalk, Conn. . . . Subscription price: \$2.00 per year in the U.S.A. and Canada; 25 cents per copy. \$3.00 per year in foreign countries; 35 cents per copy.



EDITOR and PUBLICATION DIRECTOR

Lewis Winner

Associate Editor: **David E. Pearsall II**
Assistant Editor: **Robert D. Wengenroth**
Editorial Assistant: **Eli Cohen**
Editorial Assistant: **Howard Jennings**

Art Director: **Anthony R. Aliff**

Supervisor, Circuit Diagrams:
Michael D. Bellezza

Ass't Supervisor, Circuit Diagrams:
Norman Cohen

Editorial Production: **Astrid Kelly**

CIRCULATION DEPARTMENT

Circulation Manager: **A. Goebel**

Ass't Circulation Mgr.: **A. Kiernan**

ADVERTISING DEPARTMENT

Advertising Mgr.: **Aaron L. Lafer**

East-Central Rep.: **James C. Munn**
2253 Delaware Dr.
Cleveland 6, O.
Tel.: ERview 1-1726

Published Monthly by

Bryan Davis Publishing Company, Inc.
52 Vanderbilt Ave., New York 17, N. Y.
Tel.: MURray Hill 4-0170

B. S. Davis, Pres. Lewis Winner, Vice-Pres.



Always insist on

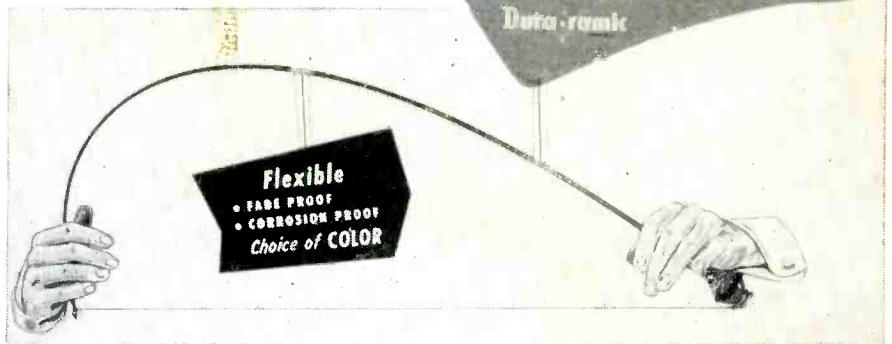

WARD AUTO AERIALS...

- FOR ★ Top quality**
- ★ Customer acceptance for over 20 years**
- ★ Reliable performance**
- ★ Easiest installation**

For every radio installation you make, a WARD AERIAL tops it off with the most dependable, acceptable and popular antenna you can buy . . . yet it costs no more than an ordinary aerial. Here's the *complete* top-quality line for every requirement:

- EIGHT BALL—ever-popular favorite
- MAJORETTE—the economy model
- PHANTOM—disappearing antenna
- TWIN REAR MOUNT—midget 8-ball twins
- MIDGET PHANTOM—twin rear mounts
- SKY QUEEN—smartly styled side mount
- LONG RANGER—longer, for extra signal
- CONTINENTAL—flex-angle side mount for all foreign cars
- DURA-RAMIC®—the original Fiberglas aerial in full colors to complement the car. Can't fade, rust, warp, break or corrode.

Order your WARD AERIALS now. Keep a few on hand all the time. Keep your customers satisfied with the . . . *World's Finest!*

WARD

PRODUCTS CORPORATION
DIVISION OF THE GABRIEL CO.

1148 EUCLID AVE.

• CLEVELAND 15, OHIO

what is available from Pyramid

A complete line of capacitors—electrolytics, paper and metallized paper for wired and printed circuit chassis . . . all made to standards which exceed even rigid military specifications. Full advertising and merchandising support.

PAPER

Type 85 LPT

Type CT

"IMP" Molded

Type PG "Glasseal," CP04, TOCP11

OIL PAPER



Type PDM, CP53



Type PLMF, CP70



Type PTIM, CP25



Type PEM, CP67, CP69



Type PKM, CP61 to CP65

Type PJ, CP70



PRINTED CIRCUIT CAPACITORS

Type BTS Autocaps

Microlytics



Type ATM Autolytics

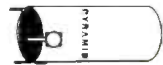

Type ACD Autolytics

METALLIZED PAPER



Type MT

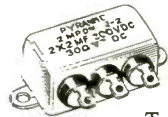

Type MPD



Type MPG



Type MPT

A new time saving, profit making capacitor resistor analyzer with incorporated quick check feature at low cost. Model CRA-2 now available. See your Pyramid representative.



ELECTROLYTICS



Type TD, TDL

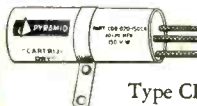

Type CDB



Type MC

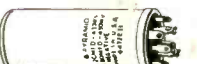

Type TM



Type DO

THE BIG NAME IN CAPACITORS AND SELENIUM RECTIFIERS TODAY.



PYRAMID ELECTRIC CO.

North Bergen, New Jersey

Burton Browne / New York

A full line of the first new design of selenium rectifiers in twenty years.

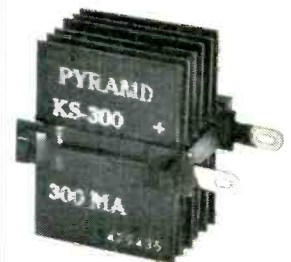

CHANNEL MASTER

Explodes a Spectacular Campaign

NATIONAL CONSUMER MAGAZINE ADVERTISING

THE FIRST PROGRAM OF ITS KIND IN TV ANTENNA HISTORY

2-Page Spreads . . . Full-Page Ads . . .
Full-Color Ads . . .

reaching into millions of American homes on
the pages of these outstanding magazines:



CHANNEL MASTER REVOLUTIONIZES ANTENNA MERCHANDISING! With large-scale national advertising and traffic-building local promotions, Channel Master now places TV antennas on the same retail level as traffic appliances. It's actually a NEW WAY for you to sell antennas — and sell more of them. Climb aboard the Channel Master brandwagon and tie in with these profit-making promotions. Get details from your Channel Master distributor.

NEW MARKETS . . . NEW CUSTOMERS . . . FOR THESE 2 GREAT NEW ANTENNAS

"TRAV
PRV"
• ideal
char
• of
•

CHANNEL MASTER®

World's first
"Twining Wave" antenna

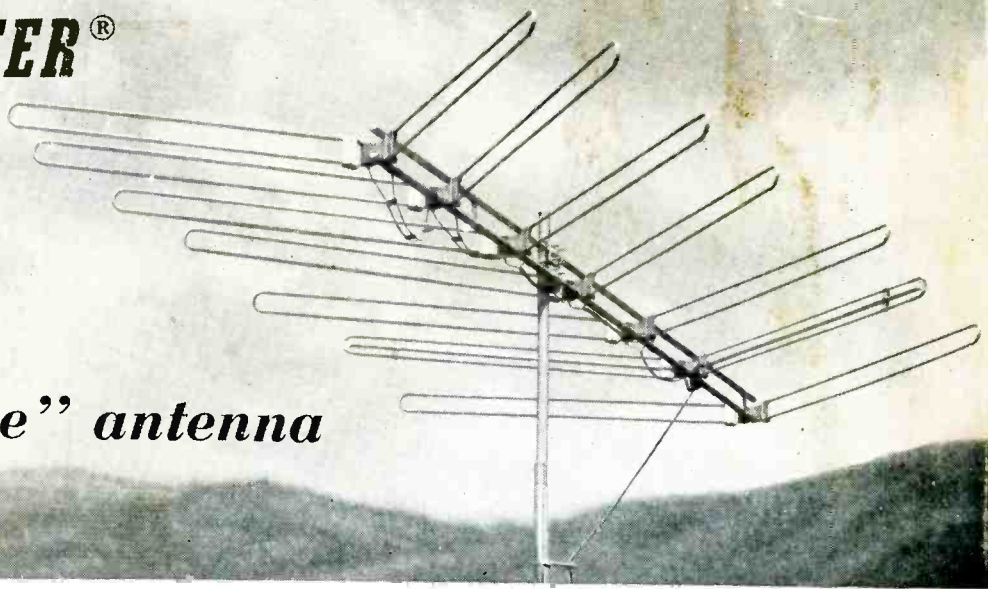

WHAT THE "TWINNING WAVE" PRINCIPLE MEANS—

- equal phase relationships on all channels
- optimum impedance matching on all channels
- equal flow of current in all dipoles on all channels
- fullest use of transmitted energy on all channels

IN SHORT — FABULOUS PERFORMANCE ON ALL CHANNELS

SENSATIONAL 3- AND 5-ELEMENT MODELS!

Amazing T-W performance for suburban and near-fringe areas, too! Wonderfully compact and rugged!



T-W 351
(5-element)

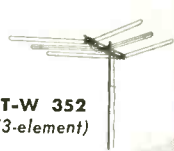

T-W 352
(3-element)

revolutionary new design provides picture quality never before possible

After two years of research—a completely new kind of VHF antenna, operating on revolutionary new electronic principles. The T-W is Channel Master's greatest antenna achievement.

ALL THREE — IN ONE ALL-CHANNEL ANTENNA

1 HIGHEST GAINS

Most powerful all-channel antenna ever developed. A single-bay T-W 350 (7-element) actually OUTPERFORMS—



any wide-spaced 5-element Yagi on each low band channel.



any stacked 10-element Yagi on each high band channel.

2 TOP FRONT-TO-BACK RATIOS

Low Band:

Better than 10:1 on every channel. HIGHER THAN ANY 10-ELEMENT SINGLE CHANNEL YAGI ON ALL CHANNELS!

High Band:

From 5:1 to 12:1. HIGHEST RATIOS OF ANY SINGLE ALL CHANNEL ANTENNA.

3 GREATEST MECHANICAL STRENGTH

The most rugged antenna ever built. "Twin Truss" design amplifies the strength of every component. And new mechanical features add still greater durability . . .

"Twin Booms" . . . Two full-length crossarms—really rugged and rigid.

2 "Super-Nests" One heavy-duty mast clamp on each crossboom . . . A TOTAL OF 4 U-BOLTS! Antenna cannot move.

"Line-Lok" Twinlead can't possibly tear away from terminals.

PROOF OF THE SUPERIORITY OF "TWIN-TRUSS" CONSTRUCTION

Look at the dramatic result when equal weights are hung on a T-W and a standard 10-element Yagi!

Write for complete technical literature.

® Trade Mark Reg. U.S. Pat. Off.

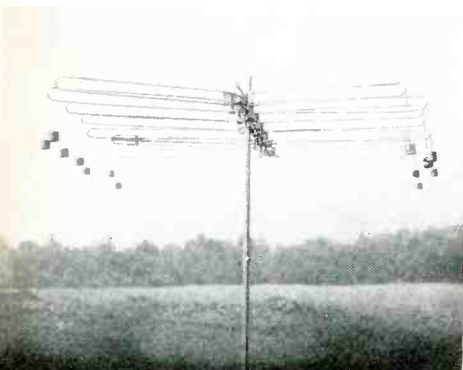
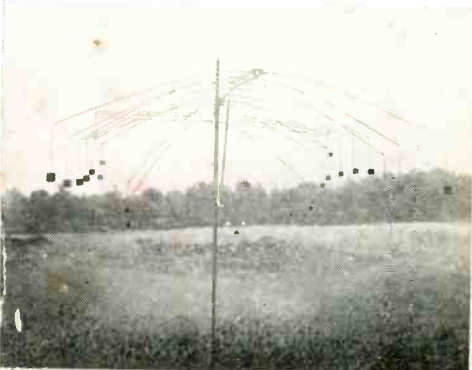
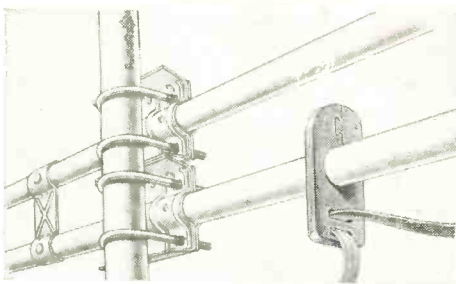

CHANNEL MASTER® "Showman"

new "Metro-Dyne" tuning
obsoletes

"Rabbit-Ears"

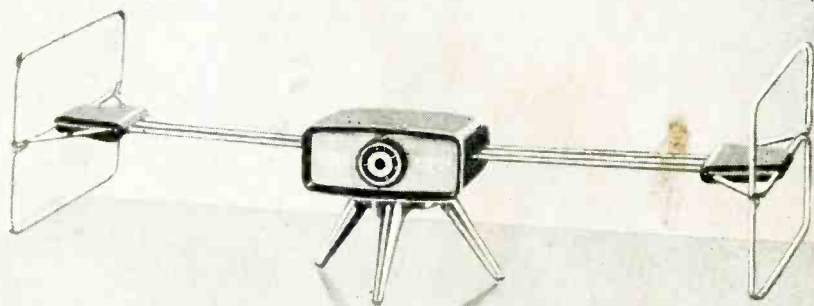

the first basic indoor antenna improvement in over 10 years

Channel Master sets an exciting new trend in TV antennas with the Showman. In appearance (so important in the sale of indoor antennas) the Showman is in a dazzling class by itself. Yet, it's a complex electronic instrument—the most powerful indoor antenna yet developed by modern science!

The SHOWMAN is perfect for color reception, tops for black-and-white. And, it provides excellent FM reception, too!

**ACTUALLY TUNES OUT "GHOSTS" AND "SNOW"!
MORE EFFECTIVE THAN ANY OTHER INDOOR ANTENNA!**



With ordinary
indoor antennas



With the
Showman

Metropolitan areas, where indoor antennas are most frequently used, are often subject to the most severe "ghosting" problems. Only the SHOWMAN, with its sensational new Metro-Dyne tuning, can overcome this difficulty. You'll be amazed at the job it does on all kinds of interference. Test it for yourself! Demonstrate it for your customers!

Channel Master stands squarely behind every SHOWMAN you sell. An unconditional money-back guarantee assures your customer of complete satisfaction.

**UNCONDITIONAL
MONEY-BACK
GUARANTEE**



"High fashion"
packaging.
Attractive,
convenient.
Ideal for
display.

Available in three "decor designs"—
to blend with any setting.

Mahogany and Gold model no. 3900	Blond and Gold model no. 3901	Ebony and Silver model no. 3902
--	---	---

what makes the
"Showman" different?

**FABULOUS
"METRO-DYNE"
TUNING!**

*The Metro-Dyne 12-Channel
"Variable Inductance" Tuner*

Ordinary switch-type antennas work by connecting various element into different combinations. METRO-DYNE tuning, on the other hand, is "variable inductance" tuning, using the same tuning principles as any TV set. It is the first broad band antenna which can be tuned to a specific channel so that it exhibits the band width characteristics of a single-channel Yagi. This selectivity cuts down tremendously on "electronic noise" and interference. A built-in auto transformer maintains a constant 300 ohm impedance match.

EASY OPERATION: the Showman is calibrated by channels. Just turn it to the same channel number as the TV set. No arms to adjust; no-guess-work or error.

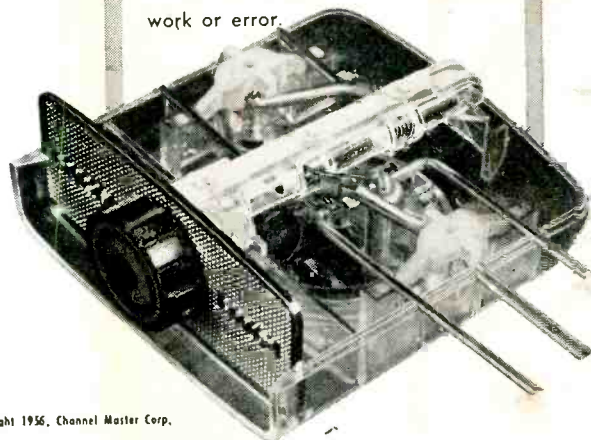

CHANNEL MASTER CORP. ELLENVILLE, N. Y.

world's largest manufacturer of television antennas and accessories

Copyright 1956, Channel Master Corp.

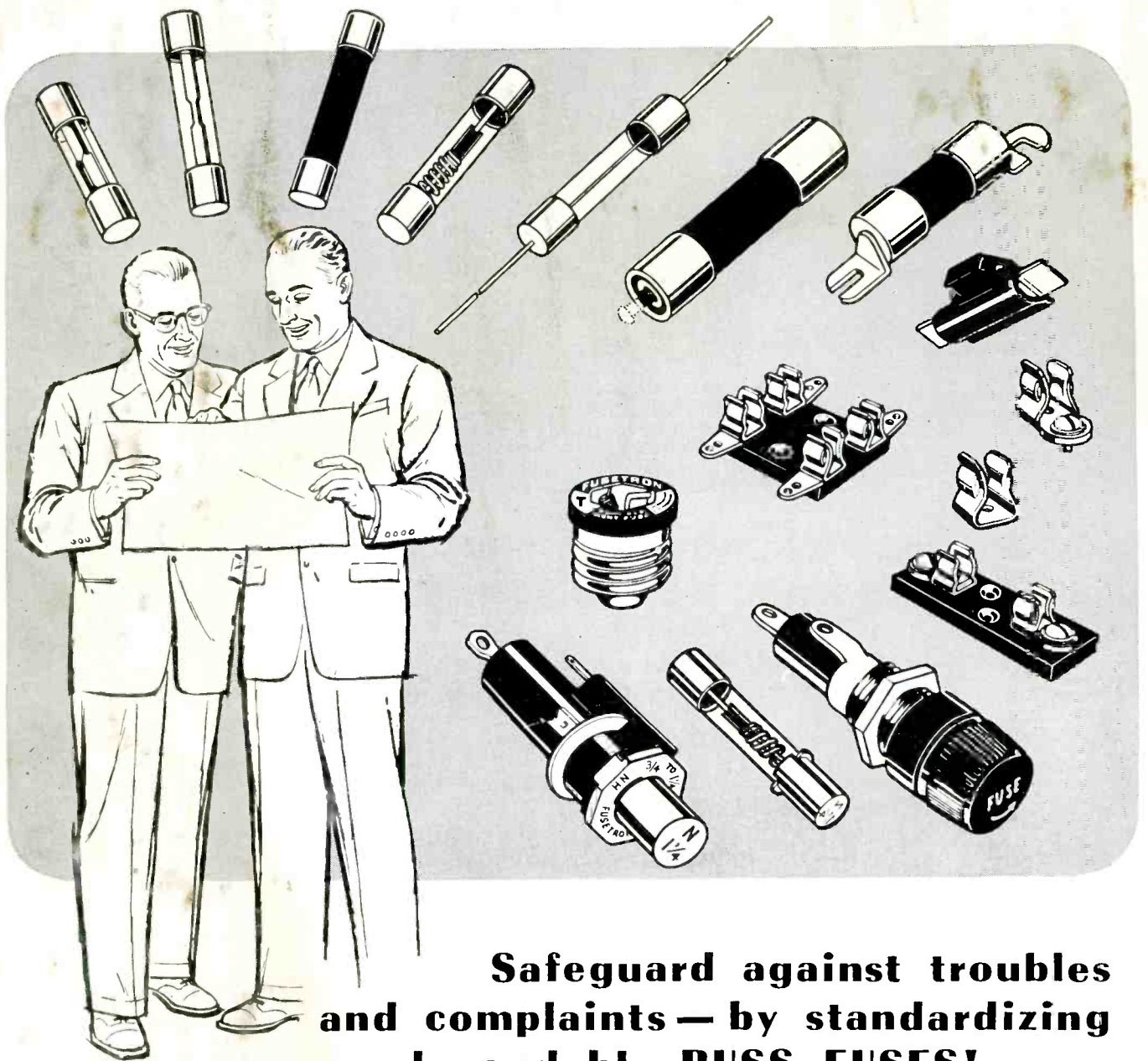

Safeguard against troubles and complaints — by standardizing on dependable BUSS FUSES!

BUSS fuses give you double protection against loss of customer goodwill because . . . BUSS fuses blow only to protect — never needlessly. To make sure of proper operation, BUSS fuses are tested in a sensitive electronic device that automatically rejects any fuse not correctly calibrated, properly constructed and right in all physical dimensions.

When you sell or install BUSS fuses . . . you are safeguarding the users of equipment against irritating, useless shutdowns due to faulty fuses blowing needlessly. And you are providing them with maximum protection against damage caused by electrical faults.

Most important, the dependability of BUSS fuses helps you avoid costly,

unnecessary callbacks. And the proper operation of BUSS fuses helps safeguard your reputation for quality and service.

Why settle for anything less than BUSS quality in fuses? The complete BUSS fuse line includes: standard types, dual-element (slow blowing), renewable and one-time types — in sizes from 1/500 amp. up . . . plus a companion line of fuse clips, holders and holders.

For more information on BUSS and Bu small dimension fuses and holders . . . Write for B SFB.

Makers of a complete line of fuses for home, farm, commercial, electronic, automotive and industrial use.

BUSSMANN MFG. CO. (Div. of McGraw Electric)
University at Jefferson, St. Louis 7, M



FROM DELCO RADIO come the **speakers** with highest performance. You trust them... so do your customers!

Engineering skills of Delco Radio and General Motors combine to offer a full line of speakers for home and auto radios, phonographs, TV, and Hi-Fi. National advertising behind the Delco Wonder Bar Radio develops a bigger service market for you! For fast service call your UMS-Delco Electronics Parts Distributor.

14 Standard Models: Designed and built to R.E.T.M.A. standards with heavily plated metal parts and Alnico-V magnets. Precision felted cones give uniform response over full operating frequency range. All are fully dustproof and dependable.

Dual-Purpose Hi-Fi Model 8007: A superior speaker for custom-built audio systems and for replacements in AM, FM, TV and phonograph sets. Size 8", 50 to 12,500 CPS frequency range; Alnico-V magnet; 10-watt power rating; 4.1 v.c. impedance; 1 3/16" voice coil.

DELCO

WONDER BAR
RADIO

DIVISION OF GENERAL MOTORS, KOKOMO, INDIANA



A GENERAL MOTORS PRODUCT — A UNITED MOTORS LINE
Distributed by Electronics Distributors Everywhere

A complete line of original equipment service parts from the
WORLD LEADER IN AUTO RADIO

SERVICE, AUGUST, 1956 • 9

n
is a
locks

avail-
setron
d fuse-
bulletin



WESTERN UNION "OPERATOR 25"

NATIONAL ADVERTISING



Raytheon Bonded Dealers are listed with Western Union "Operator 25". Potential customers needing TV or Radio repairs need only call Western Union by number and ask for "Operator 25". She'll give them the name and phone number of the Raytheon Bonded Dealer nearest the customer. More business for Bonded Dealers.



10 million readers a month will be urged to use Raytheon Bonded Electronic Technicians for their TV and Radio repairs. A powerful, exclusive advertising campaign designed solely to stimulate service business for Raytheon Bonded Dealers.



only RAYTHEON BONDDED DEALERS
 have all these business-building assets

RAYTHEON BONDED BACKING

EXCLUSIVE RAYTHEON BONDED DEALER PROMOTION MATERIAL

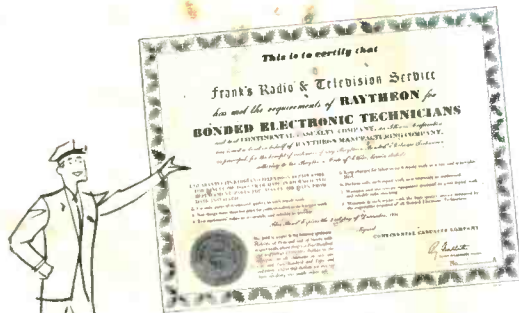

The Bonded Electronic Technician guarantee on all radio and television repair work and parts is backed by a bond issue through one of America's largest insurance companies. This important support creates customer confidence and results in more customers — more profit and more prestige.



Raytheon Bonded Dealers receive a registered Bond Certificate, Decals, ID Cards, Creed Displays — all designed to bring attention to their Bonded status. Special ads, mailing pieces and countless sales and shop aids are available exclusively to Raytheon Bonded Dealers.



Your sponsoring Raytheon Tube Distributor will be happy to discuss the Raytheon Bonding program with you. Better call him today.

RAYTHEON MANUFACTURING COMPANY

Receiving and Cathode Ray Tube Operations

Newton, Mass. • Chicago, Ill. • Atlanta, Ga. • Los Angeles, Calif.

Raytheon makes all these Receiving and Picture Tubes, Reliable Subminiature and Miniature Tubes, Semiconductor Diodes, Power Rectifiers and Transistors, Nucleonic Tubes, Microwave Tubes



Excellence in Electronics

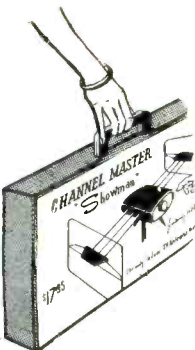

A New Look For Tools

THE ADVENT of modular assemblies, printing-wiring chassis, *pc* and miniaturized components, portable TV and its compacted construction, streamlined color-TV and transistorized equipment, has introduced a new form of design that requires a completely new approach to the repair operation.

No longer can we apply only the stock tools that served so well when standard components and routine wiring were the vogue. The installation and replacement of today's smaller parts with their delicate structure, the new chassis with their chemically-treated bases and leads, the semi-conductor replacements for tubes, the stacked printed-wiring boards with their packaged components, can only be handled efficiently by a supply of tools specially designed for the job.

Alert to this situation, manufacturers have developed brand new families of precision tools that have been carefully designed and built so that they can enter and navigate in the tiniest areas without disturbing neighboring components. Aware, too, of the need for tight control of heat, because of the plated boards and the attached frail components, every precaution has been taken in the selection of metals for the tools, particularly the power types, and soldering irons and guns.

To facilitate the use of these new-type tools, varied assortments have been made available; in some instances, they have been assembled into kits with all of the essential parts. To illustrate, the modern kit of files includes such types as ground, flat, square, oval, triangular and knife-edge.

An *exclusive* illustrated-guide report detailing the features of these new-look tools appears in this issue on pages 38 and 39.

Traffic Appliance Servicing

THE TREMENDOUS GROWTH of the small electrical appliance market, with over 300-million such units now in use, has created an ideal supplementary repair field for the Service Man.

With nearly a dozen appliances in every radio-TV home, a number of which are always in need of repair, the potential for servicing work here is enormous.

A comprehensive report on the appliances that require attention, and the tools, test equipment and replacement parts necessary for this new special assignment, is also featured in this issue, on page 42.

Phono's Diamond Jubilee

SEVENTY-FIVE YEARS ago, four years after Thomas Edison perfected his talking machine, the first commercial phono was put on the market and the first commercial records were born.

In a few weeks, this memorable occasion will receive an industry-wide toast at a huge audio exhibition at the Coliseum in New York City.

The show, a ten-day affair, will accent the fact that since 1881 the phono industry has become quite a giant, whose dollar volume this year is expected to hit a high of at least \$500-million.

In glowingly optimistic terms, experts underwriting the conclave point out that the phono and record-changer output in '56 will exceed the '55 rate by at least 25 per cent, and as a result a sale of at least 5-million units will obtain before the year is out.

The booming phono-needle business, with current sales reaching record-breaking proportions, will also be in the limelight at the show. Highlighted will be the tremendous strides effected in design and composition, particularly precious metals, such as diamonds, since the days of Edison. THROUGHOUT THE NATION, others will join in this royal tribute to the phono, justly due for the spectacularly successful industry it founded.

New Frontiers in Circuit-Tube Design

THE DEMAND for smaller radios and TV sets has presented a number of perplexing problems to tube and circuit designers. They have been asked to shrink chassis and components down to a fraction of their former size and still maintain regular receiver standards of performance.

But knotty as the problems have been, remarkable solutions have been found. How the engineering departments of two set makers went about finding these solutions and worked them into new models is told, for the first time, in this issue. In detailed reports (*with complete diagrams*) are discussed the unusual design features included in a modular radio and a 14-inch TV portable.

COLOR-TV has also made heavy demands on circuit engineers. How answers to a number of thorny problems were developed are explained in this issue, in another special report to SERVICE.

You'll find these exclusives on pages 17 to 21, and 28 and 29.—L.W.

A Field Report On

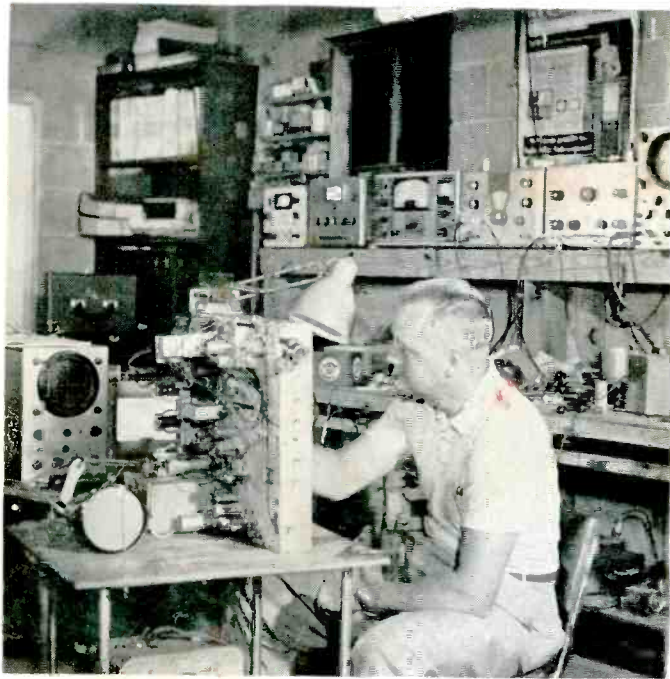

BOB WALTON checking TV chassis, mounted on portable test table in his West Frankfort service shop.



FRONT OF THE WALTON two-floor service shop.



COUNTER-STOCK - record room in shop showing day-by-day service-call bulletin board and tube-test checking equipment on roll-about table.

It WAS LATE in 1945, upon my discharge from the army, that I decided to open a service shop in a small mid-western town, West Frankfort, Illinois, appeared to be an ideal spot for location and business possibilities, and so here we settled.

At that time the housing situation was still acute. Instead of roaming about looking for a building in which to set up a shop, it was decided to build our own, and a one-room affair, 10' x 26', was constructed.

With a capital of \$1000, a basic assortment of test equipment and parts and tubes was purchased.

A short while after our shop was opened we learned that public-address system rentals could be built up into a thriving business. Enough equipment to get us started in the form of speakers, amplifiers and phonos, was purchased. The move was an excellent one, for we have found commercial sound to be very profitable. Since the opening of our *pa* department, we have added substantial quantities of audio components and test gear, too.

One of the earliest problems encountered was adequate transportation for console radio and sound system jobs. Our prewar model family car was just too small for our requirements. So we decided to buy a panel truck which resolved our problem. Today that truck is being used for television antenna installations.

Test Instruments Used

Our current complement of test equipment consists of a *vhf* sweep generator, wideband 'scope, *volt-ohmyst*, *vhf* marker, dot generator and color bar generator.

In addition, we also have three tube testers (two portable and one larger counter type), a sweep generator, marker, marker adder, wideband 'scope and *videometer*.

Auto Radio Facilities

One bench is equipped to service auto radios. This department has developed into so profitable an operation that we plan to expand it very

A Mid-West Service Shop With An 11-Year Record of Progress

soon by adding a drive-in area for auto radio repair.

When we started servicing TV sets, it was found that a simplified method of handling sets was necessary to save time and facilitate repair. After experimenting a bit, we devised a small table with casters and a 2' x 2' top.

Sets are loaded on these tables outside the shop, directly from the truck. Before the sets are rolled in, they are cleaned with an air compressor.

All repairs are made on the table units, eliminating unnecessary carting of the chassis.

Call Bulletin Board

A bulletin board is used to keep track of all our service calls. The bulletin board is blocked off into Monday through Saturday units; daily call sheets are clipped on to the proper day areas. Information on the call tab includes name of customer, address, and nature of trouble in the television or radio set. Two copies are made; one copy is put on the board for the day promised and the other copy is kept on file.

Two years ago we built a 40' x 48' warehouse-garage to store our antenna

supplies, television set inventory and rolling stock which today includes two panel trucks and two station wagons.

We've also enlarged our shop which now is 32' wide and 58' long. A second story has been added to the front part of the building. Here we keep our inventory of components, tubes and accessories, which, with the antenna installation material, has a value of approximately \$10,000.

Branded Parts Stressed

We have found that branded replacement parts give the best service for repairs.

Our customers are our best advertisement. Many live fifty miles away. Most of them call for appointments and are willing to wait while the necessary repairs are being made to their chassis.

We do advertise using the local newspaper regularly with small classified ads, some radio spots and slides in a local drive-in theatre.

Business Record Control

My wife keeps our books; she has a full-time job keeping the govern-

by **R. O. WALTON**
Walton Service Company

ment reports, sales tax and payroll records.

Our gross business has been in excess of \$100,000 per year during the last three years.

Credo of Shop

The success we have enjoyed has come from the prompt service we have rendered, the use of high-quality branded parts and a policy of technical and business honesty.

(Below)

STANDARD-BRAND inventory of replacement components and accessories for TV, radio and sound-system installation-service work.

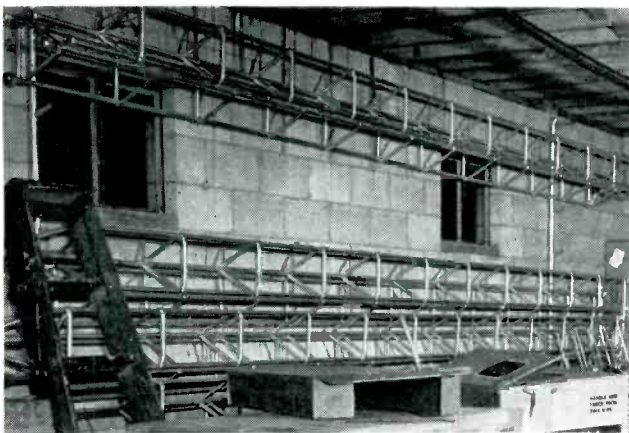

(Above)

ANTENNA TOWER supply in special warehouse that also houses an inventory of TV antennas and hardware.



THIS MONTH IN SERVICE

UHF EXPANSION CALLED KEY TO TV GROWTH--The proposed full utilization of all of the 70-ultrahigh channels would bring about a new era of growth for television. So testified the FCC chairman recently before the House Judicial Subcommittee. . . . The Commissioner said that the licensing of more stations had strengthened the hand of independents in radio and the gradual opening of uhf channels would do the same for TV.

AGREEING WITH THE FCC headman, the prexy of RETMA said that if we are to have a nationwide competitive TV service we must make full use of the uhf channels, even if this involves having practically all television in the uhf spectrum. . . . Sighting obsolescence as a key factor to all-uhf, the association chief said that if such a move was made over a 7 to 10-year period of time, the economic loss to the public could be reduced to an absolute minimum. . . . Commenting on the effect of color-TV on uhf, the industry association spokesman pointed out that we are now entering a phase of volume introduction of color sets and if the transition to all-uhf is the solution, certainly now is the time to begin the transition.

NETWORK SHIFT TO UHF BOOMS BUSINESS IN BUFFALO--Strong evidence of the upswing in business that results when the nets swing to uhf appeared in Buffalo a short while ago when WBUF-TV began carrying NBC programs. . . . Service Men were swamped with orders for uhf converters and antenna installations. . . . It was estimated that over 300,000 converters and antennas might be needed for the vhf set owners who want to pick up NBC programs.

OVER 100,000 COLOR SETS IN FIELD, STUDY SHOWS--According to an estimate charted by the director of marketing research of a tube-set maker, the present total of color-TV sets in the field is over 100,000. . . . Analyzing the buildup to this quantity, the research specialist said that in the first quarter of '55 about 1000 color sets were placed in the field; second quarter sales totaled about 2000; third quarter about 10,000; fourth quarter 22,000. In the first quarter of this year 30,000 color sets were sold and during the second quarter 40,000 more were delivered. . . . The growing number of color receivers has encouraged broadcasters to install color gear. To date, 24 stations from New York to the Coast, up to Seattle, Wash., and down to Texas and Florida are equipped to send color live.

FIRST LARGE-SCALE CLOSED-CIRCUIT SCHOOL-TV GOES TO MARYLAND--Plans for installing the nation's first closed-circuit-TV network throughout an entire public school system have been announced by the Maryland Board of Education. . . . According to the superintendent of schools, the program will begin in September with more than 6000 pupils in two high schools and six elementary schools receiving an important part of their daily instruction by television. School authorities hope to extend the program to the entire school system, which includes 47 schools, by September of '58.

TRANSISTOR SALES CONTINUE TO CLIMB--Manufacturers sold over 1-million entertainment and non-entertainment type transistors in June and nearly 5-million units (with a dollar value of over \$13-million) during the first six months of '56, according to RETMA. The half-year figure compares with slightly over a million units (with a dollar value of about \$5-million) sold during the first half of '55, an increase of nearly 400%.

38-MILLION CAR RADIOS NOW ON ROAD--A recently compiled study of the nation's car-radio audience has revealed that about 38-million cars are now radio-equipped, and that over 60% of all the families in the nation have at least one radio-equipped auto. This tremendous boost in audience compares with a figure of about 28-million reported in '54.

SPEAKERS, PHONO, CARTRIDGE PAPERS SCHEDULED FOR AUDIO ENG MEETING--The eighth annual convention of the Audio Engineering Society, which will be held concurrently with the New York High Fidelity Show, September 26-29, in the New York Trade Show Building, New York City, will feature papers on an extra-fine groove phono system, negative-feedback amplifiers using transistors, tape storage control, transistor-input stages for phono pickups, new trends in hi-fi tuner design, bass reproduction in speakers, mid-range types speakers, high-power loudspeaker systems and the application of magnets in speakers.

**ASTRON "Staminized"
CAPACITORS ARE**

rugged

ASTRON CAPACITORS HAVE THAT BUILT-IN "NO-CALL-BACK" CONSTRUCTION!

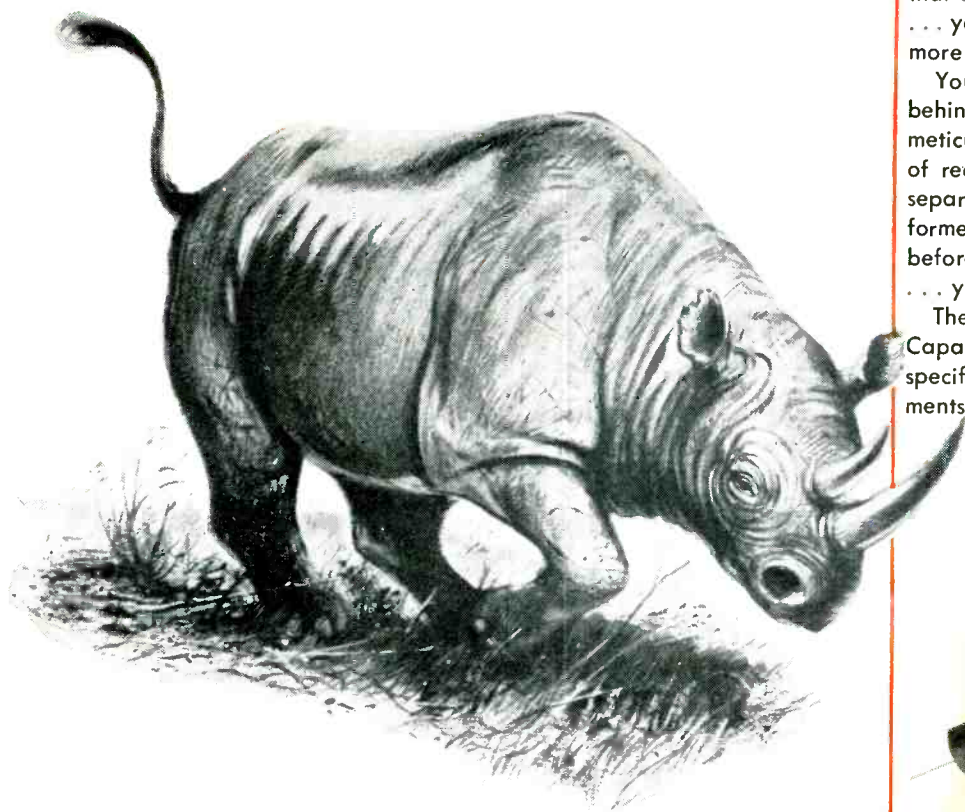

Only the very finest of raw materials pass Astron's "Selected Purchasing System". Astron's special production techniques build extra rugged capacitors that create complete customer satisfaction . . . your key to repeat business and more profit.

You can put your trust in Astron, for behind each Astron capacitor is the meticulous quality control that insures you of real staying power . . . over 10 separate production line tests are performed, plus a 100% final inspection before any capacitor is sent out by Astron . . . your guarantee of top performance.

There is an Astron "Staminized" Capacitor built especially to fill the specific, exacting replacement requirements of any job you tackle.



Safety Margin
"SM" * Minimite*



Safety Margin
"SM" * Twist Prong



Safety Margin
"SM" * Cardboard Tubular



Blue-Point (R) Molded
Plastic Paper Tubular

FREE Servicing Aid



Save time, use handy Astron pocket-sized Replacement Catalogue and Pricing Guide (AC-4D) — Write Today!

ASTRON
CORPORATION

255 GRANT AVENUE EAST NEWARK, N. J.



*Trademark

WEST COAST WAREHOUSE 9041 WEST PICO BLVD., LOS ANGELES - EXPORT DIVISION: ROCKE INTERNATIONAL CORP., 13 EAST 40TH ST., N. Y., N. Y. - IN CANADA: CHARLES W. POINTON, 6 ALCINA AVE., TORONTO, ONTARIO



**Let's slug it out with
the tube Racketeers!**

**Together we can give 'em
the knockout blow!**

PHILCO

Tube Racket-Smashing Campaign

Last year Philco sponsored the industry's first Tube Racket-Smashing Campaign. The results . . . wonderful cooperation from service dealers and praise from thousands of TV and radio owners who had been "taken over" on replacements.

Now, after one year of slugging, the tube racketeers are staggering . . . and we're ready to "knock 'em out" with another great Tube Racket-Smash-

ing Campaign. During the month of August, Philco Distributors will credit you with 5c for old, worn out tubes you bring in, toward the purchase of new Philco receiving tubes. *Your old tubes will be smashed right before your eyes.* Join the Tube Racket-Smashing Campaign today . . . for the good of the industry . . . for extra profits for you. See your Philco Distributor.

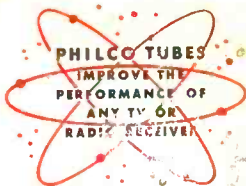

PHILCO CORPORATION
ACCESSORY DIVISION
PHILADELPHIA 34, PENNA.



COLOR-TV IF Amplifiers

Their Function and Service Requirements

by STEVE WLASUK

Engineering Department, RCA Service Co., Inc.

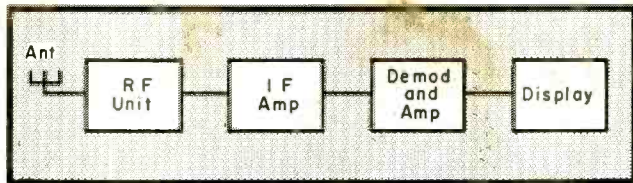

MUCH HAS BEEN WRITTEN about the *rf* unit, about the viewing picture tube, and about the demodulator and video amplifier circuits in the color-TV set. The *if* amplifier, however, has been neglected.

Basically, the *if* amplifier is used as a fix tuned-voltage amplifier device for a band of frequency usually below the received frequency. The design of the amplifier chain must be such that the signal is not materially distorted. The distortions that are possible are the same ones that have been widely publicized in audio work; 1) intermodulation, 2) amplitude, and 3) phase.

A color-*if* signal differs from a black and white signal in that it uses one more carrier frequency for information, in addition to the two used for black and white. During the in-

fant days of black and white television, a few liberties were taken in the design of a suitable *if* amplifier. Then (and now, too, in some cases) a minimum amount of sound rejection was used in the *if* amplifier. Any residual sound/picture carrier beat was usually cleaned up by the addition of a video trap tuned to the beat frequency of 4.5 mc. With a color signal, though, the quick expedient of a video trap has become meaningless. As stated, the color signal is composed of three carrier frequencies. Each is capable of intermodulating the other two. The beat frequency of the color subcarrier and sound carrier is approximately 920 kc. Obviously, a video trap designed to remove this distortion product would make the resulting signal all but worthless. Since intermodulation products are

generated by a non-linear circuit, it is natural to reason then, that all circuits should be made amplitude linear; in other words, class A.

At this point we reach a large sized hurdle. Common knowledge tells us that a diode second detector cannot be made class A and still work as a diode. To circumvent this problem the designer must consider the possibility of removing one or both of the offending carriers. The obvious choice, in the case of a color receiver, is to remove the sound carrier.

In typical color receiver *ifs* with sound traps, the first sound trap is placed before the *if* amplifier. This is done because the *if* amplifier itself is not entirely free of intermodulation. A certain degree of sound is purposely allowed to pass into the *if*

(Continued on page 18)

ABOVE - BELOW, FIGS. 1 and 2: A block diagram of the video section of a TV chassis appears in Fig. 1. A typical color-*if* chain with input and output sound traps is shown in Fig. 2.

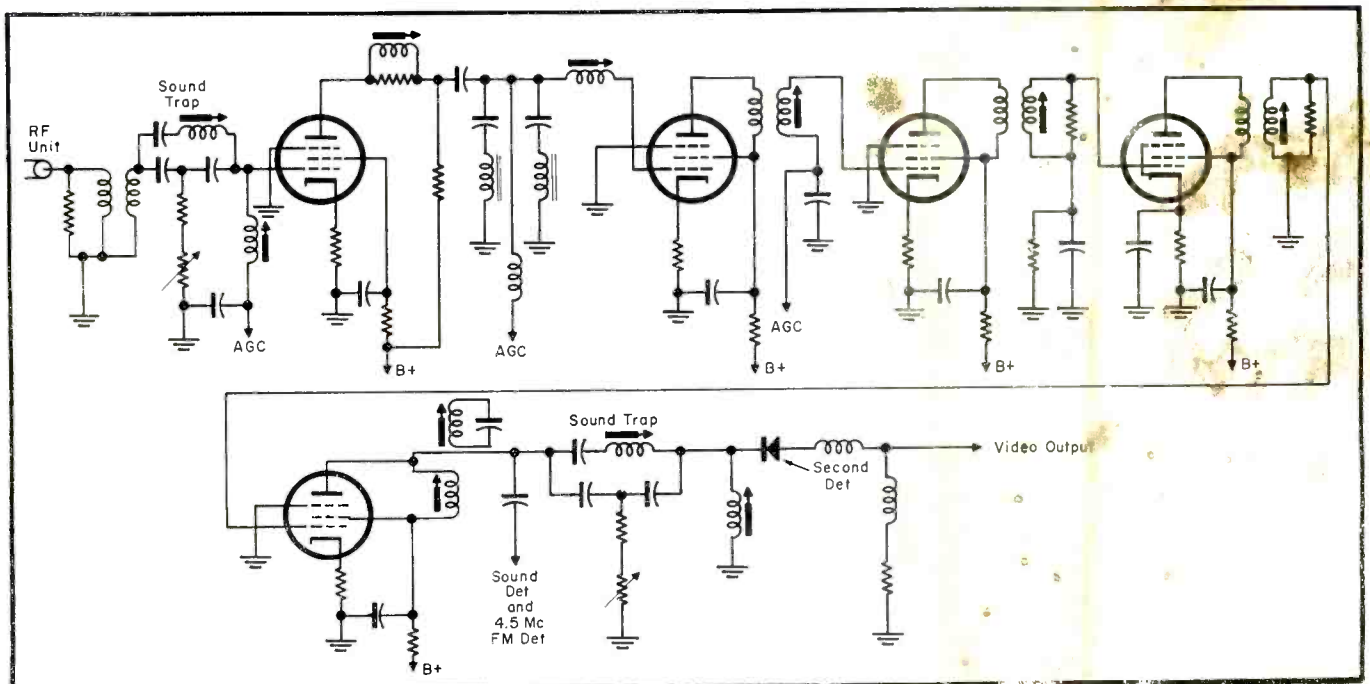

Color-TV IF Amplifiers

(Continued from page 17)

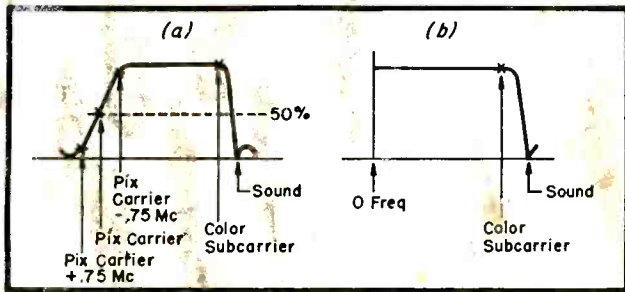

FIG. 3: FLAT FREQUENCY response for color pass band found in earlier color models. At left is if curve; at right, video output.

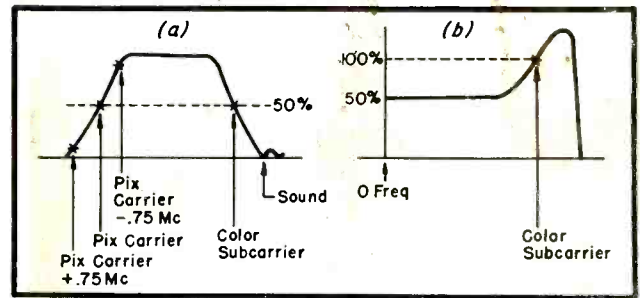

FIG. 4: CURVE of newer type color sets that serves as an alignment guide. At left is if curve; at right, video amp response.

amplifier to permit the detection and use of the 4.5-mc information at the last if tube for intercarrier sound. If all of the sound were removed before the picture if amplifier, an intercarrier type receiver, as it is known today, would be impossible.

To minimize intermodulation distortion, the signal level through the if amplifier must be carefully controlled. A good agc system, therefore, is a prime necessity for a good color receiver. The gain of the earlier stages in the if string is controlled to limit the signal amplitude. Gain control for the designer entails a careful selection of operating potentials and discreet tube type selection. For the Service Man it means a thorough check of tube performance, circuit alignment, and voltage check.

Some of the earlier color receivers were designed for flat frequency response through the color pass band. In the interest of economy and greater freedom from tuning errors, later color receivers use a modified curve as an alignment shape. With these receivers the video amplifier is de-

signed for a complimentary curve to fill the area lost by the non-flat if amplifier. So with these receivers, too, the detected information is flat, when examined after the correcting video amplifier.

A suggested method of final test or alignment of the non-flat if amplifier and compensating video amplifier is illustrated in Fig. 5. The results of examining the detected signal before and after the compensating amplifier are shown in Figs. 6a and b; it can be seen that a follows the curve of Fig. 4, since it is its video equivalent and the curve of b follows the curve of the flat if in Fig. 3.

To reproduce faithfully a TV picture (black and white, or color) the delay of picture information through the if amplifier must be the same at all points in the pass band. For example, in transmitting a square wave, the high-frequency information, corresponding to the sharp corner, must not arrive too late or too soon before the low-frequency information, corre-

sponding to the general shape of the square wave. Obviously, the corner must occur at the time it is wanted to make a corner, or else all resemblance of a square wave is lost. The design engineer must incorporate features in the amplifier to insure equal delay of signals within the pass band. Once these features are built in, the Service Man must make sure they stay built in. The best way to do this is to make sure that the component values are as called for, the lead dress as specified and the alignment exactly as shown in the service notes. This business of a special fringe alignment is out the window. To provide a good check of alignment and phase accuracy on a color set, a suitable generator¹ should be used. Such an instrument develops segments of subcarrier information at a horizontal rate to compose a series of vertical bands. Each band is banded in by black and white stripes when observed on the picture tube. If the color receiver is capable of

¹Such as RCA WR 61.

(Continued on page 45)

FIG. 5: SUGGESTED final test-alignment method for non-flat if amplifier and compensating video amplifier.

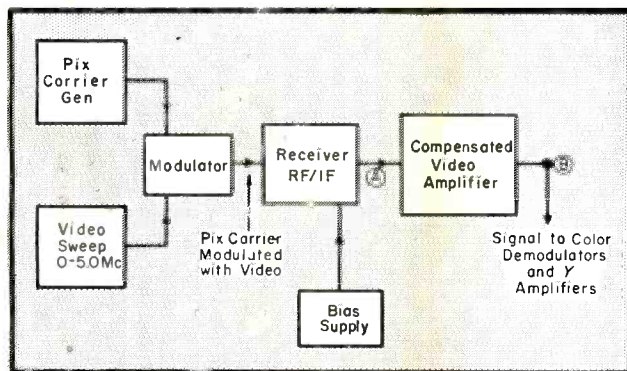

FIGS. 6 A-B: DETECTED SIGNAL, examined before and after compensating amplifier; curve in a follows curve shown in Fig. 4, since it is its video equivalent. It will be noted that curve b follows flat if curve of Fig. 3. The a curve represents the video output at A in Fig. 5; the b curve, the video output at B.

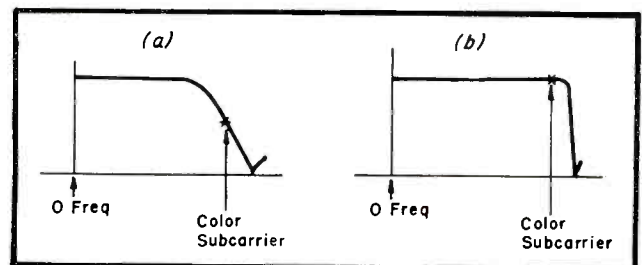

RIGHT: CIRCUIT OF LATEST RCA 21-inch color-TV model (CTC5/A) featuring printed wiring boards, including one for the if.

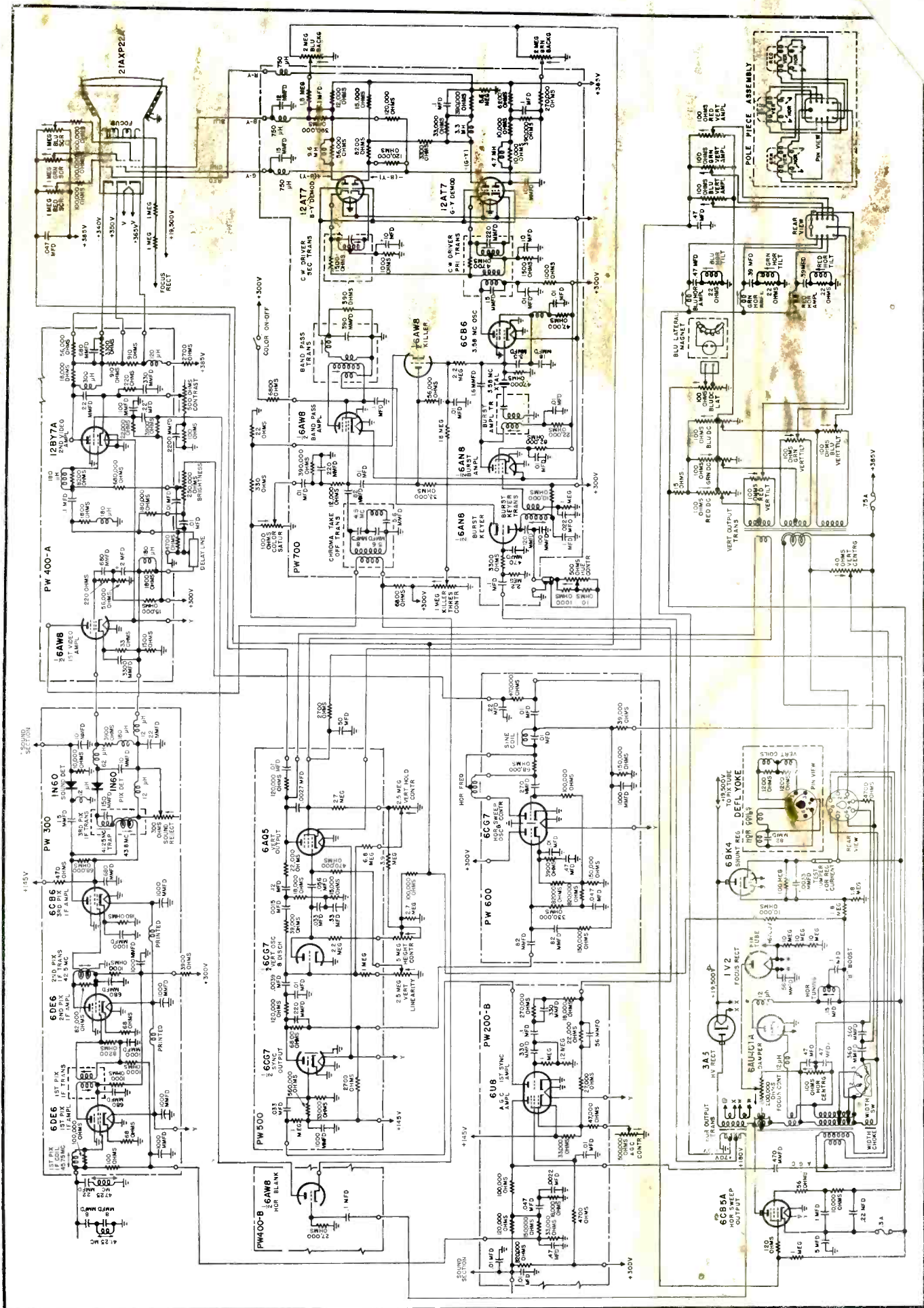

VHF 14-Inch Portable TV

With 40-Mc IF and New Multipurpose Tubes

by E. R. JAHNS, Chief, Electronic Engineering Section

Hoffman Radio; Hoffman Electronics Corp.

[See Front Cover]

THE DESIGN of portable TV receivers requires careful consideration of not only performance values under varied field and home conditions, but physical abuse encountered in carry models. Circuitry must contain a number of operational features to insure reliable reception.

The receiver diagrammed at right and on the cover* was designed with the foregoing problems in mind.

The chassis, employing 14-inch aluminized tubes operating from a 12,500-v power supply, has 13 600-ma multipurpose tubes (14 in the *uhf* model) plus the picture tube, high-voltage rectifier, selenium *afc* rectifier and a selenium rectifier protected by a 7.5-ohm fusible resistor. The multielement tubes in the *vhf* models provide 23 functions, 24 in the *uhf* series.

All models carry a seal certifying compliance with the Federal Communication Commission's oscillator radiation specifications.

The chassis, made of coated steel, provides good soldering ability as well as structural strength. For lightness, a cabinet of hardened aluminum is used. To provide protection for the picture tube, as well as minimize the possibility of damage in hand carrying, a coated-steel front mask has been included.

Circuit Features

A 300-ohm balun feeds the tuner, a neutrode turret type,¹ using a high-gain dual-grounded cathode triode (2BN4) which is neutralized and feeds a multigrid mixer (half of a 5CG8). Injection voltage is supplied by the remaining half of the 5CG8 serving as a stabilized triode.

The mixer output feeds the signal to a 3CB6 first *if* amplifier which is iron-core transformer-coupled to half of a 5U8, the second *if* amplifier. The output of this *if* amplifier is also iron-core transformer-coupled to the video

detector and *agc* rectifier, half of a 5U8. The *if* frequency is 41.25 mc for sound, and 45.75 mc for picture.

Two peaking coils, plus optimized components, feed a high-gain video amplifier (half of a 6AU8) which, in turn provides picture-tube drive through a peaking network.

The detector circuit is unique; it provides peak *agc* with a delay and simultaneous high efficiency detection with no delay.

High-frequency peaking is used on the contrast control in the video cathode circuit. Plate-to-grid degeneration further refines the picture quality.

Quadrature Sound Detector

Sound take-off (4.5 mc) is from the output of the video detector, rather than the video amplifier for *sync-buzz* elimination. The 4.5-mc output feeds a quadrature sound detector, which is, in essence, a locked oscillator with a high FM/AM ratio and an output more than sufficient to drive the audio power amplifier.

The behavior of the quadrature detector is such that in the absence of sufficient signal there is no appreciable output and once past the minimum, it provides automatic leveling so that the sound output is substantially constant. If there is a disadvantage to the quadrature detector, it is that the sound will be noise-free

above any usable picture level, but will go out when the picture level is unusable.

The sync separator (half of a 6AU8), in conjunction with the newly-developed dual-selenium horizontal *afc* rectifier and tuning circuit, serves to provide a stable (in the presence of noise or otherwise) picture; bending, twisting, and other picture peculiarities are absent.

Vertical blanking is used to eliminate retrace lines. To provide uniform sharp pictures, bar focusing is used on the picture tube.

A novel chassis layout has been developed to provide ready access to all tubes, once the interlock back is removed. The parts layout is such that most of the heat is at the top where it can be dissipated through cabinet back openings and also by the highly conductive aluminum cabinet.

To extend tube life, a 20-watt surge resistor has been worked into the circuit.

The side controls, from top to bottom, are contrast, brightness, vertical, volume and off-on switch, and channel selector with its fine tuning control.

At the rear, from top to bottom, are the vertical linearity, horizontal frequency and vertical size controls.

A small built-in antenna provides nominal pickup, and there is provision on the back for an outside or collapsible indoor antenna.

*Hoffman series 1144 (*vhf*) and 1144U (*vhf/uhf*).

¹UHF Front End Featuring Neutralized Triode Circuit; SERVICE; May, 1956.

▶ COMPLETE CIRCUIT diagram of the Hoffman 14-inch portable TV receiver, available for *vhf* and *vhf/uhf* operation.

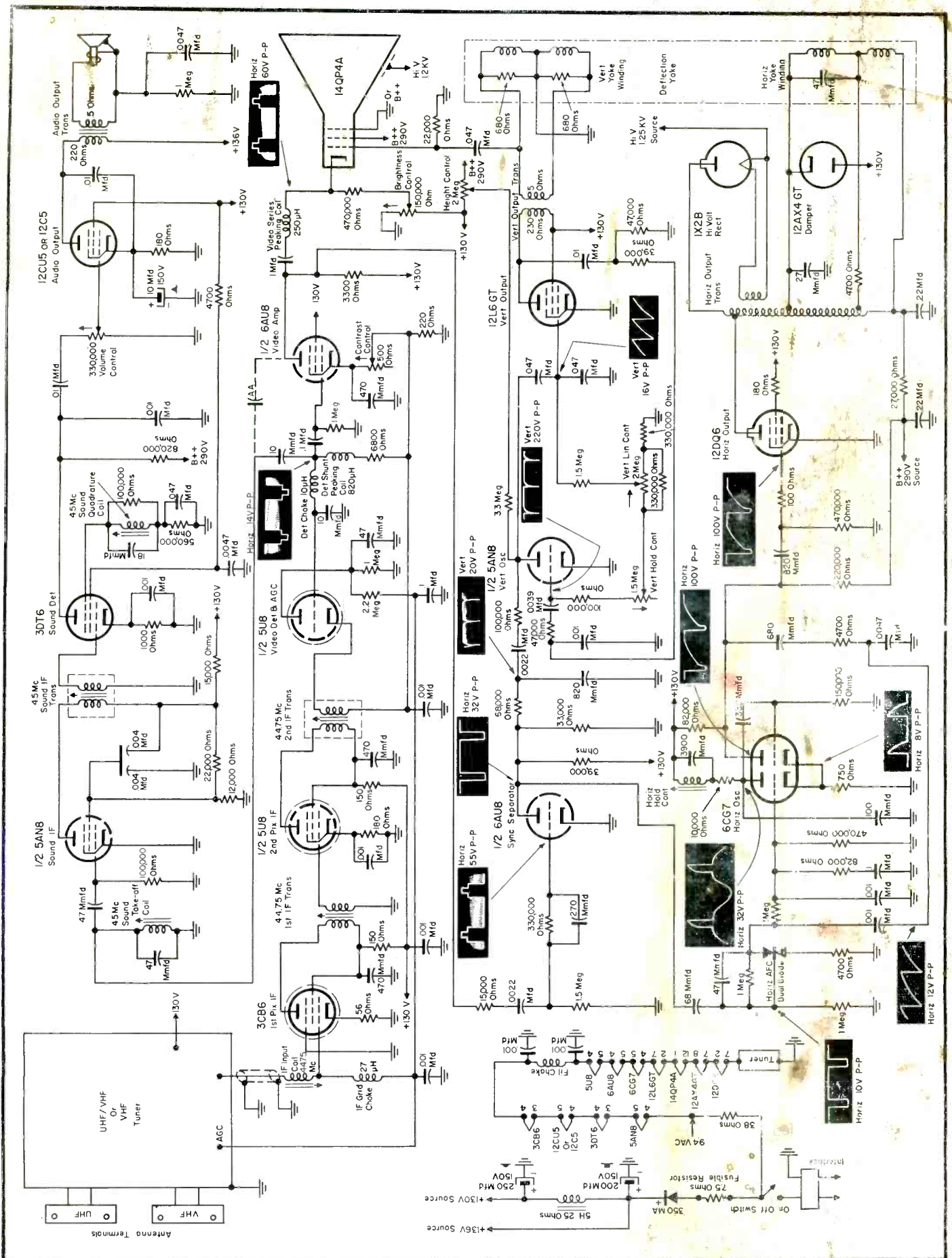

Horizontal Amplifier Tube

Methods Used By Tube Manufacturer To Insure Operation

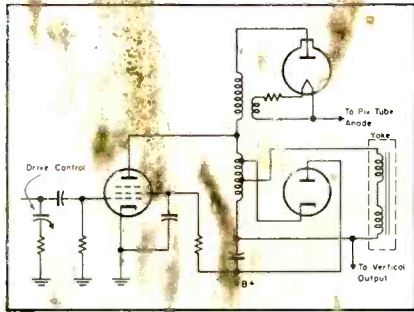

FIG. 1: SIMPLIFIED DRAWING of an amplifier stage.

EXPERIENCED TELEVISION SERVICE MEN have recognized that receiving tubes for a number of TV applications cannot be tested with any great degree of reliability on the *good-bad* types of tube testers. This is especially true of tubes for such applications as vertical amplifiers, horizontal amplifiers and oscillators. Such types are apt to show more fallacious indications than those tubes used for audio or video-*if* amplifier applications.

The horizontal amplifier has been found to be one of the most difficult to

check. The functions of a horizontal amplifier stage are:

(1)—To deflect the electron beam in the picture tube.

(2)—To supply high voltage to the picture tube anode.

(3)—To supply B+ boost to other circuits as required.

A sawtooth waveform of current through the yoke creates a magnetic field that deflects the picture tube electron beam. The ascending and descending portions of the sawtooth waveform must be of proper duration in order to give the correct trace and retrace time; T_T and T_R , Fig. 2a.

The amplitude of the peak-to-peak current should be approximately 800 to 1,000 milliamperes, depending on deflection angle and anode voltage.

A stepup transformer provides the high-voltage source from the plate pulse generated by the sudden reversal in yoke current. Rectification of the high voltage pulse provides the required anode voltage.

In many receivers, particularly those with a low B-supply voltage, the B+ boost voltage is applied to the vertical output stage and in some

cases to the horizontal oscillator. The operation of other circuits from the B+ boost supply places an additional load on the horizontal amplifier circuit for which allowances must be made in the circuit design.

The requirements of the horizontal amplifier tube are relatively simple. The tube must deliver plate-current starting at a point part way through the trace portion of the cycle, which increases from zero to a peak value of 250 to 500 milliamperes. The plate current must then go sharply to cutoff and remain at cutoff until time to conduct in the next cycle.

Tube Testing

Tube tests can be divided into three groups:

(1)—Tests which determine efficiency of operation.

(2)—Tests which determine whether the tube will operate properly.

(3)—Tests which guarantee satisfactory tube life.

Tests Which Determine Operation Efficiency: The yoke current waveform shown in *c* of Fig. 2 illustrates the portion that is contributed directly by the horizontal amplifier tube; this is the solid line. The dashed line in this plot indicates that portion of the yoke current which is derived from energy stored primarily in the inductance of the yoke during the time the horizontal amplifier tube is conducting. As shown by this waveform, the horizontal amplifier tube must start to conduct at the time the current from the stored energy approaches zero from a negative value. To insure that the horizontal amplifier tube will begin to conduct at the right time, a *plate current test* is performed with *dc* potentials at a point where the plate current has assumed a nearly linear rise. In *d* of Fig. 2 we have a more accurate waveform of the yoke current, with the plate current and stored energy portions indicated as in *2c*. The departure of the waveform of *2c* from the more ideal waveform of *2a* is due to linearity and energy loss considerations. The plate current test point



ELMER NIEHAUS testing video-amplifier tubes with special tube-checking setup. Equipment measures capabilities of video-amplifier pentodes to function without white-limiting or low gain.

TV Flicker Causes Remedies . . . Curbing Yoke-to-Width Sleeve Arcing . . . Cures for Christmas Tree Effects

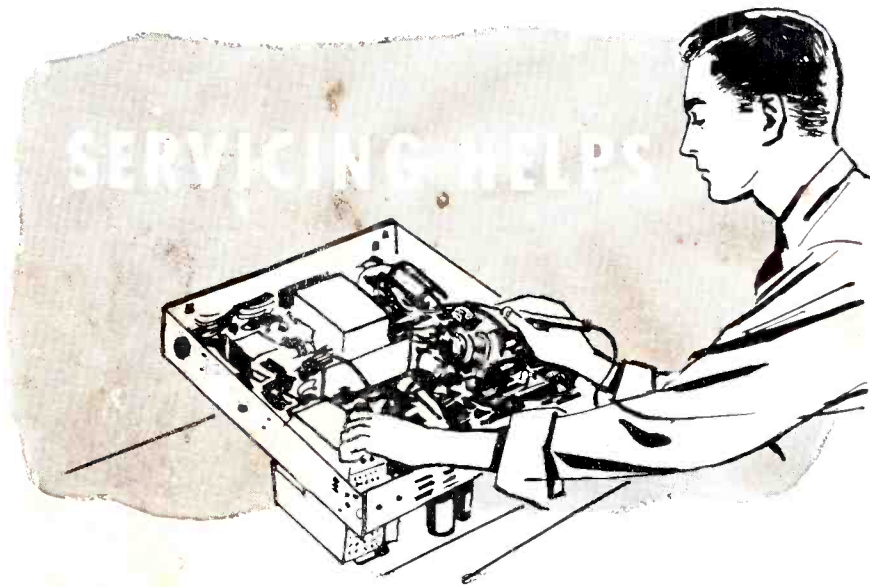

WAVERING OF picture tube brightness is often encountered where the power line voltage varies considerably. The variation must be rather rapid or the eye will diagnose the symptom as a slow change of scene level and not flicker. The trouble cannot be alleviated completely with voltage-regulated transformers.

The primary cause (*power line jumps*) is translated into a similar fluctuation of the B+ supply, although of greater magnitude. In TV sets, the scene brightness is controlled customarily by a potentiometer in a bleeder network from B+; the brightness control. The center arm goes to the undriven element, either the control grid or cathode, of the picture tube. A capacitor shunts the undriven element to the chassis, while

the other is fed with the picture signal from the video amplifier. A grid driven type of circuit is shown in *a* of Fig. 1; a cathode-driven arrangement appears in *b*. In either instance, the other element is connected to the center arm of the brightness control and a capacitor bypasses this arm. One method is really the inverse of the other.

To remove the flicker or jump condition, the capacitor bypassing the undriven arm to chassis is shunted with another capacitor (.25 to .5 mfd, preferably higher) as illustrated. In severe cases, the total added capacity can be 1 mfd. The brightness will not vary as rapidly as without this added capacity; a time lag will ensue due to the longer time constant. The set owner should be told that this delay will occur.

Additionally, an electrolytic (80 to 100 mfd) should be added to the B+ feeding the video amplifier(s). In many sets a decoupling network exists; additional capacity (not more than 10 mfd) can be added to the section around the low-frequency-compensating resistor R_{LF} . Low frequency compensation may be affected if more than 10-mfd are used. If there is no decoupling resistor, such as R_d , one should be added; its value will be about 2000 to 5000 ohms, preferably the larger, if the picture signal is not cut too much by the drop in B+ voltage to the amplifier. As a test, for the need of the resistor, the contrast control must provide enough contrast on all stations with the additional resistance.

The rating of the added capacitor

is dependent upon the B+ supply. Its leakage should be a minimum, since the leakage current will flow through the decoupling resistor, R_d , and will lower the available B+ to the video amplifier. This capacitor serves to smooth out the fluctuations, that change the amount of video signal delivered to the picture tube, by changing the gain of the video amplifier. It varies this gain, but feeds it to the picture tube as a gradual shift in the value of the background brightness, which is not so noticeable.

If a first video amplifier is employed, a decoupling resistor and an electrolytic bypass may be required. The values would be the same as for the foregoing situation.

In an extremely severe case, a voltage regulator tube might be necessary to bleed some of the B+ on the supply feeding the video amplifier. This procedure should be approached with caution, as the average set will not stand the extra drain on its low-voltage power supply.

Christmas Tree Effects

CHRISTMAS tree effects commonly associated with arcing in the damper tube, can also be attributed to trouble in the horizontal oscillator circuit. In Bendix T14 chassis, the output load 330,000-ohm resistor may create this condition when its value increases to approximately twice its original value. The receiver may also have a tendency to reproduce double images in the horizontal plane if the oscillator locks in at one-half the horizontal line frequency.

Yoke-To-Width Sleeve Arcing

TO ELIMINATE the corona or arcing that may exist between the yoke and
(Continued on page 45)

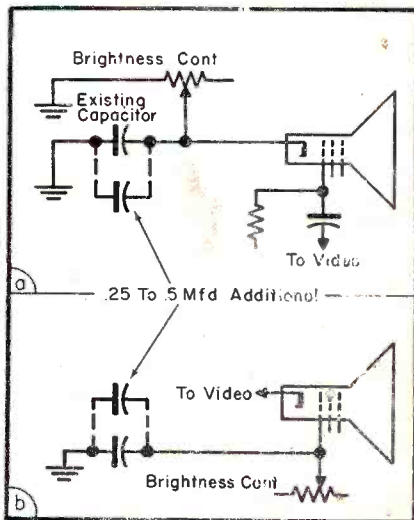

FIG. 1: GRID AND CATHODE-driven picture-tube circuitry.

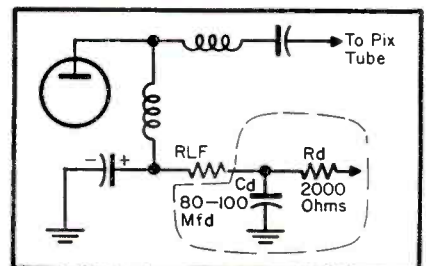

FIG. 2: DECOUPLING NETWORK (dashed lines) in which a higher-value electrolytic may have to be installed to remove flicker.

Testing Procedures

by **ELMER H. NIEHAUS**
 Standard Products Application Engineering
 Receiving Tube Department, General Electric Company

In Circuits For Which Tubes Have Been Recommended

corresponds to point X on waveform 2d.

The effect of plate current being too low at this point is shown in 2d and 2c. The dotted line A in 2d represents the plate current of a tube which is excessively low at the plate current test point. Fig. 2c shows the resultant yoke current from the combined tube current and stored current. The flat portion in the waveform results in the rate of scan across the picture tube being *slowed down* during that instant and, since the beam strikes that portion of the picture tube for a longer period of time, that portion of one scan line will be brighter than the rest. Since each scan line will exhibit this brighter portion at the same relative time, the resulting picture has a vertical bar of increased brightness. This bar is commonly called a *drive line* and appears near the center of the picture.

If the plate current is too high at the test point, the tube will conduct too early in the cycle and will dissipate part of the energy stored in the yoke. The resulting inefficiency, however, is not easily distinguishable from other inefficiencies which produce less sweep width or reduced high voltage and correspondingly reduced brightness.

The function of the drive control is to change the time in a cycle when the horizontal amplifier starts to conduct, as illustrated in f of Fig. 2. The point Y at a potential V, with respect to the control grid, can be moved from time T₁ to T₂ by the drive control. Thus, by adjustment of the drive control, operating condi-

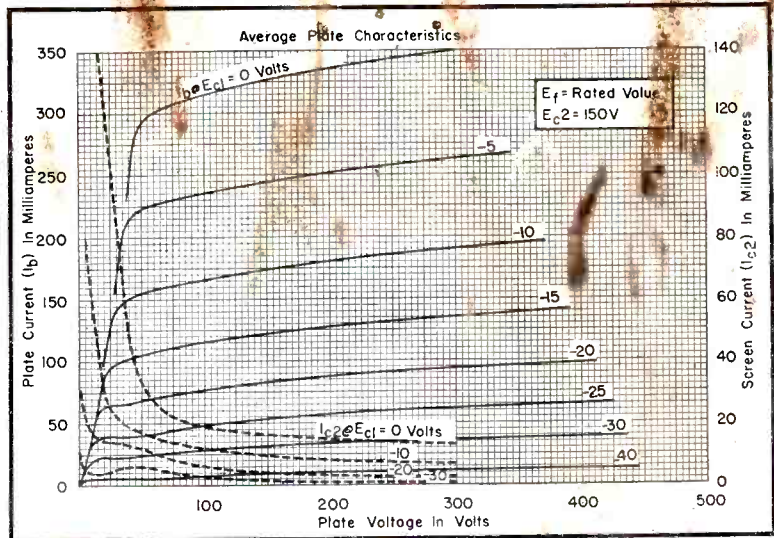

FIG. 3: PLATE FAMILY characteristics of typical 6DQ6 horizontal amplifier tube.

tions of the horizontal amplifier can be more nearly optimized. Many receivers, however, are now manufactured without variable drive controls. In these cases, the manufacturer establishes the driving voltage at the value which will be the most suitable for all tubes.

After the tube has started to conduct at the proper time it must yield an increasing amount of current, up to a peak value at zero bias of from 250 to 500 milliamperes, depending on the type being used. Furthermore, to get the maximum efficiency and output from the circuit, the tube should yield this current at the lowest possible plate voltage. Fig. 3 shows a plate-family characteristic of

a typical horizontal amplifier tube (6DQ6). To guarantee the tube's capabilities of delivering the required peak current, a plate current test is performed at zero bias and at a plate voltage just above the *knee*. A *screen current test* is performed at the same potentials to assure further that the *knee* is below the voltage designated for the tube. In Fig. 3 we see that the screen current rises rapidly below the *knee*.

The effect of low zero-bias plate current and high *knee* voltage is reduced sweep; i.e., the raster does not fill the face of the picture tube. At this condition of reduced sweep the

(Continued on page 61)

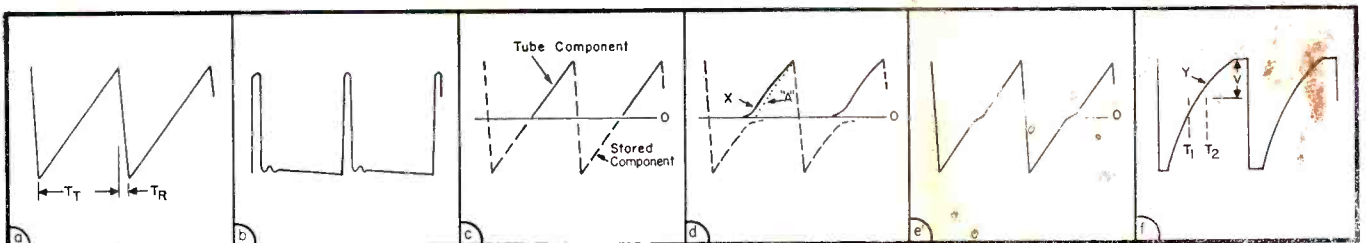

FIG. 2: CURRENT AND VOLTAGE waveforms. Yoke current is illustrated in a; plate voltage in b and the tube and stored component of yoke current appears in c. The solid line here represents the waveform contributed directly by the horizontal amplifier tube. The dashed line details the current derived from the energy stored primarily in the inductance of the yoke during the time the tube is conducting. Actual yoke current is shown in d; X here represents the plate-current test point and A the plate current that is excessively low at the test point. The effect of low plate current is illustrated in e. Drive voltage waveform appears in f. Point Y here at potential V, with respect to control grid, can be moved from time T₁ to T₂ by the drive control.

WIDE



OPEN

SPACES

keep operating temperatures down—dependability up!

RCA SELENIUM RECTIFIERS utilize modern design—*full surface ventilation* with no chance of center-core hot-spots. Note the corrugated spring-steel separators which provide positive multiple-area contacts with each plate. This open construction facilitates free-flow of air and efficient cooling of the plates, and minimizes the possibilities of overheated components in compact TV, radio, and phonograph designs.

The one-piece assembly-yoke with the molded mounting stud prevents *twisting* or *squeezing* the stack during installation. Rigid construction minimizes the possibility of "barrier" breakdowns—*gives greater assurance of dependability in operation.*

So, when you need a replacement selenium rectifier, ask your distributor for a dependable, long life RCA SELENIUM RECTIFIER. Available now in 12 types, ratings from 65 Ma to 500 Ma.



SELENIUM RECTIFIERS

Radio Corporation of America • Harrison, N. J.

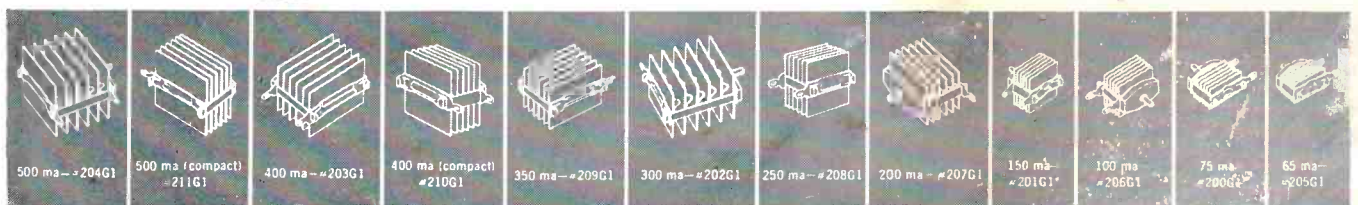

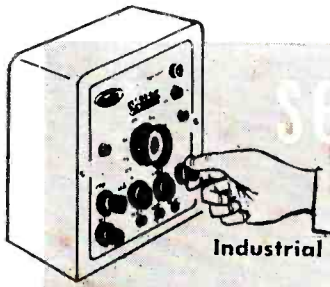

Service Engineering

FIELD AND SHOP NOTES

Industrial . . . Commercial . . . Institutional

Communications . . . Audio . . . Television Installation . . . Maintenance . . . Repair

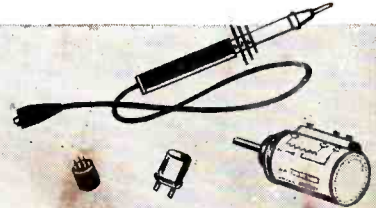

SPECIFICATIONS PREPARED by the Association of American Railroads call for separate housings for the transmitter, receiver and power supply. Such three-unit packaging is used by many of the railroads.¹

The three units of one radio set are mounted in a sturdy frame which may be locked to prevent tampering by unauthorized personnel. The same type of mounting frame may be used in both rail car and base station applications.

For almost 100 years the caboose has depended on kerosene lamps and a pot bellied stove. Now, when radio is installed, the caboose must be provided with electricity. To avoid this expense some railroads have provided train conductors with walkie-talkies. To get greater range, an external whip type $\frac{1}{4}$ -wave antenna mounted on the roof of the caboose is connected to the walkie-talkie.

Most railroads prefer more adequate radio and install an electric power supply. Diesel-engine driven generators delivering 115 volts *ac* have been tried and in most cases abandoned because of the objection by crews to noise and odor caused by the engine. In one case, labor demanded that a mechanic be added to the caboose crew to start and operate the diesel-engine generator. Thus, this type of power supply has not met with favor.

The Erie Railroad was among the first to install 32-volt electrical systems on its cabooses. Axle-driven *dc* generators, many of which were removed from old passenger coaches, are used in conjunction with lead-acid 32-volt batteries. Now used are *ac*-operated radio units requiring *dc* to *ac* motor-generator sets to convert the 32 volts *dc* to 115 volts *ac*.

The Gulf, Mobile and Ohio Railroad pioneered the use of automotive

¹Equipment of this type is manufactured by **Motorola**, **Westinghouse**, **Bendix** and **Federal**. Bendix manufactures both single and three-unit styles.

²Motorola. ³General Electric.

Railroad Radio 2-Way Servicing: Locomotive, Power and Antenna Requirements

by LEO SANDS

type batteries and charging generators on cabooses for the operation of radio equipment.

Although most railroads use the 12-volt system, some, like the Pennsylvania, in their long term planning, are considering the 32-volt system using an alternator-rectifier³ and a drive which does not use belts. There are worthy advantages to such an elaborate power supply, even if the initial cost is higher. Most railroad yards and passenger terminals are already provided with 32-volt battery charging facilities. Furthermore, the capacity of the 32-volt system is so much greater that more electrical equipment may be operated in the caboose. Some railroad executives feel that with new developments coming along, the present 12-volt electrical systems could become out-moded.

When a 12-volt electrical system is used in the caboose, the radio

equipment is generally provided with a power supply chassis which operates directly from a 12-volt source. In some instances, however, sets with *ac*-power supplies, which require the use of a *dc* to *ac* inverter, are used. *AC* operated sets are almost exclusively used in caboose installations when a 32-volt battery power source is provided, although sets are now available which will operate directly from a 32-volt *dc* source. Vibrator-type power converters which had their birth pains and motor-generator sets have proved very satisfactory.

When the caboose stands still or is moving less than 10 to 12 miles per hour, electrical power is furnished by the battery. After the caboose attains a speed of 12 to 14 miles per hour, the axle-driven *dc* generator or alternator-rectifier cuts in and provides the power for operation of the radio

(Continued on page 59)

BASIC 2-WAY EQUIPMENT requirements for a diesel-electric locomotive.

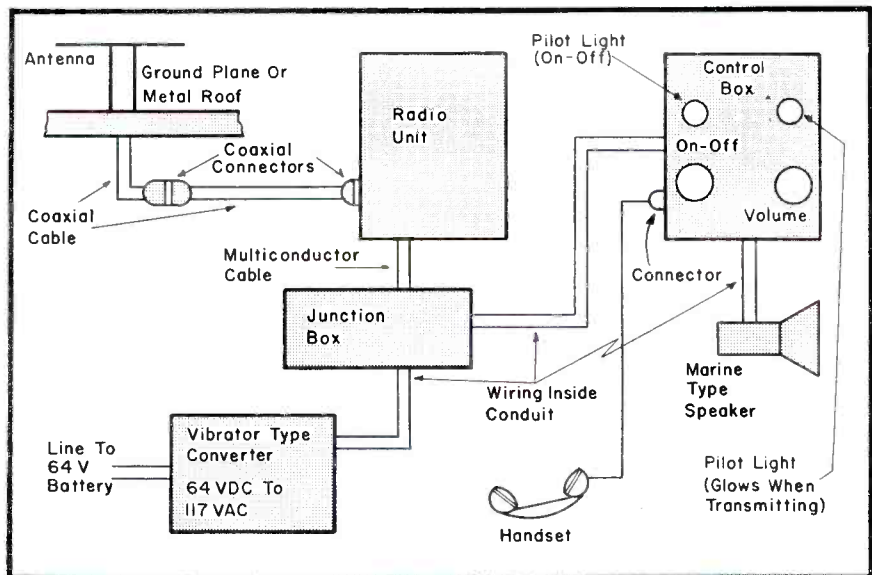

SPACE

MAN...

with a Brief Case



Science has a new kind of space man these days. He carries a brief case.

His mission is as new, as exciting and as challenging as a trip to the moon. In many cases you'll find him on the team at Remington Rand Univac, one of the engineers or technicians who have given UNIVAC the title,

"First in Electronic Computing Systems."

Futures at UNIVAC are as unlimited as the space above. New facilities, fresh working conditions are being born each day at Remington Rand Univac. New members are needed for the team. This is your chance to establish the career every man wants. Write today.

IMMEDIATE OPENINGS FOR:

ELECTRONIC ENGINEERS —

Must have degree and be experienced in pulse circuitry, digital computers, or data processing equipment.

SALES ENGINEERS —

Must have scientific, engineering or mathematical degree and be qualified to combine systems analysis, application and sales function.

PRODUCTION CONTROL —

Engineering degree preferred with 5 years' experience in Production Control Planning. To develop product program schedules and long range production plans.

ALSO OPENINGS FOR —

Physicists . . . Programmers . . . Mathematicians . . . Contract Administrators . . . and many others.

Send Complete Resume to —

Remington Rand Univac

DIVISION OF SPERRY RAND CORPORATION

at any one of these four plant locations

D. A. BOWDOIN
Dept. PJU-28
2300 W. Allegheny Ave.
Philadelphia, Pa.

FRANK KING
Dept. NJU-28
Wilson Avenue
South Norwalk, Conn.

J. N. WOODBURY
Dept. SJU-28
1902 W. Minnehaha Ave.
St. Paul W4, Minnesota

CAL BOSIN
Dept. YJU-28
315 Fourth Ave.
New York City



Complete Circuit Report On 6-Tube Modular Portable

With Det/AVC/AF and Converter Modules

by RICHARD J. HARASEK, Radio Product Engineer, Motorola, Inc.

PORTABLE RADIOS containing a tuned *rf* stage have always been quite large and very heavy, defeating the purpose and application of a portable. The portable set should be small, easily packed in a suitcase, light enough to be carried for moderate distances, and operate in very low-signal areas.

To obtain the small size, several techniques have been used. A popular approach has been the printed-wiring base. This has been found to save some space; however, one still has the problem of placing a fairly large quantity of components on a chassis.

The space-weight situation has prompted a trend toward miniaturization and a different family of components, as exemplified in modules¹, in which tiny parts can be consolidated in a stacked assembly.

The module can be considered as a three-dimensional matrix of all the components and the inter-connections required for several circuits. It is composed of a series of ceramic wafers tied together with riser wires.

The wafers act as a carrier for the circuit elements incorporated in the module; inter-connections are made by silvered circuitry on the wafers and riser wires to connect the entire stack. The risers can be cut at any position within the stack to isolate one circuit from another.

The circuit elements used in a module fall into five groups: resistors, ceramic capacitors, plastic film capacitors, coils and tube sockets. The resistors are carbon-film type on tape. The tape resistor is cemented to a wafer and under the two ends of the resistor are silvered tabs that make contact automatically to the resistive surface. The resistors are rated at ½-watt dissipation and can be operated in a high-ambient temperature without any detrimental effects. The ceramic capacitors are similar to conventional ceramics, with the exception of size. They are 17/32" square and have silvered circuitry to permit direct soldering to the wafer. Several ceramic capacitors can be placed on each side of the wafer. The plastic

film capacitor is a mylar-dielectric-wound unit with provisions for soldering directly to the wafer. These capacitors can be made very small, small enough so that capacitors up to .47-mfd at 200 *vdc* can be included in a module. A tube socket soldered directly to the top wafer completes the module; the unit can, of course, be used without a tube on the module. However, for maximum space saving the modules are used with tube sockets on the top.

Modular Construction Advantages

In the past, our plated-wiring chassis have been employed as two-dimensional units. With the advent of modules the third dimension can be used to great advantage. On the modular chassis that we have designed² there are only two components not included in the modules; a ½-watt power-supply resistor and a ceramic output-plate capacitor. This approach has enabled us to reduce the size of the chassis to half of that of a comparable conventional portable chassis; it has also substantially reduced the weight of the chassis.

A second advantage gained by the use of plated circuits and modules is uniform mass production.

Two stages that were chosen to be modularized in our chassis were the converter and the detector-first-audio amplifier. They were picked because most of the circuit elements are associated with them, and it is desirable both economically and physically to incorporate as much of the circuitry as possible in the smallest number of modules.

The detector-first-audio amplifier has all of the allied circuit elements for an *rc*-coupled audio amplifier pentode-to-pentode. In addition, a diode filter capacitor has been placed in the module; also, an *rf* bypass on



MODULE TESTING: Modular circuits are inserted on either side of bridge tester. One of the modules, a standard unit that has been previously deemed acceptable, is used as the standard in module tests. The tolerance or degree of variation between the two units shows up on the scale above the bridge. This test checks the resistance inductance and capacity deviation from the standard modular component.

¹Israel, Fred, *Stacked Modules Now Being Built Into AC-DC Portables and TV Chassis*. SERVICE, May, 1956.

²Motorola model 66-L.

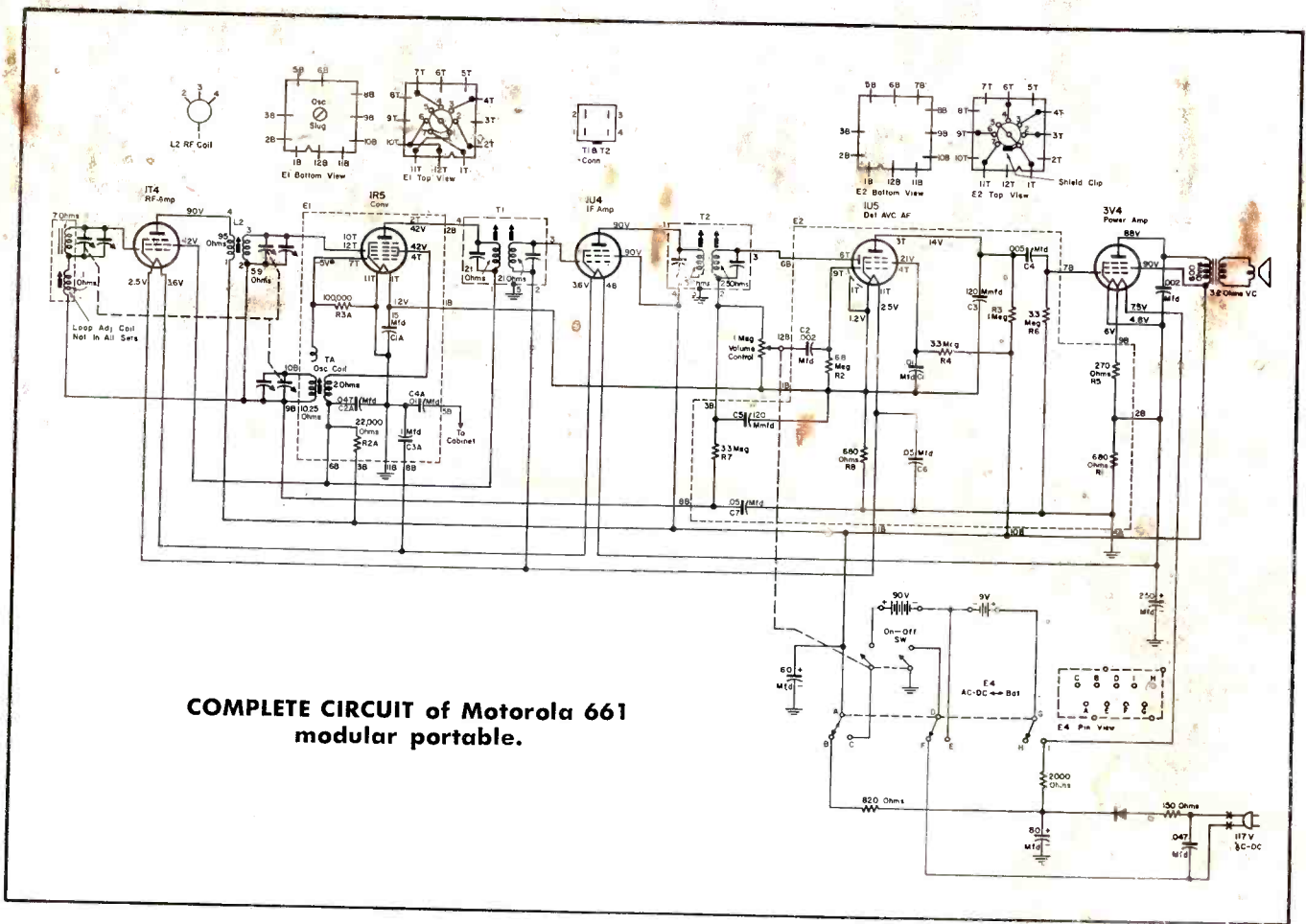

COMPLETE CIRCUIT of Motorola 661 modular portable.

the first audio plate, the *avc* network, a filament bypass capacitor, and two filament resistors on a 3V4 output tube. These resistors bleed off the plate current from the output tube so that the filament voltages will remain balanced. There are 16 components included in this module: 8 half-watt resistors, 5 ceramic capacitors, 2 plastic film capacitors and 1 tube socket.

The converter module was built around the local oscillator for its basic design, with other circuit elements, that are close physically, brought into the module. Included in the converter module are: 2 filament bypass plastic film capacitors (one on the converter filament, the other on the *rf* filament) 1 screen-dropping resistor and bypass, 1 ceramic capacitor that grounds the cabinet shell, 1 oscillator coil and oscillator grid-leak resistor and 1 tube socket, or a total of 8 components.

In the early development of the portable receiver the oscillator coil was external from the module. This resulted in a great deal of distributed capacity, due to the required layout of components and an inferior frequency range. A new approach was tried, and proved successful. The coil was placed in the module. (Two

terminal inductances had been used in the modules, but never a transformer nor an inductance with the tolerances required in an oscillator coil.)

The power output (3V4) plate padder could not be incorporated in the first audio module, because of audio regeneration developing from the proximity of this capacitor to the circuit elements of the preceding tube. An 820-ohm power-supply resistor was another component that couldn't be placed in either module.

It carried a ripple content producing a high hum condition when the receiver was operated from an *ac* line.

In the printed-wiring panels the circuitry has been placed on both sides of the panel and connected by means of plating through holes. This has been found to eliminate crossover jumpers and make a more efficient use of the base. A plated-wiring panel was specially developed for the chassis, permitting the use of up to twice as much circuitry, resulting in

(Continued on page 44)

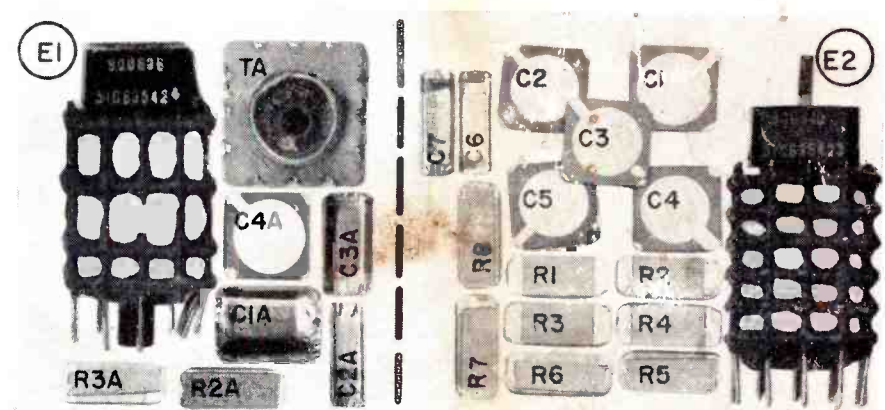

DETAILED VIEWS of module units, showing assortment of miniaturized components built into each assembly. At left is the converter module, while at right is the detector-avc-af module.

Boost Defects and Remedies

by JESSE DINES†

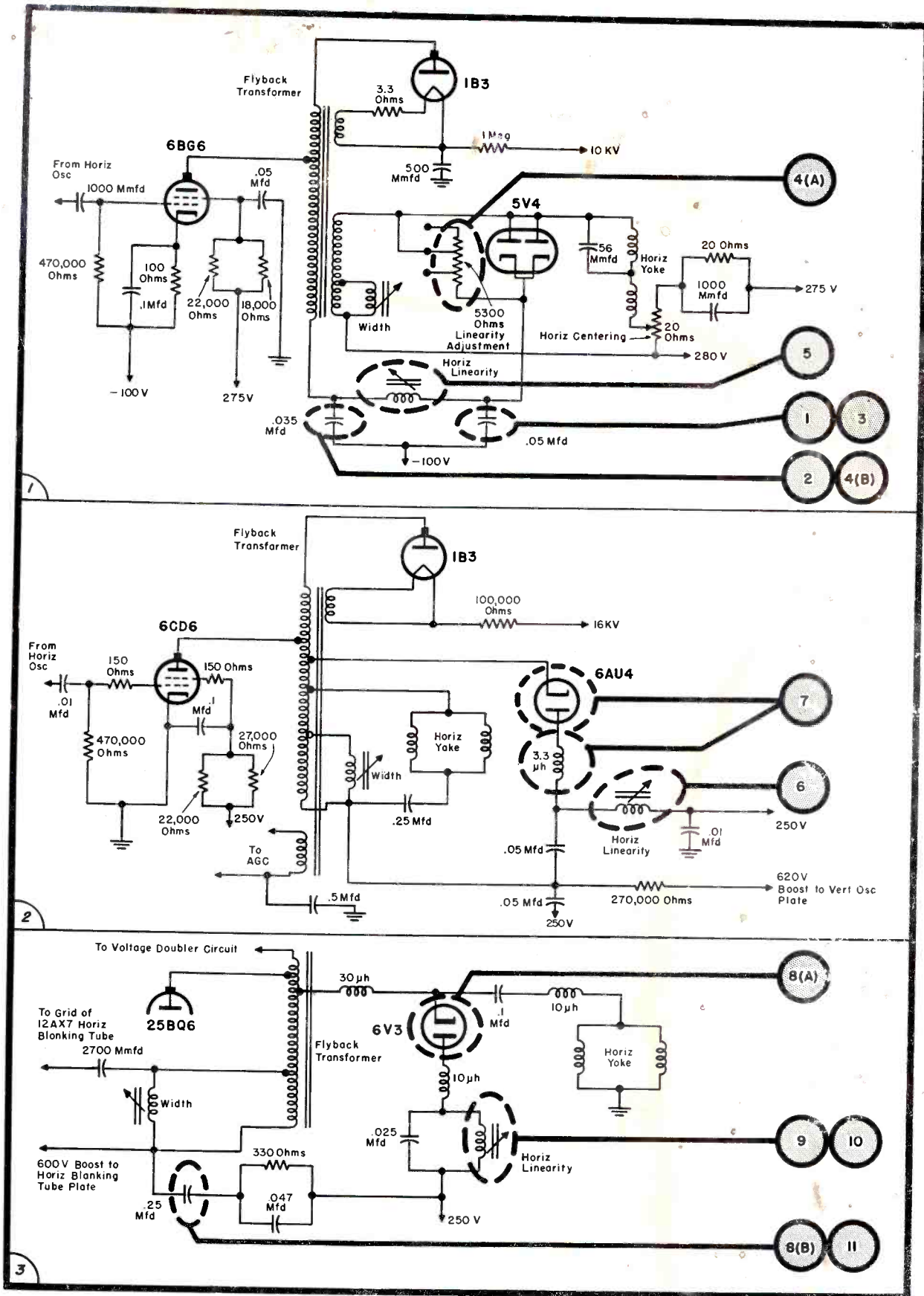

FIGS. 1, 2, 3: HORIZONTAL SWEEP circuitry illustrating sources of troubles analyzed in chart at left. The circuit in Fig. 1 was used in the original 630-type chassis. Fig. 2 shows sweep circuitry in Westinghouse V2318 and V2328. The sweep system employed in the G.E. stratopower models is shown in Fig. 3.

THE FIVE BASIC requirements of a tape recorder are: (1) Accurate speed; (2) steady speed; (3) low distortion; (4) high signal-to-noise ratio; and (5) good frequency response.

Accurate Speed: Professional machines usually maintain their speed within .3 per cent, or ± 5.4 seconds on a 30-minute recording. This accuracy is not required for the home or non-professional machine. Test tapes contain recorded beeps at 5-minute intervals, preceded by a voice announcement. To check a recorder's speed one needs only a stop watch or a watch with a second hand, and a test tape.

If playback speed of a tape machine is too fast or too slow, the pitch of any tape recorded on another unit with the correct speed will be altered, either upward or downward. Of course, if a tape is both recorded and played back on the offending machine, pitch will be accurate, regardless of the accuracy of the speed of the machine. However, to enjoy any of the many excellent pre-recorded tapes now on the market, speed of the playback must be correct. Causes of incorrect speed in a tape recorder might be a tight clutch or brake, or oil, dirt, or oxide build-up on the capstan or idler wheel.

*Such as the *Dubbings* D-110 and D-111.

Practical Considerations in

Cleanliness is vital to tape-equipment efficiency; this point cannot be emphasized too strongly. Presence of any of the substances mentioned can cause a variety of problems.

Steady Speed: A fluctuation in speed of a few cycles-per-minute is known as *wow*. A high rate of change in the speed, in the order of 10 cycles-per-second or more, is usually referred to as *flutter*. Wow and flutter can be caused by any or all of the following:

- (1) Too much holdback tension on the supply reel.
- (2) Not enough capstan pressure, possibly caused by a worn capstan.
- (3) Sticky or frozen bearings, on some part of the drive mechanism.
- (4) Defective motor.
- (5) Slipping of idler wheel, due to dirt or oil on rubber drive.
- (6) Idler not turning freely on shaft.
- (7) Flat spot on idler wheel.
- (8) Tight feed on takeup spindle, pressure roller, or flywheel shaft.
- (9) Insufficient tension on fly-wheel shaft.
- (10) Dirt on heads, capstan shaft, or capstan pressure roller.

Distortion: Distortion is almost al-

ways caused by some defect in the amplifier system, or contact between the tape and the heads. There is very little else that can go wrong with the drive mechanism that will cause distortion. Lack of high-frequency bias will cause severe distortion. Isolation of this trouble should be initiated by playing a tape that is known to have a good recording on it. If the reproduction of this tape is acceptable, then the playback circuit is not at fault.

The high-frequency bias is a super-sonic signal which is recorded upon the tape, superimposed upon the audio signal. This enables the magnetic material on the tape to perform in its region of lowest distortion. The bias is supplied by an oscillator usually incorporated in the amplifier chassis, and is usually 30 kc or more. A neon lamp across the record head serves to indicate the presence of bias, or a milliammeter, in series with the record head, indicates the presence of bias current. Since the amount of bias current varies from .60 to 8 ma, depending upon the type of machine, one should refer to service notes to check for exact bias current. Some machines use the same

COMPLETE DIAGRAM of amplifier and record-erase circuitry used in Pentron T-90 two-speed recorder.

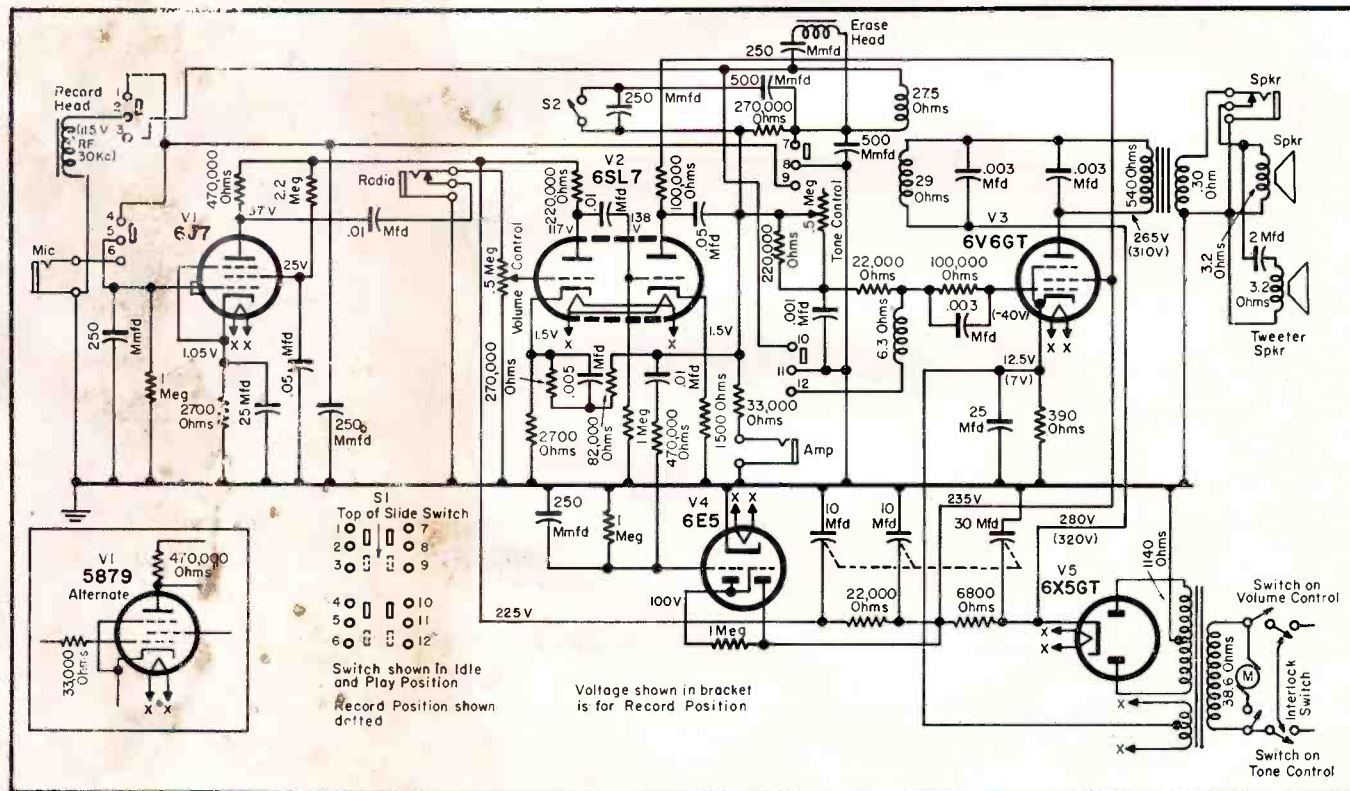

Magnetic Recording

► How Tape Is Designed and Tested In Lab and Field

► Role of the Recorder In Pickup and Playback

by **WILLIAM H. WOGLOM** and **LAWRENCE KNEES**

Quality Control Manager

Service Manager

Reeves Soundcraft Corp.



WILLIAM WOGLOM and **Lawrence Knees** preparing for a series of tape quality-control evaluation tests in lab.

oscillator for bias current and high-frequency erase current. In machines of this type, loss of bias could be caused by trouble in the erase head. Of course, in this type of a machine, loss of bias will always be accompanied by loss of erase.

Problems Encountered in Erase Circuits

When *no erase* is present, one should first check all switches by shorting them. If erase is then present, a switch is defective.

If permanent magnet erasing is being used, the magnet may have lost its magnetism, and a test using a *magnetic material* should be made. But one should not use any magnetized tools on recorders.

The pressure pad may not be holding tape against erase head.

An electromagnetic *dc* erase head may develop a defective coil. One should check with a milliammeter in series.

If *ac* erase is used, the head may be open. A neon bulb should be placed across head to check for voltage. If no voltage is present, and bias voltage is present, as indicated by the neon bulb across bias source, or by measuring grid bias of oscillator tube, then the erase head is open.

The oscillator tube or circuit (especially oscillator coil) may not be operating properly. If one tube is used for both, it may be operating satisfactorily as a power amplifier, but not as an oscillator.

The dual-track heads with separate record and erase segments may have been turned upside down on replacement. Thus, one should check to see if the erase gap is erasing the correct track.

Dirt may be present on the erase head.

If a recording has been made at an

extremely high level, complete erase may not be possible using the erase head, even though it is operating properly. In this case, a strong permanent magnet should be held near the tape while it is running, making sure not to get the magnet near the heads. This should erase the tape, but may leave a strong *dc* noise (hiss) on the tape, which can be removed by normal erase.

If *partial erase* is present, the following conditions may obtain.

Tape is not being held in close enough contact to erase head, due to the pressure pad being non-parallel to the gap. There may be dirt on the erase head.

A misaligned erase head may be in the machine. If one head is used to erase, record, and play back, misalignment will also cause low volume recording and loss of high frequencies in playback. To align the head, one should use a reel of head alignment tape containing a steady tone of about 5 kc. The recorder should be set at playback, and a *vom* connected across the speaker voice coil, or output of the amplifier. The head should be turned back and forth until the maximum reading is obtained on the *vom*.

Insufficient output of the bias oscillator will manifest itself in both poor

erase and poor recording. Poor erase, but good recording, would point the finger of suspicion at the erase head.

Another problem is *intermittent erase*.

Any of the causes of partial or total erase failure could cause intermittent erase. All tests for partial or total erase failure should be made during the absence of erase to determine the cause of this condition.

Still another difficulty is *unwanted erase*.

An erase magnet may stay in position, or a bias oscillator (in machines having separate bias oscillators) may keep running during playback, due to failure of a switch to open the circuit. If interlocks exist, preventing erasing during playback, such an interlock may fail to operate.

Signal-To-Noise Ratio: High noise level may be caused by inadequate

(Continued on page 54)

A PARTIAL schematic showing circuitry developed to obtain record bias current and erase current from a single oscillator source.

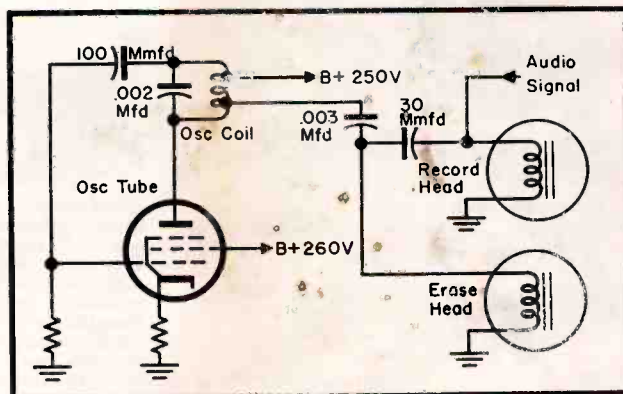

Highlights of FCC Report on COMMUNITY-TV Line Radiation Control

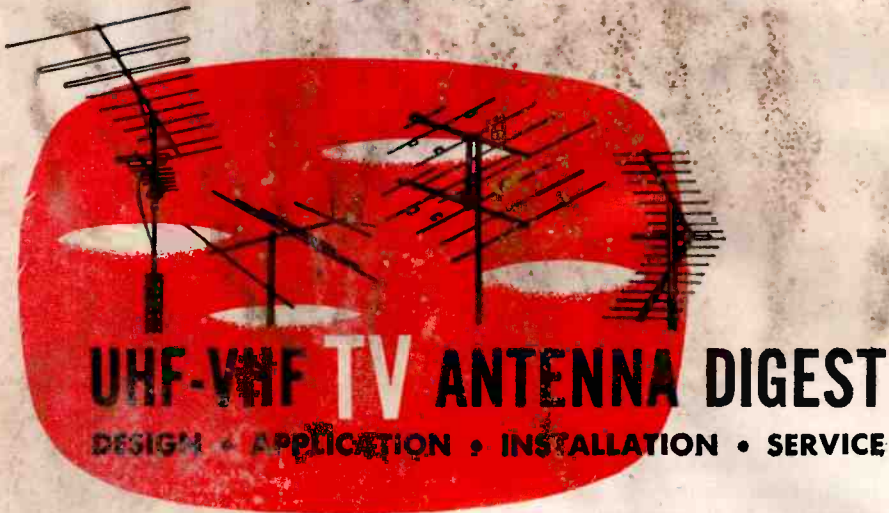

EXPERIENCE gained from investigations of community-TV line-radiation complaints by the FCC has shown that interference can be reduced to a negligible amount, if reasonably good engineering practice is incorporated in the design, installation and maintenance of the system. In many cases, it has been found that high levels of radiation results when the systems use unbalanced open-wire transmission lines carrying high signal levels.

To minimize the problem, the Commission proposed, two years ago, that CATV systems shall not radiate in excess of 10 microvolts per meter at a distance of ten feet, or more, from any point in the system, and that all existing systems would have to comply with this limit after June 30, 1955. It was also proposed that each

CATV system post a certificate indicating that measurements had been made to show compliance with the applicable rules. The conditions were proposed as prerequisites to operation without a license.

Comments on this proposal were received from the Radio-Television Manufacturers' Association (RETMA), the National Community Television Association, Inc. (NCTA) and others.

The RETMA comment stated that in most cases the radiation limits can be raised above the value proposed and still provide adequate protection to persons attempting direct reception of weak TV signals. A multiplicity of limits were recommended depending on the relation between the frequency of radiation from the CATV system and the frequency of the sig-

nal being directly received. It was also suggested that the radiation limit in uninhabited areas be set at 100 $\mu\text{v}/\text{m}$ at 100 feet, since a more stringent limit could impose an unnecessarily severe economic burden on the CATV system.

In its comment, RETMA also recommended radiation limits for CATV systems which are contingent upon the availability of a signal for direct reception on the same or adjacent channels. The review submitted by this group was criticized by the Commission who said that the plan did not indicate what steps should be taken by CATV operators if a TV station were constructed after a CATV system was placed in operation. In this case it would be difficult to establish radiation limits which are dependent on the existence of broadcast signals on the same or adjacent frequencies. There is also the further difficulty of determining the appropriate point of measurement of the direct signal since TV signals are characterized by extreme variability both in terms of time and particular location.

The FCC noted that while there may be many places where signals capable of direct reception are not available now, it is expected that this will be only a temporary situation. For under consideration are a number of rule-making proposals which will alter signal availability. One such proposal provides for the operation of co-channel amplifying transmitters in conjunction with the mother trans-

(Continued on page 58)

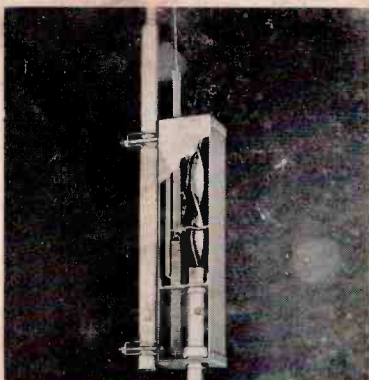

Antenna rotator that employs mechanical principle of a flat spiral helix for rotation. A slotted cross arm within the helix housing is moved downward by pull on manually-operated steel cable with a direction indicator. As the slotted arm moves downward, antenna is rotated clockwise through 360°. (Helix Model H-1; Helix Rotor Co., 220 Live Oak, Marlin, Texas.)

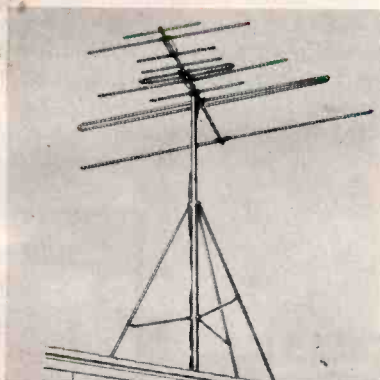

Combination tripod tower and antenna incorporating a factory-assembled ten-foot non-corrosive all-aluminum fold-out assembly mast with antenna for fringe area service, especially terrains with high winds. Supplied with lead-in, seven insulators (three attached on mount), lightning arrester, ground wire and ground rod. (Minute Mount; The Winegard Co., Burlington, Ia.)

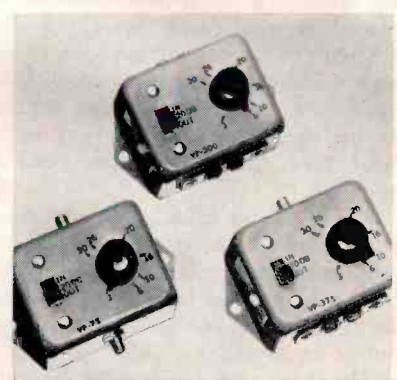

Variable attenuators (3 to 50-db) designed for control of rf signals up to 250 mc. A 3 to 30-db variable attenuator, in conjunction with a switchable 20-db pad, is said to afford a continuously variable output in two ranges. Three models are available for use on 75 or 300 ohm cables. (Varipads; Entron, Inc., P.O. Box 287, 4902 Lawrence St., Bladensburg, Md.)

shift into high gear...

with **CLAROSTAT GREENOHM**[®]

Wire Wound Resistors

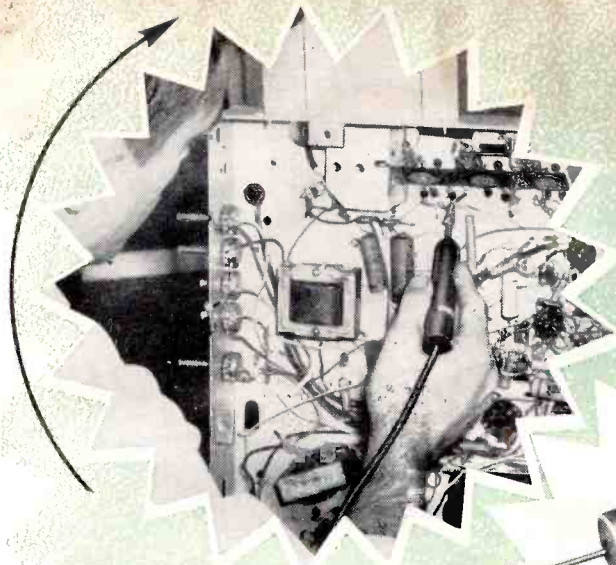

Jobs are done quicker, better, more profitably, with the right components. With **CLAROSTAT GREENOHM** wire-wound resistors you get the complete range of resistances and wattages in both fixed and adjustable. Ideal for radio and television service work when replacing original equipment such as strip-type voltage dividers or regular power resistors. Best of all, **GREENOHM** resistors won't let you down after the job is completed.

So, shift into high gear. Do your servicing quickly and surely with **GREENOHM** resistors. Ask your distributor for complete details on these **GREENOHM** resistors and other service-designed **CLAROSTAT** products.

CLAROSTAT MFG. CO., Inc. • DOVER, NEW HAMPSHIRE
In Canada: Canadian Marconi Co., Ltd., Toronto 4, Ont.

ACT NOW

GET YOUR REWARD

JOIN THE WELLER

★ OLD GUN ROUND-UP ★

YOUR WELLER DISTRIBUTOR WILL GIVE YOU

\$2.00



TRADE-IN REWARD

TRADE-IN ANY OLD
SOLDERING TOOL

ANY OLD SOLDERING GUN
OR IRON * ANY BRAND,
MAKE OR MODEL * DEAD
or ALIVE * ANY CONDITION

GET A BRAND NEW PROFESSIONAL MODEL

D-550 WELLER GUN

DUAL HEAT * 200/275 WATTS * DUAL SPOTLIGHTS * INSTANT HEAT

FOR ONLY

\$9.95

DEALER NET PRICE

WHEN YOU TRADE-IN YOUR OLD
SOLDERING GUN OR IRON

DON'T DELAY LIMITED OFFER
TRADE YOUR OLD SOLDERING TOOL NOW
FOR A PROFESSIONAL MODEL D-550
ACT NOW SAVE \$2.00

Available only from your
WELLER DISTRIBUTOR

WELLER

ELECTRIC CORP. * 601 STONE'S CROSSING ROAD
EASTON * PENNSYLVANIA

AGC Systems

A Detailed Circuitry-Tube Analysis
Covering Three Types Now in Use:
Peak-Average-Keyed

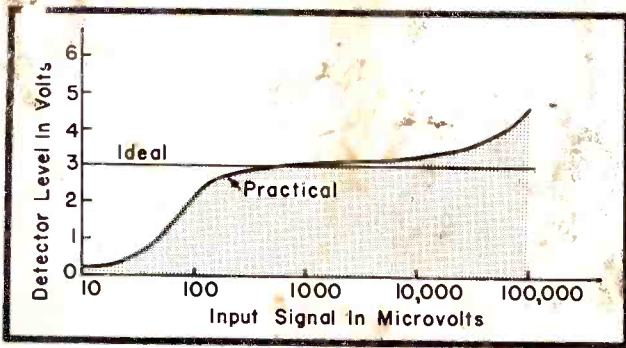

FIG. 1: IDEAL curve of input signal versus detector level output.

THE BASIC IDEA of an automatic-gain-control system is to provide a constant video signal output from the second detector. This is accomplished by feeding back to the control grids of the *rf* and *if* amplifiers a negative *dc* voltage that is proportional to the peak signal voltage output of the second detector. Thus, when the output of the second detector is increased, because of increased input signal, a greater *agc* voltage is developed. This increased negative *agc* voltage is fed back to the control grids of the amplifier tubes, moving their operating point further towards cutoff. This reduces the gain of the stages, thus reducing the output of the second detector to approximately its original value. The opposite is also true. A decrease in signal input, tending to reduce the output of the second detector causes less negative *agc* voltage to be fed back to the control grids. This increases the gain of these circuits by decreasing the bias on the amplifier tubes, increasing the output of the second detector back to approximately its original level.

The ideal curve of input signal versus detector level output is shown in Fig. 1; this is never realized in practice. The curve obtained from a good *agc* system will more likely ap-

by J. M. SHEEH

Application Engineer
Electronic Tube Division
Westinghouse Electric Corp.

proach the curve labeled *practical*. The curve will remain fairly flat from a very weak signal of less than 100 microvolts to a very strong signal of 100,000 microvolts. Many of the systems in use do not have as good an *agc* characteristic as the one shown.

All *agc* systems employ the basic idea outlined; however, there are many ways to achieve this purpose.

It is desirable to have the *agc* voltage proportional to the carrier signal strength of the received signal. In broadcast receivers the carrier level is an indication of signal strength and thus can be used as the reference level. This average amplitude of the detected carrier is an indication of carrier strength and is used as the *agc* voltage. However, in the television signal, the height of the sync pulses is used as the indication of the carrier signal strength. Because TV broadcasting employs a suppressed carrier, the average amplitude of the carrier signal is not the correct indication of signal strength. In this system,

the synchronizing pulses are adjusted to correspond to 100 per cent modulation. Therefore, this stable reference, the peak of the synchronizing pulses, is the correct indication of the signal strength.

Peak detection is used to obtain the correct *agc* voltage. A simplified version of this type of *agc* circuit is shown in *a* of Fig. 2. The output of the *if* stages is fed to the video detector (employing negative detection) and to the *agc* rectifier. This is necessary in present-day TV receivers, which have one stage of video amplification and the picture-tube cathode modulated. The output of the video detector has a load circuit time constant which is fast enough to follow the modulating frequencies of the video signal. This time constant is in the order of .3 microsecond.

The *agc* rectifier must also use negative detection because, as explained previously, a negative *dc* voltage is required for *agc* action. In *a*, $2R_2$ and C_2 are used as the circuit load. Capacitor C_2 charges up to approximately the tip of the sync pulse; the charging time constant, which is the combination of C_2 and diode impedance (diode impedance, when conducting is only a few ohms) is very short. The load circuit discharge time constant, consisting of R_2 and C_2 is made sufficiently long, so that there will be little decay between sync pulses. The *agc* feedback voltage is, thus, approximately equal to the height of the sync pulses. This is shown graphically in *b* of Fig. 2; the same *agc* voltage is obtained for both white and black picture with peak detection.

The load-circuit time constant is in the order of .1 second. This large time constant is needed to avoid critical

(Continued on page 60)

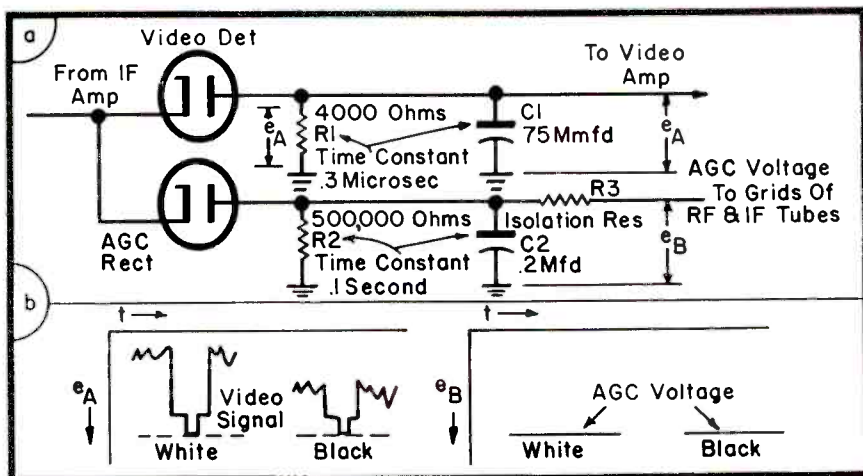

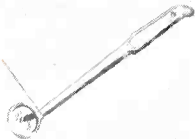

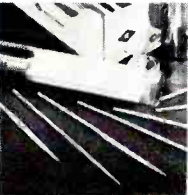
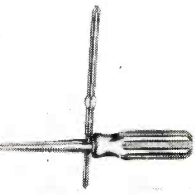
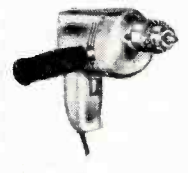

FIG. 2. SIMPLE peak *agc* system.

A Guide to **BASIC TOOLS** Needed For

Tool	Basis Assortment Description	Comments														
SCREWDRIVERS	<p><i>Regular Blade</i></p> <table border="1"> <thead> <tr> <th>Diameter</th> <th>Length</th> </tr> </thead> <tbody> <tr> <td>3/8"</td> <td>2"</td> </tr> <tr> <td>1/4"</td> <td>8"</td> </tr> <tr> <td>5/16"</td> <td>4"</td> </tr> <tr> <td>3/8"</td> <td>4"</td> </tr> <tr> <td>1/2"</td> <td>4"</td> </tr> <tr> <td>5/8"</td> <td>8"</td> </tr> </tbody> </table> <p><i>Phillips Types</i> For screws to No. 4 and from No. 5 to No. 9.</p> <p><i>Offset</i> With ratchet (medium and small).</p> <p><i>Screw Holding</i> Split shaft (medium and small).</p>	Diameter	Length	3/8"	2"	1/4"	8"	5/16"	4"	3/8"	4"	1/2"	4"	5/8"	8"	<p>Perhaps the most often used tool in shop or field. Should feature good quality alloy steel blades hardened throughout full length and fastened securely in handles. Screwdrivers are classified according to length, purpose and type of handle. One should have a sufficient variety on hand so that the right one is always available for the job.</p>
Diameter	Length															
3/8"	2"															
1/4"	8"															
5/16"	4"															
3/8"	4"															
1/2"	4"															
5/8"	8"															
	(1a, b)															
WRENCHES	<p><i>Allen</i> One <i>small</i> and one <i>large</i> set.</p> <p><i>Socket Wrenches</i> Set containing sizes 3/16" to 1/2".</p> <p><i>Open End</i> 3/4" to 1".</p> <p><i>Adjustable</i> Maximum opening 1".</p>	<p>Available in self-contained sets which are quite convenient in that they fold up like a jack-knife.</p> <p>These wrenches provide the quickest method to loosen or run up nuts or screws. Wrenches should have screwdriver type handles and work like screwdrivers, and should be deep enough to take two nuts.</p> <p>A set of open-end adjustable wrenches is desirable to permit tightening or removing hex nuts or cap screws that cannot be reached with the usual socket wrenches.</p>														
	(12)															
	(13)															
PLIERS	<p><i>Long Nose</i> 6" with side cutters.</p> <p><i>Diagonal Cutting</i> 6" type.</p> <p><i>Utility or Slip Joint</i> 6" type.</p>	<p>Used primarily for light gripping and holding and in small areas. When misused on heavier work than intended, tool jaws may break or bend so they do not close firmly on small objects.</p> <p>Intended only for wire cutting and removing wires close to point of connection. This type will cut up to 3/16" hard steel wire.</p> <p>A husky all-purpose plier with three slip-joint positions and serrated jaws; can be used as substitute for proper tool.</p>														
	(14)															
	(15)															
	(16)															
UTILITY SAWS	<p><i>Pistol Grip</i> Uses stiff steel blades about 7 1/2" long. Provided with very fine teeth, about 18 to the inch.</p>	<p>The utility saw (or key-hole hacksaw) will cut all metals including steel, bakelite, wood, etc. Blade is tapered and can get into tricky hard corners that ordinary hacksaws cannot enter. Can be used to cut circular or rectangular holes in panels and chassis when necessary.</p>														
	(17)															
SOLDERING IRONS	<p><i>General Purpose-Pencil Point</i> 35-50-100-watt models.</p> <p>Illustrations courtesy: Xcelite (1, 6); Vaco (2, 5); Kraeuter (3, 4); Esico (8).</p>	<p>Irons with screw type tips are always required in the shop. Irons should be of sturdy construction, contain a high-quality heating element that will stand up under constant use, and employ a screw type tip that can be replaced as soon as it becomes pitted and worn from repeated trimmings. Should not have sharp edges at end of the handle that could cut away at the cord where it enters.</p>														
	(18)															

Field-Bench Installation-Repair

Tool	Basic Assortment Description	Comments
SOLDERING GUNS 	<i>Light and Heavy Duty</i> 75, 100, 200, 250-watt types.	Soldering guns are especially adapted to present day servicing needs because of their instant heat feature, ability to reach connections which are accessible only through chassis cutouts and the fact that heat sensitive components can be serviced with more care than with the constant heat devices. Extra tips are available to extend the capabilities of these tools. Tips available for general soldering, miniature-component soldering, dent-removal and heavy material solder work. Built-in spotlight serves to facilitate servicing.
(9)	(9a)	
CUTTER-WIRE STRIPPERS 	<i>Pocket Size</i>	Handy tool that permits wire to be stripped and cut to size. Uses 5" ground blades for cutting. For stripping, a stop, adjustable to the proper wire size, is used.
(10)		
INSPECTION MIRRORS 		An indispensable aid; shock-proof, it permits inspection in high-voltage and low-voltage areas. Mirrors feature all-plastic construction for insulation protection.
(11)		
SOLDERING AIDS 	<i>Probe Types</i> Assorted lengths for standard, printed-wiring and miniaturized chassis.	Pencil-shaped, with colored plastic holder and pointed metal-probing and slotted-wiring ends designed to hold work being raised to soldering heat; also for twisting wires into tight connections, untwisting wires and holding sensitive components clear of points being soldered.
(12)		
FILES 	<i>Large Assortment</i> Should include large round and rat-tail, and set of precision files.	All shops should have a set of files made of high grade carbon. Kits now available contain key 5½" long files such as ground, half-ground, flat, square, oval-triangular and knife edge, all with a No. 6 cutting surface.
(13)		
REAMERS 	<i>At Least Three Sizes</i> ⅜", ⅝" and ⅞" sizes.	New screwdriver-handle type reamers have been designed for enlarging drilled holes; have added leverage of the T-type reamer but without their bulk. These reamers have a hole in the shank, where a screwdriver or a pin may be inserted for added leverage in extra heavy work.
(14)		
POWER EQUIPMENT 	<i>Power Drills</i> ⅜" type.	Reduced-size power tool. Drills can be used for general drilling or as a drill press. One model has a ⅜" geared Jacobs chuck; a gear reduction mechanism makes possible to handle heavier work without the need for up drill bits.
(15)	<i>Illustrations courtesy: Weller (9); Wen (9a, 15); Jo-El (10); General Cement (11, 12); Centralab (13); Xcelite (14).</i>	[The assortment of alignment tools and auxiliary items (terminal tools, bench vise, shears, hammers, ball-peen, brace, handband or flashing punches, drills, emery wheels, etc.) that Service should also have to insure rapid and efficient installation and repair will be detailed in another tool-guide report which will appear soon in SERVICE.]

designed expressly for color . . .
it's way ahead for Black and White

Color 'Ceptor

18 element high gain yagi for all
channels 2 through 13

with Power-Pack
shows up to

47%

more gain than the famous Winegard Interceptor

WINEGARD

Winegard Company, Burlington, Iowa

Color 'Ceptor 2 ways

PK
(7 element
Power-Pack)
\$14.95

CL4X
Ultra Sensitive
18 element
Color 'Ceptor
\$44.90



John Winegard says:

You can have a "Color 'Ceptor" absolutely free. Why? So you can demonstrate your color TV sets successfully. Our future—yours and mine—depends on color. To sell color sets, you have to show people they work.

The Color 'Ceptor is the one antenna that guarantees successful color set demonstration every time on any VHF channel from 2 through 13.

The fact that the antenna you are now using gives satisfactory results on black and white—is absolutely no guarantee . . . that this same antenna will give equally good color reception on all 12 VHF channels, particularly if you are in a low signal area. When a color picture is off—it's way off. Most often it's the fault of the antenna.

With this in mind, and mindful that the higher gain necessary for color automatically guarantees better black and white pictures, we have engineered the first all VHF channel yagi designed expressly for color reception . . . our brand new, ultra sensitive, 18-element "Color 'Ceptor" antenna, model CL-4X with "Power-Pack."

★ The "Power-Pack" is an ingenious new idea developed in our laboratories that increases the gain of the "Color 'Ceptor" . . . up to 47% over our world famous Interceptor, and at the same time, more than doubles the front to back ratio—really knocks out co-channel interference!

I know the "cobbler's children" are usually the ones that don't have shoes—and even though you sell "Color 'Ceptors," you might not get around to installing one on your own set for a long time—so to make sure you do, I am giving you a free CL-4X with your first purchase of 6 Color 'Ceptors—naturally this offer is limited.

Every Winegard jobber has my authorization to redeem 12 "Color 'Ceptor" box tops (2 from each box) for a gleaming gold anodized "Color 'Ceptor" with "Power-Pack" absolutely free. Not only can you brag that you have the best color picture in town, but the bright shining gold "Color 'Ceptor" on your roof will cause much comment—advertising you!

John R. Winegard

For further information,
see your jobber or write

WINEGARD COMPANY
Burlington, Iowa

Revolutionary GEARED DOWN 3/8" Power Drill

IDEAL FOR RADIO-TV SERVICE WORK... DRILLS



- STEEL
- STONE
- BRICK
- CEMENT
- WOOD
- PLASTIC
- EVERYTHING
- PERFECTLY

The Only Drill You Need

1/4" is too small really, for most work — 1/2" is too big. This 3/8" is just right. It gears down from high speed to 800 RPM under load, a speed suitable for all kinds of drilling, not only multiplies the usefulness of this drill, but also saves you money because now you can use and reuse regular carbon steel bits — which are used at higher speeds. Polishing, buffing, waxing, etc., go better too at this speed. Features of this big powerful new WEN Drill include GENUINE 3/8" CHUCK WITH KEY; UNIVERSAL 115 V. AC/DC 2 AMP. MOTOR for ample torque; HELICAL GEARS for smooth, quiet operation and long life; STURDY HANDLE for maximum safety and convenience; 6 FT. CORD, rubber covered, heavy duty; LUSTROUS SILVER GRAY CASE; COMPACT DESIGN, length 9", height 6"; LIGHT WEIGHT, only 3 1/2 lbs. — and many other features never before combined in a drill at anywhere near this price. A price that gives you a superb new 3/8" geared down, multi-useful power drill for the cost of an ordinary 1/4" job.

MODEL
only \$26.95

LIST

ROUNDS OUT THE WEN LINE OF HIGH GRADE—LOW COST ELECTRIC POWER TOOLS FOR HOME AND SHOP

"Quick-Hot" ELECTRONIC SOLDERING GUNS—STANDARD & SPECIAL PURPOSE TIPS				ELECTRIC SANDERS—POLISHERS			ELECTRIC POWER SAW & T		
#199 \$7.95	#199 K KIT \$9.95	#288 \$9.95	#250 \$12.95	#202 \$13.95	#303 KIT \$16.95	#404 HEAVY DUTY KIT \$19.95	#503 \$29.95	#5-T-1 \$12.95	

YOUR DEALER HAS THEM OR CAN GET THEM FOR YOU

WEN PRODUCTS, INC.

(Export sales, Scheel International, Inc., Chicago)

5808 NORTHWEST HIGHWAY
CHICAGO 31, ILLINOIS

Traffic Appliance Servicing

Essential Tools, Test Equipment and Components Required to Repair Expanding Variety of Small Electrical Appliances

by MILTON WALLACH



THE INCREASING POPULARITY of small electrical household appliances—there are more than 320,000,000 now in use—has developed an expanding repair field that is tailor-made for the Service Man.

The appliances that demand the most service (in order of attention requirements) are: Steam irons, automatic flat irons, automatic toasters, coffeemakers (both percolator and vacuum), clocks, mixers, blenders, heaters (in season), fans (in season), power tools (drills, saws, hedge trimmers, etc.), vacuum cleaners, rotisseries and broilers, waffle and sandwich grills, hair dryers, flat irons (non-automatic), heating pads and roasters.

Personal contact, established during shop and particularly field calls, plays an important role in getting a husky share of this new business. There are approximately twelve to fourteen small appliances in every home. You will be amazed to find that at least one or more of these items requires some sort of servicing at all times. An offer to look at the appliance and, if possible, make minor adjustments will not only stimulate business for you but plenty of good will, too.

In setting up facilities for appliance repair, a work bench properly

**A complete tester has been designed by the Elematic Equipment Co., 6731 S. Chicago Ave., Chicago 37, Ill.*

**Such as Simpson ac/dc volt-wattmeters, models 391-392.*

equipped should be installed. This bench should have a circuit breaker, voltmeter, ammeter, ohmmeter and a master appliance test meter* for testing irons, coffeemakers, deep fryers, waffle and sandwich grills.

Other equipment and tools required are: Small drill press with assortment of drill bits; bench vise; set of pliers (electrician's duck bill, needle nose and gas); complete set of *spintite* sockets; complete set of screw drivers; adjustable wrenches (large and small); ball peen, hammer and soft faced mallet; grinding wheel with polishing or buffing attachment; continuity tester and hack saw. Most service shops have this equipment, particularly the voltmeter, ammeter and ohmmeter; however, for high-wattage work, instruments specially designed for such applications must be used.¹

To complete a small-appliance repair, a number of miscellaneous parts specially developed for this service work are required. These parts have been assembled in kit form and are available from distributors² who specialize in appliance-repair parts.

In one of the kits are all of the necessary wrenches needed to repair steam irons; the most active repair item. Another, a gasket and grommet kit, consists of approximately one-hundred fifty pieces such as steam iron gaskets, bumper feet and grommet bushings. Also available is a solderless connector kit, which not only contains a crimping tool equipped with wire cutter and stripper, but also supplies

ten different types of terminals. An assortment of brushes for mixers, fans and small motors, is included in a carbon brush kit. In another specially-assembled carbon-brush kit there's an assortment of brushes for power tools of thirty manufacturers. Thirty assorted lamps for irons, percolators, fryers, waffle, roasters, etc., will be found in a pilot bulb kit. Porcelain and bakelite wire nuts, butt connectors and insulators have been combined in a connector kit.

In an iron-cord sleeve kit six of the most popular sizes of rubber cord sleeves for iron cord sets have been boxed.

Other kits include an appliance terminal-pin kit which consists of an assortment of terminal pins for irons, percolators, broilers, etc.; a set-screw kit, which contains six sizes of set screws for iron and toaster knobs and other appliance uses; a washer kit with an assortment of fibre and metal washers for appliance repairs, and a special insulator kit which contains nine types of porcelain insulators and bushings for irons, roasters, broilers and so forth.

These twelve kits represent a basic

(Continued on page 56)

²Distributors who specialize in appliance-repair replacement parts include: Electra-Craft Appliance Co., 348 West 42 St., New York 36; Electric Sweeper Service Co., 2034 Euclid Ave., Cleveland 15, O.; Woodall Electric Appliance Co., 1024 Boulevard, N.E. Atlanta 6, Ga.; Pearsol Appliance Co., 2223 Commerce St., Dallas 1, Tex.; Appliance Service Center, 57 Richards St., Salt Lake City 1, Utah; and Kaemmerlan Electric Co., 2727 Locust St., St. Louis 3, Mo.

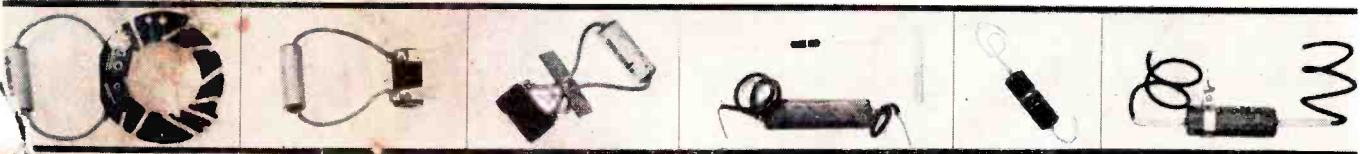

TYPICAL RESISTORS-CAPACITORS found in mixers; types and values are similar to those found in radio and TV chassis.

BE SURE YOU USE...

the right tool
for every
Alignment!

NOW... MORE THAN 70



ALIGNMENT TOOLS
AVAILABLE FOR
TV SERVICING

G-C TV "X 57 PLASTIC LONG SLIM"
SCREWDRIVER
No. Blade Length
8987 7" \$0.60 Net
8988 12" .90 Net
8989 16" 1.20 Net



G-C TV I.F. OSCILLATOR ALIGNER
No. 8272 1/4" tip dia., 6 1/2" long \$0.72 Net



G-C TV ALL-PURPOSE ALIGNER
No. 8273 7/32" shaft dia., 8" long \$0.66 Net



G-C TV CORE ALIGNER
No. 8279 7/32" shaft dia.,
7 1/2" long \$0.66 Net



G-C TV ZENITH UNIVERSAL ALIGNER
No. 8275 1/8" shaft dia., 1/4" handle,
5" long
\$0.48 Net



G-C RCA-ZENITH TV "SHORTY"
ALIGNMENT TOOL
No. 9051 7/32" shaft dia.,
2 1/2" long
\$0.45 Net



G-C RCA-ZENITH TV ALIGNMENT TOOL
No. 9050 .182" shaft dia., 3" long
\$0.18 Net



G-C TV LONG REACH ALIGNER
No. 8274 1/8" shaft dia., 9" long
\$0.72 Net

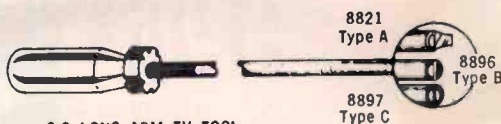

G-C LONG ARM TV TOOL
(7/32" shaft dia., 18" long)
No.

8821	Type A	\$0.90 Net
8896	Type B	.90 Net
8897	Type C	.90 Net

ALIGNMENT SCREWDRIVER
1/4" dia., 6" long \$0.27 Net
7/32" dia., 6" long .27 Net



TV-FM ALIGNMENT TOOL
5066 3/16" shaft dia.,
2 1/2" long \$0.33 Net



TV ALIGNING WRENCH
5080 7/32" shaft dia.,
6" long \$0.51 Net



K-TRAN TOOL
5097 5/32" fibre tip, 1/8" metal
tip, 6" long \$0.51 Net



TV CHANNEL TUNING TOOL
8195 1/8" shaft dia., 7 1/4" long \$0.54 Net



G-C NYLON TV LONG-REACH ALIGNER
No. 8607 .195" shaft dia.,
12 1/4" long \$1.08 Net

No matter what kind of set you're working on, there's a specially made G-C Alignment Tool to do the job. It's all part of G-C's continuing program to design and manufacture new service aids for you as soon as a new TV chassis is announced. Remember — you save time, labor, avoid damage to the chassis . . . when you use the right alignment tool for every alignment. And of course the right one is always . . . a G-C Alignment Tool!



MATCHED G-C ALIGNMENT
TOOL KITS
for Handy Home Servicing

You save money when you buy a G-C Alignment Tool Kit . . . and the tools are always handy when you need them. Many types and sizes . . . like this new set G-C DELUXE TV ALIGNMENT TOOL KIT. Durable roll type leatherette case with 16 matched tools (total value \$15.00).
No. 8280 \$7.74 Net

IT'S FREE! Your illustrated G-C Catalog 157.
At your favorite jobber . . . or write direct



GENERAL CEMENT MFG. CO.

Division of TEXTRON INC., 400 South Wyman Street, Rockford, Illinois

OFFERS YOU THE FINEST OF ALL CONICAL
DO-IT-YOURSELF KITS!



WITH THE AMAZING "PRESTO" INSTANT MOUNT ASSEMBLY

All the "Do-It-Yourself" need do is remove the antenna from the box, open elements as he would open an umbrella... and "Presto"... it's ready! Antennas are all aluminum and of highest Tenna quality.

**MODELS DK-801 AND DK-811
 SINGLE ARRAY KITS**

Consist of 1 conical array, 50' 300 ohm cable, 1 R-105 Chimney Mount, 1 R-102 Mast Standoff, 3 3 1/2" Screw-in Standoffs, 1 7" Standoff and 1 5' Galvanized Mast.

PACKED 4 TO BUNDLE

**MODELS DK-802 AND DK-812
 STACKED ARRAY KITS**

Consist of 2 conical arrays, 50' 300 ohm cable, 1 R-105 Chimney Mount, 1 R-102 Mast Standoff, 3 3 1/2" Screw-in Standoffs, 1 7" Standoff, 1 5' Galvanized Mast, plus 2 connecting bars, 1 guy ring and additional crimped mast.

PACKED 2 TO BUNDLE

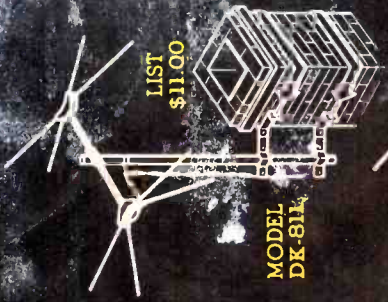

LIST \$11.00

MODEL DK-811

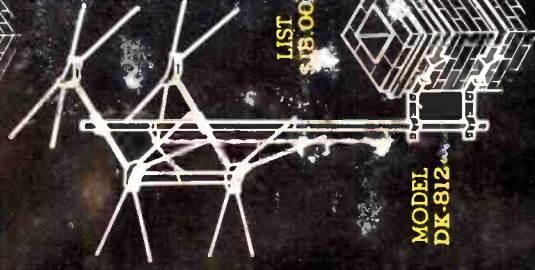

LIST \$18.00

MODEL DK-812

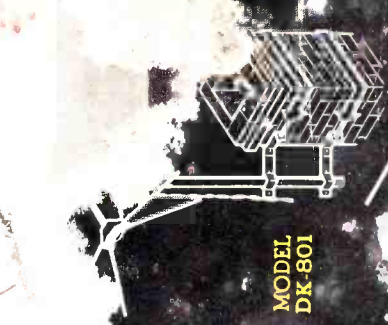

MODEL DK-801

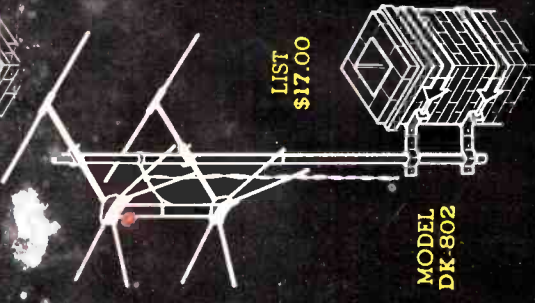

LIST \$17.00

MODEL DK-802

THE TENNA MANUFACTURING CO. • CLEVELAND 25, OHIO

6-Tube Modular Portable

(Continued from page 29)

a good saving in the size of the completed unit.

In repairing, the parts do not have to be pried loose from the circuitry. For single or double terminals, it is only necessary to heat them with a soldering iron and pull the lead through the hole. For multiple-lead components a soldering pot should be used; the entire component lead configuration should be placed in the solder pot and the component lifted off of the panel.*

It is easy to remove a defective module with a solder pot. (If a faulty component is found within the module, the entire unit should be replaced.) To insert a new unit the holes must be cleaned out by heating the solder and blowing the solder through the holes. Then the new module can then be inserted and the unit resoldered to the panel. The modules will fit the panel only one way, so it is not necessary to mark the module to obtain proper orientation. Service on the non-modular components is the same as on any other plated-wiring chassis.

A loop antenna wound on a ferrite rod that is 1/2 x 7 1/2" is used in this modular set. This is considerably larger than most ferrite antennas in use today; it is housed in a thermo-plastic handle, which can be rotated with respect to the cabinet.

This type of antenna construction has been found to offer many advantages. By necessity, the antenna is at least 1 1/2" from the metal cabinet, resulting in very little loading from the metal cabinet and complete shielding from the circuitry; therefore, extremely high antenna gain can be used without the danger of oscillation.

To obtain a high-circuit Q and still maintain tracking through the broadcast band, we added a peaking coil in series with the ferrite antenna. This adjustable coil is peaked at the low end of the band and automatically sets the antenna inductance to match the tuning capacitor.

On portables one of the hardest problems to solve is tracking through the band. The peaking coil has been found to solve this problem.

Another feature of the antenna assembly is its ability to rotate with respect to the cabinet. For best listening, the speaker should be directed towards the listener. With a rotating antenna the speaker can face forward

*A controlled temperature solder pot has been designed for this work; Motorola part 66T634994.

and the antenna turned to receive the maximum signal.

The tuning capacitor, a new unit, is designed especially for this receiver. It is, we believe, the smallest three-section gang capacitor, using commercial tolerances and frequency distribution curves. To design this capacitor into the completed receiver, it was necessary to cut a large clearance hole in the cabinet, to allow the gang frame to protrude through the cabinet. The assembly is covered by a trim plate on the outside of the cabinet.

Battery drain has been kept to a minimum consistent with good performance. The converter stage is operated at 40 volts to reduce the overall B drain, without any loss in electrical characteristics. The *if* amplifier is operated under fixed bias conditions, rather than grid-leak bias, to minimize battery drain, and to eliminate variations between tubes due to small quantities of gas present in the tube. The overall battery drain is 11 ma B and 50 ma A.

Servicing Helps

(Continued from page 24)

width sleeve in Bendix T20 chassis, a new sleeve may be necessary.

To make one, one should cut metal foil to a length of 2½" and center it on the *mylar* insulating material. The corners should be slightly rounded to reduce corona effect, and one must be sure that no rough edges or sharp corners are present to puncture the insulating material. Then the sleeve should be inserted under the yoke windings so that the open portion or slot is at the bottom of the yoke.

If insulating material is severely punctured in a critical location, it is best to replace the insulation.

Color-TV IF Amps

(Continued from page 18)

reproducing color within, but not outside of the boundaries set up by the stripes, then that receiver has sufficiently good phase accuracy to reproduce a most satisfactory picture. This same instrument, incidently, can develop an accurate picture-sound ratio; it can also be used to test the color receiver for sound rejection, the importance of which was stated earlier.

In conclusion, it may be stated that a color receiver *if* amplifier is not some *special* or tricky circuit, but rather a really good black and white *if* system that must be used in a color receiver.

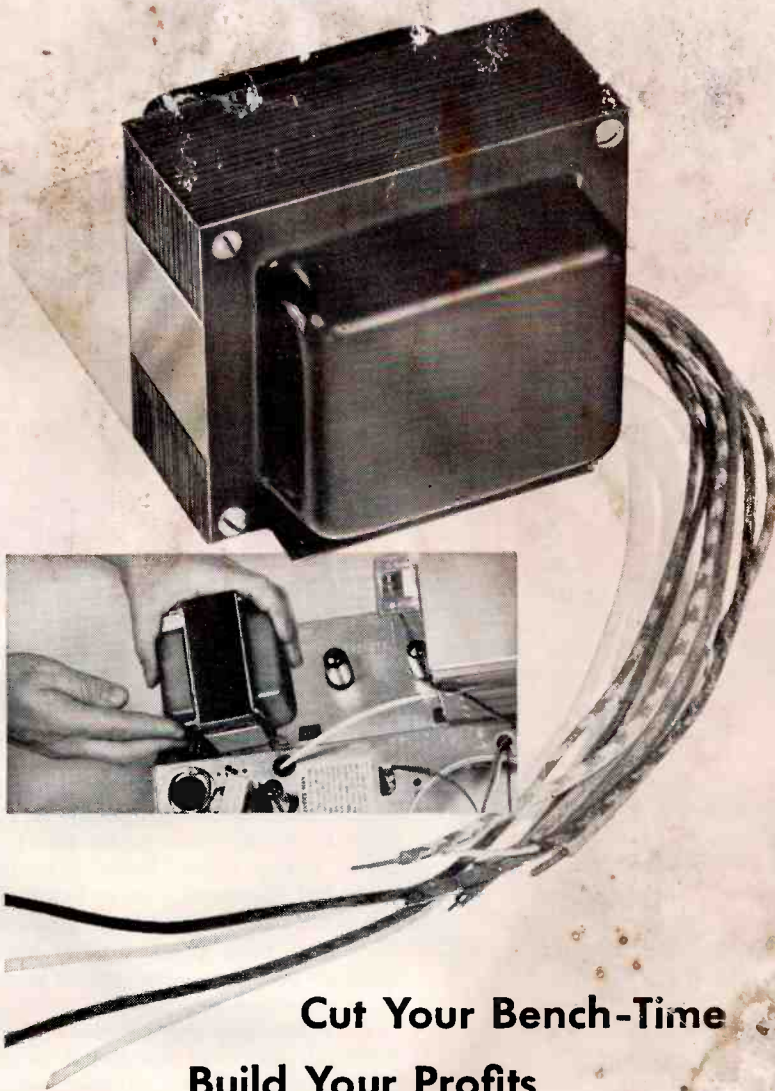

**Cut Your Bench-Time
Build Your Profits**

...use factory-tailored

RCA SERVICE PARTS

This RCA power transformer is factory-tailored as an exact replacement for the units originally built into RCA Victor means it was specifically designed to fit the chassis-punch without drilling, reaming, sawing, or filing. And, the electrical characteristics of this power transformer are precisely the same as those specified for the original part.

Designed to fit right and install fast, RCA Service Parts can cut your daily bench-time by hours. So, keep your servicing on-the-go, profitably. When you need a replacement part for an RCA Victor TV receiver, radio, or phonograph, ask your RCA Distributor for an RCA Service Part.



SERVICE PARTS

RADIO CORPORATION OF AMERICA, HARRISON, N.J.

RCA VICTOR PRODUCTS • RCA SERVICE PARTS—made for each other.

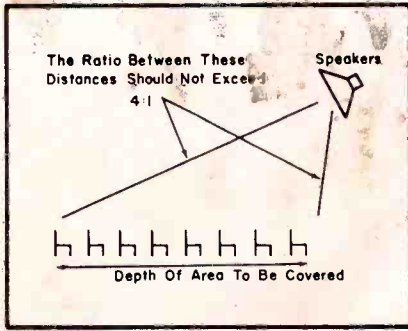

(Left)
MAXIMUM DEPTH— coverage plan for loudspeaker placement.

(Right)
POWER REQUIREMENT variations in an auditorium. Speakers in both main floor and gallery feed the same area, but power requirements differ, due to the greater volume required over the gallery.

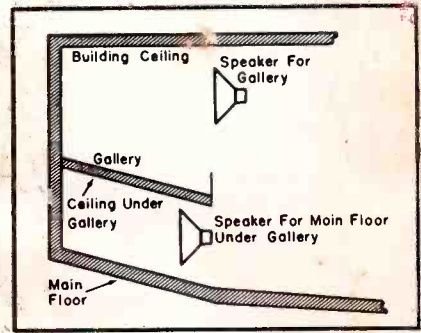

How to Place . . . Feed . . . Match . . . Phase . . . Wire Up Speakers In Large Indoor-Outdoor Areas

THE LOUDSPEAKER, the vital element in the sound system, must be carefully installed in a large-audience area to get uniform coverage. Each speaker should be regarded as a network link serving a certain section of the audience. The nearest member of the audience should be not less than one-quarter of the distance from the loudspeaker, compared with the farthest member of the audience in the same section. Such positioning helps to avoid unduly loud sound reaching some and little sound getting out to others. If it is reasonably possible, the ratio of greatest to least distance should be even smaller than the ratio mentioned.

Where the same type of loudspeaker is used throughout, each area should be approximately of the same size as all the other areas. This will mean it will be necessary to feed

all the loudspeakers with the same power.

Sometimes it is not feasible to follow this procedure throughout, due to the peculiar shaping of the areas involved. You may find, for example, that a section of the gallery is too large to divide conveniently into two areas, but is rather larger than the areas fed elsewhere. In such a case, the feed circuit should be arranged to deliver more power to the loudspeakers called upon to serve a larger area of audience.

In estimating the relative power involved, one must not forget to notice possible effects of the ceiling height. To illustrate: Suppose the space underneath a gallery is much less than the height above the gallery. As the area is approximately the same, obviously less power will be needed to feed the area under the

gallery than over it, because of the greater volume into which the sound energy can spread in the latter case.

Having placed all the loudspeakers in the approximate positions desired, the next consideration is wiring. Here one must decide on a suitable wiring system. The 70-volt line distribution technique will be found very practical for setup. Larger power amplifiers for commercial sound work (50 watts and upward) are usually provided with a high-impedance output, so that the working voltage is in the region of 70 volts, maximum.

Use of the 70-v systems as a constant-voltage line-distribution link obviates many of the losses and difficulties, in getting the right power distribution, that can occur where the natural voice coil impedance is used, but it does involve use of special

(Continued on page 51)

TOP (LEFT): A 70-volt line transformer designed to simplify chain operation of speakers.

BELOW (LEFT): WATERPROOF cover for 70-volt line transformer when used outdoors. (Courtesy-Jensen)

(Below)

A SERIES-CONNECTED line of loudspeakers, arranged so that two get more power than the rest. The + signs indicate polarity of connections for correct phasing. Assuming each speaker is 16 ohms, this arrangement consists of six parallel pairs in series; $6 \times 8 = 48$ ohms, plus two single units or $2 \times 16 = 32$ ohms, providing a total impedance of 80 ohms.

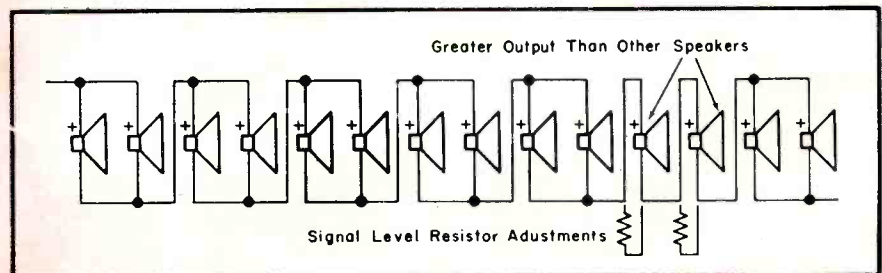

Snyder
PHILADELPHIA

SOLVES the AUTO ANTENNA PROBLEM

NEW

REPLACEMENT

ANTENNA STAFF

Another
Snyder
PHILADELPHIA
Antenn-gineered
Original

For
**FAST and ECONOMICAL
REPLACEMENT of BROKEN,
WEATHERBEATEN or
STOLEN STAFFS**

**SLIP ON
and TIGHTEN!**



RE-8

3⁹⁵
LIST

**SOCKET WRENCH
INCLUDED**

**97% UNIVERSAL
GLEAMING CHROME
60 SECOND INSTALLATION**

**RE-8 . . . FULL SIZE
COLLAPSED LENGTH 24"
EXTENDED LENGTH 56½"**

**RE-8B . . . MEDIUM SIZE
COLLAPSED LENGTH 18"
EXTENDED LENGTH 39"**

SNYDER

MANUFACTURING CO.
PHILADELPHIA • LOS ANGELES • TORONTO

Associations

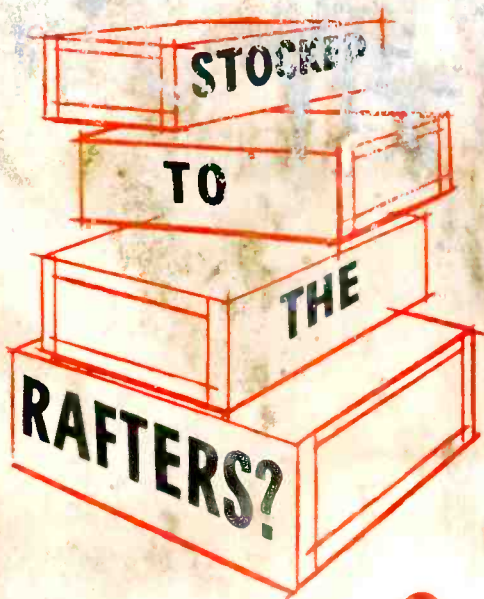

not with **api**!

API's local service and inventory facilities solve your terminal and tooling stockpiling problems.

API local service and inventory facilities stock a wide variety of A-MP terminals and tools for your service and maintenance requirements. API laboratory and service facilities are as near as your telephone. Call API's nearest branch office for service and expert technical assistance.

In addition to branch offices, API maintains a group of local telephone information centers for your convenience.



**dependability
2 ways**
The product and the product knowledge of the API man who serves you.

AMERICAN PAMCOR, INC.

Subsidiary of Aircraft-Marine Products, Inc.

181 Havercrest Ave., Havertown, Pa.

Atlanta, Ga.	Philadelphia, Pa.	Baltimore, Md.
Boston, Mass.	Pittsburgh, Pa.	Portland, Oregon
Chicago, Ill.	St. Louis, Mo.	Dayton, Ohio
Cincinnati, O.	San Francisco, Calif.	Huntington, W. Va.
Cleveland, O.	Waukegan, Wis.	Washington, D.C.
Dallas, Texas	Buffalo, N.Y.	Knoxville, Tenn.
Detroit, Mich.	Indianapolis, Ind.	Charlotte, N.C.
Hawthorne, Calif.	Kansas City, Mo.	Minneapolis, Minn.
Maplewood, N.J.	Albany, N.Y.	Richmond, Va.

*Consult the yellow pages of your local telephone directory under AMERICAN PAMCOR INC., for local telephone center number.

TEA, Texas

THE FOURTH ANNUAL three-day Texas Electronics Association's Clinic and Fair, scheduled for the Rice Hotel, Houston, beginning August 24, will feature nineteen talks by industry experts.

The keynote address will be given by **Allen B. DuMont**, chairman of the board of DuMont Laboratories.

Other speakers who will appear include **Arthur L. Chapman**, Sylvania vice president in charge of operations; **T. B. Kalbfus**, general sales manager, TV-radio division, Westinghouse; **J. B. Anger**, national sales manager, radio and phono division, Motorola; **J. T. McMurphy**, sales manager, accessories division, Philco; **W. L. Parkinson**, manager of products, G.E.; **Dorn Israel**, executive vice president in charge of engineering, Emerson; **Ray Yeranko**, national service manager, and **Russ Weber**, national sales training director, both of Magnavox; **Henry T. Paiste**, vice president in charge of service, Philco; **Joe Bannon**, national sales manager, TV division, RCA; and **Robert Middleton**, chief field engineer, Simpson.

The Texas Electronic Technicians Association of Houston, one of the oldest associations in Texas, is acting as host city for this '56 clinic, as did Fort Worth, Dallas, and San Antonio in the past years.

SRTT, California

A DYNAMIC COLOR DEMONSTRATOR built by Irving Tjomsland of Dean's Electronics, Burbank, Calif., to permit circuitry analysis and test-equipment use instruction, has been installed in the clinic rooms of the Society of Radio and Television Technicians, Inc., Van Nuys, Calif.

Commenting on the importance of this new training tool, **Stan Auerbach**, the group's technical director, said that the demonstrator will serve to explain in detail how the color system works and the steps to take to maintain operation. It will be the focal unit in an 8-month color training program now under way.

In the demonstrator all circuits which are peculiar to color-TV have been built on an *inside-out* basis, which makes it very convenient to attach all measuring equipment, demonstrate adjustments, and *for-proof-of-the-pudding* view the results. In addition circuits found only in color sets were built on a unit basis, each with its own panel, to permit modernization of any portion.



At special meeting of SRTT, Calif., when a color demonstrator was turned over to group for color-training program. Left to right: Bob Albright, program director; association prexy Arnold J. Meyer; Andy Futchik, manager of Dean's Electronics where the demonstrator was built; and Stan Auerbach, technical director of SRTT.

INDUSTRY NEWS

TEST SET MAKER EXPANSION PROGRAM

Hycon Electronics, Inc., Pasadena, Calif., has announced a regrouping program to increase production capacity. Company will augment production and engineering facilities by drawing personnel from Hycon Manufacturing, the parent company.

Many products developed by other divisions will now be marketed by Hycon Electronics.

REP REPORTER BULLETINS

The first of a series of four *Rep Reporters*, to acquaint reps with sales program plans for the rest of '56 and for '57, has been published by the Jensen Manufacturing Co., 6601 S. Laramie Ave., Chicago, Ill.

Highlighting sales meetings held during the parts show in Chicago, the first bulletin reviews sales objectives, strategy and tactics. Future issues will include tech data on Jensen loudspeakers.

2-WAY SYSTEM LEASING DEAL

A program, calling for widespread leasing of mobile radio units as regular trucking gear, has been announced by the communication equipment section of G. E. and Ryder System, Inc., one of the country's largest transport firms.

G. E. will lease two-way radio units for installation in trucks owned by Ryder Truck Rental Systems, a subsidiary of Ryder. Ryder Truck Rental will, in turn, offer radio-controlled pickup and delivery to customers obtaining transport equipment from the Ryder organization on a lease basis. Rental clients would apply to the FCC for licenses to operate their own private communication networks.

AD EXEC CELEBRATES 15TH YEAR WITH AGENCY

Paul D. Bezazian, partner in Burton Browne Advertising, recently celebrated his fifteenth anniversary with the agency, which he joined in 1941 as an account executive and treasurer.

N. Y. DISTRICT SALES OFFICE MOVED TO N. J.

The New York district sales office of P. R. Mallory and Co., Inc., has been moved to 545 Cedar Lane, Teaneck, N. J.

TEN YEARS AGO IN SERVICE

FIRST INDUSTRY REPORT on miniaturized replacement components appeared in SERVICE. Exclusive article detailed the design-application properties of self-supporting baseless tubes, metallized rectifiers and reduced-size capacitors and resistors. . . . Associations got on the bandwagon and began telling their membership about these new developments in special bulletins and during nationwide talks and clinics. . . . Don G. Mitchell, president of Sylvania, received the American Marketing Association Meritorious Service Citation at a banquet in New York from the Department of Commerce.

Not New ---
But FOUR YEARS OLD

Better for you and better for your customers because hundreds of thousands have been field tested and proved during the past four years. Don't be fooled by offers of extremely small plate sizes and narrow spacings. We have found during four years of laboratory and field testing that there is a practical minimum cell size and spacing that are needed for maximum performance and minimum service call backs.

The Tarzian High Density Rectifiers are Time Proved—don't be fooled by unrealistic ratings and sizes.

SPECIFICATIONS

Model No.	Max. A.C. Input Volts	Max. D.C. Load Current	Plate Size	Overall Length	Replaces Model
250A	130	250	1.25" sq.	1 7/8"	200-250
300A	130	300	1.4 " sq.	1 7/8"	300
350A	130	350	1.6 " sq.	2 5/32"	350
400AD	130	400	1.8 " sq.	1 1/4"	400
500AD	130	500	1.8 " sq.	1 5/16"	500

All Sarkes Tarzian Replacement Rectifiers are truly universal and will plug-in on original set replacements on Motorola, Westinghouse, Arvin and Sylvania sets.

Send for your copy of the latest Replacement Rectifier Guide. Address: Dept. S-2

Sarkes Tarzian, Inc., Rectifier Division
415 N. COLLEGE AVENUE, BLOOMINGTON, INDIANA

In Canada: 700 Weston Rd., Toronto 9, Tel. Murray 7535 • Export: Ad Auriema, Inc., New York City

New INSTRUMENTATION Developments

FILTERED DC POWER SUPPLY

A filtered *dc* power supply, *NFA*, providing a continuously variable range from 0 to 32 *v* for all current loads from 1 to 15 amps, has been announced by Electro Products Laboratories, 4500 N. Ravenswood Ave., Chicago 40, Ill.

Unit features a circuit breaker, full view meters, pilot light and carrying handles. Single control allows continuous voltage adjustments for different load conditions over specified range.



LINE-LOAD TESTER

A line-load tester, *AC-12*, for checking 110-*v ac* power-line capacity to handle appliance loads, has been announced by Precision Apparatus Co., Inc., 70-31 84th St., Glendale 27, N. Y.

Meter indicates line-load conditions directly; *Low*, *OK* or *High*; also reads actual line voltage.

CAPACITOR-RESISTOR ANALYZER

A capacitor-resistor analyzer, *CRA-2*, has been introduced by Pyramid Electric Co., 1445 Hudson Blvd., North Bergen, N. J.

Instrument provides direct reading of leakage current measurements while rated operating voltage is applied to capacitor. A vacuum-tube ohmmeter circuit displays insulation-resistance values on meter. Calibrated control permits power factor measurements of electrolytic capacitors rated as low as 6 *wdc*; as high as 600 *wdc*. This circuit also performs *in-circuit* tests for shorts, opens and intermittent high *rf* impedance.



DYNAMIC TUBE TESTER

A dynamic mutual conductance tube tester, *DynaMatic DM456*, featuring automatic setup of socket pin connections and test voltages through use of perforated plastic cards, has been developed by TeleTest Instrument Corp., 121-08 14th Rd., College Point, N. Y.

Unit is said to check more than 450 tube types used in current TV sets and radios. Tester measures 11½" x 9" x 5½".



PIC-PROBE

A 'scope probe, *Pic-Probe*, used as a pix-tube substitute that serves to check deflection circuits, yoke deficiencies and video and sync circuits in a TV receiver, has been introduced by the Radionic Industries, 3215 W. North Ave., Chicago 47, Ill.

Probe consists of two coils and a network of resistors, capacitors and diodes. Induced into windings are horizontal and vertical currents present in yoke of set under test. Integrating circuits, with damping resistors and a series of networks, form a sawtooth wave from original pulse present in pickup windings. Sawtooth wave is then fed to horizontal and vertical inputs on 'scope, giving a raster. Intensity terminal of 'scope is fed with video information from TV set, producing a picture identical to that which would appear on TV set screen. Diodes form protective circuit for 'scope tube.



TV TUBE TESTER

A TV set tube tester, *Super TV Tester 56*, for testing receiving tubes (including 600-mil series string types) and picture tubes, has been announced by Brame Manufacturing Co., 1225 Washington Ave. S., Minneapolis 15, Minn.

Unit is said to test for shorts as high as 100 megohms leakage and check grid emission conditions. Tester measures 9½" x 8½" x 4".



PROBE-LITE

A combination probe and illumination source, *Probe-lite*, featuring a long, slender probe tip for access to difficult areas, has been introduced by Phaostron Instrument and Electronic Co., 151 Pasadena Ave., S. Pasadena, Calif.

Unit uses a standard pre-focused globe and penlight battery.

FILAMENT CONTINUITY CHECKER-BIAS SUPPLY

A combination filament continuity checker (low-ohms type) and 90 *v* bias supply pack, *Fil-Pak FP-1*, has been introduced by Seco Manufacturing Co., 5015 Penn Ave. S., Minneapolis 19, Minn.

Filament checker tests TV and radio type tubes, series-string heaters (under the chassis, without removing tubes) and low-resistance circuits. Bias supply pack gives up to 90 *v* of filtered and isolated *dc* for use on low voltage and low current preamps, oscillators, etc.

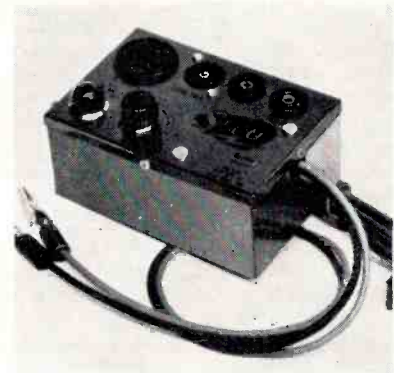

Audio

Continued from page 46)

speaker transformers at each loudspeaker.

Such transformers are usually provided with one or two secondary taps to suit the loudspeaker impedance chosen and three or four primary tapings to select different power ratings. When these transformers are used, the secondary can be permanently wired to the voice coil to suit the impedance of the unit used. Then, when the system is installed, the appropriate primary tapping can be selected to deliver the power required to this unit.

In estimating power distribution, we must remember that the total *nominal* power taken by the matching transformers is approximately equal to the power rating of the amplifier. Often power is unnecessarily wasted and the system rendered inefficient through failing to observe this simple rule.

For example, you may look round the building and believe that 5 watts will do here, and 10 watts there, and so on throughout the system. If, upon addition of these wattage requirements your answer is a 150-watt load for a 50-watt amplifier, you'll be in trouble. It will not only mean that each speaker can only obtain one-third of the power rated; it means further that the amplifier will be seriously mismatched, and it will no longer be capable of delivering even its nominal 50 watts.

The amplifier will probably deliver about 15 watts; this means that each loudspeaker will only get about one-tenth of the power originally calculated. So, if you come up with a *wrong* answer like this, it will be necessary to study your figures again and cut down the nominal power taps of the loudspeakers until the loading adds up to somewhere near 50 watts.

If a nominal of 40 or 60 is obtained, you'll be safe; this will be near

(Continued on page 52)

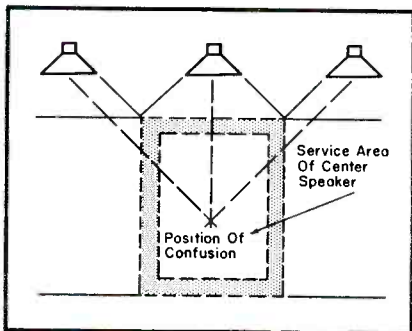

A SOURCE of confusion in sound systems, due to phasing, often overlooked.

Sonotone's 2-model line simplifies cartridge replacement!

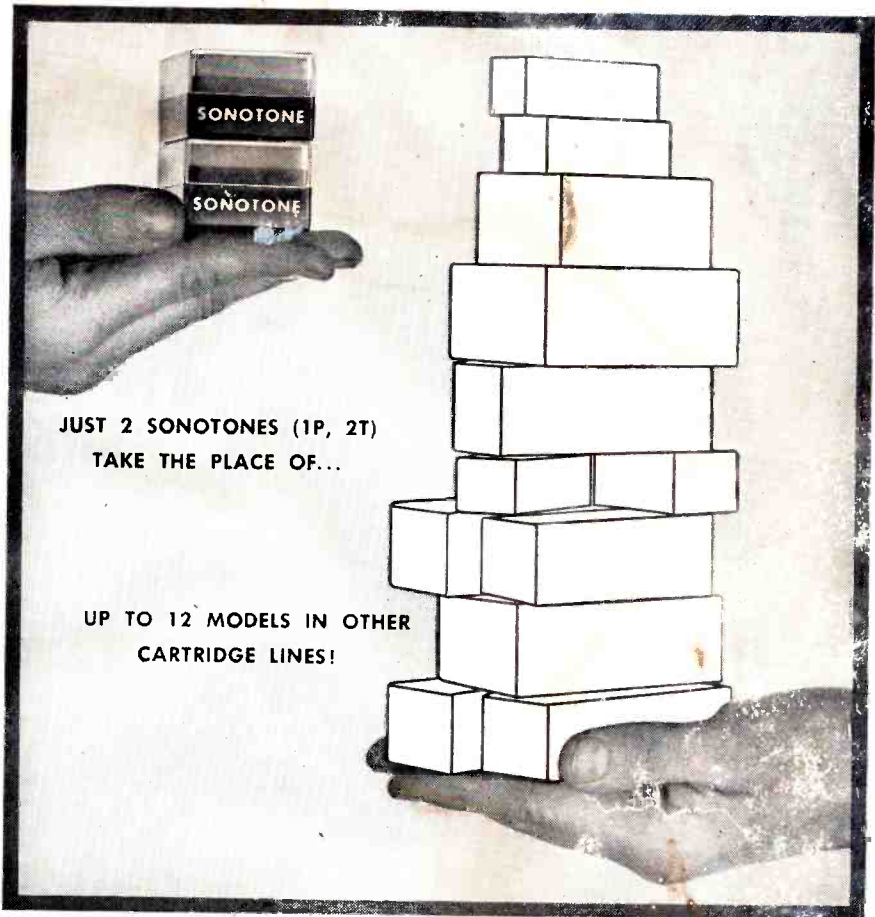

*You finish jobs faster, please customers more,
when you standardize on Sonotone Ceramics*

Why juggle a handful of different cartridges, when it's so much easier and faster to stick to just *two!* Sonotone single-needle 1P and turnover type 2T are all you need for over 90% of quality replacement jobs.

These two Sonotone cartridges fit practically any arm. They're quick to install. And remember, Sonotone cartridges are *more* than replacements. They'll give *better* response than original equipment... enhancing your reputation for quality work.

New standard of the phono industry

In more than half the quality phonographs made today by leading manufacturers, you'll find one of these Sonotone cartridges. All the more reason why *you* should standardize on Sonotone.

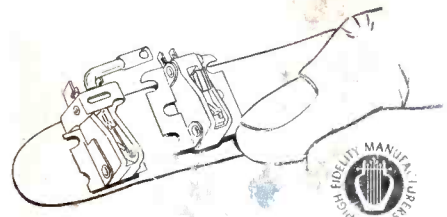

SONOTONE CERAMIC CARTRIDGES

ELMSFORD, N. Y.

In Canada, contact Atlas Radio Corp., Ltd., 50 Wingold Avenue, Toronto



AMPLIFIERS

for Public Address

Backed by the world's greatest performance record for power at low cost!



3 Popular Sizes

10, 15 and 30-watt power output. Available with phonograph top or as a complete portable ready-to-use system including microphone, speaker and case. Engineered for top performance and easy operation. A model for every need.



Send for FREE New Catalog!



PRECISION ELECTRONICS, INC.
9101-SKing Ave., Franklin Park, Ill.

Name _____

Address _____

City _____ Zone _____ State _____

95-95

BEST BUY IN HI-FI

Grommes

Build-It-Yourself Kits



The Famous Little Jewel ^{\$24.95} NET MUSIC LOVERS AMPLIFIER

Most popular hi-fi amplifier in its field, featured by Life Magazine.

Enjoy... Building Your Own.
Most complete set of instructions.

SEND FOR NAME OF THE DISTRIBUTOR IN YOUR AREA

Grommes Division of Precision Electronics, Inc.
Dept. SP-8, 9101 King Ave., Franklin Park, Ill.

- Push name of nearest distributor.
- Send L.J. Kit. Enclosed find \$5.00. balance and postage C.O.D.
- Send L.J. Kit postage-paid. Enc. find \$21.95.

Name _____

Address _____

City _____ Zone _____ State _____

10-day money back guarantee on all kits.

Audio

(Continued from page 51)

enough for an amplifier whose rating is 50 watts. Then you can expect each loudspeaker to deliver the power rated according to the tapping selected.

If you find you'll only be able to handle a few large installations for awhile, and want to budget accordingly, a substitute matching system can be used in place of 70-volt line distribution. Usually, in the absence of the necessary transformers, some kind of compromise can be worked out, using natural voice-coil impedance.

If a parallel circuit is used, the matching impedance becomes unduly low, so some kind of series or series-parallel circuit should be employed. It is a good idea to run each loudspeaker line right back from the loudspeaker to an amplifier distribution center. If each loudspeaker line is then suitably tagged, they can be connected in series and parallel until a suitable distribution system has been found to give the right amount of power required for each loudspeaker.

If all the loudspeakers require an equal power, it may be possible to connect them all in series and build up to a 70-volt line output impedance. If some need more or less power than others, then a variation will be needed.

When one or two of the loudspeakers need more than all the rest, it is a good idea to connect the larger number (that need an equal amount of power) into paralleled pairs, each of which are connected in series to form a series line. Then the units requiring additional power can be connected in series in a single arrangement. If too much power is supplied through this hookup, a suitable resistance can be connected across them to shunt away the surplus power. However, the power differential usually required is sufficient to warrant using a single loudspeaker in series with a paralleled pair chain.

If, on the other hand, there are one or two locations such as offices, where much less power is required, a series chain can be used for most of the circuits, connecting the lower powered points in parallel pairs, so they do not receive as much power.

Whichever plan is used, one must find the total circuit resistance, based on the known voice coil value, by adding the resistances in series and dividing when they are paralleled, so



"That third guy? He's the serviceman carrying the JENSEN NEEDLE!"

Coming Event

N. Y. High-Fidelity Show

Institute of High-Fidelity Manufacturers

September 26-30, 1956

New York Trade Show Building, N. Y. C.

DON'T JUST SAY CAPACITORS

Ask For Sprague By Catalog Number

Know what you're getting . . . get exactly what you want. Don't be vague . . . insist on Sprague. Use complete radio-TV service catalog C-610. Write Sprague Products Company, 61 Marshall Street, North Adams, Massachusetts.

SPRAGUE

WORLD'S LARGEST CAPACITOR MANUFACTURER

as to determine the load impedance provided for the amplifier.

If possible, it is wise to connect to an amplifier tapping that is within a 2:1 ratio, one way or the other. If the impedance works out to 150 ohms, then an amplifier tapping at 100 or 250 ohms would be successful; but, if the nearest amplifier tapping is 50 or 600 ohms, it will then be necessary to rework the circuit to get a better match.

If too high a total circuit impedance results for the amplifier, the chain should be broken down into two groups of speakers paralleled, instead of one long one in series, so as to come nearer the required impedance.

This foregoing matching method can prove to be a time-consuming process, which is why it is recommended only as a temporary move for the period when but a few installations are on schedule; for any substantial installation operation, it will be best to use the line-matching transformers.

When tying in loudspeakers phasing must also be considered. There are always certain areas in the audience where we have a group of seats at approximately equal distance from two loudspeakers. Listeners in these positions can hear both units at once. For the benefit of those in this zone, it is very important that the loudspeaker units should be in phase. If they are not, considerable confusion of sound will prevail and to many the program will be almost unintelligible.

Blind spots in pa coverage are more often due to incorrect phasing than to wrong placement of loudspeakers.

It is also possible that some may be nearest to one loudspeaker, but at equal distance from two more speakers that are a little further away on each side. If the nearest loudspeaker happens to be out of phase with the other two (and probably the rest of the system), reproduction will suffer; many will get the impression that the nearest loudspeaker is not working at all. The reverberation and echo effect of the building will be extremely exaggerated and the sound confused.

TWO ARRANGEMENTS designed so that less power can be obtained from two units in the line: At (a) the whole line is in series, giving, at 16 ohms per unit, $12 \times 16 + 8 = 200$ ohms; at (b) the chain has been split in two and paralleled, so that in the left-hand section we have $6 \times 16 = 96$ ohms, and in the right hand section $6 \times 16 + 8 = 104$ ohms (in parallel the result will be almost 50 ohms).

**One Focalizer
for all
picture
tubes.....**

the
QUAM
**QF-4 UNIVERSAL
FOCALIZER UNIT**



FREE!

Catalog 78,
listing complete
specifications of
the QUAM QF-4
Universal
Focalizer Unit.

New ceramic magnets and extended focusing range eliminate the need for more than one model ... yet provide maximum resolution with minimum spot size.

Installs in minutes, adjusts in seconds.

The QF-4 has a newly designed "quick-setting" picture centering lock and is supplied with a soft aluminum blank mounting bracket that is easily drilled to fit any mounting arrangement.

LIST PRICE \$4.25

QUAM-NICHOLS COMPANY

232 East Marquette Road
Chicago 37, Illinois

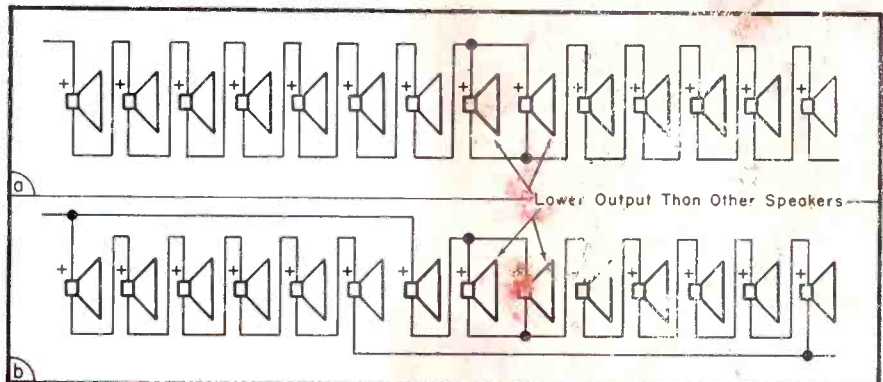

be a
man
in the
know



at no cost!

"THE CAPACITOR" comes prepaid direct to your home every month—12 times a year. 16 to 24 pages, including a complete full length technical or constructional article—AND the "TRADING POST" section for your ad. Yes, as a subscriber to the CORNELL-DUBILIER monthly magazine "THE CAPACITOR", you can use its famous "TRADING POST" section to run an advertisement (no cost to you), to SELL—SWAP—or BUY all sorts of equipment and services helpful in your business.

A service of
CORNELL-DUBILIER
world's largest manufacturers of capacitors



Editor—"The Capacitor"
CORNELL-DUBILIER ELECTRIC CORP.
Dept. S-86, South Plainfield, N. J.

—Yes Sir! Put me down for a FREE Subscription to Cornell-Dubilier's "THE CAPACITOR"

name _____
Mr. Mrs. Miss
Mr. Mrs. Miss

address (home) _____

city _____ state _____

my occupation or job title is _____

Magnetic Recording

(Continued from page 33)

erasure of a previous recording. This will be recognized by the type of noise; namely, music or speech at a very low level. If the noise is hiss, static, or hum, it has nothing to do with the erase head, and may be noise in the amplifier, magnetized heads, or noise from the tape itself. A strong hiss in the background of the signal may well be caused by a magnetized head. Demagnetizing of the head is both a test and cure. A head demagnetizer should be used; several types are available. In use, one should first turn off the recorder. Then the tips of the demagnetizer should be brought near the head core and moved up and down the length of the core three or four times, straddling the air gap at least once. Then the demagnetizer should be removed from the head very slowly. Of course, the capstan or tape guides might also become magnetized. They can be demagnetized in the same fashion.

To avoid magnetizing heads, one should follow these three rules:

- (1) Never remove a tube from the recording amplifier while the machine is recording.
- (2) Don't connect or disconnect the leads to the recorder input, or to the head, while the machine is recording.
- (3) Avoid saturating the recording amplifier with excessively high-input signals.

If the volume of playback signal is weak when recording is known to be good, one should look for a dirty reproduce head, improper positioning or tension in pressure pads, tape wound on wrong side (dull side should be in), improper alignment of reproduce head, or defective playback amplifier. When the playback section is known to be good, and tape recording sounds fuzzy, faint or distorted, the problem could be no, or insufficient, high-frequency recording bias, worn or dirty pressure pads at the record head, a dirty or defective record head, or an over- or under-recorded tape. If recordings contain distortion, and the recorded sound level is low, one should test for insufficient erase or improper bias. The bias should be checked as a matter of course, whenever the output tube is changed.

Should hum be a problem, one might look for a partial short to the chassis in a motor bypass capacitor, improper setting of the hum control, if one is present, a heater-to-cathode short in a tube, loss of a filter capaci-

tor, or an open shield in a cable to the heads.

Frequency Response: If the frequency response doesn't come up to the manufacturer's specifications, and the tape is not at fault, the heads should be checked for cleanliness and good contact. Also one should check the pressure pads and tension. If the trouble is not here, then it must be determined if it is due to a poor record or poor playback response. A previously recorded, or a test tape, which is available for such purposes, will be a big help.

If the recorder will not reproduce, the volume should be turned to maximum, the grid of the first amplifier tube touched and output on speaker checked. If 60-cycles are heard, the amplifier and speaker can be considered to be operative. If no signal is heard, then the playback amplifier may be inoperative.

If the recorder will reproduce, but will not record, if separate heads are used for record and reproduce, then the coil in the record head may be open. If one head is used for both, and the coil were open, then of course the machine would neither record nor reproduce. Dirt on the record head might cause this condition, as might a pressure pad not holding the tape in good contact with the head, or inadequate bias.

Turning away from the recorder, and considering the tape itself, we should expect a tape to have a good frequency response, sufficient strength to withstand normal starting and braking tensions in a machine, and good enough adhesion of the oxide to the base material for minimum oxide deposits on the heads, capstan, and tape guides of the machine.

Base materials used in commercial tapes today are acetate and *mylar*. Both acetate and *mylar*-base tapes are made in the standard size, or 1200' on a 7" reel, and the long-playing size, or 1800' on a 7" reel. *Mylar* base tape, alone, is also available in a still thinner gage base, which consists of 2400' on a 7" reel, or just twice the playing time of the standard tape.

In view of the different types of tapes available, Service Men should be able to give their customers information as to their various advantages. The main advantage of acetate base tapes is their lower price. *Mylar* base tape, on the other hand, is more durable, and should last indefinitely without any deterioration. *Mylar* base is also stronger, and can withstand more abuse from a machine with incorrectly adjusted tensions.

Next Month: Tape Performance Checks

how long would it take you to solve this service problem?

SYMPTOM:

Loss of horizontal hold. Hold control will not pull the picture into synchronization. Sound is normal.



There's no telling how long it might take to solve this problem with hit-or-miss methods—it's been known to take hours. With a **PHOTOFACT** Folder by your side, the job takes just minutes. Here's why:

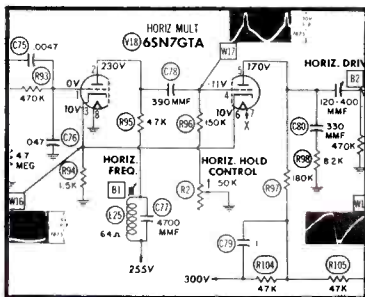
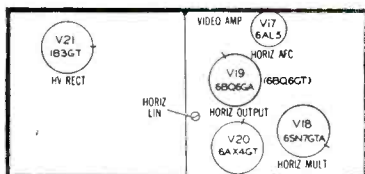

In just seconds, you locate the tubes most likely to cause this symptom by referring to the Tube Placement Chart* and Tube Failure Check Chart* you'll always find in the same place in each PHOTOFACT Folder.

In this case the trouble wasn't caused by tube failure, so...

In just seconds you refer to the Horizontal Circuit on the Standard Notation Schematic* featured exclusively in all PHOTOFACT Folders. Circuits are always laid out in the same uniform manner. The Horizontal Circuit is always located in the lower center of the schematic. In a matter of minutes you check waveforms and voltages—they're right on the schematic. And in those same few minutes you find the answer to the problem in this case history. The waveform at W17 and the voltage reading at Pin 4 show a leaky coupling capacitor C78. Yes, you have your answer in just minutes!

And PHOTOFACT, through its accurate Parts Listings*, instantly gives you a choice of the proper replacement required to accomplish the repair. You save even more time!

C74	270	500	RCM20A271K	SI270	D6-27
C75	.0047	400	RCPI0M4472M	SI4700	D6-47
C76	.047	200	RCPI0M2473M	BPD-05	DF-50
C77	4700	500	47X543	1464-0047	
C78	390	500	RCM20B391J	1469-00039	D6-39
C79	.1	400	RCPI0M4104M	P488N-1	DF-10
C80	330	500	47X570	1469-00033	D6-33

From start to finish, you solve your service problems in just minutes...you service more sets and earn more daily with PHOTOFACT by your side!

*One of 32 features found exclusively in PHOTOFACT—the world's finest service data

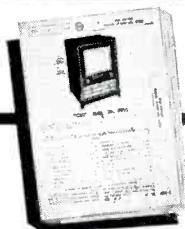

MONEY BACK GUARANTEE!

Got a tough repair? Try this—at Howard W. Sams' own risk: see your Parts Distributor and buy the proper PHOTOFACT Folder Set covering the receiver. Then use it on the actual repair. If PHOTOFACT doesn't save you time, doesn't make the job easier and more profitable for you, Howard W. Sams wants you to return the complete Folder Set direct to him and he'll refund your purchase price promptly. **GET THE PROOF FOR YOURSELF—TRY PHOTOFACT NOW!**

free



Send for Sams' INDEX TO PHOTOFACT FOLDERS—your guide to virtually any receiver model ever to come into your shop; helps you locate the proper PHOTOFACT Folder you need to solve any service problem on any model. You'll want this valuable reference guide. Send coupon now.

HOWARD W. SAM'S & CO., INC.

Howard W. Sams & Co., Inc.
2207 E. 46th St., Indianapolis 5, Ind.

- Send FREE Index to PHOTOFACT Folders
 I am a Service Technician

Name _____

Address _____

City _____ Zone _____ State _____

Choose the right Pliers for faster, better work!

Fine or Sturdy,
Long or Short Points
... KRAEUTER makes them

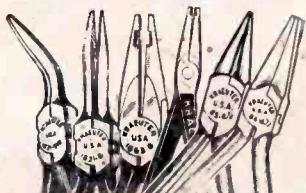

- 1631 — 5½" curved snipe nose
- 1621 — 6" snipe nose
- 1663 — 6" cutters ¼" from tips
- 71 — 8" cutters at tips of jaws
- 85 — 4½" round nose, round jaws
- 84 — 4½" flat nose

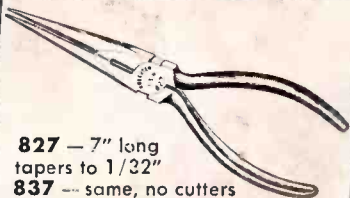

- 827 — 7" long tapers to 1/32"
- 837 — same, no cutters
- 826 — 6", 1/32" points
- 836 — 6", no cutters
- 825 — 5", 1/32" points
- 835 — 5", no cutters
- 83 — 4½", 1/32" points, no cutters

These extra-fine needle point, full polished pliers are used by the skilled electronics technician for delicate, precision wiring.

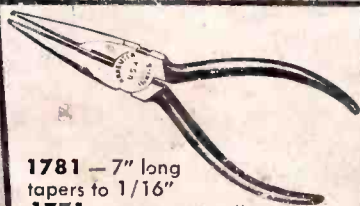

- 1781 — 7" long tapers to 1/16"
- 1771 — same, no cutters
- 1661 — 1/16" points
- 1671 — 6", no cutters
- 1641 — 5", 1/16" points
- 1643 — 5", no cutters

Standard chain nose pliers for general wiring. Polished heads, blued handles.

Your electronics distributor stocks these and other Kraeuter needle nose, diagonal, electrician's side-cutting, slip-joint, and radio-TV pliers.

KRAEUTER

Newark, N. J.

Fine Tools — Since 1860

Traffic Appliance Servicing

(Continued from page 42)

Irons—Steam	
Minor Repair	2.00
Major Repair	3.46
Old Models	4.34
Lamps	
External or Internal	3.64
Mixers	
External Repair	2.40
Internal Repair	4.03
Paint Sprayers	
All Repair	2.30
Roasters	
Minor, Terminals, Lamps, etc.	2.35
Repair or Replace Bottom Element	4.14
Replace Side Element, Body or Well	5.43
Sandwich Grill (Combination)	
External Repair	1.89
Internal Repair	3.09
Scales	
Bathroom Type Only	2.00
Shavers	
Minor, Case, Cord, etc.	1.45
Complete Overhaul	2.53
Table Broilers (Rotissomats)	
Install Cord Only	1.82
All Internal Repairs	3.75
Toasters	
Install Base, Cord, etc.	2.04
Internal, Non-Automatic Type	2.12
Internal Repair, Automatic Type	3.45
Vacuum Cleaners	
Install Cord, Switches, Brushes	2.33
Install Handles on Some Models	3.41
All Motor Repair, Overhauling	5.15
Vaporizers	
All Repairs	1.73
Waffle Irons	
Install Cord and Other Minor Repairs	1.94
All Internal Repair	3.28
Minimum Labor Charge	1.00

TABLE 1: Suggested charges for appliance repairs. Charges shown are for labor only.

stock of the items that will be required in appliance repair.

These distributors can supply a parts manual which lists and illustrates the most commonly-used parts. There are also factory-appointed authorized service stations throughout the country who can supply some parts as required. They are listed in the local classified directory.

As noted, steaming-iron repair today represents the most active appliance-service operation.

Basically there are two types of steaming irons; the *flash type* (such as



CHICAGO STANDARD TRANSFORMER CORPORATION

3507 Addison Street • Chicago 18, Illinois

General Electric and Westinghouse) and the *boiler type* (such as Casco, Presto and Rival).

The flash-type steam iron operates on the following principle; droplets of water are metered into a chamber that is part of a hot shoe or sole plate of the iron. This instantly forms steam which is then transmitted past the sole plate through drill holes.

In the boiler-type steam iron boiling water, in a chamber, transmits the generated steam through tubes to the steam chamber within the sole plate, where it then passes through its drill holes.

Steaming Iron Repairs

Disassembly and reassembly of steaming irons can be somewhat difficult because of corrosion of various screws due to electrolytic action. The wrench tool kit described is an absolute must and makes this task quite simple.

Service problems other than cord

THE NEW No-Noise TUNER-TONIC

Volume Control and Contact Restorer with Perma-Film



2 oz. bottle. Net to servicemen
\$1.00

Cleans, lubricates, protects... not a carbon-tet solution. Still available in the new 6 oz. spray can.

Net to servicemen—\$2.25

"NO NOISE"

Also available in 8 oz. bottles and quart can. At your nearest distributor.

with PERMA-FILM

Cleans, lubricates, restores all tuners including water type. Won't change or affect capacities, inductance or resistance. Won't harm insulations or precious metals, nor attack plastics. For television, radio and FM. Eliminates all noise, oxidation and dirt indefinitely.

Non-toxic, 6 oz. aerosol non-inflammatory, insures trouble-free performance. **\$3.25**

Extra economical because a small amount does the job!

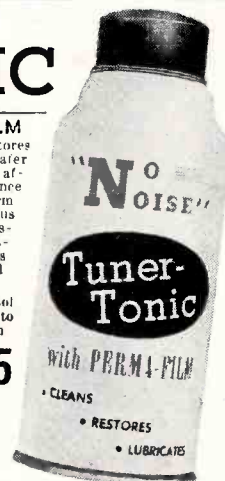

ELECTRONIC CHEMICAL CORP.

213 Communidaw Avenue

Jersey City 4, N. J.

and handle replacements generally consist of spitting conditions (staining clothes), leakage, inadequate steaming, thermostat adjusted too high or too low, and thermostat or element failure. Spitting, leakage and inadequate steaming is caused by an accumulation of various deposits, calcium, lime, etc., in the tank and passages of the boiler type iron or in the steam passages of the flash type iron. These deposits can be eliminated by using a steam iron cleaner³ and can generally be accomplished without disassembling the iron. Inadequate steaming (too hot or too cold) can usually be overcome by adjusting properly the bi-metal type thermostat

³Such as SSST.

STEAM IRON CLEANER concentrate to remove clogging scale left when tap water in iron evaporates. Deposit built up gradually in the part of iron where the water is converted into steam, acts as an insulator, hindering the further generation of steam. (Fast Chemical)



to required temperatures; an iron tester is necessary. Most modern steaming irons have an adjustment screw recessed in the center of the adjusting shaft that makes this adjustment accessible. One must be certain that the thermostat contacts are cleaned. An ignition file is recommended. On some boiler type steaming irons it may be necessary to replace or remove transfer of heat shims between the tank and sole plate of the iron

to either increase or decrease the steaming qualities.

Repair-Charge Rates

In establishing a repair-charge scale, it is suggested the labor rate chart shown in table 1, be used as a guide; the figures shown have been compiled from statistics supplied by appliance service firms throughout the country.

IF YOU REPAIR SMALL APPLIANCES . . .

. . . you'll want this new, different and complete Manual of parts and service.



HERE is the newest and best approach to cataloging ever compiled. No other catalog even remotely compares to it in efficiency and completeness. Months of painstaking study and research have gone into making this the best possible method of presenting fast moving parts for your ordering convenience. The catalog is designed to be **current for at least 4 years** and complete, new confidential price supplements will be issued annually.

Catalog contains no prices—you can use it as a counter book. Price supplement is separate.

Parts are grouped by type of appliance and by classification of item rather than by manufacturer.

STILL AVAILABLE

Every appliance repair shop needs this handy catalog. Regularly priced at \$1.50 . . . but for a limited time only it's yours for only 25c—stamps or cash (no check please) to cover cost of mailing.

128 PAGES!

SEND 25c NOW FOR YOUR COPY—OUR SUPPLY IS LIMITED

DON'T DELAY!

Fill In and Mail This Coupon NOW!

To Company in Your Area and be sure of obtaining **YOUR copy**

ELECTRIC SWEEPER Service Co. 2034 Euclid Avenue Cleveland 15, Ohio	ELECTRA-CRAFT Appliance Co. 348 West 42nd Street New York 36, N. Y.	WOODALL ELECTRIC Service Co. 1024 Bealevard, N. E. Atlanta 6, Georgia
--	---	---

To cover postage and handling we herewith send you 25c for which we are to receive copy of Catalog No. 55A without delay. For each additional catalog we are enclosing \$1.25 extra. Remember—just one free catalog to each organization.

Company

Address

City Zone State

Type of Business

Signed Title

DON'T JUST SAY CAPACITORS

Ask For Sprague By Catalog Number

Know what you're getting . . . get exactly what you want. Don't be vague . . . insist on Sprague. Use complete radio-TV service catalog C-610. Write Sprague Products Company, 61 Marshall Street, North Adams, Massachusetts.

SPRAGUE®

WORLD'S LARGEST CAPACITOR MANUFACTURER

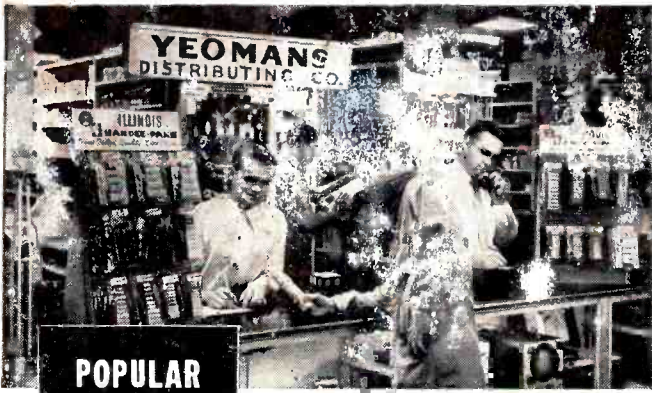

**POPULAR
WITH
SERVICEMEN**

**ILLINOIS "HANDEE-PAK"
CAPACITOR KITS**

Servicemen go for the new ILLINOIS "HANDEE-PAK" Capacitor Kit assortments because they take up little room in the service kit—are easily identified and since they are hermetically sealed in polyethylene bags, the capacitors are always factory fresh and clean! Each PAPER CAPACITOR KIT is made up of 10 assorted new Type ITC Ceramic Cased Paper Capacitors of the capacity and voltage ratings most used by servicemen. The ELECTROLYTIC KITS consist of 5 popular types.

LOOK FOR THEM ON THE NEW JOBBER COUNTER RACKS



New ILLINOIS "HANDEE-PAKS" are available at most better jobbers—carry a few "HANDEE-PAKS" in your service kit. They are the ultimate in packaging, convenience and reliability.

ILLINOIS CONDENSER CO.
1616 N. THROOP STREET CHICAGO 22, ILLINOIS

XCELITE Hand Tools
PREFERRED BY THE EXPERTS

NOW!
any "99" parts
you need—
IMMEDIATELY!

You can now replace or add any part to your XCELITE 99-PR nut driver, screwdriver and reamer roll kit immediately because your supplier has this No. 699 Replacement Kit! It has backup stock to supply the hundreds of thousands of "99" kits now in use. If you've lost a handle—want that new 1/2" XCELITE 99-39 reamer—need a new plastic roll pocket kit—your distributor can supply you in a hurry. Ask him!

XCELITE, Incorporated
Dept. V
Orchard Park,
N. Y.

For Originality
LOOK TO XCELITE

TV Antennas

(Continued from page 34)

mitter. Another action provides for the establishment of stations with a lower minimum antenna height and power, which is expected to increase the number of TV stations. For these reasons the Commission said that it felt it would not be practical to permit radiation limits to vary, depending on whether the signal being received directly was co-channel, adjacent channel, or further removed from the signal, being distributed by the cable system, part of which was radiated to produce interference to direct reception.

The RETMA comments, furthermore, the FCC added, were based entirely on considerations of b-w TV, with no consideration given to interference with reception of color-TV signals. While the presently standardized color-TV signals are not appreciably more susceptible to co-channel interference than the b-w signals, adjacent channel interference could be appreciably worse in the case of color, depending on the type of receiver in use. Therefore, the Commission noted, it would not be wise to relax the limit for adjacent channel operation in relation to the direct signal.

Reviewing community-TV antenna system designs and their relation to interference, the Washington report said that it is necessary to consider transmission of the received signals to the population center in which the programs are to be distributed. Then there is the distribution network which brings the programs into each subscriber's home. In many cases reception is on a mountain top or other general uninhabited region and the main transmission line or conveying portion of the system may pass through country which is uninhabited or sparsely inhabited. In this area, the relative danger of interference to direct reception is at a minimum and there is no need to restrict radiation close to cable, particularly since efficient transmission systems are not necessarily those with the minimum radiation. For these reasons the FCC said that special line-control provisions should apply for that part of a system that passes through uninhabited or sparsely-inhabited areas.¹

After studying carefully all of the technical briefs submitted, the FCC decided to modify its earlier proposals and finalize a radiation-control order.

The new radiation-limit rules provide that up to 54 mc, at 100', radiation shall be limited to 15 uv; from 54 to 132 mc, at 10', a limit of 20 uv shall obtain; 132 to 216 mc, at 10', a limit of 50 uv shall hold; and over 216 mc, at 100', the limit shall be 15 uv. In sparsely inhabited areas, the radiation limits were noted as 15, 400, 1000 and 15 uv for the four ranges and distances.

Existing systems will have until December 31, 1959 to comply with the new requirements. However, all CATV systems will have to take prompt and effective action with respect to any interference that may be caused during the interim period.

All new systems whose construction begins on or after October 1, 1956, and all new sections added to existing systems whose construction begins on or after October 1, 1956, will be obliged to adhere to the new rules.

¹A sparsely inhabited area was defined as an area where TV signals are not, in fact, being directly received within 1,000 feet of any part of the community antenna TV system.

Service Engineering

(Continued from page 26)

equipment and other electrical devices in the caboose plus charging current for the battery.

The actual voltage delivered to the radio equipment or to the *dc* to *ac*-conversion device varies considerably from a standing-still position to running speed. The battery, when not run down, delivers its rated voltage. Of course, the voltage reaching the set is lower because of the losses in the wiring. When the axle-driven generating system cuts-in, it must deliver higher voltage than the battery voltage to provide charging current. The voltage rises as speed increases, until it reaches the maximum permitted by the generator-regulating device. In a 12-volt system, the battery voltage rises to 14 or 15, and in 32-volt systems as high as 40 volts and even more when Edison type batteries are used.

Thus, the use of a *dc* to *ac* inverter, if regulated, has the advantage of delivering more constant voltage to the radio equipment. Voltage variation, when the radio equipment operates directly from the battery, can have an effect on radio performance. With the caboose standing still, the transmitting power and receiver sensitivity will be less than when the caboose is moving at normal or high speed.

Antenna Systems

On motor vehicles, the antenna is the usual quarter-wave vertical whip. They are also used, in some cases, on locomotive and caboose installations. Generally, special railroad type antennas are used on rolling stock. One, an *inverted top hat** antenna, is a top loaded, shortened quarter-wave antenna designed to provide adequate clearance of overhead objects. When installed on non-metallic roofs or above a metal roof, a cartwheel type ground plane is provided. Other models tagged *fire-cracker* antennas** resemble a firecracker in appearance and are also low-clearance antennas. As a general rule, the antenna must be sturdy enough to serve as a handhold and as such must be able to support the weight of a man.

Base-station antenna systems are the same as used in other kinds of mobile radio systems. However, a few railroads have installed bidirectional and unidirectional antennas to confine communications to certain areas or along the right-of-way.

*Bendix. **Motorola and FTR.

KESTER

KESTER
RESIN-FIVE
CORE
SOLDER
50/50
062

FASTER ACTING

EASIER TO USE

LONGER LASTING

THE BEST

KESTER SOLDER COMPANY
4248 Wrightwood Avenue • Chicago 39, Illinois
Newark 5, New Jersey • Brantford, Canada

SOLDER

Perma-Power
GARAGE DOOR OPENER

Opens Garage Doors
AUTO-matically

At All Distributors

manufactured by
Perma-Power COMPANY
4727 N. Damen Ave., Chicago 25, Ill.
manufacturers of electronic equipment since 1928
Export: SCHEEL INT., Chicago

**STEAM IRONS
NEED CLEANING TOO!**
get **INSIDE** clear for **MORE** steam

**SSS-T! STEAM IRON
CLEANER**

- EASY TO USE
- ODORLESS
- NON-ACID
- WILL NOT BURN
- ECONOMICAL
- MFGR. RECOMMENDED

FULL
YEAR \$1.00
SUPPLY RETAIL



A NATURAL Over-the-Counter Seller!
Used and Sold in Leading Appliance Service
Stations Coast-to-Coast:

Order from your **JOBBER** or write
us for name of your nearest supplier.

Fast Chemical Products Corp.
65 Page Avenue
YONKERS 4, N. Y.

NEW-NEW-NEW

Get your copy of the

ERIE

D-56 CATALOG

Now Available at
ERIE DISTRIBUTORS
Everywhere



More complete than ever, the new ERIE D-56 Catalog not only describes and illustrates the complete line of ERIE Electronic Components but also includes CORNING GLASS and ERIE-

TEFLON items, that are available through ERIE Distributors.

Get your copy of the ERIE D-56 Catalog now at your ERIE Distributor; if he cannot supply it, write us, giving his name.

ERIE
Electronics

ERIE ELECTRONICS DISTRIBUTOR DIVISION

ERIE RESISTOR CORPORATION

Main Offices: ERIE, PA.

Factories: ERIE, PA. • LONDON, ENGLAND • TRENTON, ONTARIO

for service and lab. work

Heathkit PRINTED CIRCUIT OSCILLOSCOPE KIT FOR COLOR TV!

① Check the outstanding engineering design of this modern printed circuit Scope. Designed for color TV work, ideal for critical Laboratory applications. Frequency response essentially flat from 3 cycles to 5 Mc down only 1½ db at 3.58 Mc (TV color burst sync frequency). Down only 5 db at 5 Mc. New sweep generator 20-500,000 cycles, 5 times the range usually offered. Will sync wave form display up to 5 Mc and better. Printed circuit boards stabilize performance specifications and cut assembly time in half. Formerly available only in costly Lab type Scope. Features horizontal trace expansion for observation of pulse detail — retrace blanking amplifier — voltage regulated power supply — 3 step frequency compensated vertical input — low capacity nylon bushings on panel terminals — plus a host of other fine features. Combines peak performance and fine engineering features with low kit cost!



MODEL
0-10

\$6950.

Shpg. Wt.
27 lbs.



MODEL
TS-4

\$4950.

Shpg. Wt.
16 lbs.

Heathkit TV SWEEP GENERATOR KIT ELECTRONIC SWEEP SYSTEM

② A new Heathkit sweep generator covering all frequencies encountered in TV service work (color or monochrome). FM frequencies too! 4 Mc — 220 Mc on fundamentals, harmonics up to 880 Mc. Smoothly controllable all-electronic sweep system. Nothing mechanical to vibrate or wear out. Crystal controlled 4.5 Mc fixed marker and separate variable marker 19-50 Mc on fundamentals and 57-180 Mc on calibrated harmonics. Plug-in crystal included. Blanking and phasing controls — automatic constant amplitude output circuit — efficient attenuation — maximum RF output well over .1 volt — vastly improved linearity. Easily your best buy in sweep generators.



AGC Systems

(Continued from page 37)

sync suppression which will occur if the time constant is less than 1/60 second, because the greater length of the vertical 60-cycle pulse would result in a more instantaneous *agc* voltage during this period of vertical sync. A time constant much in excess of 1/60 second is needed to filter adequately this vertical sync pulse and assure the correct *agc* voltage.

Advantages of this approach are:

(1) Simplicity in design. Only a few additional circuit components and one more diode tube are required.

(2) Relative cheapness because of design.

(3) The *agc* voltage obtained is a true indication of the amount of video signal output from the second detector.

There are, however, a number of disadvantages:

(1) Poor noise immunity. Sharp noise spikes will charge up the load to the peak of the noise pulse resulting in a larger *agc* voltage. Because of long time constant used, charge will be slow to leak off, resulting in video output loss during noisy periods.

(2) Small maximum *agc* voltage obtained; the peak-to-peak output of the detector being the maximum available *agc* voltage. This value is around 3 volts for all commercial designs. It is difficult to obtain more than this output from a three-stage *if* strip and still have sufficient bandwidth. This is so because the *if* strip has to be designed for nominal detector output for very weak signals with the *agc* system compensating for increases in signal strength.

Chassis are made more susceptible to overloading in strong signal areas, as there is not enough *agc* voltage available to cut tubes off sufficiently to maintain a flat response curve. The curve obtained will rise far above the ideal curve for strong signals.

This system is acceptable for a low range of input signals, but it is poor for strong signal areas. It is seldom used in new designs because its disadvantages of using an extra diode and poor noise immunity outweigh its advantages.

[Report on average and keyed *agc* systems will appear in September SERVICE.]

TRANSISTOR TRANSFORMERS

A series of input, interstage and output transformers, designed for transistor circuit applications, has been introduced by Merit Coil Products Co., Inc., 4427 N. Clark St., Chicago 40, Ill.



Interference on TV-FM with mosley "tunable" Wave Traps

New! High Q series-resonant Wave Traps for eliminating and reducing interfering signals on TV and FM.

Easy to install...Simply mount on set antenna terminal strip and attach transmission line to solderless screw connectors on Wave Trap. "Tune out" undesirable signals from amateur, FM, taxicab and other transmitters.

Mosley Wave Traps may be used on any receiver input from 50 to 600 ohms, balanced or unbalanced. To select proper Wave Trap, choose type whose range includes the frequency of interfering signal.

Available in 6 frequencies listed below.

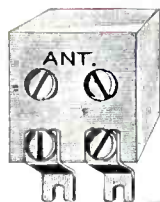

Cat. Nos.	WT.7...6.8-8.5 mc
	WT.14...13.8-16mc
	WT.21...16-21mc
	WT.41...27-55mc
	WT.78...47-110mc
	WT.165...100-230mc

List Price \$4.57

Mosley Electronics, Inc.
8672 ST. CHARLES ROCK ROAD - ST. LOUIS 14, MISSOURI

When . . . You Change Your Address

▶ Be sure to notify the Subscription Department of SERVICE at 52 Vanderbilt Avenue, New York 17, N. Y., giving the old as well as the new address, enclose address labels from your last SERVICE copy, and do this at least four weeks in advance.

▶ The Post Office Department does not forward magazines unless you pay additional postage, and we cannot duplicate copies mailed to the old address.

▶ We ask your cooperation.

Horizontal Amp Tube Tests

(Continued from page 23)

picture will also have low brilliance. High plate current will cause oversweep with part of the picture off the face of the picture tube. A width control is provided on most receivers; while the control has many forms, the usual effect of the control is to increase energy losses in the circuit.

To assure further the ability of the tube to operate satisfactorily in a receiver, a plate current test that is identical to the one described is performed, except that the filament voltage is reduced to simulate low line voltage conditions in the home.

In most cases, excessive screen current has the same effect on receiver operation as would low zero bias plate current. Most receivers use a relatively large screen resistor, so that high screen current reduces the effective screen voltage. Reduced screen voltage, in turn, results in reduced zero bias plate current. Tubes are tested at a bias voltage that yields approximately the same screen current as found in most TV receivers.

When the tube current has reached maximum, at the end of a scan line, the driving voltage goes sharply to plate current cutoff initiating retrace portion of the cycle. During the retrace portion of the cycle the high-voltage pulse is generated and the voltage on the horizontal amplifier plate rises to from 3,000 to 6,000 volts. The plate current of the tube must remain cutoff during the high pulse of voltage on the plate. Any current flow will load the stored energy and result in narrow sweep width and reduced brightness. Tubes are tested for the negative control grid voltage required to hold the plate current at cutoff when a high voltage is applied to the plate.

Tests to Determine Whether Tube Will Operate Properly: One of the first tests required to determine whether a tube will operate or not is the *test for shorts and continuity*. This test shows continuity of the interconnecting leads as well as the tube filament and both permanent and temporary shorts. Tubes are rejected for the slightest indication of a short or open, even though such an indication is temporary in nature and may not recur.

Horizontal amplifier tubes are also tested for leakage currents from heater to cathode.

[A detailed description of special tests used to check for leakage and unwanted tube currents will appear in September SERVICE.]

WHEN
PERFORMANCE
IS
AFFECTED BY
LOW VOLTAGE
CONDITIONS

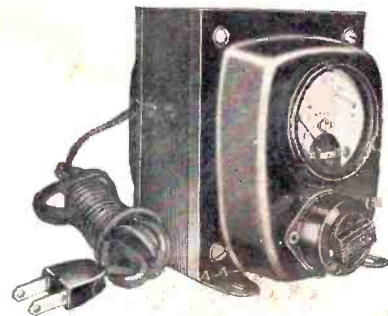

SELL THIS
ACME ELECTRIC
VOLTAGE
ADJUSTOR

TV sets are designed to operate best when voltage holds closely to 115-117 volts. Overloaded supply lines (the power industries greatest problem) may result in a voltage drop of 10 to 15% at certain times of day. Usually the TV set will function in a fashion under such low voltage conditions but with a great strain on its components. For example; narrowing of picture, output stage tube life shortened, frequent burn-out of filaments, fuzzy focus have been traced to lack of proper voltage.

These conditions can be corrected with an Acme Electric T-8394M Voltage Adjustor. Simply plug-in to convenient outlet. Plug-in television set cord into female receptacle built into adjustor. Voltmeter indicates output voltage. If voltage is incorrect turn regulating control until proper voltage is reached for best performance. Voltage range 95 to 125 volts. Tell your supply dealer you want the Acme Electric T-8394M. No other so compact, practical, inexpensive.

ACME ELECTRIC CORPORATION
478 WATER ST. CUBA, NEW YORK

Acme Electric
TRANSFORMERS

MERIT, first in exact and universal replacement transformers, yokes, coils—the only manufacturer of transformers, yokes and coils who has complete production facilities for all parts sold under their brand name.



HVO-43 FOR EXACT REPLACEMENT IN AIRLINE, GAMBLE-SKOGMO, MONTGOMERY WARD, HUDSON, TELECRAFT, ARLINGTON, FAIRMONT, TRUETONE, CORONADO, WELLS-GARDNER... USED IN OVER 25 MODELS AND CHASSIS. Another in the complete MERIT line of exact and universal replacements—the only single source for all your transformer and coil requirements.

Merit

COIL AND TRANSFORMER CORP.
4427 North Clark Street
Chicago 40, Illinois



PERSONNEL

CONRAD P. SHEARER has been appointed director of advertising and sales promotion of the Rek-O-Kut Co., 88-01 Queens Blvd., Long Island City 1, N. Y.

GEORGE C. ISHAM has been named general merchandising manager of the direct products sales department of Sylvania Electric Products, Inc. . . . HERBERT BANDES has been appointed chief engineer—semiconductors of the electronics division. . . . ALDON M. ASHERMAN is ad manager for the parts, tungsten and chemical, atomic energy and electronic systems divisions.



Isham



Sharkey

WILLIAM F. SHARKEY has been named ad manager of I.D.E.A., Inc., 7900 Pendleton Pike, Indianapolis 26, Ind.

L. BERKLEY DAVIS has been appointed general manager of the electronic components division of General Electric Co. . . . HAROLD A. STRICKLAND, JR., now heads the industrial electronics division.



Davis



Kocmoud

ROBERT C. KOCMOUD has been appointed sales promotion manager of General Cement Manufacturing Co., 919 Taylor Ave., Rockford, Ill. . . . JAMES O. SCHOCK has become industrial sales manager, and WILLIAM H. DEAN has been named sales manager of G-C Electronics.

LAWRENCE LEKASMAN, formerly sales vice president of Electro-Voice, Inc., has joined David Bogen Co., Inc., as vice president in charge of sales.

E. J. NORMAN has been promoted to sales manager of Hycon Electronics, Inc., Pasadena, Calif.

ABRAHAM FISCHER has been appointed sales and merchandising manager, Technical Products Service Department, RCA Service Company, Inc.

HUGO SUNDBERG, vice president and general manager of Oxford Electric, has been elected chairman of the speaker section of the parts division of RETMA.

F. B. OSTMAN, formerly service manager of Capehart-Farnsworth Co., has joined Federal Electric Corp., Lodi, N. J., as staff consultant to executive v-p.

Ask the
"Man-on-the-Roof"
why he prefers

South River



COMBINATION PEAK & FLAT ROOF MOUNT

MODEL PFM-30
(Fits Masts up to 1 1/2")

MODEL PFM-30 LM
(Fits Masts up to 2")

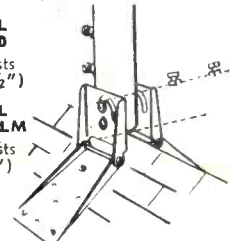

Features the patented South River "Walk-Up" — "Drop-Lock" mast socket for easy installation on either Peak, Flat or Pitched roofs. Heavy gauge pipe mast socket has two heavy duty screws and locknuts to secure mast. Factory assembled and supplied in a heavily plated rust resistant finish. U.S. PAT. #2734708

WRITE FOR NEW 1956 CATALOG

SOUTH RIVER
METAL PRODUCTS CO., INC.
South River, New Jersey

pioneer & outstanding producer of finest line of antenna mounts

TWO CALIFORNIA HI-FI SHOWS PLANNED

The Institute of High Fidelity Manufacturers has announced that high-fidelity shows will be held in Los Angeles from February 6 to 9, 1957, and in San Francisco from February 15-19.

**DON'T JUST SAY
CAPACITORS**

Ask For Sprague By
Catalog Number

Know what you're getting . . . get exactly what you want. Don't be vague . . . insist on Sprague. Use complete radio-TV service catalog C-610. Write Sprague Products Company, 61 Marshall Street, North Adams, Massachusetts.

SPRAGUE
WORLD'S LARGEST CAPACITOR MANUFACTURER

ADVERTISERS IN SERVICE

AUGUST, 1956

	Page
Electric Corp.	61
American Pamcor, Inc. (Sub. Aircraft-Marine Products, Inc.)	48
American Television & Radio Co.	64
Argos Products Co., Inc.	2
Astron Corp.	15
B & K Mfg. Co.	1
Blonder-Tongue Labs, Inc.	63
Bussmann Mfg. Co.	8
Channel Master Corp.	5, 6, 7
Chicago Standard Transformer Corp.	56
Clarostat Mfg. Co., Inc.	35
Cornell-Dubilier Electric Corp.	Inside Front Cover, 54
Delco Radio (Div. Gen. Motors Corp.)	9
Electra-Craft Appliance Co.	57
Electric Sweeper Service Co.	57
Electronic Chemical Corp.	56
Electro Products Laboratories	64
Erie Resistor Corp.	60
East Chemical Products Corp.	59
General Cement Mfg. Co., Inc.	43
The Heath Co.	60
Illinois Condenser Corp.	58
Jensen Industries, Inc.	52
Master Solder Co.	59
Maeter & Co., Inc.	56
R. Mallory & Co., Inc.	Inside Back Cover
Metric Coil & Transformer Corp.	62
Muley Electronics, Inc.	61
Ma-Power Co.	59
Mico Corp.	16
Mission Electronics, Inc.	52
Midam Electric Co.	4
Minn-Nichols Co.	53
Modiart Corp.	Inside Front Cover, 54
Radio Corporation of America	25, 45, Back Cover
Recon Mfg. Co.	10
Rington-Rand, Div. Sperry Rand Corp.	27
W. Sams & Co., Inc.	55
Schroeder Mfg. Co.	47
Schroeder Corp.	51
Shelby River Metal Products Co.	62
Shelby Products Co.	52, 57, 62
Shelby Tarzian, Inc., Rectifier Div.	49
Shelby Mfg. Co.	44
Shelby Products Corp.	3
Shelby The Gabriel Co.)	36
Shelby Electric Corp.	41
Shelby Products, Inc.	40
Shelby Co.	57
Shelby Electric Service Co.	58
Shelby Inc.	58

CATALOGS - BULLETINS

BOOKS

P. R. MALLORY AND Co., Inc., Indianapolis 6, Ind., has released a 28-page illustrated booklet reviewing the company's manufacturing activities and growth since its founding in 1916. Products now being made by Mallory include batteries, capacitors, special contacts, metallic rectifiers, resistors, switches, vibrators, welding components, and tuners.

THE GENERAL CEMENT MANUFACTURING Co., 919 Taylor Ave., Rockford, Ill., has released an 80-page catalog (No. 157) describing thousands of radio-TV service aids. Among the new products included are self-holding prods and connectors, printed-circuit repair kits, and phono drive kits.

AEROVOX CORP., New Bedford, Mass., has prepared an auto-radio replacement guide chart. Chart provides trade names, manufacturers' part numbers, twist-prong electrolytic catalog numbers, capacitance values, voltages, sizes and list prices for every popular auto-radio on the market. Listings are arranged by make of auto-radio.

CENTRALAB, 900 E. Keefe Ave., Milwaukee 1, Wis., has released a 96-page pocket control cross-reference guide No. 4. Priced at 20 cents.

SPRAGUE PRODUCTS CO., 231 Marshall St., North Adams, Mass., has prepared a 12-page replacement guide for printed circuits (K-350) used in sets made by 95 different TV and radio manufacturers. Has tables arranged alphabetically by set manufacturer with original part numbers and descriptions cross-indexed to recommended Sprague replacements. The back pages of the manual show circuit diagrams of each Sprague replacement, along with values of the resistors and capacitors in each circuit. Available from distributors or direct; enclose 6 cents to cover postage and handling.

SYLVANIA ELECTRIC PRODUCTS, INC., 100 Main St., Buffalo, N. Y., has announced a reprint of the 20-page booklet, *A Guide To Good Business*. Chapters cover original planning, surveying market conditions, selecting the best location, window displays, arrangement of service area, stock and inventory control, insurance, hints on courtesy, analyzing earning power, accounting procedures, legal aid, and selling service.

RADIO CORPORATION OF AMERICA, Camden 2, N. J., has issued an illustrated 24-page brochure, *RCA Renewal Products*, listing receiving, TV picture and industrial tubes; batteries; test equipment; service parts; high fidelity speakers; selenium rectifiers; antenna accessories, and technical literature.

Problem:

2 TV Sets
1 Antenna

Answer:



2-SET COUPLER

Model TV-42
Approved for Color TV
UHF, VHF and FM



Cost: ONLY \$2⁹⁵ LIST

Features:

- Matched resistive circuit
- Flat response - 0 to 900 megacycles
- 12db inter-set isolation
- Easy to install
- Couples 2 TV sets without ghost or smear

Application:

In class A signal areas the B-T 2-Set Coupler provides the ideal low cost solution to the problem of operating two receivers from one antenna. There are other applications. For example the TV-42 can couple a TV set and FM receiver to one antenna—or it can be used, in reverse, to couple or mix 2 antennas to one receiver.

Write for FREE BOOKLET—"TV for 2 or 3... More"
Covers all types of Multiple TV Systems

Sold by Radio-TV Parts Distributors and Jobbers

BLONDER-TONGUE LABORATORIES, INC.

Dept. LH-8 Westfield, New Jersey



Manufacturers of TV Cameras, TV Amplifiers, Boosters, UHF Converters, TV Accessories and Originators of the Masterline and 'Add-A-Unit' Master TV Systems.



Overlooking
25%
of the profitable
radio repair
business?



Electro

MODEL D-612T

DC POWER SUPPLY

lets you service

TRANSISTOR

AUTO RADIOS

(services 6/12V

tube-vibrator radios, too)

*1 out of 4 radios is an auto set

An Electro exclusive

FOR PRICES AND DATA SEND COUPON TODAY!

Electro Products Laboratories
4501-V Ravenswood Ave., Chicago 40, Ill.

Request descriptive and technical data on MODEL
D-612T Power Supply for Transistor Auto
Radios.

Name _____

Address _____

City _____ Zone _____ State _____

523 Canada: ATLAS RADIO LTD., Toronto

TV-TUBE DEVELOPMENTS

AN ALUMINIZED 90° picture tube with a short-length straight electron gun, said to reduce the tube's length by as much as two inches, has been announced by the cathode-ray tube division of Allen B. DuMont Laboratories, Inc.

The new picture tube not only features reduced neck length, but the need for an ion trap and centering magnet has been completely eliminated. In addition, it was claimed, the chance for maladjustment both at the factory and by service personnel, has been minimized.

According to the tube's designers new methods of precision jiggling of the grid cathode assembly with the cathode G₁ assembly insure precise aperture alignment in the focusing lens and in the neck of the tube. The gun can operate at anode voltages in excess of 20 kv.

THIRTEEN NEW tube types, including six designed for color-TV receivers, have been added to Sylvania's renewal line of receiving tubes.

The color types include three rectifiers, an oscillator, a voltage regulator, and a beam power amplifier.

Rectifiers are 3A2, 3A3 and 5V3. The 3A2 is a miniature, half-wave rectifier employing an indirectly heated cathode and is used as a hv rectifier in color receivers. The 3A3 is a half-wave, high-voltage rectifier, and the 5V3 is a filamentary, full-wave, high vacuum rectifier.

The color-TV oscillator, a 6BJ8, is a miniature, medium *mu* triode double diode, intended for use as a phase splitter, phase comparator and horizontal deflection oscillator. The tube features controlled heater warm-up time for series-string receivers and separate cathode connections for each section.

For voltage regulation in high-voltage, low-current supplies, a low-current sharp-cutoff beam triode (6BK4) has been designed.

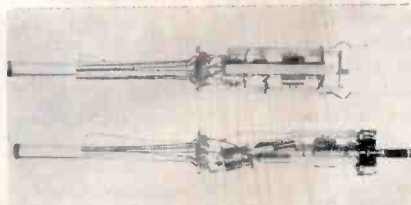

At top, short-length straight electron gun that makes possible picture tubes which are up to two inches shorter in length than conventional tubes. At bottom, presently used bent-gun design. Tubes using the short gun will be made in 24, 21, 17, and 14-inch diagonal sizes. (DuMont)

**EXPAND YOUR
PORTABLE TV
SALES**

WITH



INVERTERS

for changing your storage
battery current to

A. C. HOUSEHOLD ELECTRICITY

Anywhere...
in your own car!

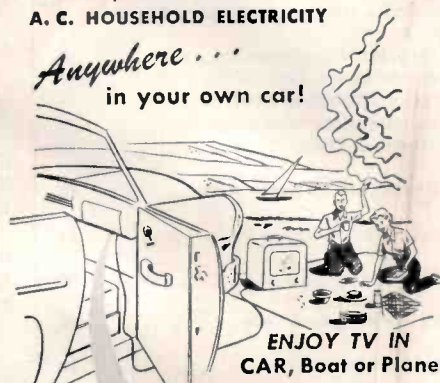

ENJOY TV IN
CAR, Boat or Plane

mounted out of sight under
dash or in trunk
compartment!



EASY TO INSTALL

EASY TO OPERATE

ATR INVERTERS

especially designed for operating
standard 110 volt A.C. portable TV sets

- also
- TAPE RECORDERS
 - WIRE RECORDERS
 - DICTATING MACHINES
 - ELECTRIC RAZORS

for

- EXECUTIVES
- SALESMEN
- PUBLIC OFFICIALS
- POLICEMEN
- FIREMEN
- OUTDOOR MEN
- REPORTERS
- FIELD INSPECTORS
- DOCTORS
- LAWYERS, ETC.

See your jobber or write factory

✓ NEW MODELS ✓ NEW DESIGNS ✓ NEW LITERATURE
"A" Battery Eliminators, DC-AC Inverters, Auto Radio Vibrator



AMERICAN TELEVISION & RADIO CO

Quality Products Since 1931

SAINT PAUL 1, MINNESOTA, U. S. A.

MISS COLOR-TV OF 1956 AND YOUR RCA TUBE DISTRIBUTOR

present:
The Famous RCA Institutes'

COLOR-TV HOME STUDY COURSE*

free of extra charge when
you buy RCA Receiving Tubes



*Expanded RCA course—includes
two new lessons, never before
offered, giving you all the
latest information on "Big Color" TV*

It is the time to enroll in RCA's extended Color-TV Home Study Course. Be set to cash in on the tremendous opportunity Color-TV holds for you. It is a practical down-to-earth course—prepared by Color-TV experts just for service technicians.

Go to your regular RCA Tube Distributor and ask for full details.

Special Certificate: If you're one of the thousands who has completed RCA's previous 9-lesson course, bring yourself up-to-date with the new advanced lessons. Special "Certificate" awarded.

This offer is for a limited time only. Enroll now and receive this durable binder for your lessons.



11 Steps to Profit in Color-TV Servicing

THE BASIC 9 LESSONS

- 1 Introduction to Color-TV
- 2 Principles of Two-Phase Modulation and Colorimetry
- 3 Principles of Color-TV Receivers
- 4 Color Kinescopes
- 5 The Color-TV System
- 6 Color-TV Receiver Circuits
- 7 Set-up and Adjustment of Color-TV Receivers
- 8 Servicing and Alignment of Color-TV Receivers
- 9 Test Equipment for Color-TV Servicing

PLUS 2 Brand New Advanced Lessons

- 10 Large Screen Color
- 11 New Color-TV Circuitry



RCA RECEIVING TUBES

RADIO CORPORATION OF AMERICA

HARRISON, N. J.