

# SERVICE

THE TECHNICAL JOURNAL OF THE TELEVISION-RADIO TRADE

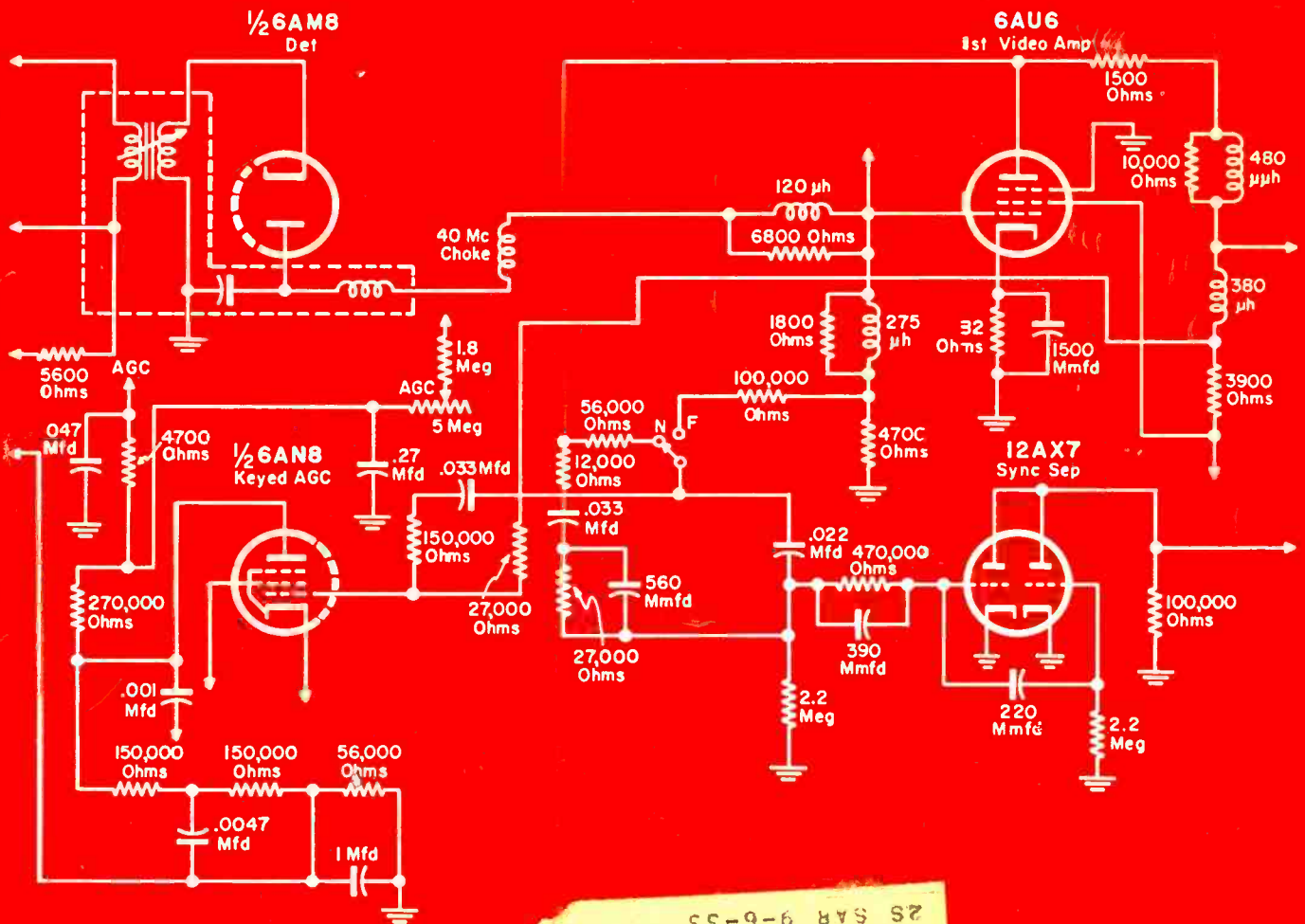

Tubeless noise-cancellation coupling network circuit in b-w TV receiver. See circuit analysis, this issue

10-57  
 R TURSE  
 CLARINEW LANE, N.J.  
 COMPTON LAKES, N.J.  
 2S SAR 9-6-55

only

# C·D·R Rotors

have  
the

**1**

**2**

**punch**

## 1. The Most Complete Line

The CDR Rotor line is COMPLETE to every detail, with a model for every application! A distinct selling advantage because YOU can give your customer EXACTLY what is required! The RIGHT CDR Rotor for the RIGHT job.

## 2. Pre-SOLD For You on TV

to millions of viewers through an extensive coverage of audiences in every important TV market. Capture this pre-sold market by featuring these nationally advertised CDR ROTORS.



**AR-22**

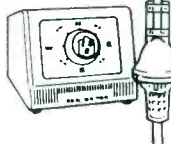

Completely AUTOMATIC version of the TR-2 with all the powerful features that made it famous.



**AR-1**



Completely AUTOMATIC rotor, powerful and dependable. Modern design cabinet. 4 wire cable.



**AR-2**

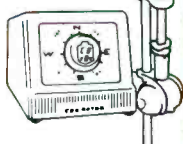

Completely AUTOMATIC rotor with thrust bearing. Handsome cabinet. 4 wire cable.



**TR-2**

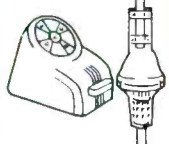

Heavy duty rotor with plastic cabinet, "compass control" illuminated perfect pattern dial. 8 wire cable.

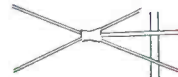

**TR-4**



Heavy-duty rotor, modern cabinet with METER control dial, 4 wire cable.



**TR-12**

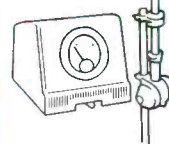

Combination value complete rotor with thrust bearing. Modern cabinet with meter control dial, uses 4 wire cable.



**TR-11**

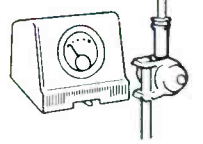

Ideal budget all-purpose rotor, new modern cabinet featuring meter control dial, 4 wire cable.



**CORNELL-DUBILIER**  
SOUTH PLAINFIELD, N. J.



**THE RADIART CORP.**  
CLEVELAND 13, OHIO



**MOST ACCEPTABLE**

FROM DELCO RADIO . . .

come the **coils**

with highest performance.

**You trust them . . . so do your customers!**

The core of quality service and really fine radio performance is always in Delco Radio coils. Delco Radio coils are made with powdered-iron cores, specially treated and compressed to exact shape on tolerance-true machines in Delco Radio's own plant. Skilled craftsmen wind and test the entire assembly so that you can depend on Delco Radio coils for *uniform* performance characteristics.

Your UMS-Delco Electronics Parts Distributor carries a complete line of Delco Radio parts, including precision-built Delco Radio coils. See him today! And, keep your eye on the Delco Wonder Bar Radio as advertised in leading consumer publications. It'll be helping you tune in to a greater service market.

**DELCO**



**RADIO**

DIVISION OF GENERAL MOTORS, KOKOMO, INDIANA



A GENERAL MOTORS PRODUCT — A UNITED MOTORS LINE  
Distributed by Electronics Distributors Everywhere

*A complete line of original equipment service parts from the*

**WORLD LEADER IN AUTO RADIO**

SERVICE, FEBRUARY, 1956 • 1

# New!

## Technician's Quickie bench

TRADE MARK

Speeds Repairs On the Spot  
Increases Profit Per Call  
Builds Customer's Satisfaction



\$895  
Dealer Net

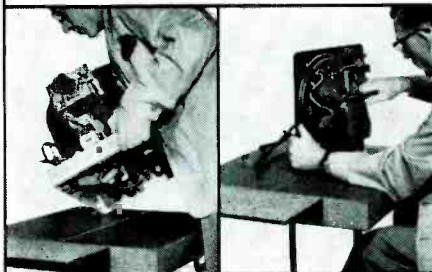

**STRONG** . . . . .  
with "Craftsmanship in Cabinets."

**VERSATILE** . . . . .  
use for any repairs.

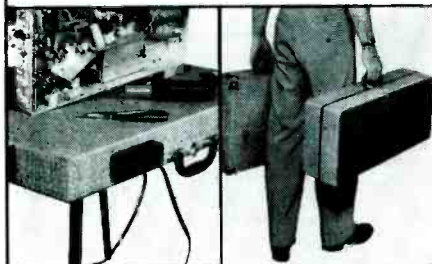

**EXTRA GADGETS**  
can easily be added. Not incl.

**CARRIES EASILY**  
only 26x11x6 1/4"  
Can fit under arm.

ASK YOUR PARTS DISTRIBUTOR  
OR WRITE FOR FOLDER

# Argos

PRODUCTS COMPANY  
310 MAIN STREET - GENOA, ILLINOIS

Vol. 25 No. 2

# SERVICE

FEBRUARY, 1956

The Technical Journal of the Television-Radio Trade

Including SERVICE—A Monthly Digest of Radio and Allied Maintenance; RADIO MERCHANDISING and TELEVISION MERCHANDISING. Registered U. S. Patent Office.

### COVER CIRCUIT

B-W TV Chassis Tubeless Noise-Cancellation Network (CBS-Columbia 3000) 22

### FEATURES

Editorial . . . . .	Lewis Winner	17
Industrial-Commercial Sound System Service Shops . . . . .	Oliver Berliner	18
A Technical Report on Tube Testers . . . . .	Robert D. Wengenroth	20
Vertical Chassis With Built-In Motorized Tuning Control . . . (Cover . With Complete Circuit) . . . . .	J. Roche and R. Tesco	22
SERVICE . . . The National Scene . . . . .		26
Remote TV Control Tuning System Circuitry (With Complete Circuit) . . . . .	Steve Wlasuk and John F. Fisher	28
'Scopes in COLOR-TV Service . . . . .	G. S. Ryant	30
Two-Way System Servicing (Service Engineering) . . . . .	George W. Vaas	32
TV-Chassis Repair Problems and Solutions (Servicing Helps) . . . . .		36
Fringe Area Co/Adjacent-Channel Antenna Installation Field Report . . . . .		40
Crossover Networks For Multiple Speakers . . . . .		42
TV Series-String Tubes . . . Circuit Classification . . . . .		54
Circuit Diagrams In This Issue . . . . .		59
Preview of Annual IRE Convention . . . . .		64

### DEPARTMENTS

Association News . . . . .	38
Ten Years Ago in SERVICE . . . . .	38
UHF/VHF TV Antenna Digest . . . . .	40
Audio Installation and Service . . . . .	42
Components . . . . .	52
Bench-Field Tools . . . . .	53
Tube News . . . . .	54
TV Antenna-Accessory News . . . . .	55
TV Accessories . . . Parts . . . . .	58
News . . . . .	59
Instruments . . . . .	61
Personnel . . . . .	62
Catalogs and Bulletins . . . . .	65
Index to Advertisers . . . . .	63

Entire Contents Copyright 1956, Bryan Davis Publishing Co., Inc.

Second-Class mail privileges authorized at New York, N. Y.; additional entry at the Post Office, Norwalk, Conn.

Subscription price: \$2.00 per year in the U.S.A. and Canada; 25 cents per copy. \$3.00 per year in foreign countries; 35 cents per copy.



EDITOR and PUBLICATION DIRECTOR

Lewis Winner

Editorial Assistant: David E. Pearsall II  
Assistant Editor: Robert D. Wengenroth  
Associate Editor: Eli Cohen  
Art Director: Anthony R. Aliff  
Supervisor, Circuit Diagrams: Michael D. Belleza  
Editorial Production: Astrid Kelly

CIRCULATION DEPARTMENT

Circulation Manager: A. Goebel  
Ass't Circulation Mgr.: A. Kiernan

ADVERTISING DEPARTMENT

Advertising Mgr.: Aaron L. Lafer  
Business Mgr.: F. W. Boyd  
Mid-West Mgr.: Stuart J. Osten  
333 N. Michigan Ave.  
Chicago 1, Ill.  
Tel.: DEarborn 2-3507  
East-Central Rep.: James C. Mann  
2253 Delaware Dr.  
Cleveland 6, O.  
Tel.: ERievew 1-1726  
Pacific Coast Rep.: Brand & Brand  
1052 W. 6th St.  
Los Angeles 17, Cal.  
Tel.: MADison 6-1371

Published Monthly By  
Bryan Davis Publishing Company, Inc.  
52 Vanderbilt Ave., New York 17, N. Y.  
Tel.: MURray Hill 4-0170

B. S. Davis, Pres. F. W. Boyd, Sec'y



# Short description of a Small Efficient TV System...

**1 antenna .. IN**  
**8 set lines .. OUT**  
**10 db signal .. GAIN**

all with  
the



## DISTRIBUTION AMPLIFIER

model DA8-B

approved  
for  
Color-TV

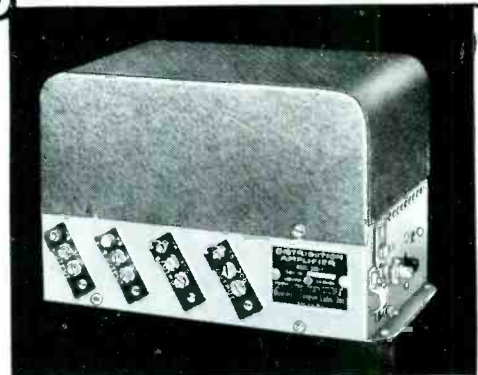

**\$89<sup>50</sup> List**

Ideal for garden apartments, motels, TV showrooms, deluxe home installations and other small TV systems. The DA8-B is a broadband, all-channel unit that requires no tuning, impedance matching devices, preamps or other special fittings.

### Features and Specifications:

- Low noise all-triode circuit
- More than 10db gain on all VHF Channels
- Inter-set isolation in excess of 22db
- Provision for 75-ohm cable or 300-ohm twin lead
- Prevents overload through 10:1 gain control range
- Built-in power supply
- Designed for continuous duty operation

NOTE: For larger systems, Blonder-Tongue will furnish Free planning service on request.

Sold by Radio-TV Parts Distributors and Jobbers.

Write for Installation Details and FREE Booklet—"TV for 2 . or 3 . or More"

Dept. KB-8

**BLONDER-TONGUE  
LABORATORIES, INC.**  
Westfield, New Jersey

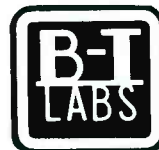

Manufacturers of TV Cameras, TV Amplifiers, Boosters, Converters, Accessories and Originators of the Masterline and 'Add-A-Unit' Master TV Systems.

*Dealers by the thousands are  
making the SWITCH  
to this great insulator idea!*

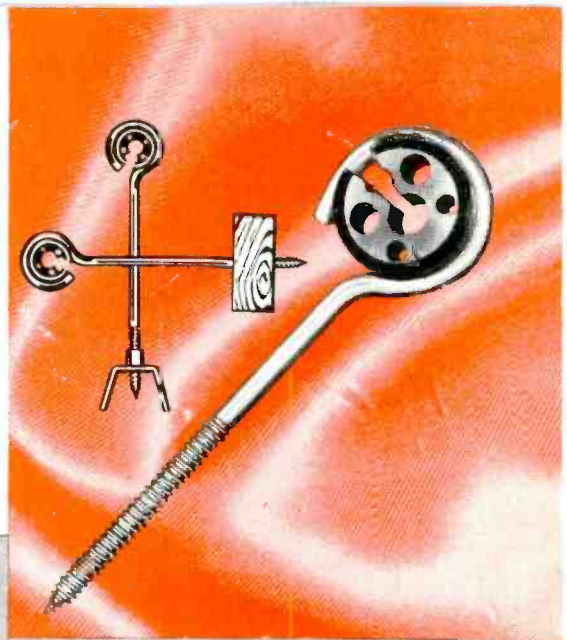

*when we say  
SWITCH  
we mean  
business!*

*New indoor antenna has  
gliding SWITCH*



Only **CHANNEL MASTER®**

**STANDOUT**  
insulators

have this revolutionary  
**2 in 1 design**

It's a wood-screw insulator  
... it's a machine-screw insulator  
... and it's **BETTER** in both applications!

STANDOUT insulators and buckles are already outselling all others — after only a few months on the market! This remarkable record provides positive proof of the solid acceptance STANDOUTs have won among dealers all over the country.

Why has the response to STANDOUTs been so enthusiastic? BECAUSE they cut space and dollar investments in accessories by more than 65% ... BECAUSE they increase space and dollar turnover by more than 200% ... BECAUSE they are easier to install, stronger, more durable.

Millions already sold!  
Here's why:

"T-Nut" buckle with 8 threads.

More threads than any other buckle (nut type or extruded) — 8 full machined threads! Tighten as hard as you want, you can't strip it!



Pointed Screw makes positive contact.

Strap won't slip while you're tightening. Won't twist or slip on mast after installation. Straps have convenient "taper-tip."



Needle-sharp point

Finer thread, sharper point means easier starting — even in hardwood. Minimizes possibility of splitting.

Ordinary standoff point.



STANDOUT point.

All popular types and sizes available, including full assortment of specialized hardware. See your Channel Master distributor

**CHANNEL MASTER'S**

new **Glide-o-Matic**

**INDOOR TV ANTENNA**

The Glide-o-Matic's sensational low-loss **gliding switch** is different from all others! Provides highest electrical efficiency ... AND — it's the most convenient to operate!

Glide-o-Matic also gives you:

- Maximum performance on all channels — VHF and UHF.
- Weighted tip-proof base — with "can't scratch" felt covering.
- Ready for COLOR TV.
- Powerful retail merchandising support.

Available in  
**4**  
popular color  
harmonies:

Mahogany	with brass	model no. 3700
Ebony	with brass	model no. 3701
Ivory	with brass	model no. 3702
Ebony	with aluminum	model no. 3703

A performance hit  
with men ...

A style hit with  
women!

Glide-o-Matic practically sells itself. Smartly styled ... blends into any setting. Packed in colorful "tell and sell" carton with convenient "carry away" handle.



**\$9.95**  
list

Also available:

**CHANNEL MASTER'S ALL-VU**  
model no. 381, all-VHF, all UHF.

\$8<sup>95</sup>  
list



**CHANNEL MASTER'S PRE-VU**  
model no. 380 all-channel VHF.

\$7<sup>95</sup>  
list



**CHANNEL MASTER CORP.**  
ELLENVILLE, N. Y.

WORLD'S LARGEST MANUFACTURER OF TV ANTENNAS AND ACCESSORIES

# THIS IS THE GUN YOU ASKED FOR

BUILT TO SERVICE MAN'S SPECIFICATIONS

*Designed* TO INCLUDE ALL THE BIG FEATURES  
EVERYBODY WANTS

- LONGER REACH TIPS
- LONGER LIFE TIPS
- MORE RIGID TIPS
- LIGHTER WEIGHT—25% less than comparable products
- SHATTER PROOF CASE

Your No. 1 Gun—ideal for the kind of work you do—and it SHOULD be, because it was designed and built specifically to meet the service man's requirements. Develops AMPLE heat—fast! Cools quickly too. Is so light, so beautifully balanced, the work goes easier. And the long, narrow, rigid tips reach right into those tight "inaccessible" places. Automatically spotlights its work. Fully guaranteed.

**WEN**  
NEW HEAVY DUTY  
MODEL  
**288**

DEVELOPS OVER 200 WATTS HEAT

*IN 5 seconds*



*"Quick-Hot"*  
ELECTRONIC  
SOLDERING GUN

JUST  
**\$9.95**  
LIST

AT BETTER JOBBERS EVERYWHERE

**WEN**

**PRODUCTS, INC.**

5808 NORTHWEST HIGHWAY • CHICAGO 31, ILL.

Export sales, Scheel International, Inc., Chicago



**geared**

*to your needs!*

**RTV**  
matched  
components  
*by*  
**CLAROSTAT**

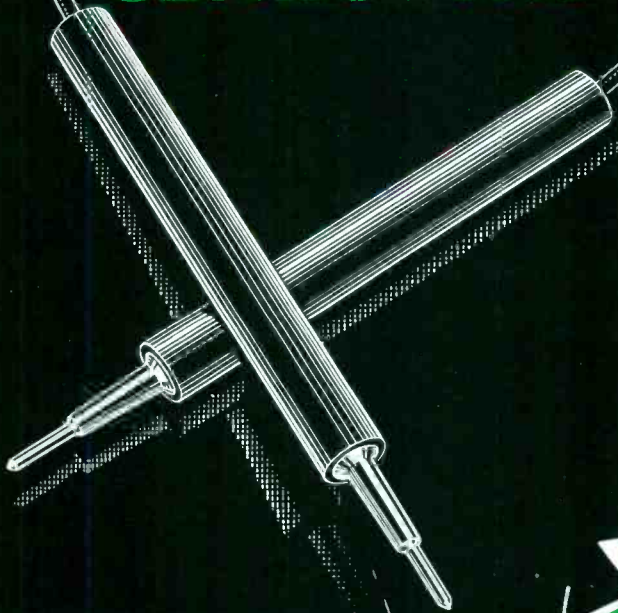

CLAROSTAT RTV replacement controls for radio and television are matched to the original components, both electrically and mechanically.

No fuss; no bother; just pull out the old control, install the CLAROSTAT RTV control called for, and the job is completed.

Ask your distributor for complete details on CLAROSTAT products geared to your needs.



**CLAROSTAT MFG. CO., INC., DOVER, NEW HAMPSHIRE**  
In Canada: Canadian Marconi Co., Ltd., Toronto, Ont.

where do you find

**PYRAMID**

CAPACITORS AND SELENIUM RECTIFIERS

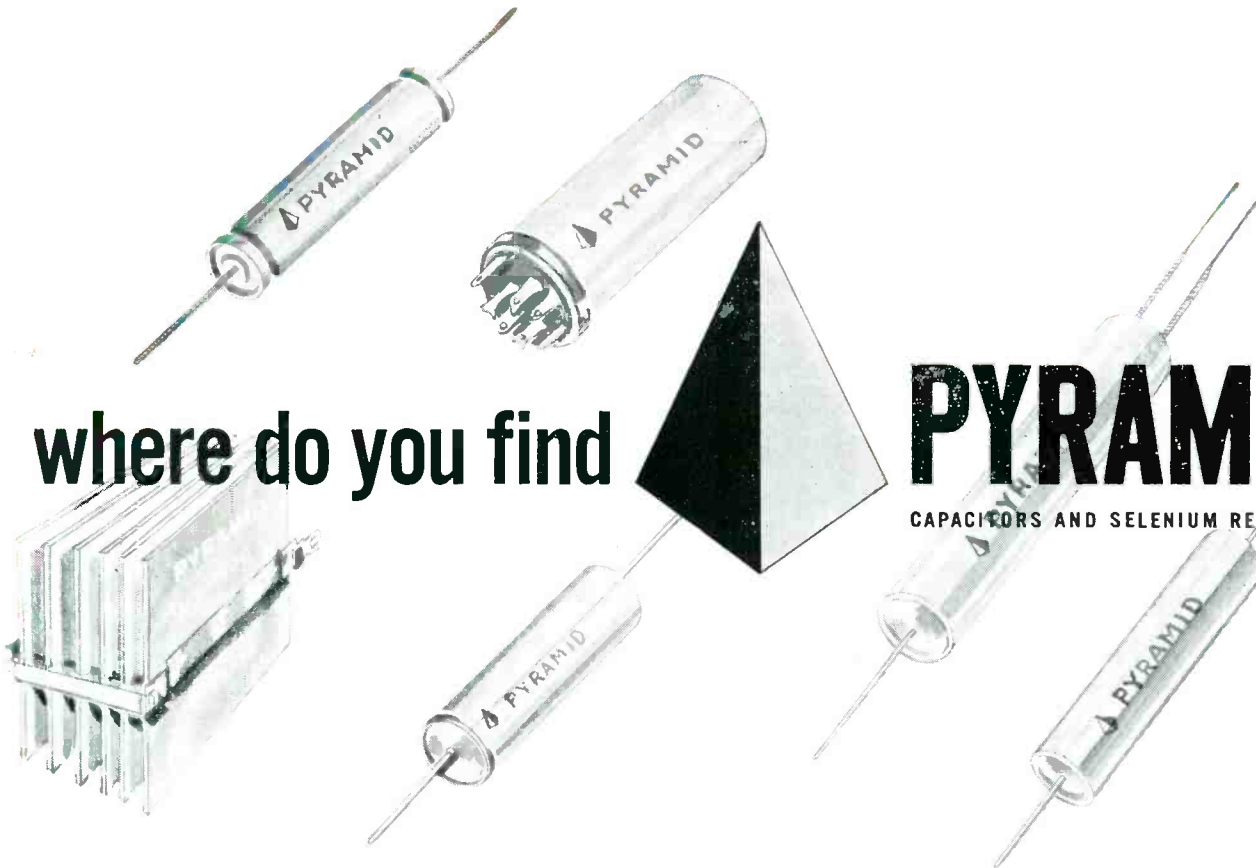

In the electronic products of all these leading brand manufacturers—where their presence testifies to PYRAMID'S high standards of quality and service.

**Admiral** **Magnavox**



**Motorola**

**CROSLEY**

*Packard-Bell*

**DUMONT**

**RAYTHEON**

*Emerson*



**SYLVANIA**

**hallicrafters**

**Westinghouse**

**Hoffman**

**ZENITH**

AND you find PYRAMID as a participant in Howard Sams PHOTOFACT—the bible of radio-television-sound field servicing—which guarantees accurate replacement with PYRAMID parts and testifies to the immediate availability of PYRAMID Capacitors and rectifiers throughout the country.

*Howard W. Sams*

**RF**  
PHOTOFACT



**PYRAMID ELECTRIC CO.**  
North Bergen, New Jersey

THE BIG NAME IN CAPACITORS AND SELENIUM RECTIFIERS TODAY...

**MR. SERVICE DEALER! INVEST IN ...  
YOUR FUTURE IN COLOR TV SERVICE  
AND EQUIP YOUR SHOP *FREE!***

**DURING THE FABULOUS**  
**PHILCO**  
**SHARE *and* PROFIT**  
**DIVIDEND OPPORTUNITY**



That's right! This is the year to equip for color and by concentrating your radio and TV Parts and Accessory purchases on Philco, you can earn FREE Philco color and B/W Test Equipment and Parts and Accessory Dividends . . . all at no extra cost! SHARE and PROFIT dividends go to work for you immediately . . . building EXTRA 100% profits because they cost you nothing. Sell them for full profit or put them to work in your own shop. Make your business prosper like never before! Now is the time to equip yourself for color servicing . . . FREE. See your Philco Distributor for details.

**NO LIMIT TO WHAT YOU CAN EARN**

Order your Parts and Accessories, then pick the dividends you need. Stock up on genuine Philco Parts and Accessories and earn the dividends of your choice through valuable SHARE and PROFIT stamps you receive with each purchase. SHARE and PROFIT stamps are redeemable at your Philco Distributor's for the dividends of your choice.

**PHILCO PUTS YOU IN THE COLOR  
SERVICE BUSINESS WITH ONE COMPACT INSTRUMENT**  
**PHILCO UNIVERSAL COLOR BAR AND  
DOT BAR GENERATOR Model 7100**

It's new . . . highly efficient . . . designed to provide the widest possible variety of functions in the minimum amount of space. PHILCO MODEL 7100 can be used to completely trouble-shoot circuits associated with

color reproduction and make accurate convergence adjustments in any color receiver made. In conjunction with your present monochrome equipment, it gives you complete color service facilities!

**PLUS OTHER VALUABLE *FREE* DIVIDENDS LIKE THESE**

- Store Aids and Fixtures
- Dealer Store Identification Signs
- Your Choice of Parts and Accessories
- 6 HP Lauson Outboard Motor



**PHILCO CORPORATION**  
ACCESSORY DIVISION PHILADELPHIA 34, PA.



# This year it's

# KINGSBRIDGE

# 3

March 19-22  
New York City

for the  
**Radio Engineering Show**

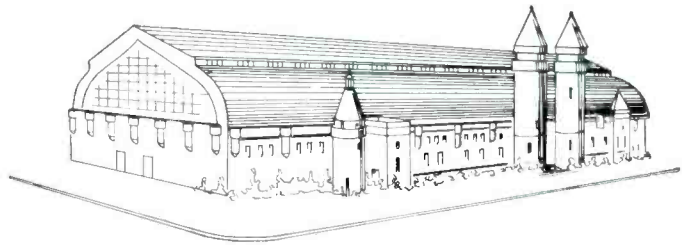

For the third year in succession, the great annual IRE Radio Engineering Show will open its doors to the industry for four spectacular days at the Kingsbridge Armory and Kingsbridge Palace in New York City. As in the preceding years, the Show will be filled to capacity with 704 exhibits and displays of the latest and newest developments in radio-electronics.

Is it too big? Not as a true representative of this giant industry. More than 200 papers presented by 22 Professional Groups at the Convention's 55 technical sessions are an accurate index to new research and development...and the 704 exhibitors represent about 80% of the productive capacity of the industry...not one whit larger than necessary to keep pace with electronic America today!

Plan now to attend the industry's most vitally important Show where

**Over 42,000\* meet!**

\*At the 1955 Show, 42,133 men and women from coast to coast and every field of radio-electronics attended the Radio Show. This year, attendance is expected to go even higher. Don't miss it!

**Over 700  
Exhibitors  
will show all  
that is NEW  
in radio-  
electronic  
engineering!**

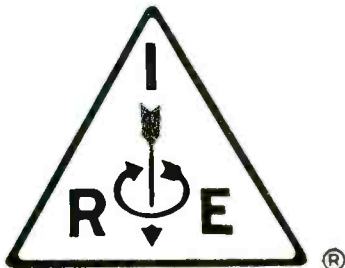

**THE INSTITUTE OF RADIO ENGINEERS**  
1 East 79 Street, New York

# STERLING JUBILEE

1931

1956

**Snyder**  
PHILADELPHIA

INDOOR

**TV**

TENNAS

*antenn-gineered for quality  
priced for all markets  
packaged for easy sales*

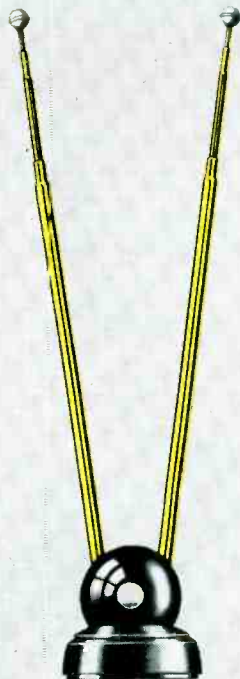

PT-S

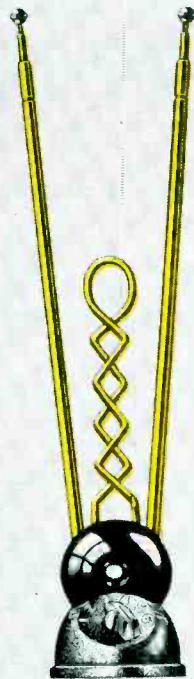

3-D

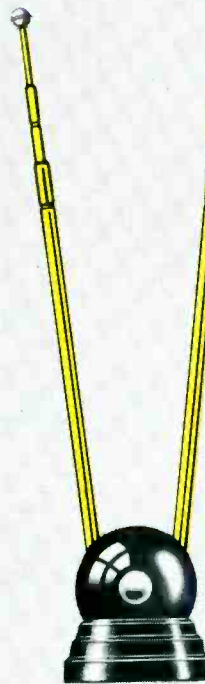

PT-X



5-D



**SNYDER** Manufacturing Company PHILADELPHIA 40, U.S.A.

# Industrial-Commercial Sound

## A Field Report



Fig. 1. Author repairing amplifier in his shop.

A GROWING NUMBER of Service Shops have begun to specialize in the installation and maintenance of portable and fixed public-address systems for civic organizations, clubs, schools, churches and business concerns. The trend has been sparked by the rising interest in sound and the mounting variety of functions in need of *pa* setups. Meetings, parties, dances,

stage productions and conferences are always in need of sound reinforcement. In each of these instances, it is possible to sell or rent, as well as service the complete project.

In our case, *pa* has been a very profitable operation, serving not only those who require temporary sound, but others who want permanent systems. The latter often require sub-

stantial planning and equipment, too. This point was solidly emphasized a short while ago when it became necessary to develop a layout for the swim-gym at the high school in Beverly Hills, California. This room, a huge affair, was found to have many unusual constructional details that required considerable study before an adequate sound installation could be made. It was learned, for instance, that the basketball floor, which could be divided by the push of a button, served as a cover for an enormous swimming pool, complete with high and low diving boards.

Prime problems encountered were echo and reverberation created by the size and shape of the structure, plus the relatively small amount of acoustic treatment. The enormous height of the building was found to allow the sound to roll around up on top and eventually come back down after considerable time delay. Another problem was high humidity. Because the building is used for swimming, heaters are used to warm the air, and the swimming pool itself creates plenty of moisture in the air.

These problems raised havoc with the original sound system, built in when the school was being built. That *pa* setup consisted of one 10-inch cone speaker suspended by a cable from the ceiling at roughly the center of the building. Actually the reasoning behind this type of installation made sense; it was mounted in a typical arena style, where the audience surrounds the acting area. The speaker was encased in a housing which attempted to fan the sound out over a 360° area.

The principal difficulties were that moisture got to the cone and voice coil of the speaker, the audience was never evenly dispersed around the speaker, so substantial power was required and feedback and echo occurred, and the speaker was never able to do a good job of covering both the playing and seating areas.

The type, quantity and location of the loudspeakers were found to provide the answer to the distribution and moisture-control problem.

Selected were compound diffraction projectors with their wide dispersion

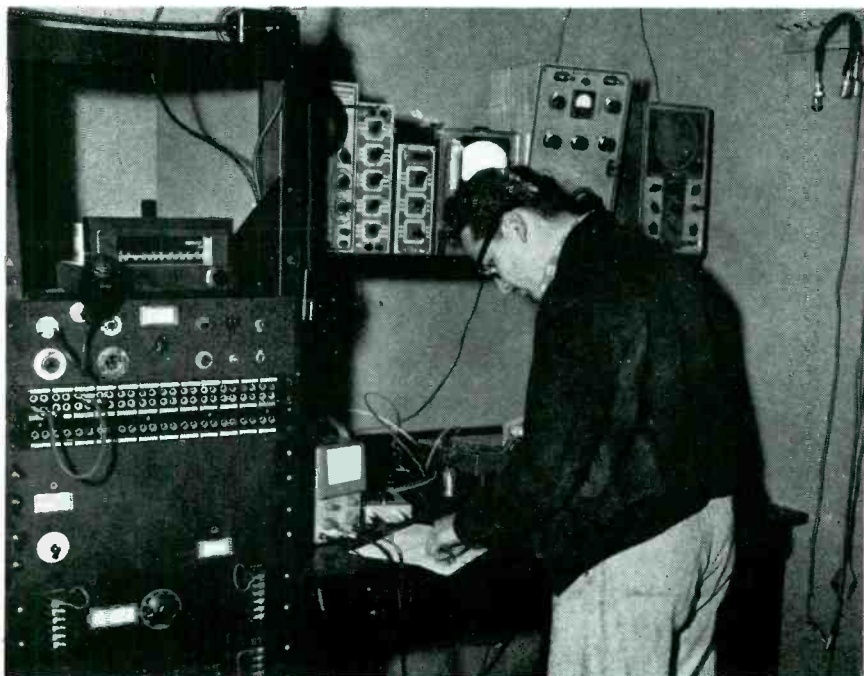

Fig. 2. View of another sound-system shop illustrating variety of test equipment and tools required in *pa*-installation, maintenance and repair.

All photos by Frank Aiello

# System Service Shops

by OLIVER BERLINER

angles, because it was necessary to use a minimum of loudspeakers fairly close to the audience.

At normal volume level, it was found possible to use a microphone twenty feet directly in front of this loudspeaker and not experience acoustic feedback. The speakers were mounted close to the wall to provide better bass response.

Due to the high moisture content in the air in the gym with its resultant rust-creating and cone-tearing aspects, we had to choose loudspeakers that contained a minimum of metal and paper. All external components had to be encased, too. Telephone terminal blocks with covers were selected at all wire junctions.

To be sure that this sound system would work under all conditions, a number of preliminary tests were made.

In an initial prelim check, a nest of four loudspeakers were tried. Although they were adequate, they were not perfectly absolute in their coverage. The sound levels throughout the building were uneven, and the power generated created too much reverberation.

A short time later, during another trial, we used six horns, three placed on each of the two long walls of the building, spaced midway between the doors. This time coverage was excellent; gone were echoes, feedback, distortion and the uncovered areas.

The present system can be operated without making any changes in levels necessary whether the gym is full or empty. The microphone can go anywhere without creating acoustic feedback, and the sound level is the same in all parts of the audience area; yet even swimmers in the noisy pool can hear the announcements.

The speaker line voltage peaks far below 70 volts; thus, no conduit was required and it was possible to use a small white-colored No. 18 size wire with moisture-resistant plastic insulation. This wire was carefully tacked down against a white ledge making it practically invisible. We used the 500-ohm taps on the speaker matching transformer which provided us with an effective load of 83 ohms (500

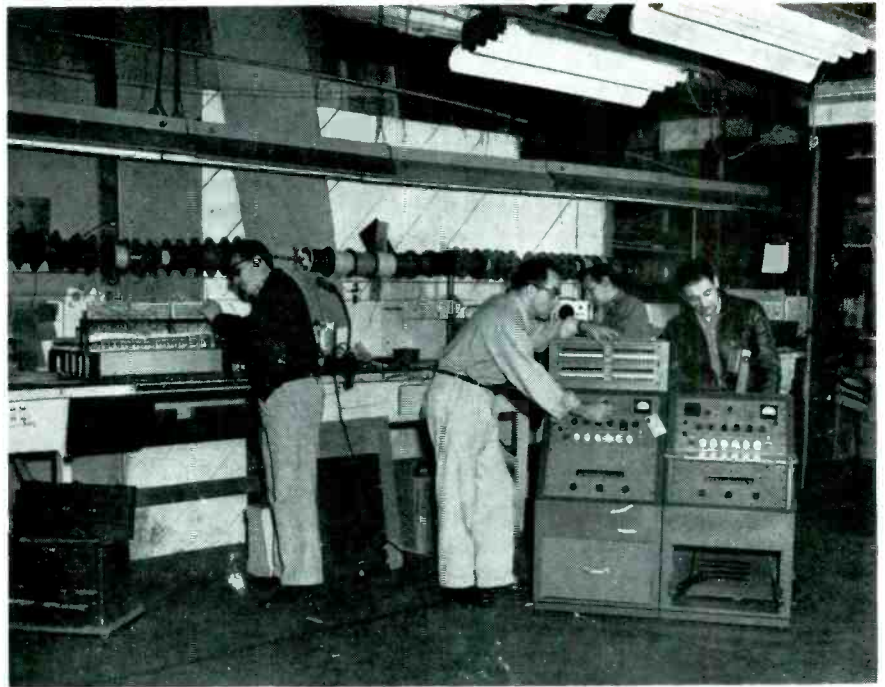

Fig. 3. Another view of a sound-specialty shop where audio equipment is tested and often rewired to meet custom-design requirements.

ohms divided by 6 speakers) placed on the 60-ohm output tap of a 25-watt amplifier.

This slight mismatch was found to be unimportant, due to the low internal resistance of the amplifier and the very low volume level at which

it operates. In addition, the load impedance greater than that of the source, desired in cases where mismatch is necessary, contributes negligible loss. At this impedance, a power loss in the cable of about 10%

(Continued on page 44)



Fig. 4. Beverly Hills High School swim-gym, where half of the playing and seating areas are covered by three speakers near entrances, and three speakers on opposite wall.

Figs. 2 and 3 courtesy Hollywood Sound and Lighting.

# A Technical

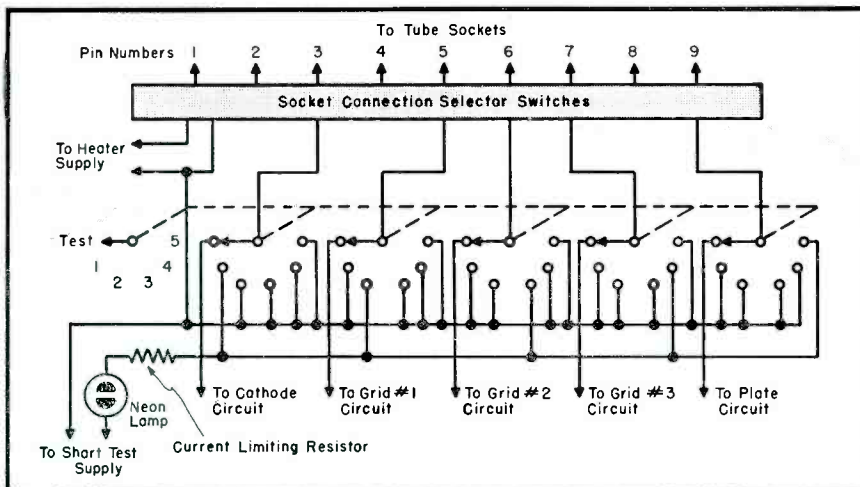
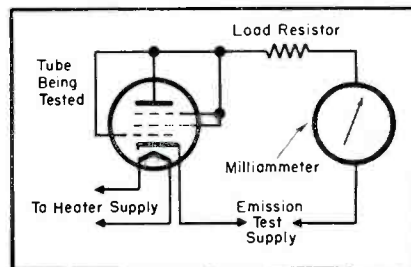

Fig. 1 (left). Basic short test circuit.

Fig. 2 (below). Emission test circuit.



THE PROFESSIONAL TYPE of tube tester has always been one of the most useful tools in the shop. With the advent of TV and advanced audio amplifiers, its importance has grown. While simple *good-bad* emission tests may suffice for tubes used in *avc* broadcast receivers, more complete tests are necessary to determine whether tubes will operate properly in the number of critical circuits found in TV and *af* chassis. It is impossible to obtain the *complete* story on the characteristics of these tubes from snap *good-bad* checks made on self-service type equipment. While tubes which test *bad* (on an emission tester) should be replaced (because their efficiency has deteriorated below an acceptable limit, and will continue to become poorer), *many* tubes which actually are not performing properly will test *good*.

A number of different types of professional tube-testers exist; each has a place in the field and on the bench. At least two types of tests are included in many checkers; the better units include more. The simplest, included in virtually all testers, is the leakage or short test. The next type, also included for at least some tube

types, is an emission test. Other models afford measurement of the transconductance (*gm*) of a tube, and many also include a gas test. There are also a number of tube testers that do not test a particular characteristic, such as emission or transconductance, but attempt to check the tube through much of its operating range, so that its general performance can be compared to typical performance.

### Short Or Leakage Tests

The short test is usually sensitive enough to detect high resistance *shorts* or leakage paths between elements for resistances as high as one quarter megohm. The basic circuit of such a test setup is shown in Fig. 1. A neon lamp, with a current-limiting resistor, is connected to each element of the tube in turn, with all other elements connected together. When a short exists in the tube, current flows from the short-test supply, which is typically 110 volts *ac*, through the lamp and resistor and through the shorted element. The switching arrangement in the figure is basic; actual circuits often utilize more complicated switches. The

short-test switch is shown in the *test* position, in which the tube elements are connected to the proper circuits for the remaining tests; to check for shorts the switch is rotated through positions 1, 2, 3, 4 and 5. Each position tests one electrode of the tube—the cathode, the grid, grid 2 (screen), grid 3 (suppressor), and plate—for shorts to all of the other elements. Connections to the proper tube-socket pins are made through a separate set of switches, indicated by the block labelled . . . *socket connection selector switches*.

The short test should be the first one made on a tube check, because shorted elements might damage the more sensitive circuits for the remaining tests. Also, leakage or shorted elements account for many tube failures in servicing; the simple short test will quickly locate these tubes.

The emission test serves generally as a basic check of a tube's ability to operate; with insufficient emission no tube can perform as specified. A basic emission test circuit is illustrated in Fig. 2. The tube is diode connected, with the grids tied to the plate. A milliammeter, in series with a current-limiting resistor, is connected from the plate and grids to the emission-test supply, which is typically 30 volts *ac*. The tube operates as a rectifier, with the meter measuring the available current. This test is very good for detector diodes, and adequate for power rectifiers. *But*, for TV high-voltage rectifiers, such as the 1B3, it is not reliable. For amplifier tubes, the emission test is incomplete; it indicates the availability of current through the tube, *but not the ability of the tube to control it*. Any tube which tests *weak* on an emission tester should be replaced, but a good test will not mean that the tube will operate properly.

Fig. 3. Schematic of basic transconductance test setup.

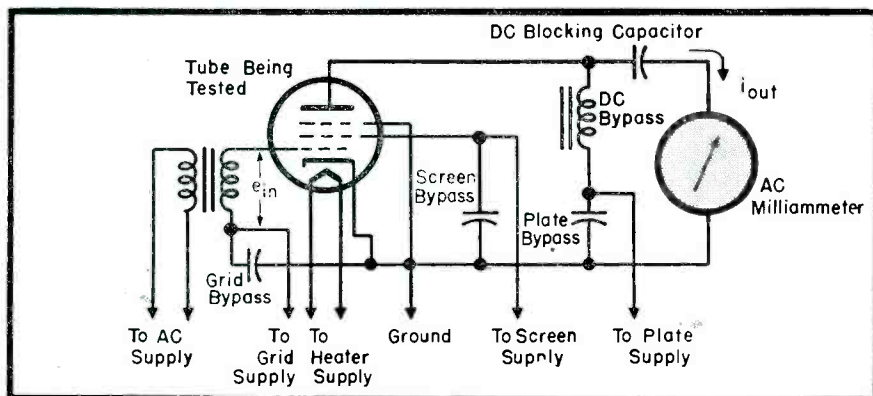



# Report on TUBE TESTERS

by ROBERT D. WENGENROTH

## Detailed Analysis of the Four Basic Types and Their Application In the Field and In the Shop

Tests have shown that there is little correlation between emission current readings and transconductance or amplification factor, so long as emission is above the minimum specified.

### Transconductance\*

Transconductance is a measure of the ability of a tube to amplify; it is the ratio of the change in plate current to the change in grid voltage which causes it, with the voltages on all electrodes except the control grid held constant. The basic transconductance test circuit is shown in Fig. 3. The tube is operated with proper *dc* voltages applied to all electrodes, and a small *ac* voltage (typically about 1 volt) is applied to the grid. The *ac* component of the plate current, which is produced by the grid signal, is measured by the *ac* milliammeter. The *ac* passes through the milliammeter, which has low impedance, and the *dc* goes through the choke coil. In typical tube testers, the actual *ac* plate current meter and *dc* feed may take slightly different forms, but in every case the meter will measure only the *ac* component of the plate current and will have low *ac* impedance. If a 1-volt signal is applied to the grid, the transconductance in micromhos is equal to the *ac* current in microamperes.

The transconductance test tells much more about the probable performance of an amplifier tube than does an emission test; however, the particular circuit in which the tube is used must be carefully evaluated when making this test. Most tube testers check the tube at a particular set of applied voltages. While for these conditions a tube may have proper transconductance, at a differ-

\*Transconductance is often referred to as mutual conductance.

ent set of conditions, as in a particular receiver, the transconductance may be very different. Another difficulty is the relatively large grid signal typically applied. A reading of 1-volt *rms* is 2.8 volts peak-to-peak; this is a very large signal for some sharp-cutoff tubes. These tubes are driven from grid current to cutoff; for this range of voltages the transconductance goes from very high to zero. The meter will read an average value which will indicate the quality of the tube for most circuits; however, it may not indicate that the tube cuts off too quickly for a circuit with fixed bias, or that it does not cut off quickly enough for a fixed bias clipper circuit. Some tubes in which 1 volt is too high a grid signal are the 6AU6, 6AW8, and 12AT7. Some testers provide smaller signals for checking this group of tubes.

It may be found that neither the emission nor the transconductance tests will disclose the full capability of power amplifier tubes to supply all of the design power output; however, these tests will permit the accurate

selection of balanced tubes for a power output system.

Gas or grid-emission checks also provide revealing information. In circuits having a high *dc* grid resistance, a tube may not operate at all even though it passes the short test, the emission test, and the transconductance test. The reason for this is that grid emission, either from gas bombardment, from a deposit of cathode materials on the grid, or from lowered insulation resistance between the grid and the screen or plate, causes the grid to go positive, upsetting the voltage distribution to the tube and overloading the circuit. The effective resistance between the grid and any other element in the tube will be too high to show on the short test, even though it can paralyze the tube. Two circuits used to test for grid emission are illustrated in Fig. 4.

The circuit of Fig. 4a measures the current directly on a zero-center microammeter. The meter should have several ranges, the most sensi-

(Continued on page 50)

Fig. 4. Basic diagrams of two gas or grid-emission test circuits. System in a employs a microammeter to measure the current, while the b circuit uses tube amplification to indicate grid current. The tube-current change, when the switch is closed, indicates grid emission.

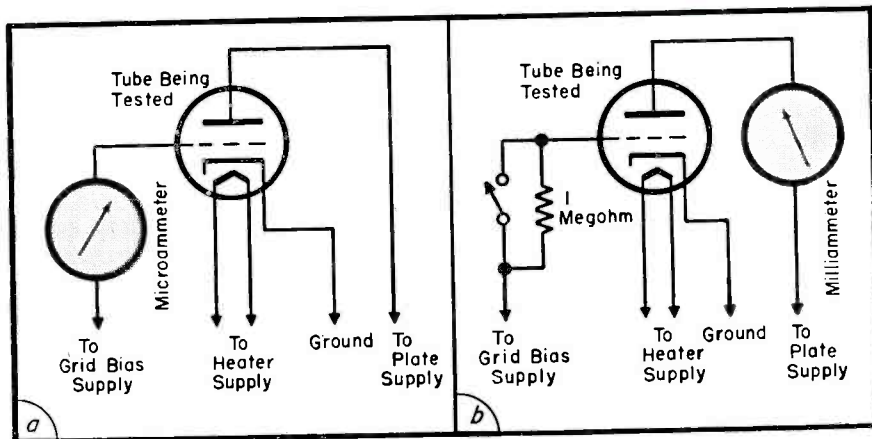

SERVICE, FEBRUARY, 1956 • 21

cut is that it automatically adjusts itself to the amplitude of the noise. The greater the amplitude of the

of noise pulses which are normally sharp spikes of short duration. The long time constant provided by the

This assures that the *agc* bias on the *rf* and *if* stages will be a function of (Continued on page 24)

Fig. 2. Push-pull triode audio amplifier, providing about 5.5 watts output, incorporated in some of the CBS 3000 series chassis.

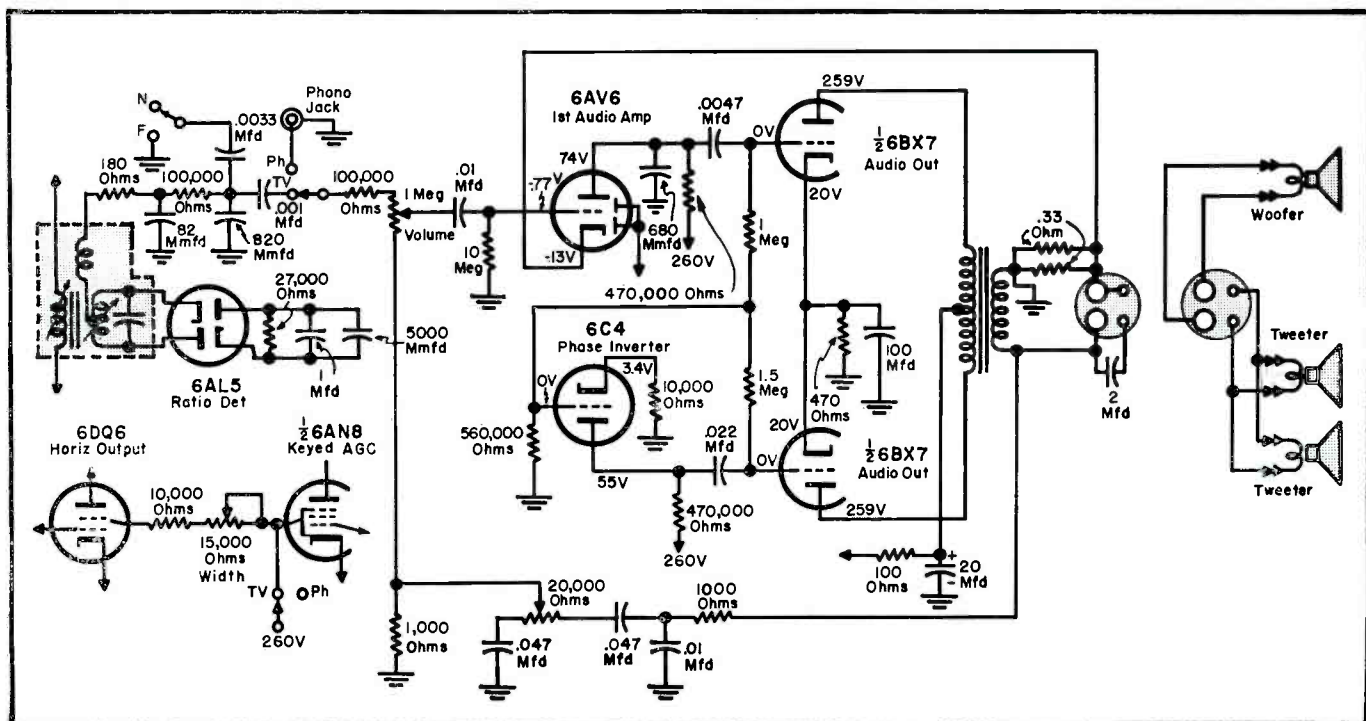

SERVICE, FEBRUARY, 1956 • 23

# B-W TV Chassis

See Front Cover and

Pages 24 and 25 for Complete

Circuit Diagram

by J. ROCHE and R. TESEO

Publication Manager

Technical Writer

Product Service Department, CBS-Columbia

Fig. 1. Detailed drawing of the complete motorized tuning mechanism used in CBS-Columbia chassis.

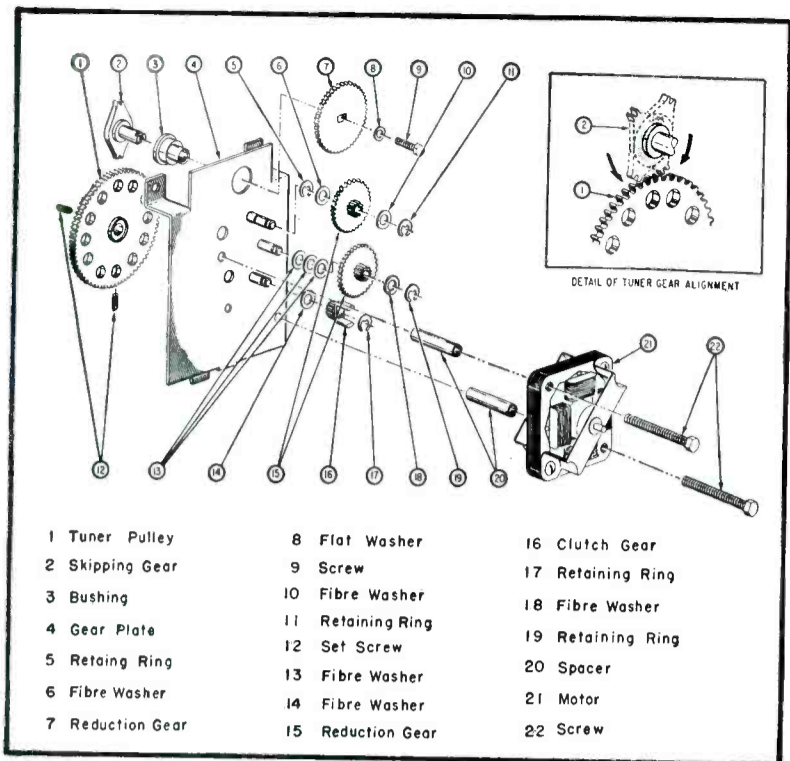

THE TREND to simplified tuning techniques featuring built-in motorized or remote control has introduced a number of design requirements.

To achieve maximum efficiency with this type of operation, very careful circuitry design must obtain.

grounded through a 470-ohm resistor.

The entire network appears to the oscillator circuit as a capacitor of very high Q. The 20,000-ohm pot across the crystal varies the effective capacity of the IN60 without substantially changing the O of the circuit. In ef-

wasting power in voltage-dropping resistors.

The video detector is followed by two stages of video amplification. The sync take-off is located in the plate circuit of the first video amplifier. This stage also functions as part of a sync

## Remote TV-Control

### Tuning System Circuitry

by STEVE WLASUK

and JOHN H. FISHER

Engineering Department

RCA Service Co., Inc.



IN ANY REMOTE-CONTROL system, tuning efficiency can be achieved by incorporating the most-used operations in the remote head. These include channel selection, fine tuning, on-off, sound volume, and picture brightness.

These remote requirements have been met in a recently-developed palm-size control unit.<sup>1</sup> To prevent ambiguous control settings, the remote controls have been so designed that they are completely disconnected from their corresponding functions at the receiver. As an example, the receiver fine tuning control, when turned to the full clockwise position, switches the receiver to remote control; turning the fine tuning control to counter-clockwise, restores the receiver to normal operation without remote control. The remote control connecting plug can, in fact, be disconnected with no effect, and the receiver operated normally.

#### Motor-Driven Null Seeker

For channel selection, a motor-driven null-seeking system has been built in. Since thirteen-position tuners are used in most chassis, a special switch arrangement was designed

for a *follower* circuit; a twelve-position selector switch is used in the remote head. The circuit used in the *follower* switch consists of two wafers with circuitry on front and rear of each wafer. The contact arrangement is such that a *null* position is present on the *follower* switch for each position of the remote-selector switch, corresponding to each of the twelve-channel positions of the tuner. The *follower* switch position corresponding to the blank space between channels 13 and 2-positions on the tuner, prevents a null and thus forces the motor to turn the detent mechanism over this space no matter what channel is selected. The circuit employed in this switching arrangement is shown in Fig. 3.

#### Capacitive Change Fine Tuner

For fine tuning, a novel capacitive change circuit is used. In the course of investigation for a suitable fine tuning device, many possible circuits were tried, including the use of a variable B+ supply for the local oscillator. While this circuit is the simplest, it was found to be the most

unsatisfactory. For instance, the local oscillator circuit found in RCA *rf* units are inherently stable for B+ variations and, hence, unsatisfactory for tuning by this method. Then, too, the use of above or below normal voltages for the oscillator was found to result in wide and unpredictable results for tube life and oscillator injection into the converter stage. A solution was found in a neon bulb circuit shown in Fig. 2. In this application, the capacity formed by the two bulb electrodes is used for control. As the bulb current is increased, the capacity also increases, and thus lowers the local oscillator frequency. To prevent interaction between the local and remote fine tuning controls, the local-remote switch is connected to the fine tuning control of the receiver.

#### On-Off Function

In the remote operation, the receiver *on-off* switch is disconnected from the circuit when the local-remote switch is in remote position. The remote *on-off* switch is connected (through a relay) when on *remote*, and disconnected on *local* when the

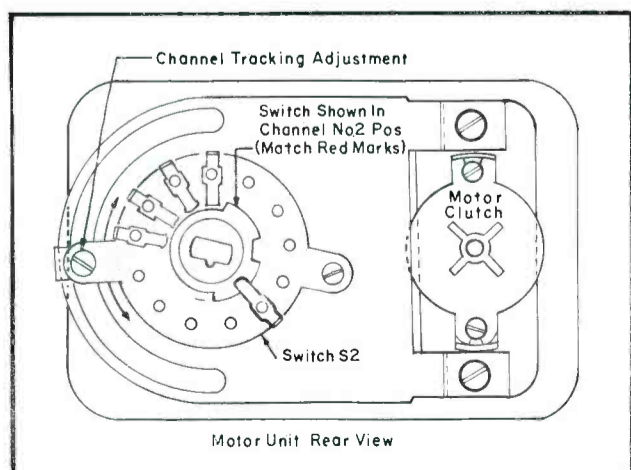

(Left)  
Fig. 1. Rear view of motor unit showing tracking adjustment.

<sup>1</sup>RCA Magic Brain remote-TV control

Fig. 2. Neon bulb circuit developed for fine tuning in remote head. Capacity formed by two bulb electrodes are used for control.

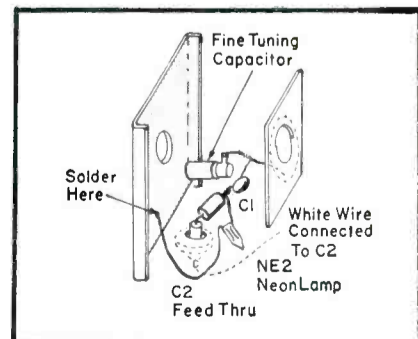

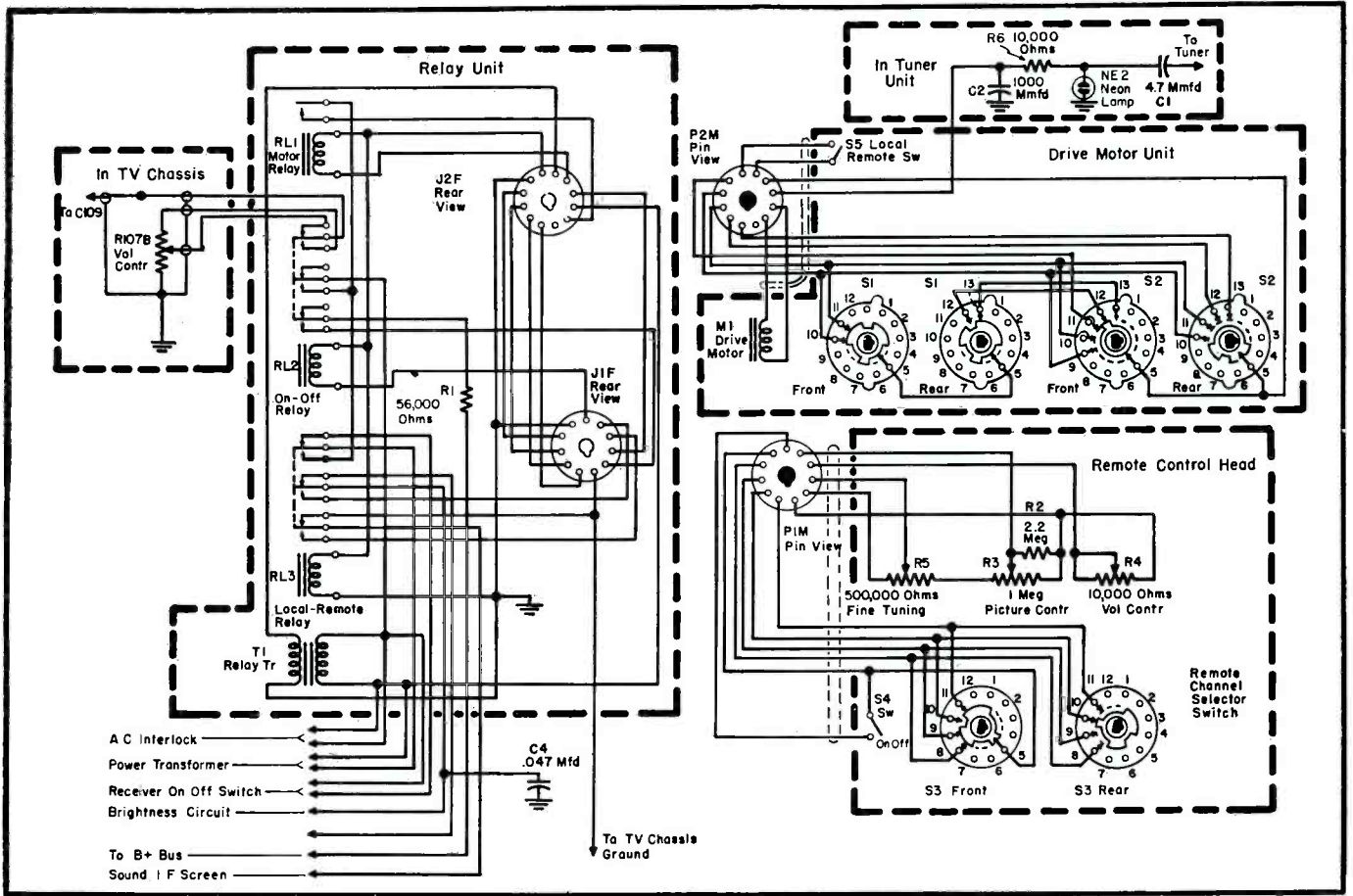

Fig. 3. Schematic of the RCA remote tuning system.

regular receiver power switch is re-connected.

The sound volume control takes two forms, as shown by Figs. 4 and 5. The choice of circuit depends on the chassis under consideration. In the Fig. 5 setup, the audio signal delivered to the speaker is dependent upon the amount of degeneration provided by the resistor and series capacitor connected from the plate of the audio output tube to the cathode of the first audio amplifier, and shunted to ground from that point to ground by a variable resistor physically located at the remote head. As the shunt resistor value is increased from zero, the output power deliv-

ered to the speaker is decreased due to the increased degeneration. With this circuit, the volume cannot be reduced to zero, regardless of how much degeneration is employed. However, the range of control is sufficient to satisfy most users. A decided advantage of this circuit is the sound improvement obtained at reduced volume levels, due to a substantial amount of speaker damping.

#### Second Volume Control Circuit

In the second form of sound volume control, the limiter screen voltage is reduced to zero by a variable shunt resistor, while the cathode of of

the same tube is biased a little positive to reduce the detector input to zero and, hence, give zero audio output. At the same time, the voltage supply for the first audio amplifier is lowered to reduce substantially any hum or buzz that may be picked up at the first audio grid circuit. Since the cathode circuit of the first audio amplifier is not changed, this method is the preferred one in those chassis that use the first audio tube as a bias clamp diode.

The brightness circuit is conventional; it is not ganged, and does not interact with the receiver control, but merely duplicates the same performance.

Fig. 4 (below). Sound if amplifier circuit with modifications required to accept the remote-control system.

Fig. 5 (right). Another sound volume-control circuit arrangement for remote connection.

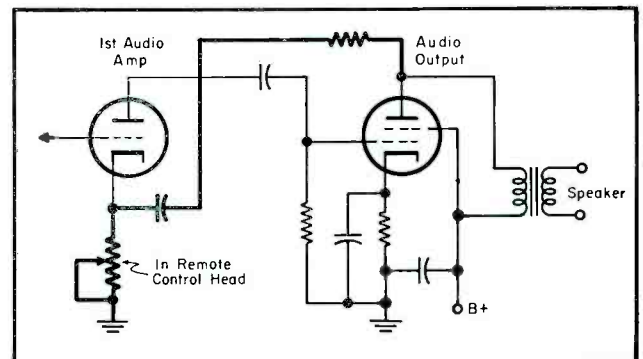
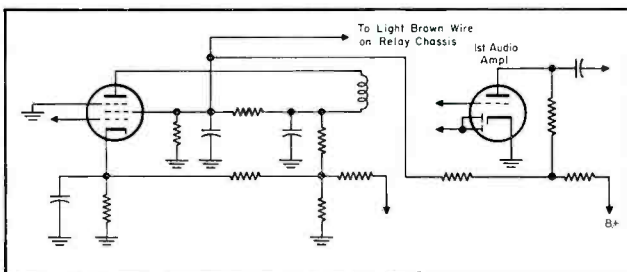

# The 'Scope In COLOR-

## General Requirements of 'Scope Response During Color-TV Installation and Repair

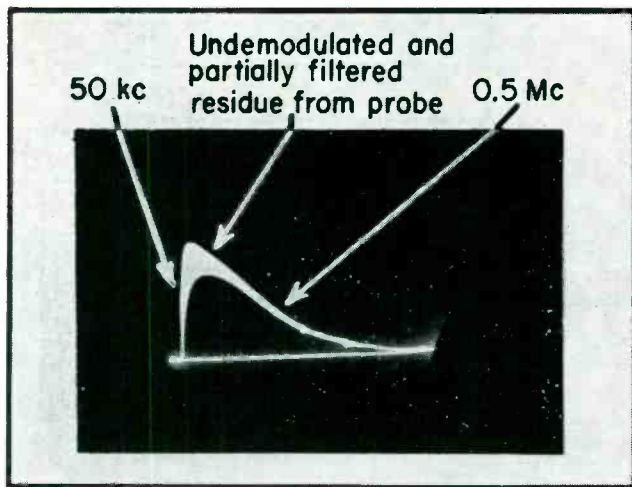

**Fig. 1 (left).** Frequency-response curve of an (R-Y) demodulator circuit in a color-TV receiver. The general appearance of the curve is somewhat similar to curves displayed by black-and-white TV circuits, but the very-low frequency band is utilized. Note the residue from the detector probe appearing on the low-frequency end of the curve.

A 'SCOPE, for use in color-TV service, must have several characteristics which can be relaxed in black-and-white applications.

The frequency response curve of an (R-Y) detector circuit in a color-TV receiver is shown in Fig. 1. Here we find that while this response curve has a general similarity to curves displayed by black-and-white circuits, it will be noted that, first, the frequency band of the circuit is very low, extending only to .5 mc. The low-frequency end of the curve extends to 50 kc, and although the circuit has response at lower frequencies, we do not see this low-frequency response in the display for two reasons; the sweep generator does not provide appreciable output below 50 kc, and the demodulator, or detector probe, which is utilized in the test, also does not have much response below 50 kc. The probe also has incomplete demodulation and filtering action at low frequencies, which accounts for the fuzzy residue seen on the curve at the low-frequency end.

To display such a frequency-response curve satisfactorily, it is only necessary that the 'scope have good

60-cycle square-wave response. Good 60-cycle square-wave response can be obtained if the 'scope has flat frequency response down to approximately 20 cps, to maintain a linear phase characteristic at 60 cycles.

In Fig. 2 another important frequency-response curve from a color-TV receiver is illustrated; the response of the chrominance bandpass amplifier, which filters out the chrominance signal band from the complete color signal delivered by the picture detector. Here again, relatively low frequencies are processed, extending from approximately 2 to 4 mc. The shape of this response curve and its frequency limits are quite important in obtaining good color reproduction. A demodulator probe is also required with the 'scope, to obtain the curve display shown in Fig. 2.

One will note that the curves illustrated in Figs. 1 and 2 appear inverted, with respect to each other. This is a function of the diode polarity in the demodulator probe which is used, and the curve becomes inverted when the polarity of the diode in the probe is reversed. Experienced oper-

ators are usually unconcerned whether the curve appears right-side-up, or upside-down, but others usually like to have control of the curve aspect, so that it appears exactly as shown in the service notes.

Hence, some 'scopes provide reversing switches in the vertical-amplifier section, so that any curve can be inverted at will, as illustrated in Fig. 4. This illustration also shows the facility of a horizontal reversing switch, whereby the low-frequency end of the curve can be made to appear at the left-hand end, or at the right-hand end of the pattern. The same curve is observed in each case, but it is seen that the curve can be displayed in four different aspects when a vertical- and a horizontal-polarity switch are provided in the 'scope.

### High-Frequency Response for Chroma Checks

In addition to good low-frequency response, the 'scope must also have good high-frequency response for various checks of the chroma signal. Fig. 5, for example, shows the out-

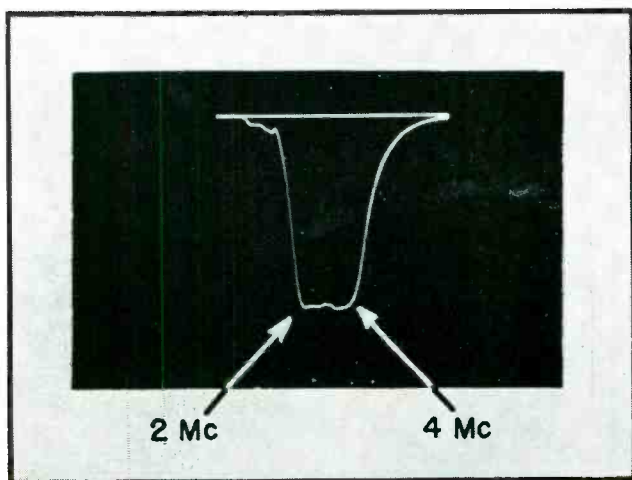

**Fig. 2 (left).** Typical bandpass-amplifier response in color receiver. Except for the fact that the center frequency of the circuit is relatively low, familiar principles of black-and-white receiver alignment apply in application of the sweep generator and 'scope.

**Fig. 3 (below).** To test the frequency response of a 'scope, one should apply the output from a known good video-frequency sweep generator to the vertical-input terminals of the 'scope as shown in this drawing.

†From a field report submitted by **Robert G. Middleton**, Chief Field Engineer, Simpson Electric Company.

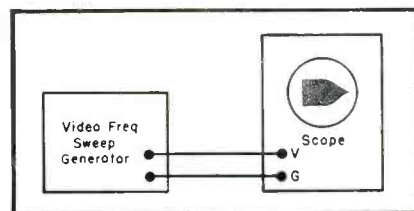

# TV Service ‡

by G. S. RYANT

**Fig. 4.** Some 'scopes provide facilities for reversing and inverting the pattern, as illustrated at right. Many like to bring the curve into the same aspect as shown in the service notes for the receiver.

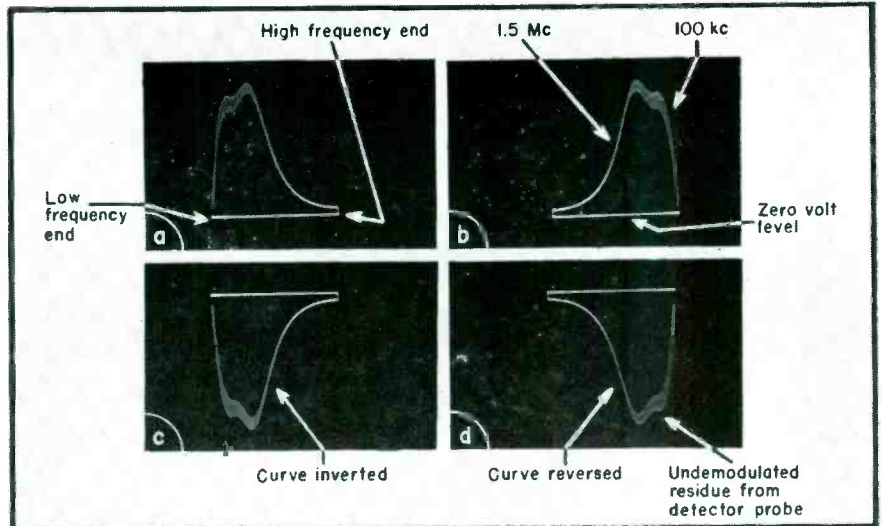

put from the picture detector in a color-TV receiver, when an NTSC color-bar signal is applied to the antenna-input terminals of the receiver, and a wide-band 'scope is applied at the output of the picture detector. The sync pulse has a fundamental frequency of 15,750 cps, but the burst and chroma signal have a frequency of 3.58 mc. It is apparent that unless the 'scope has full response at 3.58 mc, the burst and the chroma signal will not appear at full voltage is the display. Hence, one will be misled, if the 'scope attenuates a 3.58-mc signal, because it would be concluded that the receiver is not passing the 3.58-mc signal voltage as it should; in consequence, the receiver circuits would be misaligned in a misguided attempt to obtain the specified waveform.

The best way to test a 'scope for frequency response is to apply the output from a good video-frequency sweep generator to the vertical-input terminals of the 'scope, as shown in

Fig. 3. The result of this test is an undemodulated display of the video-frequency output, as shown in Fig. 6. If the frequency response of the 'scope is flat, the pattern will be flat; if the 'scope attenuates the higher frequencies, this attenuation will appear in the pattern. Of course, any deficiencies in the sweep-generator output will cause similar deficiencies to appear in the pattern; hence the necessity for using a good generator.

When the same video-frequency sweep signal is applied to the vertical-input terminals of a narrow-band 'scope, the high-frequency response appears greatly attenuated, as seen in Fig. 7. The same disparity in displays is observed when testing the wide-band versus the narrow-band facilities of a dual-band 'scope. A dual-band 'scope is often useful in color-TV servicing, because the narrow-band position provides more gain for alignment of low-sensitivity circuits, such as front ends, chroma bandpass amplifiers, etc.

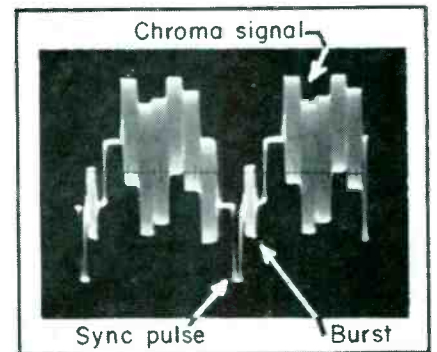

(Above)

**Fig. 5.** Typical waveform observed at the output of the picture detector in a color-TV receiver, when a color-bar signal is applied at the antenna-input terminals of the receiver, and a wide-band 'scope is applied at the output of the picture detector.

**Fig. 6 (below).** Frequency response of a typical wide-band 'scope used in color service. The vertical amplifier shows approximately 2 db attenuation at 4 mc, and this point must be kept in mind when testing color-sync and similar circuits. **Fig. 7 (below, right).** Response of a narrow-band 'scope amplifier to a wide-band video sweep signal.

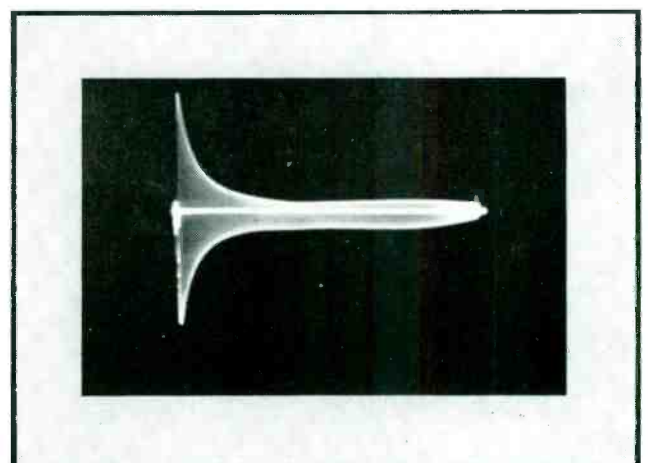
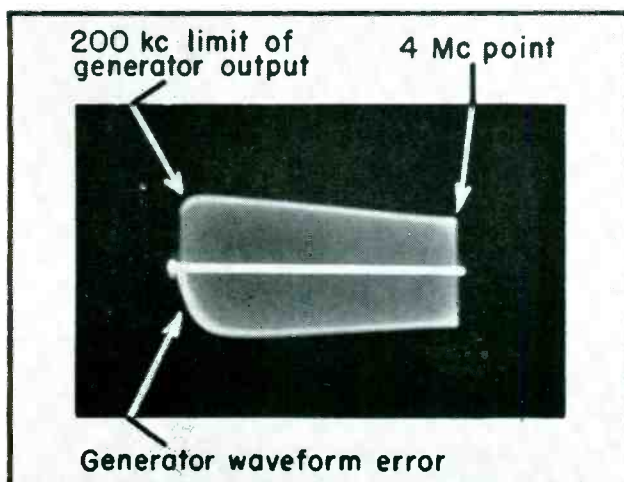

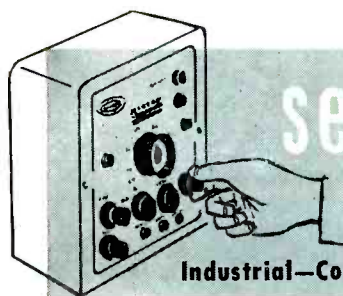

# service engineering

## FIELD AND SHOP NOTES

Industrial—Commercial—Institutional Communications—Audio-TV Installation—Maintenance—Repair

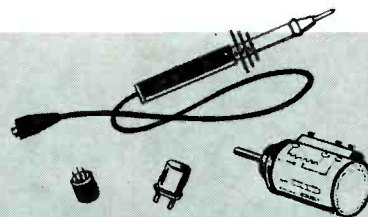

A GREAT DEAL has been done by the automotive industry to eliminate noise sources. They have produced resistor type spark plugs, resistor type cabling and suppressors for insertion in the distributor leads. As usual, a good solution to noise is a filter, and in this case the simplest filter has proven to be most efficient: a coax capacitor, usually a 0.5 mfd. Such capacitors installed in the battery lead to the regulator, in the lead from the regulator to the generator, or in the ignition key lead prove beneficial, but cannot be counted on as a cureall. Service engineers have found that it is sometimes necessary to add such capacitors at the tail lights at the various oil pressure and temperature gages before they can be sure that the noise has been suppressed.

### Problem Isolation

Once the unit has been properly installed and the vehicle noise suppressed, the service engineer can anticipate some of his future problems that must be isolated to one of four mobile areas: the transmitter, the receiver, the power supply or the installation. Ability to evaluate quickly and isolate a problem is an important function and bears a direct relation with the profits of running a 2-way repair business.

As long as the mobile units are checked periodically for frequency and modulation in accordance with the FCC rules and regulations, the base station can be used to provide a simple means of signal source and monitor. Thus, normally all that is required in the field is a tuning tool, screwdriver, and a 20,000 ohm-per-

**Right: Antenna lengths using RG-8/U coax cable. When antenna is mounted with base spring, length is measured as illustrated. If antenna spring is not used, 5" must be added to the length shown on graph. For frequencies below 33 mc, an antenna coil (with an 84" whip) should be used. Ranges and number of turns required on antenna coil are: 25 to 28 mc (10 turns), 28 to 30 mc (8 turns), 30 to 51 mc (6 turns), 31 to 33 mc (4 turns).**

## Two-Way System Servicing: Noise-Elimination Filters . . .

## Troubleshooting Receiver-Transmitter Components . . .

by **GEORGE W. VASS**, Supervisor, Communications Field Engineering  
General Electric Company

volt meter which covers the 0-3 volt range.

In the transmitter area, the two problems which will be most common are lack of power output or no modulation; it has been shown that in almost 99% of the cases of either problem the culprit will be a tube. The trouble is usually reported from the operator of the vehicle as: "I can-

not talk to the dispatcher, but I can hear him okay." Such a statement indicates that probably the antenna and installation are in order and so is the receiver, and when the equipment is low band, the possibility of a *blind spot* is remote. One can isolate the problem quickly direct to the transmitter by a quick check on fuses and

(Continued on page 34)

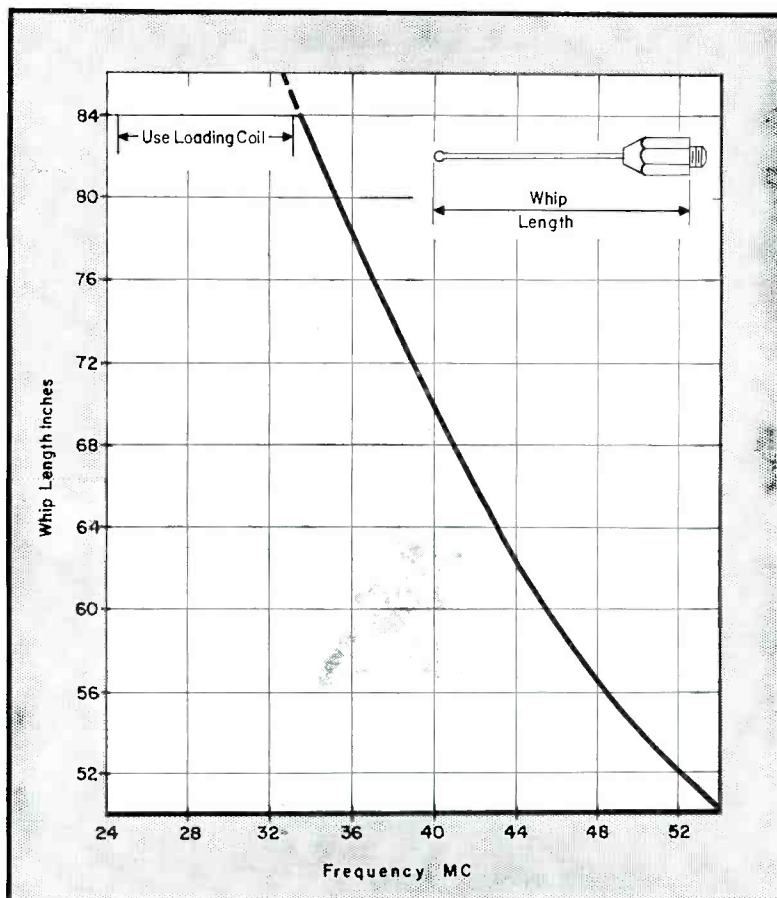

ALLIANCE TENNA-ROTOR MODEL T-12—with Tenna-Teller pointer. Gives constant and immediate readings. Highly accurate. Most modern styling. Fingertip electrical control. \$29.95

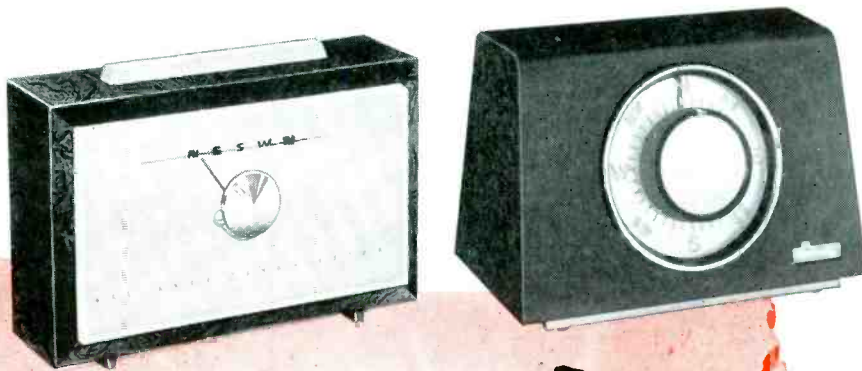

ALLIANCE TENNA-ROTOR MODEL U-98—Deluxe Model. Points antenna directly, positively, instantly to target station. The only fully automatic rotator! Just set it and forget it! \$39.95

You profit most-Coast-to-Coast

from **ALLIANCE**

**POWER-PACKED PROMOTION**



ALLIANCE TENNA-ROTOR MODEL K-22 —Economy Model. Same quality, precision manufacture. Neat, compact, fully guaranteed. \$19.95

30,000,000 "home demonstrations" on TV week after week . . . seven years of continuous Alliance TV advertising! That's solid backing for you which no other TV accessory has even approached.

And that's not all . . . Alliance magazine and newspaper advertising and point-of-sale displays provide added impact.

Millions KNOW about Alliance . . . more USERS have Alliance Tenna-Rotor.® You can't miss with the "leader"!

**Another Outstanding Profit-Maker!**



**LIFT-A-DOR**  
GARAGE DOOR OPERATOR

Radio-controlled (from car dash) automatic garage door operator —opens, closes, locks door, turns lights on and off. Factory-assembled for easy installation. Customers gleam when you tell them the low price! Models from \$79.95 up.



**THE ALLIANCE MFG. COMPANY, INC. • Alliance, Ohio**  
IN CANADA—ALLIANCE MOTORS, SCHELL AVENUE, TORONTO 10

# in ceramics

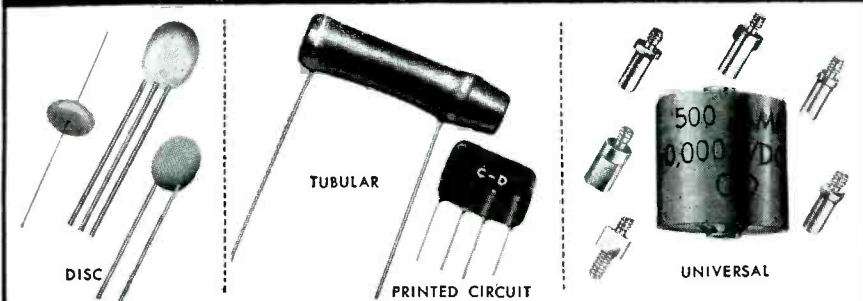

you can see why C-D is always the leader

## THE ONLY CERAMIC WITH THE MILLION-DOLLAR BODY

C-D Ceramic Capacitors are made from beginning to end under one roof in a huge plant devoted completely to ceramic capacitor production. Every process . . . every ingredient is under constant control. You can see the reasons for C-D's outstanding superior quality.

And to help you, C-D Ceramic Capacitors are packaged in compact, crystal-clear, easy to handle and always usable plastic boxes (no extra charge). That's why Distributors *who know* carry the complete C-D line. See your C-D Distributor today. He's listed in your local Classified Telephone Directory.



There are more C-D capacitors in use today than any other make.



## CONSISTENTLY DEPENDABLE CORNELL-DUBILIER CAPACITORS

PLANTS IN SOUTH PLAINFIELD, N. J.; NEW BEDFORD, WORCESTER AND CAMBRIDGE, MASS.; PROVIDENCE AND HOPE VALLEY, R. I.; INDIANAPOLIS, IND.; SANFORD AND FURQUAY SPRINGS, N. C.; SUBSIDIARY: THE RADIART CORPORATION, CLEVELAND, O.

### Service Engineering

(Continued from page 32)

**B+**. Keying the transmitter and observing the neon bulb used in the output circuit of many commercial transmitters will pinpoint the problem to being either one of power or modulation.

Should the neon bulb indicate, by its failure to glow to proper brilliance, that it's a power problem, then the stage at fault can be isolated. In the case of modulation problems, there are fewer tubes to check; usually only the audio amplifier and modulation limiter. Frequently it will be necessary to check all the way back

to the mike itself before eliminating the problem. It is true, of course, that a unit that is off frequency far enough can result in the same complaint; but if the service engineer has been observing the action of the base station discriminator, he can predict in advance that frequency is not the source, because usually frequency-drift problems are not spontaneous in nature, such as a tube or mechanical failure of a mike.

Receiver-area problems again are usually traceable to tubes. The re-

\*In low-band operation, where noise levels are likely to give false readings, the circuit should be monitored with the antenna off and antenna input terminated in approximately 50 ohms.

ceiver has a heart, which when monitored, is an excellent indication of the unit's health; this vital monitoring point is the second limiter. Most manufacturers indicate a minimum value in their instruction books that this circuit should show on noise, if the receiver is in a healthy condition. In the low-band line of our design, this minimum value is .62 volt, as read on a 0-3 volt meter.\* It is important that this circuit be monitored at the time of installation, when one knows that the receiver is in a healthy condition; this information can then be filed away.

### Other Check Points

In cases where readings are below normal and **B+** and filament voltage checked normal, then we would have to suspect a tube either in the front end or *if* strips. The first oscillator can be easily checked at its monitoring point and isolated or eliminated as a trouble source. The receiver has one more point of observation, which in effect makes it an easier unit to service; the discriminator. Monitoring this point is a fast and accurate way of knowing that the receiver is on frequency. With the exception of the antenna transformer and *rf* stage, no adjustments to the receiver should be made without reference to the manufacturer's instruction book. Usually no other adjustments will be necessary, unless frequency is to be changed, the unit is to be converted from a wide to narrow band, or one has tampered with the circuits.

Should the **B+** prove to be a source of the problem, the power supply must be examined.

The power supply has metering jacks to monitor **B+**. If **B+** appears at these points, but not at the transmitter or receiver, then the problem could be one of interconnecting cables. However, this is not usually the case. In the power supply we do not have tubes to contend with, but we do have moving parts; vibrators, dynamotors and relays. Any moving part is subject to wear and therefore these three items are definitely potential sources of trouble. The part that has the most action, the vibrator, is the most likely source, and as a tube, has a definite life span.

The dynamotor usually supplies **B+** only for the *p-a* in the transmitter. This component should not be a source of trouble *if* preventive maintenance is followed. Brushes, bearings, and armatures are all subject to wear and through preventive maintenance and replacement can be stopped from causing trouble. The relays used in the power supplies require little care. They should be in-



spected periodically, however, to assure maximum operating efficiency. If the contacts become pitted, they should be cleaned with a burnishing tool to smooth out any metallic deposits. When relay contacts carry little or no current, the contacts do not clean themselves and an insulating coating is apt to form. This coating may be removed by cleaning the contacts with a burnishing tool. One must not oil the relay bearings. When relays are in dusty locations, lubricated bearings will collect dust and grit and will wear more rapidly than non-lubricated bearings. Some of the relays used are of the multiple-contact type, and, in the unenergized position, the approximate contact spacing should be from .0625" to .125". Most important, the spacing between contacts on any multiple-contact relay should be equal so that, when the relay is energized, the contact pressures will be equal. It is necessary to check the back pressure of the antenna relay, which should be at least 15 to 20 grams.

It was mentioned earlier that there were four areas of possible problems. Three of these areas have been covered. The fourth, installation problems, stem only from the vehicle itself, if the necessary planning and care was taken during the installation of the mobile unit. Assuming that this was done, then, to insure good electrical continuity and high-operating efficiency, routine checks should be made of all mechanical and electrical connections and parts. Battery and equipment connections to the voltage source should be periodically checked for tightness. Loose or poor connections to the power source will cause excessive voltage drops and faulty operation may ensue. The vehicle generator and generator regulator should be maintained regularly to keep the generating system within safe and economical operating limits. The vehicle regulator is the basis of control and should automatically limit the charging circuit from exceeding predetermined values. If generator voltage is excessive, tubes and lights may burn out prematurely. This condition is indicated when the battery loses water rapidly. Usage of 1 or 2 ounces of water per cell per week is acceptable for batteries in continuous operation.

The anticipation of problems and the ability to analyze a system, isolating problems to the proper component part of the system, not only results in an effective communication system for the 2-way net, but a profitable operation for the mobile service engineer.

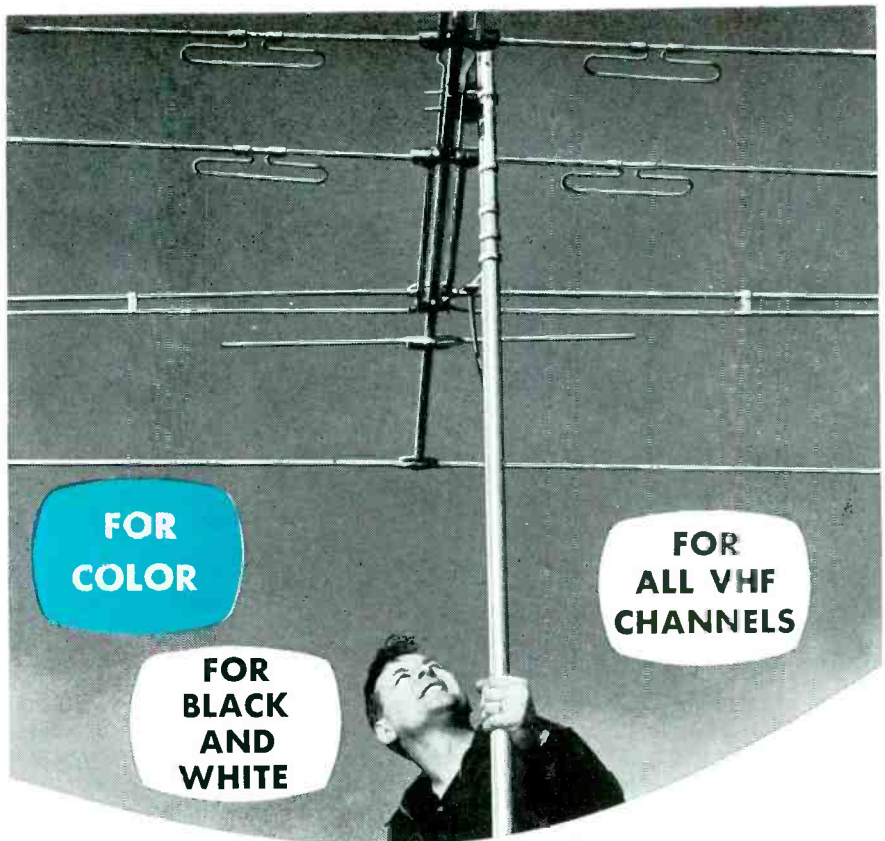

**FOR  
COLOR**

**FOR  
BLACK  
AND  
WHITE**

**FOR  
ALL VHF  
CHANNELS**

another installation...  
**on the beam!**

with a **TACO**  
**TRAPPER**

A job well done! You can guarantee the very best reception for the customer, and there'll be no costly call-backs or complaints, when you install one of the Taco family of Trapper antennas. The Trappers will outperform and outlast all the other antennas in the neighborhood.

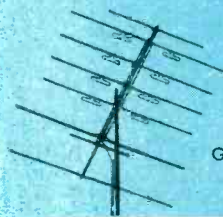

**SUPER  
TRAPPER**

Working elements  
—24 high band and  
7 low band.  
Gain up to 12 DB on  
high band and  
9 DB on low band.

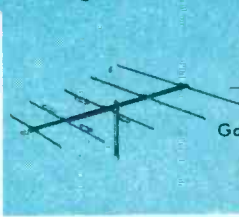

**TRAPPER**

Working elements  
—15 high band and  
5 low band.  
Gain up to 10 DB on  
high band and  
7 DB on low band.



**TRAPPER  
ROYAL**

Working elements  
—15 high band and  
5 low band.  
Gain up to 11 DB on  
high band and  
7½ DB on low band.

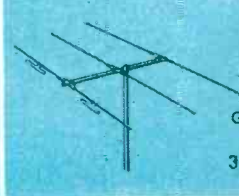

**TRAPPER JR.**

Working elements  
—7 high band and  
3 low band.  
Gain up to 8 DB on  
high band and  
3½ DB on low band.

**TECHNICAL APPLIANCE CORPORATION • SHERBURNE, N. Y.**  
In Canada: Hackbusch Electronics, Toronto 4 Ont.

# Grid-Drive Measurement . . . Improving TV Reception in Extreme Fringe Areas

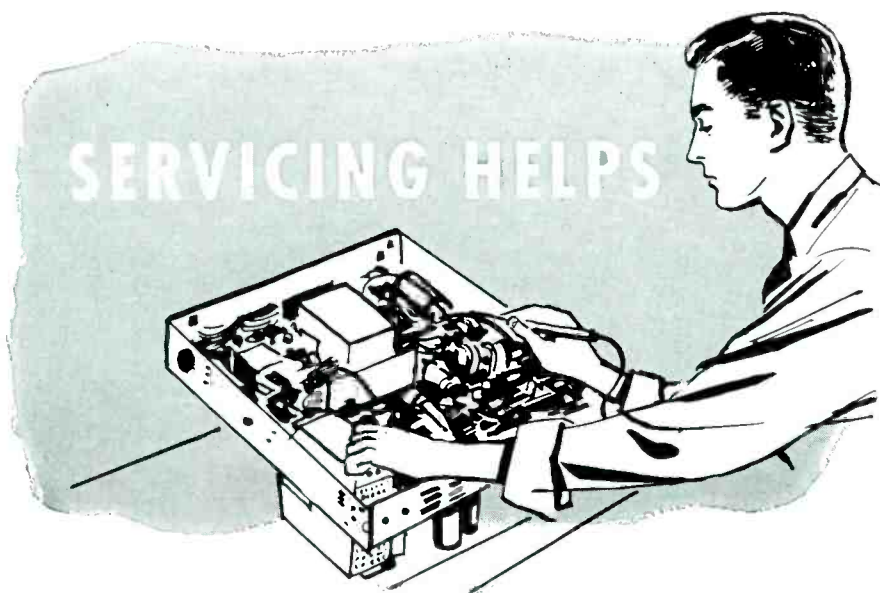

IN THE HORIZONTAL amplifier, which is an *ac* amplifier, an adequate (*ac*) signal must be present if the horizontal output is to perform its mission. Since this signal is *ac* it must be measured with an *ac* voltmeter.

The standard electronic voltmeter or the ordinary *ac* section of a portable service instrument will measure this grid drive, but differently from the more common 60-cycle power voltages. The power line voltages are indicated on the meter as *rms* or effective values. And the grid drive to the horizontal output tube's grid is measured in volts peak-to-peak.

The ordinary meter can be used for measurement of complex waveforms and the result can be interpreted in terms of peak-to-peak values. This involves only the measurement of the peak-to-peak values on a TV

chassis, known to be in good condition, with a 'scope or a peak-to-peak voltmeter. Then the voltmeter can be connected to the same circuit through a blocking capacitor to eliminate any *dc* which might be present and influence some types of meters in their indication. Such a setup is illustrated in Fig. 2; a series-blocking capacitor is connected in the line from the *hot* probe.

### Readings Obtained

The reading obtained with this *vm* arrangement will be about one-fifth to one-sixth of the peak-to-peak value.

Measurement will be found to be a fifth to a sixth because only the effective value of a 60-cycle sine

°RCA KCS96 or KCS97 chassis.

wave's *peak* (one peak only), not peak-to-peak, is being measured.

The presence of this *ac* signal, which is perhaps 15-20 volts instead of the 100 volts peak-to-peak is a sure-fire indication of horizontal oscillator trouble. Such a signal decrease means lack of signal from the oscillator due to malfunction in the coupling network.

For example, let us assume that the indicated reading is only 5 volts on the *rms* meter. The factor for conversion from peak-to-peak to *rms* has been found to be 5.4 at 15,750 cps. The peak-to-peak voltage is then  $5 \times 5.4 = 27$  volts p-p. Obviously something is wrong here or in the preceding circuitry or the oscillator, tube. To check further, we apply the *vm* to the side of the coupling capacitor ( $C_c$ ), next to the oscillator, at point B in circuit diagram of Fig. 2. Here we now measure 18 volts *rms*, or  $18 \times 5.4 = 97.2$  volts p-p, which is very close to the 100 volts required. About the lowest grid drive tolerable is 55 volts p-p. In the case just cited, the coupling capacitor ( $C_c$ ) could have lost its capacity or the adjustable drive capacitor could have too much capacity, thereby reducing the drive. In one case, it was found that the drive capacitor was shorted to the chassis, and the grid resistor returned to a common minus.

### Extreme Fringe Area TV Reception

IN EXTREMELY WEAK signal areas, far beyond *normal* reception, receiver efficiency must be at its peak.

Tubes in the tuner and the first or second picture *if* amplifier require special attention. Sensitivity or signal-to-noise ratio on RCA° sets might pos-

(Continued on page 39)

Fig. 1 (left). Schematic of sync stabilizer incorporated in RCA KCS96-97 chassis.

Fig. 2. Circuit illustrating connection of *ac vm* to determine horizontal output amplifier grid drive. A = drive at grid of horizontal output; B = drive ahead of coupling capacitor  $C_c$ .

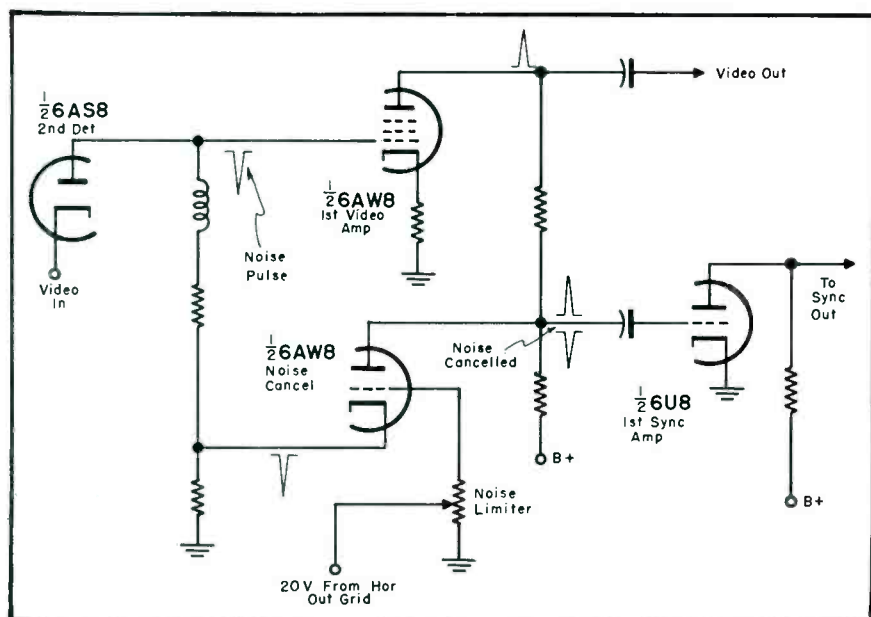
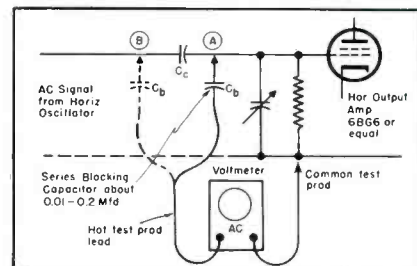

America's  
**NEW**  
Favorites!

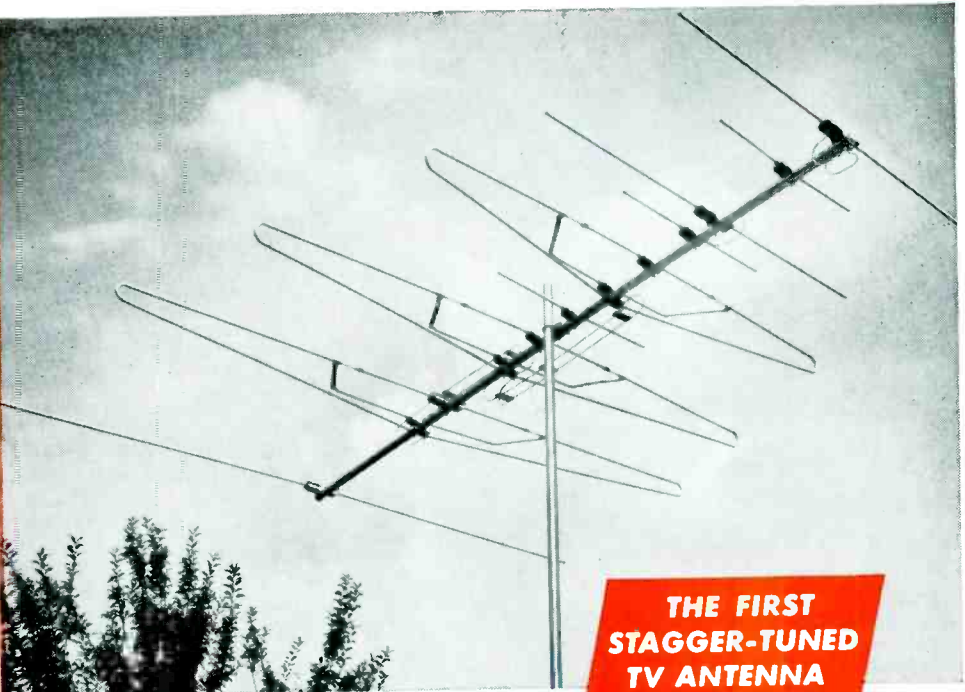

**THE FIRST  
STAGGER-TUNED  
TV ANTENNA**

**TRIO** *Zephyr Royal*

**MODEL ZR-1** PATENT NO. 2,703,840

**SUPERIOR IN**

- design
- workmanship
- performance

**highest performance ever achieved in a TV antenna**

Now, the tests of TRIO engineers have been confirmed unanimously by scores of unsolicited reports from the field. Distributors, dealers and thousands of consumers have verified these tests, proving it's the best antenna ever designed. The ZEPHYR ROYAL's performance on ALL CHANNELS, 2 thru 13, is nothing short of miraculous, thanks to its revolutionary new WING DIPOLE PRINCIPLE and STAG-

GER-TUNING developed and introduced by TRIO engineers. It is pre-assembled—uses Instalok Clamps; fiberglass insulators and riveted construction, is light-weight, yet extremely rugged. For these reasons the ZEPHYR ROYAL is America's new favorite—the No. 1 Antenna—electrically and mechanically—and one bay does it!

**TRIO** *Zephyr*

**more performance per dollar  
than any other antenna!**

The TRIO ZEPHYR is the popular choice when the extra features of the ZEPHYR ROYAL are not required. Using two of the revolutionary new wing dipoles, the ZEPHYR will outperform any other antenna in its price range on the market. Needless to say—the ZEPHYR uses the same superior construction features found in the ZEPHYR ROYAL. For its size and weight, its performance also is nothing short of miraculous!

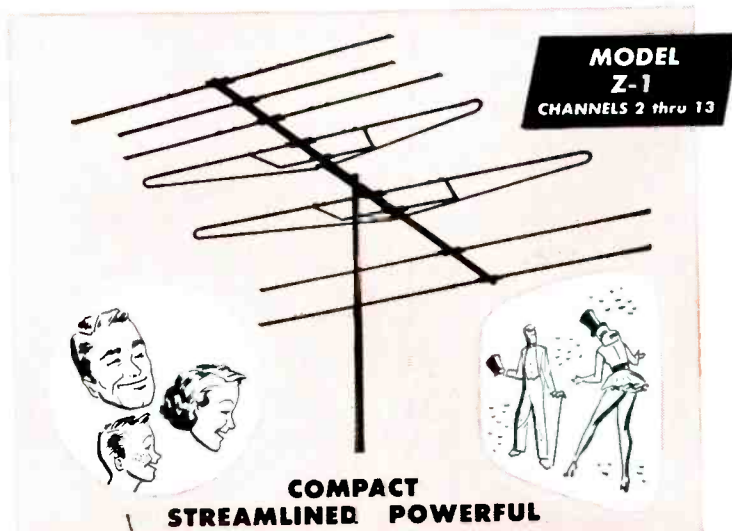

**COMPACT  
STREAMLINED POWERFUL**



**TRIO**® *Manufacturing Company*  
GRIGGSVILLE, ILLINOIS

COPYRIGHT 1955—TRIO MANUFACTURING COMPANY

**LEADER IN  
ANTENNA DEVELOPMENT**

Export Sales Div.: Scheel International, Inc., 4237 N. Lincoln Ave., Chicago, U.S.A. Cable Address: Harscheel

# A-M-P

## terminals

**your best  
connection  
for  
dependability  
and  
quality**

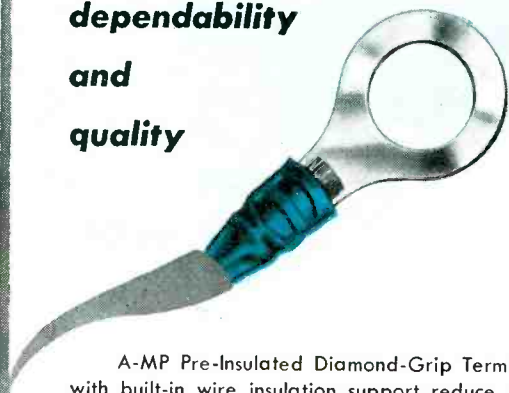

A-M-P Pre-Insulated Diamond-Grip Terminals with built-in wire insulation support reduce your maintenance cost... because they insure perfect electrical connections under the most exacting conditions. You don't have to worry about replacement.

The A-M-P Pre-Insulated Diamond-Grip Terminal is not affected by heat or cold, and vibration won't cause broken strands. Moreover, PIDG colored insulation shows you at a glance which wire size it accommodates and which tool connects it. No errors... no loss of time... and a lot of saving!

API branch warehouses in major cities stock popular A-M-P terminals and tools for maintenance and repair purposes. An API representative can prepare a Custom Fitted Kit containing just the items you need. Contact your nearest API office.

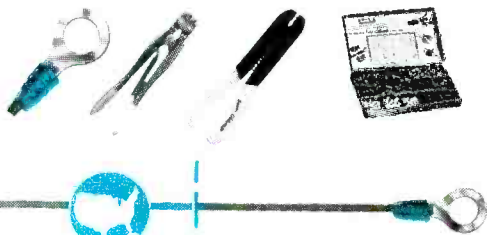

# api

\*TRADE MARK

**AMERICAN PAMCOR, Inc.**  
Subsidiary of Aircraft-Marine Products, Inc.  
181 Hillcrest Ave., Havertown, Pa.

Atlanta, Ga.  
Boston, Mass.  
Chicago, Ill.  
Cleveland, O.  
Dallas, Texas  
Detroit, Mich.  
Hawthorne, Cal.  
Maplewood, N. J.  
Philadelphia, Pa.  
Pittsburgh, Pa.  
St. Louis, Mo.  
San Francisco, Cal.

# Associations

## AEC

FORREST BAKER, formerly president of the Texas Electronics Association, has been elected temporary chairman of the recently formed American Electronic Council, set up in Chicago to query local and state associations on their views on the formation of a national organization.

Others named to temporary posts were Bert Bergenzer, vice prexy (FRSAP); Murray Barlowe, treasurer (RTG-L.Is.); and Howard Wolfson, secretary (ARTS, Chicago).

## TSDA, Chester, Pa.

WILLIAM H. MORROW is now president of the Television Service Dealers Association of Delaware County, succeeding John J. Matthews, who has become vice president.

Other officers are Joseph Bell, secretary and Peter Rapagani, treasurer.

## ARTSD, Columbus, O.

JIM CUMBOW has been elected prexy of the Associated Radio-TV Service Dealers Association in Columbus, O. Harry Walcutt is now vice president; Bob Hawthorne, treasurer; and Jack Voigt, secretary.

On the board of directors are Dick Lyle, Dave Ramsey, C. LeRoy, Fred Colton, and Dick Kassian.

## RSA, Trenton, N. J.

AT A RECENT ELECTION of the Radio Servicemen's Association, Inc., of Trenton, N. J., the following members were elected: Francis J. Wolf, president; David Van Nest, vice president; Michael E. Toth, secretary, and Charles A. Rebman, treasurer.

Frank J. Guest has been retained to serve as a member on the board of directors.

## RTSA, Pa.

RAY BLACKWOOD, chairman of the Beaver Valley chapter of RTSA, Pittsburgh, announced recently that the group celebrated its first year as an active association affiliate at a banquet, which featured a floor show, dancing and door prizes.

## TEN YEARS AGO IN SERVICE

DIRECT-VIEWING (7" and 10") and projection type (18" x 20") 13-channel TV receivers began coming off the production lines... Several manufacturers announced plans for 15" and 20" tube direct-viewing chassis... The first complete report on TV antenna installation appeared in SERVICE. Study not only covered the types of antennas available, but rotator design and solutions to such problems as ghosts, interference, radiation and master-antenna system requirements... Also featured was an exclusive review of the properties of TV signals and how receivers select video and audio... Reports served as basic texts for service association symposia and clinics throughout the country. A number of associations also published booklets with these exclusive SERVICE TV articles for distribution to their membership... The first comprehensive analysis of communication receiver design and repair also appeared in this issue; data served as the basis of many special 2-way system lectures at association meetings... Issue also featured, for the first time, circuitry for a closed circuit TV system... Henry C. L. Johnson rejoined Sylvania Electric Products, Inc., as ad manager of the radio division, and director of ad and sales promotion for the industrial electronics and international divisions, after three years of service in the Navy... J. K. Poff became service manager of the jobber division of the Astatic Corp... Victor Mucher was elected president of Clarostat Manufacturing Co., Inc. George Mucher became vice president and William Mucher treasurer.

## Servicing Helps

(Continued from page 36)

sibly be improved by using a 6BQ7A in the *rf* amplifier and a 6DE6 in the picture *if* amplifier.

Installation of the receiver must be checked. This means not only an adequate antenna installation, but also proper adjustment of such special circuits as *agc* and noise limiter in conjunction with the sync stabilizer. Proper adjustment of both the *agc* and noise limiter controls is essential to the operation to insure sync stability even under weak signal conditions.

The sync stabilizer provides a high degree of noise immunity for the sync circuits. The signal at the second detector is of negative polarity and any noise pulses present will also be negative. The polarity of the video signal and noise pulses is inverted by the first video amplifier so that the signal at the grid of the first sync amplifier is positive.

Another signal path between the second detector and the first sync amplifier is through the noise-cancellation tube;  $\frac{1}{2}$  6AW8. Since the video signal is applied to the cathode of this tube there is no polarity reversal in the plate circuit. A signal arriving at the grid of the first sync amplifier from the noise-cancellation tube will be of opposite polarity to that of the signal from the first video amplifier. Noise pulses, therefore, will be cancelled in the grid circuit of the first sync amplifier. To prevent video or sync pulses from being cancelled also, it is necessary to have a large bias applied to the grid of the noise-cancellation tube. When the bias is properly adjusted with the noise-limiter control only noise pulses will pass through the tube. If the bias is set too high, only a portion of a noise pulse will appear in the output of the noise-cancellation tube and only partial cancellation results. If the bias is set too low, sync pulses (as well as noise pulses) will be present in the output and will cause the sync from the first video amplifier to be attenuated. It is important, therefore, that the noise limiter be properly adjusted; otherwise the sync stability of the receiver could be made worse instead of better. The proper adjustment of the noise limiter, made in conjunction with the *agc* adjustment, involves the following steps.

The noise-limiter control should be set fully clockwise. This adjustment places a large negative voltage (from the grid of the horizontal output

(Continued on page 44)

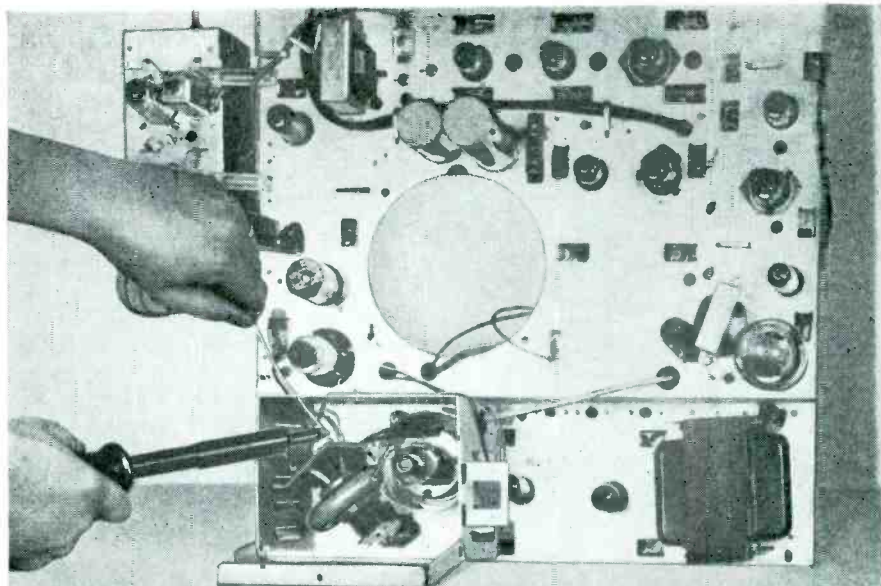

## keep your servicing on-the-go profitably, with RCA SERVICE PARTS

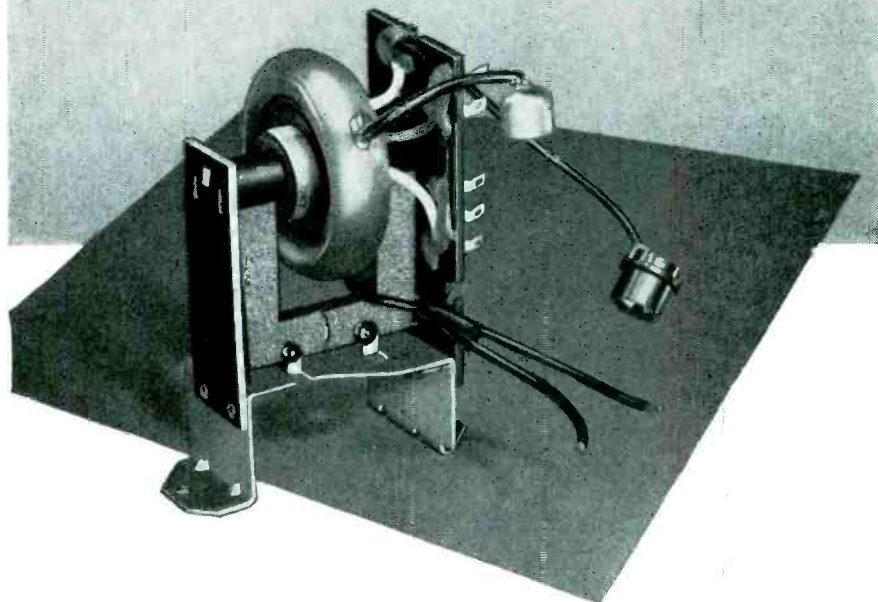

Mechanically and electrically this Horizontal-Output and High-Voltage Transformer is an exact replacement for the high-quality original used in an RCA Victor TV receiver. Like all RCA Service Parts, it is factory-tailored to cut down bench-time by fitting right, installing fast . . . without reaming, drilling, tapping, sawing, or cutting! Add outstanding performance to this ease of installation, and you'll appreciate why smart servicemen everywhere depend on RCA Service Parts to keep their servicing on-the-go profitably.

*RCA Service Parts are the only genuine replacement parts for RCA Victor radios, TV receivers, and phonographs.*



## SERVICE PARTS

RADIO CORPORATION OF AMERICA, HARRISON, N. J.

**RCA VICTOR PRODUCTS • RCA SERVICE PARTS**—made for each other!

SERVICE, FEBRUARY, 1956 • 39

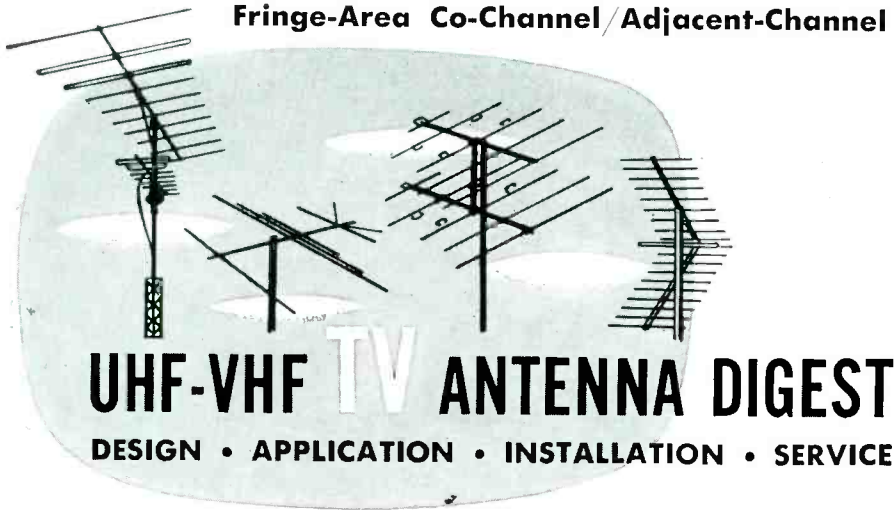

a narrower major lobe, but a minor lobe near  $94^\circ$ , were used.

A broad-band single-bay flat-yagi helix type antenna<sup>°°</sup> that met the foregoing requirements was selected for the job. It was mounted 48' above the ground on a guyed telescoping mast, with a rotator. This model, with a beamwidth of  $40^\circ$  and adequate front-to-back ratio, served to minimize interference and permit satisfactory reception.

As leads, 65' of flat twinlead line were used; the run was made as short as possible to reduce losses.

*Reflection-Ghost Problems*

In stubborn installations, like that found at this Kansas farm, it is best to study the terrain carefully, locate the sources of the reflections, plot their positions on a large-scale map of the location, and select the best installation spot and antenna for the particular reflections involved. A directional antenna enables one to obtain the approximate bearing of reflecting structures; the time delay to the reflected image indicates its distance. For reflections from the opposite direction as the station, one will find that a reflecting body that is a mile away will introduce a ghost that is displaced one-fifth of the picture width. For 1-mile reflection at right-angles to the station, displacement is reduced to one-tenth of the picture width. With this as a guide, offending windmills, metal-roofed barns, silos, or hills can be located, and suitable antenna sites selected.

(Left)

Map illustrating receiving problems at point near Clay Center, Kansas, involving pickup of seven stations from 80 to 115 miles away, with some of the transmitters operating on adjacent and co-channels. KTVH power is 240 kw.

Below: H. A. Printz assembling flat-yagi antenna for fringe-area installation.

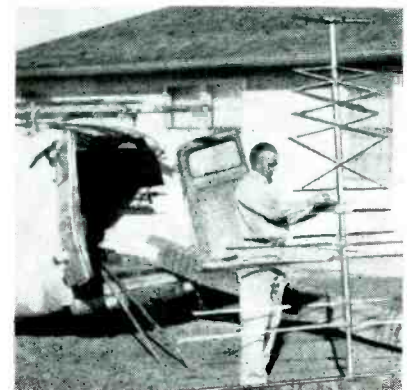

IN THE MID-WESTERN PLAINS fringe areas, interference due to in-line direction of transmitting antennas, adjacent/co-channel and reflection conditions is often a more serious problem than signal weakness. The antenna thus becomes a most critical part of a TV installation.

An interference situation involving all of the foregoing difficulties occurred recently on a farm, about 3 miles northeast of Clay Center, Kansas. At this location there are seven stations that it was felt could be picked up if all of the interference problems could be ironed out. An earlier air check revealed that signals from WIBW-TV (channel 13), the nearest station, located 80 miles away in Topeka, were subject to adjacent channel interference from higher-powered KTVH (channel 12) in Hutchinson, 105 miles away. In addition, signals from other stations on channels 5 (110 miles away), 2 (115 miles out), 3 and 10 (110 miles distant) and 10 (95 miles away) were

being roughed up by reflection and co-channel interference. The solution, it was apparent, lay in the installation of a multi-element, highly-directional type of antenna.

*Adjacent Channel Signal Paths*

In studying the interference problem, it was found that paths to WIBW-TV and KTVH were  $94^\circ$  apart. Thus an antenna having a  $40^\circ$  beamwidth at half-power (3 db) points and little pickup at a point  $90^\circ$  from the base pickup direction would be required to suppress the interfering signal. Any narrow beam antenna has minor lobes in its pattern; it is important that the peak of a minor lobe should *not* be in the direction of a source of interference in installations of this type. For example, it would be difficult to obtain effective suppression control if an antenna with

<sup>°</sup>Based on information supplied by H. A. Printz, of Printz Radio-TV Service, Clay Center, Kansas.

<sup>°°</sup>JFD SX13 Super Star-helix.

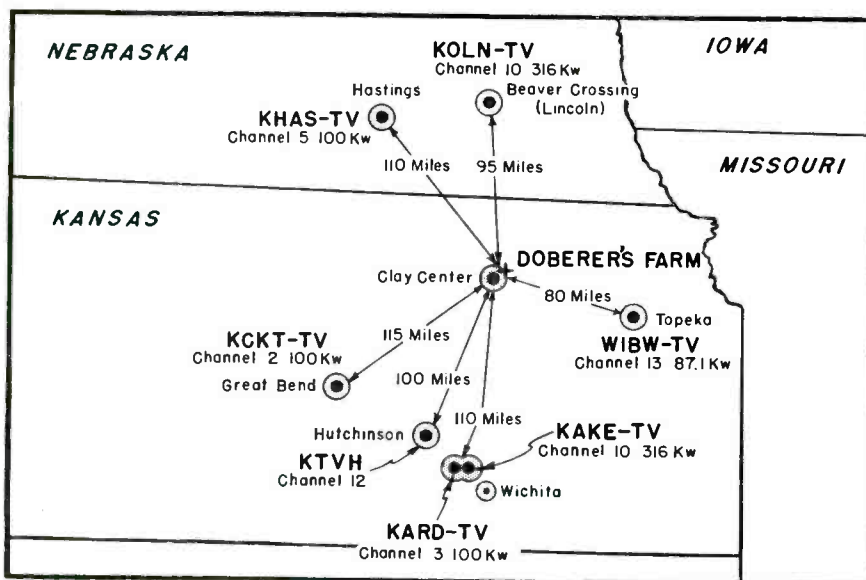

# The Facts

## PROVE...

"STAMINIZED" ASTRON CAPACITORS  
ARE THE *toughest* EVER  
DEVELOPED...

Better designs, Better materials, Better techniques  
are combined to create  
EXTRA-RUGGED, EXACT REPLACEMENT  
capacitors for every servicing need.

Talk about performance!  
Service Technicians will tell you  
"Staminized" Astron Capacitors  
make sets operate better-than-new.

Judge for yourself!

Install "Staminized" Astron Capacitors  
- - the verdict will be in your favor.

Ask your jobber for them today.

### THE BEST YET !



"SM" TWIST-PRONG



"SM" MINIMATE TUBULARS

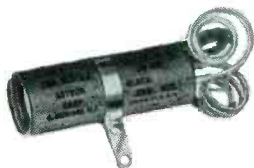

"SM" CARDBOARD TUBULARS

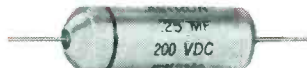

BLUE-POINT®  
MOLDED PLASTIC PAPER TUBULARS

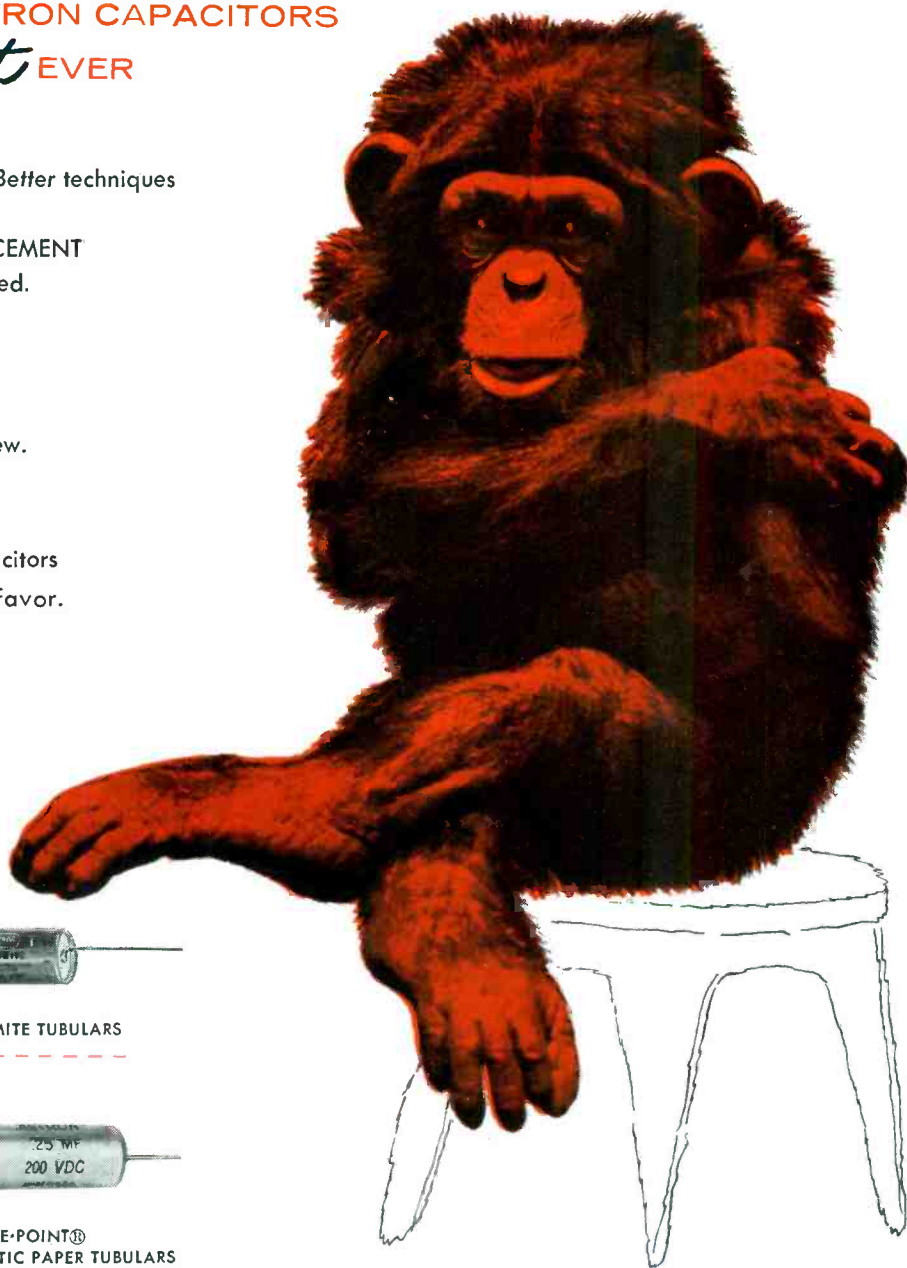

FREE... ASTRON'S NEW SERVICING AID  
Replacement Catalogue AC-4D. Write for your copy — Now!

# ASTRON

C O R P O R A T I O N

WEST COAST WAREHOUSE: 9041 West Pico Blvd., Los Angeles  
EXPORT DIVISION: Rocke International Corp., 13 East 40th St., N. Y., N. Y.  
IN CANADA: Charles W. Pointon, 6 Alcina Ave., Toronto, Ontario



255 GRANT AVENUE, EAST NEWARK, N. J.

VISIT US AT  
BOOTH 368 IRE SHOW  
MARCH 19-22

\*Safety Margin Construction — An Astron Trademark

SERVICE, FEBRUARY, 1956 • 41



# AUDIO

## INSTALLATION AND SERVICE

Phono • Tape • PA  
Cartridges • Needles • Amplifiers • Speakers

### Crossover Networks For Multiple Speakers

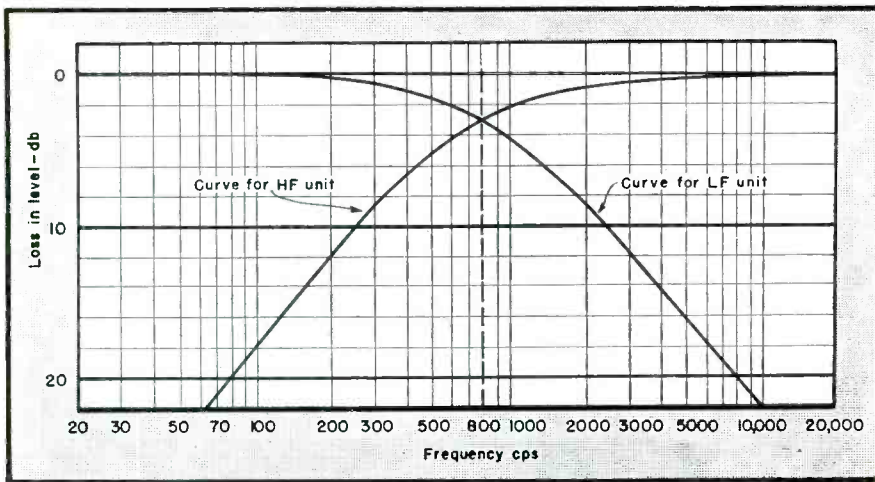

A VARIETY OF electrical crossover networks have been designed for multi-speaker systems to divide energy between woofers, tweeters and other range-extension devices that might be employed.

In the usual statement about crossover performance, assuming that its frequency is 800 cps, for example, we

are normally told that the network delivers all the energy at frequencies below 800 cps to the low-frequency unit and all the energy above 800 cps to the high-frequency unit. This is, of course, an over-simplification of the performance of any practical crossover; it is really an idealized statement of the purpose of a cross-

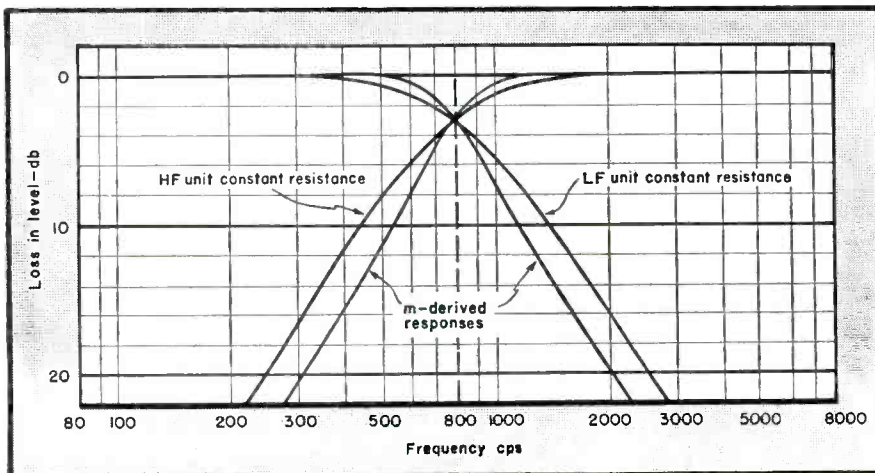

over. In practice, it is impossible to design an electrical network which will pass all the frequencies from zero to 800 cps and then infinitely attenuate 801 cycles and upwards. Even if it were possible to build such a network, its capability to do the job required is doubtful.

What is needed is a smooth transition arrangement whereby, at the crossover frequency of 800 cps, half the energy gets delivered to each unit; at frequencies below 800 cps, more and more of the energy is delivered to the low frequency unit, and above 800 cps, more and more of the energy goes to the high-frequency unit. A good form of response curve for the energy delivered to each unit is illustrated in Fig. 1.

The point to be realized is that even though a crossover is designed to give a response of this form, it will not necessarily do so unless all the impedances in the circuit are the same as those for which the crossover was designed.

Network designers follow either of two techniques in setting up a crossover package. They use completely different approaches, regardless of the number of inductances and capacitors in the unit, the frequency for which the crossover is intended, and the working impedances; one is known as the constant-resistance and the other is called the *m*-derived. Each has its own advantages.

The principal advantage of the constant resistance type is that if correct impedances are connected to the respective high- and low-frequency outputs (that is, if the unit is used with the right loudspeaker impedances) the energy distribution between the two units will be quite independent of the damping factor or source impedance of the amplifier. Today, because of the use of variable-damping amplifiers and amplifiers with a range of different fixed damping factors, this feature is extremely important.

With the foregoing type of crossover the total energy delivered from the amplifier to the combined units is always constant. There is no tendency to emphasize the frequency in the vicinity of crossover or anywhere else. But, with the *m*-derived type it is possible to get a sharper transition in the division of energy between one loudspeaker unit and the other. This means that there is a more definite division of the low frequencies to the

(Left, above)

Fig. 1. Ideal frequency response for a crossover unit.

Fig. 2 (left). Curves illustrating comparison between response of constant resistance and *m*-derived crossovers, using the same number of components in each.



low-frequency unit and the high frequencies to the high-frequency unit.

However, we must pay for this more definite transition, for the *m*-derived unit is more critical as to its terminating impedances. This means that, not only must the loudspeaker impedances be exactly right for the crossover; but also the amplifier source impedance, or damping factor, must be correct for the design of the crossover, and the right impedance tapping must be used on the amplifier output.

A comparison of the responses, with the same number of components, using constant resistance and *m*-derived nets, is shown at Fig. 2; Fig. 4 (p. 46) shows how the latter is dependent on termination.

The roll-off slope beyond crossover depends on how many inductors and capacitors are used in the crossover. The more refined types use an increased number of components, and make a more definitive division between the loudspeaker units. But it is questionable whether this is any real advantage.

It is true that this form of network reduces the possibility of undesirable interaction between the sound output from the speaker units over the range of frequencies where both of them are to some extent active. But with good loudspeaker units, properly connected to the crossover, there should not be any serious interaction with roll-offs that are not so steep; it is a fallacy to make the assumption that because the cut-off frequency of a high-frequency tweeter unit is, say, 1000 cps, the unit will suffer if it delivers any energy at all at 900 cps. And similarly it is fallacious to assume that the low-frequency unit will not deliver any energy 100 cps above the desired roll-off point. The units just become rapidly more inefficient, *but they do not suddenly stop.*

If the loudspeaker happens to be a 7-ohm unit, when it is rated at 8 ohms, the response will be upset more by a complex crossover unit than it

(Continued on page 46)

**Fig. 3. Block schematic illustrating how a universal speaker transformer can be used to match a 4-ohm unit with a 16-ohm unit and 16-ohm crossover.**

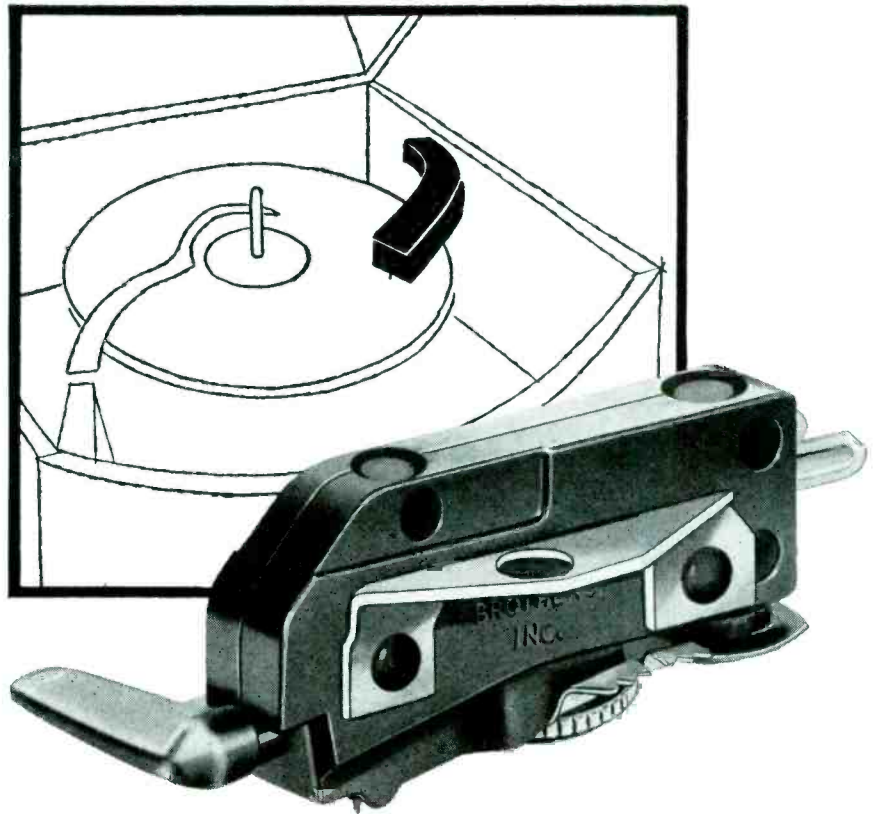
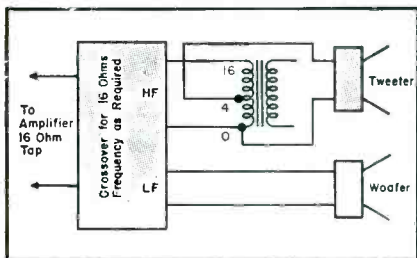

**It's Dramatically New!**

## SHURE 'TWIN-LEVER' Ceramic Phono Cartridge

*The most important advance in phono replacement cartridges since the introduction of 3 speeds!*

- To improve the quality of all conventional home phonographs!
- To replace 128 3-speed, plastic-cased, ceramic and crystal, turnover and single needle cartridges!

We make these strong claims: the "Twin-Lever" is the finest replacement cartridge ever developed! It sets a new high, leaving all other replacement cartridges far behind its brilliant level of tone superiority . . . individual needle compliance for superior 78 rpm and microgroove response . . . unique needle shift design . . . amazingly simple needle replacement.

The "Twin-Lever" offers you maximum replacement coverage with minimum investment because it handles the replacements for practically all 3-speed phonos using plastic-cased cartridges. New business and greater profits can be yours — because this "Twin-Lever" cartridge costs only \$9.50 list — *yet it can make conventional 3-speed phonos sound better than when they were new!*

See your Shure Distributor today — he has the "Twin-Lever" in stock. And here's a tip: *buy more than you think you will need* — or you'll have to go back for more mighty soon. That's how good this cartridge is. And don't take our word for it — ask your first "Twin-Lever" customer what *he* thinks!

### MODEL WC10

List Price **\$9.50**

(including two synthesized sapphire-tipped needles)

### MODEL WC10D

List Price **\$34.00**

(including a 1-mil diamond-tipped needle and a 3-mil synthesized sapphire-tipped needle)

**SHURE**

*The Mark of Quality*

# PAYS ITS WAY every day

**TESTS and  
REPAIRS  
TV PICTURE  
TUBES**

## Makes Customers Happy —Creates New Profits

Servicemen now earn new servicing dollars in minutes and build satisfied customers—with B&K Deluxe Portable CRT 400.

Spots and corrects picture tube troubles in a few minutes, right in the home, without removing tube from set! Restores emission, stops leakage, repairs inter-element shorts and open circuits. Grid cut-off reading indicates picture quality customer can expect. Life-test checks gas content and predicts remaining useful tube life. Cuts operating costs, eliminates tube transportation. Also saves money on TV set trade-in reconditioning. Profits start the very first day.

Send for Bulletin 104-S



### DELUXE CRT 400 with 4½" Plastic Meter

Weighs only 5 lbs. mounted in rugged, luggage style, carrying case covered with handsome, durable leatherette.  
Size: 11 x 7½ x 5". Net \$54<sup>95</sup>

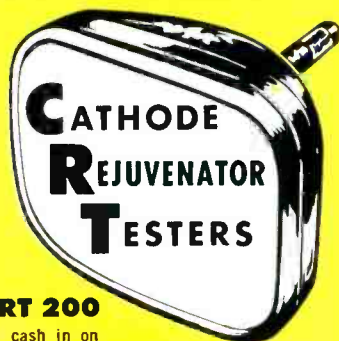

### ECONOMY CRT 200

Every serviceman can cash in on picture tube repairs with this low priced quick profit maker. Performs most of the functions of the CRT 400. Has 3" meter. In leatherette carrying case.  
Size: 11 x 7½ x 5".  
Weighs 5 lbs. Net \$39<sup>95</sup>

PROVEN IN  
THE FIELD  
EVERY DAY  
BY OVER  
20,000  
SERVICEMEN

Made by the Makers of the DYNA-QUIK Tube Tester

**B & K MANUFACTURING CO.**  
3726 N. Southport Ave. • Chicago 13, Illinois



## Servicing Helps

(Continued from page 39)

tube) on the grid of the noise-cancelation tube.

The *agc* should be adjusted clockwise until the picture bends; then counterclockwise 90°. This is a preliminary *agc* adjustment.

A barely noticeable 4.5-mc beat in the picture should be obtained by adjusting the fine tuning control, so that maximum sound *if* is applied to the sound *if* amplifier. This causes the 140-v supply voltage for the *agc* amplifier to be at maximum.

*Agc* should be readjusted for pic-

ture bend; then slowly counterclockwise 45°. This completes a *normal agc* adjustment.

The horizontal-hold control should be set counterclockwise as far as possible without making sync unstable. This sets the bias supply for the noise-limiter tube at a minimum.

The noise-limiter control should be turned counterclockwise for a shift or bend in the picture (indicating sync clipping); then clockwise 30°. Less clockwise rotation means greater noise limiting; in a noisy location control should be turned only 15° clockwise.

The horizontal-hold control should be returned to the center of its range.

## Sound Service Shop

(Continued from page 19)

is encountered, which is within the desired 15% maximum permissible.

The system has been found to be so efficient that the average power handled by each loudspeaker is about one watt, although each speaker is equipped to take 25 watts of audio. The horns are focussed down for optimum coverage and minimum echo. No attempt was made to wire the loudspeakers in phase; yet no sound cancelling has been encountered. The speakers are mounted high enough so that students will not hit or swing on them.

The old microphone was replaced with a hand-held, high-output (especially at voice frequencies) type, with a high front-to-back pickup ratio to minimize feedback. Due to the relatively short *throw* for the loudspeakers, no problem of high frequency attenuation by the air is created; if so the tone control of the amplifier can handle it.

From the foregoing it is apparent that one must be ready to overcome some odd problems when installing a public address system. In the gym case we had to consider echo, weather, feedback, response, dispersion, power and impedance considerations, plus absolute coverage to the satisfaction of many people's tastes.

This particular installation required almost forty hours of design, preparation, demonstrations, coordinating with others, and conferences; but it was well worth the effort.

## VISUAL TUBE INVENTORY



Visual tube inventory control, the See-Lect-a-Tube method, which features dispenser units which hold 250 of the most popular types of replacement tubes. When a tube is pulled from the dispenser, spring tension of channel-shaped holders prevents tubes above from sliding down and falling out. Unit can be wall-mounted near service bench. (General Electric.)

## RCA Sponsors Second Annual National TV Servicemen's Week

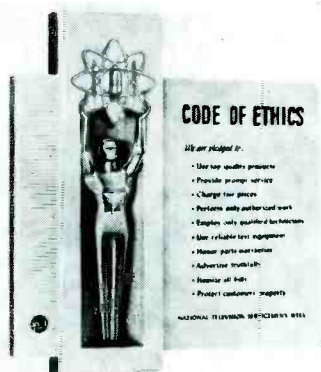

LIKE THE TV INDUSTRY itself, TV servicing has become one of the nation's fastest growing businesses. When the first post-war TV sets made their appearance in November '46, only a few hundred Service Men were available to install and service the instruments that were sold. In the ten years that have passed, industry has manufactured more than 40-million TV receivers.

The TV field could not have expanded so rapidly and on such a firm basis without the aid of Service Men. In recognition of the skill and knowledge that served to spark this progress last year RCA sponsored a *National Television Servicemen's Week*. This year, the servicing corps is receiving another well-earned tribute during a special week, beginning March 5, also under the auspices of RCA.

In addition to advertising in local newspapers, the event will receive attention on radio and TV programs and in consumer magazines.

This year, Service Men who participate in the *week*, will receive a plaque embodying the popular electronic statuette, symbol of the *week*, and a reproduction of a code of ethics, which has been drawn up to express the basic principles of good business practices that attract and hold customers.

The code pledges a Service Man to *use top-quality products; provide prompt service; charge fair prices; perform only authorized work; employ only qualified Service Men; use reliable test equipment; honor parts warranties; advertise truthfully; itemize all bills, and protect customers' property.*

A Service Man who has agreed to the pledge will receive an identification card bearing his name, his signature and a copy of the code.

Other promotional material that will be available includes chassis stickers, *code-of-ethics* postcards, quiz booklets on *How's Your Television I.Q.?* featuring 16 pages of intriguing questions and answers, and personalized indoor illuminated signs.

## CHAMPION of all Fan-Type CONICALS



- ★ BETTER LOW BAND PERFORMANCE!
- ★ BETTER HIGH BAND PICKUP!
- ★ GUARANTEED SUPERIOR TO ANY CONICAL ON THE MARKET TODAY!

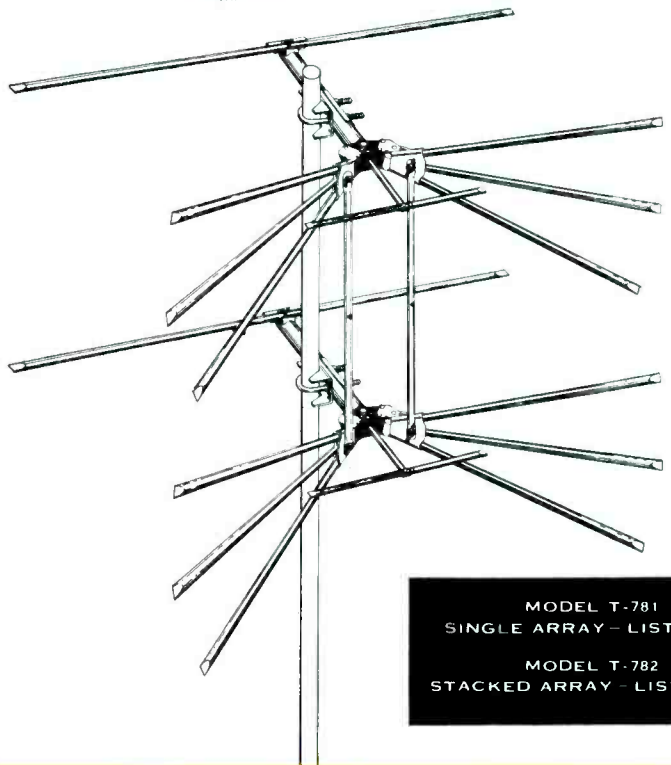

MODEL T-781  
SINGLE ARRAY - LIST \$5.56

MODEL T-782  
STACKED ARRAY - LIST \$11.53

## An Exclusive Tenna Development

Now, Tenna has combined all of the better features of the BAR-X conical and the fan-type conical into a single model to give you the ultimate in both high band and low band performance. The NEW Tenna T-781 and T-782 are guaranteed superior to any other conicals. Try this NEW Tenna conical under the toughest reception conditions and you'll be astonished with its performance. All aluminum, full size and completely pre-assembled . . . and at a low, low price.

**TENNA** Manufacturing Co.

7580 GARFIELD BLVD. • CLEVELAND 25, OHIO

One Focalizer  
for all  
picture  
tubes.....

the  
**QUAM**  
**QF-4 UNIVERSAL  
FOCALIZER UNIT**

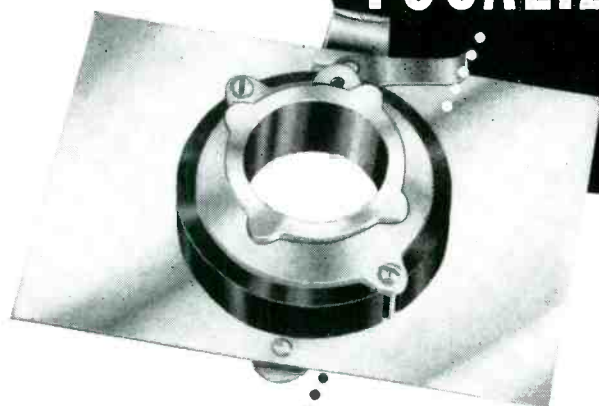

**FREE!**

Catalog 78,  
listing complete  
specifications of  
the QUAM QF-4  
Universal  
Focalizer Unit.

New ceramic magnets and extended focusing range eliminate the need for more than one model . . . yet provide maximum resolution with minimum spot size.

Installs in minutes, adjusts in seconds.

The QF-4 has a newly designed "quick-setting" picture centering lock and is supplied with a soft aluminum blank mounting bracket that is easily drilled to fit any mounting arrangement.

LIST PRICE \$4.25

**QUAM-NICHOLS COMPANY**

232 East Marquette Road  
Chicago 37, Illinois

**Audio**

(Continued from page 43)

would be if a simpler type of crossover were used.

It is not possible, some manufacturers' literature notwithstanding, to design a crossover that will match correctly two loudspeaker units of different impedances to the same amplifier output impedance. That is, we cannot use a crossover to combine a 4-ohm tweeter with a 16-ohm woofer.

If such a practice is attempted, one will find that whatever happens in the region of crossover frequency, the

impedance is transferred directly to the amplifier at frequencies away from crossover. This means that at low frequencies the amplifier will be loaded with 16 ohms, while at the high frequencies it will be loaded with 4 ohms; thus none of the amplifier output taps will be correct for the whole frequency range.

The only way to insure the right results where units have different impedances is to use a matching transformer with one or more of the units to bring them all to the same impedance, and then to use a crossover designed for that impedance. For ex-

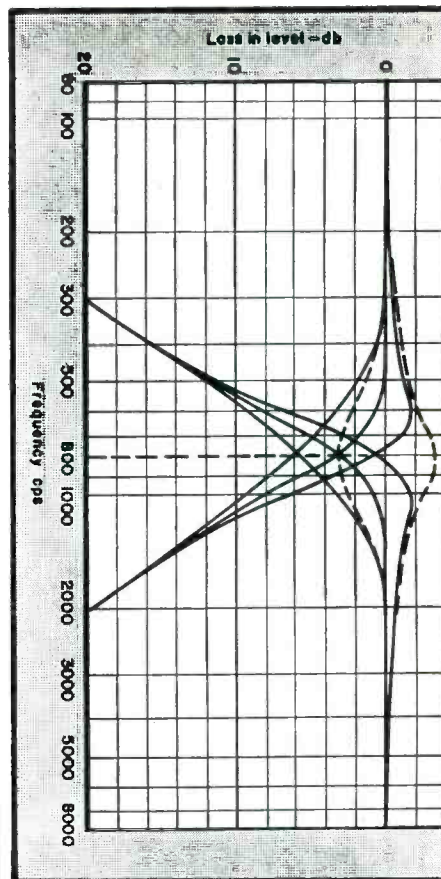

Fig. 4. Plot showing effect of damping factor used to feed m-derived type of crossover, different from the one for which it was designed. Solid lines show correct curve, with two kinds of deviation, while the dashed-line curves show the over-all output resulting from wrong damping factor.

ample, a transformer could be used to match the 4-ohm tweeter up to 16 ohms. One doesn't necessarily have to buy a special transformer designed for this purpose; a good multi-purpose speaker transformer can be used, connecting the 4-ohm tweeter to the 4-ohm tap on its secondary, while the crossover is connected to the 16-ohm tap, as shown in Fig. 3 (p. 43).

Some crossover units have been designed for universal application, using different tapings on the inductor to get different inductance values. Many of these devices consist of inductors in series with the *lf* unit and capacitors in series with the *hf* unit. Such arrangements can give good results, *provided the amplifier is correctly matched at all frequencies.*

When selecting networks, it is important to examine the types carefully. Such observation will enable one to determine what latitude can be used in applying the net to different circuits from the one for which it was designed, if necessary, and what difference may be expected by

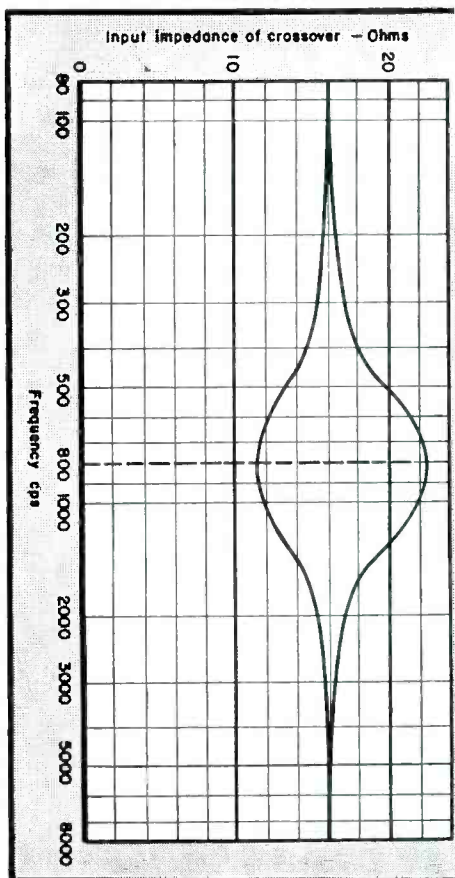

Fig. 5. Two varieties of impedance response, measured at the input to an *m*-derived crossover, when the outputs are correctly loaded, are detailed in this plot.

connecting the whole arrangement to different amplifier outputs.

If the *m*-derived type is selected to get better separation between frequencies, one should check the source impedance or damping factor that should be used for the amplifier.

One must also know the impedance that the filter itself reflects when correctly terminated. For some amplifiers this is important because if the impedance characteristic is not correct for the amplifier, the stability of the system is affected. The constant resistance type of crossover reflects an impedance which is uniformly resistive throughout the crossover region, but the *m*-derived type, to produce a sharper roll-off, has to modify the frequency characteristic by some means. This modification results in an arrangement where the total energy fed to the two loudspeaker units is no longer constant in the region of crossover, as shown at Fig. 4.

If the total energy received by the constant impedances, which each

(Continued on page 48)

# Give customers "hi-fi satisfaction" —profitably!

## THE BRILLIANT NEW "3" SERIES SONOTONE CERAMIC

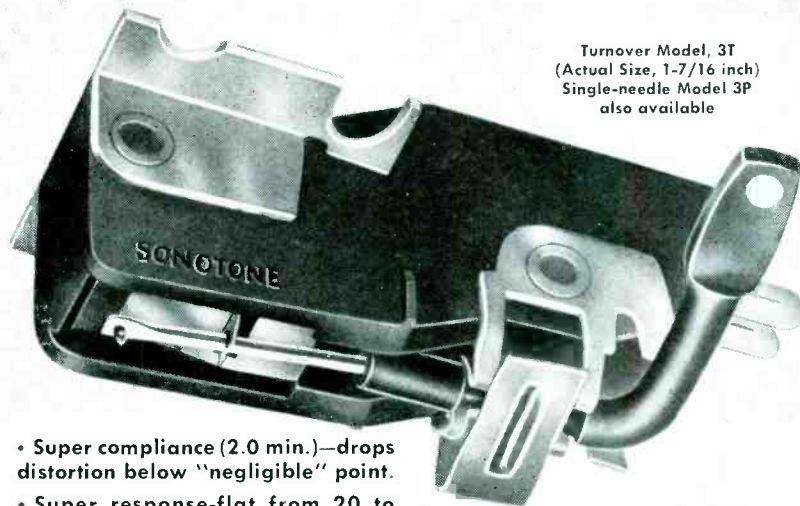

Turnover Model, 3T  
(Actual Size, 1-7/16 inch)  
Single-needle Model 3P  
also available

- Super compliance (2.0 min.)—drops distortion below "negligible" point.
- Super response—flat from 20 to 15,000 cycles, without equalization.
- Makes pre-amplifiers and equalizers obsolete.

If you've followed the development of ceramic cartridges since Sonotone pioneered them in 1946, you know of their enormous advances.

Now Sonotone presents the "3" Series, which sets utterly new standards of performance and opens the door to profitable "hi-fi" business for you.

The Sonotone "3" Series ceramic cartridge can be used as a replacement in nearly any phonograph circuit. It delivers a brilliance and clarity of sound which will be noticed and commented upon by delighted customers. Because these cartridges deliver a whopping 0.5 volts (roughly 50 times as much as most velocity types), they do not need preamplification and equalization circuits. And naturally the non-magnetic structure eliminates motor hum.

There are two basic models, a turnover (3T-S) for all record speeds and a single-needle model (3P-1S) for 33 and 45 rpm records. They have standard 1/2 or 5/8 inch mounting centers and fit any of the widely used tone arms. Prices begin at \$12.50 list (sapphire needles).

Use the brilliant new Sonotone Series "3" on your next replacement job. You'll find yourself on the way to profitable "hi-fi" business.

# SONOTONE®

CORPORATION, ELMSFORD, N. Y.



Write Department CS-26 for free cartridge replacement chart.  
In Canada—Atlas Radio Corp. Ltd., 50 Wingold Ave., Toronto.

# NOW SEALED IN PLASTIC



## New, Better Way to Stock, Sell and Service PHONO-CARTRIDGE REPLACEMENTS

For greater protection and convenience, E-V replacement phono-cartridges now come in new individual sealed-in-plastic Blister-Paks—each with full model identification, interchangeability chart and instructions. This exclusive advancement in packaging makes it simpler to carry and sell phono cartridge replacements on service calls.

### New E-V Model 47 Dual-Slide Cartridge for 78, 33 $\frac{1}{3}$ , 45 RPM

New idea in replacement phono-cartridges! The dual-slide, dual-needle Model 47 enables you to replace hundreds of different specialized types with a single general-purpose cartridge. List Price: \$9.00

## FREE NEW HANDY INTERCHANGEABILITY GUIDE

Tells at a glance exact E-V replacement model for every popular crystal and ceramic phono-cartridge. Get it now from your E-V Distributor or write to Electro-Voice.

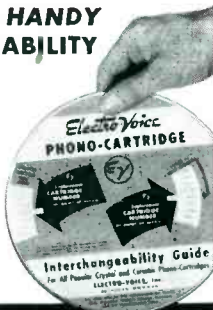

**Electro-Voice**  
ELECTRO-VOICE, INC. • BUCHANAN, MICH.

## Audio

(Continued from page 47)

loudspeaker presents to the crossover outputs, is not constant, then the impedance presented on the other side of the network, which has to take the variable amount of energy from a constant source of drive, must be variable. This means that the impedance the crossover unit reflects as an output load for the amplifier must vary in the region of crossover frequency.

One must know in what way this impedance varies. If the amplifier uses pentode-type output tubes (connected as pentodes), the load impedance may dip below the optimum load value without causing trouble as a rule, although it may affect the stability of the feedback arrangement. In the case of triode-connected outputs, the impedance may usually be allowed to rise above the nominal value without causing trouble.

In appraising networks, one should also know what types of inductors are used in crossovers; air cored, iron cored, or toroid.

Air cored coils cannot possibly cause any distortion, but they are inefficient; an appreciable fraction of the audio power gets lost in the inductor.

Toroid inductors are much more efficient, free of any practical degree of distortion, but they are much more costly.

Regular iron cores split the difference, both performance and cost-wise. (Continued on page 50)

Background music system which can play continuously all day using 45s. Unit can also be used for public address. Changer has a capacity of 25 records. Tone arm plays both sides of each record automatically. Three basic actions of stacking, tone arm movement, record changing, and re-stacking, are actuated by electro-mechanical clutches. Power is supplied by a two-pole motor and the turntable is powered by a separate continuous-duty type of four-pole motor. Basic model is equipped with a 15-w amplifier. Output impedances are 4-8-16-250 and 500 ohms; has a 70 volt constant voltage tap. (Comax, Inc., 333 West Excelsior Blvd., Hopkins, Minn.)



"Don't play it until I get back with a JENSEN NEEDLE."

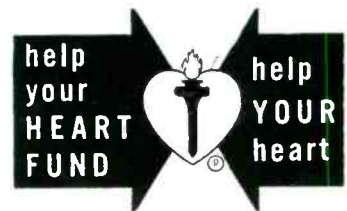

**DON'T JUST SAY CAPACITORS • DON'T JUST SAY CAPACITORS • DON'T JUST SAY CAPACITORS**

Ask For Sprague By Catalog Number

Know what you're getting . . . get exactly what you want. Don't be vague . . . insist on Sprague. Use complete radio-TV service catalog C-610. Write Sprague Products Company, 61 Marshall Street, North Adams, Mass.

**SPRAGUE**  
WORLD'S LARGEST CAPACITOR MANUFACTURER

**DON'T JUST SAY CAPACITORS • DON'T JUST SAY CAPACITORS • DON'T JUST SAY CAPACITORS**



Low frequency woofer designed for use with Quam 3A15T or 5A15T high-frequency tweeter, or similar types. Frequency response is said to be 40-5000 cps,  $\pm 5$  db; resonance point, 60 cycles. Voice coil impedance is 6-8 ohms. Power handling capacity, 10 watts. Another model with a frequency response of 30-5000 cps  $\pm 5$  db, and resonance point of 45 cycles is also available. (Models 12A10L and 15A10L; Quam-Nichols Co., Chicago, Ill.)

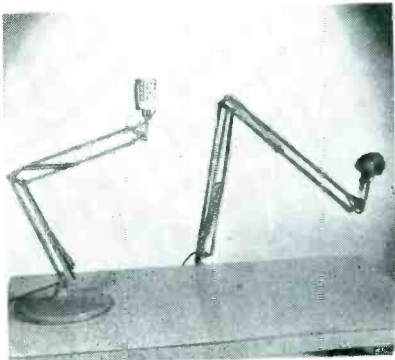

(Above)

Flexible microphone arm for industrial installations and other locations where mike flexibility and movability is desirable. (Luxo Lamp Corp., 102 Columbus Ave., Tuckahoe, N. Y.)

(Below)

High-compliance speaker said to have a suspension which results in practically a free-edge cone. Special cellular formulation of plastic is used between cone edge and supporting basket; material is claimed to be composed of microscopic cells, which are randomly interconnected so that the amount of pneumatic damping, due to stiffening of the air in these cells, depends upon the amplitude of cone motion. At large amplitudes, such as at resonance and at low frequencies damping is at maximum. (Tri-axial model 15-HTX; Racon Electric Co., 1261 Broadway, N. Y. 1, N. Y.)

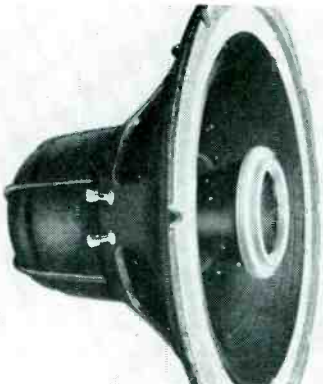

# Simpson...the most Complete Line of VOM's

Select the one that fits your needs!

MODEL  
**260**  
world's most popular!

Over half a million Model 260's have been sold to date! 20,000 Ohms per volt. You'll find it wherever quick, accurate, electrical checks are needed. It's so handy, so dependable, so sensibly priced! Ask your jobber. Price, including Adjust-A-Vue Handle, only ...

**\$38.95**

Carrying Cases from **\$6.75**

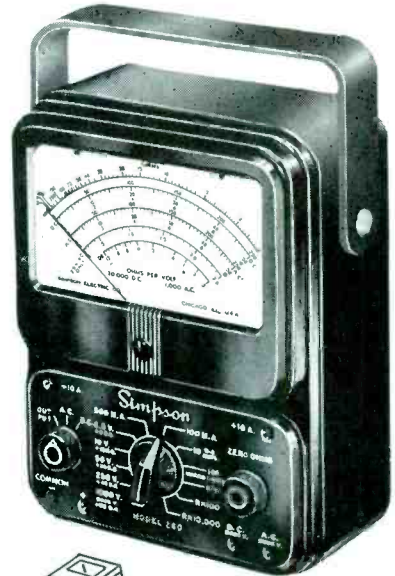

MODEL **262**

*Deluxe!*

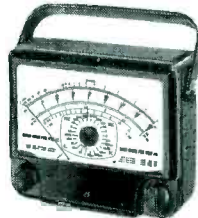

the new VOM with a 7" meter

20,000 Ohms per volt DC and 5,000 Ohms per volt AC sensitivity ... 33 ranges ... compact 7" case with Adjust-A-Vue Handle ...

**\$59.50**

Carrying Case ... **\$ 9.95**

MODEL **269**

100,000 Ohms per volt!



Most sensitive VOM

available! A Volt-Ohm-Microammeter with a big 7" meter in a compact 7" case ... 33 ranges ... Adjust-A-Vue Handle ... price complete ...

**\$88.00**

Carrying Case ... **\$ 9.95**

**NEW!**



**MIDGETESTER** Model 355—New shirt-pocket size Volt-Ohmmeter **\$29.95**  
**MODEL 240**—Small VOM; 14 ranges; up to 3000 volts AC or DC **\$26.35**  
**MODEL 230**—Small VOM; 12 ranges; up to 1000 volts AC or DC **\$24.95**  
**ROTO RANGER** Model 221—25 Separate meters at turn of a switch **\$75.00**  
**LABORATORY STANDARD**—For instrument calibration. Price on application.

**Simpson** ELECTRIC COMPANY  
World's Largest Manufacturer of Electronic Test Equipment

5200 W. Kinzie St., Chicago 44, Ill. • EStebrook 9-1121  
In Canada: Bach-Simpson, Ltd., London, Ontario

# All From One Source

These four quality lines of Electronic Components may be obtained quickly and conveniently from Distributors who stock ERIE RESISTOR CORPORATION products.



ERIE Electronic Components enjoy the reputation of having the highest quality and make up the most complete line of Ceramic Replacement Capacitors. Distributor Stock items are representative of the most common types used by dealers, servicemen, experimenters, amateurs, laboratories, project engineers, and industrials.



CORNING Glass Electronic Components include the complete line of Fixed Glass Capacitors, Direct Traverse and Midget Rotary Glass Trimmer Capacitors, and various types of Low Power, Precision and High Power Glass Resistors.



ERIE-Chemelec Teflon Electronic Components are made of the most nearly perfect insulating material available, and are ideally suited to withstand high humidity, high or low temperatures, high altitudes, high voltages, and high frequency operation. It is serviceable at any temperature from  $-110^{\circ}$  to  $550^{\circ}$ F for long periods with negligible change in critical electrical characteristics.



GRIGSBY-ALLISON Switches are known throughout the industry for dependable quality and smooth performance. They include a complete variety of styles for all types of applications.

ORDER NOW  
From Your  
ERIE  
DISTRIBUTOR



ERIE ELECTRONICS DISTRIBUTOR DIVISION  
ERIE RESISTOR CORPORATION  
Main Offices: ERIE, PA.  
Factories: ERIE, PA. • LONDON, ENGLAND • TRENTON, ONTARIO



## AMPLIFIERS for Public Address

Backed by the  
world's greatest  
performance  
record for  
power at  
low cost!



### 3 Popular Sizes

10, 15 and 30-watt power output. Available with phonograph top or as a complete portable ready-to-use system including microphone, speaker and case. Engineered for top performance and easy operation. A model for every need.



Send for FREE New Catalog!



PRECISION ELECTRONICS, INC.  
9101-S King Ave., Franklin Park, Ill.

Name \_\_\_\_\_

Address \_\_\_\_\_

City \_\_\_\_\_ Zone \_\_\_\_\_ State \_\_\_\_\_

106-55

THE BIG BOYS KNOW—  
YOUR BUSINESS REALLY  
BEGINS TO PAY OFF  
WHEN YOU START SELLING  
WALCO NEEDLES!



FOR FREE  
ILLUSTRATION  
OF LILY, WRITE:

TRADE NAME OF  
**ELECTROVOX CO., INC.**  
60 Franklin St., East Orange, N. J.

## Audio

(Continued from page 48)

between air cored and toroid types. And well-designed coils of this type, correctly used, can give results quite as good as toroids at lower cost. In fact, for frequencies below 400 cps as crossover, the regular iron core can be better than the toroid, although the cost saving is not so marked.

## Tube Testers

(Continued from page 21)

tive being, for example, 15-0-15 microamperes. The less sensitive ranges are used to ensure that the current is not too great for the sensitive position. Grid current for most tubes should be below 2 microamperes, and for many types should be only a fraction of a microampere.

The circuit of Fig. 4b (p. 21) serves to provide measurement of the current by the effect it has on tube bias, and therefore tube current. With the 1-megohm resistor shorted by the switch, the tube current is measured. Then the switch is opened, and the grid-emission current flowing through the 1-megohm resistor reduces the bias voltage, and the change in plate current is noted. The tube acts as an amplifier, with the change in plate current being equal to the grid current times the tube transconductance in micromhos.

When a grid-emission or gas test is not available, one can check for grid current in circuits where no grid current should flow, by shorting the grid resistor and noting the change in tube current, either directly, or as a change in plate voltage when the plate circuit has high resistance, or as a change in voltage across the cathode bias resistor when one is included.

Provisions for checking tubes for noise are included in many testers. Test points are connected to the short-test leads, permitting the noise developed in the tube during short testing to be fed to a receiver or a high gain amplifier. With the receiver or amplifier operating, the short-test switch is turned to each position and the tube is tapped. Intermittent shorts, too brief to produce a noticeable flash of the neon lamp, are heard as loud clicks.

Special test circuits replace the circuits described in some tube testers.

<sup>1</sup>Precision Electronic

<sup>2</sup>Dyna-quick (B and K) model 500

<sup>3</sup>Hickok model 539B



For example, in one circuit<sup>1</sup> proportional *ac* voltages are applied to the various tube elements, and the resultant *dc* plate current is metered. The plate current will depend on the emission and on the transconductance of the tube over a large portion of the operating range of the tube. By this means, it is claimed, one overcomes the limitations of single-condition testing as performed by the basic transconductance bridge.

In other special circuits, life tests are provided.<sup>2,3</sup> For this test, the heater voltage is reduced about 15 per cent, and the change in transconductance is noted. In tubes which are near the end of their useful life, the transconductance will drop below 75 per cent of the full-voltage value; a good tube will show very little drop.

#### PLANT EXPANSION IN MID-WEST



(Above)

Office-warehouse recently completed for G. F. Wright Steel and Wire Co., at 4956 S. Monitor Ave., Chicago 38. Building, a one-story steel-brick structure, contains 24,000 square feet of floor space.

(Below)

Additional building (left, foreground) which will soon be added to Howard W. Sams plant at 33rd and Sutherland Ave., Indianapolis, to house printing, warehousing and mailing activities.



# SELL General

## 36 YEARS OF RADIO-BATTERY MANUFACTURING!



### A COMPLETE LINE of RADIO BATTERIES!

By stocking the illustrated types, distributors and dealers can satisfy the large majority of replacement radio-battery sales. Immediate delivery on all types!



**11 CONVENIENT SHIPPING POINTS! WITHIN EASY DISTANCE OF MOST DISTRIBUTORS.**  
Boston, Mass.; Silver Springs, Md.; Cleveland, Ohio; Atlanta, Georgia; Dubuque, Iowa; Memphis, Tenn.; Dallas, Texas; Denver, Colorado; Los Angeles, Cal.; San Francisco, Cal.; Portland, Oreg.



#### NEW SALES-BUILDING PACKAGING

General's new labeling stimulates impulse buying . . . makes these batteries look like what they are: *fresh, dependable, powerful, long lasting.*

#### AND—A COMPLETE LINE OF GENERAL MERCURY BATTERIES FOR INDUSTRIAL ELECTRONIC AND RADIO APPLICATIONS

The fine quality of General Mercury Batteries is being used in many products with transistor or electronic circuits—like Geiger Counters — Tachometers — Guided Missiles — Pocket Radios — Numerous Test Devices, etc.

*Look to General for the Best in Batteries!*



# NOW...check flybacks WITHOUT A REFERENCE!

with the amazing, NEW

## TELETEST

### FLYBACK TESTER

1-YEAR FACTORY  
SERVICE GUARANTEE

**\$44<sup>95</sup>**

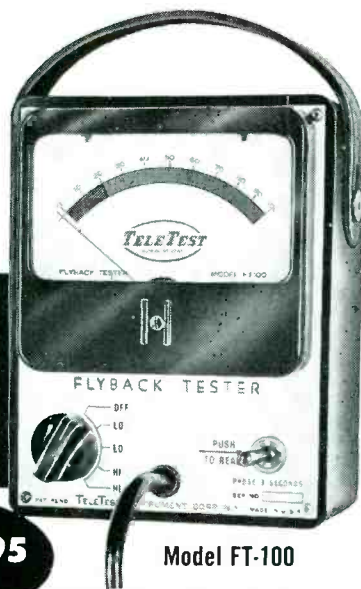

Model FT-100

*Slightly higher west of the Rockies*

Engineered for the cost-conscious serviceman, here is the first and only flyback tester that reveals even one-turn shorts without a reference transformer for comparison!! This reliable test unit indicates true flyback condition under full operating voltage—100% of the time!

No costly flyback inventory!...No speculative parts replacement!...No calibration adjustment! Unsurpassed in sensitivity and simplicity, the TELETEST Flyback Tester is preferred by discriminating service technicians for accurate and economical checking of all types of flybacks, yoke windings, width and linearity coils.

Save time, effort and money with the new TELETEST Flyback Tester!

See your local Jobber or write TODAY for complete information to:

**TELETEST**

**TELETEST INSTRUMENT CORPORATION**

Dept. S-2 31-01 Linden Pl., Flushing 54, N. Y.

**IT'S HERE AT LAST!!!**

the RMS

# "BIG SHOT"

## ALL-CHANNEL YAGI ANTENNA

This is it! The most talked about antenna in the television industry today. . . . Precision engineered to out-perform all others, the fabulous BIG SHOT miraculously produces the gain of 3 separate broad band yagis . . . eliminates complicated phasing networks that normally result in broken leads and costly errors in installation.

Years ahead in design . . . the low silhouette of the BIG SHOT reduces wind drag and lengthens the life of the installation. Ghosts and co-channel interferences are eliminated like magic . . . and sharper, clearer TV pictures assured. Completely automatic, each and every element can be easily locked securely in place.

**GUARANTEED**  
for Quality and Performance

**Radio Merchandise Sales, Inc.**  
NEW YORK 62, NEW YORK

Model **BIG-100**  
\$15.97 List

MODEL BIG-200  
(stacked) \$32.72 List

Look for  
the RMS man . . .  
for your best buy  
in indoor and outdoor  
TV Antennas,  
Antenna Rotators,  
Communications  
Systems,  
TV accessories.

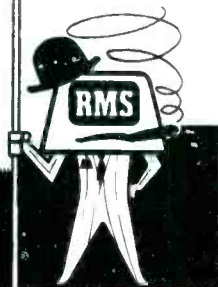

# COMPONENTS

## C-D TUBULAR PI FILTERS

A series of tubular pi filters, *Quietone*, designed to provide insertion loss values for suppression of radio noise, has been developed by Cornell-Dubilier Electric Corp., S. Plainfield, N. J.

Metal-cased, hermetically-sealed, units are made to smallest possible sizes and minimum weight for stated ratings and attenuation characteristics. Current ratings range from .1 to 50 amps; voltages are 28, 50, 100, 300 and 500 *dc*, and 115 and 125 *ac*. Frequencies are 60,400 and 1000 cps. A flatted, threaded neck provides mounting to a panel or bulkhead through a round or slotted hole and affords a ground connection to shunt unwanted currents. Further details in bulletin 171.

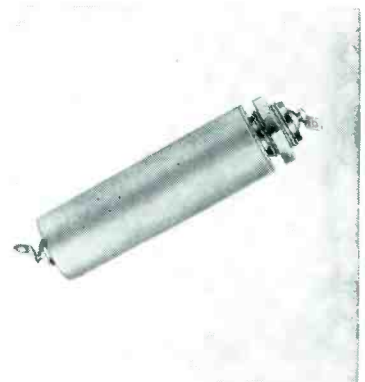

## JFD SUBMINIATURE PISTON CAPACITORS

Two models of subminiature piston capacitors, *VC9G* and *VC10G*, for use in printed circuitry and automation, have been announced by the electronics division, JFD Manufacturing Co., Inc., 6101 Sixteenth Ave., Brooklyn 4, N. Y.

Both units feature glass dielectrics and invar silver-plated rotors. *VC10G* measures 5/16" in length; *VC9G* 9/16". Capacitance range of *VC10G* is 1 to 4.5 mmfd; *VC9G* has a capacitance range of .5 to 8.5 mmfd.

## LAFAYETTE RADIO SUBMINIATURE VARIABLES

A two-gang subminiature variable, for transistorized circuitry, has been made available by Lafayette Radio, 100 6th Ave., New York 13, N. Y.

Unit measures 1" x 1" x 1/2" with self-contained variable trimmers. Capacity is 10 to 208 mmfd on antenna section and 10 to 100 mmfd on oscillator section.

## SARKES TARZIAN HIGH TEMP SELENIUMS

High-temperature selenium rectifiers, said to have been life tested for over 5000 hours and capable of operation at cell temperatures of 150° C, have been developed by Sarkes Tarzian, Inc., 415 N. College Ave., Bloomington, Ind.

Units are available in single and three-phase full-wave bridge models.

# BENCH-FIELD TOOLS . . .

## XCELITE TRANSVERSE CUTTER

A transverse cutter, 62, that has the compactness of a needle nose plier and a narrow end-nipper, and can be used for flush or other cutoff work in miniature and subminiature chassis, has been introduced by Xcelite, Inc., Orchard Park, N. Y.

Unit features a spring return which permits use of thumb and one finger in close quarters.

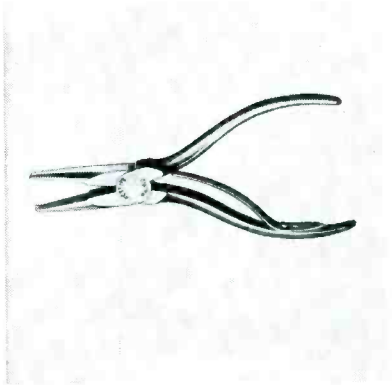

• • •

## LUXO INNER REFLECTOR LAMP

An inner reflector that reduces shade heat and permits concentration of light on small areas has been introduced by Luxo Lamp Corp., 102 Columbus Ave., Tuckahoe, N. Y.



• • •

## ESICO LUGER-GUN DISPLAY

A counter display has been designed for the Esico *Luger* soldering gun and kit of six tips by the Electric Soldering Iron Co., Deep River, Conn.

A wire rack unit, display features lightweight *Luger* soldering gun and assortment of non-annealing, non-bending broad, narrow, short, long, angled, V and straight tips.



HAVE YOU  
HEARD that  
our distributors  
will allow you  
10c credit

for each replaced  
selenium rectifier

returned —

regardless of make?

The selenium situation is critical, and reclamation is necessary to meet civilian, as well as military requirements. You can help by returning every replaced selenium rectifier to your distributor for credit.

**Sarkes Tarzian, Inc., RECTIFIER DIVISION** 415 N. COLLEGE AVE. BLOOMINGTON, INDIANA

In Canada: 700 Weston Rd., Toronto 9, Tel. Murray 7535

Export: Ad Auriema, Inc., New York City

Circuit Classification

THE TREND toward the reduction of TV chassis size and weight has led to the development of a long list of series-string tubes with heater excitation provided directly from the line.

If the heaters of conventional tubes with their varying thermal time constants were connected in series, they would be subjected to starting surges which would cause burnouts. The problem has been resolved in the series-string tubes by using standardized heater-current ratings (600 ma) and controlled warm-up periods; 11 seconds to reach 80% of full emission temperature. Controlled initial-heating periods have been attained by setting extremely close tolerances on the filament resistance and thermal capacity of each tube, so that all circuits begin to operate at the same time. Heater-to-cathode insulation of series-string tubes has been increased to prevent breakdown which might occur as the result of the increased applied voltage.

Aside from the differences in the construction and rating of filaments and heater-to-cathode insulation, most series-string tubes are identical to conventional types. Designations are normally the same as those of prototypes except for the prefix number, which indicates heater voltage. For example, the 3AL5 is the series-string equivalent of the 6AL5. Where both tubes require the same heater voltage, a new identifying suffix letter usually appears as the last character in the series-string designation; thus, the 6SN7GTB is the series-string equivalent of the 6SN7GTA.

In practice, when the total voltage required for all heaters is less than the supply voltage, a single string is used with a series resistor dropping the remaining voltage. The audio tubes are generally placed at the lower end of the line to minimize hum. If the total heater voltage requirements exceed the line voltage, two strings are usually used. An attempt to use a single string by placing two tubes requiring the same heater potential in parallel has proven unsatisfactory; if one filament should burn out, the second would almost certainly burn out, being forced to pass twice the current.

Two new tubes, identical except for heater construction and ratings, are

(Continued on page 60)

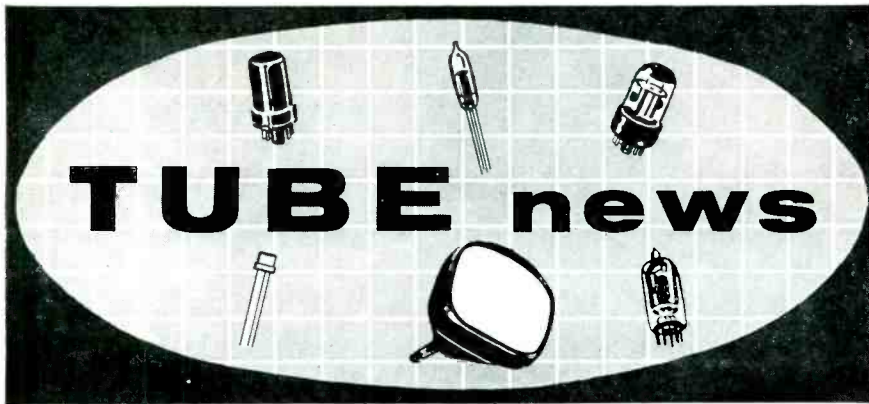

Series string type	Prototype	Function
2AF4A	6AF4A	Vhf triode
2T4	6T4	Vhf triode
3AL5	6AL5	Double diode
3AU6	6AU6	Sharp-cutoff pentode
3AV6	6AV6	Double diode—high-mu triode
3BA6	6BA6	Remote-cutoff pentode
3BC5	6BC5	Sharp-cutoff pentode
3BE6	6BE6	Heptode converter
3BN6	6BN6	Gated-beam pentode
3BY6	6BY6	Double-control heptode
3BZ6	6BZ6	Semi-remote-cutoff pentode
3CB6	6CB6	Sharp-cutoff pentode
3CF6	6CF6	Sharp-cutoff pentode
3CS6	6CS6	Double-control heptode
3DT6	6DT6	Sharp-cutoff pentode
4BC8	6BC8	Vhf double triode
4BQ7A	6BQ7A	Vhf double triode
4BZ7	6BZ7	Vhf double triode
4BZ8	6BZ8	Vhf double triode
5AM8	6AM8	Diode—sharp-cutoff pentode
5AN8	6AN8	Medium-mu triode—s-c pentode
5AQ5	6AQ5	Beam-power pentode
5AT8	6AT8	Vhf triode—sharp-cutoff pentode
5B8	—	Medium-mu triode—s-c pentode
5BE8	—	Vhf triode—sharp-cutoff pentode
5BK7A	6BK7A	Vhf double triode
5BT8	6BT8	Double diode—sharp-cutoff pentode
5J6	6J6	Medium-mu double triode
5T8	6T8	Triple diode—high-mu triode
5U8	6U8	Medium-mu triode—s-c pentode
5V6GT	6V6GT	Beam power pentode
5X8	6X8	Medium-mu triode—s-c pentode
6AU8	—	Medium-mu triode—s-c pentode
6AW8	—	Medium-mu triode—s-c pentode
6AX7	12AX7	High-mu double triode
6BA8	—	Medium-mu triode—s-c pentode
6BJ8	—	Double diode—medium-mu triode
6BN8	—	Double diode—high-mu triode
6CM7	—	Medium-mu double triode
6CN7	—	Double diode—high-mu triode
6CS7	—	Double triode
6S4A	6S4	Medium-mu triode
6SN7GTB	6SN7GTA	Medium-mu double triode
7AU7	12AU7A	Medium-mu double triode
12AV5GA	6AV5GT	Beam power pentode
12AX4GTA	12AX4GT	Half-wave rectifier
12B4A	12B4	High-perveance low-mu triode
12BH7A	12BH7	Medium-mu double triode
12BK5	6BK5	Beam power amplifier
12BQ6G/12CU6	6BQ6GTB/6CU6	Beam power pentode
12BQ6GTA	6BQ6GTA	Beam power amplifier
12BY7A	12BY7	Video pentode
12CA5	6CA5	Beam power pentode
12CU6	6CU6	Beam power pentode
12L6GT	25L6GT	Beam power pentode
12W6GT	6W6GT	Beam power pentode
15A8	—	Medium-mu triode pentode
19AU4	6AU4GT	Half-wave rectifier
19AU4GTA	6AU4GTA	Damping diode
25DN6	—	Beam power pentode

Partial listing of tubes designed for series-string TV use and standard prototypes.

(Based on data supplied by CBS-Hytron.)

# NOW! PHOTOFACT BRINGS YOU EXTRA SCHEMATIC COVERAGE

you get immediate coverage on leading receivers just as soon as they hit the market!

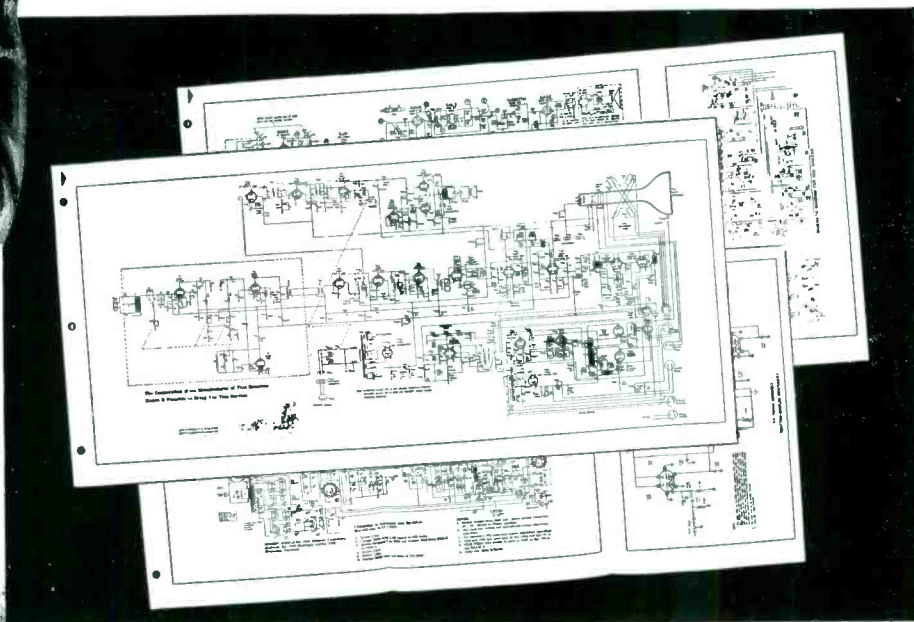

**IT'S AN "EXTRA" SERVICE—  
IN ADDITION TO REGULAR COVERAGE—  
AT NO EXTRA COST TO YOU**

Sams' PHOTOFACT now includes EXTRA schematic diagram coverage of the top manufacturers' new model releases. You get this up-to-the-minute EXTRA coverage at no extra cost in all current PHOTOFACT Sets. Look for them at your Parts Distributor today! See for yourself how PHOTOFACT keeps you current with the present output of new TV and Radio Models. Be sure to enter your "standing order" for each new monthly release of Sams' PHOTOFACT Sets—they'll put you out ahead in service work.

**remember—you get the world's finest service data —  
you get it fastest in PHOTOFACT**

**HOWARD W. SAMS & CO., INC., 2207 E. 46th., Indianapolis 5, Indiana**

SERVICE, FEBRUARY, 1956 • 55

for service and lab. work

## Heathkit PRINTED CIRCUIT OSCILLOSCOPE KIT FOR COLOR TV!

① Check the outstanding engineering design of this modern *printed circuit* Scope. Designed for color TV work, ideal for critical Laboratory applications. Frequency response essentially flat from 5 cycles to 5 Mc down only 1½ db at 3.58 Mc (TV color burst sync frequency). Down only 5 db at 5 Mc. New sweep generator 20-500,000 cycles, 5 times the range usually offered. Will sync wave form display up to 5 Mc and better. Printed circuit boards stabilize performance specifications and cut assembly time in half. Formerly available only in costly Lab type Scope. Features horizontal trace expansion for observation of pulse detail—retrace blanking amplifier—voltage regulated power supply—3 step frequency compensated vertical input—low capacity nylon bushings on panel terminals—plus a host of other fine features. Combines peak performance and fine engineering features with low kit cost!

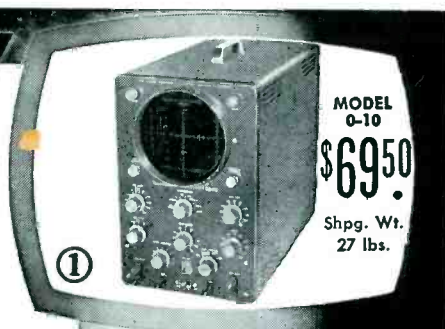

MODEL  
O-10  
\$69.50  
Shpg. Wt.  
27 lbs.



MODEL  
TS-4  
\$49.50  
Shpg. Wt.  
16 lbs.

Heathkit TV

## SWEEP GENERATOR KIT ELECTRONIC SWEEP SYSTEM

② A new Heathkit sweep generator covering all frequencies encountered in TV service work (color or monochrome). FM frequencies too! 4 Mc—220 Mc on fundamentals, harmonics up to 880 Mc. Smoothly controllable all-electronic sweep system. Nothing mechanical to vibrate or wear out. Crystal controlled 4.5 Mc fixed marker and separate variable marker 19-60 Mc on fundamentals and 57-180 Mc on calibrated harmonics. Plug-in crystal included. Blanking and phasing controls—automatic constant amplitude output circuit—efficient attenuation—maximum RF output well over .1 volt—vastly improved linearity. Easily your best buy in sweep generators.



## TV Antenna—

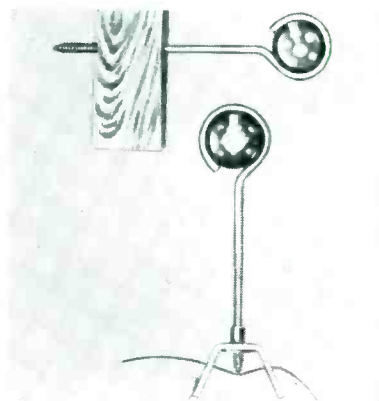

Insulator featuring double-duty thread design said to function both as a wood-screw and a machine-screw. When used in wood, insulator's needle-sharp point is claimed to provide quick starting and minimizes chances of splitting the wood. Used with buckles on TV masts, pointed screw-tip serves to dig into the strap and mast. Buckle uses a T-nut with eight full machined threads. Strap ends are tapered down to a rounded point. Choice of galvanized or stainless steel strap is available. Insulators are made of high-temper steel alloy, zinc coated and bright chromate treated. Double insulators are plated after welding. Insulator grommets are polyethylene. (Standouts; Channel Master Corp., Ellenville, N. Y.)



## SILIKONE

THE SILICONE\*-RESIN SPRAY  
MOISTURE REPELLENT

ELIMINATES BREAKDOWNS AND INCREASES EFFICIENCY OF ALL ELECTRONIC PARTS AND EQUIPMENT

SILIKONE AIR-DRYS QUICKLY TO FORM A FILM OF HIGH RESISTANCE TO DAMPNESS AND MOISTURE. ASSURES CONTINUOUS PERFORMANCE OF ELECTRONIC EQUIPMENT IN WET WEATHER, HIGHLY HUMID CONDITIONS, HIGH ALTITUDES AND SUB-ZERO TEMPERATURES.

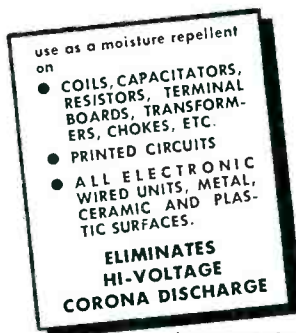

\* A Dow-Corning Product

EBCOR PRODUCTS CORP

87 MERRICK ROAD  
BALDWIN, N. Y.

### RETMA COLOR-TV ANTENNA TEST PROGRAM

The RETMA antenna section, chaired by Doug Carpenter, has announced a color-TV antenna test program among color set manufacturers to evaluate performance of antennas under varying conditions.

Set manufacturers will supply result information to RETMA engineering department, who will distribute a confidential field report to RETMA member set and antenna makers.

Participating set manufacturers include Capehart-Farnsworth, CBS-Columbia, General Electric, Hoffman Radio, Motorola, Raytheon, Stromberg-Carlson, Zenith, and Emerson Radio.

### SNYDER'S 25TH YEAR



Ben Snyder (right) president of Snyder Manufacturing Co., and Gus Snyder, partner in charge of production and technical head of the company, discussing 25th anniversary plans for '56.

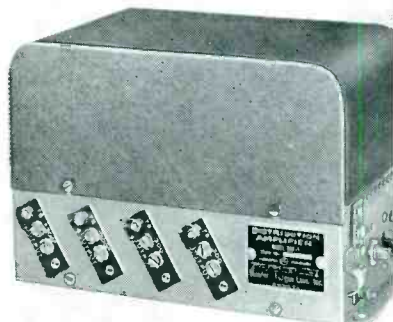

(Below)  
Distribution amplifier which provides eight isolated TV outlets with, it is said, over 10 db all-channel gain, at each outlet. Features all-triode circuitry and will handle either 300-ohm twinlead or 75-ohm coax cable. Included with unit are coax grounding clamps, solder lugs and terminating resistors for unused outlets. Self-powered. Has a built-in gain control which is claimed to provide a 10:1 range of overload protection. (Model DA8-B; Blonder-Tongue Laboratories, Inc., 526-536 North Ave., Westfield, N. J.)

# Accessory News



Tower self-supporting to 66'; or up to 200'-300' when guyed. Available in hot-dipped galvanized finish. Features an 18" equilateral design with steel cross-bracing; electrically welded throughout. (No. 40; The Rohn Manufacturing Co., 116 Limestone, Bellevue, Peoria, Ill.)

(Below)

Antennas said to be designed to eliminate co-channel and adjacent channel interference and ghosts. System consists of two antennas, one of which is vertically disposed above the other; cancellation of interfering signal, it is claimed, is accomplished by rotating one of the antennas. (Expo-I.R.I.S.; Holloway Electronics Corp., Ft. Lauderdale, Fla.)

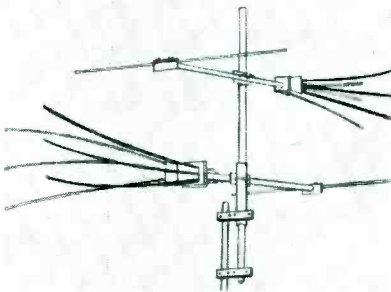

(Below)

All channel antenna said to feature photo phased element developed to make possible broad banding of yagis. Phased element is supported at point of low voltage and high current. (Dimension model; Fretco, Inc., 406 N. Craig St., Pittsburgh 13, Pa.)

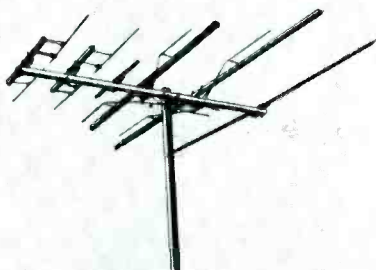

Technical assistants

## for ELECTRON TUBES

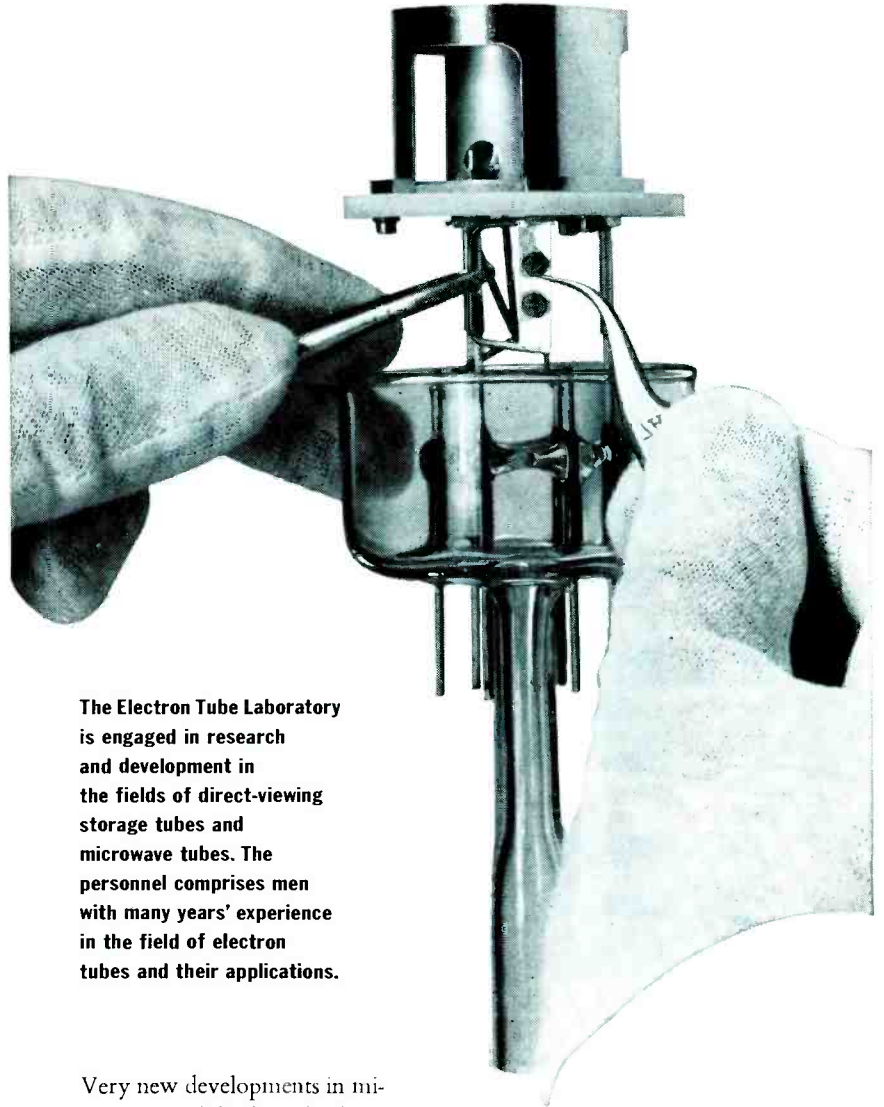

The Electron Tube Laboratory is engaged in research and development in the fields of direct-viewing storage tubes and microwave tubes. The personnel comprises men with many years' experience in the field of electron tubes and their applications.

Very new developments in microwave and display tubes have created a number of openings at the research and development level for Laboratory Assistants. At Hughes, engineers, scientists and technicians develop their ideas from inception to quantity production. Thus, assistants working with electron tube products have unlimited scope for applying their talents and skills to a wide range of military and commercial uses.

You should qualify in any **3** of the following areas:

- Electron Circuitry and Test Equipment Construction
- Mechanics and Benchwork Skills
- Tube Fabrication Techniques
- High Vacuum Techniques
- Microwave Testing
- Tube Chemistry
- Precision Assembly

SCIENTIFIC STAFF RELATIONS

### HUGHES

RESEARCH AND DEVELOPMENT LABORATORIES

Culver City, Los Angeles County, California

# KESTER

Absolutely non-corrosive and non-conductive, KESTER "RESIN-FIVE" CORE SOLDER contains an activated type of resin that gives you that fast, positive action on all your jobs . . . including the most difficult.

**KESTER SOLDER COMPANY**  
4248 Wrightwood Avenue • Chicago 39, Illinois  
Newark 5, New Jersey • Brantford, Canada

# SOLDER

help your  help your  
**HEART FUND** **HEART**

## opportunities

AT  
**BELL TELEPHONE LABORATORIES**

A career for you with one of the nation's leaders in research and development in communications and military electronics.

**ELECTRONIC TECHNICIANS**      **DRAFTSMEN**  
**ELECTROMECHANICAL TECHNICIANS**

Openings require previous training at high school, armed service school, or technical institute level and in general 2 or more years of applicable industrial or military experience.

Send your name and address for application, telephone collect within 100 miles for information, or visit us Monday through Friday. Evening interviews arranged.

**BELL TELEPHONE LABORATORIES**  
WHIPPANY, N. J. (Near Marristown)  
WHIPPANY 8-1000      EXTS. 2786, 300  
MURRAY HILL, N. J. (Near Summit)  
CRESTVIEW 3-6000      EXTS. 3078, 3204

## TV Parts... Accessories

### CBC PICTURE TUBE BRIGHTENER

A picture tube brightener, *DUB*, featuring a full sweep variable voltage control, has been announced by the CBC Electronics Co., Inc., 2601 N. Howard St., Philadelphia 33, Pa.

Unit is said to provide either isolation or brightness, automatically. Slide switch enables user to select either series or parallel to conform with wiring of receiver.

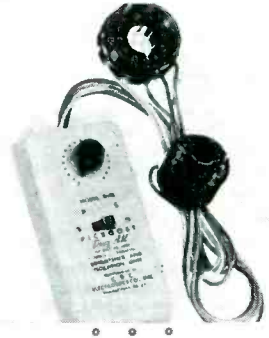

### MERIT REPLACEMENT FLYBACK TRANSFORMERS

Two flyback transformers, *HVO-50* and *HVO-52*, have been introduced by Merit Coil and Transformer Corp., 4427 N. Clark St., Chicago 40, Ill.

*HVO-50* is for replacement of Traveler TV-X-104 through TV-X-114. *HVO-52* is for replacement in Hallicrafters, Coronado, Silvertone and Truetone 55C133, -43 and -44.

### RAM ELECTRONICS FLYBACK REPLACEMENTS

Flyback replacement transformers for standard and wide-angle picture-tube chassis, have been released by the Ram Electronics Sales Co., S. Buckhout St., Irvington-on-Hudson, N. Y.

One series, the *X126*, is a composite which replaces flybacks 12E-23939 and 12E-24612 for Airline, Coronado, Firestone, Raytheon and Truetone.

The *X126* is an autotransformer-type flyback which is used in 66°-70° horizontal-deflection angle systems, delivering anywhere from 13 to 15 kv.

The second transformer, *X127*, also a composite, which covers Westinghouse V-11548, -1, -2, V-12073, V-14346, V-14627, V-15324-1, -2, and V-15650.

May operate both in the 66°-70° and 90° systems and is capable of delivering anywhere from 15 to 19 kv.

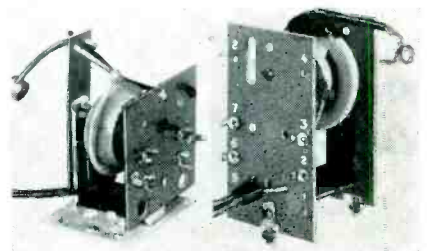



# EBY AD-60

## UNIVERSAL CHEATER-PATCHCORD

Compact - Lightweight

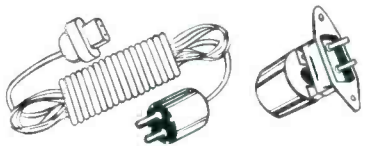

- The AD-60 is supplied in two parts - the adapter and the special cord.
- The adapter when used with any standard cheater cord converts same into a Zenith type of cord.
- Inserting the special cord into one end of the adapter, the AD-60 becomes a Zenith type of patch cord. Inserting the other end of the special cord into the adapter the AD-60 becomes a standard type of patch cord.

Carry your AD-60 and service all TV receivers.

List Price **\$2.<sup>25</sup>**

## EBY SALES CO. of N. Y.

130 LAFAYETTE STREET  
NEW YORK CITY 13, N. Y.

### Circuit Diagrams In This Issue

Tube Tester Short-Test Circuitry.....	20
Tube Tester Emission Test Circuit.....	20
Tube Tester Transconductance Test Layout.....	23
Tube Tester Gas/Grid-Emission Test Circuit.....	21
CBS-Columbia Push-Pull Audio for TV Model 3000.....	23
CBS-Columbia 3000 B-W TV (Complete Circuit).....	24-25
Neon-Bulb Circuit for RCA Remote-Head Fine Tuning.....	28
RCA Remote Tuner.....	29
Sound IF Amp Modified for Remote Link.....	29
Sound-Volume Control Revised for Remote.....	29
'Scope Check for Color Work Response.....	30
AC VM Hookup to Determine Horizontal Output Grid Drive.....	36
RCA KCS 96-97 Sync Stabilizer.....	36
Universal Speaker Transformer Hookup for Matching.....	43

**don't  
just say  
capacitors**

Ask For Sprague By Catalog Number

Know what you're getting...  
get exactly what you want.  
Don't be vague... insist on  
Sprague. Use complete  
radio-TV service catalog  
C-610. Write Sprague Products  
Company, 61 Marshall Street,  
North Adams, Mass.

# SPRAGUE®

WORLD'S LARGEST  
CAPACITOR MANUFACTURER

## News

### BRAND NAME PREFERENCE POLL UNDER WAY

The third annual study of brand name preferences among radio and TV Service Men by Brand Name Surveys, Chicago, Ill., has been announced.

Questionnaires are being mailed to radio and TV Service Men throughout the U.S. requesting preferences on a number of replacement components. Information obtained, it is said, will serve to guide manufacturers in their product development and improvement programs.

### SARKES TARZIAN ACQUIRES SILICON CORP. OF AMERICA

Sarkes Tarzian, Inc., 415 N. College Ave., Bloomington, Ind., has purchased the entire facilities of the Silicon Corporation of America.

Complete production facilities of Silicon Corp., will be moved to Bloomington and operated as part of the Sarkes Tarzian rectifier division; all key personnel have been retained.

### FTR DEVELOPS CONSERVATION PROGRAM

A selenium conservation program, featuring a kit containing reproductions of the government's appeal to conserve selenium, letters explaining the FTR program, and display banners, has been announced by Federal Telephone and Radio Co., 100 Kingsland Rd., Clifton, N. J.

Kit will be sent to FTR distributors for use by themselves and Service Men.

Kit also points out that Federal is offering merchandise credits of eight to ten cents (depending on size) for each returned rectifier, which may be passed along to Service Men.

### FREIDIN SELLS UNITED CATALOG INTEREST

Philip Freidin has announced his resignation as officer and director of United Catalog Publishers, Inc.

Samuel Roth, president of the firm, has become the sole owner. Freidin plans to conduct an agency at 604 Ashford Ave., Ardsley, N. Y.

### PHILCO TV CHASSIS TUBES NOW AVAILABLE FROM RAYTHEON

A heater-cathode type medium-mu twin triode having a semi-remote gm cut-off designed for use in low-noise vhf amplifier-cascode operation has been announced by Raytheon. Known as the 6BZ8, it has appeared in some TV receiver designs as the X155 or X155/6BZ8, and is being used in Philco chassis.

Raytheon has also released a heater-cathode type power pentode (6DQ6) designed for use as a horizontal-deflection amplifier of extremely high pervance for 90° deflection systems.

# new!

## portable

### FIELD STRENGTH METER



**OPERATES  
ANYWHERE!  
...  
NO AC LINE  
NEEDED  
...  
LIGHTWEIGHT  
...  
RECHARGEABLE  
BATTERY**



## Simpson

MODEL 498-D

The extra versatility you get in a Model 498 helps get jobs done faster. Covers all channels, UHF and VHF. Excellent for fringe areas. Measures relative field strength from 50 microvolts to 0.5 volts with continuously variable sensitivity. Also provides a 15-second tuner substitution test for servicing TV. Complete Standard Coil UHF-VHF tuner. Model 498-D operates from any one of four sources: (1) 117 ACV line; (2) internal storage battery (recharge by self-contained charger or your auto battery); (3) automobile battery; (4) external battery.

Model 498-A (117 ACV only)  
with shoulder strap . . . . . **\$14850**

Model 498-D (117  
ACV and 6.3 DCV)  
with shoulder strap,  
less battery **\$15550**

No. 5721 Storage Battery,  
12 amp  
hour capacity **\$950**



See Your Electronics Parts Distributor, or write . . .

### SIMPSON ELECTRIC COMPANY

WORLD'S LARGEST MANUFACTURER OF  
ELECTRONIC TEST EQUIPMENT

5200 W. Kinzie St., Chicago 44, Illinois  
Phone: EStebrook 9-1121

In Canada: Bach-Simpson, Ltd., London, Ont.

**New!** *the mosley*  
**4-Set TV Coupler**

IDEAL FOR:

- HOMES
- 4-UNIT DWELLINGS
- MOTELS
- STORES

LIST PRICE  
\$6.25



The new Mosley Type 904, 4-Set TV Coupler is especially designed for metropolitan television areas . . . *the major multi-set market!*

A bridging type resistive circuit distributes the signal equally to each output and provides effective isolation between sets to eliminate interaction. Signal transfer is excellent due to the constant impedance design.

The Mosley 4-Set Coupler will serve in a multitude of uses where it is neither necessary nor economically feasible to use amplifying distribution systems. Its low cost will appeal to your customers and the simplicity of installation means extra profits . . . *for you!*

AT YOUR PARTS JOBBER

**MOSLEY ELECTRONICS, Inc.**  
8622 St. Charles Rock Rd., St. Louis 14, Missouri

You are cordially invited to visit the  
**SERVICE booth (892-Audio Ave)**  
During the IRE National Convention-  
Radio Engineering Show  
At the Kingsbridge Armory, N. Y. C.  
March 19 to 22, 1956

**WHEN YOU CHANGE  
YOUR ADDRESS**

Be sure to notify the Subscription Department of SERVICE at 52 Vanderbilt Avenue, New York 17, N. Y., giving the old as well as the new address, and do this at least four weeks in advance. The Post Office Department does not forward magazines unless you pay additional postage, and we cannot duplicate copies mailed to the old address. We ask your cooperation.

**TEST and REPAIR**

**PICTURE TUBES**  
*"Right on the Job"*

**CENTURY'S CRT TESTIVATOR**

- New Profits!
- More Sales!
- Saves Time!
- Saves Trouble!

ONLY  
**14.95**

With the Model 103 CRT TESTIVATOR you can test and repair picture tubes right in the set in a matter of minutes. The TESTIVATOR tells you INSTANTLY what the trouble is and THEN FIXES IT!



**IT TESTS:** Cathode emission . . . Shorts and leakage between elements . . . Open elements . . . Probable useful life of the tube.

**IT REPAIRS:** Activates the CRT cathode by removing surface contamination . . . Restores emission giving life to weak and dim tubes . . . Clears inter-element shorts and leakage.

So easy to use . . . you just plug in, attach the TESTIVATOR socket to the base of the CRT and the accurate, easy-to-read indicators tell you what you must know. (Complete cables and instructions included.)

**FREE BONUS**—Order now and receive a handy, valuable booklet listing radio and TV tubes (incl. CRT) which can be substituted with **NO WIRING CHANGES**. Another profit maker for you!

**10 Day Free Trial—Money Back Guaranteed**

**NOW! PAY AS YOU EARN**

CENTURY ELECTRONICS CO., Dept. S-2  
111 Roosevelt Ave., Mineola, N. Y.

Enclosed is \$5.00 down payment. Please send me . . . Model 103 CRT TESTIVATOR. After 10 days, if not completely satisfied, I will return it for a refund—Or I will send \$5.00 a month until the full price of \$14.95 plus postage is paid.

Name . . . . .

Address . . . . .

City . . . . . State . . . . .

**SAVE SHIPPING CHARGES!** Enclose \$14.95 with this order . . . then we pay the shipping costs. Same return and refund privileges.

**Tube News**

(Continued from page 54)

the 4BC8 and 6BC8 medium-mu twin triodes.\* Both, 9-pin miniatures having semi remote-cutoff characteristics, were designed primarily for use in cascode-type circuits of vhf television tuners, one tube for receivers employing series-string heater connections and the other for parallel-heater connections.

Each triode of these tubes has a high transconductance, permitting high gain with corresponding noise reduction, and semi remote-cutoff characteristic to reduce cross modulation.

Two other tubes that have been added to the series-string chain are the 6AU8 and the 6BH8. Both are medium-mu triode/sharp-cutoff pentode, 9-pin miniatures. The pentode unit of each, designed primarily for video amplifier application, features high transconductance. The pentodes may also be used as video *if* or sound *if* amplifiers, as well as automatic gain-controlled amplifiers. The triode of the 6AU8, can be used as a sync-separator, sync-clipper, or phase-inverter.

\*RCA.

ask the  
**"Man-on-the-Roof"**  
why he prefers

*South River*

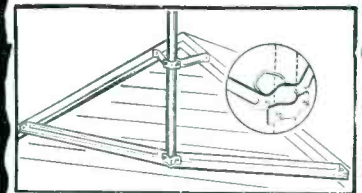

**EAVE MOUNT Model EM-48**

One piece construction of heavy gauge, embossed steel. Hot-Dip galvanized to prevent corrosion. Unique design of lower bracket gives extra strength and rigidity. Extended lip supports mast during installation. 48" spread permits generous spacing between brackets for excellent mechanical mast support. Both 3" embossed steel upper bracket and lower bracket have new "reversed" U bolt and clamp feature for Spintite fastening.

Also available with 60" spreads: EM-60.

WRITE FOR  
OUR LATEST CATALOG

**SOUTH RIVER**  
METAL PRODUCTS CO., INC.  
South River, New Jersey

pioneer &  
outstanding  
producer of  
finest line  
of antenna  
mounts

# INSTRUMENTS

## RCA VTVM

A Junior VoltOhmyst WV-77B, incorporating a *dc* voltmeter measuring from .05 to 1200 *v* in five ranges; an *ac* voltmeter offering readings from 100 *mv* to 1200 *v* (*rms*) in five ranges; and an ohmmeter measuring resistance from .2 ohm to one billion ohms in five ranges, has been developed by the RCA tube division, Harrison, N. J.

Available with a single-unit switch-probe and cable (WG-299A), with built-in switch for selection of *dc* or *ac*/ohms operation; probe is shielded and insulated to prevent accidental short circuits, grounds and shocks. Other accessories include a crystal diode probe (WG-301A) to extend frequency range to 250 mc and a high-voltage probe (WG-289) which extends *dc* rating of instrument to 50,000 *v*.

## SUPERIOR 20,000-OHMS/VOLT MULTIMETER

A 20,000-ohms/volt multimeter, TV-60, featuring a recessed 6 $\frac{3}{4}$ " 40-micro-amp mirrored-scale meter, has been introduced by Superior Instrument Co., 2435 White Plains Rd., New York 67, N. Y.

Unit can be used as a direct reading capacity meter, a kilovoltmeter and *rf* and audio signal tracer with accessory probes. *Dc* voltage is read on eight ranges from 0 to 30,000 *v*; *ac* voltage on seven ranges (at sensitivity of 5000 ohms/volt) from 0 to 7500 *v*; resistance measurements on three ranges from 0 to 20 megohms; capacity measurements on two ranges from .00025 to 30 mfd.

## TELE-TEST IN-CIRCUIT CAPACITOR TESTER

An in-circuit capacitor tester, *Capaci-Tester*, for checking coupling capacitors for leakage up to 40 megohms, has been announced by TeleTest Instrument Corp., 30-01 Linden Pl., Flushing 54, N. Y.

Tests, it is said, will not damage capacitors. Instrument can be used to check *pc* equipment; it eliminates need for unsoldering or clipping capacitors from printed board. A Wien bridge is included for measurement of capacitance from 10 mmfd to 50 mfd.

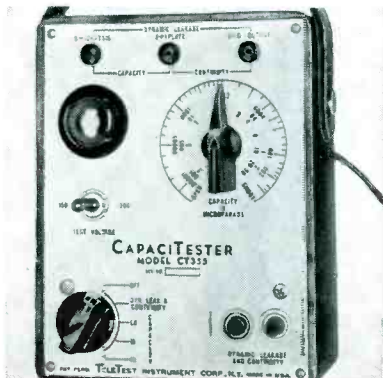

from the VOICE OF AUTHORITY IN SWEEPS...

# SPOT and FIX TV FAULTS FAST!

FREE RAM BOOK SHOWS HOW!

RAM Electronics Sales Co.  
Irvington, New York

S-2

Send me FREE 1956 RAM "PIX-A-FAULTS" BOOK.

Name \_\_\_\_\_

Firm \_\_\_\_\_

Street \_\_\_\_\_

City \_\_\_\_\_ Zone \_\_\_\_\_ State \_\_\_\_\_

Typical latest field-proven servicing data you'll find in your RAM book:



FAULT - Picture compression and stretching.

CAUSE - Capacitance value of boost capacitor (connected to linearity coil) too low.



FAULT - Trapezoidal pattern.

CAUSE - Short in horizontal winding of Yoke.



FAULT - Split picture.

CAUSE - Reversed AGC winding of H. Output Transformer; insufficient AGC voltage or reversed polarity.

For over 10 years, RAM has specialized and pioneered in sweeps exclusively. RAM designs them, makes them, counsels TV set manufacturers on them, field-services them, educates Servicemen on them — leads the industry.

No one but RAM can bring you such proven data — as shown here and in the RAM Manual. In manufacturing know-how and field experience, you can depend on RAM for...

## THE VOICE OF AUTHORITY IN SWEEPS

Send coupon today — get the BEST information from the FOREMOST manufacturer now!

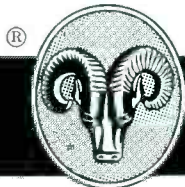

**RAM ELECTRONICS SALES CO.** - Irvington, N. Y.

Canadian Sales Division: Teleequipment Mfg. Co., Ltd., Ontario

Export Dept: Dage Corp., 219 E. 44 St., New York, N. Y.

## THE NEW MODEL TV-11

# TUBE TESTER



- Uses the new self-cleaning Lever Action Switches for individual element testing.
- Because all elements are numbered according to pin number in the RMA base numbering system, the user can instantly identify which element is under test. Tubes having tapped filaments and tubes with filaments terminating in more than one pin are truly tested with the Model TV-11 as any of the pins may be placed in the neutral position when necessary.
- Uses no combination type sockets. Instead individual sockets are used for each type of tube. Thus it is impossible to damage a tube by inserting it in the wrong socket.
- Free-moving, built-in roll chart provides complete data for all tubes.
- Phono jack on front panel for plugging in either phones or external amplifier detects microphonic tubes or noise due to faulty elements and loose external connections.

**EXTRA SERVICE**—The Model TV-11 may be used as an extremely sensitive Condenser Leakage Checker. A relaxation type oscillator incorporated in this model will detect leakages even when the frequency is one per minute.

Operates on 105-130 Volt 60 Cycles A.C. Hand rubbed oak cabinet complete with portable cover.....

**\$47.50**

**SHIPPED ON APPROVAL  
NO MONEY WITH ORDER — NO C. O. D.**

Try it for 10 days before you buy. If completely satisfied send \$11.50 and pay balance at rate of \$6.00 per month for 6 months.—No interest or Finance Charges Added. If not completely satisfied, return to us, no explanation necessary.

**MOSS ELECTRONIC DISTRIBUTING CO., INC.**  
Dept. D-217, 3849 Tenth Ave., New York 34, N. Y.

Please rush one Model TV-11. I agree to pay \$11.50 within 10 days after receipt and \$6.00 per month thereafter.

NAME \_\_\_\_\_  
ADDRESS \_\_\_\_\_  
CITY \_\_\_\_\_ ZONE \_\_\_\_\_ STATE \_\_\_\_\_

# PARKER'S PATENTED STAND-O FOR BEST INSULATION

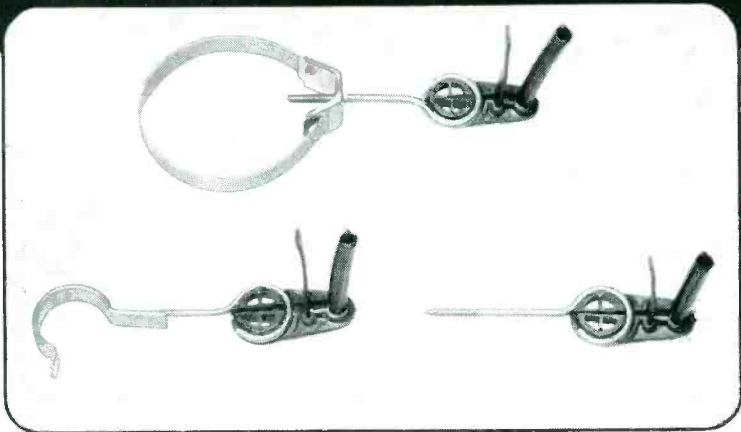

Parker Metal Goods Company has received patent rights on its complete line of STAND-O Insulators.

Recent tests conclusively prove that STAND-O Insulators improve UHF, VHF and color reception and they are interchangeable with any type of standard insulator hardware. A complete line is offered including screw eyes, machine screws, snap-ons, mast strap arms, masonry nails, drive-ins, doubles and triples.

You're assured performance-plus with patented STAND-O Insulators.

U. S. Patent #2,727,089

**PARKER METAL GOODS CO., 161 Summer St., Worcester, Mass.**

**New! COLOR  
& BLACK & WHITE  
LAB & TV SERVICE  
5" SCOPE**



**KIT  
\$79.95**

**Factory  
Wired  
\$129.50**

#460

• Flat from DC to 4.5 mc to reproduce 3.58 mc sync burst and oscillator signals in color TV sets.

- V amplifier direct-coupled and push-pull thru-out; gradual roll-off beyond 4.5 mc, useful at 10 mc.
- High V sensitivity: 25 mv/in.
- Choice of direct coupling (DC) or capacitive coupling (AC).
- 4-step frequency-compensated attenuator in both AC and DC positions.
- Built-in calibrator permits peak-to-peak voltage measurement.
- **Automatically syncs** anything visible on the screen.
- **Pre-set TV V & H sweep positions** (30 cps & 7875 cps).
- Edge-lit lucite engraved graph screen with dimmer control; filter; standard bezel fits standard photographic equipment.
- 5UP1 CRT.

Prices 5% Higher on West Coast



Write for Name of Distributor & FREE New 1956 CATALOG S-2  
84 Withers St. • Bklyn 11, N. Y.

©56 NOW IN STOCK AT YOUR NEIGHBORHOOD DISTRIBUTOR—ORDER NOW!

## Coming Event

**Tenth Annual Spring TV Conference  
April 13 and 14**

**Engineering Society of Cincinnati Bldg.  
Cincinnati, O.**

## Don't just say CAPACITORS

**Ask For Sprague By  
Catalog Number**

Know what you're getting . . . get exactly what you want. Don't be vague . . . insist on Sprague. Use complete radio-TV service catalog C-610. Write Sprague Products Company, 61 Marshall Street, North Adams, Massachusetts.

**SPRAGUE®**

WORLD'S LARGEST  
CAPACITOR MANUFACTURER

## PERSONNEL

FRANK LEBELL, 195 Second Ave., San Francisco, Cal., has been named selling agent for G. F. Wright Steel and Wire Co., in the Bay area of northern California and northern Nevada.



**Frank Lebell**



**C. T. Gabriele**

CHARLES T. GABRIELE has been appointed ad and public relations manager of Telrex, Inc., Asbury Park, N. J.

JOSEPH FRANK has been elected president of ASTON Corp., 255 Grant Ave., E. Newark, N. J.



**Joseph Frank**



**C. W. Perkins**

CLIFFORD W. PERKINS has been named secretary-treasurer of the Walter L. Schott Co. and secretary of Walsco Electronics Corp., Los Angeles, Cal.

DAVID MANBER has been named director of publicity of the JFD Manufacturing Co., 6101 16th Ave., Brooklyn 4, N. Y. . . . BRON KUTNY is now western regional sales manager.



**David Manber**



**Bron Kutny**

SIDNEY LEVY has been elected president of University Loudspeakers, Inc., 80 South Kensico Ave., White Plains, N. Y.; ARTHUR BLUMENFELD is now secretary-treasurer of the company. . . . Levy and Blumenfeld, with the late Irving Golin, founded University almost two decades ago. In conjunction to their duties as officers, Levy will serve as director of engineering, and Blumenfeld as director of production.



**Sidney Levy**



**Arthur Blumenfeld**

# CATALOGS — BULLETINS

## ADVERTISERS IN SERVICE

FEBRUARY, 1956

	Page
Alliance Mfg. Co.	33
American Pamcor, Inc.	38
American Television & Radio Co.	64
Argos Products Co., Inc.	2
Astron Corp.	41
B & K Mfg. Co.	44
Bell Telephone Labs.	58
Blonder-Tongue Labs, Inc.	3
Bussmann Mfg. Co.	10
Century Electronics, Inc.	60
Channel Master Corp.	4, 5
Chemical Electronic Engineering Co.	64
Clarostat Mfg. Co., Inc.	7
Cornell-Dubilier Electric Corp.	Inside Front Cover, 34
Delco Radio Div. General Motors Corp.	1
Ebcor Products Corp.	56
Eby Sales Co. of N. Y.	59
Electronic Instrument Co. (EICO)	62
Electronic Test Instrument Corp.	64
Electro-Voice, Inc.	48
Erie Resistor Corp.	50
General Dry Batteries, Inc.	51
General Electric	8, 9
Heath Co.	56
Hughes Research & Development Labs.	57
The Institute of Radio Engineers	14
Jensen Industries, Inc.	48
Kester Solder Co.	58
P. R. Mallory & Co., Inc.	Inside Back Cover
Merit Coil & Transformer Corp.	11
Microtran Co. Div. Crest Labs, Inc.	63
Mosley Electronics, Inc.	60
Moss Electronic Dist. Co., Inc.	61
Parker Metal Goods Co.	62
Philco Corp.	13
Precision Electronics	50
Pyramid Electric Co.	12
Quam-Nichols Co.	46
The Radiart Corp.	Inside Front Cover, 34
Radio Corporation of America	39, Back Cover
Radio Merchandise Sales, Inc.	52
Ram Electronic Sales Co.	61
Raytheon Mfg. Co.	16
Howard W. Sams & Co., Inc.	55
Shure Brothers, Inc.	43
Simpson Electric Co.	49, 59
Snyder Mfg. Co.	15
Sonotone Corp.	47
South River Metal Products Co.	60
Sprague Products Co.	48, 59, 62
Sarkes Tarzian, Inc. Rectifier Div.	53
Technical Appliance Corp.	35
TeleTest Instrument Corp.	52
Tenna Mfg. Co.	45
Trio Mfg. Co.	37
Walco-Electrovox Co., Inc.	50
Wen Products, Inc.	6
Weston Electrical Instrument Corp.	27

ELECTRONIC TEST INSTRUMENT CORP., 13224 Livernois Ave., Detroit 38, Mich., has released a 4-page illustrated brochure on their *Volta-Chek* designed to check voltages on TV picture tubes.

TODD-TRAN CORP., 156 Gramatan Ave., Mt. Vernon, N. Y., has issued replacement guide sheets on yoke and flyback replacements for CBS-Columbia and Emerson TV receivers.

ENTRON, INC., 4902 Lawrence St., Bladensburg, Md., has published a 16-page booklet explaining the physical setups of community-TV systems, their need and advantages.

ANCHOR METAL CO., INC., 244 Boerum St., Brooklyn 6, N. Y., has issued a leaflet, *Solder and Its Proper Application*, describing varied types of solder, methods of applying heat to solder, joint and fluxes, and solder-selection suggestions.

SYLVANIA ELECTRIC PRODUCTS, INC., 1100 Main St., Buffalo, N. Y., has released a revised *TV Picture Tube Comparison Chart* covering more than 170 types. Additional features include ion trap listings, focus, deflection and base diagrams. Also available is a *TV Tube Selector Guide*, a pocket-sized version with the same information.

TOBE DEUTSCHMANN CORP., Norwood, Mass., has issued a 2-page engineering bulletin *F-108*, describing screen-booth filters for use in power supply lines to shielded test rooms.

PRECISION APPARATUS CO., INC., 70-31 84th St., Glendale 27, N. Y., has announced an automatic roll chart and supplementary tube test data service, available to Precision tube test users on an annual subscription basis of \$2.00.

VACO PRODUCTS CO., 317 E. Ontario St., Chicago 11, Ill., has published a 40-page illustrated catalog covering screwdrivers, nut drivers, wood chisels, pliers, kits, specialty tools, plastic mallets and merchandising displays.

TECHNICAL APPARATUS BUILDERS, 109 Liberty St., New York 6, N. Y., has released a catalog, *PR156*, listing specifications, ratings and prices for selenium rectifiers, dc power supplies, chokes and transformers.

UNIVERSITY LOUDSPEAKERS, INC., 80 S. Kensico Ave., White Plains, N. Y., has issued a 28-page guide, *The Ultimate in Sound*, covering hi-fi speakers, multi-speaker systems and speaker enclosures.

BLONDER-TONGUE LABORATORIES, INC., 526-536 North Ave., Westfield, N. J., has released a 6-page brochure with specifications, schematics, and operating instructions on model *MCS vhf* single channel amplifier.

# MICROTRAN®

## PUTS AN END TO ALL LINE VOLTAGE HEADACHES

Insure full size, strength and sync of TV picture when low line voltage shrinks or weakens picture. All units have baked wrinkle finish, built-in AC receptacles and 6' line cord.



**NEW! LVS-153 LINE VOLTAGE STABILIZER**  
A popularly priced quality automatic voltage regulator. Stabilizes line for TV, radio or industrial use where load is constant. Input may vary between 95-130 volts, nominal output voltage regulated  $\pm 3\%$ . One model covers 125 to 300 watt range. Built-in automatic relay turns stabilizer on with equipment. Waveshape is free from distortions and frequency sensitivity of resonant type regulators. Size: 10"x5"x9 1/2" high. Weight: 10 lbs. List Price: 29.95

**DEALER NET: 17.95**



**NEW! LVB-350 METERED VARIABLE VOLTAGE ADJUSTER**  
Constant duty unit used as step-up or step-down. Automatically operated — turns on and off with set. Easily adjusted by manually turning 7-position rotary switch until built-in voltmeter reads 115 volts output. Has input switch positions for 90 thru 130 volts. Watts: 350 Weight: 7 lbs. Size: 7"x3 1/4"x3 7/8" Mtg. Centers: 5"x2 1/2" List Price: 24.75

**DEALER NET: 14.85**



**LVB-117 LINE VOLTAGE SWITCH**  
Multi tap selector switch restores line voltages of 90 thru 135 volts to 117 volts output. Calibrated neon indicator permits exact voltage adjustment. Automatically operated — turns on and off with set. Overload fuse protects against unsafe line increases. Watts: 350 Weight: 4 lbs. Size: 4 3/8"x3 1/4"x3 7/8" Mtg. Centers: 2 3/8"x2 1/2" List Price: 17.95

**DEALER NET: 10.80**



**LVB "Jr" UP-DOWN VOLTAGE BOOSTER**  
Reliable, budget-priced unit. Single switch provides 10 volt boost or drop or straight-through line. Watts: 350 Weight: 3 lbs. Size: 2 7/8"x3 1/4"x3 7/8" Mtg. Centers: 1 1/8"x2 1/2" List Price: 6.75

**DEALER NET: 4.05**

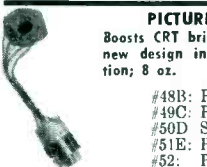

**PICTURE TUBE REJUVENATOR**  
Boosts CRT brightness. Units are resin treated; new design insures cool and buzz-free operation; 8 oz. List Price

- #48B: Parallel sets, 6 leads ..... \$2.00
- #49C: Parallel sets, 5 leads ..... \$1.50
- #50D: Series sets, 6 leads ..... \$1.75
- #51E: Parallel, isolation, 6 leads ..... \$2.25
- #52: Parallel, 2-step boost, 6 leads \$3.75
- #53: Universal, isolation & boost. \$4.25

All the above units are available for immediate delivery at your local distributor

**MICROTRAN®**   
Transformer Division, Crest Laboratories, Inc.  
Rockaway Beach 93, New York

AMERICAN TELEVISION &  
RADIO CO. ST. PAUL, MINN.

introduces the  
**new**



*Full Door Console  
Receiving Sets*

UNSURPASSED  
IN BEAUTY

UNEQUALLED  
IN PERFORMANCE

UNMATCHED IN  
QUALITY  
CONSTRUCTION

exclusive  
profitable  
dealer  
franchises  
now available

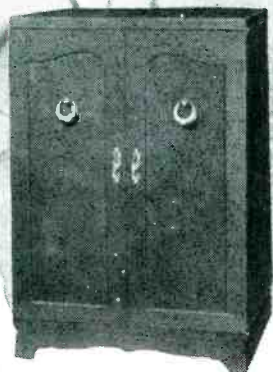

*designed  
with the  
Serviceman  
in mind  
... easy to  
get at*



WRITE TODAY FOR COLORFUL  
BROCHURE SHOWING THE  
NEW LINE OF ATR TV SETS

ALSO MANUFACTURERS OF DC-AC INVERTERS,  
"A" BATTERY ELIMINATORS, AUTO RADIO VIBRATORS



## Preview of the Annual IRE National Convention

COLOR TV, compact chassis and transistorized audio and radio equipment, which it was predicted would be the big three of '56, will receive solid recognition of this stature at the forthcoming annual convention† of the Institute of Radio Engineers, in New York City, when scores of the nation's leading specialists will unveil a number of striking developments in these fields.

Highlighting the color-TV reports will be papers on simplified models using circuitry and picture-tube design innovations. A talk on a single-gun tube project, called the *Apple System*, will reveal that an index signal within the tube can be used to show continuously the position of the scanning spot. This position information, together with the color TV signal, it has been learned, can modulate the scanning spot so that the spot illuminates the primary colors in sequence, in the proper amounts and proportions to reproduce the intended scene. The index signal is derived from a secondary emission structure within the tube.

In another color talk, a deflection yoke, aimed at simplifying electron beam convergence and deflection in a multibeam tube, will be analyzed in relation to its mechanical construction and its advantages. The yoke, a toroidal type, consisting of a single layer solenoid wound on a ferrite ring, has been designed to streamline control of raster size and of trapezoidal distortion. Two interleaved windings provide horizontal and vertical deflection. The yoke, with a low impedance, can be operated with step-down transformers.

The rapid movement toward more efficient small-component receivers and devices will be reflected by several reports on transistors and plated-board units. One such report on transistorized portable broadcast receivers will cover the application of alloy-junction *pnp* transistors to such circuits as mixer-oscillators and converters, if amplifiers (with *agc*) and second detectors. A representative audio system using a driver and a class *B* push-pull stage will be described.

†Over 700 exhibits will be on display and on demonstration at the Kingsbridge Armory, in the Bronx, N. Y. C., March 19-22. Talks will be presented during the four days at the Waldorf-Astoria, Belmont-Plaza and the Armory, N. Y. C.

# HUSH

Reg. U. S. Pat. Off.

*Chemically engineered for tuners and switching mechanism*



Hush comes in a 6 oz. pressure can with sufficient pressure to reach all contacts to *wash-away that dirt*, leaving clean and positive contacts, protected with a lasting lubricant film. Hush does not affect inductance, capacitance or resistance.

Hush also available in 2 oz., 8 oz. and 32 oz. containers.

6 oz.  
Spray  
can

**\$2.25**  
net

See your distributor  
or write to

**CHEMICAL ELECTRONIC  
ENGINEERING, INC.**

Matawan, N. J.

## HAVE YOU SEEN VOLTA-CHEK PICTURE TUBE VOLTAGE TESTER

SIMULTANEOUSLY TESTS  
**ALL VOLTAGES**  
OF THE CATHODE RAY TUBE  
**ELIMINATES GUESS WORK**

SMALL  
COMPACT  
ELECTRONICALLY  
ACCURATE  
EASY-TO-USE



SEE YOUR DISTRIBUTOR or WRITE  
ELECTRONIC

**TEST**

INSTRUMENT  
CORPORATION

13224 LIVERNOIS AVE., DETROIT, MICH.

VOLTA-CHEK MADE BY MAKERS OF THE  
NATIONALLY ACCEPTED VITAMETER

... another  
**MALLORY**  
service-engineered  
product

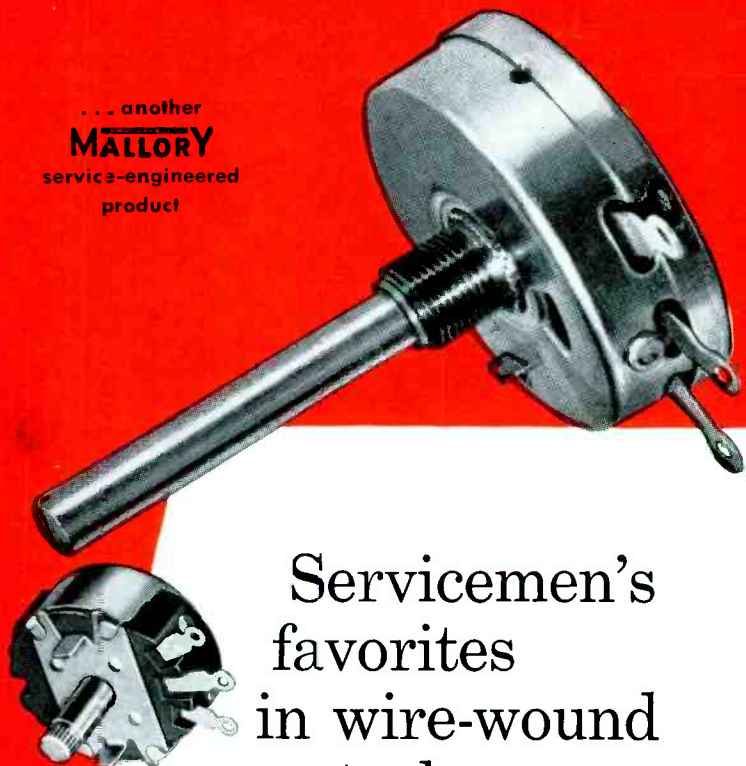

## Servicemen's favorites in wire-wound controls

You're sure of giving your customers the best when you use Mallory wire-wound controls. The choice of servicemen and manufacturers everywhere, they have set the standards of the industry for value and performance.

**They're conservatively rated**—to assure you of cool operation without need for using over-sized units.

**They're compact**—fit readily into crowded chassis locations.

**They're long lasting**—give years of stable, dependable service.

**They're uniform**—made to strict specifications to meet or exceed original equipment requirements.

Mallory 2-watt and 4-watt controls are available in resistance values and tapers to match every replacement need. Your local Mallory distributor has a complete stock—see him today!

P. R. MALLORY & CO. Inc.  
**MALLORY**

P. R. MALLORY & CO. Inc., INDIANAPOLIS 6, INDIANA

• Capacitors • Vibrators • Resistors • Controls • Switches  
• Rectifiers • Power Supplies • Filters • Mercury Batteries

Advanced  
 engineering  
 and precision-  
 manufacture  
 build

# LONG LIFE

into RCA

RECEIVING TUBES



A receiving tube that delivers, and keeps on delivering at maximum performance levels doesn't just happen—it *has to be made to happen!*

Stringent quality control checks govern each part and each process in the manufacture of all RCA Receiving Tubes. Take the RCA-6AU6, for instance: The control grid is silver-plated to minimize grid emission and to give low contact potential; carefully processed cathode materials minimize leakage and mica support is specially treated to insure low inter-electrode leakage; result—Long Life! To insure noise-free performance—is “receiver-tested.” Avoid costly callbacks—standardize each tube on RCA. Tell your distributor to fill your tube order with RCA Tubes only.



**RECEIVING TUBES**  
 RADIO CORPORATION OF AMERICA