

# RADIO • TELEVISION • ELECTRONIC

# STANDARD

The Technical Journal of the Television-Radio-Audio Trade

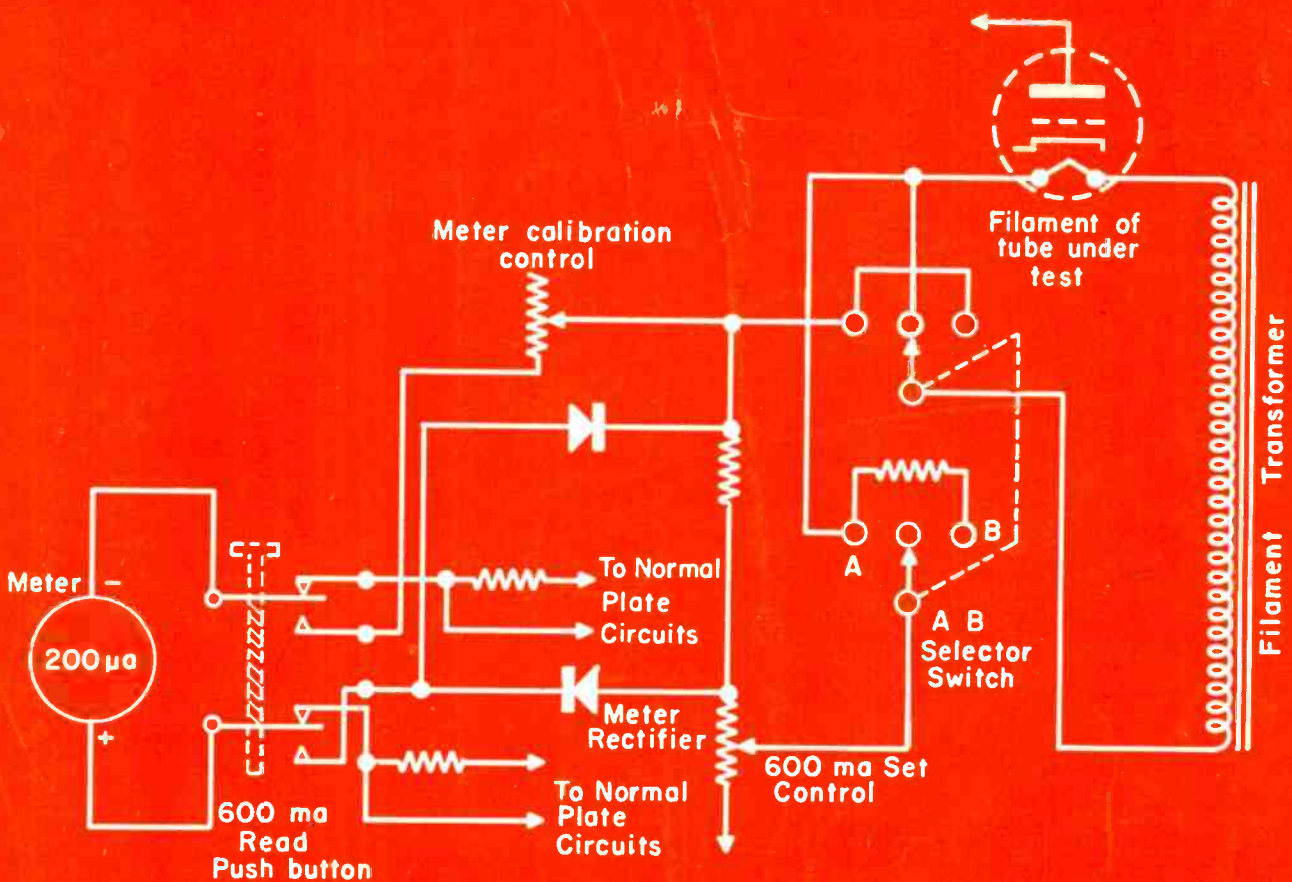

Circuit developed for tube checker to  
measure 600-ma series-string tubes.

[See circuit analysis, this issue]

4-58

C A MARTIN  
BOX 251  
GREAT BEND, N.Y.

**NOW... 3 models to choose from!**

**C·D·R automatic Rotors**  
 a type for every need  
 ...ALL 40% SHARPER TUNING  
 than any other automatic rotor

the famous  
 TR-2 now  
 available as a  
 fully automatic  
 model also...

**AR-22**

Here is the **HEAVY DUTY** rotor that is so popular everywhere...NOW COMPLETELY **AUTOMATIC!** Powerful beyond any TV need...it is tested and proven as the giant of the industry. Uses 4 wire cable.



**AR-2**

The complete, **AUTOMATIC** rotor with **THRUST BEARING**. Handsome modern design cabinet, uses 4 wire cable. Tested and proven by thousands and thousands of satisfied users, it has everything that could be asked for in a popular rotor.

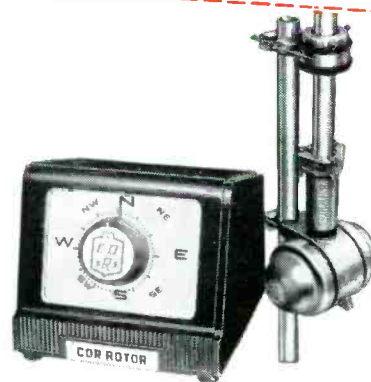

*and Pre-Sold  
 for you on TV  
 announcements  
 across the country*

**AR-1**

Same as the AR-2 without the thrust bearing.



**CORNELL-DUBILIER**  
 SOUTH PLAINFIELD, N. J.



**THE RADIART CORP.**  
 CLEVELAND 13, OHIO



**TWIN-SCREEN**

**HI-LITE**  
**Picture-Tubes**

***Every one is bright and sharp!***

It's no accident that Du Mont's new Twin-Screen Hi-Lite picture tubes provide richer contrasts and sharper focus. They feature the sharp focus of the Hi-R-gun design plus the extra brightness of an aluminized screen. Furthermore, each Twin-Screen Hi-Lite is purposely put through the same stringent tests to assure only the best of quality in outgoing products.

These outstanding uniform qualities are your guarantee that you always get a better picture tube when you specify Du Mont Twin-Screen Hi-Lite — And they cost no more than ordinary aluminized replacement types!

Ask your distributor for Du Mont "Twin-Screen Hi-Lite" the next time you buy picture tubes.

**DU MONT**

Cathode-ray Tube Division, Replacement Sales, Allen B. Du Mont Laboratories, Inc., Clifton, N. J.

**DU MONT  
Hi-R ELECTRON GUN**

**Exclusive with Du Mont! Recognized  
by customers and competitors alike as  
the finest gun available today.**



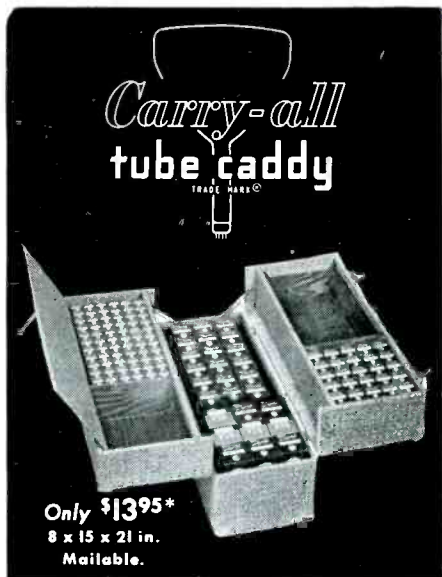

Most time-saving case ever designed for the TV technician. Carries up to 262 tubes, plus tools . . . tells the customer, "Now here is an efficient serviceman."

\*Dealer Net. Others \$8.85 to \$14.95

## ARGOS CORNER AND WALL BAFFLES LOOK BETTER, COST LESS

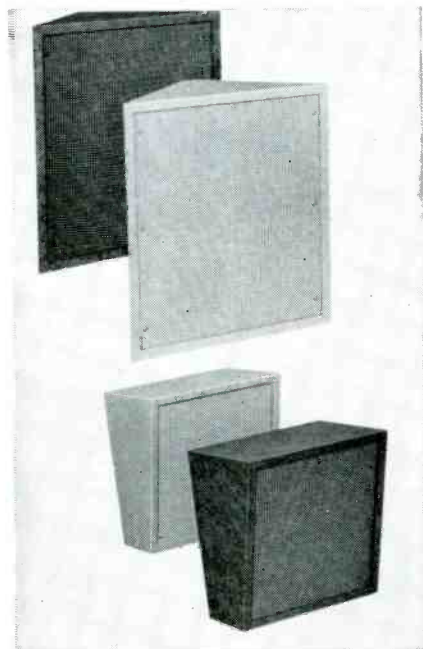

Corner baffles \$11.75 and \$16.25 list, wall baffles as low as \$4.12 in fabric covering, \$6.75 in genuine wood, list.

ASK YOUR PARTS DISTRIBUTOR



Including SERVICE—A Monthly Digest of Radio and Allied Maintenance: RADIO MERCHANDISING and TELEVISION MERCHANDISING. Registered U. S. Patent Office.

### COVER CIRCUIT

Series-String 600-MA Heater Test Schematic for Tube Checker (Sylvania 620)..... 18

### FEATURES

Audio Installation and Service..... Lee Scott	26
(Horn Design and Application for PA and Home)	
Audio Maintenance and Service Tips..... Fred R. Sailes	28
(Locating and Curing Phono and Tape Equipment Problems)	
Behind the VTVM Controls..... G. S. Ryant	12
(Chart Analysis of Circuitry and Relation to Adjustments and Set Under Test)	
Latest in Audio.....	27
Oscillators in B-W and Color TV Chassis..... Jesse Dines	10
(Report on 10 Types Now Being Used)	
Outdoor Sound..... Michael Anthony	22
(Installation, Maintenance, Operation, Servicing)	
Replacement of Metal-Clad Resistors in The Field..... Fran Chamberlain	16
(Review of Practical Techniques Found Most Effective)	
Schematics in this Issue.....	41
Ser-Cuits—Cover..... William Drummeter	18
(Series-String 600-MA Heater Tube-Checker Circuitry)	
Service . . . The National Scene.....	6
Service Engineering..... Maxwell Alberts	14
(Photoelectric Remote Controls for TV Chassis)	
Servicing Helps..... T. L. Gilford	32
(Radio and TV Repair Case Histories)	
Transistor-Tube Developments..... A. M. Kelwood	46
(Highlights of Transistorized-VHF Pocket Set; 600-MA Tubes)	
UHF/VHF Antennas and Accessories.....	21
(Pictorial Review of New Developments)	
UHF/VHF TV Antenna Digest..... Ralph G. Peters	20
(Fringe-Antenna Tower-Installation Field Notes)	
Wide-Band 'Scope Circuitry for Color-TV Troubleshooting..... Wyn Martin	24
(Modifications Developed for Standard 'Scope to Expand Width)	
Views and News..... Lewis Winner	9

### DEPARTMENTS

Association News.....	30
Bench-Field Tools.....	40
Catalogs and Bulletins.....	45
Components.....	34
Instruments.....	35
Jots and Flashes.....	48
Personnel.....	45
Ten Years Ago In SERVICE.....	30
TV Accessories . . . Parts.....	38
Index to Advertisers.....	47

Entire Contents Copyright 1955, Bryon Davis Publishing Co., Inc.

Second-Class mail privileges authorized at New York, N. Y.; additional entry at the Post Office, Norwalk, Conn.

Subscription price: \$2.00 per year in the U.S.A. and Canada; 25 cents per copy. \$3.00 per year in foreign countries; 35 cents per copy.



**EDITOR**

Lewis Winner

Assistant Editor: D. E. Pearsall II

Editorial Production: A. Kelly

**CIRCULATION DEPARTMENT**

Circulation Manager: A. Goebel

Ass't Circulation Mgr.: A. Kiernan

**ADVERTISING DEPARTMENT**

Business Mgr.: F. W. Boyd

East: Jerome J. Brookman

Mid-West Mgr.: Stuart J. Osten  
333 N. Michigan Ave.  
Chicago 1, Ill.  
Tel.: DEarborn 2-3507

East-Central Rep.: James C. Munn  
2253 Delaware Dr.  
Cleveland 6, O.  
Tel.: ERievew 1-1726

Pacific Coast Rep.: Brand & Brand  
1052 W. 6th St.  
Los Angeles 17, Cal.  
Tel.: MAdison 6-1371



Published Monthly By  
Bryan Davis Publishing Company, Inc.  
52 Vanderbilt Ave., New York 17, N. Y.  
Tel.: MUrray Hill 4-0170

B. S. Davis, Pres. F. W. Boyd, Sec'y

# It's as EASY as This

## TO INSTALL A MASTER TV SYSTEM

WITH



# Masterline UNITS

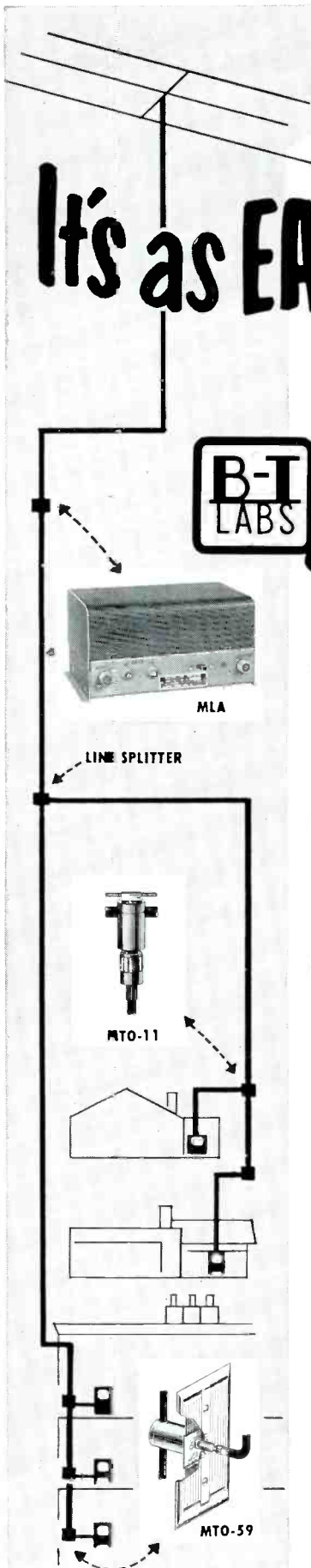

**A** Connect the antenna line to the INPUT of your Masterline MLA Line Amplifier. The signal is now amplified 37db (70 times).

**B** Connect a line splitter or line coupler to the OUTPUT of the MLA. You now have 2 or more branch lines for feeding to TV receivers.

**C** Where the branch line is run out-of-doors, connect a Masterline MTO-11 (outdoor tap-off) wherever a TV set feed line is required.

**D** Where the branch line serves as a riser inside a building, connect a Masterline MTO-59 (wall-plate tap-off) wherever an antenna outlet is required.

This is only one example of a Master TV System, to show the flexibility of Blonder-Tongue distribution equipment. There are many more, all covered in the new B-T INSTALLATION MANUAL.

Write for your Free copy to Dept. FH-8  
**BLONDER-TONGUE LABORATORIES, INC.**  
WESTFIELD, NEW JERSEY

Manufacturers of TV Cameras, TV Amplifiers, Boosters, Converters, Accessories and Originators of the Masterline and 'Add-A-Unit' Master TV Systems.

# TV CAPACITOR SERVICING DATA

## For Every Manufacturer from A to Z

### FREE FROM SPRAGUE

---

These two pocket-size manuals are the hottest radio-TV servicing guides ever produced. Both contain the most complete—and the most up-to-date—capacitor replacement information available ANYWHERE!

Keep them both handy and you'll never have to thrash around for the right capacitor replacement information. Sprague makes them all, Sprague lists them all, and Sprague distributors know them all—all to help you handle every capacitor job right every time.

What's more, you don't have to pay a red cent for these valuable, expensive-to-prepare, expensive to keep up-to-date manuals. You can get them both FREE from Sprague distributors located in every sales area in the United States. We'll be glad to send you the name of the one nearest you. Or, for 10c to cover postage and mailing, we'll gladly send you the manuals direct from Sprague Products Co., 61 Marshall St., N. Adams, Mass.

**DON'T BE VAGUE...INSIST ON**

**SPRAGUE**®

**WORLD'S LARGEST CAPACITOR MANUFACTURER**

Sprague Products Co. is the Distributors' Division of the Sprague Electric Co.

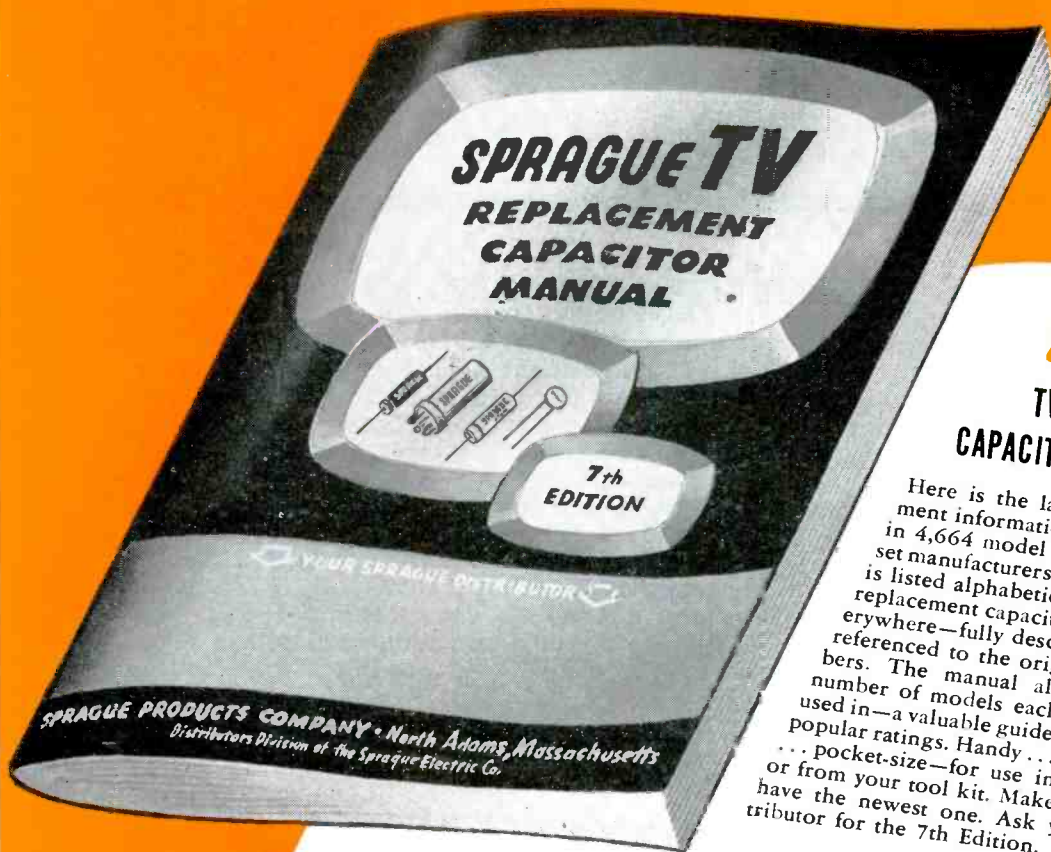

**FREE!**  
TV REPLACEMENT  
CAPACITOR MANUAL K-101

Here is the latest capacitor replacement information for every capacitor in 4,664 model TV sets made by 85 set manufacturers. Every manufacturer is listed alphabetically, with Sprague replacement capacitors—available everywhere—fully described and cross-referenced to the original part numbers. The manual also shows the number of models each capacitor is used in—a valuable guide for stocking popular ratings. Handy... convenient... pocket-size—for use in the shop or from your tool kit. Make sure you have the newest one. Ask your distributor for the 7th Edition.

**FREE!**  
CERAMIC CAPACITOR  
REPLACEMENT MANUAL K-200

This handy little guide is the most informative, the most complete manual of its kind ever published. Pocket-size, like Sprague's TV replacement Capacitor Manual K-101, it lists every conceivable ceramic capacitor and printed circuit replacement... for every television set made... during the past five years. All told, more ceramic capacitor values than can be found in any other manufacturer's line, including discs and tubulars. And each capacitor or printed circuit listed is one you can depend on for a no-call-back replacement. Ask your distributor for it today. It's new!



# SERVICE... The National Scene

18 ZONE-1 TV STATIONS RECEIVE OKEH TO INCREASE ANTENNA HEIGHT AND POWER--Under a new FCC ruling, eighteen TV stations in zone one (Northeast, North Central and Middle Atlantic) have received authorization to boost heights of their antennas up to 1250 feet above average terrain, providing power gains that will add about 4 to 5 miles to coverage patterns. . . . Up to now, maximum ceiling above average terrain in this zone has been 1000 feet, or a corresponding power reduction to compensate for the higher elevation of such locations as the Empire State Building; 1190 to 1440 feet, depending on the positions of the various arrays. . . . Stations who received the green light to up their towers, include the seven in New York City and WJAC-TV, Johnstown, Pa. (channel 6); WNBF-TV, Binghamton, N. Y. (channel 12); WBEN-TV, Buffalo, N. Y. (channel 4); WRGB, Schenectady, N. Y. (channel 6); WWJ-TV, Detroit, Mich. (channel 4); WMUR-TV, Manchester, N. H. (channel 9); WSVA-TV, Harrisonburg, Va. (channel 3); WEWS, Cleveland, O. (channel 5); WHIO-TV, Dayton, O. (channel 7); WSAZ-TV, Huntington, W. Va., (channel 3); and WHIS-TV, Bluefield, W. Va. (channel 6). . . . Allowable power increases will range from a low of .1 dbk (per thousand watts) to a maximum of 4.5 dbk, WWJ-TV being at the low end and WMUR-TV on top.

LATEST TV CHASSIS FEATURE HOST OF CIRCUIT INNOVATIONS--The parade of new TV models unveiled at recent music and furniture shows in Chicago displayed quite an assortment of novel developments. . . . Most of the vertical type sets featured 90-degree picture tubes and many had wafer-type cascode tuners and 41-Mc ifs. . . . The uhf adaptor unit of another series, built on a silver-plated chassis, employed a circuit said to provide an average signal-to-noise ratio of 11 db. . . . The if amplifier in these receivers, designed to provide a 3.25-mc bandwidth, included remote cutoff if tubes, controlled by a keyed agc circuit. . . . Also found in these models was automatic video gain in the video amplifier; this circuit, it was claimed, serves to prevent variation of picture or sound during movement of the contrast control. . . . In the sync separators noise-cancellation circuits have been included to eliminate such effects as picture roll or jitter caused by electrical interference. . . . And to provide accurate control of horizontal sync, the models have an automatic phase detector built into horizontal-deflection circuits. . . . Analyses of these circuit refinements will appear soon in SERVICE.

WESTERN STATE TV-ANTENNA INSTALLATION CODES UNDER STUDY BY EASTERN LEGISLATORS--The strict regulations covering the installation and construction of TV antennas, adopted by a number of states in the west, are being carefully reviewed by State Senators and Assemblymen in the east, for possible inclusion in new codes. Such controls were viewed as vital to the prevention of accidents caused by faulty installations. . . . One Western code, said to contain the best pattern, the Nebraskan measure, covers construction, ground-supported antennas, grounding and transmission leadins. . . . According to this ordinance, every roof-mounted mast or antenna, including base, guys, anchors, turnbuckles and other hardware, must be of non-combustible material, and either corrosion resistant or adequately treated or painted to resist corrosion. . . . Commenting on leadins, the rules say that when polyethylene ribbon or similar type leads, except coax cable with a grounded sheath are used, lightning arresters must be connected to each conductor.

NATIONWIDE ADOPTION OF TV ACCREDITATION PLAN SOUGHT BY RETMA--The program of TV Service Men accreditation, initiated by the Radio-Electronics-Television Manufacturers Association a year ago, in a few cities, has been expanded for national exposure. . . . Two methods of certification are offered. Those who successfully complete a training and upgrading course, prepared by RETMA, would receive a certificate attesting to their technical competence and skill. . . . Those who already possess the necessary degree of proficiency, would be asked to take an examination covering theory and working knowledge. . . . Courses and tests would be given by local trade and industrial schools in cooperative-community programs. . . . Service Men who complete courses in these schools, it was said, would become more closely integrated with local servicing operations, become more aware of neighborhood responsibilities and certainly profit from such community ties.--L. W.



150 field tests have proved to  
WARD jobbers:

- \* Good VHF picture at as far as 200 miles on several channels
- \* Excellent results at 100 miles
- \* Good results in areas where no other antenna was able to bring in a picture
- \* More compact—25%-75% less stacking distance
- \* Channel 2-13 response as much as 40% better than any comparable antenna
- \* Unique superior snap-lock bracket
- \* Original WARD design all aluminum supplemented spring pressure bracket—eliminates possibility of intermittent contact

TRY ONE—you'll find why the Invader is superseding all fringe and super-fringe antennas.

WARD Model TVS 356 2 bay and stacking harness \$39.95 list

WARD Model TVS 357 4 bay stacking kit (feed harness only) \$3.95

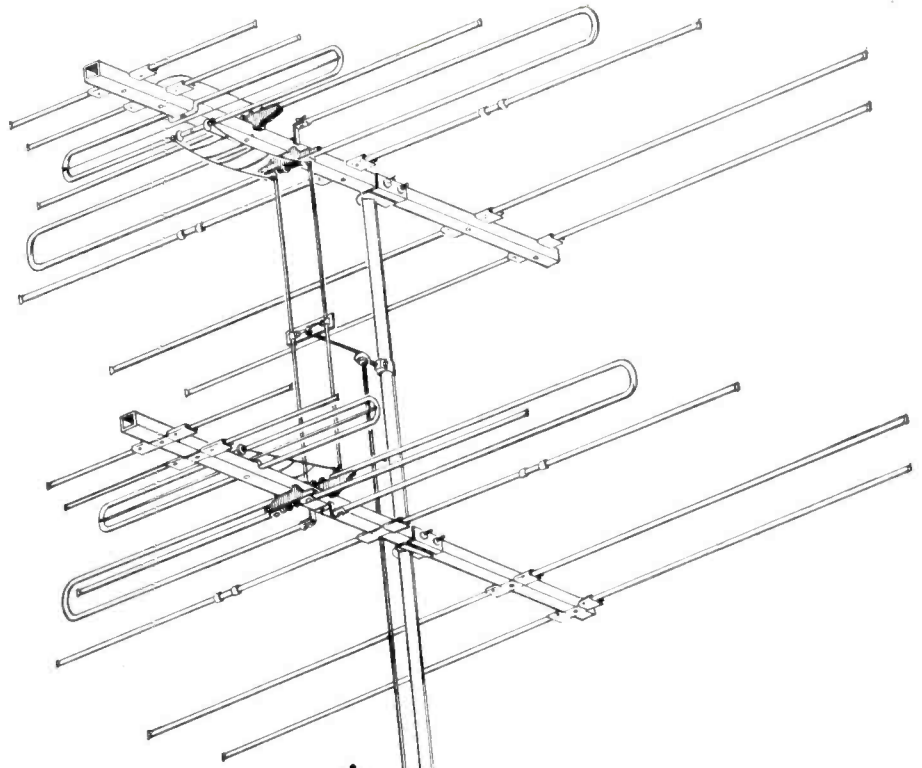

# THE INVADER\* CONQUERS

sweeps all other fringe and super-fringe antennas before it

\*an original WARD design

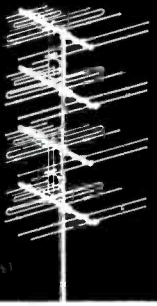

flat type Uni-plane  
Yagi for fringe  
area VHF and  
primary signal  
area UHF.

\*Documental testimonials in our files

## WARD

Products Corp., Cleveland 15, Ohio



**MR. SERVICE DEALER:  
you're ridin' high, wide  
an' handsome**

in this **RAYTHEON**

**LIFE** ad

September 12th



**It takes a heap of  
Know-How to ride herd  
on 36,000,000 TV Sets**

In only a few short years, America has created a new guild of skilled craftsmen... the electronic technicians who service the nation's 36 million television receivers. It's a big job—one that calls for a high order of technical know-how and a substantial investment in training and equipment.

Your neighborhood radio and television serviceman takes pride in his ability to serve you with skill and integrity.

He takes special pride when he has qualified as a member of the select group of Raytheon Bonded Electronic Technicians. As such he displays the Raytheon Bonded Seal and adheres to this Code of Ethics:

1. Guarantee all radio and television repair work for 90 days.
2. Use only parts of recognized quality.
3. Charge not over established prices for parts.
4. Test customers' tubes as accurately as possible.
5. Keep labor charges at a reasonable level.
6. Perform only such work as is necessary.
7. Maintain proper equipment for good repair work.
8. Maintain the highest quality service.

He has the ability and equipment to solve your TV service problems, whatever the make or model of your sets. His work is backed by a bond issued through one of America's largest insurance companies and his standing as a Raytheon Bonded Electronic Technician is your guarantee of satisfaction.



LOOK FOR THIS SEAL  
It's the symbol of Satisfactory Service



Excellence in Electronics

RAYTHEON MANUFACTURING COMPANY, Resolving and Cathode Ray Tube Operations  
NEWTON • CHICAGO • ATLANTA • LOS ANGELES  
RAYTHEON MANUFACTURING COMPANY PROVIDES RAYTHEON EQUIPMENT ELECTRONIC LOGGERS, ELECTRONIC  
INDUSTRIAL EQUIPMENT, ELECTRONIC DUPLICATORS, INDUSTRIAL EQUIPMENT, DEEP  
FREEZE AIR CLEANERS, SEMICONDUCTOR PROBES, RAYTHEON EQUIPMENT ELECTRONIC LOGGERS, ELECTRONIC  
INDUSTRIAL EQUIPMENT, ELECTRONIC DUPLICATORS, INDUSTRIAL EQUIPMENT FOR THE UNITED STATES OVERSEAS



**HOT OFF THE PRESS!  
The Sensational New RAYTHEON  
TRANSISTOR APPLICATIONS BOOK**

116 pages — over 50 practical applications — complete how-to-do-it instructions. Available from your Raytheon Tube Distributor or send 50¢ to Department P7, Raytheon Manufacturing Company, Newton 58, Massachusetts.

**MAKE THE MOST OF IT!**

Once again, Raytheon is telling your story, this time to the 26,450,000 readers of LIFE Magazine (September 12 issue) and, once again, you have a golden opportunity to cash in on this great, national promotion. All you need to do is tie in with this dramatic, colorful, full page advertisement. Use Raytheon decals, blow-ups of the ad, displays and local advertising to show customers you are the capable service dealer we're talking about. You'll increase your volume and profit and boost your neighborhood prestige to an all-time high.

Your Raytheon Tube Distributor will be happy to help you plan a tie-in campaign that will prove most effective. Call him today.



### Views and News

**A RAINBOW FOR UHF:** The future of the ultrahighs, of grave concern not only to industry but to government, recently received its brightest mantle of hope, in the form of a sensational plan by FCC Commissioner John C. Doerfer, that would shift *all* stations in nine cities, representing the major trading centers, including New York, to the high bands. This would involve the conversion of nearly 12-million *vhf* receivers now in operation in these markets!

Admitting that the costs for such a radical change would be huge, running into well over a billion dollars, the Commissioner said that this factor should not be considered as a standard by which to judge the respective equities of television viewers. He could not see why a resident of New York City should be permitted to enjoy the choice of seven channels without any conversion costs, while farmers in such states as Wisconsin, Illinois, Indiana, Connecticut or New York were denied any TV service; or at best attenuated *uhf* signals in fringe areas.

The nub of the present flurry of suggestions, it was noted, is shall urban dwellers in large areas have a multiple choice of TV service at a minimum cost, while rural people have none or a few at a much higher receiving cost, especially when at best the rural and comparatively small city dwellers cannot create a demand in excess of 7 per cent of present sales.

The Commissioner felt that large concentrations of population in the metropolitan areas would provide a market and sufficient basic economic support for *uhf* operations, with ample inducement and probable development of service to the fringe areas from stations operating in and about the peripheries of ultrahigh signals. And, he added, population and economic support, spread over a comparatively wide area, lend themselves to veryhigh operation from the central cities, such as are found in the areas outside of the northeast industrial zone of the country.

The suggested approach was viewed as one which would tend to reduce the probability of substantial portions of population in the fringe areas, in the *thin* economic areas, going without any television service.

Unless a plan of the type proposed is adopted, the FCC spokesman stressed, the ultrahigh problem will continue to be an acute one, and we will have to live with small islands of *uhf* markets and meagre acceptance of channels that are rich in their potential.

**CRUSADING ASSOCIATIONS:** Hard-hitting campaigns aimed at stabilizing service operations and enhancing the prestige of the Service Man are now in action across the nation.

In Binghamton, newspapers are carrying association advertisements striking out at service bargains, particularly those cleared through telephone-answering setups. This practice, the ads warn, certainly does not represent a sound, ethical appeal for business.

"You'll never see your doctor advertise a special sale on appendectomies," one ad headlined. Another said: "You'll never see your dentist hold a '2-for-1' sale on extraction. . . . Also, you'll never see the day when you can take your TV set in for a service 'bargain' and be sure you're getting a square deal."

In Milwaukee, as part of a campaign to eliminate fraudulent practices, an association has organized a complaint bureau. Consumers, who believe they have been overcharged or victimized in TV repair, are being urged to call the bureau, who will contact the shop against which the complaint has been lodged, to obtain an explanation and settlement of the matter. Repeated or major offenders, it was said, will be referred to the office of the district attorney.

And in Chicago, a licensing authority has been created by one group. Under this plan, any service company in the area who is willing to submit to an investigation of its facilities, its methods and history, and in addition is willing to abide by a professional code of ethics and the BBB advertising code, may become licensed.

Licensees receive stickers with license numbers for application to all sets repaired by the accredited shops.

As soon as the program is in full swing, the association expects to turn the plan over to the state's department of education and registration for enforcement.

**WELCOMED PLAUDITS:** Praising Service Men for their promptness and the quality of service rendered in installing, maintaining and repairing the nation's 40-odd-million TV receivers, the prexy of one of industrys leading tube and set producers said recently that this record of accomplishment was indeed an enviable one.

And elsewhere, the head of a service division declared that Service Men, who have played this key role in the public's acceptance, with confidence, of black and white TV, will continue to do a job in color TV, where they will be called on to display new skills and knowledge. Everyone is sure, he emphasized, that the Service Man's courteous, helpful know-how will aid materially in bringing about an orderly transition to colorcasting as a truly nationwide service.—L. W.

# Oscillators in B-W and COLOR-TV Chassis

by **JESSE DINES**

Ram Electronics, Inc.

**A Comprehensive Report on Ten Types of Circuits**

**Now Being Used in B-W/Color Front-End,**

**Vertical, Horizontal, and 3.58-Mc Oscillators**

ONE OF THE MOST important elements in the TV set, whether it be black and white, or color, is the oscillator; serving in the front end as a local generator (for both *vhf* and *uhf*), and horizontal, vertical, and color 3.58-mc portions of the video system.

Ten different types of circuits can be employed in these oscillator sections: Hartley, Colpitts, ultraudion, tuned plate, tuned plate-tuned grid, push-pull, blocking, multivibrator, electron-coupled, and crystal.

In a basic oscillator circuit, the tube, because of its amplification ability, is used to convert *dc* energy in its input circuit to *ac* energy in its output. The grid circuit network, indicated in Fig. 1, is the source of *dc* energy, and the plate circuit network represents the resultant *ac* energy. To make the oscillator self-sustaining, a feedback network is connected between the grid and plate of the tube, so that energy generated in the plate circuit may be automatically returned to the grid circuit. Inasmuch as the plate energy is always greater than the grid energy, due to amplification, the plate circuit becomes a constant source of input power to the oscillator.

The phase of the feedback voltage is such that it is *in phase* with the voltage at the grid, thus producing an

additive voltage action. Since the tube inherently produces a 180° shift between grid and plate, the feedback network must provide an additional 180° phase shift to bring the plate and grid signals into phase. To do this, the feedback network must consist of an *L-C* or *R-C* network, a tube, or the interelectrode capacitance of the tube itself may be used to provide the necessary phase shift.

Oscillations are permitted to occur, because any small voltage change in the grid or plate circuit (due to the inherent tube characteristics and the *dc* operating voltages or an input signal) is transferred from one circuit to the other, and this change increases further in amplitude until oscillations of sizeable magnitude are produced. This operation causes the plate voltage to increase and decrease alternately at a rate predetermined by the components comprising the oscillator circuit.

The local oscillator injects a signal into the converter stage (together with the composite video signal), resulting in the *if* signal. The oscillator stage (for both *vhf* and *uhf*) can be either a Hartley, Colpitts, ultraudion, or tuned-plate push-pull.

In the Hartley oscillator the inherent oscillator frequency is determined by *L* and *C* components. Fig. 2 illus-

trates effect of grid-leak bias, which results from grid current  $I_1$  flowing through the grid-cathode resistance of the tube when it conducts, when the oscillations make the grid positive, with respect to the cathode; capacitor charges with the polarity indicated in Fig. 2a. During the generation of *rf* pulses (when the grid is negative, with respect to the cathode), the capacitor discharges as shown by the  $I_2$  current; the average magnitude of voltage across  $R_1$  becomes the tube bias. The magnitude of the bias is proportional to that of the *rf* voltage generated across *L-C*.

The Hartley employs self-bias (usually grid-leak), instead of fixed bias, to permit an easier initiation of the oscillations. If a high negative bias were applied for proper circuit operation, the tube would be cut off completely, and oscillations could not start easily. It is only after the oscillations have been built up to a sizeable magnitude that  $C_1$  develops its full charge to provide bias for the oscillator.

*Rf* feedback is accomplished from plate to grid through *L*; there is a 180° voltage-phase reversal between opposite ends of a coil. *L* is tapped to

(Continued on page 43)

Right: Figs. 1 to 6

Fig. 1 illustrates basic circuitry employed in an oscillator. A shunt-fed Hartley is shown in a of Fig. 2 while a series-fed Hartley appears in b. A Hartley that is used in CBS-Columbia's 700 series is diagrammed in Fig. 3. The basic Colpitts is shown in a of Fig. 4. In b we have an adaptation of the Colpitts as found in Admiral 20 series. The basic ultraudion oscillator appears in Fig. 5 a. And in b appears a version of the ultraudion as used in DuMont RA-109/119 Inputuner. The basic circuit of a push-pull oscillator is shown in a of Fig. 6. Circuit in b illustrates the tuned-plate push-pull scheme used in the 630 chassis, developed by RCA. And in c is a *uhf* application of the circuit; Emerson 120174 chassis.

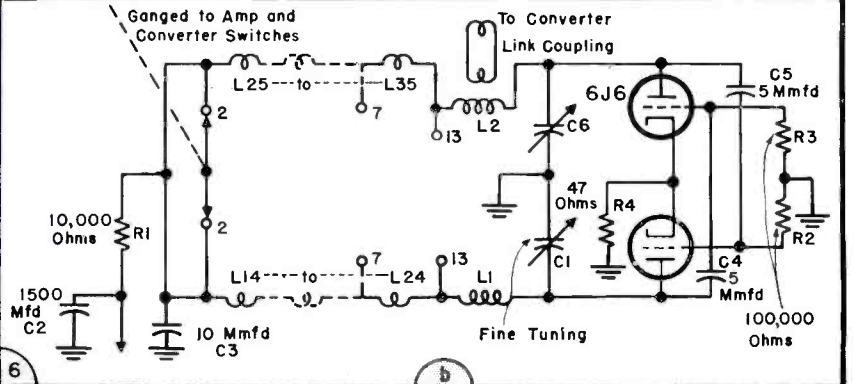
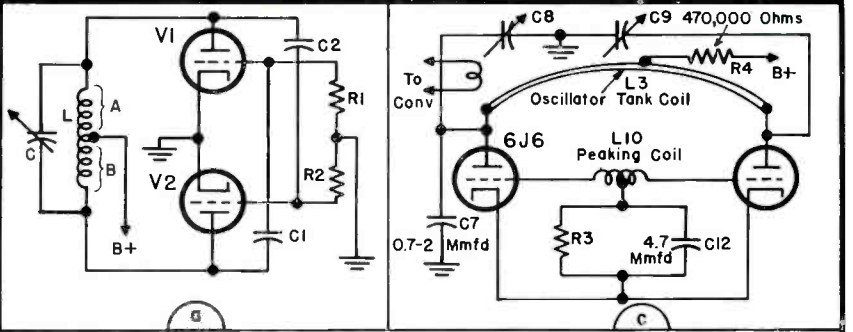
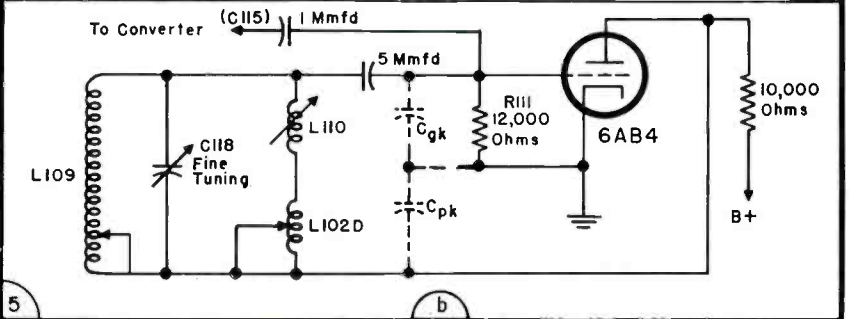
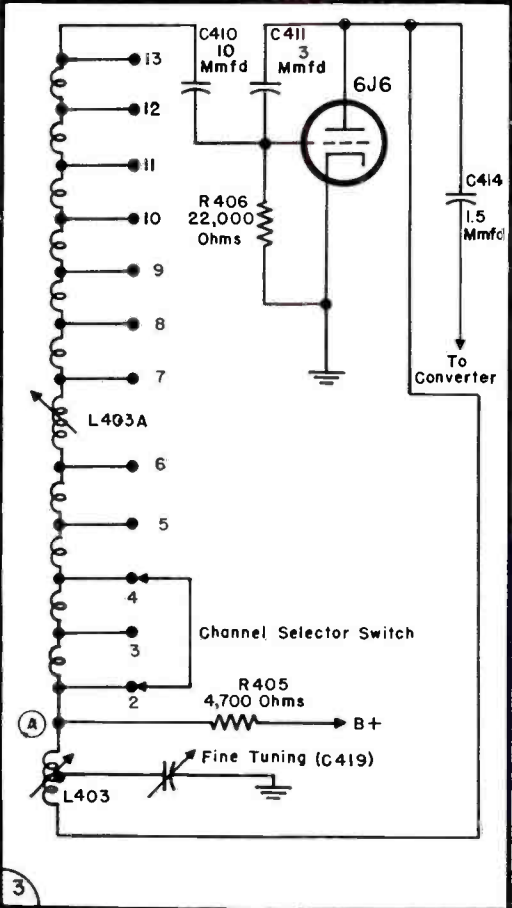
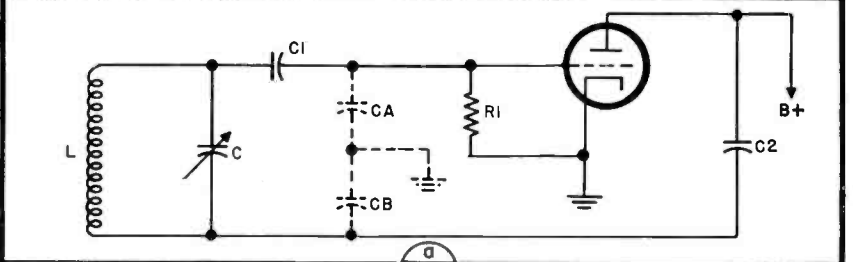
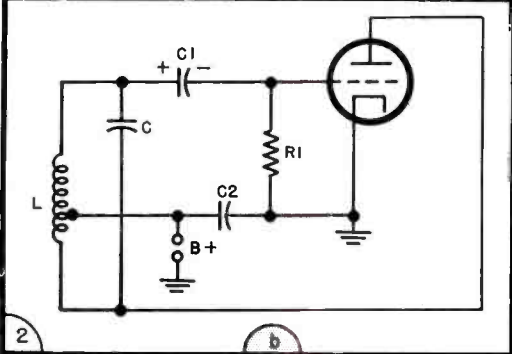
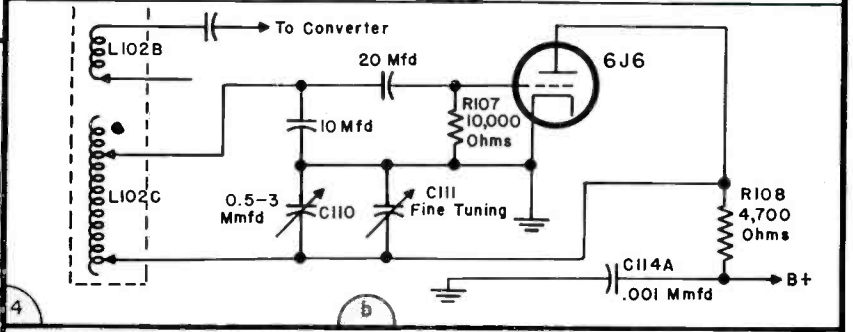
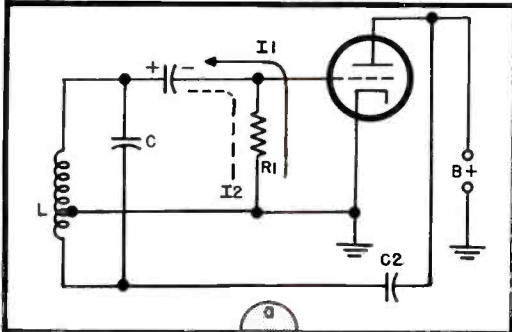
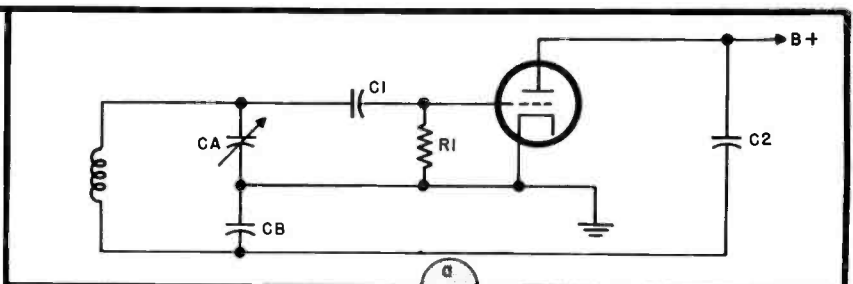
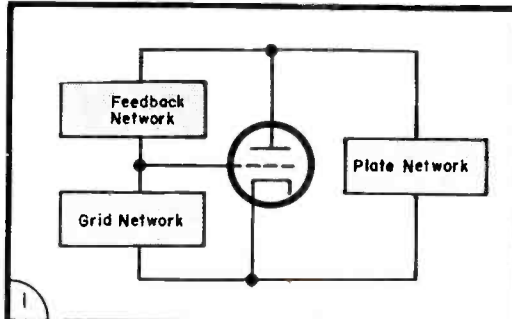

# Behind the VTVM Controls †

Design Features	Purpose in Instrument	Performance Factors
<p>High-input resistance and low-input capacitance (high-input impedance) on low-voltage <i>dc</i> ranges:</p> <p><b>The DC Probe</b></p>	<p>The <i>dc</i> probe contains a 1-megohm isolating resistor to cut down the input capacitance of the <i>dc</i> input cable to approximately 1 mmfd. The <i>dc</i> probe also prevents the shielded input cable from acting as a resonant stub.</p>	<p>In the absence of the isolating resistor, the input capacitance would be on the order of 100 mmfd, and measurement of <i>dc</i> voltage values in <i>rf</i> and <i>if</i> amplifiers, and also in local-oscillator circuits would be difficult, and in some cases impossible: <i>See circuit at right; circle 1, Fig. 1.</i></p>
<p><b>The Input Attenuator</b></p>	<p>The input attenuator comprises a chain of resistors having a total value of 9 megohms; with the <i>dc</i> isolating probe, the input resistance of the instrument is 10 megohms on all <i>dc</i> voltage ranges. The input attenuator also provides multiple ranges for wide voltage coverage in convenient steps.</p>	<p>The first range of the instrument is 1.2 <i>dc</i> volts, full scale, at an input resistance of nearly 9 megohms per volt. A 20,000 ohms-per-volt <i>vom</i> provides an input resistance of only 24,000 ohms, as against 10 megohms for a <i>vtvm</i>. This is an important factor in the measurement of <i>agc</i> and grid-bias voltages, etc.: <i>See circuit at right; circle 2, Fig. 2.</i></p>
<p>Current amplification:</p> <p><b>The Vacuum-Tube Bridge</b></p>	<p>The vacuum-tube bridge is an electronic-impedance transformer, which converts a very high impedance at the grid of the input tube to a very low impedance in the cathode circuits of the bridge tubes. The indicating meter is a low-impedance device.</p>	<p>The vacuum-tube operates as an electronic-impedance transformer by developing current amplification; the bridge is not a voltage amplifier, but a current amplifier, stepping up a very small current to the input attenuator to a large current for utilization by the indicating meter: <i>See circuit at right; circle 3, Fig. 2.</i></p>
<p>Elimination of <i>ac</i>:</p> <p><b>The Input Filter</b></p>	<p>The series resistor, working into shunt capacitance, provides a low-pass filter action, permitting the passage of <i>dc</i>, but blocking the entry of <i>ac</i> voltage. Any <i>ac</i> which escapes the low-pass filter action of the <i>dc</i> isolating resistance and shunt cable capacitance is thus eliminated by resistive and capacitive action.</p>	<p>If an appreciable value of <i>ac</i> voltage finds its way to the grid of the input-bridge tube, the grid is overdriven, and the tube becomes non-linear in its response to the <i>dc</i> voltage applied; hence accuracy of indication depends upon filtering out any <i>ac</i> voltage which may find entry into the bridge circuit: <i>See circuit at right; circle 4, Fig. 1.</i></p>
<p>Minimizing pointer shift:</p> <p><b>Twin-Triode Bridge Arms</b></p>	<p>Pointer shift from range to range, and drift during operation is minimized by balancing the two triodes across the bridge.</p>	<p>Changes in supply voltage are balanced out by the increase or decrease of currents on opposing sides; small grid currents also tend to cancel out: <i>See circuit at right; circle 5, Fig. 1.</i></p>
<p>Full-scale meter indication adjustment:</p> <p><b>Dropping Resistance</b></p>	<p>This is a service adjustment for the <i>vtvm</i>, which permits more or less dropping resistance to be inserted in series with the meter to control full-scale indication.</p>	<p>Tube tolerances, as well as component tolerances make this service adjustment necessary. In general, this adjustment will have to be changed slightly when a new tube is placed in the bridge circuit: <i>See circuit at right; circle 6, Fig. 1.</i></p>
<p>Adjustment of tube operating point:</p> <p><b>Plate-Cathode Voltage Control</b></p>	<p>This is another service adjustment which permits one to obtain the best linearity of deflection, by choosing the best operating point for the particular tubes.</p>	<p>Tube tolerances make this adjustment desirable. The instrument is first switched to the <i>DC</i> function (<i>Fig. 1, circle 8</i>) and the zero-adjust control is turned for maximum pointer deflection; item 7 (in <i>Fig. 2</i>) is adjusted to obtain an equal deflection for the <i>+DC</i> function: <i>See circuits at right; circles 7 and 8; Figs. 1 and 2.</i></p>
<p>Negative feedback:</p> <p><b>Cathode Resistors</b></p>	<p>A <i>vtvm</i> must utilize a large amount of feedback to achieve linearity of meter deflection, freedom from pointer shift due to grid <i>contact potential</i>, and accuracy of indication when tubes are changed.</p>	<p>Vacuum-tube characteristics are curved (non-linear) but can be essentially linearized by use of negative feedback. The feedback also achieves effective uniformity of meter response in spite of tube tolerances. Contact potential includes several tube factors, which show up as flow of minute grid currents; the ill effects of contact potential are minimized by negative feedback: <i>See circuit at right; circle 9, Fig. 1.</i></p>
<p>Zero-set control:</p> <p><b>Bridge Balance</b></p>	<p>Although the meter is zero-set mechanically, it may shift off-zero electrically due to bridge unbalance, caused by inequalities in characteristics or circuit action of the two triode arms. The zero-set control is an operator's control.</p>	<p>The zero-adjusting control balances the bridge by providing a suitable bias on one of the tubes to cause its value of plate current to equal the value of plate current in the other bridge tube. It is desirable to adjust the meter to zero mechanically, before checking the electrical zero-set, so that pointer shift will not occur in switching from <i>-</i> to <i>+DC</i>: <i>See circuit at right; circle 10, Fig. 1.</i></p>

Right, Figs. 1 and 2: Schematics of *vtvm* circuitry illustrating design features and their relation to instrument performance and application in troubleshooting.

# A Chart-Analysis of Vacuum-Tube Voltmeter Circuitry and Its Relation to Panel Adjustments and Receivers Being Checked

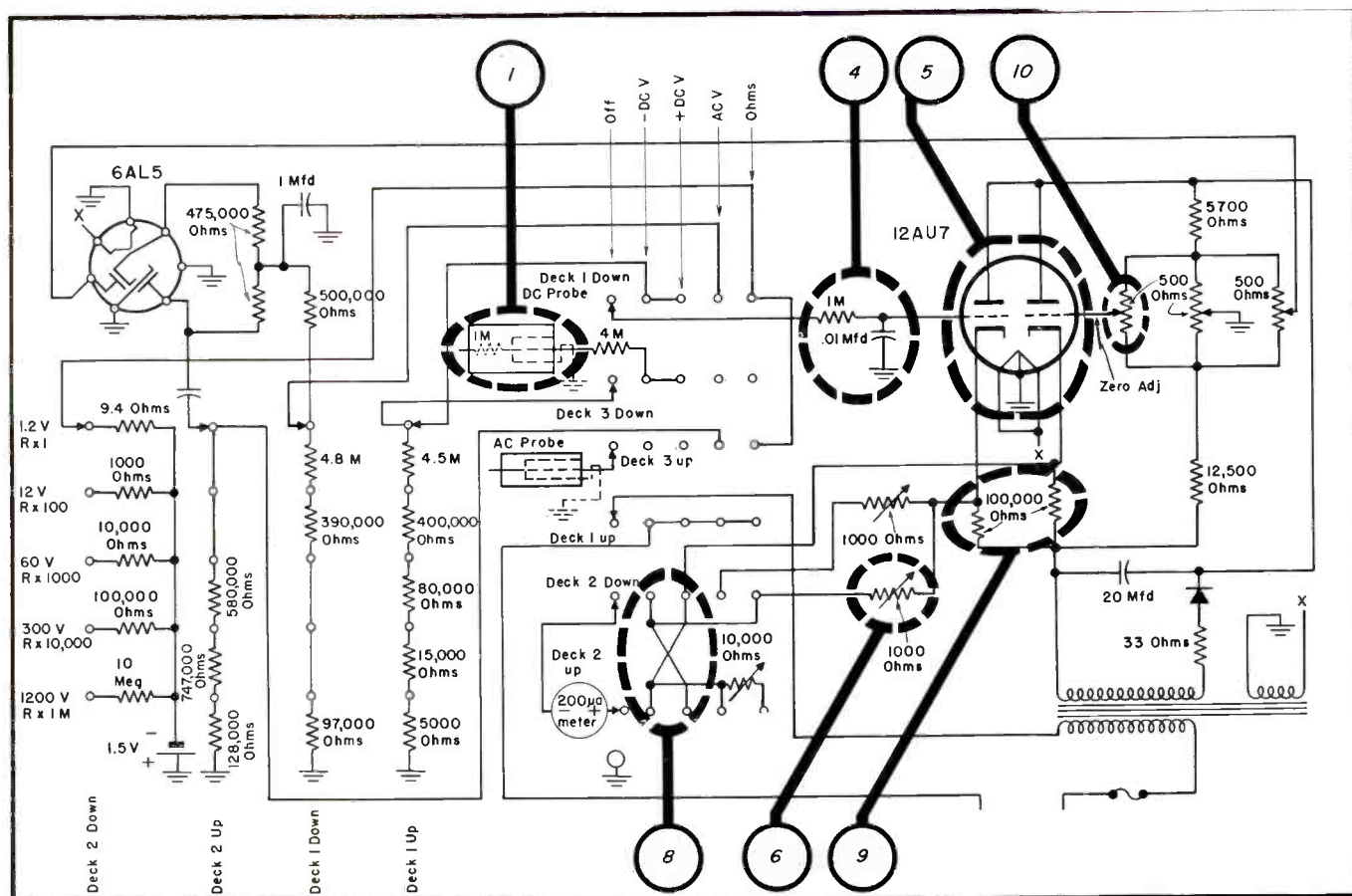

Above and below: Figs. 1 and 2.

## VTVM Dual Polarity Power Supply

THE power supply provides positive voltage to the plates of the bridge tubes, and negative voltage to the cathodes. This dual supply-voltage polarity simplifies circuitry required to obtain the correct operating point for the tubes.

The voltage drop across the cathode resistors is high, because their value is large to obtain the required amount of negative feedback. To offset this high-voltage drop and obtain an operating point on the linear portion of the triode characteristics, negative voltage is supplied to the cathode circuit: *See circuit at right; circle 11, Fig. 2.*

‡From a field report submitted by Robert G. Middleton, Simpson Electric Company.

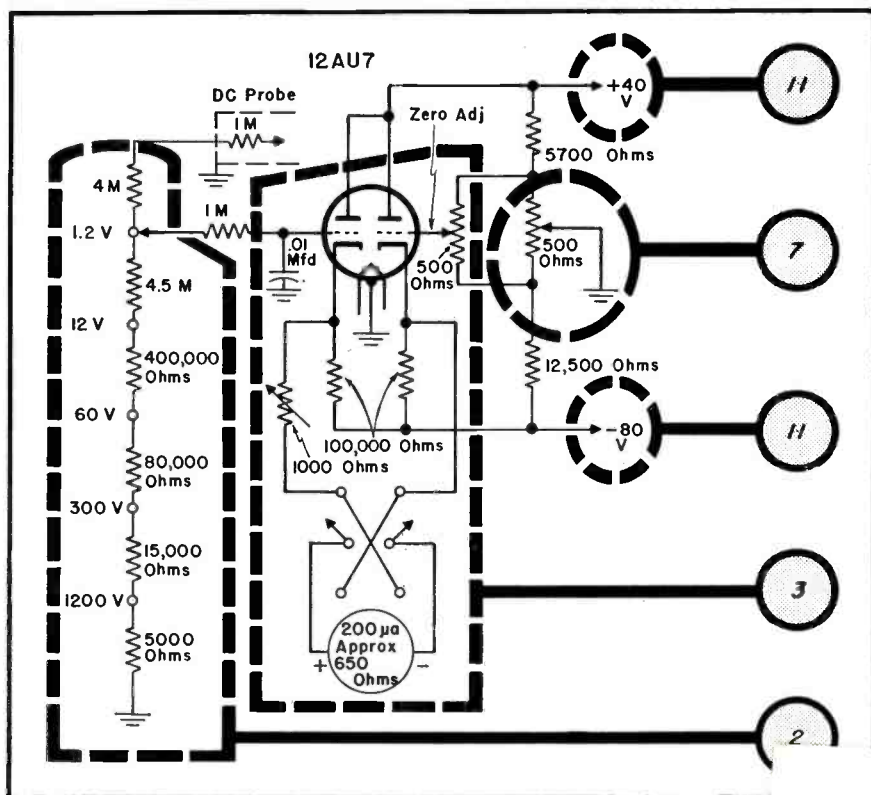

# Service Engineering

## field and shop notes

THE PHOTOCELL, since its inception an ingenious control device with innumerable applications, has now found itself in a truly unique installation; an electronic gun system to operate TV set controls.<sup>1</sup>

Developed by Zenith, four photoelectric cells are used; they are positioned around the picture tube. When a beam of light from a flash light strikes any one of these cells, thyratrons and a motor control tube actuate solenoids and relays for various operations; turning set on or off, muting the sound and turning the channel selector clockwise or counterclockwise. In addition, direct control of channel selector rotation is provided by two switches at the escutcheon top marked *ccw* and *ccw*.

A manual sensitivity control and reset switch, located at the front of the receiver in back of the receiver (on-off) volume control knob, act as controls for setting the sensitivity level of the photocells for maximum ambient

light conditions that exist within the room.

An *auto-manual* switch, located at the rear of the control chassis, is provided to disengage this chassis and photocell circuits, should manual TV operation be desired, or in case the remote units are not functioning properly.

In the control system four cadmium-sulfide crystal photocells are employed. One cell triggers a thyatron control tube (2D21) and its plate circuit solenoid controls the power input to the receiver. Another photocell triggers another 2D21 thyatron, and its plate circuit solenoid mutes the sound from the speaker. Then a pair of photocells serve to trigger a 6BX7GT motor-control tube and a pair of plate-circuit relays control the voltage applied to the motor for *ccw* and *ccw* rotation.

The four photocells used in the control are semi-conductors, extremely

sensitive to light. The action of the crystals to light energy is *resistive*; the resistance is an inverse function of light intensity and extremely high in the absence of light. With no light the crystal photocells may have as high as 100 megohms resistance, and when strongly energized by light their resistance may drop to as low as 25,000 ohms.

The 2D21 thyatron is a gas-filled tube; it acts as a sensitive-control device able to handle plate currents in the order of 100 *ma*. This feature has been found to enable its plate circuit to control switching devices such as the solenoids used in this system. When the control grid is near zero, tube conduction occurs. The tube will continue to conduct until the plate voltage is removed or becomes negative, and the control grid returned to a negative state. Since the plate voltage is *ac*, the tube will stop conducting every time the *ac* swings negative.

The *ac* voltage applied to the tube plate and control grid are from the same source and are therefore in phase. Tube conduction occurs during the positive swing of this *ac* voltage. Therefore, the plate circuit solenoids are energized by a rectified and pulsating *dc* voltage.

Due to the wide sensitivity range of crystal photocells, balance sensitivity controls are individually placed in series with each cell to equalize the

Fig. 1. The thyatron control (right) and motor-control circuits employed in the Zenith Flash-Matic photocell remote control.

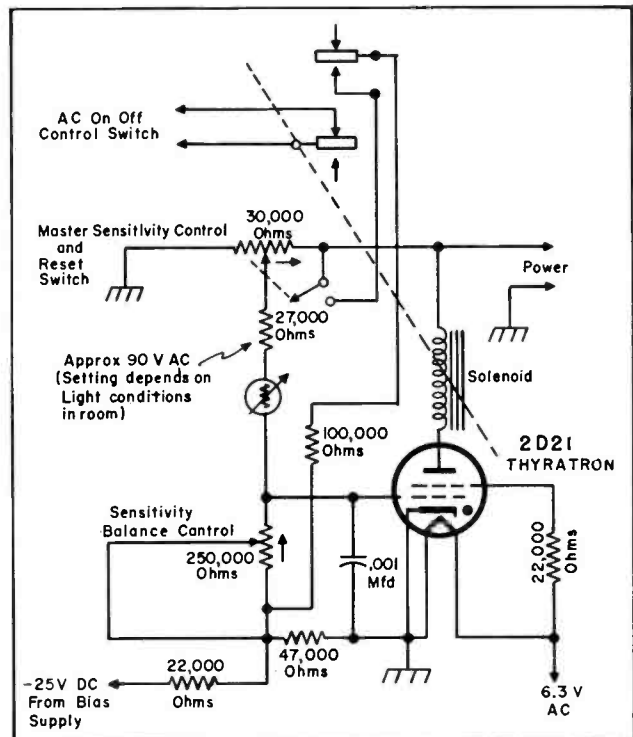
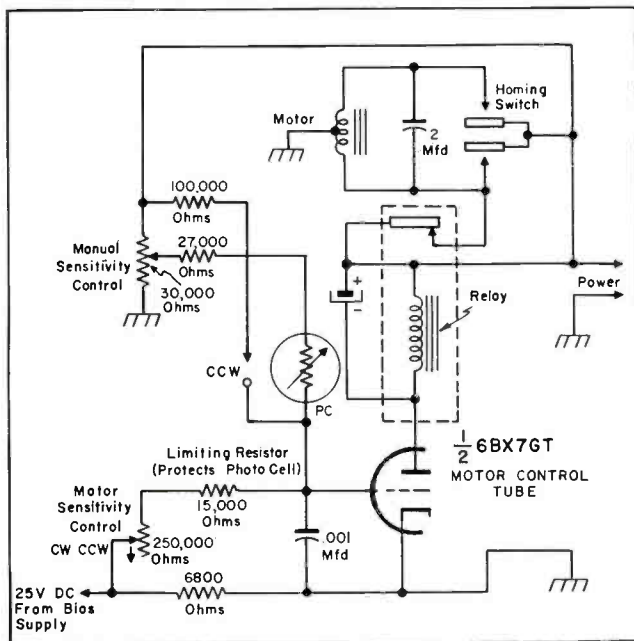

<sup>1</sup>A block diagram illustrating the system's basic operation appeared last month in *Service Engineering*.



voltage applied to the grids of the control tubes. A manual sensitivity control determines the voltage applied to all photocells. The amplitude of this voltage is approximately 90 vac, but it may be varied from zero to full line voltage by adjustment of the manual sensitivity control.

Since the crystal photocell acts as a variable resistor, when energized by light, the ac voltage applied to the grid of the thyatron by the photocell will vary when a light beam strikes it.

An autoformer, selenium rectifier, and capacitor form a negative bias supply for the thyatron control grid. When the amplitude of the ac voltage from the crystal photocell, applied to the thyatron-control grid, approaches or exceeds the zero bias point, the tube conducts and control occurs.

The action of the motor control circuit is similar to the thyatron action.

When the amplitude of the ac control voltage from the photocell swings the grid of the 6BX7GT dual triode

sufficiently positive, for an average of 9 ma of rectified dc to flow through relays in this circuit, the relays will operate. With no excitation voltage on the tube grids, no rectified dc plate current will flow since the tube is biased to cutoff. Since the relays would tend to release during the negative swings of the ac voltage and cause chatter, a pair of filter capacitors have been placed across them to smooth out this pulsating voltage, resulting in a positive holding action.

A 117 vac induction type motor is used in the drive assembly. Motor reversal is achieved by the use of two windings and a 2-mfd series capacitor. This capacitor is switched to either motor winding to cause a phase differential resulting in change of motor rotation.

A homing switch assembly, consisting of two identical switches and two index cams, is mounted on the motor drive assembly. The index cams make one revolution per channel or thirteen

revolutions during one complete rotation of the large motor drive gear. The cams are in neutral and both switches are in open position; the switches are electrically across the motor control relays. Thus when the motor control circuit relays are energized, the index cams move from neutral position and the trip latches keep the switch contacts closed, maintaining power to the motor for the balance of the cycle. Since clockwise and counterclockwise rotation is required, two cams and two switches are incorporated.

The complete assembly, with the adjustments provided, form an electrical and mechanical drive unit that is synchronized with the mechanical rotation of the TV turret turner.

An ac voltmeter, preferably a vacuum-tube type, is recommended when measuring ac voltages.

A dc milliammeter should be used when reading currents through the re-

(Continued on page 41)

Fig. 2. Complete schematic of photocell remote-control system developed by Zenith.

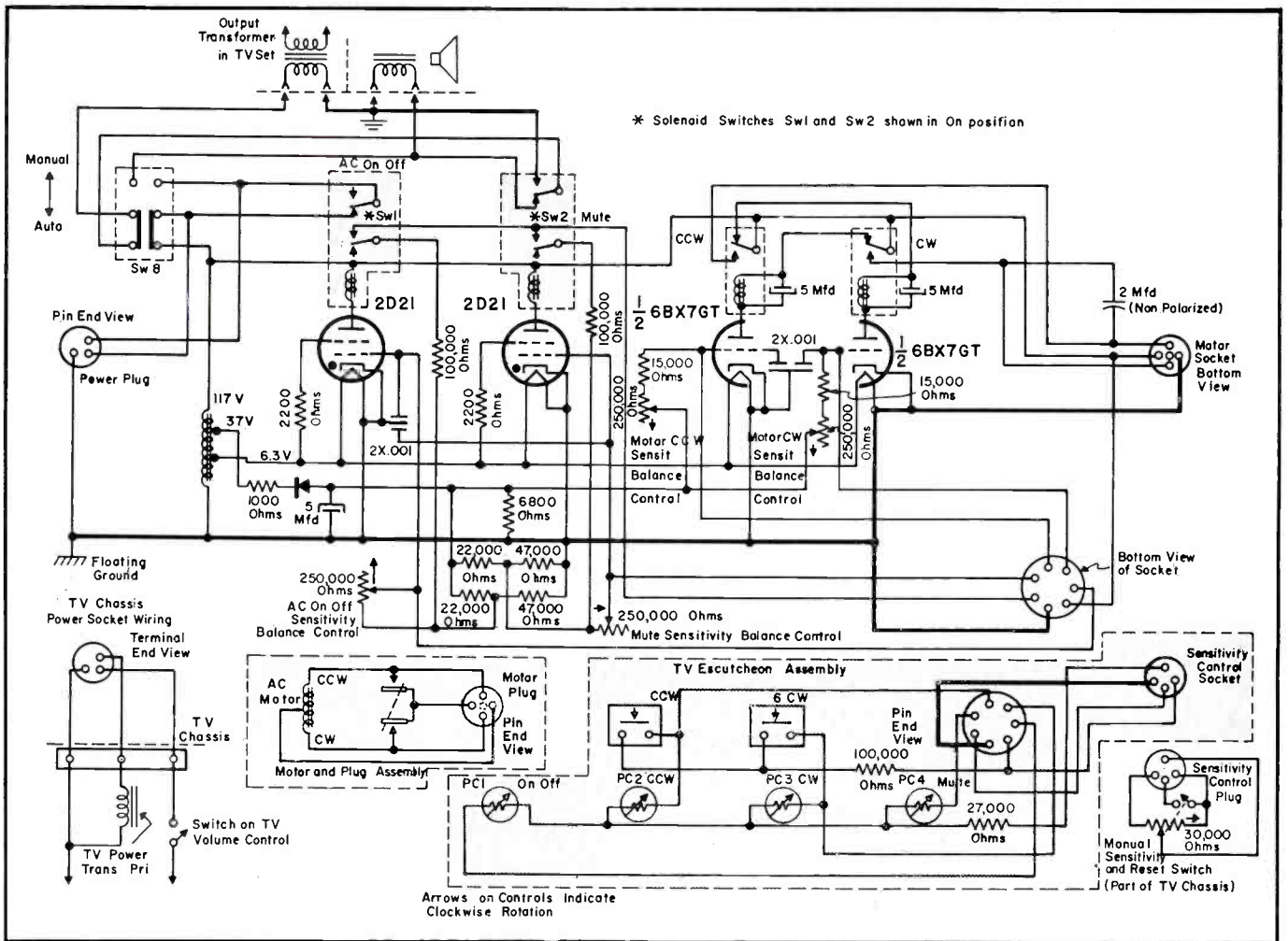

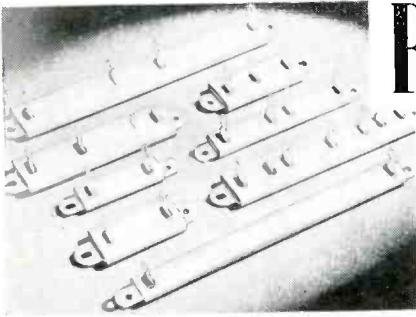

# Replacement of Metal-Clad Resistors in the Field

by **FRAN CHAMBERLAIN**, *Clarostat Manufacturing Co., Inc.*

MANY RESISTORS of special construction are being used in electronic, radio and television assemblies today. An example is the metal clad or strip resistor, specified because this type resistor, usually made to a special flat shape, can be readily mounted on the chassis, and the values of resistance, taps and even isolated sections made to order to suit exact needs of the circuit, without using more than a single unit to make up the resistances required.

At times, such special resistors can pose a problem to the Service Man in the field. In some cases, a resistor of this type may contain up to ten sections of individual resistances, which may be connected in series, or there may be breaks between them to provide circuitry isolation. It is obvious that distribution of the many types to match all of the various designs in current assemblies would be virtually impossible. Therefore, it is up to the Service Man to substitute available components.

Failures in multi-section resistors occur usually in only one section at a time. The practical solution to this problem is to use a standard resistor between the terminals of the defective section. A wide selection of suitable

resistors is available from all electronic parts distributors.<sup>1</sup>

Schematics of typical metal-clad resistors, as used initially, are shown in Figs. 1 and 2. According to the manufacturer's specification, as shown in Fig. 1, between terminals 1 and 2 the value is 90 ohms (11 watts) with a tolerance of  $\pm 10\%$ . Therefore, a resistor that would handle 11-watts and with a resistance value of between 81 and 99 ohms would make a suitable replacement.<sup>2</sup>

Other replacements could be made up by connecting two or more resistors in series or parallel to obtain wattage

or resistance value required. Continuing with Fig. 1, between terminals 2 and 3, we find that the manufacturer has specified a resistor of 56 ohms (3-watts) with a tolerance of  $\pm 10\%$ . This requires a 3-watt replacement resistor, with a resistance value of between 50.4 and 61.6 ohms.

In Fig. 2 we have an example of a 4-section metal-clad resistor with three sections operating in series, while the fourth is isolated from the other sections in regard to circuitry. Replacements for this resistor would follow the same installation pattern as for Fig. 1; between terminals 1 and 2, a 10-watt resistor of between 687.5 and 852.5 ohms would be required in this case. Between terminals 3 and 4, a resistor of 5-watts with a value of between 495 and 605 ohms would be suitable; it will be noted that there is no connection between terminals 2 and 3. Replacements between the other terminals may be found in exactly the same manner.

Finding the suitable resistor replacements, as to wattage and resistance, is not difficult since most technical literature gives the resistance and wattage values section-by-section, or the resistance and voltage at the terminals, so that the wattage can be computed. Although resistance tolerances are not always supplied, one can be reasonably safe in using a tolerance of  $\pm 10\%$  in making up replacements, since this is the tolerance usually specified by the original set manufacturer.

In selecting replacement resistors, one should choose those whose values are closest to the original. Where it is impossible to procure a resistor of the exact value, a substitute falling

(Continued on page 43)

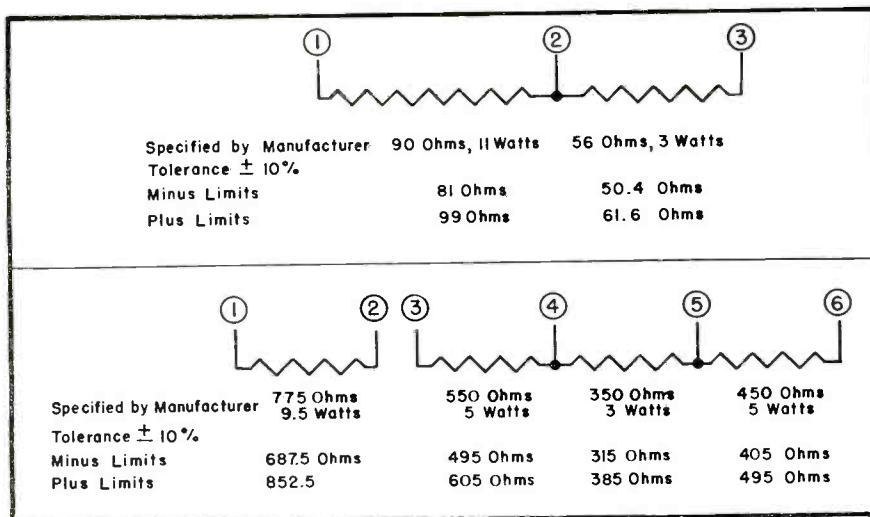

Figs. 1 (left, top) and 2 (left, bottom):

Fig. 1. Schematic of resistive section of receiver showing use of a metal-clad two-section resistor.

Fig. 2. Circuit of another resistive section of a set, illustrating use of a metal-clad multi-section resistor, with one section isolated.

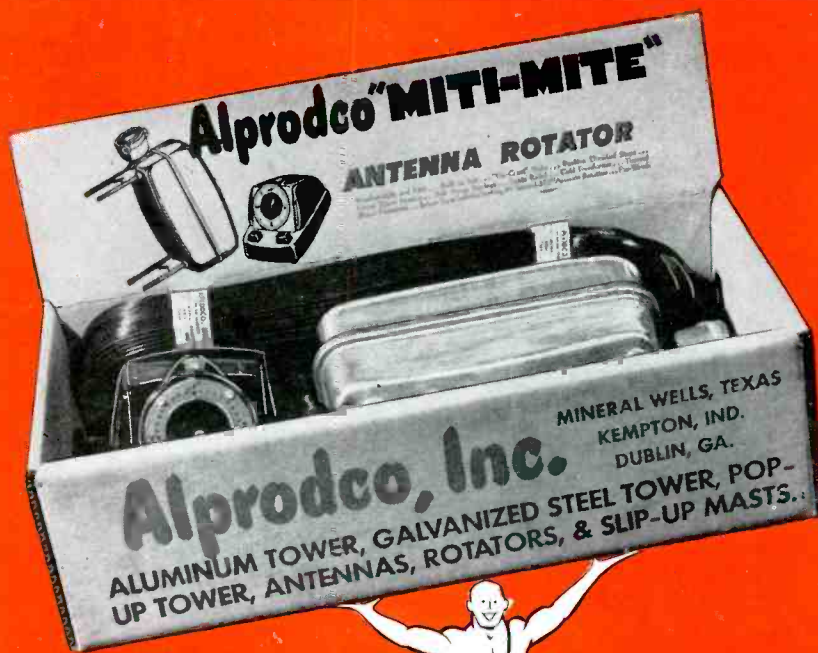

**MITI-MITE  
ROTATOR  
No. RR-2**

List Price  
**\$34<sup>95</sup>**

Introducing the

# "MITI-MITE"

## ANTENNA ROTATOR

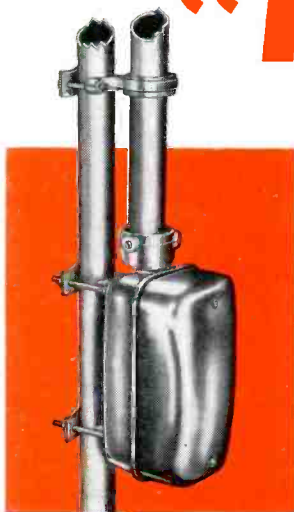

**NO-COAST BRAKE:**

The MITI-MITE "No-Coast" brake prevents drift and assures correction of direction to within less than 1° accuracy.

**MITI-MITE** is a quality product, backed by a quality name—accurate, dependable, and trouble-free.

**FACTORY GUARANTEE:** Servicing is not necessary with the MITI-MITE RR-2 Rotator. Alprodco guarantees one year of trouble-free service, and your Alprodco distributor is authorized to replace MITI-MITE rotators with new units in case of mechanical failure.

**BURN-OUT PROOF:** Thermo overload switch and electrical stop limit switches prevent damage to Alprodco MITI-MITE RR-2 Rotators caused by excessive or faulty use.

**PRE-WIRED:**

Each MITI-MITE Rotator is completely pre-wired at factory. Standard wiring includes 75 feet of lead wire.



MITI-MITE RR-2 ROTATORS are available through your authorized ALPRODCO distributor.

**LIGHT-WEIGHT:** Weighing only 8 lbs. (packing weight) and with at least 50-inch pounds of torque, the MITI-MITE gives best performance with least weight.

# Alprodco, Inc.

MINERAL WELLS, TEXAS

DUBLIN, GEORGIA

KEMPTON, INDIANA

SERVICE, AUGUST, 1955 •

## Series-String 600-Ma Heater Tube-Checker Circuitry

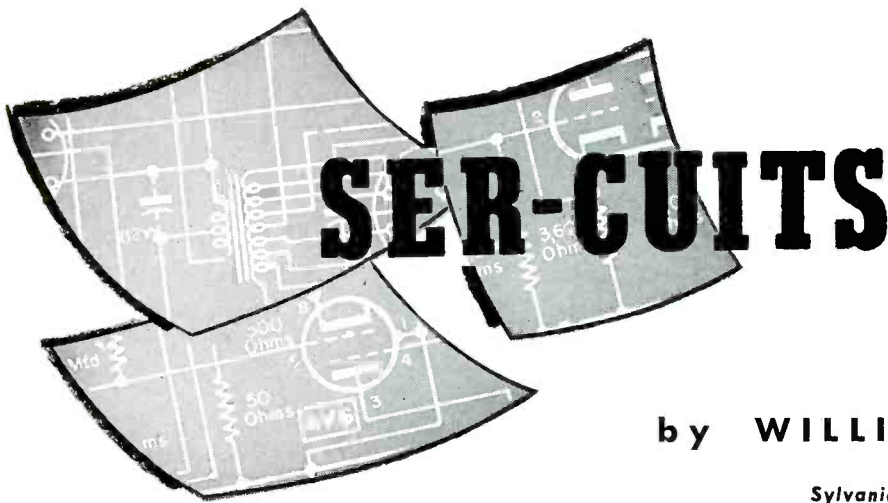

[See Front Cover]

by WILLIAM DRUMMETER

Sylvania Electric Products, Inc.

ONE OF THE LATEST trends in modern TV set design is to use the series heater string circuit.\*

This is by no means a new concept since countless radios and thousands of TV sets, embodying this principle, have been produced. An early objection to the use of the series-string arrangement in TV was based on the greater probability that the string could be burned out by one abnormal line surge, since as many as twenty tubes are used; whereas in the radio field, where the series-string idea was firmly established, only four or five tubes were involved. The controlled heater types, now available, minimize this danger by not only stabilizing the

warm-up time, but eliminating the need for a series thermistor.

Since most of the new tubes have a well-known standard tube as a prototype, it would appear as if the testing of these tubes should be quite a standard procedure. However, something new has been added to the series-string approach that has altered this concept; we are no longer dealing with the familiar constant voltage, but with constant current. Practically every tube checker uses a constant-voltage system to energize the heaters. This usually consists of a multi-tap transformer with a selector switch to choose the desired voltage. This design serves to insure that the se-

lected voltage will appear across the tube, regardless of the resistance of the filament and, hence, regardless of the current drawn (up to the rated limit of the transformer).

A constant-current system requires that the rated current be maintained at all times, with some provision for indicating directly or indirectly, whether the filament resistance is too high or low. It is important to know this relationship of current and resistance in each tube; since together they determine the power dissipated, which in turn influences the amount of emission. If the current is set to a fixed value (600 ma), then low resistance heaters will consume less power and show an emission or  $G_m$  slump, while high-resistance tubes will consume more power and may read abnormally high, or be impossible to set up for a 600-ma current.

Factory tolerances on heater current for the 600-ma series string tubes have been set to  $\pm 4\%$ . This is an optimum figure for good performance and low manufacturing cost. There still remains the problem of checking these tubes after many hours of trouble-free operation, since normal aging and long use will cause some tube failures. Failure in this case, not only means complete burnouts, emission or  $G_m$  slump, but also variation in heater resistance. For example, a 6AW8 which, at initial life would draw 600 ma at 6.3 v, might change so that with a constant voltage of 6.3 v applied for a long period, the current through the

(Continued on page 42)

Fig. 1. The 600-ma constant-current circuit incorporated in Sylvania 620 tube checker for series-string chassis tests; see cover.

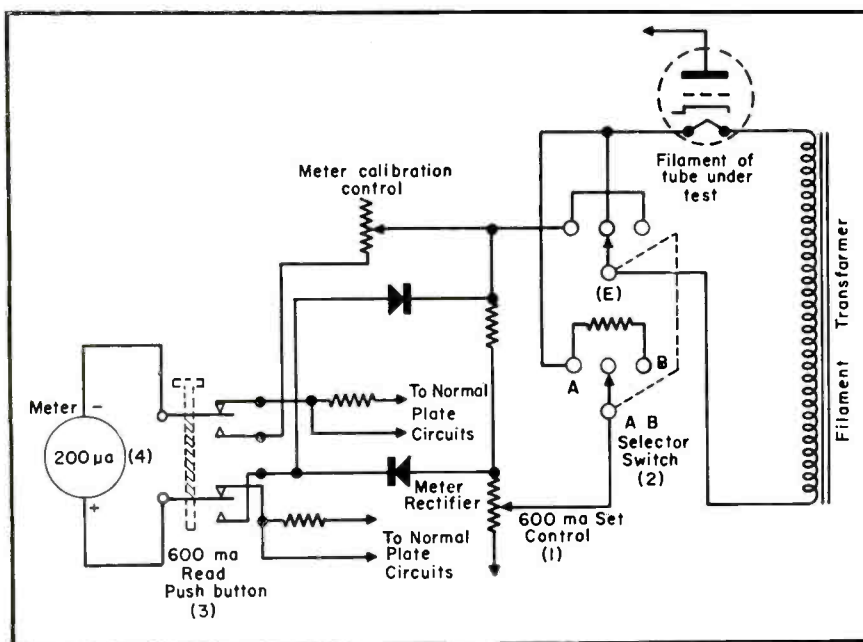

\*Reports on series-string tube behavior have appeared in *Sylvania Engineering Information Service*; Aug., 1954, and *Sylvania News Technical Section*; Jan., 1955.

*If you want  
 "Trouble-Free"  
 fuses in all  
 sizes and  
 types —  
**TURN  
 TO BUSS!***

You can depend on BUSS fuses to operate properly under all service conditions. This means that BUSS fuses will open and prevent further damage to your customers' equipment when there is trouble on the circuit.

And just as important, BUSS fuses won't blow when trouble doesn't exist. Users are not annoyed with useless shutdowns caused by needless blows.

To make sure of this "trouble-free" operation — every BUSS fuse normally used by the Electronic Industries is tested in a sensitive electronic device. Any fuse not correctly calibrated, properly constructed and right in all physical dimensions is automatically rejected.

**A complete line of fuses is available.** Made in dual-element (slow blowing), renewable and one time types . . . in sizes from 1/500 ampere up — plus a companion line of fuse clips, blocks and holders.

When it's a fuse you need — think first of BUSS. You will be protecting both the product and your good name against troubles and complaints often caused by use of poor quality fuses.

*For more information on BUSS and FUSE-TRON small dimension fuses and fuseholders . . . Write for bulletin SFB.*

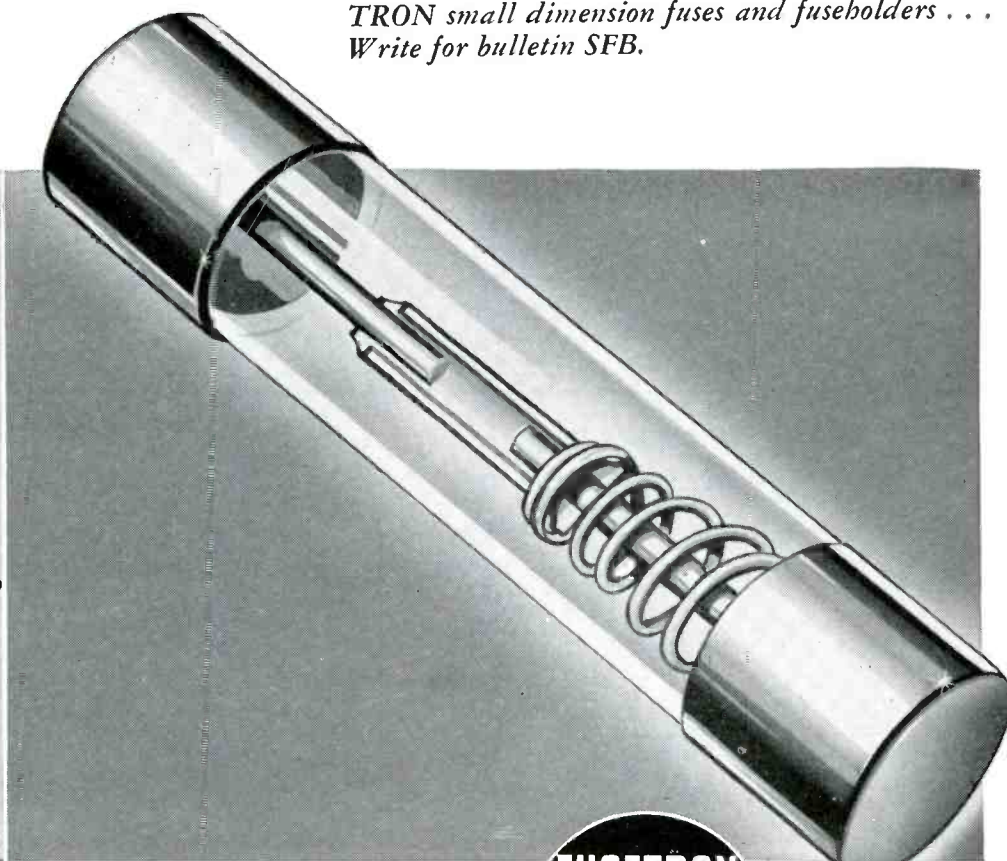
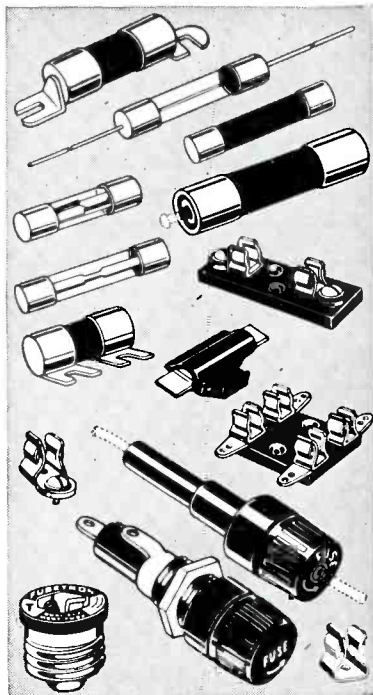

Makers of a complete line of fuses for home, farm, commercial, electronic, automotive and industrial use.

**BUSSMANN MFG. CO.** **FUSETRON** **TRUSTWORTHY NAMES IN ELECTRICAL PROTECTION** *Div. McGraw Electric Co.*

University at Jefferson



St. Louis 7, Mo.

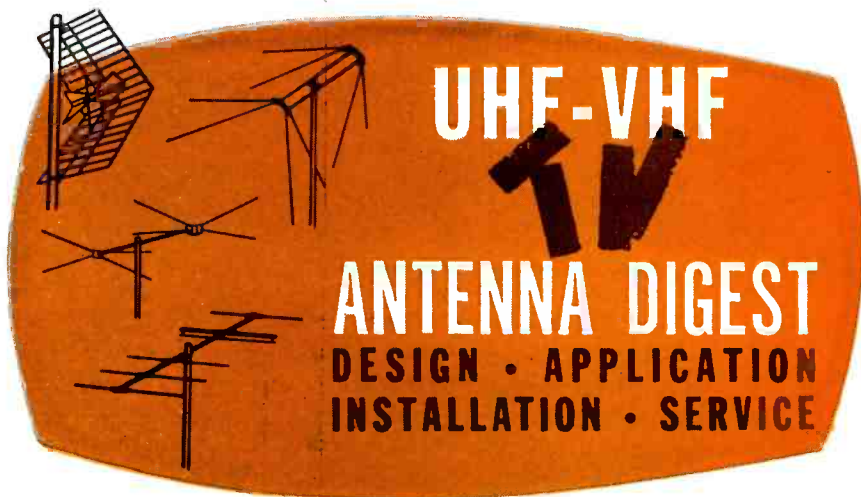

by

RALPH G. PETERS

### Fringe-Antenna Tower-Installation Field Notes‡

THE INSTALLATION OF FRINGE antenna towers, out in the fields, often is quite a project, involving the consideration of a number of unusual factors.

Wind, for instance, represents a vital problem. In tower design *recorded* wind velocity (not *indicated*) must be considered. Some towers are made to withstand a recorded wind velocity of 120 mph. At the time of fabrication, manufacturers usually build in a one-third safety factor, over and above, the 120-mph specifications. This factor is built in to prevent destruction due to hurricanes, tornadoes, severe icing, and all types of rapid weather changes.

Initial tension weight and wind pressure on guys also must be taken into account. It has been found that one-half of the total forces must be applied to guy anchors and one-half to tower. In tower design, sag, deflec-

tion and initial tension are carefully calculated so that the guy force may be uniformly distributed along the tower to allow the tower to bend uniformly, so that deflection will be proportioned to the height of the tower.

Wind loading on guys and tower must be applied in such a manner that the maximum stress can be calculated to obtain maximum strength in guy and tower.

In choosing material for the tower, it is necessary to consider the weight of the tower and all dead loads as applied at the same time wind loads are at a maximum.

When selecting a tower site, one should try to obtain the very best location. It will cost less in the long run.

Not only is it necessary to study such factors as height, line-of-sight,

and surrounding terrain, but soil conditions for erection of tower and supports, such as guy and anchors. Average soil is considered to weigh 82 pounds per square foot; anchors, always designed for a particular place because of different weight in soils, must be placed below frost line so that they will not be loosened by changing temperatures. Vertical pull of anchors is equal to at least one-half of the strength of all guys attached to them.

Even the characteristics of such items as the turnbuckles must be considered in a tower installation. Galvanized eye and jaw type have been found most satisfactory. Incidentally, guyline insulators, hardware and connections should be rated to about the breaking strength of the guyline.

‡From notes submitted by **Bob Stanley**, Liberty Tower Co.

Fig. 1. View of 50' breakover type of antenna tower and installation methods used for structure. (Liberty Tower)

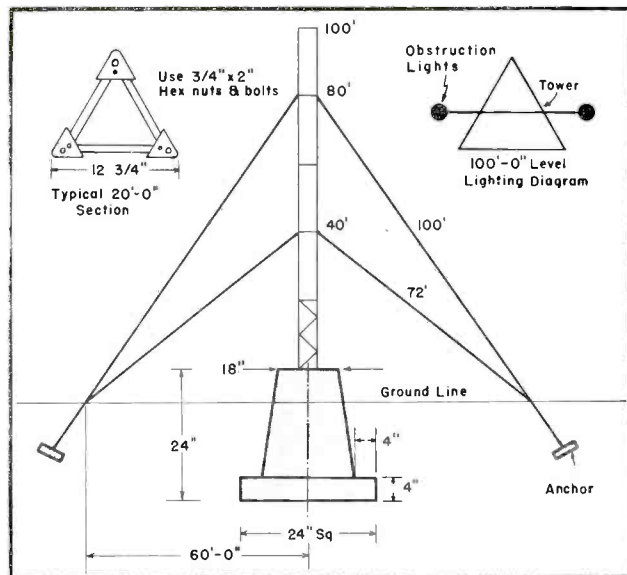
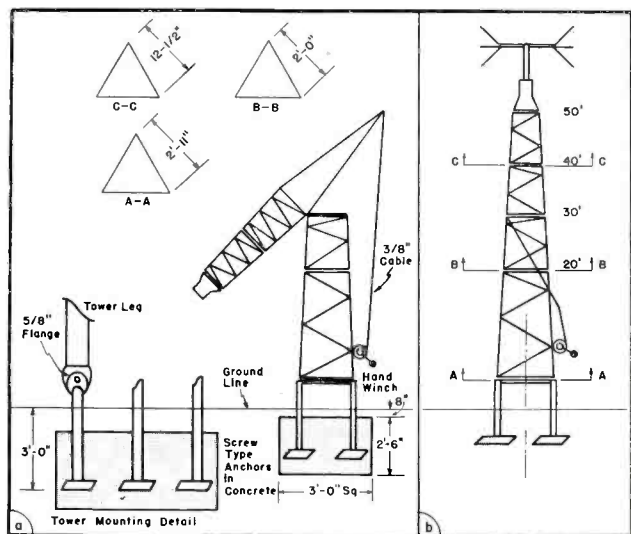
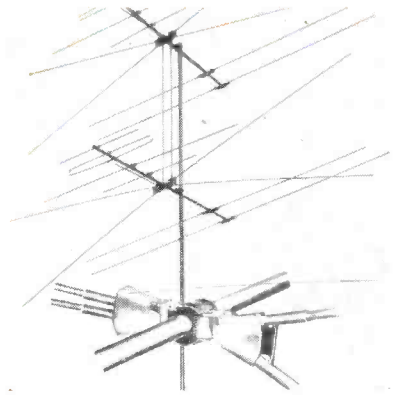
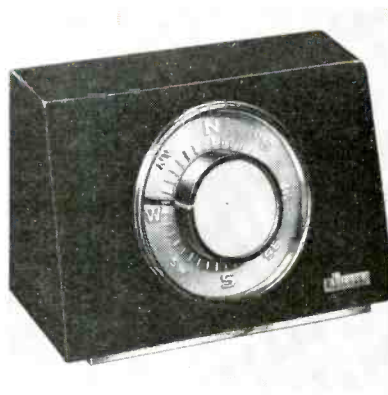

Fig. 2. A 100' tower supported by guy wires. (Liberty Tower)

# UHF/VHF TV Antennas... Accessories



Conical yagi featuring a conical head that, it is said, completely nests the elements for a tight grip. Antenna is made of aluminum, and is preassembled. All elements have seamless sleeves where they join bracket. (Model 321-A; Channel Master Corp., Ellenville, N. Y.)



Control box for TV antenna rotator. Model is said to offer positive rotation without swinging or drifting, and magnetic breaking. Arcing, it is claimed, is eliminated through introduction of self-wiping contacts. (Model U-98; Alliance Manufacturing Co., Alliance, O.)



All-channel vhf antenna with colored anodized elements; available in red, green, blue and gold. Heart of conical is a Zee-X element, said to provide equalized performance on both bands. (Zee-Beam, models 50 and 52 (single and two-bay); Welco Manufacturing Co., Burlington, Ia.)

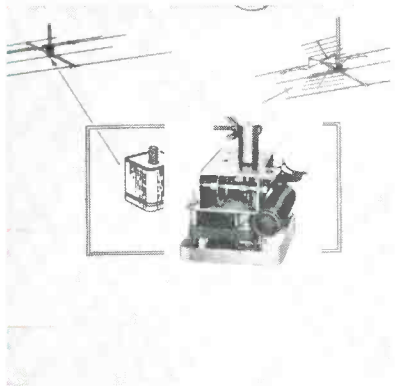

Indoor antenna with a built-in rotator for attic installation. Available for all channel uhf/vhf, and vhf only. Both units feature a reversible 24-volt rotator motor built into the boom of the antenna. VHF model utilizes a five-element single bay broadband inline antenna array; lo-hi band model features a combination of an inline antenna for vhf and a corner reflector for uhf. (Models RO-283-213; La Pointe Electronics, Inc., Rockville, Conn.)

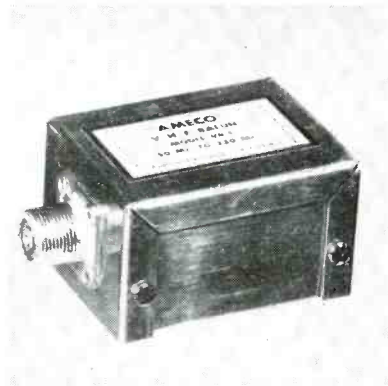

Balun designed to operate in 50 to 220-mc frequency range. May be used to couple 300 ohm-transmission line from antenna to 72-ohm input on vhf converter or receiver. While primarily designed for 72 ohm coax cable, it can be used with 52-ohm coax cable. (Model VB-1; American Electronics Co., 1203 Bryant Ave., New York 59, N. Y.)



Indoor uhf-vhf TV antenna; a 12" globe incorporating a built-in antenna. Has a brass base and rotates to any position for best reception. Leadin has a three-way clamp. (Model Globe-Tenna No. A-9265; Telco Electronics Manufacturing Co. (Division of General Cement Manufacturing Co.), 919 Taylor Ave., Rockford, Ill.)



Triangular tower, designed for community TV, installed in Jacksonville, Texas. Tower features an elevator to facilitate inspection and maintenance of tower, and antennas and amplifiers. (Liberty Tower.)

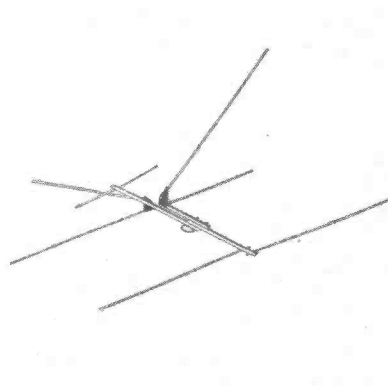

Conical featuring tuned insulators which, it is said, make it possible to eliminate the common insulator. New approach is claimed to prevent damage due to salt-air or adverse weather conditions. (Myers Allweather Antenna Corp., 350 S. Egg Harbor Road, Hammonton 1, N. J.)

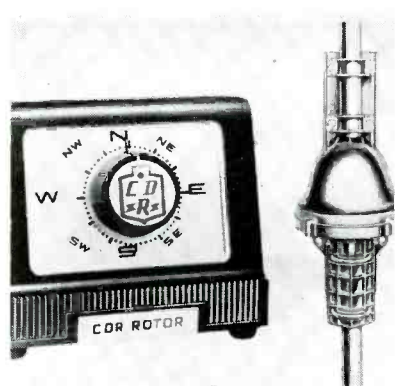

Control and antenna rotator; rotor uses a motor unit that, it is said, handles loads up to 150 pounds. Has 12 heavy-duty ball bearings in two 6 1/2" ball bearing races; mechanical brake that releases magnetically; reversible clamps that handle 7/8" to 2" masts; and three heavy-duty guy-wire lugs. (Model AR-22; The Radiart Corp., Cleveland, O., and Cornell-Dubilier Electric Corp., South Plainfield, N. J.)

# Outdoor Sound:

**Speaker Phasing . . . Acoustical**

**Arrangements . . . Use of VU Meters**

**Sound-System Wiring Practices**



(Left)

Bandstand sound installation using a 10-watt amplifier with two separate input channels, one for a high-impedance microphone and one for a high-impedance phono. Each channel has individual gain control and can be mixed and faded. (Bogen.)

FOR AVERAGE CONDITIONS of temperature and humidity, the attenuation of higher frequencies becomes a factor in the proper distribution of high quality sound in outdoor locations. The problem becomes quite serious above 3,000 cycles. At 300' the attenuation at 10,000 cycles is on the order of 10 db; this means that equalization for the far distances is required at the amplifiers. Because most amplifiers are equipped with auxiliary tone controls, this compensation can be easily made.

Another operation that must be supervised carefully in a *pa* setup is the volume control. One should not advance this control to the point where the output exceeds the power-handling capability of the speakers. Normally audience reaction can serve as a cue, for intelligibility will usually suffer when the volume setting is too high and waves of complaints from the audience will be heard. As noted earlier trumpets will not respond too well to low-bass; thus when these

speakers are used, bass must be moderated. Too great an excursion of the phenolic diaphragm in the trumpets naturally will cause distortion at the deep low frequencies and possible damage to the speakers.

## **Phasing of Speakers and Acoustical Arrangements**

When employing more than one speaker in a sound-system installation (connected either in series or parallel), it is advisable to *phase* the speakers to achieve full tonal quality and the least degree of distortion. (It has been found that speakers out of *phase* lose up to one-half of normal volume, plus resulting distortion.)

There are two types of *phasing*: Speakers facing in the same general direction and speakers facing each other.

For speakers facing in the same general direction, the speakers are in *phase* when the diaphragms move outward and inward simultaneously.

Where speakers face each other, *phasing* can be accomplished by seeing that the diaphragm of one moves outward as the diaphragm of the other moves inward.

To *phase*, it is necessary to check the *polarity* of the speaker terminals, with respect to the movement of the speaker diaphragm, and connect the terminals from speaker to speaker, according to the type of diaphragm movement or *phasing* desired.

Identical speakers' diaphragms move in the same direction when the same terminals are utilized.

When different speakers are used, the following procedure should be carried out to determine the diaphragm

movement, in respect to the speaker terminals:

One lead should be connected from a 1.5-volt dry cell to a voice coil terminal of the speaker. Then one should momentarily touch the other lead from the dry cell to the other speaker terminal, and observe direction of the cone or diaphragm movement (either inward or outward) when the circuit is closed. This direction of the movement should be noted. The terminal connected to the positive pole of the dry cell, if the movement is outward, should be identified; and the terminal connected to the negative pole, if the movement is inward, tagged. For other speaker or speakers to be checked, the foregoing steps should be repeated, and the marked and unmarked terminals connected according to the manner of electrical arrangement desired.

In simple sound systems it may be easier to check *phasing* by listening to a low audio frequency, while alternating the speaker leads. The human ear can usually detect when the low frequency is least distorted.

## **Visual Means of Control**

Because the ear is not always the best judge of volume, it is often wise to have some visual system to guide an operator. This is especially true

‡Based on field notes supplied by Mortimer Sumberg, David Bogen Co., Inc., and the engineering departments of Electro-Voice, Inc., and Stromberg-Carlson; E-V data extracted from their *Public Address Handbook*.

Projector type loudspeakers in an outdoor installation. (Courtesy Electro-Voice)

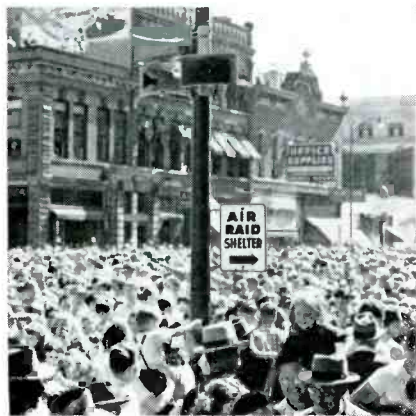



# Installation.. Maintenance.. Operation.. Servicing ‡

By MICHAEL ANTHONY

when a preamp is being used to feed a telephone line on which the volume level must never exceed a certain value.

The meter used to provide this visual means of control in Stromberg-Carlson equipment is a *vu* type, which uses a *dc* movement with a full-wave copper-oxide rectifier mounted in its case. It differs from a *db* type of meter, by having ballastic characteristics that produce a quick rise, small overswing and slow fall, to make it easy to follow rapid variations in program material. The meter actually shows a mean level based on an average over a short period of time. The instantaneous peaks that are constantly occurring during a program, do not read at full value, but at a value usually 8 to 12 db less than the actual peak.

## Meter Calibration

The meter is calibrated to read zero level, without an external resistor, when a sine wave of 1.945 volts *rms* is applied; this represents 8 db above 1 milliwatt into 600 ohms. A meter range switch connects a resistor in series with the meter to decrease the meter sensitivity by 10 db.

Music and speech are of rapidly-varying characteristics, and the meter pointer of the volume indicator responds to them in a series of kicks or deflections of varying amplitude.

Volume adjustments should be made with the intention of bringing the

greatest swings of the pointer to the 0 *vu* mark at the top of the *normal* section. None of these deflections should exceed the 0 mark and swing the meter pointer into the *excessive* section. When the program level varies over a wide range, it is possible that the weaker portions of the program will be too low in volume for satisfactory transmission.

By manually controlling the gain of the preamp, bringing up the level of the softer passages and necessarily decreasing that of the louder passages, the average volume level can be increased to a point where transmission and ultimately more enjoyable listening can be obtained.

## Preamp Mounting

When mounting a preamp in a cabinet or on a shelf, care must be taken to provide sufficient ventilation for adequate cooling.

In selecting a location for a preamp, whenever possible one should avoid proximity to power transformers, chokes or motors which might induce noise in the equipment.

Hum caused by pickup in the input transformers can be reduced by loosening the clamping ring and rotating each transformer to the position of minimum hum. The transformer must not be rotated more than 180° in either direction from its original position or the leads may be damaged.

## Sound-System Wiring

Sound-system wiring should be protected against mechanical injury and

moisture, particularly where it passes through walls or floors. Even a small amount of moisture may affect the insulation of poorly-protected wiring to such an extent as to impair the efficiency of the system.

## Open Wiring

Wiring should be separated as far as possible from water and steam pipes or electric circuits. If system wiring is not in conduit, all crossings should be at least six inches above other pipes or electric circuits.

If it is necessary to parallel such electric circuits, sound system wiring should be kept at least two feet away.

## Conduit Enclosures

When enclosed in conduit, microphone lines may be run together, but no other type of wiring should be run in the same conduit. If the shield on the microphone line is used as the return conductor, it must be insulated throughout its length from contact with conduits, etc., and grounded only at the amplifier.

If a shielded twisted pair is used for a microphone line, it is preferable to insulate the shield from contact with conduits, etc., although it may not be necessary on short runs.

Shock-vibration isolator base for use where amplifier is subjected to considerable jarring or vibration. (Bogen.)

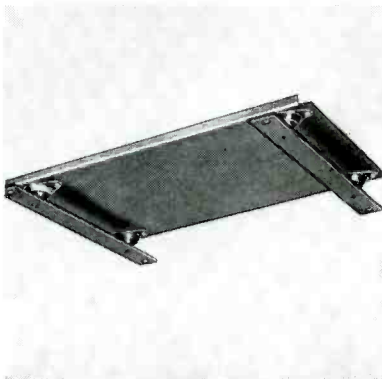

Below: Circuitry for speakers in the same general area (top diagram) and when they are far from each other.

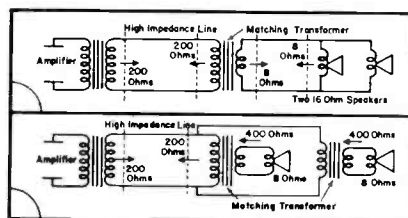

High-impedance dynamic microphone for outdoor pa installations, which features a tilting head and swivel mount, permitting semi or non-directional positions. (Astatic.)



# Wide-Band 'Scope Circuitry for COLOR-TV Troubleshooting

By WYN MARTIN

THE 'SCOPE, an extremely valuable troubleshooting tool for black and white TV receivers, is especially important in color-TV work. It not only enables one to check peak-to-peak voltages and study tube performance, but observe and measure the color-burst signal and in addition detect source and type of trouble in the chrominance circuits.

## Bandwidth Requirements

For color-TV and b-w applications, 'scopes should provide for both nar-

row and wide-band operation from *dc* to 4.5 mc.

## Alterations for Color

A modification of a 5" 'scope circuit, originally designed for general-purpose TV and electronic servicing, that it has been found affords such flexibility, is shown in Fig. 1.<sup>1</sup> In its modified form, the 'scope affords observation of wide-band frequencies with up to two inches of undistorted deflection; sensitivity in this wide-band

position is about 700 millivolts peak-to-peak per inch using a direct probe. In the narrow band, a sensitivity of about 20 millivolts per inch obtains.

After the modification has been completed, the instrument should be aligned using a sweep generator and *rf* marker source.

## 'Scope Circuitry\*

Basically, in this 'scope, the *ac* or *dc* input signal to the vertical amplifier is fed to a frequency-compensated, voltage-calibrated *ac* and *dc* voltage-attenuator network, through a shielded input cable and connector.

Direct-coupled, push-pull amplifier stages are used to minimize line-bounce, cross talk, astigmatism, and so on.

A *Potter*-type sweep oscillator is used; this is a vacuum-tube multivibrator found to have stability at high sweep rates, a fast retrace, and adequate linearity throughout a 15-cps to 30-kc range.

## Four Basic Ranges

The over-all frequency range of the oscillator is divided into four basic ranges; a vernier adjustment, which overlaps the basic sweep ranges, provides exact adjustment of the sweep frequency.

A front-panel terminal provides a 1-volt peak-to-peak *ac* signal for calibrating the screen of the *crt* for peak-to-peak voltage measurements. This feature is useful in TV signal tracing because it permits an instantaneous check of the amplitude as well as the shape of a waveform.

<sup>1</sup>Developed by RCA and included in WC-388-A modification kit for the WO-88-A 'scope.

\*Based on data in 'scope manual; published by permission of RCA, copyright proprietor.

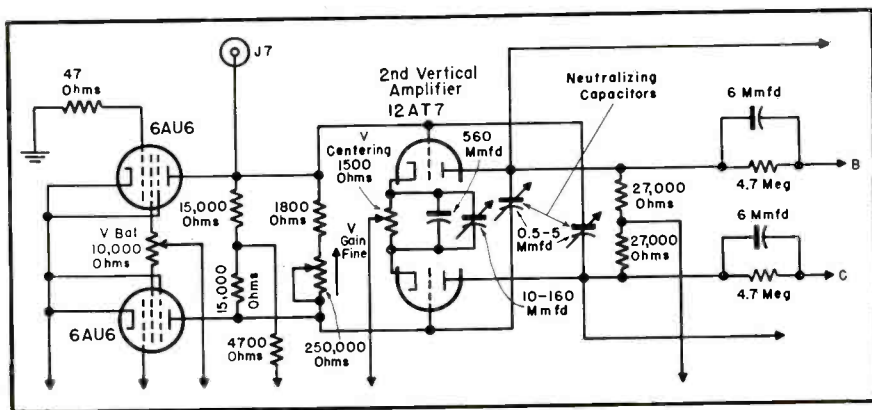
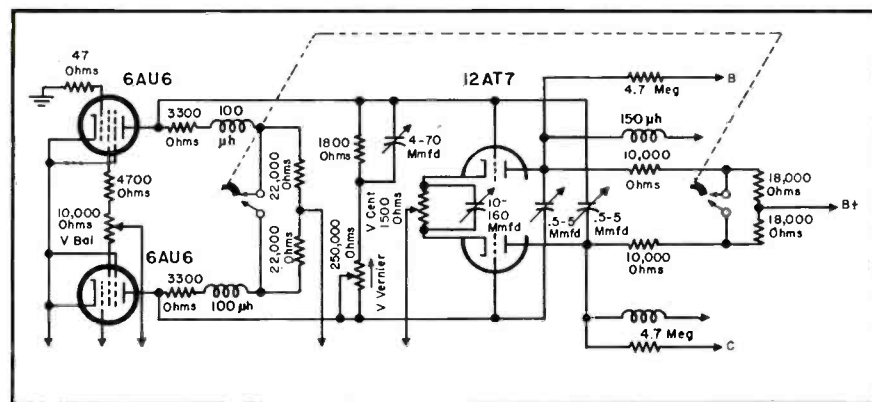

Fig. 1. Original (above) and revised (below) circuit of vertical-amplifier section of WO-88A 'scope, modified for wide-band color-TV applications. (RCA)



# KINGS of the TV FRONTIER!

## Unmatched for power and performance!

This extraordinary fringe-area powerhouse is still the most sensitive all-channel antenna made today—bar none! The SUPER RAINBOW's many "years-ahead" engineering features include the triple-powered Tri-Pole, separate high and low band operation, 100% aluminum construction, and "Snap-Lock" pre-assembly. Also in great demand . . .  
**The RAINBOW, Model No. 330.**

Model No.  
331

**SUPER RAINBOW**

## Extra elements, extra performance!

There may be antennas that resemble our TRAILBLAZER, but none can top its blazing performance. The TRAILBLAZER features extra High and Low Band directors, and full-wave directors on the High Band. It installs faster than any similar antenna, and—it's all aluminum! Especially recommended for areas with front-to-back interference problems, particularly on the Low Band. Count the elements . . . then compare the prices!

Model No.  
335

**TRAILBLAZER**

## Advanced design — and "Super-Sembled"

Look to the LANCERS for Channel Master "extras": extra elements and extra gain — at no extra cost. Completely "Super-Sembled." The SUPER LANCER gives 1½ db more gain on both the Low Band and the High Band than similar types. **The LANCER, Model No. 333,** has an extra director that provides 1½ db more Low Band gain. Count the elements . . . then compare the prices!

Model No.  
334

**SUPER LANCER**

# CHANNEL MASTER®

## All-Channel Yagis

## Unrivaled for power, popularity and price!

Servicemen everywhere are discovering an entirely new answer to the problem of multi-channel fringe-area reception: *Channel Master all-channel yagis.* These are the antennas that have what it takes to bring top TV performance to the most distant, isolated locations. And, they're ready for color, too!

Today's leading all-channel yagis are designed — *and improved* — in the Channel Master Antenna Development Laboratories. Isn't it logical to use Channel Master's famous engineering skill to solve your reception problems?



**CHANNEL MASTER CORP.** ELLENVILLE, N. Y.  
 The World's Largest Manufacturer of TV Antennas and Accessories

Copyright 1953, Channel Master Corp.

® - Trademark Reg. U.S. Pat. Off.

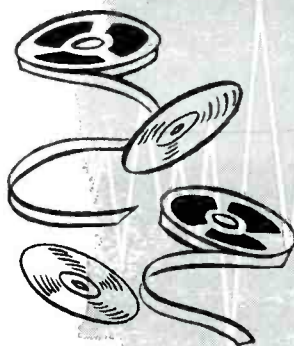

# AUDIO

## INSTALLATION AND SERVICE

### Hi-Fi - Phono - Tape - P A Amplifiers - Speakers

by LEE SCOTT

#### Horn Design and Application for PA and Home\*

THE MATERIALS used to construct horn flares play an important role in speaker performance. To illustrate, it has been found that metal horns, regardless of shape, inherently have lower power losses, caused by dissipation within their walls, than those made of non-metallic materials, such as paper or wood. Contrary to popular belief, experience and experiments have proved that stiffening the walls of a thin-walled metal horn by suitable construction, coupled with damping action (such as a ring of dissipative material on the mouth rim), can result in the elimination of unwanted vibration effects.

#### Driver Units

The driver unit, which consists of a voice coil, sound chamber, magnetic structure, and diaphragm, determines

the upper frequency limit of the horn. The throat is coupled to the diaphragm, and the latter is activated by the voice coil. Cross-sectional views of two common types of driver units are shown on page 27; the *a* unit shown incorporates a dome-shaped metal-alloy diaphragm. A *phase-correction-plug* reduces differences in path length of sound from various parts of the diaphragm to the throat. In this way, unwanted high-frequency interference occurring in the sound chamber is prevented from causing response irregularities. The *b* illustration shows a circular, or *annular*, diaphragm that is V-shaped; the voice-coil is attached to the apexes of the *V*'s. The sound chamber is formed by the clearance space around the *V*'s. It will be noted that not only is the diaphragm clamped in its outer extremities, but also at two points in

its center. The throat opening, which starts well into the driver unit, expands into the initial horn section. The main advantage of this driver unit, as compared to the one previously described, is that it minimizes interference, since the distance from any part of the diaphragm to the throat opening is relatively small.

#### Response Characteristics

The directional characteristics of horns determine the sound radiation over a listening area. The directional patterns of horns, just as those of speakers, change with frequency and are dependent somewhat on the angle at which the horn is faced. Often, it is desirable to have non-directional radiation, while at other times, the opposite is true. It is interesting to note that out of doors only the direct sound reaches the listener. Indoors, however, the low frequency energy is increased at the listening position, due to the reflecting action of the surrounding walls and structures. At relatively high audio frequencies, absorption by these structures increases so that most of the sound reaching the listener comes directly from the horn. Thus, indoor use of a horn at relatively lower frequencies is most advantageous. This desirable low-frequency response is further increased by positioning the horn in a corner of a room or at the junction of two surfaces.

Polar response must also be considered in evaluating a horn speaker. It has been determined experimentally that circular horns whose mouth diameters are equal to about one wavelength, have directional characteristics that are substantially the same as circular pistons with diameters equal to that of the horn mouth. Thus, a simple circular horn with a mouth diameter of 6" may theoretically be replaced by an imaginary piston 6" in diameter.

A study of polar patterns will reveal that as the operating frequency increases, the more directional the pattern becomes and the smaller the piston diameter. At 10,000 cps, even though the horn mouth diameters vary from 6" to 24", and the horn flares vary from 12" to 36", the difference in piston diameters is comparatively

(Continued on page 36)

Left: Triax speaker system circuitry and overall response. Schematic in *a* illustrates network in three-speaker array. Four terminal switch is used to provide adjustable hf cutoff; position 4, which yields maximum range with no cut-off filter elements inserted, can be used for tape recorder or with FM receiver output.

\*Based on information supplied by Jensen Manufacturing Co.

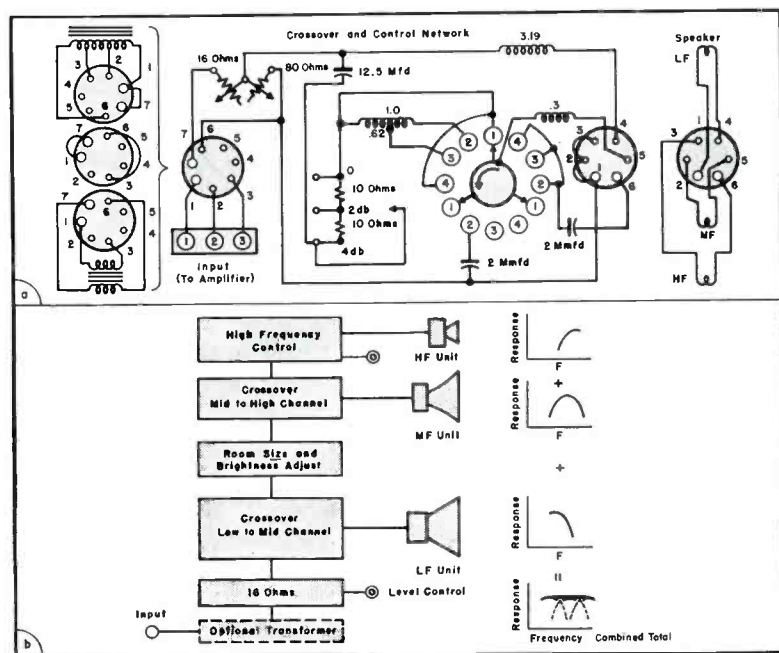

# Latest in Audio



Test speaker designed for audio checks on TV, radio receiver or phono. Tip jacks connect to 4" pm speaker, universal output transformer, 60-ohm and 90-ohm fields. Test leads said to fit male or female speaker connections. (Universal test speaker, model A6 Dunwell Manufacturing Co., Carlstadt, N. J.)



Two-way speaker system contained in TV set base-type enclosure, designed to replace the small, side mounted TV speakers. Supplied with compression-driver horn-loaded tweeter and 6 x 9 oval woofer. (Duette models DU-500 and 400; Jensen Manufacturing Co., 6601 S. Laramie Ave., Chicago, Ill.)

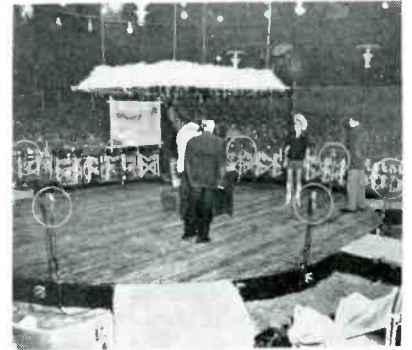

Outdoor voice-augmentation system employing ten unidirectional and two probe type microphones, installed at the Music Theater of the Villa Moderne restaurant in Highland Park, Ill. Microphones have been strategically placed around outdoor circular stage of the arena theater. (Concert line 333 and 525 microphones; Shure Brothers, Inc., Chicago, Ill.)

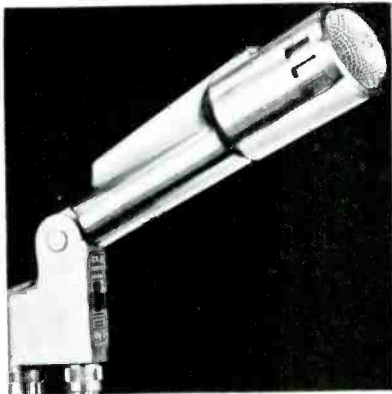

(Left)  
Cardioid dynamic microphone said to provide uniform cardioid polar pattern from 60 to 13,000 cps; output level—55 db. Line balanced to ground and phased. Alnico V and Armco magnetic iron in non-welded circuit. Has acoustalloy diaphragm and pop-proof filter to minimize wind and breath blasts. (Model 664 Variable D Cardioid; Electro-Voice, Inc., Buchanan, Mich.)



(Right)  
Combination needle storage and display cabinet which holds a maximum of 360 needles with each type of needle classified in drawer pockets. Each pocket holds up to five carded needles. One needle can be removed without touching any other or without readjusting index tab. (Jensen Industries, Inc., 7333 West Harrison, Forest Park, Ill.)

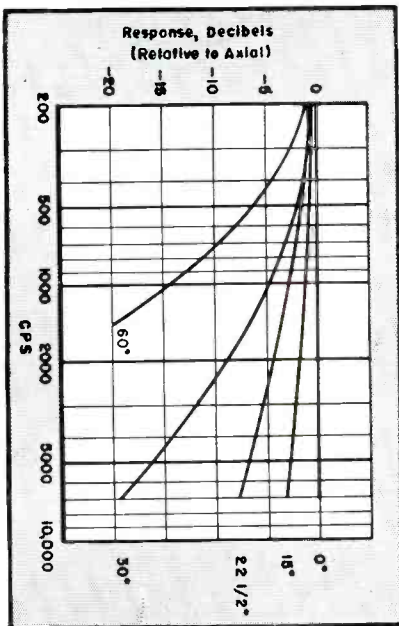

Left:

Effect of angle on the response characteristics of a 24-inch diameter horn.

Below:

Illustration of a driver unit with a conventional diaphragm (c) and annular diaphragm (b).

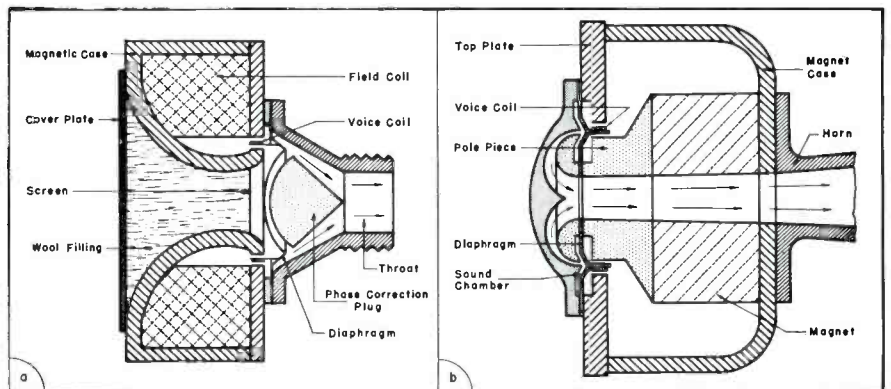

# AUDIO Maintenance-Service Tips

## Curbing Intermittent Stall in Record Changers . . .

## Stylus Replacement in Dual Styli Pickups . . . by FRED R. SAILES

## Adjustment of Damping Factor With Instruments

INTERMITTENT STALLING of the record changer in Hoffman's phono model *MW401HF* can be cured by the replacement of two of the *C* washers on the motor mount assembly. Three small washers of this type were originally used to hold the motor in position on the changer. One washer is located under the motor and should not be changed. The two exposed *C* washers should be replaced with washers larger than the original types. While making this change, the idler wheel should be cleaned and level operation should be checked. The inside bottom edge of the turntable should also be cleaned of any dirt or stray flock material.

### Stylus Replacement

IN THE RECORD changer employed in the RCA 6-HF-4 player, a dual stylus is used; it is held in position by a spring clamp. To remove this stylus, it should be held sideways and the spring clamp should be pulled away from the stylus, allowing it to drop out. When inserting the stylus one must be certain that the small diameter rod holding the styli rests in the notch of the drive arm connecting to the cartridge element.

### Damping Factor Adjustments\*

THE DAMPING FACTOR in amplifiers can be adjusted to its optimum point by instruments.\* The procedure requires the use of a square-wave generator and 'scope, set up as illustrated in Fig. 1. As in the case of adjust-

ment by ear, the work *must* be performed with the speaker placed in its final operating position in the room.

The square-wave generator should be set for very low-frequency output, preferably about 10 cps. This will give the speaker a chance to show hangover oscillations over the flat of the waveform.

With an ideal speaker, the cone will move forward on one half-cycle of the square wave, and will remain immobile during the half period, while air pressure at the microphone decays logarithmically. On the second half-cycle the performance will be repeated in the opposite direction.

If the speaker is operating under the conditions of  $Q = 1$ , a small amount of overshoot may be expected.

A badly under-damped system produces hangover vibrations after the initial stimulus of the wavefront of the square wave.

The square-wave response of an overdamped system actually is very similar to that of a system at optimum damping and the amplifier damping factor should never be raised above that point that just eliminates hangover, with slight overshoot showing on the screen of a 'scope. The cleanliness of the bass will not be improved by over-damping, but bass response will suffer.

When a square-wave generator is not available, some idea of the damping characteristics of the system can be gained by shock-exciting the amplifier with a low-voltage *dc* source feeding through a capacitor. The screen pattern will again reveal hangover oscillations, but only momentarily.

### Tape Head Alignment Adjustments

IN TAPE RECORDER-PLAYBACK equipment, the head must line up perfectly with the tape. If it does not, low output, loss of high frequencies or track overlap may result.

If the head in Crescent models 2900 and 9037 requires replacement, the complete assembly consisting of the head and head holder should be replaced. The head holder is adjusted individually to each head and sealed at the factory. When a new head is installed the following precautions should be observed.

To adjust head height a .179" gauge (between 11/64" and 3/16") should be placed near the mounting bracket and between base plate and bottom of head holder. The head should be pushed down on and the screw tightened. The gauge can then be withdrawn.

A tape on which a 3,000-cycle note has been recorded by a unit known to be in good operating condition is required for adjustment of output response. An output meter or *ac* voltmeter should be connected across the speaker voice coil of the unit to be adjusted. While the 3,000-cycle note tape is played back, the head should be pivoted back and forth on its mounting screw until maximum amplitude on the output meter is obtained. Head height must not be changed.

Track overlap should be checked by first making a recording on a *blank* tape with the unit to be tested. The tape should not be rewound, but the reels reversed and a *playback* made using another track. There should be no sound, but if what is heard is backwards, there is track overlap. To correct this it is necessary to adjust the tape guide on the side of the head holder by bending it upwards. This should move the tracks further apart.

If either the 5879 or 12AX7 tube or head has to be replaced, setting of the hum-balancing control should be

(Continued on page 39)

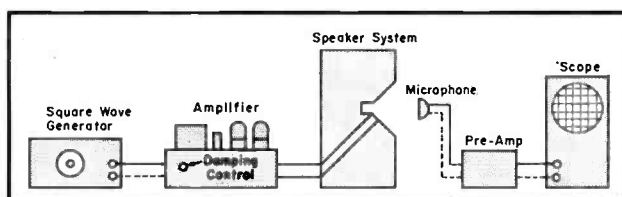

Test arrangement for adjusting amplifier damping factor to optimum position.

**YOU MUST PLEASE**  
*women*  
**YOUR CUSTOMERS**  
**IF YOU WANT**  
**TO MAKE YOUR**  
**BUSINESS GROW**

It's a woman you have to please in 76.9% of your service calls.

You'll please more women when you use tubes with the Good Housekeeping Guaranty Seal . . . CBS tubes.



CBS tubes are advertised and merchandized to millions of women in national magazines . . . and on Arthur Godfrey's Talent Scouts over both CBS Radio and CBS Television networks.

More and more women will have greater confidence in you and your service when you use tubes with the Good Housekeeping Seal . . . tubes with the respected name — CBS.

Ask your distributor for  
**CBS tubes**



**CBS-HYTRON**

Danvers, Massachusetts

A DIVISION OF

COLUMBIA BROADCASTING SYSTEM, INC.

# Association News

## TSDA, Philadelphia, Pa.

HARRISON NEEL has been elected president of the Television Service Dealers Association of Philadelphia.

Other new officers include: *Walter H. Prager*, vice president; *Elmwood S. Walker*, corresponding secretary; *Richard Schofield*, recording secretary; and *Harry J. Yust*, treasurer.

*Charles Knoell*, former prexy, was named editor and publisher of a bi-weekly newspaper, the *TSDA Bulletin*.

*Dave Krantz* was appointed head of an industry and legal problem committee, and Yust will head a committee to set up rules and regulations for the operation of independent shops and establish a code of ethics.

\* \* \*

## RTSA, Pittsburgh, Pa.

AT THE ANNUAL ELECTION of the Radio and Television Servicemen of Pittsburgh, *John F. Cochran* was reelected president.

*Philip J. Polito*, formerly second vice president was reelected first vice president, and *John Gonsowski* was elected second vice president. Both secretary *Tom Ging* and treasurer *Edmund Roberts* were reelected.

*Raymond Blackwood* has been elected chairman of the Beaver Valley chapter of RTSA. Vice chairman *Richard Cumiskey*, secretary *Leroy Bruce* and treasurer *Curtis Barrett* were reelected.

\* \* \*

## NATESA, Chicago, Ill.

SIX ASSOCIATIONS have become affiliates of the National Alliance of Television and Electronic Service Associations.

The groups are: Radio and Television Technicians Guild, Inc., Gadsden, Ala.; Associated Radio and TV Service-Shops, Borger, Tex.; Long Island Electronic Technicians Association, Inc., Oceanside, N. Y.; Middle Tennessee Television Technicians, Nashville, Tenn.; Radio and Electronic Technicians Association, New Orleans, La.; Syracuse Television Technicians Association, Syracuse, N. Y.

\* \* \*

## RTSNJ, Paterson, N. J.

HERBERT MANDL, Broadway Radio and Television Service, Passaic, N. J., will represent the Radio and Television Servicemen of New Jersey at the opening of the Austrian State TV network and the German Radio, Television and Gramophone Industry Exhibition at Dusseldorf this summer.

## TEA, San Antonio, Texas

THE THIRD ANNUAL CLINIC and fair of the Texas Electronics Association at the Gunter Hotel, San Antonio on August 26, 27 and 28, will feature talks by: *Charles Golenpaul*, Aerovox Corp., *Power of the Service Man*; *Ray Nugent*, Philco Accessory Division, *Selling Service Through Accessories*; *Hal Chase*, Television Service Association of Michigan, *Simplified Business Control*; *Frank Hadrick*, Admiral Corp., *Automation*; *Al Coumont*, RETMA, *RETMA Vocational Training Program*; and *Clint E. Walter*, RCA Service Co., *Today's Color*.

\* \* \*

## TISA, St. Louis, Mo.

HOWARD FREINER, formerly executive vice president of the Television Installation Association of St. Louis, Inc., has been named president of the group. He succeeds *Vincent J. Lutz*, who was elected chairman of the board.

Also elected were *Russ Adelman*, executive vice president; *Rudy Cretin*, first vice president; *Norman Minshall*, second vice president; *Paul Lubin*, secretary; and *Fred Reichman*, sergeant-at-arms. *Clyde Goodwin* was renamed treasurer.

Board members include, in addition to *Lutz*, *Nicholas Kocklanes*, *Ferd Meyer*, *Kenneth Garthe*, *Barney Lewis*, *Wallace Favors* and *Gus Prionas*.

\* \* \*

## EA, Kansas City, Mo.

A TELEVISION SERVICE dealers division of the Electric Association, Kansas City, Mo., is now being formed. *C. E. Barnickel*, association prexy, has appointed a six-man executive committee to serve until the first election, to be held in the fall; *Avery Fouts* has been named chairman. Other members are *Jim Blair*, *Floyd Conkright*, *Ray Crawford*, *Ralph Crooks* and *C. W. Donaldson*. Group membership will consist of company owners or service managers. Other management and supervisory personnel may become associate members.

\* \* \*

## NJTEA, Elizabeth, N. J.

A NEW ASSOCIATION, the New Jersey Television and Electronic Technicians Association, Inc., Elizabeth, N. J., has been formed. The group noted that it has been organized to promote a better understanding between the public and TV Service Men.

Officers and delegates of the Federation of Radio Servicemen's Associations of Pennsylvania at annual Luzerne County Radio Servicemen's Association conclave at Lily Lake, where ye ed was a guest speaker. (Photo by Max Leibowitz)



## TEN YEARS AGO IN SERVICE

THE END OF the war and release of substantial quantities of parts for repair and maintenance, plus the planned production of more than 3-million new radio sets before the end of the year, prompted service associations to organize series of clinics to acquaint their membership with new set-installation and repair-modernization problems. . . . Associations also began programming symposiums on FM and TV to prepare for the surge of new hi-fi and sight-sound sets. . . . It was said that the majority of the new fall sets were to be AM/FM combinations, while full-swing production of TV sets was planned for the following Spring. . . . Radio Parts and Electronic Equipment Shows, Inc., sponsored by NEDA, RMA, Association of Electronics Parts and Equipment Manufacturers and the Eastern Division of the Sales Managers Club, was formed to conduct future industry trade shows. *Herb Clough* was named president of the group; *Charles Golenpaul*, vice president; *Sam Poncher*, treasurer; and *Jerry Kahn*, secretary. The first show was tentatively scheduled for Chicago in October, 1946. . . . *Joseph B. Elliott* was named general manager of the RCA Victor home instruments division. . . . *Sidney Ludwig*, formerly chief engineer of Ward Products Corp., became owner and general manager of a new company, The Radel Manufacturing Co.



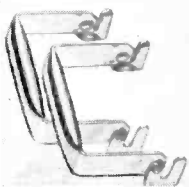

**G-C TV CHASSIS SERVICE HANDLES**  
Safer; sets are easy to carry.  
No. 9023 NET \$1.95



**G-C PRINT-KOTE SILICONE Resin Spray**  
Protection for printed circuits.  
No. 14-6 NET \$2.17



**G-C WEATHER-PROOF SPEAKER CONE DOPE**  
For drive-in theaters, etc.  
No. 9080-8 NET \$0.90



**G-C NON-TOXIC ELECTRO-TET Cleaner**  
Non-flammable, safe, fast drying.  
No. 10-G NET \$3.60

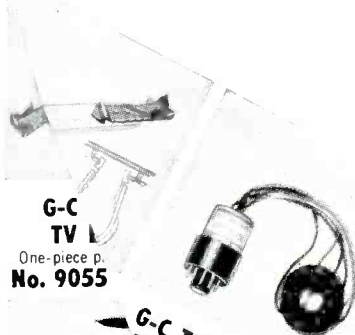

**G-C TV**  
One-piece p.  
No. 9055



**G-C TV PICTURE TUBE BOOSTER**  
Lens picture tubes.  
No. 9055 NET \$1.59



**G-C DUAL SHEET METAL PUNCH**  
Two punches: 7" & 1 1/2".  
No. 9260 NET \$3.50

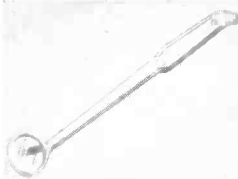

**G-C ALL-PLASTIC INSPECTION MIRROR**  
No danger of shock, shorting.  
No. 5090-P NET \$0.36



**G-C TEST SOCKET ADAPTER KIT**  
Contains 4 G-C socket adapters.  
No. 9250 NET \$6.75

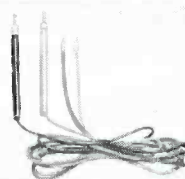

**G-C ECONOMY TEST LEADS**  
Tenite 5" prods, 50" leads.  
No. 9190 NET \$0.60



**G-C SILVER PRINT**  
Printed circuit touch-up; pu silver. 1/2 Troy oz.  
No. 21-1 NET \$2.37

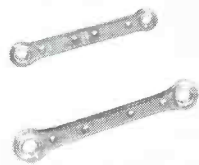

**G-C 2-WAY HEX RATCHET BOX WRENCHES**  
Two sizes: 1/4" x 3/16", 3/8" x 1/4".  
No. 9234 NET \$1.95  
9235 2.10

GENERAL



Ask For These  
**RADIO-TV SERVICE AIDS**

CEMENT

... at Your Jobber



**G-C STANDARD "NO-STRETCH" DIAL CORD**  
Diameter .028; 25' spool.  
No. 88-25 NET \$0.90



**G-C PRINT-KOTE SOLDERING FLUX**  
Liquid flux for printed circuits.  
No. 12-2 NET \$0.45

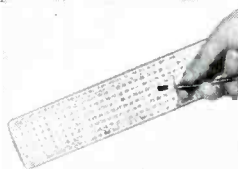

**G-C WIRE MARKERS**  
Self-sticking; pre-cut; 3 strips.  
No. 9229 NET \$0.75

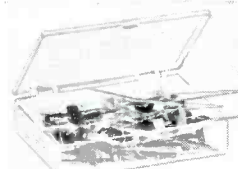

**G-C POINTER ASSORTMENT**  
Includes radial and slide types.  
No. 9120 NET \$0.99

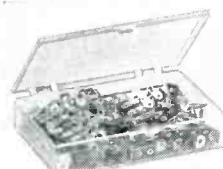

**G-C TERMINAL STRIP ASSORTMENT**  
Box of various types.  
No. 9129 NET \$0.99



**G-C SAFETY SCREWDRIVER**  
Insulated for hot circuit use.  
No. 9209 NET \$0.75



**G-C VM 33-1/3 PHONO DRIVE**  
Replacement set for VM changers.  
No. 25-E NET \$0.30

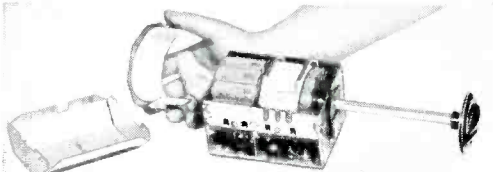

**G-C TV TUNER KLEEN-O-MATIC**  
Cleans, shields Standard coil tuners. Easy to install.  
No. 9221 NET \$1.50

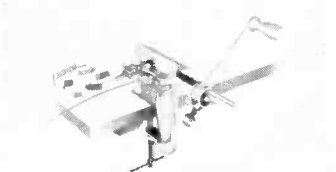

**G-C SPEEDEX SPRING WINDER**  
Make any type spring fast.  
No. 5209 NET \$14.95

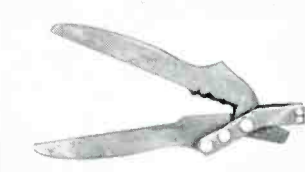

**G-C 300-OHM LINE TOOL**  
Slot, strip, cut twin leads; crimp lugs.  
No. 9220 NET \$3.95

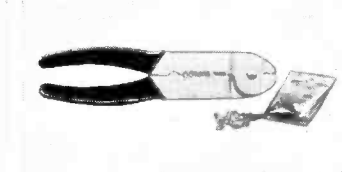

**G-C SOLDERLESS TERMINAL REPAIR KIT**  
Fastener tool and terminals.  
No. 8176 NET \$3.95

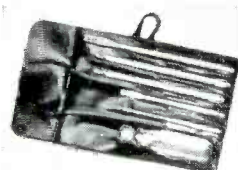

**G-C 6-PC. SCREWDRIVER KIT**  
Fitted case and complete set.  
No. 8615 NET \$1.17

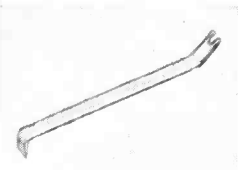

**G-C PRY-UP TUBE LIFTER**  
Protects fingers and tubes.  
No. 9213 NET \$0.15



**G-C 6-PC. HEX NUT DRIVER KIT**  
Case with sockets 3/16" to 1/2".  
No. 9206 NET \$2.40

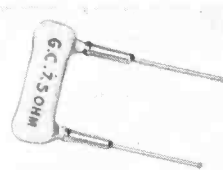

**G-C 7.5-OHM FUSE RESISTOR**  
Replacement for series-wired set.  
No. 9207 NET \$0.33

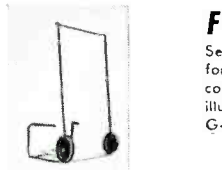

**G-C TV "PICTO-VUE" RACK & TRUCK**  
Easy to use; includes mirror.  
No. 9205 NET \$14.95

FREE!

Send postcard for your complete illustrated G-C Catalog

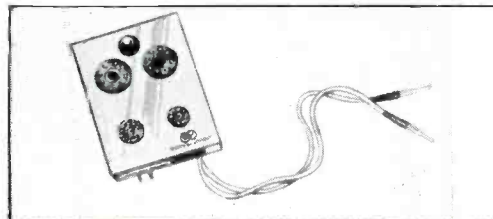
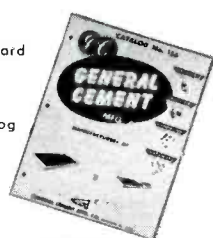

**G-C TUBE-CHECKER**

Easy-to-use series filament tube checker and continuity tester requires no tube warm-up. Simply plug tube in and get immediate check.

No. 9270 NET \$3.25



**GENERAL CEMENT MFG. CO.**

901 TAYLOR AVENUE • ROCKFORD, ILLINOIS

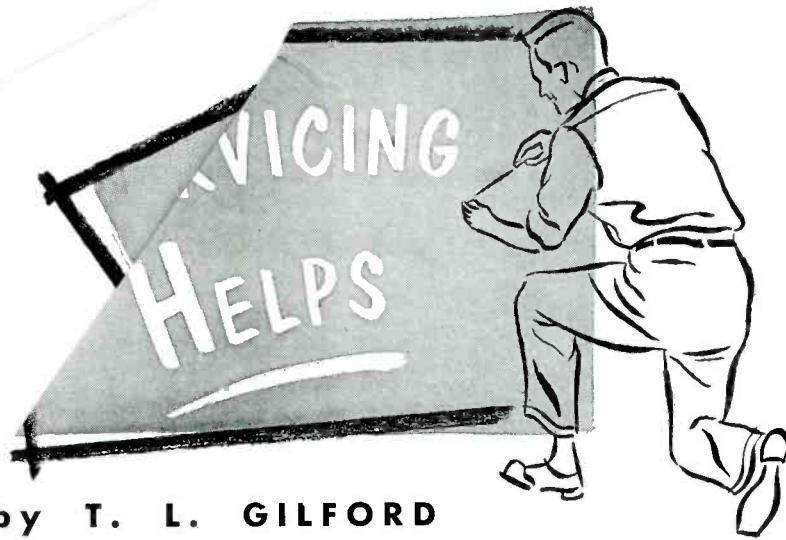

by T. L. GILFORD

## Minimizing AC Hum in Radio Chassis . . . Adjusting AGC To Remove Snow Conditions . . . Servicing Series-Tube Chassis . . .

TO MINIMIZE *ac* hum in the Stromberg-Carlson T-4 and C-5 radio sets, the buss wire running from the switch to the top of the volume control has been removed in production, and a lead run from the top side of the volume control to pins 2 and 3 of the 12AV6. This lead should be run along the side of the chassis, forming an *L*.

### Removing Snow

SOME COMPLAINTS of snowy pictures on Stromberg-Carlson models 600 and 21-22 series TV receivers have been traced to improper setting of the *agc* control. If this condition exists, the proper set-up of the *agc* control on the back of the chassis should be checked.

### Servicing Series-Tube Chassis

IN CONTROLLED-HEATER series-filament chassis, when the filament of one tube

opens, the filaments of all tubes are extinguished. Consequently, regardless of which tube filament fails, picture and sound are lost, and an effort must be made to locate the defective tube. A tube checker could be used<sup>1</sup> or substitution offers another means of attack; the latter procedure is normally slow, and unless the set is turned off each time a tube is changed, the Service Man might be exposed to a shock hazard from the chassis.

To find the *open* tube, the Westinghouse service department has devised a novel test unit, illustrated in Fig. 1.

The tool can be made from tubing or by modifying a small pocket flashlight. A low current-drain (150 mil) bulb, such as the type 40 screw base or type 47 bayonet base is required for checking across a large number of tubes. Higher voltage rating of these types assures long bulb life.

As a typical application of this

tester, let us suppose that a 3BN6 (serving as the FM detector in Westinghouse V-2316 and V-2317 chassis) were defective. The tube should be removed and pins 3 and 4 checked for continuity. If the indicator does not light, a new tube should be inserted. If the filament of this tube is good, the clip lead of the indicator should be connected to any convenient point on the chassis (B—) and the indicator pin should be inserted into the number 4 position of the 3BN6. If the indicator does not light, the open filament lies between this tube and B—, and can be located by checking at successive tube sockets and B—. If the indicator lights up, continuity exists between this tube and B—, and all the filaments between these tubes are good.

In step two, the damper (12AX4-GTA) should be removed from its socket and the indicator pin inserted into the number 8 position of the socket. The clip of the pin lead should be inserted into the number 3 position of the 3BN6 tube socket. If the indicator does not light, the open filament lies between the damper and FM detector tubes, and can be located by checking at successive tube sockets between these tubes. If the indicator lights, continuity exists between these tubes.

The damper tube should then be checked for continuity between pins 7 and 8. If continuity does not exist it should be replaced. If the filament string still doesn't function, the 41-ohm 20-watt bridging resistor ( $R_{500}$ ) should be checked.

### Slow-Blow Fuses

USE OF SLOW-BLOW type fuses in TV high-voltage circuits is *not* recommended because of their early-life failures due to metal fatigue. Therefore, when replacement is necessary a standard-type fuse should be used.

### Intermittent Tuner Trouble Cures

IN SPARTON 15V215, 15V215T and 15V215P chassis, intermittent streaking in the picture, while making fine tuning adjustments or after the fine tuning control has been set, has been found to be due to a short in the dielectric washer between the stator and rotor sections of the fine tuning capacitor. This washer must be replaced.

If the tuner has been operated for a period of time with this short, the stator section of the fine tuning capacitor and associated resistor ( $R_{x-3300}$  ohms) may be damaged and require replacement.

Fig. 1. Modified pen light that can be used to check series-filament strings.

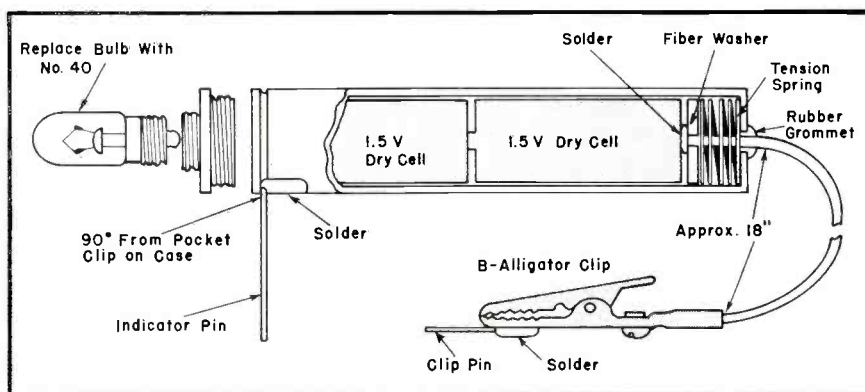

<sup>1</sup>See 600-ma tube-check report, this issue; p. 18.

# WHAT'S YOUR SERVICE PROBLEM?

FM Radios • Amplifiers and Tuners • Auto Radios • Record Changers

## PHOTOFACT HELPS YOU SOLVE IT FASTER, EASIER, BETTER, MORE PROFITABLY!

### THE WORLD'S FINEST SERVICE DATA

PHOTOFACT Service Data is the *only* service information based upon first-hand examination of the actual production-run receivers and equipment. It is authentic, uniform data developed through actual study and analysis by service engineers in the Howard W. Sams Laboratories. PHOTOFACT is the *only* data prepared from the practical point of view of the Service Technician.

Thousands of Service Technicians use PHOTOFACT daily for time-saving, profit-boosting service operations. If you've never used PHOTOFACT, you've never realized your full earning power—you've never given such complete customer satisfaction. So get the proof for yourself. Try PHOTOFACT—use it on any job. Your Parts Distributor has the Folder Sets you need for any of the 17,000 TV and radio receivers, changers, recorders, etc., covered in PHOTOFACT. Once you use this great service, we know you'll want the complete PHOTOFACT Library.



THESE GREAT FEATURES ARE EXCLUSIVE IN PHOTOFACT—THEY HELP YOU EARN MORE DAILY, HELP INSURE CUSTOMER SATISFACTION

### FULL SCHEMATIC COVERAGE

1. Famous "Standard Notation" uniform symbols are used in every schematic.
2. The same standard, uniform layout is used for each schematic.
3. Diagrams are clear, large, easy to read, easy to handle.

4. Wave forms are shown right on the TV schematics for quick analysis by 'scope.
5. Voltages appear on the schematics for speedy voltage analysis.
6. Transformer lead color-coding is indicated on the schematic.
7. Transformer winding resistances appear on the schematic.
8. Schematics are keyed to photos and parts lists.

### FULL PHOTOGRAPHIC COVERAGE

9. Exclusive photo coverage of all chassis views is provided for each receiver.
10. All parts are numbered and keyed to the schematic and parts lists.
11. Photo coverage provides quicker parts identifications and location.

### ALIGNMENT INSTRUCTIONS

12. Complete, detailed alignment data is standard and uniformly presented in all folders.
13. Alignment frequencies are shown on radio photos adjacent to adjustment number—adjustments are keyed to schematic and photos.

### TUBE PLACEMENT CHARTS

14. Top and bottom views are shown. Top view is positioned as chassis would be viewed from back of cabinet.
15. Blank pin or locating key on each tube is shown on placement chart.
16. Tube charts include fuse location for quick service reference.

### TUBE FAILURE CHECK CHARTS

17. Shows common trouble symptoms and indicates tubes generally responsible for such troubles.
18. Series filament strings are schematically presented for quick reference.

### COMPLETE PARTS LISTS

19. A complete and detailed parts list is given for each receiver.
20. Proper replacement parts are listed, together with installation notes where required.
21. All parts are keyed to the photos and schematics for quick reference.

### FIELD SERVICE NOTES

22. Each Folder includes time-saving tips for servicing in the customer's home.
23. Valuable hints are given for quick access to pertinent adjustments.
24. Tips on safety glass removal and cleaning.

### TROUBLE-SHOOTING AIDS

25. Includes advice for localizing commonly recurring troubles.
26. Gives useful description of any new or unusual circuits employed in the receiver.
27. Includes hints and advice for each specific chassis.

### OUTSTANDING GENERAL FEATURES

28. Each and every PHOTOFACT Folder, regardless of receiver manufacturer, is presented in a standard, uniform layout.
29. PHOTOFACT is a *current* service—you don't have to wait a year or longer for the data you need. PHOTOFACT keeps right up with receiver production.
30. PHOTOFACT gives you *complete* coverage on TV, Radio, Amplifiers, Tuners, Phonos, Changers.
31. PHOTOFACT maintains an inquiry service bureau for the benefit of its customers.

**HELPS YOU EARN MORE DAILY**

**ONLY \$25 DOWN**

Puts a Photofact Service Data Library in Your Shop. Ask Your Photofact Distributor—He Has the Full Easy-Pay Details.

### FREE PHOTOFACT CUMULATIVE INDEX

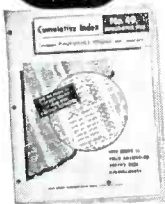

Send for it! Your guide to virtually any model ever to come into your shop; helps you locate the proper PHOTOFACT Folder you need to solve any service problem on any model. Once you have the make and chassis number, it

takes just 60 seconds to find the applicable PHOTOFACT Folder. Send coupon now for your FREE copy of the valuable Cumulative Index to all PHOTOFACT Folders.

### HOWARD W. SAMS & CO., INC.

Howard W. Sams & Co., Inc., Dept. 5-H5  
2201 E. 46th St., Indianapolis 5, Ind.

Send FREE Photofact Cumulative Index.

Name .....

Address .....

City ..... Zone ... State .....

# Snyder

PHILADELPHIA

## Auto Antennas

WORLD'S MOST COMPLETE LINE

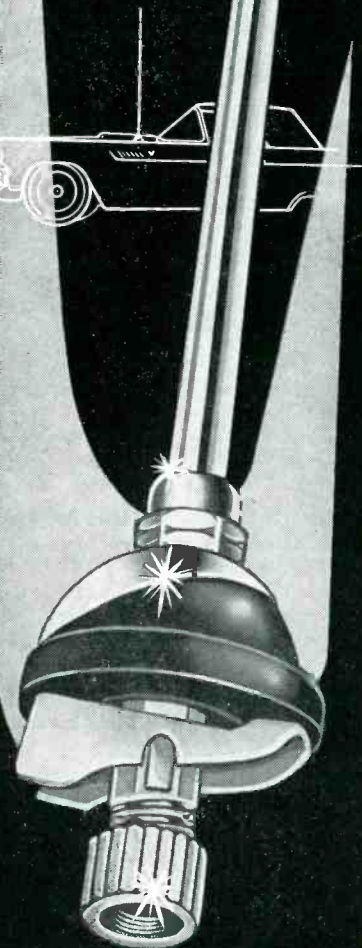

40 MODELS+

# Components

## ASTRON HIGH-TEMP CAPACITORS

Capacitors, X series, that are said to operate up to 150°C without derating, have been developed by Astron Corp., 255 Grant Ave., East Newark, N. J.

Available in hermetically-sealed tubular, *squeeze seam* and bathtub cases. Dielectric ingredients include *Mylar* and solid polyester impregnants.

\* \* \*

## CLAROSTAT WIRE-WOUND CONTROL AND POWER RESISTOR KITS

A wire-wound control kit, PD-1, has been made available by Clarostat Manufacturing Co., Inc., Dover, N. H.

Kit includes eight values (500, 1,000, 1,500, 2,000, 2,500, 3,000, 5,000 and 10,000 ohms) of series A10 4-watt wire-wound controls, two each of the four most-used shaft types and a mounting-nut wrench.

Also available are six power resistor card kits: GK1 (20 10-w Greenohm resistors), GK2 (32 Glasohm or flexible glass-insulated resistors), GK3 (36 Greenohm Jr. 5-w, axial-lead resistors), GK4 (54 5-w Greenohm resistors), GK5 (50 Greenohm Jr. 10-w axial-lead resistors) and GK6 (45 10-w Greenohm resistors).

\* \* \*

## C-D HIGH-TEMP CAPACITORS

High temperature paper dielectric tubular capacitors, *Tiger Cub* (MGT), claimed to operate efficiently from -55°C to +100°C, have been introduced by the Cornell-Dubilier Electric Corp., South Plainfield, N. J. Capacitance stability is said to vary less than 10% over operating range. Units are available in values from .001 to 1 mfd. in six voltage ranges from 100 to 1,600 *vdc*. Further details in bulletin 168.

\* \* \*

## TRANSISTOR APPLICATIONS BOOK



Raytheon's 116-page illustrated manual on Transistor Applications, describing constructional details on over 50 different types of transistorized equipment, being reviewed by Norman B. Krim, receiving and cathode-ray tube operations vice president and general manager (second from left), and group of contributing authors, left to right: Charles W. Martel, manager technical information service; Robert K. Dixon, engineering and product manager, semiconductor diodes; and Herbert F. Starke, transistor application engineer. Component, construction and test information supplied with each article in book. Copies of book may be obtained for 50 cents from Raytheon tube suppliers or direct from Raytheon Manufacturing Co., Receiving and Cathode Ray Tube Operations, 55 Chapel St., Newton 58, Mass.

ask the  
"Man-on-the-Roof"  
why he prefers

*South River*

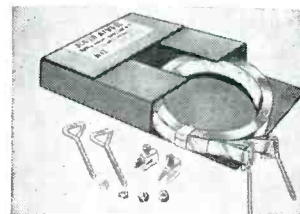

**NOW! Banding Kits NEW!**  
for EXTRA LARGE CHIMNEYS

KIT XL "ST": (Consists of)  
2—18' x 3/4" STAINLESS STEEL STRAPS  
with eyebolts attached  
2—Eyebolts Unattached  
4—Nuts to Fit Eyebolts  
2—KWIK KLIP Strapping Fasteners  
Also available, KIT XL "G", same  
as above with 18' GALVANIZED  
STRAPS.

Universal—may be used with any  
chimney antenna mount.

**SOUTH RIVER**  
METAL PRODUCTS CO., INC.  
South River, New Jersey

pioneer &  
outstanding  
producer of  
finest line  
of antenna  
mounts

## Coming Events

Sixth Annual Convention, NATESA  
August 19 to 21  
Morrison Hotel, Chicago, Ill.

Annual Audio Fair  
October 12 to 15  
Hotel New Yorker, N. Y.

ASK FOR SPRAGUE BY  
CATALOG NUMBER

Know what you're getting . . . get  
exactly what you want. Don't be  
vague . . . insist on Sprague. Use  
complete radio-TV service catalog  
C-610. Write Sprague Products  
Company, 61 Marshall Street,  
North Adams, Massachusetts.

DON'T JUST SAY  
CAPACITORS  
SAY

**SPRAGUE**

WORLD'S LARGEST CAPACITOR MANUFACTURER

# Instruments

## TRIPLETT MINIATURE VOM

A 20,000 ohms-per-volt miniature *vom*, model 310, is now being produced by the Triplett Electrical Instrument Co., Bluffton, O.

Model is said to be self-shielded for checking in magnetic fields. Has interchangeable test prod tips that fit in top of the unit to become common probe.

Ranges are: *dc* volts . . . 0-3-12-60-300-1200 at 20,000 ohms/volt; *ac* volts: 0-3-12-60-300-1200 at 5,000 ohms/volt.

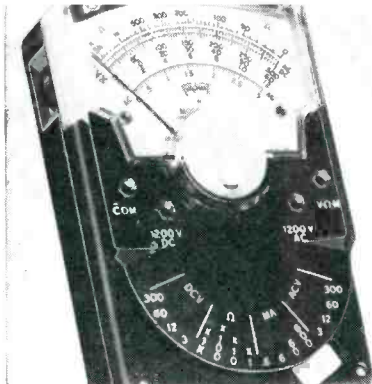

\* \* \*

## ANCHOR PICTURE TUBE TESTER

A TV picture tube tester-reactivator (Reacto-Tester, model T-400) for use in checking open connections and elements, shorted elements, cathode emission, and gaseous content, with tube in or out of set, has been developed by Anchor Products Co., 2712 W. Montrose Ave., Chicago 18, Ill.

Unit is said to reactivate low emission tubes and restore brightness.

\* \* \*

## PHILCO COLOR GENERATOR

A color-bar and dot-bar generator, model 7100, designed for white balance tests, locating distortion, aligning demodulators, making convergence adjustments and troubleshooting circuits associated with color, is now available from the Philco accessory division.

Instrument, it is said, provides signals for checking and setup of static and dynamic convergence; frequency of color oscillator; phase of demodulators; matrix circuits; color and black and white linearity. Two crystals control picture and sound carriers, and a pair of crystals control internally-generated color signals and horizontal sync pulses. Visual markers serve to identify color bars.



**HAVE YOU HEARD WHY THEY'RE PLUGGING THEM IN ?**



Smart servicemen are making more money by modernizing current TV sets with Sarkes Tarzian Plug-In Rectifiers and conversion chassis CC-1

...and it's so easy

All Sarkes Tarzian Replacement Rectifiers plug into Conversion Chassis CC1.

See your distributor.

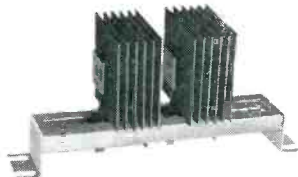

Dept. S-1 415 North College Avenue, Bloomington, Indiana

In Canada: 700 Weston Rd., Toronto 9, Tel. Murray 7535

Export: Ad Auriema, Inc., New York City

**NEW!**



**a Volt-Ohmmeter  
you can carry in  
your shirt pocket!**



**Simpson  
MIDGETESTER**  
MODEL 355  
**SELF SHIELDED!**

**\$29.95**  
including  
probe leads

The world's first practical shirt-pocket volt-ohmmeter. Rugged and accurate. Not affected by any outside magnetic influences. 10,000 Ohms per volt AC and DC! Fourteen ranges: 5 for AC voltages, 5 for DC voltages, and 4 for DC resistances.

**See your Parts Distributor**

**Simpson  
ELECTRIC COMPANY**  
WORLD'S LARGEST MANUFACTURER  
OF ELECTRONIC TEST EQUIPMENT

5220 W. Kinzie St., Chicago 44, Ill.  
EStebrook 9-1121

IN CANADA: Bach-Simpson, Ltd., London, Ontario

**Audio**

(Continued from page 26)

small; that is, only 1" or from 3.2" to 4.2". Although horns of different mouth diameters have very different characteristics at frequencies of 1000 cps, the responses are about the same when the frequency reaches 10,000 cps. With different horn flares, the response is the same at 1,000 cps and varies the most at 4,000 cps where the piston diameter ranges from 7 to 9 cps.

**Angle of Effectiveness**

The amount of response fall-off at the listening position is dependent upon both the angle that the listener is away from the center axis of the horn, as well as the frequency. The way in which these variables change is illustrated in the curves on page 27; these represent the response characteristics of a 24"-diameter horn. Here we find that as the frequency or angle increases, the response falls off considerably.

It is also interesting to note that tests have disclosed that the intensity levels of speech reproduction in the 1,000 to 4,000 cps region are of the greatest importance in establishing the best intelligibility of speech. Therefore, the polar-response characteristic, or angle, at which a horn is effective, at these frequencies, must be studied carefully to obtain faithful voice reproduction. Judging from response curves, horns should be rated to cover a total angle of not more than about 45° (22½° on each side of the horn) for general service.

**Horn Construction**

The depth, and therefore the volume, of a horn are dependent upon the lowest frequency (or highest wavelength) which one desires to reproduce. The lower the frequency desired, the larger the size of the horn. To illustrate, a horn having a throat area of one square inch and a low-frequency cutoff of 64 cps would have to be roughly 13½' long, with a mouth diameter slightly greater than 5'. Obviously, the construction of such a horn would be most impractical, because of its large size and awkwardness.

To eliminate the necessity of huge horn constructions to meet low frequency requirements, they are literally folded one or more times; this is even done when the horn cutoff frequency is relatively high (about 200-500 cps). In typical construction we often have horns with a depth of only 7 9/16" long, due to a reentrant fold; the equiva-

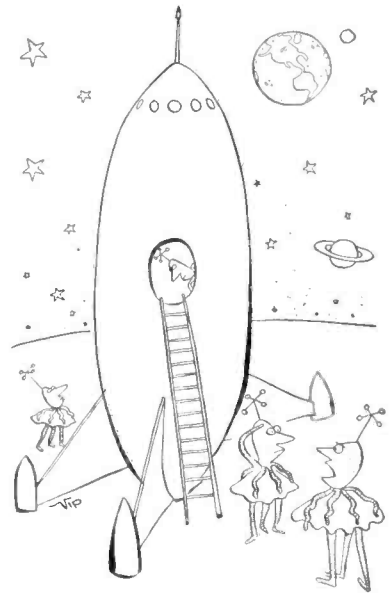

*"Your mission is to bring  
back JENSEN NEEDLES  
no matter what."*

**Easier,  
Faster**

INSTALLATIONS WITH THE

**New LA-75  
ARRESTER**

LIST  
\$1.35

Pat.  
Pending



ANOTHER  
**Radion**

FIRST

ANOTHER  
**Radion**

FIRST

ANOTHER  
**Radion**

FIRST

New twin-lead grip speeds connections.

Flame-proof, waterproof. All hardware included. UL Approved indoors or out. Carry one arrester to fit all needs. Ask your distributor now.

**THE RADION CORP.**  
1130 W. Wisconsin Ave.,  
Chicago 14, Ill.

lent length is actually  $14\frac{1}{2}$ ". Cutoff frequency of such a speaker is 350 cps and its high-frequency range is limited to about 7,500 cps.

Two-fold, three-section horns, are often only 20" deep (minus the driver unit), with a developed length of 60". The low-frequency cutoff of this speaker is about 140 cps.

Horns composed of many *elementary* units, or cells, are used to obtain a very directional response characteristic. This feature serves to minimize variations in sound intensity of direct sound with distance from the horn. Inasmuch as the dimensions of the radiating system must be great (several wavelengths) to obtain a highly directional characteristic, it is most convenient to reduce the low-frequency response.

The mouth size, as well as the relative phase and pressure of the emergent wavefront of a horn, is important in determining directional response. In a simple horn, with a large mouth, the phase and pressure vary considerably over the mouth configuration in a manner which is difficult to control; this is the reason why the horn is subdivided into many *elementary* units. Each horn may be driven by a separate driver unit, or a common driver may operate all of the individual units. Horns can have as many as twelve individual *elementary* units and twelve driver units, with a mouth area of 32 square inches.

Another important use of the horn is its application as part of a coax or triax system; that is, a speaker system which contains a conventional speaker plus a horn(s).

In one model, using dual structures, low frequencies, below 2,000 cps, are reproduced by a direct-radiator speaker.<sup>1</sup> The range above 2,000 cps is handled by means of an electrically- and -mechanically- independent compression-driver unit loaded with a six-cell horn, the latter of which has a useful coverage angle of  $110^\circ$ . The driver unit employs a plastic diaphragm, designed for freedom from break-up, in a sound chamber which is coupled to the horn throat.

A schematic of a triaxial<sup>2</sup> is shown on page 26. This speaker has three independently-driven reproducing elements, each covering a portion of the total frequency range. Low frequencies (up to 600 cps) are reproduced by a curved-diaphragm, direct-radiator speaker. Mid-frequencies (from 600-4,000 cps) are reproduced by a compression driver unit (located at assembly rear) feeding a horn which

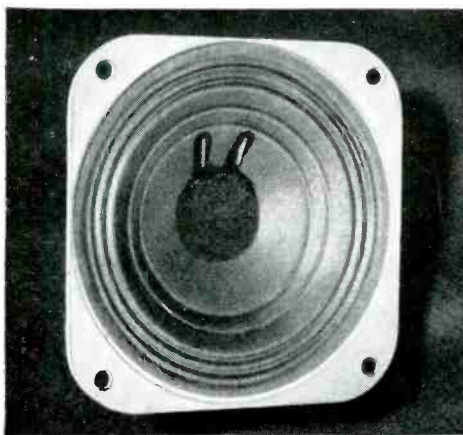

**G.E.'s Pacer "40"  
4-inch cup speaker**

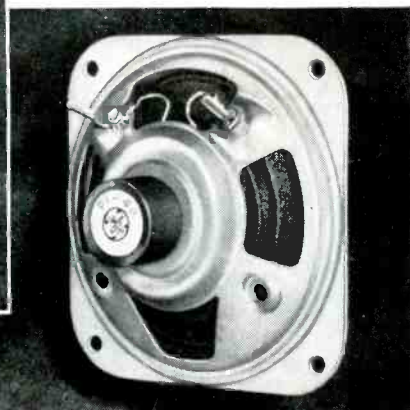

**LOW COST,  
NO YOKE,  
LESS BULK**

## G.E.'s NEW POWDERED IRON MAGNET SPEAKER

**Is easier to install, delivers all the quality  
of speakers twice its magnet weight!**

**H**ERE'S a high-quality speaker that is more compact—easier to install—yet carries a low price tag. An ideal replacement unit for standard or portable radios or TV sets, intercoms, or mobile radio installations.

### A NEW CONCEPT OF SPEAKER ENGINEERING

The PACER "40" combines unusual strength with compact design. High energy Alnico 5 magnet material, teamed with a powdered iron structure, greatly reduces flux leakage, and because the yoke is eliminated, less space is needed. Result—a *compact, all-purpose* speaker with an efficiency rating comparable to yoke-type units with twice the magnet weight.

Aluminum base voice coil assures reliable all-weather performance, provides excellent heat dissipation, and high power handling capacity. Felt dust cap prevents air gap contamination, minimizes distortion. Chipboard gasket, two-way lug type terminals.

### NOW A WIDE RANGE OF G-E SPEAKERS

G. E. catalogs a full line of loudspeakers for general replacement, PA systems, drive-ins, and hi-fi needs. In this wide line of superior speakers you will find the right model for your needs. See the quality line—the G-E line, today. Or, write: *General Electric Co., Radio & TV Dept., Section X385, Electronics Park, Syracuse, N. Y.*

*Progress Is Our Most Important Product*

**GENERAL  ELECTRIC**

passes through the low-frequency speaker; the flared diaphragm of the *lf* speaker acts as an articulated, final section of the *mf* horn. The small compression driver and horn combination, the *tweeter*, at the front of the assembly, reproduces frequencies over 4,000 cps.

A crossover and control network divide the electrical input between the reproducing elements, affording control facilities.

Good *hf* response (up to about 16,000 cps) can be obtained with most commercial horn systems. Obtaining

good *lf* response (down to about 30 cps) however, is quite another story. Floors, walls, and other large surfaces, close to the mouth of a horn, can contribute to *lf* response by creating *mirror images* on the radiating surface, thus raising radiation resistance and, in turn, the efficiency.

When placing speaker enclosures, large obstacles, such as heavily-upholstered furniture and bookcases, should be no closer than about three feet from the horn mouth. Lamps, open chairs, and the like have very little effect on speaker operation.

<sup>1</sup>Jensen H-222.  
<sup>2</sup>Jensen G-610.

# KESTER

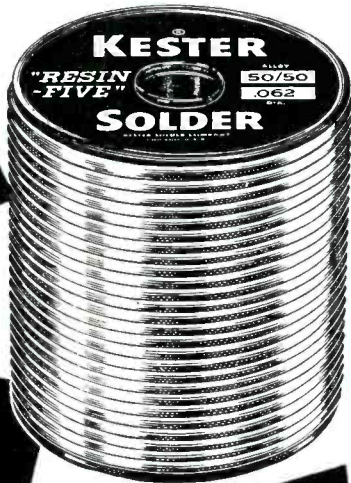

Absolutely non-corrosive and non-conductive, KESTER "RESIN-FIVE" CORE SOLDER contains an activated type of resin that gives you that fast, positive action on all your jobs . . . including the most difficult.



**KESTER SOLDER COMPANY**  
4248 Wrightwood Avenue • Chicago 39, Illinois  
Newark 5, New Jersey • Brantford, Canada

# SOLDER

## Coming Events

Institute of Hi-Fi Manufacturers Hi-Fi Show . . . November 4, 5 and 6  
Benjamin Franklin Hotel, Philadelphia, Pa.

Northern California Audio Show . . . September 30, October 1 and 2  
Sheraton-Palace Hotel, San Francisco, Calif.

## A NEW PRODUCT

by the makers of the famous **"NO NOISE"** Volume Control and Contact Restorer

## NO-NOISE TUNER-TONIC

**No NOISE**  
Volume Control and Contact Restorer with Perma-Film  
Cleans, lubricates, protects . . . not a carbon-tet solution. Still available in the new 6 oz. spray can.

Net to servicemen **\$2.25**  
2 Oz. Bottle

Net to servicemen **\$1.00**  
Also available in 8 oz. bottles and quart cans.  
Nearest distributor or write direct today.

with **PERMA-FILM**

Cleans, lubricates, restores all tuners including wafer type. Won't change or affect capacities, inductance or resistance, nor harm insulations or precious metals, nor attack plastics. For television, radio and FM. Eliminates all noise, oxidation and dirt indefinitely.  
Non-toxic, non-inflammable, insures trouble-free performance. 6 oz. Aerosol Can.  
Net to servicemen.

**\$3.25**

Extra economical because a small amount does the job!



## ELECTRONIC CHEMICAL Corp.

813 Communipaw Avenue Jersey City 4, N. J.

# TV Parts . . . Accessories

## MERIT REPLACEMENT TRANSFORMERS

Four replacement horizontal and high-voltage output transformers for use in Admiral, Crosley Super V, Hallicraifers, Sentinel and Silvertone receivers have been developed by Merit Coil and Transformer Corp., 4427 N. Clark St., Chicago, Ill.

\* \* \*

## PERFECTION MICA MAGNETIC SHIELDS

A magnetic-shielding material for use on color-TV tubes and other components designed to eliminate stray magnetic fields has been announced by Magnetic Shield Division of Perfection Mica Co., 1829 Civic Opera Building, 20 N. Wacker Dr., Chicago, Ill.

Illustration shows new material around color-TV tube. Used also between convergence coil and the yoke, where it replaces a ferrite ring.

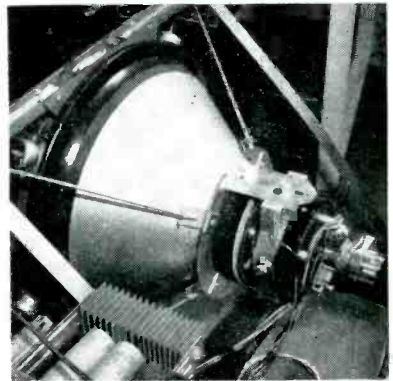

\* \* \*

## TV ANTENNA PLANT-EXPANSION CEREMONY



Mrs. Herbert H. Brown, wife of the president of Technical Appliance Corp., Sherburne, N. Y., snipping ribbons at official opening of additional Taco plant. Left to right: Howard Marsters, superintendent of shipping department; Robert Gallinger, office manager; Mrs. Brown; Howard Senkel, director of purchasing; Herbert H. Brown, president, and Frank Vassallo, production manager.



## Audio Maintenance

(Continued from page 28)

checked. An *ac vmm*, with a .1 *v* reading at full-scale deflection, or at least one-third deflection of full scale, should be connected across the speaker voice coil and the volume and tone controls turned fully clockwise. Then the control knob should be set to the playback position, and the hum balance control adjusted for a minimum reading not to exceed .1 *v*.

### Tape Troubleshooting

One common cause of trouble in tape recorders is stalling or binding. Trouble here usually stems from changing of the setting of the speed control while the recorder is in off position. This control should only be operated while the motor is rotating. To remedy this situation the speed control should be moved up and down several times while the motor is turned *on*. If this step should fail, the *fast forward* control should be held to the left as far as it will go and the take-up reel spindle manually rotated. As a last resort, if binding or stalling continues, the unit can be removed and any binding action freed.

Another annoying tape-recorder problem is failure of the actual speed to agree with the speed control setting. This is normally caused by a bent speed control bracket or broken *ears* on the drive pulley. If the bent speed control bracket cannot be repaired by hand it must be replaced. Broken *ears* on the drive pulley necessitate replacement of the entire motor.

When the tape is not pulled across the head, we must correct for slip-page; cleaning of the drive pulley, capstan shaft, flywheel and pressure roller with a petroleum solvent will usually remove this difficulty. *Carbontet* must not be used. If the roller or rubber belt appear to be oil soaked, they should be replaced. Wow or flutter is also caused by binding in the pressure roller, capstan shaft and flywheel.

### Improper Takeup Problems

Improper takeup of the tape is usually caused by a tight spindle, improper takeup spring action, a slipping drive belt, or a broken drive belt. A tight spindle should be lubricated and checked for end play. Improper takeup spring action can be checked by placing a fully loaded 7" reel on the takeup side. The reel should be rewound for about 10 sec-

Sure-  
Cure  
for  
Replacement  
Headaches:



Replace with the **BEST**

# OXFORD SPEAKERS

*Illustrated literature is available without obligation.*

... at better jobbers!



"No more worrying after you've completed your replacement jobs" . . . that's the saying of more and more servicemen every day because they've switched to OXFORD REPLACEMENT SPEAKERS.

We GUARANTEE you products that are built to be replacement speakers. We stand behind each and every speaker with a 100% guarantee against any mechanical or electrical defects for one full year.

OXFORD Replacement Speakers undergo a rigid inspection to make certain that they are as good or better than the original speaker. That's why more servicemen are switching to OXFORD . . . the replacement speakers for a better job.

**OXFORD ELECTRIC CORPORATION**

3911 SOUTH MICHIGAN AVENUE  
CHICAGO 15, ILLINOIS

EXPORT—ROBURN AGENCIES, NEW YORK CITY  
IN CANADA—ATLAS RADIO CORP. LTD., TORONTO

onds, then the control knob moved to the playback position and the action observed.

A slipping drive belt calls for a cleaning of the pulleys; a broken drive belt for replacement. The drive belt should be given a half-twist when replaced.

If the recorder plays back but does not record there's either a bad component or the switch slide is not contacting the proper terminal. Voltage and resistance readings should be checked and switch cam adjustment examined. If the latter is at fault the

set screw should be loosened, front grill plate removed, speaker mounting screws taken out and speaker swung to one side. One end of the switch spring should be carefully detached. Control knob should be pushed down on and turned clockwise to the record position. Then the switch cam should be moved manually until the first slide contact makes with only the first two wiper contacts. At all times, during this step, the switch cam must touch the arm at the end of the switch slide. The *pusher stud* should be moved

(Continued on page 41)

## Non-Snarling, Pre-Measured Wire Strand

WRIGHT Wire Strand uncoils like this →

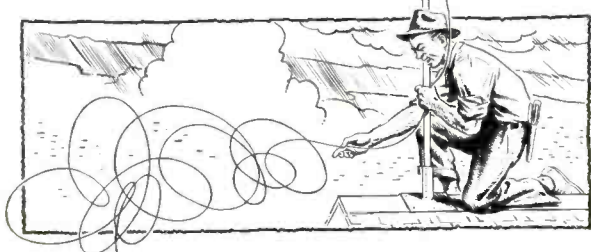

WRIGHT unique process prevents this ←

Besides the important factor of no snarling, WRIGHT TV GUY WIRE is pre-measured. Every concentric coil measures two feet —time and money saver in guying antennas. WRIGHT TV GUY WIRE has great flexibility and is heavily galvanized . . . continuous connected coils.

Prompt deliveries from stocks in Worcester, Chicago, Atlanta, New Orleans, Houston, Dallas and Los Angeles.

**G. F. WRIGHT STEEL & WIRE CO.**  
249 Stafford St. • Worcester, Mass.

# Bench-Field Tools . . .

## VACO COLOR-KEYED NUT DRIVERS

Color-keyed nut drivers, to expedite identification, have been introduced by Vaco Products Co., 317 E. Ontario St., Chicago 11, Ill.

Units feature different color shafts for different size sockets. Available in four shaft lengths: 1½" 3", 5½" and 8¼". Also available is a plastic stand-up kit, K-7, containing seven sizes of sockets from 3/16" through ½".

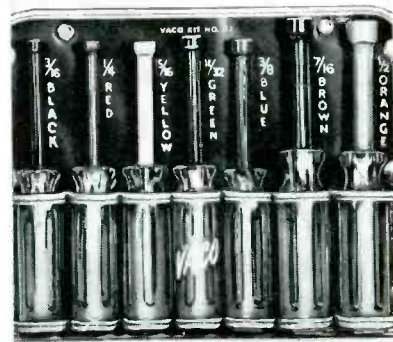

\* \* \*

## ELECTRONIC CHEMICAL TUNER-TONIC

A tuner cleaner, *Tuner-Tonic*, has been developed by Electronic Chemical Corp., 813 Communipaw Ave., Jersey City 4, N. J.

Product is said to clean, lubricate and restore tuners, including wafer-types. Cleaner, it is claimed, does not change or affect capacitance, inductance or resistance. Comes in aerosol containers.

\* \* \*

## LITTELFUSE LIMITED-CURRENT FUSES, HOLDERS

Limited-current fuses and holders, *LC* designed to eliminate over-fusing, have been announced by Littelfuse, Inc., 1865 Miner St., Des Plaines, Ill.

Fuses are manufactured in three different lengths with seven widths of bayonet-locking tabs on the fuse caps. Fuse post will accept only its own amperage range and type, regular or slo-blo. Holder snaps into chassis mounting hole and locks into place by means of a snap-in type lock washer.

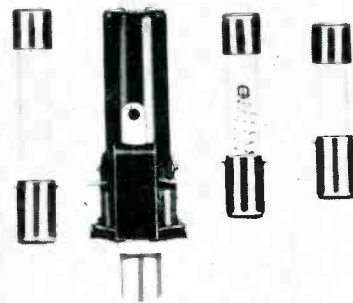

nothing...  
no, NOTHING!

No other product made will clean a control like

**Penetrex**



by the makers of GEMCO Re-Fractors



**Great Eastern M'fg Co.**  
B'klyn 12, N. Y.

**DON'T** Just say capacitors

Ask For Sprague By Catalog Number  
Know what you're getting . . . get exactly what you want. Don't be vague . . . insist on Sprague. Use complete radio-TV service catalog C-610. Write Sprague Products Company, 61 Marshall Street, North Adams, Massachusetts.

**SPRAGUE**

WORLD'S LARGEST CAPACITOR MANUFACTURER

## N. Y. TRADE SCHOOL OFFERS FREE SERVICING COURSES

The Queens Evening Trade School, 47th Ave., and 37th St., Long Island City 1, N. Y., has announced free courses in radio and TV servicing to be offered in the fall. Registration for all classes will be held at the school on Sept. 12th and 13th from 7 to 9 P.M.

## Audio Maintenance

(Continued from page 39)

to the record position and the set screw tightened. The switch spring must be reconnected.

Weak recording and playback or no sound at all can be caused by dirt on the surface of the head, a weak or dead head or tube and open *micro* and *radio-phono* input jacks. The head surface can be cleaned with a lint-free cloth which has been moistened with *petroleum solvent*. A weak or dead head should be replaced and head alignment procedures carefully followed. Weak or dead tubes should be replaced and the input jacks checked for continuity.

If the *erase* does not remove completely previous recordings, the trouble is in either a bad 6V6GT or a defective head. A 6V6GT may work effectively as a power amplifier, but not as an oscillator which is necessary for erasing.

## Service Engineering

(Continued from page 15)

lays or solenoids. A *vom* or a 20,000 ohms-per-volt meter is recommended for *dc* bias voltage measurements.

For effective control the flashlight must be in good working condition. A poor light, due to weak batteries or poor focus, caused by a defective bulb, will result in poor operation. Weak batteries should be replaced when necessary and a check made to see that the *light spot size* is small to insure a concentrated beam.

It is important to locate the TV receiver so that direct or diffused sunlight or light from lamps will not strike the photocells.

Accidental operation of the photocells can also occur by reflected light from a mirror, white garment or highly reflective object within the room. To eliminate or minimize this undesirable effect the location of the TV set within the room should be made carefully.

To localize trouble the *auto-manual* switch should be set to the *auto* position and the relays or solenoids actuated or pushed with an insulated screwdriver. If so doing results in proper control, the trouble is ahead of these circuits, such as defective tubes or photocells. However, if this mechanical movement has no effect on control operation, trouble is probably beyond that point, such as switch or motor trouble. All cable and plug connections should be checked.

Improper *ac* (on-off) or mute op-

*for happy satisfied customers*

**DON'T JUST MAKE A REPLACEMENT  
...MAKE AN IMPROVEMENT**

with a

# QUAM

*Adjust-a-Cone*<sup>®</sup>

## SPEAKER

Ask for **QUAM**  
the quality line,  
for all your  
speaker needs.

The performance of a set can be no better than the performance of its loudspeaker—and QUAM speakers will make any set sound better—because of their patented design, heavier magnetic structures, and because a QUAM replacement speaker is an exact replacement—designed to do a specific job.

That's why servicemen all over the country have named QUAM their preferred brand of replacement speaker, by a wide margin (Brand Name Surveys, April, 1954).

**FREE** The QUAM catalog listing over 100 exact replacement speakers.

**QUAM-NICHOLS COMPANY**  
222 East Marquette Road • Chicago 37, Illinois

eration can sometimes be caused by poor contact connection of the switches located in the control chassis. The contacts should be checked to see that they are *making* and *breaking* properly. Defective switches should be replaced, if necessary.

If the solenoid assemblies tend to *stick* mechanically, *lubriplate* should be applied to the solenoid plunger shafts where they enter the coil frames, ride on the switch brackets and pass through the eyelets in the switch pressure plate. A small amount of *lubriplate* should also be applied to the motor drive gears.

## Schematics In This Issue

	Page
Admiral 20 Colpitts Oscillator.....	11
CBS-Columbia 700 (Hartley) Oscillator....	11
Colpitts Oscillator.....	11
Du Mont RA 109/119 Inputuner Oscillator.....	11
Emerson 120174 Ultrahigh Oscillator.....	11
Metal-Clad Two-Section Resistive Circuitry.....	16
Metal-Clad Multisection Resistor Circuitry.....	16
Push-Pull Oscillator.....	11
RCA 630 Tuned-Plate Push-Pull Oscillator.....	11
RCA WO-88A 'Scope Vertical Amplifier for Wide Band Use.....	24
RCA WG-388-A 'Scope Vertical Amplifier.....	24
Series-Fed Hartley Oscillator.....	11
Series-String Filament Checker.....	32
Shunt-Fed Hartley Oscillator.....	11
Sylvania 620 600-Ma Constant-Current Circuit (Cover).....	18
Triax Speaker System.....	26
Ultraudion Oscillator.....	11
VTVM Circuitry.....	13
Zenith Flash-Matic Photocell Remote Control.....	15
Zenith Flash-Matic Thyatron and Motor Control Circuits.....	14

want **COLOR TV**  
**KNOW-HOW?**

get this new book

"Color Television  
for the  
Service Technician"

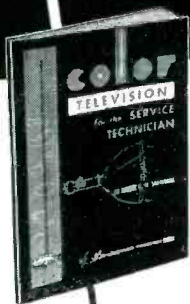

another  
great book  
by Albert C. W.  
Saunders

Here is Saunders at his best, employing his vast teaching experience to prepare the Service Technician for practical Color TV servicing. The entire subject is treated in easy-to-understand language, supported by a wealth of clear illustrations. Major emphasis is placed on Color Receiver installation and servicing. Here are the fact-packed chapters:

**CHAPT. 1. Colorimetry:** Discussion of color, hue, saturation, purity, brightness, color matching, color terminology.

**CHAPT. 2. Color TV:** Origin and content of the color signal; transmission; the color TV transmitter and camera; the luminance signal.

**CHAPT. 3. Color Carrier:** The chrominance signal, bandwidth, modulation, color sync signals; obtaining I and Q signals; transmission of luminance, chrominance and sync signals.

**CHAPT. 4. Color Signal Analysis:** The Color Signal; formation of Y, I and Q signals; scalar and vector quantities; doubly-balanced modulators.

**CHAPT. 5. Tricolor Picture Tube:** Types of color picture tubes; how they operate, construction and characteristics.

**CHAPT. 6. Color Receivers:** Descriptions of current color circuits; convergence adjustments and procedures; installation adjustments for specific models.

Prepare for Color TV with the help of this practical, valuable book. 116 pages. Fully illustrated. 8½ x 11".

ORDER SC-1  
Only \$2.50

ORDER  
TODAY!

**HOWARD W. SAMS & CO., INC.**

Order from your Parts Jobber today, or write to Howard W. Sams & Co., Inc., 2207 E. 46th St., Indianapolis 5, Ind.

My (check) (money order) for \$..... enclosed.  
Send ..... copy(ies) of "Color TV for the Service Technician" (SC-1, \$2.50).

Name.....

Address.....

City..... Zone..... State.....  
(outside U.S.A. priced slightly higher)

## Ser-Cuits

(Continued from page 18)

tube would be 650 ma; 25 ma above recommended operating current. This tube, when placed in a series-string circuit and fed 600 ma, would then have a voltage drop of about 5.8 volts. The obvious result is that the tube runs cold and performance suffers.

It is possible to get a reading on such tubes on conventional constant-voltage tube checkers, but the example cited would probably pass; in fact, it might even read higher than a tube with a normal heater resistance. Series-string tubes with voltage ratings of 2.35, 3.15, 4.2, 4.7, or 8.4 v, would fare even worse, since normal tube checkers do not carry such filament taps, and the next highest or lowest tap would be used giving rise to erroneous readings.

### Tube Checker Facilities

One accurate way to pick out such faults is to apply a constant current to the tube being tested and reject those which show abnormal readings. In one model tube checker\* such a constant-current source is provided; the feature serves to avoid the need for the addition of new voltages to the filament-selector switch.

A variable resistor is placed in series with the filament of the tube under test by means of a 600 ma A selector switch (2 in Fig. 1). The current flowing through this variable resistor and hence the tube, can be read by depressing a button marked 600 ma meter; 3 in illustration. This switch places the tube checker meter, 4, in such a position that it reads filament current instead of plate current. The switch is so arranged that it can be depressed to read filament current at any time, during any test without danger to tube or checker. The variable resistor is adjusted so that the meter pointer reads on the 600 ma set line. All other settings are the same as those used in the regular tube setup. A B position places an additional fixed resistor (5) in series with the 600 ma set control to provide for tubes with higher filament voltage ratings. The A and B notations appear under the A column of the roll chart, immediately following the filament-voltage selector switch position, such as 6.3 A.

The checker also embodies a composite transconductance and emission check, as well as the resistance short-checking principle. The latter feature makes it possible to detect leakage in critical tubes.

\*Sylvania 620.

## ATLAS Cobra-Jectors

- wide angle dispersion
- indestructible fiber-glass
- all-weather construction



CJ-30  
Net \$24.00

Weatherproof  
universal line  
transformer,  
\$5.10 Net.

CJ-14  
Net \$16.80



Designed for wide angle coverage, paging, high efficiency intercom, sensitive talk-back. Tops in articulation. Convenient omni-directional mounting bracket. In appearance, they're "beauts".

SPECIFICATIONS	CJ-30	CJ-14
Input pwr (cont.)	15 w	5 w
Input imp.	4 or 8 Ω	4, 8 or 45 Ω
Response (cps)	250-9,000	400-10,000
Dispersion	120° x 60°	120° x 60°
Bell Size	14" x 6"	9½" x 5½"
Over-all length	14"	8½"

Amazing "power packages"—use the Cobra-Jectors for the "tough" jobs.



WRITE FOR COMPLETE CATALOG  
**ATLAS SOUND CORP.**  
1442—39 St., Bklyn. 18, N. Y.  
In Canada:  
Atlas Radio Corp., Ltd., Toronto, Ont

### ON THE SALES FRONT

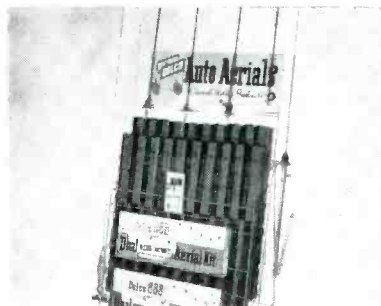

Delco auto antenna sales stand that holds approximately 30 antennas. Four new antennas, added to the Delco line and included in display, are universal top mount model for one-man installation on cowl or fender; windstream top mount type; model designed for side cowl mount for truck application or older replacement; and dual rear mount model for installation on rear fenders or deck.

(Below) Hugo Sundberg, vice prexy and general manager of Oxford Electric Corp., (right center) presenting first annual Oxford award for outstanding sales performance, for '54, to John Hill (left center) of J. T. Hill Sales Co., Los Angeles, during recent Oxford annual Sales meeting in Chicago. At left is Vic Wollang, Oxford distributor s-m; right, Dick Hill, Hill Sales.



## Resistor Replacements

(Continued from page 16)

into the tolerance range can be used. Wattages pose a lesser problem, as it is always possible to use a resistor of higher wattage. The only wattage limitation is the physical dimensions of the substitute unit.

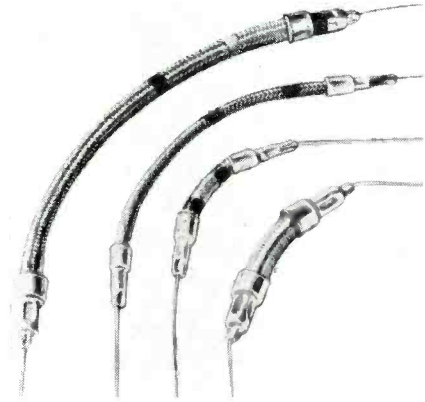

Above: Low-wattage flexible resistors commonly used for substitution of sections of metal-clad resistors. (Clarostat)

Below: Assortment of fixed and adjustable resistors that can be used as substitutes for metal-clad and cylindrical tapped-power types. (Clarostat Greenohms)

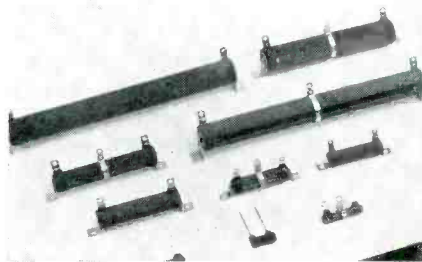

## B-W/Color-TV Oscillators

(Continued from page 10)

provide the proper cathode voltage;  $C_2$  is a *dc* blocking capacitor which prevents *dc* from being applied to the oscillator grid. The  $B+$  supply is *shunt-fed* to the oscillator plate; that is, it is connected from the tube plate to ground and *dc* does not flow through the tank circuit. In a *series-fed* Hartley, as shown in Fig. 2*b* (p. 11), the  $B+$  supply is connected to the  $L$  center-tap.

A Hartley oscillator circuit, employed in the CBS-Columbia 700-series, is shown in Fig. 3 (p. 11). Here, we find that the channel selector switch shunts out one or more of the series coils when it is turned. These coils, together with  $L_{403A}$  and  $L_{402}$  (coarse-frequency adjustments which are factory-set), correspond to coil  $L$  in Fig. 2*b* (p. 11).  $A$  in Fig. 3 (p. 11) represents the point where  $L$  is tapped in Fig. 2*b*.  $C_{419}$  is a

this TV serviceman uses

# STANCOR

## EXACT REPLACEMENT TRANSFORMERS

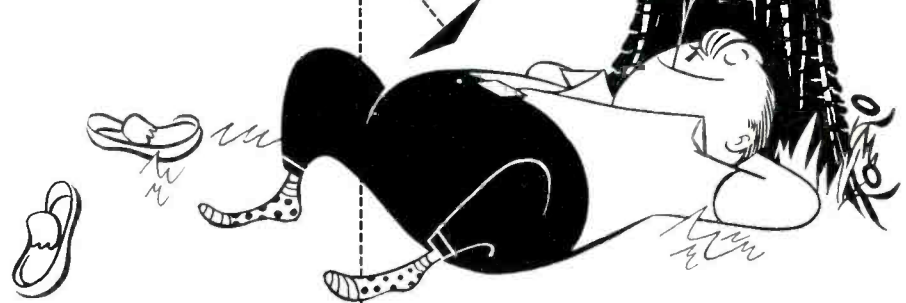

There are now 59 Stancor exact replacement flybacks covering all major TV set manufacturers and many private label brands. The latest units include 6 new Zenith replacements that give you

**71% ZENITH**  
EXACT REPLACEMENT  
FLYBACK COVERAGE

and 6 new General Electric replacements that give you

**79% G. E.**  
EXACT REPLACEMENT  
FLYBACK COVERAGE

You too can take life easy and have time to spare when you use Stancor exact replacements. No changing of circuits, no drilling of holes . . . you just take out the defective unit and replace it with a Stancor Transformer that exactly duplicates the original.

**FREE** The New Stancor TV Transformer Replacement Guide, listing accurate replacement data on almost 8500 TV models and chassis of 116 manufacturers. If you haven't received your copy see your Stancor distributor or write Chicago Standard Transformer Corporation.

## CHICAGO STANDARD TRANSFORMER CORPORATION

3588 ELSTON AVENUE  
CHICAGO 18, ILLINOIS

Export Sales:  
Roburn Agencies, Inc.  
431 Greenwich Street  
New York 13, N. Y.



fine tuning capacitor that is connected across only a portion of  $L_{103}$ ; it is a front-panel manual adjustment.  $C_{411}$ , a 3-mmfd capacitor, provides additional feedback from plate to grid of the 6J6 oscillator tube. A 10-mmfd capacitor and 22,000-ohm resistor,  $C_{410}$ - $R_{409}$ , provide the grid bias for the stage. This particular oscillator is series-fed, since the plate voltage is connected to point  $A$  through a 4700-ohm resistor,  $R_{406}$ . The oscillator output is fed to the mixer tube for injection through a 1.5-mmfd coupling capacitor,  $C_{314}$ .

The basic Colpitts oscillator circuit is shown in Fig. 4*a* (p. 11). The difference between this regenerative method

and the Hartley is that the former uses a split-capacitor arrangement, whereas the latter employs a tapped-coil. In the Colpitts  $L$ - $CA$ - $CB$  form the resonant circuit of the oscillator; either  $CA$  or  $CB$  may be made variable to change the oscillator frequency.  $R_1$  and  $C_1$  form the bias, and  $C_2$  is a *dc* blocking capacitor. Feedback results from plate to grid via the resonant tank circuit.

The Colpitts oscillator is used in the Admiral 20 series; this circuit is shown in *b* of Fig. 4. The tank consists of  $L_{102C}$ ,  $C_{100}$  (10 mfd),  $C_{110}$ , and  $C_{111}$ ; these

(Continued on page 44)

# SAVE WITH THE NEW



## ERIE DISC and GP CERAMICON *Kits*

### HERE'S WHAT YOU GET

- ① 100 High Stability ERIE Disc or Tubular Ceramicon
- ② 18 Popular Values
- ③ Handy, Convenient 18 Section Plastic Storage Case
- ④ Exceptional Value

### HERE'S WHAT YOU SAVE REGULAR PRICE

100 ERIE Disc or  
Tubular Ceramicons . . . \$15.00  
18 Section Plastic Case . . . 1.75  
**Total Value \$16.75**

**YOU PAY . . . . . \$10.65**  
**YOU SAVE . . . . . \$ 6.10**

**ORDER NOW  
From Your  
ERIE  
DISTRIBUTOR**

**ERIE**  
*electronics*

**ERIE ELECTRONICS DISTRIBUTOR DIVISION  
ERIE RESISTOR CORPORATION**  
Main Offices: ERIE, PA.  
Factories: ERIE, PA. • LONDON, ENGLAND • TRENTON, ONTARIO

for service and lab. work

## Heathkit PRINTED CIRCUIT OSCILLOSCOPE KIT FOR COLOR TV!

① Check the outstanding engineering design of this modern printed circuit Scope. Designed for color TV work, ideal for critical Laboratory applications. Frequency response essentially flat from 5 cycles to 5 Mc down only 1½ db at 3.58 Mc (TV color burst sync frequency). Down only 5 db at 5 Mc. New sweep generator 20-500,000 cycles, 5 times the range usually offered. Will sync wave form display up to 5 Mc and better. Printed circuit boards stabilize performance specifications and cut assembly time in half. Formerly available only in costly Lab type Scope. Features horizontal trace expansion for observation of pulse detail — retrace blanking amplifier — voltage regulated power supply — 3 step frequency compensated vertical input — low capacity nylon bushings on panel terminals — plus a host of other fine features. Combines peak performance and fine engineering features with low kit cost!

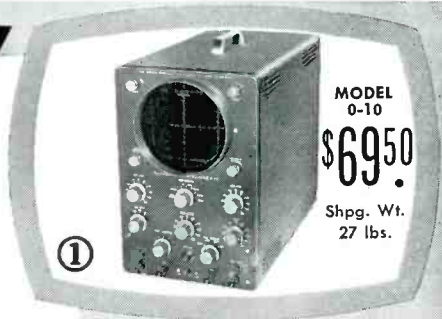

## Heathkit TV SWEEP GENERATOR KIT ELECTRONIC SWEEP SYSTEM

② A new Heathkit sweep generator covering all frequencies encountered in TV service work (color or monochrome). FM frequencies too! 4 Mc — 220 Mc on fundamentals, harmonics up to 880 Mc. Smoothly controllable all-electronic sweep system. Nothing mechanical to vibrate or wear out. Crystal controlled 4.5 Mc fixed marker and separate variable marker 19-60 Mc on fundamentals and 57-180 Mc on calibrated harmonics. Plug-in crystal included. Blanking and phasing controls — automatic constant amplitude output circuit — efficient attenuation — maximum RF output well over .1 volt — vastly improved linearity. Easily your best buy in sweep generators.

**Heath  
COMPANY**  
A SUBSIDIARY OF DAYSTROM, INC.  
**BENTON HARBOR 11, MICH.**

WRITE FOR FREE CATALOG  
...COMPLETE INFORMATION

(Continued from page 43)  
capacitors (in parallel) are equivalent to  $CA$  and  $CB$ , respectively, of Fig. 4a (p. 11).  $C_{110}$ , a .5 to 3-mmfd variable, is a coarse-frequency adjustment and is factory set;  $C_{111}$  is the fine tuning control. The bias circuit is formed by a 20-mmfd capacitor and 10,000-ohm resistor ( $C_{108}$  and  $R_{107}$ ), and  $R_{108}$ - $C_{114}$  (4700 ohms and .001 mfd) form a decoupling network for  $B+$ . Link coupling is provided for converter coil  $L_{102B}$  through  $L_{102C}$ . The channel selector switch inserts different coils in the circuit (for  $L_{102B}$  and  $L_{102C}$ ) for proper channel selection.

The basic ultraudion oscillator circuit is shown in Fig. 5a (p. 11). At a glance it would seem that it is simply a tuned-grid oscillator. However, if the interelectrode capacitances from grid-to-cathode ( $CA$ ) and plate-to-cathode ( $CB$ ) are considered as part of the circuit, then we find that the circuit becomes, in essence, a Colpitts oscillator. In this case,  $CA$  and  $CB$  become the split capacitors mentioned previously.  $L$  and  $C$  form the resonant circuit and  $C$  is used to vary the oscillator frequency.  $R_1$  and  $C_1$  form a bias network and  $C_2$  is a blocking capacitor.

The *Inputuner*, found in the Du-Mont RA-109/119 chassis employs an ultraudion oscillator; Fig. 5b. The tank circuit consists of  $L_{109}$ ,  $C_{118}$ ,  $L_{110}$ ,  $L_{102D}$ , and  $C_{8K}$ - $C_{PK}$  (interelectrode capacitances). Variable inductor  $L_{109}$  is the channel selector;  $L_{110}$  and  $L_{102D}$  are coarse-frequency adjustments, factory set, while  $C_{118}$  is a fine tuning control.

### Push-Pull Oscillators

The push-pull oscillator provides a larger power output than is possible with a single tube. Two tubes in push-pull, rather than in parallel, are used to avoid adding the interelectrode capacitances of the tube; minimizing the tendency of generating parasitics and extending maximum frequency at which the oscillator may be operated.

The basic circuit of a push-pull oscillator is shown in Fig. 6a (p. 11), where the plate circuit is tuned by  $C$ - $L$ , making it a tuned-plate push-pull oscillator. When the circuit is in oscillation, the energy existing in section  $A$  of coil  $L$  is equal and opposite to the energy in section  $B$ ; this makes  $V_1$  and  $V_2$  conduct alternately. Each tube, therefore, contributes energy to the tank circuit at the proper time, causing the voltage across it to double (neglecting circuit and tube losses) in amplitude.  $C$  is variable to alter the oscillator frequency;  $C_1$  and  $C_2$  are the feedback capacitors and also serve (together with  $R_1$  and  $R_2$ ) to produce bias voltage.

[To Be Continued]

a bear for punishment



**C-D does it again  
with its new Cub**

*Outperforms any other  
molded tubular*



- \* A better-looking tubular with
- \* A better humidity seal.

Get more for your money by insisting on C-D's new "CUB-KIT".

For your nearest C-D authorized jobber see the Yellow Pages of your Classified Phone Book. Write for Catalog to: Dept. S85, Cornell-Dubilier Electric Corporation, South Plainfield, New Jersey

CONSISTENTLY DEPENDABLE  
**CORNELL-DUBILIER**  
CAPACITORS



*There are more  
C-D capacitors in  
use today than any  
other make.*

PLANTS IN SO. PLAINFIELD, N. J.; NEW BEDFORD, WORCESTER AND CAMBRIDGE, MASS.; PROVIDENCE AND HOPE VALLEY, R. I.; INDIANAPOLIS, IND.; SANFORD AND FUGUAY SPRINGS, N. C. SUBSIDIARY: RADIART CORP., CLEVELAND, OHIO

## PERSONNEL



ALTON K. MARSTERS, formerly vice president and general manager of the packaging machinery division of Colt Manufacturing Co., has been named general sales manager of CBS-Hytron, Danvers, Mass.



A. K. Marsters



M. P. Fieldman

M. P. FIELDMAN, formerly general manager of Halldorsen, has been named a vice president of Perma-Power Co., 4727 N. Damen Ave., Chicago 25, Ill.

\* \* \*

VERNON A. DUPY has been promoted to director of procurement, scheduling and general merchandising of the United Motors Service Division of the General Motors Corp. . . . EDWARD L. LAPE has succeeded Dupy as general sales manager.

\* \* \*

JOHN BENTIA has been elected president and general manager of Alliance Manufacturing Co., Alliance, Ohio. . . . Other officers include ARIES VERNES, vice president; R. D. DETTMER, secretary; ROBERT DUNN, treasurer.

\* \* \*

LARRY H. KLINE has been appointed manager of commercial product sales for the electronics division of Thompson Products, Inc., 23555 Euclid Ave., Cleveland 17, Ohio.

## Catalogs and Bulletins

TUNG-SOL ELECTRIC, INC., 95 Eighth Ave., Newark 4, N. J., has released a 16-page cartoon booklet featuring a picture story of the aluminized picture tube; its theory and manufacture. Booklet also pays tribute to the Service Man, his skill and importance in the community, in a series of cartoon illustrations.

\* \* \*

RECOTON CORP., 52-35 Barnett Ave., Long Island City, N. Y., has published an 8-page replacement needle guide, cross-referenced with original manufacturers' cartridge and needle part numbers.

\* \* \*

GEE-LAR MANUFACTURING CO., 819 Elm St., Rockford, Ill., has issued illustrated 16-page catalog 57, listing TV, radio and instrument knobs, switches, plugs, jacks, sockets and accessories.

\* \* \*

UNITED SERVICE MOTORS, G.M. Building, Detroit 2, Mich., has published seven Delco distributor-dealer parts bulletins covering antennas, capacitors and resistors, vibrators, transformers, speakers, hardware, suppression components and auto radio controls.

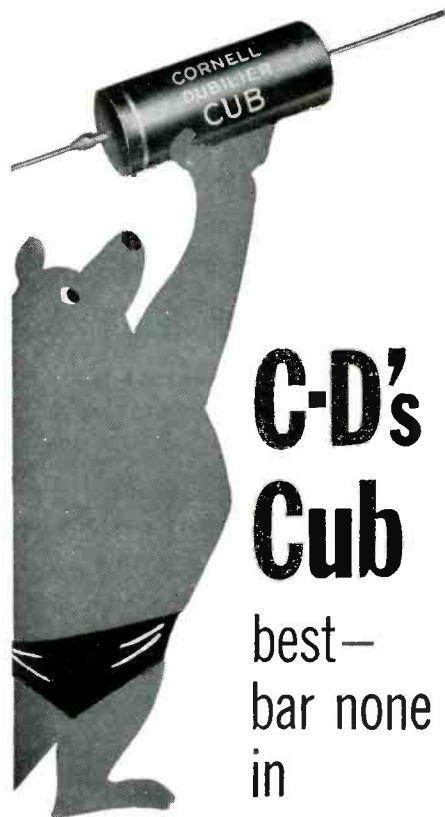

**C-D's  
Cub**

best—  
bar none  
in

**molded tubular  
capacitors**

The C-D "Cub" capacitor has proven itself the best on the market today—by out-lasting, out-performing, out-selling any other replacement capacitor for radio or TV. For consistent high quality—always rely on C-D, the only tubulars with the built-in extras required in servicing sets today. That's why distributors *who know*, carry the complete C-D line.

**Special! "Cub-Kit" with bonus plastic service dispenser. IT'S FREE!**

Ask your C-D Distributor. He's listed in your local Classified Telephone Directory.

CONSISTENTLY  
**CORNELL-DUBILIER**  
DEPENDABLE



THERE ARE MORE C-D  
CAPACITORS IN USE TODAY  
THAN ANY OTHER MAKE.

PLANTS IN SO. PLAINFIELD, N. J.; NEW BEDFORD, WORCESTER AND CAMBRIDGE, MASS.; PROVIDENCE AND HOPE VALLEY, R. I.; INDIANAPOLIS, IND.; SANFORD AND FUGUAY SPRINGS, N. C.; SUBSIDIARY, RADIART CORP., CLEVELAND, OHIO; VENICE, CALIFORNIA

# This is the 2-Set TV COUPLER

## Rated No. 1

• • • by a nationally known independent product quality rating group as the result of tests made on 10 leading two-set couplers for:

- IMPEDANCE MATCH
- SIGNAL TRANSFER
- TWO-SET ISOLATION

### MOSLEY 902



List Price \$3.95

Rated **FIRST** in overall quality for weak signal reception means; the MOSLEY 902 Dual Match 2-Set TV Coupler can be sold and installed in practically any TV area with full confidence that your customers will be completely satisfied!

Available at Radio and Television Parts Distributors — coast-to-coast.

**Mosley Electronics, Inc.**  
8622 ST. CHARLES ROCK ROAD  
ST. LOUIS 14, MISSOURI

**WHEN YOU CHANGE YOUR ADDRESS**

Be sure to notify the Subscription Department of SERVICE at 52 Vanderbilt Avenue, New York 17, N. Y., giving the old as well as the new address, and do this at least four weeks in advance. The Post Office Department does not forward magazines unless you pay additional postage, and we cannot duplicate copies mailed to the old address. We ask your cooperation.

# Transistor-Tube Developments

by A. M. KELWOOD

THE SUCCESSFUL application of transistors in the audio-amplifier section of portables has accelerated the development of a number of special transistor types for such circuitry.

One manufacturer<sup>1</sup> has designed a *p-n-p* type<sup>2</sup> for the class *B* push-pull power-output stages of battery-operated portable radio receivers and audio amplifiers operating at power levels of approximately 100 milliwatts. The transistor is hermetically sealed, utilizes an insulated metal envelope, and has a linotetrar 3-pin base. It is about  $\frac{1}{4}$ " in diameter and has a maximum seated length of  $\frac{1}{2}$ ".

In a common-emitter circuit, the device has a large-signal base-connection-to-collector *dc*-current-amplification ratio of 70. Two of these transistors in a class *B* push-pull audio circuit with common emitter are said to have a power gain of 30. The collector dissipation of this transistor, depending on circuit conditions, may be as high as 50 milliwatts.

Also available are a pair of *p-n-p* types<sup>1</sup> designed for low-power, audio-frequency amplifier service, such as in hearing-aid applications.

The body of one, 2N77, is approximately  $\frac{1}{4}$ " in diameter and  $\frac{3}{8}$ " in

length, whereas the body of the second type, 2N105, is approximately  $\frac{1}{8}$ " in diameter and  $\frac{1}{4}$ " in length.

The 2N77, in a common-emitter circuit, has a collector-to-base-connection current-amplification ratio of 55; a matched-impedance, low-frequency power gain of 44 db; a collector-to-emitter alpha frequency cutoff of 700 kc; and a low noise factor of 6.5 db average. The collector dissipation, depending on circuit conditions, can be as high as 35 milliwatts.

The 2N105, in a common-emitter circuit, has a collector-to-base-connection current-amplification ratio of 55; a matched-impedance, low-frequency power gain of 42 db; a collector-to-emitter alpha frequency cutoff of 750 kc. The collector dissipation, depending on circuit conditions, can be as high as 35 milliwatts.

Not only have transistors been employed in *af* amplifiers, but as *rf* amps and detectors, too. A recently-developed completely-transistorized unit,<sup>3</sup> a radio timepiece, fixed tuned to 121.95 kc, includes transistors in three *rf* stages, a beat-frequency oscillator, a detector and an audio amplifier stage. Two microvolts to the first *rf* stage, the designers say, will yield an audio output only 6 db below maximum. Power is provided by two penlight batteries connected in series to supply 3 volts. Total current drain is 3 milliamperes; thus, the unit can be operated

<sup>1</sup>RCA    <sup>2</sup>RCA 2N109    <sup>3</sup>Motorola

Fig. 1. Circuit of 121.95-kc fixed-tuned transistorized receiver developed by Motorola.

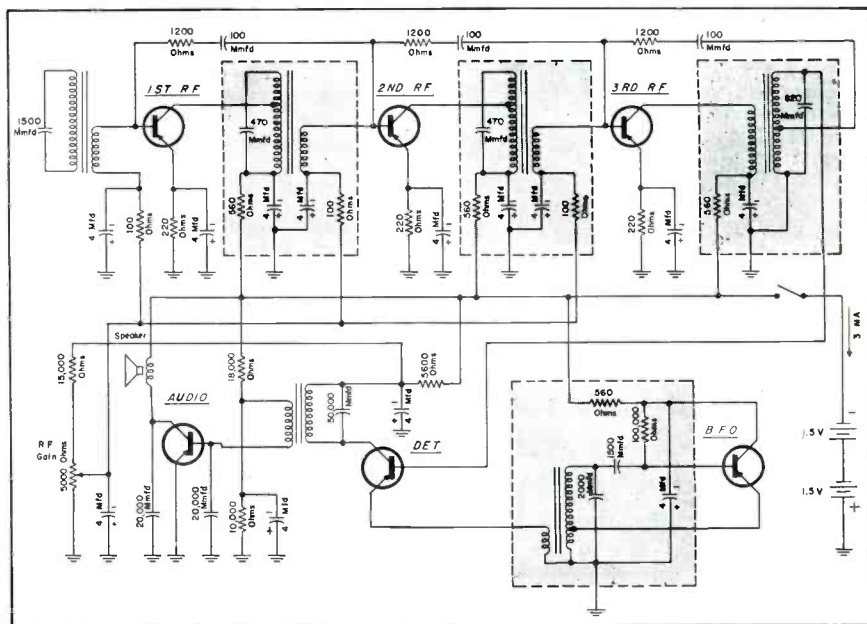



## ADVERTISERS IN SERVICE

AUGUST, 1955

	Page
Alprodc Co. ....	17
Argos Products Co. ....	2
Atlas Sound Corp. ....	42
Blonder-Tongue Labs, Inc. ....	3
Bussmann Mfg. Co. ....	19
CBS-Hytron (Div. Columbia Broadcast- ing System) ....	29
Channel Master Corp. ....	25
Chicago Standard Transformer Corp. ....	43
Cornell-Dubilier Electric Corp. Inside Front Cover, 45	
Allen B. DuMont Laboratories, Inc. ....	1
Electronic Chemical Corp. ....	38
Electronic Publishing Co., Inc. ....	47
Erie Resistor Corp. ....	44
General Cement Mfg. Co. ....	31
General Electric ....	37
Great Eastern Mfg. Co. ....	40
The Heath Co. ....	44
Hughes Research & Development Labs. ....	48
Jensen Industries, Inc. ....	36
Kester Solder Co. ....	38
P. R. Mallory & Co., Inc. Inside Back Cover	
Mosley Electronics, Inc. ....	46
Oxford Electric Corp. ....	39
Quam-Nichols Co. ....	41
The Radiart Corp. .... Inside Front Cover, 45	
Radio Corp. of America. .... Back Cover	
The Radion Corp. ....	36
Raytheon Mfg. Co. ....	8
Howard W. Sams & Co., Inc. ....	33, 42
Simpson Electric Co. ....	36
Snyder Mfg. Co. ....	34
South River Metal Products Co., Inc. ....	34
Sprague Products Co. ....	4, 5, 34, 40, 47
Sarkes Tarzian, Inc., Rectifier Div. ....	35
Ward Products Corp. ....	7
G. F. Wright Steel & Wire Co. ....	40

continuously six hours a day for about 25 days on one pair of batteries. The moral to this development, it was noted, is that we should not wait for the ultimate perfection of the transistor before we make use of it in logical and practical applications. In comparison to vacuum tube development, it was said, the transistor is at a stage comparable to the earlier models of vacuum tubes such as the old 201-A. But, it was emphasized, there are a large number of applications where the introduction of transistors will result in improved reliability with satisfactory performance.

All parts of this transistor set, except the batteries, speaker, rf gain control, on-off switch, a loopstick antenna and tuning capacitor, were mounted on a printed-circuit chassis.

Audio output has been measured as 3 milliwatts maximum to speaker.

Tube engineers also have been active in creating a family of new types for a variety of applications. Triode-pentode nine-pin controlled warm-up miniatures, the 5AT8 and 5X8, are now available; six-volt heater versions of these have also been designed, the 6AT8 and 6X8.<sup>4</sup>

These are four versions of the same tube; two with different heater current and two with different basing. These combination medium-mu triodes/sharp-cutoff pentodes were designed primarily for use in oscillator-mixer service in TV and FM receivers.

In all four tubes, the heater connections are made to the usual pins, 4 and 5.

<sup>4</sup>G.E.

### Ask For Sprague By Catalog Number

Know what you're getting . . .  
get exactly what you want.  
Don't be vague . . . insist on

**DON'T  
JUST SAY  
CAPACITORS**

Sprague. Use  
complete ra-  
dio-TV serv-  
ice catalog  
C-610. Write  
Sprague  
Products  
Company,  
61 Mar-  
shall Street,  
No. Adams,  
Mass.

**SPRAGUE**  
WORLD'S LARGEST CAPACITOR MANUFACTURER

## 1st with all prices

Dave Rice's Official Pricing Digest answers a need long-felt by Servicemen—List or resale prices for every replacement part or component at your fingertips.

*Over 300 pages; covers  
more than 60,000 items*

Compiled like a telephone book (1) Alphabetical by Manufacturer (2) Alphabetical by Product Category (3) Numerical by Part Number. Price and identify any replacement item in seconds—as easy as 1-2-3.

## 1st handy sized reference in the industry

9 3/4" long by 3 3/4" wide . . . convenient for counter, pocket, tool box or tube caddy.



## 1st completely revised four times each year

Publication dates are October, January, April and July. Prices will be current on each publication date.

## 1st in savings

Time and money savings—no wasted effort—no calls to your distributor to check prices. No undercharges—no overcharges when you price your tubes and parts from the Official Pricing Digest.

## 1st issue October, 1955

PRICE \$2.50 PER COPY—will pay for itself many times over by giving you CORRECT PRICES where and when you need them.

*available exclusively thru  
your parts distributor*

See him now and place your order for the first issue.

*Electronic Publishing Co., Inc.*  
180 North Wacker Drive  
Chicago 6, Illinois

# Apply Your Electronics Experience

ENGINEERS AND  
PHYSICISTS WITH  
ELECTRONICS TRAINING  
ARE NEEDED TO  
CONDUCT CLASSROOM  
AND LABORATORY  
PROGRAMS ON ADVANCED  
SYSTEMS WORK IN THE  
FIELDS OF RADAR FIRE  
CONTROL, ELECTRONIC  
COMPUTERS, GUIDED  
MISSILES.

*The proper functioning of the complex airborne radar and computer equipment produced by Hughes requires well-trained maintenance crews in the field.*

At Hughes Research and Development Laboratories in Southern California engineers assigned to this program are members of the Technical Staff. As training engineers they instruct in equipment maintenance and operation for both military personnel and field engineers.

*Prior to assignment, engineers participate in a technical training program to become familiar with latest Hughes equipment. After-hours graduate courses under Company sponsorship are available at nearby universities.*

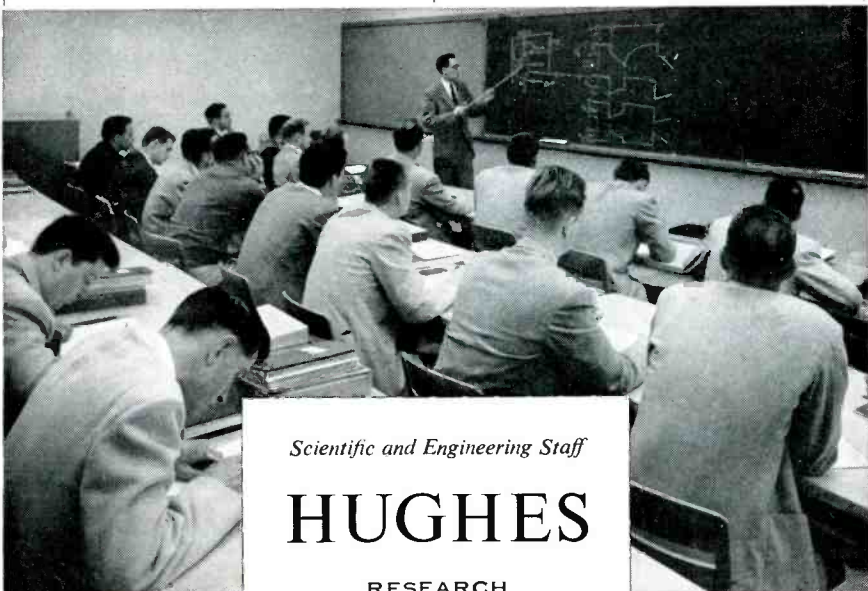

*Scientific and Engineering Staff*

## HUGHES

RESEARCH  
AND DEVELOPMENT  
LABORATORIES

*Culver City, Los Angeles County, California*

## JOTS AND FLASHES

CLOSED-CIRCUIT TV is rapidly becoming one of industry's liveliest members, involved in a growing chain of unusual installations. Recently a TV-eye system was installed by the drive-in branch of the Delaware County National Bank, Chester, Pa., for quick, remote confirmation of check signatures. The video tie, using RCA gear, links two drive-in teller booths with the central signature department in the main bank building, located across the street. Camera is installed in the signature room, and is connected by closed-circuit with a TV receiver in each of two drive-in booths. When withdrawal checks are presented, the teller, without leaving his booth, confirms the signature by requesting the records department, by intercom, to flash the appropriate signature card on his TV receiver. . . . A 50 per cent increase in sales has been reported by a supermarket in Mesa, Arizona, as the result of the installation of a store-wide music system. So successful is the present installation that the operators plan to double the present quantity of speakers in the near future to get even better musical coverage. At present, there are sixteen G.E. 12-inch dual coax speakers recessed in the ceiling of the store's grocery and meat departments. According to Automation Laboratories, Phoenix, who installed the system, it was possible to relieve the back wave of the ceiling-mounted speakers by cutting off the tops of each electrical (high-hat) enclosure. Thus, the entire hung-ceiling became an infinite baffle of highly dampened acoustical tile. . . . Northern California Audio Shows, Inc., who will hold their third annual audio show at the Sheraton-Palace Hotel, San Francisco, Cal., September 30, October 1 and 2, have announced that exhibitors will include hi-fi component manufacturers, factory reps, hi-fi distributors, hi-fi shops and record manufacturers. . . . C. A. Swanson has become general sales manager of Standard Coil Products Co. Inc., succeeding Louis Martin who has resigned. . . . A 226-page service manual on wave propagation and other aspects of vhf and microwave radio relay systems has been prepared by the government service department of the RCA Service Company, Inc., Camden, N. J. The book is available from RCA Service at \$2.00, postpaid. . . . Silicon power diodes, that it is said can convert 5 to 15 amperes of ac to dc at temperatures as high as 371° F, have been announced by Raytheon. In multidiode bridge and star configurations, the silicon diode rectifier units are being applied to dc motor supplies, battery chargers, magnetic amplifier servos, and a wide variety of low and medium voltage electronic B+ supplies. . . . The '55 Radio Fall meeting, sponsored by the engineering department of the Radio-Electronics-Television Manufacturers Association and the IRE professional groups committee, has been scheduled for Oct. 17, 18 and 19 at the Hotel Syracuse, Syracuse, N. Y. . . . Ampli-Vision a division of International Telemeter Corp., has appointed Graybar Electric Company, Inc., national distributor of its components used in community TV systems, master antenna systems, and closed-circuit TV systems. . . . Plans for expanding G.E. receiving tube facilities, by construction of a new building at Owensboro, Ky., were announced recently. New building will be on a 90-acre site.

P. R. MALLORY & CO. INC.  
**MALLORY**  
APPROVED PRECISION PRODUCTS

P. R. MALLORY & CO. INC.  
**MALLORY**  
APPROVED PRECISION PRODUCTS

P. R. MALLORY & CO. INC.  
**MALLORY**  
APPROVED PRECISION PRODUCTS

# Extra Vibrator Performance... without Extra Cost

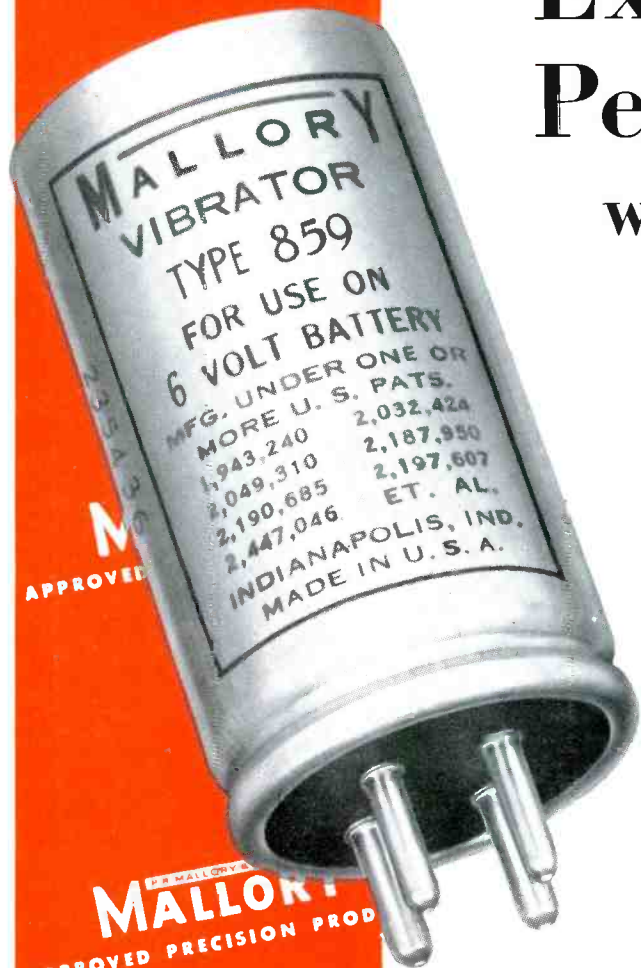

**IN THE MALLORY 25th ANNIVERSARY VIBRATOR,\*** mechanical hum has been squelched right at its source. In any mounting position . . . prongs up, side-wise, or prongs down . . . this is the quietest vibrator ever. And it costs no more than the previous Mallory vibrators which it replaces!

**TOP ELECTRICAL PERFORMANCE**—for hundreds of hours. These test oscillograms show how Mallory vibrators are adjusted to excellent wave form, and continue to produce this performance for hundreds of hours. Note that even after long service, the 'scope shows complete freedom from hash, off-frequencies or variations in amplitude . . . no evidence of contact chatter or bounce.

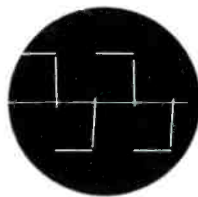

Ideal vibrator wave form

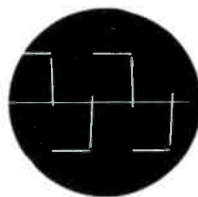

New Mallory vibrator

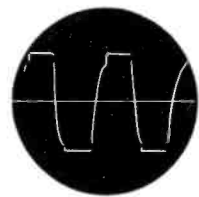

Mallory vibrator after hundreds of hours of service

In every respect, the new Mallory vibrators live up to the reputation for long, dependable service which has made Mallory vibrators the leading choice of servicemen and manufacturers.

Your Mallory distributor carries the new models, with part numbers identical with those you've been using. Call him soon . . . and order your supply of the quietest vibrators you've ever used.

\*Patent Applied For

P. R. MALLORY & CO. INC.  
**MALLORY**  
APPROVED PRECISION PRODUCTS

P. R. MALLORY & CO. INC.  
**MALLORY**  
APPROVED PRECISION PRODUCTS

APPROVED PRECISION PRODUCTS

APPROVED PRECISION PRODUCTS

P. R. MALLORY & CO. INC.  
**MALLORY**

CAPACITORS • CONTROLS • VIBRATORS & SWITCHES • RESISTORS  
RECTIFIERS & POWER SUPPLIES • FILTERS & MERCURY BATTERIES

APPROVED PRECISION PRODUCTS

P. R. MALLORY & CO. Inc., INDIANAPOLIS 6, INDIANA



**BY POPULAR DEMAND!**  
**... the new**  
**... the improved**

# **RCA "TREASURE CHEST"**



**LARGER—**  
 holds more tubes!

**STRONGER—**  
 built to last longer!

**MORE PROFESSIONAL LOOKING—**  
 helps build your prestige!

Here it is—the *new, improved* RCA "Treasure Chest"! Use it to carry a full selection of receiving tubes with you on your service calls. Use it to carry small tools. Use it to display the world-famous brand name—RCA—and let it work for you to build your business by instilling customer confidence.

**STARTING NOW . . .** For each RCA Picture Tube, or every 25 RCA Receiving Tubes you purchase, your RCA Tube Distributor will give you one RCA "Treasure Note." Save 20 "Treasure Notes" and your RCA Tube Distributor will trade them for the *NEW* RCA "TREASURE CHEST." This rugged, custom-built tube-carrying case is *not for sale* anywhere, at any price!

*Here's more treasure . . .*  
 the RCA  
**"MULTICORD"!**



It's an all-in-one power cord with two popular types of "cheater" receptacles; a hard-rubber, 3-way power outlet for test equipment, soldering gun, etc.; and a clamp-on work light. A real time-saver for busy service technicians! It's yours FREE of extra cost for only 5 RCA "Treasure Notes."

These offers expire at midnight, August 31, 1955 so act promptly. Don't miss out . . . Order your RCA Picture Tubes and RCA Receiving Tubes and start collecting valuable "Treasure Notes" now!



**RADIO CORPORATION OF AMERICA**  
 TUBE DIVISION  
 HARRISON, N. J.