

# SERVICE

**VOL. 23**

THE TECHNICAL JOURNAL OF THE TELEVISION-RADIO TRADE

**MARCH  
1954**

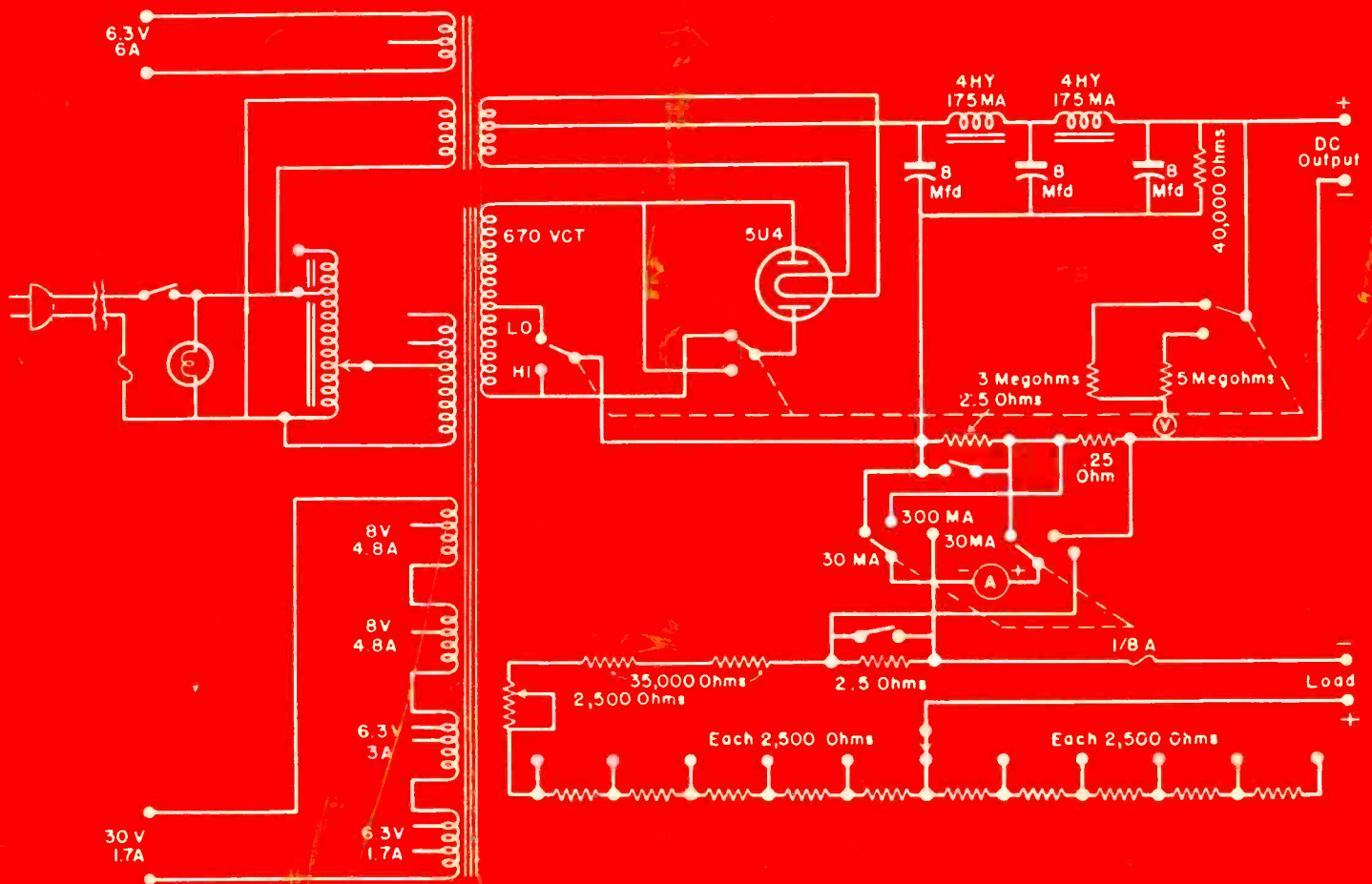

Boosted B-supply test unit with source of variable power; up to 400 v at 175 ma or 750 v at about 100 ma.

[See circuit analysis in this issue]

PEARSON/RADIOATV 2-59  
3062 E 65 ST  
CLEVELAND 27, OHIO  
SU S 3-5-54 GR

it's new  
it's new  
it's new  
it's new  
it's new

**It's What You've Been Asking For!**

**it's new**

it's new  
it's new  
it's new  
it's new  
it's new

# the TR-4 C★D★R Rotor

still the most powerful TV rotor, enough power to turn any array.

**NOW...With Meter Cabinet Using 4-Wire Cable**

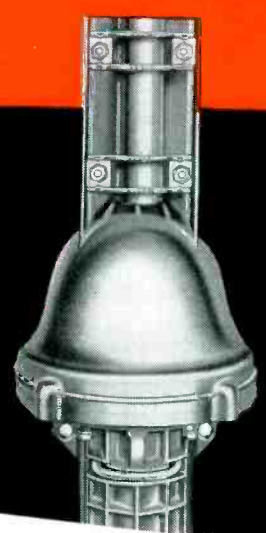

### Model TR-4

the de-luxe HEAVY DUTY ROTOR complete with modern design meter control dial cabinet, using 4 wire cable.

**\$53.95**

also these models **TR-2 • TR-11 • TR-12**

**CORNELL-DUBILIER**  
SOUTH PLAINFIELD, N. J.



**THE RADIART CORP.**  
CLEVELAND 33, OHIO



# NEW



**TIGHTEST SEAL**  
LOCKS IN PERFORMANCE

**TOUGHEST SHELL**  
LOCKS OUT TROUBLE

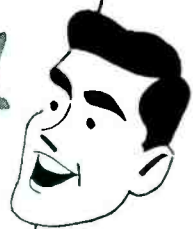

**ATTRACTIVE YELLOW MOLDED PLASTIC SHELL**  
Non-inflammable. Will not burn or melt under soldering iron or flame.

**BONDED SEAL**  
Positive, heat resistant, non-inflammable bond seals leads and shell, locks out humidity.

**FIRMLY SECURED LEAD**  
Can't be pulled out, even under soldering iron heat.

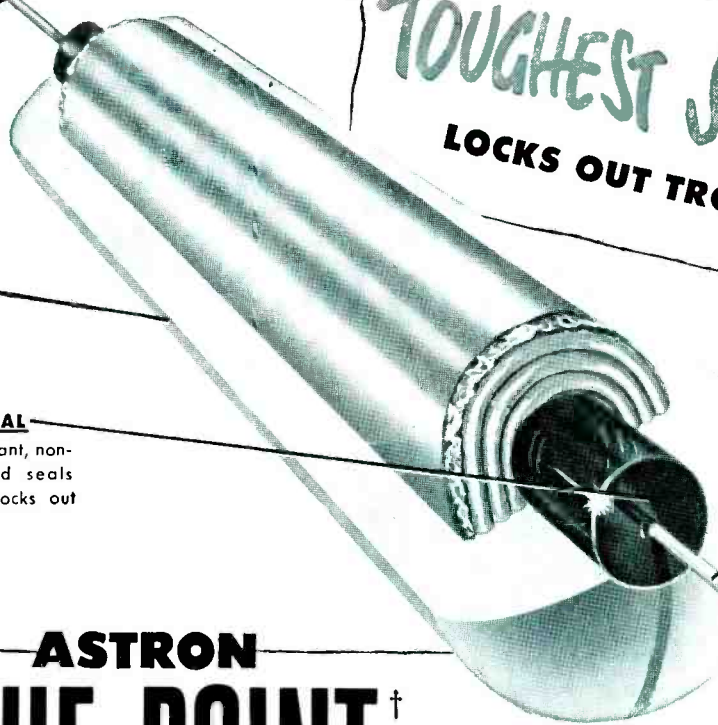

PATENT PENDING

## ASTRON BLUE-POINT<sup>†</sup> MOLDED PLASTIC PAPER Capacitors

THE NEWEST ADDITION  
TO THE **SM**<sup>†</sup> LINE

Yes, the ASTRON BLUE-POINT's *tighter seal* and *tougher shell* give you heat and moisture protection to a degree never before possible—providing a longer life and greater dependability than has ever been achieved in a molded plastic capacitor! BLUE-POINT is a capacitor you can rely on *completely*, under every condition.

BLUE-POINT is suitable for continuous operation at 85°C. The bonded seal uses a special thermo-setting, heat-resistant, non-inflammable bonding agent—*positive* protection

against moisture. Solder leads as close to the capacitor as you like—they *won't* pull out! Every BLUE-POINT is clearly marked with voltage and capacitance, bears outside foil identification. Every BLUE-POINT is *tested* and *guaranteed*. Look for the ASTRON BLUE-POINT when you buy capacitors from your jobber, or if he doesn't carry it, send us his name. Insist on ASTRON BLUE-POINT, the capacitor you *know* you can depend on. Order a supply today.

For complete performance characteristics, specifications and listings, write to Department S for Bulletin AB-20A.  
DEPEND ON—INSIST ON

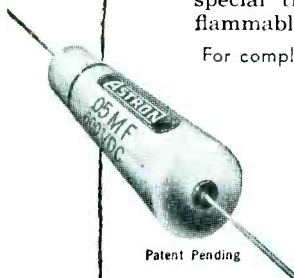

Patent Pending

<sup>†</sup>Trade Mark  
\* Safety Margin



**ASTRON CORPORATION**  
255 Grant Avenue, East Newark, New Jersey

In Canada: Charles W. Pointon, 6 Alcina Avenue, Toronto 10 Ont.

*Visit*

**THE ASTRON EXHIBIT**  
Booth 368  
I.R.E. Radio Engineering Show  
March 22-25

8 vertical outputs  
 3 deflection yoke  
 1 filter choke  
 5 width and linearity controls  
 17 exact replacement flybacks  
 23 TV power transformers

**55 NEW TV REPLACEMENT COMPONENTS HAVE BEEN ADDED TO THE STANCOR LINE**

28 flybacks (27 exact duplicates)  
 55 TV power transformers  
 8 deflection yokes  
 9 width and linearity controls  
 15 vertical outputs  
 8 blocking-oscillators  
 3 focus coils  
 5 filament transformers  
 22 filter chokes  
 19 audio outputs

**STANCOR**

**YOUR MOST COMPLETE SOURCE OF TV REPLACEMENT TRANSFORMERS**

**NOW 172 TV REPLACEMENT COMPONENTS ARE IN THE STANCOR LINE**

Ask for Stancor's new TV Replacement Guide listing replacement applications for these transformers in 6800 TV models and chassis. FREE from your local Stancor distributor, or from Chicago Standard Transformer Corporation.

Stancor transformers are listed in Sams Photofact Folders and in Counterfacts.



**CHICAGO STANDARD TRANSFORMER CORPORATION**

**3588 ELSTON AVE. • CHICAGO 18, ILL.**

EXPORT SALES: Roburn Agencies, Inc., 39 Warren Street, New York 7, N.Y.



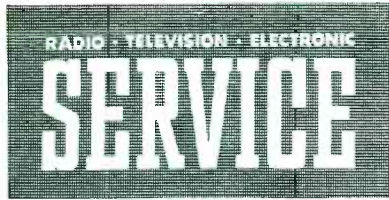

**LEWIS WINNER**  
Editor

**B. BLOCK**  
**F. WALEN**  
Assistant Editors

Including SERVICE—A Monthly Digest of Radio and Allied Maintenance: RADIO MERCHANDISING and TELEVISION MERCHANDISING. Registered U. S. Patent Office.

Association News	73
Audio Installation and Service (Feedback Problems and Solutions). By Kenneth Stewart and Paul Edwards	50
Color/B-W TV, Hi-Fi and Transistor Sessions at '54 IRE Convention. By Wyn Martin	44
Color Television (Hue and Saturation Chart). By Andrew J. Elwood	70
Color TV Developments (Progress Report on Components and Tubes Designed for Color TV). By Douglas J. Marisen	36
Color TV Receiver Circuitry (Survey of Special Circuits Used in Color Chassis). By W. L. Roberts	66
Phase Splitters for Hi-Fi Audio. By Mark Vino	40
Safety With Selenium Rectifiers. By Ronald L. Ives	32
Ser-Cuits (Analysis of TV Chassis Designed To Eliminate Pix-Sound Drift). By M. W. Percy	42
Service Engineering (2-Way Emergency Power Supplies). By Thomas K. Beamer	58
Service . . . The National Scene	29
Servicing Boosted-B Voltage Circuits in TV Receivers (Cover). By J. C. Geist	34
Servicing Helps (For TVI . . . UHF Snow . . . Auto Radios). By T. L. Gilford	54
60-Cycle Buzz Troubleshooting (Localizing and Curing Troubles). By Clark R. Alisen	38
Ten Years Ago	73
Tube News (Closed Circuit ITV Camera Tubes). By E. A. Teverson	48
TV Antenna Digest (Mechanical Factors Involved in Design and Construction). By Ralph G. Peters	46
Views and News. By Lewis Winner	27
VTVM Performance Characteristics (Report on Designs and Applications). By Donald Phillips	56

**CIRCUITS**

Audio Amplifier Modified to Eliminate Rectification Signals	54
Boosted-B Power-Supply Test Unit (Cover)	35
Boosted-B Test Points in Horizontal-Deflection Circuit	35
Color-TV Dynamic-Convergence/Focus Circuit	36
Color-TV Selenium-Cell Power Supply	32
Color-TV Subcarrier Oscillator	68
Cross-Coupled Self-Balancing Phase Splitter	41
Emergency Power-Supply for 2-Way Remote Console	58
Feedback Networks with Capacitor Nets	50
Floating Paraphase Phase Splitter	41
Horizontal-Deflection Circuitry	34
Hum-Reduction Circuitry	52
Linear Taper in Floating-Paraphase Circuit	41
Mattison Silver-Rocket High-Low Sync Clipper Circuit	42
Mattison Tunable Built-In VHF Booster	43
Powerline Filter to Kill TVI	54
Pulse-Tripler 30-KV Supply	38
Selenium-Rectifier Circuit With Limiting Resistor	33
Selenium-Rectifier Supply With Filament Transformer	32
60-Cycle Buzz-Problem Areas	39
Speaker-Headset Audio System for Aircraft	59
Symmetrical Voltage-Doubler Selenium Supply for Large Screen TV	32
Tapped-Voltage Phase Splitter	41
Vidicon 8-MC Cascode Preamp	48
VTVM Circuit Arrangements	56
Westinghouse V-2282-1 Color Chassis Filament Lineup	66
Westinghouse V-2282-1 Color TV Schematic	67

**COVER**

Boosted-B Power-Supply Tester (Geist)	35
---------------------------------------	----

**Index to Advertisers**

Index to Advertisers	103
----------------------	-----

**Manufacturers**

Catalogs and Bulletins	84
Jots and Flashes	103
News	64
New Parts . . . Tools . . . Instruments	76
On Book Row	85
Personnel	62
Rep Talk	60
TV Parts . . . Antennas . . . Accessories	74



Entire Contents Copyright 1954, Bryan Davis Publishing Co., Inc.  5  
Published monthly by Bryan Davis Publishing Co., Inc.

52 Vanderbilt Avenue, New York 17, N. Y. Telephone Murray Hill 4-0170

Bryan S. Davis, Pres. F. Walen, Sec. John Iraci, Adv. Mgr. A. Goebel, Cir. Mgr.  
Mid-West Rep.: Stuart J. Osten, 333 N. Michigan Ave., Chicago 1, Ill. Tel.: DEarborn 2-3597  
East-Central Rep.: James C. Munn, 2253 Delaware Dr., Cleveland 6, O. Tel.: ERiewick 1-1726  
Pacific Coast Rep.: Brand & Brand, 1052 W. 6th St., Los Angeles 17, Cal. Tel. MADison 6-1371

Entered as second-class matter June 14, 1932, at the Post Office at New York, N. Y., under the Act of March 3, 1879. Subscription price: \$2.00 per year in the U. S. A. and Canada; 25 cents per copy. \$3.00 per year in foreign countries; 35 cents per copy.

**NEW**



completely assembled

**6 and 12 Volt**

**DC POWER SUPPLY**

**At a comparable KIT PRICE**

**Only \$39<sup>95</sup> net**

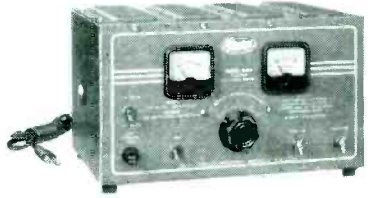

MODEL D-612

**UNMATCHED . . .**

**FOR TESTING AND SERVICING**

0 to 8, 0 to 16v. completely variable  
0 to 10 amps. at 12 v. continuous

This unbeatable combination of performance and dependability makes the D-612 an invaluable aid to you for testing and service work. AND . . . it's backed by Electro's recognized reputation of high quality products.

**CHECK!**

**COMPARE THESE FEATURES**

- Operates all auto radios. For relays, phone circuits, low voltage devices, electroplating and battery charging.
- Less than 5% ripple over rated ranges.
- Patented EPL conduction cooling.
- Withstands high overloads.
- Same top quality as other EPL models.

**Write for details or see your nearest parts jobber!**



**ELECTRO PRODUCTS LABORATORIES**  
4501-Sa N. Ravenswood Ave., Chicago 40, Ill.  
RUSH FREE BULLETIN DC-123

Name \_\_\_\_\_

Street \_\_\_\_\_

City \_\_\_\_\_ Zone \_\_\_\_\_ State \_\_\_\_\_

Canada: Atlas Radio Corp., Ltd., Toronto

# Now... SOLDERING MADE TWICE AS EASY!

**FIRST, the Soldering Aid.**  
Now, the **NEW CBS-HYTRON  
SOLDER DISPENSER**  
makes soldering *twice as easy.*

No more tangling with haywire coils of solder. Your thumb on knurled control wheel of unique Solder Dispenser feeds solder . . . retracts it neatly when job is done . . . without waste. A one-hand tool, Dispenser eliminates time out to unroll and straighten solder. Holds 72 inches of solder . . . a month's supply. It's compact . . . light . . . convenient . . . pencil-like . . . with handy pocket clip. Soldering becomes a pleasure with this time-and-money saver. Servicemen say, "Wouldn't be without it."



**FREE** . . . **APRIL 15  
THROUGH MAY 31**

You can get this complete package free from April 15 through May 31. Your CBS-Hytron distributor will give you a free Solder Dispenser (loaded with 20 Refills) . . . and a plastic tube of 80 additional Refills. Enough to last 5 months.



**HOW TO USE.** Your CBS-Hytron Solder Dispenser comes ready to use . . . with 20 lengths of 0.050-inch, 40/60 activated rosin core solder.

**To start:** Point Dispenser vertically downward. Shake a length of solder into position . . . at the same time rotating the knurled wheel toward you to begin the feed. Roll out an inch of solder and go ahead with the job. Need more solder? Just rotate the wheel with your thumb. When through, turn wheel away from you to draw unused solder back into Dispenser.

Knurled cap of Dispenser unscrews for refilling. Your package of 80 specially cut and sealed Refills gives you four months' supply. Plus the month's supply already loaded in the Dispenser.

Your new Solder Dispenser is fun to use . . . a natural companion to your Soldering Aid. And your Dispenser saves you time and money, too. Get yours today!

**WITH YOUR ORDER FOR CBS-HYTRON TUBES . . . ONLY 75 RECEIVING OR 3 PICTURE TUBES** . . . just order 75 CBS-Hytron receiving tubes . . . or 3 CBS-Hytron picture tubes. Your CBS-Hytron distributor will give you this valuable, time-and-money saver . . . *free*. Remember, offer is limited to April 15 through May 31. And the unique Solder Dispenser and Refills are available *only* on this special offer.

**ACT NOW!**

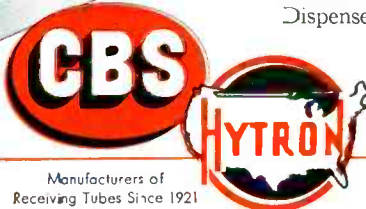

Manufacturers of  
Receiving Tubes Since 1921

**CBS-HYTRON** Main Office: Danvers, Mass.

A Division of Columbia Broadcasting System, Inc.

A member of the CBS family: CBS Radio • CBS Television  
Columbia Records, Inc. • CBS Laboratories • CBS-Columbia • and CBS-Hytron

RECEIVING • TRANSMITTING • SPECIAL-PURPOSE • TV PICTURE TUBES • CRYSTAL DIODES AND TRANSISTORS  
4 • SERVICE, MARCH, 1954



# Your Own Portable "TV Station" For Receiver Adjustment

**NEW!**

# PHILCO

## TELEVISION PATTERN GENERATOR

**DEVELOPS BOTH RF  
AND VIDEO OUTPUT**



### A Must for Areas Where Continuous Station Broadcasts are Not Available

Now use the dot and line patterns from the new PHILCO Model G-8005 to check linearity, focus, astigmatism, blooming and high voltage regulation. Trouble shoot receivers on any channel, 2 through 6, or with video output. The PHILCO G-8005 Television Pattern Generator is an instrument especially adapted for service work . . . designed to save you time.

### PHILCO MODEL S-8200 3" OSCILLOSCOPE

A sensitive, portable unit adaptable to either bench or field service. **VERTICAL AMPLIFIER:** DC coupled, Sensitivity—0.05V rms/inch. Frequency Response—0.1 mc/s within 6DB. DC coupled Vert. Amplifier circuits and low capacity probes facilitate video circuit trouble shooting. Built-in voltage calibrator permits use as high sensitivity vacuum tube voltmeter. **HORIZONTAL AMPLIFIER:** Sensitivity—0.5V rms/inch. Frequency Response—10 cps to 125 KC/s within 6DB. Sweep Circuit Frequency—Variable 15 to 30,000 cps . . . preset frequencies at vertical and horizontal sweep rates.



### Look at These Philco Features . . .

1. Provides new white dot pattern and either white or black vertical lines for *all* cathode ray tube circuits.
2. Easy to operate: connect Pattern Generator output to TV set. Select proper test pattern. Accurately check both the vertical and horizontal sweep circuit performance.
3. External Sync. Jack improves stabilization in many special cases. Provides wide range operation.
4. A custom type instrument with new and novel circuits designed to reduce service time in both laboratories and service shops.

**AVAILABLE THROUGH YOUR PHILCO DISTRIBUTOR  
ON A NEW SPECIAL PAYMENT PLAN**



Take advantage of the great  
**SHARE and PROFIT Program**  
on Philco Receiving Tubes  
Parts and Accessories  
**NOW AT YOUR PHILCO DISTRIBUTOR**



See PHILCO Exhibit at I.R.E. Show, March 22 - 25, Kingsbridge Armory, New York City.



*For auto radio repairs  
that are right the first time...*

*...use Mallory Precision Parts*

You need have no worries about customer call-backs . . . if you use Mallory components in your repair work. Mallory vibrators, capacitors and controls are precision-designed . . . precision-built . . . to give you and your customers precision performance.

That's why it is to your advantage to depend on Mallory components for all your service jobs—automobile radios . . . TV sets . . . home radios.

*For UHF television conversions, Mallory converters lead the field.*



All these Mallory components are designed for high temperatures . . . an essential for auto radio service

### *Mallory Vibrators*

were the first vibrators on the market and Mallory produces more for set manufacturers than all other makes combined. The Mallory Vibrator's patented, tuned mechanism assures long, dependable performance. Use them always . . . and be sure you have a copy of the latest MALLORY VIBRATOR GUIDE. It's a complete cross reference listing and service guide.

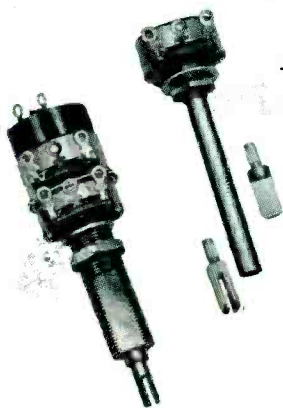

### *Mallory Midgetrols®*

will meet all your control needs in both single and dual types. They are easy to install because of simplified design and construction. Accurate resistance values and extremely smooth taper curves mean long, trouble-free performance. Ask your Mallory Distributor for a copy of the MALLORY AUTO RADIO CONTROL GUIDE.

### *Mallory Capacitors*

are widely used and preferred as original equipment by radio and TV set manufacturers. *The design and precision construction of Mallory Capacitors assure longer life up to 85°C—in all standard ratings.* Mallory FPs are the only fabricated plate capacitors for the replacement market. Mallory Plascaps® with superior moisture-proofing and permanently secured leads are right for your plastic tubular capacitor needs.

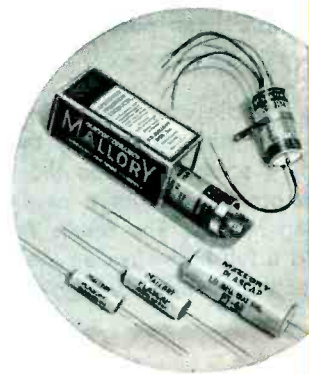

P. R. MALLORY & CO. Inc.  
**MALLORY**

CAPACITORS • CONTROLS • VIBRATORS • SWITCHES • RESISTORS  
RECTIFIERS • POWER SUPPLIES • CONVERTERS • MERCURY BATTERIES

**APPROVED PRECISION PRODUCTS**

**P. R. MALLORY & CO. Inc., INDIANAPOLIS 6, INDIANA**

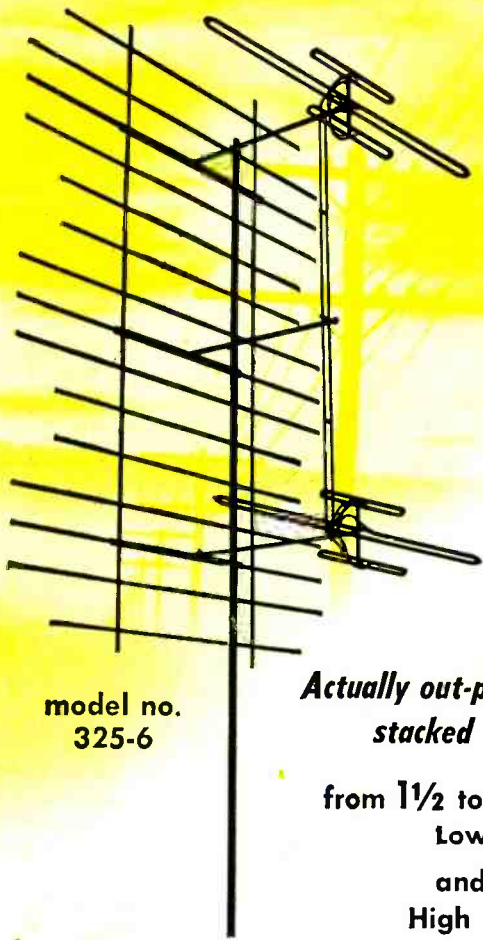

model no.  
325-6

**Actually out-performs the  
stacked CHAMPION**

**from 1½ to 3 DB more  
Low Band gain  
and 1 DB more  
High Band gain!**

Channel Master proudly introduces the SUPER CHAMP — the newest addition to the Champion antenna family. The Super Champ is a super-powerful antenna that provides extraordinary VHF-UHF reception at greater distances than has ever before been possible.

**How it Works:**

The Tri-Pole assemblies of the stacked Champion have been wider-spaced by the addition of a third reflecting screen between the antennas. These antennas are joined with a newly-designed half-wave stacking harness. The result: Tri-Pole assemblies are spaced a full half-wave on the Low Band, increasing both Low and High Band gain.

**Champion Performance on UHF**

In addition to its sensational VHF performance, Channel Master's entire Champion series — including the Super Champ — has been carefully designed to provide excellent reception on the UHF band. Write for complete technical details.

**AVAILABLE TWO WAYS:**

**1. As a complete antenna, model no. 325-6**

Consists of two Tri-Pole assemblies, three reflecting screen assemblies and a special stacking harness for wide-spaced Tri-Pole. **\$54.17**  
list

**2. As a Conversion Kit, model no. 325-7**

For converting standard 2-bay Champions into Super Champs. Consists of reflecting screen and specially-designed stacking harness. **\$14.58**  
list

**CHANNEL MASTER'S** *new*  
**SUPER CHAMP**

featuring wide-spaced stacking of Tri-Pole assemblies

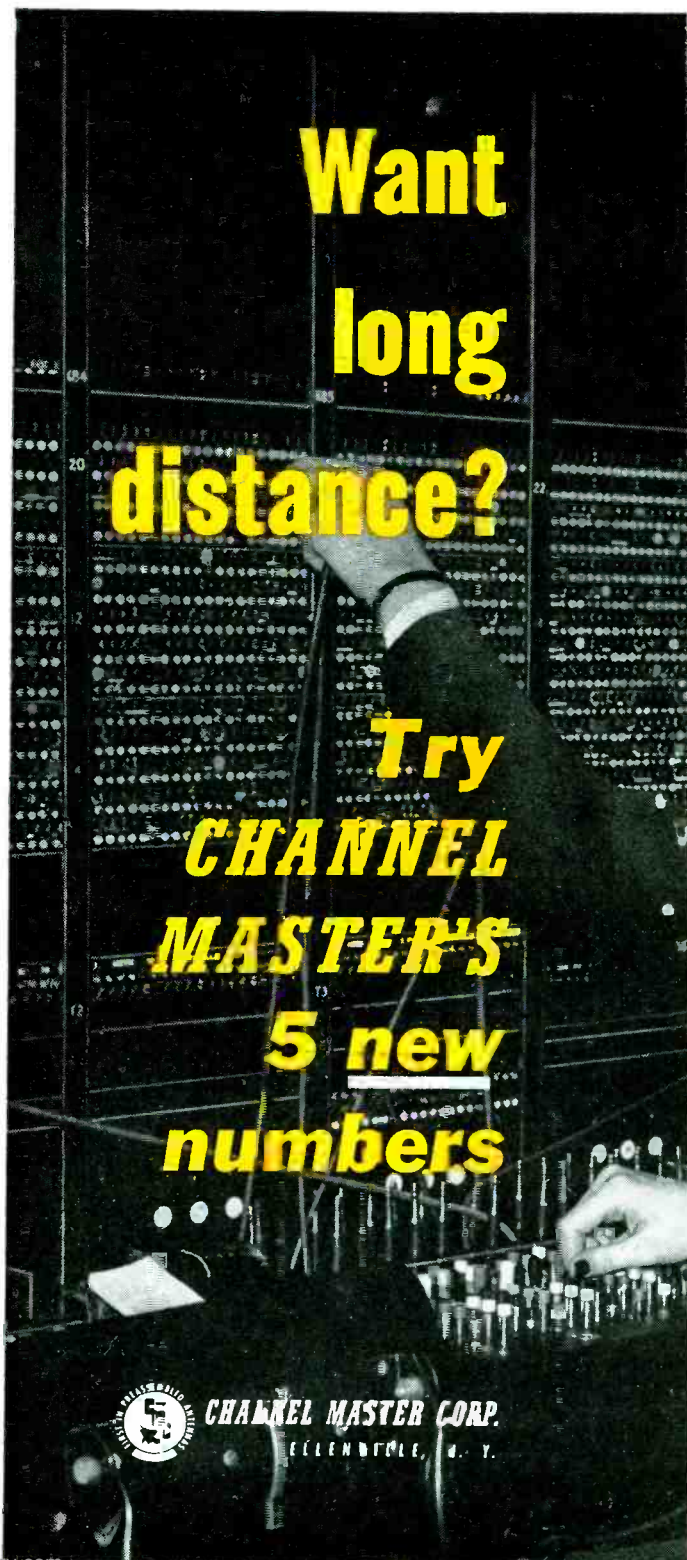

**Want  
long  
distance?**

**Try  
CHANNEL  
MASTER'S  
5 new  
numbers**



**CHANNEL MASTER CORP.**  
ELLENDFOLE, N. Y.



# Designed for **POWER!** Low Priced for **ACTION!**

These new antennas are the most sensitive of their type — feature Channel Master's famous built-in quality at remarkable low prices, to help you meet competition on any level.

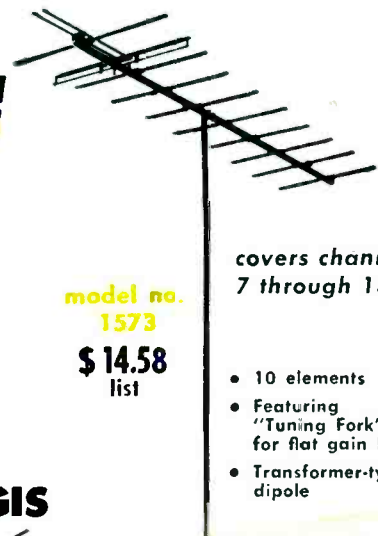

model no.  
1573  
\$14.58  
list

covers channels  
7 through 13

- 10 elements
- Featuring "Tuning Fork" for flat gain level
- Transformer-type dipole

## CHALLENGER BROAD BAND YAGIS

Here's Broad Band coverage with the high gain and directivity of the Yagi. Ideal for areas served at present by two or more VHF stations or the same band and areas where new VHF stations are being added to present ones, on the same band. Feature 100% aluminum construction; are completely preassembled. They give high gain across the band; high front-to-back ratio. Can be stacked for extra sensitivity.

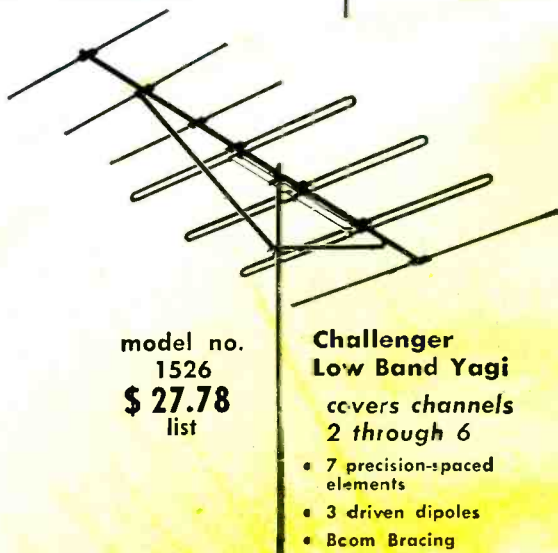

model no.  
1526  
\$27.78  
list

**Challenger  
Low Band Yagi**

covers channels  
2 through 6

- 7 precision-spaced elements
- 3 driven dipoles
- Boom Bracing

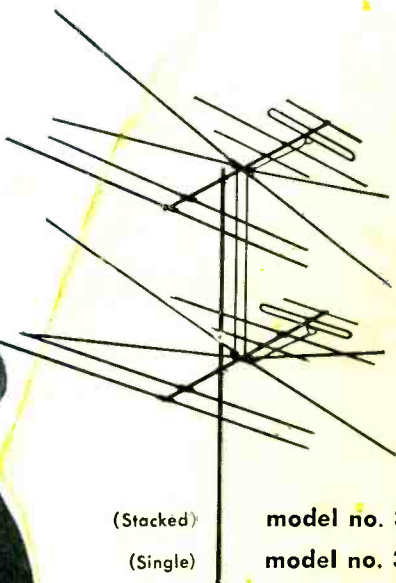

(Stacked)

model no. 321-2 \$25.97 list

(Single)

model no. 321 \$12.64 list

## GLOBE TROTTER

- All-channel VHF fringe area coverage.
- All-channel UHF primary area coverage.
- 100% aluminum construction.
- Completely preassembled — no loose hardware.

## MULTI-BOW

covers channels 14 through 83

- Outstanding fringe area reception.
- All-aluminum, solid sheet elements.
- "Free-Space" terminals.
- Heavy-duty welded wire screen, bright zinc electroplated.

model no.  
410  
\$11.11  
list

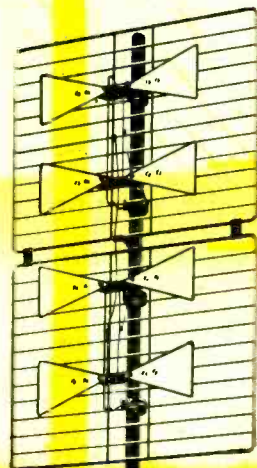

The World's Largest Manufacturer  
of Television Antennas

Copyright 1954 Channel Master Corp.

# SERVICE MAN'S DREAM

... the most compact TV set ever made!

(Yet easily accessible)

## CROSLY SUPER-V IS DRAMATICALLY DIFFERENT INSIDE

Here's one set that is designed with the TV service man in mind. Removing the back of the Super-V plainly exposes all secondary controls and every tube in the set. And as you know, 9 out of 10 service calls merely require the change of a tube.

For any other service job, it's as simple as opening the hood of your car, no chassis to pull, just slide the entire Super-V cabinet up off the chassis. More repairs can be made in the home. You can get at the works immediately and without obstruction, service the Super-V in lots less time than you'd spend on an ordinary set.

The Super-V is a cinch to install. It's compact, weighs only 53 pounds. And in many places, you'll find its built-in antenna is all you need for perfect reception. Service men who've seen the Super-V call it the greatest forward step ever taken in TV chassis design.

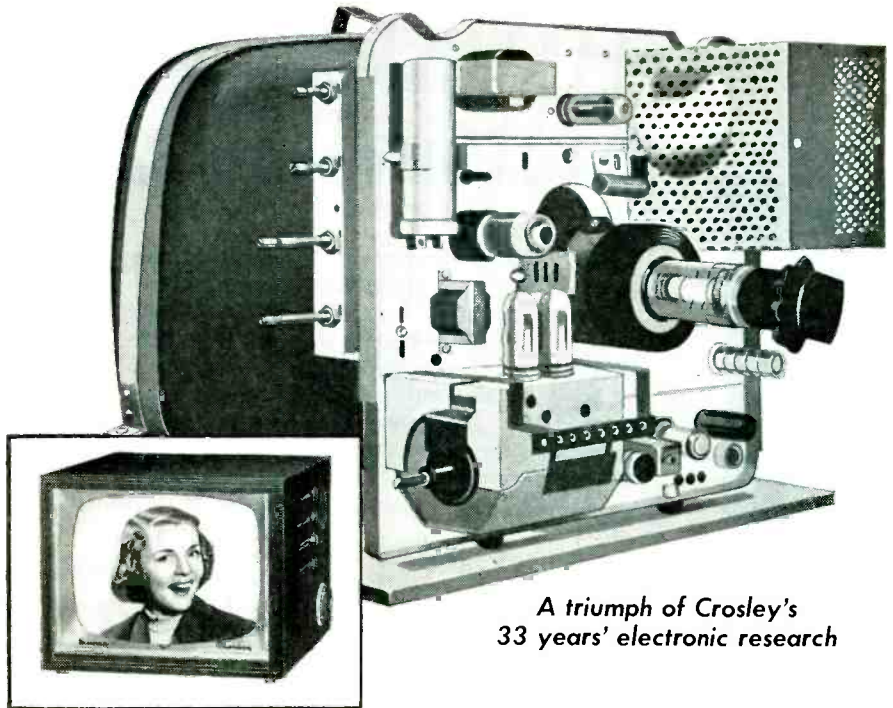

A triumph of Crosley's  
33 years' electronic research

# CROSLY

17-INCH

# Super-V

- TAKES UP TO  $\frac{1}{3}$  LESS SPACE THAN OTHER 17" TVs—FITS WHERE OTHER SETS WON'T
- FRONT ALL SCREEN—CONTROLS ON THE SIDE
- CHOICE OF THREE FINISHES (MAHOGANY, WALNUT, BLOND)
- FULL-YEAR WARRANTY ON PICTURE TUBE—90 DAYS ON CHASSIS PARTS
- ROLLING OFF CROSLY PRODUCTION LINE IN VOLUME—PRICED FOR PROFIT AND ACTION NOW!

FOR MORE INFORMATION ON THE SUPER-V  
CALL YOUR CROSLY DISTRIBUTOR NOW!

Suggested retail prices start at

\$ **139**<sup>95</sup>  
coast to coast

(Walnut-finished)

You can **SELL** them better on a **CROSLY**

Division **AVCO** Corporation  
St. Louis



# NEW

*truly functional*

## TUBE CHECKER

*by*

## WESTON

with new features for  
greater accuracy and time-  
saving facility in all testing

- Provides accurate meter measurement of leakage resistance as high as 5 megohms between tube elements.
- Permits high transconductance measurements, with ranges 3000/6000/12000/24000 micromhos.
- Multiple switching protects against early obsolescence, allows making any combination of tube connections.
- Element switching permits checking and comparing individual sections of twin-section tubes without changing selector switch.
- Only *one* socket for each type tube base eliminates plugging tubes into wrong sockets.
- Sockets for all type bases . . . including acorn and 7 and 8 pin subminiatures.
- 19 filament voltage settings—.65 to 115 volts. 5 plate voltages - 20 to 177 volts. A 45-volt source for testing subminiature types.
- Grid bias, plate voltage and meter sensitivity adjustable.
- Large, readable fan-shaped meter . . . new roll chart with complete, up-to-date data on all tubes.

Complete data on the new Model 981 Type 2 available in bulletin form. Write . . . WESTON Electrical Instrument Corporation, 614 Frelinghuysen Avenue, Newark 5, New Jersey.

5539

*Available through leading distributors*



WESTON  
Model 981 Type 2

# WESTON *Instruments*

To build a healthy, growing service business...

# YOU NEED THESE 6 NEW

# WALSCO

# SERVICE ITEMS



### NEW WALSCO CLEAN-O-MATIC...

Covers contacts on "Standard Coil" tuners and keeps them clean, silent, oxidation-free. Very easy to install. Tube of "Tunerlub" and crocus cloth included.

Cat. No. 1200

\$1.50 net

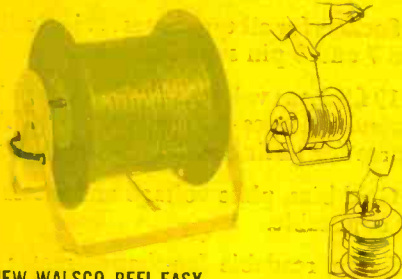

### NEW WALSCO REEL-EASY

Portable wire reel holder. Light, durable, compact—weighs only 1½ lbs. Handy to carry, easy to dispense lead-in wires. Eliminates tangled cables.

Cat. No. 503

\$3.60 net



### NEW WALSCO VIEW BINS

Keeps small parts handy, sorted, visible and dust-free. Sturdy, tilt-type, spill-proof drawers reveal contents. No hidden corners. Silver hamertone finish. Welded steel.

Cat. No. 1010-6 bin

\$4.95 net

Cat. No. 1010-12 bin

9.50 net

Cat. No. 1010-24 bin

16.95 net

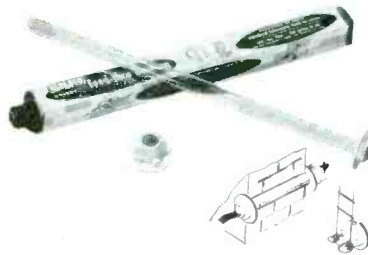

### NEW WALSCO FEED-THRU BUSHING

Bring antenna cables into the house the professional way. This bushing fits all lead-in and rotor cables. Terminate "open line" outside... bring flat line through bushing to set. Fits walls up to 16". Requires ¾" hole.

Cat. No. 1551

\$1.17 net



### NEW WALSCO TOOLS

New I.F. alignment tool for all UHF RCA, Zenith and other sets.

Cat. No. 2527

\$0.42 net

"Slug Saver" front end alignment tool for all "Standard Coil" tuners. Impossible to lose slugs with this patented tool.

Cat. No. 2528

\$0.63 net

Solder-ease tool. Bristles of brush and prongs of stainless steel. Solder will not stick.

Cat. No. 2529

\$0.99 net



### NEW WALSCO GUY-TITE

Tighten guy wires faster and better with this new Walsco tool. Does the job of a turnbuckle at a fraction of its cost.

Cat. No. 1568 Box of 100

\$3.60 net

Cat. No. 1566 Tool and 18 tites

4.95 net

## WALSCO ELECTRONICS CORPORATION

3602 Crenshaw Blvd. • Los Angeles 16, Cal f.

Canadian Factory Distributor: Atlas Radio Corp., Ltd., 560 King St. West, Toronto 2-B.  
Overseas Distributor: Ad Auriema, Inc., 89 Broad St., New York 4, N.Y.



# **SOLVED!** Your TV tuner small parts problem!



THE STANDARD TUNER  
(not included in kit)

Get the handy, all-new  
**STANDARD Tuner  
Replacement  
Parts Kit  
No. 1011**

IN TV IT'S STANDARD

**Standard**  
COIL PRODUCTS CO., INC.

CHICAGO    LOS ANGELES    BANGOR, MICH.  
NO. DIGHTON, MASS.

Export Agent:

Rocke International Corporation, 13 E. 40th St., New York City

Now... 104 small TV tuner parts are at your fingertips in one convenient, low-cost kit that's sturdy, compact, fully labeled for quick reference. You get the most-called-for parts servicing Standard tuners series TV-200, TV-1500, TV-2000 and TV-2200. Each item is individually boxed, except the very small.

**More Profit**—\$25.03 worth of tuner parts for only \$22.50.

**Save Time**—Hard-to-find tuner parts right at hand for quick, sure selection.

**Build Customer Goodwill**—Replace tuner parts direct from your Standard kit, so your customer will *know* each part is completely new.

Plan now to speed up your service work, bring new order and efficiency to every job. Get your Standard tuner replacement parts kits today! Call, write or wire your parts jobber, or address Standard Coil Products Co., Inc., 2085 N. Hawthorne Ave., Melrose Park, Ill.





# draw a bead on quality...

**IF YOU'RE IN  
TV SERVICE FOR KEEPS**

Television service is big business—one of the fastest growing in the nation. If you're shooting for all the marbles and aiming for the secure future TV service provides, remember today's service builds tomorrow's reputation.

As in any big business, the strongest foundation for the future is a reputation built upon sound technical and business methods. In TV service, it's good business to back up your highly specialized workmanship with the highest quality replacement parts.

You can depend on Du Mont quality picture tubes to do more for your service.



Photo by Robert R. Long — From PHOTOGRAPHY ANNUAL

**Replacement Sales, Cathode Ray Tube Division  
Allen B. Du Mont Laboratories, Inc., Clifton, N. J.**

**PIONEER IN BIG PICTURE TUBES • ORIGINATOR OF THE FAMOUS BENT-GUN AND SELFOCUS •  
LEADER IN HIGH-RESOLUTION • MAJOR SUPPLIER TO MOST FINE TELEVISION RECEIVER MANUFACTURERS**

Trade-Mark



Now a

# COLOR

## TELEVISION

### HOME STUDY COURSE

by RCA Institutes



"Color Television is here—not around the corner, or in the developmental labs, but here! The big question now is . . . Are You ready for Color TV?"

"You may now have a successful TV servicing business. When color sets come to your bench for servicing, will you be able to handle them?"

"Color Television is a vast new field, embodying entirely new concepts . . . principles of light and vision, radically new circuitry."

#### First Home Study Course in Color TV

Now is the time to prepare. Now, for the first time, you can train yourself for the

opportunities in this brand-new field. The just-announced RCA Institutes Home Study Course is the *first* home study course covering all phases of color television. Offered only to those already experienced in radio-television servicing, it explains the "why" of basic theory, as well as the "how-to-do-it" of servicing techniques.

Planned and written by RCA instructors, the entire course is based on the practical experience of RCA engineers—the men who have pioneered in the research and development of color television since the very first color experiments, many years ago.

Remember when black-and-white television first became a reality? Overnight, the demand for men who knew television grew. Even now, a shortage of qualified servicemen exists. Think, then—of the even greater demand for servicemen who will understand the many additional problems of color reception!

#### Costs so little to gain so much

RCA Institutes makes it easy for you to prepare yourself now for color television. Not only is the cost of the home study course for qualified servicemen extremely low, but you pay for the course on a pay-as-you-learn basis.

RCA Institutes conducts a resident school in New York City offering day and evening courses in Radio and TV Servicing, Radio Code and Radio Operating, Radio Broadcasting, Advanced Technology. Write for free catalog on resident courses.

Send for **FREE Booklet**—Mail the coupon, today. Get complete information on the RCA INSTITUTES Home Study Course in Color Television. Booklet gives you a general outline of the course lesson by lesson. See how thoroughly you can learn Color TV. Mail coupon in envelope or paste on postal card.

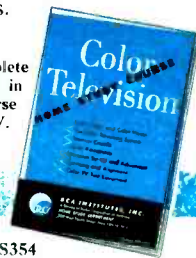

#### MAIL COUPON NOW!

RCA INSTITUTES, INC., Home Study Dept., 5354  
350 West Fourth Street, New York 14, N. Y.

Without obligation on my part, please send me copy of booklet "RCA INSTITUTES Home Study Course in COLOR TELEVISION." (No salesman will call.)

Name \_\_\_\_\_ (please print)

Address \_\_\_\_\_

City \_\_\_\_\_ Zone \_\_\_\_\_ State \_\_\_\_\_



**RCA INSTITUTES, INC.**  
A SERVICE OF RADIO CORPORATION of AMERICA  
350 WEST FOURTH STREET, NEW YORK 14, N. Y.

# Another Outstanding Service Success Story...

## with SYLVANIA!

From Basement Repair Shop  
to prosperous Service Business...  
featuring Sylvania Tubes, Parts  
and Promotion Programs!

The steady and substantial growth of the Ball Television and Radio Service, from basement shop to the large handsome brick building, shown below, is a tribute to the fair practices and alert policies of the owner, Mr. Ted Ball.

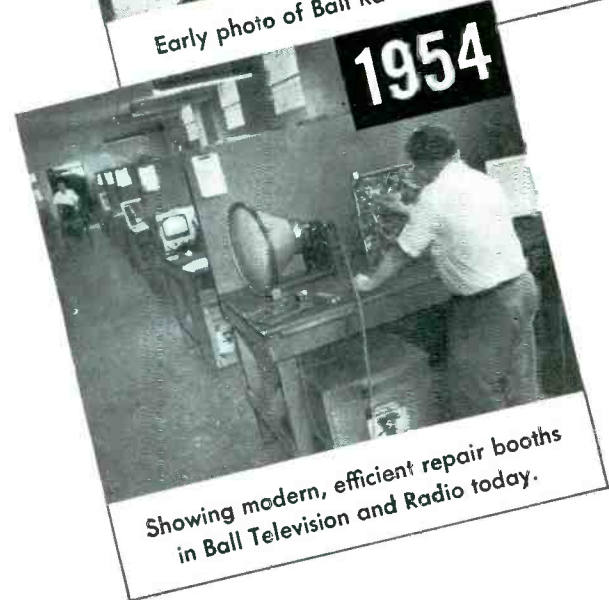
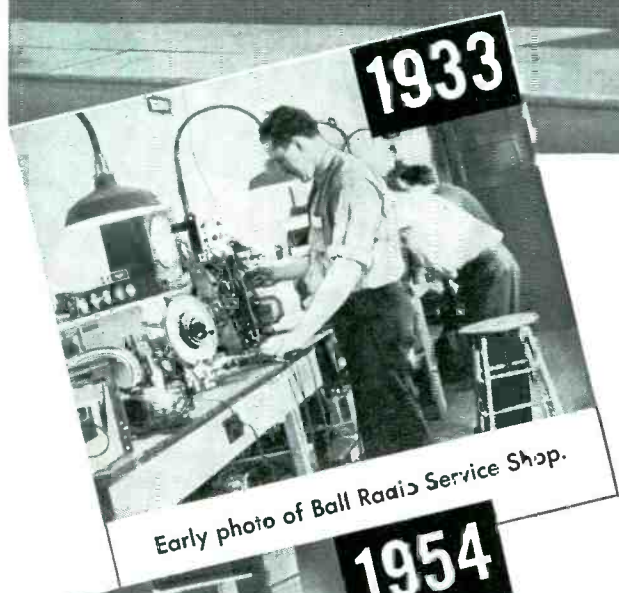

Says Mr. Ball: "My men are as skilled and experienced as any you'll find anywhere, and each is instructed to do the best job possible with the best of parts... and that, of course, includes Sylvania Tubes."

Ted Ball is another important Radio-TV Service Manager that appreciates the quality performance, dependability, and the nation-wide high reputation of Sylvania products.

Mr. Ball also knows about the business-boosting power of Sylvania's promotion and display offers. Find out how Sylvania can step up *your* business. Your friendly Sylvania Distributor is ready and anxious to give you full cooperation. Call him today.

# SYLVANIA

Sylvania Electric Products Inc., 1740 Broadway, New York 19, N. Y.



In Canada: Sylvania Electric (Canada) Ltd., University Tower Bldg. St. Catherine St., Montreal, P. Q.

**LIGHTING • RADIO • ELECTRONICS • TELEVISION**



# Everything in this ad **FREE** With Orders For "Eveready" Portable Radio Batteries!



## FREE BATTERIES!

Bonus batteries to sell  
at 100% profit!

## FREE MOTION-DISPLAY!

Powered by a single "EVEREADY" flashlight battery, the moving hand catches your customer's eye . . . gets big impulse sales! Displays your featured portable. Has special provision for promoting radio service. Measures 25" x 20" x 8".

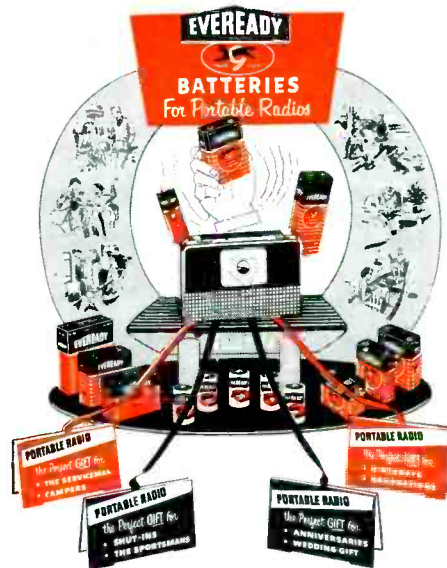

## FREE DEALER-HELPS!

Banners . . . streamers . . . replacement guide . . . dummy batteries. *All* to help you sell more "EVEREADY" batteries!



### DON'T MISS THIS OFFER!

Place your pre-season orders now for "EVEREADY" radio batteries on the special order blank available through distributors. Start making extra profits on year-round sales of portable sets and service, and "EVEREADY" batteries. Order today! Quantity of displays is limited - act quickly.

*The terms "Eveready", "Mini-Max", "Nine Lives" and the Cat Symbol are registered trade-marks of Union Carbide and Carbon Corporation*

### NATIONAL CARBON COMPANY

A Division of Union Carbide and Carbon Corporation • 30 East 42nd Street, New York 17, N. Y.

District Sales Offices: Atlanta, Chicago, Dallas, Kansas City, New York, Pittsburgh, San Francisco

IN CANADA: Union Carbide Canada Limited, Toronto

# \$500,000 IN PRIZES

*... easy to win*

# 503 PRIZES!

## \$2000 - 1st prize

\$500 - 2nd prize,

\$100 - 3rd prize

100 - \$10 prizes,

400 - \$5 prizes

## HOW TO WIN

To win one of these 503 prizes all you have to do is complete in 25 words or less "I like Pyramid capacitors because\_\_\_\_\_." You fill in this statement on a Pyramid contest entry blank which can be obtained from any electronic parts jobber selling Pyramid capacitors. You have this entry blank countersigned by your jobber or one of his salesmen and forward it to us attached to a Pyramid Dry Electrolytic Capacitor box top - the top being the part which carries the description of the item. There is no limit to the number of entries which you may make in this contest but each entry must be accompanied by a box top. Full rules for the contest appear on the entry blank.

It's so easy. Here is the kind of statement that might win:

*"I like Pyramid capacitors because they always check out perfectly and don't deteriorate and so I know I won't have to call back at my expense."*

*"I like Pyramid capacitors because the line is so complete that I can always get what I need and don't have to worry about an off-brand capacitor."*

## PYRAMID



### PYRAMID FEATURES:

- ① Only one quality—the best at no premium. All Pyramid capacitors are made of materials commanded by rigid military specifications.
- ② All Pyramid capacitors are non-hygroscopic.
- ③ Highest quality insulator material used in all production results in low leakage factor.
- ④ Exclusive non-contamination technique guarantees close tolerances and no deterioration. Peak performances for life.
- ⑤ Pyramid capacitors operate unchanged at ambient temperature of 85° centigrade.
- ⑥ Designed by service technicians across the country for their requirements.
- ⑦ Individually packaged for protection.
- ⑧ Permanently legible, high visibility ratings on each item.
- ⑨ 100% absolute electronic inspection before shipment.

Pyramid is in its 10th year as a leading manufacturer of high-quality capacitors.

**PYRAMID ELECTRIC COMPANY**  
1445 HUDSON BOULEVARD  
NORTH BERGEN, N. J.



# ADVANCED FLYBACKER CUTS DOWN SERVICE TIME

## RCP Model 123 Provides Fast, Reliable Test of Flyback Transformers and Yokes.

Designed for speedy servicing of the horizontal output circuit in all TV receivers, the Flybacker is the latest design to come from the laboratories of the Radio City Products Co., 152 W. 25th Street, New York 1, N. Y.

Extremely sensitive, the Model 123 Flybacker immediately shows up a single shorted turn in a flyback transformer or yoke. Its light, portable design serves to advantage in the shop and in the home.

All tests can be carried out with the components in place in the TV receiver. Call-backs can be prevented by checking all flyback transformers and yokes in stock for opens, shorts, etc. Flybacker tests are also applicable to inductive windings on any transformer, choke speaker, solenoid, relays, etc., where the impedance is not relatively low. In fact, the instrument may be used as a proportional AC Ohmmeter.

### Easy to Operate

Minimum of connections necessary. All you do is remove flyback plate caps—set switches—apply leads and then read meter. The slightest change in inductance due to a shorted turn or the effect of intermittents shows up on the meter immediately as "BAD."

First introduced in December of last year, the instrument was an immediate success. Service users everywhere have heaped praise upon its efficiency and advanced design.

### Here's what they say—

Punxsutawney, Pa.

"Remarkable instrument—Congratulations!"

Cincinnati, Ohio.

"Very good!"

Brooklyn, N. Y.

"Excellent unit—very versatile

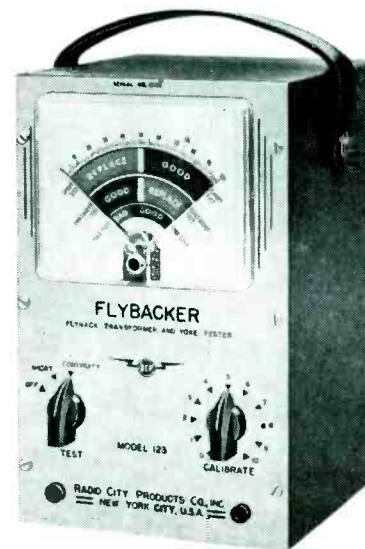

The RCP Flybacker is reasonably priced at only \$39.75

—needed by every serviceman  
—has already paid for itself!"

Donora, Pa.

"Wonderful instrument. . . ."

## PERFECTED PEAK-TO-PEAK MEASUREMENT ACHIEVED WITH VTVM "DO-ALL"

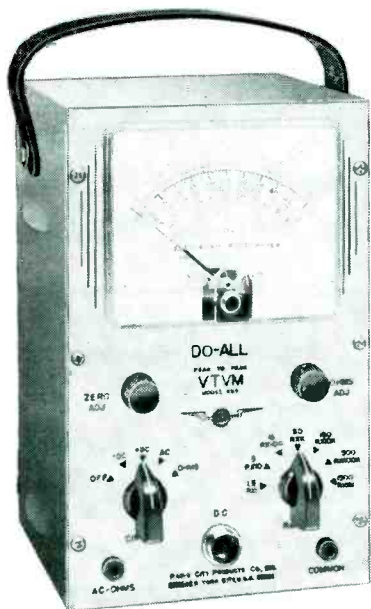

RCP Model 655 provides for the accurate measurement of complex waveshapes.

New circuit developments inherent in the RCP Model 655 provide for the efficient and accurate measurement of complex waveshapes. It gives a true reading measurement of complex and sinusoidal voltages with necessary peak-to-peak or RMS value read directly for the analysis of waveforms in video, sync and deflection circuits.

Service users indicate a greater efficiency is attained since sets can be serviced as the manufacturers say—the peak-to-peak way. The combination of this P. to P. meter and service notes to match, take the guesswork out of service and speed up the overall service operation.

Versatility of measurement, built into each Model 655, serves a variety of industrial applications in the service of vibrator power supplies, AC generators and all equipment utilizing any type of waveform or DC.

The range and the coverage available with the RCP Model 655 provides a multitude of advantages. For example, peak-to-peak AC measurements of from .2V to 4200V on 7 ranges; AC RMS measurements of .1V to 1500V on 7 ranges; DC measurements of from .02V to 1500V on 7 ranges; RESISTANCE measurements of from .2 ohms to 1,000 Megohms on 7 ranges.

Match the Model 655 with any peak-to-peak VTVM—You will find that comparable performance can only be found in much higher priced instruments. Of high impedance design, the Model 655 makes use of an electronic balanced push-pull circuit and peak-to-peak rectification. The result is an absence of circuit loading, waveform error or frequency distortion.

Considering the many advantages available, the price—only \$59.50—beats any competitive product on the market.

For further information write Dept. S-3, Radio City Products Co., 152 West 25th Street, New York 1, N. Y.

# FACTS

# NOT JUST CLAIMS

**FACT-** 53 CLAIMS GRANTED  
IN 5 UNITED STATES PATENTS

#2,585,670; 2,609,503; 2,625,655; 2,644,091; 2,661,423, others pending.

**FACT-** These antennas positively receive ALL channels 2-83 from ALL directions without a rotor motor.

**FACT-** These antennas have consistently OUT-GAINED and OUT-PERFORMED all others in actual public demonstrations.

**FACT-** These antennas will unquestionably OUT-PERFORM all others, on YOUR roof, with YOUR set, or YOUR money back.

**FACT-** SAVES YOU MONEY. Eliminates rotor motor, uses only ONE transmission line, uses only ONE antenna for both UHF & VHF—and only ONE simple, quick installation.

**FACT-** Perfect pictures have consistently been received as far as 3 times the guaranteed distances.

**FACT-** ONLY one antenna, ONLY one transmission line, ONLY one installation. You solve once and for all your PRESENT and FUTURE antenna problems.

**MONEY BACK GUARANTEED TO RECEIVE All CHANNELS 2-83 FROM All DIRECTIONS AND POSITIVELY OUTPERFORM All OTHER ANTENNAS WITH OR WITHOUT A ROTORMOTOR**

**Guaranteed**  
60 mi UHF  
60 mi VHF



**SUPER 60**

LIST PRICE  
**\$36.75**  
SEE YOUR JOBBER

**Guaranteed**  
100 mi VHF  
30 mi UHF



**ULTRA 150**

LIST PRICE  
**\$43.50**  
SEE YOUR JOBBER

**9 POSITION ELECTRONIC ORIENTATION SWITCH**

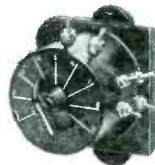

PRICE INCLUDES

Antenna arrays - necessary stacking bars - 9 position switch - switch-to-set coupler - necessary hook-up harness - 7 1/2" stand-offs Individually boxed in mailable carton.

**NEW POLYMICALENE**  
4 CONDUCTOR TRANSMISSION LINE

- Low Loss External Air Dielectric
- Matched Impedance
- Eliminates End Sealing
- Eliminates Condensation
- Up to 50% Less Loss Than Tubular When Wet
- Easily Spiraled
- No Breaking or Shorting
- Patents Pending - T. M. Reg.

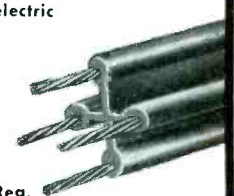

**ALL CHANNEL ANTENNA CORP.,**

70-07 Queens Blvd., Woodside 77, N. Y.

Hickory 6-2304



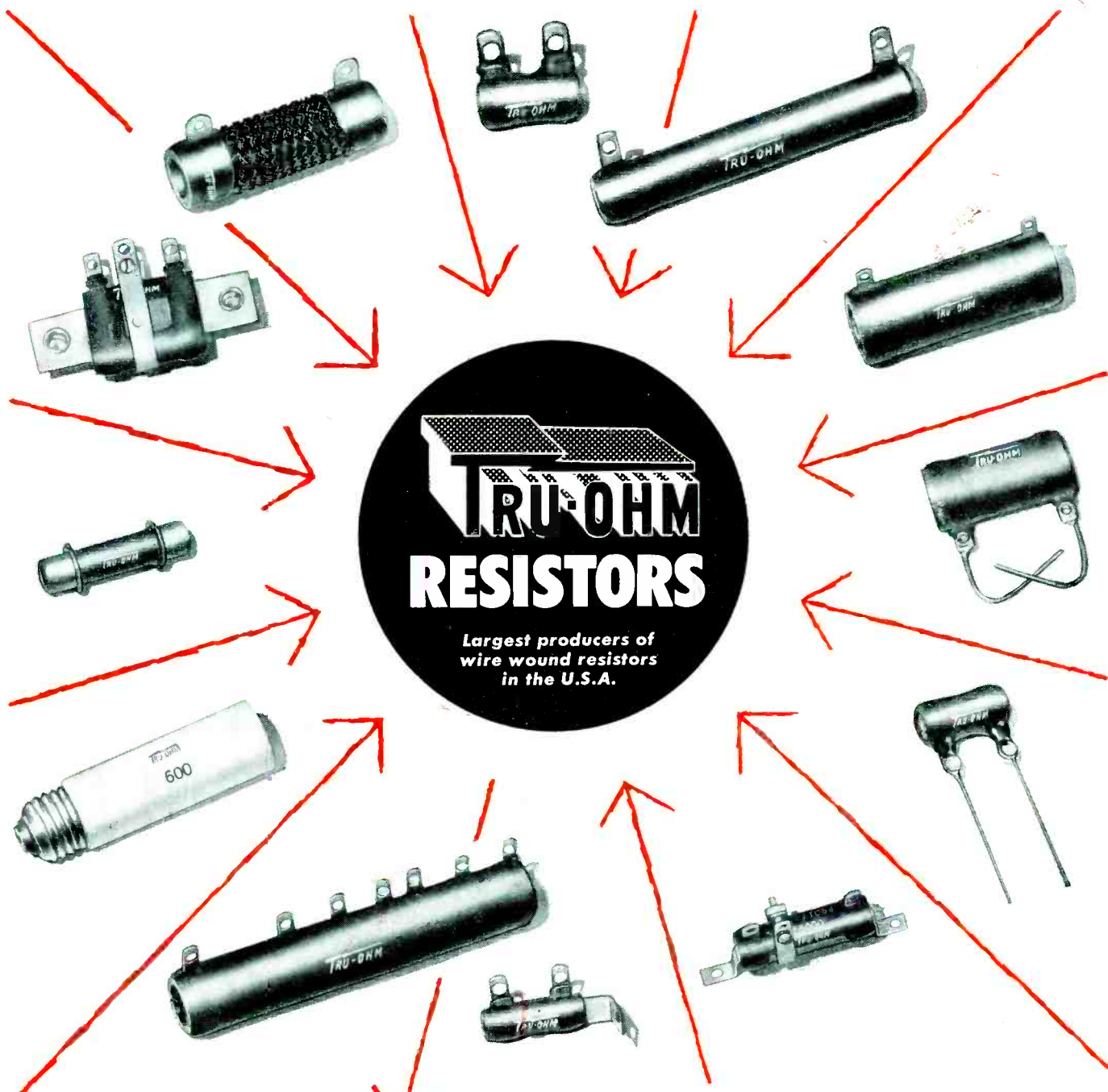

We assure you of prompt delivery and courteous service of the finest WIRE WOUND RESISTORS available . . . from stock or to your specifications.

TRU-OHM resistors are attractively boxed for easy reference and convenient storage.

Write for our latest catalog.



TRU-OHM POWER RHEOSTATS and RESISTORS are sold through recognized jobbers.



General Sales Office: 2800 N. Milwaukee Avenue, Chicago 18, Ill.  
 Factory: Huntington, Indiana

MANUFACTURERS: Power Rheostats, Fixed Resistors, Adjustable Resistors, "Econohm" Resistors, "Tru-rib" Resistors

*"I'm proud to be  
a Savings Bonds salesman  
for Uncle Sam . . ."*



**CHARLES M. WHITE**

*President  
Republic Steel Corporation*

*"I'm proud to be a Savings Bonds salesman for Uncle Sam and I urge every business executive in the nation to advance the cause of American enterprise in this way.*

*"Every one of us at Republic Steel is proud of the results of our Payroll Savings campaign: 96.7 per cent of our employees saving systematically from each pay in U. S. Savings Bonds. These results were possible only because all 68,344 of us at Republic were part of an enthusiastic team. We feel that this is the best way we can demonstrate our appreciation of the efforts to have a sound dollar and a stable economy."*

● 96.7% of Republic Steel's 68,344 employees — over 66,000 men and women — are enrolled in the Payroll Savings Plan.

● These 66,000 members of Republic's "enthusiastic team," as Mr. White so aptly terms them, are investing more than \$16,000,000 per year in U. S. Savings Bonds.

● In addition to building personal security, these men and women of Republic are making a very important contribution to America's "efforts to have a sound dollar and a stable economy."

Certainly Republic Steel's Payroll Savings record is outstanding—one of the best in the country. But it is not unique. Other companies have comparable records, measured in percentage of employee participation, or in annual Savings Bond purchases.

In every company with a high percentage Payroll Savings Plan you will find that the president or top executive appreciates the importance of the Plan and what it means

to personal and national security. He knows that 45,000 companies have Payroll Savings Plans . . . that 8,000,000 employees of these companies are investing more than \$160,000,000 per month in Savings Bonds . . . that the cash value of Savings Bonds held by individuals today is more than 36 billion dollars—and rapidly mounting, thanks largely to the steadily increasing family of Payroll Savers. He is 100% behind his company's Payroll Savings Plan, and everybody in the company knows it. He takes personal pride in watching employee participation grow to 60%, 70%, 80%, or, perhaps, the high 90's.

If you are not making this important contribution to America's effort for a sound dollar and a stable economy, a wire or letter to Savings Bonds Division, U. S. Treasury Department, Washington, D. C., will bring prompt cooperation from your State Director. He will show you how easy it is to join Mr. White and thousands of other executives as a Savings Bond Salesman for Uncle Sam, with a company Payroll Savings Plan that you can be proud of.

*The United States Government does not pay for this advertising. The Treasury Department thanks, for their patriotic donation, the Advertising Council and*

**SERVICE**





**Snyder**  
PHILADELPHIA

**DIRECTronics**  
build **SALES**

Fringe Area VHF/UHF  
**SUPER Directronic®**  
**TV ANTENNA SYSTEM**

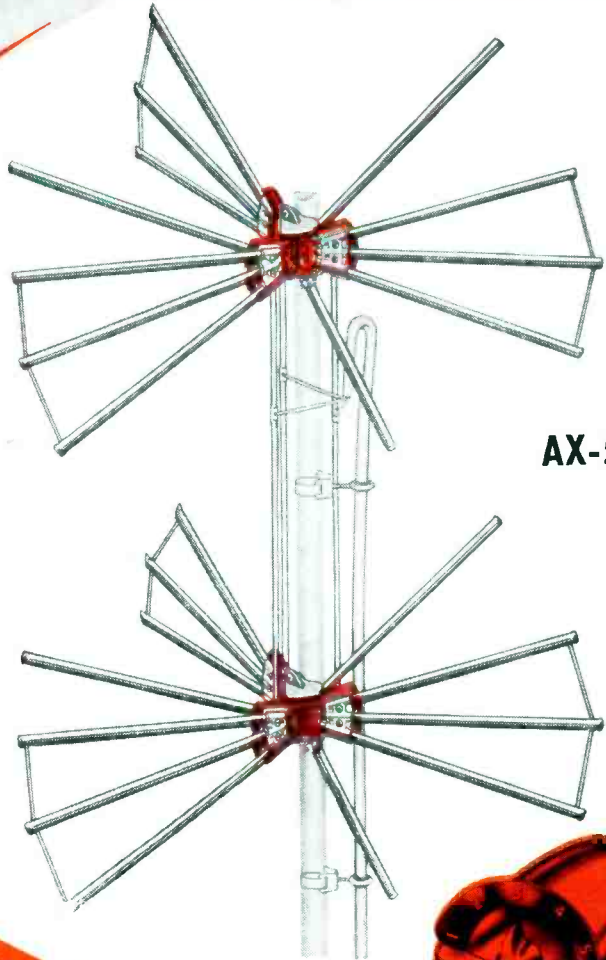

**AX-524**

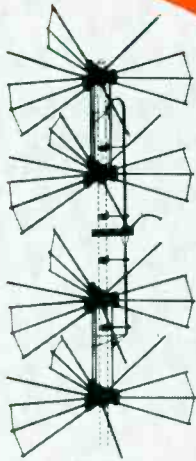

**AX-548**  
**ULTRA-FRINGER**

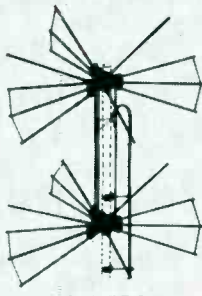

**AX-524**  
**FRINGE-AREA**

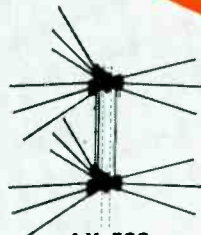

**AX-599**  
**FRINGE-AREA**



**AX-56**  
**METROPOLITAN**



**Directronic®**  
**6-Position BEAM SELECTOR**

**SNYDER**

SNYDER MFG. CO., PHILADELPHIA 40, U.S.A. • BELLEVUE TUBE MILL, INC., PHILADELPHIA 40, U.S.A.  
SNYDER ANTENN-GINEERS LTD., TORONTO, CANADA • WORLD EXPORT: ROBURN AGENCIES, INC., N.Y.

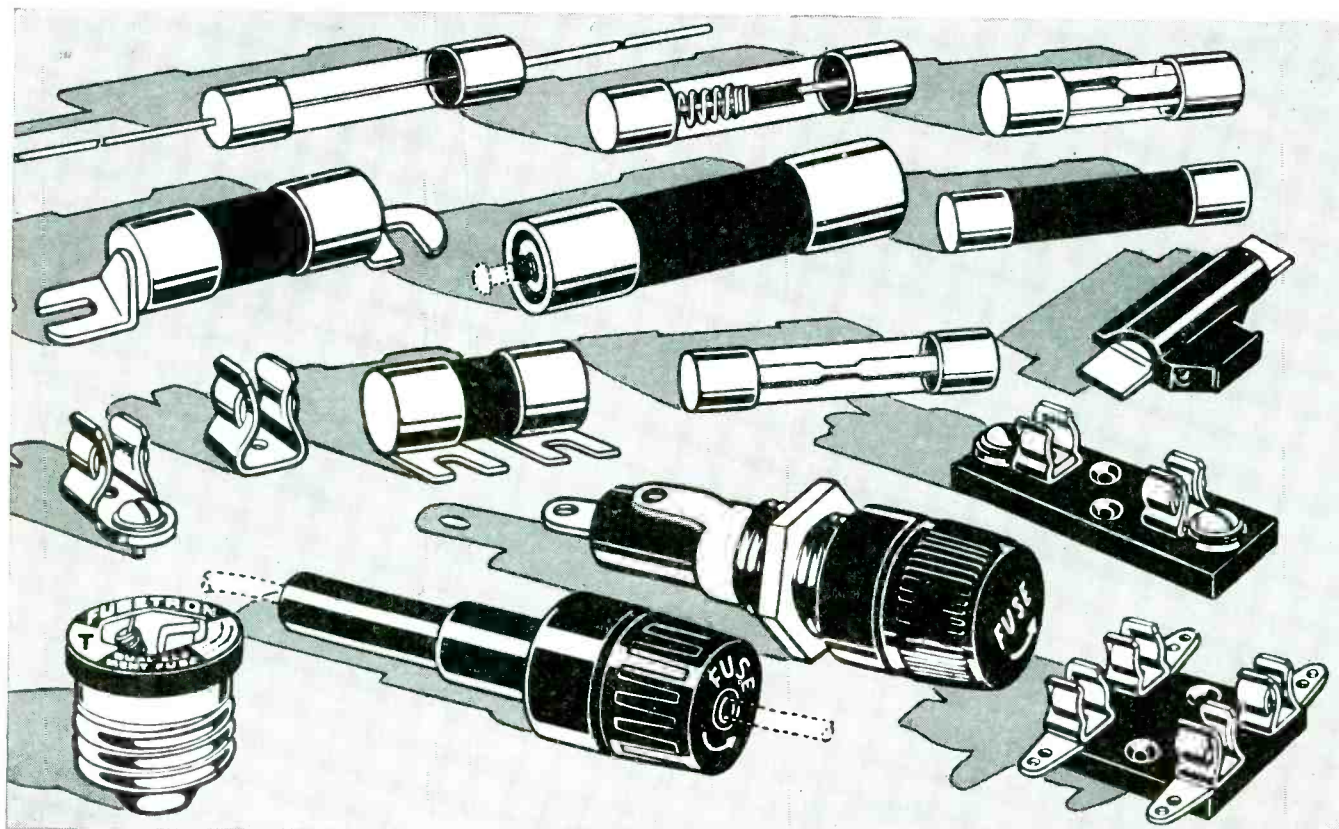

## WHY YOU WILL FIND IT PROFITABLE to STANDARDIZE on BUSS FUSES



### BUSS OFFERS A COMPLETE LINE OF FUSES

It is easy and economical for you to choose the exact fuse for your requirements. Select from dual-element (slow blowing) renewable and one-time types . . . in sizes from 1/500 ampere up, plus a companion line of fuse clips, blocks and holders.

A fuse is a small but significant component part — for a faulty fuse that fails to protect — or a fuse that blows needlessly may reflect, in your customer's mind, on your product or service.

Dependable electrical protection is not an accident with BUSS fuses.

The makers of BUSS fuses maintain rigid quality control by testing every fuse in a sensitive electronic device that rejects any fuse not properly calibrated, properly constructed and right in all physical dimensions.

That is why you can be sure that a BUSS fuse will always operate as intended under all service conditions.

"Trouble-free" BUSS fuses can help protect your goodwill, reputation and profits.

Then be profit wise, change your buying and stock records today — to standardize on genuine BUSS fuses.

*For more information mail this Coupon ▼*

BUSSMANN Mfg. Co. (Division of McGraw Electric Co.)  
University at Jefferson, St. Louis 7, Mo.

Please send me bulletin SFB containing facts on BUSS small dimension fuses and fuse holders.

Name \_\_\_\_\_

Title \_\_\_\_\_

Company \_\_\_\_\_

Address \_\_\_\_\_

City & Zone \_\_\_\_\_ State \_\_\_\_\_ S-354

### In sales and service capitalize on the BUSS trademark.

Millions and millions of BUSS fuse installations in homes, on farms and in industry have firmly established BUSS as the known brand. When you furnish a BUSS fuse your customer accepts it as the best possible fuse. So let the BUSS trademark help, in its own little way, to build your reputation for quality and service.

Makers of a complete line of fuses for home, farm, commercial, electronic and industrial use





# BLACK BEAUTY<sup>®</sup> TV TUBULARS

first and still finest...  
accept no substitutes



Imitation, they say, is the sincerest form of flattery. If so, you who have installed some of the 250,000,000 Black Beauty Telecaps in the past 7 years can be mighty proud. Few Sprague developments have been so closely copied as this capacitor in which you have placed your confidence.

Black Beauty imitations are available in almost every color imaginable . . . including black! But no other molded tubular can equal the unprecedented record set by Sprague TV Tubulars since 1947 when they were first introduced.

Don't be vague — insist on Sprague Black Beauty Telecaps for your TV and radio service needs! There is only one Sprague Black Beauty, and it has no equal. Accept no imitations.

Write today for the complete Sprague television and radio service catalog C-609 to Sprague Products Company,\* 61 Marshall Street, North Adams, Mass.

There is a Sprague Distributor in every sales area in the United States. Write for the name of your nearest source of supply today.

#### SPRAGUE

dry-assembly phenolic malded paper capacitors offer:

- extra high insulation resistance
- minimum capacitance change with temperature variations
- absence of drift with repeated heating and cooling

Don't Be Vague... Insist on

# SPRAGUE

WORLD'S LARGEST  
CAPACITOR MANUFACTURER

\*Sprague Products Company is the Distributors' Division of the Sprague Electric Company

# CALL BACKS COST MONEY...

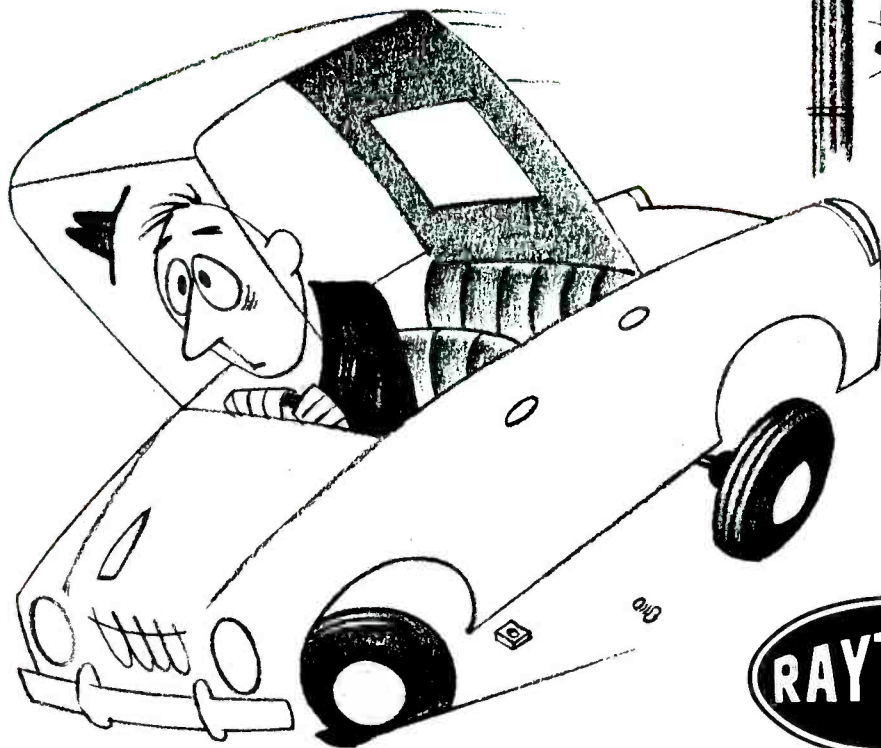

**AVOID  
THEM  
WITH  
THE**



## SERVICE SAVER PLAN

available through your **RAYTHEON TUBE DISTRIBUTOR**

The Raytheon Service Saver Plan, which permits customers to identify about 85% of all the troubles that may occur on the screen of a defective TV receiver — *and accurately transmit this information to the Service Dealer via telephone* — is helping to minimize costly call-backs two ways.

First, when a Service Dealer goes on a call knowing in advance what ails a TV receiver (thanks to Raytheon's Service Saver Plan), he goes completely equipped to do

the job — no more running back to the shop for tubes or parts.

Second, customers frequently call about TV receiver trouble when a minor control adjustment is all that is needed to correct the fault. The Raytheon Service Saver Plan helps Service Dealers avoid these needless, unprofitable calls.

Ask your Raytheon Tube Distributor to tell you how to put the Raytheon Service Saver Plan to work for you.

**RAYTHEON RADIO AND TELEVISION TUBES** cut call-backs, too! Their outstanding quality reduces early tube failures to a minimum. Use them. You'll find them Right ... for Sound and Sight ... and you!



**RAYTHEON MANUFACTURING COMPANY**

Receiving Tube Division  
Newton, Mass., Chicago, Ill., Atlanta, Ga., Los Angeles, Cal.

*Excellence in Electronics*

RAYTHEON MAKES ALL THESE:  
RECEIVING AND PICTURE TUBES • RELIABLE SUBMINIATURE AND MINIATURE TUBES • SEMICONDUCTOR DIODES AND TRANSISTORS • NUCLEONIC TUBES, MICROWAVE TUBES



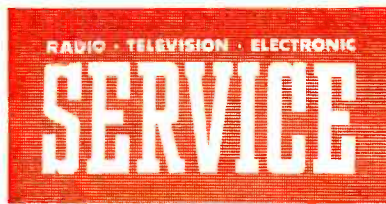

### **Selling Skill**

IT'S IMPOSSIBLE to substitute price for quality in a sales appeal, for price can never be the criterion of a successful service business; one must give value above all.

Words of wisdom . . . delivered during a recent commencement exercise in New York<sup>1</sup> by the prexy of RETMA, which everyone should study and follow carefully.

Expanding on this theme, the industry association spokesman said that the Service Man's best advertisement, which will sell of one's self and his service business, has been and will always be customer satisfaction, and the good reputation which superior service creates for anyone in a community. This does not imply that one should be a modest violet; one should also arrange to merchandise the commodity *service*. It can take the form of a well-planned direct-mail promotional program, or ad campaign in newspapers or over a local station. But the best advertisement will always be the set owner who likes the manner in which a shop conducts its business and the capable workmanship available.

Service, it was emphasized, has always been a particularly competitive business. One always has to offer know-how in a sales effort; its an important ingredient in every Service Man's kit. But, it is equally important to know how to sell this skill—by offering value in the form of ability, earnestness and adroitness.

### **Tape Shakes Hands With Service Men**

IT HAS often been said that independent service shops represent the ideal centers for the expert care of tape recorders. Some have gone along with this premise, tried it out on local levels, and found it very practical. Now, the plan has begun to receive national support from a West Coast manufacturer<sup>2</sup>, who has decided to appoint independents to maintain and repair tape recorders. According to the present program, tape servicing depots will be set up in each of the metropolitan areas of the country. Currently, temporary appointments have been made in New York, Chicago, Cleveland and San Francisco, and negotiations are underway with many in cities of relative importance.

Describing the new project, the company's sales manager pointed out that arrangements should be very profitable for independents. Specifically, the company will pay service depots \$1.00 for each unit that is registered by a consumer from the geographical territory assigned to them during each calendar month. In other words, effective the date a service contract is signed, and continuing until such contract is terminated, each time a consumer buys a tape recorder and registers that instrument with a factory warranty card, a service depot will receive credit for \$1.00 from the company. In addition to that source of income, depots will receive compensation from the plant (at a fixed rate), for labor performed on each job during the in-warranty or 90-day service parts-exchange period.

### **A Glistening Tribute**

SERVICE MEN, who on many occasions have received rounds of pleasant accolades, recently were really hailed, and by none other than a veteran member of the FCC.

The servicing of standard-band TV equipment is a complex project, he declared, and the repair of many types of ultrahigh gear is even more involved. And, when color sets begin entering the home, the expertness required for installation and maintenance of these models will become even more pronounced, he added. Truthfully, he said, the knowledge required to install properly and repair TV receivers and assorted equipment transcends the technical ability needed to service all other household devices. In his opinion, Mr. and Mrs. Set Owner must realize that every TV Service Man is actually playing . . . "an increasingly important role in servicing the American home."

### **Colorama in Philadelphia**

COLOR TV will officially walk off the drawing boards in a few weeks and make its gala debut in the rooftop ballrooms of the Bellevue-Stratford in Philadelphia. Here, for the first time, one of the most complete arrays of color receivers, test equipment, components and special color tubes ever collected, will not only be on display, but in actual operation.

Over a dozen manufacturers will have on exhibition their latest color set models, which will receive color signals from a flying-spot scanner; in addition, live pickup of color programs will be offered. Instrument makers will unveil their latest test gear, such as wide-band 'scopes, and dot and bar generators. There'll also be on review large cutaway displays of the newest types of color tubes. And production-line test gear and master-antenna systems for color receivers will be perking. On view, too, for the first time, will be a color fundamental display.

In addition to this spectacular exhibition, which has been insured for \$1-million, industry's leading exponents of the art will discuss every phase of color receiver, part and instrument design and application in a series of lecture-demonstrations arranged by *ye editor*. One talk will feature a comprehensive report on color test patterns, supported by dozens of typical examples.

This truly will be the event of the year; a sparkling treat!

Circle these dates—April 2-3-4—and the place—the Bellevue-Stratford, in Philadelphia<sup>3</sup>.—L. W.

<sup>1</sup>RETMA graduation ceremonies at N. Y. Trade School.

<sup>2</sup>Berlant Associates.

<sup>3</sup>For complete registration details write to Lou Smith, Council of Radio and TV Service Associations, 6957 Old York Rd., Philadelphia 26, Pa.

# WARD'S **new** majorette points the way

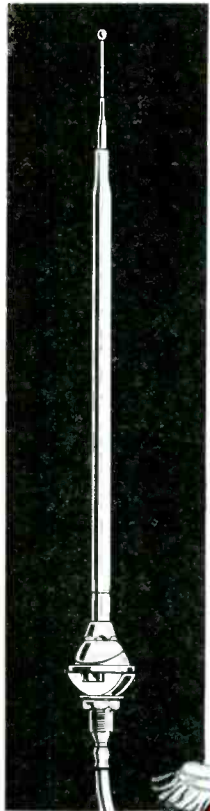

a new leader in aerial value!  
custom quality! volume price!  
triple chromed brass!  
Ward's 8-ball mount!  
top performance!

*"Fall in" now  
for the sales parade*

Ward's new Majorette possesses every important feature of the world famous 8-Ball auto aerial . . . 3 sections, extending to a full 56" . . . triple chromed on Admiralty Brass . . . with Ward exclusive 8-Ball top cowl or fender mount . . . genuine Elektran lead cable . . . a truly top-flight aerial, priced to meet the keenest competition. Place your order now! Get in the sales parade today. Model TA-3 — 36" lead. Model TB-3 — 54" lead.

Installed completely from the outside



THE **WARD** PRODUCTS CORP.

DIVISION OF THE GABRIEL COMPANY

1148 Euclid Avenue, Cleveland 15, Ohio

In Canada: Atlas Radio Co., Ltd., Toronto, Ont.



# SERVICE... The National Scene

10-MILLION COLOR SETS BY '58 FORECAST--There'll be 10-million polychrome receivers in operation within four years, according to an official of one of the nation's largest color-set producers. In an address before an electrical association meeting in Pittsburgh recently, he declared that the real color spurt will begin in '55 when at least a half-million r/g/b sets would probably reach the consumer market, and in subsequent years production will begin to race along to at the millions-plus rate. . . . Of the 100,000 color sets that are expected to be made this year, it was said that about 30,000 will probably go to dealers as demonstrator models, and another 10,000 will be sent out to broadcasters, special field depots, and labs. Thus, it was noted, about 60,000 sets might reach the consumer. . . . Commenting on the color-programming schedule of one network during '54, the setmaker executive declared that during the first quarter there'll be 2½ hours of colorcasting, and during the second quarter 5 hours weekly will be devoted to color. During the third quarter, on-the-air time will be increased to 7 hours a week, and during the final quarter of '54, 10 hours will be devoted to color telecasts. One other large network has announced that it will eventually reach the same hourly schedule by mid-summer.

OVER 6-MILLION HOMES NOW WITHIN UHF RANGE--In a report offered in New York recently, RETMA's board chairman declared that 6½-million homes are now within range of ultra-high stations, and over 3½-million have either purchased converters or complete receivers for uhf pickup. His survey also revealed that nearly 15-million homes now within range of TV signals have no sets at all. It was also disclosed that of the 27-million sets now in use, only 30% are of the 17" or larger type, and at least 20% are well over four years old.

80,000 OLD-SET PIX TUBES FAILING WEEKLY--In a survey of sets that have been in use for several years it has been found that picture tubes have begun to show the wear of time and are now failing at an 80,000-per-week rate. It was noted that this is about 20% above the '53 failure level. . . . This tube-breakdown analysis confirms an earlier report that almost one out of every seven TV sets in use today is expected to require a new picture tube during the year, the high-replacement figure representing a very normal development, with so many old chassis in operation.

MULTIPLE STEREOPHONIC HI-FI TRANSMISSIONS SLATED FOR WASHINGTON--Simultaneous broadcasting from a single FM transmitter, of two or more different programs, providing stereophonic sound, is expected to become an early feature of an FM station in Washington, D.C. Using two separate microphones, programs will be transmitted over two different layers of a multiplex system, and picked up on special receivers which will separate the two signals and provide dual output to pairs of speakers. . . . Stereophonic transmission has been attempted earlier using the facilities of two FM outlets or simultaneous AM and FM broadcasts. The present plans represent the first official attempt at sending twin signals from a single transmitter.

TVI STILL BOUNCING AROUND ON 21 AND 41-MC BANDS--Notwithstanding efforts made by manufacturers to design their chassis skillfully to eliminate all forms of TVI, many 21 and 41-mc set owners are still being plagued by interference. In the upper-region *if*, the troubles have been caused by expanding doctor-call services, some taxicab systems, police cars, and even a number of FM sets. In many cases, it has become necessary to shift the tuning of the *if* passband to some other frequency that is free of the interference. This has been done, in some instances, by realigning the *if* amplifiers so that an adjacent channel trap can tune exactly to the interfering frequency. Many service shops in certain areas which have been hard hit by this recurring trouble are being kept quite busy making such frequency shifts. . . . The recent extension of the ham band to 21.45 mc has also raised havoc with some chassis which still employ the lower 21-mc *if*. One manufacturer recently announced the use of a 21.9-mc frequency to overcome this possible problem. . . . The bugaboo of tuner radiation on either frequency has been minimized by many through the application of adequate shielding and modified circuit networks to assure low radiation fix. . . . The entire balky problem of interference has prompted RETMA to ask a committee to develop an industry program, calling for the voluntary suppression of spurious radiation, which can be submitted to FCC for approval.

# SERVICE... *The National Scene*

TRIO OF TV LICENSE BILLS SPONSORED BY N. Y. STATE LEGISLATORS--In a surprise move by two Assemblymen and a Senator three identical licensing measures were introduced a short while ago in the New York State legislature. The measures stipulate that on or after October 1, anyone in the business of servicing TV receivers shall be required to obtain a license from the Secretary of State of New York, and pay an annual fee of \$25. . . . The Secretary of State would have full power, according to this ordinance, to prescribe and examine the qualifications of applicants. He would also be authorized to set up rules and regulations involving minimum standards of service, the minimum number of employees in proportion to the number of sets to be serviced, and the rates to be charged. In addition, the bill states, the Secretary of State would have the power "in his own discretion", or upon the verified complaint of anyone, to revoke or suspend a license. And, no new licenses would be issued for a period of one year from the date of revocation, and then "only in the discretion of the Secretary of State, and upon such terms and positions as he may describe." Licensees would also be obliged to use a standard form of contract for all jobs. . . . No examination would be required, the bill noted, if the applicant had been engaged in the business of servicing on January 1 of last year, and had been in the service business for a full year within the period of five years up to '53. . . . According to the measure, those who violate the bill's provisions would be guilty of a misdemeanor and punishable by a fine of not more than \$500, or by imprisonment for not more than 90 days, or possibly both. . . . At this writing, it has been reported, the Assembly has shelved the measure, and the Senate, it is said, will probably do likewise. It was generally agreed in the Assembly that the act was too dictatorial and restrictive. . . . Members of the Assembly and Senate were flooded with protests from service associations which declared that the measures actually censured every Service Man and subjected all to the will of one person.

HEATER DEFECTS FOUND CAUSE OF SUDDEN TUBE BREAKDOWN--A study recently completed by a government agency disclosed that defects in the heater represented a major factor in sudden tube failures. And such defects were found to be caused by not only the structure of the element itself, but its physical properties. Researchers found that early 6AK5s were particularly weak in heater design. Tests with one lot of 6AK5s, connected up in series, revealed that the tubes could not be operated at any continuous rate without affecting performance. This defect has been eliminated in new types now available. The 12AT7 was also found to display heater weakness and leakage trouble. . . . In other tests on tube efficiency, the government group found that the 12AU7 was more efficient than two separate triodes of equivalent design, and many 6AQ5s suffered from an improper power rating. A particularly hard glass was suggested as the solution to the latter difficulty.

ITV ACTIVITY BOOMS--Industrial television and its closed-circuit links, is no longer a stepchild of the TV family. ITV has been acknowledged now as a solid, practical medium, with unlimited application possibilities. . . . In 1953, over \$6-million were spent for ITV equipment and installation; more than ten times the amount expended in '52. And for '54-'55, it has been guesstimated that at least \$10-million will be spent for tie-line telecasting facilities involving cameras, monitors, coax, and installation, servicing and maintenance. . . . Not only can ITV be used for department stores, but in heavy industry, at banks, and even in the medical world; also to cope with fire and mine disasters, and to control traffic, inspect factory lines, and oversee production. It will eventually find a valued place in the home and the general business world, too. ITV is really up front now.\*--L. W.

\*See *Tube News*, this issue, page 48.



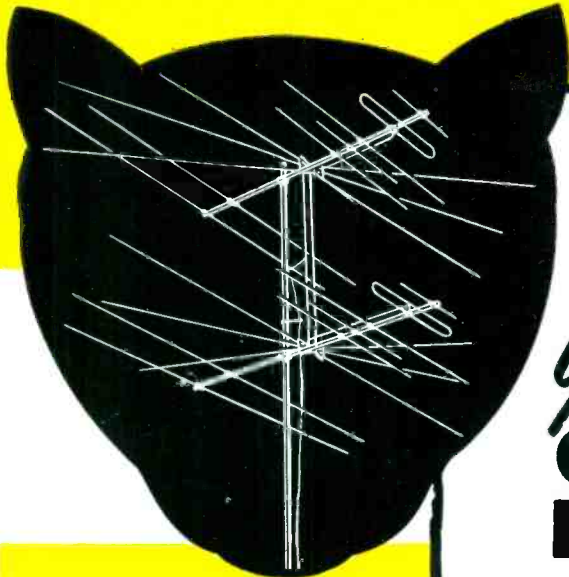

"BIG JOE" all channel VHF antenna  
BJ-10 single bay; BJ-20 stacked

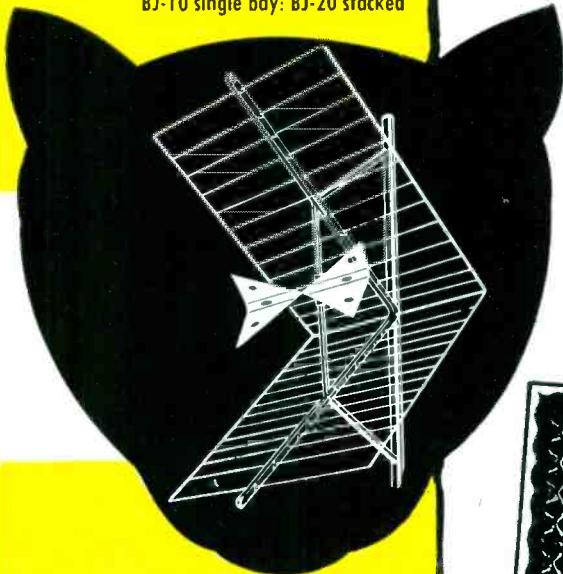

UHF Ultra Cor-Tenna, Model 706  
(Available stacked as Model 706-2)



Model UV-3 Triple-tie cross-over filter

# TESCON ...

## You are Guaranteed OUTSTANDING PERFORMANCE

by

TESCON'S unique and exclusive engineering . . . rugged construction, spectacular reception, easy "snap-in" assembly, split-second installation, strongest signal . . . features that make these the most outstanding antenna values at any price! Regardless of the antenna requirement, there is a TESCON model available that will do the perfect job, with the highest gain. Leaders in the TESCON line are the "BIG JOE"—the first antenna to cover all VHF channels with tremendous db gain — and the Ultra Cor-Tenna — one of the most powerful UHF corner reflector antennas known with a gain of up to 14.8db!

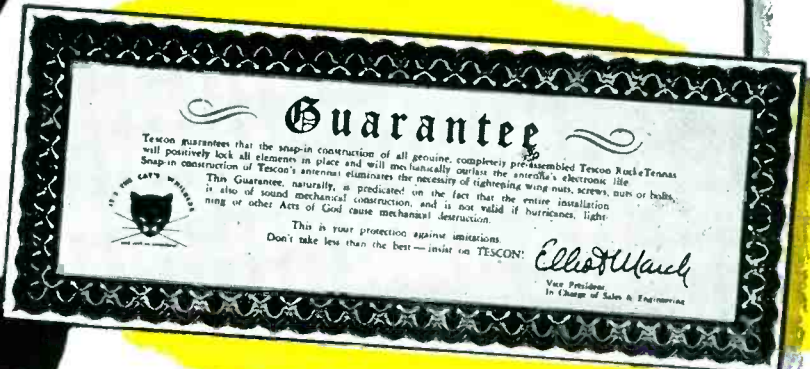

Write TESCON today for literature on the complete line of antennas and mounts for UHF, VHF and UHF-VHF.

# TESCON

TV PRODUCTS COMPANY  
SPRINGFIELD GARDENS 13 NEW YORK



and just as sensitive!

©m

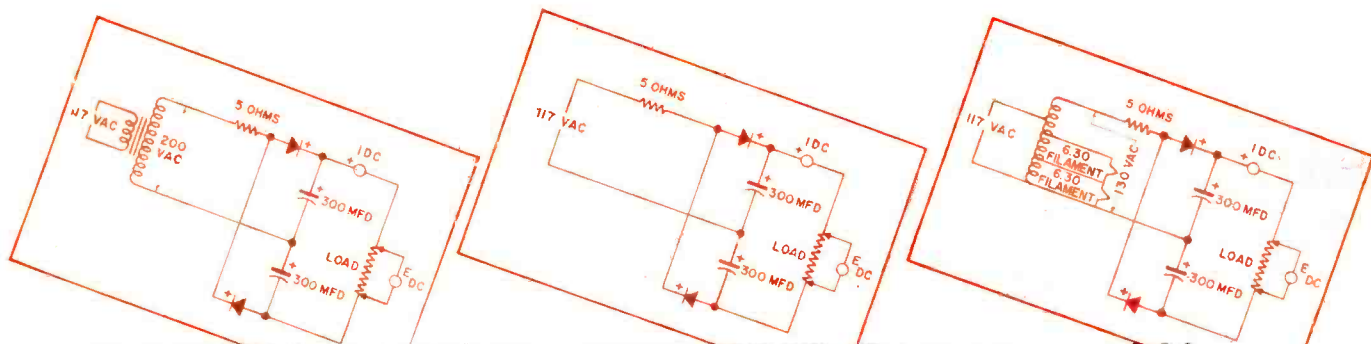

# SAFETY With SELENIUM Rectifiers

by RONALD L. IVES

THE RECTIFYING PROPERTIES of selenium have been known for almost three quarters of a century; and commercial selenium rectifiers have been in use for about two decades. Use of selenium rectifiers is increasing, as they are comparatively inexpensive, compact, relatively efficient, and highly dependable when not overloaded.

During the last decade there have appeared many articles outlining the supposed hazards incident to the use and misuse of selenium rectifiers. Concurrently, many word-of-mouth stories concerning the toxicity of selenium vapor have been circulated. According to some of these tales, selenium rectifiers are potentially almost as dangerous as atom-bombs; according to others, selenium rectifiers are entirely safe for use anywhere, and under any conditions.

Most of these accounts contain undeniable elements of truth, although the decimal point has been sadly misplaced in many instances. The toxicity of some selenium compounds, such as hydrogen selenide, is great and undeniable. What, then, are the dangers incident to the use of selenium rectifiers?

Selenium rectifiers, as commonly manufactured, consist of a coating of gray elemental selenium (*selenium B*) on a metal plate, which usually also serves as a cooling fin. The total weight of selenium in such a rectifier is usually considerably less than ten per cent of the weight of the entire unit. When operated at reasonable temperatures and current densities, such a rectifier loses selenium, by sublimation (direct transition from a solid to a vapor state, without passing through a visible liquid intermediate stage), at a very

slow rate, measurable in molecules per hour, and detectable by odor only if the rectifier is operated in a small confined space for a considerable time. Loss of weight by a selenium rectifier in continuous service, due to sublimation, is *considerably* less than one part per million per month of operation. Under any normal or tolerable operating conditions, this dissemination of metallic selenium vapor is both harmless and inoffensive; and amounts of any known selenium compound that could be formed from it are likewise harmless and inoffensive.

When, however, a selenium rectifier is overloaded to the point where it burns out, a relatively large amount of selenium is vaporized in a very short period. Inspection of a number of burned-out selenium rectifiers disclosed that about one fourth of the selenium in them was vaporized. In consequence, a burnout of a selenium rectifier may release into the atmosphere not more than about three per cent of the weight of the unit as selenium vapor, a small part of which *may* oxidize.<sup>1</sup> This release of vaporized selenium is not an insidious thing, and is amply evidenced by a foul odor, somewhat like that of a fire in a privy vault, so that there is no possibility of its occurring undetected, and hence constituting a hidden danger.\*

Industrial safety standards indicate that total maximum safe exposure is eight hours daily to a concentration of 0.1 milligram of selenium per cubic meter of air. Multiplying the milligrams of selenium per cubic meter of air, by the time, in minutes, of exposure, a C-T factor of 48 is obtained. This indicates that exposure of 1

minute to selenium vapor in a concentration of 48 milligrams per cubic meter will have approximately the same effect as exposure for 8 hours (480 minutes) to a concentration of 0.1 milligram per cubic meter. It has been found that the maximum safe exposure to the highest concentration of selenium likely to occur as a result of a burnout of a 500-milliamperere rectifier, producing a possible concentration of 70 milligrams per cubic meter, is 0.7 minute, or 42 seconds. This is ample time to enter the room where the burnout occurred, pull the plug, open the windows, turn on a fan, and walk out again. The only adverse effect likely to be experienced is slight nausea and retching, because, for most people, the odor of selenium becomes intolerable long before the concentration becomes physiologically dangerous.

A number of natural phenomena also *load the dice* in favor of safe use of selenium rectifiers. Elemental selenium has a very low vapor pressure, so that, at room temperature, the equilibrium concentration of selenium vapor is considerably less than 0.1 milligram per cubic meter, the maximum allowable industrial concentration. At the melting point of

\*A standard 500-milliamperere selenium rectifier weighs about 71 grams. A small room, 10' x 10' x 10', contains 30 cubic meters of air. If a rectifier is burned out in this room without ventilation, and all of the vaporized selenium remains in the air, the concentration of selenium vapor (assuming that 3 per cent of the total weight of the rectifier, or 2,130 milligrams, becomes selenium vapor) is about 70 milligrams per cubic meter. This, a theoretically maximum value, is about 700 times the maximum allowable concentration of selenium for continued exposure, but is also considerably below the probable LD50 concentration† for white rats. Experimental evidence shows that when white rats are exposed for eight hours to an atmosphere containing approximately 35 milligrams of selenium vapor per cubic meter, ten per cent of them will die of pneumonitis, an inflammation of the lungs similar to pneumonia.

†The LD50 concentration is the dosage which will be lethal to 50% of the animals exposed.

Circuits above illustrate typical selenium rectifier systems designed for b-w and color TV. Circuit at left will deliver about 450 v at 700 ma; center, 235 v at 800 ma; right, 265 v at 600 ma. (Sarkes Tarzian.)

<sup>1</sup>The term *may* is here used to imply doubt, as it has not been demonstrated conclusively that vaporized elemental selenium does oxidize on contact with air.



## Vapors Released During Operation or Burnout Found to be Harmless

Fig. 1. View of a 100-milliampere selenium rectifier after an intentional burnout with 220 volts of ac applied across terminals. Note the hole burned in end plate, and incrustations of condensed selenium (plus steel and varnish) on mounting.

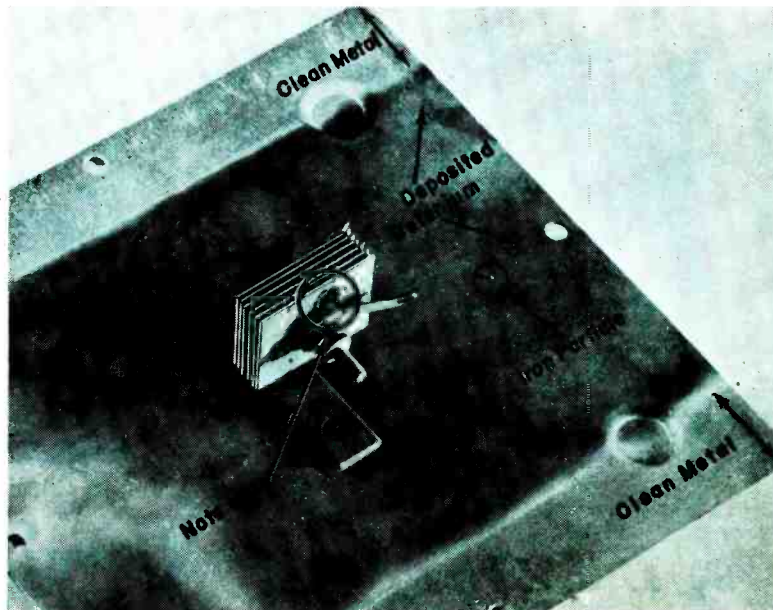

solder, the equilibrium concentration is only about two milligrams per cubic meter; detectable by smell, but not harmful for short occasional exposures. Because of this very low vapor pressure, a high concentration of selenium vapor, such as might be produced by a rectifier burnout, cannot be maintained at room temperature for any appreciable time. The selenium vapor condenses rapidly; some of it on adjacent cold surfaces, producing the familiar reddish-brown to black incrustations; the rest as small particles (fine dust) about a millionth of an inch in diameter. These slowly settle out of the air, so that the concentration of selenium particles becomes small in a relatively short time.

To give added confirmation to the foregoing empirical considerations, some tests of actual selenium rectifier burnouts were made. A standard 100-mil selenium rectifier was mounted, by means of an angle bracket, in the center of a 7" by 7" steel plate. With the plate inverted, so that the rectifier was underneath, 220 volts ac, from an industrial line (current substantially unlimited) was applied across the rectifier, effectively burning it out (and also blowing two 30-amp protecting fuses in the line). Appearance of the rectifier and mounting plate after burnout are shown in Fig. 1. It will be noted that a hole

was burned in the cooling fin by the heavy currents, and incrustations of condensed selenium appeared in the center of the plate. Burnout, under these conditions, with substantially unlimited current available, is much more severe than can occur in ordinary communications or amusement equipment. Current through the rectifier, during burnout, was at least 300 times its normal rating, and applied voltage was approximately double rated value.

Before burnout, the rectifier weighed 20.4247 grams; and the mounting plate 236.1745 grams. After burnout, the rectifier weighed 19.7264 grams; and the mounting plate 236.2408 grams. Loss of weight of the rectifier was .7023 gram, or about 3½% of its original weight. Gain in weight of the mounting plate, resulting from condensation of vapors, was .0663 gram. If we assume that all of the material lost by the rectifier, and not condensed on the mounting plate, was selenium, then this burnout released into the local environment .6360 gram of selenium, or about 3.114 per cent of the original weight of the rectifier. Actually, of course, an appreciable, but not easily determinable, frac-

tion of the sublimated material was varnish and steel (from the hole burned in the plate). X-ray diffraction photographs of the condensate produced such a complicated pattern that the nature of the material could not be determined with any confidence; test results merely showing that the condensate was by no means pure selenium. From these test results, one can state with assurance that not more than three per cent of the weight of a conventional selenium rectifier will be vaporized by any burnout likely to occur in actual practice; and that not all of the vapor will be selenium.

Theoretical and practical considerations both show that the amount of selenium released by a rectifier burnout, even when conditions are worse than are likely to be encountered in actual practice, is well within safe physiological limits. Additional support to this evaluation was furnished by the records of the National Electrical Manufacturers' Association,\* which disclose that during more than fifteen years of manufacture, use, and occasional misuse of selenium recti-

(Continued on page 81)

Fig. 2. Circuit illustrating use of limiting resistor and fuse to prevent severe burnouts of selenium rectifiers. For values of current-limiting resistor, see p. 81.

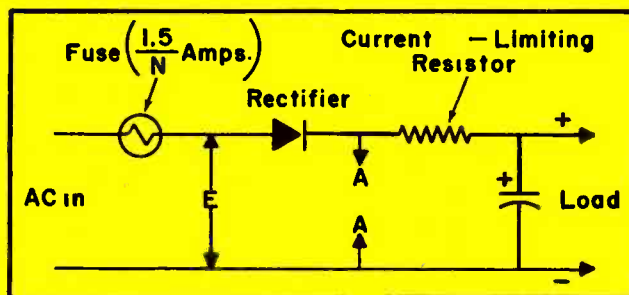

\*NEMA News Bulletin 40; November 10, 1952.

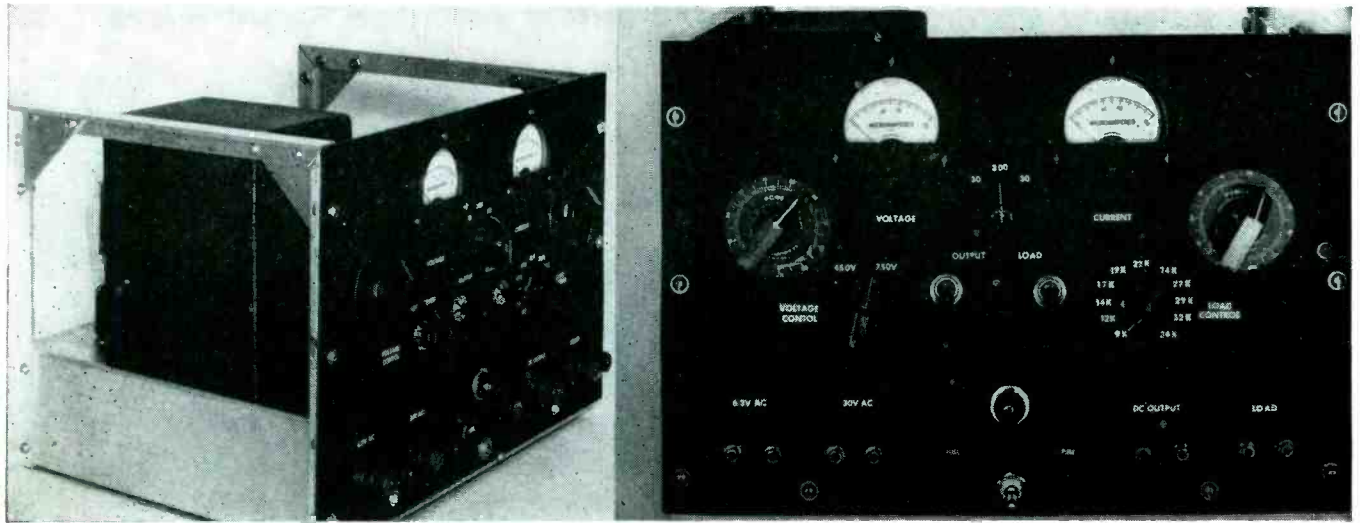

by J. C. GEIST

# Servicing BOOSTED-B

THE HORIZONTAL-DEFLECTION circuits used in modern TV receivers with the boosted *B*-voltage feature have no direct analogy in the older type of radio or communication sets, and therefore field service procedures for these newer circuits have not yet been highly developed. The *boot-strap* arrangement used in some designs wherein the boosted *B* voltage is used to power the exciting stages of the deflection circuits can, under some types of failures, be quite difficult to troubleshoot. Schematics of horizontal deflection circuits used in two typi-

cal TV receivers are shown in Figs. 1 and 2. These circuits have been redrawn somewhat in an attempt to show more clearly the specific portions being considered. In these designs the horizontal and vertical oscillator circuits, as well as the plate of the horizontal output tube, derive power from the boosted *B* voltage. In some designs the screen-grid of the horizontal output tube and the first anode of

the picture tube are also powered from the boosted *B* voltage.

There are a large number of different troubles which can develop in the circuit of these and similar designs which will materially reduce the boosted *B* voltage. Under such conditions, of course, a large portion of the receiver will operate improperly or will be completely inoperative. The fact that part of the *B* voltage for the horizontal deflection circuits is derived from the horizontal deflection output (*boot-strap*), prevents troubles from being pin-pointed by conven-

Fig. 1. Typical horizontal-deflection circuit.

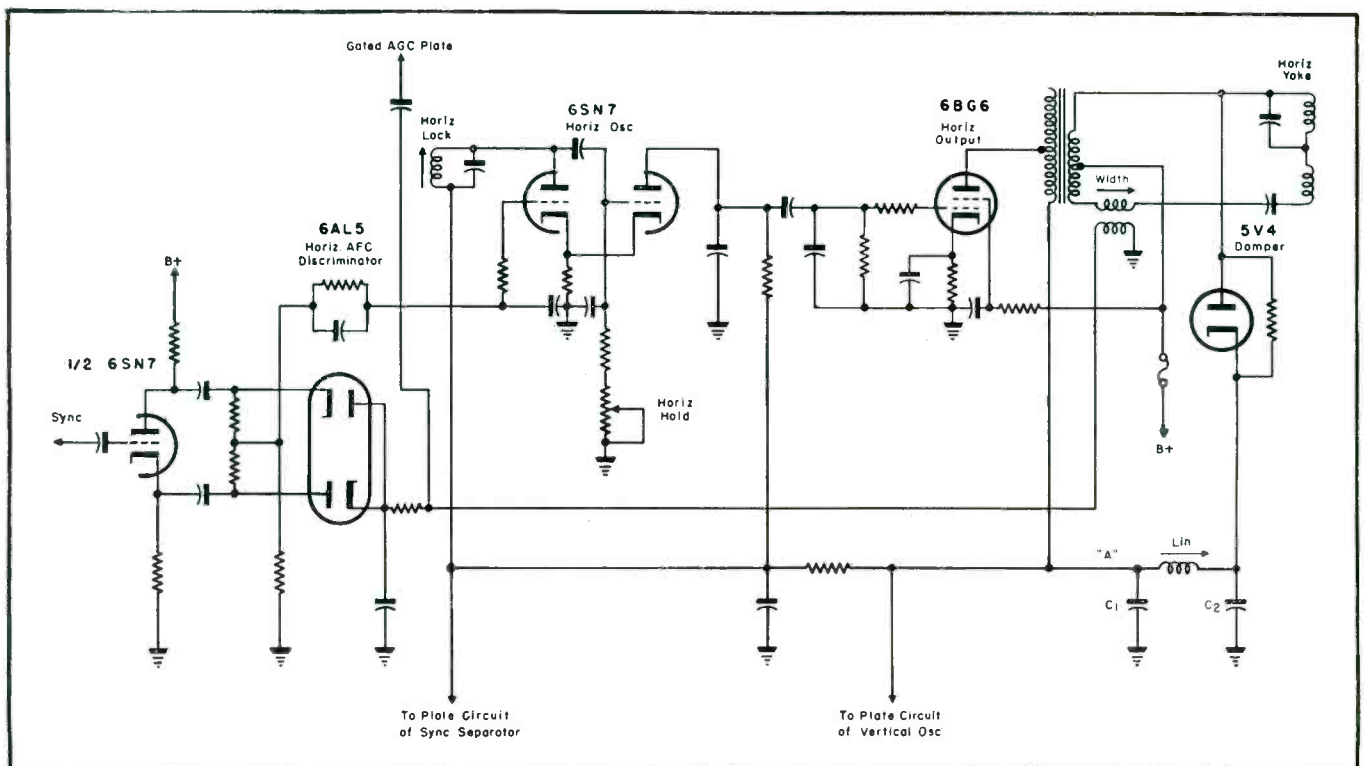



(Left)

Front and side views of boosted-B power-supply tester. The current-meter selector switch and meter-shunting switches are grouped conveniently in the center of the panel. In the center position the power supply output current is measured continuously on a 300-ma meter range. In the left position the output current is measured on a 30-ma range only when the left-hand meter shunting switch is depressed. In the same manner, when the switch is on the extreme right position current through the load is measured on a 30-ma scale only when the right-hand meter shunting switch is depressed. The positions of the load-resistance control switch are marked on the panel to show the approximate resistance available from each tap. Finer load adjustments can be made by means of the rheostat load control. Aluminum angles on either side of the chassis were used to strengthen the panel and provide convenient means for handling the relatively heavy unit.

(Right)

Fig. 2. Another type of horizontal-deflection circuit, showing boosted-B test points.

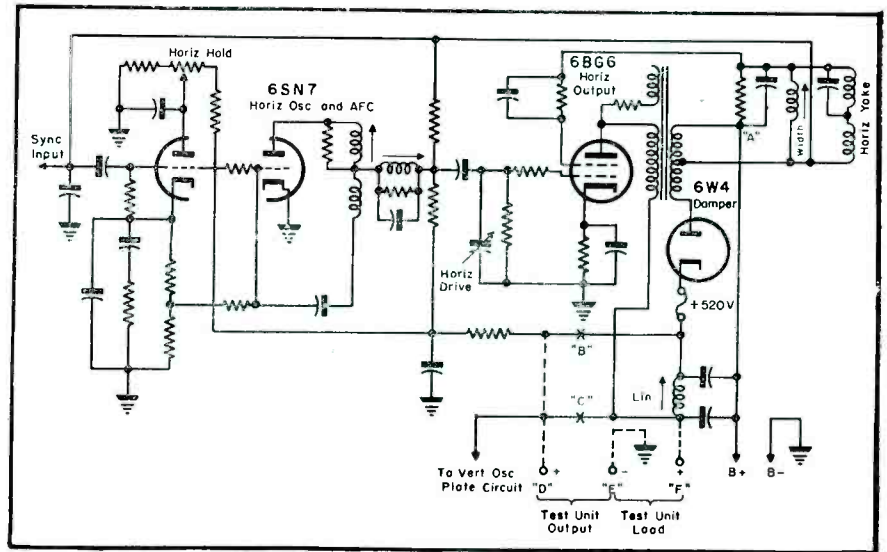

# Voltage Circuits in TV Receivers

[See Cover]

tional voltage-measuring techniques. It is, of course, simple to trace the trouble to *reduced boosted B voltage*, but since this voltage is derived from the proper operation of preceding circuits, it is not always easy to determine the exact cause of the trouble.

A resistance test will quickly show whether or not resistors have radically changed values or capacitors have shorted. The actual value of the boosted *B* voltage will, in some cases, give a clue to the source of the trouble. For instance, if either of the boosted *B* filter capacitors,  $C_1$  or  $C_2$  in Fig. 1, are shorted no voltage will be present at point *A*. Even the power-supply *B* voltage from the fuse through the transformer secondary and the damper tube will be shorted to ground. (In some cases such a short would be sufficient to blow the fuse.) Conversely, if a voltage nearly equal to the power-supply *B* voltage is present at point *A*, there is no low-resistance short to ground on the *B*-voltage bus in the horizontal deflection circuits. There are numerous faults which are not nearly so straightforward as shorted capacitors or open resistors which, without an effective test procedure, can easily require an inappropriate amount of time (and frustration) in substituting suspected parts. Every Service Man knows how very difficult the problem can be if by chance two or more parts are faulty at the same time. What is needed, just as for troubleshooting any circuit, is a systematic method for promptly isolating the fault.

One promising method of isolating the type of fault being described ap-

pears in the use of an external power source to supply the *B* voltage to those stages which normally obtain power from the missing boosted *B*. By this means the conventional methods of testing can be followed to insure that the proper excitation voltage is reaching the grid of the horizontal output tube, after which further troubleshooting, as necessary, can be more easily performed on the horizontal output circuits.

There are several possible approaches to the design of a suitable power-supply test unit for this application. Probably the least expensive design would provide a maximum voltage of 400 at about 50 ma, to be

connected in cascade with the receiver power-supply *B* voltage to provide the boosted-*B* power. In any case, it is necessary to have a source of variable *dc* voltage which is capable of being adjusted to provide the maximum value of boosted *B* voltage to be encountered. As will be explained, it is also desirable to include a variable-resistance power-dissipating element to simulate the load on the boosted-*B* circuits.

The circuit diagram of a test unit designed specifically for this application appears on the cover and in Fig. 3. The design also incorporates additional features resulting in a versa-

(Continued on page 82)

Fig. 3. Circuit (see cover) of power-supply test unit, which also supplies sufficient heater and plate power for most TV sets; and the variable *dc* output and the low-current milliammeter make it ideal for checking and reforming electrolytics, too.

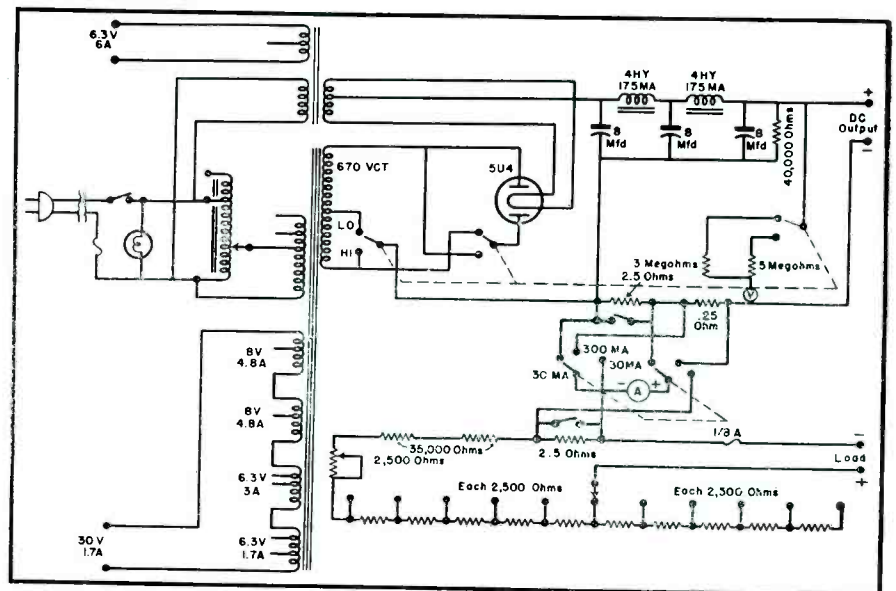

## Progress Report on Components and

### Tubes Designed for Production-Type Color TV Receivers

# COLOR TV developments

by DOUGLAS J. MARISEN

FOR THE SPECIAL DEFLECTION, convergence and focusing requirements of tricolor picture tubes and the allied circuitry involved in the complete color system of receivers, an intriguing new family of components and tubes has been developed.

Included in the parts chain are vertical dynamic-converging and dynamic-focusing transformers, vertical-deflection output transformers, horizontal dynamic-converging and dynamic-focusing transformers, vertical-isolation inductors, purifying coils, horizontal-output and *h<sub>v</sub>* transformers, and deflecting yokes.<sup>1</sup>

Receiving tubes especially developed for color TV include a versatile two-in-one, triode-pentode (6AN8), useful in at least eight different color-receiver applications; a sharp-cutoff beam triode for *h<sub>v</sub>* regulator service (6BD4); a half-wave rectifier tube for *h<sub>v</sub>* pulsed-rectifier service (3A3); a pentagrid amplifier for gated amplifier service (6BY6); and a half-wave rectifier tube for damper applications (6AU4GT).<sup>2</sup>

The 6AN8, a two-in-one tube of the nine-pin miniature type contains a medium- $\mu$  triode and a sharp-cutoff pentode in one envelope. The triode

unit, featuring relatively high zero-bias plate current, is useful in low-frequency oscillator, sync-separator, sync-clipper, and phase-splitter circuits. The pentode unit, featuring high transconductance, can be employed as an *if* amplifier, video amplifier, *agc* amplifier, and reactance tube.

The 6BD4, a low-current beam triode of the sharp-cutoff type designed for voltage regulation of *h<sub>v</sub>* low-current *dc* power supplies, has a maximum *dc* plate-current rating of 1.5 *ma* and a maximum plate-dissipation rating of 20 watts.

The 3A3 is a half-wave rectifier of the glass-octal type utilizing an indirectly heated cathode. Designed for use as a rectifier of *h<sub>v</sub>* pulses produced in scanning systems of color TV sets, it is rated to withstand a maximum peak inverse plate voltage of 30,000 and can supply a maximum peak plate current of 80 *ma* and a maximum average plate current of 1.5 *ma*.

A seven-pin miniature type, the 6BY6 is a pentagrid amplifier designed especially for use as a gated amplifier, and also as a combined sync separator

and sync clipper. Tube design includes separate base-pin terminals for grids 1 and 3. Each of these grids can be used independently as a control electrode. Has a sharp-cutoff characteristic which is said to facilitate good sync clipping and noise cancellation with relatively low values of input signals.

The 6AU4GT is a half-wave rectifier of the glass-octal type for damper-diode service, and is useful in color TV and in b-w receivers utilizing picture tubes having 90° deflection. Rated to withstand a maximum peak inverse plate voltage of 4,500, the tube can supply a maximum peak plate current of 1,050 *ma* and a maximum *dc* plate current of 175 *ma*.

In production now also is the tricolor picture tube, the 15GP22, which is capable of producing either a full-color or a b-w picture 11½" by 8⅝" with rounded sides.

The tube utilizes three electrostatic-focus guns spaced 120° apart with axes parallel to the tube axis; magnetic deflection; electrostatic convergence; and an assembly consisting of a shadow mask and a plane, tricolor, *Filterglass* phosphor-dot (screen) plate located between the shadow mask and a clear-glass faceplate.

The tricolor phosphor-dot plate, which serves as the directly viewed screen, carries an orderly array of small, closely spaced, phosphor dots arranged in triangular groups (trios). Each trio consists of a green-emitting dot, a red-emitting dot, and a blue-emitting dot. The phosphor-dot plate has approximately 195,000 dot trios or 585,000 dots and is metalized after

(Continued on page 88)

(Left)

Dynamic-convergence and focus circuits for tricolor tube. (RCA.)

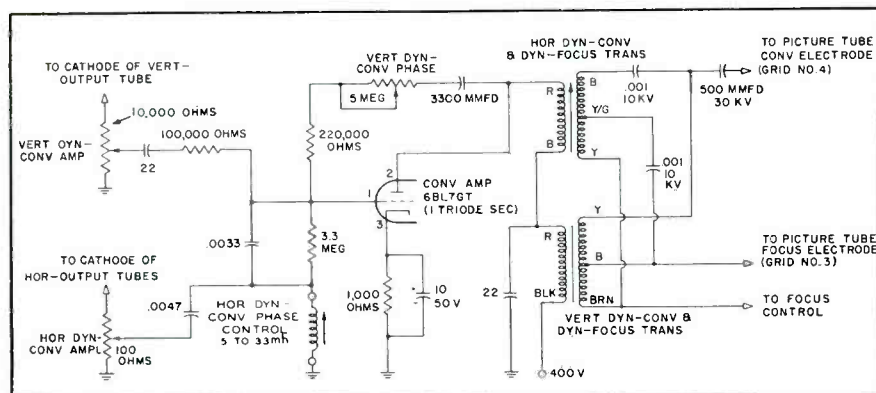



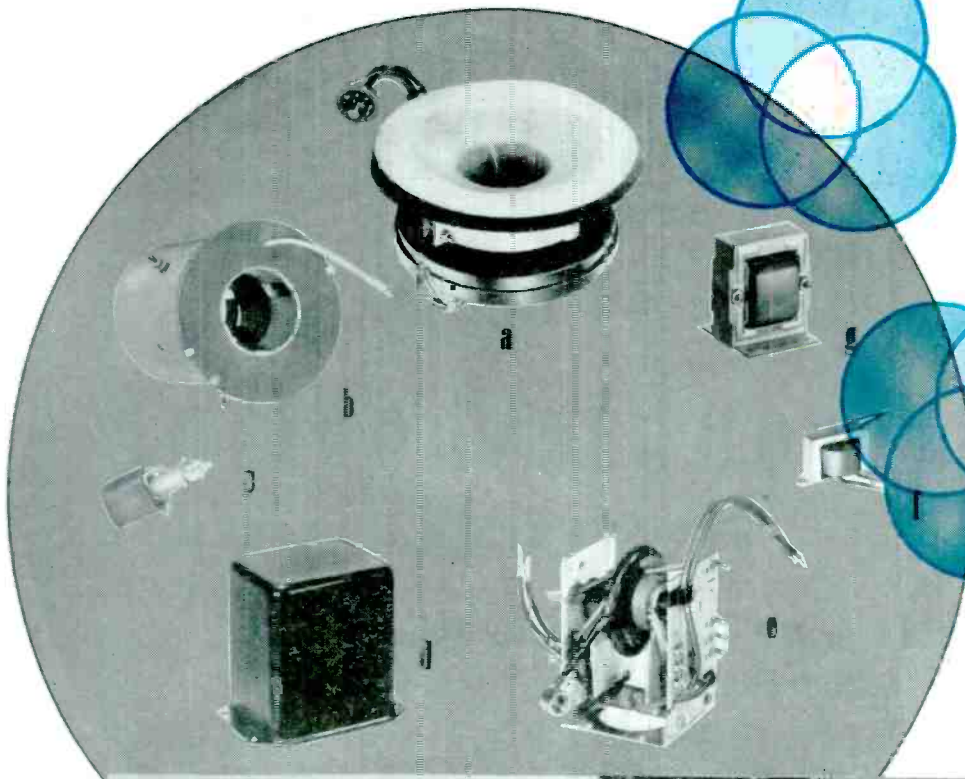

(Left)  
 Assortment of components developed for color TV: a = purifying coil; b = horizontal dynamic-converging and dynamic-focusing transformer; c = vertical dynamic-converging and dynamic focusing transformer; d = horizontal-output and hv transformer; e = vertical deflection inductor; f = vertical deflection output transformer; g = deflecting yoke. (RCA)

(Below)

At left: Typical color receiver using 41 tubes and a 15-inch tricolor picture tube. (G.E.).  
 Right: Checking deflecting yokes for tricolor tubes. (RCA)



Right: Components developed for color TV models. At left is a field neutralizing coil used around the faceplate section of the picture tube to neutralize effects of extraneous fields; fields are neutralized by adjustment of the direction and amperage of current through the coil. Coil body consists of a flexible polythene coil form which supports 150 turns of No. 26 insulated copper wire. Completed assembly is covered with a double layer of plastic insulated tape, as shown in rear of photo. Foreground view illustrates coil construction; two layers of plastic tape were peeled back to show wires in place in Y channel form. At right is a variable inductance designed for color TV chassis. (Neutralizing coil views from Anchor Industrial and Penn-Tran; variable inductance illustration from Crest Laboratories.)

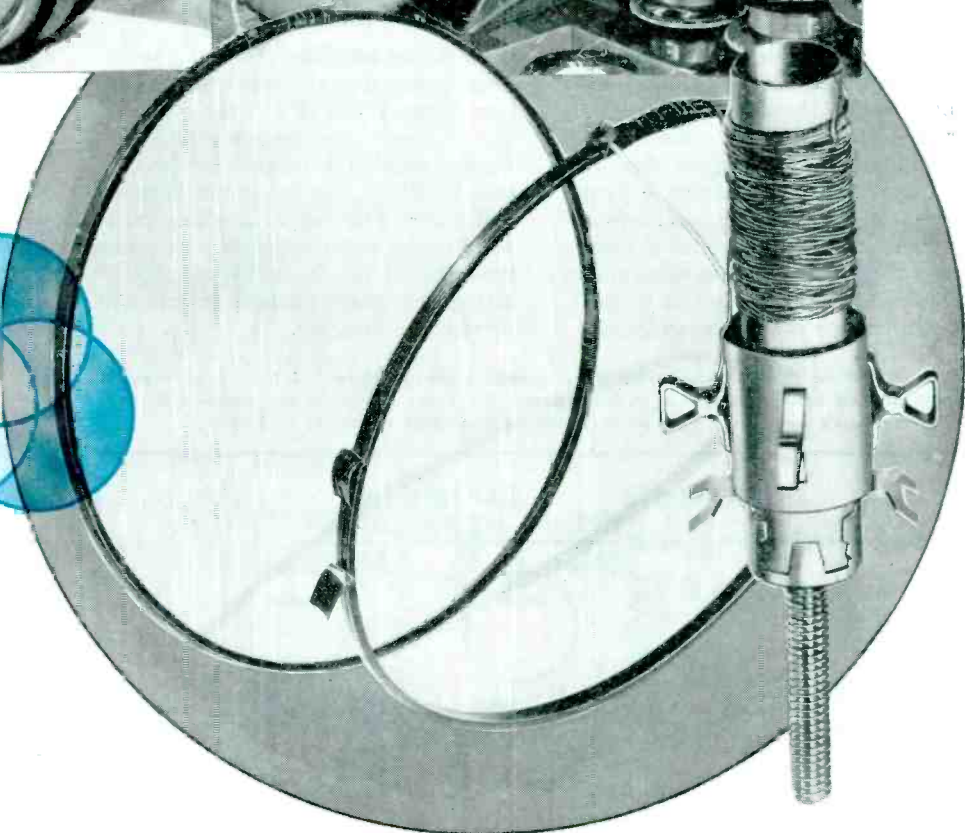
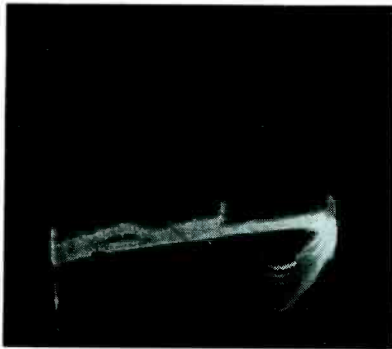

Fig. 1. Appearance of a typical buzz pulse caused by stray field from the picture tube. The shape of the pulse varies considerably as the brightness control is turned. When the screen is dark, the pulse disappears.



# TV Chassis 60-Cycle Buzz Troubleshooting

by CLARK R. ALISEN

## Localizing and Curing Buzz in HV Supply, Video Amp and Picture-Tube Circuitry or Allied Components

IN RUNNING DOWN 60-cycle buzz, it may be found necessary to check the high-voltage supply, video amp, picture-tube shielding and components used in these circuits.

1: If a TV receiver has been converted from one using a glass picture tube to one with a metal-type picture tube, better shielding of the picture tube may be required to eliminate the buzz. (High-voltage buzz will appear on the 'scope screen as shown in Fig. 1; see also Fig. 2.)

2: In case the *hv* power supply is not the source of the tunable buzz (indicated by buzz level remaining constant as the brightness control is turned), one should turn the contrast control, while listening to the buzz level and observe the picture contrast. (This latter test will be valid only for receivers in which the contrast control varies the grid bias of the video amplifier, and in which the sound signal is passed through the video amplifier.)

3: If the receiver is one in which the sound passes through the video amplifier, but with a contrast control which does not vary the grid bias of the video amplifier, external variable bias should be supplied to video amp to see if buzz can be eliminated.

4: If the buzz level can be eliminated or greatly lessened before the picture loses satisfactory contrast, then the video amplifier is probably at fault. The video-amplifier tube(s) should be checked for signal-handling capability, and best-performing tube selected.

5: Video-amplifier buzz is sometimes common to all receivers of a certain type. When this is the case and line voltage is low, an automatic line-voltage regulating transformer will be found helpful; the additional voltage will increase the signal-handling capability of the video amplifier. The tube type should not be changed without making necessary changes in lead and screen resistors, etc.

6: To check the operation of the video amplifier, the *dc* and peak-to-peak *ac* operating voltages must be measured. These voltages should check within 20% of the values published in the service manual for the receiver. One should also check the plate, screen, and cathode resistance values. Tolerances are usually 10%, but may be more or less in various instances. Once again, the service manual should be consulted, this time for tolerances.

7: Peaking coils in the video amplifier should be checked for faulty damping resistors or for shorted turns, which can affect *hf* circuit response.

8: One should also check the proportions of the horizontal sync pulse, to determine whether sync clipping is taking place in the *if* or in the video amplifier. Excessive heterodyne sync buzz is generated when the sync pulse is clipped, since the amplifier is then operating in a non-linear manner.

9: Bypass capacitors along the heater string should be checked for opens, which can cross-couple *hf* buzz voltages from other receiver sections into the video amplifier.

10: The common bypass capacitors between the video amplifier and the sync amplifier, and sync-control circuits should also be checked.

11: If it is determined that the buzz is not being generated in the video amplifier, the *if* amplifier should be in-

(Continued on page 86)

Fig. 2. Circuit of typical pulse-tripler 30-kv supply. Pulse doublers and triplers offer poorer regulation than half-wave rectifier systems. Hence, the beam current in the picture tube more often develops a buzz pulse in the *hv* field from a doubler or tripler.

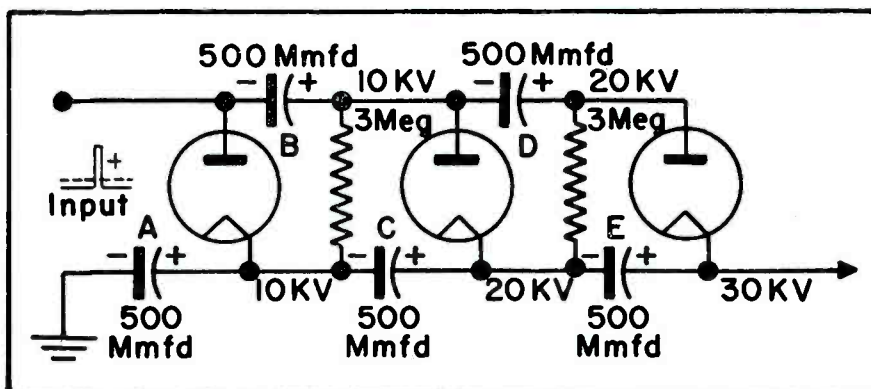

Right . . . Fig. 3. Block diagram of a typical TV chassis illustrating 60-cycle buzz problem areas. Above is a detailed study of these trouble spots; specific areas circled and numbered are similarly keyed in analysis.



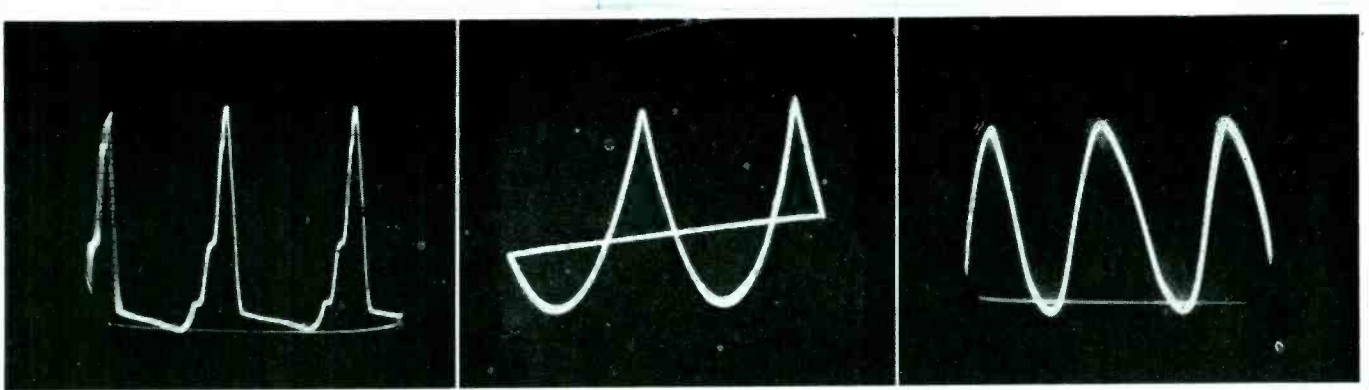

Fig. 4. Buzz waveforms found at the output of the audio amplifier vary greatly in waveshape, depending upon the particular receiver fault which generates the buzz. An experienced ear can tell something of the waveshape of the buzz, even before the 'scope is applied. Buzz waveforms shown here, from left to right, represent a transition from hard to soft buzz.

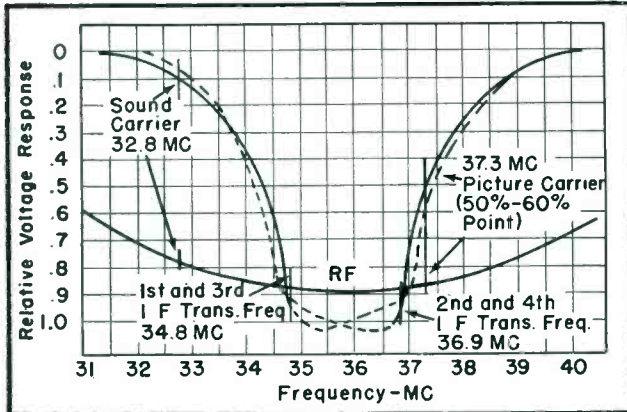

Fig. 5. It is quite essential that the sound carrier be properly placed on both the if response and on the rf response curves to minimize buzz. The sound carrier should be at the 5% or 10% point on the if response curve. The sound carrier should be placed at same level on rf response curve as picture carrier. Otherwise, heterodyne sync buzz will be excessive; Fig. 6.

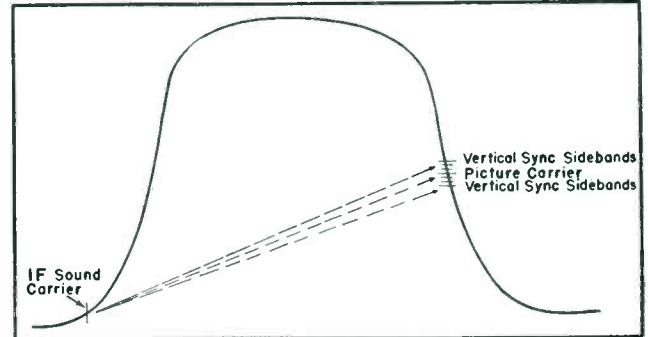
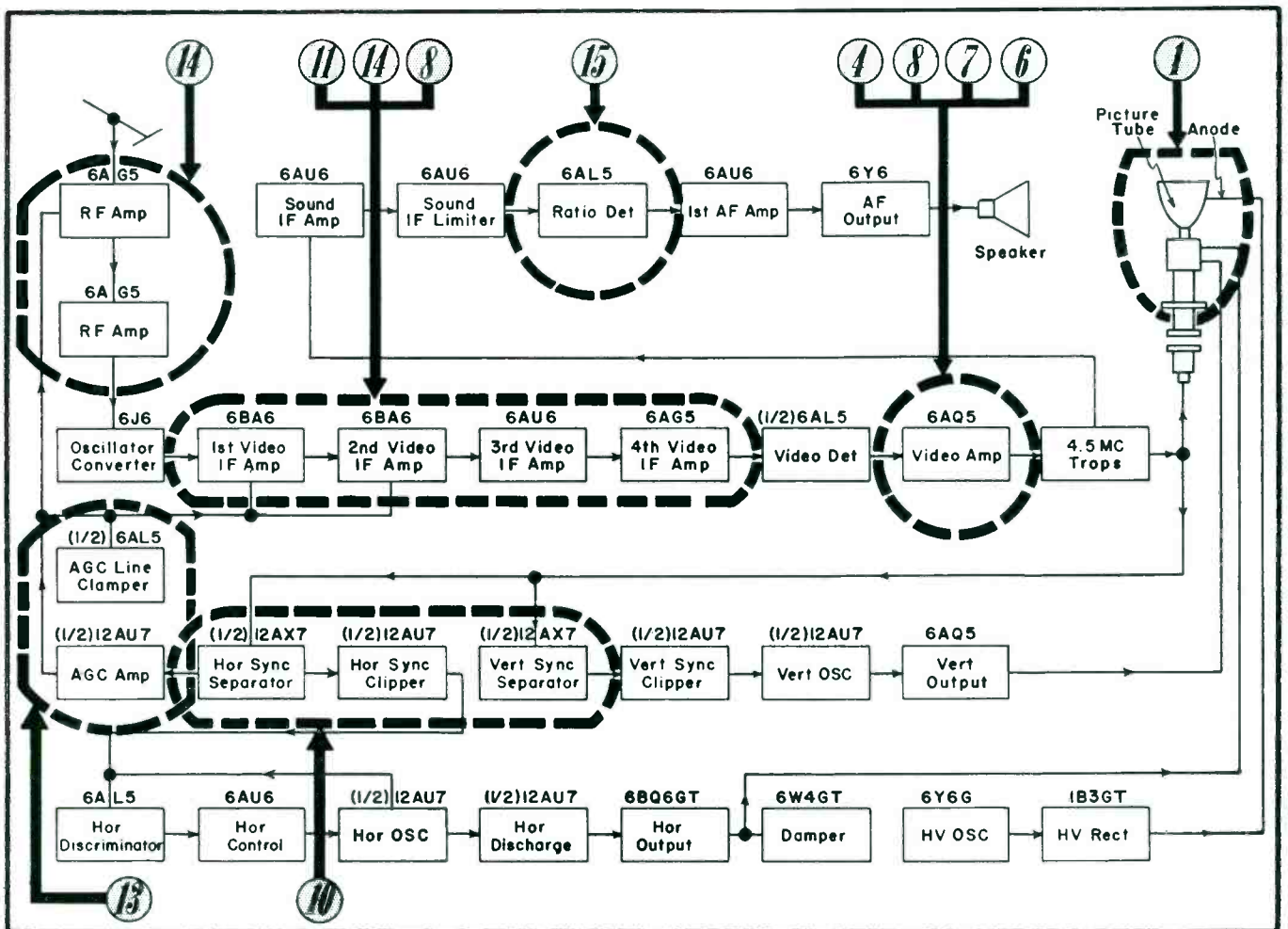

Fig. 6. Heterodyne sync buzz is generated in the if amplifier because the picture and sound signals beat together to form the 4.5-mc second if signal. Since the picture signal has the vertical sync-pulse sidebands in the region of the picture carrier, it is impossible to keep the sync-pulse frequencies from beating with the sound if signal and generating buzz. (Courtesy Precision Apparatus Co.)



# Phase Splitters For

THE PHASE SPLITTER, which is also known as the *phase inverter*, is that part of the audio amplifier which divides the signal into two parts, each opposite in phase from the other. This division is necessary to provide the proper excitation for each half of the push-pull output stage.

Phase-splitter circuitry in commercial receivers has been pretty standard for years. But with the advent of the greatly increased interest in *hi-fi*, and with the boom in the manufacture of separate audio amplifiers, the Service Man is likely to encounter many different types of phase splitters. The intelligent servicing of modern audio stages therefore requires a knowledge of the working principles of various phase-splitter circuits. Without such knowledge it becomes impossible to follow an orderly signal-injection technique working back from the output stage grids, or to spot the causes of certain minor defects in push-pull operation, such as improper balance.

## The Tapped-Voltage Phase Splitter

In Fig. 1 appears the circuit of the old war-horse of phase splitters, the *tapped voltage* circuit, in which the signal output of the first triode,  $V_1$ , is applied to a voltage divider made up of resistors  $R_1$  and  $R_2$ . The signal from the top of the voltage divider goes directly to the grid of one output tube, while the signal from the tap, which is a small fraction of the output of  $V_1$ , is fed to a second triode,  $V_2$ . The second triode then amplifies the tapped signal back to its full original value, and couples it to the grid of the other output tube.

The signal at the tube's plate is always  $180^\circ$  out-of-phase with the grid input signal, and thus the voltage input to  $V_2$  is  $180^\circ$  out-of-phase with the voltage input to  $V_1$ , precisely the condition required for push-pull operation. It can be seen that the triode,  $V_2$ , is in the circuit for the sole purpose of inverting the signal phase before the signal goes to the second output tube, and it is  $V_2$  rather than the combination of  $V_1$  and  $V_2$  which is most properly called a phase inverter.

The cut-in voltage produced by  $R_1$  and  $R_2$  must exactly compensate for the voltage amplification of  $V_2$  if the signal is to be balanced. The typical component values shown in the schematic will achieve approximate bal-

ance, and if a more precise balance is desired a potentiometer may be substituted for  $R_2$ . Readjustment of the balance setting of such a potentiometer may be required, however, when changes due to the aging of circuit components and tubes take place.

## The Floating Paraphase

The circuit of Fig. 2, called the *floating paraphase*, provides a certain degree of self-balance, and is more likely to remain in proper adjustment over a period of time. This circuit may be thought of as a variation of the phase splitter of Fig. 1. Signal voltage tapped from the output of  $V_1$  is again passed through a phase-inverting triode and fed to  $V_2$ , but this time the tapped voltage is a large fraction of the total. The special feature of the paraphase is that a large part of the output of  $V_2$  is applied back across the input resistor  $R_2$ , constituting negative feedback and cutting down the effective gain of  $V_2$ . There are thus two signals across  $R_2$ , of opposite phase, and they tend to cancel each other to the point of circuit balance, if the values of the circuit components are about right. Since the circuit of Fig. 2 is more stable than that of Fig. 1, and uses the same number of parts, it is generally considered a superior design.

The even-harmonic distortion in a balanced push-pull amplifier is considerably less than that in an unbalanced one, and the addition of a variable potentiometer (linear taper) to the circuit of Fig. 2, making possible an accurate balance adjustment, may be a worthwhile procedure in a conversion job from ordinary to high-quality audio. The potentiometer is connected into the circuit as shown in Fig. 3, and adjusted for balance by one of the methods described previously.<sup>1</sup>

One of the best and simplest of such methods, involves the use of the low-impedance secondary winding of any output transformer placed in series with the common  $B+$  return line of the output stage, as shown in Fig. 3. A 'scope or pair of earphones is then connected across the high impedance primary of the test transformer, and the balance potentiometer adjusted for minimum output signal in the earphones or 'scope, using either a test

audio signal or normal program material. Once the balance has been established, the self-balancing characteristics of the floating paraphase design tends to keep the circuit in adjustment.

This self-balancing feature, as a matter of fact, makes it practical to dispense with the potentiometer and to secure initial balance by experimenting with different values of  $R_1$  or of  $R_2$ , using that value of resistor which produces the best results. Reducing the value of  $R_1$  will have the opposite balancing effect of reducing the value of  $R_2$ , so that the easiest procedure is to bridge temporarily each of these resistors in turn with test resistors of different value, and then to connect the appropriate bridging resistor into the circuit permanently. In the balanced condition  $R_1$  will normally have a somewhat lower value than  $R_2$ . An unbypassed, common cathode resistor for  $V_1$  and  $V_2$  improves balance in all of the circuits discussed.

## Cathode Loading

The phase splitter of Fig. 5 (p. 86) which has become very popular in recent years, is called the *split-load* or *cathode-loaded* circuit. Since the signal current through each of the load resistances,  $R_{L1}$  and  $R_{L2}$ , must always be the same due to their series connection, phase-splitter balance is determined entirely by the relative values of these load resistances, and can be checked with nothing more than a good ohmmeter. In checking for balance it must be remembered, however, that the grid resistors following the phase splitter are effectively in parallel with each of their associated load resistors, and that the grid resistors as well as the load resistors must be matched to each other.

The series relationship between  $R_{L1}$  and  $R_{L2}$  also keeps the polarity of the signal across each resistor, considered from the same direction, the same. But going around the circuit from plate to cathode it will be seen that the signal is taken from the *hot* end of the load resistor at the plate and from the *cold* end at the cathode; the signals at each point relative to ground, then, are opposite in phase.

Tube characteristics have no effect on balance in this phase splitter, and because of the partial cathode-follower



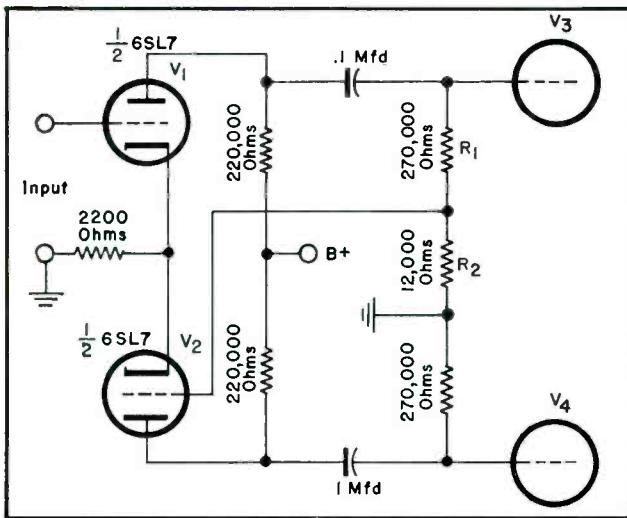

Fig. 1. Tapped-voltage phase splitter, with common circuit values. For more accurate balance a 15,000-ohm linear taper potentiometer may be substituted for  $R_2$ . The signal to  $V_2$  may also be tapped from the plate resistor of  $V_1$ , through a capacitor.

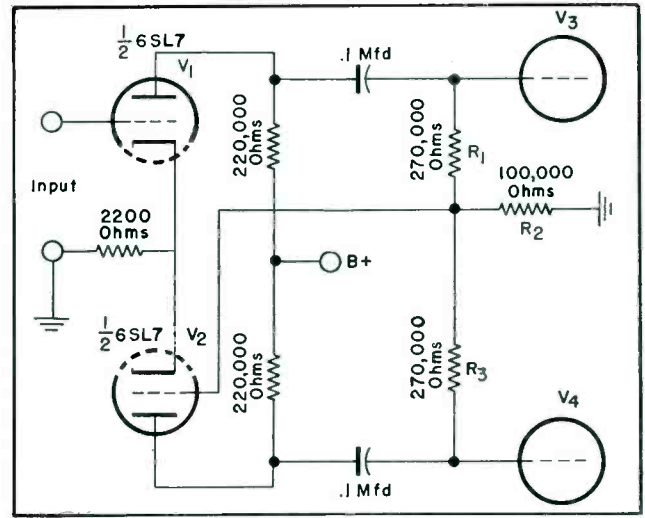

Fig. 2. Floating paraphase phase splitter, self-balancing within limits.

action and heavy negative feedback the circuit is especially stable and distortion free. In some cases imbalance in the output stage is counterbalanced at this earlier point, in which case perfect balance of the phase splitter alone is no longer sought, and a balance potentiometer is used to regulate the relative values of  $R_{L1}$  and  $R_{L2}$ .

Fig. 6 (p. 87) illustrates the most

popular application of the split-load circuit, in the well-known Williamson design used by many different amplifier manufacturers. The distinguishing feature of this application is that the bias for the phase-splitter tube consists of the difference between the cathode-to-ground voltage, approximately +105 volts, and the grid-to-ground voltage, approximately +100 volts, the latter

secured from the previous direct-coupled plate.

### Other Phase Splitters

The three phase splitting circuits described are the most common, and account for the vast majority of ampli-

(Continued on page 86)

Fig. 3. Balance potentiometer (linear taper) inserted in floating-paraphase circuit. Once the balance is set the circuit tends to keep itself in balance. For alternate method of balancing, without potentiometer, see text.

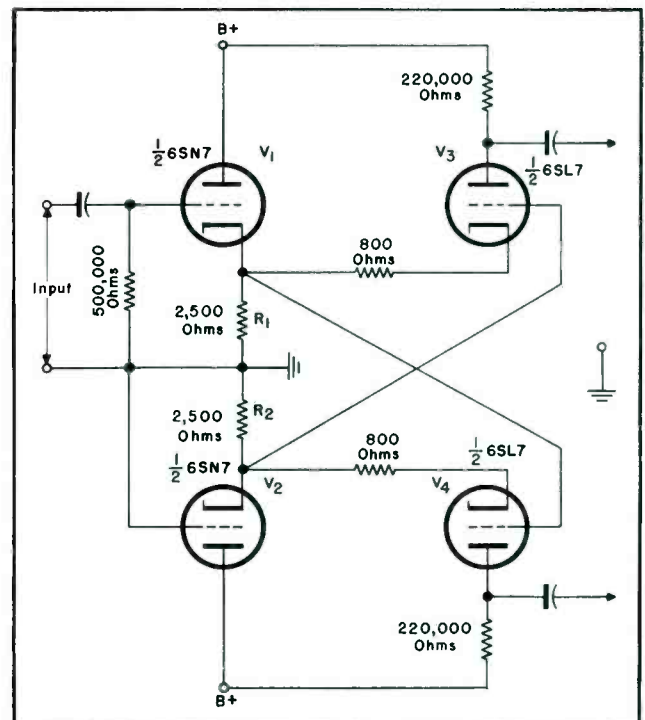
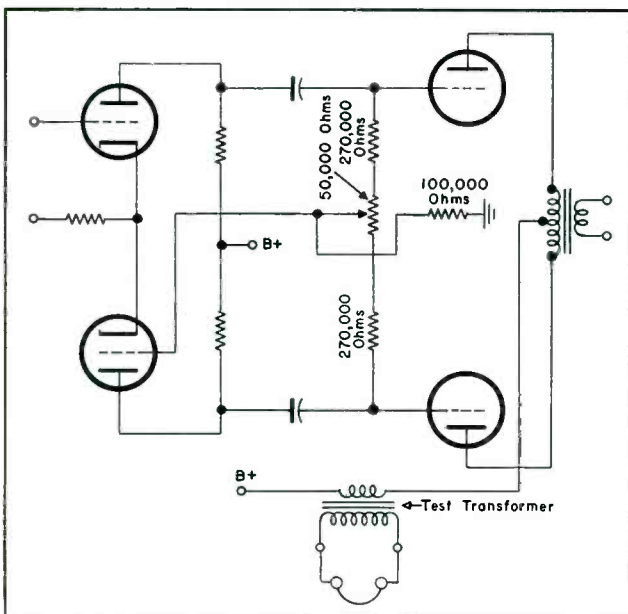

Fig. 4. Cross-coupled, self-balancing phase splitter.





the chassis and can be shut off separately, but is automatically turned on and off with the receiver. Two 6J6 twin triode tubes are used in a push pull, neutralized circuit. One 6J6 is used as an *rf* amp. covering channels 2 to 6 and the second covering channels 7 to 13. Two pigtail type neutralizing capacitors (1.2 mmfd) are used to prevent feedback and eliminate regeneration.

### Cascade UHF Amp

Also available for this improved chassis is a *uhf* amp which uses a cascode circuit. The amp, built in, has one *if* amp stage (6BZ7 or 6BK7A) claimed to have an 18-db gain, and a crystal diode mixer and one oscillator (a 6AF4 or 6T4). As in the case of the booster, antenna is connected to amp by a short length of 300-ohm coax.

### Stewart-Warner VHF/UHF Chassis

ANOTHER INTERESTING approach to TV circuitry design is illustrated in Fig. 3; the *v/u rf* tuner used in Stewart-Warner receivers.†

Used here is all-wave turret type tuner, which consists of two separate chassis joined together as one unit. The front section tunes the *uhf* stations, channels 14 to 83, and incorporates 2 preselector stages; a 6AF4 or 6T4 tube as the oscillator and a 1N82 crystal as the mixer. The rear section performs a dual function in that it tunes all the *vhf* stations, channels 2 to 13 and operates as a 41-mc *if* amplifier when the receiver is tuned to any *uhf* channel. It incorporates a 6BZ7 or 6BQ7A as a cascaded *rf* amplifier for *vhf* operation and as a cascode 41-mc *if* amplifier for *uhf* operation. A 6U8 is used as a mixer-oscillator for *vhf* and as a 41-mc *if*

†Federal K111.

‡Models 21C-9340; 21T-9340; 24C-9360 and 27C-9350.

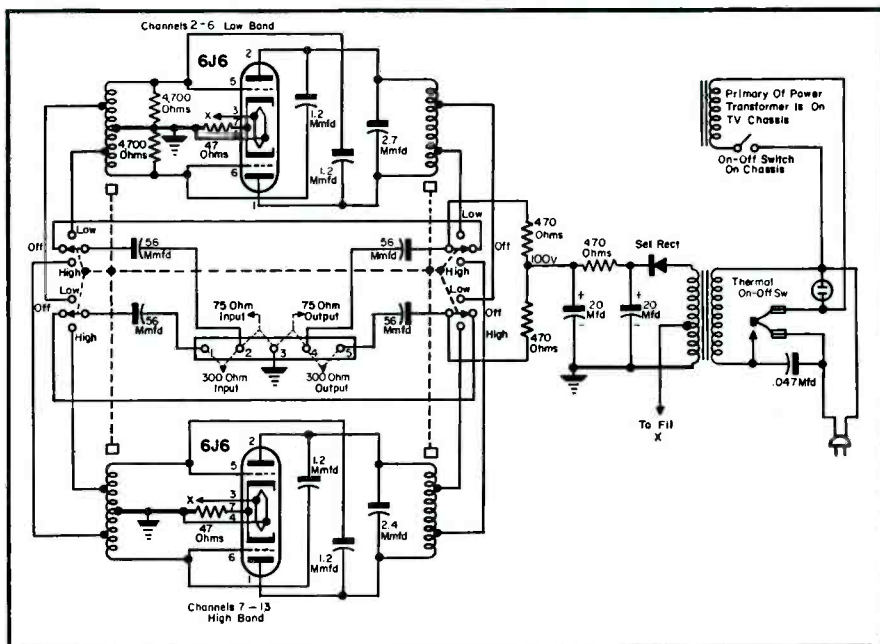

Fig. 2. Circuit of tunable built-in vhf booster, used with Mattison 630 chassis.

amplifier for *uhf*. In the *uhf* position, the oscillator section of the 6U8 is rendered inoperative.

### Fine Tuning Control

Fine tuning of both the *vhf* and *uhf* channels are performed by the same control. The shaft of the fine tuning control rotates two separate pieces of dielectric material simultaneously between two separate sets of capacitor plates connected to their respective *uhf* and *vhf* oscillator tank circuit.

### UHF Operation

UHF channel selection is accomplished in a dual manner. Rotation of the *uhf* turret, which is accomplished by turning the middle shaft or middle knob, sets into position a coil assembly that can be tuned through a range of 10 channels. For example, channels 20 to 29, 30 to 39 etc. Eight different

coil assemblies are used and they are removable for replacement. There are nine settings of the *uhf* turret, one of which is blank containing no coil assembly. For *vhf* operation, the *uhf* turret is placed in the blank position. For tuning of an individual *uhf* channel, the inner shaft or front knob is turned to the second digit of the desired station within the range of 10 channels set previously. This rotates three eccentric cams of a dielectric material through a group of capacitor plates. These plates are connected to the 2 preselector stages and the oscillator circuit.

The *uhf* signal entering the tuner is first fed through a high pass filter consisting of two capacitors (1 and 2 mmfd) and a pair of inductances that attenuate all frequencies below 470 mc. It is then coupled to the first preselector circuit which consists of a coil

(Continued on page 92)

Fig. 3. Stewart-Warner *uhf/vhf* *rf* tuner circuitry.

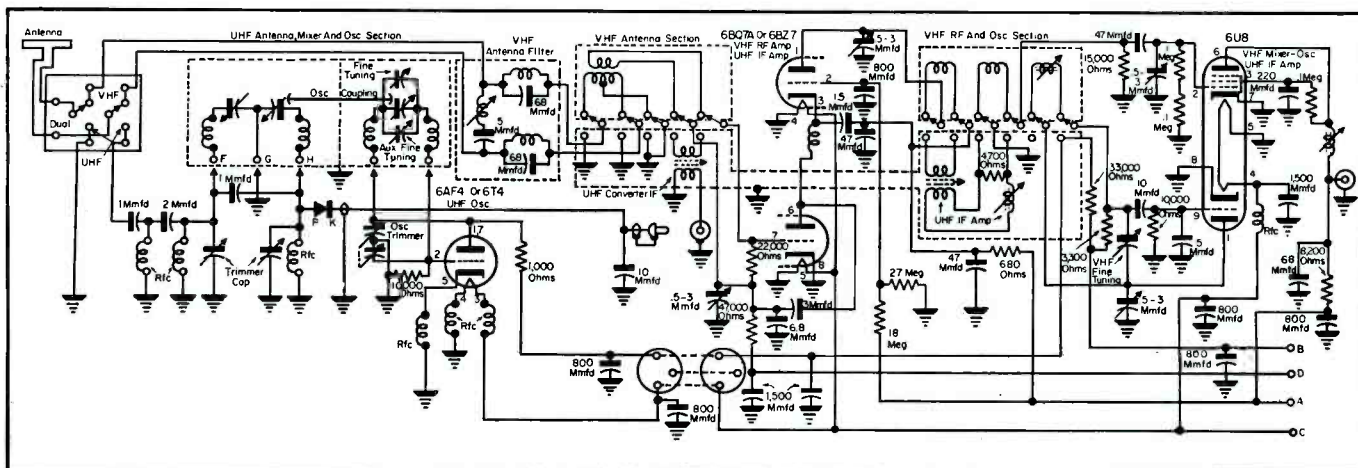

# Color/B-W TV, Hi-Fi and Transistor Sessions at the '54 IRE Convention

by WYN MARTIN

COLOR AND B-W TV, *hi-fi* and transistors will receive featured attention at the IRE annual convention,<sup>‡</sup> with the country's foremost specialists disclosing for the first time complete accounts of the latest developments in the field.

On the *hi-fi* front, *B. B. Bauer* and *John Medill* of Shure<sup>1</sup> will describe a *miniature uni-directional microphone*, for *hi-fi*, said to be inobtrusive and highly uni-directional, with directional characteristic obtained by using a miniature ribbon element in combination with a phase shift network. It is known that unobtrusiveness of microphones is a function of both the size and directional characteristics which influence the distance between the microphone and the performer. According to these engineers, this unit has a depth of 1 7/8", a width of 1 1/8" and a super-cardioid directional pattern; the pattern is claimed to provide a directivity factor of 3.7 and a distance factor of 1.9 as compared with 1 for omnidirectional microphones.

## Hi-Efficiency Power Amp

In a discussion of the design and performance of a new class-B power amplifier said to be capable of developing 50 watts of audio power at 70 per cent over-all plate circuit efficiency with less than 1 per cent distortion, *B. Bereskin* of the University of Cincinnati,<sup>2</sup> will review the factors which control the performance of class B power amplifiers and the manner in which these factors apply to this and other high-quality power amplifiers. Criteria and tests developed for the determination of the permissible high frequency rolloff of power delivering capacity for power amplifiers, will also be analyzed and experimental verifica-

tion of these criteria and tests will be presented.

A system of two driver tubes employed to provide signals at the grids of power stages consisting of a cathode follower and a plate loaded tube in parallel for signal output, will be revealed by *C. T. Hall*.<sup>3</sup> The new approach is said to provide signals differing by a constant which may be any developed signal, such as the output voltage of a single-ended push-pull system.

The advantages are claimed to be much greater drive with conventional tubes and voltages, a high order of balance with a constant difference, nominal source impedance, and tolerance to conventional differences in tubes and parameters. The method is said to have been utilized in the development of low distortion triode and beam-power amplifiers.

## Color Receiver Reports

Reporting on the evolution of a self-balancing phase detector for color receiver reference oscillators, *E. G. Clark*<sup>2</sup> of Philco will describe present methods involving the conventional balanced diode-phase detector found to have desirable characteristics once exact balance is achieved; however, the upper limit on sensitivity is determined largely by the exactness of balance and the level of subcarrier available with good phase stability

<sup>‡</sup>Meetings will be held at the Waldorf-Astoria and Shelton Hotels, and the Kingsbridge Armory in New York City on March 22, 23, 24 and 25.

<sup>1</sup>Tuesday, March 23, P.M., Jade Room, Waldorf-Astoria.

<sup>2</sup>Tuesday, March 23, A.M., Faraday Hall, Kingsbridge Armory.

<sup>3</sup>Tuesday, March 23, A.M., Faraday Hall, Kingsbridge Armory.

<sup>4</sup>Wednesday, March 24, A.M., Grand Ballroom, Waldorf-Astoria.

versus time. Research has shown that the reproducibility of the performance of such a system is determined by the quality of the balance. This constitutes a factory alignment problem as well as a field service problem.

Alternate approaches employing sync detectors have been suggested to improve system line-voltage stability by changing loop gain distribution to favor reactance tube stabilization. Previous systems, it has been found, have suffered from phase center voltage instability as a result of being susceptible to either supply voltage or gating voltage drift.

The self-balancing phase detector system is claimed to achieve excellent stability through a combination of time gated sync and a bi-polar detector. The system is also said to feature almost unlimited *dc* sensitivity.

Through the use of colorimetric principles, a method has been developed for the theoretical prediction of the nature and extent of color distortions to be expected from a color TV receiver employing a sequential picture display device. Such a method, illustrated by its application to a Lawrence single-gun tube using sequenced color signals which are handlimited to approximately 0-8 mc, will be analyzed by *D. C. Livingston*<sup>2</sup> of Sylvania Electric. It has been determined that relatively little color distortion should occur in this case, a prediction which has been confirmed experimentally. The method is said to be sufficiently versatile to render it useful in studies on the comparative merits of various methods for operating any given sequential-display device.

In another report on single-gun color TV picture tubes *S. K. Altes* and *A. P. Storm*,<sup>2</sup> G. E., will show how  
(Continued on page 96)



# ELECTROLYTICS

FROM THE

*Specialist*  
IN THE FIELD!



## LARGEST MIDWEST MANUFACTURER CELEBRATES 20th YEAR HAS PRODUCED MILLIONS OF CAPACITORS

ILLINOIS CONDENSER CO. manufactures the finest electrolytic capacitors in the entire industry!

This specialization is important to YOU! It means that ILLINOIS electrolytics are the most advanced in the field, incorporating design and manufacturing excellence found in no others.

ILLINOIS "firsts" are many since they have pioneered and are still pioneering in this important field of electronics. A few of these advancements are: rugged all aluminum internal structure, exclusive patented molded cap structures with molded in terminals, balanced and neutral electrolytes for long life and wide temperature ranges.

That's why ILLINOIS capacitors are first choice of service engineers as well as most leading manufacturers of electronic equipment. You'll find ILLINOIS capacitors in TV-Radio and communications around the world.

Chances are ILLINOIS manufactures just the electrolytic you need for your product — and if not, who is better qualified to design and build one to your exact specifications?

Your Jobber can supply you with any standard ILLINOIS electrolytic — so be sure to see him first!

Write — TODAY — for ILLINOIS CONDENSER's new catalog which lists more than 400 different electrolytics. In addition it contains a wealth of electrolytic capacitor information!



Reg. U. S. Pat. Off.

## ILLINOIS CONDENSER COMPANY

1616 N. THROOP STREET

CHICAGO 22, ILLINOIS

# Mechanical Factors Involved in TV Antenna Design and Construction\* . . .

## Survey of Antennas, Accessories and Hardware for UHF and VHF TV

by RALPH G. PETERS

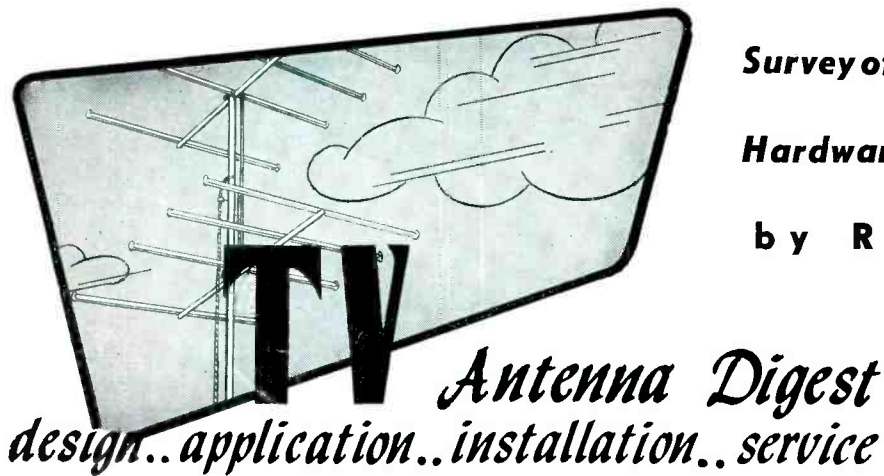

MANY TV ANTENNA INSTALLERS have found that an antenna's mechanical quality or the durability of its makeup constitutes a major factor in design and usually determines selection. Besides electrical performance, it has been found necessary to consider such long-range factors as structural strength, wind effects, fatigue limits, vibration characteristics, corrosion resistance, and insulation efficiency. Pre-assembly and rigging time are important, too, since an antenna that requires less installation time can increase the number of installations possible in a working day.

In designing an antenna that will meet current critical requirements, me-

chanical designers must query those in field engineering, sales, lab research and purchasing to learn the problems of the day. Field engineers are obliged to describe the problems that have arisen with the type of antenna under consideration. They must report on the similar designs that might exist and what improvements one should seek to incorporate.

There are three questions channeled to sales:

What desirable features of an antenna have superseded all others? What are the packaging considerations? What will be the selling price?

And the purchasing department is requested to detail the present and

future outlook in regard to the availability and price trends of steel and aluminum sheet, tube and rod; also, plastic materials, die casting metals, cadmium, nickel and zinc.

Lab personnel must consider the maximum physical tolerances than can be employed in dipole, director or reflector, and the dimensions, spacings or angles, without detrimental effect.

At a conference revolving about the production of a conical one point was strongly emphasized. Since labor is the installer's highest priced commodity, a design that would simplify installation and drastically reduce rigging time, would have maximum utility and demand. For example, a design that would permit the simultaneous and automatic guiding of each dipole into its respective position when an antenna is opened would be extremely helpful to a Service Man.

Several designs of a model with such a feature were recently prepared for a manufacturer. And a model was evolved which included optimum mechanical qualities, freedom from distortion or possibility of breaking the elements, and faster assembly time; then construction materials and forming processes were considered. This required a study of the possible materials, processes and fastenings, and a check list was prepared. In the materials column were included copper, brass, aluminum, steel, aluminum (die cast), zinc (die cast), bakelite, acetate, butyrate, lucite, polystyrene, vulcanized fibre, fibre glass, sheet plastics and wood. Eleven processes were noted: sand casting, die

(Continued on page 97)

Mechanical structure, which must provide for stresses and strains of winds, snowstorms and rain, is illustrated in design shown. Spring at rear of cross-arm was included to permit temperature expansion and contraction without affecting security of the two reflector elements gripped by spring and wing nuts. This temperature provision was integrated in dipole bracket. Dipole rods were fitted into plastic channels, and backing plate locked against plastic yoke with T-nut and internal-external lock-washer. Element-rods were dowel reinforced. (JFD)

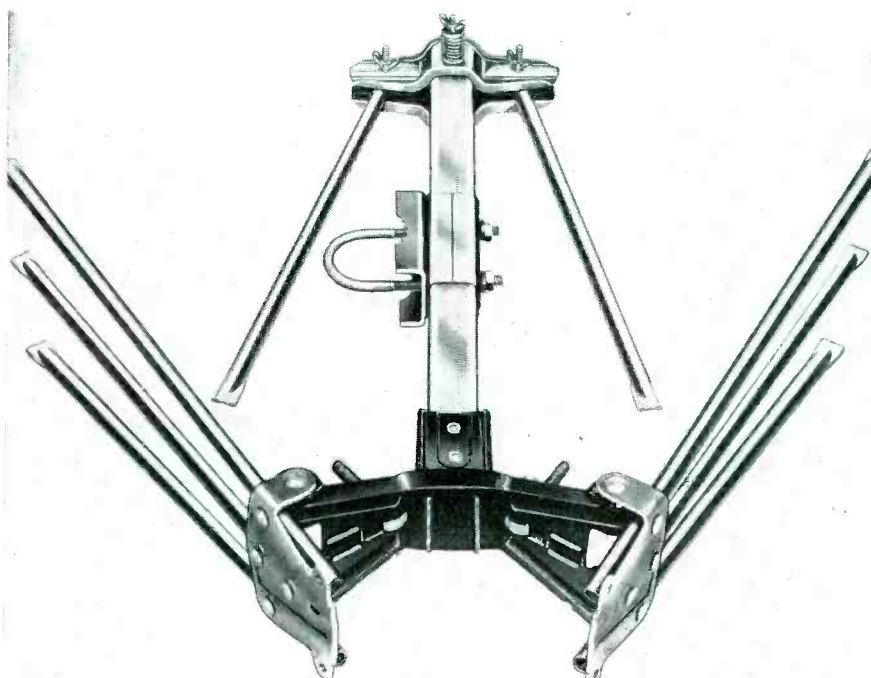

\*From a report prepared for SERVICE by R. J. Rizzo, mechanical engineering consultant, who designed the mechanical construction of the Jetenna conical and other antennas and accessories produced by JFD.



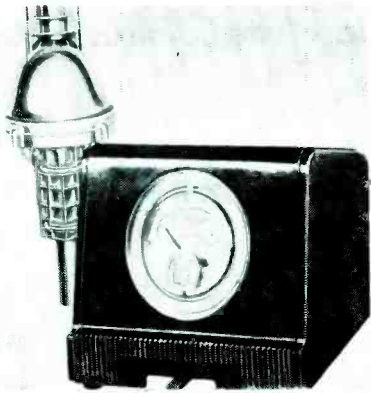

Antenna rotator and meter cabinet using 4-wire cable. Unit is said to be able to handle as much as a 150-pound load. Has 12 heavy-duty ball bearings in two 6½" ball-bearing races; reinforced die cast housing; heavy-duty precision gears; reversible clamps that handle ⅞" to 2" masts, and 3 heavy-duty guy wire lugs. For mast, tower or platform mounting. (Model TR-4 CDR; Cornell-Dubilier/Radiart Corp.)



Add-a-set inductive coupler, utilizing a hi-core transformer, that operates two TV sets from one antenna on all vhf channels on either 72 or 300-ohm line. Unit is said to isolate antenna and receiver by the use of individual transformer windings, minimizing interreceiver action. (Model AM-74; Tele-Matic Industries, Inc., 1 Joralemon St., Brooklyn, New York.)

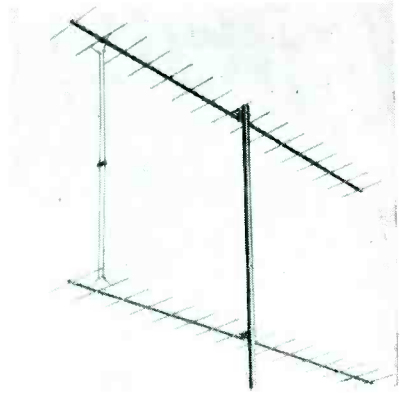

A 16-element wide-band uhf yagi, of delta-weld construction. Has a delta-matched dipole for 300-ohm match. Can be designed to cover up to 21 channels. Antenna is said to have an average gain of 11 db single and 14 db stacked. (Sweet 16 Model 420; Channel Master Corp., Ellenville, N. Y.)

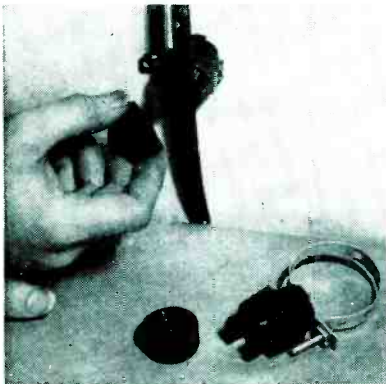

Quick-service types of uhf lightning arresters; screw type for direct mounting to baseboards or windowsills; and a strap type for attachment to antenna masts and cold-water pipes. Screw cap forces the line against staple contacts in the arrester which pierce the insulation and make electrical contact with the wire. Can be used with virtually all types of 300-ohm uhf tubular, oval, foam, and jacketed lines. (Models 234A1 and 235A1; RCA.)

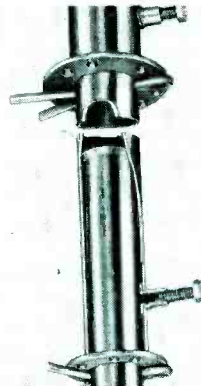

Telescoping tower which features nine thread rivnut and hex bolt said to lock positively tubes in any position and prevent swaying. Cotter pin resting on guy ring, with full bearing surface, locks tubes in assembled position. Flare at bottom of tubing to permit easy sliding and minimize cocking and scratching. In extended position, there is a minimum of 6" tubing telescoped for stability. (IE Manufacturing, 325 N. Hoyne, Chicago 12, Ill.)

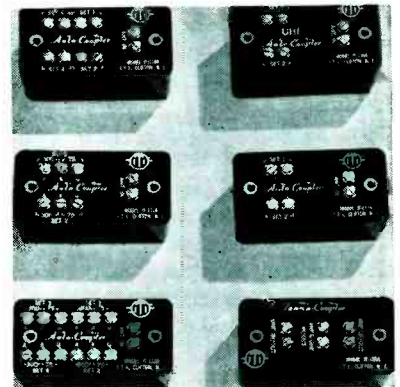

Indoor/outdoor multiple receiver couplers which use individual rf transformers to feed up to eight receivers with low insertion loss and good-isolation. UHF auto-coupler uses wide-band hybrid ring principles to feed two uhf receivers or converters from a single antenna. (Industrial Television, Inc., 369 Lexington Ave., Clifton, N. J.)

UHF yagi with a rigi-channel frame to which aluminum driven and parasitic elements are welded. Antenna utilizes a Taco grid reflector, an assembly similar to the screen-grid assembly used in Taco uhf antennas. Said to eliminate performance problems prevalent with single rod reflectors. Grid reflector is combined with eight directors. Available in single, two and four stack models, shipped with phasing bars. (Technical Appliance Corp., Sherburne, N. Y.)

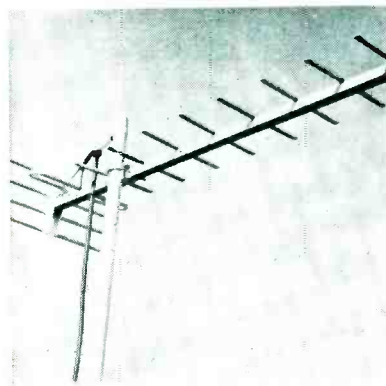

Conical vhf antenna with element ends riveted to head to prevent shedding. Has a non-hygroscopic head. Full length, 48", elements are used with the optimum forward angle. Available in single or two-bay models with phasing harness. (Colomite; Trio Manufacturing Co., Griggsville, O.)

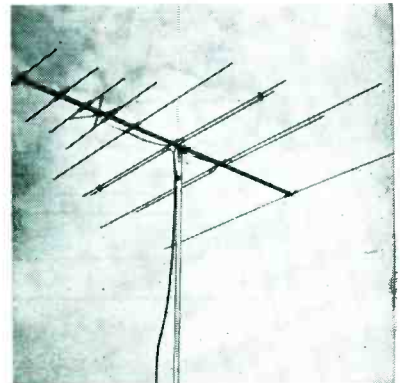
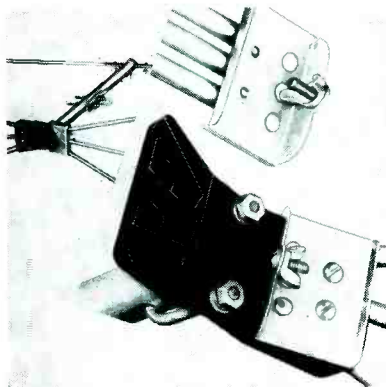

All-channel vhf antenna with a forward high-channel section that is delta-X-matched and coupled directly to a T-matched rear section, which is cut for the low channels. Both sections are electrically coupled together with phasing links for 300-ohm termination. Utilizes drawn aluminum elements with crimped ends and reinforcing throughout. (Vee-D-Xtra Special SP-11; La Pointe Electronics, Inc., Rockville, Conn.)

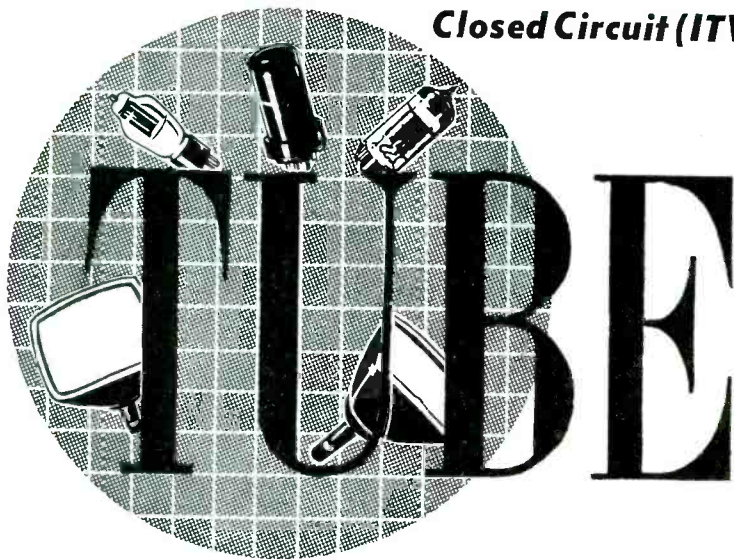

by E. A. TEVERSON

# News

WITH THE DEVELOPMENT of highly efficient midget cameras and compact control units, ITV has demonstrated that this method of telecasting over wired circuits has tremendous potentialities.

In its present state, ITV systems can be used in factories and labs, arsenals, air force bases, shipyards, universities and hospitals, jails, banks, and stores. Applications include remote control of related operations and the flow of materials, monitoring of dangerous, remote, or inaccessible processes; materials handling; traffic control; guarding of entrances and exits; remote viewing of records and documents or meters and instruments; visual presentation of educational materials and demonstrations.

The camera in one system<sup>1</sup> contains four tubes, including a vidicon pickup tube. Any home-type TV receiver can be used without modification as a monitor, the system connecting through the set's antenna terminals. Any unused channel from channel 2 to 6 inclusive can be used.

Heart of the ITV system is the vidicon camera tube which utilizes a photoconductive layer as its light-sensitive

element. The tube has a signal electrode, which is a transparent conducting film on the inner surface of the faceplate; a light-sensitive element consisting of a thin layer of photoconductive material deposited on the signal electrode; a fine mesh screen located adjacent to the photoconductive layer; focusing electrodes, and an electron gun for producing a beam of electrons.

Each element of the photoconductive layer is an insulator in the dark but becomes slightly conductive when it is illuminated and acts like a leaky capacitor having one plate at the fixed positive potential of the signal electrode and the other floating. When light from the scene being televised is focused on the photoconductive-layer surface next to the faceplate, each illuminated layer element conducts slightly, depending on the amount of illumination on the element and thus causes the potential of its opposite surface (on the gun side) to rise in less than the time of one frame toward that of the signal-electrode potential. Hence, there appears on the gun side of the entire layer surface a positive potential pattern, composed of the

various element potentials, corresponding to the pattern of light from the scene imaged on the opposite surface of the layer.

### Low-Velocity Beam Scan

The gun side of the photoconductive layer is scanned by a low-velocity electron beam produced by the electron gun. This gun contains a thermionic cathode, a control grid (grid 1), and an accelerating grid (grid 2). The beam is focused at the surface of the photoconductive layer by the combined action of the uniform magnetic field of an external coil or *pm*, and electrostatic fields of additional grids. One grid serves to provide a uniform decelerating field between itself and the photoconductive layer so that the electron beam will approach the layer in a direction perpendicular to it; a condition necessary for driving the surface to cathode potential. The beam electrons approach the layer at low velocity because of the low operating potential of the signal electrode.

When the gun side of the photoconductive layer with its positive potential pattern is scanned by the electron beam, electrons are deposited from the beam in sufficient quantities until the surface potential is reduced to that of the cathode, and thereafter are turned back to form a return beam which is

(Continued on page 94)

‡From copyrighted tube-news notes prepared by RCA.

<sup>1</sup>RCA TV Eye.

(Left)

Schematic of preamp designed for recently-developed high-resolution type of vidicon (6326) which employs a low-noise cascade circuit having an 8-mc bandwidth. (RCA.)

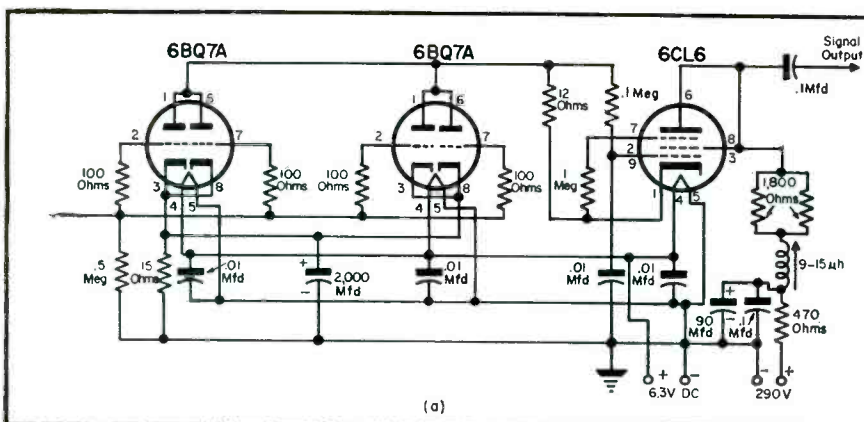



**GENERAL INSTRUMENT** all channel UHF converter

**Number ONE**  
**in performance!**



**first** in Buffalo, N. Y. —  
“Good clear black and white picture.”

**first** in Springfield, Mass. —  
“Very good reception (4 UHF channels). Distance from one UHF station 50 miles.”

**first** in Jacksonville, Fla. —  
“Reception very good.”

These are three more reports of thousands received proving the amazing performance of the General Instrument all channel UHF converter.

**FIRST.. in side-by-side tests**

**JOBBERs:**  
some choice territories still remain open. Write for details.

**General Instrument & Appliance CORPORATION**

Subsidiary of  
GENERAL INSTRUMENT CORPORATION  
829 Newark Avenue • Elizabeth 3, N. J.

Visit us at booth #362  
...the I.R.E. show

# Proper Use of Feedback‡ . . . Pictorial Review of New Speakers,

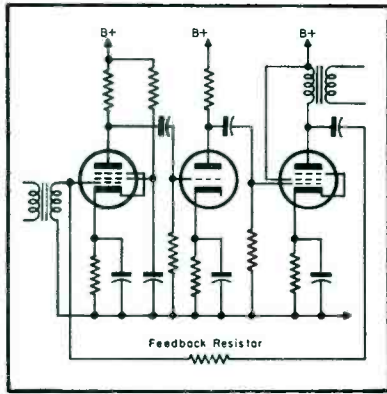

(Above)

Fig. 1. A circuit of this type is often claimed to improve the response of the input transformer. If it does, this is quite incidental to the action of feedback.

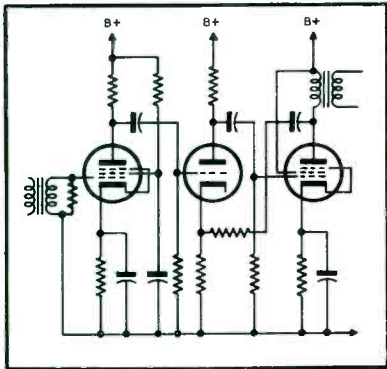

(Above)

Fig. 2. A modification to the circuit of Fig. 1 that separates the regular function of the feedback from improvement of the input-transformer response.

(Below)

Fig. 2a. Three different ways of connecting up a capacitor into the feedback network to overcome the difficulty due to an unbalanced response, as at Fig. 4 (p. 51).

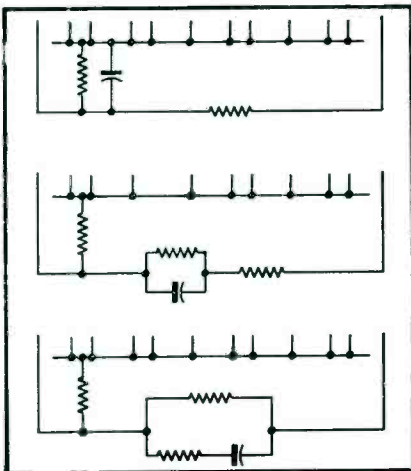

by **KENNETH STEWART**  
and **PAUL EDWARDS**

FEEDBACK is often applied to improve input characteristics. This approach does not always provide the positive results expected. A remark often heard is that feeding back to the first grid, as shown in Fig. 1 will improve the response of the input transformer. This happens only because the feedback provides an effective secondary shunt for the transformer; this could be done just as effectively, and without the loss of gain, as noted in Fig. 2. Using the circuit of Fig. 1, input and output impedances are interdependent, because either will affect the amount of feedback, and hence modify its effect on the other. The circuit of Fig. 2 largely avoids this interdependence, using simple resistive damping to straighten out input response, and applying feedback solely for modifying output source impedance, and distortion clean-up.

But feedback is useful for improving frequency response, isn't it? Well, this is a dangerous statement to affirm or deny, without qualification, and one

can spend hours trying to qualify it and still come short of satisfaction. The fact is that each case must be considered on its merits. If a response tends to *die* slowly, application of negative feedback will pull it up, and extend the range, resulting in a more sudden ultimate roll-off.

Fig. 3 shows an *ideal* response, with different degrees of feedback employed to obtain wider range within closer tolerances. It also shows the effect of too much feedback. In Fig. 4 we have an unbalanced response curve; here feedback that provides good results at one end of the response is not satisfactory for the other end. Fig. 5 shows a type of response that is practically impossible to improve with feedback. Any feedback at all will make this kind of response run into peaking.

With the type of response illustrated in Fig. 4, it is usually possible to compromise by using a capacitor somewhere in the feedback network. Fig. 2a shows a typical feedback cir-  
(Continued on page 52)

‡From a report prepared specially for SERVICE by **Norman Crowhurst**, audio consultant.

(Right)

Fig. 3. A range of curves with balanced response, showing the effect of different degrees of feedback. The interval between consecutive curves is 6 db feedback in each case.

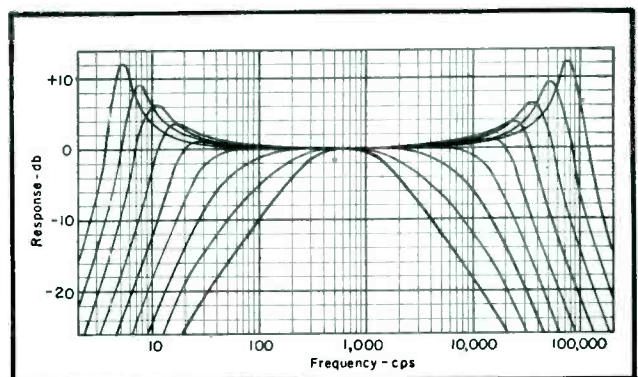



# Enclosures, Amplifiers, Changers and Microphones



Audio oscillator said to be suitable for sine wave signal measurement over a 20 cps to 1-mc range. A resistance-capacity tuned type oscillator and a cathode follower in the output system are employed. Deposited carbon resistors used in frequency determining network. (Model 411; Clough-Brenkle Co., 6014 Broadway, Chicago 40, Ill.)



Portable two-way loudspeaker system with 8" heavy duty woofer and a multi-cell horn compression driver tweeter, plus a built-in frequency dividing system. Portable, said to have a 20-watt power rating, is 11" x 23 1/4" x 11 1/4" and weighs 21 pounds. (Duette DU-202; Jensen Manufacturing Co., 6601 South Laramie Ave., Chicago 38, Ill.)



Transcription player with pickup said to utilize lifetime-lubricated bronze bearings that lower lateral pressure on record grooves. Pickup also features wrist-action, wherein only mass of pickup head rests on the record groove, and a micarta mounting swivel which insulates pickup for separate grounding. (Califone Corp., 1041 N. Sycamore Ave., Hollywood 38, Calif.)

Loudspeaker featuring a three-way system; two lf drivers, a 600-cycle crossover together with a hf multi-cellular horn with a hf driver. In addition, system includes an ultrahigh-frequency driver and associated network. (Continental; Stephens Manufacturing Corp., Culver City, Calif.)

Clip-on, said to provide a side-car type arrangement with 1/2" mounting holes for any two standard cartridges, permitting tracking of twin grooves of binaural records. (Cook Laboratories, Inc., 114 Manhattan Street, Stamford, Conn.)

Hand-held (dynamic, carbon-type) microphone, designed for mobile, police, ship-to-shore, and aircraft communications as well as paging and intercom systems. Includes die-cast aluminum cantilever-action switch. (501 Series; American Microphone Co., 370 S. Fair Oaks, Pasadena 1, Calif.)



Fig. 4. Curve illustrating unbalanced form of response (solid line) which does not improve with feedback (dotted line).

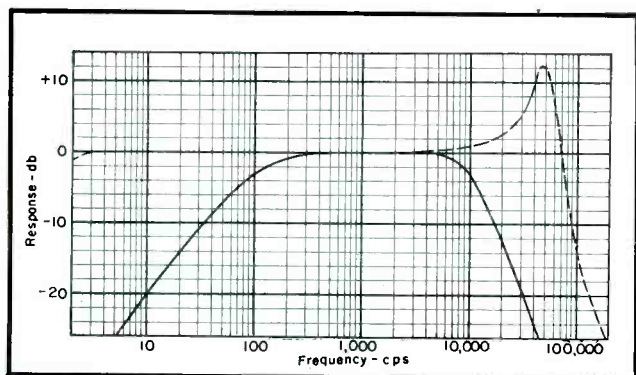
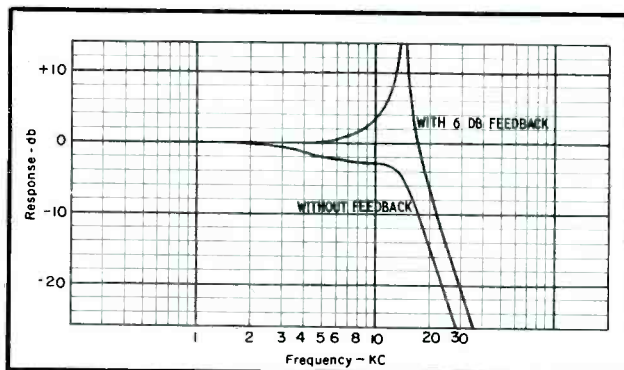
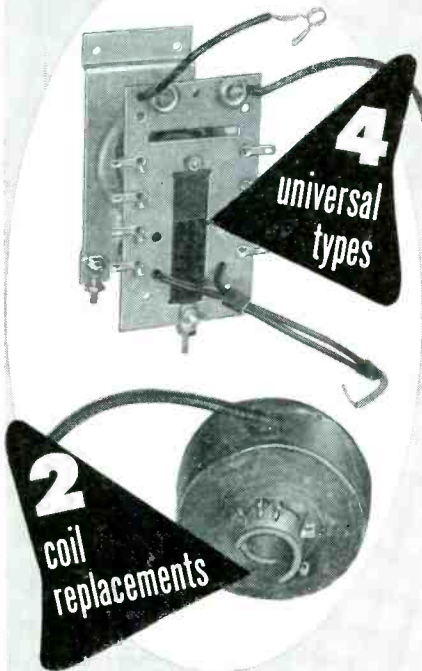

Fig. 5. Response that cannot be treated at all with feedback. Here only 6-db feedback produces instability.



# 6 NEW TRIAD FLYBACKS



As evidence of Triad's continuing efforts to meet your TV replacement needs — exactly and completely — 6 new flybacks have been added to the line. A total of 19 are now available, with more being added all the time. These flybacks are precisely engineered for specific replacements and carefully constructed of the finest materials. Their resulting high performance and long life insures satisfied customers and helps you build and hold your service business.

Type No.	List Price	Description
D-31	\$11.00	Universal type. Universal mounting. Replaces RCA 231-T1
D-32	11.00	Has AGC tapped winding. Matches all yokes.
D-33	11.00	Universal type. Universal mounting. Has AGC tapped winding similar to D-32, but low impedance secondaries.
D-35	11.00	Universal type. Universal mounting. Replaces RCA 223-T1, 224-T1, 230-T1 and 232-T1.
DA-36	5.50	Coil only. Replaces coil in Zenith Part No. S-18567.
DA-37	5.50	Coil only. Replaces coil in Zenith Part No. S-19032.

Available from stock. See your jobber for these — and all of your TV replacements.

Write for Catalogs TR-54L and TV-54L



4055 Redwood Ave., Venice, Calif.

## Audio

(Continued from page 51)

cuit, and illustrates too some ways in which a capacitor can be used to overcome the peaking tendency at one end.

Now let us probe preamp design and its relation to feedback. What, for instance, does feedback do to hiss and hum? Hum must be reduced so that it does not come in with the signal, which is where most amplifiers are most susceptible to pick up hum. Assuming that the hum is due to a residual ripple on the plate feed to some of the stages within the feedback loop, the effect of the feedback will depend on what is involved to apply it. By direct comparison, connecting and removing the feedback link will show that feedback will reduce the amount of hum, provided it is coming in at some point within the feedback loop. But often extra gain is needed to throw away in feedback; that gain wouldn't be used if feedback was not required. In this case hum level may be raised by increasing the gain, and feedback will only put it back to its previous level.

This will always happen if the hum is coming in at an early stage, before the extra gain point. On the other hand, if hum is coming in on the plate

Fig. 6. Hum in a pentode first-stage plate supply can more readily be reduced by feedback than in a triode first stage. In schematic (a), hum introduced at a will be reduced by raising the coupling-resistor value. Hum introduced in tube (or at b) will not be reduced by raising coupling-resistor value. Increasing gain in feedback loop shown in diagram (b) will only reduce hum introduced after first stage.

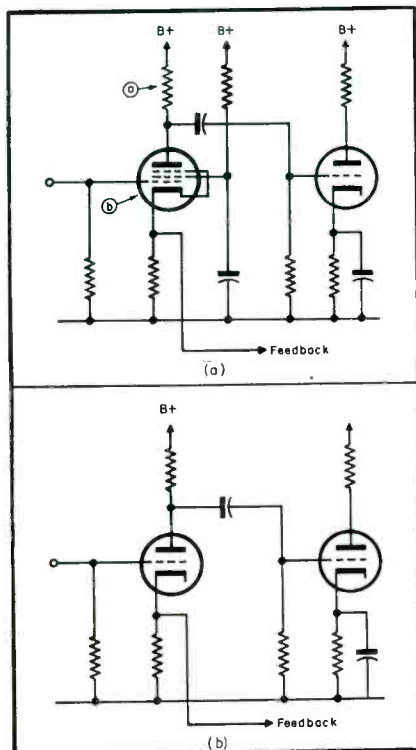

SERVICE MEN  
KNOW THERE IS  
JUST ONE

# EVER-QUIET



Since 1949

the Original Volume Control  
& Contact Restorer

EVER-QUIET is a free-flowing liquid that leaves no powder residue.

- Does Not Arc or Affect Inductance, Capacitance or Resistance.
- Harmless to Metals, Insulation and other Fine Finishes.
- Contains No Carbon "Tet," Gums or other Adhesive Chemicals.

2-Ounce Bottle with Handy Dispenser—Only 59¢ Reg. U.S. Pat. Off.

EVER-QUIET is made by the manufacturers of HUSH—The TV-Tuner Cleaner that Sprays On.

EVER-KLEER—The TV Tube Cleaner in the Plastic Spray Bottle.

All products liability protected by one of America's largest underwriters.

Ask your local distributor for EVER-QUIET or write:

**CHEMICAL ELECTRONIC ENGINEERING, INC.**

283 Main St. Matawan, N. J.

**SWITCHCRAFT**  
INC.  
New "MINI-MIX"

Miniature 2-Input  
Audio Mixer

- Size—Only 2 1/16" x 1 13/16" x 1 1/16"
- No external cables—connects directly to equipment.



Part No. 310 "Mini-Mix"—Phone Jack connector inputs with Phone Plug output fitting standard jacks.

Part No. 320 "Mini-Mix"—Microphone connector inputs and output mating with standard mic connectors.

LOW COST \$7.95 U.S.A. LIST PRICE

Ideal for use with Tape, Wire or Disc Recorders; Amplifiers, Musical Instruments, etc., Separate gain control knobs for mixing located directly "in line" with inputs eliminate confusion in selection. Attractive brown finished case—nickel plated accessories.

**SWITCHCRAFT**  
INC.

1310 N. Halsted St., Chicago 22, Ill.

AVAILABLE AT ALL  
LEADING RADIO PARTS JOBBERS



supply to the first tube such as a pentode, increasing the plate-coupling resistor will increase gain without increasing the hum voltage at the plate, and the feedback, applied in the grid circuit will reduce the ultimate hum. However, it is not good to rely on feedback to reduce hum in plate circuits, because plate supply ripple has a habit of coming up as electrolytics age. It is better to take steps to see that hum is of sufficiently low level without such trickery. If the first stage is of the triode type, then little extra gain can be obtained by increasing the plate resistor, and the gain must be picked up elsewhere. Unless the gain can be added before the feedback loop, without increasing hum level, feedback will not then cut down the final hum level. Fig. 6 illustrates these cases.

What about hiss and tube noise? In all except very poorly-designed audio equipment, the hiss heard comes in at the first stage, because the signal level is lowest here. However, surely feedback into the grid circuit will cut it down. Unless a particularly noisy tube is used, or else an unnecessary low input impedance prevails, hiss will be due to thermal noise in the input circuit resistance; so an increase in gain must inevitably increase noise in the same ratio as it increases signal. And then feedback should cut down the noise in the same ratio again, putting us back where we started. Probably, too, the feedback will do good in some other direction, so why not use it?

The fact is that feedback often increases noise level under these conditions. The easiest way to understand this is to realize how noise differs from signal in its waveform characteristic. Any regular signal has a periodic waveform, which allows the feedback network to build up a replica in anti-phase; but the kind of noise that produces hiss, consists of the random movement of charges or a series of irregular *happenings*. Noise is often described as a signal containing a uniform distribution of all frequencies from zero to infinity. Which-ever way it is viewed, if feedback is to neutralize it effectively the feedback signal must get back to the input at the same instant as it starts its way through the amplifier from there (zero loop delay time) which is impossible. Hence, it is likewise impossible for feedback to negate noise completely in the same way as it does regular or periodic signals. In practice this means that an amplifier with feedback, including the first low level stage, will have a higher hiss level than one with-

(Continued on page 97)

# Sangamo Dry Electrolytics

Live many seasons  
for heap good  
reasons

**these wire lead  
tubular capacitors  
will not deteriorate  
with age**



Use Sangamo dry tubular electrolytics for trouble-free replacements. You don't have to worry about premature failure. Long life is really built into these capacitors. They have exceptional staying power because:

- 1 A super-seal keeps the electrolyte from evaporating even under the toughest conditions of heat and humidity.
- 2 All these capacitors are aged at 85° C to build a tough dielectric film that will stand up under high heat.
- 3 All aluminum container prevents the "creeping" corrosion that occurs in capacitors when any other metal is permitted to contact the electrolyte.
- 4 Sangamo electrolyte is really pure. Continuous laboratory control of every batch keeps the chlorine ion concentration to less than 10 parts per million. That's 99.999% pure, or better!
- 5 No lead breakage. Sangamo uses a special wire that resists bend fatigue. A specially designed rivet that "cradles" the lead gives additional protection.

P. S. These wire lead tubulars fit those tight corners—Their compact design gives maximum capacity in minimum space. See your Sangamo Distributor for all your capacitor replacement needs.



## SANGAMO ELECTRIC COMPANY

MARION, ILLINOIS

SC54-4

# Servicing Helps

**Curing Excessive Snow on UHF TV Chassis . . . Stopping Noise in '53 Buick Auto Radios . . . Modifying Audio Circuits To Eliminate TVI . . . Soldering Coax Plugs . . . Checking Defective Horizontal Amp Cathode Capacitors . . .**

**by T. L. GILFORD**

FIELD REPORTS have indicated that on some CBS Columbia 821 *uhf* chassis excessive snow has appeared on all channels. In the production of the 800 series chassis variable capacitor type *uhf* tuners have been used. On the front top left-hand corner of this tuner a test point extends beyond the front. When inserting the chassis into the cabinet a certain percentage of test points might have been bent down and shorted to the mounting bracket. This would result in excessive snow. To restore the receiver to satisfactory operation the test point must be bent away from the tuner mounting bracket.

## TVI In Audio Stages†

THE GRID CIRCUIT of the first audio stage of a TV receiver, usually requires from a fraction of a volt to a few volts of bias. Any *rf* signal from a nearby radio station (taxi, police, military or amateur) strong enough to overcome this small bias, or sufficient to cause rectification as a consequence of nonlinear grid voltage/plate current relationship, will be rectified, and if amplitude modulated will appear as an audio signal passing through the audio amplifier, together with the audio signal of the station to which one is actu-

ally tuned. An FM or unmodulated carrier of moderate intensity may be observed as hum or distortion. A strong FM or unmodulated carrier would reduce the audio output level of the station to which the receiver was tuned. If the interfering signal is keyed, program reception will follow with breaks in volume. This type of interference will be evident on all TV channels regardless of receiver tuning adjustments.

To identify this type of interference, the output of the last *if* amp can be momentarily shorted through a capacitor to ground. If the interfering signal persists, it is most probably due to pickup in the first audio amplifier, and the following corrective procedures should be applied. If the interference discontinues, the trouble is not due to pickup in the audio stages but probably to intermodulation in the *rf* or *if* stages. These same effects can occur on AM and FM receivers, phono and *pa* amplifiers, hearing aids, and other high-gain audio devices.

Complete elimination of rectification troubles depends entirely on pre-

venting the *rf* from being rectified, for once rectification occurs it is impossible to separate or filter the interference from the desired signal.

To prevent rectification from occurring, steps should be taken to provide a low-impedance path for *rf* between grid and cathode of the audio amplifier tube. A typical first audio amplifier with typical changes necessary to eliminate rectification are shown in Figs. 1a and b.

The bypass capacitor shunting the tube input provides such a low impedance at *rf* frequencies that it practically shorts out any *rf* signals at this point, and the series choke, or resistor, helps to prevent the *rf* from reaching the grid. The choke arrangement will give best results, but the carbon resistor is almost as effective.

As in the *ac/dc* type of standard broadcast receivers, bypassing the heater of a combined detector/first-audio stage to ground, with a .01-mfd capacitor, will often prove helpful; screen and suppressor grid bypassing must be adequate, however.

In extremely strong signal fields it may be necessary to filter the second audio amplifier, or output amplifier, in

(Continued on page 100)

Fig. 1a and b. Modified audio amplifier circuit designed to eliminate rectification of undesired *rf* signals. Where the value of the grid resistor is large it may be necessary to change the value of resistors to as low as 1 megohm. This will not appreciably affect the gain of the desired audio. However, care should be taken in the choice of values for bypass capacitor and series resistor or inductance to maintain the grid circuit preeminently resistive to audio frequencies. Choke or resistor and capacitors should be mounted directly at the grid pin of the tube socket with the shortest possible lead length between grid and cathode. For grid-cap type tubes, the grid lead should be shielded and the bypass capacitors connected as close to the grid cap as practicable.

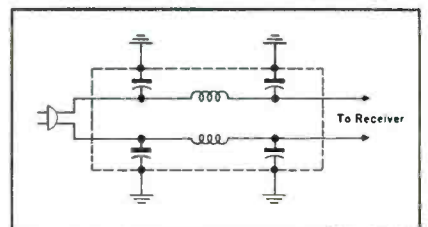
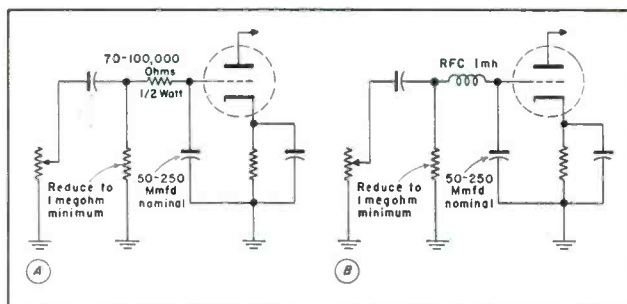
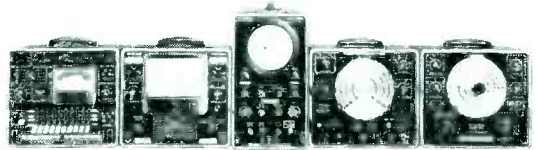

Fig. 2. Basic elements for construction of a powerline filter. Coils are 3" wound with length of No. 18 enamel on 1/2" diameter form. Capacitors are .001 to .01 mfd, 600 v rated, mica or ceramic. It is important that these filters be enclosed in a metallic shield to prevent direct pickup of signal, and the entire equipment carefully constructed electrically, with wire size appropriate to the load and effectively grounded either direct or through a .01-mfd, 600 v capacitor in the case of *ac/dc* sets with chassis which cannot be connected directly to ground. A water pipe or other plumbing is usually an effective ground.





You'll Find a  
***PRECISION E-200***



**in Every Other Service Lab in the Country!**

**THIS FAMOUS SIGNAL GENERATOR** provides — at a practical, sensible price — the accuracy, stability, range, functions and long-lived reliability that are so necessary to the efficient Service-Lab.

**THIS FAMOUS SIGNAL GENERATOR** has consistently set unparalleled standards of performance and value.

**THIS FAMOUS SIGNAL GENERATOR**, along with the other instruments in the PRECISION line, has kept pace with the ever-increasing requirements of modern servicing and maintenance, AM-FM-TV.

# E-200-C

The Modern Multi-band  
**SIGNAL-MARKING GENERATOR**  
for TV-FM-AM Alignment



- ★ Frequency Coverage: 88 KC to 240 MC (To 60 MC on fundamentals)
- ★ Direct Reading in 9 bands on easy-reading 6½" dial.
- ★ 1% Accuracy and exceptional stability on all bands assured through use of the famous PRECISION "Unit-Oscillator" construction.
- ★ 0-100% Modulation controlled at front of panel.
- ★ AGC-AVC Substitution voltage, continuously variable on expanded scale from 0-50 volts D.C.
- ★ Hand Calibrated: each instrument is individually calibrated against 'PRECISION' standards.

NET PRICE: \$78.50 complete with tubes, RG type coaxial output cable and 96 page operating text 'Servicing by Signal Substitution'. Black ripple-finished, portable, steel case, 10½" x 12" x 6".



**PRECISION Apparatus Company, Inc.**  
92-27 HORACE HARDING BLVD., ELMHURST 6, N. Y.

Export Division: 458 Broadway, New York 13, U.S.A. Cables: Morhanex  
Canada: Atlas Radio Corp., Ltd., 560 King Street W., Toronto 2B

# V T V M

by DONALD PHILLIPS

## Performance Characteristics ‡

**Streamlined Report on Instrument's Properties and Used**

### Characteristics of Instrument

**1:** NEGATIVE FEEDBACK in the cathode circuit stabilizes the arrangement against excessive drift, as well as pointer shift on different ranges, due to contact potential. The isolating resistor in the *dc* probe head greatly reduces the input capacitance of the *vtvm*, and minimizes disturbance of tuned circuits.

**2:** A VOLTAGE-REGULATOR tube added to circuitry shown below serves to stabilize the *vtvm* against pointer shift due to line-voltage variation. The linearity of scale calibration depends upon the amount of negative feedback which can be used, and this in turn depends upon the sensitivity of the meter movement which is used.

**3:** THE ADDITIONAL TUBE used in the cathode-coupled circuit permits a bridge connection of the meter, and a choice of zero-left or zero-center operation. The voltage-regulator tube is not needed because the bridge arrangement largely balances out line-voltage variations. The variable insertion of *B+* voltage provides zero setting.

### Typical Applications

**1:** MEASUREMENT OF *dc* voltage values, even in high-resistance low-voltage circuits. Responds to *dc* input voltages only, but can be used to measure *ac* voltage values when a diode rectifier probe is utilized ahead of the isolating resistor. The meter is zero-left mechanically, but zero-center electrically, so that either positive or negative voltage values can be measured without use of a polarity switch.

**2:** APPLICATIONS in this instance are the same as described in 1. The vacuum-tube voltmeter is preferable to a simple voltmeter in TV service work because it does not throw tuned amplifiers into oscillation (as in various types of *if* circuits), and because it permits measurement of *dc* voltage values in the presence of high-frequency *rf* voltages, such as at the grid of a local oscillator.

**3:** AS IN THE ARRANGEMENT shown in 2, the cathode-coupled bridge circuit responds to *dc* input voltages only, but can be used to measure *ac* voltage values when provided with an accessory rectifier probe. These setups are also used to measure resistance values up to 1,000 or more megohms, by means of suitable ohmmeter circuits ahead of the *vtvm*.

‡First of a series of analyses, based on data supplied by William B. Coon, chief electronic engineer, Simpson Electric Company.

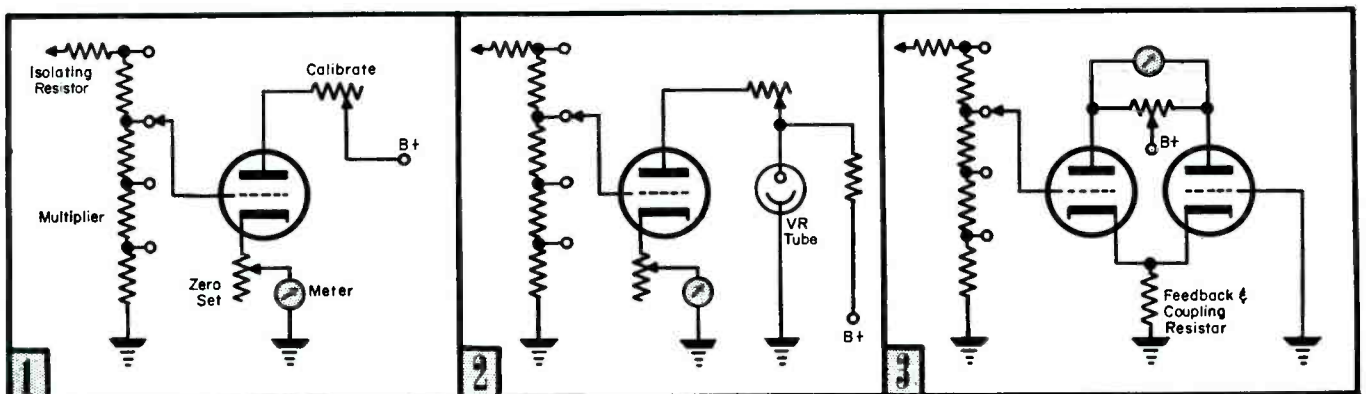



*Now*

# G-E TUBES ARE SERVICE-TESTED FOR TV-SET INTERCHANGEABILITY!

## IN INDIANAPOLIS: ➡

Howard W. Sams & Co., Inc., regularly checks the performance of current-production G-E tubes in all popular TV chassis, at various line voltages.

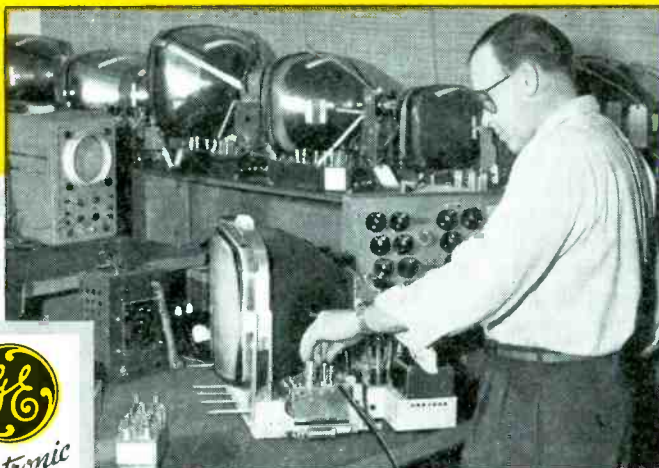

## AT GENERAL ELECTRIC:

the Howard Sams reports are studied, and any case of unsatisfactory tube performance receives detailed investigation. Corrective steps in manufacture or testing follow at once. ⬇



● A General Electric executive micro-inspects a tube structure for proper assembly.

**Simplify your tube requirements, reduce call-backs, with G-E interchangeable tubes!**

**S**INCE September, 1953, the Howard Sams TV-radio technical organization has checked G-E receiving tubes for servicing interchangeability. A number of tubes of each type—fully representative of normal production—are tested periodically in TV chassis of different makes. Accurate instrumentation is employed.

Any unsatisfactory tube performance in any chassis is reported to General Electric. There, further tests are held to confirm the Howard Sams finding, and establish the cause of the difficulty. With the aid of laboratory study, corrective steps are decided on by G-E tube management and applied immediately. These may take the form of an improvement in manufacture or inspection, or revised test specifications.

*Result:* you are always installing tubes that are more fully interchangeable and high-quality! Your General Electric tube distributor is your source for a product that is constantly being improved! *Tube Department, General Electric Company, Schenectady 5, New York.*



● A General Electric plant employee, using a comparator, checks a greatly magnified tube grid.

# GENERAL ELECTRIC

161-1A2

# Service Engineering

## field and shop notes

by

THOMAS K. BEAMER

A MAJORITY of the privately-owned two-way communication systems in use today are of the remote-controlled variety, using a base station, consisting of the main transmitter, one or more fixed tuned receivers, and an antenna which can be located anywhere from a few blocks to many miles from the central control point. In most cases the antenna tower, together with the base station, are located outside the city limits, while the remote-control unit site is in the downtown area within the main office of the licensee.

Sooner or later licensees realize the real value of a two-way system, particularly during a storm emergency which causes power failure and a break in two-way contact.

Full protection against power failure can be had only by providing both the base station and the remote control unit with an emergency source of primary power that is automatic in operation. More often such an installation will require two separate power supplies, since due to the distance between the station and control point, the equipment will rarely be fed by the same utility line.

Emergency power for the base station offers no problem and such a pro-

vision is usually provided for during the construction of the station. One has only to select the power unit meeting his needs from the many gasoline driven units now available.

Providing emergency primary power for the remote-control console presents more of a problem. A gasoline line-driven alternator cannot be used, for it certainly would be highly objectionable to those in a busy office. Then, too, size and appearance is of prime importance. In a search for a solution, a low-powered ac supply that was fully automatic in operation was evolved.<sup>1</sup>

### Mounting of Components

The various parts, other than for the storage battery, were all mounted on a 10"x14"x3" black steel chassis with a bottom plate. The bottom plate was found to provide added rigidity to the chassis and at the same time offer some degree of protection to relay contacts against corrosion caused by the fumes from the battery emitted during stand-by operation. The battery charger, current-limiting resistor and rotary converter were mounted top-side. Relays, fuse holders, pilot lamps,

etc., were located on the underside. All wires through the chassis were protected by rubber grommets. The battery connection terminals were insulated from the chassis through the use of a terminal board cut from a heavy sheet of micarta.

### Converter

The rotary converter<sup>2</sup> selected was a 6-volt dc model drawing 20 amperes from the storage battery during operation, with an output conservatively rated at 62 watts at 115 v ac.

### Battery Charger

The battery charger,<sup>3</sup> an extremely small unit, offers a charging rate which tapers during operation from a high of 4 to a low of 2 amperes. It was fastened to the chassis by metal screws. All leads to and from the charger were cut off and run through the mounting chassis. Care must be exercised when shortening the output leads as one is positive and the other negative polarity. It is important that the polarity be followed through the relays into the storage battery.

### Current Limiting Resistor

It will be found that the lowest charging rate of the charger will be much too high for day-in and day-out service. At first one might suggest the use of a charger of the trickle-charge type. While it is true that the supply unit may not be called upon to supply power for long periods at a time and may remain in standby for many weeks, the utility lines may fail to sup-

Fig. 1. Schematic of emergency power supply for a remote console.

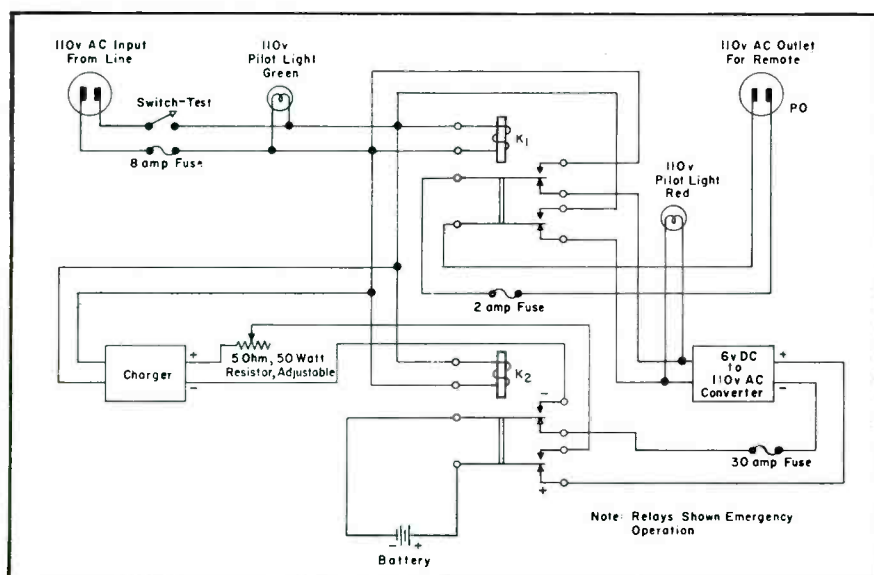

<sup>1</sup>From notes prepared for SERVICE by W. L. Farmer, Mobile Radio Service.

<sup>2</sup>Mobile Radio Service MRS-6-110.



# Emergency Power Supplies for Remote- Control Consoles Used in Two-Way Communication Systems‡

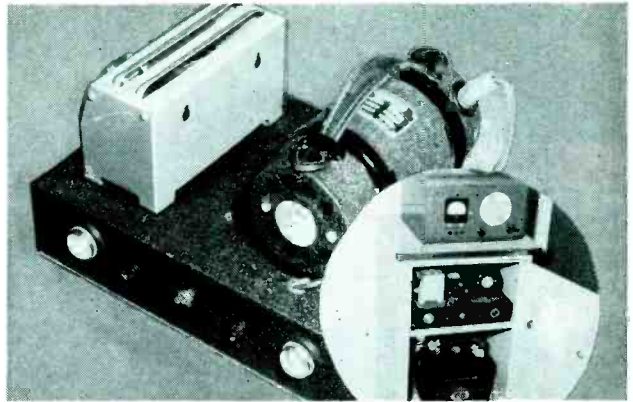

(Right)  
Left, front view of emergency supply, showing battery charger, current-limiting resistor and rotary converter. Below, right, a deluxe remote installation with an emergency power supply.

ply power for long periods up to four hours, and this would drain some 80 amperes from the battery. It is, therefore, better to use a current-limiting resistor with a sliding contact so that the desired charging rate can be selected at will. A 5-ohm resistor with a power rating of 30 watts and having an adjustable sliding contact was used. With a setting at 4 ohms, found to be best, the current into the battery during standby will be approximately .5 ampere. The charging rate can be easily adjusted to meet the needs of the installation. With a rate of .5 ampere and under normal seasonal temperatures it will rarely be necessary to add water to the battery cells oftener than twice each month.

### Relays

A pair of double-pole double-throw relays<sup>4</sup> with 115-v ac windings were selected. The contacts on these relays must be kept clean and enough spring tension maintained to make good firm contact. Any contact resistance on the charging relay will prevent the battery from receiving the very low trickle rate. The need for a small amount of water to be added once during each two-week period will serve as a good indication that the contacts are offering very little resistance.

### Test Switch

A small single-pole single-throw toggle was inserted for testing the operation of the unit. The same test could have been made by merely pulling the line cord from the utility outlet; however, it was found much simpler to operate the switch. The switch is operated each time an inspection is made of the cell water level. The nor-

mal position of the switch is closed. Opening of the switch simulates emergency operation.

### Theory of Operation

The operation of the unit is based on the automatic operation of the two relays. With the test switch closed and with power from the utility service flowing into the unit via the line cord, the relays with their field coils connected to the ac line, are energized drawing the pole pieces and movable relay contacts to the lower position.

It will be noted that the two lower contacts on one relay ( $K_1$ ) are also connected in parallel with the relay coils and the input line. The two movable contacts of this relay are connected to the female chassis mounting power outlet into which the line cord from the radio remote control unit is inserted. By energizing this relay the utility power merely flows from the

line through the relay into the remote control console.

The battery-switching relay ( $K_2$ ) has battery leads connected to the pair of movable contacts. The output or charging current from the battery charger is connected to the two lower contacts of the relay and when the relay is energized the battery is placed on charge. In this position a green pilot lamp lights up, indicating that the emergency power supply is in standby operation.

During a power line failure, or at any time the switch is opened, energizing voltage is removed from the relay field coils and the input circuit of the battery charger. The springs on the movable contacts of the relays pull the contacts to the upper pair on each relay.

The closing of the top pair of contacts on the battery-switching relay with its two movable contacts removes  
(Continued on page 102)

Schematic of combination loudspeaker, amplifier and power-supply system\*, designed to replace or supplement headphones in aircraft cockpits. Primary power of 115 v, 400 cycles at approximately 45 watts, is required for operation. Signal input circuit, is designed to bridge directly across the regular aircraft headphone jack. Four watts of audio output, with less than 10% distortion, it is said, are provided by two 5686 pentode amplifier tubes operating in a push-pull output circuit; frequency response is flat within 3 db from 100-3500 cps. A normal installation would include two units, one for the pilot and one for the co-pilot so that each can monitor a separate channel.

(\*Bendix design)

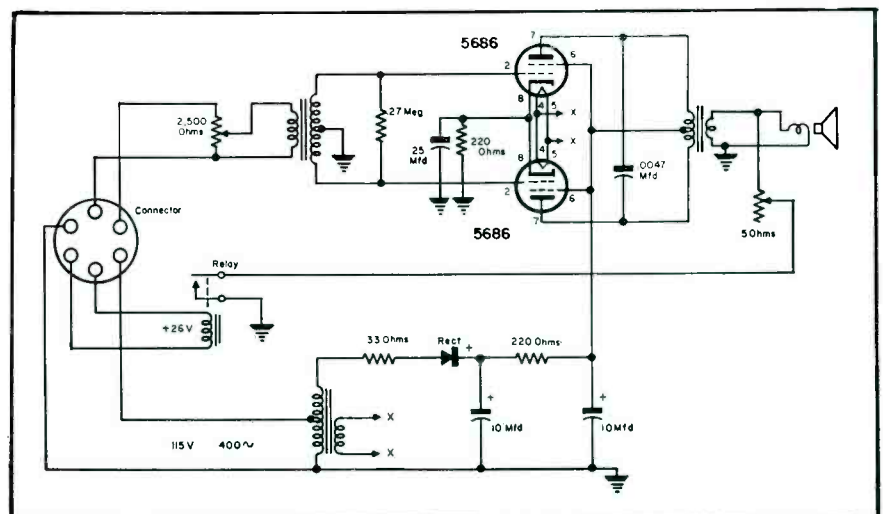

<sup>3</sup>Carter Super Converter model A1060CW.

<sup>4</sup>Mallory model 6AC4-2.

<sup>5</sup>Potter and Brumfield PR11-A.

# Halldorson's *New*

## FB412 FLYBACK

An exact replacement for Part No. C201-21025-1

Services **83** models and chassis of

## AIRLINE RAYTHEON TRUETONE

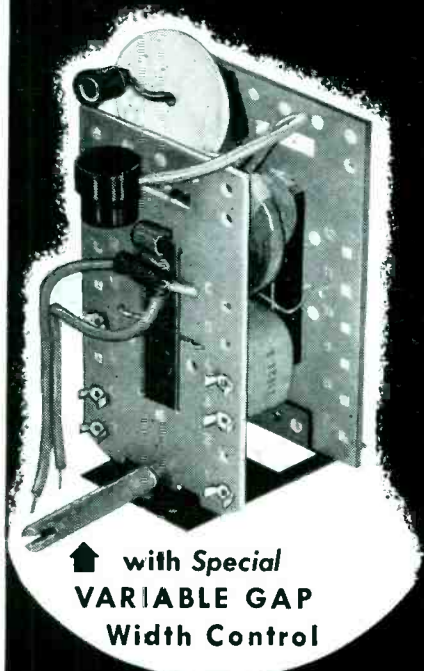

↑ with Special **VARIABLE GAP Width Control**

Another needed flyback for fast, economical *sure-fire* servicing. Get it now—at your distributor—and be ready to service these popular TV sets not covered before. Quality-made by one of the oldest firms in the business.

Write for descriptive Bulletin No. 116 today.

**HALLDORSON TRANSFORMER CO.**  
4500 N. Ravenswood Ave.  
Chicago 40, Illinois

For your convenience Halldorson Replacements are now being listed in **PHOTOFACTS and COUNTERFACTS**

**Halldorson**  
QUALITY Transformers SINCE 1913

# PERSONNEL



JAMES H. LYNCH has been appointed vice president in charge of sales of the Kelton Co., Inc., Amory St., Boston, Mass.

\* \* \*

FRANK X. LAMB has been appointed vice president, and ROSWELL W. GILBERT, assistant to the president, of the Weston Electrical Instrument Corp., Newark, N. J.



Frank X. Lamb



Roswell W. Gilbert

\* \* \*

CLIFF KNOBLE has been named advertising manager of the TV and radio division of the Raytheon Manufacturing Co., Chicago, Ill. . . . JOHN H. KELLEY has been appointed sales manager of the division.



Cliff Knoble



John H. Kelly

\* \* \*

FRED M. LINK has joined Du Mont as director of operations for a newly formed mobile communications department. . . .

ALFRED Y. BENTLY has been placed in charge of advanced planning for the TV receiver manufacturing division.

\* \* \*

KENNETH C. MEINKEN, JR., formerly vice president and general sales manager of the National Union Radio Corp., has been appointed sales manager of the Automatic Manufacturing Corp., Newark, N. J.

\* \* \*

MERLE CAIN, formerly G.E. Chicago district rep, has been appointed distributor sales manager for the V-M Corp., Benton Harbor, Mich.



Merle Cain



Bron Kutny

BRON KUTNY, formerly educational director of Emerson Radio, is now a field engineer for Channel Master Corp., Ellenville, N. Y.

\* \* \*

MURRAY PLATT, president of Platt Manufacturing Corp., New York City, has been elected president of the Link Radio Corp. Associated with Platt will be JAMES B. FERGUSON, chief engineer, and LARRY STRAW, sales manager, formerly of Bendix.

# ATLAS PROJECTORS



**9 models to choose from for EVERY application**

The performance-proved ATLAS Double Re-entrant ("DR") design combines compactness with unequalled high efficiency and uniform response in a rugged, stormproof, demountable construction. The larger size horns are excellent for greatest efficiency and low-frequency response. Where space and cost limits exist, the smaller horns are recommended. For complete details on "DR" Projectors and the famous ATLAS line of Public Address and Microphone Stand equipment . . .

WRITE NOW for FREE Catalog 553



**ATLAS SOUND CORP.**

1442 39th St., Brooklyn 18, N. Y.  
In Canada: Atlas Radio Corp., Ltd., Toronto, Ont.

WILLIAM A. READY, formerly president of the National Co., has been elected to the board of directors of Browning Laboratories, Inc., Winchester, Mass.

\* \* \*

DEAN L. NORDQUIST has been appointed assistant advertising manager for Electro-Voice, Inc., Buchanan, Mich.

\* \* \*

VITO RACANELLI has been named advertising manager of Chicago Standard Transformer Corp., Chicago, Ill.

\* \* \*

IRA LANDIS, formerly treasurer, has become president of Herman H. Smith, Inc., Brooklyn, N. Y., succeeding Smith who died recently.



Ira Landis



Michael F. Callahan

MICHAEL F. CALLAHAN is now vice president in charge of manufacturing for all CBS-Hytron plants. . . . EDGAR K. WIMPY has been named director of general engineering. . . . DR. RUSSELL R. LAV has been made director of research and development. . . . Other appointments announced were: CLIFFORD HUGHES, plant manager of the Newburyport receiving tube plant; ELWOOD W. SCHAFER, manager of color planning; J. FARLEY, director of quality control.



WALTER C. LEDERER, formerly district sales manager and on the advertising staff, has been named sales promotion manager of the television and broadcast receiver division of the Bendix Aviation Corp., Baltimore, Md.

\* \* \*

RALPH MENDEL has been appointed vice president in charge of the engineering products division of Radio Receptor Co., Inc., Brooklyn, N. Y.

\* \* \*

GEORGE KOLLAR has been named special assistant to L. M. FINNEY, Jr., sales manager, of The Finney Co., Cleveland, Ohio. . . . VICTOR TREBULES has been promoted to plant superintendent.



George Kollar



Victor Trebules

\* \* \*

RAUL H. FRYE has been appointed vice president in charge of engineering of the National Co., Inc., Malden, Mass. Frye was formerly with Raytheon as general manager of the special products division.



Raul R. Frye



William H. Rickards

WILLIAM H. RICKARDS, formerly with Radiart Corp. and Cleveland Electronics, has been named director of engineering of the Ward Products Corp., division of the Gabriel Co.

\* \* \*

ROBERT A. HOAGLAND has been appointed sales manager of the Aerovox-New Bedford Division, Aerovox Corp., New Bedford, Mass.

\* \* \*

F. BIRNEY FARRINGTON, founder of the firm, has been reelected president of Xcelite, Inc., Orchard Park, N. Y. Others elected were: JOHN O. OLSEN, vice president; CLARENCE SCHWABEL, secretary, and ARCH WARDEN formerly sales manager, treasurer.



E. B. Farrington



A. Warden

\* \* \*

DR. NORMAN PICKERING, technical director for Philharmonic Record, Inc., and director of research of Pickering and Co., Inc., has been appointed visiting professor of music at The City College. Pickering will conduct a course in *music acoustics* during the spring term, dealing with acoustical problems in broadcasting, recording and in the concert hall.

INSURE CUSTOMER SATISFACTION . . .

**OHMITE**®



**WIRE-WOUND  
RESISTORS**

Provide an  
**EXTRA MARGIN  
OF SAFETY**

One replacement resistor that doesn't hold up can cause a faulty repair job . . . and one faulty repair job can cost you one good customer. For your higher wattage replacement needs, the most dependable resistors you can buy are OHMITE wire-wound resistors. They provide an *extra margin of safety* that puts your mind at ease, and helps you build confidence among your customers. OHMITE vitreous-enameled resistors have all-welded construction for greater reliability. Brown Devil resistors are available in 5, 10, and 20-watt sizes, 0.4 to 100,000 ohms. Other fixed resistors to 200 watts. Dividohm adjustable resistors, useful as voltage dividers, available in sizes from 10 to 200 watts, and 1 to 100,000 ohms. Order a supply, today.

**OHMITE  
MANUFACTURING COMPANY**

3642 Howard St., Skokie, Illinois  
(Suburb of Chicago)

Write for  
Stock  
Catalog



**OHMITE**

*Be Right With*

**DEPENDABLE RESISTANCE UNITS**

THE

*American*

IDEA

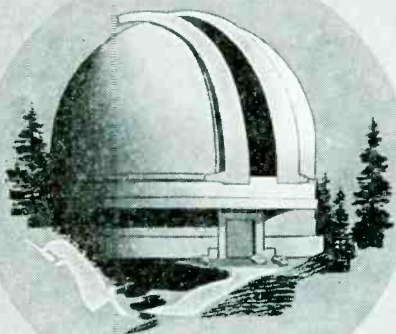

*"To find and follow  
the better way" . . .*

Out of the vision of Dr. George Ellery Hale came the great "American Idea" that resulted in the creation of the "Glass Giant of Pclomar"—world's largest telescope—to gather new light from the farthest stars for the searching eye of science.

With us, the "American Idea" is, by directed effort and applied know-how, to continue to lead in bringing you electronic products of the highest quality.



INSIST ON  
AMERICAN  
REPLACEMENT  
CRYSTAL  
CARTRIDGES

Send for FREE catalog 46



American microphone co.

370 South Fair Oaks Ave. • Pasadena, 1, Calif.

#### RCA TUBE CONTEST

A \$50,000 contest, which will award 400 prizes to radio-TV Service men offering the best reasons for using and recommending RCA picture and receiving tubes, has been announced by the tube department, of the RCA Victor Division, RCA, Harrison, N. J.

Contest is the heart of a consumer-aimed *Tell and Sell* campaign designed to tell the Service Man's side of radio-TV servicing. Promotion will also employ national radio and TV advertising, a variety of in-store display and sales promotion material. Contest requires the completion, in 25 words or less, of the sentence beginning *I use and recommend RCA tubes because. . . .* Contest will close midnight, April 30, 1954.

Grand prize is a choice of a '54 DeSoto hard-top convertible or a '54 Dodge panel truck, plus a full set of RCA test equipment. Second prize is an 11-instrument set of RCA test equipment, or a \$1000 U.S. Savings Bond. Third prize is an RCA 3-way console featuring 21" TV, AM-FM radio, and phono. Prizes four to 400 include room air conditioners, stoves, clock and portable radios, movie cameras and wrist watches. Duplicate prizes will be awarded to distributor salesmen who assist winning dealers.

Sales-aids include color window or counter displays built around a life-size baby portrait; tube-display rack; a three-by-four-foot outdoor display sign; door-display which rings when customers enter store; and an *edge-lit* indoor sign for wall or counter display.

\* \* \*

#### PYRAMID EXPANDING

Plans for doubling its present manufacturing facilities have been announced by the Pyramid Electric Co., 1445 Hudson Blvd., North Bergen, N. J.

Currently celebrating its 10th anniversary, Pyramid recently opened a second plant in Gastonia, N. C., for the manufacture of paper and motor starting capacitors.

A catalog supplement, *DE*, which lists 272 electrolytics is now available.

\* \* \*

#### TRAILER LOADS OF ANTENNAS



Shipment of two trailer loads of Big Joe antennas sent by Tescon to the Cameron Company, Rock Island, Ill. Left to right: Don Weller, Park Jackson, John Summy, Ray Pockrandt, Cameron sales personnel; Scotty Cameron, owner of Cameron, and Elliot March, sales manager of Tescon-TV Products.

#### SIMPSON TV CHALLENGE CLINICS

Service meetings, featuring *challenge clinics*, to which TV Service Men are invited to bring their *dog* receivers for diagnosis and repair by a field engineer, have been inaugurated by the Simpson Electric Co., 5200 W. Kinzie St., Chicago 44, Ill.

Clinics are being conducted by *Bob Middleton* throughout this country and Canada, who acts as speaker demonstrator and diagnostician.

Company has also inaugurated a house organ, *The Technician's Timesaver*, a four-page publication which points out profitable shortcuts to faster TV servicing. Each issue covers, in part, the formal discussions and demonstrations made at the meetings.



Bob Middleton

\* \* \*

#### KERDEN CHEMICAL MOVES

The Kerden Chemical Co., manufacturer and distributor of *Carbon-Tet*, has moved to new quarters at 6400 Herman Ave., on Cleveland's west side, where it will share occupancy with parent company; Products Packaging, Inc., and Products Sales, Inc.

Officers of company are *Leo R. Kundtz*, president; *Arthur J. Frey*, vice president and *Theodore F. Ward*, secretary-treasurer.

\* \* \*

#### DU MONT PICTURE TUBE SELECTOR

A pocket-size, slide-rule *picture tube selector*, which is said to solve most picture-tube replacement problems has been made available by the cathode-ray tube division of Allen B. Du Mont Laboratories, Inc.

Selector gives electrical values, basing, and important physical features for thirty-six major replacement picture tube types. Over one-hundred other tube type listings are indexed according to interchangeability with the basic types.

Selector is being made available through all distributors of Du Mont Teletron replacement picture tubes.



Du Mont Picture Tube Selector



**YOUR TICKET TO  
THE GREATEST  
"SHOW" ON EARTH!  
...G-C SERVICE AIDS**

**FREE! New G-C Catalog  
... get it today.**



**G-C AMO MINIATURE  
TUBE PULLER**  
Prevents tube breakage,  
burned fingers.  
For 7-pin tubes  
No. 5093—List \$1.80  
For 9-pin tubes  
No. 8106—List \$1.80

Successful servicing of the greatest "show" on earth—television—calls for fast, economical, customer-pleasing performance. The G-C Service Aids shown here are typical of the almost four thousand items now available to help you do a better job . . . with greater volume, greater profits.



**G-C MINIATURE  
TUBE PIN  
STRAIGHTENER**  
For 7-pin tubes  
No. 5191, List \$1.25  
For 9-pin tubes  
No. 8105, List \$1.25



**G-C DUPLEX TUBE  
PIN STRAIGHTENER**  
Precision dies  
straighten both 7- &  
9-pin tubes.  
No. 8655, List \$2.50



**G-C ALLEN-BRISTO  
WRENCH KIT**  
Twelve wrenches for  
both hex and spline  
screws.  
No. 5028, List \$1.80



**G-C CABINET  
REPAIR KIT**  
Complete, in metal  
box, full instruc-  
tions.  
No. 901, List \$7.50



**G-C TEST LEAD PLUG  
INTERCHANGE KIT**  
Interchanges alliga-  
tor clips, banana  
plugs, etc.  
No. 7743, List \$3.25



**G-C DIAL CABLE  
TOOL**  
Aids in replacing  
worn cables, dial  
springs.  
No. 5096, List \$0.85



**G-C TV & RADIO  
DIAL CABLES**  
Extra thin Nylon  
.025" dia. Chemi-  
cally treated. 25-ft.  
spool. No. 75A-25,  
List \$1.40.



**G-C 14-L  
PHONO DRIVE**  
Specially molded for  
RCA 45-RPM, com-  
plete.  
No. 14-L, List \$1.00



**G-C 195 RCA TV  
TUNER BELT**  
For RCA series 8T,  
8TC, 8TK, 9TC, etc.  
No. 195, List \$0.50



**G-C NE-O-LITE  
TESTER**  
Handy for 60 v AC  
to 550 v AC-DC.  
No. 5100, List \$0.60



**G-C HIGH FIDELITY  
RECORDING WIRE**  
Finest quality stain-  
less steel, with  
leaders. 1-hr. spool.  
No. 5171, List \$5.00



**G-C MASTER-TONE  
RECORDING TAPE**  
Plastic base, high  
frequency response.  
1270-ft. reel.  
No. 5180, List \$5.50



**G-C NEW TV  
SAF-T-RACK**  
Holds any TV chas-  
sis safely.  
No. 8045, List \$5.45



**G-C SPEEDEX  
WIRE STRIPPER**  
New, fully automat-  
ic, delayed action.  
12 models.  
No. 766, List \$8.25



**G-C TUBE & PARTS  
EXTRACTOR**  
Same as Signal  
Corps TL-201.  
No. 5092, List \$1.65



**G-C "TUX"  
TOOL KIT**  
Handy, flexible,  
roomy.  
No. 8943, List \$3.95



**G-C GENERAL  
SKRATZ STIK**  
Handy, fast on wal-  
nut, mahogany, oak  
cabinets.  
No. 909, List \$0.50



**G-C SILVER PRINT**  
Pure silver, for  
touching up printed  
circuits. 1 Troy oz.  
No. 21-2, List \$7.75



**G-C RUF-KOAT  
WRINKLE VARNISH**  
Air dries; black,  
gray or brown col-  
or. 2 oz.; specifi-  
color.  
No. 60-2, List \$0.65



**GENERAL CEMENT MFG. CO.**

901 Taylor Avenue Rockford, Illinois

# COLOR TV

by **W. L. ROBERTS**

Westinghouse Research Laboratories

## Receiver Circuitry

**Design and Operation of Special Circuits Found in**

**Color Chassis Used for Decoding . . . Matrixing . . .**

**Color-Burst Separation . . . Color Subcarrier Generation**

ESSENTIALLY COLOR TV receivers are black-and-white sets with additional circuitry and with the present-day picture tubes replaced by tricolor types. The complexity and type of the circuits used depends to a certain extent upon the type of tricolor picture tube employed.

### Color Decoding

In current b-w receivers, the signal derived by the video detector is applied directly to the picture tube for presentation. Unfortunately, as the state of the color TV art now exists it is not possible to apply the chromaticity signal directly to the picture tube. The circuits in receivers using currently available tricolor tubes must

produce signals which correspond directly to the three primary colors. These signals may be proportional to the  $E_R$ ,  $E_B$ , and  $E_Y$  signals generated at the transmitter or they may be proportional to the so-called difference signals,  $(E_G - E_Y)$ ,  $(E_R - E_Y)$  and  $(E_B - E_Y)$ . When the latter signals are combined additively with the luminance signal ( $E_Y$ ), the primary color signals  $E_G$ ,  $E_R$  and  $E_B$  are obtained. To produce any of these signals, therefore, the receiver must incorporate a color decoder or desampler, although ultimately a tricolor picture tube may perhaps be developed that will perform the decoding automatically.

For decoding color signals the circuit, illustrated in block form in Fig. 1 (p. 68), can be used. The video de-

detector in the receiver has two outputs; one a wide-band output representing the  $E_Y$  or luminance signal; the other of smaller bandwidth being the chromaticity signal. The former signal is almost identical with the video signal obtained after detection in a present-day TV receiver. However, the latter signal, after passing through a band-pass filter, must first be demodulated and separated into its  $E_Q$  and  $E_I$  components. This is accomplished by the  $Q$  and  $I$  demodulators to which are fed in quadrature the outputs of a 3.58-mc reference oscillator, which is synchronized to the color burst signal.

A demodulator is similar to a modulator or mixing stage in that it is a

(Continued on page 68)

Filament lineup of all of the tubes used in complete Westinghouse color receiver. In dashed insert below (right) is the filament chain for tubes used in rf amp and mixer-osc section of set.

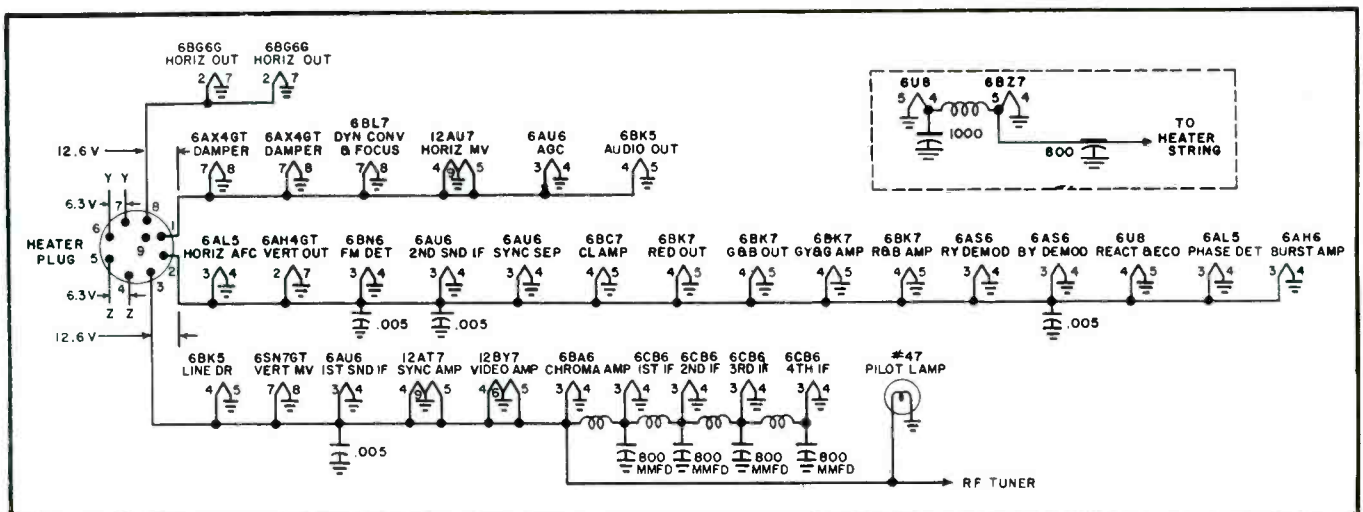



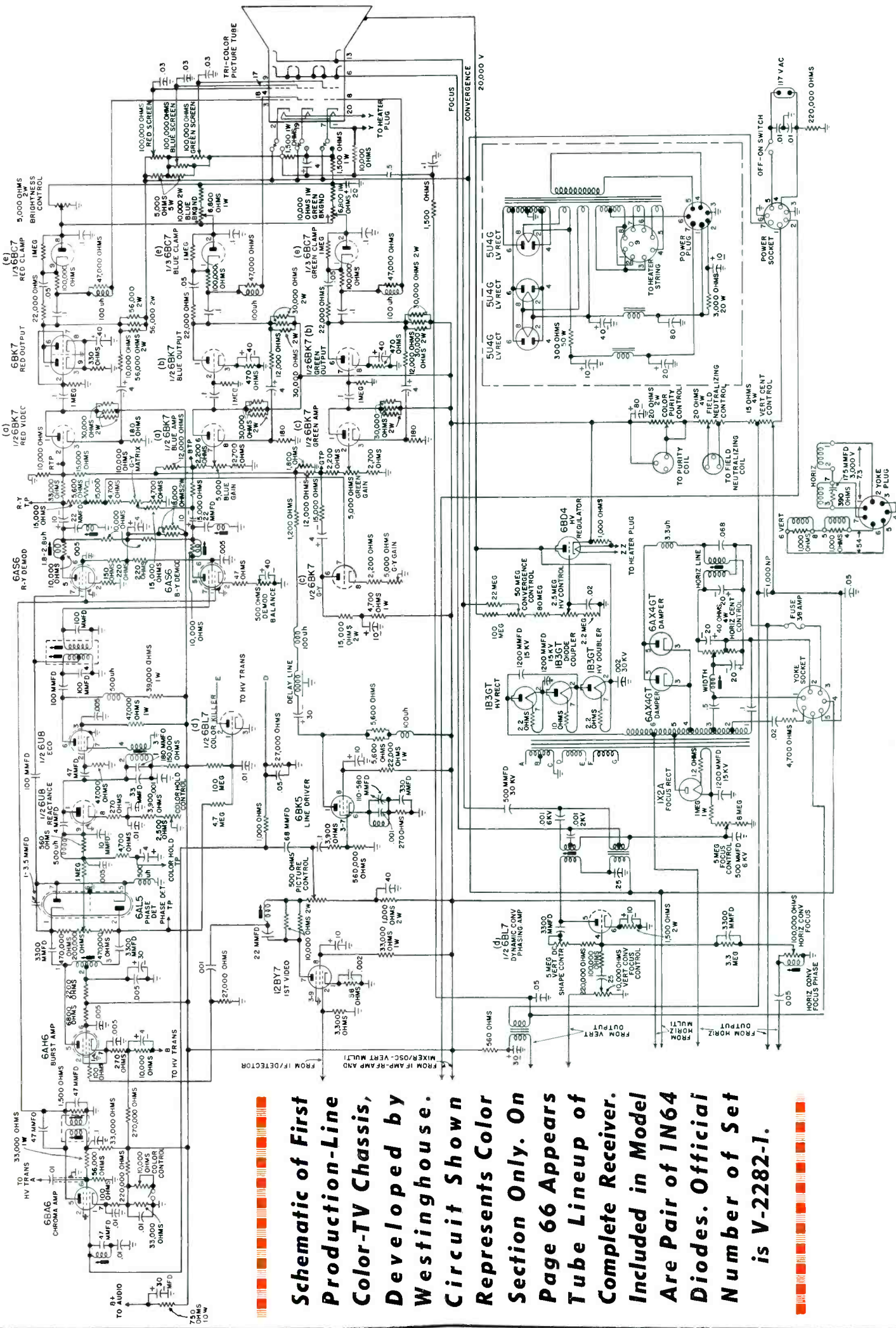

**Schematic of First  
 Production-Line  
 Color-TV Chassis,  
 Developed by  
 Westinghouse.  
 Circuit Shown  
 Represents Color  
 Section Only. On  
 Page 66 Appears  
 Tube Lineup of  
 Complete Receiver.  
 Included in Model  
 Are Pair of 1N64  
 Diodes. Official  
 Number of Set  
 is V-2282-1.**

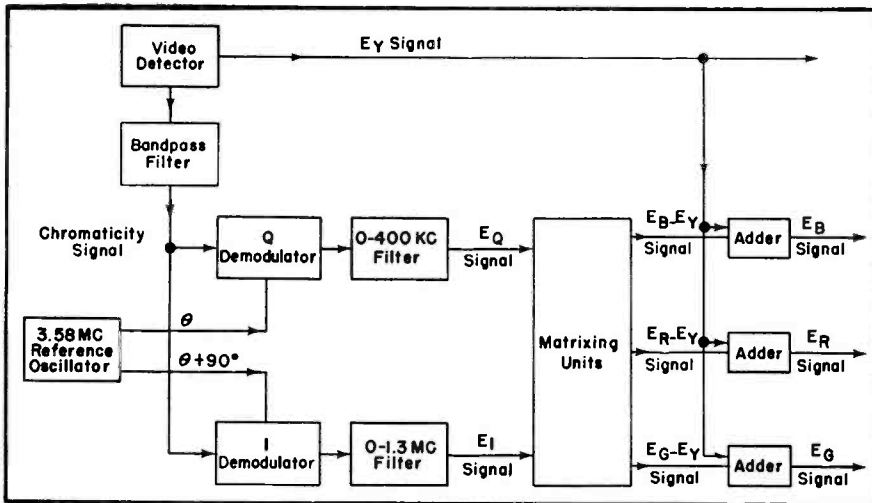

Fig. 1 (left). Block diagram of circuit used for decoding color signals.

non-linear device into which is fed the signal to be demodulated and the output of the reference oscillator. Tubes with sharp cut-off suppressor characteristics are usually employed for this purpose and the 6AS6 serves admirably for this purpose. The signal to be demodulated is usually fed to the control grid and the reference oscillator output to the suppressor grid. At the anode the difference signal is the required demodulated output and it is separated from the other signals present by means of filters.

After emerging from the demodulators, the  $E_Q$  and  $E_I$  signals pass through their respective filters which limit the bandwidth of the  $E_Q$  signal to 400 kc and the  $E_I$  signal to 1.3 mc.

### The Matrixing Units

The next step lies in the production of the  $(E_R - E_Y)$ ,  $(E_G - E_Y)$  and the  $(E_B - E_Y)$  signals. It can be shown that

$$(E_R - E_Y) = .625 E_Q + .948 E_I \quad (1)$$

$$(E_G - E_Y) = 1.735 E_Q - 1.068 E_I \quad (2)$$

$$(E_B - E_Y) = .641 E_Q - .284 E_I \quad (3)$$

This means that to produce the  $(E_R - E_Y)$  signal, 62.5% of the  $E_Q$  signal must be added to 94.8% of the  $E_I$  signal. Similarly to arrive at the  $(E_G - E_Y)$  signal, 1.068 times the  $E_I$  signal must be subtracted from 1.735 times the  $E_Q$  signal. The  $(E_B - E_Y)$  signal is composed of 64.1% of the  $E_Q$  signal combined with 28.4% of the  $E_I$  signal, the polarities of both signals being reversed. These difference signals are obtained from the adding or matrixing units as shown in Fig. 1.

Matrixing units are usually linear passive resistance networks. A simple circuit for the addition of three signals developed from low impedance sources is shown in Fig. 2 and from a study of the diagram it is apparent that attenuation of the signals occurs. If one of the signals has to be subtracted, then a phase reversing device such as a tube or transformer must be em-

ployed, as illustrated in Fig. 3. To maintain the frequency response of such mixing units over the whole video spectrum, the resistors are usually shunted with small capacitors. This is necessary because the output of a mixer is usually applied to the grid of a tube with a certain grid input capacity. This capacity would attenuate high-frequency components of the mixed signal were shunting capacitors not employed.

Addition and subtraction can also be accomplished directly with tubes. Fig. 4 shows an arrangement for the addition of three signals using three pentodes, and Fig. 5 shows an arrangement for obtaining a difference signal using two triodes.

To each of the outputs of the matrixing units the  $E_Y$  signal is added in the three adding stages, and this process results in the procurement of  $E_R$ ,  $E_G$  and  $E_B$  signals corresponding to the red, green and blue primaries.

### Separating the Color Burst Signal

In all color TV receivers, it is necessary to generate a 3.58-mc signal which is held in exact synchronization with the color subcarrier oscillator at the transmitter. This exact synchronization is necessary for accurate color decoding and to facilitate this synchronization, the color burst signal is radiated from the transmitter after each horizontal synchronization pulse.

Separation of the color burst signal from the composite video signal must be accomplished in each receiver and for this purpose a gated amplifier (or more simply, a gating stage) is used. To this stage is fed the composite video signal and also a series of gating pulses which permit the amplifier to be operative only for the duration of the pulses. These gating pulses are developed from the horizontal time

(Continued on page 80)

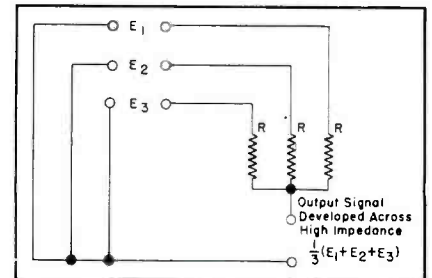

Fig. 2. Network used for addition of three signals.

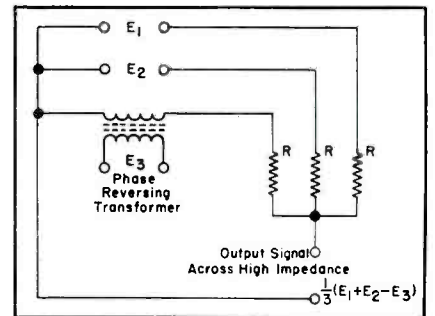

Fig. 3. Circuit that can be used for subtracting one signal from the sum of two others.

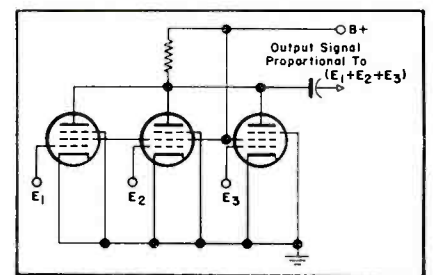

Fig. 4. An arrangement for the addition of three signals using three pentodes.

Fig. 5. Circuit designed to provide a difference signal using two triodes. Output is proportional to the difference of the two input signals.

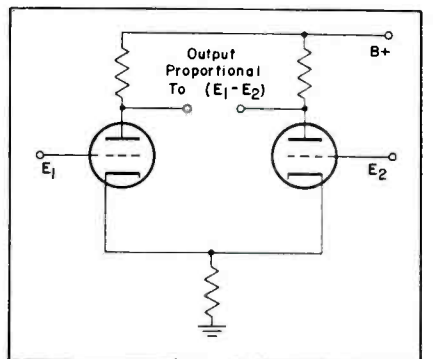
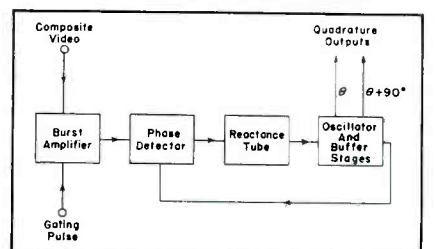

Fig. 6. Setup of oscillator employed to control automatically the frequency and phase of the color subcarrier oscillator.





# TeleMatic Triumph

13 db GAIN\*

IN UHF RECEPTION



\*Only 8 db  
Noise Figure  
with the

## Amazing New TeleMatic Booster!



Write for  
Brochure  
A126

The TeleMatic UHF BOOSTER is an outstanding achievement in creative engineering. It is all NEW . . . every component of this powerful instrument was designed and built by TeleMatic . . . the receiver tube was developed specifically for UHF amplification . . . the tuning unit embodies a new approach that achieves 13 db amplification with only 8 db noise figure . . . many times the gain of any other UHF BOOSTER on the market.

**TELEMATIC**  
INDUSTRIES INCORPORATED

3 Joralemon Street, Brooklyn 1, N. Y.

AVAILABLE THROUGH PARTS DISTRIBUTORS FROM COAST TO COAST

# TELEVISION

## Hue and Saturation . . .

## Transmission and Color

## Composition Values

by **ANDREW R. ELWOOD**

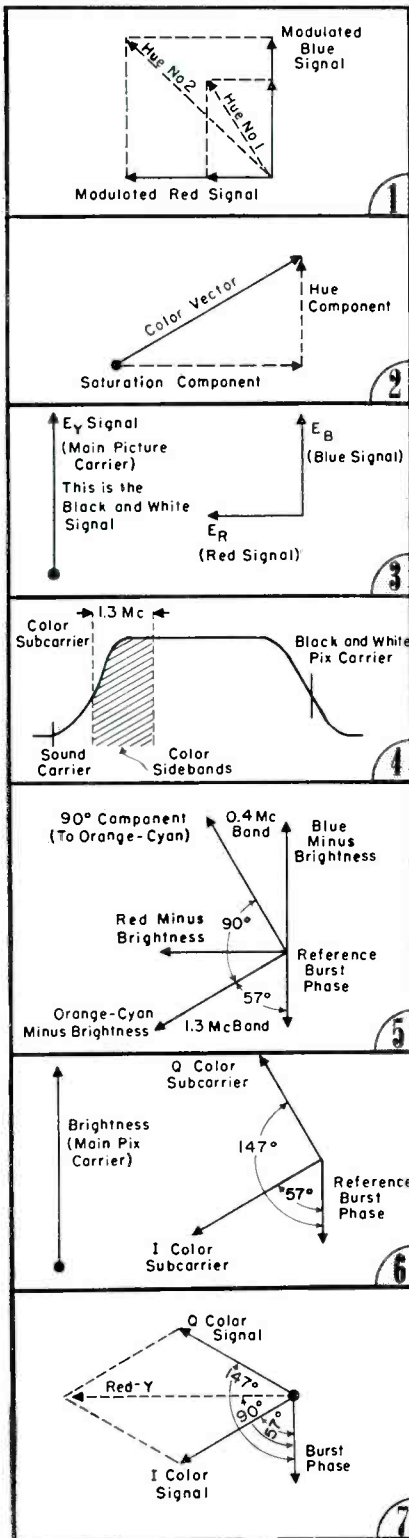

(1)

THERE ARE TWO ways of looking at the modulation of the primary vectors in a color signal. Perhaps most simply, we can look at the changing lengths of the red and the blue vectors, and state that the red and blue primaries are being amplitude modulated. Then, looking at the resultant of these modulated vectors, we can state that the end result is a single vector, the phase of which represents *hue*, and the length of which represents *saturation*.

(2)

STILL ANOTHER way of looking at the color vector is to break it down into two components at right angles to each other, and then define one component as representing *hue*, and the other component as representing *saturation*. This is illustrated at left. These viewpoints are extremely important, because in many reports hue and saturation are analyzed with a different viewpoint in mind. No confusion will result as long as one recognizes and understands these variations.

(3)

ANOTHER SOURCE of confusion is the practice of representing the *brightness* (black-and-white) signal voltage as  $E_Y$ . Unless this notation is clearly defined one might be confused into thinking that  $E_Y$  is meant to represent yellow, instead of brightness; this is a dangerous point, since  $E_G$  and  $E_B$  are commonly used to represent the green and blue signal voltages, respectively. One must remember that  $E_Y$  is an exception, and almost always will indicate the black-and-white signal voltage.

(4)

FORTUNATELY, the problem of compressing the color signal into one channel with the black-and-white signal is eased by the fact that the color signal does not require a 4-mc bandwidth. Actually, a bandwidth of 1.3 mc has been found sufficient for the color signal, as illustrated at left.

(5)

SOME COLORS require more bandwidth than other colors. In color TV transmission, no more bandwidth is used than is actually necessary, because interference problems arising between the color and the black-and-white signal are minimized by restricting the bandwidth of the color signal. The color of orange-cyan requires the greatest bandwidth in transmission (1.3 mc), while the other 90° component of the color signal need have a bandwidth of only 0.4 mc, as shown at left. Filters are used at the transmitter to restrict the bandwidths of the two color subcarrier signals.

(6)

THUS, one can appreciate this fact; the signals which are radiated are not the basic black-and-white, red-minus-brightness, and blue-minus-brightness voltages, but instead are black-and-white, a color subcarrier at 57° from reference burst, and a color subcarrier of the same frequency at 147° from reference burst, as indicated at left.

(7)

THESE RADIATED color signals are not the primary colors, but it is obvious that by suitable modulation of these radiated color-signal voltages, the primary color signals can be generated, or, any hue in the color spectrum can be similarly generated. How a red color signal is generated is shown in the vector at left; generation of red-minus black-and-white from the radiated  $I$  and  $Q$  color signals.



famous

telrex

4-BAY

# "CONICAL-V-BEAMS"®

**-the acknowledged champion in 1948 and STILL CHAMPION!**

Install genuine Telrex "Conical-V-Beams," the Patented uni-directional, one transmission line array. Models for Ch. 2 to 13 or Ch. 2 to 83. See and hear the difference

If UHF is available or expected, install Telrex "Duo-Band Conical-V-Beam" series. The perfect for rotation hi-gain... hi-F-to-B all-band one transmission line array with automatic transition from low to hi band with no lossy "distribution" pads.

"Conical-V-Beams" are designed for easy stacking as required for your particular reception area. 1 bay "C-V-B" for pri-area, 2 bay "C-V-B" for sec-area, 4 bay "C-V-B" for fringe areas... If a 4 bay "C-V-B" does not provide a usable TV picture, TV reception is either impossible or impractical!

Broadbanded single channel highest gain, hi-F-to-B yagis also available from Telrex Antenna Headquarters, builders of world renowned communication yagis for amateur or commercial use.

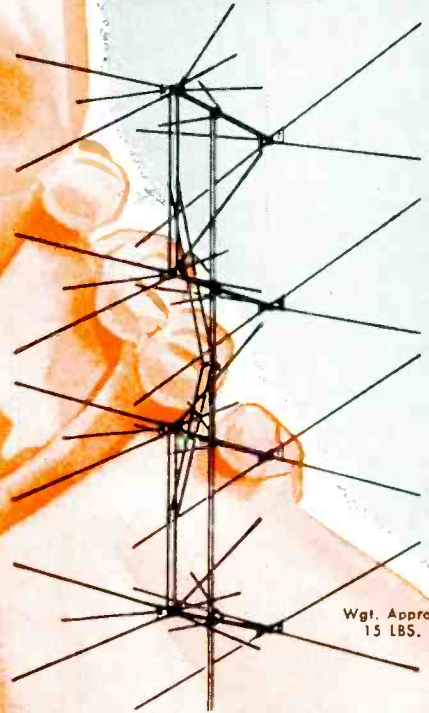

Wgt. Approx. 15 LBS.

### CHAMPION-FOR-DISTANCE MODEL 8X-TV\*

The Ultimate in long distance arrays. Guaranteed to out-perform any antenna or combination of cut-to-frequency antennas. When used with Duo-Band splines it comprises the ultimate from Ch. 2 to 83. Unequaled for reception up to 200 miles.

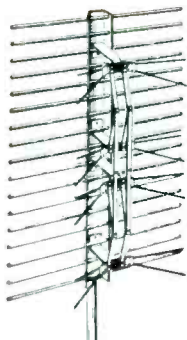

### ULTRA-HI GAIN UHF "CONICAL-V-BEAM" MODEL 84

- Four bay uni-directional array
- All in-phase signal addition at all frequencies with no lobe splitting
- All-aluminum light weight and rugged

### PRE-ASSEMBLED, PRECISION TUNED 5-ELEMENT YAGI

- High gain, broad-band response
- Excellent 300 ohm impedance match.



- High F-to-B ratio

WRITE FOR COMPLETE TELREX BULLETINS, TODAY!

telrex INC. **BETTER BY DESIGN**  
"CONICAL-V-BEAMS"

\*PATENTED

ASBURY PARK 4, NEW JERSEY

Insist on a genuine "Conical-V-Beam." Look for the Telrex Trade-Mark!

**NEW,  
SMARTLY  
STYLED**

# ALLIANCE

## TENNA-ROTOR

The only FULLY AUTOMATIC antenna rotator!

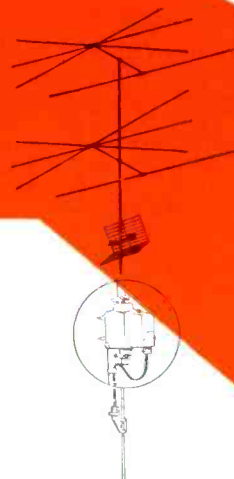

**REDESIGNED ROTATOR UNIT**—Speed increased to 2 rpm. **New double-action magnetic anti-drift brake.** Smoother synchronization with control units.

**Sell the product with the feature that's exclusive!**



MODEL U-83  
AUTOMATIC

## *It's Automatic!*

*The new automatic Alliance Tenna-Rotor sells on sight! They all ask for Model U-83!*

### **Here's how Alliance pre-sells for you!**

- 1. New styling**—"style's the thing" . . . Alliance has it!
- 2. TV advertising** that sells customers! Plus newspapers—magazines!
- 3. The automatic feature** sells itself! No fumbling—no hunting—just "set it—forget it". Pointer turns automatically to any selected direction and stops.

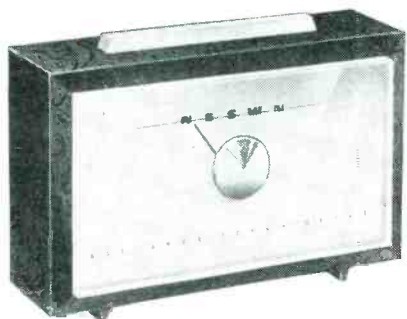

**MODEL T-10**, finger-tip electrically controlled Alliance Tenna-Rotor with direction indicator dial. Extremely accurate. Compact. Modern styling by Reinecke & Associates, leading national designers. Redesigned inside and out . . . . . Price: **\$44.95**



### **ALLIANCE UHF CONVERTER**

...adds all UHF channels—the recognized quality converter built to last! Unexcelled picture quality . . . Price: **\$42.50**

**OVER 1,250,000 ALLIANCE TENNA-ROTORS NOW IN USE!**

**ALLIANCE MANUFACTURING CO., ALLIANCE, OHIO**



## ARTSNY

TO HANDLE the large number of calls that have been pouring in over a central exchange, as a result of the WNBT-WNBC campaign, arrangements have been made to route the phone messages through a special telephone line at ARTSNY headquarters in New York City, with a full-time association secretary handling all calls.

A complete call-channelling schedule has been mapped out to expedite service traffic throughout the greater New York area. All complaints will also be handled through this key exchange.

This is truly an enterprising effort which reemphasizes the important service an association can provide for its members.

### RTA, Long Beach Calif.

INSTALLATION of the '54 officers of the Long Beach Radio Technicians Association was held recently at a special meeting. Among those now serving one-year terms are: *Lee Johnson*, president; *Harold Freeman*, treasurer; *Bob Bergman*, secretary; *Harry E. Ward*, public relations chairman; *Merlyn Cochems*, technical vice president; and *L. E. Peterson*, dealer vice president.

Association now covers the greater portion of southern California, with, it is said, the largest technical group on the west coast.

### RTSA

FERDINAND J. LYNN has been reelected president of the Radio and Television Service Association of Western New York.

Other officers elected include: *Ted Telaak*, vice president; *John G. Wick*, secretary (reelected); *Nicholas Mitri*, assistant secretary; *Pascal Pratt*, treasurer, and *Sterling Williams*, sergeant-at-arms.

### RTG, Long Island

THE FIRST ISSUE of *The Guild News* of the Radio Television Guild of Long Island, an extremely attractive 6-page magazine under the editorship of Murray Barlowe, appeared recently. Articles featured in this slick association paper cover flyback transformer testing, building of a color set, and color TV activities. Also included is a list of Guild members who can lend a hand on repairing specific brands of TV chassis.

On the staff are: *Al Weill* and *Harold Cobb*, business editors; *Chris Stratigos*, photo editor; *Ralph Milne*, technical editor, and *Jack Buck*, advertising.

Congratulations to RTG for creating and publishing this imaginative and helpful journal.

### TSA, Michigan

IN RECENT ISSUES of *TSA News*, the official journal of the Television Service Association of Michigan, whose new editor is *Rod Marien*, color TV, public relations, and shop specialization have been highlight topics.

One issue contained a revealing report on the appearance of TSA president *Harold Chase*, *Larry Howard*, technical director, and *Joe Grey*, chief engineer of the Meissner Corp., plus station engineers, on a half-hour panel program on WJBK-TV, debating reception and channel 2. Discussed were the effects of a recent power increase involving set adjustments and antenna checks required to clear up power-boost difficulties.

# ASSOCIATIONS

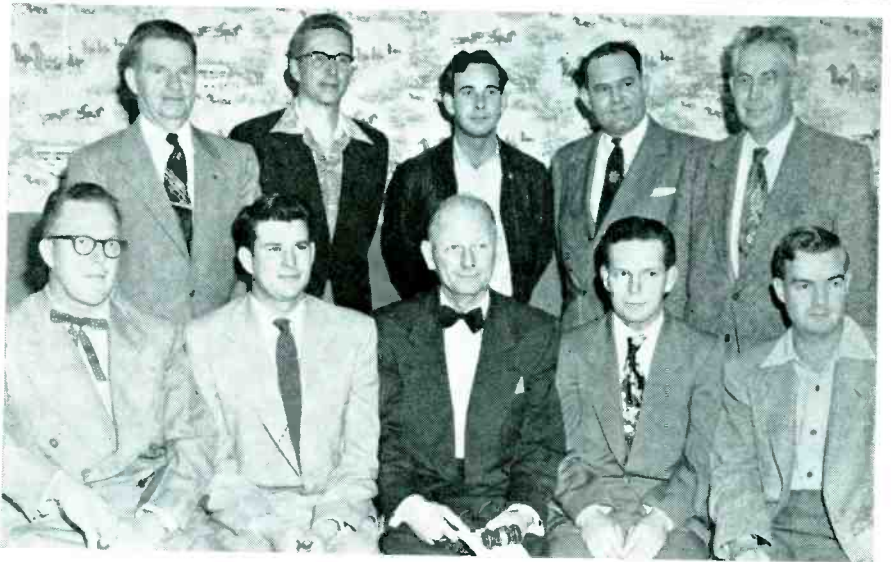

Officers of RTA, Long Beach, Calif., left to right (top row): Clarence Spencer, assistant treasurer; Joe Martin, technical advisor; Fred Abrams, assistant public relations; Elwyn Ley, trade consultant; Harry E. Ward, general chairman public relations. Seated, left to right: Bob Bergman, secretary; L. E. Peterson, dealer vice president; Lee Johnson, president; Merlyn Cochems, technical vice president, and Harold Freeman, treasurer.

### RTA, San Antonio

ALBERT R. NIEHAUS is the current president of the San Antonio Radio and Television Association, Inc., San Antonio, Texas. Other officers include: *Elmo Bohmann*, vice president; *Ora G. Fretz*, secretary; *Thomas F. Boyd*, treasurer; and *H. M. Willmann* and *Esteban Z. Viera*, directors.

*C. R. Bowman*, of P. R. Mallory Co., spoke recently to the group on color TV, and also appeared during a *q* and a period offering practical suggestions on a variety of TV problems.

Group has made plans to introduce a G.E. business course soon which will include a series of one-hour business prac-

tice and one-hour technical talks. Course, designed to teach the Service Man how much his business is making or costing him, will be co-sponsored by a local distributor and the association.

### RSA, Binghamton

HAROLD HAZZARD has been elected president of the Radio Service Association of Binghamton, N. Y. *George Potusky* was elected vice president; *Harold Burdick*, secretary, and *Clinton Wolfe*, treasurer.

Members of RSA had been asked by city officials to offer a report on a proposed licensing measure. They disapproved the suggested legislation and asked the councilmen to shelve the plan.

## TEN YEARS AGO

BLACK MARKET trading of tubes were reported to have created an artificial shortage in many areas of the country. . . . WPB issued a directive authorizing additional production and installation of industrial sound systems, citing the important role *pa* systems have played in improving employee morale and subsequently increasing production. . . . AM antenna coupling and switching methods were detailed in a comprehensive report. . . . Front cover showed schematic of two-stage resistance-coupled amplifier oscillator section of a resistance-tuned oscillator with a frequency range of 7 cps to 70 kc. . . . *S. Young White*, consulting engineer for General Communications Co., Boston, spoke before the Radio Club of America at Columbia University, on *vlf* tuning systems. His talk covered the theory and economics of tuning by parallel and concentric lines, cups, sliding contact coils, variable capacitors of special design, and core tuning by iron and conductive cores in relation to their performance under temperature, voltage,

humidity and vibration conditions. . . . *C. L. Pugh* was appointed rep for Utah Radio Products Corp. in Ohio, West Virginia and western Pennsylvania. . . . Universal Microphone Co., Ltd., changed its name to Universal Microphone Co., with *James L. Fouch* and *Cecil L. Sly* continuing as president and vice president, respectively. . . . *Harry A. Lasure* was elected president of the Southern California chapter of the Reps. At Mid-Lantic election *Sam Jeffries* was named prexy; *W. S. Trinkle*, vice president; *Norman Sewell*, secretary, and *J. H. McKinley*, treasurer. . . . *R. L. Hanks* was named sales manager of receiver sales of G.E. . . . *Ludwig Arnson*, president of Radio Receptor Co., Inc., was awarded the Marconi Memorial Medal of Achievement for forty years of service to radio communications development. . . . *Larry F. Hardy* was elected vice president in charge of the Home Radio division of Philco. . . . *Paul J. Pfohl* was appointed sales manager of the Muter Co.



**QUIETROLE**  
 TRADE MARK REG. U.S. PAT. OFF.  
**ELIMINATES NOISE**  
**THE SAFE\*CLEAN WAY!**

**"The ORIGINAL  
 NON-INFLAMMABLE  
 NON-CONDUCTIVE  
 LUBRICANT CLEANER"**

Available in  
 2 oz., 4 oz., 8 oz.



QUIETROLE . . . the original and most reliable lubricant cleaner quiets noisy television and radio controls, switches\* and other moving parts. Why take less . . . avoid imitations . . . order QUIETROLE, developed after years of research.

**NO GUM! NO GOO!  
 NO GRIME!**

Carried by recognized jobbers . . . everywhere!

\*Unequaled for TV front end switches. Contains no "thinner".



manufactured by  
**QUIETROLE**  
**COMPANY**  
 Spartanburg, South Carolina

# TV Parts... Accessories

## CENTURY DYNATRACER

A portable test instrument, *Dynatracer*, designed to trace TV signals through the sound, sync, *afc*, vertical and horizontal sweep circuits, is available from Century Electronics Co., 8509 21st Ave., Brooklyn, N. Y.

Unit features a system of picking up signal from one section of the receiver and feeding it through a network to the other portions of the set. Will also trace voltage, 50-500 *ac/dc*, and locate faulty capacitors, resistors, coils and transformers.



Century Dynatracer

## MERIT SYLVANIA FLYBACK/SCAN CHOKE REPLACEMENTS

An exact-universal flyback replacement transformer, *HVO-13*, that replaces four of the present units and covers 39 different chassis and over 160 different Sylvania models, has been developed by the Merit Coil and Transformer Corp., 4427 North Clark St., Chicago 40, Ill.

Original mounting bracket must be employed since it is a part of the chassis proper; unit is supplied as a core and coil only. Enclosed with unit is a filament lead wire to be used in the event the original filament leads, due to heat, crack when removing the defective unit.

Also available is an exact replacement unit for the Sylvania horizontal scan choke (241-0002) C-2980, for use with the following chassis: 1-108; 1-139; 1-168; 1-186; 1-227 and 1-231.

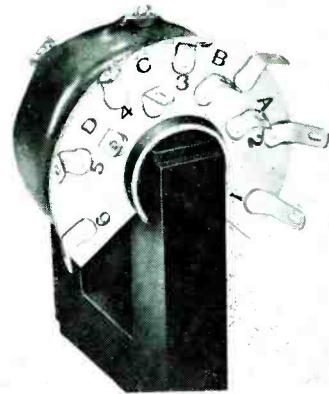

Merit HVO-13

## CAREER OPPORTUNITIES for ENGINEERS

Desiring the challenge of interesting and diversified projects—  
 Wishing to work with congenial associates and modern equipment and facilities—  
 Seeking permanence of affiliation with a leading company and steady advancement—  
 Will find these in a career here at GENERAL MOTORS.

Positions now are open in **ADVANCED DEVELOPMENT** and **PRODUCT DESIGN**  
**COMMERCIAL AUTOMOBILE RADIO**  
**MILITARY RADIO, RADAR AND ELECTRONIC EQUIPMENT**  
**ELECTRONIC COMPONENTS**

**INTRICATE MECHANISMS** such as tuners, telemetering  
 mechanical linkages, controls, etc.

**ACOUSTICS**—loud speakers, etc.

Inquiries invited from recent and prospective graduates as well as experienced men with bachelors or advanced degrees in physics, electrical or mechanical engineering. Salary increases based on merit and initiative. Vacations with pay, complete insurance and retirement programs. Relocation expenses paid for those hired.

All inquiries held in confidence and answered—**WRITE or APPLY to**  
**DELCO RADIO DIV. GENERAL MOTORS CORP. Kokomo, Indiana**



**SYLVANIA 7" 'SCOPE**

A 7" 'scope, 404, for designing and servicing TV receivers, has been announced by Sylvania Electric Products Inc., Radio and TV Division, Williamsport, Pa.

Instrument features flat response from 10 cycles to 2.2 mc; a sensitivity of .01 volts (10 millivolts per inch); input impedance of 5 megohms and 26 mmfd; frequency-compensated attenuator; vertical and horizontal polarity reversing switches, and *lv* and demodulator probes.



Sylvania 'Scope

**MILLER SUBMINIATURE IF UNITS**

Subminiature 455-kc *K-Tran* type if transformers, 10-C1-2, have been introduced by the J. W. Miller Co., 5917 S. Main St., Los Angeles 3, Calif.

Transformer, 1/2" square x 1 1/2" high, utilizes a ferrite shell core material that is said to offer the gain and bandwidth characteristics previously obtained in larger ifs.



Miller Subminiature IF Transformer

**WALSCO TUNER CLEANER**

A tuner cleaner, *Clean-O-Matic*, designed to fit Standard Coil tuners and clean and protect all contacts, except the one in use, has been developed by Walsco Electronics Corp., 3602 Crenshaw Boulevard, Los Angeles, Calif.

A brass cover, that encircles the tuner, is said to prevent radiation. Also included with the cleaner is a small tube of *Tunerlub* and a crocus cloth for cleaning highly oxidized contacts.

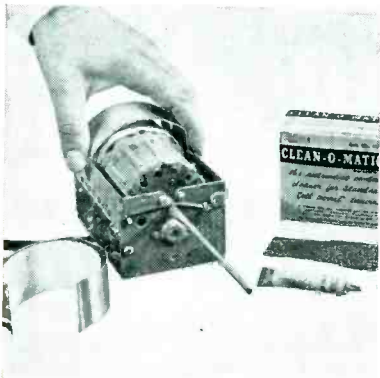

Walsco Clean-O-Matic

**of television signal generators**

- more sweep
- greater RF output
- better stability
- increased accuracy
- unlimited flexibility
- lower cost

**model TVG-2**

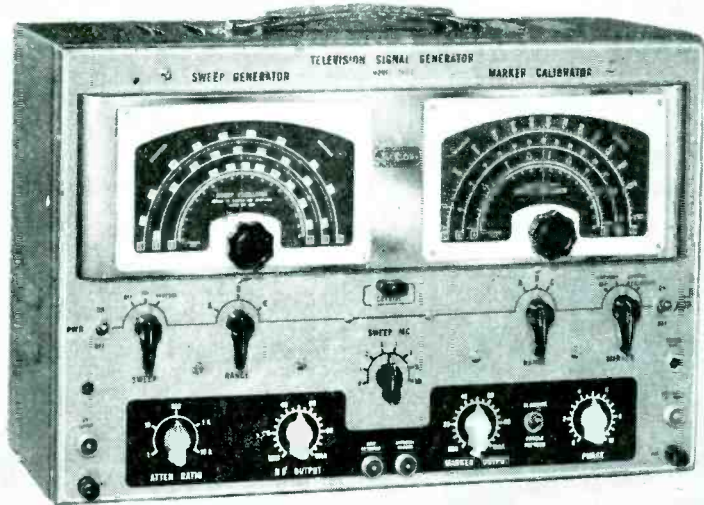

See your electronics distributor or write.

**"service engineered" test equipment**

JACKSON ELECTRICAL INSTRUMENT CO.  
DAYTON 2, OH O

IN CANADA:  
THE CANADIAN MARCONI CO.

Announcing  
AN  
ADDITION TO  
THE

**PHALO** *Trans*

FAMILY OF  
TRANSMISSION  
LEADS

• • •

**300 Ohm  
Tubular Twin  
Transmission Lead**

(Produced under Amphenol  
License No. 2,543,696)



Full Technical Data on Request

PHALO PLASTICS CORPORATION  
25-3 Foster St., Worcester, Mass.

**Insulated Wires, Cables  
and Cord Set Assemblies**

# Tools . . . Instruments Parts . . .

## RAYTHEON BROW LIGHT

A servicing aid, *Brow-Lite*, that features a flashlight worn on the forehead, has been introduced by the receiving tube division, Raytheon Manufacturing Co., Newton, Mass.

Directing light automatically to a spot, light leaves both hands free for work. Features a snorkel socket which adjusts light to any angle. Using standard parts, the light is pocket size and is constructed of plastic.

\* \* \*

## ASTRON HIGH-TEMP CAPACITORS

High-temperature, metallized paper capacitors, *Hy-Met*, that feature the use of a solid thermosetting impregnant which is said to eliminate all possibilities of impregnant leakage has been introduced by the Astron Corp., 255 Grant Ave., East Newark, N. J.

Designed for operation over the temperature range of  $-55^{\circ}$  to  $+125^{\circ}$  C, capacitors are available in metal and paper tubular, as well as bathtub containers; including MIL-C-25A case styles and sizes. Metal-cased capacitors are hermetically sealed with glass-to-metal terminals.

A technical data bulletin *AB-19* describes standard sizes, ratings, mounting styles, test specifications and engineering performance characteristics.

\* \* \*

## SIGHTMASTER INDICATOR-REPEATING FUSE

A patented indicator-repeating fuse, that features a neon indicator which lights up when a fuse ceases to function, has been introduced by Sightmaster Corp., New Rochelle, N. Y.

Unit has six positions on the fuse, and it can be used repeatedly, it is claimed, without replacement. A twist of the switch makes the fuse function again as a new fuse. Available in ratings of 15, 20, 25, and 30 amperes.

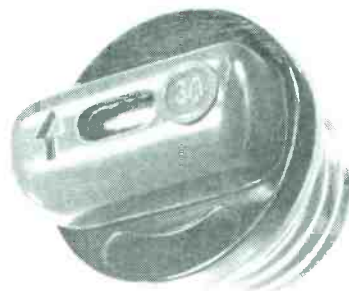

Sightmaster Fuse

Preferred for  
Original Equipment  
Proven for  
Replacement

**O  
X  
F  
O  
R  
D**

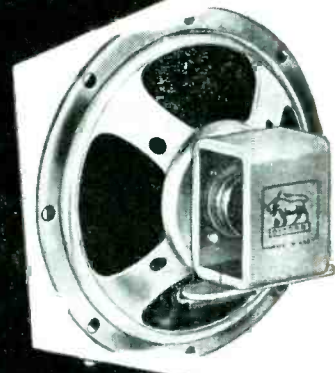

**Speakers**

Available from leading jobbers!

**OXFORD ELECTRIC CORP.**

3911 S. Michigan Ave., Chicago 15, Ill.

EXPORT: ROBURN AGENCIES, N.Y.C., N.Y.

In Canada: Atlas Radio Corp., Ltd., Toronto

## CLAROSTAT 10-WATT POWER RESISTOR KIT

A *GK-1 Greenohm* fixed wire-wound 10-watt power resistor kit, is now available from the Clarostat Manufacturing Co., Inc., Dover, N. H.

Kit consists of 20 fixed wire-wound resistors of the most popular ohmage. Resistors are mounted by means of metal clips to a two-color board which serves as an inventory reminder. As resistors are removed, ohmage of the particular resistor appears on the board. Board has two metal eyelets for hanging on wall.

A 15-watt resistor, *series C8JJ*, has been added to the Greenohm line. It measures 2" long by  $\frac{1}{2}$ " diameter, and is available in resistance range from 1 ohm to 10,000 ohms.

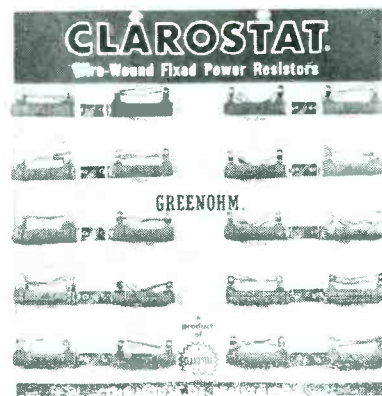

Clarostat Power-Resistor Kit



**TRIPLETT VOLT-OHM-MIL-AMMETER  
CASE**

A neolite case, 639-N, for three models of volt-ohm-mil-ammeters, 630, 630-A and 630-T, is now available from the Triplett Electrical Instrument Co., Bluffton, Ohio.

Case is constructed with a built-in stand that rests the unit at a 45° angle when in use. Also has a back compartment that contains room to store an instruction book, leads, the stand and small tools. For carrying, case has a handle. Snaps encase the unit during transport.



Triplett Case

\* \* \*

**ALPHA ROSIN-FILLED SOLDER**

Rosin-filled solder, *Cen-Tri-Core*, consisting of a solder wire coated with rosin over which is formed the outer solder sleeve, has been developed by Alpha Metals, Inc., 56 Water St., Jersey City 4, N. J.

Available in all alloys, diameters and flux core percentages. Rosin is said to be non-corrosive and electrically non-conductive.

\* \* \*

**R & R DIAL SAW**

A tool, *Dial Saw*, designed to cut any size hole from 1/8" to 2 1/2" diameter in metal, wood, plastics, etc., has been announced by Robertson and Ruth, Box 534, Elmhurst, Ill.

Utilizes three electronically heat-treated high-speed steel cutting blades which are adjusted simultaneously by rotating a calibrated dial. By removing the pilot drill, unit can be used as a rotary planer or grooving tool, cutting any width from 1/8" up. Can be used with hand drill, both electric and manual, drill press, lathe and milling machines.

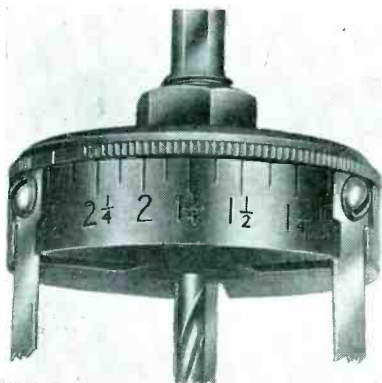

B and R Dial Saw

The *FIRST STEP* in

**HIGH  
FIDELITY**

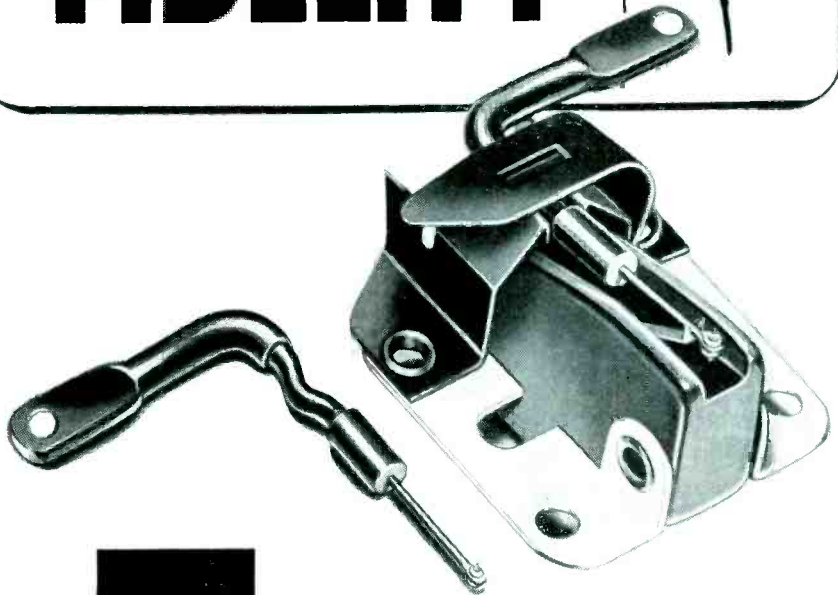

**TITONE**

**CERAMIC CARTRIDGE**

There is no wiser investment a phonograph owner can make than a TITONE ceramic cartridge.

Costing no more than ordinary "replacement" cartridges, TITONE gives a world of difference in results — an entirely new experience in true high-fidelity sound, no matter what the make of phonograph.

And only *two models* will replace most present-day installations!

**No other cartridge gives all these features!**

No preamplifier or equalizer needed • Unaffected by moisture or temperature • Wide frequency range • Outstanding response • High sensitivity • Low distortion • High compliance • No hum pickup • Superior tracking ability • Wide adaptability • Proper groove fit • Only needle rotates • Simple to replace

( Used by America's foremost manufacturers of high-fidelity phonographs, TITONE is an original discovery and development of the Sonotone laboratories. Literature available. )

ELECTRONIC APPLICATIONS DIVISION

**SONOTONE CORPORATION**

Elmsford, New York

# NEW for TV

# NOW

operate 2 TV sets from  
1 antenna at same time  
(VHF-UHF)

WITH BOOST  
IN  
SIGNAL STRENGTH

WALDOM Electronic

*Duo-Tenna*

TV DISTRIBUTION AMPLIFIER



Install  
anywhere indoors.

- Booster effect improves picture quality in "fringe" as well as metropolitan areas.
- Reduces existing noise and "snow" conditions.
- When used with single UHF Converter, converts TWO sets to UHF.
- Broad band width. (Ideal for color telecasts.)
- Save cost and installation of second antenna.
- Easily installed.

It will PAY you to get the  
whole story. Write to —

**WALDOM**  
ELECTRONICS INC.

## WILLIAMS OPEN-END BOX WRENCHES

A line of open-end box wrenches *Superwrenches*, that features slimmer heads, longer and narrower handles, has been announced by J. H. Williams and Co., 400 Vulcan St., Buffalo 7, N. Y.

Wrenches are said to permit nut rotation in more difficult and confined quarters. Both heads have same size openings in a range of sizes from 1/4" to 1 5/8".



Williams Superwrenches

## BRADFORD WIREWOUND RESISTORS

A high-voltage insulated wirewound resistor, *Cer-Ohm*, that features ceramic insulation, has been announced by Bradford Components, Inc., 33 Bishop St., Bradford, Pa.

Units are fabricated with 2, 3, 5, 7, 10, 15 and 20-watt ratings, using *Tophet C*, *Evanohm*, or other resistance wire. Produced with standard 5% and 10% tolerances.

Low wattage and ohmic wirewound resistors are also available. Wound on phenolic cores, in 1/2", 1 and 2 watts, resistors have a resistance range of .3-20, 3-1000 and 5-2000 ohms.

## C-D SUBMINIATURE TANTALUM-FOIL ELECTROLYTICS

Subminiature tantalum electrolytics, 9/16" long and 3/16" diameter have been developed by Cornell-Dubilier Electric Corp., South Plainfield, N. J.

Capacitors cover an operating temperature range from -55° C to +85° C. Has wound foil type construction. Thirty-five units are available, ranging in capacity from .01 to 8 mfd, and from 3 *wdc* to 150 *wdc* in both polarized and non-polarized types.

Engineering bulletin 525 contains complete details.

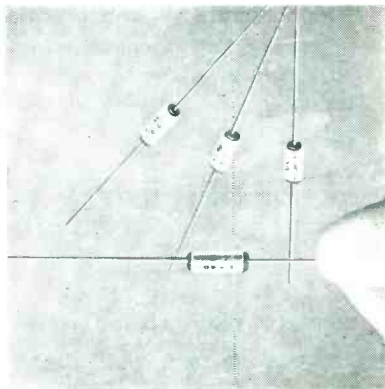

C-D Tantalum Capacitor

BE Sure with **CORNISH**

# Wires

Identified with  
QUALITY since the swaddling  
days of Radio. The era of  
Television finds them, more  
than ever, the Serviceman's  
Friend.

TV LEAD-IN CABLES  
ANTENNA CONTROL CABLES  
INTERCOMMUNICATION CABLES  
COAXIAL CABLES  
MICROPHONE CABLES  
SHIELDED CABLES  
TEST LEAD WIRES  
HOOK-UP WIRES  
PORTABLE CORDS  
REPLACEMENT CORD SETS

**CORNISH WIRE COMPANY, INC.**  
50 Church Street, New York 7, N. Y.

## JUSTRITE PORTABLE LIGHTS

Portable lights, *Yellow Flash 8* and *Headlights*, are now available from the Justrite Manufacturing Co., 2061 N. Southport Ave., Dept. SM, Chicago 14, Ill.

*Flash* is a 12-volt lantern which operates on 8 standard batteries, and is said to throw a beam over a mile. Features a square shape and flat base, swivel head, 2 1/2" reflector, and is 3"x3"x8". Can be converted into 6-v lantern battery.

One headlight is identical to the flash, except that the reflector and bulb unit is attached to a head band, and the battery unit is in a separate case. Another headlight operates on four standard batteries and throws a beam 1500'. Both headlights have reflectors mounted on a swivel base.

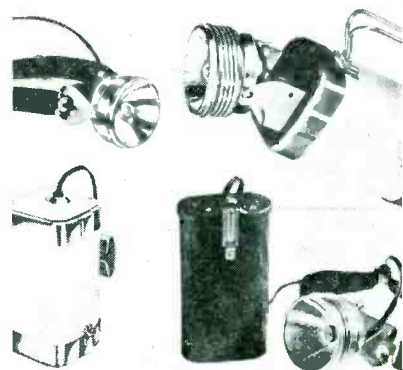

Justrite Portable Lights



**UTC REGULATING TRANSFORMER**

A regulating transformer, R-49, to adapt electrical appliances to poor line-voltage conditions, has been introduced by the United Transformer Co., 150 Varick St., New York City.

Unit is said to handle a load up to 350 watts. Equipped with cord and plug input; standard receptacle outlet. A locking switch provides settings for 115 v output with input line voltages of 85, 90, 95, 100, 105, 110, 120, or 125, 50/60 cycles.

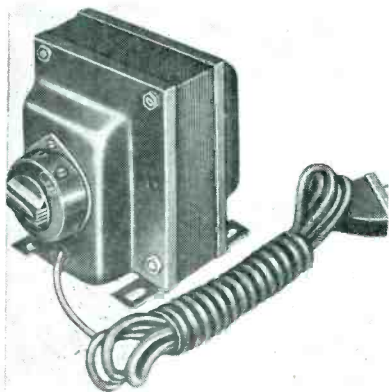

UTC Regulating Transformer

\* \* \*

**NEWAGE VIBRATING PEN**

An electric magnetic vibrating pen, *Actograp*, that it is said will engrave on all metals, has been announced by Newage International, Inc., 232 E. 42nd St., New York 17, N. Y.

Screw adjustment at tip enables operator to scribe thick or thin lines, as well as adjust depth of the engraving. Point, made from a special material, can be resharpened with a smooth file, or by grinding. Equipped with transformer made for ac, single phase, voltage selector for 100-110, 200-220, or 230-250 volts.

\* \* \*

**LINDGREN PORTABLE SCREEN ROOM**

A table-model screen room, *Portascreen*, which is a prefabricated miniature unit, cubical in shape, measuring 35½" x 35½" x 35½", has been introduced by Erik A. Lindgren & Associates, 4515 N. Ravenswood Ave., Chicago 40, Ill.

Featuring double shielded screening, unit is said to have an attenuation of over 100 db from 5 to 10,000 mc.

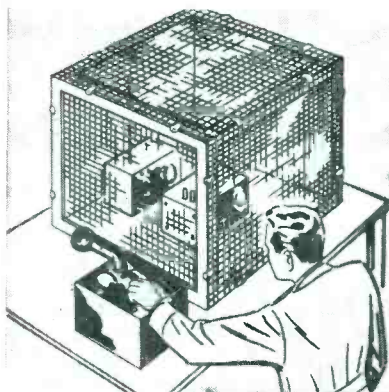

Lindgren Screen Room



**HAROLD J. SCHULMAN**

NATIONAL SERVICE  
MANAGER  
of  
**DU MONT**  
and  
CHAIRMAN,  
SERVICE COMMITTEE,  
**RETMA**  
SAYS:

... a product as complex as a television receiver cannot possibly be maintained satisfactorily without timely, understandable and helpful service information.

"Every manufacturer tries in his own way to develop service helps that will keep his product performing the way in which it was designed to perform. But in the final analysis, it is only through the efforts of the experts in the field, like yourself, that servicemen can expect a steady flow of all-inclusive service information.

"We have found your publications to be consistently high in quality and integrity. We particularly single out your current Parts Replacement Information program as a service to the industry.

"We hope you continue to help the service technician service our products intelligently and well through your fine service publications."

**NOW AVAILABLE  
RADIO MANUAL 23!**

Up-to-the-minute information  
on all home AM, FM radios  
built during 1952 and 1953.  
(Place your order with your jobber)



**Tek-File**  
is now only \$1.50 per pack

..... AVAILABLE *NOW* - TV 12!

For easier radio servicing... use Rider's 23 AM-FM Radio Manuals

**JOHN F. RIDER**

PUBLISHER, INC.  
480 Canal Street, New York 13, N. Y.

In Canada,  
Mr. Charles W. Pointon  
1926 Gerrard Street, East  
Toronto, Ontario

Export Agent:  
Roburn Agencies, Inc.  
39 Warren Street  
New York 7, New York

West Coast Office:  
4216-20 W. Jefferson Blvd  
Los Angeles, California

Cable Address:  
Roburnage N. Y.

You get no "knocks"



with  
**AEROVOX**

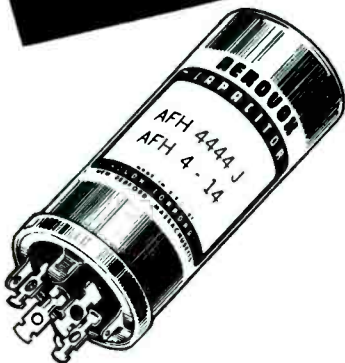

Take twist-prong electrolytics, for instance. Aerovox Type AFH (85° C) listings are outstandingly complete.

It's easy to pick the right number—capacity, voltage, combination-wise—for any job. And of course it is bound to "fit like a glove." Install it—forget it. Aerovox dependability never lets you down.

You get no "knocks" with Aerovox. The profit is all yours.

**GET THE FACTS!**

Latest Aerovox catalog contains outstanding selection of capacitors and resistors for profitable servicing. Ask your distributor for your copy.



**AEROVOX CORPORATION**

NEW BEDFORD, MASS.

See your Aerovox distributor!

In Canada: AEROVOX CANADA LTD., Hamilton, Ont.

## Color TV Circuitry

(Continued from page 68)

base circuit and are coincident with line retrace or flyback period. In some circuits, the gating pulses and the video signals are mixed at the grid of a pentode which is normally non-conducting due to positive bias on the cathode. Only for the duration of the gating pulse does the grid reach a sufficiently positive potential to permit conduction. In other circuits, gating is accomplished using 6AS6s which have sharp cut-off suppressor characteristics. In these cases, the video signals are fed to the control grid and the gating pulses to the suppressor.

### Color Subcarrier Generators—Controlled Oscillator Type

To generate 3.58-mc signals in each color TV receiver, two methods are readily available. One involves the use of an oscillator and the other a crystal shock-excited by the color burst signal.

The oscillator circuit is shown in a block schematic diagram in Fig. 6 (p. 68). It is held in synchronization with the *burst* signal by means of the reactance tube and the phase detector. This circuit really constitutes a servo-system. If the output of the 3.58-mc oscillator is exactly the same frequency as and in the correct phase relationship with the color *burst* signal, there is a zero output signal generated by the phase detector. However, if the frequency of the oscillator differs from that of the burst signal, a positive or negative *dc* potential will be developed by the phase detector and applied to the reactance tube. The application of this voltage to this tube will automatically bring the frequency of the oscillator into exact synchronization with the burst signal.

### Crystal Filter Subcarrier Generator

The circuit employing a crystal filter is shown in Fig. 7 and its function is as follows: The signal from the

Fig. 7. Block diagram of circuit that generates color subcarrier signals by shock excitation of a crystal filter.

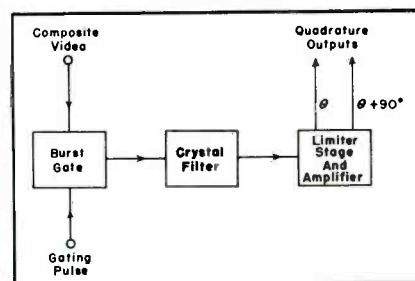

## New...! SELF SUPPORTING ROOF MOUNT

Speeds Antenna  
Installations

Eliminates  
Guy Wires

Increases  
Television Sales

Reduces  
Installation Cost

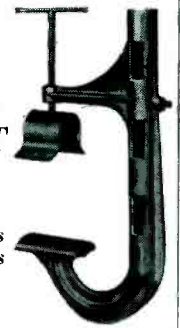

Reduce your antenna installation cost... and home trials... by 75% with MILLS Roof Clamp.

One man easily, firmly erects 10 ft. antenna in minutes on 80% of roofs.

Eliminates roof damage; no holes; no guy wires.

PROVED... by over 3 years testing on 350 city and rural roofs.

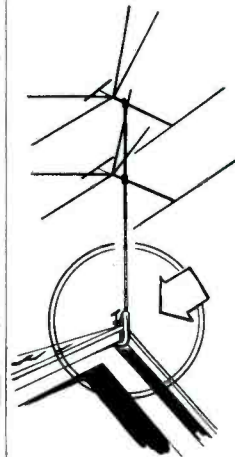

**MILLS  
PRODUCTS CO.**  
Burr Oak I, Mich.

DEALERS—F.O.B. Factory—Lots 1 to 6—  
\$6.95 — 6 to 12—\$6.60 — 12 or more \$6.25.

video detector is fed to the burst gate to which is also fed a gating pulse which allows the tube to operate only during the reception of the burst signal. The output of this tube, which consists of the 3.58-mc burst signal is applied to a crystal filter. The crystal in this circuit is shock excited by the burst and continues to oscillate with a decaying amplitude. For its amplitude to decay sufficiently slowly the effective *Q* of the circuit must be at least 8,000 and with this value, the amplitude of the oscillation in the filter decays only 10% during the transmission of one line of the TV picture. The effective bandwidth with this *Q* value is 440 cps. For this purpose, crystals have to be carefully cut, otherwise the decay of the oscillation is not simply exponential.

The output of the crystal filter is then applied to a limiter stage, the output of which consists of a 3.58-mc sine wave of constant amplitude and is equivalent to the output of the oscillator previously described.

The output of both the oscillator and the limiter stage of the crystal circuit must consist of two 3.58-mc sine waves phased 90° with respect to each other for application to the *I* and *Q* demodulators.



## Selenium Rectifiers

(Continued from page 33)

fiers no known cases of injury due to selenium have occurred. Because many million selenium rectifiers have been manufactured and used during this time, and many thousands of these have burned out in service due to old age or misuse, it appears that danger from the selenium in rectifiers is substantially nil under any conditions likely to be encountered in practice. Certainly, under normal conditions of installation and use of selenium rectifiers, there is no danger of selenium poisoning. During manufacture, ordinary good housekeeping and ventilation seem to be adequate to prevent selenium poisoning.

When a selenium rectifier burns out, both prudence and aesthetics make prompt and adequate ventilation mandatory. Because selenium has a strong, unpleasant, and easily detectable odor (for most people), possible danger from vaporized selenium is never hidden. When this odor is present in a room, the procedure is to ventilate until the odor disappears. When a selenium rectifier in a piece of equipment burns out, the odor can be dissipated rapidly by use of an ordinary vacuum cleaner, with the intake inside the equipment, and the outlet into a vent or toward an open window.

Complete elimination of selenium rectifier burnouts would, of course, completely eliminate high-temperature vaporization of selenium. This is probably impractical even though some selenium rectifiers, operated within their ratings, have given more than ten years of continuous service. Prevention of severe burnouts, such as that shown in Fig. 1, however, is entirely possible, through the use of a current limiting resistor and fuse, as shown in Fig. 2 (p. 33). In this circuit, the maximum current inflow through the rectifier equals 1.414 times the line voltage, all divided by the circuit resistance. Thus, if the current-limiting resistor is one ohm per volt, peak current through the rectifier cannot exceed 1.414 amperes (we will call it 1.5 for simplicity) during the initial charging of the capacitor, or if the first filter develops a dead short. At this current, the rectifier may be damaged, but will not suffer a violent or sudden burnout. Voltage drop due to such a resistor (one ohm per volt) is only .001 volt per milliamperes of drain per ohm; a negligible value in most instances. This drop can be offset, in many instances, by adding capacity to the first filter. Insertion of a fuse of proper

(Continued on page 82)



Only  
**\$29<sup>95</sup>**  
LIST

## the STAR performer AMONG UHF CONVERTERS

As an established service-dealer, know the relative merits of all UHF converters. This means more than pretty cabinets or glittering generalities or bargain prices. It's performance that counts. And Granco's superlative performance—the best by test—is based on these absolute essentials:

★ **COAXIAL TUNING:** Most efficient UHF tuning system known. Precision-ground metal slug sliding in and out of precision-ground glass tube for mechanical and electrical accuracy. No troublesome noise-producing wiper contacts. Highest stability. Provably better UHF reception.

★ **FINE TUNING:** No "on-again off-again" tuning with Granco. Fine tuning is simple and positive with high-ratio single tuning knob. Permits "on the button" tuning without need of safecracker's touch!

★ **PRESELECTION:** Tuning circuits reject unwanted signals and images—only the desired channel is tuned in. A "must" in areas having two or more channels, UHF or VHF. Granco preselection means cleaner, sharper, more pleasing pictures.

★ **AMPLIFICATION:** Low-loss tuning and associated circuitry, plus high-gain amplification of only the tuned-in channel, provides the finest reception in TV.

ask for data

from your distributor or from us. Compare Granco UHF converters with all others. Make your own comparative tests. You're the judge!

**GRANCO** PRODUCTS INC.  
36-17 20th Ave., Long Island City 5, N. Y.  
AVAILABLE AT LEADING JOBBERS

**OVER 24,974,906\***  
have heard about  
**ANACONDA**  
"FOAM-LINE"

**THE UHF-VHF Line for "all-channel, all-weather reception"**

**Sell Them!**

**They're waiting to Buy!**

Advertisements in these leading national publications are making consumers aware of the need for ANACONDA "FOAM-LINE" . . . has all the fine features you want, PLUS the CONSUMER DEMAND. \*Compiled multiple figures

Write for samples and complete descriptive literature . . .

SOLD THROUGH JOBBERS ONLY . . .

"National distributors and warehouse for ANACONDA denishath television and radio wires and cables"

**Columbia WIRE & SUPPLY CO.**

2850 Irving Park Road • Chicago 18, Ill.

**Selenium Rectifiers**

(Continued from page 81)

value (1.5/N amperes) will protect the rectifier and input circuits should a short circuit occur across points A-A. Various other rather obvious circuits can be used to limit current, and, in many industrial installations, use of a high reactance transformer will effectively keep rectifier circuit currents within reasonable limits.

**Acknowledgments**

The writer is indebted to James Welsh, Industrial Division, Cornell Aeronautical Laboratory, for use of test equipment and high current lines; to the U. S. Public Health Service for toxicological information; and to Dr. Malcolm Burton, of Cornell University, for X-ray diffraction tests.

**Boosted-B Servicing**

(Continued from page 35)

tile universal power supply. For instance, the unit will supply sufficient heater and plate power for most TV receivers, and the variable dc output and low-current milliammeter make it ideal for checking and reforming electrolytics.

The unit consists of a source of variable dc power (up to 400 volts at 175 ma or 750 v at somewhat less than 100 ma), a source of variable ac power (up to 30 v at 1.7 amp), a fixed source of heater power (6.3 v at 6 amp) and a variable resistance load. Meters and switches are provided to allow measurement of the voltage and current being delivered to the load resistance. A switch is also provided to switch from full-wave to half-wave rectification to provide a wider range of dc output voltage for a reasonable sized power transformer. This switch, S2, includes a section to switch the voltmeter from a 450 to a 750-v range. Milliammeter switching is done in the negative leads so that standard low-voltage switches can be used. The meter transfer switch is a standard rotary wafer which switches the 150-microamp meter to a 30 or 300-ma shunt in the power circuit or a 30-ma shunt in the load circuit. Spring-return meter-shunting switches must be held open to read current on the 30-ma scales.

The power transformer is a multi-winding unit originally designed for a 117-v, 60-cps/6 or 12-v, dc vibrator power supply.<sup>1</sup> The various extra windings in series were found to make a convenient source of adjustable ac

<sup>1</sup>Superior Powerstat used in the power-transformer primary to provide continuously variable output voltage.

**XCELITE Hand Tools**  
PREFERRED BY THE EXPERTS



"I'll Fight the First Man Who Touches My New Xcelite TV Stand-off Insulator Plier!"

No more tool-snatching! If you want to open and close standoff insulators quick and easy—buy your own Xcelite 10" TV Standoff Insulator Plier! Only \$4.35 list.



- Heavy-duty
- Forged rib lock design
- All-Purpose

**AND REMEMBER!** Your Xcelite Dealer has a full line of special-purpose radio and TV pliers and snips, ruggedly made for long, hard use. See him today!

**XCELITE, Incorporated**  
(Formerly Park Metalware Co., Inc.)  
Orchard Park, N. Y.  
Dept. V

**For Originality**  
LOOK TO **XCELITE**

**TV-RADIO SERVICE LIBRARY**

HERE IS LATE INFORMATION IN A HANDY FORM FOR RADIO AND TELEVISION REPAIRMEN, SERVICEMEN AND STUDENTS



**2 VOLS. \$6 COMPLETE \$11 A MO. PAY ONLY \$1**

AUDELS T.V.-RADIO SERVICE LIBRARY—Highly Endorsed—1001 Facts—Over 1552 Pages—625 Illustrations, Diagrams of Parts. Presents Important Subjects of Modern Radio, Television, Industrial Electronics, F.M., Public Address Systems, Auto, Marine & Aircraft Radio, Phonograph Pick-Ups, etc.

**IT PAYS TO KNOW!**

The Basic Principles—Construction—Installation—Operation—Repairs—Trouble Shooting. Shows How to get Sharp, Clear T.V. Pictures. Install Aerials—How to Test, Explains Color Systems, Methods of Conversion, Terms, etc. Includes Ultra High Frequency (U.H.F.)—Valuable for Quick Ready Reference & Home Study. Tells How to Solve T.V. & Radio Troubles—Answers Your Questions.

Get this Information for Yourself. 7 DAY TEST—ASK TO SEE IT!

**MAIL ORDER**

AUDELS Publishers, 49 W. 23 St., N.Y. 10, N.Y.  
Mail AUDELS T.V. RADIO SERVICE LIBRARY 2 Vols. \$6 on 7 days free trial. If O. K., I will remit \$1 in 7 days and \$1 monthly until \$6 is paid. Otherwise I will return them.

Name \_\_\_\_\_  
Address \_\_\_\_\_  
Occupation \_\_\_\_\_  
Employed by \_\_\_\_\_



power. A standard power transformer could be used and if desired the variable *ac* could be supplied from a separate 24-volt transformer.

The unit was assembled on a 10" x 12" x 3" chassis with a 13½" x 6" masonite panel.

### Applications

In using the test unit, a step-by-step fault-isolation study is made. To illustrate a typical application, let us suppose that the circuit in Fig. 2 (p. 35) has developed a fault in the horizontal oscillator section which has reduced the boosted *B*-voltage at the fuse to approximately the same value as the +*B* voltage at point *A*. To isolate the fault the following procedure should be followed:

(1) Plate cap from horizontal output tube should be removed.

(2) The boosted *B*-voltage leads should be opened at *B* and *C*.

(3) The two voltage leads should be connected together and the *dc* output of the test unit connected to point *D* and ground as shown by the dotted lines. The current meter selector switch should be turned to the 300-*ma* position.

(4) With the receiver turned on, the voltage applied to point *D* should be increased until it reaches the rated value of boosted *B* voltage (rated voltage listed for the cathode of the 6W4 damper).

(5) The circuits connected to the horizontal oscillator and control tubes should be probed until the proper grid excitation is applied to the grid of the output tube. An excessive current reading, of course, indicates a short or excessive leakage to ground.

(6) With rated boosted *B* voltage applied to point *D* one should now measure the current being supplied by the test unit. (Be sure the current is less than 30 *ma* on the 300-*ma* scale before switching to the 30-*ma* scale.)

(7) Now the receiver should be turned off. After setting the load control to the maximum-resistance tap, the test unit load should be connected between points *E* and *F* as shown by the dotted lines in Fig. 2 (p. 35) (observe polarity), thereby replacing the load represented by the horizontal oscillator and control tube and the vertical oscillator, by the test-unit load.

(8) Plate cap on the horizontal output tube should be replaced and the receiver turned on. Then the current-selector switch should be turned to the load circuit and the current flowing in

(Continued on page 86)

# Crystal or Ceramic?

## An analysis of factors to be considered in the replacement of phonograph pickup cartridges

- 1 How Do Crystal and Ceramic Pickup Cartridges Generally Compare?**

The chief differences are two: The ceramic cartridge is relatively immune to damage from excessive heat and/or humidity, while the crystal pickup cartridge is subject to damage and deterioration when exposed to excessive climatic conditions. The second difference is output. The ceramic cartridge has only 1/3 to 1/2 the voltage output of a comparable crystal unit. In all other respects the two types are very much alike and one can be made to equal the other in frequency response and ability to track in the record grooves.
- 2 Can Ceramic Pickup Cartridges be Substituted for Crystal Pickup Cartridges?**

Yes, providing the output voltage and response of the ceramic is comparable to the crystal. If not comparable, the associated circuit must be modified to provide the necessary frequency characteristics and additional gain.
- 3 What are the Usual Results When Ceramic Pickup Cartridges are Substituted for Crystal Pickup Cartridges Without Making any Circuit Changes?**

To make up for the generally lower voltage of the ceramic cartridge it is necessary to operate the phonograph at a higher volume control setting. Sometimes the phonograph does not have the additional gain available without excessive hum pickup.
- 4 Are any Manufacturers Currently Using Ceramic Phono Cartridges in Their Original Equipment Production?**

Yes. However, they do not use ceramic pickup cartridges interchangeably with crystal pickup cartridges in the same model phonograph. Individual circuits are patterned to either ceramic or crystal phono cartridges.
- 5 What is the Actual Output of Crystal vs. Ceramic Cartridges?**

Generally speaking, crystal cartridges have three to five times the output level of comparable ceramic cartridges for 78 rpm—two to three times for fine groove and 3-speed designs.
- 6 Are Ceramic Cartridges Considered Superior to Crystal Cartridges?**

The greatest climatic enemy is humidity. They are superior only insofar as their natural resistance to excessive heat and/or humidity is concerned. The crystal cartridge generally is higher in output level than the ceramic cartridge.
- 7 Is it True that Hot and Humid Climates Dictate the Use of Ceramic Pickup Cartridge over Crystal?**

Either a ceramic or a specially-protected crystal such as the Shure "HS" (Hum-Seal) series should be used where extreme humidity conditions exist. Ceramics (but not the crystals) can withstand temperatures above 125°F without permanent damage.
- 8 What is the Risk in Recommending the Substitution of a Ceramic for a Crystal Unit When Making a Phono Cartridge Replacement?**

The phonograph manufacturer generally modifies his circuits when changing from crystal to ceramic cartridges; so it can be assumed as unwise to use ceramic cartridges as replacements for crystal cartridges. On the same basis, it would be unwise to use crystal cartridges as replacements for ceramic cartridges.
- 9 In the Final Analysis What Factor Should be Carefully Considered?**

Equipment manufacturers utilize highly skilled engineering staffs. They devote a great deal of research and testing to the specification and selection of phono cartridges giving the most desirable performance with their particular equipment. The safest procedure is to rely on the manufacturer's own experience—and replace a crystal cartridge with a crystal cartridge, a ceramic cartridge with a ceramic cartridge.

SHURE

This analysis has been prepared as a service to the industry by Shure Brothers, Inc., Manufacturers of both Crystal and Ceramic Phonograph Pickup Cartridges. If you are interested in obtaining extra copies (including a specific output level comparison chart) write SALES DIVISION

SHURE BROTHERS, Inc.

Manufacturers of Microphones and Acoustic Devices • 225 W. Huron St., Chicago 10, Ill. Cable Address: SHUREMICRO

## SERVICE MEN LIKE TO USE TUNG-SOL TUBES

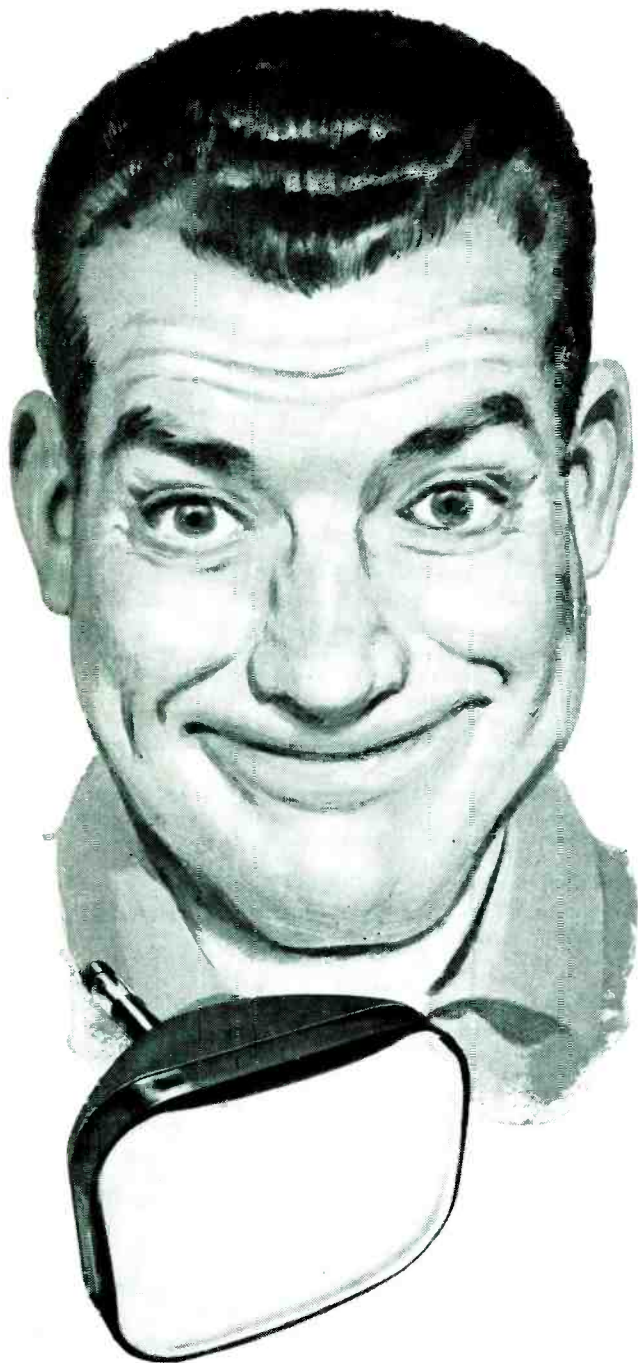

Tung-Sol business practices are on the same high level with Tung-Sol Tube quality—and service men have always profited from both. It pays to use Tung-Sol Tubes.

**TUNG-SOL<sup>®</sup>**  
dependable  
**PICTURE TUBES**



TUNG-SOL ELECTRIC INC., Newark 4, N. J.  
Sales Offices: Atlanta, Chicago, Columbus,  
Culver City (Los Angeles), Dallas, Denver,  
Detroit, Newark, Seattle.

## Catalogs and Bulletins

ELECTRO-VOICE, INC., Buchanan, Mich., has released a 16-page *hi-fi* brochure, *Tools for Building Temples of Tone*, describing three basic types of equipment needed for *hi-fi* reproduction, from the source through the amp and speaker system. Brochure tells how to choose components for home wide-range systems, and illustrates typical home installations and a suggested home entertainment center. Priced at \$10.

\* \* \*

UTAH RADIO PRODUCTS CO., INC., 1123 E. Franklin St., Huntington, Ind., has prepared a catalog, *AR100*, listing the correct replacement speakers for, it is said, more than 95% of the auto-radios. Catalog is indexed by make of auto, receiver manufacturer, model number and speaker part number, with Utah replacement designation.

\* \* \*

JFD MANUFACTURING CO., INC., 6101 Sixteenth Ave., Brooklyn 4, N. Y., has issued a brochure on antenna package merchandising, featuring an article and descriptions of antenna accessory kits. Points discussed include unit control requirements, quality control, non-obsolescence, cutting off installation time and multi-purpose items.

\* \* \*

WARD PRODUCTS CORP., Division of The Gabriel Co., 1148 Euclid Ave., Cleveland 15, Ohio, has announced publication of a promotion kit, consisting of display material, mailing stuffers, newspaper mats, TV slides and commercials, and radio commercials, describing their line of *Tele-vanes*, decorative TV antennas.

\* \* \*

THORDARSON-MEISSNER, Dept. C, Mt. Carmel, Ill., has released a 32-page TV replacement guide, listing flybacks, peaking coils, horizontal syncs, focus coils, deflection yokes, width controls, vertical outputs, ringing coils, and *ifs*, for approximately 6000 TV models. Guide also features schematics and catalog material.

\* \* \*

RIVER EDGE INDUSTRIES, 8 River Edge Rd., River Edge, N. J., has issued a 12-page catalog, *W-54*, describing custom speaker and TV cabinets, with as many as 15 finishes available for most models.

\* \* \*

XCELITE, INC., Orchard Park, N. Y., has released a catalog detailing screwdrivers, nut drivers and pliers. Illustrated and described are assorted screwdriver points, screwholders, beryllium-copper TV focalizer adjusters and pliers for opening and closing TV standoff insulators.

\* \* \*

JENSEN MANUFACTURING Co., 6601 S. Laramie Ave., Chicago 38, Ill., has prepared a 6-page promotional folder, *ES*, describing the *Duette* two-way *hi-fi* loudspeaker system for fixed and portable applications.

\* \* \*

JAMES KNIGHT Co., Sandwich, Ill., has published a handbook of crystal and oscillator theory, the *Crystal Handbook*, which provides general performance data, temperature coefficient and size factors. Cost, \$1.00 per copy.

\* \* \*

JAN HARDWARE MANUFACTURING Co., INC., 25-30 163rd St., Flushing 58, N. Y., has issued a brochure describing an offset extension shaft coupler, jack cover, *crt* bezel for flat or curved faces, panel bearing and shaft assembly, insulated coupling assembly, bushing extender, and shaft lock.



## On Book Row

TV TROUBLESHOOTING AND REPAIR GUIDEBOOK—VOLUME 2. BY ROBERT G. MIDDLETON: A continuation of first volume, new publication includes more than 450 test 'scope waveforms related to difficulties in receivers. Applications of all types of test equipment are also analyzed. Features tables of cause and effect on troubles in front ends, video *if*, sweep circuits and other portions of the TV receiver.—156 pages, 8½" x 11", paper bound, priced at \$3.30; John F. Rider, Publisher, Inc., 480 Canal St., New York 13, N. Y.

\* \* \*

WESTINGHOUSE COMPOSITE TV SERVICE MANUAL, 1947-1954: A plastic-edition that can lie open on the bench, manual includes a photograph of every Westinghouse model with set number; schematic with 'scope waveforms and critical voltage points; step-by-step *if* alignment charts for traps and audio *if* sections; top and bottom views of TV chassis and a complete parts list for each model. Where a radio is part of the model, schematic and alignment steps for broadcast and FM bands are also included. Installation, adjustment, and antenna information for *uhf* receptors and all-channel timers are also described.—127 pages, 12" x 15", priced at \$1.75; Westinghouse Electric Corp., distributors.

\* \* \*

TELEVISION, A WORLD SURVEY. . . . BY UNESCO: Report prepared by United Nations offers a country-by-country survey of television, with detailed information on the history of TV in each country. Disclosed are technical facilities available or planned for the future, programming and reception facilities, number and characteristics of transmitters. Other subjects covered are color television and the training of personnel for new stations. Charts included estimate number of receivers, potential audience, date of first broadcast, technical experiments now under way, and other information.—184 pages, 6" x 9½", paper bound, priced at \$1.75; UN Bookshop, or Columbia University Press, 2690 Broadway, New York 27, N. Y.

\* \* \*

RECEIVING TUBE SUBSTITUTION GUIDEBOOK—SUPPLEMENT 2. . . . BY H. A. MIDDLETON: Second supplement features 134 TV picture tube substitutions as well as 190 receiving tube substitutions. Total listing in the main volume and two supplement series exceeds 3,500. An accumulative index covering all tube substitutions listed in the three publications is also contained in the second supplement.—48 pages, 8½" x 11", paper bound, priced at \$.99; John F. Rider, Publisher, Inc.

\* \* \*

THE RADIO AMATEUR'S HANDBOOK. . . . 31ST EDITION: Written by the headquarters staff of the American Radio Relay League, this newest edition has 27 chapters, including a new section on semiconductor devices (crystal diodes and transistors). Also featured are new high frequency transmitter designs; revised chapter on *vhf* reception; mobile antennas; TVI; power supplies, measurements and test equipment; radiotelephony techniques; four chapters on amplitude, frequency and phase-modulation systems; theoretical and practical information on propagation, receivers and converters, and transmitters for *vhf* and microwaves, as well as 95 charts and tables, plus 497 tube-base diagrams and 85 basic formulas.—800 pages, 6½" x 9½", priced at \$3.00; American Radio Relay League, Inc., West Hartford 7, Conn.

## CUSTOMERS LIKE SERVICE MEN WHO USE TUNG-SOL TUBES



Tung-Sol hi-performance tube quality is a dependable safeguard against call-backs that cut into service work profits. Keep that in mind and remember—it pays to use Tung-Sol Tubes.

**TUNG-SOL<sup>®</sup>**  
dependable  
**TUBES—DIAL LAMPS**

TUNG-SOL makes All-Glass Sealed Beam Lamps, Miniature Lamps, Signal Flashers, Picture Tubes, Radio, TV and Special Purpose Electron Tubes and Semiconductor Products.



SERVICE, MARCH, 1954 • 85



## You make More Profit in less time with Webcor Hi-Fidelity changers

When your customer wants a hi-fi installation, better put in a Webcor changer. For two reasons. First, because a Webcor takes just a few minutes to install. So you make more profit on each job. And second . . . you don't have to "sell" your customer on a Webcor changer. Through national ads, publicity and word of mouth, millions of Americans think of Webcor as the TRUE high-fidelity changer. So your reputation is well made when you suggest a Webcor 3-speed automatic changer. If you are not presently handling profitable Webcor products, call your distributor today!



Webcor Hi-Fi 3-speed changers are world famous for quality. With Webcor you have:

- A choice of TWO different sizes
- A choice of THREE different colors
- A choice of TWO pickups (magnetic or ceramic)

PLUS . . . exclusive Velocity Trip, Step Drive, powerful motor super-thick Flocking, Balanced Tone Arm. From \$49.50.

All music sounds better on a Webcor<sup>®</sup>  
Chicago 39, Illinois

©wcor1954

## Boosted-B-Servicing

(Continued from page 83)

the load measured. The load-control tap switch and variable resistor should be then adjusted to the position at which the current flowing in the load is equal to the current being supplied by the test unit power supply. If the horizontal deflection circuits are functioning properly the boosted *B* voltage will be at approximately its rated value.

Judgment must, of course, be used in interpreting these measurements, since the boosted *B* voltage often varies somewhat from its rated value in a receiver operating normally. If the horizontal deflection output circuits and boosted *B*-voltage circuits are not functioning properly, troubleshooting these circuits can be carried on by conventional methods, since the test unit power supply allows the horizontal oscillator to function and supply normal excitation to the horizontal output tube.

While the foregoing procedure may seem to be rather involved compared to the procedures used in some of the more conventional TV circuits, it is actually not complex. After using the method a few times it will be found very convenient to isolate quickly the fault to either the horizontal oscillator or the horizontal output circuits, and allow troubleshooting to proceed with proper *B*-voltage provided to the oscillator plate circuits.

## 60-Cycle Buzz

(Continued from page 38)

investigated, by providing adjustable override bias, and then observing the behavior of picture and sound as the bias level is varied.

12: If the buzz disappears from the sound signal before the picture loses satisfactory contrast, as the bias voltage is increased on the *if* amplifier tubes, the *acc* circuit should be checked. In most cases, this difficulty is caused by leaky *agc* capacitors. Fixed-bias sources in the *if* amplifier circuit should also be checked.

13: If the buzz does not disappear from the sound signal before the picture loses satisfactory contrast, the alignment of the *rf* and *if* amplifier circuits should be checked: see Fig. 5 (p. 39).

14: Alignment of the ratio detector should also be checked. When a limiter is used to drive the ratio detector, alignment is not so critical, but if a limiter is not used, buzz can be greatly increased by misalignment.

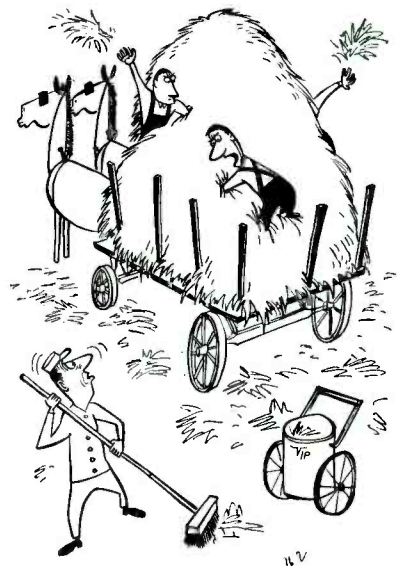

"Joe dropped the JENSEN NEEDLE . . . we've got to find it."

## Phase Splitters

(Continued from page 41)

fiers. Other circuit designs used commercially include:

(1) The transformer phase splitter, illustrated in Fig. 7. In this circuit advantage is taken of the fact that the two ends of a transformer winding are always 180° out of phase with each other. Although transformer audio coupling was quite common in commercial sets of an earlier period, it is very rare today. Its use is generally restricted to amplifiers in which the type of bias for the output stage re-

Fig. 5. Cathode-loaded phase splitter.

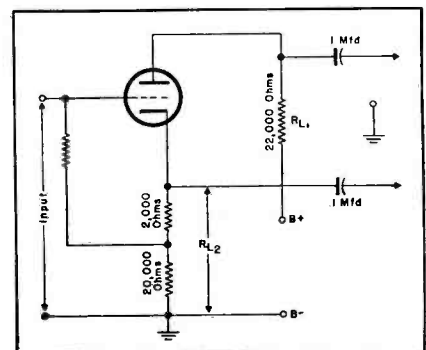



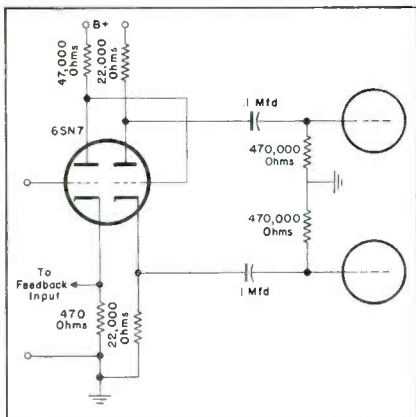

Fig. 6. Cathode-loaded phase splitter as used in the Williamson circuit design.

quires a particularly low value of grid resistance, and does not permit the use of the usual high-value grid resistors. High-powered industrial amplifiers are liable to use fixed bias and transformer phase-splitting, which is stable and double-free, but, for equivalent fidelity, expensive and bulky.

(2) The cross-coupled phase-inverter, illustrated in Fig. 4; p. 41. This is a self-balancing circuit in which the voltage across each cathode load resistor,  $R_1$  and  $R_2$ , is coupled to both  $V_3$  and  $V_4$ , but in opposite phase to each tube. It may be seen that  $R_1$  is a cathode resistor for  $V_3$ , and a grid resistor for  $V_4$ , while  $R_2$  is a cathode resistor for  $V_4$  and a grid resistor for  $V_3$ . Since cathode and grid input signal voltages are opposite in polarity, the same signal is coupled to each tube in opposite phase.

#### Testing the Phase Splitter

Whether the phase splitter consists of one tube with a split load, two separate tubes, or a dual-section tube, it must be tested as a device with two separate outputs relative to ground. An audio test signal must be injected at the single input, and the signal at each output tube grid checked, preferably with a 'scope. This is not a very good method for checking balance, because a slight imbalance may be correcting for an inverse imbalance in the output tubes, but gross imbalance, distortion, hum, noise and other defects can be noted and localized to a particular section of the phase splitter. The signal can also be checked with the 'scope at intermediate points between the phase-splitter input and the grids of the output tubes, following an analysis, as in this article, of the path followed by each half of the signal.

When grid or plate resistors are replaced in phase-splitter circuits reliance should not be placed on color codes; an ohmmeter should be used to match the value of the resistor to its



# TECH-MASTER

## Custom-Built TV CHASSIS

### Are A Credit to Your Skill...

when you *do a job on*  
a custom installation

When you've been commissioned to do your best ... when you're being paid for the finest... that's the time to remember that TECH-MASTER backs your skill with the finest line of custom-built TV chassis in the field.

- The custom installation field offers a vast potential for expansion and profit!
- One satisfactory installation is a valuable recommendation for another and another!
- TECH-MASTER TV CHASSIS are specifically designed and built for custom installations!
- The finest components and the finest craftsmanship assure years of fine performance!

SO — when your customer wants custom installation — give him custom quality with

#### TECH-MASTER GOLD MEDAL SERIES

##### Quality TV Chassis for Custom Installation

**MODEL 2430:** Latest, improved 630 type circuit; for picture tubes up to 24". Audio connection for optional use of external amplifier.  
Net Price..... (Less Kine)..... \$189.50

**MODEL 2431:** Same as 2430, but with true fidelity, Push-Pull audio amplifier.  
Net Price..... (Less Kine)..... \$199.50

**MODEL 2439:** For new 90° kinescopes, (24" rectangular, 27" and 30").  
Net Price..... (Less Kine)..... \$262.50

At All Leading Radio Parts Distributors

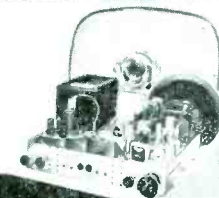
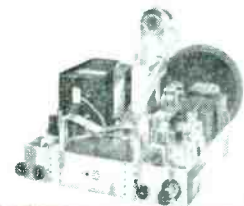

**TECH-MASTER CORPORATION**  
RADIO and TELEVISION  
445 BROADWAY, NEW YORK 13, N. Y.

MAKERS OF CUSTOM-BUILT TV CHASSIS, QUALITY TV KITS AND HIGH FIDELITY AUDIO EQUIPMENT

Write for  
Detailed Data

mate. Coupling capacitors do not have to be so accurately matched, but substitute values should not be employed.

#### Phase Splitter Hum

The phase splitter is usually the highest level voltage amplifier stage in the entire amplifier. In addition the most common types of feedback network include the phase splitter within the feedback loop, and therefore

this stage should not be expected to be a major source of hum. However, the cathode-loaded phase splitter is particularly susceptible to one type of  
(Continued on page 88)

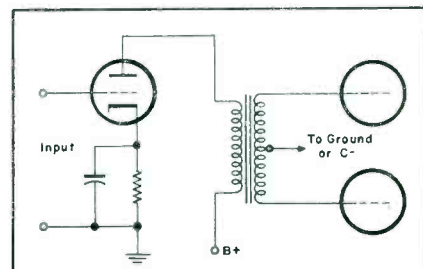

Fig. 7. Transformer phase splitter: Rugged, stable, and suited to fixed bias circuits, but bulky and expensive.

# KESTER

Since the most important single step in Radio-Television Servicing is soldering . . . it's just plain good sense to use the best — KESTER SOLDER . . . Key Name in Solder for More Than 50 Years.

**FASTER ACTING**

**EASIER TO USE**

**LONGER LASTING**

**THE BEST**

**KESTER SOLDER COMPANY**  
4248 Wrightwood Avenue • Chicago 39, Illinois  
Newark 5, New Jersey • Brantford, Canada

# SOLDER

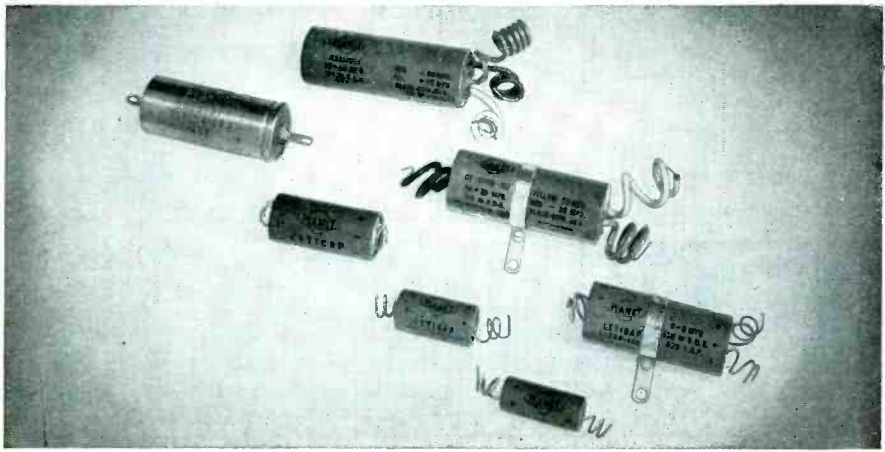

## Planet Capacitors "Engineered for Quality"

1 year service guarantee

Custom engineered to your specifications or supplied from stock, Planet capacitors meet the highest standards of the industry. Every capacitor is tested mechanically and electrically throughout its manufacture.

This rigid system of quality control makes our unconditional one-year guarantee possible. But making Planet capacitors right from the start means reasonable prices too!

**PLANET MANUFACTURING CORPORATION**  
225 BELLEVILLE AVENUE  
BLOOMFIELD, N. J.



WRITE for Catalog 206-B, listing specifications on stock items.

## Phase Splitters

(Continued from page 87)

hum; that due to heater-cathode leakage, because the cathode is at such a high potential relative to ground. This is especially true when the cathode-loaded phase splitter is not coupled directly to the output tubes but to push-pull drivers.

It is to be expected that the designer of the amplifier took the necessary precautions with regard to heater-cathode leakage, but small tube defects, that would go unnoticed in circuits where the cathode is at or near ground potential, can in this case produce a strong hum, predominantly 60-cycle in nature. The solution, of course, is to change the tube. It should be noted that the faulty tube may check perfectly in most tube checkers.

<sup>1</sup>Vino, Mark, *The Maintenance of Hi-Fi Audio Systems*; P. 38, SERVICE, Oct., 1953.

## Color TV Developments

(Continued from page 36)

application of the phosphor dots to give increased light output and contrast as well as to prevent ion-spot blemish.

The metal shadow mask, interposed between the electron-gun structure and the phosphor-dot plate, contains round holes equal in number to and centered with respect to the dot trios.

### New Color Components‡

The vertical isolation inductor, one of the new parts developed for color sets, is a two-section coil designed to operate as an inductive element in a filter network between the vertical-deflection and the vertical-centering circuit. By means of the filter network, a high impedance is inserted between the respective circuits to isolate the ac component in the vertical coils from ground. This isolation of the ac component effectively reduces the capacitance between the vertical and horizontal coils with resultant reduction of capacitance between the horizontal coils and ground. Thus, a shorter retrace time is achieved for the horizontal-deflection circuit.

The new deflecting yokes, for use with tricolor picture tubes having a horizontal deflection angle of 45°, employ horizontal and vertical coils that have been wound to produce proper magnetic fields for the simultaneous deflection of three beams. In addition, they are flared widely at the end of the yoke, placed nearest the tube fun-

‡From copyrighted data prepared by the electronic components section of RCA.



nel, to provide the required flux distribution for optimum convergence. Yoke also features a precision-shaped ferrite core which consists of 8 separate ferrite sections fitted to form a single unit having a chamfered front which corresponds with the shape of the funnel-to-neck section of the picture tube.

A flame-retardant polyethylene liner is used to provide insulation between the yoke coils and the grounded coating.

The yoke must not be used for picture-tube neck support; optimum performance requires centering the yoke on the axis common to the three beams, moving the yoke along the neck of the picture tube, and moving the yoke rotationally about the neck.

The purifying coil, which serves to obtain multibeam alignment, is included in an assembly which has three magnets for positioning the individual beams, and a magnetic shield. Entire unit is designed for mounting on the neck section of the tricolor picture tube, and is equipped with a clamp for attachment to the neck.

The purifying coil produces a transverse magnetic field which can be adjusted by rotation of the coil and by change of current in the coil to provide accurate alignment of the common axis of the beams so that the common axis coincides with the axis of the picture tube. Thus, when the beams are focused, converged, and deflected, they approach each hole in the shadow mask at the proper angle to strike the centers of their appropriate color dots, producing color purity.

The beam-positioning magnets are supported by the shield of the assembly and are spaced at 120° intervals to correspond with the positions of the picture-tube guns. They provide positioning of their associated beams in a direction perpendicular to the change in beam direction produced by an electrostatic convergence lens.

The magnets are threaded and slotted at both ends to provide ease and accuracy of adjustment. A red dot identifies the north pole of each magnet; effect of magnet on beam position is reversible by inserting the opposite end of the magnet into the shield.

The shield section is a *Nicaloi* magnetic affair which serves to isolate the beams passing at low velocity, through the neck section of the tricolor picture tube, from effects of extraneous magnetic fields.

The color-set horizontal-output and *hw* transformer has been designed for operation with a single *hw* rectifier



for the IRISH  
.....and  
Everyone  
Else

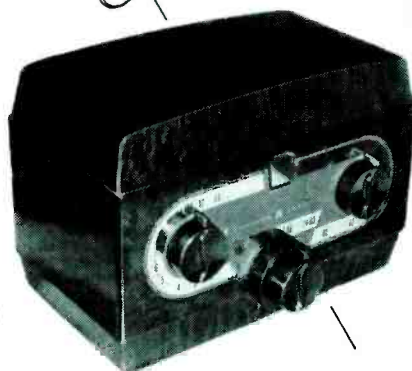

**CONVERTER-BOOSTER**  
UHF CONVERTER—VHF BOOSTER

## ONE UNIT DOES THE WORK OF TWO

Sure, and on St. Patrick's Day and every other day of the year, here's something worth jiggling about! Here's the one unit that gives you *both* UHF Converter and VHF Booster in one attractive, compact cabinet that is designed to blend beautifully with any TV set. It has proved outstandingly satisfactory in *all* present UHF operating areas. Gives *any* TV set *all* UHF channels and *all* VHF channels remain open. Takes an easy five minutes to install and your customers like the neater installation, easier operation and better performance.

MANUFACTURED BY

**SUTTON ELECTRONIC COMPANY, LEXINGTON, KENTUCKY**

tube for the ultor supply, and can supply an output of 20 *kw* when driven by a single 6CD6G operating from a 400-volt *B* supply.

This transformer has a multi-tapped auto-transformer winding and four isolated windings. The auto-transformer winding supplies the high voltage and provides connections to deflecting yoke, damper and driver tubes, and width control. Other taps on this winding supply voltage pulses for keyed-*agc* circuits and voltage for a 1X2B *hw* rectifier supplying the *dc*

voltage to the focusing electrode of the picture tube. Voltage for the converging electrode of the picture tube is obtained from a bleeder resistor in the *hw* supply to the ultor. The isolated secondary windings supply filament power to the *hw* and focusing-voltage rectifiers as well as voltage pulses for the color-sync circuit.

When used in a regulated circuit, the unit can supply 20 *kw* at 750 microamperes to the ultor of the picture

(Continued on page 90)

## Color TV Developments

(Continued from page 89)

tube, 4 kv to the focusing electrode, and 10 kv to the converging electrode. This circuit, utilizing a 6BD4 beam-triode as a shunt regulator, is said to be capable of maintaining regulation within  $\pm 2\%$  from full load to no load.

A ferrite core is used in construction, and the coils are impregnated.

To couple the vertical-dynamic output of the convergence amplifier to both the converging electrode (grid 4) and the focusing electrode (grid 3) of the 15G122, a vertical dynamic-converging and dynamic-focusing transformer is used. It supplies vertical dynamic-correcting voltages for combining with the dynamic-correcting voltages supplied by the horizontal dynamic-converging and dynamic-focusing transformer. These combined dynamic-correcting voltages are superimposed on the dc voltages for grids 3 and 4 to provide changing electrostatic fields, which maintain proper focus and convergence of the beams as they traverse the flat shadow mask of the tricolor picture tube.

A potted type of construction is used for this assembly.

The horizontal dynamic-converging and dynamic-focusing transformer, which is a variable-inductance unit with a tapped secondary, has been designed for operation at the horizontal-scanning frequency of 15,750 cps, and utilizes an adjustable ferrite core to permit tuning of the transformer to the scanning frequency. The output of this unit, as observed on a scope, is tuned to maximum by adjusting the ferrite core; a scope probe should be connected to the insulation of the green lead of the transformer and adjusting should be done with the transformer installed in the circuit.

In typical tricolor deflection, hv, dynamic-focus and convergence circuits, the horizontal-deflection and hv circuit uses a single horizontal output tube and a single rectifier for supplying the ultor voltage.

A single 6CD6G has been selected as the horizontal output tube, and a 6AU4GT as the damper diode. The cathode of the diode receives a positive peak voltage of approximately 3,820 during the retrace interval. Because this value is less than the 4,500-volt peak-pulse heater-cathode rating, the heater can be grounded at either of its terminals. The socket must be capable of withstanding this 3,820-volt pulse without breakdown or leakage.

An inductive width control, having a range of approximately 18 to 70 mh, is connected in parallel with the hori-

**NEW MULTIMETER KIT** \$26.50

**SIGNAL TRACER KIT** \$23.50

**NEW SCOPE KIT** \$59.50

**CONDENSER CHECKER KIT** \$19.50

**VACUUM TUBE VOLTMETER KIT** \$24.50

**TUBE CHECKER KIT** \$29.50

**SIGNAL GEN. KIT** \$19.50

**GRID DIP METER KIT** \$19.50

### Heathkit TEST EQUIPMENT

**BUILD YOUR OWN — INCREASE KNOWLEDGE — SAVE MONEY — BUY DIRECT FROM MANUFACTURER . . .** Top quality instruments in kit form featuring latest design and circuit developments. Completely detailed step-by-step construction manual—clear pictorials—complete schematics. All sheet metal work punched, formed and finished. Low kit prices include tubes, chassis, cabinet and all necessary constructional components.

Kits for the school—service shop—industrial laboratory—hobbyist, etc.

Write for free catalog for further information.

**HEATH COMPANY**  
BENTON HARBOR 11,  
MICHIGAN

## Check THESE N. J. R. T. TUBE PRICES 70% to 90% OFF LIST

TYPE	PRICE	TYPE	PRICE	TYPE	PRICE
1A7GT	\$.45	6AJ5	\$.73	6K6GT	\$.37
1B3GT	.67	6AK5	.75	6L6	.62
1H5GT	.38	6AL5	.37	6R7	.40
1L4	.59	6AQ5	.37	6S4	.38
1N5GT	.62	6AQ6	.33	6S8GT	.51
1R5	.48	6AT6	.37	6SA7GT	.41
1S5	.40	6AU4GT	.70	6SD7GT	.39
1T4	.48	6AV6	.40	6SK7GT	.39
1U4	.48	6AV6	.37	6SL7GT	.49
1U5	.40	6AX4GT	.55	6SN7GT	.50
1X2	.65	6BA6	.40	6SQ7GT	.37
3A4	.43	6BA7	.57	6T8	.57
3LF4	.49	6BC5	.49	6U8	.59
3Q4	.48	6BD6	.45	6V6GT	.38
3Q5GT	.48	6BE6	.37	6W4GT	.42
3S4	.48	6BG6G	1.20	6W6GT	.45
3V4	.50	6BH6	.45	6X4	.35
5A2	.50	6BJ6	.41	6X5GT	.35
5U4	.55	6BK7	.89	7E6	.35
5U4G	.55	6BL7GT	.65	7F8	.63
5Y3GT	.39	6BQ6GT	.70	12AL5	.40
5Z3	.45	6BQ7A	.92	12AT6	.35
5Y4G	.39	6BZ7	.95	12AT7	.65
6A3	.57	6C4	.39	12AU6	.38
6A6	.49	6CB6	.45	12AU7	.55
6AB4	.42	6CD6G	1.15	12AV6	.50
6AF4	.92	6F6	.45	12AV7	.60
6AF6	.75	6J5	.40	12AX4GT	.55
6AG5	.47	6J6	.50	12AX7	.55

**Guarantee**  
ALL NJRT TUBES ARE BRAND NEW AND FULLY GUARANTEED FOR ONE YEAR

TYPE	PRICE	TYPE	PRICE
12BA6	\$.40	35A5	\$.49
12BA7	.57	35B5	.38
12BE6	.41	35C5	.38
12BH7	.65	36L6GT	.45
12BY7	.65	35W4	.37
12BZ7	.65	35Z3	.43
12SA7	.58	35Z5GT	.45
12SK7	.58	42	.40
12SL7GT	.49	43	.53
12SN7GT	.50	45	.53
12SQ7	.55	50B5	.41
12SR7 met	.55	50C5	.41
12V6GT	.50	50L6GT	.59
19BG6G	1.15	70L7GT	1.07
19T8	.75	76	.42
25BQ6GT	.75	117Z3	.39
25L6GT	.40	117L7GT	1.19
25W4GT	.45	807	1.25
25Z6	.37		

**T.V. PIX TUBE BRIGHTENER** \$1.39  
For T.V. sets where voltage supply is low **AC LINE BOOSTER** with safety fuse and switch \$5.95

**FREE** FIVE 1L4 TUBES INDIVIDUALLY CARTONED LIST \$11.25 WITH EVERY ORDER OF \$25.00 OR MORE. Many 7 volt types not listed. All tubes individually boxed. For orders under \$10 add \$1 handling charge. Tubes offered subject to prior sale. Prices subject to change. All orders shipped F.O.B. 2% discount if full remittance accompanies order. 25% deposit on c.o.d. shipments. **SEND FOR FREE TUBE LISTING**



**NEW JERSEY TELEVISION SUPPLY CO.**  
Sole Distributor of NJRT Tubes  
906D WESTFIELD AVE., ELIZABETH, N. J. EL. 3-6166



zontal windings of the deflecting yoke. This type of width control has been found to be best suited for this circuit because its use does not entail a serious loss in ultor power.

Electrical centering can be provided by a center-tapped pot which controls the *dc* through the horizontal windings of the deflecting yoke. The centering control must provide a minimum of 100 *ma* in either direction through the horizontal windings of the yoke. Two isolating chokes, one of 16 *mh*, the other of 70 *mh*, are required between the terminals of the horizontal windings and the centering control.

In the deflection-yoke circuit, a neutralizing capacitor of 250-300 *mmfd* must be used. In addition, a network consisting of a 4,700-ohm resistor and a pair of 200-*mmfd* capacitors, connected to the center tap of the horizontal winding of the deflecting yoke, serves to improve neutralization. These neutralization components must be mounted on the terminal board of the yoke. In the case of a b-w yoke, improper neutralization causes the appearance of vertical bands on the left side of the raster, together with uneven vertical displacement of the scanning lines. In the case of a tricolor picture tube yoke, the effect of improper neutralization has been found to be more severe because each beam is displaced by a different amount, making it impossible to obtain proper beam convergence on the left side of the picture.

Some means of protection must be provided for the 6CD6G in the event of the loss of driving voltage. The value of the cathode resistor and the screen-grid resistor must be chosen carefully so that the plate dissipation of the 6CD6G under such conditions does not exceed more than 2½ times its maximum rating of 15 watts. The use of a screen-supply voltage lower in value than the plate-supply voltage makes possible the choice of resistors which will limit plate dissipation.

# first requisite FOR HIGH FIDELITY

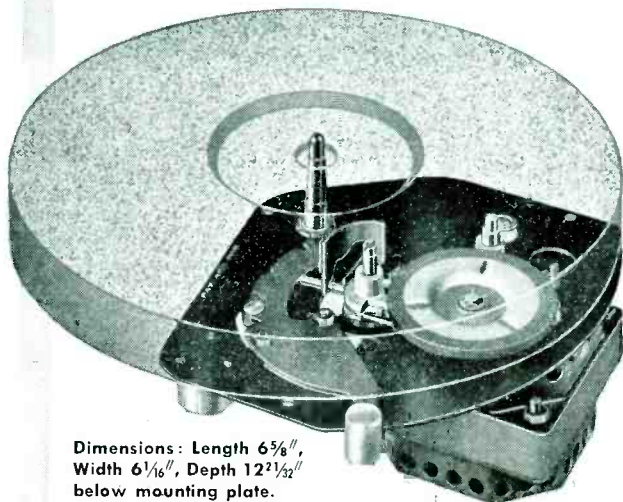

Dimensions: Length 6 5/8",  
Width 6 1/16", Depth 12 1/2"  
below mounting plate.

## GENERAL INDUSTRIES Model DSS (4-pole) Phonomotor

Typical of General Industries' leadership in phonomotor design and engineering is this three-speed phonomotor, produced expressly to meet the rigid requirements of true, high-fidelity reproduction.

Model DSS is ideally suited for use with magnetic pickups. Its heavy-duty 4-pole, 4-coil motor holds stray field radiation to an absolute minimum. Moving speed shift lever to "OFF" position automatically disengages idler wheel from motor shaft and cuts off the current to the motor.

The Model SS, 3-speed phonomotor is well adapted to hi-fi systems where crystal or ceramic pickups are used. Idler wheel is disengaged from motor shaft during non-operating periods. Power by a 2-pole, shaded-pole type motor.

General Industries also offers a complete line of single and dual-speed models powered for either 2 or 4-pole motors. Write for complete information, including specifications and quantity price quotations.

**THE GENERAL INDUSTRIES CO.**  
DEPARTMENT MF • ELYRIA, OHIO



DESIGNED FOR STREAMLINED SERVICE

AT FIRST RETMA GRADUATING EXERCISE

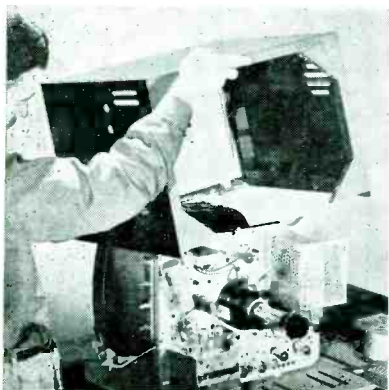

(Right)  
Among those participating in activities celebrating initial graduating class of the RETMA training program at the New York Trade School, left to right: W. L. Parkinson, G. E.; L. A. Goodwin, RCA; Floyd Makstein, Emerson Radio; G. N. Goldberger, Precision Apparatus Co.; E. Anthony, G. E. and H. J. Schulman, Allen B. Du Mont Labs, chairman of RETMA Service Committee.

(Left)  
Portable TV model featuring a vertical plane chassis with all tubes accessible from the back of receiver without removing the chassis from cabinet. To get at chassis, Service Man removes a few screws and lifts off bonnet-type cabinet, exposing all functional parts. (Crosley)



# Ser-Cuits

(Continued from page 43)

connected between terminal *F* and a capacitor plate.

From here it is coupled through a 1-mmfid ceramic to the second preselector stage that consists of a coil connected between terminal *H* and a capacitor plate. There is one capacitor plate that is common to both preselector stages which is grounded through terminal *G*. These preselector coils and capacitor plates are mounted on a form and are tunable through a range of 10 channels. Selection of any one channel is accomplished by varying the amount of dielectric material between the capacitor plates.

A 6AF4 is operated as the *uhf* oscillator and its tank circuit consists of two capacitor plates and a coil connected to each plate. These oscillator coils and capacitor plates are mounted on the same form as the preselector coils and capacitor plates, and forms a complete coil assembly that is tunable through a range of 10 channels. Correct selection of any one channel is achieved by varying the amount of dielectric material between the oscillator plates. The dielectric for the oscillator and preselector stages is in the shape of an eccentric cam and ganged together on the same shaft.

Fine tuning is accomplished in a similar manner with the exception that the dielectric material is on a separate shaft and rotates between the bottom section of the oscillator capacitor plate. The frequency range of fine tuning on all *uhf* channels is approximately 2 to 3 mc.

Auxiliary fine tuning is accomplished by adjusting a metal slug between the oscillator capacitor plates on the coil form. On some tuners, auxiliary fine tuning is performed by a screw mounted on the face of the *uhf* drum, which varies the capacity between the oscillator plate and ground. On other tuners this auxiliary fine tuning screw is mounted on the coil form.

The output of the oscillator is capacitively coupled to the second preselector stage by a short length of wire; one end is close to one of the oscillator plates and the other end is close to the second pre-selector plate.

This oscillator frequency and *uhf* signal are then fed to a 1N82 crystal operating as a *uhf* mixer. This action produces the desired *if* of 41-mc which is fed through a coax cable and connected to the primary of a *uhf* transformer mounted on a 41-mc contact board.

This board maintains electrical contact in the circuit of the 6BZ7 and

ALL RADIO AND TV TYPES

**CLOSE OUT**

**SET MANUFACTURERS' INVENTORY**

# TUBES

Standard Brand Warranty • BRANDED • Bulk or Individually Boxed

0A4G . . . . \$ .50	6AC7 . . . . .68	6CB6 . . . . .42	6U8 . . . . .59	19T8 . . . . .61
0Z4 . . . . .49	6AG5 . . . . .46	6CD6G . . . . 1.08	6V6GT . . . . 38	25AV5GT . . . 1.05
1B3GT . . . . .65	6AH6 . . . . .88	6B5 . . . . .76	6W4GT . . . . 41	25BQ6GT . . . 75
1B24 . . . . .4.95	6AK5 . . . . .75	6F6GT . . . . 45	6W6GT . . . . 41	25L6GT . . . . 40
11A . . . . .47	6AL5 . . . . .31	6H6 . . . . .49	6X4 . . . . .35	25Z6GT . . . . 37
1R5 . . . . .46	6AQ5 . . . . .37	6H6GT . . . . 49	6X5GT . . . . 35	33 . . . . .29
1S4 . . . . .40	6AQ6 . . . . .36	6J4 . . . . .99	6J4 . . . . .59	34 . . . . .29
1S5 . . . . .38	6AS5 . . . . .62	6J5GT . . . . 34	12A6 . . . . .39	35B5 . . . . .38
1T4 . . . . .46	6AT6 . . . . .36	6J6 . . . . .50	12AT6 . . . . 31	35C5 . . . . .38
1U4 . . . . .46	6AUG . . . . .36	6J7G . . . . .49	12AT7 . . . . 57	35L6GT . . . . 42
1U5 . . . . .38	6AV5GT . . . 79	6K6GT . . . . 36	12AU6 . . . . 34	35W4 . . . . .32
1X2A . . . . .65	6AV6 . . . . .36	6K7G . . . . .49	12AU7 . . . . 52	35Z5GT . . . . 33
2X2A . . . . .33	6BA6 . . . . .33	6L6GA . . . . 99	12AV7 . . . . 60	50B5 . . . . .41
3A8 . . . . .33	6BA7 . . . . .57	6SA7 . . . . .59	12AY7 . . . . 72	50C5 . . . . .41
2E22 . . . . 1.45	6BC5 . . . . .46	6SA7GT . . . . 61	12BA6 . . . . 40	50L6GT . . . . 59
3B24W . . . . 2.95	6BE6 . . . . .67	6SC7 . . . . .81	12BB6 . . . . 41	117Z3 . . . . .39
3D6 . . . . .25	6BF5 . . . . .69	6SE5 . . . . .58	12BH7 . . . . 53	801A . . . . .19
3B26 . . . . 1.95	6BG6G . . . 1.16	6SG7 . . . . .59	12H6 . . . . .49	803 . . . . .2.95
3Q4 . . . . .48	6BH6 . . . . .45	6SH7 . . . . .65	12J7 . . . . .29	814 . . . . .2.95
3Q5GT . . . . 48	6BJ6 . . . . .46	6SJT . . . . .54	12SA7GT . . . 58	832A . . . . 4.95
3S4 . . . . .46	6BL7 . . . . .65	6SK7 . . . . .69	12SG7 . . . . 61	836 . . . . .2.95
4C35 . . . . 24.95	6BN6 . . . . 72	6SK7GT . . . 37	12SH7 . . . . 49	866A . . . . 1.49
5FP14 . . . . 9.95	6BQ6 . . . . 70	6SL7GT . . . 49	12SK7GT . . . 46	5670 . . . . 1.45
5U4G . . . . .49	6BQ7 . . . . 76	6SN7GT . . . 46	12SN7GT . . . 46	5718 . . . . 4.95
5Y3G . . . . .36	6C4 . . . . .31	6SQ7GT . . . 37	12SQ7GT . . . 49	6101CT . . . 4.95
6A6 . . . . .35	6C5 . . . . .41	6SR7 . . . . .49	12SR7 . . . . 49	9003 . . . . 1.10
6AB7 . . . . .69	6C5GT . . . 41	6T8 . . . . .57	12Z3 . . . . .39	
	6C6 . . . . .49	6U7 . . . . .49	19BG6G . . . 1.15	

More than 400 types in stock — Include all your needs when ordering.

MINIMUM ORDER: \$10.00. Terms: 25% with order, balance C.O.D. Please include postage. All prices subject to change without notice. F.O.S. New York City, mail order division.

## TRANSAMERICA ELECTRONICS CORP.

120 LIBERTY STREET • NEW YORK 6, N. Y.

### THE ORIGINAL Cross-Bar Generator

Designed in 1951 and granted U. S. Design Patent No. 169,112

Still the best buy because: It is the ONLY Cross-Bar Generator selling for less than \$50, which includes its own built-in power supply. Connects direct to receiver Antenna Posts—NO CONNECTION TO CHASSIS OR ANY TUBE. This is a truly professional instrument—not an adapter!

## TV CROSS BAR GENERATOR



TV BAR GENERATOR COMES COMPLETE WITH SHIELD LEADS AND DETAILED OPERATING INSTRUCTIONS. ONLY

**\$39.95**  
NET.

**SHIPPED ON APPROVAL**  
**NO MONEY WITH ORDER — NO C. O. D.**

**THROWS AN ACTUAL BAR PATTERN ON ANY TV RECEIVER SCREEN!**

#### Two Simple Steps

1. Connect Bar Generator to Antenna Post of any TV Receiver.
2. Plug Line Cord into A.C. outlet and Throw Switch.

Result: A stable never-shifting vertical or horizontal pattern projected on the screen of the TV receiver under test.

#### FEATURES:

- Provides linear pattern to adjust VERTICAL linearity, height, centering
- Provides linear pattern to adjust HORIZONTAL drive, width, peaking, linearity, centering.
- Provides vertical sweep signal for adjusting and synchronizing vertical oscillator discharge and output tubes.
- Provides horizontal sweep signal for adjusting and synchronizing horizontal oscillator A.F.C. and output tubes.
- Provides horizontal sweep signal to check H.V. section of fly-back and pulse operating power supplies.

Try it for 10 days before you buy. If completely satisfied send \$9.95 and pay balance at rate of \$5.00 per month for 6 months.—No Interest or Carrying Charges Added. If not completely satisfied, return to us, no explanation necessary.

MOSS ELECTRONIC DISTRIBUTING CO., INC.  
Dept. D-15, 3849 Tenth Avenue, New York 34, N. Y.  
Please rush one TV Bar-Generator. I agree to pay \$9.95 within 10 days after receipt and \$5.00 per month thereafter.

Name \_\_\_\_\_  
Address \_\_\_\_\_  
City \_\_\_\_\_ Zone \_\_\_\_\_ State \_\_\_\_\_



6U8, only when the tuner is set for *uhf* operation. The board is switched in by a cam action on the rear of the *uhf* drum which, at the same time, breaks contact between the *vhf* drum and its associated circuit. The reverse of this occurs during *vhf* operation. The secondary of the *uhf* transformer is connected to the input circuit of the 6BZ7, which is now operating as a 41-mc amplifier. The 6BZ7 is a dual triode and is connected in the circuit as a direct-coupled grounded-grid amplifier. A *uhf if* coil couples the output from the plate, pin 1, of the 6BZ7 to the grid input of the pentode section of the 6U8, which operates as a 41-mc amp during *uhf* operation. When in *uhf* operation, one terminal on the 41-mc contact board is left open, thus removing plate voltage from the triode section of the tube inoperative. Signal output from the 6U8 is coupled through a plate coil, to a coax socket on the tuner and then fed to the receiver's *if* amplifiers.

#### VHF Operation

From the antenna, the signal is first fed to a 41-mc trap network, which is tunable from the top of the tuner. The output of this trap is coupled to the individual antenna coil section consisting of a balanced primary to minimize noise pickup on the transmission line and an *rf* grid coil which couples the incoming signal to the grid of the first section of the 6BZ7 *rf* amplifier. The inductance and amount of coupling of the tuned antenna input circuit are changed for each channel so that a constant input impedance of 300 ohms is maintained. This provides maximum transfer of energy to the *rf* amplifier stage, particularly when interconnection between an outdoor antenna and the receiver is made with 300-ohm transmission line.

The *rf* amplifier tube is a dual-triode and is connected in the circuit as a direct-coupled ground-grid type amplifier. This circuit was developed to meet the demand for an *rf* amplifier that would provide more nearly equal gain on both the low and high *vhf* channels, while keeping inherent tube noise to a minimum. The circuit can be thought of as two triode tubes in series, the first or driver unit acting not as an amplifier, but rather as an antenna impedance matching device and also as a variable cathode impedance, or bias source, for the second, or grounded-grid unit. In addition the first unit of the *rf* amp acts as a power amp due to its extremely low plate impedance, which is in reality the cathode circuit of unit two,

and converts the weak signal voltage from the antenna to a low voltage-high current signal which is then applied to the cathode of unit number two. The signal-coupling unit between the first and second units is a series peaking coil, similar to that found in a video amplifier circuit. Its purpose is to form a series resonant circuit with the input capacity of the second unit. The coil is so made as to resonate at a frequency slightly higher than channel 13. In a standard pentode type amp, the gain falls off rapidly as progressively higher channels are selected. With the use of the plate to cathode peaking coil an almost

equal gain can be realized for all *vhf* channels.

The *rf* amp has an inherently low-interelectrode capacity due to physical design; this factor in conjunction with the low-output impedance of the first section is responsible for the low noise factor at this stage. While neutralization of the first unit is not necessary, due to its low plate to grid capacity, additional noise reduction has been realized, with only a slight decrease in gain, by the addition of a neutralizing capacitor. Due to the low output impedance of the stage, it is not necessary that the neutralizing capacitor be tunable.

An outstanding design for EVERY application

## CORNELL-DUBILIER

UHF AND VHF TV ANTENNAS

Here—in one brand name is the answer to ALL your antenna requirements! A full range of antennas—all precision manufactured... with highest quality materials... each an outstanding value. Make sure of the best installation possible... SPECIFY C-D!



CONSISTENTLY DEPENDABLE

**CORNELL-DUBILIER**

SOUTH PLAINFIELD, NEW JERSEY



ROTORS • CAPACITORS • VIBRATORS • ANTENNAS • CONVERTERS

**NEW SUPER POST TOWERS**  
for TELEVISION ANTENNAS  
in FRINGE AREAS

Available  
In Heights  
from 47 ft.  
to 100 ft.

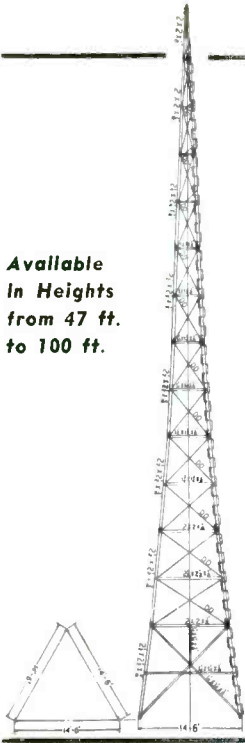

**TOWERS OF STRENGTH  
TO LAST A LIFETIME**

Self-supporting tower built up of galvanized steel sections. No guy wires necessary. Easy to erect. Safe and resistant to high wind. Available in heights 47 ft., 60 ft., 73 ft., 87 ft., and 100 ft. with bases in proportion.

**FRINGE AREA TV BUYERS  
MUST HAVE SPECIALLY BUILT  
TOWERS FOR CLEAR RECEPTION**

Tower and the TV set go hand in hand as a package sale to rural TV buyers. Provides an extra sale and profit to dealers. An excellent fast selling accessory for jobbers and dealers.

**TERRITORIES OPEN FOR  
JOBBER DEALER FRANCHISE**

Write for complete structural details, packing, prices, discounts, and territorial assignment.

MANUFACTURED BY  
**AERMOTOR CO.**

DEPT. 6403, 2500 ROOSEVELT ROAD • CHICAGO 8, ILL.  
BUILDERS OF STEEL TOWERS SINCE 1888

**NEW HANDI-PACK**  
prevents tangling  
... keeps wire clean

**Tuf-Guy**  
"ten-spot"

The GUYWIRE that is  
spot marked every 10 feet  
for easy measuring.

Write Dept. SV-3 for complete FENWIRE lline.  
**FENTON COMPANY**  
15 MOORE ST. • NEW YORK 4, N. Y.

**FENWIRE**  
Sold Through Jobbers Only

**PROFIT**  
with no after effects  
when you sell the  
**Golden Wand** line

UHF VHF FM

Eliminate refunds on returned merchandise! That is exactly what you do when you sell the Golden Wand line. Golden Wand antennas are guaranteed for customer satisfaction. Order this popular seller now! Heavy-weight, walnut mahogany felted base. Admiralty brass dipoles finished in sparkling gold. Polystyrene insulators that match the base and gold finish hardware. 3-section, velvet smooth telescopic action, free from dripping oil. Brass will not rust.

MODEL NO. TG-62

**\$5.95**  
LIST

SEND TODAY! for our price catalog.

**PEERLESS PRODUCTS INDUSTRIES**  
816 N. Pulaski Rd., Chicago 51, Illinois

**Tube News**

(Continued from page 48)

not utilized. Deposition of electrons on the scanned surface of any particular element of the layer causes a change in the difference of potential between the two surfaces of the element. When the two surfaces of the element, which in effect is a charged capacitor, are connected through the external signal-electrode circuit and the scanning beam, a capacitive current is produced and constitutes the video signal. The magnitude of the current is proportional to the surface potential of the element being scanned and to the rate of scan. The video-signal current is then used to de-

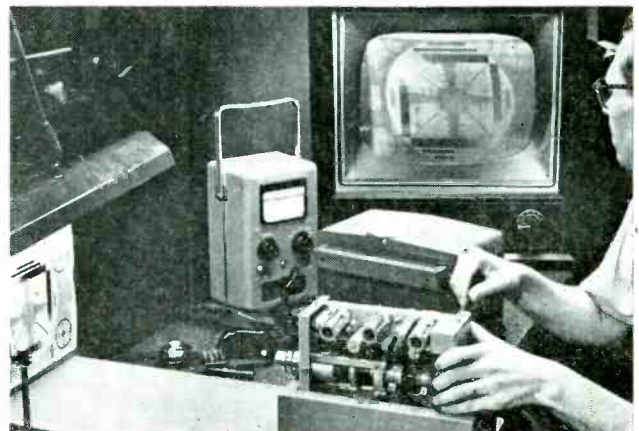

Checking circuits of a closed-circuit TV camera. (RCA)









# The Coupler Story by GEMCO

More than two years ago our engineers  anticipated the possibility of two TVs in the average home and set about developing a no-loss, low cost, 2 set coupler. The standards for

acceptability were high   This had to be the lowest loss system made, at a

modest price  Finally, a finished product was handed to our battery of TV Joes  for field testing. Reports came pouring in  GEMCO had a coupler



with interlaced Hi-Q R.F. transformer that was far and away superior to anything else around. No condensers, no resistors 

but HI-Q WINDING Exclusively. Then our production staff went to

work on small details such as non-slip screws, hot tinned lugs etc.,

all the little things that would insure tight connections, no oxidizing,

easy installation and top-notch performance. AND...



NOW YOU CAN REPLACE THOSE HIGH LOSS COUPLERS WITH INEXPENSIVE GEMCO HI-Q COUPLERS—THE LOWEST LOSS COUPLERS IN THE INDUSTRY.

**GREAT EASTERN MANUFACTURING CO.**  
BROOKLYN 12, NEW YORK



velop a signal output voltage across a load resistor. The signal polarity is such that for highlights in the scene the grid of the first video-amplifier tube swings in a negative direction.

### Beam Alignment

Alignment of the beam is accomplished by a transverse magnetic field

UHF germanium mixer diodes designed for circuit frequencies up to 3,000 mc with, it is said, a noise figure of 10-14 db at 500 mc. Type shown is for solder-in applications where space is limited; model also available for either clip-in or solder-in application. Diodes are direct replacements for uhf diodes now being employed as mixers in TV tuners and converters. (GO2 and GO2A; International Rectifier Corp., El Segundo, Calif.)

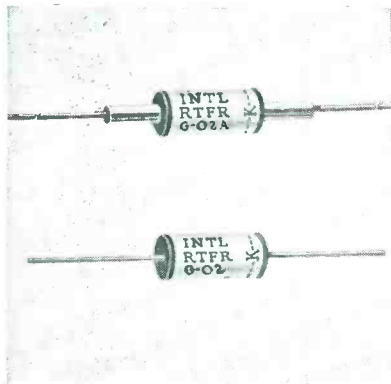

produced by external coils located at the base end of the focusing coil.

Deflection of the beam is accomplished by transverse magnetic fields produced by external deflecting coils.

### Four Lenses Available

Four lenses have been developed for the camera. They include three f/1.5 lenses of 13, 25, and 50-millimeter focal length, respectively, and a 4" f/2.7 lens; all adjustable focus. The lens furnished with the camera is a fixed focus 2" f/4.5.

Twin-x socket wrenches developed to replace eight hex-head socket wrenches. Sizes marked on each wrench. (G.E.)



Below: At recent transistor-award ceremonies in Los Angeles, held by Raytheon who sponsored \$10,000 transistor application contest. Presentation to the top four prize winners was made by John A. Hickey of the receiving tube division in ceremonies held in Philadelphia, Washington and Los Angeles. Robert T. Bayne second from right (below), Los Angeles, Calif., won first prize of \$5,000 in the nation-wide contest, for his design of an ac meter employing two Raytheon CK722 transistors and four Raytheon CK705 germanium diodes. Distributor T. Henry, received \$100 award for selling transistors to Bayne. Second prize of \$1,000 was awarded to Peter G. Sulzer, Kensington, Md., for his entry of a transistorized af and voltage standard. G. Franklin Montgomery, Bethesda, Md., and Lt. Robert Perkins, a navy dental officer, were awarded \$1,000 and \$500, respectively, for third and fourth prizes. Left to right: B. Winters and K. Turner, salesmen, Perlmuth-Colman Assoc., Southern Calif. Raytheon reps.; J. I. Perlmuth, partner, Perlmuth-Colman Assoc.; T. Henry; R. Bayne, and J. A. Hickey, Raytheon assistant distributor sales manager, industrial tubes.



"Service-Master saves me up to one hour of service time every day"

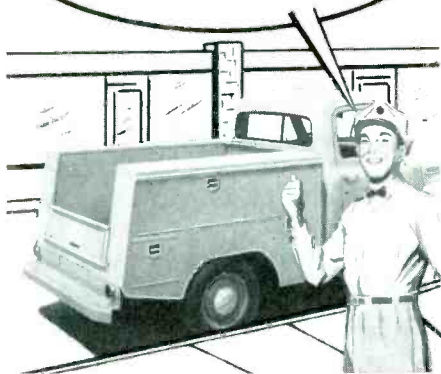

## Service-Master

### THE IDEAL RADIO AND TELEVISION SERVICE BODY

Here's the body that takes a completely equipped shop to the job, and saves up to 75 minutes per day. Using the latest average service base rate of 6 cents a minute and an average saving of 30 minutes a day... Service-Master saves \$478.00 worth of time a year. Available in sizes for 1/2, 3/4, 1, and 1 1/2 ton chassis — regardless of age or make. The coupon below will bring complete details, with no obligation to you.

### MAKE YOUR PICK-UP TRUCK A SERVICE TRUCK, TOO!

## SERVICE-TWINS

for 1/2 and 3/4 ton pick-up trucks



These easy-to-install tool and material compartments are finished in baked-on, medium-dark green enamel. Parts bins are built-in. Doors have slam-action catches, with locks keyed alike. Available with overhead rack.

**McCABE-POWERS AUTO BODY CO.**  
5900 No. Broadway • St. Louis 15, Mo.

Please send me complete details on:  
SERVICE-MASTER  SERVICE-TWINS

Name \_\_\_\_\_

Company \_\_\_\_\_

Address \_\_\_\_\_

City & State \_\_\_\_\_

NS

## IRE Sessions

(Continued from page 44)

direct modification of the NTSC dot-sequential signal in the receiver is possible and can be achieved in various ways.

In still another discourse on color TV picture tubes, C. G. Lob<sup>4</sup> also of G. E., will outline the development of a new type of tricolor tube using a screen with vertical phosphor stripes alternating red-green-blue, red-green-blue, and so on.

Continuing the survey of color TV set design problems, the significance of some receiver errors on flesh color reproduction will be covered by Harold Weiss<sup>2</sup> of G. E.

It has been found that the deviations in chromaticity caused by errors in various color TV receiver signals can be evaluated in terms of *just noticeable color difference units* suggested by MacAdams. The significance to flesh color reproduction of errors in the  $R'$ ,  $G'$ , and  $B'$  signals, in the composite subcarrier amplitude and phase, in the detected  $R'-Y'$ ,  $B'$ ,  $Y'$ ,  $I'$  and  $Q'$  signals, as well as in the  $Y'$  signal, have been plotted. Greatest sensitivity has been found to departures from optimum values by the  $R'$  and  $G'$  signals and by  $Y'$  in the negative direction. Preliminary experiments have indicated that much larger signal errors than is generally believed permissible will prove acceptable to the average viewer.

A means to control automatically the driving waveform and hence the damping in TV vertical deflection circuits will be described by H. E. Thomas, S. DeMars and M. Jones<sup>3</sup> of Federal Telecommunication Labs, Inc.

The output tube in a TV-set deflecting system contains inductive reactance in its plate circuit. Due to rapid reversal of sweep circuits in this circuit it has been common practice to damp the resultant transients by so shaping the driving sawtooth voltages that electronic damping of these transients results. However, a fixed amount of damping must vary with the amplitude of the sawtooth voltages which may vary with height, linearity or tube changes in the course of operation.

### Transistorized Chassis Paper

Transistorized AM receivers have been considered by many. The requirements relating to the component circuits of such receivers and the problems connected with the application of transistors to the local oscillator, *if* amp, converter, *if* amp second detector, *agc*, and audio amps will be discussed by A. P. Stern and J. A. A. Raper<sup>3</sup> of

## New and Popular

# Mueller

### PRODUCTS

#### COMPLETELY INSULATED



Alligator Clip,  
New No. 62  
Insulator Covers  
Mueller 60 Series  
Alligator Clips.

#### NEEDLE CLIP

Pierces insulation—  
makes quick contact  
anywhere along insu-  
lated wire. No. 50-C.



#### WEE-PEE-WEE CLIP

A small slim-nosed clip  
for miniaturized cir-  
cuits. Phosphor bronze  
No. 88.



#### STAND-OFF INSULATOR

The most  
versatile!  
Grips masts,  
guy wires  
or gutters.  
No. 135.

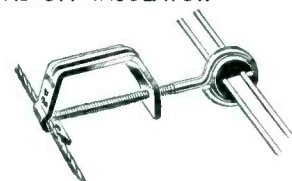

Send for Free Samples and Catalog 810

**Mueller Electric Co.**  
565 E. 31st STREET CLEVELAND 14, OHIO

G. E. Several *transistorized* solutions and diagrams of complete transistor receivers will be displayed and described. Desirable overall characteristics of various receiver types and problems involved in meeting these requirements with transistors will also be reviewed.

### Color TV Symposium

In a symposium on color TV,<sup>5</sup> organized by *ye editor*, the significant possibilities of tape for video recording will be probed by Harry F. Olsen and a team of six specialists from RCA, and John T. Mullin of Bing Crosby Enterprises. Other subjects that will be covered during this session include color film scanner circuits by J. F. Fisher, Philco; color characteristics of a TV film scanner by Jesse Haines of DuMont; and factors in the design of keyed clamping circuits by R. N. Rhodes, RCA.

### The SERVICE Booth

At the huge Kingsbridge Armory in the Bronx, where the annual IRE Radio Engineering Show will be held, in conjunction with the convention, SERVICE will be located in booth 892 on *Audio Avenue*.

<sup>5</sup>Wednesday, March 24, P.M., Astor Gallery, Waldorf-Astoria.



## Audio

(Continued from page 53)

out feedback over the first stage, but using the same overall gain.

In one instance, designers used feedback in two separate places, with equalization inserted between the stages. It was found that there was some 10 to 15 db gain to spare for feedback, and an attempt was made to put more of the available feedback on the first stage to reduce hiss, but it was found it came up. Eventually, all of the feedback was placed on the later stage, and a lower hiss level was obtained. Also distortion was brought to a lower value by this means; a higher level output stage produces more non-linearity than the low level input stage.

When all of the aspects of feedback's action are understood, common sense will dictate the best or right place to apply it. But it is surprising to find that many people still regard feedback as a fairy godmother to dispel all their troubles.

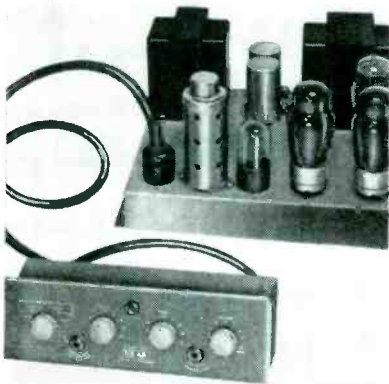

Amplifier-preamp combination with master control unit. Has tape recorder jacks, input and output, and four master controls which include input selector with 6 positions (tuner, tape, AES, NARTB, FFR, Col. lp); treble control, with 8 stages, covering a 25-db range; bass control, also with 8 stages, covering a 25-db range, and a volume control, with continuously variable gain, plus on-off switch. Model incorporates ultra-linear 10-watt circuit, including a pair of KT-61 beam power output tetrodes in push-pull. Preamp is a 2-stage feedback unit. (Model Leak TL/10; British Industries Corp., 164 Duane St., New York 13.)

## TV Antennas

(Continued from page 46)

casting, compression molding, injection molding, press brake, blanking (die), blank and draw (die), cut, carry, cutoff and form (die), form-secondary (die), multi-slide, and wire form. A variety of fastenings were itemed: weld, spot weld, braze, solder, rivet, stake, stitch, clinch, spin over, extrude and spin, and patent types.

Keeping in mind volume of sales, function, assembly operations and plant facilities, butyrate, injection molded,

## THIS VOLTAGE ADJUSTOR

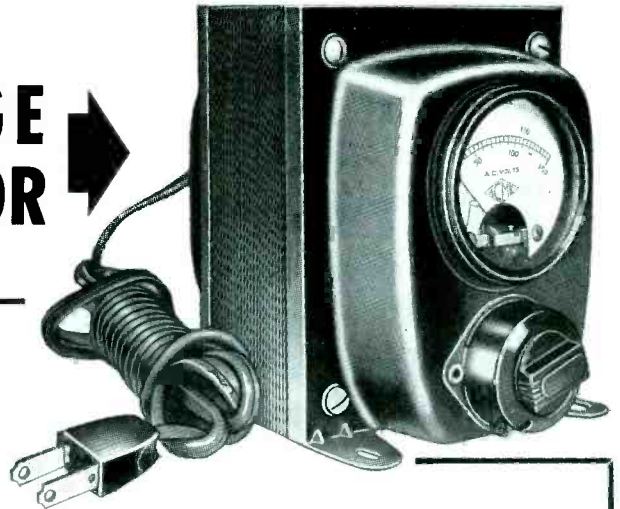

T-8394M MANUAL  
VOLTAGE ADJUSTOR

## IS EASY TO USE ON SERVICE CALLS

Where low voltage is affecting TV reception the serviceman can detect the conditions immediately with a T-8394M Acme Electric Voltage Adjustor.

To determine line voltage, set the tap switch at 115 volts. The meter reading will show the exact incoming line voltage.

### REPRODUCING LOW VOLTAGE EFFECT

The T-8394M Voltage Adjustor can also be used to reproduce the operating condition about which the customer complained. For example, the customer complains that evening program pictures flicker and shrink but daytime pictures are alright.

This indicates low voltage conditions in the evening. By adjusting the tap switch to 97 volts the condition may be duplicated. This quickly convinces the set owner that good performance can be sustained with a T-8394M Voltage Adjustor. A sale is made.

### NOT A GADGET

The T-8394M Voltage Adjustor is small and compact. It is supplied with a primary cord and a secondary receptacle. Just plug the cord into any convenient outlet — then plug the television cord into the secondary receptacle. No tools are necessary.

The Acme Electric T-8394M Voltage Adjustor is a high quality variable voltage type transformer that has been on the market for 25 years. Regulation is adjustable over a range from 95 to 125 volts. It is a dependable, low cost voltage regulator that can adjust voltage to the exact amount necessary for top TV performance. Write for Bulletin VVA-190.

## ACME ELECTRIC CORPORATION



MAIN PLANT: 473 Water Street • Cuba, N. Y.  
West Coast Engineering Laboratories:  
1375 West Jefferson Boulevard • Los Angeles, Calif.  
In Canada: Acme Electric Corp. Ltd.  
50 North Line Road • Toronto, Ontario

was selected for the yoke of the antenna, and aluminum, progressive cut, carry, cutoff and form die was chosen for clamps and other vital sheet metal parts. For fastenings, steel, double head  
(Continued on page 98)

(Right)

Adjustable indoor antenna said to be suitable for uhf and vhf. Features twin coils for horizontal adjustment which extend 28", closed position to 40" extended. Dipoles rotate to 10° to 90° angle. Has a device for locking dipoles in tuned position; slides up to unlock, down to lock. (Decor-Tenna; Midwest Naturlite Co., 228 W. Kinzie St., Chicago 10, Ill.)

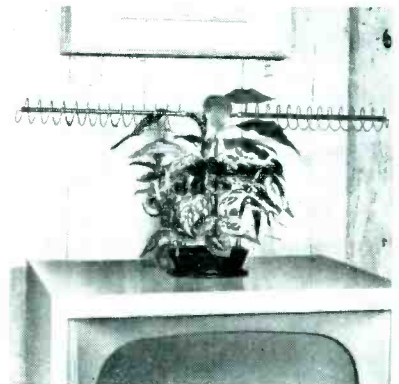

# SERVICE TECHNICIANS: FOR YOUR SHOP!

## THE COMPLETE PHOTOFACT SERVICE DATA LIBRARY

(world's best TV-Radio service data)

in this one handy  
file cabinet

YOURS FOR ONLY

**\$25** DOWN  
NO CARRYING  
CHARGES

1. If you now own some Sets of PHOTOFACT Folders, you can COMPLETE your present library this EASY-PAY-WAY
2. If you've never used PHOTOFACT, you've never realized your full earning power. Put this file cabinet with its 220 Sets of PHOTOFACT Folders to work... starting right NOW!

YES, ONLY \$25 DOWN PUTS  
THE COMPLETE PHOTOFACT  
LIBRARY IN YOUR SHOP...  
COVERS OVER 17,000  
TV, RADIO, RECORD  
CHANGER, RECORDER  
AND AMPLIFIER  
MODELS

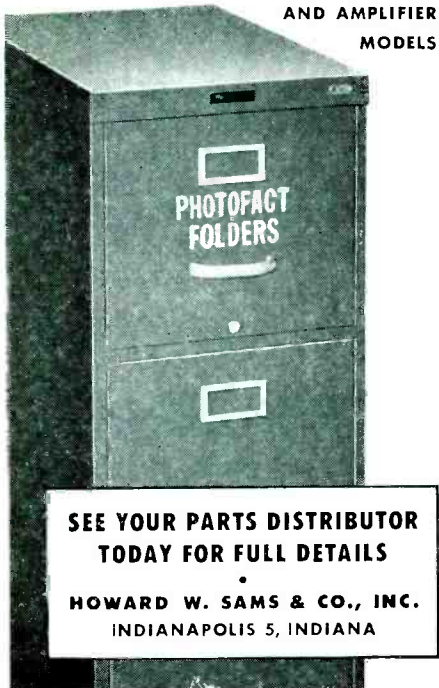

SEE YOUR PARTS DISTRIBUTOR  
TODAY FOR FULL DETAILS  
HOWARD W. SAMS & CO., INC.  
INDIANAPOLIS 5, INDIANA

## TV Antennas

(Continued from page 97)

machine, hopper feed, rivets were approved. It was decided to use 1" square, seamless aluminum for the cross-arms and 3/8" diameter, seamless or butt-seam aluminum for the dipoles. And for dipole reinforcement solid aluminum alloy rod was selected.

With this information, it becomes possible to prepare formal detail drawings of the parts, the design of each being compatible with the tool and process which will be used to produce it. An accurate estimate of all costs can then be prepared, followed usually by a discussion of minor refinements that might be included. A model can then be constructed, each detail executed by a shop capable of reproducing faithfully the specifications called for on the drawings. When completed, the components can be assembled, and several tests conducted to verify rigging time, performance, resistance to wind and rain, etc. Upon satisfactory completion, the design can be frozen and detail prints distributed for purchasing of materials, tool designs and other production equipment. Finally, the advertising and merchandising programs can also be outlined, including necessary data for packaging, instruction sheets, labels, etc.



Polyethylene 7-strand 28 copper (20 gauge) lead with sponge feature. Said to be suitable for uhf and vhf. Supplied on 1000' non-returnable reels. (Spongee; Imperial Radar and Wire Corp., 820 E. 233d St., N. Y. 66.)

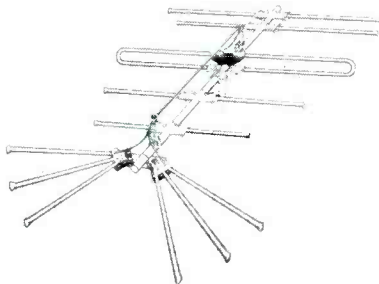

## The RADELCO CORNER REFLECTOR UHF Model US-151

IS MADE FOR UHF AREAS WHERE  
GHOSTS ARE VIOLENT AND  
INTERFERENCE IS ROUGH!

- ★ EASY TO INSTALL!
- ★ OPENS LIKE A BOOK!
- ★ MOUNTS IN FRONT OF MAST, NOT BEHIND IT!

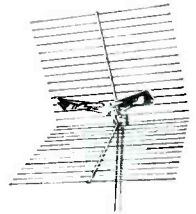

### ASSURES CLEARER, SHARPER TELEVISION PICTURES!

- It's a superb high gain, extremely directive, broad band antenna with ample ability to banish ghosts and reject interference. Covers all UHF channels.

ORDER FROM  
YOUR NEAREST  
PARTS JOBBER

**\$745**  
LIST

**SENSATIONALLY LOW PRICED**

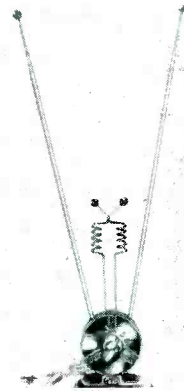

Vhf/uhf indoor antenna with telescoping vhf rabbit ears and a 6-position rotary switch that is said to regulate electrically the wavelength of a uhf Q-phaser. The housing for the internal contact wheels is an adaptation of the JFD panorama ratchet-grip molded bakelite housing. (Model TA 145; JFD Manufacturing Co., Inc., 6101 Sixteenth Ave., Brooklyn 4, N. Y.)

(Left)

Conical-yagi vhf combination designed for ultra-fringe area reception. Features eleven 3/8" aluminum elements, five of which are preassembled; other six can be locked into a lock plate. (Model AX-670, Snyder Manufacturing Co., Philadelphia 40, Pa.)



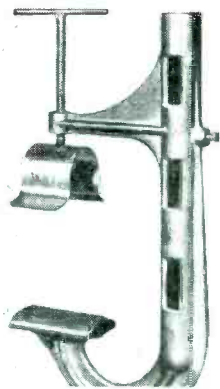

Self-supporting antenna gable clamp for slate and steep roofs. Can be attached to peak of gable. Cast alloy said to be tested to handle stress 100% above average use load. (Mills Products Co., Burr Oak, Mich.)

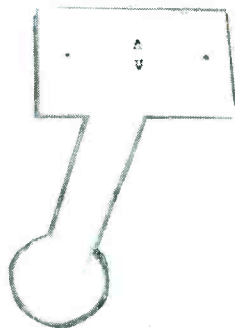

Thru-the-wall antenna tube constructed of polystyrene. Said to handle coax, ladder, round or flat lead. Requires a 3/4" hole. Solderless; comes with plug and screws for mounting. Features miniature wall plate 1 3/4" x 2 3/4" in size, and patented self-aligning contacts. (Javex, P. O. Box 646, Redlands, Calif.)



(Left)  
Distribution broad-band amplifier which permits the use of a pair of TV sets from a single antenna and also acts as a booster. (Duo-tenna; Waldom)

(Below)  
Indoor uhf antenna finished in simulated wrought iron and bronze and boxed with lead wire. (Model TV-215; Ward Products Corp., Division of The Gabriel Co.)

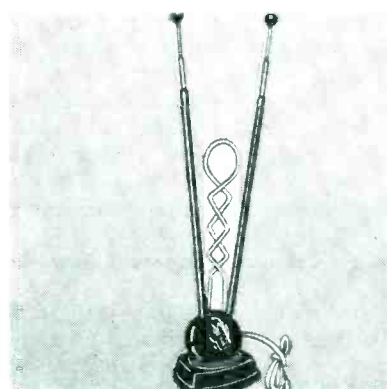
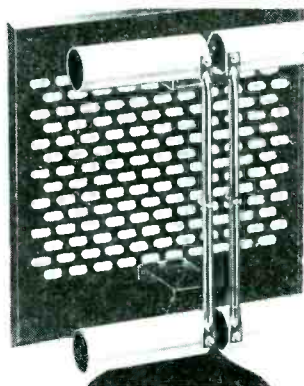

Indoor uhf/vhf brass-dipole antenna with a criss-cross phasing element and a six-position selector switch. Equipped with NevaTip base. Also available with nickel plated brass elements. (K-38 and KN-38; RMS, 2016 Bronxdale Ave., New York 62, N. Y.)

**HICKOK**  
Model 695

**VHF SWEEP GENERATOR**

- Fundamental output on all frequencies.
- All Electronic sweep.
- .5 volt fundamental output.
- Triple shielding prevents leakage.
- Continuously variable tuning.
- Write for technical details...

**THE HICKOK ELECTRICAL INSTRUMENT CO.**  
10521 DUPONT AVE., CLEVELAND 8, OHIO

VIDAIRE • VIDAIRE • VIDAIRE

**Vidaire**

**ELIM-A-TRACE**

**VERTICAL RETRACE LINE ELIMINATOR**

- Eliminates vertical retracing lines in picture when brightness control is turned up.
- Makes picture viewable on weak picture tubes.
- View picture without strain in fringe areas.

**Vidaire**

**TEL-ATTEN**

**SIGNAL ATTENUATOR**

- Eliminates overloading due to strong signals.
- Reduces buzz in intercarrier sets.
- 1000 to 1 change in signal reaching antenna posts.
- Vernier adjustment for all signal areas.

**Vidaire**

**KINE-LITE**

**C.R.T. REJUVENATOR**

- Renews brilliance and contrast of picture.
- Prolongs life of old picture tubes.
- Two connecting plugs.
- No soldering necessary.

**Vidaire**

**TELE-COUPLER**

**2 SET COUPLER**

- Permits use of one antenna with two TV sets.
- Reduces effects of local oscillator radiation from one TV set to another.
- Filter action reduces interference at IF frequencies.

TELETYPE UNIT  
VE  
BY ADJUSTING THE  
RETINA  
LIFE

**Vidaire** Electronics MFG CO.  
EXECUTIVE OFFICES AND PLANT  
576 WEST MERRICK RD., LYNBROOK, N. Y.

**FREE MAIL THIS COUPON**

VIDAIRE ELECTRONICS  
576 West Merrick Rd  
LYNBROOK, N. Y.

Please Send FREE  
 Latest catalog (A)  
 "TV INTERFERENCE AND ITS REMEDIES"

NAME \_\_\_\_\_  
 ADDRESS \_\_\_\_\_  
 CITY \_\_\_\_\_ STATE \_\_\_\_\_

a bear for punishment



C-D does it again  
with its new Cub

Outperforms any other  
molded tubular

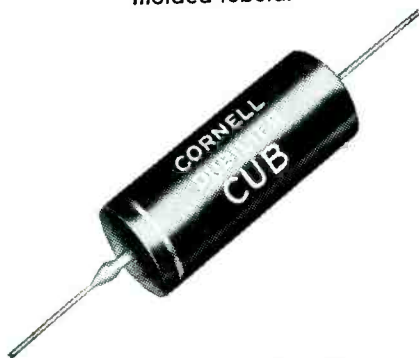

- \* A better-looking tubular with
- \* A better humidity seal.

Get more for your money by insisting on C-D's new "CUB-KIT".

For your nearest C-D authorized jobber see the Yellow Pages of your Classified Phone Book. Write for Catalog to: Dept. S34, Cornell-Dubilier Electric Corporation, South Plainfield, New Jersey

CONSISTENTLY DEPENDABLE  
**CORNELL-DUBILIER**  
CAPACITORS



There are more  
C-D capacitors in  
use today than any  
other make.

PLANTS IN: SOUTH PLAINFIELD, N. J.; NEW BEDFORD, WORCESTER  
AND CAMBRIDGE, MASS.; PROVIDENCE AND HOPE VALLEY,  
R. I.; INDIANAPOLIS, IND.; SANFORD AND FLOUAY SPRINGS,  
N. C. SUBSIDIARY: RADIART CORP., CLEVELAND, OHIO

## Servicing Helps

(Continued from page 54)

the same manner. Where the interference is strong enough to be feeding into stages after the first audio amplifier, care should be taken that no phase inverter stage is affected by filter installation.

Series-heater strings should be well bypassed to prevent the signal from entering the tube through the heater leads. Both sides of the *ac* line may be bypassed to the chassis with .01 to .1 mfd (value non-critical), 600-v rated capacitors.

A tube shield, if used, should be checked for positive ground connection. If the tube is unshielded, it may be necessary to install a shield. Lead dress should be carefully checked; *rf* pickup may occur on long volume-control leads running to the front of the chassis. Receiver wiring may represent an appreciable portion of a wavelength at the higher frequencies and therefore pickup considerable *rf* energy.

In isolated instances, a volume control with ungrounded shaft may be found. Pickup on the shaft, especially when the hand is placed on the gain control, as in adjusting volume, is considerable. The cure in this case is to install a control having a shaft insulated from the terminals, so that the shaft may be grounded to the chassis.

Dual and triple-purpose tubes, when performing several functions, such as detector, first audio and *avc*, present a special problem because of interelectrode capacitance, and the common cathode which feeds from one circuit to another.

Where the usual remedies for preventing *rf* rectification on the grid of a triple-purpose tube do not cure the condition, the audio section of the multiple circuitry may be removed and incorporated with a separate tube, preferably mounted on a small sub-assembly bracket under the chassis. The standard first audio circuit can then be wired to the new sub-assembly with the added resistor, bypass capacitor and lower value grid leak incorporated as modifications in circuitry.

### Extraneous Interference Sources

An unwanted *rf* signal may get into the receiver audio circuits as a result of a direct pickup through inadequate shielding or tube input shielding, but more commonly will be introduced through power-line coupling or through the antenna and transmission line. Any measures taken to prevent or attenuate *rf* energy other than the desired signal from entering the set at

the antenna or other paths will be found helpful.

This can be accomplished in stubborn cases when the interfering signal is introduced through the power source, by installing a powerline filter; commercial plug-in line filters are available and particularly suitable where space is limited, as in compact *ac/dc* receivers. Bypass capacitors for *rf* in the line may also be tried.

An appropriate line filter may be installed as close as possible to the receiver antenna input transformer, if the interference is entering by that path.

### Soldering Coax Plugs<sup>1</sup>

CONSIDERABLE TROUBLE in video patch plugs and coax line connections has been traced to improper soldering technique. In some cases, cold-soldered connections have been the cause of the problem, but the majority of failures have been found to be due to excessive heat and improper positioning of the plug while cooling. The resultant damage to the polystyrene often does not show up immediately but later movement of the cable will produce a direct short between the inner conductor and shield or, in some cases, increase the leakage factor of the polystyrene.

An effective method of stripping and soldering shielded coax cable is shown in Fig. 3. In removing the vinyl jacket, one must use care to avoid nicking or cutting through the shield braid. The braid and polystyrene should be stripped and the soldered connections made quickly with a hot, clean, well-tinned iron. Shield braid

<sup>1</sup>Submitted by John B. Ledbetter.

Fig. 3. Techniques found effective in soldering coax plugs. Shield braid should be twisted and soldered as in a, or soldered all around as in b, and the cable allowed to remain straight until insulation has cooled. Detailed cutaway view of soldered plug appears in c.

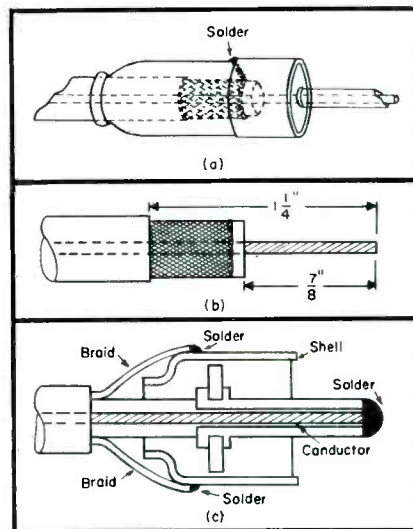



## CUT CALL BACKS

Install 1000 Volt Capacitors  
at No Extra Cost

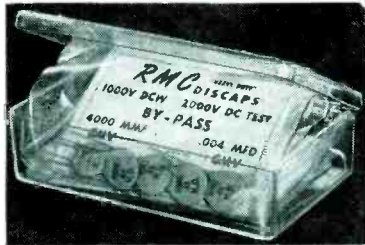

### RMC DISCAPS . . .

The Ceramic Capacitors  
TV Manufacturers Depend On

With RMC's expanded DISCAP line you can install 1000 V.D.C.W. ceramic capacitors at the same price as ordinary units.

DISCAPS provide added insurance against call backs and is your best protection of service profits.

RMC DISCAPS are supplied in handy, reusable molded plastic boxes. Contents and ratings are determined at a glance.

Ask your jobber for RMC DISCAPS . . . approved and used by leading manufacturers.

**RADIO MATERIALS CORPORATION**  
Factories at Chicago, Ill. and Attica, Ind.

For the name of your nearest RMC jobber contact:

**JOBBERS SALES COMPANY**  
NATIONAL DISTRIBUTORS FOR RMC DISCAPS  
146 BROADWAY PATERSON 1, NEW JERSEY

should be twisted and soldered, or soldered all around and the cable allowed to remain straight out from the plug until the insulation has cooled. Placing the shell of the plug in a vise or holding the tip with pliers will help to dissipate excessive heat.

#### UHF Match-Box Converters

EARLY CBS-COLUMBIA model 1000 chassis had pin 7 on the 6V6 tube socket grounded and pin 2 going to 6.3-*v* filament.

On the match-box converters designed for these sets, pin 2 has been grounded. On all model 800 and recent model 1000 chassis, pin 2 has been grounded.

Before connecting match-box converters to any model 1000 in the field one should check the set with an *ac* voltmeter to make sure that pin 7 is alive and pin 2 grounded. If this is not so, the chassis must be opened and filament connections to the 6V6 socket reversed; otherwise damage may be caused to the output coil in the *uhf* match-box converter.

If preferable, the brown and yellow filament leads of the *uhf* converter cable to the 6V6 can be cut and re-

<sup>1</sup>From Delco auto-radio service notes.

<sup>2</sup>From Stromberg-Carlson TV service data.

spliced; yellow to brown, brown to yellow. However, this unit then can not be used later with an 800 or a new 1000 chassis without reconnecting the cable wires back the original way.

#### Burnt 1800-Ohm Filter Resistors<sup>1</sup>

INTERMITTENT auto sets, which use a push-pull output with an input transformer, are often found with scorched-appearing 1800-ohm filter resistors.

When using an input transformer, the grid of the 6V6 has very low *dc* resistance to ground; 6V6 and 12V6 have been known to have an internal short from screen to grid. This can short *B+* through the input transformer. This will not cause the *A* current to double and blow a fuse, but it will cause the 1800-ohm filter resistor to smoke and discolor. The short, being concealed within the tube, will be difficult to find, especially if it is intermittent.

#### Noisy '53 Buick Push-Button Models<sup>2</sup>

ON '53 BUICK push-button sets one side of the antenna trimmer is grounded to a bracket which holds the trimmer in place. The bracket is mounted to a wrap-around. Ground and mounting connection is made secure by a screw. If the screw is slightly loose, vibration of the trimmer can set up *noise*.

#### Defective Horizontal Amp Cathode Capacitor Check<sup>2</sup>

OCCASIONALLY SMALL PICTURE-TUBE SIZE can be traced to a defective cathode bypass capacitor on the horizontal amplifier tube. A quick check can be made by temporarily connecting the cathode to ground. If the capacitor is defective, there will be an appreciable change in size of the picture. If the capacitor is good there'll be only a very small change.

#### AGC Adjustment

THE STROMBERG-CARLSON 600 series TV receivers, with the exception of the 621, are now being built with a variable *agc* control. On the first models, this control has been mounted next to the high voltage cage on top of the chassis. On later models, dual control will be placed with the noise cancellation control. The purpose of this control will be to eliminate on *if* beat, which may be produced in extremely strong channel 6 areas. The control should be turned clockwise to eliminate this disturbance. A 500,000-ohm potentiometer is connected in series with a 390,000-ohm resistor (*R*<sub>207</sub>).

There are more C-D capacitors in use today than any other make.

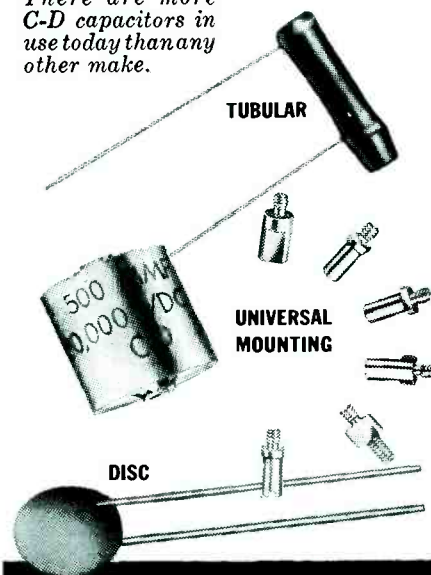

There's a C-D ceramic with the "Million Dollar Body" for every requirement

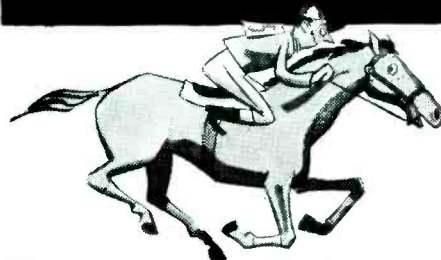

Every one a winner

A line of the most popular, fast-moving sizes, in both general purposes and temperature compensating types. Ask your C-D jobber about them today! He's listed in your local Classified Telephone Directory. For catalog write to Dept. 34A, Cornell-Dubilier Electric Corp., South Plainfield, New Jersey

CONSISTENTLY DEPENDABLE  
**CORNELL-DUBILIER**  
CAPACITORS



PLANTS IN SO. PLAINFIELD, N. J.; NEW BEDFORD, WORCESTER AND CAMBRIDGE, MASS.; PROVIDENCE AND HOPE VALLEY, R. I.; INDIANAPOLIS, IND.; SANFORD AND FUGAY SPRINGS, N. C. SUBSIDIARY: RADIART CORP., CLEVELAND, OHIO

# PRIZE CONTEST!

**NAME OUR NEWEST TV SERVICE BOOK  
WIN VALUABLE CASH PRIZE!**  
Many other prizes, including cash, test instruments, TV magazine subscriptions, etc.

**ABSOLUTELY NO OBLIGATION**  
to enter contest.

**WE WANT BEST NAME**  
Full contest particulars included  
with your order.

## NEW! 1954 TV CONSULTANT TV Serviceman's Silent Partner



New, easy-to-use way to solve toughest TV troubles. UHF sect. includes conversions, installations and servicing. Modern alignment methods shown by pictures, diagrams and simple directions, tell exactly what to do and how to do it. Practical pointers on use of all TV Test Instruments. Over 300 pix, raster and sound symptoms. Detailed directions tell where and how to find faulty parts. Over 135 **RAPID CHECKS**, many using pix tube as trouble locator. 125 illustr. of scope wave forms, diagrams, station patterns, show various defects—take mystery out of TV. **NO THEORY—NO MATH—NO FORMULAS**—just practical service info. covering all types of TV sets.

Only.....\$2

## NEW! 1954 TV TUBE LOCATOR All Pix Tubes Listed!



Money-making Time Saver tells which tubes to replace to cure every type of tube trouble. Over 135 such TV troubles listed with clear charts or quickly locating the faulty tubes. Copyrighted **TROUBLE INDICATING TUBE LOCATION GUIDES** for over 3000 most popular models from Admiral to Zenith plus **PIX TUBES** used in each model! 1947 to 1953 models. A storehouse of valuable TV servicing info. priced very low for large volume sales.

Only.....\$1

## NEW! Trouble Shooting PIX GUIDE incl. TV TERMS Explained

Sect. 1 is a fully illustrated **GUIDE** to oft-recurring pix faults. Causes and cures explained. Copyrighted **Trouble Indicating** illustrated chart tells where troubles start in typical TV set—illustrations show resulting faulty TV pictures. Sect. 2 explains hundreds of TV terms in non-technical language. **SPEEDS UP TV SERVICING—HELPS YOU DO A BETTER JOB FASTER!**

Only.....\$1



## NEW! TV TROUBLE TRACER Vol's 1 & 2 Now Ready!

70 Common TV troubles traced to source and cured. Copyrighted trouble indicating tube location guides covering over 1200 most popular TV models—many models different from those shown in **TV TUBE LOCATOR**. Each contains over 70 illustrations and tube location guides. Forty most common picture troubles illustrated, with symptoms described, causes given and remedies prescribed.

Vol. 1 Only 50¢

Vol. 2 Only 50¢



## H. G. CISIN, PUBLISHER

- Order from your Jobber today, or if not stocked, write to
- Harry G. Cisin, Dept. S-20  
Amagansett, New York**
- Enclosed find \$..... Send
- TV Consultant  Locator
- TV Pix Guide  TV Tracer Vol. 1
- TV Tracer Vol. 2
- Include with order full particulars about **PRIZE CONTEST!**

Name .....

Address .....

City..... Zone..... State.....

## Service Engineering

(Continued from page 39)

the battery from charge position and connects it to the 6-*v* input end of the rotary converter. The 115-*v ac* output of the converter is then connected to the two upper contacts of  $K_1$ .

Having lost its energizing voltage,  $K_1$  now has its two movable contacts resting against its two upper contacts. Now that the converter is delivering power, output is passed through the relay and out into the radio control unit. Now a red pilot lamp, connected in parallel with the converter output, lights up indicating that the power supply is in emergency operation.

A resumption of voltage to the power unit input-line cord terminals will immediately place the power unit in normal or stand by operation.

Tests have proved that the test switch can be opened while the dispatcher is making a transmission. It was found that due to the rapid operation of the emergency power unit no words were ever lost or even garbled.

Although the units were originally designed for emergency operation of a special type of console installation,<sup>5</sup> it was found that they will perform equally well while delivering emergency power to other consoles.<sup>6</sup> They will supply steady *ac* to any device whose power demand does not exceed the converter output.

<sup>5</sup>Motorola PA-827OH remote control.

<sup>6</sup>Such as those made by RCA or G.E.

## TUBE GLASS PREHEATER

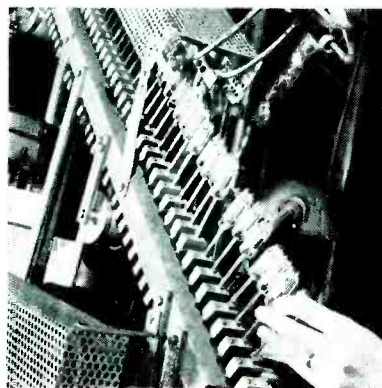

Preheater for tempering the glass of tubes, designed to expedite tube production. Known as a broken-back preheater, in contrast to older-styled, circular preheater, development consists of an automatic conveyor belt, which feeds radio tube mounts to the sealing machine operator and the heater-unit itself. Operator places tube mounts into bulbs and then loads them into conveyor belt, which transports each tube through preheater to sealing machine operator. (Sylvania)

## THE NEW TV DYNATRACER

\$495

Ppd.  
or C.O.D.  
+ Chgs.



- Traces TV Signals and Voltages
- Locates Defective Components
- Requires No Additional Equipment

This sensationally new piece of test equipment is ideal for trouble-shooting television sets in the home or in the shop. The "DYNATRACER" will outperform more expensive testers and should pay for itself on first repair.

A Must For Every TV Technician  
**SPECIFICATIONS:** The "DYNATRACER" is a self-powered quality test instrument designed to trace TV signals through any Video, Sound, Sync, AFC, Horizontal or Vertical Sweep Circuit—will isolate trouble to a stage or component.

**ADDED FEATURE:** The "DYNATRACER" will also trace voltages (50/500 V. AC/DC) and instantly locate open, shorted, intermittent or leaky (up to 20 megohms) condensers, resistors, coils, transformers, etc.  
Instruction and Trouble-Shooting Book Enclosed  
**10-DAY MONEY-BACK GUARANTEE**  
Cut out ad, attach name and address, with \$5 bill, check or money order, and mail to

**Century ELECTRONICS CO.**

8509 21st Ave., Dept. 306, Brooklyn 14, N. Y.

## YOU SHOULD OWN A MICRO CIRCLE CUTTER



A well built tool for those odd size holes. Cuts through 1/4" of steel. Has **MICROMATIC SIZE ADJUSTOR**. Comes complete with tool steel cutting bit for extra long service. . . . Specify round (7/16") or square shank. See your local distributor or write us. **PRECISE MEASUREMENTS CO.**  
942 Kings Highway, Bklyn. 23, N. Y.

## Opportunity for Large Earnings

Sales Engineers wanted to actually demonstrate, with antenna trailer, a New Patented, Rotorless, All Direction, All Channel, UHF-VHF, TV, FM Antenna. Limited Traveling. Write

**ALL CHANNEL ANTENNA CORP.**  
70-07 QUEENS BLVD., WOODSIDE 77, N. Y.

## WHEN YOU CHANGE YOUR ADDRESS

Be sure to notify the Subscription Department of **SERVICE** at 52 Vanderbilt Avenue, New York 17, N. Y., giving the old as well as the new address, and do this at least four weeks in advance. The Post Office Department does not forward magazines unless you pay additional postage, and we cannot duplicate copies mailed to the old address. We ask your cooperation.

## Correction

IN THE COLOR TV article by W. Kay Browne, which appeared in the February, 1954, issue of **SERVICE**, the equation in Fig. 3 should have read:  $E_y = 0.59 E_a + 0.30 E_R + 0.11 E_B$ .



# JOTS AND FLASHES

To DISPEL confusion as to what constitutes *hi-fi* and to install product confidence, an industry group in Chicago have formed a High-Fidelity Institute, with *J. J. Kahn* as commissioner; the institute plans to consider ways and means of keeping the public advised as to what to look for in buying *hi-fi*, and publicize the functions and applications of various units and components, and methods of utilizing them to the best advantage. . . . Headquarters have been established at 1 N. LaSalle St., Chicago 2. . . . *The International Sight and Sound Exposition, Inc.*, sponsors of the '54 Hi Fi Show, to be held at the Palmer House, Chicago, September 30th, October 1st and 2nd, will occupy an additional floor at the hotel this year. . . . *Berry W. Cooper*, general manager of the Delco Radio Division of General Motors, reported recently that more than 27,000,000 autos and trucks are equipped with radios. . . . *Ralph M. Rouse*, prexy of the Quietrole Co., has announced the purchase of a building site, in Spartanburg, S. C., where a new plant will be

erected. . . . Two new organizations have been appointed to act as reps for Quietrole. For western Pa., and W. Va., the *Mike Roth Sales Company*, 13947 Cedar Road, Cleveland, Ohio, and the *Sam Karns Co.*, 36 Oak Ave., Tuckahoe, N. Y., will represent Quietrole in Metropolitan New York and northern N. J. . . . *Dean Electronics Co., Inc.*, phono manufacturers, have moved to 425 Devoe Ave., Bronx 60, N. Y. *Phil Simon* is president of the firm. . . . *Permo, Inc.*, 6415 Ravenswood Ave., Chicago, has become a participant in the Photofact services of Howard W. Sams & Co., Inc. . . . *Frank H. Shepard, Jr.*, has been elected president of The Radio Club of America, Inc. *Frank A. Gunther* is vice-president; *Joseph J. Stantley*, treasurer; *O. James Morelock*, corresponding secretary; and *W. Gordon Russell*, recording secretary. . . . *Arie Liberman*, president and chief engineer of Talk-A-Phone Co., Chicago, has received a patent on his *dynasonic design*. . . . *Raymond L. Johnson* is now with the Instrument Division of Allen B. Du Mont Laboratories, Inc., as a technical sales engineer. . . . *Robert W. Barnitt* has become a coordinator-writer in the Du Mont *pr* department.

FOR CLEARST,  
STEADIEST RECEPTION

# Boost UHF Before Conversion



133-A

UHF AutoBooster

List Price \$49.95

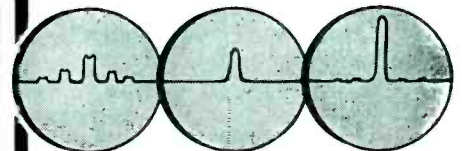

Typical Receiver-Converter Response

UHF AutoBooster Response

Combined Receiver-Converter-AutoBooster Response

Now you can boost the power of the *desired* signal, and tune out *interfering* signals—with the new ITI 133-A UHF AutoBooster.

This great new booster increases station power nearly *ten times*. Even under the most unfavorable conditions, the 133-A provides *clear, steady, interference-free* pictures. It's the ideal working companion for all UHF and UHF-VHF systems. In *fringe* areas, it provides a lower noise figure, eliminating snow, and a high gain which compensates for strip or converter losses. In *primary* areas, it affords increased selectivity, eliminating interference, and a grounded grid RF which suppresses oscillator radiation. It is tunable over the entire UHF range. Write for technical data sheet today.



INDUSTRIAL  
TELEVISION, INC.

369 Lexington Avenue Clifton, New Jersey

## ADVERTISERS IN SERVICE, MARCH, 1954

Acme Electric Corp.	97	Ohmite Mfg. Co.	63
Aernotor Co.	94	Oxford Electric Corp.	76
Aerovox Corp.	80	Peerless Products Industries	94
All Channel Antenna Corp.	20	Phalo Plastics Corp.	76
Alliance Mfg. Co.	72	Philco Corp.	5
American Microphone Co.	64	Planet Mfg. Corp.	88
American Phenolic Corp.	60, 61	Precise Measurements Co.	102
Astron Corp.	1	Precision Apparatus Co., Inc.	55
Atlas Sound Corp.	62	Pyramid Electric Co.	18
Audel, Publishers	82	Quietrole Co.	74
Bussmann Mfg. Co.	24	RCA Institutes, Inc.	15
CBS-Hytron (Div. Columbia Broadcast- ing System)	4	Rad-El-Co. Mfg. Co.	98
Century Electronics Co.	102	The Radiart Corp.	Inside Front Cover
Channel Master Corp.	8, 9	Radio Corp. of America	Back Cover
Chemical Electronic Engineering Co.	52	Radio City Products Co., Inc.	19
Chicago Standard Transformer Corp.	2	Radio Materials Corp.	101
H. G. Cisin	102	Raytheon Mfg. Co.	26
Columbia Wire & Supply Co.	82	John F. Rider Publisher, Inc.	79
Cornell-Dubilier Electric Corp.	100, 101	Howard W. Sams & Co., Inc.	93
Cornell-Dubilier-Radiart	93	Sangamo Electric Co.	53
Cornish Wire Co., Inc.	78	Shure Brothers, Inc.	83
Crosley Div. Avco Mfg. Co.	10	Snyder Mfg. Co.	23
Delco Radio Div. General Motors Corp.	74	Sonotone Corp.	77
Allen B. DuMont Laboratories, Inc.	14	South River Metal Products Co., Inc.	104
Electro Products Laboratories	3	Sprague Products Co.	25
Fenton Co.	94	Standard Coil Products Co., Inc.	13
General Cement Mfg. Co.	65	Sutton Electronic Co.	89
General Electric	57	Switchcraft, Inc.	52
The General Industries Co.	91	Sylvania Electric Products, Inc.	16
General Instrument and Appliance Corp.	49	TV Products Co.	31
Granco Products, Inc.	81	Sarkes Tarzian, Inc., Tuner Div.	Inside Back Cover
Great Eastern Mfg. Co., Inc.	95	Tech Master Corp.	87
Halldorson Transformer Co.	62	Telematic Industries, Inc.	69
The Heath Co.	90	Telrex, Inc.	71
Hickok Electrical Instrument Co.	99	Transamerica Electronics Corp.	92
Illinois Condenser Co.	45	Triad Transformer Corp.	52
Industrial Television, Inc.	103	Tru-Ohm Products Div. Model Engineer- ing & Mfg., Inc.	21
Jackson Electrical Instrument Co.	75	Tung-Sol Electric, Inc.	84, 85
Jensen Industries, Inc.	86	U. S. Treasury Dept.	22
Kester Solder Co.	88	Vidaire Electronics Mfg. Co.	99
P. R. Mallory & Co., Inc.	6, 7	Waldom Electronics, Inc.	78
McCabe-Powers Auto Body Co.	96	Walsco Electronics Corp.	12
Mills Products Co.	80	The Ward Products Corp. Div. The Gabriel Co.	28
Moss Electronics Dist. Co., Inc.	92	Webster-Chicago Corp.	86
Mueller Electric Co.	95	Weston Electrical Instrument Corp.	11
National Carbon Co.	17	Xcelite, Inc.	82
New Jersey Television Supply Co.	90		



MAKE IT EASY FOR YOURSELF  
*...Better for your Customers*

BY USING THE **NEW**

# South River CHIMNEY UNI-MOUNT

**H**ere's a combination every service man will find unbeatable. The new South River Chimney Uni-Mount offers you every advantage—quicker, easier installation—because of the convenience of a one-piece mount. The snap-in feature makes inserting the mast a simple, quick operation. And, the unique, sure, banding closure—the exclusive South River Kwik-Klip—enables you to speedily tighten the banding to complete a perfect installation.

Your customers will appreciate the solidity, extra rigidity and permanence of the Uni-Mount, with heavy-gauge, stainless-steel strap. You can point with pride to another South River installation that has made money for you and has enhanced your reputation as a first-rate service man.

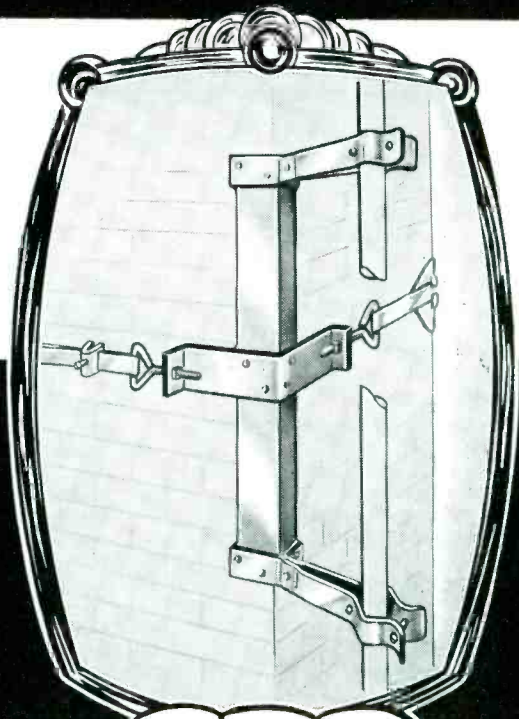

**U M - 1**

## SOUTH RIVER CHIMNEY UNI-MOUNT MODEL UM-1

is constructed of heavy-gauge steel, riveted for extra strength. It is hot-dip galvanized for lasting weather-proof coating and features the snap-in mast holders with flared lips. Generous 18" spacing between mast holders provides firm support. This model is available with one heavy-gauge, stainless-steel strap, the Kwik-Klip Banding Closure and clever new Chimney Corner Guards.

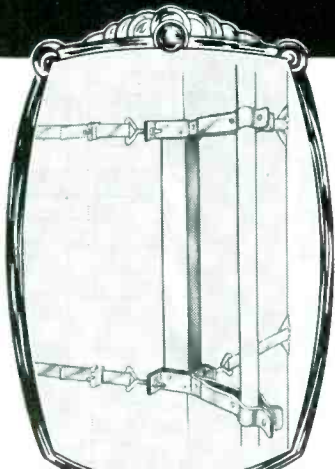

**U M - 2**

## MODEL UM-2

with two heavy-gauge, stainless-steel straps, is complete with all of the other features listed above.

Sold by leading parts jobbers from coast to coast.

Write for your copy of  
 South River's complete 1953 catalog.

*South River*

**METAL PRODUCTS CO., INC.**

South River, New Jersey

PIONEER AND OUTSTANDING PRODUCER OF THE FINEST LINE OF ANTENNA MOUNTS

IN CANADA: A.T.R. ARMSTRONG LTD., TORONTO



SALES CHART

“...And here we started using  
the **TARZIAN TUNER**”

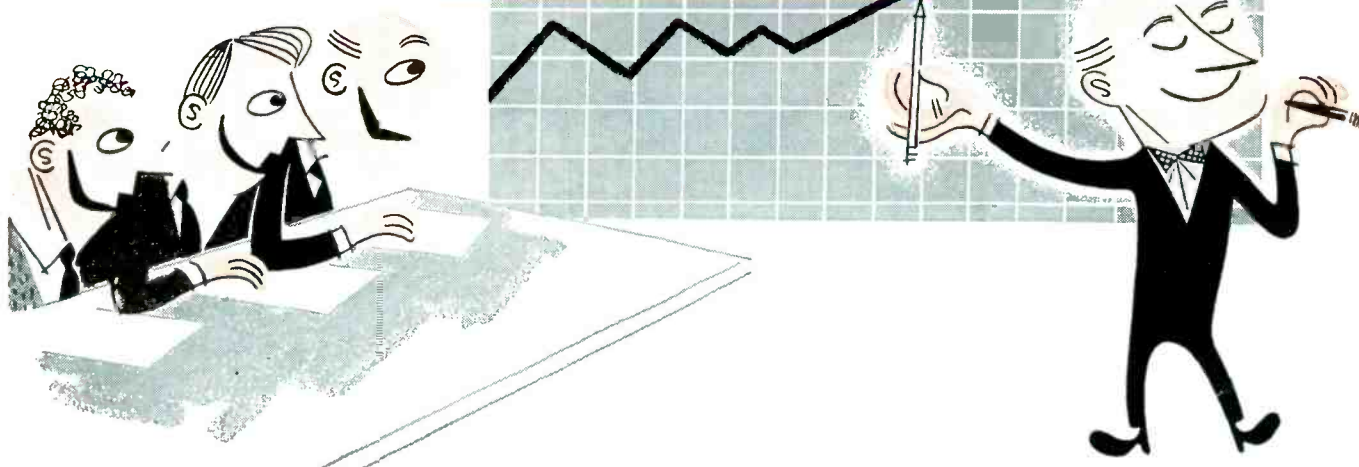

Sure, that's an exaggeration, but  
it's no exaggeration when we say:

**MOST OF THE BETTER SET MANUFACTURERS USE  
THE TROUBLE-FREE TARZIAN TUNER**

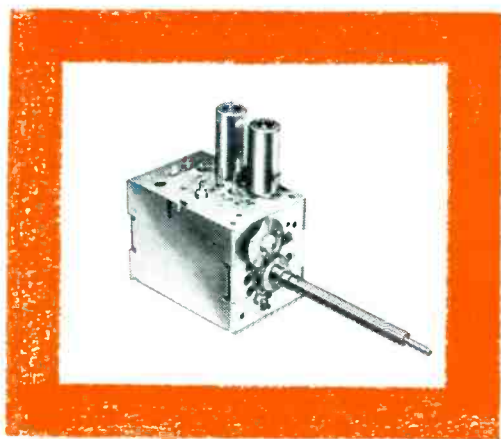

The Tarzian Tuner — first with all-channel  
UHF engineered into a VHF tuner — has,  
and is still contributing to the excellent and  
high quality performance of most of the  
best known receivers on the market today.



**SARKES TARZIAN, Inc.** • Tuner Division • Bloomington, Indiana

# \$50,000 "TELL & SELL" CONTEST

For Dealers and Servicemen\* who use RCA Tubes



**1954 DeSoto Automatic "Hard-Top"**—170-H.P. Fire Dome V8 engine, Power-Flite Transmission, Power Steering . . . completely equipped, including radio and heater.

**1954 Dodge DeLuxe 1/2-Ton Panel Truck**—complete with "Truck-o-matic transmission," radio, heater and accessories . . . plus a full set of RCA Test Equipment, aluminum ladder, and winner's business name and address on truck panel.

## Here's all you do—

Get an entry blank from your RCA Tube Distributor Salesman. Complete the following sentence in 25 additional words or less:—

*"I use and recommend RCA Tubes because"*  
It's as easy as that . . . and you may enter as often as you like, but each entry must be on an official entry blank.

## Hints to help you win

See your RCA Distributor Salesman right away. He has a copy of the "clue book" waiting for you. This book contains full details on the whole exciting "Tell and Sell"

Campaign, including contest rules.

You may win first prize . . . so don't waste a moment. Contest closes April 30, 1954.

\*Your RCA Distributor Salesman will be glad to help you . . . because if you win, he wins a duplicate prize!

# 400 FABULOUS PRIZES

including:

- \* TV sets
- \* Watches
- \* Cameras
- \* Air Conditioners
- \* Test Equipment
- \* Radios
- \* Ranges

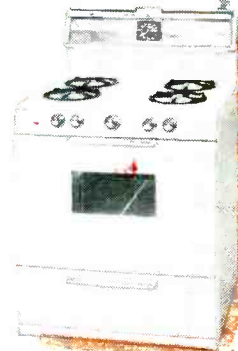
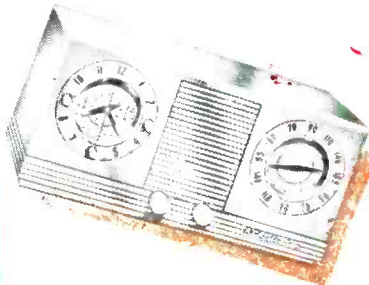

**RADIO CORPORATION of AMERICA**  
ELECTRON TUBES  
HARRISON, N. J.