

SERVICE

AUDIO
ISSUE

An 8-watt ac dc amplifier
[See page 2]

JUNE
1952

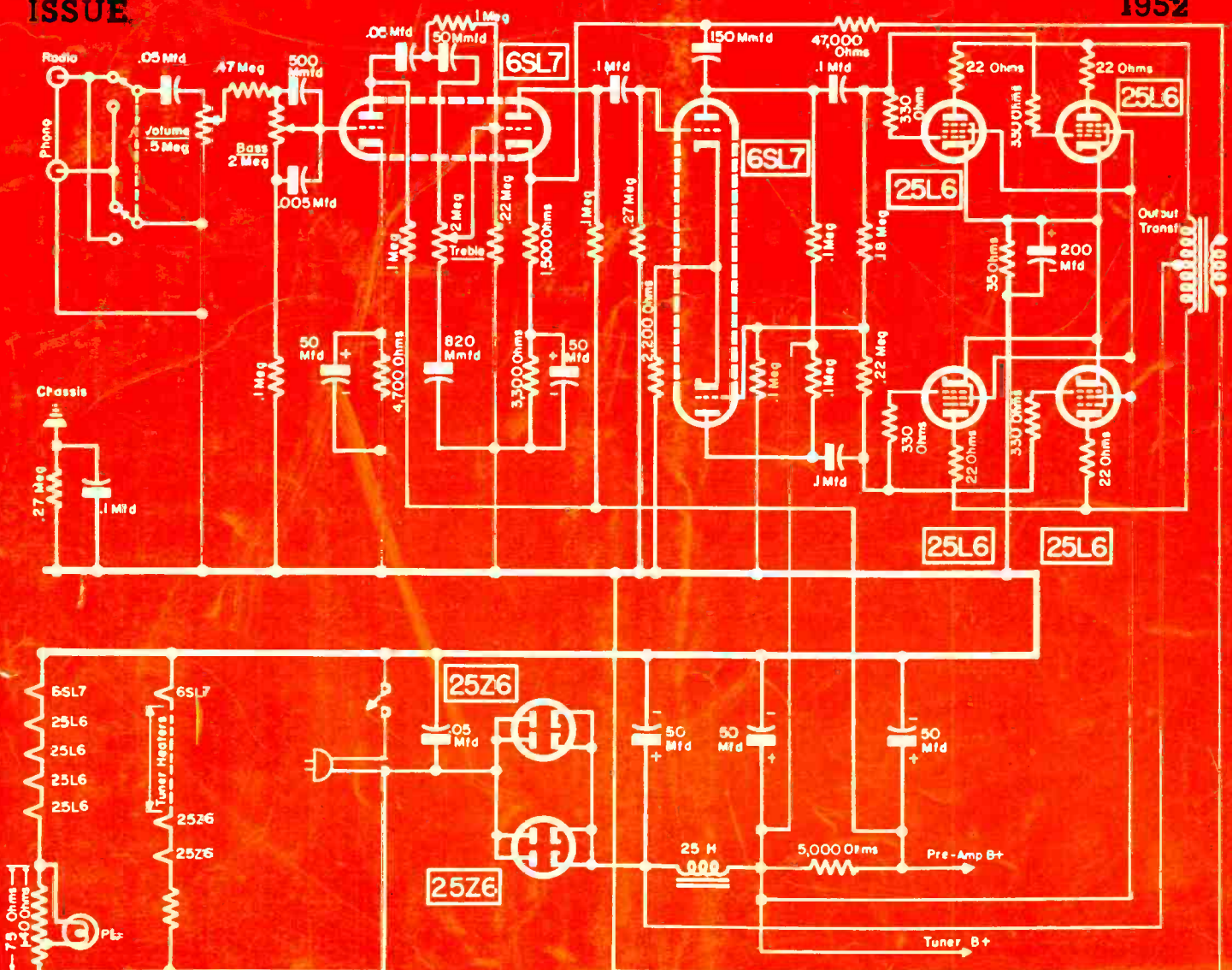

IT'S ALL NEW

**the Rotor of Tomorrow
HERE TODAY!**

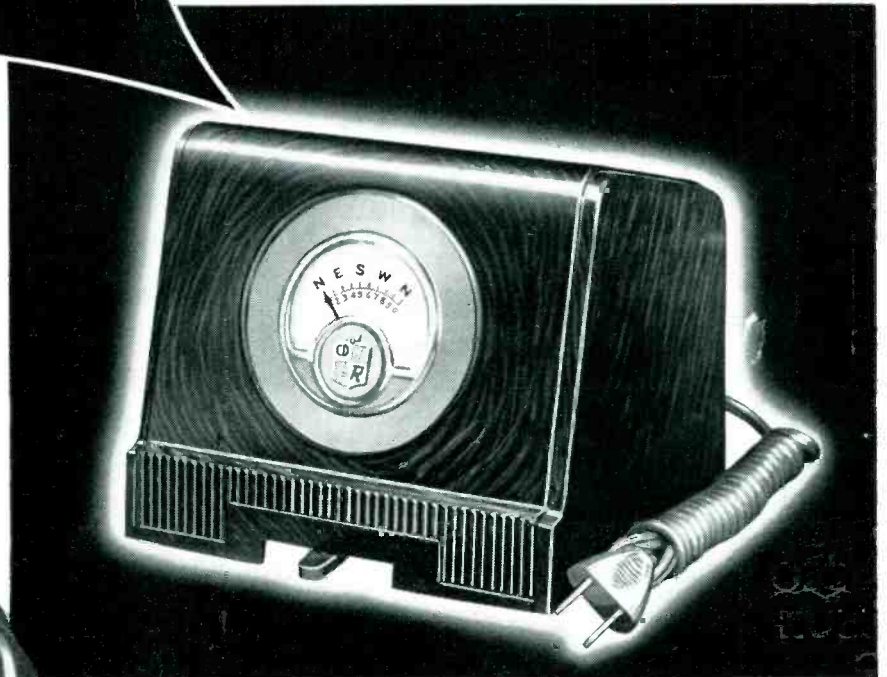
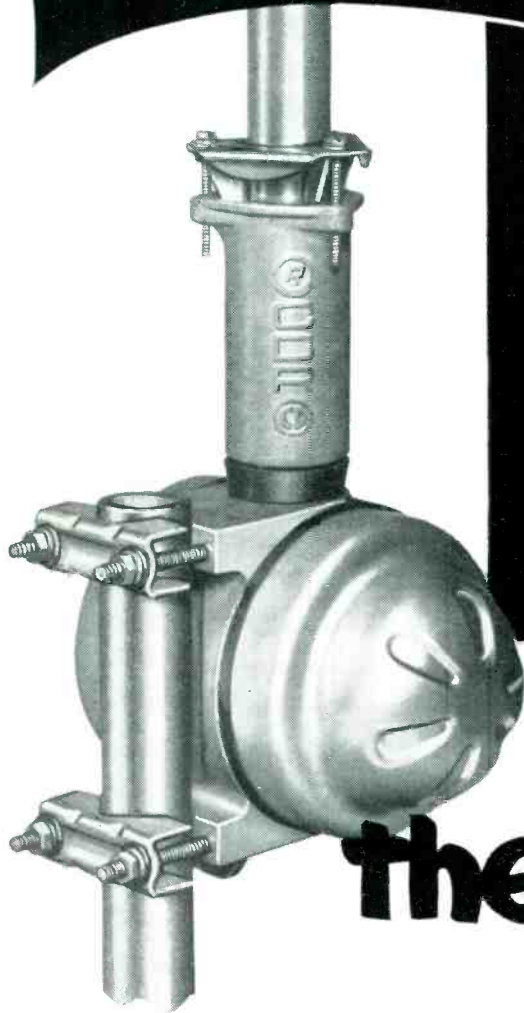

the  **Rotor**

The NO.1 ALL-PURPOSE ROTOR That Has Everything!

Designed to give the trade everything they've asked for. To do this, it's taken time . . . lots of time and money and engineering skill . . . and NOW WE HAVE IT . . . the best possible ALL-PURPOSE ROTOR! It's TOPS! Order them at your jobber NOW . . . be the FIRST with the BEST in your area!

MODEL TR-11 Complete rotor with handsome modern design plastic cabinet and meter control dial...fingertip lever...using 4-wire cable **\$44.95**

- ★ Quick Mounting Antenna Mast Collet
- ★ Speedy Installation—No Loose Parts to Assemble
- ★ Takes Antenna Masts up to 1½" OD
- ★ High Torque
- ★ Instant Locking—will not drift
- ★ Instantly Reversible—makes complete revolution in 45 seconds
- ★ Completely Weather-proofed—Thoroughly Water-proofed
- ★ Less wind resistance
- ★ High strength with low weight
- ★ Fits standard towers

THE **RADIART** CORPORATION
CLEVELAND 13, OHIO



SUBSIDIARY OF



CORNELL-DUBILIER
SOUTH PLAINFIELD, NEW JERSEY



for greater speed and
accuracy of TELEVISION INSTALLATIONS
in any locality use the new

Simpson

MODEL 488

TV FIELD STRENGTH METER

In addition to location of maximum signal areas, the Simpson Model 488 Television Field Strength Meter is also ideal for antennae orientation, comparison of antennae systems, adjustment of TV signal boosters and checking antennae and lead-in installations to list but a few of the many functions available . . . THE 50 MICROVOLT FULL SCALE RANGE IS AN OUTSTANDING FEATURE FOR THOSE CONCERNED WITH FRINGE AREA INSTALLATIONS WHERE MAXIMUM EFFICIENCY MUST BE ATTAINED . . . The 500, 5,000 and 50,000 micro-volt ranges extend the usefulness of the Simpson Model 488 into areas of higher signal strength. The large 4½-inch modernistic meter is easily read from a considerable distance and all controls and connections are arranged for greatest accessibility. Model 488 is housed in a beautiful gray hammerloid finished case for greater portability. LINE VOLTAGE: 105-125 volts, 50-60 cycles. SIZE: 8" x 11" x 8½".

WEIGHT: 11½ lbs. Shipping weight 15 lbs.
DEALER'S NET PRICE, including operating instructions and shoulder strap . . . \$89.50

SIMPSON ELECTRIC COMPANY

5200 WEST KINZIE STREET, CHICAGO 44, ILLINOIS

Phone: COLUMBUS 1-1221

In Canada: Bach-Simpson, Ltd., London, Ontario

CONSERVE
CRITICAL
MATERIALS



VIKING

speakers by
Jensen

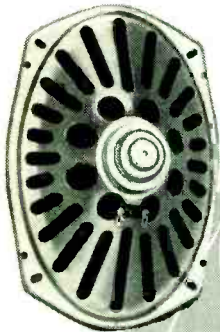

For Automotive Replacement



Jensen

JENSEN MANUFACTURING COMPANY
DIVISION OF THE MUTER COMPANY
6601 S. LARAMIE AVE., CHICAGO 38, ILLINOIS
IN CANADA:
COPPER WIRE PRODUCTS, LTD., LICENSEE

Viking Speakers are ideal for automotive replacements. Designed and manufactured by Jensen, one of the world's largest suppliers of original automotive equipment speakers, they incorporate the fine engineering and production skills which go into every Jensen product.



Vol. 21, No. 6

RADIO · TELEVISION · ELECTRONIC

June, 1952

SERVICE

LEWIS WINNER
Editor

F. WALEN
Assistant Editor

Registered U. S. Patent Office
Including *Radio Merchandising and Television Merchandising*

| | |
|--|----|
| Association News | 71 |
| At the Parts Show | 61 |
| Audio Installation and Service (Noise in Recording and Reproducing Systems). By Kenneth Stewart | 29 |
| Auto Radio Installation and Service (Tracing and Curing Troubles External to Receiver). By Solomon Heller | 38 |
| Business Aids (Extra Sales During Service Calls) | 48 |
| Hi-Quality Audio for AC/DC Radio-Phonos (Cover). By Edgar M. Villchur | 22 |
| Phono Needle and Record Wear. By E. J. Marcus | 24 |
| Ser-Cuits (UHF/VHF Receiving Systems). By M. W. Percy | 40 |
| Service . . . The National Scene | 19 |
| Servicing Helps. By M. A. Marwell | 44 |
| Supplementary PA Stadium Installation. By N. H. Crowhurst | 34 |
| Ten Years Ago | 71 |
| Tube News (IAX2 Application Notes). By L. M. Allen | 36 |
| Views and News. By Lewis Winner | 17 |
| Wire and Tape Recorder Servicing. By Jack Darr | 30 |

AUDIO INSTALLATION AND SERVICE

| | |
|--|----|
| Noise in Recording and Reproducing Systems | 29 |
| Phono Motor Characteristics | 32 |
| Tape Recorder Design | 58 |
| Turntable Speeds | 56 |
| Wow and Rumble | 32 |

CIRCUITS

| | |
|--|----|
| Auto Ignition Circuitry | 38 |
| 8-Watt AC/DC Amplifier (Cover) | 23 |
| Inverter Filter Circuit | 22 |
| Masco Dual-Speed Dual-Track Tape Amplifier | 29 |
| Output Circuit of Typical Recorder | 30 |
| Packard-Bell TV Chassis Modifications to Provide Width Reduction | 44 |
| Sylvania 1-387-1 Receiver Changes with 6AU6 Replaced by 6BC6 | 44 |
| UHF/VHF Inputs | 40 |

COVER

| | |
|---|----|
| Hi-Quality AC/DC Amplifier (Villchur) | 23 |
|---|----|

SERVICING HELPS

| | |
|---|----|
| Clearing Up Vertical Sync Drift | 46 |
| Curing Overshoot in TV Chassis | 44 |
| Eliminating Oscillator Buzz | 44 |
| Gaining Horizontal Stability | 46 |
| Iron-Core IF Adjustments | 69 |
| Removing Horizontal Jitter | 47 |
| TV Booster Modification | 47 |
| Width Reduction and Improved Keying Pulse | 46 |

| | |
|----------------------------|----|
| Index to Advertisers | 72 |
|----------------------------|----|

Manufacturers

| | |
|---|----|
| Jots and Flashes | 72 |
| News | 66 |
| New Parts . . . Tools . . . Instruments | 49 |
| Rep Talk | 60 |
| TV Parts . . . Antennas . . . Accessories | 62 |



Entire contents Copyright 1952, Bryan Davis Publishing Co., Inc.

Published monthly by Bryan Davis Publishing Co., Inc.

52 Vanderbilt Avenue, New York 17, N. Y.

Telephone MURRAY Hill 4-0170

Bryan S. Davis, Pres. Paul S. Weil, Vice-Pres., Gen. Mgr. F. Walen, Sec. A. Goebel, Cir. Mgr.
Mid-West Representative: Stuart J. Osten, 333 N. Michigan Ave., Chicago 1, Ill. Telephone: DEarborn 2-3507
East-Central Representative: James C. Munn, 2253 Delaware Dr., Cleveland 6, Ohio. Telephone: ERview 1-1728
Pacific Coast Representative: Brand & Brand, 1052 W. Sixth St., Los Angeles 14, Calif. Tel.: Michigan 1732

Entered as second-class matter June 14, 1932, at the Post Office at New York, N. Y., under the Act of March 3, 1879. Subscription price: \$2.00 per year in the United States of America and Canada; 25 cents per copy. \$3.00 per year in foreign countries; 35 cents per copy.

NOW . . . VOLUME III!
96 new photos
over 200 pages!

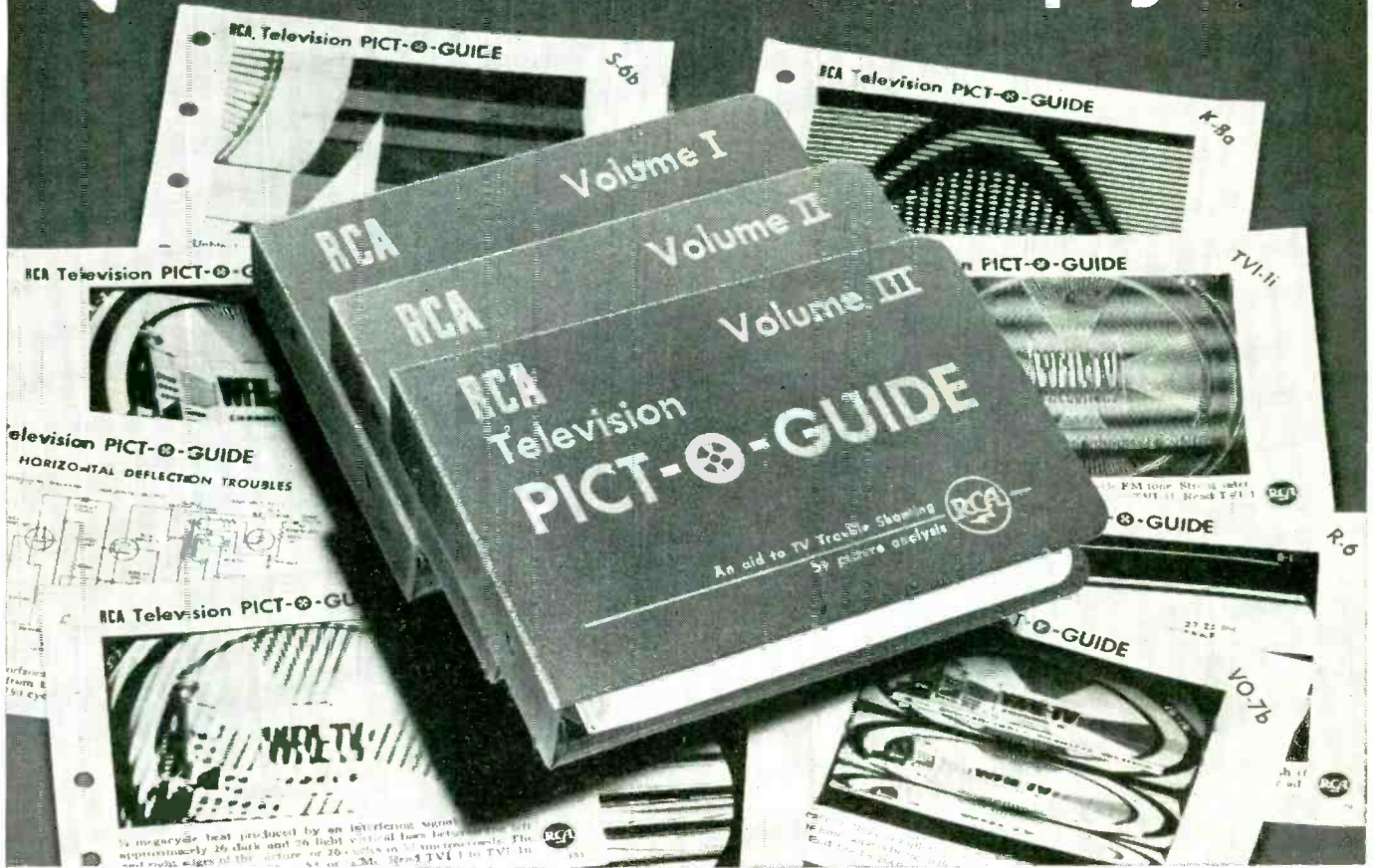

TAKS.®

YOURS —Vol. I, II, or III . . . with each order for 75
RCA receiving tubes or 3 RCA kinescopes

THE RCA Tube Department proudly announces the publication of Volume III of the famous RCA TELEVISION PICT-O-GUIDE . . . another significant addition to the PICT-O-GUIDE series, recognized as the most useful, practical servicing information in the industry for helping you locate and solve TV troubles by picture analysis.

Authored by John R. Meagher, RCA's noted TV Service Authority, Volume III contains completely new data on television interference, built-in and external ghosts, hum troubles, and a host of

trouble-shooting techniques applicable to all TV sets. It's information you can't afford to be without.

For a limited time only, you can have your choice of PICT-O-GUIDE Volume I, II, or III with each order for 75 RCA receiving tubes or 3 RCA kinescopes. It's as simple as that.

This is your chance to get the complete set of three matched volumes to bring your library up-to-date. But don't miss out on this limited offer! Place your qualifying tube order with your RCA Tube Distributor at once.

PLUS THIS BONUS

"TV Servicing Supplement"—*Trouble Shooting "Tough" Sets or "Dogs."* This indispensable book by John Meagher tells you how to handle the really tough TV sets . . . the ones that take the most time to analyze and repair. It's a "Post-graduate course" in TV trouble-shooting. You get a bonus copy with each Pict-O-Guide volume you earn. This is a bonus offer you won't want to miss!

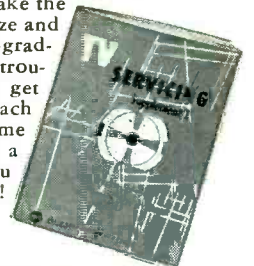

RADIO CORPORATION of AMERICA
ELECTRON TUBES

HARRISON, N. J.

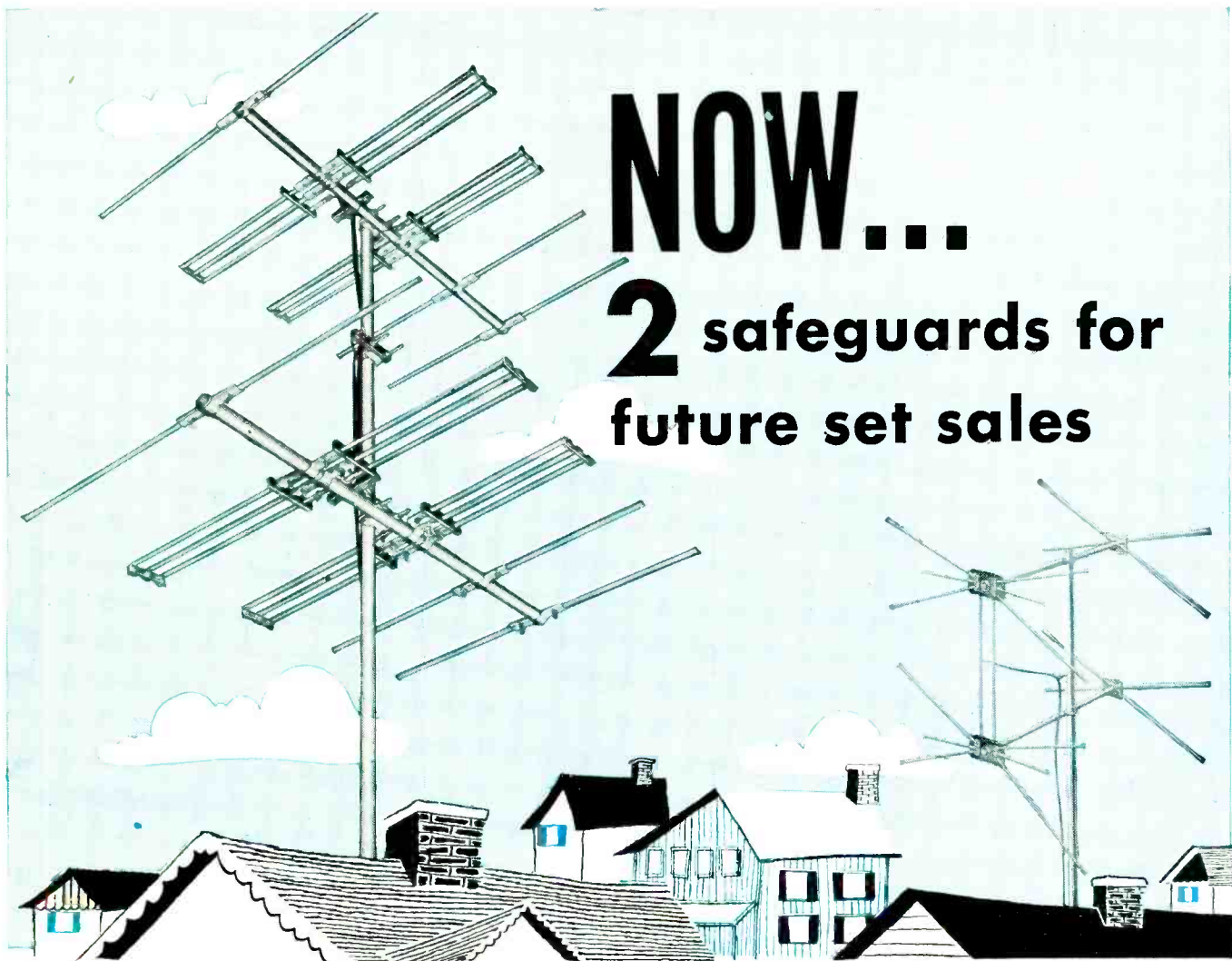

NOW...

2 safeguards for future set sales

With *tomorrow's* sales depending upon the picture quality you deliver *today*, here's a directional antenna you can install with confidence . . . the new Skysweeper* Yagi!

Built to the same high standards that have made the Skysweeper all-purpose conical antenna so popular, this 5-element Yagi assures superb two-channel reception.

You provide sharp, brilliant pictures that seem to put the viewer in the same room as the performers . . . thanks to advanced design, higher gain and high front-to-back ratios that eliminate co-channel interference.

Proof? Try this great new Yagi or the Ferro Skysweeper conical on television's toughest testing grounds—the outlying fringe areas. You'll get rave reports on your very first installations!

For these are the antennas that eliminate antenna failures, cut call-backs, safeguard future sales . . . and *net you more profit!* Write for complete information—today!

*T. M. Registration Pending

A complete line of accessories

LEAD WIRE—fully insulated, stranded, 300-ohm wire in convenient 100, 250, 500 and 1000-foot lengths.

GROUND RODS—solid steel, copper plated. Pointed for easy driving. 4' lengths.

ROOF MOUNTS—strong, rugged, for use on any type roof: flat, gable or ridge.

CHIMNEY BRACKETS—a variety of supports to handle any and all situations.

LIGHTNING ARRESTERS—small, compact, guard against fire hazards of lightning. Positive contact.

STAND-OFF INSULATORS—Convenient, easy to install. Types for every installation.



FERRO ELECTRIC PRODUCTS, INC.

A Subsidiary of Ferro Corporation

KIRKLAND, ILLINOIS

MERIT

tv full-line* components give universal coverage

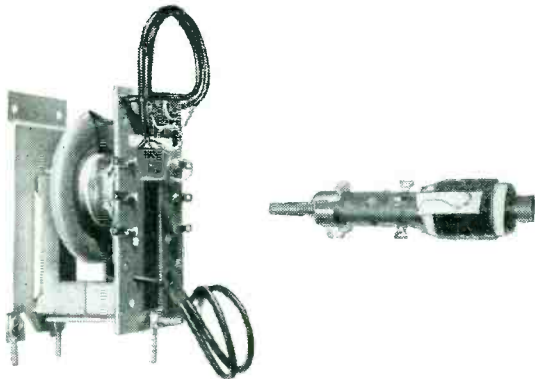

NEW IMPROVED HVO-7 FOR GREATER COVERAGE

Tapped AFC Winding. Covers Admiral Chassis 21-24 Series.

MWC-1 UNIVERSAL WIDTH COIL
(3-27 MH) A Tapped Secondary for AGC or AFC.



"COSINE" YOKES
Complete with leads & network.

MATCHED FOR DIRECT DRIVE

MDF-30

HVO-8

**A-3080 Vert. Mtg.
A-3081 Horiz. Mtg.
Autoformer**



IF-RF COILS

Only complete line of TV replacements.



KIT NO. 1000
MATCHED SET
FOR SPEEDY
PROFITABLE
SERVICE!

MERIT . . . HQ for PRACTICAL TV Service Aids

- MERIT'S 1952 Catalog No. 5211 with new MERIT IF-RF Coils.
 - Other MERIT service aids:
 - TV Repl Guide No. 404, 3500 models & chassis.
 - Cross Ref Data, IF-RF Coils, Form No. 14.
- See your Jobber or write: Merit Coil and Transformer Corp., 4425 Clark Street, Chicago 40.



These three MERIT extras help you:
Exclusive: Tapemarked with specs and hook-up data.
Full technical data packed with every item.
Listed in Howard Sams Photofacts.



**Merit is meeting the TV improvement, replacement and conversion demand with a line as complete as our advance information warrants!*

BURTON BROWNE ADVERTISING

103 BIG PRIZES FOR

To be given in G.E.'s great **B&S&B***

THREE BRAND-NEW



LOOK AT THESE BEAUTIFUL PRIZES YOU CAN WIN!



MEN'S CALENDAR WATCH, a handsome Benrus with gold expansion band, plus gold wind-proof cigarette lighter and matching gold cuff links and tie bar. All fitted in a smart and distinctive case.



LADIES' WRIST WATCH, a beautiful Benrus hinged-cuff "Embraceable" with safety chain; also, chic gold earrings and a stunning pendant-and-brooch combination. Can be a wonderful gift from you.

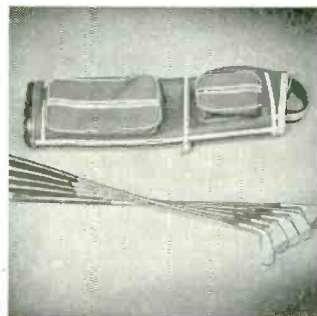

MATCHED GOLF IRONS, Wilson, with long-lasting nylon Wilson golf bag. Nos. 2, 5, 7, 9, and putter, Gene Sarazen Stroke-master model. Clubs, nationally distributed, can be filled in any time.



FISHING KIT, 27 items in a double-tray cork-lined tackle box. Gep glass casting rod, Green Hornet level-wind reel, fish rule and scale, Pflueger spoons and spinners, plugs, hooks and leaders.

SERVICE DEALERS!

Promotion Contest topped by

'52 DODGE TRUCKS!

***B. S. B.—Bigger Summer Business** tells the story! Increase your profits and walk off with a brand-new Dodge panel truck! General Electric's B. S. B. Contest offers you this double bonus.

The contest's loaded with 103 prizes! It's primed with new sales-getting helps for you, as shown at right. Contest starts now and ends August 15—weeks that are summer radio-TV check-up time for millions.

Yardstick of the contest will be how successfully you promote your own service business in terms of *planning, originality, and results*. G. E. will support you with special full-page tie-in ads in national magazines read by 35,000,000.

First prize to each of the three top winners will be a new '52 Dodge panel truck, handsomely lettered with your name and address.

100 other prizes—all big values, all mighty attractive!

ENTER NOW—HERE'S HOW!

● **Phone, write, or see your G-E tube distributor** for (1) descriptive folder that gives all details about the contest, (2) streamers, mailers, and other promotion items to help you win!

From the folder you will learn exactly what the contest covers, how to obtain and fill in your entry blank, how to make your promotion a success, what records to keep, and what type report to send in when the contest is over.

Five men of national prominence in the radio-TV service industry will serve as judges. Their names and positions are given in the contest folder. Act today! Profits plus a costly prize are waiting for you!



GENERAL  ELECTRIC

161-1A3





THE LITTLE INDIAN SAYS.

you know you're right
when you service with

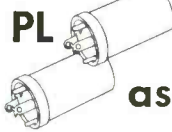
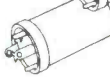

SANGAMO
"Twist-Tab" Replacement
Capacitors

Sangamo Type PL  Dry Electrolytics
are used  as original equipment by
all major TV set manufacturers 



Here's "good medicine" for ailing TV sets (and servicemen's headaches, too)! Sangamo "Twist-Tab" (Type PL) Electrolytics are *exact* replacements

—they assure long life and dependable performance at 85° C. and under conditions of high surge voltages and extreme ripple currents often found in TV applications.

"Twist-Tabs" are compact, light in weight and easy to mount. They are used by leading TV manufacturers . . . and they are available from the largest listing of capacities and voltages available in the industry.

Ask your distributor for a copy of the Sangamo TV Replacement Catalog. It's easy to use and helps you choose the *right* replacement every time.

Those who know

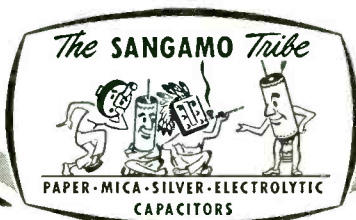

...choose Sangamo

SANGAMO ELECTRIC COMPANY
MARION, ILLINOIS

SC52-8

IN CANADA: SANGAMO COMPANY LIMITED, LEASIDE, ONTARIO

8 • SERVICE, JUNE, 1952

HIS CHOICE IS

Regency

LARGEST SELLING VHF BOOSTER AT ANY PRICE!

MR. BEN FARMER
SALES MANAGER, RAULAND CORPORATION
ONE OF THE FIRST TV-DX ENTHUSIASTS
PHOTOGRAPHED IN HIS CHICAGO SUBURBAN HOME



ALSO MAKERS OF THE

Regency UHF CONVERTER

BURTON BROWNE ADVERTISING

the tower servicemen dreamed up!

the TEL-A-RAY

SWING-OVER * TOWER

A serviceman's dream — an antenna tower that swings over to the ground for servicing — now being produced by Tel-a-Ray! The Swing-Over Tower makes all other types obsolete because it is the easiest tower for servicing ever made. Built from steel angles with welded construction, the Swing-Over Tower is guaranteed to withstand wind and weather. Yet one man can lower the tower top to the ground, or raise it, in just three minutes. Competitively priced and guaranteed, the Swing-Over Tower will be your biggest item in 1952.

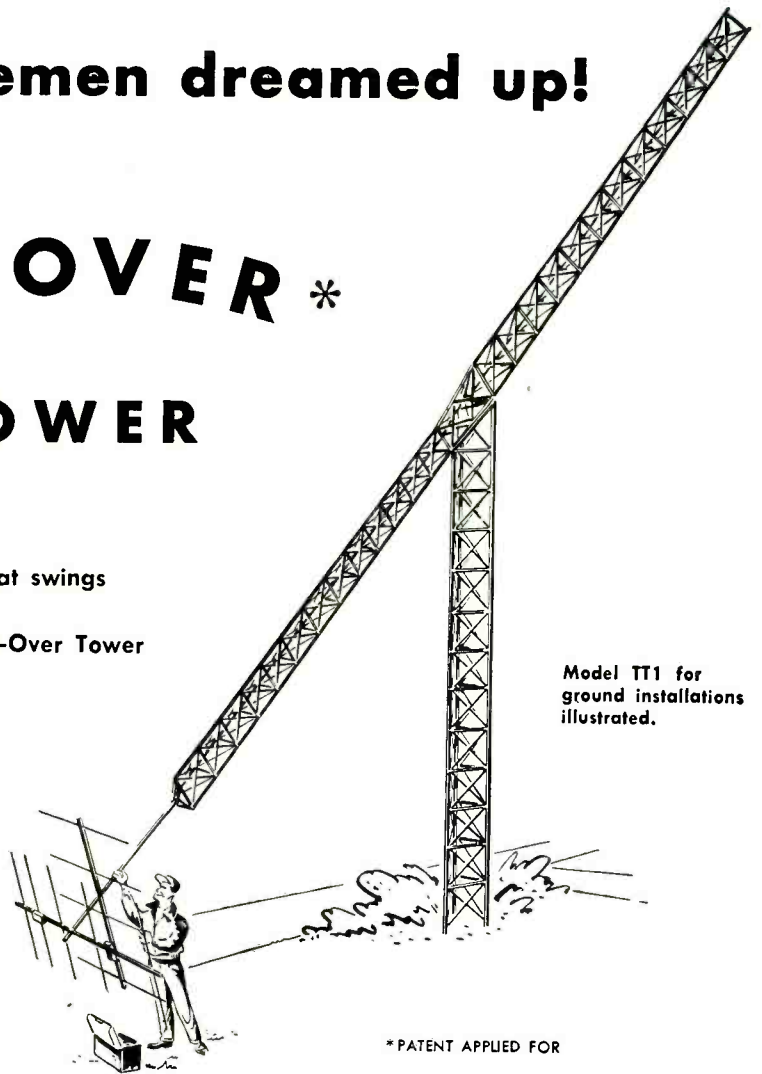

Model TT1 for ground installations illustrated.

* PATENT APPLIED FOR

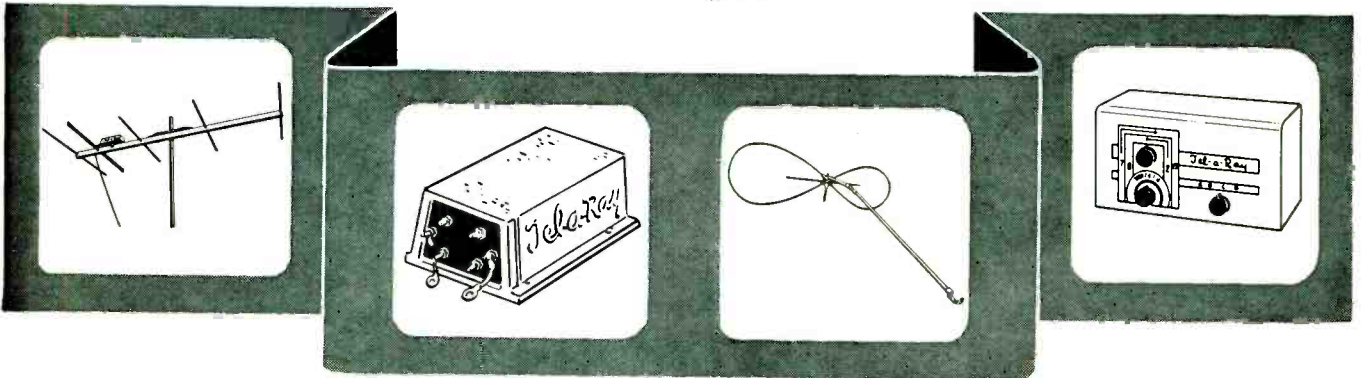

These Tel-a-Ray products are bringing more and better reception to television viewers every day . . . and bigger profits to their dealers: Left: The Model T antenna pulls in good reception up to 200 miles away! Cannot rust or corrode. Perfect for all fringe area reception. Left center: To complement the Model T antenna, the only antenna-mounted, low-cost preamplifier on the market, the model TB. High signal gain, low noise ratio make it outstanding.

Right center: The low-priced Butterfly antenna . . . receives 13 channels and FM radio in primary areas . . . completely guaranteed . . . swivel-mount permits erection anywhere! Right: The new Switching Booster (Model PTB1) — for areas where more than one channel can be received with separate antennas. Switches channels and antennas with one knob. Four antenna inputs. Furnishes high gain from antenna and voltage for four preamplifiers. A necessity in the fringes.

WRITE TODAY FOR COMPLETE INFORMATION



You are **DOUBLY** safe

when you use

BUSS FUSES



The BUSS slide-cover metal box protects fuses — handier to use.

The name BUSS represents over 37 years specializing in fuses.

Each individual BUSS fuse is tested in an electronic device to insure proper operation.

You can always be sure a BUSS fuse will open to protect—but will not open needlessly.

Complete TELEVISION FUSE LIST Shows proper fuse to use

- How fuse is mounted • What fuse protects •

© 1951, Bussmann Mfg. Co.

Division McGraw Electric Co.

ADMIRAL to CENTURY

CLARION to MAJESTIC

MAJESTIC to SENTINEL

SETCHELL-CARLSON to ZENITH

AUTO RADIO FUSE LIST

Did You Get Your Copy of the **NEW**

BUSS TELEVISION FUSE LIST?

It's free!

The new BUSS Television Fuse List gives complete up-to-the minute information on all fuses used in today's T-V sets. Plus — the latest Auto Radio Fuse List.

Shows what fuse to use — how fuse is mounted — and circuit fuse protects.

Chart can be hung on wall for ready reference — or — carried in pocket or tool kit when making service calls.

On back of chart are illustrations and dimensions of all fuses specified in listings, to be of added assistance in selecting proper fuse to use.

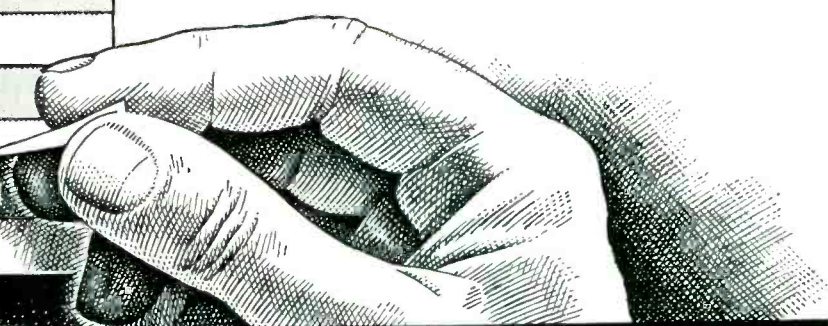

*IF You Can Use a Copy...
Send the Coupon Today*

This complete fuse list helps Service or Counter men know what fuses are needed to service any T-V set — and helps store-keeper know what fuses he should stock.

BUSSMANN MFG. CO.
University at Jefferson St. Louis 7, Mo.
Division of McGraw Electric Company

BUSSMANN Mfg. Co. (Division of McGraw Electric Co.)
University at Jefferson, St. Louis 7, Mo.

Please send a copy of the BUSS Fuse Application Chart.

Name _____

Title _____

Company _____

Address _____

City & Zone _____ State _____ S-652

way out yonder in the fringe areas...



WALSCO

MODEL M ANTENNA OUT-PERFORMS ALL OTHERS

BEYOND the city limits... way out where the tall grass grows, WALSCO Model M Antennas are producing sharper, crystal-clear TV pictures. Almost anywhere in the fringe areas, the amazing Model M will out-perform, out-last any competitive all channel antenna.

Once you install... *that's all*. No costly call-backs that eat up your profit. Guaranteed sturdier, more dependable in *any climate*. Chromate-coated magnesium cross-arms have a structural strength almost equal to steel, yet are $\frac{1}{3}$ lighter than aluminum. Positive corrosion resistance *anywhere*, any time of the year. Elements are made of high-conductivity, super-strength aluminum alloy, reinforced with Swiss "Permalum." Install the WALSCO Model M... the most *dependable* all-channel fringe area antenna.

walSCO quality earned its reputation

WALSCO

WALTER L. SCHOTT CO. 3225 EXPOSITION PLACE, LOS ANGELES 14, CALIF. BRANCH: CHICAGO 6, ILL.

**The
Webcor[®] "106"
recommended by
servicemen**

Custom
installation by
Voice & Vision Inc.

There's good reason why radio service dealers are installing thousands of Webcor "106" Diskchangers every week.

First of all, the simplicity of the Webcor design enables the servicemen to make quick, easy installations.

And second, once installed there is an absolute minimum of adjustment and repair.

And the customer recognizes that the name Webcor by Webster-Chicago means that he is buying a nationally advertised product.

There's big promotion news on the Webcor Diskchangers—call your distributor today.

If it's made by Webster-Chicago,

*it's **Webcor***

... and if it's Webcor

it is the finest

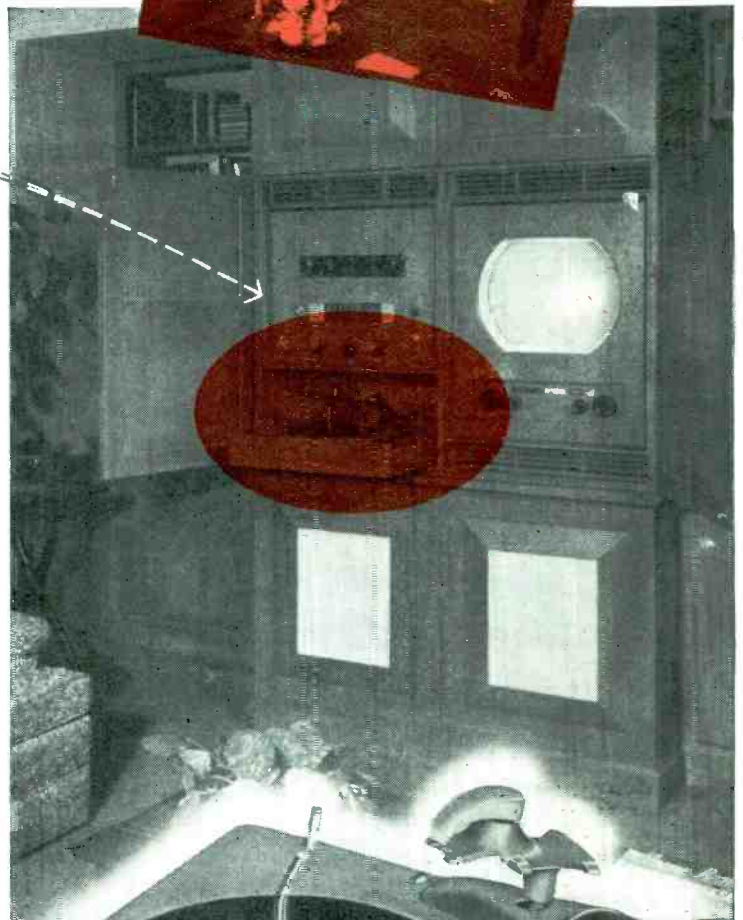

*Webcor is a registered trade name for products manufactured by

WEBSTER-CHICAGO 

SERVICE, JUNE, 1952 • 13

HOW EASY

can YOU make tv servicing?



Try this simple rule used successfully by thousands of service technicians.

Take advantage of the set manufacturer's service literature.

This is the key to easy, successful servicing which is overlooked by a surprising number of service technicians. They believe, strangely enough, that the more oversimplified the data they purchase the less their servicing problems. They think that because the servicing information on a set is condensed, that data will be easier to work with. How wrong this approach is can be measured by the fact that servicing data *in itself* is worthless. Its only value comes from its use as a guide to receiver diagnosis and repair. Doesn't it make sense then that the most complete data will be the best because it makes your diagnosis and repair job easier?

Rider data is complete data with a bonus!

For 22 years Rider has been the only publishing source for complete, factory issued, official servicing data. From large, easy to follow schematics... circuit explanations... stage by stage alignment curves... page after page of troubleshooting test patterns... waveforms...

clear, enlarged chassis views... circuit changes... to complete unpacking instructions; Rider gives you the complete story including all manufacturer's production changes... in accurate, organized, unedited form. PLUS A NEW FEATURE: A LISTING OF ABSOLUTELY GUARANTEED REPLACEMENT PARTS. The parts listed must meet the physical and electrical performance ratings of the original equipment used in the receiver... or you get your money back. (Look for this new Rider feature beginning with Rider TV Manual 10 and Rider TV TEK-FILE Pack 57.)

Rider Servicing data available two ways!

Rider TV Manuals Vols. 1 to 9

Complete data for manufacturer's receivers produced during a certain period. (The newest, TV 9, (just published) covers October 1951 through February 1952.) Each manual contains over 2000 (8½ x 11) pages in permanent binder, with an index covering the contents of all manuals. Manuals are perfect for shop use and permanent reference. Price \$24.00 each.

Rider TV TEK-FILES Packs 1 to 56

The contents of a typical TEK-FILE Pack are pictured below. In TEK-FILE Packs you buy complete Rider servicing data for only one, two, or a few manufacturers according to your needs. Notice that each pack is made up of standard file folders for easy use. Only \$2.00 each pack.

TEK-FILE EXTRA.

Many packs contain TEK-FILE Handies... 3 x 5" index cards giving manufacturer's trouble cures plus production changes. Vital data for permanent repairs!

DON'T BE SWITCHED!

Rider TEK-FILE is *Not* the same as any other publisher's service. If your jobber doesn't carry them **DON'T BE SWITCHED.** Write us direct... We'll sell you. (Please include your jobber's name.)

TRY A PACK

To judge TEK-FILE'S superiority, buy one pack for the next receiver you service. If you don't agree it's best... return



the pack to us within seven days and we'll send you a full refund. **TRY ONE TODAY!**

FREE Rider TEK-FILE indexes are at your jobber's. If he's out, write us.

OUT SOON!

Rider **RADIO** TEK-FILES! Same style as TV TEK-FILES. Now, get your complete radio servicing data this easy, economical package way. Ask your jobber.

John F. Rider Publisher, Inc. 480 Canal St. New York 13, N. Y. West Coast office: 4216-20 W. Jefferson Blvd. Los Angeles, Calif.

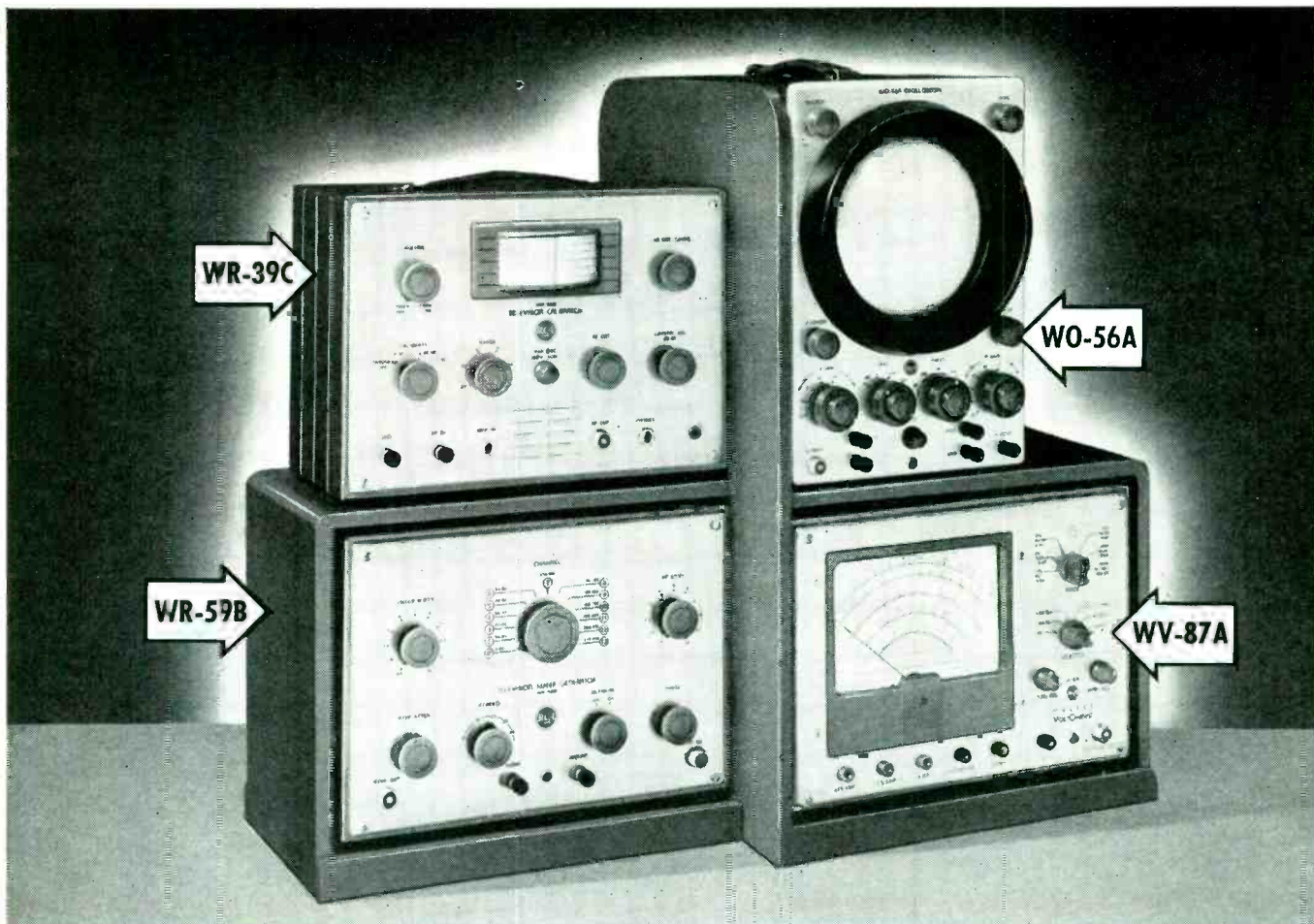

NOW... the RCA **UNIFIED** test position

Provides the best in television-servicing facilities

THE new RCA 4-position deluxe rack will add beauty and convenience to your test set-up. You'll like the way this service-engineered rack increases your operating efficiency... you'll be surprised to see how precious bench space is conserved. Furthermore, you'll be amazed how easy it is to get one of these handsome 4-position racks from your RCA Test Equipment Distributor. The rack accommodates four test instruments as illustrated.

WR-39C **Television Calibrator.** Variable-frequency oscillator provides fundamental output over entire range, with crystal-controlled check points at 2.5-Mc and 0.25-Mc intervals. Provides 4.5-Mc crystal-oscillator signal for intercarrier alignment and for dual markers at TV carrier frequencies. The WR-39C is a heterodyne frequency meter, a crystal standard (with 3 crystals supplied), a bar-pattern generator, and a TV re-broadcast transmitter.

WR-59B **Television Sweep Generator.** Covers all TV channels on preset fixed positions. Continuous tuning range from 300 Kc to 50 Mc covers video and intermediate frequencies. High-precision vibrating capacitor provides up to 12-Mc maximum sweep width, flat within ± 1 db, with good linearity. Has dual-piston attenuator for varying output voltage from 0.1 volt to 5 microvolts. Includes blanking for zero-reference line on 'scope.

WO-56A **Television Oscilloscope.** Uses 7" CR tube and direct-coupled, 3-stage, push-pull, vertical and horizontal amplifiers. Dual controls for "coarse" and "fine" adjustments. Frequency-compensated and voltage-calibrated attenuators on both amplifiers. Response flat within -2 db from dc to 500 Kc, within -6 db at 1 Mc. Vertical deflection sensitivity, 10.6 rms millivolts per inch. Magnetic shield on CR tube reduces effects of external fields.

WV-87A **Master VoltOhmyst*:** Has big $8\frac{1}{2}$ " easy-to-read meter. Measures dc voltages accurately in high-impedance circuits, even with ac present. It also reads rms values of sine waves and the *peak-to-peak* values of complex waves or recurrent pulses, even in the presence of dc. Measures resistance from 0.1 ohm to 1000 megohms, current from 10 microamperes to 15 amperes. Features $\pm 1\%$ tolerance multiplier and shunt resistors, a meter movement having an accuracy within $\pm 2\%$ and a tracking error of only $\pm 1\%$, high input resistance, zero-center scale adjustment for discriminator alignment, dc polarity-reversing switch, and sturdy metal case for good rf shielding.

For complete details, see your RCA Test Equipment Distributor, or write Commercial Engineering, Section FX56, Harrison, New Jersey, for descriptive folders on the individual instruments.

*Reg. U.S. Pat. Off.



RADIO CORPORATION of AMERICA

TEST EQUIPMENT

HARRISON, N. J.

Makeshift replacements...reduce picture quality

*Replacements with Raytheon Television
Tubes assure picture quality*

Right for Sight



**RAYTHEON PICTURE
TUBES**

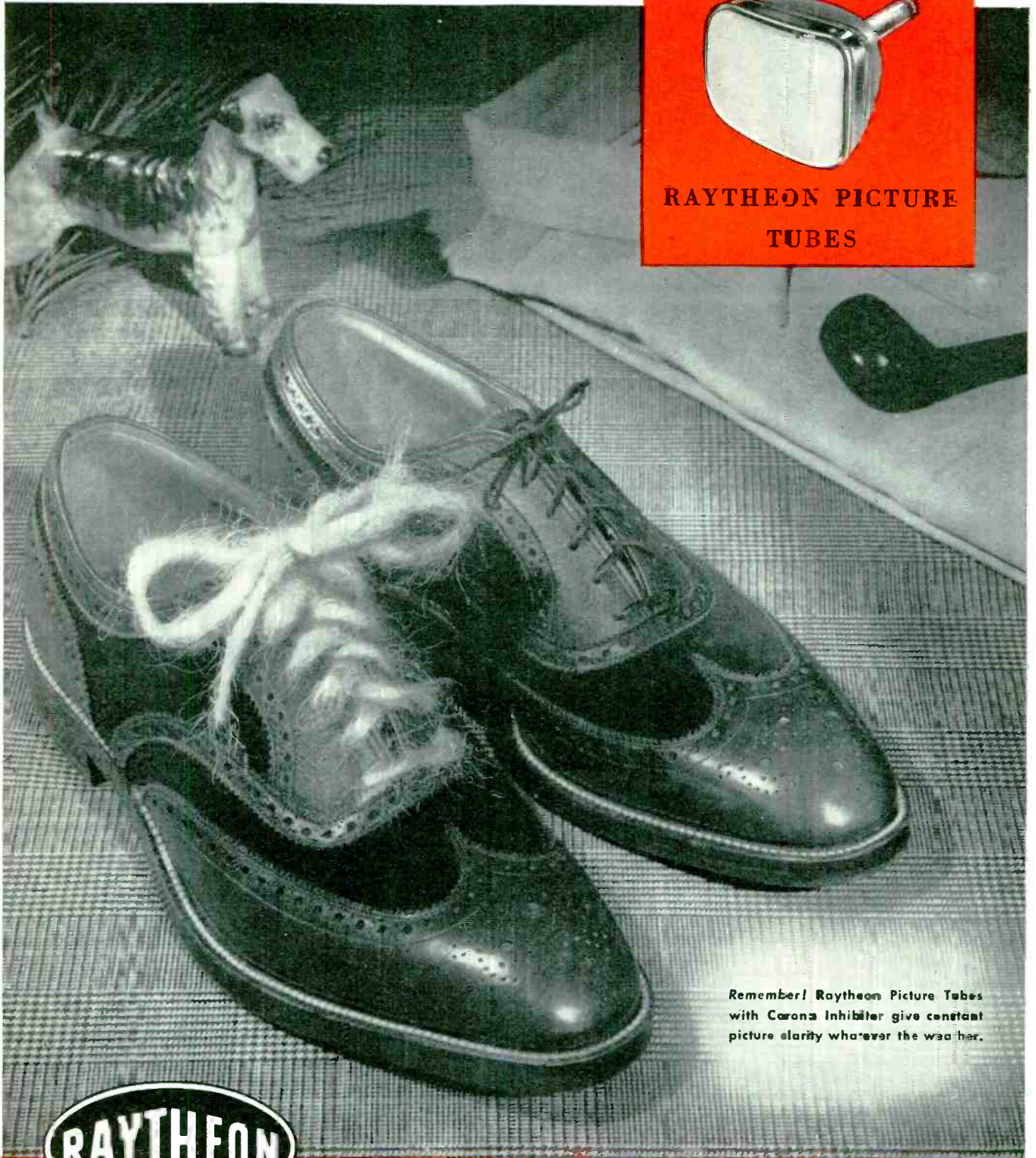

Remember! Raytheon Picture Tubes
with Carona Inhibitor give constant
picture clarity whatever the weather.



Excellence in Electronics

RAYTHEON MANUFACTURING COMPANY

Receiving Tube Division

Newton, Mass., Chicago, Ill., Atlanta, Ga., Los Angeles, Calif.

RECEIVING AND PICTURE TUBES • RELIABLE SUBMINIATURE AND MINIATURE FLBES • GERMANIUM DIODES AND TRANSISTORS • RADIO TUBES • MICROWAVE TUBES •



The Flourishing Audio World

SINCE THE PIONEERING DAYS of the galena crystal and 201As, WD11s and the 199s, there has been one link in the receiving chain that has been continuously a bouncing favorite, and to many an exciting pastime . . . *audio*. Then, the key to quality reproduction centered about huge conical sheets of treated paper and towering goose-necked trumpet speakers which required a dolly to truck. Phonos were a novelty then, but their occasional use in stations fascinated countless. As the catwisker faded from the scene and improved triodes and multi-element tubes became commonplace, audio enthusiasm raced along, attracting not only new circles of fans, but many members of the engineering fraternity who began to concentrate in extensive research and development. Their efforts were not in vain, for their concerted attention has resulted in a striking supply of components and accessories that have propelled audio interest to a new high.

The enthusiasm today no longer revolves about one item, but all of the basic six units which are normally employed in an ultra-fidelity audio system: turntable or changer; pickup and its vital accessory, the needle; input tuner; amplifier; speaker; and enclosure. Service Men have discovered that consumers have become substantially familiar with the technical aspects of the six elements, and are willing to have the best combinations assembled to provide them with that fascinating wide-range reproduction they have been hearing so much about. As a result, the boys in the shop have found that they must keep pace with all developments, and acquire a working familiarity with the latest products, so that they might provide their clients with setups and installations that will merit solid acceptance, and prompt others to request similar projects.

Audio, which only a few years ago

was a not too strong factor in the service shop, has zoomed to the front.

This fact was revealed quite forcefully during a special survey conducted by SERVICE. In a *test* mailing to 1,000 independent Service Men subscribers located throughout the country, a representative return indicated that nearly 90% stock, sell and install phono cartridges. The survey also revealed that 78% stock and sell phono needles, while 77% stock and sell phono pickups. About 70% indicated that they sold and installed speakers and speaker cabinets, and over 75% recorded the fact that they do quite a business in record changer sales and installation. Audio amplifiers were disclosed as an item of import, too, with nearly 69% actively engaged in stocking and selling such units. Even tape and wire recorders have risen in popularity among Service Men, with nearly 50% of the service shops surveyed indicating that they were now actively engaged in that business. High-fidelity interest, which had a very small following not too long ago, today, according to the survey, is a factor in over 45% of the service shops.

The boys have found that audio can no longer be discounted and pigeon-holed as an incidental item in the service shop. It has become a full-fledged rugged partner, with year-round healthy earning possibilities. You'll find resounding evidence of these virtues in the timely, revealing audio articles, appearing in this, our *annual audio issue*.

Service Men Are Gentlemen

TV SERVICE MEN, who have been harshly criticized for their behavior and dress, have found a robust friend who says that the public, at large, believes that they are *competent, prompt and polite*.

The discoverer of this enlightening view has been none other than the

country's leading market research expert, Elmo Roper. Conducting a nationwide public opinion poll for a leading set manufacturer, he found that when the set owners who had had service calls were asked to evaluate the work done, only 7% expressed dissatisfaction. A sizeable majority, over 65%, replied that the work was *really good*, while about 15% described it as fairly good. When asked if the Service Men, who called to install or service the receiver, were pleasant and courteous, only a fraction of 1% offered a negative reply, according to Roper. Almost 9 out of 10 of these respondents, or about 88%, indicated that the Service Men were *pleasant or courteous*, while another 6% considered their manners satisfactory. The survey also revealed that the public maintained a similar high opinion of the *promptness* of Service Men, with 3 out of 4 questioned indicating that they thought that the work had been done in a reasonable length of time.

Commenting on the survey, the president of the service company, operated by this set manufacturer, said that results clearly proved that the thousands of independent Service Men have discharged their responsibility with a remarkable success. He pointed out that the need for installation and servicing for the millions of TV sets now in use, without a doubt the most complex instrument ever introduced into the home, constituted an immense challenge which the service industry has met squarely and honestly. TV could not be the nationwide medium it is today, emphasized this prexy, if it were not for the tremendous job that is being and has been performed by everyone in the servicing industry.

The stirring whole-hearted stamp-of-approval facts evinced by the poll should prove invaluable to every Service Man. So that all may thoroughly review this good-news information uncovered by Roper, a *complete report* on the poll is now being prepared for SERVICE by those who developed the program and participated in it. It will appear in an early issue of this journal. Here is a story which should not be missed.—L. W.

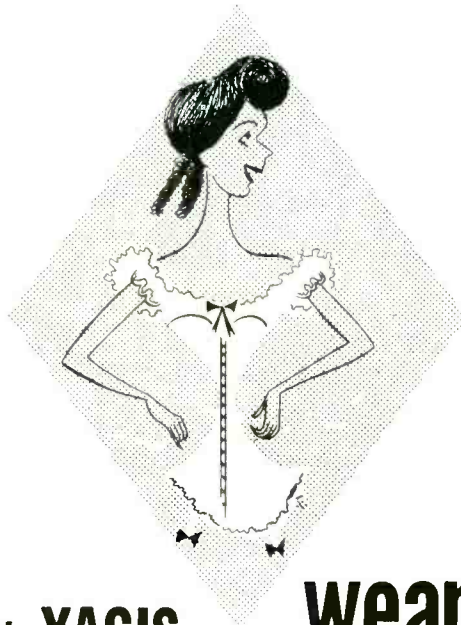

this gave us
the greatest
ANTENNA IDEA
of the year!

**RMS super
multi-element YAGIS**

wear a steel brace

RMS 8 and 10 element Yagis can't sway, can't rock, can't pitch . . . they're braced with the unique steel support . . . Here's one more development out of many RMS engineering accomplishments designed to produce more efficient higher quality television accessories. Steel braces can be purchased separately. Write for complete details covering our complete line of multi-element Yagis, or see your local RMS jobber.

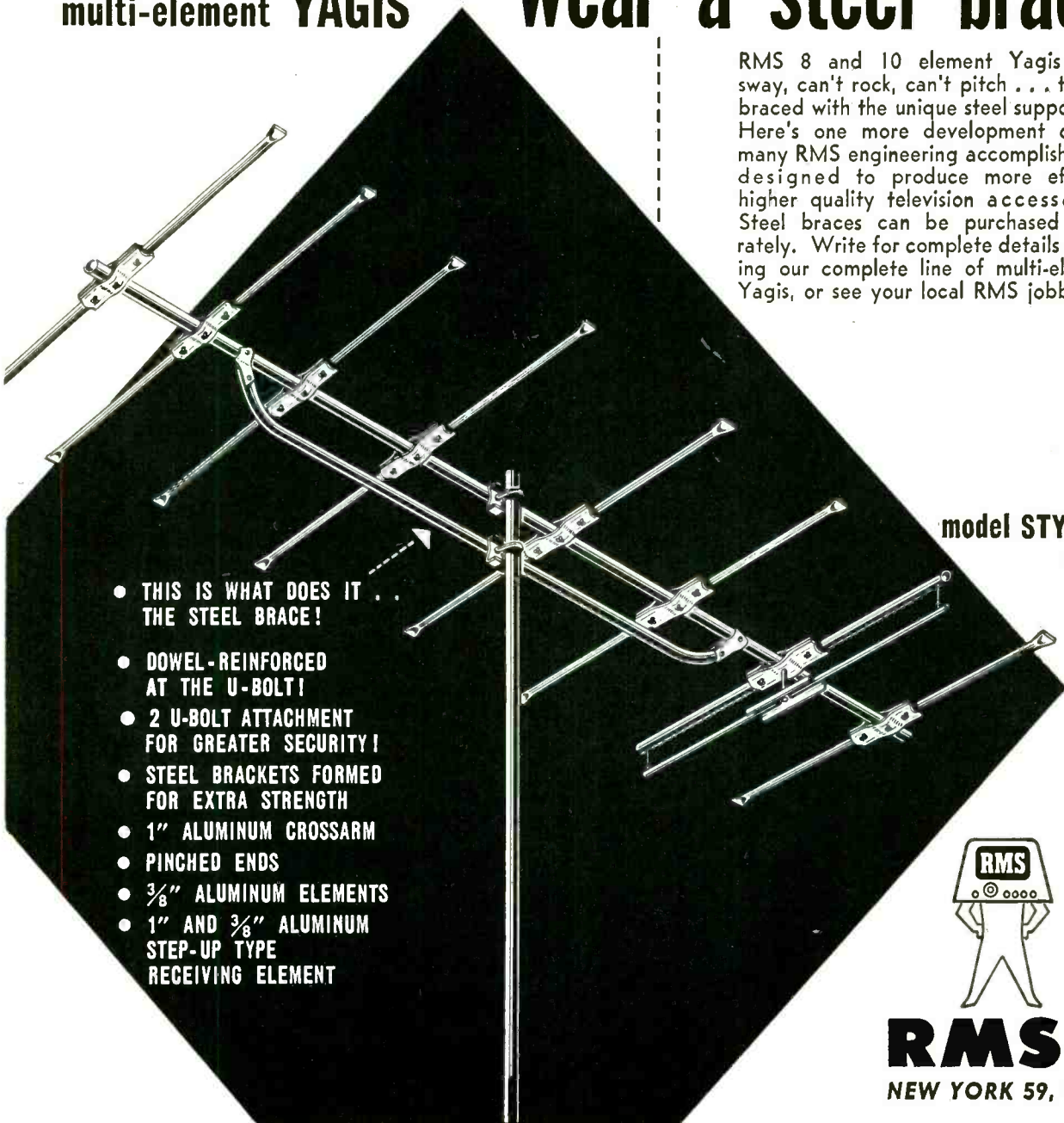

- THIS IS WHAT DOES IT THE STEEL BRACE!
- DOWEL-REINFORCED AT THE U-BOLT!
- 2 U-BOLT ATTACHMENT FOR GREATER SECURITY!
- STEEL BRACKETS FORMED FOR EXTRA STRENGTH
- 1" ALUMINUM CROSSARM
- PINCHED ENDS
- 3/8" ALUMINUM ELEMENTS
- 1" AND 3/8" ALUMINUM STEP-UP TYPE RECEIVING ELEMENT

model STYL 8 —
Illustrated

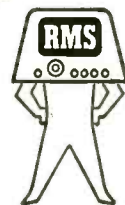

RMS INC.
NEW YORK 59, N. Y.

SERVICE...The National Scene

PROPER TRAINING--ADEQUATE EQUIPMENT VIEWED AS UHF INSTALLATION INSURANCE--The well-informed Service Man, equipped with adequate test and installation equipment, will have little to worry about during the ultrahigh era, according to the manager of the servicing contract section of one set manufacturer. Appearing before the Television Council in Elkhart, Ind., he said that such knowledge and equipment will provide solid insurance against any trouble regardless of the complexity of the job. It was pointed out that on uhf it will be necessary to consider the same receiving peculiarities inherent in low-band operation, with particular concentration on the beam effect and the shielding difficulties that often exist and tend to eliminate or bounce the signal, requiring reflection-pickup facilities. Commenting on the overall problems of service management that are expected to increase when the country becomes dotted with stations, the setmaker's representative declared that . . . "TV servicing can be and should be a sister to the merchandising program, not subordinate to it." He felt that the Service Man's professional status must be recognized and respected in such a program; a move which will be profitable to all concerned.

TVI DISCUSSED AT WASHINGTON CLINIC SESSION--A unique 4-day clinic devoted to the problems of TV interference was conducted recently in Washington, under the joint sponsorship of the Electric Institute of Washington, RTMA and a Washington TVI committee. Arranged in two parts, the clinic featured demonstrations of assorted interference patterns most frequently encountered, and a question and answer period devoted to TVI problems. . . . The clinic was highlighted by an extremely topical talk and an additional demonstration of interference patterns. . . . A comprehensive report on these sessions will appear in an early issue of SERVICE. Watch for it.

QUALITY FRINGE INSTALLATIONS CALLED IDEAL AID TO FUTURE BUSINESS -- Every fringe-area installation executed with skill and care can be a boon to future business, members of the Madison (Wisconsin) Appliance Association were told recently by the managing director of NARDA. Every satisfied customer, he said, represented seed from which may spring hundreds of sales when the new stations start coming on the air. Describing the external installation procedures and accessories which have been found to guarantee outstanding performance in the weak-signal areas, the association exec said that exactly oriented antennas, mounted on well-anchored tall towers, represented an extremely important factor. In addition, he pointed out that boosters should be installed at the antenna if possible to avoid excessive signal-to-noise ratio. And all safety factors must always be considered. Any guying should be done with strong airplane cable on at least three sides to resist the strongest winds. It is important, he said, to nurse the signal along to maximum strength and clarity so that the performance will presell viewers on the potentials of a full TV service that will prevail when the new stations start telecasting.

NEW HAMPSHIRE SERVICE MEN ADOPT CODE OF ETHICS--In a move to rout unscrupulous practices, and familiarize setowners with the quality servicing facilities that are available in the community, a new radio and television association in Manchester, New Hampshire, has adopted a code of ethics, and also announced that the code will be featured in an advertising campaign. Advertisements, it was said, will stress the high standards that every member of the association will adhere to strictly, not only in the shop but in the field. During the meeting, in which the code and advertising program were discussed, Warren Davis served as temporary chairman, and Emile Gelinas acted as temporary secretary.

SERVICE... *The National Scene*

MICHIGAN'S GOVERNOR DECLARES SELF-POLICING BEST WAY TO COMBAT COMPLAINTS--In a stirring talk before members of the TSA and MTTA in Detroit, Michigan, G. M. Williams, governor of Michigan, declared that the best way to eliminate all complaints in the servicing industry is through a rigid policy of self-policing Supporting this premise, the corporation counsel of Detroit added that no city ordinance will be necessary if Service Men police themselves to prevent all acts of fraud. . . . Describing a survey of complaints received by distributors, the service manager of a national setmaker's distributing company said that only ten per cent of the complaints were of a technical nature, but suspected overcharging constituted about 40 per cent of the complaints. The improper handling of customers seemed to be cause of most of the trouble, he pointed out. All these faults, he said, could be readily rectified through an educational program, aided by a sound policing plan.

FOUR-DAY TV TRAINING PROGRAM CONDUCTED FOR MONTREAL SERVICE MEN--The Montreal Technical School in Canada played host recently to a four-day clinic on TV servicing. Cosponsored by RTMA, the sessions featured instruction by members of Al Saunders school in Boston. The information supplied was basic in nature, designed to be supplemented by a complete home-study course. Commenting on the training program, the general service manager of a large set manufacturer, acting as chairman of the meeting, declared that the future of TV in Canada will depend to a large extent upon the availability of servicing facilities. It might be impossible, he said, for any manufacturer, dealer or even independent service group to supply all of the service that might be required. Accordingly, every effort must be made, he emphasized, to prepare immediately for the training of men so that all receivers are properly installed and effectively serviced. He felt that the future of TV in Canada depends upon how the opportunities are developed. In his opinion, the manufacturer, distributor, dealer and Service Man must be a closely knit unit to insure a bright future for television.

NEW COLOR DEFINITIONS AND INSTRUMENTS ON WAY--When color does become an actuality, Service Men will have to become familiar with a new family of terms and test equipment. During a recent meeting in Cincinnati, it was learned that one of the new unusual types of instruments that might obtain will be a vectorscope, a high-speed phase indicator capable of displaying on the screen of a 5" 'scope the instantaneous phase and amplitude of the color subcarrier. It has already been used successfully as a monitor for certain color signal generators, and it is said that it is potentially useful as an aid in the alignment of color receivers. Functionally, the instrument employs two sets of balanced modulators to perform the various functions of deriving the phase coordinates, remodulating an auxiliary subcarrier and producing a radial shift of a vector display. In this manner, it was said, the phase indication can be made to cover 360° and the ambiguity of the angle presentation can be avoided. . . . Some of the color terms with which Service Men will have to be familiar are: video decoders, sampling, phase error, reference, chromaticity, fringing and breezeway.

IN THE MAILBAG--In a recent note to ye editor, S. William Scott, president of the Employer's Association, Inc., and chairman of the Council of Radio and Electronic Service Men in Los Angeles, declared . . . "I look forward to receiving your magazine each month not only for its valuable technical content, but for the other interesting articles you print." Peter Kotula, noted that SERVICE was . . . "A very informative magazine." And according to George A. Mishlance, SERVICE articles are . . . "The most interesting in any of the magazines I buy." Many thanks, gentlemen, for these continuing plaudits.--L.W.



**MEET
THE NEW
● PYRAMID
imp**

**MOLDED TUBULAR
PAPER CAPACITORS**

important!

"IMPS" are molded in rugged thermo-setting plastic!



important!

"IMPS" are IMPervious to moisture!



important!

"IMP" leads are securely anchored!



important!

"IMPS" will withstand temperature of 100°C. (212°F.) — the boiling point of water!



"imps" are now available to the service trade in all popular ratings, in 200, 400 and 600 volt ranges.

Write now for complete literature—and your free sample!

**MAIL THIS COUPON FOR
FREE SAMPLE**

YOUR NAME _____

COMPANY NAME _____

ADDRESS _____

CITY, ZONE, STATE _____

PYRAMID ELECTRIC COMPANY
1445 Hudson Blvd., North Bergen, N. J., U. S. A.



**Filters, 8-Watt Amplifier and Matching Arrangements
Developed to Provide Ultra-Fidelity Results From
Converted or Custom-Built AC/DC Radio-Phono
Combinations.**

Hi-Quality Audio for

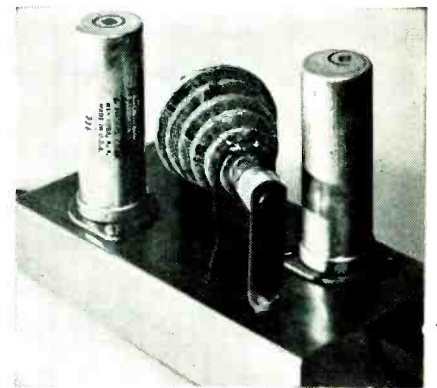
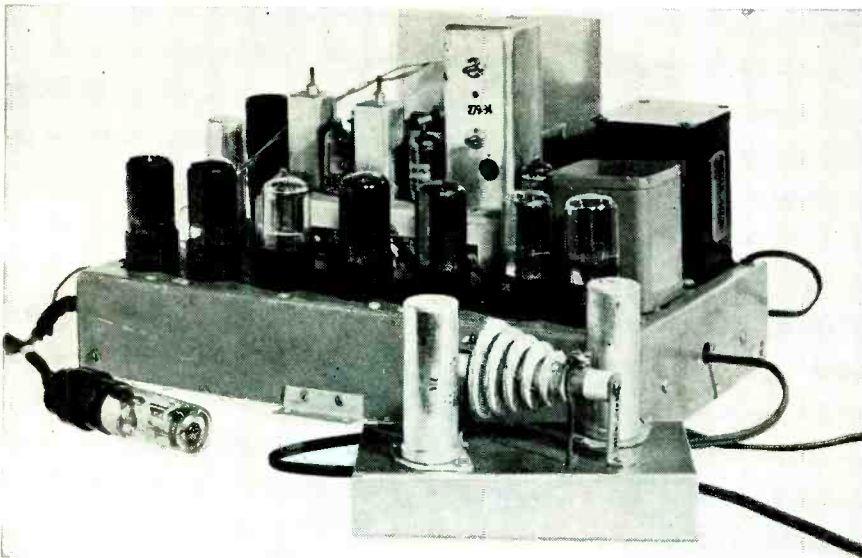

(Above)
Inverter filter unit.

(Left)
AC/DC amplifier and converted ac tuner.

(Photos by David Hebb)

THERE ARE MANY areas in New York, Boston and elsewhere where *dc* is still used. Residents of these neighborhoods are faced with a knotty problem when purchasing a radio-phono, as the commercial market does not offer any quality *ac-dc* combination, or its components. Fortunately, the problem can be solved by the Service Man through conversion or custom building.

A radio-phono which can operate on either alternating or direct current must include special features. First, since 3-speed *ac-dc* record changers are not available, the *dc* input to the changer motor must be inverted to *ac*. This must be accomplished without the operator of the set being constantly reminded of the inverter by noise, or by the necessity for controlling a separate unit. Second, the tuner and audio amplifier must contain transformerless power supplies. While an *ac-dc* amplifier is not unusual, it becomes a special item when a supply of 8 watts power output at low distortion is a requirement, too.

The Record Changer

Noiseless operation of an *ac* record changer from a *dc* source can be readily and inexpensively achieved by the use of a good, shielded 50-watt in-

verter, suspension mounted, and connected to a filter circuit of the type shown in Fig. 1. This filter suppresses electrical disturbances produced by the vibrator and prevents them from feeding back into the line, from which they would normally be coupled to the set both directly and by radiation. Inverter *hash* has been accepted as a necessary evil too often. Properly built *ac-dc* units, which use the Fig. 1 filter have been found to produce no audible inverter noise at any setting of the volume control, even when the audio systems are the high gain, wide frequency range type suitable for reluctance pickups, and therefore most sensitive to hash.

The filter is the conventional *pi*

Fig. 1. Inverter filter circuit. The *rf* choke is a 6-millihenry unit rated at 350 mils, with a 12-ohm maximum *dc* resistance. The electrolytics, 50-mfd, are 150 *wv* type with a common negative. If can-type electrolytics are used, the common negative cans must be insulated from the chassis.

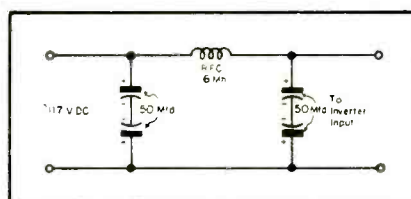

type, with a somewhat unconventional combination of component values. Its electrolytics are connected *back-to-back* so that no damage can occur if the set is plugged into the power outlet with incorrect polarity. When can-type electrolytics are used care must be taken to insulate the cans from the chassis, because if the two common negatives are connected together the *rf* choke is almost shorted out for one line polarity. The leads between the filter and the inverter input should be as short as possible, and the entire assembly must not be located physically near components with high gain ahead of them, particularly the pickup lead. Where a good layout is not possible, shielding of the filter leads and even of the filter itself may be necessary. Proper interconnection between the various shields and ground points for noiseless operation can be best determined by trial and error, since it may vary with different equipment.

Only one exception to the effectiveness of this filter has been observed. The difficulty was caused by bad house wiring, which during hours of heavy current use dropped the *dc* voltage at the power receptacle almost 20 volts. Vibrator chatter and hash were then

PHONO NEEDLE and

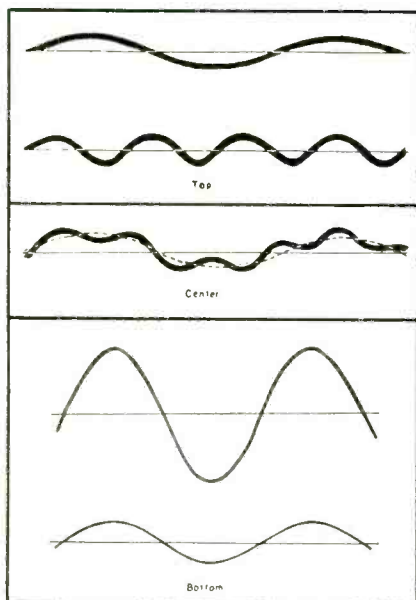

Figs. 1 (top), 2 (center) and 3 (bottom). In Fig. 1 appear waveforms illustrating (at top) a low-frequency note and (below) a high-frequency note. A combination of the two notes is shown in Fig. 2. A sound wave picture is depicted in Fig. 3, the top waveform being that of a high-amplitude signal, while the bottom waveform illustrates a low-amplitude signal.

FOR PROPER LISTENING PLEASURE it is, of course, necessary to maintain all components of a phono playback system in good condition. One would not expect a torn speaker cone to function properly nor could we hope for proper performance from an amplifier with bad tubes.

The average consumer is aware of the necessity of replacing worn out or damaged parts such as tubes and speakers; the same consumer is not yet fully aware of the aesthetic and financial loss caused by worn phono needles.

Actually a modern phono playback *needle* is not a sharp pointed object, but conical shaped with a smooth hemi-spherical tip. The maintenance of the smooth round contour is essential so that the *needle* can properly trace the undulating path of the record groove. Incidentally, the term *stylus* is preferable to *needle* which has the connotation of a sharp point.

With the advent of microgroove records, a renewed interest has been displayed in recordings. The microgroove recordings offer many advantages with which we are all familiar; they are longer playing, are made of unbreakable vinylite, have an excellent frequency range, and with proper care will last a long time.

For these reasons people are once

again becoming avid record collectors. A single home record library can contain anywhere from a score of records to several hundred. Since a single 12" *lp* microgroove record retails for over \$4.00, the investment in a home record library often ranges from a hundred to well over a thousand dollars. Thus, the problem of record wear has become acute and of particular concern to the enlarged phono audience.

There are a number of causes of stylus wear. It has been found that the following factors are the most important in relation to stylus and record wear: Stylus material; record material and condition of record; stylus pressure; compliance of pickup; and design of pickup arm.

There are other variables which will affect stylus wear, but the five listed are the major ones to be considered.

Characteristics and Functions of Records and Styli

A record is a flat disc containing wavy spiral grooves which were originally cut into the master recording by an accurately shaped cutting tool. The waves in the groove correspond to the wavelength of the sound which was originally recorded. Thus, a sound wave with a frequency of 10,000 cps, will cause the cutting stylus to vibrate 10,000 times per second. In order for the playback stylus to transmit this sound, it too must vibrate 10,000 times per second. The size of the recorded wave depends upon the frequency and amplitude of the sound, upon the diameter of the record and the speed of the recording. A low-frequency note will cause the formation of a wave with a comparatively long distance between crests. A high-frequency note will produce small waves with short distances between crests; Fig. 1. A combination of the two sounds will produce a wave as shown in Fig. 2. High amplitude will cause an increase in height of the crest of a wave of a given frequency, while low amplitude will cause the reverse; Fig. 3.

Since the record rpm is constant, the linear distance of a recorded wave of given frequency decreases with the diameter of the record. For example, a 10,000-cps note has a wavelength of .002" at the outside grooves of a 12" 33 $\frac{1}{3}$ rpm record. The same note recorded 6" from record center has

Fig. 4. Chart illustrating frequency response characteristics of the piano and several popular type instruments. Frequency range of some instruments, such as piccolo, oboe, violin, cymbals, and bassoon often reach 12,000 cps.

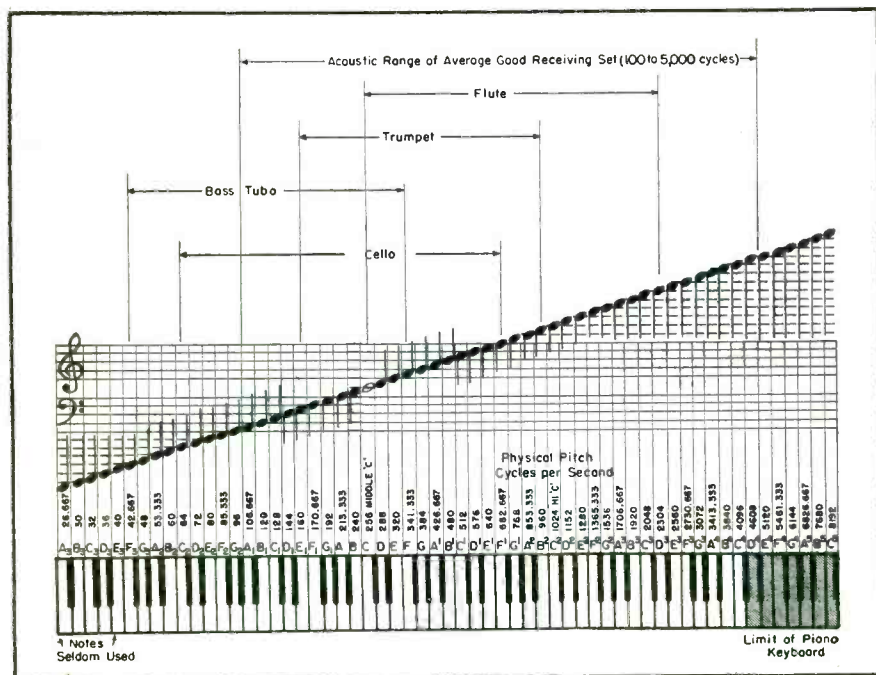

RECORD WEAR

Lucid Analysis, Based on Detailed Investigation of Needle and Record-Wear Conditions, Particularly Those Concerning LP Records, Offers Complete Review of the Specific Causes of Damage and How Some of the Major Problems Can be Overcome.

by **E. J. MARCUS***

Audio Consultant

a wavelength of .001", and at 3" from center the wavelength decreases to .0005". In order for a playback stylus to enter between the crests of a 10,000 cps note, the stylus can not have a flat larger than .0005". If the flat is too large, then the stylus will bridge across the crests of the recorded sound wave.

In Fig. 4 appears a frequency chart which illustrates that a musical tone contains a fundamental frequency accompanied by overtones, i.e. higher frequencies which give an instrument its characteristic sound. For example, a note from a piano has a far different sound than a note of the same pitch coming from a trumpet, due to its overtones. Many of the overtones associated with a musical note of almost any frequency will not be faithfully reproduced by a stylus with worn sides. Thus, when a stylus becomes

worn, it fails to reproduce the fundamental higher frequency notes and distorts the overtones of the lower frequencies. Accordingly, as stylus wear increases the piano sounds less and less like a piano and the same is true for all other sounds. There is no longer any fidelity of reproduction. A spherical tip can respond to all of the recorded sound within the range of the human ear.

Figs. 6 and 7 clearly illustrate, in cross sectional views, the shape and

*Author of numerous articles on records and needles including, *The Diamond as a Phono Stylus Material*, and *Problem—To Hear What's on Disks*, published in the *New York Times*.

fit of a new and a worn stylus in record grooves.

Principal Causes of Record Wear

The type of stylus material is probably the single most important factor which must be considered in record wear. Phono styli have been made of everything from soft cactus to diamond, the most durable of all substances. In view of what is required for proper and practical playback of recorded sound, it has been found that the ideal stylus material should possess: Durability or resistance to abrasive wear (ability to maintain a spherical tip after use); highly polished surface (low coefficient of friction); good heat conduction; strength, and a high *Young's Modulus* (no damping or filtering action).

When it is realized that the pressure at the contact area between stylus and

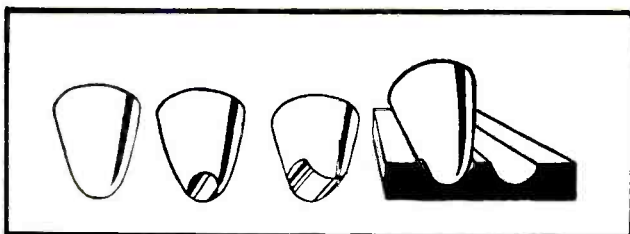

Fig. 5a. Views of needle tips, showing progressive nature of wear; needle eventually forms shoulders and settles deep in record groove. (Courtesy *Fortune Magazine*, September, 1939.)

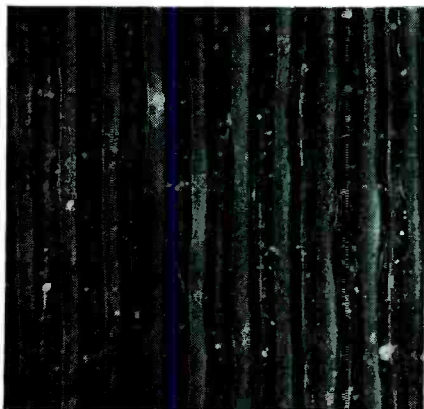
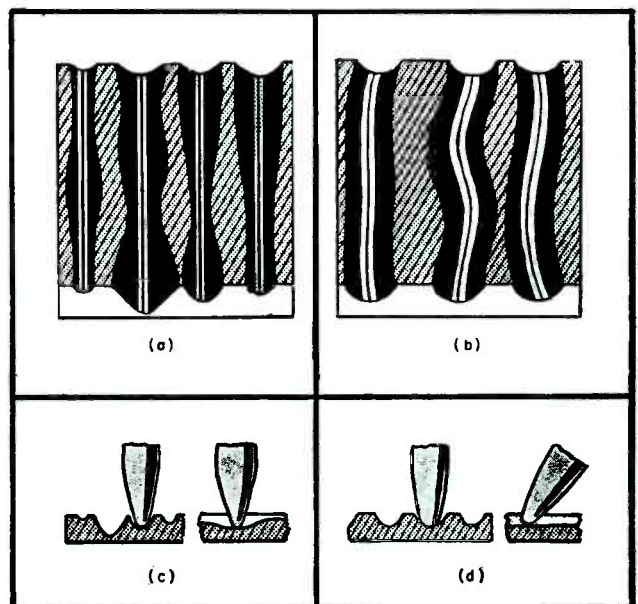
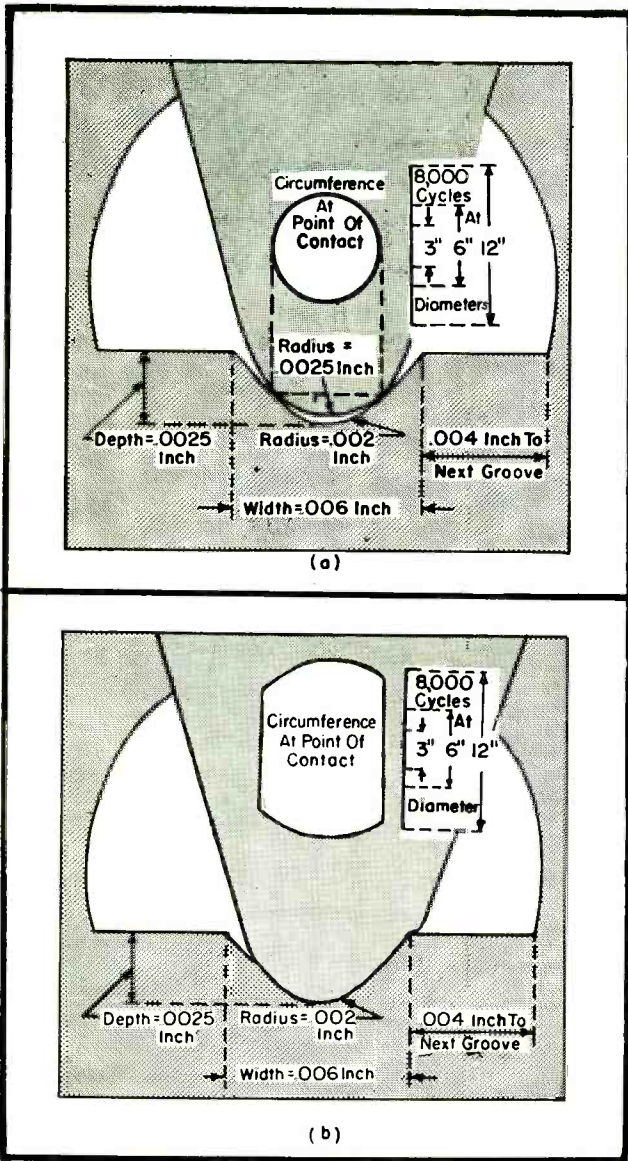

Fig. 5b (Left) Photomicrograph of record groove with worn stylus particles and atmospheric dust. (Courtesy *Duotone*)

Fig. 5c. Record grooves and needle motion. At left (a) we have hill and dale grooves, while at right (b) are lateral grooves. In hill and dale operation, the needle rises and falls to reproduce vibration. In the lateral type of movement, the needle vibrates from side to side, as rapidly as 12,000 times per second. The lateral cuts usually have 100 grooves to the inch, while the hill and dale or vertical cut has 143 to the inch. (Courtesy *Fortune Magazine*, September, 1939)





Figs. 6 and 7. At (a) groove and needle size compared with an 8-ke wavelength at different diameters at 78 rpm. What happens when any needle is worn to fit the groove, with resultant flats, is illustrated in (b) drawing. Since the flat on one side of the needle is greater than the wavelength of 8000 cycles, even at an 8" diameter, reproduction of this or any higher frequency is impossible. (Adapted from *Briggs Sound Reproduction*; based on original work of C. E. Watts.)

record groove with a 1/4-ounce pickup is about 26 tons per square inch, you will immediately understand why the stylus has to be durable. Only the hardest and most durable of all materials can be expected to withstand this tremendous pressure. It must be remembered that the pressure is more or less constant on the needle tip

while it is in contact with the groove, whereas this pressure is momentary at any given spot in the groove as the record spins past the stylus. The stylus tip must endure the pressure along the half mile of groove contained on one side of a 12" lp. Photomicrographs of a steel stylus before and after one play on a side of a 10" shel-

Fig. 8. Photomicrograph of a new steel needle tip. (Courtesy Duotone)

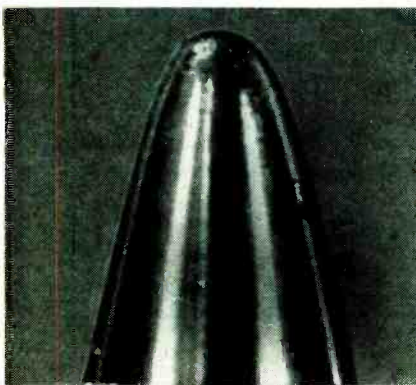
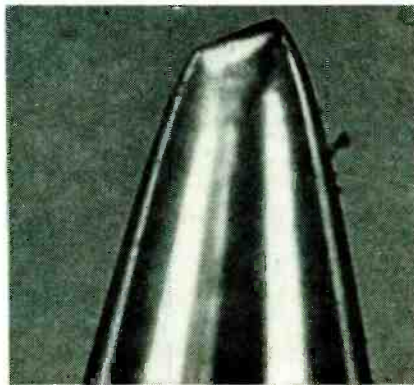

Fig. 9. Photomicrograph of steel needle worn after 1 play. (Courtesy Duotone)



lac record, appear in Figs. 8 and 9.

In Figs. 10 and 11, we have photomicrographs showing the wear produced on microgroove osmium alloy and sapphire styli. Fig. 12 shows the spherical shape of a diamond stylus after 2,000 plays on microgroove records. Diamond is able to maintain its shape due to the fact, long since established in physics laboratories, that it is 90 times more resistant to abrasive wear than sapphire, the next best material.¹

A survey of the articles and books of ten leading audio experts has been found to reveal almost unanimity of opinion in that osmium is not satisfactory for microgroove records because of its lack of durability, sapphire requires frequent replacement when used on microgroove, and diamond is the only stylus material which will maintain its shape for prolonged playing on microgroove records.

Need for Polished Surface

A smooth surface finish is also essential. A rough surface on a stylus will cause abrasion of groove walls, resulting in permanent damage and distortion. Diamonds can be polished to a degree of lustre higher than that of any other substance.

Good heat conductivity is desirable; at least from a theoretical standpoint. Although no data have been obtained, it is logical to assume that under pressures of 26 tons psi and with movement of 20" per second, a great deal of heat will be generated, resulting in a burning of both stylus and groove surfaces. Diamond and osmium are good conductors of heat, while sapphire is not.

Strength or resistance to pressure or sudden force is a necessary feature of a good stylus. It has been found that the diamond can withstand four to ten times more pressure on a radius than can sapphire. In studies con-

¹A. Rosiwal, *K. Akad. d. Wissenschaften, Wien*, 1893, No. 11 and 1917.

Fig. 10. Photomicrograph of osmium needle after 15 hours of play on lp. (Courtesy Duotone)

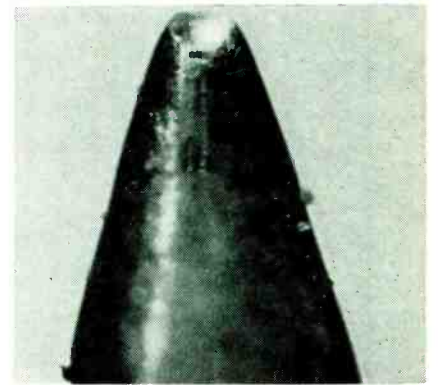

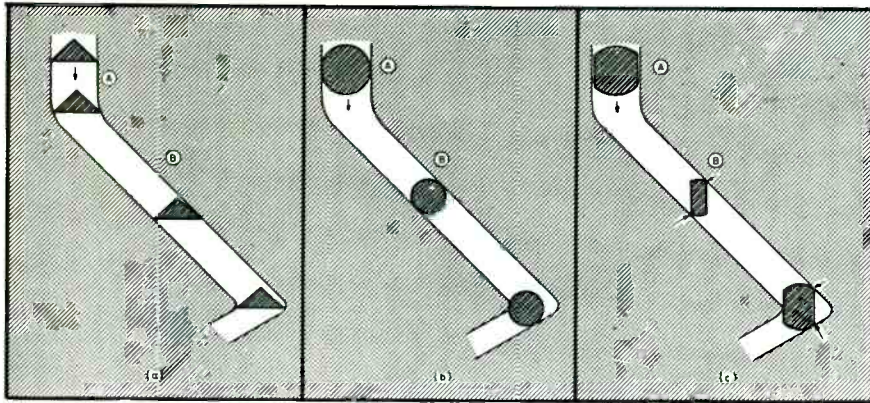

Fig. 13. Diagrammatic representation of *pinch effect*. Illustration at left shows path of cutting stylus. Styli do not rotate, and therefore a sideways excursion results in a narrowing of the groove within the moving record. The tracking of a properly-shaped stylus is shown in the center diagram. The playback stylus is conical and has a spherical tip. Contact with groove walls is made at sides of tip. This shape presents a smooth curved surface to the groove walls at all times despite *pinch effect*, and permits an easy rise and fall of the pickup. This results in a minimum of groove damage. At right appears the results effected by a worn stylus, where the worn playback stylus settles low in the record groove. Edges have been formed on four corners. In a relatively unmodulated section (A) of record groove, a large flat stylus section comes in contact with the groove walls. This results in distortion. When the stylus edges encounter a bend in the groove, as at (B), the groove walls are damaged.

ducted by scientists², it has been noted that diamond has a breaking strength of 790,000 kg/sq cm, while sapphire has a breaking strength of 130,000 kg/sq cm. Experience has shown that diamond styli are very rarely damaged in normal use.

It is necessary to avoid a damping action in the stylus material. All of the vibrations caused by the moving groove waves must be faithfully transmitted to the stylus arm to provide fidelity of reproduction. The hard materials are excellent in this respect. Soft stylus materials such as cactus, act as filters, soaking up a considerable amount of the vibrations. They should not be seriously considered by anyone interested in quality of reproduction.

Effect of Worn Stylus Upon Groove

As a stylus wears, a flat is first produced on either side of the spherical tip at the contact point. These flats become progressively larger.

²Schuler and Dimpker, *Zeitschrift f. Instrumenten kunde*, Vol. 55, 1935, p.63.

Fig. 11. Photomicrograph of sapphire needle after 30 hours of play on *lp.* record. (Courtesy Duotone)

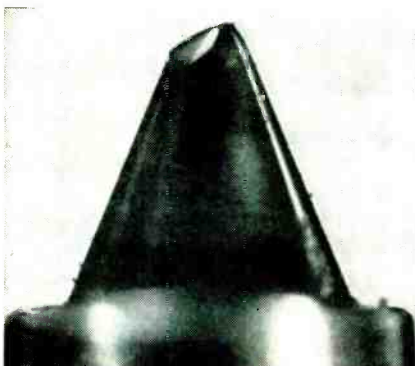

Eventually the wear becomes so pronounced that the stylus sinks down into the groove and shoulders over the top of the groove. It is a physical impossibility for a worn stylus with a flat larger than the wavelength of a recorded sound to reproduce that sound. As wear progresses, there is a progressive decrease in the frequencies which can be reproduced. In addition, there is an increase in surface noise and distortion of overtones. These conditions escape notice for a longer period in poorer quality equipment, which is incapable of reproducing anything over 5,000 to 6,000 cps. High-fidelity audio equipment reveals the weaknesses of styli much sooner. However, aural tests cannot be relied upon for detection of stylus wear, and a visual examination, preferably by microscope, is necessary. Aural memory is poor and the user cannot remember the quality obtained when the stylus was new. By the time the stylus wear has progressed to the extent where it can be readily detected by ear, considerable record damage has occurred. A glance at the photomicrographs of the worn styli will show a great resemblance to a chisel or plowshare. The effect of using a worn stylus is not dissimilar to using a cutting tool. The sharp edges produced by wear cut into wave crests, especially in loud passages containing high frequencies. The wear is worse near the center of the record.

Pinch Effect

There is a variation of groove width caused by the original cutting stylus. The groove is narrower at the sharp bends in high amplitude sections due to a sideways excursion of the flat cutting stylus. This is a familiar con-

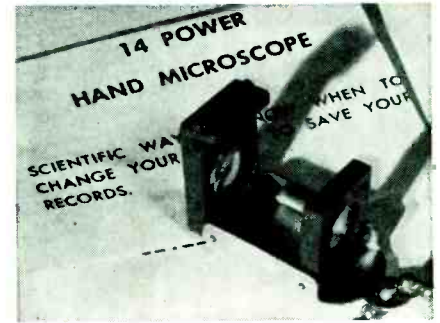

Fig. 14. A 14-power hand microscope, with which a Service Man can examine a needle while it is in the pickup arm. Such an examination can reveal to customer actual extent of needle wear and damaging effect on records. Microscope folds into compact unit and can be conveniently carried on person or in tool kit. (Duotone Duoscope)

dition known to recording engineers as the *pinch effect*. When a new spherical tip is pinched at high amplitude sections it can ride upwards without excessive damage to the groove. A worn stylus choking the groove has a tendency to plow through the kink in the groove rather than rise and fall.

When vinylite microgroove records were first introduced it was the opinion of some audio engineers that stylus wear would be reduced to a bare minimum. It is known now that even unfilled vinylite will wear styli and what is even more surprising, microgroove styli wear out faster than standard groove styli. This occurs despite lower stylus pressure and slower turntable speeds.

An interesting theory on stylus-wear pertaining to vinylite records is the stylus-wear/record-wear cycle. The particles worn off the stylus tip fall into the grooves and upon subsequent playing become imbedded in the plastic material. These particles are highly abrasive and shorten stylus life and as a concomitant, record life is also decreased. Diamond is ideal in this respect in that very little is worn away to fall into the grooves. Therefore, vinylite records which have been

(Continued on page 52)

Fig. 12. Photomicrograph of diamond needle after 2000 plays (about 1000 hours) on *lp.* record. (Courtesy Duotone)

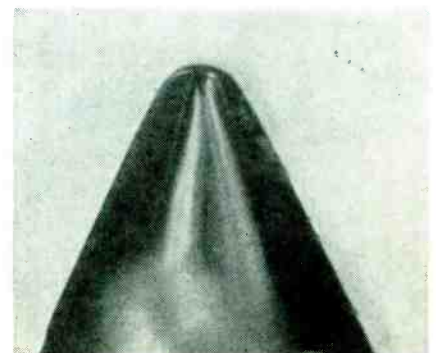

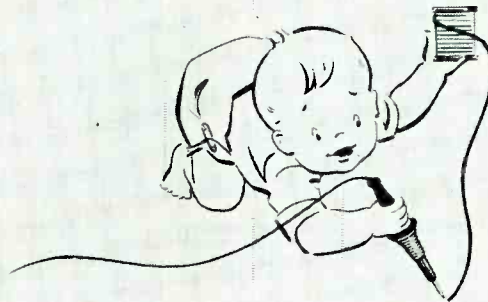

SO SIMPLE...

KESTER "RESIN-FIVE" CORE SOLDER

SO SIMPLE... to give good service



- Non-corrosive and non-conductive... in diameters of $\frac{3}{32}$ ", $\frac{1}{16}$ " and smaller.

KESTER'S "Resin-Five" Core Solder has long enjoyed the greatest popularity as the best solder for all electronic work, radio and TV. That's because it was originally developed to save you time and money... the right combination of tin and lead—flux, too—to simplify and speed up your work. And it's true also of Kester's companion product, Plastic Rosin-Core Solder. Choose either one... and you have the best!

Your Jobber has Kester. Tell him you want "Resin-Five" or "Plastic Rosin"... both genuine Kester Solders. You'll be glad you did!

KESTER SOLDER COMPANY
4248 Wrightwood Ave., Chicago 39
Newark 5, New Jersey • Brantford, Canada



AUDIO installation and service

Phono-Tape-Wire-PA-Amplifiers-Speakers

by KENNETH STEWART

Noise in Recording and Reproducing Systems: Wow and Rumble Defects and Cures . . . Phono Motor Characteristics . . . Turntable Speed Problems. Tape Recorder Design . . . Ultra-Fidelity Amplifiers . . . Equalization Preamplifiers.

IN RECORDING, and reproducing systems, *noise* has always been a problem and a challenge to many. Broad solutions have been difficult to find because of the variety of noises in the equipment and system itself that must be considered. Several years ago, a committee was established in the IRE to probe the assortment of existing noise conditions and then set standards which might be used to devise curbs. Their work has been outstanding, providing a firm pattern and valuable guide to industry.

Reporting on the project at an IRE

national meeting, A. W. Friend of RCA Labs declared that it has been found that *noise* actually refers to any output power which is of any frequency differing from those of the signals applied to the input terminals of the recording amplifier, except for those output signals which consist of harmonics of the input signals and intermodulation products, and flutter and wow.

In *magnetic recording*, noise was described as that which is generated in the reproducing head during the reproducing process. It was said to be

“ . . . produced by undesired variations of the magnetomotive force in the medium which are applied across the scanning gap of an initially demagnetized head, when the medium moves with the desired motion relative to the scanning device.”

The presence in a recording medium of the condition which produces the desired modulation (like transmission in a film, slope of a groove, or magnetism in a wire or tape) was also noted as a factor which results in an increase in noise in comparison with the condi-
(Continued on page 32)

Fig. 1. Circuit of amplifier used in Masco dual-speed dual-track tape recorders.

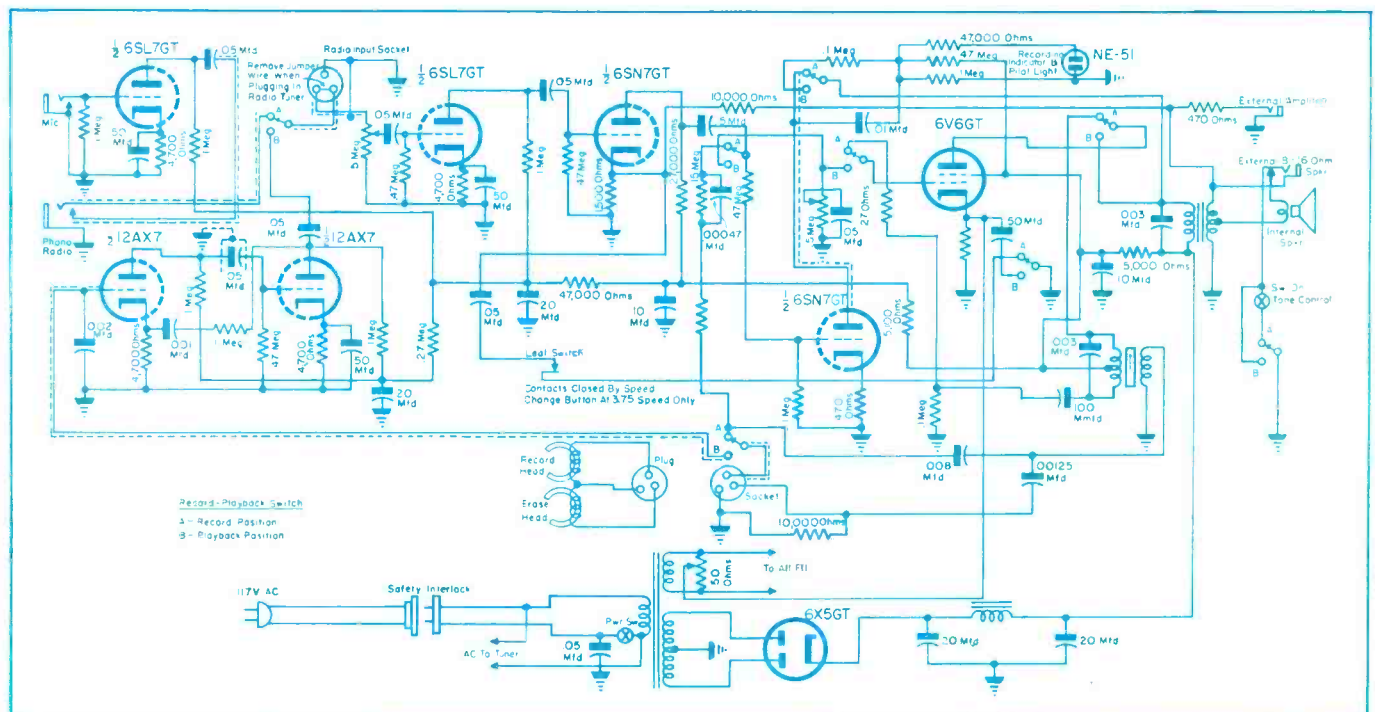

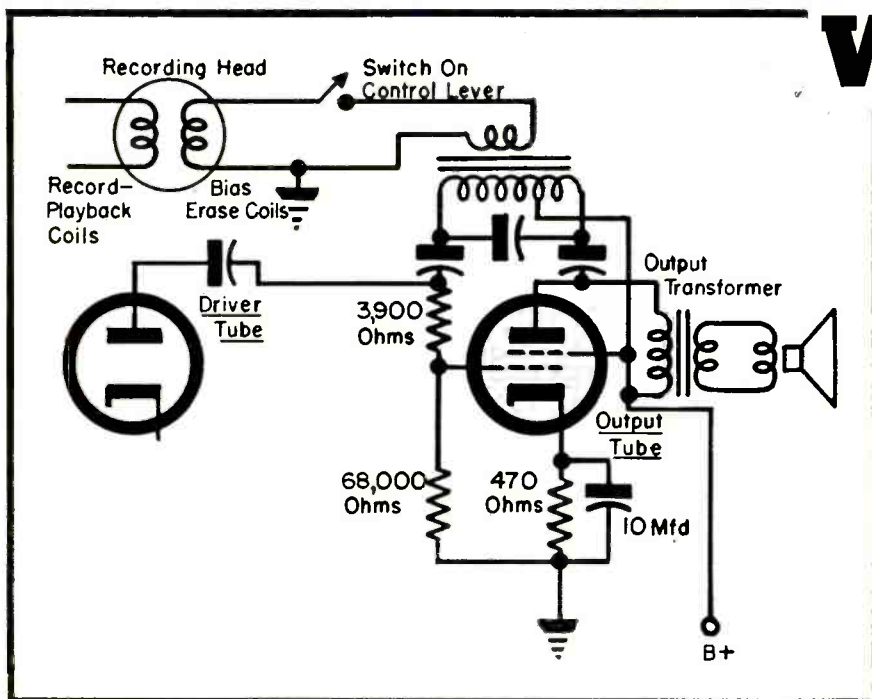

Fig. 1. Output circuit of typical recorder. The pentode is used as a power amplifier on playback and as the bias oscillator while recording. A triode drive tube furnishes the recording signal, while the pentode supplies the bias voltages.

Tracing and Solving Problems in the Transporting Mechanism (Felt Brakes..Drives..Level Winds..Drums..Motors) and Amplifiers and Bias Oscillators.

THE LAST FEW YEARS have witnessed a striking expansion of the wire and tape recorders market on many fronts; homes, schools, offices, etc. With the increased use of these instruments in the consumer field has appeared a new profitable medium for the Service Man. The actual servicing of this type of equipment should present no problem to anyone who has specialized in audio amplifier work.

Basic Principles of Magnetic Recording

The theory of magnetic recording is not new, having been first discovered by Valdemar Poulsen, a Danish physicist, in 1896. For a long time, it remained only a laboratory curiosity, due to difficulties in materials and design. New alloys and methods of applying coating to tape, have brought magnetic recording into the everyday life of many. Today, almost all of the transcribed network programs are processed on tape or wire. Thousands of units have been sold for dictating work, interview recording, speech and musical training, etc.

Theoretically, the principles of magnetic recording are quite simple: A magnetic medium, tape or wire, is passed over a *recording head*, a coil, which is supplied with a current, modulated at an audio frequency. This

current causes a change in the residual magnetism of the medium. To playback this recording, the medium is passed over a *playback head* which is a coil of wire connected to the input of a high-gain amplifier. The changes in the magnetism of the medium induce corresponding currents in the coil, which are amplified and reconverted to sound.

In practice, of course, the procedure is not quite so simple, and many practical problems had to be solved before efficient recording and playback equipment could be made. To obtain proper magnetic characteristics, a *dc bias* was first tried, in addition to the audio currents. This was found to produce poor quality, and increased noise. It was then found that the problem could be overcome by *supersonic bias* voltage, usually around 35-50 kc, at a low voltage during recording, and a somewhat higher voltage, at the same frequency, for *erasing*.

This development was probably responsible, more than any other, for the popular adoption of magnetic recording. The fact that a recording medium could be used over and over again, made an instant hit. Mistakes could be erased, or an entire new program recorded over any previous recording.

The wire used for recording is a special alloy, usually with a stainless-

steel base, about .004" in diameter. It is supplied on standard spools, providing fifteen minutes, thirty minutes and one hour of recording time, at the standard wire-recording speed of 7.5 inches per second. Tape recorders normally use a plastic tape, similar to cellophane, about 8-mm wide, which is coated on one side with a very finely divided ferrous coating, carrying the recording. Paper tapes are also available, but the plastic types are much more durable and are gradually supplanting the paper. Contrary to a commonly held belief, wire has been found to be capable of providing better fidelity than tape. The result, of course, depends upon the quality of recorders and associated equipment.

Servicing Problems

There are two major units to consider in servicing: the *transporting mechanism* and the *amplifier*, with microphone and recording head.

The transporting mechanism must provide a means of moving the wire or tape across the recording head at an absolutely constant speed, and a means for rewinding it when finished recording. Variations in recording speed can produce flutter and wows in the recording. To rewind, the mechanism is reversed, and speeded up. Some of

TAPE Recorder SERVICING

by JACK DARR

Quachita Radio Service

the tape recorders offer a choice of three speeds; 3 inches per second, for long playing; 7.5 inches per second, which is standard, and 15 inches per second, for high-fidelity recording. A *fast-forward* speed is included on some machines to permit editing of tapes; reaching some particular spot on the tape quickly, so that it may be checked and cut out if necessary. Speed changes are made by selecting different sized drive-rollers, usually by means of levers.

In tape-recorders, and particularly in wire-recorders, the medium must have a tension applied during recording, to insure a tight fit over the recording head. In wire recorders, this also insures a level wind on the spools. Most machines use a *level-wind*, like a fishing-reel, to distribute the wire evenly on the spools. This is accomplished by an eccentric, which moves the recording head up and down, usually at the rate of one full swing to 10 turns of the drums.

To assure tension on the wire at all times, felt *brakes* are used, on most wire-recorders. These are mounted below the drums, with their drag controlled by switching levers. The drag is applied to the feed spool, in *run* position, and to the take up drum, in *rewind*. When the lever is switched to *off* position, drag is applied to both drums, to prevent over-run and spillage of the wire. The average tension on these brakes should be about a half-ounce; that much pull should be used to pull wire off a drum, at rest.

The brakes, themselves, are small felt pads. If they become soaked with

oil, they must be cleaned, by washing out with carbon-tet and drying thoroughly. Tension is usually applied to the brakes by springs, and adjusted by bending small metal arms holding the springs. This brake-tension is the first item that should be tested, whenever a wire-recorder is serviced. This can be done by turning on the machine, threading up and allowing it to reach full speed, in either direction. Then the equipment should be shut off quickly and watched closely for any signs of *over-run*. You should be ready to grab the spools, in case they are too loose.

Drives used on most machines are very similar to the familiar record-changer drive. A small rubber-tired idler wheel is driven by the motor shaft, and still another idler is driven by the first, to obtain the higher speed needed for rewinding. If slippage is found, the idlers should be cleaned well with carbon-tet, and surfaces of the rubber roughened slightly with fine sandpaper, to insure good traction. Motor and drives should be checked for over-oiling, which might obtain as a result of home-lubrication jobs. The whole assembly should be washed out with carbon-tet, if necessary, to prevent oil and grease from getting back into the machine. Oiling of the motors themselves is usually unnecessary; a few drops of oil on the small felt washers at each end of the armature will suffice for a long time.

The *level-wind* should also be adjusted via a screw adjustment. A perfect adjustment should permit a rise and fall, just enough, to give an even

distribution of the wire on the spools. At the bottom, the wire should be about $\frac{1}{2}$ " from the bottom flange and at the top, the wire should be about $\frac{1}{8}$ " from the top flange. It is important to see that old grease has not caked on the slider; this will prevent free movement. Old caked lubricant should be washed out and a very thin coat of *lubriplate* or white vaseline applied. If the level-wind sticks, it may cause piling of the wire at the top, and a spillage; this may also be the result of the wire winding too high, and catching in the notch of the takeup spool.

Spills

Spills, the most annoying of all wire-recorder troubles, are usually caused by loose brakes on one of the drums. When the machine is stopped, the drum will continue to revolve, throwing the wire from it, and causing several turns of wire to fall under the drum. The wire is so fine that it easily finds its way under the spools, around shafts, and practically everywhere else. The best way to avoid spills is to check brakes before operating the machine. At least a five-minute run should be made and the wire on the takeup drum then inspected. If it is wound smoothly and tightly, the brakes on the supply drum are probably good. Now it is possible to rewind and note the condition of the wire on the supply spool. If there are loose loops showing, the takeup-drum brake is too loose.

If you do get a bad spill while working on a recorder, it is important to
(Continued on page 54)

Fig. 3. The tape path in a recorder. The capstan is driven by the motor, while the tape is pulled by it because it is held firmly against a rubber surface by the pressure roller, which is movable. The takeup reel is pulled by the motor, while in play or record position; this is to take up tape. The supply reel is pulled in rewind position and takeup is released.

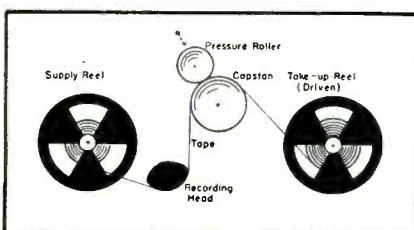
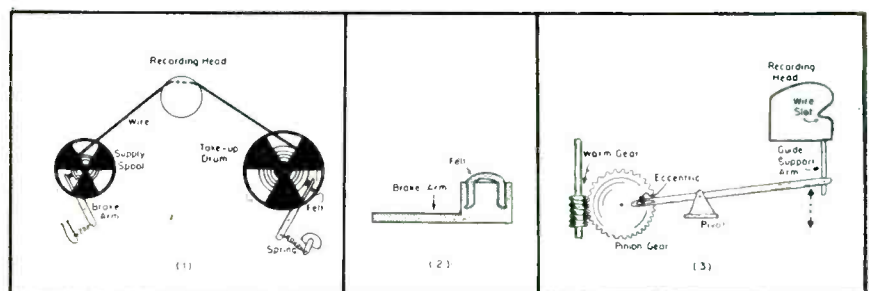
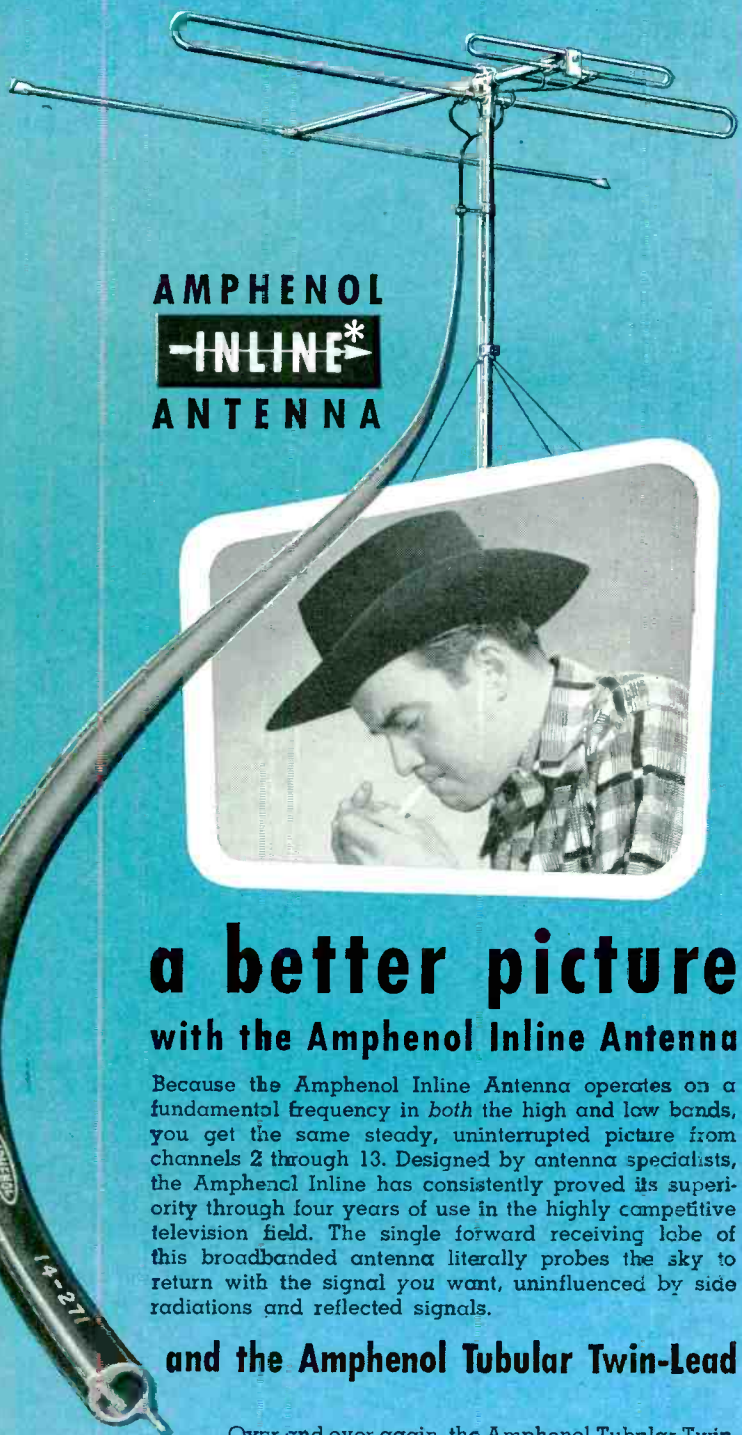

Fig. 2. At left appears the wire path on a wire recorder, using a typical level-wind mechanism. In center is illustrated a side view of the brake arm and the felt pad used. At right is a simplified sketch of a level-wind mechanism. Head is raised or lowered by the arm.





**AMPHENOL
-INLINE*
ANTENNA**

**a better picture
with the Amphenol Inline Antenna**

Because the Amphenol Inline Antenna operates on a fundamental frequency in both the high and low bands, you get the same steady, uninterrupted picture from channels 2 through 13. Designed by antenna specialists, the Amphenol Inline has consistently proved its superiority through four years of use in the highly competitive television field. The single forward receiving lobe of this broadband antenna literally probes the sky to return with the signal you want, uninfluenced by side radiations and reflected signals.

and the Amphenol Tubular Twin-Lead

Over and over again, the Amphenol Tubular Twin-Lead has been established as the one satisfactory answer to the need for an economical TV lead-in for use in those trouble areas where conventional twin lead cannot be used. The tubular construction of high grade polyethylene provides a protected area, using air as the dielectric, between the conductors. This provides low-loss and constant impedance at all times, unaffected by any exterior condition.

This book contains . . .

a complete, yet condensed evaluation of the various types of antennas on the market today, graphs and illustrations clarifying their various characteristics, and information on the use of rotators, lightning arrestors, etc. Obtain your free copy from your Authorized Amphenol Distributor.

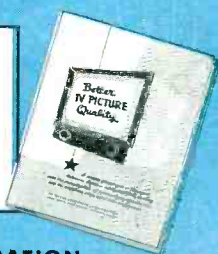

AMERICAN PHENOLIC CORPORATION
1830 SOUTH 54TH AVENUE • CHICAGO 50, ILLINOIS

Audio

(Continued from page 29)

tion of no modulation. This extra noise, which is modulated with the signal, is *modulation noise*.

Signal-to-noise ratios, also covered in the committee review, were described as the quotient of the integrated signal power output, at a specified maximum value of distortion, over a specified bandwidth, to the total noise power output integrated over the *same* band of frequencies.

Wow and Rumble Defects*

The motor system has often been found to be a base cause of noise. When, for instance, there's any variation in turntable speed, usually once with each revolution of the turntable, *wow* results. Its effect is such that a change in pitch (distortion) is heard at definite intervals. For example, if *wow* is present, a record on which a 1,000-cycle note is cut will not reproduce (when played) a note of constant pitch, but the pitch will change at regular intervals to a lower value, producing a *wow* effect. Any of the following conditions might cause *wow*: dirt under and around the idler-wheel assembly; idler-wheel spring loose or missing; flat spot on idler-wheel tire or turntable; loose or worn pulley belt; oil or grease on idler-wheel tire, pulley, pulley belt, or drive shaft; and speed-control knob not in proper position.

Another noise problem is *rumble*, which may be caused by a flat spot on the idler wheel or a dynamic unbalance of the rotor. The vibration resulting from such a condition is transmitted mechanically to the turntable and pickup, and hence is reproduced as a low-frequency sound by the amplifier and speaker associated with the record player. In the case of the 1,000-cycle note recording, any rumble that is present would be heard as a low-frequency note which is continuously modulating the 1,000-cycle note.

Another motor problem, causing noise, is *end play*. This usually appears in motors designed to be mounted with the rotor in a horizontal plane. Because of the thrust of the rotor, the spacers between the shoulder on the rotor shaft and the bearings, become worn or cracked. As a result, there is too much end play and *noise*. Many changers employ vertically mounted motors with thrust bearings that prevent end play.

In a motor that uses a commutator, another source of possible *noise* trouble may arise. The field in this type of motor is in series with the commutator, the series connection being made through the use of brushes which ride over the segments of the commutator. Eventually these brushes become worn down, cracked, or chipped, because of either long use, overloads for long periods of time, or excessive current caused by a shorted coil. Sparking at the brushes can result if the armature has too much play or if there is lack of tension in the brush springs. When the brushes are loose, they are usually worn out. Brushes must be replaced if any of these defects appear. Incidentally, the spring should never be stretched.

When motors having commutators and brushes are used in phono systems, they are usually of the universal type; that is they will work on either *ac* or *dc*.

Phono Motor Characteristics*

Since motors can be a base source of noise, it is wise to

*Based on copyrighted Philco service notes.

(Continued on Page 56)

ANOTHER CBS-HYTRON FIRST YOU'LL BE BUYING SOON

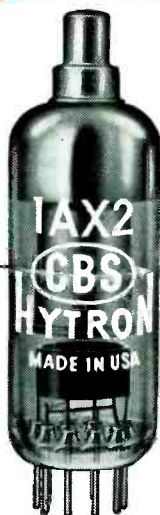

CBS-HYTRON 1AX2

NEW HEAVY-DUTY TV HIGH-VOLTAGE RECTIFIER CAN TAKE IT!

TV high-voltage rectifiers take a beating: Terrific variations occur in applied filament voltage... 0.8 to 2.4 volts! Sudden arcs in the rectifying system place destructive electromechanical stresses on the filament. And the increasingly larger TV picture tubes demand peak emission and peak inverse voltage simultaneously. The new CBS-Hytron 1AX2 was especially designed to take such rough treatment and come up smiling.

1AX2 DATA

The CBS-Hytron 1AX2 is a compact, 9-pin miniature TV pulse rectifier. Plate is brought out to top cap and filament is oxide-coated. Absolute maximum ratings are: peak inverse plate voltage, 25,000 volts; d-c load current, 1.0 ma.; and steady-state peak plate current, 11.0 ma.

Typical Operation — TV Pulse Rectifier

| | |
|------------------------------|-----------------|
| Filament voltage | 1.4 v \pm 10% |
| Filament current | 650 ma |
| Positive-pulse plate voltage | 20,000 v |
| Negative-pulse plate voltage | 5,000 v |
| Peak inverse plate voltage | 25,000 v |
| D-c output voltage | 20,000 v |
| D-c load current | 300 μ a |

BOTTOM VIEW
OF SOCKET

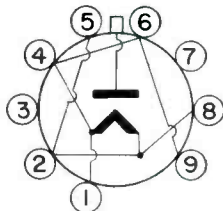

ADVANTAGES OF NEW CBS-HYTRON 1AX2

- 1 Rugged, high-wattage filament of CBS-Hytron 1AX2 has adequate peak emission for the new, larger TV picture tubes. 1AX2 may be run simultaneously at both its peak inverse voltage and maximum d-c current.
- 2 Higher load of 1AX2 filament on transformer tends to regulate filament voltage. Eliminates need for limiting resistor. Yet lower plate-to-filament capacitance (0.7 μ f) of 1AX2 prevents loss of high voltage.
- 3 Insulated tension bar (patent applied for) through center of 1AX2 coiled filament limits destructive movement of filament by electromechanical stresses.
- 4 Filament of 1AX2 is located in base and shielded to eliminate bombardment of cool ends of filament by gas molecules.
- 5 An overloaded 1X2A may be replaced with its big brother, the CBS-Hytron 1AX2, by simply removing the limiting resistor. In rare cases, it may be necessary to add another turn to the secondary of the filament transformer to obtain the required 1.4 volts for the 1AX2.



MAIN OFFICE: SALEM, MASSACHUSETTS

SERVICE, JUNE, 1952 • 33

Supplementary PA



Flexible Sound System Developed to Provide Comprehensive Coverage for Audience of 36,000 at Wembley Stadium, London, Eng.

Left: View of the Wembley Stadium illustrating vastness of arena and position of some of the speakers.

IN EQUIPPING large meeting places or stadiums with *pa* systems, there are usually many special problems to consider and solve. It is necessary to study the manner in which the microphones will be used, the coverage concentration required for large, medium and small audiences, and sound distribution that will obtain when indoor, tent cover or outdoor conditions prevail.

Recently, all of these problems and others, too, appeared when the Wembley stadium had to be readied for the International Convention of Jehovah's Witnesses. The stadium had been set up for close speaking. For the *assembly* affair, this arrangement had to be changed, since in this instance the speakers use a normal, sometimes soft and rather fast, conversational voice, at some distance from the microphone. Informal discussions by a group spread around a microphone also had to be considered in placing the pickup unit. In sporting events, the announcements are often supplementary to other forms of communication (such as a scoreboard) and may be repeated, so that failure to hear a word or two can be rectified by the audience themselves.

For the talks and discussions at the assembly, it was noted that the audience would be dependent on hearing every word, to get the benefit of the program. Thus this condition had to be considered carefully. The speed and style of delivery at sports meetings, together with volume adjustment, make it possible to minimize the effect of bad spots of echo confusion. In assembly meetings, this method is not applicable.

The presence of people speaking, not only different dialects of English, but also completely different languages, and understanding others only by very careful attention, meant that every word had to be clearly intelligible everywhere. Here was another extremely critical problem. For some sessions it was found necessary to sectionalize the stadium, so that assemblies in different languages could be held in different parts at the same time.

The vastness of the place meant that, when the necessary equipment was available, miles of cable would be required to connect it up.

To complicate matters, the stadium had been scheduled for assembly meetings on alternate days, and on the reg-

ular evenings, greyhound racing and speedway meetings were to be held as usual, and all special equipment had to be out of sight on those evenings.

Preliminary tests showed that the weak places for hearing were in the covered area of the stands, where all the seating was located, the frontal areas for standing being well served by the existing equipment. The weakness was due to the considerable distance from the pole-mounted speakers around the track to the back of the stand, where reflected sound returns to create confused areas mid-way up the stand.

Speaker Mountings

To overcome this, thirty flared cabinet loudspeakers were installed around the roof-front, to feed the seated area, and the pole-mounted speakers were operated at lower level, to feed just the standing enclosure without causing confusion in the covered area.

These cabinet speakers were also used for the foreign language assemblies. To save wiring an ingenious two-way plugging arrangement was

Fig. 1. Arrangement employed to permit use of the same loudspeakers and cabling for the main circuit (top) or the local amplifier (bottom).

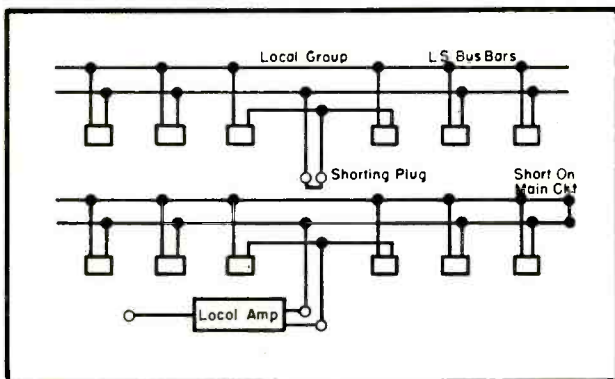
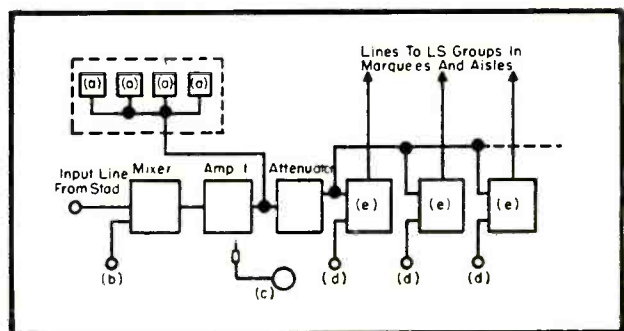

Fig. 2. Block diagram of equipment installation at cafeteria headquarters: Workers section is at (a); input for blanket announcements is at (b); at (c) is the microphone for the cafeteria announcements; inputs for local announcements in one or more marquees or in the access ways are at (d); at (e) are the subsidiary amplifiers.



Stadium Installation

by N. H. CROWHURST

employed; Fig. 1. The main power amplifier, a 60-watter, feeding the supplementary speakers by means of a 100-volt line, fed those intended for alternative local use through a shorting plug, conveniently mounted in the area. When the foreign language assemblies were on, the main power amplifier output circuit was short-circuited to prevent interaction, and the output from a local *pa* set injected into the shorting-plug socket, thus feeding only into the local group and not the main bus-bars. In this way as many as six different points were operated simultaneously without interaction. Ordinary 6-watt amplifiers, with the addition of a 100-volt output matching transformer, were used for this service.

Microphone Positions

The main platform was out on the *pitch*, where up to four microphones were required. The orchestra, used for leading the singing and playing incidental music, was located in a glass enclosed section of the north stand. A choir was also located in the section of stand immediately in front of this. This composite program source was to be fed to the entire stadium, and also to the cafeteria camp, operated outside for the benefit of all conventioners, in 8 large marquees. Additionally, the cafeteria department was required to make their local announcements.

Amplifier Locations

To provide these facilities, microphone amplifiers were installed for the platform and orchestra and choir, with electronic mixing circuits, controlled remotely from a panel installed in the box normally used for greyhound racing. Switches, ganged to the quick-fade switching, controlled *ls* groups to prevent acoustic feedback. The outputs from the microphone amplifiers, at 600 ohms, were combined in a fixed mixing network, and fed into one of the main stadium amplifier's inputs

(with suitable attenuation), and also into the 60-watter feeding the supplementary system. The same 600-ohm line was extended to another glass-enclosed section, provided with a buffer amplifier for feeding a number of tape recorders brought by conventioners, and over to the cafeteria marquees, where it fed into a number of 6-watt amplifiers for different sections, using twenty or more loudspeakers in all. Local announcements were introduced by the arrangement shown at Fig. 2.

Use of Low-Power Amps

From the foregoing it would seem that a large number of amplifiers were required, but some economy was effected by using the 6-watt amplifiers for both cafeteria and foreign language assembly service, transferring them from site to site as required, the wiring being previously installed.

Headphone Monitoring

An interesting facility was provided to achieve unity in singing, a real difficulty in so large an audience. The conductor on the pitch was equipped with headphones, served with sound direct from the orchestra enclosure. The orchestra and choir each had local conductors who took their cue from the men with the headphones. The main body of the audience could all see him (but not his headphones, because of the great distance). As a result,

the singing was all *dead in sync*, truly impressive from so large a crowd.

Manpower Requirements

Some readers might think that a job like this must have been done by a large *pa* organization, and would be beyond the scope of the small man. But no *pa* organization was called in. A *staff* of about 20 practical men from different parts of the country, who were attending the convention, cared for all *pa* requirements. The equipment was, in the main, brought in by local groups, the exception being the main amplifiers, which were specially built some time ago by the author for assemblies of this type, but on a smaller scale. Jehovah's Witnesses do not come from the higher salary brackets, so cost had to be minimized, consistent with giving a high standard of service. A news reporter, covering the convention, commented that he had never heard such clear and adequate *pa*.

Plug-Socket Facilities

All equipment installed inside the stadium was provided with plug and socket connections, enabling the whole supplementary installation to be removed or reinstalled in under 30 minutes. This, of course, called for close scheduling of duties by the *staff*.

(Right)

Fig. 3. Layout of equipment in stadium.

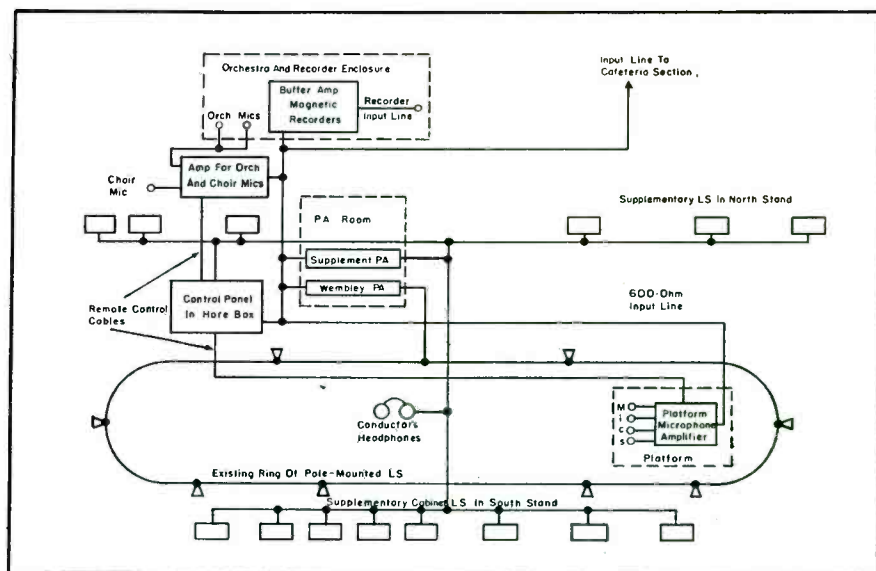



TUBE

News

by L. M. ALLEN

Design and Adjustment of Centering and Ion-Trap Magnets in Electrostatic-Focus Circuits . . . 1AX2 Application Notes †

ONE OF THE MOST COMMON causes of failures in TV chassis has been the *hv* rectifier tube. It has been found that there are several possible reasons for the short-life conditions. Prominent among the causes is the wide range of filament voltages encountered in television sets in the field. Line-voltage variations, adjustment of horizontal drive control, differences in horizontal oscillator tubes as well as horizontal amplifier tubes, and different flyback transformer designs contribute to a situation wherein the filament of the rectifier tube may be operating at values as low as 0.8 volt or as high as 2.4 volts.

Another factor that has been found to prompt early failure is the effect of electromechanical stressing of the filament, caused by the very high electrostatic fields existing between it and the

surrounding plate structure. Sudden changes in this potential, when high-voltage arcs occur anywhere in the system, subject the filament to stresses which can cause breakage where the filament is attached to its support rods. According to Hytron, the use of tungsten wire for the filament base in both of the popular *hv* rectifier tubes prevents a true weld of the tungsten to the nickel support rods. Instead, the tungsten wire is imbedded into the support rods, to provide a good mechanical and electrical joint, but not as good as should be possible with a complete flow of the metals.

In designing a new tube, the 1AX2, these factors were considered and as a result, several structural changes

were included. The position of the filament was changed and it is now located in the base of the structure, surrounded by a shield which has been found to eliminate bombardment of its cool ends by gas molecules. The filament itself is a spiral of nickel alloy ribbon. The use of a nickel-base filament wire was found to permit true welding of the filament to its supports. In addition, an insulated tension bar was included and passed through the center of the coiled filament to limit the amount of movement that can be caused by electrostatic stress.

To support the higher average currents required by the larger picture tubes, the *hv* rectifier must be capable of meeting its full ratings for both current and voltage simultaneously. To

(Continued on page 68)

Roxanne, of the *Beat the Clock* program, with Sylvania tube number 1,000,000,001, which will mean two all-expenses paid cruises to Bermuda for the lucky consumer who receives it.



At a recent billionth-tube ceremony in the Emporium, Pa., radio-tube plant of Sylvania Electric; H. Ward Zimmer (right), executive vice president, congratulating Matt Burns, manager of the radio tube division, who holds the billionth tube in his left hand. Next to Burns is George Rishell who, on an original developmental grant of \$500 in 1924, produced Sylvania's first radio tube, a 201A, and set up the first tube production line. Rishell is holding the company's first tube. Harold Rainier, left, manager of the renewal sales department and George Sommers, general sales manager for the division, also took part in the ceremony.



Five new additions to the G. E. high-reliability tube line: Rear, left to right, the GL-6072, a twin triode; the GL-6137, a remote cutoff pentode; and the GL-6201, a twin triode. Front, the GL-6136, a sharp-cutoff pentode, and the GL-6135, a medium-mu triode.

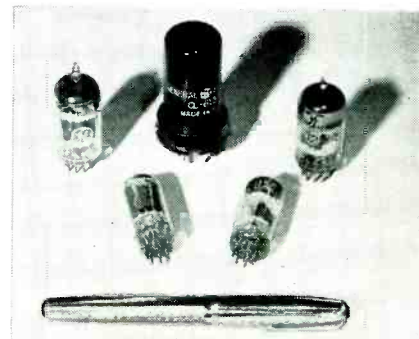



INDIVIDUAL NEEDLE PACKAGE

NEW...

**the Complete
Phonograph
Needle Line**

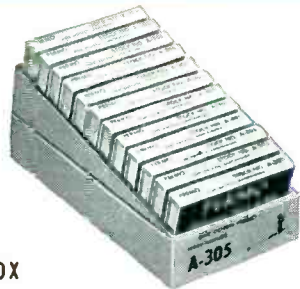

"12 IN 1"
DISPLAY BOX

NEW...

**Specific Cartridge
To Needle
Data**



"36 IN 1"
DISPLAY CASE

NEW...

**Practical
Packaging
and
Display**

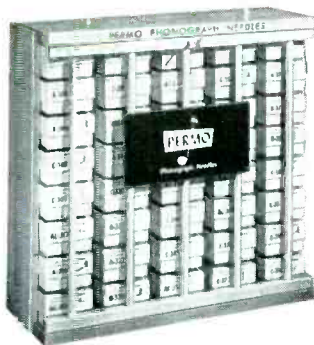

"40 DOZEN
IN 1"
DISPLAY
CABINET

NEW...

**Simple Inventory
Control —
Accurate
Re-order System**

Buy the line that's complete in every detail!

PERMO *phono-needles*

See Your Distributor...

EXTRA: Write for your complete 36-page catalog now — it's just off the press! Gives full details on the profit-packed Permo line.



PERMO, Inc., 6415 RAVENSWOOD AVENUE, CHICAGO 26, ILLINOIS

MANUFACTURERS OF "FIDELITONE", "PERMO-POINT" AND "PERMO" PRODUCTS
LONG-LIFE PHONOGRAPH NEEDLES • RECORDING TAPE AND WIRE • RECORD BRUSHES

Auto Radio

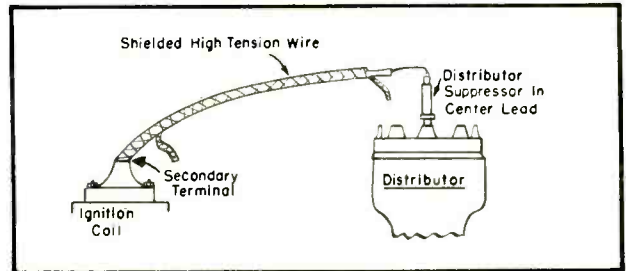
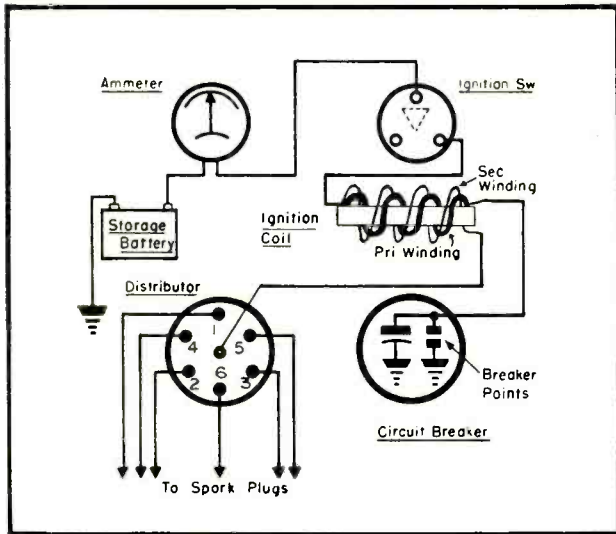

(Above)

Fig. 2. Location of distributor suppressor.

(Left)

Fig. 1. Wiring diagram of an ignition circuit.

HOME SET Service men are often reluctant to enter auto radio servicing because of the difficulties they feel are associated with the activity. Repairs on auto sets are basically no more difficult to complete than those involved in home chassis, and the servicing jobs are often quite extensive, resulting in substantial income. There are, of course, special problems peculiar to auto radios that must be considered. Also, troubleshooting may, in some cases, require an elementary knowledge of automobile construction.

Two unpleasant features of the auto-radio service business—interference problems, and the difficulties associated with pulling a set—have changed considerably for the better in recent years. The interference problem has become a relatively minor one in modern car receivers. Pulling, while in some cases still a tedious item, is usually quite simple and uncomplicated.

No unusual expense need be involved in getting set up for auto-radio servicing. A drive-in space is desirable, but not essential. The service shop owner can make arrangements with a nearby garage to provide not only drive-in space but solicit the business, and possibly even supply employee help for set-pulling (when necessary), in exchange for a per-

centage of the profits, or a flat fee.

The chief piece of equipment needed is a 6 *v dc* source capable of energizing the car radio in the shop. A storage battery may be used for this purpose, or a suitable power unit** of adequate current-handling capacity that converts 110 *v ac* to 6 *v dc* may be purchased. (It is assumed that 110 *v*

Fig. 3. Placement of spark plug suppressors. Only one spark plug is shown, although many are, of course, present.

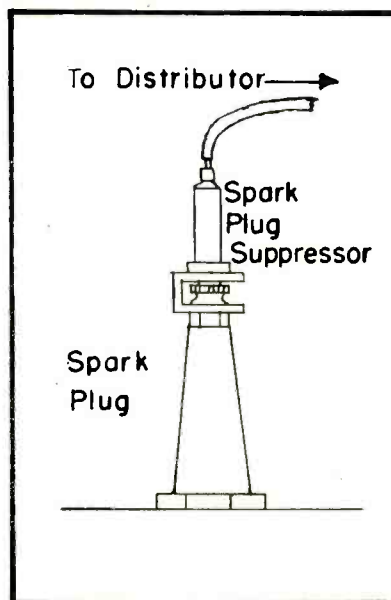

ac is supplied to the service shop.) Other items that are handy are one or two car antennas, clip-on leads, substitute auto-radio speakers, etc. Tools and test instruments used in home receiver work will, of course, also be required.

Basic Differences Between Auto Radios and Home Sets

The space available in the car for the auto radio is necessarily limited; this means that the car receiver must be built quite compactly. Servicing, in some sets particularly, is at close quarters, so to speak; but certainly not more so than in *personal* or camera-type portables.

The vibration and wide shifts in temperature that the auto radio is subjected to make rugged set construction essential. Many of the components used are sturdier than those employed in home receivers. Slight defects—a noisy tube, for example—that might not noticeably impair reception in a home receiver, will be very noticeable in the auto radio, due to the constant jarring to which the latter is exposed. Auto radio Service Men must consequently be more careful, more comprehensive in their work, making sure to eliminate every possible source of trouble, no matter how small,

Installation and Service

by SOLOMON HELLER*

Part I of a Series: Differences Between Auto and Home Chassis . . . Tracing and Curing Troubles External to the Receiver . . . Operation of Ignition Systems Components and Their Relation to Interference.

that the car's movements may magnify.

A small antenna must be used on the auto radio receiver, due to space limitations. Signal pickup will therefore be relatively poor. The receiver must therefore be very sensitive, or have a high gain, to make up for the insufficient signal input.

Permeability-tuned front-end circuits—i.e., tuned circuits in which the capacitor is fixed, and the coil inductance is variable—are commonly used, because they are not as affected by jarring as capacitively-tuned circuits, and occupy less space.

The power supply of the auto radio is quite different from that of the home receiver in certain respects. The 6 *v dc* provided by the storage battery is changed into low *ac* by a vibrator, stepped up by a transformer, and rectified (as well as filtered), to supply the required *B* voltages.

Thorough shielding, and extensive bypassing and filtering are necessitated by the location of the auto receiver in the vicinity of the electrical system of the car.

Another point of difference between the car radio and the home receiver

in many cases is the use, in the car set, of a low-resistance speaker field coil which will pass the large current needed to energize it. *PM* speakers are also used in some sets.

When trouble is reported in the reception of an auto radio, the Service Man must determine whether its source is external to the car or external to the set, but in the car, or in the antenna, or in the receiver proper.

Determining If Trouble Is External to Car

Since the car radio is highly sensitive, to compensate for its poor antenna pickup, it will readily receive interfering or undesired signals, as well as desired ones. The interfering signals referred to are noise pulses, produced by the electrical system of the car, or by sources outside the car. If the source of interference is outside

the car, nothing can generally be done about it by the Service Man. He should know enough, however, to recognize the source of the trouble, to prevent wasting time in unnecessary checking.

High power lines, electrical devices, ignition systems of other cars, etc., can all produce noise in the car radio. This type of interference can be readily identified because it is present only in certain localities. As soon as the car moves out of the area where the noise fields are strong, its reception will improve.

Interference Sources in the Car Itself

When the interference or noise originates in the car itself, the noise will be present wherever the car goes, except in the case of tire and wheel static. Before remedies can be applied, the source of the noise must be determined. Possible sources may be

(Continued on page 55)

*Co-author of *Television Servicing*.

**Cataldo, J. T. *Auto Bench Power Supply*, SERVICE, January, 1951.

Fig. 4. Generator capacitor installation. At *A* is the field terminal; capacitor must not be connected here. (Courtesy Motorola)

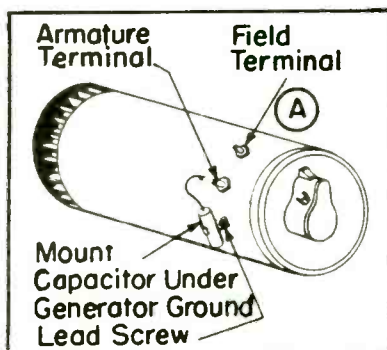

Fig. 5. A typical distributor suppressor installation. (Courtesy Motorola)

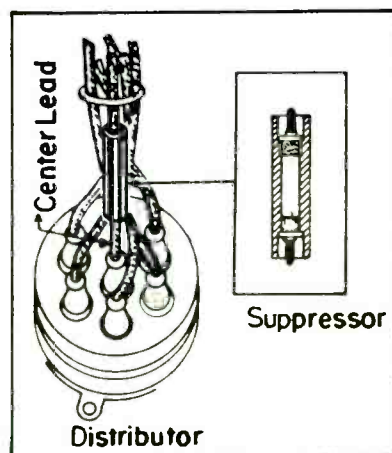
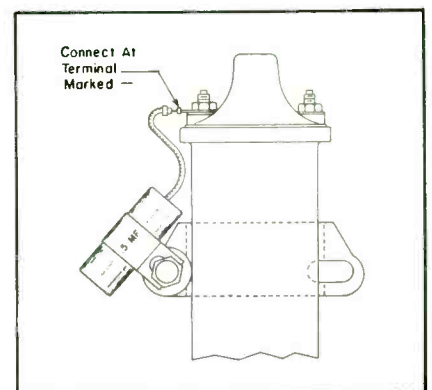
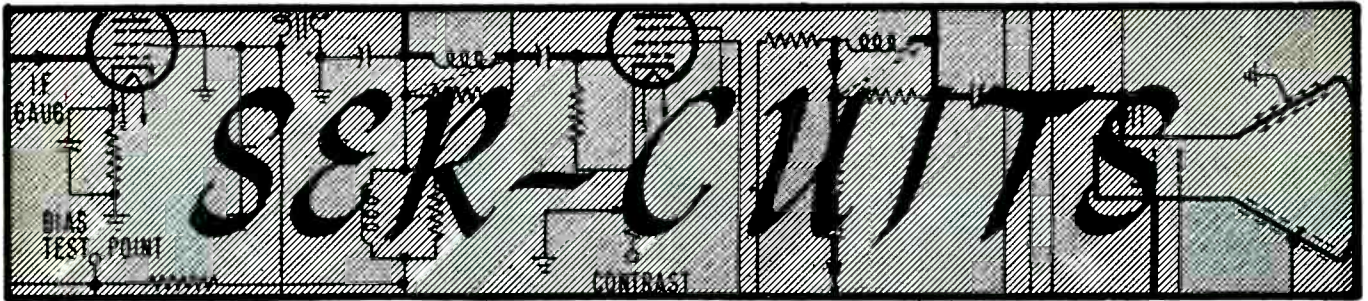

Fig. 6. An ignition coil capacitor installation. (Courtesy Motorola)





by M. W. PERCY

Comparison of Ultrahigh and Veryhigh Receiver Design . . . Features of Ultrahigh Tuner Using Curved Line Structure

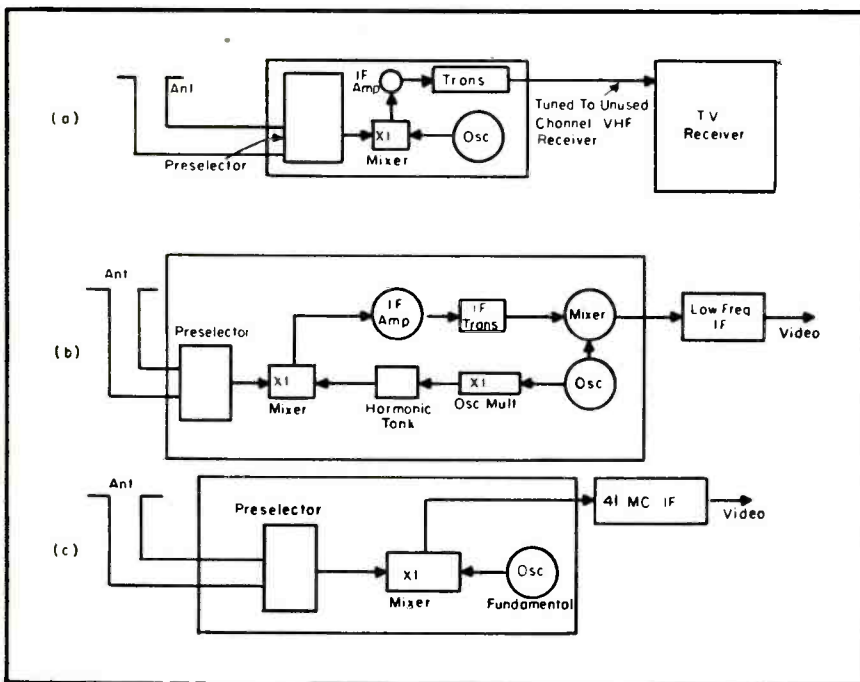
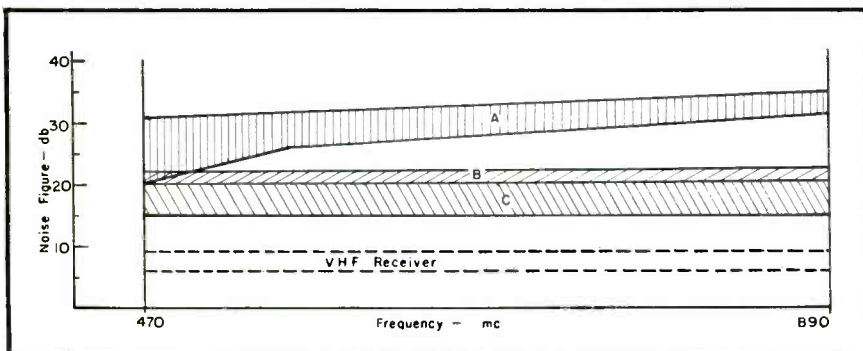

Fig. 1. Three probable approaches to ultrahigh receiver design.

Fig. 2. Noise figure of ultrahigh front ends, detailed by Varone of Admiral.



ULTRAHIGH TV receiver development and design, during the past few weeks, has been as a top priority project in many plants, with the front ends or tuners receiving practically all of the attention. Concentration on this portion of the chassis has been acute because it is the tuner which must perform probably the most important function, detect a weak signal. In addition, the sensitivity of the front end is also a direct measure of the maximum sensitivity of the complete receiver.

Discussing the various problems which must be considered in evolving tuners for the higher frequencies, at the recent IRE *uhf* symposium,† Ralph A. Varone of Admiral noted that the figure of merit of sensitivity or the *noise* figure, is a particularly important design factor. This figure has been defined as the ratio of the total noise power at the input terminals of the receiver compared to the total thermal noise power of the antenna itself.

Reviewing the three probable approaches to *uhf* receiver design, Varone said that the converter might be used to change the receiver from a single superhet to a double super employing two oscillators. The *uhf* oscillator would be located in the converter proper, while the *lf* oscillator represents the tuner of the *vhf* receiver. One of the unused channels of the receiver can be used as the *hf if* amplifier. In operation, the *uhf* signal picked up on the antenna is conducted through a preselector and mixed with the *uhf* oscillator by means of a germanium crystal. Then, explained Varone, the

(Continued on page 42)

†Conducted by IRE Professional Group on Broadcast and TV Receivers.

SIX QUALITY FEATURES OF ALL TUNG-SOL PICTURE TUBES MEAN BETTER TV RECEIVER OPERATION

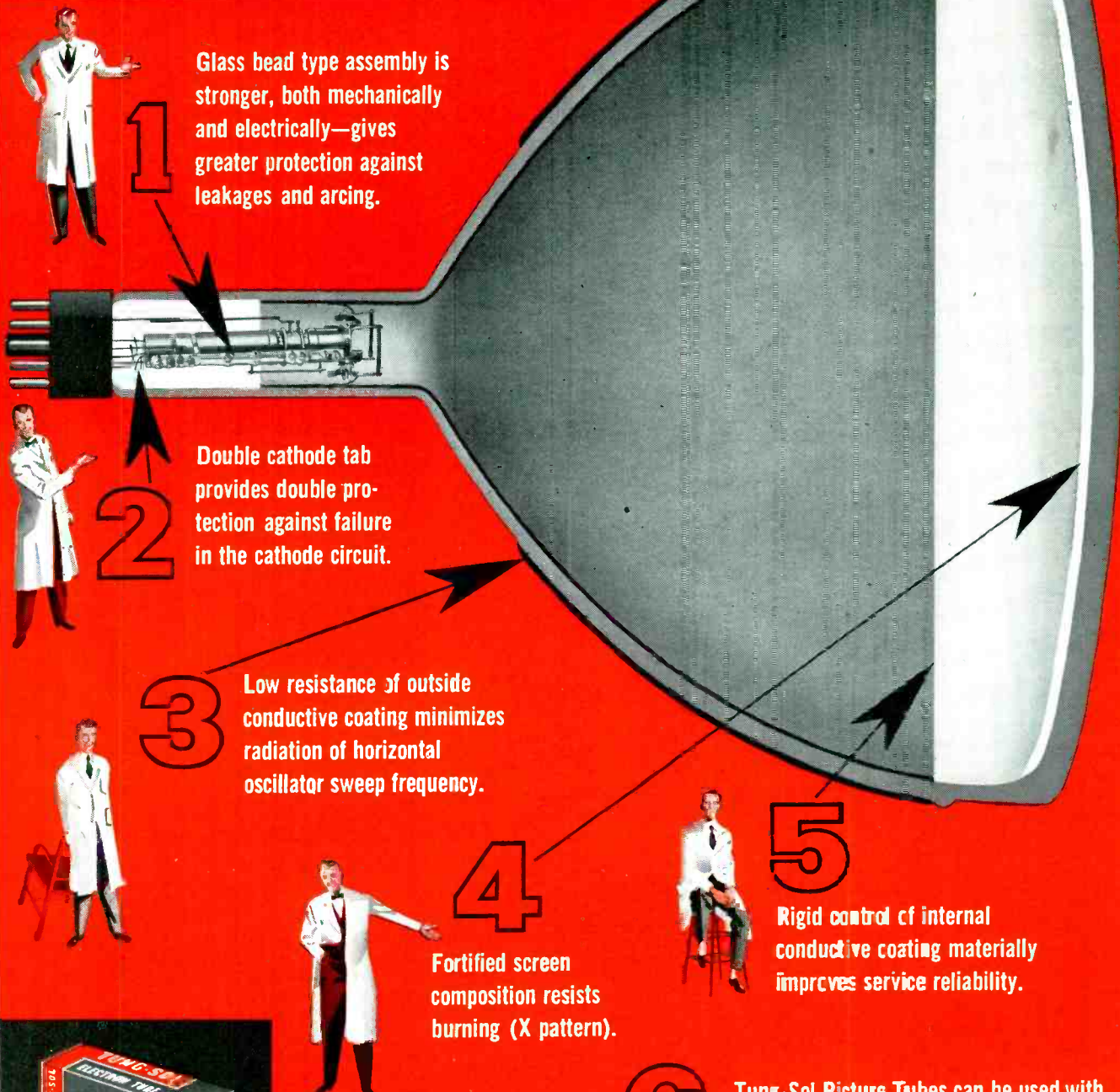

1

Glass bead type assembly is stronger, both mechanically and electrically—gives greater protection against leakages and arcing.

2

Double cathode tab provides double protection against failure in the cathode circuit.

3

Low resistance of outside conductive coating minimizes radiation of horizontal oscillator sweep frequency.

4

Fortified screen composition resists burning (X pattern).

5

Rigid control of internal conductive coating materially improves service reliability.

6

Tung-Sol Picture Tubes can be used with single or double field ion trap designs.



TUNG-SOL®
 RADIO, TV TUBES, DIAL LAMPS
Dependable

TUNG-SOL ELECTRIC INC., Newark 4, N. J. • Sales Offices: Atlanta • Chicago • Culver City (Calif.) • Dallas • Denver • Detroit • Newark
 Tung-Sol makes A1-Glass Sealed Beam Lamps, Miniature Lamps, Signal Flashers, Picture Tubes, Radio, TV and Special Purpose Electron Tubes.



No Searching

with C-D's line of "UP" electrolytics

... simplifies your TV replacement problems



- The only twist-prong electrolytic line with complete replacement coverage!
- Saves you hours of "hunting time".
- Follow the C-D TV Guide, and you automatically meet and beat the manufacturer's requirements for every TV set.
- See your local C-D jobber today (he's in your local Classified Phone Directory) for C-D's Television Replacement Guide TVR 7A or write to Dept. S.62, Cornell-Dubilier Electric Corp., South Plainfield, N. J.



CONSISTENTLY DEPENDABLE
CORNELL-DUBILIER
 CAPACITORS

PLANTS IN SO. PLAINFIELD, N. J. • NEW BEDFORD, WORCESTER AND CAMBRIDGE, MASS. • PROVIDENCE, R. I.
 INDIANAPOLIS, IND. • FUQUAY SPRINGS, N. C. • SUBSIDIARY, RADIART CORPORATION, CLEVELAND, OHIO.

Ser-Cuits

(Continued from page 40)

if output is amplified with a low noise amplifier whose output is connected to the input terminals of the *vhf* receiver.

In another system, it is possible to use a *uhf* converter employing the double superhet principle. Only one oscillator is used in this instance, thus minimizing the spurious responses and permitting the use of a low *if* of 21 mc in the *vhf* set. In such a circuit, the output of a typical *vhf* oscillator like

the 6J6 is fed simultaneously to a *lf* mixer and a crystal. Then, it was explained, oscillator harmonic output of the crystal is fed to a harmonic tank which is tuned in the *uhf* band below the signal frequency by an amount equal to the first *if*. The output of the oscillator harmonic tank is fed to a germanium crystal mixer, and the *uhf* signal picked up on the antenna is conducted through the pre-selector to the same germanium crystal mixer. Varone explained that the beat between the oscillator harmonic and the *uhf* signal, which is the first *if* is applied to a low noise amplifier, ampli-

fied and then applied to the *lf* mixer and amplified in the *lf* video amplifier in the usual way. The signal frequency, he added, is changed by varying the frequency of the oscillator and that of the first *if* amplifier simultaneously. It was noted that the full band can be covered in three steps by changing the multiplying factor of the oscillator multiplier; typical multipliers for the oscillator in the *uhf* band are 2, 3 and 4.

The straightforward single superhet is the third approach. Here the *uhf* portion consists of a preselector, a germanium crystal mixer and a fundamental oscillator operating in the *uhf* band. In this instance, the output of the crystal mixer is fed to a low noise, 41-mc *if* amplifier.

Analyzing noise figures for these circuits, Varone declared it has been found that the external converter with the double superhet and two separate oscillators was the least sensitive or most noisy; it only competes with the other two front ends at the extremely low end of the band.

The double superhet approach employing one oscillator and a crystal multiplier was found to have a noise figure of 20 to 22 db essentially uniform across the *uhf* band.

The single superhet approach, employing a crystal mixer and fundamental oscillator with a 41-mc video amplifier was noted as the least noisy, its noise figure being in the range of 15 to 20 db.

It was emphasized that in all three systems, the noise was considerably more than in present day *vhf* models. The noise figure range of *vhf* sets were said to be between 6 and 9 db.

Continuing this analysis and reviewing the sensitivity of these three systems, the Admiral specialist said that tests showed that the single superhet was less sensitive by 6 to 14 db, while the double superhet employing a single oscillator was less sensitive by 14 to 16 db, and the external converter was on an average 20 db less sensitive. Actually, he noted it may be less sensitive by as much as 29 db, at the high end of the band.

Reviewing the fundamental *uhf* components used in all three cases, the germanium crystal mixer, oscillator and a low noise *if* amplifier, Varone said that all of these components have been found to serve their purpose, particularly the crystal mixer, for without it, the higher frequencies would have not been penetrated. However, he added, industry is in need of new components that will make possible more sensitive receivers. It was noted that there is urgent need for a *rf* amplifier with a low noise figure and adequate

power gain. According to Varone, the tube used in such a system should be of the grounded grid type or of a similar design.

Tuned-Line Tuner

Last month, several tuning systems developed for *uhf* and described at the IRE national convention were reviewed. One type of tuner, not detailed, was the curved tuned-line unit, developed by H. F. Rieth of Kingston Products.

The line was said to be shaped in a radius to gain compactness, as well as, to simplify the slider and tuner drive mechanism. Tuning was described as being accomplished by using silver plated sliders having zero backlash.

It was noted that the overall *rf* circuit of the converter consisted of a stationary balanced transmission line type antenna coupling loop, a tunable preselector transmission line, and crystal mixer. The transmission line type of antenna loop was described as being mutually coupled to a preselector line, coupling being employed to correct the small variation of preselector *Q* with frequency to obtain a near constant loaded bandwidth. This was achieved by physically locating the loop closer to the preselector line at the *hf* end of the range. The oscillator and preselector lines were said to be made of $\frac{1}{4}$ " wide curved parallel strips of silver-plated brass. A parallel line of adjustable electrical length was noted as serving as the tuning means.

Describing the preselector circuit, Rieth said that its design was based on a halfwave transmission line developing an unloaded *Q* of 600 with complete absence of dead spots or spurious responses and having a line characteristic impedance of 125 ohms. In covering this frequency range the line shorting slider has a 4" travel. A crystal mixer is directly coupled to the output shorted end of the lines and the antenna is mutually coupled to the shorted input end of the lines.

To receive *uhf* stations between 470 and 890, it was noted that the local oscillator tunes from 275 to 695 mc when the *vhf* set is tuned to channel 10. The basic oscillator design was said to have an upper limit of 1100 mc which is much higher than required for *uhf* tuner application and being a quarterwave design is very stable.

The warm-up drift of the local oscillation at the high-frequency end of the band was said to be approximately +250 kc and approximately -250 kc on the low end of the band. The frequency was said to stabilize after approximately five minutes of operation. The maximum deviation due to line

(Continued on page 69)

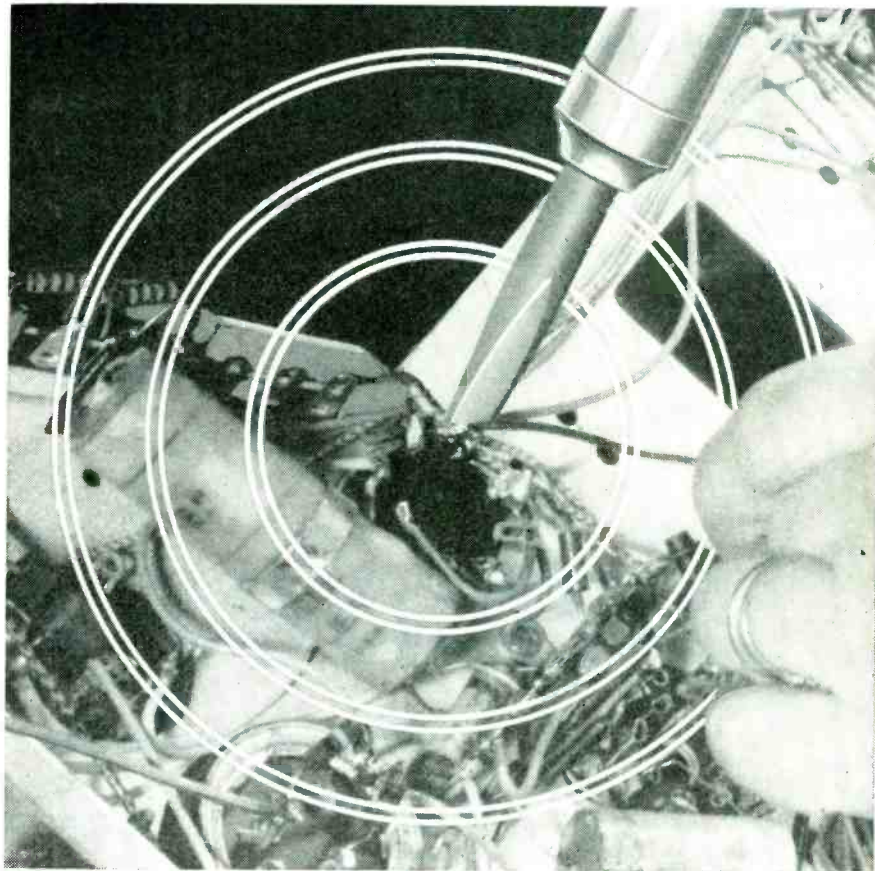

You can't beat a soldered connection

for electrical conductivity and permanence!

SOLDERED connections eliminate loss of current, fire hazard, radio interference and excess heat which result from loose, corroded, arcing NON-SOLDERED connections.

For over 50 years experts have specified American Beauty Electric Soldering Irons. They know American Beauty Irons are built to LAST LONGER, OPERATE DEPENDABLY and BE SERVICED QUICKLY.

Build better with solder . . .
Solder better with
American Beauty
SOLDERING IRONS

WRITE FOR FREE LITERATURE

Dependable • Durable • Efficient

SINCE 1894

AMERICAN ELECTRICAL HEATER COMPANY
DETROIT 2, MICHIGAN

A-100

SERVICE, JUNE, 1952 • 43

Curing Overshoot in TV Chassis . . . Eliminating Oscillator Buzz . . . Width Reduction and Improved Keying Pulse . . . Clearing Up Vertical Sync Drift . . . Troubleshooting Hints for DuMont Chassis . . . Gaining Greater Horizontal Stability . . . Removing Smear and Trailing Whites . . . Avoiding Negative Pictures . . . Adjusting Permeability-Tuned IF Transformers . . .

Servicing Helps

by M. A. MARWELL

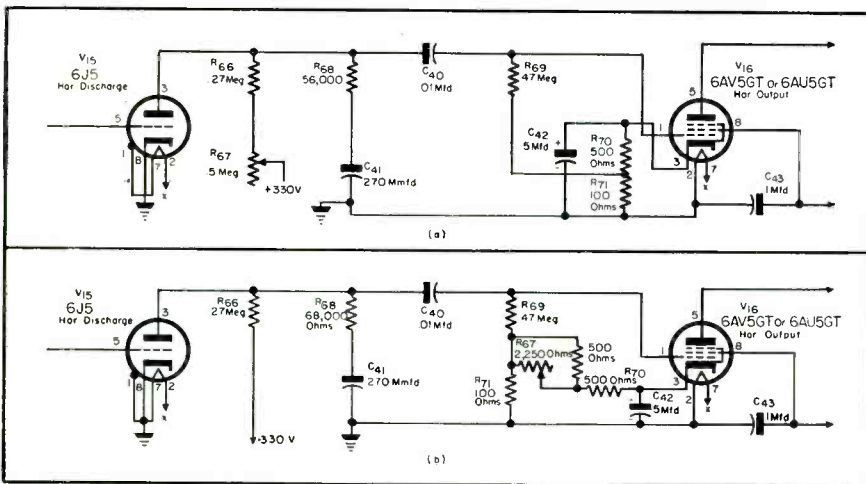
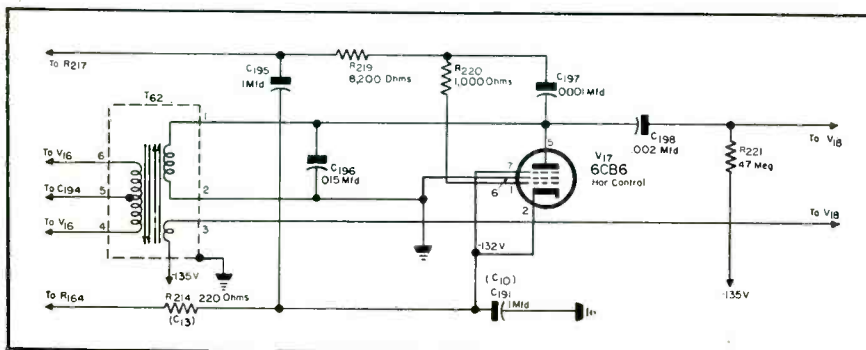

Fig. 1. Circuits illustrating changes made in Packard-Bell TV chassis to provide a further reduction in width with the horizontal drive control in areas where high line voltages are encountered. Above (a) appears original circuit, while below (b) is the revised circuitry. The junction of the .05-mfd capacitor (C_{41}) and the 5600-ohm resistor (R_{70}) was moved from tap 3 to 1, which changed the turns ratio with reference to the keying pulse tap, increasing the keyed pulse for the keyed *age* about 75%.

Fig. 2. Partial schematic of Sylvania 1-387-1 TV chassis C13 in which the 6AU6 horizontal control tube was changed to a 6CB6 and a 220-ohm resistor (R_{214}) was inserted in the cathode of the tube to provide greater horizontal stability.



IN THE PACKARD-BELL 26-tube TV chassis, models 2621-2622-3021, the video amplifier is flat to 4 mc. On some stations and during various programs, a certain amount of *overshoot* has been encountered due to this frequency response. This appears in the picture as a slight halo effect of white following black. To reduce this effect it has been found necessary to remove the 330-mfd capacitor (C_{27}) from the cathode of the 6K6 video amplifier to ground. This will also have quite a noticeable effect in low-signal or fringe areas where a reduction of noise in the picture will be apparent.

Some cases of 60-cycle buzz will also be noticed in these models, which is caused by leakage between the elements of the 12AX7. One section of this dual triode is used for the first audio stage and the other section for the automatic noise-inverter stage. This section is connected directly to the video signal and any leakage within the tube will cause a considerable amount of 60-cycle signal to be impressed on the grid of the first audio stage.

In the 24-tube series of Packard-Bell, models 2421-2422-2423, which do not employ a frequency response as wide as the 26-tube chassis, some overshoot or halo effect has been noticed on some stations. This can be reduced by clipping the 330-mfd capacitor (C_{24}) from the cathode of the second video amplifier to ground. Due to the physical layout of these chassis, it has been possible to bring a lead from the

(Continued on page 46)

For the **clearest** picture of campaign progress...



Rauland PICTURE TUBES

Man, what a year for TV—and TV service profits! The richest menu of regular attractions ever offered to viewers... PLUS the party conventions, the campaign, the elections and inauguration! When viewers need replacement picture tubes, they'll want them fast—and good.

So remember that Rauland alone

offers these replacement profit advantages:

- The *most complete* line of replacement picture tubes... a far better supplement for your regular tube line than a second line of receiver tubes.
- The faster, *surer* installation adjustment made possible by the patented Indicator Ton Trap.

• The dependable, uniform *extra* quality that so many smart service men depend on for assured customer satisfaction.

• • •
Remember, Rauland research has developed more "firsts" in picture tube progress since the war than any other maker. And this leadership pays off... in your customers' satisfaction.

THE RAULAND CORPORATION



Perfection Through Research

4245 N. KNOX AVENUE • CHICAGO 41, ILLINOIS



Oh, yes, Most of the Better Sets Use the TARZIAN TUNER

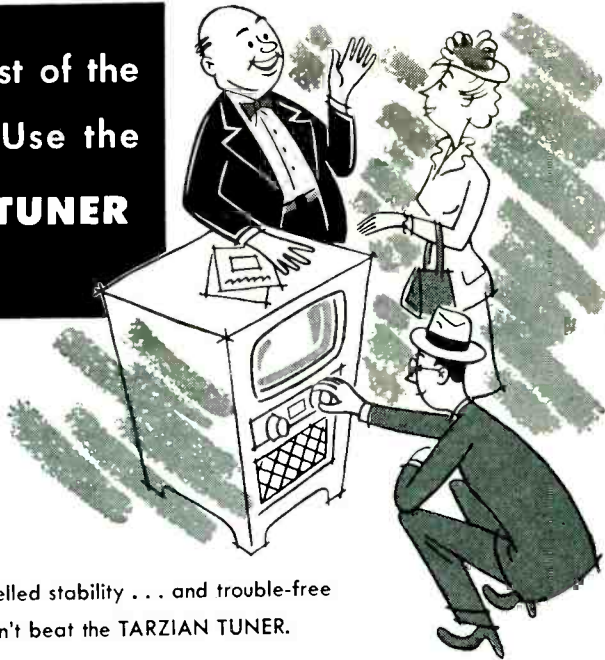

For selectivity . . . unexcelled stability . . . and trouble-free performance, you just can't beat the TARZIAN TUNER.

Certainly, the Tuner improves the receiver, and the sensible, but simple, application to UHF is making the Tarzian Tuner more popular than ever.

Technical, descriptive terms such as "low oscillation radiation" . . . "good matching" . . . "good input balance" . . . "uniform vernier range on low and high channels" may not mean much to the average buyer of a TV set, but it all adds up to

IMPROVED OVERALL PERFORMANCE OF THE SET HE BUYS

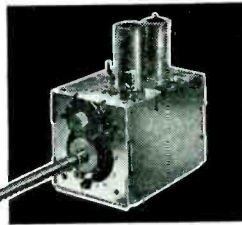

SARKES TARZIAN, Inc., Tuner Division, Bloomington, Ind.

TARZIAN MADE PRODUCTS

Tuners Air Trimmers Selenium Rectifiers Cathode-Ray and Receiving Tubes

STATIONS WTTT (5000 WATTS) AND WTTV (CHANNEL 10)
OWNED AND OPERATED BY SARKES TARZIAN IN BLOOMINGTON

Service Helps

(Continued from page 44)

330-mmfd capacitor to the top of the chassis near the low-voltage power transformer, where it is grounded. Clipping this wire will remove the capacitor from the circuit without the necessity of removing the chassis from the cabinet.

Field reports have revealed that *lockout* has also occurred in some of the 24-tube models. It has been found that this has been caused by the wide

variation in grid cutoff voltage encountered with electrostatic tubes. On some tubes, where the grid cutoff was in the vicinity of 35 to 45 volts, advancement of the contrast control beyond normal caused the grid of the picture tube to draw current. This, in turn, reduced the high voltage, thereby reducing the keying pulse below normal for the keyed *agc*. When this happened the *if* strip was found to be running wide open, which aggravated the situation even more. To compensate for this condition, a 100,000-ohm resistor should be inserted between the

arm of the brightness control and the picture-tube cathode. This form of cathode limiting controls the amount of current that can be drawn by the plate of the picture tube without affecting the high-voltage regulation.

Minimizing Vertical Oscillator Buzz

Due to the spacing between the 6J5 vertical oscillator and the 6V6 audio output in Packard-Bell chassis, 60-cycle buzz has appeared. This can be cured by replacing a glass 6J5 with a metal tube. This condition has been most noticeable when the set is not tuned to a station.

Width Reduction and Improved Keying Pulse

In some areas where high-line voltages are encountered, excessive width has appeared in some P-B chassis. It was found impossible to correct this by any setting the horizontal drive control. To overcome this defect, the junction point of the .05-mmfd (C_{44}) capacitor and 5,600-ohm (R_{73}) resistor should be moved from tap 3 to 1. This will change the turns ratio with reference to the keying pulse tap, thereby increasing the keyed pulse for the keyed *agc* about 75 per cent. Thus, the keyed *agc* will become more stable under varying line-voltage conditions. See Fig. 1, page 44.

DuMont Service Notes‡

Due to variations in tube manufacture, it has been found that a percentage of the 6BL7s (vertical oscillator) used in DuMont RA-160 models, will heat up to the point of becoming erratic when a shield is placed over the tube. It is recommended that the shield be removed when the set is installed.

Complaints of vertical sync drift usually can be cleared up by removing the shield. If the vertical drift still persists, after the tube cools, the 6BL7 should be replaced and the shield left off.

Microphonic sound, not caused by tubes . . . All models: Probable fault is a loose clip on top adjusting screw of the sound discriminator transformer. To correct the trouble, the clip should be soldered to the top of the transformer can.

Unstable horizontal sync, no bias present at grid of reactance tube with antenna disconnected . . . RA-109A and 130A: The negative 12-volt filter capacitor, C_{205} , is probably shorted, and should be replaced.

‡Based on copyrighted notes appearing in *DuMont Service News*.

Horizontal pull, buzz in sound . . . RA-109 FAS, RA-130A: The *if* amplifier stage input and output transformers, T_{401} or T_{402} , are misaligned, and should be realigned.

No vertical or horizontal hold and picture appears overloaded . . . RA-112A-113-117A-147A: L_{214} , at the narrow band sync amplifier grid, will be open and should be replaced.

No high voltage . . . RA-112A-113-117A-147A: No high voltage; when C_{201} , a .02-mfd $B+$ boost capacitor, is shorted a raster appears. This has been found when there is a defective 6W4 damper tube, which should be replaced to cure the trouble.

Horizontal jitter at top of picture . . . RA-112A-113, 117A-147A: This fault is caused when the coupling capacitor, C_{204} , between the second sync clipper and horizontal control tube, is leaky. This tube should be replaced.

Loss of vertical and horizontal sync . . . RA-112A-113, 117A-147A: The coupling capacitor between sync detector and first sync clipper, C_{201} , may be open, and should be replaced.

Excessive vertical retrace lines and 60-cycle buzz in sound . . . RA-119A: In this instance, the vertical relay opens on slightest disturbance when the vertical size or vertical hold controls are adjusted. The probable fault is a defective vertical output transformer, which should be replaced.

Booster note: When using the Electro-Voice *tenna-top* booster with the DuMont RA-119A model, the relay in the booster junction box will burn out unless it is modified. It is recommended that a resistance of 0.1 to 0.2 ohm be connected in parallel with the relay winding to remedy this condition. A suitable resistor can be made up by connecting five, 1-ohm 1-watt resistors in parallel. The present relay is designed to operate with receivers using a maximum of 500 watts.

Video IF-Section Faults*

Smear and trailing whites, when originating in the *if* system, are usually the result of misalignment or a defective component which changes the bandwidth of the section.

Smear is usually caused by misalignment of the *if* stages having pole frequencies at or near the video *if* carrier frequency, or by a bandpass of insufficient width in the *if* section.

Trailing whites are caused by excessive response to the high intermediate

(Continued on page 69)

*From Philco troubleshooting handbook.

G-C not one line but 5!

1 RADIO-TV CHEMICALS



More than 85 different products, like this Television Tube Kote, comprise the G-C chemical line. And they're available in convenient sized bottles and tubes as well as handy sampler kits.

2 ALIGNMENT TOOLS AND EQUIPMENT



Everything needed for the service bench or on the job, available in kits or separately. The Speedex Automatic Wire Stripper, shown here, is a time and labor saver on stranded and solid wires.

3 ACCESSORIES AND SERVICE AIDS



Dial drives, cables, belts, knobs, reels, recording wire and tape connectors, tube sockets, switches, terminal strips—literally hundreds and hundreds of necessary items are included in this G-C line . . . and available in displays and kits.

5 TV ANTENNAS AND HARDWARE



There are no finer antennas on the market than the G-C Master-Line. Back this up with a complete line of stand-offs, chimney and wall mounts, tools, and all the other components . . . all made by G-C . . . for greater profit and customer satisfaction.

4 RADIO HARDWARE



G-C's big line of nuts, bolts, set screws, and all the rest of these much-in-demand items are conveniently packaged in jars, envelopes, boxes, displays and racks. Easy to stock, easy to service!

Write Today! for G-C's big new 80-page catalog which gives you complete details on all G-C products. It's Free!



GENERAL CEMENT MANUFACTURING CO.

901 Taylor Avenue, Rockford, Illinois

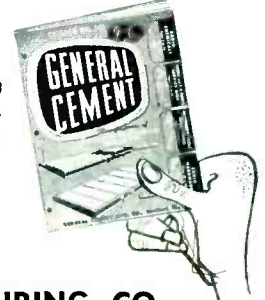

**BE SAFE . . .
BE SURE . . .**

**INSTALL VEE-D-X
LIGHTNING ARRESTERS**



VEE-D-X lightning arresters provide your customers with the finest, safest arresters ever made for TV and FM—including both two and four wire installations.

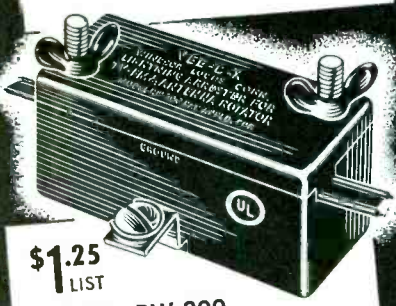

\$1.25
LIST

MODEL RW-200

Most popular full size arrester for standard 2-wire transmission line. Exclusive saw-tooth contact points assure positive electrical connection.

MODEL RW-204 \$1.50 LIST

For four-wire transmission. Same in appearance as the RW-200.



\$2.00
LIST

MODEL RW-300
For Extra Heavy Duty

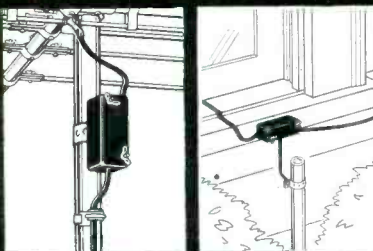

Models RW-200 and RW-204 are also available, at no extra cost, with strap for mast or pipe mounting. No wire stripping required on any VEE-D-X arrester.

THE LaPOINTE-PLASCOMOLD CORP.
Windsor Locks, Conn.

**Business
Aids . . .**

[In response to many requests, arrangements have been made to feature every month in SERVICE a column devoted to a discussion of Business Aids for the Service Shop, based on queries submitted by readers of SERVICE. Topics to be reviewed will include advertising, bookkeeping, customer relationship, filing systems, displays, direct mail, etc. These columns are being conducted by a veteran Service Man with over a quarter of a century experience in the field, who is currently operator of a large Service Shop, and is also extremely active in association affairs. If you have a business-aid problem, send it to ye editor, and every effort will be made to publish a solution in an early edition of SERVICE.]

Dear Don Kay:

Last month the extra-sale possibilities revolving about audio accessories were detailed. Are there any other extras that can be sold during the home repair call?—A.F.F.

Dear A.F.F.:

Yes, there are several other extras that can be sold during the visit to the customer's home.

While you are there you may be requested to repair a radio, TV or phono. In each case there is a possibility of an extra sale.

In the case of a large AM console radio only, you can suggest the installation of a FM unit, or the addition of a three-speed changer to be set on top or in a separate cabinet, which in addition to holding the changer can be used to store records. All units can be installed in a combination cabinet, which is available in all styles. If the set is a combination radio-phono, and the owner has a large home or estate, you can suggest the installation of extra speakers in the den, playrooms or the outside grounds.

In a home that has only a TV receiver, you can sell the changer, and perhaps soon a new uhf adapter. If the receiver has a small 10" or 12" picture tube, and you are familiar with conversions, you can suggest that they think about picture tube enlarging. Converting these small picture receivers is a profitable business and should not be bypassed, but the job should not be undertaken if you are not equipped with knowledge and understanding of circuitry and cabinetry. Many TV sets are still operating on an indoor or built-in antenna, and a little time can be spent to demonstrate possibilities of improved results by using a regulation antenna placed outside on a short pole. Of course, in hotels and apartments you may be restricted to indoor installations only, but you can ask and then try for the extra sale. When in the customer's home for service on a TV chassis, do not fail to mention that you also repair radios, phonos and auto radios. If it is an auto radio, you can advise the customer that you will be happy to take care of it, if

(Continued on page 61)

Choice of the Leaders!
ELECTROX
D.C. POWER SUPPLIES!

Leading companies—General Motors • Sears Roebuck • Goodrich • Lincoln-Mercury • Western Auto Supply • Firestone • many others—have standardized on ElectroX D.C. Power Supplies for demonstrating and testing auto radios and other low voltage D.C. equipment. And servicemen everywhere have followed their lead—for the ElectroX is today's outstanding D.C. Power Supply . . . in performance and dollar-for-dollar value!

NEW MODELS!

Two new ElectroX Models are now available—compact—dependable—low cost! They deliver smooth, hum-free D.C. which will operate practically any auto radio—either push-button or manually tuned. They are designed to give the utmost in reliable, dependable service.

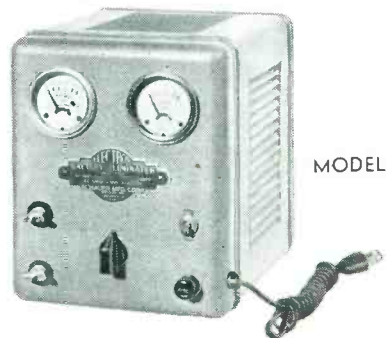

MODEL AR-5

Delivers 6 volts D.C.—smooth, hum-free. Output voltage adjustable for any load current between 3 to 15 amperes, indicated by 0-15 ampere D.C. ammeter; 0-8 volt D.C. voltmeter. Size: 7½" wide, 9¼" deep, 8" high.



MODEL AR-4

Same size, constructed to same high standards as Model AR-5 above, except output voltage is not adjustable. Delivers 6 volts D.C. at approx. 15 amperes.

ORDER NOW FROM YOUR DISTRIBUTOR. WRITE FOR FREE COPY OF BULLETIN 1467 GIVING COMPLETE DETAILS.

Rectifier Division
SCHAUER MANUFACTURING CORP.
4512 Alpine Ave. Cincinnati 36, Ohio

SELL Jensen
PHONO NEEDLES
For Any Type
Record Player

Please send me FREE Jenselector. Picks the proper replacement needle.

Name _____
Address _____
City _____ State _____
Jensen Industries, Inc., 931 S. Wood St., Chicago 12

Parts... Instruments... Tools

SPRAGUE HV FLAT-PLATE CERAMICS

A line of flat-plate ceramic capacitors, *Bulplate*, for high-voltage uses, has been announced by the Sprague Products Company, 61 Marshall St., North Adams, Mass.

Available in ratings for 1,000, 1,500 and 6,000-dc *acv*. Values range from 4.7 to 4,700 mmfd for 1,000-volt types; from 4.7 to 220 mmfd for 1,500-volt types; and from 4.7 to 470 mmfd for 6,000-volt capacitors. Ceramics are said to feature moisture-resistant insulating coating, and are rated for 85°C operation.

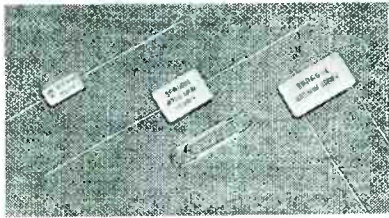

* * *

RCP TUBE TESTER AND VTVM

A combination test instrument, *808*, featuring a receiving and picture-tube tester, a reactivator, and a *vvm* and ohmmeter, has been introduced by Radio City Products Co., Inc., 152 W. 25th St., New York 1, N. Y.

Tube tester checks standard, miniature, noval base and subminiature tubes. Picture-tube tester is said to check magnetic-deflection types without removal from set or carton. Reactivator is claimed to revive dim or bad TV picture tubes. *VTVM* is a 17-range instrument for *ac* or *dc*. Employs a balanced-bridge type push-pull circuit, and features an impedance of 25 megohms. Ohmmeter reads resistances from 0.2 ohm to 1,000 megohms on five ranges. A high-voltage multiplier probe is said to extend the range of the *vvm* to 30,000 volts.

A 3-inch 'scope, with a frequency response of 2 db from 20 cycles to 150 kc, has also been introduced by RCP.

Instrument is said to feature vertical sensitivity of 20 mv (.020 volt for 1" *rms* deflection on tube) and horizontal sensitivity of .6v; input impedance, vertical, .5 megohm shunted by 50 mmfd and horizontal, 1 megohm shunted by 70 mmfd.

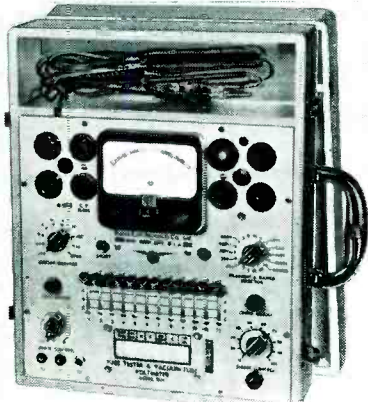

SIMPSON CAPACITY BRIDGE

A reengineered version of the *model 381* capacity bridge has been announced by Simpson Electric Co., 5200 W. Kinzie, Chicago, Ill.

Instrument circuit is said to facilitate capacity measurement; press of button provides the desired range and bridge arm can be adjusted for maximum meter deflection. Capacity can be read on the scale.

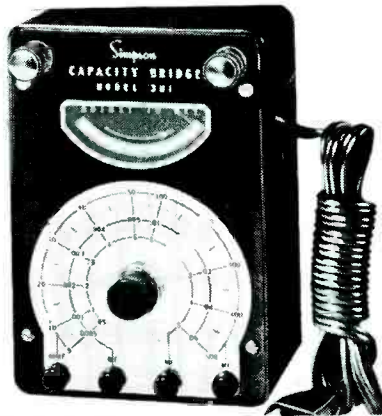

* * *

BURGESS POCKET FLASHLIGHT

A pocket flashlight, *Zebra Light*, the size of three cigarettes, has been announced by Burgess Battery Company, Freeport, Illinois.

Flashlight features slim cells, and plastic case that is contour-shaped in design. Equipped with a snap-action switch. Packaged one dozen lights to a colored counter merchandiser; cells are packed in the lights to make one package.

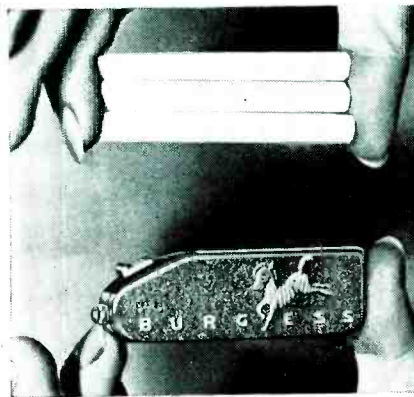

* * *

DALE DEPOSITED CARBON RESISTORS

A new line of Dalohm deposited carbon resistors, (non-wire wound) has been announced by Dale Products, Inc., Columbus, Nebraska.

Three resistance ranges (50 ohms to 5, 10 and 50 megohms) are offered. Voltage coefficient is said to be less than 0.002% per volt with the average coefficient about 0.0012%. Resistors are supplied with 1 per cent tolerance and are calibrated at 25° C.



ASTRON CAPACITORS

A subminiature paper capacitor, type *AQ*, specifically designed for operation at temperatures through 125° C, has been announced by the Astron Corp., 255 Grant Ave., E. Newark, N. J.

Incorporating Astron X-250 high temperature impregnant, capacitors are said to offer stability over a temperature range from -65° C to +125° C, without derating.

Hermetic sealing is provided by use of glass-to-metal seal terminals. Available in a variety of hermetically sealed metal tubular cases and construction styles.



* * *

PRESTOLE CAPACITOR CLIP

A capacitor clip featuring a retaining tongue on each side that supports the clip by gripping tightly to the mounting surface, has been announced by the Prestole Corp., Toledo, Ohio.

Prestole capacitor clips are being offered in seven sizes.

* * *

VAN CLEFF PLASTIC ELECTRICAL TAPE

A plastic electrical tape, .010" thick, that is said to be resistant to weather, oils, acids, alkalis and corrosive chemicals, has been introduced by Van Cleff Bros., Inc., Division of Johns Manville.

* * *

TRIPLETT VTVM

A *vvm*, *model 650*, with one probe which can be used to make peak-to-peak *acv* and *rj* measurements has been announced by The Triplett Electrical Instrument Co., Bluffton, Ohio. Frequency coverage is said to be from 20 cps to well over 110-mc with one probe. Tester has one volt full scale reading on both *ac* and *dc*. *RF* probe with short leads provides for *hf* measurements. Tester has zero center mark for FM discriminator alignment. High-input impedance of 11 megohms on *dc* is claimed to allow for accurate measurements without loading the circuit under test. Has separate 1 *acv* and 5 *acv* scales.

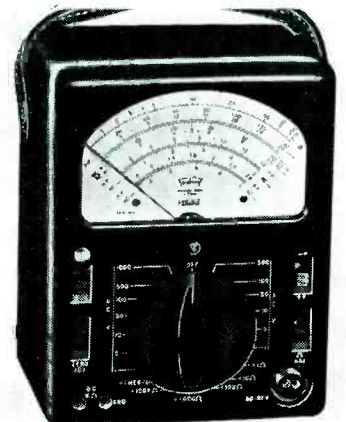



Every serviceman needs this!

Plastic Leatherette Wallet NEEDLE CARRIER

- Holds 12 ind. carded needles with all necessary tools for installation
- Creates "impulse buying"
- Saves times on service calls
- Makes extra sales for YOU!
- Allows serviceman to make up to 90% of installations on 1st call

Colorful dubonnet, gold lettering, 4 transparent acetate compartments — each holds 3 needle cards.

**Here's the Newest
MILLER Special Deal:**

Wallet, Manual, one dozen needles
\$15.00 list value
... servicemen's cost... **\$7⁹⁵** complete

You'll make fast, quick sales, volume profits... every serviceman must have needles... you make extra money, your customers do too... dozen Miller needles include Astatic, RCA, Shure, Columbia, etc.

**Sold through
jobbers ONLY!
ORDER TODAY!**

M. A. Miller Manufacturing Co.

1165-1169 East 43rd Street, Chicago 15, Illinois

Manufacturers of the world's largest line of long-life playback and recording needles
Selected by the world's largest manufacturer of original equipment

Canadian representatives: ATLAS RADIO CORP., LTD., 560 King Street West, Toronto, Ontario, Canada

Hi-Q Audio

(Continued from page 23)

ance is aided by the partially self-balancing *paraphrase* phase inverter system and by the common unbypassed cathode resistor of the dual triode feeding the output grids.

Twenty db of negative feedback from voice coil to voltage amplifier cathode has also been found to help push-pull balance, improve frequency and damping characteristics, decrease hum level, and drastically reduce distortion. The large amount of feedback incorporated in the design has been based on the assumption that a

high-quality output transformer will be used. An output transformer of ordinary grade may require reduction of the amount of feedback by an increase in the value of the 47,000-ohm resistor, R_{20} . As in other amplifiers, the quality of the transformer will largely be the limiting factor in the quality of the amplifier.

Parasitic oscillations, sometimes sounding like speaker rattle, are frequently encountered in parallel push-pull circuits. These oscillations are prevented by stopping resistors in the output plate and grid circuits, and by careful layout of the output stage leads. The wiring must be dressed

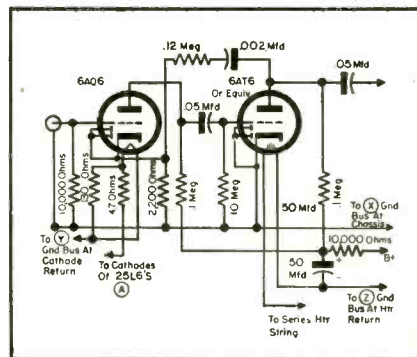

Fig. 4. Preamp for the reluctance pickup, illustrating how the ground buses must be returned properly; x, y and z, as indicated in Fig. 3 on page 23.

in such a manner as to avoid stray coupling between the plates of one half of the stage and the grids of the other half.

Susceptibility to *ac* hum is increased when a transformer power supply is used, because of the half-wave rectification and because some heaters are above *ac* ground potential and cannot suffer a center tap connection. The familiar *ac-dc* table model radio does not have an audio system capable of properly reproducing low frequencies, and thus the hum voltage goes unnoticed, but it is there.

The problem of high-voltage supply hum has been solved by heavy filtering of the $B+$ supplying the voltage amplifiers and output screen grids. Although the 25L6 plate loads are fed directly from the rectifier cathode, to secure maximum output plate voltage and to save the cost and space requirement of a 200-mil choke, no significant hum is introduced. Use of a relatively unfiltered plate supply for the output stage was found to be possible by the hum-reducing characteristics of the push-pull and feedback circuits.

To avoid filament hum the heater string has been arranged above ground in the order of amplification level of the stages, and, when a pre-amp for magnetic pickups is used, the filament of the lowest level stage is supplied with *dc* cathode current from the output tubes. It may be significant, in the case of a heater receiving *ac*, which of the two pins is at a higher potential above ground, particularly when the tube is a dual unit serving two stages in cascade. Another precaution which has been taken, with respect to heater induced hum, is the use of filament-dropping resistors of such value as to provide heater voltages slightly lower than normal. In converting low-level stages of an *ac* set it is sometimes necessary to decrease further the filament voltage of a particular stage through the con-

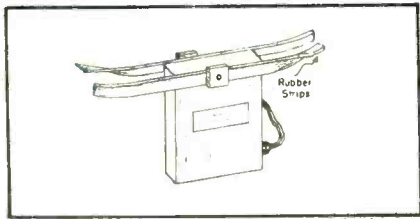

Fig. 5. Mechanical suspension for the inverter.

nection of a shunt resistor across the heater terminals.

There is still another source of hum. This appears as a result of the formation of small *ac* potentials between different ground return points, potentials which may, through careless layout, find their way to signal input circuits. Ground returns are therefore connected physically in the positional sequence shown in the amplifier diagram. With this sequence of grounds the *ir* drop of return current in the ground bus can never be inadvertently injected into the signal channel.

One of many possible arrangements of the stages preceding the phase inverter, providing a moderate degree of independent boost or cut of both treble and bass, appears in Fig. 3. The voltage amplifier stages already existing in equipment being converted can usually be substituted with little or no change. There must not be any control or tone equalization within the feedback loop, and all coupling capacitors within this loop should be no less than .1 mfd.

If a reluctance pickup is to be used the preamp of Fig. 4, or its equivalent, should be added. The heater of the first triode forms part of the bias resistance of the 25L6s, and the heater of the second triode displaces the phase inverter heater in its position next to ground. No change need be made in the filament dropping resistor.

The Tuner

The *rf* section of a good AM/FM table model radio may be used as the tuner, or an *ac* tuner can be converted quite simply and with little sacrifice of performance, without disturbing any circuits except the *B+* and filament supply. The power supply of the amplifier will also serve the tuner; *B+* may be taken from the amplifier choke at the point shown and connected to the input of the tuner filter network. If the tuner contains its own power supply the input power line must not have an independent plug, since opposite polarities between tuner and amplifier plugs will create a direct short across the line. Interconnection between a tuner power line and that of the amplifier has to be made either permanently or by polarized plug and socket.

Your most valuable business asset is a **SATISFIED CUSTOMER!**

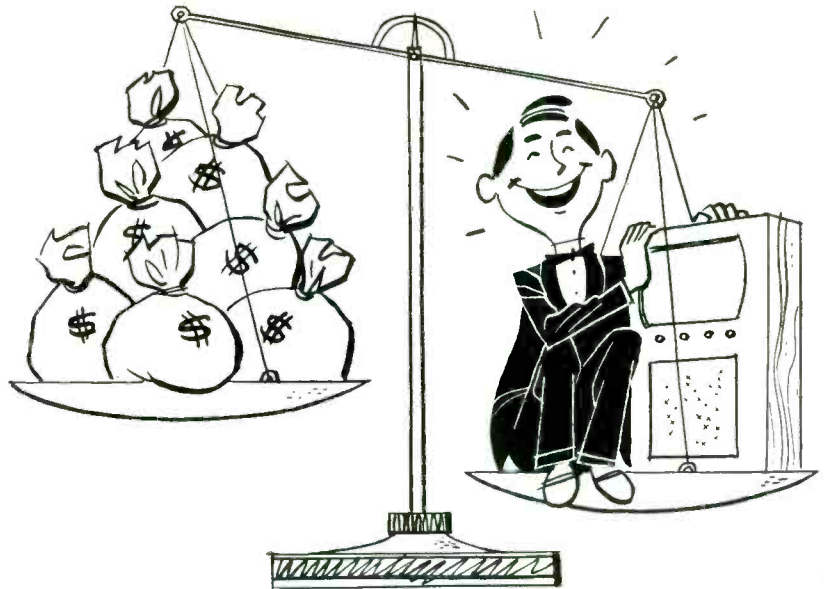

insure customer good will with **DEPENDABLE OHMITE RESISTANCE UNITS**

Don't endanger your business reputation by using "just-as-good" replacement parts. Protect customer good will with OHMITE resistance units—known the world over for dependability.

Servicemen, amateurs, and engineers everywhere agree that these quality components provide *extra* reliability and long life. Insist on OHMITE resistance units... it's good business!

OHMITE MANUFACTURING COMPANY, 4879 Plourney St., Chicago 44, Ill.

Send for stock catalog

Be Right with...

OHMITE®

RHEOSTATS • RESISTORS • TAP SWITCHES

10,000,000* Waiting to be SOLD!



**Perma-Power
TV TUBE
BRITENER**



* Over 10,000,000 television sets were purchased prior to 1951. Each of these has a picture tube which is getting dimmer . . . 10,000,000 set owners need the "TV TUBE BRITENER."

- Prolongs tube brilliance; fully automatic
- Isolates filament; relieves cathode — filament shorts
- Eliminates nuisance calls
- Protects tube guarantee
- Made to sell; packaged to sell
- Producing sales everywhere



"TV TUBE BRITENER" was designed by engineers to produce sales for television servicemen. Adds brilliance to any picture tube; extends useful life of tube for year or more; adaptable for all tubes with duodecal base. Write for complete, illustrated literature. SOLD through recognized wholesalers ONLY. ORDER TODAY!

Perma-Power COMPANY

4721 N. Damen Ave., Chicago 25, Ill.

"Manufacturers of electronic equipment since 1928"

Needle-Record Wear

(Continued from page 27)

played only with diamond will be necessarily free from a surface charge of abrasive stylus particles. Thus, the harmful wear effect cycle produced by abrasive particles of stylus materials other than diamond, is practically eliminated with the use of diamond.

Atmospheric dust contains abrasive particles and records kept in a clean condition will definitely last longer. Absence of abrasive dust will help break the stylus - wear/record - wear cycle.

Import of Stylus Pressure Control

Lowering the stylus pressure will reduce wear, but even the weight of 4 to 6 grams used in many modern pickups give stylus pressures measured in tons per square inch. Microscopic examination of osmium and sapphire microgroove needles after as few as twenty-five playings with pickup weights of 6 grams have revealed large flats; proving that wear does not disappear with the lower pressures.

Lateral movement of the stylus by the record groove (in a lateral recording) is responsible for the transmission of recorded wave vibrations which can then be translated by the pickup amplifier, etc., back into sound. Lateral compliance can be accomplished with magnetic cartridges which do not depend upon a twisting action of the stylus arm. Vertical compliance can be obtained by proper design of stylus arm or stylus assembly. Compliance in either direction will help reduce stylus and record wear. A pickup which stiffly resists lateral and vertical movements produced by the record will cause excessive wear.

Proper pickup arm design is a

Variation of wavelength with frequency at various cutting speeds. (From Briggs Sound Reproduction; original plot appeared in IEE Journal, H. Davies, July 1947)

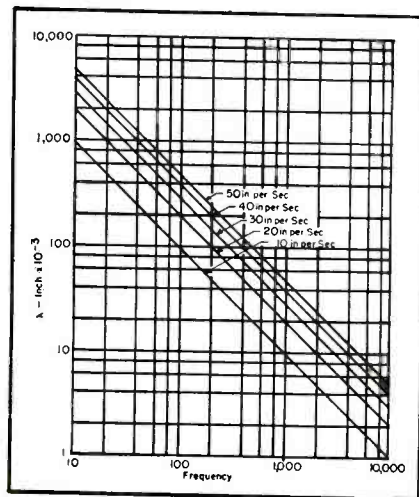

necessary requisite in any attempt to minimize wear. A good pickup arm should embody: Low mass, to reduce moment of inertia; vertical compliance or the ability to ride with warped records; lateral compliance (smooth bearings in arm post; can be used with off-center records); lateral balance, and ability to track at low pressures.

Very few records are perfect. Almost all have holes slightly off center after they have been put on and off the turntable post a dozen times or so. Warpage is almost always present to some extent. A pickup arm must yield to the erratic movements caused by these defects or it will add to the record destruction. At the same time it must track perfectly.

Diamonds and Diamond Styli

Experience has shown that there are certain questions in the minds of record collectors which are frequently asked. One usually centers about the query: "Will a diamond cut my records?" People are aware that rough diamonds, or diamonds which have been deliberately lapped to give them sharp edges, are used to cut glass. It must be remembered that only diamond can cut another diamond effectively. Once the diamond stylus has been given its smooth rounded tip by polishing with diamond powder at high speeds, (and this is a slow process) it is exceedingly difficult to change the smooth contours by normal use on a phono record. The surface, being smooth, rides the grooves with a minimum of friction. Since there are no edges to tear at the groove walls, there is a minimum of groove damage. If it were possible to obtain a substance a hundred times harder than diamond, then it would be used for a stylus tip.

Long-Life Advantages of Diamond

Another question seems to be: "Aren't diamond styli very expensive?" They do cost more, but they are the least expensive investment a record collector can make. This is true even in cases where the diamond stylus costs more than the record player. For diamond styli have a long life and worn styli can damage hundreds of dollars worth of records. Incidentally, more care is exercised in the selection of the raw material (genuine African diamonds) than for gem purposes. Diamonds selected for use as playback styli are examined through a high powered binocular stereoscopic microscope for imperfections, while jewelers merely use an 8x loupe.



NEW!

UNIVERSAL REPLACEMENT HI-VOLTAGE "DOORKNOB" CERAMIC...

FURNISHED WITH SCREW-IN TERMINALS TO MEET EVERY NEED!

An ingenious screw-in terminal system makes Sprague's new type 20DK-T5, 500 mmf, 20,000 volt molded case ceramic capacitor fit most every TV set. All you have to do is select the proper set of terminals, two twists of the wrist, and there you are!

With this new Sprague development, you need only one capacitor in your kit to service sets up to 21" tubes.

Sprague's 20DK-T5 "Doorknob" ceramic is molded in genuine thermosetting plastic, non-flammable and moisture-resistant. Guard rings are molded in both faces to lengthen the surface leakage path. Write for complete catalog C-608 to Sprague Products Co., 61 Marshall St., North Adams, Mass.



Don't Be Vague!
Insist On Sprague

WORLD'S LARGEST
CAPACITOR MANUFACTURER

NEW! 2ND EDITION of the only complete reference on AUDIO!

"The Recording & Reproduction of SOUND"

by OLIVER READ

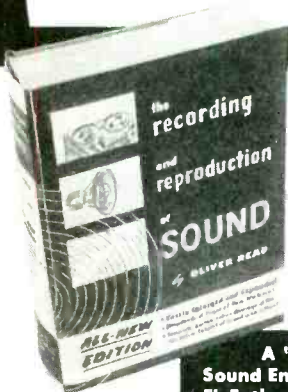

Completely revised and vastly enlarged new edition

OVER
800
PAGES

A "Must" for
Sound Engineers, Hi-Fi
Enthusiasts, P. A. Men,
Broadcasting Stations,
Recording Studios, Students

largest selling
book in its field

CONTENTS:

A Partial List of Authoritative Chapters:

Behavior of Sound Waves; Basic Recording Methods; Lateral Disc Recording; Microgroove Recording; The Decibel; Phono Reproducers; Stylis; Microphones; Loudspeakers and Enclosures; Dividing Networks and Filters; Attenuators and Mixers; Home Music Systems; P.A. Systems; Amplifiers; AM and FM Tuners—PLUS HUNDREDS OF OTHER SUBJECTS

Now you can have all the *right* answers to *any* subject in the field of Audio. Learn how to select and get the most out of recording equipment. Tells you how to select the proper amplifier for given applications, how to test amplifier performance, how to eliminate hum. Explains microphone, speaker and pickup principles and selection factors. Shows how to utilize inverse feed-back, expanders and compressors. Covers hundreds of subjects—a vast wealth of reliable information found in no other single volume. If you work in the field of Audio, this book belongs in your library. Order your copy today!

6" x 9" ONLY \$7.95
Hard Covers
800 pages 700 illustrations

**ORDER
TODAY**

Order from your Parts
Jobber, or write direct to
HOWARD W. SAMS & CO., INC.
2201 E. 46th St., Indianapolis 5, Ind.

My (check) (money order) for \$.....
is enclosed.

Send copy(ies) of *The Recording &
Reproduction of Sound (RR-2)*. \$7.95 per copy.

Name.....

Address.....

City.....State.....

Wire-Tape Servicing

(Continued from page 31)

stop the machine as quickly as possible. Do not attempt to save the whole wire; this will usually be impossible, and will only lead to loss of time and temper. The supply spool should be removed and as much wire as possible recovered, winding by hand. When the tension gets too great, the wire should be cut. Next, if the takeup drum is removable, the process should be repeated. If the drum can't be removed, as much of the wire as possible should be freed by turning the takeup drum by hand. The wire should be cut and the cover plate removed, exposing the mechanism. Occasionally, you will be able to recover a few more turns of wire; usually, you will not. With a crochet hook and long-nose pliers, the rest of the wire should be removed and cut, tying the ends of the wires on the spools together, using a square knot, and then clipping the ends. Due to the speed with which the wire travels, quite a bit of wire can be lost without making too noticeable a break in the continuity. In any case, it is wiser to cut spilled wire out, than to try and salvage it.

Tape is not subject to this trouble, although a good-sized overrun on a tape-machine can cause quite a tangle. The tape may be recovered entirely, with a little care, since it is too large to get entangled in and under the drums, like the wire.

The takeup drum of a tape machine is pulled, to wind up the tape as it is recorded, but the main driving force is furnished by a rubber capstan and idler wheel. Slippage of this idler can cause wows and slowing of the recording. The surface of the rubber should be cleaned with sandpaper, and both capstan and idler should be washed clean and dry with carbon-tet. If any drag exists in the drums or drive, they should be lubricated very sparingly with lubriplate or similar material. Any excess lubricant should be wiped off with a cloth, to prevent its being thrown into the drives. Some tape machines have a spring-belt drive; slippage of this drive may be due to excess lubrication. Carbon-tet should be used for wash out. The tension on these drives should be checked to insure sufficient speed.

Recording heads on both tape and wire recorders should be kept clean, since dust, dirt or hardened grease will prevent proper action when recording. Tape heads should be washed with a soft cloth and carbon-tet.

[To Be Continued]

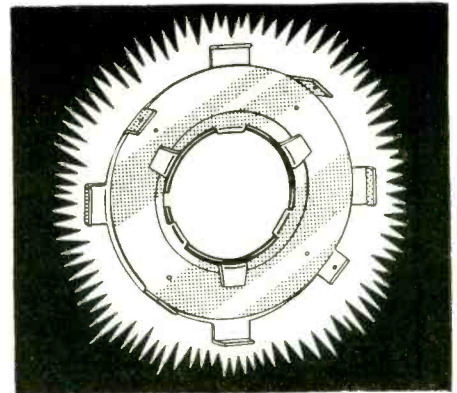

CENTER TV PICTURES IN 3 SECONDS

with the
PERFECTION
BeamaJuster

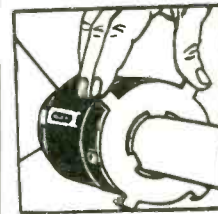

1. Snap BeamaJuster on back cover of tube yoke. (Fits any standard yoke and any size tube.)
2. Rotate BeamaJuster as shown here for approximate centering of picture.
3. Make final adjustment by sliding outer plate of BeamaJuster vertically or horizontally.

Order today from your supplier!

PERFECTION ELECTRIC COMPANY
2635 South Wabash Ave., Chicago 16, Illinois
Makers of Perfection Speakers, Ion Traps and
B. O. (Barkhausen Oscillation) Eliminators.

An Essential Grille for Engineers



Model 12-A

The Model 12-A Flush Mounting Grille is made to house a 12" speaker. The 14½ x 17 solid border is henderized and prime coated for painting. The grille proper can be either prime coated or have a beautiful chrome plated finish. We recommend the chrome for looks, and when it is used no grille cloth is necessary.

Two of these grilles mounted in any auditorium will enhance the appearance of the room and when used with the NP-1268 12" PM Speakers an all around pleasing and satisfactory sound installation can be assured.

Write for literature on our
Speakers, Cabinets, Grilles and Baffles.

WRIGHT, Inc.

2237 University Ave., St. Paul 4, Minn.

Auto Radio

(Continued from page 39)

summarized as: Ignition interference; generator interference; and tire and wheel static.

To understand how the first two sources can produce interference, their function in the car must be considered.

The Ignition System

The cylinders of the engine in the car contain a mixture of air and gas that is ignited to start the engine. A spark is used to ignite the air-gas mixture. The ignition system generates this spark.

Two electrodes, across which a large difference in potential builds up, are the direct source of this spark. When the difference in potential between the electrodes is great enough, an arc-over or spark takes place, and current jumps the gap to complete the circuit. The electrodes between which the spark appears are part of the *spark plug*.

The gap between the spark plug electrodes is not large, but the density of the air-gas mixture is quite high; several thousand volts potential difference must be present between the electrodes before this air-gas mixture breaks down. The high-voltage generating part of the ignition system is referred to as *high-tension*.

The auto radio Service Man should be familiar with the following components of the ignition system, as illustrated in Fig. 1:

(1) The *distributor*, which causes a spark to appear at the correct spark plug, at the correct time. More than one spark plug is used in the engine; their number is determined by the number of cylinders the engine contains. The distributor is basically a rotary selector switch, which distributes the spark to the point where it is needed, when it is needed there.

(2) The *ignition coil*, which is a transformer that changes the 6 v applied to it into several thousand volts.

(3) A *breaker*, or device that interrupts the ignition coil primary circuit, changing the applied *dc* voltage into an alternating voltage that is stepped up by the secondary.

(4) The *spark plug*.

The ignition system, as far as the auto radio is concerned, acts as a spark-gap transmitter. Noise pulses covering the entire *rf* spectrum are generated during the sparking process. These *rf* signals are fed to the ignition wiring, which acts as a transmitting antenna, and are radiated from there. If no shielding was present, the igni-

for ALL-CHANNEL
RECEPTION!

The Greatest!

ALL-BAND MULTI YAGI by Clear Beam

Featuring! THE NEW

"FLIP-OPEN" ASSEMBLY

- NO NUTS!
- NO BOLTS!
- NO TIGHTENING!

Simply "FLIP-OPEN" — and Install!

LIST PRICE
~~\$13.00~~

ClearBeam converts the famed super-directional Yagi to a sensational new broadband antenna for peak reception on ALL channels. ClearBeam's Multi-Yagi with its double-driven 7 elements covers the entire hi and low band with the brilliant performance you'd expect from the conventional single-channel Yagi. And you get the plus of rugged construction . . . extra value . . . and new "Flip-Open Assembly" features!



Clear Beam

TV ANTENNAS AND ACCESSORIES
The largest and most complete antenna line manufactured under one roof
100 PROSPECT AVENUE • • • BURBANK, CALIFORNIA
ROCKWELL 9-2141 CHARLESTON 0-4886

tion-produced noise pulses would blanket the entire broadcast band, and make satisfactory reception of desired signals impossible.

The metal hood that goes over the motor is one of the shielding units employed. The hood is interposed between the engine and the antenna (in the case of a side or roof antenna) and will, if properly grounded, tend to prevent radiation of ignition signals to the antenna. When the hood does not make good contact with the car frame (which serves as common ground for the radio) it will not act effectively as a shield, and ignition noise may be heard.

Ignition-derived noise may be recognized by its short, staccato character. Its frequency is the same as that of the spark plug firings. When the motor is speeded up, the frequency of the noise will increase.

Ignition noise may be picked up through the antenna or leadin, or by way of the chassis. Before remedies are considered, the Service Man will have to determine which path of entry the noise pulses are taking. To do so, the antenna lead should be disconnected from the set. If the noise stops, or becomes much less noticeable, it is probably entering the receiver by way of the antenna.

Audio

(Continued from page 32)

be completely familiar with their design and operational characteristics.

Motor speeds vary between 3,500 rpm, which is the approximate speed of a two-pole induction motor, and 1,300 rpm, the approximate speed of a four-pole induction motor.

The shaded-pole motor makes use of the shaded-pole starting methods, which is most frequently used for starting light-load motors. Shaded poles are obtained by placing a short-

circuited low-resistance coil on a section of each pole piece.

This type of motor operates in the following way: When the flux is increasing in each pole during the first half of the cycle, a portion of the flux passes through the shaded section. This flux induces a current in the shading coil, and the direction of the current is such that it opposes the flux entering the coil. At first, therefore, the greater portion of the flux passes through the unshaded sections of the poles. However, this flux soon reaches

(Continued on page 58)

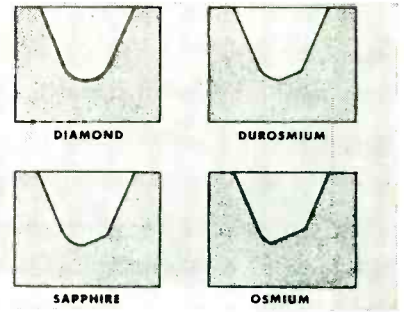

Wearing characteristics of diamond, sapphire, osmium and recently announced Jensen alloy, Durosium needles. Durosium needles are available in all three point sizes: 3 mil (for 78 rpm records), 1 mil (for 33 1/3 and 45 rpm), and 2 mil (for all-purpose requirements). (Illustration supplied by Jensen Industries, Inc., 329 South Wood St., Chicago 12, Ill.)



TELEVISION'S CROWNING ACHIEVEMENT IN ...

easy servicing

**Brilliant
Bendix
TV**

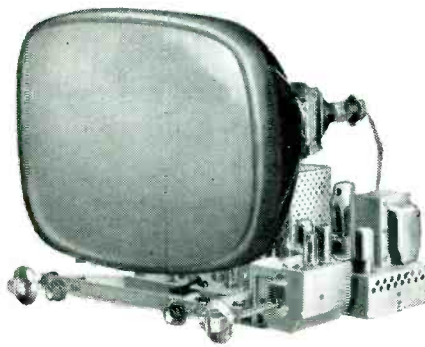

Bendix is proud that its new TV receivers feature the finest picture science has ever produced.

Bendix is proud, too, that its new Power Master Chassis is one of the fastest in the business to service. In compactness, in simplicity of circuit arrangement—in every way—it's a *far more accessible, far easier chassis to service.*

Since service time influences profits, new Bendix* TV thus helps you *keep your profits.* It also helps you give customers more efficient service.

Full details about both the Power-Master Chassis and the Long-Range Chassis can be found in the new Bendix Technical Data Handbook. Send for your free copy today.

*REG. U. S. PAT. OFF.



**THE NAME
MILLIONS TRUST**

Get Your Free Copy of
This Valuable Pocket-Size
Tech Data Handbook

Includes schematic drawings,
technical data and a handy
memo pad. Mail coupon to
Service Dept. 88, Bendix TV
and Radio, Baltimore 4, Md.

I'd like free schematics and tech data
about BENDIX TV.

NAME _____
COMPANY _____
ADDRESS _____
CITY, ZONE, STATE _____



Stylus pressure gauge which checks the weight exerted by any tone arm or pickup on record grooves. (Garrard Sales Corp., 164 Duane Street, New York 13, N. Y.)



Merchandising service setup designed for Permo's 113 types of replacement needles. Name and number or numbers of cartridge the needle fits are printed on each individual package. Installation tools, accessories and instruction sheet are supplied in each individual needle package when required. Individual color identification on packages containing needles with 1 mil, 3 mil, compromise tips and twin tips. Red packages are for 1 mil needles; green packages are for compromise tips and twin tips for all 3 speeds; blue packages are for 3 mil tip for 78 rpm. Individual needle packages have a slip attached, to be removed at time of sale. This slip is inserted in the top of stock-display-reorder case. Stock arrangement in limited storage space provided in boxes of practical design. Stock-display-reorder case designed to hold 48 needles: 35 in display, and 12 in backup. Assortments available are: The 38, (one each of 38 fast-moving needles packed in 1 stock-display-reorder case; the 73, (73 needles, 62 different types packed in 2 stock-display-reorder cases); the 108 (108 needles, 74 different types, packed in 3 stock-display-reorder cases) and the 144 (144 needles, 75 different types, packed in 4 stock-display-reorder cases).



Console designed for two-studio use and suited for use in public address and recording installations. Has 4 separate preamps, two booster amps, a line amplifier and a monitor amplifier, all mounted on one chassis. Also employs miniature plug-in power supplies for plate and filament supply, and for relay and signal light operation. Console is equipped with six mixing potentiometers, four of which are connected through switching keys to eight low level microphone or turntable inputs. The other two are connected with four line inputs, providing a total of twelve inputs, any six of which may be mixed simultaneously. Output channel can be switched to either of two output lines automatically connecting the control room telephone to unused line. An emergency amplifier switch permits instant replacement of the line amplifier with the monitor amplifier. All controls are color coded. Available input impedances are 50, 150, 300 or 600 ohms and the output impedance is 600 ohms. The system gain is said to be 100 db (including a 6-db isolation pad); frequency response is ± 1 db, 20-20,000 cycles and the signal-to-noise ratio is 74 db. (Model 230B; Altec Lansing Corp., 9356 Santa Monica Blvd., Beverly Hills, Calif. Distributed by Graybar Electric.)



Phono amplifier (2-watts) designed for use with any record changer utilizing a crystal pickup cartridge. Unit may also be used as a public address amplifier or an intercom system, by addition of a microphone or a speaker and output transformer connected to the amplifier in reverse. Uses 1 12AT6 and 1 50C5, plus a heavy duty selenium rectifier. (Model PA150; Vidair Electronics Mfg. Co., Lynbrook, N. Y.)

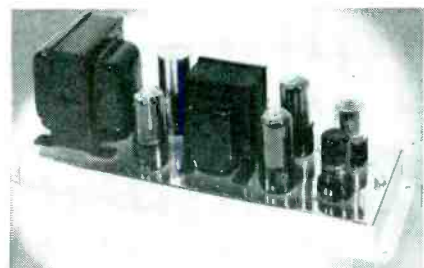

High-fidelity audio amplifier which features a direct-coupled, split-load triode phase inverter driving push-pull 6V6 power output tubes. Use of 13 1/2 db inverse feedback around the entire amplifier is said to result in a 4:1 output damping factor or an output internal impedance of 2 ohms at the 8-ohm tap. Power output is said to be 10 watts ± 1 db, 15 to 20,000 cps. Hum and noise level is claimed to be 70 db below rated output. (Craftsmen 400; The Radio Craftsmen, Inc., 4401 N. Ravenswood Ave., Chicago 40, Ill.)

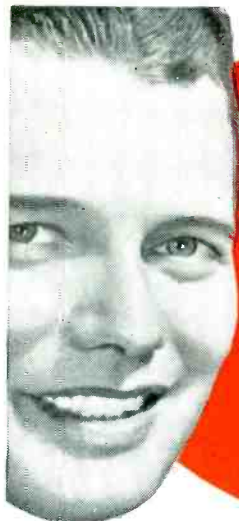

SIX BIG REASONS WHY BURGESS

IS THE PORTABLE RADIO
BATTERY LINE FOR '52!



XX45
RADIO B
BATTERY



2R
RADIO A
BATTERY

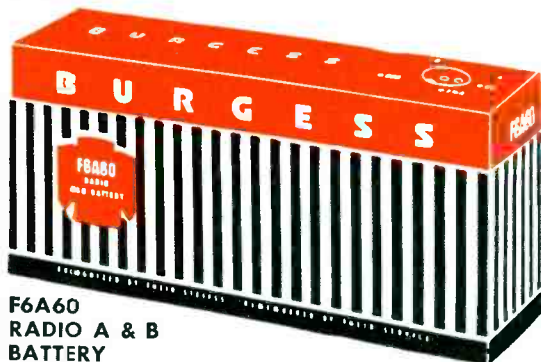

F6A60
RADIO A & B
BATTERY

1 Most Complete Line!

Burgess has the only complete battery line. Because they make batteries for every dry battery use, consumer acceptance is greater for Burgess Radio Batteries.

2 Highest Quality!

Burgess product quality is tops. More than 40 years of making only dry batteries, protects dealer reputations... Burgess quality control is your best guarantee of satisfied customers and repeat business.

3 Manufacturer Identity!

There's no private label competition with Burgess... and there's no question about the manufacturing source, either. You can be sure that every Burgess Battery you sell is a product of Burgess Battery Company.

4 Nationally Advertised!

Burgess advertising is a real sales help all along the line. Folks really remember those distinctive two-color ads in leading national magazines... you'll see it reflected on your profit sheet all through the year.

5 Oldest Line!

Burgess is the oldest line for radio dealers and servicemen. Burgess was first to see the great future of portable radios... that's why it's the major radio battery line today.

Best Promotional Program:

6

You'll like the aggressive way Burgess promotes sales for you in '52! For instance, the 1952 portable radio promotion... (the Burgess Portable Battery Prize Carnival)... is the soundest, most complete sales promotional program ever organized.

Order Your Stock from Your
Burgess Distributor Today!

BURGESS BATTERIES

BURGESS BATTERY COMPANY FREEPORT, ILLINOIS

TEST-ADJUST TELEVISION SETS AT Your CONVENIENCE

Even without station test pattern or in remote, weak signal areas!

A television set will produce a picture only when it is supplied with a COMPOSITE VIDEO SIGNAL. To check any TV set properly, you must have a COMPOSITE VIDEO SIGNAL.

Every TV station sends a COMPOSITE VIDEO SIGNAL when telecasting a program or a test pattern. This COMPOSITE VIDEO SIGNAL is composed of—(1) a synchronizing and blanking signal to lock the free running raster into a frame of two interlaced fields, and—(2) a video signal to control the amount of light and produce the picture (which may be a program scene or a test pattern for analysis purposes).



SUPREME MODEL 665

The SUPREME COMPOSITE VIDEO GENERATOR provides the same type of sync and blanking signal as the TV station—even the equalizing pulses. In addition, it incorporates a video section which generates a special test pattern for analysis and adjustment of TV sets. Other patterns or pictures can be presented by using auxiliary equipment connected to the special "gated" video input section of this versatile instrument. The Model 665 should not be confused with the cross-hatch or bar-pattern generators. The Supreme Model 665 supplies a COMPOSITE VIDEO SIGNAL.

Why lose time and money waiting for that ideal scene or test pattern to check a TV set? In fringe or weak signal areas, you are strictly in the "driver's seat" with a SUPREME COMPOSITE VIDEO GENERATOR. Write SUPREME, Inc., Dept. D-7, GREENWOOD, MISSISSIPPI, for descriptive folder.

Our 25th Year

SUPREME

Testing Instruments

"SUPREME BY COMPARISON"

TUBE TESTERS • OSCILLOSCOPES
SIGNAL GENERATORS • MULTI-METERS
FOR RADIO AND TELEVISION

Audio

(Continued from page 56)

its maximum value, at which time the rate of change of flux density is zero. The opposing *emf* in the shading coil then becomes zero, so that considerable flux then links this coil. Later the opposing *mmf* (magnetomotive force) of the shading coil ceases; the current in this coil is then lagging its *emf*. After the flux in the unshaded portion of the pole begins to decrease, the induced current in the shading coil tends to prevent the flux then existing in the shaded pole from decreasing. The flux reaches its maximum value in the unshaded pole first. The effect of the shading coil is to retard, in time phase, a portion of the flux, so that there is a motion of the flux density across the pole face from the unshaded side to the shaded side. This flux cuts the rotor conductors, inducing currents in them, which in turn, produce a torque sufficient to start the motor.

Turntable Speed Reduction*

To rotate the turntable at the correct speed, a speed-reduction drive system must be used to couple the motor to the turntable. One type of drive system makes use of reduction of gears. However, the most common system in use employs a pulley-run drive mechanism. In one version of this system, the shaft of a speed-reducing pulley is coupled by means of a belt to the rotor shaft, and an idler wheel is used to couple the pulley to the rim of the turntable. In the Philco chassis the speed-reducing pulley provides three different speeds and reduces the rotor speed from approximately 3,250-3,400 rpm to 78, 45, or 33½ rpm. Contrary to popular belief, the idler wheel has nothing to do with the turntable speed. As its name implies, it is merely an idler, and is incorporated to drive the turntable by friction. In another version of the pulley-rim drive system, direct cou-

pling is used rather than belt coupling.

Tape Recorders

In tape recording playback equipment, the motor is a particularly important item. In some models, such as the Masco DC-37 and LD-37 series, the idlers have all-rubber surfaces ground on their own centers to achieve concentricity and eliminate wow and flutter. See p. 32 for circuit of Masco amplifier.

Concentricity is achieved by turning the flywheel on its own center.

Motor is a 4-pole type with oil-less bearings.

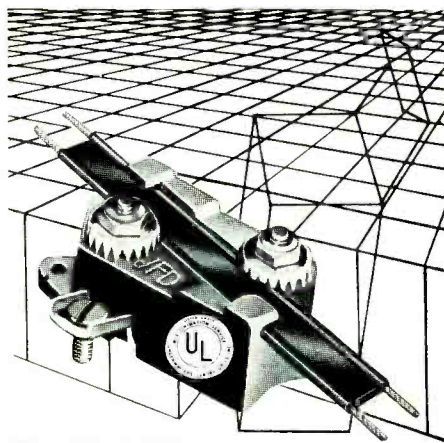

JFD "LITTLE-GIANT"

TV lightning arresters

millions sold!

because they have proved their worth in safety and sales!

no. AT105 \$1.25 list
no. AT105S (with strap) \$1.50 list
write for Form No. 84



JFD Mfg. Co.
Brooklyn 4, N.Y.
BEnsonhurst 6-9200

world's largest manufacturer of TV antennas & accessories

**SPEAKERS
NEED
REPAIRING**

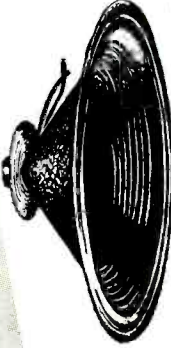

**RECONE WITH A
WALDOM
CONE**

Quicker, less expensive speaker servicing means greater profits. Speed up your speaker repair jobs ... **FREE Waldom 24-page Replacement Cone Manual** ... covers 750 different TV, FM and AM receivers.

WRITE FOR YOUR FREE COPY TODAY. THERE IS NO OBLIGATION

A Waldom Cone for the Finest Tone

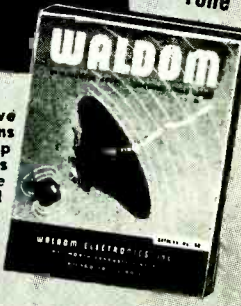

WALDOM ELECTRONICS INC., 911 N. LARRABEE ST., CHICAGO 10, ILLINOIS



Megaphone using a transistor amplifier, demonstrated recently by Richard F. Shea, of General Electric's electronics laboratory. The amplifier units demonstrated achieved a peak power output of one watt.

Recorder-Playback Amplifier

The amplifiers in the Masco magnetic player series employ a 12AX7 as an equalized tape playback preamp; a 6SL7GT as a dual-purpose microphone voltage and intermediate amplifier; a 6SN7GT dual purpose tube as a *record* output amplifier driver in *playback* and monitor amplifier in *record*; a 6V6GT as a 60-ke bias and erase oscillator in *record* and power output amplifier in *playback*; and a 6X5GT fullwave rectifier.

The unit also features an AM tuner (models D-37R, LD-37R and DC-37R) with four tubes: 6BA6 *rf* amplifier; 6BE6 oscillator-converter; 6SF7 *if* amplifier and detector; and a selenium rectifier.

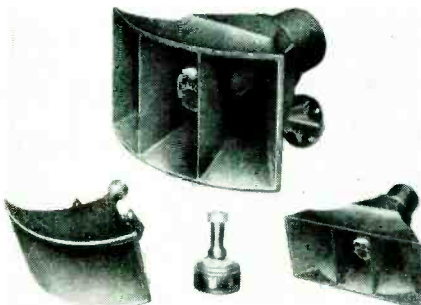

Horns and loudspeakers for sound systems, which incorporate non-resonant cast aluminum bells. Two types (COB-15 and COB-16) are of reentrant design, will handle 25 watts and are provided with driver units enclosed in watertight covers. Response range is said to be 350-11,000 cps; horizontal dispersion 60°, vertical dispersion 30°. Has serrated cast aluminum mounting brackets. Another type (RE-32) is of straight horn design, with a nominal cutoff at 500 cycles. Thread size is 1 3/8"-18 for standard driver units. Horizontal dispersion 90°, vertical dispersion 60°. Also available is a driver, (model CHU) a 15,000-cycle unit for use with the RE-32 horn when the latter is employed as a tweeter in 2 and 3 way high-fidelity systems. (Racon Electric Co., 52 East 19th St., New York 3, N. Y.)



OSMIUM

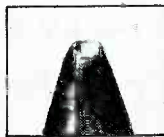

after 15 playing hrs.

SAPPHIRE



after 30 playing hrs.

DIAMOND



after 1000 playing hrs.

why the DUOTONE Diamond is the perfect needle for all record players!

Yes, now your customers can see for themselves how their regular phono needles begin to wear after just a few plays...ruining expensive records—marring reproduction. To help you sell the profitable Duotone Diamond...proved far superior to all ordinary needles by actual laboratory tests...Duotone has produced the Duoscope (shown above). With this 14 power pocket microscope your customers can actually see needle wear. The perfect sales clincher for the Duotone Diamond!

Duosopes, that list at 50¢ each, mounted 24 to a display card are available from your Duotone distributor. Each Duoscope comes in a cellophane envelope...complete with instructions. Order yours today.

Remember, there is a Duotone Diamond for every 45, 33 1/3 and 78 rpm record player.



DUOTONE

KEYPORT, NEW JERSEY

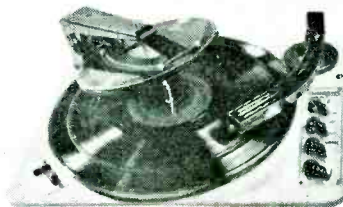

Three-speed record changer which features a heavy-duty four pole, direct drive, induction-type, governor-controlled motor. Also incorporated are pause and repeat controls (Type CD-43; Thorens Co., New Hyde Park, New York.)

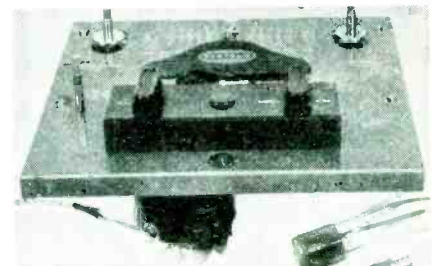

A basic tape mechanism with two recording and playing speeds: 3 3/4" and 7 1/2". Push button operation for speed change. Has two heads; one record and playback, the other *ac* erase. Motor is a four shaded pole, self-starting induction, balanced. Recording bias frequency is 32 kc. (Pentron Corp., 221 E. Cullerton St., Chicago 16.)

**DON'T throw it away...
Weak Picture Tubes CAN
be Saved!**

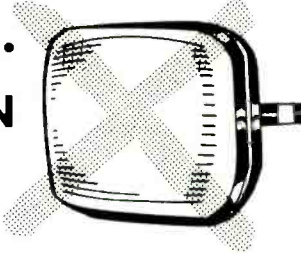

Use a
**Picture Tube
Rejuvenator**

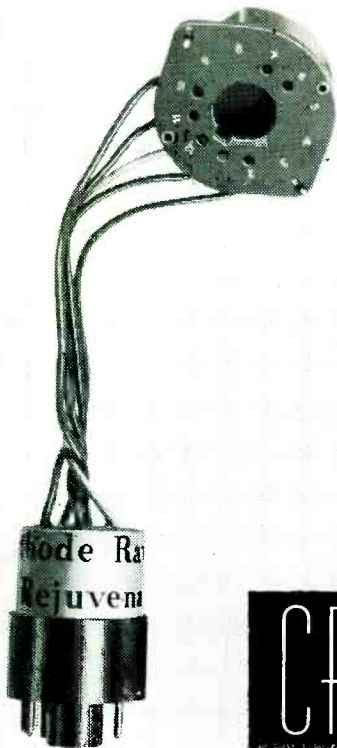

Simple Plug-in Unit
Permanent Hook-up
No Exposed Wires
Usable on All Size Tubes
Automatically Operated
Only \$3.85 Dealer Net

Pat. applied for Available at Local Jobbers



LABORATORIES, INC.

WHITEHALL BUILDING
FAR ROCKAWAY, NEW YORK

Rep Talk

NATIONAL MEMBERSHIP in *The Reps* has reached the total of 535 senior and associate members. . . . *Chicagoland* chapter, which is now the largest unit in the organization with 74 members, recently elected one senior and seven associates: *John Newman*, 3352 N. Central Ave., Chicago, senior; *Howard Christianson*, R. Edward Stemm Co., 5705 W. Lake St., Chicago 44; *Robert S. Dunn*, L. W. Beier Co., 6518 W. North Ave., Chicago 35; *William Ellinger, Jr.*, Ellinger Sales Co., 6663 Northwest Highway, Chicago 31; *Melvin Halinton*, 5500 West Devon, Chicago 30; *Raymond L. Ripley*, George Pettit Co., 549 W. Washington, Chicago 6; *Samuel J. Wiley*, Wilson Sales Agency, 2750 W. North Ave., Chicago 47; and *Eugene Wesselman*, Jerry Golden Co., 2750 W. North Ave., Chicago 47. . . . New York Chapter, second largest chapter, with 70 members, recently elected two senior and two associates: *Irving W. Woolf*, 135 Liberty St., New York 6; and *Sydney H. Baum*, 70-15 Fleet St., Forest Hills 75, L. I., were named seniors; *Alan Woolf*, 135 Liberty St., New York 6; and *Victor E. Jenkins*, J. M. Forshay, 27 Park Place, New York 7, became associates. . . . *Buckeye* chapter has elected one senior and six associates: *Emmet J. Tydings*, 1565 McFarland Rd., Pittsburgh 19, Pa., senior; *John W. Crosby* and *V. D. DeLong*, Scott and Steffen, Inc., 1836 Euclid Ave., Cleveland 15; *Robert W. Denniston*, Charles R. Moss Co., 1817 Marloes Ave., E. Cleveland 12; *John J. Hemberger*, 1621 Euclid Ave., Cleveland 15; *John F. Meyers Jr.*, 367 Brynild Rd., Columbus 2; and *Robert N. Vendeland*, Neal Bear Corp., West Richfield, Ohio, associates. . . . *California* chapter has elected two associates: *Phillip R. Crocker*, 625-3rd St., San Francisco, and *Erwin A. Larson*, 6450 Hollis St., Emeryville, Calif. . . . *Dixie* chapter has elected two senior members: *William C. Jaudon*, Box 744, Lutz, Fla., and *Foy M. Howard*, 2908 Hutchinson, Charlotte, N. C., both with Stanley K. Wallace Associates, Lutz, Fla. . . . *Empire State* chapter has elected *H. M. Wadsworth*, 509 Balsam St., Liverpool, N. Y., as a senior member. . . . *Missouri Valley* chapter has elected *Henry Kolshorn*, P. O. Box 207, Belton, Mo., as an associate member. . . . *Pacific Northwest* chapter has elected *M. K. Widdeking*, 719 Second Ave. W., Seattle 99, Wash., as a senior member. . . . *New England* chapter has elected *Albert A. Schaal, Jr.*, Box 18, Stow, Mass., as a senior member. . . . *Wolverine* chapter has elected *Lawrence F. Zuffina*, 14611 Alma, Detroit 5, to senior membership, and *Robert W. Collins*, 13338 Elgin, Huntington Woods, to associate membership. . . . The *Los Angeles* chapter of the *Reps* presented a brief case to *Dr. Ralph L. Power*, its executive secretary-treasurer, as a token of appreciation for his attendance awards the past two years and for his activity in promoting chapter attendance. *John T. Hill*, vice president, made the presentation speech. . . . *Cliff Landis Sales Co.*, 8-11 Roosevelt Ave., Jackson Heights, N. Y., has been named sales rep for the picture-tube division of the Allen B. DuMont Labs, Inc., in the New York metropolitan area.

Equipto STEEL 12-inch DRAWERS



Will Not Damage Costly Parts!

- Ignitions • Voltage Regulators • Lead-in Cables • Anchors • Pipe Hangers • Anything with loose wire ends kept completely safe from accidental damage • Small Transformers • MC Pickup Cartridges • Small "Mikes" • Small brackets • Phonograph Needles • Bolts & Nuts • Drive Rings • Bridle Rings

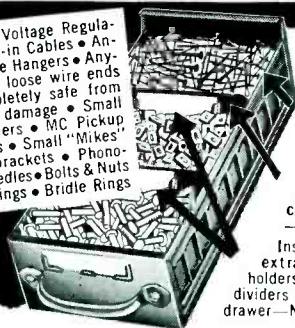

One piece construction - front, back, bottom, with all-welded sides—

NO HOLES
Embossed grooves along the sides for cross dividers—

NO HOLES
Instantly visible, extra large label holders on all cross dividers and on front of drawer—**NO HOLES**

**STOCK SAVING • MONEY SAVING
WASTE PREVENTION**

What good are parts that have been mangled? None! And they cost the repair man money. Too much money to overlook the fact that Equipto drawers and cabinets are designed to prevent waste and damage to valuable parts. When stopping to realize that every time you pull an ordinary drawer out, one with open slots along the sides, small parts can not help protruding and very easily catch on the frame and either break or damage beyond repair; and every time this happens it costs you from a few cents to many dollars. Multiply this by a very few times and you are really losing money. After all, you are in business to make money. Stop wasting your parts and money!

- NO. 8**
8 DRAWERS
12" DEEP
- NO. 11**
18 DRAWERS
12" DEEP
- NO. 22**
18 DRAWERS
18" DEEP



◀The handiest unit you ever had for taking care of your small parts. Stack, use individually or as insert in shelving or under counters. A wonderful item for sales in stores or for keeping small parts handy in Electrical, Radio and TV repair shops. Equipto's most popular item

Stack them high for the convenience ▶ of lots of drawer space.



Equipto Division of Aurora Equipment Co
790 Prairie • Aurora, Illinois
Phone: Aurora 9231

Write for
FREE
Catalog



At the Parts Show

Two DAYS of seminars and conferences highlighted the '52 Parts Show at the Conrad Hilton Hotel in Chicago. Among those who appeared were *Charley Golenpaul*, Aerovox Corp., New Bedford, Mass., serving as moderator of the industry panel, and *Milton Deutschmann*, Radio Shack Corp., Boston, and *Ralph Walker*, Walker-Jimieson, Inc., Chicago (*distributors*); *Harry Kalker*, Sprague Products Co., North Adams, Mass., and *H. H. Rainier*, Sylvania Electric Products, New York (*manufacturers*); and *Dave Marshank*, Marshank Sales Co., Los Angeles and *Dan R. Bittan*, D. R. Bittan Co., New York (*representatives*). . . . *Paul H. Bolton*, Washington, D. C., executive vice president of the National Association of Wholesalers, discussed *How the Parts Distributor Can Help His Customers Improve Their Public Relations*. . . . *Arthur Motley*, publisher of *Parade Magazine*, addressed the Parts Show annual dinner. . . . Feature of the *Webster-Chicago* display in their booth was an automatic slidefilm presentation of the Webcor line of automatic record changers. A series of 30 color slides, projected on a screen, was used to illustrate technical details of the various units. Another projection unit was used in Webster-Chicago's display room to present a similar illustrated story on wire and tape magnetic recorders. . . . *Jensen* featured a *Silver Anniversary Sound Theatre* in the upper Tower Room of the Conrad Hilton. Demonstrated was a reproducer with an 8-foot column, and a cubic content of 46'. Response was claimed to be 20 to 20,000 cps. In cooperation with *Jensen*, but as an independent show, *Magnecord* demonstrated, on an alternating basis in the Tower Room, a binaural recording process. . . . *Fretco, Inc.*, displayed TV antennas, open-wire transmission lines, towers, mounting equipment, etc. . . . All-plastic TV alignment tools were shown by the *General Cement Manufacturing Co.* . . . In *Raytheon's* booth, receiving tubes and voltage stabilizers were displayed. . . . The tube department of the *RCA Victor Division* showed a conversion kit, *Converkit*, a package of components providing for the conversion of TV receivers to use pictures up to 21-inch size. . . . *Ram Electronics Sales Co.*, Irvington - on - Hudson, N. Y., distributed its replacement manual for TV components. . . . *British Industries Corp.*, exhibited a line of audio equipment including a *Garrard* record changer, Leak amplifier and preamp, *Wharfedale* 12-inch

You'll Always Find What You Need In The...

CD Skyhawk

TV ANTENNA LINE

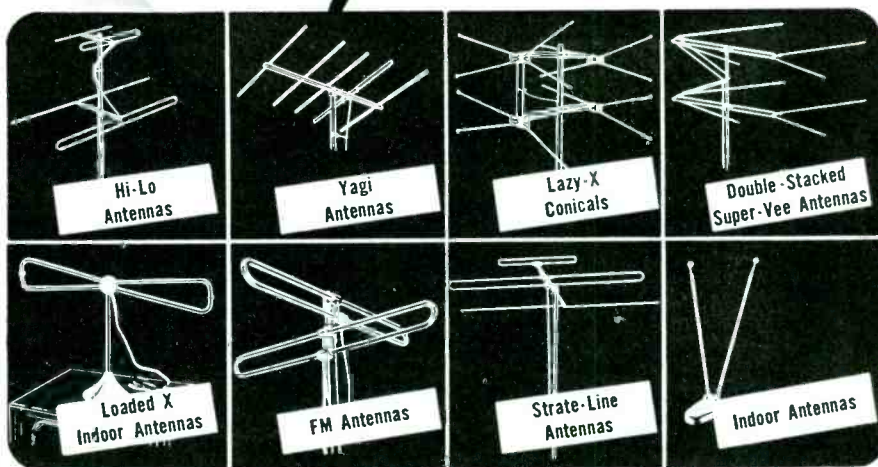

and you'll find excellence in performance and quality, too!

When you, as a serviceman intent on really serving his customers, choose CORNELL-DUBILIER SKYHAWK TV ANTENNAS, you save time, trouble and money. These are facts. C-D makes an antenna for every requirement and these SKYHAWK antennas have a reputation for top quality and excellent performance—which adds up to customer satisfaction. Why hesitate? — Choose CORNELL-DUBILIER SKYHAWK TV ANTENNAS.

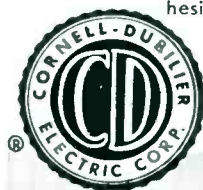

CONSISTENTLY DEPENDABLE
CORNELL-DUBILIER
SOUTH PLAINFIELD, NEW JERSEY



- ROTATORS
- CAPACITORS
- ANTENNAS
- VIBRATORS
- CONVERTERS

loudspeaker and an *R.J.* speaker enclosure. . . . *David Bogen Co.* offered a line of preamps, intercom systems and tuners. . . . *Oak Electronics Co.*, Buffalo, N. Y., displayed a 3-stage booster for TV and FM. . . . *Deal Products Inc.*, Easton, Pa., featured tubular TV towers at their booth. . . . *NEPCO*, Pittsburgh, Pa., displayed a line of antennas, wire and accessories for TV. . . . *The Ward Products Corp.* announced and displayed six new TV antennas at the Show. One antenna, *U-Vee*, was described as the first combination *uhf-vhf* antenna for primary and fringe operation.

Business Aids

(Continued from page 48)

they will drive their car over to your shop.

Outdoor antenna installations also hold another source of extra sales. The advantages of installing a motor on the antenna can be described to the customer.

It is advisable to carry price lists on all the items that can provide extra sales; make sure that you leave one for the home owner to study at his leisure. It is important also to be sure that your name and address are permanently imprinted on each price list. And, don't forget, follow up your sales leads.

Sincerely,

DON KAY.

RIDER BOOK SHELF

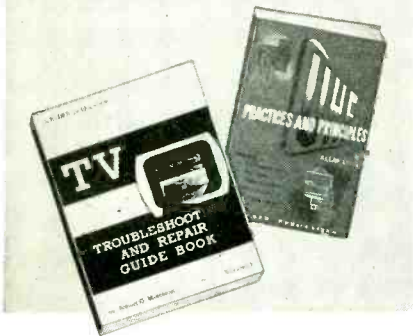

1 TV TROUBLESHOOTING AND REPAIR GUIDE BOOK

by R. G. Middleton

A new practical book designed to make your tv servicing *easy*. It tells—in easy-to-read language—how to spot receiver troubles... and how to correct them permanently. You'll find enough practical data in one chapter to repay the low cost of this book many times over. Typical chapters include: Receiver Differences and Waveforms; Visual Alignment; Troubleshooting Sync Circuits; Locating Sweep Troubles; Causes and Cures of Receiver Buzz; Test Equipment Kinks. Indexed and illustrated with over 190 (8½ x 11") pages bound in durable art cover -----\$3.90

2 UHF PRACTICES AND PRINCIPLES

by A. Lytel

A new, up-to-the-minute book that clears away the confusion and misunderstanding most people have about UHF. Written in clear, easy-to-understand terms, this book covers both fundamental theory and practical, working applications with special emphasis on television. Present-day brand name converters are thoroughly covered, including circuit descriptions and schematics. Here is profitable and practical reading for anyone who will be working with UHF. Typical chapters include: UHF Receiving Antennas; Electromagnetic Radio Waves; Transmission Lines; Waveguides. Illustrated and indexed with approx. 400 (5½ x 8½") pages bound in cloth cover. \$6.60

Buy these books now at your jobbers... leading bookstores... or—

MAIL THIS COUPON—TODAY—

JOHN F. RIDER, Publisher, Inc.
480 Canal Street, New York 13, N. Y.

Please send me book(s) circled. I understand, if not satisfied, I may return them within 10 days for full refund. 1 2

NAME _____

ADDRESS _____

CITY _____ ZONE _____

STATE _____ S-6

(Please Print)

TV Parts... Accessories

RAM AIR-CORE AUTOTRANSFORMER

An air-core autotransformer, X068, that is said to be a direct replacement for components used in the new RCA, Emerson and Capehart-Farnsworth TV sets, has been announced by Ram Electronics Sales Co., Irvington-on-Hudson, N. Y.

Transformer is claimed to deliver 11-13-kv output for 14-20" TV picture tubes, and since it has been designed for direct-drive circuits, the Ram Y70F30/3 direct-drive deflection yoke is recommended as its associated component.

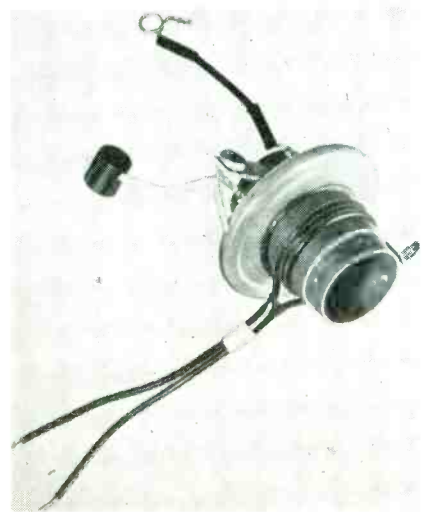

NATIONAL UNION TV AND RADIO TOOL KIT

An all-purpose 17-piece tool kit, designed especially for television and radio service work, contained in a heavy plastic roll, which can also be worn as an apron, or fastened to the wall, has been announced by the National Union Radio Corporation, 350 Scotland Road, Orange, N. J.

Tool kit, available free from N. U. distributors, with the purchase of 250 tubes, contains socket wrenches with hollow shafts to accommodate volume controls and extra-long bolts. There is a choice of a regular type handle and a right-angle ratchet drive. Also included are various sizes screw driver blades for both slotted and Phillips head screws.



South River NEWS

South River Replacement Banding Kits Now Available

- KIT A:** (Consists of)
 2—12' ¼" GALVANIZED STEEL STRAPS with eyebolts attached
 2—Eyebolts Unattached
 4—Nuts to Fit Eyebolts
 2—KWIK KLIP Strapping Fasteners

KIT B:
 Similar to KIT A, except furnished with stainless steel banding and special plated hardware.

KIT C:
 Similar to KIT B, except furnished with ¾" width stainless steel banding.

NOTE: ALL SOUTH RIVER CHIMNEY MOUNTS ARE NOW AVAILABLE WITH STAINLESS STEEL STRAPPING.

South River Antenna Mounting Accessories are carried by every leading TV Parts Jobber from coast to coast.

New catalog mailed to all Dealers and Service Men.

Write, if you haven't received yours!

SOUTH RIVER METAL PRODUCTS CO., INC.

SOUTH RIVER, N. J.

PIONEER AND OUTSTANDING PRODUCER OF FINEST LINE OF ANTENNA MOUNTS

G-C ANTENNA LINE CLIP

A three-way TV antenna line clip that can be attached to the antenna leadin without solder, has been introduced by General Cement Manufacturing Co., 919 Taylor Ave., Rockford, Illinois.

Clip (for which a patent has been applied) can also be hooked up sideways and it can also be connected to the RCA plug-in type terminals.

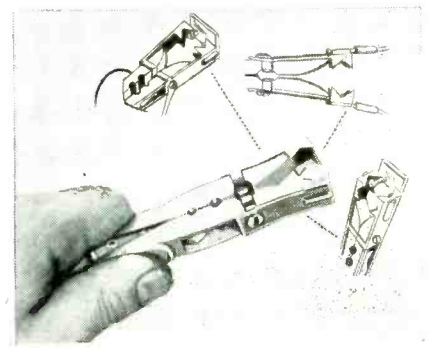

GLEAM TV ANTENNA

A Tenna-Ship indoor antenna, built with a ceramic base resembling the hull of a ship with sails of fibre glass, has been announced by Victoria Sales Co., 619 N. Michigan Ave., Chicago, who are national sales reps for the antenna. Comes in three color combinations: ebony with red sails and beige or chartreuse with contrasting sails. Overall dimensions are 22" h x 20" w.

VEE-D-X BOOSTER AND LIGHTNING ARRESTER

A single-channel booster, *OB-S*, that features a low-loss antenna bypass switch which is said to permit the signal to pass directly from the antenna to the receiver without disconnecting the booster, has been announced by the LaPointe Plascomold Corp., Windsor Locks, Conn.

Lightning arresters, including a strap mount for masts and pipes, an open-wire model, and a single-screw type for simplified installations, have also been announced.

Strap-mount type, *RW-200-S* and *RW-204-S*, feature straps with gripping prongs for non-slip mounting on all size masts and pipes. Open-wire arrester, *RW-310*, is designed with brass connecting blocks and prong-tooth washers. Models, *RW-210* and *RW-214*, modifications of the *RW-200* and *RW-204*, are made with a single wood screw for mounting on wood surfaces.

* * *

DU MONT TELE-MIRROR

A TV service aid, *Tele-Mirror*, has been announced by the Allen B. Du Mont Laboratories, Inc.

Mirror, designed by Du Mont engineers, is an 8"x10" unit, with a target sight printed on the surface of the mirror. The service-aid can be attached to a chair in front of the receiver by a spring clamp which enables the Service Man to adjust the mirror to the proper viewing angle.

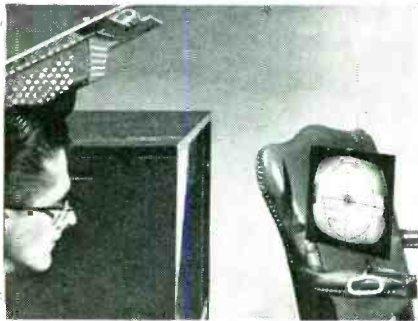

* * *

RADION LIGHTNING ARRESTERS

Two lightning arresters, *QLA2* and *LA2*, that will fit 300-ohm leadin, has been announced by the Radion Corp., 1130 W. Wisconsin Ave., Chicago 14, Ill.

Arresters are said to fit open, jumbo, oval, perforated or standard types of wire, and are designed for use on installation indoors and outdoors. Model *LA2* includes a mast-mounting strap. Both models have a four-place mounting bracket.

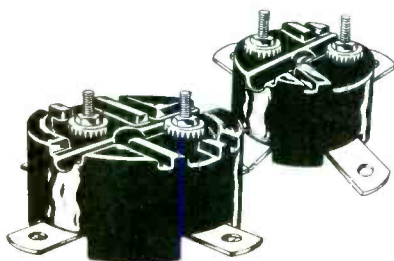

the BIG 10

fabulous
10 element
Yagi

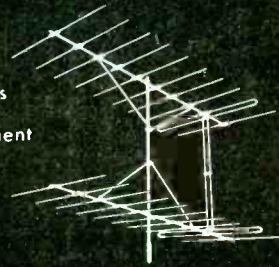

- The highest gain Yagi in TV history: 12 DB single, 14½ DB stacked (78% stacking gain).
- "Boom Braced" (low band) to prevent picture flicker.

600 Series

5 element
Yagi

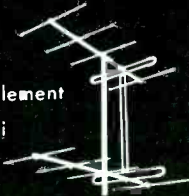

- Highest gain of any 5 element Yagi: over 9 DB single, 12 DB stacked.
- Full 100% stacking gain!

4

4

major benefits are provided by Channel Master Z-Match Yagis which are essential to better, more profitable fringe installations. No other Yagi gives you any of them! However, in the Z-Match Yagi, you get all 4 features — at no extra cost.

*do
you
get
these*

Major Benefits

in your present TV installations?

1. Adjustable impedance eliminates mismatch to 300 ohm line in single and stacked arrays.
2. Wider spaced elements, on longer cross-arms, for still higher gain.
3. Up to 100% additional gain in stacking.
4. And you don't pay for stacking bars!

List Prices

| Ch. | 600 | BIG 10 |
|------|-------|--------|
| 7-13 | 7.65 | 13.89 |
| 2-3 | 17.65 | 31.94 |
| 4-5 | 16.67 | 28.47 |
| 6 | 16.67 | 25.69 |

Write for new catalog

MEMBER



CHANNEL MASTER CORP.
ELLENVILLE, N. Y.



STANDARD WOOD PERIOD-STYLED TV CABINETS

Seven period-styled models have been added to the series 503 TV cabinet line of the Standard Wood Products Corp., 43-02 38th St., Long Island City, N. Y. One period cabinet is of the French Provincial style.

Cabinets will house all 630-type chassis and all others of similar dimensions, and all sizes of round and rectangular tubes. Each model is supplied with all necessary mountings for picture tube and yoke, and is available in mahogany, walnut, ebony or blonde. Models may also be supplied with record changer pullout drawer at the bottom. Size 40" high, 24" wide, 24" deep.

JFD OPEN-WIRE LEADIN

An open-wire transmission line, *Super-Gain* TW6-100, TW6-250 and TW6-500, that is said to deliver 1/6 the decibel loss of regular leadings, has been produced by the JFD Manufacturing Co.

Wire, made of copper lead with a steel core and insulated with polystyrene spacers, is claimed to have a 400-pound breaking-point tensile strength.

* * *

TECH-MASTER DC-AC TV RECEIVER

A *dc-ac* television receiver, Videola, which is a 17" receiver developed primarily for *dc* use, has been introduced by the Videola Corp., 447 Broadway, New York 13, N. Y. Morton Sydney is sales manager.

EICO

**gives you Laboratory Precision at
Lowest Cost!**

NEW EICO
Instruments and **KITS**

...with a complete line

221K VTVM Kit \$25.95
Wired \$49.95

625K Tube Tester Kit \$34.95
Wired \$49.95

320K Sig. Gen. Kit \$19.95
Wired \$29.95

145K Sig. Tracer Kit \$19.95
Wired \$28.95

425K 5" Scope Kit \$44.95
Wired \$79.95

315K Deluxe Sig. Gen. Kit \$39.95
Wired \$59.95

HV Probe \$6.95

511K VOM Kit \$14.95
Wired \$17.95

360K Sweep Gen. Kit \$34.95
Wired \$49.95
C-5 5mc Crystal \$3.95

RF Probe Kit \$3.75
Wired \$5.95

1040K Battery Elim. Kit \$25.95
Wired \$34.95

ELECTRONIC INSTRUMENT CO., Inc.
84 WITHERS STREET, BROOKLYN 11, N. Y.
© 1952, Electronic Instrument Co., Inc.

Due to unsettled conditions, prices and specifications are subject to change without notice. Prices 5% higher on West Coast

T. V. PRODUCTS CONICAL ANTENNA AND MAST JOINER

A conical antenna, that is preassembled and features a patented construction assembly, has been announced by the T. V. Products Co., 152 Sanford Street, Brooklyn 5, N. Y.

A swaged-end mast joiner, MJ-10, for joining masts that are 1 1/4" od has also been developed. Unit is protected by a polychrome coating that is claimed to withstand corrosion.

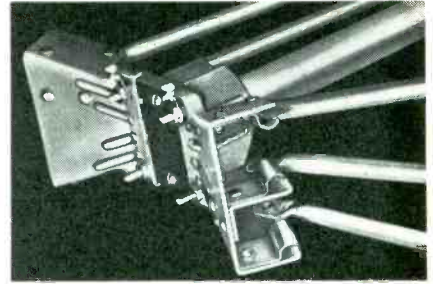

EBCO TV PICTURE-TUBE CHECKER-REACTIVATOR

A portable TV picture-tube checker-reactivator, model 10, has been developed by Electronic Beam Corp., 923 Old Nepperhan Ave., Youkers 3, N. Y.

Picture tube can be checked and reactivated without removing it from the set or carton. Reactivation is claimed to be completed within 15 minutes. Tubes may be checked for shorts, cathode emission and leakage. Unit is self-powered and measures 9" x 6" x 5".

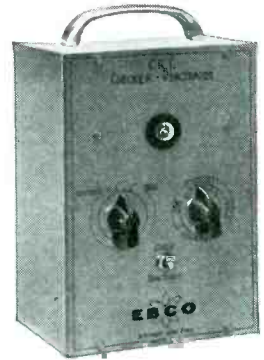

EPCO FOUR TV-SET COUPLER

A TV set coupler, model TS-4, designed to operate four TV sets from one antenna through a network of bifilar impedance-divider transformers, that are said to have good high-pass filter action with no inter-set coupling, has been announced by EpcO Electronics, Inc., 140 Liberty St., New York 6, N. Y.



**This TECHNICAL INDEX is one reason
you need this 28-page volume!**



IT'S THE *University*
TECHNILOG

The new 1952 compilation of valuable information that explains and simplifies the application of loudspeakers. A real time and money saver for dealers, contractors, service men and installation designers. The most authoritative, single piece of literature ever published on loudspeakers. It's yours FREE.

TECHNICAL INDEX

| | |
|---|---------|
| SELECTING THE PROPER LOUDSPEAKER SYSTEM | Page 4 |
| METHODS OF CONNECTING SPEAKERS TO THE AMPLIFIER | Page 8 |
| IMPEDANCE MATCHING | Page 9 |
| CONSTANT VOLTAGE DISTRIBUTION SYSTEM | Page 12 |
| IMPEDANCE MATCHING TRANSFORMERS | Page 16 |
| EFFECTS OF MISMATCH UPON POWER TRANSFER | Page 16 |
| CONTROLLING LOUDSPEAKER VOLUME | Page 20 |
| OVERLOAD PROTECTION OF LOUDSPEAKERS | Page 22 |
| PHASING LOUDSPEAKERS | Page 23 |
| REVERBERATION | Page 23 |
| BAFFLING A CONE SPEAKER | Page 26 |

ADDRESS REQUESTS TO YOUR DISTRIBUTOR

Not just a catalog!

Includes both technical and product data in factual, concise form with dozens of helpful explanatory photographs, charts and tables. Features much engineering information available NOWHERE ELSE!



UNIVERSITY LOUDSPEAKERS • INC

80 SO. KENSICO AVE., WHITE PLAINS, NEW YORK

MILLER FRINGE-AREA ANTENNA

A fringe-area antenna, *Fringe Master*, that is preassembled and it is claimed can be put together quickly, has been developed by Miller TV Co., 6806 Fountain Ave., Hollywood 28, Calif.

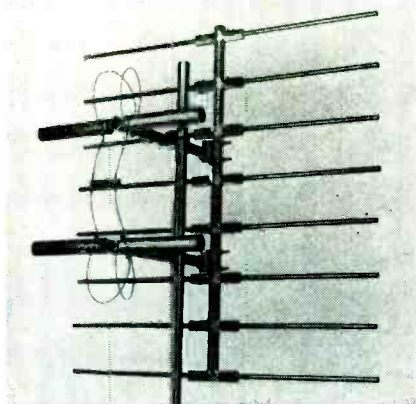

* * *

EL-TRONICS 'SCOPE

A scope, that features a verticle amplifier of 5-mc bandwidth with 4" of vertical deflection without overload and a sweep oscillator variable from 10 cycles to 150 kc, has been introduced by El-Tronics, Inc., 2665 N. Howard St., Philadelphia 33, Pa.

Slotted design in the light shield is said to permit easy removal of graduated scale, while a green light filter reduces external light interference. Vertical amplifier has a sensitivity of 20 millivolts rms-per-inch of deflection, a frequency response of 20 cycles to 5 mc that is down 3 db at 5 mc; a square-wave response that is claimed to be a duplication of all square waves between 50 cycles and 1 mc with a maximum tilt of 5% for 50 cycle square wave; a maximum input potential of 1,000 volts peak-to-peak; and an input attenuator of X1, X10, X100 positions that is frequency compensated.

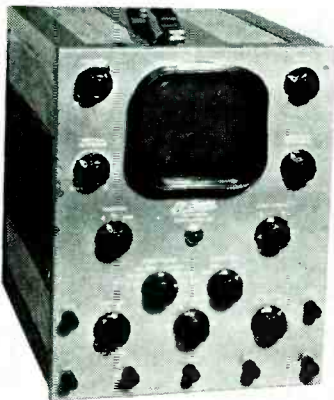

* * *

JFD VEE-BEAM ANTENNA

A vee-beam antenna, *Q800*, featuring a bracket design for preassembled elements, has been introduced by the JFD Manufacturing Co., Inc., 6101 16th Ave., Brooklyn 4, N. Y. Twin booms of the antenna are riveted together through an oversized Bakelite insulator, which is said to prevent the boom from slipping, sliding or turning.

Available as a single or stacked array, which are claimed to provide a gain of 7½ and 11 db, respectively.

announcing . . .



the **TENNA-MAST**
TRADE MARK
. . . by **TENNA-TRAILER**

There is nothing really new about the Tenna-Mast, except that we are now making these remarkable masts available, separately from the Tenna-Trailer, for permanent installations. User's of Tenna-Trailers have long been familiar with Tenna-Mast's many outstanding features. On demonstrations they have been detaching the Tenna-Mast from the Trailer and leaving them on location. Their customers have liked the Tenna-Mast's neat appearance, no guy wires and many other fine features. Now, dealers all over are beginning to stock and sell the Tenna-Mast on fringe area locations.

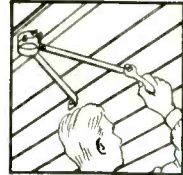

Drill two lag screw holes and mount the Stand-Off Bracket.



After attaching the antenna, "walk-up" the mast into position and fasten the bracket.

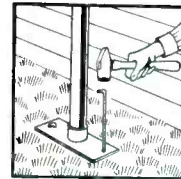

Drive the two 24" steel rods through the base plate and attach a grounding connection to one of the rods.

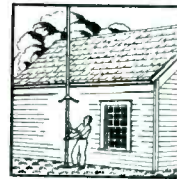

Then crank up the mast to its full 50-foot height . . . That's all . . . Total time of installation averages one hour.

TENNA-TRAILERS?

Sure we are still making them. Bigger and better than ever. Over 3,000 in daily use all over the United States and Canada!



Write for Descriptive Literature and Price Lists

THE TENNA-TRAILER COMPANY

321 North Plum Street

Pontiac, Illinois

RMS LIGHTNING ARRESTER

A UL-approved lightning arrester, model *LA-3*, designed to accommodate both twin lead and open transmission line, has been announced by R M S, Inc.

Twin lead is located on the arrester by placing it between the inner edges of the guides molded into the unit. Open line, on the other hand, is positioned on the outer edges of the guides. A saw-tooth washer and wing-nut pressure provide contact with the conductor.



NEW SOUND BOOK BY READ

An 800-page second edition of the Oliver Read book, *The Recording and Reproduction of Sound*, has been published by Howard W. Sams and Co., Inc., Indianapolis 5, Indiana.

Covering the entire subject of audio, this revised and enlarged edition offers authoritative data on lateral disc recording, microgroove recording, magnetic tape and wire recording, magnetic film recording, pickups, preamplifiers — equalizers, home music systems, speech input systems, acoustics, *pa* sound systems, AM and FM tuners, record manufacture, audio measurements, and complete recording systems.

Text contains over 700 illustrations, and is priced at \$7.95.

VIS-U-ALL TUBE and TOOL CASE

TRADE MARK REGISTERED

Only 16 x 13 1/2 x 7 1/2 in., closed. Weighs only 7 1/2 lbs. (21 lbs. when full)



Holds 107 Tubes and All Tools for TV Home Service

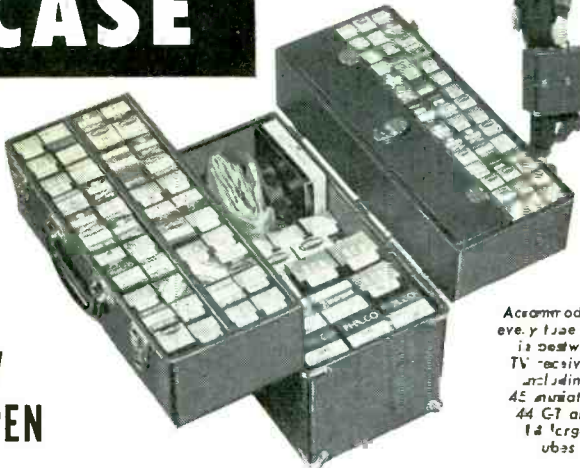

Accommodates every tube used in postwar TV receivers including 45 miniature 44 C7 and 14 large tubes

EVERYTHING IN FULL VIEW WHEN CASE OPEN

No hidden tubes. Easy to find the tubes you want, when you want them. Saves time. Holds tubes snugly and protects them against breakage. Tool compartment, 15 1/2 by 3 by 2 1/2 inches in size; accommodates all tools ordinarily needed for home service calls. Case is made of strong plywood with durable leatherette covering. Sturdy clasp fasteners and convenient luggage-type handle. Handiest case you ever saw, and a real boon to busy service men. Order yours now! If not satisfied, return within ten days and your money will be refunded.

NET PRICE

\$14.95
Case Only

Send check or money order. We will ship day order is received.

TELEVISION ENGINEERS, INC.

1539 W. Harrison Street • Chicago 7, Illinois

Copyright, January 1, 1952

NEWS

NORMAN FYLER NOW WITH HYTRON

Norman Fyler, formerly with Sarks Tarzian, Inc., and RCA Princeton Labs, has been appointed supervisor of development of TV picture tubes for Hytron Radio and Electronic Co., Salem, Mass.

His group will carry on advancement development that will supplement the work of the factory engineering department which continues under the supervision of A. Harcher, chief factory engineer.



Norman Fyler



Martin L. Roth

* * *

MARTIN ROTH APPOINTED SOUTH RIVER S-M

Martin L. Roth is now sales manager of the South River Metal Products Co., Inc., South River, N. J.

Roth had previously been South River sales rep in New York State, New England, New Jersey and Pennsylvania.

* * *

MALLORY REPLACEMENT VIBRATOR GUIDE

A replacement vibrator guide is now available from P. R. Mallory & Co., Inc., Indianapolis 6, Ind.

Guide contains cross-reference charts, specifications, and installation instructions for replacing car-radio and other types of mobile communication equipment vibrators and their accessory buffer capacitors with Mallory replacements. Listed are original equipment receiver manufacturer and model numbers with the numbers of the corresponding Mallory replacement vibrators. Capacity values of secondary buffers and replacement capacitors are also given.

Other cross-reference charts included are: vibrator types with their applications; original equipment vibrator numbers with correct replacements; replacement vibrator numbers with correct replacements. Listings are supplemented by detailed diagrams and instructions showing installation procedures for vibrators and also by an automobile battery ground chart. To provide complete information on the use of buffer capacitors of proper value, a series of reference circuits are pictured to show how the buffer is wired into the supply.

* * *

VOORHAAR NAMED TACO SALES PROMOTION MANAGER

Fred Voorhaar has been appointed sales promotion manager of the Technical Appliance Corporation, Sherburne, N. Y.

Voorhaar was formerly assistant manager of the parts and accessory division of Zenith Radio Corp.

Build YOUR OWN TEST EQUIPMENT

Heathkit AUDIO GEN. KIT \$34.50

Heathkit TELEVISION GENERATOR KIT \$39.50

Heathkit SIGNAL TRACER KIT \$19.50

Heathkit CONDENSER CHECKER KIT \$19.50

Heathkit IMPEDANCE BRIDGE KIT \$69.50

Heathkit HANDITESTER KIT \$13.50

Heathkit TUBE CHECKER KIT \$29.50

Heathkit PUSH-PULL 5" OSCILLOSCOPE KIT \$43.50

Heathkit ELECTRONIC SWITCH KIT \$19.50

Heathkit BATTERY ELIMINATOR KIT \$24.50

Heathkit R.F. SIGNAL GEN. KIT \$19.50

Heathkit VACUUM TUBE VOLTMETER KIT \$24.50

HEATH COMPANY
BENTON HARBOR 11, MICHIGAN

EXPORT AGENT
BOCKE-INTERNATIONAL CORP.
13 E. 40th St.
NEW YORK 17 (4)

**NEW EDITION OF DU MONT
PICTURE-TUBE DATA CHART**

The latest edition of the *Picture Tube Data Chart*, has been announced by the picture-tube division, Allen B. Du Mont Laboratories, Inc.

Chart, suitable for wall mounting, lists the electrical and physical characteristics for any modern RTMA-registered TV picture tubes. Charts are obtainable from local Du Mont distributors.

* * *

**PYRAMID APPOINTS KOHL AND
LEVISON**

Bert Kohl has been named assistant sales manager, and William P. Levison, Jr., has been appointed advertising manager of the Pyramid Electric Co., North Bergen, N. J.

Kohl has been with Pyramid since '50. Levison was formerly with Lewin, Williams and Saylor, Inc., advertising agency.



Bert Kohl

W. P. Levison, Jr.

* * *

**A. S. JOHNSON JOINS RADIO
CRAFTSMEN**

A. S. Johnson has been named executive assistant of The Radio Craftsmen, Inc., 4401 No. Ravenswood, Chicago, Ill.

Johnson formerly was industrial sales manager and products manager of Webster-Chicago Corp., and previously had been with Colonial Radio Corp., Buffalo and the radio division of General Motors Corp., in Detroit.

* * *

**S. B. WILLIAMS NAMED ASSISTANT TO
SYLVANIA PREXY; G.W. GRIFFIN, JR.,
BECOMES DIRECTOR OF PUBLIC
RELATIONS**

Samuel B. Williams has been named assistant to Don Mitchell, president of Sylvania. Williams has been director of public relations at Sylvania since '49.

George W. Griffin, Jr., formerly manager of the G.E. news bureau at Schenectady, N. Y., has succeeded Williams as director of public relations at Sylvania.



S. B. Williams

* * *

MEINKEN, JR., APPOINTED N. U. V-P

Kenneth C. Meinken, Jr., has been appointed vice president, in charge of equipment sales, of picture tubes, receiving tubes and government business, of the National Union Radio Corp., Orange, N. J. He had been midwestern sales manager.

RCP

is FIRST again
with this
**TV-RADIO TESTER
and REACTIVATOR
Combination!**

MODEL 808

**TV-RADIO-CR
TUBE TESTER &
VT VOLTMETER**
All in One Unit:

- A TUBE TESTER
- A CATHODE RAY TUBE TESTER
- A CATHODE RAY TUBE REACTIVATOR
- A VACUUM TUBE VOLTMETER (AC-DC)
- AN OHMMETER

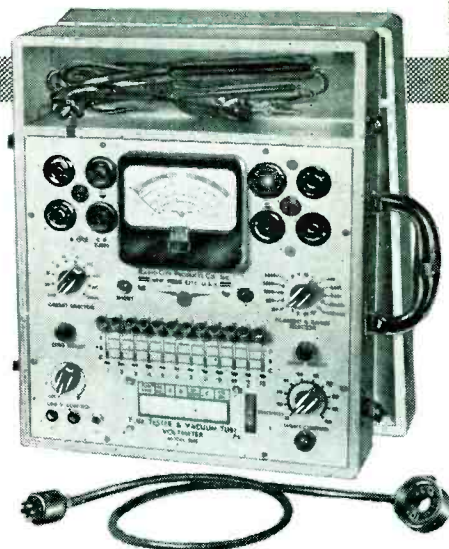

THE TUBE TESTER: All the features of the famous 323 Dynoptimum free point tube tester—protected against obsolescence—tests all modern standard, miniature, novel base and subminiature tubes.

THE CATHODE RAY TUBE TESTER: Will check all magnetic deflection type Television Picture tubes. Locates and isolates all shorts or leaks.

THE REACTIVATOR: Revives and Reactivates many otherwise Dim or Bad Television Picture tubes. Can also be used on other tubes.

THE VTVM: This really outstanding 17 Range instrument is a VT Voltmeter for AC as well as DC. Balance bridge type push-pull circuit. Draws negligible current due to high impedance of 25 megohms. Discriminator alignment scale with zero center. AC & DC

volts 0 to 5-25-100-250-1000-db-20 to 16, -6 to 30, 6 to 42, 14 to 50, 26 to 62.

THE OHMMETER: Reads all Resistances 0.2 ohms to 1000 megohms on 5 ranges. Use this instrument also to check condensers for leakage and shorts.

Housed in handsome hand-rubbed oak carrying case with test leads, isolation probe, batteries, etc. Size 12½" x 12¾" x 4¾", weight 12½ lbs.

MODEL 808—complete, **\$99.95**
ready to operate..... **NET**

High Voltage Multiplier Probe for Model 808. Extends Range of VTVM to 30,000 volts.

MODEL No. HVMP-1..... \$8.95
NET

Write for catalog on the RCP Line to Dept. SM-6.

RADIO CITY PRODUCTS CO., INC.
152 WEST 25th ST.—NEW YORK 1, N. Y.

PRECISION CATALOG

A 12-page catalog has been released by Precision Apparatus Co., Inc., 92-27 Horace Harding Blvd., Elmhurst, N. Y.

Described are *vtvms*, probes, sweep signal generators, tube and battery testers, picture-tube testers, and circuit testers. Included in the catalog is a descriptive analysis of *Principles of Electronic Tube Testing*.

* * *

VEE-D-X '52 CATALOG

The '52 24-page VEE-D-X TV catalog describing the complete line of VEE-D-X antennas and accessories has been released by The LaPointe Plascomold Corp., Windsor Locks, Conn.

RCA BATTERY CAMPAIGN

A set of battery selling and promotional tools, designed to aid Service Men is now available from the tube department of the RCA Victor Division, Harrison, N. J. Campaign objective is to establish Service Men as local headquarters for RCA batteries and portable radio service, and to build repeat business. Program features window, counter, and in-store displays; merchandising and promotional aids, and is supported by radio and TV advertising.

Displays include precision barometer display, mounted on a mahogany plaque; battery counter and floor mat, personalized with the dealer's name; motion display which depicts representative outdoor activities in which portable radios play an important part.

SO IMPORTANT — it was
Featured in Special Article
in
The New York Times

Jan. 28, 1952
FREE copy
of article on request

**UNIT REACTIVATES
TV PICTURE TUBES**

Small Electronic Device Tests
Sets at Home and May Add
Year or More of Use

By T. R. KENNEDY Jr.

A small electronic device that can be applied to home television receivers to test and reactivate the picture tube without removing the tube from the set, resulting in renewed brightness in many and prolonged useful life, has been placed on the market for the first time by a New York manufacturer.

In some cases, it was said, the picture tube may be made almost as good as new and given as much as a year's useful life before replacement is necessary.

The instrument is small and compact. It weighs three pounds, costs little and is simple to operate. Picture tubes, some of them new and never in a receiver, have shown remarkable improvement in brilliance and definition after a few minutes of reactivation here in the last few days.

Although the principle of its operation is not new, cathode-ray tube manufacturers have used it for years in the initial making of picture tubes—its incorporation in a small

The almost immediate urgent need for such an instrument, which also soon may be produced in kit form for home assembly, is apparent. Eight to ten million TV picture tubes, Transvision engineering estimate, have now been in use for three to four years or more, and "probably are in need of test and reactivation to renew their brightness." Unfortunately, their brightness, it was pointed out, seldom can be detected short of comparing the old tubes with new ones in lately produced sets.

Furthermore, picture tubes in their original cartons in stores may have lost some of their brightness, which has been described as a "kind of aging process" to which all large cathode-ray tubes and similar devices are subject.

Such tubes, in the current area most in use today, cost from \$25 to \$55. New picture tubes can be tested and reactivated without removing them from their cartons, and tubes in TV sets without removing the tubes from the receivers. It is done by attaching a standard picture-tube socket to the instrument, turning a switch on the tester-reactivator, and noting the glow of a small neon bulb as a condition of the tube is indicated directly on a dial of the meter which is plugged into an AC home electric socket. The receiver, meanwhile, is not turned on.

In some cases the test and reactivation, accomplished in less than two

men-
ber"
It
N.



**TRANSVISION CR TUBE
TESTER - REACTIVATOR**

performs 2 vital functions:

- Tests Picture Tubes
- Renews Brightness of Dim Picture Tubes

It's a TESTER:

Without removing picture tube from set, you apply this precise instrument to:—

- Measure Cathode emission
- Locate shorts between elements
- Locate high resistance shorts or leakage as high as 3 megohms

It's a REACTIVATOR

for dim CR Picture Tubes

Revives dim TV Picture Tubes, without removal of tubes from sets. Reactivation works on many tubes with low light output, if there's no mechanical break in tube. 110 V—60 cycles. Weighs only 3 lbs. One or two applications pays for instrument.

SATISFACTION GUARANTEED
If money refunded if you return the instrument in 10 days in good condition. **\$19.95 NET**

—RUSH THIS COUPON—
TRANSVISION, INC.
NEW ROCHELLE, N. Y.

() Send me ___ CR Tube Tester-Reactivator(s).
() Enclosed find \$___ deposit. Balance C.O.D.
() Enclosed find \$___ in full. Send prepaid.

Name _____
Address _____
City _____ State _____

Tube News

(Continued from page 36)

meet this requirement necessitates adequate wattage and area in the filament to support the peak emission current. Lab and field tests have indicated that the 1AX2 can be operated at full ratings for both dc and peak inverse voltage simultaneously.

It has been also found that a further advantage of the high-wattage filament design is its effect on the regulation of typical flyback transformer filament windings.

Another feature of the 1AX2 is the elimination of the need for a filament series-limiting resistor employed in most designs. Because of the centering of the design at 1.4 volts, it was determined that most of all the existing designs could use the new type tube without any limiting resistor; the 1AX2 could be used as a replacement in the majority of sets now in the field by simply removing whatever series-limiting resistor is presently employed. The high current drain required by the 1AX2 filament offers a simple limiting or regulating effect upon the supply which tends to narrow the voltage spread. As with all filamentary tubes, it is important to keep the filament voltage applied to the 1AX2 within its ratings, if maximum life is desired. The heavier filament current of the 1AX2, however, has been found to help minimize variations in filament voltage caused by the many variables mentioned earlier.

In replacing earlier rectifier tubes with the 1AX2, it may be found that the available filament voltage is too low, even after removing the limiting resistor. Where this occurs the turns of the filament winding should be increased from one to two to obtain the required amount of voltage.

Design and Adjustment of Centering and Ion-Trap Magnets*

In a picture tube utilizing magnetic focus, the electron beam is generally centered, as well as focused, by the magnetic focusing device. In a picture tube utilizing electrostatic focus, the electron beam is centered by means of a small external magnet used exclusively for that purpose. This magnet, however, deflects the electron beam and may, therefore, cause defocusing. To minimize defocusing, it is important that the field of the centering magnet be uniform; to provide varying degrees of centering, it is necessary to

*Based on copyrighted notes prepared by the RCA tube department. ¹Gauss represents the centimeter-gram-second electromagnetic unit of magnetic induction.

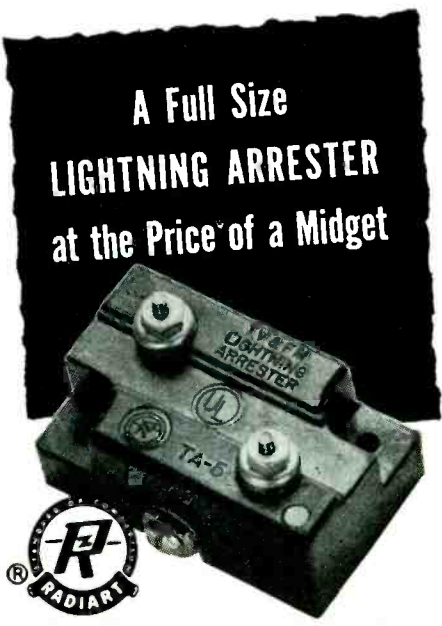

**A Full Size
LIGHTNING ARRESTER
at the Price of a Midget**

LIGHTNING ARRESTER

MODEL TAs Real protection against lightning and static charges — the RADIART Lightning Arrestor has all the features! Fits anywhere... inside or out... handles standard or jumbo leads... no wire stripping necessary... does not unbalance the line... low internal capacity... no loss of signal... internal resistance "leaks off" static discharges!
UNDERWRITERS LABORATORIES APPROVED.

THE RADIART CORPORATION
CLEVELAND 13, OHIO

have the field strength of the magnet adjustable to zero. Adjustment can be obtained by using two uniform fields of equal strength which can be rotated to aid or oppose each other. A magnet having a maximum field strength of 8 gauss¹ placed directly behind the base end of the deflecting yoke will produce sufficient centering for a picture tube having a horizontal deflection angle up to 70° and operating at a voltage as high as 18 kv.

In the design of a centering magnet, particular attention must be given not only to uniformity of the magnetic field but also to straightness of the field lines. Nonuniform fields and curved lines produce serious defocusing, especially with electrostatic-focus tubes designed to operate at low focusing voltages. Field uniformity can be measured with a gauss meter and a jig. The jig employs a bakelite rod with five holes, which permits insertion of the gauss-meter probe. The probe is first inserted in the center hole, and the magnet to be tested is slipped over the rod and moved up and down until the point of maximum field strength is located to line up with the tip of the probe.

[To Be Continued]

INCREASE EARNINGS

TESTING and SERVICING

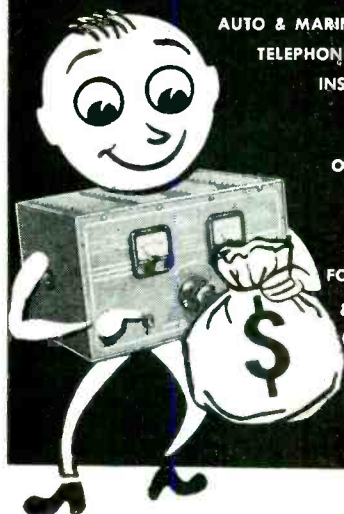

AUTO & MARINE RADIOS.
TELEPHONE CIRCUITS.
INSTRUMENTS.
RELAYS.

OTHER LOW
VOLTAGE
DEVICES.

FOR PLATING
& BATTERY
CHARGING.

MODEL
"BJ"
JUNIOR

ELECTRO LOW-COST FILTERED DC POWER SUPPLY

End costly storage battery failures . . . save time and money with the "BJ" JUNIOR. Exclusive EPL conduction cooling doubles rectifier power rating and provides lowest cost per ampere output over any other type. Dissipates over 3 times the heat and withstands high overloads. Top quality components assure dependability and long life.

NET \$37.50

- 1 to 12.5 amperes 6 volts continuous output with a peak instantaneous rating of 25 amperes.
- 3 to 9 volts at other loads.
- Heavy duty selenium rectifiers, transformer and choke.
- AC ripple less than 0.4 volts at 6 volts DC 8 amperes.

FOR HEAVY DUTY APPLICATIONS
MODEL "B" 6 VOLTS DC
1-20 AMPERES. NET \$49.80

See Your Jobber Today!
Write for New Folder!



ELECTRO PRODUCTS LABORATORIES

4501-Sj Ravenswood Ave., Chicago 40, Illinois
IN CANADA: ATLAS RADIO CORP. LTD., TORONTO

Ser-Cuits

(Continued from page 43)

voltage drift was pointed out as being approximately 70 mc throughout a 95 to 125-volt range of line change.

Analyzing the *if* amplifier circuit. Rieth said a cascode type was used with a 6BK7 double triode. With the *if* amplifier aligned to *vlf* channel 10 (195 mc) and series coupled to the crystal mixer, the output of the mixer is amplified and allows the converter noise to dominate the noise of the *vlf* receiver as well as isolate the *uhf* and *vlf* oscillators from each other. This arrangement was also said to provide additional *vlf* selectivity against images of the *vlf* signal and against other signals which would introduce spurious responses. It was also noted that this system also provides extra attenuation to radiation of *vlf* oscillators.

Detailing the performance factors of the tuner, Rieth said that noise factors of 16.5, 18.2, 19.3 and 22 have been obtained at 500, 600, 700 and 800 mc. Image rejection at these frequencies was said to be 42, 31, 24 and 14, respectively.

Service Helps

(Continued from page 47)

frequencies, due to misalignment. They may also be caused by any condition which is evidenced by too short a drop-off of the high-frequency side of the *if* response curve.

A negative picture, if originating in the *if* section, is the result of overloading of one or more stages. This overloading usually occurs in the third or fourth *if* stage.

In some early Philco dual-chassis TV receivers, overloading occurred in the fourth *if* stage. The trouble can be corrected by adding additional bias to the stage and raising the plate voltage slightly. The cathode-bias resistor should be changed from 150 to 220 ohms, and the plate-load resistor from 6800 to 5600 ohms.

Zenith IF Transformer Adjustment

The *if* transformers incorporated in Zenith radio model J615, 6J05 chassis, are the permanently-tuned type, with the upper coil the secondary and the lower the primary. When adjusting these *if* transformers, a tuning wrench should be inserted into the top slug, rotated until maximum output is obtained, and then dropped down to the lower slug and the same operation repeated.

to the
music lover,
audio hobbyist
or
professional:



PRESENTING

the new Jensen Brochure 1020—20 comprehensive pages about high fidelity sound and its equipment—including the Jensen Silver Anniversary line . . . loudspeakers and cabinets of unprecedented importance to everyone seeking the finest quality attainable today.

write for your free copy!

Jensen

JENSEN MANUFACTURING COMPANY
DIVISION OF THE MUTER COMPANY
6601 S. LARAMIE AVE., CHICAGO 38, ILLINOIS
IN CANADA:
COPPER WIRE PRODUCTS, LTD., LICENSEE

BURTON BROWNE ADVERTISING



JOE B. HIGGINBOTHAM, JR.

Nuberg, Ga.

**THANKS,
Mr. Higginbotham!**

Radio Receptor Co., Inc.
West 19th Street
New York 11, N.Y.

Gentlemen:

Please send me your pamphlet on the design, application and servicing of selenium rectifiers.

Although I have serviced many receivers which have selenium rectifiers I have very little information on them and believe your pamphlet would be a valuable asset to my shop.

I use your rectifiers, supplied by Southeastern Radio Parts Co. and Specialty Distributing Co. of Atlanta, Ga., and like them very much. Also I appreciate your consideration of the radio repairman in that you supply a data sheet with each rectifier and the trouble taken to print the servicing information.

Yours Truly

Joe B. Higginbotham Jr.
Joe B. Higginbotham Jr.



SELETRON RECTIFIERS

... And our thanks go as well to the other thousands of servicemen and hams who insist upon top performing SELETRON Selenium Rectifiers in electronic circuits and as replacements in Radio and TV sets.

You can depend on SELETRON all ways... Full technical information is always available without obligation. Look for Howard W. Sam's Red Book Supplement listing SELETRON replacements, and write us for Bulletin No. 104-S.



SELETRON DIVISION

RADIO RECEPTOR COMPANY, INC.

Since 1922 in Radio and Electronics

Factory: 84 North 9th St., Brooklyn 11, N. Y. • Sales Department: 251 West 19th St., New York 11, N. Y.

Scala OSCILLOGRAPH PROBES

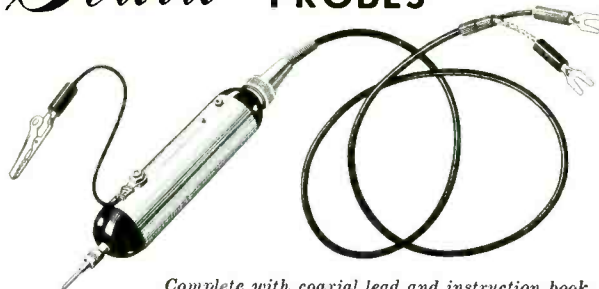

Complete with coaxial lead and instruction book.

A NEW TOOL TO MAKE TV SERVICING Easier, Faster, More Accurate AND MORE PROFITABLE

No probes made anywhere do the job of SCALA oscillograph probes so efficiently, so easily. Use with your present scope... low cost will be paid ten times over in a month. Check your local distributor or write factory and specify model number:

BZ-1 SIGNAL TRACING PROBE... locates dead I.F. stages, marks ratio detector curve, calibrates marker generator, adjusts video amplifiers, checks output of sweep generator, views response of single I.F. stage, traces buzz pulse in sound I.F. strip. Can be used with V.T.V.M. Contains demodulator of low-capacitance, high-impedance design, useful to 225 MC.

BZ-2 LOW CAPACITY PROBE... makes it possible to trace video, sync or sweep waveforms through high-impedance circuits without causing waveform distortion due to circuit loading. Cuts the effective input capacitance of scope by a factor of 10 and gives an attenuation of 10 to 1.

BZ-3 100:1 VOLTAGE DIVIDER PROBE... is very useful in trouble-shooting horizontal sweep circuits. It may be applied directly to plate of horizontal output tube or at the plate of the damper tube to check the operation waveforms and to measure their peak to peak voltages without impairing the wave shape or incurring danger to the oscillograph.

SCALA RADIO CO., 2814 - 19th St., San Francisco 10, Cal.

WHEN YOU CHANGE YOUR ADDRESS

Be sure to notify the Subscription Department of SERVICE at 52 Vanderbilt Avenue, New York 17, N. Y., giving the old as well as the new address, and do this at least four weeks in advance. The Post Office Department does not forward magazines unless you pay additional postage, and we cannot duplicate copies mailed to the old address. We ask your cooperation.

RESERVE SPACE NOW

in the important

JULY

TV Antenna and Accessory Issue

AUGUST

Pacific Coast Electronic Show Issue

Forms close 25th preceding month.

SERVICE-paid circulation now over 35,000



RETAILS AT
\$144.95

Slightly higher west of the Rockies.

A tool... A friend... A teacher

... the EICOR TAPE RECORDER

offers you the ultimate experience in sound reproduction.

DEMONSTRATE and SELL —

EDUCATE and RE-SELL . . .

You will find that your best salesman will be the customer who bought an EICOR.

DEALERS — For

information on

contacting your

nearest distributor

Write — Dept. S-6



Eicor, Inc.

1501 W. CONGRESS ST.
CHICAGO 7, ILLINOIS

ASSOCIATIONS



NATESA

MID-YEAR MEETING of the National Alliance of Television and Electronic Service Associations was held at the Conrad Hilton Hotel in Chicago recently.

Jack McDowell of TV Service Engineers of Kansas, introduced a unique emblem tie at an association meeting recently. The TSE emblem was imprinted in striking colors. Service Men who would like to duplicate the McDowell tie can contact him at 7919 Sante Fe Drive, Overland Park, Kansas.

Radio and Television Servicemen of New Jersey's active group is now headed by president Rhodes, vice president Bremy, treasurer Weinberg and legal council Gelman.

RETA AND ART, B. C.

THE SECOND MEETING of the provincial council of the Radio Electronic Technicians Association and the Associated Radio Technicians of British Columbia was held in the Canadian Forestry Association Hall recently, and was presided over by Monte Lennox. The following directors was also present: Tom Grant, Ray Winstone, Dalton Newberry, J. A. Clarke, W. Filtness, D. Banfield, E. Young and W. Wilson.

Approximately 200 gummed stickers of the RETA crest have been handed out to chapter representatives. There are about 800 available for distribution to other provinces at cost.

RTG, Florida

FIRST ISSUE of the monthly bulletin of the Radio and Television Technicians Guild of Florida, Inc., has been published. Thomas N. Middleton is editor of the publication, and Robert Martin is advertising manager.

TEN YEARS AGO

RUNNING *Your Service Shop for the Duration* was the subject of a feature article in SERVICE by Alfred A. Ghirardi. . . . One of the chassis, made shortly before the WPB stop-production ruling went into effect, a Westinghouse M108 4-range, 6-tube *ac* model, featured a split primary power transformer allowing a parallel connection for 110-volt use and a series connection for 220 volts. A slotted plug was used for the changeover. Receiver also used *if* regeneration of the screen-grid tickler type and plate-to-plate inverse feedback obtained by a 2-megohm resistor from *af* output plate to first *af* plate. . . . A Sears Roebuck Silvertone model 7900 was also rated as featuring a split primary-power transformer for 110 or 220 volts. The output stage was a 6K6 with an unbypassed 680-ohm cathode resistor. . . . In a *state of the industry* report, R. T. Schottenberg, then sales manager of the Astatic Corp., told Service Men that they . . . "have a very definite responsibility during these trying times." He told the boys that it was their job to keep 'em listening, and carry on . . . "somehow in spite of the difficulty of securing replacement parts." . . . Harry Kalker, of Sprague Products Co., stated that . . . "Service Men are lucky fellows these days. They've got a bigger job to do than ever before. It's a job that holds bigger opportunities for profit. Above all, it is one that holds tremendous opportunity for emergency service to the nation in seeing to it that at least one radio is kept working in every American radio-equipped home."

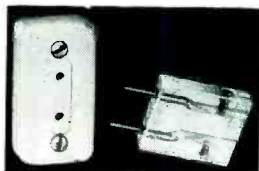

Cat. No. 343-PK
List Price \$1.05

Compact TV lead-in terminal or tap socket. Molded Polystyrene. In brown or ivory. With mating transmission line plug.



Cat. No. 311
List Price \$3.00

Solderless Transmission Line Socket mates with Input Adapter, right, for convenient lead-in connection to set or booster.

Cat. No. 304
List Price \$3.30

Input Adapter attaches to antenna terminal strip on set or booster. Mates with Line Socket, left, for quick connect-disconnect.



MOSLEY ELECTRONICS 2125 LACKLAND ROAD, OVERLAND, MISSOURI

MOSLEY PLUGS and SOCKETS for BETTER TV INSTALLATIONS

Use these MOSLEY Low Loss Plugs and Sockets on every TV installation job for neat, efficient, constant impedance connections of standard 300 ohm transmission line to set or booster. Save installation time—prevent call backs—with these solderless, sturdy MOSLEY accessories. Your customers will appreciate their convenience, too!

NEW IMPORTANT BOOK FOR
• SOUND TECHNICIANS
• AUDIO ENGINEERS
• CUSTOM BUILDERS

VOLUME 3! HOWARD W. SAMS' "AUDIO AMPLIFIERS"



Full Analysis of
50 Important
Audio Amplifiers
and 22 Popular
FM & AM Tuners
Based on Actual
Study of the
Equipment

Covers Latest Audio Equipment

Latest volume in the SAMS' "AUDIO AMPLIFIERS" Library. Provides detailed, clear, uniform analysis of 50 important audio amplifiers, and full coverage of 22 FM and AM tuners, produced during 1950. Each unit is thoroughly analyzed in from 4 to 10 pages; includes circuit diagrams, design data, parts information, full technical coverage described in uniform detail and profusely illustrated by photographs and diagrams. Based on study of the actual equipment. Entirely new material, continuing audio equipment coverage begun in Vols. 1 and 2 (see below). Never before available in a single complete, accurate compilation. Indispensable to public address and sound technicians, custom installers, BC engineers and students—a "must" for everyone in the field of Sound. 362 fact-packed pages; 8½ x 11"; sturdily bound.

ORDER AA-3. Only \$3.95



VOLS. 2 and 1 "AUDIO AMPLIFIERS"

VOL. 2. Covers 104 well-known audio amplifiers and 12 important tuners produced during 1949. Includes uniform, detailed circuit and design data based on original lab study of the actual equipment. Profusely illustrated. 368 pages; 8½ x 11"; durably bound.

ORDER AA-2. Only \$3.95

VOL. 1. This is the initial volume covering audio equipment produced after the war, through 1948. Covers 102 audio amplifiers and FM tuners, plus data on important wire and tape recorders. 352 pages; fully illustrated; in sturdy binding, 8½ x 11"

ORDER AA-1. Only \$3.95

OWN ALL THREE VOLUMES FOR A COMPLETE, AUTHORITATIVE SOUND LIBRARY

HOWARD W. SAMS & CO., INC.

Order from your Parts Jobber today, or write direct to HOWARD W. SAMS & CO., INC., 2201 East 46th Street, Indianapolis 5, Ind.

My (check) (money order) for \$..... enclosed. Send the following books:

AA-3. AA-2. AA-1. \$3.95 each

Name.....

Address.....

City.....Zone.....State.....

ATR

For
**AC CURRENT
ANYWHERE**



**STANDARD
AND HEAVY DUTY
INVERTERS**

For Inverting D. C. to A. C. . . .
Specially Designed for operating A. C.
Radios, Television Sets, Amplifiers, Ad-
dress Systems, and Radio Test Equip-
ment from D. C. Voltages in Vehicles,
Ships, Trains, Planes and
in D.C. Districts.

ATR ✓ NEW MODELS
✓ NEW DESIGNS
✓ NEW LITERATURE

"A" Battery Eliminators, DC-AC Inverters
Auto Radio Vibrators

See your folder or write factory

AMERICAN TELEVISION & RADIO CO.
Quality Products Since 1931
SAINT PAUL 1, MINNESOTA-U.S.A.

JOTS AND FLASHES

THE NUMBER of TV receivers in operation in this country may exceed the number of homes with electricity by 1960, according to *Dr. W. R. G. Baker*, G. E. vice prexy and general manager of the electronics division. He said that market research has indicated that 53-million sets will be in operation by '60, more than three times the present number and five-million more than the number of homes expected to have electricity by that time. . . . A total of 7,231,186 replacement tubes were sold during the first quarter of this year, according to a RTMA report. It was also reported that large rectangular picture tubes (16 inches up) represented 98 per cent of sales in the quarter, while a year ago, only 84 per cent of the tubes sold to manufacturers were rectangular in form, and 94 per cent were 16" in size or larger. . . . *Newark Electric Co.* has moved to larger quarters at 223 W. Madison St., Newark, N. J. . . . *Sylvania Electric* is negotiating a lease for a \$50,000-square foot factory building to be erected in the York, Pa., area. New plant will be used for the fabrication of metal parts and will be operated as a unit of the parts division, which has headquarters at Warren, Pa. . . . A notebook by Ed Noll describing the practical application of TV test equipment, has been announced by *The Paul H. Wendel Publishing Co., Inc.*, P.O. Box 1321, Indianapolis 6, Ind. . . . *Central Television Service* has been appointed by the Graybar Electric Co., as the official service organization for Hoffman TV sets in the Chicago area. . . . *R. W. Fordyce*, general sales manager of Bendix Radio, TV and broadcast receiver division of Bendix Aviation Corp. resigned recently to enter the distributing business in Miami. . . . Thirty pioneer broadcasting personalities were honored recently by Sylvania at a luncheon, attended by 200 representatives of show business, press and the radio and TV industry, commemorating the production of the billionth radio tube; simultaneously, President Truman was presented with a plaque by *Don Mitchell*, president of Sylvania Electric, at a White House ceremony on the occasion. President Truman received a gold replica of the billionth tube, identical to that presented to the pioneers at the luncheon. . . . A quarter century of service to the radio and electronics industries was marked recently by the *Capitol Radio Engineering Institute* of Washington, D. C., with a silver anniversary banquet, held in the East Room of the Mayflower Hotel.

ADVERTISERS IN THIS ISSUE

SERVICE INDEX—JUNE, 1952

| | |
|---|------------------------|
| AMERICAN ELECTRICAL HEATER CO. | 43 |
| Agency: The Agency Co., Inc. | |
| AMERICAN PHENOLIC CORP. | 32 |
| Agency: Burton Browne, Advertising | |
| AMERICAN TELEVISION & RADIO CO. | 72 |
| Agency: Firestone-Goodman Adv. Agency | |
| BENDIX RADIO | 56 |
| Agency: MacManus, John & Adams, Inc. | |
| BURGESS BATTERY CO. | 57 |
| Agency: Ruthrauff & Ryan, Inc. | |
| BUSSMAN MFG. CO. | 11 |
| Agency: Oakleigh R. French & Associates | |
| CHANNEL MASTER CORP. | 63 |
| Agency: Duso Advertising, Inc. | |
| CLEAR BEAM TV ANTENNAS | 55 |
| Agency: Stillier-Rouse & Associates | |
| CORNELL-DUBILIER ELECTRIC CORP. | 42 |
| Agency: Reiss Advertising | |
| CORNELL-DUBILIER RADIART | 61 |
| Agency: Stern and Warren | |
| CREST LABORATORIES | 60 |
| Agency: Bachenheimer-Lewis, Inc. | |
| DUOTONE CO. | 59 |
| Agency: Cont'l Adv. Agency, Inc. | |
| EICOR, INC. | 70 |
| Agency: Sander Rodkin Adv. Agency, Ltd. | |
| ELECTRONIC INSTRUMENT CO., INC. | 64 |
| Agency: H. W. Hauptman Co. | |
| ELECTRO PRODUCTS LABORATORIES, INC. | 69 |
| Agency: Clarence M. Gotch Associates | |
| EQUIPTO DIV., AURORA EQUIPMENT CO. | 60 |
| Agency: Vernon S. Weller | |
| FERRO ELECTRIC PRODUCTS, INC. | 4 |
| Agency: Fuller & Smith & Ross, Inc. | |
| GENERAL CEMENT MFG. CO. | 47 |
| Agency: Paul J. Stoffen Co. | |
| GENERAL ELECTRIC | 6, 7 |
| Agency: Maxon, Inc. | |
| HEATH CO. | 66 |
| Agency: G. Dean Arend, Advertising | |
| HYTRON RADIO & ELECTRONICS CO. | 33 |
| Agency: Bennett, Walther & Menadier, Inc. | |
| JFD MFG. CO., INC. | 58 |
| JENSEN INDUSTRIES, INC. | 48 |
| Agency: Paul J. Steffen Co. | |
| JENSEN MFG. CO., INC. | 3, 69 |
| Agency: Burton Browne, Advertising | |
| KESTER SOLDER CO. | 28 |
| Agency: Paul J. Steffen Co. | |
| LA POINTE-PLASCOMOLD CORP. (VEE-D-X) | 48 |
| Agency: The F. W. Prella Co. | |
| P. R. MALLORY & CO., INC. | Inside Back Cover |
| Agency: The Altkin-Kynett Co. | |
| MERIT COIL & TRANSFORMER CORP. | 5 |
| Agency: Burton Browne Advertising | |
| M. A. MILLER MFG. CO. | 50 |
| Agency: Sander Rodkin Adv. Agency | |
| MOSLEY ELECTRONICS | 71 |
| Agency: Bartz Adv. Agency | |
| OHMITE MFG. CO. | 51 |
| Agency: The Fensholt Co. | |
| PERFECTION ELECTRIC CO. | 54 |
| Agency: Scantlin & Co. | |
| PERMA-POWER CO. | 52 |
| Agency: Sander Rodkin Adv. Agency, Ltd. | |
| PERMO, INC. | 37 |
| Agency: Symonds, MacKenzie & Co. | |
| PYRAMID ELECTRIC CO. | 21 |
| RADIART CORP. | 68, Inside Front Cover |
| Agency: Stern and Warren | |
| RADIO CITY PRODUCTS CO. | 67 |
| Agency: Jaman Advertising, Inc. | |
| RADIO CORPORATION OF AMERICA | 3, 15, Back Cover |
| Agency: J. Walter Thompson Co. | |
| RADIO MERCHANDISE SALES, INC. | 18 |
| Agency: Heid Associates | |
| RADIO RECEPTOR CO. | 70 |
| Agency: Walter J. Zimmerman & Associates | |
| THE RAULAND CORPORATION | 45 |
| Agency: MacFarland, Aveyard & Co. | |
| RAYTHEON MFG. CO. | 16 |
| Agency: Walter B. Snow & Staff | |
| REGENCY DIV. I.D.E.A., INC. | 9 |
| Agency: Burton Browne, Advertising | |
| JOHN F. RIDER PUBLISHER, INC. | 14, 62 |
| Agency: Cont'l Adv. Agency, Inc. | |
| HOWARD W. SAMS & CO., INC. | 54, 71 |
| Agency: George Brody, Advertising | |
| SANGAMO ELECTRIC CO. | 8 |
| Agency: Arthur R. Mogue, Inc. | |
| SCALA RADIO CO. | 70 |
| Agency: Richard Meltzer Adv. Inc. | |
| SCHAUER MFG. CO. | 48 |
| Agency: The Keeler & Stites Co. | |
| WALTER L. SCHOTT CO. | 12 |
| Agency: Tilds & Cantz | |
| SIMPSON ELECTRIC CO. | 1 |
| Agency: Burton Browne, Advertising | |
| SOUTH RIVER METAL PRODUCTS CO., INC. | 62 |
| Agency: Art-Copy Adv. Agency | |
| SPRAGUE PRODUCTS CO. | 53 |
| Agency: The Harry P. Bridge Co. | |
| SUPREME, INC. | 58 |
| Agency: Getz Grenshaw Adv. Agency | |
| SARKES TARZIAN, INC. | 46 |
| Agency: H. L. Ross, Advertising | |
| TEL-A-RAY ENTERPRISES, INC. | 10 |
| Agency: Keller-Crescent Co. | |
| TELEVISION ENGINEERS, INC. | 66 |
| Agency: E. H. Brown Adv. Agency | |
| TENNA-TRAILER CO. | 65 |
| Agency: Glen Price | |
| TRANSVISION, INC. | 68 |
| Agency: H. J. Gold Co. | |
| TUNG-SOL ELECTRIC, INC. | 41 |
| Agency: E. M. Freystadt Associates, Inc. | |
| UNIVERSITY LOUDSPEAKERS, INC. | 64 |
| Agency: George Homer Martin Associates | |
| WALDOM ELECTRONICS, INC. | 58 |
| Agency: Alan Adv. Agency | |
| WESTER-CHICAGO CORPORATION | 13 |
| Agency: Fuller & Smith & Ross, Inc. | |
| WRIGHT, INC. | 54 |
| Agency: Kay Advertising, Inc. | |

The "Fittingest" thing you ever saw . . .

MALLORY MIDGETROL®

Dual Concentric Volume Controls



FIT 'EM FAST . . . FIT 'EM EASY

- In just five steps that take less than five minutes, you assemble a dual control that gives you the precise resistance values you need.
- Directions are short, easy to follow and you need no special tools . . . no soldering.
- Front and rear sections are factory-assembled and inspected.
- Instant AC switch attachment without control disassembly.

MAKE YOUR CUSTOMERS HAPPY

- Longer lasting resistance elements even in extremes of temperature and humidity.
- Better and more accurate taper curves resulting from precision processing methods.
- No pigtail connections to break—thanks to Mallory's exclusive sliding contact that gives EXTRA quiet operation.
- Minimum wobble with Mallory exclusive two-point shaft suspension.

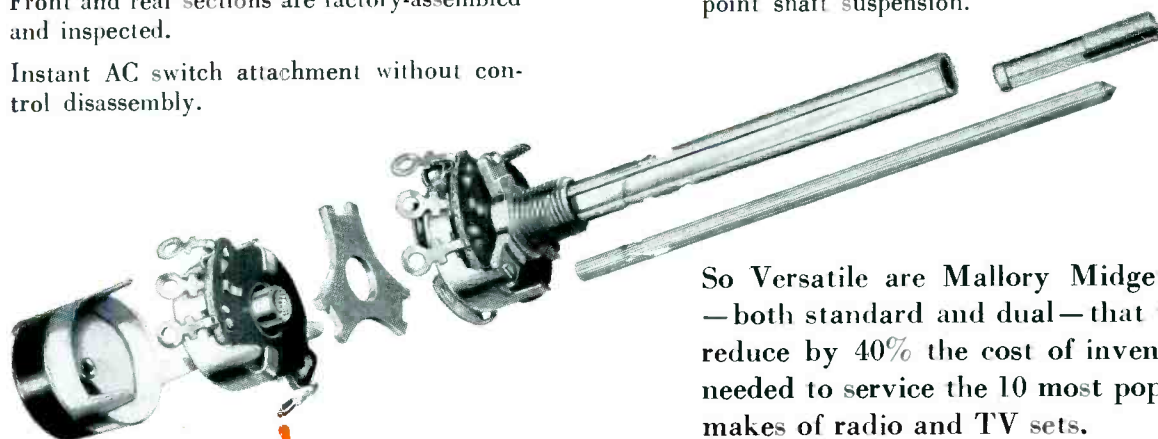

So Versatile are Mallory Midgetrols —both standard and dual—that they reduce by 40% the cost of inventory needed to service the 10 most popular makes of radio and TV sets.

You can build more than 10,000 different combinations with Mallory Midgetrols and do it fast . . . easily. Each dual control you build duplicates exactly the control it replaces. The Mallory Midgetrol Line, in addition to dual concentrics, includes round shaft, standard controls with the advantages of stable, two-point shaft suspension, instant AC switch attachment. Ready adaptability to split-knurl and flatted type knobs.

**Make Sure!
Make it Mallory!**

P. R. MALLORY & CO. Inc.
MALLORY

CAPACITORS • CONTROLS • VIBRATORS • SWITCHES • RESISTORS
• RECTIFIERS • VIBRAPACK* POWER SUPPLIES • FILTERS
*Reg. U.S. Pat. Off.

APPROVED PRECISION PRODUCTS

P. R. MALLORY & CO., Inc., INDIANAPOLIS 6, INDIANA

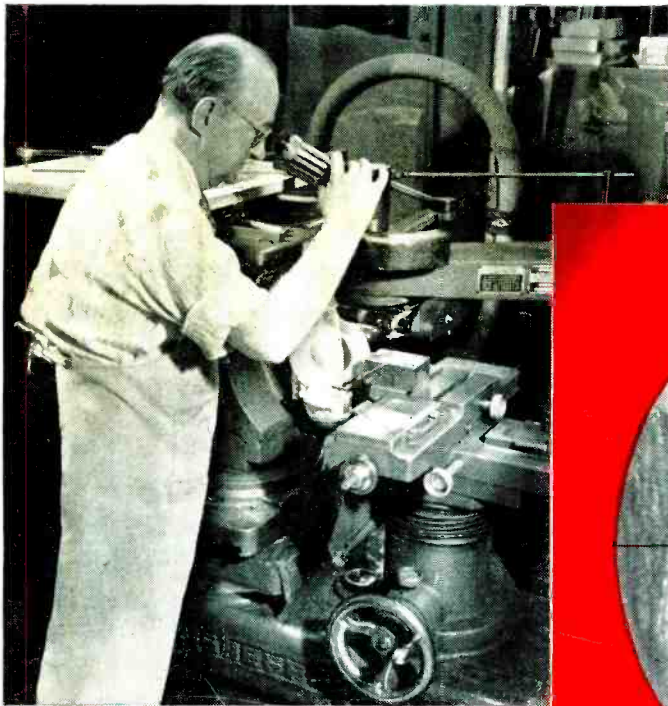

1. The machine that grinds the die.



2. The die that forms the cathode sleeve.



3. The cathode sleeve that helps make the tube.



Take a look at **quality** being born

DIMENSIONAL ACCURACY of the cathode sleeve is a vital factor in providing top-quality tube performance. And cathode-sleeve accuracy begins with the forming die.

What you see above are the two sections of a typical cathode-sleeve forming die, just as it is viewed by the die maker through a 30-power microscope. The die is finished in a

"profile grinder" which employs a 50-to-1 pantograph that traces a template and precisely guides the grinding operation. The result is a die accurate to better than one ten-thousandth of an inch!

Such painstaking precision finishing of dies used to stamp, punch, and form critical tube parts is one more step contributing to the top

quality of RCA Tubes. In this way, RCA closely guards its own reputation for quality ... and yours as well.

With RCA Kinescopes, as well as with RCA Receiving Tubes, **TOP-QUALITY CONTROL** makes the difference.



RADIO CORPORATION of AMERICA
ELECTRON TUBES

HARRISON, N. J.

TMKS. (R)