

SERVICE

APRIL
1952

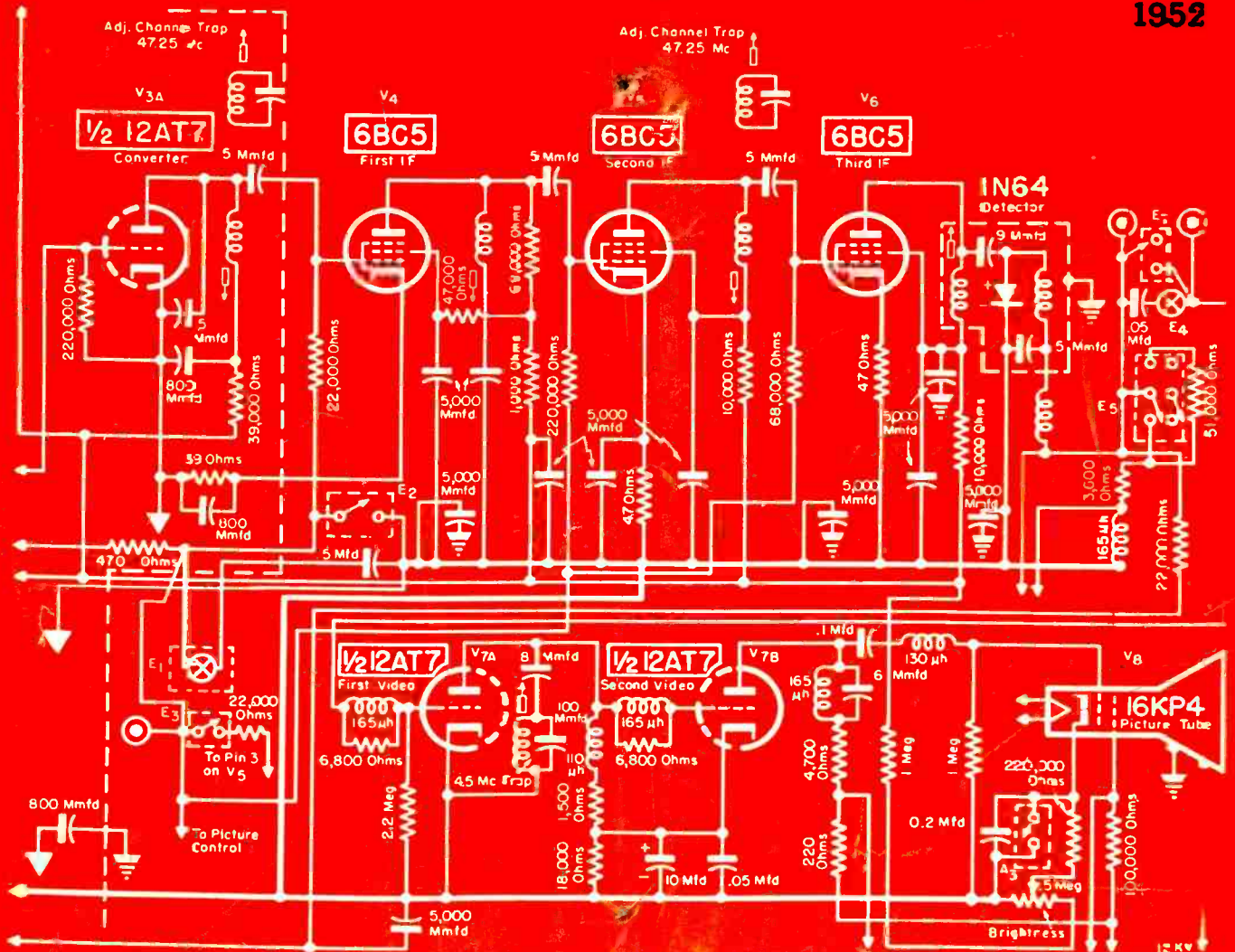

Converter, IF, detector and video stages for a TV dynamic demonstrator.

See page 21

ACCEPTED



by servicemen and
electronics experts . . .

as the **GREATEST** Improvement in Vibrators in 17 Years

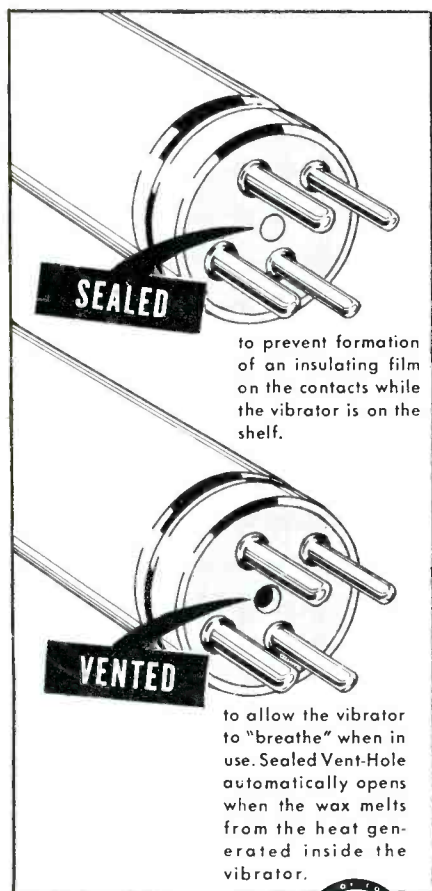

SEALED

to prevent formation of an insulating film on the contacts while the vibrator is on the shelf.

VENTED

to allow the vibrator to "breathe" when in use. Sealed Vent-Hole automatically opens when the wax melts from the heat generated inside the vibrator.



Experts everywhere agree that this is the greatest advancement in vibrator design in the last 17 years! That's because NOW . . . with the RADIART SEAL VENT . . . the vibrator is sealed BEFORE it is used . . . and VENTED after it is put into use! The RED SEAL rubber-faced bakelite plug prevents formation of an insulating film on the contacts. Heat generated when the vibrator is put into service melts the wax out of the sealed vent-hole and permits air circulation . . . FOR LONGER LIFE AND EVEN GREATER PERFORMANCE! Give your customers the best . . . give them RADIART . . . the STANDARD OF COMPARISON.

SUBSIDIARY OF



THE RADIART CORPORATION CLEVELAND 13, OHIO

VIBRATORS • AUTO AERIALS • TV ANTENNAS • ROTATORS • POWER SUPPLIES

Largest Automobile Service Market!

Nearly half of all radio-equipped cars are equipped with Delco Radios . . . a total of more than 7 million. Think of this in terms of the service market.

There's big-volume opportunity right at your own front door when you are prepared to service this market with original equipment and universal parts.

Delco Radio parts are of uniform high quality—made and guaranteed by the world's largest maker of automobile radios.

Your nearby United Motors wholesaler can supply your requirements for Delco Radio service parts—promptly.



DELCO RADIO PARTS

A GENERAL MOTORS PRODUCT



A UNITED MOTORS LINE

DISTRIBUTED BY WHOLESALERS EVERYWHERE

DELCO RADIO

DIVISION OF GENERAL MOTORS CORPORATION

KOKOMO, INDIANA

no other fan conical

assembles so fast

performs so well!

JETENNA

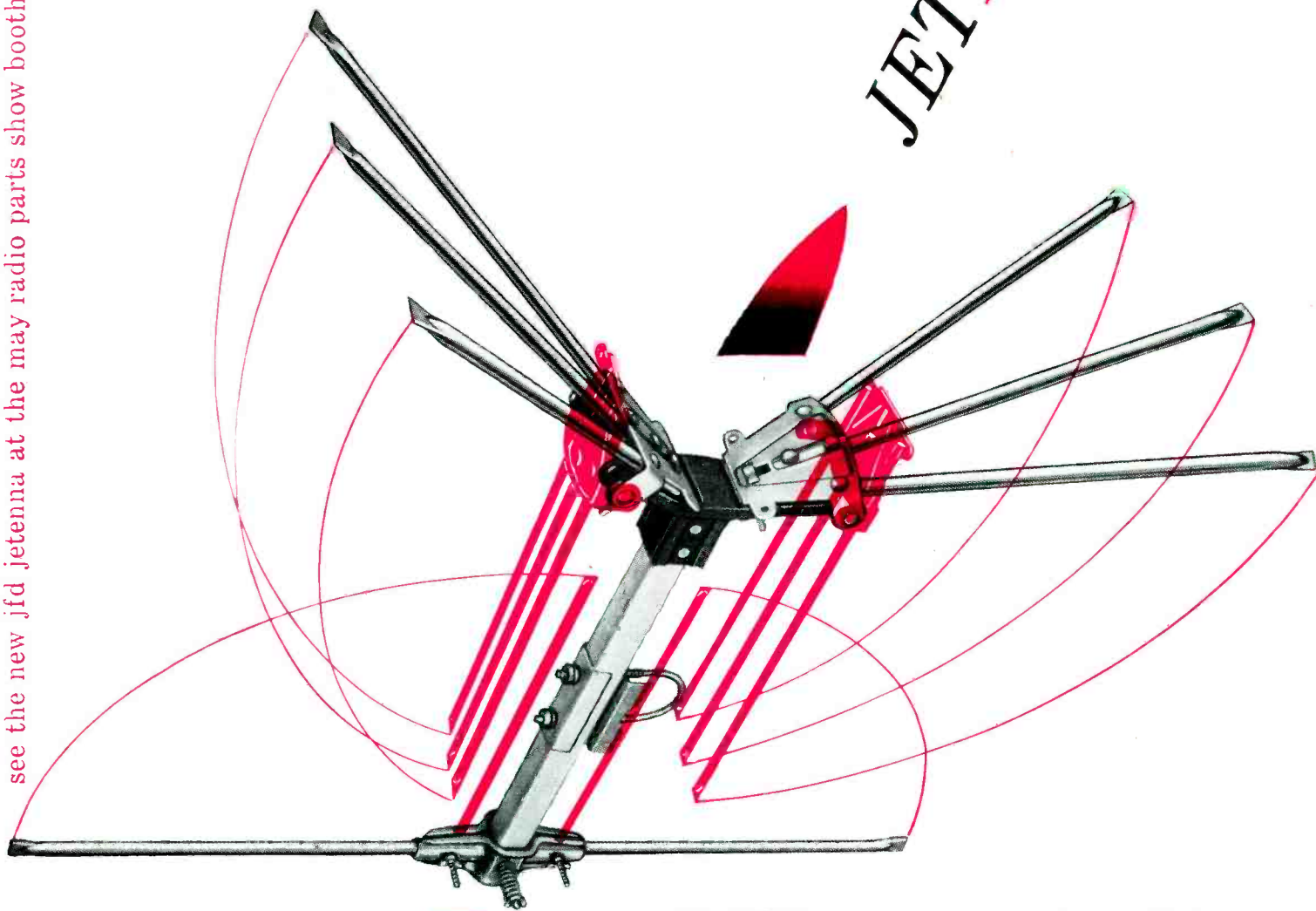

JFD JETENNA, the conical with the jet-action assembly, has absolutely no separate parts to put together—the slowest part is opening the carton! Just swing out the elements, tighten two “T” bolts and two wing nuts and it’s assembled! Front elements automatically fan out as they are swung forward. Reflector elements are spring-loaded to lock into position for tightening. 1” square seamless crossarm, seamless elements and element brackets are of high tensile strength aluminum—unbreakable head is of all weather, high dielectric material. Solid, unbreakable “vibration dampers” do not absorb moisture or swell and will not rot out. SEE YOUR JOBBER OR WRITE FOR FURTHER INFORMATION ABOUT THIS REVOLUTIONARY NEW ANTENNA.



JFD MFG. CO., BROOKLYN 4, N.Y.
BENSONHURST 6-9200
*world's largest manufacturer
of TV antennas and accessories*

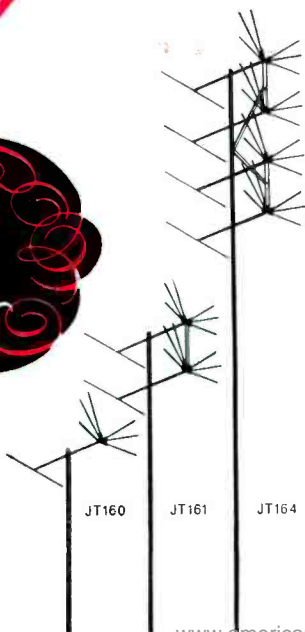

JT160

JT161

JT164

JT160 SINGLE BAY 12.50 LIST
JT161 STACKED 26.40 LIST
JT164 DOUBLE STACKED 56.80 LIST

see the new jfd jetenna at the may radio parts show booth 578 or room 516



LEWIS WINNER
Editor

F. WALEN
Assistant Editor

Registered U. S. Patent Office
Including Radio Merchandising and Television Merchandising

Association News	74
Audio Installation and Service (Tape Record-Playback/Tape-Disc Amplifiers and Mechanisms). By Kenneth Stewart	34
Business Aids (Serving New Communities)	63
Locating Temperature-Induced Faults in TV Receivers. By J. C. Geist	33
Loudspeaker Mountings. By Edgar Vilchur	26
Reforming Selenium Rectifiers. By J. T. Cataldo	50
Ropes and Ties in Antenna Installations. By Donald Phillips	24
Ser-Cuits (TV Chassis LV Selenium-Cell Power Supplies). By M. W. Percy	40
Service . . . The National Scene	21
Servicing Helps. By M. A. Marwell	44
Ten Years Ago	78
Troubleshooting 3-Way Portables. By Jack Darr	30
Tube News (Twin Triodes for Vertical Deflection Circuits.) By L. M. Allen	52
TV Dynamic Demonstrator (Cover). By Wyn Martin	54
Views and News. By Lewis Winner	19

AUDIO INSTALLATION AND SERVICE

Portable-Remote Tape Equipment	36
Servicing Tape Recorders	38
Tape-Disc Amplifier	34
Tape-Disc Mechanical Systems	34

CIRCUITS

Admiral Video Amplifier Modified to Reduce Smear	44
Filament String Driven from Cathode Current of 117L7, 50L6, etc., Pentode Section	31
Filament String in 3-Way Portables	31
G.E. Dynamic Demonstrator (Cover)	55
Philco TV Chassis LV Power Supply	40
Power Supply Basic Circuitry for 3-Way Portable	30
Selenium Full-Wave Voltage Doubler	42
Selenium Half-Wave Voltage Doubler	42
Selenium Rectifier Forward-Current Test Circuit	42
Selenium Rectifier Reforming Circuits	50
Selenium Rectifier Reverse-Current Test Circuit	42
Sonar PRA Tape-Recorder Amplifier	35
Sylvania Brightness Control Improvement	48
Sylvania Horizontal Phasing Modification	48
Sylvania HV Circuit Altered to Eliminate Sparkhausen Interference	46
Synchroguide Horizontal Oscillator and AFC Circuit	33
Wilcox-Gay 1C-10 Tape-Disc Recorder-Playback Amplifier	34

COVER

TV Dynamic Demonstrator (G.E.)	54
--------------------------------------	----

SERVICING HELPS

First Aid for Pliers	48
Germanium Crystal Replacements Procedures	44
Improving Interlace	46
Improving Vertical Hold in Fringe Areas	46
Increasing Anode Lead Protection	46
Providing Correct Oscillator-Injection Voltage	46
Reducing Picture Smear	44
Removing Small Horizontal Size	46

Index to Advertisers

.....	80
-------	----

Manufacturers

Jots and Flashes	80
News	58
New Parts . . . Tools . . . Instruments	75
Rep Talk	62
TV Parts . . . Antennas . . . Accessories	56



Entire contents Copyright 1952, Bryan Davis Publishing Co., Inc.

Published monthly by Bryan Davis Publishing Co., Inc.

52 Vanderbilt Avenue, New York 17, N. Y. Telephone MURray Hill 4-0170

Bryan S. Davis, Pres. Paul S. Weil, Vice-Pres., Gen. Mgr. F. Walen, Sec. A. Goebel, Cir. Mgr.
Mid-West Representative: Stuart J. Osten, 333 N. Michigan Ave., Chicago 1, Ill. Telephone: DEarborn 2-3507
East-Central Representative: James C. Munn, 2253 Delaware Dr., Cleveland 6, Ohio. Telephone: ERview 1-1725
Pacific Coast Representative: Brand & Brand, 1052 W. Sixth St., Los Angeles 14, Calif. Tel.: Michigan 1732
Suite 1204, Russ Building, San Francisco 4, Calif. Telephone: SUTter 1-2251

Entered as second-class matter June 14, 1932, at the Post Office at New York, N. Y., under the Act of March 3, 1879. Subscription price: \$2.00 per year in the United States of America and Canada, 25 cents per copy. \$3.00 per year in foreign countries; 35 cents per copy.

world's finest coaxial speaker
world's best coaxial value

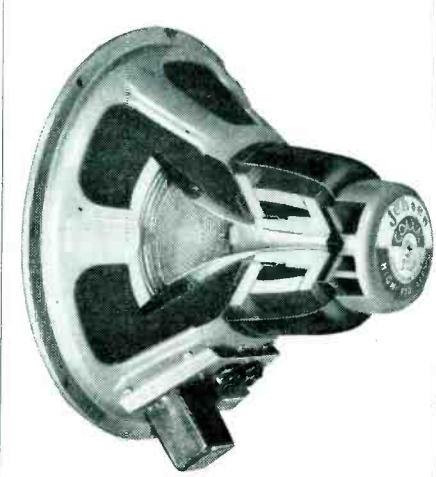

the Jensen H-510
with acoustic lens*

In cleanness and presence, in thrilling realism of reproduction, the H-510 is unsurpassed by any other coaxial regardless of cost. Has acoustic lens*, advanced type compression driver h-f unit and many other features. Write for descriptive literature.

*First loudspeaker to employ the acoustic lens.

Jensen
Manufacturing Company

division of The Muter Company
export department at the factory

6601 S. Laramie
Chicago 38



Display measures 27" wide x 22" high x 9" deep

YOURS... AT NO EXTRA COST... THIS GIANT YEAR-ROUND DISPLAY!

STOP them... TELL 'em... SELL 'em — ALL YEAR 'ROUND with the big, new, portable-radio and "Eveready"-battery sales kit featuring this striking, all-season window display.

One side of the display highlights spring and summer sportcasts. When baseball season's over, simply reverse the side panels to spark fall-winter sales with reminders of the big football broadcasts. The realistic hand in the display shows customers at a glance that you're featuring a *portable* set.

Kit also contains streamer, pennants, acetate "service" poster, dummy batteries and complete, up-to-date replacement guide. The **WHOLE KIT** is **YOURS** at no extra cost with an order for "Eveready" portable-radio batteries totaling \$25.00 or more at dealer prices.

ACT NOW... offer expires June 30, 1952.

SEE YOUR DISTRIBUTOR NOW ABOUT THE BIG "EVEREADY" RADIO-BATTERY BONUS OFFER

The terms "Eveready", "Mini-Max", "Nine Lives" and the Cat Symbol are trade-marks of Union Carbide and Carbon Corporation

NATIONAL CARBON COMPANY
A Division of Union Carbide and Carbon Corporation
30 East 42nd Street, New York 17, N. Y.

District Sales Offices: Atlanta, Chicago, Dallas, Kansas City,
New York, Pittsburgh, San Francisco

IN CANADA: National Carbon Limited, Montreal, Toronto, Winnipeg

"BATTERY-ENGINEERED BY
BATTERY MANUFACTURERS FOR
BEST BATTERY PERFORMANCE!"



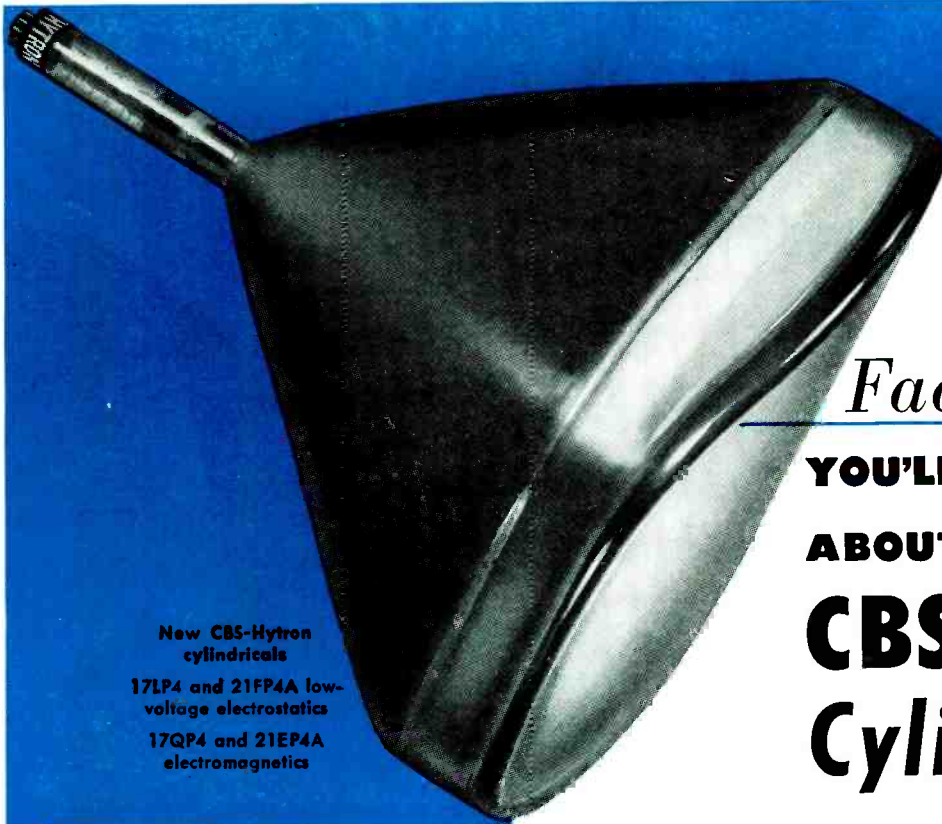

New CBS-Hytron
cylindricals
17LP4 and 21FP4A low-
voltage electrostatics
17QP4 and 21EP4A
electromagnetics

Facts YOU'LL WANT TO KNOW ABOUT NEW CBS-HYTRON Cylindricals

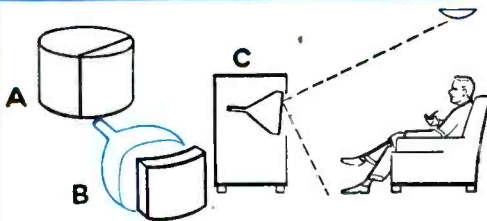

WHY CBS-HYTRON CYLINDRICAL?

To eliminate reflected glare? How? Simple as ABC: A. Imagine a cylinder; slice it vertically. B. You now have the shape of the face plate of a cylindrical tube: curved horizontally; straight, vertically. C. Light falling on this surface at an angle from above is reflected at the same angle... downward. Tilting the tube directs glare downward even more, away from the viewer's eyes.

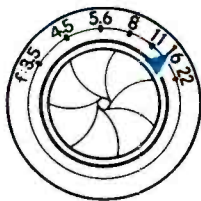

WHY CBS-HYTRON SHIELDED LENS?

With this shielded lens in the electron gun, greater depth of field and better definition are achieved. Just as when you stop down the diaphragm of a large, fast camera lens (f/3.5) to a small aperture (f/16). Distortion caused by interaction of external electrostatic fields used to focus and accelerate the electron beam is avoided. Focusing is easier, less critical. Slight changes in voltages and currents do not cause drift.



WHY CBS-HYTRON BLUE-WHITE SCREEN?

Ever notice how a shirt laundered with bluing appears whiter? With the CBS-Hytron blue-white screen, whites appear whiter; blacks, blacker. Picture definition is crisper. In fringe areas, the expanded gray scale of the blue-white screen gives noticeably clearer pictures. No wonder CBS-Hytron's original blue-white screen is fast becoming the standard preferred by consumers for best definition.



MAIN OFFICE: SALEM, MASSACHUSETTS

These are just a few reasons why it's smart to demand CBS-Hytron... original studio-matched rectangulars. Try the new CBS-Hytron cylindricals yourself. Discover for yourself why 9 out of 10 leading set manufacturers pick CBS-Hytron.

OOG BONGO WALSCO FRINGO

(Translation)

"WALSCO MODEL M ANTENNA OUT-PERFORMS ALL OTHERS IN FRINGE AREAS"

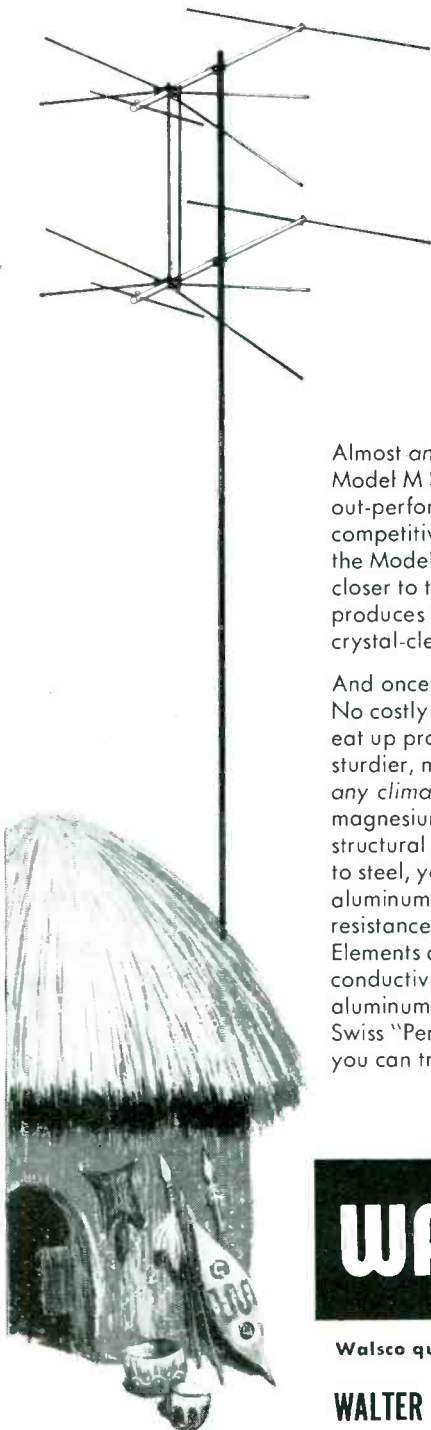

Almost anywhere, the WALSCO Model M Signal King will out-perform, out-last any competitive antenna. It's a fact... the Model M brings fringe areas closer to the TV transmitter... produces sharper, crystal-clear pictures.

And once you install... *that's all*. No costly call-backs that quickly eat up profit. Guaranteed sturdier, more dependable in *any climate*. Chromate-coated, magnesium cross-arms have a structural strength almost equal to steel, yet $\frac{1}{3}$ lighter than aluminum. Positive corrosion resistance in severest weather. Elements are made of high-conductivity, super-strength aluminum alloy, reinforced with Swiss "Permalum." Here is quality you can trust *anywhere!*

WALSCO

Walsco quality earned its reputation

WALTER L. SCHOTT CO.

3225 Exposition Place, Los Angeles 18, Calif.
Branch: Chicago 6, Illinois

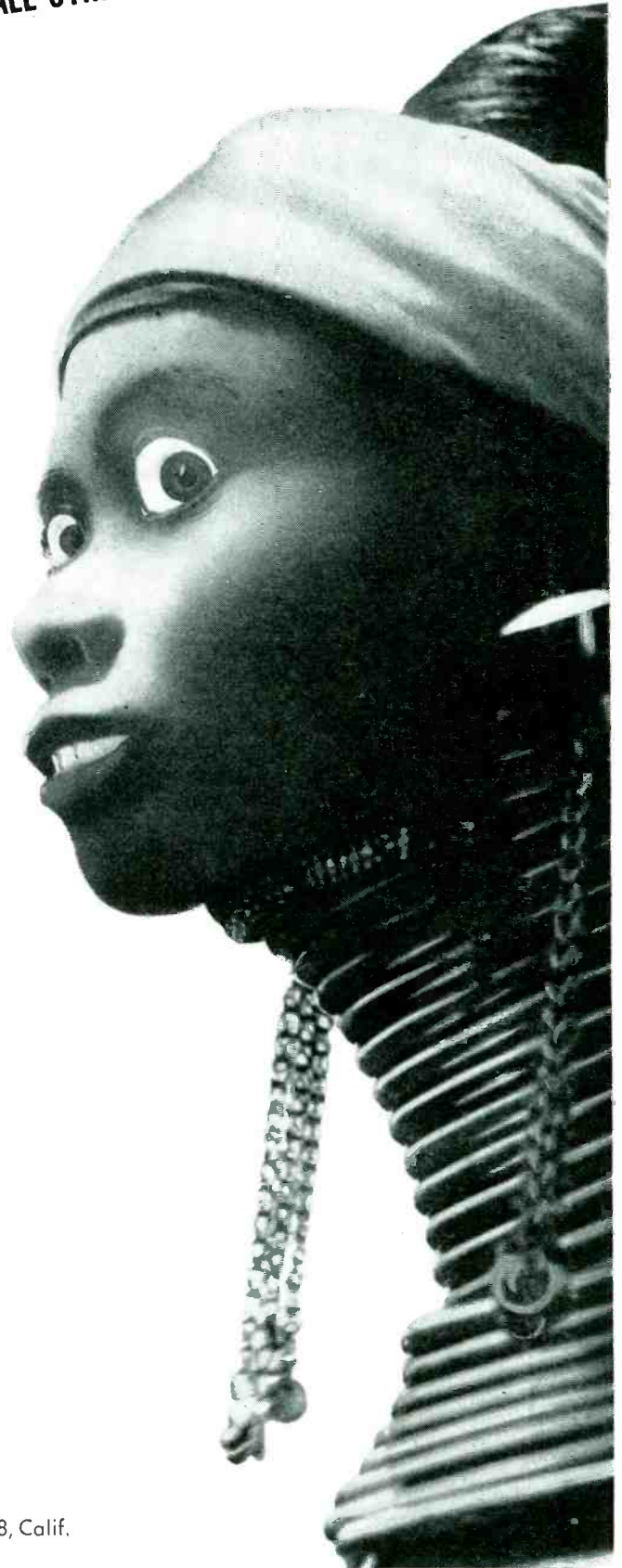

MERIT

tv full-line* components give universal coverage

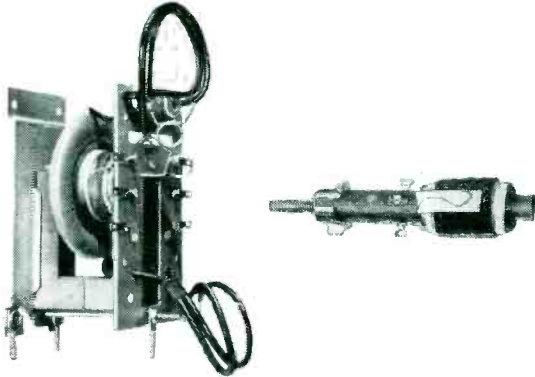

NEW IMPROVED HVO-7 FOR GREATER COVERAGE

Tapped AFC Winding. Covers Admiral Chassis 21-24 Series.

MWC-1 UNIVERSAL WIDTH COIL
(3-27 MH) A Tapped Secondary for AGC or AFC.



IF-RF COILS

Only complete line of TV replacements.



KIT NO. 1000
MATCHED SET
FOR SPEEDY
PROFITABLE
SERVICE!

BURTON BROWNE ADVERTISING

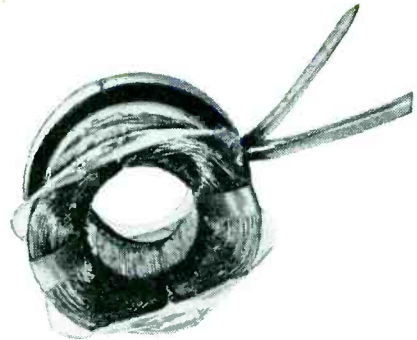

"COSINE" YOKES

Complete with leads & network.

MATCHED FOR DIRECT DRIVE

MDF-30

HVO-8

A-3080 Vert. Mtg.
A-3081 Horiz. Mtg.
Autoformer

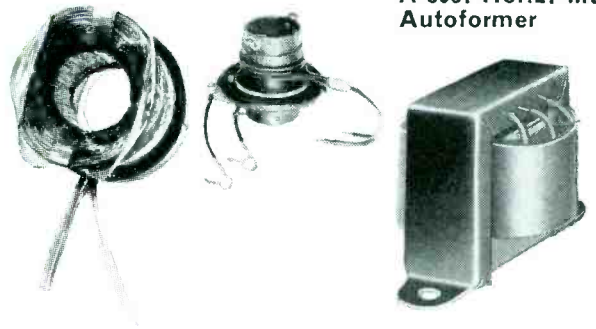

MERIT . . . HQ for PRACTICAL TV Service Aids

- MERIT'S 1952 Catalog No. 5211 with new MERIT IF-RF Coils.
 - Other MERIT service aids:
 - TV Repl Guide No. 404, 3500 models & chassis.
 - Cross Ref Data, IF-RF Coils, Form No. 14.
- See your Jobber or write: Merit Coil and Transformer Corp., 4425 Clark Street, Chicago 40.



These three MERIT extras help you:
Exclusive: Tapemarked with specs and hook-up data.
Full technical data packed with every item.
Listed in Howard Sams Photofacts.



**Merit is meeting the TV improvement, replacement and conversion demand with a line as complete as our advance information warrants!*

It's Here!

TV9

The latest Rider Television manual designed to make your TV servicing easy. Large, easy-to-follow schematics — lots of photos — troubleshooting test patterns — waveforms — complete factory parts lists — enlarged chassis views — circuit changes — everything you need to do a fast, easy and thorough servicing job!

With a Rider TV Manual you eliminate call-backs and repairs are positive and final . . . because for each set you service, Rider provides you with all the factory-issued data direct from the manufacturer. No one knows his receiver better than the manufacturer who made it. Nothing cut — nothing edited . . . everything is organized and indexed for speed and accuracy.

Rider's TV9 contains more than 2,000 pages (8½ x 11") covering new models . . . \$24.

BUY IT AT YOUR JOBBER'S

Note: A complete Rider TV manual and radio manual shelf is the solution for all your servicing problems. They make servicing easy! Get these vital editions at your jobber's . . . today.



JOHN F. RIDER

PUBLISHER, INC.
480 Canal St., N. Y. 13, N. Y.

SIX QUALITY FEATURES OF ALL TUNG-SOL PICTURE TUBES MEAN BETTER TV RECEIVER OPERATION



1

Glass bead type assembly is stronger, both mechanically and electrically—gives greater protection against leakages and arcing.



2

Double cathode tab provides double protection against failure in the cathode circuit.



3

Low resistance of outside conductive coating minimizes radiation of horizontal oscillator sweep frequency.



4

Fortified screen composition resists burning (X pattern).



5

Rigid control of internal conductive coating materially improves service reliability.

6

Tung-Sol Picture Tubes can be used with single or double field ion trap designs.



TUNG-SOL®

RADIO, TV TUBES, DIAL LAMPS

Dependable

TUNG-SOL ELECTRIC INC., Newark 4, N. J. • Sales Offices: Atlanta • Chicago • Culver City (Calif.) • Dallas • Denver • Detroit • Newark
Tung-Sol makes All-Glass Sealed Beam Lamps, Miniature Lamps, Signal Flashers, Picture Tubes, Radio, TV and Special Purpose Electron Tubes.

The TRIO ROTATOR

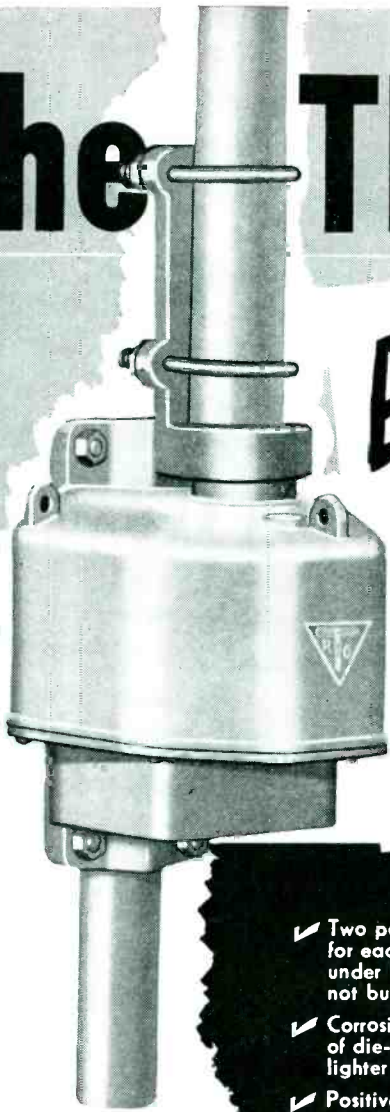

Easy to Sell!

It's easy to sell a product with as many plus features to talk about as the TRIO ROTATOR. In design, in construction, appearance; it is by far the outstanding TV antenna rotator in the market today!

Stays Sold!

In addition to providing a powerful sales story, the features listed below are your assurance of complete customer satisfaction: Assurance that the TRIO ROTATOR will give dependable performance year in and year out — in all kinds of weather!

- ✓ Two powerful 24 volt motors used — one for each direction of rotation. Each motor under load only fraction of time — will not burn out!
- ✓ Corrosion resisting, weatherproof housing of die-cast aluminum for greater strength, lighter weight, perfect alignment of parts!
- ✓ Positive electrical stops at ends of 360° rotation prevent damaging or twisting of leads!
- ✓ Will support heavy TV arrays — even in 80 MPH winds!
- ✓ Permanently lubricated with special grease that functions perfectly in high and low temperature extremes!
- ✓ Ball-bearing end thrusts on all shafts, including motor! Main shaft vertical load carried on large oversized "Oillite" self-lubricating bearing!
- ✓ All motors, shafts and gears mounted on a rugged, one-piece casting for true alignment and longer life!
- ✓ 1 1/16" diameter tool steel main shaft and mast holder will withstand 4500 inch pounds bending moment!
- ✓ Rotator and mast holder fits any pipe size up to 2" OD!
- ✓ Precision built to extremely close tolerances!



Smartly Styled

DIRECTION INDICATOR

The TRIO Direction Indicator is housed in a sturdy plastic cabinet of graceful lines. It is a beautiful instrument that will blend harmoniously with any furniture style.

Utmost ease in selecting the desired antenna direction is provided by a new "finger tip" control that operates at a light touch and the easy-to-read dial face that clearly and instantly indicates the exact antenna position.

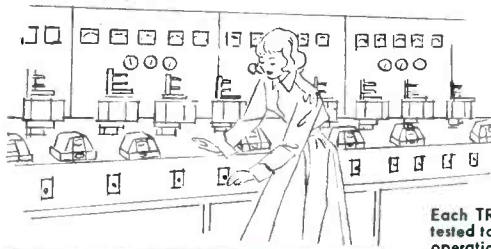

**FULLY TESTED
BEFORE
SHIPMENT**

Each TRIO ROTATOR is thoroughly factory tested to the equivalent of 3 months of constant operation. This, plus an additional torque test guarantees each unit to be perfect in every detail of assembly.

The TRIO ROTATOR's sound design and construction has been proven by three years of extensive field testing under every extreme of weather.



TRIO Manufacturing Company
GRIGGSVILLE, ILLINOIS

For YOU, the Local Radio Dealer and Serviceman . . .

We're beating a path to your door



HOW? By telling millions of radio listeners and television viewers that *you, the local Radio dealer-serviceman . . .* are best qualified to sell and install RCA Radio Batteries. The RCA Battery message, beamed out on our big national

network radio and TV programs, is building BIG RCA Battery demand for you. Portable radio owners everywhere will be *beating a path to your door*. Be ready for them . . . stock, promote, and sell RCA Radio Batteries.



Here are 3 more ways we are helping you

1. We help you advertise on the RCA Battery carton itself. A printed message on the carton of each volume-type RCA Battery tells the owner of a portable radio to come to you, his radio dealer, when it's time to buy replacements. And right on the batteries there's a space where you can stamp your own name and address to pull repeat business back to you.

2. We channel our principal battery distribution to YOU as a radio dealer and serviceman. And because radio outlets are the primary source for RCA Batteries, you get profitable repeat business from portable-radio owners in your community.

3. We will continue to provide fast, reliable battery service backed by a nation-wide warehousing and

distribution organization geared to the needs of the radio trade.

Now! Get ready to fill the sizzling demand for RCA Batteries . . .

They're *competitively priced* for fast, easy sales. They're *geared to your Radio trade*. And your personal stamp on the batteries you sell directs new customers and old friends *to your door*. So call your RCA Battery Distributor . . . get lined up for this profitable big volume business . . . *RIGHT NOW*.



RADIO CORPORATION of AMERICA
RADIO BATTERIES
HARRISON, N. J.

SERVICE, APRIL, 1952 • 11

For the **clearest** picture of campaign progress...



Rauland PICTURE TUBES

Man, what a year for TV—and TV service profits! The richest menu of regular attractions ever offered to viewers... PLUS the party conventions, the campaign, the elections and inauguration! When viewers need replacement picture tubes, they'll want them fast—and good.

So remember that Rauland alone

offers these replacement profit advantages:

- The *most complete* line of replacement picture tubes... a far better supplement for your regular tube line than a second line of receiver tubes.
- The faster, *surer* installation adjustment made possible by the patented Indicator Ton Trap.

- The dependable, uniform *extra* quality that so many smart service men depend on for assured customer satisfaction.

Remember, Rauland research has developed more "firsts" in picture tube progress since the war than any other maker. And this leadership pays off... in your customers' satisfaction.

THE RAULAND CORPORATION



Perfection Through Research

4245 N. KNOX AVENUE • CHICAGO 41, ILLINOIS



the PERMO Line

MADE TO ORDER FOR THE COMPONENT PARTS TRADE



The Permo Line gives you everything you need to make needle replacements fast, easy and profitable. You get (1) Handy and accurate service data, (2) Individual needle packages complete with (3) Installation tools and accessories with instructions, and (4) Stock-display and re-order case. See your jobber for fast-moving assortments or individual needles.

Developed Scientifically

Engineered Specifically

Made Precisely

Priced Competitively

Packaged Practically

Simple Inventory Control

Installation Tools, Accessories and Instructions Supplied

Complete Service Data

National Distribution

PERMO, INC.

6415 Ravenswood, Chicago 26, Illinois

MANUFACTURERS OF 'FIDELITONE', 'PERMO-POINT' AND 'PERMO' PRODUCTS
LONG-LIFE PHONOGRAPH NEEDLES • RECORDING TAPE AND WIRE • RECORD BRUSHES

It's what's on the other end of the tuning knob that counts most!

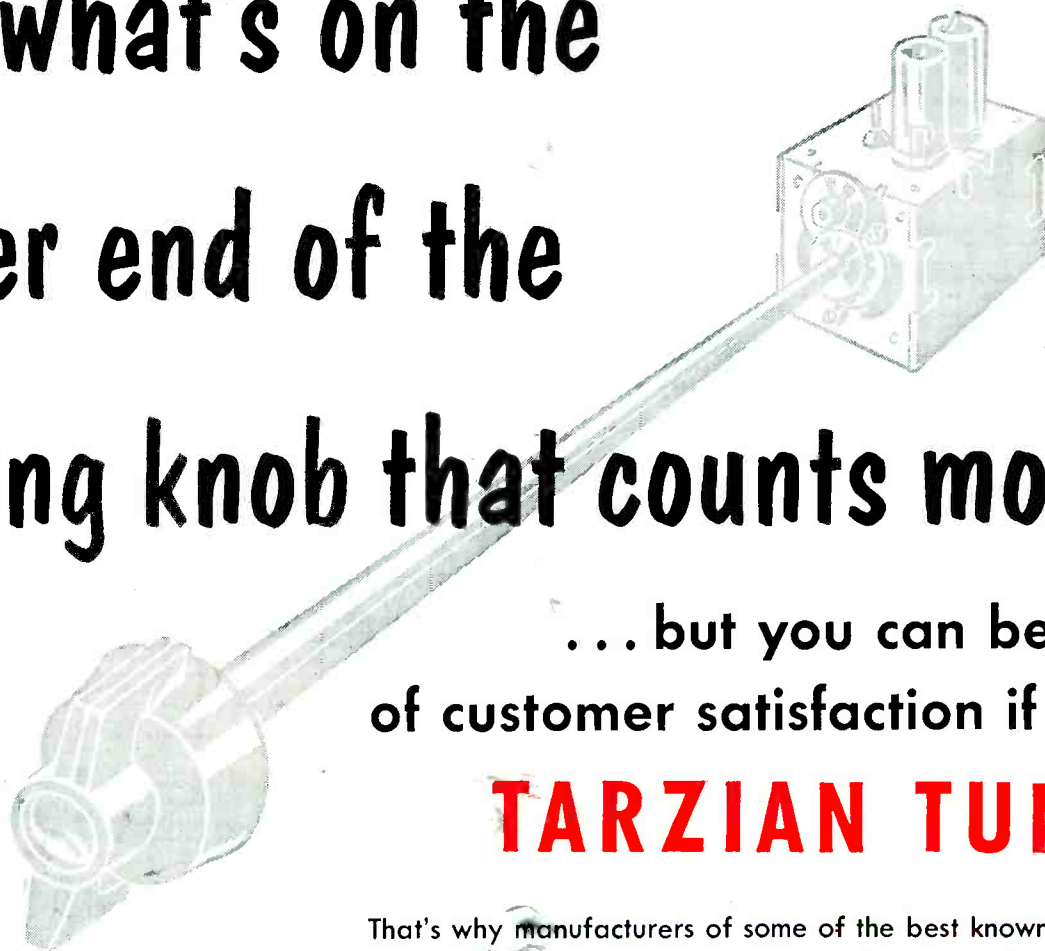

... but you can be sure
of customer satisfaction if it's a

TARZIAN TUNER

That's why manufacturers of some of the best known Television sets on the market today rely on the trouble-free TARZIAN TUNER for the excellent performance of their sets.

The buyer of a TV receiver very rarely—if ever—sees the real "brain"—the tuning mechanism—of his television set.

In the case of the TARZIAN TUNER, it's a compact, precision-built unit, scientifically-engineered and produced to assure unexcelled selectivity and reception . . . especially in fringe areas.

No other commercial unit possesses so many of the desirable features found in the TARZIAN TUNER.

Engineers of leading set manufacturers are quick to appreciate, too, the sensible—but simple—approach to UHF through the TARZIAN TUNER.

SARKES TARZIAN, Inc., Tuner Division, Bloomington, Ind.

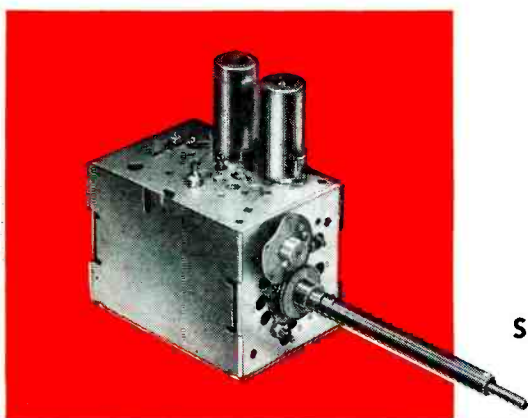

Tarzian Tuners and Tarzian Picture Tubes are available for the growing replacement market. Write for complete information.

TARZIAN MADE PRODUCTS



STATIONS WTTT (5000 WATTS) AND WTTV (CHANNEL 10)
OWNED AND OPERATED BY SARKES TARZIAN IN BLOOMINGTON

The
Webcor[®] "106"
 recommended by
servicemen

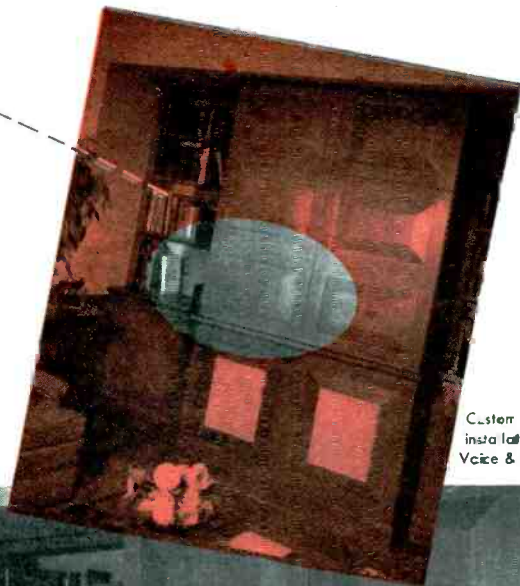

Customer
 installation by
 Voice & Vision, Inc.

There's good reason why radio service dealers are installing thousands of Webcor "106" Diskchangers every week.

First of all, the simplicity of the Webcor design enables the servicemen to make quick, easy installations.

And second, once installed there is an absolute minimum of adjustment and repair.

And the customer recognizes that the name Webcor by Webster-Chicago means that he is buying a nationally advertised product.

There's big promotion news on the Webcor Diskchangers—call your distributor today.

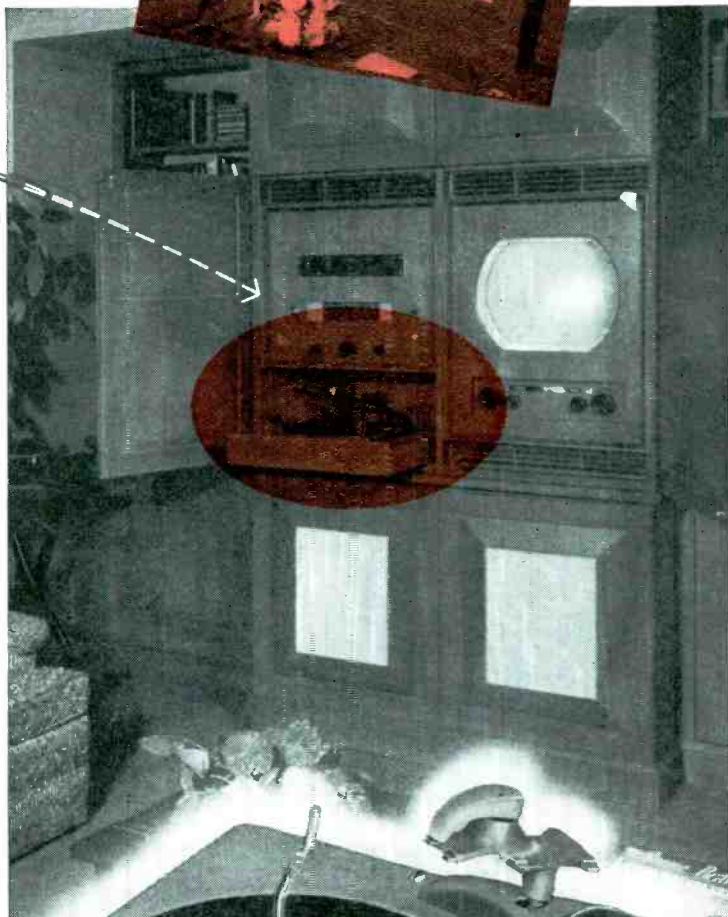

If it's made by Webster-Chicago,

*it's **Webcor***

... and if it's Webcor

it is the finest



*Webcor is a registered trade name for products manufactured by

WEBSTER-CHICAGO 

BUILD A BIGGER ON POWERFUL G-E



AMERICA'S BIGGEST MAGAZINES PRESELL G-E TUBES!

- 35,000,000 people read G-E full-page tube ads. 35,000,000 TV owners and enthusiasts see *proof* month after month that General Electric tubes are superior!
- Every message emphatically directs these owners to you—the serviceman with the General Electric tube sign. The ads tell

- why patronizing *your* shop means brighter, sharper, more lifelike television pictures in the home.
- Take advantage of the big local market that G-E tube advertising creates for you! Make real money by selling G-E tubes to a *presold* television public!

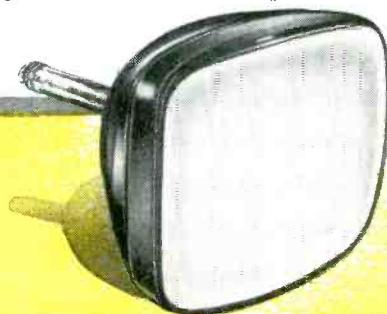

BUSINESS "LIFE" AND "POST" ADS!



We install
Aluminized TV Picture Tubes

"up to 100% brighter!"

AS ADVERTISED IN LIFE AND SATURDAY EVENING POST

**THIS SIGN PUTS G-E
NATIONAL ADS
TO WORK FOR YOU!**

EVERY MINUTE of every hour, people who have read G-E tube advertising pass your shop. They want to know where to go for service. Use these colorful gummed streamers to tell them *you* install G-E tubes!

21" WIDE, the streamer is just the right size for your door or window. Blow-ups of LIFE-POST ads, supplied from time to time, can be mounted beneath. For counter giveaway, or for display where space is limited, actual-size ad reprints are available to you regularly.

YOUR G-E TUBE DISTRIBUTOR will be glad to supply you with streamers and reprints. See, phone, or write him today! Get *all* the tube and service business "Up to 100% brighter!" will bring to your door! *Tube Department, General Electric Company, Schenectady 5, New York.*

GENERAL  ELECTRIC

1G1-1A2

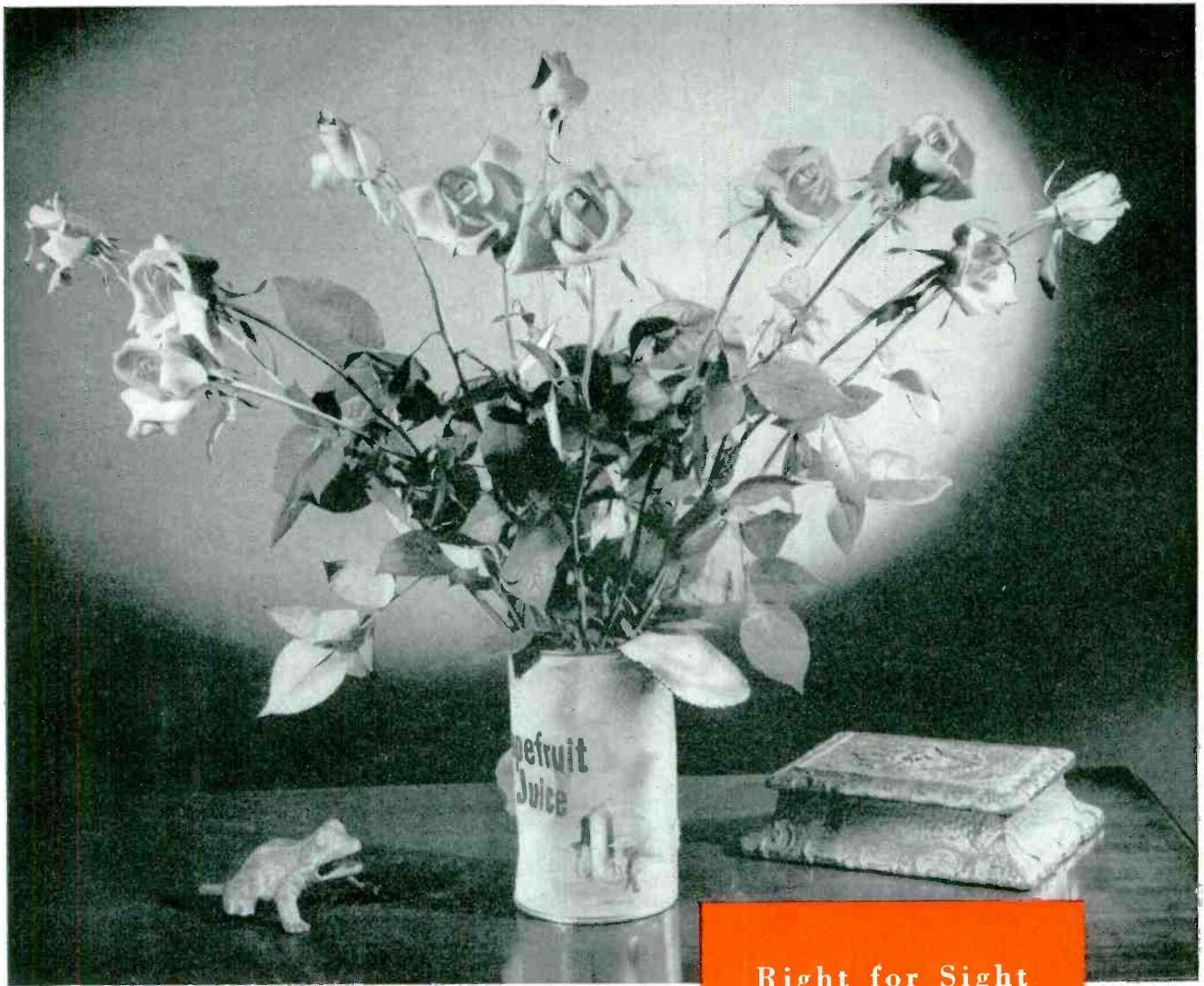

Makeshift Replacements
Reduce Picture Quality

Replacements with
Raytheon Television Tubes
assure picture quality

Right for Sight



RAYTHEON PICTURE
TUBES



Excellence in Electronics

RECEIVING AND PICTURE TUBES • RELIABLE SUBMINIATURE AND MINIATURE TUBES • GERMANIUM DIODES AND TRANSISTORS • RADIAC TUBES • MICROWAVE TUBES

Don't forget! Raytheon Picture Tubes with Corona Inhibitor
give constant picture clarity whatever the weather.

RAYTHEON MANUFACTURING COMPANY

Receiving Tube Division

Newton, Mass., Chicago, Ill., Atlanta, Ga., Los Angeles, Calif.

SERVICE

Streamlined Troubleshooting

IN SERVICING, the ability to recognize a fault and pinpoint the problem can be quite an asset. This is particularly true in checking TV chassis with its complex array of components and tubes. Knowing where to look when the audio or video begin to misbehave, can not only expedite repair, but insure the rapid replacement of the proper part or tube. Quite a few ingenious techniques have been evolved to guarantee such swift, accurate servicing. Many of these methods have been described in *SERVICE* during the past few months.

Recently, there appeared a unique approach to the failure-recognition problem that has been described as strikingly simple, yet very effective. Based on the wise premise that in the majority of instances troubles in a TV receiver, especially during the *first few months* of use, are due to one or more defective tubes, the system revolves about the use of chassis layouts showing tube positions, typical picture-tube defect results and trouble cure procedures.

In an explanation of the application of the method, in a troubleshooting handbook,* it was noted that there are over a dozen base problems that might be solved with the picture-tube/tube-layout check plan. To illustrate, no light or raster on the picture-tube screen might be due to *first*, defective 1B3 or 1X2 high-voltage rectifiers; *second*, defective 6CD6 horizontal-output tube; *third*, bad 6SN7 horizontal oscillator; or *fourth*, poor 6BY5 damper. The sequence in which tubes should be changed is important, it was said, and thus all of the layouts carry a series of numbers indicating which tubes should be pulled first, second, etc. The explanations are also supplemented by a few key checks that should precede tube pulling. For instance, in the no-light-or-raster situation, it is necessary first to try turning brightness to maximum, then removing the high-voltage cap and sparking to chassis, and if a spark occurs ($\frac{1}{4}$ " to $\frac{1}{2}$ ") checking the beam bender. If no spark occurs, then it becomes necessary to change the tubes in the order prescribed.

Other typical problems that it is said can be solved by this tube-changing

technique are: horizontal wiggle or weave; no sound but picture is normal; no picture and no sound but raster is normal; no light on picture tube screen but tube filaments light up; no picture but raster and sound are normal; lack of width but sound is normal; horizontal foldover but all other indications appear normal; lack of vertical sync but picture appears normal; vertical black line in picture (Barkhausen oscillation) appearing mostly on low channels; jagged and broken lines caused by horizontal gunboating or squealing; very dim raster and excessive width; insufficient height but width is normal; loss of both vertical and horizontal sync but picture appears normal; and loss of both horizontal and vertical sync, where the picture appears washed out and gray or negative.

Many have pointed out that this simplified approach may become a general pattern for basic troubleshooting. However, unfortunately there are countless other troubles to consider, too, and these difficulties can only be solved if an extremely thorough knowledge of circuitry obtains and accurate test equipment is employed. Both the rapid check technique and subsequent thorough checks with instruments do represent an ideal combination for streamlined troubleshooting.

A Mobile Training Plan

RURAL AREA Service Men often find it difficult to visit centers where they can view the latest in instruments and techniques. Many manufacturers have attempted to solve the problem by routing show trucks to these communities, with a variety of the latest test gear and accessories on display. Believing that the Service Man would like to see not only an assortment of test instruments, but a typical setup in which the equipment is actually employed, one set maker decided to send out a *service shop on wheels*, which could also be used for training purposes.

The truck, equipped with over a thousand dollars worth of test instruments, and a portable antenna which can be elevated to a 75-foot height, has been on tour throughout the Wisconsin areas, and has been received enthusiastically. Service Men are in-

vited to special sessions and are shown how to locate trouble in chassis, how to align circuits and how to install chassis to secure maximum performance.

The manufacturer has felt that this training service shop on wheels will not only help educate Service Men, but create a rich friendship and strong interest in their products.

Several other chassis producers have already indicated an intense interest in this novel plan, and disclosed that they too might have service shops on wheels roving around the country to help train Service Men.

Congratulations to this pioneering set maker and the others who plan to follow along on this stimulating educational program.

The Industrial-TV Parade

CLOSED-CIRCUIT TV, a favorite project in the early days of videocasting, which with the advent of active TV broadcasting dived to obscurity, has returned to the arena, and with quite a swish.

In countless plants, stores and offices throughout the country, private-wire viewcasting has become a favorite item, with broadcasters, dealers and Service Men participating profitably in the plan. Broadcasters have found that they can lend-lease their cameras, lights and monitor equipment; dealers can supply the necessary assortment of receivers, and Service Men can install the receivers, coax lines, and also be on hand to monitor and repair to assure continuing operation.

There are unparalleled opportunities in this reactivated field, which it has been said will become a robust member of the TV installation and servicing business.

The Parts Show

THE WEEK OF MAY 19 will be an exciting one for industry. The annual *Radio and TV Parts Show* will be held from the 19-22, and the first midwestern *Audio Fair* on the 23rd and 24th, both at the Conrad Hilton Hotel in Chicago. We'll be there for both events in room 604A for the *Parts* show, and room 747 for the *Audio* affair. Hope we'll be seeing you.—L. W.

*Philco.

HIS CHOICE IS

Regency

LARGEST
SELLING
VHF
BOOSTER
AT ANY PRICE!

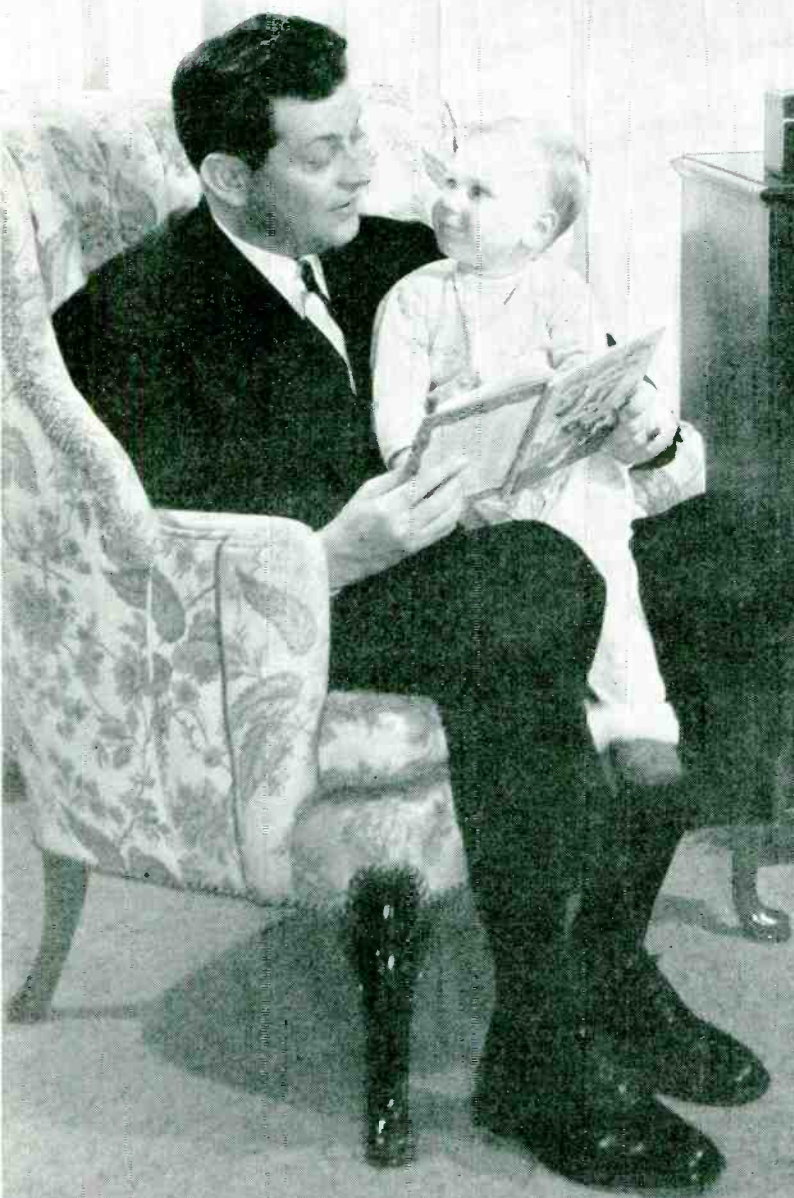

MR. JACK HUGHES
PROMINENT VICE PRESIDENT
LITTELFUSE, INC.
PHOTOGRAPHED IN HIS HOME

ALSO MAKERS OF THE

Regency

UHF CONVERTER

BURTON BROWNE ADVERTISING

www.americanradiohistory.com

SERVICE... *The National Scene*

FCC CURB ON DIATHERMY INTERFERENCE BECOMES OFFICIAL JUNE 30--Those annoying horizontal bars which roam down the picture-tube screen, because of radiating diathermy gear, should begin disappearing rapidly on or after June 30, when the FCC rules calling for either the use of equipment operating within prescribed frequencies and tolerances, or filtered and screened equipment, becomes a legal requirement. Operation of all diathermy instruments after June 30 will have to be confined to assigned bands of 13,553.22-13,506.78, 26,960-27,280, and 40,660-40,700 kc, with center frequencies of 13.56, 27.12 and 40.68 mc. Harmonic radiations on frequencies other than those specified will have to be suppressed so that radiations do not exceed a strength of 25 microvolts per meter at a distance of 1000 feet or more. In the main, equipment manufactured before July 1, '47, will be found flagrant transmitters, and will require a rectified and filtered-plate power supply, power-line filters, and operation within a completely shielded room or space. According to the FCC, the installation of such equipment will require the attention of a competent engineer who can supply the Commission with field-intensity measurement data, indicating that radiations have been reduced to the 25 microvolt-per-meter level established in the rules. Competent engineers have been defined as those who have either a formal technical education or practical experience, and who are fully qualified not only to operate field-intensity measuring equipment, but evaluate the resulting measurements. It is believed that many Service Men can meet these qualifications . . . The ruling also poses another important servicing problem. While diathermy machine operators will be normally responsible to take steps to eliminate interference, they will not be involved if the interference arises from direct if pickup of the fundamental frequency used by diathermy equipment. To reduce or eliminate this type of interference, which incidentally appears on all channels and will occur in the 27-mc region, wave traps, shields and power-line filters will be necessary. Solutions may, in some instances, be affected by retuning the receiver if amplifier to frequencies above or below those of the interfering signal . . . A comprehensive analysis of the components, accessories and techniques, which can be used to eliminate the interfering signal, at either the source or receiver proper, will appear in an early issue of SERVICE. Watch for this extremely important report!

EXPERTS FIND COMPATIBLE COLOR STILL YEARS AWAY--A perfect compatible color-TV system is still at least five years away, according to DuMont's director of research, Doc Goldsmith, who spoke on the subject recently before a joint meeting of the AIEE and IRE in Chicago. In his opinion, it is now possible to get color fidelity but not crispness. It was also indicated that the high cost of the color tube, which would more than double the price of black-and-white chassis, was another serious problem to overcome. It was pointed out that definite strides have been made in color receiver and transmitter design, and eventually practical moderate-priced color-TV equipment will be available.

SERVICE MEN IN NATION'S CAPITAL SEEKING LEGISLATION--A plan to license TV Service Men, under consideration for months in the District of Columbia, began to receive serious consideration a few weeks ago when a group of shop owners met to discuss a cooperative campaign in which licensing benefits would be highlighted in an advertising program. It was noted that while many months will pass, perhaps as many as twelve, before such a law can be placed into effect, it was important to begin a drive now to acquaint everyone with the problems and potential solutions. The cooperative group also declared that they would set up a 12-point code of ethics, which would be exploited in newspaper advertising. The code, it was said, would set standards for workmanship and materials, and prescribe a guarantee of 90 days on antenna installation and repair, and 30 days on all shop labor, with a 90-day warranty on all parts used. It is expected that about a \$1000 will be spent weekly for the legislation code-of-ethics advertising drive.

SERVICE... The National Scene

N. J. SERVICE MEN DENOUNCE PROPOSED TRUST-FUND BOND BILLS--A pair of measures, introduced in the New Jersey legislature, which would create special trust funds as a means of guaranteeing performance of TV service contracts, and require performance bonds, have been soundly censured by a service association group in the state. It was pointed out that the performance bonds would cause endless complications and disputes, and that the premiums required would be very costly. According to the president of the servicing association, the proposed ordinances would actually increase the cost of service and drive reliable shops out of the field. Policing of TV Service Men in New Jersey would be a tremendous undertaking, requiring a large staff of investigators, administrators, and others, it was said. . . . Not only has the service group found the proposals objectionable, but members of the Chamber of Commerce have also indicated that the measures as drafted would create problems that would prove costly to TV set owners.

HOME FIX-IT TV BOOK ADVERTISING BARRED IN ST. LOUIS--Complying with a request from a local service association, the leading dailies in St. Louis recently agreed to refrain from running advertising on home repair TV guides, until all questionable statements, insuring rapid service with a minimum of equipment and knowledge, were deleted. It was reported that this was the first time that large metropolitan dailies had censored this type of advertising as a result of service association pressure; an interesting indication of the growing influence of associations.

COMMUNITY-TV PROJECTS INCREASING--The hilltop-TV signal-feed service, introduced about a year ago, has become such a flourishing business for scores, that countless are now planning to enter the scene with unique operations. One proponent has gone to the FCC and asked for permission to build an experimental station, located about 75 miles from Los Angeles, to receive signals from 7 stations, amplify them, and retransmit them on the same channels on which the stations are operating, on reduced power. The proposal indicated that a directional receiving antenna would be located on top of a peak within line-of-sight of Mount Wilson, and another directional antenna would be used for retransmitting scrambled signals to residents in the Palm Spring valley. Only those who subscribe to the service and had a code card could, of course, unscramble these signals. . . . In Maryland, three antennas have been mounted atop a hill, permitting reception of signals from transmitters 100 miles away. Via some four miles of coax cable, signals are being piped into subscribers homes. . . . Many extremely remote communities, which may not be serviced by TV stations for many years, and those which are located in deep valleys, or white areas, have been cited as excellent prospects for these community system chains.

UHF RANGE CALCULATOR NOW AVAILABLE--It is now possible to estimate coverage of ultra-high stations with the aid of a slide-rule type calculator, recently developed by a transmitter maker. This unique forecaster provides field-strength information, range in miles versus power, and the lower edge frequencies of channels 14-83. While the calculator was originally designed for broadcasters, it should prove quite helpful to Service Men who can determine possible coverage of stations scheduled for their locales.

NETSDA HAILS SERVICE--Writing to ye editor, Dick Devaney, secretary of the National Electronic Technicians and Service Dealers Associations, said recently: "At the last meeting of NETSDA, your magazine, SERVICE, and its editor, were commended very highly for their interests in and comments on association activities. . . . SERVICE is to be congratulated on the many fine and constructive articles published, and we wish you and your editor continued success in the years to come." Many thanks, gentlemen. We are truly grateful for your enthusiastic comments.--L. W.

Now...in the beautiful
New RMS Booster...
 the first real
 contribution to
 Booster Engineering



The TV Booster may be considered a dam of power. In ordinary boosters, this power may spill over, thus overloading the tube and setting up noise or "snow." In an attempt to avoid this, ordinary boosters do not make use of maximum possible gain.



SP-6's easily operated external gain control is like a dam spill-way. It cuts down the tremendous power to the point *just before* overload. Thus, for each channel, the highest practical gain possible brings in a clearer picture than might be obtained with a conventional booster.

EXTERNAL GAIN CONTROL



MODEL SP-6[®]
PENTODE TUBE BOOSTER

\$29⁹⁰
LIST



also **A NEW RMS TRIODE TUBE BOOSTER... MODEL SP-6J**

America's first and oldest booster manufacturer now offers you a choice in TV Boosters unmatched for their fine performance and tasteful styling. Impressively low noise level in both boosters; each approved by Underwriters Laboratories, each carries a *full year guarantee* with RMA 90-day warranty on parts.

See Your Local RMS Jobber
 Visit our booth at The Chicago Parts Show!

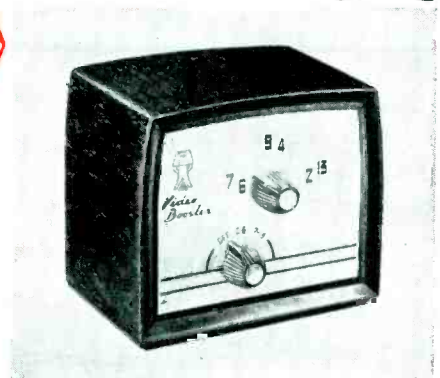

SP-6J TRIODE TUBE BOOSTER \$29.90 LIST

RMS INC. NEW YORK 59, NEW YORK

Knots, Ties, Hitches and Rigging Methods Which Can Be Used To Mount Antennas and Accessories on Pitched Rooftops.

ROPES and TIES in

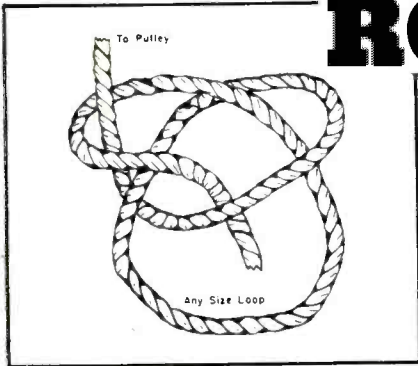

(Above)

Fig. 1. Bowline knot; loop may be any size necessary.

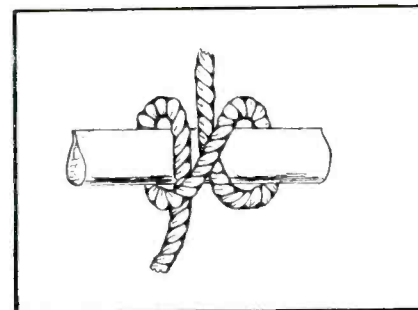

(Above)

Fig. 2. The clove hitch, which can be used to tie ropes to trees, poles, or to hold any round objects.

‡Marline.

KNOTS, TIES, HITCHES and rigging might seem to be a rather strange subject to discuss in a technical journal, but in high TV work and on rooftops, the right knot at the right place, and a piece of stout rope, can not only save a lot of work, but one's neck, too.

Few houses, unfortunately, are built with flat roofs. To erect a heavy antenna on the steep sloping surfaces usually found, it is necessary to use some kind of gear that will enable us to move about and work with safety. To digress a moment, proper footgear is an absolute necessity: rubber *lug* type soles are ideal. A rooftop job should never be attempted with leather-soled shoes.

Now back to the ropes: A piece of half-inch manila rope, about 75-100 feet long, has been found to make an ideal safety line. Two or three more pieces, about the same length, can be used to hoist antennas, tools, parts, etc., to the rooftop, and for guying temporary poles.

Rope is used by the foot and sold by the pound. After ropes have been purchased the lengths needed should be measured and the ends whipped. Sailors used to do this with waxed twine,‡ but you can do just as well by wrapping three or four turns of good friction tape tightly around each end, about an inch from the end. This will prevent the end from fraying out and unwrapping. All ropes should be

coiled up neatly and tied, so that they are ready for instant use.

One or two small pulleys, known as *single-blocks*, are very useful; they should fit the rope you use. Too big a pulley will cause the rope to slip off and jam. Pulleys should have a ring or eye on the top, also the size of the rope, so that they may be fastened to poles, etc.

A Typical Installation

Let us now suppose a two-stacked antenna and rotator are to be installed on a twenty-foot mast atop a two-story house with a steeply-pitched rooftop. First, your extension ladder should be put up, raising it high enough so that at least two rungs are above the eaves. Now one coil of rope should be taken with you on the first trip. If there is a convenient chimney, a loop of rope should be flipped around it, keeping both ends in your hand, and then the doubled ropes can be used to pull yourself to the ridge of the roof. By holding to the ropes, it will be possible to stand up and walk right up on the steepest roof. If there aren't any chimneys, it will be necessary to throw the rope all the way over the house, and anchor it to a tree, pipe, or similar stout object, on the other side. Now, the other ropes should be taken to the rooftop, and the end of one of them dropped off to a clear space. A helper below can now tie the antenna, mast,

(Below)

Fig. 3. Pole hitch used for holding loads, antennas, etc.

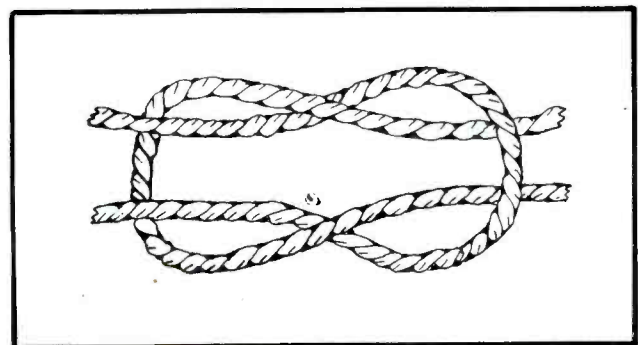
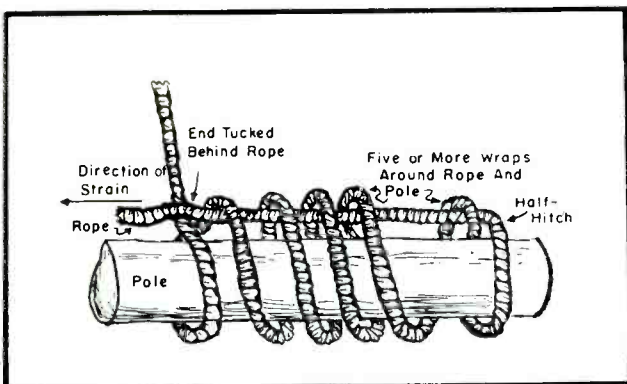

(Above)

Fig. 4. Square knot.

Antenna Installations

by DONALD PHILLIPS

rotator, etc., to the rope and everything can be hauled up to the roof. This approach will be found much easier than carting of the antenna and accessories up a swaying ladder.

To be certain that *you* stay on the rooftop yourself, you should estimate the length of rope necessary to reach almost to the eaves; a loop should be tied around your waist, and the end firmly tied to a chimney. Thus, if you should slip, you'll only slide as far as the eaves.

The best knot for this operation is a bowline. To tie it, a small loop should be made in the rope, about four feet from the end. The short end of the rope should be passed through the loop, up and around the rope itself, then back through the loop. It should be pulled tight; you'll have a bowline knot and a loop that will never slip or jam.

To avoid dropping bundles of antenna parts, masts, etc., off the roof, they should be tied together with short ends of rope and lashed to chimneys, etc. If there aren't any chimneys, two

Pole-hitch used to tie antenna mast and gin-pole together, to hold antenna erect after pulling up. To tie, half-hitch is thrown around poles, using loop of rope. Then rope is wrapped up the poles, for seven or more turns, and loop tucked in at end to hold.

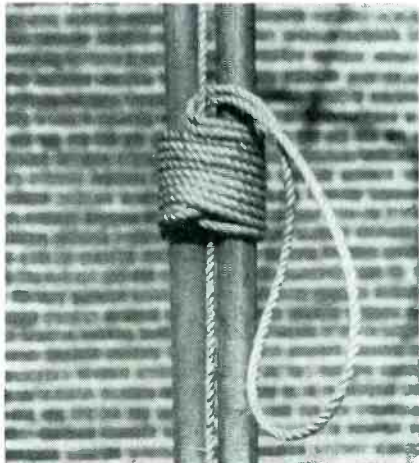

bundles can be made, one being hung one on each side of the roof-ridge.

The raising of a long mast and antenna, while balancing yourself on a rooftop, is often a problem. A bit of gear that will help out is a *gin-pole*, similar to those used by linemen to erect light-poles. They set up another temporary pole close to the permanent pole. The hoisting gear, pulleys and ropes are fastened to the top of the gin-pole, and the pole is pulled up and set in place.

You can make a lightweight, portable unit, suitable for use on a roof, out of two pieces of *thinwall* electrical conduit, one small enough to slip into the other, three ropes, and one of your blocks; 1" and 1 1/4" are good sizes. A hole should be drilled in the larger piece about twenty inches from one end, and a bolt put through it to keep the small piece from slipping all the way down. On the lower end of this, there should be installed a *fork* of wood or metal, so that it may be set across the ridge of a roof. On one end of the smaller piece, two holes should be drilled at right angles; four

Overall view of rigging, set up on ground. Man, at right, pulls up on fall (hoisting rope through pulley) while helper, at left, steadies antenna and mast. Note *shears*, made of two pieces of 1 x 4 plank, with bolt through top, used to hold mast while assembling. Bottom of shears is tied together with light rope, to prevent spreading too far.

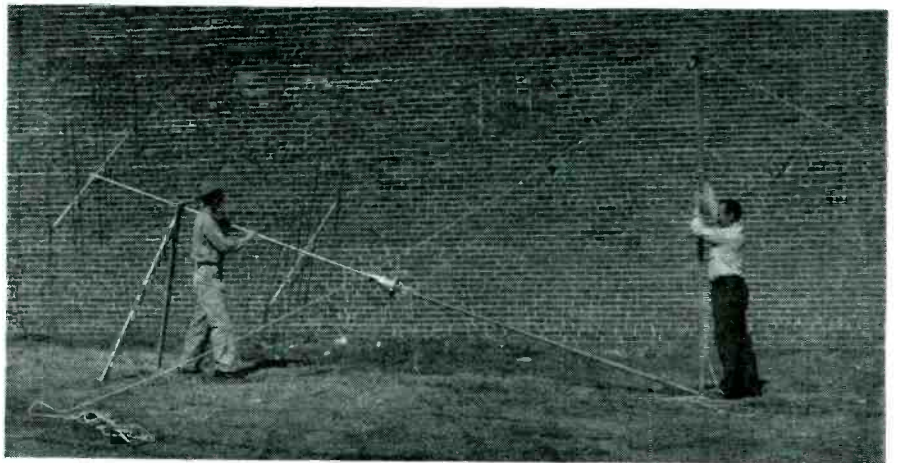

Mast and gin-pole just after erection. Mast and antenna are erect, being held by knot around both pole and mast. Guy wires, lead-in and rotator cables, omitted in this illustration for pictorial clarity, should be attached while mast is still resting on shears, before raising.

loops of heavy wire should be made threaded through these holes. Ropes should be tied to three of these and your block fastened to the fourth. The block should have a rope about fifty

(Continued on page 64)

LOUDSPEAKER Mountings

by EDGAR M. VILCHUR

Instructor, Division of General Education
New York University

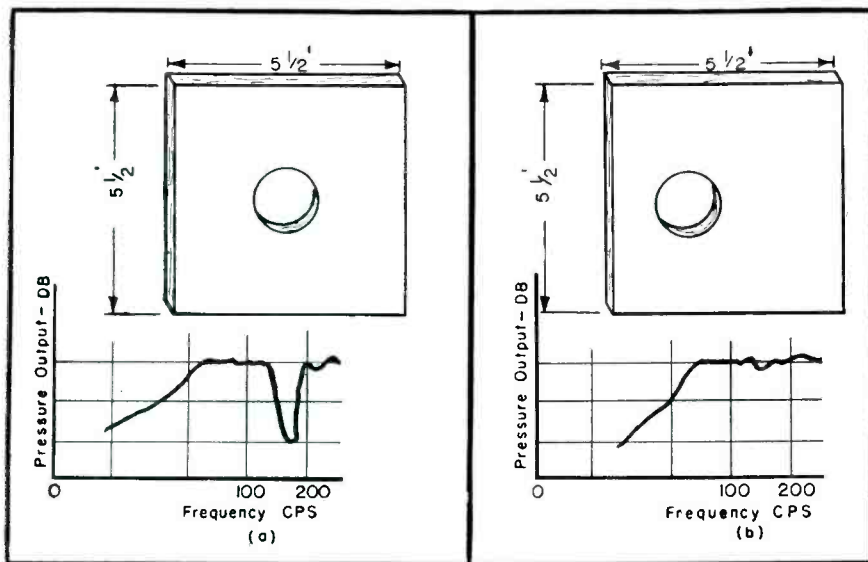

Fig. 1. Frequency-response results when speakers are mounted in baffle center as at (a) and off-center as at (b).

IN THE AUDIO SYSTEM, the loudspeaker and its enclosure are vital elements in the reproducing link. Its effectiveness is predicated on many related electrical, mechanical and acoustical factors. It has been found, for instance, that a direct-radiator speaker, in free space, acts as a doublet* at low frequencies, when the cone itself is an inadequate separator between front and back. Air compressed by the front of the cone, instead of working against the air of the room, leaks around the speaker

edges to fill in the vacuum at the back. When the speaker is mounted on a baffle, however, this leakage is prevented. Since the front of the cone can now work only on the air ahead of it, coupling between the cone and the air of the room is considerably improved. The back of the cone receives an equal increase of air load.

Most plane baffles are not so large as to prevent all interaction between front and back. When the path between the front and back of the speaker

Fig. 2. Speaker mountings. In (a) and (b) appear improper wall mountings, while in (c) and (d) are two proper methods which can be used to mount speakers. If separate baffles are used, they must be very sturdy.

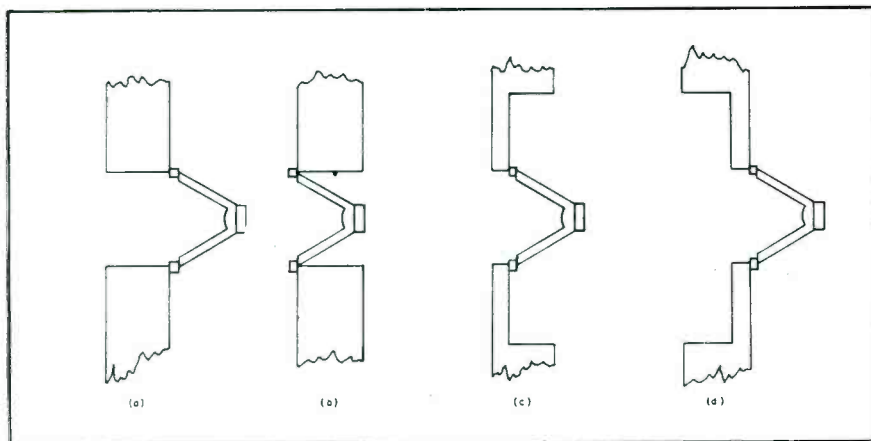

is slightly less than one-half the wavelength of the frequency being reproduced, destructive interference sets in. From this point an output of the system falls off sharply as the frequency is lowered, at the rate of 12 db per octave in terms of pressure, assuming no speaker deficiency.

The required dimensions of a baffle for efficient acoustical coupling down to a given frequency may be easily calculated. First, it is necessary to find the wavelength of the desired cutoff frequency, which is equal to the speed of sound in air (about 1100 feet per second) divided by the frequency. The necessary baffle diameter will be slightly less than half of this wavelength. A baffle with a diameter of $5\frac{1}{2}'$, for instance, will begin its low frequency drop a little below 100 cycles, and speaker output in dynes/cm will be down 12 db, at about 45 cycles.

Sound radiated from the back of the speaker will reach the front exactly out of phase with the front wave when the path distance is equal to one wavelength. A very pronounced dip in output will therefore occur at the frequency whose wavelength is equal to the baffle diameter. Mounting the speaker asymmetrically in the baffle provides many paths of varying lengths at which such cancellation will occur, spreading out and effectively neutralizing the dip. In Figs. 1a and b are illustrated the frequency response characteristic of a speaker mounted in plane baffles $5\frac{1}{2}'$ square. Center mounting is used in one case and off-center mounting in the other. Asymmetrical positioning of the speaker is, of course, only called for when there is a free acoustical path from front to back.

The Infinite Baffle

If the plane baffle is so large that all interplay between front and back is prevented, it is called an *infinite*

* A doublet source of sound consists of two adjacent point sources, each vibrating out of phase with the other. Not much sound can be radiated from such a source, because rarefactions created by one-half will be filled by the compressed air created by the other half, and vice versa. To increase the efficiency of the doublet it is necessary to insert a partition between the two halves to prevent the interflow of air currents.

Lucid Practical Analysis of the Design and Application Features of Various Types of Mountings Used for Speakers, Such as Infinite Baffles, Cabinet Type Infinite Baffles, Open-Back Cabinets, Bass-Reflex Cabinets.*

baffle. The effect of such a baffle may be achieved practically by mounting a speaker in the wall of a room, a stairwell, or the door of a closet (the clothes need not be taken out). Except for the architectural inconveniences involved, this is one of the simplest and best systems of speaker baffling, especially for speakers with a low resonant frequency. The cutoff effect of the plane baffle is, of course, not present, low frequency cutoff being determined by the resonant frequency of the speaker system. Since the infinite baffle does not decouple the speaker from the air load at low frequencies, as a plane baffle of limited dimensions would, the benefits of the air load in lowering the resonant frequency and damping voice coil excursion in the low range are fully applied. The nature of the materials and the air spaces involved are usually such that these benefits are procured without any new resonances being introduced into the system.

Care must be taken to see that the speaker does not face, either forward or backward, into a long pipe-like enclosure in which air-column resonance will be set up. In the condition shown in Fig. 2a reflections from the open end of the pipe in front of the speaker

will create standing waves, and the pipe will itself *speak* into the room when it is stimulated at its resonant frequency. In the setup illustrated in *b* the pipe behind the loudspeaker will exert extra pressure against the cone at column resonance. Two methods of properly mounting a loudspeaker in a wall appear in *c* and *d*. Although the pipe length has not been changed there will be very little sound reflected from the open end, as the impedance discontinuity between the large opening and the outside air is small.

Mounting Location Requirements

The mounting location for the speaker should be chosen to command as much of the room area as possible. Because of the restricted radiation pattern of the higher frequencies there is an advantage in having the speaker face into the room's long dimension, unless normal listening positions will not be at the end areas.

The more restricted the solid angle into which the speaker faces the better will be the air bite at low frequencies. A corner location is best but often impractical, and so the solid angle is more frequently limited in one direction only by locating the speaker, or

the bass speaker of a multi-unit system, near the floor or ceiling.

The Cabinet Type Infinite Baffle

A second method for producing the effect of an infinite baffle involves mounting of the loudspeaker in a totally-enclosed cabinet. It is true that a sealed enclosure of any size or construction will stop the free path between the front and back of the cone. However, several new adverse results, worse than the conditions we are trying to cure, may be created.

First, the compliance of the speaker mechanical system is stiffened by the air of the enclosure. This air must be compressed for the cone to move back and stretched for the cone to move forward, and it becomes part of the entire mechanical resonant system. The resonant frequency of the system is made higher as a result, raising the low frequency cutoff, and shifting resonant emphasis to a region of the sound spectrum where it is more annoying.

The obvious way to avoid this effect is to make the enclosure stiffness negligible by providing sufficiently large volume. Unless the cubic capacity of the enclosure is great enough so

Fig. 4. Operation of the bass reflex cabinet, with electrical and mechanical analogies: M_s = mass of mechanical system (cone, voice coil and air load); C_s = compliance of the speaker mechanical system (rim and voice-coil suspensions); M_p = mass of air in port, including air load; C_e = compliance of air in enclosure; F = magnetomotive force applied to voice coil; R_s = mechanical resistance of speaker mechanism (friction and radiation resistance); and R_a = acoustical resistance of Helmholtz enclosure (acoustical friction and radiation resistance at port).

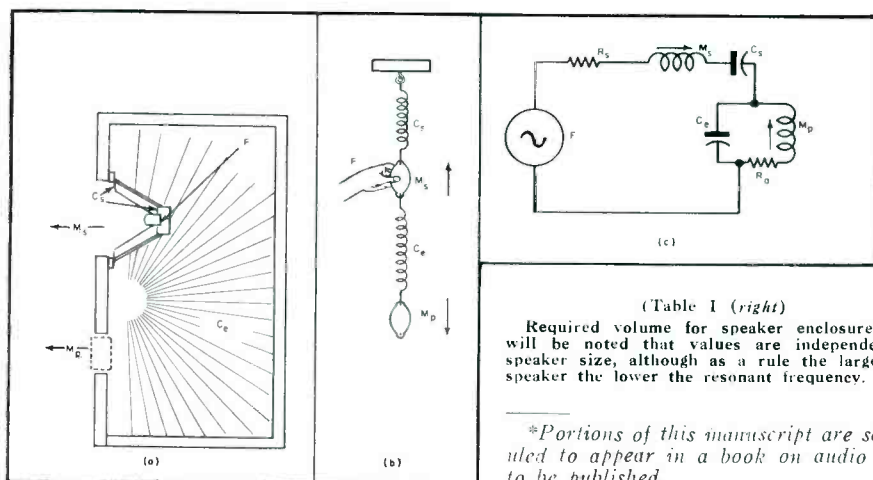

(Table I (right))

Required volume for speaker enclosures. It will be noted that values are independent of speaker size, although as a rule the larger the speaker the lower the resonant frequency.

*Portions of this manuscript are scheduled to appear in a book on audio soon to be published.

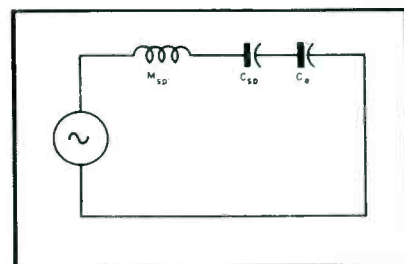

Fig. 3. Equivalent electrical circuit which illustrates operation of speaker mechanical resonant system. M_{sp} represents the mass of the speaker mechanical system; C_{sp} , compliance of the speaker mechanical system, and C_e , the compliance of the air in cabinet. The latter serves to decrease the total capacity of the system.

Resonant frequency of speaker mechanical system	Minimum cabinet volume for infinite baffle mounting	Minimum cabinet volume to raise frequency no more than 30%
40 cps	16 cubic feet	12 cubic feet
60 cps	10 cubic feet	6 cubic feet
80 cps	6 cubic feet	3 cubic feet

Loudspeaker Mountings

(Continued from page 27)

that the added stiffness has little effect on the speaker resonant frequency, the cabinet cannot properly be called an infinite baffle. The necessary enclosure volume for a speaker of given size cannot be calculated by use of a simple rule. The resonant frequency of the speaker mechanism and the value of speaker compliance must be taken into account. It is possible, however, to list the general order of minimum dimensions which are required for infinite baffle mounting of typical speakers with various resonant frequencies. These data appear in table 1 (p. 27). When the volume of a speaker enclosure must be limited, a little *cheating*, in the way of providing a few openings at the back of the cabinet for pressure relief, does more good than harm.

A second trouble encountered with cabinets is the setting up of independent standing-wave resonances created by internal reflections. Such resonances are particularly annoying because they occur at higher frequencies. They may be eliminated by lining the inside of the cabinet with sound absorbent material to damp out the oscillatory reflection. The same effect is produced by filling the entire volume with some soft cottony substance. When special lining material¹ is used padding one side of parallel faces may be sufficient. Ordinary rug cushioning, tacked to all inside surfaces, is effective, too.

Certain other undesirable effects must be guarded against in the design and construction of speaker cabinets, whether they are the totally enclosed type or not.

The walls of the cabinet are one source of unwanted resonance. Unlike a stringed instrument's wooden belly, which contributes to the tone of the sound, a good cabinet does not vibrate in sympathy with the music. Concrete or brick enclosures are ideal, but involve obvious inconveniences. Wooden cabinets must be sturdily built, with joints glued and reinforced. No material thinner than $\frac{3}{4}$ " stock should be used anywhere, including the back, and the builder will do well to attach cross-bars firmly to the larger panels to increase stiffness. Totally enclosed cabinets have greater pressure exerted against their walls than cabinets which are partly open, and must be particularly well braced.

The grille cloth in front of the speaker may also affect performance. This cloth must be of very loosely woven material like burlap or light monk's cloth. A simple check of the suitability of a cloth may be made by holding it to one's lips and blowing through it. There should be no appreciable resistance to the flow of air. Acoustical resistance in the cloth will affect treble frequencies to a greater extent than the bass, and if the weave is tight enough the compliance of the speaker suspension system will be stiffened by the enclosed air in front of the cone.

A metal grille for decoration and protection will not be harmful if it cannot rattle and if it does not obstruct any appreciable area of the speaker cone.

Performance is also improved by designing the cabinet so that the front does not form a right angle with the sides. Diagonal or curved corners may be used instead, which mitigate irregularities in frequency response caused by diffractive effects around the cabinet edges. The diffracted waves have a phase relation to the directly radiated sound which varies with wavelength, producing reinforcement at some frequencies and cancellation at others.

¹Such as Kimsull.

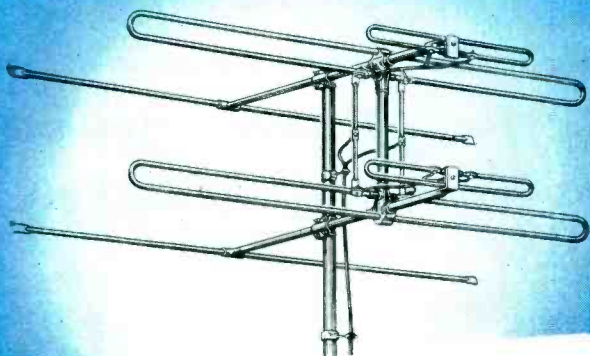

AMPHENOL

this 
Book



... contains information never before available in a concise, readable form. It presents a complete discussion of the factors and conditions which affect television reception and the reasons for good TV pictures. The one single factor which contributes the most to Better TV Picture Quality is the television antenna. The best and most expensive TV set can present a picture no better than that received by the antenna.

This book gives a detailed discussion, complete with illustrations and graphs, of the various types of antennas, their characteristics and performance under given conditions. In addition, the book contains information on the problem of coordinating the antenna with the location.

Your Authorized Amphenol Distributor has a free copy of this book waiting for you—ask for yours today!

AMERICAN PHENOLIC CORPORATION
1830 SOUTH 54th AVENUE • CHICAGO 50, ILLINOIS

AMPHENOL

The last two design factors are less important than those preceding, and many cabinets do not take them into consideration.

The Open Back Cabinet

The open back cabinet has a pronounced air resonance, usually somewhere below 200 cycles. The effect is to produce accentuation and boominess in the region of the resonant frequency, qualities undesirable for natural reproduction, but often accepted commercially as simulating a rich bass.

The Bass Reflex Cabinet

The dimensional requirements of an infinite baffle enclosure are difficult to meet. Smaller volumes may be used, and the stiffness of the enclosed air counterbalanced by a separate air mass coupled to the enclosure. This system is most popularly associated with the name *bass reflex*.* Reflex cabinets are also called tuned port enclosures, vented enclosures, and acoustical phase inverters.

In the extensive literature on tuned port enclosures it is possible to find the system alternately described as improving and making worse frequency range, providing evenness of low frequency response, and causing damping, and distortion. Design data variously includes instructions for tuning the system to a frequency below, equal to, or above the resonant frequency of the speaker, and often the resonant frequency of the speaker is ignored. Rigorous accounts of the tuned port enclosure usually rely heavily on mathematics or rather complex analogous circuit treatment.

The bass reflex cabinet is a Helmholtz resonator. The entire bulk of enclosed air acts like a spring, and the mass of air in the port (together with the outside air load which it engages) like a suspended mass. It is important to remember that the mode of resonance is not that of the air column; the larger interior dimension of the cabinet is small compared to the wavelength of the low frequencies involved. There are no paths within the cabinet large enough for oscillatory reflection and standing waves to be set up in the bass, and the reflection of higher frequencies is damped out by the absorbent lining. The resonant frequency of the acoustical system is determined exclusively by the volume of the enclosure and the dimensions of the port.

When the compliant volume of air in the enclosure is stimulated by the speaker cone at low frequencies it is

*Trade name of Jensen Manufacturing Co. recently released for general use.

(Continued on page 67)

Alprodco

ALUMINUM TOWERS

TV • FM • AM

BROADCASTING
AND
RECEIVING

The Height of
Perfection

ALPRODCO AIRCRAFT ALUMINUM TOWERS

- Lower Cost per Installation
- Easy to Install
- Light Weight
- Strong
- Long Lasting
- Attractive

Alprodco Towers are sold
through local parts distributors.

Write for literature and
full details.

ADDRESS DEPT. E

Alprodco, Inc.

KEMPTON, INDIANA
MINERAL WELLS, TEXAS
DUBLIN, GEORGIA

Troubleshooting

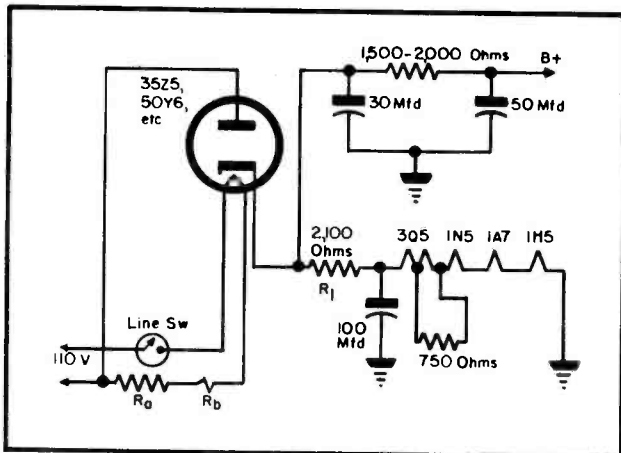

(Left)

Fig. 1. Basic schematic of power supply for 3-way portable. The rectifier is usually a half-wave 35Z5 or 117Z3, or selenium stack, 100 ma or over. To prevent overload, a 750-ohm resistor is shunted across half of the 3Q5 filament; it carries part of the plate current.

(Right)

Fig. 2. Partial schematic of filament string driven from cathode current of pentode section of 117L7, 117P7, 50L6, 50B5, etc. When plug of line cord is inserted into receptacle, circuit is completed for battery operation.

Locating and Curing Problems in AC/DC/Battery Portable Power-Supply Systems

PORTABLE RECEIVERS, during the past few years, have become extremely popular. Their smaller size, increased sensitivity, economical operation and improved audio have spurred interest and acceptance. Tubes, of course, have played a key role in design improvements, notably the 1.4-volt miniatures, and even the subminiatures.

While some of these little sets are powered solely by dry batteries, the largest number use the so-called *three-way* circuit, working on batteries, *ac* or *dc*, with a built-in *ac/dc* power supply, a switch providing contact to the batteries or power supply.

The circuits used are more or less conventional four or five-tube superhets, sometimes with one stage of tuned *rf* amplification. Filaments are usually series connected to simplify switching. Selenium rectifiers or high-voltage tube rectifiers are used to supply power when the set is used on *ac*. An interlock switch, operated by inserting the line plug into slots in the chassis, is sometimes provided to make the changeover from battery to *ac/dc* and prevent misconnections. The changeover switch is about the most complicated part of the whole set. Fortunately, they offer very little trouble.

Many problems are encountered when switching the power supply over from battery to *ac/dc*. An *ac/dc* supply must furnish the set with exactly the same operating voltages as the dry batteries, and at the same time provide a reasonable amount of protection from

line voltage surges which can cause damage to the delicate tubes. Designers have met this problem successfully by the use of a series-filament string, operated from a battery of series-connected cells, or from the last few volts of the high-voltage supply. Large electrolytic filters, as high as 250 mfd are used to remove the *ac* hum from the filament supply. A bleeder resistor, with at least a 5-watt rating, is used to drop the high voltage to the necessary amount.

Line-voltage variations naturally affect these sets to a great extent. To prevent surges from overloading the sensitive filaments, they are usually run at a nominal voltage of 1.2 to 1.25 *v* per tube, with a normal line of 115 volts, to allow for over-voltage conditions from line surges. Negative temperature coefficient resistors, developed recently, and employed to provide added protection, have found wide application in late model portables. With some changes, they may be installed in older models.

Servicing Three-Way Portables

The power supply requires most attention during portable set servicing. In Fig. 1 is illustrated a typical power supply for a set with a 7.5-volt filament string. The bleeder resistor, R_1 , is usually a 2,000-ohm unit. On a five-tube set, the tubes would require 9 volts; 4 tubes at 1.4, and 1 at 3 volts. The *B* supply is taken from the cathode of the rectifier, *dry* or

tube, passed through a pi-section filter consisting of a 1,500 to 2,000-ohm resistor, and two filters, usually of 50 to 30-mfd 150 *uv dc* value. Also taken from the cathode is the filament voltage, through a 2,000-ohm filament dropping resistor. A filament filter capacitor, from 100 to 250 mfd, at 25 volts, is connected to the load end of this resistor.

Initial Checks

When encountering trouble in a portable it is necessary to check first the total output voltage at the rectifier cathode. Due to the nature of the power-supply, any drop in voltage here will cause a severe loss of performance. At least 120 volts should obtain, with a 115-volt line. If in doubt, the voltage should be measured across the oscillator filament. This, of course, is the most sensitive tube in the string. If a 1.2-volt reading is obtained on *ac*, the power supply is probably all right. Low voltage at the rectifier may be traced to low emission of a tube rectifier; low emission of selenium rectifier; open, low or high-power factor in the input filter; or an overload caused by a short somewhere in the *B*-supply bus. On several occasions, selenium rectifiers have been found to have an emission just a few volts low; enough to cause trouble in these sensitive sets. If a dry rectifier will not show a full 120 volts under load, with a good input filter and no shorts, a new one should be

3-Way Portables

by JACK DARR
Ouachita Radio Service

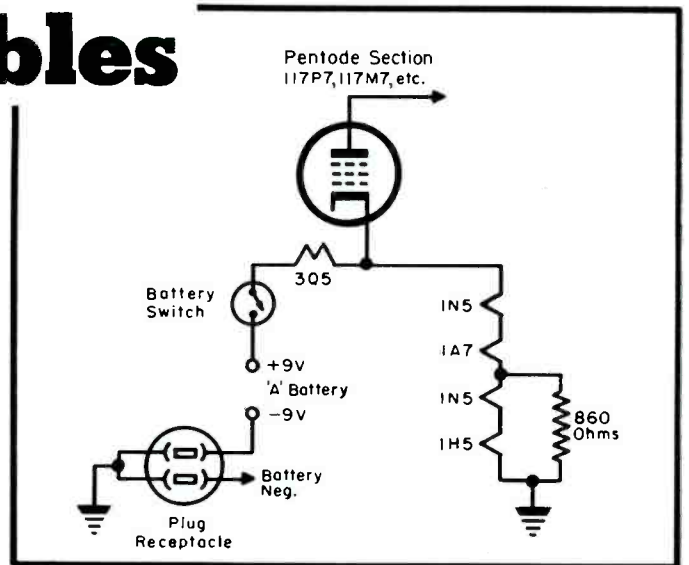

substituted. This will probably clear up the trouble.

All rectifiers, dry or tube, use a small *surge* resistor, connected in either the plate or cathode circuit. Its function is the same in either place; protection of the rectifier and set from damage due to sudden surges in the line voltage. Values of these range from 27 to 47 ohms. It is important to avoid using resistors with over $\frac{1}{4}$ -watt rating in replacement. The small resistors will blow out on an overload, and may save the rectifier or input filter from further damage. When tracing low-voltage trouble, the surge resistor should be checked for excessive voltage drop. Cases have been found where the surge resistor rose in value when heated, causing excessive voltage drop.

Filament-dropping resistors can cause trouble, if their value shifts. Quite a few sets use resistors encased in metal housings; these sometimes open inside the housing. They may be bridged with a good resistor, using the old lugs; the wire-wound resistor should be gouged with a knife to be sure it won't reclose under heat, thus lowering the total value of the resistance and overloading the tubes. One should never add to nor subtract from the stated value of a filament resistor. If the filament voltage is low, with a normal input, and the resistor tests at its rated value, with an accurate ohmmeter, the chassis should be checked carefully before adding or shunting resistance.

This move is important because tubes with deactivated filaments may suffer such a severe change in resistance that they upset the filament voltage for the whole string; shunt resistors may have been replaced with incorrect values; there may be a wiring short, or an internal leakage in one

of the tubes. Any of these problems can occur. Thus, it is important to troubleshoot and not be too quick to blame the trouble on the filament resistor. If necessary, the resistor can be replaced temporarily with an exact duplicate; it may be failing to hold its rated value under load.

Filters are usually dual or triple electrolytics; 50-30 at 150 volts, and 200 at 25 volts are typical examples. Filters should be tested carefully for high power factor, and especially for leakage between sections. In one set it was found that the 3Q5 output tube would blow whenever the switch was snapped on with batteries installed; the switch went from *off* through *bat-*

tery to *ac/dc*. As the switch contacts passed through *battery* the filter charged to 90 volts, then discharged, through the leakage between sections, across the filament string; 90 volts across a 3-volt filament can provide only one result!

Weak tubes can cause a good deal of trouble. If one tube in a string has an incorrect filament resistance, it will upset the balance of voltages on the entire string. Voltage across each tube should be checked at the socket contacts. If one tube shows incorrect voltage, it should be replaced and rechecked. Low and weak oscillator tubes can give a great deal of trouble. A small autotransformer for checking[†], permitting the line voltages to

(Continued on page 70)

†SERVICE, September, 1951.

Fig. 3. Typical schematic of filament string in three-way portable, with chain of shunt and series resistors. Bias voltages for power output tube, 3Q5, if tube and delay voltage for *avc* are tapped off different points, on the link of resistors. The volume control also returns to the filament string. All switches are ganged, working as one switch.

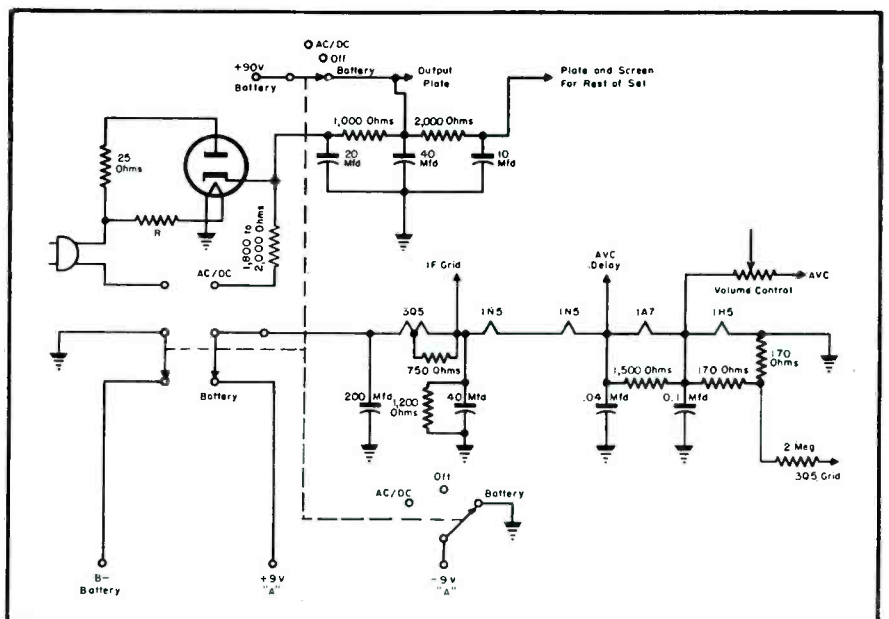

TAKE IT FROM AN EXPERT



H. L. DALIS, INC.
New York

For 18 Years It Has **Paid** to be
a **Snyder** **DISTRIBUTOR**
PHILADELPHIA



Directronic



YAGI

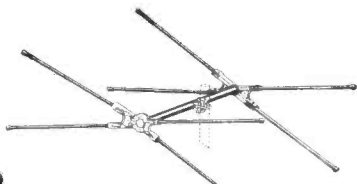

CONICAL



INDOOR

BECAUSE SNYDER GIVES

- complete line TV and AUTO aerials
- products with a "Market Edge"
- new products first
- advanced engineering
- consistent advertising
- participation promotion planning
- proper pricing
- fair merchandising
- 21 years of know-how



AUTO

SNYDER MFG. CO.

PHILADELPHIA

H. L. DALIS, INC., 175 VARICK ST.—METROPOLITAN NEW YORK DISTRIBUTOR

LOCATING Temperature-Induced FAULTS in TV Receivers

by J. C. GEIST

Temperature-Checking Technique, Featuring Recording of Voltage and Waveshapes Throughout Suspected Circuit in Hot and Cold Condition, Found to Localize Trouble Area Accurately and Eliminate Guess-and-Try Part-by-Part Substitution.

SOME OF THE MOST DIFFICULT and time consuming types of receiver faults occur only after the chassis has heated up during operation, and often then only when the set is in its cabinet. These faults are even more difficult to locate in television models because of the increased complexity of the circuit networks employed. It certainly behooves any serious television Service Man to develop a systematic method of attacking this type of receiver fault.

One pitfall that must be guarded against in attacking temperature induced faults is the erroneous conclusion that the repair has been accomplished by the replacement of a tube or readjustment of a circuit without actually locating the exact cause of the improper operation. *Quicky* service of this type only invites repeat calls and ultimate customer dissatisfaction.

The first step, then, should be to observe the actual fault. If the receiver is in its cabinet, it should be placed in operation until the fault occurs to get a first-hand observation of the trouble. If the fault does not occur within the normal temperature-stabilization time of about an hour, it may be necessary to raise the temperature of the receiver by reducing the air circulation of the cabinet. A small blanket completely covering the cabinet will be effective for this purpose. If the set is not in the cabinet it can be operated while completely covered with a blanket until the fault occurs.

Once the malperformance is care-

fully observed it is usually possible to deduce the general circuit area in which the fault is located. Adjustment of the appropriate controls while the receiver is malfunctioning will aid in locating the general area. To locate the exact part causing the trouble is something else again!

Having determined generally in which circuit the faulty part is located the receiver should be set up on the test bench so that it can be operated while covered with a blanket and so that the direct blast of a fan can be directed at the underside of the chassis.

The use of the blanket and fan will allow rapid changes from the hot to cold condition so that the time the service bench is tied up can be minimized.

To locate the faulty part it is necessary to operate the receiver from a cold start and rapidly record the wave shapes and amplitudes of several points in the suspected circuit and the voltages on each terminal of the tube or tubes directly connected with this circuit. Considerable time can be saved and accurate *cold* measurements ob-

(Continued on page 72)

Fig. 1. Synchroguide horizontal oscillator and afc circuit used as example to illustrate use of temperature technique in tracing trouble.

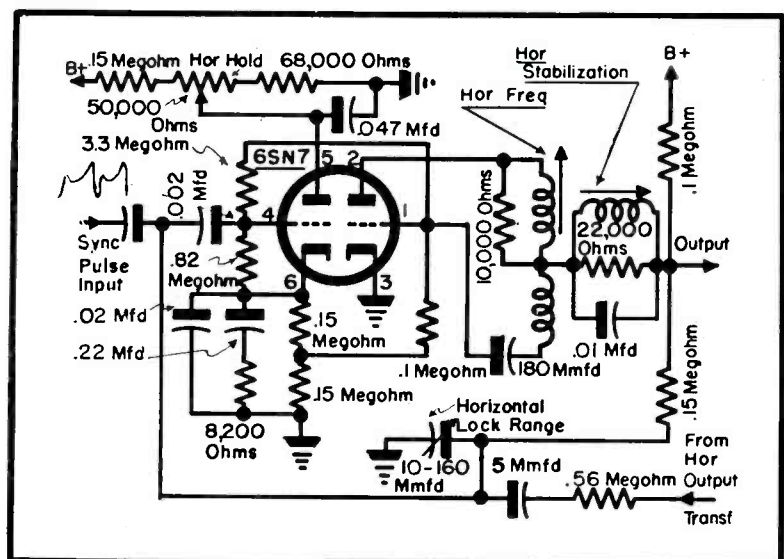

AUDIO *installation and service*

Phono-Tape-Wire-PA-Amplifiers-Speakers

by KENNETH STEWART

Mechanical and Electrical Characteristics of Tape Record and Playback Mechanisms and Amplifiers, and Tape-Disc Systems . . . Features of Portable Tape Recorders, Auto-Radio Speaker Kits, Hi-Fi Tape Heads, and Battery-AC Hi-Power PA-Phono Equipment

THERE ARE MANY who have quite a collection of phono records which they prize and enjoy listening to often, but feel also that tape offers many unique possibilities. For this audience there have been produced combination tape-phono units as exemplified in the tape-disc amplifier discussion last month[†]. Another interesting example of this

type of design appears in Fig. 1, a Wilcox-Gay unit (1C series, type 1C10) with which it is possible to play standard 78 records; it is only necessary to position a control knob in the phono position. With the control knob in the phono posi-

tion, a function shift lever depresses presses both front and rear lift levers, thus disengaging both the front and rear reel clutches. This eliminates the driving of the tape, and the only function the unit performs is to actually turn the turntable. In playing records, the rear portion of the pickup arm is depressed, and a standard playback

Fig. 1. Schematic of Wilcox-Gay 1C-10 tape disc recorder-playback amplifier. The S₁ switches in 6SJ7 and 12AX7 circuit have four functions: Mike, disc play, auxiliary contact and tape play. The S₂ switches, at extreme right, are used to provide contact for record on disc, record on tape and play on speaker.

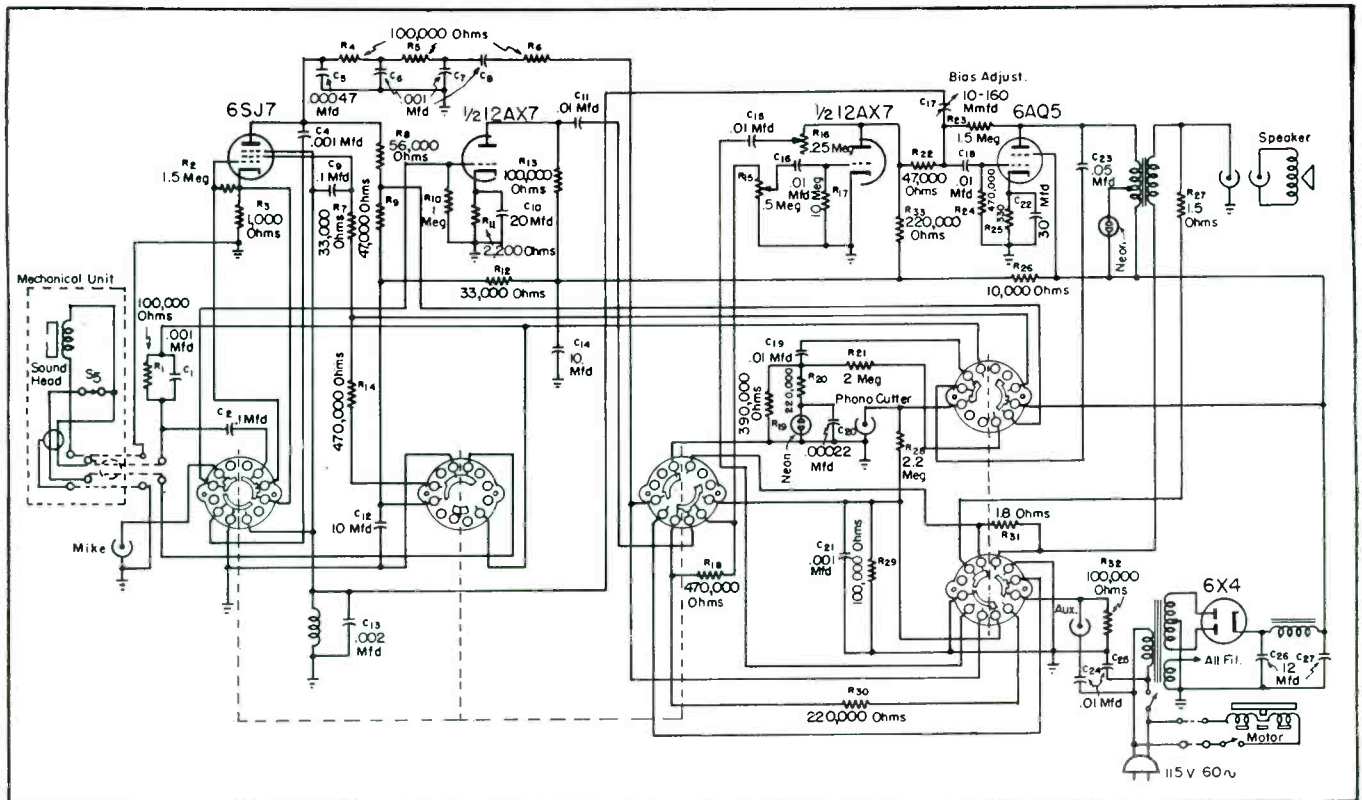

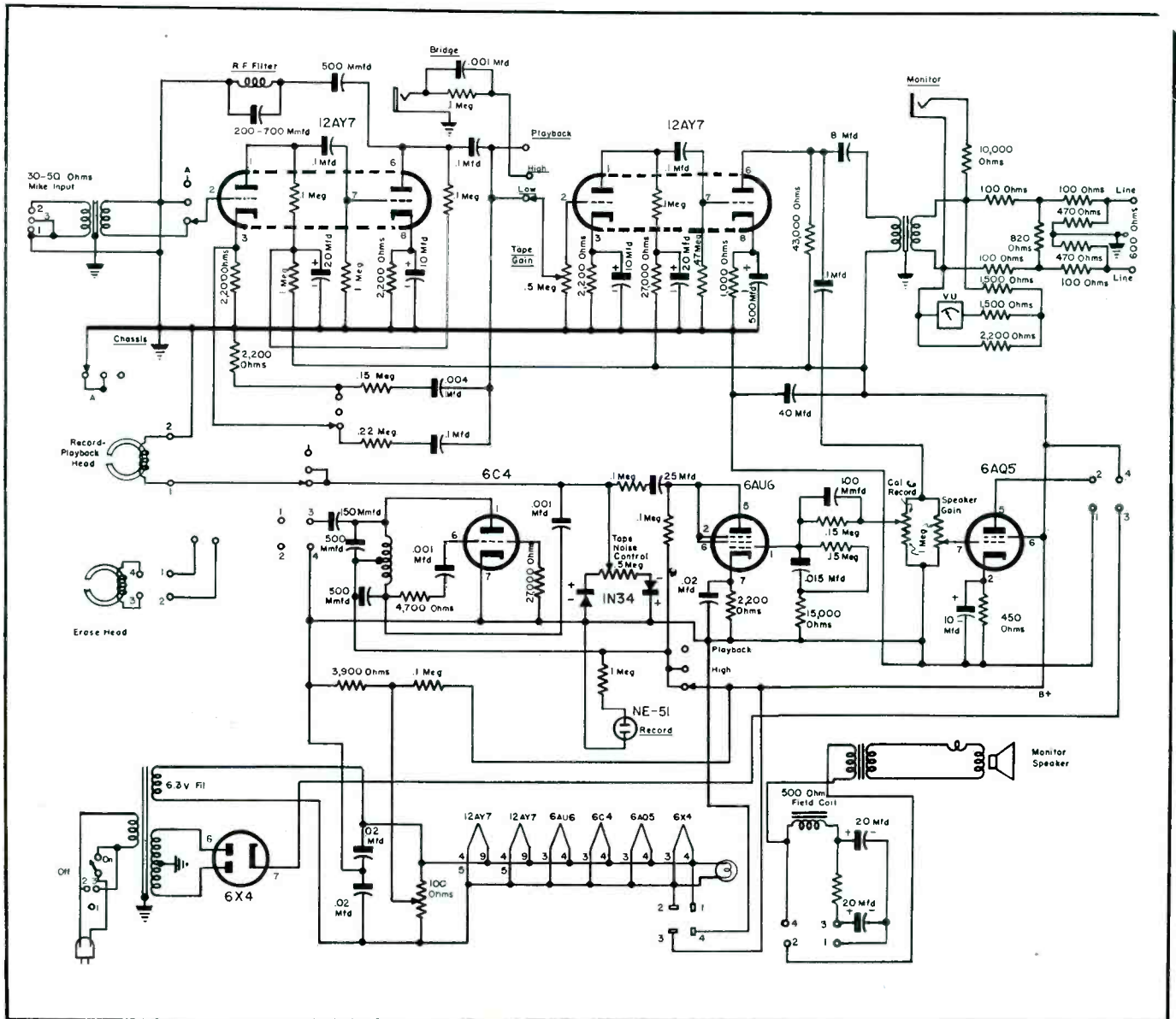

Fig. 2. Circuit of Sonar model PRA tape-recorder amplifier, an analysis of which appears on pages 36 and 38.

needle is inserted in the pickup cartridge; it is held in position with a thumb screw.

The model diagramed permits the cutting of disc recordings from recorded information on the tape, or any external source which might be fed into the amplifier. To cut home recordings, it is necessary to remove the playback needle from the pickup cartridge, a standard 5/8" recording stylus, being inserted. The recording blank is placed on the turntable, being sure that the off-center hole of the recording blank is inserted over a drag pin, thus assuring the disc to revolve constantly with the turntable. The pickup arm is lifted off a tone arm rest and the point of the cutting stylus is placed on the outer edge of the recording blank at the approximate location at which the

recording is to start. These operations are performed with the control knob in the *off* position. The rear of the pickup arm is lifted by the finger extending to the right side. At a certain point, there will be a definite feeling of the pickup arm locking into position; and at this location, a follower arm engages the lead screw. It is now only necessary to move the control knob into the phono position if the recording is being done from some source other than the tape. With the proper setting of the amplifier controls, the information will be recorded on the disc; it is desirable that occasionally the thread from the cutting stylus be wiped toward the center of the turntable so as to wrap around the turntable spindle.

This tape-disc series incorporates

features for automatic shutoff upon the completion of the recording or playback of a reel of tape. This is accomplished by the tension of the tape holding a mercury switch assembly in a position so that the mercury switch is closed, thus permitting power to be supplied to the motor. When in the record or playback position and the tape tension is released as a result of all the tape being wound on the forward reel, the switch assembly which includes the mercury switch is permitted to tip in a manner opening the motor circuit, thus automatically stopping the unit.

Frequently, it is desirable to record a half-hour program of music; this can be accomplished by recording music from records to tape. To eliminate any interruptions between

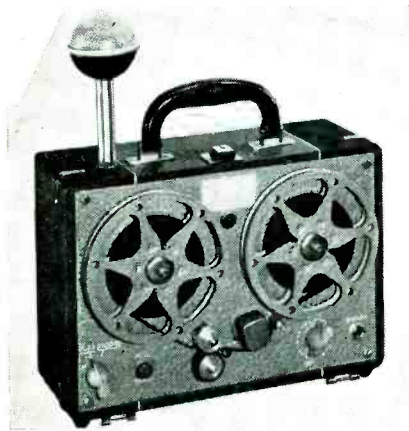

(Above)

Battery-operated midget tape recorder which carries its own power supply of flashlight batteries. Has a detachable non-directional microphone which plugs directly into the microphone input jack, and is supported by its own tubing. An auxiliary table stand, complete with extension cable, is also available to permit recordings to be made where it is desirable to have the recorder remotely located. Cabinet measures 11½"x8½"x5½", and weighs 9¼ pounds, including batteries. Uses a spring-wound drive motor that, it is said, will run 15 minutes on a single winding, and may be rewound during operation. A warning light flickers on approximately one minute before rewind is necessary. Two hours of recording are accommodated on a reusable 5' reel of standard ¼" wide tape. Tape speed is 1⅞" per second. (Interviewer: Amplifier Corp. of America.)



(Above)

High-output record-playback head, designed to provide high fidelity sound reproduction from ¼" magnetic coated recording tape. Head is said to have a frequency response flat within 1 db from 100 cycles to 7000 cycles at a tape speed of 7.5" per second. At a tape speed of 15" per second, the maximum frequency response is said to be increased to nearly 12,000 cycles. Signal output is in the order of 5 mv. Head utilizes a track width of .200". Impedance is 1000 ohms at 1000 cps. Constructed so that normal tension of tape keeps it in contact with the head without the need of felt pressure pads. Designed for single track recording on ¼" tape. (TD-701 Head; Indiana Steel Products Co.)

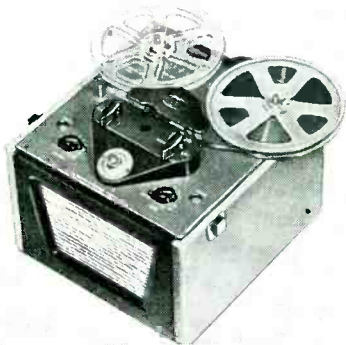

(Left)

Tape player which operates on either 3¾" or 7½" per second speeds. Available either as a self-contained unit with speaker and amplifier or with preamp only, ready to plug into any existing amplifier, radio or TV set. Both feature double track operation and two speeds. Also available with single track (full width heads) for broadcast applications. (Models PB-1 and PB-A2; Pentron Corp.)

records, it is possible, at the conclusion of one record, to stop the forward reel by hand, thus releasing the tape tension and permitting the mercury switch assembly to open the motor circuit. At this time, the records can be interchanged on the turntable, the pickup arm again placed on the second record, and the tape tension tightened by a slight clockwise rotation of the forward reel. This will again position the mercury switch assembly so as to close the motor circuit, thus starting the recording process. This procedure can be continued until the entire reel of tape is recorded. When it is played back, there will be no apparent interruptions from one record to the next.

Portable-Remote Tape Unit

To accommodate the requirements of those who want to use tape exclusively and in a professional way, designers have evolved several units, using novel circuitry. An example of this approach appears in Fig. 2 (p. 35), which illustrates the amplifier of a tape recorder which can be used for portable or remote studio recording. Three heavy-duty torque motors dynamically balanced are used in the mechanism (Sonar PTM) which is also provided with magnetic slipping clutches that are said to have no mechanical discs or felt pads to wear. Mechanism will accommodate standard NAB and RTMA tape reels measuring 10½", 7", 5" and 3".

Machine is equipped with erase-record and playback heads, each individually shielded, and featuring ring-type construction with individual adjustment for orientation. With a tape torque-control switch it is possible to either lift the tape and open the pinch drive capstan for rewind or fast forward, or engage the tape and close the pinch drive against the capstan for record or playback operation.

The amplifier has a built in rf filter which enables the unit to operate alongside a high-power transmitter. Unit will record and feed a telephone line simultaneously, as well as a hi-fi monitor amplifier. The record head may also be used for playback. The third head when interconnected with a preamp or the plug in a preamp in

(Continued on page 38)



Minnesota's Governor C. Elmer Anderson at his desk in the capitol building in St. Paul tape recording a talking letter to Generals Matthew B. Ridgway and James A. Van Fleet and troops in Japan and Korea. The Governor's talking letter accompanied a shipment of 12 tape recorders and 4,800 reels of recording tape donated to the men in Korea by Revere Camera and Minnesota Mining.

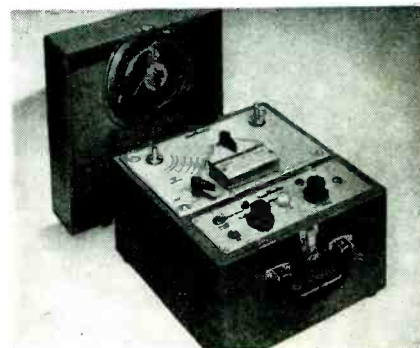

(Above)

Tape recorder, designed for operation with the user's own audio amplifier and speaker. Includes a tape transport mechanism and matching self-powered preamp with push-pull supersonic bias-erase oscillator. Operates at standard tape speed of 7.5 inches per second; maximum speed variation 2% (95 to 125 volt ac line variation). Has a dual-track head for ¼" width tape; manual reversal. Affords one hour of recording. Has neon record level indicator. Inputs for both radio-phono and microphone. Output impedance 17,000 ohms (audio output to 4 volts). Frequency response said to be 70-8000 cycles, 3±db; signal-to-noise ratio, 42 db. (PT-121; tapeMaster, Inc., 13 W. Hubbard St., Chicago 10, Illinois.)

(Below)

Rear seat auto speakers. One model includes a 6½-inch pm Adjust-A-Cone speaker. Another, a deluxe model, includes a 6x9 inch pm Adjust-A-Cone speaker. The 6½-inch speaker features a 1.47 ounce alnico V magnet and is supplied with a three-position switch for dash mounting; ample cable for any installation; hocked grill screen; baffle plate; and miscellaneous hardware and installation instructions. The deluxe model features a 2.15-ounce alnico V speaker, three-position switch for dash mounting; sufficient cable for any installation; hocked grill screen; baffle plate; sponge rubber gasket and miscellaneous hardware and installation instructions. (Types AS-1 and AS-2; Quam-Nichols Co.)

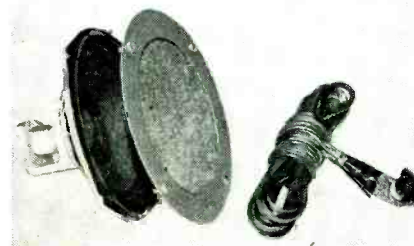

Now ... a NEW Junior VoltOhmyst* ...the WV-77A

For all regular measurements and specialized measurements as illustrated.

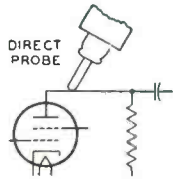

MEASURES AC VOLTS ... such as signal voltage on plate of af tube.

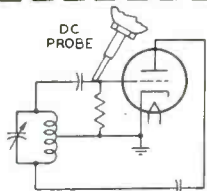

MEASURES DC VOLTS ... such as oscillator grid bias. One-megohm resistor in probe prevents circuit loading.

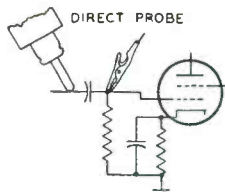

MEASURES RESISTANCE ... such as leakage in coupling capacitor up to 1000 megohms.



Just one probe cable and one slip-on probe handle all measurements.

Check these important features ...

- ✓ Accurate laboratory calibration.
- ✓ Meter electronically protected against burn-out.
- ✓ Metal case shielding ... extra stability in rf fields.
- ✓ Sturdy 200-microampere meter movement.
- ✓ Carbon-film 1% multiplier resistors ... dependability plus.
- ✓ Zero-center scale ... for discriminator alignment.
- ✓ Frequency response flat from 30 cps to approximately 3 Mc.
- ✓ High ac input resistance for greater accuracy.
- ✓ Constant dc input resistance ... 11 megohms on all scales.
- ✓ Negative feedback circuits for greater over-all stability.
- ✓ Ohms cable always positive ... for quick leakage measurements of electrolytic capacitors.
- ✓ Polarity reverse switch ... eliminates cable switching.
- ✓ $\pm 3\%$ over-all accuracy on +dc scales, and $\pm 5\%$ on ac and -dc scales.

An all-electronic ac-operated vacuum-tube volt-ohmmeter by RCA ONLY \$47.50.

Includes DC probe, AC direct probe and cable, ground lead, and alligator clip.

The RCA WV-77A VoltOhmyst* provides the extra features you have tried to find in an inexpensive VTVM. Using the famous Volt-Ohmyst electronic bridge circuit, 200-microampere meter movement, and carbon-film multiplier resistors, the WV-77A incorporates features you would expect to find only in more expensive instruments. Sturdily built ... calibrated against laboratory standards ... and backed by a 12-month warranty ... the WV-77A has the durability, versatility, and accuracy to please discriminating customers such as service technicians, engineers, amateurs, and military personnel.

As a DC Voltmeter it measures dc from 0.05 volt to 1200 volts in five ranges. Uses 1-megohm resistor in isolating probe; probe has less than 2-uuf input capacitance. Has 11-megohm input; useful for measuring high-resistance circuits such as oscillator, discriminator, and avc.

As an AC Voltmeter it measures ac from 0.1 volt to 1200 volts rms in five ranges.

Uses high-impedance diode tube as signal rectifier. Frequency range is more than adequate for measurement of power line, audio, and ultra-sonic frequencies.

As a wide-range Ohmmeter the WV-77A measures resistance from 0.2 ohm to 1 billion ohms in five ranges. Requires only 1.5-volt battery as burn-out protection in measuring such low-power elements as battery-type tube filaments.

The all-new RCA WV-77A VoltOhmyst comes completely equipped with probes and cables as illustrated. For complete details, see your RCA Test Equipment Distributor today ... or write to RCA, Commercial Engineering, Section DX56, Harrison, N. J.

Accessories Available on Order

The WG-289 High-Voltage Probe and WG-206 Multiplier Resistor extend the dc range of the WV-77A to 50,000 volts.

The WG-264 Crystal-Diode Probe extends frequency range of the WV-77A to 250 Mc.

*Reg. U. S. Pat. Off.

Available from your
RCA Test Equipment
Distributor



RADIO CORPORATION of AMERICA
TEST EQUIPMENT
HARRISON, N. J.



One of the needle manufacturing processes used by Permo to be featured in a forthcoming TV film, *Industry in Action*, sponsored by NAM. Program, to be aired by nearly 65 TV stations throughout the country, is currently being filmed at the plant by NBC newsreel cameraman Earle Crotchet.

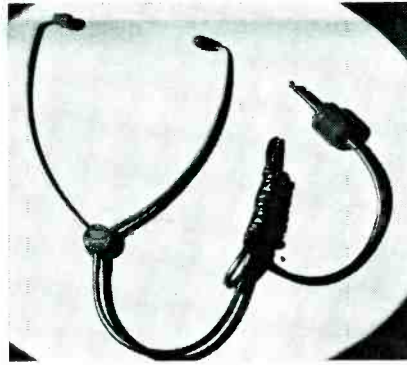

Lightweight headset designed for all-day wearing. Said to feature a high fidelity range. (Dyna-set; Telex).



Counter display-merchandiser for replacement phono needles introduced by Jensen Industries, Inc. Of blond mahogany, cabinet is said to provide space for a balanced stock of needle replacements for every type of phono and record player.

one model (RTA-12) will enable simultaneous monitoring from tape.

Recorder

The recorder (model PTE) consists of a mechanism and amplifier in one case and another amplifier with its associated speaker and power supply mounted in a second case. The mechanism when inter-connected with the amplifiers comprises a complete recorder and monitor as selected by a switch for simultaneous monitoring, as well as a three-channel mixer.

Rewind time of the recording mechanism is said to be 58 seconds for 2500' of tape.

Amplifier/Power Supply Unit and Speaker Monitor

The amplifier/power unit and speaker monitor features an input source impedance (microphones) of 30/50 ohms; input load impedance of 30/50

ohms. bridging, $\frac{1}{2}$ megohm; output (source-load) impedance of 600 ohms balanced through a 6-db *H* pad; power gain of 110 db. ± 3 db; input level of -62 db to -48 db (bridging input level of -10 db to $+10$ db); signal-to-noise ratio, said to be better than 50 db; output level of $+8$ dbm; and frequency response of 20 to 20,000 cps, ± 2 db less than 2 per cent total harmonic distortion. Tube complement in this unit comprises 2-12AY7, 1-6C4, 1-6AQ5, 1-6AU6 and 1-6X4.

Single button carbon microphone which is said to have a 100 to 4500 cps range. Designed for hand use, mike has a double-pole, single throw switch, with relay and microphone circuits normally open (press-to-talk). The carbon element is said to be moisture- and fungus-proofed. Switch control button is positioned for ease of thumb operation. Hang-up bracket, for holding the mike on wall, panel or dash, is standard equipment. Has anti-rattle prongs which slip on or off a button on the back of the mike. Also standard is four-conductor, self-coiling cable with oil-resistant Neoprene rubber cover. It has a retracted length of 12 inches, extended length of five feet. A coiled spring cable protector is mounted at the microphone. (Model 10M5; Astatic.)



Three-Channel Mixer

In the three-channel mixer the input source impedance is through microphones 1, 2 and 3 at the rear of the chassis. The output impedance is 600-ohms balanced through a 6-db *H* pad. The input level is from -62 to -48 db. Unit employs pads, 3-L type 20 steps, 2 db per step.

Circuit Description

The input stage utilizes a 12AY7, each half being cascade resistance coupled. When the unit is in the playback position, the record playback heads connects directly to the input grid. Selective inverse feedback is employed for bass boost. When recording from microphone, the selective feedback is left intact, but the bass boost is cut out.

A second 12AY7 is also in cascade, and capacity coupled to the output transformer feeding a balanced *H* pad, 600 ohms, having a 6-db insertion loss. The output circuit feeds the recording amplifier, which is a 6AU6 triode connected, and fed through a calibration control mounted on top of the chassis. A 6AQ5 power amplifier gets its drive from the input of the recording amplifier. A 6C4 furnishes approximately 150 volts at 75 kc for the erase, and approximately 50 to 60 volts of bias. A 6X4 tube functions as a full-wave rectifier. In the filament circuit there's an adjustable hum control, which need

not be touched, unless the 12AY7 are changed.

Servicing Aids

To edit or *Q* the tape, the tape should be removed from between the pinch drive and capstan and placed under the capstan. The tape knob should be turned to either 7 or 10, and the selector at either *S* position on the selector knob. The takeup reel should be rotated clockwise by hand to go forward. To go backward, the feed supply reel should be turned counter clockwise. Either the record head or monitor head may be used, assuming the third head is plugged into a preamp.

To remove a section of tape, the tape should be picked out from under the three heads by sliding it out of the tape guides.

After stopping the mechanism from its normal play position, and before

(Continued on page 66)

Portable 16" MicroDisc Recorder which permits recording and playing of full hour of speech or music on a single disc $4\frac{3}{4}$ " in diameter, operating at 16 revolutions per minute and at a pitch of 448 lines per inch. Absence of a conventional turntable is said to eliminate modulation and distortion of bass frequencies. Unique design of the lathe and feed screw is claimed to afford extreme accuracy of pitch. Also features spiralling. (Model P16-450 MicroDisc Recorders; Audio and Video Products Corp., 730 Fifth Avenue, New York 19, N. Y.)



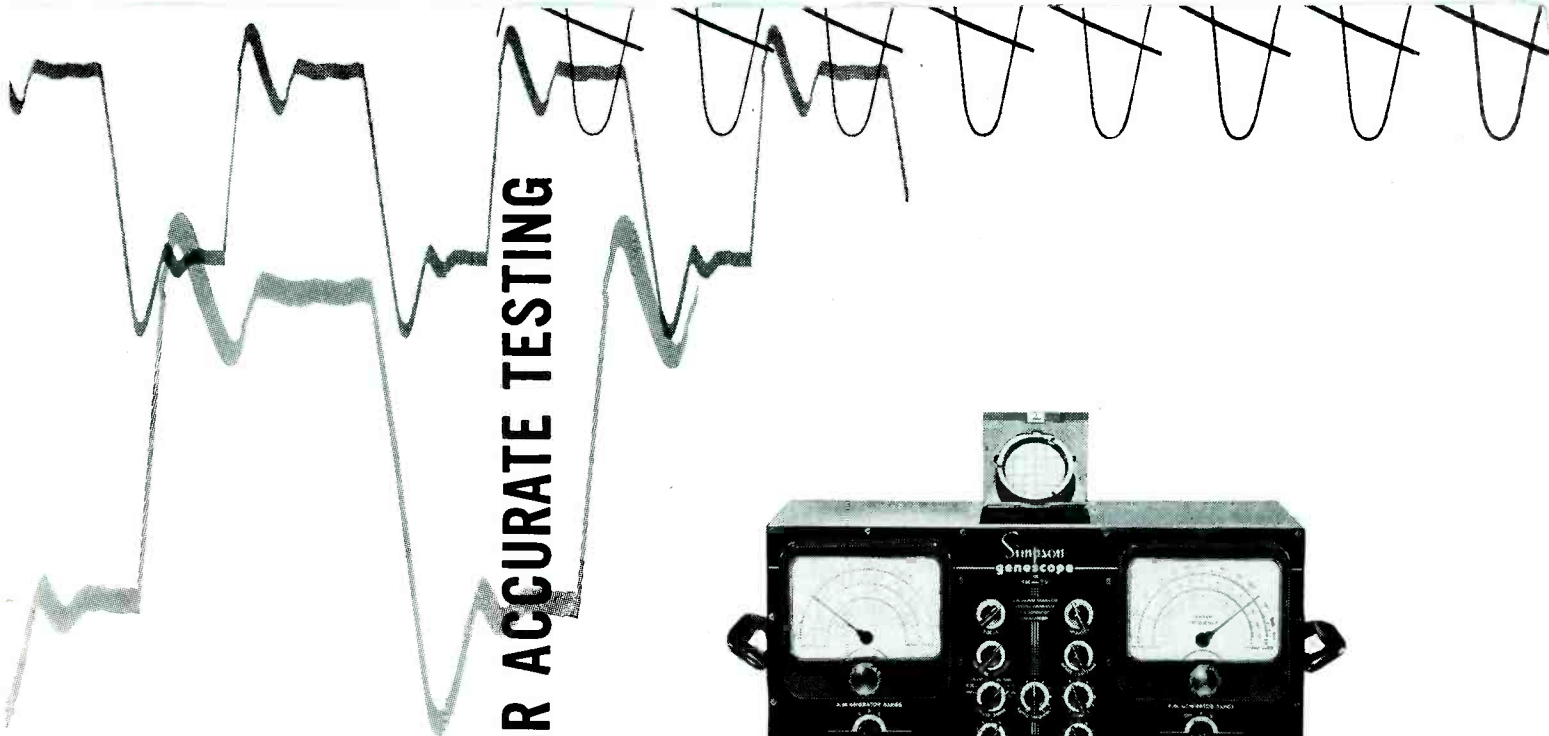

SIMPSON MODEL 480 GENESCOPE FOR ACCURATE TESTING

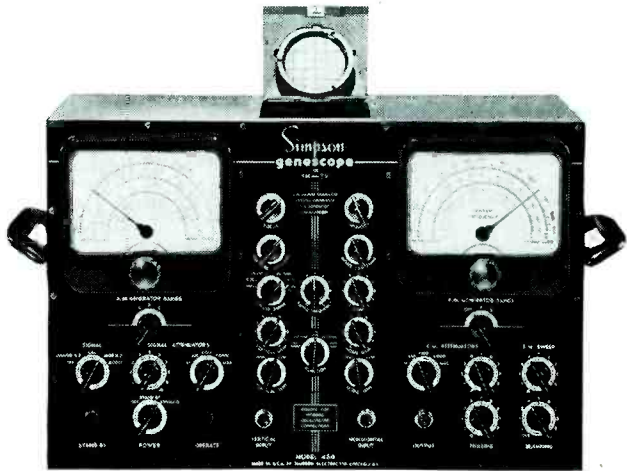

- Provides all the necessary signal sources for proper alignment and servicing of FM and TV receivers
 - Includes the Simpson High Sensitivity Oscilloscope, complete in every detail and equipped with a high frequency crystal probe for signal tracing
 - Independent, continuously variable attenuators and step attenuators for both AM and FM units offer complete control of output at all times—from the high level required for front end adjustment to extremely low levels for fringe area peaking operations
 - Multiple shielding, generous bypassing and adequate line filtering reduces signal leakage to a negligible factor
 - A 0-15 megacycle sweep is provided by means of a noiseless specially designed sweep motor based on the principles of the D'Arsonval meter movement for fine control and lasting accuracy
 - The exclusive Simpson output cable (illustrated on the right) includes a variable termination network which is quickly adapted to provide open, 75 or 300 ohm terminations—the addition of a pad provides attenuation and isolation. The use of appropriate resistors across certain terminals will provide any other termination required. A .002 MFD blocking condenser can be added on any termination for use on circuits containing a DC component
 - The FM generator output voltage is constant within .2 DB per MC of sweep.
- Model 480 \$395.00

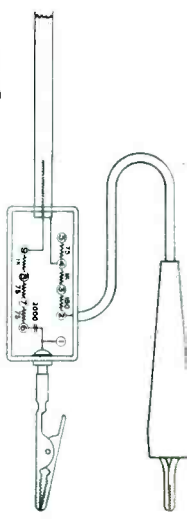

*approved by
service managers of:*

- admiral**
- zenith**
- motorola**
- emerson**
- hoffman**
- hallicrafters**



Also available without the oscilloscope as Simpson Model 479 TV-FM Signal Generator. Model 479 \$269.00

Simpson Instruments That Stay Accurate Are Available From All Leading Electronic Distributors

SIMPSON ELECTRIC COMPANY
5200 W. Kinzie St., Chicago 44, Illinois • Phone: COLUMBUS 1-1221 • In Canada: Bach-Simpson, Ltd., London, Ont.

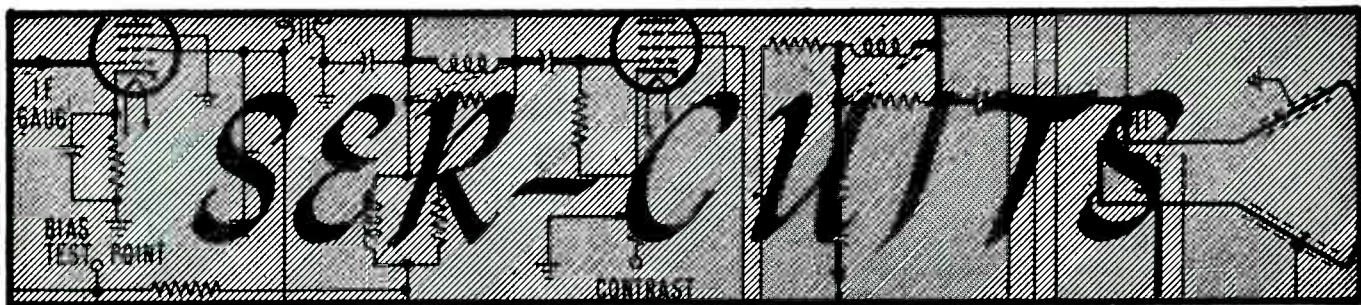

by M. W. PERCY

Analysis of TV Chassis Low-Voltage Power Supply Using Selenium Rectifiers*

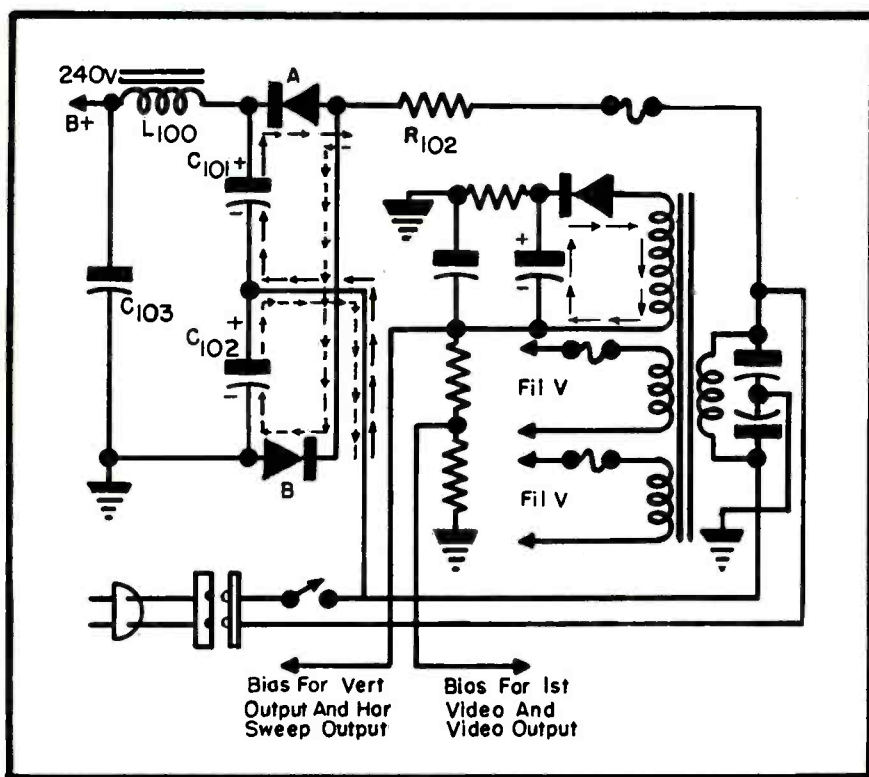

Fig. 1. Circuit of full-wave voltage-doubler system used in Philco TV chassis low-voltage power supply.

OUR NATIONAL DEFENSE PROGRAM, calling for substantial stockpiling of many types of raw materials normally employed in the production of chassis, has made it necessary to design equipment to affect material economies.

The selenium rectifier has become one of the popular items in this substitute program, serving to replace a tube and transformer in many of the power supplies, quite effectively. Their unique properties have been found valuable not only in current conver-

sion, but circuit streamlining. When rated properly for the load they are to carry, these cells operate at a low temperature. Thus, frequency drift due to heat changes in the oscillator circuits are minimized. In addition, lower temperatures increase the life expectancy of other components in the chassis. The rectifiers have also been found to have good regulation and

*Based on copyrighted notes prepared by Philco.

provide instantaneous operation. They are also compact and lightweight.

Selenium Rectifiers

The construction of these rectifiers is based on the concept that certain combinations of thin films of metal permit electrons to flow more easily in one direction than in the other. In a selenium rectifier, a specially prepared film of selenium is placed on a metallic surface such as iron or aluminum. Over the selenium a thin layer of dielectric is placed; then a thin coat of metallic alloy is sprayed on top of the dielectric to provide a counter electrode.

When this cell is placed in a *ac* circuit, electrons pass from the selenium film to the counter electrode with very little opposition, but when the polarity of the voltage across the rectifier is reversed, very little current is passed in the opposite direction.

All metallic rectifiers permit some reverse current to flow. This reverse current must be considered when determining the load versus the rating of the rectifier to be used, since the heat loss is incident to its flow.

The forming time or molecular change in structure of the rectifier is of the order of a few seconds, while the deforming time is a matter of minutes.

Accordingly, as noted last month,[‡] a protective resistor is included in the design of the rectifier circuit to prevent a molecular break down during the initial surge of reverse current. This resistor has a comparatively low value ranging from 50 ohms for a 25-milliampere rectifier to 10 ohms for 425 milliamperes and higher. The basic building block of metallic rectifiers is a

[‡]Service, March, 1952.

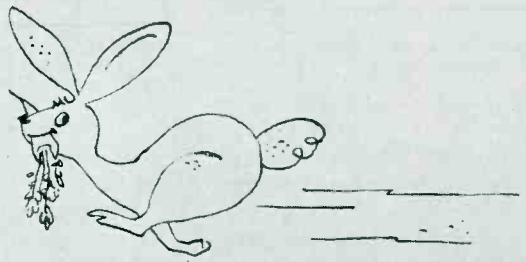

FAST

KESTER "RESIN-FIVE" CORE SOLDER

FAST . . . On Every Soldering Job

Kester has two Solders for you . . . Kester "Resin-Five" Core Solder, the newest development, and Kester Plastic Rosin-Core Solder, the old reliable.



- Diameters of 1/16 inch and smaller available, besides the 3/32 inch.

Either product, but especially "Resin-Five," does the work fast, enables you to get the job out quickly and make room for more of that profitable servicing.

With Kester "Resin-Five" Core Solder, the flux being of the activated Resin-type, you can solder anything and everything . . . even those badly oxidized parts! Yet, "Resin-Five" Flux is absolutely non-corrosive and non-conductive.

Your Jobber has Kester! Be sure to ask for "Resin-Five" or "Plastic Rosin" . . . they are the genuine Kester products.

KESTER SOLDER COMPANY

4248 Wrightwood Ave., Chicago 39
Newark 5, New Jersey • Brantford, Canada



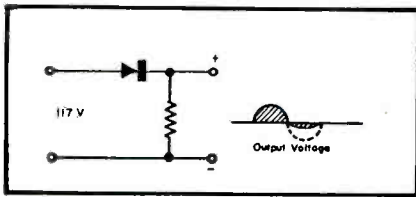

Fig. 2. Output during one cycle across one selenium rectifier.

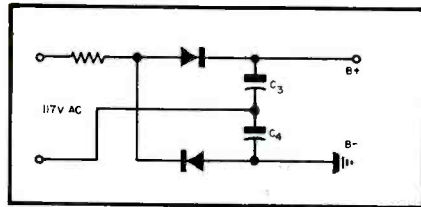

Fig. 3. Circuit of basic full-wave voltage doubler, which features better voltage regulation and a ripple frequency double that of ac supply; thus it is easier to filter.

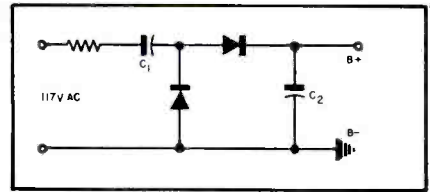

Fig. 4. Circuit of basic half-wave voltage doubler, in which ac supply is common with negative dc output and thus hum problems are minimized.

single cell or plate. Each cell is capable of withstanding only a given amount of voltage before molecular stress becomes too great and the dielectric punctures; therefore, it becomes necessary to place the cells in series to withstand the operating voltage. The individual cells are separated from each other by conducting washers to allow maximum dissipation of heat.

Voltage Doubler Circuits

The voltage doubler is the most frequently used transformerless voltage-multiplier circuit. Under no dc load, the output voltage of a voltage doubler circuit has been found to be 2.82 times the rms value of the input voltage.

In a half-wave-doubling circuit, the ac supply is common with the negative dc output hence minimizing hum difficulties; in addition it is not necessary to use identical capacitors for voltage doubling.

The advantages of the full wave or symmetrical voltage doubler are said to be lower ripple, better voltage regulation and ripple frequency double that of the ac supply making it easier to filter.

Low-Voltage Power Supply

In Fig. 1 appears the circuit of a low-voltage B+ power supply, a full-wave voltage doubler, used in Philco chassis.

In this circuit, the line voltage is impressed across the filament transformer and two selenium rectifiers. One side of each rectifier is tied together on the line voltage side. When the positive cycle of the line voltage is impressed at the line side of rectifiers A and B, rectifier A, permits electrons to pass in the direction indicated by the solid arrows.

Capacitor C₁₀₁ will charge almost to the full input voltage, the top side charging positive and the bottom negative. When the negative cycle of the line voltage appears at the juncture of rectifiers A and B, rectifier B will pass current and allow electrons to flow in the direction indicated by the dotted arrows.

Capacitor C₁₀₂ now charges up to almost the full line voltage, the bottom

side charging negative in relation to the top side.

Since the output is connected across the two capacitors in series, the output voltage is the addition of the charge on each capacitor.

Resistor R₁₀₂ protects the rectifiers by limiting the initial current surge. The choke L₁₀₀ and capacitors C₁₀₃ are part of the filter network. The filament supply section utilizes a transformer with three secondary windings. One of the windings supplies filament voltage for all the sweep circuits, and the second supplies the filament voltage to the rest of the stages; a third winding supplies voltage to a half-wave rectifier to provide a negative dc bias to the first video, second video, vertical output and horizontal output stages.

Servicing Selenium-Rectifiers¹

A damaged selenium rectifier may result from failure of the rectifier or faulty operation of the component of the set. When a selenium rectifier must be replaced, the current draw of the B+ circuit should be checked to be sure it is within the rating of the rectifier. The cabinet and chassis should be

checked to be sure that ventilating openings have not been blocked off, or restricted, preventing proper cooling.

Visual Inspection

Trouble may be indicated by melting of the alloy which covers most of one side of each plate and which forms the cathodes of the rectifier. Such melting may be due to excessive temperature of the rectifier caused by current overload, or by restricted ventilation causing the temperature of the rectifier to rise above the melting point of the alloy. The melting may be indicated by a thickening of the alloy at the bottom edge of the plates or by the presence of drops of solderlike metal below the rectifier.

Inspection of the alloy area at the center of the plates around the contact washer may show burning or discoloration. A burning, all around the contact washer, may result in an open circuit and the rectifier should be replaced. Discolored or burned spots may be observed on the alloy away from the contact washer. Such spots have been caused by sparking on the plates, resulting from application of higher than rated voltage to the rectifier. They may also occur when voltage is first applied after a long period of idleness. These spots are self-healing and will not affect the operation of the rectifier unless an area equal to about 20 per cent of a plate has been burned, or unless sparking is persistent. In either case, the rectifier should be replaced.

Troubles

The troubles found in selenium rectifiers will generally appear under one of the following classifications: Open-circuited rectifier resulting in no B+ voltage; high-forward resistance rectifier resulting in low B+ voltage; short-circuited rectifier resulting in burned-out line resistor or opening of circuit protecting device; low reverse

(Continued on page 78)

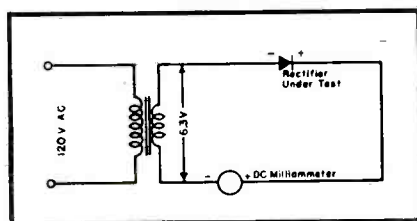
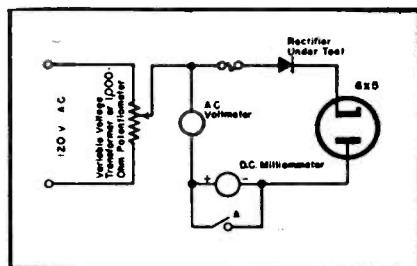

Fig. 5. Forward current test for selenium cells. (Courtesy FTR)

Fig. 6. Reverse-current test circuit; A represents a short-circuiting switch. (Courtesy FTR)



¹From an article by Walter F. Bonner appearing in *Replacement Guide*, published by Federal Telephone and Radio Corp., 100 Kingsland Rd., Clifton, N. J.; priced at \$.50.



GENERAL ELECTRIC SPEAKERS FOR EVERY APPLICATION!

G-E SPEAKERS

CATALOG NUMBER	SIZE (INCHES)	MAGNET WEIGHT (OZS.)	RATING POWER (WATTS)	V. C. IMP. (OHMS)	V. C. DIAMETER (INCHES)	RESONANCE (CYCLES)	RESPONSE (CYCLES)	BAFFLE OPENING (INCHES)	SHIPPING WEIGHT LBS. OZS.
400D	4	1.3	4	3.2	3/4	185	140 to 7,000	3 1/2	10
402D	4	1.0	4	3.2	3/4	185	140 to 7,000	3 1/2	10
403D	4	.68	4	3.2	3/4	185	140 to 7,000	3 1/2	8
500D	5	1.3	4	3.2	3/4	160	125 to 8,000	4 3/4	12
503D	5	.68	4	3.2	3/4	160	125 to 8,000	4 3/4	10
525D	5 1/4	1.3	4	3.2	3/4	160	120 to 7,000	4 3/4	12
526D	5 1/4	1.0	4	3.2	3/4	160	120 to 7,000	4 3/4	12
527D	5 1/4	.68	4	3.2	3/4	160	120 to 7,000	4 3/4	12
625D	6 1/2	1.3	4	3.2	3/4	140	110 to 9,000	5 3/4	14
626D	6 1/2	1.0	4	3.2	3/4	140	110 to 9,000	5 3/4	14
650D	6 1/2	2.98	8	3.2	3/4	150	100 to 10,000	5 3/4	1 6
703D	6x9	1.47	8	3.2	3/4	100	70 to 13,000	8 3/4 x 5 1/2	1 12
800D	8	2.98	8	3.2	3/4	100	80 to 11,000	6 3/4	1 12
810D	8	6.8	12	3.2	1	100	80 to 10,000	6 3/4	2 8

CATALOG NUMBER	SIZE (INCHES)	MAGNET WEIGHT (OZS.)	RATING POWER (WATTS)	V. C. IMP. (OHMS)	V. C. DIAMETER (INCHES)	RESONANCE (CYCLES)	RESPONSE (CYCLES)	BAFFLE OPENING (INCHES)	SHIPPING WEIGHT LBS. OZS.
818D	8	6.8	12	8.0	1	100	80 to 10,000	6 3/4	2 10
1000D	10	6.8	12	3.2	1	75	60 to 7,000	8 3/4	3 12
1001D	10	14.5	25	8.0	1 1/4	70	60 to 8,000	8 3/4	5 2
1003D	10	9.0	25	8.0	1 1/4	70	60 to 8,000	8 3/4	3 14
1012D	10	3.16	12	3.2	1	75	60 to 7,000	8 3/4	3 6
1018D	10	6.8	12	8.0	1	75	60 to 7,000	8 3/4	3 12
1200D	12	6.8	12	3.2	1	75	60 to 8,000	10 3/4	4 12
1201D	12	14.5	25	8.0	1 1/4	70	50 to 13,000	10 3/4	6 8
1203D	12	9.0	25	8.0	1 1/4	70	50 to 13,000	10 3/4	5 2
1212D	12	3.16	12	3.2	1	70	60 to 8,000	10 3/4	4 4
1218D	12	6.8	12	8.0	1	70	60 to 8,000	10 3/4	4 8
400C22	4	1.3	4	3.2	3/4	200	160 to 7,000	3 1/2	10
525C18	5 1/4	1.3	4	3.2	3/4	160	120 to 7,000	4 3/4	12

... AND ALL OF THEM HAVE THESE FEATURES!

- ★ **Aluminum Voice Coil**—your speaker's best insurance against *moisture* or extremes of temperature.
- ★ **Alnico 5 Permanent Magnets** help deliver maximum sensitivity.
- ★ **Plated Finish.** Special chemical treatment protects the luster and effectiveness of metal parts.
- ★ **All-weld construction**—for rigidity of frame and controlled flux density.
- ★ **100% inspection of each speaker** (not spot checking!) for electrical and mechanical operation.



GET THIS
CHART IN
FILE CARD
SIZE—
FREE!

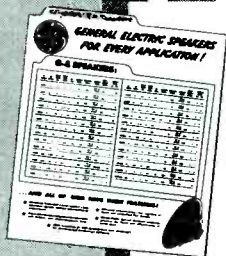

General Electric Company, Section 342
Electronics Park, Syracuse, New York
Please send me your ready reference speaker chart.

NAME.....
ADDRESS.....
CITY..... STATE.....

GENERAL ELECTRIC



Reducing Picture Smear . . . Germanium Crystal Replacement Hints . . . Providing Correct Oscillator Injection Voltage . . . Peaking Changes . . . Improving Interlace . . . Removing Small Horizontal Size . . . Increasing Anode Lead Protection . . . Improving Vertical Hold in Fringe Areas . . . Increasing Fringe Area Sync Stability . . . First Aid for Pliers

Servicing Helps

by M. A. MARWELL

FIELD REPORTS have disclosed that on some Admiral chassis (21B1 series) picture smear or poor picture definition has appeared. The cause of the trouble has been traced to incorrect tuning. Receivers were being tuned incorrectly due to 4.5-mc beat interference being present in the picture when the tuning control was tuned to best picture position. When tuning to eliminate the interference in the picture, incorrect setting of the fine tuning control for best picture resulted.

To reduce or eliminate 4.5-mc interference in the picture the following

steps have been recommended: Peaking coil, L_{304} , should be removed and replaced with a peaking coil which has a three-pi winding; coil 73A11-1. (If this coil is not available, two 73A5-9 peaking coils connected in series, with short leads, should be used; coils should not be more than $\frac{3}{4}$ " apart. A 22,000-ohm $\frac{1}{2}$ -watt resistor should be connected across this two coil-assembly.) Then peaking coil L_{303} should

be removed and replaced with a 73A5-14 peaking coil (blue dot). (If this part is not available, the old coil can be left in the receiver and a 33,000-ohm, $\frac{1}{2}$ -watt resistor wired across it). A series resonant trap, L_{305} , should now be connected between pin 4 of the 6AC7, V_{305} , and chassis ground. The trap should be mounted in the chassis hole located between the 6AC7 and 12AU7, V_{305} and V_{303} respectively, with the 6.8-mmfid capacitor, C_{322} , connected to pin 4 of the 6AC7. The trap should be tuned by watching the picture and adjusting the slug for minimum 4.5-mc interference. If greater accuracy is required, the trap should be adjusted in the following manner: Using clip leads, short circuit pin 1 of the 6AU6, V_{201} , to chassis ground and connect a 50-mmfid capacitor between pin 8 of V_{305} and pin 7 of V_{201} . Set the channel selector to a TV station having the strongest signal. Tune the fine tuning control for loudest sound. Using a non-metallic alignment screwdriver, carefully adjust the trap slug for minimum sound.

No attempt should be made to adjust the 4.5-mc trap with a grid dip meter since the reading will not be correct.

RCA TV Service Notes†

Several different types and makes of crystals are used in the current line of RCA chassis; 1N60, 1N64 and CK706. These crystals have slightly different characteristics and may not be directly interchangeable. In production, these differences are taken

†RCA 17T151-3-4-5, 17T160-2-3, 17T172-K-3-K-4-K, 21T159, 21T165, 21T176-7-8-9 TV receivers.

Fig. 1. Modifications required in Admiral chassis video amplifier circuit to reduce picture smear. The components included in dotted areas are to be used only if specified substitute parts are not available. Changes include addition of trap (a); replacement of L_{303} with part 73A5-14 or shunting with 33,000-ohm resistor (b); replacement of L_{304} with part 73A11-1 or connecting part 73A5-9 in series, shunting both coils with a 22,000-ohm resistor, as shown in (c).

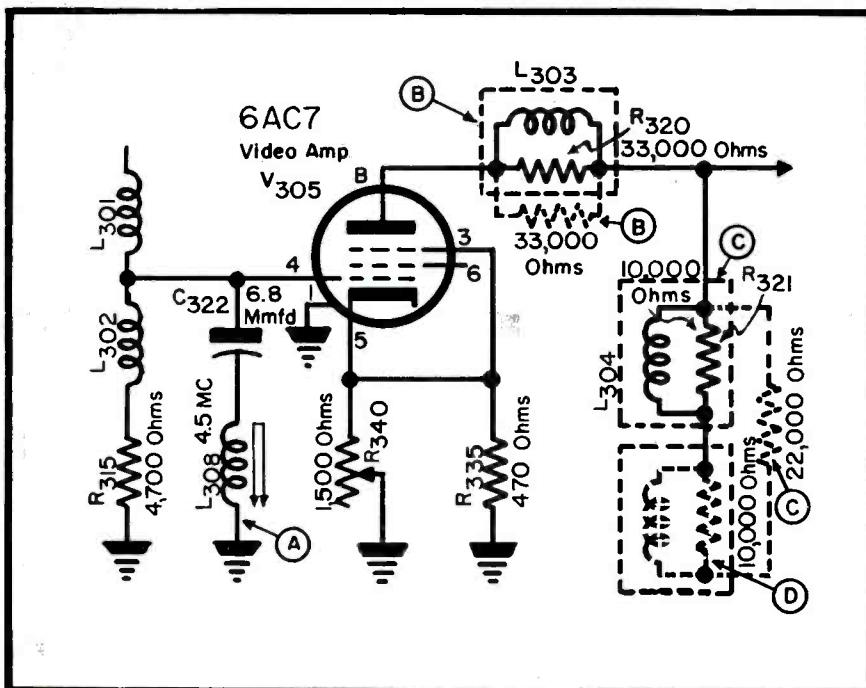

Industrials



Communications

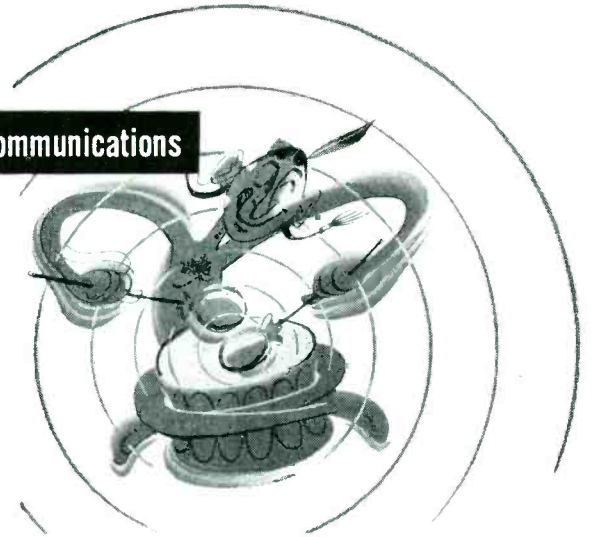

SANGAMO
Capacitors



papers



micas



buttons



electrolytics

Those who know...choose Sangamo
**for every radio and
electronic application**

SANGAMO Capacitors have been the choice of discriminating users for a quarter of a century. Radio servicemen, amateurs, electronic engineers, the Armed Services—all testify to the design, construction, honesty of characteristics, and conservativeness of ratings of Sangamo capacitors.

Television

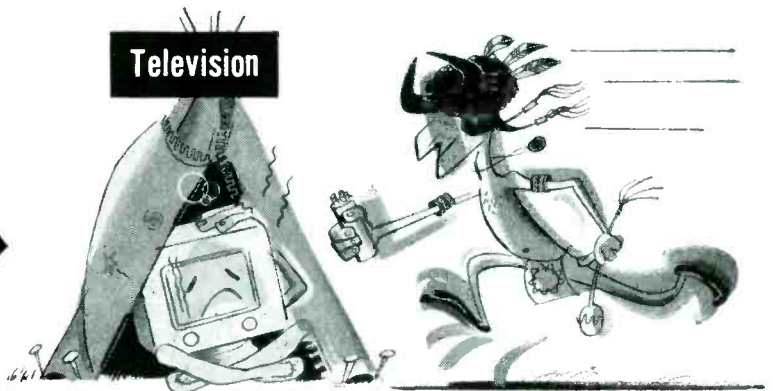

Armed Services



**SANGAMO
ELECTRIC COMPANY**

MARION, ILLINOIS

IN CANADA

SANGAMO COMPANY LIMITED, LEASIDE, ONTARIO

SERVICE, APRIL, 1952 • 45

care of by varying the value of a 10,000-ohm resistor, R_{151} , which is located in T_{100} . However, to take care of different crystals, this resistor may vary from 5,600 ohms to 10,000 ohms.

Replacement Precautions

If the crystal is to be replaced, one of the same make and type should be used. However, if desired, the entire transformer and matching resistor may be installed. In any event, the overall response should be checked.

If a crystal is replaced, care should be taken to see that it is connected in the proper polarity. Since germanium crystals are marked differently than selenium rectifiers, confusion may result. Selenium rectifiers are marked + and - to show the polarity of the dc output voltage. Germanium crystals are marked to show the polarity of voltage that must be applied to obtain maximum current flow. The cathode end of a germanium crystal may be coded with green paint or marked -. The anode end may not be coded or may be coded +. In schematic symbols, the anode is shown as an arrow and the cathode as a flat bar. In T_{100} , the anode (+) end is connected to terminal A and the cathode (-) end to terminal D. Care should also be taken not to overheat the crystal with the soldering iron as damage to the crystal may result.

Crystal Detector Protection

As a protection against damage to the crystal detector, a 220-ohm $\frac{1}{2}$ -watt resistor has been added in series with the screen of the 6AG7 video amplifier, V_{110} .

Adjacent-Channel Picture-Trap Frequency Change†

The adjacent-channel picture trap in T_{104} has been tuned to 39.25 mc rather than 39.75 mc. This has been found to result in slightly more sound sensitivity when operating the receiver in fringe areas. The change has also been found to provide slightly higher adjacent channel-picture rejection when the fine tuning is adjusted so as to roll the picture carrier up on the slope of the ij response, as is done in receiving weak signals.

Oscillator Injection Voltage†

If low oscillator injection voltage is encountered in the rf unit, KRK11, it may be necessary to select a 6X8 tube which will give proper injection when the rf unit is properly aligned. RF

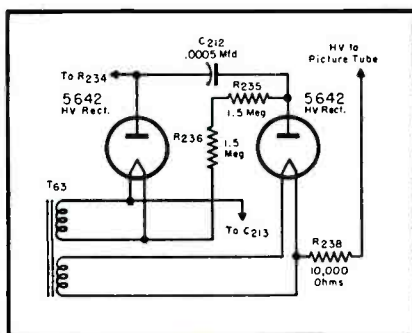

Fig. 2. Circuit of hv part of Sylvania chassis showing how Sparkhausen interference can be eliminated. This type of tunable interference, which consists of one or more vertical lines of black and white dots (salt and pepper) on the left side of the screen, may be introduced, increased or decreased by changing the setting of the brightness control. To correct, a 10,000-ohm 12-watt resistor should be added in series with the high-voltage anode lead of the picture tube, as shown above. This resistor is located in the high-voltage scan box inside the hole through which the hv anode lead passes. Stubborn cases of this interference may require the use of a shielded 300-ohm lead from the antenna terminal board to the tuner.

units in which these changes have been made are marked M1.

Peaking Changes in RCA 21-Inch Receivers

The following changes have been made in late production 21-inch receivers to increase the frequency response of the video amplifier. The peaking coil, L_{115} - R_{174} , has been replaced by a 500-microhenry coil, L_{113} ; L_{106} has been changed from 250 to 500 microhenries. A 1,000-ohm $\frac{1}{2}$ -watt resistor has been added in series with the picture-tube cathode.

Deflection Trouble Symptoms in RCA 21-Inch Models

If there is observed foldover or a white bar in center of raster on the 21-inch chassis, the trouble may be caused by a low-screen voltage on the 6CD6 due to R_{233} or R_{235} being open. A defective L_{106} may cause low brilliance, change in picture size and linearity.

Poor interlace may also occur in these models. To prevent coupling between the vertical and horizontal sweep circuits, thus causing poor interlace, the red lead from the yoke socket to the hv transformer should be dressed under the lance on the side of the hv cage. To prevent parasitic oscillations in the horizontal sweep circuit, C_{185} should be connected from pin 2 of V_{110} to ground, instead of from the nearby terminal board to ground.

Magnetized Electron Gun Trouble

In certain picture tubes such as the 17CP4, 21AP4 and 17QP4, electron-gun parts may become magnetized, resulting in poor focus. To demag-

netize these tubes, a 630TS receiver em focus coil should be connected to 110 volts ac and the coil passed slowly over the picture tube neck, past the gun, and slowly withdrawn.

Stromberg-Carlson Service Aids

Small Horizontal Size . . . Model 321 and 324 Series: In this series of Stromberg-Carlson receivers reports of small horizontal size have been traced to loss in capacity of the 5-mfd capacitor, C_{204} , bypassing the cathode of the 6AV5 horizontal amplifier tube. Capacitor should be replaced by a 5-mfd 50-volt capacitor that is capable of withstanding the current and heat in this position.

Picture Bending at Top . . . Model 321-324 Series: The tendency for the picture to bend horizontally at the top has been reduced by increasing the value of R_{104} in the cathode of the 6SN7 horizontal oscillator from 1,500 ohms to an 1,800-ohm $\frac{1}{2}$ -watt resistor.

Increased Anode Lead Protection . . . Model 317: To increase the insulation of the picture-tube anode lead on the receiver, a 17 $\frac{1}{2}$ -inch length of No. 4 vinylite tubing (.208 id) should be used to encase the anode lead wire.

Improving Vertical Hold in Fringe Areas . . . Model 421 Receiver: Vertical holding action in fringe areas has been improved by inserting a 150,000-ohm $\frac{1}{2}$ -watt resistor between the plate of the 6SN7 second sync clipper, V_{17} , and the input to the vertical integrating network. The vertical-holding action in fringe areas can be improved by the addition of this resistor in early-model receivers.

Stewart-Warner Service Helps

On all 19-tube Stewart-Warner chassis, circuit changes can be incorporated to increase fringe-area sync stability. A 10-megohm $\frac{1}{2}$ -watt resistor should be added from pin 4 of the 6SN7GT sync amplifier tube to 140 v B+. Pin 6 of the 6AC7 video amplifier should be disconnected from 140 v B+ and an 8,200-ohm 1-watt resistor should be inserted. Then a 12,000-ohm 1-watt resistor should be added from pin 6 of the 6AC7 to chassis ground. Finally, a .25-mfd 200-volt capacitor should be added from pin 6 of the 6AC7 to ground.

These modifications should not be included on chassis located in strong or moderate signal areas.

Eliminating Power Line Hum

In all types of ac-dc receivers, a small amount of 60-cycle hum can be

the tower servicemen dreamed up!

the TEL-A-RAY

SWING-OVER * TOWER

A serviceman's dream — an antenna tower that swings over to the ground for servicing — now being produced by Tel-a-Ray! The Swing-Over Tower makes all other types obsolete because it is the easiest tower for servicing ever made. Built from steel angles with welded construction, the Swing-Over Tower is guaranteed to withstand wind and weather. Yet one man can lower the tower top to the ground, or raise it, in just three minutes. Competitively priced and guaranteed, the Swing-Over Tower will be your biggest item in 1952.

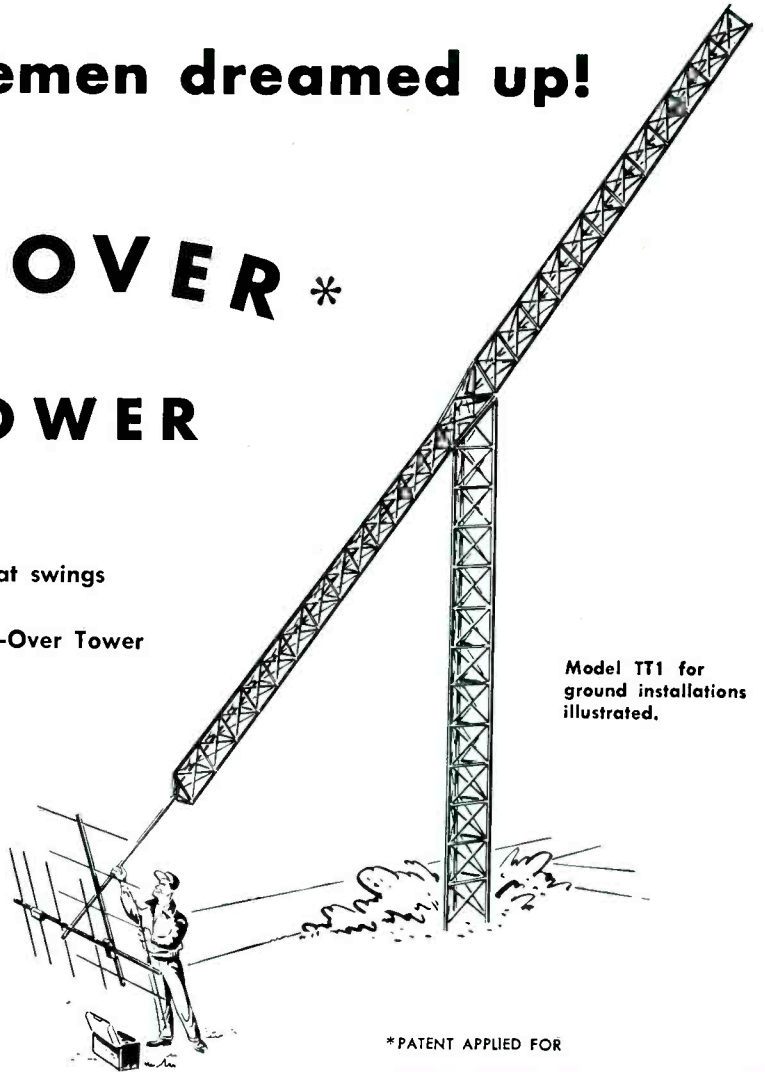

Model TT1 for ground installations illustrated.

*PATENT APPLIED FOR

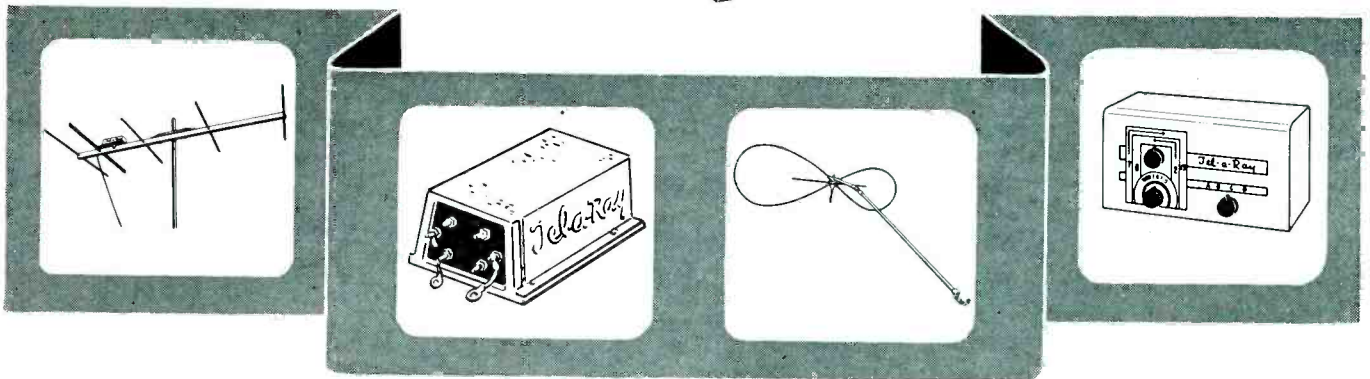

These Tel-a-Ray products are bringing more and better reception to television viewers every day . . . and bigger profits to their dealers: Left: The Model T antenna pulls in good reception up to 200 miles away! Cannot rust or corrode. Perfect for all fringe area reception. Left center: To complement the Model T antenna, the only antenna-mounted, low-cost preamplifier on the market, the model TB. High signal gain, low noise ratio make it outstanding.

Right center: The low-priced Butterfly antenna . . . receives 13 channels and FM radio in primary areas . . . completely guaranteed . . . swivel-mount permits erection anywhere! Right: The new Switching Booster (Model PTB1) — for areas where more than one channel can be received with separate antennas. Switches channels and antennas with one knob. Four antenna inputs. Furnishes high gain from antenna and voltage for four preamplifiers. A necessity in the fringes.

WRITE TODAY FOR COMPLETE INFORMATION

Tel-a-Ray

ENTERPRISES, INCORPORATED
BOX 3325
HENDERSON, KENTUCKY



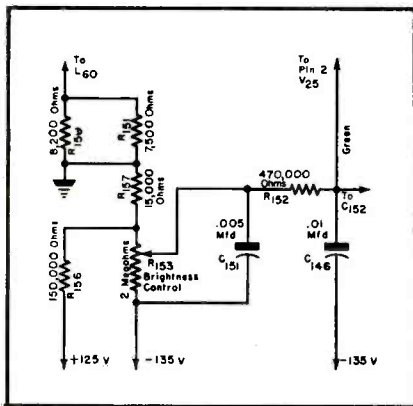

Fig. 3. To improve operation of the brightness control in Sylvania 1-437-3 TV chassis CO2, two resistors, 150,000 and 15,000 ohms, respectively (R150 and R151), have been added, as illustrated above.

heard if the power cord is improperly connected to the power outlet. Such hum can usually be eliminated by reversing the power plug in the outlet. If hum modulation is still present, causing audio distortion in Stewart-Warner 9162-9164 clock models, it is suggested that the .05-mfd *avc* capacitor (J8) be disconnected from chassis ground and reconnected to B-. Receivers which include the letter B in the *series* code stamped on the cabinet back incorporate this change.

First Aid for Pliers**

Pliers, more than any other tools, are mechanical extensions of your fingers. They add power to your hands. They can bend, hold, push, pull, twist, straighten, tighten, loosen, join or cut almost anything. Their very toughness, versatility and ability to take punishment often leads to their misuse or neglect. Thus, like fingers themselves, they occasionally suffer injuries which can be simply treated with first aid at the scene.

Pliers require very little care. Rust is their greatest enemy. Even the moisture from sweaty hands can start pliers rusting like any other steel tools.

Oil is the effective defense. An occasional drop of oil in the joint will keep pliers working freely. A rub-down with an oily rag will form a rust-preventive film.

Reasonable caution when storing pliers will preserve their life indefinitely. If they must be stored in a damp place, they should be rolled in an oily rag and kept in a metal box or can. Better still, they should be given a light coat of wax.

Pliers often develop ills which reduce their efficiency, but which can usually be corrected. Some of these repairs are simple; some require mechanical ability. The prime requisites are care and patience. The common ailments are: heavy rust, rust

tightened joint; broken noses; loose, tight or jumpy rivets; dull cross-check; dull cutting edges.

Bad rusting or rust-tightened joints require soaking in kerosene for anywhere from a couple of hours to a couple of days. A putty knife and steel wool will take off the loosened rust. A few drops of penetrating oil will help to free the joint. Once freed, opening and closing the pliers will gradually work the rust loose from the concealed parts of the joint.

Broken noses or tips can generally be ground off even. A hand or electric bench grinder will do the job. The tool's temperature must be kept down by pressing lightly against the wheel and dipping in water frequently.

If the nose is open, that is, if the tips do not touch properly, a wedge or piece of steel about 1/16" thick should be placed midway of their length. Then holding securely on a firm base, it should be tapped gently with a hammer about 1/2" from the tip. This should be repeated on the other nose.

Loose, tight or jumpy rivets require the use of a ball peen machinist's hammer and a solid operating block. This block can be of steel, 2" x 4" about 6" long, a piece of railroad rail, an anvil or a heavy vise on a sturdy bench. For the first three it is necessary to have a hole at least 1/2" in diameter in the top. This hole need be only 1/4" deep. When using a vise, the jaws would be opened 1/2". Pliers should always be oiled before starting repairs on the rivet.

Loose rivets can be treated by placing the closed pliers flat on a flat section of the operating block, with the solid side down. The top half of the rivet should be hit with the flat head of the hammer.

Tight rivets can be cured in a similar manner. The pliers should be opened to the first tight spot with the solid side placed down over the hole of the operating block. The rivet should be hit with the flat head of the hammer.

Jumpy rivets are usually caused by a loose star point on the solid side of the rivet. The pliers should be opened to the jump, or catch, and jiggled slightly. Oil will ooze around the loose star or stars. Then the pliers should be placed on the block and the loose star point tapped lightly with the round head of the hammer. A good rivet is one that allows the joint to open smoothly and easily with one hand. It may be necessary to perform all of the foregoing operations before it works properly.

Dull cutting edges present the most

**Based on a report prepared by Utica Drop Forge and Tool Corp.

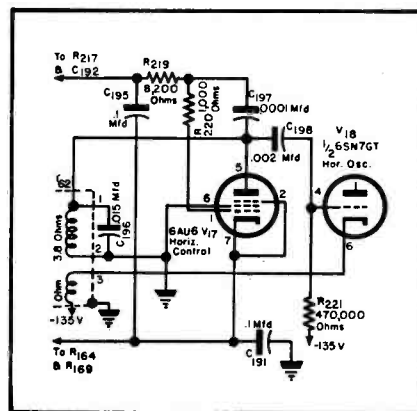

Fig. 4. To improve horizontal phasing in Sylvania 1-437-3 TV chassis code CO2, a 0.1-mfd 200-v capacitor has been added between the cathode of the 6AU6 horizontal control tube and ground.

difficult problem for first aid. Before doing any work on the edges, it is important to make sure that the joint is acting properly. Then the pliers should be held to the light with the cutting edge away from you. If irregular, open nicks can be seen through the edge, it is faulty. Good edges will be even and straight along their entire length, regardless of whether they can cut or not.

After this examination, the pliers should be opened and placed in a vise. A medium fine India stone should be run across the entire edge, keeping the stone horizontal. A triangular stone works most easily and it will not be necessary to remove the rivet to separate the halves of the pliers. The same should be done for the other edge. This will even them up and remove minor nicks and burrs. You can check against the light as before, and notice where the edges touch. If they meet along the entire edge, you are ready for sharpening. If they do not, you'll have to stone across the edges (both of them) where they meet. Stoning must be even on both sides.

Sharpening Pliers

To sharpen, and this requires the surgeon's touch, the pliers should be placed in a vise open with the head flat. A few strokes should be taken with the stone on the outside bevel of the edge. The established angle of the cutting edge is critical. It will be necessary to keep the angle while stoning. The stone, of course, should be kept oiled. The process should be repeated on the other cutting edge. You should then check against the light for evenness. Now you can try a test cut on a piece of bond paper. If the edges cut only part way or don't

(Continued on page 66)

TRIPLET
3435

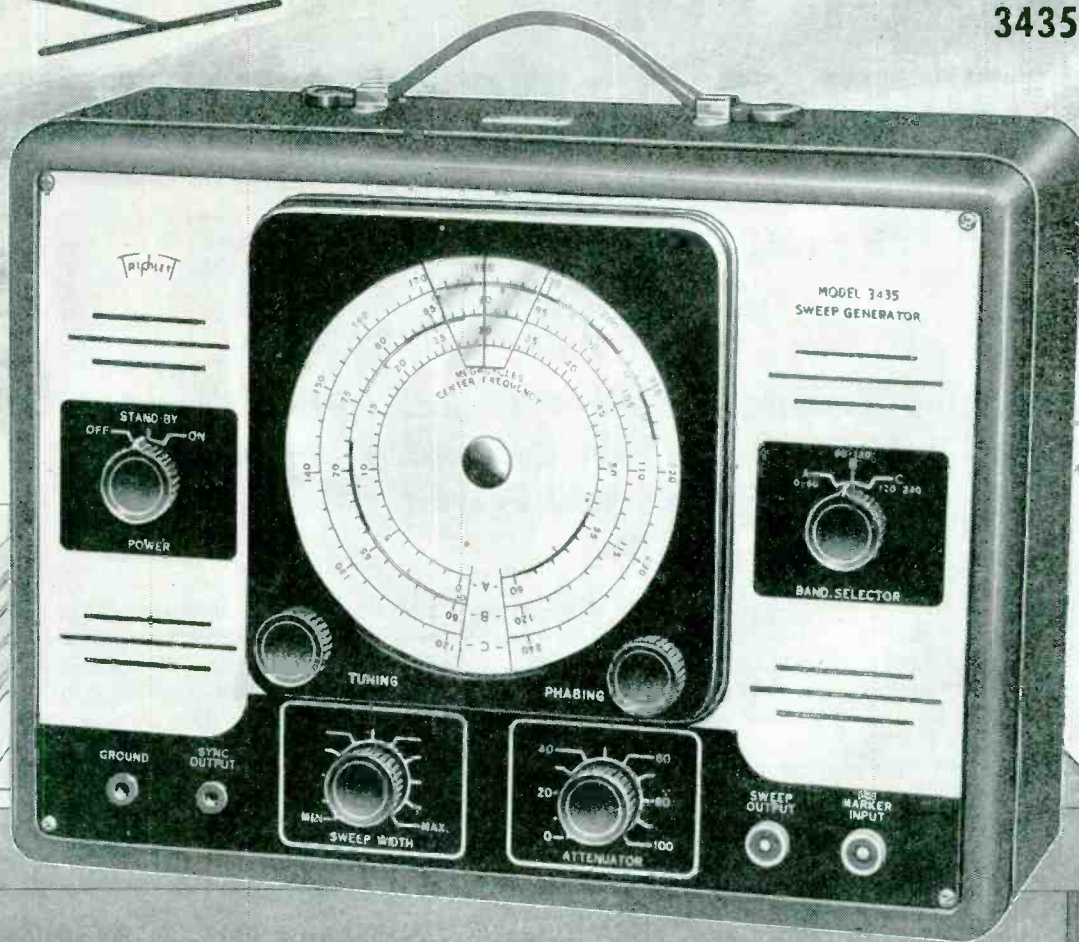

Only \$114.50 and you're in Profitable TV Testing

Value-wise you can't make a smarter buy. For if you have a good Signal Generator to use as a marker with 3435, this new Triplet Sweep saves you real money! Performance-wise it's Triplet Engineering at its best. There are no complications in use. Continuous range coverage to 240 MC for all TV carrier and IF frequencies. There are no gaps in frequency, and continuous tuning is provided over all TV and FM bands. Note MAIN frequency dial, marked with channels as well as frequencies; continuously variable sweep width, effective from 500 KC to 12 MC; the PHASE controlled sweep voltage for scope horizontal input; the STANDBY switch for temporary silencing of generator during other testing. These and many other features make Triplet 3435 an outstanding "buy." See it today at your distributor's.

TRIPLET ELECTRICAL INSTRUMENT COMPANY, BLUFFTON, OHIO

FOR THE MAN WHO TAKES PRIDE IN HIS WORK

YOU CAN USE ANY A.M. SIGNAL GENERATOR

... but if you are critical you'll appreciate this Wide Range Test Oscillator — Triplet 3432. Five fundamental ranges—165 KC to 40 MC. Two Harmonic ranges 36-120 MC, directly calibrated. Completely Shielded. Seven directly calibrated 330° scales. Illuminated Dial. Try it today.



TRIPLET

Triplet

Reforming of SELENIUM RECTIFIERS*

by J. T. CATALADO

Assistant General Manager
International Rectifier Corp.

Reforming Technique Evolved to Recondition Stored And Idle Stacks So That Continuing Maximum Efficiency Will Prevail

CONSIDERABLE CONCERN has frequently been expressed in the deformation of selenium rectifiers. Recent investigations have indicated that deforming of selenium rectifiers occurs during extended periods of storage. This deformation is comparable to the action occurring in electrolytic capacitors, and results in an abnormal behavior which may destroy the rectifier when use is attempted. It is possible, in most cases of such deformed rectifiers, to restore the unit to full normal operation by the application of a specified reforming procedure.

Deformation Action

The deformation of the rectifying elements is manifested by an increase in the forward and a decrease in the reverse resistance, resulting in a higher forward voltage drop and an increased reverse current, respectively. These changes in the rectifier characteristics are a result of chemical reactions between the various materials used in the construction of the component. Although the increase in forward resistance results in some permanent reduction of output voltage after reforming, it is not detrimental to the rectifier nor the operation of the

majority of the equipments in which used. However, the decreased reverse resistance before reforming, although a temporary effect, may cause permanent damage to the rectifier stack due to excessive initial reverse current flow upon application of the rated voltage. From tests of at least five years, it has been found that the reverse current may be reduced to normal or near normal by subjecting the units to a reforming procedure prior to their use.

Reforming Procedure

The reforming procedure on one plate or one half-wave stack consists of the application of a reduced *dc* voltage in the reverse direction of normal current flow, i.e. from the counter-electrode to the base plate. The voltage applied is gradually increased until a value of 120% of the rated voltage of the rectifier stack is reached. With more than one plate or half-wave stack, it is possible to arrange these plates so that *ac* or *dc* potential may be used for reforming with a preference for *ac*

since it is more readily obtainable, and more convenient to use. The magnitude of voltage to apply and the duration of this application are indicated in Fig. 1. Typical reforming circuits are shown in Fig. 2. It should be noted that two half-wave stacks are required for connection into the circuit using *ac*. They are connected in such a manner that the forward currents are bucking; therefore, the only current flowing will be the reverse current. To accomplish the same purpose, only one center-tap or one bridge stack is required.

During the application of the voltage, if the stack begins to sputter or spark, the voltage should be decreased to a lower value at which sputtering or sparking does not occur. This voltage should be maintained for a few minutes before it is increased to the next step. Usually, damaged and badly deformed rectifiers will exhibit this sparking and sputtering effect. Badly

(Continued on page 79)

Fig. 1. Curve of applied inverse voltage versus time for reforming of selenium rectifiers.

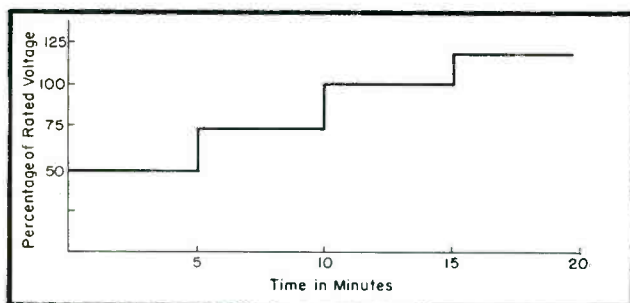

*Prepared while metallic-rectifier project advisor in the Components and Materials Branch of the Signal Corps Engineering Labs.

Fig. 2. Typical circuits for reforming selenium rectifiers. In (a) are half-wave rectifiers; in (b) center-tap rectifiers; and in (c) a single-phase bridge.

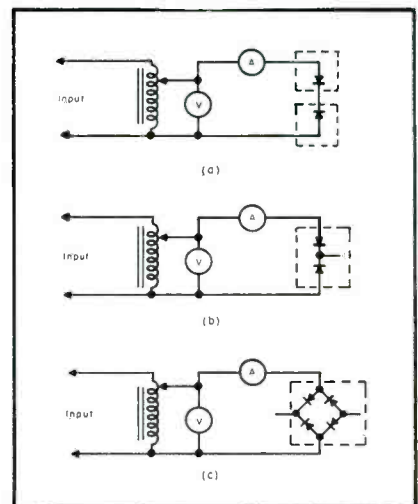

This Amazing MAGNA-TIP SCREW DRIVER!

4 Screw Drivers in 1



...with every 100 Sylvania

Receiving Tubes or 4 Picture Tubes
purchased between April 1st and May 15th

"SAVES HOURS
IN RADIO
AND TV WORK!"

It's the greatest time-saving tool you ever saw! Just slip the right-sized bit in place and a permanent Alnico magnet charges the bit...holds both your bit and screw in place for fast, easy, one-hand operation.

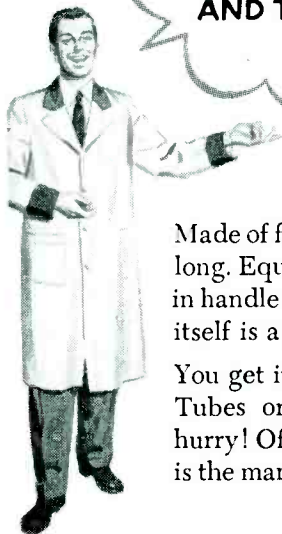

Lifetime quality

Made of fine tool steel, this slim-shaft driver is 8½ inches long. Equipped with 2 Phillips and 2 slotted bits, (3 bits in handle compartment and one in shank). And the shank itself is a power driver for ¼-inch hex-head screws.

You get it FREE when you buy 4 Sylvania TV Picture Tubes or 100 Sylvania receiving tubes. But, better hurry! Offer closes May 15th. Your Sylvania Distributor is the man to see . . . TODAY!

"NEVER LOSES
ITS MAGNETIC
GRIP!"



SYLVANIA



RADIO TUBES; TELEVISION PICTURE TUBES; ELECTRONIC PRODUCTS; ELECTRONIC TEST EQUIPMENT; FLUORESCENT TUBES, FIXTURES, SIGN TUBING, WIRING DEVICES; LIGHT BULBS; PHOTOLAMPS; TELEVISION SETS

SERVICE, APRIL, 1952 • 51



TUBE

News

by L. M. ALLEN

Twin Triodes for Vertical-Deflection Circuits . . . Low-Voltage Rectangular Glass and Metal-Envelope Picture Tubes

A VARIETY OF NEW TUBE types for TV with unique operational features have appeared recently.

For the vertical deflection circuit, for instance, there has been developed a medium- μ twin triode of the 9-pin miniature type; 12BH7.* It is also useful in phase-inverter or amplifier circuits in *ac/dc* equipment as well as in many diversified applications including multivibrators and oscillators in industrial control devices.

In vertical deflection circuits, one unit of the 12BH7 may be used as the vertical deflection amplifier, and

the other unit can serve as a vertical oscillator.

Each triode unit is independent of the other except for the common heater which is center-tapped to permit either 12.6 or 6.3-volt operation.

Another twin triode, 6BX7GT**, has been designed for the vertical output stage as a combined vertical deflection amplifier and vertical oscillator. According to the manufacturer the tube will reduce vertical distortion on receivers which are operated from a low B+ supply voltage, and provide

*RCA.

**G.E.

better linearity and more sweep at a low driving voltage.

Among typical operating characteristics for each section are a cutoff voltage of 40 with 250 volts on the plate and 80 milliamperes plate current at zero bias with 100 volts on the plate.

The tube has a maximum plate supply voltage rating of 500 as a vertical deflection amplifier.

Picture Tubes

The electrostatic focus picture-tube family has also had several new additions. (Continued on page 69)

Revolving exhibit of American Structural Products glass products used in radio and TV, including 21-inch all-glass rectangular picture tube, on view at recent IRE national convention in N. Y. City. Looking on left to right: W. E. McWhorter, G. Proyor Molloy and John P. Gleason, ad manager, field engineer and eastern regional sales manager of company.

Tiny subminiature tubes produced by Raytheon used in lightweight receiver-transmitter developed for the Signal Corps. Tiny set, weighing 6½ pounds, is an FM model which can operate on 44 frequencies.

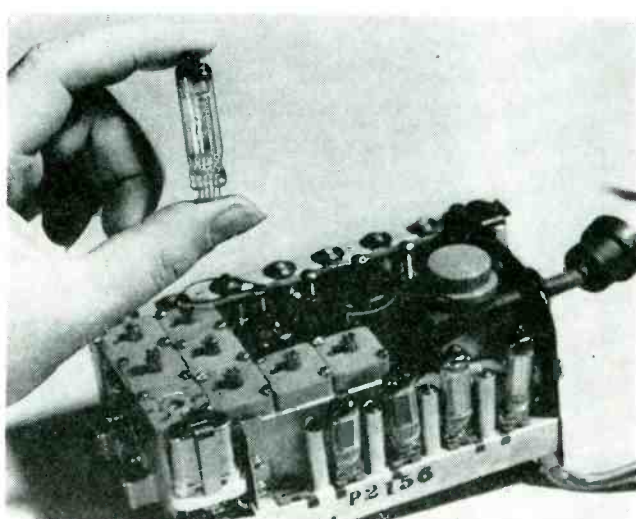

New 1952 HEATHKITS

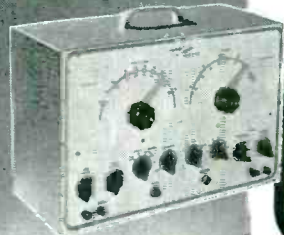

Heathkit
TELEVISION
GEN. KIT \$39.50



Heathkit
ELECTRONIC
SWITCH KIT \$19.50



Heathkit
AUDIO GEN.
KIT \$34.50



Heathkit
CONDENSER
CHECKER KIT \$19.50

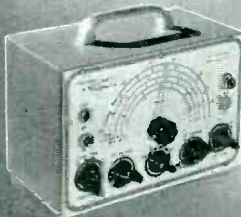

Heathkit
R. F. SIGNAL
GEN. KIT \$19.50



Heathkit
A.C. VOLTMETER
KIT \$29.50



Heathkit
SQUARE WAVE
GEN. KIT \$29.50



Heathkit
INTERMODULATION
ANALYZER KIT \$39.50



Heathkit
AUDIO FREQ.
METER KIT \$34.50

Heathkit 5" OSCILLOSCOPE KIT

- New "spot shape" control for spot adjustment — to give really sharp focusing.
- A total of ten tubes including CR tube and five miniatures.
- Cascaded vertical amplifiers followed by phase splitter and balanced push-pull deflection amplifiers.
- Greatly reduced retrace time.
- Step attenuated — frequency compensated — cathode follower vertical input.
- Low impedance vertical gain control for minimum distortion.
- New mounting of phase splitter and deflection amplifier tubes near CR tube base.
- Greatly simplified wiring layout.
- Increased frequency response — useful to 5 MC.
- Tremendous sensitivity .03 RMS per inch Vertical .6V RMS per inch Hor.
- Dual control in vernier sweep frequency circuit — smoother acting.
- Positive or negative peak internal synchronization.
- Multivibrator type Wide Range Sweep Generator.

A brand new 1952 Heathkit Oscilloscope Kit with a multitude of outstanding features and really excellent performance. A scope you'll truly like and certainly want to own.

The kit is complete with all parts including all tubes, power transformer, punched and formed chassis, etc. Detailed instruction manual makes assembly simple and clear — contains step-by-step instructions, pictorials, diagrams, schematic, circuit description and uses of scope. A truly outstanding value.

MODEL 0-7
SHIPPING WT. 24 LBS.

\$43.50



Heathkit VACUUM TUBE VOLTMETER KIT

- New styling — formed case for beauty.
- New truly compact size — Cabinet 4 1/8" deep x 4-1/16" wide x 7 3/8" high.
- Quality Simpson 200 microamp meter.
- New ohms battery holding clamp and spring clip — assurance of good electrical contact.
- Highest quality precision resistors in multiplier circuit.
- Calibrates on both AC and DC for maximum accuracy.
- Terrific coverage — Reads from 1/2V to 1000V AC, 1/2V to 1000V DC, and .1 to over 1 billion ohms resistance.
- Large, clearly marked meter scales indicate ohms, AC Volts, DC Volts, and DB — has zero set mark for FM alignment.
- New styling presents attractive and professional appearance.

The 1952 Model Heathkit Vacuum Tube Voltmeter! Newly designed cabinet combines style and beauty with compactness. Greatly reduced size to occupy a minimum of space on your work-bench. Covers a tremendous range of measurements and is easy to use. Uses only quality components including 1% precision resistors in multiplier circuit for greatest accuracy, Simpson 200 microamp meter with easy to read scales for fast and sure readings.

All parts come right with kit, and complete instruction manual makes assembly a cinch.

MODEL V-5
SHIPPING WT. 5 LBS.



\$24.50

YOU SAVE BY ORDERING DIRECT FROM MANUFACTURER

SOLE AGENTS
RADIO INTERNATIONAL CORP.
133 E. 43rd ST.
NEW YORK CITY (15)
Cable: AR144-N.Y.

The **HEATH COMPANY**

... BENTON HARBOR 11, MICHIGAN

TV Dynamic Demonstrator

by WYN MARTIN

[See Front Cover]

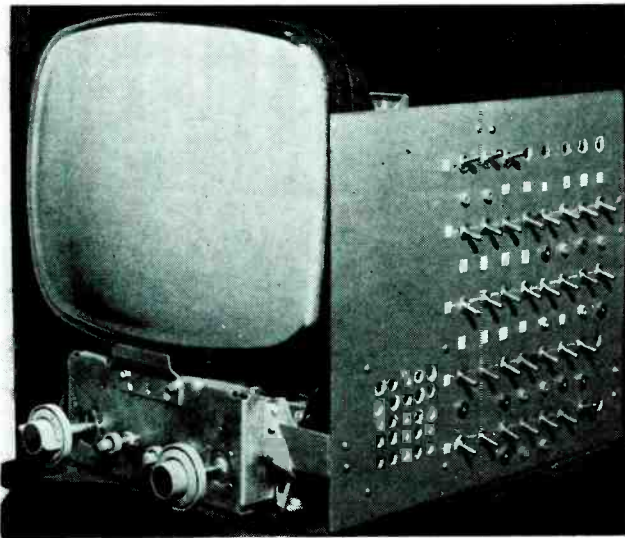

Fig. 1 (right). Complete circuit of G.E. TV dynamic demonstrator, which can be used to duplicate many of the more common troubles and faults which appear quite often in the general run of servicing.

Fig. 2 (left). View of demonstrator chassis and switching panel.

Switch No.	Trouble	Effect
A1	Open 125-mfd B+ filter.	Dim picture; size shrunk; ripple.
A2	Open 80-mfd B+ filter.	Hum; weave in picture.
A3	Shorted .2 mfd bypass; brightness circuit.	Bloom.

Table I. Power supply and miscellaneous trouble checks.

Switch No.	Trouble	Effect
B1	One section of vertical yoke shorted.	Vertical keystone.
B2	One lead to vertical yoke open.	No vertical deflection.
B3	3.6-megohm leakage of .01-mfd coupling.	Top of picture blanked.
B4	Open .01-mfd coupling capacitor, vertical blanking.	Retrace lines in picture.
B5	Open .1-mfd capacitor.	Vertical hold has no effect; picture folded.
B6	6.8-megohm leakage of .1 mfd coupling to 12AU7.	Poor vertical linearity; foldover.
B7	Filament-cathode leakage in 12SN7 vertical multivibrator.	Vertical hold has no effect.
B8	Open cathode bypass in 12AU7 vertical amplifier.	Low vertical size; poor vertical linearity.

Table II. Vertical deflection circuit problems.

Switch No.	Trouble	Effect
C1	One section of horizontal yoke shorted.	Horizontal keystone.
C2	47-mmfd across horizontal yoke increased to 510 mmfd.	Striations on raster.
C3	Open width coil.	Excessive width.
C4	4000-ohm screen resistor of 25BQ6 increased to 12,000 ohms.	Inadequate width.
C5	.5-mfd capacitor coupling horizontal yoke open.	Dim raster; poor horizontal linearity.
C6	Low side of yoke open.	Single white vertical line on tube.
C7	.1-mfd horizontal linearity open.	Poor horizontal linearity; bright vertical bars; inadequate width.
C8	1-megohm grid resistor of 25BQ6 decreased to 170,000 ohms.	Compression right side of picture.

Table III. Horizontal deflection circuit problems.

IN THE STUDY OF TV CIRCUITRY and troubleshooting, the dynamic demonstrator is a particularly handy instrument, serving to duplicate actually many of the more common troubles and faults which appear quite often in the general run of servicing. By means of a group of toggle switches mounted on a textolite or masonite panel, it is possible to introduce a faulty condition or component into a TV chassis and display on the picture-tube screen the exact effect. On the cover, this month, and in Fig. 1, appear the circuits used in such a demonstrator, designed by G.E.

A 14" by 17½" panel, mounted on the side of a 16T3 or equivalent chassis features space for more than 40 switches, arranged in groups of eight, to cover base circuits. For instance, row *A* is miscellaneous; row *B* is for vertical circuits; row *C* for horizontal circuits; row *D* for sync circuits, and row *E* for video *if* and video amplifier circuits.

Test Jacks

Another feature of the demonstrator is the inclusion of 18 test jacks adjacent to the various switches which will materially change the waveforms or otherwise effect voltage readings. Thus, provision is made for connecting a meter or scope in order to duplicate troubleshooting procedure. Two *B* jacks are included in a central location.

Typical Problems

In tables I, II and III appear characteristic problems which can be created by throwing the various switches.

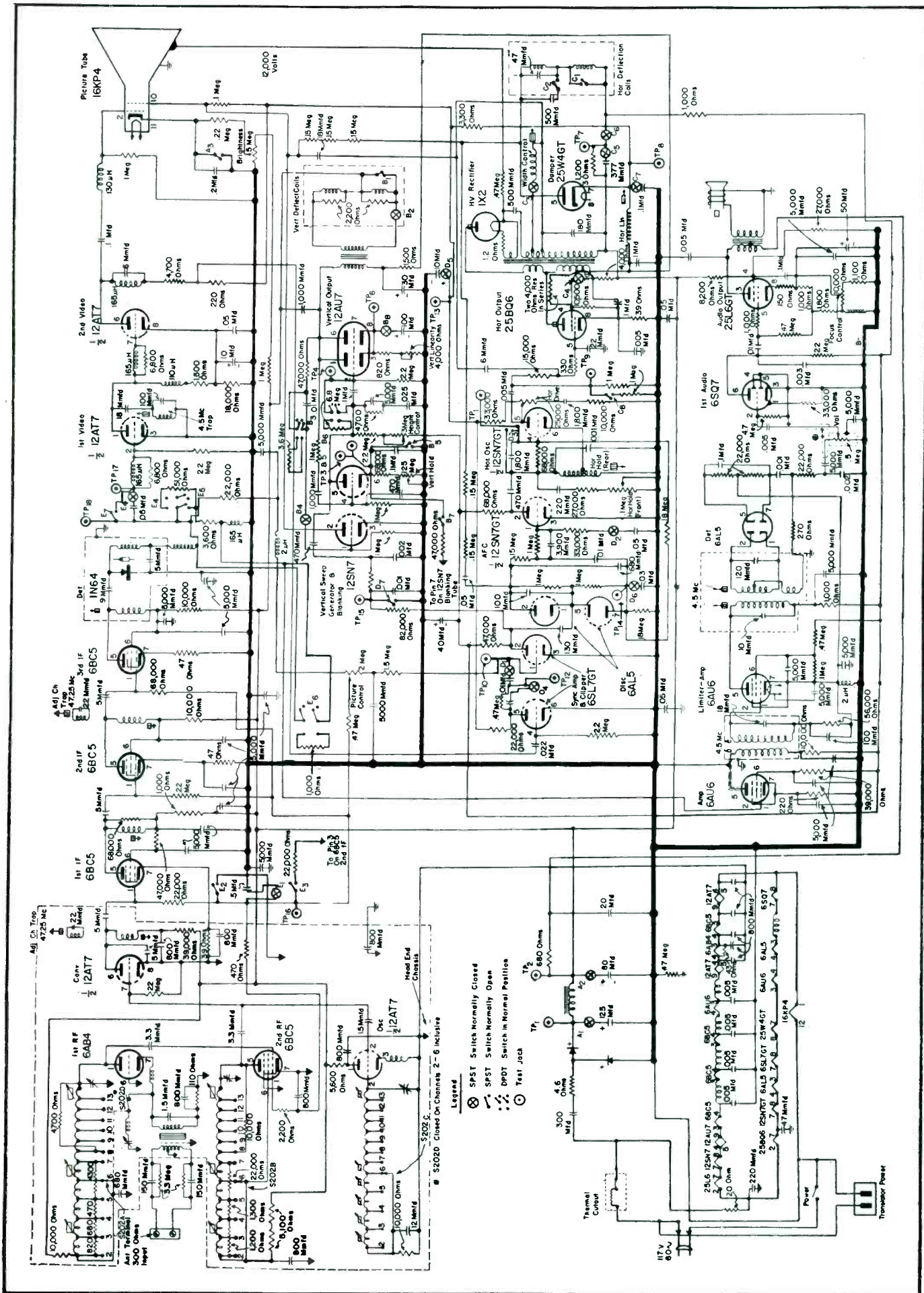

New TV Parts...Accessories

CHANNEL MASTER TV ANTENNA MOUNT

An antenna mounting structure that is said to permit side-by-side stacking of 4-yagi antennas, has been introduced by the Channel Master Corp., Napanoch Rd., Ellenville, N. Y.

Mount provides for the installation of 4 low-band yagis for a single channel, 2 pair of yagis for 2 different channels, and any combination of broad-band and yagi antennas on one mount.

Structure is made of heavy-gauge seamless-steel tubing, zinc plated. Full-wave spacing for each specific channel is marked. Featuring a sliding arrangement which is claimed to simplify installation, mount may either be assembled at the top of the tower or assembled on the ground and swung up into position.

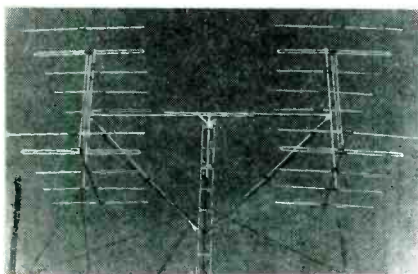

* * *

PERMA-POWER TV TUBE BRIGHTENER

A TV picture-tube brightener, that is said to restore normal screen appearance by increasing electron emission, has been introduced by Perma-Power Co., 4721 N. Damen Ave., Chicago 25, Ill.

Unit provides three boost positions on selector for correct degree of brilliance. Can be installed in either 5 or 6-pin base. Isolates filament and is claimed to relieve cathode-filament shorts.



* * *

PLASTOID HEAVY TWIN LEAD

A heavy 300-ohm twin lead for TV antennas, made of polyethylene or alathon, has been developed by Plastoid Corp., New York, N. Y.

Lead-in has a thickness of .100", with a maximum variance of .005". Both leads are imbedded in the plastic, and are said to withstand friction, bending and weathering to a greater degree than thinner constructions.

FRETCO FRINGE-AREA ARRAY

A broadband colinear array, *Fretaray*, that is said to retain high gain on all channels, has been developed by Fretco, Inc., 1041 Forbes St., Pittsburgh 19, Pa. Only one transmission line is required.

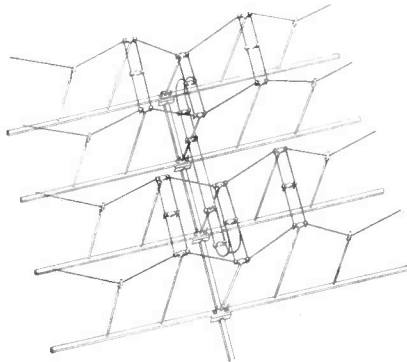

* * *

JAVEX DUAL-FEED WALL PLATE

A wall plate, *TV-2*, that feeds two TV receivers from a single-antenna has been produced by Javex, Garland, Texas.

Units are designed for a maximum service distance of 50 to 65 miles, and are said to require no wall box or wall opening. Plates can also be connected in series and used where small amounts of attenuation are necessary to obtain optimum performance.

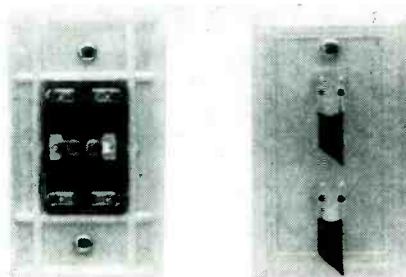

* * *

JFD 10-ELEMENT YAGI

A 10-element yagi, *Baline*, with a matching transformer system, has been announced by the JFD Manufacturing Co., Inc., 6101 Sixteenth Ave., Brooklyn 4, N. Y.

Antenna is claimed to produce 52 per cent more gain than 5-element types. Antenna is cut to exact channel wavelengths. Available in both single and stacked models.

* * *

INDUSTRIAL TV HIGH-VOLTAGE SUPPLY

A high-voltage regulated *dc* supply, *IT-99T*, has been introduced by Industrial Television, Inc., 359 Lexington Ave., Clifton, N. J.

Unit provides 5, 10, and 15-*kv* voltages for the operation of special oscillograph and other picture tubes. Primary power requirements are 300 *v* at 45 ma *dc* and 6.3 *v* at 1.4 amperes.

•

[See page 77 for additional new-products news.]

REGENCY BOOSTER WITH CIRCUIT STABILIZER

A circuit stabilizer* has been included in a booster model, *DB-520*, produced by I.D.E.A., Inc., Regency Division, 7900 Pendleton Pike, Indianapolis 26, Indiana. Stabilizer is said to provide both inductive and capacitive neutralization to assure maximum stability on all 12 *chf* channels.

Other features of the new booster are said to be *off-on* switch of three ampere capacity, 120 volt *ac*; single tuning knob; push-pull triode in balanced circuit; link coupling; improved circuit control for greater tracking accuracy; and broad-band response.

Patent Applied For.

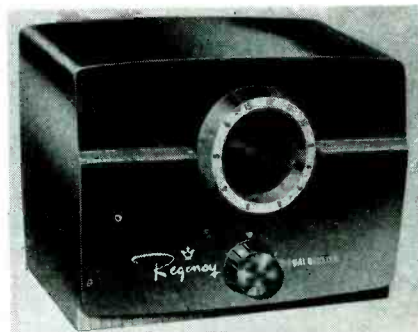

* * *

SNYDER INDOOR TV ANTENNA

An all-channel indoor TV antenna, *P-TZ*, has been introduced by Snyder Manufacturing Co., Philadelphia, Pa.

Antenna, featuring all-way orientation, is supplied with a 42" twin-x cable, and features four telescopic dipoles, mirror finish and a heavy cast base of modern design.

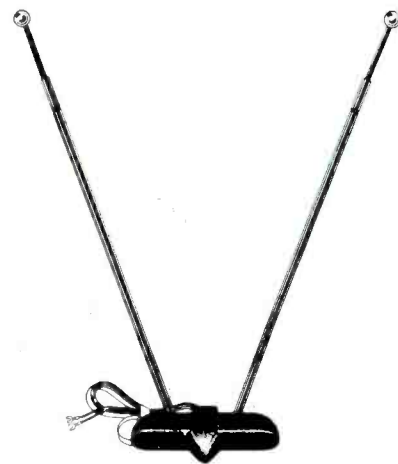

* * *

SOUTH RIVER CHIMNEY STRAPPING

A replacement kit of strapping for chimney mounts, models *A*, *B* and *C* have been announced by South River Metal Products Co., Inc., 377-379 Turnpike, South River, N. J.

Kit *A* is composed of galvanized strapping and hardware. Kits *B* and *C* contain stainless steel strapping and specially-plated hardware.

**TRADE ASSOCIATES PICTURE-TUBE
TESTER**

A portable picture-tube tester, 4" x 5" x 6", permitting checking with the same voltages as occur in actual operation (with the exception of the anode check) and checking for shorts, has been developed by Trade Associates, Inc., 128 S. 1st St., Brooklyn, N. Y. Fuses for protecting the meter and the unit with line and socket plug-in cords are provided.

Instrument provides checks on emission, gas, brightness control and beam current to the anode. Also tests all magnetically deflected picture tubes.



* * *

RMS TV BOOSTERS

Pentode, SP-6, and a triode-tube, SP-6J, TV boosters have been announced by Radio Merchandise Sales, Inc., 1165 Southern Blvd., New York 59, N. Y.

Pentode-tube booster, features external gain control which is said to permit the attainment of high gain before overloading.

Triode booster features low noise level with high gain.

Both boosters are approved by Underwriters Laboratories.

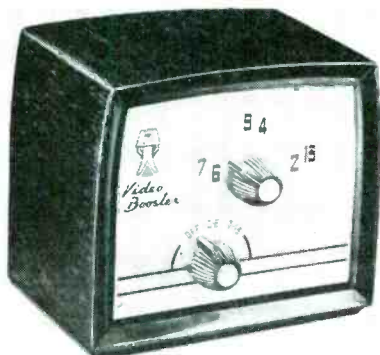

RMS triode booster.

* * *

**EBCO TV PICTURE-TUBE CHECKER-
REACTIVATOR**

A portable TV picture-tube checker-reactivator, model 10, has been developed by Electronic Beam Corp., 923 Old Nepperhan Ave., Yonkers 3, N. Y.

Picture tube can be checked and reactivated without removing it from the set or carton. Reactivation is claimed to be completed within 15 minutes. Tubes may be checked for shorts, cathode emission and leakage. Unit is self-powered and measures 9" x 6" x 5".

* * *

BAKER MASTS

A fitted-end mast, 10 AM, has been introduced by The Baker Manufacturing Corp., Evansville, Wisconsin.

Unit, a 10' mast, has a tapered joint for stacking 10' sections together to make higher masts. Constructed of 1 1/4" od Perma-Tube steel, masts are packaged 15 pieces per bundle.

for **Radio and
Television**

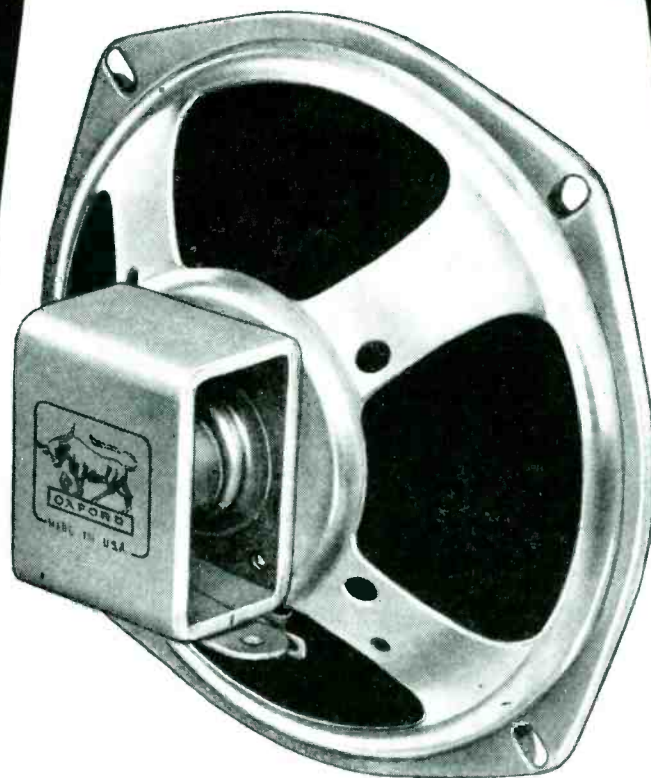
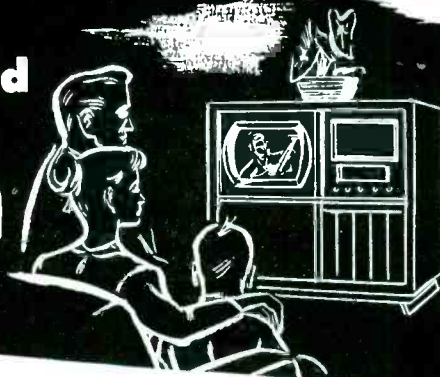

it's
**OXFORD
Speakers**

A copy of our latest catalog will be sent upon request.

Available at leading jobbers!

**Preferred for original equipment
... Proven for replacement!**

Other Oxford Speakers for:
Portable Sets • Auto Radios • P.A. Systems • Outdoor and Weatherproof Applications • High Fidelity • Intercom

**OXFORD
ELECTRIC CORPORATION**

3911 S. Michigan Ave. • Chicago 15, Ill.
EXPORT: ROBURN AGENCIES, NEW YORK CITY



STANDARD TRANSFORMER TV CATALOG/REPLACEMENT GUIDE

A TV transformer catalog and replacement guide has been published by the Standard Transformer Corp., 3581 Elston Ave., Chicago, Ill.

Edition lists 2416 TV models and chassis made by 82 manufacturers, and 107 transformers in the catalog section. Guide also lists manufacturers alphabetically. All models and chassis are arranged in numerical order and each replacement transformer is listed with the original manufacturer's part number.

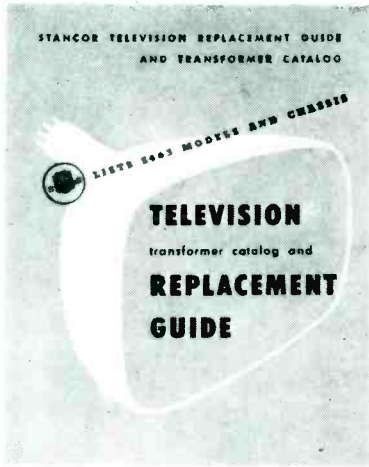

TANNER NOW NEW AEROVOX AD DEPARTMENT HEAD

William B. Tanner has been appointed director of advertising for a recently formed advertising department for Aerovox Corp., including the Hi-Q division and the Wilkor Products, Inc., a subsidiary.

He was formerly advertising and personnel manager of the Hi-Q division, formerly known as the Electrical Reactance Corp.

Fred P. Donati, advertising manager of Aerovox, will continue in that position and act as assistant to Tanner in handling advertising of all divisions and subsidiaries.

G.E. SELENIUM RECTIFIER BOOKLET

A 28-page booklet, GET-2350 describing basic characteristics and the applications of selenium rectifier stacks, has been announced by the lighting and rectifier department of the General Electric Company, Schenectady 5, N. Y.

Booklet features charts, graphs, and tables illustrating the principles of rectification, and the characteristics, manufacture, circuit design, and application of selenium rectifiers.

RMS ADDS PERSONNEL

Edward Cappucci has been named plant superintendent for Radio Merchandise Sales, Inc., New York, N. Y. He was formerly with the George S. May Company.

Gene Reich has been named to head the quality control section. He was formerly with Magnavox. Rubin Agdern continues as production manager.

Now on the sales engineering staff is Mal Greenberg, formerly branch manager for Conlan Electric.

Harold Merson is now chief electronic engineer.



NIEMANN APPOINTED HYTRON EASTERN S-M

Louis H. Niemann has been named eastern sales manager of Hytron Radio and Electronics Co., Salem, Mass. Niemann replaces Fred Garcelon who has been promoted to assistant to John Q. Adams, vice president in charge of sales.



Louis H. Niemann

WILLIAM B. KESSLER REJOINS DALIS

William B. Kessler has been appointed sales manager of the Industrial Division of H. L. Dalis, Inc.

Kessler has rejoined the company after a short leave. He was formerly field sales manager.



William B. Kessler

CHANNEL MASTER APPOINTS DISTRICT SALES MANAGERS

Three district sales managers have been named by the Channel Master Corp., Ellenville, N. Y.

Edward S. Hill will call on distributors in the southeast, Sam R. Alexander, the southwest, and Oscar K. Leisher, the central Pennsylvania and Maryland territory.



Above, left: S. R. Alexander

Above: E. S. Hill



Left: O. K. Leisher

ALPRODCO CATALOG

A 4-page catalog, listing all components that are used in erecting TV antenna towers, including an economy *Tower-Pac* and commercial accessories, has been released by Alprodco, Inc., Kempton, Indiana, Mineral Wells, Texas or Dublin, Georgia.

RADION OPENS SECOND PLANT

A second manufacturing plant at 1130 W. Wisconsin Ave., Chicago, has been completed for the Radion Corp. Plant will house both raw material fabrication facilities and assembly lines for civilian items. Radion now has available 40,000 square feet of space.



G.E. HI-FI BOOKLET

A 31-page booklet on high fidelity reproduction, *Why Variable Reluctance*, is now available from G. E. dealers. Booklet, written by Mark Woodworth, Norm Cromwell and Roy Dally, contains nineteen illustrations and 18 charts or diagrams.

Featured are five sections containing information on the theory of operation of the variable reluctance cartridge; preamps and equalization circuits; comparison of diamond and sapphire styli; converting to high fidelity; and a final section devoted to data sheets, styli and cartridge replacement charts for phono combinations and record changers, tone arm, speaker and triple-play cartridge features and specifications, cartridge output curves. Also offered are tables describing electrical characteristics of various G. E. cartridges.

Booklet includes information on low and high-frequency compensation, comparison of abrasive action of records, explanation of stylus pressure, when to replace the stylus, the basic requirements for high fidelity, record changer modernization and proper wiring connections to convert to variable reluctance. Priced at 25 cents a copy.

CEADER AND SUNDBERG REELECTED OXFORD PREXY AND V-P

At the annual stockholders and directors' meeting of the Oxford Electric Corp., directors were all reelected and the following officers were also reelected; J. D. Ceader, president; Hugo Sundberg, vice president and general manager; David E. Davis, secretary-treasurer.

RADIO AMATEUR'S HANDBOOK

The 29th edition of *The Radio Amateur's Handbook*, featuring a radio construction section, reference work and training text for class or home study, has been published by The American Radio Relay League, West Hartford 7, Conn.

Book contains 784 pages, including catalog section and 13-page topical index, plus 459 tube base diagrams and 85 basic formulas.

Discussed are high-frequency receivers, power supplies, *vhf* and *uhf* apparatus and techniques, fundamental electrical laws and circuits, and TV-interference reduction and elimination.

Priced at \$3.00.

JERROLD APPOINTMENTS

Caywood C. Cooley, formerly chief field engineer, has been appointed sales manager of Jerrold Electronics Corp., N.E. corner 26th and Dickinson Sts., Philadelphia 46, Pa.

Carl W. Schmelzle, formerly a technical rep for Philco, has been named assistant sales manager.

Robert J. Tarlton, formerly general manager of the Panther Valley Television Co., Inc., has been named to succeed Cooley as chief field engineer.



Caywood C. Cooley

Robert J. Tarlton

* * *

WARD AUTO ANTENNA CATALOGS

Catalogs on auto antennas have been released by Ward Products Corp., Division of The Gabriel Co., 1523 East 45th St., Cleveland 3, Ohio. One catalog offers data on the Ward line including the 8-Ball Phantom and Air-King antennas. It also describes available counter displays and other merchandising material.

Also available is a 4-page brochure, 54-153, covering a line of mobile antenna rods, bases and springs. Folder describes 20 separate standard rods, special designs for rooftop and motorcycle models, as well as bases and springs to handle standard rods.

A catalog-sales promotion piece has also been announced. Copy describes auto antennas, and recently introduced Elektran lead cable.

* * *

KENNETH E. JONES BECOMES MOTOROLA-N. Y. SERVICE DIRECTOR

Kenneth E. Jones, formerly a field service engineer in the Chicago area, has been named director of service of Motorola-New York, Inc.

* * *

EANNARINO WINS REP PLAQUE

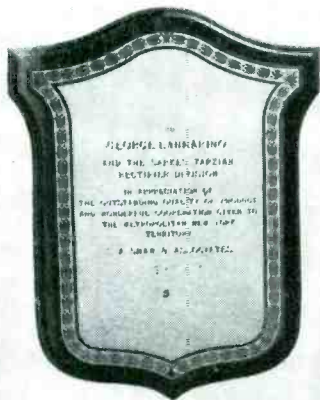

Plaque presented to George Eannarino and the Sarkes Tarzian Company, selenium rectifier division, in appreciation of quality of product and efforts put forth by the organization, by Sam Shaw, New York rep of Tarzian, during a recent dinner in N. Y. C. Among those attending the presentation were Sarkes Tarzian, Eannarino, Emmet Cameron, Stan Niciejewski, Walter Petrosky and representatives of the company.

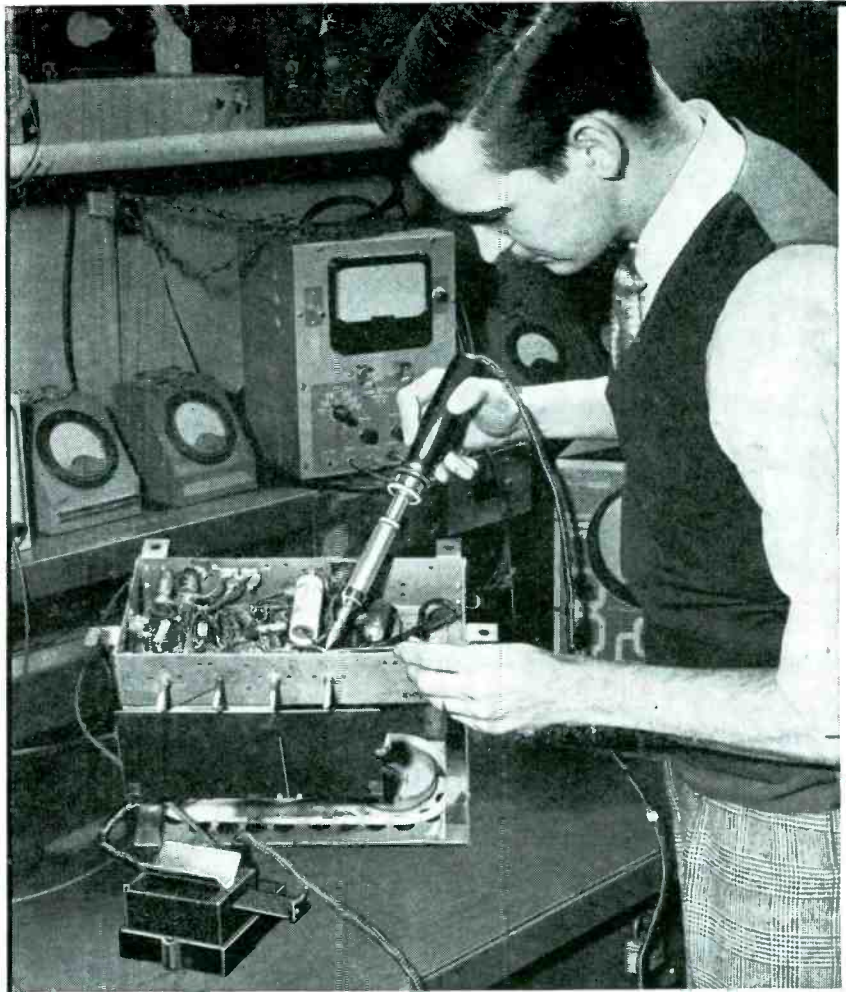

... **SERVICEMEN, AMATEURS, TECHNICIANS SELECT-**

**American Beauty
SOLDERING IRONS**

for
**TOP SOLDERING
PERFORMANCE!**

Outstanding performance coupled with durability of construction make American Beauty electric soldering irons the choice of discriminating users in all fields

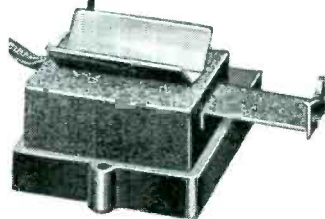

122

TEMPERATURE REGULATING STAND

Providing heat-regulation for all sizes of electric soldering irons, this stand is adjustable for all heats up to full working-temperature. Assures longer life of iron and tip.

For descriptive catalog pages write Dept. 5-23

**AMERICAN ELECTRICAL HEATER CO.
DETROIT 2, MICH.**

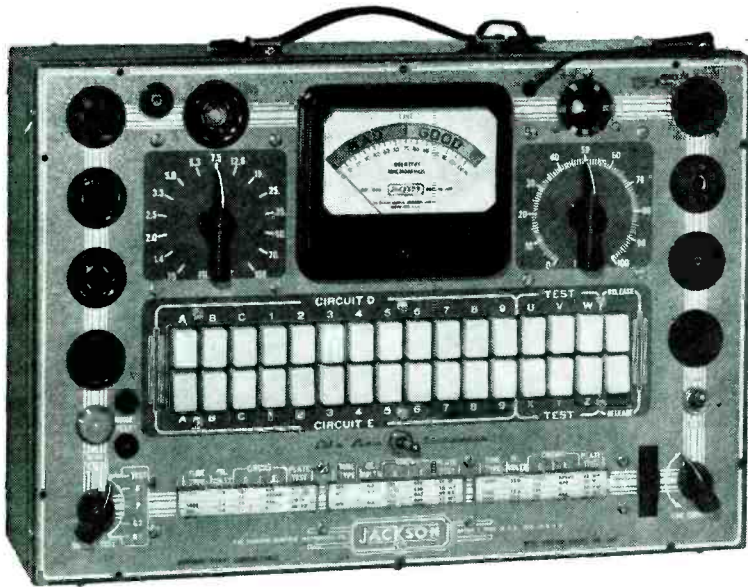

Dependable—Simple—and, "Service-Engineered"

JACKSON "Dynamic" * Tube Tester

Here is the tube tester used and recommended by manufacturers, laboratories and smart service organizations. Uses the "Dynamic" principle, pioneered by Jackson. Here are just a few of its major features.



Sequence Switching—no obsolescence with this amazing switch. Simple to use. Tube elements not connected together. Each element gets the right load or the right voltage.



Complete Shorts and Noise Tests

You test every element for shorts. Because tube elements are tested separately, you get a true picture of tube operation. Switch position shows which element is shorted—helps you locate source of circuit trouble.



Life-Line Indicator

Reduces normal heater or filament voltage. Tells you if tube is approaching the end of its life. Helps avoid troublesome call-backs. Insures more satisfied customers.

There are many more advantages to this fine Jackson tube tester—big, 4" meter—sockets for every type of tube, including sub-miniatures, blanks for future types—built-in roll chart. For the complete story, fill in and mail coupon today.

Available in bench, counter, or portable styles. Prices as low as

\$94⁵⁰

Jackson Electrical Instrument Company
Department 48
16-18 S. Patterson Blvd.
Dayton 1, Ohio

Gentlemen:
Please send information on:

- Model 648 Tube Tester Complete Jackson Line
 Low Cost Challenger Line TV Instruments

NAME _____

ADDRESS _____

CITY _____ ZONE _____ STATE _____

MY DISTRIBUTOR IS _____

JACKSON

"Service-Engineered"
Test Equipment
Dayton 1, Ohio

Tube Testers—Television Generators—
Oscilloscopes—AM-FM Generators—
Audio Oscillators—Condenser Checkers—
Vacuum Tube Voltmeters.

*TM REGISTERED U. S. PATENT OFFICE

VACO SOLDERLESS TERMINAL CATALOG AND SALES DISPLAY

A catalog and kit-counter display, describing the Lynn lightning-solderless terminal, has been announced by Vaco Products Co., 317 E. Ontario St., Chicago, Ill.

Catalog describes the complete line of 35 different types of solderless terminals and connectors, crimping tools and a terminal cross-reference chart.

Counter display holds a complete service kit in a plastic box, and pictorially describes the products' uses. Measures 7" x 14".

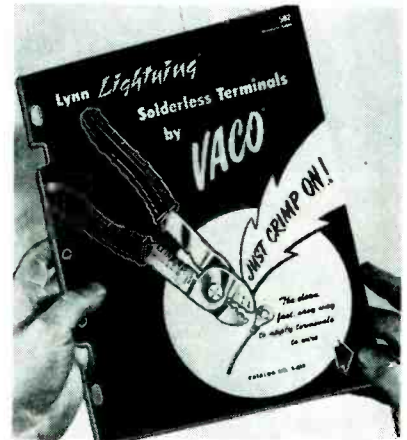

* * *

WILLIAM L. PARKINSON NOW G.E. PRODUCT SERVICE-MGR

William L. Parkinson has been named manager of product service of the G. E. receiver department.

He had been in charge of receiver department product service since 1950 and until his appointment was manager of that service.



W. L. Parkinson

* * *

RCA PARTS CATALOG

A parts catalog listing more than 16,000 parts contained in RCA Victor TV receivers, radios, and phonographs, as well as a cross reference of replacement cabinets, is now available through RCA parts distributors.

Parts are listed in numerical order by stock numbers, and each listing includes description, package quantity, and suggested list price, enabling the Service Man to furnish his customers with price information. Catalog will be revised and reissued periodically to keep it up-to-date with new parts and price changes.

* * *

JFD CONICAL ANTENNA CAMPAIGN

A conical antenna, *Jet-Tenna*, model Q660, that features an umbrella-action assembly principle developed by the JFD Manufacturing Co., Inc., 6101 16th Ave., Brooklyn 4, N. Y., will be featured in an ad-sales campaign.

Assembly of the antenna is similar to snapping an umbrella into place. Has a fan front and a single reflector, a 35°-tilt dipole, and elements made of 3/8"-od seamless aluminum. Dipole head is molded of *tenite* plastic.

**BRUCE E. VINKEMULDER NAMED
SANGAMO DISTRIBUTOR S-M**

Bruce E. Vinkemulder has been named distributor sales manager of the Sangamo Electric capacitor division, Marion, Ill. Ill.

Vinkemulder joined Sangamo in '46 and has been in charge of engineering publications for electronic equipment.



B. E. Vinkemulder

* * *

SIMPSON CATALOG

A 4-page catalog and price list, form 2052, which contains illustrations of test instruments and panel meters, including scope calibrator, model 276, has been released by the Simpson Electric Co. (Mel Buehring), 5200 W. Kinzie, Chicago, Ill.

Detailed are specifications, ranges, weights and dealer's net prices.

* * *

DUMONT DECAL

A weatherproof decal is now available from the picture tube division of the Allen B. Du Mont Laboratories, Inc., 750 Bloomfield Ave., Clifton, N. J.

Decal, designed in three colors, featuring an illustration of a TV picture tube with copy reading *Du Mont Teletron Sales Service*, is available to Service Men. May be used on store windows, truck panels and store doors.



* * *

BATTERY SALES CITATION



W. L. Rothenberger (left), manager of RCA Victor's eastern region, presenting special citation, honoring Bruno-New York for record-breaking sales of RCA radio batteries during '51, to David Wagman (right), Bruno sales manager, and Sidney Pressler (second from left), manager of Bruno's radio parts department. H. F. Bersche, manager of RCA Tube Department renewal sales, looks on.

LOOK CLOSELY...

*and you'll see why
They outperform all others!*

**OHMITE *Little Devil*
INSULATED COMPOSITION
RESISTORS**



COMPACT SIZE

Extremely small for their current capacity — ideal for the *smallest* equipment.

TEMPERED COPPER LEADS IMBEDDED DEEP IN THE BODY

Differential tempering of *locked-in* leads prevents sharp bends and resistor damage.

INDIVIDUALLY MARKED AND COLOR-CODED

Quick, positive identification is easy. No guesswork or mistaken identity!

RATED AT 70C (158F)

Withstand extremes of heat, pressure, and humidity without deterioration.

MOLDED PLASTIC COMPLETELY SEALS AND INSULATES

Have high mechanical and insulating strength. Meet JAN-R-11 requirements.

When you use OHMITE *Little Devils* on your repair jobs, you can be sure of dependable resistor performance. That's because these tiny, rugged units are designed and built to high standards unmatched by any other composition resistor. Little Devils come in 1/2-, 1-, and 2-watt sizes in $\pm 5\%$ or $\pm 10\%$ tolerances, in standard RTMA values from 10 ohms to 22 megohms. In the 1-watt size, $\pm 10\%$ tolerance, values as low as 2.7 ohms are available.



OHMITE MANUFACTURING COMPANY

4878 Flournoy Street, Chicago 44, Illinois

WRITE FOR BULLETIN 135

Be Right with **OHMITE**

RHEOSTATS • RESISTORS • TAP SWITCHES

SERVICE, APRIL, 1952 • 61

All Channel Reception

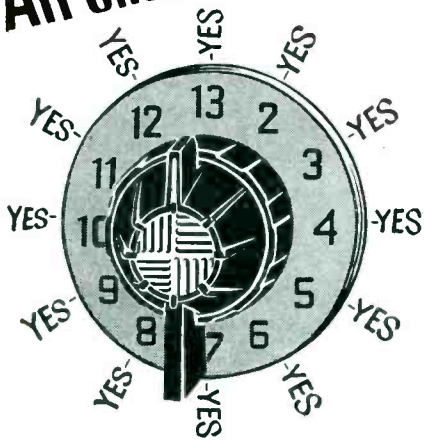

With Extra Performance

WHERE YOU NEED IT

WITH **DUBL·VEE**

BY **WORKSHOP**

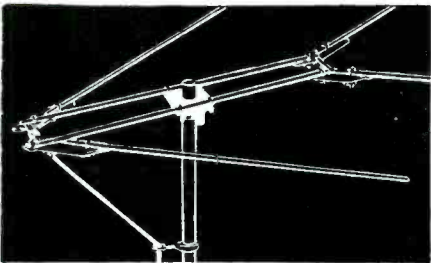

In the high bands . . . it's the original patented Dubl-Vee specially designed by WORKSHOP engineers to "bring-in" extra signal on channels 7 thru 13, while retaining excellent reception on channels 2 thru 6.

Gains up to 8 db for single bays and 10 db for double bays assure maximum signal. Rugged, streamlined construction cuts wind resistance. Only the Dubl-Vee gives these performance extras . . . tops for signal and tops for strength.

On your next installation, install the WORKSHOP Dubl-Vee . . . the original Dubl-Vee designed and patented by WORKSHOP . . . at radio parts distributors everywhere.



**THE
WORKSHOP
ASSOCIATES**

Division of the Gabriel Co.
135 Crescent Road
Needham Heights 94, Mass.

Rep Talk

MILTON S. ROTH, formerly jobber sales manager of the Radiart Corp., has formed his own rep sales company at 4397 Groveland Rd., Cleveland 18, Ohio, and will represent the JFD Manufacturing Co. and United Transformer Co. in Ohio, Kentucky and surrounding areas. . . .

William E. Fry and Co., 510 Porter Building, Kansas City, Mo. (Kansas, Missouri, Iowa and Nebraska); *Fred Hill Co.*, 266 First Ave., Minneapolis, Minn. (North and South Dakota, Minnesota and western Wisconsin); *George Davis Sales Co.*, 5259 E. Beverly Blvd., Los Angeles, Calif. (southern California, Arizona and Las Vegas, Nevada); and *Sherwood P. French*, 721 Garland Dr., Palo Alto, Calif. (northern California and Reno, Nevada) have been appointed reps for the Pentron Corp., Chicago, Ill. . . .

John I. Moss, formerly head of the contract planning section of the Navy Bureau of Ships, has joined the George Pettit Co., 549 W. Washington, Chicago, Ill., as industrial sales manager. . . . *Dick Hyde Co.*, 3879 Tennyson St., Denver, Colo., has been named rep for the Astron Corp., in New Mexico, Colorado, Utah, Wyoming and South Dakota. . . . *Tim Coakley* has been appointed factory rep for the New England area for Industrial Television, Inc. . . .

Michael Scott Co., 90 Edmunds Rd., Wellesly Hills, Mass., has been appointed rep for John F. Rider Publisher, Inc., in the New England area (Connecticut, Maine, Massachusetts, New Hampshire, Rhode Island and Vermont). . . .

Paul W. Leighton, formerly with Socony Vacuum Oil Co. has joined Kenneth E. Hughes Co., 17 W. 60th St., New York 23, N. Y., as rep covering industrial accounts in the metropolitan New York area. . . . *George E. Harris*, Municipal Airport, Wichita, Kansas, has been appointed rep for the General Transformer Co., in Kansas, Missouri, Nebraska and Iowa. . . .

Neely Enterprises, Hollywood, Calif., has been appointed rep in California, Arizona, Nevada and New Mexico, for A-V Tape Libraries, Inc., N. Y., and Markel Products Co., Buffalo, N. Y. . . . *George Davis* has moved to larger quarters at 5259 E. Beverly Blvd., Los Angeles 22, Calif. . . . *G. S. Marshall Co.*, Pasadena, Calif., has been named rep in California, Arizona and New Mexico for Eastern Air Devices, Brooklyn, N. Y. . . .

James Pickett, prexy of the N. Y. Chapter of the Reps, has named William Gold, Joseph Sprung, Wally Shulan, Jules Bressler, Harry Finkelstein, Cliff Landis, and Frank Brennan as delegates to the '52 national convention of the Reps in Chicago, in May. Alternates selected were Sam Shaw, Dave Sonkin, Dan Bittan, Leo Freed, Ben Joseph, Barrett Border, Adolph Schwartz, and William Hicks.

Milton S. Roth



PLYMOUTH Quality

Antenna Mounts

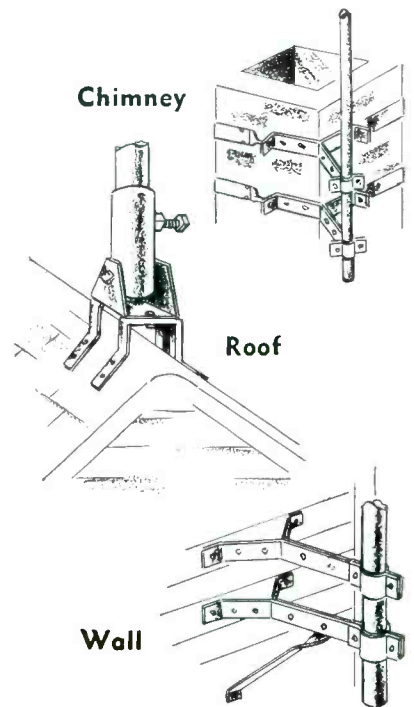

Individually packaged, complete with hardware, ready for installation. Send today for free catalog showing entire line and price list. More than 15 styles in stock.

PLYMOUTH electronic corp.

50 KINGSBURY STREET
WORCESTER 10, MASS.

.. STOP... RIDER TV 9

... AT YOUR JOBBERS

ORDER NOW

.....SEE PAGE = 8

SELL *Jensen*
PHONO NEEDLES
For Any Type
Record Player

Please send me FREE Jenselector. Picks the proper replacement needle.

Name _____

Address _____

City _____ State _____

Jensen Industries, Inc., 331 S. Wood St., Chicago 12

Business Aids . . .

[In response to many requests, arrangements have been made to feature every month in SERVICE a column devoted to a discussion of Business Aids for the Service Shop, based on queries submitted by readers of SERVICE. Topics to be reviewed will include advertising, bookkeeping, customer relationship, filing systems, displays, direct mail, etc. These columns are being conducted by a veteran Service Man with over a quarter of a century experience in the field, who is currently operator of a large Service Shop, and is also extremely active in association affairs. If you have a business-aid problem, send it to ye editor, and every effort will be made to publish a solution in an early edition of SERVICE.]

Dear Don Kay:

A short distance from my shop a new development of single family and multiple-dwelling homes is now under way. I would very much like to know how I can contact new purchasers of these homes to advise them of the availability of my services. —V.T.L.

Dear V. T. L.:

Several contact methods have been found effective.

If a sample home, completely furnished, is to be made available to prospective buyers, arrangements can be made with the builder to install a radio, television or phono system in the sample home. A sign, for placement near the installed equipment, should be provided; the sign, a small, neat affair, should contain your name, address and telephone number. You might also place a small business-card or pamphlet container near the chassis or speaker; the pamphlet can outline to a prospective buyer the advisability of dealing with your organization.

If prior installation is not permissible, an attempt should be made to secure a list of home buyers. These data can be obtained from the builder or agent. Then you can use direct mailings or a personal approach to solicit. If names of prospective home buyers are available, the possibilities of built-in facilities, such as lead-ins, speaker and perhaps video systems should be described in special letters or during personal visits.

The advance contact will also introduce your service shop, whose facilities cannot only be used for new equipment work, but the repair and installation of gear now owned. You might arrange to pick up this equipment, make any necessary repairs or adjustments, and install in the new home.

In the event that advance lists of names can not be obtained and you have to wait until the homes are occupied to secure such names, you can then prepare letters congratulating the new home owners, welcoming them to the new community, and pointing out that you hope you can be of service to them.

MR. SERVICEMAN:

You Need These 3 G-C Television Chemicals



NEW G-C RED-X CORONA DOPE

Prevent corona shorts on high voltage TV circuits with this new G-C dope. Easy to apply. Air dries faster. Excellent high voltage insulating qualities.

No. 50-2 2oz. bottle
List \$1.20

G-C TELEVISION CEMENT

Popular cement for completing repairs on TV sets and for installation work. Seal antenna lead connectors; keep bolts and nuts tight. Useful on speakers, antennas, rotors, many others.

No. 34-2 2oz. tube List \$0.55



G-C TELEVISION TUBE KOAT

Fast-drying conductive coating for re-coating outside of picture tubes where scratched or peeling. Use also to coat inner part of TV cabinet to prevent high voltage leaks and static discharges.

No. 49-2 2oz. bottle List \$1.20

G-C FIRST CHOICE OF SERVICEMEN. Today servicemen everywhere know G-C . . . know that G-C stands for top quality merchandise. Insist on G-C products . . . they're your best buy!

FREE CATALOG . . . WRITE TODAY!



**GENERAL CEMENT
MANUFACTURING COMPANY**

901 Taylor Avenue, Rockford, Illinois

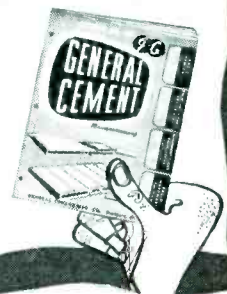

there is only **1** **JC YAGI**

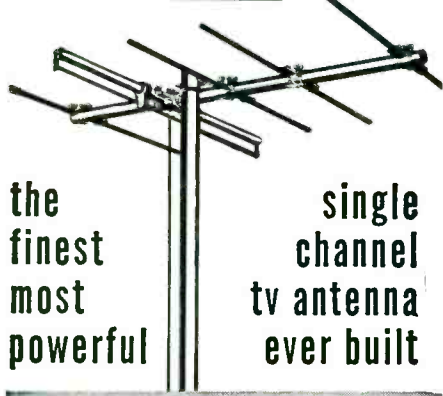

the finest most powerful single channel tv antenna ever built

FOR SUPERPOWER

INSTALL **JC** STACKED ARRAYS

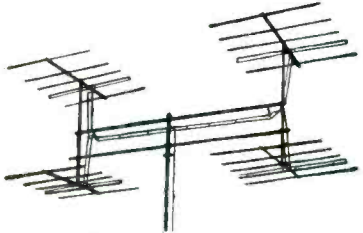

4 stacked side-by-side array. Ideal for powerful long distance reception in hilly and mountainous terrain.

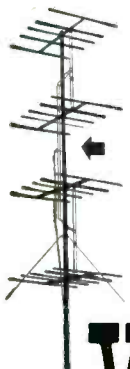

4 stacked vertical array. Extremely high gain and excellent signal-to-noise ratio. Ideal for areas with relatively flat terrain.

Double-stacked array with half-wave spacing. Provides added gain and better signal-to-noise ratio.

VEE-D-X

The World's Most Powerful TV Antenna Systems

THE LaPOINTE-PLASCOMOLD CORPORATION
Windsor Locks, Connecticut

Gentlemen:
Send me complete technical information on the JC Yagi and its stacked arrays.

Name
Street
City Zone State.....
Please check Jobber Dealer Technician

Ropes and Ties

(Continued from page 25)

feet long through it, with knots tied in the ends, to keep it from running out of the block. A knot can be tied in the rope about fifteen feet from one end; this will prevent the rope pulling up through the pulley accidentally.

To set up the rigging, it should be assembled by slipping the smaller half into the lower end, setting the fork firmly astraddle the ridge, and guying it out, fastening the ropes to vent-pipes, chimneys, or even to the eaves, at the corners. A couple of heavy metal hooks, to catch over the eaves, may come in quite handy. The guying should be as tightly as possible, so that it won't slip under load.

Next, the mast-base should be fastened near the bottom of the gin-pole. Incidentally, the pole should be set up where the mast is going to be erected. The bottom of the mast should be fastened into the base; most of the masts permit this, and the mast will swivel up into position. The rotator, antenna, and all mast-top gear should be assembled, seeing to it that everything is firm and tight. The lead-in connection should also be made. Now the rotator cables can be fastened in place, and everything is ready to go.

At this moment, your mast should be lying on the rooftop, down the ridge, away from the gin-pole. Your rope from the pulley should be tied to the mast, at a point which will come out just below the pulley, after the mast is raised. For instance the gin-pole should be 18 feet high for a 20' mast. The rope should be tied about 17' from the base of the mast. The exact distance isn't particularly important; experience will reveal about

Detail of top of mast and gin-pole, showing method of attaching guy-ropes and pulley: Note eyes or grommets used on ends of ropes to prevent cutting. Two methods are shown: Eye at left of mast, spliced in; eye at right, tied in with wire. Either one is suitable, if properly made. *Slip-pole-hitch* shown below rotator is tied like *pole-hitch*, but the lower knot is not a conventional half-hitch. This lower turn is merely wrapped around mast, and then at least eight turns wrapped above it. Then the loop at the end is tucked under top turn and pulled through enough to hold. End of rope hangs down mast, so that the hitch may be pulled loose from below, without climbing pole. This hitch *must* be pulled *very tight* to hold properly.

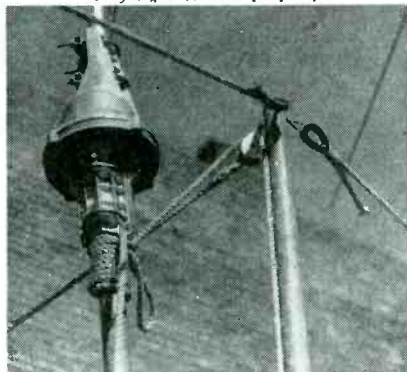

Choice of the Leaders!
ELECTROX
D.C. POWER SUPPLIES!

Leading companies—General Motors • Sears Roebuck • Goodrich • Lincoln-Mercury • Western Auto Supply • Firestone • many others—have standardized on ElectroX D.C. Power Supplies for demonstrating and testing auto radios and other low voltage D.C. equipment. And servicemen everywhere have followed their lead—for the ElectroX is today's outstanding D.C. Power Supply . . . in performance and dollar-for-dollar value!

NEW MODELS!

Two new ElectroX Models are now available—compact—dependable—low cost! They deliver smooth, hum-free D.C. which will operate practically any auto radio—either push-button or manually tuned. They are designed to give the utmost in reliable, dependable service.

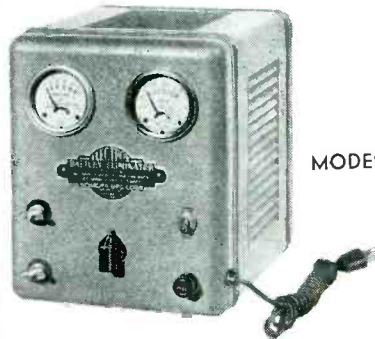

MODEL AR-5

Delivers 6 volts D.C.—smooth, hum-free. Output voltage adjustable for any load current between 3 to 15 amperes, indicated by 0-15 ampere D.C. ammeter; 0-8 volt D.C. voltmeter. Size: 7½" wide, 9¼" deep, 8" high.



MODEL AR-4

Same size, constructed to same high standards as Model AR-5 above, except output voltage is not adjustable. Delivers 6 volts D.C. at approx. 15 amperes.

ORDER NOW FROM YOUR DISTRIBUTOR. WRITE FOR FREE COPY OF BULLETIN 1467 GIVING COMPLETE DETAILS.

Rectifier Division
SCHAUER MANUFACTURING CORP.
4512 Alpine Ave. Cincinnati 36, Ohio



Ask for the **SMITH** Roof Mount FOR TV MASTS Made of Sturdy Cast Aluminum

- JUST WHAT TELEVISION INSTALLERS HAVE BEEN LOOKING FOR.
- 1—ALL ALUMINUM CASTINGS WITH PLATED STEEL BOLTS.
 - 2—TESTED TO WITHSTAND ANY NORMAL LOAD UP TO 1500 LBS.
 - 3—WILL TAKE TUBING O D ¾" TO 2".
 - 4—THE ORIGINAL SADDLE MOUNT FOR ROOF RIDGE.
 - 5—CAN BE USED ANY PLACE ON ROOF.
 - 6—IDEAL MOUNT FOR TALL MAST.
 - 7—HOLDS BASE OF PIPE AT FIXED POSITION FOR RAISING OR LOWERING.

Thousands in use. Ask your Jobber—or write for Circular
SMITH ELECTRIC MFG. CO.
Ashland, Ohio

where to tie by eye. A *pole-hitch* should be used here. A half-hitch should be tied around the mast, using about fifteen feet of rope, from the end. At least five turns of rope should be wrapped around the mast, and a loop tucked between the rising rope and the mast. This tie will make a slip-knot; after the mast is raised, the knot may be pulled loose by jerking the loop out and shaking the rope down.

Now, to set up the mast. One man can steady the mast, while another pulls up the rope to do the actual hoisting. As the mast reaches the vertical, the first man moves to the base to steady it. As the mast rises into place, it may be held there by wrapping several turns of rope around it and the gin-pole. This will hold it fast until the mast guys, which should be heavy wire, are fastened, and the mast plumbed and tied down permanently. The hitch may be loosened to allow the mast to be plumbed, if necessary.

To lower the gin-pole, only one guy-rope should be loosened. The pole may then be lowered by one man, while the other steadies it.

The setting up of gin-poles and fastening of guy-ropes might appear to be unnecessary *trigger-work*; with practice, though, it will be found that the gin-pole can be set up and guyed inside of ten minutes. Its use will save far more than that amount of time on the actual job. A major benefit derived from this operation is that the unwieldy mast and the fragile antenna are under absolute control at all times during the process of erection. Even a gust of wind will not upset the poles and cause you to lose the whole rig over the side. One antenna array dropped from a rooftop can cost more than several gin-poles.

Rope Tricks

If it does become necessary to reach a point beyond range of your ladder a *bosun's chair* can be used. This is a bowline knot with a swing-seat board in it, for comfort, and a rope thrown over a handy tree-limb, or other support. A pulley should not be used. You can sit in the loop and pull yourself up, hand over hand. It's not as hard as it sounds. When you reach your destination, two or three turns of rope should be wrapped around your leg; it will be possible to stay in this position in comfort as long as necessary.

To join two lengths of rope so that they won't come apart, a *square knot* should be used. This is simply two

(Continued on page 66)

Just Published

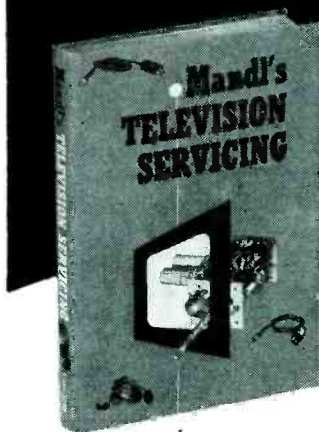

EXACTLY what you want in servicing instruction

- detailed, illustrated trouble-shooting procedures
- for every flaw or failure you're likely to encounter in any TV receiver
- completely and clearly indexed for quick reference

You'll find

Handy lists of troubles that may occur in each section of the TV receiver and the exact procedures for correcting each.

Large clear block diagrams of typical commercial circuits for tuners, focus control systems, R-F voltage supply, sync separator systems and all other basic TV receiver circuits.

New original photographs showing actual symptoms of trouble on TV screens to aid identification.

Full explanation of unusual, hard-to-find troubles and how to fix them, as well as all ordinary defects.

Complete instruction on the use of testing equipment, and oscilloscope patterns to facilitate the checking of test results.

Ways of improving overall performance; how to improve gain, reduce ghost reception, minimize interference.

Special servicing instruction for color TV and for VHF and UHF receivers.

Whatever the trouble, in picture or sound, you'll be able to put your finger on it quickly and accurately with the aid of this book. More important, you'll KNOW HOW TO FIX IT, without guesswork or trial and error, and with full assurance that the trouble is REALLY CORRECTED.

A complete master index, in clear, convenient tabular form, lists over 100 trouble symptoms—all the various hums, sound distortions, streaks and bars on picture, focus defects and all others that you're likely to find—with the probable causes of each and the page on which full servicing instruction for that particular fault is given.

You won't have to thumb through batches of manufacturers' notes, never sure that you have the right directions for the latest improvements or changes. Here are the instructions you need for correcting trouble in each circuit in any set, and the CLEAR UNDERSTANDING of each circuit you need in order to BE SURE that the adjustments you make will achieve the desired results.

300 illus.
A handy 421-page,
fact-packed guide

and much more

Are these top-ranking aids on your working reference shelf?



Fischer's RADIO & TV MATHEMATICS

"An extremely useful reference," wrote *Radio News* about this unique book. Here are step-by-step solutions, showing what formulas to use and what numerical values to substitute, for HUNDREDS of typical radio and TV servicing, construction, and operational problems, arranged under radio topics for quick reference.

Noll & Mandl's TELEVISION & FM ANTENNA GUIDE

A basic course on antenna theory combined with a complete handbook on antennas and their installation. Shows how to pick the right antenna for the site, determine the best position for it, install transmission line for maximum efficiency and all other practical details for getting the most out of the antenna system.

Noll's TV FOR RADIOMEN

Explains very clearly and fully all basic principles of television reception, the essentials of TV transmission, and the construction and operation of each part of modern TV receiving systems; and gives step-by-step instruction in installation, adjustment, alignment, and basic trouble-shooting procedures. A basic book for anyone in television servicing, noted for clarity and completeness. Here are all the fundamental why's and how's by a man known throughout the country as a leading authority on the technical aspects of television.

See them ON APPROVAL

Look them over. If you're not entirely satisfied you may return the books without further obligation.

The Macmillan Co., 60 Fifth Ave., New York 11

- | | | |
|--------------------------|-----------------------|--------|
| <input type="checkbox"/> | Mandl's TV Servicing | \$5.50 |
| <input type="checkbox"/> | TV for Radiomen | \$7.75 |
| <input type="checkbox"/> | Radio & TV Math. | \$6.75 |
| <input type="checkbox"/> | TV & FM Antenna Guide | \$6.25 |

Please send me the books checked at left. I will either remit in full or return the books in 10 days.

Signed

Address

PHOTOFACT Users Write Our Best ADS!

Hundreds of unsolicited letters tell what the world's finest Radio & TV Data means to Service Technicians



Mac Kellman
306 Garfield Place
Brooklyn 15, N. Y.

"Just as a technician can't do without a V.O.M., he can't do without PHOTOFACTS! In our shop—as well as thousands of TV service organizations—we pride ourselves on having the first to the latest sets of PHOTOFACT. SAMS has helped us out of many TV and radio headaches with its simple, precise layouts, schematics, alignment data and parts replacements."



Douglas G. Thompson
224 E. Woodrow St.
Tulsa, Okla.

"PHOTOFACTS are the best of all schematics. I get them all as soon as they are published."



Reuben C. McClenon
1628 N. Rockeblave St.
New Orleans, La.

"I never fail to get PHOTOFACTS, as they make servicing very easy. Keep up the good work."

NOW! GET THE PROOF FOR YOURSELF!

FREE

We'll send you a Free Photofact Folder on any receiver listed in "PF Index & Technical Digest."

Learn for yourself—at our expense—how PHOTOFACT pays for itself by earning bigger repair profits for you! Select any Folder from the PF Index (if you haven't an Index, get a free copy from your distributor). When you write us for your Free Folder, be sure to state Photofact Set and Folder Number as shown in the Index. Get your Free Folder now. Examine, use, compare—see why you can't afford to be without PHOTOFACT!

HOWARD W. SAMS & CO., INC.
2201 East 46th Street • Indianapolis 5, Indiana

(Continued from page 65)

overhand knots, tied in reverse, so that each rope makes a loop and comes back out where it went in.

Here's another emergency rig that has been found to be handy at times. After tying three ropes to the top rung of an extension ladder, it should be raised as high as needed; then it should be guyed firmly in place with the ropes. It then becomes a firm platform on which to work. A rig of this type was recently set up to erect a twenty-foot mast, rotator, and a two-stacked Yagi antenna; it was all assembled at ladder-top, with comparative ease.

A final word. All knots should be tied firmly and tight, and tied to something that won't break. Ropes should be in good shape, not frayed or cut. Truly, you'll save time and money if you *know the ropes!*

¹Based on notes supplied by Jack Darr.

Audio

(Continued from page 38)

starting the unit again, the takeup reel should be turned clockwise to remove tape slack.

There are no mechanical brakes or clutches that require any cleaning. The only parts to be cleaned periodically are the pinch drive, capstan and the three heads. Carbon tetrachloride or carbona should be used for this purpose. Once a year the mechanism should be removed from the case and two drops of light high-grade oil placed in each cup; there are two cups to a motor, and the rubber pouch and flywheel should be cleaned with carbona soaked in a clean cloth.

Servicing Helps

(Continued from page 48)

cut at all, a few more strokes should be taken.

Generally, only the outside bevel will require sharpening, but if necessary the inside bevel may be stoned also, but with caution. It is not necessary for the pliers to cut bond paper if they will cut the wire you normally use. Cutting bond paper is the supreme test for edge accuracy.

By now the patient should be in good shape and ready to go back on the job. An oil massage followed by avoidance of drafts and rough treatment should keep him there.

XCELITE Hand Tools
PREFERRED BY THE EXPERTS

GOOD NEWS FOR YOU —New XCELITE Tools!

Besides these new pliers designed exclusively for electrical, radio and electronic use, XCELITE brings you UNIDRIVER, the screwdriver with 5 quick-change blades! See these and other top tools at Booth 320 at the Chicago Show, Hotel Conrad Hilton, May 19-22. See you there!

Birney, Arch, Bill and the Two Charleys

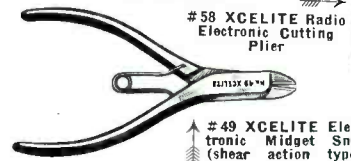

XCELITE INCORPORATED

(Formerly Park Metalware Co., Inc.)
Dept. V, ORCHARD PARK, N. Y.

Canadian Representatives:

CHARLES W. POINTON
1926 Gerrard St., E.
Toronto, Ontario

For Originality
LOOK TO XCELITE

BUYING ANTENNAS?

Buy by This Mark—
The Seal of Quality Products
and Sound Business Practices



C. & M. MANUFACTURING CO.
Eastondale, Mass.

CAMBURN, INC.
Woodside, L. I., N. Y.

CHANNEL MASTER CORP.
Ellenville, N. Y.

THE FINNEY CO.
Cleveland 3, Ohio

HY-LITE ANTENNAE, INC.
New York 51, N. Y.

JFD MANUFACTURING CO., INC.
Brooklyn 4, N. Y.

RADELCO MANUFACTURING CO.
Cleveland 25, Ohio

THE RADIART CORPORATION
Cleveland 2, Ohio

RADIO MERCHANDISE SALES, INC.
New York 59, N. Y.

WALTER L. SCHOTT COMPANY
Los Angeles 18, California

SNYDER MANUFACTURING CO.
Philadelphia 40, Penna.

T-V PRODUCTS CO.
Brooklyn 5, N. Y.

WARD PRODUCTS CORP.
Division of The Gabriel Co.
Cleveland, Ohio

THE WORKSHOP ASSOCIATES
Division of The Gabriel Co.
Needham Heights 94, Mass.

Loudspeaker Mountings

(Continued from page 29)

uniformly compressed and expanded, alternately pushing and pulling the mass of air in the port. Thus the cone is coupled to the air in the room in two ways: directly through its front surface, and indirectly through its back surface, which has an elastic connection to the air mass of the port.

At the enclosure's resonant frequency the coupling between the cone and the air in the port is at its highest efficiency; that is, for a given cone excursion the air in the port will be moved the most. The fact of maximum excursion may be demonstrated by the analogy of the rubber band and suspended weight which was used previously. If a stimulus is applied to the elastic member, and the hand holding the rubber band is moved up and down, it will be seen that the weight is displaced the most (as a matter of fact, quite a bit more than the source) at the resonant frequency of the system.

The first principle of tuned port operation may therefore be stated as: At the resonant frequency of the enclosure and port the back of the speaker cone is strongly coupled to the outside air, by virtue of large motion induced in the mass of air in the port. This mass is sometimes referred to as a virtual piston or diaphragm since it is made of air only, but it exerts real pressure against the outside air in the same way that a diaphragm of more substantial material would.

The second principle of the tuned port enclosure is that, at resonance, motion of the air in the port is approximately 180° out of phase with motion of the back of the cone. This, too, may be verified experimentally. When the hand holding the suspended weight and rubber band moves up and down at the resonant frequency the weight will move down as the hand moves up, and vice versa. The phase shift is characteristic of the behavior of both the mechanical and acoustical systems at resonance; it has nothing to do with the acoustical path length between the back of the speaker and the port.

Fig. 4 (p. 27) illustrates the operation of the tuned port cabinet, with mechanical and electrical analogies. On the basis of the principles described, it is now possible to examine the performance of this system, and of its analogies, at different frequencies.

At resonance of the speaker mechanism, the tendency is for a maximum voice coil travel and velocity. At resonance of the Helmholtz enclosure the cone is coupled most tightly to the air in the port, loading the voice

tiny
but
tough!

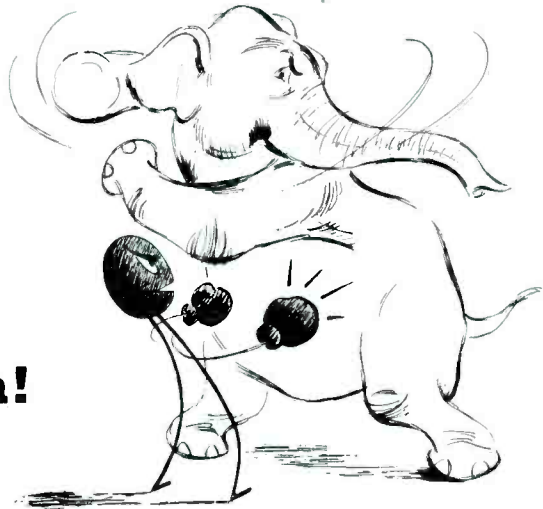

only C-D TINYMIKE* CERAMIC CAPACITORS
surpass the "Electrode Pull Test"

C-D's newly designed wire terminal holds so firmly that the wire will part before the lead can be torn from the electrode. The leads on C-D's TINYMIKES withstand as much as 5 lbs. direct pull and over 10 lbs. sideways pull.

For replacement or design purposes, TINYMIKES, ceramic capacitors are the highest quality you can buy. C-D's unique facilities permit close control of ceramic production from start to finish.

Your local jobber now has all the popular numbers in TINYMIKE ceramics. See your local classified telephone book for name and address. Capacities range from 50 to 150 mmfd. $\pm 20\%$, and 500 to 10,000 mmfd. guaranteed minimum capacity. All TINYMIKES are stamped clearly with capacity in micro-microfarads.

South Plainfield, N. J.; New Bedford, Worcester and Cambridge, Mass.; Providence, R. I.; Indianapolis, Ind.; Fuquay Springs, N. C., and subsidiary, The Radiart Corp., Cleveland, O.
CORNELL-DUBILIER ELECTRIC CORPORATION
South Plainfield, New Jersey



CORNELL-DUBILIER

CAPACITORS

BEST BY FIELD TEST



coil to a maximum degree, and the tendency is towards minimum voice coil travel. These two resonances, if they are matched in frequency, work against each other. Thus, at mutual resonance of the speaker and Helmholtz enclosure, voice-coil travel will be severely reduced from its former maximum. Acoustical output will be kept up, however, because of the fact that the port is also radiating sound, with an excursion of its air which exceeds cone excursion. Motion of air in the port is 180° out of phase with motion of the rear of the cone, and port radiation is therefore in phase with direct speaker output.

At mutual resonance of the two suspensions, in the mechanical analogy,

the motion of the first weight, representing the mechanical system of the speaker, will be greatly reduced for the same applied force. The second weight, representing the air in the port, will move in the opposite direction with maximum excursion.

In considering the electrical analogy current flow must be substituted for velocity. The series and parallel resonant circuits are anti-resonant to one another. At resonance the current through M_s will be cut down because of maximum impedance of the parallel resonant circuit, but the loop current through M_p will be at a maximum. These two currents will have approximately a 180° phase relationship. The

(Continued on page 68)

SO IMPORTANT— it was
Featured in Special Article
in

The New York Times

Jan. 28, 1952

FREE copy
of article on request

**UNIT REACTIVATES
TV PICTURE TUBES**

Small Electronic Device Tests
Sets at Home and May Add
Year or More of Use

By T. R. KENNEDY, Jr.

A small electronic device that can be applied to home television receivers to test and reactivate picture tubes without removing the tubes from the set, resulting in renewed brightness in many and considerably longer useful life, has been placed on the market for the first time by a New York manufacturer.

In some cases, it was said, the picture tube may be made almost as good as new and given as much as a year's useful life before replacement is necessary.

The instrument, which is small and compact, weighs three pounds, costs as little as the average lunch box, costs little and is simple to operate. Picture tubes, some of them new and never in a receiver, have shown remarkable improvement in brilliance and definition after a few minutes of reactivation here in the last few days.

Although the principle of its operation is not new—cathode-ray tube manufacturers have used it for years in the initial making of picture tubes—its incorporation

The almost immediate urgent need for such an instrument, which also soon may be produced in large quantities for home assembly, is apparent. Eight to ten million TV picture tubes, Transvision engineers estimate, have now been in use for three to four years or more, and "probably are in need of test and reactivation to 'renew' their brightness." Unfortunately, test and reactivation, it was pointed out, seldom can be detected short of comparing the old tubes with new ones in lately produced sets. Furthermore, picture tubes in their original cartons in stores may have lost some of their brightness, which has been described as a kind of aging process, to which all large cathode-ray tubes and similar devices are subject. Such use today, cost from \$25 to \$65. New picture tubes can be tested and reactivated without removing them from their cartons, and tubes in TV sets without removing the tubes from the receivers. It is done by attaching a standard picture tube socket to the tube, which is plugged into an AC home electric socket. The receiver, meanwhile, is not turned on. In some cases the test and reactivation is accomplished in less than two

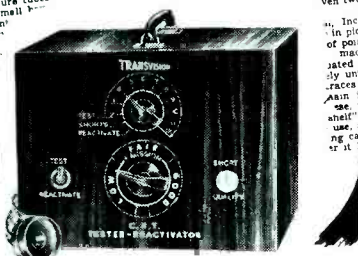

**1 TRANSVISION CR TUBE
TESTER - REACTIVATOR**

performs 2 vital functions:

- Tests Picture Tubes
- Renews Brightness of Dim Picture Tubes

It's a **TESTER**:

Without removing picture tube from set, you apply this precise instrument to:—

- Measure Cathode emission
- Locate shorts between elements
- Locate high resistance shorts or leakage as high as 3 megohms

It's a **REACTIVATOR**

for dim CR Picture Tubes

Revives dim TV Picture Tubes, without removal of tubes from sets. Reactivation works on many tubes with low light output, if there's no mechanical break in tube. 110 V—60 cycles. Weighs only 3 lbs. One or two applications pays for instrument.

SATISFACTION GUARANTEED or money refunded if you return the instrument in 10 days in good condition. **\$19.95** NET

—RUSH THIS COUPON—
TRANSVISION, INC.

DEPT. S4 NEW ROCHELLE, N. Y.

() Send me CR Tube Tester-Reactivator(s).

() Enclosed find \$___ deposit. Balance C.O.D.

() Enclosed find \$___ in full. Send prepaid.

Name _____

Address _____

City _____ State _____

(Continued from page 67)

small resistive components in the circuit change the perfect out-of-phase relationship only slightly, as is also the case in the acoustical and mechanical original.

At frequencies other than the resonant one the speaker and the Helmholtz resonator each assume a net character, either mass or compliant. At some frequency above, and at some frequency below resonance the net mass of one will resonate with the net compliance of the other, causing two new resonant peaks of voice coil velocity, each less extreme than the original single peak which they replace. These peaks, in turn, may be reduced by introducing the right amount of acoustical resistance into the system. This can be done in a controlled manner by tacking layers of loosely woven cloth across the port opening. The cabinet lining material also adds to the acoustical resistance.

In the electrical analogy, current flow through M_s will exhibit the same double peaked behavior. The two new resonant points will be formed by the net inductance of one circuit and the net capacity of the other. The effect of R_a is to lower the Q of the entire circuit, reducing the double peaks. R_a also allows more real power to be absorbed from the generator at low frequencies. The layers of resistive cloth across the port opening, in addition to damping the peaks, control the distribution of this added power between actual radiation of sound and frictional losses in the cloth.

The Helmholtz resonator is not susceptible to harmonic operation. As the frequency of the reproduced signal is raised above the resonance region, the port becomes progressively decoupled from the back of the cone, and sound radiated from the port shifts its phase relationship to that coming directly from the speaker. At high frequencies

the back wave is effectively damped out by the cabinet lining.

The output-versus-frequency curve just below resonance is lifted by the lower of the two new peaks, but then speaker radiation falls off more quickly than it would in a totally enclosed cabinet. Motion of the air in the port shifts its phase relationship with motion of the speaker cone, and interflow of air currents between speaker and port, or doublet operation, sets in.

By far the most important effect of the tuned port enclosure is the reduction of voice coil travel at resonance, and the attendant reduction of speaker distortion at a frequency where the latter is normally at its worst. The large excursion of the air in the port, which has substituted for a large voice-coil excursion, does not have to work against a relatively clumsy and nonlinear mechanical suspension system. Other advantages of a properly-adjusted reflex enclosure lie in the transient performance associated with the reduction of the resonant peak. It is obvious that these effects will only take place fully if the enclosure has the same resonant frequency as the mounted speaker mechanism.

There is one very important disadvantage of the tuned port enclosure. The use of resonant devices, whether mechanical or electrical, must involve careful and controlled adjustment, or effects far different from those expected will result. One would not think of correcting the if response curve of a television receiver, for example, by blindly installing an anti-resonant circuit without precise adjustments relative to the frequencies con-

..STOP... RIDER TV 9

... AT YOUR JOBBERS

ORDER NOW

.....SEE PAGE = 8

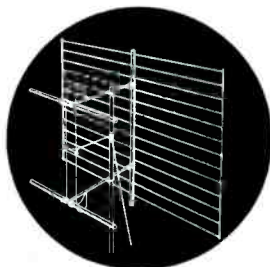

"Positively Amazing Performance!"

is what they are all saying about the new ALL-CHANNEL

GONSET "RADARRAY"

"Model C"

High gain and front-to-back ratio on all 12 channels. No side lobes. Ideally suited where maximum gain is required on several channels, or where ghosts, co-channel or adjacent channel interference problems exist in combination. Eliminates or greatly reduces oscillator interference troubles.

Ruggedly constructed yet light enough to be used on a rotor. Another engineering achievement by the originators of prefabricated open-wire line for T-V. Write for our "Fringe Area" brochure.

available at most dealers

GONSET CO. 801 S. MAIN ST. BURBANK, CALIF.



cerned. Yet, reflex cabinets are often used without any consideration of the particular speaker to be mounted. Stating the size of speaker is not enough, because commercial speakers of the same size have varying resonant frequencies. Uneven bass response, hangover, and a generally boomy quality may result from this lack of care.

Tube News

(Continued from page 52)

tions recently, with 17, 20 and 21-inch types.

The 17-inch tube is an all-glass, rectangular type featuring low-voltage electrostatic focus, magnetic deflection, and a cylindrical Filterglass faceplate with a toric inner surface; 17LP4*.

The cylindrical outer surface of the faceplate is said to reduce effectively in the vertical plane any reflections of bright objects as compared to the reflections produced by a spherical contour. The toric inner surface of the faceplate affords a practical compromise between a cylindrical inner surface and a spherical inner surface generally desired for yoke design and for required bulb strength with minimum weight.

The focusing electrode in the tube has its own base-pin terminal so that designers have a choice of focusing voltage for best results. The voltage for the focusing electrode can be obtained from the low-voltage *dc* supply of the receiver.

In addition, the tube has an external conductive bulb coating which with the inner conductive coating forms a supplementary filter capacitor; an ion-trap gun requiring an external, single-field magnet; a screen size of $14\frac{3}{8}$ " x $10\frac{1}{2}$ "; a diagonal deflection angle of 70° ; a horizontal deflection angle of 65° ; and a weight of 19 pounds, approximately.

The 20 and 21-inch tubes* are also rectangular picture tubes utilizing low-voltage electrostatic focus and magnetic deflection. One is a 20-inch glass type (20MPA) and the other a 21-inch metal-shell tube (21MP4).

Tube Features

The 20-inch model has a spherical Filterglass faceplate; an external conductive bulb coating which with the internal conductive coating forms a supplementary filter capacitor; a screen size of $17\frac{1}{4}$ " x $13\frac{1}{4}$ "; and a weight of 27 pounds, approximately.

The 21-inch model also has a spherical, frosted Filterglass faceplate; a



REPLACE WITH V-M

REPLACE WITH V-M

REPLACE WITH V-M

REPLACE WITH V-M

V-M TRI-O-MATIC[®] 950 Record Changer

FEATURES: AUTOMATIC SET DOWN SELECTION — All size records, 7", 10", 12". No controls necessary. ● POSITIVE RECORD PROTECTION — Records are LOWERED — NOT DROPPED — on spindle shelf, and flat air cushion dropped to turntable. ● COMPLETELY AUTOMATIC OPERATION on all records — 33 $\frac{1}{3}$, 45, and 78 rpm; 7", 10" and 12". POSITIVE INTERMIX of any TEN 12" or 10" records of the same speed. ● AUTOMATIC SHUTOFF — All sizes, all speeds. Tone Arm returns to REST and motor shuts off. ● DUAL NEEDLE — Reversible Cartridge. ● COMPLETELY JAMPROOF ● SIMPLE, CENTRALIZED CONTROL ● MINIMUM MOUNTING SPACE — 13 $\frac{3}{8}$ " width x 11 $\frac{7}{8}$ " depth, over-all height 7 $\frac{1}{4}$ ".

Installation is easy, too. Pre-cut mounting boards are available to make the job even more simple!



V-M CORPORATION BENTON HARBOR, MICHIGAN

screen size of $18\frac{3}{8}$ " x 14", and a weight of about 18 pounds.

Both types have an ion-trap gun requiring an external, single-field magnet; a diagonal deflection angle of 70° ; and a horizontal deflection angle of 66° . The focusing electrode in each type has its own base-pin terminal.

Focusing Voltages

Because the focusing electrode (grid 4) operates at low voltage and takes very low current, the focusing voltage can be obtained from a potentiometer

between the boost voltage and the negative terminal of the grid-1 supply voltage, or from a fixed tap on the low-voltage *dc* supply for the receiver. When fixed focus is used, designers can set the focusing voltage at a value which will give good results from their particular operating voltages. If somewhat better performance is desired, adjustment of the focusing voltage will be provided. With either method, focus can be maintained automatically with variation in line voltage and with adjustment of picture brightness.

EICO

gives you Laboratory Precision at
Lowest Cost!

NEW **EICO**
Instruments and **KITS**

... with a complete line

Over 100,000 servicemen have bought one or more EICO Kits and Instruments. That's the proof of EICO's leadership in value to the serviceman!

For latest precision engineering, finest components, smart professional appearance, lifetime performance and rock-bottom economy—see and compare the EICO line at your jobber's today before you buy any higher-priced equipment! You'll agree, with over 100,000 others, that only EICO Kits and Instruments—no other—give you the industry's greatest values for the industry's lowest costs!

Read the full story on the complete EICO line. Write today for your free latest Catalog S-4.



221K VTVM Kit
\$25.95
Wired \$49.95

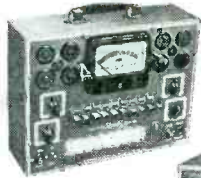

625K Tube Tester
Kit \$34.95
Wired \$49.95

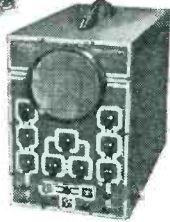

425K 5" Scope Kit
\$44.95
Wired \$79.95



320K Sig. Gen. Kit
\$19.95
Wired \$29.95

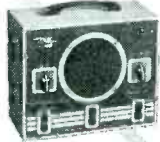

145K Sig. Tracer
Kit \$19.95
Wired \$28.95



315K Deluxe Sig.
Gen. Kit \$39.95
Wired \$59.95



HV Probe \$6.95



1040K Battery Elim.
Kit \$25.95
Wired \$34.95



511K VOM Kit
\$14.95
Wired \$17.95



360K Sweep Gen. Kit
\$34.95
Wired \$49.95
C-5 5mc Crystal \$3.95



RF Probe Kit \$3.75
Wired \$5.95

ELECTRONIC INSTRUMENT CO., Inc.
84 WITHERS STREET, BROOKLYN 11, N. Y.
© 1952, Electronic Instrument Co., Inc.

Due to unsettled conditions, prices and specifications are subject to change without notice. Prices 5% higher on West Coast

3-Way Portables

(Continued from page 31)

be lowered a step at a time, is a great help. The oscillator filament voltage can be checked while lowering input voltage. If the tube will still oscillate at a voltage of 1.1, it will usually give satisfactory service. Some tubes have been found to work satisfactorily on voltages as low as 1.

Shunt and series resistors may also be found in the filament string in some sets. If these change with aging, they can cause trouble. Once again the filament voltages should be checked at the tubes themselves to locate the trouble. These resistors have been included in the circuit to bypass the various plate and screen currents around the filaments. Such a shunt resistor will always be found across the output half of the center-tapped filament on a 3Q5, a very popular output tube in portables. These resistors carry the plate return current, and prevent overloading of the delicate filament. It is possible for half of the filament to open up, leaving the shunt resistor to carry the current. The set will still operate, but it will be very weak.

In the main, battery packs for these sets use the standard RTMA sockets with 8 pins in a circle, and a dead pin for a locator, off-center in the circle, so that the plug can be inserted only one way into the battery. Some attempts have been made to use non-standard plugs. These sets should be changed over to fit standard batteries. The *B* voltage is usually 90 for the larger sets, 67.5 for the tiny portables. The *A* voltage is decided by the number of tubes in the set. Most battery packs offer 7.5 or 9 volts. Very small models use one or two flashlight cells as an *A* supply.

Unusual circuits are found in some sets. One popular set uses, instead of battery type output tubes, a 70L7 rectifier-pentode. When operating on *ac*, the battery output tube is switched out of the circuit. Plates of the two output tubes are connected to the ends of the output transformer and the *B* voltage is fed into the center tap. Filament voltage for the remaining battery tubes is derived from the cathode current of the pentode section. Leaky coupling capacitors and leaky plate bypass units can cause the 70L7 plate current to increase to a point where it will cause tube burnouts in the battery tubes. Capacitors should therefore be checked carefully and replaced if there is any doubt. For safety, ceramics should be used when making replacements.

Some models use 50B5-35W4s in place of the 70L7-117L7, etc. When

FOR PERFECT PICTURE CENTERING IN ELECTRO-STATIC TUBES

Use the **NEW** PERFECTION *Kine-Center*

Here is the simplest of all centering devices for the new electrostatic tubes. It is also the most efficient and positive—as your own tests will prove.

- **Quickly Mounted.** Slip the Kine-Center over the tube neck and tighten the holding screw. It stays firm. No wobble. No wiggle.
- **Finger-Tip Control.** Picture is centered by rotating the two rings either independently or together.
- **Positive Centering.** Once adjusted, the rings stay put.
- **No Distortion of Focus** as with many other centering devices.

Order today from your supplier!

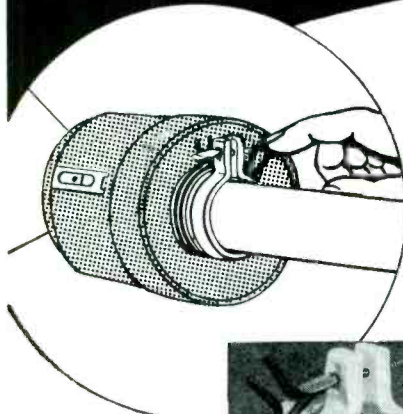

MORE EFFICIENT
Rings are closer to deflection yoke (the most effective operating area) and to the tube neck. They are stabilized magnetically.

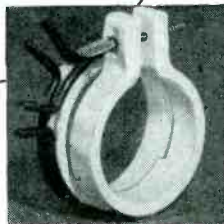

PERFECTION ELECTRIC COMPANY
2635 South Wabash Avenue, Chicago 16, Illinois
MAKERS OF PERFECTION SPEAKERS AND TELEVISION COMPONENTS



attempting to replace the rectifier with a selenium rectifier in this type of circuit, one should not forget that the rectifier must also supply the heavy plate current for the 50B5 tube, which is more than the total drain of the battery tubes. A 100-ma selenium rectifier will easily handle the battery tubes in a portable, but the plate drain of the larger tubes will severely overload the 100-ma type. If this replacement is absolutely necessary, a 150 ma or 200-ma rectifier should be used and adequate provisions made for cooling.

Dry Rectifier Replacements

The dry rectifiers make admirable replacements for tubes such as 117Z3, 35Z5, 50X6, when these tubes are used as straight rectifiers, and not doublers. Doublers may be replaced by using two dry rectifiers. They also eliminate the need for the dropping resistance in the line cord used with 35- and 50-volt rectifier tubes. If tube and heater cord are both defective, it is wise to substitute with a selenium rectifier. This unit will also give the added advantage of instant starting.

When mounting selenium rectifiers, they should be placed above the chassis, if at all possible. This will allow much better heat dissipation. If the rectifier is in an exposed place, and there is the danger that the user might receive a shock, a screen cage, made from hardware cloth, should be installed. The filament voltages should be checked carefully, as the lower rectifier voltage drop can result in an overload for the filaments. This can be adjusted by changing the value of the surge resistor. It is customary to run filament strings a little lower than the actual rating to provide surge protection. For a 9-volt string, 8 volts are sufficient to give adequate performance and protect the tubes from overload.

Importance of Cable-Plug Tests

When testing these sets, the condition of the battery cables and plugs should not be overlooked. Worn or frayed wiring or broken plugs can cause a great deal of trouble.

Alignment Check

As a final test, each set should receive a full and careful alignment. Due to the adverse conditions under which these little sets are expected to operate, correct alignment is *essential* for satisfactory performance. If possible, antenna trimmers should be



Colorful dubonnet, gold lettering, 4 transparent acetate compartments — each holds 3 needle cards.

Every serviceman needs this!

Plastic Leatherette Wallet

NEEDLE CARRIER

- Holds 12 ind. carded needles with all necessary tools for installation
- Creates "impulse buying"
- Saves times on service calls
- Makes extra sales for YOU!
- Allows serviceman to make up to 90% of installations on 1st call

Here's the Newest
MILLER Special Deal:

Wallet, Manual, one dozen needles
\$15.00 list value **\$7⁹⁵**
... servicemen's cost ... complete

You'll make fast, quick sales, volume profits ... every serviceman must have needles... you make extra money, your customers do too ... dozen Miller needles include Astatic, RCA, Shure, Columbia, etc.

Sold through
jobbers ONLY!
ORDER TODAY!

M. A. Miller Manufacturing Co.
1165-1169 East 43rd Street, Chicago 15, Illinois

Manufacturers of the world's largest line of long-life playback and recording needles
Selected by the world's largest manufacturer of original equipment

Canadian representatives: ATLAS RADIO CORP., LTD., 560 King Street West, Toronto, Ontario, Canada

aligned after the set has been installed in the cabinet, and batteries set in place, etc. Almost all of the trimmers in these sets are inaccessible; sometimes they can be adjusted, by using a screwdriver whose handle has been cut off and blade ground down. It should be made as short as possible. If alignment in the cabinet is impossible, the chassis should be slid out enough to gain access to trimmers and adjusted. Behavior when set is replaced in cabinet should be noted. If it goes off too far, a different setting on the trimmers should be tried. On some sets, replacement of the original loop antenna with one of the new ferrous-cored antennas may help the

performance. The higher Q obtainable may improve the set quite a bit, if carefully aligned.

Portable Servicing Opportunities

Although some of the cheaper makes of portables are beyond improvement, many of them are capable of surprisingly good performance. Careful attention to every detail of the job will make a satisfied customer for you. The possibilities of replacement battery sales, too, should not be overlooked during summer and winter! The carry-along boxes offer many opportunities in service and sales; be prepared to take advantage of them.

Temperature Faults

(Continued from page 33)

tained by studying the circuit diagram and chassis layout before the receiver is turned on. It is also helpful to prepare a simple form with appropriate space for each measured value before any measurements are taken. The cold condition can also be better maintained by directing the blast from the fan on the set during this operation. After recording the *cold* data the fan should be turned off, the set covered with the blanket and allowed to run until the fault occurs. When it does occur and with the receiver hot, the exact same information that was recorded when the set was cold should now be measured and recorded. If there are any significant differences in the *hot* and *cold* data a clue to the faulty part has been uncovered; if not the original determination of the area of the fault was incorrect and the *hot* and *cold* measurement must be repeated in another circuit. (The line voltage should be the same for both the *hot* and *cold* measurements.)

If there is a significant change in any measured value, the receiver itself should be ignored while a careful study of the recorded data is made. Here the will power to resist any further work with the receiver will pay off in time saved. A detailed study of the circuit diagram and the recorded data should be made in an attempt to correlate the difference in measured value with the possible failure of each part in the circuit. A clear understanding of the circuit involved and a systematic study of the data will usually limit the possibilities to one or two parts which can be replaced. After the suspected parts are replaced, the receiver should be adjusted for normal operation when cold (after normal 5 minute warmup) and then run while covered with the blanket to insure that the parts replaced were indeed the faulty ones.

The technique described was recently applied to a receiver, featuring syncroguide horizontal *afc* (Fig. 1, p. 33), which operated normally every time it was turned on from a cold start, but lost horizontal sync after about 45 minutes of operation. It was concluded that the trouble was somewhere in the horizontal oscillator or horizontal *afc* circuits.

A high-impedance scope probe was connected to the control tube grid (pin 4) and the data listed in table 1 was recorded. The scope showed normal control-tube input when the receiver was cold and no appreciable change in level when hot. However, a study of table 1 and the circuit reveals that: (1) Voltages on pins 1 and

NOW THERE ARE 2 GRAYBURNE Loopsticks!

FERRI-LOOPSTICK and VARI-LOOPSTICK

Grayburne Loopsticks, with magic Ferrite cores, obsolete conventional radio loops, improve reception amazingly over entire broadcast band, and pull in hard-to-get stations that normally can't be heard with ordinary loops.

Highest Sensitivity: Average Q is 250, unaffected by adjacent metallic or inductive elements.

Omni-Directional: Equally sensitive and efficient at every angle. No more turning or moving receivers to get better reception.

Greater Receiving Range: Greater, more uniform amplification over a wider frequency range—all at higher signal-to-noise ratio.

Performance-Proved: After comparative tests, service dealers coast to coast have bought 100,000 Loopsticks in only 5 months!

FERRI-LOOPSTICK: Just set and forget! For permanent installations, new or replacement, where user desires to make no further changes once Loopstick has been set for maximum overall efficiency. **List 75¢.**

VARI-LOOPSTICK: Has advantages of Micrometer Adjustment and one-hole Snap-in Mount! For peaking efficiency on several stations consecutively, station jumpers and DX tuners. Peak resonance for any station is quickly obtained. **List \$1.00.**

Write for name of your nearest Grayburne distributor and free booklet "Ferrites and Their Applications."

WELCOME, BROTHER 'VARI'!

Many Servicemen want your New Micrometer Adjustment and Snap-in Mount!

GLAD TO JOIN THE CAUSE, BROTHER 'FERRI'!

You've done a wonderful job for 100,000 sets in only 5 months!

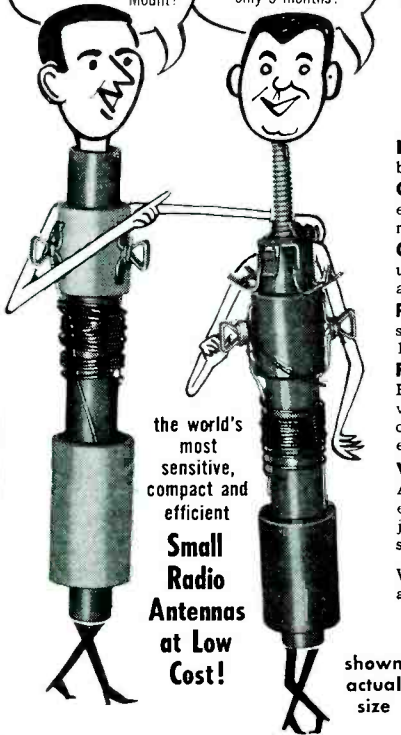

the world's most sensitive, compact and efficient Small Radio Antennas at Low Cost!

shown actual size

GRAYBURNE

Grayburne means Quality Electronic Components

GRAYBURNE CORPORATION, 103 Lafayette St., New York 13, N. Y.

MOSLEY ROOF-THRU

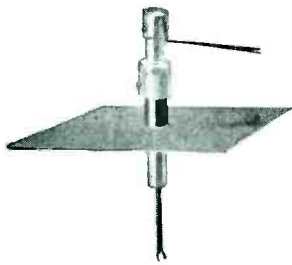

Cat. No. 624

MOSLEY ROOF-THRU
List Price—\$5.84

We're looking forward to meeting you at the May show. We cordially invite you to visit us in Space 119.

The Leak-Proof Roof Entrance for TV and FM Transmission Line and Rotator Control Cable

- Permits shorter lead-in with less loss of signal energy—less interference pick-up!
- Prolongs life of transmission line by keeping it out of weather!
- Eliminates unsightly wires on outside of house!
- Easy to install on new or old buildings!
- Copper flashing and plastic bushing unaffected by weather—provides perfect seal against weather leaks!

Available from Your Radio Parts Jobber

MOSLEY ELECTRONICS

2125 Lackland Road, Overland, Missouri

Speakers
Need
Repairing?

Recone with a
**WALDOM
CONE**

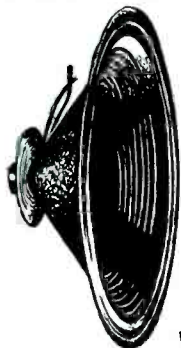

Speakers are hard to obtain. Recone with Waldom cones.

Send for your FREE WALDOM Replacement Cone Manual Catalog!

FREE, 24-page manual is yours without obligation. Data on over 750 TV, FM, AM speakers. WRITE TODAY!

• WALDOM CONES

... maximum efficiency, R.M.A. warranty, true low frequency response, unconditionally guaranteed.

WALDOM ELECTRONICS, INC. 911 N. Larrabee St., Chicago 10, Ill.

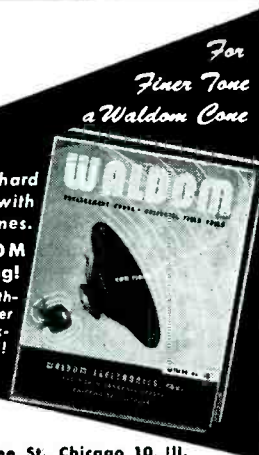

For
Finer Tone
a Waldom Cone

Pin	Cold Voltage		Hot Voltage	
	CC	C	CC	C
1	-94	-90	-92	-89
2	+254	+249	+251	+249
4	-23	-23	-24.5	-15.6
5	+142	+220	+140	+220
6	+4.5	+4.5	-5.2	+9.4

Table I
Horizontal oscillator and control-tube voltages at extremes of horizontal-hold control

2, the oscillator tube, are not changed appreciably; (2) voltage range on pin 5, the control tube plate, is not changed appreciably; and (3) voltages on pins 4 and 6, the grid and cathode of the control tube, change considerably between the *hot* and *cold* measurements.

From these data it appeared that the trouble was centered around a change in the bias voltage developed at the control tube cathode and the bias being applied to the grid of that tube. At the counterclockwise (cc) or low voltage end of the horizontal-hold control, the voltage at the cathode changes from positive to negative and the grid voltage drops slightly. In the clockwise (c) or high-voltage end of the hold control the cathode voltage became more positive and the grid voltage became less negative. Since the cathode voltage was changing more radically it was concluded that the fault was in the cathode network and that the grid voltage was following this change as a result of the connection through R_1 (820,000 ohms). In the high-voltage position of the hold control the control tube would be drawing more current and an increase in cathode voltage could result from an increase in a pair of 150,000-ohm cathode resistors, in series. Faults in C_1 and C_2 (.02 and .22) then appear to be ruled out since partial shorts in either of these capacitors would tend to decrease the voltage developed on the cathode. In the low-voltage position of the hold control the control tube would be drawing less current, and a change from positive to negative voltage on the cathode could result from an increasing negative voltage at the junction of the cathode resistors through the 100,000-ohm resistor connected to the highly negative grid of the oscillator tube. The junction of the cathode resistors could become more negative if the 150,000-ohm unit was increased. It was, therefore, concluded that this cathode resistor was increasing value as the receiver's temperature was increased. In this case it was possible to verify this conclusion by turning on the receiver from a cold start and applying a hot soldering iron directly to the body of the resistor. Within several minutes the fault occurred. (It had taken about 15 minutes to induce the fault when operating

*
Compare
Clear Beam's
T-MATCH YAGIS

From Every Angle...



Clear Beam

TV ANTENNAS and ACCESSORIES

The Largest and Most Complete Antenna Line
Manufactured Under One Roof

100 PROSPECT AVENUE
BURBANK, CALIFORNIA

Charleston 0-4886

ROckwell 9-2141

under the blanket.) The resistor was replaced and the receiver operated normally through another heat cycle.

Summarizing, there are five basic points involved in the hot-cold service check:

- (1) The fault should be caused to occur so that first-half observation can be made.
- (2) The general circuit area of the fault should be estimated.
- (3) Voltage and wave shapes, throughout the suspected circuit in the hot and cold condition, should be recorded.
- (4) The set should be ignored and the recorded data studied in de-

tail.

- (5) The suspected component should be replaced and a heat cycle repeated to verify the correction.

Of course, all temperature-induced faults will not be as simple and straightforward to locate as indicated. However, once developed as a standard systematic technique the procedure described will be found to save time and parts by eliminating *guess-and-try* part-by-part substitution or gross part replacement. It will also minimize the everpresent possibility of causing other faults during extensive replacement operations.



VIKING
speakers
by **Jensen**

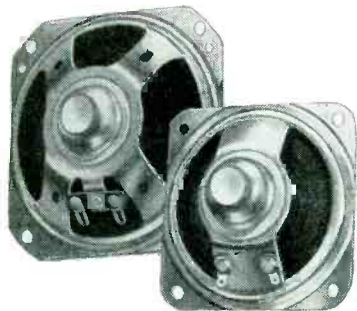

low cost replacement
speakers by Jensen . . .
makers of the World's
Finest Loudspeaker—
the G-610 Triaxial

Jensen

JENSEN MANUFACTURING COMPANY
DIVISION OF THE MUTER COMPANY
6601 S. LARAMIE AVENUE • CHICAGO 38, ILLINOIS

Viking speakers—
manufactured with the
same engineering and
production skills which go
into every Jensen product—
are designed especially for
low-cost replacement and
utility applications. The
Viking line includes 12
models from 3½" to 12"
with 4" x 6", 5" x 7" and
6" x 9" ovals, all P.M.
An accessory bracket,
designed especially for the
Viking series, solves
chassis and transformer
mounting problems.

BURTON BROWNE ADVERTISING

ASSOCIATIONS



Recently elected officers of the Florida Radio and Television Technician's Guild. Left to right: Thomas M. Middleton, secretary; Shan Desjardines, vice president; A. Ed Stevens, treasurer and Steven Petruff, president.

FRSAP

JOHN RIDER received the annual plaque of the Federation of Radio Servicemen Associations of Pennsylvania at the Hotel Harrisburger, Harrisburg, Pa., recently, in recognition of . . . "his outstanding achievements on behalf of the electronic servicing industry, the radio and TV technician, and his wholehearted encouragement of their associations." Carl Smith, prexy of the Central Pa. Radio Technicians Association (Williamsport) presented the plaque to Rider.

In his acceptance speech, Rider praised the unity that exists within the state federation and its progressiveness and many accomplishments since its formation. He pointed out that there was more work to be done in organizing Service Men. In his opinion, within each state where individual associations exist, state federations should be formed to overcome and meet local problems.

Also present at the award meeting were Albert Coumont, service manager of RTMA; Ed Cahill, prexy of the RCA Service Co.; Dan Creato, legal counsel for RCA Service Co., and Dave Krantz, chairman of the Federation.

Cahill discussed the future of uhj

and cited the increasing need for competent Service Men to take care of the problems in the new channels.

TISA

AN OPEN FORUM MEETING on the problems of service shop operators was sponsored recently by the Television Installation Service Association in Chicago. The official registration indicated that over 380 attended.

Many problems, such as fix-it-yourself book advertising, parts warranties, failure of some manufacturers and distributors to cooperate, factory operated service, licensing and unions were discussed.

A secret ballot on unionization and licensing revealed that no concerted opposition toward unionization exists. Many were in favor of a state law based on a *medical profession bill*. This bill would license both technicians and shops.

[See Ten Years Ago; p. 78]

.. STOP... RIDER TV 9
... AT YOUR JOBBERS
ORDER NOW
.....SEE PAGE = 8

Tools . . . Instruments Parts . . .

INSULINE HV TIP JACK

A high-voltage tip jack, 1889, has been announced by the Insuline Corporation of America, 3602 35th Ave., Long Island City, N. Y.

Insulation is of nylon, and is said to withstand 10,000 volts. Spring contact is made of one piece of phosphor bronze and takes standard phone tips and test prods. Jack is furnished with a molded washer that affords protection against shorts to a metal panel.

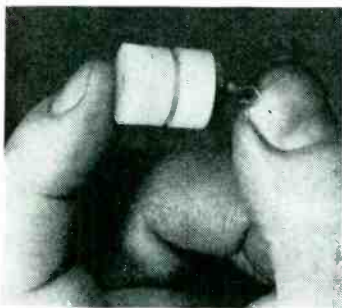

* * *

SCHAUER BATTERY ELIMINATORS

An improved design of *Electrex* battery eliminator, AR-5, featuring adjustable output voltage, has been introduced by the Schauer Manufacturing Corp., 4500 Alpine Ave., Cincinnati 36, Ohio. Principal changes include a complete redesign of the case and addition of ammeter to accompany the single voltmeter formerly supplied.

Model is said to deliver smooth, hum-free 6 volts *dc*, adjustable for any load current between 0-15 amperes. Unit is 7½" wide, 9¼" deep and 9" high.

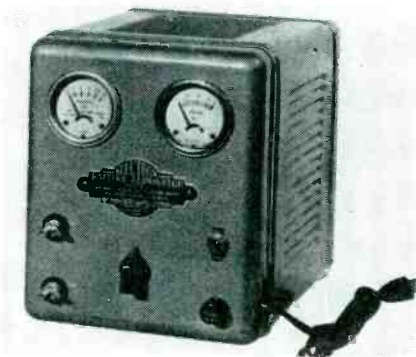

* * *

WARD LEAD CABLE

Lead cable, for auto antennas, that is said to provide complete shielding, high *Q*, low loss, and positive cable connections, has been produced by Ward Products Corp., Division of The Gabriel Co., 1523 East 45th St., Cleveland 3, Ohio.

the BIG 10 is terrific!

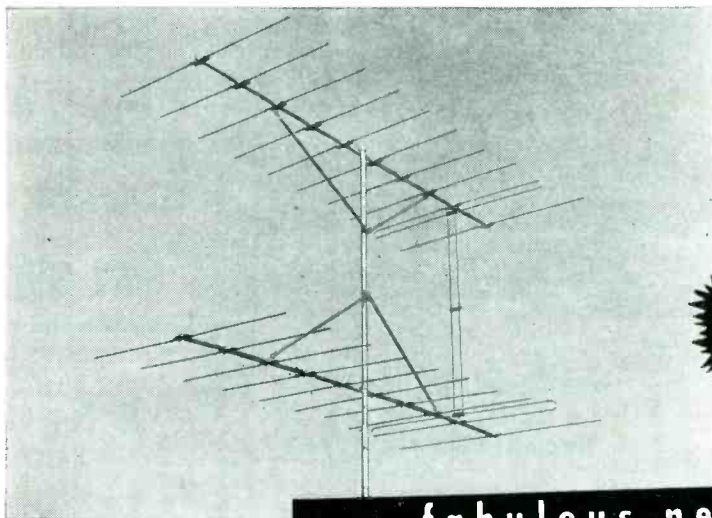

12
DB single

14½
DB stacked

**CHANNEL
MASTER'S**

fabulous new
10 Element Yagi

COMPARE these 10 Terrific Features!

- 1 10 Elements — more signal, less noise, less rear pickup.
- 2 Highest gain of any Yagi ever developed.
- 3 Over 30% more gain than any 8 element Yagi.
- 4 This antenna can be stacked, with 78% additional gain over single bay.
- 5 Includes the famous Z-Match system.
- 6 **You don't pay for stacking bars.**
- 7 Excellent 300 ohm match in all installations.
- 8 "Boom Braced" to prevent crossboom "bounce" which causes picture flicker.*
- 9 Two piece "Swej-Lok" cross-boom for simplified stocking, handling, and installation.*
- 10 Completely pre-assembled.

*Low Band only

LIST PRICES	
ch. 7—13	ch. 2 or 3 31.94
\$1388	ch. 4 or 5 28.47
	ch. 6 25.69

CHANNEL MASTER CORP.

ELLENVILLE, N. Y.

SIMPSON 'SCOPE CALIBRATOR

A 'scope calibrator, model 276, featuring direct meter readings, is now available from the Simpson Electric Co., 5200 W. Kinzie, Chicago, Ill.

Calibrator is a companion piece for model 476 microscope. 'Scope features vertical mounting of the picture tube, and operates from 117 v, 50-60 cycles and can be used with any 'scope. Provides a sine-wave output which is used directly on a 4½" meter. Meter is calibrated directly in *rms*, peak, and peak-to-peak values. Six ranges are provided with peak-to-peak full-scale values of 1, 2.5, 10, 25, 100 and 250 volts that are said to have an accuracy of 3%. Each range is continuously adjustable from zero to full scale value.



JOE B. HIGGINBOTHAM, JR.

Nuberg, Ga.

**THANKS,
Mr. Higginbotham!**

Radio Receptor Co., Inc.
West 19th Street
New York 11, N.Y.

Gentlemen:

Please send me your pamphlet on the design, application and servicing of selenium rectifiers.

Although I have serviced many receivers which have selenium rectifiers I have very little information on them and believe your pamphlet would be a valuable asset to my shop.

I use your rectifiers, supplied by Southeastern Radio Parts Co. and Specialty Distributing Co. of Atlanta, Ga., and like them very much. Also I appreciate your consideration of the radio repairman in that you supply a data sheet with each rectifier and the trouble taken to print the servicing information.

Yours Truly

Joe B. Higginbotham Jr.
Joe B. Higginbotham Jr.



SELETRON RECTIFIERS

... And our thanks go as well to the other thousands of servicemen and hams who insist upon top performing SELETRON Selenium Rectifiers in electronic circuits and as replacements in Radio and TV sets.

You can depend on SELETRON all ways... Full technical information is always available without obligation. Look for Howard W. Sam's Red Book Supplement listing SELETRON replacements, and write us for Bulletin No. 104-S-2



RR RADIO RECEPTOR COMPANY, INC. RR

SELETRON DIVISION

Since 1922 in Radio and Electronics

Factory: 84 North 9th St., Brooklyn 11, N. Y. • Sales Department: 251 West 19th St., New York 11, N. Y.

DATES TO REMEMBER

MAY 19-22

Radio Parts—Electronic Equipment Show

MAY 23-24

AUDIO FAIR

Both at CONRAD HILTON HOTEL, CHICAGO

MAKE YOUR SPACE RESERVATION PROMPTLY
for the doubly-important

MAY SHOW ISSUE of SERVICE

WHEN YOU CHANGE YOUR ADDRESS

Be sure to notify the Subscription Department of SERVICE at 52 Vanderbilt Avenue, New York 17, N. Y., giving the old as well as the new address, and do this at least four weeks in advance. The Post Office Department does not forward magazines unless you pay additional postage, and we cannot duplicate copies mailed to the old address. We ask your cooperation.

T.V. DEVELOPMENT AUTO-RADIO ANTENNA BOOSTER

A booster for auto-radio antennas, model TD-10, has been introduced by T. V. Development Corp., 2024 McDonald Ave., Brooklyn, N. Y.

Made of triple chrome-plated brass, booster is rustproof and non-corrosive. When closed it measures about 25" and the telescopic design permits an expansion up to 66". Employs a 360° rotation principle.

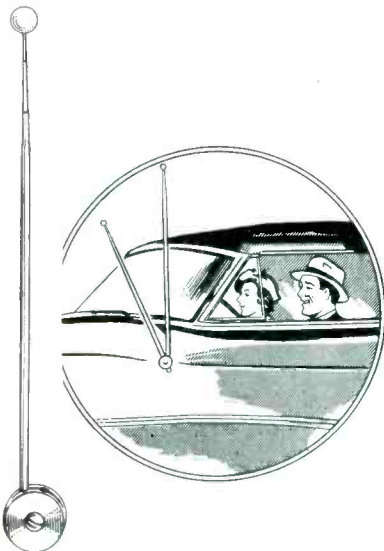

GRAYBURNE FERRITE RF CHOKES

RF chokes, *Ferri-Chokes*, with ferrite core material, have been announced by Grayburne Corp., 103 Lafayette St., New York 13, N. Y.

Four models are available: *F-25*, 2.5 mh at 125 ma; *F-50*, 5 mh at 125 ma; *F-100*, 10 mh at 125 ma; and *HD-25*, 2.5 mh at 300 ma. Chokes may be supplied in inductance values from 500 microhenries to 250 millihenries, either pie or solenoid-wound, in various types of mountings and windings, upon specification.

Variable *rf* chokes, that have an inductance as high as 10 to 1 have also been produced by Grayburne.

Incorporating ferrite cores, chokes are available in two models: *V-6* 0.65 to 6 mh; *V-25*, 5 to 43 mh.



Above: Grayburne variable *rf* choke; below, fixed choke.

* * *

TRADE ASSOCIATES VOLTOHMMETER

A volt ohmmeter that tests *ac* and *dc* voltages in ranges of 1, 10, 50, 100, 500 and 1,000, and *dc* milliamperes at 1, 10 and 100, has been introduced by Trade Associates, 128 South 1st St., Brooklyn, N. Y.

PRECISE MARKER GENERATOR KIT

A *rf-af*-TV marker generator kit, 630, that is said to reach 110 mc on fundamentals and 330 mc on harmonics, has been introduced by Precise Development Corp., Oceanside, N. Y.. Kit provides a complete factory preassembled and calibrated *rf* head.

Included in kit are pre-tuned *rf* head, cathode-follower output, stepping attenuator, external modulation, speech amplifier, crystal marker, crystal amplitude control, *rf* and *af* stand-by, Wien bridge *af* oscillator, Colpitts *rf* oscillator, drum dials, coax fittings, individually tuned coils, constant output impedance, filtered line, vernier tuning on *rf* and *af*, separate *rf* section, shielding, and each band separately loaded for constant output from range to range.



TV Parts

[See pages 56 and 57 for additional new product news.]

ERIE HV BYPASS CAPACITORS

Two high voltage TV bypass capacitors, *Ceramicons 412* and *411*, which are said to be designed primarily to supply *hv* power-supply filtering for TV receivers, have been announced by the Eric Resistor Corp., Erie, Pa. Style *412* is rated at 20 kv and style *411* at 10 kv.

Case insulation is of low-loss, molded thermosetting plastic, which it is claimed provides a moisture seal. Ring convolutions are molded into the surface of the 20-kv capacitor, to prevent surface leakages. Convolute design is said to increase the effective surface creepage path by more than 14%.

* * *

MALLARD TV TOWER AND MAST

A TV tower and telescoping mast, which can be extended to 40', have been announced by the Mallard Manufacturing Co., 6025 N. Keystone Ave., Chicago 30, Ill.

Mast, which weighs 30 pounds, consists of three telescoping sections of thin-wall conduit, 1½", 1¼" and 1" *od*, the sections being locked in extended position by cotter pins and shimmed to prevent vibration. Two U-bolt clamps, 16" apart, secure mast to tower.

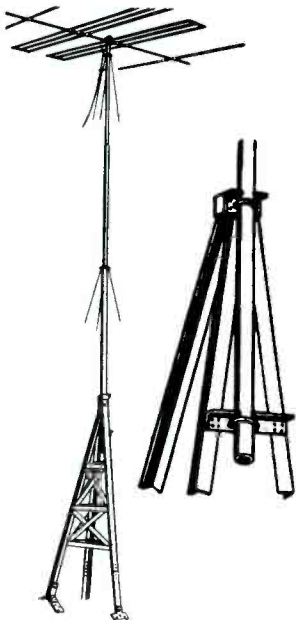

* * *

TELEMATIC IGNITION FILTER

An ignition filter, *WT-28*, that is said to eliminate or reduce ignition interference from TV receivers, has been developed by Telematic Industries, Inc., 1 Joralemon St., Brooklyn, N. Y.

Unit is an antenna feeder filter tuned to ignition frequency peaks, and consisting of resonant shunt inductance and series line capacitance that is said to provide high attenuation of ignition interference. Housed in a shielded case, and can be installed at the antenna terminals of TV receiver.

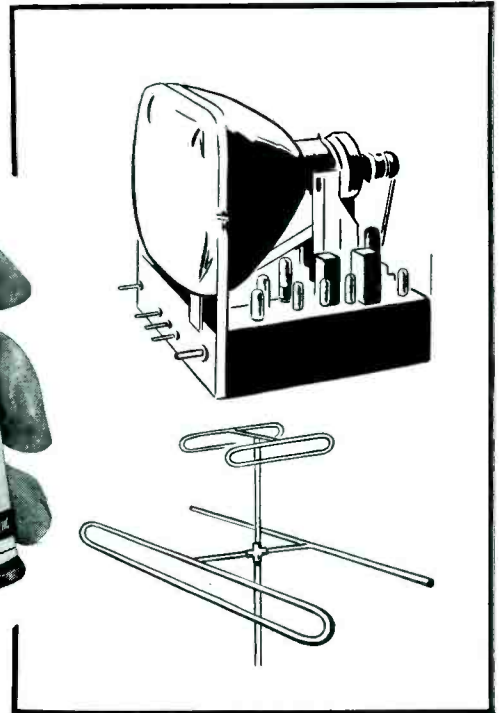

PREVENT CORONA

in high voltage circuits with



ACRYLIC SPRAY

Advertised in
The SATURDAY
EVENING POST

Spray on antenna and lead-in terminals, too; Krylon prevents corrosion and pitting

Krylon is an *acrylic* spray — not a vinyl plastic. Spray it, right from the 12 oz. aerosol can, on the high voltage coil and insulation... in the socket of the high voltage rectifier... on component parts of the high voltage rectifier circuit. Krylon dries in a few minutes to form a permanent protective coating of high dielectric strength.

Both inside the set and on the antenna, Krylon seals and protects... makes TV sets perform better, longer... cuts down service calls... builds customer good will. Two types — clear (list \$1.95) and nonconducting aluminum (list \$2.25). Also in gallons for application by brushing or dipping. See your jobber, or write direct.

KRYLON, Inc. Dept. 604

2601 North Broad St. Philadelphia 32, Pa.

JFD TELESCOPING TOWER MAST

A tower mast for fringe area use, *Zoom-Up*, that is constructed of 5 telescoping sections which reach a height of 50', has been announced by the JFD Manufacturing Co., Inc.

Sections are constructed of seamless steel, zinc plated. Available in seven combinations of 10' sections; two models at 30' lengths; one model at 40', and another at 50'. Fifty-foot model is equipped with a base mount.

* * *

SPICO INDOOR ANTENNA

An indoor antenna, model *TV-8*, that is said to be guaranteed against breakage, rust or tilt under normal use, has been introduced by Spirling Products Co., Inc., New York 13, N. Y.

JERROLD RF ATTENUATOR

An *rf* attenuator, designed for 72-ohm input and output matching over the 0 to 250-mc range, has been introduced by Jerrold Electronics Corp., N.E. Cor. 26th and Dickinson St., Philadelphia 46, Pa.

Provides attenuation from 0 to 82 db by a switching arrangement. Attenuator is claimed to be accurate within 1% of the maximum attenuation, and the feed-through insertion loss less than 0.5 db at 250 mc.

Available in two models: Model *A-72*, for use with RG-59/U cable, and model *A-72X* for use with RG-11/U cable. Connectors and two male cable connectors are included.

South River

★★ NEWS ★★

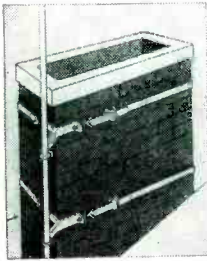

**DUO-MOUNT
ANTENNA
BASE
Model
DM-36**

(U.S. Patent
2482575)

A low-priced, two-piece mount of alloy steel with rivet construction . . . hot-dip galvanized. Specially designed "U" bolts will accommodate masts from 5/8 to 1 1/2" O.D. With hardware. (Available with or without "Kwik Klip" feature. ALSO AVAILABLE WITH STAINLESS STEEL STRAPPING.)

South River Antenna Mounting Accessories are carried by every leading TV Parts Jobber from coast to coast.

New catalog mailed to all Dealers and Service Men. Write, if you haven't received yours!

**SOUTH RIVER METAL
PRODUCTS CO., INC.**
SOUTH RIVER, N. J.

PIONEER AND OUTSTANDING PRODUCER
OF FINEST LINE OF ANTENNA MOUNTS



Low Cost Powerful P. A.!

COMPLETE • READY TO USE

Tops for powerful indoor-outdoor use; ideal for electioneering. Easy portability. Covers 4,000 persons indoors, up to 25,000 sq. ft. outdoors. Full 30 watts usable output; 2 high-imp. mike inputs, 1 phono input, each with separate volume control; tone control; fidelity ± 2 db from 40-20,000 cps. Complete system includes: 30 watt amplifier and tubes, Electro-Voice "Cardax" unidirectional mike with adjustable floor stand and 20' cable; 2 General Electric 12" PM speakers, each with 30' cable; portable carrying case holds all, 16 3/4" x 12 3/4" x 25". For 110-130 v., 60 cy. A.C. Shpg. wt., 75 lbs. Complete, less only phono top.

93-372. Complete 30 Watt System. Only \$119.75
93-340. 3-Speed Phono Top for above. Only \$16.95
Available on Easy Terms—write for details

FREE See the 212-Page ALLIED Catalog for other Sound Systems, ranging from 8 to 80 watts. Write for Free copy of Radio's leading Buying Guide today.

ALLIED RADIO

833 W. Jackson Blvd., Dept. 23-D-2, Chicago 7, Ill.

Ser-Cuits

(Continued from page 42)

resistance rectifier resulting in low $B+$ voltage or hum in loudspeaker; and overheated selenium rectifier resulting in melted alloy on the rectifier plates.

Ohmmeter Test

An ohmmeter of the conventional type employing a battery and meter for measuring resistance may be used for a rough check of a selenium rectifier.

The leads from the ohmmeter should be placed on the terminals of the rectifier in one direction, and then reversed, reading the resistance each time. Two high-resistance readings will indicate an open-circuited rectifier. Two low-resistance readings will indicate a short-circuited rectifier. One low and

one-high resistance reading will show that the rectifier is functioning as a rectifier. It will not, however, show whether the forward resistance is sufficiently low or the reverse resistance sufficiently high for satisfactory performance.

Forward-Reverse Current Tests

Circuits which can be set up to test the forward and reverse-current resistance of a selenium rectifier appear in Figs. 5 and 6 (p. 42). When voltage is first applied to a good rectifier the reverse current will be high and will rapidly decrease while the voltage is applied. A short-circuiting switch is used to protect the meter during the high current or forming period. It would be desirable to use a variable voltage transformer or a potentiometer to increase the voltage gradually, protecting the tube in the event the rectifier has low reverse resistance.

Trouble	Possible Condition	Procedure
No $B+$ voltage.	Open line resistor. Open rectifier.	Test for ac voltage between switch and $B-$. If okeh, test for ac voltage between rectifier + and $B-$. If okeh, check stack for open circuit.
Low $B+$ voltage.	High forward resistance rectifier. Leaky or low capacity capacitor. Excessive $B+$ current.	Test rectifier for forward resistance. If okeh, test capacitor for capacity and leakage. Test $B+$ circuit for excessive tube current or partial short circuit due to defective components.
Hum in loud-speaker.	Leaky or low capacity capacitor. Low reverse resistance rectifier.	Test capacitor. If okeh, test rectifier.
Sparking or dark spots on plates of rectifier.	Deformed rectifier.	If sparking occurs after set has been inoperative for a long time, leave it on as rectifier will probably reform. If sparking continues, test rectifier reverse resistance. If reverse current is high or sparking persists, replace rectifier.
Burned out line resistor.	Defective capacitor. Defective rectifier. Shorted load.	Test for shorted rectifier or capacitor. Check load for excess current or intermittent shorts.

Selenium troubleshooting chart. (Courtesy FTR)

TEN YEARS AGO

THE DEFENSE PROGRAM introduced shortage problems. . . . *Servicing Help* solutions covered intermittent noise in Airline models; distortion at medium or low-volume levels and whistles around 600 kc in Airline models; burned-out volume control in Crosley 154; microphonics, improving power output, eliminating fluttering, converting phonomotor for use on 50-cycle ac lines in Philco models, and loop repairs in a Philco model. . . . A two-tube record player, using a single-beam power tube in an amplifier having an undistorted power output of 2.25 watts and a maximum output of

4.5 watts, was the cover feature. A high-level crystal pickup had sufficient output voltage to drive a 50L6GT to full power output with standard commercial records. . . . Joe DeMambro, Boston distributor for National Union, spent his spare time as an air-raid warden in the Brighton-Allston section. . . . Ken Hathaway, formerly director of Chicago Radio Parts Show, was reported as having become an industrial specialist in the Army Signal Corps, stationed in Washington. . . . Art Moss, secretary of NRPDA, resigned his post and became associated with the Pollock Co., Groton, Conn.

Selenium Rectifiers

(Continued from page 50)

deformed rectifiers can also be identified by their inability to complete the reforming process without excessive overheating. The plate temperature should not exceed 50°C to 60°C when reforming at room temperature of 25°C to 35°C.

The criterion to determine whether the rectifiers have successfully been reformed is the magnitude of the reverse current flowing at 100% rated voltage after undergoing the reforming process. As a rule, rectifiers having reverse currents of not more than 5% of the rated forward current are considered as properly reformed and will probably give years of useful service. Rectifiers having reverse currents of between 5 and 10% of the rated forward current are questionable. The condition of the protective coating and other physical features should be used to evaluate their worth. A reverse current of over 10% of the rated forward current indicates that the rectifier is permanently damaged and should be discarded, since it cannot be reformed. Occasionally, connecting the rectifier to normal voltage and load (after it has been subjected to the reforming procedure), will aid in reducing the reverse current. Careful observance of the temperature of the plates must be experienced.

It has been determined that a large percentage of the otherwise useless selenium rectifiers may be restored to full normal operations.

The instructions presented are of a general nature and are to be used as a guide. This procedure need not be followed scrupulously, since it is known that some selenium rectifiers will reform quickly while others will not reform at all. Moreover, a sharp demarcation of the exact value of reverse current for any rectifier can not be made. Consequently, a certain amount of technical judgment should be exercised in the evaluation of the reformed rectifiers.

BRACH AUTO-ANTENNA DISPLAY

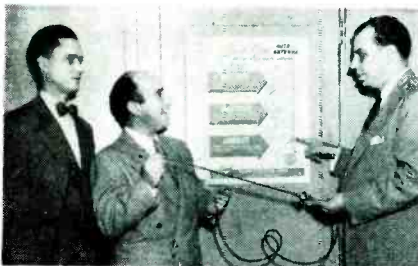

Ira Kamen (right) reviewing recently introduced Brach auto-antenna display with Milton Fisher of Fisher Distributing Corp., and Sol Verter.

Especially Designed for Radio & TV!



NO. 2195
SERVICE KIT

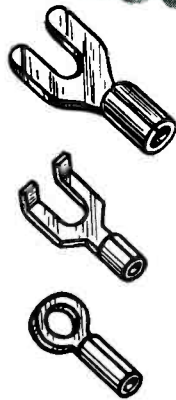

Now you can get a positive, trouble-free connection on every terminal... as fast as you can close your hand. No messy soldering or waiting for an iron to heat! With a Lynn *Lightning* service kit you just strip primary wire from 10 to 22 gauge with handy, combination stripping and crimping tool... select the proper terminal... then *crimp* it on. Every job quick, clean, professional-looking! Kit comes complete with crimping tool, 10 different types of terminals in 11-bin, clear plastic box. Only \$8.50

Two New Television Screw Drivers

Reach hard-to-get-at spots with the new Vaco AT 510 non-metallic, fiber shank driver for critical tuning and aligning work... the 10" blade gives you all the length you need. Adjust the new type focalizers with specially designed Vaco Beryllium-copper drivers... non-magnetic, yet nearly as hard as steel for adequate torque without interference with the Ion trap field. Full information on other aligning tools, nut setters and special radio tool kits on request. Write for FREE catalog.



317 E. Ontario St., Chicago 11, Ill.

In Canada: Vaco-Lynn Products Co., Ltd.
204 Laurier Ave., W., Montreal 8, Que.

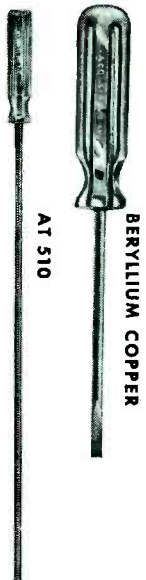

PACIFIC COAST TRAINING MEETING

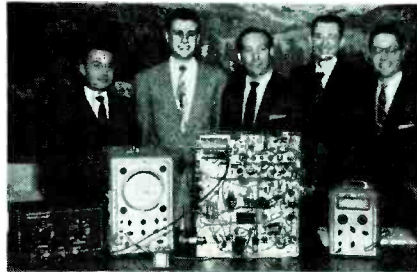

At a recent service training meeting, sponsored by Kaye Halbert and WRESCO, K-H distributor, held at the San Francisco Merchandise Mart. Left to right: Dave Praschan, Kaye-Halbert service manager; Jerry Rapaport, WRESCO prexy; Harry Kaye, president of Kaye-Halbert; Fred Miller, Kaye-Halbert director of engineering and research; and Ed Altshuler, Kaye-Halbert national marketing director.

ASTATIC PREXY VISITS WEST



L. D. Calhoun, president of The Astatic Corp., with his wife and daughter in Phoenix, Arizona, during a Western business trip stopover.

JOTS AND FLASHES

AUDIO QUALITY, in the early days of TV completely discounted, and subsequently neglected, too, even though it was believed that an interest in improvement might obtain, will no longer continue to be a stepchild. For the clamor for better sound has grown, and plunged audio into the limelight. Recently, during a survey, the quality of sound was described as being almost important as the quality of the picture. According to *Scott Radio*, who made the study among 162 families, quality of sound ran second to picture clarity in an importance-rating chart. . . . *James A. Sullivan* has joined the sales staff of *Oxford Electric Corp.*, Chicago, Ill. . . . Recorded material in the fields of documentary, ethnography, drama, religion, sound effects, science, foreign language courses, and others, will be published in May in a *Classical and Educational Record Guide*, by the *Audio-Master Corp.*, 341 Madison Ave., New York 17, N. Y. There will also be included a cross-referenced listing of all important classical music recordings in three speeds. Priced at \$2.00. . . . The executive offices of the *National Appliance and Radio-TV Dealers Association* has moved to larger headquarters in the Merchandise Mart, suite 1141. NARDA headquarters were formerly located at 1437 Merchandise Mart. . . . *Matticks Manufacturing Co.*, 4156 E. Pacific Way, Los Angeles 23, Calif., has announced the development of a new line of soft plastic mallets. Seven models are included in the line with head weights varying from 1 to 14 ounces, head diameters between 3/4" and 2", and head lengths between 2 3/4" and 4". . . . The 2,112-page volume in *Rider's TV Manual* series, Volume 9, will be available from distributors shortly. Over 40 manufacturers are represented with data, covering the October '51-February '52 period. . . . *Sola Electric Co.* has published a 22-page booklet, *CV-142*, describing constant voltage transformers, and including a cross reference guide. Four new types are also included in the catalog. . . . The *Pentron Corp.*, 221 E. Cullerton St., Chicago 16, Ill., has issued a booklet, *See, Hear! Tape Recording Offers You*, to dealers for distribution to customers. . . . *Joseph Holzman* has been appointed industrial sales engineer for the *Insuline Corp. of America*. He will work out of the company's factory and main office in Long Island City, N. Y. . . . *Precise Development Corp.*, Oceanside, N. Y., has released a series of catalog sheets describing a *rf-af-TV* marker generator; vacuum-tube voltmeter; universal *af* sync square and pulse generator; *rf* probe and high-voltage probe. . . . Automobile set production has risen from 3,459,061 in '47 to 4,542,920 last year. This represents a rise of from 17 per cent of the total radio output in '47 to 36 per cent in '51. . . . Three Cleveland radio stations, WTAM, WHK, WERE, have adopted the 45-rpm system of recorded music recently. . . . The Chicago-land chapter of the *Reps* has announced the inauguration of a service for mid-western jobbers and manufacturers. A complete listing of lines and products handled by the members of the chapter has been made available at the secretarial office, 600 S. Michigan Ave., Chicago 5, Ill.

ADVERTISERS IN THIS ISSUE

SERVICE INDEX—APRIL, 1952

ALLIED RADIO CORPORATION	78
Agency: George Brodsky, Advertising	
ALPRODDCO., INC.	29
Agency: Paul J. Steffen Co.	
AMERICAN ELECTRICAL HEATER CO.	59
Agency: The Hubbell Adv. Agency	
AMERICAN PHENOLIC CORP.	28
Agency: Burton Browne, Advertising	
AMERICAN TELEVISION & RADIO CO.	80
Agency: Firestone-Goodman Adv. Agency	
ANTENNA MANUFACTURERS ASSN.	66
Agency: The Hubbell Adv. Agency	
CHANNEL MASTER CORP.	75
Agency: Duso Advertising, Inc.	
CLEAR BEAM TV ANTENNAS	73
Agency: Shiller-Rouse & Associates	
CORNELL-DUBILIER ELECTRIC CORP.	67
Agency: Reiss Advertising	
DELCO RADIO DIV. GENERAL MOTORS CORP.	1
Agency: Campbell-Ewald Co.	
ELECTRONIC INSTRUMENT CO., INC.	70
Agency: H. W. Hauptman Co.	
GENERAL CEMENT MFG. CO.	63
Agency: Paul J. Steffen Co.	
GENERAL ELECTRIC	16, 17, 43
Agency: Maxon, Inc.	
GON-SET CO.	68
GRAYBURNE CORPORATION	72
Agency: H. W. Hauptman Co.	
HEATH COMPANY	53
Agency: G. Dean Arend, Advertising	
HYTRON RADIO & ELECTRONICS CO.	5
Agency: Bennett, Walther & Menadier, Inc.	
JFD MFG. CO.	2
JACKSON ELECTRICAL INSTRUMENT CO.	60
Agency: The Parker Adv. Co.	
JENSEN INDUSTRIES, INC.	62
Agency: Paul J. Steffen Co.	
JENSEN MFG. CO., INC.	3-74
Agency: Burton Browne, Advertising	
KESTER SOLDER CO.	41
Agency: Paul J. Steffen Co.	
KRYLON, INC.	77
Agency: Gray & Rogers	
LA POINTE-PLASCOMOLD CORP.	64
Agency: The F. W. Prella Co.	
THE MACMILLAN CO.	65
Agency: Atherton & Currier, Inc.	
P. R. MALORY & CO., INC.	Inside Back Cover
Agency: The Pitkin-Kynett Co.	
MERIT COIL & TRANSFORMER CORP.	7
Agency: Burton Browne Advertising	
M. A. MILLER MFG. CO.	71
Agency: Sander Rodkin Adv. Agency	
MOSLEY ELECTRONICS	72
Agency: Bartz Adv. Agency	
NATIONAL CARBON CO., INC.	4
Agency: Wm. Esty Co., Inc.	
OHMITE MFG. CO.	61
Agency: The Agostoli Co.	
OXFORD ELECTRIC CORP.	57
Agency: Sander Rodkin Adv. Agency	
PERFECTION ELECTRIC CO.	70
Agency: Seantlin & Co.	
PERMO, INC.	13
Agency: Symonds, MacKenzie & Co.	
PLYMOUTH ELECTRONIC CORP.	62
Agency: Howard-Wesson Co.	
RADIART CORP.	Inside Front Cover
Agency: Stern and Warren	
RADIO CORPORATION OF AMERICA	11, 37, Back Cover
Agency: J. Walter Thompson Co.	
RADIO MERCHANDISE SALES, INC.	23
Agency: Heid Associates	
RADIO RECEPTOR CO.	76
Agency: Walter J. Zimmerman & Associates	
RAULAND CORPORATION	12
Agency: MacFarland, Aveyard & Co.	
RAYTHEON MFG. CO.	18
Agency: Walter B. Snow & Staff	
REGENCY DIV. I.D.E.A., INC.	20
Agency: Burton Browne, Advertising	
JOHN PUBLISHER, INC.	8, 62, 68, 74
Agency: Conti Adv. Agency, Inc.	
HOWARD W. SAMS & CO., INC.	66
Agency: George Brodsky, Advertising	
SANGAMO ELECTRIC CO.	45
Agency: Arthur R. Mogge, Inc.	
SCHAUER MFG. CORP.	64
Agency: The Keebler & Stites Co.	
WALTER L. SCHOTT CO.	6
Agency: Tilds & Cantz	
SIMPSON ELECTRIC CO.	39
Agency: Burton Browne, Advertising	
SMITH ELECTRIC MFG. CO.	64
SNYDER MFG. CO.	32
Agency: Brooks and London	
SOUTH RIVER METAL PRODUCTS CO., INC.	78
Agency: Art-Copy Adv. Agency	
SYLVANIA ELECTRIC PRODUCTS, INC.	51
Agency: Cecil & Presbrey, Inc.	
SARKIS TARZIAN, INC.	14
Agency: H. L. Ross, Advertising	
TEL-A-RAY ENTERPRISES, INC.	47
Agency: Keller-Crescent Co.	
TRIO MFG. CO.	10
Agency: Bartz Adv. Agency	
TRANSVISION, INC.	68
Agency: H. J. Gold Co.	
TRIPLETT ELECTRICAL INSTRUMENT CO.	49
Agency: Western Adv. Agency, Inc.	
TUNG-SOL ELECTRIC, INC.	9
Agency: E. M. Freystadt Associates, Inc.	
V-M CORPORATION	69
Agency: Maynard Sales & Adv. Counsel	
VACO PRODUCTS CO.	79
Agency: Kenilth-Breslich, Inc.	
WALDOM ELECTRONICS, INC.	72
Agency: Ad. Agency	
WEBSTER-CHICAGO CORPORATION	15
Agency: Fuller & Smith & Ross, Inc.	
WORKSHOP ASSOCIATES, INC.	62
Agency: The Hubbell Adv. Agency	
XCELITE, INC.	78
Agency: Melvin F. Hell Agency, Inc.	

ATR

Makes it easy to DEMONSTRATE AND TEST D.C. APPARATUS FROM A.C. LINES



"A" BATTERY ELIMINATORS

For DEMONSTRATING AND TESTING AUTO RADIOS

New Models . . . Designed for testing D.C. Electrical Apparatus on Regular A.C. Lines. Equipped with Full-Wave Dry Disc Type Rectifier, Assuring Noise-less, Interference-Free Operation and Extreme Long Life and Reliability.

NEW MODELS

NEW DESIGNS

NEW LITERATURE

"A" Battery Eliminators, DC-AC Inverters Auto Radio Vibrators

See your jobber or write factory

AMERICAN TELEVISION & RADIO Co.

Quality Products Since 1931

SAINT PAUL 1, MINNESOTA-U.S.A.



First Choice with Servicemen Everywhere . . .

MALLORY VIBRATORS

Servicemen know Mallory Vibrators give long, dependable performance—performance that keeps their customers happy. In fact, servicemen prefer Mallory Vibrators by a 2 to 1 margin, according to a recent survey. Mallory Vibrators give you . . .

- 1—Slow contact impact for minimum wear
- 2—High contact pressure for low resistance
- 3—Fast contact break for reduced arcing, pitting

Only from Mallory—with its patented, tuned vibrator mechanism—do you get this important three-way performance combination. It helps you beat the comeback problem. It's the reason manufacturers use more Mallory Vibrators as original equipment than all other brands combined. Follow their lead . . .



**Mallory Vibrator Deals Help
Keep Inventory Down . . .
Include Parts Chest At
No Additional Cost**

You can service 47 different radio makes with the 6 vibrator types in these Mallory special deals. And you get a handy parts chest at no additional cost when you buy at your regular discount price. Ask your distributor for details today.

Make Sure! Make it Mallory!

P. R. MALLORY & CO. Inc.
MALLORY

CAPACITORS • CONTROLS • VIBRATORS • SWITCHES • RESISTORS
• RECTIFIERS • VIBRAPACK* POWER SUPPLIES • FILTERS

*Reg. U.S. Pat. Off.

APPROVED PRECISION PRODUCTS

P. R. MALLORY & CO., Inc., INDIANAPOLIS 6, INDIANA



How we *spot* "shady characters"
before they can damage your business

THE instrument you see is working for you. A sensitive light-measuring device, it is used like a doctor's stethoscope, to explore the surface of a picture tube for screen imperfections the unaided eye would fail to detect.

Employing a photosensitive surface and color filters, this device does two jobs. It checks not only the uniformity of brightness, but also the *color* values from center to edges of the faceplate.

Why is this important? It is important because RCA has learned, through long

experience in the manufacture of picture tubes, that the best picture—the picture having superior quality—calls for unusually rigid processing controls of the phosphor and its application. The light-measuring device spots any departure from RCA's established brightness and color standards. Result? "Shady characters"—those tubes that would produce pictures lacking in fine quality—*never reach your shop.*

This constant vigilance and *quality control* at *all* stages of manufacture assure

that RCA standards will be met. In this way, RCA guards its own reputation for quality . . . and *yours as well.*

With RCA Receiving Tubes, as well as RCA Kinescopes, **TOP-QUALITY CONTROL** makes the difference.



RADIO CORPORATION of AMERICA
ELECTRON TUBES

HARRISON, N. J.