

SERVICE

OCTOBER
1951

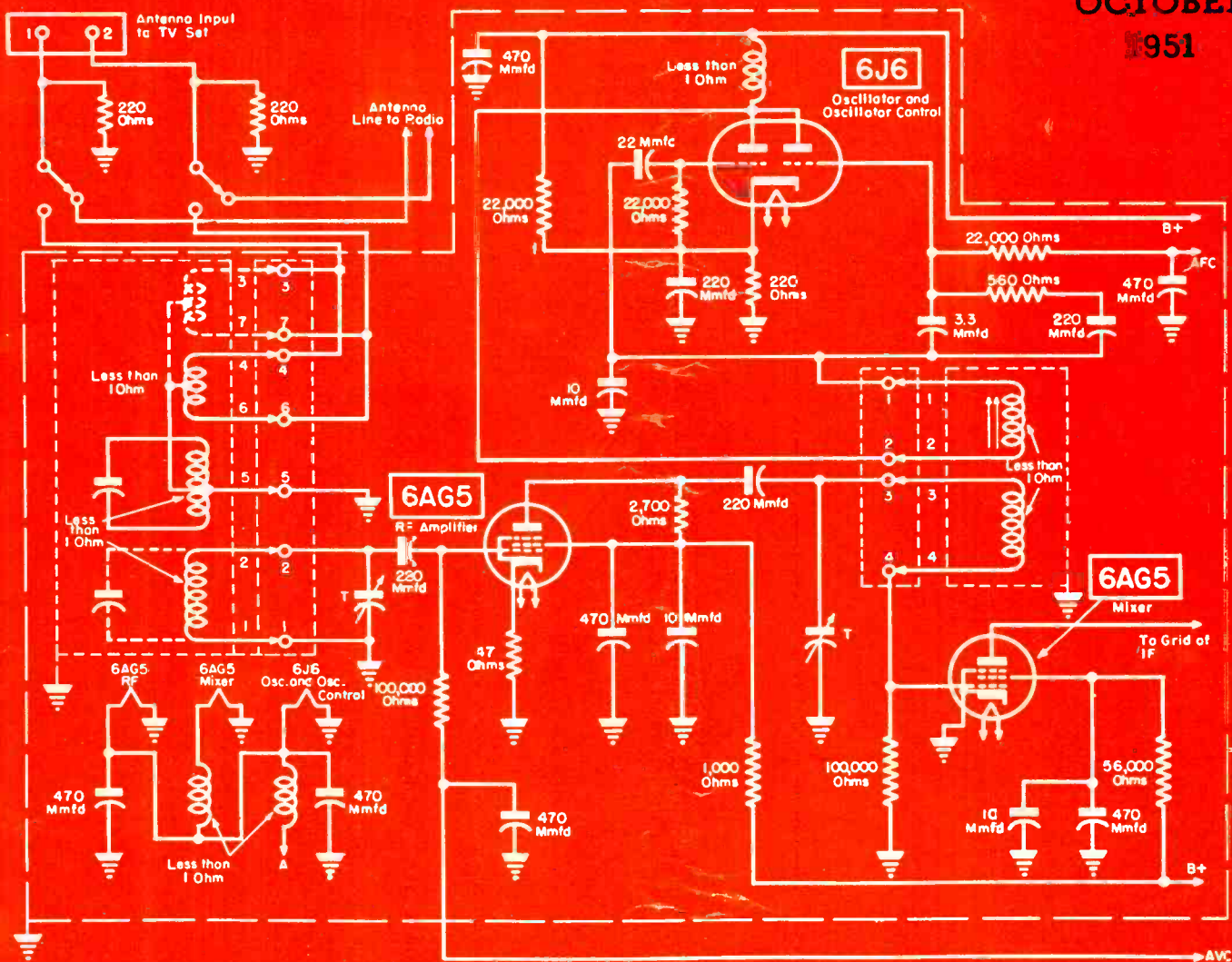

Eight-channel turret tuner featuring use of 6J6 as a local oscillator and reactance tube.

[See page 21]

Assured Balanced
Performance On
Both Audio and
Video Signals

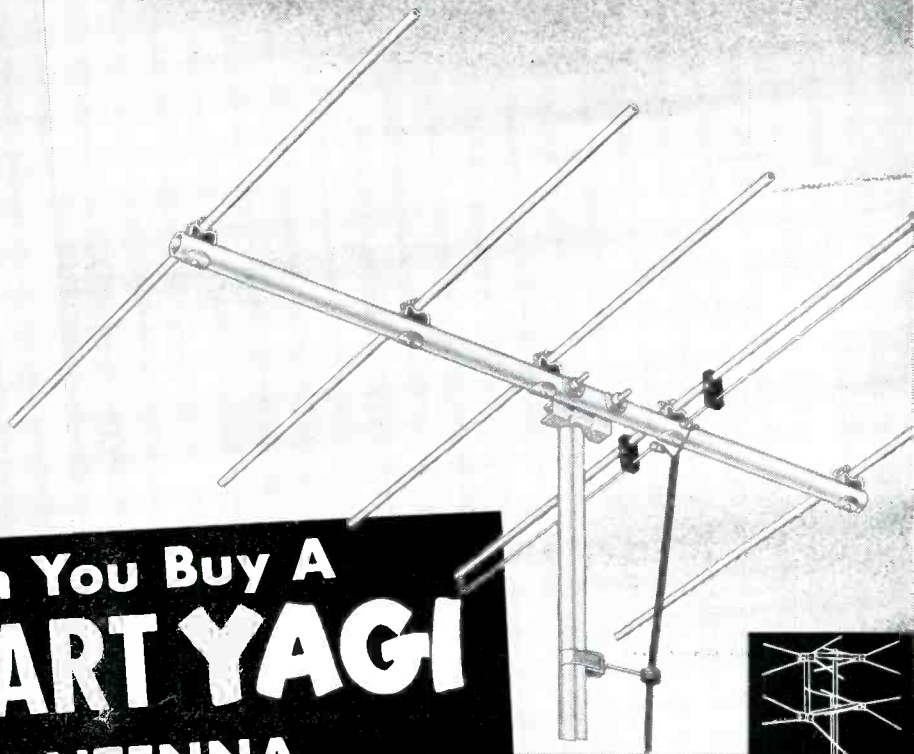

When You Buy A
RADIART YAGI
TV ANTENNA

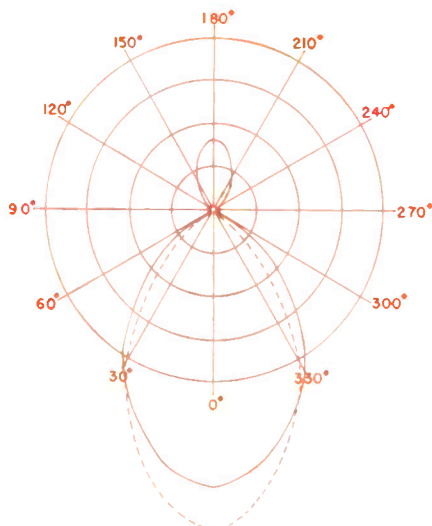
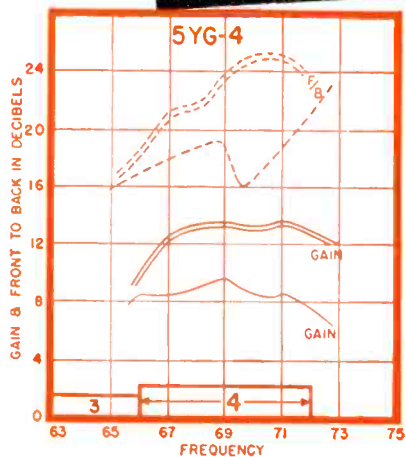

YAGI response curves for all channels available from your RADIART distributor . . . or write direct to us . . . Specify Form F885.

You **KNOW** it covers the entire **6 Megacycle Band width** in the specific channel for which it was designed

The perfect answer to the need for maximum signal pickup in "fringe" areas. Each YAGI is cut for a specific channel and may be used singly or doubly stacked. Nothing skimpy or shortcut in their manufacture either — each RADIART YAGI covers the full band width of its channel.

CHECK THESE FEATURES:

- Pre-assembled Fold-out Design for FAST Installations
- Over 8 lb. Forward Gain
- Excellent Front-to-Back Ratio
- Narrow Beam Width That Develops High Signal-to-Noise Ratio
- Low Standing Wave Ratio
- Sturdy Construction For Lasting and Dependable Performance.

You Can't Beat A RADIART Antenna On A TELE-ROTOR . . . It's Tops!



THE RADIART CORPORATION

CLEVELAND 2, OHIO

VIBRATORS • AUTO AERIALS • TV ANTENNAS • ROTATORS • POWER SUPPLIES



2-YEAR ALL-WEATHER TESTS

Show G-E Speakers Unsurpassed for Long-Life!

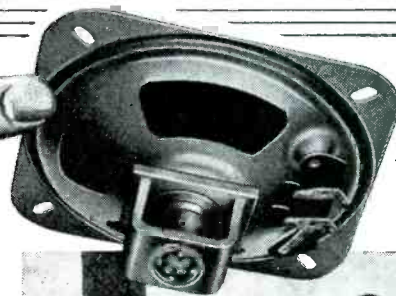

Twenty-seven sizes to choose from... and they're all G-E!

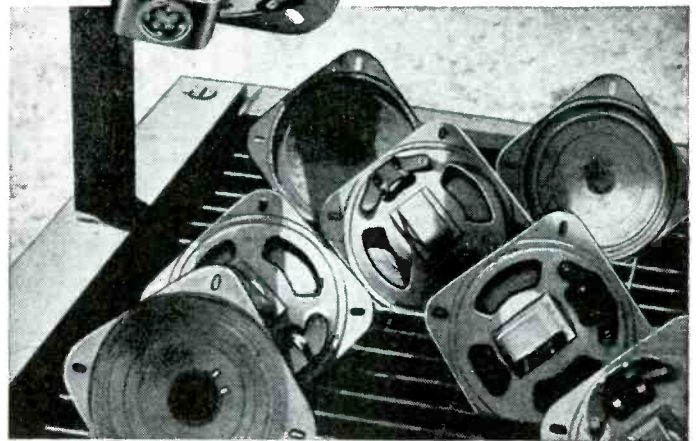

▲ Unretouched photo shows only slight tarnish on speakers. Special G-E plating gives excellent protection to steel frames, none of which were corroded after grueling tests.

★ After two years exposure to hot sun, rain, sleet and snow — with no shelter whatever in any season — 7 out of 8 General Electric speakers played well enough to perform in your radio set!

These recent tests at Electronics Park subjected the speakers to many times the abuse they would receive under years of actual playing conditions, indoors or out. It boils down to one more dramatic proof of this fact: *You can depend on General Electric quality — in design, in engineering, in construction.*

Your customers are entitled to this quality. How are your stocks of General Electric speakers?

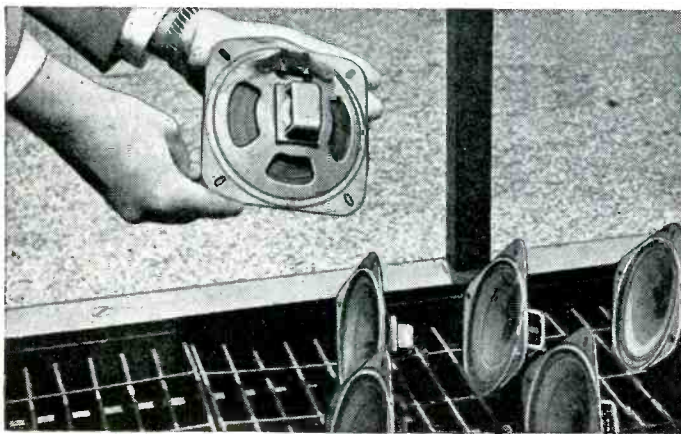

◀ Racked on exposure tray, speakers were checked at intervals for 2 years, then taken apart and examined for wear. Outdoor-type cones were warped only slightly, G-E aluminum voice coils were like new.

STYLUS and CARTRIDGE REPLACEMENT GUIDE

General Electric Co., Section 391
Electronics Park, Syracuse, N. Y.

Yes — send me latest speaker information plus new booklet on G-E Styli and Cartridges.

NAME _____

ADDRESS _____

CITY _____ STATE _____

You can put your confidence in—

GENERAL ELECTRIC

Famous Products by

Jensen

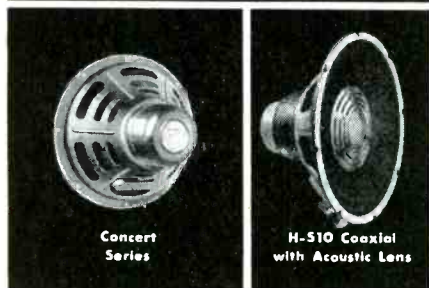

Concert Series

H-510 Coaxial with Acoustic Lens

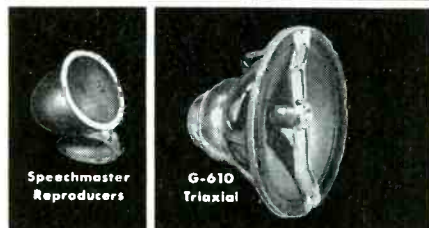

Speechmaster Reproducers

G-610 Triaxial

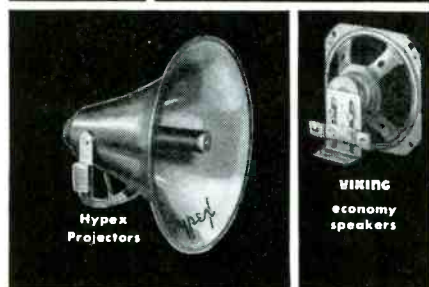

Hypax Projectors

VIKING economy speakers

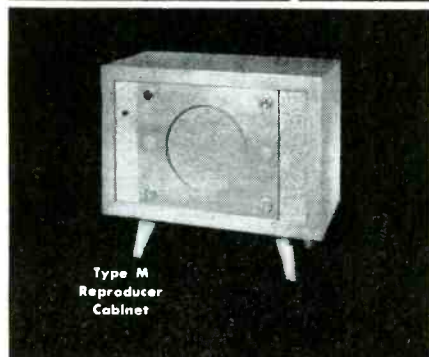

Type M Reproducer Cabinet



Extended Range

Standard Series

Jensen MANUFACTURING COMPANY

Division of the Muter Company
6601 S. LARAMIE AVENUE CHICAGO 38, ILLINOIS

BURTON BROWNE ADVERTISING

Vol. 20, No. 10

RADIO • TELEVISION • ELECTRONIC

SERVICE

October, 1951

LEWIS WINNER
Editor

F. WALEN
Assistant Editor

Registered U. S. Patent Office
Including Radio Merchandising and Television Merchandising

| | Page |
|---|------|
| Association News | 50 |
| Audio Installation and Service (Speaker Characteristics) By Kenneth Stewart | 34 |
| Eight and Twelve-Channel Turret Tuners (Cover). By Wyn Martin | 29 |
| Fringe Reception Requirements. By Bill Claps | 20 |
| Music . . . The Modern Production Tool. By Lawrence J. Epstein | 26 |
| Ser-Cuits (AM/FM Chassis . . . TV Continuous Tuners). By M. W. Percy | 36 |
| Service . . . The National Scene | 17 |
| Servicing AFC Circuits. By Solomon Heller and Peter Orne | 30 |
| Servicing Helps. By M. A. Marwell | 40 |
| Simplified Testers for the Service Shop. By Philip H. Greeley | 22 |
| Ten Years Ago in Associations | 51 |
| Tube News (Wide-Angle Large Picture Conversion). By L. M. Allen | 45 |
| View and News. By Lewis Winner | 15 |

AUDIO INSTALLATION AND SERVICE

| | |
|---|----|
| Selecting Speakers for Broadcast and TV Chassis | 34 |
|---|----|

CIRCUITS

| | |
|---|----|
| Capacitor-Discharge Short-Blower Test Circuit | 24 |
| Capehart, Magnavox and Sylvania Sync Circuits | 56 |
| DuMont 73C Inputuner | 38 |
| Hi-Voltage Neon Tester | 24 |
| Large Picture-Tube Conversion Circuitry | 46 |
| Loudness-Control Circuits | 61 |
| Packard-Bell Sync Amplifier Alterations for Fringe Areas | 42 |
| Parallel-Resistor Neon Tester | 22 |
| Pentode (6AK5 or 6AG5) Permeability Tuned RF Amp | 20 |
| Philco 8-Channel Turret Tuner (Cover) | 29 |
| Philco (48-700, 48-1000, 48-2500 and 49 Series) Revised for Inputuners | 38 |
| RCA BX55 Oscillator-Coil Circuitry | 42 |
| RCA 1R81 AM/FM Chassis | 37 |
| RCA 7T103 Modified for Improved Fringe-Area Pickup | 40 |
| Selenium and Germanium Rectifier Circuits | 42 |
| Stewart-Warner IF Amplifier Changes to Improve Sensitivity and Sync Stability | 42 |
| Triode (6J6 or 12AT7) Permeability-Tuned RF Amp | 20 |

COVER

| | |
|---|----|
| Eight and Twelve-Channel Turret Tuners (Philco) | 29 |
|---|----|

SERVICING HELPS

| | |
|--|----|
| Circuit Revisions for Fringe-Area Pickup | 40 |
| Horizontal Drive Adjustments | 42 |
| Improving Sensitivity and Sync Stability | 40 |
| Oscillator Coil Substitutions | 42 |
| Selenium and Germanium Diode Circuitry | 42 |

Index to Advertisers

| | |
|---|----|
| Manufacturers | 80 |
| Jots and Flashes | 80 |
| News | 65 |
| New Parts . . . Tools . . . Instruments | 63 |
| Rep Talk | 74 |
| TV Parts . . . Antennas . . . Accessories | 49 |



Entire contents Copyright 1951, Bryan Davis Publishing Co., Inc.

Published monthly by Bryan Davis Publishing Co., Inc.

52 Vanderbilt Avenue, New York 17, N. Y.

Telephone MURray Hill 4-0170

Bryan S. Davis, Pres. Paul S. Weil, Vice-Pres., Gen. Mgr. F. Walen, Sec. A. Goebel, Cir. Mgr.
Mid-West Representative: Stuart J. Osten, 333 N. Michigan Ave., Chicago 1, Ill. Telephone: Dearborn 2-3507
East-Central Representative: James C. Munn, 2253 Delaware Dr., Cleveland 6, Ohio. Telephone: ERview 1-1726
Pacific Coast Representative: Brand & Brand, 1052 W. Sixth St., Los Angeles 14, Calif. Tel.: Michigan 1732
Suite 1204, Russ Building, San Francisco 4, Calif. Telephone: SUTter 1-2251

Entered as second-class matter June 14, 1932, at the Post Office at New York, N. Y., under the Act of March 3, 1879. Subscription price: \$2.00 per year in the United States of America and Canada; 25 cents per copy. \$3.00 per year in foreign countries; 35 cents per copy.

JUST OFF THE PRESS! YOU CAN GET IT FREE!

FROM YOUR SYLVANIA DISTRIBUTOR

when you buy 100 Sylvania Receiving Tubes
or 2 Sylvania Picture Tubes!

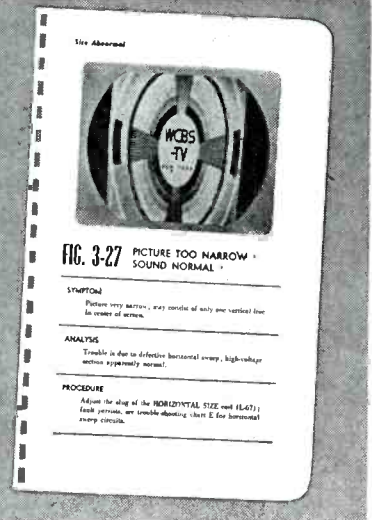
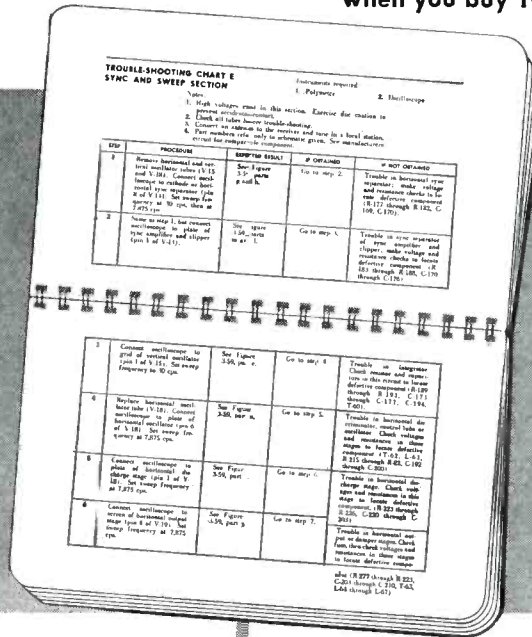
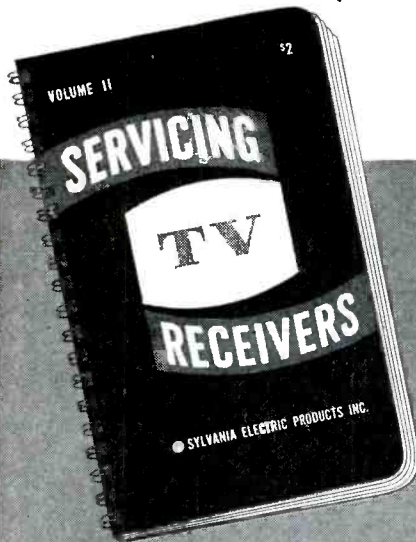

Offer good only Sept. 15, 1951 to Nov. 1, 1951. ACT NOW!

SERVICING TELEVISION RECEIVERS — VOL. II

Not just a revised, brought-up-to-date version of last year's book . . . but a completely new, re-worked volume, prepared by an expert TV servicing-writing team!

Sylvania has long recognized your need for a more advanced, more complete, more systematically organized television service manual. Now, after months of careful preparation, this book is ready . . . VOLUME II, SERVICING TELEVISION RECEIVERS. It's yours FREE OF EXTRA CHARGE when you buy 100 Sylvania Receiving Tubes or 2 Sylvania Picture Tubes.

This new book, written around a popular 1951 TV receiver, contains servicing techniques for all the most recent circuits. Its information applies to most all TV sets in use today. In addition, it contains a systematic method of locating, isolating and correcting troubles . . . by far the clearest, easiest, simplest method yet devised for servicing present day receivers.

Get your FREE service book now. Offer expires Nov. 1. See or write your Sylvania distributor today!

Here's what this volume contains, how it helps you!

How to sectionalize trouble by picture analysis. For this, 41 photographs of abnormal TV pictures and their analyses are presented.

How to isolate faulty stage by use of 6 special trouble shooting charts—one for each section of receiver. Charts give step by step procedure, expected results, action required, instruments required. Charts provided for following sections: power supply, video, sound, sync., and sweep, high-voltage.

How to locate defective part—by trouble shooting charts based on voltage and resistance measurements and tube testing. Actual voltage and current readings to be encountered are listed.

Adjustment and alignment of television receivers. Alignment procedures for rf tuner, video if, sound if and discriminator; adjustment of ion trap, focus coil, deflection coils.

**150 PAGES! 5 BIG CHAPTERS!
80 PICTURES AND DIAGRAMS!
WIRE-O-BINDING keeps book flat!
HEAVY COVER, TOUGH, COATED PAGES
to stand rough, constant handling!**

SEE YOUR SYLVANIA DISTRIBUTOR FOR YOUR FREE COPY TODAY!

SYLVANIA

Sylvania Electric Products Inc.,
Emporium, Pa.



RADIO TUBES; TELEVISION PICTURE TUBES; ELECTRONIC PRODUCTS; ELECTRONIC TEST EQUIPMENT; FLUORESCENT TUBES, FIXTURES, SIGN TUBING, WIRING DEVICES; LIGHT BULBS; PHOTOLAMPS; TELEVISION SETS

NEW PARA-CON ANTENNA COMBINES PARABOLIC & CONICAL PRINCIPLES



Barbara Lee—Rising TV Star, WEWS Cleveland

Sight Sells It

After all, people buy TV sets to enjoy the picture. It just makes sense that the antenna bringing in the best picture brings in the best entertainment and the most customer satisfaction. Hook a Para-Con onto any set and you'll agree—it sells on sight.

Any TV Set Performs Better With a Para-Con Antenna

Every set performs better when conditions are better. Install Para-Con when older sets are starving for a stronger signal. Install a Para-Con when any set is being drowned in a sea of local interference. In the majority of set installations, Para-Con makes both old and new sets perform at their peak. To be on the safe side every time, install the sensationally performing new Para-Con antenna and forestall TV troubles at both the reception and the service end.

Proved in Thousands Of Installations

Spectacular success has been achieved in practically every installation. Even in locations far removed and in difficult terrain where other more elaborate arrays were tried and failed, PARA-CON aerials not only bring in brighter, clearer pictures but seize and channel in stations where dependable reception has not been possible with an ordinary antenna. Ward's new PARA-CON Antenna has been field tested in thousands of installations . . . proved far and away better.

Singles Out The Stations High Front to Back Ratio

The new Para-Con design achieves an unusual capacity to obtain sharp directivity over all the television spectrum. Para-Con principles afford greater power and less interfering noise on each channel.

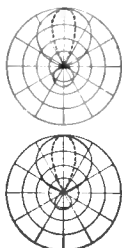

One Antenna Covers All Channels

The Para-Con antenna reaches out and grasps all channels. The Ward Para-Con has an exceptionally low standing wave ratio combined with a spectacular high gain advantage on all channels.

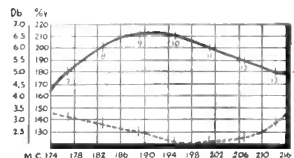
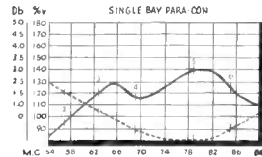

No Ghost Hunts

No more skeletons in your customer's TV closets. Scientifically determined direct impedance matching characteristics eliminate many ghosts. Para-Con's revolutionary design transfers the maximum power from the antenna to the receiver with a minimum of reflections.

Profit-Wise Dealers Prefer Para-Con*

The antenna is one of the most important and critical components of a TV receiver. Nearly 20% of all TV service calls result from faulty antennas. The general all-around, high performance of Ward's Para-Con antenna gives customer satisfaction right from the initial installation. Expensive call-backs due to antennas are slashed. Ruggedly built for long lasting trouble-free service Para-Con withstands winds and weather. Easy to handle and quick to install . . . saves time and expense.

See your distributor for Ward's answer to your antenna problems.

*Trade Mark.

Solves 9 out of 10 Installation Problems—Challenges Comparison

Two best features are incorporated into one BEST antenna. The praiseworthy features conical type aerials possess for supplying full audio and full video bandwidth reception are used with a parabolic design that gives the Para-Con a concentration of signals. Para-Con is engineered to concentrate the maximum wave energy on the antenna by providing all-around, unmatched performance . . . perfect picture clarity . . . long customer satisfaction.

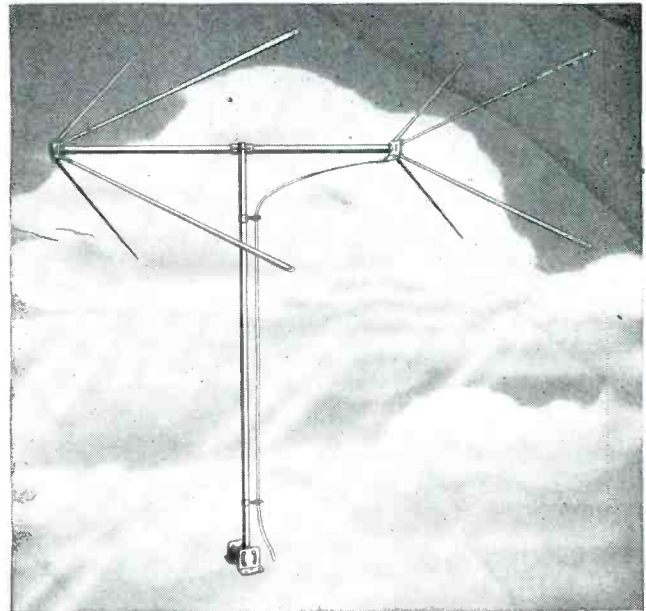

The First In TV To Use Parabolic Principle

Parabolic antennas have long been used in special applications for concentrating weak signals onto driven elements. The brilliant results of Ward Para-Con are now setting new performance standards on all channels and in most every area. Ward's Para-Con Antenna is different. It's new. Now it is possible for one antenna to meet and solve many of the local problems of installation and reception.

Ideal For All Band Fringe Areas

In fringe areas where selection of a number of channels is available, Ward's stacked Para-Con models provide the ideal compromise antenna for maximum results on all bands. Stacked in either two or four bay arrays, the Parabolic design reflectors reach out, gather and concentrate maximum energy on the antenna elements.

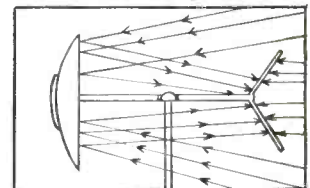

Diagrammatic sketch showing how parabolic reflectors gather in and concentrate energy on conical elements.

WARD

PARA-CON

(Combining Parabolic and Conical Principles)

ANTENNAS

THE WARD PRODUCTS CORPORATION, Division of The Gabriel Co.
1523 E. 45th Street, Cleveland 3, Ohio
IN CANADA: ATLAS RADIO CORP., LTD., TORONTO, ONT.

JUST DIAL THE TYPE...

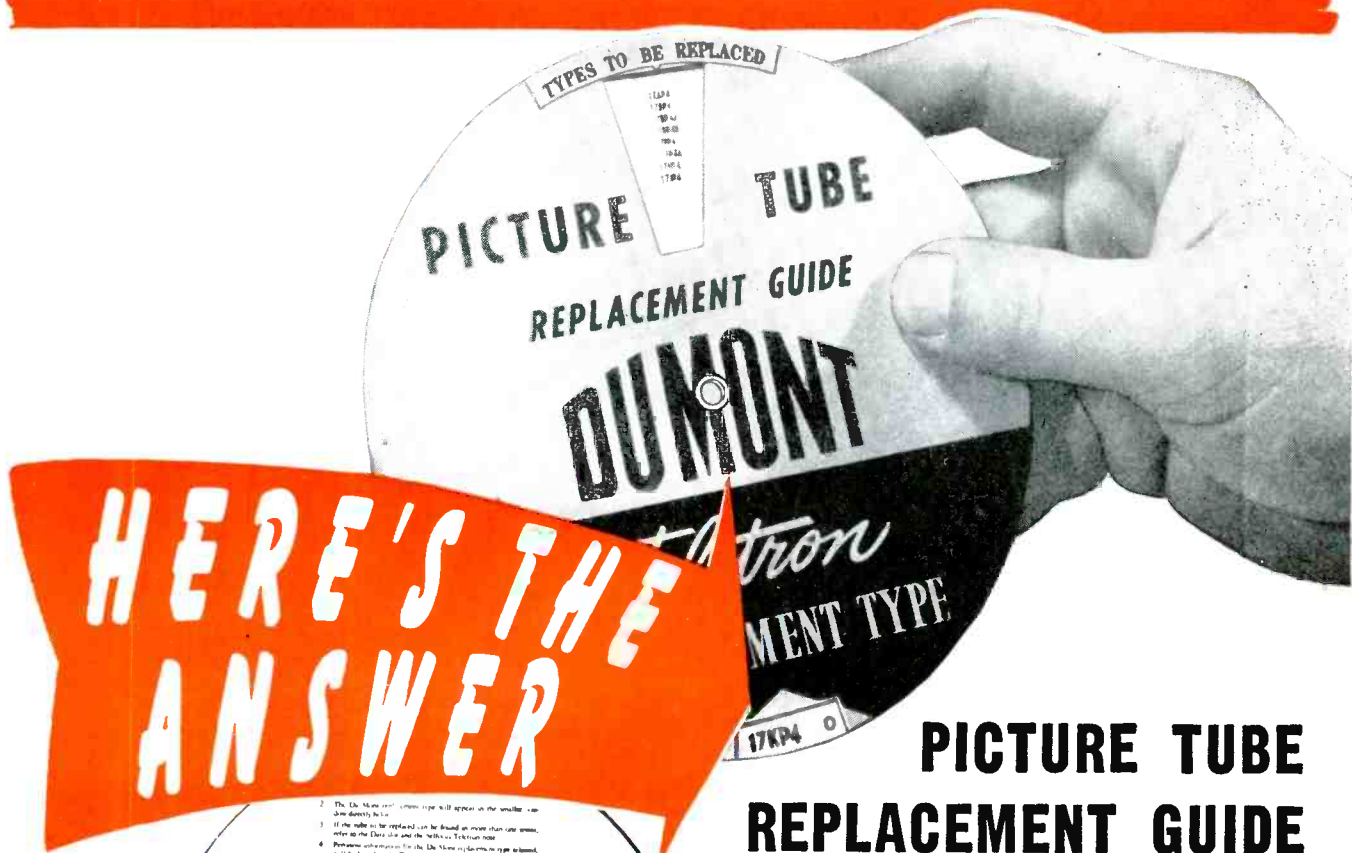

HERE'S THE ANSWER

PICTURE TUBE REPLACEMENT GUIDE

No thumbing through pages and comparing characteristics to arrive at the correct replacement — merely turn the dial to the desired tube type and PRESTO! there's the correct replacement type. These Du Mont TV Picture Tube Selectors are available through your Du Mont Teletron distributor. Get yours today.

DATA

| Model | Bracket | Temp. | Temp. | Max. Cathode | Fast Burnout |
|-------|---------|-------|-------|--------------|--------------|
| 18B74 | 70" | Co. | 165/8 | 200 | 10 |

CODE KEY

- RT: Rectangular
- CT: Cold Cathode
- GT: Green Glass Face Plate
- ET: External Conductive Coating

NOTES

- All Du Mont Teletron replacement types listed comply with the standard 3 pin standard base.
- All Du Mont Teletron replacement types listed comply with the standard 10 pin standard base.
- In selecting a replacement type, check the pin configuration and the base type.

THE SELFOCUS TELETRON

Several adjustments may be required by using the Selfocus Teletron for replacement. Operation is as usual. Focus and scan are adjusted by changes in grid voltage as in the following instructions.

To replace the Selfocus Teletron for a tube on which a Selfocus Teletron has been used, simply remove the P.T. and replace the picture tube.

Final adjustment of the Selfocus Teletron system should be made after the picture tube is in place and the television set is in normal operation.

If a replacement is required, the replacement should be made in accordance with the instructions on the replacement type.

Cathode-ray Tube Division
 ALLEN B. DU MONT LABORATORIES, INC.
 750 Bloomfield Avenue, Clifton, N. J.

Electrical characteristics of each replacement type are shown on the rear of the Selector when the type is dialed. This is the information necessary for those conversion jobs that spell profits for you.

ASK YOUR DU MONT DISTRIBUTOR

CATHODE-RAY TUBE DIVISION
 ALLEN B. DU MONT LABORATORIES, INC.
 CLIFTON, N. J.



*TRADE MARK



THE LITTLE INDIAN SAYS.

For All TV Replacements Use Sangamo "Twist-Tab" Capacitors!

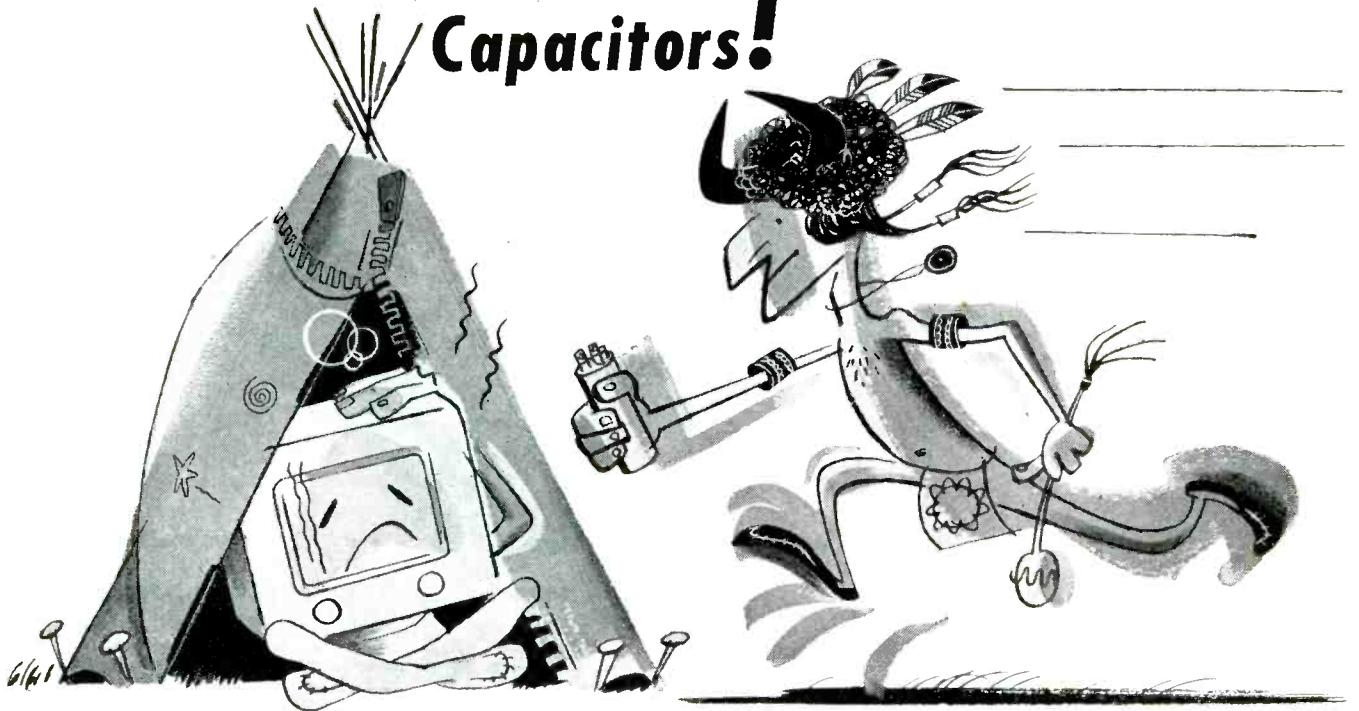

Sangamo Type PL Electrolytics



Sangamo Type PL "Twist Tab" Electrolytics are *exact replacements* for all television sets or any other application requiring long life and dependable performance at 85° C under conditions of extreme ripple currents and high surge voltages.

Sangamo "Twist Tabs" are available in a wide range of capacities and voltages. They are sealed in round aluminum cans and have twist-prong tabs for washer or direct chassis mounting.



Ask your Sangamo Distributor for a copy of the new Sangamo TV Replacement Catalog. It's easy to read, easy to use, and provides one point ready reference.

Your Assurance of



Dependable Performance

SANGAMO ELECTRIC COMPANY

SPRINGFIELD, ILLINOIS

IN CANADA: SANGAMO COMPANY LIMITED, LEASIDE, ONTARIO

SCSI-8A

*Largest
Selling Booster*

AT ANY PRICE!





They may
look alike - be shaped alike
 but **National Video**
 picture tubes deliver
 better performance

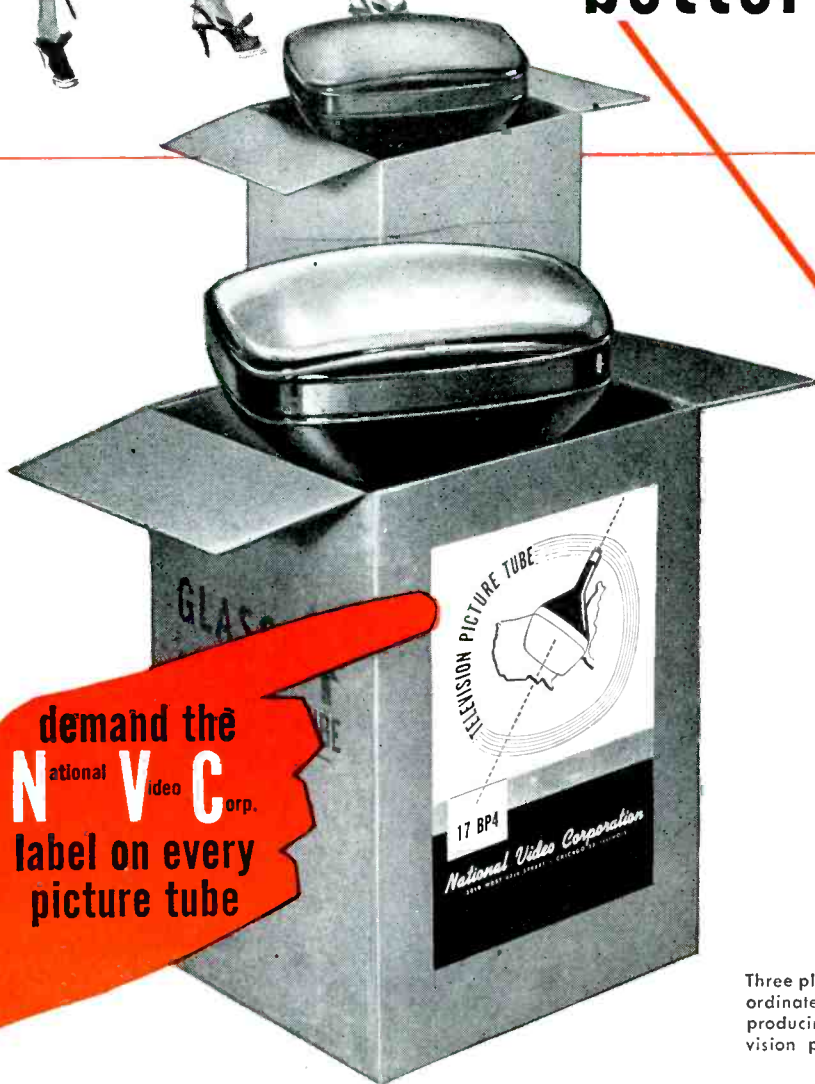

better components
better processing
better assembly

Through every step of manufacturing—
 perfection—that's why the N. V. C.
 picture tube delivers the better
 performance. Designed for conversion
 and replacement in every standard make
 television set and engineered to
 give even a clearer, better and
 more lasting picture.

Write for the name of our
Representative nearest you.
 3019 W. 47th St. Chicago

You will quickly see
it pays to tie in with N. V. C.

Three plants with over 17 acres of co-
 ordinated machinery and personnel,
 producing the world's finest tele-
 vision picture and receiving tubes.



National Video Corporation

3019 W. 47th St.
 Chicago

Grays Lake
 Illinois

901 W. Huron St.
 Chicago

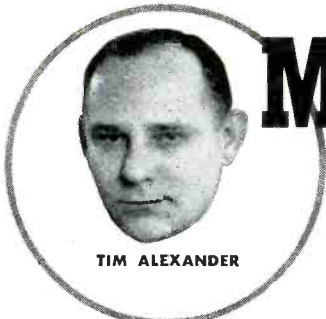

TIM ALEXANDER

Motorola



MAX SCHINKE

Admiral



FRANK SMOLEK

ZENITH



FLOYD MAKSTEIN

Emerson

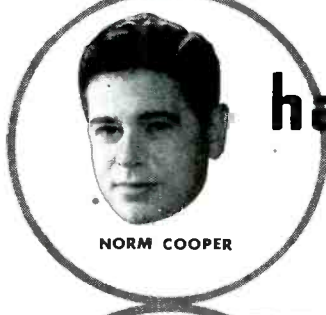

NORM COOPER

hallicrafters

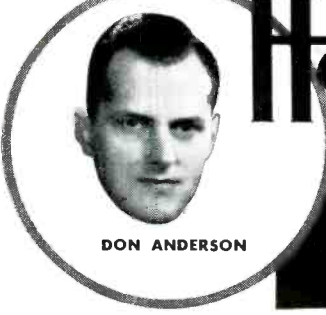

DON ANDERSON

Hoffman

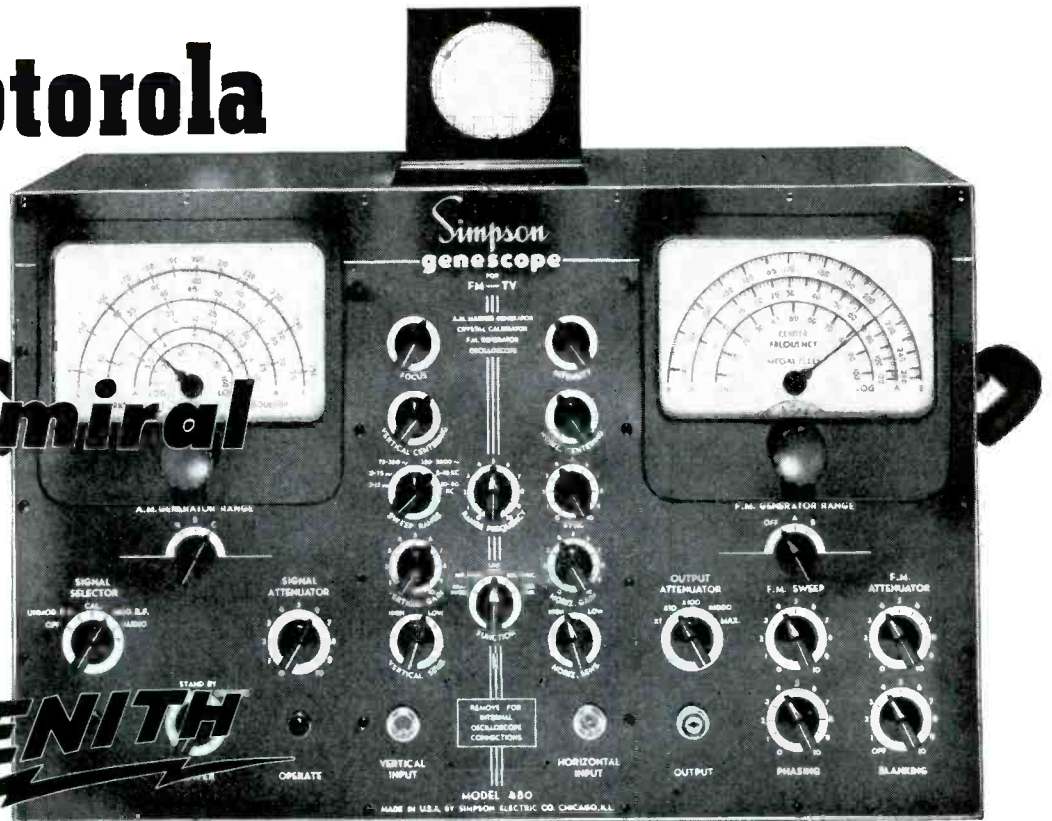

LEADING EXPERTS
RECOMMEND

Simpson Model 480 GENESCOPE for TV-FM Servicing

These leading manufacturer's service managers agree — the Simpson Model 480 Genescope is perfectly designed for proper testing, servicing and alignment of all TV and FM receivers!

THE SIMPSON MODEL 479 TV-FM SIGNAL GENERATOR

Exactly the same circuits, ranges and functions as the Model 480, with the exception of the oscilloscope.

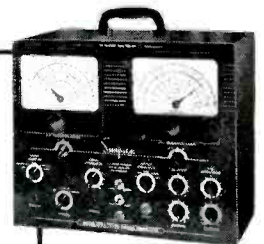

BURTON BROWNE ADVERTISING

Simpson ELECTRIC COMPANY

3200 West Kinzie Street • Chicago 44, Illinois • Phone: COLUMBUS 1-1221

In Canada: Bach-Simpson, Ltd., London Ontario

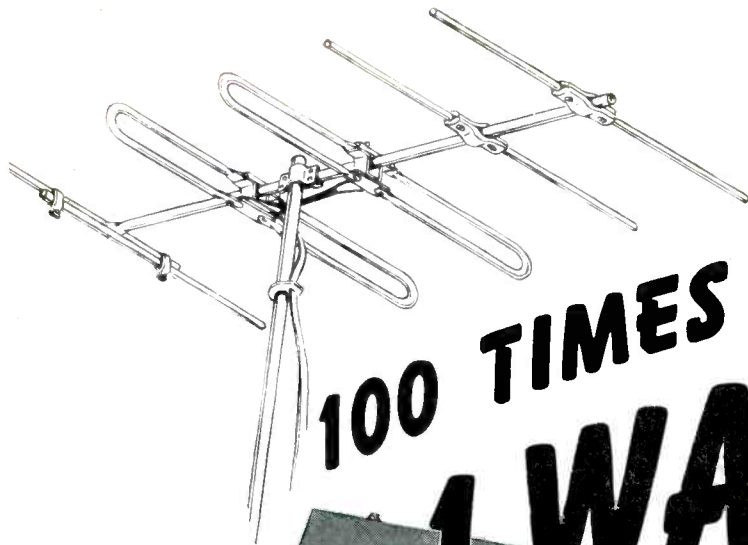

**100 TIMES THE POWER -
1 WATT Output**

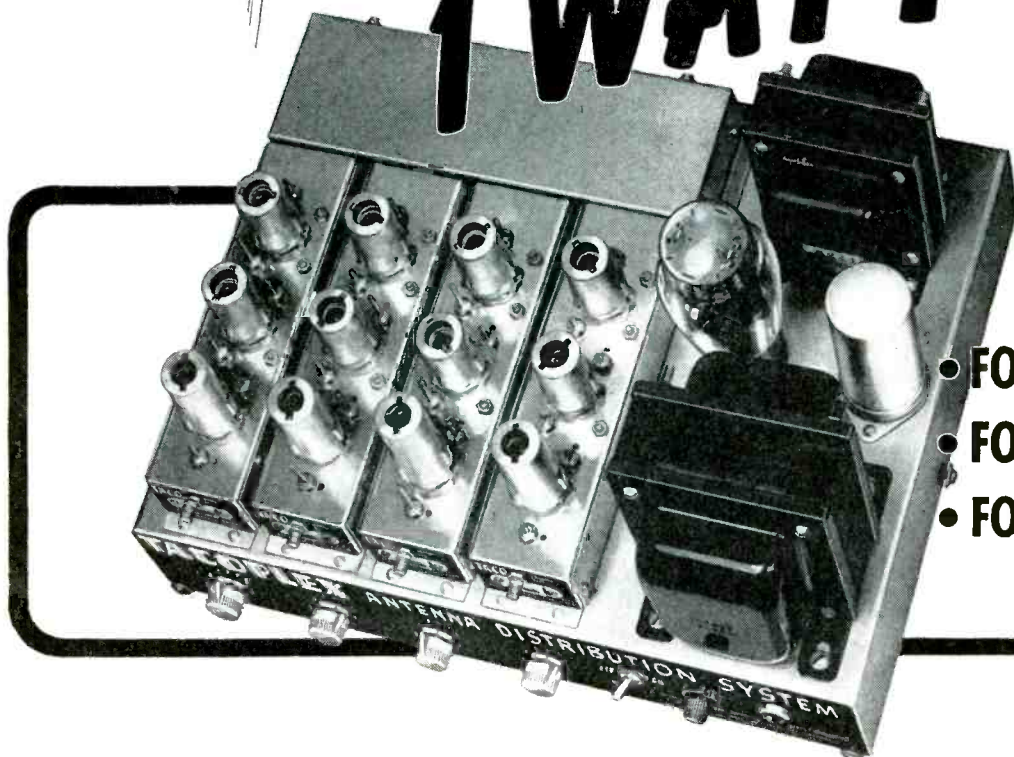

- FOR COMMUNITIES
- FOR APARTMENTS
- FOR STORES

TACOPLEX

MASTER ANTENNA DISTRIBUTION SYSTEM

The master antenna system that fills all needs — Up to one full watt of undistorted power output for those long runs necessary in community and larger apartment house installations. The high gain of the Tacoplex System is ideal for fringe area use. A full line of component-assemblies provides great flexibility in initial setup as well as future growth of the system. Fully UL Approved.



TACOPLEX

TECHNICAL APPLIANCE CORPORATION

SHERBURNE, N. Y.

TV, FM, and AM, Antennas and Antenna Systems

In Canada:
Stromberg-Carlson Co., Ltd.,
Toronto 4, Ont.

You get all five...with RCA Batteries



1. **RADIO TRADE DISTRIBUTION**

(less competition from non-radio outlets)

2. **Radio-Engineered Quality**

3. **Top Brand Acceptance**

4. **Greatest Array of Selling Aids**

5. **Completely Rounded Line**

You get 5-Way Help when you stock and sell RCA Radio Batteries . . . the line that's geared to the radio trade.

Radio Trade Distribution means less competition from non-radio stores in your area. It means your RCA Battery customers come back to you again and again. *More repeat sales. Better profits.*

Radio-Engineered Quality means increased customer satisfaction because of longer battery life . . . *extra listening hours. Satisfied customers are repeat customers. Bigger sales. Better profits.*

Top Brand Acceptance means faster sales because customers are pre-sold on the RCA name. People know and trust every product that bears the famous RCA monogram. *Bigger sales. Better profits.*

Greatest Array of Selling Aids means plenty of sales help right at the point of purchase. Signs, displays, merchandisers, and servicing aids . . . all these help you sell the RCA battery line. *Bigger sales. Better profits.*

Completely Rounded Line means you can fill practically every battery requirement. This complete line provides a type for almost every portable and farm radio need. *More sales. Better profits.*

Contact your local RCA Battery Distributor today. You'll find out how profitable it is to switch now to RCA . . . the battery line that's geared to the radio trade.



RADIO CORPORATION of AMERICA
RADIO BATTERIES **HARRISON, N. J.**

THE NEW PRECISION CR-30 CATHODE RAY TUBE TESTER

TESTS ALL TV PICTURE TUBES

(MAGNETIC AND ELECTROSTATIC)

'SCOPE TUBES AND INDUSTRIAL CR TYPES

for True Beam Current (Proportionate Picture Brightness)
Tests ALL CR Tube Elements—Not Just a Limited Few

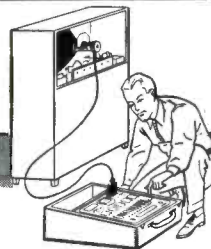

IN FIELD OR SHOP
Tests CR Picture Tubes
Without Removal from
TV Set or Carton!

The new Precision CR-30 fills an obvious gap in the test equipment facilities employed by TV service and installation technicians.

Because of the absence of a reliable cathode ray tube tester, up to 50% of so-called "rejected tubes" are found to be fully serviceable and should rightfully never have been "pulled out."

Proven product of extended development, the CR-30 has been

specifically engineered to answer the question, "Is It the TV Set or is it the Picture Tube?"

The Precision CR-30, a complete and self-contained Electronic Instrument, incorporates a TRUE BEAM CURRENT Test Circuit. The CR-30 checks overall electron-gun performance for proportionate picture brightness as well as additional direct testing facilities for accelerating anodes and deflection plate elements.

The Precision CR-30 should not be confused with mere adapters connecting to ordinary receiving tube testers which were never designed to meet the very specialized needs of CR tube checking. Similarly, it is not to be confused with neon-lamp units or similar devices of limited technical merit and which do not check all CR tubes or all tube elements.

GENERAL AND TECHNICAL SPECIFICATIONS

- ★ Tests All Modern Cathode Ray Tubes:—Magnetic and Electrostatic, 'Scope Tubes and Industrial Types.
- ★ Tests All CR Tube Elements:—Not just a limited few.
- ★ Absolute Free-Point 14 Lever Element Selection System, independent of multiple base pin and floating element terminations, for Short-Check, Leakage Testing and Quality Tests. Affords maximum anti-obsolescence insurance.
- ★ True Beam Current Test Circuit checks all CR Tubes with Electron-gun in operation. It is the Electron Beam (and NOT total cathode emission) which traces the pictures or pattern on the face of the CR tube.

Total cathode emission can be very high and yet Beam Current (and picture brightness) unacceptably low. The CR-30 will reject such tubes because it is a true Beam Current tester. Conversely, total cathode emission can be low and yet Beam Current (and picture brightness) perfectly acceptable. The CR-30 will properly pass such tubes because it is a true Beam Current tester. The significance of the above rests in the fact that Beam Current (and picture brightness) is primarily associated with the condition of the center of the cathode surface and not the overall cathode area. (See illustration below)

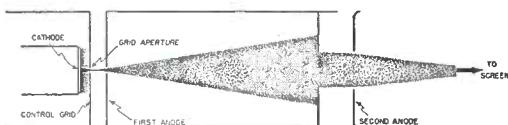

- ★ Voltage Regulated, Bridge Type VTVM provides the heart of the super-sensitive tube quality test circuit. Such high sensitivity is also required for positive check of very low current anodes and deflection plates.
- ★ Micro-Line Voltage Adjustment
Meter-monitored at filament supply.
- ★ Accuracy of test circuits closely maintained by use of factory adjusted internal calibrating controls; plastic insulated, telephone type cabled wiring; highest quality, conservatively rated components.
- ★ Built In, High Speed, Roller Tube Chart.
- ★ Test Circuits Transformer Isolated from Power Line.
- ★ 4 5/8" Full Vision Meter with scale-plate especially designed for CR tube testing requirements.
- ★ Heavy Gauge Aluminum Panel etched and anodized.
- ★ PLUS many other "PRECISION" details and features.

SERIES CR-30—In hardwood, tapered portable case, with hinged removable cover. Extra-Wide Tool and Test Cable Compartment. Overall Dimensions 17 1/4 x 13 3/4 x 6 3/4". Complete with standard picture tube cable, universal CR Tube Test Cable and detailed Instruction Manual.

Shipping Weight:—22 lbs. Code: Daisy
NET PRICE:—\$99.75

See the new CR-30 on display at leading electronic equipment distributors. Place your orders now to assure earliest possible delivery.



PRECISION APPARATUS CO., INC.

92-27 Horace Harding Boulevard, Elmhurst 6, New York

Export Division: 458 Broadway, New York, U.S.A. Cables—Morhanex
In Canada: Atlas Radio Corp., Ltd., Toronto, Ontario

Double Barreled PROFITS with Louis Bros.

**"picture perfect"
antennas**

NEW

"SELF-LOCK"
CONSTRUCTION
cuts time

NEW

ANTENNA
INSURANCE
makes sales

*No Tools, No Screws,
No Wing Nuts,*



and they're insured

**SWING-OUT ELEMENTS
LOCK INTO POSITION!**

With just a flick of the wrist, all elements swing out and automatically lock securely and permanently into place, giving positive electrical contact. You need absolutely *no hardware, no tools, no time!* So simple a *child* could assemble it!

This revolutionary new development in assembly design is an exclusive feature of Louis Bros. Series 400 Picture-Perfect Antennas.

Every Louis Bros. "Picture Perfect" Antenna is covered by the St. Paul Mercury-Indemnity Co. *at no cost to you.* An individual insurance certificate is enclosed with each package. You'll find this *extra* protection to your customer a powerful talking point in selling *more* installations. We provide you with window decals and other effective point-of-sale display to help you get this important story across.

*Look!
No Tools
Needed*

Louis Bros.

**"picture perfect"
antennas**

3543 E. 16th St., Los Angeles 23

Order Louis Bros.
Picture-Perfect Antennas
from your jobber today!

*The Insured Antenna
With Assured Performance*



The Television and Radio Service Dealer who can point with pride to his Raytheon Bonded Electronic Technician Certificate . . .



customer confidence with his Bonded, cash-protected method of doing



business . . . who can instantly



identify himself to his customers with the

Raytheon Creed Display, the Bonded Decal and the Raytheon Bonded Identification Card

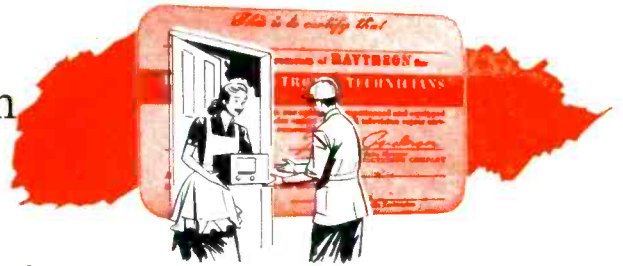

. . . is the Service Dealer whose business is booming.

If your business is bogged down, better ask your Raytheon Tube Distributor if you can



qualify for this Raytheon

Bond that costs you nothing, but

adds plenty to your cash receipts.



RIGHT... FOR SOUND AND SIGHT®



RAYTHEON MANUFACTURING COMPANY

Receiving Tube Division

Newton, Mass., Chicago, Ill., Atlanta, Ga., Los Angeles, Calif.

Excellence in Electronics

RADIO AND TELEVISION RECEIVING TUBES, CATHODE RAY TUBES, SPECIAL PURPOSE TUBES, SUBMINIATURE TUBES, MICROWAVE TUBES

RADIO • TELEVISION • ELECTRONIC
SERVICE

Custom Installation Popularity

ONE OF THE MOST dependable and profitable enterprises of service shops in the early days of listening—*custom installations*—whose popularity had dwindled to a depressing low during the immediate postwar period, has regained its appeal and is streaking along to the limelight position it occupied for so many years.

Three factors appear to be specifically responsible for the enthusiastic return: striking improvements in audio systems, increased size of direct-viewing picture tubes and the reactivated building and renovation era. Several shop operators have found the new interest to be so keen that they've begun to devote full time to the effort. In Chicago, a few Service Men and former setmaker engineers have developed a lively following not only in their own town, but throughout the middle west, installing complete audio and TV systems priced as high as \$1,000 and more. The operators of this custom project have found that there is still a dominant interest in good music and a corresponding need for reproducing systems that feature ultra high-fidelity results. As a result they have designed an assortment of speaker and amplifier setups which can be worked into a wide variety of room arrangements to satisfy the audio tastes of the man of the house, as well as the decorative requirements of Mrs. Consumer.

Even video has been blessed with considerable planning, with the equipment being placed in either special cabinets or within the wall to provide best viewing.

The built-in wall theme has become a particularly popular type of service for the custom-shop operator. Originated in the early days of television, but restricted in its application because of small screens, today it is an extremely lively practice featuring, in the main, the use of the larger type

of direct-viewing tubes. Some shops have continued to feature the use of projection, feeling that it is possible to secure a large and more attractive acceptable type of picture for the home owner. Several Service Men have conceived extremely interesting and novel methods for installation with striking decorative possibilities. In one instance, there has been evolved an automatic technique featuring receiver and picture operation through the facilities of a single switch. With the switch in *on* position, a framed picture mounted in front of the tube recedes into the wall, and the receiver is automatically turned on. In the *off* position, the picture tube slides back into position, and the framed picture comes into view. The technique has been acclaimed by so many that the possibilities of complete wall-picture kits are being considered. Such kits would contain a picture track, motor, frame-enclosed print, switches, etc. In addition, there would be provided a remote control which would permit tuning from any position in the room.

In some instances, Service Men have featured the custom installation of two TV sets, operating from a single antenna. Chassis with the smaller tubes which no longer are identified by the 10-inch variety, but rather by the 14- and 16-inch type, and larger-screen models using 19-, 20- or 24-inch tubes, represent the normal complements of the custom two-set package.

Some manufacturers have noted the return trend to the custom installation, and are producing receivers and associated components which include high-fidelity speaker and phono systems. In other instances, only chassis are being marketed and accompanied by descriptions of flexible arrangements possible with a variety of speaker and phono assemblies.

With the return of custom installations, the Service Man has been pro-

vided with another effective tool which can produce many profitable entries in the ledger.

Red and Black Conversions

WITH THE DEVELOPMENT of extensive lines of large-type picture tubes, Service Men have become more conscious than ever of conversion possibilities. And with the announcements that there are also available all of the accessories required to complete the conversion projects, the interest has really skyrocketed.

In the past, the larger tubes have been installed with the aid of an assortment of components. Unfortunately, many of the early-type conversions were not always satisfactory because of an inept choice of components, and also a lack of familiarity with the original circuit. As a result, in many instances, there appeared a continuing flow of complaints requiring callbacks, complaints which noted inadequate picture size, jumpy pictures and distortion at maximum positions of contrast and brightness, all due to the fact that in the original circuitry no provisions had been made for the wider angle and larger viewing areas of the picture tubes. And the random parts, selected for the modifications, aggravated the situation.

The kits now available for conversion have been carefully selected and developed to take into consideration many of the circuit variables which existed in the early chassis. As always, to guarantee affirmative results, Service Men must still be sure that they understand the circuits involved so that they can intelligently modify not only the deflection and yoke systems, but the allied circuits, if necessary, to provide reliable reception, and eliminate any possibility of callbacks. Today, all conversions can be successful; the proper parts are available and the installation know-how can be provided by Service Men thoroughly familiar with circuits.—L. W.

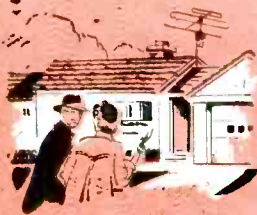

... Seen the Most in hundreds of thousands of TV homes — Alliance Tenna-Rotor is the universal favorite everywhere!

TAKE A DRIVE AROUND ANY TV TOWN—SEE FOR YOURSELF! AND, THAT'S WHY THE ALLIANCE BOOSTER'S SO POPULAR TOO!



... Seen the Most because they're demonstrated right in the homes of 35 million television viewers! Both the Alliance Booster, Tenna-Scope, and Alliance Tenna-Rotor film Commercials deliver an impact that's terrific — repetitive — continuous! And, they deliver that impulse to buy!

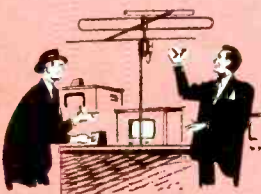

... Seen the Most on the sales counters of smart dealers! IT PAYS TO DISPLAY ALLIANCE PRODUCTS BECAUSE THEY'RE SEEN THE MOST AND SOLD THE MOST!

NOTE: Alliance Tenna-Rotor is a TV Antenna Rotator. Alliance Tenna-Scope is a TV Booster.

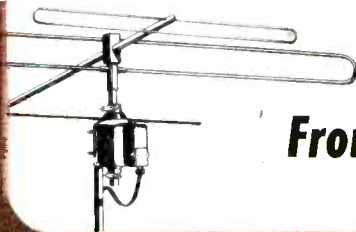

From Coast-to-Coast

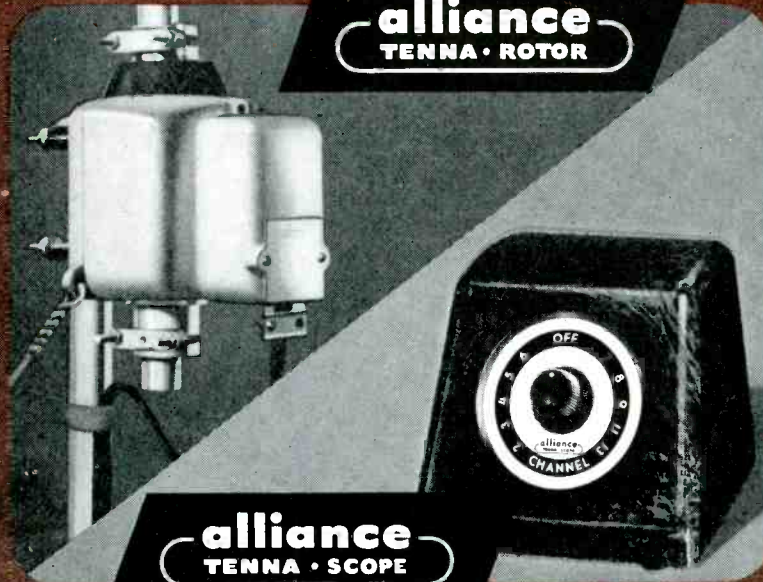

Sold the Most

BECAUSE THEY'RE

Seen the Most

*M*illions of free home demonstrations make sales! Thirty-five million viewers see Alliance TV Films in 12 million homes every week! Both Tenna-Scope, the Alliance Booster, and the famous Alliance Tenna-Rotor enjoy unequalled exposure to viewers in the major TV markets where you sell!

ALLIANCE MANUFACTURING COMPANY • Alliance, Ohio

SERVICE...The National Scene

RTMA SERVICE PLAN APPLAUDED AND CENSURED--A program offered by industry's manufacturing association, designed to solve problems arising from TV servicing and featuring the retaining of a full-time liaison expert to coordinate practices and policies between setmakers and Service Men, has found many enthusiastic supporters as well as many sharp critics. Among those who felt that the plan was not satisfactory were prexies of the service groups in Chicago, as well as the state federation in Pennsylvania. The midwestern association head declared that the plan did not adequately solve difficulties with service-data distribution, warranties and distributor operation. According to the chairman of the eastern servicing group, the problems of chassis design and corrective servicing notes have not been provided for effectively in the program. Spokesmen for the industry association have indicated that it will be impossible to answer individually the complaints fired at them, but that positive action will be taken to solve definitely each of the problems posed by servicing organization leaders. The first step in this direction was the appointment of E. W. Merriam, former chairman of the RTMA service committee, and formerly DuMont service manager, as service manager for the association. It will be his task to promote training courses for Service Men, suggest training-course programs, and work with representatives of Service Men's organizations throughout the country.

LICENSING PROPOSAL REJECTED IN MILWAUKEE--A municipal ordinance which sought to impose licensing restrictions on Service Men in Milwaukee was shelved by the city councilmen after a meeting with members of the local dealers associations, BBB and servicing groups. It was explained that there are plans afoot which will guarantee voluntary corrections of all difficulties that the legislation sought to erase. In a biting rejoinder against the bill, NEDA's executive vice prexy, Lou Calameras, declared that too often the independent Service Man has been required to bear the total responsibility of defective TV sets; whereas, criticism should be directed against other branches of the industry which should be held accountable for many of the problems blamed on the Service Man.

L. A. N. Y. TV LICENSING MEASURES PRAISED BY SERVICE GROUPS--In Los Angeles and in New York, as well as Philadelphia, bills which would provide legal policing of TV Service Men have been heartily approved by association leaders. According to the chairman of the educational committee of PRSMA, licensing of electronic Service Men would lead to the betterment of the technical servicing profession. Agreeing that licensing does not guarantee technicians of superior quality, ability or virtue, the program does provide that in the future the Service Man will be better equipped by education and practice to do his job more competently, and earn the continued respect and financial responsibility to which he is entitled. A Pacific coast motion, which was passed overwhelmingly, was described as insuring accurate servicing by Service Men qualified through experience and examination. The New York City proposal was noted as being the only salvation for the legitimate independent Service Man by the association's prexy, who emphasized that only licensing can force incompetent, financially irresponsible Service Men to retire from the scene.

SETMAKERS PARTS WARRANTY PRACTICES DECLARED MISLEADING--In a blistering attack on the imposition of parts warranties on the price of TV receivers, the prexy of NARDA declared recently that such practices conflict with public interest because . . . "The public is often of the mistaken belief that this warranty gives a measure of service protection, when actually it only applies to the picture tube or other parts which the consumer is not qualified to examine for flaws, remove from the set, or replace."

SERVICE...The National Scene

UHF-COLOR CHASSIS PROVISIONS REVEAL INTERESTING DEVELOPMENTS--In an effort to produce receivers that may eventually be used for channels 14-83, and receive mechanical color, manufacturers have begun to include and indicate that they will provide unique circuitry up front, as well as in the output, to permit such pickup. One of the most interesting developments to appear on the ultrahigh scene has been a full-range tuner which not only provides for twelve-channel very high performance, but uhf switch positions which can change the tuner to an amplifier for ultrahigh if. In the ultrahigh position the tuner becomes a low-noise 41-mc amplifier for 41-mc if models, and a 130-mc amplifier for 21-mc chassis. In the latter instance, the designers report, a double superhet system is used for uhf. Other features of the tuners include a bandpass bandwidth of 8-mc, and a crystal mixer matched for rf and if impedances.

CANADIANS ADOPT CAR-RADIO SERVICE-RATE SCHEDULE--Up in Okanagan, Canada, there is now an auto-radio installation schedule in force which provides for a minimum charge of \$1.75 for the removal of a receiver involving repair and reinstallation, with an additional charge at the rate of \$3.50 an hour if more than 15 minutes are required for the repair. If a simple receiver is to be installed, there is a minimum charge of \$4.50, with \$3.50 charges being made thereafter. For antenna installation, the \$3.50 rate was described as being a minimum.

SERVICE CLUB IDEA GROWING--Cooperative programs featuring a membership service plan involving an annual cost of \$10, appear to be winning favor among many around the country. In Chicago there is in operation a so-called TV service club which is said to have a membership of many thousands. According to the officers, home service calls are billed at \$1.95; whereas, shop jobs are charged at a \$4.95 rate. A standard outdoor-antenna installation costs \$19.95. Any additional parts required, other than those required for the antenna, are sold to members at a 20 per cent discount. Picture-tube warranties are also included in the plan with a charge of \$7.95 for a 10-inch tube, \$9.95 for a 12-inch tube, \$11.95 for a 16-inch tube, \$14.95 for a 19-inch type, all on a one year basis. In view of increased costs, the \$4.95 charge may be increased to \$6.95 very soon. The group has reported that the service has been found so satisfactory that over 80 per cent of their subscribers have renewed membership.

WESTERN NEW YORK GROUP FORMS ASSOCIATION--The founding of an association of TV and service organizations, whose specific purpose would be to improve relations with manufacturers, and provide the public with a better understanding of the charges for service, is now underway in Buffalo. It is expected that about 40 shops may eventually participate, and that the first move will be to prepare a chart of standard prices for common services which will serve as a guide for the shops as well as the consumer. Other plans of the group include the preparation of a proposal directed to manufacturers requesting that they pay part of the installation costs and continue to supply replacement parts required in receivers during the warranty period.

N. Y. SERVICING GROUP OPENS CLUB ROOM-CLINIC--To promote spirited interest in association activities and make it possible for members to discuss technical problems and find solutions by actually making tests on typical gear, the Associated Radio Television Servicemen of New York have established what is believed to be the first club room and service clinic, which will be open seven days a week. Located in downtown New York City, and designated as the official headquarters of the association, the room has been not only set up for trouble-shooting studies, but as a library with a substantial assortment of the latest in the technical book world. The association certainly merits a resounding round of applause for this enterprising move, which will not only be beneficial to all the members of the group, but afford a striking example for others to follow--L. W.

ANCHOR Boosters

First in Preference!
First in Fringe
Reception!

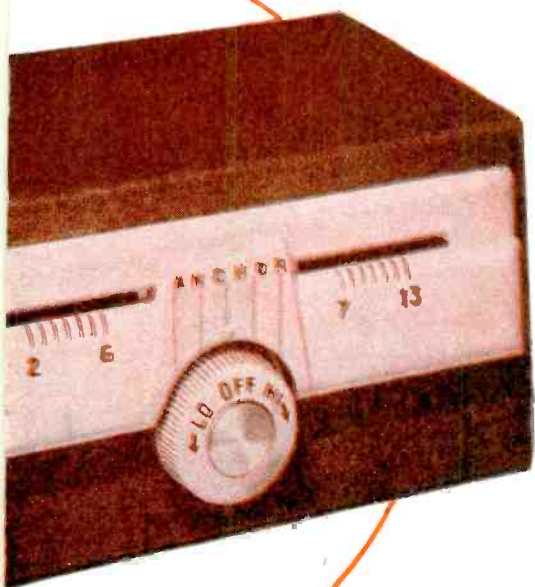

REACHING NEW

horizons

*Anchor engineering
always a year ahead!*

ANCHOR RADIO CORP.

2215 SOUTH ST. LOUIS AVENUE
CHICAGO 23, ILLINOIS

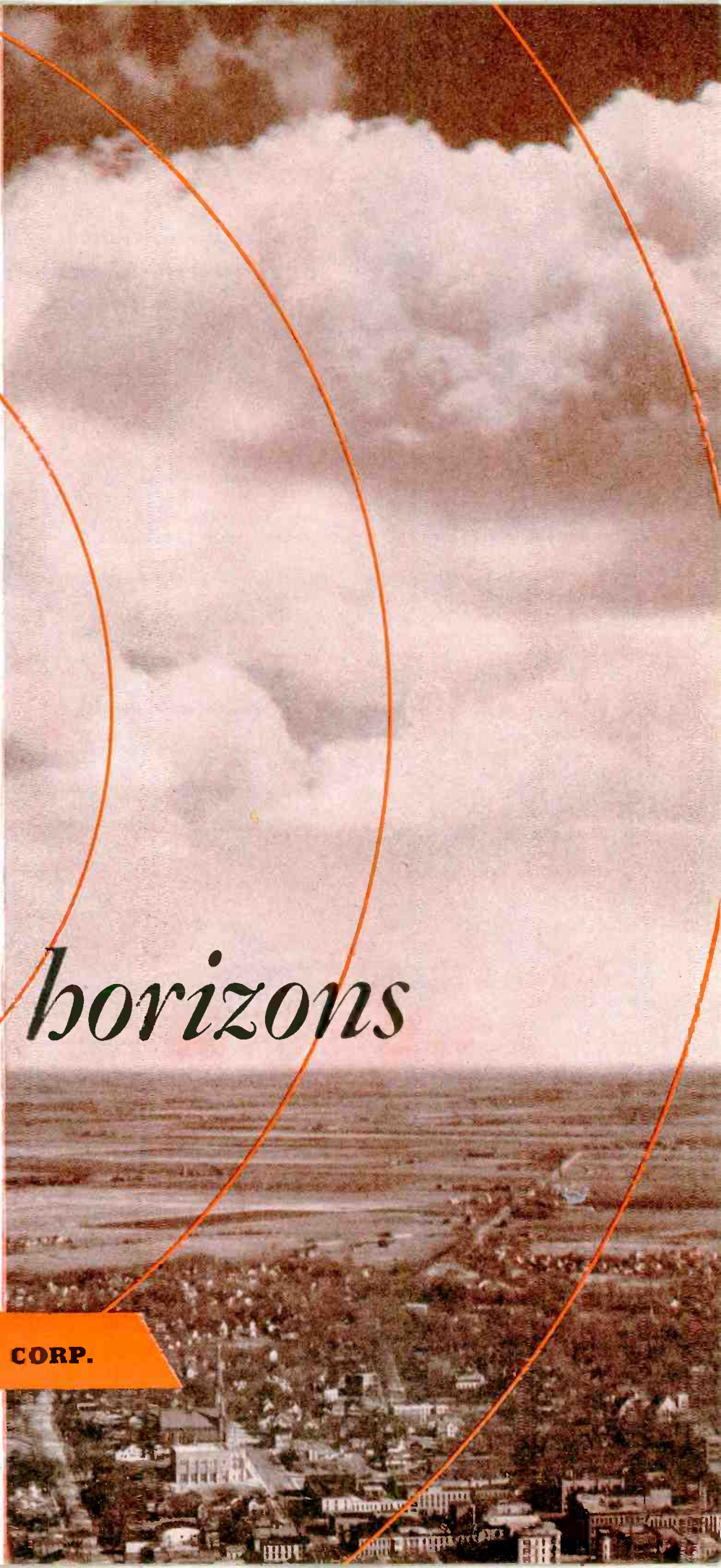



Fringe Reception

Report on Characteristics of High-Gain Boosters and Properly-Aligned Receivers Revealed by Field Tests to Play Key Role in DX Pickup.

(Left)

Bill Claps checking 6J6 and 6AK5 boosters after 50-mile field test.

FRINGE AREAS, envisioned as a land of opportunity for Service Men, have been found to be truly a world of unlimited possibilities, not only in sales, but in installation and service.

To insure fringe pickup, it is, of course, necessary to be sure that all of the equipment, including receiver, antenna and particularly the booster, features the essential reliable high-gain characteristics. The receiver, for instance, should have full bandpass characteristics, in both *rf* and *if* sections, to provide good picture detail, supported by a reasonable black and white contrast. The antenna must be fairly broad to respond to all frequencies that can be received, and in some cases should favor the stations that come in poorest.

Installation Requirements

Since full bandpass is the first requisite for picture detail, why then should anyone advocate peaking of the circuits to bring up the gain of the set. Fringe area customers certainly are entitled to the same good receiver per-

formances enjoyed by the city dweller. Naturally, it is recognized that, considering receivers of like quality, those used for fringe installations cannot provide equal performance to those used in the city, since TV signals attenuate very rapidly and make it necessary to look for further aids to equalize the situation.

These aids consist of better antenna systems and preamps, or boosters.

Booster Characteristics

A booster being an *rf* amplifier, embodying one or two stages of amplification, is no *miracle unit*. A good booster should have gain, good signal-to-noise ratio and should be free of self-regenerative tendencies.

Noise is naturally easily seen on the picture tube, and is commonly referred to as snow. Therefore, it is of great importance that no noise be added by the booster, to the noise picked up with the signal. Obviously a good picture could not be distinguished if a booster were to add noise over the strength of

the signal, even though that signal itself as received at the antenna, would be above the noise level. If the antenna is unable to receive the signal above the noise level, no booster can correct the situation.

Triodes Verses Pentodes

There have been many who have debated for or against the use of triode or pentode amplifier tubes. While triodes, generally, have been found, in tests, to have less noise when compared with pentodes, the results reflect only one test frequency, the tests concerning themselves with the tubes alone, and not with circuitry problems. In applying these tubes in booster circuits, results can be quite different than those achieved during tests made on the tubes themselves.

As a rule, it has been found that triodes require considerable amount of loading to simplify neutralization. Pentodes, on the other hand, can be operated with a minimum of tube and

(Below)

Fig. 1. Basic circuitry of single-tube permeability-tuned *rf* amplifier using a pentode of the 6AK5 or 6AG5 type. It will be noted that this application requires but two resistors and three capacitors, whose values are not critical.

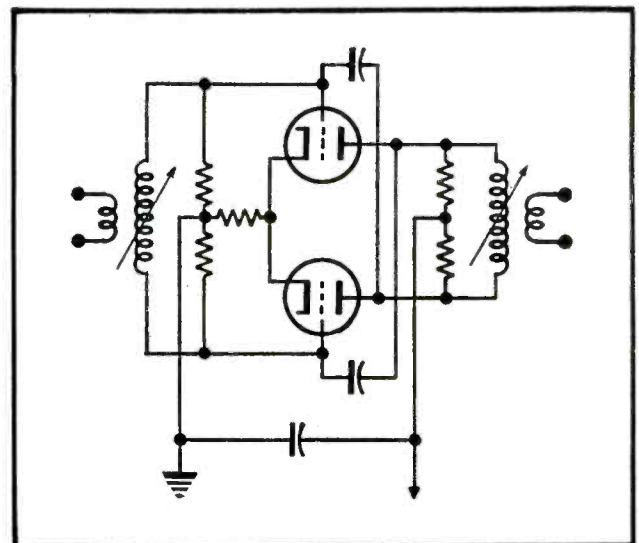
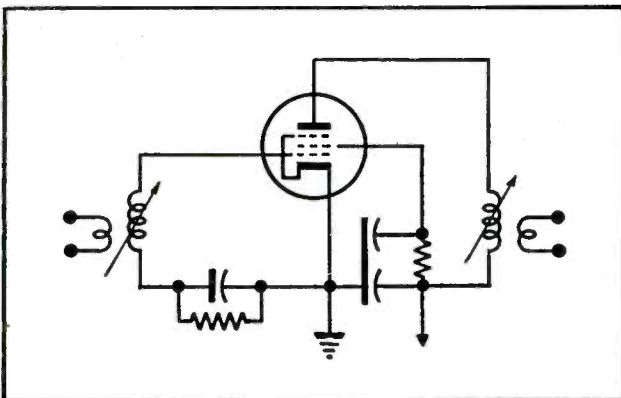

Fig. 2. Basic circuitry for one-tube permeability-tuned *rf* amplifier, featuring use of the 6J6 or 12AT7 triodes. In this instance it is necessary to use five resistors, and three capacitors, with the values of two being quite critical.

Requirements

by **BILL CLAPS** Chief Engineer, Anchor Radio Corp.

circuit components, such as resistors. Of the triodes, the most commonly used tube for boosters is the 6J6; for the pentode type *rf* amplifiers, the 6AK5 is used. Another factor in favor of the 6AK5 is its effectiveness on the high bands, where maximum gain is even more necessary than for the low-band use.

Further reasoning indicates that since it is necessary to load the circuits employed with the 6J6s, no difference in noise generated can be detected in the better boosters using a good 6AK5 circuit from one using a 6J6. Therefore, in weighing the foregoing facts, it can be safely assumed that since the 6AK5 pentode performs better on the high band frequencies, it should be the preferred tube type for boosters. The fact that the pentode type of tube is generally better for high-frequency operation is further emphasized through its universal application in TV tuners by tuner and receiver manufacturers.

Booster Tuning Characteristics

At present, boosters are available with either the 6AK5 or 6J6 types. There are two other properties that vary in booster design; tuning and switch methods.

There are boosters, for instance, of the broad-band type which cannot be tuned. Referred to as the automatically-tuned type, it is necessary to consider whether or not they can provide maximum gain and freedom from outside noises or side band interference. Since it has been found that broad-band boosters must cover quite a frequency range, it is difficult to provide gain over the whole band even though two tubes might be paralleled. Coupled to this is the common fault that side band and FM interference are greatly amplified. The only justification for the use of broad-band type boosters is their simplicity in operation through the absence of tuning controls. They will work well where the gain required is not too great and other interference is at a minimum.

Recommendations for most installations are therefore in favor of the

tunable type boosters. This type of preamp should have a minimum of 5 to 6-mc bandwidth, when measured 3 db down, with uniform gain over either the low or high TV spectrum.

The type of tube and method of tuning should not affect the final outcome. Personal research, during the past four years has indicated that better results can be achieved with a 6AK5 and the permeability type tuning employing a minimum of circuit loading.

Oddly enough, after designing the best booster possible, which has good gain, high selectivity, an excellent bandwidth and is free from regenerative tendencies, the problem of oscillation still exists when the unit is placed in service.

Field tests have proved definitely, however, that in all cases where oscillation due to regeneration was present, simple remedies could be used to overcome all difficulties.

An interesting illustration of this point occurred during a test at our plant, involving a popular name brand receiver of the intercarrier sound type. This receiver worked satisfactorily at the plant. The set was then taken out to a test location some 60 miles away from the nearest TV transmitting station. At this site it was almost impossible to prevent oscillation on the receiver, while testing a number of competitive boosters. The tendency to oscillate was, of course, more pronounced on the boosters having the most gain. Significantly, it was almost impossible to tune audio and video signals together, even though all the boosters tested had sufficient band pass characteristics. Upon return from the field test, every piece of equipment used during the test was completely checked. All boosters checked okeh. Even the antenna, a double *V* type, which by the way was found to have too high of an impedance match, certainly could not be blamed for the trouble.

It was felt that perhaps the alignment of the TV receiver should be checked, and here is where the trouble was discovered. It was found that the video *if* strip was peaked so that it

(Continued on page 54)

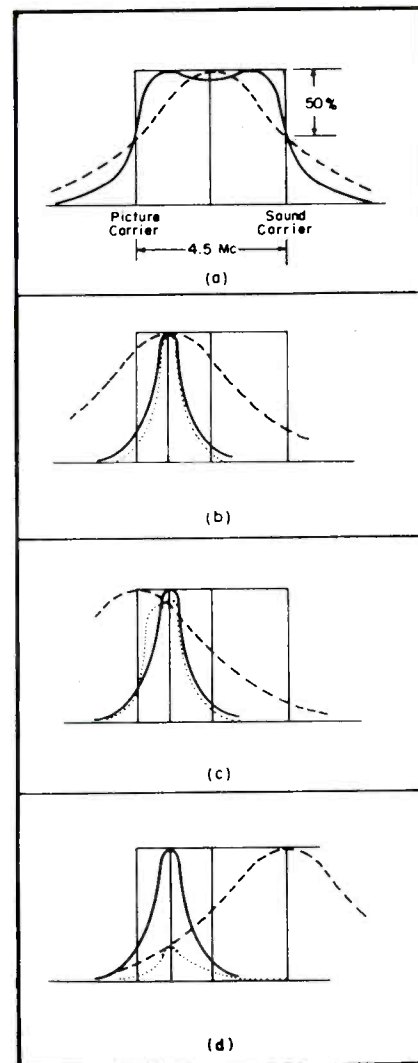
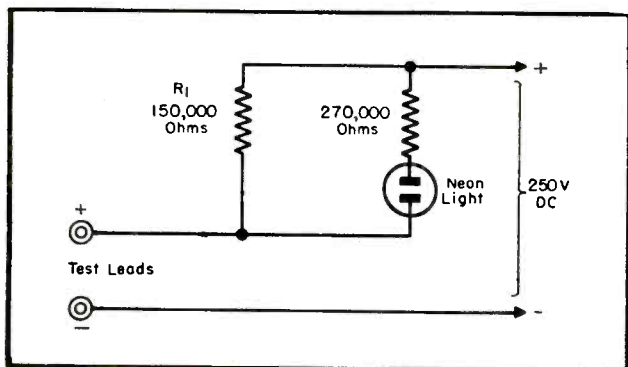

Fig. 3. Plot *a* illustrates minimum requirements for acceptable performance, the solid line showing overall response of a TV set that has been properly aligned, and the dashed lines indicating the minimum bandwidth response of the TV preamp. Curves in *b*, *c* and *d* illustrate response that is below the minimum requirements and not acceptable. The solid line in *b* represents the response of an improperly-aligned TV set tuned for brightest picture. The dashed line is the response of the preamp tuned for brightest picture, and the net effect is shown in the dotted line, with less sound and an increase in noise level because of narrowing bandwidth. The solid lines in the *c* and *d* plots show the response of the TV chassis when improperly aligned and tuned for brightest picture. However, the dashed line in *c* represents the preamp result when it is tuned for the best picture, while the dotted line shows the net effect; less sound, picture level increased and slightly improved bandwidth. The dashed line in *d* represents the results when the preamp is tuned for best sound. The net effect, in this instance, shown by the dotted lines, is that the sound is increased by the amount of gain of the preamp, and the picture level is reduced. In all of the foregoing cases, the narrow bandwidth of the TV set can also be caused by regeneration due to external wiring and accentuated by very low signal level operation. The actual net effect, as demonstrated in these examples, refers specifically to the amount of signal present at the point of sound and picture operation. In those chassis featuring intercarrier sound, the response naturally includes that of the tuner and the complete *if* amplifier section. In addition, the audio speaker level, after the point of separation, is determined by the video carrier, mixing with the audio signal. The speaker level can only be raised by increasing the weaker of the two signals or both by the same amount.

SIMPLIFIED TESTERS

For the Service Shop

by PHILIP H. GREELEY



Design and Application of Neon Lamp Hi-Lo Resistance Checkers ... Capacitor Discharge Unit ... Hi-Voltage Tester for TV.

Fig. 1. Parallel-resistor neon tester.

OFTEN, IN THE SHOP and particularly the field, there are moments when small simplified testers are quite handy in providing not only a clue to troubles, but serving as valuable checkers for defective components and allied gear.

Neon Indicators

The neon indicator, used for high-voltage circuit testing, has been found to be an effective member of this test family.

General effectiveness of the neon bulb and series resistor combination can be improved by the use of a parallel resistor shown in the circuit of Fig. 1. In this instance, a neon bulb of $\frac{1}{4}$ or $\frac{1}{10}$ watt is used in a circuit including a 270,000-ohm series resistor and a 150,000-ohm parallel resistor, each of $\frac{1}{2}$ or 1-watt rating. Pin jacks for test leads are provided. A supply voltage of 200 to 250 has been found to be high enough to be effective without risking damage to capacitors or other circuit components where tests may be applied.

The 150,000-ohm resistor controls the neon lamp *on-off*, showing with respect to the resistance value applied between test leads. For this value the neon lamp glows where a resistance of less than about 250,000 ohms is connected across test leads. This neon circuit can serve as a rapid high-low resistance checker, and in addition pro-

viding time limited flashes of the neon lamp on capacitor charging currents.

This test can also be used as a preliminary indicator of the *freshness* or condition of electrolytics having a working voltage higher than the test voltage. The lamp will glow on charging current and will then go out, if and when leakage resistance rises to a high value. Dirt in a variable tuning capacitor or closeness and touching of plates at different settings can be readily noted by flashing of the bulb and by minor sparks or arcs at plate contact areas. Sometimes the tuning capacitor must be disconnected, but not in many high-resistance *avc* circuits. Also, the neon test will give a brief flash on charging a bypass capacitor in an *avc* circuit. Ceasing the test and re-trying, after a moment, should give a second flash if the high value resistors in the circuit are satisfactory.

Coil Break Tracing

Often a break in a fine wire coil can be located by watching, for a minute, a spark or arc at the break. If this break is accessible, as in a lead or terminal connection, repair can be made without need for making a replacement. Although this tester employs high voltage, its current is resistance limited to under 2 ma, which cannot damage usual circuit components. Where bypass capacitors and insulation are rated for 200 working

volts or higher, a test voltage up to 250 does not incur risk of puncture.

In one interesting and extremely effective application, the neon circuit has been used to quiet noisy volume controls. Perhaps 80 per cent of control noise results from dirt or corrosion in the metal-to-metal slider contact, while the carbon resistor strip and contact may be perfect. It is possible to disassemble many noisy controls, clean and polish contacts and restore them to good operation; but often only a quick two-minute quieting job is justified, and this repair is possible with the aid of the neon tester. First, some cleaning solvent, preferably mixed with about 20 per cent light lubricating oil, should be squirted into a control at a terminal or seam to soften or wash out old grease. Then one lead of the neon voltage tester should be clipped on the volume control center terminal and the other lead on either outside terminal, and the control worked back and forth. The applied high voltage seems to break down poor conducting surface films that cause noise on the weak audio voltages normally present in volume control circuits.

Capacitor Discharge Device

A sort of companion to the neon voltage tester is a capacitor discharge *short blower*, illustrated in Fig. 2. Occasionally, shorts or low resistance leakage paths are found in apparatus,

You ARE HELPING TO BUILD THIS PLANT!

Your increasing demand for Hytron tubes is helping to build this fine, ultra-modern plant. Located at Danvers, Massachusetts, it will be the most modern receiving-tube plant that engineering know-how can build.

And this is more important to you. Its advanced equipment and skilled staff will — we promise — give you the best tubes your money can buy. Because Hytron sincerely believes only the best is good enough for you.

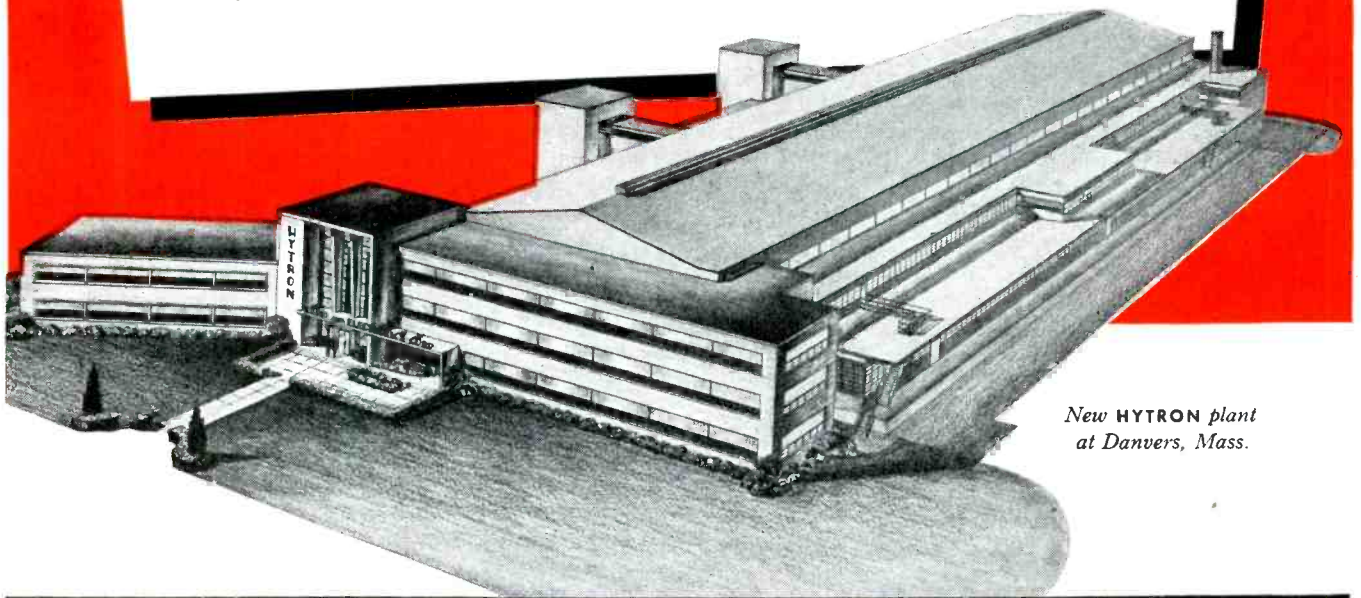

New HYTRON plant at Danvers, Mass.



NEW NAME ADDED

The famous red-white-and-blue Hytron carton has added a famous symbol: CBS. Yes, Hytron is proud to be a division of the Columbia Broadcasting System, Inc. — with greatly expanded opportunities to grow in service to you. Two respected names now guarantee you unsurpassed tube performance. CBS-Hytron is your sign of the very best in electronic tubes. Look for the attractive carton. Be sure to demand the best: CBS-Hytron.



MAIN OFFICE: SALEM, MASSACHUSETTS

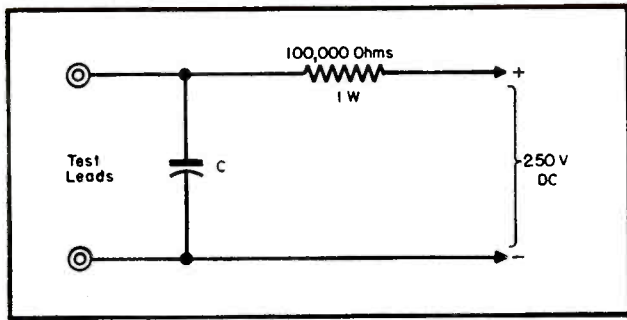

Fig. 2. Capacitor-discharge short-blower test circuit.

caused by accumulations of soot, dirt or surface corrosion, which may be difficult to remove completely by mechanical means. However, a poor or inferior conductor formed by surface dirt can be readily burned out by a heavy electrical current of such short duration that no heating of or damage to even a fine wire good conductor is risked. In the circuit, capacitor *C* is charged through a 100,000-ohm resistor from any available *dc* voltage source; then, when test leads are connected across a poor conductor, capacitor *C* is discharged suddenly with a blow-out of the faulty conductor. The amount of current discharged is directly related to the value of capacitor *C*, which may be of about 2-mfd paper or oil type for general usage.

Checking Variable Capacitors

Variable tuning capacitors which have become noisy because of dirt can also be readily cleared by this capacitor discharge. Plates that touch must be straightened, but the strong spark occurring at a point where plates nearly touch has been found to show exactly where the straightening is required. Where a capacitor has been cleared to show no sparking on an applied 250 *v*, there will be no leakage trouble at normal tuned circuit voltages.

Short-Clearing Tests

Besides clearing certain circuits or units, the capacitor discharge has been found useful in locating some circuit breaks or poor connections by watching for a spark. This capacitor discharge should always be used with caution: it is important to avoid putting it across a delicate conductor such as the filament of a dry cell tube, or a small portion of a volume control resistor, and the volume control should be set near center for a high resistance value between terminals. Most circuit or short clearing possi-

bilities of the capacitor discharge gadget will be found in grid, tuning, or other circuits where applied voltages are too small to break down leakages.

Definitely, the capacitor discharge is a *strong arm* cure. It should be used intelligently and only where it is likely to be helpful or as a last resort in attempting to clear or find trouble in a part otherwise no good. Although the capacitor discharge is infrequently employed, the set-up cost is small and the device is quick and effective in doing some jobs otherwise tedious or impossible.

High Voltage Tester

When checking TV high voltage power supplies, it is convenient to provide a tester adapted to show if high *ac* voltage is applied to the high voltage rectifier tube, 1B3 or equivalent. A high voltage failure can occur either forward of or behind the high voltage rectifier tube, and time can be saved by determining if the horizontal-flyback circuit or equivalent is working. Even the smallest NE-2 neon bulb has been found to be well suited as a voltage indicator and the circuit need not be completed except through air, though a small capacitive radiator formed by about one square inch of metal will increase the neon glow.

Neon Tester Structural Features

For complete safety in making high voltage tests, this low cost neon tester may be made as illustrated in Fig. 3. A strip of bakelite or plastic about 7" long, 3/4" wide and 1/8" thick serves to carry a neon bulb having one lead clamped or soldered to a metal radiator, and the other lead soldered or clamped to a metal rod or wire probe. Any convenient mounting method may be employed; the only important consideration is to make the strip long enough so the tester can be used without bringing one's fingers within two inches of the metal radiator. The

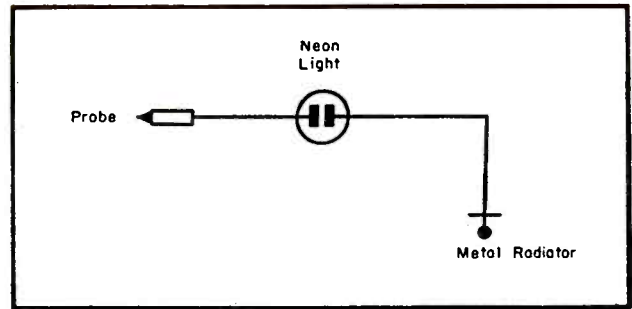

Fig. 3. Hi-voltage neon tester.

probe should be secured by short tinned copper wires passed through holes drilled in the strip, and the neon bulb can be held by the metal radiator cut so that portions are bent down and under the insulating strip, with other ends of the radiator bent up and around ends of the bulb. If high voltage *dc*, as well as *ac*, testing is desired, the radiator may be grounded or connected to negative by a lead, and an extension resistor (preferably totaling about 100 megohms) for the probe can be made up by connecting five 20-megohm 1/2-watt resistors in series.

There are many low-cost simple gadgets that can be made up for any special need. Each may be regarded as an added small tool or aid which readily pays for itself in time saved or in doing something otherwise difficult in the first few times it is used. All further uses, then, are definitely in the net profit column. In practical service work some of these simple items have been used extensively with a very high ratio of service value with respect to cost. Trouble finding is an art wherein simple and likely troubles should receive first consideration with a follow-up on more complex matters where needed.

Conserving Solder

Expensive core solder is often wasted if *dull* or slightly corroded wire leads, often found on new resistors and capacitors, are not pretinned before being used in apparatus. More flux than solder is required to clean *dull* surfaces. Some ordinary lump rosin, obtainable from paint stores, may be melted down on a piece of cardboard or masonite for use as a flux bath for pre-tinning wire leads. Plain solder or even reclaimed solder run on the soldering iron tip from old work, can be used in the flux bath. If desired, the flux bath may be made extra active by salting lightly with ammonium chloride as the rosin is

(Continued on page 52)

3 Important Rauland Policies

...Are they
paying off for you?

1 Did you know that Rauland's Replacement Picture Tube Warranty and Adjustment Policy provides a 6 months warranty from the date of purchase by the consumer? And that all Rauland replacement tubes now carry a triple registration card providing protection for jobber, dealer and consumer?

2 Did you know that Rauland provides a full 120-day price protection on distributor inventory of replacement picture tubes? That Rauland distributors can carry a stock adequate for their territories without risk of loss through price adjustment?

3 Did you know that Rauland offers valuable premium points for the prompt return of warranty registration cards? Each card returned promptly entitles dealer and distributor to premium points redeemable in valuable merchandise prizes.

• • •

If you have not received full details on all of the above, write, phone or wire your distributing contact on Rauland tubes. If you have not received your prize merchandise catalog, use the coupon below today.

THE RAULAND CORPORATION



Perfection Through Research

4245 N. KNOX AVE. • CHICAGO 41, ILLINOIS



The Rauland Corporation
4245 N. Knox Ave., Chicago 41, Illinois

Please rush premium merchandise catalog and full information on:

Earning Premium Prizes 6 Months Warranty
 Distributor Price Protection

Name _____

Address _____

City _____ State _____



MUSIC...The Modern

Whistle While You Work . . . good advice for everyone. (With apologies to Walt Disney's popular cartoon movie.)

Comprehensive Evaluation of Music and its Relationship to Human Behavior Response, and its Corresponding Application Possibilities in the Plant, Office, Store, Shop, etc.

SINCE THE DAYS of ancient civilizations music has played a most profound role in the lives of mankind. One need but recall the traditional *sea chanties* used by sailors in the days of the sail ship or the rhythmic compulsion of the *Volga Boatmen* as weary laborers hauled heavily laden barges up the turbulent river. Who of us can say we are not stirred by the military band on parade, or lulled to sleep by soft mellow incidental music at the end of a hard day's work? Every form of music has a purpose for

its existence, a job it's expected to do. There is clinical evidence that music affects our respiration and metabolism, changes our pulse rate, and even alters our perception of sensory stimuli. These being the physiological reactions to the nature of what we hear, it is easier to understand why it is that a worker will respond to the dullness of some repetitive operation with a boredom which materially affects

*Wyatt and Langdon, *Fatigue and Boredom in Repetitive Type Work*, Medical Research Council, London, 1938.

his efficiency, unbeknown even to himself.

Testing the effect of music in just such an instance, where paper *snappers* were being manufactured by a small group of workers, each snapper requiring 30 seconds for completion, two scientists* checked production rates, with and without music. The rate of production was checked first for 30 days without music, followed by 65 days of music, broken up in various periods to determine effectiveness of the time of day selected. A 6 per cent increase resulted from morning music, 4.4% from music played in four periods during the day, 2.6% from one period each morning and afternoon. That music certainly had a beneficial effect.

During other studies involving physical reactions to music, the grip of ten men was tested with and without music in the background.** Two thirds exerted considerably more strength than usual, when listening to a lively march.

Attitude, the Worker and Music

Psychologists are generally agreed that a person's attitude toward something will materially affect physical reaction and hence response. The incidents already cited tend to substan-

**Tests conducted by C. M. Diserens, University of Cincinnati.

Reflex speaker in typical tool and die shop, which provides wide-angle coverage.

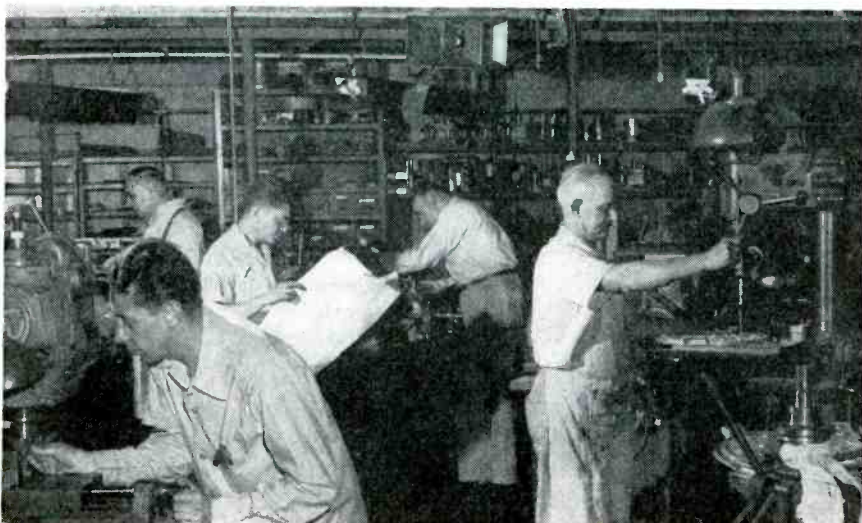

Production Tool

by LAWRENCE J. EPSTEIN

University Loudspeakers, Inc.

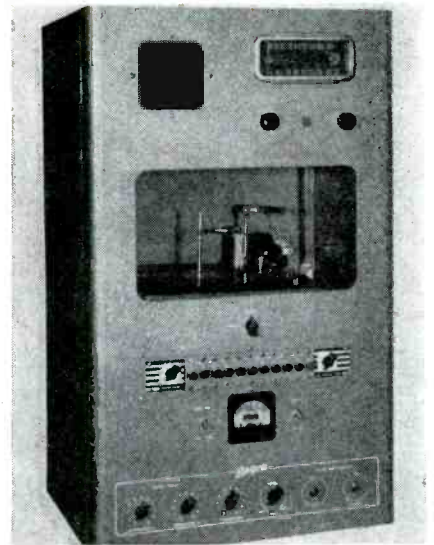

Typical plant broadcasting system, which features a tuner, record changer and switching setup. (Courtesy Bogen; model SB50)

tiate this belief. What, then, is a worker's reaction to his job; and if music helps change his attitude what does he believe it does for him?

Boredom is perhaps one of the most detrimental factors affecting production rate and quality. To carry this further, boredom may be defined as a consciousness of uniformity and repetition. It may be the kind of work being performed, or possibly a reaction which coincides with the time of day. For instance, an interview with 350 workers revealed that the great majority believed that time drags worse during the first two hours of each half of the work day. In short, when we are obliged to do something over and over, we try to improvise in our reaction to each repetition, per-

haps subconsciously, in an effort to keep from remaining bored. Mechanical operations, being as specialized as they are in today's manufacturing techniques, do not permit a wide enough latitude of such improvisation, resulting therefore in a deterioration of accuracy and increase of rejects.

In probing the latter point, 88 female radio tube assemblers were studied over a period of weeks.† The idea was to determine the effect upon rejections by music of various tempos as against no music at all. Both slow and fast types of music resulted in less scraggage than complete absence of music.

It is increasingly apparent therefore,

†According to a report by J. H. Humes in the *Journal of Applied Psychology*.

that music does help alleviate boredom, and thereby remedy, somewhat, situations which are the natural result of modern technology. We now have some idea of how the worker reacts to music, but how does he feel about its employment? What does he think it does for him? According to the results of a questionnaire*** distributed to 229 radio equipment workers: 64% believed music improved their feelings towards their associates; 93% believed that music helped them when they were tired; 79% believed that music soothed their nerves; 48% believed that music helped their digestion; 89% believed that music helped them in performing wearisome and monotonous tasks, and 77% believed

(Continued on page 28)

Music saves money . . . avoids waste by relieving monotony and reducing rejects.

Music in the plant is actually equivalent to the addition of more personnel, for it boosts net yield at less cost.

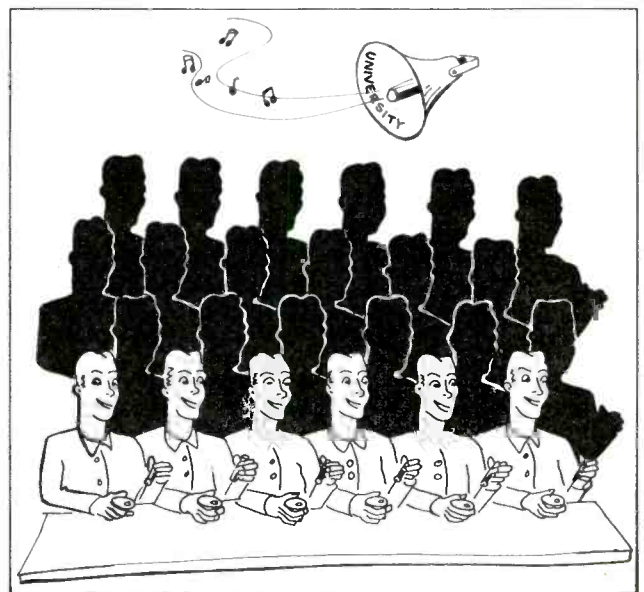

Proof Positive

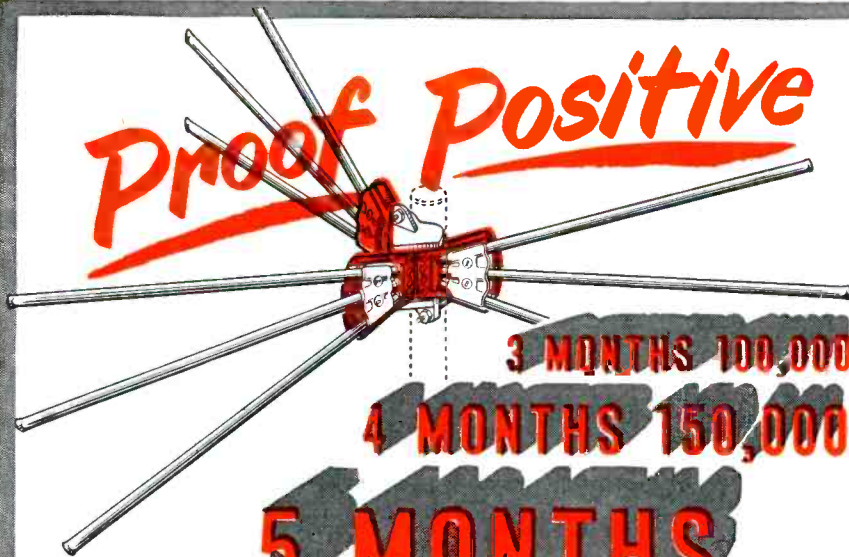

3 MONTHS 100,000

4 MONTHS 150,000

5 MONTHS

200,000

Snyder

PHILADELPHIA

Directronic

MOTORLESS

TV AERIAL SYSTEMS

360° ELECTRONICALLY-SWITCHED BEAM

SNYDER MFG. CO.

PHILADELPHIA

NEW YORK: H. L. DALIS, INC., 175 Varick St.

PHILADELPHIA: ALMO RADIO CO., 412 N. 6th St.

CHICAGO: RADIO PARTS CO., 612 W. Randolph St.

CLEVELAND: CHAS. FRESHMAN & CO., 4015 Prospect Ave.

SAN FRANCISCO: KAEMPER & BARRETT, 1850 Mission St.

BALTIMORE: WHOLESALE RADIO PARTS CO., 311 W. Baltimore Ave.

EXPORT: ROBURN AGENCIES, INC., 39 Warren St., New York

CANADA: VAN DER HOUT ASSOCIATES, LTD., 90 Richmond St., W., Toronto

Music

(Continued from page 27)

that music helped them forget their worries.

Music is good for every one. If you whistle or sing while you work, providing you may, your lungs will be exercised, renewing the air in them to the expulsion of fatiguing body poisons; blood is caused to circulate more freely by the muscular action, supplying energy to the points of the body where needed for the performance of work.

How to Use Music

Music in industry should be regarded as much a tool to greater efficiency as any other production device of more tangible nature. However, one must not be misled in thinking that production quantity and quality may be greatly improved with merely indiscriminate introduction of music. Judicious application of the right program material and in the right manner is essential. There appears to be a definite pattern to the technique of programming, as the following examples will bear out.

Effect of Gradual Introduction of Music

In a test conducted**** on an assembly line on which special control boxes were being built and wired, the with-and-without music study was made over a period of many weeks. Before the test began it was generally assumed that those on the line had reached a peak production rate. If the production yield could be improved in this line as a consequence of music, this would certainly be an acid test. During the first official week of the test, no music was employed. During the second week, music was used only during rest periods. Production, dur-

(Continued on page 78)

***Reported by W. A. Kerr, RCA.

‡University Cobra 12. ****At Operadio plant.

Wide-angle paging speaker†, which provides a continuous power of 12 watts and has a dispersion of 120° x 60°.

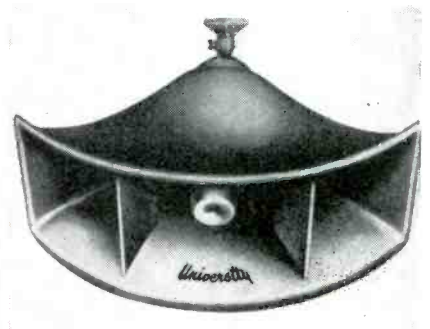

Eight and Twelve-Channel TURRET TUNERS*

by WYN MARTIN

WITH THE FORTHCOMING ULTRAHIGHs being studied closely by set manufacturers for required circuitry in not only complete chassis but converters, tuners are receiving particularly acute attention for their *vhf-uhf* coverage possibilities. Some labs have indicated preference for turret tuners which they say can be converted for low and high-band pickup through the use of tuning strips. Others have noted continuous tuning offers similar flexibility in wide-range coverage.

An example of the turret-type of tuner described by some as quite adjustable for the upper and lower bands appears on the cover this month. An eight-channel tuner, employed in Philco receivers, it features use of input coils which are overcoupled. One set of windings is a tertiary winding, and is used, along with the over-coupling, to provide a 6-mc response. All coils are on a common form.

Antenna Input Coupling

The antenna-input circuit is coupled into a 6AG5 *rf* amplifier tube. The plate load of this tube is a series-resonant circuit. The plate is shunted through a 2700-ohm resistor. The response of this stage is essentially flat over a 6-mc bandwidth, and provides good interference rejection.

The mixer coil and the oscillator tank circuit are on a common snap-in coil form.

Coil Assembly Mount

The coil assemblies are mounted in a channel selector, which switches the desired coils in and out of the circuit as required. With this arrangement, an unlimited number of channel combinations may be had for any locality.

The local oscillator employs one half of a 6J6 in a shunt-fed, modified Col-

[See Front Cover]

pitts circuit. The oscillator plate circuit is slug-tuned for station setup.

The other half of the 6J6 is used as a reactance tube. A portion of the oscillator voltage is fed to the grid of the reactance tube through a phase-shifting network consisting of a 560-ohm resistor, the input capacitance of the tube, and incidental circuit capacitance. A 220-mmfd capacitor is used for *dc* blocking, while a 3.3-mmfd capacitor serves to neutralize the tube. The reactance tube is used to correct any frequency drift of the oscillator, to maintain a constant intermediate frequency. In operation, the action of the phase-shifting network causes the grid voltage, and consequently the plate current, to be out of phase with the oscillator plate voltage. The phase shift is such that the plate current of the reactance tube leads its plate voltage; since the plates of the oscillator and reactance tubes are tied together, this voltage-current relationship represents an effective capacitance across the oscillator tank circuit. The amount of *dc* bias on the reactance tube controls the amount of effective capacitance. A more positive bias increases

the plate current, and hence, the effective capacitance; a more negative bias decreases the plate current and the effective capacitance.

DC Bias

The *dc* bias for the reactance tube is obtained from the FM ratio detector in the sound section. The circuit is so arranged that an increase in mean frequency of the sound *if* (caused by an increase in the local-oscillator frequency) produces a positive voltage, thereby decreasing the oscillator frequency to produce the proper intermediate frequency. A decrease in the mean frequency of the sound *if* (caused by a decrease in the local-oscillator frequency) produces a negative voltage, thereby increasing the oscillator frequency to re-establish the correct intermediate frequency. This automatic control of the oscillator frequency eliminates the need for a high-ratio vernier tuning control.

12-Channel Tuners

Some Philco models have featured use of 12-channel turret tuners, with 12 antenna *rf* snap-in coils and 12 mixer-oscillator snap-in coils. As the turret is rotated, the terminals of the appropriate antenna-*rf* and mixer-oscillator coils are brought into contact with the two contact panels which provide connections to the antenna, *rf* mixer, and oscillator circuits.

Channel-Switch Features

This type of channel switch has been described as providing the low contact resistance and low inductance which is so essential to high-frequency reception. A 6AG5 tube is used as an *rf* amplifier, and a 6J6 is used as an oscillator-mixer. The tuner is built into a well-shielded subchassis.



Color TV adapter, the *DuMatic Switch*, announced by the receiver sales division, Allen B. Du Mont Laboratories, Inc. Color switch 4½" long, 3" wide and 1½" deep, can be installed on the rear of the set, bolted to the chassis, permitting the set to be changed from 525-line reception to the 405 lines employed by the CBS-color system.

*Based on notes supplied by Philco.

Servicing AFC

Fig. 1. Noise pulses may cause premature sync in trigger-synchronized circuits, causing several lines of the picture to tear out, as illustrated in pulse-plot below.

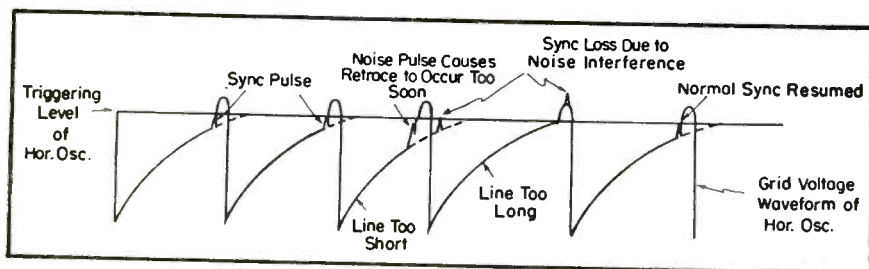

SYNC Circuits

by SOLOMON HELLER* and PETER ORNE

Part I of Three-Part Analysis of Automatic Frequency Control Systems Used to Control Horizontal Sweep Oscillator, Covering Need for Circuitry and Defects in Trigger-Sync Setups Which Make It Necessary to Use AFC.

THE AUTOMATIC-FREQUENCY CONTROL circuits used to control the horizontal sweep oscillator are among the most difficult of all television circuits to understand and service.

In the early TV receivers two basic circuits were used to shape the horizontal and vertical sync pulses to the forms required for proper triggering of the sweep oscillators. One was the integrator and the other was the differentiator.

The vertical pulse came through the integrator in a fairly satisfactory manner. Trouble, however, was encountered in getting the horizontal pulse to synchronize the horizontal deflection system properly. There were two chief difficulties: Noise and oscillator instability.

Noise, a random disturbance, covers all frequencies. Only at frequencies 4 kc and higher, mostly higher, does noise begin to affect TV reception however, because it is not effectively radiated at lower frequencies. Since the differentiator is essentially a high-pass filter network, it will pass the high-frequency noise pulses, and permit them to reach the horizontal oscillator.

Now, if noise comes in with the horizontal sync pulses, a noise pulse, rather than the sync pulse itself, is apt

to trigger the horizontal oscillator. The oscillator will start to conduct at the wrong time, or at a different time during each cycle affected by noise, as a result, and synchronization will be impaired; Fig. 1.

This type of trouble is not as serious in the integrator. The integrator will respond to noise, just like the differentiator. A cascade integrator (Fig. 2) will, however, respond appreciably only to long-duration noise pulses, due to the long time constant of its rc circuit. Short-duration noise pulses will not persist long enough to charge up the long time-constant integrator network to any great extent. Since most noises are of short duration, impairment of vertical synchronization by noise is not generally a serious problem.

A single-stage integrator will respond appreciably to short-duration noise disturbances, whereas a cascade integrator will not, as illustrated in Fig. 2. We might expect that, if a single differentiator responds to noise pulses, its noise-rejection characteristic would be improved by adding a number of differentiator circuits in cascade. However, that is not so. Putting a number of differentiating networks in cascade will only sharpen the output signal pulses, as can be seen from Fig. 3b. The amplitude of both noise and sync pulse signals, however, will be unaffected, and noise will still,

as a result, be able to change the oscillator's triggering time.

Differentiator Response

The basic reason that the differentiator responds to noise pulses lies in the fact that it is sensitive to any sudden rise and fall in the amplitude of the signal at its input. Thus, the differentiator produces an output only at the rising and falling edges of the flat-topped horizontal sync pulses. In between these edges, the differentiator is fully charged, and therefore does not pass on information regarding the flat-topped section of the signal. Only when the incoming sync signal reaches the end or lagging edge of its flat top, and decreases in amplitude, does the discharge of the capacitor cause an output pulse to appear across the resistor (across which the output is taken off). Since the differentiator will respond only to the amplitude, and not the width of a signal, a noise pulse whose duration is much shorter than that of the sync pulse, but whose amplitude is just as large, will produce just as much of an output as the sync pulse.

Now, if a circuit that utilized the entire width of the sync pulse for synchronization purposes were present, it would be possible to discriminate between narrow-width noise pulses, and comparatively large-width

*Instructor at American Radio Institute; co-author of "Television Servicing."

MERIT

Merit TV full-line* Components For Conversion or Replacement

MDF-30—new 70° "full focus" distributed winding "cosine" yoke—complete with network. For direct drive tubes up to 24".

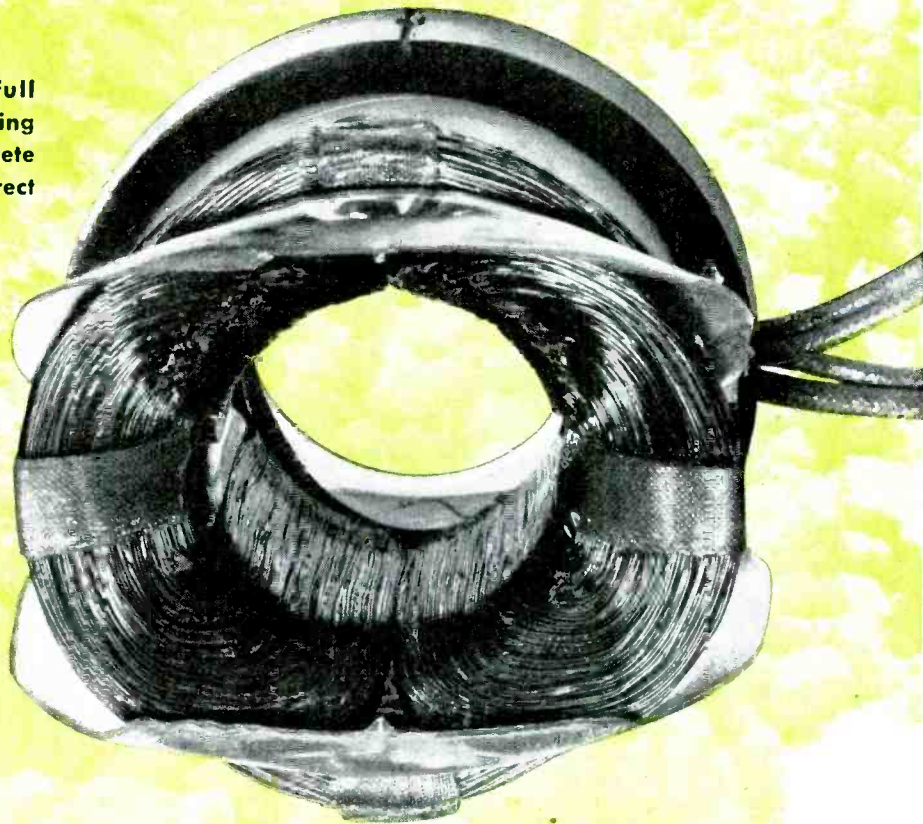

HVO-8—air core "flyback" for direct drive systems.



BURTON BROWNE ADVERTISING

Merit... HQ for TV Service Aids

Keep ahead of TV conversion and component replacement service problems—write MERIT... HQ for TV Service Aids...



FREE
Sept. 1951
Issue #404

These 3 Merit extras help you:

Exclusive: Tapemarked © with specs. and hook-up data.
Full technical data packed with every item.
Listed in Sam's Photofacts.

*Merit is meeting the TV replacement component and conversion demand with a line as complete as our advance information warrants!

MERIT TRANSFORMER CORPORATION
4425 N. Clark St., Chicago 40, Illinois

INLINE
ANTENNA

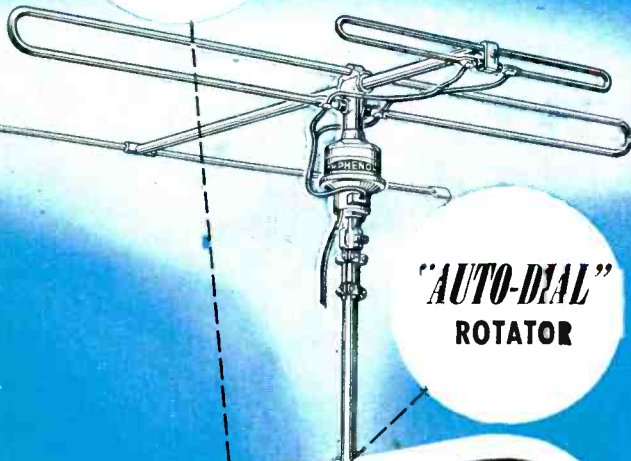

"AUTO-DIAL"
ROTATOR

**Perfect
TV Picture
COMBINATION**



REISSUE
PAT. NO. 12 273

Technical men know that Amphenol's patented "Inline" antenna construction means superior electrical characteristics i.e., a single forward lobe to "pick up" the strongest signal — no minor lobes to receive reflected or spurious radiations. When this single lobe is accurately pointed to the desired signal by Amphenol's "Auto-Dial" antenna rotator, technical men know what any layman can see . . . the picture is the best there is!

For the best TV picture on any channel, from any direction,

Amphenol's "Inline" antenna and Auto-Dial rotator . . .

the unbeatable combination by **AMPHENOL**

AMERICAN PHENOLIC CORPORATION
1830 SOUTH 54th AVENUE CHICAGO 50, ILLINOIS

AFC Sync Circuits

(Continued from page 30)

sync pulses. An *afc* system is essentially that type of a circuit.

Oscillator instability is another reason for the use of *afc* in horizontal sync circuits. The horizontal oscillator's stability is relatively poor, due to the high frequency at which it operates. Slight changes in the interelectrode capacitances of the tube, as the temperature of the set changes, will cause a corresponding change in the frequency at which the oscillator operates. Synchronization will thus be upset, and a resetting of the horizontal hold control will become necessary.

Incidentally when the oscillator drifts to a frequency lower than its initial one, the sync pulse can still pull it back into the correct frequency of operation; Fig. 4a. When the drift, however, causes the oscillator to operate at or above the frequency of the sync pulse, the pulse will be unable to effect sync. This is true because the sync pulse, which produces synchronization by initiating the retrace, must arrive *before* the oscillator's free-running retrace. (If it arrives *later*, the oscillator will have already gone into retrace; Fig. 4c.) Only a faster-running sync pulse, i.e., one that operates at a higher frequency than the oscillator, will satisfy this condition.

If the oscillator, then, drifts to a frequency higher (or considerably lower) than that of the incoming sync pulse, sync will be lost when a simple triggering system like that provided by a differentiator is present. If an *afc* system is used, however, proper correction for the change in frequency

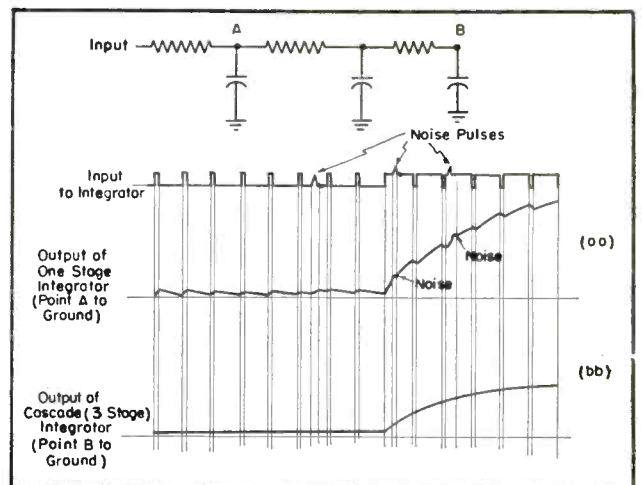
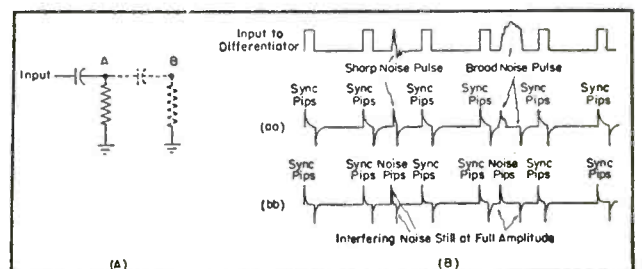

Fig. 2. Effect of noise on single-stage and cascade integrator. In *aa* appears the noise and horizontal sync pulses present in one-stage integrator output, although reduced in amplitude. The plot in *bb* shows noise and horizontal sync pulse signals, which are less than 1/300 of the amplitude of the integrated vertical sync pulse.

Fig. 3. Characteristics of two-stage differentiator, which will have the same effect on the amplitude of noise pulses passing through it as a single-stage differentiator. At *aa* is the output at point A of the differentiator, while at *bb* appears the output at point B of differentiator. It will be noted that the pulses, though sharpened, have the same amplitude as at A.



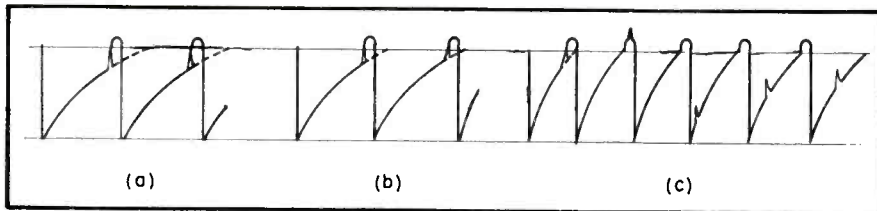

Fig. 4. Plot illustrating that the oscillator must be slower running than the sync pulse to be properly synced by the latter. At *a* the oscillator frequency is below normal and still syncs properly. In *b* the oscillator frequency is normal, slightly below sync pulse frequency. Condition in *c* represents an oscillator frequency which is too high, sync being lost except for occasional line.

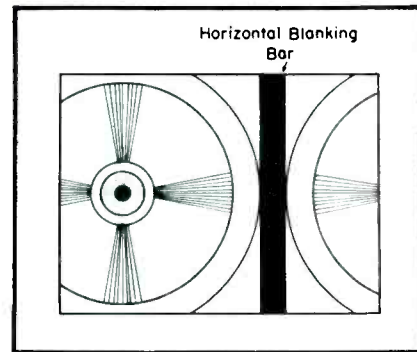

Fig. 5. When the receiver's horizontal oscillator operates at the same frequency as at the transmitter horizontal oscillator, but is not in phase with it or doesn't start and finish its cycle at the same time as the latter, the horizontal blanking bar will appear as illustrated above.

caused by drift will be made, and sync will be maintained.

Drift is not a serious problem in the vertical-oscillator circuit, since the frequency of the vertical oscillator is much lower than that of the horizontal oscillator.

AFC in AM Chassis

Broadcast AM receivers featured use of *afc* a long time ago, to control drift in the *rf* oscillator. The basic method used was the same that is now employed in automatic-frequency control of the horizontal sweep oscillator. In operation, some of the oscillator output is fed back through a correction circuit to the input in such a way that when any frequency change takes place, the feedback voltage will cause the oscillator to change its frequency correspondingly, and return to its correct operating point.

How AFC Minimizes Noise

The reduction of noise interference by an automatic frequency control sync system is due to three chief characteristics of *afc*: Flywheel effect, utilization of the entire width of the sync pulse, and averaging of sync pulses. Let us analyze these effects one by one:

Flywheel Effect: Any noise that might cause synchronization at an incorrect instant is going to change the frequency of the oscillator, or will try to do so. This tendency is counteracted by the *afc* system's flywheel effect. That is, the *afc* circuit will tend to keep on running at its former frequency, in spite of the blotting out

of the sync pulse or its incorrect timing (due to a superimposed noise pulse). This action is similar to that of a car engine, which tends to keep running because of the flywheel, in spite of some misfires. To state the matter differently, due to the frequency control imposed by *afc*, no sudden changes in the frequency of the horizontal oscillator can occur. The frequency-changing effect of noise is, therefore, counteracted.

Maintenance of Sync

An *afc* circuit's flywheel effect, then, permits synchronization to be maintained when one or a number of sync pulses are lost. In a trigger-sync system, on the other hand, if one sync pulse is lost, the next horizontal line will be ripped out, since proper synchronization depends on the presence of the sync pulse. A number of lines, rather than one line, may be ripped out if one sync pulse is lost, since several sync pulses may come and go before synchronization is restored.

The *afc* system is not affected similarly by the obliteration of sync pulses, because it does not use these pulses to produce synchronization directly; it employs them primarily to bring the receiver oscillator into phase with the transmitter oscillator.

If the *afc* circuit performs so well in the absence of sync pulses, one may wonder why we have the sync pulses present at all. The answer is that the *afc* action is not perfect, due to drift in the tube used for frequency correction and inability of the *afc* system to compensate for differences in phase between the horizontal oscillator signal at the transmitter, and the hori-

zontal oscillator signal at the receiver, when sync pulses are absent. This imperfect action of the system, preventing as it does the correction of phase differences, may cause the horizontal blanking bar to be seen in the picture; Fig. 5. When only a small number of sync pulses are missing, however, the system's flywheel effect is great enough to prevent the occurrence of a noticeable difference in phase.

Compensation for Loss of Sync

Due to its flywheel effect, an *afc* circuit will compensate for loss of sync caused by poor *dc* reinsertion. *Dc* reinsertion tends to be imperfect in many sets, since grid-leak and other economical, but not perfect reinsertion circuits, are employed. The inadequate *dc* restoration will affect the sync pulses most during the vertical retrace, since the *dc* level of the sync pulses is highest at that time (Fig. 6) and maximum restoration is needed then.

When *dc* reinsertion is inadequate, the sync pulses will not be lined up uniformly, and one or more pulses may be lost in consequence; Fig. 7. In a trigger-synchronized circuit, the poor *dc* restoration will result in the loss of a number of horizontal lines. This will occur because, when one sync pulse is lost, the oscillator frequency shifts abruptly. The succeeding sync

(Continued on page 55)

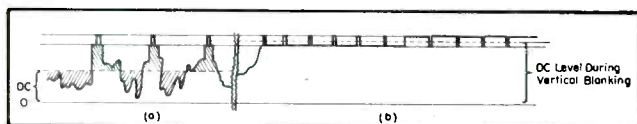
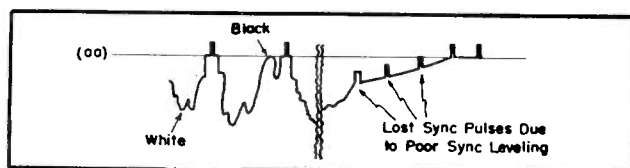

Fig. 6. Plot showing that the *dc* level of the sync pulses is greatest during the vertical blanking interval, because no varying video signal is present to reduce it, at this time. At *a* is the *dc* level of the horizontal sync pulses during vertical trace, while at *b* are the *dc* levels of the horizontal sync pulses during vertical blanking.

Fig. 7. Result of improper *dc* restoration is shown here; several sync pulses may be lost because their amplitude is greatly reduced by the drop in their *dc* levels. At *aa* is the sync separator cutoff level. The separator does not conduct below this level. Therefore, the pulses fall below and they will not appear at the sync separator output.



AUDIO installation and service

Phono-Tape-Wire-PA-Amplifiers-Speakers

by KENNETH STEWART

Electrical, Mechanical and Economic Considerations Involved in Selecting Speakers for Average-Type Broadcast and TV Chassis... Features of Tape Recorders, AM/FM Tuners with Preamp, Dual Speaker Systems, Corner Speakers, Remote Amplifiers, and 33 and 78 Cartridges.

IN SELECTING SPEAKERS of the moving-coil director-radiator type, which are normally found in most broadcast and TV receivers, most chassis manufacturers find it necessary to consider, in the main, two factors, cost and loudness, which often are not the best requisites for quality reproduction. Many Service Men usually find themselves faced with the problem of explaining not only to set-owners, but to those who are interested in installing improved speaker and amplifier systems, why this practice exists. A while ago, during a national IRE meeting in New York, a representative* of a prominent manufacturer de-

ecided to offer an interpretation of this situation, which provided one of the frankest and most revealing reviews on the subject ever presented.

According to this expert, to simulate both the deep bass and brilliant highs of a high-quality, wide-range system, speakers for use on systems with limited *af* range are usually chosen to exaggerate the low-and high-frequency ends of the range that is reproduced. Where circuit designers have difficulty reducing power-line hum to a satisfactory minimum, the choice is usually a speaker with the low-frequency cutoff set well above the power-line frequency. In addition, if

noise and distortion are present in the circuits, speakers chosen are usually those with limited *hf* response.

During demonstrations in crowded and noisy display rooms, consumers often find that the typical speaker, with strong resonant peaks at both the high- and low-frequency ends, can be heard above the noise better than the best and most expensive speaker that could be bought, a reaction that suddenly changes at home, it was pointed out. The peak between 1,000 and 3,000 cps, which sounded so brilliant at first, becomes more and more

(Continued on page 57)

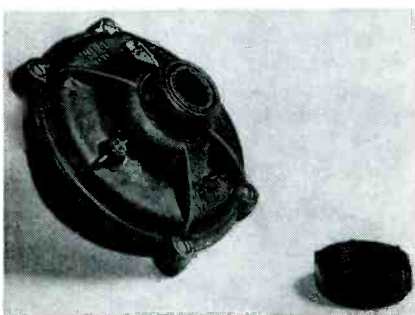

Driver unit, said to be capable of handling 30 watts. Has a patented *self-install* diaphragm assembly, featuring all elements of the vibrating system permitting instant replacement of assembly at the point of speaker operation with a screwdriver. Terminal corrosion has been eliminated through use of enclosed terminal block integrally molded into high impact phenolic case. The head of the unit is a zinc alloy casting. Unit is universal and can be coupled to any standard straight or re-entrant trumpet. (Model DQ; Audicraft, Inc., 77 South 5th Street, Bklyn., N. Y.)

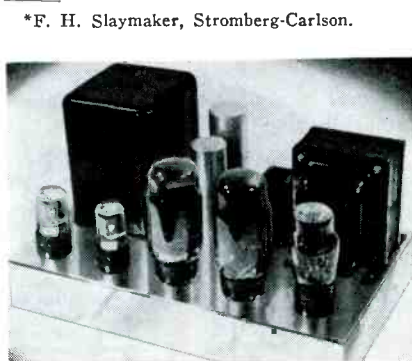

*F. H. Slaymaker, Stromberg-Carlson.
Twelve-watt amplifier featuring use of triodes based on Williamson circuit. Has 20 db of inverse feedback around entire amplifier. Total harmonic distortion said to be less than 0.1% at 10 watts at mid-frequencies; intermodulation distortion less than 0.5% at 10 watts; frequency response, ± 0.1 db, 20 cps to 20,000 cps, ± 2 db, 5 cps to 100,000 cps. (Model 500; The Radio Craftsmen, Inc., 4401 N. Ravenswood Ave., Chicago 40, Ill.)

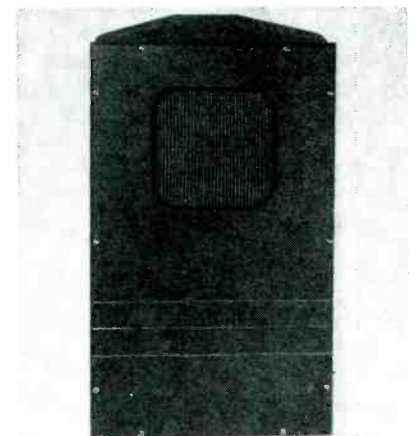

Corner-type speaker baffle designed to accommodate an 8" speaker, which is said to provide a frequency range of from 30 to 12,000 cps. Finished in maroon leatherette, the unit is 14" wide, 24" high and 9 1/2" deep. (Permoflux Corp., Chicago, Ill.)

WV-77A JUNIOR VOLTOHMYST

- ✓ Sturdy 200-microampere meter movement
- ✓ Meter electronically protected against burn-out
- ✓ Metal case shields instrument from rf fields
- ✓ Carbon-film 1% multiplier resistors for lasting accuracy
- ✓ Response flat from 30 cps to 3 Mc on 3-, 12-, and 60-volt ranges
- ✓ DC input resistance, 11 meg-ohms on all dc ranges
- ✓ Pointer can be zero-centered for TV and FM discriminator alignment
- ✓ Equipped with dc-polarity reversing switch
- ✓ Negative-feedback bridge circuit for greater stability
- ✓ More convenient . . . with new-type slip-on probe
- ✓ Polarity of ohms probe is positive . . . for checking electrolytics
- ✓ Durable, "full-view" 4½" plastic meter case



WV-97A SENIOR VOLTOHMYST

Has all the features of the WV-77A and, in addition, the following features . . .

- ✓ Peak-to-peak direct measurement of complex waves from 0.2 volt to 2000 volts
- ✓ Has 7 non-skip ranges for resistance and voltage measurements
- ✓ All full-scale voltage points increase in a uniform "3-to-1" ratio
- ✓ Response flat from 30 cps to 3 Mc on 1.5-, 5-, 15-, 50-, 150-, and 500-volt ranges
- ✓ Covers wider ac and dc voltage ranges
- ✓ Especially useful as TV signal tracer
- ✓ Has etched aluminum panel
- ✓ Wider overlap of scales—more accurate readings
- ✓ Reads rms and peak-to-peak values of sine waves simultaneously up to 1500 volts rms and 4200 volts peak-to-peak



The dc ranges of both the WV-77A and WV-97A can be extended to 50,000 volts with accessory WG-289 High-Voltage Probe and WG-206 Multiplier Resistor. Accessory WG-264 Crystal-Diode Probe extends the frequency range of both instruments to 250 Mc.

YOUR CHOICE of 2 great RCA VoltOhmysts*

WV-77A—Accuracy and Versatility at a Low Price

Unquestionably the greatest value in all-electronic, ac-operated, vacuum-tube volt-ohmmeters . . . the WV-77A is factory-built and factory-calibrated against the finest laboratory standards. Comes complete with tubes, battery, probes, cables and instruction booklet . . . ready to use.

Equipped with five ranges each; for dc voltage, ac voltage, and resistance. It measures dc from 0.05 to 1200 volts; ac from 0.1 to 1200 volts rms; and resistance from 0.2 to 1 billion ohms. Superior in every respect to the famous 195-A.

*Reg. U. S. Pat. Off.

Ask your RCA Test Equipment Distributor for complete technical data folders, or write RCA, Commercial Engineering, Section 56JX, Harrison, New Jersey.

WV-97A—Especially useful for Television Servicing

The WV-97A combines in one instrument an unusual array of features of interest to every service technician.

The new Senior VoltOhmyst measures dc voltages from 0.1 volt to 1500 volts in high-impedance circuits, even with ac present. It reads the rms values of sine waves and the peak-to-peak values of complex waves or recurrent pulses, even in the presence of dc. Its electronic ohmmeter has seven ranges to measure resistances from 0.2 to one billion ohms.

An outstanding feature is its usefulness as a television signal tracer . . . made possible by its high-input resistance, wide frequency range, and direct reading of peak-to-peak voltages.



RADIO CORPORATION of AMERICA
TEST EQUIPMENT
HARRISON, N. J.

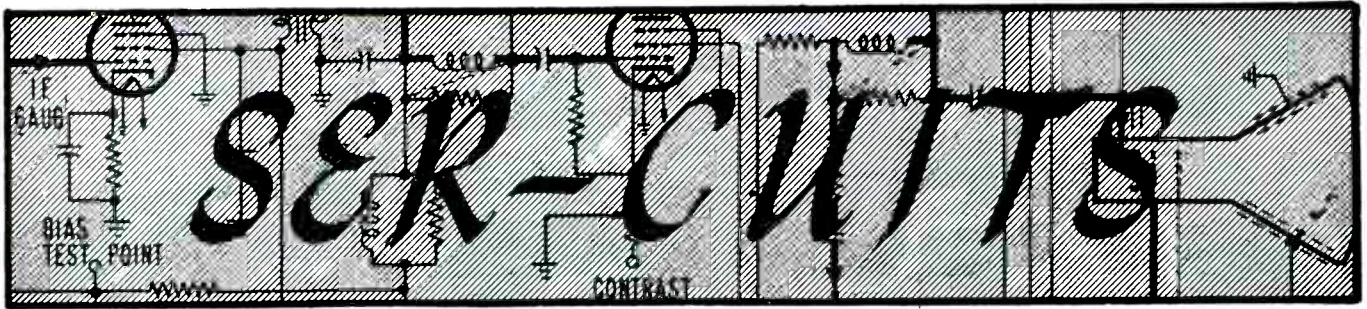

by M. W. PERCY

Circuitry Features of Table Model AM/FM Receiver With Eight-Inch Speaker . . . Characteristics of TV Variable-Inductor Continuous-Tuning RF Assembly.

IN THE EARLY DAYS of FM development, it was believed that it would be impossible to produce simplified AM/FM chassis, which might be compared to the popular broadcast table models, in view of the many tubes demanded by FM circuitry. Time has proved that view in error, for today there are several compact receivers available with AM and FM features.

An excellent example of this design trend is illustrated in Fig. 1, representing the RCA 1R81, popularly known as the Livingston.

The FM portion features a separate built-in antenna, while for AM reception, a ferrite antenna is provided.

Added sensitivity has been gained by shielding the FM tuner and incorporating three-gang tuned *rf* circuits for both AM and FM. Shielding the tuner has also reduced oscillator radiation to a negligible minimum, in conformance with recent FCC regulations.

Tubes Used

For *rf* amplification, a 6AU6 is used. A 6X8 serves as a mixer and oscillator. The mixer section of the 6X8 operates as a pentode on AM reception and as a triode on FM reception. This was found to provide best signal-to-noise ratio.

In the *if* amp section is a 6BA6. A 6AU6 has been included as a driver. The familiar 6AL5 acts as a ratio detector. For AM detection, *avc* and *af* amp, a 6AV6 has been inserted. In the output is a 6V6GT.

A five-range switch is provided for selection of AM or FM tuning ranges;

selection and distribution of *avc* voltages. (full *avc* is applied in AM position; delayed *avc* is applied in FM position.); application of B+ voltages to the plate and screen circuits of the 6AU6 and 6X8; (disconnected in phono position); control of the audio input to volume control; switching of mixer section of 6X8 from pentode operation on AM to triode operation in FM position.

The audio voltage controlled by the volume control is amplified by the 6AV6 and 6V6GT.

The FM antenna input is capacity coupled to the power line. Under average conditions the receiver does not require an external antenna. However, provision is made for the use of external antenna, if desired.

Servicing Precautions

In servicing, there are several precautions which must be followed. The diode lead from the second *if* must be dressed away from filament lead going to 6AV6 audio tube socket.

The lead from lug terminal B of the first FM transformer to the rear switch wafer terminal 10 should not be changed from the original; 3" long plus or minus 1/4" of No. 22 copper vinylite covered.

The *ac* leads from power switch on volume control should be dressed as far as possible from the audio leads and audio coupling capacitors near or connecting to the volume control terminals. The ground straps between the *rf* shelf and the main chassis should not be relocated. The connection point of the 10-mmfid (C_{10}) capaci-

tor is critical; therefore it should not be altered. It must be connected to the function switch and not to the *if* transformer.

DuMont Inputuner

During the past few months, several types of tunings systems* used in TV chassis have been described, featuring in the main, switch and drum-type systems. In Fig. 2 appears a continuous-tuning type of tuning employing the *inputuner* (DuMont T3C), which has been featured in all of the DuMont chassis and models made by several other manufacturers.

This tuner provides continuous tuning of all *vhi* TV and standard FM broadcast channels.

Facility of tuning has been aided by the incorporation of an electro-mechanical skip mechanism which automatically eliminates the portion of the frequency spectrum between the high end of the FM band (108 mc) and channel 7 (174-180 mc). Thus, the number of turns of the knob required to cover the range from channel 2 through 13 has been reduced from six turns, of previous DuMont tuners, to four turns for the T3C type. This reduction in tuning motion is said to have been achieved without the loss of band spread of the *hf* channels.

Tuning of the standard FM broadcast services is accomplished by

(Continued on page 38)

*See analysis of 8 (cover diagram) and 12-channel turret tuner, this issue.

Fig. 1, right. Schematic of RCA 1R81 AM/FM chassis, which features a phono-input jack and range switch. In phono operation, the *if* amplifier is free floating, or not returned to ground, although the plate and screen voltages are applied. However, the grid cannot go positive due to its being tied to the *if* amplifier grid through 1,200-ohm and 2.2-megohm resistors. If there were a positive voltage on the 6AU6 grid, it would conduct as a diode. It is desirable to have the *if* amplifier draw current under all operating conditions to provide best voltage regulation.

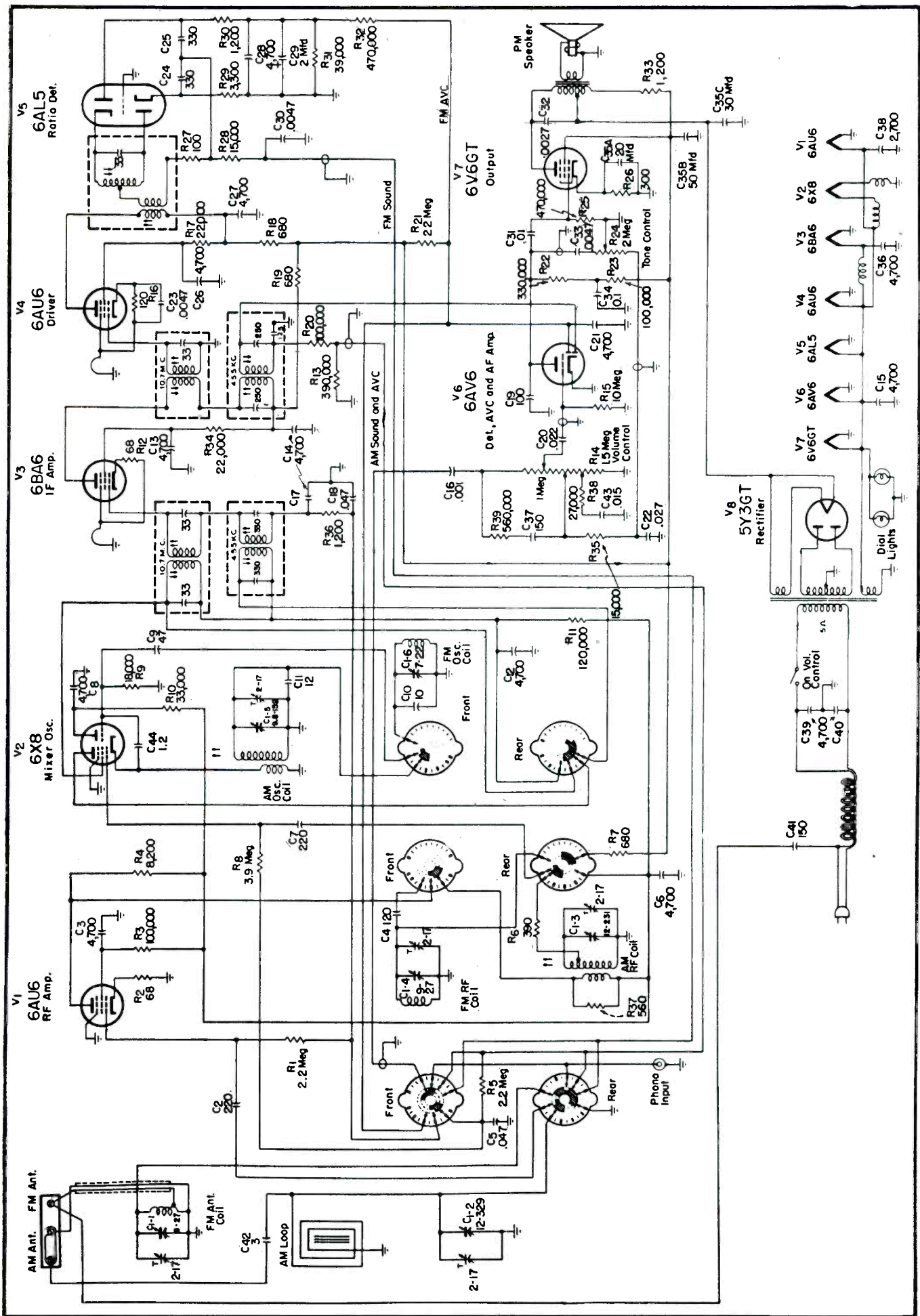

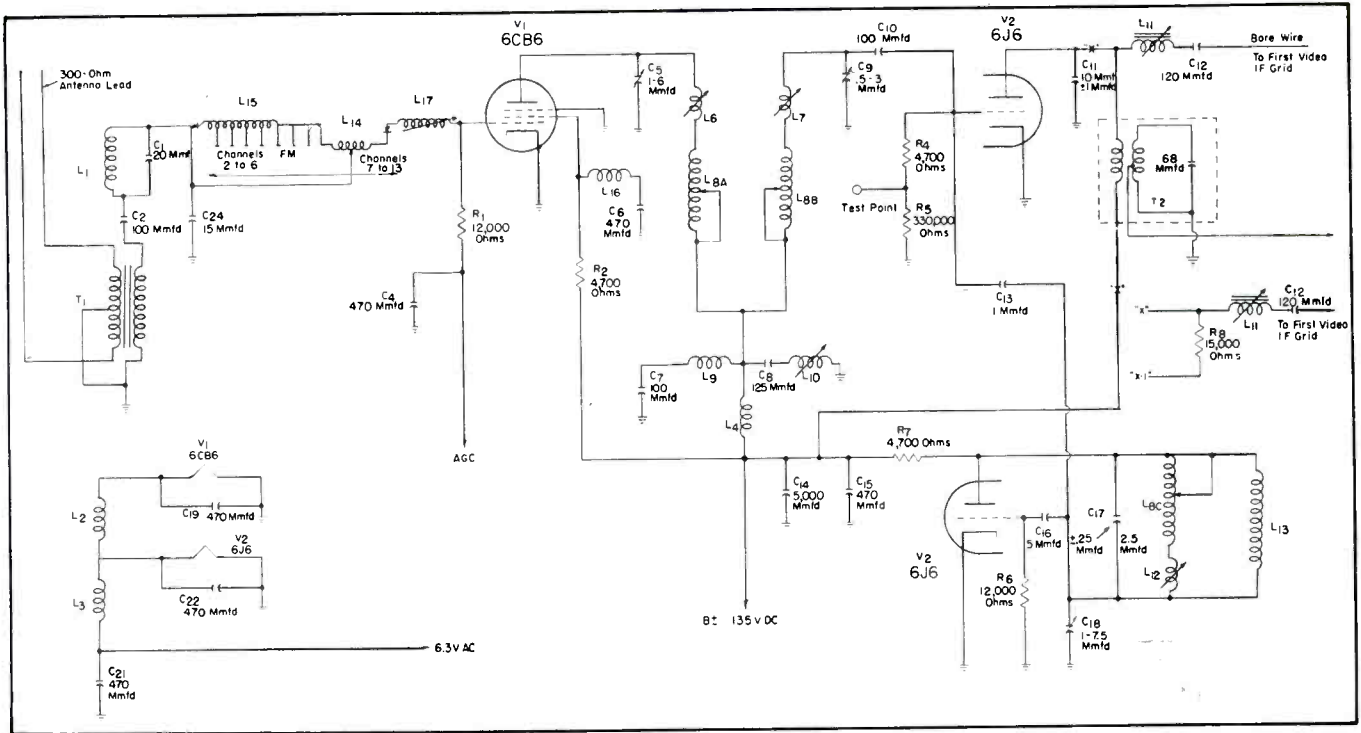

Fig. 2. Circuit of the DuMont T3C inputuner, which features continuous tuning coverage for TV and FM pickup. Points x represent contacts for type T3C3 and T3C4 tuners; see p. 53 for tuner data.

using the sound *if* system of the TV set as an FM receiver.

The mechanical design of the tuner as to size, shape, and mounting hole locations are such that it is mechanically interchangeable with the original tuners used in many of the dual-channel receivers now in use.

The circuits of the *inputuner* have been developed around a three-gang

variable inductor known as the *Mal-lory-Ware Inductuner*. This shielded, miniature unit of the spiral winding type incorporates the skip or jump tuning feature, including *rf* tuning, mixer tuning and oscillator tuning.

A special fourth tuned circuit, used to tune the antenna input, is mechanically coupled to the main tuning shaft by a part of the same gear train which drives the indicator dial.

The input circuit is designed for 300-ohm antenna systems and the tuner is supplied with an 18" length of 300-ohm twin lead for connection to the antenna.

The incoming signal is applied to the primary of a transformer which is center tapped to ground. The construction of this transformer is such that balanced input operation is obtained with a high balance to off-balance ratio over the entire TV range. This is said to reduce the effect of leadin pickup.

The secondary of the input transformer feeds the signal to the tuned input circuit through an *if* trap. This circuit, parallel resonant in the *if* band, rejects interfering signals falling in the *if* range of frequencies. From the *if* trap the signal is capacitively coupled to the resonant circuit consisting of a 15-mmfd coupling capaci-

tor, two series-connected variable inductors, an adjustment inductor, and the input capacitance of the 6CB6.

The input circuit is tuned to resonance with the low-frequency channels and the FM band by taps on a fixed

(Continued on page 53)

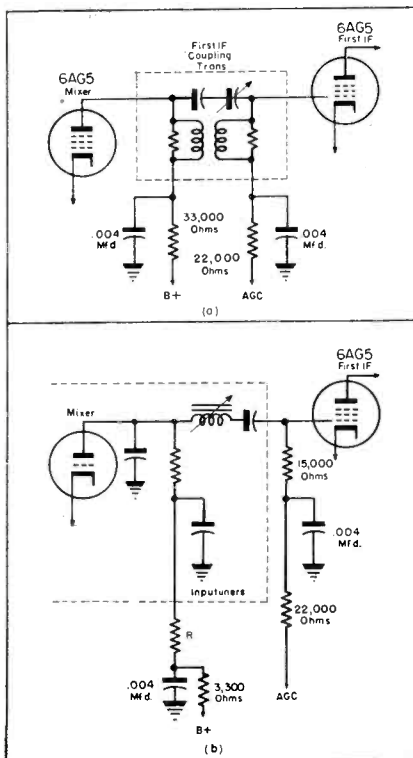

Figs. 3 and 4, left and right. Fig. 3a illustrates original Philco tuner coupling circuit (48-700, 48-1000, 48-1001, 48-1050 and 48-2500) and in b appears a revised circuit using *inputuner*. In Fig. 4a appears another Philco coupling circuit for the 49 series, while a revised circuit using an *inputuner* is shown in b.

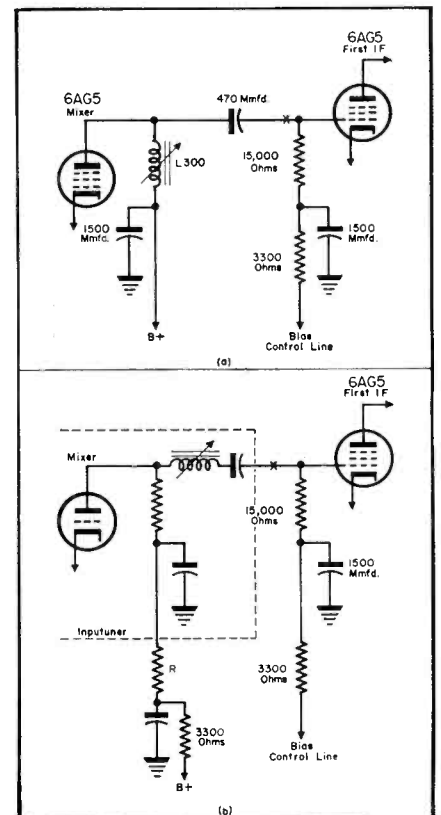

**KESTER
SOLDER**

Give top quality TV service with Kester "Resin-Five" Core Solder

TV—the nation's fastest growing business demands the nation's number 1 solder. Kester "Resin-Five" Core Solder, formulated especially for TV, will out perform any solder of the rosin-core type. It easily solders such metals as brass, zinc, nickel-plate, copper, and ferrous alloys.

**MADE ONLY FROM NEWLY MINED
GRADE A TIN AND VIRGIN LEAD**

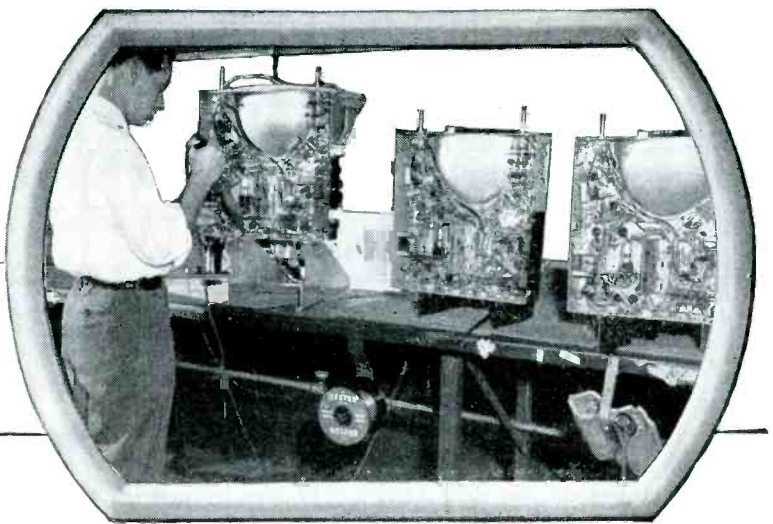
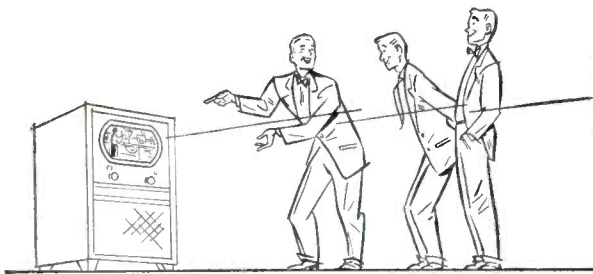

'Resin-Five' Core Solder

non-corrosive . . . non-conductive

Kester... Standard for the TV and Radio Fields

"Resin-Five" flux is more active and stable than any other rosin-type flux. Yet it is absolutely non-corrosive and non-conductive.

**FREE SOLDERING BOOKLET—Send for Your
Copy of—Soldering Simplified**

Kester Solder Company
4248 Wrightwood Avenue • Chicago 39, Illinois
Newark, New Jersey • Brantford, Canada



Servicing Helps

by M. A. MARWELL

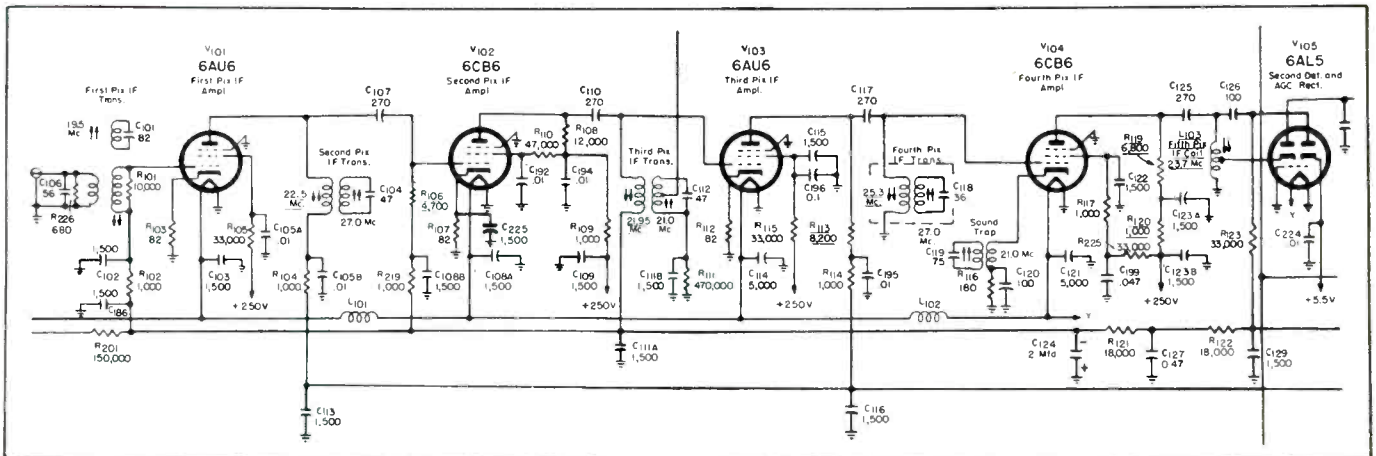

Fig. 1. Partial schematic illustrating changes required in RCA 7T103 to increase gain for fringe-area reception.

IN FRINGE AREAS where additional sound gain is desirable, in RCA models 4T101 through 4T141, 7T103 through 7T143, 9T105 through 9T147, it has been found possible to provide a 4 to 1 increase in sound gain, by altering the circuit as indicated in Fig. 1. Changing the second pix *if* grid resistor (R_{106} in 17 and 19 inch models and R_{107} in 14-inch models) from 8200 to 4700 ohms; changing the third pix *if* plate load resistor (R_{113} in 17 and 19-inch models and R_{115} in 14-inch models) from 1800 to 8200 ohms; changing the fourth pix *if* plate isolating resistor (R_{120} in all models) from 6800 to 1000 ohms; removing the fourth pix *if* plate load resistor and peaking coil (R_{119} and L_{111} in all models . . . in some cases, L_{114} will be found wound on R_{119}). In place of R_{119} and L_{111} , which were removed, a 6800-ohm resistor should be installed. A 1500-mmf ceramic capacitor should be installed across the second pix *if* cathode resistor (pin 2 of V_{102} to ground). The shortest possible leads should be used. The picture *if* amplifier must then be realigned, using the following peak frequencies: Second pix *if* transformer (T_{102} all models)—22.5 mc; third pix *if* transformer (T_{103} all models)—21.95 mc; fourth pix *if* transformer (T_{104} all

models)—25.3 mc; fifth pix *if* coil (L_{103} in 17" and 19", L_{102} in 14")—23.7 mc. In the final step the picture *if* amplifier must be sweep aligned to obtain the same overall response as shown in the service data. It is recommended that 6 volts of negative bias be applied to the picture *if* bias bus circuit during alignment.

Packard-Bell Fringe Area Provisions

Some recent circuitry developments on Packard-Bell models 2111-2112-2113 and 2114 have been found

Circuit Revisions for Fringe-Area Pickup . . . Improving Sensitivity and Sync Stability . . . Horizontal Drive Adjustments . . . Oscillator Coil Substitutions . . . Selenium-Germanium Diode Circuitry.

to have provided a marked improvement in fringe area reception, both in overall gain and stability.

Most of the instability encountered in weak signal areas was found to be caused by noise pulses of quite long duration. Changes were made as shown in the input of the first sync amplifier in Fig. 2. The lead dress of the .01 coupling capacitor was found to be critical. The capacitor should be placed directly over the 12AU7 sync amplifier socket, with the connecting lead approximately $\frac{3}{4}$ " long as shown in Fig. 3.

Due to overload conditions in some areas, another sound trap has been located in the second picture *if* stage and the screen by passed in the third picture *if*. These changes are shown in Fig. 4.

Stewart-Warner Revisions

Sensitivity and sync stability on the current Stewart Warner chassis can be further improved by incorporating the changes shown in Figs. 5 and 8. One modification (Fig. 5) has been incorporated in 9126 receivers coded Series C. In modifying the circuit, the sound trap coil and 240-mmf capacitor

(Continued on page 42)

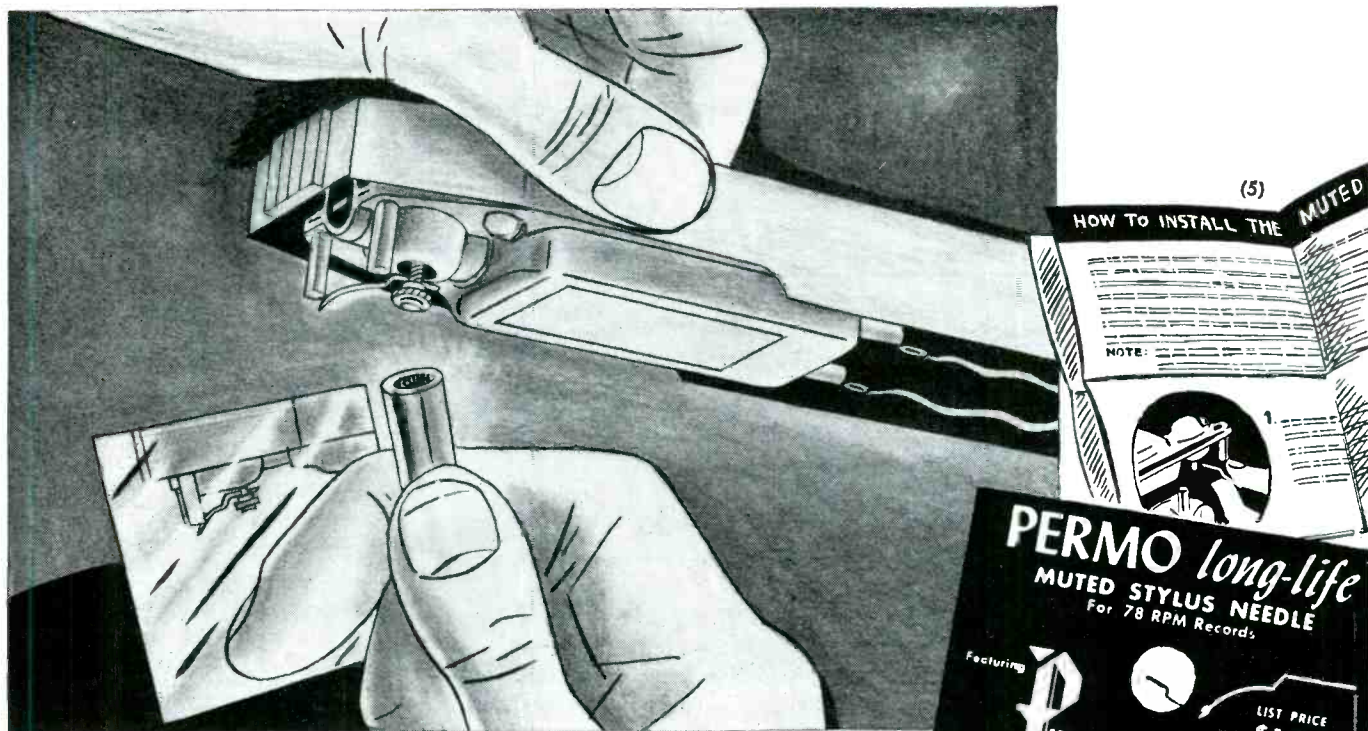

YOU SAVE TIME — MAKE MONEY — WITH PERMO *long-life* PHONO NEEDLES

Here's why:

1. COMPLETE "Facts" — Here is a needle replacement guide that's complete, authentic, accurate—one that tells *specifically* what needle goes *where*. It's Permo's "Phonograph and Needle Facts", and Permo took the time to do it right. A guide that gives you *everything* you need to know for fast, easy replacement needle sales.

2. COMPLETE NEEDLE STOCKS — Individually packaged Permo Long-Life Phono Needles come to you on convenient display cards. Each display card carries a full set of replacement needles for one manufacturer's sets.

3. REASONABLE INVESTMENT — Complete initial needle stocks and "Facts" for all post-war Admiral and Philco sets are yours for less than \$12.00 dealer cost. Make high profits selling the easy-replacement needle line—Permo Long-Life!



NO FUMBLING!

YOU GET EVERYTHING YOU NEED IN ONE PACKAGE

Permo Long-Life Phono Needles are individually packaged with *installation tools* where necessary, *spare parts* (nuts, screws, etc.) and *complete installation instructions*. The C-320 Muted Stylus package (above) for example, contains: (1) needle (2) wrench (3) mirror (4) extra nut (5) installation instructions. You get *everything* you need in one complete package when you buy Permo Long-Life needles.

NOW AVAILABLE
Admiral, Columbia and Philco "Facts" and Replacement Needles. Others coming soon! Write for your free copies of the "FACTS".



PERMO, INC. *Champion of Perfection*

6401-33 N. RAVENSWOOD AVE.

CHICAGO 26, ILLINOIS

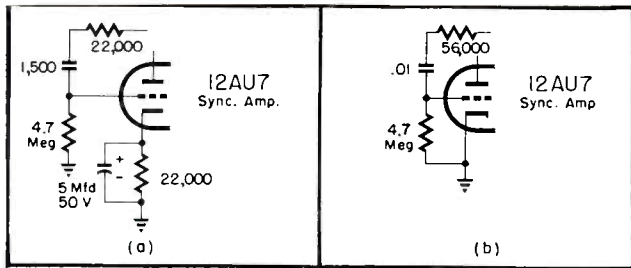

Fig. 2. Before and after revisions in input of first sync amplifier of Packard-Bell chassis evolved to remove instability in weak signal areas.

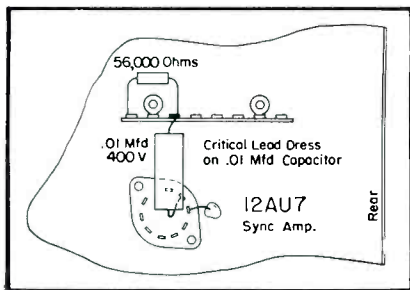

Fig. 3. Actual wiring layout for changes indicated in Fig. 2.

is removed from the cathode circuit of the first *if* 6AU6 amplifier tube.

Cathode Resistor Change

The resistor in the cathode circuit of the first *if* amplifier tube must be changed from 270 to 82 ohms and connected to ground.

New Trap Coil Assembly

A new trap coil assembly² is then installed into the plate circuit of the 6AU6. The new trap coil is inserted in the hole previously occupied by the old coil. A 3.3-megohm 1/2 watt resistor is then connected from pin 1 to pin 6 of the 6AU6 keyer *agc* (6AG5) on chassis coded *Series A*. A 3.3-megohm 1/2 watt resistor is also connected between the *agc* line and 120 volt B+ supply. The new trap coil should be aligned to the old trap frequency of 22.4 mc. After completing this con-

version, the fourth *if* stage should be changed in frequency from 24.75 to 24.9 mc.

Sylvania Service Note

The horizontal drive control on Sylvania chassis may be adjusted on a received station signal for maximum high voltage at the picture tube anode, and maximum picture size. Both steps should be made at the point where horizontal center picture crowding disappears. The drive control should be set fully clockwise and backed off counterclockwise to the correct setting.

Horizontal Drive Control Adjustment

If current limiting resistors are used with straight filament 5642 tubes the horizontal drive control should be adjusted as follows: The brightness control should be set to *maximum* and the horizontal drive control adjusted for maximum picture brightness which will be at a point when center picture crowding disappears. Blooming will be caused by improper adjustment of the horizontal drive control.

Fig. 8. Stewart Warner TV chassis (9202 and 9303) modifications affording improved sensitivity and sync.

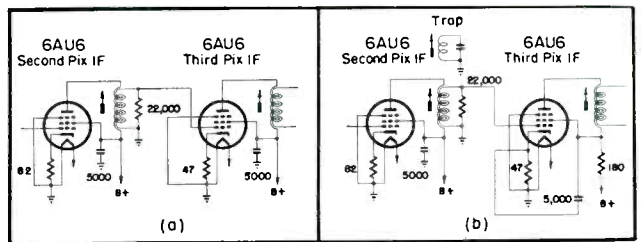
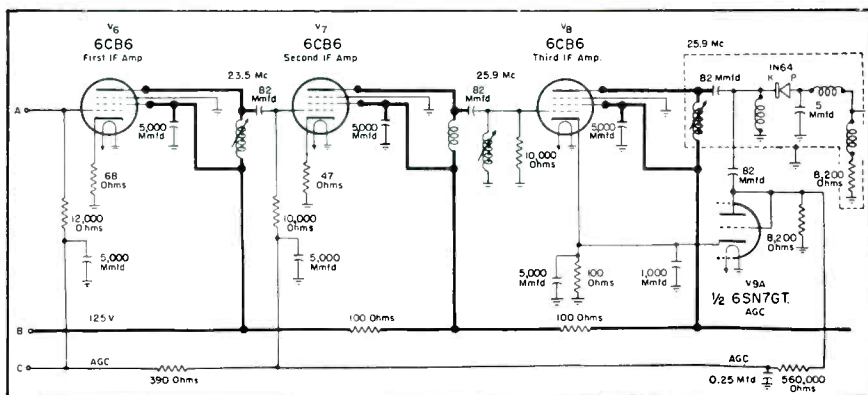
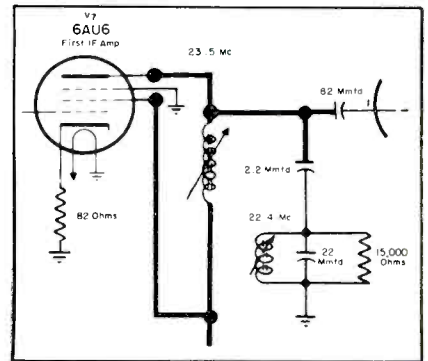

Fig. 4. Original and revised second and third picture *if* stages in Packard-Bell models featuring use of an additional sound trap and a screen bypassing change, provided to correct overload problems.



(Above)

Fig. 5. First *if* amplifier in Stewart Warner chassis altered to improve sensitivity and sync stability.

(Below)

Fig. 6. Oscillator-coil circuitry for RCA BX55, featured in some chassis. Oscillator coil has an adjustable core. Coil should be adjusted for maximum output at 600 *kc* while rocking the gang.

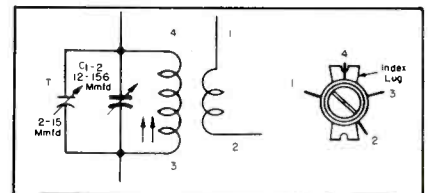

(Below)

Fig. 7. Circuits for selenium (a) and germanium rectifiers (b) whose elements appear to look alike schematically, but differ substantially in application and operation. Selenium rectifiers are generally employed for power rectification, while germanium crystal diodes are used for signal rectification or detection. The polarity coding may lead to some confusion since they are coded differently. The coding on the selenium cells indicate the *dc* polarity which will result, while the coding on germanium diodes indicates the *dc* polarity that must be applied to obtain maximum current flow. (From RCA service notes.)

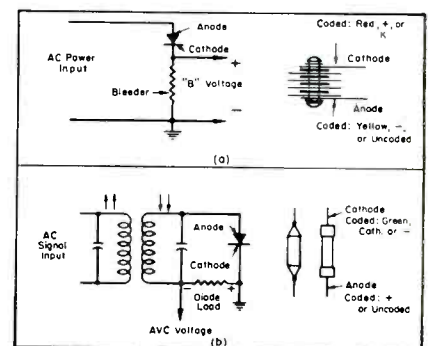

TUNG-SOL CHANGES ITS NAME . . .

same trademark



same tradename

TUNG-SOL

same products

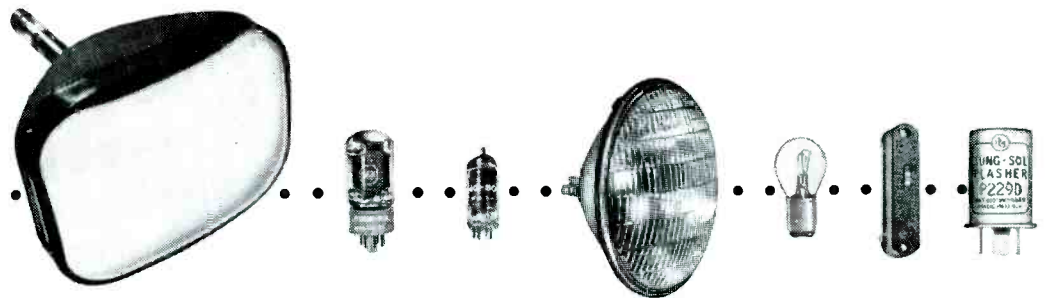

same quality

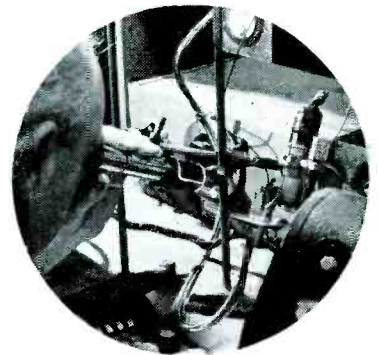

same service



but a brand new corporate name . . **TUNG-SOL ELECTRIC INC.**

(FORMERLY TUNG-SOL LAMP WORKS INC.)

TUBE News

by L. M. ALLEN

Circuitry and Components for Wide-Angle Large Picture Tube Conversions

WITH THE ADVENT OF LARGER wide-angle picture tubes, there appeared a keen interest in the conversion possibilities of ten and twelve-inch chassis. It was said that these modifications would be possible if wide-angle accessories were available. Accordingly, labs initiated development programs and soon were able to announce that all of the required conversion components could be produced. Recently, complete kits of parts* for large-screen conversions began coming off the line, featuring four types of distributed-winding deflection yokes to accommodate most circuit requirements, horizontal deflection output and *h_v* transformers, and width and linearity controls.

Yoke Features

The deflection yokes are said to have three important characteristics: edge to edge focus made possible by the distributed winding technique; short overall length (2¾") which lends itself for use on short necked picture tubes, and yoke windings, so fabricated, that they will retain their



Virginia Poppele, daughter of Jack Poppele, vice president in charge of engineering of WOR, who as a result of her accurate prediction, during a television prediction party staged by RCA Victor, that the first video signal would span the country on August 10, has been rewarded with a TV set and a trip to Hollywood.

shape under conditions of high humidity and temperature.

Yoke Types

The yokes, when properly matched into the horizontal and vertical circuits, will sweep any picture tube that has a deflection angle of 70° or less. Specifically, there is a yoke with 560-ohm resistors, 51-mmfd capacitor and leads, for use in transformer type cir-

cuits¹; one without resistors, capacitor and leads²; another with 560-ohm resistors, 51-mmfd capacitor and leads, for use in autotransformer type circuits³; and a fourth without resistors, capacitor and leads.⁴

Yoke Voltage Rating

The yokes are said to be capable of withstanding high potential test between windings and between any winding and the core, or any exposed metal contained in the yoke assembly.

Horizontal Deflection Output and HV Transformer

The second unit in the kit, the horizontal output transformer⁵, is of the flyback variety, with three windings and is capable of delivering 12 to 13 kv of accelerating potential to the picture tube. The primary is tapped and acts like an autotransformer. The high end of the autotransformer steps up the voltage produced by the inductive kick when the plate current of the output tube is cut off. This high voltage is rectified and used as accelerating potential on the picture tube. The secondary is so wound to match the plate of the output tube to the deflection yoke. The third winding is a heavy duty single turn to supply fila-

⁵DuMont H1A1.

*DuMont. ¹DuMont Y2A1. ²DuMont Y2A2. ³DuMont Y2A5. ⁴DuMont Y2A3.

Does the Job...

**BETTER
FASTER**

RADIX

Wire

300 OHM TWIN LEAD

**TV
TRANSMISSION
CABLE**

More than 3 times

- ➔ The Tensile Strength
- ➔ The Breaking Load
- ➔ The Flexing Strength

**Copper Weld and
Plastic Construction**

than Stranded Copper

- ★ Excellent Conductivity at TV Frequencies
- ★ Superior Strength—Longer Life
- ★ Resists Breakage—Weather Resistant
- ★ Easy to Strip—No Strands to Cut
- ★ Speedy Installation—No Twisting of Strands

SPECIFICATIONS

- ★ .55 mil Webb
- ★ High "Q" Polyethelene Insulation
- ★ Wound on 5000 Ft. Returnable Reels

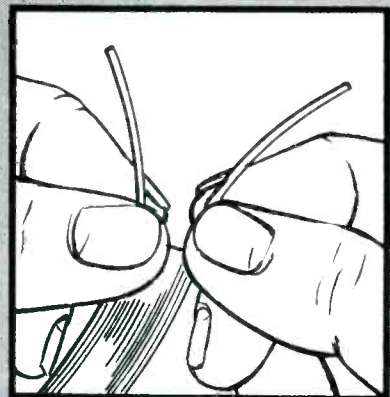

QUICK, EASY INSTALLATIONS WITH RADIX
CABLE... STRIPS QUICKLY... NO STRANDS
TO TWIST TOGETHER... JUST STRIP... LOOP
OVER AND YOU'RE ALL SET!

The Radix Wire Co.

2800 EAST 55th ST. CLEVELAND 4, OHIO

See for yourself —
send for a free sample

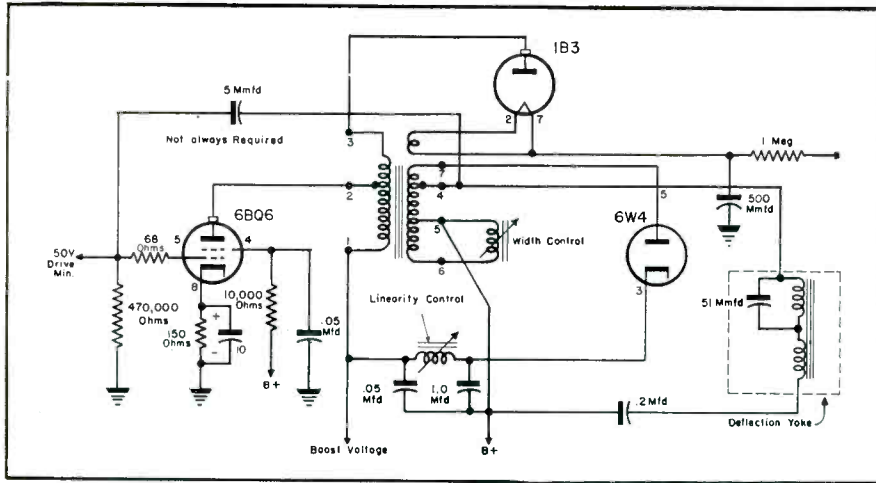

(Conversion circuits: above and below.)

Figs. 1 and 2. Circuitry which can be used to convert 10 and 12-inch receivers to accommodate larger wide-angle picture tubes, using new deflection yoke, linearity and width controls, and horizontal-deflection output and *h_v* transformer. In the circuit shown in Fig. 1, the 5-mmf capacitor, a 3,000-v unit is not always required. In both circuits, the 500-mmf capacitor is a 20-kv type.

ment voltage to the high voltage rectifier tube.

Voltage Ratings

The transformer is said to be able to withstand a minimum of 3 kv high potential between the secondary winding and core, and a minimum of 20 kv to the rectifier tube.

Ferrite Core Provided

It is equipped with a universal mounting bracket that allows it to be mounted either on its side or bottom. A ferrite core insures the required efficiency.

Conversion Parts

It has been found possible to convert a 630 TV receiver to a large screen size by using these parts plus a 6V6, a 6W4†, 3000-ohm 5-watt resistor, 1-

mfd 600 v and 500-mmf 20-kv capacitors. In Figs. 1 and 2, two types of conversions, using these components, are illustrated.

Focus-Coil Resistance Change

On the larger screen tubes it may be necessary to employ a focus coil with greater resistance than the one in the 630 receiver. The resistance of that focus coil is 247 ohms. A focus coil with a resistance of about 500 ohms might be necessary.

In converting a 630 chassis, the electrically energized ion trap is usually cut out of the circuit and a new *pm* beam bender substituted the type depending on the picture tube selected.

†If 2000 v pulse voltage on the 5V4 damper tube is exceeded, it will be necessary to use a 6W4.

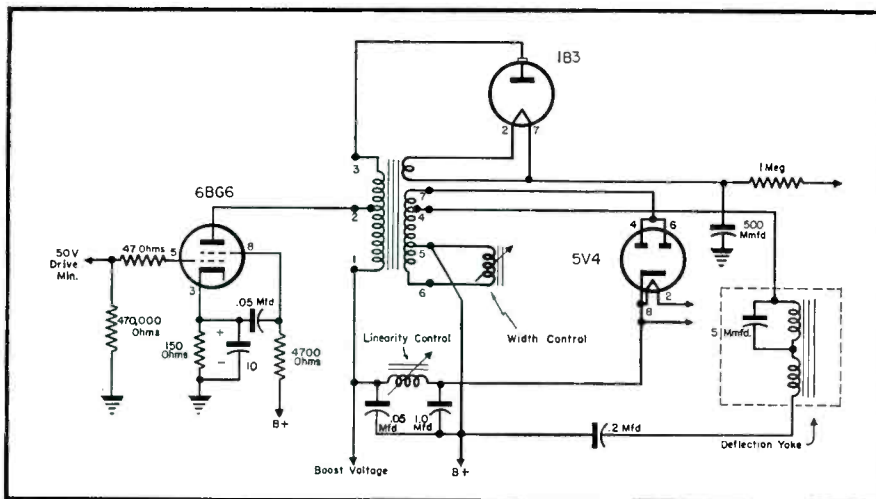

Pocket-sized TV picture tube replacement selector which, at a spin of a wheel, indicates the correct replacement type for worn-out picture tubes, announced by Allen B. Du Mont Laboratories, Inc., Cathode-ray Tube Division, 750 Bloomfield Ave., Clifton, N. J. Conversions are determined by checking the technical data at the rear of the selector, showing through slots for the given type.

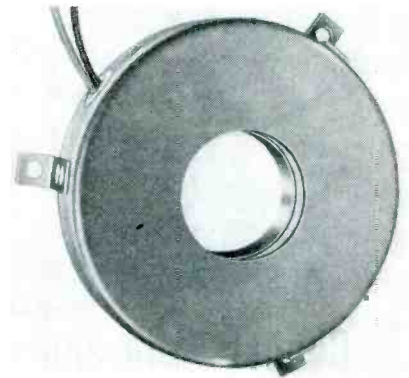

Focus coil, *F-11* (equivalent to RCA 202D2), for use with direct viewing picture tubes, requiring external magnetic focusing, announced by Standard Transformer Corp., Chicago. Has a *dc* resistance of 470 ohms; maximum ma 140, and diameter 4 1/4", with mounting centers 2 11/16" radius 120° apart.

TV deflection yoke, *Cletron Universal*, designed with anastigmatically corrected coils that is claimed to provide a sharper focus over the entire picture area, announced by Cleveland Electronics, Inc., 6620 Euclid Ave., Cleveland 3, Ohio. It is said to be insulated against high temperature up to 90° C.

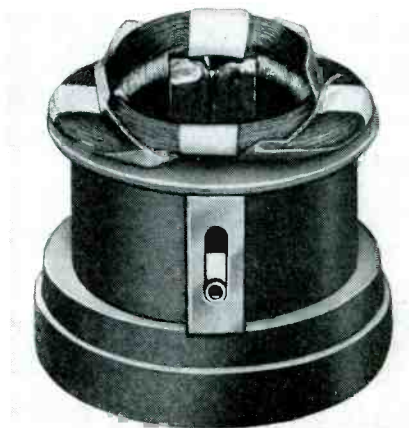

New 1952 HEATHKITS

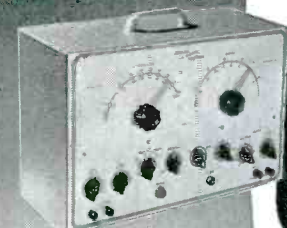

Heathkit
TELEVISION
GEN. KIT \$39.50

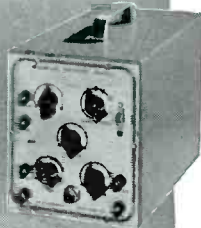

Heathkit
ELECTRONIC
SWITCH KIT \$19.50



Heathkit
AUDIO GEN.
KIT \$34.50

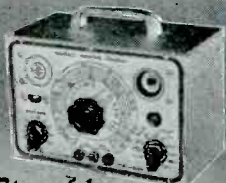

Heathkit
CONDENSER
CHECKER KIT \$19.50

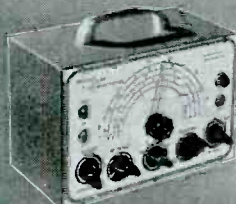

Heathkit
R. F. SIGNAL
GEN. KIT \$19.50



Heathkit
A.C. VOLTMETER
KIT \$29.50



Heathkit
SQUARE WAVE
GEN. KIT \$29.50



Heathkit
INTERMODULATION
ANALYZER \$39.50

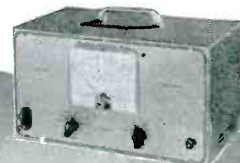

Heathkit
AUDIO FREQ.
METER KIT \$34.50

Heathkit 5" OSCILLOSCOPE KIT

- New "spot shape" control for spot adjustment — to give really sharp focusing.
- A total of ten tubes including CR tube and five miniatures.
- Cascaded vertical amp inners followed by phase splitter and balanced push-pull deflection amplifiers.
- Greatly reduced retrace time.
- Step attenuated — frequency compensated — cathode follower vertical input.
- Low impedance vertical gain control for minimum distortion.
- New mounting of phase splitter and deflection amplifier tubes near CR tube base.
- Greatly simplified wiring layout.
- Increased frequency response — useful to 5 MC.
- Tremendous sensitivity .03 RMS per inch Vertical .6V RMS per inch Hor.
- Dual control in vernier sweep frequency circuit — smoother acting.
- Positive or negative peak internal synchronization.
- Multivibrator type Wide Range Sweep Generator.

A brand new 1952 Heathkit Oscilloscope Kit with a multitude of outstanding features and really excellent performance. A scope you'll truly like and certainly want to own.

The kit is complete with all parts including all tubes, power transformer, punched and formed chassis, etc. Detailed instruction manual makes assembly simple and clear — contains step-by-step instructions, pictorials, diagrams, schematic, circuit description and uses of scope. A truly outstanding value.

MODEL O-7
SHIPPING WT. 24 LBS.

\$43.50



Heathkit VACUUM TUBE VOLTMETER KIT

- New styling — formed case for beauty.
- New truly compact size — Cabinet 4 1/8" deep x 4-1/16" wide x 7 3/8" high.
- Quality Simpson 200 microamp meter.
- New ohms battery holding clamp and spring clip — assurance of good electrical contact.
- Highest quality precision resistors in multiplier circuit.
- Calibrates on both AC and DC for maximum accuracy.
- Terrific coverage — Reads from 1/2V to 1000V AC, 1/2V to 1000V DC and 1 to over 1 billion ohms resistance.
- Large, clearly marked meter scales indicate ohms, AC Volts, DC Volts, and DB — has zero set mark for FM alignment.
- New styling presents attractive and professional appearance.

The 1952 Model Heathkit Vacuum Tube Voltmeter! Newly designed cabinet combines style and beauty with compactness. Greatly reduced size to occupy a minimum of space on your work-bench. Covers a tremendous range of measurements and is easy to use. Uses only quality components including 1% precision resistors in multiplier circuit for greatest accuracy. Simpson 200 microamp meter with easy to read scales for fast and sure readings.

All parts come right with kit, and complete instruction manual makes assembly a cinch.

MODEL V-5
SHIPPING WT. 5 LBS.

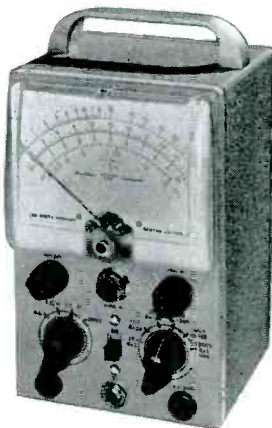

\$24.50

YOU SAVE BY ORDERING DIRECT FROM MANUFACTURER

EXPORT AGENT
ROCKE INTERNATIONAL CORP.
13 E. 40th ST.
NEW YORK CITY 16
CABLE: ARLAB-N.Y.

The HEATH COMPANY

... BENTON HARBOR 11, MICHIGAN

*"I want to see
Americans save . . ."*

JOHN L. COLLYER

President, The B. F. Goodrich Company



"I want to see Americans save for their own personal security, and I want to see them, as stockholders in our government, urge economy in all phases of our national life in order to provide national security against aggression."

By their rapidly mounting participation in the Payroll Savings Plan, Americans *are* saving for their personal security, fighting the menace of inflation and making a major contribution to America's defense against aggression. In Mr. Collyer's own company 80% of the 38,000 employees throughout the company have already enrolled in the Plan, with two large divisions still to report.

As Chairman of the Ohio Payroll Savings Advisory Committee, Mr. Collyer knows what is being accomplished by leaders of industry, top management and labor in their joint effort to step up the Payroll Savings Plan. A few recent figures should be interesting to those not so familiar with the national picture:

- In the steel industry campaign, Carnegie-Illinois Steel Corporation (now U. S. Steel Company), recently raised its payroll participation from 18% of 100,000 employees to 77% . . . Columbia Steel Company of California went from 7.9% to 85.2% . . . American Bridge Company signed 92.8% of the workers in the large Ambridge plant . . . 87%

of Allegheny-Ludlum Steel Corporation's 14,000 employees are now on the Payroll Savings Plan . . . Crucible Steel Company of America, reinstating its plan, signed up 65% of its 14,500 employees.

- In the aviation industry, Hughes Aircraft Company went from 36% to 76%; Boeing Aircraft enrolled 10,000 new names before Christmas.

Some dollars and cents figures? In the last quarter of 1950, sales of \$25 E Bonds—the denomination so popular with payroll savers—increased 2.5% by 245,000 bonds more—over the last quarter of 1949.

If you do not have The Plan That Protects the personal security of your employees, the national economy and our country's defense, phone, write or wire to U. S. Treasury Department, Savings Bonds Division, Washington Building, Washington, D. C. Your State Director is ready to help you install a Payroll Savings Plan or step-up your employee participation.

The U. S. Government does not pay for this advertising. The Treasury Department thanks, for their patriotic donation, the Advertising Council and

S E R V I C E



New TV Parts...Accessories

BLONDER-TONGUE AUTOMATIC PREAMP

An automatic 4-stage TV amplifier, *CA-1-M*, that is said to provide a gain of 30 db, has been announced by Blonder-Tongue Laboratories, 38 N. Second Ave., Mt. Vernon, N. Y.

Unit employs two 6J6s and 2 6BQ7s, and has a built-in transformer to provide a line match for both 75- and 300-ohm lines. Equipped with on-off switch and a signal light.



* * *

TELE-BEAM FRINGE-AREA ANTENNAS AND ACCESSORIES

A line of antennas and accessories for fringe-area installations have been introduced by Tele-Beam Industries, Napa, Calif.

Included are TV antennas, TB2, a 3-element beam model; TB3, stacked array; yagis; hi-lo TV arrays; and colinear arrays for fringe-area reception. A telescopic mast from 20' to 50', adjustable from 10'; and a preselector, model S covering channels 2-13 with 10-db gain claimed for channels 4-5-7-9, are also available.

* * *

CELOMAT DUAL COLOR WHEELS

A dual color wheel that is said to permit both color and black and white viewing without change-overs, has been announced by the Celomat Corp., 521 West 23rd St., New York City.

Wheel has two clear plastic discs with color segments. For black and white viewing, the wheels are kept stationary; the colored segment sections of the wheels fall below the screen, and the black and white picture is transmitted through the clear plastic upper half of the discs.

* * *

DAVIS RHOMBIC ANTENNA

A rhombic antenna that is said to eliminate stacked arrays and overcome the problems of fringe and ghost area reception, has been announced by Davis Electronics, 3047 W. Olympic Blvd., Los Angeles 6, Calif.

Antenna has a tilt of 15° that is claimed to provide a 12 db gain and a directivity of 12°. Can be matched to all lead-ins without a matching transformer.

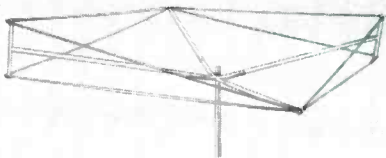

RADIART CHIMNEY MOUNT, ROTATOR AND LIGHTNING ARRESTER

A chimney mount, *Spee-Dee*, for use with masts up to 1 3/4" od, and a lightning arrester, TA5, that is claimed to eliminate the necessity of stripping wires, have been announced by the Radiart Corp., Cleveland 2, Ohio.

Chimney mount features the absence of nuts and bolts for tightening the straps around the chimney. A ratchet lock is used to wind up the straps and lock them in place.

Arrester has sharp-toothed cup washers that pierce the insulation, and is said to have a low internal capacity and high internal resistance.

Rotator, *Tele-Rotor Cub*, 502B, is said to feature true in-line thrust between antenna and mast.

A 3/4" steel shaft with in-line, reamed, oilless bearings, rotates on a steel ball. Available in a mahogany plastic cabinet containing an indicating meter for tuning.

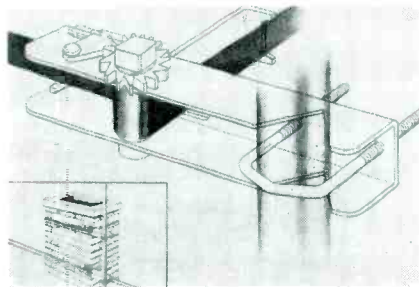

Radiart chimney mount

Radiart rotator

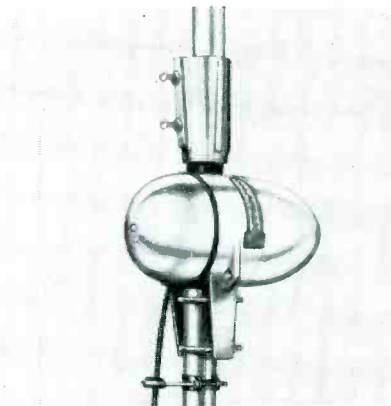

* * *

DRAKE HI-PASS TV FILTERS

High-pass TV filters, *TV-300-54 HP*, designed to attenuate *rf* interference from police radio stations, etc., in the region of the new higher *if*'s being incorporated in some of the late model chassis have been announced by R. L. Drake Co., 11 Longworth St., Dayton 2, Ohio. Filter has a cut-off frequency of 54 mc and an infinite attenuation frequency of 43.5 mc.

MOSLEY TV TRANSMISSION LINE FEED-THROUGH

A feed-through bushing, *Roof-Thru*, that is said to permit direct entrance of TV transmission line through the roof without allowing moisture to enter, has been announced by Mosley Electronics, 2125 Lackland Rd., Overland, Missouri.

Device consists of an acrylic plastic bushing combined with a copper flashing plate that is installed in buildings under construction, or in existing structures, by lifting a few shingles, drilling a hole 1" in diameter through the roof sheathing, inserting the *Roof-Thru*, and then replacing the shingles over the copper flashing.

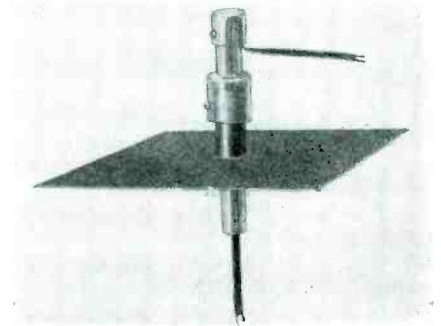

* * *

LOUIS BROS. ANTENNAS

A line of antennas, 400 series, has been produced by Louis Bros., 3543 16th Street, Los Angeles 23. Six different types pre-assembled at the factory, are available. Feature a *self-lock* design. All elements are said to swing out at a touch, and by spring action automatically lock in place.

* * *

VIDAIRE COLOR ADAPTER

A color adapter with provisions for adjusting height, vertical linearity, focus, width and phase, horizontal frequency and vertical frequency, is now available from Vidaire Television Company, 576 W. Merrick Road, Lynbrook, N. Y. Three models are available: model CA-400, to be used with receivers employing the *Synrolok*; model CA-401, for receivers using the *Synroguide*; and model CA-402, for receivers using the *multivibrator*.

* * *

GRAYBURNE INTERFERENCE ELIMINATOR

A TV interference eliminator, *Clear-Pix*, which contains a network of a tuneable iron core and capacitor adjustable over the 88-110 mc band, has been developed by Grayburne Corp., 103 Lafayette St., New York 13, N. Y.



ASSOCIATIONS



Representatives of the various member chapters of the Federation of the Radio Servicemen's Association of Penna., who attended the annual Clam Bake held by the Radio Servicemen's Association of Luzerne County (Wilkes Barre) at Lily Lake.

NETSDA

DELEGATES FROM FIFTEEN member chapters of the National Electronic Technicians and Service Dealers Association, delegations from the Radio and Television Servicemen's Association of Pittsburgh, Inc., and guests of the Television Contractors Association of Philadelphia were present at a recent meeting in Philadelphia.

The Trenton group, headed by David Van Nest, presented application for membership to NETSDA, which was voted on and accepted. Thus, the Trenton Radio and Television Service-

men's Association became the sixteenth chapter in NETSDA. Dave Krantz of Philadelphia and Max Leibowitz of New York were named to NETSDA's industry relations committee to assist Norman Selinger, vice-president of NETSDA in Washington, D. C. in making a representation to the Federal Trade Commission. James Daly of PRSMA was appointed chairman of a committee which will formulate a national code of ethics.

It was announced that the secretary's office of NETSDA will soon start issuing a bi-monthly bulletin to member chapters and to all other radio

Service association executives, during recent demonstration of RCA compatible color in New York. Left to right: standing: Jack Barton, Television Service Contractors Association, Detroit; Mort Farr, National Appliance and Radio Dealers Association, Philadelphia; Al Haas, Television Contractors Association, Philadelphia; Bob Roach, Television Service Contractors Association, Pittsburgh; Al Saunders, Radio Technicians Guild of Boston; and James Burns, Television Associates, Washington, D. C. Kneeling before set are Dave Kranz, Federation of Radio Servicemen's Association of Penna., Philadelphia, and E. C. Cahill, RCA Service Company prexy, who was host to the group during the test.



and TV service and dealers associations.

FRSAP

MEMBERS AND OFFICERS of the Radio and Television Servicemen's Association of Pittsburgh, Inc., voted to join the Federation of Radio Servicemen's Association of Pennsylvania as an active chapter. George R. Sharpe has been elected FRSAP president. Other new officers are Samuel Avins, secretary and counsel, and Ed Roberts, treasurer.

A. G. Petrasek of the RCA Victor Tube and Part Sales Division has begun delivering a series of lectures on television servicing and business before FRSAP chapters. The first talk was offered before PRSMA. Similar lecture arrangements have been made with Erie Resistor, the G. E. tube and test equipment division, Raytheon Television, and several others to fill out the balance of the year.

ARTSNY

THE ASSOCIATED RADIO and Television Servicemen's Association of New York has obtained a club room consisting of three thousand square feet at 5 Rutgers Street, New York City, which, in addition to being a club room, will serve as a complete service clinic and office.

Many ARTSNY members have taken ads in the classified telephone directory.

RSA, Ithaca

Ben De Young of the Radio Servicemen's Association of Ithaca has announced that RSA members are helping him on a fund raising campaign for a cause close to his heart, The Cerebral Palsy Fund.

The program committee has developed new educational and business training lectures that will be presented to its membership at its meetings.

RSA, Trenton, N. J.

AT A RECENT ELECTION of the Radio Servicemen's Association of Trenton, New Jersey, George Owens was elected president. Francis Wolf has been elected vice-president and Charles Redman, secretary. David Van Nest

TEN YEARS AGO

From the Association News Page of
SERVICE, Oct.-Nov., 1941

JOHN F. RIDER presented a plan for a local radio Service Men's association, which was to be called the Radio and Electrical Appliance Service Association, Inc., at a meeting held at the Park Central Hotel. The proposed platform stated that the association would guarantee the work done by its members; establish standard trade practices; establish a program acquainting the public with the problems of maintenance; provide legal advice; act as a clearing house for all complaints; provide an insurance plan for bonding its members and insuring the services rendered, insofar as possible; prepare technical standards for its membership, offer a qualifying test to shop owners and employees actually engaged in service work; maintain an educational program providing, if necessary, a school for the benefit of the personnel of association members; provide an advisory service to its members in matters relating to advertising, business practices, etc.; prepare a code of ethics which shall be maintained by its membership. Officers of the association were: president, John F. Rider; vice president, Edward Lowe; treasurer, Charles Ollstein. . . . Norman B. Neely, Tom Bissett and Frank Koessler, all of Norman B. Neely Enterprises, presented informal talks on *FM, General Considerations and Circuit Descriptions*, before the Radio Technicians Association, Long Beach, Calif. Several pieces of equipment were demonstrated, notably the REL model 517 monitor receiver and the REL model 517-CS speaker.

has been named delegate to the NETSDA. Trenton's delegates have been requested to present application for membership to NETSDA. An announcement has been made that the Trenton association will cooperate with other groups in New Jersey in meeting and discussing state problems.

RTSA, Pittsburgh

THE RADIO AND TELEVISION Servicemen's Association of Pittsburgh, Inc., has applied for membership in the Federation of Radio Servicemen's Association of Pa.

The association has set up a Federal Credit Union to help small shop owners and the independent Service Men obtain additional finance for

(Continued on page 52)

SOMETHING TO

REMEMBER

MEMO

about
SPRAGUE
Twist-Lok^{*}
TV
Capacitors



● More twist-prong electrolytic capacitors are made by Sprague than by any other manufacturer. . . . And Sprague naturally lists the largest, most complete line for exact TV replacement applications.

● And when you use a Sprague Twist-Lok TV Capacitor, you can be sure it's dependable. No costly callbacks will jeopardize your profit or your reputation. Your business judgment will tell you to *accept no substitutes*.

GET YOUR NEW SPRAGUE TV CAPACITOR REPLACEMENT MANUAL TODAY!

Besides making the largest TV capacitor line, Sprague makes it easy for you to pick the correct replacement for practically any television receiver! Just off press, this NEW 3rd edition of the famous Sprague Manual is jam-packed with up-to-the-minute replacement recommendations for critical capacitors in 964 TV sets of more than 60 brand names.

FREE from your Sprague parts distributor or send 10c directly to Sprague to cover handling and mailing costs.



★Trademark



PRODUCTS COMPANY

61 Marshall St.
NORTH ADAMS, MASSACHUSETTS
(Distributors' Division of the Sprague Electric Company)

PIONEERS IN ELECTRIC AND ELECTRONIC DEVELOPMENT

ANASTIGMATICALLY

CORRECT

UNIFORM FOCUS

UNIVERSAL TV DEFLECTION YOKES

**FOUR MODELS DIRECTLY REPLACE
IN 80% OF ALL TV RECEIVERS**

CLETRON Yokes include the latest advances in design to simplify replacements and large picture tube conversions. Excellence in quality and workmanship combine to give the finest possible performance in a TV receiver.

Anastigmatically corrected coils are used in all units to insure sharp focus over the entire picture area.

High-temperature insulating materials provide for widely varying conditions without breakdowns.

Quadruple formvar insulation affords maximum protection from high voltage failures.

Write for complete information today.

LIST PRICES:

For 55° Deflection Angle . . . \$7.50
For 70° Deflection Angle . . . 10.50

CLEVELAND ELECTRONICS, INC.

6618 Euclid Ave. • Cleveland 3, Ohio

Morhan Exporting Corp., 458 Broadway, NY, NY.



Quality manufacturers of a complete line of

**Radio TV Speakers
Waterproof Speakers
TV Lightning Arresters**

Cletron

Association News

(Continued from page 51)

their business and the purchasing of test equipment.

ATTA, South Jersey

RODGER HAINES is now president of Allied Television Technicians Association of South Jersey. Paul Matlack is vice-president; Bob Blazer, secretary, and Gordon Laney, Treasurer. A nominating committee has been appointed to select a list of candidates for election of officers at the next meeting. The membership committee has designed a program to extend its

membership drive to all of South Jersey.

TA, Washington, D. C.

TELEVISION ASSOCIATES, Inc., Washington, D. C., under the supervision of J. T. Burns, president, and Norman Selinger, vice president, are preparing a series of technical lectures and business forms. The membership committee is contemplating a drive to obtain members from all service organizations in Washington, D. C.

A committee has been appointed to investigate all licensing bills that are being presented in various municipalities and states, the results of which

will be used as a guide in the formulation of a licensing bill for Washington, D. C.

Burns, who is also chairman of the NETSDA membership committee is being kept quite busy meeting association delegates and answering mail noting how to form an association or obtain membership in the national group.

PR SMA

THE PHILADELPHIA RADIO SERVICEMEN'S Association has appointed a committee to publicize the new state licensing bill which had been approved by the group, to the public, and Servicing dealers and technicians in the area. Jim Daly, PRSMA prexy, has been named to the joint electronic-radio committee on service.

A new and active program has been set up for the associations' magazine, the PRSMA News.

RSA, Luzerne County

THE RADIO SERVICEMEN'S ASSOCIATION of Luzerne County, Wilkes Barre, Pa., recently played host to the entire membership of the Federation of Radio Servicemen's Association of Pa., at their annual Clam Bake at Lily Lake.

The entertainment committee is making final arrangements for the annual Fall Show and technical meetings, as arranged for by the speakers and lecture bureau of the State Federation.

Simplified Testers

(Continued from page 24)

melted down on the board with the soldering iron. The chloride is corrosive and should be used only when pre-tinning where all will be vaporized by a hot iron. The rosin-chloride mixture will clean fine enameled wire such as Litz if a very hot iron is used. Pre-tinned leads readily take solder when wired into circuits, eliminating gobs of excess solder.

G. E. TECHNI-TALK EDITOR HONORED

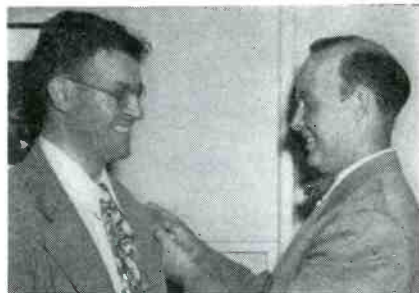

Roland G. Kempton, editor of Techni-talk, who prepared lessons on conversion for the G. E. advanced course for TV Service Men, left, receiving a pin honoring him as the first G. E. TV servicemaster from G. A. Bradford, right, tube department advertising and sales promotion manager. Those who complete the course, which also includes material on TV troubleshooting, will receive TV servicemaster pins and plaques embossed with their name. The courses are available through G. E. tube distributors.

Ser-Cuits

(Continued from page 38)

inductor and to channels in the high band by a continuously variable inductor. This is accomplished automatically through the gearing mechanism.

AGC voltage is applied to the grid circuit of the 6BC5 pentode *rf* amplifier through a 12,000-ohm grid resistor.

A double-tuned bandpass circuit couples the plate of the *rf* amplifier to the grid of the mixer tube ($\frac{1}{2}$ of the 6J6). A compensated system of bottom-side coupling elements, comprising three inductors and a 100- and 125-mmfd capacitors, provide correct bandwidth and signal energy transfer over the entire tuning range.

The oscillator circuit, which uses one-half of the 6J6, consists of a variable inductor, series inductor and shunt inductor. This combination is resonated by a 2.5-mmfd and 1 to 1.75-mmfd capacitor, and the tube interelectrode capacitances.

The oscillator is coupled to the grid of the mixer through a 1-mmfd capacitor.

**Two different types of mixer-plate circuit arrangements are available: T3C1 and T3C2 use the output transformer to serve the dual purpose of acting as a sound trap to prevent the sound *if* carrier from degrading the picture and as a source of energy to feed the sound *if* amplifier. The takeoff to the input of the sound *if* amplifier is provided by a tap on the secondary of the output transformer. A powdered-iron tuning slug of this transformer permits the trap to be tuned over a range of 19.5 mc to 22.5 mc. A grid coupling coil feeds the video *if* grid which is usually returned to the *agc* line of the receiver through a 10,000-ohm resistor. This coil, which is located in the rear left hand corner of the unit, can be tuned by its screw adjustment over a range of 18.5 mc to 30 mc. The frequency to which this coil is adjusted in any particular receiver depends on the sequence of stagger tuning. Tuner types T3C3 and T3C4 are supplied with the mixer plate network in a different manner. Since these tuners are for use in receivers in which the sound trap with its sound *if* takeoff is after the first *if* video tube, the sound trap is not supplied, and its primary is replaced by a 15,000-ohm resistor which provides plate voltage for the mixer. A grid coil covering a range of 18.5 to 30 mc should be tuned to the specified frequency.

Correction

IN THE CIRCUIT DIAGRAM of the plug-in booster, which appeared in the August issue of SERVICE, the screens of V_1 and V_2 should have been connected together to the variable inductance feeding the plate of V_1 , and the cathode and grid of V_2 should have been connected to ground through the $\frac{3}{4}$ -megohm and 220,000-ohm resistors.

"I've tried them all, and have found your DUBL-VEE to be tops."

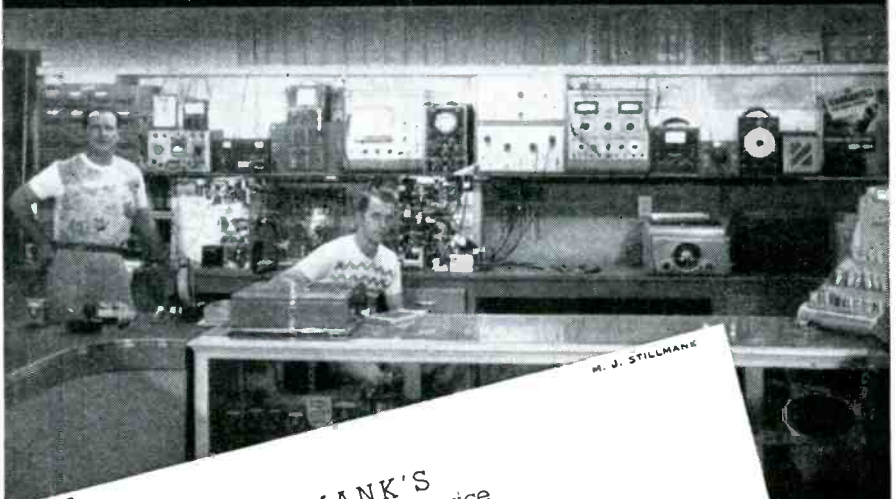

STILLMANK'S
Radio & Television Service
"THE ONLY THING WE SELL IS SERVICE"
2368 NORTH NEVA AVENUE
CHICAGO 35, ILL.

June 26, 1951

The Workshop Associates
Division of The Gabriel Company
135 Crescent Road
Needham Heights 94, Massachusetts

Gentlemen:

For nearly a year I've been installing your DUBL-VEE antennas which I purchased from Radio Television Supply Company here in Chicago. I wanted to write you this letter to tell you how satisfactory these antennas have been.

In this area, we have Channels 4, 5, 7 and 9. Thus, an all channel antenna is necessary. I've tried them all, and have found your DUBL-VEE to be "tops". We get excellent pictures on all channels with the DUBL-VEE, and, here in the "Windy City", the antennas have stood up wonderfully.

I've always regarded Workshop as the leader in antenna engineering. Your DUBL-VEE has convinced me this is true.

Sincerely yours,

Milton J. Stillmank

We might add that the Workshop DUBL-VEE is the original patented DUBL-VEE antenna. For outstanding TV reception be sure to specify it.

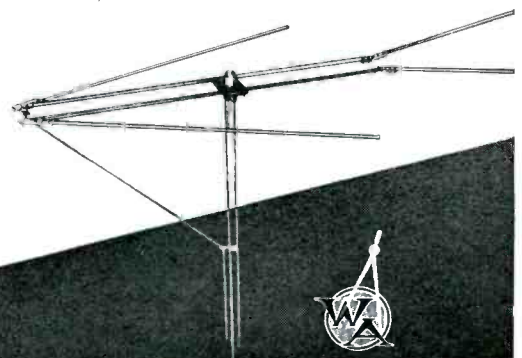

The WORKSHOP ASSOCIATES
DIVISION OF THE GABRIEL COMPANY

Specialists in High-Frequency Antennas

135 Crescent Road, Needham Heights 94, Massachusetts

MOSLEY Low Loss TV Accessories . . .



provide **BETTER TV PICTURES**
through more efficient
installation!

NEW! FLUSH MOUNTED SOCKET-SWITCH

The answer to multi-channel TV reception. Provides easy, instant change-over to any one of three antennas. Ingenious MOSLEY design assures constant impedance at each switch position. Unit recesses in standard electrical outlet box and takes standard double receptacle plate. Eliminates unsightly and inefficient hawire. Sturdily made of low-loss acrylic plastic. All metal parts are non-ferrous.

Cat. F-10—MOSLEY Socket-Switch List \$3.75

MOSLEY TRANSMISSION LINE PLUG for plugging transmission line from receiver to MOSLEY SOCKET-SWITCH listed above.
Cat. 301 List \$.48

MOSLEY SINGLE FLUSH SOCKET for 300 ohm line. For terminating TV transmission line lead-in concealed in wall. Fits standard electrical outlet box and receptacle plate. Terminal spacing of 1/2". Will accept either MOSLEY 301 or 302 Plugs. Made of low-loss plastic with non-ferrous hardware. For antennas installed without rotator.
Cat. F-1—MOSLEY Single Flush Socket List \$1.67

MOSLEY DUAL FLUSH SOCKET for 300 ohm line. Same as F-1 above but provides two sockets for installations using two individual antennas with separate lead-ins.
Cat. F-11—MOSLEY Dual Flush Socket List \$2.09

MOSLEY FLUSH SOCKET for Four wire rotator control. Provides low-loss socket connection for 300 ohm TV lead-in same as F-1 listed above. In addition a second socket permits a neat efficient connection of four wire rotator cable. Fits standard outlet box and dual receptacle plate.
Cat. F-14—MOSLEY Flush Socket List \$2.09

MOSLEY FLUSH SOCKET for Five wire rotator control. Same as F-14, above, except rotator socket is for Five wire control cable.
Cat. F-15—MOSLEY Flush Socket List \$2.09

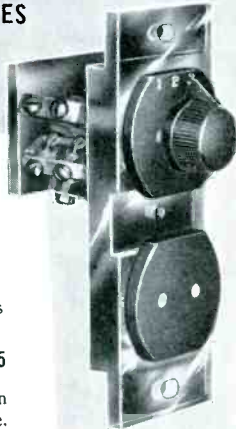

F-10
FLUSH MOUNTED
SOCKET-SWITCH



F-1
SINGLE
FLUSH SOCKET

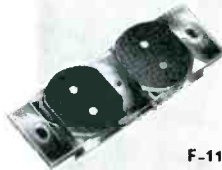

F-11
DUAL
FLUSH SOCKET

MOSLEY
W O F Q Y

Electronics

2125 LACKLAND OVERLAND, MISSOURI

A SINGLE SOURCE OF SUPPLY

MOSLEY ELECTRONICS manufactures the only complete line of antenna transmission line connectors, plugs, sockets and other accessories. MOSLEY products are solderless and designed for maximum electrical efficiency. Install MOSLEY accessories with complete confidence. Write for new Catalog No. 50-51.

Fringe Reception

(Continued from page 21)

had only a little over 1-mc bandpass. After properly aligning the receiver, the field test was repeated and results were found to be extremely satisfactory. Incidentally, all the boosters tested performed well, depending on their inherent gain.

Fringe Pickup Demands

The test also revealed that it was possible to connect the two-stage booster of our manufacture to the set without the use of the shielded cable. The gain being very high, tuning was critical. However, properly connected

with the shielded lead, the installation was found to be exceptionally stable.

Judging from experience, it appears that good fringe installations demand not only better antennas and boosters, but a check on alignment before the set is installed. Of course, only the Service Man with the proper equipment is qualified to attempt this.

One might ask why a brand new set should necessitate alignment. One explanation is that today's production is geared so high that it is usually impossible to give each set the individual attention that would be required. The problem of alignment is,

of course, not so important when the set is used in signal areas of sufficient strength.

Antenna Selection

In selecting antennas, it should be remembered that certain qualifications are necessary for distance, frequency range to be covered and man-made noise characteristics of each particular territory. The booster also should be selected on the basis of requirements, and in no case should a two-stage high-gain unit be employed, where a single-stage type with lower gain is sufficient. Where high-gain boosters are required, it is of utmost importance that the receiver be perfectly aligned for best possible reception.

Response Curve Checks

In this respect it is important to note that the response curves should be checked on all circuits affecting bandpass characteristics. To do this correctly the Service Man should closely follow the instructions contained in the manual furnished by the set manufacturer or other sources.

Where there are built-in antennas they must be totally removed and shielded leads utilized for connecting the preamps to the receivers. The shielded lead should preferably be continued right into the tuner section of the receiver whenever possible.

For best reception and customer satisfaction, it is important to follow all of the printed instructions usually supplied with receivers, boosters and antennas.

AT THOMAS BOOTH DURING
NEDA SHOW



Visitors to the Thomas Electronics' booth during the recent NEDA Show at Cleveland, Ohio: Rob Cushman, Newhope Corp., representing Thomas; Hans A. Soms, Westcheser Co., Inc.; Lee Locke, The Newhope Corp.; Hy Morgenlander, Green Tele-Radio; Lee Harper, Cleveland model, and Haven L. Cheney of Thomas Electronics.

AFC Sync Circuits

(Continued from page 33)

pulses don't arrive at the correct time to properly initiate retrace and effect synchronization until several lines have gone by.

Horizontal Tearing

The resultant tearing out of horizontal lines will be observed most often at the top of the picture, since, as was pointed out a paragraph ago, the greatest effect of poor *dc* restoration occurs during and right after the vertical blanking interval, when the top of the picture is beginning to be scanned.

AFC and Phasing

When an *afc* circuit is present, and poor *dc* restoration exists, the *afc* action serves to keep the oscillator operating at the correct frequency for the twenty lines or so during which the vertical retrace occurs, even when one or more sync pulses are lost. When the sync pulses start to come in at more uniform levels some time after the vertical retrace, no lines will be lost while the oscillator is being pulled into the correct frequency and phase (as in the case of the trigger-synchronized circuit), since the oscillator is already operating at the correct frequency, and will pull into the correct phase immediately.

Utilization of the Entire Width of the Sync Pulse: Many *afc* circuits employ the entire sync pulse for sync, instead of using merely the leading edge of the pulse, as the simple differentiator network does. When a simple differentiating network is used for synchronization, a noise pulse must only have sufficient amplitude, and arrive close enough to the end of the trace, to upset synchronization. When an *afc* circuit is used, on the other hand, a noise pulse must, if it is to upset sync, not only satisfy the conditions just cited, but must also have the same duration as the horizontal sync pulse or about five microseconds. Since most *hf* noise pulses have very much shorter durations, they will be discriminated against by the *afc* circuit, and prevented from interfering with synchronization.

Averaging of Sync Pulses: An *afc* circuit generally employs a time-constant or *rc* network that causes the

(Continued on page 56)

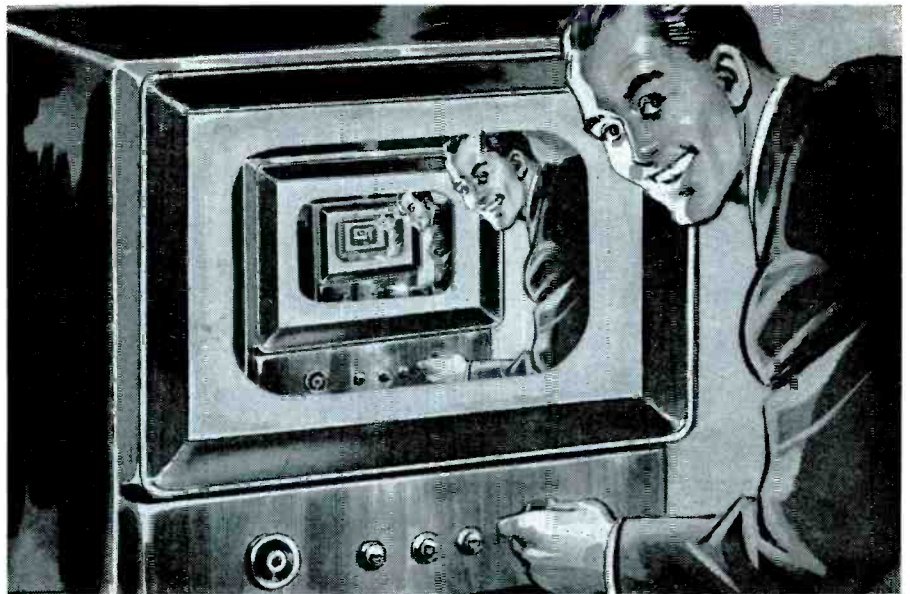

YOUR MOST VALUABLE ASSET... A SATISFIED CUSTOMER!

You endanger your business reputation when you use "just-as-good" replacement parts. Customer good will is your most valuable business asset—don't take a chance on losing it. Use quality OHMITE resistance parts—known the world over for dependability—and be sure your customers are satisfied. Thousands of servicemen, amateurs, and design engineers everywhere prefer OHMITE for long, trouble-free service. Take a tip from them... it's good business!

OHMITE MANUFACTURING COMPANY
4878 Flournoy St., Chicago 44, Ill.

Write FOR
STOCK CATALOG



Be Right with

OHMITE®

RHEOSTATS • RESISTORS • TAP SWITCHES

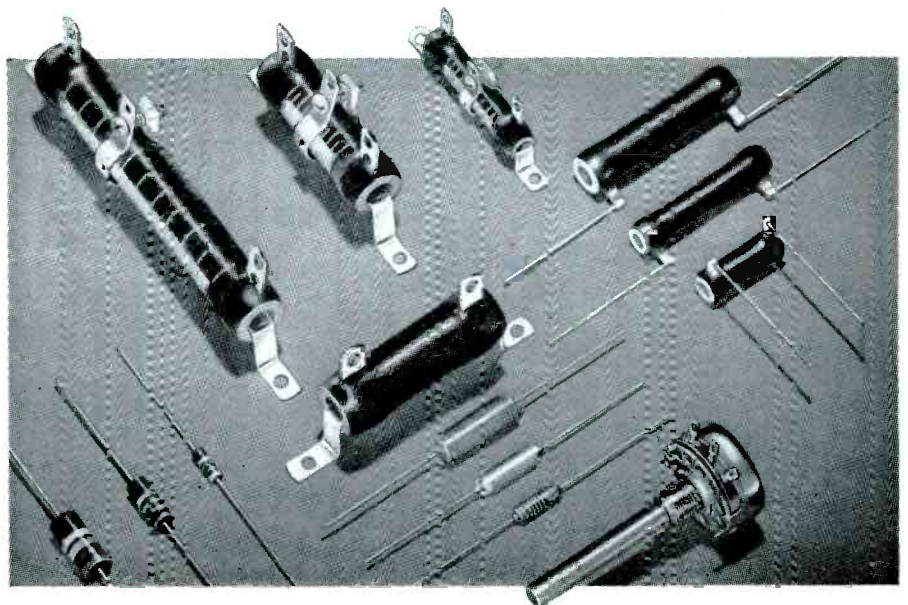

Keep Picture Quality UP Keep Service Calls DOWN



**JUST PRESS THE BUTTON,
SPRAY IT ON —
NO SPECIAL
EQUIPMENT NEEDED!**

Spray on antenna and lead-in terminals

Krylon prevents corrosion and pitting, even in salt-spray areas. It seals antennas and connections in a waterproof acrylic (not vinyl) blanket. (When aluminum finish is desirable, use special aluminum Krylon.)

Spray on high voltage circuits

Spray Krylon on the high voltage coil and insulation . . . in the socket of the high voltage rectifier . . . on component parts of rectifier circuit. Helps prevent corona because of its high dielectric strength.

Two types—clear and non-conducting aluminum. Both have exactly the same qualities. Packed in 12 oz. aerosol spray cans. List prices: \$1.95 clear, \$2.25 aluminum. Also available in gallons for application by brushing or dipping. See your jobber, or write direct.

KRYLON, INC., Dept. 610
2601 No. Broad St., Philadelphia 32, Pa.

Advertised in
"The Saturday
Evening Post"



THE ACRYLIC SPRAY THAT PREVENTS TV TROUBLE

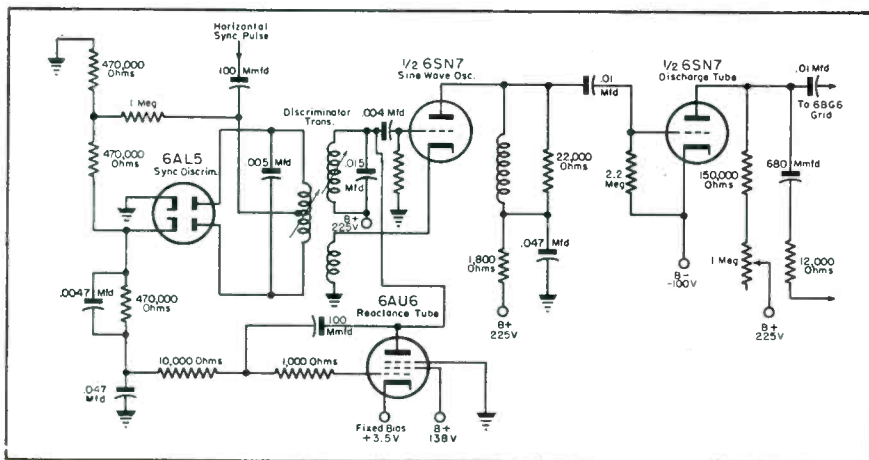

AFC Sync Circuits

(Continued from page 55)

circuit to respond to a group of sync pulses, rather than one pulse alone. If one of the sync pulses in the group has made friends with a positive-going noise pulse, one of the other sync pulses is probably very chummy with a negative-going noise pulse. The two opposing noise pulses will tend to cancel out, if the sync pulses are added or averaged. The noise pulses will *not* cancel out, on the other hand, if the circuit responds to one sync pulse at a time, as is the case in the differentiator.

Sync Pulse Averaging

Due to this averaging of sync pulses, an *afc* circuit will not allow horizontal synchronization to be upset by a large black area occurring near the end of a line. Such a large black area represents a video signal that is almost as high as the horizontal sync pulse; Fig. 7. When it occurs near the end of a line, i.e., the end of the trace in a trigger-synchronized circuit, it may cause premature triggering, and thus upset synchronization. In an *afc* circuit, however, a dark area (black signal) present near one horizontal sync pulse will not do much damage because it is averaged up, and its effects spread over a large number of sync pulses; it is diluted, so to speak.

(To Be Continued)

Left: Schematic illustrating a slight variation of the 630 sync circuit presently used in models produced by Capehart, Magnavox and Sylvania. The differences between this circuit and the standard are: The 6AC7 has been replaced by a 6AU6 connected to give capacitive reactance; the 6AC7 acted as inductive reactance. The sine wave oscillator is a modified Armstrong using one-half of the 6SN7; in the 630 a 6K6 was used as a modified Hartly oscillator. In the oscillator output, instead of the shaping network, a ringing coil has been inserted. This coil is excited to dampened oscillations every time the plate begins to draw current and the first cycle of these high frequency oscillations acts to trigger the discharge tube. A width control has been added in the discharge tube plate circuit for greater ease of adjustment; it more or less replaces the drive control of the 630. A slight variation of this circuit is sometimes used where a 12AU7 replaces the 6SN7. The circuit is the same and only the three components in the oscillator section are altered: The discriminator transformer has a different part number; grid return resistor has a value of 47,000 ohms instead of 560,000; plate decoupling resistor has a 3900-ohm value instead of 1800 ohms.

Audio

(Continued from page 34)

shrill and piercing as time goes on, and the resonant bass that sounded strong and deep in the store becomes an indefinite and annoying thump, thump. Of course, it was noted, all the high frequencies can be removed by turning down the tone control and thus eliminating the *hf* peak, but there is little that can be done about the bass peak, but learn to like it.

Peaked Response

Peaked response, the audio specialist said, is the inevitable consequence of the methods usually used in choosing the speaker. The course of reasoning usually followed, for anything but the most expensive custom-built equipment, is quite logical and natural. To keep costs down, the field magnets and the voice coil are made small. This results, he noted, in low power sensitivity and also, as a by-product, a sharper bass resonance. Since, in a product where it is vital to watch the costs, higher-power output tubes cannot be used nor the power supplies enlarged, other ways of compensating for the low power sensitivity must be found. Thus, it was shown, speaker designers or suppliers are then called upon to provide speakers which will give more *umph* which is easily provided by using a straight-sided cone, light in weight and of rather hard

(Continued on page 58)

AM-FM tuner which includes a built in power supply and multistage audio circuit. AM section is of the superhet type, designed to provide a broad band flat top curve. FM circuit employs two ground grid *rf* stages, a separate oscillator and triode mixer stage, two stages of *if* amplification and a ratio detector. Both the AM and FM sections incorporate *avc* and a magic eye. Multistage amplifier includes a preamp for variable reluctance pickup and contains a four-channel selector switch for AM, FM, phono and spare; three-step selection of record crossover frequencies; equalization for variable reluctance pickup; filter for $33\frac{1}{3}$ recording characteristic use; variable control of rise and droop in both treble and bass, and a continuously variable volume control. Cathode follower used in output stage enables the tuner to be connected to any power amplifier with a high impedance input. (Model 303A; Altec Lansing Corp., 9356 Santa Monica Blvd., Beverly Hills, Calif.)

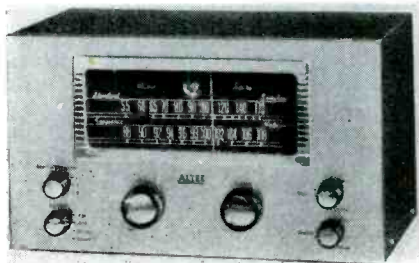

Handle your replacement business the *EASY* way!

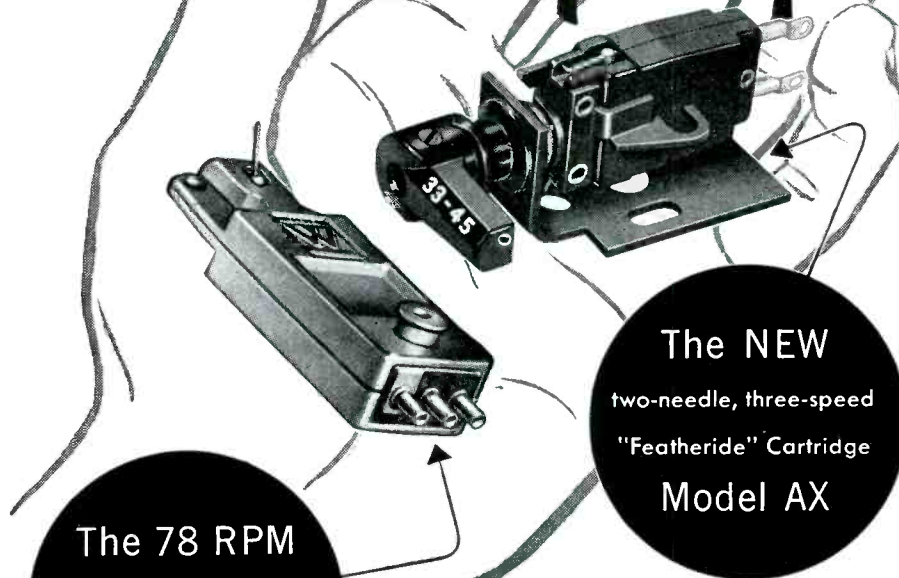

The 78 RPM
"twin" output
"Featheride" Cartridge
Model WS

The NEW
two-needle, three-speed
"Featheride" Cartridge
Model AX

The Model WS replaces
more than 100 different
types for 78 RPM records

The WS cartridge can be installed in any $\frac{1}{2}$ " standard tone arm. The one cartridge develops either $1\frac{1}{2}$ volts or 4 volts at $\frac{3}{4}$ ounce tracking pressure. The Model WS is furnished complete with a factory-tested, osmium-tipped replaceable needle, rest button, terminal clips, extra needle screws and instructions for installing. The Dri-Seal protected crystal and the exclusive Dri-Pack container assure a cartridge always ready to deliver peak performance.

Featheride cartridges are made only by Webster Electric Company, Racine, Wisconsin. Established 1909.

Small investment...
fast turnover...

no replacement chart needed



The Model AX
replaces today's two-needle,
three-speed cartridges

This two-needle, three-speed replacement cartridge ends the need for replacement charts and big inventories.

The Model AX cartridge is a complete unit, including twist mechanism, cartridge, needles and instructions for installing in any standard $\frac{1}{2}$ " mounting. Model AX twist mechanism is easily removed when cartridge is to be installed in tone arms in which such mechanism is an integral part. Double-protected against moisture by the Dri-Seal crystal and Dri-Pack packaging.

Write for descriptive folder to Webster Electric Company, Racine, Wisconsin. Established 1909.

WEBSTER ELECTRIC
RACINE ♦ WISCONSIN

"Where Quality is a Responsibility and Fair Dealing an Obligation"

PHOTOFACT Users Write Our Best ADS!

Hundreds of unsolicited letters tell what the world's finest Radio & TV Data means to Service Technicians



Norman H. Otto
726 Cherry Ave.
San Bruno, Calif.

"The extent of your PHOTOFACT service amazes me more and more at each publication. Your new P.F. Index is very handy."



E. A. Randall
4710 Annette St.
New Orleans, La.

"I have all PHOTOFACT Folders and use them quite often. Your circuit diagrams help plenty and save a great deal of time. I have been in service work since 1934."



Harry Larrison
1723 Oakwood Ave.
Akron, Ohio

"In my opinion, PHOTOFACT is to radio and TV servicing what the five cent cup of coffee was to the American scene of yesterday—and this isn't idle praise, but cold facts, proved by the needs of everyday servicing."

NOW! GET THE PROOF FOR YOURSELF!

FREE

We'll Send You a FREE Photofact Folder on any postwar receiver listed in the PF Index.

Learn for yourself—at our expense—how PHOTOFACT pays for itself by earning bigger repair profits for you! Ask for a FREE Folder covering any postwar AM, FM or TV receiver listed in the PHOTOFACT Cumulative Index. Examine it. Put it to work at your bench—then judge for yourself!

WRITE FOR FREE FOLDER TODAY!

HOWARD W. SAMS & CO., INC.

2201 East 46th Street • Indianapolis 5, Indiana

Audio

(Continued from page 57)

material. The result is a speaker offering a large peak around 100 to 150 cps and another peak, or group of peaks in the 1,000-to-3,000-cps region. The light cone was said to sound loud because of the sharp resonant peaks, presence of considerable non-linear distortion and the fact that such a cone is almost always strongly directional at the high frequencies. Speakers that are directional usually sound louder on the axis, than those which are not. Since many listening tests are made on the axis, directional speakers compare very favorably in loudness with those having smoother response.

Loudness as a Criteria

On the basis of making loudness a criterion for selection, very irritating types of speakers have become an accepted standard for most sets, an emphasis that, it was said, has puzzled many. For instance, when the salesman tells a customer that one set with ten watts is twice as powerful as another with only five watts, the customer naturally assumes that one model is going to sound twice as loud. Instead, the sound authority noted, the human ear acts so peculiarly that the five-watt set sounds very little louder at all. A set would have to have 48 watts of audio power available, it was pointed out, to sound twice as loud as one with five watts. A shift in emphasis from loudness to smoothness and naturalness of sound, plus listening tests covering a longer period of

Duo-speed portable tape recorder, featuring push-button speed change for either 3 3/4" or 7 1/2", automatic amplifier equalization in either speed, 2 hours continuous performance on 7" reel at 3 3/4" per second. Push-button editing key is said to permit correction of recordings on any section of the tape while playing. Has a magic eye recording indicator. Interlock switch prevents accidental erasure and tape spillage. (Pentron Corporation, 221 East Cullerton Street, Chicago 16.)

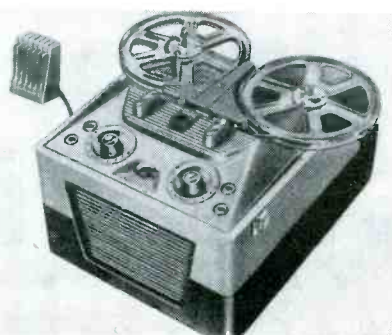

Presenting THE NEW Mueller NEEDLE CLIP



Actual Size

PIERCES INSULATION TO MAKE QUICK CONTACT

Solid bronze, non-corroding. Wire centers itself in notched jaw. Teeth on sides of jaw allow use for many other applications.

— USED IN —

Electric and radio service shops
Telephone and power company
testing and maintenance
Laboratory test work
Hooking up truck trailer lights
Field telephone and signal work

SEND FOR FREE SAMPLE AND CATALOG 810

Mueller Electric Co.

1565 E. 31st St., Cleveland 14, Ohio

time would do much to alleviate the situation, the audioman declared.

Influence of Electrical Difficulties

Because acoustics, vibrations, and the psychology of hearing are rather specialized subjects, relatively few people have become acquainted with them. Thus, speakers are often called upon to perform feats of magic in eliminat-

Portable transcription player featuring *Varipole* speed control, which is said to permit gradual adjustment of turntable speed from 25% below normal to 10% above normal. Players include as optional feature, *fluid sound*. (Califone Corp., Dept. JO, Hollywood, Calif.)



ing electrical difficulties, when actually they can do no such thing. As cited earlier, the low-frequency resonance is often placed at 100 or 150 cps, instead of at 50 or 60 cps in the attempt to reduce the 60-cps power-line hum. However, hum which comes from the power supplies is more likely to be 120 cps or 180 cps than 60 cps, and a resonance near 120 cps aggravates the hum rather than reduces it. In TV chassis, the familiar hum or buzz which comes from the vertical sync pulses was noted as covering the whole audio spectrum which frequency cutoffs can not cure. Rattles, which may be due to minute amounts of peak clipping or short-lived oscillations in the amplifier, are often blamed on the speaker since such electrical defects do not show on conventional distortion meters. Speakers with limited high-frequency response were, it was said, usually chosen to eliminate the rattles. When thermal noise or record hiss is present in the circuits, limiting the high response also makes the noise less noticeable, but the cure does not stop there. Systems with limited high response sound dull and muffled, unless something is done about it. Usually, the remedy used for the muffled sound involves exaggeration of the high frequencies just below the *hf* cutoff, a modification that does nothing more than bring the noise level up again.

Diaphragm Response Features

In speakers, each resonant mode of vibration of the diaphragm has a frequency-response characteristic of its

(Continued on page 60)

Two-speaker portable public-address system which features two 12" speakers in a split case with 17-watt amplifier providing inputs for 2 mikes and 1 phono. A similar model is available with a 25-watt amplifier and inputs for 3 mikes and a phono. Either model can be provided with remote control for all mikes from any distance up to 2,000'. Both are U/L approved. (Model H-1512R; Newcomb Audio Products Co., 6824 Lexington Ave., Hollywood 38, Calif.)



THERE'S A SILVER LINING

*This happy "gent" no more is pining
He's found the OXFORD "silver lining" . . .*



Countless manufacturers have truly eliminated the "clouds" in their equipment by using OXFORD SPEAKERS . . . the finest available.

The illustrated Communications Receiver, Model S-38B, manufactured by the Hallicrafters Co., is typical of a fine product utilizing the unsurpassed performance of OXFORD SPEAKERS.

The next time you think of speakers . . . think of OXFORD . . . manufacturers of speakers for over a quarter of a century.

Put a "silver lining" on your next replacement "cloud" by selecting an OXFORD SPEAKER . . . for TV, FM, AM, AUTO, PA, and outdoor applications.

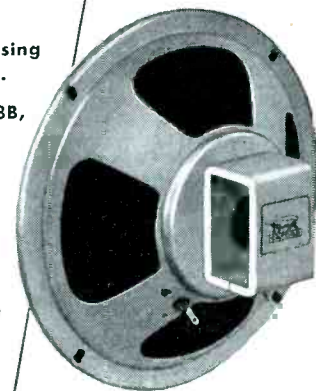

Oxford Speakers are available at leading jobbers.

A copy of our latest catalog is available upon request.

OXFORD ELECTRIC CORPORATION

3911 South Michigan Avenue • Chicago 15, Illinois
EXPORT: ROBURN AGENCIES, NEW YORK CITY

Audio

(Continued from page 59)

own; thus the overall frequency range is obtained in much the same manner as the broad band in an amplifier having a large number of stagger-tuned and overcoupled stages. To some extent, it was said, the smoothness of the response curve and the bandwidth can be controlled. Low-frequency cutoffs can be controlled by employing series resonant circuits in the vibrating structure; the center supporting spider plus the corrugated edge surround acting as the compliant element, and the cone and voice coil plus the air load acting as the mass. The audio authority then noted that the height of the peak just above the low-frequency cutoff can be controlled by the amount of damping introduced into the mechanical circuit. This damping, he said, can be in the form of viscous doping materials around the edge or electrical damping from a low-impedance amplifier. The *hf* region is affected by the shape and size of the cone and the material from which it is made. The popular curved cone speakers, it was said, usually have a large number of very sharp peaks of approximately equal amplitude in the high-frequency region. The straight-sided cones usually show fewer and broader peaks, but the amplitude of the peaks in the 1,000 to 3,000 cps region is much higher than for the curved cone speaker. Generally, it was pointed out, hard cone materials make the peaks sharper and higher, while softer materials makes them broader and not so high. The edge surround affects the magnitude of the peaks, in the high-frequency region too. A non-elastic material of moderate mechanical resistance, such as

The New
CREST MODEL 50
**Multi-Frequency
Crystal Oscillator**

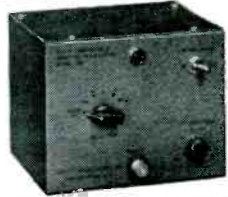

**A Must for I.F. Alignment,
for Factory or Service Lab.**

SPECIFICATIONS

- HIGH OUTPUT.....1 volt
- OUTPUTS.....5 xtal freqs.
- RANGE.....4 to 50 MC
- ACCURACY.....± .01%
- MODULATION.....400 Cycles

*Price net with terminated
output cable, less crystals* **\$68⁵⁰**

Write for illustrated brochure
CREST LABORATORIES INC.
Whitehall Building
Far Rockaway, L. I., N. Y.

carpincho leather, has been found to reduce the *hf* peak. It has also been found that treating the edge of the more common molded cone with viscous cements can reduce the *hf* peak, in addition to reducing the response at the *lf* resonance point.

Importance of Listening Tests

Listening tests were described as one of the best ways to evaluate speakers. Therefore they should not be

(Continued on page 62)

Manual describing over 1,500 phono and radio-TV combinations equipped with or which can effectively use crystal or ceramic cartridges. Listed are sets made by 123 manufacturers dating from '38 to '51. (Manual 66; Shure Brothers, Inc., 225 W. Huron St., Chicago 10, Ill.)



Remote-control 20-watt amplifier with an 8-position record-compensator which adjusts for any recording characteristic. Selector switch changes from phono, tuner, TV, or other high-level inputs. Automatic loudness control is said to boost treble and bass at decreasing volume to compensate for human ear's insensitivity to high and low frequencies at low volumes. Individual 3-channel continuously-variable tone controls have control range from 6 db/octave boost, through flat response, to 6 db octave attenuation. Input-level adjustment for matching to almost any pickup. Has provision for adding separate dynamical noise suppressor. Tubes: 12AX7, 2-12AU7, 5VAG, 6SN7, 6J5, 2-6L6. (Model 214-A amplifier; Hermon Hosmer Scott, Inc., 385 Putnam Ave., Cambridge 39, Mass.)



Consecrated
to Quality Output and
Golden Rule Service



FIXED CAPACITORS

The three popular types here illustrated are specified by leading set makers, and they fit as perfectly into the SERVICE scheme. They are small . . . adaptable . . . the product of lifetime experience in Capacitor engineering. Use them with complete assurance of maximum satisfaction through, high standards of quality control.



MINIMITE—Metal tubular dry electrolytics—Compact, hermetically sealed capacitors with exceptionally low leakage—capable of withstanding high surge voltage—exceptionally long shelf life—ideally suited for under chassis mounting.

EY—Twist prong dry electrolytics—most popular type used by television and radio set manufacturers; simple to mount, specially processed for long-life operation at ambient temperatures up to 85° C.; Centrifuge electrolyte impregnation; spot welded cathode tabs; excellent stability; low leakage.

AM—Molded paper tubulars—designed for continuous operation at 85° C.; molded in high temperature, heat resistant plastic compound for perfect seal against most severe humid conditions; won't cold flow at 100° C.

WRITE FOR CATALOG AC-2

ASTRON CORPORATION

255 Grant Ave., East Newark, N. J.

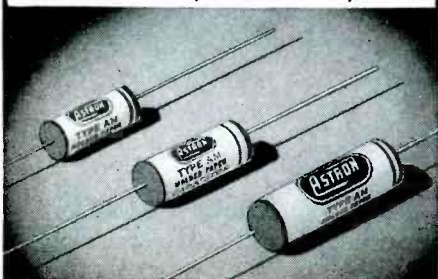

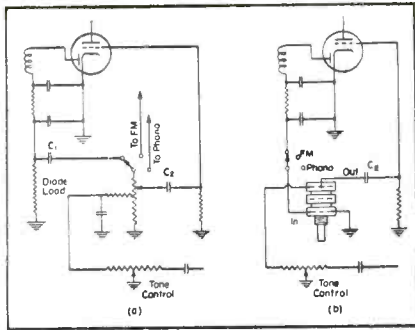
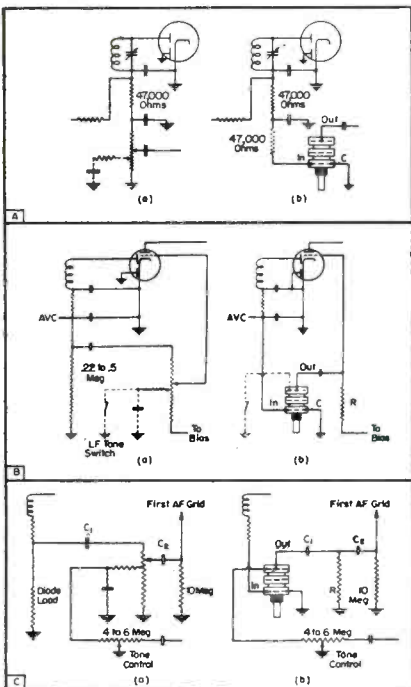

Fig. 1. Amplifier circuitry with (b) and without (a) loudness controls. Some amplifiers use a .5-megohm control in the plate circuit of such tubes as the 6J7, 7C7 and 12SJ7. The loudness control should only be used in such circuits if in its normal usage it is never operated above 60% of its rotation. Above this value of rotation, the impedance will drop to approximately .2 megohm causing a loss of gain.

[Circuits above and below, courtesy IRC]

Fig. 2 (A, B and C). In A appears a standard (a) and revised control circuit (b) in an AM receiver, where the volume control is the diode load. In some instances, the original volume control will be found to use a fixed stop of 50,000 ohms to replace the 47,000-ohm resistor. If this is the case, a 47,000-ohm resistor will have to be added as indicated. If, in the original circuit, there's a tap on the control for tone compensation, components connected to this tap will have to be omitted. The circuits in B, original (a) and revised (b), where the volume control is in the first audio grid, feature the loudness control as a replacement for the diode resistor, and a fixed resistor equal to the total resistance of the original control used to replace the original control. In some instances, the resistor R will have to have a value of from 4.7 to 15 megohms and be connected directly to ground to furnish bias voltage to the first audio stage. In the third circuit, C, the volume control is tone compensated with a combination variable low-frequency and high-frequency tone control. Here, the loudness control replaces the diode resistor, with resistor R taking the place of the original volume control using the same resistance. The original compensation resistor and capacitor are not used. The terminal of the tone control that originally went to the junction of the compensation resistor and capacitor should be connected to the loudness control as indicated in the revised circuit at (b). It is also possible to eliminate R and connect a 10-megohm resistor directly to the output of the loudness control through C₂, in which case C₁ is not used.



COMPLETE
ANTENNA
WITH BASE
AND 84" MAST
LIST \$11.00



COMPLETE
ANTENNA
WITH BASE,
SPRING AND
84" MAST
LIST \$13.25



SWIVEL BASE
Model MB-1
LIST \$5.00



SWIVEL BASE
AND SPRING
Model MB-2
LIST \$7.25



STEEL MASTS
Model MM-84
84" Long
LIST \$6.00
Model MM-96
96" Long
LIST \$6.75

RADELCO

GIVES YOU THE YEAR'S OUTSTANDING VALUE IN COMMUNICATION ANTENNAS!

BUILT FOR THE HARDEST MOBILE
USE...BUT AT A PRICE LESS THAN
HALF THE COST OF OTHER MAKES

*It Defies all
Comparison!*

Compare it with any Communication Antenna on the market today. Compare its rugged construction, its high quality materials, its fine workmanship, its attractive design . . . then compare its extreme low cost. Compare it any way you wish to . . . and the more you compare it, the better you'll like it. Truly, it's the standout value of the year in Communication Antennas!

SWIVEL BASE, Model MB-1

Has adjustable split-ball with positive locking feature to maintain angular adjustment at all times. Permits mast to be vertical regardless of body contour. Indented hex head locking screw with hex wrench furnished. Insulator mounting plate is of black Bakelite with moisture proof rubber gasket to withstand both ageing and cracking. Heavy steel backup plate.

SWIVEL BASE AND SPRING, Model MB-2

Spring is of oil-tempered heavy spring steel to withstand toughest shocks, vibration and extreme temperatures. Responds instantly upon contact with overhead obstructions to prevent mast damage. Flexible lead through center of spring maintains constant electrical impedance. Has 3/8" threaded fitting on end of spring to receive stud of mast.

SPRING TEMPERED STEEL MASTS, MM-84 and MM-96

Made of chrome silicon steel, this mast has exceptionally high tensile strength . . . can be bent 90° and still return to its original vertical position. It is taper ground with a corrosion resistant surface finish, fits either MB-1 or MB-2 mounting base or any standard base.

PLACE ORDERS NOW WITH YOUR
NEAREST PARTS JOBBER

RADELCO MANUFACTURING CO.
CLEVELAND 25, OHIO

VIDAIRE

COLOR

ADAPTER

ENGINEERED AND DESIGNED FOR
FIELD SEQUENTIAL COLOR SYSTEM



\$14.95 NET

- ★ EASY TO INSTALL - SIMPLE TO ADJUST.
- ★ ALL COLOR PICTURE CONTROLS ON REAR PANEL FOR EASY ADJUSTMENT.
- ★ INSTRUCTIONS AND WIRING DIAGRAM FURNISHED.
- ★ TONED TO MATCH TELEVISION CABINETS.
- ★ INCLUDES A WIDTH AND VERNIER PHASING ADJUSTMENT.

Available in the following models.

CA-400 HOR. SYNCROLOK **CA-401** HOR. SYNCROGUIDE
CA-402 HOR. MULTIVIBRATOR

Distributors write for details.
Choice territories still open

VIDAIRE ELECTRONIC MFG. COMPANY
576 W. MERRICK ROAD DEPT. TV LYNBROOK, L. I., NEW YORK



\$14.95 NET

HIGH FIDELITY SOUND

FOR YOUR T.V. SET

Simply remove output tube and plug into socket. This superbly engineered High Fidelity Push Pull Amplifier flat within 1.5 DB from 80 to 20,000 cycles.

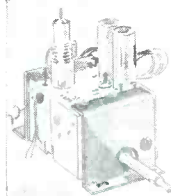

HAVING TROUBLE INSTALLING STAND- ARD TUNERS IN PHILCO RECEIVERS?

Remove the old tuner and install the new simply by using four screws with these SPECIALLY DESIGNED brackets—Saves 75% of installation time.

\$1.00 net
Minimum Order, 3 Sets

Send money order or check with order and save C.O.D. fee and postage.

Audio

(Continued from page 60)

the hurry-up, snap-judgement variety begun after all the electrical circuit design has been completed. In such a test, it was emphasized, the decision is almost certain to be in favor of the loudest speaker in the group being tested. Instead, the listening test should be carried on over a period of time covering several weeks, and should be part of the over-all design routine. Over the longer period many of the irritating factors mentioned, it was said, will become more and more noticeable.

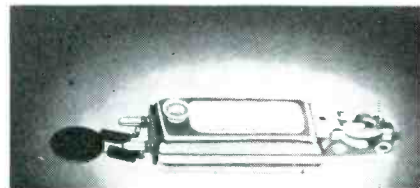

Top, turnover vertical drive cartridge which is said to feature extended frequency response to 10,000 cps and track at low needle point pressure (8 grams). Standard 1/2" bracket mount has elongated holes. Below, 78-rpm lever-type dual-voltage cartridge which has a specially designed needle guard to protect crystal from breakage. Equipped with slip-on condenser-harness for dual-voltage output, 1.5 or 3.75 volts. (Models W22AB-T (top) and W42BH (bottom); Shure Brothers, Inc.)

Changer, with a 3-speed unit, which uses a completely enclosed, shielded, 4-pole motor. Turntable sits on a ball race. Slipping is said to be reduced to a minimum by positive drive together with a special finish on the motor pulley. (Coltaro, manufactured in England; represented by Rockbar Corp., 13 East 40th Street, New York 16, N. Y.)

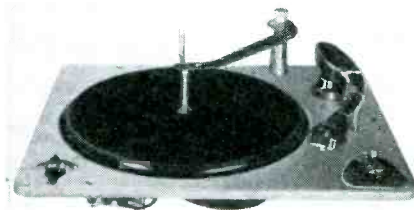

2-SET COUPLER DEMONSTRATION TELECAST



Robert N. Vendeland explaining operation of 2-set Brach coupler during a morning telecast over WEWS-TV, Cleveland, for the benefit of Service Men adjusting and installing TV sets. Program was conceived by Herb Farr of Pioneer Radio Supply.

ILLINOIS ELECTROLYTIC CAPACITORS

of "Time Tested Quality"

for EVERY ELECTRONIC APPLICATION

Seventeen years of production experience, making millions of quality capacitors, has created this complete, outstanding ILLINOIS CONDENSER line. There's a full Jobber line of capacitors for every TV and radio replacement purpose; capacitors for the entire electronics industry—capacitors that meet the highest standards of dependability.

This engineering and manufacturing experience enables ILLINOIS CONDENSER COMPANY to meet every demand for new capacitor types, whether for peace or defense applications.

Write for catalog or tell us your needs. There is an ILLINOIS ELECTROLYTIC CAPACITOR exactly suited for the job—a capacitor of "Time Tested Quality."



ILLINOIS CONDENSER CO.
1616 NORTH THROOP STREET • CHICAGO 22, ILL.

Export Division: 15 Moore St., New York 4, N. Y., U. S. A.
CABLE ADDRESS: "MINTHORNE"

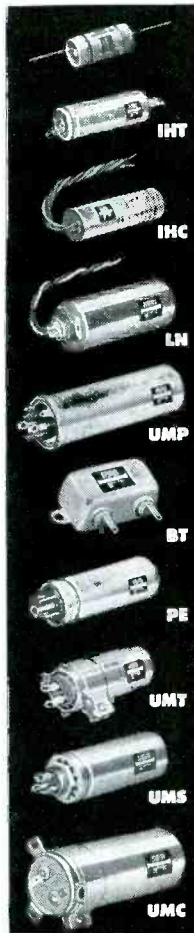

New Parts . . . Instruments . . . Tools

PARK METALWARE SPRING FASTENER SCREWDRIVER HANDLES

A spring fastener in the handles of all Xcelite CK-3 sets, that is said to hold reversible blades by friction alone, has been produced by Park Metalware Co., Orchard Park, N. Y.

Spring is set in the slot of a hex bushing, then imbedded in the hollow plastic handle. Blades for this handle have a hex portion in their center which fit the hex bushing in the handle. With a blade inserted, the curved portion of the spring exerts pressure on the hex part of the blade to hold it in the handle.

Handle may be used alone as a 7/16" nut driver. Spring fastener acts as a holder on the 7/16" nut, that is claimed to prevent it from dropping out of the handle.

* * *

C AND G WIRE CUTTER

A wire cutter, *Jim Handy*, that snips wire up to 18 gauge, has been produced by the C & G Manufacturing and Sales Co., P. O. Box 1525, Columbus, Ohio. Cutter employs a trigger-type lever.

* * *

RADELCO SWIVEL-BASE ANTENNAS

Swivel-base antennas with two types of bases, have been announced by the Radelco Manufacturing Co., 7580 Garfield, Cleveland 25, O. One base, *model MB-1*, has adjustable split-ball with positive locking feature to maintain angular adjustment at all times. Base is said to permit mast to be vertical regardless of body contour. Indented hex head locking screw with hex wrench furnished. Insulator mounting plate is of black bakelite with moisture-proof rubber gasket to withstand both aging and cracking.

Another type (illustrated) features a base and spring, *model MB-2*. Spring is of oil-tempered heavy spring steel to withstand toughest shocks, vibration and extreme temperatures. Responds instantly upon contact with overhead obstructions to prevent mast damage. Flexible lead through center of spring maintains constant electrical impedance. Has 3/8" threaded fitting on end of spring to receive stud of mast.

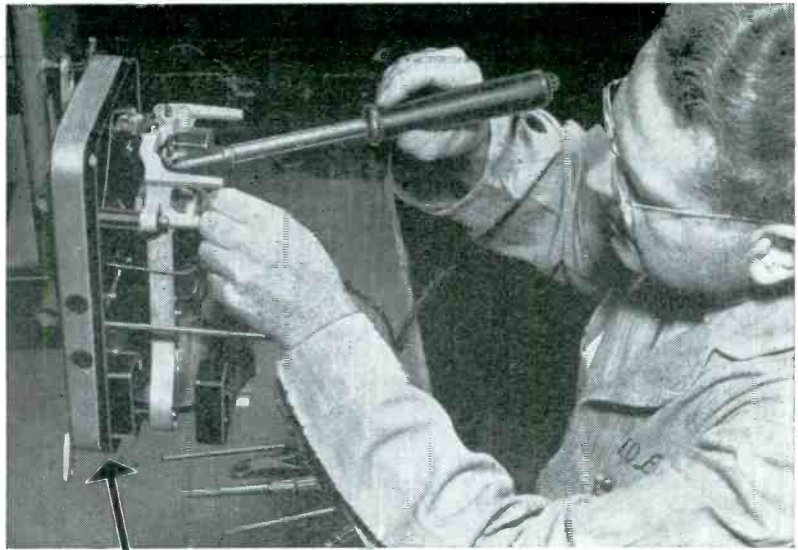
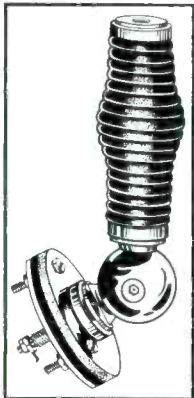

American Beauty

**SOLDERING IRONS
for PRODUCTION JOBS
LARGE or SMALL!**

For descriptive catalog pages write Dept. S-2



DEPENDABLE • DURABLE • EFFICIENT • SINCE 1894

AMERICAN ELECTRICAL HEATER CO.
DETROIT 2, MICH.

120

ATLAS Built to take it!



ATLAS DR PROJECTORS, non resonant, uniform response, sturdy, storm proof, compact, demountable.

Regardless of the application Atlas Sound speakers are built to "take it." In the Armed Forces . . . Industrial plants . . . public gatherings . . . under any climatical conditions, Atlas Sound speakers stand up.

Over twenty years' experience in the manufacture of sound equipment goes into every Atlas product.

Years of diligent research in Electro Acoustics and constant experimentation in mechanical developments guarantees quality, complete and lasting satisfaction.

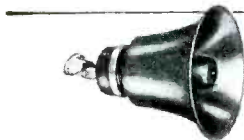

ATLAS PAGING AND TALK BACK SPEAKERS with ATLAS "Ainico-V-Plus" driver unit. A medium size speaker ruggedly constructed 12 watt input power.

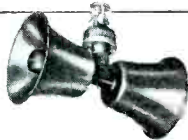

Dual speaker excellent for industrial and talk back applications, simplifies installation in long corridors, hallways, etc.



A super efficient sub-miniature speaker produces clear intelligible speech at a minimum input power.



ATLAS De-Luxe "Ainico-V-Plus" Driver Units with built in "uni-match" transformers. 30 watt input.



ATLAS "FULL GRIP VELVET ACTION" MICROPHONE STANDS. No slipping—No noise—No rattle—No scratching—No wear.

Write for new No. 551 catalog

ATLAS SOUND CORP.
1442 - 39th STREET, BROOKLYN 18, N. Y.
in Canada, Atlas Radio Corp., Ltd., Toronto, Ont.



UNITED SHIELDED LEADS

Shielded leads, with proportioned air and polyethylene dielectric, have been announced by the United Technical Laboratories, Morristown, N. J.

Shielding of leads is said to eliminate stray pickups, feedback or other undesirable coupling effects. Leads are supplied in 3' lengths with an approximate 9/32" od, and are claimed to have a maximum capacity of 25 mmfd. Black connectors are supplied at each lead end for grounding shield, and red connectors are supplied for circuit or instrument connection.

* * *

HYTRON-CBS PICK-UP STICK

A pick-up stick, with a wax tip that picks up screws, nuts, etc., dropped into inaccessible spots in radio chassis, has been announced by Hytron-CBS, Salem, Mass. Stick doubles in as a pencil. Priced at five cents, the stick is available from jobbers or distributors.



* * *

CLAROSTAT WATERPROOF CONTROLS

A series of waterproof controls in a wide range of resistances and wattages, have been announced by Clarostat Mfg. Co., Inc., Dover, N. H.

A rubber O ring is used on the shaft that is said to create a water tight seal which will stand pressure equivalent to a 6' head of water. A similar rubber O ring is used on the mounting surface of the bushing performing the same function as the shaft O ring seal.

You'll find it

FASTER

in the

MASTER



\$1.95

No More
Files of
Small
Catalogs and
Loose
Literature



This special offer available ONLY thru Distributors (Publisher's price is \$6.50). The Distributors absorb the bulk of the cost for the privilege of printing their ad on the front cover.

When you BUY--SELL--SPECIFY you must have the MASTER

This single volume replaces all other small catalogs

Over 90% of the products manufactured in the Radio-Electronic-Television Parts and Equipment Industry are catalogued in this BIG 1100 page MASTER Buying Guide. Complete descriptions, with specifications and illustrations are written and compiled by each manufacturer covering such products as: tubes, instruments, TV parts, transformers, capacitors, resistors, test equipment, relays, coils and antenna equipment. Also, recording and PA systems, intercoms, tools, hardware, switches and thousands of associated products. IT'S YOUR "RADIO BIBLE"—SAVES YOU TIME AND MONEY.

BE MASTER-Minded—GET your copy NOW from local Distributor

UNITED CATALOG PUBLISHERS, INC.
110 Lafayette St., New York 13, N. Y.

ONLY available thru Distributors at this special \$1.95 price

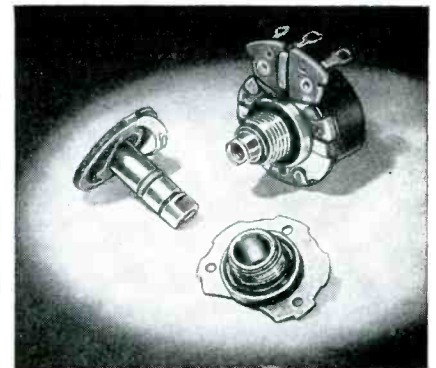

* * *

HELLER ONE-HAND STAPLER

A heavy-duty pocket-sized stapling gun has been introduced by The Heller Co., 2153 E. Superior Ave., Cleveland 14, Ohio. Operator holds material in place with one hand, then shoots staples that are said to be five times normal size into wood.

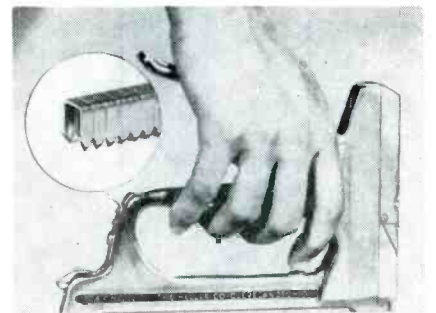

JULIUS FINE AND KEN BROCK PROMOTED

Julius Fine has been appointed commercial products sales manager for both the Ward Products and Workshop Associates Divisions of The Gabriel Co. In this position, he will direct all distributor sales.

Kenneth S. Brock, formerly commercial sales manager for Workshop, has become advertising and sales promotion manager for the two divisions.



Ken Brock

Julius Fine

* * *

HICKOK BROCHURE

A 4-page brochure describing a lab-type tube tester, null reading device and a short tester, has been published by Hickok Electrical Instrument Co., 10514 Du Pont Ave., Cleveland 8, Ohio.

Tube tester, *model 700*, a mutual conductance type, places separate voltages on each element of tube, which can be varied and measured by separate rheostats and meters in each circuit. A short and leakage tester, *model 7002*, is also described. Detailed are technical features of the null reading apparatus, *model 7001*, which is also designed for use with tube tester.

* * *

RCA PICTURE-TUBE PROMOTION CAMPAIGN

A picture-tube *gold-rush* promotion campaign, featuring treasure chests and golden coins, has been announced by the RCA tube department.

Heart of the promotion is said to be an offer of *paydirt* in the form of a *treasure chest* to each dealer or Service Man who purchases ten RCA picture tubes during the campaign. The promotion now in effect will continue until November 16.

The *treasure chest* is a lightweight, luggage-type tube and tool-carrying case containing a roll-up tool kit with a variety of standard and Phillips-type screw-drivers, a liquid-resistant drop cloth, a 24-page book containing basic data on virtually every type of picture tube on the market, a book on television servicing written by RCA service authorities, five TV program holders intended as souvenirs for the Service Man's customers, a 16-page yearly tube movement and inventory guide, and a manual on receiving tubes for radio and television.

IT'S CARTRIDGE

Check-up TIME!



REPLACE INEFFICIENT PHONO-CARTRIDGES NOW with Modern, Lightweight, Compliant E-V CARTRIDGES



DETERIORATED

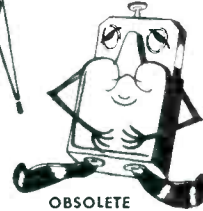

OBSOLETE

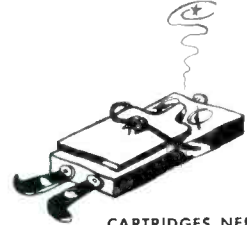

CARTRIDGES NEED NOT BE COMPLETELY DEAD TO NEED REPLACEMENT



WORN OUT

This is a good time to contact record-player owners and check the condition of their phono-cartridge. If it is not reproducing properly or is causing excess record and needle wear, chances are the cartridge has deteriorated or is obsolete—and should be replaced. You'll make new replacement sales, and open the way to other service business, too! A modern, lightweight, compliant E-V cartridge will give fullest record enjoyment and longer record life. You can demonstrate the difference. Remember, you can make most replacements with fewer E-V models!

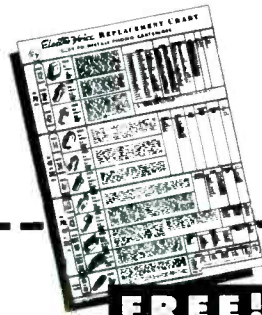
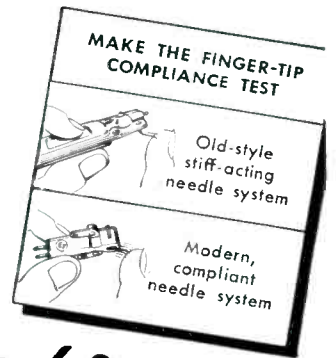

FREE!

REPLACEMENT CHART
Large, Complete Replacement Chart. Gives handy cross-reference and valuable data. Tells when to replace a phono-cartridge. Ask your E-V Distributor or send for it now.

Electro-Voice INC.

411 CARROLL STREET • BUCHANAN, MICHIGAN
Export 13 East 40th St., New York 16, U.S.A. Cables: Arlab
TV BOOSTERS • MICROPHONES • HI-FI SPEAKERS • PHONO-PICKUPS

Electro-Voice, Inc., Dept. S10-1
411 Carroll St., Buchanan, Michigan
Send FREE Cartridge Replacement Chart.

Name (PLEASE PRINT)
Address
City Zone State
 Service-Technician Dealer Record Fan

FOR PERFECT PICTURE CENTERING IN ELECTRO-STATIC TUBES

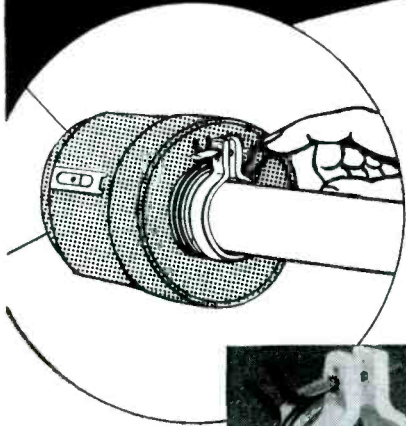

MORE EFFICIENT
Rings are closer to deflection yoke (the most effective operating area) and to the tube neck. They are stabilized magnetically.



Use the **NEW** PERFECTION *Kine-Center*

Here is the simplest of all centering devices for the new electrostatic tubes. It is also the most efficient and positive—as your own tests will prove.

- **Quickly Mounted.** Slip the Kine-Center over the tube neck and tighten the holding screw. It stays firm. No wobble. No wiggle.
- **Finger-Tip Control.** Picture is centered by rotating the two rings either independently or together.
- **Positive Centering.** Once adjusted, the rings stay put.
- **No Distortion of Focus** as with many other centering devices.

Order today from your supplier!

PERFECTION ELECTRIC COMPANY

2635 South Wabash Avenue, Chicago 16, Illinois
MAKERS OF PERFECTION SPEAKERS AND TELEVISION COMPONENTS



SERVICEMEN!! DEALERS!!

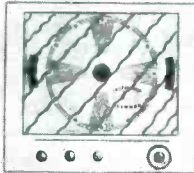

STOP TELEVISION INTERFERENCE

with the INTERFERENCE ABSORBER

Keep your own set and your customers' sets in trim condition. Eliminate most of the annoying types of interference that spoils good reception. Handy connections make attaching easy. Improves fringe area pictures. EVERYBODY LIKES GOOD RECEPTION

only **2⁹⁵** Attach the famous INTERFERENCE ABSORBER to any set and eliminate interference.

Manufactured and sold by **TELERON COMPANY**
41-05 Lawrence St., Flushing, N. Y.

ORDER TODAY! Use handy coupon and order what you need for yourself and your customers.

TELERON COMPANY Dept. SM
41-05 Lawrence St., Flushing, N. Y.
Enclosed is: (\$3.00 each) \$.....
Send me Interference Absorbers.
Name
Address
City..... State..... Zone.....

Fringe Areas!

Brach Air General gives more gain than a stacked yagi, on every TV channel!

Tested... best performance. Strongest construction. Air General, Brach TA-450 is the only antenna tested to give you highest gain... withstand high winds, and ice loading. Has non-hygroscopic high-impact insulators; rugged triangular construction; quick rig assembly... and other exclusive features. Guaranteed highest DB gain on all channels... better than any yagi. Order today!

FREE Send for new booklet, "How to get the most out of fringe area installations" by Ira Kamen, leading TV antenna authority.

Brach MANUFACTURING CORP.
200 Central Ave., Newark 4, N. J.

HI-LO EXPANDS

An additional plant building, adjacent to the present plant at 3540 North Ravenswood Ave., Chicago, will soon be in operation by the Hi-Lo TV Antenna Corp.

* * *

COLUMBIA PLANT BROCHURE

Now available is a brochure describing the facilities and products of the Columbia Wire & Supply Co., 2850 Irving Park Rd., Chicago 18, Ill.

Illustrated are planning and layout facilities, rubber capping, attaching of terminals, automatic braiding and shielding, multi cutting, automatic cutting and stripping, coiling and winding, multi conductor twisting, heavy cable stripping, press assemblies, etc.

* * *

JACK THOMAS JOINS TACO ENGINEERING STAFF

Jack Thomas, formerly with the antenna lab of Ohio State University, has joined the engineering staff of Technical Appliance Corp., Sherburne, N. Y. Thomas has been assigned to the government contract division.

* * *

DR. W. R. G. BAKER TO RECEIVE IRE MEDAL OF HONOR

Dr. W. R. G. Baker, vice president and general manager of the G. E. electronics division at Syracuse, has been voted the IRE medal of honor.

Dr. Baker was cited for his "early technical contributions to the radio transmitter art, his long sustained and effective leadership of institute and industry engineering groups and his outstanding service to the Institute." Award will be made at IRE annual convention in March.

* * *

SELSOR NOW NATIONAL VIDEO JOBBER S-M

Louis Selsor, formerly with DuMont and Thomas, has been named jobber sales manager of National Video Corp., Chicago. He will be in complete charge of picture tubes sales through jobbers and dealers.



D. C. Stixrood (right), National Video general manager, and Louis Selsor, jobber sales manager.

* * *

HUTMACHER JOINS SOUND, INC.

Ray R. Hutmacher, formerly sales manager of Permoflux Corp., has been elected vice president in charge of the contract division of Sound, Inc., 221 E. Cullerton St., Chicago, Ill.

HANSEN ELECTED RPEES PRESIDENT

Charles A. Hansen, of Jensen Manufacturing Co., has been elected president of the Radio Parts and Electronic Equipment Shows, Inc. Others elected were: Sam L. Baraf, United Transformer Co., vice president; W. D. Jenkins, Radio Supply Co., secretary, and Lew W. Howard, Triad Transformer Manufacturing Co., treasurer.

Dates for the four-day '52 show, to be held in Chicago, were set for the week of May 18th.

* * *

DU MONT SERVICE NOTE BULLETINS

TV service notes, included in monthly editions of *Service News*, are now available from Allen B. Du Mont Laboratories, Inc., Teleset Service Control Dept., 35 Market St., East Paterson, N. J.

Typical subjects covered in the issues are interference, installation, fringe-area problems, troubleshooting hints and test equipment use. Subscription form and sample copy available on request.

* * *

N. U. APPOINTS HUBER AND MAURER DISTRICT MANAGERS

Edward G. Huber is now district sales manager for the New Jersey territory, and David Maurer has been named district manager for the metropolitan New York territory of the National Union Radio Corp., Orange, N. J.

Huber will headquarter at New Market, N. J., and Maurer at 170 Hawthorne St., Brooklyn 25, N. Y.

* * *

APPROVED EQUIPMENT CATALOG

A 12-page catalog featuring audio, testing, FM-AM, AM and TV equipment, has been released by Approved Electronic Instrument Corp., 142 Liberty St., New York 6, N. Y.

Described are a TV linearity pattern generator, FM-AM tuner, 10-watt audio amp, a preamp, TV booster, 4-tube miniature broadcast superhet tuner, universal power supply and a signal generator kit.

* * *

HENRY VITARELLI APPOINTED BURLINGAME S-M

Henry Vitarelli, formerly general manager of Herold Radio and Phono Corp., and assistant to the president of Electronic Corp. of America, has been appointed sales manager for the distributor and merchandising divisions of Burlingame Associates, 103 Lafayette St., New York 13, N. Y.



Henry Vitarelli

* * *

MERIT REPLACEMENT GUIDE

A '51 TV Replacement Guide and Catalog, listing a line of TV transformers and components, has been published by the Merit Transformer Corp., 4427 N. Clark St., Chicago 40, Ill.

Detailed are manufacturers and model numbers, showing the manufacturers part number and Merit replacements.

COMPETENT

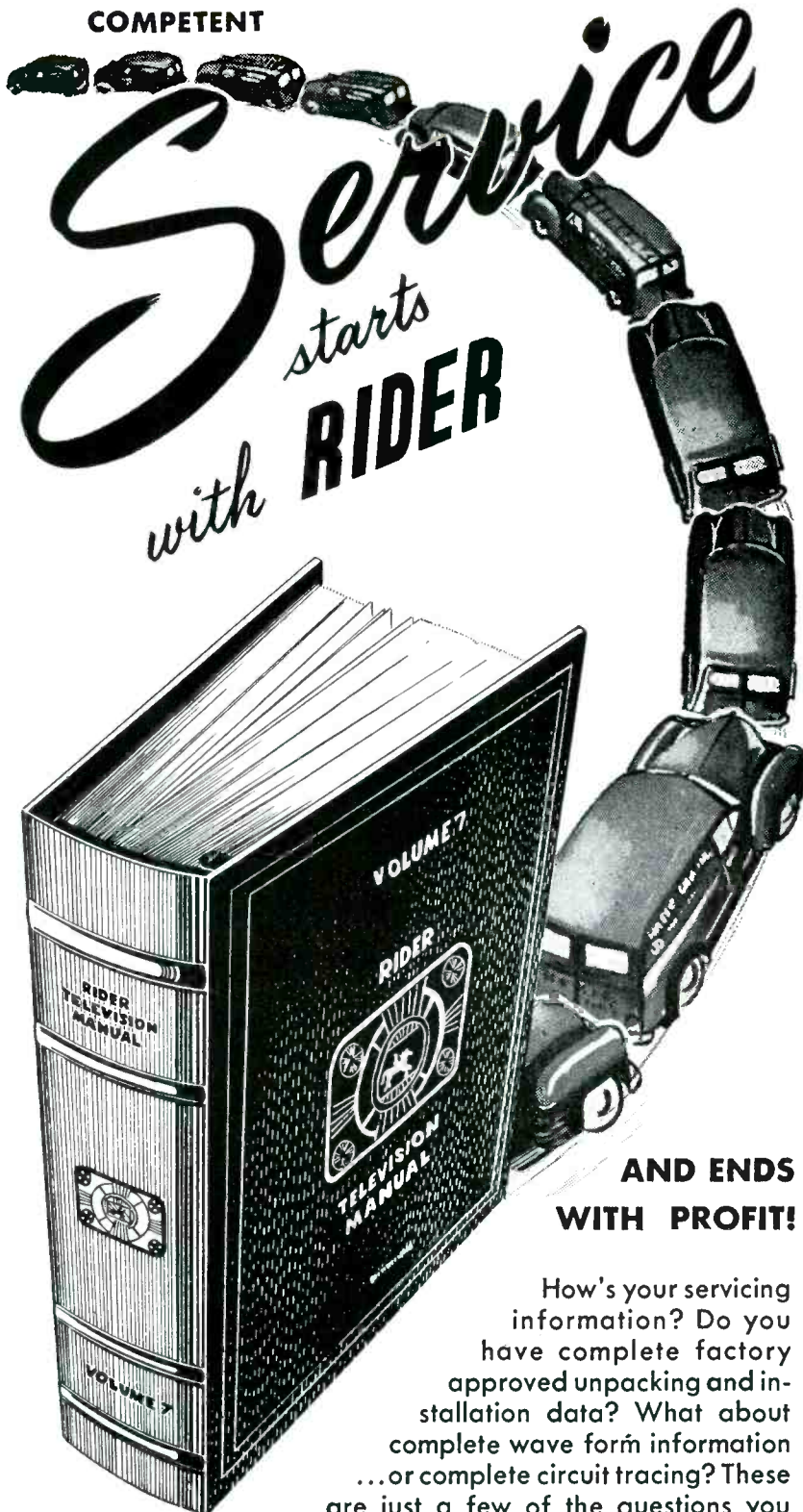

AND ENDS WITH PROFIT!

How's your servicing information? Do you have complete factory approved unpacking and installation data? What about complete wave form information ...or complete circuit tracing? These are just a few of the questions you can't answer "yes" to unless you have the Rider TV manuals! For Rider is the only source that gives you *all* the information about *all* the sets in all manufacturers' lines, including automatic record changers. Ask your jobber to show you the latest Rider TV manual today.



JOHN F. RIDER Publisher, Inc.
480 Canal Street, New York 13, N. Y.

... if you are commercially or professionally interested in TV, you must read

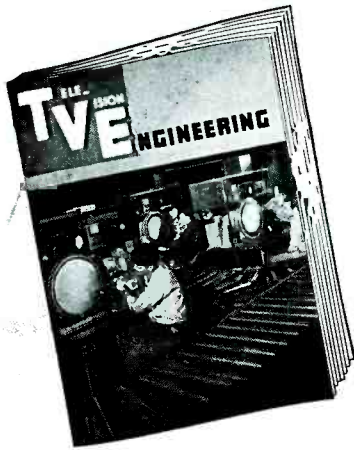

TELEVISION ENGINEERING

every month!

Devoted exclusively to TV Research . . . Design . . . Production . . . Operation . . . Instrumentation

TELEVISION ENGINEERING is the *only* trade publication which directs its *entire* editorial content to executives and engineers who design, manufacture, operate and maintain television receiving and transmitting equipment—both commercial and educational.

Every issue is chock full of timely and thorough TV articles, authored by outstanding specialists. You'll find practical, carefully prepared reports and papers on such vital subjects as . . .

Color TV Systems . . . Ultrahigh Receiver-Transmitter Design Problems . . . Tube Production-Line Techniques . . . TV Broadcast Equipment . . . Camera Tube Research . . . Glass, Plastics and Metal in TV . . . TV Test Equipment in the Plant . . . Film Recording . . . Flying Spot Scanners . . . Tone Amplifiers for TV Films . . . Compact Motors for TV . . . TV Component Design . . . Mechanical Design Factors in Antennas . . . Quality Control Charting . . . Microwave Relays . . . Receiver and Transmitter Servicing . . . Production Aids . . . Instrument Activities . . . TV Sound Systems . . . Studio Lighting.

Enter your subscription NOW . . . Fill out the coupon below
(Not sold on newsstands)

MAIL COUPON

TeleVision Engineering
52 Vanderbilt Ave., New York 17, N. Y.

Here is my remittance for my subscription to **TeleVision Engineering** at the

SPECIAL RATE . . . 3 years (36 issues) only \$5.

(1 year subscription \$3.)

NAME

ADDRESS

CITY ZONE STATE

For our confidential records, open only to the Audit Bureau of Circulation, please supply the following information:

Occupation Title

Department in which employed

Operation

Production

Research

Employed by

Nature of Business

(State if TV Manufacturer, TV Broadcast Station, etc.)

CENTRONICS EXPANDS

The facilities of Centronics Co., 41-05 Lawrence St., Flushing 55, N. Y., have been expanded to permit the fabrication to order of any coil needed for radio or TV sets, regardless of the age of the chassis. Price sheet available upon request. Melvin Marcus is general manager of Centronics.

* * *

ALLIED RADIO AND RAYTHEON CO-SPONSOR SERVICE MEETING

A joint meeting, sponsored by Allied Radio Corp., and Raytheon recently in Chicago, featured a talk by Robert Gill, Raytheon-Belmont TV engineer, on *How to Interpret What You See*.

With the aid of movies and illustrations, Gill explained how to solve tough TV service problems by proper reading of picture-tube images.

Additional service meetings have been scheduled for the coming fall and winter months, according to S. H. Levey, sales manager of Allied, and C. W. Hoshour, service director of Belmont.

* * *

ROWLAND NAMED WORKSHOP CHIEF RESEARCH ENGINEER

Howard Rowland has been appointed chief research engineer of The Workshop Associates, division of The Gabriel Co., 135 Crescent Rd., Needham, Mass.

* * *

GRIFFIN SYMBOL STAMPS

A set of 20 symbol stamps, each one mounted on 1/4-inch plexiglass and centered on inscribed cross lines so that one may see where the impression is going to appear on drawings, has been introduced by the John Griffin Co., 2157 James Ave., St. Paul 5, Minn. Included with each set is a bottle of opaque ink and two facing ink pads.

* * *

HARRIS NOW PREXY OF ANTENNA MANUFACTURERS ASSOCIATION

Harold Harris, sales manager of Channel Master Corp., was recently elected president of the Antenna Manufacturers' Association, 366 Madison Ave., N. Y. 17. Ken Brock, in charge of advertising and publicity for the Workshop Associates and Ward Products division of the Gabriel Co., is now vice prexy. Edward Finkel, of J. F. D., continues as treasurer.

* * *

N. U. FLUORESCENT SIGNS

Two new designs for the N. U. fluorescent signs have been announced.

Signs are made of heavy-gauge steel sprayed with a gold bronze finish. Stark white letters are on an opaque green background. An opening in the bottom of the sign, permits light to shine on the area below. Chain can be used to hang the sign over counter or over window display.

Models available from N. U. distributors for \$8.95 each plus shipping charges from Cincinnati, Ohio.



1 x BTA = 12 x Ord U *

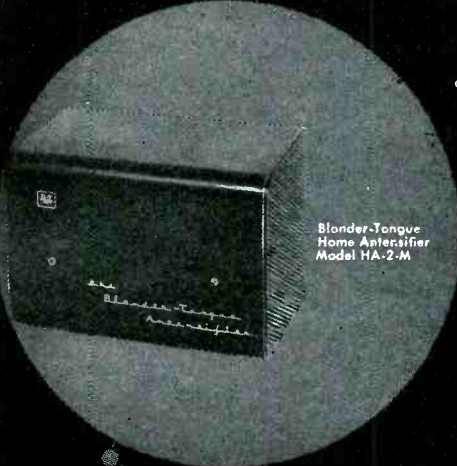

Blender-Tongue Home Antensifier Model HA-2-M

*One Blender-Tongue antensifier replaces 12 ordinary boosters. Automatically amplifies all channels 16 times

TV boosters and master antenna systems

BLONDER-TONGUE LABORATORIES • 38 W. Second Ave., Mt. Vernon, N. Y.

BUY A BETTER ANTENNA

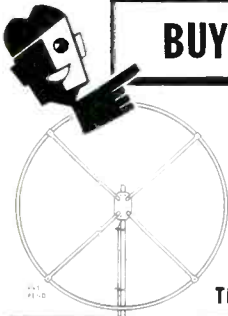

It's Circle-X for clear, sharp pictures on all channels, compare it and note the superiority . . .

Buy Circle-X chimney mounts, twin lead, guy wire, ground rods, wrenches, etc.

TRY A CIRCLE-X ON YOUR NEXT INSTALLATION

Air express or parcel post, special delivery direct from factory to you through your distributor.

CIRCLE-X ANTENNA CORP.
511 MARKET ST., PERTH AMBOY, N. J.

CIRCLE-X
ANTENNA CORPORATION

WHEN YOU CHANGE YOUR ADDRESS

Be sure to notify the Subscription Department of SERVICE at 52 Vanderbilt Avenue, New York 17, N. Y., giving the old as well as the new address, and do this at least four weeks in advance. The Post Office Department does not forward magazines unless you pay additional postage, and we cannot duplicate copies mailed to the old address. We ask your cooperation.

**MEETS BIG INDUSTRIAL NEED
For Testing
And Servicing...**

• Aircraft, tank, marine, auto radios and electronic equipment • Relays and solenoids • Telephone circuits • Laboratory instruments • For low voltage devices • For plating



**CONTINUOUSLY VARIABLE,
0-28 VOLTS
at 15 AMPERES**

Electro
ELECTRONIC EQUIPMENT

NEW MODEL "N" ALL-PURPOSE DC POWER SUPPLY

Provides hum-free direct current in variable voltages from AC source. Never before has a DC power supply with this output range and dependability been available at this moderate price. Exclusive "Electro" application of selenium rectifiers increases rectifier power rating and lowers cost per ampere output. A single control provides continuous voltage adjustments for different load conditions over the specified range. Highest quality components and special design withstand high overloads. Net **\$175**

Specifications

Up to 36 volts at 6 amperes.
5% ripple at 10 amps., facilities provided for extra filtering.
Special O2 Arsenval type voltmeter, ammeter accurate to 2%.
Superior Powerstat provides incremental voltage adjustments.
Bridge type selenium rectifiers.
115 volt 50/60 cycle input.

OTHER MODELS

| | |
|---|--|
| Model "B" DC Power Supply 6 Volts 1-20 Amps. Net \$49.80 | Model "BJ" DC Power Supply 6 Volts 1-12.5 Amps. Net \$37.50 |
|---|--|

ELECTRO PRODUCTS LABORATORIES
4501-SM N. RAVENSWOOD AVE., CHICAGO, 40, ILL.

Name _____
Firm _____
Street _____
City _____ Zone _____ State _____

Mail Coupon for Bulletin

In Canada • ATLAS RADIO CORPORATION • LTD. • TORONTO

-here's what you call **RUGGED**

90-10000 CPS
EXTENDED
RESPONSE



University
Model SA-30
UTILITY
HEAVY DUTY
DRIVER UNIT

30 WATTS
CONTINUOUS
DUTY

MATCHES ANY
SYSTEM OR
AMPLIFIER

SELF-ALIGNING
RIM-CENTERED
ASSEMBLY

RUGGED DIE-CAST
ALUMINUM
HOUSING

Additional exclusive features include Bakelite Screw Type Terminal Strip, Gland Nut Type Cable Entrance, Special 45 ohm Transformer Tap, and Equalized Palate Type Breakdown Proof Diaphragm Assembly - write Desk 19.

An Engineering Achievement of **UNIVERSITY LOUDSPEAKERS INC.**
80 So. Kenjico Ave., White Plains, New York

G.E. TANTALYTIC CAPACITOR BOOKLET

A booklet, *GEC808*, describing tantalytic* capacitors has been announced as available from the General Electric Co., Schenectady 5, N. Y.

Booklet is illustrated with photographs, line diagrams, and test-data graphs.

Tantalitic capacitors are designed for low-voltage *dc* applications where very small size, lightweight, long operating- and shelf-life are major considerations. They are rated 0.1 to 50 mmfd, 150 volts *dc*, and have an operating temperature range of -55 to +85 C, with a maximum loss of only 35 per cent capacitance at -55 C.

*Reg. trade-mark of G. E.

SAMS' AF AMPLIFIER BOOK

The third volume of *Audio Amplifiers and Associated Equipment* has been published by Howard W. Sams & Co., Inc., Indianapolis.

Presents a detailed analysis of fifty audio amplifiers, and full coverage of 22 FM and AM tuners.

Each unit is analyzed in 4 to 10 pages, with all circuit and design data based on actual original laboratory study of the equipment itself.

Fully illustrated, with 352 pages, the text is available at \$3.95.

G.E. FLUORESCENT BALLAST PUBLICATIONS

Two booklets on fluorescent lamp ballasts have been announced by G. E.

The first, a 20-page booklet (*GEA-5731*), explains in non-technical language how a fluorescent lamp works and the part the ballast plays in its operation. Illustrated with cartoons and diagrams, the book reviews the role of the ballast in modern fluorescent lighting and the contributions it has made to the industry.

Of a more technical nature, the second publication, *GEA-5672*, deals with the G. E. system of *sound-rating* its ballasts. The four-page brochure describes how the company's ballasts are classified according to the amount of natural hum they emit. It explains how these ratings can be put to use by fixture manufacturers, electrical contractors, and architects, and gives a typical example of application. The booklet includes a table listing the catalog numbers of G. E. ballasts according to their sound ratings from group *A* (extremely quiet) to group *F* (quite audible).

RIDER'S MONTHLY TEK-FILE

A new data service, *Tek-File*, available on a monthly basis, has been announced by John F. Rider, Publisher, Inc., 480 Canal St., New York 13.

Each *Tek-File* will contain a minimum of 128 pages, equivalent to 8 1/2" x 11" size. For reference, each manufacturer's data will be stapled into an individual file folder, and marked for instant identification. The amount of manufacturers to be included in a single release will depend on the volume of material.

A variety of selections will be available each month so that the Service Man may buy only the data he needs. Each *Tek-File* will contain a cumulative index for the entire series published.

Boxed *Tek-File* will be priced at \$2.00 each.

THE WORLD'S LEADING TWIN LEAD TELEVISION LIGHTNING ARRESTER

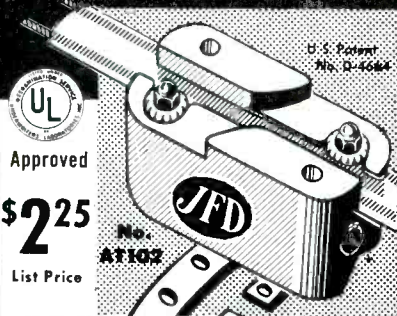

Approved
\$225
List Price

JFD

completely waterproof

SAFE TV GUARD

Protects television sets against lightning and static charges. Simple to install everywhere and anywhere... no stripping, cutting or spreading of wires. More than 500,000 in use today!

See your jobber or write to -

JFD MANUFACTURING CO., INC.
6109-K 16th Ave., Brooklyn 4, New York
FIRST in Television Antennas and Accessories

YOUR COPY of NEW 1951 COMPLETE GREYLOCK CATALOG

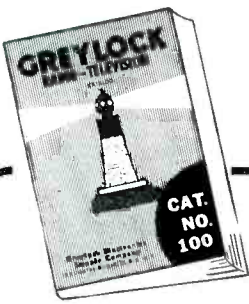

IS NOW
READY!
Send for it
Today!

68 Pages

crammed full of Radio - Electronic - Television quality merchandise at

terrific savings! Many standard lines carried, including:

BOGEN Challenger Line, Boosters
JACKSON Instruments
RIDER Publications
CORNELL-DUBILIER Vibrators, Converters, Rotators

- SPRAGUE
- REGENCY
- HYTRON
- BURGESS
- ELECTRO-VOICE
- JENSEN

High quality Greylock Tubes still available at some of Today's best prices.

If you sell or service Radio, TV or Electronics equipment, you can't afford to be without this GREAT BUYING GUIDE! Write NOW for your copy (unless already on our mailing list).

Dept. S-11

GREYLOCK ELECTRONICS SUPPLY CO.
115 Liberty Street • New York 6, N. Y.

**GEORGE PETETIN NOW PICKERING
ASST. S-M**

George P. Petetin, Jr., has been appointed assistant sales manager for the Pickering line of record playing magnetic cartridges, preamplifiers, compensators, and arms. Petetin will make his headquarters at Pickering offices in Oceanside, Long Island.

* * *

**KAYE-HALBERT NATIONAL SERVICE
CORPORATION FORMED**

A national service company has been announced by Kaye-Halbert Corp., Los Angeles, Calif.

* * *

**PARKINSON NAMED RTMA SERVICE
COMMITTEE CHAIRMAN**

W. L. Parkinson, of G. E., has been appointed chairman of the RTMA Service committee. He succeeds E. W. Merriam.

Mr. Parkinson served as chairman of the committee for two terms in 1946-48.

* * *

G.E. NAMES P. H. LESLIE TV S-M

Paul H. Leslie has been appointed television sales manager in the General Electric Company's receiver department. He succeeds David Davis who has been promoted New York district manager for the department, with headquarters in New York City.

* * *

**RADIO RECEPTOR EXPANDING
GERMANIUM PRODUCTION**

An increase in plant capacity to manufacture germanium diodes has been announced by Radio Receptor Co., Inc., Brooklyn, N. Y.

* * *

**EMPIRE STATE DISTRIBUTORS AND
REPS COSPONSOR FOURTH ANNUAL
CLAMBAKE**

The fourth annual NEDA Empire State Chapter Clambake was held recently in conjunction with the Empire State Chapter of the *Reps* at Uhl's Grove, near Albany, N. Y.

NEDA members on the committee were Dave Marks, Fort Orange Distributing Co., Albany, chairman; Ed Taylor, E. E. Taylor Co., Albany, and Al Page, Trojan Radio Co., Troy, N. Y.

Joe Marsey was the *Reps'* chairman, assisted by Gordon LeRoy, Harry Murray, Don McNeil and Tom Wendling.

* * *

**ROGERS JOINS REEVES SOUNDCRAFT
AS SALES V-P**

Frank B. Rogers, Jr., formerly with Ampro, has been appointed to the executive staff of Reeves Soundcraft Corp. as vice president in charge of sales.

Sales of the complete Reeves line of sight and sound equipment will be under Rogers' supervision. This includes recording discs and tapes, magnetic film, picture tubes for TV, Air Design transformers, Bergen wire rope products, and light metal alloy drawings, spinings, and stampings.

Also under Rogers' direction will be sales of Magnastripe, a patent process stripping of magnetic oxide on standard film for special uses in magnetic projectors.

NEW! STANCOR



Here are three of the newest additions to the most complete transformer replacement line in the industry.

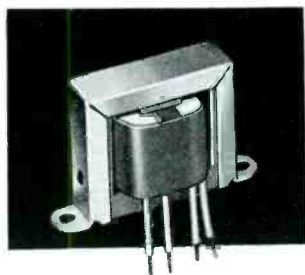

**A-8124, VERTICAL BLOCKING-OSCILLATOR
TRANSFORMER**

A three winding transformer for replacement in 7 Dumont models, 9 Crosley models and Stromberg Carlson model TV-125. See Stancor Bulletin 384.

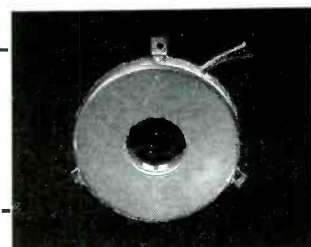

FC-11, FOCUS COIL.

For use with picture tubes up to 24". Equivalent to RCA 202D2. See Stancor Bulletin 385.

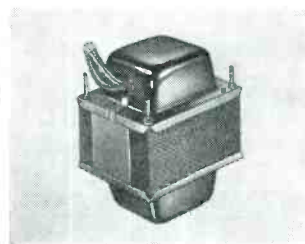

P-8163, TV POWER TRANSFORMER

Equivalent to RCA 75508 (971316-1), used in 28 RCA models. See Stancor Bulletin 388 for a complete list.

Your Stancor distributor has data sheets on these new Stancor TV transformers. Ask him for the latest Stancor Bulletins.

Other new Stancor TV components include **DY-8**, **DY-9**, and **DY-10**, 70° deflection yokes with ferrite cores, nylon coil bobbins and anti-astigmatic focusing (resulting from "cosine" distributed windings) for tubes up to 24". **A-8131**, an air core "flyback" for direct drive circuits, to be used with **DY-10**.

STANCOR TV TRANSFORMER CATALOG AND REPLACEMENT GUIDE lists transformer replacements for over 1500 TV models and chassis. Available FREE from your Stancor Distributor.



STANDARD TRANSFORMER CORPORATION

3588 ELSTON AVENUE, CHICAGO 18, ILLINOIS

LINDBERG INSTRUMENT EXPANDS

The Lindberg Instrument Co. are now located at 1808 Harmon Street, Berkeley 3, Calif., in a plant four times larger than the former building. Provided are full facilities for two engineering laboratories, tool, die and model shop, manufacturing and assembly area, storage and offices.

TRIAD TRANSFORMER BULLETIN

A bulletin, 451, describing miniature transformers for portable equipment, voice frequency audio components, power transformers (combined plate and filament), filament transformers and filter reactors, has been released by Triad Transformer Manufacturing Co., 2254 Sepulveda Blvd., Los Angeles 64, Calif.

EICO

gives you Laboratory Precision at
Lowest Cost!

NEW EICO

Instruments and KITS

...with a complete line

Over 50,000 servicemen have bought one or more EICO Kits and Instruments. That's the proof of EICO's leadership in value to the serviceman!

For latest precision engineering, finest components, smart professional appearance, lifetime performance and rock-bottom economy—see and compare the EICO line at your jobber's today before you buy any higher-priced equipment! You'll agree, with over 50,000 others, that only EICO Kits and Instruments—no other—give you the industry's greatest values for the industry's lowest costs!

Read the full story on the complete EICO line. Write today for your free latest Catalog S-10



221K VTVM Kit
Kit \$25.95
Wired \$49.95

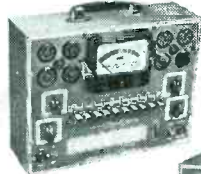

625K Tube Tester
Kit \$34.95
Wired \$49.95

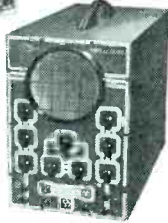

425K 5" Scope Kit
Kit \$44.95
Wired \$79.95



320K Sig. Gen. Kit
Kit \$19.95
Wired \$29.95

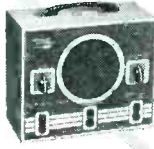

145K Sig. Tracer
Kit \$19.95
Wired \$28.95



315K Deluxe Sig. Gen. Kit
Kit \$39.95
Wired \$59.95



HV Probe \$6.95



1010K Battery Elim.
Kit \$25.95
Wired \$34.95

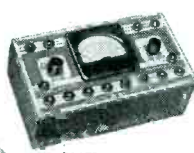

511K VOM Kit
Kit \$14.95
Wired \$17.95



360K Sweep Gen. Kit
Kit \$34.95
Wired \$49.95
C-5 5mc Crystal \$3.95



RF Probe Kit \$3.75
Wired \$5.95

ELECTRONIC INSTRUMENT CO., Inc.
276 NEWPORT STREET, BROOKLYN 12, N. Y.

Due to unsettled conditions, prices and specifications are subject to change without notice.
Prices 5% higher on West Coast

RESERVE SPACE NOW FOR NOVEMBER SERVICE

Mailed to the radio and TV servicing industry's buying power mid-November, the PEAK of the FALL BUYING SEASON. Last forms close Nov. 1.

TUBES

Every
Critical
Type

FULLY GUARANTEED—BRAND NEW—IMMEDIATE DELIVERY

.59

5U4G
5Y3GT
6AL5
6AU6
6AV6
6BE6
6J5GT
6K5GT
6K6GT
6W4GT
35W4
35Z5GT

.69

1R5
1U4
3S4
3V4
6BA6
6SA7GT
6SK7GT
6SN7GT
6V6GT
6X5GT
6BJ6
12AT6

.79

1B3GT
3Q4
12AU7
12SA7GT
12SK7GT
12SN7GT
12SQ7GT
35L6GT
50L6GT
6CB6
6BH6
25L6GT

.99

1X2A
5V4G
6BC5
6AG5
6AC7
6J6
6T8
6AB4
12AV7
12BH7
12SC7
12SG7

1.29

6AH6
6BC6
6CD6
6BQ6
6BN6
6AK5
12AT7
19C8
19T8
25BQ6
19BG6
70L7GT

300 ohm twin lead, pure copper and polyethylene, \$19.50 per thousand feet, 1500 ft. to a roll.

TERMS: Orders for less than \$25, add 10% to above prices.
25% deposit with order, balance C.O.D. F.O.B. New York City
All Merchandise Subject to Prior Sale.

Supreme Radio & Television Co.

136 LIBERTY STREET, NEW YORK 6, N. Y.

TV Parts

[Additional new-product news on pages 49, 73, 76 and 77.]

ELECTRO-VOICE AUTOMATIC TV BOOSTER

A two-stage self-tuning TV booster, 3002 *Tune-O-Matic*, that utilizes two 6BK7s, one for the high and one for the low bands, has been announced by Electro-Voice, Inc., Buchanan, Michigan.

Booster, 6 $\frac{7}{8}$ "x3 $\frac{1}{8}$ "x3 $\frac{5}{8}$ ", may be concealed behind the TV set, and plugged in between the receiver and an ac outlet.

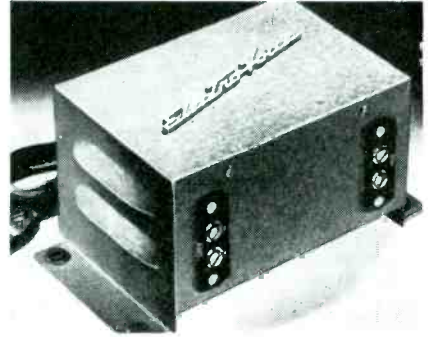

TACO 5-ELEMENT TWIN-DRIVEN YAGI

A 5-element twin-driven yagi, *Super 980*, designed for the extreme fringe areas, has been announced by Technical Appliance Corporation, Sherburne, N. Y.

Consists of three parasitic elements, two directors, one reflector, and two driven elements. Driven elements are folded dipoles connected in parallel with a terminal impedance matching the 300-ohm twin-lead line. Available as a single or stacked array.

SOUTH RIVER TV ANTENNA FLOOR STAND

The antenna-mount line of the South River Metal Products Co., Inc., South River, New Jersey, has been included on 7-foot display floor merchandiser. Actual mounts and accessories are attached to the display to show how the various products are used.

Floor-stand display is available to distributors.

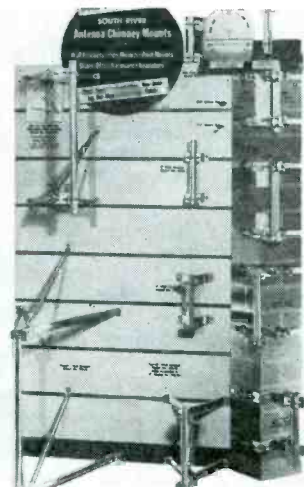

CHANNEL MASTER YAGIS

A new yagi antenna, the *Z-Match*, that is claimed to provide perfect match to 300-ohm lines for both single and stacked arrays, has been announced by Channel Master Corporation, Ellenville, N. Y.

The yagi features adjustable impedance. Antenna has wider spaced elements which are cited as providing higher gain, narrower lobe, and better rear rejection on all installations.

No extra connecting rods are said to be needed. When antennas are stacked, the center bars of the folded dipoles are removed, reducing the impedance of each antenna and automatically creating a 300-ohm match for the stacked array. The removed center bars are then used as 1/2-wave connecting rods.

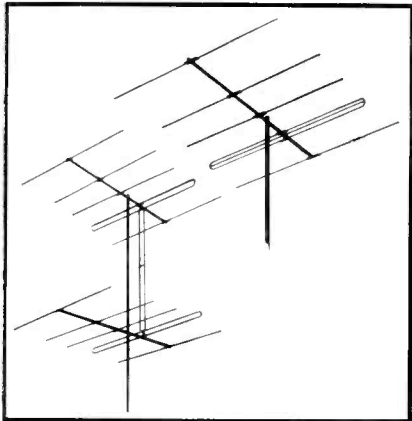

* * *

DUMONT CAPACITORS

Molded capacitors that are said to be perfectly centered have been announced by Dumont Electric Corp., 308 Dykman Street, New York 34, N. Y.

Available in all sizes and two types: Standard type PM with paper dielectric and mineral oil impregnant for temperatures up to 85°C; high temperature type TM with thermofilm dielectric for temperatures up to 150°C.

* * *

WARD INSTALLATION KITS

Two TV antenna kits, *Installation Kits*, with all the components required for a TV antenna installation, have been announced by Ward Products Corp, 1523 East 45th St., Cleveland, Ohio.

For local installations, there is a single stack package, model TV-105 and, for fringe areas, a double stack, model TVS-103. Each package includes a conical antenna, mast, lead-in, standoffs, pipe strap, base, and other installation material. The double stack package has an additional antenna bay and mast.

* * *

VIDAIRE TV PP AMPLIFIER

A push-pull sound amplifier, *A-130*, to be used with TV receivers that utilize a single tube for sound output, has been produced by Vidair Television Co., 576 W. Merrick Road, Lynbrook, New York.

By removing the 6K6, 6V6 or 6Y6 sound output tube and plugging in the amplifier, the overall frequency response of the sound system is said to be increased. Response is claimed to be flat within 1.5 db between 80 to 20,000 cycles. Unit uses one 6J5GT and two 6K6GT tubes.

Why G-E dial lamps are seen

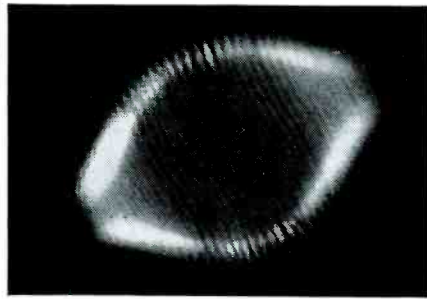

OLD FILAMENT. High notes often cause the filaments and lead-in wires of radio dial lamps to vibrate. In old-style lamps, they vibrate to frequencies different from those of the noise. This produces a whipping action (above) which eventually tears the filament apart.

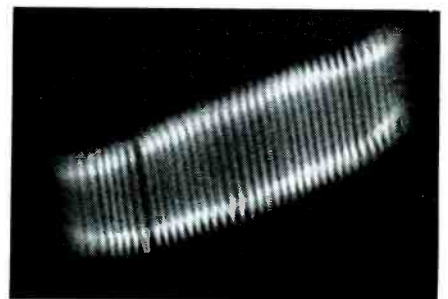

NEW FILAMENT. By redesigning the filament supports of G-E radio dial lamps, General Electric engineers matched the frequencies and greatly reduced the effects of vibration (above). As a result, G-E radio dial lamps give longer, more dependable service.

...but not heard

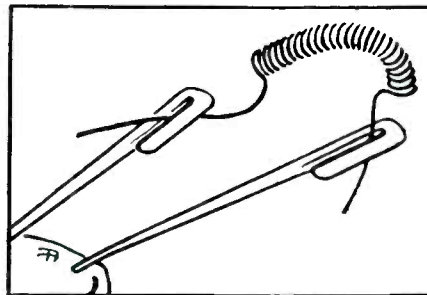

OLD-TYPE JOINT. Some types of dial lamps actually cause "static". Old-type clamp joints in the bulb (above) often permit changes in resistance or tiny arcs that cause the lamp to radiate bothersome interference.

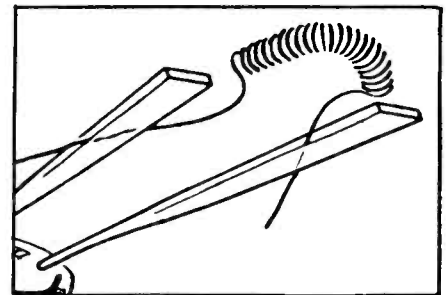

IMPROVED JOINT. To prevent dial lamps from being "noisy", General Electric developed a better joint—one with tungsten filament legs pressed firmly into the softer metal of the lead-in wire. It's another reason why G-E dial lamps insure customer satisfaction!

GENERAL  ELECTRIC

RCA 17-INCH LV ELECTROSTATIC PICTURE TUBES

A 17-inch picture tube, 171P4, utilizing low-voltage, electrostatic focus has been announced by the RCA tube department. Design not only eliminates the need for a focusing coil or magnet, but also makes it possible to obtain the voltage for the focusing electrode from the low-voltage *dc* supply of the receiver.

Because the focusing electrode operates at only 0 to 2.5 per cent of the value for the final high-voltage electrode, and takes very low current, the focusing voltage can be obtained from a fixed or adjustable tap on the receiver's *dc* supply.

The focusing electrode has its own base-pin terminal to permit choice of focusing voltage for best results.

A metal-shell type, this tube employs magnetic deflection and an ion-trap gun which requires an external, single-field magnet. It furnishes a picture 14-5/8 inches by 11 inches, with slightly curved sides and rounded corners, on a frosted Filterglass faceplate.

QUAM NICHOLS OUTPUT TRANSFORMERS

A complete line of *Tru Match* output transformers, designed to match the voice coils of the original equipment, has been announced by Quam Nichols Co., Chicago. Line consists of twenty-five output transformers, individually packaged, with complete information on matching characteristics and suggestions on the selection of units for specific applications enclosed in each box.

JOE B. HIGGINBOTHAM, JR.

Nuberg, Co.

THANKS,
Mr. Higginbotham!

Radio Receptor Co., Inc.
West 19th Street
New York 11, N.Y.

Gentlemen:

Please send me your pamphlet on the design, application and servicing of selenium rectifiers.

Although I have serviced many receivers which have selenium rectifiers I have very little information on them and believe your pamphlet would be a valuable asset to my shop.

I use your rectifiers, supplied by Southeastern Radio Parts Co. and Specialty Distributing Co. of Atlanta, Ga., and like them very much. Also I appreciate your consideration of the radio repairman in that you supply a data sheet with each rectifier and the trouble taken to print the servicing information.

Yours Truly

Joe B. Higginbotham Jr.
Joe B. Higginbotham Jr.



SELETRON RECTIFIERS

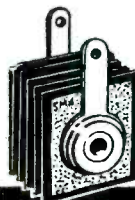

... And our thanks go as well to the other thousands of servicemen and hams who insist upon top performing SELETRON Selenium Rectifiers in electronic circuits and as replacements in Radio and TV sets.

You can depend on SELETRON all ways... Full technical information is always available without obligation. Look for Howard W. Sam's Red Book Supplement listing SELETRON replacements, and write us for Bulletin No. SE-10

SELETRON DIVISION
RADIO RECEPTOR COMPANY, INC. RR

Since 1922 in Radio and Electronics
Factory: 84 North 9th St., Brooklyn 11, N. Y. • Sales Department: 251 West 19th St., New York 11, N. Y.

THREE TYPES OF
TWIN LINE CONNECTORS GIVE
YOU A CHOICE FOR ANY
INSTALLATION
PROBLEM!



No. 14-0
A general purpose polarized connector.

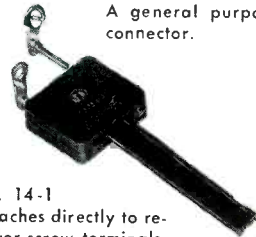

No. 14-1
Attaches directly to receiver screw terminals. Eliminates cutting line to install a connector.

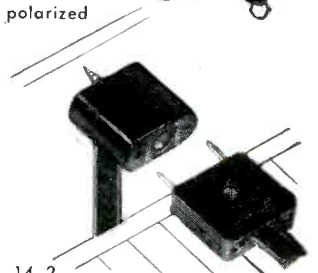

No. 14-2
A baseboard connector; serves as junction for antenna lead-in and inside lead to set. Mount them in parallel to accommodate the receiver in various locations.

Grayhill

4532 W. Madison Street

GET DETAILS—Write for
the Grayhill Catalog
NOW

Chicago 24, Illinois

GEORGE DAVIS, Los Angeles, Calif., has been named rep for the Peerless division of Altec Lansing Corp., in southern Calif. . . . C. R. Strassner Co., Los Angeles, Calif., have been appointed rep for Electrical Communications Inc., covering Calif., Arizona, Nevada and New Mexico. . . . Ron Merritt, Seattle, Washington, has been appointed northwest rep for Gertsch Products, Inc. . . . G. W. Delsell has been named rep for Eicor, Inc., covering Texas and adjoining states. . . . William Carduner and William Lichter have formed a manufacturers' rep company at 164 Duane St., New York City. . . . Roderick R. Harris, formerly of Arthur H. Harris Co., has joined the rep staff of Harold A. Chamberlin, Boston,

Rep Talk

Mass., and will cover the Conn. and western Mass. territories. . . . Dave Dolin, 2635 S. Wabash Ave., Chicago, Ill., has been appointed rep for Eureka Television and Tube Corp., in the Chicago area and in parts of Iowa, Indiana and Wisconsin. George Epstein, Dage Corp., 40 Hudson St., New York City, has been named exclusive export manager of Eureka, covering South America and Europe. . . . Cecil Webb has joined Leslie M. DeVoe, Indianapolis, Ind., as rep for Oxford

Electric Corp., in Indiana and Kentucky. . . . Burlingame Associates, 103 Lafayette St., New York City (New York, New Jersey and Pennsylvania), and Walter Brauer and Associates (Ohio, western Pennsylvania and eastern Kentucky) have been named reps for TV-Q Custombilt Corp. . . . Stang Sales Co., 509 Fifth Ave., New York 17, N. Y., has been appointed rep for Astron Corp., covering New Jersey, except Trenton and Camden, and Connecticut adjoining New York through Bridgeport. . . . Land-C-Air Sales Co., 1819 Broadway, New York City, have been named rep for Blonder-Tongue Labs in metropolitan New York, New Jersey, Maryland, Delaware, Wash-

Newly elected officers of the Radio Parts and Electronic Equipment Shows, Inc., sponsors of the '52 Electronic Components and Equipment Show which will be held in Chicago the week of May 18 (left to right): Lew W. Howard, Triad Transformer, treasurer; Sam L. Baraf, United Transformer, vice president; W. D. Jenkins, Radio Supply, secretary, and Charles A. Hansen, Jensen, president

Meeting of the RPEES Board of Directors at Ashville, N. C., at which plans for the '52 show were made (clockwise): Herbert W. Clough, Belden; Lew W. Howard, Triad Transformer; Jerome J. Kahn, Stancor; Kenneth C. Prince, show manager; Charles A. Hansen, Jensen; Samuel J. Spector, Insuline; John H. Cashman, Radio Craftsmen; Sam L. Baraf, United Transformer; W. D. Jenkins, Radio Supply, and Byron C. Deadman, Northern Radio and Television.

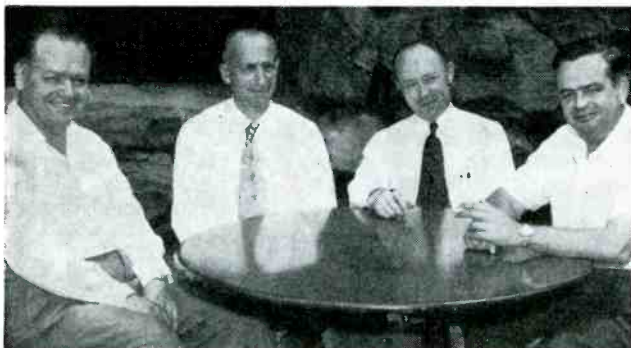



R. R. Harris

ington, D. C. and eastern Pennsylvania to Harrisburg. *Elmer W. Oszman*, 8 W. 26th St., Minneapolis, has been appointed rep in Minnesota. . . . *Jack McKinney* and *Bob Nesbitt*, Amphenol reps, cover their Texas territory in a plane. . . . Five new members, four senior and one associate, have been elected to the Chicagoland Chapter of *The Reps*. Senior members include: *Roger Clark*, 6349 N. Clark Street, Chicago 26; *Dave Dolin*, 2635 S. Wabash Ave., Chicago 16; *Ralph T. Sullivan*, 542 S. Dearborn St., Chicago 5; and *Wesley L. Wilson*, 2750 W. North Ave., Chicago 47. Associate member is *Frank Gassner*, of Gassner & Clark Co., 6349 N. Clark Street, Chicago 26. . . . *Irving Woolf* has become Louis Bros. rep in Metropolitan New York, and *Willis Wink* is now a rep of the company in upper New York State. . . . *Stanley A. Harris Co.*, 318 Harvard St., Brookline 46, Mass., has been named sales rep for the cathode-ray tube division of DuMont. They will cover jobbers throughout New England, including Maine, New Hampshire, Vermont, Rhode Island and Massachusetts.



Jack McKinney (right), one of Amphenol's reps, at Chicago's Lake Front Airport in his new Ryan Navion plane. Plane is piloted by associate, Bob Nesbitt.

G. E. ADVANCED TV SERVICE COURSE

An advanced course in television service, including lessons on set conversion, is now being offered by the G. E. tube department, Syracuse, N. Y.

Radio and TV Service Men can sign up for the course through their distributors. Graduates receive a sterling silver lapel pin and a thermoplastic plaque embossed with their name. Course emphasizes application of theoretical material presented in an earlier tube department course.

Subjects covered include methods of obtaining set conversion business, cost estimations on chassis and cabinet work, solutions of difficult chassis and cabinet problems, methods of increasing width and height of the picture, and ways to use the conversion business to step up new set sales. Only Service Men who have taken the first course are eligible to enroll in the advanced course. However, a Service Man may enroll in both courses at the same time through his distributor.

billings need boosting?

AUG SEPT OCT NOV DEC

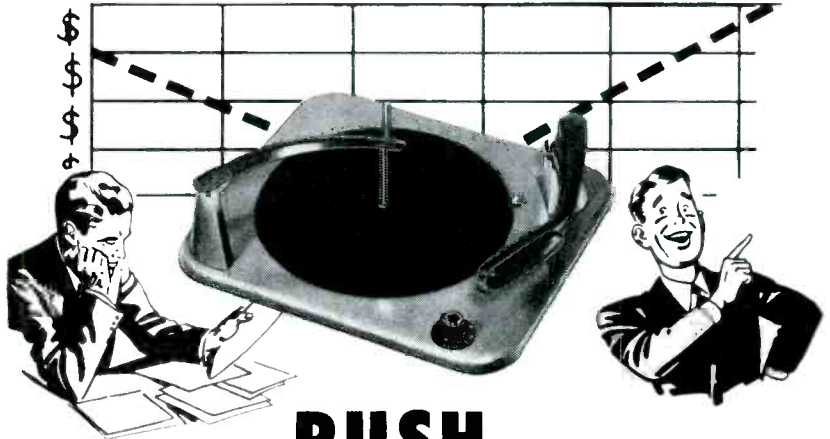

PUSH

V-M tri-o-matic® RECORD CHANGERS!

There's good money to be made, in selling and installing V-M tri-o-matic replacement changers — the ideal unit to replace obsolete one- and two-speed record changers.

- Original Equipment in Most Top-Brand Combinations
- Nationally Advertised
- Exclusive Features
- Easy Installation (precut mounting boards available)
- Minimum Mounting Space — 13 3/8" wide x 11 1/8" deep, over-all height 7 1/4".

For a demonstration and full details about the amazing V-M tri-o-matic, contact your V-M jobber



V-M Corporation BENTON HARBOR, MICH.

News Briefs

JAVEX, Garland, Texas, is distributing counter-window or wall sales display aids, displaying a 300-ohm wall plate with plug and twin-lead and high-voltage probes. . . . Copperweld Steel Co., Glassport, Pa., has purchased the outstanding stock of Flexo Wire Co., Inc., Oswego, N. Y. . . . Tung-Sol Lamp Works, Inc., has changed its name to Tung-Sol Electric, Inc. . . . V-M Corp., Benton Harbor, Mich., has been honored by the Blinded Veterans Association for its part in furthering employment opportunities for blind people. . . . Sherwood Forest, a 250-home

development now under construction in Euclid, Ohio, will feature the multiple built-in TV outlet system developed by Brach. . . . A second volume of *The Color Television Notebook*, containing technical information of color TV systems, receiver circuitry for the CBS-color system, details of the CBS-Columbia companion receiver and the Tele-Tone receiver, has been announced by the Paul H. Wendel Publishing Co., Inc., Indianapolis, Ind. . . . Earl Woods has been appointed national sales manager of TV-"Q" Custombilt Corp. . . . George Wedemeyer has been elected '52 president of NEDA.

**BRAND NEW
PROFIT MAKER**



**FOR
RADIO
SERVICE
MEN!**

Model AR-3
ElectroX Vibra-
tor Analyzer &
Power Supply

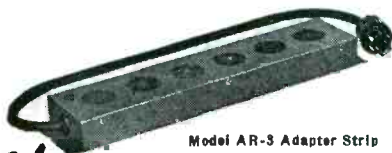

Model AR-3 Adapter Strip

**New ELECTROX
VIBRATOR ANALYZER
AND POWER SUPPLY**

Here's a new ElectroX test unit that's indispensable for shops servicing auto radios, 2-way mobile communication systems or other equipment using 6-volt vibrators.

TWO VALUABLE TEST UNITS IN ONE! This instrument combines an adjustable POWER SUPPLY that provides smooth, hum-free direct current in any voltage needed to test auto radios, with a VIBRATOR ANALYZER that thoroughly tests practically all synchronous and non-synchronous vibrators found in auto radios today!

TESTS OVER-ALL VIBRATOR PERFORMANCE! Vibrator Analyzer accurately determines shorted and otherwise defective vibrators and predicts vibrator failures before they occur. It measures starting voltage, current consumption, output voltage and indicates irregular operation. Subjects vibrator to voltage conditions normally encountered when connected to the electrical system of the car. Over-voltage is available for starting vibrators with oxidized contacts. A standard oscilloscope can be attached for wave form observation.

It's a top quality test instrument—a must for every service shop. It safeguards your auto radio repairs—increases your parts sales—steps-up your efficiency and earnings. **ORDER NOW FROM YOUR DISTRIBUTOR.**

Writer for Free Bulletin No. 1466, Giving Full Details

Rectifier Division
SCHAUER MANUFACTURING CORP.
2078 Reading Road • Cincinnati 2, Ohio

JFD 4- AND 5-BAY YAGI ARRAYS

The antenna division of the JFD Manufacturing Co., Inc., 6101 Sixteenth Ave., Brooklyn 4, N. Y., has announced 4 and 5-element yagi arrays for channels 7-13.

Double stacked arrays include low-loss jumper feeder systems. Design is said to provide gain up to 20 db over tuned dipoles. Has half-wave spacing which it is claimed not only affords increased signal resulting from the larger intercepting surfaces, but also takes advantage of gain increases resulting from in-phase interaction between bays.

Yagis are constructed of all-aluminum tubing and incorporate high impedance collector elements.

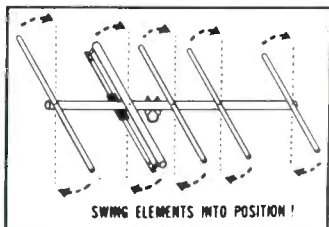
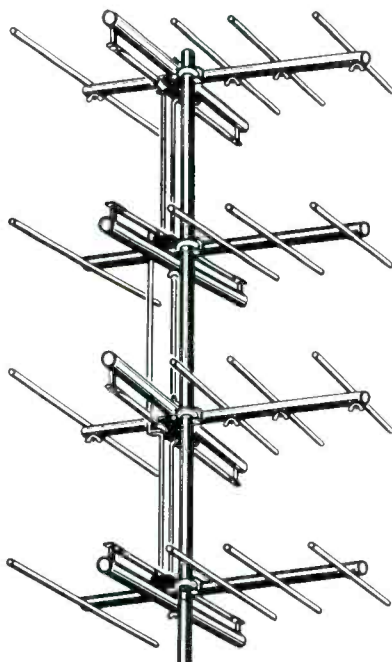

SWING ELEMENTS INTO POSITION!

**MOST
POWERFUL
combination for
SINGLE CHANNEL
RECEPTION**

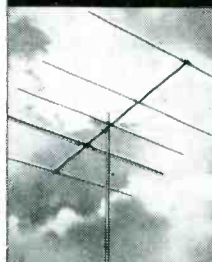

**VEE-DX
"JC" YAGI**



**VEE-DX
Outboard
BOOSTER.**



VEE-DX

THE LaPOINTE-PLASCOMOLD CORPORATION
Windsor Locks, Conn.

KENWOOD MOUNTING BRACKET

A parapet mounting bracket, model 106, for antenna masts up to 1½" in diameter, has been introduced by the Kenwood Engineering Co., Inc., Kenilworth, N. J.

Available for use on walls up to 13½" thick, the mount employs four claw-like members, with hardened cone-point set screws, which clear the coping and extend to the wall. A cam at each side of the frame is said to provide vertical support on tile or stone coping regardless of contour.

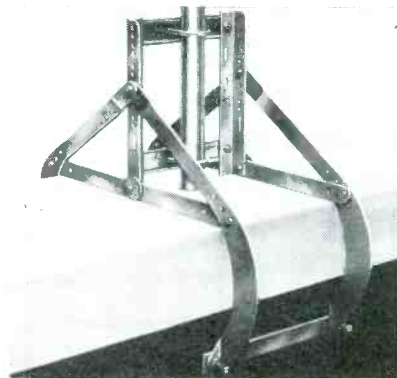

TELREX YAGIS

A series of 5-element yagi arrays that are individually cut for channels 2 through 13 (Y5x1-7 and Y5x2-7) has been produced by Telrex, Inc., Asbury Park, N. J. Antennas are said to achieve an impedance step-up ratio of 20:1 for standard 300-ohm lines.

Thousands sold . . . making possible a . . .
NEW LOW PRICE!
on the new **Tele-Tune** ★
TV BOOSTER ANTENNA



**4
QUICK-SELLING
FEATURES**

- Vastly improves reception of television sets.
- Rejects and reduces "Ghosts," Noise and "Snow."
- Provides additional pickup.
- Enhances any room with its rich appearance.

Greatly reduced price will give you a greater retail sales volume.

TERRITORIES STILL AVAILABLE FOR LIVE WIRE DISTRIBUTORS — WRITE!

CITY TOOL ACCESSORIES CORP. • 3831 W. Lake St. • Chicago 24

ELECTRO-STEEL PICTURE-TUBE RESTORER

A device, *Picboost*, that is said to restore worn-out picture tubes has been introduced by Electro-Steel Products, Inc., 641 Arch St., Philadelphia 6, Pa.

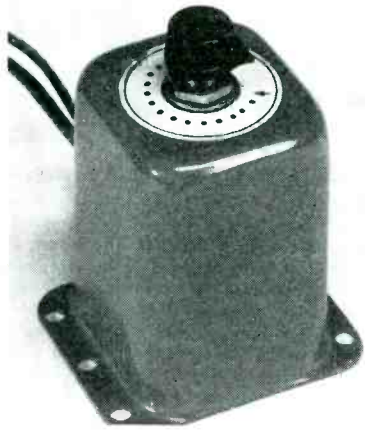

TECH-MASTER 24-INCH TUBE TV CHASSIS

Three custom built TV chassis, 2430, 2431P, and 2431C, for 24-inch picture tubes, have been announced by Tech-Master Products Co., 443 Broadway, New York City.

Model 2430 has been designed for picture tubes requiring from 65° to 70° horizontal deflection. Supplied with 5x7 pm speaker. Model 2431P is similar to 2430 but contains in addition push-pull audio and a phono input jack, and is supplied with a 12" pm speaker. Model 2431C is the same as 2430, but with a continuous tuner, push-pull audio, and phono-input jack, allowing for coverage of both TV and FM bands, and supplied with a 12" pm speaker.

All three models include an *afc* horizontal hold, employing sync discriminator transformer; three-stage sync amplifier, separator, and clipper circuit; and FM sound systems employing discriminator type audio detector. Also featured are noise saturation circuits; three-stage audio *if* system; four-stage, stagger-tuned video *if* system; adjacent channel traps; and direct coupling for use with keyed *agc* circuits.

HAYGREN TV INSTALLATION ACCESSORIES

TV installation accessories, featuring an aluminum impregnated-on-steel finish that is claimed to retard rust, have been introduced by Haygren Electronic Manufacturing, Inc., 436 18th St., Brooklyn 15, N. Y. Included are a universal foot mount, a peak, roof or corner mount, 3½" and 6" wall brackets, pipe mount, 18" adjustable wall mount, and a combination adjustable 18" and 3½" wall mount.

Featured in the line also are a chimney mount antenna base, Y-27, and stationary wall mounts, WM 12, in 12", 15", 18" and 24" sizes, which hold masts up to 1½" od.

Right: Haygren wall mounts.

SAVE HERE! TUBES VERY LOWEST PRICES Receiving-Transmitting-TV

RMA Guaranteed—Standard Brands

| | | | |
|------|-------|-------|--------|
| 0Z4 | \$.50 | 6K6 | \$.69 |
| 1A5 | .69 | 6K7 | .59 |
| 1A7 | 1.09 | 6L6 | \$1.79 |
| 1B3 | 1.19 | 6SA7 | .79 |
| 1R5 | .79 | 6SK7 | .69 |
| 1X2A | 1.19 | 6SN7 | 1.09 |
| 5U4 | .79 | 6S07 | .69 |
| 5V4 | 1.39 | 6T8 | 1.39 |
| 5Y3 | .49 | 6V6 | .89 |
| 6AB4 | .99 | 7C4 | .89 |
| 6AC7 | 1.29 | 7F8 | 1.59 |
| 6AG5 | 1.29 | 12AL5 | .89 |
| 6AH6 | 1.89 | 12AT7 | 1.29 |
| 6AK5 | 1.89 | 12AU7 | 1.19 |
| 6AK6 | 1.19 | 12AV7 | 1.29 |
| 6AL5 | .79 | 12AX7 | 1.19 |
| 6AQ5 | .69 | 12BA7 | 1.19 |
| 6AT6 | .69 | 12SA7 | .79 |
| 6AU6 | .79 | 12SK7 | .79 |
| 6AV6 | .69 | 12SQ7 | .69 |
| 6BA6 | .79 | 19BG6 | 2.89 |
| 6BC5 | .89 | 19T8 | 1.39 |
| 6BD6 | 1.09 | 25BQ6 | 1.29 |
| 6BG6 | 1.89 | 35/51 | .89 |
| 6BH6 | .89 | 35A5 | .98 |
| 6BJ6 | .89 | 35L6 | .89 |
| 6BN6 | 1.39 | 35W4 | .69 |
| 6BQ6 | 1.59 | 35Y4 | .98 |
| 6C4 | .79 | 35Z5 | .59 |
| 6CB6 | .89 | 39/44 | .49 |
| 6CD6 | 2.79 | 50A5 | 1.19 |
| 6H6 | .79 | 50B5 | .98 |
| 6J6 | 1.19 | 50L6 | .75 |

TV PICTURE TUBES

Full Year's Guarantee, Brand New, Black Face, Standard Brands, Sealed Cartons

| | | | |
|-------|---------|--------|---------|
| 10BP4 | \$22.95 | 17BP4 | \$24.95 |
| 12LP4 | 22.95 | 19AP4A | 29.95 |
| 14BP4 | 22.95 | 20CP4 | 33.95 |
| 16GP4 | 29.95 | 24AP4 | 69.95 |
| 16HP4 | 31.95 | | |

| Genuine Molded Condensers | | Electrolytic Condensers | |
|---|----------------|-------------------------|--------------|
| Fresh Stock—All Mineral Oil Filled 100% Centrifuge — Meets Jan. C91 Tests | | Ea. Lots of 10 | |
| ALL 600 VOLTS | | 20 x 20—150V. | \$.30 \$3.70 |
| Cap. | Per 10 Per 100 | 40 x 40—150V. | .45 4.30 |
| .001 | \$.79 \$6.90 | 50 x 30—150V. | .45 4.30 |
| .002 | .79 6.90 | 25—25V. | .19 1.50 |
| .005 | .79 6.90 | 20—250V. | .29 2.59 |
| .01 | .89 7.90 | 8—450V. | .39 3.69 |
| .02 | .99 8.90 | 10—450V. | .39 3.69 |
| .05 | 1.09 9.90 | 16—450V. | .59 5.69 |
| .1 | 1.25 11.50 | | |

All Guaranteed Fresh Stock!

ROSE CO. FEATURES FAMOUS PRECISE KITS

NO OTHER PROBE HAS THESE FEATURES! The most practical, foolproof and sturdy High Voltage Probe in the industry today! Check each of these amazing features—see why this value packed Probe is a must for every serviceman & engineer.

- ★ Multiple Insulation: 2 areas of air insulation, inside plastic insulation and an outside plastic insulation protects you against voltage breakdown.
- ★ Mechanically Shock-proof Construction: Double spring suspension system, stainless steel springs and fibre cushions to maintain vertical and horizontal shock resistant characteristics.
- ★ Interchangeable tips: An alligator clip plus the conventional probing type included.
- ★ Swivel Lead Connection: No snagging cable or high strains with special fixed slip-ring arrangement.
- ★ Interchangeable Resistors: For use with any V.T.V.M. or 20,000 ohms per V. meter.



- ★ Three Large Flash Guards: For added protection.
- ★ Sturdy, Non-Porous Shell Construction: For safety, long use and dependable service.

Shipping weight: 1 lb.
Model 999
(Wired only)
\$6.98
Complete

New Precise Vacuum Tube Voltmeter leaves nothing to the imagination—no guesswork. Every reading is true, accurate . . . Precise. Build it yourself easily—quickly and you'll have the most dependable and long-lasting instrument in your shop. Increase stability, get greater accuracy with the Precise reflex circuit. Get more dollar-for-dollar value!

Check, compare these unusual specs:

- ★ Ceramic, precision resistors —1% or better.
- ★ Special, separate 5 V. AC scale for accuracy on low voltages.
- ★ Frequency range: Up to 250 megacycles with PRECISE model 914 Probe.
- ★ Voltage range: Up to 30,000 V. with PRECISE Model 999 High Voltage Probe.
- ★ Burn-out proof circuit.
- ★ 25 Megohm input impedance on DC.
- ★ Complete with test leads & internal battery.
- ★ Special 3-color rapid construction—instruction books that explain each step being wired & the purpose of the circuit.
- ★ 10 lbs., 9½" x 6" x 5".



Complete!
Model 909-K
\$25.98
Factory Wired,
Model 909
\$44.98

FREE: Write for catalog . . . tubes, parts and accessories for radio and TV! Also special electronic instruments catalog. Minimum order: \$5.00. 25% deposit with order, balance C.O.D. Include postage with order. All merchandise subject to prior sales. F.O.B. New York, N. Y.

The ROSE Company
102-A PARK PLACE COrland 7-6195 NEW YORK 7, N. Y.

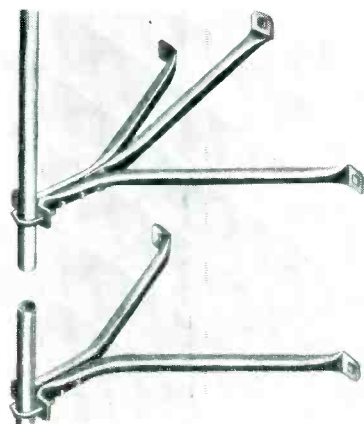

VEE-D-X FOUR-ELEMENT ANTENNA

A 4-element antenna, the JM-45, for dual channel 4 and 5 areas, has been announced by The LaPointe Plascomold Corp., Windsor Locks, Conn.

JFD 4-WAY ANTENNA SWITCH

A TV 4-way antenna switch, AS4, has been announced by the JFD Manufacturing Co., Inc., 6101 Sixteenth Ave., Brooklyn 4, N. Y..

Switch may be used with four antennas. A constant-impedance rotary type with silver-to-silver contacts, it is said to provide maximum energy transfer.

AMPERITE

Studio Microphones
at P.A. Prices

Ideal for
BROADCASTING
RECORDING
PUBLIC ADDRESS

"The ultimate in microphone quality," says Evan Rushing, sound engineer of the Hotel New Yorker.

• Shout right into the new Amperite Microphone—or stand 2 feet away—reproduction is always perfect.

• Not affected by any climatic conditions.

• Guaranteed to withstand severe "knocking around."



Models
RBLG—200 ohms
RBHG—Hi-imp.
List \$42.00



"Kontak" Mikes
Model SKH, list \$12.00
Model KKH, list \$18.00

Special Offer: Write for Special Introductory Offer, and 4-page illustrated folder

AMPERITE Company, Inc.

561 BROADWAY • NEW YORK 12, N. Y.

Canada: Atlas Radio Corp., Ltd., 560 King St. W., Toronto

SHOOT TV TROUBLE FAST!

With H. G. CISIN'S
Copyrighted Rapid

"TV TROUBLE SHOOTING METHOD"

EARN more money! Locate television troubles by this *quick*, entirely *new* method. Rapid checks enable you to locate all faults in record breaking time regardless of make or model! 160 Picture, Raster, Sound trouble symptoms. Over 100 Rapid Checks including over-all alignment checks, 26 illustrations; simplified step-by-step directions!

H. G. CISIN, well-known to radio men as a recognized electronic engineer, inventor, technical author and educator, has trained thousands of television technicians, many of them now owning their own prosperous TV service organizations. The results of his years of experience are embodied in this remarkable **TV TROUBLE SHOOTING METHOD**.

HERE'S PROOF! J. B. Seiler, Chicago, writes: "Rush another copy. Am tickled to death with results. Your book hasn't failed me yet." G. E. Hirsch, Jamaica, N. Y.: "Congratulations! Your book extremely under-priced. Very ingenious in its logical use of cause and effect, should be in every TV tool kit."

INCREASE your earning power with the most valuable aid to TV servicing ever written!
Guaranteed, Money Back in 5 Days If Not Satisfied!

Send Your Name & Address Today. \$1 POSTPAID . . .

RUSH COUPON NOW!

H. G. CISIN, CONSULTING ENGINEER
Dept. S-6, 200 Clinton St., Bklyn. 2, N. Y.

Enclosed is \$_____ for which please rush _____ copies (postpaid) of your **TV TROUBLE SHOOTING METHOD**.

Name _____

Address _____

City _____ Zone _____ State _____

Music

(Continued from page 28)

ing the second week, dropped from an average of 45% to 43.66%. This was attributed to the letdown believed to be experienced by the workers who had to return to their work without music. Beginning with the third week, music was played for ½ hour at 11:00 in the morning and at 3:00 in the afternoon. There was an immediate improvement which leveled off and continued in the fourth week. Scheduling was changed in the fifth week to 2½ hour periods during the forenoon and afternoon. Reaction to this was slight. However, subsequent attention to program material and selection preference, indicated by the workers, boosted the production average to 51.8%. In terms of manpower, it was found that production increased on an already proficient line for the equivalent of six extra workers for each 100 employed!

Music and Safety

Does music help maintain safety? Many have found that it does. In an experiment conducted by the Safety Section of Frankford Arsenal, Philadelphia, although introduction of music increased production, at the same time it decreased accidents substantially; in one shop by as much as 35%. This



INDIANA'S

E-ZEE-ON
ION TRAPS

Easy To Install — Easy To Adjust

Here's an ion trap that fits any picture tube neck and can be installed and adjusted in a jiffy *with just one hand*.

It's **INDIANA'S E-ZEE-ON Ion Trap**—a compact, efficient ion trap made of one piece of permanently magnetized Cunife. **E-ZEE-ON** does a better job too because it provides an even magnetic field pattern that results in brighter, more uniform picture definition. It's just the beam-bender for conversion jobs, working efficiently on large and small tubes.

Look for the colorful **E-ZEE-ON** display carton on your jobber's counter. Try an **E-ZEE-ON Ion Trap** on your next job—you'll save time, please your customer, and be amazed at its efficiency.

Write for illustrated folder describing the **E-ZEE-ON Ion Trap**.



THE INDIANA STEEL PRODUCTS CO.
VALPARAISO, INDIANA
Specialists in Packaged Energy Since 1908

is really not difficult to understand when one considers that monotony and fatigue are both alleviated, as already shown, and these are precisely the

| Time | Purpose | Sample Selections |
|----------------------|---|---|
| 8:30-8:45 | Wake up . . . set pace | Marching Along Together Beer Barrel Polka Stein Song Washington Post March Riders in the Sky |
| 9:15-9:30 | Prefatigue . . . ward off that settled, in the rut feeling | Look for the Silver Lining I'll Follow My Secret Heart Perfidia Two Guitars Skater's Waltz |
| *10:40-11:15 . . . | Fatigue . . . overcome boredom, stimulate senses and interest | Merry Widow Waltz Cielito Linda Chattanooga Choo Choo La Comparsita Mimi Whistler and His Dog Chinatown |
| 12:00-1:00 | Lunch . . . aid digestion, maintain good frame of mind | Afternoon of a Faun Kalua Skies I Didn't Know What Time It Was A Pretty Girl Is Like a Melody Blue Danube Zing Zing, Boom Boom |

Typical programming.

IT'S SENSATIONAL!

**CLEARBEAM'S
NEW ALL-CHANNEL
RHOMBIC**

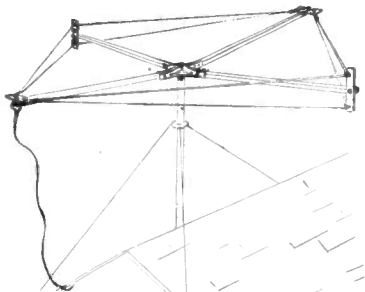

**Electronically Engineered for
LONG DISTANCE
(DX) RECEPTION
and unusually
SHARP DIRECTIVITY
Over the Entire TV Spectrum**

Clear Beam

TV ANTENNAS & ACCESSORIES
100 Prospect Ave., Burbank, Calif.
ROckwell 9-2141 • CHarleston 0-4886

factors that encourage carelessness and cause accidents.

Music Versus Bonus

If you want to keep the cooperation of workers in a plant where you pro-

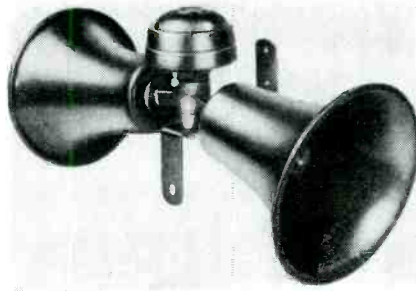

Two-way paging speaker* with a power of 25 watts and frequency of 400 to 6,000 cps.

pose to do an installation, it might be wise not to stress this point, except in the boss' private chambers. A New York mailing-service firm treated its several hundred employees to *wired music* and offered a bonus as well, as incentive to complete a particularly important rush job on time. Well, production rose 29%; but, when the job was completed and the bonus withdrawn, a production increase of 7 to 10% over the original output resulted as the music service was maintained.

System-Selling Aid

Appraising this example purely on the facts presented, while a salary bonus incentive can be said to have certain inalienable benefits to worker and employer alike, it would seem that a music system could conceivably be sold on the basis of paying for itself to some degree out of a portion of a bonus which may be contemplated.

*University 2W25.

[To Be Continued]

| Time | Purpose | Sample Selections |
|------------|---|--|
| 2:15-2:45 | Prefatigue . . . combat drowsiness | Hello, Frisco, Hello Sweet Sue Green Eyes Night and Day Say Si Bon In the Mood Carioca |
| *3:40-4:15 | Fatigue . . . beat boredom, stimulate interest so as to make time pass and overcome clockwatching | California Here I Come Careless Some Enchanted Evening Hawaiian War Chant Come On 'a My House My Bonnie Lies Over the Ocean This Is the Army Mr. Jones |
| 5:10-5:30 | Closing . . . stimulate mind and body to combat weariness at home | There's Gonna Be a Great Day Country Fair Robert E. Lee Victory Polka Mexican Hat Dance Happy-Go-Lucky March (Sousa) |

*These periods presume rest periods have preceded, thereby sending employees back to their work with music, as subtle consolation.

Typical programming.

NEW a "must" book for every TV Service Technician

"Servicing TV in the Customer's Home"

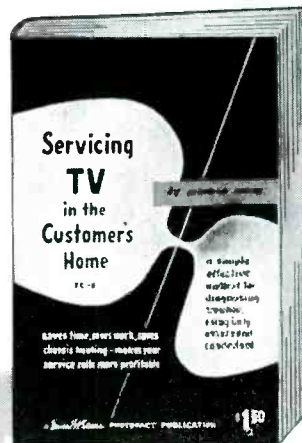

**SAVES TIME
SAVES WORK
Earns More for You on Outside Service Calls**

shows how to diagnose trouble using capacitor probe and VTVM

Here's the book you've been asking for—practical, proved help to make your outside TV servicing really effective and profitable. Saves time, work and chassis hauling . . . shows you how to make successful repairs on the spot. You learn the following: 1. A simple, effective method for tracing down trouble, using your VTVM and a simple capacitor probe. 2. Methods for finding your way around a strange circuit—shows you how to "pull tubes" and diagnose trouble by observing audio and picture effects. 3. How to judge TV set performance by analysis of the test pattern. 4. Methods for making adjustments in the field. You'll want this essential, profit-building book. Handy pocket size; sturdy cover. **\$1.50**

ORDER TC-1. Only . . . Pays for itself on the very first job.

HOWARD W. SAMS & CO., INC.

Order from your Parts Jobber, or write direct to **ORDER TODAY**
HOWARD W. SAMS & CO.,
2201 E. 46th St., Indianapolis 5, Ind.

Send . . . copy(ies) of "SERVICING TV IN THE CUSTOMER'S HOME," \$1.50 per copy.
(Check) (money order) for \$. . . enclosed

Name
Address
City State

EXTRA!

ATR

"A" BATTERY ELIMINATORS

Makes it easy to DEMONSTRATE AND TEST D.C. APPARATUS FROM A.C. LINES

for DEMONSTRATING AND TESTING AUTO RADIOS

New Models . . . Designed for testing D. C. Electrical Apparatus on Regular A. C. Lines. Equipped with Full-Wave Dry Disc Type Rectifier, Assuring Noise-less, Interference-Free Operation and Extreme Long Life and Reliability.

NEW MODELS **NEW DESIGNS**
NEW LITERATURE

"A" Battery Eliminator, DC-AC Inverters
Auto Radio Vibrators

ATR See your jobber or write factory

AMERICAN TELEVISION & RADIO CO.
Quality Products Since 1931
SAINT PAUL 1, MINNESOTA—U.S.A.

JOTS AND FLASHES

INSTALLATION CERTIFICATION by association groups has become quite a vogue in the middle west. In Rockford, Ill., for instance, there has been formed the Rockford Certified TV Installation and Service Association, Inc., to establish, promote and maintain a code of ethics among radio and TV dealers and Service Men, which will guarantee every installation. Members of the group have pledged to uphold a six-point program, declaring that all the work will be only by competent and qualified Service Men, only the best approved materials will be used, all safety regulations and building codes will be adhered to, ample protection against lightning damage will be provided, TV owners' personal property will be protected by insurance and every precaution will be made to make all installations safe electrically and mechanically. Further details on this and other similar programs appear on page 18 of this issue.

Robert Hertzberg, 2512-84th St.,

Jackson Heights 70, N. Y., has established a consulting publications and public relations service for radio manufacturing and merchandising firms and associated advertising agencies. . . . Masco Electronic Sales Corp. will henceforth handle the sale of equipment made by Mark Simpson. . . . Henry J. Arbeiter has been appointed vice president and Daniel J. McCarthy has been named assistant secretary-treasurer of Jerrold Electronics Corp. . . . The *Telrex Service News* is now in its second year of publication. Distributed free by direct mail or through local distributors, the magazine carries installation hints, tek-talks, reception problems, and new product news. . . . Dan Kamrow, formerly of *Domestic Engineering*, has been appointed to the advertising and sales department of Permoflux Corp. . . . Newark Electrical Co., 323 West Madison St., Chicago, Ill., has acquired a lease on a five-story building at 223-225 West Madison St., which they plan to occupy after the first of the year.

ADVERTISERS IN SERVICE—OCTOBER, 1951

| | | | |
|---|-------------------|---|--------------------|
| ALLIANCE MFG. CO. | 16 | MERIT TRANSFORMER CORP. | 31 |
| Agency: Foster & Dunham, Inc. | | Agency: Burton Browne, Advertising | |
| AMERICAN ELECTRICAL HEATER CO. | 63 | MOSLEY ELECTRONICS | 54 |
| Agency: Dudgeon, Taylor & Bruske, Inc. | | Agency: Rudolph Bartz, Advertising | |
| AMERICAN PHENOLIC CORP. | 32 | MUELLER ELECTRIC CO. | 58 |
| Agency: Burton Browne, Advertising | | NATIONAL VIDEO CORP. | 8 |
| AMERICAN TELEVISION & RADIO CO. | 80 | Agency: A. Martin Rothbardt, Inc. | |
| Agency: Firestone-Goodman Adv. Agency | | OHNITE MFG. CO. | 55 |
| AMPERITE CO. | 78 | Agency: The Penholt Co. | |
| Agency: H. J. Gold Co. | | OXFORD ELECTRIC CORP. | 59 |
| ANCHOR RADIO CORP. | 19 | Agency: Sandler Rodkin Adv. Agency | |
| Agency: Symonds, MacKenzie & Co. | | PERFECTION ELECTRIC CO. | 66 |
| ASTRON CORPORATION | 60 | Agency: Scantlin Co. | |
| Agency: Hart Lehman, Advertising | | PERMO, INC. | 41 |
| ATLAS SOUND CORP. | 64 | Agency: Wm. Hoffman & Associates | |
| Agency: H. W. Hauptman Co. | | PRECISION APPARATUS CO., INC. | 12 |
| Agency: MacManus, John & Adams, Inc. | | Agency: Shappe-Wilkes, Inc. | |
| BLONDER-TONGUE LABS. | 69 | RADIART CORP. | Inside Front Cover |
| Agency: Lester Harrison, Inc. | | Agency: Stern and Warren | |
| BRACH MFG. CORP. | 66 | FAD-EL-CO. MFG. CO. | 61 |
| Agency: Conti Adv. Agency, Inc. | | Agency: Lehman Wood | |
| CIRCLE-X ANTENNA CORP. | 69 | RADIO CORPORATION OF AMERICA | 11, 35, Back Cover |
| Agency: Homer Harding | | Agency: J. Walter Thompson Co. | |
| H. G. CISIN | 78 | RADIO RECEPTOR CO. | 74 |
| Agency: A. D. Adams, Advertising | | Agency: Walter J. Zimmerman & Associates | |
| CITY TOOL ACCESSORIES CORP. | 76 | THE RADIX WIRE CO. | 45 |
| Agency: Wesley E. Sharer & Associates | | Agency: Stern and Warren | |
| CLEAR BEAM TV ANTENNAS | 52 | RAULAND CORP. | 25 |
| Agency: James Housie Co. | | Agency: MacFarland, Aveyard & Co. | |
| CLEVELAND ELECTRONICS, INC. | 59 | RAYTHEON MFG. CO.—RECEIVING TUBE DIV. | 14 |
| Agency: The White Adv. Co. | | Agency: Walter B. Snow & Staff | |
| CREST LABORATORIES, INC. | 60 | REGENCY DIV. D.E.A., INC. | 7 |
| Agency: Miller Adv. Agency | | Agency: Burton Browne, Advertising | |
| ALLEN B. DU MONT LABORATORIES, INC. | 5 | JOHN F. RIDER PUBLISHER, INC. | 67 |
| Agency: Austin C. Lescarboursa & Staff | | Agency: Conti Adv. Agency, Inc. | |
| ELECTRO PRODUCTS LABORATORIES, INC. | 69 | THE ROSE CO. | 77 |
| Agency: Clarence M. Gotsch Associates | | Agency: A. D. Adams, Advertising | |
| ELECTRONIC INSTRUMENT CO., INC. | 72 | HOWARD W. SAMS AND COMPANY, INC. | 58, 79 |
| Agency: H. W. Hauptman Co. | | Agency: George Brodsky, Advertising | |
| ELECTRO-VOICE, INC. | 65 | SANGAMO ELECTRIC CO. | 6 |
| Agency: Henry H. Teplitz, Advertising | | Agency: Arthur R. Morge, Inc. | |
| GENERAL ELECTRIC | 1 | SCHAUER MFG. CORP. | 76 |
| Agency: Maxon, Inc. | | Agency: The Keeler & Sutes Co. | |
| GENERAL ELECTRIC LAMP DEPT. | 73 | SIMPSON ELECTRIC CO. | 9 |
| Agency: Batten, Barton, Durstine & Osborne, Inc. | | Agency: Burton Browne, Advertising | |
| GRAYHILL | 74 | SNYDER MFG. CO. | 28 |
| Agency: Merchandising Advertisers, Inc. | | Agency: Brooks and London | |
| GREYLOCK ELECTRONIC SUPPLY CO. | 70 | SPRAGUE PRODUCTS CO. | 51 |
| THE HEATH CO. | 47 | Agency: The Harry P. Bridge Co. | |
| Agency: G. Dean Arend, Advertising | | STANDARD TRANSFORMER CORP. | 71 |
| HYTRON RADIO & ELECTRONICS CO. A DIV. OF COLUMBIA BROADCASTING SYSTEM, INC. | 23 | Agency: Burnet-Kuhn Adv. Co. | |
| Agency: Bennett, Walther & Menadier, Inc. | | SUPREME RADIO & TELEVISION CO. | 72 |
| ILLINOIS CONDENSER CO. | 62 | SYLVANIA ELECTRIC PRODUCTS, INC. | 3 |
| Agency: Rudolph Bartz, Advertising | | Agency: Cecil & Freshley, Inc. | |
| INDIANA STEEL PRODUCTS CO. | 78 | TECHNICAL APPLIANCE CORP. | 10 |
| Agency: Rudolph Bartz, Advertising | | Agency: Austin C. Lescarboursa & Staff | |
| IFD MFG. CO., INC. | 70 | TELERON CO. | 66 |
| Agency: Shappe-Wilkes, Inc. | | Agency: Eloise Galinger | |
| JENSEN MFG. CO. | 2 | TUNG-SOL ELECTRIC, INC. | 43 |
| Agency: Burton Browne, Advertising | | Agency: E. M. Freytag Associates, Inc. | |
| KESTER SOLDER CO. | 39 | UNITED CATALOG PUBLISHERS | 64 |
| Agency: Paul J. Steffen Co. | | Agency: Burton Browne, Adv. | |
| KRYLON, INC. | 56 | UNIVERSITY LOUDSPEAKERS, INC. | 70 |
| Agency: Gray & Rogers | | Agency: George Homer Martin Associates | |
| THE LA POINTE-PLASCOMOLD CORP. (VEE-D-X) | 76 | V-M CORPORATION | 75 |
| Agency: The F. W. Prellie Co. | | Agency: Sales & Adv. Counsel | |
| LOUIS BROTHERS | 13 | VIDAIRE ELECTRONIC MFG. CO. | 62 |
| Agency: The Mayers Co., Inc. | | WARD PRODUCTS CO. | 4 |
| P. R. MALLORY & CO., INC. | Inside Back Cover | Agency: The Hubbell Adv. Agency | |
| Agency: The Atkin-Kynett Co. | | WEBSTER ELECTRIC | 57 |
| | | Agency: Hamilton Adv. Agency, Inc. | |
| | | U. S. TREASURY DEPT. | 48 |
| | | THE WORKSHOP ASSOCIATES, INC. | 53 |
| | | Agency: Larrom Randall, Advertising | |



You wouldn't want a car that drives only in circles!

Of course not. What you want is a car that will go where you want it to go. And so it is with volume controls, too... a survey of hundreds of servicemen revealed the importance you place on adaptability to the job at hand. Naturally, you want a control that is easily tailored to *any* job.

Make Sure! Make it Mallory!

Using the Mallory Midgetrol* helps you make sure that the installation is exactly as you want it... easier for you and insuring complete customer satisfaction.

There are three big reasons why the Midgetrol $1\frac{5}{16}$ " control does a better job... because the *permanently fixed tubular brass shaft* can be adapted for any popular knob in a few seconds... because AC switch attachment is simple and positive... because the precision-controlled carbon element gives

smoother taper, quieter operation, more accurate resistance value and less drift in TV sets.

These same advantages are available in the Dual Concentric Midgetrol, tailor-made on the job to match each specific requirement. It is assembled in five easy steps, in less than five minutes, using complete, *factory-inspected* control sections. You can make over 10,000 different combinations from sub-assemblies available in distributor stocks.

Make it Mallory and make sure! Ask your distributor to show you the Mallory Midgetrol... with the features that make installation faster and surer than ever.

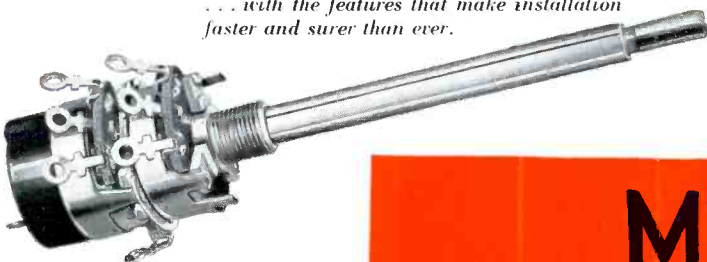

Complete Dual Concentric Midgetrol illustrated. Single section control available in complete line of resistance values.

P. R. MALLORY & CO., Inc.
MALLORY

CAPACITORS • CONTROLS • VIBRATORS • SWITCHES • RESISTORS
• RECTIFIERS • VIBRAPACK* POWER SUPPLIES • FILTERS

*Reg. U.S. Pat. Off.

APPROVED PRECISION PRODUCTS

P. R. MALLORY & CO., Inc., INDIANAPOLIS 6, INDIANA

Now! Stake out your claim for the Giant RCA "TREASURE CHEST"

... to help you do a better job in less time and
in the "professional" manner that inspires respect

You get all these valuable servicing aids for
only **10 RCA golden "TREASURE TOKENS"**



- ✓ Handsome, sturdy Tube and Tool Carrying Case ... holds over 100 tubes to meet every normal service call.
- ✓ Big 48" Red-and-White Drop Cloth ... a magic carpet to "customer confidence."
- ✓ Handy 6-Piece Ratchet-type Screwdriver Kit ... all the sizes you need for everyday service work.
- ✓ New Improved RCA Tube Movement and Inventory Guide ... a yearly record of your business.
- ✓ New "RCA Kinescopes" Booklet ... complete conversion, interchangeability and characteristics data.
- ✓ 5 Leatherette TV Program Holders ... ideal souvenir gifts for your service calls.
- ✓ Plus an extra dividend of the 24-page bulletin "Receiving Tubes for AM, FM, and Television Broadcast"—Form 1275-E—together with latest tube price lists.

Here's all you do

With every purchase of an RCA kinescope, of any type, you will receive a golden RCA "Treasure Token." Save these coins on the key chain provided. When you have collected 10 coins, present them to the RCA Tube Distributor from whom you obtained them, and receive, *without cost*, the complete RCA "Treasure Chest" of outstanding service aids.

The RCA "Treasure Chest" is *not for sale*. You can earn it *only* by presenting 10 RCA "Treasure Tokens" to your regular RCA Tube Distributor.

Start prospecting for your golden coins right *now!* This offer expires on November 16, 1951. Your RCA Tube Distributor has a sample RCA "Treasure Chest" for your inspection. See him today!

Extra Bonus!

With every 2 RCA kinescopes you buy, you will receive, along with your "Treasure Tokens," a bonus copy of a new book, "TV Servicing" ... a compilation of the famous "Radio Service News" articles, together with brand-new material by RCA Television Specialists.



RADIO CORPORATION of AMERICA
ELECTRON TUBES HARRISON, N. J.