

SERVICE

March
1948

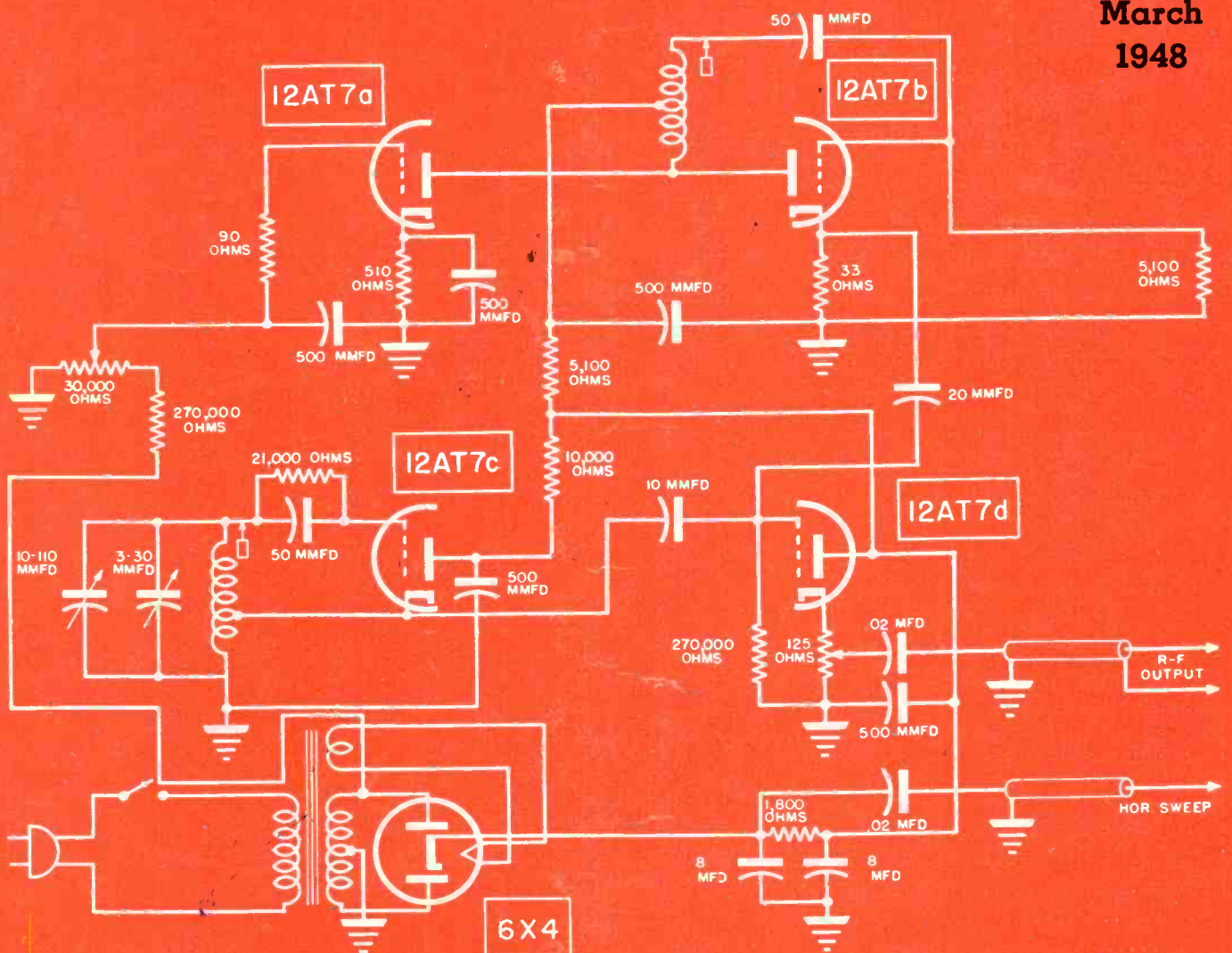

Sweep signal generator for f-m and tv with two r-f oscillators, mixer, horizontal sync circuit and 60-cps frequency-controlled reactance modulator.

[See page 2]

save 1,000 service hours
with this complete, up-to-date

c-d capacitor manual

For Radio Servicing

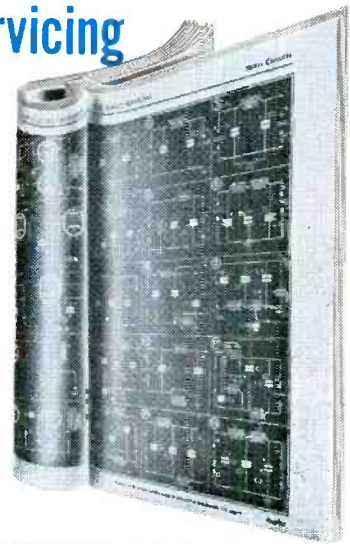

4th Edition by popular request!
OVER 400 PAGES!

Pocket Size—Accurate Parts Tables—Easy Circuit Diagrams

Why hunt and peck for the right capacitor replacement? This complete manual shows you the correct unit at a glance. Simplified tables and diagrams help you service any new or old radio set *faster, easier, more profitably*. You can save 1,000 hours or more in service time. Call your Cornell-Dubilier jobber now or mail coupon for your copy. List price \$1.00. Cornell-Dubilier Electric Corporation, Dept. S3, South Plainfield, N. J. Other Plants in New Bedford, Worcester, and Brookline, Mass., and Providence, R. I.

FOR RADIO SERVICING

Manufacturer and Model No.	C.D. Type and Size	CAPACITY μFD					VOLTAGE					Temp. Coe.	Subst. No.	Min. Dia.	Max. Dia.	
		C1	C2	C3	C4	C5	C1	C2	C3	C4	C5					
ALLIED RADIO CORP. 81000	81000	10	10	10	10	10	50	50	50	50	50	50	1	1	1/8	1/4
81000-10000	81000	10	10	10	10	10	50	50	50	50	50	50	1	1	1/8	1/4
81000-20000	81000	10	10	10	10	10	50	50	50	50	50	50	1	1	1/8	1/4
81000-30000	81000	10	10	10	10	10	50	50	50	50	50	50	1	1	1/8	1/4
81000-40000	81000	10	10	10	10	10	50	50	50	50	50	50	1	1	1/8	1/4
81000-50000	81000	10	10	10	10	10	50	50	50	50	50	50	1	1	1/8	1/4
81000-60000	81000	10	10	10	10	10	50	50	50	50	50	50	1	1	1/8	1/4
81000-70000	81000	10	10	10	10	10	50	50	50	50	50	50	1	1	1/8	1/4
81000-80000	81000	10	10	10	10	10	50	50	50	50	50	50	1	1	1/8	1/4
81000-90000	81000	10	10	10	10	10	50	50	50	50	50	50	1	1	1/8	1/4

CORNELL-DUBILIER • WORLD'S LARGEST MANUFACTURER OF CAPACITORS

FILL IN — MAIL COUPON TODAY!

Cornell-Dubilier Electric Corp., Dept. S3
South Plainfield, New Jersey

Please rush my copy of the new C-D Capacitor Manual for Radio Servicing. I am enclosing \$1.00 money order () check () stamps ()

my jobber is.....
Name.....
Shop.....
Address.....
City..... Zone..... State.....



1910



1948

mica
dykanol
paper
electrolytic

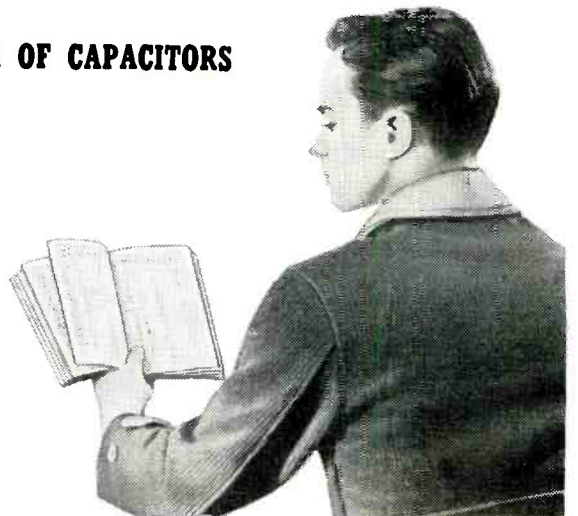

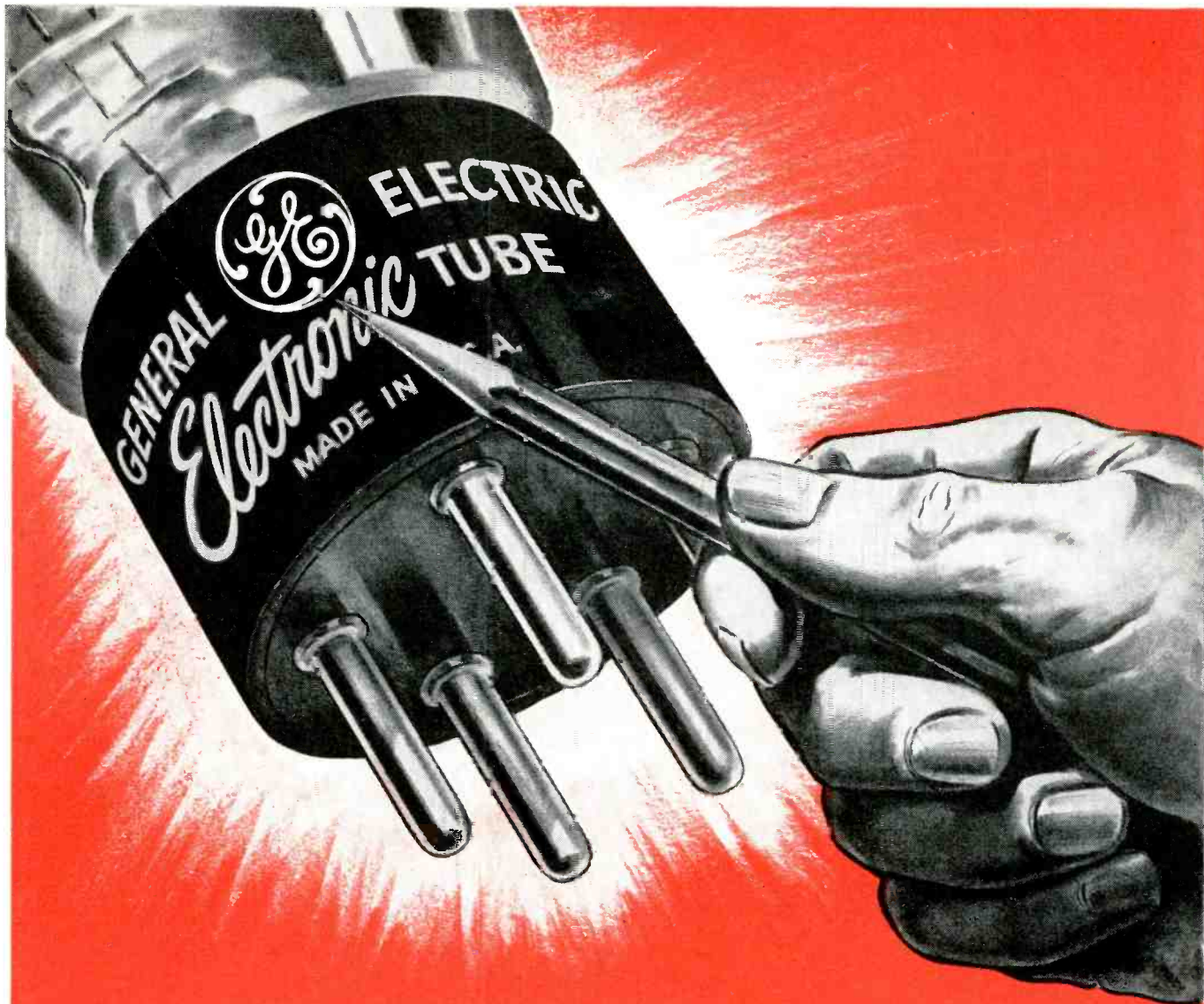

No other name means so much!



GENERAL  ELECTRIC

176-GA3-8880

FIRST AND GREATEST NAME IN ELECTRONICS

RADIO • TELEVISION • ELECTRONIC
SERVICE

LEWIS WINNER
Editorial Director

F. WALEN
Assistant Editor

ALFRED G. GHIRARDI
Advisory Editor

	Page
Association News	28
Conversion Efficiency of Loudspeakers. By E. M. Edwards	24
Curbing TV Receiver Proximity Interference. By Ira Kamen	20
F-M/TV Sweep Signal Generator (Cover)	48
'Scope Wave Patterns. By Alvin A. Baer	22
Ser-Cuits (TV Receivers)	32
Servicing Helps. By P. M. Randolph	26
Ten Years Ago in Associations	28
Tips on Soldering. By R. W. Kise	38
Tube News (TV Tubes). By L. E. Stewart	30
TV Antenna-Receiver Installation Methods. By Edward M. Noll	18
Views and News. By Lewis Winner	17
 CIRCUITS	
Belmont 21A21	34
G.E. 901/910	36
Motorola VT-71	32
Silver 909 (Cover)	48
Stagger-Tuned 6AG5 Video I-F Amplifier	30
Stagger-Tuned 6AU6 Video I-F Amplifier	31
 COVER	
F-M/TV Sweep-Signal Generator (Silver 909)	48
 SERVICING HELPS	
Converting F-M Dipole for TV Use	26
F-M/TV Dipole Antenna-Length Chart	26
Installing Crystal Filter in Hallicrafters S-40	26
 Index to Advertisers	 60
 Manufacturers	
News	58
New Products	49
Jots and Flashes	60

Entire contents Copyright 1948, Bryan Davis Publishing Co., Inc.



Published monthly by Bryan Davis Publishing Co., Inc.
52 Vanderbilt Avenue, New York 17, N. Y. Telephone MURray Hill 4-0170



Bryan S. Davis, President Paul S. Weil, Vice Pres.-Gen. Mgr. F. Walen, Secretary A. Goebel, Circulation Manager

Cleveland Representative: James C. Munn, 2253 Delaware Dr., Cleveland 6, Ohio. Telephone: ERIEview 1726

Pacific Coast Representative: Brand & Brand, 1052 W. Sixth St., Los Angeles 14, Calif. Telephone Michigan 1732
315 Montgomery St., San Francisco 4, Calif. Telephone Douglas 4475

Entered as second-class matter June 14, 1932, at the Post Office at New York, N. Y., under the Act of March 3, 1879. Subscription price: \$2.00 per year in the United States of America and Canada; 25 cents per copy. \$3.00 per year in foreign countries; 35 cents per copy.

HOWARD W. SAMS WINS "OSCAR" FOR AID TO RADIO SERVICE INDUSTRY!



The handsome plaque awarded to Howard W. Sams carries the inscription: "The Federation of Radio Servicemen's Associations of Pennsylvania Award to Howard W. Sams in Recognition of His Outstanding Efforts in Behalf of the Radio Service Industry, 1947." The award is a tribute to the practical usefulness of PHOTOFACT Publications—the world's finest radio service data—in-dispensable to the Radio Serviceman.

PHOTOFACT Publications Cited as Outstanding Effort in Behalf of Servicemen

"For Outstanding Efforts in Behalf of the Radio Service Industry"—reads the citation of the first annual award bestowed on Howard W. Sams by the Federation of Radio Servicemen's Associations of Pennsylvania. The "Oscar" was presented before a group of over 600 persons, including many radio industry leaders, at a banquet held on January 12, 1948, at Philadelphia's Bellevue-Stratford Hotel. The surprise ceremony was arranged as a demonstration of appreciation for the significant, practical aid made available to Radio Servicemen in PHOTOFACT Publications, and for the efforts of the SAMS' organization in behalf of the Radio Service Industry. This spontaneous demonstration marks a milestone in the Radio Service field. It is a healthy sign of growing recognition of the Serviceman's importance to the Radio Industry.



These Are the Award-Winning Service Aids that Earn More Money for You!



Own PHOTOFACT Volumes 1, 2 and 3—world's most complete, accurate, practical radio service data manuals. Here is everything you need for faster, easier, more profitable servicing—bound in easy-to-use volumes. Exclusive Standard Notation Schematics; photo views keyed to complete replacement parts lists; exhaustive electrical and mechanical analysis of every set covered. Brings you right up to January 1948! Have the exclusive advantages that are now earning bigger profits for thousands of servicemen!

Vol. 1. All post-war models up to Jan. 1, 1947.
Vol. 2. Models from Jan. 1, 1947 to July 1, 1947.
Vol. 3. Models from July 1, 1947 to Jan. 1, 1948.

YOUR PRICE, EACH VOLUME, IN EASY-TO-USE DELUXE BINDER . . . \$18³⁹



Radio Receiver Tube Placement Guide

Shows you exactly where to replace each tube in 5500 radio models, covering 1938 to 1947 receivers. Each tube layout is illustrated by a clear, accurate diagram. Saves time—eliminates risky hit-and-miss methods. You'll use this handy

pocket-sized book every single day. 192 pages, completely indexed. Order several copies now. **ONLY . . . \$1²⁵**



Dial Cord Stringing Guide

The book that shows you the *one right* way to string a dial cord. Here, for the first time, in one handy pocket-sized book, are all available dial cord diagrams covering over 2300 receivers, 1938 through

1946. Makes dial cord restringing jobs quick and simple. A "must" for every service bench and tool kit. Order your copies now. **ONLY . . . 75c**

1947 Automatic Record Changer Manual

Nothing like it! Complete, accurate data on over 40 post-war models. Exclusive exploded views, photos from all angles. Gives full change cycle data, information on adjustments, service hints and kinks, complete parts lists. PLUS—for the first time—complete data on leading WIRE, RIBBON, TAPE and PAPER, DISC RECORDERS! 400 pages; hard cover; opens flat. Order now! **ONLY . . . \$4⁹⁵**



BOOST YOUR EARNING POWER!

Mail This Order Form

to HOWARD W. SAMS & CO., INC.
2924 E. Washington St., Indianapolis 6, Indiana.

My (check) (money order) for \$ enclosed.

- Send SAMS' TUBE PLACEMENT GUIDE(S) at \$1.25 per copy.
- Send PHOTOFACT Volume 3 (including Sets Nos. 21 through 30) in DeLuxe Binder, \$18.39.
- Send Volume 2. Send Volume 1 (\$18.39 each).
- Send SAMS' 1947 AUTOMATIC RECORD CHANGER MANUAL(S) at \$4.95 each.
- Send SAMS' DIAL CORD STRINGING GUIDE(S) at \$0.75 per copy.

Name

Address

City State

HOWARD W. SAMS & CO., INC.
INDIANAPOLIS 6, INDIANA

Export—Ad. Auriema—89 Broad St., New York 4, N. Y.—U. S. of America
Canada—A. C. Simmonds & Sons, 301 King St., East—Toronto, Ontario

PHOTOFACT SERVICE

"The Service that pays for itself over and over again"

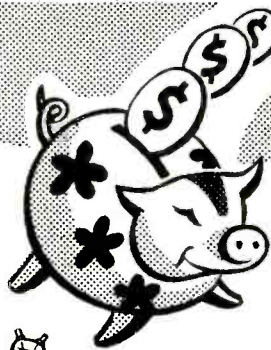

The New PRECISION "612" is your answer to Economical, Positive, Tube and Battery Testing



612-C (illustrated). In modern chrome-trimmed, Counter type cabinet. Dull black ripple finish on heavy gauge steel. 16 x 13 1/2 x 7", sloping to 3" at front.
Complete: - \$63.95

612-P-In hardwood, Portable case with tool compartment, Size 12 x 13 x 6" Complete: - \$61.95

612-MCP-Open style Metal Case Portable, fine dull black ripple finish on heavy gauge steel. Size 10 1/2 x 12 x 6"
Complete: - \$59.95

612-PM-In standard size Panel Mount 12 1/4 x 19" with dust cover. For rack cabinet or wall mounting.
Complete: - \$61.95

- ★ Positive Free-Point Tube Testing
- PLUS ★ Highest Practical Obsolescence Insurance
- PLUS ★ Utmost Simplicity of Operation
- PLUS ★ "Precision" Quality and Workmanship
- PLUS ★ Moderate Cost ... Impressive Design

The new Series 612 is a modern, **free-point, lever-operated Cathode Conductance Tube Tester** representing the culmination of extended and intensive development in the field of modern tube checking requirements. It answers the ever-present need for **positive tube testing results at moderate cost**, with full conformity to "Precision's" high standards of workmanship, performance and quality components.

The new "600" line affords tube testing parameters based upon the time-proven emission testing principles as recommended by both tube manufacturers and R.M.A.; plus innumerable circuit features which render it incomparable amongst instruments in its category.

TUBE AND BATTERY TESTING FEATURES

- ★ Tests all modern tube types including 7 pin Acorns, button 7 and Novel 9 pin types, dual-capped H.F. tubes, FM and TV amplifiers, etc.
- ★ Filament voltages from 3/4 to 117 volts.
- ★ Absolute Free-Point 10 element lever selection for both short and merit tests.
- ★ 4 1/2" wide vision meter. 2% Accuracy.
- ★ Dual HI-LO short-check sensitivity.
- ★ Individual Tests of Multi-Section Tubes including tuning indicators, gas rectifiers, oscillator-converters, etc.
- ★ Ballast Unit Tests.
- ★ Micro-Line adjustment - continuously variable.
- ★ Pilot and signal light tests.
- ★ Noise and Condenser test pin jacks.
- ★ Dynamic "under-load" test for all popular radio A, B, and C dry batteries.
- ★ Built-in, brass geared roll chart.
- ★ Anodized, deep-etched, heavy gauge aluminum panel.
- ★ Panel-mounted Fuse extractor Post.
- ★ Telephone type cabled wiring using plastic-insulated moisture resistant hook-up wire.

SERIES 620 TUBE, BATTERY AND SET TESTER RANGES TO 3000 VOLTS, 12 AMPERES, + 64DB, 10 MEGOHMS

A COMPLETE, PORTABLE, SERVICE LABORATORY providing every essential feature for general purpose test and check of modern radio and electronic equipment.

Incorporates the identical tube test circuit and battery testing features of the Series 612, (described above) PLUS a complete A.C.-D.C. Multi-Range Circuit Tester of 1000 ohms per volt sensitivity.

CIRCUIT TESTING FEATURES

- ★ 5 A.C.-D.C.-Output Voltage Ranges: to 3000 volts.
- ★ 5 D.C. Current Ranges: to 12 Amperes
- ★ 3 Resistance Ranges: self-contained: to 10 Megohms.
- ★ 5 Decibel Ranges from -12 to +64 DB.
- ★ Full rotary Range and Function Selection.
- ★ 2 pin jacks serve all standard ranges.
- ★ 1% Wire-wound and Metallized Resistors.
- ★ 400 microampere 4 1/2" Meter. 2% accuracy.
- ★ All Circuits Insulated from power line.

The Series 620 is available in the same four model types as described for the series 612 (above)

620-C - Counter Cabinet.....Net Price \$84.30
620-P - Portable Case.....Net Price \$82.30
620-MCP - Metal Case Port.....Net Price \$80.30
620-PM - Panel Mount.....Net Price \$82.30

SEE these new "Precision" Test Instruments now on display at all leading radio parts and equipment distributors, or write directly for the Precision 1948 catalog describing the full Precision line of quality Electronic Test Instruments.

PRECISION
TEST EQUIPMENT

Standard of Accuracy

PRECISION
APPARATUS COMPANY INC.
92-27 HORACE HARDING BOULEVARD
ELMHURST 6, NEW YORK

Export Division: 458 BROADWAY, NEW YORK CITY, U.S.A. • Cables: MORHANEX

SAVE TIME — SAVE MONEY SAVE TUBES....

With the New HYTRON Miniature Pin STRAIGHTENER

Ever cursed the pins of miniatures when they broke as you fussed to straighten them with your fingers or with long-nose pliers? Unfortunately the pins have to be pliable to avoid cracked buttons. But you can make pin straightening easy and safe.

For only 49c — less than cost — a fraction of normal price, you can own a new Hytron Miniature Pin Straightener. You then merely press a 7-pin miniature gently into the Straightener until the button base seats squarely. Presto, the pins are straight again! Best of all, avoiding just one broken tube can pay for the Straightener twice over.

Features: precision die of wear and rust resistant steel for long life and close tolerances, production-tested, easy clean-out, adapted to hand or bench use. It's faster, cheaper, safer to use the Straightener *always* before plugging in miniatures. You need three Pin Straighteners — for bench — for field tool kit — for counter. *Available only from Hytron jobbers.* Order yours today.

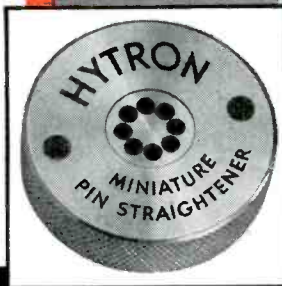

ONLY 49c
AT YOUR HYTRON JOBBER'S

A PREVIEW

The Hytron Miniature Tube Pin Straightener and Handy Tube Tapper are just the beginning. Watch for more lower-than-cost Hytron tube tools designed especially for you. They will save you time — help you make more money. Follow the Hytron ads for announcements. Order the tools from your Hytron jobber.



Hytron Handy Tube Tapper — novel and useful tool locates elusive intermittent "shorts" and "opens". Pencil, eraser, and tube tapper. Fits breast pocket. Compact and nonmetallic. Rugged and effective. Only 5c at your Hytron jobber's.



TUBES ARE KNOWN BY THE COMPANY THEY KEEP

Bendix MRT-3A, 152-162 mc f-m taxicab transmitter uses Hytron tubes generously.

Companies with top names like Bendix pick top quality components. You, too, choose the best when you ask for Hytron. Join the leaders. Specify Hytron tubes.

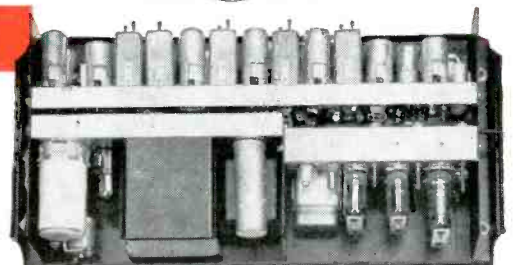

SPECIALISTS IN RADIO RECEIVING TUBES SINCE 1921

These service tools made available to you on a non-profit basis by both Hytron and its jobbers.

HYTRON

RADIO AND ELECTRONICS CORP.



MAIN OFFICE: SALEM, MASSACHUSETTS

SERVICE, MARCH, 1948 • 5

RIDER MANUALS

Mean
**SUCCESSFUL
SERVICING**

BELL HAS ALL 16 (AND VOLUME XVII) ON ORDER

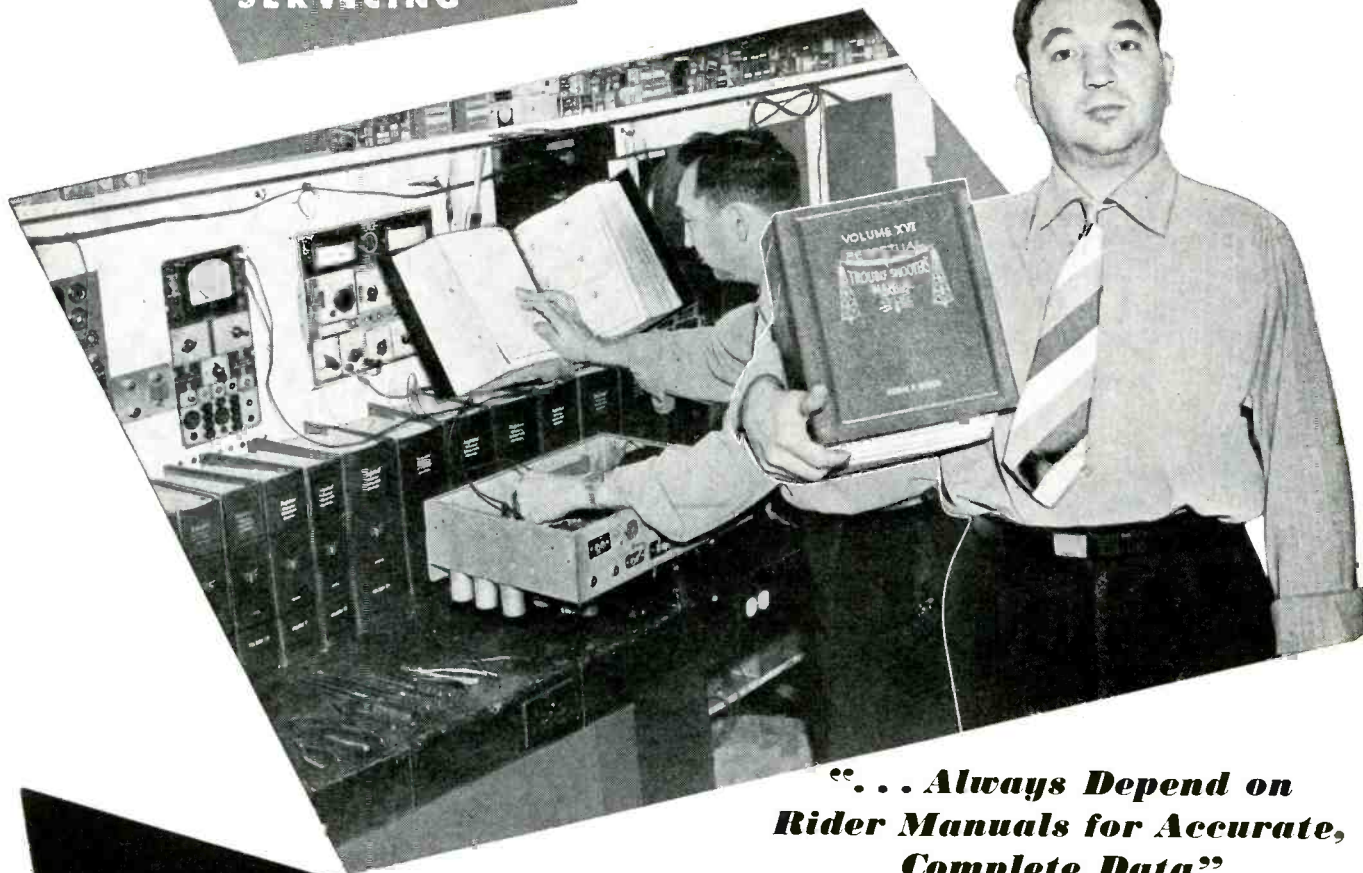

**"... Always Depend on
Rider Manuals for Accurate,
Complete Data"**

"We have always depended on Rider Manuals for accurate, complete radio servicing data. They have never let us down, in fact they have contributed to the profitable operation of our shop," says Sam Spaber of Bell Radio Co., Bell, Calif.

So say successful servicemen everywhere, over whose benches you will find well-used copies of all 16 Rider Manuals. For, during the past seventeen years, money-making shops have depended upon "The World's Greatest Compilation of Radio Servicing Data" for authentic

presentations of manufacturers' original servicing data on American-made receivers issued since 1920. This is vital information.

Rider Manuals keep pace with the manufacturers' releases. Volume XVII, just out, contains both FM and AM sets, record changers and wire recorders. The separate "How It Works" book explains theory and complexities of new receivers. Hundreds of Rider-exclusive "Clarified-schematics," time-saving breakdowns of multi-band jobs, are also in Volume XVII.

Nowhere else but in Rider Manuals will you find such coverage!

You NEED ALL 17—ORDER TODAY

VOLUME XVII.....	\$15.00	Record Changers and Recorders	\$ 9.00
Volume XVI	8.40	Master Index, (covering Manuals,	
Volume XV	18.00	Vols. 1 to XV)	1.50
Volumes XIV to VII (ea. vol.) ..	15.00		
Volume VI	11.00		
Abridged Manuals 1 to V (one vol.)	17.50		

NOTE: Individual Volumes VI, VII and VIII will be replaced after this year by a single Abridged Manual Vol. VI to VIII.

JOHN F. RIDER, PUBLISHER, Inc., 404 Fourth Avenue, N. Y. 16
Export Agent: Rocke International Corp., 13 E. 40th St., N.Y.C. Cable ARLAB

VOL. XVII
(Brings your Rider Manuals up-to-the-minute)
JUST OUT!
1600 PAGES—Plus
"How It Works" Book
\$15.00 (Less than a penny a page)
Your Jobber is taking orders for
DELIVERY NOW!

Watch for Publication
Date in Late Spring
**RIDER
TELEVISION MANUAL**

*Give Your Shop the Sign
of Successful Servicing* **RIDER MANUALS**

Are you Building a Business ... or Burning your Bridges?

Would you patronize a dentist who filled your teeth with plaster of Paris?

Would you trust your children's lives to a doctor who prescribed cut-rate pills?

Your business, too, is built on *customer confidence!* And your reputation is too valuable to risk with inferior or unknown products. The cost of the parts you use in the average repair job is insignificant com-

pared with your investment in *your reputation.*

That's why we say—**YOUR CUSTOMERS AND YOUR REPUTATION CAN AFFORD ONLY THE BEST! . . . SPRAGUE.**



CAPACITORS

SPRAGUE

*KOOLOHM
RESISTORS

• T.M. Reg.
U. S. Pat. Off.

SPRAGUE PRODUCTS COMPANY, North Adams, Mass.

JOBGING DISTRIBUTING ORGANIZATION FOR PRODUCTS OF SPRAGUE ELECTRIC CO.

**Reach for a SPRAGUE
and Know You're Right!**

The superiority of the new Sprague type TM High-Temperature Molded Paper Capacitors didn't happen by chance. You can use this better unit in your work today only because of more than four years of intensive research and one of the largest retooling programs in Sprague's history. That's why we can say "*The First Truly Practical Molded Paper Tubulars are Sprague TM's*"—and it is also the reason you can use them on any job with confidence and pride.

- Highly Heat Resistant
- Moisture Resistant
- Non-inflammable
- Conservatively Rated
- Small in Size
- Mechanically Rugged
- Completely Insulated

**UNCONDITIONALLY
GUARANTEED!**

You can stake your reputation on Sprague replacement parts. If used at rated capacitance and voltage, they are **UNCONDITIONALLY GUARANTEED** to give satisfactory performance. Insist on Sprague and get the best!

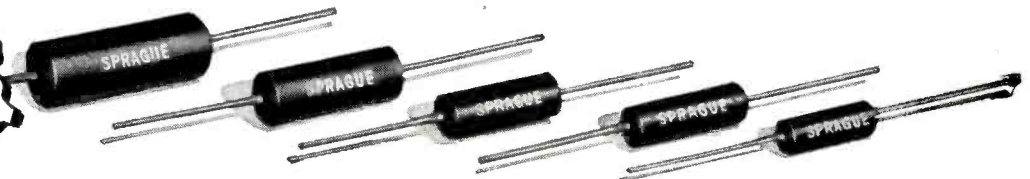

THORDARSON



DEPENDABILITY AND VERSATILITY FOR INDUSTRY

1. LOW VOLTAGE - LOW CURRENT
 2. LOW VOLTAGE - HIGH CURRENT
 3. HIGH VOLTAGE - HIGH CURRENT
 4. HIGH VOLTAGE - LOW CURRENT
- WHERE QUALITY IS A NECESSITY...

Thordarson has the answers to many electrical problems that daily confront industry. With a background of over 25,000 active specifications in their files, built up over 53 years of leadership in the field, Thordarson supplies the leaders with their large variety of stock types of transformers as well as the hundreds of special types built to customer specifications or resulting from recommendations of our own engineers upon studying the various requirements submitted to them by industry.

With this background, you know that your Thordarson equipment, purchased from stocks of a jobber or directly under special specifications, is of top-notch quality — sure to deliver unmatched performance. If you require the best, there is no unit either too large — or too small that Thordarson can't deliver.

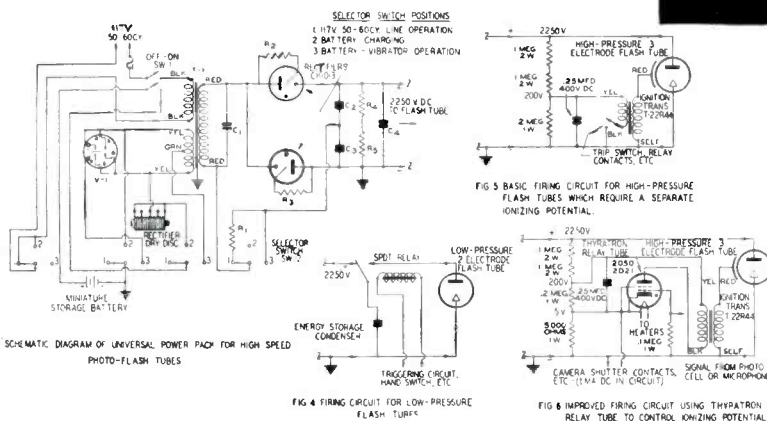

PHOTO FLASH POWER SUPPLY

Here is another Thordarson FIRST... a typical example of Thordarson engineering skill that has helped established leadership in the field. This circuit features:

- A.C. Line or Portable Battery Operation
- Charging Time — 10 to 15 Seconds
- A.C. Line Battery Recharge Feature
- Light Compact Low Drain Power Transformer
- Power Supply Output — 2250 V. D. C.
- Storage Condenser Delivers 75 Watt-Sec. Energy Element
- Adaptable Trigger Circuits for 2 or 3 Tubes
- Cold Cathode Rectifiers Employed in a Voltage Doubling Circuit

OUR ENGINEERING STAFF IS AVAILABLE TO SOLVE YOUR PROBLEMS FOR YOU UPON REQUEST

Whatever your position in the field of electronics Thordarson can serve you better. Our large variety of stock types fill almost every need. For extraordinary conditions, send us your problems and our engineering staff will come up with the right answers.



The New Thordarson Catalog Is Now Available, Send For Your Copy Today.

THORDARSON

Manufacturing Quality Electrical Equipment Since 1895
 500 WEST HURON CHICAGO 10, ILLINOIS
 A Division of Maguire Industries
 Export — Scheel International Inc.

MAKE YOUR SHOP THE BEST IN TOWN!

ASK YOUR DISTRIBUTOR RIGHT AWAY ABOUT THE **N. U. TRIPLE-AID PLAN**

Now you can have the finest radio service facilities in your community . . . the kind of efficiency that will mark yours as the **"Best Shop in Town."**

It won't be costly either, for National Union, through your N. U. Distributor, has worked out a really low-cost Triple-Aid program. It will help build your reputation for complete customer satisfaction.

Put this Triple-Aid Plan to work for you—now!

1. Ask your N. U. Distributor to help you (the Easy N. U. Way) to bring your service laboratory up to date. With modern test and service equipment you will be able to handle the toughest service job quickly, easily and economically. You'll be the **"Best Service Equipped Shop in Town."**
2. Ask your N. U. Distributor to provide you with N. U. Technical Service Bulletins, Tube and Service Parts Data and educational information that will make you the **"Best Technically Equipped Shop in Town."**
3. Start using tested N. U. "Business Builders"—now. They are planned especially for you. They'll advertise your modern test facilities—sell your technical ability—and publicize your friendly, efficient service. You'll be the **"Best Salesman in Town."**

Here's a tip: Look to your N. U. Distributor for business counsel—he's an **"Old Timer."**



NATIONAL UNION RADIO CORPORATION

ORANGE, NEW JERSEY

RECEIVING TUBES • TRANSMITTING TUBES • CATHODE RAY TUBES • TELEVISION TUBES • SPECIAL PURPOSE TUBES
PHOTOTUBES • BALLASTS • BATTERIES • CAPACITORS • PANEL LAMPS • VIBRATORS • VOLUME CONTROLS

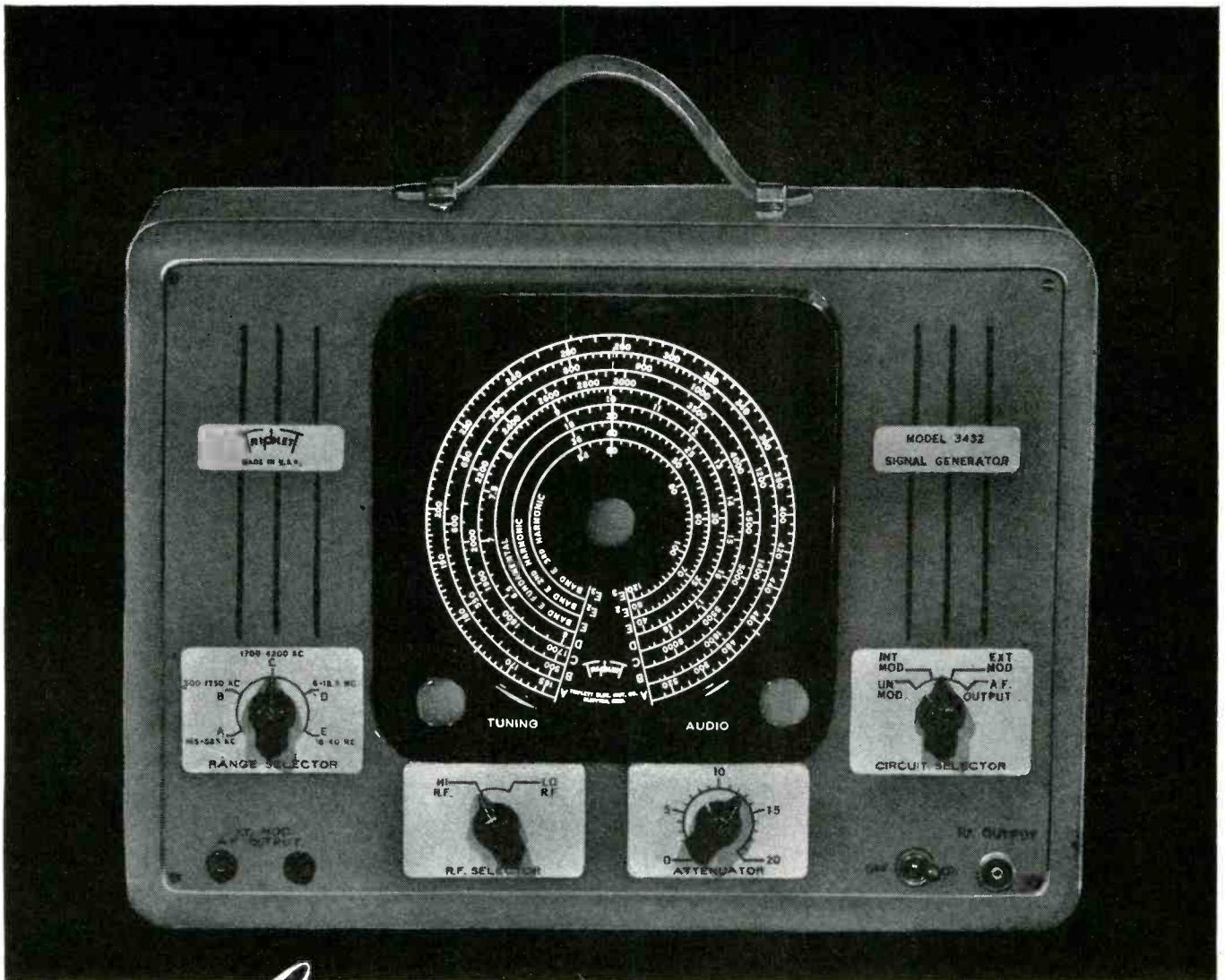

Look at that dial!

It's Triplet's new method of dial lighting—one of the features of Model 3432 Signal Generator. The dial is BIG (330°) and correctly illuminated . . . accurately calibrated . . . quickly readable at a glance . . . with 10 to 1 Ratio Vernier Tuning for ease of adjustment. The seven long scales on the dial of Model 3432 have five fundamental ranges 165 KC to 40 MC and two harmonic ranges directly calibrated 36 MC to 120 MC. Variable 400 cycle modulation 0 to 100%; special copper plated internal shielding, R.F. attenuation—and many other features that have to be seen—and used—to be fully appreciated. Model 3432 is a Triplet top value that's priced right. See it now and buy it from your distributor.

Model 3432
Illuminated Dial
Signal Generator

NEW TRIPLET TELEVISION TESTERS COMING
WATCH

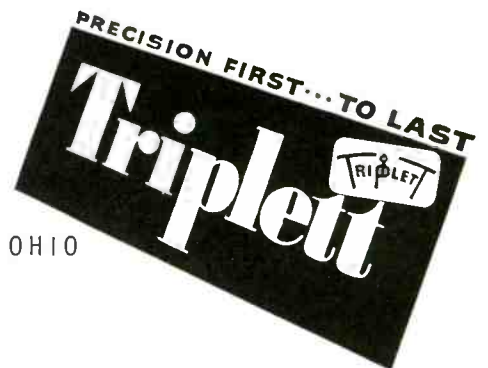

TRIPLET ELECTRICAL INSTRUMENT COMPANY, BLUFFTON, OHIO

In Canada: Triplet Instruments of Canada, Georgetown, Ontario

Buy Quality - Buy SANGAMO

Since 1923 Sangamo Capacitors have had a reputation for high inherent quality. Discriminating users have learned to rely on Sangamo for excellent design and construction, honest characteristics and conservative ratings. There is a Sangamo Mica or Paper Capacitor to fill your every need.

Type 71



DIACLOR IMPREGNATED CAPACITORS

Designed for use on broadcast and aircraft transmitters, and in many varied high voltage circuits. These small-sized, light-weight, long-lived capacitors have high insulation resistance, high dielectric strength, and low power factor. Available within a range of 600 to 6000 V. D. C. W. or higher.

Type 20-21



METAL-CASED MINERAL OIL PAPER CAPACITORS

Extremely popular because of their excellent bypass and coupling qualities. They offer unusually stable performance from 55° C below zero to 85° C above zero. These "Jack-of-all-Trades" Capacitors are available within a range of 200 to 2000 V. D. C. W.

Type 40



DIACLOR FILLED FILTER CAPACITORS

Particularly suitable for use in communications equipment, industrial electronic, and other high voltage filter applications. They are enclosed in aluminum containers designed to facilitate mounting, and have an insulating washer and spade lug for insulating from the chassis.

Type 50



MINERAL OIL BYPASS CAPACITORS

Primarily intended for bypass applications. Their characteristics are excellent for R. F. and A. F. bypass, audio frequency coupling, and A. C. circuits, under all humidity conditions and at temperatures up to 85° C, subject to RMA standard temperature/voltage adjustment.



Sangamo manufactures a complete line of paper, mica and silver capacitors. Write for Catalog No. 76C for full information.

PAPER • MICA • SILVER • CAPACITORS

SANGAMO
ELECTRIC COMPANY
SPRINGFIELD • ILLINOIS

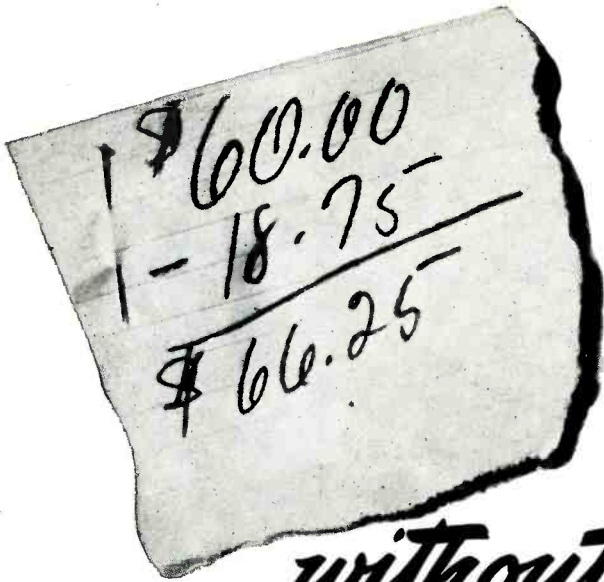

How 19,000 companies up take-home pay *without upping payrolls*

Can you deduct \$18.75 from \$60.00 and get \$66.25? Yes. And the way you can do it is mighty important to your company—and to the nation!

You start with \$60, representing someone's weekly take-home pay. You deduct \$18.75 for the purchase of a U.S. Savings Bond. That leaves \$41.25. But \$41.25 isn't what the worker takes home. He takes home \$41.25 *plus a \$25 Savings Bond*. Total (assuming he holds the Bond till maturity): \$66.25.

WHAT 19,000 COMPANIES HAVE LEARNED

In the 19,000 companies that are operating the Payroll Savings Plan for the regular purchase of Savings Bonds, employees have been more contented in their jobs—absenteeism has decreased—even accidents have been fewer!

Those are the "company" benefits the Plan provides, in addition to extra security for individual employees.

But the Plan has other, far-reaching benefits of basic importance to both your business and the national economy...

SPREADING THE NATIONAL DEBT HELPS SECURE YOUR FUTURE

The future of your business is closely dependent upon the future economy of your country. To a major extent, that future depends upon management of the public debt. Distribution of the debt as widely as possible among the people of the nation will result in the greatest good for all.

How that works is clearly and briefly described in the free brochure shown at the right. Request your copy—*today*—from your State Director of the U. S. Treasury Department's Savings Bonds Division.

ACTION BY TOP MANAGEMENT NEEDED

The benefits of regular Bond-buying are as important today as ever—but war-time emotional appeals are gone. Sponsorship of the Payroll Savings Plan by a responsible executive in your company is necessary to keep its benefits *advertised to your employees*.

Banks don't sell Savings Bonds on the "installment plan"—which is the way most workers prefer to buy them. *Such workers want and need the Payroll Savings Plan.*

Those are the reasons why it's important to make sure that the Plan is adequately maintained in your company.

The State Director will gladly give you any assistance you wish.

"The National Debt and You,"

a 12-page pocket-size brochure, expresses the views of W. Randolph Burgess, Vice Chairman of the Board of the National City Bank of New York—and of Clarence Francis, Chairman of the Board, General Foods Corporation. Be sure to get your copy from the Treasury Department's State Director, Savings Bonds Division.



The Treasury Department acknowledges with appreciation the publication of this message by

SERVICE

This is an official U.S. Treasury advertisement prepared under the auspices of the Treasury Department and the Advertising Council



The **ONLY**
Complete Servicing Reference
on ALL Pre-War and Post-War Receivers

25% More Listings
Than the
5th Edition

Accurate
Authoritative
Complete
in One
Volume



SALES of previous editions offer the best evidence of its worth.

Edition	Year	Copies sold
1st	1937	51,000
2nd	1938	25,000
3rd	1939	55,000
4th	1941	60,000
5th	1946	75,000

Here's what you get:

Data on correct replacement parts

Circuit information

Servicing hints

Installation notes

IF peaks

Tube complements and number of tubes

References to Rider, giving volume and page number

RESERVE YOUR COPY NOW

Ready April 1st— The 6th Edition

Mallory Radio Service Encyclopedia

Here it is—up to date—the only accurate, authoritative radio service engineers guide, complete in one volume—the Mallory Radio Service Encyclopedia, 6th Edition.

Made up in the same easy-to-use form that proved so popular in the 5th Edition, it gives you the complete facts on servicing all pre-war and post-war sets . . . volume and tone controls, capacitors, and vibrators . . . circuit information, servicing hints, installation notes, IF peaks, tube complements and

number of tubes . . . and in addition, cross-index to Rider by volume and page number for easy reference. **NO OTHER BOOK GIVES YOU ALL THIS INFORMATION**—that's why it's a **MUST** for every radio service engineer.

25% more listings than the 5th Edition. Our ability to supply these books is taxed to the limit. The only way of being sure that you will get *your* copy *quickly* is to order a copy today. Your Mallory Distributor will reserve one for you. The cost to you is \$2.00 net. It's the buy of the year.

THE MALLORY RADIO SERVICE ENCYCLOPEDIA

Complete—Authoritative—All in One Volume

P. R. MALLORY & CO. Inc.
MALLORY

CAPACITORS . . . CONTROLS . . . VIBRATORS . . .
SWITCHES . . . RESISTORS . . . RECTIFIERS . . .
VIBRAPACK* POWER SUPPLIES . . . FILTERS
*Reg. U. S. Pat. Off.

APPROVED PRECISION PRODUCTS

P. R. MALLORY & CO., Inc., INDIANAPOLIS 6, INDIANA



Long Life

As the sphinx and pyramid have withstood the ravages of time over the centuries gaining their reputation for longevity, the mighty Radiart VIBRATOR has proven itself to be long lasting even beyond its normal expected effectiveness. This quality of long life helps to make Radiart VIBRATORS outstanding and cuts to a minimum expensive duplicate installation costs. This is one of the factors that brings customers back to servicemen, satisfied and asking for Radiart by name and number. Dealers everywhere know when they sell Radiart, they sell quality. On this concept, your success and ours is assured.



The Radiart Corp.
CLEVELAND 2, OHIO

TELEPHONE CHERRY 3573

The Drive-In Theatre Equipment Company, Inc.
Manufacturers of NATIONAL AUTO VOICE In-car Speaker Units

2110-2130 SUPERIOR AVENUE
CLEVELAND 14, OHIO

January 20, 1948

Mr. R. S. Fenton, Sales Manager
Parts Section, Receiver Division
Electronics Department
General Electric Company
1001 Wolf Street
Syracuse, New York

Dear Mr. Fenton:

We would like at this time to express our appreciation for your expeditious handling of our recent rush order for 5 1/4" PM Speakers.

The speakers used in the Drive-In Theatre in-car units must meet more rigid standards than those ordinarily required commercially. The Drive-In Speaker is subjected to the most adverse weather conditions, and must be able to stand up over a period of years without appreciable impairment of its electrical characteristics. The voice coil form, and the cone proper, must be impervious to moisture or direct rainfall.

It may be of interest to you to know that after a survey of the speaker field, we chose the GE Speaker as the one best able to meet our exacting requirements. The aluminum voice coil form is ideal for our work, since there is no danger of expansion due to moisture absorption. The speakers met Navy type tests such as shock, vibration, temperature, salt spray, and frequency response requirements.

Since standardizing on GE speakers, our customer reaction has been entirely satisfactory.

Very truly yours,
DRIVE-IN THEATRE EQUIPMENT CO., INC.

E. B. Brady

President

Speakers
that mean
business...

FOR YOU!



THE LETTER reproduced here speaks for itself and —G-E Speakers. The superb engineering which makes this speaker ideal for outdoor use, also makes it ideal for replacement in home receivers, where widely varying conditions of dryness and humidity affect speaker performance.

Here is an opportunity to develop the speaker replacement market to its fullest extent and push the outdoor theatre market.

G-E Speakers are competitively priced—and in quality they are outstanding. Build speaker business now. Send us your order.

For complete information write:
General Electric Company, Electronics Department,
Electronics Park, Syracuse, New York.

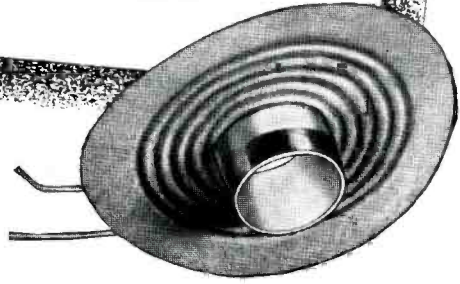

ALUMINUM FOIL BASE
VOICE COIL



GENERAL  ELECTRIC

100-G2

WARD sets the stage



**-for a "boom"
in FM and
Television
aerial sales**

An intensive consumer advertising campaign in the Saturday Evening Post and leading newspapers is convincing millions of present and prospective FM and Television set owners that:

- (1) *Quality reception is difficult, if not impossible, without a good outside dipole antenna.*
- (2) *Ward "Magic Wand" FM and Television Aerials offer the finest FM and Television reception at modest cost.*

Alert radio dealers are finding this campaign exceedingly helpful in creating extra sales and profitable installation jobs. In addition these dealers are winning satisfied customers who can now enjoy the true beauty of FM or television reception.

Available in straight or folded dipoles for both FM and television bands (reflector kits available), Ward "Magic Wand" Aerials are products of the world's largest makers of aerials for car and home.

Listing at only \$9.00 to \$12.00 (reflector kit \$5.25) they are priced to encourage volume sales and an adequate profit margin.

Phone or see your nearest Ward distributor today for full details on how to capitalize on this hard-hitting consumer advertising for Ward "Magic Wand" FM and Television Aerials; or write direct to:

THE WARD PRODUCTS CORPORATION
1527 East 45th Street, Cleveland 3, Ohio

DIVISION OF THE GABRIEL COMPANY

EXPORT DEPT.: C. W. Brandes, Mgr., 4900 Euclid Ave., Cleveland 3, Ohio.
IN CANADA: Atlas Radio Corp., 560 King St., W., Toronto, Ont., Canada.

As
Advertised
in the
Saturday
Evening
POST

WORLD'S
LARGEST MAKER
OF AERIALS
FOR CAR AND HOME

WARD
Magic Wand
FM AND
TELEVISION
AERIALS

FM-TELEVISION AERIAL OPPORTUNITY! WARD PRODUCTS CORP.

1527 E. 15th St., Cleveland 3

Please advise how I can profit from your national advertising for "Magic Wand" FM and Television Aerials.

NAME _____

COMPANY NAME _____

ADDRESS _____

STATE _____ CITY AND ZONE _____

MY JOBBER IS _____

RADIO • TELEVISION • ELECTRONIC
SERVICE

TV and the Service Man

TELEVISION has struck its stride and with gusto! Today there are over quarter of a million tv receivers. February production was nearly 36,000 units representing an annual production rate of more than 430,000, an increase of 141% over the average 1947 month's output. This accelerated interest has projected tv installation and servicing up front, way up front. As we noted last month, tv is no longer a service of a few areas. Not only do we have stations in the key trading spots of the country but in the smaller sites too, and more to come. And the network links, for years on the drawing board, are now becoming a fact. In October, an AT&T coaxial link will join Cleveland, Detroit, Toledo, Milwaukee, Chicago and St. Louis. In December, these cities will join the eastern network which consists of Boston, New York, Philadelphia, Baltimore, Washington and Richmond. Radio-relay links are extending coverage, too. The Boston-to-New York link, only discussed last month, as a future possibility, is now in operation.

A few months ago it was believed that about a score of companies might be producing tv models. Today, there are over 50 in full scale production.

Tv has become quite a business, and it's still a baby. It's growing and growing fast and Service Men can grow with it, keeping pace with the developments, seeking every opportunity to learn what makes the tv set tick and acquiring the know-how which we discussed last month.

As our contribution to this expanding industry, the contents of this issue are, in the main, devoted to tv . . . covering such important factors as installation, servicing, receiver design, instruments, antennas and tubes. And in future issues tv will continue to be featured in many articles.

In This Issue

THE ALL-IMPORTANT subject of tv installation is thoroughly analyzed by Edward M. Noll of Temple University . . . page 18. On-the-spot photos of a typical installation illustrate the vital points Service Men must follow in tv installation today. Noll analyzes the careful planning procedure required, detailing such factors as the initial

survey, pretesting of the receiver in the Service Shop, checking of antenna with test receiver, positioning of the receiver and the use of operating instructions for the benefit of the customer.

On page 20 will be found another extremely important discussion, the curbing of tv receiver proximity interference. This article, prepared by Ira Kamen, discloses the remedies for such problems as local oscillator re-radiation, leading ghosts, poor image-rejection response, unregulated power systems and sweep circuit reradiation.

The *Ser-Cuits* section, this month, is devoted to an analysis of three unusually interesting types of television receivers. The discussion which begins on page 32 covers tv models using electrostatic-deflection picture tubes and magnetic-deflection projection-type picture tubes. In these analyses will be found a step-by-step discussion of the variety of circuits used. Reasons for the design and use of the circuits are explained carefully. Full-page circuits appear within this comprehensive circuit feature of SERVICE.

Television antennas are also featured in an article, this month, on page 26. This presentation by P. M. Randolph provides an unusually useful antenna-length chart for tv and f-m dipoles. Randolph also tells how to convert an f-m dipole for television-receiver use on the six lower channels.

A handy television-test instrument is also described this month. The discussion, on page 48, covers a sweep signal generator for tv and f-m.

The *Tube News* section (page 30), this month, is also devoted to tv, with an analysis of stagger-tuned video i-f systems using 6AG6, 6AU6, 6BA6, 6AK5, 6BJ6 and 6BH6 miniatures. Typical circuits are offered. Also appearing in this discussion, are some useful notes on the 5TP4 projection tube, which, incidentally, is used in the projection receiver described in the circuits section.

Read these articles carefully and keep them for ready reference. You will find them mighty handy for your television installation and servicing work.

Servicing Opportunities

F-M has opened many new fields for the Service Man. We've mentioned taxicabs, trucks, commercial buses, etc.

And now we have the public-service bus equipped with f-m, buses serving northern Kentucky and metropolitan Cincinnati, another blueprint idea come to life! About 150 cars in this bus line will eventually be equipped with special f-m receivers. The sets feed from six to eight speakers per bus.

A bus line in Virginia is also experimenting with this type of f-m service. Others will fall in line soon. The Service Man can play a major role in installing this equipment, servicing it and even setting up a plan to sell the receivers to local bus companies through a cooperative dealer arrangement.

There appears to be quite a bit of new business around for the progressive Service Man!

F-M Radio Relay

MANY have inquired about the number of stations in the f-m continental network . . . who they were and where they are located. There are 27 stations in the network, nineteen of which are connected by a radio link, and the remaining eight by wire. The link stations are: WWHG, Hornell, N. Y.; WKNP, Corning, N. Y.; WIBX-FM, Utica, N. Y.; WGTR, Paxton, Mass.; WMNE, Mt. Washington, N. H.; WNHR, Cambridge, Mass.; WNLC-FM, New London, Conn.; WIZZ, Wilkes Barre, Pa.; WBCA, Schenectady, N. Y.; WBIB, New Haven, Conn.; WDRC-FM, Hartford, Conn.; WFMZ, Allentown, Pa.; WBAB-FM, Atlantic City, N. J.; WLAN-FM, Lancaster, Pa.; WLOB, Claremont, N. H.; WCFR, Fall River, Mass.; WABX, Harrisburg, Pa.; WXNJ, Plainfield, N. J., and WFMO, Jersey City, N. J. Wire-line stations are: WASH, Washington, D. C. (*key*); WFIL-FM, Philadelphia, Pa.; W2XMN-W2XEA, Alpine, N. J. (New York City); WBNF-FM, Binghamton, N. Y.; WSYR-FM, Syracuse, N. Y.; WHFM, Rochester, N. Y.; WBEN-FM, Buffalo, N. Y., and WHLD, Niagara Falls, N. Y.—L. W.

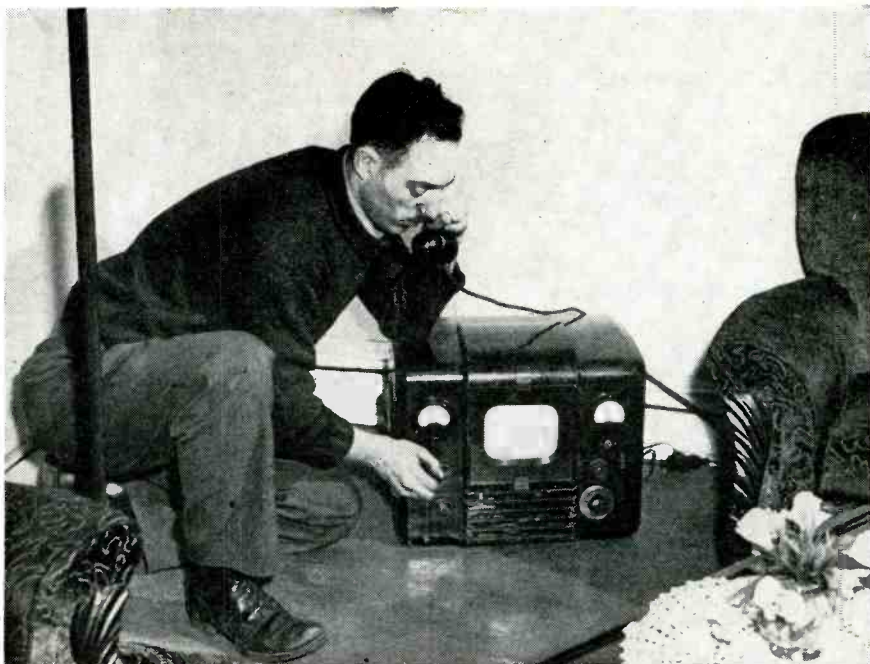

Left: Receiving instructions on orientation of television antenna from Service Man in apartment with test television set. Above: Instructing antenna man how to orient the antenna to secure maximum results on tv receiver.

TV Antenna-Receiver Installation Methods

Installation of Television Receiver And Antenna Requires Careful Planning, And Involves An Initial Survey, Pre-Testing of Receiver In Service Shop, Detailed Check of Antenna With Test Receiver, Positioning of Set And Use of Lucid Operating Instructions

THE PERFORMANCE of a tv receiver is a function of the installation as well as the receiver proper. A painstaking installation is the most economical path to customer satisfaction.

Customer confidence gains with every inconvenience removed. For instance, there's no need to make the customer's home a receiving department or his living-room an assembly line. In the main, television receivers should be assembled at the shop and given an eight-hour test before they are delivered. In transit between shop and customer they can be wrapped in moving blankets and ride where they are not subject to shock.

The following procedure, used and

by **EDWARD M. NOLL**

*Instructor in Television
Temple University*

recommended by the Pioneer Television Company of Philadelphia, has created substantial respect for workmanship and installation effectiveness in this area.

Initial Survey

Initial survey of location is of paramount importance and involves a number of decisions; type of antenna, antenna position and tentative orienta-

tion, type of support and guying, location of receiver, and path of transmission line. Choice of antenna type itself is often a difficult task because it is dependent on relative signal strengths, number and frequency of stations, direction of stations, and signal-to-noise ratios. Generally, the antenna is either broad-band or cut for the weakest station, and is directed toward that station. In areas in which all signals are weak separate antennas are often necessary. Likewise, antennas must be directed away from noise sources whenever possible. The type and height of mast depends on location and building structure. Support and guying of mast to withstand

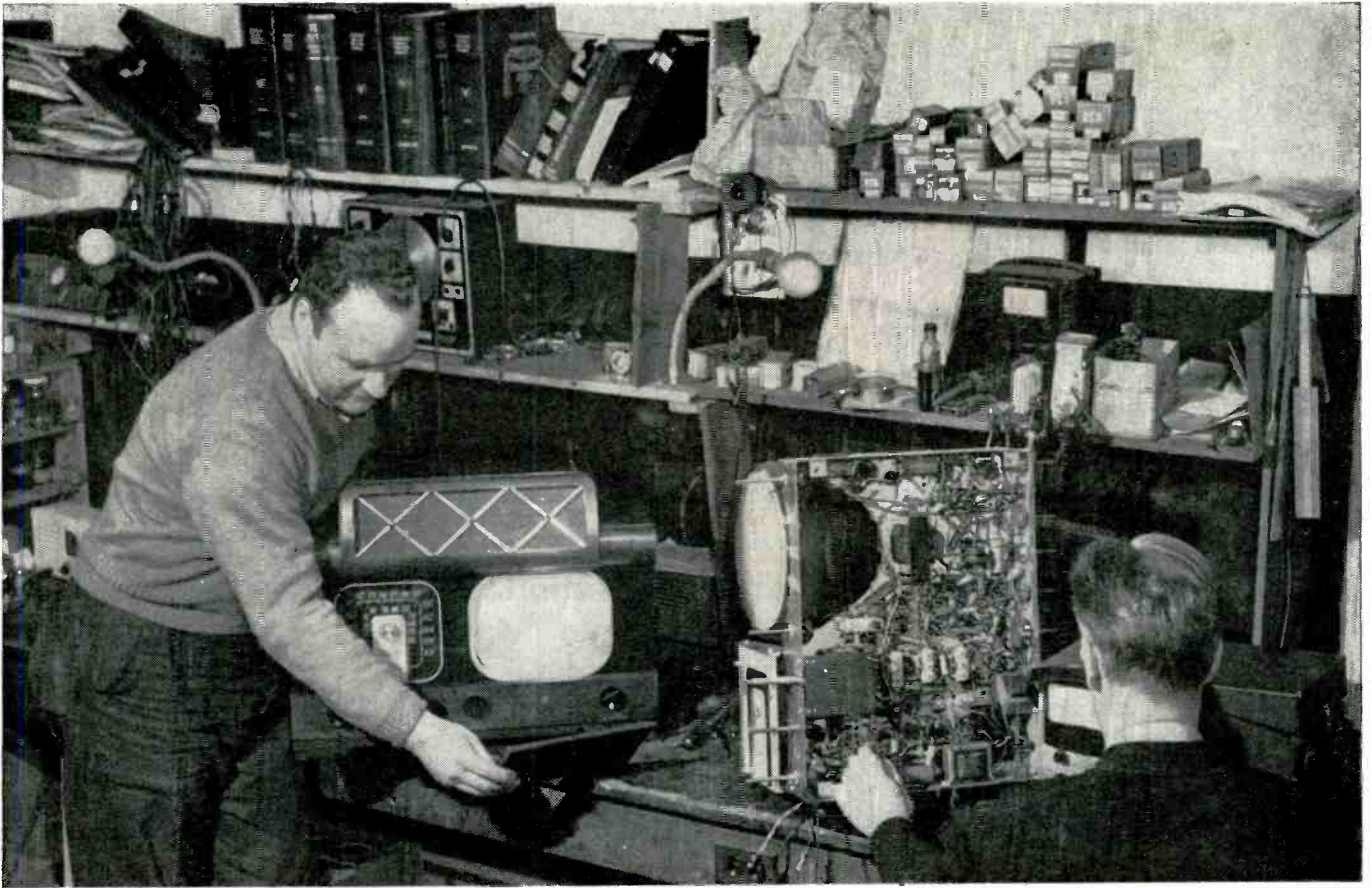

Above: Testing television set in Service Shop before delivery to customer's home. Receivers are subjected to an eight-hour test to assure maximum operating efficiency when installed. Service Man at left is checking horizontal and vertical sync controls. Point-to-point voltage tests are being conducted by Service Man at right.

high winds is very important. The antenna mast must lock-in tightly after orientation to prevent a shift in antenna element position and antenna directivity over a period of time, a frequent cause of gradually degenerating performance.

The general positioning of the receiver in the house should be ascertained and a plan evolved for running

the transmission line unobtrusively and rigidly. Transmission line should be tied down and isolated from metallic and other surfaces against which it may rub or transfer signal.

Antenna Installation

On many jobs the survey and antenna installation proceed concu-

rently in the hands of an experienced crew.¹ The most important consideration in the erection of the antenna is rigid support and effective guying, when necessary, to withstand wind and prevent shifting of position. The

(Continued on page 40)

¹Most service groups use a two-man crew.

Right: Blanketed, tested television receiver being brought to truck for delivery to customer.

Instructing customer on use of controls on television receiver.



Curbing TV Receiver Proximity Interference

Remedies For Such Problems As Local Oscillator Reradiation, Leading Ghosts, Poor Image Rejection Response And Unregulated Power Systems. Serious Problem of Sweep-Circuit Reradiation Thoroughly Analyzed

by **IRA KAMEN**

*Commercial Radio Sound Corp.
New York City*

THE PROBLEMS OF INTERFERENCE where tv receivers operate in close proximity to each other and to broadcast receivers are becoming acute in many areas. Most of the problems are the result of design defects in some of the tv receiver circuits.

First, let us analyze where tv receivers operate in close proximity to each other and to broadcast receivers.

We have: (1) Multiple dwellings, (2) hotels, (3) dealer establishments, (4) attached private homes, (5) schools, and in other minor groups in tv studios, industrial buildings, etc.

The problem of tv interference and receiver design defects has been carefully considered in the design of master antenna systems, such as the type illustrated in Fig. 1, and components have been incorporated to preclude the possibility of an inherent defect in any one tv receiver from affecting the operation of another tv receiver connected to the system.

Now let us analyze the types of interferences which have been found when tv receivers operate in proximity to other tv receivers or on a common transmission line.

Problem 1—Local oscillator reradiation: This is caused by failure to provide a preselector ahead of the converter stage, lack of shielding, circuit coupling between antenna inputs and local oscillators. Many tv models have a combination of these defects.

The interference manifests itself by showing *r-f* lines in the pattern of the affected receiver, as shown in Fig. 2. This condition is most prominent when the poorly designed receiver is on channel 2 (54-60 mc) and another tv receiver is operating on channel 5. You can readily see that the local

oscillator frequency of the offending receiver (incoming frequency plus i-f frequency) is transmitting a signal in

the channel 5 band (76-82 mc). In cities, other than those using the New York channels, the problem will be acute between channels 1 and 4, and 3 and 6.

This interfering signal has been found to upset tv receivers when their

Fig. 1. Apartment house a-m/i-m/tv master antenna system. (Courtesy Commercial Radio Sound Corp.)

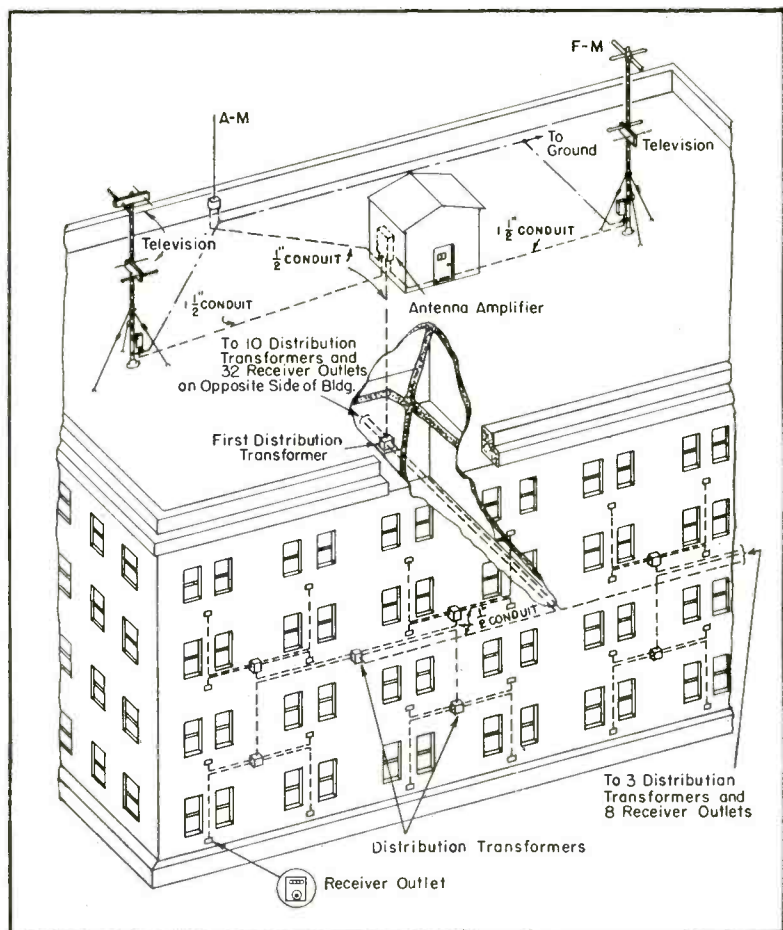

respective antennas are as much as 100' apart. The reradiated r-f signal from the offending tv receiver local oscillator couples into the antenna input circuit, climbs the cable, goes into the antenna and makes the tv receiver act like a low-powered transmitter. Many a ham has been erroneously blamed for causing this interference.

During demonstrations, with tv receivers at low signal levels, the reradiating receiver has been found, in many cases, tearing the picture on another receiver when the channel 2 to 5 tuning combination exists, even though the offending tv receiver is not connected to an antenna.

Solution A: Install a multiple antenna system.¹ Multiple dwellings, dealers and other establishments equipped with master-antenna systems will find that the special transformers and isolation outlets prevent the defective receiver from reradiating any further than the outlet. Master antenna systems providing 3 to 5,000 microvolts of tv signal to each tv receiver minimize the effect of the r-f interference as the signal-to-interference level is so high.

Solution B: Locate offending receiver as far as possible physically from other tv receivers.

Solution C: In private homes, a pre-selector could be installed ahead of the reradiating receiver.

Solution D: A trifilar transformer² (70 ohms unbalanced to 300 ohms balanced) installed with coaxial line will considerably reduce the reradiating signal level; Fig. 3.

Problem 2—Leading ghosts: This condition is usually found in poorly shielded tv receivers installed in strong signal areas and is most prevalent in those receivers with 300-ohm balanced inputs.

The cause of leading ghosts is explained in Fig. 4. These leading ghosts are only a problem when several hundred feet of cable are installed between the tv receiver and its antenna and where extremely strong signals are present in the location where the tv receiver is installed. Many an installer has found an external antenna adjustment impossible because of the direct signal pick-up and amazed that an indoor antenna provided more satisfactory pictures.

Solution: An investigation of one of these amazing stories, where the indoor signal, fifteen floors below the

roof, provided a better signal than the rooftop, revealed that the problem was direct pickup. The following corrective steps were taken:

(A) Installed coaxial line between antenna and tv receiver.

(B) Removed the 300-ohm line between external and internal receiver input and connected a 70-ohm coax to one side of the tv sets's balanced 300-ohm transformer input and ground, which matched the 70 ohms; $\frac{1}{2}$ the number of turns were used, therefore $\frac{1}{4}$ the impedance or $300/4 = 75$ ohms.

(C) Used a high-gain antenna array so that maximum signal was fed into the tv receiver from the external antenna.

By taking these corrective steps it was found that the pictures and the signal-to-noise ratio from the external antenna was a great improvement over the amazing indoor antenna. Direct pickup in average signal areas does not present a problem because the external signal is so much stronger than the direct pickup that it swamps the direct signal to a level where it is not visible.

A good test to determine if direct pickup is going to be a problem is to turn on the tv receiver and look at the strength of the pictures without an antenna. A steady high-definition picture may mean you have a serious problem to solve.

Problem 3—Sweep-circuit radiation: The horizontal sweep circuits, which include the deflection coils, radiate high-level harmonic interference signals which blanket the broadcast band with beeps. Large tube and projection tv sets have been the worst offenders. Tests with loop antenna a-m receiver midgets have indicated that the interfering sweep harmonics can be picked up in a 100' radius from many of the present tv receivers. During a master-antenna system demonstration, where ten tv receivers were operating simultaneously, a radio dealer establishment a floor below and approximately 75' away found he could not demonstrate his a-m radio receivers because of the high level sweep circuit radiation from the tv receivers under test.

In an apartment house, the situation is, of course, more acute. Many a Service Man has credited the beeps as an alignment difficulty. Removal of the a-m receiver from the customer's apartment, of course, eliminated the beeps.

There is no solution to this problem except to locate the a-m receiver as
(Continued on page 41)

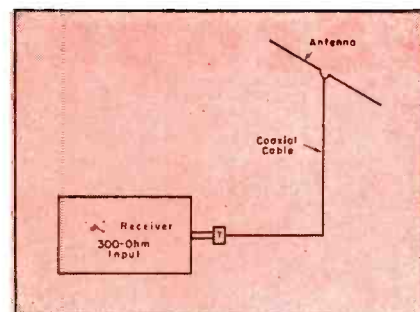

Fig. 3.—Reducing a reradiated signal level with a trifilar transformer (50/70-ohm unbalanced input to 300-ohm balanced output). The twin-lead between the receiver and the transformer is a 300-ohm line and made as short as possible. The coaxial cable lead is an RG58 or 59/U.

Fig. 2. Typical r-f interference pattern on picture-tube screen. (Courtesy Belmont Radio.)

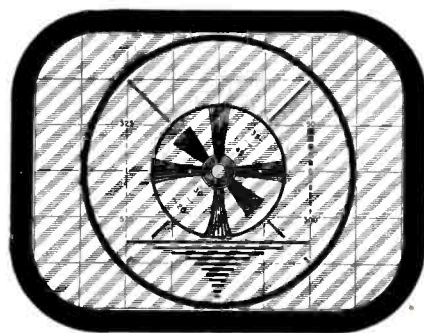
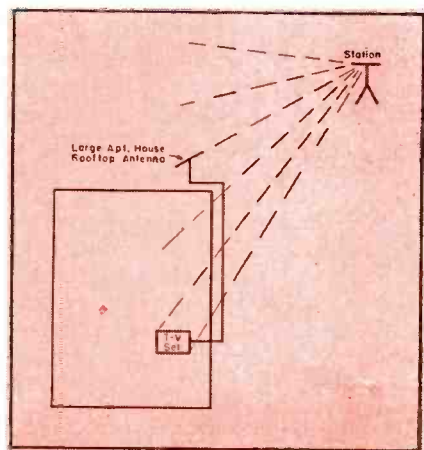

Fig. 4. The cause of leading ghosts is explained in this figure. Signal picked up by the antenna has a time delay in cable before it reaches the television set. The direct tv signal is picked up by the receiver (due to insufficient shielding) and reaches the r-f circuits before the signal from the antenna.



¹Such as the RCA Antenaplex system.

²RCA.

'Scope Wave Patterns

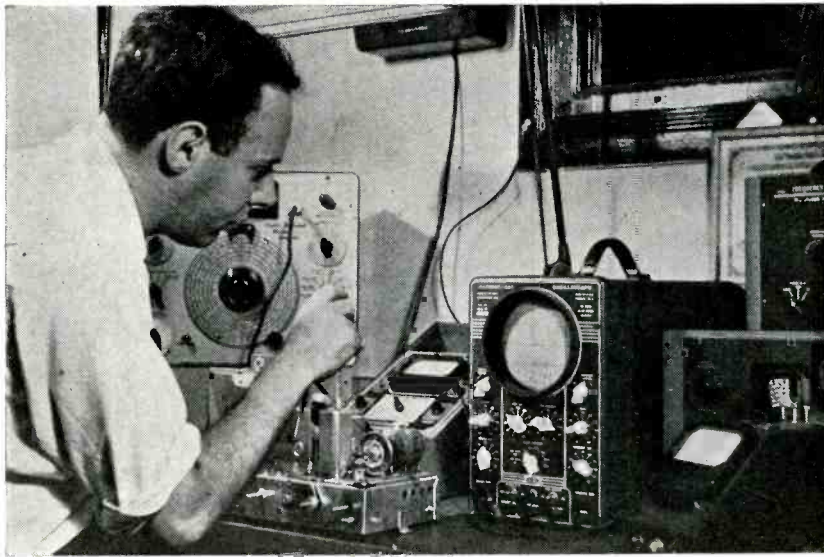

Using a 'scope in practice.

How To Use Controls On The 'Scope To Secure Proper Wave Patterns. Typical 'Scope Pictures Illustrate Methods Of Operation

THE OSCILLOSCOPIC representation of a particular a-c wave may take several different forms. For this reason, it is important that the influence that the various controls of the 'scope exert on the pattern be determined and recognized.

As an example, let us take Fig. 1. This is a Lissajou figure of two a-c waves, identical in frequency, applied simultaneously to both the horizontal and vertical inputs. To obtain this picture, the local sawtooth oscillator was turned off by means of the switch on the coarse frequency control. In this picture the two voltages were photographed at the moment they were 90° out of phase. An elliptical figure is the result of the amplitude of the horizontal input signal being higher than that to the vertical input. If both voltages were of equal amplitude, as well as frequency, a perfect circle would result.

Fig. 2 shows a Lissajou pattern of a 2:1 frequency ratio. Assuming that the input to the vertical amplifier of the 'scope is a 60-cycle wave, the input to the horizontal amplifier is thirty cycles. In other words, the vertical

¹See article on *How the Scope Works* in January, 1948, SERVICE, for basic scope-operation data.

by ALVIN A. BAER

Meybaer Radio
New York City

trace has moved up and down twice, while the horizontal trace moved across the face of the screen once. Here again the phase relationship will change the appearance of the resulting figure.

Figs. 3 and 4 show frequency ratios of 3:1 and 4:1, respectively. The patterns usually rotate slowly, and may be likened to figures holding hands, and slowly turning in a circle, like children dancing. As in the previous illustrations, the frequency ratio is de-

Fig. 13. The setup that was used to create the patterns described in this paper.

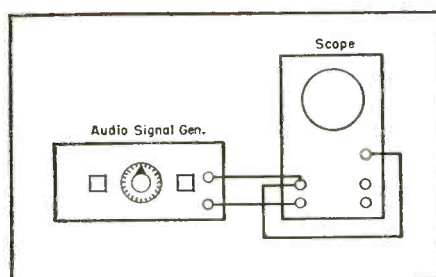

termined by counting the peaks.

Fig. 5 shows a complicated voltage ratio, 3:2. It will be noted that three peaks can be counted vertically, while two peaks appear horizontally.

It is suggested that the 'scope user acquaint himself with these various forms, by applying 60 cycles to the horizontal input and the output of an audio signal generator to the vertical input. Most 'scopes have a 6-volt 60-cycle binding post on their panel, which can be used for this source, by connecting to the horizontal input; Fig. 6.

Lissajou figures may be considered as an indirect representation of a-c wave forms. By using the local sawtooth oscillator, which is usually connected internally and controlled by means of the coarse and fine frequency controls, a direct representation of a-c forms in more familiar pattern may be obtained.

Here, again, the 'scope controls will be responsible for the patterns obtained. This point is graphically demonstrated in Figs. 7, 8 and 9. In Fig. 7, a high frequency a-c waveform has been correlated with the positioning of the fine and coarse-frequency controls, so that three peaks are displayed. An examination of the picture shows

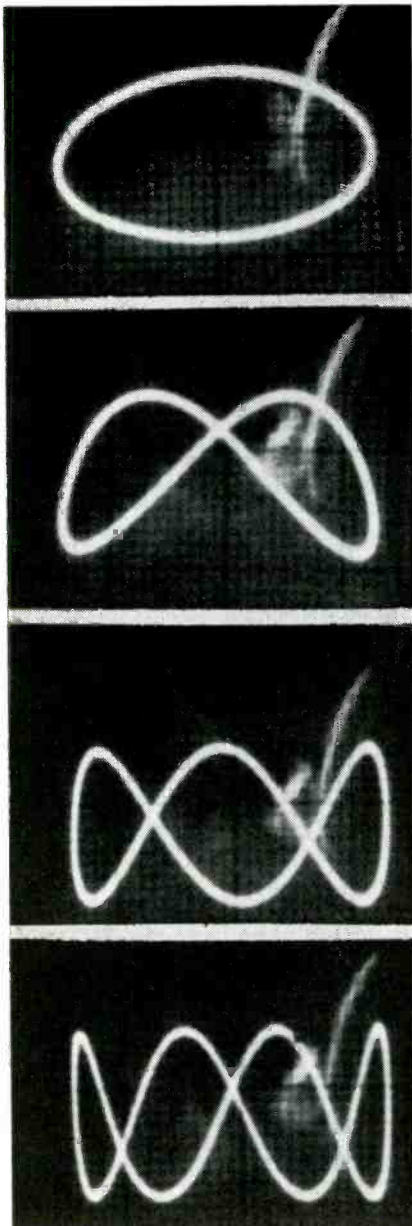

Figs. 1, 2, 3 and 4 (top to bottom). Fig. 1 illustrates a Lissajous figure of two a-c waves, identical in frequency, applied simultaneously to both horizontal and vertical inputs. In Fig. 2, we have a Lissajous figure of a 2:1 frequency ratio. Figs. 3 and 4 illustrate patterns with frequency ratios of 3:1 and 4:1.

fine waveform in conventional display; frequency is 5,000 cycles.

Fig. 8 is another picture of the same

Figs. 10 and 11 (left and right). In Fig. 10 appears an aggravated form of Fig. 9, with a hum potential increased so that the modulating effect of hum is more evident. Fig. 11 shows what happens when the two frequencies are more closely associated.

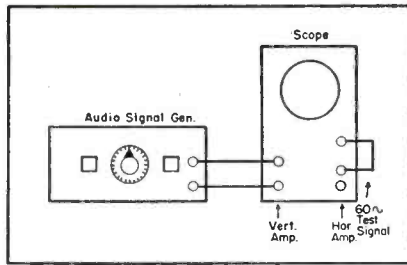
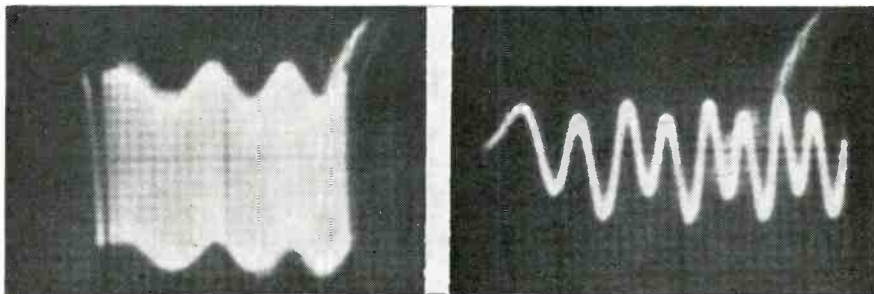

Fig. 6. Applying 60 cycles to the horizontal input and the output of an audio signal generator to the vertical input to study 'scope patterns.

wave, but the frequency of the local sawtooth oscillator has been reduced, by means of the frequency controls, so that many more peaks appear. The wave detail has been reduced, and the result is a series of closely spaced sine waves.

Fig. 9 shows the same wave at a much lower setting of the frequency control. Now, the high-frequency wave appears as a solid wall. However, it will be noted that there is a ripple on both the top and bottom of the signal. This ripple effect betrays the presence of some secondary a-c voltage in the signal. By noting the coarse-frequency control setting, an approximation of the frequency of this secondary voltage may be determined. In this case it happens to be 60-cycle hum. It will be noted that there is a resemblance between this picture and the conventional representation of a modulated signal. It can be seen then that two audio frequencies may act the same as a modulated signal.

Fig. 10 shows an aggravated form of Fig. 9. Here, the hum potential has been increased, so that the modulating effect of hum is more evident.

Whereas Figs. 9 and 10 show the intermodulation of two widely separated audio frequencies, Fig. 11 shows what happens when the two frequencies are more closely associated. This pattern is an extreme representation of a fundamental sine wave and its second harmonic. Fig. 12 shows what has actually happened. It is important that the voltage relationship be kept in
(Continued on page 43)

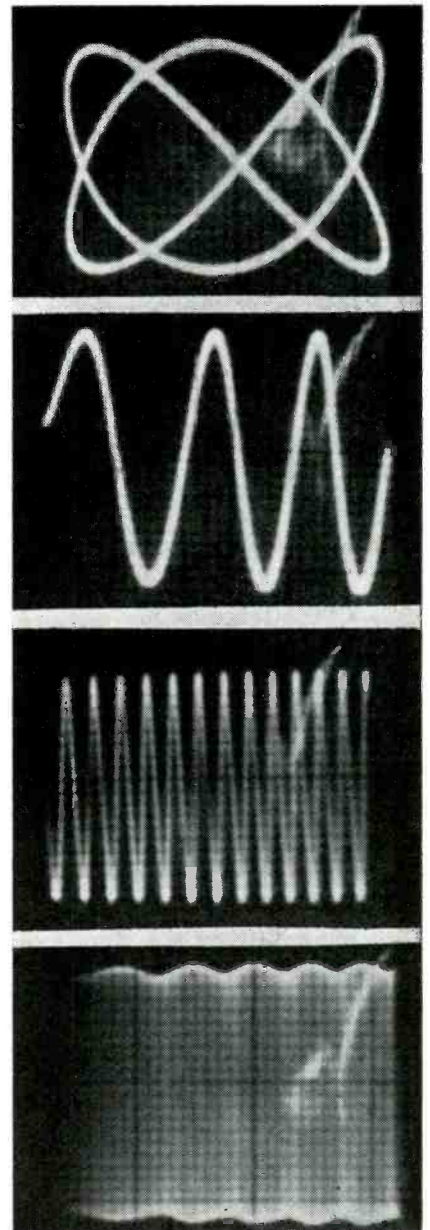

Figs. 5, 7, 8 and 9 (top to bottom). Fig. 5 shows a complicated voltage ratio of 3:2. In Fig. 7 we see three peaks that result from a correlation of a high frequency a-c waveform by positioning of the fine and coarse frequency controls. In Fig. 8 appears another picture of the same wave (Fig. 7), but the frequency of the local sawtooth oscillator has been reduced by means of frequency controls so that many more peaks appear. In Fig. 9 we see the same wave but at a much lower setting of the frequency control.

Fig. 12. In Figs. 9 and 10 we have the intermodulation of two widely separated audio frequencies and in Fig. 11 is shown what happens when the two frequencies are more closely associated. Patterns in this figure illustrate what has actually happened in these three instances.

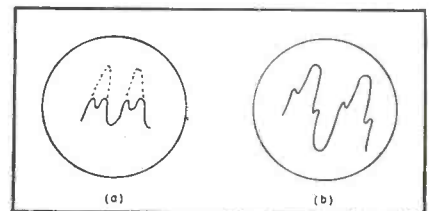

Conversion Efficiency Of Loudspeakers

Obtaining Maximum Intensity of Sound With Minimum Power Input. Sound Pressure Value Chart Shows Power Required Per Speaker, Distribution Angle And Proper Size Amplifier Required

THE ABILITY to make an efficient sound survey and then submit an estimate with the assurance that it will be competitive, is limited almost wholly by the Sound Man's technical background and experience. The most common obstacle to the successful planning of any p-a installation is the problem of providing satisfactory

by **E. M. EDWARDS**

sound in different types and sizes of industrial areas where considerable variations in noise level exist. Not only must great care be exercised in the selection of the proper speakers for optimum voice or music distribution or both, but of equal importance,

the number of speakers necessary and the determination of the amount of audio power required to drive each speaker at the desired level. The solution of the latter automatically provides the answer to the sound installations chief pitfall — the economic choice of loud-speakers and amplifier.

Available data which treats sound coverage in terms of number of watts input required for so many cubic or square feet of area for a given industry, in many instances disregards the efficiency of the loudspeaker in its calculations. Since the ultimate purpose of a sound system is to provide sound at a predetermined level, merely specifying watts input per speaker without taking into consideration the *conversion efficiency* of the particular speaker is quite misleading.

The conversion efficiency of a loudspeaker is the ratio of the useful acoustical output to the electrical power input. Constantly improving techniques in the design of unit-driven reflex projectors have reflected themselves in conversion efficiencies of the order of 40 to 50% as compared with 2 to 10% of the conventional cone speaker. The difference in input power requirements for a given sound output thus becomes very apparent.

Since large-scale reproduction of sound has become commonplace, efficiency becomes an all-important consideration. High-power audio frequency amplifiers are costly and it becomes logical to reduce the amplifier output to a minimum by the use of high efficiency speakers. The price differential between a 35-watt amplifier, which may represent the maximum actually required for a well planned system and a 100-watt amplifier determined from haphazard data, automatically reflects itself in the final price quotation and can readily spell the difference between a successful transaction and the loss of a sale.

In table I appear data disclosing the sound levels available from an as-

(Continued on page 42)

Trumpet ^{aa}	Driver Unit ^{aa}	Dispersion Angle	Watts Input to Voice Coil	Sound Pressure in db*				
				Distance from Loudspeaker				
				10'	20'	40'	80'	160'
Reflex ¹	25 Watts ^a	90°	1 Watt	103	97	91	85	79
Reflex ²	25 Watts ^b	90°	1 Watt	100	94	88	82	76
Reflex ³	25 Watts ^b	90°	1 Watt	100	94	88	82	76
Reflex ⁴	25 Watts ^b	80°	1 Watt	100	94	88	82	76
Reflex ⁵	12 Watts ^c	75°	1 Watt	96	90	84	78	72
Radial Reflex ⁶	25 Watts ^a	360°	1 Watt	93	87	81	75	69
Radial Reflex ⁷	25 Watts ^b	360°	1 Watt	90	84	78	72	66
Radial Reflex ⁸	12 Watts ^c	360°	1 Watt	86	80	74	68	62
Radial Reflex ⁹	25 Watts ^b	360°	1 Watt	90	84	78	72	66
Paging/Talk Back ⁹	Built-In	90°	1 Watt	95	89	83	77	71
Radial Communication/Talk Back ¹⁰	Built-In	360°	1 Watt	85	79	73	67	61
Paging/Talk Back ¹¹	Built-In	120°	1 Watt	87	81	75	69	63
Paging/Talk Back ¹²	Built-In	90°	1 Watt	97	91	85	79	73
Radial Communication/Talk Back ¹³	Built-In	360°	1 Watt	87	81	75	69	63
Submergence Type Unit ¹⁴	Built-In	360°	1 Watt	84	78	72	66	60
Submergence Type Unit ¹⁵	Built-In	150°	1 Watt	91	85	79	73	67
Submergence Type Unit ¹⁶	Built-In	120°	1 Watt	91	85	79	73	67

aa, bbUniversity

¹Type GH with 6½' air column and 85 cycle low-frequency cutoff; type LH with 4½' air column and 120-cycle low frequency cutoff.

²Type GH.

³Type LH.

⁴Type PH with 3½' air column and 150-cycle low-frequency cutoff.

⁵Type SMH with 2½' air column and 200-cycle low-frequency cutoff.

⁶Type RLH with 5' air column and 120-cycle low-frequency cutoff.

⁷Types RLH and RPH, RPH having a 4' air column and 150-cycle low-frequency cutoff.

⁸Type RSH with 3' air column and 180-cycle low-frequency cutoff.

⁹Same as 8.

¹⁰Type IB-8; 12 watts, 300 to 6,000 cycles.

¹³Type MM-2; 15 watts, 300 to 6,000 cycles.

¹¹Type IB-8; 12 watts, 300 to 6,000 cycles.

¹⁴Type MM-2TC; 15 watts, 300 to 6,000 cycles.

¹²Type MIL; 3 watts, 400 to 9,000 cycles.

¹⁵Type PAH, 80 to 6,000 cycles.

¹³Type CR; 18 watts, 250 to 6,000 cycles.

¹⁶Type SAH, 90 to 10,000 cycles.

¹⁴Type RCR; 18 watts, 250 to 6,000 cycles.

¹⁷Type MAH, 100 to 6,000 cycles.

¹⁵Type MSR; 15 watts, 250 to 6,000 cycles.

*Measured with G-R sound level meter 759B (0 db, 10⁻¹⁰ watts per sq. cm. (.0002 dyne)).

Note I: To increase the sound pressure 3 db, double the input power. To increase it 6 db, quadruple the input power.

Note II: Doubling the distance from the loudspeaker will result in a drop of 6 db. Reducing the distance to the loudspeaker 50%, will result in an increase of 6 db.

Table 1. Sound pressure values measured on mouth axis.

Uniform Resistance

Mallory carbon
controls are accurate
in overall
resistance value



You will find no variation in the resistance values of Mallory carbon controls. Frequent, critical inspections reject the imperfect, and pass only those carbon elements of the resistance values specified on the labels.

Recently dozens of controls from leading manufacturers were tested competitively for overall resistance value. Mallory controls averaged within 2% of specified resistance, the closest tolerance of any group in the test.



Every carbon element that goes into Mallory controls is individually inspected to be sure that its resistance value is the same as specified on the labels.

In volume controls you look for uniform

resistance, accurate tapers, silent operation and long life. Mallory gives you all four, and more, too. The Mallory trade mark is your assurance that the volume control, vibrator or capacitor you buy is the finest that can be made.

The Mallory 1485 Control Deal

This attractive metal cabinet contains the 15 Controls and 9 Switches that will take care of 90% of your service calls. Its arrangement makes inventory control almost automatic—saves you frequent trips to the distributor's counter. It contains a rack for your Radio Service Encyclopedia. You pay only for the Volume Controls and Switches; the cabinet is included in the deal at no extra cost to you. Check your Mallory distributor on this special offer.

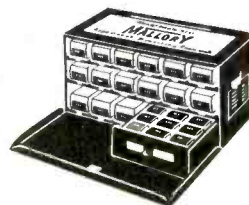

Visit us at
Booths 84, 85, 86
I. R. E. Show
Grand Central
Palace
New York
March 22-25

P. R. MALLORY & CO., Inc.
MALLORY

CAPACITORS . . . CONTROLS . . . VIBRATORS . . .
SWITCHES . . . RESISTORS . . . RECTIFIERS . . .
VIBRAPACK* POWER SUPPLIES . . . FILTERS

*Reg. U. S. Pat. Off.

APPROVED PRECISION PRODUCTS

P. R. MALLORY & CO., Inc., INDIANAPOLIS 6, INDIANA

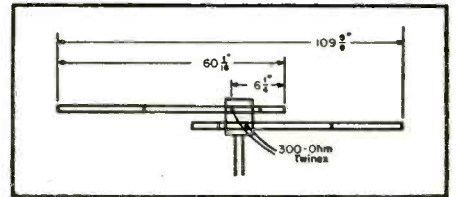
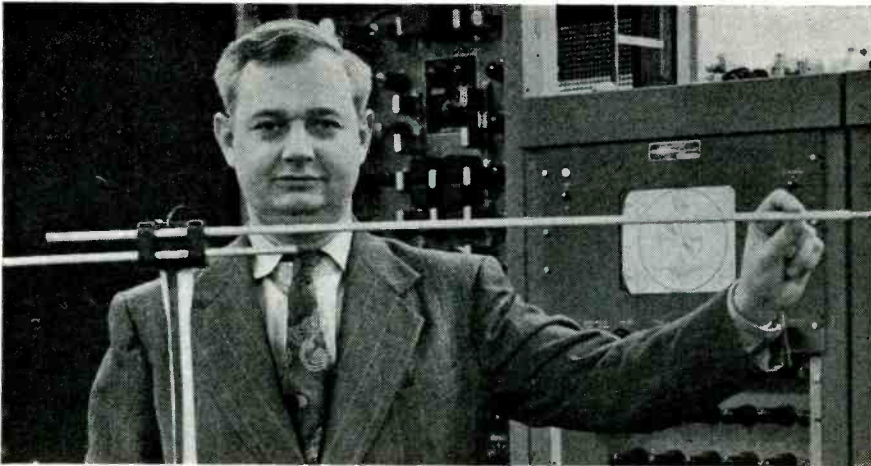

Fig. 2. Converting an f-m dipole for tv use on channels 1 to 6. The $\frac{1}{4}$ " tubing is telescoped inside of the original elements.

Fig. 3. Don H. Kresge of Bendix Radio with a converted f-m antenna.

Servicing Helps

F-M/TV Dipole Antenna Length Chart ... Converting F-M Dipole For TV Use ... Installing Crystal Filter in Hallicrafters S-40

SERVICE MEN are often confronted with the problem of determining lengths of antennas to be used for television and f-m, particularly, where it is possible to operate on indoor systems. The plot of Fig. 1 will come in quite handy for this purpose. It provides the lengths of antennas for the thirteen channels from 54 to 216 mc,* and includes the f-m and tv bands.

The chart was plotted for straight dipole antenna types which, by the way, can be made of twin conductor material such as twinex,¹ which is available in 300-ohm, 150-ohm and 75-ohm impedances.

As a check on the accuracy of the length of the antenna provided by the plot, the following formula can be used:

$$L = \frac{1}{2} \text{ wavelength}$$

$$L_{\text{feet}} = \frac{492 \times .94 \text{ (end effect)}}{\text{frequency (mc)}}$$

$$L_{\text{inches}} = \frac{5,549.76}{F_R \text{ (mc)}}$$

To achieve comparatively broadband coverage with these antennas, the lengths should be cut for the mid-frequencies of the desired bands, closer to the preferred station. Incidentally, the lengths can be made 4" or

by **P. M. RANDOLPH**

5" longer and snipped off during testing.

In placing the indoor antennas, it is necessary to spot them carefully in the room since the height, length and width of the room controls the operating efficiency of the antenna.

Warning

Indoor tv antennas will only work satisfactorily where a substantial signal exists and there are few surrounding interfering elements. While the indoor antennas will work in some locations effectively, the outdoor antennas will always provide best results.

F-M Dipole Conversion

Outdoor f-m antennas of the dipole type² can be converted to provide pick-up for low tv bands, one to six.

¹Amphenol, Federal, etc.

²Bendix ADIFOO.

*Channel 2, 54-60 mc; 3, 60-66 mc; 4, 66-72 mc; 5, 76-82 mc; 6, 82-88 mc; 7, 174-180 mc; 8, 180-186 mc; 9, 186-192 mc; 10, 192-198 mc; 11, 198-204 mc; 12, 204-210 mc; 13, 210-216 mc.

**Television f-m antenna-length plot prepared by David A. Miller.

***Television conversion data prepared by D. H. Kresge, Manager, Radio and Television Service, Bendix Radio.

The method of conversion is shown in Fig. 2. Two long pieces of tubing ($\frac{1}{4}$ x 30") are inserted in the ends of the f-m antenna elements to form two new elements, each measuring 60 $\frac{1}{4}$ " long. These new pieces of tubing may be made to press fit snugly inside of the original f-m dipole elements by slightly flattening the ends of these original elements.

The total length of this antenna will be 109 $\frac{3}{8}$ ". Completely new elements may be used; .375" OD, .049" wall.

Installing Crystal Filter I-F In S40

MANY SERVICE MEN have inquired about the installation of a crystal filter unit in professional type receivers, such as the Hallicrafters S40. The conversion may be made by changing the first i-f stage, shown in Fig. 4, to a crystal filter unit as shown in Fig. 5. The unit can be installed temporarily via a 5-prong socket or permanently.

The permanent installation requires a selectivity control (a 250,000 ohm pot) with a s-p-d-t switch for cutting the crystal filter network in and out of the circuit.

Two additional controls for selectivity and phasing, will have to be installed on the front panel.

A crystal i-f transformer will also be needed. If such a transformer is not

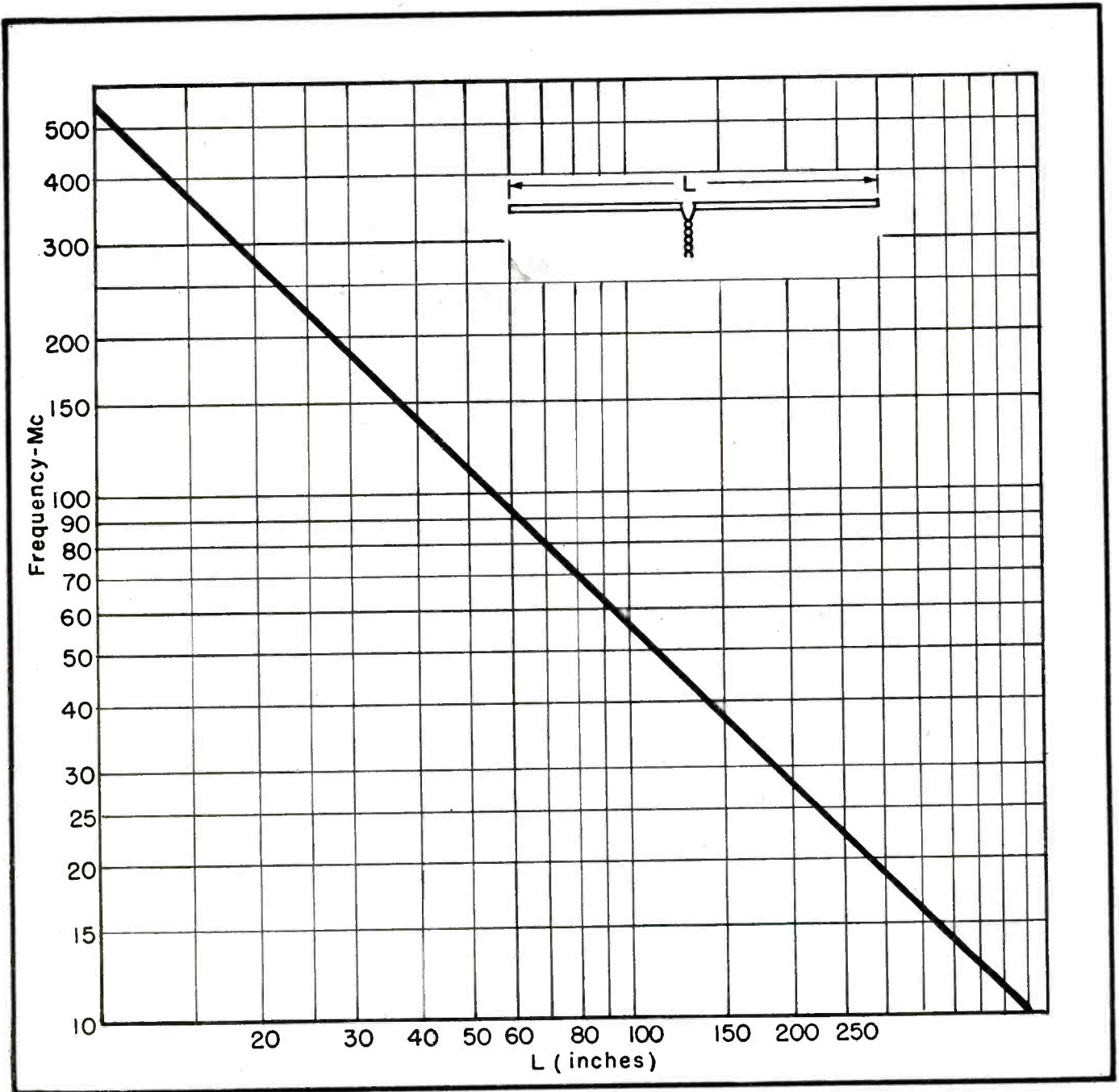

Fig. 1. Plot providing lengths of antennas to be used for television and f-m on all 13 channels.

readily available, a standard iron core type i-f transformer may be converted to the purpose. It is only necessary to remove the shunt capacitor from the

secondary, and tighten the coupling between primary and secondary. Since less inductance is required on the secondary than in conventional transformers, the iron core should be adjusted until most satisfactory operation is obtained.

resonant at the i-f frequency. This may be constructed from the secondary of

(Continued on page 47)

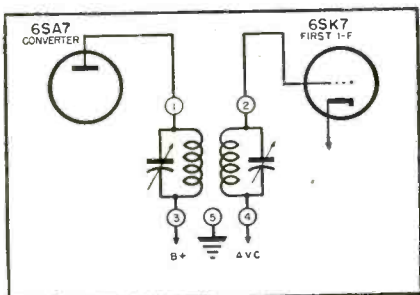

The tuned circuit in the grid return of the first i-f is a tuned circuit

Fig. 4 (left). The first i-f coupling circuit in the Hallcrafters S40.

Fig. 5. Circuit of Fig. 4 converted to a crystal filter system. Points 1 to 5 refer to socket contacts if a removable type of filter is planned. A limiting resistor of 5,000 ohms is used in series with the selectivity control to prevent shorting of the first i-f grid circuit.

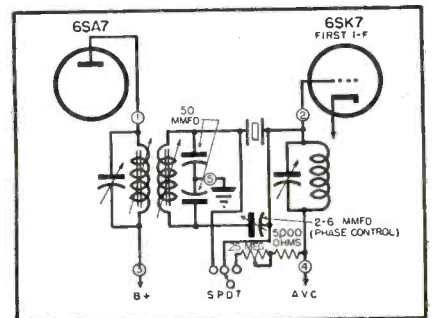

ASSOCIATIONS



ARSNY

THE FIRST BULLETIN of the Associated Radio Servicemen of New York, Inc., was released recently. Edited by Kurt J. Goldbeck, the bulletin covers the report of the grievance committee, the recently inaugurated disabled veterans' project and other association news. The grievance committee report stated that only twenty complaints had been received after the committee's offer to handle customer complaints had been published. And seventeen of these complaints were settled immediately. As a result of this excellent record, many of the broadcast commentators who had been critical of Service Men activity in New York revised their opinion and went on the air praising the Service Men and urging the Service Men to join the ARSNY.

An unusual disabled veterans project is being studied by ARSNY. The plan suggests that Service Men who have inoperative or unsaleable receivers should donate them to the associa-

tion for repair and transfer to the veterans' hospitals. Volunteers from the association will devote time and services to make the necessary repairs. Hal Sheffel, who produces a program on WMCA entitled "Something Should Be Done About It," has been supporting this interesting project during his broadcasts. WMCA is carrying spot announcements, publicizing the veterans plan, too.

Offices of the Associated Radio Servicemen of New York, Inc., are now at 545 Fifth Avenue, New York 17.

LVRSA

GORDON JACOBY, corresponding secretary of the Lehigh Valley Radio Service Association, Allentown, Penna., has notified us that their 15th Annual Banquet and Electronics Exhibit will be held on March 29th at the Elks Club in Phillipsburg, N. J.

During a recent meeting, the executive committee of the association was

instructed to study the proposal to join the Federation of Radio Servicemen's Association of Pennsylvania.

RTG

JAMES L. SHEPLEY, secretary of the Radio Technicians' Guild, Whaling City Chapter, New Bedford, Mass., has reported that a new set of bylaws have been prepared for the association.

Standish L. Smith of the New England Telephone and Telegraph Co. addressed a recent meeting of the RTG on audio response. Mr. Smith, who was a communications officer during the recent war, analyzed such factors as flat response, binaural effects, cabinet resonance and audio degeneration. The boys were told how audio degeneration can be used to overcome distortion in the amplifier. Mr. Smith also described the use of high and low-pass filters for boosting

(Continued on page 47)

TEN YEARS AGO

From the Associations News page of SERVICE, March, 1938

TWENTY-FOUR local chapters had joined the RSA. . . . The first issue of RSA house organ had been mailed. Featured were circuit diagrams of Zenith receivers. . . . The chief engineer of KDAL, addressed the Duluth chapter of RSA, discussing broadcasting and the Service Man. John T. Springer, Ed Nys and Gary Kasberg were in charge of another meeting during the month held at a night club. . . . Don Stover and S. A. Frank were chosen as nominees for District Ten of the Freeport Chapter of the RSA. A. G. Mohaupt presented an interesting lecture on the 'scope during one of the meetings. . . . The Flint Chapter celebrated its first year of affiliation with the RSA with a dinner and dance. At an election meeting, W. Stiles was elected president, H. Wilke, vice president, James Pugh, secretary, and W. Mudge, treasurer. . . . John Rose was nominated for the office of director from District Nineteen of the Binghamton Chapter of RSA. Walter

Jones of Sylvania spoke to the boys at a meeting at Ithaca, N. Y. . . . The Jackson Electrical Instrument Co. sponsored a talk on test equipment before the Chicago Chapter of RSA. During a previous meeting, eleven manufacturers of test equipment participated in an instrument show. . . . The metropolitan New York Chapter of RSA prepared a series of technical meetings under the supervision of Ed Mandeville. George Duvall was chairman of the chapter, Selig Rosengarten, secretary, and J. J. Gonoud, treasurer. . . . A cooperative advertising campaign was planned by the Manchester Chapter of RSA. The chapter also adopted a new constitution. . . . RCA sponsored a technical session for the Davenport Chapter, which was held in the People's Power Building, Moline, Illinois. Klauss Electric Company donated door prizes. . . . Horace Perry, member of the Boston Chapter of RSA, presented a talk on the use of test equipment. Plans were

announced for a cooperative advertising campaign to promote the betterment of servicing conditions in the Boston area. . . . B. Burlingame talked to over 100 members of the Newark RSA Chapter. . . . RCA and Philco arranged for technical sessions before the Newark chapter. . . . D. C. Shaw, branch manager for United Motors Service Company, talked before a group of the Buffalo chapter on "What Follows Saturation." At another meeting Mr. Gerhardt of Philco discussed the subject of "Servicing Ten Million Philcos." . . . George Becker of the Multi-Arc Labs. addressed the Radio Service Association of California, analyzing vacuum tube manufacturing problems. At another meeting Charles F. White of the University of California told the boys about "Distortion in Diode Detection Circuits." He also presented some interesting facts on the "new infinite impedance detector."

**NEW!
VERSATILE!
EFFICIENT!**



TUBE CHECKER YTW-1



Obsolescence is the big problem with tube checkers. The new YTW-1 has been especially designed to guard against early obsolescence. Blanks, mounted with locking rings, for easy removal, provide for future tube types that may be developed. This, together with exceptional circuit switching flexibility, makes the YTW-1 an outstanding piece of equipment—the tube checker you must have on your bench.

The YTW-1 is crammed full of features which servicemen will appreciate. Study them carefully—then place your order.

- Checks virtually all receiving type tubes, including the nine pin types. Tuning indicator tubes are checked by visual indication—just as if they were operating in a set.
- Tube checker "short" light remains "on" unless there is a short. This gives constant indication of the YTW-1's operation.
- Loads are so chosen that tubes "on their way out" will show up as weak or questionable, even though their mutual conductance may be within factory tolerances. This is a prime advantage of the emission check.
- Where tubes have internal "jumpers" it is possible to tell that "jumpers" are present and they are indicated on the roll chart by asterisks.
- Makes "short" tests with minimum stress on delicate tube elements. It is possible to directly identify the shorted elements.
- Like numbered pins on all sockets are connected—sockets for tubes developed in the future, easily connected.
- Roll chart is placed directly under the levers for easy reading and fast operation and can be readily removed for replacement.
- The YTW-1 includes an exceptionally accurate d-c voltmeter.

Save time—save money—speed service—order the YTW-1 today. For complete information write: *General Electric Company, Electronics Park, Syracuse, N. Y.*

GENERAL  ELECTRIC

164-G2

SERVICE, MARCH, 1948 • 29

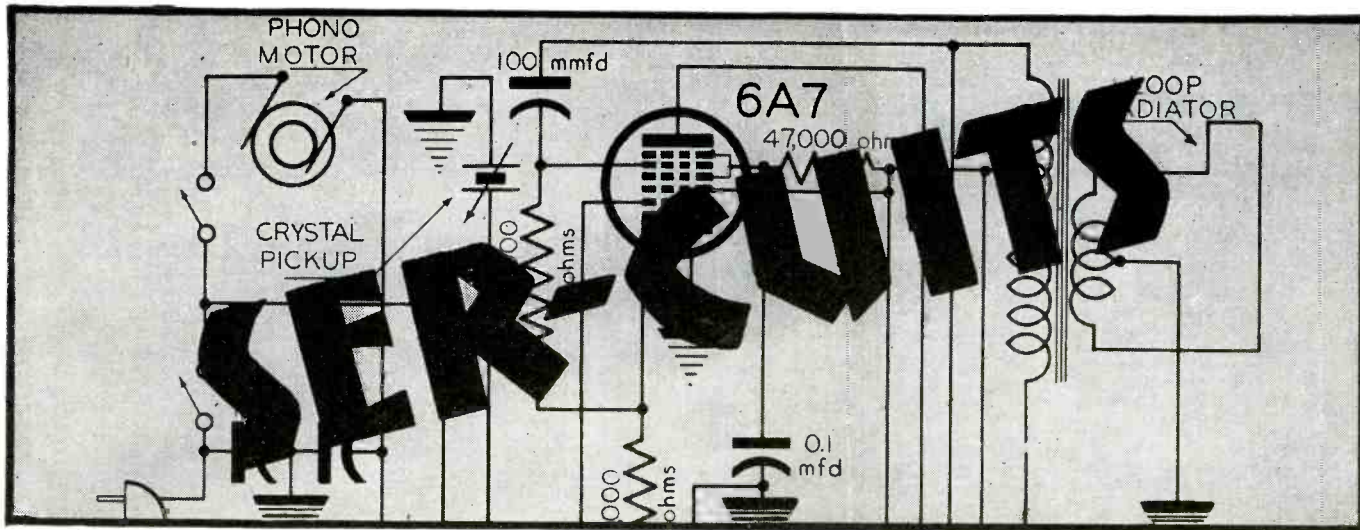

Analysis of TV Receivers Using Electrostatic-Deflection Picture Tubes and Magnetic-Deflection Projection-Type Picture Tubes; Motorola VT71, Belmont 21A21 And G. E. 901 and 910

MANY CIRCUIT INNOVATIONS have been incorporated in the new tv receivers.

In Fig. 1 appears an interesting example of this advanced type of design. Here we have the Motorola VT71, featuring an electrostatic picture tube, the horizontal scanning being at 15,750 cps and the vertical scanning at 60 cps. The receiver, a 14-tube direct-viewing model, features an automatic brightness stabilizer and automatic gain control. The picture i-f carrier frequency on channels 1 to 6 is 26.4 mc and on channels 7 to 13, 22.5 mc. The sound i-f carrier frequency on channels 1 to 6 is 21.9 mc and on channels 7 to 13, 27 mc. Audio discriminator bandwidth is 250 kc between peaks.

The r-f unit consists of a 6AG5 r-f amplifier and a 7F8 dual triode, one section of which is the r-f oscillator and the other the converter. Switching is accomplished by means of a three-wafer eight-position station-selector switch, providing complete coverage of the thirteen channels. Iron core coils, mounted to the switch wafers provide the correct impedance match of the antenna input to the 6AG5 r-f amplifier and also provide channel selectivity. Since the input impedance of the r-f amplifier decreases inversely as the square of the frequency, this impedance becomes comparatively low for channels 7 to 13. The Q of the circuit is 6 and the bandwidth is 25 mc. Since the band-

width is great, there is no need for tuning here. The coils in the input circuit of the 6AG5 are tuned at the video carrier of its channel, while the coils in the output circuit of the 6AG5 are tuned at the audio carrier of the channel for the lower channel only. This provides a flat-topped input response of the proper bandwidth.

The i-f amplifier is a bit different from the conventional coupled system. Wide-band results are obtained with three stages of i-f. The converter plate uses a tuned transformer and each successive i-f amplifier utilizes one tuned circuit each. The transformer and following plate coils are tuned to different frequencies to obtain adequate gain and bandwidth. The i-f coils are tuned as a group for a bandpass curve. The converter transformer is an overcoupled bandpass transformer, also covering the same bandwidth. To keep the i-f bandwidth constant for all settings of the gain (contrast) control, the input capacity of the controlled tubes must be maintained relatively constant. This is done by using unbypassed cathode resistors. Connecting these control tubes in series from B- to B++ provides a simple means of preventing the disturbing of the load distribution between the two busses.

A contrast control varies the bias of the 6AG5 first and second i-f amplifiers. This is done by connecting the two tubes in series between B++ and B-, providing current flow through

both tubes as a group, returning the grid of the second i-f amplifier to B+ or a fixed voltage. As the grid voltage of the first i-f amplifier becomes more negative, the cathode potential of the second i-f amplifier rises proportionately, effectively causing the grid of this tube to become more negative. Thus, the contrast control controls manually the output of these amplifier tubes and consequently, the output of the video amplifier.

The detector is a half-wave rectifier, using a germanium crystal (1N34), which also acts as converter providing the difference frequency between the video i-f and the audio i-f (it produces a 4.5 mc f-m audio signal).

A pair of 230-microhenry coils and a 15-mmfd capacitor are used as a low-pass filter in the crystal circuit to filter out i-f harmonics. This unit is completely shielded to prevent regeneration. A .1-mfd capacitor and 1-meg-ohm resistor in the input grid circuit of the video amplifier tube, 6AU6, provide a small biasing voltage for the video amplifier and prevent contact potential of the video amplifier from biasing off the crystal and causing a loss of sensitivity on weak signals.

In the video amplifier, the 6AU6 also acts as a noise limiter. The output of the second detector is in a negative direction and noise peaks drive the 6AU6 beyond cutoff, thus being clipped. The video output is taken through a filter network consisting of a 350-microhenry coils and 39,000-

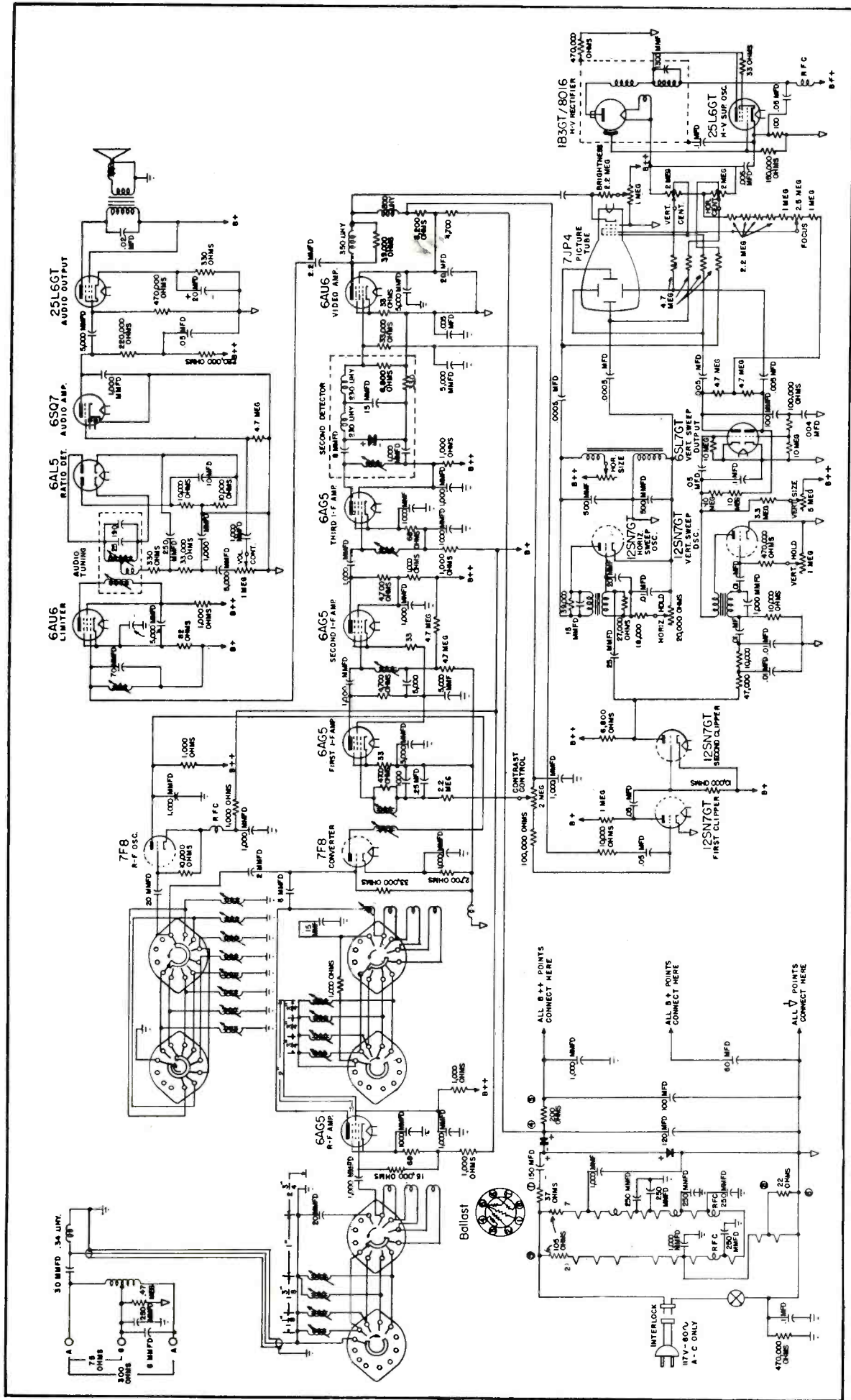

Fig. 1. Motorola VT71 using a 7" electrostatic-deflection picture tube.

ohm resistor, and fed to the cathode of the picture tube; feeding the cathode is equivalent to feeding the grid due to the high picture-tube plate resistance. It is necessary to feed the picture tube this way, because the output of the video amplifier is positive. This filter tends to provide uniform gain of the stage at the higher frequencies.

The a-c brightness stabilization system in this Motorola model is quite unique. Self-bias is developed on the picture tube by the beam current flowing through an 8.2-megohm resistor. The total picture tube cathode current develops a bias voltage across this resistor which automatically sets the correct picture tube bias for line voltage and high voltage variations. The bias is also independent of picture contrast. The video signal is coupled capacitively to the cathode of the picture tube through a .05-mfd capacitor. Thus, the instantaneous average potential developed on the tube varies about the average value of the picture signal.

The second audio i-f frequency (4.5 mc) is obtained from the second detector which acts as a converter for the video (26.4 mc) and audio (21.9 mc) i-f frequencies. This signal is amplified by the video amplifier and removed from the video plate through 2-mmfd and 70-mmfd capacitors and an adjustable iron-core input grid coil, which acts as a bandpass filter. The variable coil is used to peak the filter to 4.5 mc. A 5,000-mmfd capacitor shunted across a 220,000-ohm resistor provide grid leak bias for the limiting amplifier tube, a 6AU6. This tube also provides amplification of the 4.5-mc audio i-f.

Clippers

The triode sections of a 12SN7 are used as a first and second clipper in this Motorola receiver. These circuits serve to separate the horizontal and vertical synchronizing pulses from the video signal, applying them to the horizontal and vertical sweep oscillators. The purpose of the synchronizing pulses is to properly trigger the oscillators at the correct moment and keep the receiver scanning in synchronism with the transmitter. The initial sync separation takes place in this clipper section. The video signal is taken from the output of the video amplifier and fed through a 10,000-ohm resistor and .05-mfd capacitor to the grid of the first clipper. With no sig-

(Continued on page 36)

TRAIN FOR GOOD PAY IN A FIELD THAT ISN'T CROWDED!

**New! Different! Easy to Understand!
Opportunities Everywhere!**

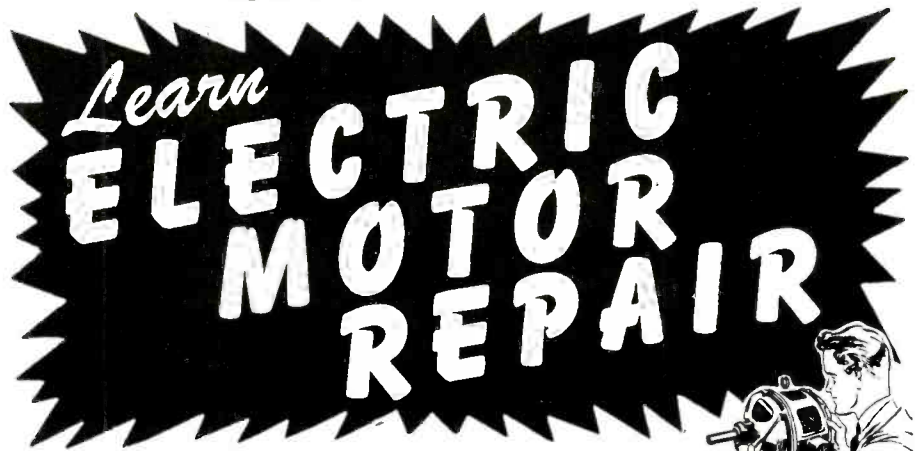

This Big Training Course Book Teaches You Every Step of the Work... for Only \$5 Complete

Get where the real profits are—in Electric Motor Repair! There are more motors than any other type of electrical equipment. Good repair men are scarce and well paid. Now, for the first time in modern training history, you can learn this work at home, QUICKLY, in spare time, for only \$5. **ELECTRIC MOTOR REPAIR**, the big new 570-page training course book is especially written for beginners. No previous experience is needed. Start training now for better pay and big opportunities in a field that isn't crowded.



Based on this big book alone, you can TRAIN FOR PROMPT, PROFITABLE SERVICE ON PRACTICALLY ANY MOTOR IN COMMON USE!

**570 Pages
Over 900
Special
Illustrations
and Diagrams**



PRACTICE FROM IT for 5 full days!

ELECTRIC MOTOR REPAIR BOOK teaches you the work from the very beginning. Over 900 specially prepared diagrams and pictures make your training easier and **TWICE AS FAST**. You learn every step of the work from motor trouble diagnosing to repair—from simple motor cleaning and adjustments to complete rewinding. Covers every type of motor in common use and **BOTH** mechanical and electrical motor control systems. Quick reference guides show exactly how to handle specific jobs. When a certain type of motor comes in for repairs. Just look it up. The book shows exactly what to do, exactly how to do it. Unique Duo-Spiral Binding divides book into 2 sections so that both text and related illustrations can easily be studied together.

"BORROW" IT AT OUR RISK!

ELECTRIC MOTOR REPAIR is the ideal, easy-to-understand book for beginners. Hundreds of motor repair shops use it for training new helpers and for daily use at the bench. Send coupon today! Practice from **Electric Motor Repair** for 5 full days. If not more than satisfied—if you're not fully convinced that, at last, here is the ideal training for YOU, just send the book back. Every cent of your money will be cheerfully refunded **AND NO QUESTIONS ASKED!**

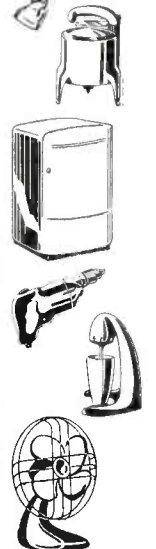

5-DAY MONEY-BACK GUARANTEE

Dept. S-38, Murray Hill Books, Inc.,
232 Madison Ave., New York 16, N. Y.

Send me a copy of "ELECTRIC MOTOR REPAIR" for which I enclose \$5 (\$5.50 foreign); or send book C.O.D. for this amount (no foreign C.O.D.'s) and I will pay Postman \$5 plus postal charges when he delivers it to me. If book is not satisfactory for any reason, I'll return it within 5 days and you guarantee to refund my \$5.

Name
Address
City & Zone State

Mail coupon today! . . .

YOU CANNOT LOSE!

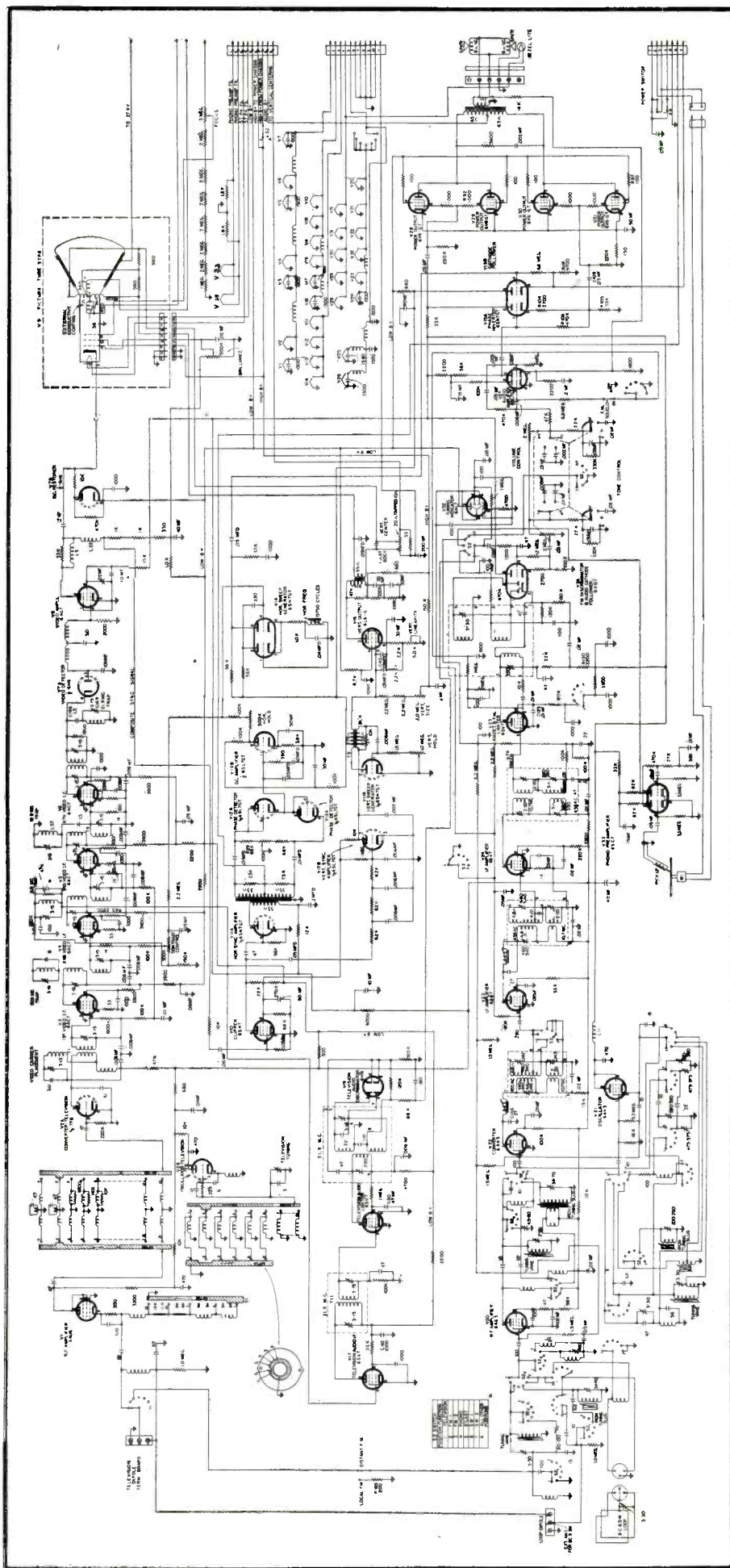

nal applied, the tube has zero bias. With the signal applied the positive polarity sync pulse voltage causes the grid to become positive and draw grid current. This charges the .05-mfd coupling capacitor negatively causing a steady bias voltage to develop across a 100,000-ohm resistor, which is connected to the *agc* circuit and the contrast control, which has a value of 2 megohms. The biasing voltage developed in this manner prevents plate current from flowing except on the positive synchronizing pulses. An amplified current, controlled by these pulses, develops in turn, sync pulses across a pair of load resistors, which have a value of 470,000 ohms and 6,800 ohms. This output is then applied to the grid of another triode section of the 12SN7 where clipping of the outward peaks is accomplished, resulting in double clipping for better syncing of the picture, even under adverse signal conditions. The second clipper grid resistor, the 6,800-ohm unit, is of a low value so as to maintain wide-band response of the sync pulses at this point. Zero bias is used so that the pulses always go negative beyond cutoff for clipping the irregular envelope and noise peaks.

The high voltage power supply is also quite unusual employing a separate high-voltage oscillator, 25L6GT, connected as a triode, which generates a frequency of approximately 140 kc. The r-f plate voltage is stepped up to a peak voltage of over slightly 6,000 through an auto transformer. The primary is roughly tuned to the natural frequency of the high-Q secondary. The 6,000 peak volts appearing on the secondary coil are applied to the plate of the high-voltage rectifier tube, 1B3GT/8016. Current drain is approximately 350 microamperes. Due to peak rectification, the d-c output of the rectifier remains close to peak plate voltage. A .005-mfd capacitor maintains the plate voltage substantially constant for low-frequency load variations. Feedback to the oscillator grid is obtained by a capacitive coupling device consisting of a coil spring mounted around the rectifier tube envelope.

In the voltage divider network, two 2-megohm potentiometers provide beam centering adjustment while an additional 2.5-megohm potentiometer is employed for focusing. The second anode voltage for the picture tube is taken from the common center taps of the centering controls.

The low-voltage power supply provides filament and plate voltage for all

Fig. 3. GE 901 and 910 tv receiver using a magnetic-deflection projection-type picture tube, the 5TP4.

of the circuits, except the high-voltage system. The filament string is a series-parallel circuit arranged to serve the .3-ampere tubes and the .6 ampere required for the picture tube. Filament of the ratio detector and audio amplifier (6S8GT) is placed in series with the picture-tube filament next to B- to reduce the audio hum. Since it is a .3-ampere tube it was necessary to place a 22-ohm resistor in parallel with the filament of the 6S8GT.

Plate supply is a voltage-doubler system using selenium rectifiers.

Belmont 21A21

In Fig. 2 appears another electrostatic-deflection tube tv model, one of the earlier types, using a 7GP4 picture tube. In this model, a 6AK5 is used in the r-f amplifier, with a higher-than-normal bias to reduce the input loading on the high-band coils. A 2,200-ohm resistor is used to damp the low-band coil.

The gain of the r-f amplifier is controlled by an avc voltage developed by the video-detector current.

The antenna is transformer coupled to the input of the r-f amplifier and is connected to a balanced coupling coil to provide a substantially constant input impedance of 300 ohms to the antenna throughout each band.

Inductance of the coils is varied by means of slugs. On the high band, the shunt capacitance (the inter-electrode capacitance of the tube) is large with respect to the coil. To increase the size of the coil and maintain the same effective reactance, a trimmer is connected in series with the coil.

The converter also uses a 6AK5 biased by cathode bias (680-ohm resistor shunted by a 150-mmf capacitor). The oscillator voltage appearing on the grid causes rectification and charges the grid resistor and capacitor combination, a 1-megohm unit and a 4-mmf capacitor.

The output of the r-f amplifier is coupled to the converter through a single tuned plate load 6-mc wide. The converter grid is coupled to the oscillator by the 4-mmf capacitor.

The converter i-f transformer is double-tuned to a center frequency of 25.25 mc and over-coupled to provide a bandwidth of 3.5 mc.

In the oscillator we have a 6C4 connected as a modified Colpitts using the cathode-to-grid and cathode-to-plate inter-electrode capacities to maintain oscillation. The oscillator is tuned 26.5 mc above the picture carrier.

In the video assembly are the first and second i-f amplifier and picture-

(Continued on page 52)

Now... at a sensationally
LOW PRICE!
ECA QUALITY
FM & TELEVISION

Sweep Signal
GENERATOR

\$34⁹⁵ COMPLETE

ECA
ELECTRONIC CORP. OF AMERICA

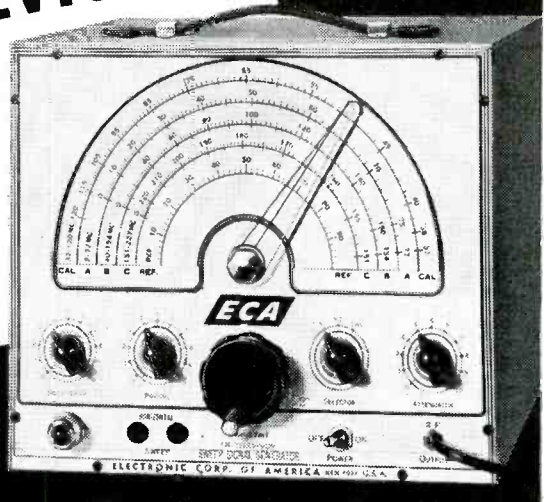

**A MUST
FOR FM
& TELEVISION
SERVICE
SHOPS!**

Here's great news for FM and TV Service Shops! A new, top quality sweep signal generator—product of a manufacturer with vast resources, advanced engineering "know-how", and war-time experience in producing test equipment. **DIRECT FROM THE FACTORY**—at a phenomenally low price!

Ready for delivery
first week in April

FRONT PANEL CONTROLS

- Sweep width 500 KC to approx. 10 MC
- Phasing control
- Tuning vernier control 10 to 1 ratio
- Selecto switch FM—RF—CAL
- RF Output control
- 60 cycle horizontal sweep output
- Amphenol RF output shielded connector

FREQUENCY RANGE

- 3 BANDS**
(No band switching necessary)
(2 to 227 Megacycles)
- 2—77 MC
 - 40—154 MC
 - 151—227 MC
 - Calibration and reference scales
 - Dial scale length

TUBE LINEUP

- 6C4—Fixed frequency modulated oscillator
- 6C4—Continuously variable beat frequency oscillator
- 6C4—Mixer—Cathode follower output tube
- 5Y3—Rectifier tube

GENERAL INFORMATION

- High frequency insulation throughout
- Maximum output 500,000 U/V
- Power required 105-125 Volt 50-60 AC 35 Watts
- Power line filter built in
- Special Midline capacity tuning condenser
- Pilot light line indicator
- Generator output can be used either frequency modulated or pure RF

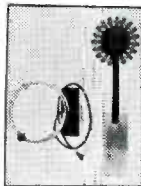

RADIATION LOOP AND ALIGNMENT WAND

Provides loose coupling. Checks loop-oscillator tracking. Increases efficiency of receiver's alignment or mistacking. Enables the service engineer to make gain measurements. Professional appearance and instructions.

results. May be used on any signal generator. Complete with operating instructions. **\$5⁹⁵**

FM FRONTEND

Complete with 3 tubes, including Magic Eye. 88-108 MC.

For use with 10.7 MC I.F.S., high Q resonant tuned lines. Heavy silver overlay on lines and contactors. High frequency insulation throughout I-F stage, detector, and oscillator. Large 7" silderule dial. Chassis floated, non-microphonic.

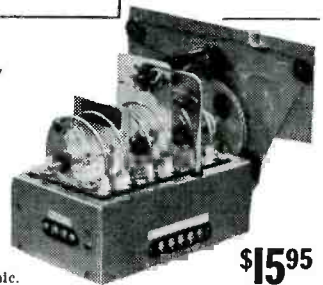

\$15⁹⁵

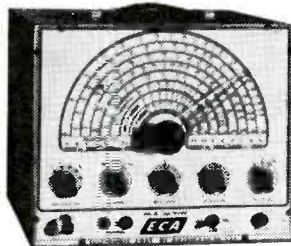

AM SIGNAL GENERATOR

8 RF bands. Frequency coverage 100KC-75 MC. External modulation from 40 to 30,000 cycles. Internal modulation at 440 cycles. Phase shift audio oscillator and internal modulator. A.C. 105 to 120 volts, 50 to 60 cycles. Special Hammarlund variable condenser; 3 step RF attenuator. Continuously variable RF-AF attenuator control. Ultra stable two terminal RF oscillator. Pilot light line indicator. Cathode follower output tube. Modulator percentage continuously variable from front panel. Internal or external, 0 to 100%. Heavy 16-gauge steel cabinet. Complete with 4 (standard brand) tubes. Amphenol co-axial connecting cable, ground cable, operating instructions and guarantee. **\$32⁵⁰**

BACKED BY ECA WITH R.M.A. GUARANTEE. WRITE FOR ECA CIRCULAR ON PARTS AND ADDITIONAL EQUIPMENT. RUSH YOUR ORDER TODAY... TO INSURE PROMPT DELIVERY. ORDERS FILLED IN SEQUENCE AS RECEIVED. PRICES F.O.B., N.Y.C.

ELECTRONIC CORPORATION OF AMERICA

353 WEST 48th STREET • NEW YORK 19, N. Y. • PHONE: CIRCLE 6-1985

Cable Address: ECAEPLT

Tips On Soldering*

Types of Solder and Flux to Use ... Preparing Iron ... Applying Flux ... Pretinning Aluminum Surfaces ... Applying Heat and Solder Properly ... Retinning Surfaces ... Rules for Caring of Iron

WHILE SOLDERING is a relatively simple procedure, there are some rules which should be followed if the soldering is to be successful and the joint soldered a sound one. These rules are simple.

What Is Soldering?

Soldering is the joining together of two metallic materials by means of a third material, solder. This bond is made possible by raising the temperature of the materials to be joined to the melting point of the solder. In joining these materials, the solder goes through four stages: It melts, wets and flows, is drawn into the joint by capillary attraction, and it cools and solidifies.

Equipment

Soldering Iron: The wattage of the soldering iron required for a given job depends on the material to be soldered, speed of soldering required, type of solder used and the relative efficiency of the iron selected. For instance, a copper part of a given size and weight will require more heat to be soldered than a comparable steel part because it conducts heat much faster. The best method of choosing the proper irons in the case of high speed continuous soldering is by test on the work to be soldered.

Solder: Solder is composed of tin and lead in various percentages. The solders most commonly used are 40-60,

Figs. 1a and b (top) and 2a and b (bottom). How to add strength to soldered joint by securing it to a terminal is illustrated in 1a and b. In 2a and b are shown methods of joining wire to gain support in a soldered joint.

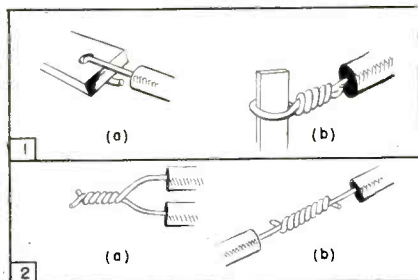

by **R. W. KISE**

*Industrial Heating Division
General Electric Company*

50-50, and 60-40, the first percentage figure indicating the tin content.

The 40-60 and 50-50 solders are good general purpose solders, while

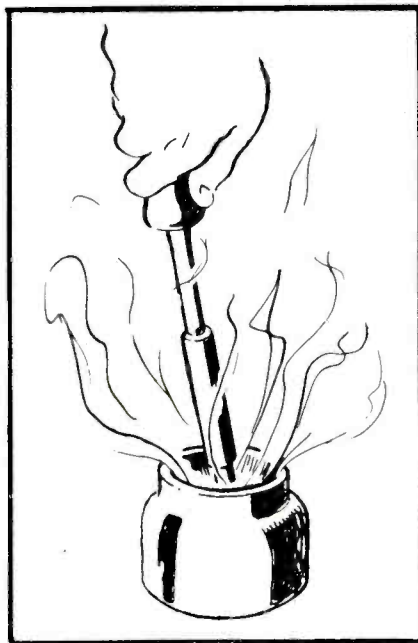
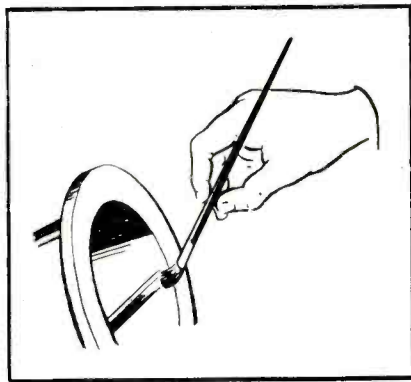

Fig. 3. Flux should never be added to the tip of the iron but to the part to be soldered.

Fig. 4. Applying separate liquid or paste flux with a paddle or brush.



the 60-40 solder is best on high speed continuous soldering and, because it is free-flowing at lower temperatures, is best for the amateur.

Flux: The purpose of a flux is to remove oxide films that are always present, and to prevent further oxidation during the heating of the joint. Flux is no substitute for proper preliminary cleaning where grease, paint, dirt, rust, or heavy oxides are present. Proper selection of the flux depends upon the material to be soldered; see Table 1.

Rosin flux is non-corrosive and should be used when soldering electrical connections and where corrosive residue cannot be removed by cleaning. Rosin should also be used when soldering near insulation or on pretinned surfaces.

In all other cases where the joint can be thoroughly cleaned of corrosive residue after soldering, acid or active flux can be used. This particular flux should be kept away from insulated wire or similar materials, however, since the insulating properties would be destroyed by the acid or acid fumes.

Flux is available (a) incorporated as a core, or in grooves, in wire solder, called flux core solder, or (b) in the form of paste, liquid, or powder for separate application.

Mechanical Strength

Solder should not be depended on alone for strength, whenever it is possible to support the joint by mechanical means. For example, it is often

Fig. 5. Applying iron to joint to secure maximum heat on surface to be soldered.

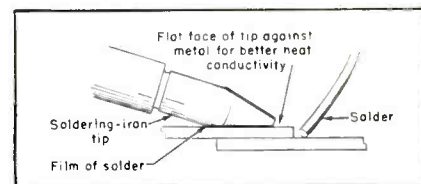

Base Material or Applied Finish	Rosin Flux	Aniline-phosphate Flux	Zinc-chloride Flux
Hot tin dip	Yes	Yes	Yes
Hot solder dip	Yes	Yes	Yes
Electro tin 0.0005"	Yes	Yes	Yes
Electro tin 0.0002"	1	Yes	Yes
Silver plate	2	Yes	Yes
Cadmium plate	3	3	Yes
Nickel plate	No	Fair	Yes
Galvanized steel	No	No	6
Copper	4	Yes	Yes
Brass	4	Yes	Yes
Phosphor-bronze	4	Yes	Yes
Beryllium-copper	No	Fair	Yes
Aluminum-bronze	No	No	5
Silicon-bronze	No	Yes	Yes
Zinc and zinc plate	No	No	6
Monel	No	Fair	Yes
Nichrome	No	No	Yes
Steel	No	No	Yes
Stainless steel	No	No	7

1. Parts finished with 0.0002 in. electro-tin plate should be soldered within a short time. Otherwise, difficulty may be encountered. This thin coating can be preserved if treated in hot palm oil or its equivalent.
2. Electro-silver-plated parts are readily soldered with rosin if the plated parts are soldered within a reasonable length of time after plating. Parts carried in stock over long periods may corrode or tarnish sufficiently to prevent rosin flux from being effective.
3. Cadmium plate over brass, bronze, or copper solders well with rosin-aniline or zinc-chloride fluxes. Cadmium plate over steel is not readily soldered with rosin flux. However, if the steel is given a pre-plate of copper before cadmium plating, then rosin is a very effective flux.
4. Copper-brass, and phosphor-bronze can be soldered with rosin flux if they are mechanically or chemically cleaned prior to soldering. If these alloys have tarnished slightly, rosin flux will not produce good soldering. Chemically cleaned copper, brass, and phosphor-bronze can be protected and preserved with a "water-dip" lacquer coating, which does not impair subsequent soldering.
5. Aluminum-bronze is not readily soldered unless it has been specially cleaned. Kolene cleaning salts are effective.
6. A zinc-chloride flux containing free hydrochloric acid should be used on zinc, zinc-plated parts, or galvanized steel.
7. Stainless steel can be soldered with zinc chloride if it is chemically cleaned, but there are proprietary stainless-steel fluxes, formulated for stainless steel, which are more active than common zinc chloride.

Table 1. Fluxes which can be used on different base materials or finishes.

possible to add mechanical strength to the work by securing it to the terminal with a few turns of the wire; Figs. 1a and 1b. In joining wire, the wire should be twisted together for greater strength; Figs. 2a and 2b. Where facilities are available, spot welding is recommended as a means of obtaining mechanical strength on such items as

(Continued on page 53)

*From an article which appeared in *Mill and Factory*.

FOR QUICKER SALES AND PROFITS

Show. Suggest... Sell

Webster-Chicago RECORD CHANGERS

The Choice of Music Lovers



\$42⁵⁰ LIST

Slightly higher West of Rockies

MODEL 156 with Automatic Stop

Model 156 embodies the most advanced features of record changer design—a vastly improved pick-up arm that accommodates a cartridge of low needle pressure—automatic shut-off—simpler, faster, more positive changer action.

Model 156-27 supplied with G. E. variable reluctance pickup, \$44⁵⁰



\$33⁷⁵ LIST

Slightly higher West of Rockies

MODEL 50 for Small Radio-Phonograph Combinations

Compactly designed for use with smaller radio-phonograph combinations. Precision-built for trouble-free operation. Base dimensions: 12 x 12 $\frac{1}{8}$ in. Vertical space requirements: 6 $\frac{1}{2}$ in. above, 2 $\frac{1}{2}$ in. below top of mounting board.

Made by the Makers of WEBSTER-CHICAGO

Wire Recorders and Nylon Phonograph Needles

WEBSTER-CHICAGO

5610 BLOOMINGDALE AVENUE • CHICAGO 39, ILLINOIS

TRANSVISION

12" TELEVISION KITS— Standard and DeLuxe Models



12" KIT (Table Model)

Picture Size 1½ Times LARGER
than with 10" Tube!

A big 75 square inch picture

Sharp, steady picture achieved with advanced Transvision television circuit. Picture has remarkable brightness even in lighted room (no darkening of room is required). IDEAL FOR HOME or COMMERCIAL INSTALLATIONS.

12" TRANSVISION TELEVISION KIT
Standard Model LIST \$289.00

12" TRANSVISION TELEVISION KIT
DeLuxe Model with Superb Built-in F.M.
RADIO. Tops in value. LIST \$359.00

FM RADIO CONVERSION UNITS:
All Transvision 12" STANDARD Television
Kits can now be had equipped with superb
FM Radio at the following small additional
charges:

For 12" KITS ALREADY ASSEMBLED,
FM Conversion Unit LIST \$12.50

For new 12" KITS (non-assembled), FM
Conversion Unit LIST \$7.95

ENLARGING LENS (15")

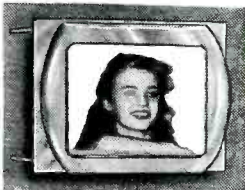

15" Picture Enlarging Lens

ENLARGES
and
CLARIFIES
the
PICTURE



Optically
Ground
and Polished

Engineered by Transvision, this new plastic lens does two things—it enlarges and clarifies the picture. Has wide angle of vision. When placed about 1" from 12" or 10" tube, this lens almost doubles the picture area; when placed further away, it increases the enlargement still more. Optically ground and polished; 50% greater light transmission than equivalent glass lens; 1/3 weight of glass lens of similar magnification power. Equipped with adapter for installation on cabinets.

List

15" lens (125 sq. in. picture)....\$36.95

12" lens (75 sq. in. picture).... 25.95

10" lens (52 sq. in. picture).... 19.95

All prices fair traded. All prices 5% higher west of the Mississippi River.

See your local distributor, or for further information write to:

TRANSVISION, INC. DEPT. S.
385 North Ave. New Rochelle, N. Y.

TV Installation Methods

(Continued from page 19)

antenna must be high and in the clear. Incidentally, it has been found that in city areas the signals often seem to be in layers and an increase in signal strength is often encountered when antenna is lowered. This condition is attributed to a shift in the vertical angle directivity of the antenna as its wavelength above a ground is changed.

In city areas and noisy locations the best antenna position can only be found by searching for it. This is particularly the case when optimum performance is desired on a number of stations. To assist in this task it is wise to set up a phone link between roof and test receiver at tentative receiver location in the house. The antenna is shifted to various positions and performance checked as to signal strength, noise and reflections. When an optimum point is found, antenna is securely clamped in that position.

The antenna installation should be neat, present as little an eyesore as possible, and must be made without damage to customer's property.

Receiver Installation

The actual antenna installation and orientation, made with the assistance of a test receiver, permits a thorough check of antenna performance. While the actual antenna installation is being made the customer's receiver is possibly under test at the shop on its eight-hour continuous run. If any component in the receiver is on the borderline it is likely to go out on this sustained run. In addition the receiver can be tuned, if necessary, and adjusted for peak performance before it reaches the customer's house.

A shop-tested receiver, carefully

conveyed to the consumer's home will provide peak performance as soon as receiver is turned on.

Receiver Positioning and Customer Instructions

The customer's cooperation must be obtained in choosing a position for the receiver. The receiver should be positioned at some point which does not require shifting of furniture whenever the set is to be used. It is preferable to have the equipment away from intense lighting at night and away from bright sunlight for daytime viewing.

Operating procedure should be explained carefully. This is extremely important for a thorough understanding of tuning will provide optimum results for the set owner and free the Service Man from unnecessary call-backs for minor adjustments. The Service Man should observe and guide the customer as he goes through tuning procedures. Concise written instructions can be prepared and left with customer to augment verbal instructions.

Effectiveness of Plan

The foregoing procedures present a direct approach to tv installation. They do not require any increase in man-hours and most definitely cut down return calls and installation uncertainties.

The customer's house is not used for receiver assembly and there is no collection of debris to be carted away. Actually, at the instant the customer's receiver is turned on he will see a clean picture, which is likely to remain so for a considerable period of time.



LOOK TO

THE "SWEETEST" NUT DRIVER YOU EVER USED!



Yes, "sweet" in looks, feel, balance and quality workmanship. It's a genuine XCELITE with new, larger, better gripping handle. Precision-formed blades of top grade tool steel, double heat-treated—polished or chrome-plated. In the sizes you use. Ask your dealer for XCELITE! * Originators—not Imitators

PARK METALWARE CO., INC.
Dept. V — Orchard Park, New York

QUALITY TOOLS

PREFERRED BY EXPERTS

* FIRST TO USE PLASTIC FOR SCREWDRIVER HANDLES

TV Interference

(Continued from page 21)

far as possible from the tv set in the neighboring apartment or home.

Serious Problem

This is a serious problem and requires immediate attention by industry. Mr. and Mrs. Public will become mighty disillusioned when they find that their tv receivers will prompt complaints from their neighbors because of the interference generated by their tv receiver. When regular tv shows are transmitted for the daytime audience and the tv receiver in an apartment house begins interfering with a-m reception, and the Service Man reports that the *beeps* in the a-m set are being caused by "tv receiver interference from the woman on the third floor," quite a bit of explaining will be required. When apartment houses are equipped with amplified a-m master antenna systems, the higher level a-m signals fed into the receivers may mask the level of the sweep-circuit interference.

General Problems

Some of the recently-released low priced tv receivers have compromised their circuits so much that the following defects can be expected.

(A)—Poor image rejection response which shows up badly when the tv receiver is connected to a master antenna system where the f-m signals are at a high amplified level. A bypass filter at the tv receiver antenna input terminals does much to eliminate this interference.

(B)—Unregulated power supplies that throw hold circuits out of adjustment. This condition arises where the line voltage may vary 5 volts or more with the load of receivers, tv sets and electrical apparatus. A regulator³ on the main line supply to the tv receiver will keep the voltage steady. Most shops were never wired to anticipate the load of simultaneous operation of many tv receivers in addition to other equipment.

These new problems supplement the interference signals from prewar diathermy x-ray, ultra-violet and neuro-surgical equipment which flagrantly violates the FCC regulations (over a dozen Eastern companies lease prewar diathermy equipment).

³Sola type.

As great an achievement as Television itself!

HICKOK MODEL 610

TELEVISION ALIGNMENT GENERATOR



A brand new idea in Radio Test Equipment

1. Directly calibrated in frequency—range from 10 megacycles to 250 megacycles.
2. Sweep width completely variable from 0-15 megacycles.
3. Crystal Controlled.
4. Accurate attenuation in five stages—calibrated directly in output ratios.
5. Plenty of voltage output.
6. High degree of accuracy.
7. Coaxial cable—to give minimum standing wave ratio in output line.
8. Phasing Control.

Get all these Features

This new Generator, designed and built with the customary HICKOK skill is a "must" for the Service Man who hopes to do any Television Servicing. The eight features listed above give you some idea of the job it will do. But that's not all. There are 5 other outstanding features so revolutionary, so necessary for profitable Television servicing that we will not disclose them until a substantial number of instruments are ready for distribution. We are now in production on this outstanding addition to the famous HICKOK line. Price \$159.00. Write for further information today.

**Plus 5 OTHER
OUTSTANDING
FEATURES**

THE HICKOK ELECTRICAL INSTRUMENT COMPANY
10521 DUPONT AVENUE CLEVELAND 8, OHIO

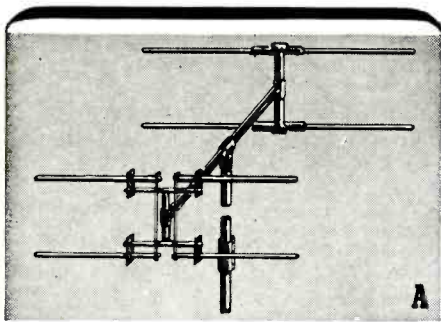

A

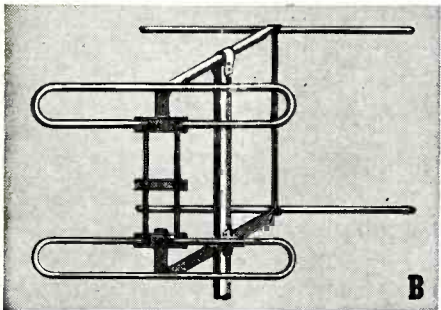

B

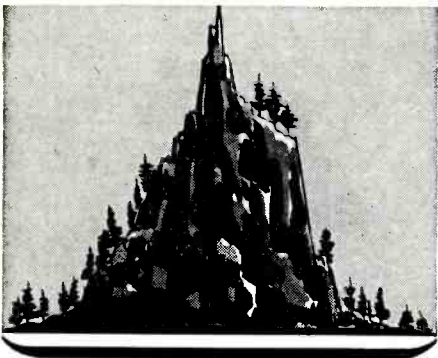

"TOPS"

IN TELEVISION

★What performance! That's what set-owners say about their TACO Television and FM antennas. ★H-type with reflector (A) covers two television bands plus FM bands. Frequency response flat within 3 db. Single H-type adequate within 15-20 miles of typical television transmitter; beyond, with reflector. ★Latest Type stacked folded dipole (B) intended for subnormal signal areas. Stepped-up gain. Highest signal-to-noise ratio. Makes television and FM feasible in otherwise hopeless locations. ★And very important, TACO antennas are exceptionally rugged.

State your reception requirements. Your jobber will provide the correct TACO antenna — for television, FM, AM or short-wave. Latest catalog on request.

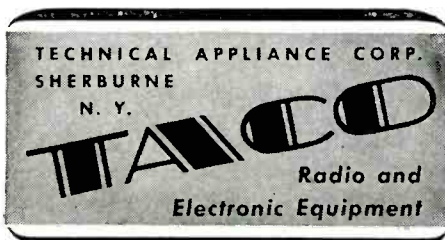

In Canada: STROMBERG-CARLSON CO., Ltd.
TORONTO 4, CANADA

Speaker Conversion Efficiency

(Continued from page 24)

sortment of trumpets¹ using different driver units and the sound levels of loudspeakers with built-in driver units. Particular attention should be paid to the subscript notes, since they are the key to the relationship of power input, sound level and area of distribution. Knowing the dispersion angle of a given speaker and the distance it is to cover, it becomes relatively simple to determine the approximate area of the arc of sound distribution for any pre-determined sound level.

The average noise levels existing in typical industrial plants are shown in table II. Numerous measurements were made in a number of similar industrial establishments with the same sound level measuring instrument employed in obtaining the sound levels in table I and the results averaged. Voice and signals were then transmitted over an amplified system at a volume level sufficient to assure consistent performance. Another series of measurements were made and the results again averaged. From these tests it was determined that a loudspeaker level approximately 10 db higher than the ambient noise level was necessary to satisfactorily override the existing noise. Similar measurements were then made with program material which included incidental music. A loudspeaker level approximately 16-db higher than the noise level was found to be satisfactory. Correlating the information in tables I and II, it became possible to approximate the amount of power required for a given speaker to deliver a pre-determined sound level at a given distance.

In Fig. 1 appears an illustration of conversion efficiency obtainable in a

¹University.

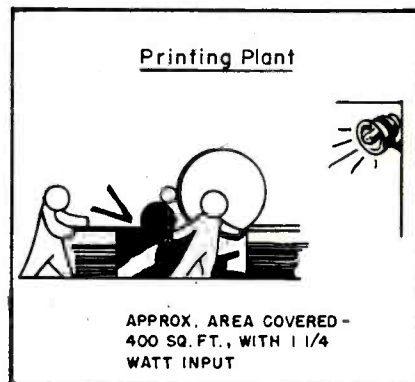

Fig. 1. Conversion efficiency obtainable in a typical installation, using a 12-watt paging and talkback-type speaker. In a machine shop, a reflex loudspeaker trumpet with a 25-watt unit can cover 1,500 square feet with a 5-watt input. A 3-watt paging and talkback speaker can be used in a department store to provide 1,600 square feet coverage with 1-watt input.

typical installation. The sound distribution area served by a specific type of loudspeaker must take into con-

Industry	DB Level
Boiler Factory	105
Riveting	95
Factory (Noisy)	90
Machine Shop (Average)	85
Screw Machine	85
Punch Press	80
Printing Press	80
Restaurant (Noisy)	80
Factory (Average)	75
Assembly Plant	70
Shipping and Receiving	70
Stenographic Room	65
Department Store	65
Restaurant (Average)	60
Stockroom	60
Garage	55
Office (Average)	50
Storage Warehouse	50
Quiet Office	40

Table II. Noise levels for typical industries.

Permoflux SPEAKERS

YOUR JOBBER CAN SUPPLY YOU!

Permoflux quality and dependability—the same as supplied to the major set manufacturers—is your assurance of complete customer satisfaction. You'll find Permoflux Speakers easy to install and readily available in both PM and Electrodynamic types. You'll find too, that it pays to give your customers "tops in tone" with a Permoflux Replacement Speaker.

TWO COMPLETE FACTORIES TO SERVE YOU

PERMOFLUX WRITE FOR FREE BULLETIN

PIONEER MANUFACTURERS OF PERMANENT MAGNET DYNAMIC TRANSDUCERS

PERMOFLUX CORPORATION

4900 WEST GRAND AVE., CHICAGO 39, ILLINOIS
236 SOUTH VERDUGO ROAD, GLENDALE 5, CALIFORNIA

sideration the ambient noise level of the particular industry. Of course, consideration must be given to the likelihood of increased noise due to future changes in physical layout, addition of factory machinery, etc. Obstructions and presence of sound absorbing material will also materially affect sound distribution. Sufficient reserve power must be incorporated in the amplifier to provide for any such emergency.

Units of Area

Although the foregoing technique is universally applicable, no installation is a law unto itself and slight variations may be called for under certain conditions. The sole criteria of a successful system is *ease of hearing* and this can only be accomplished by providing an even and adequate sound level. Working in terms of *units of area* rather than the *over-all area* will accomplish this aim.

'Scope Patterns

(Continued from page 23)

mind. What the 'scope is showing is the voltage sum of two sine waves.

Both waves have started off by increasing in amplitude. However, the harmonic has started to reverse its polarity after following the path of the slower fundamental half way. Thus, we have two voltages, one rising, the other falling. When the fundamental reached its peak, the harmonic was reaching its peak but in the opposite direction. The result was a dip where we should have had a peak. Fig. 12a shows the two voltages in phase. In Fig. 12b, the phase has shifted and the dip appears along the sine curve of the fundamental.

System Used

All of the foregoing patterns were created artificially with a setup shown in Fig. 13. It is suggested that the 'scope user set up the same layout and experiment with various combinations of frequency, using 60 cycles as the base. For example, 3rd, 4th and 5th harmonics may be created, as well as other intermodulation effects. In this manner, complex waveforms may be recognized and analyzed where encountered.

PLACE IT RIGHT ON TOP OF YOUR OSCILLOGRAPH!

DU MONT TYPE 264-A Voltage Calibrator



for peak-to-peak voltage measurements
and calibration of any oscillograph!

HERE'S HOW...

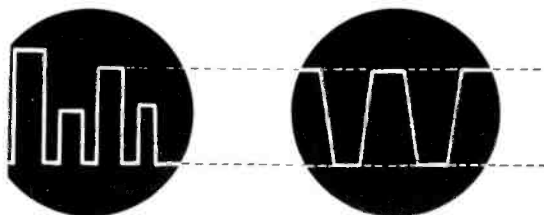

Typical complex signal: peak-to-peak voltages unknown.

Adjust amplitude of this calibrating signal to match any desired peak of unknown signal. Read voltage from dial setting of calibrator. (Note that Type 264-A, unlike other instruments, measures the amplitude of any individual peak.)

★ This handy, new Du Mont instrument is yours, practically for the asking. Just ask our jobber to show it to you—how it works, and what it can do for you, the radio serviceman. Remember, you can use it with any oscillograph! You can measure the amplitude of any part of a complex signal, or calibrate your oscillograph, and there is no lead-switching whatsoever!

HIGHLIGHTS...

Independent of line-voltage variations.

Direct-reading.

Convenient to use.

Low-priced.

Small and compact.

Range: 0-0.1; 0-1.0; 0-10; 0-100 volts.

Accuracy: plus/minus 5% of full scale on each range, with variations in line voltage as great as plus/minus 10%.

Input Impedance: 20 uuf (signal connected through calibrator).

Fuse: 1/2 amp.; 115 volts, 50-60 cps., 20 watts.

Size: 4 1/2" x 8" x 5 3/4".
Weight: 5 lbs.

ASK YOUR JOBBER TODAY FOR THIS
LOW-PRICED CONVENIENT INSTRUMENT!



No More Guesswork



with OHMITE Little Devil

COMPOSITION RESISTORS

You never have to guess about the resistance and wattage of any Little Devil resistor. Every unit is not only color-coded but individually marked for quick, positive identification. Millions used in critical war equipment. Standard RMA values from 10 ohms to 22 megohms, in 1/2, 1, and 2-watt sizes. Tol. ± 10%. Also ± 5% in 1/2 and 1-watt sizes.

Available Only Through OHMITE Distributors

Ohmite Manufacturing Co.
4878 Flournoy St., Chicago 44, Ill.



OHMITE

Tube News

(Continued from page 31)

study, must be put back in its original position.

The grid-No. 2 (screen) bypass capacitors used in the Fig. 3 amplifier are of the ceramic button type and are mounted as close as possible to the tube base pins. Heater chokes are employed to prevent undesirable coupling between stages. The untuned type of choke which serves to decouple each stage from the common supply impedance is generally satisfactory. In extreme cases, however, it may be necessary to use tuned parallel circuits resonating at the i-f frequency in place of the chokes. Resistance-capacitance filters are included in each plate circuit to prevent coupling through the common B+ line. Although the amplifier will work satisfactorily with certain of these decoupling circuits omitted, such practice is not recommended because the arrangement of the leads become more critical.

It is important to use mechanical arrangements which afford short leads so that wiring capacitances may be kept to a minimum value. The control-grid and plate circuit leads must not be dressed against the chassis but should be spaced away from it so as to minimize capacitance to ground.

A typical i-f transformer used in these amplifiers is shown in Fig. 4. They are usually shielded, although satisfactory results may be obtained without the use of individual shields because no two circuits are tuned to the same frequency. Removing the shields, however, may seriously affect the ease of circuit adjustment because regeneration may occur before the circuits are properly aligned.

Rejection traps of the absorption type are somewhat critical with respect to coupling and, therefore, ad-

Type Employed in Four-Tube Complements	Over-all Gain ¹	Effective Average Stage Gain
6AK5	10,000	10.0
6AG5	6,500	9.0
6AU6	3,000	7.5
6BA6	1,280	6.0
6BJ6	Not measured	...
6BH6	Not measured	...

Table 1. Average gain-per-stage values for 4-tube setups shown in Figs. 1 and 2, and similar systems.

¹Over-all video i-f gain was, in this instance, considered as the amount of d-c voltage developed by the video detector per a-c (rms) volt applied to the grid of the first i-f stage. Over-all gain data were obtained by applying a 23.5-mc signal to the control grid of the first i-f stage. Mixer gain, therefore, was not included as part of the video i-f gain. The band-pass characteristics of the system were obtained by placing a 6BA6 in the mixer position and applying the i-f signal to its control grid.

Install your own

PRIVATE Telephone System

With these self-contained magneto ringing phones.



Price, complete with handset and battery

\$12.95 EACH

F.O.B. DAYTON, O.

Stock No. B-588 N

- No external power required. Operates on a standard radio "C" battery. Easy to install - requires only two wires or one wire and ground. Two or more units can be used on the same line.
- You'll find them useful on the farm, on construction projects, in the factory, on broadcast remotes, in your business and wherever you need communication. Good up to 50 miles.
- These telephones are not toys. They are Army surplus - slightly used, checked and inspected. Guaranteed to be in excellent condition. Dimensions: 5 1/4" x 6 1/2" x 9 1/2". Shipping weight 16 lb.

SEND CHECK OR MONEY ORDER.

SREPCO

STANDARD RADIO & ELECTRONIC PRODUCTS CO.
135 E. SECOND ST. DAYTON 2, OHIO.

FREE! Send for it NOW!

ALLIED'S NEW CATALOG

Everything in Radio for Everyone in Radio



Radiomen! Here's the new 172-page ALLIED Buying Guide that brings you everything you need in radio and electronic equipment! Here's the newest and best in test instruments, sound systems and P. A. equipment, thousands of parts, tubes, tools, books—the world's largest stocks, at lowest money-saving prices, ready for instant, expert shipment. Send for your FREE copy of the new ALLIED Catalog—today!

ALLIED RADIO CORP., Dept. 19-C-8
833 W. Jackson Blvd., Chicago 7, Ill.

Send FREE New ALLIED Catalog

Name.....

Address.....

ALLIED RADIO

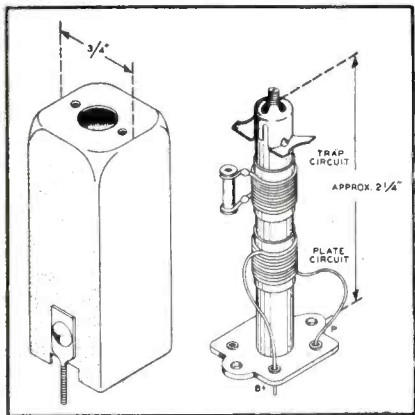

Fig. 4. Mechanical details of the i-f transformer used in stagger-tuned systems.

justment of the spacing between the coils may be required. The traps reflect a low impedance at their parallel-resonant frequency, thereby providing attenuation. At a slightly lower frequency, the traps introduce a high impedance effecting a slight rise in the response curve. The cathode rejection traps are tuned to attenuate this response. The coil in the cathode circuit of the fourth i-f stage must be in series resonance with the stray cathode-to-ground capacitance at a frequency approximately equal to the resonant frequency of the adjustable iron-core plate coil of this tube. If the coil and capacitance are not in resonance, a loss in stage gain will result because of the degenerative effect of the inductive reactance in the cathode circuit.

Alignment Procedure

In aligning the i-f system, a fixed-frequency signal generator is used and a theoretical alignment frequency is applied to the grid of each stage starting at the last i-f stage and working back to the converter grid. A low-capacitance high-frequency voltmeter is connected to the plate circuit of the stage being aligned and the tuned circuit adjusted for maximum output. After each circuit has been tuned to the theoretical alignment frequency, a sweep generator may be used to check the over-all response. Only slight additional adjustment of the i-f coils should be needed to provide proper response.

5TP4^a TV Tube Corona Control

A HIGH-VOLTAGE SYSTEM may be subject to corona, especially when the humidity is high, unless suitable precautions are taken. Corona, which is

SEVENTY TYPES NOW AVAILABLE



EM and PM REPLACEMENT SPEAKERS

HERE AT LAST is a complete line of electrodynamic and Alnico 5 speakers to fill every replacement need. **Inspect them! Try them! Utah Speakers** are rugged in design, made with precision and care to give better performance, longer. Ask for them today at your jobber's.

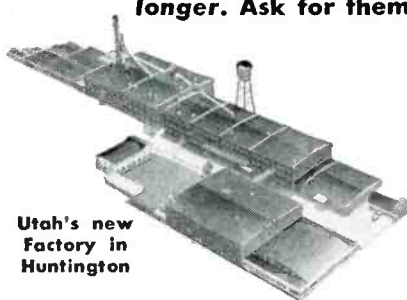

RADIO PRODUCTS
HUNTINGTON, INDIANA
DIVISION OF INTERNATIONAL DETROLA CORP.

THE STANDARD OF QUALITY SINCE 1921

an electrical discharge appearing on the surface of a conductor when the voltage gradient exceeds a certain value, causes deterioration of organic insulating materials, induces arc-over at points and sharp edges, and forms ozone, a gas which is deleterious to many insulating materials. Sharp points or other irregularities on any part of the high-voltage system may increase the possibility of corona and should be avoided. Thus smooth,

^aRCA projection tube, operated with 27,000 volts.

rounded contours and surfaces are must factors here.

To avoid the possibility of corona developing between the bulb and the metal support ring, a band of conductive coating in contact with the second-anode contact button is applied to the 5TP4 around the rim of the bulb. With properly designed metal support rings, no corona will occur between the bulb and support. If the support is made of an insulating material, however, corona may occur un-

(Continued on page 46)

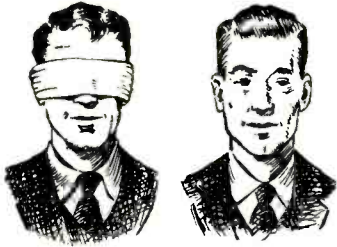

Who Will Get the Better Job?

The Serviceman Who Looks Ahead Will Get Ahead . . .

Don't play blind man's buff with your future! Are you, like many other professional servicemen, so wrapped up in your present routine work that you are losing sight of where you will be tomorrow?

The radio industry is expanding so fast, that it is doubtful any serviceman can truthfully say he has kept pace with all the major developments. Thousands of new men have joined the ranks of the radio industry creating new competition for you. New developments create demands for more advanced technical ability. You can't afford to be a "pre-war model." You must "re-tool" your technical knowledge in order to keep pace.

If you are wise, you will look ahead and start now to increase your technical ability with the thorough, practical technical training for which thousands of professional servicemen have enrolled with CREI since 1927. This is real, honest-to-goodness practical engineering training that leads to better jobs presented by modern radio, electronics and television, and security in the knowledge that you are capable of coping with tough problems.

CREI courses are still available at pre-inflation prices and today give you more thorough instruction service per dollar than ever before—on convenient terms. It costs you nothing to read the interesting facts. Please write today.

Veterans: CREI is "G. I." Approved

Mail Coupon-Free Book

If you want a more secure future and want to make more money, let us prove to you we have the training you need. To help us intelligently answer your inquiry—please state briefly your background of experience, education and present position.



Capitol Radio Engineering Institute

16th & Park Rd., N. W., Dept. S-3
Washington 10, D. C.

Mail me your 24-page booklet, "CREI Training for Your Better Job in Radio Electronics." I am attaching a brief resume of my radio experience, education and present position.

Check Practical Radio Electronics
One Course Practical Television

Name

Street

City..... Zone..... State.....

I am entitled to training under G.I. Bill.

Tube News

(Continued from page 45)

less the portions of the support assembly near the tube face are made conductive. Both the insulating and conductive coatings on the 5TP4 are black to reduce reflection of light and resultant loss of picture contrast.

The conductive coating on the neck of the bulb, which is provided primarily to prevent corona between yoke and the glass neck, must be grounded, preferably by means of a grounding clamp at the base end of the coating. The clamp must not grip the neck so tightly that it sets up glass strains which may eventually cause cracks, but it should exert sufficient pressure to insure good contact. The resistance of the coating is sufficient to prevent damping of the deflection yoke. Because of this high resistance, a contact area at least one-quarter of one square inch must be used. This coating must not be scratched and must never be washed with liquids likely to soften or dissolve lacquers.

As further precautions to prevent corona, the deflection yoke must present a smooth surface electrically to the bulb support ring. The contour of the yoke winding should approximate the contour of the bulb, departing gradually from it toward the outer edge of the winding. The yoke windings must not touch the cone of the bulb above the reference line (approximately at junction of cone and neck).

TV Tube Handling

Because finger marks may cause high-voltage leakage paths, the tube should always be handled at the neck or that part of the tube having a conductive band. It should never be handled at insulating-coating portions.

[The foregoing application note data are based on copyrighted material supplied by RCA.]

MILLIONTH RECORD CHANGER



Mayor Martin H. Kennelly of Chicago receiving the millionth postwar record changer made by Webster-Chicago Corp.

TELEVISION FIELD ENGINEERS

Attractive positions available for neat, intelligent, aggressive young men. A thorough knowledge of radio theory and servicing is essential. Television experience not necessary. These positions entail traveling. In reply give full resume of experience, education, and salary expected.

BENDIX RADIO DIVISION

Bendix Aviation Corporation
EAST JOPPA ROAD
TOWSON, MARYLAND

GIANT PENNY SALE

EXTENDED THROUGH APRIL 30
PAY 1¢ MORE—GET 2

Your tremendous response made us hunt up more items we know you need—because you asked for them. GREATER BUYS THAN EVER! PHENOMENAL BARGAINS EVERY ONE!

For example, electrolytic FP type cans, nationally advertised brand 40/20 MF 150 wvdc sell for 49¢ ea. YOU GET 2 FOR 50¢.

2 gang variable 420 MF, standard superhet RMA cut plate with 2" pulley #MV217 sells for \$ 1.50. YOU GET 2 FOR \$1.60.

Filter Chokes, Resistors, Ceramic Sockets, High Voltage Transformers, Relays, Selenium Rectifiers, Westinghouse Meters, Connectors, Rheostats, Condensers, Tubes and hundreds of other parts.

WRITE FOR SPECIAL 1¢ SALE CATALOGUE— for the BUYS OF A LIFETIME!

Universal/general corp.

365 Canal St., Dept. K, N. Y. 13, N. Y. WA. 5-9642

Sterling METERS

Greatly valued by service men for over 40 years.

Pocket Type D.C.	Panel Type A.C. or D.C.
AMMETERS	AMMETERS
VOLTMETERS	VOLTMETERS
VOLTAMMETERS	MILLIAMMETERS

See your distributor or write for circulars.

The STERLING Mfg. Co.
9205 Detroit Ave., Cleveland 2, O.

Servicing Helps

(Continued from page 27)

a 455 kc i-f transformer. If it simplifies construction, an iron core type may be used. If a permanent installation is not used the can of the crystal i-f transformer should be grounded to the fifth prong of the socket.

Circuit operation is simple, and is explained by Fig. 6. Essentially, the crystal and tuned circuits may be considered as two high-impedance networks, forming a signal divider network to the grid of the first i-f tube. As the potentiometer resistance is reduced, the impedance represented by the tuned circuit is reduced. This brings into action the high impedance of the crystal at other than resonant frequency, and the resulting selectivity is increased. The phasing control is used to balance out the coupling capacitance introduced by the crystal holder, thereby further increasing the circuit selectivity.

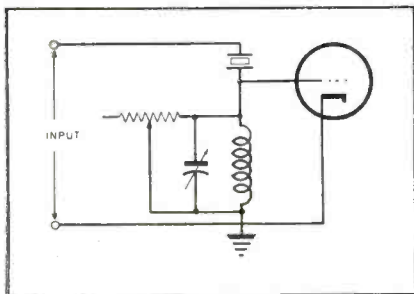

Fig. 6. The divider network established by the crystal and tuned circuits. As the potentiometer resistance is decreased, the impedance relationship between the crystal and tuned circuit is increased, thereby increasing the filter action of the crystal.

Associations

(Continued from page 28)

or attenuating frequencies in the amplifier.

RSA

A NOTE FROM R. A. BREGENZER states that the Radio Servicemen's Association of Pittsburgh, Pa., will soon reorganize. It is expected that the association will soon have as many members as it had in the pre-war era.

GBESA

A LICENSING ORDINANCE was recently introduced by the Green Bay Electronics Servicemen's Association, Green Bay, Wisconsin. According to the ordinance, all Service Men would be required to obtain a license to operate in the city. Some 42 members of the association signed a petition for the ordinance which it is understood is patterned like the Madison, Wisconsin, Law enacted some ten years ago.

Sell a **HUSHATONE***
wherever private
listening is desired!

in the home...

Where "cops and robber" yarns are swell for the kids but rough on adults. Sell a "HUSHATONE" too where illness or infirmity compel radio listening in bed —without disturbing others.



in private clubs...

Where "silence is golden", the "HUSHATONE" permits individual selection and individual listening without blaring radio irritation.

in hospitals...

Already in use by the thousands, the "HUSHATONE" offers hospitals in your territory private, morale-building listening. And remember the "HUSHATONE" can be disinfected, and is durable. There are no parts to loosen or wear out.



Write today for the full story on the
"HUSHATONE"

*Trade Mark Reg.

THE *Brush*
DEVELOPMENT COMPANY

3405 Perkins Avenue • Cleveland 13, Ohio, U.S.A.

MAGNETIC RECORDING DIV. • ACOUSTIC PRODUCTS DIV.

INDUSTRIAL INSTRUMENTS DIV. • CRYSTAL DIVISION

SERVICE, MARCH, 1948 • 47

QUAM

Adjust-a-Cone SPEAKERS

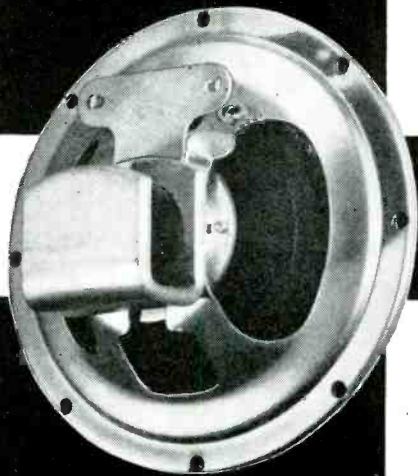

LOOK FOR THE

U-SHAPED

COIL POT

Electro Dynamic and P. M. Speakers in the following sizes: 3 1/2", 4", 4"x6", 5", 5 1/4", 6 1/2", 6"x9", 7", 8", 10" and 12".

**BUILDERS OF FINE
SPEAKERS SINCE 1923**

Write for Catalog

QUAM-NICHOLS COMPANY

526 East 33rd Place
CHICAGO 16, ILLINOIS

Chicago

INSTRUMENTS

Quality at Low Cost!



POCKET VOLT-OHM-MILLIAMMETERS for ONLY \$5.25

Anyone can now own a good volt-ohm-milliammeter. There is a Chicago V.O.M.A. priced at only \$5.25. Chicago "Featherweights" that slip easily into the pocket are the original miniature radio test instruments. They are popular throughout the world.

For years, Chicago Instruments have given radio men accurate, dependable service. And because of simplicity of design and freedom from "gadgets" we have been able to hold down prices to a fraction of what you would normally pay for instruments of similar quality.

Chicago Instruments are available in a variety of ranges and sensitivities. You may see them at your Suppliers or get the complete details by writing for Bulletin No. 10.

CHICAGO INDUSTRIAL INSTRUMENT CO., 536 W. ELM ST. CHICAGO 10, ILL.

F-M/TV Sweep Signal Generator

(See Front Cover)

A SWEEP-SIGNAL GENERATOR¹ for f-m and tv is diagrammed on the front cover this month.

The circuit consists of two r-f oscillators, mixer, filter and horizontal sync circuit and a power-line frequency-controlled reactance modulator.

One portion of the oscillator, 12AT7b, has an iron-slug fixed-tuned coil for 114 mc. Its 114-mc center frequency is swept at a 60-cps rate over a range of from approximately 40 kc to 5 mc, both above and below center frequency, by reactance-modulator tube, 12AT7a. The actual sweep rate is double the line frequency or 120 sweeps per second for a 60-cycle line.

The 114-mc output of the b section of the 12AT7 is fed from a 33-ohm resistor in its cathode circuit through a 20-mmfd capacitor to the mixer, 12AT7b, which a second variable frequency oscillator, 12AT7c, also feeds through a 10-mmfd coupling capacitor. This tunable oscillator covers the 112 to 37-mc range.

Calibration

The inner dial scale on this generator is calibrated in difference frequency between the two oscillators; 114 - 112 mc = 2 mc on the dial, 114 - 37 mc = 77 mc, etc. The middle dial scale is calibrated as 60/154 mc. in terms of the second harmonic of the first or difference-frequency range. The outer scale is calibrated as 155/226 mc, this range being provided by the sum frequencies of the two oscillators, where 114 + 37 = 151 mc, while 114 + 112 = 226 mc.

Output Control

In this sweep generator which is, of course, to be used for visual circuit alignment only, the output voltage is controlled by an output potentiometer of 125 ohms, which operates over a range of approximately 1/2 volt maximum, to a level low enough to reduce the 'scope beam trace to zero. The output impedance varies from approximately 5 ohms at minimum to 125 ohms at maximum output.

¹McMurdo Silver 909.

NEW PRODUCTS



HYTRON MINIATURE TUBE PIN STRAIGHTENER

A miniature tube pin straightener has been announced by Hytron Radio & Electronics Corp., 76 Lafayette Street, Salem, Mass.

The pin straighteners, built of special stainless steel and aluminum, are turned out in an automatic screw machine. Has mounting holes for bench use, as well as a comfortable shape and knurling for hand use.

* * *

TINIT SOLDERING COMPOUND

A powder-form soldering compound, Tinit, for receiver use has been announced by Tinit Manufacturing Co., P.O. Box 794, Denver, Col.

The compound, which contains tin, can be put into corners and inaccessible places, a small amount of heat being required for soldering. The compound is said to penetrate grease and dirt, and can be used on all metals, including sheet aluminum.

The product has been sold for many years to automotive, refrigeration and other jobbers.

* * *

OAK RIDGE ANTENNA COLLAR CLAMP

All aluminum collar clamps to hold f-m or tv antenna and reflector elements on mast or cross arm in place more permanently, have been announced by Oak Ridge Antenna Co., 239 E. 127 St., N.Y.C. Clamps prevent the elements from twisting or slipping out of position.

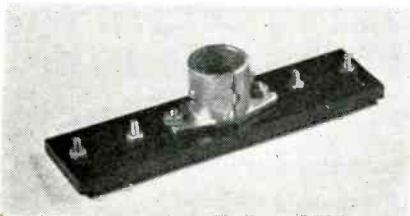

RCP SERVISHOP INSTRUMENT

A service shop in a carrying case, model 8073 Servishop, has been announced by Radio City Products Company, Inc., 152 West 25th Street, New York 1, N. Y. Said to be the equivalent of six instruments; tube tester, multimeter, f-m signal generator, a-m signal generator, audio oscillator, and capacity tester.

Tube tester tests all the new miniature tubes, and has all the features of RCP's model 322, with 800 listings in the tube charts. The capacity tester reads *good* or *bad* for leakage of electrolytics, for paper or micas. Both the f-m and a-m signal generators are set for four needed calibration frequencies and are similar to models 720 and 710. The audio oscillator has a 400-cycle output.

Ranges of the multimeter are: d-c and a-c voltmeters . . . 0/10/50/500/1,000 volts (1,000 ohms per volt); d-c milliammeter . . . 0/1/10/100/1,000; d-c ammeter . . . 0/10 amperes; ohmmeter . . . 0/500/5,000 ohms, and 0/0.1/1/10 meg-ohms; db meter . . . -8 to +15, +15 to 29, +29 to 49, +32 to 55 db; output meter . . . 0/10/50/500/1,000 volts.

* * *

MALLORY NOISE FILTER

A noise filter, type X6, has been announced by P. R. Mallory & Co., Inc., Indianapolis.

The filter is installed between the plug of the offending appliance and the wall outlet.

A display card explaining the use of the filter has been designed to carry six of the units on the face of the card.

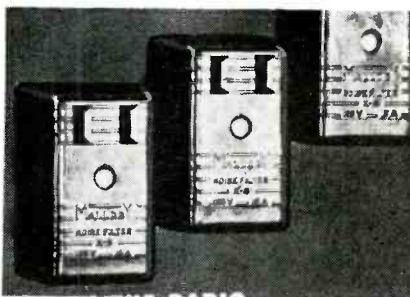

WEBSTER CHICAGO WIRE RECORDER

A wire recorder, model 78, for connection to existing amplifier circuits, has been announced by Webster-Chicago Corp., 5610 W. Bloomingdale Avenue, Chicago 39, Ill.

Unit with push-button controls, consists of a wire transporting mechanism, pre-amplifier, interstage amplifier, oscillator and built-in power supply. Has calibrated recording level meter.

* * *

BRACH SIGNAL BOOSTER SYSTEM

A *Puratone Signal Booster System* has been announced by L. S. Brach Manufacturing Corp., Newark 4, New Jersey.

The signal booster system was developed by Brach electronic engineers in conjunction with Professor J. L. Potter of Rutgers University, and Wesley Kidd of Chicago. It covers a frequency range of .3 to 20 mc for a-m operation, and 85 to 110 mc for f-m. Uses wide-band, dual video-type amplifier circuits which are said to assure faithful reproduction of speech and music on all stations at an average tone level.

The installation consists of a dual-dipole antenna array supported by an aluminum mounted mast mounted on the roof of a building. Signals from the antenna are carried to the signal-booster amplifier by means of shielded coaxial cable in a 1" conduit. Wide-band amplifier provides sufficient over-all gain and limiting at low noise levels to any number of receivers.

(Continued on page 50)

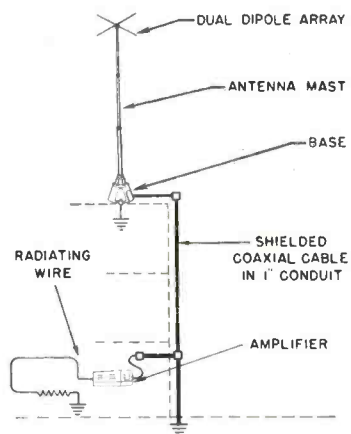

JUST OUT! **FM TRANSMISSION and RECEPTION**
by John F. Rider and Seymour D. Uslan

New BROADCAST OPERATOR'S HANDBOOK
by HAROLD E. ENNES, Engineer, Station WIRE
Here are coordinated facts, standards of good operating practice written by an operator in operators' language.
288 Pages . . . \$3.30

For radio servicemen, who can look to FM as a big part of their future profits—for the "ham" who is considering narrow band FM—for the student who is grooming himself for activity in the electronic field—this new book explains both the theory and servicing of f-m receivers. Its text is equally valuable to every persan interested in this phase of electronics and will serve as a valuable handbook for engineers.

NEW RIDER 99'r
over 130 pages
only . . . 99c
JUST OUT!

The unique publication principle employed in the production of this new book is as practical as its contents. It is offered in two editions identical in contents, printing quality and paper—differing only in covers.

UNDERSTANDING VECTORS AND PHASE — Vector presentations are widely used in conveying latest radio technical information. This book is a must for students.

OVER 300 FACT-PACKED PAGES
(substantial paper cover) **\$180**
Hard back cloth cover, **\$2.70**

BY THE PUBLISHER OF RIDER MANUALS

JOHN F. RIDER PUBLISHER, INC.
404 FOURTH AVENUE, NEW YORK 16, N. Y.

Sightmaster

LEADS AGAIN WITH THE BEST VALUE IN QUALITY TELEVISION!

The New
SIGHTMASTER 15
with FM RADIO
\$595.00



in Mahogany or Walnut; plus installation and Fed. Excise Tax
One of the LARGEST DIRECT-VIEW TABLE MODELS AVAILABLE, featuring the brilliant 15" picture-tube. Only Sightmaster GIVES YOU THESE ADVANTAGES: A 15" Table Model with 120 sq. in. direct view picture...Built-in F.M. Radio Receiver...Twin speakers...A CHOICE of CABINETS in beautiful hand-rubbed Mahogany, Walnut, or Blonde (at slight additional cost) to suit every taste... One Year Sightmaster Warranty... Exclusive Franchises
Expanding Manufacturing Facilities Enable Us to Invite Participation of an Additional Number of Dealers on a Protected Franchise Basis.

THE SIGHTMASTER CORP.
Manufacturers of Television Receivers Exclusively
220 Fifth Ave., New York 1, N. Y. MUrray Hill 9-0174
Philadelphia Office: 1500 Walnut Street

New Products

(Continued from page 49)

VERTROD TV/F-M ANTENNA

A tv/f-m antenna. Continental type, with adjustable dipole elements, calibrated in megacycles, has been announced by Vertrod Corp., 17 Williams St., Brooklyn 7, N. Y.

Adjustable dipole elements are mounted in a five-foot tempered aluminum alloy mast. Can be mounted at any angle making it adaptable for use in all positions. Antenna kit is equipped with the necessary elements, insulator, mast, and universal base mounting bracket.

* * *

VANDRUFF REAR SEAT AUTO SPEAKER

An auto rear-seat speaker has been announced by VanDruff Specialties, 8695 State Street, South Gate, California.

Speaker has a heavy duty G.E. 6 1/2" Alnico V p-m unit. Grills are designed for flexibility to permit installation in any automobile. A three-way switch is provided.

* * *

VISION RESEARCH SIGNAL BOOSTER

An r-f amplifier, with self-contained power supply, for tv signal boosting has been announced by Vision Research Laboratories, 87-50 Lefferts Boulevard, Richmond Hill, N. Y.

The booster is a selective amplifier, and thus tends to reject unwanted off-channel interference. A two-position switch provides amplifier and normal operation.

When in off position the antenna is connected directly to the television receiver and thus has no effect upon normal signals which require no boosting.

Available in three models: TVL, channels 1-6; TVII, channels 7-13; and FM, 88 to 108 mc.

* * *

EICO VTVM

A vtvm, model 221, has been announced by Electronic Instrument Company, Inc., 926 Clarkson Avenue, Brooklyn 3, N. Y.

Has electronic a-c and d-c ranges: 0-5, 10, 100, 500, 1,000 volts. Electronic ohmmeter measures from .2 ohm to 1,000 megohms in 5 ranges. Wide range db scale. Automatic overload said to prevent meter burn out.



KAPPLER WIDE-BAND SUPERHET A-M TUNER

A wide-b and a-m tuner has been developed by the Kappler Company, 7302 Melrose Ave., Los Angeles 46, Calif.

Has a bridge-type balanced modulator in a superheterodyne circuit. Also features an infinite impedance second detector which provides an extremely high ratio of d-c to a-c.

Performance characteristics: Output, 1 volt across 500 ohms for 100% modulation; noise level, 75 db below 1 volt; pass band, 20 kc, down 3 db 10 kc either side of carrier frequency; power, 42.5 watts at 117 volts 50/60 cycles; antenna, single wire or balanced line.

* * *

CLAROSTAT CONTROL AND RESISTOR REPLACEMENT KIT

A replacement kit, Han-D-Kit No. 5, has been released by Clarostat Mig. Co., Inc., 130 Clinton St., Brooklyn, N. Y. Kit contains twelve of the most popular values of plain, tapped and slip-drive controls, together with a selection of twelve attachable shafts and four ad-a-switches; six ballast tubes most generally called for; five Greenohms or 10-watt wire-wound power resistors; plus a double-ended wrench, authorized service plaque, copy of latest catalog, and a registration card calling for a free copy of the new Clarostat service manual, all packed in a green-finished steel cabinet.

Remember
Mr. Service Man....
with Wright Verified Speakers



Model NP-615 6" PM Speaker

Strong, Sturdy Construction Allowing
Least Amount of Field Losses

Write for Catalogue and Verified Guarantee

The **FIRST COST**
is
The **LAST COST**

W R I G H T

INC.

2235 University Avenue
SAINT PAUL 4, MINNESOTA

ELECTRONIC LAB CONVERTER

Converters for use on tv sets in d-c metropolitan areas have been announced by Electronic Laboratories, Inc., Indianapolis.

Two types have been developed, model 110R15 for table model tv receivers, and model 110R30, for console models.

* * *

NEWCOMB AUDIO RACK ASSEMBLIES

Basic elements for cabinet type rack systems have been announced by Newcomb Audio Products Co., 6824 Lexington Ave., Hollywood 38, Calif.

Cabinet, 59½" high x 23½" wide x 16" deep, will accept six 9" x 20⅜" panels. Units which can be used in the rack include 60-watt p-a (model K-60P-900), pre-amplifier (model KX-6-900), dual channel pre-amplifier (model PR-2-450), monitor speaker, phono-changer, etc.

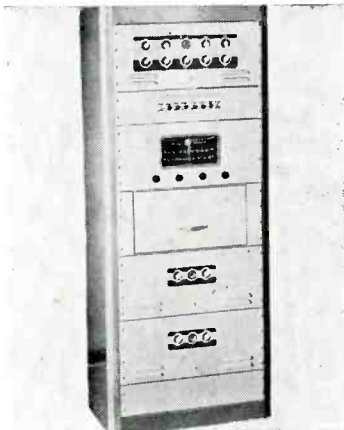

TRIPLETT VOLT-OHM-MIL-AMMETER

A 20,000 ohms-per-volt d-c multi-range volt-ohm-mil-ammeter, type 2405-A, has been announced by the The Triplett Electrical Instrument Co., Bluffton, Ohio.

Thirty-five ranges: Voltages to 1,000 d-c at 20,000 ohms/volt and a-c at 1,000 ohms/volt; d-c current ranges from 0-50 microamperes to 10 amps; a-c amps to 10; db, -10 to +55. Also provides output and capacitor tests.

Has a plug-in, pre-calibrated rectifier.

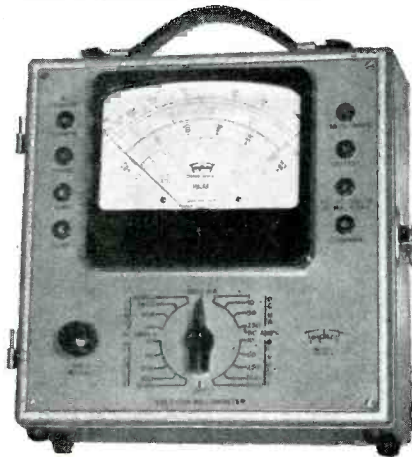

* * *

ULLMAN MAGNETIC TOOLS

Magnetic tools, *Maginnicks*, of the all angle ball joint type, which can be used to retrieve nuts, bolts and other ferrous items, have been announced by Ullman Products Corporation, Ullman Bldg., B'klyn (15) N. Y.

COLLINS TV/F-M ANTENNA

An f-m/tv antenna which can be used on the thirteen tv 44-216 mc and 88-108 mc f-m channels has been announced by Collins Machine Co., 56-21 Northern Boulevard, Woodside, N. Y.

Consists of two broad-band dipoles connected by frequency-selective circuits to a common transmission line, 73 to 300 ohms impedance.

* * *

NATIONAL UNION CAPACITORS

A line of 131 types of replacement capacitors has been announced by National Union Radio Corp., Newark, N. J.

Types include metal tube, cardboard sleeve dry electrolytics in singles and duals (*Numite*); super-seal cardboard tubular dry electrolytics with mounting strap in dual and triples (*Nucarmite*); aluminum can, screw base dry electrolytics in singles and duals (*Thredmount*); twist-tab mounting aluminum can dry electrolytics in singles, duals, triples and quadruples (*Treistab*); and small paper tubulars for multiple parallel or series-combination installations (*Nupamite*).

* * *

KOILED KORDS TEST LEADS

Retractable test leads have been announced by Koiled Kords, Inc., Hamden, Connecticut. Test leads, in conventional red and black colors, are made in 48" retracted lengths which will extend to 20'. The ratio is 1' of retracted Koiled Kord to 5' extended.

Inquiries may be addressed to E. L. Love, sales manager, Koiled Kords, Inc., Box K, Hamden, Connecticut.

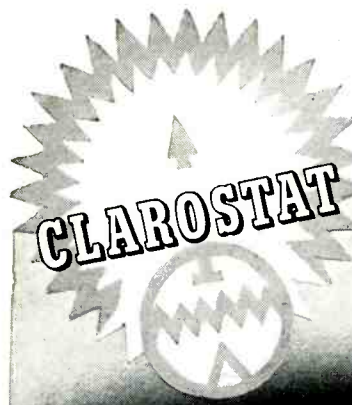

CLAROSTAT

does it again!

GIANT VALUE

HAN · D · KIT

NO. 5



★ **Most** replacements for **least** parts stock! Fastest-moving types and values. No duds. Every item a "must" in everyday servicing. Neatly packed in handsome green steel box with hinged top. Handy as filing cabinet, strong box, or odds-and-ends box. A \$30.15 value for \$15.07 your cost!

- 6 BALLAST TUBES
- 12 VOLUME CONTROLS
- 4 AD-A-SWITCHES
- 5 GREENOHMS

PLUS

DURAL HAN-D-WRENCH
 AUTHORIZED
 SERVICE PLAQUE
 CLAROSTAT
 "KNOW-HOW" DATA

Order this Hand-D-Kit from your Clarostat jobber NOW, while this "special" is available!



CLAROSTAT

Controls and Resistors

CLAROSTAT MFG. CO., Inc. · 285-7 N. 6th St., Brooklyn, N. Y.

Ser-Cuits

(Continued from page 37)

detector stages, employing double-tuned circuits overcoupled to have a 3.5-mc bandwidth, with a 25.25-mc center frequency.

The first and second video i-f amplifiers use 6AH6s with the first video i-f avc controlled. The second stage feeds one-half of a 6AL5 as a conventional a-m detector, which feeds the video amplifier. The other half of the 6AL5 provides a dual purpose. Its input time constant is such that it holds its bias just above picture black level and delivers separated super sync to the sync amplifier. Because of this action, the tube can also provide avc voltage, which is used on the r-f tube and first tube of both i-f strips.

In the audio unit are the first and second audio i-f amplifiers and the audio detector, using single tuned i-f coils peaked at 22.25 mc, with an f-m ratio detector. The first and second audio i-f amplifiers use 6BA6s and the first audio i-f tube is avc controlled.

The audio detector amplifier tubes are duo-diode-triode 6AT6s, serving both as an f-m ratio detector and as two stages of audio amplification. The diode currents of the ratio-detector portion of the 6AT6s develop an f-m audio voltage across a 22,000-ohm resistor with a 1,500-mmfd capacitor bypassing the audio i-f frequency. The cathode current of the triode section of the 6AT6 also passes through the 22,000-ohm resistor, placing a d-c voltage drop in series with the diode circuit. This makes it necessary to use a compensating network, a 22,000-ohm resistor and 25-mfd capacitor, in the cathode circuit of the 6AT6 audio-detector amplifier.

There is also a noise rejection circuit in the ratio detector which utilizes a 33,000-ohm resistor and 5-mfd capacitor.

In the high voltage supply, a 6V6GTG is used as a tuned plate r-f oscillator with two additional windings on an oscillator coil to provide high a-c voltage and filament voltage for a 1B3GT/8016 rectifier tube.

In the video output stage, a 6AH6 is used, biased by the rectified video signal appearing on the grid, and is d-c coupled to the picture tube grid. This arrangement with a heavy bleeder on the screen optimizes d-c restoration.

The sync amplifier and limiter share a 6SL7. The first section amplifies the sync signal obtained from the sync separator diode of the picture detector, and the second section acts as a limit-

ing cathode follower which clips off the noise peaks and supplies constant sync voltage to multivibrators.

A 6SN7 is used in the vertical sawtooth generator as a conventional cathode-coupled multivibrator with an integrating circuit feeding sync pulses to the first grid.

Another 6SN7 is used in a horizontal sawtooth generator and also as a conventional cathode-coupled vibrator with a differentiating circuit. The vertical multivibrator can be adjusted with a vertical-hold control to sync at 60 cycles, while the horizontal multivibrator is adjusted with a horizontal-hold control to sync at 15.75 kc.

A 5U4 full-wave rectifier is used in the low-voltage power supply to supply 300 volts d-c at 200 ma.

The 7GP4 is operated with the heater grounded and the second anode at a +3,000-volt potential.

G.E. 901 and 910

In Fig. 3 appears another current model television receiver using, however, an electrostatic focus, magnetic deflection-type projection tube, the 5TP4. A very high voltage is supplied to the plate of this tube, 27,000 volts.

In this receiver one 6AU6 is used as an r-f amplifier, a 7F8 as a converter oscillator, 6AC7s in four stages of video i-f, 6H6 as a video detector/d-c restorer, 6AG7 as a video amplifier, 6SH7 as a clipper, 6SN7GT as a horizontal-sync amplifier and vertical sweep, 6SL7GT as a horizontal discriminator and vertical-sync amplifier, another 6SL7GT as a horizontal discriminator and d-c amplifier, a pair of 6SN7GTs in horizontal sweep generator and phase inverter stages, 6L6G as a vertical sweep output, 6SG7 for tv audio i-f, 6SV7 as a tv audio limiter, 6H6 as a tv audio discriminator, 6AG5 as an r-i amplifier, a pair of 6AK5s in oscillator and converter stages, 6SG7 in one i-f amplifier and 6SV7 in another i-f amplifier, with another 6SV7 as an a-m detector and f-m limiter, 6AQ7 as an f-m discriminator and audio-cathode follower, 6SL7 as an audio amplifier, four 6V6GTs in pushpull audio output, 6AL7 as a tuning indicator, 6SC7 as a phono pre-amplifier, three 5U4Gs as rectifiers, two 6BG6Gs for horizontal sweep output, 6AS7G for horizontal damping and four 1B3GTs as high-voltage rectifiers.

The video tv i-f in this receiver is 22.4 to 26.4 mc. The i-f for the tv audio is 21.9.

This model is a combination broadcast, f-m, tv and shortwave unit covering the low and high bands on the f-m channels and the 9.4 to 9.9 and 11.6 to 12.1-mc shortwave bands.

Visit **ATR Booth 137**
 AT RADIO PARTS SHOW
 May 11th-14th
CURRENT
CONVERSION
 WITH **ATR** QUALITY PRODUCTS



BATTERY ELIMINATORS
 for DEMONSTRATING and TESTING AUTO RADIOS

- New Models . . . Designed for Testing D.C. Electrical Apparatus on Regular A.C. Lines. Equipped with Full-Wave Dry Disc Type Rectifier, Assuring Noiseless, Interference-Free Operation and Extreme Long Life and Reliability.
- Eliminates Storage Batteries and Battery Chargers.
 - Operates the Equipment at Maximum Efficiency.
 - Fully Automatic and Fool-Proof.
 - Type 60-ELIA . . . Rated Output 6.3 Volts at 6.5 Amperes.
 - Type 120C-ELIO . . . Rated Output 6.3 Volts at 14 Amperes.

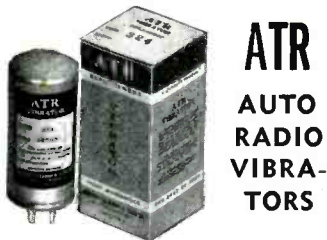

Designed for Use in Standard Vibrator-Operated Auto Radio Receivers. Built with Precision Construction for Longer Lasting Life.



For Inverting D. C. to A. C.

Specially Designed for Operating A.C. Radios, Television Sets, Amplifiers, Address Systems, and Radio Test Equipment from D.C. Voltages in Vehicles, Ships, Trains, Planes and in D.C. Districts.

Write for New ATR Catalog—Today!

AMERICAN TELEVISION AND RADIO CO.
 Quality Products Since 1931
 SAINT PAUL 1, MINNESOTA — U. S. A.

Soldering

(Continued from page 39)

cans, containers, etc. Soldering (*tackling*) at a few spots serves the same purpose.

Soldering Procedure

Cleaning: The work to be soldered must be free of dust, dirt, and other foreign materials. You should not depend on soldering flux to remove dirt, grease, paint, rust, or heavy oxide coatings. Proper preliminary cleaning is essential for good soldering joints. Before starting to solder, work should be cleaned with sandpaper, wire brush or chemical cleaner. Acids should be avoided unless it is possible to rinse thoroughly to remove residue.

Preparing the Iron: Tip of the iron should be tinned with solder as soon as it is hot enough to melt the solder. The resultant solder film prevents oxidation. If screw tip type irons are being used, after the tip is up to temperature, it should be screwed in tightly. This will improve heat conductivity to the tip and prevent flux fumes from corroding the tip threads. The iron will not operate satisfactorily unless this precaution is taken.

Applying Flux: The purpose of a flux is (a) to dissolve any oxide that covers the surfaces of the work to be soldered, and (b) to prevent oxide from forming when heat is applied to the work, so that the solder can flow into the seams and unite with the metal surfaces. Flux should be applied to the part to be soldered, never to the tip of the iron; Fig. 3. When core solder is used, the flux in the core melts at a low temperature and covers the work, thus preventing oxidation as the part approaches the temperature required to melt the solder. If a separate liquid or paste flux is used, it can be applied to the work with a brush or paddle; Fig. 4. In no case should the tip be dipped into the flux, either before or during heating. In any case, it should be applied before the work be-

(Continued on page 54)

Fig. 6. When soldering wire joints, etc., iron should be held underneath work.

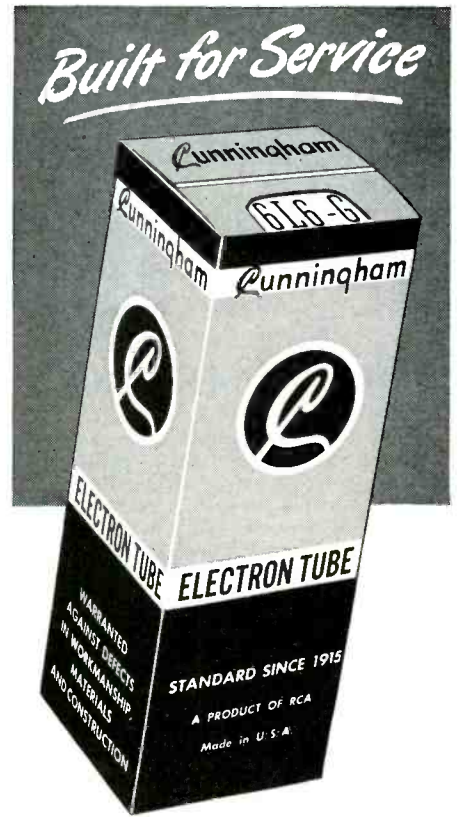
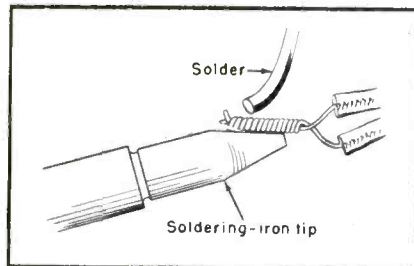

Servicemen's choice!
 in . . .



• When it comes to Cunningham tubes, Massachusetts votes a straight ticket. Cunninghams are in the public eye because their top performance and long life make them the outstanding renewal tubes. Cunninghams are *your* ticket when new tubes are called for.

See your
CUNNINGHAM DISTRIBUTOR

HATRY & YOUNG of Mass. Boston
 HATRY & YOUNG of Mass. Lawrence

Cunningham Tubes
 A product of
RADIO CORPORATION OF AMERICA
 Harrison, N. J.

Now Small Size, Heavy Duty, Trouble-Free

5-WATT VITROHM

Wire Wound Fixed Resistors

Now . . . for extra reliability in many installations . . . for longer service and steadier performance . . . you can use this compact, low-wattage Type 5F resistor. Resistance wire is insulated and protected by WARD LEONARD's own Green Vitreous Enamel of exclusive formula developed in the WL laboratories. Tough, hard, moisture and acid resistant. Quickly conducts away generated heat. Easily mounted by its wire leads.

WARD LEONARD ELECTRIC COMPANY

Radio and Electronic Distributor Division

53-E West Jackson Blvd., Chicago 4, U. S. A.

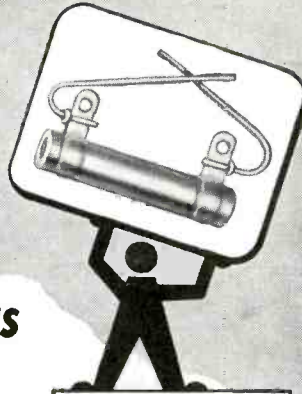

TYPE 5F • 5 WATTS

1" long x 5/16" diam.

Available from stock in resistances from 1 ohm to 5000 ohms.

Made available only by WARD LEONARD thru Authorized Distributors everywhere

WARD LEONARD

RELAYS • RESISTORS • RHEOSTATS

Electric control devices since 1892

Send for Catalog D-30

Gives handy data and information on various types of Resistors and Rheostats available from stock.

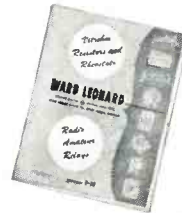

RADIO SERVICE MEN . . .

Use only the **ASTATIC** TYPE "QT" Replacable Needle Model or Sapphire Tip Applied For

Find Astatic's New "QT" Phonograph Cartridges Ideal for Practically every Replacement Demand

● For quiet, faithful reproduction, freedom from needle talk, relatively high output, and excellent tone range, the "QT" Cartridge is a modern replacement favorite. In addition, this new Cartridge is reasonably priced, simple to mount and connect, and designed for long life and record protection. Special literature is available.

THE Astatic CORPORATION
CONEAUT, OHIO
IN CANADA: CANADIAN ASTATIC LTD. TORONTO, ONTARIO

Astatic Crystal Devices Manufactured under Brush Development Co. patents.

Type "Q" Matched Replacable Needles used with Model "QT" Cartridges



Soldering

(Continued from page 53)

comes hot enough to oxidize from the heat. If acid flux is used, it should be no stronger than necessary, and used sparingly. It should be confined to the part being soldered and kept away from the iron, especially the threads of the screw tip type irons.

Pretinning for Soldering: The best soldered joints are obtained when the surfaces to be joined are pretinned with solder. This consists of coating the surface of the joints with solder after it has been properly cleaned and fluxed. Some metals are easily tinned by merely spreading the solder over their surfaces with a hot iron. It may be necessary, however, to work the solder onto the surface of some metals with a rubbing action with the hot iron. For instance, in soldering aluminum the metal must be brought up to soldering temperature and the solder rubbed onto the surface of the aluminum by means of a wire brush. Repeated heating and rubbing is necessary to properly pretin so that good soldering of the part is possible. This mechanical rubbing, in the case of pretinning aluminum, can be eliminated by using tin-zinc solder containing a minimum of 60 per cent tin. This solder can be applied to aluminum by merely rubbing it on the aluminum surface with the flat side of the tip without the use of any flux or mechanical scrubbing, as mentioned previously. Pretinning is necessary when soldering all metals if an air- or watertight joint is expected. Copper, brass, steel, wire, sheet, and strip are available tinned, ready for soldering.

Applying Heat: The next step in the soldering procedure is to bring the temperature of the joint to be soldered up to the melting point of the solder. To do this, the tip should be applied to the joint in such a way that the

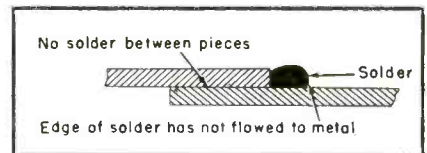
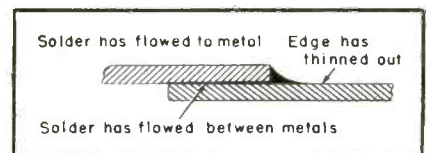
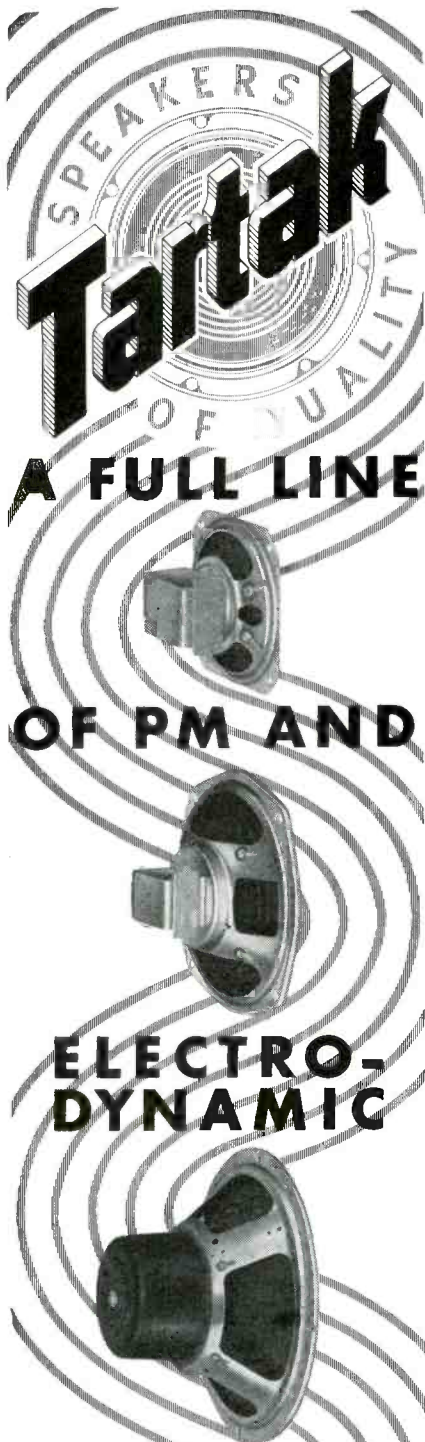

Fig. 7. What happens to the solder when the work is not hot or clean enough.

Fig. 8. How the solder flows properly when the joint has been brought to the proper temperature.





SPEAKERS
for the trade, in
3, 4, 5, 6, 8, 10 & 12 in. sizes

Tartak speakers are available near you for immediate shipment and at competitive prices. You can install or sell Tartak with confidence—there is none better. Write for specifications and prices.

Over 2 decades in Speakers

TARTAK SPEAKERS, Inc.
MANUFACTURING DIVISION
3120 E. PICO BLVD.
LOS ANGELES 23, CALIF., U.S.A.

largest area of the tip working face comes in contact with the work; Fig. 5. There must be a heavy film of solder between the working face of the tip and the joint being soldered. Therefore, pressure is not necessary since this film of solder conducts the heat from the tip to the work. A dry tip which does not have this film of solder to help conductance of the heat will take a longer time to bring the joint up to proper temperature.

When soldering wire joints and similar work, it is best to hold the iron underneath the work; Fig. 6. This makes it easier to apply the solder and enables the tip to support the solder until the joint becomes hot enough for the solder to flow into it.

Applying the Solder: Solder should be applied to the *work or joint being soldered*. This is the best guarantee that the work is up to the proper temperature. The solder should flow *onto* the metal and *into* the joint. Merely melting the solder is not enough, it must flow *onto* the metal. Fig. 7 shows a cross-section of a joint where the solder melted, but because the work was not hot enough (or clean enough), the solder did not flow. Fig. 8 shows a joint properly soldered. Here the solder flowed onto the clean metal after the joint had been brought up to the proper temperature. It will be noted that in Fig. 7 the solder tends to hold together and consequently did not thin out at the edge. In Fig. 8 the solder has been attracted by the metal. It will also be noted that the edge of the solder has thinned out and the solder has been drawn between the metals by capillary attraction.

Soldering Rules: In soldering a vertical surface, solder should be applied to trough formed by the tip of the iron and the surface to be soldered, and

(Continued on page 56)

Fig. 9. In soldering vertical surfaces, solder should be applied to trough formed by the tip of the iron and surface, with iron then pressed against the surface.

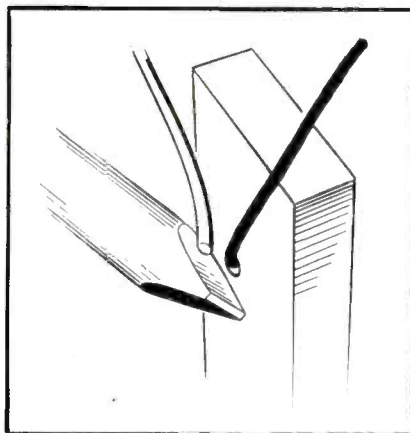

Servicemen's choice!
in . . .



● Cunningham tubes continue to carry Illinois because of their long-standing record of reliability. The quality of Cunningham tubes accounts for their long terms of service. That's why—when you carry Cunninghams—more customers will come your way. Cast *your* vote for Cunningham tubes!

See your
CUNNINGHAM DISTRIBUTOR
WALKER-JIMIESON, INC. Chicago
TRI-CITY RADIO SUPPLY Rock Island



University LOUDSPEAKERS

- can whisper, too!

And that's important because the primary purpose of any loudspeaker is to convey intelligence and not just make a loud noise. UNIVERSITY loudspeakers — with the highest conversion efficiency of any speaker of comparable size — not only give *maximum* sound output with *minimum* power input, but reproduce every detail and inflection of the voice at all levels from a whisper to a shout.

**A JOB-RATED SPEAKER
FOR EVERY APPLICATION!**

REFLEX TRUMPETS



A wide variety available for every requirement — voice, music, paging and talk-back. Weather-proof, sturdy construction for years of dependable use.

DRIVER UNITS

Several high efficiency models with continuous power capacities up to 25 watts and response to 15,000 cycles. All unconditionally guaranteed for one year.



PAGING, CALL-BACK SPEAKERS



Available in many types and power ranges. Compact design, high conversion efficiency and high sensitivity. Standard voice coil impedances permit easy installation.

SUPER POWER SOUND PROJECTORS

Many sizes—100, 150 and 300 watts with conservative ranges to a few miles. Excellent quality even at full power. Ideal for installation in aeroplanes and church steeples.



EXPLOSION PROOF SPEAKERS



Radial and directional types for use in mines, refineries, railroads and ships. Immune to live steam, salt-spray or complete immersion. Power handling capacity 15 watts.

24-page technical catalog available on request.



UNIVERSITY LOUDSPEAKERS · INC.

80 SO. KENSICO AVE., WHITE PLAINS, N. Y.

Soldering

(Continued from page 55)

then the iron should be pressed against the surface; Fig. 9. In soldering a horizontal surface, solder should be applied to the upper side of the part to be soldered and allowed to flow downward around the part (Fig. 6). In soldering electrical connections, care should be taken not to burn insulation or contacts. In this instance, soldering must be done quickly. In soldering seams, work should be arranged in such a way that a trough is formed, enabling the solder to flow down and through the seam. The flat tip of the iron should be placed against the work and followed with solder at the side of the tip. Repeated action helps to fill the seam.

Too much solder should not be used — just enough to do the job. Surplus solder can be removed with the hot tip of the iron, or with a file.

Cooling: When sufficient solder has been applied and it has flowed onto the metal and into the joint, the tip of the iron should be slid from the work — not lifted. This will insure an even soldered surface. The work should be allowed to cool until the metal is well below the freezing point of the solder. During this cooling period, the parts must remain absolutely fixed in respect to each other. The slightest movement of the parts at this time will result in a partially fractured joint which will not have satisfactory strength or hardness.

Cleaning: After the parts have cooled, proper cleaning to prevent cor-

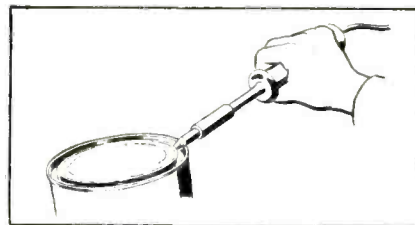

Fig. 10. Iron should not be used to pry open cans.

rosion should be considered. Rosin residue will not cause corrosion and need not be removed unless subsequent flaking may be harmful. Acid flux must always be removed if corrosion is to be avoided.

Care of the Soldering Iron

- (a)—Your soldering iron should not be abused. It is not built to withstand careless handling. It should be used only to solder, not to hammer or to pry; Fig. 10.
- (b)—The cord of your iron, when not in use, should be wrapped neatly around the handle, or hanked loosely. Avoid unnecessary dam-

Fig. 11. Iron cord should not be hung on a nail or hook.

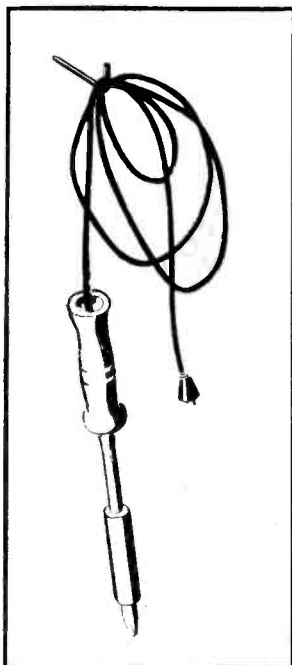

AT LAST!
ELEMENTS OF
MAGNETIC TAPE
RECORDING
and 999
APPLICATIONS

AVAILABLE
FOR ONLY
25c

by **A. C. SHANEY**

Contains schematic diagrams

AMPLIFIER CORP. of AMERICA

398-3 Broadway, New York 13, N. Y.

GREYLOCK

A DEPENDABLE NAME IN
RADIO TUBES

GT, Glass and Miniature Types

All Tubes Individually Boxed
12SA7, 12SK7, 12SQ7, 50L6, 12AT6, 12BA6,
12BE6, 35W4, 50B5 each 39¢
1R5, 1S5, 1T4, 3S4, 3Q4, 6AK5, 6AC5,
6AC7, 6AQ5, 6BE6, 6BA6, 6AU6, 6BJ6,
6X4 each 49¢
12L7, 70L7, 117L7 each 59¢
All Tubes Carry RMA 90-Day Guarantee

PM SPEAKERS

4" Alnico No. 5 each \$1.19
5" Alnico No. 5 each 1.29

TERMS: Net C.O.D. No order accepted for less than \$5.00.

WRITE FOR BARGAIN CATALOG S-3

Greylock Electronic Supply Co.
30 Church Street New York 7, N. Y.

age caused by hanging the iron on a nail or hook by its cord; Fig. 11. Also, avoid pulling, jerking or twisting the cord. Keep the cord away from sharp tools or the hot tip of the soldering iron.

(c)—The tip of your iron should be kept tinned at all times by occasionally flowing solder and flux over its working surface. Rubbing the tip over a piece of steel wool at intervals during soldering will restore the original lustre to the tinning and keep the tip clean.

(d)—Your iron will overheat if allowed to idle for long periods, or if the work being soldered is extremely lightweight for the soldering iron being used. Iron must be disconnected for short periods if it tends to burn the flux and blacken the copper, since a burned tip will not solder satisfactorily. The black oxidation will insulate the tip and prevent proper heat transfer to the work.

If this happens, the tip must be retinned, as follows:

(1)—Allow iron to cool.

(2)—Clean working surface with steel wool or light sandpaper. Unless tip is pitted, do not file.

(3)—Reconnect iron. Apply flux to working surface unless core solder is used. Hold solder against tip until solder melts. Cover working area (about one-half inch on all sides) with solder.

(4)—The copper tip of your iron will occasionally become pitted. This is natural since copper, which has high heat conductivity and is therefore best for tips, oxidizes easily and, being soft, wears away. When pitting occurs, the pitted section can be filed with a fine file to a smooth surface, removing no more copper than is absolutely necessary. To retin, the method outlined in (3) should be followed.

It is important to remember that your soldering iron is a tool, and should be treated as such. You should learn to use it properly and to maintain it as you would any other tool, and it will keep you out of soldering trouble and serve you for a long time.



Servicemen's choice!
in ...



● Cunningham tubes carry the field in Kentucky... win, place and show. That's because Cunninghams are built for top performance from post to finish. More reason for you to "make it Cunningham in '48" when new tubes are called for.

See your
CUNNINGHAM DISTRIBUTOR

ELECTRONIC DISTRIBUTORS... Lexington
UNIVERSAL RADIO SUPPLY CO.,
Louisville
CENTRAL ELECTRONIC SUPPLY CO.,
Owensboro

Cunningham Tubes

A product of
RADIO CORPORATION OF AMERICA
Harrison, N. J.



Mail coupon for FREE copy of this great, new Concord Catalog—a vast, complete selection of everything in Radio, Television, and Test Equipment. Thousands of items... latest 1948 prices. LOWER prices on finest-quality RADIO SETS, PHONO-RADIOS, RECORD CHANGERS, RECORD PLAYERS, RECORDERS—wire and disc, PORTABLES, AMPLIFIERS, COMPLETE SOUND SYSTEMS, TESTERS. Latest listings of all well-known, standard, dependable lines of radio parts and equipment. 4,212,014 SATISFIED CUSTOMERS CANNOT BE WRONG! Concord's quarter-century reputation for Customer Satisfaction is the reason Radio Men (the Experts who Know) keep coming back to CONCORD. At CONCORD, YOU MUST BE COMPLETELY SATISFIED or your money will be refunded.

CONCORD
RADIO CORPORATION

CHICAGO 7 ATLANTA 3
901 W. Jackson Blvd. 265 Peachtree St.
Downtown Chicago Branch, 229 W. Madison
Lafayette Radio Corp.

Free

NEW COMPLETE *Concord*

**RADIO
CATALOG**

160 VALUE-PACKED PAGES

23 pgs. Radio and Television
Sets • 62 pgs. Radio Parts
18 pgs. Sound Amplifiers and
Accessories • 23 pgs. Ham Gear
9 pgs. Electronic Test Equipment

Mail **COUPON TODAY!**

CONCORD RADIO CORPORATION, Dept. 203
901 W. Jackson Blvd., Chicago, 7, Ill.
Yes, rush FREE COPY of the comprehensive new Concord Radio Catalog. (Please Print)

Name.....

Address.....

City & Zone..... State.....

RCA PHONO REPLACEMENT GUIDE

A guide which shows the exact replacement crystal to use in RCA Victor phonos has been prepared by the RCA tube department.

Folder contains outline diagrams of the crystal cartridges used in the pickup arms, diagrams showing the shape, mounting holes, and other necessary information. Folder also contains two indexes, one listing phono by model number showing the proper crystal replacement for each, and the second listing RCA crystals by stock number and showing what RCA phono they may be used in.

RCA's *Magic Tone Cell* and *Silent Sapphire Crystal Pickup* are also described in the folder. The *Tone Cell* is recommended for modernization of 69 RCA radio-phonos models.

* * *

SUPREME, INC. ACQUIRES SUPREME INSTRUMENT CORP.

Supreme, Inc., has acquired the manufacturing rights, facilities and assets of the Supreme Instruments Corporation. The new corporation is composed of executives, representatives and key employees of the old company.

Supreme Inc., will continue to sell test equipment and meters under the name *Supreme*.

No immediate changes of personnel or policy are contemplated.

Officers and directors are E. G. Perkins, president; D. S. Hill, vice president; and C. A. Carroll, secretary and treasurer. Directors include H. W. Burwell, R. M. Campion, Harper Johnson, and B. O. Burlingame.

* * *

BACE TELEVISION CORP. APPOINTING DISTRIBUTORS FOR MULTI-UNIT TV MODEL

The Bace Television Corporation, Hackensack, N. J., are now selecting distributors for its *multi-unit* set which comprises any number of viewing screens operated from one central control unit.

* * *

WAHLGREN NOW PREXY OF WCEMA, INC.

Wallace Wahlgren, San Francisco, has been elected president of WCEMA, which was recently incorporated in California. The organization membership is spread over the states of California, Oregon, Washington, Idaho, Utah, Nevada and Arizona with two main groups, the Los Angeles and San Francisco councils.

These councils will alternate in staging annual show, the show for 1948 being held at the Los Angeles Biltmore on Sept. 30 and Oct. 1 and 2.

WCEMA has been voted as an active sponsor in the Radio Parts Industry Coordinating Committee activities.



RADIO'S OLD TIMERS TO MEET AT PARTS SHOW ROUND-UP

Radio's Old Timers, *ROT*, are preparing for their annual round-up at the parts show in May.

The second annual affair, a cocktail party, will be held in private dining room No. 2, at the Stevens Hotel, from 5:00 to 7:00 P.M. on Monday, May 10, just ahead of the Radio Industry Banquet. Only paid-up members of *ROT* will be able to attend.

ROT was created in prewar days as a common meeting ground for those who have been in radio in a commercial way for a long period of years. Anyone who believes he is eligible for membership in this *honorary* society is urged to communicate with John O. Olsen, president, Radio's Old Timers, 1456 Waterbury Road, Lakewood, Cleveland, Ohio.

* * *

UNGER BECOMES WARD S-M

Roy Brown Unger has been appointed sales manager of Ward Products Corp.

He was formerly assistant sales manager of the jobber division.



* * *

JOHNSON APPOINTED HICKOK SALES MANAGER

H. D. Johnson, formerly assistant sales manager for The Hickok Electrical Instrument Co., has been appointed sales manager, succeeding the late Robert Williams.



RIDER MANUAL VOLUME XVII OUT IN MARCH

Volume XVII of the *Perpetual Troubleshooter's Manuals*, published by John F. Rider, Publisher, Inc., 404 Fourth Avenue, New York 16, N. Y., has been scheduled for delivery during this month.

Volume XVII will contain more than 1,600 pages and will also have the companion *How It Works* book and cumulative index for volumes XVI and XVII.

Clarified schematics will be carried on in volume XVII.

* * *

ELECTRONIC LABS REORGANIZED

Electronics Laboratories Inc., Indianapolis, Ind., have received a loan of \$285,000 from R.F.C. and have set up a new organization. Norman Kevers is president, and Walter Peek, vice president, in charge of sales.

* * *

WEBSTER-CHICAGO APPOINTS PARSONS SALES REP.

Newell B. Parsons has been appointed sales representative for Webster-Chicago Corp., 5610 W. Bloomingdale Avenue, Chicago 39, Illinois.

Parsons will cover the Chicago and Milwaukee trading areas.

* * *

MAGNETAPE RECORDER CATALOG

An 8-page catalog 4901, has been published by the magnephone division of Amplifier Corp. of America, 398-31 Broadway, New York 13, N. Y.

Described are seventeen standard and portable models, ranging in playing time for a single reel of magnetic tape from 15 minutes to 8 full hours.

* * *

ESPEY TV TRAINING KIT ADOPTED BY RTS

A tv training Kit, produced by the Espey Manufacturing Company, 528 E. 72nd St., N.Y. 21, N.Y., has been adopted as a basic tv training tool in the courses given by the Radio-Television School of New York.

* * *

G. F. PLATTS NOW CLIPPARD V-P

George F. Platts has been appointed executive vice president of Clippard Instrument Laboratory, Inc., 1125 Bank Street, Cincinnati, Ohio.

Mr. Platts holds the rank of Commander, U.S.N.R., and during World War II served in connection with the #2 Secret Weapon Project, receiving a commendation ribbon from the Secretary of the Navy for his services. He was formerly general manager of the electric products division, McQuay-Norris Mfg. Co., St. Louis, Mo.

WRIGHT VERIFIED SPEAKERS

They Glorify the Tone

W R I G H T

2235 University Avenue .. Inc. .. St. Paul 4, Minnesota

M. V. MANSFIELD CO.

DISTRIBUTORS OF NATIONALLY KNOWN RADIO & ELECTRONIC PARTS, TUBES & EQUIPMENT. PROMPT SERVICE.

937 LIBERTY AVE., PITTSBURGH 22, PA.

KRIM NAMED MANAGER OF RAYTHEON RECEIVING TUBE DIV.

Norman B. Krim has been appointed manager of the receiving tube division of Raytheon Manufacturing Co.

Mr. Krim succeeds Carl J. Hollatz, vice-president of Raytheon's subsidiary, Belmont Radio Corp., who has become general manager of Belmont.



* * *

TELEVISION INTRODUCED TO BOSTON BY TRANSVISION AND SIGHTMASTER

The engineering staff of Transvision and Sightmaster joined forces with the Boston Bell Telephone Co. and CBS, during the first tv show in Boston, installing 14 tv receivers in Filene's department store.

An all-day show was put on in the windows on three sides of Filene's Washington Street store. Program originated in New York and was flashed to Boston over the A.T.&T. microwave link.



* * *

SOLAR PROMOTES ALFRED S. GARTNER

Alfred S. Gartner has been named assistant sales manager of Solar Manufacturing Corporation.

Mr. Gartner has been with Solar for nearly five years.

MILLING BECOMES COMMERCIAL VICE PRESIDENT OF RCA SERVICE COMPANY

J. A. Milling has been appointed to a newly-created post of commercial vice president of the RCA Service Company. Prior to his new appointment, Mr. Milling was general manager of the parts division of the RCA tube department.



* * *

GEORGE KOCH OF SIMPSON DEAD

George Koch, secretary, director and sales manager of the Simpson Electric Company, passed away on Sunday, February 15, 1948 after a brief illness.

Mr. Koch was sales manager of the Simpson Electric Company for 14 years. He was formerly associated with Ray Simpson at the Jewell Electrical Instrument Company from 1922 until 1932.

* * *

JABLON JOINS ESPEY

W. W. Jablon, formerly of Hammarlund Manufacturing Company, has been elected vice president of the Espey Manufacturing Company, Inc., 528 East 72 Street, New York City. He will head both the jobbing and special products divisions.



* * *

SUPREME PUBLICATIONS F-M/TV SERVICING MANUAL

An f-m/tv manual, *Most-Often-Needed F.M. and Television Servicing Information* has been published by Supreme Publications, 9 South Kedzie Ave., Chicago 12, Ill. Presents specific factory instructions on adjustment and repair of many popular models. Also offered are a variety of installation and servicing data.



Servicemen's choice!

... Murals for modern selling

● Cunningham's outstanding Mural displays are scientifically designed to create a modern selling atmosphere in your store. They will give your store more "sell" per square foot. Each is silk-screened in rich oil colors on heavy, washable stock. They are fadeproof and are easily applied to walls, windows and panels with cellulose tape.

Available in either vertical or horizontal form, these exciting displays will brighten up your place of business, emphasize your services, and identify you with the famous Cunningham brand. Get a set from your Cunningham Distributor today!



BUY FROM YOUR JOBBER

TINIT
CONTAINS ENOUGH
SOLDER FOR SMALL JOBS!

Difficult radio repair jobs can be handled easily with TINIT because TINIT contains enough tin for small jobs without additional solder. In powder form, it makes tough jobs easy because you can get it into tight places! You know it's tinned with TINIT because you can see it! Cleans, tins and fluxes all metals including sheet aluminum, penetrates rust, grease and dirt in one easy operation! Twenty years on the market. Sold by automotive, refrigeration, tinning supply and other jobbers.

TINIT MFG. CO., INC.
P. O. Box 794, Denver, Colo.



TINY... but MIGHTY OIL TUBULAR CAPACITORS

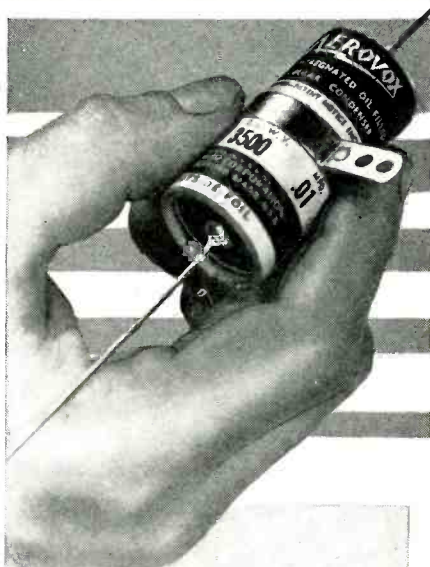

● For superlative performance and longest life in tight spots or mighty compact assemblies. Oil-impregnated, oil-filled. Fully sealed against oil leakage or moisture penetration. Metal case insulated — not connected to capacitor section. Outer insulating tube. Center mounting strap.

Previously in 400, 600, 1000 and 2000 v. D.C.W. ratings, but now extended to 2500, 3000, 3500 and 4000 v. for television and other higher-voltage applications.

See Our Jobber . . .

● Order Aerovox Type 89 oil tubulars for your severe-service needs. Ask for latest catalog. Or write us.



**FOR RADIO-ELECTRONIC AND
INDUSTRIAL APPLICATIONS**

AEROVOX CORP., NEW BEDFORD, MASS., U.S.A.
Export: 13 E. 40th St., New York 16, N.Y. • Cable: 'ARLAB'
In Canada: AEROVOX CANADA LTD., Hamilton, Ont.

JOTS AND FLASHES

SERVICE CLINICS patterned like the recent Town Meeting of Radio Technicians held in Philadelphia have been temporarily scheduled for New York, Los Angeles, St. Louis and Kansas City. The meetings will feature talks on the business and technical aspects of servicing and may also provide an exhibit on test equipment of today. Harry Ehle, who was chairman of the Town Meeting Committee, reported that 97% of the Service Men interviewed after the Town Meeting indicated that they got enough out of the meetings to justify the effort and would like to have another one next year. . . .

Life memberships in the PRSMA were awarded to Bob Baggs of the Harry P. Bridge Co. and Harry Kalker of Sprague Products at the Town Meeting of Technicians in Philadelphia. . . . The Federation of Radio Service Men of Pennsylvania presented an award to Howard W. Sams for outstanding contributions to the Servicing industry in 1947, during the Town Meeting. . . . A subcommittee of the National Electrical Wholesalers Association's Service and Repair Parts Committee are making a study of the distributors problems involved in installation and servicing of tv receivers in metropolitan New York. . . . Jack Clume, general merchandise manager of Air King Products died recently as a result of injuries suffered in an automobile accident. . . .

A 172-page catalog, No. 115, has been released by Allied Radio Corporation, 833 W. Jackson Blvd., Chicago 7, Illinois. The catalog contains data on some 10,000 items, including test equipment, batteries, p-a systems, phono, wire, disc and tape recorders, etc. . . . Larry E. Gubb of Philco has been appointed to the finance committee of the Committee for Economic Development. . . . Ben Lehman has resigned as vice president and general manager of Radio Wire Television, Inc. . . . Robert J. Harrington is now assistant director of sales for Industrial Television, Inc., 359 Lexington Avenue, Clifton, N. J. He was formerly with Allen B. DuMont Labs. . . . Samuel S. Egert was recently elected president of the New York Chapter of The Representatives. William Gold was named vice president and Ben Joseph, secretary-treasurer. . . . Oak Ridge Antenna Co. are now located at 239 E. 127th Street, New York City. . . . Eckstein Radio & Television Co. have moved to LeRoy, Minnesota. . . . The National Bureau of Standards have released a 200-page book on "Safety For the Household." It's known as NBS Circular 463 and may be obtained from the Superintendent of Documents, Washington 25, D.C. for 75c. . . .

Bittan-Nevins Co. will hereafter operate under the name of D. R. Bittan Co., Inc., 53 Park Place, New York 7. D. R. Bittan is president. Raymond Steckel, vice president and Bernard Brown, treasurer. . . . A 64-page catalog has been released by Radolek Co., 601 W. Randolph Street, Chicago 6, Ill. . . . Specialty hardware and component parts for tv are now being featured by the Christie Television Corp., Oakford, Pa. . . . Hatry and Young, 203 Ann Street, Hartford, Conn., recently celebrated their 20th anniversary. . . . DuMont has reached an agreement with the Crosley Corp. to manufacture tv receivers under its patents. . . . Video Television Inc., are now located at 239 E. 127th Street, New York City. Burt U. Levy is president of the company. . . .

ADVERTISERS IN THIS ISSUE

SERVICE INDEX—MARCH, 1948

AEROVOX CORPORATION	60
Agency: Austin C. Lescarboursa & Staff	
ALLIED RADIO CORPORATION	44
Agency: George Brodsky, Advertising	
AMERICAN TELEVISION & RADIO CO.	53
Agency: Firestone-Goodman Adv. Agency	
AMPLIFIER CORP. OF AMERICA	56
Agency: H. J. Gold Co.	
THE ASTATIC CORPORATION	54
Agency: Wearstler Advertising, Inc.	
BENDIX RADIO DIV. BENDIX AVIATION	46
Agency: MacManus, John & Adams, Inc.	
THE BRUSH DEVELOPMENT CO.	47
Agency: McCann-Erickson, Inc.	
CAPITOL RADIO ENGINEERING INSTITUTE	46
Agency: Henry J. Kaufman & Associates	
CHICAGO INDUSTRIAL INSTRUMENT CO.	48
Agency: Turner Adv. Agency	
CLAROSTAT MFG. CO., INC.	52
Agency: Austin C. Lescarboursa & Staff	
CONCORD RADIO CORP.	57
Agency: E. H. Brown Adv. Agency	
CORNELL-DUBILIER ELECTRIC CORP.	Inside Front Cover
Agency: Reiss Advertising	
ALLEN B. DUMONT LABS., Inc.	43
Agency: Austin C. Lescarboursa & Staff	
ELECTRONIC CORPORATION OF AMERICA	37
Agency: Ray-Hirsch Co., Inc.	
FEDERAL TELEPHONE & RADIO CORP.	32
Agency: Rickard & Co.	
GENERAL ELECTRIC CO.	I, 15, 29
Agency: Maxon, Inc.	
GREYLOCK ELECTRONIC SUPPLY CO.	56
Agency: Bergman-Jarrett Co.	
HICKOK ELECTRICAL INSTRUMENT CO.	41
Agency: White Adv. Company	
HYTRON RADIO & ELECTRONICS CORP.	5
Agency: Henry A. Loudon, Advertising	
INTERNATIONAL RESISTANCE CO.	49
Agency: John Falkner Arndt & Co., Inc.	
P. R. MALLORY & CO., INC.	13, 25
Agency: The Aitkin-Kynett Co.	
M. V. MANSFIELD CO.	58
MURRAY HILL BOOKS, INC.	35
Agency: The Harry P. Bridge Co.	
NATIONAL UNION RADIO CORP.	9
Agency: VanDine Adv. Agency	
OHMITE MFG. CO.	44
Agency: The Penhall Co.	
PARK METALWARE CO.	40
Agency: Melvin F. Hall Agency, Inc.	
PERMOFLUX CORPORATION	42
Agency: Turner Adv. Agency	
PRECISION APPARATUS CO.	4
Agency: Shappe-Wilkes, Inc.	
QUAM-NICHOLS CO.	48
Agency: Triangle Adv. Agency, Inc.	
RADIART CORP.	14
Agency: Ohio Adv. Agency	
RADIO CORPORATION OF AMERICA	53, 55, 57, 59. Back Cover
Agency: J. Walter Thompson Co.	
JOHN F. RIDER PUBLISHER, INC.	6, 50
Agency: Lansford F. King, Advertising	
HOWARD W. SAMS & CO., INC.	3
Agency: George Brodsky, Advertising	
SANGAMO ELECTRIC CO.	11
Agency: Arthur H. Mogar, Inc.	
SIGHTMASTER CORP.	50
Agency: H. J. Gold Co.	
SOLAR CAPACITOR SALES CORP.	Inside Back Cover
Agency: O. S. Tyson & Co., Inc.	
SPRAGUE PRODUCTS CO.	7
Agency: The Harry P. Bridge Co.	
STANDARD RADIO & ELECTRONICS PRODUCTS CO.	44
Agency: Mount Printing Co.	
STERLING MFG. CO.	46
TARTAK SPEAKERS, INC.	55
Agency: Sylvester-Meader Adv. Co.	
TECHNICAL APPLIANCE CORP.	42
Agency: Austin C. Lescarboursa & Staff	
THORDARSON	8
Agency: Ohio Adv. Agency	
TINIT MFG. CO.	59
Agency: Bill Bonsib Adv. Agency	
TRANSVISION, INC.	40
Agency: H. J. Gold Co.	
TRIPLETT ELECTRICAL INSTRUMENT CO.	10
Agency: Western Adv. Agency, Inc.	
U. S. TREASURY DEPT.	12
UNIVERSAL GENERAL CORP.	46
Agency: Galles Adv. Agency, Inc.	
UNIVERSITY LOUDSPEAKERS, INC.	56
Agency: George Homer Martin Associates	
UTAH RADIO PRODUCTS DIV. INTERNATIONAL DETROLA	45
Agency: Bonsib Adv. Agency	
WARD LEONARD ELECTRIC CO.	54
Agency: Henry H. Teplitz, Advertising	
WARD PRODUCTS CORP.	16
Agency: Burton Browne, Advertising	
WEBSTER-CHICAGO	39
Agency: Fuller & Smith & Ross, Inc.	
WRIGHT, INC.	51, 58
Agency: Kay Advertising, Inc.	

**BETTER
THAN
EVER!**

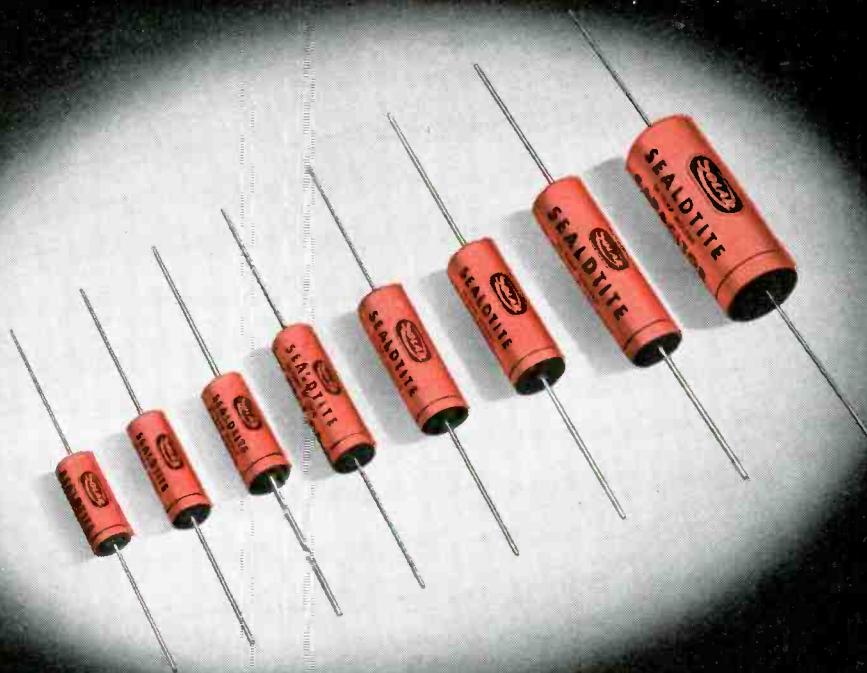

HI-TEMP* SEALDITE* TUBULARS STAND UP IN **HOT SPOTS**

Check these advantages:

- ✓ **HEAT-RESISTANT TO 100°C**
- ✓ **PROVEN SUPERIOR MOISTURE RESISTANCE SINCE 1939**
- ✓ **SQUEEZE-PROOF HOUSINGS OF MOLDED PLASTIC COMPOUND**
- ✓ **HALOWAX SECTIONS TO 600 VOLTS**
- ✓ **MINERAL OIL SECTIONS FOR 1000 AND 1600 VOLTS**
- ✓ **MAXIMUM SPACE ECONOMY**
- ✓ **EASY-TO-READ RED LABELS**
- ✓ **NO INCREASE IN PRICE**

There's one sure way of getting all-purpose paper capacitors. Specify and insist on Solar SEALDITES.

Solar's new Hi-Temp plastic molding compound makes these pioneer molded tubulars a universal choice for all automobile and home radio applications—bypass capacitors, coupling capacitors, or buffer capacitors.

Securely sealed against atmospheric moisture by a tough molded armor, Sealdtite Capacitors maintain their exceptionally high insulation resistance throughout their extremely long life. Unlike conventional tubulars, Sealdtites have no cardboard tubes to grow soggy, or internal voids to collect moisture.

Hi-Temp Sealdtite Capacitors have attractive red labels in bold, easy-to-read type. Their smooth surface attracts no dust and drips no wax.

**BE WISE! STANDARDIZE ON
SEALDITE CAPACITORS**

AD-135

*Trade Mark of Solar Mfg. Corp.
North Bergen, N. J.

SOLAR CAPACITORS
"Quality Above All"



OVERWHELMING ACCEPTANCE!



- Month after month, RCA Batteries continue to smash all previous sales records.

The reasons for this unprecedented acceptance are conclusive—

RCA Batteries are designed for *radiomen* . . . to sell through *radio* outlets. And they're backed by the greatest name in radio—RCA.

RCA Batteries are your assurance of immediate customer acceptance and greater profits.

SELL RCA BATTERIES—THE COMPLETE LINE FOR THE RADIO AND ELECTRONIC TRADE



TUBE DEPARTMENT

RADIO CORPORATION of AMERICA

HARRISON, N. J.