

# SERVICE

January  
1947

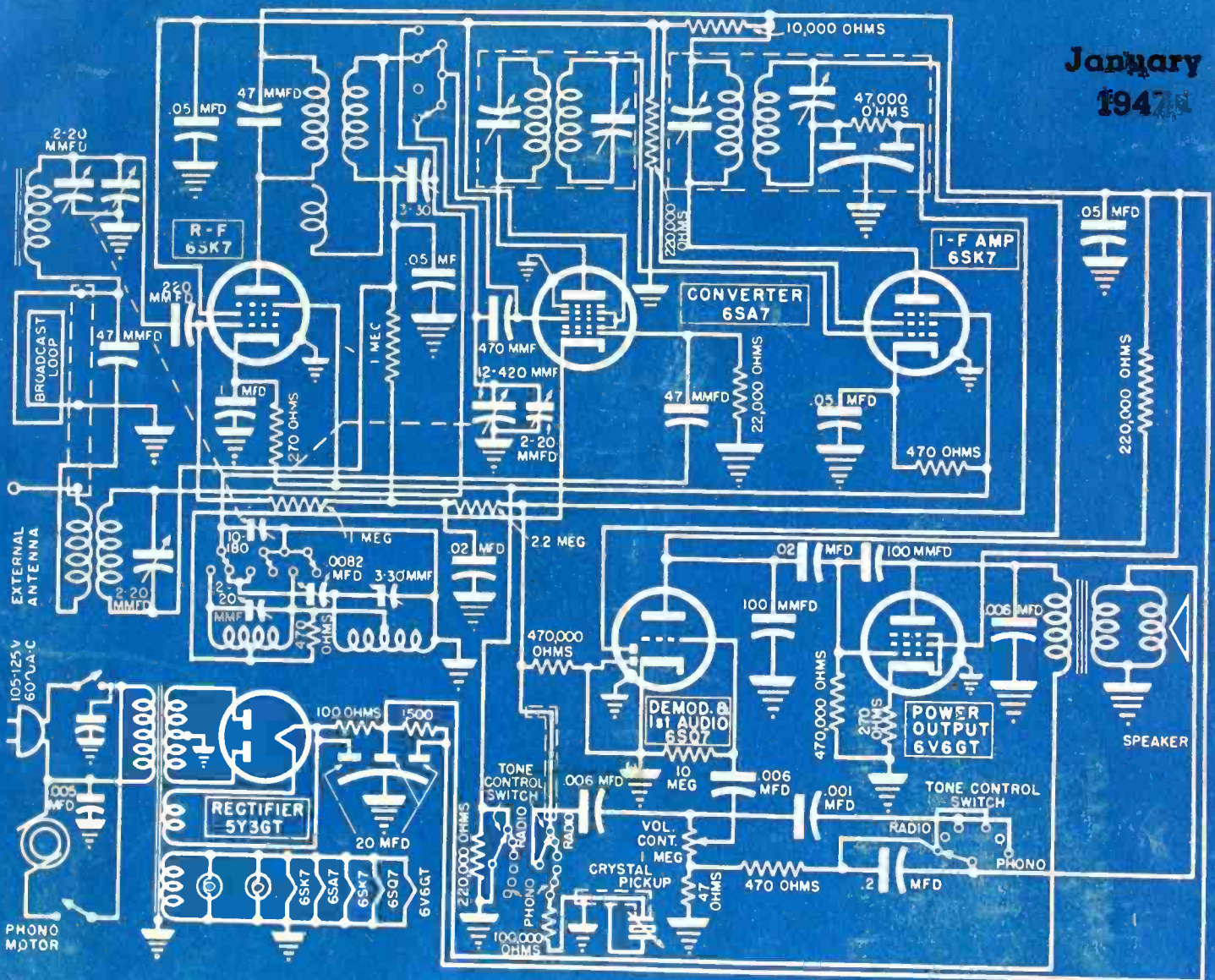

Low-impedance loop 2-band 5-tube  $\omega$ -c receiver featuring audio-voltage degeneration.

[See page 33.]

# Brother, want 3 extra hands?

Then drop a few seeds in the mailbox! C-D has them ready for you . . . punchy mailing pieces . . . to let the whole neighborhood know you're alive. And that's only one part of a complete promotional program we've prepared for you. Look around! The field is getting crowded; now is the time to promote yourself. And here is a program—complete—packaged—that'll give you three extra hands and make you "the" service shop in your community.

And watch the customers grow! You can't expect radios will break down faster to help your volume . . . but when they do get out of wack, you can bet the customers will take them to shops they've heard about. So get the ball rolling with the new C-D Sales Promotional Program that will help you grow—not only in 1947—but in 1948 and 1949.



## USE THESE C-D HELPS AVAILABLE THROUGH YOUR LOCAL JOBBER!



NEWSPAPER MATS

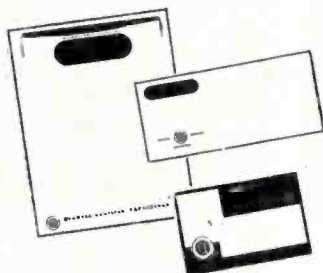

STATIONERY LABELS



DECALS



WINDOW CARDS



POSTCARDS — just address and drop in mailbox!



MATCH BOOKS —

**KEEP YOUR REPUTATION GROWING WITH TOP QUALITY PARTS**



C-D's "dwarf tigers" are long life units. Heat and humidity don't get them out of the picture. Real quality . . . real reputation-builders.

**OF COURSE YOU'LL WANT YOUR FREE SUBSCRIPTION TO THE "CAPACITOR"**

All the important radio data of the month, condensed for you. Write now: Cornell-Dubilier Electric Corp., South Plainfield, New Jersey.

NAME \_\_\_\_\_

ADDRESS \_\_\_\_\_

CITY \_\_\_\_\_

STATE \_\_\_\_\_

ZONE \_\_\_\_\_

ALL AVAILABLE THROUGH YOUR LOCAL C-D JOBBER

# Cornell-Dubilier

WORLD'S LARGEST  
MANUFACTURER OF

# Capacitors



MICA • DYKANOL • PAPER • ELECTROLYTICS



**RADIO  
TUBES**

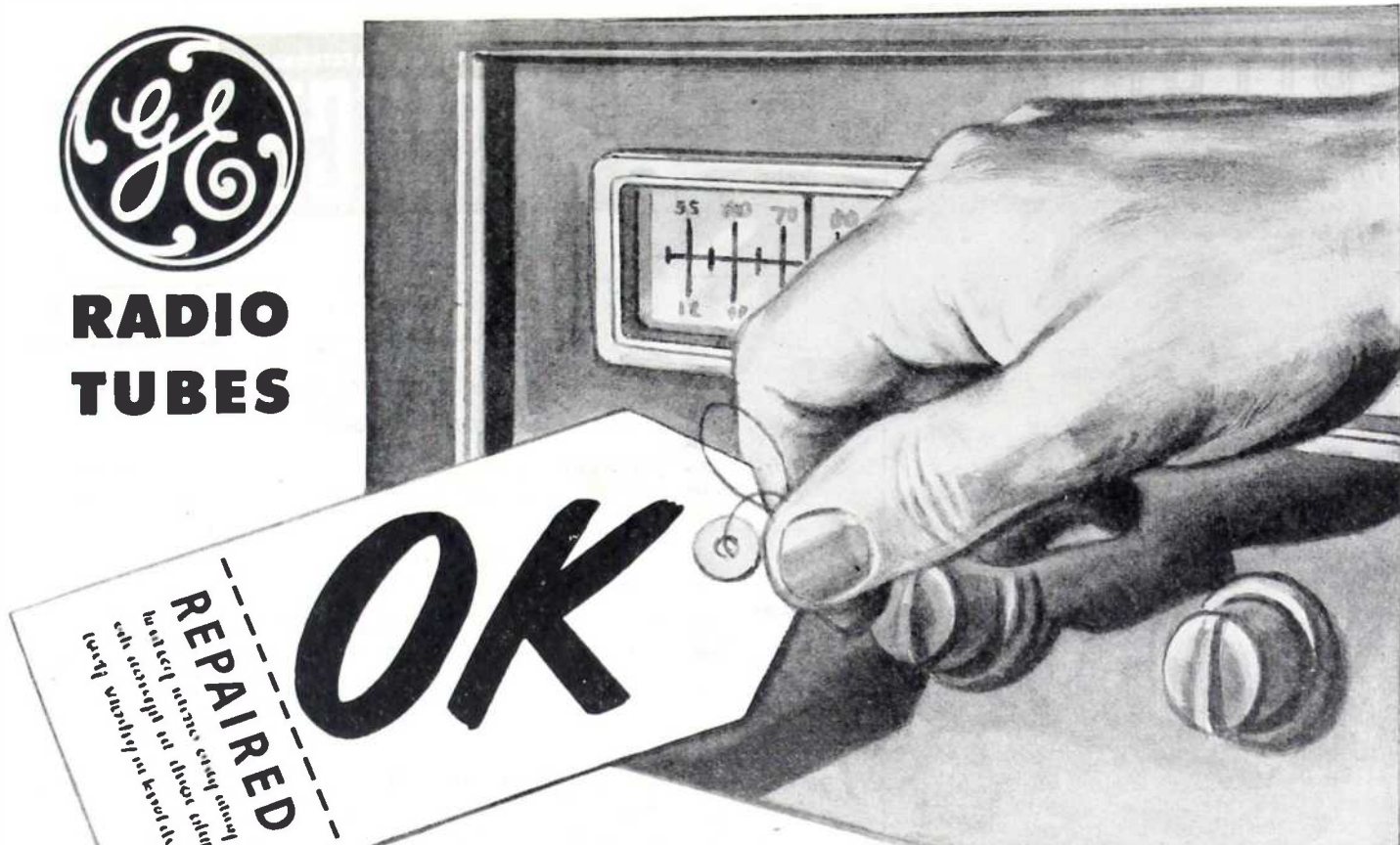

**A REPAIR JOB WELL DONE!**

*...That's what "OK" means when  
the tubes you've installed are G-E's*

**F**IRST off, you've pleased your customer by putting General Electric tubes in his set he gave you to repair. For the G-E monogram is more than a familiar symbol to him—it stands for **QUALITY**.

Second, you've done yourself a good turn, because G-E radio tubes *won't let you down*. The set you've just tagged "OK" will play better than ever, and will keep giving the kind of satisfaction that builds friendship for you and your shop.

When your client is asked to recommend a radio repair source (as happens regularly) he'll give *your* name. That's the sort of helpful person-to-person advertising that makes your business grow, and fattens your profit-account.

So that your radio service always may enjoy top standing in your community ... replace faulty tubes with high-quality, long-lived G-E's—**THE BEST!** *Electronics Department, General Electric Company, Schenectady 5, N. Y.*

*G.E.'s fact-filled Tube Characteristics Book ETR-15 will help you in your radio service work. Send for your copy. It's free!*

**GENERAL**  **ELECTRIC**

176-F1-8850

FIRST AND GREATEST NAME IN ELECTRONICS

SERVICE, JANUARY, 1947 • 1

# EDITORIAL

IN RUNNING A PROFITABLE SERVICE SHOP, the relationship of time and efficiency to cost of repair is quite a factor . . . a factor that too many Service Shop owners do not seem to appreciate. Analyzing this important business problem, one Service Man said, in a recent letter to SERVICE, that he had found the setting up of a time-efficiency-cost approach imperative to success today.

Such a program, our correspondent noted, is not too difficult to place into operation providing the Service Man is completely familiar with circuits and the test equipment required to find trouble. Knowing what instrument to use and how to interpret trouble symptoms can save many hours of circuit probing.

Commenting on charges and time, another major item in the efficiency program, our correspondent said: "There is no reason why a skilled man and a rather slow individual should charge the same rate. That is why so-called standardized charges are not too fair. The efficient man who charges a high rate and does work in less time will actually cost the customer less than the man who takes quite a bit of time and charges a low rate. To illustrate this point, suppose one Service Man charges at a \$5.00-an-hour rate. If he can repair the set in 15 minutes, the charge is but \$1.25 for labor which is quite low. However, if the unskilled individual, charging at the rate of \$2.00 an hour, requires an hour to puzzle out the trouble, his charge is really \$.75 more than the first one. The well-trained Service Man can repair more rapidly, complete more jobs and earn more."

Group operation of Service Men in a shop also offers many advantages in the program, says our correspondent. He notes that such an arrangement offers a variety of experience and permits specialization on a particular kind of job. Thus, repair of record changers, auto receivers or console sets could be assigned to specialists. Such an efficient operational approach can cut costs down for the customer but still provide a substantial profit to the Service Man.

We feel that the time—efficiency—cost repair subject is so important that we have scheduled several articles, discussing various phases, for early publication in SERVICE. Undoubtedly, there are many Service Men who have a variety of opinions on this subject. We would very much appreciate receiving these comments so that they might be included within the contemplated series of articles. Hope we'll be hearing from you!

# RADIO · TELEVISION · ELECTRONIC SERVICE

Reg. U. S. Patent Office

Vol. 16, No. 1

January, 1947

**LEWIS WINNER**  
Editorial Director

**ALFRED A. GHIRARDI**  
Advisory Editor

**F. WALEN**  
Managing Editor

	Page
Audio Amplifier Equalization Methods. By Willard Moody . . . . .	11
G.I. Bill of Rights Home-Study Benefits for Veterans. By George Hartman . . . . .	18
New Models . . . . .	34
Old Timer's Corner . . . . .	30
Operating the Vomax. By M. E. Lewis . . . . .	36
Set-Cuits. By Henry Howard . . . . .	14
Servicing Helps. By Frank C. Keene . . . . .	20
Signal Tracing with a V-T-V-M. By Robert G. Herzog . . . . .	22
Tools and Service Aids for the New Service Shop. By Alfred A. Ghirardi . . . . .	24
Tube News This Month . . . . .	16
<b>CIRCUITS</b>	
Admiral 10A1 . . . . .	15
H-F A-M Converter for 87.75 mc. . . . .	28
Bendix 676B, C and D (Cover) . . . . .	33
Westinghouse H125/126 . . . . .	28
Zenith 6D015/6D030 . . . . .	26
<b>COVER</b>	
2-Band Loop Set (Bendix 676B, C and D) . . . . .	33
<b>SERVICING HELPS</b>	
Hum Cures in Voltage-Doubler Circuit (Kadette 1140) . . . . .	20
High Frequency Trimmer Adjustment . . . . .	20
Vibrator Failure Cures (G.E. 250) . . . . .	20
Index to Advertisers . . . . .	52
<b>Manufacturers</b>	
New Products . . . . .	45
News . . . . .	46
Jots and Flashes . . . . .	52

Copyright, 1947, Bryan Davis Publishing Co., Inc.

Published monthly by Bryan Davis Publishing Co., Inc.  
52 Vanderbilt Avenue, New York 17, N. Y. Telephone Murray Hill 4-0170



**Bryan S. Davis, President**  
**Paul S. Weil, Vice Pres.-Gen. Mgr.**



**F. Walen, Secretary**  
**A. Goebel, Circulation Manager**

Chicago Representative: Lawrence Wehrhelm, 5510 W. Lemoyne Ave., Chicago 51, Ill.; Telephone MERrimac 7919

Cleveland Representative: James C. Munn, 2656 E. 126th St., Cleveland 20, Ohio; Telephone CEDar 7783

Pacific Coast Representative: Brand & Brand, 1052 W. Sixth St., Los Angeles 14, Calif.; Telephone Michigan 1732

Brand & Brand, 1085 Monadnock Bldg., San Francisco 5, Calif.; Telephone Douglas 4475

Entered as second-class matter June 14, 1932, at the Post Office at New York, N. Y., under the Act of March 3, 1879. Subscription price: \$2.00 per year in the United States of America and Canada; 25 cents per copy. \$3.00 per year in foreign countries; 35 cents per copy.

# New! Exclusive!

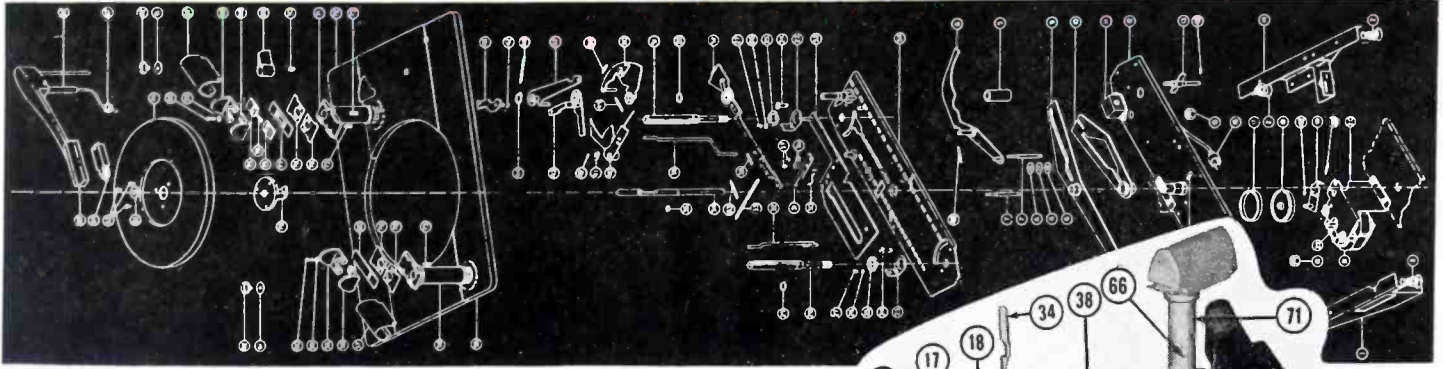

## PHOTOFACT<sup>\*</sup> FOLDERS analyze all post-war RECORD CHANGERS!

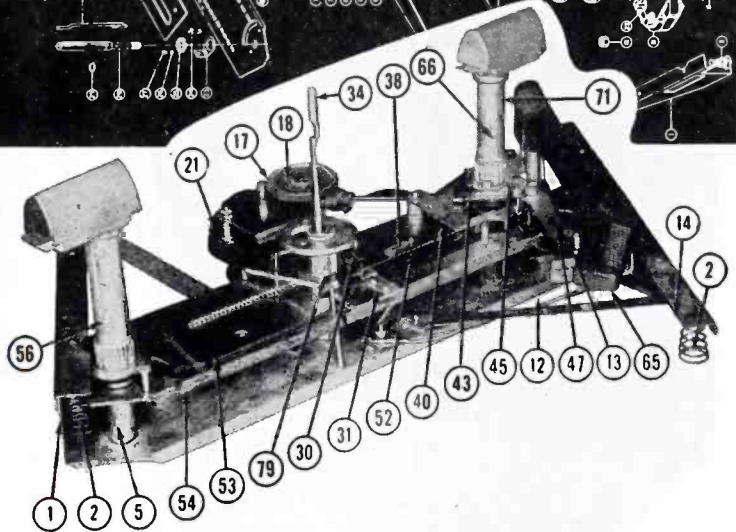

Post-war radio is barely a year old, but already there are 40 different record changers on the market. Do you know who makes them? How they operate? How to service them in case of breakdown? Do you know where you can get up-to-the-minute results of life tests that are now being run?

This vital information now becomes a regular PHOTOFACT FOLDER Service at no Extra Cost to You! Clear-cut photographs, exclusive big line drawings, parts lists, operation details, trouble-cause-and-remedy charts, tell you everything you need to know to do a workmanlike job—help you do twice as many repair jobs a day.

PHOTOFACT FOLDERS save valuable time in many other ways. They make it easy to

diagnose trouble, hunt defective parts, make adequate replacements in *all* the latest radios, phonographs, record changers, recorders, communication systems and power amplifiers. Data and photographs are made from actual examinations of instruments—not from reprinted or copied information.

The cost? Only \$1.50 for each set of 40 folders. Actually they cost you nothing, for they pay for themselves over and over again in time saved. **Over 25,000 radio service engineers now use and depend upon PHOTOFACT FOLDERS.** Why let service problems stump you? PHOTOFACT FOLDERS help you lick every one of them! See your nearest distributor or use the convenient coupon.

### PUBLICATION DATES:

Set No. 11 . . . . . January 10  
Set No. 12 . . . . . January 25

Cut this out and MAIL IT TO YOUR DISTRIBUTOR. If you do not know his name and address, send it directly to Howard W. Sams & Co., Inc., 2924 East Washington Street, Indianapolis 6, Indiana, and we will see that your nearest distributor gets it. In Canada, write to A. C. SIMMONDS & SONS, 301 King Street East, Toronto, Ontario. Canadian Price, \$1.75.

#### PLEASE PRINT

Send Vol. 2, Set No. 12       Send Vol. 2, Set No. 11

Send me Volume 1 (including Sets Nos. 1 to 10) with De Luxe Binder, \$18.39. Individual Sets Nos. 1 to 10, \$1.50 each.

Send me a De Luxe Binder (at \$3.39)

My (check) (money order) (cash) for \_\_\_\_\_ is enclosed.

(If you send cash, be sure to use registered mail.)

Name \_\_\_\_\_

Address \_\_\_\_\_

City \_\_\_\_\_ Zone \_\_\_\_\_ State \_\_\_\_\_

Company Name \_\_\_\_\_

My Distributor's Name \_\_\_\_\_

City \_\_\_\_\_

\*Trade Mark Reg.

HOWARD W. Sams & CO., INC. RADIO PHOTOFACT SERVICE

In Canada—write to A. C. SIMMONDS & SONS, 301 King Street East, Toronto, Ontario

**ALL SET FOR**

*Modern Servicing...*

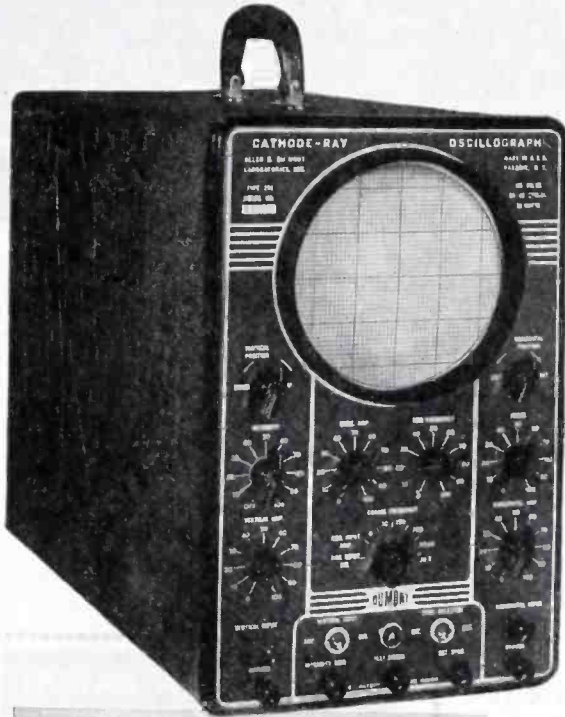

**DU MONT Type 274**  
**THE "MUST" INSTRUMENT**  
**designed for the go-getter**  
**serviceman**

▶ At only \$99.50, here's your "Best Buy" today. Note its many fine features. With this popular instrument, you're ready to tackle the widest range of profitable service jobs today, and the still more profitable jobs coming up soon. A Type 274 Oscillograph pays for itself over and over again. Here's how:

**FEATURES AT A GLANCE . . .**

- Big, detailed, easily-studied traces on the 5" Type 5BPI cathode-ray tube.
- Frequency Range: Sine wave response (at full gain) uniform within  $\pm 20\%$  from 20 to 50,000 c.p.s., down less than 50% at 100,000 c.p.s.
- Linear Time Base: Variable from 8 to 30,000 c.p.s. Synchronization from vertical amplifier or external signal.
- Deflection Sensitivity: Amplifiers at full gain, 0.65 r.m.s. volt/in.; direct,  $\pm 18$  r.m.s. volts/in.
- Power Supply: 115 volts, 50-60 cycles. Approx. 50 watts. Fuse protection: 1 amp.
- Weight: 35 lbs. Dimensions: 14" x 8 $\frac{3}{8}$ " x 19 $\frac{3}{8}$ ".
- And handsome! Green wrinkle-finish steel cabinet. Plastic carrying handle. Modern design green front panel with white characters. Black knobs.

**TELEVISION RECEIVERS . . .**

Forecasts indicate that within the next year thousands of television sets will be produced, bought, installed. Much of the servicing of the complex circuits is easily and quickly performed by the serviceman equipped with a Du Mont Type 274 Oscillograph.

**F-M RECEIVERS . . .**

For faithful reproduction of tonal values, F-M receivers must be aligned right "on the button." For this critical job, too, Type 274 provides the best method of servicing.

**A-M RECEIVERS . . .**

The exceptional versatility of Type 274 can be put to good use with standard A-M receivers. For the accurate adjustment of radio and intermediate frequency circuits, as well as trouble-shooting audio-frequency amplifiers, this instrument is a time-saving tool.

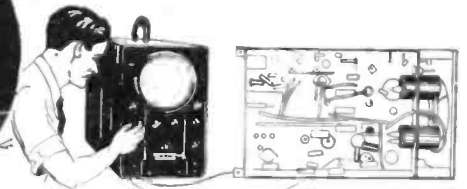
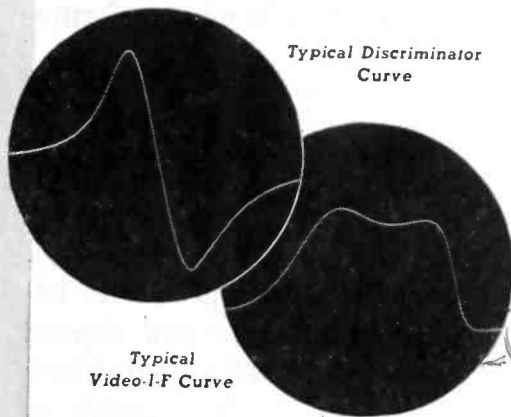

▶ **ASK YOUR JOBBER TO SHOW YOU THE NEW DU MONT TYPE 274 OSCILLOGRAPH, OR WRITE US FOR LITERATURE.**

© ALLEN B. DU MONT LABORATORIES, INC.

**DU MONT** *Precision Electronics & Television*

ALLEN B. DUMONT LABORATORIES, INC., PASSAIC, NEW JERSEY • CABLE ADDRESS: ALBEEDU, PASSAIC, N. J., U. S. A.

# New!

## Series 200

# A RELAY BY GUARDIAN with Interchangeable Coils

### BUILT IN TWO PARTS

★ Two basic parts—a coil assembly and a contact assembly—comprise this simple, yet versatile relay. The coil assembly consists of the coil and field piece. The contact assembly consists of switch blades, armature, return spring, and mounting bracket. The coil and contact assembly are easily aligned by two locator pins on the back end of the contact assembly which fit into two holes on the coil assembly. They are then rigidly held together with the two screws and lock washers. Assembly takes only a few seconds and requires no adjustment on factory built units.

A.C. Coil Assemblies available for 6 v., 12 v., 24 v., 115 v.  
D.C. Coil Assemblies available for 6 v., 12 v., 24 v., 32 v., 110 v.



SERIES 200 RELAY

## On Sale at Your Nearest Jobber NOW!

See it today! . . . this amazing new relay with interchangeable coils. See how you can operate it on any of nine different a-c or d-c voltages—simply by changing the coil. Ideal for experimenters, inventors, engineers.



### TWO CONTACT ASSEMBLIES

The Series 200 is available with a single pole double throw, or a double pole double throw contact assembly. In addition, a set of Series 200 Contact Switch Parts, which you can buy separately, enables you to build dozens of other combinations. Instructions in each box.

### NINE COIL ASSEMBLIES

Four a-c coils and five d-c coils are available. Interchangeability of coils enables you to operate the Series 200 relay on one voltage or current and change it over to operate on another type simply by changing coils.



Your jobber has this sensational new relay on sale now. Ask him about it. Or write for descriptive bulletin.

# GUARDIAN ELECTRIC

1617-A W. WALNUT STREET CHICAGO 12, ILLINOIS

A COMPLETE LINE OF RELAYS SERVING AMERICAN INDUSTRY

AT LAST!

# THE BASIC KIT

YOU'VE ALWAYS WANTED!

- ALL-METAL CABINET
- HANG ON WALL—SET ON SERVICE BENCH
- INDIVIDUAL, IDENTIFIED COMPARTMENTS
- ATTRACTIVE YELLOW, BLUE AND SILVER FINISH
- FACTORY PACKED

NEW **IRC** RESISTOR KIT  
CONTAINS COMPLETE VARIETY OF STOCK  
NEEDED FOR YOUR DAY TO DAY WORK!



## Basic Kit Contents

- 160 IRC Type BTS New, 1/2 watt metallized filament Resistors
- 115 IRC Type BTA New, 1 watt metallized filament Resistors
- 35 IRC Type BT-2 2 watt—metallized filament Resistors
- 60 IRC Type BW-1/2 1/2 watt—wire-wound Resistors
- 20 IRC Type BW-1 1 watt—wire-wound Resistors
- 20 IRC Type BW-2 2 watt—wire-wound Resistors
- 22 IRC Type AB 10 watt Power wire-wound Resistors
- 16 IRC Type ABA 10 watt Power wire-wound adjustable Resistors
- 6 IRC Type EPA 50 watt Power wire-wound adjustable Resistors
- 7 IRC Type ESA 80 watt Power wire-wound adjustable Resistors
- 6 IRC Type X-3 Bands—additional bands for adjustable Resistors
- 2 IRC Type MW-2J Bleeder-type Resistors
- 2 IRC Type M-1034 Bleeder-type Resistors

Free! Neat, Handy,  
All-Metal Cabinet  
free with Basic Kit  
of resistors ordered  
at standard resistor  
prices. Cabinet is not  
sold separately.



• YOU ASKED US FOR IT! HERE IT IS! THE IRC BASIC KIT—a wide-variety stock of most-needed resistor sizes and types that equips you to do just about any job you'll encounter in your day to day work. This unusually handy and convenient assortment of items was carefully selected through an exhaustive study of orders and a survey of IRC distributors and dealers.

The IRC Basic Kit is a practical planned time-saver, particularly suited to the needs of servicemen, schools, colleges, research labs and Industrial Maintenance Departments. The Resistor Assortments are so arranged that in most cases even a shortage of stock in any one range may be compensated for by using two other ranges in series or parallel. The power wire wound resistors included are useful in replacing many power resistors used in old-time receivers and as ballast resistors in some of the more modern AC-DC receivers. Additional adjustable bands are included in the Kit for use in making up bleeder sections.



## INTERNATIONAL RESISTANCE CO.

401 N. BROAD ST., PHILADELPHIA 8, PA.

In Canada: International Resistance Co., Ltd., Toronto, Licensee





**MI-6203  
VARACOUSTIC**

This high-quality, ruggedly constructed velocity microphone has a slide adjustment, giving choice of directional, bi-directional or non-directional characteristics at will.



**MI-4036  
JUNIOR VELOCITY**

Small—lightweight—bi-directional. Low in cost, high in quality. Popular throughout the PA field . . . excellent for studio and stage work, recording and announce use.



**MI-6207  
AEROPRESSURE**

Ideal for outdoor use. Reversible paracoustic baffle sharpens or broadens directional characteristics. 60-10,000 cycle response. High sensitivity.



**MI-6228  
AERODYNAMIC**

Popular priced, small, streamlined. Excellent performance . . . ideal for close-talking and announce work.

**WIDE CHOICE OF STANDS  
DESK AND FLOOR TYPES**

Attractively finished in chrome and black. Low cost. Variety of fittings to match standard microphones.

## Popular RCA Microphones for every speech and music range

RCA produces them all . . . pressure-dynamic, velocity and crystal . . . uni-directional, bi-directional, non-directional . . . for indoor or outdoor use on speech and music.

The microphones illustrated here were selected from the new complete line of RCA Package Sound Equipment. In this line you will find every item needed for matching up an efficient sound assembly from RCA Package Units . . . amplifiers, speakers, baffles, turntables, recorders, portable PA systems and reproducers.

*This line sells fast.* Why not start the ball rolling by getting additional information on RCA Microphones and the rest of the profitable RCA Package Sound Line?

**WRITE TODAY** to Sound Equipment Section, Dept. 76-A, Engineering Products Dept., RCA, Camden, N. J.



**SOUND EQUIPMENT**  
**RADIO CORPORATION of AMERICA**  
 ENGINEERING PRODUCTS DEPARTMENT, CAMDEN, N. J.

In Canada: RCA VICTOR Company Limited, Montreal

**JUST  
OUT**

# VOLUME XV

**ONE FEATURE ALONE  
WILL REPAY THE ENTIRE  
COST TO YOU...  
TIME, AND TIME, AND  
TIME AGAIN!**

For years and years on end—for as long as 1946 receivers are in use—Volume XV will continue to pay you annual cash benefits by providing authorized time-saving servicing data complete and bound in a systematic form, always ready for easy reference. For 16 years Rider Manuals have proved their value. For 16 years they have constantly been improved; the owners of Volume I, purchased 16 years ago are still deriving benefits from it. A library of Rider Manuals is a lifetime-profit-paying-investment.

Volume XV incorporates the latest Rider "first"—"clarified schematics," a plus service on which we have spent tens of thousands of dollars in order to save you hundreds upon hundreds of hours each year. Also, with each copy of Volume XV there is included the separate book "How it Works," a practical guide to the theories of operation of the new technical features of the latest receivers. It explains the functions of those "gimmicks" and "gadgets" which can cause time-wasting headaches if not recognized and understood. These and other exclusive analyses by our engineers will be found in "How it Works" another Rider "first."

Many post-war sets are equipped with record players and changers; these are covered in Volume XV.

All the popular brands of "Ham" communication receivers are included in Volume XV.

You are brought up to date on all Scott receivers by Volume XV.

Yes, on the 1984 pages of Volume XV, covering the sets of 121 American Manufacturers and the 150 pages of "How it Works" you will find the data and services that will make it pay its profitable way far years to come.

Be sure of your copy. Avoid disappointment, place your order with your jobber today.

#### OTHER RIDER MANUALS

Volumes XIV to VII, each volume .....	\$15.00
Volume VI .....	11.00
Abridged Manuals I to V (1 vol.) .....	17.50
Record Changers and Recorders .....	9.00

*"clarified schematics"*

"clarified schematics" do a job which you have had to do on every multi-band receiver and combination set coming into your shop. "clarified schematics" break down the composite diagrams of hundreds of complicated multi-band receivers, providing you with exclusive, individual schematics of each and every circuit as it exists with each turn of the wave band or equipment switch. With a "clarified-schematic" before you, you save the time heretofore spent tracing out an original schematic to find which components are in operation under different positions of the wave band switch. We have saved this time for your shop, by doing it for you in our laboratories. Alone, this one feature will repay the entire purchase price of Volume XV and return an additional cash profit on your investment year after year.



**PRICE  
\$18.00**

**YEAR AFTER**

**YEAR AFTER YEAR**

**RIDER MANUALS**

**Keep pouring profits for Servicemen**

**JOHN F. RIDER PUBLISHER, INC. • 404-4th AVENUE • NEW YORK 16, N. Y.**

Export Div.: Rocke-International Corp., 13 E. 40 St., N. Y. C. Cable: ARLAB

#### OTHER RIDER BOOKS

<b>Inside the Vacuum Tube</b> Solid concept of theory and operation	\$4.50
<b>Understanding Microwaves</b> Provides foundation for understanding	6.00
<b>Radar</b> Entertaining, revealing, in lay language	1.00
<b>The Cathode Ray Tube at Work</b> Accepted authority on subject	4.00
<b>Frequency Modulation</b> Gives principles of FM radio	2.00

<b>Servicing by Signal Tracing</b> Basic Method of radio servicing	4.00
<b>The Meter at Work</b> An elementary text on meters	\$2.00
<b>The Oscillator at Work</b> How to use, test and repair	2.50
<b>Vacuum Tube Voltmeters</b> Both theory and practice	2.50
<b>Automatic Frequency Control Systems</b> —also automatic tuning systems	1.75

<b>A-C Calculation Charts</b> Two to five times as fast as slide rule	7.50
<b>Hour-A-Day-with-Rider Series—</b>	
On "Alternating Currents in Radio Receivers"	
On "Resonance & Alignment"	
On "Automatic Volume Control"	
On "D.C. Voltage Distribution"	\$1.25 each



This new Rider Book, soon to be announced, will be of lasting usefulness to everyone interested in any phase of radio.

where you see the  
name **STANCOR**  
you can count on  
**SERVICE**

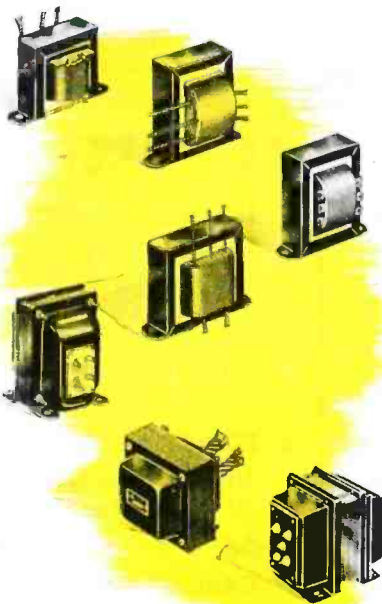

The famous black-and-yellow STANCOR emblem stands for SERVICE . . . in guaranteed transformer performance . . . and in the friendly helpfulness of the Authorized STANCOR Distributor . . . who stands behind the product he sells. . . . Yes, wherever you see the STANCOR emblem you know you will find the most complete selection of Replacement and General Purpose Transformers . . . advanced designs . . . and the universal application that make STANCOR first with radio service men. . . . You bet you can look to STANCOR . . . for the standard of performance that assures you of satisfied customers.

standardize on

**STANCOR**



**TRANSFORMERS**

STANDARD TRANSFORMER CORPORATION · 1500 N. HALSTED ST., CHICAGO 22, ILL.

# SYLVANIA NEWS

## RADIO SERVICE EDITION

JAN. Prepared by SYLVANIA ELECTRIC PRODUCTS INC., Emporium, Pa. 1947

### RADIO SERVICEMEN! YOU NEED THIS NEW OSCILLOSCOPE FOR RAPID ALIGNMENT AND TROUBLE-SHOOTING

To make your servicing job easier and faster, Sylvania developed the 3-Inch Cathode Ray Oscilloscope, Type 131.

This accurate measuring device is especially useful in rapid receiver alignment, distortion locating, general trouble-shooting.

Now you can quickly and easily solve problems met in radios and electronic equipment.

Note characteristics and special features below.



### CHARACTERISTICS and SPECIAL FEATURES

- 1. Sylvania 3API Cathode Ray Tube** — Accelerating potential, 650 volts. Electrostatic deflection and focus. Tube is shock-mounted and well protected from stray magnetic and electrostatic fields by efficient shielding. Panel visor shades face of tube permitting oscilloscope use in well-lighted rooms. Removable calibrating screen also included.
- 2. INPUT IMPEDANCES —**  
Vertical amplifier — approximately 1 meg., 30 mmf. at full gain.  
Horizontal amplifier — approximately 1 meg., 50 mmf. at full gain.
- 3. AMPLIFIER FREQUENCY RESPONSE —**  
Sine wave uniform within 3 db. from 10 cycles to 100 kilocycles.
- 4. DEFLECTION FACTOR —**  
Through amplifiers — 0.5 volts per inch.  
Direct — approximately 17 volts per inch.
- 5. HORIZONTAL SWEEP —**  
Direction — left to right.  
Frequency range — 15 to 40,000 cycles.  
Synchronizing signal sources —  
Internal (vertical signal)  
External; 60 cycles.
- 6. POWER SUPPLY —**  
105-125 volts, 50-60 cycles.  
40 watts power consumption.  
1 amp. line fuse provided.
- 7. CABINET DIMENSIONS —**  
10 $\frac{1}{8}$ " high, 7 $\frac{3}{4}$ " wide, 13 $\frac{3}{8}$ " deep.  
*See your Sylvania Distributor.*

# SYLVANIA ELECTRIC

Emporium, Pa.

MAKERS OF RADIO TUBES; CATHODE RAY TUBES; ELECTRONIC DEVICES; FLUORESCENT LAMPS, FIXTURES, WIRING DEVICES; ELECTRIC LIGHT BULBS

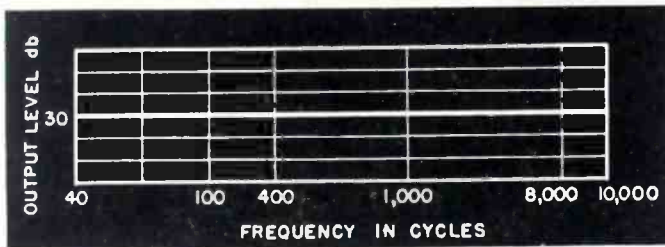

Fig. 1. Typical response curve of a high-fidelity amplifier.

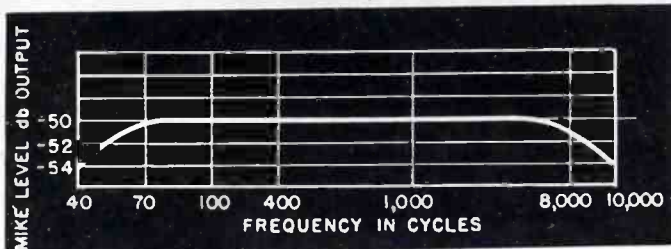

Fig. 2. Response of a microphone 1 db down at 8000 cycles and 4 db down at 10,000 cycles.

# Audio Amplifier EQUALIZATION METHODS

by WILLARD MOODY

EQUALIZATION OF AUDIO-AMPLIFIER systems may be required to correct frequency response for deficiencies in a loudspeaker, baffle, mike, phono pickup, radio tuner or for the acoustic qualities of a building. The theoretically ideal frequency-response curve of an amplifier is one which is perfectly flat, but this is only a starting point. The shape of the curve must be altered to fit the installation conditions and the characteristics of associated equipment.

### Tone Controls

The altering of the response curve of the amplifier is usually accomplished through the use of tone controls. The treble or bass response may be picked up in this way. To illustrate this point, suppose that we have an amplifier with

a response such as that in Fig. 1, and a mike with a response equivalent to that in Fig. 2. The amplifier response is perfectly flat over the 40- to 10,000-cycle range, which is possible with the finest modern equipment. The mike, however, is down 2 db at 50 cycles and 4 db at 40 cycles. Also, the mike response is down 1 db at 8,000 and 4 db at 10,000. In many systems, exceptionally good high-frequency response would not be necessary but in a high fidelity type of installation it would be required. Assuming the over-all curve is to be flat from 40 to 10,000 cycles, we can boost the amplifier gain as shown in Fig. 4.

On the assumption that the mike level is -50 db below .006 watt standard reference level, at 400 cycles (a standard test frequency) and the amplifier output is to be +30 db above

.006 watt, the gain in the amplifier required to give +30 db output with a -50 db mike would be 80 db. This gain is constant over the range for a given constant input signal and the rated output of +30 db. Therefore, if the mike power output drops off and is down 4 db at 40 cycles and 10,000 cycles, the amplifier without equalization will have an output of 30 - 4 or 26 db as shown in Fig. 3. Using equalization, the output of the amplifier is maintained constant at +30 db, but the gain is varied. This gain variation occurs at a definite rate, according to the slope of the curve between 70 and 40, and between 7,000 and 10,000 cycles.

The amplifier requires the -50 db input level to give full +30 db output power. In view of this and the fact that the amplifier gain is constant for

Fig. 3. Overall response curve of microphone and amplifier.

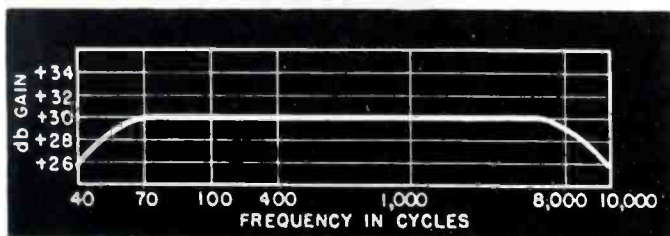
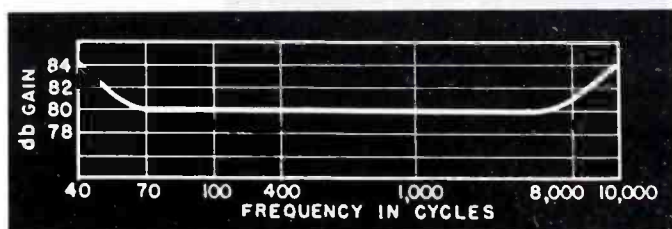

Fig. 4. Equalized amplifier-response curve.



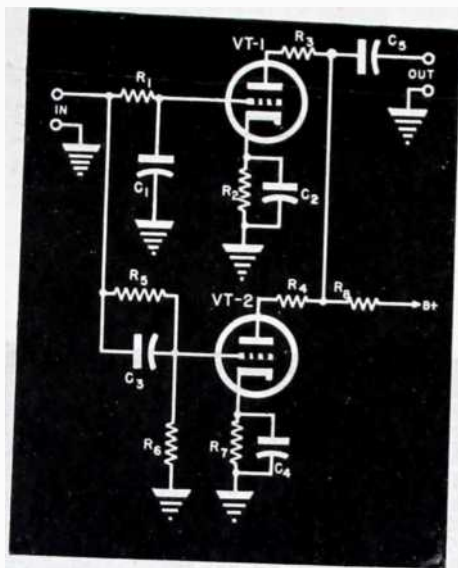
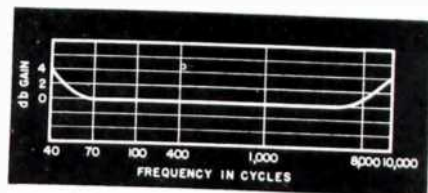

Fig. 5 (right). Pre-amplifier gain characteristic for overall equalization.

Fig. 6. Pre-amplifier for equalizing: VT-1 is a low-frequency amplifier and VT-2 is a high-frequency amplifier.



a given volume-control and tone-control setting, a pre-amplifier with the desired frequency response characteristic may be used, or in many cases we can simply adjust the tone and gain controls on the main amplifier to equalize the output. There is, however, a practical limit to this procedure. For best results, a reasonably strong input signal should be supplied to the amplifier input to keep hum and noise down. By using a conservatively rated amplifier, one capable of giving an output of +35 db, at -50 db input, less strain will be placed on the amplifier system. As a matter of fact, sometimes less emphasis than it deserves is placed on the idea of conservative rating since the amplifier and general system efficiency tends to decrease somewhat with age, causing loss of output.

### Pre-Amplifier Gain

The pre-amplifier for the foregoing application should have a zero gain from 70 to 7,000 cycles, and a gradual rise in gain from 70 to 40 and from 7,000 to 10,000 cycles. The required response curve is shown in Fig. 5. By

increasing the response at the low and high ends of the band, using an arrangement such as that in Fig. 6, the ideal response curve of Fig. 5 may be approached. VT<sub>1</sub> serves as a low-frequency amplifier. The purpose of R<sub>1</sub> is to prevent shorting the mike input by means of C<sub>1</sub> which bypasses the highs. The relative gain can be controlled by the choice of tube, operating voltages and the resistance and capacitance values. The Service Man may experiment with various values for a particular job and needed gain.

### Crystal Mike Use

A crystal, high-impedance mike working into a high-impedance amplifier input circuit may be used, if the circuit of Fig. 6 is employed. VT<sub>2</sub> is a high frequency amplifier. C<sub>a</sub> is made relatively small in value, perhaps .001 to .005, and R<sub>s</sub> may be about 250,000 to 2 megohms. R<sub>a</sub> may be about 500,000 ohms with the other values experimentally determined. The action is to permit the high-frequency current to flow in C<sub>a</sub> and R<sub>a</sub>. This current flowing in R<sub>a</sub> develops a high-frequency audio voltage across the grid resistor to drive the grid of VT<sub>2</sub>. The amount of low-frequency voltage is small, since the reactance of C<sub>a</sub> at low frequencies is high, and R<sub>s</sub> is in opposi-

tion to the flow of high-frequency and low-frequency current. This opposition is bypassed by C<sub>a</sub> for highs but not for lows.

### High-Frequency Boosters

A very common trouble is that the high-frequency response of a mike drops off due to the use of a relatively long line and the shunt capacitance effect of the line. By shunting the amplifier input with a parallel L-C resonant circuit, the high frequency level can be boosted: Fig. 7. The line impedance is in series with the mike. If there is a voltage drop along this impedance, the voltage at the amplifier input will be smaller by the amount of the drop. The mike, line, and amplifier-input impedances form a voltage divider. By making the mike-input circuit a low-impedance type, running a 50- to 500-ohm line and using coupling transformers, the line loss at high frequencies may be reduced, but the transformers themselves, unless of good quality, may introduce resonances and cause non-linear response. By using the L-C equalizer circuit, better results may be obtained under certain conditions. The amplifier input capacity is shunted by L and adds to C. Therefore, the frequency of resonance of L-C may be made slightly greater than the top frequency in the range, for example 12,000 cycles if the top is 10,000. The L-C circuit will tend to boost the signal voltage in frequency

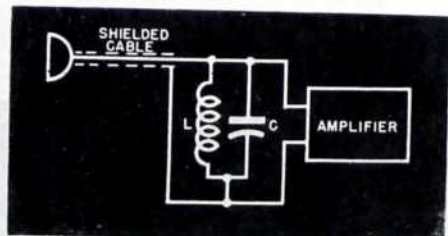

Fig. 7 (left). Boosting high-frequency level by shunting amplifier input with a parallel L-C resonant circuit.

Fig. 8. Boosting low-frequency region with a parallel L-C resonant circuit. L and C are resonant at 80 or 100 cps or some point desired in the low range of the audio band for bass boost.

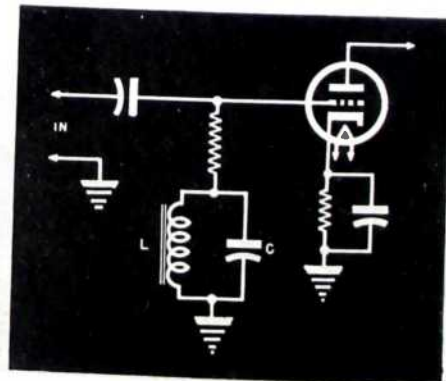
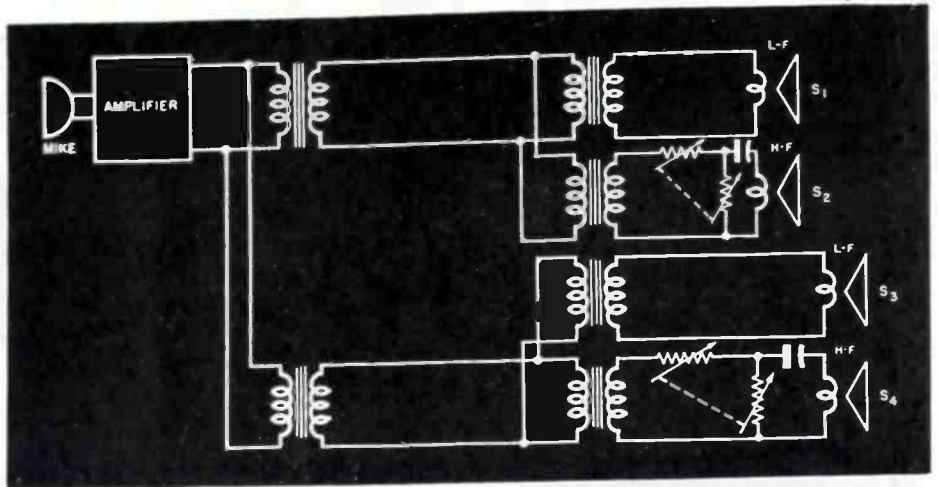

Fig. 11. Combination low-frequency and high-frequency reinforcement system.



of resonance. The values may be found experimentally.

Another common trouble is the lack of low-frequency bass response. In many cases this may be due to using an amplifier which does not have the necessary power output to handle low-frequency notes. Adequate reproduction of low notes requires more power than equivalent level high notes. By using better loudspeakers, such as those made with Alnico V magnets in the p-m cone and p-m driver units, better conversion efficiency and more sound output for a given electrical input may be obtained. Using a larger baffle on a cone dynamic or a suitable projector horn, low-frequency response may be improved without applying amplifier equalization.

#### Low-Frequency Boosters

Where a boost in the low-frequency region is required, a parallel  $L-C$  resonant circuit, as shown in Fig. 8, may be used. The tube may be one of the voltage amplifiers in the main amplifier or in a pre-amplifier. The  $L-C$  combination may be installed in a plate circuit, as shown in Fig. 9. If a peak is desired at 100 cycles, the  $L-C$  combination is selected to resonate at this frequency. To control the bass-boost-

ing effect, the  $L-C$  combination may be shunted with a resistance whose value is determined experimentally. Values of 1 megohm to 10,000 ohms may be tried.

#### Loudspeaker Setups

When the loudspeakers used with the system prove inefficient at high audio frequencies, and the mike or other pickup tends to drop off slightly on the highs, they may be picked up by using a small pre-amplifier with a reduced value of coupling capacitance. Ordinarily, a .01 or .05 mfd-coupling capacitor would be used. By using a smaller value of .006 or .005, the higher frequencies will receive greater emphasis. Even smaller values down to .001 may be used in some cases, the best being determined experimentally. If necessary, tweeter loudspeakers may be added to the system to bring up the high frequency output. Some loudspeakers may be very poor on the highs, even though considerable high-frequency power is fed into them. Using the tweeters, the regular speakers will carry the major part of the sound but reinforcement of the highs with an improvement in fidelity and equalization will be obtained. Standard units of this type have 15-ohm

voice coils, but other impedance values may be obtained.

#### Tweeters and L-Pads

Suppose, as an illustration, that the system uses two p-m drivers at 10 watts each, to carry low- and medium-frequency power, and the amplifier is coupled to the speakers using 500-ohm lines. We then have the arrangement in Fig. 10. If we add two tweeters, we may use the arrangement in Fig. 11.  $L$  pads may be used at each tweeter to control the power levels and prevent overloading and rattling. Impedances should be matched.

#### Preventing L-F Power Leaks

To prevent low-frequency power being fed into the tweeters, a series capacitor may be connected in each tweeter voice-coil circuit. Values used may range from 1 or 2 mfd to 8 or 16 mfd. Electrolytics can be used. As an alternative, where the powers are not higher than about 15 watts input to each loudspeaker, a coaxial type speaker, which has a wide range, can be used. Such loudspeakers, or equivalent, may be used as replacements for older types having limited fidelity.

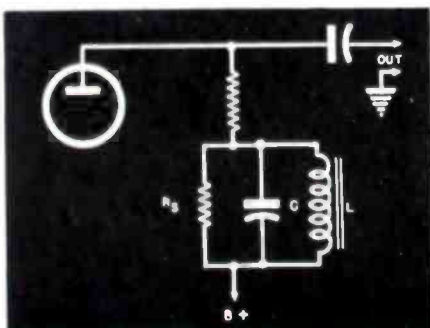
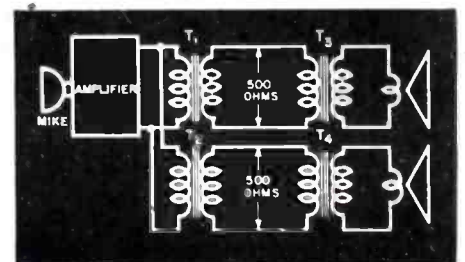
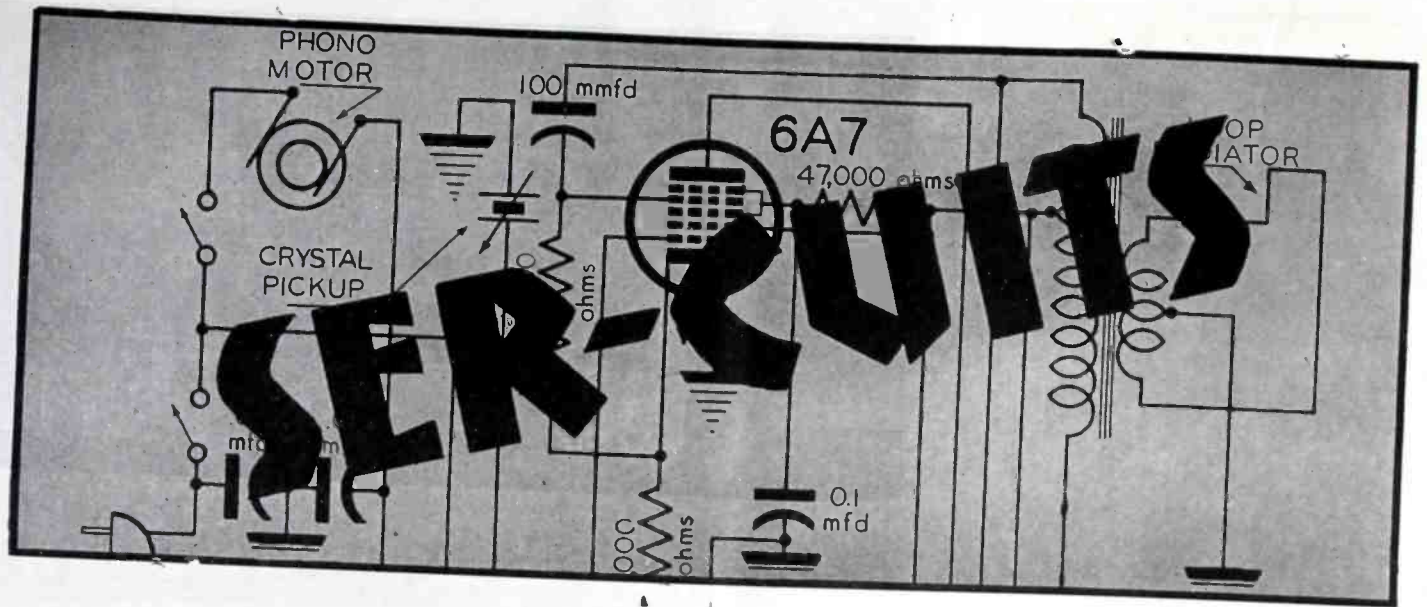

Fig. 9 (left).  $L-C$  combination in plate circuit for low-frequency response boost.  $R_s$  is a shunt for controlling the magnitude of boost.

Fig. 10 (right). Setup for two p-m drivers to carry low and medium-frequency power.





by HENRY HOWARD

A RECEIVER WITH several unusual features is shown in Fig. 1, Admiral chassis No. 10A1. This model covers three short-wave bands with spread tuning, and has manual and push-button broadcast permeability tuning. Converter push-button adjustments are made with capacitors. A 3-gang tuning unit is used for all bands except the push-button position which uses only two tuned circuits. A bandswitch applies resistance coupling between r-f amplifier and converter in this position.

#### 6SK7 I-F Amplifiers

Two 6SK7 i-f amplifiers are used, but in a very unconventional manner, the first stage contributing to selectivity but not to sensitivity by virtue of a cathode-follower circuit. A conventional input i-f transformer feeds the grid circuit but the output is taken from the cathode across 1,500 ohms and through a 20-mmfd capacitor to a single-tuned circuit which feeds a standard type i-f amplifier. A separate B filter isolates the two i-f stages.

#### Use of 6SQ7

The double diode of a 6SQ7 is used for second detector-avc, the triode section being unused. The triode sections of two more 6SQ7s serve as first audio and inverter, the diodes being unused. A push-pull 6F6 stage follows. Degeneration is introduced through resistors in two circuits; from first a-f anode to its 6F6 anode through 1-meg-ohm and 470,000-ohm resistors connecting plate and grid of the inverter tube. Voltage divider from which the inverter is excited is also composed of

two 470,000-ohm resistors. A 1-meg-ohm volume control has two taps which are tied into a versatile 5-button tone control. The control removes a .002-mfd shunt capacitor from the first audio output for boosting the treble for *voice*; removes a .001-mfd capacitor for *normal*; introduces a .005-mfd capacitor in series with 47,000 ohms for the lower tap bass compensation for *music*; introduces .01-mfd unit in series with 100,000 ohms for the higher volume control tap for *alto*, and replaces the .01-mfd capacitor with a .005-mfd unit for *bass*. The radio section is desensitized for phono operation by introducing 150,000 ohms in the screen supply to the first four tubes.

#### Zenith 6D015/6D030

A receiver with a sharp cut-off r-f amplifier is shown in Fig. 2, Zenith's 6D015/6D030, chassis 6C05. A 12SJ7 is resistance coupled to a 12SA7 converter through 10,000 ohms, 100 mmfd and a 22,000-ohm grid leak to the avc bus. A wave trap shunts the 12SA7 input.

#### Miniature RF-Pentode

A 220-ohm resistor is connected between oscillator grid and the grid (capacity) winding. Again, the avc bus is biased through a 15-megohm resistor from the grid. A new type miniature r-f pentode, 12BA6, is used as an i-f amplifier. This tendency to mix standard octal and miniature types represents a new trend and, we think, a healthy one.

The output transformer has a hum bucking primary tap, the B load of the entire receiver except power tube plate being taken through part of the primary in series with 470 ohms. An additional R/C filter section is inserted between transformer and B load.

#### Westinghouse H-125/126

A 6-tube a-c/d-c model, Westinghouse H-125/126, using a 12SK7 r-f amplifier, 12SA7 converter, 12SF7 i-f/detector/avc, 12SJ7 a-f and 35A5 output is shown in Fig. 3.

The r-f amplifier is resistance coupled to the converter. An i-f wave-trap is shunted directly across the 12SK7 output.

#### Filter System

The plate of the output tube is supplied high voltage directly from the 35Z5 rectifier; the screen and the remainder of the tubes are supplied from a 1,500-ohm and dual 50-mfd filter. Two additional filters, 82,000 ohms and .025-mfd for the plate, and 470,000 ohms and 0.1-mfd for the screen, are used in the first a-f stage. A ½-meg-ohm volume control is tapped at 100,000 ohms for high- and low-level bass compensation, made possible by a 47-mmfd capacitor shunting the high end

(Continued on page 26)

[The circuits of the Admiral, Zenith and Westinghouse models appear on pages 15, 26 and 28. Also appearing on these pages are voltage and alignment data.]



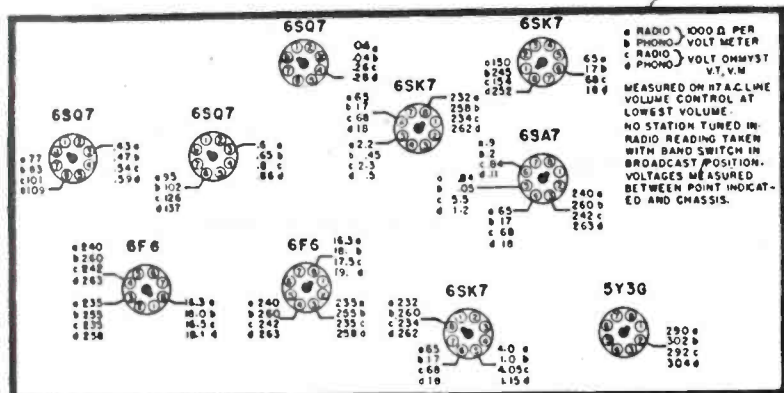
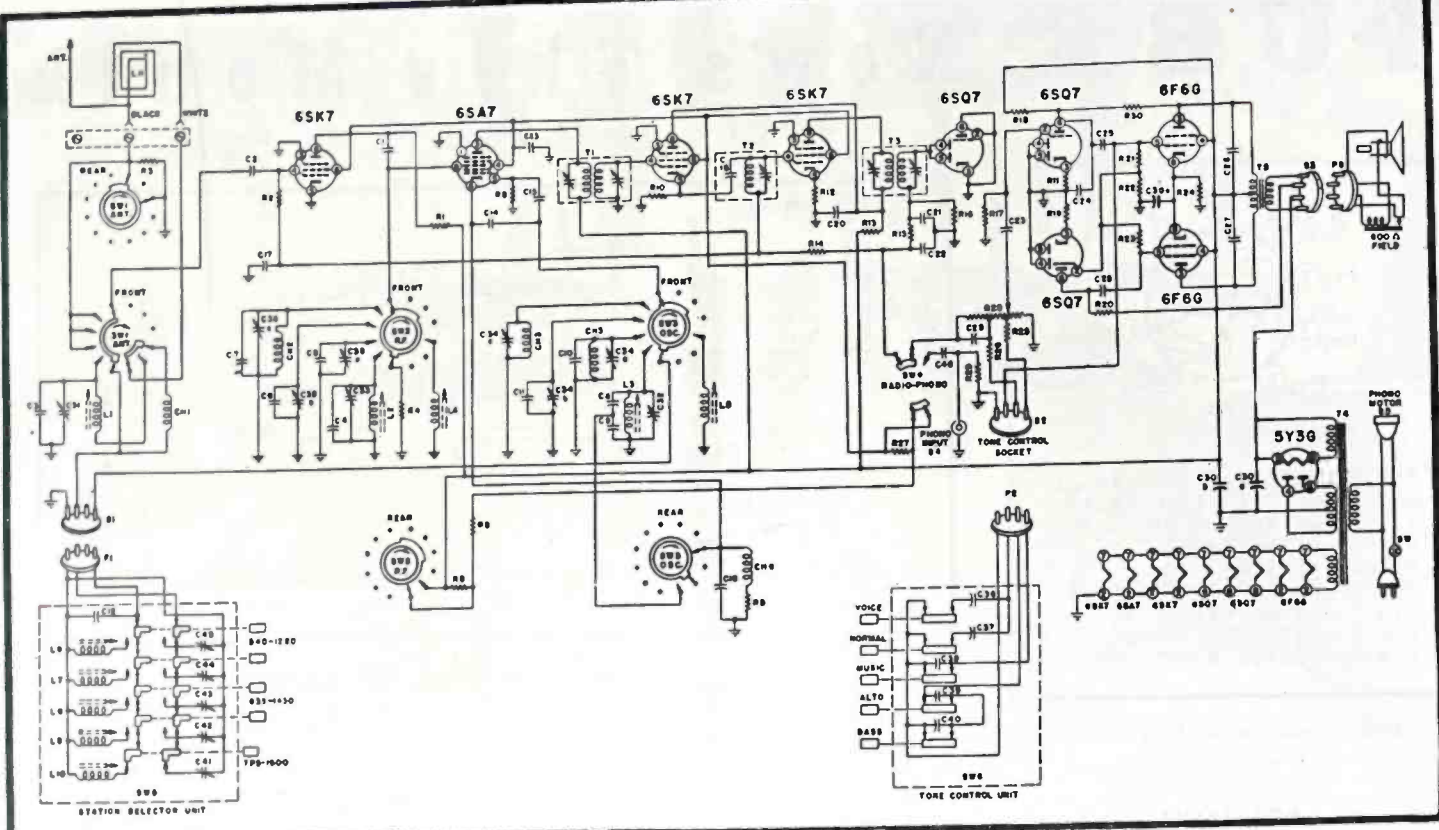

Fig. 1, above, Admiral 10A1, 9-tube a-c receiver featuring permeability and mechanical-tuning systems. Left, diagram of voltages for the Admiral receiver. Left, below, alignment procedure for Admiral 10A1. Note: If before aligning receiver it becomes necessary to change a tuning slug, set the gang to wide open position, unsolder and remove old slug. Set slug-adjusting screw about one-half way down. Place new slug so that 1 1/2" of its length is above coil form. Then solder in position making sure that the slug does not slip during the operation and that the slug wire is straight. The receiver can then be realigned as indicated in the chart. Below, list of parts.

- Loop must be connected during alignment. Check the set screws that hold the tuning drum to the shaft to see that they are tight and that the drum has not slipped on the shaft.
- In the wide open position the stop on the rear of the dial drum must be against the stop post.
- With the gang wide open, all slugs should be 1 1/2 inches out of their coil forms. If there is any serious deviation of if there has been any tampering, turn the adjusting screws until this distance is corrected.
- Be sure both the set and the signal generator are thoroughly warmed up before starting alignment.
- Turn receiver Volume Control full on.
- Use lowest output setting of signal generator that gives a satisfactory reading on meter.
- Proceed in sequence as outlined below.

STEP	CONNECT SIGNAL GENERATOR TO	DUMMY ANTENNA BETWEEN RADIO AND SIGNAL GENERATOR	SIGNAL GENERATOR FREQUENCY	TUNING GANG SETTING	ADJ. TRIMMERS IN FOLLOWING ORDER TO MAX.
1	6SA7 Grid (Pin #8)	.1 MFD.	455 K.C.	Pointer to upper limit	E, D, C, B, A
2	Before proceeding to step 3 check pointer travel as outlined under paragraph below headed "Pointer Adjustment." Set Band Change Switch to Broadcast Position.				
3	White Loop Lead	10 MMFD. If not available wrap several turns of the generator lead around the white loop lead.	1605 K.C.	Pointer to upper limit	F, G, H
4	White Loop Lead		1300 K.C.	Set Pointer to 1300 mark on slide rail (See Dial Diagram A)	I, J, K
5	Set Band Change Switch to 49 Meter Position.				
6	White Loop Lead	400 Ohms	7.5 Mc.	Pointer to upper limit	L, M
7	White Loop Lead	400 Ohms	7.2 Mc.	Set Pointer to 1500 mark on slide rail	N, O
8	Set Band Change Switch to 31-25 Meter Position.				
9	White Loop Lead	400 Ohms	12.5 Mc.	Pointer to upper limit	P, Q
10	Set Band Change Switch to 19-16 Meter Position.				
11	White Loop Lead	400 Ohms	18.0 Mc.	Pointer to upper limit	R, S

RESISTORS		
Symbol	Description	Part Number
R1	10,000 Ohms, 1/2 Watt	60B14-103
R2	470,000 Ohms, 1/2 Watt	60B5-474
R3	47,000 Ohms, 1/2 Watt	60B8-473
R4	475,000 Ohms, 1/2 Watt	60B8-474
R5	8,200 Ohms, 1/2 Watt	60B14-822
R6	10,000 Ohms, 3/4 Watt	61A1-3
R7	22,000 Ohms, 1/2 Watt	60B8-223
R8	100 Ohms, 1/2 Watt	60B8-101
R9	1,500 Ohms, 1/2 Watt	60B8-152
R10	1,500 Ohms, 1/2 Watt	60B8-152
R11	470 Ohms, 1/2 Watt	60B8-471
R12	470 Ohms, 1/2 Watt	60B8-471
R13	1,000 Ohms, 1/2 Watt	60B8-102
R14	470,000 Ohms, 1/2 Watt	60B8-474
R15	47,000 Ohms, 1/2 Watt	60B8-473
R16	270,000 Ohms, 1/2 Watt	60B8-274
R17	1.0 Megohm, 1/2 Watt	60B8-103
R18	270,000 Ohms, 1/2 Watt	60B8-274
R19	1,000 Ohms, 1/2 Watt	60B8-102
R20	270,000 Ohms, 1/2 Watt	60B8-274
R21	470,000 Ohms, 1/2 Watt	60B8-474
R22	470,000 Ohms, 1/2 Watt	60B8-474
R23	470,000 Ohms, 1/2 Watt	60B8-474
R24	270 Ohms, 2 Watt	60B20-271
R25	47,000 Ohms, 1/2 Watt	60B8-473
R26	100,000 Ohms, 1/2 Watt	60B8-104
R27	150,000 Ohms, 1/2 Watt	60B8-154
R28	1 Megohm Volume Control	75B3-3
R29	1 Megohm, 1/2 Watt	60B8-105
R30	1 Megohm, 1/2 Watt	60B8-105

CAPACITORS		
Symbol	Description	Part Number
C1	20 mmfd. Mica	63B7-5
C2	200 mmfd. Mica	63B7-20
C3	33 mmfd. Silver Mica	63B1-33
C4	390 mmfd. Silver Mica	63B1-34
C5	250 mmfd. Silver Mica	63B1-35
C6	63 mmfd. Silver Mica	63B1-27
C7	40 mmfd. Silver Mica	63B1-36
C8	140 mmfd. Silver Mica	63B1-38
C9	1000 mmfd. Mica	63B5-103
C10	200 mmfd. Silver Mica	63B1-14
C11	15 mmfd. Silver Mica	63B5-5
C12	60 mmfd. Silver Mica	63B5-13
C13	.1 mfd. 400 Volts	64B1-20
C14	50 mmfd. Mica	63B5-11
C15	50 mmfd. Mica	63B5-11
C16	250 mmfd. Mica	63B5-22
C17	.05 mfd. 200 Volts	64B1-52
C18	20 mmfd. Mica	63B5-5
C20	.1 mfd. 400 Volts	64B1-20
C21	50 mmfd. Mica	63B5-11
C22	50 mmfd. Mica	63B5-11
C23	.002 mfd. 600 Volts	64B1-14
C24	500 mmfd. Mica	63B5-27
C25	.005 mfd. 600 Volts	64B1-12
C26	.005 mfd. 600 Volts	64B1-12
C27	.005 mfd. 600 Volts	64B1-12
C28	.005 mfd. 600 Volts	64B1-12
C29	250 mmfd. Mica	63B5-22
C30	50 mfd. 350 Volts	67C6-25
C30a	20 mfd. 25 Volts	
C31	3-40 mmfd. Trimmer	66A12-3
C32	3-40 mmfd. Trimmer	66A12-3
C33	3-40 mmfd. Trimmer	66B8-3
C34	3-40 mmfd. Trimmer	66B8-3
C35	3-40 mmfd. Trimmer	66B8-3
C36	3-40 mmfd. Trimmer	66B8-3
C37	3-40 mmfd. Trimmer	66B8-3
C38	.002 mfd. 600 Volts	64B1-14
C39	.002 mfd. 600 Volts	64B1-12
C40	.01 mfd. 400 Volts	64B1-25
C41	.002 mfd. 600 Volts	64B1-12
C42	12-170 mmfd. Trimmer	66A12-1
C43	23-290 mmfd. Trimmer	66A12-2
C44	40-400 mmfd. Trimmer	66A12-3
C45		
C46	007-600 volts	64B1-14

# TUBE News This Month

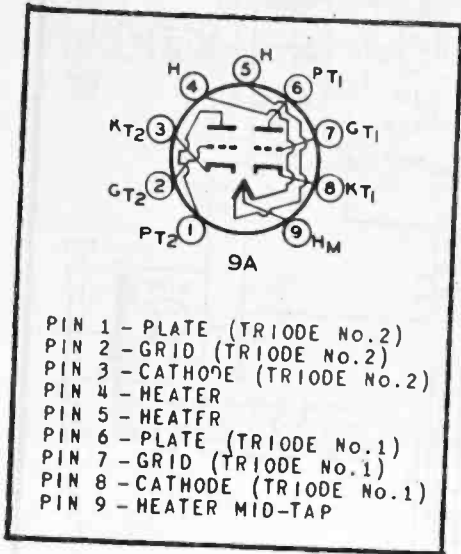

Socket connections for RCA 12AU7.

### RCA 12AU7

THE 12AU7 IS A HEATER-CATHODE type of medium- $\mu$ , twin-triode amplifier featuring a small glass envelope with integral button 9-pin base, separate terminals for each cathode, and a mid-tapped heater to permit operation from either a 6.3- or 12.6-volt supply.

Having characteristics which are very similar to those of the larger types, 6SN7GT and 12SN7GT, the 12AU7 like these types is useful in many applications including multivibrators, synchronizing amplifiers, oscillators, mixers, and industrial-control devices.

### Electrical Characteristics

Heater, for unipotential cathodes:

Heater arrangement	Series	Parallel
Voltage (a-c or d-c)	12.6	6.3
Current (amperes)	0.15	0.3

National Union 2C53.

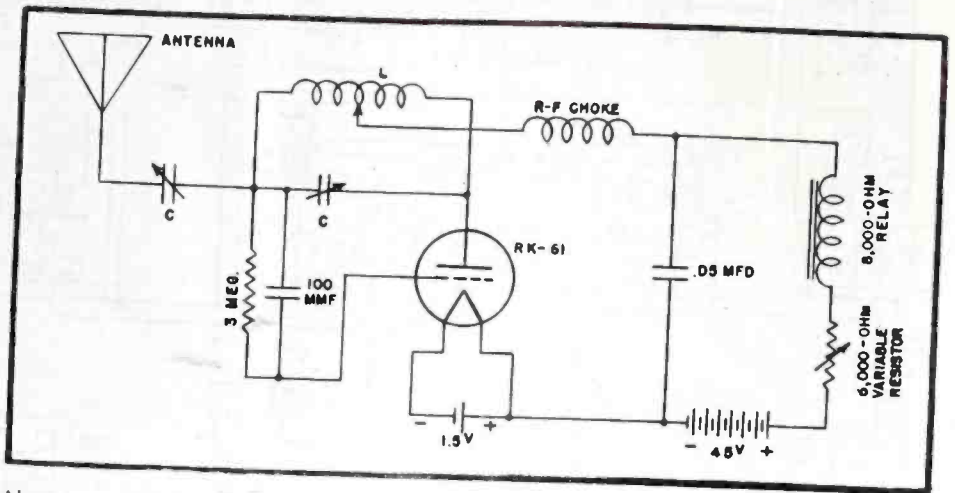

Above, remote control circuit for Raytheon RK-61. Below, typical regulator circuit for N. U. 2C53.

Direct interelectrode capacitances:*	Triode unit $T_1$	Triode unit $T_2$
Grid-to-plate (mmfd)	1.5	1.5
Grid-to-cathode (mmfd)	1.6	1.6
Plate-to-cathode (mmfd)	0.50	0.35

Transconductance (micromhos)	3100	2200
Plate current (ma)	11.8	10.5

Maximum circuit values (for maximum rated conditions):

Grid-circuit resistance for cathode-bias operation (megohm), 1 max.; for fixed-bias operation, .25 max.

### General Electrical Characteristics

Plate voltage	100	250
Grid voltage	0	-8.5
Amplification factor	19.5	17
Plate resistance (ohms)	6250	7700

\*With no external shield.

### Class A<sub>1</sub> Amplifier Data

Maximum ratings, design-center values (values are for each unit):

(Continued on page 44)

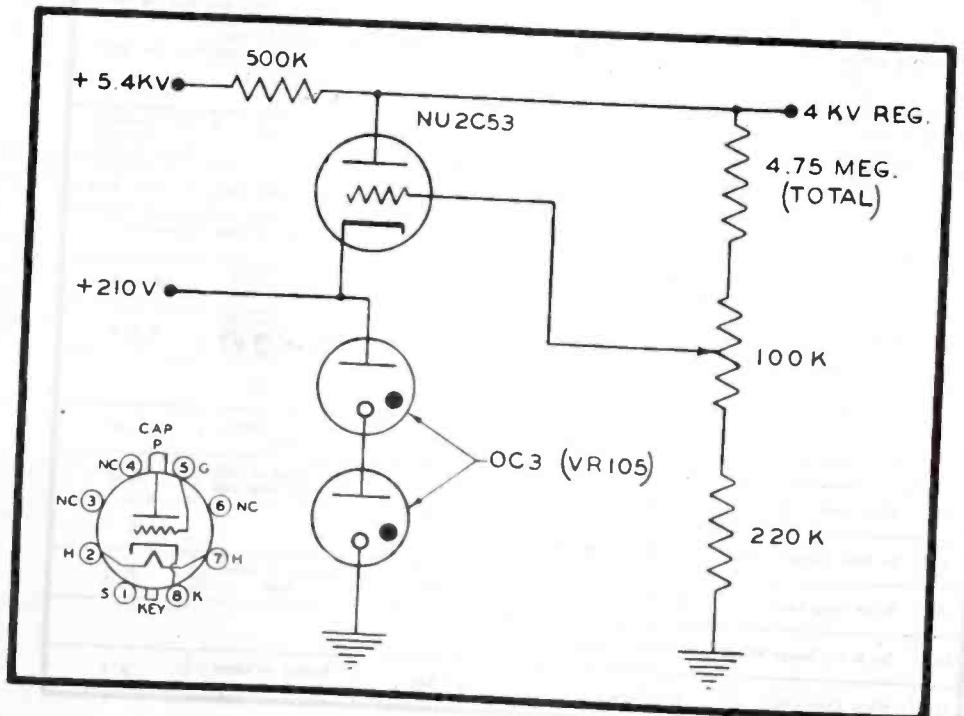



# I Will Show You How to Learn RADIO by Practicing in Spare Time

I Send You Big Kits of Radio Parts

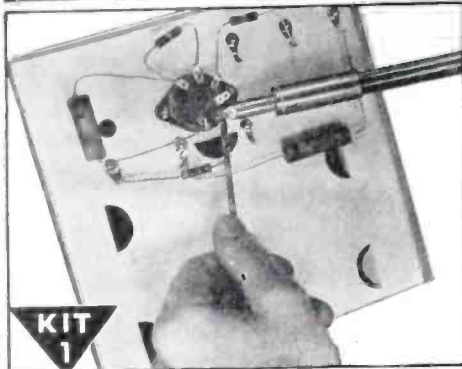

KIT 1

I send you Soldering Equipment and Radio parts; show you how to do Radio soldering; how to mount and connect Radio parts; give you practical experience.



KIT 2

Early in my course I show you how to build this N. R. I. Tester with parts I send. It soon helps you fix neighborhood Radios and earn EXTRA money in spare time.

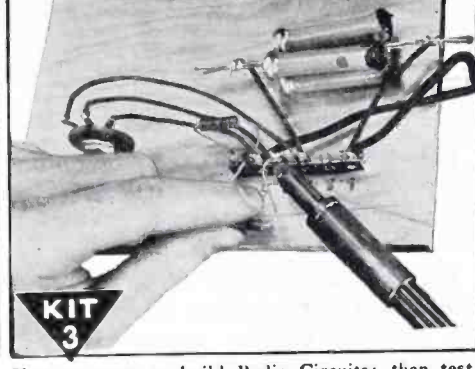

KIT 3

You get parts to build Radio Circuits; then test them; see how they work, learn how to design special circuits; how to locate and repair circuit defects.

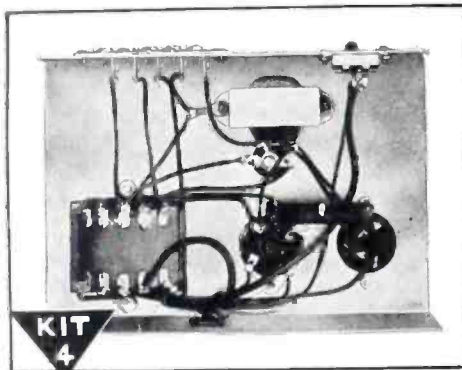

KIT 4

You get parts to build this Vacuum Tube Power Pack; make changes which give you experience with packs of many kinds; learn to correct power pack troubles.

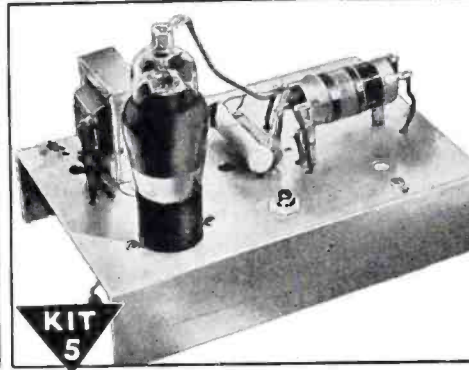

KIT 5

Building this A. M. Signal Generator gives you more valuable experience. It provides amplitude-modulated signals for many tests and experiments.

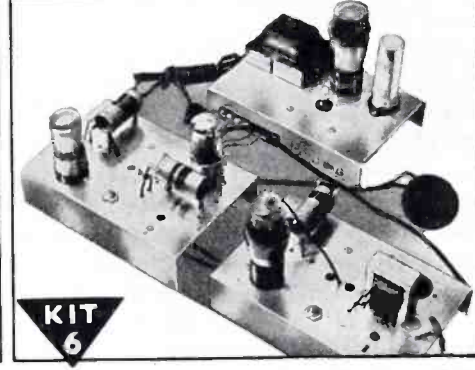

KIT 6

You build this Superheterodyne Receiver which brings in local and distant stations—and gives you more experience to help you win success in Radio.

## I Will Train You at Home - SAMPLE LESSON FREE

APPROVED for training under G.I. BILL

Do you want a good-pay job in Radio—or your own money-making Radio Shop? Mail Coupon for a FREE Sample Lesson and my FREE 64-page book, "How to Be a Success in RADIO—Television, Electronics." See how N. R. I. gives you practical Radio experience at home—building, testing, repairing Radios with BIG KITS OF PARTS I send!

Many Beginners Soon Make Good Extra Money in Spare Time While Learning

The day you enroll I start sending EXTRA MONEY JOB SHEETS. You LEARN Radio principles from my easy-to-grasp, illustrated lessons—PRACTICE what you learn with parts I send—USE your knowledge to make EXTRA money fixing neighbors' Radios in spare time while still learning! From here it's a short step to your own full-time Radio Shop or a good Radio job!

Future for Trained Men is Bright in Radio, Television, Electronics

It's probably easier to get started in Radio now than ever before because the Radio Repair business is booming. Trained Radio Technicians also find profitable opportunities in Police, Aviation, Marine Radio, Broadcasting, Radio Manufacturing, Public Address work. Think of even greater opportunities as Television and Electronics become available to the public! Send for free books now!

Find Out What N. R. I. Can Do for You

Mail Coupon for Sample Lesson and my 64-page book. Read the details about my Course. Read letters from men I trained, telling what they are doing, earning. See how quickly, easily you can get started. No obligation! Just MAIL COUPON NOW in an envelope or paste it on a penny postal. J. E. SMITH, President, Dept. 7AZ3 National Radio Institute, Pioneer Home Study Radio School, Washington 9, D. C.

Our 33rd Year of Training Men for Success in Radio

Good for Both - FREE

Mr. J. E. SMITH, President, Dept. 7AZ3 National Radio Institute, Washington 9, D. C.

Mail me FREE, without obligation, Sample Lesson and 64-page book about how to win success in Radio—and Television, Electronics. (No salesman will call. Please write plainly.)

Age.....

Name .....

Address .....

City .....

(Please include Post Office zone number)



My Radio Course Includes TELEVISION • ELECTRONICS FREQUENCY MODULATION

APPROVED FOR TRAINING UNDER GI BILL

# GI BILL OF RIGHTS

## Home-Study Benefits For Veterans

by GEORGE HARTMAN

Student Service Department  
National Radio Institute

MOST VETERANS OF WORLD WAR II are entitled to certain educational benefits under the *GI Bill of Rights*.

However, hundreds of veterans who cannot attend a *resident school* are passing up this opportunity to get further education and training.

Veterans with regular jobs, veterans who do not live in towns where there are adequate schools, veterans with heavy family responsibilities, veterans who cannot get into colleges or universities are among the many who are not taking advantage of their GI educational privileges.

The GI-education door is not closed to these men, for there are approved correspondence courses available which provide a substantial education. Under the *amended* Public Law 346, the courses of about forty correspondence schools have been approved, and are now available to qualified veterans.

Correspondence courses can be taken at home, and studied in the way that best suits personal convenience and circumstances.

A correspondence-course feature worth noting is that *only one-fourth* of the time spent on the course will be charged against your eligibility. In other words, if it takes twelve months to finish a correspondence course, only three months will be charged to your total eligibility.

### Correspondence Course Enrollment

I am not authorized by the Veterans Administration to advise anyone on these matters, and nothing I say should be considered as *official*. However, I have personally enrolled for training under the GI Bill, and I have helped many veterans get started with GI correspondence courses, so I believe the following information to be reasonably accurate.

Regardless of what you may have heard, it really is comparatively simple to enroll. Very little *red tape* is involved. The first thing to do is to apply for your *Certificate of Eligibility*. This is done by writing to your

Veterans Administration Regional Office, or contacting the local Contact Office for the proper application blank. Or you may request the blank from any correspondence school which is approved under the GI Bill. A copy of Form 1950b, the *enrollment* blank for a correspondence course, should also be requested.

A photostat or certified copy of your Discharge should accompany your application.

A signed copy of your *Certificate of Eligibility* and a filled-out copy of Form 1950b should be forwarded to the school of your choice.

If you should happen to enroll for a correspondence course that does not satisfy you, you can resign from the course. Under the law the Veterans Administration will pay a small registration fee to the school with which you enroll. And from that point on payment is made *only for lessons which you complete*.

The course you study *must be good, must satisfy you, must give you the training you want*. You are *the boss* when you enroll for a correspondence course.

### General Information

*Who is eligible for training?*

You probably are eligible for training under the GI Bill of Rights if you served 90 days or more in the Armed Forces, on or after September 16, 1940, and before World War II ends officially, and have been discharged from service. If you were discharged because of service incurred injury or disability, you may be eligible even if you served less than 90 days.

*Is a person eligible for training regardless of age?*

Yes. Your age has nothing to do with it.

*Will the money paid for your training be charged against any future "bonus" a veteran may receive?*

No. Not according to the GI Bill as amended December 28, 1945.

*Is any subsistence allowance given in connection with correspondence school training?*

No. You do not get a subsistence allowance when you take only a correspondence course.

*How can a person find out what correspondence courses are available under the GI Bill?*

Write to the schools which give courses in which you are interested, and ask if they can enroll you under the GI Bill. Or write the National Home Study Council, 839 17th Street, N. W., Washington 6, D. C., and ask for a list of schools giving correspondence courses under the GI Bill.

*Can I take more than one correspondence course?*

Yes, you can take correspondence courses, or resident courses, until your eligibility is used up or your objective is accomplished. It would be wise to contact various correspondence schools and study their course data carefully.

You do not obligate yourself in any way by applying for the Certificate.

### Employers of Veterans

Employers who are giving *On-the-Job Training* to veterans of World War II may find it worth while to see about using approved correspondence courses in connection with their *On-the-Job Training Programs*. Local Veterans Administration officials can supply the latest information on this subject.

## TUBES - PARTS

RADIO DEALERS - SERVICEMEN

Send for our list of available tubes and repair parts.  
Sylvania, Tung-Sol, Ken-Rad.

M. V. MANSFIELD CO.  
937 LIBERTY AVE. PITTSBURGH 22, PA.

**THEY'RE BETTER THAN EVER**

*and they cover  
every requirement*

- 1** Better impregnation to eliminate moisture
- 2** Better hermetic sealing for longer life
- 3** Quality control during manufacture



## MALLORY PAPER TUBULARS

**Y**OU want quality in the paper tubulars you buy — of course! Otherwise your replacement work won't stand up. Mallory gives you the quality you want.

But Mallory gives you quantity, too. Quantity in a wide assortment of ratings

and sizes that meet all requirements that come your way.

That's the story in a nut shell—whether you're looking for wax impregnated cardboard tubulars or oil impregnated ones. The Mallory Catalog and your Mallory Distributor both prove that—

➔ **YOU EXPECT MORE AND GET MORE... FROM MALLORY**

**P. R. MALLORY & CO. Inc.**  
**MALLORY**

VIBRATORS... VIBRAPACKS®... CAPACITORS... VOLUME CONTROLS... SWITCHES... RESISTORS... FILTERS... RECTIFIERS... POWER SUPPLIES.

\*Reg. U. S. Pat. Off.

**APPROVED PRECISION PRODUCTS**

**P. R. MALLORY & CO., Inc., INDIANAPOLIS 6, INDIANA**

# SERVICING HELPS

by FRANK C. KEENE

I RECENTLY received a Kadette 1140 with hum trouble for servicing. I have the phase inverter working, but seem to have trouble with the circuit of the cathode capacitor, a hum persisting in all the combinations I tried. Can you help?—J. E. Ries.

The trouble usually can be corrected by checking the voltage doubler circuit of the Kadette 1140 which uses a 25Z5 as a voltage doubler; Fig. 1

Let us analyze this circuit, by first tracing, at points A and B, during that portion of the a-c cycle when point A is positive with relation to B. The circuit for diode 1 is shown in a. Since a positive voltage is being applied to the diode plate, the tube is conductive, and a positive voltage is established across C<sub>1</sub>, causing it to charge. When A is negative with respect to B, the diode does not conduct, and no voltage appears across C<sub>1</sub>.

In b we have the same circuit for diode 2. However, here point A is now connected to the cathode. Thus the tube will conduct only when B is positive with relation to A. This action will charge capacitor C<sub>2</sub>. Therefore on one-half of the a-c cycle capacitor C<sub>1</sub> will charge, and on the other half of the cycle capacitor C<sub>2</sub> will charge. It will be noted that these two capacitors

Fig. 1. (Ries query). Voltage doubler-circuit of the Kadette 1140. In a and b appear individual diode circuits. Although the filter capacitors are inserted in different portions of the circuit, since the circuit components are in series, the action is identical for both diodes. However, for diode 1 conduction will only occur when point A is positive with relation to point B, while the opposite is true for diode 2.

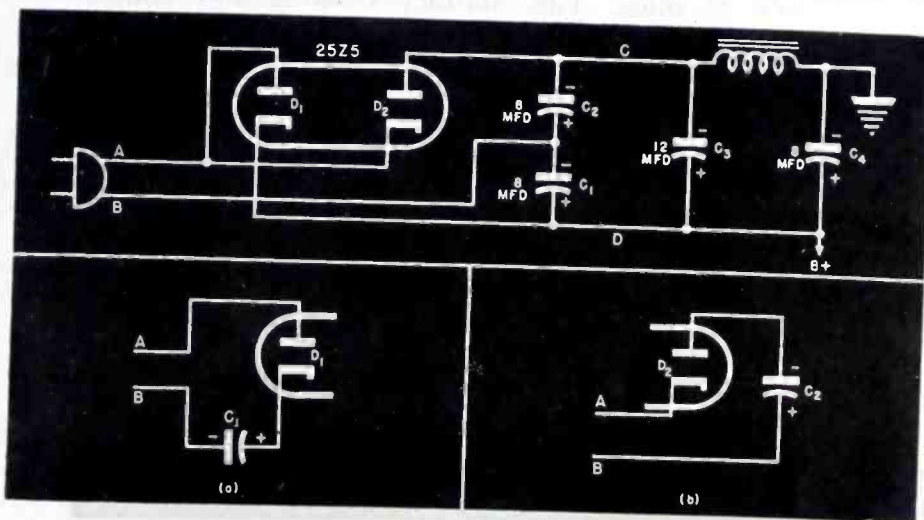

are in series, very much like two batteries. Therefore, when the two capacitors discharge they are in series, so that although the capacitors individually are charged with 110 volts, their combined discharge voltage is 220 volts.

Points C and D may be considered in the same manner as the output of any rectifier system, in that one point is positive and the other negative. For this particular receiver, the choke has been placed in the negative leg, and the two filter capacitors, C<sub>3</sub> and C<sub>4</sub>, are connected in the conventional manner.

I HAVE NOTICED THAT many small receivers, which have parallel trimmers for high-frequency adjustment, suffer from objectionable squealing after alignment. Can this be cured?—Richard A. Van Aman.

There is no completely satisfactory answer to this problem. The trouble is usually due to the absence of a tuned r-f stage. Improvement can only be obtained, if at all, by some redesign of the receiver. One such solution is the inclusion of an i-f wave trap in the antenna circuit. A typical circuit is shown in Fig. 2. The trap itself may be an unshielded transformer, series tuned. By tuning this coil to the i-f frequency, any spurious responses due to the i-f frequency mixing with incoming signals may be partially or entirely eliminated.

In another solution a series padder can be inserted in the oscillator circuit; Fig. 3. This is equivalent to a low-frequency tracking trimmer and

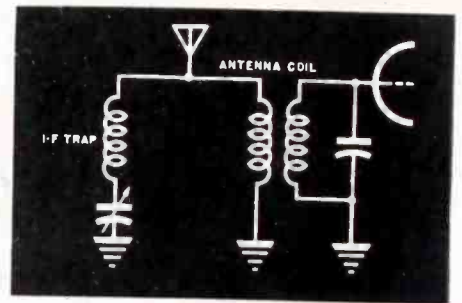

Figs. 2 (above) and 3 (below). Wave trap diagrams used to analyze the Van Aman query. In Fig. 2 we have an i-f wave trap in the antenna. Series padder in the oscillator circuit is shown in Fig. 3.

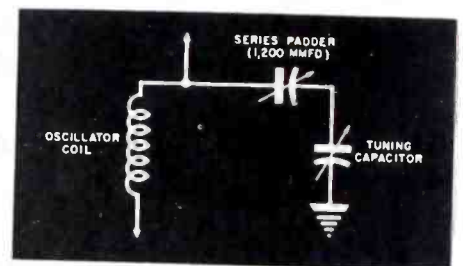

may help in improving the tracking and response at the low-frequency end of the dial.

A third aid is to change the i-f frequency slightly. A change of 5 kc in the i-f frequency may sometimes prevent parasitics in certain localities where strong signals are present.

The converter and i-f tubes should be changed experimentally, even though they check okeh on a tube checker. Quite often the tube characteristics have changed sufficiently to cause parasitic response.

It should be noted that old receivers are more susceptible to this trouble than new ones. This is particularly true of the small cabinet midsets. The continued heat generated in these receivers tends to distort the capacitor plates, which will cause poor tracking. In such cases, it is doubtful if any answer can be found to the problem.

## G.E. 250—Vibrator Failure Cures

Failure of the vibrator unit, REU-001, may be treated in the following manner:

(1) The vibrator should be removed from the receiver and a resistance check made with an ohmmeter across terminals C and R.

(2) If the resistance checks approx-

(Continued on page 30)

# *The* MEISSNER



# *Analyst*

## THE FINEST MODERN SERVICE INSTRUMENT!

Now available . . . the new postwar Meissner Analyst . . . the most modern and complete service instrument on the present-day market. Tests receivers and locates faults by the signal tracing method . . . the fastest and most reliable method to date. Entirely fundamental in its testing procedure, it can not become obsolete. Not just another signal tracer, the Meissner Analyst is engineered to do your service job in the most efficient manner possible. See it at your jobber's today.

**ELECTRONIC DISTRIBUTOR AND INDUSTRIAL SALES DEPARTMENT**

**MAGUIRE INDUSTRIES, INCORPORATED**  
936 N. MICHIGAN AVE. • CHICAGO 11, ILLINOIS

# SIGNAL TRACING With the V-T-V-M

by ROBERT G. HERZOG

Consulting Engineer, Electronic Designs, Inc.

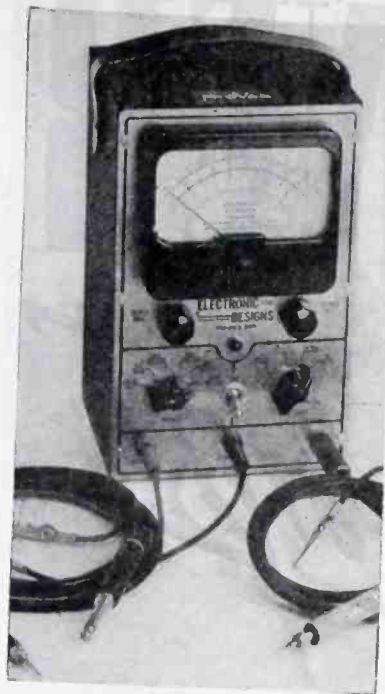

Fig. 1. View of the vacuum-tube voltmeter-ohmmeter.

produced. This model, capable of measuring a-c/d-c voltages from .05 to 1,000, also provides for the checking of resistances from .2 ohm to 1,000 megohms. And with a probe<sup>2</sup> tracing of a-f and r-f signal voltages is possible.

## Checking Capacitors

Capacitors can also be checked with this type v-t-v-m. In operation the probe is used to measure the amount of signal across the capacitor. If the capacitor is operating properly, little or no signal will appear across it. However, a substantial signal is indicative of a high power factor, or low or open capacity. Gain, oscillator performance and the tracing of stray fields are other application features of the v-t-v-m. For instance, the value of an a-c signal voltage at successive points in a receiver is indicative of the gain. In

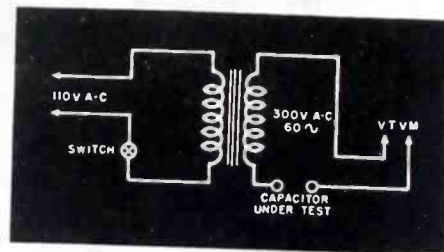

Fig. 2. Circuit for capacitor test with a v-t-v-m.

ONE OF THE MOST EFFECTIVE servicing instruments is the vacuum-tube voltmeter. It can be used in a variety of applications, such as signal tracing and checking of capacitors, a-c or d-c voltage, resistance, etc. It can also be used at the higher frequencies where f-m broadcast and television activity is now centered.

## Design Features

The versatile application possibilities of the v-t-v-m unit provides for many unusual circuit design features. In one model,<sup>1</sup> recently developed, a self-calibrating feature has been in-

checking oscillator performance with the v-t-v-m, the output signal of the oscillator can be measured directly with the probe with negligible loading.

## V-T-V-M Sensitivity

Sensitivity plays an important role in the v-t-v-m. A sensitivity of .05 volt, as included in the recently developed model, is extremely useful in effectively tracing stray fields. The probe is used in this procedure and when moved through any appreciable field will provide a proportion indication of the field.

<sup>1</sup>Provac, Electronic Designs, Inc.  
<sup>2</sup>Ediprobe (Registration Pending, U. S. Patent Office).

## Probe Features

The probe, a very useful tool of the vacuum-tube voltmeter, also permits a check on the r-f voltage ranges and output (db). Incidentally the probe developed for the v-t-v-m illustrated in Fig. 1 has an r-f voltage range of 0 to 3, 10, 30 and 50.

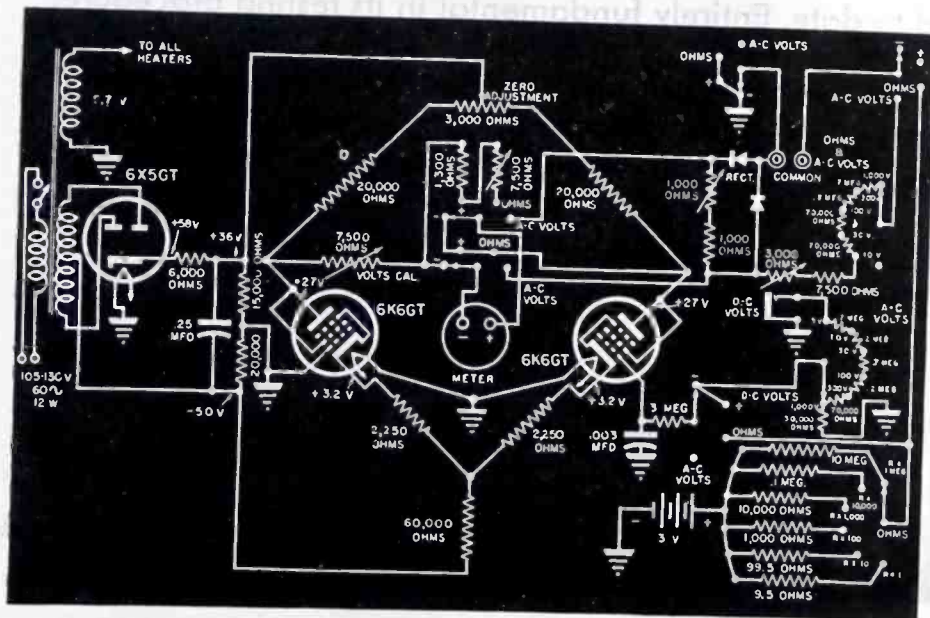

Fig. 3. Circuit of vacuum-tube voltmeter.





Miniature  
Power  
Rectifier  
35W4  
for  
AC-DC  
receivers

## TUNG-SOL DEALERS

*can't help talking about it!*

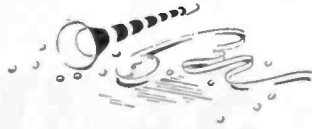

"I have been in business a long time and I have a few pet policies that I know pay off. The first is to make all parts replacements with items of *proven* quality. Then when I do a job it stays done . . .

"Then there is price. The fellow who buys cut-rate is welcome to it. I make a fair charge for labor and therefore I'm entitled to make the full mark-up on tubes

and other parts. That's good business.

"I prefer TUNG-SOL tubes for my repairs. Of course, I sell them over the counter too. TUNG-SOL Tubes are top quality; they stand up. And furthermore, TUNG-SOL has always regarded their jobbers, dealers, and servicemen as partners. There go the whistles . . . Happy New Year, everybody!"



**TUNG-SOL**

*vibration-tested*

**ELECTRON TUBES**

**TUNG-SOL LAMP WORKS, INC., NEWARK 4, NEW JERSEY**  
Sales Offices: Atlanta • Chicago • Dallas • Denver • Detroit • Los Angeles • New York  
Also Manufacturers of Miniature Incandescent Lamps, All-Glass Sealed Beam Headlight Lamps and Current Intermittors

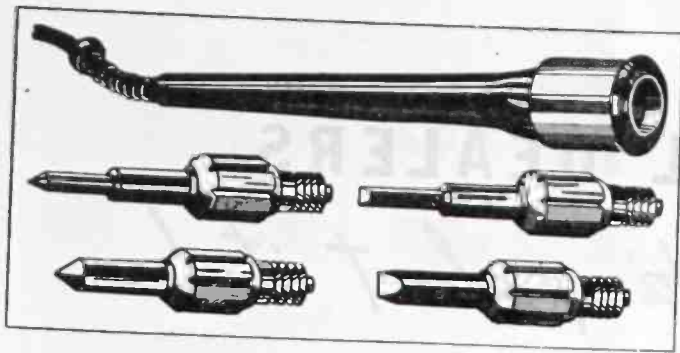
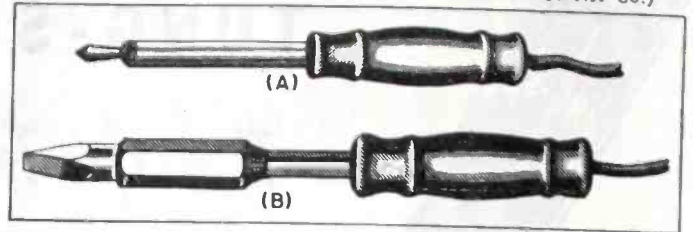

Fig. 2 (below). Two supplementary soldering irons, for light and heavy work. At A, small 1/4" iron for work on midget and miniatures; B, medium-heavy 3/8" tip iron for heavy work.

(Courtesy Hexacon Electric Co.)

Fig. 3 (left). Ungar soldering pencil and interchangeable tips.

(Courtesy Radio Electric Service Co.)



# TOOLS And SERVICE AIDS For the NEW SERVICE SHOP

by ALFRED A. GHIRARDI

Advisory Editor

[Part VIII . . . Supplementary Special-Purpose Tools and Servicing Aids]

SERVICING AIDS SAVE SERVICE MEN'S TIME might well be a slogan that every Service Man should have printed on a sign and tacked up somewhere over his service bench. It would serve as a constant reminder of the fact that a few dollars spent for purchase of a servicing aid of demonstrated usefulness will repay him handsome dividends in valuable time saved every time it is used. Since in most cases the servicing aid also enables him to do a better job, an *extra* dividend is obtained.

The purpose of this article is to carry through the discussion of last month concerning additional special-purpose tools and servicing aids that make the Service Man's work easier and faster. A list of suggested items is presented herewith.

### Supplementary Special-Purpose Tools and Servicing Aids

- Set of chassis jacks, guards or cradles
- Electric soldering irons:
  - 1 medium-heavy 200-watt size with 5/8" diameter tip

- 1 light-weight 60-watt size with 1/4" diameter tip, or soldering pencil type

(As alternatives, one or more of the other types of soldering irons described here may be purchased instead)

- Temperature-regulating stand for soldering irons
- Alcohol soldering torch
- Auto radio cable servicing machine
- Riveting and eyeleting set
- Cherry riveting gun and rivets
- Steel staple driver and staples
- Wire strippers
- Tube extractor
- Knob pullers
- Tweezers:
  - Set of 3 or 4 (approximately 4 1/2" long) having points of various styles and shapes

- Test light (neon type)
- Alignment tool kit (additional)

### Chassis Jacks, Guards and Cradle

It is the tubes, i-f transformer cans, electrolytic filter capacitor terminal studs, push-button tuning assemblies, tuning dials, or other protruding parts which frequently suffer when heavy chassis of receivers, p-a amplifiers, etc., are turned upside-down on the test bench and rest on these components (often in a tilted position) while they are being worked upon. The careful Service Man understands that if a heavy chassis is supported sufficiently high above the surface of the test bench so that no protruding components are able to touch the bench, the likelihood of damage to any of them will be virtually eliminated. Some Service Men are in the habit of propping up heavy chassis with old batteries, blocks, boxes and what-not, but a much more workmanlike and direct solution to this problem lies in the use of inexpensive chassis jacks, guards, or cradles designed especially for the purpose. They are available in several styles.

A simple design of metal chassis jack is illustrated at (A) of Fig. 1. As many as are required (never more than four) are placed under the chas-

(Continued on page 42)

Fig. 1. Three types of chassis supports; A and B, courtesy General Cement Mfg. Co., C, courtesy Acro Electric Co.

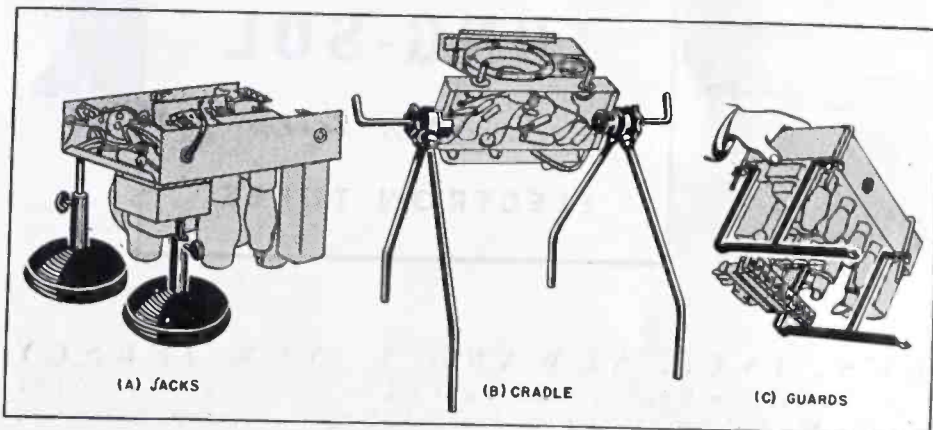

# A Handy Guide

TO

# SPRAGUE EL

## SELF-MOUNTING MIDGET CAPACITORS (Can Type)

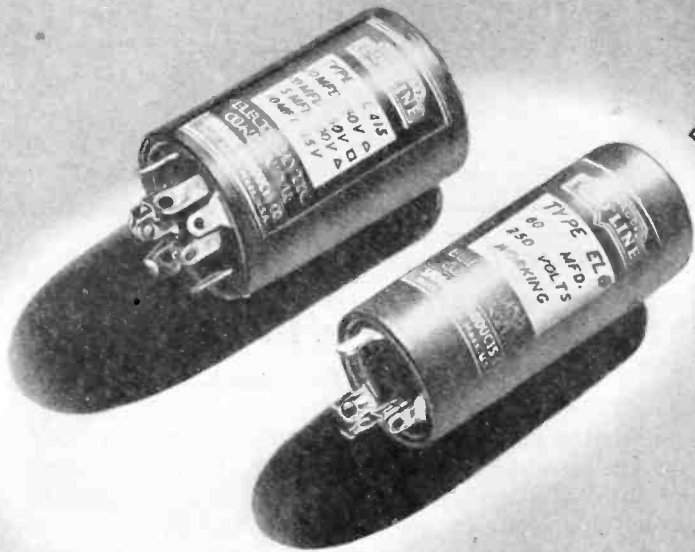

**Easier to install...**  
**Tops for Dependability**

Time is money in radio servicing. Save it—make more of it—by using Sprague Type EL can type dry electrolytic capacitors for every possible replacement use. They're small enough to fit anywhere. They're absolute tops in dependability. And you can mount them in a jiffy, either by direct chassis mounting or by means of their convenient twist prongs. Both bakelite and metal washers are supplied with each unit.

Ask for Sprague Type EL Capacitors by name!

# SPRAGUE

PRODUCTS CO., NORTH ADAMS, MASS.

### SINGLE SECTION

Catalog No.	Mfd.	Voltage DC working	Dimensions	
			D	L
EL-13	3000	10	1 1/4	3
EL-111	1000	15	1 1/4	3
EL-121	2000	15	1 1/4	3
EL-142	40	25	3/4	2
EL-112	100	25	1 1/4	2 1/4
EL-152	500	25	1 1/4	2
EL-122	1000	25	1 1/4	2 1/4
EL-50	150	50	1 1/4	2 1/4
EL-55	500	50	1 1/4	2 1/4
EL-31	30	150	3/4	2
EL-51	50	150	3/4	2 1/4
EL-14	40	200	1	2
EL-12	20	250	3/4	2
EL-30	30	250	3/4	2 1/4
EL-42	40	250	1	2
EL-6	60	250	1	2 1/4
EL-203	15	300	3/4	2
EL-33	30	300	1	2
EL-53	50	300	1	2 1/4
EL-123	125	300	1 1/4	3
EL-5	50	350	1	3
EL-125	125	350	1 1/4	3
EL-10	10	400	3/4	2
EL-20	20	400	1	2
EL-80	80	400	1 1/4	2 1/4
EL-1	10	450	3/4	2
EL-15	15	450	1	2
EL-2	20	450	1	2 1/4
EL-3	30	450	1	3
EL-4	40	450	1	3
EL-115	10	525	1	2

### DUAL SECTION

EL-242	40-40	25	1	2
EL-250	50-50	50	1	2
EL-221	20-20	150	1	2
EL-231	30-15	150	1	2
EL-230	30-30	150	1	2
EL-24	40-20	150	1	2
EL-35	50-30	150	1	2
EL-25	50-80	150	1	2
EL-26	60-60	150	1	3
EL-101	10-10	250	1	2
EL-120	20-20	250	1	2
EL-245	40-40	250	1	3
EL-21	10-10	300	1	2
EL-253	15-15	300	1	2
EL-22	20-20	300-25	1	2
EL-23	30-30	300-350	1	3
EL-32	30-20	350	1	3
EL-254	15-15	400	1	2 1/4
EL-214	80-10	400	1 1/4	3
EL-210	10-10	450	1	2
EL-251	15-10	450	1	2 1/4
EL-220	20-20	450	1	3
EL-240	40-40	450	1 1/4	3

### TRIPLE SECTION

EL-325	20-20-20	25	1	2
EL-335	30-30-30	50	1	2
EL-313	10-30-30	150	1	2
EL-320	20-20-20	150	1	2
EL-224	40-20-20	150	1	3
EL-340	40-40-40	150	1	3
EL-321	30-20-100	150-150-6	1	2
EL-222	20-20-20	150-150-25	1	2
EL-324	30-20-20	150-150-25	1	2
EL-332	30-30-20	150-150-25	1	2
EL-43	30-40-25	150-150-25	1	2
EL-343	40-30-20	150-150-25	1	2
EL-351	50-30-100	150-150-25	1	2
EL-352	50-50-20	150-150-25	1	2 1/4
EL-355	10-15-15	250	1	2
EL-315	10-15-30	250	1	2
EL-354	40-20-20	250	1	3
EL-331	15-15-20	250-250-25	1	2
EL-334	30-30-20	250-250-25	1	2 1/4
EL-314	10-20-30	250-250-350	1	3
EL-316	10-10-10	300	1	2
EL-333	20-20-20	300-300-25	1	2
EL-341	40-15-20	300-300-25	1	2 1/4
EL-102	10-10-20	350-350-25	1	2
EL-153	15-10-20	350-350-25	1	2
EL-326	15-15-20	350-350-25	1	2 1/4
EL-212	20-10-20	350-350-25	1	2 1/4
EL-323	30-20-20	350-350-25	1	3
EL-311	10-10-10	400	1	2 1/4
EL-342	15-15-40	400-400-25	1	2 1/4
EL-322	20-20-20	400-400-25	1	3
EL-310	10-10-10	450	1	2 1/4
EL-344	15-15-10	450	1	3
EL-362	20-15-10	450-300-300	1	3
EL-363	10-10-20	450-350-25	1 1/4	2
EL-364	15-20-20	450-350-250	1 1/4	2
EL-345	10-10-10	450-450-25	1	2
EL-202	10-10-20	450-450-25	1	2
EL-312	10-20-20	450-450-25	1	3
EL-353	15-15-20	450-450-25	1	3
EL-205	20-15-20	450-450-25	1	3
EL-350	20-20-20	450-450-25	1	3
EL-330	30-30-20	450-450-25	1 1/4	2 1/4
EL-360	15-15-10	450-450-300	1	3
EL-215	15-15-15	450-450-350	1	3

### QUADRUPLE SECTION

EL-434	30-30-30-40	150-150-150-25	1 1/4	2
EL-433	40-40-30-20	150-150-150-25	1 1/4	2
EL-452	50-50-50-20	150-150-150-25	1 1/4	2
EL-422	40-20-10-20	200-200-200-25	1 1/4	2
EL-412	10-10-10-20	300-300-300-25	1 1/4	2
EL-432	40-40-20-20	350-300-300-25	1 1/4	3
EL-415	20-10-5-10	350-350-350-25	1 1/4	2
EL-442	20-20-20-20	400-400-400-25	1 1/4	2 1/4
EL-410	10-10-10-10	450	1 1/4	2
EL-420	20-20-20-20	450	1 1/4	3
EL-421	20-15-15-20	450-350-350-25	1 1/4	2
EL-423	20-15-20-20	450-450-25-25	1 1/4	2
EL-425	20-20-30-30	450-450-300-300	1 1/4	3
EL-431	10-10-10-20	450-450-450-25	1 1/4	2
EL-424	40-30-10-20	450-450-450-25	1 1/4	2

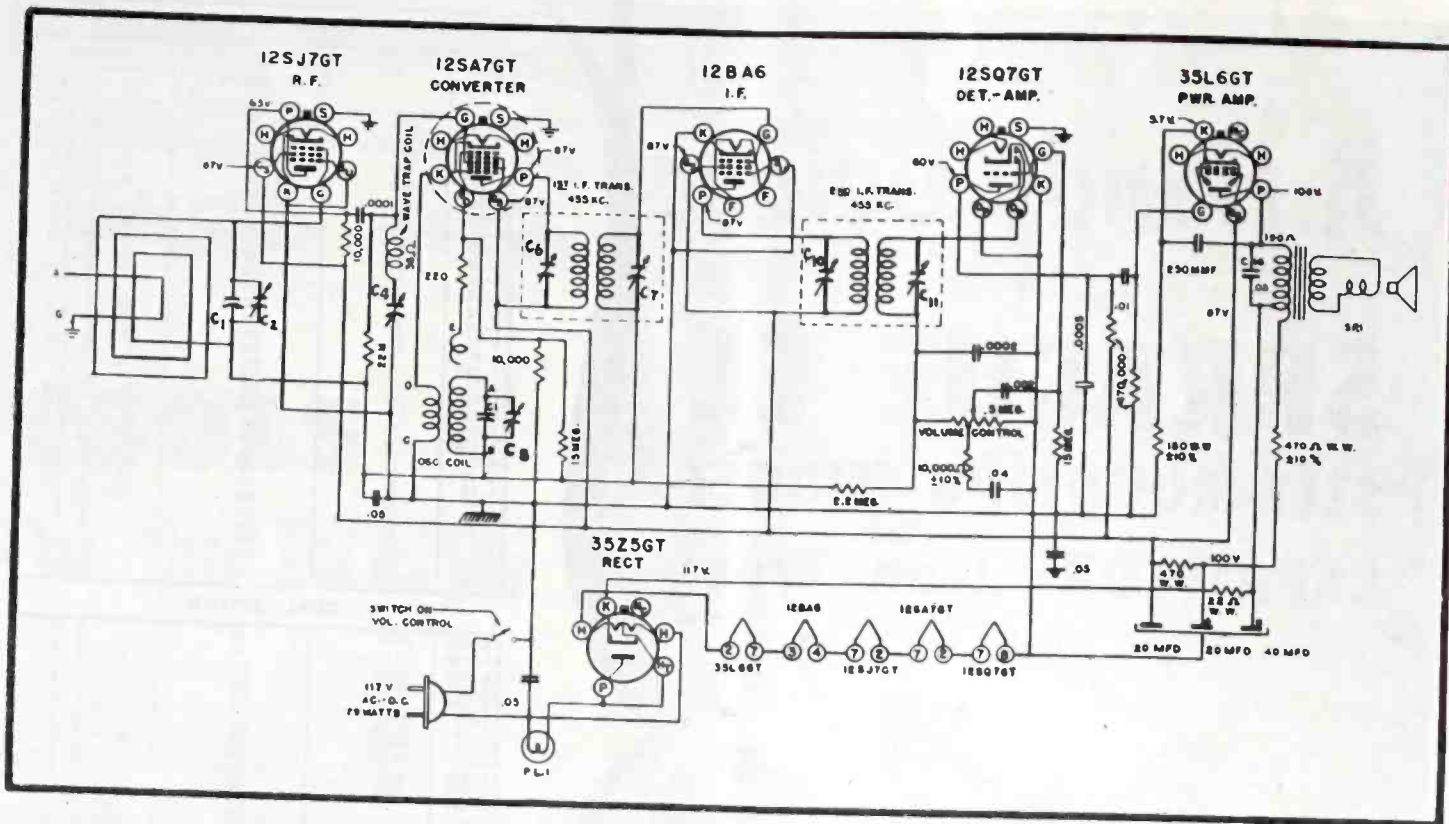

Fig. 2. Zenith 6D015/6D030 a-c/d-c 5-tube receiver.

## SER-CUITS

(Continued from page 15)

and the standard low level resistance-capacity network shunting the low end of the control.

### Motorola 65T21, 65T21B

Several unconventional circuits have been included in the Motorola models 65T21, 65T21B. These are 2-band table models using 6SG7s for converter and i-f, and a separate 6J5 oscillator. The loop primary is in series with the s-w antenna transformer primary, serving as an internal antenna. The oscillator plate is grounded through a .05-mfd capacitor and isolated by 1,000 ohms. Cathode-to-cathode coupling is used for signal injection.

Permeability tuned i-f transformers are tuned with fixed 115-mmfd capacitors.

The tone-control system is quite in-

teresting. A 1-megohm volume control is tapped for tone control and shunted by a 1-megohm fixed resistor. The tone control, however, is a composite design in which two circuits are varied by one potentiometer arm; the bass compensating circuit of the volume control, and the high frequency (treble) shunting a .005-mfd capacitor. The pot has a 1-megohm value and the bass components are 33,000 ohms and .005 mfd.

A voltage divider is used for both first audio and power tube bias, the IR drop across 270 ohms, 39 ohms and 22 ohms being used for the 6K6, while

a drop across 39 ohms serves the first a-f. The 6SQ7 also has a 3.3-megohm grid leak.

### Stewart-Warner 9003-B

An unusual antenna input system is used in Stewart-Warner's 9003-B 2-band receiver. An external antenna feeds the loop primary in series with the s-w transformer primary; the loop is a balanced low-impedance unit feeding an iron-core input transformer.

A 6SK7 tuned r-f amplifier is used on manual tuning on b-c but is shunted out when push-buttons are used as well as on s-w. Both the r-f and i-f tubes have unbypassed cathode resistors.

The second detector is a 6SQ7 used for the diodes only. A shorting phono jack is placed at the high side of the volume control, the contacts opening when a phono plug is inserted. The low side of the control is connected directly to the 6SJ7 first a-f cathode

Fig. 2a. Alignment procedure for Zenith 6D015/6D030.

OPERATION	CONNECT OSCILLATOR	DUMMY TO ANTENNA	INPUT SIG. FREQUENCY	SET DIAL AT	TRIMMERS	PURPOSE
1	Converter Grid	.5 Mfd.	455 Kc.	600 Kc.	C-6, C-7, C-10, C-11	I.F. Alignment
2	Single Turn Loosely Coupled Loop		455 Kc.	600 Kc.	C-4	Adjust Wave Trap
3	"		1600 Kc.	1600 Kc.	C-8	Set Oscillator to Dial Scale.
4	"		1400 Kc.	1400 Kc.	C-2	Antenna Alignment

here's  
the meter  
they're all  
talking  
about

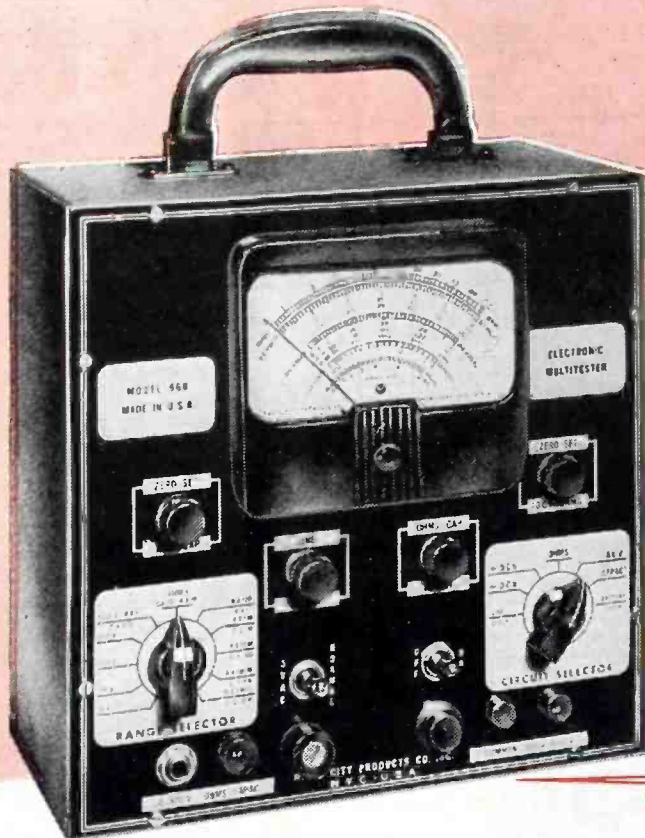

AC-DC VACUUM-TUBE  
VOLT-OHM-CAPACITY  
METER Model 668



## THE METER THAT BRINGS LABORATORY STANDARDS TO YOUR SHOP

Yes, this is the meter that was always "just around the corner". But now it's here—and brother, it has *everything*.

Laboratory precision—broad versatility—amazing economy—and the ruggedness and dependability for which RCP instruments have long been noted.

Model 668's comprehensive scope and accuracy will

help you to solve your toughest trouble-shooting problem. And with voltage, resistance, and capacity meters in a single unit you can speed up your service jobs—step up your profits.

Ask to see this remarkable instrument next time you visit your jobber. Dollar for dollar, it out-performs every other instrument in the field.

### Model 668 features

- The only unit with a vacuum-tube voltmeter available which measures to 6,000 volts AC and DC.
- Meter provided with both mechanical and electrical zero adjustment.
- Exclusive RCP circuit design eliminates all errors due to line-voltage fluctuations and gives RMS measurement values.
- Ohmmeter battery check under load conditions assures maximum accuracy.
- Model 668 is a vacuum-tube voltmeter that is also a vacuum-tube capacity meter.
- Vacuum-tube voltmeter\* measures signal and output voltages from 10 to 250,000 cps. at even the highest values.
- Meter cannot be damaged by using the low range on a high-voltage reading.
- D-C voltmeter readings can be taken without affecting the constants of circuits under test.

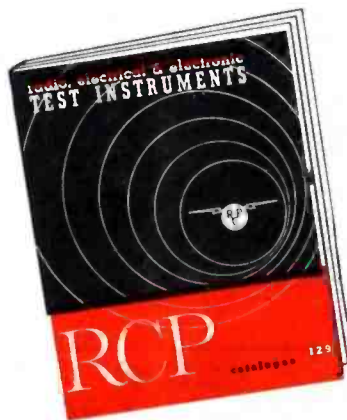

### Ranges

**A-C VACUUM-TUBE VOLTMETER:**— (Direct reading) Input capacity of 0.00005 mfd at terminals of instrument. Input resistance of 160 megohms on 1,500 and 6,000 volts and 16 megohms on low ranges.—Seven ranges: 0/3/6/30/150/600/1,500/6,000 volts.

**D-C VACUUM-TUBE VOLTMETER:**— (Direct reading) Sensitivity of 160 megohms on 1,500 and 6,000 volts and 16 megohms on low ranges.—Six ranges: 0/6/30/150/600/1,500/6,000 volts.

**VACUUM-TUBE OHMMETER:**— (Direct reading) from 0.1 ohm to 1,000 megohms. Seven ranges: 0/1,000/10,000/100,000 ohms; 0/1/10/100/1,000 megohms.

**CAPACITY METER:**— Measures from 0.00005 to 2,000 mfd.—Seven ranges: 0/0.002/0.02/0.2/2/20/200/2,000 mfd.

If you'd like to have a complete display of America's finest line of testing equipment, write for a free copy of Catalog No. 129.

**RCP INSTRUMENTS—BEST FOR EVERY TEST**

**RADIO CITY PRODUCTS COMPANY, INC.**

127 WEST 26th STREET



NEW YORK 1, N. Y.

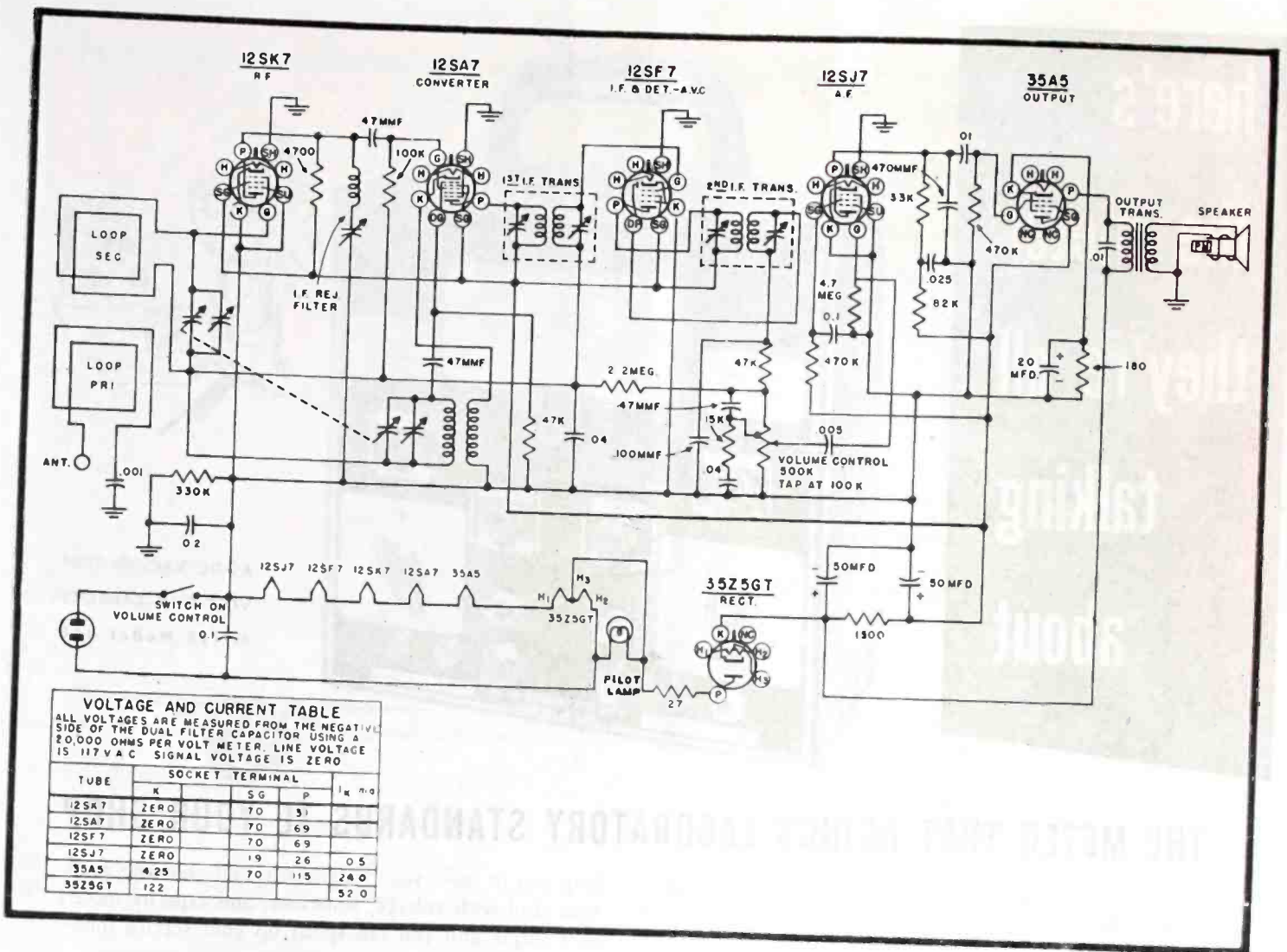

**VOLTAGE AND CURRENT TABLE**  
 ALL VOLTAGES ARE MEASURED FROM THE NEGATIVE SIDE OF THE DUAL FILTER CAPACITOR USING A 20,000 OHMS PER VOLT METER. LINE VOLTAGE IS 117 V A C. SIGNAL VOLTAGE IS ZERO.

TUBE	SOCKET TERMINAL			I <sub>k</sub> mA
	K	5G	P	
12SK7	ZERO	70	31	
12SA7	ZERO	70	69	
12SF7	ZERO	70	69	
12SJ7	ZERO	19	26	0.5
35A5	4.25	70	115	24.0
35Z5GT	122			52.0

Fig. 4. High frequency a-m converter for broadcast receiver described by Sarkes Tarzian at the recent Rochester Fall Meeting of the IRE and designed to tune in the experimental high frequency a-m station W9XHZ in Bloomington, Indiana. The plate coil in the circuit of the 9002 tube consists of two turns of silvar. Plate and screen voltages for the 12BA6 and 9002 is 130; plate voltage for the 12BA6 is 117. Cathode voltage for the 12BA6 is 1.8 and for the 35W4, 145. The input frequency is 87.75 mc; oscillator frequency 86.25 mc and output frequency 1.5 mc.

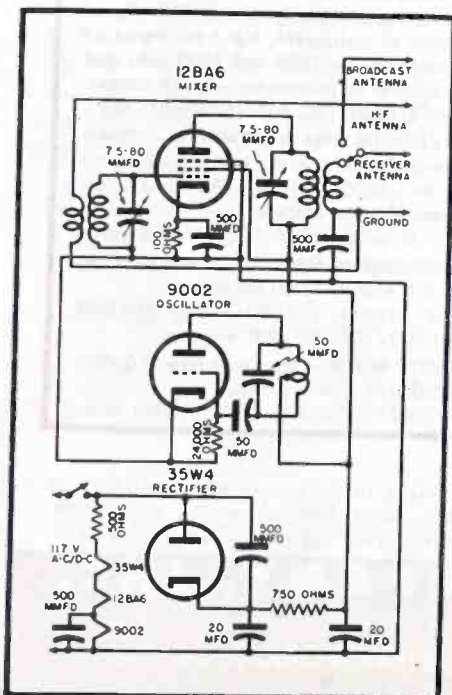

Fig. 3. Six-tube a-c/d-c Westinghouse H125-H126 featuring an untuned r-f amplifier, adjustable i-f rejection trap and high and low-level bass compensation.

which eliminates the need of an audio bypass capacitor across the 2,200-ohm cathode resistor. This is a stabilizing resistor, not a bias resistor, the bias being obtained by a 4.7-megohm grid leak. The screen grid receives degenerative voltage from the output transformer through a .25-mfd blocking capacitor. The screen supply resistor is a 2.2-megohm unit. Bias for the

6K6 output stage is obtained from 330 ohms placed between the high voltage center-tap and ground.

**Belmont 6D11**

The Belmont 6D11 is an a-c/d-c compact model with a tuned r-f amplifier and untuned resistance coupled first detector. The external antenna on this receiver feeds a shunt circuit comprised of a loop-loading coil and a loop primary in one branch and a 4,700-ohm resistor in the other. A .002-mfd series capacitor is also employed. The loading coil boosts the antenna coupling at low frequencies. A resistance-coupled detector

(Continued on page 35)

Fig. 3a. Alignment procedure for Westinghouse H125/H126.

Steps	Connect Signal Generator to—	Adjust Signal Generator to—	Tune Radio Dial to—	Adjust for Maximum Output
1	12SF7 grid in series with a .01 mfd. capacitor	455 kc	quiet point near 1600 kc.	primary and secondary 2nd i-f transformer
2	12SA7 grid in series with a .01 mfd. capacitor	455 kc	quiet point near 1600 kc.	primary and secondary 1st i-f transformer
3	12SA7 grid in series with a .01 mfd. capacitor	455 kc	quiet point near 1600 kc.	repeat 1 and 2
4	antenna terminal	455 kc	600 kc	adjust i-f rejection trimmer for minimum output
5	antenna terminal in series with a 50 mmfd. capacitor	1615 kc	gang at minimum	oscillator trimmer
6	radiated signal from signal generator	1400 kc	1400 kc	adjust antenna trimmer



**This Is  
Good  
News!**

...our greatly increased production on Simpson Model 260 makes it available to you NOW at your jobber's

The Simpson 260 is easily the world's most popular set tester for television and radio servicing. You cannot touch its precision, its useful ranges, or its sensitivity in any other instrument selling for the same price or even substantially more.

It has been a long time since we have been able to produce enough 260's to meet the demand, because the 260 has consistently out-sold every other remotely similar test instrument. The reason is simple: it out-performs and out-values them all. Simpson advanced engineering and unyielding standards of quality and precision manufacture enable it to *stay* accurate under conditions ordinary instruments cannot survive.

Incidentally—production on other Simpson instruments is clearing, too. We feel confident that it will not be long before you can buy those Simpson instruments you have waited for.

Ask your jobber for the Simpson 260—he has it now!

**SIMPSON ELECTRIC COMPANY**  
5200-5218 W. Kinzie St., Chicago 44, Ill.

**Simpson**

INSTRUMENTS THAT STAY ACCURATE

**SIMPSON 260, HIGH SENSITIVITY SET TESTER  
FOR TELEVISION AND RADIO SERVICING**

Ranges to 5000 Volts—Both A.C. and D.C.  
20,000 Ohms per Volt D.C.  
1000 Ohms per Volt A.C.

At 20,000 ohms per volt, this instrument is far more sensitive than any other instrument even approaching its price and quality. The practically negligible current consumption assures remarkably accurate full scale voltage readings. Current readings as low as 1 microampere and up to 500 milliamperes are available.

Resistance readings are equally dependable. Tests up to 10 megohms and as low as 1/2 ohm can be made. With this super sensitive instrument you can measure automatic frequency control diode balancing circuits, grid currents of oscillator tubes and power tube, bias of power detectors, automatic volume control diode currents, rectified radio frequency current, high-mu triode plate voltage and a wide range of unusual conditions which cannot be checked by ordinary servicing instruments. Ranges of Model 260 are shown below.

Price, complete with test leads ..... \$38.95  
Carrying case ..... 5.55

Volts D.C. (At 20,000 ohms per volt)	Volts A.C. (At 1,000 ohms per volt)	Output
2.5	2.5	2.5 V.
10	10	10 V.
50	50	50 V.
250	250	250 V.
1000	1000	1000 V.
5000	5000	5000 V.

Milli-amperes	Micro-amperes	Ohms
D.C.		
10	100	0-1000 (12 ohms center)
100		0-100,000 (1200 ohms center)
500		0-10 Megohms (120,000 ohms center)
(5 Decibel ranges: -10 to +52 DB)		

ASK YOUR JOBBER

# FLASH RAD-EL-CO



INTRODUCES A NEW CONCEALED TYPE AERIAL, ESPECIALLY DESIGNED FOR FENDER MOUNTING ON NEW 1947 CARS!

**The New RAD-EL-CO Aerials, Models FM-3 and FM-4 Lead the Field in Beauty, Performance, Rigidity — and Ease of Installation.**



The new Rad-El-Co's give you all of these profit-making, customer-satisfying advantages. ● Beautifully designed with all visible parts finished in glistening chrome. Enhances car appearance. Looks like factory installation. ● Longer aerial length provides stronger signal. FM-4 extends to 72", collapses to 6". FM-3 extends to 55", collapses to 5". ● One inch seamless aluminum shield tube reduces capacity losses, assures better reception. ● Screw-on aircraft type lead connection and radar type cable. ● Waterproof construction with gasket seals in both mast and mounting. ● Massive fittings and special mounting base vise-locks aerial to fender, eliminating vibration and rattle. ● No weak plastics to crack or shatter. ● Truly, the finest of all aerials.

## ATTRACTIVE LIST PRICES

RAD-EL-CO Model FM-3 (3 Section) \$7.45

RAD-EL-CO Model FM-4 (4 Section) \$8.75



**RAD-EL-CO MANUFACTURING CO. • CLEVELAND 3, OHIO**

## SERVICING HELPS

(Continued from page 20)

imately six ohms and the vibrator will not start, it should be replaced with a new one.

(3) If the resistance checks an infinite or high value, the vibrator should be opened up by unsoldering the base from the can. A resistance check should then be made across the terminals of the operating coil, and across the 220-ohm resistor. The operating coil should check approximately six ohms. If the coil is open, the vibrator must be replaced with a new one. If

the resistor is open, the resistor should be replaced.

(4) If the resistance across terminals *C* and *R* checks approximately 220 ohms, the starting contacts that short out the 220-ohm resistor do not make contact. This condition may be corrected by opening the vibrator and turning the small adjustment screw on the resistor side of the vibrator very slowly in the clockwise direction until the resistance across terminals *C* and *R* reads approximately six ohms. Care should be taken to see that this adjustment screw is not turned beyond the point where contact is made, and the 220-ohm resistor is shorted out.



## OLD TIMER'S CORNER

by **SERVICER**

DROPPED INTO BILL'S RADIO STORE the other evening just before the regular monthly meeting of the *Village Radio Servicemen* to which we both belonged. There was Bill seated at his desk with his head between his hands and a very gloom look on his face.

"What's the matter, chum?" I queried. "It's these advertisements," Bill groaned.

"What's with the ads? I know that you are one of the most prolific advertisers in this burg. Can't pick up an evening paper, or listen to the local radio station without hearing your name and the latest dope on radio sets," I concluded.

"It's not that," Bill explained. "It's the fact that no matter what I do, no matter how much space I take in the 'Evening Star' or how much time I take on the local station, I don't get results."

"How do you know?" I asked.

"Well, most of my ads are keyed. That is, I use a street address or a man's name who does not exist and when the customer comes in and asks for that man, I know it is in response to the ads."

"Lately there have been less and less responses," he concluded sorrowfully.

"Who writes the ads?" I asked. "Are you your own advertising agency? Or are you one of those smart people who hires an expert to do his writing for him?" I rejoined acidly.

"Look here, Old Timer," said Bill, "I am just as good as any advertising agent. I know the radio business. I know the trade, and I know what people like and dislike. Why shouldn't I write my own ads?"

"That's a long story, Bill," I answered. "But if out of all the people that try to write their own ads, you turn out to be one in million, then you might have a chance that you would be successful. Otherwise you just won't be," I concluded.

"That's plain silly," said Bill hotly. "I should know how to write the ads. When I go into another radio store, I'm a customer aren't I? And if I am a customer, then I ought to know what I like. If I know what I like as a customer, I ought to be able to write what other customers like," Bill finished with conviction.

"Tain't so," I said. "But if you know so much about the likes and dislikes of the customers, how come you are down in the dumps about the ads not pulling? If you really want to know, I can tell you, because I went through the same thing myself not too many years ago. And, believe me, chum, I learned plenty."

"Okay, okay, you fair-haired boy . . . give out with the wisdom!" Bill said caustically.

"Well, first let's assume that you feel that you *are* a customer, at least in the sense that you can go into another radio



shop and know what you do and what you do not like. Does this really make you a customer, like one who has never owned a radio shop? Of course it doesn't. And as a matter of fact, don't you go into the other radio store with an owner's attitude? Don't you go in there to find out what he is doing, how he is doing it and what results he is getting? You don't go in there to buy, do you? You go in there with the back of your head all filled up with the idea that you, too, are a radio shop proprietor. And it's with that idea that you look around.

"So forget the false idea that just because you wander into another's radio store that makes you the same as a customer who might—quite by accident—read your ads.

"Now that you have that out of your mind, you will tell me again that you know the radio business and all about it. You know an i-f transformer from a capacitor. And you know a resistor from a megacycle. Therefore, you reason, you can write an ad that pulls. Well, you are just making two plus two equal to seven, if you figure that way.

"What you should try to understand, is that the ads are read by customers who know little if anything about the innards of any radio set beyond that there are bulbs in it. The average customer does not know an i-f transformer from a soldering lug. Nor does he have to, to buy a set. He knows what he wants in terms of enjoyment, in terms of distance stations he can listen to, in terms of how well his latest collection of swing or serious music will sound on the combination. That's what he knows about.

"The average advertising agency has a well-developed nose for what John Q. Public wants. A really fine, first-class advertising agency won't give a tinker's dam what you like. The agency is only interested in what the public likes. And in that manner it can serve you best.

"They'll write copy from the customer's viewpoint, not yours. They will know what the customer wants to hear, how to attract his attention, and how to hold it long enough to put your sales message across. Furthermore they'll know how to clinch it in good English.

"Too many Service Shop operators feel if the advertising copy does not suit them, then it is no good. And that's where they make their greatest mistake. It is not supposed to please the store owner. It is not written for the Service Shop owner's consumption. Actually the Service Shop owner should have nothing to do about the copy, only pay for it.

"Now you take your radio programs. They are also being written by you, Bill. Do you know what the customer likes to hear? I can see that you are about to explode, since you, too, listen to the radio every night, not to mention all day while you are repairing the sets in your shop.

"But that does not by itself give you the knack of knowing what the listeners want. You know what you want. But you cannot know what the customers want. Why? Because if you had that sixth sense you would be in the advertising business and not the radio business.

"There are, of course, many exceptions to the rule. In some instances, the heads of some large companies have been actually trained as advertising men before they became heads of their respective firms. They have the training. But even among those you will find few who do

(Continued on page 35)



Meet Alfred A. Ghirardi—servicing expert and author of the most widely used books in radio technical publishing history.

**I'LL TEACH ANY  
AMBITIOUS SERVICEMAN  
TO WORK BETTER,  
FASTER, MORE  
PROFITABLY!**

**... OR REFUND Every Cent of YOUR MONEY!**

Where will you be when servicing competition again gets tough? What will happen when you are called upon to repair the highly complicated F-M and Television equipment? Or industrial Electronic equipment? Whether you have the

basic training these famous books shown here are so well equipped to give—OR WHETHER YOU DON'T—will tell the story!

Read these two Ghirardi servicing books for five full days. If you're not fully satisfied return them and every cent of your money will be refunded and no questions asked!



This big manual-size Ghirardi Handbook is worth another man in your shop.

**ELIMINATES TEDIOUS TESTING**  
← on 4 jobs out of 5

Maybe you've tried servicing short cuts before—NOW try the one method that really works—the one that pays for itself in time saved on the very first job. There's no magic about it. In this big 4-lb. 744-page Manual-Size RADIO TROUBLESHOOTER'S HANDBOOK Ghirardi supplies you with a carefully tabulated compilation of common troubles (and their remedies) that account for about 90% of the service work on almost every model of radio in use today—over 4800 models of 202 manufacturers. You just look up the Make, Model and Trouble Symptom of the radio you want to repair. Four times out of five all troubleshooting and testing will be eliminated. More than half your time will be saved. The Handbook will tell you exactly what the trouble is likely to be—and exactly how to repair it. Ghirardi passes on to you the priceless servicing experience obtained from thousands of hours of tedious troubleshooting so that you may save your own precious time and make your work EASIER. In addition, there are over 300 pages of repair data and diagrams, tube charts, tuning alignment and transformer data, color codes, etc., designed to help you repair ANY RADIO EVER MADE better, faster, more profitably. Only \$5 complete—and sold on our UNRESERVED 5-DAY MONEY-BACK GUARANTEE BASIS.

**DON'T BE A "HACK"!**

Learn PROFESSIONAL Servicing by Modern Scientific Methods

MODERN RADIO SERVICING is Alfred A. Ghirardi's famous COMPLETE 1 VOL. COURSE in professional radio-electronic service work. It gives you the kind of training that will be your "Open, Sesame!" to the better money-making opportunities that only scientifically and thoroughly trained servicemen will be in a position to grasp—including profitable industrial electronic work. It explains all types of radio-electronic test instruments. It shows you how to analyze circuits scientifically; how to use all types of test instruments for troubleshooting; how to test, repair and replace components; how to make substitutions—how to handle every phase of radio repair work from A to Z by approved time-saving MODERN methods. Absolutely "tops" either as a basic course or as a "refresher" course on any type of work that puzzles you. Worth its weight in gold in giving you real know-how and paying your way for a profitable radio-electronic-television future. No other book can compare with this one for complete, easily understandable instruction on every phase of service work. "I recently finished a course in a N. Y. radio school, and all my learning at the school did not help me to understand and repair radios as quickly as did this one book. I made my money back on one job alone!" writes Henry Miller of Brooklyn, N. Y. 1300 pages—706 illustrations—720 self-test review questions. Only \$5. 5-DAY MONEY-BACK GUARANTEE.



**STOP GUESSING,  
MISTER!**

Get where the good money is—by learning to handle even the most complicated jobs profitably!



**HAVE A LOOK AT THEM-NOW!**

Murray Hill Books, Inc., Dept. S-17,  
232 Madison Ave., New York 16, N. Y., U.S.A.

Enclosed find \$..... for books checked; or  send C.O.D. (in U.S.A. only) for this amount plus postage. If not fully satisfied, I may return the books within 5 days for full refund.

RADIO TROUBLESHOOTER'S HANDBOOK \$5 (\$5.50 foreign).

MODERN RADIO SERVICING \$5 (\$5.50 foreign).

MONEY-SAVING COMBINATION OFFER: Both big books—over 2000 pages—only \$9.50 for the two (\$10.50 foreign).

Name .....

Address .....

City & Dist. No.....State.....

**MONEY-SAVING  
OFFER**

Let the HANDBOOK save time on common service jobs. Let MODERN RADIO SERVICING train you for PROFESSIONAL electronic service work. Get BOTH big books at special Money-Saving Combination price of only \$9.50 for the two. Mail coupon today!



# FOR COMPACT HIGH FIDELITY EQUIPMENT

Ultra compact, lightweight, these UTC audio units are ideal for remote control amplifier and similar small equipment. New design methods provide high fidelity in all individual units, the frequency response being  $\pm 2$  DB from 30 to 20,000 cycles. There is no need to resonate one unit to compensate for the drop of another unit. All units, except those carrying DC in Primary, employ a true hum balancing coil structure which, combined with a high conductivity outer case, effects good inductive shielding. Maximum operating level +10 DB. Weight -  $5\frac{1}{2}$  ounces. Dimensions -  $1\frac{1}{2}$ " wide x  $1\frac{1}{2}$ " deep x 2" high.



**FOR IMMEDIATE DELIVERY**

From Your Distributor

Unit shown is actual size. 6V6 tube shown for comparison only.

## ULTRA COMPACT HIGH FIDELITY AUDIO UNITS

Type No.	Application	Primary Impedance	Secondary Impedance	$\pm 2$ DB from	List Price
A-10	Low impedance mike, pickup, or multiple line to grid	50, 125, 200, 250, 333, 500 ohms	50,000 ohms	30-20,000	\$15.00
A-11	Low impedance mike, pickup, or line to 1 or 2 grids	50, 200, 500 ohms	50,000 ohms	50-10,000 multiple alloy shield for extremely low hum pickup	16.00
A-12	Low impedance mike, pickup, or multiple line to push pull grids	50, 125, 200, 250, 333, 500 ohms	80,000 ohms overall in two sections	30-20,000	15.00
A-18	Single plate to two grids	8,000 to 15,000 ohms	80,000 ohms overall, 2.3:1 turn ratio overall	30-20,000	14.00
A-24	Single plate to multiple line	8,000 to 15,000 ohms	50, 125, 200, 250, 333, 500 ohms	30-20,000	15.00
A-25	Single plate to multiple line 8 MA unbalanced D.C.	8,000 to 15,000 ohms	50, 125, 200, 250, 333, 500 ohms	50-12,000	14.00
A-26	Push pull low level plates to multiple line	8,000 to 15,000 ohms each side	50, 125, 200, 250, 333, 500 ohms	30-20,000	15.00
A-30	Audio choke, 300 henrys @ 2 MA 6000 ohms D.C., 75 henrys @ 4 MA 1500 ohms D.C., inductance with no D.C. 450 henrys				10.00

The above listing includes only a few of the many Ultra Compact Audio Units available . . . write for more details.

**United Transformer Corp.**  
 NEW YORK 13, N. Y.  
 150 VARICK STREET  
 EXPORT DIVISION: 13 EAST 40th STREET, NEW YORK 16, N. Y. CABLES: "ARLAB"

## 2-BAND LOOP SET

(See Front Cover)

AUDIO-VOLTAGE DEGENERATION is again popular in many types of receivers. The feedback loop used, in most cases, includes the first audio and power amplifier stages including the output transformer; in other words, the entire audio system. Only in this manner can the benefits of inversed feedback be fully realized.

In the circuit on the front cover this month, Bendix models 676B, C, and D (2-band a-c) the feedback principle is effectively illustrated. In this model auto-feedback voltage is applied to low side of volume control, hence to the first audio grid. The loop includes a switch-type tone control which works in conjunction with the volume control. A small capacitor in series with the feedback loop favors the degeneration of high frequencies, boosting the bass notes. Further bass boost is obtained by shunting a .001-mfd capacitor across the volume control with a 470-ohm limiting resistor. The feedback voltage is fed through the 470 ohms and across 47 ohms to ground. Additional high-frequency degeneration is provided by a 100-mmfd capacitor connected between plate and grid of the 6V6 power tube.

The r-f section of the receiver uses a 6SK7 t-r-f amplifier on the broadcast band while short-wave signals are fed through an antenna input transformer directly to the 6SA7 converter. A low-impedance loop is used in the pickup system.

On phono operation, 220,000 ohms is placed between the r-f/i-f cathodes and ground, completely desensitizing these amplifiers to prevent signal leakage into the volume-control circuit.

### SYLVANIA AT WEST COAST SHOW



Representatives of Sylvania at their show booth at the recent West Coast Electronic Manufacturers Association exhibition in Los Angeles. Left to right: W. G. Patterson, Sylvania West Coast renewal tube sales representative; Vi Berry, Sylvania show committee representative, and F. E. Gilbert, Jr., equipment tube sales representative.

# TOMORROW'S PRODUCTS TODAY...

STOCK DELIVERY



Featherweight Miniature

## TEST INSTRUMENTS

Compact — Accurate — Priced Right!

- Jeweled Meter • Range Selector Switch
- All multipliers bridge tested for 1% accuracy
- Zero adjustment—built in batteries
- Molded bakelite case only 3-15/16" x 2-7/8" x 2"



### MODEL 450A

Volt — Ohm — Milliammeter

A fine instrument having a sensitivity of 1000 ohms per volt.  
Ranges: Volts DC, 0-5/10/50/500/1000;  
Mills DC, 0-1;  
Ohms full scale, 0-5000/50,000/500,000;  
Ohms center scale, 30/300/3000.

NET complete with batteries **9.75**

### MODEL 451A

AC-DC

Volt — Ohm — Milliammeter

A dependable instrument of wide utility—sensitivity 1000 ohms per volt.  
Ranges: Volts AC, DC, and Output Ranges, 0-10/50/100/500/1000;  
Ohms full scale, 500,000.  
Ohms center scale, 7200.



NET complete with batteries ..... **13.65**

### MODEL 451B

Same instrument as above but has 2500 ohms per volt sensitivity.

NET complete with batteries ..... **15.15**



### MODEL 452A

Volt — Ohmmeter

A superb instrument—100 microampere meter gives 10000 ohms per volt sensitivity.  
Ranges: Volts DC, 0-10/50/100/500/1000;  
Ohms full scale, 0-2000/20,000/200,000/2 Megs;  
Ohms center scale, 30/300/3000/30,000.

NET complete with batteries ..... **13.65**



### MODEL 312

Volt — Ohm — Milliammeter

An economy pocket meter featuring a 2" moving vane meter.  
Reads: AC-DC volts, 0-25/50/125/250;  
Mills AC-DC, 0-50;  
Ohms, 100,000;  
mfd. .05-15.  
Jacks provide range selection.

NET Complete with cord and plug ..... **6.00**

## CONDENSER SPECIALS

Guaranteed first quality.

"The best at the lowest price"

Mfd.	Voltage	Net				
10	25	27¢				
25	25	36¢				
100	25	52¢				
10	50	32¢				
8	150	32¢	30/20	150	88¢	
16	150	42¢	100/30	150	94¢	
20	150	44¢		20	250	59¢
30	150	47¢		8	450	44¢
20/20	150	70¢		16	450	64¢



# Attention GI JOE!

Here's Your Opportunity to

## Start Your Own RADIO SERVICE SHOP

Complete Starting-in-Business Package Stocks of

TEST EQUIPMENT TUBES, PARTS, TOOLS **\$350 up**

Act quickly! Meet the pent up demand for radio service. Turn your special service training into a profitable business of your own. No fuss. No worry. Here's everything you need—\$350 up. Details upon request. Write, wire or phone.

### PHILCO BEAM OF LIGHT

Selenium cell only, no holder, postpaid ..... **1.80**  
(Puts new life in Philco Chargers.)



"One with every car radio service job"

Emergency trouble lite. 12' cord reaches anywhere on car. Insert plug in cigar lighter on any car. Gives light—where needed—when needed—a "natural" for installing and servicing car radios—use it—sell it to your customer—for added profit.

1 lighter lite in box **2.50**  
1 dozen ..... **1.88 ea.**  
2 dozen ..... **1.67 ea.**  
4 dozen ..... **1.50 ea.**

### SHORT WAVE RECEIVERS

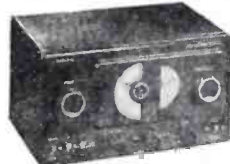

HALLICRAFTERS S-38 ..... **39.50**  
S-40 (REPLACES S20R) ..... **79.50**  
HAMMARLUND HQ129X ..... **161.40**  
SPEAKER IN MATCHING CABINET ..... **11.85**

20% deposit required on all C.O.D. orders.  
2% transportation allowance on orders of \$25.00 or more accompanied by payment in full.

SEND FOR FREE BARGAIN BULLETIN

# RADIO SUPPLY & ENGINEERING CO., Inc.

126 SELDEN AVE. DETROIT 1, MICH.

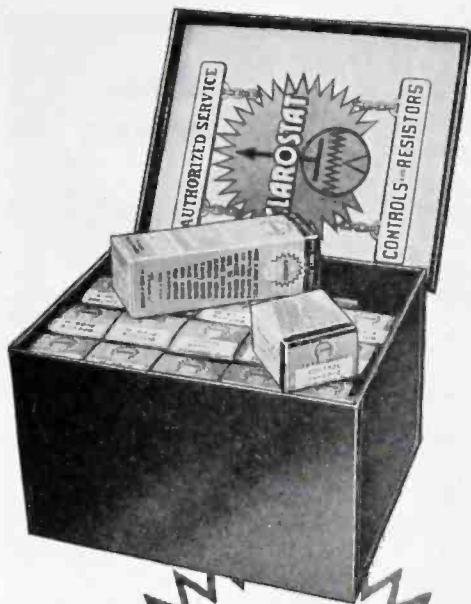

*You asked for it!*

**SERVICEMAN'S  
KIT No. 4**

★ With this kit you're ready to service upwards of 95% of the standard radios. And you can keep the kit complete by re-ordering individual items.

**CONTROLS and SWITCHES**

Kit contains 17 selected volume and tone controls. Most popular ohmages and taps. Also 8 Ad-A-Switches—both s.p. and d.p. types. Plus 4 Glasohms (glass-insulated flexible resistors).

**PLUS-DATA and PLAQUE**

Packed in a neat, sturdy, green-lacquered steel cabinet (no advertising or outside label). Kit includes Clarostat Volume Control Selector and Authorized Service plaque. A big \$32.15 value; "special" to you at only \$17.79!

★ Ask Our Jobber . . .

Ask for this "special"—get yours before the supply runs out. If you're not acquainted with the nearest Clarostat jobber, write us and we'll bring you together.



CLAROSTAT MFG. CO., Inc. · 285-7 N. 6th St., Brooklyn, N. Y.

**NEW MODELS**

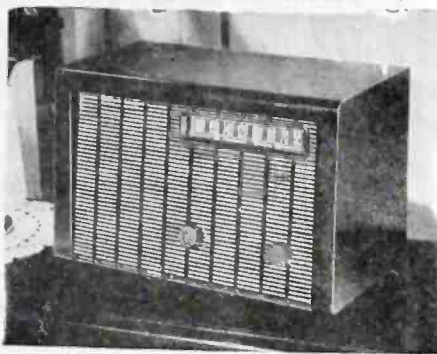

National Union, model 571, 5-tube a-c/d-c receiver.



Echophone 4-tube farm type receiver, model EC-600.

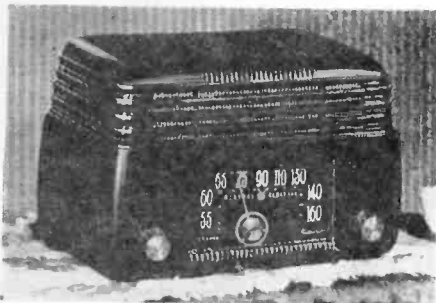

G.E. a-c/d-c 5-tube receiver, model 200.

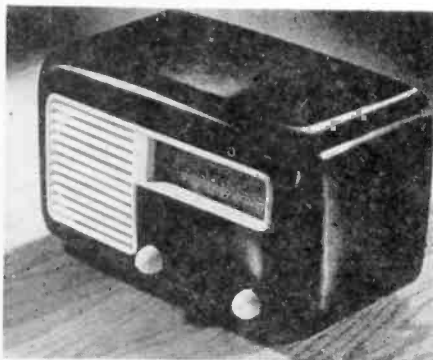

Above, Detrola 5-tube a-c model.

Below, Westinghouse 5-tube farm-type receiver, the Ruralist.

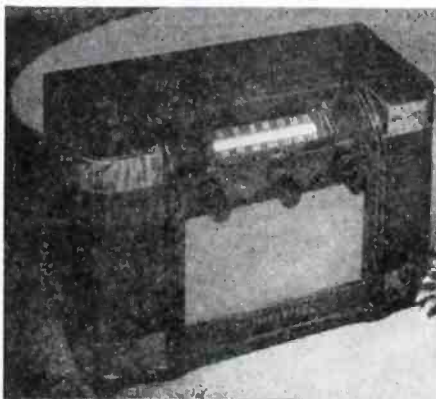

**M U E L L E R**



**CLIPS**

*For Quick Temporary Connections*

- Made in 10 sizes—from the tiny wee-pee-wee to the 300 ampere Big Brute.
- Offered in both steel and solid copper.
- Red and black rubber insulators to fit each size.
- A complete line with

**A CLIP FOR EVERY PURPOSE**

Send for free samples and catalog 810

*Mueller Electric Co.*

1565 E. 31st St. - Cleveland, Ohio



**Clippard**  
**ELECTRONIC VOLT-  
OHMMETER, MODEL 406**

We invite comparison of this instrument with any at any price for appearance, ruggedness, accuracy, stability. 0-1 to 1,000 volts U.H.F., A-C., D-C. 0-1,000 megohms. Pen-type dual-diode A-C probe. No extras to buy. Send for details or order today.

**\$89.50**  
NET

from Jobber or F.o.b. Cin.

**CLIPPARD INSTRUMENT LAB., Inc.**

1129 Bank Street, Dept. 3, Cincinnati 14, Ohio

## SER-CUITS

(Continued from page 28)

operates with a 4,700-ohm plate load resistor, .0001-mfd coupling capacitor and 100,000-ohm grid leak. The suppressor grid of the 12SK7 i-f amplifier is returned to the B- side of a 390-ohm cathode bias resistor instead of to the cathode directly. The 12SK7 r-f stage has a 100-ohm bias resistor. The use of a p-m speaker, with no facilities for hum bucking in the voice coil, necessitates a filter section ahead of the power tube plate supply. This supply uses a 40-mfd, 180-ohm and 20-mfd first filter. A 35L6 screen is fed by a second filter section of 1,200 ohms and 20 mfd, which also supplies the remainder of the receiver.

## OLD TIMER'S CORNER

(Continued from page 31)

their own ad writing. Mostly they hire high-priced writers to do it for them.

"So I say to you, Bill, if your ads are not pulling, and if you are doing the writing yourself, you would do better to turn the whole thing over to a first-class agency and let them sweat out the ads and the copy for the broadcasts. You sit back. Don't interfere, but demand results. If you don't get them, then you can gripe. In the final analysis you can change agencies if you don't get results from the first one. But do not think that just because you had a bit of luck in the beginning, or because you can write a bit now and then, that you can turn out the same type copy or advertisements as a person who is making that sort of thing his or her life's work."

Well, it took a lot of arguments to win Bill over, but he finally got himself an agency. And what do you know? It was a bad move on my part to tell him all that stuff, because now I have to get myself an agency again, too. I always could outwrite Bill. But with that new agency doing his stuff, I have been losing too many new customers to him. The only way to fight fire is with fire, I says. But what a fool I was to light one in the first place!

## TOOTH-BRUSH HOLDER FOR SCREWS

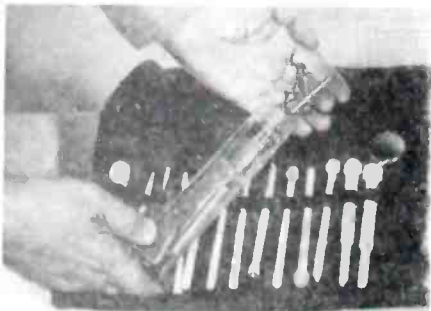

Heavy glass tooth-brush holders make convenient containers for screws, bolts and assorted small parts. Holder has the advantage of being transparent so that parts may be seen without removing all the items.

## When making that Service Call

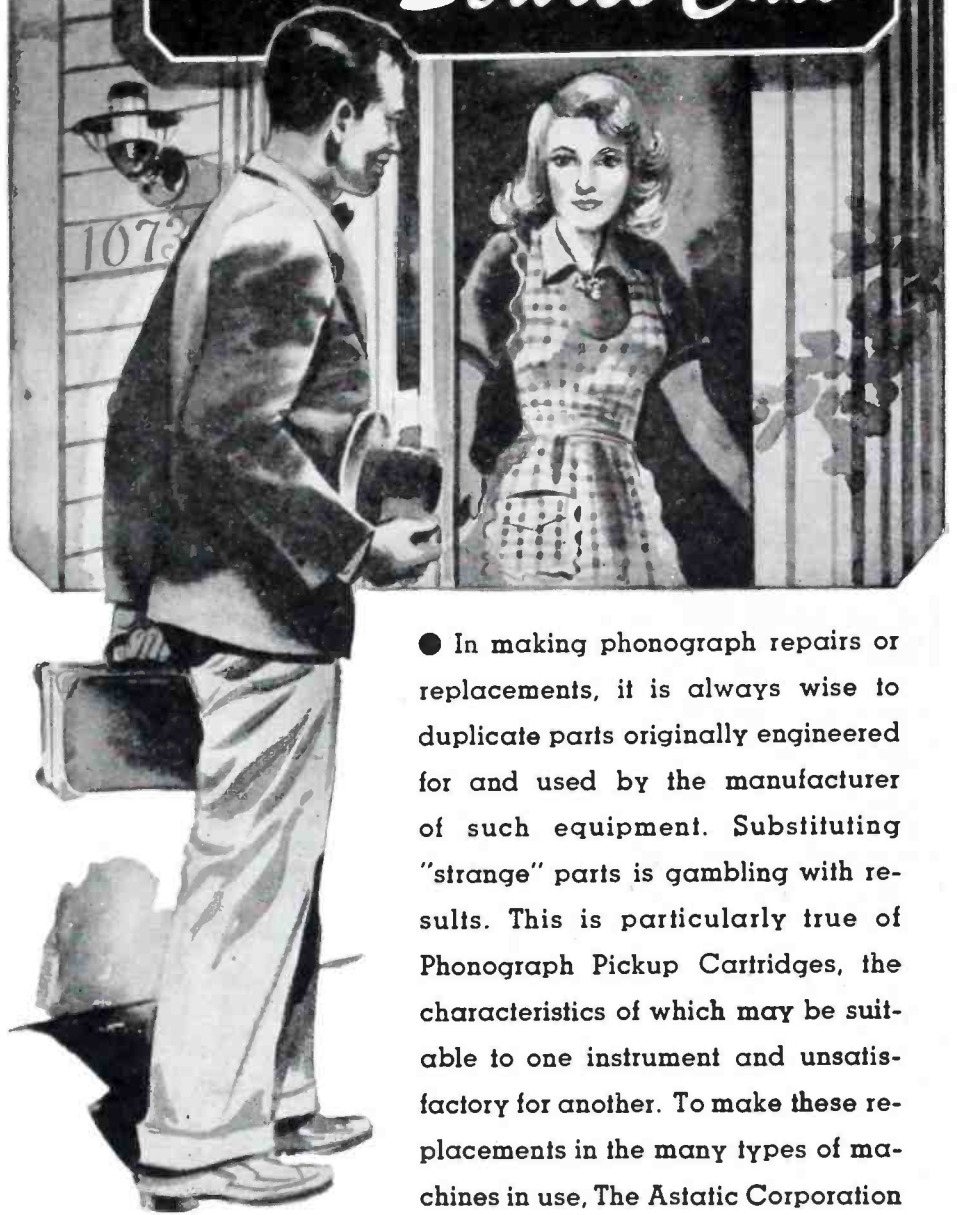

● In making phonograph repairs or replacements, it is always wise to duplicate parts originally engineered for and used by the manufacturer of such equipment. Substituting "strange" parts is gambling with results. This is particularly true of Phonograph Pickup Cartridges, the characteristics of which may be suitable to one instrument and unsatisfactory for another. To make these replacements in the many types of machines in use, The Astatic Corporation manufactures and ships thousands of

Crystal Cartridges in different but necessary types, each day. Keep Astatic Crystal Pickup Cartridges in your service kit and insure speedy, satisfactory replacements with full measure of operating efficiency.

THE  
*Astatic*  
ASTATIC CORPORATION  
CONNEAUT, OHIO

IN CANADA: CANADIAN ASTATIC LTD., TORONTO, ONTARIO

Astatic Crystal Devices Manufactured  
under Brush Development Co. patents.

Visit your Radio Parts  
Jobber or Write for New  
Catalog.

# HELLO! CHECK THESE "GET ACQUAINTED" VALUES! SPEAKERS

**5" P.M.** 1 oz. Alnico 5 Magnet **\$139**  
6 for \$8.00

6" PM 2.15oz. Alnico 5 Magnet ..... 2.79  
8" PM 20 oz. Slug \$4.95 12" PM 20 oz. Slug 8.95

## VOLUME CONTROLS

**1/2 MEG** with switch and 2" shaft **75¢**  
6 for \$4.25

Kit of 10 assorted controls, without switch, \$1.95

## WIRE

Approximately 400 ft. of Wire in assorted colors and gauges, solid and stranded in 2 to 4 feet lengths, **99¢** per pkg.  
2 pkgs. for \$1.90

#20 shielded wire, stranded, per ft. .... \$0.3  
2 conductor mike cable, per ft. .... .06  
Radio grade spaghetti, 1c ft., #20 solid push-back, 1c ft.

## CABINETS

**PORTABLE PHONOGRAPH CASE** two-toned Leatherette finish, Dimensions 15-3/4" L x 14-3/4" W x 8" H **\$995**  
Portable Automatic Phono-graph Record-Changer Case **\$1495**

## TRANSFORMERS

**70 MIL POWER TRANSFORMER 600V**  
6.3V @ 3 Amp. C.T., 5V @ 3 Amp. **\$295**  
3 for \$8.00

50 Mil Power 500V, 6.3V @ 2 Amp. 5V @ 2 Amp. ..... \$1.95  
90 Mil Power 500V, 6.3V @ 3.5 Amp. 5V @ 3 Amp. .... 3.25  
120 Mil Power 500V, 6.3V @ 5 Amp. 5V @ 4 Amp. .... 4.25  
50L6 Output ..... .59  
6V6 Output ..... 1.69  
8 Watt Universal Output ..... 1.29

2 Post V.M. Record Changer... \$17.95  
3 for \$52.00

## CONDENSERS

**TUBULAR PAPER CONDENSERS**  
All 600 Volt test

MFD	PRICE EACH	PER 100	MFD	PRICE EACH	PER 100
.01	.08	\$6.50	.001	.08	\$6.50
.02	.08	6.50	.002	.08	6.50
.05	.10	8.00	.005	.08	6.50
.1	.12	9.00	.006	.08	6.50
.25	.17	13.50	.5	.26	22.50

## "ILLINOIS" ELECTROLYTICS

MFD	VDC.	PRICE	MFD.	VDC.	PRICE
10	25v	.25	50	150v	.50
100	25v	.55	8	450v	.38
12	50v	.38	10	450v	.43
16	150v	.35	16	450v	.55
20	150v	.38	20	450v	.60
24	150v	.38	40	450v	.88
30	150v	.40	100	15v	.49

## DUALS

16-16	150v	.58	50-30	150v	.76
20-20	150v	.65	8-8	450v	.65
30-30	150v	.70	10-10	450v	.70
40-20	150v	.70	20-20-20	150v	.99

10% discount on all electrolytics if purchased in lots of 20 or more  
Mica Condensers, All sizes 8c each

## RESISTORS

1/4 watt, all sizes ..... 2c  
1/2 watt, all sizes ..... 3c  
1 watt, all sizes ..... 4c  
5 watt wire-wound ..... 18c  
10 watt wire-wound ..... 20c  
25 watt wire-wound ..... 30c  
Resistor kit containing 100 insulated resistors in popular sizes of 1/3, 1/2, 1 and 2 watt \$1.95

All items subject to prior sale  
Minimum order, \$3.00 — 20% with order, balance C.O.D. We prepay express on \$50.00 orders in U. S. A. Write for catalog.

**ELECTRONIC PARTS, Inc., Dept. B1**  
622 W. Randolph St. Chicago 6, Ill.

# Operating The Vomax

by M. E. LEWIS

Part II of an analysis with practical operation and maintenance data based on twelve months of field experience.

CONTINUING OUR DISCUSSION on the use of the Vomax, let us now study r-f and i-f measurement applications.

It must be remembered that to measure any voltage, two connections must be made to its source. These are made in all except r-f and i-f measurements by the red and black test leads on the instrument. In r-f and i-f measurements these two connections are made to the circuit to be measured, one by the tip of the r-f probe to the *high* side of the circuit, the other by the metal r-f probe shell contacting the *low* (usually chassis) side of the circuit. The r-f probe houses the diode rectifier and

the required resistors and capacitors. At usual broadcast band and i-f amplifier frequencies, the *return circuit* need not be through the r-f probe shell, but may be through the black test lead connecting *COM.GND.* jack to receiver chassis. Above 20 mc the return circuit *must be directly to the probe shell* without long intervening connecting lead if accuracy is to be maintained.

### Allowing for Input Capacity in R-F

With any voltmeter capable of measuring r-f voltages some input capaci-  
(Continued on page 38)

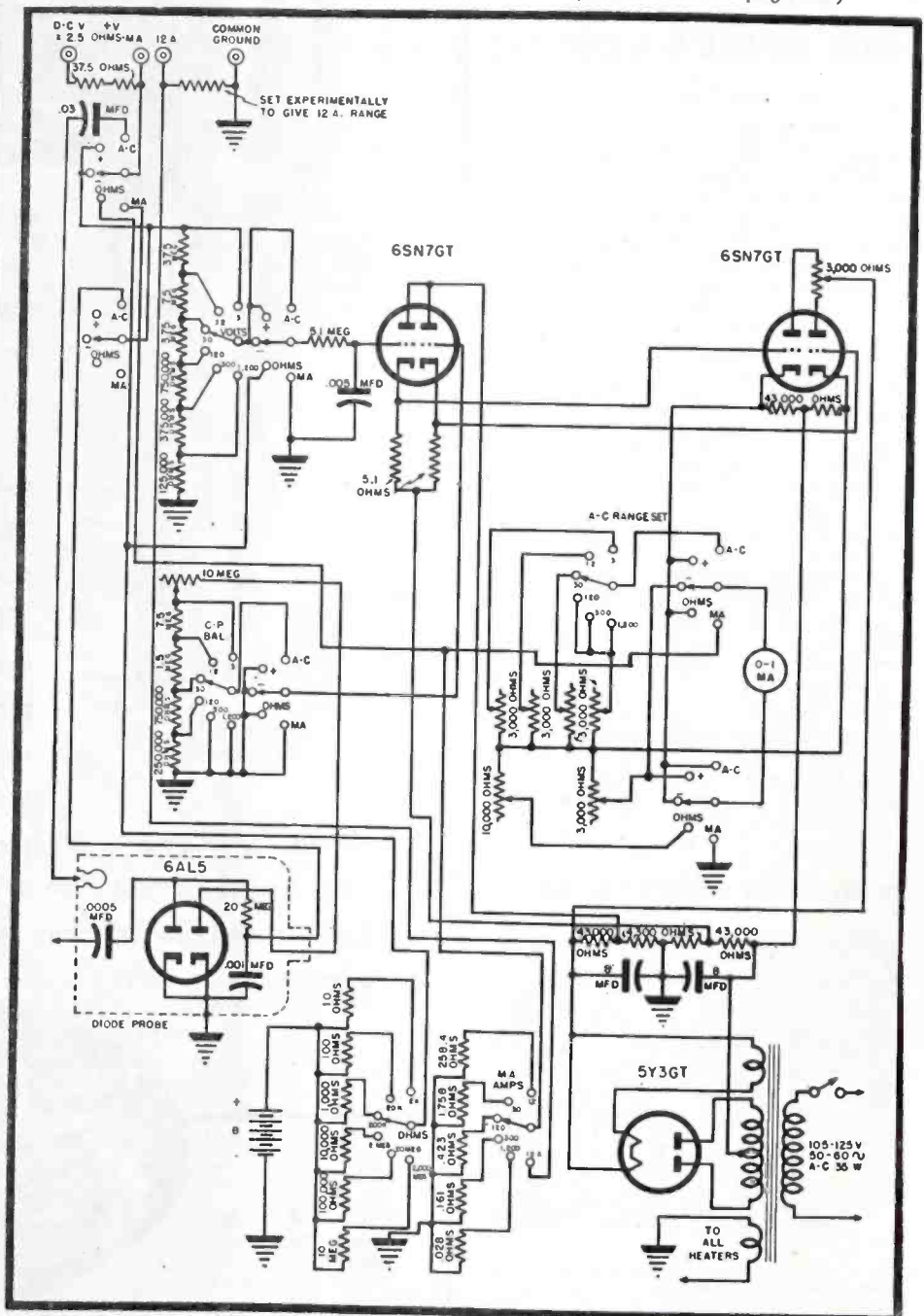

Fig. 1. Circuit diagram of the Vomax.

# Model 2450 ELECTRONIC TESTER

★  
There's never been a tester like this!

Here's a tester with dual voltage regulation of the power supply DC output (positive and negative), with line variation from 90 to 130 Volts. That means calibration that stays "on the nose"! That means *broader service* from a tester that looks as good as the vastly improved service it provides. This model includes our Hi-Precision Resistor which outmodes older types.

**HIGHLIGHTS** — 42 ranges: DC and AC. Volts: 0-2.5-10-50-250-500-1000 • DC MILLIAMPS: 0-0.1-1.0-10-50-250-1000 • OHMS: 0-1000-10,000-100,000 • MEGOHMS: 0-1-10-100-1000 • CAPACITY IN MFD: 0-.005-.05-.5-5-50 • LOAD IMPEDANCE: 51 megohms on DC Volts • CIRCUIT LOADING: Low frequencies. Circuit loading equal to 8 megohms shunted by 35 mmfd. High frequency circuit loading equal to 8 megohms shunted by 5 mmfd.

Detailed catalog sheets on request.

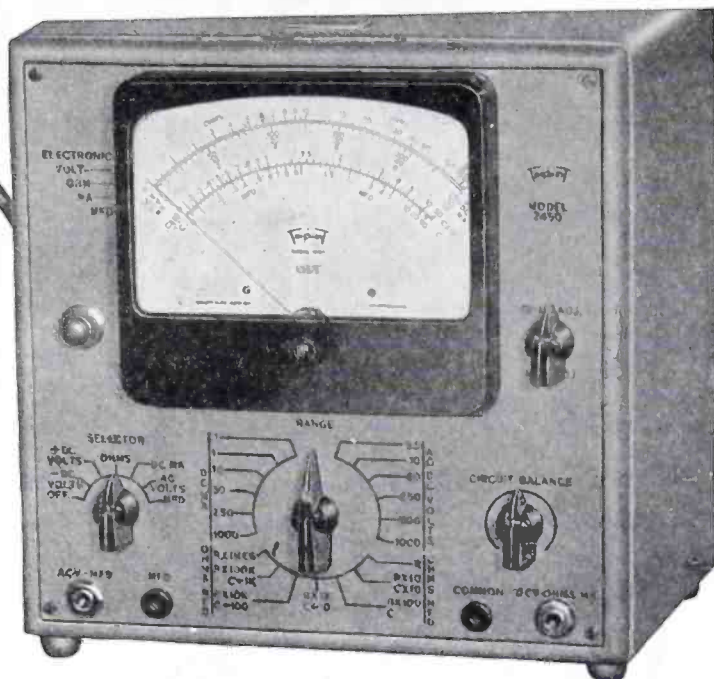

*Precision first  
...to last*

# Triplet

ELECTRICAL INSTRUMENT CO. BLUFFTON, OHIO



# OLSON FREE

## Gift-of-the-Month Club

**Join Now**  
AND GET THIS MONTH'S GIFT!  
**100 CIGARETTES FREE!**

The smokes are on Olson this month! Your choice of Lucky Strikes, Camels, Chesterfields. Smoke 'em or give 'em away. MAIL THE APPLICATION TODAY and you'll get the Olson Gift Coupon!

Do you want the MOST for your money? Do you insist on getting GOOD radio parts? Then the Olson Gift-of-the-Month Club is your dish!

HERE'S HOW YOU JOIN: Just fill out the Application below, mail it, and you're a member. NO DUES — WE PAY THE GIFT-BILL!

HERE'S HOW IT WORKS: (1) Each month you will get a list of Olson Radio Bargains, with a coupon good for the Gift-of-the-Month. (2) Enclose the gift coupon with your order for a low minimum or more, and we will send you the gift FREE. (3) No obligation. You can order or not, as you please, any time.

**Paste This Application on a Postcard and Mail Today!**

### OLSON RADIO WAREHOUSE

73 E. MILL ST., DEPT. 68, AKRON, OHIO

**Application:** Please enroll me in Olson's Gift-of-the-Month Club. I am interested in getting more value for my money. Membership will cost me nothing.

NAME \_\_\_\_\_

ADDRESS \_\_\_\_\_

CITY \_\_\_\_\_ STATE \_\_\_\_\_

# Presenting The New Improved JFD REMOTE-O-CABLE REPLACER

Servicemen's  
Net Cost  
**\$67.52**

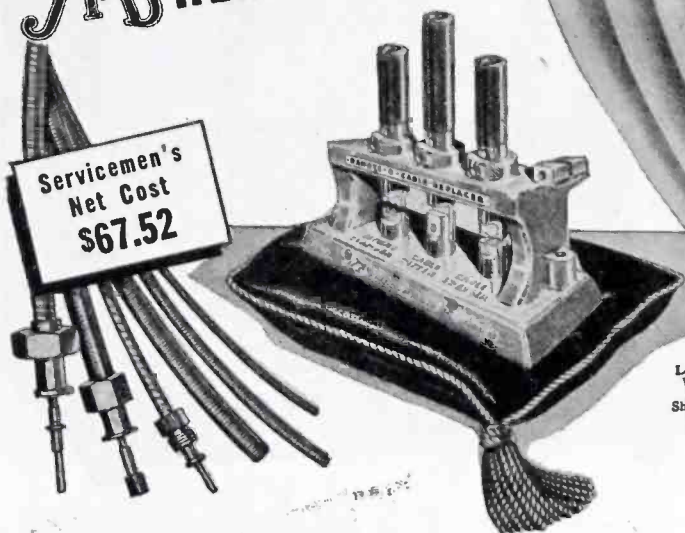

Length 10 1/2 in.  
Width 4 3/8 in.  
Height 13 in.  
Shipping Weight  
29 1/2 Pounds

## The Most Efficient Auto Radio Tuning Cable-Servicing Machine in Use Today!

- 1 SWEDGES SHAFTING TO PREVENT UNRAVELLING.
2. CUTS SHAFTING TO EXACT LENGTH.
3. REPLACES OLD FITTINGS ON NEW SHAFTING.
4. CASING GROOVE MAKES CUTTING EASY

J. F. D. MANUFACTURING CO., 4111 FT. HAMILTON PKWAY, B'KLYN, N. Y.



## Dial Belt Kits • Key Wrenches Speaker Shims • Alignment Kits



### G-C SERVICEMEN'S DIAL BELT KITS

Fine woven re-  
placements for all  
sets. Easy to in-  
stall. Supplied in  
kits of various  
quantities, with  
steel box.

No. G-25 — Kit of  
25 belts. List .... **\$6.70**

### G-C HEXAGON AND BRISTO KEY WRENCHES



Essential key wrenches for  
every serviceman. Both types  
made of special alloy metal,  
properly hardened.

No. 5029—Kit of 6 Hex key  
wrenches in leatherette  
case. List ..... **50¢**

No. 5070—Kit of 6 Bristo key  
wrenches in leatherette  
case. List ..... **50¢**

### G-C SWEDISH SPEAKER SHIMS

The best shims for centering  
voice coils. With steel shims  
adjustments can be made in  
a few minutes. Made of  
Swedish Steel.

Very flexible,  
a permanent  
tool. Kit con-  
sists of 4 sizes,  
gold-lettered  
snap case. 18  
shims to kit.  
No. 701. List .... **65¢**



### G-C No. 5024 PROFESSIONAL ALIGNMENT KIT

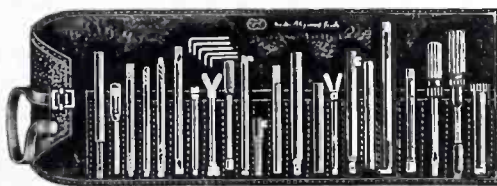

A Complete Alignment and Neutralizing Kit in  
Leatherette Case. Kit contains 30 different tools,  
can completely service any set. Handy to carry in roll type case. List. .... **\$19.95**

Available at all leading distributors.  
Write for catalog today!

RADIO DIVISION DEPT. F

**GENERAL CEMENT Mfg. Co., Rockford, Ill., U. S. A.**  
Manufacturers of over 3,000 products • Sales offices in principal cities

(Continued from page 36)

tance is inescapably associated. By careful design this may be held down close to the actual plate-to-cathode capacity of the diode used as the a-c rectifier. In a precision meter the d-c input capacity can be reduced to a fraction of a micromicrofarad by the simple device of a series resistance in the test prod, a resistance which isolates the meter capacity from the circuit being measured quite effectively. In a signal tracer, for example, this device may also be used, for in it we are not concerned with reading accuracy to a very few per cent. Such a capacity-isolating resistor may not be used in series with the input of an a-c voltmeter rectifier for the power (as contrasted to voltage alone) required, even though it be very small, will result in large errors in meter reading. Such errors are a function of the source resistance. A given a-c voltage measured across a low-resistance power-transformer winding, for example, would give a totally different meter reading from the same voltage when present in a high-resistance grid circuit.

Input capacitance of the v-t diode may be reduced to about 8 mmfd with a standard tube of adequate cathode emission and insulation resistance to stand usefully high applied voltages. In the Vomax the input resistance is made to look like 6.6 megohms, but we are left with its inescapable shunt capacity. This is of no consequence until we attempt to measure r-f voltages present across tuned circuits. Fortunately the solution is simple. Suppose we want to measure the grid voltage present across an r-f transformer tuned secondary. The r-f probe tip and shell is contacted to the circuit (tip to grid, shell to chassis) and the receiver r-f (or i-f) circuit trimmer capacitor is readjusted to enough less capacity to allow for the 8 mmfd the r-f probe has added. Then it is necessary to determine the amount of trimmer capacitor readjustment necessary to allow for r-f probe capacity added, while the probe is so contacted to the circuit. This is done by adjusting the trimmer to yield the same signal strength from the speaker with the r-f probe added as before the circuit contact was made.

### Decibel Meter

A power-output meter for measuring power output of audio amplifiers, used as an output indicator in receiver-circuit alignment, is actually an a-c voltmeter provided with meter scales automatically translating a-c voltage across a known resistive load into decibel fig-



BEST ON THE ROAD!

SURE, IT'S A  
WARD  
AERIAL

Every Ward model has been tested and approved by car and radio set manufacturers — your proof of quality inside and out.



WARD

Aerials

World's largest manufacturers of antennas. We specialize in car, home, amateur and special communications applications, including FM and television. Write for full details.

THE  
WARD PRODUCTS  
CORPORATION

1523 EAST 45TH STREET  
CLEVELAND 3, OHIO

In Canada — Atlas Radio Corp.,  
560 King St., W., Toronto, Ont., Canada

ures; there are three such scales, -10 to +50 db, on the Vomax. These scales are accurate upon the basis of usual rating of 0 db equalling 1 milliwatt in 600 ohms.

#### Maintenance

With over a year's experience it has become possible to plot a *trouble pattern* for Vomax.

As might be expected, tube failure is first in frequency of physical troubles. Fortunately new tubes can be installed in place of originals that have failed without upsetting calibration more than a per cent or two. This is because degeneration in the tube circuits of the instrument is so great as to divorce variations almost completely in tube characteristics from affecting meter accuracy. The predominant feature of tube failures, very small indeed in total, is the development of heater-to-cathode leakage in the two 6SN7GT tubes used in the d-c voltmeter circuit. This shows up as slow drift of initially properly set meter zero on D.C.+ or D.C.- functions. The remedy is replacement of one or both tubes as required. A second remedy, now permitted by the tube makers, is reduction of heater voltage. This is accomplished by inserting a .9-ohm resistor between the originally grounded 6.3-volt lug of the power transformer and ground. In recent models this resistor has been incorporated. Actually 6SN7GT tubes exhibiting heater-cathode leakage too high to allow use without slow meter zero drift are usually satisfactory for amplifiers, etc., and so should not be discarded after replacement.

Ageing 6SN7GT tubes can be troublesome too, making it impossible to establish meter zero with the *SET V. ZERO* knob, even to the point of meter going off scale first in one direction, then in the other, as *FUNCTION* knob is shifted from D.C.+ to D.C.- positions. The remedy is replacement of one of both 6SN7GT tubes. Development of a poor ground to panel from the 125,000-ohm resistor (*RANGE* switch mounting nut loosened) can account for slow d-c zero drift.

Allowing ohmmeter batteries to run down, to be jarred out of their mounting clips and short-circuit internally, can cause trouble. If run down so that *ADJ.Ω* knob will not bring meter pointer up to full scale these batteries should be replaced. If they are allowed to deteriorate to the point of oozing electrolyte, this electrolyte can damage the wiring cable, *RANGE* and *FUNCTION* switches.

BUILT FOR  
SERVICE



Cunningham  
Electron Tubes

#### What will Boost your Sales?

Cunningham is going to help you in every phase of your business, to aid you in boosting 1947 profits. Among other things, you'll get the best in sales promotion material throughout the year... designed to bring in business and move your stock faster. You'll see the first promotional eye-catcher in this space next month. Watch for it.

Cunningham tubes are *built for service*. Assure customer satisfaction by replacing old tubes with "big C's" — their dependable performance have made them favorites for over 30 years.

For expert guidance—TURN THE PAGE →

Cunningham  
Electron Tubes

A product of  
RADIO CORPORATION OF AMERICA  
Harrison, N. J.

# Automatic Combinations—NOW!

The New Arnold Shure Automatic Wired Record Player ready for immediate delivery.

The Shure automatic record player connects easily to any radio. Its featherweight crystal pickup and quiet, smooth changer action assure high quality playing of ten 12" records or twelve 10" records. Every one of your customers can now own a fine automatic combination at a remarkably low cost.

Shure players are shipped complete with A.C. cord and shielded cable—only 2 wires to connect and it's ready to play.



Your price only \$21.92 net

F.O.B. Chicago, Illinois

OPA Retail Price — \$31.30 — Zone 1

OPA Retail Price — 33.87 — Zone 2

Orders are now being accepted for immediate delivery—no waiting. Terms: 2% check with order. Or 25% deposit, balance express C.O.D.

## PHONO AMPLIFIERS

1-Tube Phono. Amplifier.....	\$2.35 ea.
3-Tube Phono. Amplifier.....	4.50 ea.

## PM SPEAKERS

4" Alnico (5) PM Speaker.....	\$1.39 ea.
5" Alnico (5) PM Speaker.....	1.49 ea.
6" Alnico (5) PM Speaker.....	1.89 ea.

## TUBULAR ELECTROLYTICS

100-MFD-25 V...\$ .22 ea.	10-MFD-450 V...\$ .29 ea.
10-MFD-30 V... .22 ea.	16-MFD-450 V... .39 ea.
20-MFD-150 V... .22 ea.	10-10-MFD-450 V... .59 ea.
30-MFD-150 V... .29 ea.	20-20-MFD-150 V... .29 ea.
40-MFD-150 V... .39 ea.	30-20-MFD-150 V... .39 ea.
50-MFD-150 V... .45 ea.	40-30-MFD-150 V... .45 ea.
8-MFD-450 V... .25 ea.	50-30-MFD-150 V... .69 ea.

## HOLLANDER RADIO SUPPLY CO.

549 West Randolph Street

Chicago 6, Illinois



## UNIMETER

This unit fulfills an extremely important need for general utility portable service equipment. It has wide range coverage for both a-c and d-c measurements of voltage, current measurements on d-c and the popular ranges on resistance.

The UM-3 is designed to clearly indicate all the functions which aid in the prevention of application of high voltages when preparing for current or resistance measurements.

Other G-E units for better servicing include: CRO-5A Oscilloscope, PM-17 Electronic Voltmeter, YYW-1 High Voltage Multiplier.

For details write:

General Electric Company,  
Electronics Department,  
S-6411, Syracuse 1, New York.

Electronic Measuring Instruments



**GENERAL ELECTRIC**

177-E3

**UM-3**

Failure of power transformers is one of the standard headaches. Despite conservative design and operation it just will happen occasionally. In Vomax a warning occurs before this rare type of failure. Since power transformer failures almost always start as short-circuits between turns of the fine-wire-wound high-voltage secondaries, this will cause significant variation of a-c voltage measured, at the separate 5Y3GT rectifier tube plates (tube out of socket). This in turn will cause slow drift of d-c volts meter zero. Replacement of power transformer is indicated if high-voltage secondary shows a difference in voltage between halves of over  $\pm 10\%$ . The 8-mfd filters will, like all electrolytics, sometimes give trouble after extensive use. Remedy is replacement should they test *short* or show excessive leakage.

### Effects of High Humidity

In extremes of humidity, or when the unit has not been operated for some time, accumulation of atmospheric moisture on its high resistance circuits can cause the d-c volts meter zero not to be identical (out more than 2%) for different settings of the RANGE switch. A 30-minute warm-up will evaporate moisture from the 50-megohm d-c voltage divider circuits in most cases. Where this does not help, or to avoid loss of time, the remedy is to make sure certain internal connections are *in the clear*; do not touch metal parts or other connecting wires. The lead from the +V-Ω-MA jack to the switch should be cleared from contact with other parts. Leads from the 37.5-megohm resistor to the A.C. + D.C. - Ω/MA switch should be checked carefully too. The 5.1-megohm resistors going to the grids of the right hand of the 6SN7GT should also be checked, to see that these wires contact only the terminals to which they are soldered. The .005-mfd capacitor should be checked for absence of leakage.

### A-C Meter Zero Setting

If a-c meter zero does not coincide with D.C.+ zero, it can be due to aging of the 6AL5 dual u-h-f rectifier in the r-f probe (if known not to be due to red test lead tip inserted in +V-Ω-MA jack contrary to instructions in checking zero coincidence). The trouble can be due to use of a *floating* (un-sheathed, poorly grounded) a-c power line. Grounding case through a panel thumb nut will cure this. If not the chassis should be removed from its

# OHMITE

## Little Devil

INSULATED  
COMPOSITION  
RESISTORS



Resistance  
and Wattage  
marked on  
**EVERY UNIT**

Here is a new composition resistor—tiny but exceptionally rugged. Not only color coded, but individually marked for quick identification. *Little Devils* are sealed and insulated by molded plastic. They dissipate heat rapidly, have a low noise level and low voltage coefficient, are light, compact, and easy to install. Millions of these units have proved their value in critical war equipment. Available from stock in Standard RMA values from 10 ohms to 22 megohms. Tolerance  $\pm 10\%$ .

Available only from Ohmite Distributors  
**OHMITE MANUFACTURING CO.**  
4877 Flournoy St., Chicago 44, Ill.

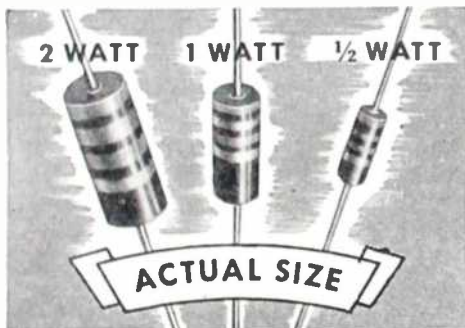

Send Now for  
Bulletin No. 127

Gives complete data and list of RMA values. Includes dimensional drawings and handy color codes.



Be Right with...

# OHMITE

RHEOSTATS  
RESISTORS • TAP SWITCHES

case, D.C. + meter zero set with SET V. ZERO knob, panel grounded to a known good ground, and after shifting FUNCTION knob to a-c while leaving SET V. ZERO knob set to yield correct zero on D.C.+, the 10-megohm pot should be adjusted to establish correct a-c zero. If through adjustment of the pot for the one setting of SET V. ZERO knob establishing correct D.C. + meter zero, meter pointer on a-c cannot be brought up to zero, then a resistor of between 2 and 10 megohms connected from COM. GND. jack to the outer lug of the pot to which a circuit connection is soldered, will solve the problem. If meter pointer cannot be brought down to zero by adjustment of the pot (panel grounded during adjustment) then one of two remedies exist. The first, least desirable, is installation of a new 6AL5 tube in the r-f probe which will let a-c zero properly. The more economical method is to reverse the original r-f probe circuit wiring so that connections originally made to socket lug 2 are transferred over to lug 7, and vice versa.

Should the r-f probe appear to be insensitive, it can be due to development of leakage in the .001-mfd mica and should be replaced. This condition can be checked by removing the r-f probe, connecting its shell to one side of a known 50- or 60-cycle a-c voltage, the other side to a .25-mfd capacitor and the free lead of the capacitor (temporarily replacing the .03-mfd tubular oil) to the spring contact found on the inside surface of the steatite r-f probe head. If the .001 is leaky, the meter will read significantly low, using its 120-volt a-c range to measure the power line.

It should be mentioned that a draftsman's error occurred in the first *Instruction Book* circuit diagram. The connection from the top contact of the A.C. + D.C. - / $\Omega$ MA switch labeled A.C., was inadvertently drawn to the top of the 20-megohm resistor. It should go, as in Fig. 1, to the point of the 20-megohm resistor and the .001-mfd mica, and has always done so in factory production.

LESTER AND LEHMAN VISIT  
HALLICRAFTERS



Frank Lester, left, and Ben Lehman of Lafayette Radio, New York, during a recent visit to Hallicrafters, Chicago.

# Cunningham Electron Tubes



## BUILT FOR SERVICE

What will sell your Service?

The most profitable service shop is the busiest one. That's why it's so important to pay special attention to building up a large clientele. And this can be done only by *selling* your biggest stock-in-trade . . . *dependable* service work. Watch this space every month for the ideas which Cunningham has developed to help you build your business.

And remember, too, that your personal prestige for dependability is enhanced when you replace worn-out tubes with Cunningham's. Cunningham tubes are *built for service*.

For more sales—TURN THE PAGE ➔

# Cunningham Electron Tubes

A product of  
RADIO CORPORATION OF AMERICA  
Harrison, N. J.

# SILVER "VOMAX" WITH YOU CAN—



Post-war design and construction at pre-war uninflated price is the secret of overwhelming demand for "VOMAX", the true v.t.v.m. Unequaled at any price, it is bought and used by the Bureau of Standards, Navy, F.C.C., C.A.A., schools, universities, research laboratories—and by thousands of experience-wise service technicians. You, too, will find "VOMAX" your greatest profit meter. Only \$59.85 at your favorite jobber.

OVER 35 YEARS OF RADIO ENGINEERING ACHIEVEMENT

*McMurdo Silver Co., Inc.*

T240 MAIN ST., HARTFORD 3, CONNECTICUT

Measure every type and kind of voltage in receiver design and servicing. "VOMAX" increases your efficiency and profits by equipping you to measure r.f., i.f., a.f.—actual signal volts—a.v.c., a.f.c., discriminator—a.c. and d.c. volts. Input resistance is so astronomically high you can measure directly even in the highest resistance circuits. "VOMAX" is also your output db. meter; measures direct current up thru 12 Amp. auto set range; resistance up to 2,000 megohms.

Send postcard for new catalog of measuring instruments, communication receivers, transmitters, kits and parts. See them at your favorite jobber.

## TOOLS

(Continued from page 24)

sis at the most convenient points, and each is quickly adjustable to whatever height is necessary to support the chassis evenly and steadily. Their simple construction makes them quickly adjustable to any chassis regardless of size or shape. They require little space on the test bench when not in use. This type is also useful for supporting phonograph motorboard and automatic record changer assemblies, etc.

Rigid clamp-type guards which may be used to elevate an inverted chassis sufficiently to protect the tuning dial, tubes, coils, etc., from damage are illustrated at (B). These are easily and quickly applied by means of the hook bolts provided, and are adjustable to fit all average-size chassis. As shown in the illustration, when working on the chassis it can be turned or tipped to any position without damaging any of the protruding parts.

The chassis cradle illustrated at (C) provides a somewhat more elaborate means of supporting a chassis. Special mechanical clamps are provided to hold any chassis up to 21" long. Once the chassis is clamped to the cradle, it may be rotated to any desired angle to

facilitate the work that is to be done on it, and may be locked in this position by means of the locking wheels near the clamps. Special straight clamps are available for holding sub panels and other flat pieces when necessary.

### Additional Soldering Irons and Accessories

In the first article of this series a good, dependable general-purpose electric soldering iron of either 80- or 100-watt size and having a  $\frac{3}{8}$ " diameter

Fig. 4. Two types of quick-heating soldering guns. A, courtesy Weller Mfg. Co.; B, courtesy Baker-Phillips Company.

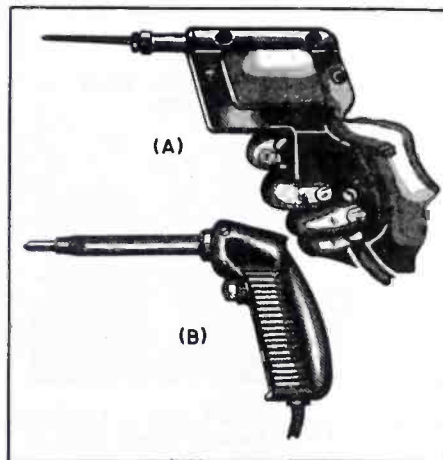

screw-type tip was listed as one of the basic tools for the Service Shop. This medium size iron is the very minimum of soldering equipment that a Service Man can get along with and it is suitable for all general work around the shop. It has now become common practice to have on hand more than one soldering iron—usually three or more. In addition to the medium iron you will want a medium-heavy iron and a small light iron. Besides enabling you to use the right size iron for each type of job, having more than one iron on hand provides a safety factor against tieup of your operations should the heating element of your general-purpose iron burn out unexpectedly some day. This is important for it might take several days or weeks to obtain a replacement.

The medium-heavy iron, a 200-watt size containing a  $\frac{5}{8}$ " diameter tip, will be satisfactory for jobs requiring more heat than the 100-watt general purpose iron will supply. This iron will be useful for soldering shielding, chassis ground spotting, grounding heavy bonding braid in auto radio installations, etc. One is illustrated at (B) of Fig. 2.

A small iron having a  $\frac{1}{4}$ " tip and rated at around 60 watts is illustrated at (A). An iron of this size is desirable when working on small midget sets and the new *personal* type miniature receivers, for getting into tight places, and where excessive heat would damage a part.

The small pencil soldering irons rated at around 25 watts are widely used for work on the miniature receivers because of the very small wire and very small components employed in such receivers—also because of the necessarily crowded chassis. An extremely useful pencil-type iron, for which the four different sizes and shapes of interchangeable screw-type tips shown are available for meeting all soldering problems in small midget and miniature receivers, is illustrated in Fig. 3. Because of its small size a cork handle is provided near the tip to prevent burns to the operator.

An ordinary electric soldering iron which remains heated constantly during the day, so as to be always sufficiently hot for soldering at a moment's notice whenever it is required, necessarily has a shortened life and its tip suffers from oxidation, requiring frequent cleaning and retinning. A recent type of soldering iron for the Service Man designed to overcome this is the soldering gun.

Soldering guns have current flowing through their heating elements only while they are actually being used for soldering. When the current is switched on, they heat up to full sol-

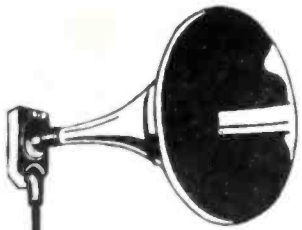

## Vocal-Aire The World's Loudest Loudspeaker

Air-column speakers are something really new in sound. The idea is so new that it may take a little thinking to grasp it, but it's really quite simple.

A diaphragm driver is actually a piston air compressor of variable speed. Its low efficiency is suitable for indoor use, but to cover large outdoor areas higher efficiency is required.

The logical means is an ordinary air compressor. We couldn't use this simple method of generating audio power until VOCAL-AIRE driver units were developed. In this system, steady air pressure is modulated by the Voice Valve just as your larynx modulates your breath to produce speech. Since generation of air pressure is not the function of the driver unit we don't need tremendous 500-watt amplifiers.

The compressed air supply comes from a motor or gas-engine unit or from any other available source. For portable use, the gas-engine compressor also supplies the 110-volt A.C. for the amplifier.

A special amplifier has been designed to match the VOCAL-AIRE driver unit. The impedance of the driver varies with the frequency of the signal and the VOCAL-AIRE amplifier matches this condition to achieve peak efficiency.

The coverage of these speakers may be hard to accept—but two drivers, each driving a pair of horns, cover the Yale Bowl which is 900' long, 500' wide and seats 75,000 persons. Two 20-watt amplifiers in cascade are all that is needed, one amplifier for each driver unit.

The compressor can be switched on and off remotely, from mike or amplifier... or a switch at the mike may be used to control plate voltage for stand-by.

**Servicemen:** If you haven't read up on air column speakers, we'll be glad to send you literature describing our system and if you have occasion to service our equipment, a request on your business stationery will bring you a free copy of our Service Manual.

**Vocal-Aire Sound  
Systems are made by**

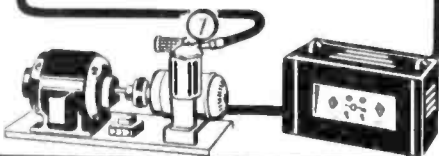

**DILKS, INC.  
NORWALK, CONN.**



dering heat within a few seconds. Two types are illustrated in Fig. 4. They both appear at first glance to be like a pistol; they are, in fact, operated in the same manner, since each is provided with a trigger switch for turning on the current whenever soldering is to be done. Unlike the conventional types of soldering irons, the gun types require a transformer (therefore can be operated from a-c power lines only) that converts the 115-volt power from the a-c line to a high current at low voltage which, flowing through the heating element, quickly brings it to full soldering heat within a few seconds after the trigger switch is pressed. In the iron illustrated at (A) this high current flows directly through the soldering tip itself, which is in the form of a single-turn copper loop or hairpin. In the iron shown at (B), the usual type of sleeve and tip is made to be a covering for the heating loop. The manufacturer supplies the necessary line step-down transformer with each iron. Iron (A) draws 100 watts from the power line, and is designed to work only from a 115-volt, 60-cycle a-c line, but without the transformer iron (B) may be operated also from a standard storage battery (car battery) if necessary. This latter feature is desirable when installing marine radio equipment on small pleasure boats, etc., where only a 6-volt battery source of power is available.

Since these soldering guns are compact, have slender tips and a pistol grip handle that places the hand in a natural position when soldering, they are extremely easy to use, especially when working in tight spots and on small receivers.

For the Service Man who prefers the standard type of soldering iron, but desires the convenience which the bent or hatchet form affords (since most soldering jobs are performed on up-turned chassis, and thereby the handle of a hatchet type iron may be held in the more natural, horizontal position while the iron tip points downward to the joint to be soldered) the hatchet form of standard type iron illustrated in Fig. 5 is available.

[To Be Continued]

Fig. 5. A hatchet type iron that provides hatchet form in a conventional-type electric soldering iron. (Courtesy Hazcon Electric Co.)

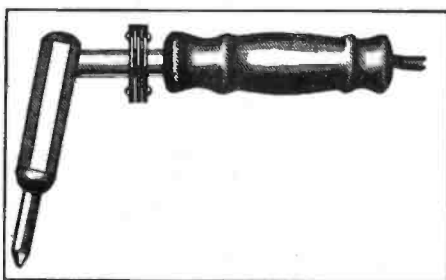

## Cunningham Electron Tubes

**What will solve  
your tube problems?**

The right kind of technical data at your finger tips is one answer to your tube problems... and a sure way to speed up all of your servicing work. Watch this space for important announcements of new technical aids Cunningham will have for you.

The other answer to your tube problems is big "C". Because Cunningham tubes are built for service... give your customers dependable, quality performance year after year.

For more service—TURN THE PAGE →

## Cunningham Electron Tubes

A product of  
RADIO CORPORATION OF AMERICA  
Harrison, N. J.

Order from LAKE!  
You'll Make No Mistake!

# RADIO CABINETS & PARTS

NOW AVAILABLE!



Postwar  
2 Post  
RECORD-  
CHANGER

With luxuri-  
ous brown  
leather-  
ette portable  
case. 15" L. x

15" W. x 10" D. Latest electronic develop-  
ments make this modern record-changer the  
finest on the market today!

Changer ..... **\$18.50**  
Cabinet for same..... **\$8.95**

## DE LUXE RECORD-CHANGER and AMPLIFIER CASE

De luxe changer case with ample room for am-  
plifier. Overall dimensions: 20" L. x 16" W. x  
10" H. Sturdily built of 3/4" plywood, de luxe  
brass hardware throughout. Inside dimensions:  
15 1/2" L. x 14 1/4" W. x 9 1/2" H

Net ..... **\$12.95**



DELUXE  
PHONO  
CABINET

Covered in lux-  
urious, genuine  
brown leather-  
ette, has de-  
luxe brass

hardware throughout, made completely of ply-  
wood with brown plastic handle, has padded  
top and bottom. Motor board 14" x 14 1/2".  
Overall dimensions 16" L x 15" W x 8" H.

Your net price ..... **\$8.95**



Portable Phono-  
graph Case of sturdy  
durable plywood, in  
handsome brown  
leatherette finish.  
Inside dimension  
16 1/2" long, 14" wide,  
9 1/2" high. Has blank  
motor board. As il-  
lustrated. Specially  
priced at

**\$6.95**

Also blank table cabinets of walnut veneer in  
the following sizes, with speaker opening on  
left front side: (\*Note: \*7 has center speaker  
grill.)

- #1 — 8 1/4" L x 5 1/2" H x 4" D.....\$1.95
- #2 — 10 1/4" L x 6 3/8" H x 5" D.....\$2.75
- #3 — 13 1/2" L x 7 7/8" H x 6 1/4" D.....\$3.25
- #7\* — 10 3/4" L x 7" H x 5 1/2" D.....\$2.50

\*Speaker Opening in center of front side.

All types of radio cabinets and parts are  
available at Lake's Lower prices. A large  
stock is listed in our catalog.

### SERVICEMEN— RETAILERS

Write today for our new, illustrated  
16-page catalog NR-116. It's free. Get  
on our mailing list. Dept. D.

Write for our SPECIAL CATALOG on micro-  
phones, amplifiers and sound equipment.

**Lake Radio Sales Co.**  
615 W. Randolph Street  
Chicago 6, Ill.

# TUBE News This Month

(Continued from page 16)

Plate voltage ..... 300 max.  
Plate dissipation (watts)..... 2.75 max.  
Cathode current (ma)..... 20 max.

Direct interelectrode ca-  
pacitances:

Grid to plate (mmfd) .. .62  
Grid to cathode (mmfd) 5.20  
Cathode to plate  
(mmfd)..... 2.30

Peak heater-cathode voltage:

Heater negative with respect  
to cathode ..... 180 max.  
Heater positive with respect  
to cathode ..... 180 max.

Mechanical Ratings

Maximum overall length.....3 7/8"  
Maximum seated length.....3 3/8"  
Maximum diameter .....1 1/8"  
Bulb .....T9  
Base .....8-pin octal  
Cap .....Small  
Mounting position .....Any

Mechanical Characteristics

Mounting position .....Any  
Maximum overall length.....2 1/8"  
Maximum seated length.....1 1/8"  
Length from base seat to bulb top  
(excluding tip) .....1 1/8" ± 3/8"  
Maximum diameter .....7/8"

Typical Operation—Shunt Regulators

Series Resistance ..... .5 meg.  
Unregulated input voltage.. 5.4 kv  
Regulated output voltage... 4 kv  
Cathode voltage ..... 210 volts  
Plate current ..... .9 ma  
Load current ..... .6 ma

## NATIONAL UNION 2C53

THE 2C53 IS A VERY HIGH-MU TRIODE de-  
signed for use in regulated power sup-  
plies or voltage amplifiers operating at  
plate potentials between 1 and 8 kv. Tube  
is particularly useful as a shunt regulator  
in equipment requiring stabilized output  
voltage essentially independent of line  
voltage variations and variations in load  
current.

Low capacities, high gain, and high-  
voltage ratings make this tube also suited  
for television and oscilloscope sweep cir-  
cuits employing electrostatic deflection.

## RAYTHEON RK61

THE RK-61 IS A SUB-MINIATURE thyrat-  
ron tube designed for remote control  
circuits. Similar in characteristics to the  
RK62.

Can be used as a self-quenching super-  
regenerative detector to operate a high-  
resistance relay in the plate circuit upon  
reception of a signal.

Electrical Characteristics

Filament voltage (d-c)..... 1.4  
Filament current (amperes)..... .05  
Average tube voltage drop (at  
1.5 ma) ..... 30  
Plate voltage ..... 45  
Relay resistance (ohms) 5,000 to 10,000  
Plate current (ma, no signal) 1.0 to 1.5  
Plate current (ma, with signal) 0.1 to 0.5

In the circuit on page 16 the 45-volt  
plate supply battery can be removed, and  
the circuit adapted for use with a 60-  
cycle a-c plate supply. When operating  
properly, the tube should be oscillating at  
audio-frequency except during reception  
of an r-f signal, under which condition a-f  
oscillation should disappear.

If the capacitance of the plate bypass  
capacitor is reduced and the relay replaced  
by a pair of headphones, the circuit will  
operate as a conventional superregenera-  
tive receiver with a plate supply voltage  
as low as 30 volts. Operation at frequen-  
cies above 100 mc is not recommended.

Electrical Ratings

Maximum ratings:

Heater voltage ..... 6.3 ±10%  
Anode voltage ..... 8000 max.  
Plate current (average,  
ma) ..... 5.0 max.  
Plate current (peak,  
ma) ..... 100 max.  
Grid voltage ..... -200 max.  
Plate dissipation  
(watts) ..... 12 max.  
Heater cathode  
voltage ..... ±300 max.  
Heater ..... Unipotential cathode  
Voltage ..... -6.3 ±10%  
Current (amperes) .. .30  
Amplification factor... 500  
Plate resistance (meg-  
ohms) @ E<sub>b</sub> = 4 kv .525  
Transconductance (mi-  
cromhos) @ E<sub>b</sub> =  
-5 v..... 950

# OUR NEW CATALOG IS READY

PLUGS

PILOT LIGHT SOCKETS

JACKS

BARRIER TERMINAL STRIPS

HARDWARE, etc.

The Herman Smith Catalog is a volume that belongs in the "stock" of every dealer and serviceman. You'll find hundreds of items . . . many of the hard-to-find variety. All first quality . . . all fully guaranteed. Send for your FREE copy today.

**HERMAN H. SMITH, Inc.**

405 44th Street, Brooklyn 20, N. Y.

## The HOUSE OF A MILLION RADIO PARTS

**SPECIAL TIME AND MONEY SAVERS FOR SERVICEMEN!**

No. 100C—Kit of 100 By-pass and Buffer Condensers. \$20.00 Value . . . . . \$5.82  
 No. 101R—Kit of 100 1/2-watt resistors . . . . . 1.95  
 No. 102K—Kit of 100 Assorted radio knobs—plastic and wood—set screw—pushons . . . . . 5.91  
 No. 103T—Kit of 50 Assorted Trimmer and padder condensers—*a Real Buy!* . . . . . 3.93

Thousands of other bargains available—bargain catalog included with order.

**LIFETIME SOUND EQUIPMENT CO.**

Dept. 87

Toledo 2, Ohio

## NEW PRODUCTS

### BRUSH CRYSTAL MICROPHONE

A desk-type crystal microphone, BA-106 Acoustical, that is said to provide essentially flat response from 40 to 6,000 cps with output level 50 db below 1 volt dyne/cm<sup>2</sup> open circuit, has been announced by The Brush Development Company, 3405 Perkins Avenue, Cleveland 14, Ohio. Microphone has high impedance and can be used with amplifier or recorder employing high impedance input.

Supplied with 8' cable, plug and removable base, which converts microphone to hand mike for home-recording use.

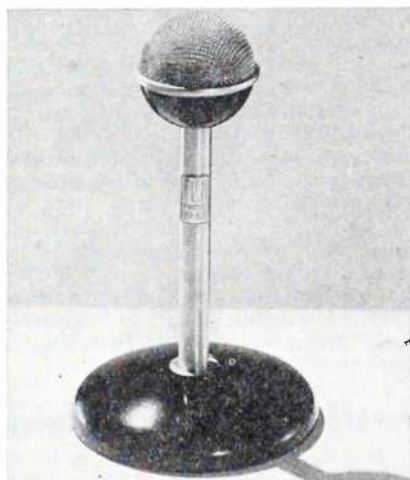

\*\*\*

### RESISTANCE PRODUCTS WIRE-WOUND RESISTORS

Two kits of precision wire-wound resistors have been announced by Resistance Products Company, Division of Electronic Manufacturing Company, 714 Race Street, Harrisburg, Pennsylvania.

The No. 1 kit is composed of half precision resistors and half matched pair resistors. The No. 2 kit consists of all precision resistors. Kits contain all resistors necessary for building a meter (400-microampere 500-ohms) and are designed for use with the Marion meter.

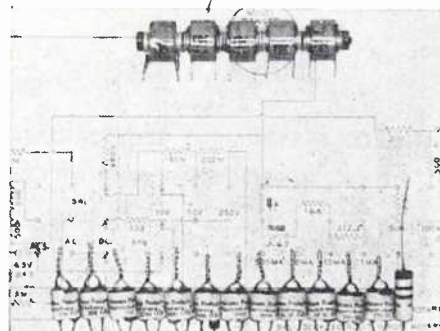

\*\*\*

### CLAROSTAT VOLUME CONTROL REPLACEMENT KIT

An assortment of volume and tone controls with attachable switches, servicing upwards of 95% of standard replacement needs, packed in a steel cabinet, kit No. 4, has been announced by Clarostat Mfg.

(Continued on page 48)

# Cunningham Electron Tubes

Who will point the way?



Cunningham will turn over this space each month to an editorial by an eminent authority on radio servicing. He will give you the benefit of his vast experience in the technical and business end of servicing, and write on such important topics as trends in servicing, the service shop of tomorrow, where to look for new business.

Look for these vital editorials in this space every month. And remember that "Built for Service" is more than a slogan . . . it's a fact.

*Built for Service*

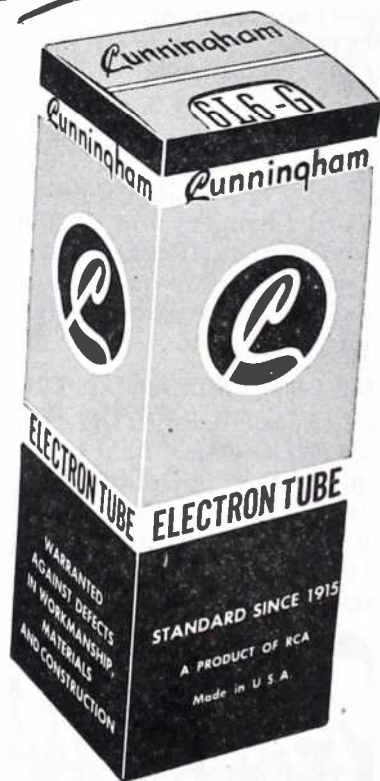

## Cunningham Electron Tubes

A product of RADIO CORPORATION OF AMERICA  
 Harrison, N. J.

Just  
Out!

**CONCORD**  
Bargain Catalog of  
**RADIO**  
Equipment  
FOR  
Immediate Shipment



**THOUSANDS OF ITEMS!  
OUTSTANDING VALUES!**

Just off the press—48 exciting pages of radio parts, equipment, and supplies for dealers, servicemen, amateurs, maintenance, testing, building and experimenting—Thousands of items **NOW IN STOCK** and ready for **IMMEDIATE SHIPMENT!** Big feature sections of Radio Sets, Communications Receivers, Amplifiers, Replacement Parts, Ham Gear, Record Players and Portables, Record Changers and complete Sound Systems. Page after page of bargains in top-quality standard-make radio parts and electronic equipment.

**Mail Coupon NOW for FREE COPY**  
Mail coupon below **TODAY** for your **FREE COPY** of this latest Concord Buying Guide and Bargain Catalog of Radio needs you can order for **SAME DAY SHIPMENT** from complete stocks in Chicago and Atlanta.

**CONCORD**

**RADIO CORPORATION**  
**LAFAYETTE RADIO CORPORATION**  
CHICAGO 7, ILL.      ATLANTA 3, GA.  
901 W. Jackson Blvd.      265 Peachtree St.

CONCORD RADIO CORP., Dept. S-17  
901 W. Jackson Blvd., Chicago 7, Ill.  
Yes, rush **FREE COPY** of the new Concord Bargain Catalog.

Name.....  
Address.....  
City..... State.....

**NEWS**

**N. Y. U. RADIO-TELEVISION COURSES**

A series of non-credit courses in electronics, radio, and television has been prepared by New York University, to begin February 5 at the Washington Square branch in N. Y. City.

In addition to the basic courses in mathematics, physics, and a-c and d-c circuits which are prerequisites for further study, the program will include: *Elements of radio and electronics, applied electronics, television circuits, u-h-f television circuits and operation and maintenance of television equipment.*

There are no academic prerequisites for admission to the program. All courses are held during the evening hours. They are directed towards those who wish to gain a detailed working knowledge of the theory, in addition to application of the theory. There will be demonstrations of equipment, as well as field trips to power stations, radio studios, etc.

The course on the operation and maintenance of television equipment is being offered for the first time with the cooperation of DuMont. It is to be given at the DuMont studios under the supervision and instruction of S. R. Patremio, chief engineer of WABD.

**PARKER NOW SYLVANIA TECHNICAL ADVISER**

Henry W. Parker has been named technical adviser for Sylvania Electric Products, Inc. The new post has been created to stimulate review of industrial and scientific developments of interest to the central engineering laboratories and to propose new projects in research and development.

At present Mr. Parker is cooperating with the United States Department of Commerce, Office of Technical Services, Technical Industrial Intelligence Division.



**HICKOK INSTRUMENT SERVICE DEPOT**

An eastern-area service station for servicing and repairing of all types of Hickok equipment has been set up at 339 W. 44th St., N. Y. C., under the management of Kenneth E. Hughes, district representative of the Hickok Electrical Instrument Company.

Station is equipped to give service on oscillographs, radio tube and set testers, signal generators, volt-ohm milliammeters, chargicators, milliammeters, ammeters, voltmeters, wattmeters, industrial analyzers, etc.

**FELDMANN NOW BOARD CHAIRMAN OF NATIONAL UNION**

C. Russell Feldmann has been named chairman of the board of directors of

National Union Radio Corporation. Kenneth C. Meinken, formerly assistant to the president and associated with National Union since 1941, succeeds to the office of president and continues as a member of the Board.

Other Corporation officers elected are Winfield H. Carey, formerly chief accountant, to the office of treasurer, and Jerome V. Deevy, formerly assistant secretary, to the office of secretary.

Executive offices of National Union remain at 57 State Street, Newark, New Jersey.

**LAFFERTY NOW HALLICRAFTERS GENERAL SERVICE MANAGER**

Bruce R. Lafferty has been appointed general service manager of the Halli-crafters Company of Chicago.



©Bachrach

**CLAROSTAT VOLUME CONTROL CROSS-INDEX GUIDE**

A volume control cross-index guide has been issued by Clarostat Mfg. Co., Inc., 130 Clinton Street, Brooklyn 2, N. Y. The guide consists of a collection of cards printed on both sides with the complete cross-index of corresponding type num-

**18 YEARS IN RADIO**

**Get This New Catalog By This Old Firm**

Latest developments in radio and electronic parts and devices, newest ham gear, gadgets to delight the heart of the experimenter, bargains in war surplus supplies.



- Buy from B-A
- Save Time
- Save Money
- Get the Newest
- Deal with This Old House



It's **FREE** To You

**MAIL COUPON TODAY**

Don't delay, get your copy of this book.

BURSTEIN-APPLEBEE CO.,  
1012 McGee, Kansas City 6, Mo.

Send me **FREE** new catalog. SERVICE

I AM \_\_\_\_\_  
STATE CONNECTION IN INDUSTRY \_\_\_\_\_  
NAME \_\_\_\_\_  
ADDRESS \_\_\_\_\_  
TOWN \_\_\_\_\_ STATE \_\_\_\_\_





# We CUSHIONED *this spindle*

## TO PROTECT RECORDS

On any single-post record changer, there's a weight of about six pounds on the spindle ledge when the changer is loaded. When the machine changes records, this weight falls on the bottom record of the remaining stack. The resulting shock ordinarily causes excessive record wear. But the exclusive Webster cushioned spindle absorbs shock—"babies" records. Webster changers effectively protect records—avoid chipped edges and excessive center hole wear.

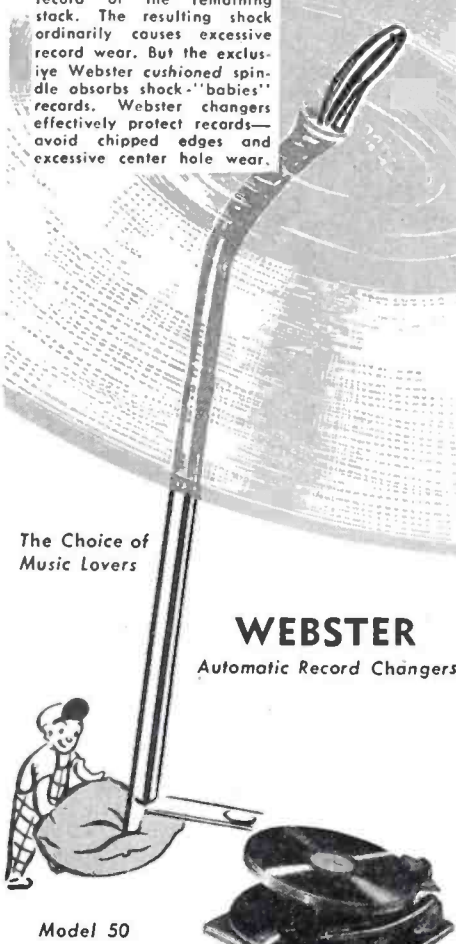

The Choice of  
Music Lovers

**WEBSTER**  
Automatic Record Changers

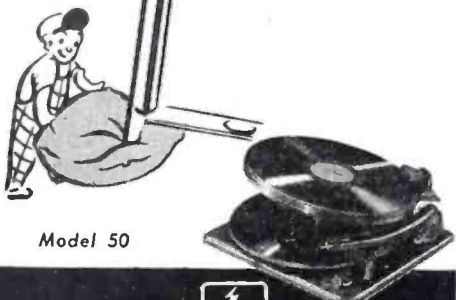

Model 50

**WEBSTER CHICAGO**  
5610 Bloomingdale Avenue  
CHICAGO 39, ILLINOIS  
32 years of Continuous Successful Manufacturing

bers of four leading volume control manufacturers, arranged in numerical order.

The Guide may be had free of charge from any Clarostat distributor or by writing the company direct.

\* \* \*

## RICHARD K. PEW APPOINTED SERVICE MANAGER OF COLONIAL RADIO

Richard K. Pew has been named service manager for Colonial Radio Corporation, a subsidiary of Sylvania Electric Products, Inc.

For eleven years prior to joining Colonial Radio Mr. Pew was with General Motors Corporation as director of parts and service operations for the Eastern Aircraft Division and as sales and service manager of the Delco Radio Division in Michigan and Indiana.



## LAKE CATALOG

A 16-page catalog, NR-116, has been released by Lake Radio Sales Company, 615 West Randolph Street, Chicago 6, Illinois.

Described are a variety of capacitors, resistors, cabinets, hardware, coils, sockets, tools and accessories, transformers, plugs, jacks, speakers, baffles, auto antennas, microphones, amplifiers, pickups, test equipment, etc.

\* \* \*

## SYLVANIA TECHNICAL BULLETINS

Three bulletins describing tube testers, type 139 and 140; type 134 Polymeter; and type X-7018 modulation meter, have been released by the radio tube division of Sylvania Electric Products, Inc.

The tube tester bulletin covers units supplied in both counter and portable models for testing all elements of tubes used in broadcast, f-m and television receivers and many other types of electronic apparatus in which receiving type tubes are used.

The Polymeter booklet analyzes this combination instrument used for troubleshooting and checking of electronic circuits.

# OPPORTUNITY FOR RADIO MEN!

There's big money in motor repair work! Prices are good. The field is not crowded. The home appliance repair business is a vast one, and motor service is a highly important part of it. Here's the book that will train you easily and quickly!

# Learn ELECTRIC MOTOR REPAIR



Easily . . .  
Quickly . . .  
for ONLY \$5

## IT PAYS TO SPECIALIZE IN "SOMETHING DIFFERENT"



Every day, more and more electric motors are being used BOTH in home electric appliances and in industrial equipment. Ours is truly an Electric Age—and the motor repair expert is one of its most valuable men!

**ELECTRIC MOTOR REPAIR**, the unique new book by the publishers of famous Ghirardi Radio-Electronic volumes, teaches you the work from the very beginning. Explains every detail of motor trouble diagnosing, repair and rewinding. Covers a-c and d-c motors, synchronous motors and generators and BOTH mechanical and electronic control systems. Quick-reference guides show exactly how to handle specific jobs. Invaluable for beginners or for actual bench use in busy shops.

## SHOWS YOU HOW EVERY STEP OF THE WAY



Based on what can be learned from this big book alone, you can train yourself for prompt, PROFITABLE motor service. Every type of work is demonstrated VISUALLY by more than 900 easily-understood diagrams, all indexed for quick, on-the-job reference. The unique Duo-Spiral Binding divides book into 2 sections permitting BOTH text and related illustrations to be seen AT THE SAME TIME. Lies open flat on bench while you work. 580 pages.

## "BORROW" IT FOR 5 DAYS!

Send coupon now! Practice from **ELECTRIC MOTOR REPAIR** for 5 full days. Then, if not more than satisfied, return book to us and every cent will be cheerfully refunded—and no questions asked!

## 5-DAY MONEY-BACK GUARANTEE

Dept. S-17, MURRAY HILL BOOKS, Inc.  
232 Madison Ave., New York 16, N. Y.

Enclosed find \$5 (\$5.50 foreign) for my copy of the big **ELECTRIC MOTOR REPAIR** book; or  
 send C.O.D. (in U.S.A. only) for this amount plus postage. If unsatisfactory for any reason, I may return book in 5 days and have my money refunded.

Name .....

Address .....

City & Dist. No. .... State .....

## TRINKLE ANNUAL PARTY FOR SPRAGUE PHILADELPHIA JOBBERS



Philadelphia parts distributors of Sprague Products at the annual party of Wilmer H. Trinkle, Sprague representative in Philadelphia. Dinner speakers included Harry Kalker, Sprague Products Company sales manager.



RAYTHEON  
Radio Tube  
BETTER RECEPTION  
RAYTHEON  
Radio Tube  
MADE IN U.S.A.  
RAYTHEON COMPANY - Newton, Mass.  
12SA7 6T/G

Raytheon tubes give peak performance. They have been built to this high level of maintained quality through continual testing and research by a company that is recognized everywhere as one of the advanced guard leading the way into the new era of electronics.

**RAYTHEON**  
MANUFACTURING COMPANY

*Excellence in Electronics*  
RADIO RECEIVING TUBE DIVISION  
NEWTON, MASS. • CHICAGO

*You Can Now SIGNAL TRACE with a "Pencil"\**

# PROVAC

featuring **EDIPROBE**  
\*Pencil-thin RF probe



The PROVAC electronic vacuum tube volt-ohmmeter permits the laboratory engineer and radio service technician to measure every voltage required in the design laboratory and radio servicing.

Measure R.F. with the same ease as measuring D.C. with the latest development in R.F. probes. It is no longer necessary to guess at which point the signal stops.

DC Ranges: 0 to 3-10-30-100-300 and 1,000 volts. All ranges have a constant input resistance of 11,000,000 ohms. Accuracy 3% ±

AC Ranges: 0 to 10-30-100-300 and 1,000 volts. Sensitivity: 1,000 ohms per volt. Accuracy 5% ±

Electronic Ohmmeter Ranges: 0-1,000 ohms, 0-10,000 ohms, 0-100,000 ohms, 0-1 megohm, 0-10 megohms, and 0-1,000 megohms.

R.F. Voltage ranges 0/3-10-30-50 Volts to be measured on 100 Volt range.

Bridge Amplifier Circuit Meter individually calibrated for use with set of test leads, signal tracer probe and batteries.

**Features of the EDIPROBE**

- Smallest R.F. probe made.
- Frequency range 60 Cycles to over 100 Megacycles.
- Effective circuit loading: 3 mmf. and 1 megohm.
- Can be used as an output meter.
- Can be used for measuring decibels.
- Checks condensers for open circuit.
- Works with any standard V.T.V.M.

PROVAC Model ED 100 (with EDIPROBE) **\$5950** VTVM Model 100 (without probe) **\$5250** EDIPROBE (RF Probe) **\$985**

Jobbers and dealers write for exclusive Territory Distribution. Orders addressed to us will be credited to your nearest dealer.

Write Dept. SA for FREE Technical Manual

**ELECTRONIC DESIGNS, Inc.**  
IRVINGTON, NEW YORK



EDIPROBE \$985

## NEW PRODUCTS

(Continued from page 45)

Co., Inc., 130 Clinton St., Brooklyn 2, N. Y.

The kit contains 17 controls, 8 switches and 4 glass-insulated flexible resistors. Also included in the kit are the Clarostat volume-control selector or cross-index of various brands and types.

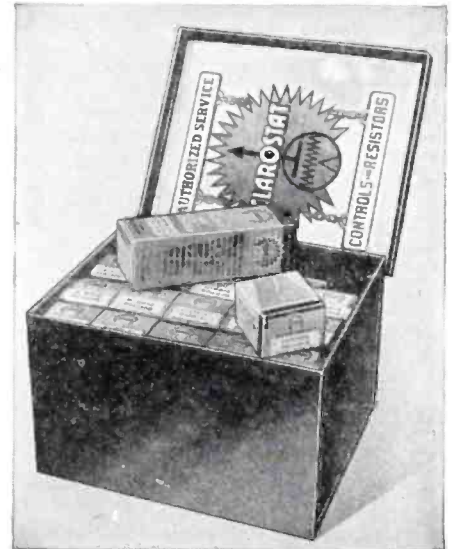

\* \* \*

### SOLAR CAPACITOR ANALYZER

A lightweight capacitor analyzer, model CBB, has been placed in production by Solar Manufacturing Corporation, 285 Madison Avenue, New York 17, N. Y.

Measures capacitors from 10 mmfd to 800 mfd. Magic-eye tube is used for Wien bridge balance indication, while simplified neon-lamp test circuits are used for visual checks of the insulation resistance of electrostatic capacitors and the leakage current of electrolytic capacitors.

Instrument may also be used as a line-frequency resistance bridge covering a range of 50 ohms to 2 megohms.

Complete details appear in Solar catalog IN-2.

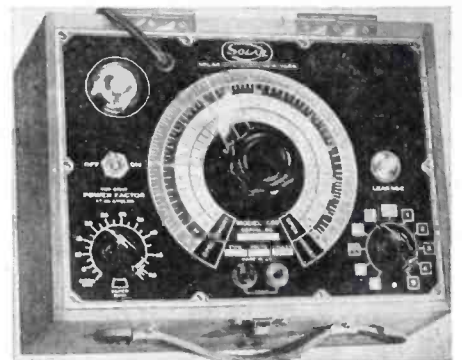

\* \* \*

### WARD WINDOW ANTENNAS

A line of house and window antenna masts, engineered for vertical polarization, has been developed by the Ward Products Corporation, 1523 East 45th Street, Cleveland.

Both types of masts feature a telescopic design, and are said to be weatherproofed with cadmium plating.

House mast extends to 12' and is collapsible to 4' for easy handling. The win-

dow type extends to 8', and may be collapsed to 40'.

House mast has a built-in lightning arrester.

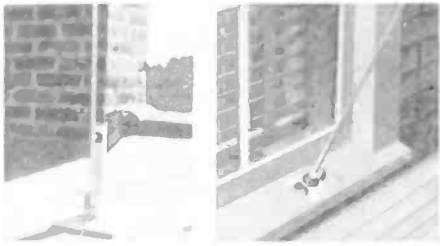

\*\*\*

**PRECISION APPARATUS PORTABLE  
MULTI-TEST CHECKER**

A portable combination mutual-conductance-type vacuum-tube checker, battery tester and 37-range a-c/d-c multi-range set tester, with ranges to 6,000 volts a-c and d-c at 20,000 ohms-per-volt d-c, has been developed by Precision Apparatus Co., Inc., 92-27 Horace Harding Blvd., Elmhurst, L. I., N. Y.

Known as 954-P electronic tube-battery-set tester, the unit tests all tubes with filament voltages to 120. Tests portable dry batteries from 1.5 to 135 volts. Each tube and battery is tested under load conditions and merit is directly read on 3-colored "Replace-weak-good" scale, in addition to a calibrated reference scale. Features an automatic push-button system; free-point element terminal selection to locate terminals of all filaments.

Provides measurement of 60 microamperes to 12 amperes; resistance to 60 megohms and db ranges to +70.

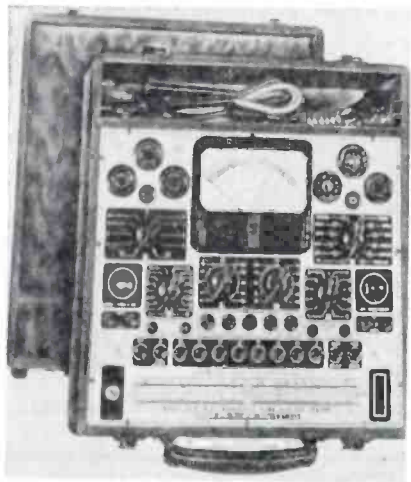

\*\*\*

**INDUSTRIAL DEVICE MIDGET NEON  
PILOT LIGHT**

A miniature neon lamp that is said to consume under 1/10 watt and operate at

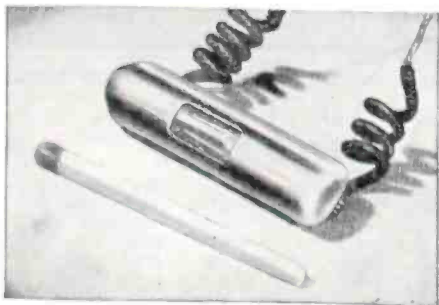

**AMERICA'S TOP QUALITY AMPLIFIER**

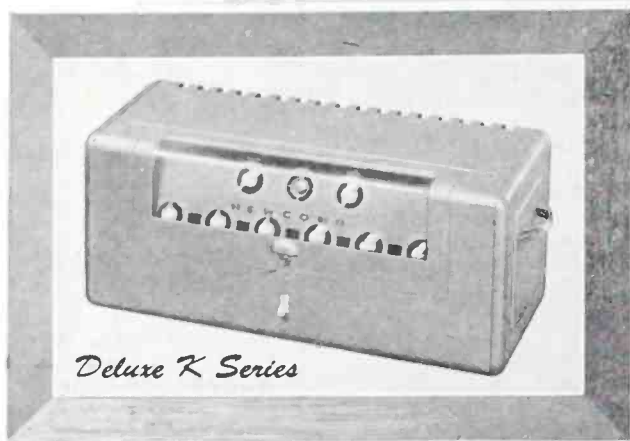

*Deluxe K Series*

A reputation for quality is our most priceless asset. The performance and operation of the Newcomb Deluxe K-Series of amplifiers form outstanding proof of the reason for that reputation.

Incorporated in every K-Series model is a combination of control features never before offered in any amplifier, plus — Uniform power output throughout the useful band of frequencies . . . Frequency response: 20 to 20,000 cycles within 1 d.b. . . . Master volume control . . . Individual, dual-acting tone controls for bass and treble . . . Thru-vision, plastic keylock control panel cover . . . Exclusive plug-in input transformer socket for instant conversion from high to low impedance . . . and many other features that spell top quality in sound reproduction.

• All NEWCOMB amplifiers are precision-built, tested and re-tested, to guarantee laboratory performance and long, dependable operation.



**AUDIO PRODUCTS COMPANY**

Dept. E, 6824 Lexington Avenue • Hollywood 38, California

Send for details of our complete line of sound equipment.

any voltage from 75 to 250, a-c or d-c, has been produced by Industrial Devices, Inc., 22 State Road, Edgewater, N. J.

The unit requires two 13/64" holes in panel or mounting surface to take the mounting studs and nuts. The standard studs are 3/8" long.

\*\*\*

**ELECTRICAL REACTANCE  
CAPACITORS**

A series of Hi-Q feed-through tubular ceramic capacitors ranging from 5 to 17,500 mmfd, has been announced by the Electrical Reactance Corporation, Franklinville, New York.

Fitted with brass, cadmium-plated feed-through bushings soldered to the outer electrode. Size range of bushings, .243" od, 28 thread to 3/8" od, 24 thread, class

No. 2 fit. Lengths, exclusive of hex head are 3/2" to 1 1/8", accommodating capacitors from .125" od to .272" od.

\*\*\*

**ELECTRO-VOICE DYNAMIC AND  
CRYSTAL MICROPHONES**

Two general-purpose dynamic and crystal microphones have been announced by Electro-Voice, Inc., Buchanan, Michigan.

Dynamic, model 610, employs E-V Acoustalloy diaphragm, which is said to withstand high humidity, extremes of temperature, salt air, and severe mechanical shock. Uses Alnico V in magnetic circuit. Output level is -53 db. Avail-

(Continued on page 50)

able in Hi-Z (direct-to-grid, 25,000 ohms), 50, 250 or 500 ohms impedance.

Crystal microphone, model 910, employs a high capacity moisture-sealed crystal, and duralumin diaphragm. Output is -48 db. High impedance.

Both microphones have a built-in cable connector and use standard  $\frac{3}{8}$ "-27 thread for stand mounting. Equipped with 8' or 20' shielded synthetic rubber jacketed cable.

Models have a 15° fixed tilt. Frequency response is said to be substantially flat from 50-8000 cps. Polar pattern is non-directional at low frequencies, becoming directional at higher frequencies.

Complete information in catalog No. 101.



\* \* \*

#### TECHNICAL APPLIANCE DIPOLES

Dipole antennas for f-m and television have been announced by Technical Appliance Corporation, 41-06 De Long St., Flushing, New York.

Lead-in is ribbon-type transmission line comprising two stranded conductors insulated by a band of polystyrene that is said to result in low loss per 100' of .02 db at 10 mc, 1.25 db at 50 mc, 2.1 db at 100 mc, with 300-ohm surge impedance. To avoid high losses resulting from the use of ordinary friction or rubber tape

## NEW PRODUCTS

(Continued from page 49)

at such high frequencies, special low-loss splicing tape is available.

Enamel-finished steel tubing is used for supporting members. Dipoles are of aluminum tubing.

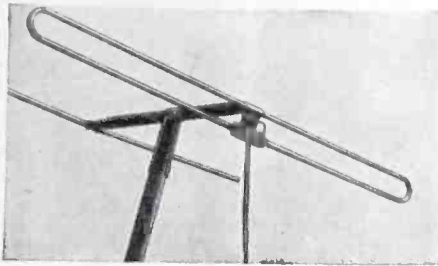

\* \* \*

#### THORDARSON AUDIO-AMPLIFIERS

A group of 1,000-watt audio-amplifiers for use in vibration testers were recently built by the Thordarson Electric Manufacturing Division of Maguire Industries.

Amplifier features include harmonic distortion and frequency deviation held to a minimum of from 25 to 1500 cycles per second, with an over-all gain of 96 decibels, at an input impedance of 100,000 ohms; hum level is held 48 db below full output



\* \* \*

#### PERCO REPLACEMENT ADJUSTABLE INDUCTANCE COIL

Miniature oscillator coils, 9/16" x 3/4"

for replacement use in receivers employing a pentagrid converter and 455/6 kc i-fs have been announced by Pioneer Electric and Research Corporation, 7212 Circle Avenue, Forest Park, Illinois. A bifilar winding acts as the grid coupling capacitor when required and its inductance is adjustable by means of a movable iron core.

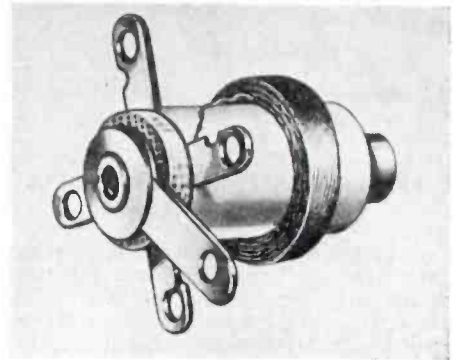

\* \* \*

#### G. E. CAPACITOR-RESISTOR BRIDGE

A portable capacitor-resistor bridge, type YCW-1, has been announced by the

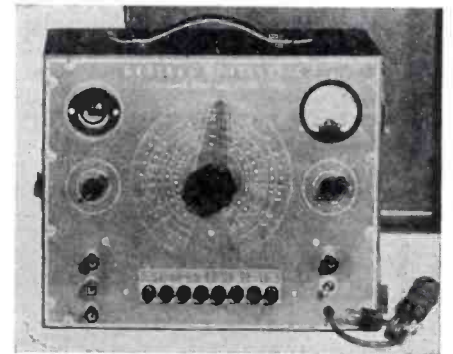

## RADIO WHOLESALE REPAIRS

JUST SEND US THE RADIO PREPAID. WE REPAIR AND RETURN C.O.D. YOU ADD MARKUP AND DELIVER. WE FIX THEM ALL. 48 HOURS SERVICE. OUR LOW PRICES MEAN MORE MARKUP PROFITS FOR YOU. SHIP THAT RADIO TODAY. . . .

YOUR RADIO DOCTOR . . . 397 MELROSE STREET  
BROOKLYN 6, N. Y.

## J. V. Duncombe Co.

WHOLESALE DISTRIBUTOR

ELECTRONIC EQUIPMENT, TUBES and PARTS

1011 West 8th Street Erie, Pa. Phone: 23-544

ALL NATIONALLY KNOWN RADIO PARTS—AMATEUR SUPPLIES. NATIONAL UNION, PENNSYLVANIA AND RCA TUBES

## CRITICAL RADIO TUBES

MOST TYPES IN STOCK

50L6 . . . . . \$ .75	1N5 . . . . . \$ .90	25Z6 . . . . . \$ .68
35Z5 . . . . . .58	1R5 . . . . . 1.10	117Z3 . . . . . 1.10
117L7 . . . . . 1.60	6K7 . . . . . .68	12SA7 . . . . . .90
12SQ7 . . . . . .75	32L7 . . . . . 1.33	12SK7 . . . . . .75

BRAND NEW, IN SEALED CARTONS, 100% GUARANTEED REPAIRMEN and DEALERS: Write for complete list and discounts. RADIO EXPERTS 178 EAST 33rd STREET Dept. S PATERSON 4, N. J.

## In PHILADELPHIA — — — it's ALMO

TRY US FIRST!

## ALMO RADIO COMPANY

509 ARCH STREET - PHILADELPHIA 6, PENNA. Lo-3-0513 Lo-3-4559

## — YOU GET PERSONAL SERVICE AT SCENIC —

• MAIL ORDERS OUR SPECIALTY •

SUPREME 585 v.t.v.m. . . . . \$63.50	SIMPSON 215 v.o.m. . . . . \$32.50
SUPREME 582 audolyser . . . . . 127.00	SIMPSON 280 v.o.m. . . . . 38.95
TRIPLETT 2405 v.o.m. . . . . 56.75	RCP 802-N tube & set tester . . . 59.50
TRIPLETT 2432 sig. gen. . . . . 88.50	DUMONT 274-5" 'scope . . . . . 99.50
McMURDO-SILVER "Vomar" . . . . . 59.85	DUMONT 208-B 5" 'scope . . . . . 235.00
McMURDO-SILVER "Sparr" . . . . . 39.90	ELECTRONIC Design Voltohmmyst 52.50

• NEW CATALOG AVAILABLE ON REQUEST •  
25% deposit should accompany C.O.D. orders.

SCENIC RADIO & ELECTRONICS CO.

53 PARK PLACE

NEW YORK 7, N. Y.

## WHEN YOU CHANGE YOUR ADDRESS

Be sure to notify the Subscription Department of SERVICE at 52 Vanderbilt Ave., New York 17, N. Y., giving the old as well as the new address, and do this at least four weeks in advance. The Post Office Department does not forward magazines unless you pay additional postage, and we cannot duplicate copies mailed to the old address. We ask your cooperation.

specialty division of the electronics department of G. E.

Measures capacity from .000005 to 200 microfarads in three ranges and resistance from 5 ohms to 20 megohms in two ranges. Using the wein-bridge principle with standards of  $\pm 1$  for capacitance and  $\pm 2\%$  for resistance, bridge balance is indicated by a visual indicator tube. Measurements are obtained by varying a potentiometer with a knob and a pointer until maximum shadow angle is obtained on indicator tube; capacitance and resistance values are also indicated by the pointer.

Insulation resistance, leakage current and power factor are among the other electrical characteristics of capacitors that may be measured by bridge. Insulation resistance and leakage current are indicated directly on a  $2\frac{1}{2}$ " instrument mounted in panel. Power factor is measured on the high-capacity range by a potentiometer in series with standard resistance which has a scale of 0% to 50%.

**WARD LEONARD 5-WATT WIRE-WOUND FIXED RESISTORS**

A 1" long x  $\frac{1}{8}$ " diameter wire-wound 5-watt Vitrohm resistor, type 5F, has been announced by the Radio and Electronic Distributor Division, Ward Leonard Electric Co., 53 West Jackson Blvd., Chicago 4, Illinois.

Resistance wire is wound on core and silver-soldered to terminal bands.

Available from stock in ranges from 1 to 5,000 ohms.

Catalog D-2 contains complete data.

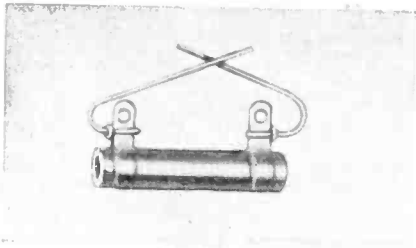

**G. C. PHONO TURNTABLE STAND**

A phono turntable stand adjustable to any turntable and holding work about 15" above the bench, has been announced by the General Cement Manufacturing Co., 919 Taylor Avenue, Rockford, Illinois. Pivoted clamps permit record changer to rotate so that the bottom mechanism can be worked on. Stands are constructed of steel.



**COLLARO BRITISH RECORD CHANGERS**

Collaro British-made a-c automatic record changers with magnetic pickup, model 196, are now available in this country through Micro-Sonic Corporation, 44 West 18th Street, New York 11, N. Y.

*Success Formula*

**OS/AJC\***

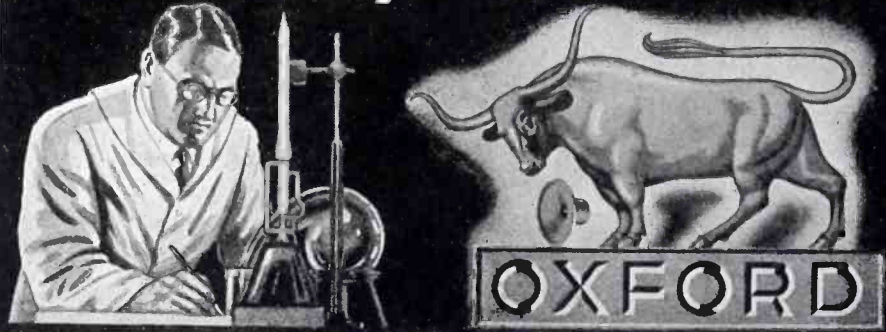

**\* OXFORD SPEAKERS / ALL JOBBERS' CHOICE**

In producing the OXFORD SPEAKER, every effort has been taken to make it the most outstanding unit of its field. That these efforts have been crowned with success is attested to by the fact that over 77 radio manufacturers have used more than 1,500,000 OXFORD SPEAKERS in their 1946-1947 line of receivers.

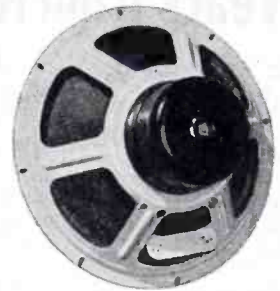

Successful merchandising for the jobber must consist of plentiful sales at a profit. Dissatisfied customers or poor products do not encourage jobber sales. When offering OXFORD SPEAKERS, the jobber is positive that the product meets exacting specifications and that he will have a well-satisfied customer.

The versatility of the OXFORD SPEAKER line assures that a jobber can fill nearly every order for a replacement or public address system installation unit. And he can do this without a "special" speaker. That is why it can be truly said of OXFORD SPEAKERS that they are the ALL JOBBERS' CHOICE.

By consistent and continuous research into new materials and production methods, the OXFORD SPEAKER has been perfected to a high degree. This, coupled with wartime-developed modern manufacturing processes and careful quality control checks, assures the buyer of an OXFORD SPEAKER that he has a superior unit.

Copyright, 1946, Oxford Radio Corporation.

**OXFORD RADIO CORPORATION**

3911 SOUTH MICHIGAN AVE., CHICAGO

Records may be repeated, automatically, via a single control. Reject, stop and starting operations are also incorporated in the same control.

Changer will play up to eight 10" and 12" records, intermixed.

**BROWNING A-M/F-M TUNER**

An a-m/f-m tuner has been announced by Browning Laboratories, Inc., Winchester, Mass. Separate r-f and i-f systems are used for both bands and the entire r-f section for f-m uses miniature tubes.

The tuning range on the f-m band extends from 87 to 109 megacycles and on the broadcast band from 530 to 1650 kc.

The Armstrong circuit is employed in the f-m section with two cascade limit-

ers to ensure maximum noise rejection. Provision is made for the new 300 ohm twin-lead cables for antenna systems. The same antenna is used for both f-m and a-m obviating the necessity for separate leads.

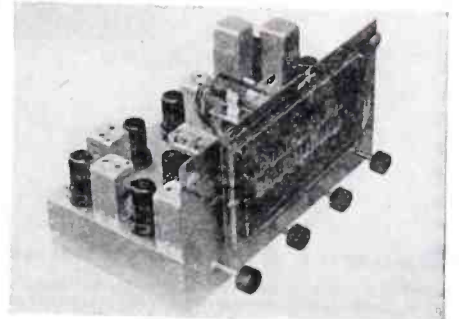

# CAPITOL RADIO ENGINEERING INSTITUTE

—Where Professional Radiomen Study—

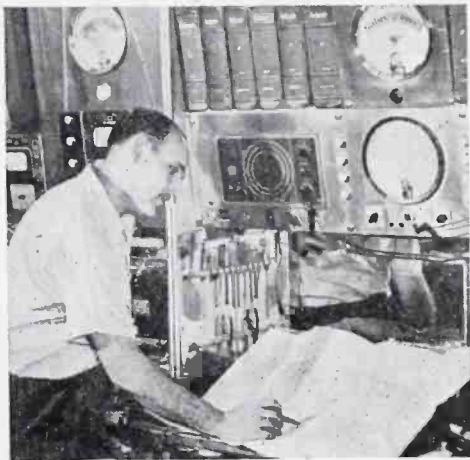

—“Service” Mag. Photo

## Where Will YOU Be 10 Years from NOW?

Radio Servicing Will Advance Unbelievably in the Next Decade

Will you be a Trained Radio-Electronics Technician holding a highly-skilled well-paid position? . . . OR will you be just another serviceman who “muffed” his BIG opportunity back in '47.

A CREI course in modern Radio-Electronics Engineering will give you a broad professional working knowledge through advanced training. You will learn new technical methods and techniques in Television, FM, UHF, Radar—the kind of knowledge and skill that rates the confidence of your employer; the respect of your associates; marks you as an alert, aggressive man; singles you out for the better jobs that are “wide-open” ahead.

Prepare for the opportunities that are YOURS. If you acquire the “know-how” NOW, you will be ready to commandeer the BIG, well-paid jobs that are open only to skilled, technically trained men.

The FREE Booklet will tell you the whole story. Write for your copy today! Don't pass up this opportunity or you'll regret it in 1957.

### MAIL COUPON NOW

Capitol Radio Engineering Institute,

Dept. S-1  
16th and Park Road, N. W.  
Washington 10, D. C.

Please send me your new, illustrated FREE BOOKLET describing CREI Home Study Courses for immediate spare-time training.

Name \_\_\_\_\_  
Street \_\_\_\_\_  
City \_\_\_\_\_ Zone \_\_\_\_\_ State \_\_\_\_\_

Check Course  Practical Radio Engineering  
 Practical Television Engineering

I am entitled to training under the G. I. Bill.



Member of National Home Study Council—National Council of Technical Schools—and Television Broadcasters Assn.

## JOTS AND FLASHES

A \$50,000 NATIONAL “radio-in-every-room” sales-promotion campaign will soon be inaugurated by RMA. . . . David Wald, president of DeWald Radio Mfg. Corp., New York City, has been elected a director of the RMA governing board to fill vacancy caused by recent resignation of Ross D. Siragusa, president of Admiral Corporation. . . . George M. Gardner, president of Wells-Gardner & Co., Chicago, has also been elected a director of RMA governing board to fill the vacancy caused by death of A. S. Wells, former RMA president and director. . . . Paul H. Eckstein, formerly with Hallicrafters, has become assistant general sales manager of the Domestic Appliance Division of Pressed Steel Car Company, Chicago, Illinois. . . . Members of the Radio Servicemen's Association of Luzerne County, Pa., were recent guests of the f-m station WIZZ. The servicing of f-m receivers was discussed at the meeting. . . . Louis S. Kimball has been elected vice president in charge of operations of the Colonial Radio Corp., subsidiary of Sylvania. Mr. Kimball was formerly general manager of the fluorescent fixture division of Sylvania. . . . Electronic Laboratories, Inc., Indianapolis, will produce 6-, 8- and 12-tube model receivers in 1947. Receivers will feature “orthosonic” twin-amplifier speaker systems. The 12-tube models will provide for a-m/f-m reception. . . . Walter H. Dyer has resigned as sales manager of the automobile radio division of Zenith. . . . Samuel L. Sack, former vice president and chief engineer of Transmitter Equipment Mfg. Co., Inc., has been named president and chief engineer of a new company, Supreme Transmitter Corporation, 280 Ninth Avenue, N. Y. 1, N. Y. Leon L. Adelman is vice president and sales manager and Charles Sheer has been named research director and consultant. . . . A folder describing four models of television receivers has been released by RCA. Models described include 630TS, table model, with a 52-square-inch picture; 621TS, table model, with a 23-square-inch picture; 641TV, console, with a 52-square-inch picture; and 648PTK, console model, with a 300-square-inch picture. . . . William A. Rupp has joined the advertising staff of the home instruments department of RCA Victor. . . . Wilfred A. Sechrist has been named director of marketing for Ellinwood Industries, Los Angeles, Calif. . . . A jewel-tip permanent-type phonograph needle (Aeropoint Emerald UHF) is now being advertised nationally by the Aero Needle Company, Chicago. . . . C. J. Anthony has been appointed merchandising manager for John Meck Industries, Plymouth, Indiana. Amos H. Carey is now director of manufacturing for John Meck. . . . Maurice Kraay, W9HEI, of Munster, Indiana, recently won a Hammarlund Super-pro receiver in the trade-name contest conducted by Sun Radio and Electronics Co., Inc., 122-124 Duane Street, N. Y. C. 7. . . . The eleventh edition of the “Volume Control Guide” is now being compiled by Centralab and will be available soon. . . . Pyramid Electric Co. has acquired an additional single-story plant at Paterson, N. J. General offices and main plant are at 415-421 Tonnele Avenue, Jersey City 6, N. J. . . . Sam H. Harper, recently appointed eastern sales manager for John Meck, visited the plant at Plymouth, Indiana.

## ADVERTISERS IN THIS ISSUE

SERVICE INDEX—JANUARY, 1947

ALMO RADIO CO. . . . .	50
THE ASTATIC CORPORATION. . . . .	38
Agency: Wearstler Advertising, Inc.	
BURSTEIN-APPLEBEE CO. . . . .	45
Agency: Frank E. Whalen Adv. Co.	
CAPITOL RADIO ENGINEERING INSTITUTE. . . . .	52
Agency: Henry J. Kaufman & Associates	
CLAROSTAT MFG. CO., INC. . . . .	34
Agency: Austin C. Lescarboursa & Staff	
CLIPPARD INSTRUMENT LABORATORY. . . . .	34
Agency: Savage & Talley	
CONCORD RADIO CORP. . . . .	46
Agency: E. H. Brown Adv. Agency	
CORNELL-DUBILIER ELECTRIC CORP. . . . .	Inside Front Cover
Agency: Reiss Advertising	
DILKS, INC. . . . .	49
Agency: Shappe-Wilkes Inc.	
ALLEN B. DUMONT LABS., INC. . . . .	4
Agency: Austin C. Lescarboursa & Staff	
J. V. DUNCOMBE CO. . . . .	50
ELECTRONIC DESIGNS, INC. . . . .	48
Agency: Bass & Weber Co., Inc.	
ELECTRONIC PARTS, INC. . . . .	30
Agency: Campbell & Reynolds	
GENERAL CEMENT MFG. CO. . . . .	38
Agency: Sander Rodkin Adv. Agency	
GENERAL ELECTRIC CO. . . . .	40
Agency: Maxon, Inc.	
GUARDIAN ELECTRIC . . . . .	5
Agency: Kennedy & Co.	
HOLLANDER RADIO SUPPLY CO. . . . .	40
Agency: Turner Adv. Agency	
INTERNATIONAL RESISTANCE CO. . . . .	0
Agency: John Falkner Arndt & Co., Inc.	
J.F.D. MFG. CO. . . . .	58
Agency: Bergman-Jarrett Co.	
LAKE RADIO SALES CO. . . . .	44
Agency: Sander Rodkin Adv. Agency	
LIFETIME SOUND EQUIPMENT CO. . . . .	45
Agency: The Miller Agency Co.	
McMURDO SILVER CO., INC. . . . .	42
Agency: Edward Owen & Co.	
MAGUIRE INDUSTRIES, INC. . . . .	21
Agency: City Adv. Agency	
P. R. MALLDREY & CO., INC. . . . .	19
Agency: The Altink-Kynett Co.	
M. V. MANSFIELD CO. . . . .	50
MUELLER ELECTRIC CO. . . . .	34
MURRAY HILL BOOKS, INC. . . . .	31, 47
Agency: The Harry P. Bridge Co.	
NATIONAL RADIO INSTITUTE. . . . .	17
Agency: Van Sant, Dugdale & Co., Inc.	
NEWCOMB AUDIOPRODUCTS CO. . . . .	49
Agency: Stevens-Hall Advertising	
OHMITE MFG. CO. . . . .	41
Agency: The Fensholt Co.	
OLSON RADIO WAREHOUSE. . . . .	37
Agency: The Jessop Adv. Co.	
OXFORD RADIOD CORP. . . . .	51
Agency: Signal Corp.	
RAD-EL-CO MFG. CO. . . . .	30
Agency: Lehman Wood	
RADIO CITY PRODUCTS CO., INC. . . . .	27
Agency: Reiss Advertising	
RADIO CORPORATION OF AMERICA . . . . .	7, 39, 41, 43, 45, Back Cover
Agency: J. Walter Thompson Co.	
RADIO EXPERTS . . . . .	50
RADIO SUPPLY & ENGINEERING CO., INC. . . . .	38
Agency: Karl G. Behr Adv. Agency	
RAYTHEON MFG. COMPANY. . . . .	48
Agency: Burton Browne, Advertising	
JOHN F. RIDER PUBLISHER, INC. . . . .	0
Agency: Lansford F. King, Advertising	
HOWARD W. SAMS & CO., INC. . . . .	3
Agency: The Altink-Kynett Co.	
SCENIC RADIO & ELECTRONICS CO. . . . .	50
SIMPSON ELECTRIC COMPANY. . . . .	29
Agency: Kreicker & Meloan, Inc.	
HERMAN H. SMITH, INC. . . . .	45
Agency: Shappe-Wilkes Inc.	
SOLAR CAPACITOR SALES CORP. . . . .	Inside Back Cover
Agency: O. S. Tyson & Co., Inc.	
SPRAGUE PRODUCTS CO. . . . .	25
Agency: The Harry P. Bridge Co.	
STANDARD TRANSFORMER CORP. . . . .	9
Agency: Burnet-Kuhn Adv. Co.	
SYLVANIA ELECTRIC PRODUCTS INC. . . . .	10
Agency: Newell-Emmett Co.	
TRIPLETT ELECTRICAL INSTRUMENT CO. . . . .	37
Agency: Western Adv. Agency, Inc.	
TUNG-SOL LAMP WORKS, INC. . . . .	23
Agency: E. M. Freystadt Associates, Inc.	
UNITED TRANSFORMER CORP. . . . .	32
Agency: Shappe-Wilkes Inc.	
THE WARD PRODUCTS CORP. . . . .	52
Agency: Burton Browne, Advertising	
WEBSTER-CHICAGO CORPORATION . . . . .	47
Agency: William Hoffman & Associates	
YOUR RADIO DOCTOR. . . . .	50

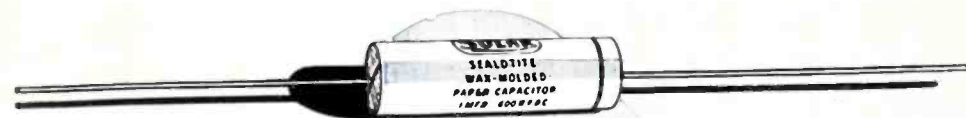

## CROSS-SECTION of a SUCCESS STORY

### "SEALDTITE" BY SOLAR

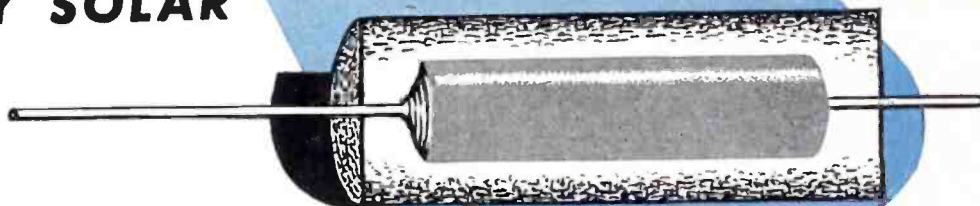

In 1939 Solar pioneered the first wax-molded paper capacitor—the now famous "Sealdtite". Its success was immediate. Manufacturers, servicemen, amateurs everywhere acclaimed the new, solid, tough, MOISTURE-PROOF "Sealdtite"—the capacitor with the truly protective molding. Since then the demand for Solar's "Sealdtite" has spread like wildfire. Thousands of capacitor users have found it best by test. Today, "Sealdtite" capacitors rank first with engineers; for engineers don't guess — they know.

*P. S. Do you read The Solar System for regular news on developments in the capacitor field? If not, drop us a note to place your name on the mailing list without charge.*

Ⓢ SO 1681 A

**SOLAR CAPACITOR SALES CORP.**  
285 MADISON AVENUE • NEW YORK 17, N. Y.  
ELECTROLYTIC, PAPER and MICA CAPACITORS



# SELL RCA BATTERIES...



## RCA Batteries are radio-engineered for extra listening hours

There are good reasons why RCA Batteries are in the lead today—reasons that add up to bigger profits and repeat sales for you.

1. **RCA Batteries Are Long-Lasting**—Because they're *engineered for radio*, every RCA Battery has the correct capacity for the current drain of the radio set it was designed for. That's one reason why your customers get *extra* listening hours from RCA Preferred Type Radio Batteries.

2. **RCA Batteries Have "Balanced Life"**—

All "A-B" types are so designed that *both* sections deliver effective voltage for the *full* life of the battery pack. That's another reason why your customers get *full value* from every RCA "A-B" Battery they use.

3. **You Get a Balanced Line**—RCA keeps up-to-date on battery types. There is an RCA Battery type for most receiver models. It's seldom you have to turn a customer away when you handle the RCA line of Radio Batteries.

4. **RCA Batteries Sell Themselves**—RCA is the greatest name in radio. Your customers know that the RCA trade mark means a quality product.

Smart packaging, competitive prices, RCA quality, and "radio-engineering," add up to outstanding customer acceptance. That's why you'll want to hitch on to the fastest moving radio battery line *now*. See your local RCA Distributor today for full details.

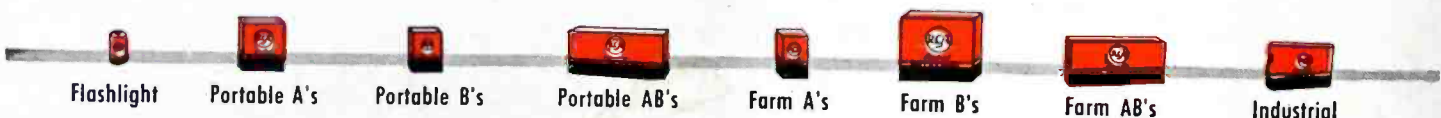

**TUBE DEPARTMENT**

**RADIO CORPORATION of AMERICA**

**HARRISON, N. J.**