

SERVICE

NOV 1 1945

December
1945

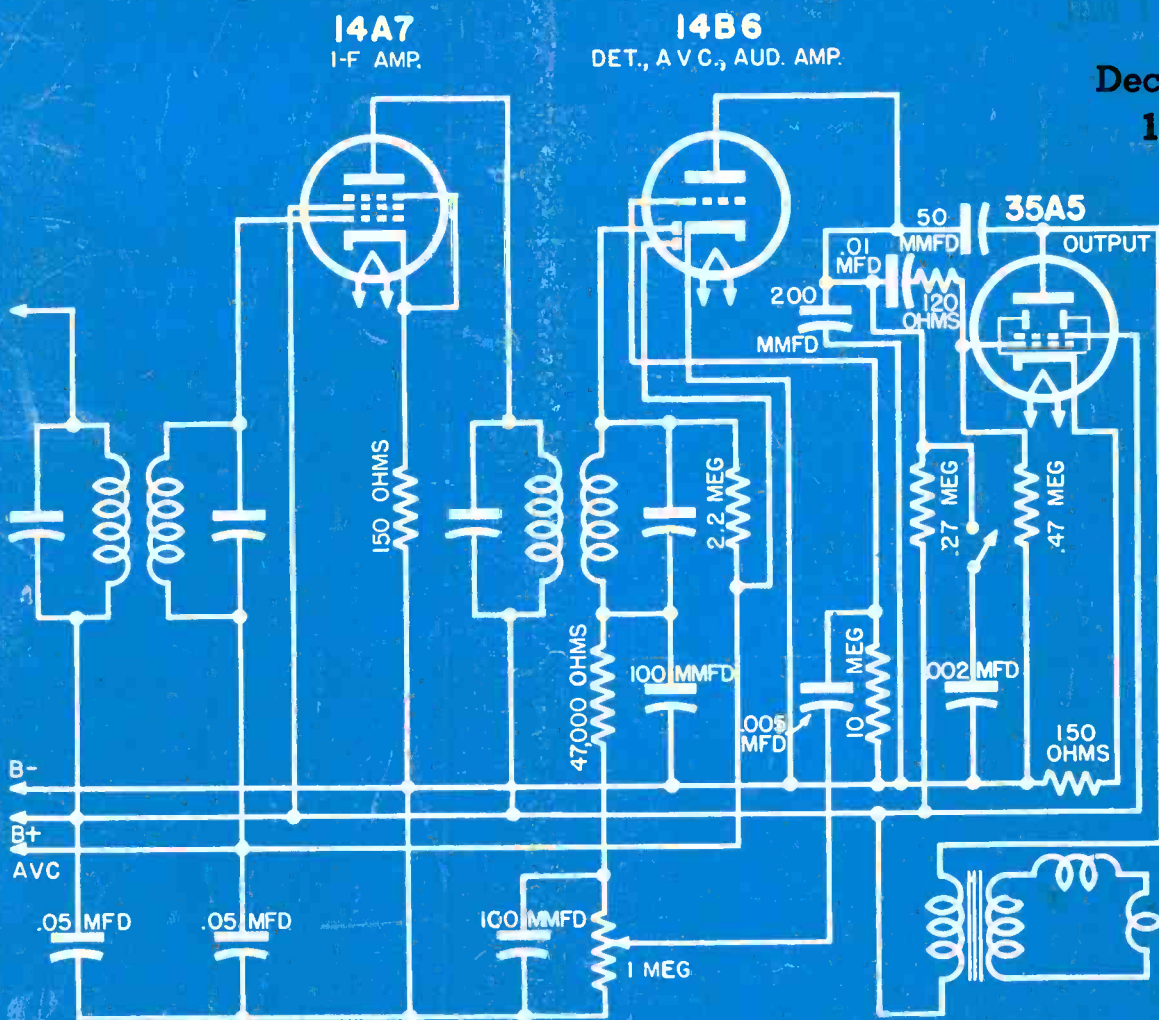

The i-f, detector-avc-audio amplifier and output stage of a postwar 5-tube a-c/d-c tuned-loop receiver. (See page 63.)

He reads the "C-D Capacitor" and gets a chance to look around



He's not a stunt man. Just a regular radio guy like you and all the others. The reason he rides so easy is that he gets a good head start . . . keeps his nose to the ground, but has his eyes wide open. Every month he pinches a couple of minutes off his working time to read the C-D Capacitor and get the tip-off on short cuts in servicing.

Imagine! A whole month's worth of service helps that you can swallow at one sitting! Nothing for you to do . . . not a penny to send; just write us and "The Capacitor" will come to you by mail regularly. Twelve times a year we'll send you this helpful, pocket-sized magazine. Write to: "The Capacitor", Cornell-Dubilier Electric Corporation, South Plainfield, N.J.



A TIMELY POSTER FOR YOU!



An attractive blue and yellow display card for your window or wall that reads "we use no war-weary surplus". It conveys to your customers that you use only genuine and original C-D Capacitors in all service jobs. Ask your local jobber for this poster today!

HAVE YOU SEEN THIS CATALOG?



Quick, easy, condensed reference that gives you a comprehensive listing of the most complete line of capacitors made. Remember Cornell-Dubilier for all your servicing needs. Send for Catalog #195.



PRACTICAL E Z's!

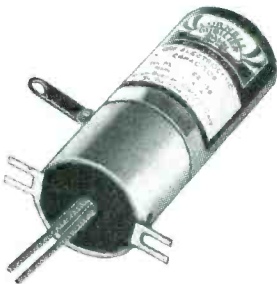

Here's one of several types of capacitors that wins the serviceman's award for "all-around replacement." Adaptable for upright or under-chassis mounting, E Z's incorporate C-D's famous etched foil features in design and construction.

CORNELL-DUBILIER
the greatest name in
CAPACITORS

KEN-RAD

CATHODE-RAY TUBES

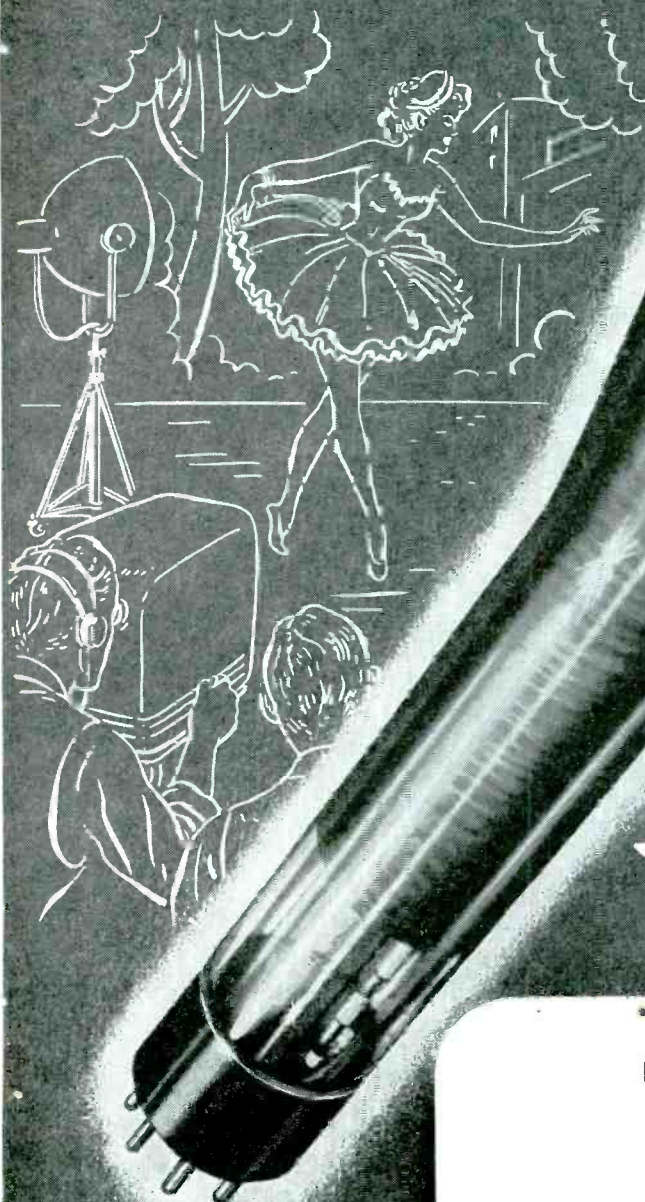

*Better
than ever*

► Our great new age of television will owe much to the picture-sharpness and realism offered by Ken-Rad Cathode-Ray Tubes . . . Added facilities for research, testing, and production promise still finer tube performance . . . Tomorrow's big market for Ken-Rad television tubes is but one of many profit opportunities for Ken-Rad dealers.

✈
● Write for your copy of "Essential Characteristics" the most complete digest of tube information available.

178-DEE-4850

KEN-RAD

DIVISION OF GENERAL ELECTRIC COMPANY

OWENSBORO, KENTUCKY

EDITORIAL

SERVICE

A Monthly Digest of Radio
and Allied Maintenance
Reg. U. S. Patent Office

Vol. 14, No. 12 December, 1945

LEWIS WINNER
Editorial Director

ALFRED A. GHIRARDI
Advisory Editor

F. WALEN
Managing Editor

WITH over 100 models of some forty manufacturers now on the production lines, after having been price approved by the OPA, we find that the postwar program is at long last under way. While receivers are not being made in any great quantities because of parts shortages and labor problems, it is promising to note that there is production, production that we're certain will be stepped up during the next few months.

Most of the receivers made thus far have been of the a-m, five to six-tube model type, with 4½" to 6" speakers. Some of the receivers are featuring automatic phono operation with crystal pickups. Several push-button models have also been made, featuring six and eight-button controls. The a-c/d-c/battery models have included self-charging switches, a feature that will probably be included in many house line-battery types next year. In the main, the models are covering the broadcast band. A few have included the short-wave band. About a dozen console models also have been announced. These are all a-m, with from seven to eight tubes, and with phono systems.

To facilitate installation and maintenance, several manufacturers have announced that they will include simplified servicing notes with every receiver. Where the models become complex, simplified tracer circuits are planned. Incidentally, many of the multi-tube multi-system receivers will actually be less complex than the prewar models, due to the use of new combination tube types, simplified circuit systems and smaller components. However, the standards will be necessarily higher because of the higher gain and improved fidelity provided. Thus more care than ever will be exercised in manufacture, a care that will demand close scrutiny by every Service Man. It will be up to the Service Man to maintain these standards in repair and maintenance.

A thorough knowledge of circuits and complete familiarity with component design and fabrication are *musts* in the postwar receiver servicing program. Continuous study and reading of such articles that appear in SERVICE are essentials in this program. Returning G.I. Service Men can brush up on radio servicing by attending special courses now being given at trade schools throughout the country. In New York, for instance, the Manhattan Trade Center offers complete basic and refresher courses that will prove quite handy in starting up the right way.

Service Men will, in 1946, also find many new fields to service. We've described some of these in past editorials . . . aircraft, apartment houses, plants, etc. A particularly lucrative field is marine craft. With thousands of large and small boats soon to appear with receivers and transmitters, there'll be an urgent call for Service Men. As in aircraft, commercial licenses will be required to operate and then service the equipment. But the extra effort required to secure the license will pay substantial dividends. And we must not forget the radio installations in schools, shops, auto-shop restaurants and dozen of other businesses using radio, that offer excellent installation and servicing opportunities for the Service Man.

1946 should be a profitable and active year for every active Service Man!

	Page
Automatic Noise Limiters. By Thomas T. Donald	13
AVC-Detector-AF Systems. By Robert L. Martin	22
Cross Modulation, Beat Notes and R-F Whistles. By A. M. Ross	16
Interstation Noise Suppression Systems. By J. George Stewart	40
Old Timer's Corner	54
Postwar Receivers	32
Ser-Cuits. By Henry Howard	34
Servicing Helps	52
Servicing the Oscillograph (Part VI). By S. J. Murcek	36
Sub-Miniatures (Tube Data). By Roger Etton	20
350 Speaker P-A System	53
Volume and Tone Control Resistors (Part X of a Series on Receiver Components). By Alfred A. Ghirardi	26

Circuits	
Detrola 408 (AVC/Detector/A-F)	22
Espey F-M (F-M/I-N-S)	41
Freed 57A-71A (F-M/I-N-S)	41
G.E. L 651 (AVC/Detector/A-F)	22
G.E. 20 (AVC/Detector/A-F)	23
Hallcrafters SX-28 (A-N-L)	14
Hammarlund SP-200X (A-N-L)	16
Meissner 9-1053-4 (F-M/I-N-S)	41
Motorola 65 BP 1-2-3-4	42
National NHU (A-N-L)	15
National NC-44B (AVC/Detector/A-F)	24
RCA QU 52C (AVC/Detector/A-F)	23
RCA QB1 (AVC/Detector/A-F)	24
RME 41-42 (A-N-L)	15
RWT B92 (AVC/Detector/A-F)	24
Sub-Miniature Amplifier	20
Sub-Miniature Receiver	48
Stromberg-Carlson 1000H, J-1100H (Cover)	63
Ward BR-474 (AVC/Detector/A-F)	22
Ward 62-271 (AVC/Detector/A-F)	22
Ward 93 WG-1000/1001	34

Cover	
5-Tube Postwar Receiver (Stromberg-Carlson 1000 H, J, 1100H)	63

Servicing Helps	
Dial Drive Installation Notes	52
G.E. 60	52
Phlico 112-112A	52
Sparton 410, 420	52
Synchronous Motor Record Players	52

Index to Advertisers	
	64

Manufacturers	
News	56
New Products	59
Jots and Flashes	64

Copyright, 1945, Bryan Davis Publishing Co., Inc.

Published monthly by Bryan Davis Publishing Co., Inc.

52 Vanderbilt Avenue, New York 17, N. Y. Telephone Murray Hill 4-0170



Bryan S. Davis, President
Paul S. Weil, Vice Pres.-Gen. Mgr.



A. Goebel, Circulation Manager
F. Walen, Secretary

James C. Munn, 10515 Wilbur Avenue, Cleveland 6, Ohio: Telephone SWEETBRIAR 0052

Pacific Coast Representative: Brand & Brand, 1052 W. Sixth St., Los Angeles 14, Calif.; Telephone Michigan 1732

Entered as second-class matter June 14, 1932, at the Post Office at New York, N. Y., under the Act of March 3, 1879. Subscription price: \$2.00 per year in the United States of America and Canada; 25 cents per copy. \$3.00 per year in foreign countries; 35 cents per copy.

John Dce
RADIOS REPAIRED

We use
Centralab Radiohms
exclusively

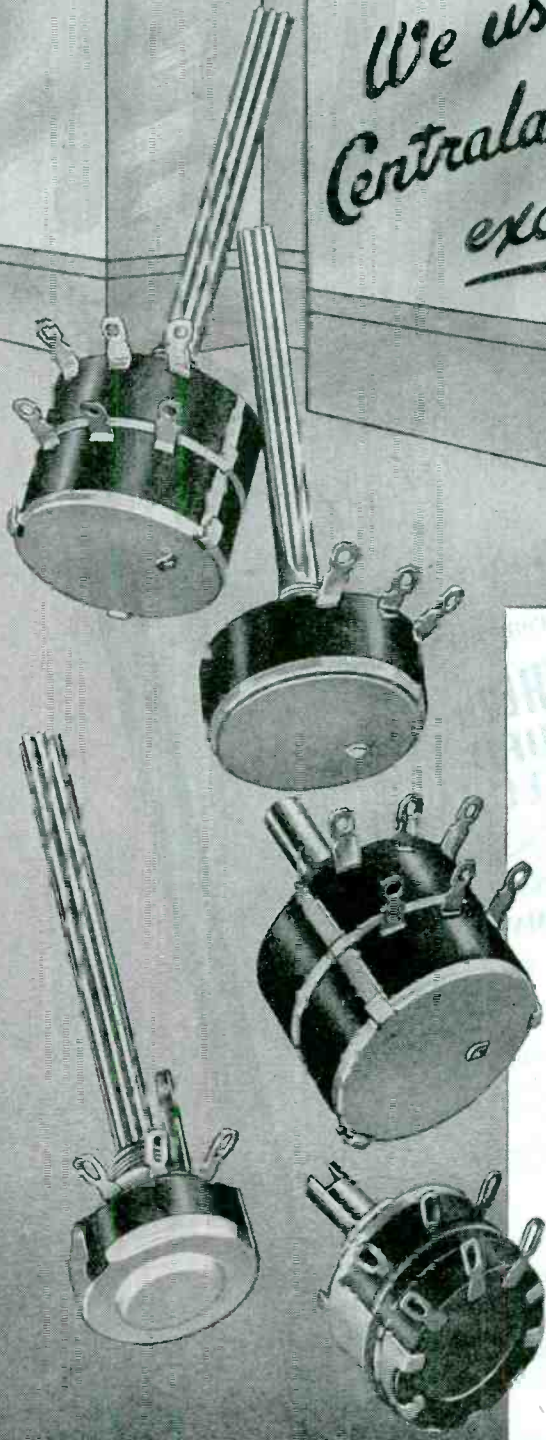
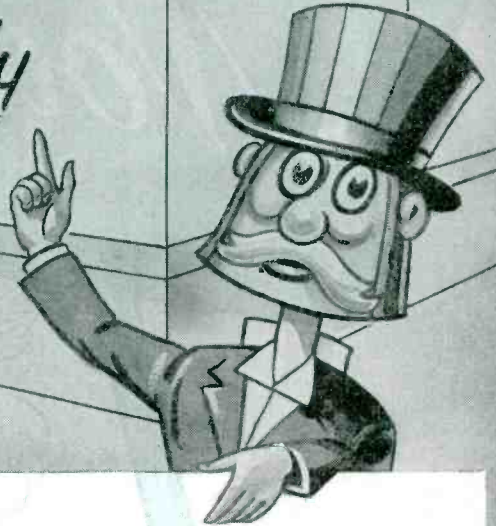

OLD Man Centralab knows what he is talking about . . . for today it is as true as it was twenty years ago . . . that Centralab Radiohms represent **QUALITY** in Volume Controls. Today the service man cannot afford to take chances so he must be doubly sure. That is why, if he is wise, he will always specify **CENTRALAB** for all his replacement jobs.

The familiar blue and white carton is his guarantee of goodness.

See your nearest Centralab jobber.

Centralab

Division of GLOBE-UNION INC., Milwaukee

Producers of Variable Resistors • Selector Switches • Ceramic Capacitors,
Fixed and Variable • Steatite Insulators and Button-type Silver Mica Capacitors.



Now

YOU

THIS IS TO CERTIFY THAT

Frank's Radio Service
has met the requirements to qualify as

**RAYTHEON
BONDED
ELECTRONIC TECHNICIANS**

A Surety Bond Has Been Issued by the
WESTERN NATIONAL INDEMNITY COMPANY,
Expiring the _____ day of _____ 194____, Bonding This Firm to:

1. GUARANTEE ITS RADIO REPAIR WORK FOR 90 DAYS FROM DATE PERFORMED and REPLACEMENT PARTS FOR 90 DAYS FROM DATE INSTALLED.
2. Use only parts of recognized quality in its repair work.
3. Not charge more than list price for parts ably as possible.
4. Test customers' tubes as accurately and reliably as possible.
5. Keep charges for labor at a fair and reasonable level.
6. Perform only such work as is authorized.
7. Maintain the high quality service indicated by the experience required of all Bonded Electronic Technicians.
8. Maintain and use test equipment essential to good repair work and reliable tube checking.



Signed and Sealed

RAYTHEON MANUFACTURING COMPANY
A. E. Akroyd, Distributor and Member

By *[Signature]*
WESTERN NATIONAL INDEMNITY COMPANY
A. E. Valerius, Secretary in Charge

West. Office and National - 172 West Jackson Street, Chicago 4, Illinois

can become a

BONDED ELECTRONIC TECHNICIAN

If you can qualify for this new, revolutionary Raytheon merchandising program, you can be sure of greater sales and profits than ever before . . . and you can forget your worries about "security" in the peacetime years ahead.

This program is the perfect answer to those who have been suggesting licensing, government regulation and other impractical "remedies" to protect the public from unethical radio service dealers.

The bond certificate illustrated, showing the code of ethics and 90 day guarantee, and backed by one of the nation's largest surety firms, will be issued to *each* service dealer who can meet the necessary qualifications.

It is only one unit in a *complete* plan which includes the largest, most effective selection of displays and helps ever offered to the radio tube industry.

As a Bonded Electronic Technician, you will **STAND OUT** in your community as the **TOP** radio service dealer . . . the one to be trusted with all kinds of radio service, the one in whom the public can have complete confidence.

So for more service business, increased sales of tubes and other parts, apply to your Raytheon distributor to become a Bonded Electronic Technician. Remember, for your protection Raytheon tubes are distributed only by leading parts wholesalers.

Raytheon
Manufacturing Company
RADIO RECEIVING TUBE DIVISION

NEWTON, MASS. - LOS ANGELES - NEW YORK - CHICAGO - ATLANTA

RAYTHEON
Radio Tubes



DEVOTED TO RESEARCH AND THE MANUFACTURE OF TUBES FOR THE NEW ERA OF ELECTRONICS

E.L.

AUTO RADIO VIBRATORS LAST 33% LONGER, RUN LIKE NEW "ALL THE WAY"!

E.L. Auto-Radio Vibrators give you and your customers, for the first time, the benefits of important advances in vibrators made by E.L. for vital war applications.

These precision-built, top quality synchronous and non-synchronous vibrators, developed and perfected by E.L. for the armed forces, are of the balanced resonance type with 8 contacts—twice as many as other makes in the non-synchronous types. These features, combined with a "quick-make, quick-break" action of the contacts, makes them last 33% longer and operate more efficiently and quietly. Their output-voltage and starting-voltage requirements are held virtually constant throughout the entire life-span.

4 MODELS MEET 95%
OF ALL AUTO-RADIO
REPLACEMENT NEEDS!

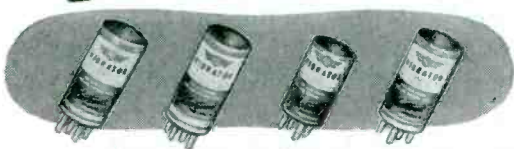

Only 4 models of E.L. Vibrators (models 1703, 2089, 2041 and 2088) to service the 1,122 auto-radio models which comprise 95% of the market. Smaller inventory, faster turnover, larger profits for both distributors and dealers! E.L.'s standardization plan is the most comprehensive ever offered in auto-radio vibrators! Order now from your distributor, and get the wall chart telling which E.L. Vibrator to use for most makes and models of auto-radios as far back as 1936.

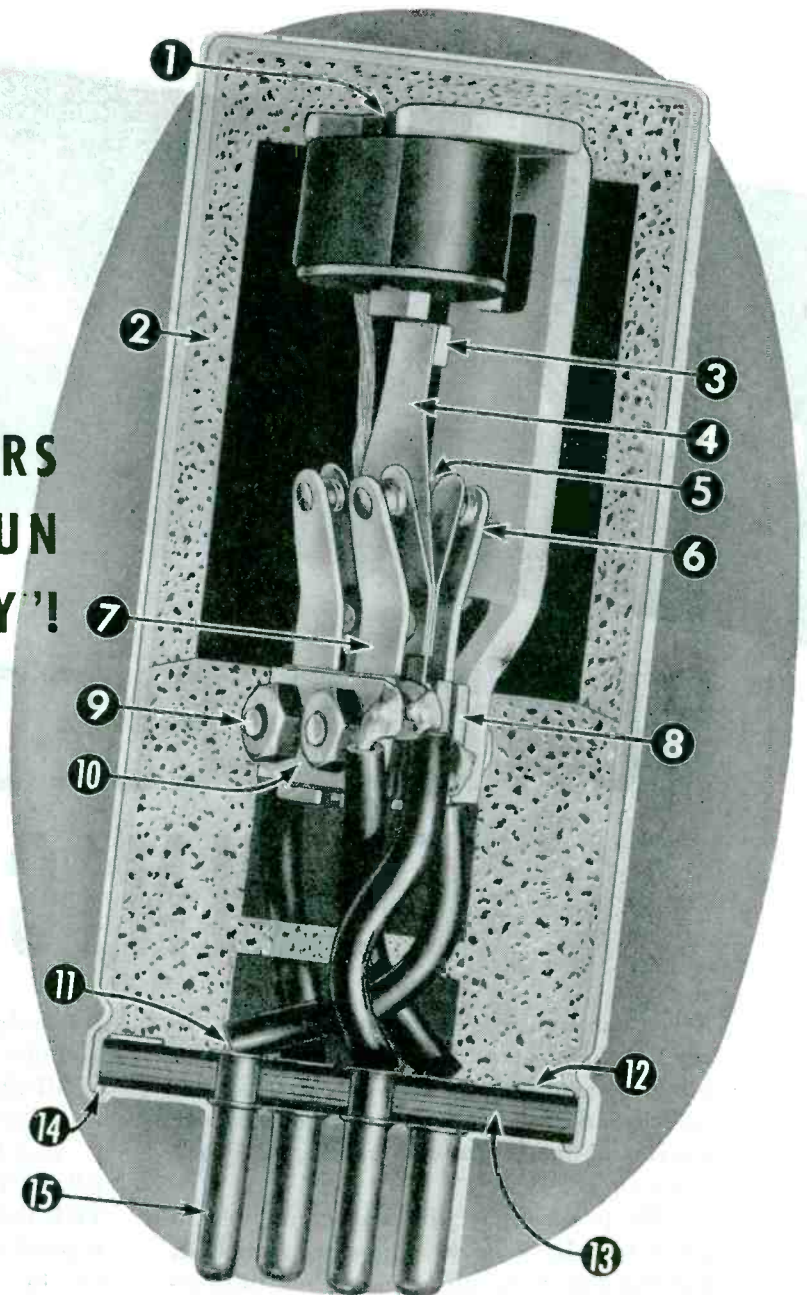

E.L. AUTO-RADIO VIBRATORS BUILT FOR LONG SERVICE

1. Welded pole piece assures permanent accuracy of adjustment.
2. Synthetic sponge sound insulation molded to fit contour of vibrator.
3. Face of center reed weight is surface-ground to improve magnetic coupling.
4. Center reed uniformly stressed to prevent breakage.
5. Reed and side contact arms are specially tempered.
6. Side contact arms are silver-plated to prevent corrosion.
7. Spot-welding of fingers, in contact against each other and the center reed, reduces voltage drop in center-reed assembly.
8. Accurately ground bakelite spacers give structural accuracy and dimensional stability.
9. Double-screw stack helps maintain accurate adjustment.
10. Pressure plate on top of stack keeps stack tight under tension over wide ranges of temperature.
11. Extra-flexible roped wire used as leads to avoid any possibility of breakage.
12. Steel ring, molded into shock mount, centers and holds vibrator upright when can is sealed.
13. Neoprene wafer in hermetically sealed vibrators effectively seals vibrator against atmospheric pressure changes and moisture.
14. Metal can, spun at bottom, seals vibrator against dust and dirt.
15. Silver-plated pins assure minimum contact resistance.

COPYRIGHT 1945 ELECTRONIC LABORATORIES, INC.



**Auto Radio
VIBRATORS**

Electronic

LABORATORIES, INC.
INDIANAPOLIS

VIBRATORS AND VIBRATOR POWER EQUIPMENT FOR LIGHTING, COMMUNICATIONS, ELECTRIC AND ELECTRONIC APPLICATIONS

"ASK FOR
SPRAGUE ATOMS
BY NAME"

SPRAGUE TRADING POST

A FREE Buy-Exchange-Sell Service for Radio Men



FOR SALE—2½-watt transmitter and receiver (mobile); 1 Carter dynamotor 350v, 150 ma output; Win. Co. dynamotor 300v, 75ma output; Mallory 6v type VP-522 Vibration pack, all used less than 15 hours. \$60. T/5 Lyle A. Wiggen, Bldg. 2A, Apt. 3, Baldwin Manor, Aberdeen, Md.

WANTED—Record player, amplifier, motors, pick-ups, mike, P.A. system, typewriter, mimeograph and small radio. E. G. Bartlett, Atlanta, Mo.

SELL OR TRADE—Two 16mm silent motor driven; one 35mm silent with 300 ft film and 35mm sound projector with film-speaker amplifier. Daniels Radio Clinic, 1114 North "C" St., Fort Smith, Ark.

FOR SALE—Set Rider's manuals, Vols. 1 to 5 abridged and 6 to 13, \$100; Astatic model FP18 low pressure crystal pickup with permanent sapphire stylus, \$8.50. Also other equipment. Want good recorder with inside out feed and magnetic cutter. Prefer two speed. Also new 3526 tube. Joseph D. Copeland, 66 Clark St., Portland 4, Maine.

WANTED—Volt-ohm meter dial to replace one on Weston model 301, 1000 ohms per volt meter. Edward Falcon, 2218 Elginth Ave., Tampa, Fla.

FOR SALE—Car radio, new, Ford adjustable, 6F2D. Make offer. George Payad, 125 E. Main St., Staunton, Ill.

WANTED—One ea. 1C5G, 1H5G and 1A7G type tubes or same in GT/G types. Cpl. J. R. Tucker, Sq. U., Lowry Field, Denver, Colo.

SELL OR TRADE—30-watt amplifier, 15" Utah 26 watt speaker, 8" and 10" blank records and phone-pickup with volume control. What have you? Fred Simonian Company, Inc., 85 Shepard St., Lynn, Mass.

WANTED—Circuit diagram of multimeter model 4102 made by American Instruments Co., S/Sgt Dale E. Kemper, 4112 AAF, B.U. Olmstead Field, Middletown, Pa.

WANTED—Riders manuals and service manuals; also test equipment. Muka Radio Service, 383 W. 47th Place, Los Angeles 37, Calif.

FOR SALE—RCA 46 power pack, \$10; speaker, \$4; and RCA 35 power pack, \$7. F. J. Forsyth, 302 Claymont Gardens, Claymont, Del.

URGENTLY NEEDED—Good signal generator and Riders 9 to 14. Mason & Mosely, 1528 Florida St., Memphis 9, Tenn.

FOR SALE—Universal 15mm dynamic mike with transformer, \$9. Motor generator 6v to 200 volt at 50 mills, \$5; 80 and 40 meter crystals—805-0-850 Thordarson transformer, 2½ meter transceiver. Paul Lessor, St. Marys, Pa.

WILL TRADE—Miscellaneous radio parts. Want late model Chrysler auto radio with push button tuning. Frank Dane, 3852 Eagle St., San Diego 3, Calif.

FOR SALE—Radio tubes! What types do you need? Hoepner Radio, 1613 W. 4th St., Davenport, Iowa.

FOR SALE—Truetone portable complete with 1H5, 1A7, 3Q5 and 1N5 tubes. Needs 70L tube, \$25. Louis Sandoz, 409 Gibbs Road, Navy Point, Pensacola, Fla.

SELL OR TRADE—Factory rebuilt Neon transformers as follows: 2—1500v @ 30ma outdoor; 2—12,000v @ 24ma outdoor; 1—12,000v @ 30ma outdoor and 1—12,000v @ 24ma indoor type. Ted Solarz, 3033 S. Pulaski Road, Chicago 23, Ill.

FOR SALE—New tubes. 1F6, 1D7G, 1B4/951, 1E7G, 950, 84, 6SN7GT, 6N6G, 85, 78, 6W6GT, 6AF6G, 6SJ7GT, 12SR7, 14C7, 6X5GT and 26 in limited quantities. 25% off list. Franks Radio Lab., New London, Iowa.

WILL TRADE—Pflueger Silkcast level winding reel with 50 yards black ghost line. Hardly used; also 4½" tubular steel casting rod with pistol grip handle. Want tube tester in good condition. Herman Schneider, Jr., 1305 N. Zane, Stop 7, Martins Ferry, Ohio.

FOR SALE—New tubes in cartons at list postpaid. Types 6F5, 6H6GT, 6K8GT, 6X5GT, 6SR7GT, 6SQ7GT, 7A7, 12SA7GT, 21A, 27, 42, 80, etc. Need test equipment. Edward Howell, Rt. 2, Dillon, S. Carolina.

SELL OR TRADE—Atwater Kent radio or Majestic A and B battery eliminator. Want sewing machine. George Tomisek, 3033 S. Homan Ave., Chicago 23, Ill.

FOR SALE—20-40 watt, dual channel, 65, 110v, amplifier. Radio Electronic Service, 1300 Green Ave., Bay City, Mich.

WANTED—850, 86D and 861 tubes, also 0-10RF ammeter, 0-1000 mill d-c; 0-300 mill d-c milliammeter 0-15 volt a-c meter 301 style or similar. N. Q. Stover, P. O. Box 722, York, Pa.

WANTED—Cradle type handphones and receiver from French phone for Intercom. Midget pocket radices, R-F 25 mh chokes with primary. Fred Wheeler, Custer, S. Dak.

FOR SALE—Superior 1280 tube and set checker, like new; Superior T-12 signal generator; Readrite signal generator, battery operated, as is, \$5; also a-c and d-c meters and Western Electric Hard Hearing aid. Edward Vockerath, 1746 N. Campbell, Chicago 47, Ill.

WANTED—Complete set Rider's manuals. John F. Lau, Farmers Exchange, 632 Cedar St., Perry, Okla.

SELL OR TRADE—Howard #430B communication receiver, in good condition. Want tube tester, V-O-M or what have you in radio test equipment? J. Cantor, 1504 E. Genesee St., Syracuse 10, N. Y.

FOR SALE—Robson-Burgess multimeter which handles a-c d-c voltages, d-c milliammeter, high and low range ohmmeter. Weltner Radio Service, 518 Kansas Ave., Hlawatha, Kans.

WANTED—Echophone EC-1. State price and condition. Richard L. Bruce, 836 Beech St., Manchester, N. H.

FOR SALE—Late N.R.I. course of 65 complete lessons and questions. Cash or will trade for late tester or signal generator. Leslie Johnson, 319 E. 64th St., Los Angeles 3, Calif.

FOR SALE—P.A. amplifier; 2 hi. imp. mike inputs, 1 hi. imp. phono input—dual tone controls. Matching output. Kingsbury Radio Service, 1111 Sixth St., Nevada, Iowa.

URGENTLY NEEDED—Oscillator coil for General Motors #251 radio. Have coil that could be repaired and rewind. McCrary Radio Service, 60 E. Hone St., Westerville, Ohio.

FOR SALE—Two cinaudagraph 12" p.m. speakers without transformers, \$15; Rola 12" dynamic speaker without trans., 1,000 ohm field, \$10; Readrite tube tester #430 \$20; Radio City Products tube and set tester—meter needs repairs—\$30; record player with cabinet and 4 watt a-c amplifier, \$50. Official Radio Service manual, Vol. 7, \$10. John Handzo, 419 Fern Place, Elizabeth 2, N. J.

WANTED—25B8 or 12B8 tube. Will pay list price plus postage. Newburgh Radio Service, 3652 East 73rd St., Cleveland 5, Ohio.

FOR SALE—Following tubes: 1A5, 1C5GT, 1D7G, 1F5G, 1H5GT, 1H16G, 1J6G, 1N5GT, 1P5M, 1V, 2A5, 2A6, 2W3, 2X3, 5W4, 5Y4G, 5Z4, 6A8, 6F6G, 6H6, 6SA7, 6K7M, 6U5/6G5, 12A7, 12SA7, 12SK7GT, 2A4, 26, 27, 31, 35A, 41S, 80, 78 and 85. Irford Radio Service, 2907 Sixth St., New Westminster, B. C., Canada.

SELL OR TRADE—Dayrad tube tester—1½ volt; power transformers and dynamic speakers. Want oscilloscope. Ed's Radio Service, 708 Sixth St., Dell Rapids, S. Dak.

WANTED—Pre-war edition of amateur call book and 1941 A.R.R.L. Handbook.

Morton Bardfield, 4 Brinslev St., Dorchester 21, Mass.

SELL OR TRADE—Clough-Brengle oscillograph #105; Weston selective analyzer #665; 15 radio chassis transformers—power or output. Want 10-watt or over amplifier with speaker and mike. Romeo Beaulieu, 105 Grove St., Elizabeth, N. J.

FOR SALE—G-E amplifier unit R81-SOF, 105-125v, 50-60 cycles, 120 watts maximum input, with 9-tube receiver to match John Madeline, 201 Beverly Road, Brooklyn 18, N. Y.

URGENTLY NEEDED—Late model tube tester. Also d-c volt-ohmmeter. James Moffitt, Warrensburg, N. Y.

FOR SALE—Pair Baldwin type C phones, \$4; Pair Auth 1100 ohm phones, \$3; Jewell test panel with a-c meter and 3-c ma meter, \$10; 2-250's and 2-485's, \$3; 12" deluxe Jensen speaker 12 P.M.C.T., \$13; and two signal transmitting keys—new. William Rasmussen, 91-37 184th St., Jamaica 3, N. Y.

FOR SALE—1 each, new 155, 6SA7, 1H4G, 6J7M, 6I7G, 6K7G, 6K7M, 6H7, 6H6G, 1N5, 1H5, 1A7, 6SR7 and 6SK7 tubes. Also have two output transformers, 1 input transformer, 100 assorted resistors, 55 assorted condensers; Sterline R-401 tube tester and Meissner coils No. 14-1027, 14-1022, 19-1996 and 18-6859. R. R. Bailey, Huntsville, Ontario, Canada.

WANTED—Simpson Model 260 set tester. Cash or what do you want? Daniel McGlinn, 431 Carsonia Ave., Pennside, Reading, Pa.

FOR SALE—New Vomag in factory carton; Simpson 333 tube tester and rebuilt battery signal generator, not calibrated, \$100. M. F. Tehan, 507 48th St., Brooklyn 20, N. Y.

URGENTLY NEEDED—Sweep oscillators for television r-f and i-f alignment. Television Tech, Box 94, Hattboro, Pa.

WILL TRADE—Sonora turntable, complete with pickup, tone control and 78 rev. motor. Want condenser pack for G-E K-62 or Victor R-11 receiver, crystal headphones; a-c foundation volt meter. C. E. Edgar, Pismo Beach, Calif.

URGENTLY NEEDED—September, 1943, issue of Radio Craft. Will pay any price within reason. C. T. Lehman, 57 E. Emaus St., Middletown, Pa.

WANTED—Late model communication receiver; Presto transcription playback turntable for 16" discs; and Capheat automatic record changer. Frank Dane, 3852 Eagle St., San Diego 3, Calif.

Dept. S-125, SPRAGUE PRODUCTS CO., North Adams, Mass.

Jobbing distributing organization for products of the Sprague Electric Co.



SPRAGUE CONDENSERS KOOLOHM RESISTORS

T.M. REGISTERED U. S. PATENT OFFICE

Obviously, Sprague cannot assume any responsibility, or guarantee goods, services, etc., which might be exchanged through the above advertisements

**OUT IN
DECEMBER**

**IT'S EASY TO READ
AND UNDERSTAND**

**IT'S "THIRD
DIMENSIONAL"**

IT'S FUNDAMENTAL

IT'S TIMELY

IT'S A BARGAIN

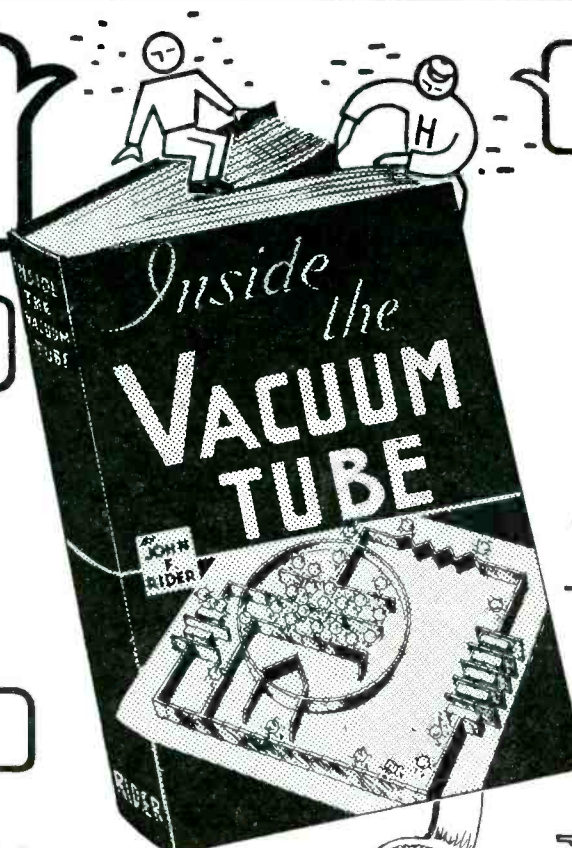

424
Pages
\$4.50

This is not just another book on the vacuum tube, but a typical Rider Book, offering a new approach to the subject—presented with a technique that makes its message clear and easy to understand. Here is a solid, elementary concept of the theory and operation of the basic types of vacuum tubes upon which can be built more advanced knowledge.

After explaining the electron theory, the text presents a discussion on electrostatic fields, on the theory that the reader's understanding of the distribution and behavior of the fields within a tube will give him a better picture of why amplification is accomplished within a tube and how the grids and plates are interrelated.

To give a clear physical picture of its subject, the book

employs novel physical devices. For example, certain diagrams and graphs are repeated, to reduce to a minimum the bother of turning pages back and forth to read text and drawings. Another innovation is the use of anaglyphs, "three-dimensional" pictures of phenomena heretofore seen only in two dimensions. Viewed through glasses supplied with the book, they are invaluable aids toward the rapid understanding of the text.

Although this is an elementary book on a fundamental subject, therefore a goldmine for the student; developments in radio and the new fields of television and microwaves make it a must for the libraries of servicemen, amateurs and engineers. Place your order today.

OTHER RIDER BOOKS

RIDER MANUALS (14 VOLUMES)
Volumes XIV to VII . . . \$12.50 each volume
Volumes VI to III . . . 9.50 each volume
Abridged Manuals I to V
 (1 volume) . . . \$15.00
Automatic Record Changers and
Recorders . . . 7.50
The Cathode Ray Tube at Work
 Accepted authority on subject . . . 4.00

Frequency Modulation
 Gives principles of FM radio . . . \$2.00
Servicing by Signal Tracing
 Basic Method of radio servicing . . . 4.00
The Meter at Work
 An elementary text on meters . . . 2.00
The Oscillator at Work
 How to use, test and repair . . . 2.50
Vacuum Tube Voltmeters
 Both theory and practice . . . 2.50

Automatic Frequency Control Systems
 —also automatic tuning systems . . . \$1.75
A-C Calculation Charts
 Two to five times as fast as slide rule . . . 7.50
Hour-A-Day-with-Rider Series—
 On "Alternating Currents in Radio Receivers"
 On "Resonance & Alignment"
 On "Automatic Volume Control"
 On "D-C Voltage Distribution" . . . 1.25 each

JOHN F. RIDER PUBLISHER, INC. 404 FOURTH AVE., N. Y. 16, N. Y.

Export Division: Rocke-International Electric Corp. 13 E. 40th Street, New York Cable: ARLAB

*—and Don't
Forget*

RIDER MANUALS

*are Now Complete
in 14 Volumes*

They Provide Schematics and Essential Servicing Data on American Made Radio Receivers.

RADIART

1946 "DELUXE" AERIALS

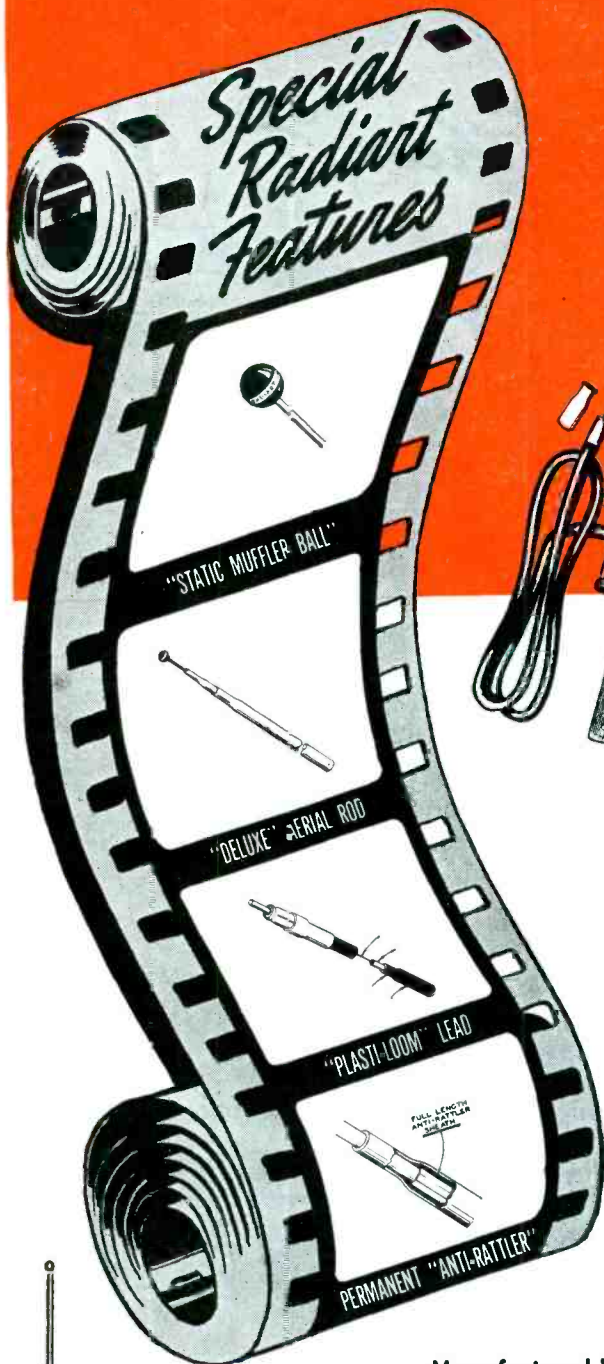

AGAIN . . . RADIART SETS THE STANDARD!

With new features — highest quality materials — and super values, RADIART AERIALS are the Sensation of 1946.

The "Plasti-Loom" Lead (long enough for all installations) and Antimonial Admiralty Brass are two outstanding Radiart features. They make RADIARTS greater values than ever before.

Also, every RADIART AERIAL is complete — no extras to buy — another reason why RADIART is the line to sell in 1946.



Ask your Radiart Jabber how you can get one of these snappy RADIART AERIAL COUNTER DISPLAYS.

Manufactured by the Makers of RADIART "Correct Replacement" Vibrators.

Radiart Corporation

3571 W. 62nd STREET

Export Division
25 Warren St., New York 7, N.Y.

CLEVELAND 2, OHIO

Canadian Office
455 Craig St., W., Montreal, Canada

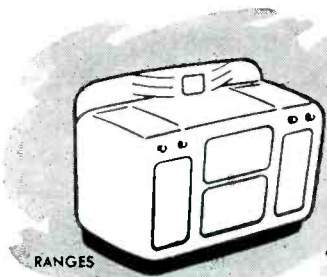

RANGES

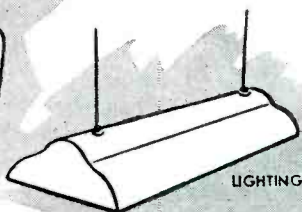

LIGHTING

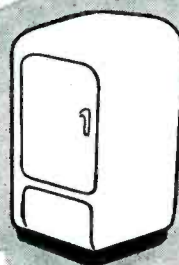

REFRIGERATORS

Working with any of these.?

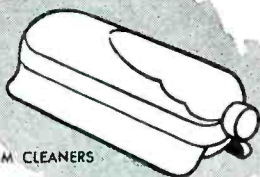

VACUUM CLEANERS



LAMPS

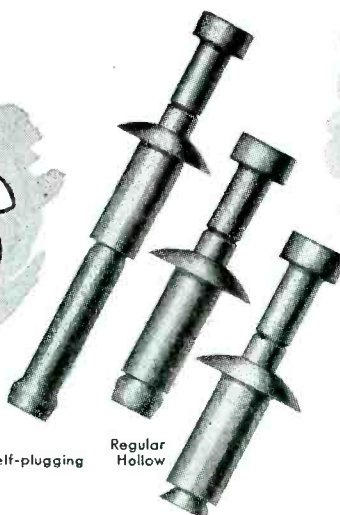

Self-plugging

Regular Hollow

Pull-through Hollow

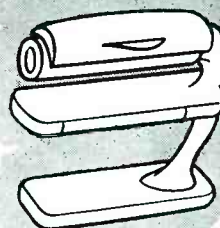

IRONERS

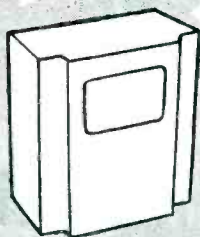

RADIO, TELEVISION

If you are, you should know about Cherry Blind Rivets—the rivets that speed up fastening and cut down costs.

Cherry Rivets upset with a controlled pulling action created by small, easy-to-handle Cherry Rivet guns. These rivets can be applied in pliable or brittle materials as well as all sheet metals.

One operator can complete any Cherry Rivet installation, blind or not, from one side—without bucking.

There is no need for access to both

sides of the installation as is required for ordinary rivets or for nuts and bolts. Cherry Rivets upset on curved as well as flat surfaces, in rubber, leather, fabrics, enameled surfaces, plywood.

Generous material thickness and hole size tolerances—unusual shank expansion—high clinching force—exceptional strength values and vibration resistance—all make Cherry Rivets ideal for electrical manufacturing or repair.



CHERRY RIVETS. THEIR MANUFACTURE & APPLICATION ARE COVERED BY U. S. PATENTS ISSUED & PENDING

For more information, ask your nearest jobber for illustrated Manual D-45 or write the Cherry Rivet Co., Department A-268, 231 Winston Street, Los Angeles 13, California.



Cherry Rivet
Company
 LOS ANGELES 13, CALIFORNIA



DUMONT *TYPE* **P6** **PAPER CAPACITORS**

HEATPROOF

DUMONT CONDENSER ENDS ARE SEALED WITH BAKELITE RESINOID TO WITHSTAND 350° F. CONTINUOUS OPERATION

MOISTUREPROOF

*UP TO 100% HUMIDITY
P6 . . . Sealed Under Vacuum. NO AIR VOIDS to Cause ENTRY of MOISTURE*

SMALL SPACE

*1/4" OD x 7/8" LONG AT 600 VOLTS
Compact . . . Solves Space Problems*

LONG LIFE

*NO HIGH TEMPERATURES or HIGH PRESSURE
Used in the Manufacture of These Condensers . . . Thus Assuring Long Life and High Surge Rating to these units*

▼ *Prices and samples on application*

DUMONT
ELECTRIC CO.
MFRS OF
CAPACITORS FOR EVERY REQUIREMENT
34 HUBERT STREET NEW YORK, N. Y.

SYLVANIA NEWS

RADIO SERVICE EDITION

DEC. Published by SYLVANIA ELECTRIC PRODUCTS INC., Emporium, Pa. 1945

SYLVANIA NATIONAL ADVERTISEMENT SALUTES SERVICEMEN FOR A JOB WELL DONE

**SYLVANIA
SERVICEMAN
SERVICE**

by
FRANK FAX

There's a wealth of valuable aids to your business—just waiting for you to take advantage of them. You can help yourself to these "better business" methods by calling on your Sylvania distributor, or by writing to me at Sylvania Electric, Emporium, Pa.

Many of these Sylvania aids are described in an interesting folder entitled "Multiplying Pennies." The items are classified in four groups: store identification material, sales promotion items, business forms and stationery and technical literature. Among them are attractive window displays with real customer-pulling power, a simplified bookkeeping system for your business, interesting folders to present to your customers, advertising mats, technical manuals and "Helpful Hint" booklets for radio servicing.

Be sure to look into the opportunities these aids to your business open up for you. Ask your Sylvania distributor now, or write to me, for a "Multiplying Pennies" folder.

Let us thank...
the Radio Serviceman
... for a job well done!

Despite lack of radio parts and materials...
his skill and experience...
have kept millions of radios going strong!

Now that the war's over...
he's more than ever AT YOUR SERVICE...
and he has available SYLVANIA RADIO TUBES!

SYLVANIA ELECTRIC

Makers of Radio Tubes, Fluorescent Lamps, Fixtures, Wiring Devices, Electric Light Bulbs, Electronic Devices.

Servicemen, this is *your* ad!

Yes, the ad shown above is all for you. It appears December 8th in *The Saturday Evening Post*, thanking you for keeping on the job during the war.

Sylvania Electric, as well as countless American radio owners, owes you a lot of thanks for doing such an expert job when tubes and radio parts were so scarce. This ad is meant to give you the boost that you have earned.

Besides just thanking you, you will find this ad building good will for your business—*right in your own community*. Everybody will be reading it, and remembering the confidence he has in your work.

And more and more people will be asking for Lock-In and other famous Sylvania tubes—for they have learned that Sylvania and the serviceman work best together.

SYLVANIA ELECTRIC

Emporium, Pa.

MAKERS OF RADIO TUBES; CATHODE RAY TUBES; ELECTRONIC DEVICES; FLUORESCENT LAMPS, FIXTURES, WIRING DEVICES; ELECTRIC LIGHT BULBS
12 • SERVICE, DECEMBER, 1945

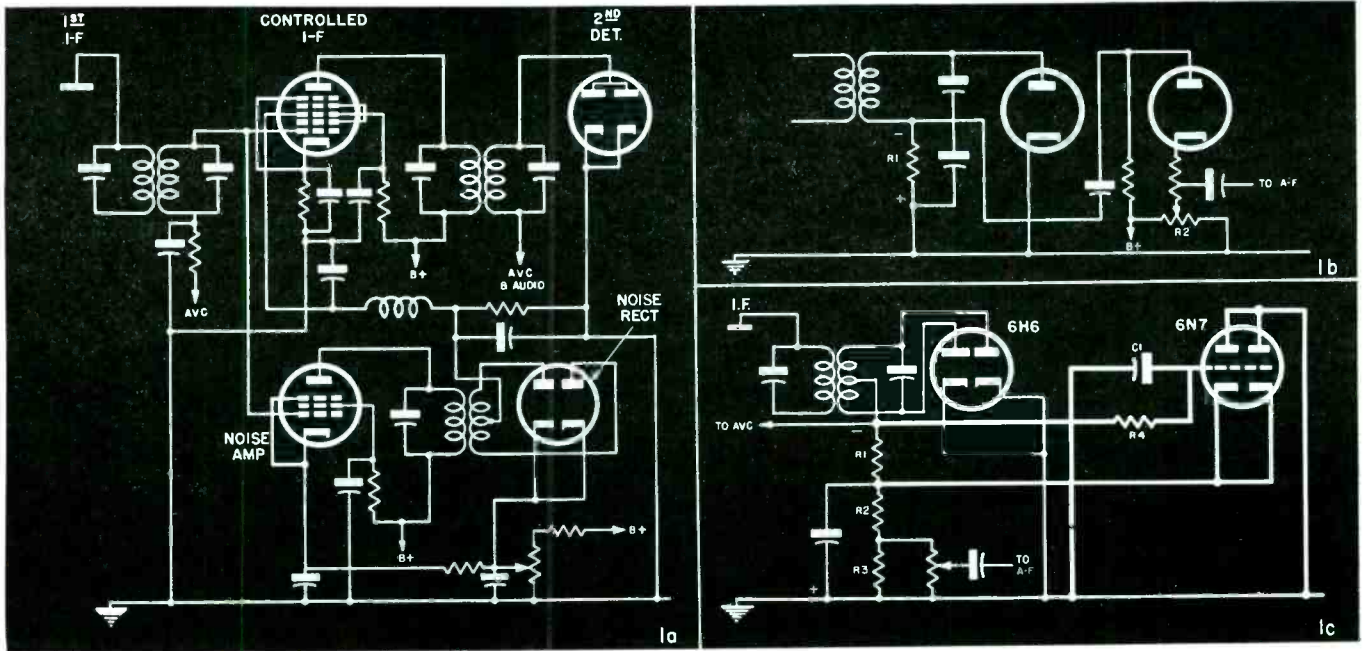

AUTOMATIC NOISE LIMITERS

MANY circuit improvements featured in the better type home receivers are also included in the communications type receiver. However, because of the special applications of the communications receiver, these circuit designs usually have to be expanded. The squelch or automatic noise limiter (a-n-l) is an excellent example of such treatment. In home s-w receivers, noise limiters are used to reduce static and local noise interference. Since some limitation is usually imposed on tone quality by a-n-l use, this feature is usually not used in home receivers designed for b-c reception alone. In communications receivers, which are used for communications in the ham bands the automatic noise limiter sometimes makes the difference between a readable and unreadable signal.

Most a-n-l systems operate to silence the receiver momentarily upon

the receipt of a sharp, high-amplitude signal, such as we encounter in static and other sharp noises. Transient noises, such as ignition interference, have steep wave fronts, occur momentarily with relatively long pauses, and consist mostly of high audio-frequency components. Thus systems have been designed which sharply attenuate these high-amplitude, high audio-frequency, short-duration com-

Fig. 1 (above). Three basic a-n-l circuits. In a, a noise amplifier is used in conjunction with a noise rectifier to momentarily blank out the signal by overbiasing the i-f amplifier. A series diode type is shown in b. By setting the bias of the second diode to the level of the desired signal, any voltage, such as a sharp noise pulse, in excess of the desired signal, will be clipped. Fig. 1c shows an automatic type of noise control which blanks out any noise signal in excess of 100% modulation.

ponents, and thereby facilitate signal reading.

Basic Circuits

Three basic circuits for momentarily quieting a receiver are shown in Fig. 1 a, b, c. The a-n-l circuit of Fig. 1a consists of a noise amplifier and noise rectifier. In operation, any signal fed to the grid of the controlled i-f tube, a 6L7, is also fed to the grid of the noise amplifier. The bucking bias voltage on the cathode of the noise rectifier is set to the amplitude of the desired signal. Any sudden noise input voltage of appreciably greater amplitude than the desired signal, will be rectified by the 6H6 noise rectifier. This rectified

by **THOMAS T. DONALD**

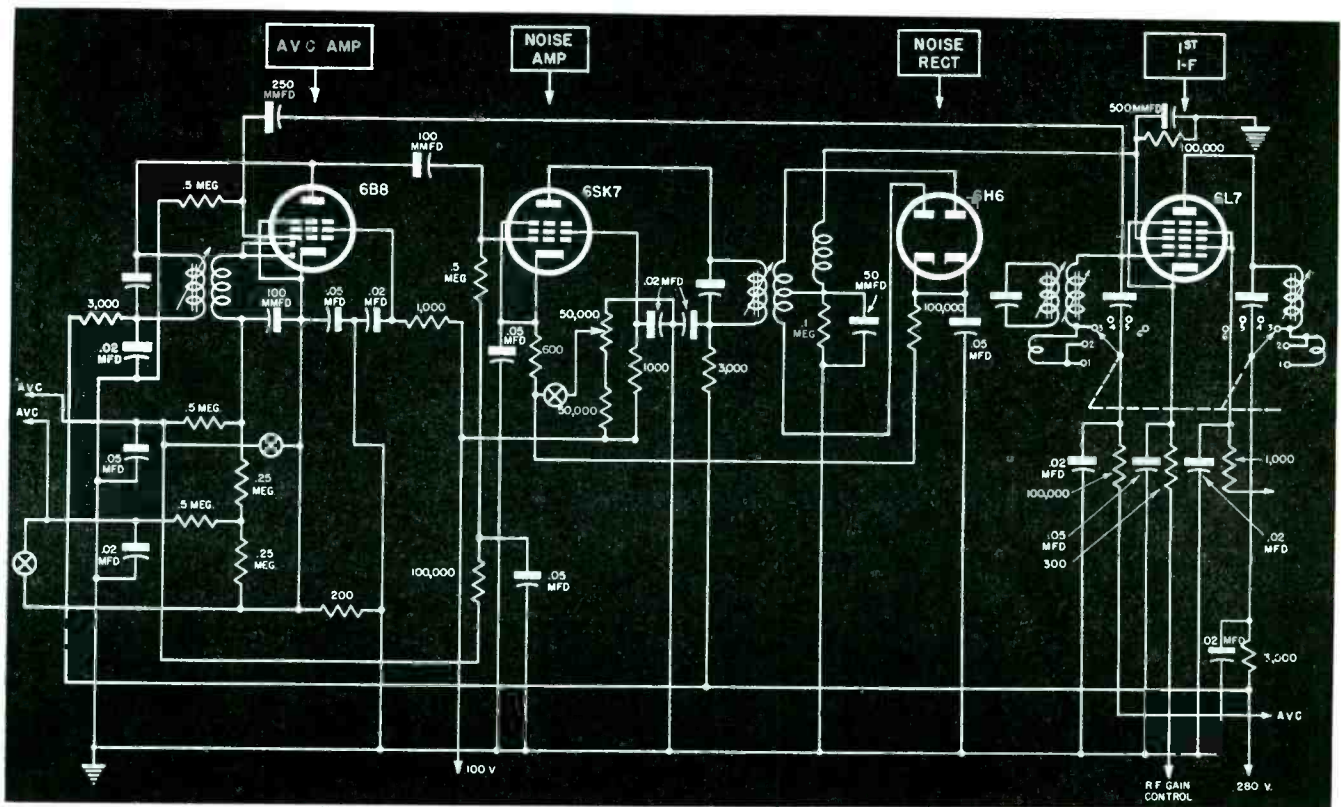

Fig. 2. The a-n-l circuit of the Hallicrafters SX 28. This circuit is identical in operation to that shown in Fig. 1a. The avc amplifier is used to amplify the noise voltage as well as the avc voltage.

noise voltage, by biasing the second control grid of the 6L7, will momentarily bias the tube to cutoff, thereby rendering the receiver inoperative for the duration of the noise signal. The effectiveness of the circuit is controlled manually by adjusting the bucking bias voltage applied to the cathode of the noise rectifier. The circuit operates on the principle that most noises are of short duration, with relatively long intervals between pulses. Since the quiet period of the receiver is only a few microseconds, there is no apparent discontinuity in the received signal.

Series-Valve Noise Limiters

Fig. 1b shows a second type of noise limiter operating at the second detector stage. This is known as a series-valve noise limiter. The operation of this circuit depends on the conductivity of the second, or limiting diode. Its conductivity depends on the plate maintaining a positive relationship to the cathode. Any signal detected by the first diode will create a voltage, across R_1 , of negative polarity with relation to ground. Since this negative voltage will vary depending on the modulation of the received signal, and since it is applied to the plate of the second diode through the coupling capacitor, the net voltage on the plate of the second diode will be a function of this voltage and the posi-

tive plate voltage applied from the power supply. (This action may be considered as a form of voltage modulation.) As long as the negative voltage does not exceed the positive plate voltage, the second diode will conduct. Therefore, by setting the arm of R_1 to a voltage level which is equal to the amplitude of the desired signal, the sudden, sharp, high-amplitude noise impulses are clipped.

Automatic Control

Fig. 1c shows a third type of noise limiter which needs no manual control, since it automatically adjusts itself to the signal. The value of R_1 is so chosen that the voltage on the control grid of the 6N7 is double the cathode voltage of the same tube, with relation to ground. Since the plate of the 6N7 returns to ground, this is equivalent to putting a positive voltage on the plate of the tube, and a negative voltage on the control grid. Since the voltage on the plate is of the order of +4 volts, and that on the

grid —2 volts, the tube may be considered as being non-conductive. R_1 and C_1 constitute a filter network which removes the audio-modulation component of the received signal from the 6N7 control grid. However, the cathode voltage, or by inverse relationship, the positive plate voltage, will follow the amplitude of the audio modulation. For values up to 100% modulation, the cathode voltage will approach, but never drop below the control grid voltage. However, for modulations in excess of 100%, the cathode voltage will drop below the grid voltage, which is biased by the carrier alone. Under these conditions, the grid becomes positive with relation to the cathode, and the tube becomes conductive. The 6N7 is chosen, and operated in parallel, since it has a very low plate-to-cathode impedance. Since the plates of the 6N7 return to ground a low impedance shunt load is imposed across the audio input.

Hallicrafters SX28

Most communications receivers use some form of one of these three basic a-n-l circuits. Figure 2 shows an adaptation of Fig. 1a as used in the Hallicrafters SX28. A 6B8 serves a dual purpose, in that it acts as both a noise amplifier and a avc amplifier. The a-n-l control, instead of controlling the bucking bias on the noise

rectifier alone, also controls the gain of the second noise amplifier, 6K7, by increasing the bias on this tube and, at the same time, the bias on the 6H6 noise rectifier. Another feature is the high audio-frequency characteristic of the 6H6 noise rectifier. By using a balanced-type transformer to feed the noise rectifier, very little of the i-f frequency appears across the detector load circuit. This permits the use of a low-pass filter. This low-pass filter permits the passage of high audio frequencies without attenuation, for biasing the second input grid of the 6L7. Since, as stated previously, high audio frequencies make up the greater portion of noise signals, the effectiveness of the limiter is thereby increased for the higher frequencies, through the application of higher voltage levels to the second 6L7 grid for high audio-frequency noise components.

Hammarlund SP-200X

The a-n-l system used in the Hammarlund SP-200X (Fig. 3) is similar to the one shown in Fig. 1c. A resistor and capacitor has been added to increase the effectiveness of the circuit. As previously stated, noise pulses are of very short duration. For this reason a very fast time constant is used in the RC network in the cathode of the 6H6 detector, about .0000125 second. This same network also improves the operation of the a-n-l, since at the same time that the grid goes positive with relation to the cathode, a higher plate voltage is applied to the plate of the 6N7, thereby increasing its conductivity.

National NHU

Fig. 4 shows the a-n-l system of the National NHU communications receiver. This circuit is similar to that shown in Fig. 1b. However, here an infinite impedance detector is used, necessitating some changes in the circuit. Since the two sections of the twin triode are cathode coupled, the signal voltage applied to the cathode of the noise limiter stage is positive. Ground, in this case, is positive with relation to B—. The grid and plate are hooked up in a semi-diode circuit, in that the grid is positive with relation to cathode, as well as the plate. A sharp noise pulse of voltage in excess of the plate-grid voltage will place the cathode at a higher potential than the plate-grid. This renders the tube non-conductive for the duration of the noise pulse. The time constant of the

(Continued on page 46)

Fig. 3. An adaptation of the circuit of Fig. 1c; Hammarlund SP 200X. The RC network in the plate circuit is used to improve the effectiveness of the a-n-l action.

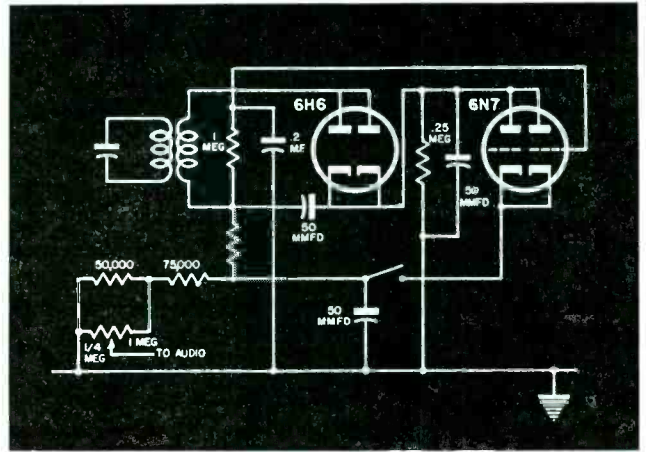

Fig. 4. National NHU using the Lamb noise silencer of Fig. 1b. Since an infinite impedance detector is used in place of a diode, the relationship of the noise diode is changed. This is due to the inverse voltage developed across the audio load resistor with relation to ground.

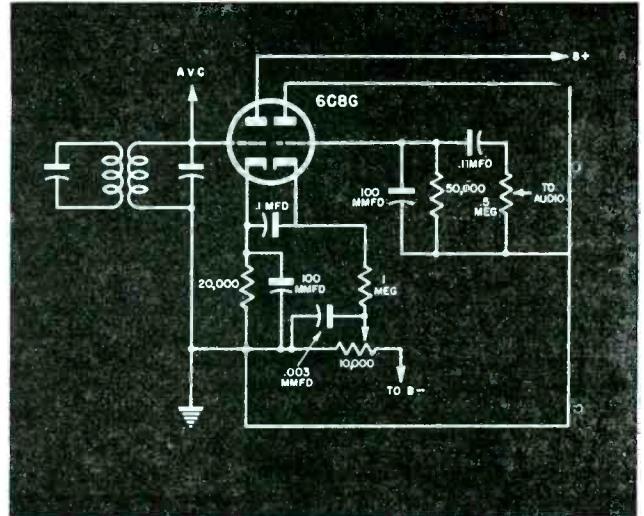
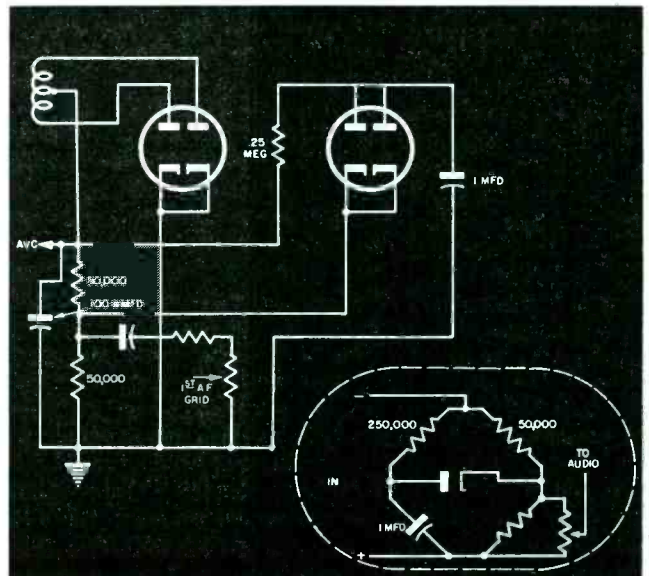

Fig. 5. The a-n-l circuit of the RME 41-43. This circuit is similar to that shown in Fig. 1c. The insert shows how this circuit may be interpreted as a Wheatstone Bridge type of circuit.



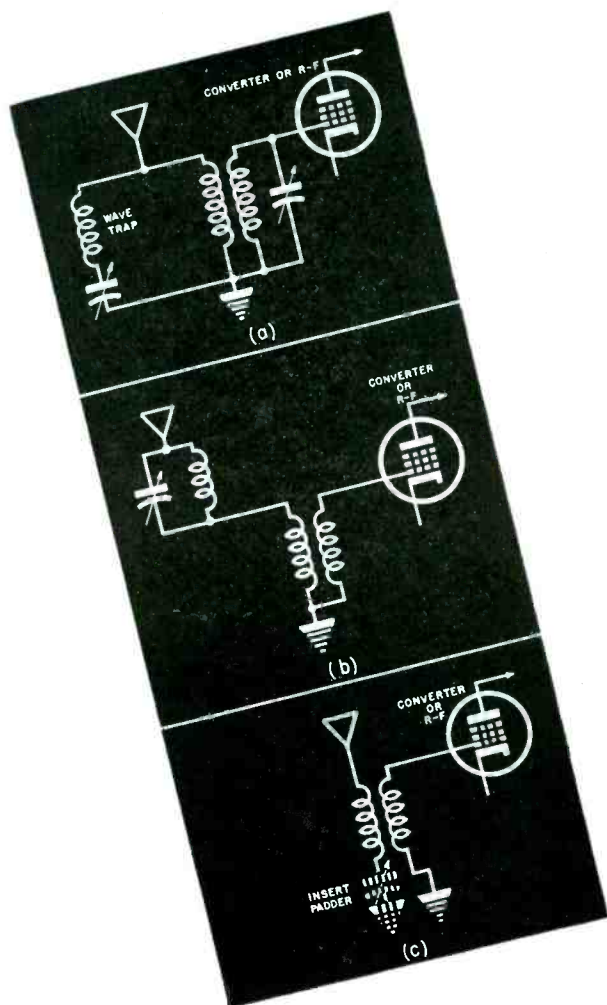

Fig. 1. Three methods of reducing interference from strong local signal transmissions. In *a* is shown a parallel type of wave trap familiar to most Service Men. Parallel is used in the sense that the trap is in parallel with the antenna coil. In *b* a series type of wave trap is shown. Note that intrinsically, the wave traps are the inverse of their position in the circuit; a series type trap is used in parallel, and vice versa. Fig. *1c* shows how the primary of an antenna coil may be adapted to a wave trap by adding a padder capacitor in series with the primary. Since most receivers use high-impedance primaries, a small padder must be used to tune in the b-c range. Otherwise turns must be removed from the primary to bring the circuit within resonant range.

CROSS MODULATION

BEAT NOTES and R-F WHISTLES

by A. M. ROSS

THE signal-interference and whistle complaint has always been a provoking problem for the Service Man. Often the trouble is further complicated by the fact that the interference may be local, or caused by the receiver itself. Thus it becomes necessary to evaluate the source as well as the remedy.

Studying the Problem

To study the problem, an experiment can be conducted on superheterodyne receivers, preferably those with two-ganged tuning capacitors. First a r-f signal generator should be con-

nected to the input of the receiver and then the gain of the signal generator turned up to a level of .1 volt or more. Then some local station, around 900 kc should be tuned in on the receiver and the signal generator dial rotated through the b-c band. You will note many beat note points on the dial.

Reasons for Beat Notes

The reason for the large number of beat notes can be traced to the three tuned circuits in the receiver, each one

at a different frequency. These are the r-f, oscillator, and i-f stages. Innumerable spurious response combinations are possible. H. K. Morgan¹ has shown that the more common beats respond as follows:

$$nO \pm nS, nO \pm I/n, nI + S/n, \text{ and } nO + S/n$$

where, O = oscillator frequency
I = intermediate frequency
S = signal or radio frequency
n = the harmonic order (i.e., first, second, third, etc., harmonic)

Where the complaint involves inter-

¹H. K. Morgan, Pro. IRE, p. 1,164; Oct. 1935

The Best-Known Name in Tubes

offers you the best
chance to build
your service
business

Now RCA Offers a Complete Line
of Dry Batteries, Too

Listen to
"The RCA Victor Show,"
Sundays, 4:30 P.M.,
EST, NBC Network

In Metal, Miniature, or Glass—

THE FOUNTAINHEAD OF

MODERN TUBE DEVELOPMENT IS RCA



62-6636-99

RADIO CORPORATION OF AMERICA

TUBE DIVISION • HARRISON, N. J.

LEADS THE WAY . . . In Radio . . . Television . . . Tubes . . .
Phonographs . . . Records . . . Electronics

ference of a second station interfering with the desired signal, the signal generator method can be used as a quick check for trouble. First the frequency of the beat notes should be compared with a listing of the local stations. For example, in the New York City area a whistle is often heard on WEA, 660 kc. The interference has often been traced to a 1,560-kc signal, WQXR. Since the i-f frequency of many receivers is 455 kc, 910 kc represents its second harmonic. This, added to 660 kc equals 1,570 or 10 kc away from WQXR, causing a high-pitched whistle on WEA. In other words, WEA and WQXR both come through the i-f when the receiver is tuned to 660 kc. For this condition, the i-f should be retrimmed to 460 kc.

Close-to-Station Locations

In locations where the receiver is close to a transmitter, a signal may be picked up at twice the station frequency. For example, a 650-kc signal may be received at 1300 on the dial. This is due to the second harmonic of the signal beating against the fundamental frequency of the local oscillator. The only possible cures are a well shielded chassis, or a wave trap tuned to the interfering signal, or both; Fig. 1. A large sheet of tinfoil or leadfoil cemented to the bottom of the cabinet will sometimes provide the necessary shielding. In this respect, the added shielding may detune the receiver due to the proximity of the shielding to unshielded coils mounted underneath the chassis. Therefore, when the set is aligned external to the cabinet, the chassis should be placed on a similar piece of tinfoil. In addition, glass-type converter tubes should either be shielded or replaced with their metal prototypes, making sure that the ground lug on the socket is grounded.

I-F Frequency Trouble

In some cases the i-f frequency is the cause of the trouble. For example, a signal of i-f frequency, usually an aircraft-beacon signal, may be the cause of the whistle. Or the second or third harmonic of the i-f frequency (for example for a 455 kc i-f, 910 kc is the second harmonic and 1365 kc the third) may cause the whistle.

When an i-f stage is energized with a signal, it becomes a source of radiating energy. This energy may be coupled back to the r-f section to cause the interference. Four methods may be used to prevent this condition. One involves the use of a wave trap in the

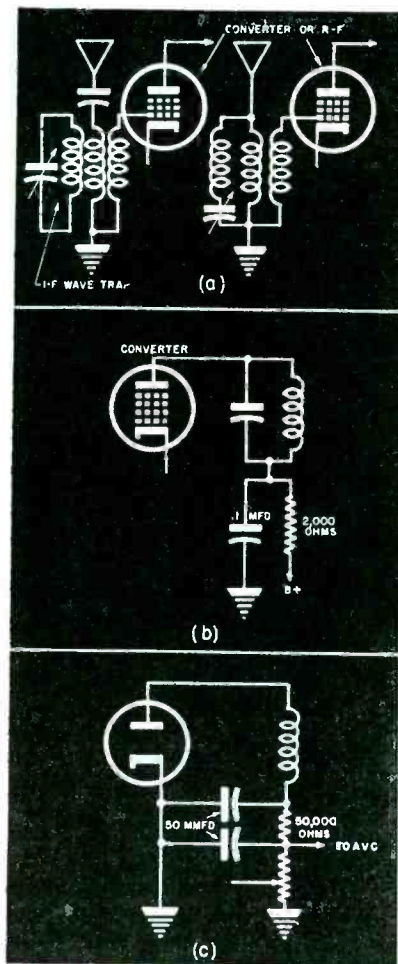

Fig. 2. Three methods of removing i-f interference. In a, a wave trap tuned to the i-f frequency is used in the antenna circuit. In b, an RC filter is used in the plate feed of the converter to remove any i-f feedback. A similar method for use in the detector circuit is shown in c.

antenna circuit tuned to the i-f frequency; Fig. 2a. The second method calls for the installation of a similar trap in the second detector. The third method requires the installation of metal shields under the chassis between r-f and i-f sections, or the rearrangement of the wiring so that pickup between r-f and i-f is minimized. In the fourth method an RC filter is used in the plate feed to the r-f or converter stage; Fig. 2b. Sometimes, the installation of a simple RC network in the diode return is effective, since it prevents feedback through the avc system; Fig. 2c.

Cross-Talk

In older type receivers, a particularly troublesome type of interference is adjacent channel interference or cross-talk. This is usually evidenced by the presence of the interfering signal only when the desired signal is on

the air. When the desired signal is off the air, the interference vanishes. The interfering station can be heard when the desired station signal is unmodulated. This may be remedied by reducing the coupling between primary and secondary in the antenna stage. It will be necessary to realign the antenna tuning capacitor trimmer after this is done. Where screen-grid tubes are used, the substitution of variable-mu types may also eliminate the trouble.

Signal Rectification

External cross modulation is due to signal rectification in wires or other metal bodies in the vicinity of the receiver or its antenna. Poorly soldered connections, or poor contacts in the antenna, ground, power line, metal conduit, tin roof, or even metal window frames may be the source of the trouble. The trouble is usually evidenced as one or more signals being received at dial settings other than their assigned frequency. The new setting, where a single station is involved, will usually be some harmonic of the station. In two or more stations are the cause, the new setting will be any sum or difference of the station frequencies. This condition only arises where the signals are of high local intensity. This particular type of trouble is easily isolated by removing the receiver to the shop bench and noting if the condition still exists.

Remedies

If the interference is proved to be local, several remedies are possible. The antenna and ground should be checked for loose connections. In private homes where the BX cable is exposed, as in the basement, the ground clamp to the cold water pipe should be checked. Ground clamps should be added where possible. Where the station signal is being rectified in the power line, the trouble may show up as a strong modulation hum on the station carrier. A line filter or two .1-mfd capacitors across the line placed inside the receiver may remove this condition. For a-c/d-c receivers, a .1-mfd capacitor across the line helps sometimes.

Shielded Lead-Ins

If the trouble persists, a shielded leadin, or a low-impedance antenna

(Continued on page 62)

Minimum

SERVICE CALLS



*Sales that
stay put*

MODEL 56 WEBSTER RECORD CHANGER

... as new as the Post-War Era

As you know—the amount of profit to be made largely depends on the service expense required. That's why Webster Record Changer, Model No. 56, can be depended upon for increased earnings. Also—it's easier to sell. Webster's famous name—plus new brilliance of performance and new mechanical perfection mean quick and lasting customer acceptance. The facts below tell the story.

- ✓ Perfectly crafted — highly styled — beautiful lines.
- ✓ Changes all standard records. Plays ten 12" or twelve 10" records in one loading.
- ✓ Fast change cycle — approximately 4 seconds.
- ✓ Simple, fool-proof operation. Can not be "jammed."
- ✓ Automatic shut-off after last record has played.
- ✓ Feather light needle pressure.
- ✓ Longer life for records — no cracks — no chipped edges.
- ✓ Dependable heavy duty Webster 4 Pole motor — cushion mounted for silent operation. No audible rumble or "wow."
- ✓ Records drop quietly — velvet soft heavy-pile turntable covering.
- ✓ Installation done from top — quick, easy mounting.
- ✓ 14-inch square mounting base. Over-all depth — above and below mounting board — 9 inches.
- ✓ Built for lasting performance. Practically no service calls are required.

KEEP UP A GOOD HABIT—BUY **VICTORY BONDS**



**ASK YOUR
DISTRIBUTOR
ABOUT IT!**

WEBSTER  **CHICAGO**

5610 BLOOMINGDALE AVENUE
CHICAGO 39, ILLINOIS

31 YEARS OF CONTINUOUS SUCCESSFUL MANUFACTURE

SERVICE, DECEMBER, 1945 • 19

SUB-MINIATURES

by ROGER ETTON

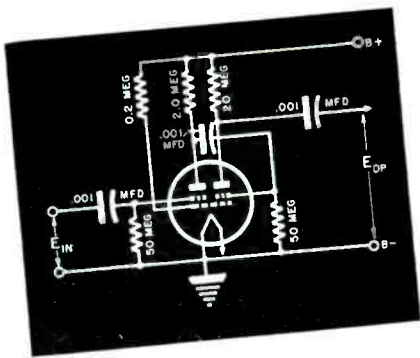

Fig. 1. Typical amplifier circuit using a double space-charge tetrode voltage amplifier of the hearing-aid type.

THE wartime development of the tiny radio-proximity fuze receiver-transmitter¹ using sub-miniature components and tubes has prompted the design of tiny pocket-type receivers using sub-miniature parts and tubes. Engineering of the

sub-miniature tubes has been quite advanced, several companies having already announced quite a few types.

These tubes are not to be confused with standard miniature types, which

(Continued on page 47)

¹Ralph G. Peters, *The Radio Proximity Fuze*, COMMUNICATIONS; October, 1945.

Type	Class	Bulb Size	Filament Rating		Use	Plate Volts	Negative Grid Volts	Screen Volts	Plate Current (ma)	Screen Current (ma)	Plate Resistance (ohms)	Amplification Factor	Ohms Load for Stated Power Output	Undistorted Power Output (milliwatts)
			Volts	Amp.										
1C8	Triode Heptode	Diam. 3/8" Length 1 1/2"	1.25	.040	Converter	45	0	45	0.4	1.0	about 1 meg.
1Q6	Diode Pentode	Diam. 3/8" Length 1 3/8"	1.25	.040	Det. Amp.	67.5	0	67.5	1.1	0.3	500,000	Gain = about 50
1V5	Pentode	Diam. 3/8" Length 1 3/8"	1.25	.040	Power Amp.	67.5	4.5	67.5	1.8	0.35	185,000	25,000	50
1W5	Pentode	Diam. 3/8" Length 1 1/2"	1.25	.040	R-F Amp.	45	3.0	45	0.8	0.2	250,000	40,000	15
						67.5	0	67.5	1.7	0.4	500,000

Fig. 2 (above). Tentative characteristics of Sylvania sub-miniature proximity fuze style tubes.

Tube	Type	Filament		Plate Volts	Negative Grid Volts	Screen Volts	Plate Current (ma)	Screen Current (ma)	Plate Resistance (ohms)
		Volts	Amp.						
1W5	sub-miniature	1.25	.040	67.5	0	67.5	1.7	.4	500,000
2E32	sub-miniature	1.25	.050	22.5	0	22.5	.35	.3	350,000
1T4	miniature	1.4	.050	45	0	45	1.7	.7	350,000
1N5	standard	1.4	.050	90	0	67.5	3.5	1.4	500,000
				90	0	90	1.2	.3	1,500,000

Fig. 3 (above). Comparison of sub-miniature, miniature and standard tube characteristics.

Type	Filament Voltage	Filament Current	Maximum Heptode Plate Voltage	Maximum Heptode Screen Voltage	Maximum Triode Plate Voltage	Maximum Total Cathode Current	Minimum External Signal Grid Bias	Frequency Converter	
								Plate voltage (heptode)	Screen voltage (heptode grids 2 and 4)
2G22	1.25	50 ma	45	45	45	2.0 ma	0 volts	22.5	22.5
								Oscillator plate voltage (triode)	22.5
								Signal grid bias (heptode grid 3)*	0
								Oscillator grid resistor (triode)	50,000 ohms
								Plate current (heptode)	200 μ a
								Screen current (heptode)	300 μ a
								Oscillator plate current (triode)	1 ma
								Oscillator grid current (triode)	30 μ a
								Conversion plate resistance (approx.)	0.5 meg

Figs. 4 (above) and 5 (below). Fig. 4 shows the preliminary characteristics of a Raytheon triode-heptode sub-miniature frequency converter. In Fig. 5 are preliminary data on the Raytheon diode-pentode sub-miniature detector-amplifier.

Type	Filament Voltage	Filament Current	Maximum Plate Voltage	Maximum Screen Voltage	Maximum Cathode Current	Operating Characteristics	
						CLASS A ₁	RESISTANCE-COUPLED AMPLIFIER
2E42	1.25	30 ma	45	45	1.0 ma	Plate voltage	22.5
						Screen voltage	22.5
						Control grid voltage*	0 volt
						Plate current	0.4 ma
						Screen current	0.15 ma
						Plate resistance	0.25 meg
						*Grid resistance = 5 megohms	
						RESISTANCE-COUPLED AMPLIFIER	
						Plate supply voltage	22.5
						Screen supply voltage	22.5
						Load resistance	1 meg
						Screen resistance	5 meg
						Voltage gain	20
						DIODE RATINGS	
						Minimum diode current with 10 volts d-c applied	0.5 ma
						Maximum diode current for continuous operation	0.25 ma
						(The diode plate is located at the negative end of the filament.)	

New!

Series 200

A RELAY BY GUARDIAN with Interchangeable Coils

BUILT IN TWO PARTS

★ Two basic parts—a coil assembly and a contact assembly—comprise this simple, yet versatile relay. The coil assembly consists of the coil and field piece. The contact assembly consists of switch blades, armature, return spring, and mounting bracket. The coil and contact assembly are easily aligned by two locator pins on the back end of the contact assembly which fit into two holes on the coil assembly. They are then rigidly held together with the two screws and lock washers. Assembly takes only a few seconds and requires no adjustment on factory built units.

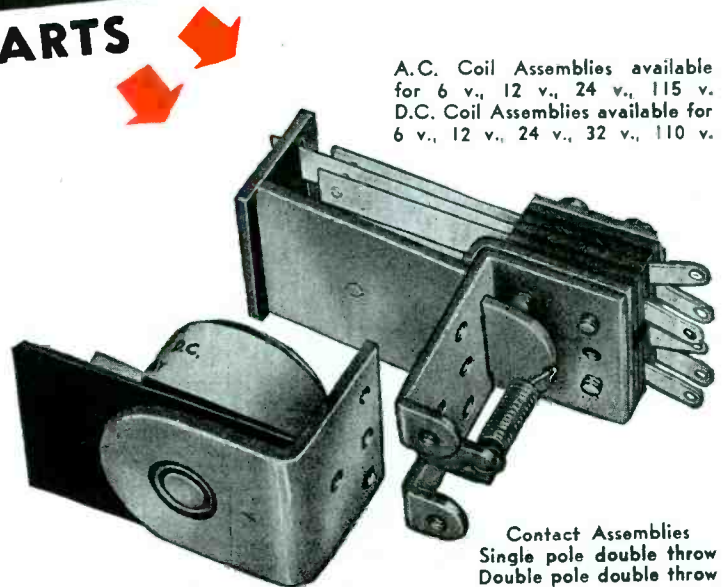

A.C. Coil Assemblies available for 6 v., 12 v., 24 v., 115 v.
D.C. Coil Assemblies available for 6 v., 12 v., 24 v., 32 v., 110 v.

Contact Assemblies
Single pole double throw
Double pole double throw

SERIES 200 RELAY

On Sale at Your Nearest Jobber NOW!

See it today! . . . this amazing new relay with interchangeable coils. See how you can operate it on any of nine different a-c or d-c voltages—simply by changing the coil. Ideal for experimenters, inventors, engineers.



TWO CONTACT ASSEMBLIES

The Series 200 is available with a single pole double throw, or a double pole double throw contact assembly. In addition, a set of Series 200 Contact Switch Parts, which you can buy separately, enables you to build dozens of other combinations. Instructions in each box.

NINE COIL ASSEMBLIES

Four a-c coils and five d-c coils are available. Interchangeability of coils enables you to operate the Series 200 relay on one voltage or current and change it over to operate on another type simply by changing coils.



Your jobber has this sensational new relay on sale now. Ask him about it. Or write for descriptive bulletin.

GUARDIAN  **ELECTRIC**
1617 W. WALNUT STREET CHICAGO 12, ILLINOIS
A COMPLETE LINE OF RELAYS SERVING AMERICAN INDUSTRY

AVC - AND A - F

by **ROBERT L. MARTIN**

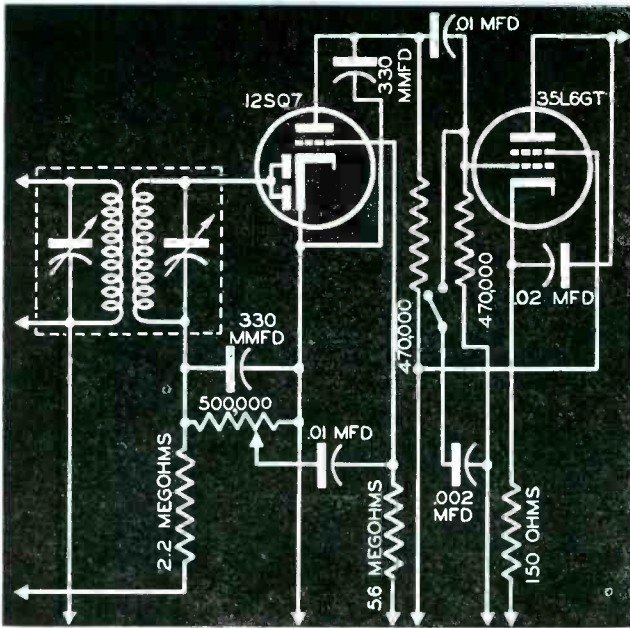

Fig. 1. Diode detector circuit used in G.E.L.-651. Diodes are connected in parallel for minimum diode resistance.

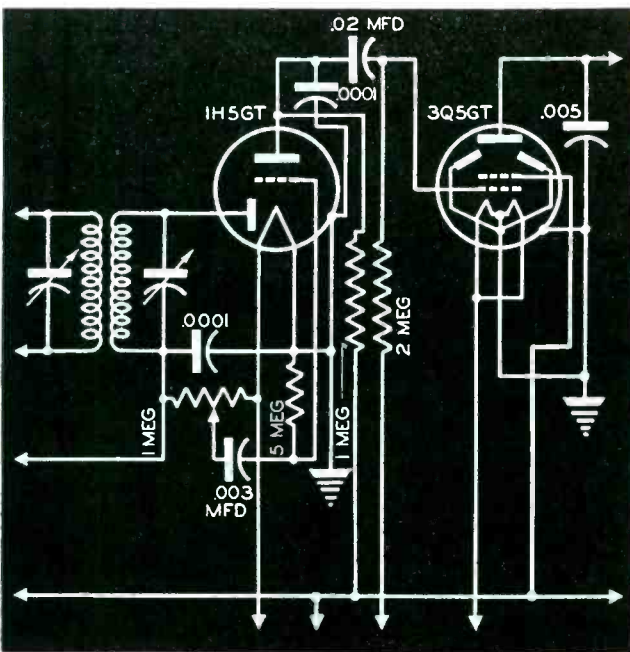

Fig. 2. Battery model receiver, Ward 14 BR-474, using a combination detector-avc-amplifier circuit. Note the small audio coupling capacitors used to minimize cabinet resonance. The r-f bypass capacitor at the first audio output usually has a value of 50 or 100 mmfd.

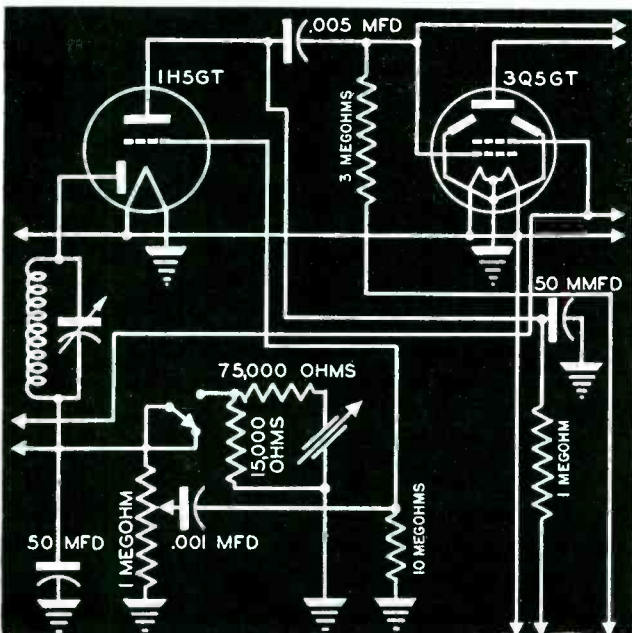

Fig. 3. Detroit 408 battery-phonograph model with a combination detector system.

ONE of the most interesting sections of the modern receiver is the avc/detector/a-f combined circuit, featuring the diode detector. Diode detectors are preferred in these circuits because their greater linearity permits less distortion and because of the simple means of obtaining avc from the detector. These advantages far outweigh the disadvantages, such as reduction of selectivity due to the absence of amplification in the detector.

Diode Detector Tubes

Almost any tube at all will serve well when connected as a diode detector for intermediate frequencies. The 6H6 dual diode was originally introduced as a detector, but has been largely supplanted by the more economical diode-triode, duplex diode-triode and diode-pentode combination types of tubes. The triode sections are available in both low and high mu, the low-mu tubes originally being used with audio coupling transformers. Typical tubes used included 6R7, then the 6SR7, 6ST7, etc. The high-mu triodes and pentodes are designed for resistance coupling, providing an audio gain of 20 to 50, the latter figure being common for pentodes.

Gain is the principal objective in a loop-fed portable receiver because of the limited pickup, not only in the first audio amplifier stage but throughout the set. In other words, quality is exchanged for gain. In large sets, on the other hand, it is usually permissible to use another tube or two. Thus the sacrifice is in the other direction, gain for quality.

G. E. L-651

One of the simplest of diode detector circuits, in a duplex-diode-triode application, is shown in Fig. 1; G. E.

*See SERVICE, August, 1945, for additional data on second detector-avc systems.

DETECTOR SYSTEMS *

L-651. The diodes are connected in parallel for minimum diode resistance in a half-wave rectifier circuit. The diode-load resistor is the volume control itself, the usual values being $\frac{1}{2}$ to 2 megohms. Battery sets generally use higher values than standard a-c or a-c/d-c receivers. The bypass capacitor shunting the diode-load resistor is necessary for detection and also serves to bypass the unwanted i-f to ground. Typical values for this capacitor run from 100 to 250 mmfd. Too low a value leads to insufficient bypassing which often results in screeching signals, while too high a value will bypass the high audio frequencies, causing a loss in treble.

Audio Capacitor Values

The a-f coupling capacitor between the volume control and the first a-f grid usually lies between .001 mfd and .01 mfd depending upon the value of the grid leak and the proportion of bass response desired. For instance, a .001-mfd or .002-mfd capacitor will attenuate the lows, minimizing hum output and giving a greater apparent power output. This is important in the less expensive receivers and portables. Since the ear is much more sensitive to the middle range than to the bass, a given amount of power will appear increased when the bass is removed. Most first audio stages are biased by means of grid leaks with values of 2 to 15 megohms, the higher values being used in battery sets. The product of the coupling capacitor and grid leak values must not be excessive or the time constant will be too great. Then the change in volume will lag behind the manipulating of the volume control. The optimum values for capacitor and leak for the average receiver are .005-mfd and 6.8 megohms. The circuit shows a shunt capacitor at the 35L6 input used for tone control.

Ward 14-BR-474

A detector/avc/audio amplifier circuit similar to that shown in Fig. 1, used in this instance in a battery

Fig. 4. RCA QU52C with a single diode detector and bass-compensated volume control. A .005-mfd capacitor and 10-megohm resistor are used for audio coupling.

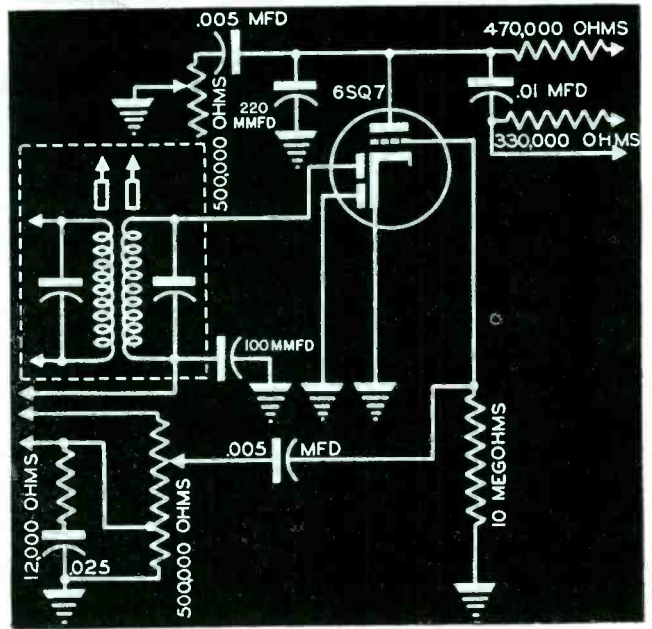

Fig. 5. The G.E. 20 receiver using an extra amplifier stage to provide for the loss in gain caused by degeneration. A tertiary winding on the output transformer supplies the feedback voltage which is fed to the cathode of the 6J5 through a 3300-ohm bias resistor.

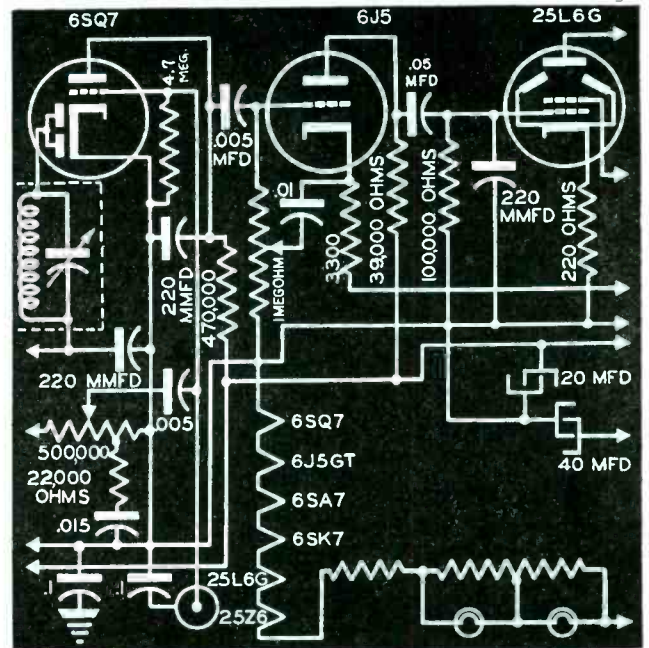
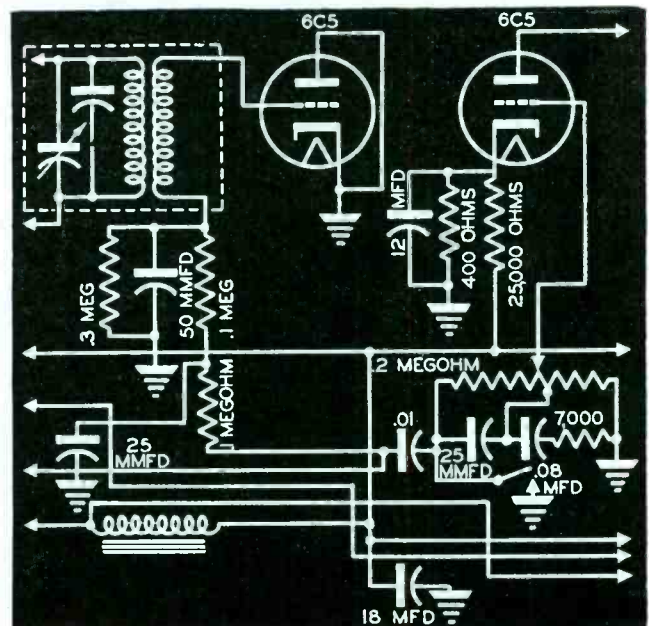
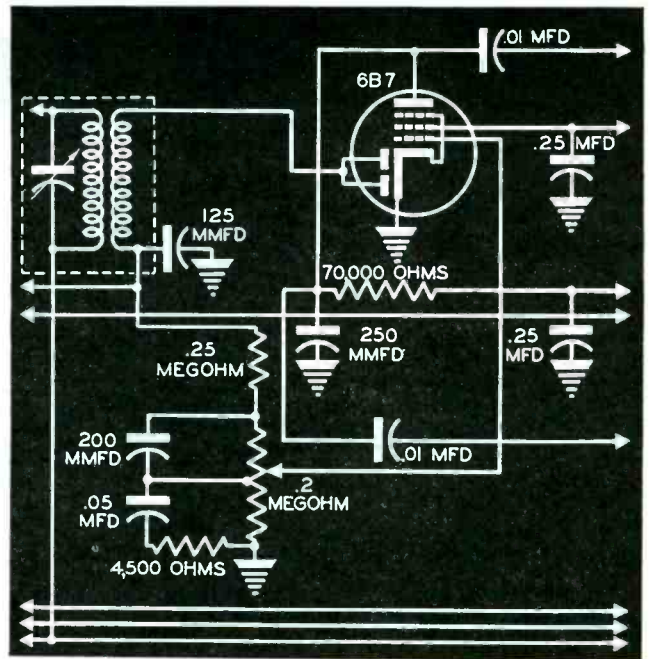
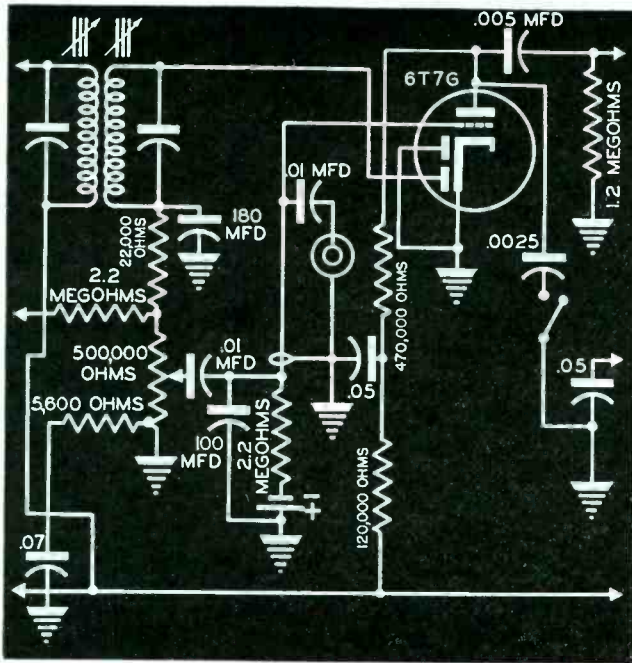

Fig. 6. Ward's 62-271, with a triode used as a diode; grid is plate and plate is grounded. Enforced cathode bias is applied to the first audio instead of the usual cathode resistor. This is done by bleeding some d-c from the B supply through a potentiometer.





model is shown in Fig. 2; Ward 14-BR-474. Small first audio coupling capacitors have an additional advantage in portables, minimizing cabinet resonance. This is particularly important in portables because the case is all enclosed. The triode plate resistor in battery sets usually has a value of $\frac{1}{2}$ or 1 megohms in contrast to $\frac{1}{4}$ to $\frac{1}{2}$ megohms for larger receivers. The higher values permit an increase in gain, necessary in portables. In addition with higher values of resistors, smaller coupling capacitors are used. An r-f bypass capacitor of 50 or 100 mmfd is usually employed at the first audio output.

Detrola 408

A Detrola 408 battery-phonograph

Figs. 7 (above, left) and 8 (above, right). In Fig. 7 appears the combination detector system of a 6-volt 150-mil farm receiver, RCA QB1. A series resistor precedes the volume control for r-f filtering. In Fig. 8 we have the 6B7 double-diode pentode as a detector-amplifier; Radio Wire Television B92. A 41 follows this tube as a triode driver.

phono pickup. A .001-mfd capacitor is used. A pair of 3Q5 output tubes are connected in parallel.

RCA QU52C

A 6SQ7 single-diode detector and bass compensated volume control are featured in the RCA QU52C, shown in Fig. 4. A 22,000-ohm resistor is conected in series with the $\frac{1}{2}$ -megohm control. The latter is tapped at 125,000 ohms for the compensating shunt consisting of a .025-mfd capacitor and 12,000-ohm resistor. This receiver uses a .005-mfd capacitor and a 10-megohm resistor for audio coupling. An iron core i-f transformer feeds the detector diode. The other diode is grounded. A variable tone control,

(Continued on page 49)

combination circuit is shown in Fig. 3. The input to the volume control is switched from detector output to the

Figs. 9 (below, right) and 10 (below, left). The National NC-44B communications model with a 6SQ7 detector amplifier system appears in Fig. 8. Cathode bias is used here instead of the usual grid-leak bias. Fig. 9 shows the 3A8GT combination detector system of the Motorola 41H. The single diode detector is fed by the pentode section serving as an i-f amplifier.

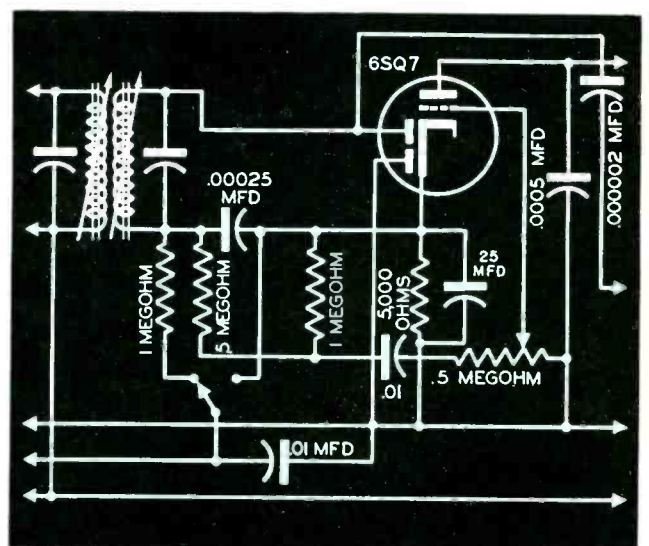
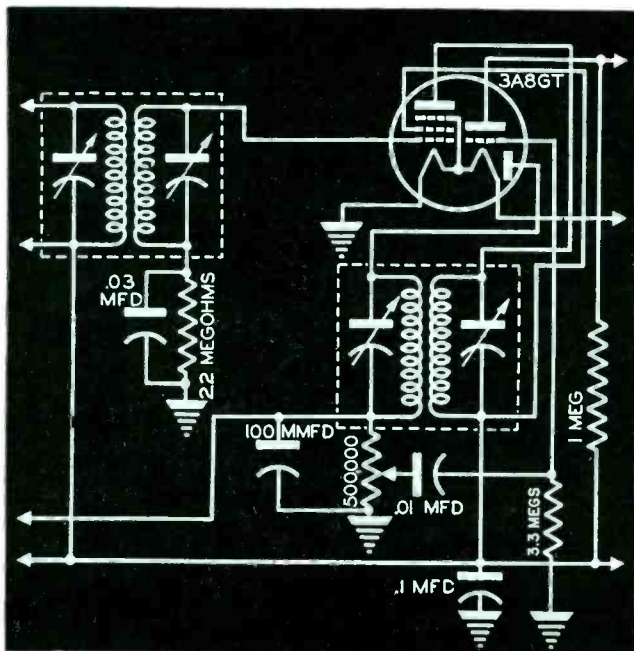



THEY'RE RADIO-ENGINEERED



*That's Why RCA Batteries
Will Outsell All Others!*



THE RCA radio battery line, streamlined to 35 Preferred Types, satisfies the requirements of 99% of all battery-powered radio sets. With your help, RCA batteries will outsell all others.

Built to radio standards, specifically for use in radio sets, RCA batteries are designed to give your customers more listening hours per battery dollar. Tell *that* to your customers and watch them buy!

RCA, with a quarter of a century of radio

experience, is the best-known name in radio. And that name is working for *you!*

The RCA seal on your radio batteries is a guarantee of public acceptance, of public confidence, of public demand.

Listen to
"THE RCA SHOW," Sunday, 4:30 P. M., EWT
NBC Network

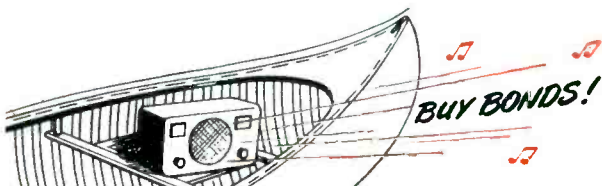

62-6736-109

RADIO CORPORATION OF AMERICA

TUBE DIVISION • HARRISON, N. J.

LEADS THE WAY... In Radio... Television... Tubes...
Phonographs... Records... Electronics

VOLUME AND TONE

THE variable wire-wound and carbon-element resistors employed as volume and tone controls are far more subject to trouble than are *fixed* resistors. This is so because their vital parts are subjected to handling, mechanical motion and some wear almost every time the set owner turns the receiver on or off or tunes to a new station and subsequently adjusts the volume or tone to the desired value. Consequently, they receive even more operation cycles than do the tuning dial and capacitor.

This repeated operation of the contact arm eventually causes wear of the moving parts and of the resistance element. The latter, because of the nature of the resistance materials that must be employed¹, is not particularly rugged even when new.

Locating Difficulties

As a rule, faults that have developed in volume and tone controls quickly make their presence known, because rotation of the control knob of the unit while the receiver is in operation results in annoying noise, intermittent operation, or otherwise unsatisfactory control of the volume or tone. Such performance is extremely annoying to the set owner—especially in the case of a volume control—so he usually does something about having it repaired. As a rule, volume and tone-control troubles are responsible for a substantial percentage of the Service Man's repair and replacement work.

Common Troubles

(1)—*Change in Resistance*: Wearing away of the carbonaceous resistance film, or the fine nichrome wire, employed for the resistance element¹ will cause its cross-sectional area to decrease, and the total resistance of the control to *increase*. However, this resistance increase in itself is not ordinarily of great importance, because exact values of maximum resistance are fortunately not required in ordinary volume or tone-control circuits. Variations of as much as 20% or even more in the total resistance of such controls are perfectly satisfactory in ordinary receiver circuits. Only where the volume control is employed as a part of the power voltage-dividing system is it necessary to observe fairly close tolerance.

However, if the control unit em-

Part Ten of a Series on Receiver Components

by **ALFRED A. GHIRARDI**

Advisory Editor

plays a critical resistance taper, such wear may alter it and the smoothness of the control action. Also, if the unit is employed as a current-carrying type of control, excessive wear may cause overheating and eventual destruction of the resistance element, as will be explained later.

(2)—*Noise*: One of the most important demands made upon a volume or tone control is that it be electrically noiseless in operation. The chief objectionable result of continued use and wear of the resistance element is the development of *noise* when the control is manipulated. This is caused by sudden variations in resistance that result as the contact arm is moved. These sudden resistance variations cause corresponding variations in the currents or voltages controlled by the volume or tone-control circuit, resulting in sudden current or voltage impulses. These, when amplified enormously by the high-gain receiver circuits, are heard in the loudspeaker as loud, scraping noises.

Noise, or even intermittent operation, usually results from the fundamental cause of *imperfect contact*. If imperfect or variable contact develops between the resistance element and the contact-making element¹ at any point in its travel, or at any other point in the electrical circuit of the control, noise or intermittent operation

will result. This may be brought about by any of several conditions, the most common of which are: (1)—Loss of spring tension (or non-uniform spring tension) in the contact arm; (2)—dirt (or the formation of a glazed non-conducting surface) on the resistance element, the contact surface, or the shaft slip-ring and wiper contact surface; (3)—loose or corroded terminal rivets.

Manipulation of the volume or tone control shaft while the receiver is turned on will reveal this trouble either by the *scratchy* noise issuing from the loudspeaker or failure of the unit to smoothly control the volume or tone.

Volume controls used in diode circuits are often unnecessarily replaced because of apparent noisy operation when, in many cases, the noise is due to excessive diode current flowing through the volume control. It is good practice to test or replace the tube associated with the diode control, to assure that any abnormal diode current condition does not exist, before changing the volume control. Changing the volume-control circuit to the more recent type in which no diode d-c flows through the volume control will cure noise due to this cause in all diode controls. The circuit change recommended will be presented in the next article of this series.

Open-Circuits

(3)—*Opens*: In both carbon and wire-wound controls (especially the older types), movement of the contact arm directly over the surface of the resistance element may eventually wear away the carbon deposit or the nichrome resistance wire sufficiently to create an open circuit. However, *opens* caused directly by wear are not the most common. A control will become excessively *noisy* long before this condition is reached. *Opens* are more frequently the result of a secondary action. If the resistance element experiences much wear, its resistance and the heat generated in it in the worn area increase while its heat-dissipating capability *decreases*. Consequently, if it is being employed as a current-carrying type of control, such wear may cause it to become overloaded by normal current, or momentary excessive current. This may eventually cause an intermittent or full *open* by development of hot-spots and burning

This series of articles on *Fixed and Variable Resistors* has been especially prepared by Mr. Ghirardi in response to the numerous demands of newcomers to servicing for detailed construction, operating and servicing information on the various components that go to make up modern receivers.

This series constitutes a valuable reference which even experienced Service Men will find worthwhile as a refresher and for new servicing ideas. We would appreciate receiving suggestions for the subjects of future articles in the series.—Ed.

¹Part 6. SERVICE, August, 1945.

CONTROL RESISTORS

out of the resistance element. An ohmmeter check will reveal this condition.

An *open* volume control will not provide proper control of volume, even though it may permit partial transfer of the signal in some volume control circuits.

(4)—*Shorts*: Because of the way volume and tone controls are designed, *shorts* do not often occur in them. However, in those units in which the metal case is *hot* and an insulating bushing is employed between the chassis and the mounting bushing of the control, a defective insulating bushing or washer will often create a short to the chassis. Such trouble can usually be located only after all leads to the control have been unsoldered and an ohmmeter test is then made between each terminal of the control and the chassis.

Repair Versus Replacement

There is no doubt but that the best service policy is to *replace* a faulty volume or tone control with a suitable replacement unit whenever this is possible, for a repaired unit seldom gives as long or satisfactory service as does a new one.

There are general recommended procedures for selecting the correct replacement volume and tone controls for *standard listed* receivers, *orphan* and *unlisted* receivers. In many instances it is more expedient to repair than to replace such controls. The methods of repairing all types of volume and tone controls will be explained in the next article of this series.

"Standard" Listed Receiver Replacements

(1)—*Use of Manufacturer's Replacement Lists and Guides*: Sufficient accurate manufacturer's volume and tone-control replacement information is now available to Service Men to permit the selection of the correct replacement unit for almost all *standard listed* receivers (those manufactured by the standard name receiver manufacturers). Most receiver manufacturer's service sheets supply specifications for the proper control to use. In addition, schematic diagrams of

Manufacturer and Model	IRC PART NUMBERS Use Control Switch Shaft	See Note Page 12	Ohms
EMERSON RADIO & PHONOGRAPH			
375LW	Vol. *D13-137	41	16 1M Ω
409, 410, 411 (A4 Ch.)	Vol. *D16-119	41	16 20M
429, 410, 411 (U4C Ch.)	Vol. D14-125	41	16 75M
415, 416 (V4LA Ch.)	Vol. *D16-119	41	10, 16 20M
420 (V4 Ch.)	Vol. *D15-119	41	10, 16 20M
667	Vol. J-525	S	1M Ω
678 (2nd type)	Vol. J-938	S	500M
	Tone Obtain from original Mfr. N.S.		
L755	Vol. D1-50	S	4, 8, 10 5M
	Tone D11-120		16 25M
M756	Vol. D1-50	S	4, 8, 10 5M
	Tone D11-120		16 25M
S758	Vol. D1-50	S	4, 8, 10 5M
770 (AW7 Ch.)	Vol. *D13-137	41	16 1M Ω
	Tone D11-120		16 25M
965	Vol. J-525	S	1M Ω
CS	Vol. D16-116	41	16 10M
E, KS	Vol. D16-116	41	16 10M
F	Vol. D16-116	41	16 15M
J6	Vol. D16-116	41	16 10M
	Tone D13-123		16 50M
KS	Vol. *D14-116	41	16 10M
T, TS	Vol. D16-116	41	16 10M
EMPIRE ELECTRICAL PRODUCTS			
40 SW	Vol. *D13-133	41	16 500M
51	Vol. *D13-133	41	16 500M
71	Vol. *D13-133	41	16 500M
40AC	Vol. *D14-116	41	16 10M
40DC	Vol. D16-116	41	16 10M
456A	Vol. *D13-133	41	16 500M
468B	Vol. *D13-133	41	16 500M
479C	Vol. *D13-133	41	16 500M
480C	Vol. *D13-133	41	16 500M
500AC	Vol. *D14-116	41	16 10M
	Tone *D13-123		16 10M
500DC	Vol. D16-116	41	16 10M
550AC	Vol. D16-116	41	16 10M
	Tone *D13-123		16 50M
60DAC	Vol. *D14-116	41	16 10M
	Tone *D13-123		16 50M
700DC	Vol. D16-116	41	16 10M
	Tone *D13-123		16 50M
ERLA (See Electrical Research Labs.)			
ESPEY MFG. CO. INC.			
875	Vol. *D13-133	41	16 500M
	Tone *D13-133		16 500M
5111	Vol. *D13-133	41	16 500M
	Tone *D13-133		16 500M
7111	Vol. *D13-137	41	16 1M Ω
	Tone *D13-133		16 500M
7161, 7163	Vol. *D13-137	41	16 1M Ω
	Tone *D13-133		16 500M

Fig. 1. Portion of a typical page from a control manufacturer's volume- and tone-control replacement guide compiled for the Service Man's guidance. (Courtesy IRC)

the typical volume and tone-control circuits² employed in receivers, and the recommended type of control to be employed in each one; comprehensive lists, manuals and guides that

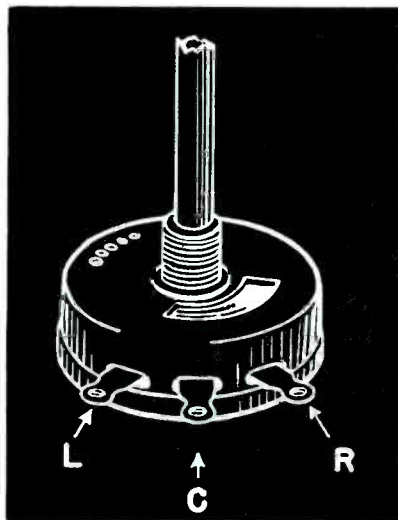

specify the type number of the particular manufacturer's replacement control recommended to be used in each receiver model listed (see Fig. 1); and many other helps are distributed to Service Men by leading manufacturers of replacement controls. Every Service Man should collect as many of these control manufacturer's manuals and guides as he possibly can, and make a practice of consulting them in his control replacement work. A surprisingly large amount of useful general information about the various types of controls can also be picked up from them.

Exact Duplicates and Standards

(2)—*"Exact Duplicates" and "Standard" Units*: When consulting the replacement lists and guides of some control manufacturers, it will be noticed that in many instances two or more types of controls are listed. One type is the *exact duplicate*, mechanically and electrically, of the original control in the receiver and is guaranteed to fit and operate without mechanical or electrical changes. These controls have shafts of the proper type and length, taps and internal C-bias resistors when required, proper switches mounted, and incorporate any special mechanical or electrical features required.

Inasmuch as it would require a considerable amount of time, trouble and expense to work up a complete line of individual *exact duplicate* replacement controls for use in the several thousand models of standard receivers now in use, many listings are mainly suggestions for using *standard model* controls units closely approximating the requirements of the receiver so that they can be satisfactorily installed if certain minor mechanical changes (if any) such as alteration of shaft length, bushing, etc., are first made in them.

List of Checks

The Service Man will do well to distinguish between such listings of *exact duplicates* and *standard* units. The former are in accordance with the original specifications of the set designer and manufacturer; the latter

Fig. 2 (left). Customary terminal designation for volume or tone controls when facing shaft end of control.

²For a comprehensive explanation of the various volume and tone control circuits employed in radio receivers see *Volume Control Circuits* by Robert L. Martin, SERVICE; June and July, 1945.

are simply improvisations that have been found acceptable in practice. The *exact duplicate* type should be employed as a replacement whenever it is available.

Unlisted, Orphan and Private-Brand Receiver Replacements

Frequently, orphan, private-brand, loft or other such receivers are encountered for which no published volume or tone control replacement information or schematic diagram is available. In such cases, the matter of selecting the correct replacement control becomes somewhat more complicated. The following procedure is recommended³:

(1) Before removing the faulty control, or even unsoldering the leads, the control circuit should be traced and then a schematic circuit diagram should be made. Also, it is important to note the connections of the leads to the control and make a pictorial sketch of the lead connections to prevent wiring mistakes when connecting the leads to the new control later.

(2) The faulty control should be removed from the chassis.

(3) Then the diameter and depth of the control should be measured and recorded.

(4) The shaft diameter and length can then be measured and recorded and a note made of the type of end provided for the knob.

(5) The next step involves the measurement of the overall resistance of the control with an ohmmeter. If the resistance element is open, it will be necessary to open the control and measure the value of resistance to each side of the open. The overall resistance can then be arrived at by adding these two values. If the element is burned out, it will be necessary to measure the various remaining sections of the resistance, and from their total, estimate the amount of resistance that has been destroyed, so as to obtain the original overall resistance value.

(6) We then determine the maximum wattage the control will be called upon to dissipate in normal use. The maximum current it will be called upon to carry can be determined by inserting a d-c milliammeter in series with its circuit, with the receiver turned on. If its resistance element is open, a fixed resistor of equal value may be substituted temporarily. The maximum wattage the resistor must dissipate⁴ may then be calculated by

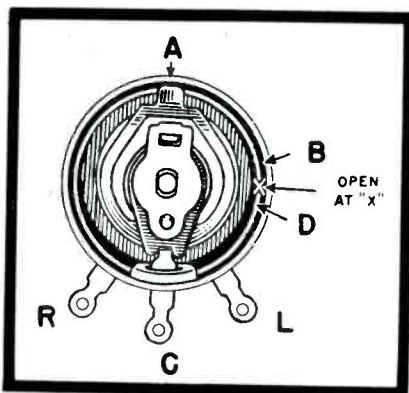

Fig. 3. Rear view of wire-wound control having an "open" resistive element. The terminal designations L and R indicate left- and right-hand positions. Method of checking the taper in a control of this type is explained on page 30.

multiplying the square of the maximum current in amperes by the resistance of the control in ohms, i.e., $I^2 \times R$. This quantity is especially important in the replacement of carbon-element type controls in bias-type control circuits in cases where two or more stages are controlled through the unit, or where considerable bleed current is carried.

(7) It is now necessary to note whether the control is of the wire-wound or the carbon type. Wire-wound controls are generally used for values up to approximately 10,000 ohms, and usually for antenna-shunt control, bias control (or a combination of both) and for voltage-dividing applications. This is not always the case, however, for carbon-element controls are made in values of maximum resistance ranging approximately from 1 to 20,000 ohms (and in 2-watt and 4-watt ratings). Carbon-element controls are ordinarily used in applications where a total resistance above approximately 10,000 ohms is required.

(8) Since the taper or resistance-variation characteristic of a volume

³Courtesy Yaxley Replacement Volume Control Manual, P. R. Malloy & Co., Inc.

⁴It should be remembered that the maximum safe power-dissipation rating (applying to the maximum-resistance setting) of tapered controls is less than that of corresponding linear controls of similar physical size, depending on the resistance-taper curve. In general, those controls having the steeper taper curve have the lower rating.

Also, the wattage rating specified by the control manufacturer always applies to the maximum-resistance setting only. For intermediate points of rotation, the dissipation rating in watts decreases—the amount depending upon the steepness of the taper of the resistance element. For a detailed discussion, see Part 7, SERVICE; September, 1945.

⁵The various resistance tapers obtainable in standard replacement controls, and the type of control circuit each is particularly suited for, were described and illustrated in Part 7, SERVICE; September, 1945.

or tone control actually is more important than its exact overall resistance, the taper of the faulty control should be ascertained in order to select a replacement that will duplicate the action obtained with the original control.

One way of determining the type of taper required is to study the volume control circuit employed, as determined in (1). When this is known, the proper type of taper required for proper operation in this type of control circuit may be ascertained by reference to the replacement control manufacturer's catalog⁵. This method is especially useful in cases where the resistance element of the control has been so badly damaged that it is difficult (or impossible) to make resistance measurements on it.

The original taper can be determined with fair accuracy by measurement if the resistance element (either wire or carbon) is in fair mechanical condition, even though it may be open in one or more places.

Determining Taper

To determine the taper of a control wherein the resistance element is not open, that is, where there is continuity between the left hand terminal, L, and the right hand terminal, R, the following procedure should be applied:

(1)—Place the control in the position shown in Fig. 2, with the moving arm and shaft set at the center of its rotation.

(2)—With a suitable ohmmeter measure the resistance between terminal L and terminal C. Make note of the value.

(3)—Measure the resistance between terminal C and terminal R, and compare the last reading with the first.

If the resistance between terminals L and C is lower than the resistance between terminals C and R the control has a left-hand taper.

On the other hand, if the resistance between terminals L and C is higher than that between terminals C and R the control has a right-hand taper.

If the resistance of the two halves of the control is the same on both sides of the center of rotation of the moving arm, i.e., when the resistance between terminals L and C is of the same value as that between terminals C and R, the control is without taper and is therefore called a linear control because the resist-

Finer in Performance AND NOW — Smarter in Appearance with

INTERCHANGEABLE COLORED FLANGES

ROUND OR SQUARE... AT NO EXTRA CHARGE



Marion Glass-to-Metal Truly Hermetically Sealed 2½" and 3½" Electrical Indicating Instruments

- 12 different iridescent colors—blue, red, green, silver, gold, etc.—in keeping with the modern trend of high-styling radio and electronic equipment. Supplied on special order at no extra charge.
- Interchangeable round or square shapes simplify instrument stocking problems; a minimum stock permits universal application of the two basic Marion "hermetic" instruments.
- The eye-appeal of these colored flanges will be especially welcomed among the ham and experimenter market. The bright colors will also lend themselves to attractive window and interior displays.

Remember—Marion "hermetics" cost no more than most competitive unsealed instruments. And they're being delivered in ever-increasing quantities. For details of a Marion Franchise, write to our Jobber Sales Division.



MARION ELECTRICAL INSTRUMENT CO.

MANCHESTER, NEW HAMPSHIRE

Jobber Sales Division: Electrical Instrument Distributing Co.
458 BROADWAY NEW YORK, N. Y.

ance increases linearly with rotation of the moving arm.

To determine the taper of a control wherein there is an open in the resistance element, the following procedure can be applied:

Fig. 3 should be referred to during this check. This diagram shows a rear view of a wire-wound control with an open at the point marked X. It will be noted that the terminals bear the designations left-hand, L, and right-hand, R, as they are when facing the shaft end of the control.

(Although a wire-wound control is shown, these instructions also apply to carbon type controls.)

(1)—To determine the taper, the moving arm should be placed in the center of its rotation, as in Fig. 3.

(2)—The resistance between terminal R and terminal C should be measured and a note made of value.

(3)—Then the resistance between terminal C and the edge of the open marked B should be measured.

(4)—We now have to measure the resistance between terminal L and the edge of the open marked D.

(5)—In the last step we have to add the values obtained in steps three and four, to obtain the resistance of right-hand half of control.

With the values of the two halves of the control known, a comparison will quickly indicate what the taper is, as was explained previously.

Checks for Additional Opens

If there is more than one open, the above method should be followed, with the exception that the values of resistance between the different open places will have to be measured and then all added together to compare resistance of the two halves of the control.

The foregoing method of determining the taper by comparing the resistances of the left and right-hand halves of the resistance element is a rough and ready method applicable in most cases. However, whenever it is necessary to check the exact shape of the taper characteristic employed in any control, it

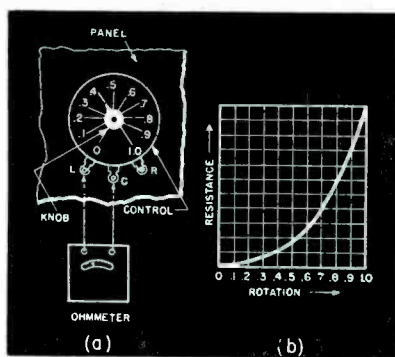

Fig. 4. Method of checking the resistance taper of a volume or tone control. At a appears the method of connecting the control and ohmmeter, while at b we have a plot of the readings taken.

may be done very readily by mounting the control on the rest of the panel and fastening it in place with its terminals pointing downward, as shown at (a) in Fig. 4. A knob (preferably one of the bar, or pointer, type) should be placed on the shaft and adjusted so that when the shaft is turned all the way to the left (just before the on-off switch snaps off) the position of the knob pointer can be marked in pencil on the panel. The knob should be fastened in this position, and position of its pointer marked. Then the knob should be turned all the way clockwise and the position of its pointer marked again. This total rotation should then be divided into 10 equal parts, by means of radial lines drawn on the panel.

An ohmmeter is then connected to the left-hand terminal L and to the center terminal C of the control. Now, with the control rotated all the way to the left (just before the on-off switch snaps off) the first resistance reading is taken, which in most instances will be zero. We continue by taking a reading of the resistance at every 1/10 of the total rotation, from left to right. Then the readings are plotted on graph paper, as illustrated at (b) of Fig. 4. The graph produced will indicate the taper of the control. That illustrated at (b) indicates a typical

left-hand taper.

(9) If the control is tapped, the resistance between the left-hand terminal L, and the tap should be measured.

(10) At this point the following information will have been collected:

- (a)—Control circuit employed.
- (b)—Diameter and depth of control.
- (c)—Shaft dial diameter, length, shape.
- (d)—Overall resistance.
- (e)—Maximum wattage the control is called upon to dissipate.
- (f)—Type (wire-wound or carbon).
- (g)—Taper.
- (h)—Tap value (if control is tapped).

All of this information is necessary for intelligent selection of the correct replacement control from the control manufacturer's catalog.

Useful Suggestions about Replacement Controls

The physical size of the replacement control may, or may not, have to be the same as that of the original unit, depending upon the available space. Replacement unit must be small enough to fit into the space.

The shaft-length diameter and type of end should be such that the unit works satisfactorily when installed. The use of the newer types of midget controls designed to be used with plug-in shafts makes it possible to replace, both mechanically and electrically, over 90% of the midget control requirements by carrying a small stock of only five or six controls and a kit of the various types and sizes of plug-in shafts.⁶

Carbon-element controls which have abrupt tapers generally cause noise troubles sooner than those having more gradual tapers. Practically all volume controls designed for audio-circuit use have a taper that is gradual over approximately the first 50% of rotation and much steeper thereafter, but some of these units have a much more abrupt change of taper in the 50-70% rotation region than do

(Continued on page 51)

⁶Part 9, SERVICE, November, 1945.

Fig. 5. High voltage insulating coupler applied to control that must be used in high-voltage circuits as in television and c-r oscillographs. Sectional view of coupler construction appears below. Further data on coupler and use appears on page 51.

(Courtesy Clarostat Mfg. Co., Inc.)

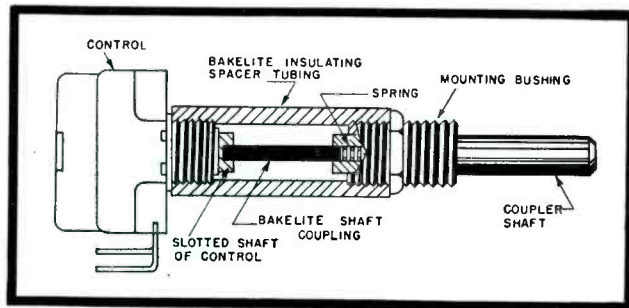
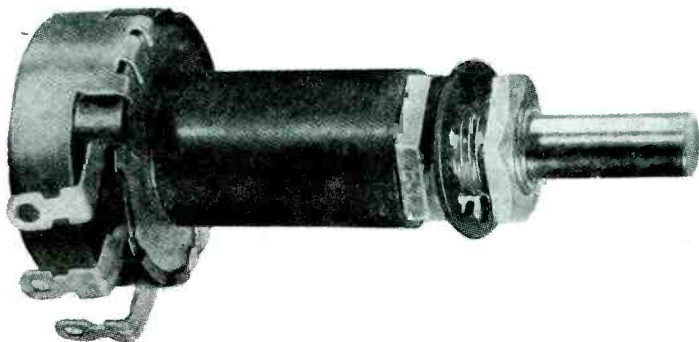



for every transformer application

FOR THE SET MANUFACTURER

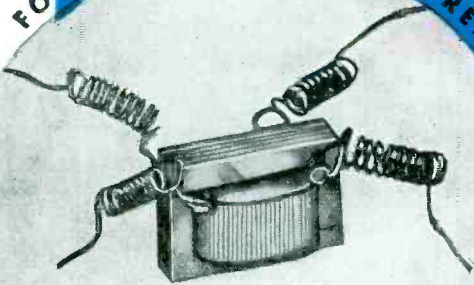

Miniature components to match the new "Proximity fuse" miniature tubes. Output and input transformers, and reactors with dimensions 9/16" x 3/4" x 5/8".

FOR THE RESEARCH LABORATORY

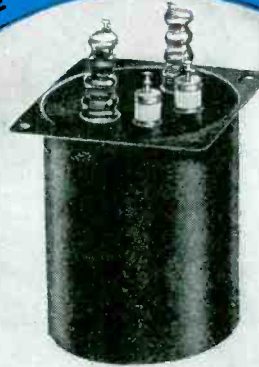

Typical of the special units produced by UTC is this high gain, 100 cycle, matching transformer. Primary impedance 500 ohms, secondary impedance 37,500,000 ohms, shielding suitable for—160-DB signal level.

FOR THE RADIO AMATEUR

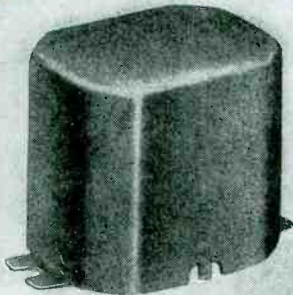

UTC Special Series components cover the entire range of amateur and low priced PA requirements . . . attractively cased . . . economically priced.

FOR THE BROADCAST STATION

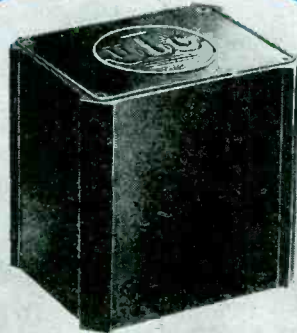

UTC linear standard transformers are the ultimate in high fidelity design . . . frequency response guaranteed ± 1.5 DB 20 to 20,000 cycles . . . Low wave form distortion . . . Extremely low hum pickup.



ALL PLANTS

United Transformer Corp.

150 VARICK STREET

NEW YORK 13, N. Y.

EXPORT DIVISION: 13 EAST 40TH STREET, NEW YORK 16, N. Y.,

CABLES: "ARLAB"



FIRST
AWARD

JUNE 23, 1944

FIRST RENEWAL
WITH STAR... DEC. 16, 1944

SECOND RENEWAL
WITH STAR... MAY 26, 1945

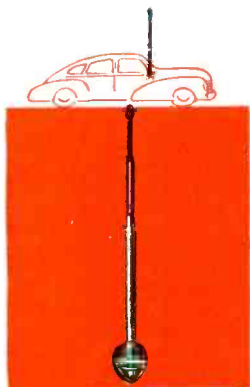

ICA "ROCKER"

A new swivel aerial, adjustable to any angle; fits contours of all car bodies.

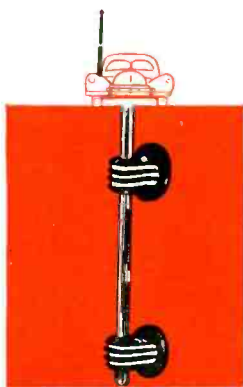

ICA "SIDE COWL"

Noiseless, rattleproof and rust proof; in five different lengths; two-, three- and four-section telescopic.

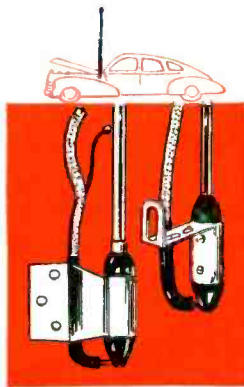

ICA "UNI-MOUNT"

Eliminates drilling of holes into body of car; one aerial for all type mountings.

Immediate Delivery!

AUTO RADIO ANTENNAS

The new Insuline antennas are rolling off the production line. Quality—as always—is the prime factor in the new ICA design. Check the eight important features below and see why Insuline has so long led the field.

1. Improved design—modern streamline beauty.
2. Beautiful triple-chromium plated—will enhance appearance of all cars.
3. All Antennas employ newly designed, sturdy bakelite insulators.
4. Brass inserts with attachments assure permanent corrosion-proof contact and wear.
5. Patented brass shim contacts used on all telescopic joints to prevent "rattling" and vibration. Contacts are permanent.
6. Static discharge tear-drop bead supplied on all aerials.
7. Brass tubing scientifically tapered on ends to prevent moisture and dust from entering tubes.
8. All antennae supplied with fool-proof spring tensioned Lo-Loss cables protected by heavy shielded loom to prevent noise pickup.

An assortment of sizes and types to meet the needs in different locations and conditions. Used as standard equipment by car manufacturers, U. S. Government agencies, police departments, secret service department, rangers, and on farm tractors, etc. The current ICA catalog, detailing the full line of ICA antennas is yours for the asking.

Remember: All ICA Antennas are rattle-proof and rust proof.

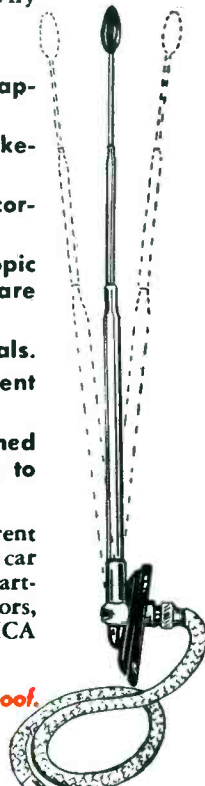

POSTWAR RECEIVERS



Above and below, Magnavox combination receivers. Models feature 12" speakers, automatic record changers, push-button tuning, variable selectivity, high-fidelity band expander, bass control and continuously variable treble control. Both a-m and i-m chassis will be made; a-m chassis will have 9 tubes, including rectifier and tuning eye; i-m chassis will have 8 tubes. Power output of a-m model, 12 watts.



Below Stromberg-Carlson industrial designer's conception of a television sound receiver of the future.

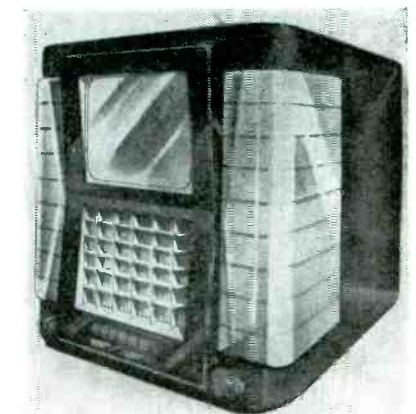

insuline

Insuline Corporation of America

INSULINE BUILDING • LONG ISLAND CITY, N. Y.



HANDLE MORE JOBS IN A LOT LESS TIME!

**THE GREATEST TIME SAVER
IN SERVICING HISTORY** ▼



Above and below, G.E. a-c/d-c tube superhets. Model above is for broadcast only, while receiver below covers broadcast and short wave bands.



Below, Stewart Warner 7-tube 3-band a-c model with iron-core push-button tuning for broadcast and short-wave bands. Audio system uses inverse feedback.

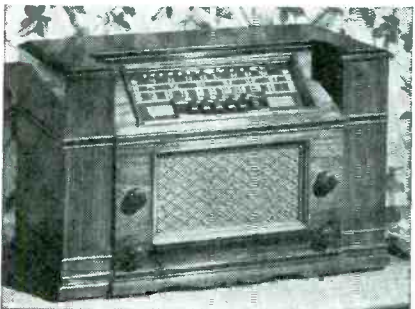

Below, Stewart Warner 6-tube a-c broadcast band combination. Output is 4 watts. Has a low impedance loop.

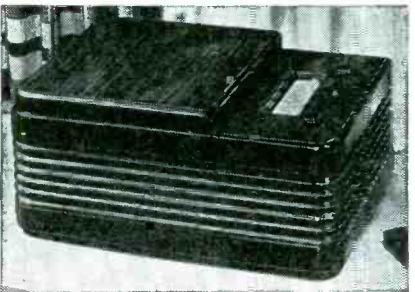

Below, Belmont 6-tube a-c/d-c broadcast band model, using 12 SK7s as r-f and i-f amplifiers, 12SA7 as a converter, 12SQ7 detector-audio, 35L6GT power output and 35Z5GT rectifier.

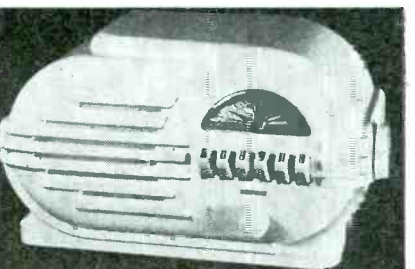

Radio servicemen everywhere say that A. A. Ghirardi's **RADIO TROUBLESHOOTER'S HANDBOOK** (3rd Edition) helps them **TURN OUT TWICE AS MUCH WORK IN A GIVEN TIME!** Four times out of five, it tells exactly how to repair a set—without any elaborate testing whatever!

Actually, this big 4-pound, 744-page manual-size Handbook is a complete guide to quick, easy repairs on **PRACTICALLY EVERY RADIO RECEIVER NOW IN USE.**

4,800 DIFFERENT RADIO MODELS

Its 404-page Case History Section gives full details on common trouble symptoms, their causes and remedies for **OVER 4,800 DIFFERENT RADIO MODELS.** It describes the trouble exactly, tells exactly what to do to repair it. It eliminates much testing—helps you do **TWO OR MORE** jobs in the time normally required for one—repair cheap sets profitably—train new helpers, etc.

Equally important are hundreds of other pages specifically geared to today's needs—dozens of hints on the proper substitution of tubes and parts; i-f alignment peaks for over 20,000 superhets; transformer troubles, etc., and hundreds of graphs, tube charts, data, etc.—all carefully indexed so you can find what you need in a hurry. Price only \$5 complete (\$5.50 foreign) on our **UNRESERVED 5-DAY MONEY BACK GUARANTEE!**



**EVERY
CONCEIVABLE SERVICE
SUBJECT!**

Milliameters, ammeters and voltmeters; Methods and instruments for measuring resistance; ohmmeters; How to build your own instruments; Tube checkers; Set analyzers; Point-to-point testing; Test oscillators; Preliminary trouble checks; AVC and QACV circuits; Troubleshooting; Testing components; Repairs; Obscure radio troubles; Aligning and neutralizing; Auto radios; All-wave radio servicing; Marine radio; Interference reduction; How to start and operate a Radio-Electronic service business, etc., etc.

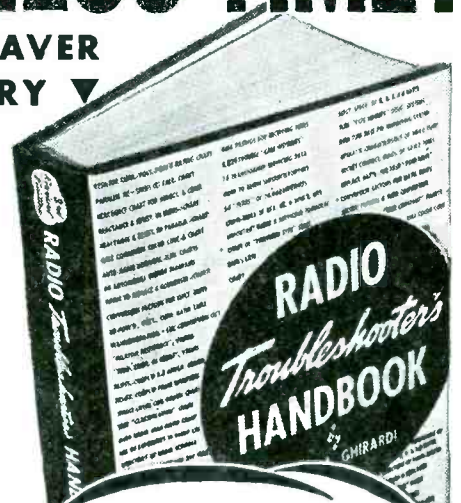

NOT A STUDY BOOK!
You don't study this Handbook! Simply look up the radio's Make, Model, and the Trouble Symptom—and go to work!
Eliminates useless testing on 4 JOBS
OUT OF 5!
ONLY \$5 COMPLETE

Ghirardi Complete Guide to MODERN PROFESSIONAL RADIO SERVICE WORK

Test Instruments, Troubleshooting, Repair

Once in a blue moon a technical book is written that is so important, so complete, and so easy to understand that it is used and recommended universally by members of a profession! A. A. Ghirardi's **MODERN RADIO SERVICING** is that kind of a book—AND MORE!

Actually, it is the only single, inexpensive book giving a complete course in modern Radio Repair work in all its branches. Explains all necessary test instruments . . . even how to build your own; how to troubleshoot ALL makes of receivers, analyze their circuits, test components; make adjustments; repairs, etc.—all step-by-step. Used for reference, it serves as a beautifully cross-indexed volume for "brushing up" on any type of work that may puzzle you. 1300 pages, 720 self-testing review questions, 706 illustrations and diagrams. \$5 complete (\$5.50 foreign) **5-DAY MONEY-BACK GUARANTEE.**

See Money-Saving Offer Coupon

5-DAY MONEY BACK GUARANTEE

MURRAY HILL BOOKS, Inc., Dept. S-125
232 Madison Ave., New York 16, N. Y.

- Enclosed find \$..... for books checked (send postpaid) or
- send C.O.D. (in U.S.A. only) for this amount plus postage. If not fully satisfied, I may return the books in 5 days for full refund.
- RADIO TROUBLESHOOTER'S HANDBOOK**
\$5 (\$5.50 foreign)
- MODERN RADIO SERVICING**
\$5 (\$5.50 foreign)
- MONEY-SAVING COMBINATION**—Both books (over 2040 pages of invaluable service data) for only \$9.50 (\$10.50 foreign).

Name

Address

City & Dist. No. State

Please print or write plainly.

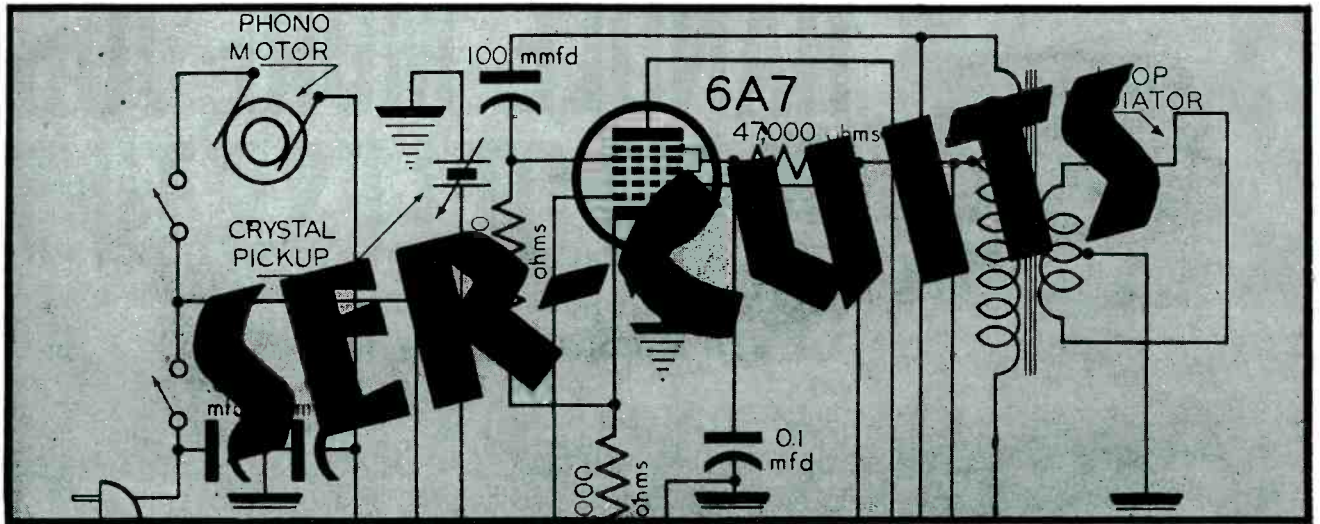

WITH high-fidelity receiver popularity growing daily, many Service Men are showing quite a lively interest in these models. As a result SERVICE has been receiving requests for analyses of high fidelity types, such as the Ward 10-tube chassis, shown in Fig. 1; model 93WG-1000/1001. This is an interesting receiver with several unusual features.

by HENRY HOWARD

from loop or foil plus external antenna. With antenna operation on the broadcast band, a supplementary 5-mmfd

capacitor provides capacity coupling for increasing the high-frequency sensitivity. A multi-turn broadcast primary is bypassed by a 250-mmfd capacitor to allow short-wave signals to get by without attenuation. The band-switch is arranged to short lower-frequency coils in high-frequency operation in all three sets of tuned circuits

Fig. 1. The Ward 10-tube high-fidelity receiver.

(Continued on page 42)

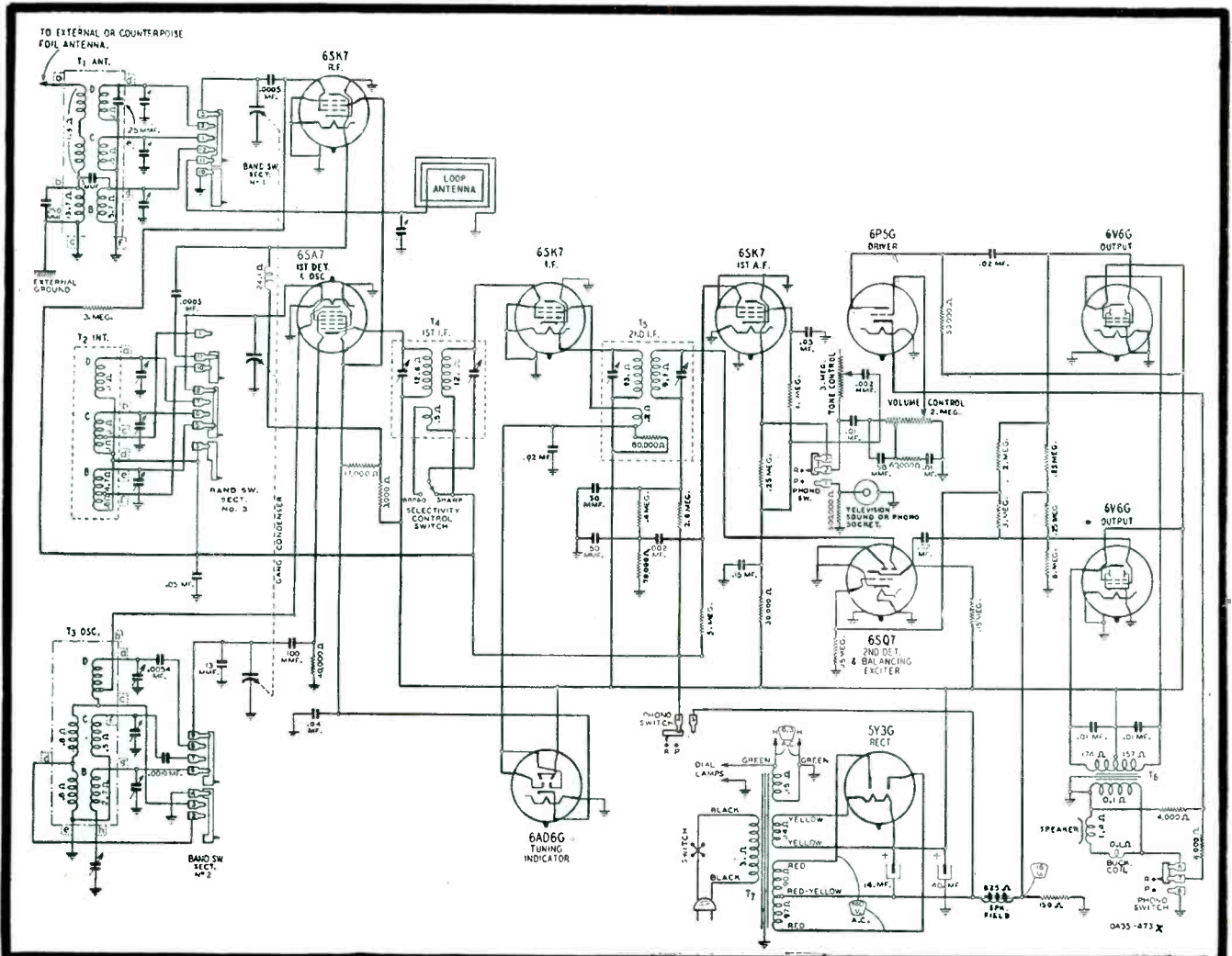

Sell the make all homes know best!

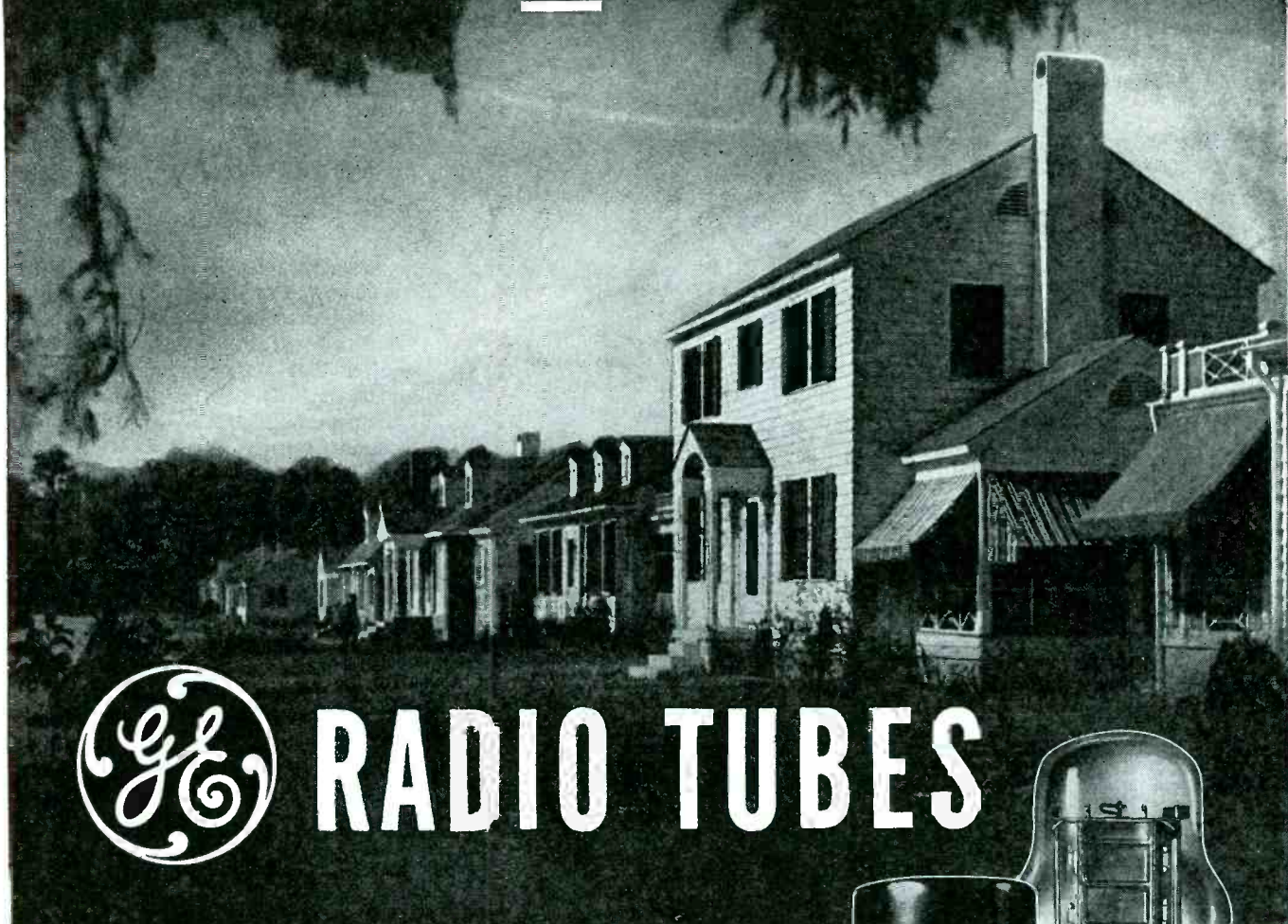

RADIO TUBES

GET OFF to a fast start by selling G-E radio tubes. Every home-owner knows and respects the famous G-E monogram—gives a friendly welcome to products bearing that symbol. G-E radios, lamps, refrigerators, and other appliances—one or more are sure to be in dependable daily use, building preference for tubes made by General Electric.

● G-E radio tubes are advertised in national magazines with a total circulation of 30,000,000; also over the air to 7,000,000 radio homes. User preference *plus* strong advertising make the G-E tube franchise a top profit-producer. Investigate this opportunity. Write for information about G-E tube selling rights to *Electronics Department, General Electric Company, Schenectady 5, N. Y.*



Hear the G-E radio programs: "The World Today" news, Monday through Friday, CBS. "The G-E All-Girl Orchestra," Sunday, NBC. "The G-E House Party," Monday through Friday, CBS.

GENERAL ELECTRIC

S E R V I C I N G T H E O S C I L L O G R A P H

THE effectiveness of external synchronization may be tested through the simple expedient of tracing the waveform with a fountain pen, or with a china marking pencil, subsequently reversing the a-c voltage applied to the input terminals of the vertical amplifier. It will be observed that the new trace written by the beam is exactly 180° out of phase with the pattern traced on the screen of the tube under the conditions described in last month's discussion.

If the synchronization control switch is now turned to the *INT* position, and the synchronization control potentiometer is advanced slightly to secure good synchronization, it will be observed that the new pattern written on the screen is exactly 90° out of phase with the pattern previously traced. Further, it will be found that reversal of the a-c input voltage which is impressed across the vertical amplifier input terminals effects a 180° reversal of the wave pattern, but that the pattern is still 90° out of phase with the trace marked on the screen. Obviously, under one of the preceding conditions, the new wave pattern is 90° out of phase with the marked pattern, and under the remaining condition, the new pattern attains a 270° phase relation with respect to the marked pattern. Finally, if an a-c input potential which is readily varied in phase is substituted for the a-c input potential, it will be observed that variation of the relative phase position of the input voltage effects no alteration in the phase position of the pattern, whereas, if the synchronization control switch is again operated to the *EXT* position, the variation in the phase position of the input voltage is readily reproduced as an appropriate motion in the pattern traced.

Sine-Wave Signal Voltages

Under certain conditions, it is necessary to effect other deflection of the beam along the horizontal or *X* axis, than that provided by the linear time-base oscillator system. Thus, it may be desirable to apply a sine-wave signal voltage to the input terminals of the horizontal amplifier. Here, it is necessary to reduce the intensity of the

essary if the image is to be properly recorded on photographic film.

[Part Six of a Series]

Television-Type Tubes

by S. J. MURCEK

electron beam to zero to prevent possible damage to the electron screen. The linear time-base oscillator coarse-frequency control is then rotated to the *off* position, which connects the input terminals *H* and *G* of the horizontal amplifier to the actual input circuit of the horizontal amplifier. The desired voltage source may be then connected to these terminals, and the intensity of the beam advanced carefully until a horizontal trace appears on the screen. If no trace appears, the luminous spot being clearly visible as a spot, the intensity control must be returned to the zero position, and the horizontal gain control advanced. Then a second test may be made to ascertain if horizontal deflection of the beam is present. Once a horizontal deflection of the electron beam is obtained, the brightness of the pattern may be increased to the desired level by clockwise rotation of the intensity control.

Intensifier Electrode

Where an intensifier electrode is used in the oscillograph tube, a suitable intensifier voltage control switch is usually mounted on the control panel. This switch must be left in the *off* position until a suitable recurrent pattern is written on the screen. Then the switch can be thrown to the *on* position to intensify the luminosity of the written wave pattern. In general, however, it will be found that the use of the intensifier electrode is usually not advantageous, except under the condition that voltage impulses of short duration and high voltage level are under observation, or under the condition that the pattern written is to be photographed. In the former, the intensifier electrode serves to render visible extremely sharp wave fronts or cusps which are not otherwise visible to the eye, and in the latter, the increased clarity and heightened luminosity of the wave pattern is nec-

essary if the image is to be properly recorded on photographic film.

Oscillographs incorporating television-type tubes which utilize an intensifier electrode generally incorporate a separate rectifier and filter power supply system for the development of high voltages required. The intensifier electrode voltage supply actually consists of the voltage available from a low-voltage source, and from a second power supply which rectifies and filters the total potential. Protection of the oscillograph against mechanical vibration and severe physical shock is of prime importance. The instrument should never be placed on the housing of a motor or transformer which vibrates or hums audibly. Where it is necessary to place the instrument near a forging hammer, or near the source of sharp, loud sonic impulses, such as those arising from the discharge of explosives, the cabinet of the device should be placed on a sponge rubber mat to protect it from severe physical shocks. These precautions are necessary to protect the electrode alignment and the heater tube structure as well as those of the remaining tubes in the instrument.

Magnetic Leakages

The magnetic leakage field present in the immediate vicinity of transformers and motors, as also in the welding throat of resistance welding devices, is also of considerable importance. Therefore, the oscillograph must be placed well away from the sources of such leakage fields since the penetration of the field through the magnetically permeable cabinet of the device is unavoidable. Where a strong leakage field is present within the cabinet of the oscillograph, the image written on the screen will be distorted, giving a false representation of voltage variations under observation. Further, if the field is of considerable intensity, the heaters of the picture tube and the supporting tubes are subject to *magnetric motoring*. Under the latter condition, if the leakage field is a static

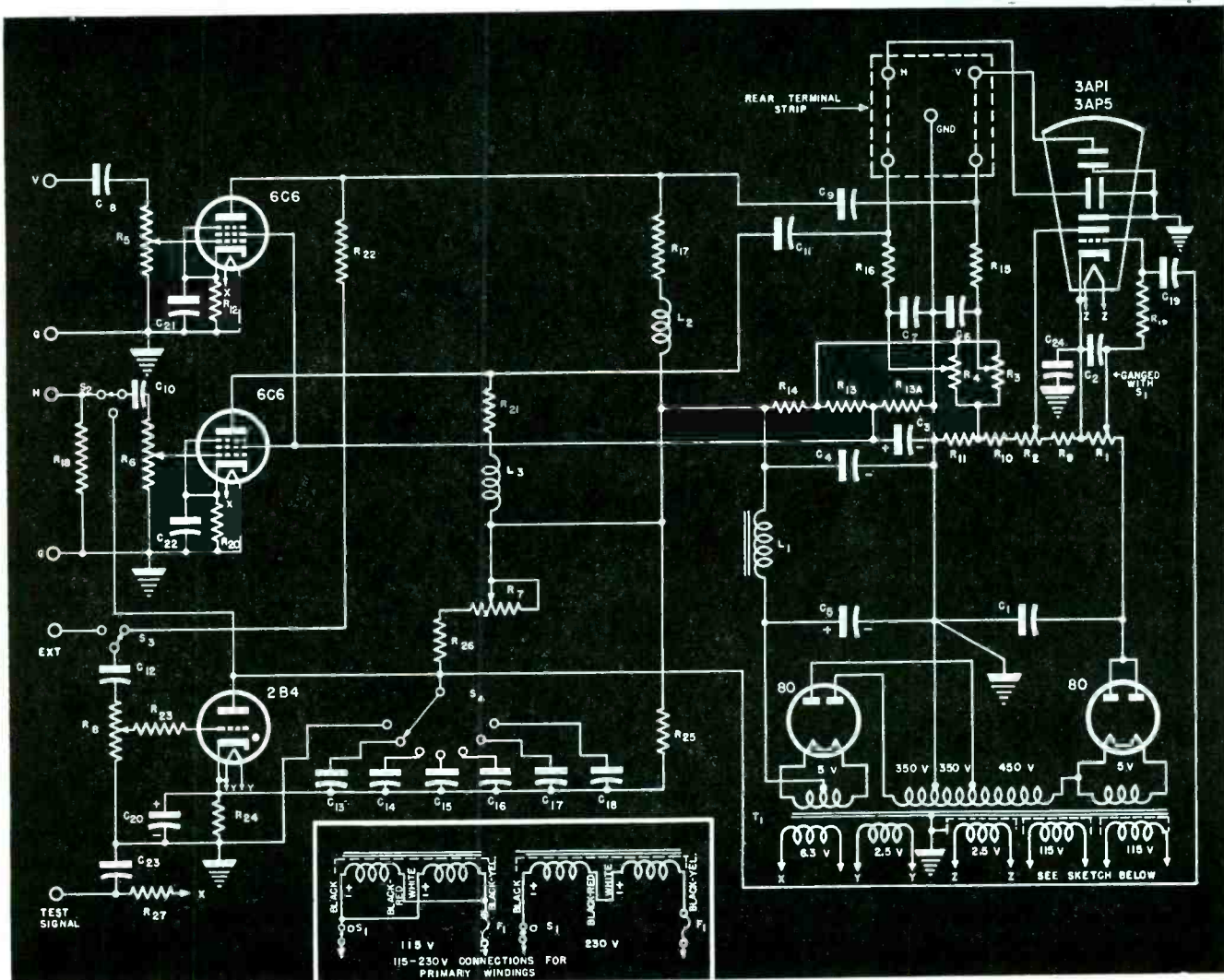

Fig. 1. Circuit of Du Mont 164 E oscillograph.

field, the a-c field built up around the tube heaters by the heater currents reacts with the stray leakage field to provide action motion. This is in the form of severe vibration to the tube heaters, subjecting these to failure from crystallization of their metal structures. The heater of a tube which operates in a strong magnetic leakage field becomes extremely brittle and is subject to early fracture with slight mechanical shock.

Since the screen is exposed to damage or breakage by flying foreign objects, the cabinet must always be placed so that this hazard is reduced to a minimum. The hazard to the tube is reduced considerably if a calibrated transparent plastics chart is placed before the screen.

Mechanical Wear Problems

Despite the maximum amount of protection and care, mechanical wear of certain components or eventual failure of capacitor dielectrics or of certain types of resistance elements may cause instrument failure. In gen-

eral, cessation of oscillograph operation occurs with the open-circuiting of a potentiometer resistance element, failure of an operating switch contact, or puncture of the dielectric in a capacitor due to its deterioration.

Component failure may interfere with satisfactory vertical deflection. This trouble becomes evident when the luminous spot does not write the vertical component of a test screen pattern. The defect may be due to (1)—Burnout of the vertical amplifier pentode heater; (2)—open circuit in the extreme maximum end of the vertical gain-control potentiometer; (3)—puncture of the pentode screen grid capacitor; (4)—open-circuited plate coupling capacitor; or (5)—open pentode plate-loading resistor.

Rapid Tests

Rapid diagnosis of the actual defect is facilitated in the complete analysis

may be accomplished without removing the oscillograph from the cabinet. In testing the defective vertical gain potentiometer, for instance, the shaft of the potentiometer may be first turned to the extreme maximum position in order that the slider arm contacts the ungrounded positive terminal of the resistance element. Then application of a small signal potential, at this juncture, should effect vertical deflection of the beam. If, however, no vertical deflection of the beam occurs, it is apparent that the vertical gain potentiometer resistance element is intact.

The succeeding step in the analysis of the vertical deflection system defect involves the removal of the vertical deflection-plate connecting link at the rear of the cabinet. With this link removed, an a-c potential of approximately 100 volts must be impressed between terminal H and GND. If the linear-time base system is properly adjusted, it should then be possible to secure vertical deflection of the beam. Here, it should be observed that failure of the a-c test potential to deflect the

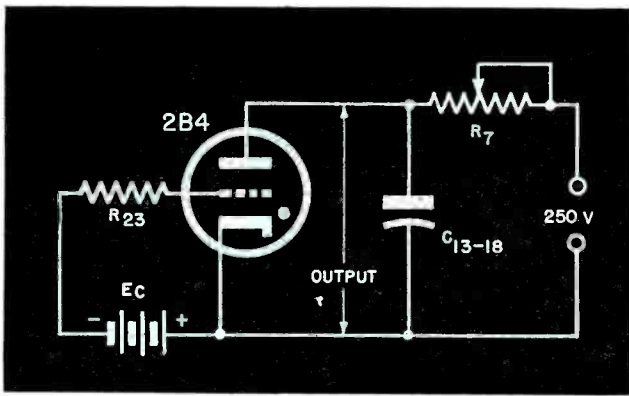

Fig. 2. Elementary circuit of a linear time-base oscillator circuit. The plate voltage at which the thyatron, 2B4, begins to conduct is determined by the negative grid-to-cathode potential.

beam along the vertical axis indicates the existence of a defect within the kinescope tube or its socket. These conditions are not generally encountered in normal service, unless the oscillograph has been subjected to high vertical deflection potentials or has been used in a damp atmosphere.

If it is found necessary to remove the oscillograph from the cabinet the high-voltage circuit rectifier tube should be removed from its socket. This will permit operation of the vertical amplifier low-voltage circuits, and the hazard of exposed high-voltage circuits will be minimized. With the removal of the high-voltage rectifier diode, the oscillograph may be connected to an a-c power source for further circuit examination.

Localization of Defects

Continued procedure in localization of the vertical amplifier system defect begins with the removal and testing of the vertical amplifier pentode. Failure of the latter is a common defect encountered in vertical deflection systems. Should the pentode prove to be satisfactory, it is then necessary to take a voltage reading with a voltmeter having an internal resistance of 1000 ohms-per-volt. This check should be made between the plate contact in the pentode socket and the oscillograph chassis. The reading should be about 125 volts. This voltage also indicates that the pentode plate-loading resistor is intact, necessitating further testing of the amplifier circuits. A voltage reading taken between the screen-grid contact in the tube socket and the chassis of the oscillograph must range between 85 and 90. A reduction from this value, or its complete absence indicates that the screen electrode bypass capacitor C_s in Fig. 1, is defective or short-circuited.

Should the entire test procedure prove that the vertical amplifier is all right then we know that the pentode

plate-coupling capacitor is open-circuited. To detect this condition a small signal voltage should be impressed across the input terminals of the vertical amplifier system. Then a vacuum-tube voltmeter is used to read the deflection voltage between the free vertical deflection plate and the chassis of the unit. Obviously, absence of any voltage between these points in the circuit shows that the coupling (C_o) capacitor between the vertical amplifier pentode plate and the free vertical deflection plate is open.

Temporary Repairs

When the vertical amplifier gain control potentiometer is found defective, a temporary repair to the resistance element may be effected by connecting a fixed resistor, $\frac{1}{4}$ -megohm, between the slider arm and the ungrounded terminal of the resistance element.

Other defects which may affect the operation of an oscillograph are indicated by the failure of the horizontal deflection system to effect horizontal deflection of the beam. Here, the failure may involve either the vertical amplifier or the linear time-base oscillator system, or both. In the former instance, the testing procedure involved approximates that applied in the instance of the vertical amplifier. The testing is facilitated, however, by the provision for the direct connection of the horizontal amplifier input system to an external sweep-voltage source.

Capacitor Troubles

If the failure of the horizontal deflection system is confined to a single position of the linear time-base frequency coarse-range switch, the trouble will be traced to a punctured timing capacitor. In making the replacement, care should be taken to see that the replacement is of the same voltage rating and capacity rating as the original capacitor. A

temporary repair can be effected through connection of a nearly similar capacitor into this switch contact position.

The failure of the thyatron relaxation tube in the linear time-base oscillation circuit is readily detected through operation of the coarse-sweep frequency selector switch. Here, operation of the switch from one capacitor terminal to a succeeding capacitor effects a momentary deflection of the beam because of the rise in the uncharged capacitor potential from the zero to the maximum voltage level.

Timing Capacitor Defects

In several commercial cathode-ray oscillographs, the high frequency timing capacitor in the linear time-base oscillation circuit is permanently connected between the slider arm of the selector switch and the chassis of the device. Obviously, if this capacitor short-circuits, the entire system is incapacitated. This is indicated by the lack of a potential between the switch contact arm and the unit chassis. This check can be made with a d-c voltmeter having an internal resistance of 1000 ohms-per-volt, with the high-voltage rectifier tube removed from its socket.

Synchronization Control Checks

An open circuit in the resistance element of the synchronization control potentiometer tends to render the linear time-base oscillator inoperative. Thus, if the shaft of this potentiometer is so positioned that the slider arm rests on the ungrounded portion of the resistance element, the control grid circuit of the relaxation thyatron is effectively open and the tube refuses to conduct and thus relax the charge on the timing capacitor. This simple test may be accomplished without removal of the oscillograph from its cabinet. A temporary repair may be effected by the same method used for the vertical amplifier gain control.

Wave Pattern Drifts

It is often observed that the image or wave pattern tends to drift along either the vertical or horizontal axis. This condition is an obvious indication that either the vertical or horizontal deflection plate series resistor (R_{15} and R_{16}) in Fig. 1 is open circuited, or that either of the position control potentiometers is open. The latter condition is usually accompanied by more severe indications of trouble. Where the series deflection resistor is defect-

(Continued on page 44)

A New Jensen Coaxial

TYPE H

WITH *Compression-type* HIGH-FREQUENCY SPEAKER

The first of a new series of JENSEN Coaxial Speakers, combining in one coaxial assembly a horn-type high-frequency speaker with a cone-type low-frequency unit. By unique design, the cone of the low-frequency unit forms a part of the high-frequency horn, thereby dispensing with a separate horn. An integral two-channel network gives the desired crossover characteristics. Thus this new Coaxial Speaker provides the quality of reproduction so essential and desirable for radio receivers and phonographs for home entertainment, particularly for FM reception and high quality phonograph recordings.

The distribution characteristics of the Type H Coaxial are excellent and, when installed in a suitable enclosure such as a Bass Reflex cabinet, its performance covers the entire frequency range useful in home reproduction.*

Type H Coaxial, illustrated here with field coil low-frequency speaker and *ALNICO 5* high-frequency unit, is designed for manufacturers. Other models for more general use, incorporating *ALNICO 5* design in both high-frequency and low-frequency units, will shortly be announced.

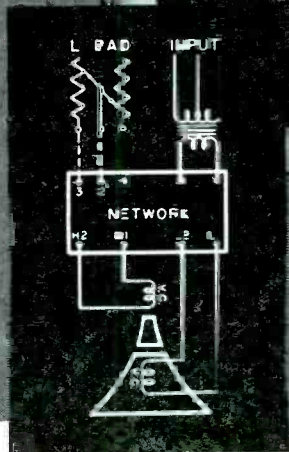

Low Frequency Motor

High Frequency Driver

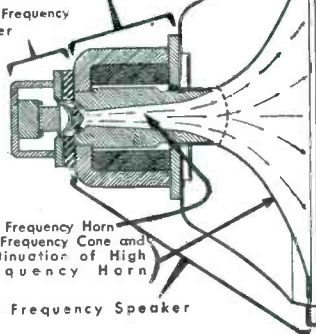

High Frequency Horn
Low Frequency Cone and
Continuation of High
Frequency Horn

Low Frequency Speaker

TYPE H SPECIFICATIONS

Power rating 25 watts maximum, in speech and music systems. Input impedance 16 ohms. Field 14-20 watts. List price approximately \$100.00.

*See No. 3 JENSEN Monograph: "Frequency Range in Music Reproduction," for discussion of useful frequency ranges.

Other Coaxials Now Available!



These Type J Coaxials, improved over prewar design, offer low-cost Coaxial performance in home radio receiver and phonograph entertainment.

JAP-60 (1 1/2-inch) with HF Control Switch. List price **\$79.45**

JHP-52 (1 1/2-inch) with HF Control Switch. List price **\$56.15**

JCP-40 (1 1/2-inch) HF Level Control extra. List price **\$33.45**



SPEAKERS WITH

ALNICO 5

JENSEN RADIO MANUFACTURING COMPANY • 6621 S. LARAMIE AVE. • CHICAGO 38, ILLINOIS
IN CANADA - COPPER WIRE PRODUCTS, LTD. • 137 OXFORD STREET, GUELPH, ONTARIO

Specialists in Design and Manufacture of Fine Acoustic Equipment

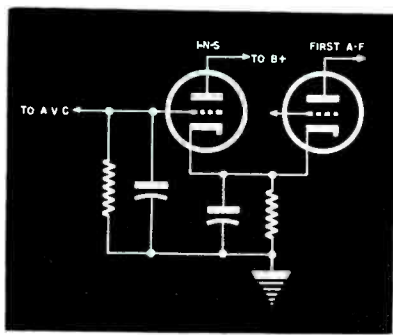

Figs. 1 (left) and 2 (right)
 Fig. 1. A typical interstation noise suppression circuit. When no signal is present, the first audio tube is biased to cutoff. Upon tuning in a signal, the i-n-s tube is biased to cutoff, removing the excessive bias on the audio tube.
 Fig. 2. A typical i-n-s stage featuring two methods of controlling its effectiveness. The use of controls in the i-n-s circuit permits setting it to the appropriate point for local noise conditions.

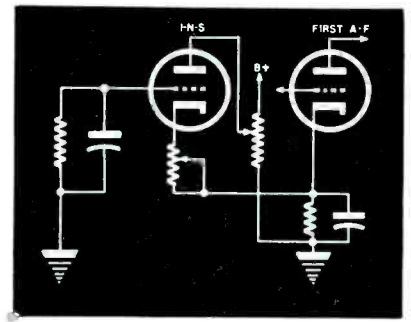

INTERSTATION NOISE

AN inherent characteristic of f-m receivers is high interstation noise. That is, when tuning from station to station, where no signal is present, static, and other forms of interference are more pronounced than in equivalent a-m receivers. This condition is due to the wide-band acceptance of the f-m receiver. For this reason, most f-m receivers feature some form of interstation noise suppression or squelch system, popularly known as i-n-s.

by J. GEORGE STEWART

How I-N-S Operates

The operation of the i-n-s stage is based on the biasing of an audio tube to cutoff when no station signal is being received. The circuit may be applied in one of three forms.

(1)—A switch may be used to cut the i-n-s system in or out of the receiving system.

(2)—Effectiveness of the i-n-s system may be adjustable.

(3)—The i-n-s stage may be permanently installed with no method of control.

Generally, a switch is incorporated in the i-n-s stage, so that its operation may be cut out for the reception of weak signals. This is necessary since i-n-s operation distorts the audio recovery of weak signals, or prevents their pickup entirely.

Typical I-N-S Stage

Fig. 1 shows a typical interstation noise suppression stage. The i-n-s tube is generally a high cathode-current type. The cathodes of the i-n-s tube and the first audio tube are connected to a common resistor. The control grid of the i-n-s tube is connected to the avc system of the receiver, or some source of rectified signal voltage. Since the cathodes of the two tubes are connected in parallel, when no avc voltage is applied to the control grid of the

i-n-s tube, its cathode current is high, and the resultant bias voltage on the first a-f tube is of cutoff value. When a signal is received, the grid of the i-n-s tube is biased negative, reducing that portion of the cathode current supplied by the i-n-s tube, and restoring the effective bias on the audio tube to a normal value.

Switching

From the foregoing, it can be seen that unless the incoming signal is sufficiently strong to develop a high avc, or bias voltage on the i-n-s control grid, the a-f tube may operate at some high value of bias that may cause audio distortion. For this reason, most i-n-s circuits contain some form of switching system, which permits cut-out and weak-signal reception. Other systems consist of both a switch and some form of control. Usually the *B* supply to the i-n-s plate or screen grid is varied or the effective bias on the a-f tube is varied, so that the system may be set to the appropriate operating point for local conditions. This method is illustrated in Fig. 2.

In this diagram, both methods of i-n-s action control are shown, although only one method is used in practice. Either method serves to regulate that portion of the bias voltage on the first a-f tube supplied by the i-n-s stage. The cathode type of control is preferred, since the characteristic action of the squelch is not affected as much.

Meissner 9-1053-4 A-M /F-M

In Fig. 3 appears the i-n-s circuit used in Meissner 9-1053-4 f-m/a-m receiver. A 6AC7 is used as the i-n-s

stage to squelch a 6SQ7 first audio stage. With no station signal present, the bias on the 6SQ7 is 3 volts. This is sufficient to reduce the plate current to cutoff, and corresponds to a cathode current of 1.4 ma. With 90 volts on the plate of the 6SQ7, and a bias of 1 volt, its plate current is approximately .2 ma. For the 6SQ7 cathode resistor, 2,200 ohms, this would account for .44 bias volt, provided the cathode of the 6AC7 were not in parallel with it. Therefore, any avc voltage equal to or in excess of that required to reduce the cathode current of the 6AC7 to less than .3 ma., would open the first audio stage.

Potentiometer Uses

The switch in the cathode of the 6AC7 is used to cut out the i-n-s for reception of weak signals. To reduce the effectiveness of the i-n-s in localities where weak signals are received, a potentiometer across the screen-grid bleeder resistor, shown in dotted form in Fig. 3, could be adjusted so that the bias voltage on the 6SQ7 is reduced to some value below 3 volts. This voltage value should be selected so that no distortion is introduced when receiving weak signals, yet retaining some of the noise suppression.

Freed 57A-71A

Fig. 4 shows the i-n-s system used in the Freed model 57A-71A. Here, no switch is provided to cut out the i-n-s. Only one limiter stage is used in this receiver, and no avc voltage is applied to the r-f section. The rectified grid voltage of the limiter stage is used to actuate the magic eye, and operate the i-n-s. In the Freed model 40 F-M, a switch is incorporated in the

Fig. 3. The i-n-s system used in the Meissner 9-1053-4. With no signal present, the bias on the 6SQ7 first audio tube is 3 volts, or cutoff bias. A fairly strong signal reduces the cathode current of the 6AC7, which in turn, reduces the bias on the first audio tube to 1 volt, or operating bias.

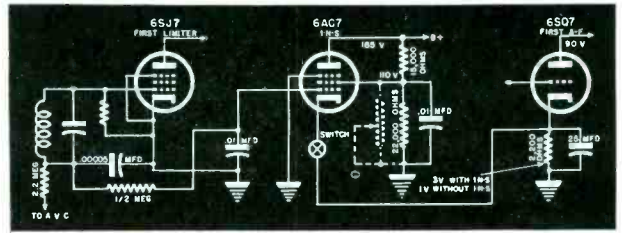

SUPPRESSION SYSTEMS

cathode of the i-n-s stage. For the average listener, weak-signal reception is unimportant, since any signal too weak to operate the i-n-s, would be too weak to operate the limiter. The resultant noise level, riding in with the signal would therefore make the signal unsatisfactory. Many receiver manufacturers therefore make the i-n-s system correlate its action with the limiter, so that the former operates properly for any signal which actuates the latter to its proper performance.

Fig. 4. The Freed 57A-71A i-n-s system. No cutoff switch is used in this circuit, since any signal too weak to operate the i-n-s would be too weak for satisfactory listening.

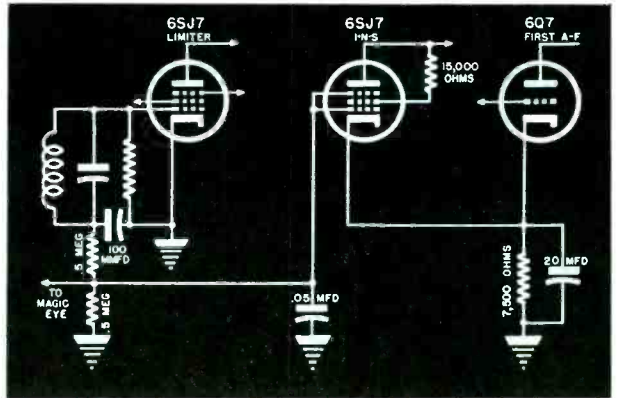

Espy A-C / D-C F-M

In Fig. 5, a 14A4 is used for the i-n-s stage in Espy's f-m a-c/d-c receiver. Although the path of the actuating voltage is devious, it traces back to the limiter grid voltage developed across the bracketed resistors. Essentially, the circuit is identical to those of Figs. 3 and 4. However, the squelch action in this model is *soft*. That is, the noise is merely reduced to a comfortable level, so that the objectionable high level of interstation noise is materially reduced.

the resultant of improper control-grid or cathode voltages.

Adding an I-N-S Stage

Those owning f-m receivers without i-n-s stages may object to the high-interstation noise. This can be remedied by adding an i-n-s stage which includes but one tube, several resistors and capacitors.

In many f-m receivers, the first

audio stage is a single triode. For such receivers, a triode-pentode may be substituted, using the pentode portion for the squelch stage. This method is particularly adaptable to a-c/d-c type receivers, where the series filament voltage is unaffected by the introduction of a dual-purpose tube. It is suggested that when adding a squelch stage, its action be fixed. In this way, any objections to image responses in the receiver, by the set owner, are satisfied.

Checking I-N-S Stages

In checking i-n-s stages, it should be noted that their operation is dependent on d-c voltage characteristics. Where distortion is traced to this portion of the receiver, the bias on the first a-f tube should be checked, in the presence of an r-f signal. If this voltage is found to be high, the next step is to check the effective avc voltage being applied to the i-n-s control grid. The trouble will be found to be

Fig. 5. An a-c/d-c type of i-n-s circuit, used in Espy f-m receivers. Because of the low available plate voltage, the action of this circuit is *soft*, that is, the interstation noise is reduced to a comfortable level.

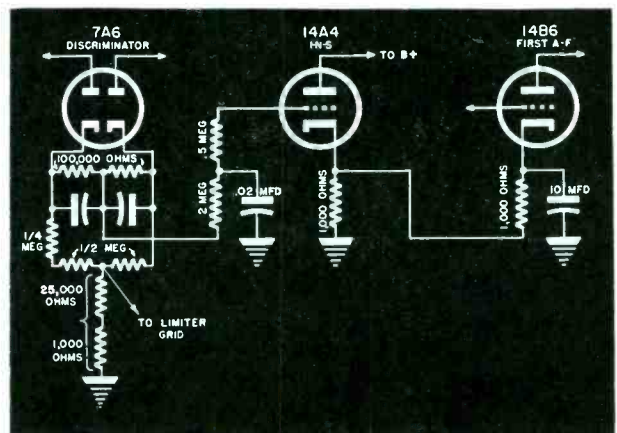

S E R - C U I T S

to prevent unwanted absorption at certain resonant points. The r-f stage is impedance coupled to the 6SA7 detector; the plate choke must be a good one because of the three bands to be handled. The coupling lead is tapped down on the detector coils to reduce the load of the r-f amplifier, thereby increasing the Q of the circuit and, hence, its selectivity.

The oscillator uses cathode ticklers for the two lower-frequency bands and a tapped coil for the highest frequency. Selectivity is controlled in the first i-f transformer by connecting a tertiary winding in the secondary circuit for broad tuning. The second i-f transformer is similar but the tertiary is connected in series with the screen for degeneration. The audio amplifier is unconventional in the use of a 6SK7 first audio with the volume control following this stage. The audio tap from the rectified output of the detector is taken well down on the load resistor, across 70,000 ohms of a total of 470,000, which sacrifices signal voltage but improves the detector linearity. A decoupling filter of 30,000 ohms and .15-mfd acts to prevent feedback.

A 2-megohm tapped volume control feeds a 6P5G driver. A 6SQ7 picks off some of the driver's output for phase inversion to feed the push-pull 6V6 output. One of the diodes serves as the second detector, the other is grounded. The tone control is conven-

(Continued from page 34)

tional. The driver cathode is connected to the voice coil of the speaker in radio operation, but not on phono, for introducing degeneration. The voltage is taken from the midpoint of an 8000-ohm potentiometer. The d-c bias value is effectively two-4000 ohm resistors in parallel, or 2000 ohms with no by-pass capacitor.

Firestone S-7406/3

The Firestone S-7406/3 is another example of interesting high-fidelity design. This is a 3-band receiver with an electrostatically shielded loop, tuned r-f stage with a 3-gang capacitor and four 6SQ7s for detector, avc and audio. This model uses a separate 6J5 oscillator with grid-to-grid coupling to a 6SA7 mixer. A standard 6SK7 i-f amplifier feeds a single diode of the first 6SQ7 which acts as detector only. Avc is obtained by rectifying the voltage picked directly from a 6SK7 plate through a small capacitor by the diodes of a second 6SQ7. A third 6SQ7 serves as first audio while a fourth acts as a phase inverter. The tone control is tied to

Fig. 2. Portable Motorola battery a-c/d-c receiver. An untuned r-f coupling transformer is used to increase the gain of the receiver. The coupling in this transformer is adjustable through the use of a 5-mmfd gimmick.

the volume-control bass compensating circuit, so that with the grounded arm at the top, a capacitor is placed across the volume control to reduce highs while with the arm at the bottom, the shunting effect of the capacitor is removed and the bass compensating capacitor is cut out. This reduces the bass.

Motorola 65BP 1-2-3-4

In Fig. 2 we have a battery a-c/d-c high fidelity portable, Motorola 65BP 1-2-3-4. A 5-mmfd gimmick is used to increase the coupling in the r-f coupling transformer, thereby increasing the gain of the receiver. This gimmick consists of a stiff piece of wire connected to the secondary of the r-f transformer, whose coupling to a small coil, connected to the primary of the same transformer, may be varied. There is no physical connection between the two parts. The effective capacitance is estimated at 5 mmfd.

A novel method is used to bias the 3Q5 power amplifier. The control grid of the 3Q5 is returned to terminal 7 of the 1H5GT. This places the filament of the 3Q5 at 4.5 volts positive with relation to the control grid. The 720-ohm resistor and 20-mfd capacitor is used to provide additional filtering for this bias voltage. The additional current drain through the 3Q5 filament is negligible.

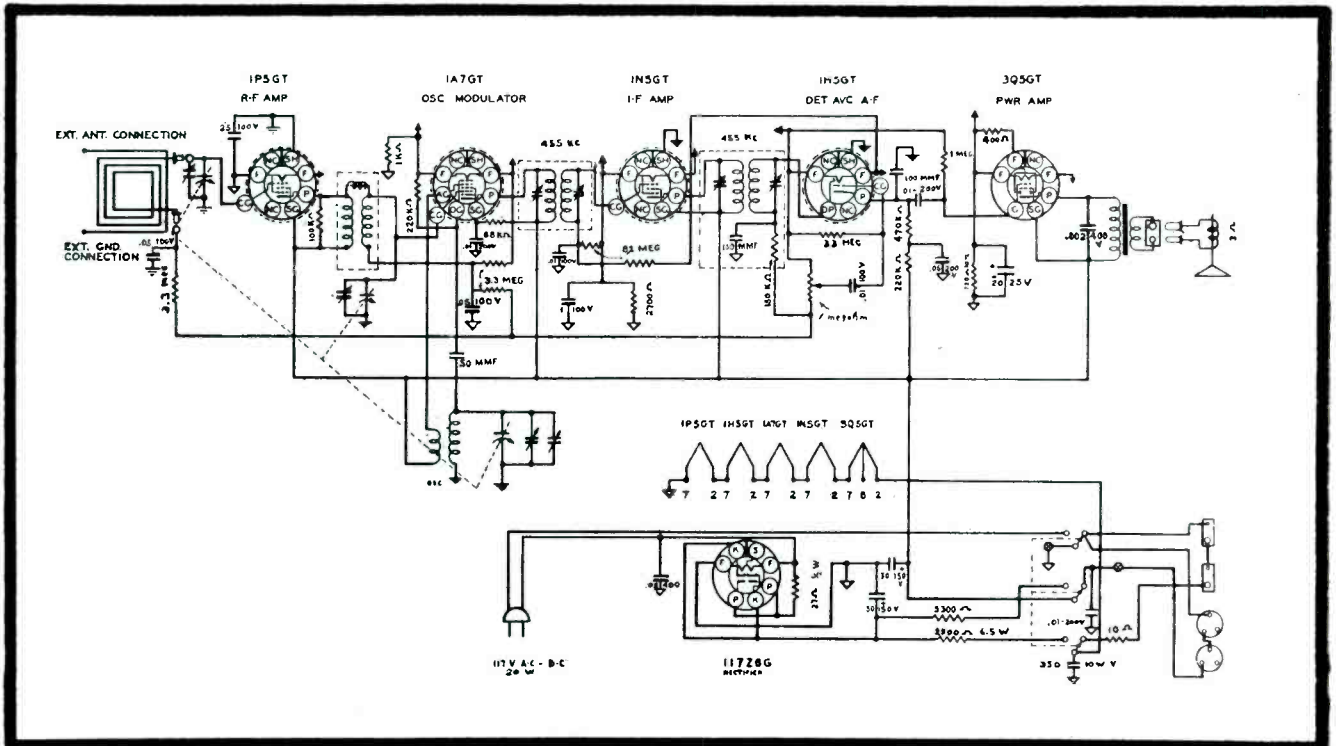



READY TO SERVE YOU AGAIN!



Thordarson has returned from the war and is ready now to serve its many customers. *Thordarson* regrets there has been an interruption in service performance to regular customers and that orders could not be filled during the war. Here's the reason.

The superior quality of *Thordarson* transformers and other electronic devices was recognized immediately by Uncle Sam at the outbreak of the war and *Thordarson* production (100%) was required to fill all-important government orders.

Now the same high quality that was so acceptable in the recent emergency is available to you. *Thordarson* transformers—always the gauge of superior quality and unexcelled performance—are now even better because of many new additions and developments made during the war. *Thordarson* research-engineering plus *Thordarson* quality team together in the production of better equipment and devices for the electronics industry.

New distribution policies and sales promotion plans make *Thordarson* products and complete informative data on their application and use available to all customers—everywhere!

ALWAYS THINK OF THORDARSON FOR TOP-NOTCH TRANSFORMERS!

500 WEST HURON ST., CHICAGO, ILL.



ORIGINATORS OF TRU-FIDELITY AMPLIFIERS

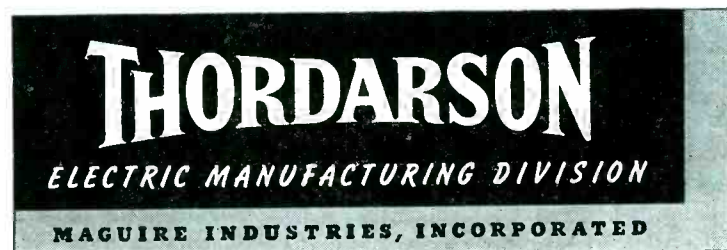

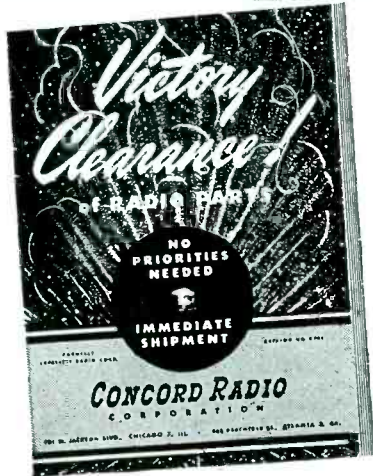

RADIO PARTS ELECTRONIC EQUIPMENT



FREE! CONCORD Victory Clearance Flyer

Ready now! 32 Bargain-packed pages listing thousands of standard-make, top-quality radio parts and electronic supplies—now available without priority at low VICTORY CLEARANCE prices. The values listed below are typical of the important savings offered in Meters, Condensers, Transformers, Resistors, Controls, Relays, Switches, Test Equipment, Generators, Microphones, Tools, and hundreds of Repair, Replacement, and Accessory Parts.

<p>D.C. Milliammeters</p>  <p>2 1/2" flange mtg. type. Metal case dull black finish. G. E. 0-200 M. A. C10650. Specially priced. \$4.95</p>	<p>Output Transformer</p>  <p>Hermetically sealed. Six studs, 1, 2, and 3 are pri. 4, 5, and 6 the sec. Pri. ind. at 5 V. 1000 cy. 20 H. Ratio sec. to pri. 3.02:1. Size: 3 1/4 x 2 1/4 1/4". 5B5045 Your cost... \$1.95</p>
---------------------------------------------------------------------------------------------------------------------------------------------------------------------------------------------------------------------------------------------	-------------------------------------------------------------------------------------------------------------------------------------------------------------------------------------------------------------------------------------------------------------------------------------------------------------------------------

Immediate Shipment from
CHICAGO or ATLANTA

Huge stocks in two convenient warehouses—one in CHICAGO and one in ATLANTA—are ready to supply you quickly with needed parts of dependable nationally-known quality—and at VICTORY CLEARANCE prices that mean real savings. Mail the coupon below NOW for your FREE copy of CONCORD'S VICTORY CLEARANCE Flyer.

CONCORD

RADIO CORPORATION

Lafayette Radio Corporation

CHICAGO 7, ILL. **ATLANTA 3, GA.**
901 W. Jackson Blvd. 265 Peachtree Street

CONCORD RADIO CORPORATION
901 W. Jackson Blvd.
Dept. S-125, Chicago 7, Ill.
Please RUSH FREE copy of
CONCORD'S new 32-page VICTORY
CLEARANCE Flyer.



Name.....
Address.....
City..... State.....

OSCILLOGRAPH SERVICING

(Continued from page 38)

ive, it is customary to replace both series resistors.

Where the vertical or the horizontal potentiometer fails to center the pattern written on the screen, despite complete rotation of the control shaft, we usually find a leaky or short-circuited deflection plate-coupling capacitor in the coupling circuit. Again, if the tube fails to write the expected pattern and a fluorescent glow is observed along an edge of the screen when the intensity and focus potentiometers are advanced in a clockwise direction, the trouble will be found to be an open resistance element in the vertical or horizontal-positioning control potentiometer.

Lower Edge Fluorescence

A green or fluorescent glow along the lower edge of the fluorescent screen indicates that the positive side of the vertical-control potentiometer resistance element is open. Counterclockwise rotation of the potentiometer shaft causes the image to move rapidly in an upward direction, leaving a fluorescent glow at the upper edge of the electron screen. Thus, a fluorescent glow at the extreme left-hand position of the screen indicates that the horizontal-control potentiometer resistance element is open circuited, and that the slider arm of this potentiometer rests on the negative portion of the resistance element. The position-control potentiometers incorporate high resistance elements, and should therefore be replaced immediately.

Inability of the focusing potentiometer to properly focus the beam on the fluorescent screen is obviously an indication that the potentiometer is defective. Operation of the potentiometer results in the development of a diffused glow over the entire surface of the fluorescent screen once the slider arm of the potentiometer rests on the positive portion of the resistance element. The potentiometer, in this instance, should be replaced immediately.

Intensity Control Opens

An open circuit in the resistance element of the intensity-control potentiometer precludes the possibility of the development of a screen pattern, as long as the slider arm of the potentiometer rests on the negative portion of the resistance element. Operation of

OHMITE RESISTORS *for accurate trouble-free* SERVICE

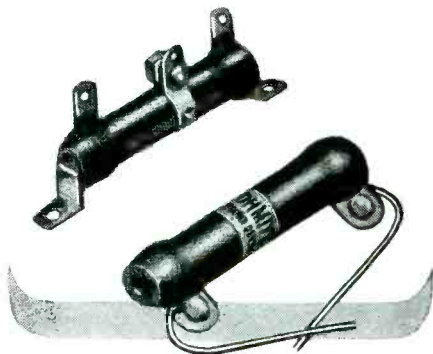

Time-proved, battle-proved, service-proved... Ohmite Brown Devils and Adjustable Dividohms will again be the favorite of radio servicemen who want and use the best for resistor replacements.

For information about these and other Ohmite Resistors, write for Stock Unit Catalog 18.

SEND FOR HANDY OHM'S LAW CALCULATOR

Figures ohms, watts, volts, amperes—quickly, accurately. Solves any Ohm's Law problem with one setting of the slide. Send only 10c in coin for handling and mailing. (Also available in quantities.)



OHMITE MANUFACTURING CO.
4879 Flournoy Street • Chicago 44, U.S.A.

Be Right with **OHMITE**
RHEOSTATS • RESISTORS • TAP SWITCHES

the potentiometer in such a manner that the slider arm contacts the positive portion of the open-circuited resistance element results in the development of a bright, suffused screen glow, with attendant inability of the focusing control potentiometer to properly focus the electron beam on the fluorescent screen. The transition from the former to the latter condition occurs abruptly with the counter-clockwise rotation of the intensity control potentiometer control knob. When this condition occurs, the defective potentiometer should be replaced, inasmuch as a temporary repair with a fixed resistor will not permit the fine, continuous control of the beam intensity.

General Servicing Problems

In general, servicing of the cathode-ray oscillograph is similar to receiver servicing. The general precaution of removing the high-voltage rectifier tubes when making vertical or horizontal deflection system voltage tests must be observed. Hence, necessary testing of the high-voltage circuit components should be carried out with the proper ohmmeter or component tester, whether the latter be an inductance or a capacitance tester. All d-c voltage measurements should be carried out with units having an internal resistance of 1000 ohms-per-volt, since the resistances incorporated in the amplifier and deflection circuits are very high. Finally, if there is definite indication, from preliminary pattern analysis that one of the c-r potentiometers is open-circuited, the high-voltage filtering capacitor must be discharged. This is accomplished by short-circuiting the plate and one of the heater contacts directly at the high voltage rectifier tube socket.

When the improper operation of the oscillograph necessitates the replacement of one of its components, the replacement should be effected with a component of equal or better quality.

RAILROAD RADIO ANTENNA SYSTEM

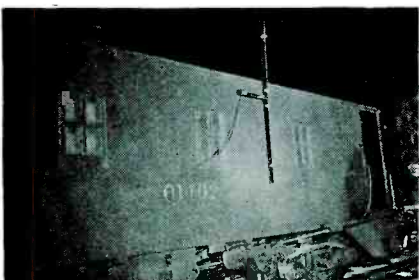

Half-wave antennas used in an 118-mc f-m system aboard the Denver and Rio Grande Western R.R. (Courtesy Galvin Mfg. Co.)

**The Line
That Reaches
'Round
the World**

With a proven background of honorable service on far-flung battlefronts around the world, Amphenol components—greatly improved by wartime experience and augmented in number, style and type—are now available to normal markets. Simplifying both buying and selling, this wider selection of high quality, tested items can be procured from one manufacturer. To know these popular Amphenol products better—write today for the new Condensed Catalog No. 72.

AMERICAN PHENOLIC CORPORATION
CHICAGO 50, ILLINOIS
In Canada • Amphenol Limited • Toronto

**U.H.F. Cables and Connectors • Conduit • Cable Assemblies
Connectors (A-N, U.H.F., British) • Radio Parts • Plastics for Industry**

Attention GI JOE!

Here's Your Opportunity to be First to

Start Your Own RADIO SERVICE SHOP

Complete Starting-in-Business
Package Stocks of

TEST EQUIPMENT
TUBES, PARTS, TOOLS

\$350 up

Act quickly! Meet the pent up demand for radio service. Turn your special service training into a profitable business of your own. No fuss. No worry. Here's everything you need—\$350 up. Details upon request! Write, wire or phone



TRIPLETT Volt-Ohm-Milliammeter

A. C. - D. C. Volts
0-10-50-250-1000-5000
at 1000 ohms per volt.
D. C. Milliampers
0-10-100-500
Ohms 0-300-250,000
Case Black molded
3 1/4" x 5 7/8" x 2 1/2".
\$16.00 net

Good News! ALL PRIORITIES LIFTED

HALLICRAFTERS SX-28A



\$223

SUPER DEFIANT	SX25	\$94.50
SKY CHAMPION	S20R	60.00
SKYRIDER MARINE	S22R	74.50
SKY RANGER	S39	110.00
ECHOPHONE	EC1A	29.50

ORDERS FILLED AS RECEIVED!!!

MASCO AMPLIFIERS



Complete with tubes.

17 Watt	30.30
25 Watt	42.60
35 Watt	54.60
50 Watt	70.50

17 Watt with Phono-top	42.30
25 Watt with Phono-top	52.20
35 Watt with Record-changer	89.10

PHILCO BEAM OF LIGHT

Selenium Cell only, no holder **1.80**

20% deposit required on all C.O.D. orders. 2% transportation allowance on orders of \$25.00 or more accompanied by payment in full.

RADIO SUPPLY & ENGINEERING CO., Inc.
126 SELDEN AVE. DETROIT 1, MICH.

Write for
FREE CATALOG

AUTOMATIC NOISE LIMITERS

(Continued from page 15)

RC network of the infinite impedance detector is very fast, as will be noted from the parts values.

RME 41-43

In Fig. 5 we have the a-n-l circuit of the RME 41-43. This system is an adaptation of the automatic a-n-l system shown in Fig. 1c. Here, again, the percentage modulation is used to control noise pulses. Since the cathode of the noise limiter is at a higher positive potential than the plate of the same tube, no conduction takes place. However, the RC network in the feeder line to the plate of the limiter diode keeps the voltage on the plate at carrier level, while the cathode voltage of the same tube varies with the modulation. When the modulation exceeds 100%, the voltage on the plate of the noise limiter becomes positive with relation to its cathode, and the tube acts as a low-impedance path across the audio feeder network. We note that the 1-mfd capacitor returns the a-n-l plate to the ground side of the audio network, thereby placing the diode across the audio load. The insert in Fig. 5 shows the circuit reduced to a bridge network to further explain its action.

Servicing Problems

Component value plays an important role in a-n-l action. The usual troubles encountered in their servicing involves either no action or distortion of the signal. Component values should be checked closely, and replacement should always be made with identical values. Since the cathodes of the a-n-l tubes are at r-f or a-f potential, they are a frequent source of hum caused by cathode to filament shorts. The tubes used in the a-n-l stage should always be checked where hum conditions arise. It should also be noted that a-n-l systems are most effective where the signal strength is high. Weak signals will usually prevent adequate noise limiting.

F-M ANTENNA



Courtesy Galvin

The f-m antenna of the Miami police department.

FILTER CONDENSER Bargains!



Thousands of rugged, oil-filled, oil-impregnated condensers at ridiculously low prices. Write for list! New Time Payment Plan if desired.

BIG NEW CATALOG!

By mailing us your name and address, you will be among the first to get a copy of our own big new catalog, plus latest announcements of new and bargain components and equipment. Write today! Address Dept. S of nearest Newark branch.



CHICAGO
Newark ELECTRIC Company
115-117 W. 45th St. NEW YORK 19
323 W. Madison St. CHICAGO 6

VELOCITY

P.G. DYNAMIC



THE FINEST MICROPHONES
AMPERITE
FOR PUBLIC ADDRESS & RECORDING

MICROPHONES
THAT SURPASS
THE HIGHEST RE-
QUIREMENTS OF
BROADCASTING,
PUBLIC ADDRESS,
AND RECORDING

KONTAK MIKES



Write for Catalog

AMPERITE COMPANY
561 BROADWAY NEW YORK, N. Y.

SUB-MINIATURES

(Continued from page 20)

are comparatively much larger in size. The new tubes measure approximately $1\frac{1}{2}$ " in height (neglecting prong length), are oblong in diameter with the longer side about $7/16$ " and the shorter less than $3/8$ ". They are available in two styles, based or with flexible leads.

Hearing-Aid and Sub-Miniature Similarities

These new tubes are almost identical in appearance to those used in hearing aids. In both styles of mount, the leads come out of the glass envelope in a straight line, with a polarizing mark on the glass envelope. Sockets for use with these new type tubes are also polarized. At present, four types are available; triode-heptode for converter use, sharp cut-off pentode for use as a r-f amplifier, diode pentode for detector first audio applications, and a power pentode for output circuits. Thus, a complete superheterodyne re-

(Continued on page 48)



Figs. 6 (above) and 7 (below). In Fig. 6 appears a Belmont pocket receiver using the new sub-miniature type tubes. Receiver is 3 " wide, $3/4$ " thick, and $6\frac{1}{4}$ " high. Weighs about 10 ounces, including batteries. Fig. 7 shows a cross-sectional view of the sub-miniature tube used in the receiver.

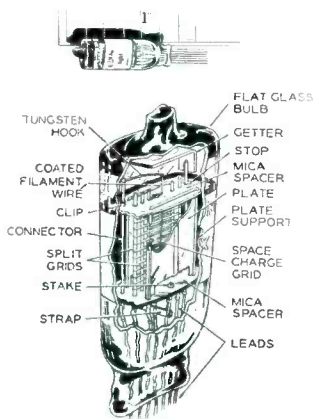

The Answer TO YOUR INSTRUMENT PROBLEMS

Burlington

PANEL INSTRUMENTS

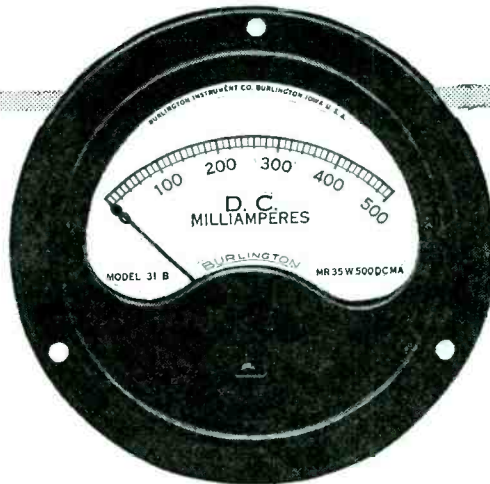

Burlington Panel Instruments are designed and built to give dependable service with guaranteed accuracy. They are available in a complete line of AC or DC Ammeters, Voltmeters, Milliammeters, and Microammeters. The wide selection of sizes and case styles offer instruments that are ideal for your particular application.

Write today for full details — our engineers will recommend the precision Burlington Instruments required to solve your instrument problems.

BURLINGTON INSTRUMENT CO.
402 Fourth St., BURLINGTON, IOWA



PANEL INSTRUMENTS • VOLTAGE REGULATORS • AUTOMATIC SYNCHRONIZERS • FREQUENCY REGULATORS

Everything FOR THE SERVICE DEALER

We have, ready for immediate delivery, a complete stock of tools, replacement parts, inter-communication systems, public address systems, test equipment . . . everything in radio equipment for the progressive service dealer. For big profit items . . . for quick delivery . . . place your order now with Leo.

6 TUBE AC-DC KIT

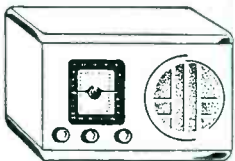

Complete, ready for assembly.

\$23.75

Cat. No. 7-691

A two-band, superheterodyne kit with all tubes, speaker, chassis, and all parts for easy assembly. Broadcast band from 540 to 1620 KC. Short wave from 5.7 to 18.3 MC. Cabinet, \$5.25.

WRL MULTITESTER

All purpose tester. Money back guarantee.

\$18.75

less leads

Cat. No. 16-439

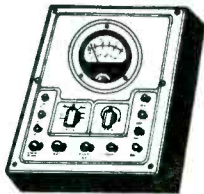

Handles AC DC Voltmeter, DC Milliammeter, high and low range Ohmmeter. 3" meter with sturdy D'Aronsvial movement. Size 5½x8x3¼.

Exclusive at WRL!
Our latest flyer . . .
12 page V-J edition of merchandise and radio values. FREE.
Handy Tube-Base Calculator . . . 25c
Giant Radio Reference Map, 3½x4½ ft. . . 15c

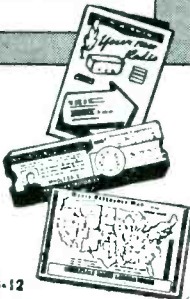

MAIL TODAY 8-12

Wholesale Radio Laboratory
744 West Broadway Council Bluffs, Iowa

Rush _____ WRL Multitesters. Cost, \$ _____

Send _____ 6-tube AC DC Kits and cabinets. Cost, \$ _____

I want a tube-calculator. 25c enclosed.

Ship me your radio map. 15c enclosed.

Send me your new V-J Flyer free.

Enclosed is \$ _____; Balance C.O.D.

Name _____

Address _____

Town _____ State _____

I am an amateur; experimenter; service man.

We invite industrial inquiries for electronic equipment and devices of all kinds.

QUICK SERVICE FROM LEO
"same day" delivery service from the heart of the nation . . . on anything in radio. Order today.



**Wholesale
RADIO LABORATORIES**

SUB-MINIATURE TYPE TUBES

(Continued from page 47)

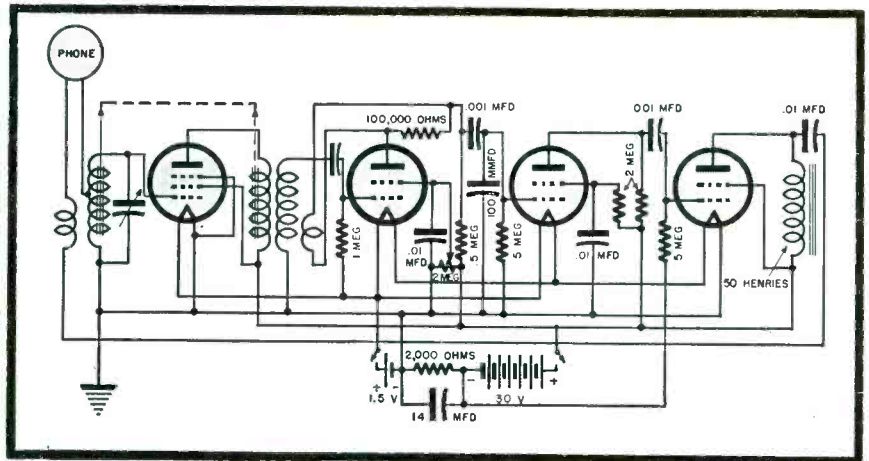

ceiver may be designed around these tubes.

As shown in Fig. 2, the filament voltage for all types is 1.25 volts at current drains varying from 30 to 50 ma. The use of 1.25-volt filaments permits their use from 1½-volt sources to an end voltage of 1. Raytheon types operate at plate voltages ranging from 22½ to 45, while the Sylvania types can be used with plate supplies up to 67½ volts.

Fig. 3 shows the comparative characteristics of sub-miniature, miniature and standard size filament type r-f pentodes. It will be noted that the gain for the sub-miniature type compares favorably with the others, considering the low plate and filament voltages and currents. Circuit applications are identical to those for miniature types, as we note in Figs. 1 and 8. In Fig. 1

Fig. 9. Components used in receiver diagramed above.

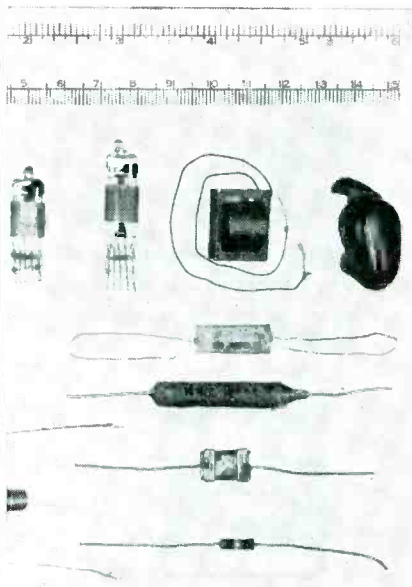
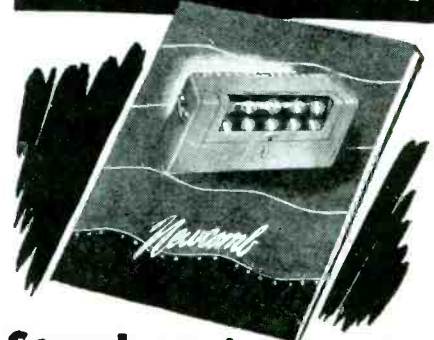

Fig. 8. Circuit of a sub-miniature type receiver using a 1T4 r-f, 3401 detector, 3402 a-f and 3403 output. The 3400 type tubes were made by Microtube Laboratories.

we have a typical amplifier circuit using a double space-charge tetrode voltage amplifier. Fig. 8 illustrates a complete receiver using sub-miniature tubes and components.

AN ENTIRELY NEW LINE



Sound equipment by NEWCOMB

Our newest amplifiers offer greater excellence in sound reproduction than ever before available to the public address field. Designed by an organization devoted exclusively for seven years to the perfection of sound equipment, they embody all the benefits of today's most advanced electronic achievements.

Send for the catalog . . . you'll find no other amplifier has so many advantages.

THE SOUND OF QUALITY

Newcomb
AUDIO PRODUCTS CO.
MANUFACTURERS
DEPT. E. 2815 S. HILL STREET
LOS ANGELES 7, CALIFORNIA

AVC/DETECTOR/A-F SYSTEMS

(Continued from page 24)

.005-mfd capacitor and a $\frac{1}{2}$ -megohm rheostat, is connected across the triode output.

G. E. 20

An example of how an extra amplifier stage is used to make up for the loss in gain due to degeneration is shown in Fig. 5; G. E. 20. The 6SQ7 amplifier, similar to the one in Fig. 4, feeds a 6J5 second or intermediate audio stage which, in turn, feeds a 25L6 output tube. A tertiary winding on the output transformer supplies the feedback voltage which is fed to the cathode of the 6J5 through a 3300-ohm bias resistor. The grid leak of the intermediate stage serves as the variable tone-control resistor. A phono jack is connected directly to the first audio grid.

Ward 62-271

A circuit using a 6C5 triode as a diode with the grid as plate, the plate being grounded, is shown in Fig. 6; Ward 62-271. This detector has an unusually high load resistor, .3 megohm, and, hence, a low value capacity shunt, .50 mmfd. A 2-section i-f filter with two .1-megohm resistors precedes a 2-megohm tapped volume control. This arrangement constitutes an a-c load potentiometer with the 6C5 first audio grid tapped down .2 of a megohm which reduces the a-f loading and, consequently, the distortion. The volume control, which is directly in the first a-f grid circuit, has a 25-mmfd capacitor shunting the high end, providing a boost to the treble frequencies. This may be considered an equalizer for flattening the audio response. An .08-mfd capacitor and 7000-ohm resistor shunt the low end of the control for bass compensation. An enforced cathode bias is applied to the first audio instead of the usual cathode resistor. This is accomplished by bleeding some d-c from the B supply through a potentiometer consisting of 25,000 ohms, from B+ to cathode and 400 ohms from cathode to B— (ground). An audio bypass of 12 mfd shunts the 400-ohm unit.

RCA QB1

A 6-volt 150-mil tube farm receiver circuit appears in Fig. 7; RCA model QB1. A series resistor ahead of the

(Continued on page 50)



Here's How CREI Prepares You Now
for

A Better Job and a Secure Career in RADIO-ELECTRONICS

Add CREI technical training to your present experience—
then get that better radio job you want—
make more money—enjoy security

CREI practical home-study training in Radio-Electronics Engineering equips you with the ability to go after—and get—a better-paying, secure radio job.

Now, that the war is over, each good radio-electronics job will go to the man best qualified. Employers are once again "choosey" in selecting the best-trained, best-equipped men for the best jobs. So, face the facts! You must keep pace with the industry and start anew to add to your store of radio-electronics knowledge.

In the CREI proved course of home-study training, you learn not only **how** . . . but **why**! Easy-to-read-and-understand lessons are provided you well in advance, and each student has his personal instructor who corrects, criticizes and offers suggestions on each lesson examination. This is the successful CREI training for which more than 10,000 professional radiomen have enrolled since 1927.

Your ability to solve tough problems on paper and then follow-up with the necessary mechanical operation, is a true indication that you have the **confidence** born of **knowledge** . . . confidence in your ability to get and **hold** an important job with a secure, promising future. These jobs are available for radiomen with the necessary modern technical training. Investigate CREI home study training . . . and prepare now for security and happiness in the years to come!



WRITE FOR
FREE 36-PAGE
BOOKLET

"Your
Opportunity in
the New World of
Electronics"

If you have had professional or amateur radio experience and want to make more money, let us prove to you we have something you need to qualify for a better radio job. To help us intelligently answer your inquiry—PLEASE STATE BRIEFLY YOUR BACKGROUND OF EXPERIENCE, EDUCATION AND PRESENT POSITION.

CAPITOL RADIO ENGINEERING INSTITUTE

HOME STUDY COURSES IN PRACTICAL RADIO-ELECTRONICS
ENGINEERING FOR PROFESSIONAL SELF-IMPROVEMENT

Dept. S-12, 3224 - 16th Street, N. W., Washington 10, D. C.

Contractors to U. S. Navy—U. S. Coast Guard—Canadian Broadcasting Corp.
Producers of Well-trained Technical Radiomen for Industry

Member: NATIONAL COUNCIL OF TECHNICAL SCHOOLS

NEW SOLDERING GUN

THE SPEED IRON*



Patent Applied For

100 Watts 115 Volts 60 Cycles

Soldering Heat in 5 Seconds

Wherever you have a soldered joint in radio, electrical or electronic repair and service work, the Speed Iron will do the job faster and better.

The transformer principle gives high heat—in 5 seconds—after you press the trigger switch. Convenient to hold with a pistol grip handle, the compact dimensions of this new soldering tool permit you to get close to the

*T.M. Reg. U. S. Pat. Off

joint. The copper loop soldering tip permits working in tight spots. The heat is produced by the high current flowing through the soldering tip—permitting direct and fast transfer to the soldered connection.

If you want to save time on soldering jobs with a tool that is ready to use in 5 seconds, get a Speed Iron today. See your radio parts distributor or write direct.

WELLER MFG. CO.

DEPT. S-1 • EASTON, PA.

AVC/DETECTOR/A-F SYSTEMS

(Continued from page 49)

volume control for r-f filtering and reducing a-f loading, is used here, too. The second filter capacitor consists of a .01-mfd audio coupling capacitor in series with a 100-mmfd capacitor shunting the 6T7 grid. Note the bias cell and 2.2-megohm grid leak. A .0025-mfd tone capacitor shunts the first audio output.

RWT 892

An extreme example of reduced detector loading is used in the circuit of Fig. 8; Radio Wire Television B92. Considerable detector output may be sacrificed because a 6B7 double-diode pentode is used, followed by a 41 connected as a triode driver for a 6A6 class B output amplifier. A degenerative link begins at the voice coil and runs through a .01-mfd capacitor to the first audio plate. The diode load consists of a .25-megohm resistor and a .2-megohm volume control. Both high boost and bass compensation are featured. A separate resistance/capacity filter of 20,000 ohms and a .25 mfd supplies the 6B7.

National NC-44B

In communications receivers it is customary to provide an avc-cutoff switch for manual volume control, particularly when using a beat oscillator for c-w reception. The beat oscillator is usually connected to the second detector, as in the National NC-44B; Fig. 9. With avc working, we have a continuous r-f detector input with the consequent high avc bias, killing the sensitivity of the receiver. When avc is turned off, one or more r-f stages may be overloaded by strong signals. Thus an r-f gain control is provided in addition to the usual a-f control. In this receiver, cathode bias is used on the 6SQ7 instead of the usual grid-leak bias.

Motorola 41H

A circuit using a 3A8GT combination tube for i-f, detector and a-f appears in Fig. 10; Motorola 41H. A single diode detector is fed by the pentode section serving as i-f amplifier. No avc is fed to this section which has a 2.2-megohm grid leak anti-blast bias. This system is usually restricted to receivers having little pickup. The ½-megohm volume control acts as the diode load resistor with a .01-mfd coupling capacitor and a 3.3-megohm leak for the triode first audio section.

R.C.P. first in world sales*



★ Radio City Products have built and sold more vacuum tube voltmeters than any other manufacturer in the world.

MODEL 668 VACUUM TUBE VOLT, OHM, CAPACITMETER

VACUUM TUBE AC AND VACUUM TUBE DC voltmeters are provided in this quality testing unit. A highly accurate instrument, sensitive and flexible, designed to speed production testing.

ACCURACY—Line Voltage Adjustment gives accuracy on capacity measurements.

Matched-pair multiple resistors are $\pm 1\%$ accurate.

Circuit eliminates all errors due to line voltage fluctuations.

Accurate capacitometer reads direct in microfarads—40,000,000 to 1 measurement ratio.

SAFETY—Meter cannot be damaged by using low range on high voltage reading.

No danger of shock on high resistance or low capacity measurements.

Entire instrument is thoroughly shielded.

Easy replacement of line fuse at front panel.

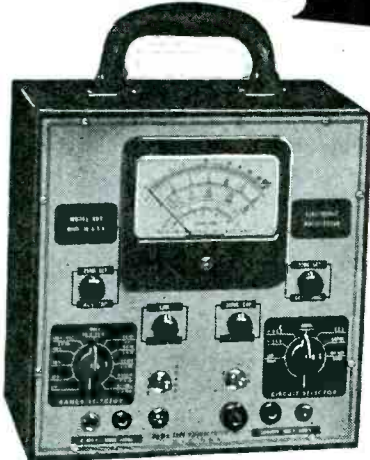

RANGES

DC VACUUM-TUBE VOLTMETER—Direct Reading. Sensitivity: 160 to 16 megohms. Six ranges: 0-6-30-150-600-1500-6000 Volts. Voltmeter readings can be taken without affecting circuit constants. ★ AC VACUUM-TUBE OHM-METER—Direct Reading. Input capacity 0.00005 mfd. at terminals of instrument. Input resistance: 160 to 16 megohms. Seven ranges: 0-3-6-30-150-600-1500-6000 volts. Measures signal and output voltages from 10 cps to 10,000 cps. ★ VACUUM TUBE OHMMETER—Direct reading. From 0.1 ohm to 1,000 megohms. Seven ranges: 0-1-100-10,000-100,000 ohms: 1-10-100-1,000 megohms. ★ CAPACITY METER—Accurate measurements from 0.00005 to 2,000 mfd. Seven ranges: 0-0.002-0.02-0.2-2-20-200-2,000 mfd.

MODEL 668. Size 9¼" x 9¼" x 7¾". Weight 7¾ lbs. Available for 110 volt, 60 cycles, ac.; 210-270 volt, 50-60 cycles.

RADIO CITY PRODUCTS CO., INC.

127 West 26th Street,  New York 1, N. Y.

VOLUME AND TONE CONTROLS

(Continued from page 30)

others. When selecting the proper control for audio-grid circuit replacement work, it is wise to choose a unit having not too abrupt a change of taper at this region.

Caution: It is entirely possible that in many cases the replacement control specified by the replacement control manufacturer's list, manual, or guide will not correspond exactly in type, taper or even in resistance value with the faulty unit found in the receiver. The reason could well be that the receiver was serviced for volume or tone-control trouble previously by another Service Man and, due to the war-time shortage of controls (or some other procurement difficulty) that existed at the time, a control of incorrect specifications was installed as an expedient to get the set working, even though an entirely satisfactory volume or tone control was not provided in this procedure.

When such cases are encountered, it will be advisable to use the replacement unit recommended in the replacement-control manufacturer's manual or guide, rather than to simply insert a control identical with the faulty one. A study of the type of control circuit employed in the receiver will serve as a check in case of doubt, since the new unit to be installed should be of the type and specifications to fit the requirements of the particular type of control circuit and tubes employed.

High-Voltage Couplers for Controls

Standard controls are usually supplied with the center terminal and moving member insulated from the mounting bushing and case. For applications where controls must be used in high-voltage circuits (such as in television equipment, cathode-ray oscillographs and other electronic applications), one manufacturer has provided a high-voltage insulating coupler in the control assembly. As shown in the two illustrations of Fig. 5, this feature takes the form of a bakelite spacer tubing that screws on to the regular control mounting bushing at one end, and carries a metal bushing through which a shaft protrudes at the other, with an enclosed bakelite shaft coupling joining this shaft and the slotted short shaft of the control. The spacer-coupler can be of any required length to withstand the existing operating voltage, but the two types available at present will withstand an insulation breakdown of either 3,000 or 10,000 volts a-c between the control proper and its shaft and mounting.

This type of coupler is now being made available with certain types of midget composition-element controls

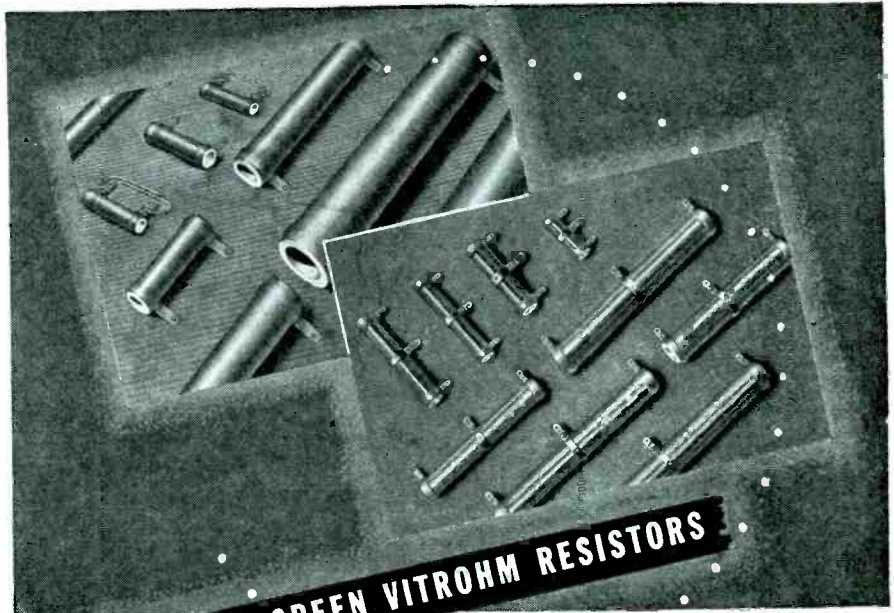

LOOK FOR GREEN VITROHM RESISTORS

The Green Vitrohm Enamel used in the manufacture of all Ward Leonard Vitrohm Resistors and Rheostats is an exclusive development of Ward Leonard Laboratories—the result of more than 50 years of intensive research in resistor enamels.

Pick the Resistor with the Green Vitrohm Enamel and you pick the best. Now available at your Radio and Electronic Parts distributor.

Write for your free copy of our Radio and Electronic Resistor Catalog.

WARD LEONARD ELECTRIC CO.



Radio and Electronic Distributor Division
53 West Jackson Blvd., Chicago, Ill.



and with wire-wound and multiple-type controls.

In the next article of this series, repair and reconditioning of volume and tone controls will be explained.

(To be continued)

At right, preheating tube device used at General Electric to check tubes in warmed-up condition and thus determine in-use efficiency. Correlated data also serve to assist the development engineer in improving tube design and construction.



SOCKET PREHEATING

First Choice

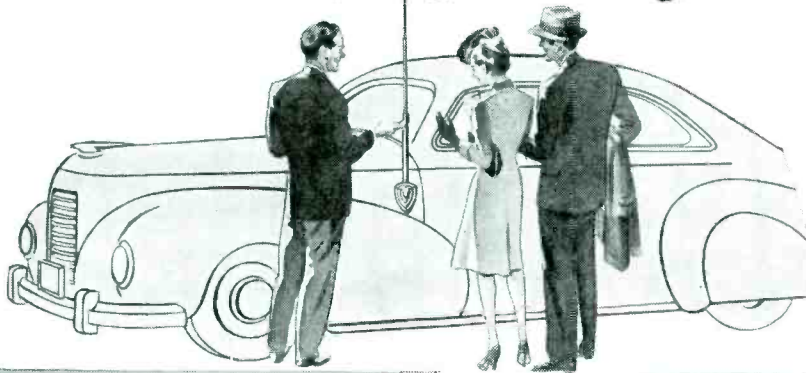

... OF AMERICA'S AUTO DEALERS

The same precision workmanship and the same fine quality mark Ward Antennas now as before the war. But now there are added reasons of new design and newly-engineered efficiency which will give Ward Antennas an even greater margin of preference with America's auto dealers. For extra profits that satisfied customers always bring, order Ward—world's finest antennas for car and home.



Buy Victory Bonds

THE WARD PRODUCTS CORPORATION

1523 E. 45th St., Cleveland 3

WARD

Antennas

TIME WILL TELL!

33 Years of Experience

● THE HALLDORSON COMPANY has continuously manufactured for industry since 1913. Since inception, this firm has been and is still an individual firm . . . not a subsidiary or branch of another company. Each and every HALLDORSON transformer is backed by 33 years of experience, research and actual field knowledge. A new and more complete line of transformers is now being developed in the HALLDORSON laboratories. Soon . . . we hope, in the very near future . . . these transformers will be available.

JOBBER: Get on our mailing list today!

THE HALLDORSON COMPANY

SINCE 1913

4500 Ravenswood Avenue • Chicago 40, Illinois

HALLDORSON Vacuum Sealed TRANSFORMERS



SERVICING HELPS

Sparton 410, 420

No reception from 550 to 800 kilocycles, reception above 800 kc erratic at times: Condition due to dirty wiper contacts that ground the rotor of tuning capacitor. Shaft and wiper should be cleaned with carbon tetrachloride, applied with a small art brush, rotating the condenser while applying.

Philco 112-112A

Inoperative: Usually the input or output transformers have open windings. Of course the proper way is to replace the transformer. But, if the customer is willing, a resistor can be placed across the open winding, and a capacitor from that point to the other winding will effect a very satisfactory repair.

Synchronous Motor Record Players

Wavering of speed, especially on slow music: While cleaning and oiling will improve operation, the condition may reappear. Thus it has been found better to use the following method, involving a small repair to the center shaft. This shaft, which is fixed to the turntable, works on a single ball bearing. The ball bearing wears a spot in the shaft. Enough of the shaft should be ground off to remove all trace of the spot. Shaft should then be cleaned, oiled and replaced.

New Dial Drive Installation

New cables tend to slip on shaft, even though there is sufficient spring tension: To cure, a small amount of resin should be powdered on the cable. To provide a base for the resin carbon tetrachloride or alcohol can be used. A very small amount should be applied or the cable will follow shaft. If too much has been applied, brushing with carbon tetrachloride or alcohol over the shaft and cable will help.

Claude M. Prew

G. E. 60

High-pitched audio squeal: Traced to volume control. The control should be cleaned with carbon tetrachloride. A piece of No. 30 wire should be inserted under the U clamp on the shaft to take up any play. The carbon strip should be lubricated with graphite (lead pencil).

Art Mohr

350-SPEAKER P-A SYSTEM

A 350-SPEAKER p-a system was recently installed in the Rochester plant of Stromberg-Carlson.

Complete control of the system is achieved with a master console. This unit controls a two-channel system for either paging or music to thirteen groups of speakers throughout offices and factories. A third channel, for recording, may be used when each of the other two channels is in use.

In addition to the thirteen groups of speakers the new console controls thirty power amplifiers, eight microphone locations using ten microphones, a radio tuner, and a transcription player.

It is possible to control the broadcasting of music throughout the plant while permitting the operator to page any desired section without affecting the music in the others.

The input panel controls, by key switches, linking of ten microphones on either paging, music, or recording pre-amplifiers. A key switch is provided to connect the transcription player to either the radio music or the recording pre-amplifiers. Keys are also provided for fire, emergency, or time signals. Radio is connected by a key switch. Seven individual mixers enable the operator to control the level. Eight telephone circuits connect the console with the local plant telephone switchboard, so that paging calls can be handled effectively by the sound system operator.

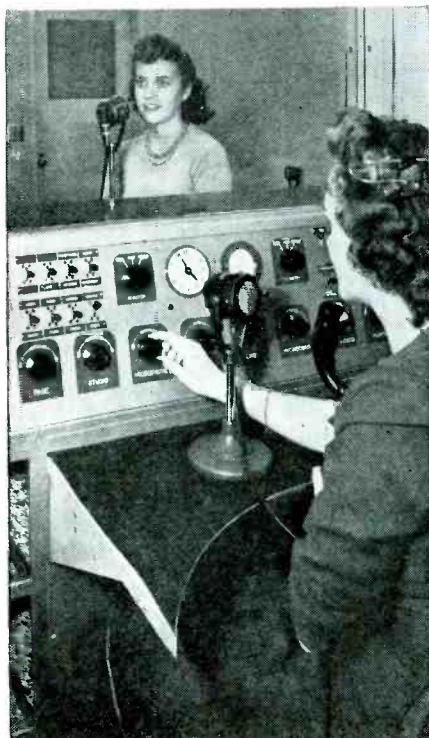

Christmas Greetings

We wish to thank all our friends in the trade for their good will in 1945. 1946 looks better!

cornish WIRE COMPANY, INC.

15 Park Row, New York City, New York

"Made by Engineers for Engineers"



At left, a view of the console and the glass-partitioned studio used for special employee plant broadcasts. To the left of the console are the recording pre-amplifiers and additional key switches. Above appears an overall view of the console, which includes the broadcast receiver. Programs picked up by the receiver are also piped into the console and over the p-a plant system.



PHONO-RADIO MATCHING UNIT

BOON FOR SERVICERS! A time-saver and moneymaker that just had to come . . . fruit of ADAPTOL initiative and research, supported by technical help from your own profession.

HOW SIMPLE! Without removing anything from either housing . . . without even breaking a circuit . . . you can install this long-wanted convenience wherever there is a radio to be utilized for reproducing record entertainment!

THINK OF THE technical data you DO NOT have to wade through! And the time you can save! And the satisfaction for your customers, while you are making a nice profit and adding to your professional prestige!

ANY
RECORD
PLAYER

ADAPTOL
supplies the
MISSING LINK

write
QUICK
for the
WHOLE STORY

ANY
RADIO

ADAPTOL COMPANY

260 Utica Avenue, Brooklyn 13, New York



OLD TIMER'S CORNER

by **SERVICER**

ABOUT the most debated topic in a town today is surplus. Seems as if everyone has something to say about it. We had quite a session on the subject a few nights ago during one of our weekly meetings. Roy started the ball rolling by telling us how keen he was about surplus parts. He had just returned from the Big City, where he had visited a surplus warehouse.

"I tell you," gushed Roy, "it was the sweetest and the most complete assortment of parts I have seen in a long time."

"Did you buy some?" asked John.

"Yep, I did," said Roy. "And what's more I think that I shall be in a position to do some fancy buying from now on. Wait till you see the hard-to-get parts I pick up!"

"How do you figure that?" asked John. "You don't think that you can really use those parts in just the same condition in which you bought them, do you?"

"Well," continued Roy, "there is a thing to be done here and there to make them work. But for the most part they will fit with a bit of tailoring. And I for one would rather repair than not repair, if you get what I mean, and I think that you do!"

Pete's Argument

"You boys don't know what you are talking about," broke in Pete. "I've been listening to you tell how you are going to make a killing and have parts that are hard to get."

"Don't you agree?" asked Eddie. "At least Roy here will surely have parts!"

"Sure he'll have parts," continued Pete, "but what kind of parts?"

"This idea that surplus is the answer to your problems is all wrong."

"And how do you figure that all out," asked Roy.

"Well, it's true there's quite a surplus load about. We find everything from 1/8-watt resistors, and maybe even smaller ones, to complete Navy and Army receivers. And to be sure it should be sold to someone. But we shouldn't buy!"

"The manufacturers are now just getting under way. They will be bringing out parts that will fit and parts that will go into the greatest majority of sets now on the market and to come on the market after a little while. It is expected that the Service Man will want to get his repairing down to a science and that he will want to repair each same set the same way with the same type of parts."

Tolerance Problems

Tolerances of the surplus pieces are going to vary all over the map. Most

IT'S NEW! IT'S POST-WAR SUPREME Model 565 VACUUM TUBE VOLTMETER

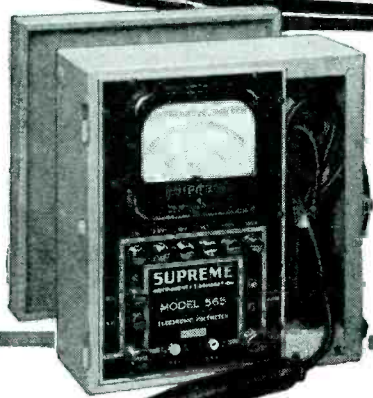

NEW PROBE Streamlined
Hand Fitting Incorporating
new High Frequency Diode

RANGES:

DC—0-1, 2.5, 10, 50, 250, 500
AC—0-1, 2.5, 10, 50, 250

EXTENDED TO 5000 VOLTS BY EXTERNAL MULTIPLIERS

INPUT RESISTANCE:

DC—80 megohms on 1 volt range; 40 megohms on 500 volt range
AC—40 megohms on 1 volt range; 20 megohms on 250 volt range

INPUT CAPACITY OF PROBE: 5 micro-micro farads

FREQUENCY RANGE:

Negligible frequency error from
50 cycles to 100 megacycles.

SUPREME INSTRUMENTS CORPORATION GREENWOOD MISSISSIPPI

sets can be fixed with 20% resistors and 20% capacitors. That is what we have been using since radios were brought into us for repair. The surplus stuff *might* be 20% or rejects with broader plus or minus ratings.

"You are not going to be able to tell which was manufactured yesterday or just before the end of the war, and what was manufactured sometime late in 1941 or the beginning of 1942. So you won't know the part's shelf life. And don't tell me that that is not important. We all know that it makes a great deal of difference if we use a fresh electrolytic or one that has been around for a few years.

Guarantees

"Then there is the matter of guarantees. Which surplus material is guaranteed under the standard RMA guarantee? None! And what are you fellows going to do when something pops and you want the part replaced by a manufacturer? Sure, I know, that doesn't happen very many times, but when it does, it certainly is a nice feeling to know that not everything is lost in the transaction.

Manufacturer's Helps

"And then there's another matter which I throw before you for consideration. Are we as Service Men really helping the manufacturers as much as we would want them to help us? How can we ask them to take the trouble to help us with our technical problems, which are many, and which we blithely throw into the respective laps of the tube manufacturer, the resistor manufacturer and the capacitor manufacturer? Is it fair to buy surplus and then if the part's don't work, ask a manufacturer why they don't? Or should we show our loyalty by staying with the firms that helped get us established. I think that while we are debating that the manufacturer's should be backing us up, we should be supporting the manufacturers with our business.

Credits

"And last but not least," concluded Pete, "we can better establish ourselves on the credit side of the ledger by dealing with the first-line manufacturers through our distributor. Once we have that credit established, then we can sail along without much trouble through good times and bad. All of that we lose by splurging in surplus.

No Deal for Surplus

"That's why I think that surplus offers no deal for us. I, for one, am buying parts made by old-time manufacturers. They will come through in time for me, I'm sure. And they won't let the rest of you fellows down either."

JOIN THE MARCH OF DIMES
FIGHT INFANTILE PARALYSIS
JANUARY 14-31
 The National Foundation for Infantile Paralysis

Just Published!

THE FIRST OFFICIAL RADIO & ELECTRONIC INDUSTRY **BUYERS' GUIDE**

A comprehensive publication of over 100 pages containing many new features, including:

"A Book that Should Be on the Desk of Every Radio Executive"

- A List of Manufacturers of Radio and Electronic components with the names and addresses of their regional representatives.
- A geographical list of Manufacturers' Representatives.
- A "Where to Buy It" section.

NO ADVERTISEMENTS—Issued purely as a service to the Radio Parts Industry and distributed gratis by

"THE REPRESENTATIVES" OF RADIO PARTS MANUFACTURERS, INC.

The members of this organization have an average of more than 12 years experience in serving the needs of their customers.

Cooperative periodic interchange of ideas between members on non-competitive matters offers distinct advantages to principals and customers.

Sensitive to local conditions, members are in a position to advise on trends affecting design, engineering, policy, etc.

They maintain their own organizations with trained personnel and are constantly on call.

Get your free copy from any member of The Representatives or write direct to the Secretary

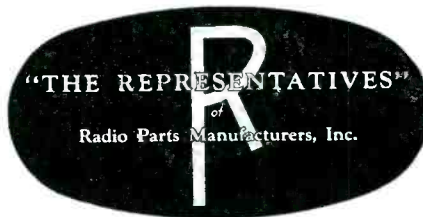

DAVID SONKIN
 National Secretary
 347 Fifth Avenue
 New York 16, N. Y.

INTER-CITY TELEVISION SYSTEM

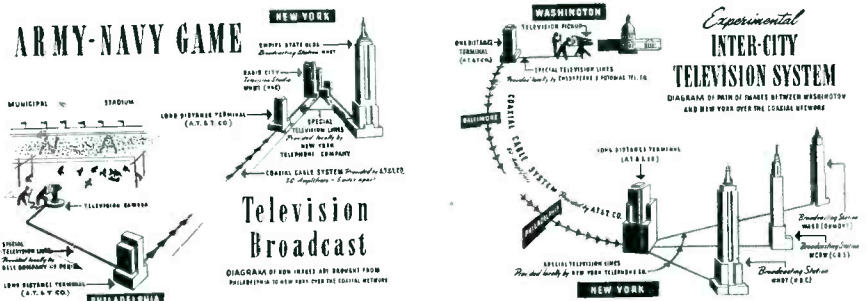

How recent television programs have been broadcast from city to city. At left, above, appears the Army-Navy football game setup from Philadelphia. At right, above, appears the link used to transmit from Washington, D. C., to New York and over three stations in the New York area. Similar links will be used throughout the country as television transmitters are installed.

G-E TUBE CHECKER

Quick, easy, accurate tube checking which saves you time and trouble and keeps your customers happy—that's the job the TC-3P is built to do. Line Voltage and tube quality, or shorts, may all be checked on one selector switch. Individually operated switches permit placing the proper voltage on the proper pin of the tube. The G-E Tube Checker is available in either the Portable (TC-3P) or Counter Model (TC-3). Write: Specialty Division, Electronics Department, General Electric Company, Syracuse, New York.

GENERAL ELECTRIC

177-D1

Electronic Measuring
Instruments

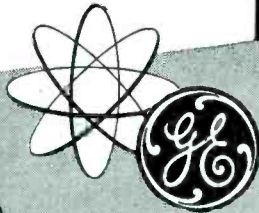

TC-3P

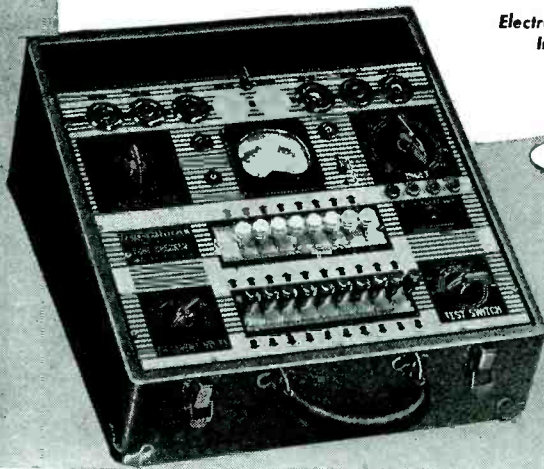

NEWS

RIEDEL RESIGNS FROM RAYTHEON

Edgar S. Reidel has resigned from the Raytheon Manufacturing Company. For 13 years he was general sales manager of the receiving tube division. Mr. Reidel was one of the nine original organizers of the RMA at Chicago in 1923.



* * *

JESTER, KARET AND OGILVIE WIN MAGUIRE PROMOTIONS

Oden F. Jester has been named general sales manager of the radio and phonograph division of Maguire Industries, Inc.

Mr. Jester will direct sales of Meissner radiophonographs and other products to be made by the Meissner manufacturing division at Mt. Carmel, Illinois, record changers and similar products of the Maguire plant in Bridgeport, Conn., products of the Thordarson Electric manufacturing division in Chicago and of the Radiart Corp. subsidiary in Cleveland, Ohio.

Robert M. Karet has been appointed manager of the electronic distributor and industrial sales department of Maguire Industries.

Under Mr. Karet's direction, all distributor and industrial sales of Maguire subsidiaries serving the electronic field will be coordinated.

Mr. Karet will make his headquarters at 936 North Michigan Avenue, Chicago.

Allan R. Ogilvie has become a vice-president of Maguire Industries and placed in charge of the Bridgeport, Conn., plant.

Mr. Ogilvie was formerly chief engineer of the electronics division. Carlton Wasmansdorff succeeds Mr. Ogilvie.

* * *

REPRESENTATIVES OFFICIAL BUYERS GUIDE

The *Representatives of Radio Parts Manufacturers, Inc.*, have announced that a 130-page *Radio And Electronic Indus-*

BUS-LINE RADIO SYSTEM



Experimental f-m two-way system aboard bus operating between Arlington, Virginia, and Washington, installed recently by G.E.

Watch

MILO

Headquarters for Radio
and Electronic Equipment

of **NATIONALLY KNOWN PRODUCTS**

Component Parts
Recorders
Testing Equipment
Sound Equipment
FM and Television Radios

Selling to
Industrial Firms, Schools,
Amateurs, Servicemen, etc.

Milo Features Trained Sales Technicians to Expedite
and Handle Your Orders with Utmost Efficiency!

MILO

Radio and Electronics Corp.

200 GREENWICH STREET, NEW YORK 7, N. Y., BEekman 3-2980

LAKE'S

RADIO Cabinets, Parts & Equipment

for
Your Every Need!



Portable Phonograph case in brown leatherette covering. Inside dimensions 17½" long, 7½" wide, 7½" high. Has blank motor board and opening for speaker. As illustrated at left, specially priced at

\$7.95



Portable Phonograph case, of sturdy durable plywood, in handsome brown leatherette finish. Inside dimensions: 16½" long, 14" wide, 9½" high. Has blank motor board. As illustrated above, specially priced at

\$6.95

Also blank table cabinets of walnut veneer in the following sizes, with speaker opening on left front side: (*Note: *7 has center speaker grill.)

# 1 — 8¼"	L x 5½"	H x 4"	D \$1.95
# 2 — 10¼"	L x 6¾"	H x 5"	D \$2.75
# 3 — 13½"	L x 7¾"	H x 6¼"	D \$3.25
# 7 — 10¾"	L x 7"	H x 5½"	D \$2.50
# 8 — 17"	L x 9"	H x 8½"	D \$4.50
# 9 — 21"	L x 9¼"	H x 10½"	D \$5.50

* Speaker Opening in center of front side. Cabinets available in Ivory color and Swedish Modern. Write for prices.

POWER TRANSFORMERS

4, 5 or 6 Tube — 6.3V at 2 amp.	\$1.49
50 Mill Power Transformer	
7, 8, or 9 Tube — 6.3V at 3 amp.	\$1.89
70 Mill Power Transformer	

SOUND ACCESSORIES

Complete line of amplifiers, microphones, speakers, and sound accessories.



All types of radio cabinets and parts are available at Lake's lower prices. A large stock is listed in our catalog.

SERVICEMEN—RETAILERS
Join our customer list today.
Dept. D

Write for our NEW, 12 page, illustrated, elaborate catalog!

Order from Lake!
You'll make no mistake!

Lake Radio Sales Co.
615 W. Randolph Street
Chicago 6, Ill.

try Buyers' Guide is now ready for distribution.

This book contains an alphabetical listing of component manufacturers, addresses, products and a geographical list of their representatives or their regional sales offices. A feature is a *Where to Buy It* section with an alphabetical list of radio components and sources of supply.

The directory is being distributed gratis to purchasing agents and executives of radio and electronic manufacturers, radio and electronic distributors, laboratories, colleges, etc. Requests may be directed to any member of *The Representatives* or to the national secretary, David Sonkin, 347 Fifth Avenue, New York 16, N. Y.

* * *

AIREON PIEZOELECTRIC CRYSTAL CATALOG

A crystal catalog has been published by the Aireon Manufacturing Corporation, Kansas City, Kansas.

Principal types of crystals described in the catalog are: Octal type with cylindrical metal shield and standard eight pin base; three-pin, two-channel, aircraft type; standard two-pin phenolic holders for various kinds of mobile and stationary installations (banana or pin plugs); and variable air-gap mounting with screw top electrode.

* * *

OPERADIO IMPEDANCE CALCULATOR

An impedance calculator, 5" in diameter, designed to aid in matching loudspeaker lines to an amplifier for sound systems with 500, 1,000, 4,000, 8,000 or 16,000-ohm loudspeakers, has been developed by engineers of Operadio Manufacturing Co., St. Charles, Illinois.

Scales for 500, 1000, 4000 and 8000-ohm loudspeakers are incorporated on three revolving discs. Total group impedance of all loudspeakers is obtained by matching specific ohm scales to the number of loudspeakers involved in a sound installation. Available to sound men for 25¢, direct or from distributors.

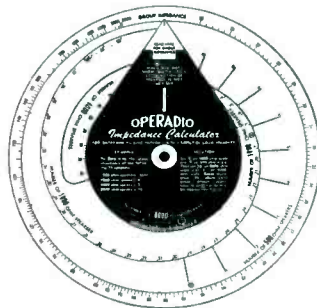

* * *

L. J. WRONKE JOINS HALLICRAFTERS

Louis J. Wronke, Inc., Oak Park, Ill., industrial designers and engineers, has merged with the Hallicrafters Company.

The Wronke Corporation's president, Louis J. Wronke, has joined Hallicrafters as chief mechanical engineer and director of design.

* * *

ALLIED RADIO LAUNCHES RAYTHEON BONDED PLAN

Allied Radio, 833 W. Jackson Boulevard, Chicago, Ill., announced adoption of the Raytheon bonded plan at a recent dinner meeting of dealers. A. D. Davis, president, and W. F. Marsh, sales manager, analyzed the plan. (Full details (Continued on page 58))



● Now, more than ever before, you just can't afford to take a chance with questionable capacitors. In other words, be sure that the capacitors you install are "going to stay put."

And that's precisely where Aerovox capacitors come in. They're fresh. The popularity of the Aerovox line means quick turnover of jobber stocks. You can be sure that Aerovox capacitors are of current production. And that's especially important in electrolytics. Don't take a chance with unlabeled or questionable capacitors!

● Ask Our Jobber . . .

Ask about the various types of capacitors you need. Ask for copy of our latest catalog—or write us direct. Meanwhile—look for that YELLOW label, which means Aerovox, and Aerovox means DEPENDABLE capacitors.

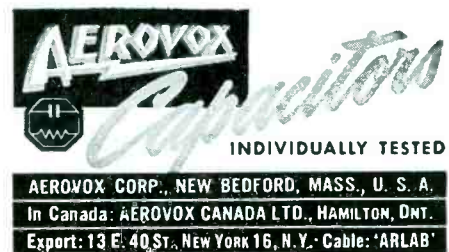

AERVOX CORP., NEW BEDFORD, MASS., U. S. A.
In Canada: AEROVOX CANADA LTD., HAMILTON, ONT.
Export: 13 E. 40 ST., NEW YORK 16, N. Y. Cable: 'ARLAB'

AMERICAN CAPACITORS

DRY ELECTROLYTIC & PAPER DIELECTRIC



SPECIFICATION SHEETS ON REQUEST

ALL STANDARD TYPES • PRECISION ENGINEERED FOR DEPENDABILITY

AMERICAN CONDENSER CO.

4410 NO. RAVENSWOOD AVE. • CHICAGO 40, ILL.

NEWS

(Continued from page 57)

of the plan appeared in the November issue of SERVICE).

* * *

GENERAL CEMENT DIAL BELT DISPLAY

A dial-belt display stand has been announced by the General Cement Manufacturing Co., 919 Taylor Avenue, Rockford, Ill.

* * *

NEWS OF THE REPRESENTATIVES

O. P. Smith, 660 N. Dearborn St., Earl T. Champion, 4753 N. Broadway, and Gordon E. Gray, 1 N. Pulaski Rd., have become members of the Chicagoland chapter of the Representatives.

A. B. Smedley, 15 N. Euclid Ave., Pasadena, Cal., has become a member of the Los Angeles chapter.

At the annual election of the Pacific Northwest chapter, Lloyd Marsh was elected president; Ralph James, vice president; and George Norris, secretary-treasurer.

John J. Hagerty, 1010 Francis Palms Bldg., Detroit, Mich. was recently accepted as an associate member of the Wolverine chapter.

The following members of the Chicagoland chapter have moved: J. E. Goode, 412 So. Green St., Chicago 7; Bob Whan, 4717 Madison St., Chicago 44; and Wm. J. Johnston, 549 W. Randolph St., Chicago 6.

•

REMOTE CONTROL TELEVISION ANTENNA



Remote control antenna system, developed by Farnsworth for television reception, to eliminate ghosts or shadows that are apparent on receivers in large cities where skyscrapers are numerous and in mountainous regions such as in California. Within the case are two motors, one for orientation and one for tuning. Four push buttons on a control board allow for the receiver operator to rotate the antenna clockwise or counterclockwise through 180° and to increase or decrease the frequency of resonance.

A deluxe installation has a three-section arm extension with a frequency range of 2½ : 1, from 46 to 117 mc. Smaller antenna system has two sections with a frequency range of 1.8 : 1 or 46 mc at bottom and when extended, to 85 mc at the top.

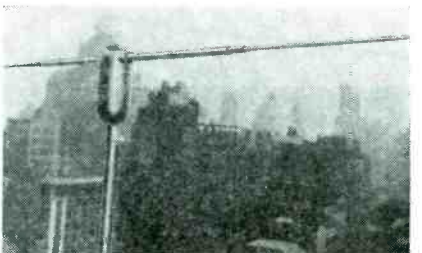

SPEED UP REPAIRS WITH THESE G-C AIDS!



FREE STEEL CABINET

G-C Dial Belt Kits

Every Serviceman needs a G-C Dial Belt Kit. Save money—be ready for that repair job. Finest woven fabric replacements. Easy to install—no stretch—no adjustments. Supplied in kits of 25, 50, 100, 200 or 300 Belts. In sturdy metal box with slide-in drawer. Free Belt Guide and measuring device.



G-C Dial Drive Cables

G-C has a complete line of Dial Drive replacement cables. Available by the spool for prompt servicing of all sets. Every Serviceman should have a complete assortment. Best quality—extra strength. Preferred by Radio Men everywhere.

G-C Radio Service Cement

The best Cement for Speaker and Radio Work. Especially suitable for cementing replacement cones and repairing rattling and torn cones. Also used on glass, to seal adjustments, hold wires in place, etc. Dependable, vibration proof, waterproof and fast drying.



Write for New G-C Catalog No. 146 and G-C Dial Belt and Service Book

Immediate Delivery on all G-C Products

Order From Your Radio Parts Jobber
ALWAYS ASK FOR G-C PRODUCTS



GENERAL CEMENT MFG. CO.
ROCKFORD, ILLINOIS

EFFECTIVE JANUARY ISSUE

TRIM SIZE OF SERVICE WILL BE INCREASED TO 8¾" x 11⅝"
BLEED PLATES SHOULD MEASURE 8⅞" x 11⅞"

PAID CIRCULATION OVER 10,000 ABC

NEW PRODUCTS

TRIPLETT VOLT-OHM-MILLIAMMETER

A volt-ohm-milliammeter, type 2405, with 25,000 ohms-per-volt (d-c), has been announced by the Triplett Electrical Instrument Co., Bluffton, Ohio.

Ranges are: D-c volts 0-10-50-250-500-1000, at 25,000 ohms-per-volt; a-c volts... 0-10-50-250-500-1,000, at 1,000 ohms-per-volt; d-c amperes... 0-10; a-c amperes... 0-0.5-1-5-10; d-c milliamperes... 0-1-10-50-250; d-c microamperes... 0-50; ohms-megohms... 0-4000-40,000 ohms/4-40 meg-ohm; output... capacitor in series with a-c volts. Has a 6" model 626 micro-

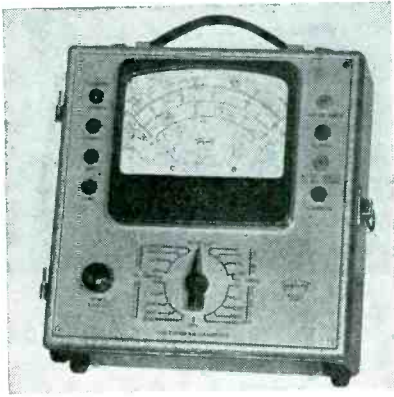

ammeter, adjusted to 40 microamperes. Metal case, 10" x 10" x 5 3/4". Weight, approximately 11 pounds. Leather strap handle for portable use. Batteries self-contained.

* * *

STRUTHERS-DUNN REVERSING CONTACTOR

Heavy duty reversing contactors, type 135CXX, have been produced by Struthers Dunn, Inc., 1321 Arch Street, Philadelphia, 7, Pa.

Designed for use with polyphase motors up to 1 h-p, single-phase motors to 3/4 h-p, and is available for from 110 volts to 600 volts a-c. Consists of two 3-pole contactors mechanically interlocked. For control operation on door and window operating devices, machine tool cross feeds, etc. Size: 5 3/4" wide x 4" high x 1 7/8" deep. Weight, approximately 2 1/2 pounds.

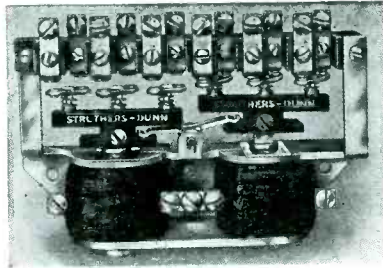

* * *

DUMONT 7" TELEVISION TUBE

A 7" television receiver tube, type 7EP4, has been developed by the Allen B. Du Mont Labs., Inc., Passaic, N. J. Provides for a normal screen image of 5 3/4" wide by 4 1/4" high.

Tube is 15 1/2" long. Accelerating potential is 2500 volts.



* * *

G.E. MIDGET THYRATRONS

All-metal midget thyratrons, type GL-502A, have been announced by the tube division of G.E.

The GL-502A is an inert-gas-filled. (Continued on page 60)

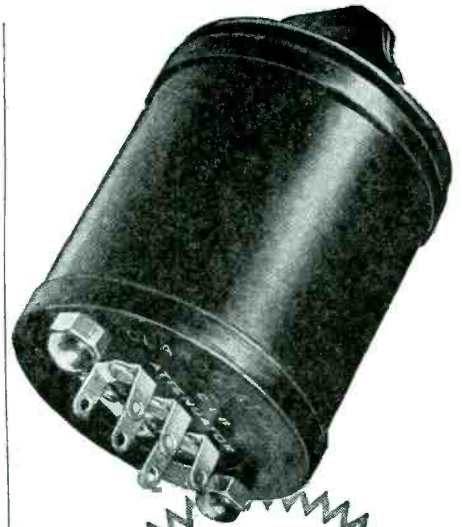

Sound-System CONTROLS

★ This compact, inexpensive, constant-impedance output attenuator (Clarostat Series CIB) will dissipate 10 watts at any setting. Operates noiselessly without distortion. It is highly recommended as an individual speaker control in a multi-speaker P-A system. Linear attenuation in 3 db steps up to 30 db, and then final step to infinity. Insertion loss is zero.

The Clarostat standard line (listed in latest catalog) also includes wire-wound T-pads and L-pads of the constant-impedance type for use in sound systems where the associated equipment in circuit must remain within the limits of a required constant value.

★ Ask Our Jobber...

Ask him about Clarostat sound-system controls, as well as other controls and resistors you require. Ask for latest catalog—or write us direct.

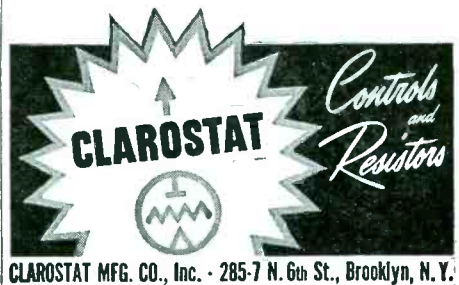

FREE TO YOU

COLOR CODE and OHMS LAW CALCULATOR

Great Time Saver

Burstein-Applebee of Kansas City offers you this great convenience FREE. Easy to work. Solves many problems in a jiffy. FREE to Radio men, electronic engineers and others in the business. Attach coupon to your letterhead.

MAIL COUPON NOW



BURSTEIN-APPLEBEE CO.
1012 MCGEE ST.
KANSAS CITY 6, MO.
Send me FREE Color Code and Ohms Law Calculator along with latest catalog.

I am _____ STATE CONNECTION IN INDUSTRY

NAME _____

ADDRESS _____

TOWN _____ STATE _____

To Do the Job

BETTER . . .

FASTER . . .

EASIER

THERE'S A

**SHOCK-PROOF
BREAK-PROOF**

AMBERYL-HANDLE
VACO DRIVER

OR
SMALL TOOL
TO
HELP YOU

**173
VACO TYPES**

Yes, Vaco has created more than just a variety of screw drivers. Vaco has built the exact type of screw driver to do the particular job that can be tedious and troublesome when an ordinary driver is used. No wonder mechanics who do precision work say Vacos are "tops" among all drivers. Vacos, with gleaming Amberyl handles, are shock-proof and break-proof. Write for catalog.

VACO

PATENTS MAKE JOBS

PRODUCTS CO.

317 E. ONTARIO STREET
CHICAGO, ILL.

Canadian Warehouse:
540 King St. W., Toronto, 2

NEW PRODUCTS

(Continued from page 59)

double-grid thyratron with negative control characteristics. The control characteristic is said to be independent of ambient temperature over a wide range. Net weight, two ounces. Height, 2½"; diameter, 1⅝".

* * *

SIMPSON TUBE TESTER

A mutual conductance tube tester has been announced by the Simpson Electric Company, Chicago.

Features a method of testing tubes in terms of percentage of rated dynamic mutual conductance. Tube under test is compared with the standard rated micromho value for that tube. Colored zones on the dial coincide with the micromho rating or percent of mutual conductance, indicating that the tube is good, fair, doubtful or definitely bad.

Has ten push-button switches and nine rotating switches of six positions. An automatic re-set button returns all switches to normal when the test is completed. Tube chart is provided. Overall size, 15½" x 9½" x 6½".

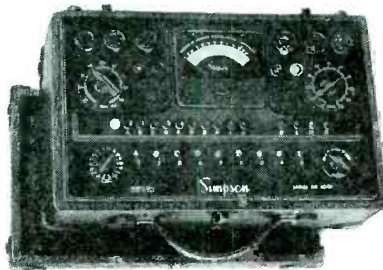

* * *

CLARK 30-WATT AMPLIFIERS

Thirty-watt amplifiers have been announced by the Clark Radio Equipment Corporation, 4313 Lincoln Avenue, Chicago, 18, Ill.

Features include: Three input circuits, one high impedance (500,000 ohms) phonograph, plus two high impedance (500,000 ohms) microphone channels; microphone gain is said to be 125 db, phonograph 85 db; two speaker sockets with impedance tap switch providing 4, 8, 16, or 500 ohms; individual bass and treble boost or attenuation (bass equalizer variable, said to be from -12 db at 50 cycles to +18 db at 70 cycles, treble equalizer from -12 db to +21 db at 10,000 cycles);

frequency response said to be ±2 db from 50 to 10,000 cycles; hum level said to be about 55 db below maximum output with bass control on full.

Tubes: 3-7C7s, 1-7F7, 1-6SN7, 2-6L6s, 1-5U4. Power consumption: 150 watts at 117 volts, 60 cycles.

Dimensions: 10" high, 20" wide including handles, 11⅝" deep.

* * *

**SHALLCROSS 1.5-WATT
HERMETICALLY-SEALED RESISTORS**

Hermetically-sealed 1.5-watt resistors, type 1105, have been announced by the Shallcross Mfg. Company, Jackson and Pusey Avenues, Collingdale, Pa. Size 2 1/16" long x 7/8" diameter. Maximum ratings are 1 megohm resistance and 1,000 volts. Wound with nickel chromium wire.

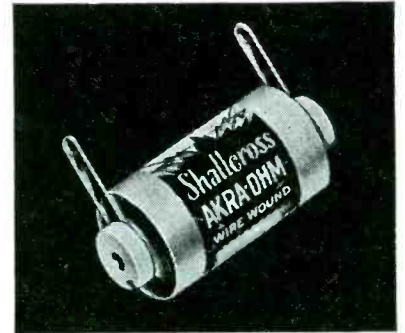

* * *

G. E. INDUSTRIAL SOLDERING IRONS

Industrial soldering irons, ranging from 75 to 300 watts, with 3/8" x 1/4" tips have been announced by the industrial heating division of G.E.

Irons are said to have quick recovery and high reserve-heat capacity. Parts subjected to high temperatures use calorized (surface-alloyed with aluminum) copper and 18-8 stainless steel. Heating units are replaceable.

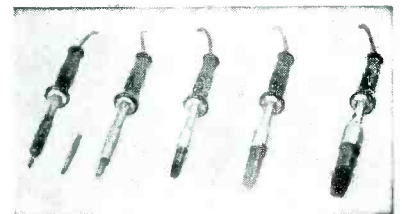

* * *

**E. F. JOHNSON TO MAKE PLUGS AND
DIAL LIGHT ASSEMBLIES**

The E. F. Johnson Company, Waseca, Minnesota, has acquired all tools, inventory and manufacturing rights for Mallory-Yaxley cable connectors, pilot and dial light assemblies, tip plugs and tip jacks.

Seven- and twelve-wire cable polarized connectors will be produced. They will be

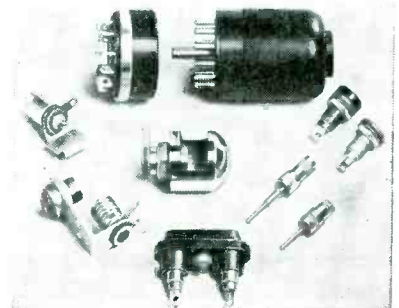

STANCOR

Transformers

THE STANDBY OF SERVICEMEN

Call your nearest Stancor Jobber—or write us for his address

**STANDARD TRANSFORMER
CORPORATION**

1500 NORTH HALSTED STREET • CHICAGO



available with several types of mountings for both the receptacle and pin plugs.

Dial lights will be supplied as shell assemblies and with slip-on brackets. Tip plugs will be of the solderless type and supplied in a long and short length. Tip jacks will be available with either metal or bakelite type heads and with round and hexagon heads. Twin tip jacks are molded bakelite and will be available in two types, shorting and non-shorting.

* * *

OPERADIO RAILROAD LOUDSPEAKERS

Railroad-type loudspeakers engineered for railroad traffic control or intercommunication have been developed by Operadio Manufacturing Co., St. Charles, Illinois.

Has a pressure neutralizing grill and filter, which is said to eliminate air pressure on diaphragm when loudspeaker is used on the exterior of an engine or caboose. Also has stream filtration to



New MODEL 450 TUBE TESTER

Designed especially for the service man who wants to give better service. Speedy operation is assured by newly designed rotary selector switch which replaces the usual snap, toggle or lever action switches. Tests all tubes up to 117 volts including 4, 5, 6, 7L, Octals, Loctals, Magic Eye, Hearing Aid, Thyratrons, Single Ended, Floating Filament, Mercury Vapor Rectifiers, also Pilot Lights. Tests shorts and leakages up to 3 Megohms in all tubes. Tests both plates in rectifiers. Has many other new features and advantages that any good service man will appreciate after five minutes use. **Only \$39.50** Immediate Delivery.

Write for latest bulletin showing hundreds of other hard-to-get items at money-saving prices.

Lifetime
SOUND EQUIP. CO., Dept. 66
911-913 JEFFERSON AVE., TOLEDO 2, OHIO

avoid accumulation of soot or dirt. Speaker housing is sealed and weather-proofed.

* * *

WELLER SOLDERING GUN

A transformer type electric soldering gun, model B, which is said to come to temperature in 5 seconds, has been developed by the Weller Manufacturing Company, Easton, Pa.

Has a trigger switch. Current is broken the minute the finger is removed from the trigger and the tool is laid on the bench.

Consumes 100 watts; operates on 115 volts, 60 cycles.



* * *

ANGLO CONSTANT-SPEED D-C MOTORS

Constant-speed d-c motors especially adaptable to synchronous operation have been announced by the Anglo Corporation, 4234 Lincoln Ave., Chicago.

Motor is self-starting. Current consumption is from .06 to 1 watt. Shaft speeds may be geared from 1 revolution every 24 hours up to 600 rpm.

Available for use at 1½, 3, 6, 12, 24, 32 or 110 volts.

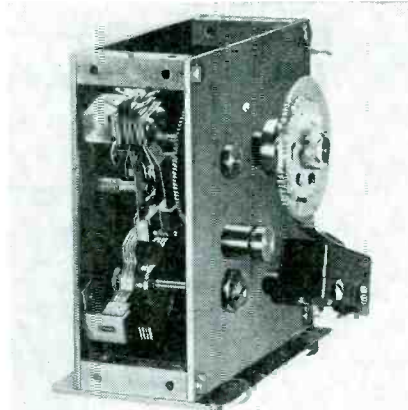

* * *

PARAGON TIME SWITCHES

Time switches, 300 series, with telechron motors, have been developed by the Paragon Electric Company, 37 West Van Buren Street, Chicago 5, Illinois.

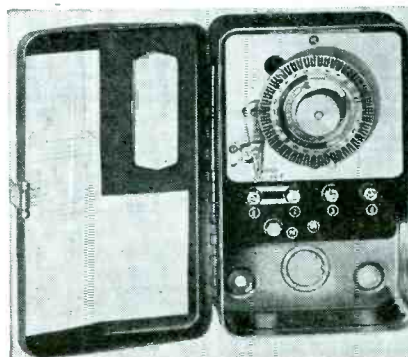

DEPENDABLE!

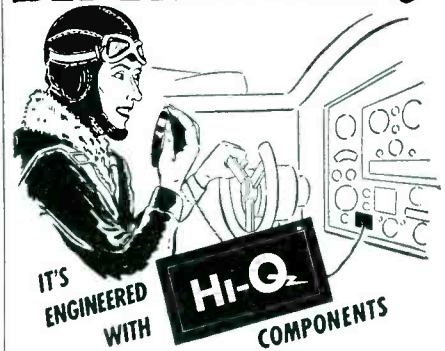

Made right . . . to work right . . . and stay right. Whether in stock ratings or to your own specifications you will find Hi-Q components precise, dependable and long lived. Send for samples and complete information.

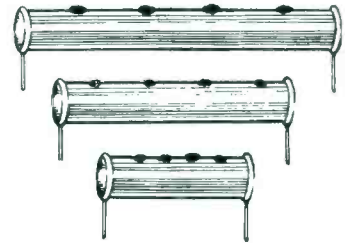

Hi-Q Ceramic Capacitors are of titanium dioxide (for temperature compensating types) and are tested for physical dimensions, temperature co-efficient, power factor and dielectric strength. CI type with axial leads; CN type with parallel leads.

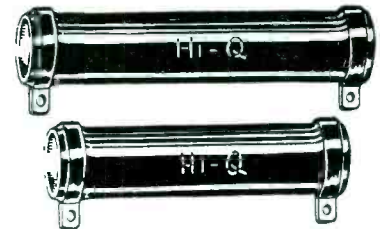

Hi-Q Wire Wound Resistors can be produced promptly and in quantity — with quality physical specifications and high performance electric specifications.

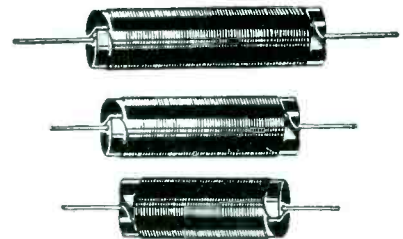

Hi-Q Choke Coils are uniform in their high quality performance. Ruggedly constructed for long service.

ELECTRICAL REACTANCE CORPORATION
FRANKLINVILLE, N. Y.

RADOLEK CROSS MODULATION

(Continued from page 18)

Radio-Electronic Service Parts

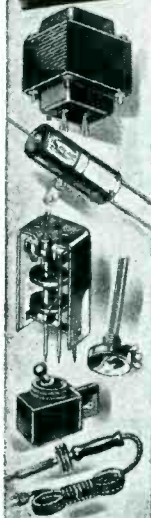

Large stocks assure the finest and most complete selections of all available items at lowest prevailing prices. Thousands of active buyers depend on us for their entire Radio repair and replacement requirements. Because we understand service problems, every order is expedited for delivery in double quick time. Everything we do is planned for convenience and satisfaction to our customers. You will find it profitable to make Radolek your buying headquarters.

FREE BUYING GUIDES

Because of existing conditions we keep our customers right up to the minute on available merchandise by releasing supplements frequently instead of sending our regular Big Profit Guide once a year. Send the coupon now to get these Free Buying Guide Supplements as they are issued.

FREE!



FAST SERVICE!

RADOLEK CO., Dept. S-109
601 W. Randolph St., Chicago 6, Ill.

Please send FREE Buying Guide Supplements

NAME _____
ADDRESS _____

ORDER FROM RADOLEK

system may be necessary. The direction of the antenna and its length should also be varied. In one case, running a ground from the electric outlet plate to the radiator removed modulation hum. All possible sources of poor metal contacts should be investigated to determine if they are the offenders.

Identical Symptoms

Since the symptoms are identical for a number of possible troubles, some ra-

tionalization will be necessary where the previous conditions are encountered. However, it should be borne in mind that many of the small receivers cannot be improved due to their construction. This is particularly true of the t-r-f, three-tube receivers. Although these receivers are not subject to the ills of superheterodyne types, adjacent channel interference is common and very little can be done to improve their selectivity. This lack of selectivity should not be confused with cross modulation.

AN OLD TIMER

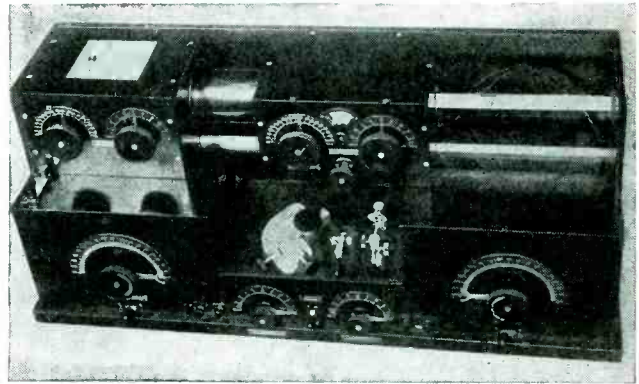

Crystal receiver used in the 1920s aboard ocean-going vessels throughout the world.

NEED ANY RADIO TUBES?

SEND US YOUR LIST

Extra-Special! By-Pass Condenser Kit—Handy assortment of one hundred most popular sized tubulars from .001 to .1 Mfd. inclusive. All 600 V. All fully guaranteed. Per kit . . . \$5.95

Aerial Kits—Complete including instructions. (Individually boxed) . . . 75¢

Insulated Resistor Kit—100 most pop. sized Deluxe Asst. 1/4, 1/2, 1 Watt R.M.A. color coded . . . Per kit \$2.75

Radio Knob Kit—50 Bakelite Set Screw for 1/4" shaft Deluxe Asst. . . . Per kit \$3.69

Hookup Wire—No. 20 Vinylite Covered. Solid Copper Core. 100 ft. indiv. boxed . . . 69¢

Write for Complete Catalog of Hard-to-Get Items

NATIONAL RADIO DISTRIBUTORS

Dept. S, 140 West 42nd Street New York 18, N. Y.

WARTIME RADIO SERVICE

1500 tested radio tube substitutions and other valuable information.

Keeps 'em Playing in spite of the tube shortage—only \$3 postpaid. Order now.

CITY RADIO COMPANY

East Washington at 5th St.

Phoenix, Ariz.

Ted McElroy

World's Largest Manufacturer of Wireless Telegraphic Apparatus

COMPLETE CENTRAL OFFICE EQUIPMENT

McElroy Manufacturing Corp.

32 Brookline Avenue • Boston, Massachusetts

IMMEDIATE DELIVERY ON TEST INSTRUMENTS!

SIMPSON 260 v.o.m. \$33.25	RADIO CITY 705 sig. gen. . . . \$49.50
TRIPLETT 625-N v.o.m. 37.50	RCP 805 tube & set tester. . . . 89.50
TRIPLETT 666-H v.o.m. 16.00	DUMONT 3" oscillograph. . . . 105.00
TRIPLETT 2413 tube tester. . . . 45.00	Also, many other types available.
SOLAR CE-1-60 cond. checker. . . 44.90	Write to us on your needs.
SUPERIOR CA-11 sig. tracer. . . 18.75	25% deposit should accompany
SUPERIOR 400 multimeter . . . 52.50	C.O.D. orders.

SCENIC RADIO & ELECTRONICS CO., 53b Park Pl., N. Y. 7

RADIO SERVICE—FLAT RATE SCHEDULES

The world's finest, most complete radio service flat rate books and tube substitution data. Used coast to coast. Request information.

RADIO EQUIPMENT CO. 1415 W. FRANKLIN AVE. MINNEAPOLIS 5, MINN.

TUBES—PARTS

RADIO DEALERS—SERVICEMEN

Send for our list of available tubes and repair parts. Sylvania, Tung-Sol, Ken-Rad.

M. V. MANSFIELD CO.

937 LIBERTY AVE. PITTSBURGH 22, PA.

FREE CATALOG

Radio parts, test equipment, P.A. accessories, amateur supplies, technical books. Send today for your free copy to Dept. K-12.

RADIONIC EQUIPMENT CO.

"Chancellor Radio"

170 NASSAU STREET, NEW YORK 7, N. Y.

5-TUBE POSTWAR RECEIVER

(See Front Cover)

THE i-f and audio system of a Stromberg-Carlson 5-tube post-war receiver, model 1000H, J and 1100H, is shown in the front-cover diagram this month.

The receiver features a loop tuned 14A7 r-f, resistance-coupled 14Q7 converter and 14A7 i-f stage. The latter stage has an unbypassed 150-ohm cathode resistor supplementing an avc bias.

Multiple Use of Diode

One of the diodes of a 14B6 used as a demodulator—avc—audio amplifier serves as a detector, the other being tied to the avc bus to supply a small bias from contact potential. The avc circuit is taken off at the high end of the detector transformer through a 2.2-megohm resistor, while the demodulated signal feeding the audio amplifier is taken from the low end through a 47,000-ohm resistor. This resistor, between detector and volume control, prevents overloading

of the detector by the 14B6 triode, and with a 100 mmfd r-f bypass across a 1-megohm volume control serves to filter out r-f modulation.

A volume-control pickoff feeds the first audio grid through a .005-mfd capacitor and 10-megohm grid leak. The low side of the control is bypassed to both the avc bus and B+ through a pair of .05-mfd capacitors. Coupling to the power tube is achieved by a .01-mfd capacitor in series with a 120-ohm resistor, with a .47-megohm leak and 150-ohm cathode bias resistor, without a bypass capacitor. A .002-mfd capacitor across the first audio output shunts a fixed 200-mmfd bypass for increased bass effect. High frequency degeneration, or negative feedback, is provided by a 50-mmfd capacitor connected from the power tube's plate to the first audio plate. The capacitor is too small to affect bass frequencies appreciably; hence the bass gets through in full strength, the treble being somewhat attenuated as well as somewhat improved.

For Soldering in
Tight Places . . .

DRAKE

No. 400 Soldering Iron

Smallest Industrial Iron
Ever Designed

60 Watts — 1/4 in. Tip
Only 9 in. long. Wt. only 8 oz.

This mighty mite is backed by DRAKE's 25 years of soldering iron manufacturing experience. The high quality and long-service of DRAKE Soldering Irons have made them outstanding favorites with all types of radio men everywhere. The DRAKE No. 400 is an outstanding value at



Only \$4.50
List

Drake Has an Iron
for Every Purpose.
Ask Your Radio
Parts Jobber

DRAKE ELECTRIC WORKS, INC.

3656 LINCOLN AVE., CHICAGO 13, ILL.

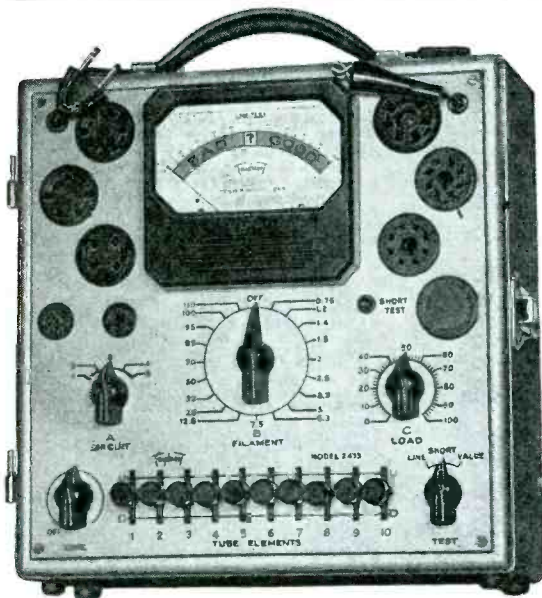

Precision first
...to last



Triplet

ELECTRICAL INSTRUMENT CO. BLUFFTON, OHIO

The New Speed-Chek Tube Tester

MORE FLEXIBLE • FAR FASTER • MORE ACCURATE

Three-position lever switching makes this sensational new model one of the most flexible and speediest of all tube testers. Its multi-purpose test circuit provides for standardized VALUE test; SHORT AND OPEN element test and TRANSCONDUCTANCE comparison test. Large 4" square RED • DOT life-time guaranteed meter.

Simplicity of operation provides for the fastest settings ever developed for practical tube testing. Gives individual control of each tube element.

New SQUARE LINE series metal case 10" x 10" x 5 1/2", striking two-tone hammered baked-on enamel finish. Detachable cover. Tube chart 8" x 9" with the simple settings marked in large easy to read type. Attractively priced. Write for details.

Model 2413

is another member of
the NEW TRIPLET
Square Line



Additional Features

- Authoritative tests for tube value; shorts, open elements, and transconductance (mutual conductance) comparison for matching tubes.
- Flexible lever-switching gives individual control for each tube element; provides for roaming elements, dual cathode structures, multi-purpose tubes, etc.
- Line voltage adjustment control.
- Filament Voltages, 0.75 to 110 volts, through 19 steps.
- Sockets: One only each kind required socket plus one spare.
- Distinctive appearance makes impressive counter tester.

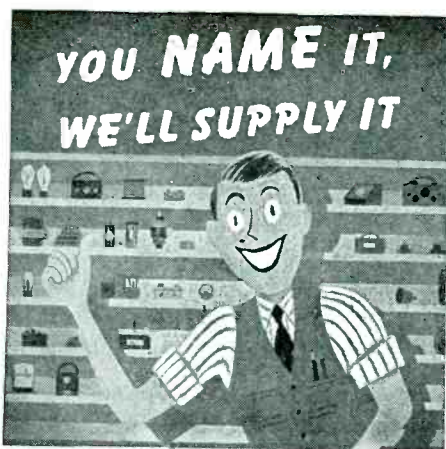

EVERYTHING IN RADIO AND ELECTRONICS

R. W. T., world's oldest and largest Radio Supply House is ready again with tremendous stocks of sets, parts and equipment. You can depend on our quarter-century reputation for quality, sound values and super-speed service. Orders shipped out same day received. All standard lines already here or on the way, including: National, Hammarlund, R. C. A., Hallicrafters, Bud, Cardwell, Bliley and all the others you know so well.

Originators and
Marketers of
the Famous

Lafayette Radio

Radio Wire Television Inc.

100 Avenue of the Americas, New York 13
(Formerly Sixth Avenue)
Boston, Mass • Newark, N. J.

"No supplier anywhere has a bigger stock of Radio and Electronic equipment. Test equipment, Public Address equipment, Communications equipment. If your engineering problem requires special equipment, we'll make it. Write today. Dept. FL-5."

JOTS AND FLASHES

COMPETENT Service Men will play an important role in keeping Mr. and Mrs. Public sold on television, said Paul E. Carlson, merchandising manager of the consumer products division of DuMont, at a recent meeting of home furnishings specialists. . . . About 60% of the present set owners plan immediate purchase of receivers, according to Frank Mansfield of Sylvania, who recently completed a set survey. Over 18,000,000 receivers are expected to be sold, he said. . . . Lt. Kenneth C. Prince, U.S.N.R., was recently awarded the Bronze Star Medal by Vice Admiral Charles Lockwood, Commander Submarine Force Pacific Fleet. Lt. Prince was formerly legal counsel for the Sales Managers Club, Western group. . . . Marshall Field and Company, Chicago, has received an exclusive dealer franchise for Scott receivers. . . . J. Kelly Johnson, formerly with Hammarlund Manufacturing Company, has opened a consulting engineering office at 55 West 42 Street, New York City. . . . Milo Radio and Electronics Corporation have announced the opening of their offices at 200 Greenwich Street, New York City. . . . G. Porter Burgess is now regional manager in the south and southwest for the Galvin Manufacturing Corporation. . . . Captain Pierre H. Boucheron, U. S. N. R., who recently returned from active duty and joined Farnsworth as director of public relations, addressed a recent meeting of the Radio Club of America in New York City. . . . Snyder Manufacturing Company, Philadelphia, have opened a sales office in the 333 Building, Chicago. Dwight Nelson and Leo Gibrich will headquarter at the new office. . . . Robert M. Brotherson has been named National Union district manager for Michigan, Kentucky, southern Indiana including Indianapolis, and Ohio, except Mahoning, Columbiana, Jefferson and Trumbull counties. . . . Ray L. Hoeffler has been appointed Zenith district sales manager for Philadelphia, Baltimore, Washington, and Norfolk. Edgar F. Lindgren will be district manager for Atlanta, Charleston, Charlotte, Raleigh, Jacksonville, Roanoke, Knoxville, and Chattanooga. Robert I. MacClellan will be district manager for Cleveland, Columbus, Toledo and Pittsburgh. . . . E. J. Dykstra has been named Bendix district manager for the Chicago area. Mr. Dykstra was formerly with Farnsworth.

ADVERTISERS IN THIS ISSUE SERVICE INDEX—DECEMBER 1945

ADAPTOL CO.	54
Agency: Hart Lohman Advertising	
AEROVOX CORPORATION	57
Agency: Austin C. Lescarboursa & Staff	
AMERICAN CONDENSER CO.	58
Agency: A. L. Addison	
AMERICAN PHENOLIC CORPORATION	45
Agency: Evans Associates, Inc.	
AMPERITE CO.	46
Agency: H. J. Gold Co.	
BURLINGTON INSTRUMENT CO.	47
Agency: Weston-Barnett, Inc.	
BURSTEIN-APPLEBEE CO.	59
Agency: Frank E. Whalen Adv. Co.	
CAPITOL RADIO ENGINEERING INSTITUTE	49
Agency: Henry J. Kaufman & Associates	
CENTRALAB DIV. GLOBE-UNION INC.	3
Agency: Gustav Marx Adv. Agency	
CHERRY RIVET CO.	10
Agency: Dana Jones Co.	
CITY RADIO CO.	62
CLAROSTAT MFG. CO., INC.	59
Agency: Austin C. Lescarboursa & Staff	
CONCORD RADIO CORPORATION	44
Agency: E. H. Brown Adv. Agency	
CORNISH WIRE CO., INC.	53
Agency: Hart Lehman, Advertising	
DUMONT ELECTRIC CO.	11
Agency: A. Rothschilds	
DRAKE ELECTRIC WORKS, INC.	63
Agency: William Hoffman & Associates	
ELECTRICAL REACTANCE CORP.	61
Agency: Scheel Adv. Agency	
ELECTRONIC LABORATORIES, INC.	6
Agency: Burton Browne, Advertising	
GENERAL CEMENT MFG. CO.	58
Agency: Turner Adv. Agency	
GENERAL ELECTRIC	35, 56
Agency: Maxon, Inc.	
GUARDIAN ELECTRIC	21
Agency: Kennedy & Co.	
HALLDORSON CO.	52
Agency: Burton Browne, Advertising	
INSULINE CORPORATION OF AMERICA	32
Agency: S. R. Leon Co.	
JENSEN RADIO MFG. CO.	39
Agency: Burton Browne, Advertising	
KEN-RAD DIV. GENERAL ELECTRIC CO.	1
Agency: Kircher, Helton & Collett, Inc.	
LAKE RADIO SALES CO.	57
Agency: Sander Rodkin Adv. Agency	
LIFETIME SOUND EQUIPMENT CO.	61
Agency: The Miller Agency Co.	
McELROY MFG. CORP.	62
Agency: Shappe-Wilkes Inc.	
M. V. MANSFIELD CO.	62
MARION ELECTRICAL INSTRUMENT CO.	29
Agency: Shappe-Wilkes Inc.	
MILO RADIO & ELECTRONICS CORP.	56
Agency: Burke & Wayburn Adv. Co.	
MURRAY HILL BOOKS, INC.	33
Agency: The Harry P. Bridge Co.	
NATIONAL RADIO DISTRIBUTORS	62
Agency: Burke & Wayburn Adv. Co.	
NATIONAL UNION RADIO CORP.	Back Cover
Agency: Hutchins Adv. Co., Inc.	
NEWARK ELECTRIC CO.	46
Agency: Charles Brunelle	
NEWCOMB AUDIO PRODUCTS CO.	48
Agency: Gail Hall Advertising	
OHMITE MFG. CO.	44
Agency: Henry H. Teplitz, Advertising	
RADIART CORPORATION	9
Agency: Kenneth H. Kolpian	
RADIO CITY PRODUCTS CO., INC.	50
Agency: Bless Advertising	
RADIO CORPORATION OF AMERICA TUBE DIVISION	17, 25
Agency: Kenyon & Eckhardt, Inc.	
RADIO EQUIPMENT CO.	62
RADIONIC EQUIPMENT CO.	62
Agency: Hirschon-Garfield Co.	
RADIO SUPPLY & ENGINEERING CO.	46
Agency: Karl G. Heber Adv. Agency	
RADIO WIRE TELEVISION, INC.	64
Agency: S. T. Seldman & Co.	
THE RADOLEK CO.	62
Agency: Turner Adv. Co.	
RAYTHEON MFG. CO.	4, 5
Agency: Burton Browne, Advertising	
THE REPRESENTATIVES	55
Agency: Lansford P. King	
SCENIC RADIO & ELECTRONICS CO.	62
SOLAR CAPACITOR SALES CORP. Inside Back Cover	
Agency: O. S. Tyson & Co., Inc.	
SPRAGUE PRODUCTS CO.	7
Agency: The Harry P. Bridge Co.	
STANDARD TRANSFORMER CORP.	62
Agency: Burnet-Kuhn Adv. Co.	
SUPREME INSTRUMENTS CORP.	54
Agency: O'Callaghan Adv. Agency, Inc.	
SYLVANIA ELECTRIC PRODUCTS, INC.	12
Agency: Newell-Emmett Co.	
THORDARSON ELECTRIC MFG. DIV. MAGUIRE INDUSTRIES, INC.	43
Agency: City Adv. Agency	
TRIPLETT ELECTRICAL INSTRUMENT CO.	63
Agency: Western Adv. Agency, Inc.	
UNITED TRANSFORMER CORP.	31
Agency: Shappe-Wilkes Inc.	
VACO PRODUCTS CO.	60
Agency: Duane Wanamaker—Advertising	
WARD LEONARD ELECTRIC CO.	51
Agency: E. M. Freystadt Associates	
THE WARD PRODUCTS CORP.	52
Agency: Burton Browne, Advertising	
WEBSTER-CHICAGO	19
Agency: William Hoffman & Associates	
WELLER MFG. CO.	50
Agency: Beaumont, Heller & Spurling, Inc.	
WHOLESALE RADIO LABORATORIES	48
Agency: Pfeiffer Adv. Agency	

you can't put the squeeze
on SEALDTITE
CAPACITORS

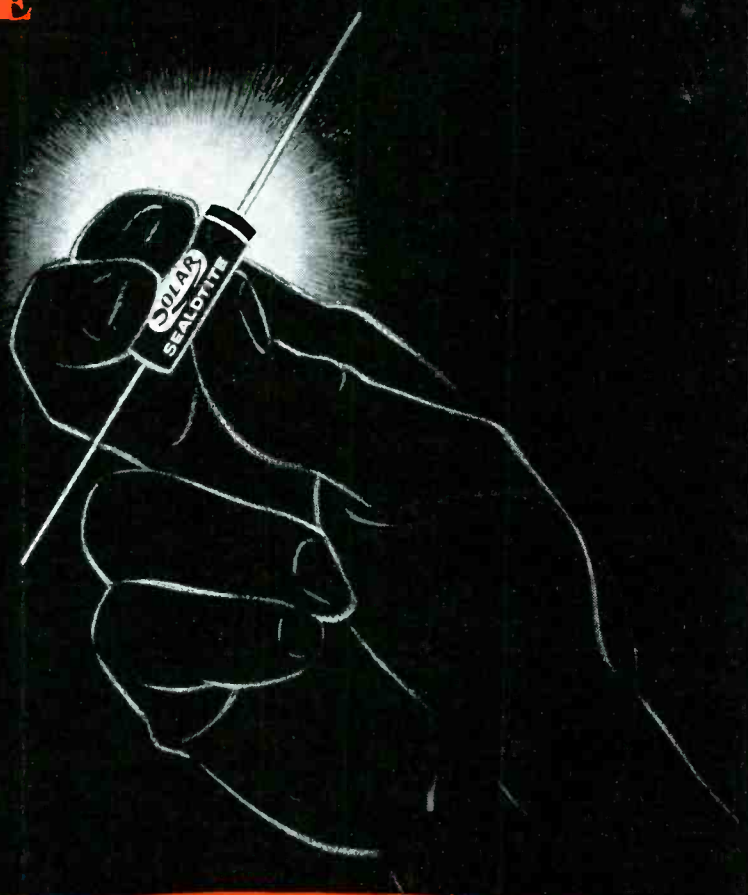

Just try it . . . Take a genuine "Sealdtite" capacitor and try to *squeeze* it. No results. You'll find it has no soft spots, which in ordinary tubulars provide room for moisture, the capacitor's worst enemy, because the Solar capacitor has an internal winding of high quality paper and foil, skillfully *molded* into *solid* plastic.

No moisture can penetrate this protective case and its substantial construction permits rough handling, assures long and *reliable* service.

Use "Sealdtite" capacitors. Send for your copy of Catalog SC-1. Any Climate—Any Atmosphere—Any Service.

SOLAR

BAYONNE PLANT
WEST N.Y. PLANT

A TOTAL OF TEN ARMY-NAVY
EXCELLENCE AWARDS
SOLAR CAPACITOR SALES CORP.
285 MADISON AVENUE, NEW YORK CITY



... now, in a striking new
package for profitable service business

Key to the powerful N. U. merchandising plans that are now ready to go to work for service dealers—is the most striking package design in the radio parts field.

In this smart, modern, stream-line container, all N. U. branded products will be packaged—adding tremendously to their shelf-display and eye-appeal.

You can count on it—nothing has been left

undone to make the National Union family of products the most profitable of all for the service dealer. In engineering, in product performance, in sales policy, and in merchandising—the N. U. line is in a class by itself in meeting today's needs of the Service Dealer and Parts Distributor.

NATIONAL UNION RADIO CORPORATION
NEWARK 2, NEW JERSEY

NATIONAL UNION RADIO TUBES AND PARTS

Transmitting, Cathode Ray, Receiving, Special Purpose Tubes • Condensers • Volume Controls • Photo Electric Cells • Panel Lamps • Flashlight Bulbs

