

RADIO • TELEVISION • ELECTRONIC

# SERVICE

A MONTHLY DIGEST OF RADIO AND ALLIED MAINTENANCE

Video amplifier I-F system of television receiver with 8.25-mc. and 14.25-mc. interstage-coupling wave traps. (See page 41.)

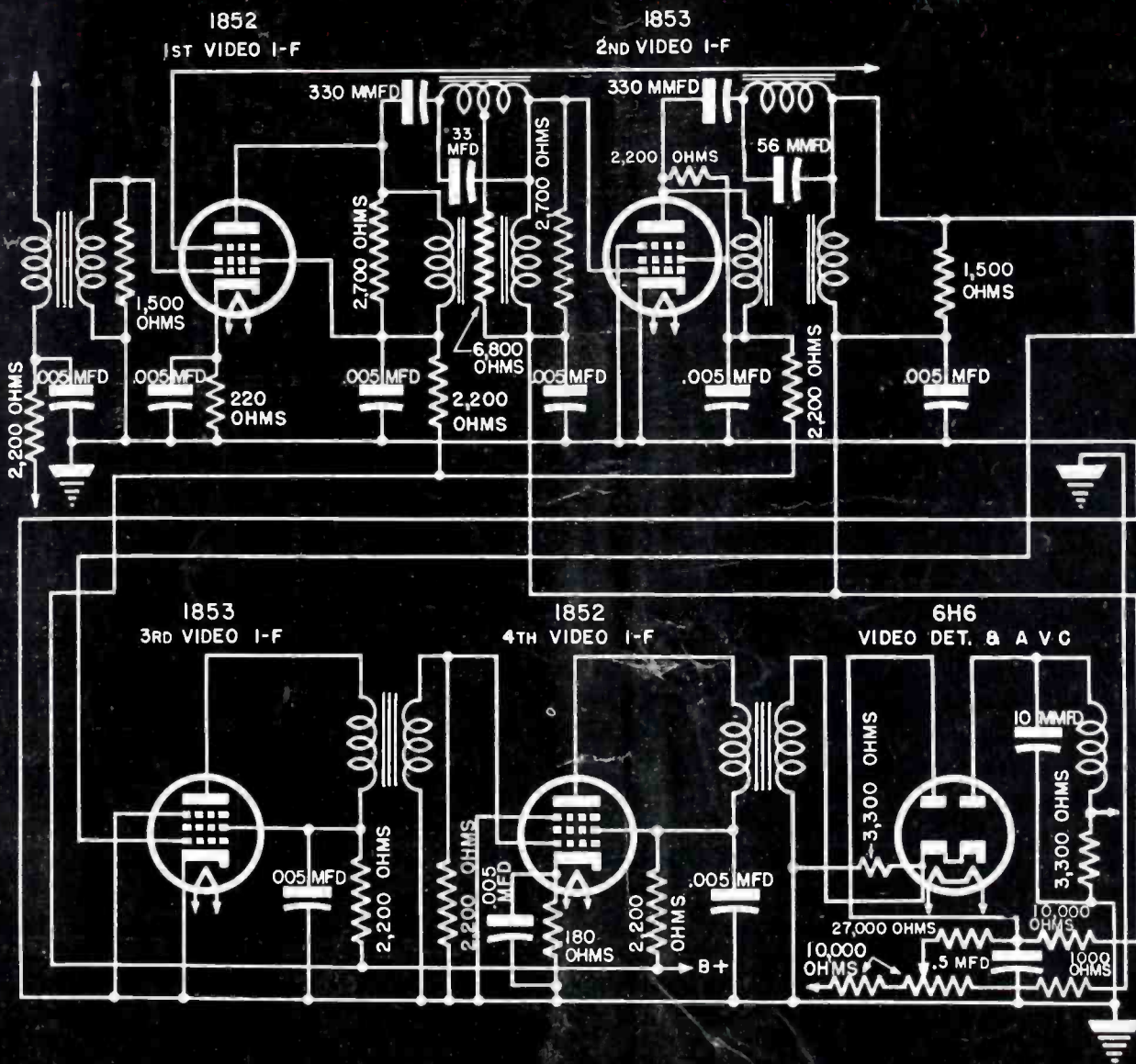



*In  
War—  
In  
Peace...*

**RADIART VIBRATORS** (INDIVIDUALLY ENGINEERED FOR PROPER REPLACEMENT)  
**GIVE Exceptional Service!**

The high quality of RADIART VIBRATORS is well known to servicemen everywhere. That high quality has characterized all Radiart Products that have been and are being used by the Armed Forces on all fronts. As production for civilian users expands it will continue to increase the demand for RADIART VIBRATORS.

**LIMITED SUPPLY UNTIL V-J DAY**

While production for civilian users may increase gradually, by far the greater part of our production will continue to be required for U.S. Armed Forces. We must and will meet all of their schedules on time.

**FEWER VIBRATOR TYPES SIMPLIFIES STOCK PROBLEM**

By eliminating many little used types of vibrators Radiart has been able to increase production of all popular types. Now the dozen or so types of RADIART VIBRATORS necessary for over 7/8ths of all replacements are more readily obtainable.

Consult the Radiart Vibrator Catalog for complete information on all vibrators for all installations. The Radiart Line is the most complete for all replacement purposes.



**Radiart Corporation**

3571 W. 62nd STREET • CLEVELAND 2, OHIO  
 EXPORT DIVISION: 25 Warren Street • New York 7, N.Y.

# KEN-RAD

Little Giant **MINIATURE TUBES**



*Better than ever*

● Everywhere the sturdy performance of portable radios is a tribute to the quality and dependability of Ken-Rad Miniature Tubes... Now that important new research and manufacturing facilities have been added, Ken-Rad users will benefit in tube performance and value that are *better than ever*... Ken-Rad dealers will reap still larger profits.

Write for your copy of  
"Essential Characteristics"  
the most complete digest of  
tube information available.

# KEN-RAD

OWENSBORO, KENTUCKY

178-DB-8850

# EDITORIAL

**T**HE new allocations transferring f-m from the 42-mc region up to 92-106 megacycles, will project many servicing problems that will require extensive study. The frequency shift will introduce many types of converters to extend ranges, and two-band receivers to provide for reception of the 42-mc stations as well as the higher frequency stations when they go on the air. To accommodate the higher- and lower-frequency channels, receiver engineers will offer various forms of v-h-f antenna pickups, and tuning and switching systems that will be quite unlike the medium-frequency circuit designs. Receivers for the higher frequencies only will be featured by manufacturers, too. Chassis layout will be an extremely important factor, for v-h-f components, with their exacting construction demand careful relative placement. All of which means that the Service Man will have to study every v-h-f servicing problem very carefully. He will have to set up new standards of procedure to accelerate future repairs.

Instruments will become more important than ever in this new servicing program. The instrument will simplify the servicing procedure; it will serve to locate the trouble more rapidly and remedy it more accurately.

In view of the variety of circuit designs that will be included in f-m receivers, SERVICE has arranged for a series of articles describing these new features. The first of these articles will appear in the August issue. Prepared by an f-m specialist, the articles will analyze all details to simplify and expedite servicing. Watch for this series! And if there are any f-m circuit problems that puzzle you, send them in. We will include the analyses in these discussions.

**L**ETTERS from many indicate a lively interest in current books on radio fundamentals. We've read two such books during the past weeks that we believe Service Men will enjoy. Both are very informative and quite easy to follow: D. J. Tucker, *Introduction to Practical Radio*; and Ralph G. Hudson, *An Introduction to Electronics*. Both are published by Macmillan.

**V**IDEO sets may become a room feature of hotels soon. According to a survey conducted by the Hotel New Yorker, 71.2% favored the introduction of television in hotel rooms as soon as possible. Surveys among hotels in other cities also indicate a favorable interest. A striking new field that should be of significant interest to every Service Man.

# SERVICE

A Monthly Digest of Radio and Allied Maintenance

Reg. U. S. Patent Office

Vol. 14, No. 7

July, 1945

**LEWIS WINNER**

Editorial Director

**ALFRED A. GHIRARDI**

Advisory Editor

**F. WALEN**

Managing Editor

	Page
Cathode-Ray Tubes (Design, Application, Servicing). By S. J. Murcek .....	13
Direct Viewing Television .....	33
Old Timer's Corner .....	34
Ser Cuits. By Henry Howard .....	26
Servicing Helps .....	40
Simplified Conversion of Auto Sets for Home Use. By J. George Stewart .....	20
Use of Resistors in Tube Substitutions. By Alfred A. Ghirardi .....	28
Variable Condenser Servicing. By Edward Arthur .....	16
Volume Control Circuits (Part II). By Robert L. Martin .....	22
Wave Traps. By Willard Moody .....	24
<b>Circuits</b>	
G.E. HM 225B/226B (Cover) .....	41
Motorola 59 BP1/2 .....	26
<b>Cover</b>	
G.E. HM 225B/226B (Television I-F System) .....	41
<b>Servicing Helps</b>	
Columbia SG8 .....	40
Emerson 109, Chassis U4A .....	40
Silvertone 101-571 .....	40
U. S. Radio and Television 28 .....	40
Zenith 8S432, 434, 449, 450, 458, 459, 460, 461, 462 (Chassis 5810) .....	40
<b>Index to Advertisers</b> .....	48
<b>Manufacturers</b>	
News .....	42
New Products .....	46
Jots and Flashes .....	48

Copyright, 1945, Bryan Davis Publishing Co., Inc.

Published monthly by Bryan Davis Publishing Co., Inc.

52 Vanderbilt Avenue, New York 17, N. Y. Telephone MURRAY HILL 4-0170



Bryan S. Davis, President

Paul S. Weil, Vice Pres.-Gen. Mgr.

James C. Munn, 10515 Wilbur Avenue, Cleveland 6, Ohio; Telephone SWEEBRIAR 0052

Pacific Coast Representative: Brand & Brand, 816 W. Fifth St., Los Angeles 13, Calif.; Telephone MICHIGAN 1732



A. Goebel, Circulation Manager

F. Walen, Secretary

Entered as second-class matter June 14, 1932, at the Post Office at New York, N. Y., under the Act of March 3, 1879. Subscription price: \$2.00 per year in the United States of America and Canada; 25 cents per copy. \$3.00 per year in foreign countries; 35 cents per copy.

# CONSOLIDATED VULTEE USES **RAYTHEON** TUBES

*in Electronic Recorder for Flight Testing*

No more tedious pencil notations . . . no more bulky camera equipment! An amazing "electric brain" developed by Consolidated Vultee Aircraft Corporation now helps this firm test its new planes *electronically*.

This remarkable device, consisting of a transmission unit in the plane and a receiving-recording station on the ground, employs a large number of famous Raytheon High-Fidelity Tubes.

It's just one of thousands of examples that prove an important point: *where dependable performance is vital, you will find Raytheon Tubes*. That means Raytheon Tubes can be relied upon to help you do your best service work and thus build your business steadily.

Switch to Raytheon Tubes now . . . and watch for a revolutionary merchandising program that Raytheon is developing for your benefit!

*Increased turnover and profits, plus easier stock control, are benefits which you may enjoy as a result of the Raytheon standardized tube type program, which is part of our continued planning for the future.*

Raytheon Manufacturing  
Company

RADIO RECEIVING  
TUBE DIVISION

Newton, Mass. • Los Angeles  
New York  
Chicago • Atlanta

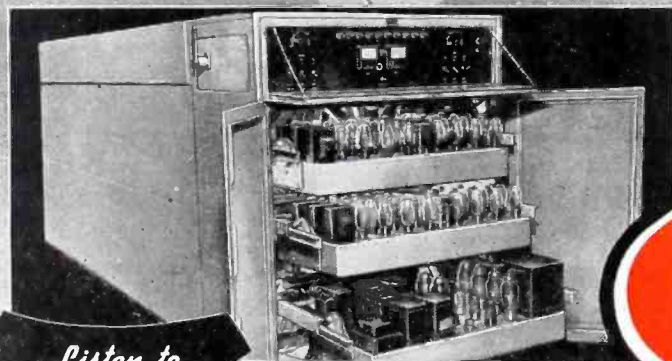

*Listen to*  
"MEET YOUR NAVY"  
AMERICAN BROADCASTING CO.  
Every Monday Night  
Coast to Coast  
181 Stations

ALL FOUR DIVISIONS HAVE BEEN  
AWARDED ARMY-NAVY "E" WITH STARS

*Devoted to Research and the Manufacture of Tubes for the New Era of Electronics*



# SPRAGUE TRADING POST

A FREE Buy-Exchange-Sell Service for Radio Men



## SPRAGUE TC TUBULARS

The most famous, most widely used by-pass capacitors in the entire history of Radio. Ask for them by name!

*Not a Failure in a Million*

**WANTED**—Phono motor with turntable. George T. Crawford, RT2C Communications Dept. N.A.S., Seattle 5, Wash.

**WANTED**—Supreme #571 or similar sig. gen.; Riders Manuals, Marv's Radio Service, Spring Valley, N. Y.

**FOR SALE**—Stancor output transformer; 18-watt output power amplifier and 6F6, 6L6 tubes. Earl H. Swen, Gilby, N. Dak.

**WILL TRADE**—Sig. gen. d-c millimeter and 3" c.r.o. tube for 35mm or small reflex camera. Walter Cruz, 2912 Ridgeway Drive, Lincoln Acres, Calif.

**WANTED**—Fully equipped radio store in south or midwest. Cash or trade store vicinity N. Y. C. George Rado, 101 Ellwood ave., Mt. Vernon, N. Y.

**FOR SALE**—Philco home recording kit part #45-2820 also cutting head and gears. What have you? Wm. Krelchbaum, 1010 Walnut st., Lebanon, Pa.

**WILL TRADE**—#1612 Triplett tube checker for 16 or 8mm movie projector. A. J. Huonder, Larpenteur & East aves., St. Paul 6, Minn.

**WANTED**—35Z5, 50L6 or 35L6 tubes; also short wave receiver. T/Sgt. Prince A. Harris, 816 Montgomery st., Briarfield Manor, Newport News, Va.

**FOR SALE**—New and used tubes 6L6, 45, 30, 58, 56 and others. Ferguson Radio & Electric, Box 44, Fair Grove, Mo.

**WILL TRADE**—1945 test instruments for hard-to-get tubes. Raymond J. Rowell, 1640 Steiner ave., Birmingham 7, Ala.

**FOR SALE**—Supreme tube tester; Riders 1 to 11; 1/4 h.p., 115v d-c motor and 4 Maytag motors. William Phillips, 1636 W. Va. ave., Clarkesburg, W. Va.

**WANTED**—Portable tube tester with instructions. Cpl. V. Furio, Co. C. 1689th C. E. Bn., Camp Gruber, Okla.

**FOR SALE**—1942 Motorola push button auto radio; Solar CB-160 condenser & resistor analyzer; 1937 Ford custom fit Philco auto radios; Arvin 8-tube auto radio. Paul Capito, 637 W. 21st st., Erie, Pa.

**URGENTLY NEEDED**—Recorders for cash. Raymond Gee, 861 Clay st., San Francisco 8, Calif.

**FOR SALE OR TRADE**—Portable Hammond varityper with six sets of alphabets. Want phonograph recorder and experimental tubes, h.f. acorns; pin seals, etc. Joseph E. Shrober, 2912 Dunmurry road, Dundalk, Baltimore 22, Md.

**WANTED**—8mm movie projector; exposure meter; enlarger; Graflex camera; etc. Charles W. Schecter, R #2, Scenic Drive, Muskegon, Mich.

**FOR SALE**—2-35Z5, 2-12SQ7, 1-12K7, 1-12AH7, 1-12Z3, 1-6C8, 2-6F8, 1-6C5, 1-7B6, 1-84, 3-30 new, and several used tubes. \$25. Armorer Radio Service, Bancroft, Iowa.

**WANTED**—"T" dial meter only, with double window for Supreme radio analyzer #540. State price. "A bombed out radio serviceman", Joseph Scicluna, c/o Cables, Wireless Ltd., St. Georges, Malta.

**FOR SALE OR TRADE**—1-12SQ7, 4-0Z4 and 2-1H5 tubes. Want 12A7 tube. Larry Mattingly, 1313 Weyler ave., Louisville, Ky.

**URGENTLY NEEDED**—Set and tube testers also sig. gen. F. A. Bohaty, Box 2063, Ancor Canal Zone.

**FOR SALE**—Radio parts, tubes, battery eliminators, transformers, etc. Philip S. Kem, 115-51-134th st., South Ozone Park, Long Island 20 N. Y.

**WANTED**—Instructions for Million tube tester DD. F. C. Brown, Put-In-Bay, Ohio.

**FOR SALE OR TRADE**—Slightly used 1K-54 and RCA 807 tubes. Want test equipment and fabrication supplies. George Prokop, 212 S. Catalina, Redondo Beach, Calif.

**WANTED**—lv tubes; 50L6, 25B8 and 32L7; late model tube tester; communication receiver; record player and small fan. Southwestern Equipment and Appliance Co., 1118 Houston, Fort Worth 2, Texas.

**FOR SALE**—H. O. Boehme 9-G portable recorder, records with pen and ink Morse code or dots on paper tape 350 words per minute. Cost \$444. Eblen, Room 409, 2 Broadway, New York 4, N. Y.

**URGENTLY NEEDED**—6F5 GT tube. Cash or trade 6SQ7 or 6SK7 tube. M. L. Boehm, 1924 E. Dayton st., Madison, Wis.

**FOR SALE**—ATR inverter and G-E portable radio. Will sell or trade. What have you? Bischoff's Valley Radio Service, 1830 7th ave., Beaver Falls, Pa.

**FOR SALE**—6v genemotor; 80- and 40-meter ham crystals; 2 1/2-meter transceiver a-c or d-c; transformers, tubes, etc. Need good 8mm projector. Paul P. Lesser, St. Mary's, Pa.

**WANTED**—Late tube tester; V-O-M and channel analyzer. E. G. Harlegio, 829 Wood st., Bethlehem, Pa.

**WILL TRADE**—1C5, 12SQ7, 50L6, 6C8G, 6L6, 6N7, 6V6, 6J5, 6C5, 6C6, 6D6 and 76 tube for sig. gen. Will pay difference. Bill Wrocklage, 134 Ricardo Place, Hackensack, N. J.

**WANTED**—Meissner's kit 12-1028 "custom" 12 illustrated page 36 Meissner's manual "How to Build". CVO Wm. F. Raymond, 579th AAF Band, March Field, Calif.

**FOR SALE**—Scarce new and used tubes 30% off ceiling. Write for list. Mill Radio, 1579 Mill st., Lincoln Park 25, Mich.

**WANTED**—Rider chanalyst or Meissner analyst and Hickok #19X or 188X sig. gen. Kenneth E. Johnston, 1306 E. 54th st., McLoughlin Heights, Vancouver, Wash.

**WANTED**—Sig. gen. and vacuum tube voltmeter, also U.T.C. S-10 driver transformer. Ray Butts, 408 - 35th st., Cairo, Ill.

**FOR SALE OR TRADE**—Superior sig. gen. #1230. Want tube checker. Fenner's Radio Service, 1130 W. 6th st., Freeport, Texas.

**FOR SALE**—Weston #689 ohmmeter; case; test leads and dry cell included. Pvt. L. B. Converse, 309 N. 2nd st., Temple, Texas.

**WILL TRADE**—168K7GT, 168Q7GT or 6AGGT tubes for 45Z3 and 45Z5 tubes. Johnell's Radio Hospital, 358 Hayes ave., McDonald, Ohio.

**WANTED**—Voltohmeter or tube test. battery eliminator 115v a-c input, output 6.3v d-c, 6.5 amps. John L. Masters, 3082 E. 19th st., Cleveland 15, Ohio.

**FOR SALE**—6K7, 6A8, 35Z5, UX200, 6F6, 77, 183, 2A5, 6AD7 80, 6C5, 6J7, 41 and other tubes. E. Bencke, 170 E. 96th st., New York City 28, N. Y.

**FOR SALE OR TRADE**—N.U. 2031 monotron 3" picture sig. gen. tube; 5" photo-electric cell in case; 6" Cathode Ray tube. Want F.M. tuner complete or kit; record-changer-recorder; 25D8, 25G8, 70L7, 12B8, 32L7 tubes. What have you? F. J. Dillion, 1200 N. Olive Drive, Hollywood 46, Calif.

**WANTED**—Riders manuals; 117v, 35L6 and 35Z5 tubes, Phillips Radio Service, 4305 N. Western, Oklahoma City, Okla.

**FOR SALE**—Weston #643 ammeter scale 0 to 10 amp d-c \$12.50. William Budd, 33 Clendenny ave., Jersey City 4, N. J.

**WANTED**—Tube discards with okay filaments for experimental purposes. Morris Wilkins, Box 15, Wyoming, Ont.

**FOR SALE**—Solar capacitor analyzer CB 1-60, \$32. Want 1A5, 1H5, 1N5, 50Z7, 80, 6SF5 tubes. Clyde W. Wimer, 800 Wampum ave., Elwood City, Pa.

**WANTED**—Portable recorder. Frank Jenkins, 1103 Jackson St., Marshalltown, Iowa.

**FOR SALE**—Supreme automatic radio analyzer #385; 16mm, 750 silent projector; two 8-tube console radios and one Motorola auto radio. Fred C. Koller, 1014 N. Richmond St., Chicago 22, Ill.

**SELL OR TRADE**—Jackson audio sig. frequency oscillator and inter-communicator speakers. Want high-fidelity a.m. tuner. Charles H. Wallace, 532 Foster Road, Staten Island 12, N. Y.

**FOR SALE**—Used and tested tubes #01A. Also 7 used #99 tubes. E. C. Entler, Bonaparte, Iowa.

## SEND US YOUR OWN AD TODAY!

For over two years now, the Sprague Trading Post has been helping radio men get the materials they need or dispose of radio materials they do not need. Literally thousands of transactions have been made through this service. Hundreds of servicemen have expressed their sincere appreciation of the help thus rendered.

Send your own ad to us today. Write **PLAINLY**—hold it to 40 words or less—confine it to radio materials. If acceptable, we'll gladly run it **FREE OF CHARGE** in the first available issue of one of the five radio magazines wherein the Trading Post appears every month.

HARRY KALKER, Sales Manager.

Dept. S-75, SPRAGUE PRODUCTS CO., North Adams, Mass.

Jobbing distributing organization for products of the Sprague Electric Co.



# SPRAGUE CONDENSERS KOOLOHM RESISTORS

T.M. REGISTERED U. S. PATENT OFFICE

Obviously, Sprague cannot assume any responsibility, or guarantee goods, services, etc., which might be exchanged through the above advertisements

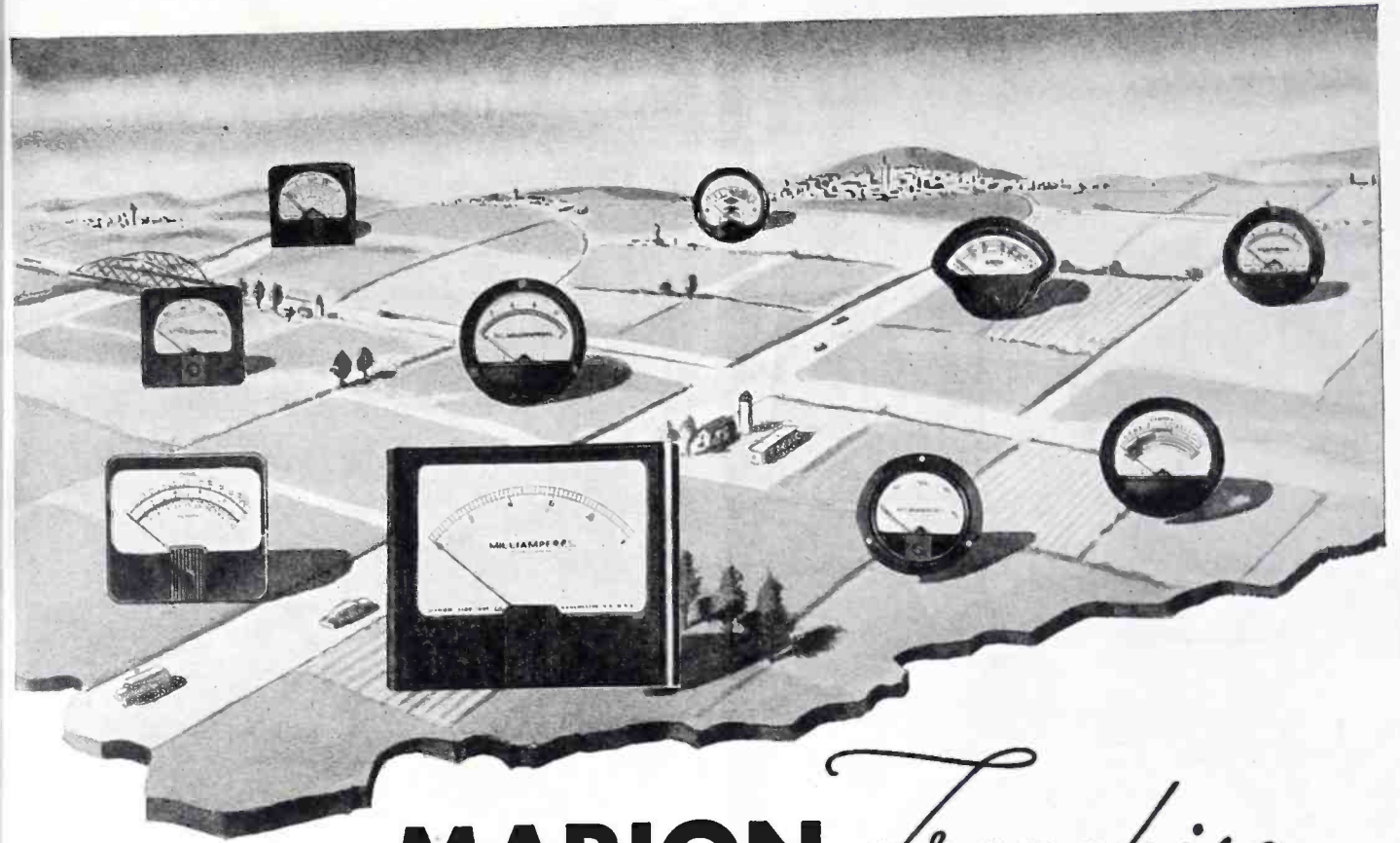

# ...A **MARION** *Franchise*

## is a profitable investment

**because** Marion offers you a complete line of quality electrical indicating instruments, designed and constructed for long, trouble-free performance.

**because** Marion provides a sound merchandising "package" including the new "MeterTester" which will do a man-sized job in helping you sell more instruments.

**because** Marion prices are competitive all along the line, and yet you are assured of a healthy slice of profit in every instrument that you sell.

**because** Marion makes certain that all Marion Jobbers are fully protected against unfair practices and cut-throat competition.

**because** Marion helps attract customers to you by a full-scale, consistent advertising campaign in leading radio and electronic publications.

### Why Marion Instruments Provide Better Service Over a Longer Period of Time

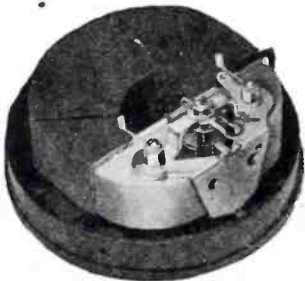

- 1% Accuracy
- Full soft iron pole piece
- Beryllium copper instrument frame
- Solid Alnico magnet
- Beryllium copper mounting bracket
- Individually made metal scale plate (white coated)

For complete details regarding a Marion Franchise, write to our **JOBBER SALES DIVISION**



**MARION ELECTRICAL INSTRUMENT CO.**

MANCHESTER, NEW HAMPSHIRE

Jobber Sales Division: Electrical Instrument Distributing Co.  
458 BROADWAY NEW YORK, N. Y.



more efficient  
... in miniature

The modern high speed grinder can perform many tasks that are impossible with the old fashioned grindstone. Like the miniature electronic tube, it is a striking example of the modern trend of increased efficiency with reduced size.

TUNG-SOL foresees great possibilities in the use of miniature tubes. In most circuits miniatures do a better job than large tubes. Their lower capacity and high mutual conductance and their shorter leads with resulting lower lead inductance make them practically essential for many high-frequency applications.

The added advantages of miniatures are their small size and reduced weight.

The new radio sets and other electronic devices will undoubtedly use a large number of miniatures. When this equipment is on the market, TUNG-SOL Jobbers and Dealers will be in a position to supply miniatures as well as the G-GT's-metal and large glass tubes for serving every type of equipment.



ACTUAL SIZE

# TUNG-SOL

*vibration-tested*

## ELECTRONIC TUBES

TUNG-SOL LAMP WORKS INC., NEWARK 4, NEW JERSEY  
 Also Manufacturers of Miniature Incandescent Lamps, All-Glass Sealed Beam Headlight Lamps and Current Intermittors





**PERFECTION IS OUR ONLY AIM!**



**REMEMBER AND BUY IN THE 7TH!**



**J**apan knows the magical efficiency of Detrola-built mine detectors and other electronic devices. With the eclipse of the Rising Sun, Detrola will manufacture distinctive radio and television receivers... sturdy record changers... all of unparalleled value.

**DETROLA RADIO**

DIVISION OF INTERNATIONAL DETROLA CORPORATION  
DETROIT 9, MICHIGAN

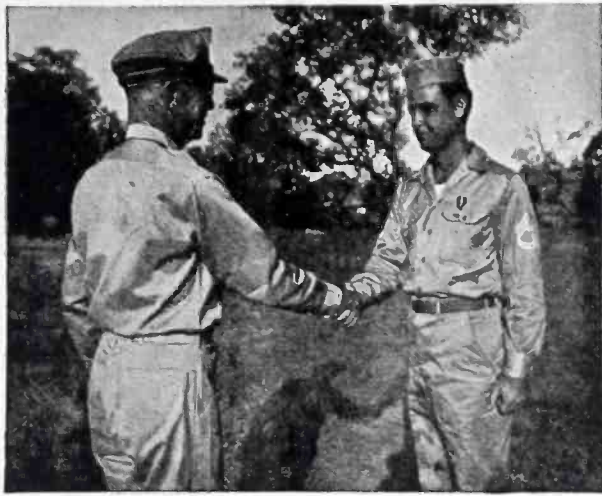

# ***The Pace of Victory Permits Only A Congratulatory Handshake!***

American Industry well merits a decoration for its brilliant record in the Mighty 7th! But, as our newly decorated Pacific heroes quickly return to combat, so industrial leaders aren't resting on their laurels. ***Back into Bond action***—they are now busy consolidating recent Payroll Savings Plan gains!

***First***, many executives are now patriotically working to retain the substantial number of new names recently enrolled during the 7th War Loan. By selective resolicitation, they are urging all new subscribers to maintain Bond buying allotments.

***Second***, many are also employing selective resolicitation to urge every worker who increased his or her subscription in the 7th to continue on this wise, saving-more-for-the-future basis.

Help to curb inflationary pressures and harvest peacetime prosperity by holding the number of Payroll Savings Plan subscribers—and amounts of individual subscriptions—to the mark set in the Mighty 7th!

*The Treasury Department acknowledges with appreciation the publication of this message by*

**SERVICE**



HERE'S THAT NEW  
**TRIPLITT**  
**625-N**

## LONG SCALE, WIDE RANGE VOLT-OHM-MILLIAMMETER

### DOUBLE SENSITIVITY

#### D. C. VOLT RANGES

0-1.25-5-25-125-500-2500 Volts,  
at 20,000 ohms per volt for greater accuracy on  
Television and other high resistance D.C. circuits.

0-2.5-10-50-250-1000-5000 Volts,  
at 10,000 ohms per volt.

#### A. C. VOLT RANGES

0-2.5-10-50-250-1000-5000 Volts,  
at 10,000 ohms per volt.

#### OHM-MEGOHMS

0-400 ohms (60 ohms center scale)  
0-50,000 ohms (300 ohms center scale)  
0-10 megohms (60,000 ohms center scale)

#### DIRECT READING OUTPUT LEVEL DECIBEL RANGES

-30 to +3, +15, +29, +43, +55, +69 DB

#### TEMPERATURE COMPENSATED CIRCUIT FOR ALL CURRENT RANGES D. C. MICROAMPERES

0-50 Microamperes, at 250 M.V.

#### D. C. MILLIAMPERES

0-1-10-100-1000 Milliampères, at 250 M.V.

#### D. C. AMPERES

0-10 Amperes, at 250 M.V.

#### OUTPUT READINGS

Condenser in series with A.C. Volts for output readings.

#### ATTRACTIVE COMPACT CASE

Size: 2½" x 5½" x 6". A readily portable, completely insulated, black, molded case, with strap handle. A suitable black, leather carrying case (No. 629) also available, with strap handle.

#### LONG 5" SCALE ARC

For greater reading accuracy on the Triplet RED • DOT Lifetime Guaranteed meter.

#### SIMPLIFIED SWITCHING CIRCUIT

Greater ease in changing ranges.

Write for descriptive folder giving full technical details

*Precision first  
...to last*

# Triplet



ELECTRICAL INSTRUMENT CO. BLUFFTON, OHIO

# PRECISION is a weapon in MT. CARMEL, ILL.

They use it effectively, too, these men and women who make up Meissner's *precision-el*, for many of them have sons, brothers and loved ones on the battle fronts. The photographs on this page show a few of these precisioneers who fight on the home front with precision and electronic skill as their weapons.



Precision is a family affair at Meissner. Here a letter from the front lines affects two families, and you can see that it's good news that will be reflected in the quality of their work when their rest period is over.



He's a veteran back from active service in the Pacific, but he's still fighting—this time on the home front with the men and women of Meissner. The traditions of precision quality he's learning here will be a weapon he can use after peace.



He splits thousandths of an inch as he does his war job. The "know how" that he and hundreds of Meissner *precision-el* have acquired is one more reason why you will be able to depend on Meissner quality after V-Day.



On the way to battle are these cartons of electronic war equipment. He sends them off with a smile, for he knows that the work of Meissner's *precision-el* will help bring his family together again soon.

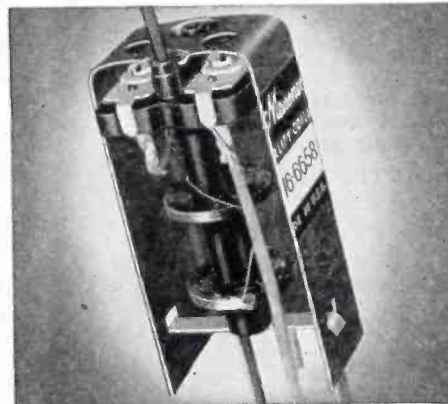

### "Step Up" Old Receivers!

These Meissner Ferrocatt I. F. input and output transformers are getting top results in stepping up performance of old worn receivers. Special powdered iron core permits higher "Q" with a resultant increase in selectivity and gain, now available for frequency range 127-206. Ask for numbers 16-5728 input, 16-5730 output. List \$2.20 each.



# MEISSNER

MANUFACTURING COMPANY • MT. CARMEL, ILL.

ADVANCED ELECTRONIC RESEARCH AND MANUFACTURE  
Export Division: 25 Warren St., New York; Cable: Simontrice

WHERE THE CONSUMER'S

RADIO DOLLAR

WILL BE SPENT



*Here's Why*

MECK NATIONAL ADVERTISING SELLS THE PUBLIC ON THE DEALER

You, Mr. Independent Dealer, have the "edge" on the huge radio market that naturally belongs to you.

But the "undecided" 64% of the buyers in your community could easily change their buying habits—and shift the volume elsewhere.

The only manufacturer who is actively fighting this battle for the Independent Dealer—is Meck. It will pay you to tie in with this program. Ask about the Meck Preferential Dealer Plan.



*John Meck*

JOHN MECK INDUSTRIES, Inc., PLYMOUTH, INDIANA



# MECK RADIOS

TABLE MODELS • PORTABLES • AM-FM • CONSOLE COMBINATIONS • PHONOGRAPHS

# SYLVANIA NEWS

## RADIO SERVICE EDITION

JULY

Published by SYLVANIA ELECTRIC PRODUCTS INC., Emporium, Pa.

1945

### SYLVANIA SERVICEMAN SERVICE

by  
FRANK FAX



One of the most direct sources of information about the industry, particularly for radio servicemen, is Sylvania Electric's well-informed 8-page monthly bulletin—*Sylvania News*.

This interesting and helpful paper was started in the early 1930's for the purpose of supplying repairmen with a handy reference file that would contain past and current news of those items that would benefit them most.

Many features of special interest to radio servicemen are dealt with, making the 8-page *Sylvania News* a really helpful bulletin for repair shops all over the country.

Subscriptions are *free* to radio servicemen. To have your name placed on mailing list, just write to Frank Fax, Sylvania Electric, Emporium, Pa.

#### LEST WE FORGET



THIS STANDS FOR  
HONORABLE  
SERVICE TO  
OUR COUNTRY

## WIDE USE OF "LOCK-IN" TUBES BY THE MILITARY SEEN INFLUENCING SET DESIGN

### *Repairmen Should Prepare For Servicing High Frequency Sets Carrying These Tubes*



The armed forces have been using millions of Sylvania Lock-In Tubes of various types. During 1944 alone, millions of a *single type* tube, of lock-in construction, were supplied.

Why? Because the mechanical and electrical features of the Sylvania Lock-In are better, more rugged than any other tube made. Most important is the fact that, because of this electrical perfection, the lock-in can handle high and ultra-high frequencies much more efficiently, as necessary for FM and television.



*Yes m'am, I carry those radio tubes especially made for this high frequency set.*

Because of this special construction the Lock-In Tube has no trouble taking in its stride the recent FCC assignment of the band between 88 and 106 megacycles to frequency modulation. In fact it is right in step with the continuing trend of the industry toward higher frequencies.

# SYLVANIA ELECTRIC

Emporium, Pa.

MAKERS OF RADIO TUBES; CATHODE RAY TUBES; ELECTRONIC DEVICES; FLUORESCENT LAMPS, FIXTURES, WIRING DEVICES; ELECTRIC LIGHT BULBS

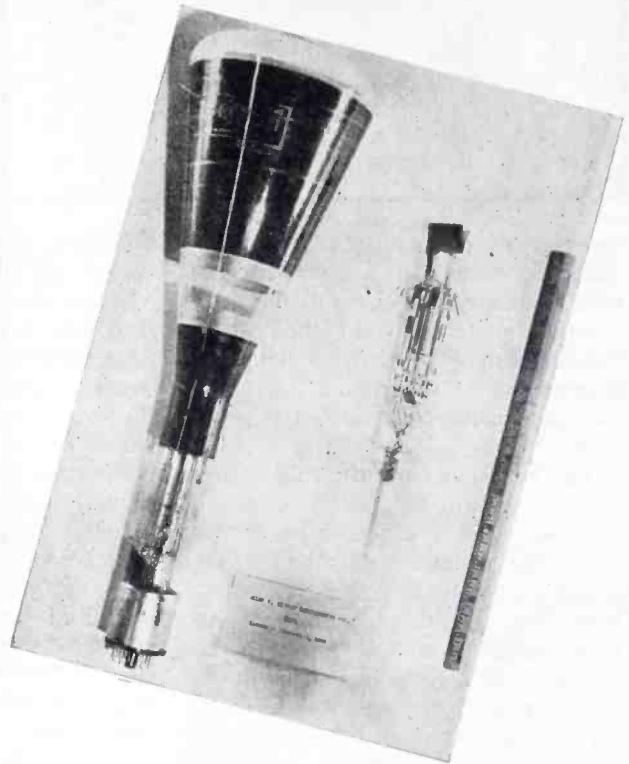
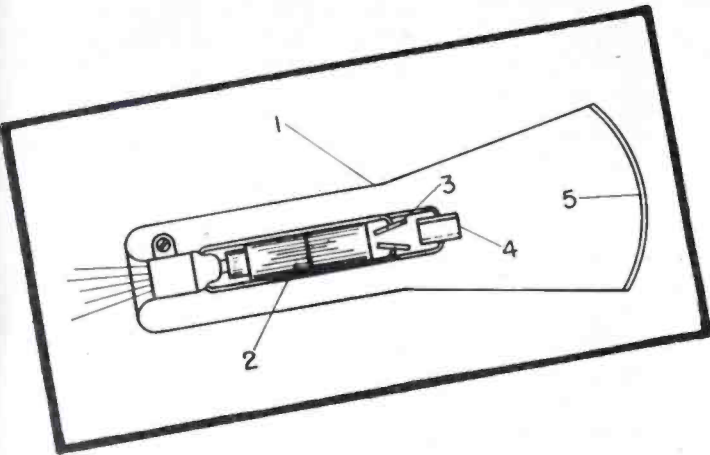

Figs. 1 (above) and 2 (right). Fig. 1 . . . Elementary construction of the cathode-ray tube. The electron gun, 2, focuses a tight beam of electrons on the fluorescent target screen, 5, causing the latter to glow brilliantly at this point. Movement of the beam in a horizontal direction, or vertically, by means of the deflection plate pairs, 3 and 4, respectively, causes the glowing spot to write a luminous line across the screen in a corresponding direction. The entire electronic system is enclosed in the evacuated glass envelope shown here. Fig. 2 . . . DuMont cathode-ray tube with 5-inch electron screen. The electron gun structure incorporated into this tube is shown to the right.

# CATHODE-RAY TUBES

## DESIGN . . . APPLICATIONS . . . SERVICING

[Part One of a Series]

by S. J. MURCEK

THE cathode-ray tube is the visual counterpart of a meter. When used in an oscilloscope, various types of voltages and voltage waveforms may be both seen and measured.

In general, the cathode-ray tube is a variation of the receiving or transmitting tube. It differs from the conventional vacuum tube, however, in that the various electrodes incorporated into its structure represent the electronic equivalent to the conventional *optical or lens* system. Further, the tube contains several special electrodes which are not usually used in standard vacuum-tube structure.

The mechanical components and general construction of the cathode-ray tube are shown in the elementary drawing, Fig. 1. Here, the specially designed glass envelope 1 contains the electron gun, 2, together with its associated deflection plates, 3 and 4. The envelope is evacuated to the lowest pos-

sible air pressure, and the interior of the flattened major end of this envelope is coated with the fluorescing electron screen material, 5.

In Fig. 3 we have the construction of the cathode-ray or electron gun; the complete gun structure is shown to form a tightly-focussed beam of moving electrons. Incorporated into the gun structure are the tungsten cathode heater, 1, cathode electron emitter thimble, 2, control grid barrel, 3, first anode, 4, which acts to focus the beam, and the second anode, 5. Although the horizontal, 6, and the vertical plates, 7, which are utilized to

deflect the electron beam position, are shown attached to the electron gun structure, these electrodes are not normally considered a part of the electron gun.

So that the heater filament retains its form under long and continued operation, it is usually manufactured from *non-sag* (crystallized), tungsten wire.<sup>1</sup>

The cathode thimble, 2 in Fig. 3, is a cup-shaped nickel electrode which is coated on its outer surface with a mixture of emissive oxides, consisting especially of barium oxide, together with a suitable chemical binder. These oxides are characterized by their ability to emit large amounts of free electrons<sup>2</sup> at relatively low-cathode thimble operating temperatures. In the

<sup>1</sup>J. H. Kurlander, *Radio Panel Lamps and Their Characteristics*, Proceedings IRE; April, 1936.

<sup>2</sup>H. Reich, *Theory and Applications of Electron Tubes*, Edition 1, pp. 21-23, paragraphs 2-5.

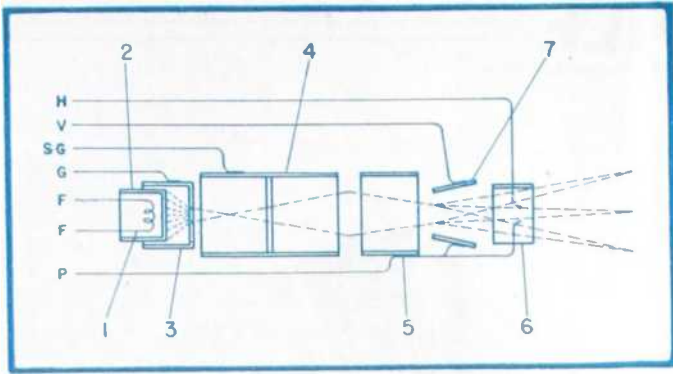

Fig. 3. . . Operation of the electron gun. The tungsten heater, 1, causes cathode, 2, to emit electrons which are concentrated into a small volume by control grid, 3, always electrically negative with respect to cathode. Note the bending of the electron beam by the deflection plate system.

manufacture of these tubes, the chemical binder material is chosen with great care to insure that losses of the active emitting material from the cathode thimble, usually evident as flaking or evaporation of the coating, are much less than in the conventional receiving tube.

The emission from the tube cathode thimble appears as a cloud or *aura* of electrons which radiate or move away from the cathode thimble in such manner as to include the greatest volume about the thimble.<sup>3</sup> These electrons would eventually stray beyond the possibility of practical application were it not for the presence of the negatively charged control grid thimble 3; since like electrical charges repel each other, the thimble concentrates the electron cloud into a compact volume by means of negative electrostatic repulsion.

The grid thimble is a cup-shaped electrode somewhat greater in diameter than the cathode thimble, pierced through the true center of its circular surface by a very small beam-forming

aperture. Electrostatic attraction provided by the remaining positively charged electrodes of the gun structure functions to draw a portion of the electron cloud through the grid orifice in such a manner that an electron stream or *beam* results. Further, since the control grid is usually negative with respect to the cathode of the tube, the grid functions to control the number of electrons in the beam, and therefore the beam *intensity*, through retardation of the cathode electron emission.

Initial attraction of the electrons from the vicinity of the cathode thimble is supplied by the positively charged first anode barrel, 4 (Fig. 3). The first anode is slightly larger in diameter than the control grid thimble, and is provided with several beam apertures. Thus, since the electron beam is given initial acceleration by the first anode, the velocity of each individual electron is sufficient to prevent its attraction to the surface of this electrode, and the electron stream passes through

<sup>3</sup>M.I.T. Staff, *Applied Electronics*, page 10, sect. 10 (The Schottky Effect).

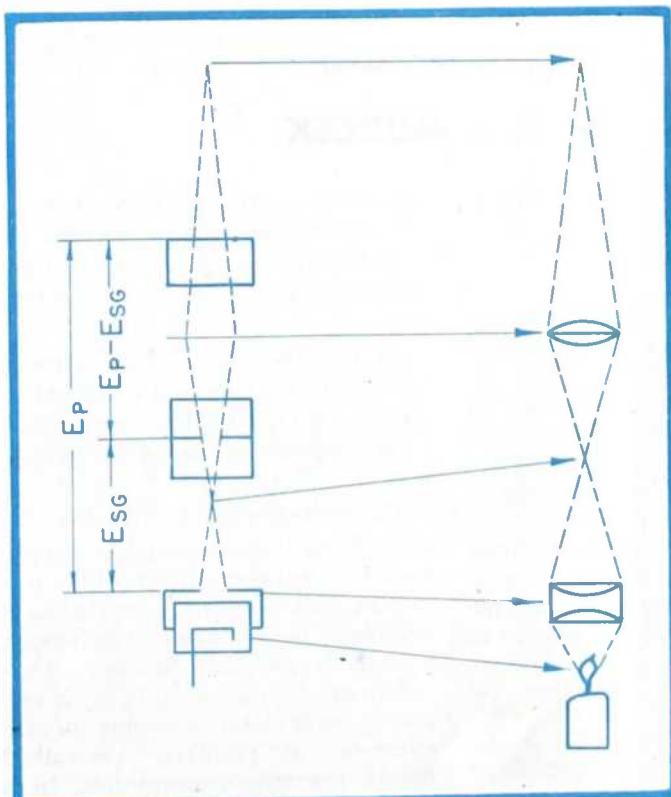

Fig. 4. . . Comparison of optical and electronic lens systems. Here, the control grid of the electron gun and the condenser-lens system of its optical analogy perform similar functions. Further, the voltage difference present between the first and second anodes of the electron gun has a marked resemblance to the analogous position of the optical convex lens. In either instance, a tightly focused beam is incident on the respective optical targets.

the several apertures in the anode barrel.

Additional acceleration is imparted to the electron beam by the second or final anode, 5, which is merely a metal cylinder affixed to the extreme of the gun structure. This electrode operates at a potential which is positive with respect to both the tube cathode and the first anode.

From the preceding discussion, it may be observed that the first anode is effectively a form of the conventional vacuum-tube screen grid, and the final anode of the conventional plate. In the conventional vacuum tube, the screen functions to accelerate the electron stream attracted from the cathode by the plate. In the cathode-ray tube the first anode performs this function. In the latter case, however, the electrons contained in the beam are not collected by the anode in the form of a current, but continue beyond the final anode to form a cathode-ray beam.

Since the initial velocity imparted to the electrons in the beam results from the attraction provided by the positively charged first anode, any increase in the voltage difference existing between the cathode and this electrode results in increased beam electron velocity. Consequently, the electron transit time from the cathode orifice to the target or screen which lies beyond the second anode, is correspondingly shorter. The repulsion existing between the individual electrons in the electron beam acts for a correspondingly shorter interval, and the dispersion of the beam, which may be readily viewed as the cross-sectional area of the electron column, is reduced to a negligible quantity. Thus, as the first anode potential, or the *focussing* voltage, is increased, the cross-sectional area of the electron beam at the target is decreased, and the area of the target which is covered or *bombarded* by the electrons in the beam decreases in a similar manner.

Increases in the first anode potential must eventually approach a limit which is the voltage at which the second anode operates. This is self-evident when it is considered that the acceleration imparted to the cathode-ray of electron beam by the second anode occurs as the result of the higher potential existing between this electrode and the tube cathode, or specifically, the potential difference existing between the first and second anodes. Therefore, as this potential difference is decreased, the acceleration imparted to the cathode ray is decreased in like proportion. It is this voltage relationship which suggests that the mechanical construction of the electro-

<sup>4</sup>M.I.T. Staff, *Applied Electronics*, page sect. 6a (Analogy with Light Optics).



gun effects an optical result on the generated electron column.<sup>4</sup>

The optical nature of the cathode-ray tube electron gun may be observed from Fig. 4, where this electrode structure is compared with a conventional optical projection system incorporating a radiant light source, together with a system of condensing and projection lenses. In this illustration, we note that the condenser lens system functions similarly to the cathode-ray gun control grid, concentrating the emitted light rays of the radiant light source on the projection lens system, the latter exhibiting the properties of the first and second anodes respectively. In the latter case, since the distance existing between the second lens and the light source is representative of the second anode potential, the distance between the first lens, representing the first anode, and the light source must be varied or adjusted to bring about the final concentration of the light beam on the target surface.

Most cathode-ray tubes employ an electron screen which consists of *willemite* (a zinc-sulphate-binder mixture). The material is sprayed on the inner surface of the glass envelope, in the manner discussed previously. Willemite fluoresces with a characteristic green glow when bombarded by an electron beam. Thus, when the electron screen is subjected to bombardment by the cathode-ray or electron beam in the cathode-ray tube, the spot or area which is under bombardment glows green. Adjustment of the first anode potential permits reduction of the glow area to a small pinpoint of light which, when the electron beam is caused to move from side to side, writes a continuous or solid line of green light.

The appearance of a continuous or straight line on the electron screen is the result of a combination of two well-known physical phenomena; the persistence of vision and the afterglow or persistence of fluorescence in the electron screen. Persistence of vision in the human eye is the ability of the eye to retain a characteristic image for a short interval after the disappearance of the image on which the eye has been focussed. It is this characteristic of the human eye which permits a succession of related events, such as a series of film pictures, to provide the optical illusion of the motion picture. In the cathode-ray screen, the rapid motion of the fluorescent light spot results in the appearance of the illusion of a solid, continuous line of fluorescence. This illusion is aided by the actual persistence of the fluorescent glow of the electron screen.

Fluorescent screen materials which

produce glow colors other than green are available for application in cathode-ray tubes, these *phosphors* producing white or blue fluorescence under electron bombardment.<sup>5</sup> The green fluorescing willemite screen is most often selected because the characteristic green glow is most readily seen under appreciably high levels of daylight illumination. The willemite screen requires less beam electron acceleration, and therefore less final anode potential for generation of fluorescence in the screen material.

The development of the blue and white fluorescing *phosphors*, which use higher beam electron velocities, required the production of better envelope vacuums than for the willemite screen. Since better evacuation of the tube envelope results in decreased resistance to the motion of the beam electron, such evacuation results in increased beam velocities.

The electron beam is, in reality, a current of electricity which occurs without necessitating the actual presence of a suitable conductor. Hence, the electron screen, as well as the interior of the tube envelope, soon acquire an appreciable negative charge, which slowly creeps to the tube cathode, as well as to the leads of the remaining electrodes. This negative charge effects a reduction in the velocity of the electron beam, as well as some dispersion of the beam near the target. This is due to the electrical repulsion between the beam electrons and those collecting on the screen and the interior surface of the tube envelope.

Some types of cathode-ray tubes are provided with a special electrode which is designed to reduce the negative charge collecting on the interior surfaces of the cathode-ray tube envelope.<sup>6</sup> This electrode is, in reality, a coating of colloidal graphite (*aquadag*), covering the interior surface of the tube envelope nearest the electron screen. It is connected to a source of voltage somewhat greater than that applied to

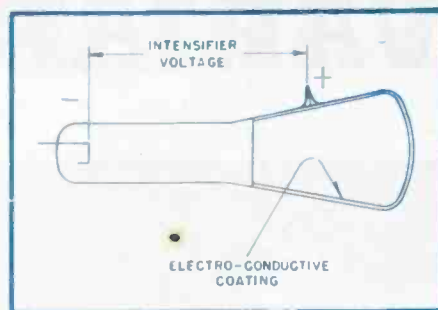

Fig. 5. . . The DuMont intensifier electrode. This electrode is a coating of colloidal graphite which clears the electron screen of low-velocity electrons. This activity is prompted by a high positive voltage level effecting attraction of these electrons.

the final anode of the tube. This positive charge clears the interior of the envelope surface of parasitic negative charges. Because of the presence of this *intensifier* electrode, as well as the increased beam velocity and target concentration, the resultant fluorescent spot is brighter or more intense, and of lesser cross-sectional area, than in the conventional cathode-ray tube. The intensifier electrode is illustrated in Figs. 2 and 5.

In actual operation, the heater of the cathode-ray tube is usually energized from a suitable source of a-c energy. The negative control grid potential is obtained by operation of the cathode electrode at a slightly positive potential, usually variable, since the control grid-to-cathode negative potential controls the fluorescent spot brilliance. The cathode, control grid, first anode and final anode operating potentials are obtained from a single d-c source. The intensifier potential is usually supplied from a separate power rectifier-filter supply.

<sup>5</sup>P. S. Christaldi, *Practical Guide for C. R. Design*, DuMont Laboratories, page 28.

<sup>6</sup>P. S. Christaldi, *Practical Guide for C. R. Design*, DuMont Laboratories, page 27.

[To Be Continued]

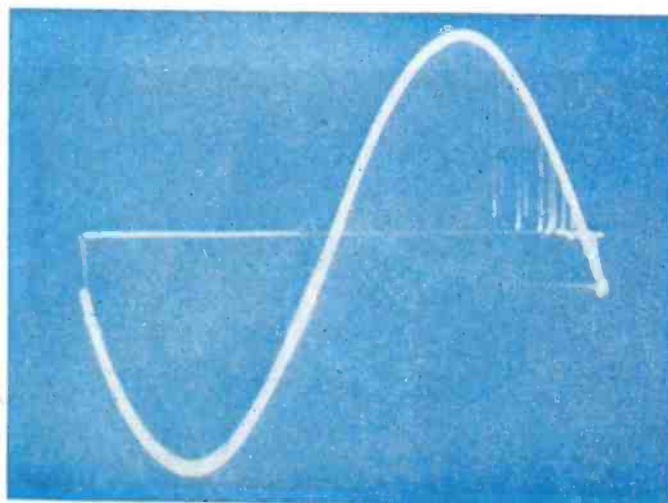

Fig. 6. . . How an a-c sine wave appears on the screen of a cathode-ray tube. It is apparent here that the electron beam is caused to move over the screen surface like an electrical pencil, in accordance with two functions: (1) horizontally, equal time units (*microseconds*), and (2) vertically, sine-proportional voltage increment and decrement.

# VARIABLE CONDENSER SERVICING

by EDWARD ARTHUR

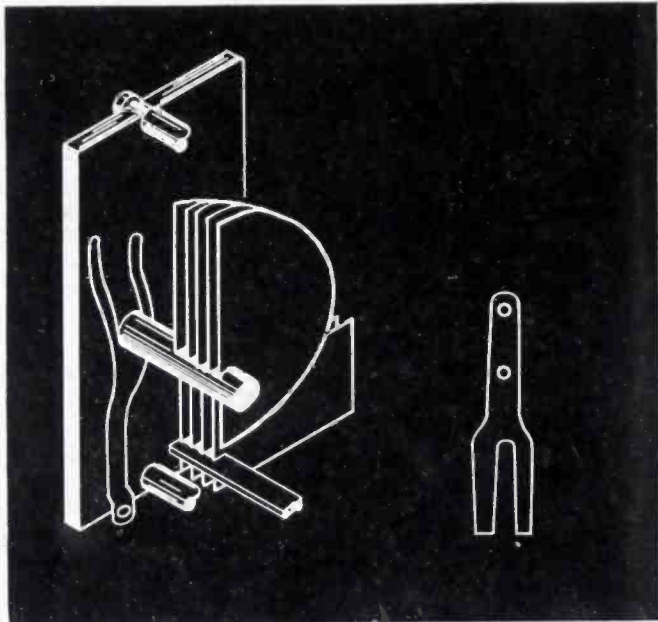

Fig. 1. . . . Construction and placement of fingers in a variable condenser. Fingers should be cleaned and bent for increased pressure to prevent noisy operation.

**T**UNING and trimmer condenser defects represent a particularly disagreeable form of repair problem for the Service Man. Most defects are mechanical, and while the average radio repair shop is not equipped for any extensive mechanical work, numerous types of repairs are possible. Since wartime conditions and receiver obsolescence make exact replacement almost an impossibility, an immediate shop repair is the best solution, even if tedious.

### Tuning Condenser Defects

Any one of six conditions may be caused by a defect in the tuning condenser. These are:

(1)—Inoperative receiver; caused by a dead short between the rotor and stator sections.

(2)—Inoperative over a portion

of the tuning range; traced to bent rotor or stator plates.

(3)—Noise; apparent when turning the dial, or may be intermittently present during reception.

(4)—Intermittent reception; similar to that caused by a defective volume control, and may be traced to the tuning condenser if striking the cabinet or chassis causes the signal to stutter.

(5)—Microphonics; condition is similar to that caused by a microphonic tube.

(6)—Oscillation; an electrical defect which may be cured by proper shielding of the tuning condenser.

### Inoperative Receiver

A shorted tuning condenser may easily be checked with an ohmmeter. Before testing it is first necessary to

remove the connections to the stators. If shorted, even with the rotor plates out, the trouble will be found to lie in the trimmer condenser mounted on the stator assembly. The adjustment screw is usually the offender, shorting the plate of the trimmer to the body of the tuning condenser. A repair is effected by replacing the non-metallic washer used to insulate the screw from the trimmer plate. Another source of trouble is the mica washer. If the mica insulator is suspected, the trimmer plate should be checked for sharp metal splinters before replacing the washer. The point where the short exists may be easily located by momentarily applying some voltage, about 6 volts, across the suspected condenser, and watching for the spark. This, in itself, may burn out the metal sliver, and effect the necessary repair. Spare mica washers may be obtained by purchasing a high-capacity trimmer, which usually has a number of them. A word of caution . . . make sure that the connection from the coil to the particular condenser being checked is removed before applying the voltage.

### Partial Shorts

When a portion of the tuning range is inoperative, usually accompanied by a scraping sound just before the dead portion of the dial is reached, and invariably the low-frequency end, the trouble may be traced to bent rotor or stator plates. Sometimes the same condition is caused by metallic particles, or small pieces of solder on the plates. In one case, a set was inoperative over a small portion of the dial at the middle frequencies. This was traced to a metal sliver jutting out

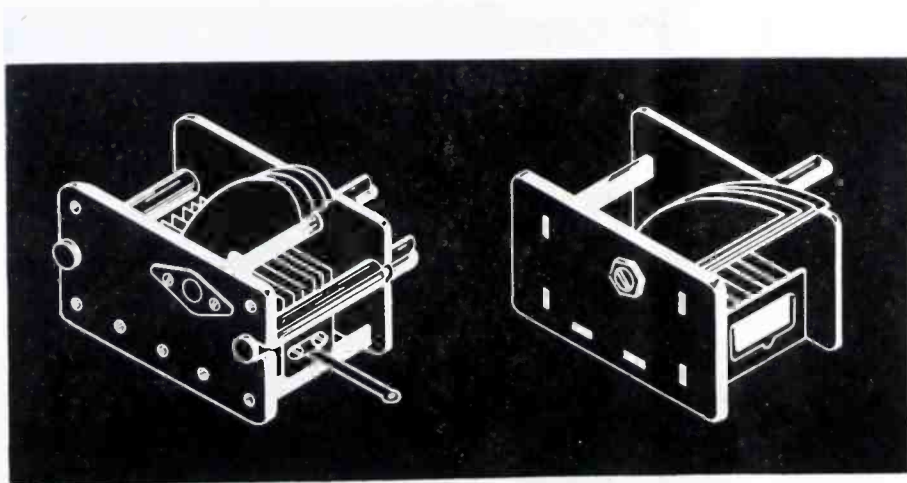
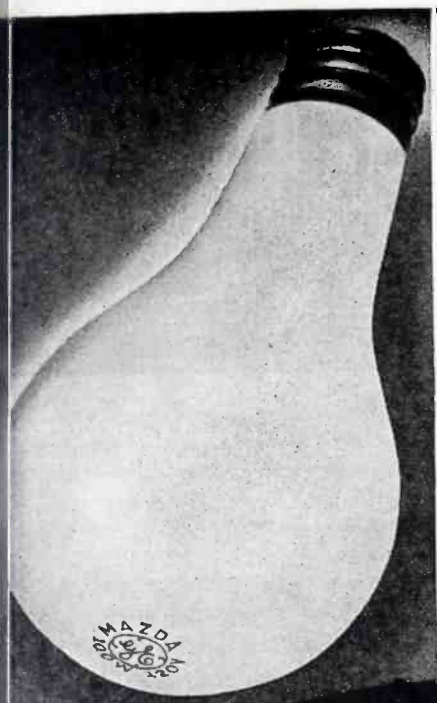

Fig. 2. . . . Two types of end-bearing assemblies. Both types are adjustable for loose or worn rotor assemblies.



**FM radio also brings you Jeanette MacDonald in natural color**

The glowing tube you see here is the new FM tube. It's the only tube that can reproduce the rich, natural color of the FM broadcast. It's the only tube that can reproduce the rich, natural color of the FM broadcast. It's the only tube that can reproduce the rich, natural color of the FM broadcast.

**GENERAL ELECTRIC**  
**FM RADIO**



**PRESTIGE + POPULARITY = PROFITS**

**PLAN NOW FOR PROFITS—  
from tomorrow's big market  
for G-E electronic tubes!**

IT'S time NOW to look ahead—plan ahead—to when electronic tubes will again be available in volume to increase the figures on the profit side of your ledger. People then, as always, will buy what they know—and respect. They have known and bought G-E Mazda lamps for decades, until this name has become a symbol for light. Now they see G-E electronic tubes in full-page General Electric radio advertisements that run in 19 leading national magazines reaching

30,000,000 readers every month. In addition, G-E tubes each week reach the attention of listeners in 7,000,000 radio homes. Under the very eyes of radio dealers and service men a big, profitable market tomorrow—when G-E tubes can be supplied to all who want them—is being built. Retailers who look confidently ahead to prosperous times, are making G-E tubes a "must" for their post-war stocks. Think back over the years to how G-E Mazda lamps have swelled the cash receipts

of thousands of stores! Then think forward to the new, identical opportunity offered to radio dealers and service men by G-E electronic tubes! Soon this opportunity will be yours. Prepare to take early advantage of what it offers you in the way of assured income and fullest participation in the benefits of G-E leadership. Write for the name of your nearest G-E tube distributor. Address *Electronics Department, General Electric, Schenectady 5, N. Y.*

**Hear the G-ERadio programs:** "The World Today" news, Monday through Friday, 6:45 p. m., EWT, CBS. "The G-E All-Girl Orchestra," Sunday 10 p. m., EWT, NBC. "The G-E House Party," Monday through Friday, 4 p. m., EWT, CBS.

**GENERAL  ELECTRIC**

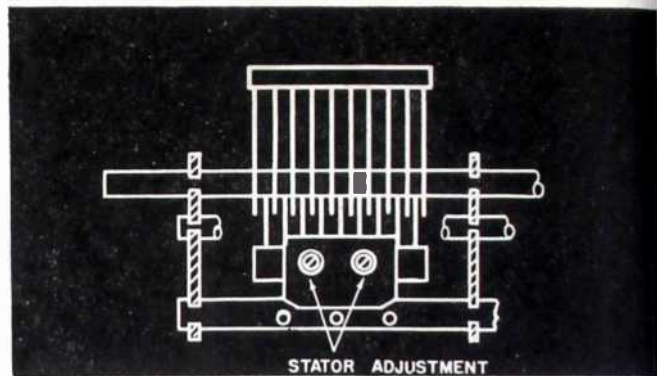
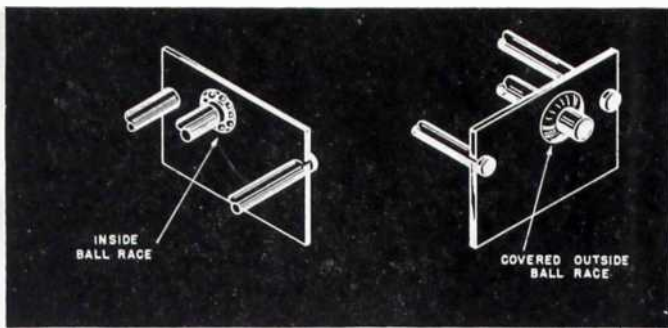

Figs. 3 (left, above) and 4 (right, above). . . Fig. 3 shows the inner and outer ball races of rotor assemblies. In Fig. 4 we see the adjustment screws used for relocating stator plates.

from the middle binder on the stator assembly, and touching the high point of a straight-line-frequency cut plate of the rotor. The exact point of short may be determined by using the voltage method previously outlined, and watching for the spark. It is advisable to use some non-metallic blade to straighten bent plates, rather than a screwdriver, since the latter may often create metal slivers itself, or scratch the plate and cause additional trouble. The fact that a rotor does not ride in dead center between the stator plates does not affect the linearity of the tuning condenser, so long as they do not touch. Where the rotor plates ride on the outside of the stators, the position of the plate is important, and care should be exercised when bending them. Incidentally, on old-type receivers, these outside rotor plates may be used to align the receiver, by bending them away from the stator to decrease capacitance, or toward the stator for an increase.

### Noise

Noisy operation, particularly when tuning, is usually due to dirty fingers. These fingers are fork-shaped springs attached to the body of the tuning condenser and exerting a spring pressure on the rotor shaft. They tend to corrode after in use for some time, and cause a poor contact to ground from the individual sections of the tuning assembly. In some condensers these fingers are removable. If removable they may easily be cleaned with some very fine sandpaper, and lightly coated with graphite before replacing. Be sure to increase the tension by bending them slightly before inserting them in their proper place. Do not use oil. A good rule to follow is to solder individual pigtailed between each finger and chassis.

In some cases the fingers are either soldered directly to the tuning condenser body, or held in place with an eyelet. A thin, folded piece of sandpaper, inserted between the rotor shaft and the finger, pulled back and forth a few times, while rotating the shaft, will often clean the finger and shaft effectively. If the pressure of the finger on the shaft is felt to be weak (this

may be determined by noting the pressure on the sandpaper while cleaning), the pressure may be increased by carefully bending the finger with long-nose pliers, using a twisting motion.

Another point where noise may originate is in the dial mechanism controlling the rotor movement. The noise is caused by the rotor shaft, or the dial mechanism rubbing against the chassis during some portion of the tuning cycle. This condition is usually created by the condenser body having shifted from its original position, and may be traced to the anti-microphonic rubber grommets. Their continued subjection to heat causes them to disintegrate or harden. Replacement is the best solution. If this cannot be done, the judicious use of rubber bands and fibre washers is recommended as a substitute to bring the tuning condenser back to its original position.

Sometimes the noise is only apparent on the high-frequency bands of multi-range receivers. If none of the previous suggestions help, it may be necessary to attach a pigtail directly from the rotor to ground. This may be done by drilling and tapping a small hole on the rotor shaft, attaching the pigtail with a screw, allowing sufficient length to permit rotation, and soldering the other end directly to the chassis.

Sometimes noise may be caused by the entire rotor assembly shifting. This shift may be due to wear, or to a loosening of the small pressure plate mounted on the rear plate of the tuning assembly. If the plates have shifted forward, that is, to the front of the tuning condenser, the best solution is to replace the ball bearings around the forward end of the rotor shaft with a slightly larger size. If the wear is in the rear, the repair will depend on the type of bearing assembly used. If a single ball bearing is used, in combination with a pressure plate, a slightly larger bearing will help. Sometimes the pressure plate itself is the cause of the trouble. A small washer inserted inside the plate may do the trick. Some

tuning condensers have movable stators, held in place with screws. Where this condition exists, loosening the screws and readjusting the stators is all that is necessary. When the stators are riveted in place the rivets may be replaced with short screws. If the stators are soldered in place, it is inadvisable to try this type of repair.

The brute force method is a last resort. For this operation it is necessary to remove the tuning condenser from the chassis. The rotor is then removed from the body of the tuning condenser. We then place the stator in a vise, and squeeze until the distance between the front and rear plates has been reduced, usually a fraction of an inch. The size vise necessary for this operation is not standard equipment of the average radio repair shop, but the nearest auto repair shop will be found to have the necessary size. This method was used in a few cases, and found to be surprisingly effective.

### Intermittent Operation

Intermittent operation, that is, a sudden increase or decrease in volume level, often originates in the tuning condenser. This condition may be localized in the tuning condenser by tapping the unit lightly with the rubber end of a pencil. There are only two connections to each section of the unit; one is the finger, and the other is usually soldered to the underside of stator. The repair of trouble in the finger has been previously outlined. However, the soldered connection to the stator is often found to be broken. This condition is usually caused by the movement of the tuning condenser incidental to dialing. Most often, the solder breaks away from the wire, causing a condition similar to a cold soldered joint. These connections should be checked carefully to make sure that the wire is firmly soldered in place.

Where rubber grommets are used, a pigtail is sometimes soldered from the screw holding the grommet to chassis to effect a ground. This is also a possible source of intermittent operation. This point should be checked carefully to make sure that a good contact is established.

[To Be Continued]

# Smaller Size... More Convenient!

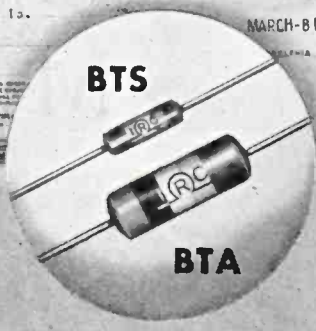
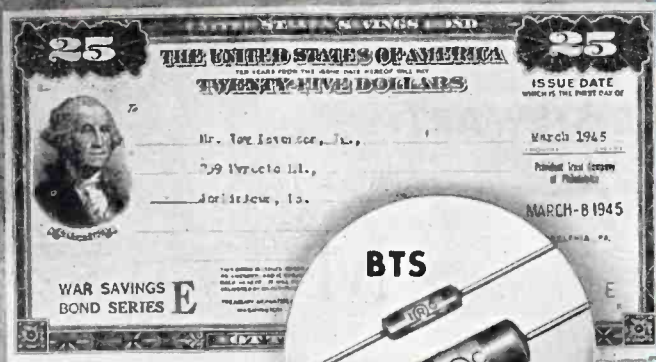

Uncle Sam too, found it more convenient to reduce the size of his E Bonds. Value remains same.

## EQUAL IN QUALITY AND "VALUE"

### HERE'S WHY THE BTS AND BTA DO A "BIG RESISTOR" JOB . . .

Wattage ratings are based on the ability of a resistor to dissipate heat efficiently. The universal method of determining the rating is by measuring, under load, the resistor's temperature rise at 40°C. ambient. IRC's BTS and BTA, 1/2-watt and 1-watt resistors are very efficient in heat dissipation because of their exclusive Metallized design plus the greater heat conductivity of the new copper leads, thinner insulating walls, and new molding methods which create greater density in the molded materials. Consequently, even though much smaller in size than the former types BT-1/2 and BT-1, they fully qualify as 1/2 and 1-watt units in all respects.

During the war, IRC's production of BTS and BTA Resistors has been absorbed for use in war equipment where size and quality were of primary importance. Numerous expansions have geared IRC's production to war-time needs and these resistors are now available to servicemen and dealers.

BTS size is no bigger than the 1/4-watt units you will be replacing and should be used for greater safety in 1/4-watt applications. Naturally, Type BTS is completely dependable in all 1/2-watt jobs. The BTA is smaller than pre-war 1-watt resistors, has a low temperature rise, therefore a great safety factor, and is a highly satisfactory replacement for all 1-watt units. These are modern resistors for modern space requirements and the many, many millions used in Allied war equipment testify to their greater dependability.

Chart shows how closely the new, smaller BTS parallels the heat-dissipating characteristics of the BT-1/2 Resistor, long considered the quality standard of the industry. Likewise, the BTA curve closely approximates that of the BT-1.

**COMPARATIVE TEMPERATURE RISE IRC TYPE BTS and BT-1/2 RESISTOR**

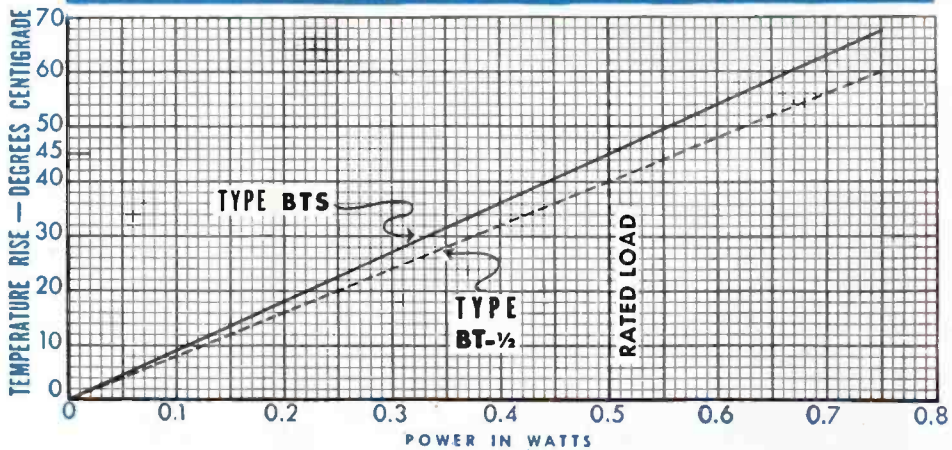

**INTERNATIONAL RESISTANCE CO.**  
 Dept. 23-G 401 N. BROAD STREET • PHILADELPHIA 8, PA.

IRC makes more types of resistance units, in more shapes, for more applications than any other manufacturer in the world

# SIMPLIFIED CONVERSION OF AUTO SETS FOR HOME USE

by J. GEORGE STEWART

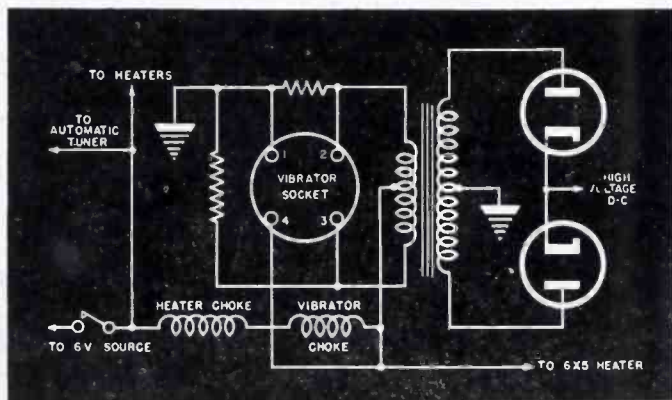

Fig. 1. . . The power supply system of the Motorola 500 auto radio. The dual diode rectifiers shown are ordinarily single-envelope tubes.

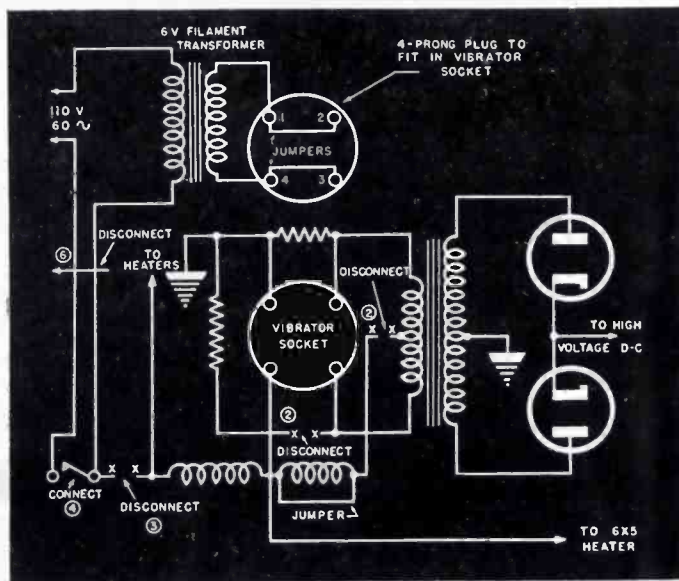

Fig. 2. . . Method of converting the Motorola 500 to a-c home-use operation. To reduce the necessary changes to a minimum, we use a 4-prong plug which fits into the vibrator socket. The filament transformer is mounted externally. Note that the heater choke has been connected to terminal 4.

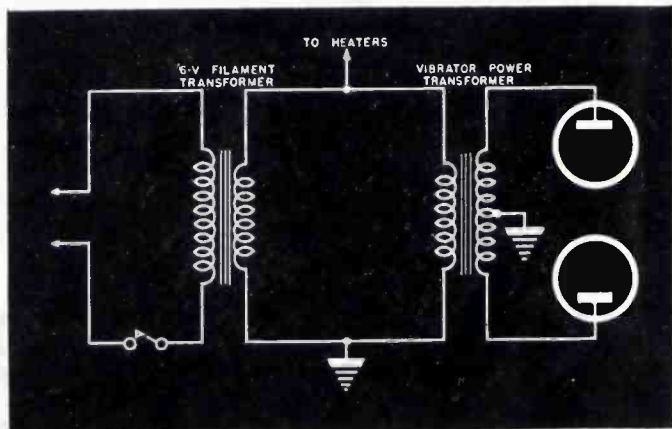

Fig. 3. . . Here we have a generalized concept of the conversion. The simplicity of the operation is shown quite clearly. If a 6-ampere filament transformer is not available, two smaller units may be used in parallel, or one for the power supply and the other for the filament supply. Autotransformers may also be used.

**M**OST types of auto radios can be easily converted for a-c home use. The only components necessary are a 6-volt filament transformer, an adapter to fit into the vibrator socket, possibly a new speaker, and some very simple cabinet, or cabinet work.

In Fig. 1 we have the vibrator circuit of a typical auto radio, Motorola 500. Fig. 2 shows the same circuit converted to a-c operation. The necessary circuit changes are:

(1) Adapter is connected to 6-volt winding of filament transformer, as shown in Fig. 2, and plugged into vibrator socket.

(2) We then disconnect the 50-ohm resistor attached to terminal 1-3 of the vibrator socket. It is also necessary to disconnect the center-tap on the primary of the vibrator transformer and tape.

(3) Connections to the line switch are then removed and ends taped. We must also remove or tape A lead.

(4) Then the line switch is connected in series with the primary of the filament transformer and the line cord.

(5) A p-m speaker installation is the next step.

(6) Since this particular receiver has an automatic tuning mechanism it should be disconnected.

Most late model auto radios use p-m speakers; others have no automatic tuning mechanism, so that steps 5 and 6 may be unnecessary.

For the average auto radio, a filament transformer capable of delivering 5 or 6 amperes at 6 volts is ample. If this is not available, two smaller transformers may be used in parallel, or split into a vibrator supply and a filament supply. About 2 amperes at 6 volts is usually sufficient for the vibrator transformer supply. The necessary filament current may be determined from the tube complement. The rectifier filament should not be forgotten in computing the necessary filament current.

The transformer or transformers should be mounted on a wooden board  
(Continued on page 38)

# WELDING GLASS TO METAL "COULDN'T BE DONE"...

HUMIDITY-PROOF  
SHOCK-PROOF  
LEAK-PROOF

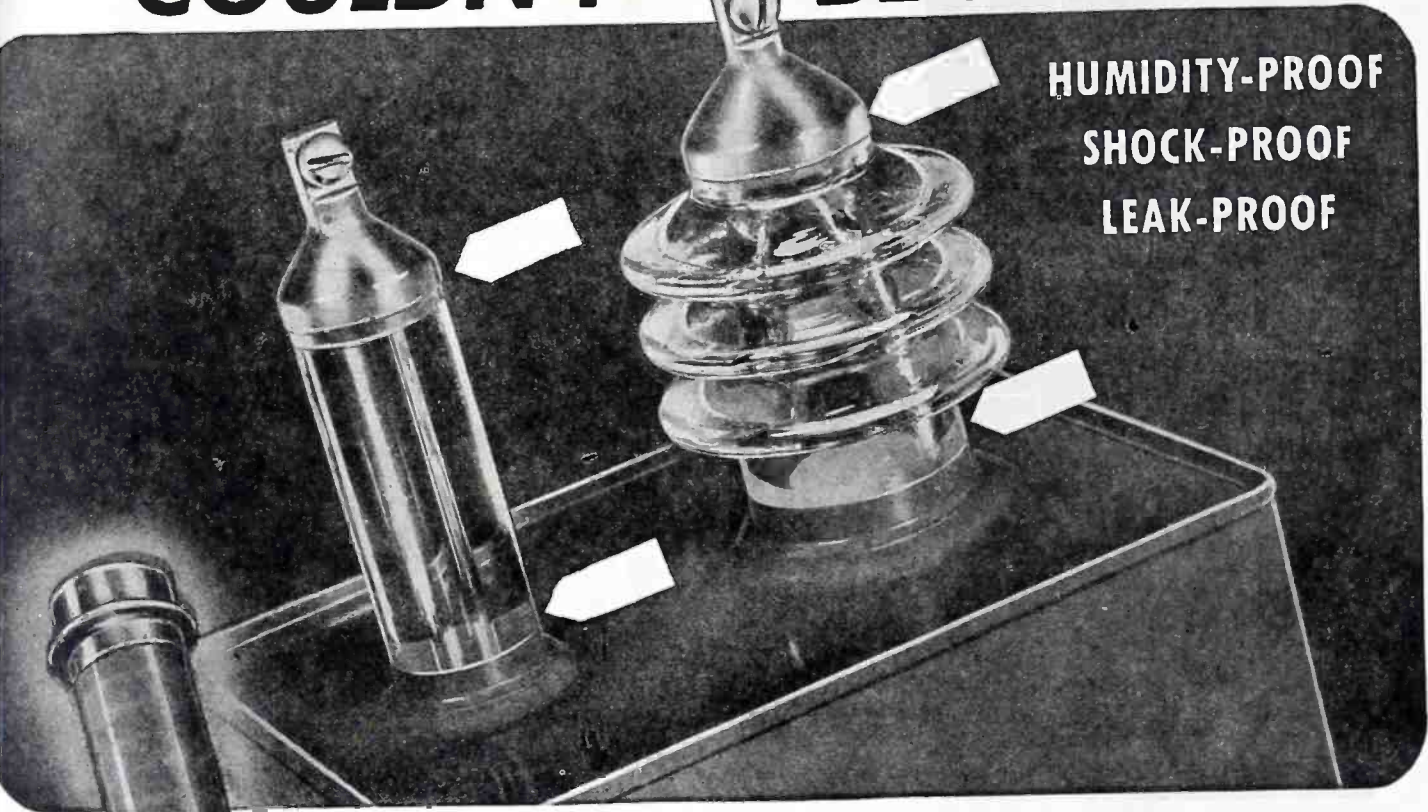

... but here it is!

If you want to have a look at the Capacitors and Resistors of tomorrow, step in and see what has been going on in the Sprague Engineering Laboratories (if wartime restrictions would permit!). Then it will be easy to understand why Sprague has been a FIVE TIME WINNER of the coveted Army-Navy "E" Award!

against shock—and doing it without the use of glass bushings or adjacent metal rings with "matched" temperature coefficients of expansion. Actually, there were many "scientific" reasons why glass could not be fused to metal—but Sprague not only proved that it could be done, but done economically and in tremendous quantities.

A typical example is the Sprague Electric Co. glass-to-metal seal. This amazing development answers the old problem of sealing Capacitors and Resistors against leaks and moisture, guarding them

This sort of accelerated wartime engineering is reflected throughout the entire Sprague line—and that means unsurpassed quality for every unit used on every day radio work!

**THE TRADING POST  
CONTINUES!**

Sprague's famous free buy, sell, or exchange advertising service "THE SPRAGUE TRADING POST" appears on page 4 — of this issue — and will continue to appear as long as wartime shortages create a need for it. Meanwhile, we'll appreciate it if you continue to use Sprague Capacitors and Koolohm Resistors—and to ask for them by name!

**SPRAGUE PRODUCTS COMPANY, North Adams, Mass.**

*(Jobber Sales Organization for Products of the Sprague Electric Co.)*

# SPRAGUE



**CAPACITORS FOR EVERY SERVICE, AMATEUR AND EXPERIMENTAL NEED**

# VOLUME CONTROL CIRCUITS

by ROBERT L. MARTIN

[Part Two]

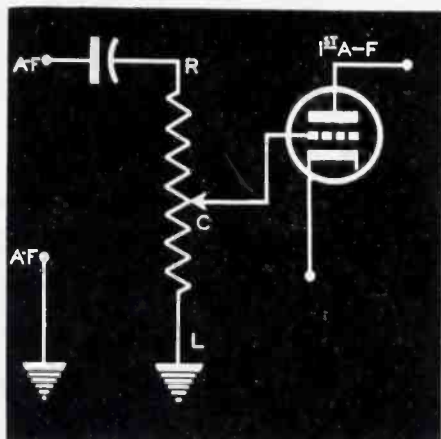

Fig. 14 (above) and 15 (below). Fig. 14. . . Volume control used between detector and first a-f. In Fig. 15 the control is across secondary of a-f transformer.

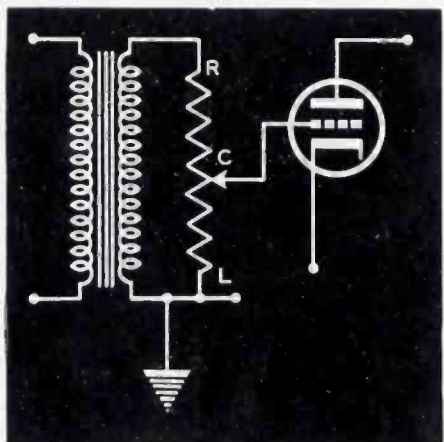

Fig. 16. . . Same as Fig. 15, except that control arm is connected to ground.

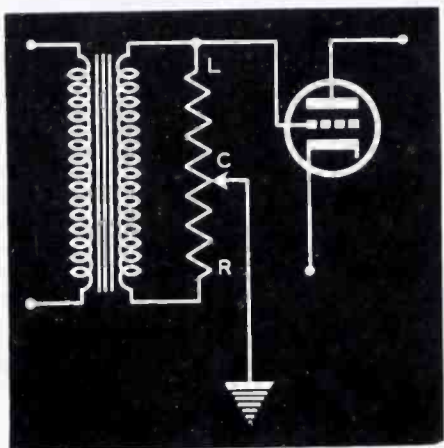
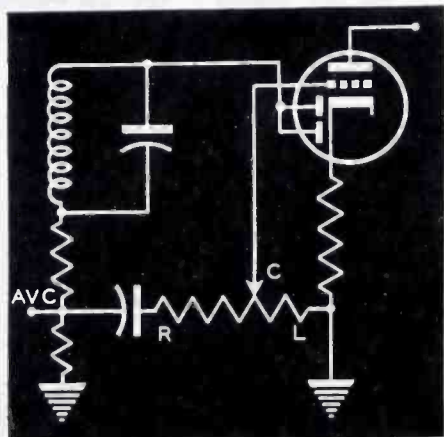
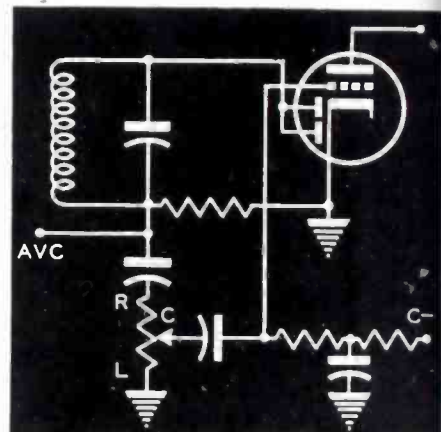

Fig. 17. . . Most popular type of volume control, used with duo-diode-triodes.



Circuits courtesy of P. R. Mallory & Co., Inc.; Yaxley Replacement Volume Control Manual.



Figs. 18 (above) and 19 (below). Fig. 18 is similar to Fig. 17, except that control is in diode return. A poor type of control system is shown in Fig. 19; d-c flows in the control causing noisy operation.

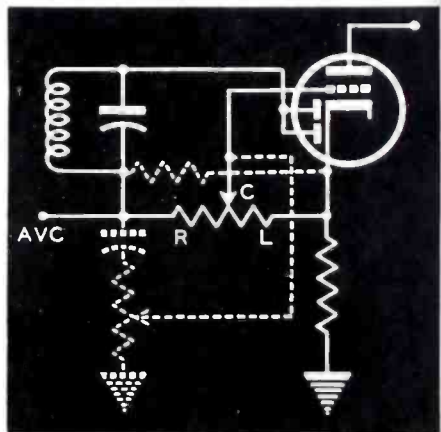
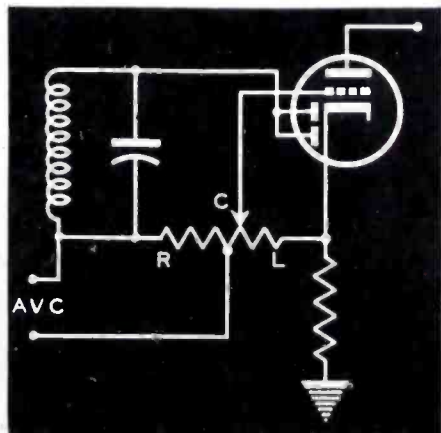

Fig. 20. . . Tapped control for source of reduced avc voltage.



IN the previous discussion, we covered controls used in receivers without avc. In this, the concluding installment, avc, tone compensation and other special types of control circuits are described.

The function of an avc system is to supply a constant signal voltage at the detector for a very wide range of signal levels at the antenna. This voltage appears at the high side of the audio volume control, as at R in Fig. 14. It is then only necessary to control the audio input to the a-f amplifier right after the detector. Left-hand tapers of 0.1 to 2 megohms are usually used. An extremely popular control circuit, it has been applied in many novel forms.

Since no r-f or d-c (other than the minute grid current) flows through the control, it is quiet in operation. Thus in Figs. 15 and 16 we have potentiometer controls used in conjunction with audio transformers. Complete detector-avc circuits appear in Figs. 17 and 18. In Fig. 19 we have a volume-control circuit that provides for diode-load resistor action by the control. This is a noisy system since d-c (rectified r-f) flows through the control. In servicing a control connected in this manner, the circuit should be changed as shown in the dotted diagram. The control is usually  $\frac{1}{2}$  or 1 megohm, the condenser .01 to .05 mfd.

Fig. 20 shows a tapped control, the tap being used for reduced avc voltage. This method is used often on one or two tubes, as well as the tubes controlled by the full avc line.

A tone compensation circuit is shown in Fig. 21. This is an important system. Because of the ear's non-linearity in sensitivity to low and high notes at different sound levels, this system of control is quite useful. As the volume is reduced, the ear loses bass response faster than treble. Therefore, a perfect system of volume control should decrease treble faster than bass. The simplest method of accomplishing this effect is with a condenser and resistor in series and connected to a tap on the control. Some elaborate controls have more than one tap linked to a network.

A variable fidelity control, independent of the audio volume control is  
(Continued on page 35)



**TELEVISION, MORE THAN EVER, IT WILL PAY TO**

**SELL THE TUBES WITH  
THE BEST-KNOWN NAME**

television servicing is going to be big business.

It's also going to be profitable business. For it's a complex and skillful operation and your customers are going to pay more . . . and *expect* to pay more . . . than for ordinary radio servicing.

Renewal tubes will account for a large share of the increased cost, for television sets require many more tubes. In addition, each set must have a large picture tube which, while costing much less than pre-war types, thanks to continuing RCA research, is bound to be many times the price of the ordinary receiving tube.

When your customer pays out that kind of money for a single tube, you can bet he'll insist on having *the best*. And the prestige of the tubes you give him will go a long way towards establishing your shop in his mind as *the place* for television service.

RCA tubes give you the prestige you need to make *occasional* customers *regular* customers. RCA tubes are accepted . . . your customers know them and rate them tops, because, year after year, the RCA name has been associated with leadership in tubes.

Television is no exception. RCA television-tube developments like these *made electronic television possible* . . . and they will bring television profits to you years earlier. They also built television prestige for RCA, which, in turn, is passed on to you every time you display the RCA seal . . . every time you put an RCA tube in a customer's set.

Give your servicing business every break you can after the war. Make the most of your chances by identifying yourself with the *best-known name in tubes*.

**The Fountainhead of Modern Tube Development is RCA**



Listen to "THE MUSIC AMERICA LOVES BEST," Sundays, 4:30 PM, EWT, NBC Network

**RCA TUBE ADVANCES THAT MADE TELEVISION HISTORY**



**Iconoscope Tubes**

—the camera tubes that made all-electronic television possible, bringing high definition to the television screen.



**Kinescope Tubes**

—first step in electronic television—have been speeded in development by RCA research.



**Orthicon Tubes**

—specially developed by RCA as camera tubes for outdoor work where light intensity cannot be controlled—a big step forward in outside pickups of special events.



**High-Intensity Projection Tubes**

—an exclusive RCA development that helped make possible large-screen television for home use, as demonstrated by RCA early this year.



62-6636-94

**RADIO CORPORATION OF AMERICA**

RCA VICTOR DIVISION • CAMDEN, NEW JERSEY

LEADS THE WAY . . . In Radio . . . Television . . . Tubes  
Phonographs . . . Records . . . Electronics

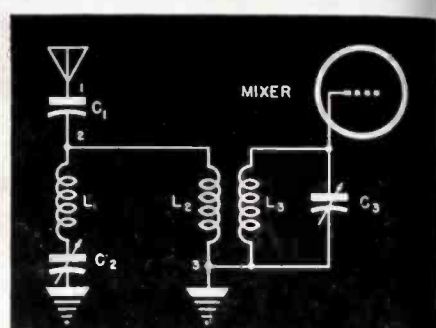
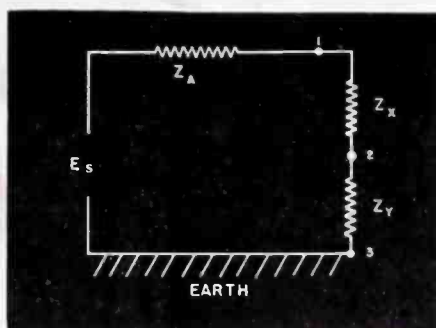
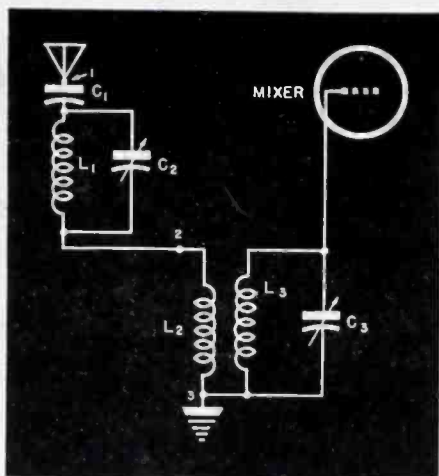

# WAVE

Figs. 1 (above), 2 (top center) and 3 (top right). . . . Fig. 1. . . Here we have a parallel-type wave trap in series with the antenna circuit.  $L_1 C_2$  form a high-impedance trap at resonance, reducing the interfering signal voltage across  $L_2$ . Fig. 2 shows a simplified concept of this principle. In Fig. 3 we have a series-type trap in parallel with the antenna coil primary. Here  $L_1 C_2$  form a low-impedance path for the interfering signal.

by WILLARD MOODY

YEARS ago, wave traps were in the gadget classification and used quite experimentally as a remedy for all types of troubles. Today, however, they are important factors in receiver and accessory design, serving very definite purposes.

We might broadly define a wave trap as a combination of inductance and capacitance that may reject or pass certain frequencies. The simplest form consists of a small coil shunted with an adjustable trimmer and located in the antenna circuit, Fig. 1. In this circuit,  $L_1$  and  $C_2$  are the wave-trap elements, forming a parallel resonant circuit. Condenser  $C_1$  is simply a series condenser which has low impedance at the operating frequency. It is used to prevent short circuiting of the power line in the event the antenna is grounded or an a-c/d-c set is connected to some other radio receiver's antenna.

## Trap Design

In designing one form of trap, it is important to know the inductance, capacitance and resistance properties of the antenna. If the antenna wire is fairly long it may have appreciable inductance, and if the wire is remote from the ground the capacity-to-ground will be small. The resistance of the usual antenna wire will be fairly low. Suppose, for the sake of simplicity, we assume the impedance of the antenna to be resistive,  $L$  and  $C$  reactance values being opposite and equal, as they would be for a resonant circuit. When an incoming radio wave cuts the antenna, it induces a voltage, as we see

in the simplified equivalent circuit of Fig. 2. The impedance of the combination of  $L_1$  and  $C_2$  is represented as being  $Z_x$ . The input impedance of the receiver across terminals 2 and 3 is  $Z_y$ . If the impedance  $Z_x$  of the wave trap is made very high, at resonance, the current in the series circuit will be small. The voltage drop across  $Z_y$  will then be small, so that only a very small signal voltage is applied to the receiver input circuit. If  $L_1$  and  $C_2$  is tuned to 456 kc, the i-f of a typical set, code interference at 456 kc will be minimized, but signal frequencies away from 456 kc will not be affected to any great extent. This is exactly what we desire. We note, too, that when the ratio of  $Z_x$  to  $Z_y$  is large, a greater percentage of the available code interference or other interfering voltages will appear across the wave trap. Thus the series connection shown is useful when the input impedance of the radio is low. If the input impedance of the receiver is high, the alternative arrangement shown in Fig. 3 is preferable. The condenser  $C_1$  may be assumed to be a short circuit for r-f at the operating frequency, since its impedance is very low.

## Reducing Code Interference

From Fig. 4, we can see that the lower  $Z_x$  is made the less voltage will appear across  $Z_x$ . Since the voltage across  $Z_x$  is also the voltage across  $Z_y$ , which is the receiver input impedance, less current will flow in  $Z_y$  and the response of the receiver at the frequency of code interference, so far as the mixer is concerned, will be greatly reduced. As  $Z_y$  is made higher in value,  $Z_x$  becomes more effective. Therefore the shunt wave trap is better to use

when the input impedance of the receiver is high.

## Doublet Antennas

When the set uses a doublet antenna, wave traps may be connected as shown in Fig. 5. Here  $L_1$  and  $C_1$  are connected in series with the low-impedance primary circuit of the receiver, and also in series with the mixer grid circuit. Usually, only one wave trap is necessary. Either connection may be used. If the mixer grid connection is used, the leads should be kept short and direct. It will be necessary to realign the receiver for best results as the installation of the wave trap and disturbance of wiring will upset the original receiver alignment. If the wave trap is shielded, it may upset the capacity in the tuned circuit too much and thus a primary circuit connection may work out better. In some cases shielding is necessary to prevent re-radiation of the interfering signal from the wave trap into a following signal circuit in the receiver. When the set has a loop antenna, a wave trap in series with the primary circuit of the loop is not very effective; the series-grid connection should be used.

## Local Station Problems

In practical servicing it may be found that interference is often due to a local high-power broadcasting station. Receiver selectivity will usually be poorer at the high-frequency end of the band, and monkey chatter and cross talk may be experienced if one station on the band is very much stronger than any of the other stations. By cutting down the signal strength of the local station, without reducing it to zero signal strength, better reception often can be obtained. When tuned to the local station, overloading and distortion will be avoided by using a wave

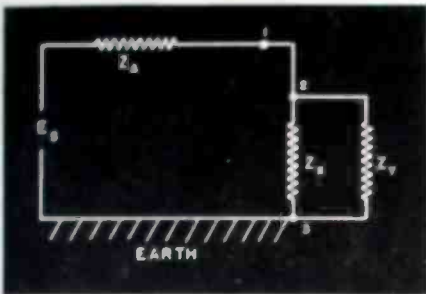

Fig. 4 (left). . . A simplified concept of Fig. 3.  $Z_x$  represents the wave-trap impedance path for the interfering signal. If  $Z_x$  is small enough,  $Z_Y$ , which represents the antenna coil primary, will be nearly shorted by  $Z_x$  at the interfering frequency.

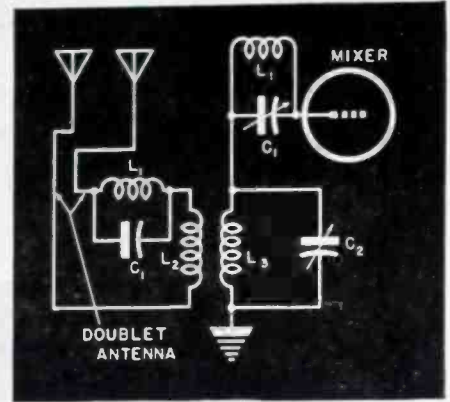

Fig. 5 (above). . . The wave trap represented by  $L_1C_1$  is shown, in this circuit, in series with one leg of a doublet system.

# T R A P S

trap. This will afford improved reception of other stations, without distortion and squealing. Any of the wave traps illustrated may be used, bearing in mind the general principles discussed. The wave trap might be tuned to 1,400, as an example, instead of to 456. If too much attenuation of the signal results, the wave trap may be detuned slightly which will cut its ability to reject the signal. However, detuning the wave trap may mean that some other desired signal is attenuated.

### Wave-Trap Q

The  $Q$  of the wave trap can be controlled with resistance. In the series type, resistance may be added to the wave trap in series with  $L$  or  $C$ , and in the parallel type a resistance may be simply shunted across the tuned circuit. Then, in both cases, the wave trap is tuned to resonate with the desired signal, but the selectivity and  $Q$  are controlled by increasing the resistance from zero to a value that gives the best results. Usually, simply detuning the wave trap will prove satisfactory, without using resistance.

### Loading Resistance

One way of determining the amount of loading resistance required is to use a 1-megohm volume control, varying it until the required selectivity is obtained. This is somewhat tricky, however. In addition, the control may have capacity, making adjustments difficult. When the resistance is satis-

factory, disconnect the control and measure the resistance in the circuit with an ohmmeter. Then substitute a small carbon resistor for the control resistance.

### Wave-Trap Adjustments

Adjustments on a wave trap should be made with an insulated tool, such as a bakelite rod, to avoid detuning.

### Choke Coil Uses

The old practice of connecting a small choke coil in series with the antenna is still useful in some instances. A 2.5-mh short-wave type choke could be used in eliminating 2,450-kc police calls. The writer has found that a wave trap offers better results in preventing police-call interference. Usually the trouble arises when the receiver is located within walking distance of the police transmitter.

### Construction Details

Although wave traps may be purchased, emergencies often demand building one in the shop. In constructing a wave trap we have to determine the inductance of the coil. Formulas are usually employed. However, an experimental method using a v-t voltmeter and signal generator can be used, Fig. 6. In determining resonance,  $C_1$  is set at near maximum capacity. The vacuum-tube voltmeter is set to read low r-f voltages of the order

of  $\frac{1}{4}$  volt or less. Generator dial is then adjusted until an indication of resonance is obtained, shown by maximum voltage across  $Z$ . The input impedance of the vacuum-tube voltmeter is  $Z$  and is assumed to be largely resistive, or to have negligible effect on the frequency of the wave-trap circuit.

### Test Frequencies

At first, the generator output voltage may be set to maximum by adjusting the attenuator full clockwise. A test frequency higher than the expected frequency of the wave trap is chosen for first adjustments and then gradually the frequency is reduced. A receiver may be used for indicating the presence of the signal, but may behave in somewhat troublesome fashion due to harmonics, beat notes, etc. By using a high test frequency and then going lower, the above troubles may be minimized. When the frequency of resonance is established, the combination of  $L$  and  $C$  may be used either in a series or shunt circuit in the receiver. In both series and parallel resonance the same basic formula for resonance applies;  $f = 1/2 \pi \sqrt{LC}$ .

### Series L-C Circuits

Some Service Men have amplitude-modulated r-f oscillators for carrier current work which also may use wave traps to avoid interference, Fig. 7. By using series  $L-C$  circuits tuned to the operating frequency, the transmitter avoids sending other than 300-kc current into the line, tending to minimize interference with broadcast sets. The receiver picks up only 300-kc signals and not broadcast signals or code.

Figs. 6 (left) and 7 (below). In these two figures we have two methods of determining the characteristics and behavior of shop-built wave traps.

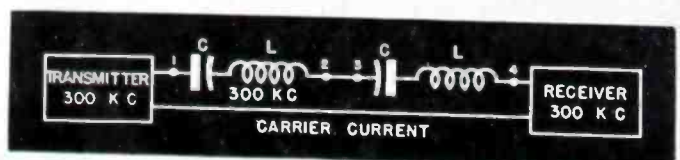
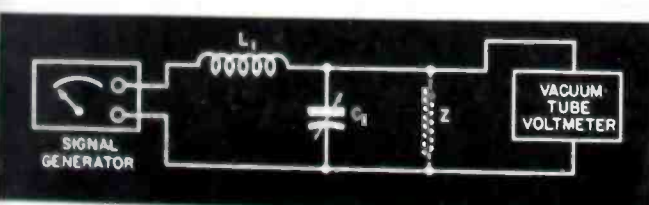

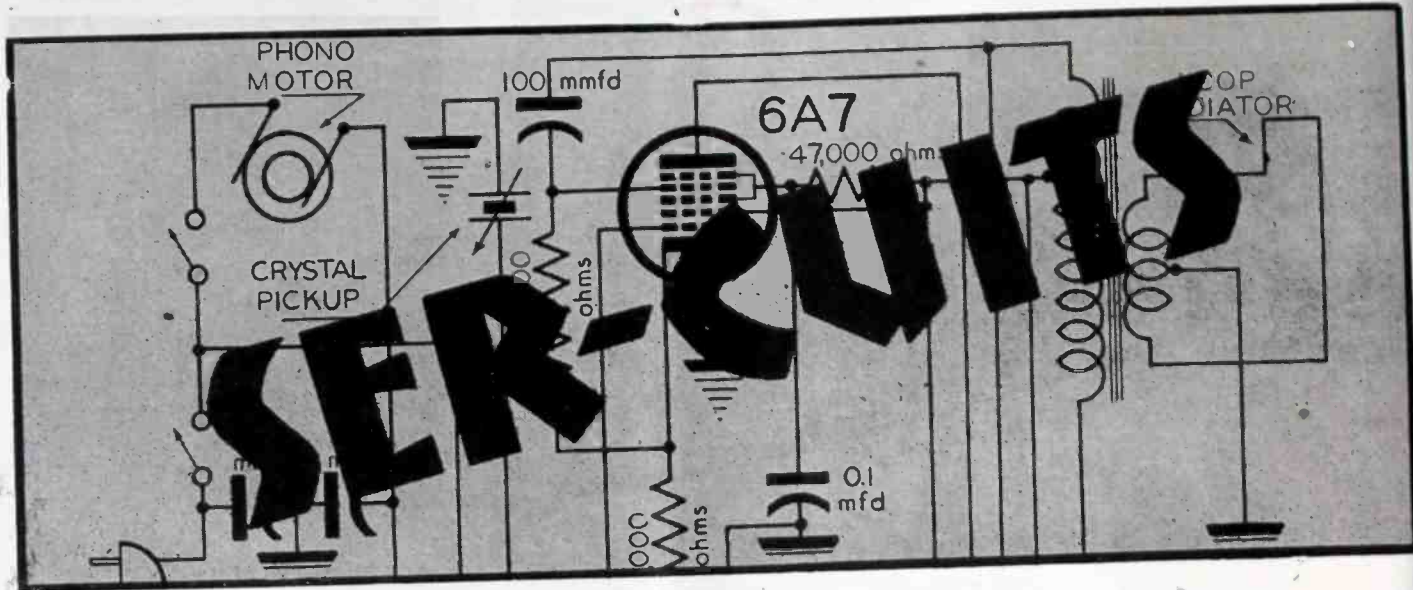

# SERVICES

**I**N response to numerous requests, the portable Motorola 57BP1/2, Fig. 1, will be analyzed in this section, this month. This is a standard 4-tube-and-rectifier unit with a plug-in loop antenna and series connected filaments. The filament voltages are well compensated for drops due to plate currents with unique resistor links. In the  $A+9$ -volt circuit of the 3Q5 power tube, we have a 400-ohm shunt across the negative half of the filament, then a 39-ohm series resistor. This is followed by a 680-ohm shunt across the remaining tubes to  $A-$ . After the next tube, the 1N5 i-f, there is another shunt to  $A-$ , 1,200 ohms. No com-

by **HENRY HOWARD**

pensation is used for the remaining 1H5 and 1A7. A 9-volt battery is used for a total of  $7\frac{1}{2}$  volts of filaments. The 39-ohm series resistor takes care of the difference and also contributes a little buffer action, reducing the surge of filament current when the set is turned on, to protect the weakest filament.

The 1A7 converter has a 68,000-ohm screen dropping resistor and is biased

from the avc system which is tied to the positive end of the 1A7 filament. A 0.1-mfd bypass capacitor shunts the filament. Another bypass is connected from the junction of the 1H5 and 1N5 filaments to  $A-$ . This keeps the r-f or i-f currents from travelling through the filaments, causing unwanted feedback. The 1N5 is biased by a 8.2-megohm resistor tied to  $1\frac{1}{2}$  volts negative with respect to its own filament. The 1-megohm volume control also acts as the diode detector load resistance. The 3Q5 output tube is biased by  $7\frac{1}{2}$  volts drop through the filaments and resistors through a 2.2-megohm grid leak.

Fig. 1. Four-tube portable Motorola 57 BP 1/2, with a compensated series-filament circuit.

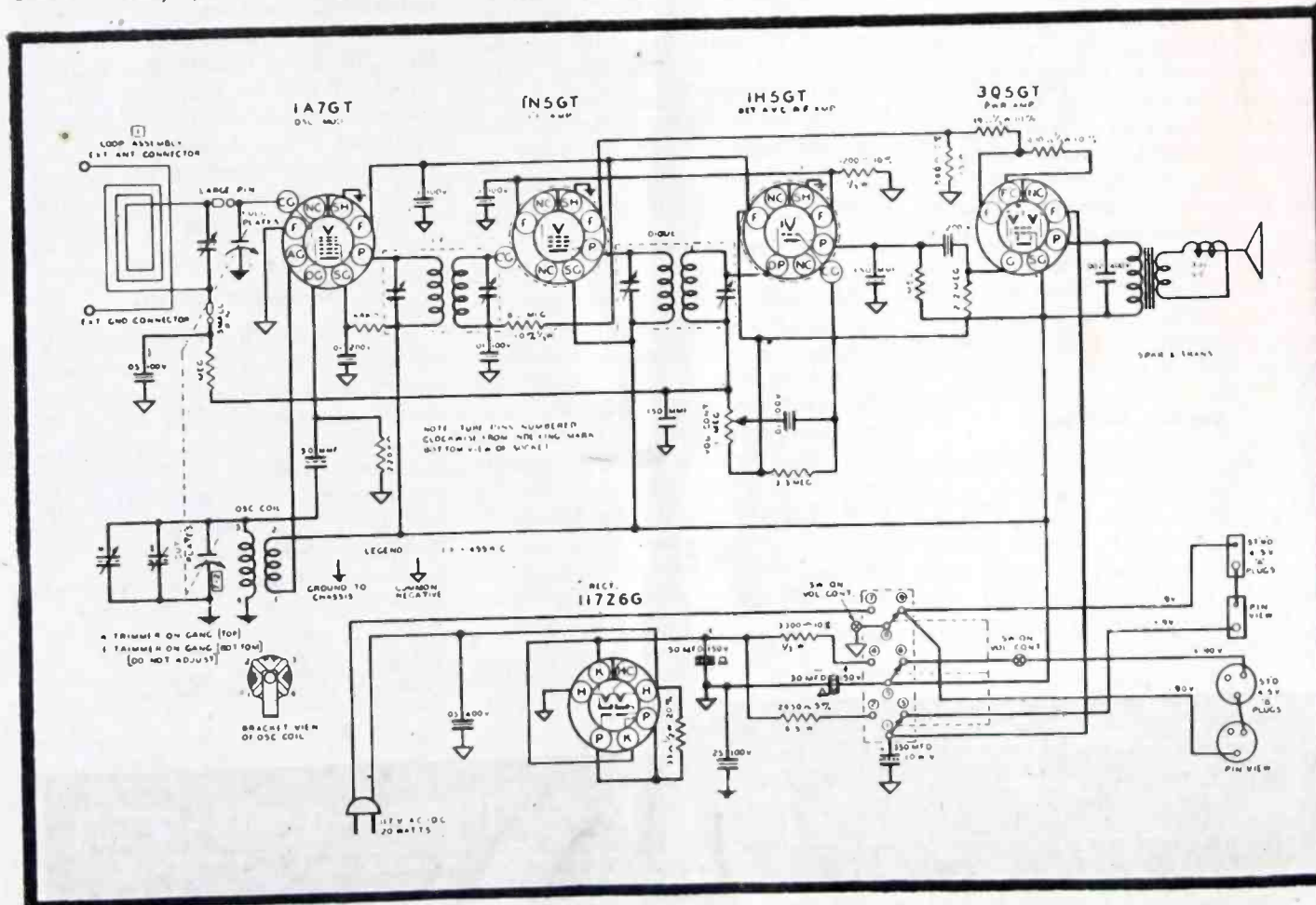

# TRANSFORMER COMPONENTS

*for every application*

## RADIO

Set components



Radio Filters

## TELEPHONY

Loading Coils



Repeat Coils



Pulse Transformers



Mine Detection Components



Selective Amplifier Filters

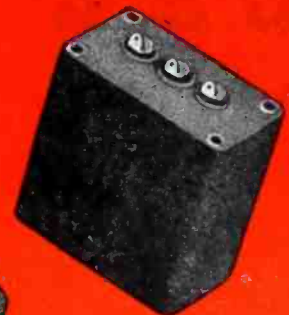

Inter-phone Amplifier Components



## DETECTION

## AMPLIFICATION

*Foremost Manufacturers of Transformers to the Electronic Industry*



ALL PLANTS

May we cooperate with you on design savings for your applications... war or postwar?

*United Transformer Corp.*  
150 VARICK STREET  
EXPORT DIVISION: 13 EAST 40th STREET,  
NEW YORK 13, N. Y.  
NEW YORK 16, N. Y., CABLES: "ARLAB"

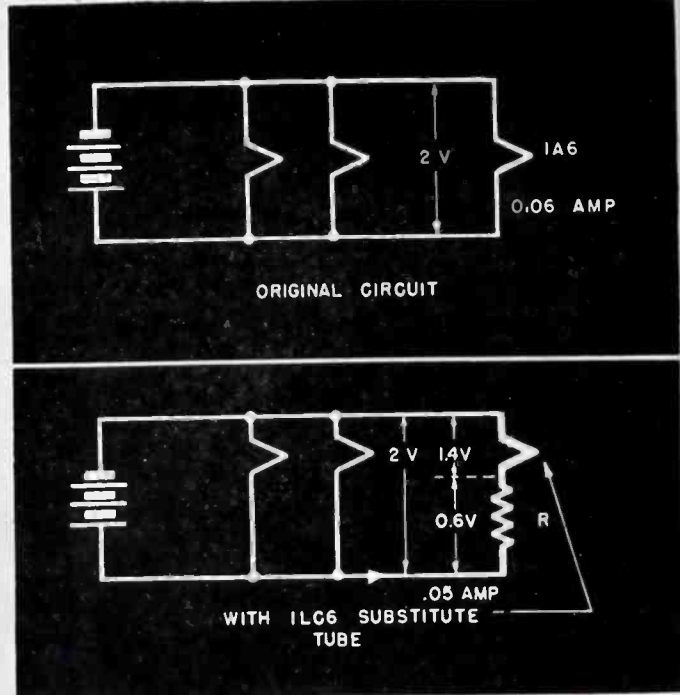
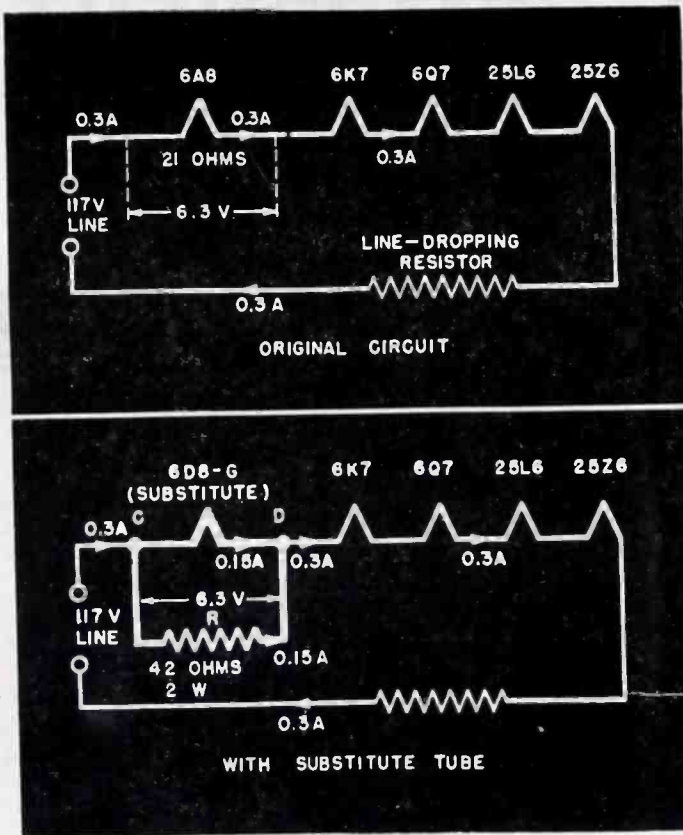

Figs. 2 (above) and 3 (left). . . In Fig. 2, we have an additional resistor, *R*, included in the circuit. This is required in the filament circuit of a substitution tube of lower filament voltage and current rating. Fig. 3 illustrates the heater circuit string of an a-c/d-c receiver before and after substitution tube of lower heater-current rating is inserted.

# USE OF RESISTORS

[Part Five of a Series]

by **ALFRED A. GHIRARDI**

Advisory Editor

SEVERAL typical examples applying to tube substitutions in 150- and 300-milliampere tube-heater strings are offered in this month's discussion. The particular tube types and substitutions chosen here as examples are typical of the situations the Service Man meets in his work. The principles involved in making other substitutions, however, are essentially the same, regardless of tube types.

A diagram of the simple heater circuit employed in a very common and popular type of a-c/d-c receiver is shown at top of Fig. 3. Let us assume that the 6A8 pentagrid converter (heater rated at 6.3 volts and 0.3 ampere) becomes faulty, and it is impossible to obtain another tube of this type. Assume that after looking up our tube substitution directory or chart and noting the recommended types listed as substitutes for a 6A8, we find that of all those types recommended as substitute a 6D8G is the only one we can obtain. This tube is similar in characteristics to the 6A8, but its heater is rated at 6.3 volts and only 0.15 ampere.

Since the heater of this substitution tube requires only 0.15 ampere, we must shunt it with a resistance that will bypass  $0.30 - 0.15 = 0.15$  ampere

of the total 0.3-ampere heater current in the string bottom of Fig. 3. Using the formula  $R = E/I$ , we find the value of this resistor to be

$$R = E/I = \frac{6.3}{0.15} = 42 \text{ ohms}$$

The wattage this resistor must dissipate is

$$W = E \times I = 6.3 \times 0.15 = 0.9 \text{ watt}$$

To provide an adequate factor of safety a 2-watt size resistor should be used.

When the substitution tube is inserted, and resistor *R* is connected in place as shown in Fig. 2, the total heater string current divides; 0.15 ampere flows through the 6D8G heater and 0.15 ampere flows through *R*. Hence the total current between points *C* and *D* is  $0.15 + 0.15 = 0.30$  ampere, the same as when the 6A8 tube was used. So the current bypassed through resistor *R* compensates for the difference in heater cur-

rent between the 6A8 and 6D8G tubes. The currents in all the other tubes and circuits will remain unchanged.

This example illustrates one of the simpler types of problems. Others gradually increasing in complexity will now be presented.

## Substituting a 6.3-v 150-ma Tube for a 12.6-v 150-Ma Type

To make this substitution, a resistor, *R*, will have to be added in series with the 6.3-volt heater of the substitution tube so that the 12.6-volt drop that existed originally between points *C* and *D* will also occur between these points when the substitution tube is used, Fig. 4. In this way, the sum of the voltage drops across the entire heater circuit remains unchanged. The voltage drop to be produced in resistor *R* is equal to  $12.6 - 6.3 = 6.3$  volts. Using the formula  $R = E/I$ , we find that

$$R = E/I = \frac{6.3}{0.15} = 42 \text{ ohms}$$

The wattage this resistor must dissipate is

$$W = E \times I = 6.3 \times 0.15 = 0.9 \text{ watt}$$

To provide an adequate factor of

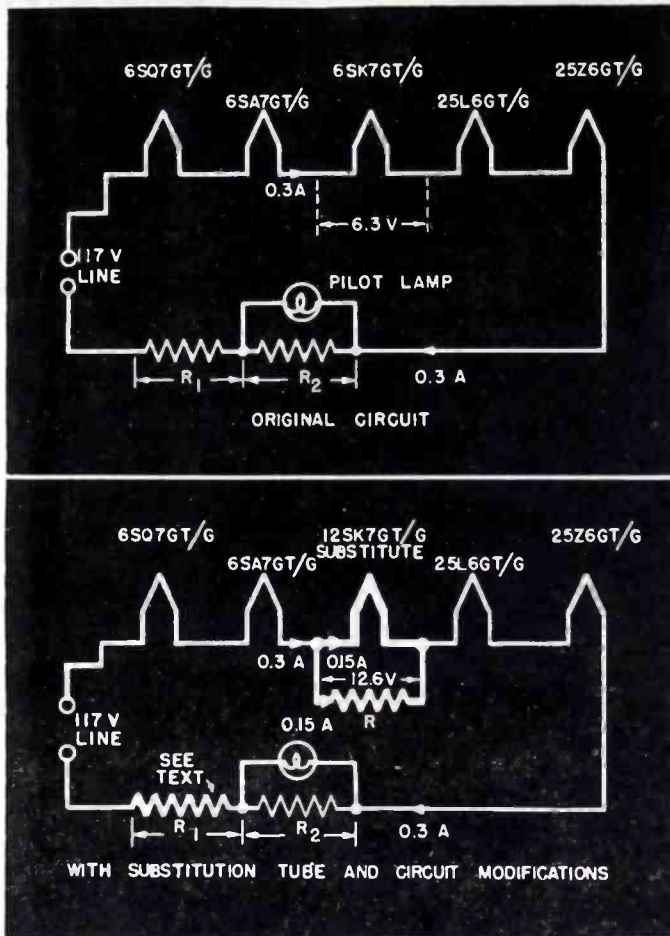
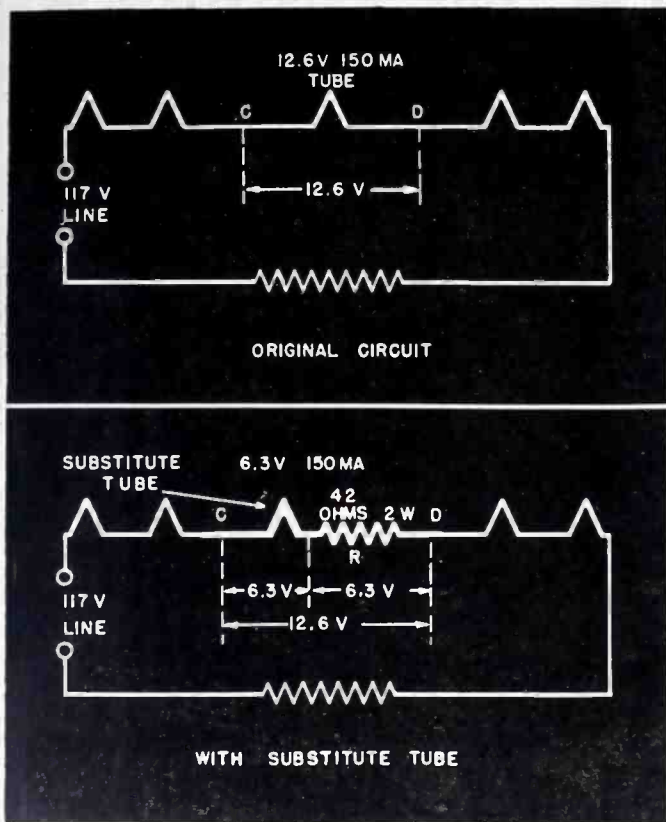

Figs. 4 (above) and 5 (right). . . In Fig. 4, we have a heater string of an a-c/d-c receiver before and after a substitution tube of lower heater voltage is substituted. Fig. 5 shows the before and after heater circuit when a substitution tube of lower heater voltage and higher heater current is substituted.

# IN TUBE SUBSTITUTIONS

safety at least a 2-watt size resistor should be used.

## Substituting a 35-V 150-Ma Tube for a 50-V 150-Ma Type

In this instance we proceed as outlined above. Voltage drop to be produced in series resistor is  $50 - 35 = 15$  volts. Value of the series resistor required is

$$R = E/I = \frac{15}{0.15} = 100 \text{ ohms}$$

The calculated wattage is  $W = E \times I = 15 \times 0.15 = 2.3$  watts, but to provide an adequate factor of safety at least a 5-watt size should be used.

## Substituting a 25-V 300-Ma Tube for a 50-V 150-Ma Type\*

This is a somewhat more complicated situation than those we have discussed thus far, for both the voltage and the current ratings of the substitute tube differ from that of the original.

Let us consider the original circuit in Fig. 5, which shows a typical heater circuit arrangement used in a great many a-c/d-c receivers. It employs 150-ma (0.15 ampere) tubes, which, incidentally, are scarce nowadays. It differs from those shown previously

in that no series line-dropping resistor is used, and a pilot light is lighted from a tap on the filament of the 35Z5GT/G tube. No series line-dropping resistor is necessary, because the sum of the voltages required across the entire heater string is  $12.6 + 12.6 + 12.6 + 50 + 35 = 122.8$  volts.

Let us assume that a receiver having such a heater circuit is to be repaired, and that upon testing it the 50L6GT is found to have an open heater. At the present time this is one of the most difficult tube types to obtain. Then let us assume that of all the tubes listed as recommended substitutes for this type, only a 25L6GT/G tube is available. The heater of this tube is designed for 25-volt 300-ma operation. The heater of the faulty 50L6GT was designed for 50-volt 150-ma operation.

The 25L6GT/G can be employed as

\*If the receiver employs a line-dropping resistor in the line-cord, and a tube of heater current higher than that for which the line-cord resistor is rated is to be substituted in the receiver, the line-cord resistor should be eliminated from the circuit altogether. A suitable wire-wound resistor of correct resistance and wattage dissipation ratings for the purpose should be connected in place of it and mounted in a location where it will be adequately ventilated. The latter often is a difficult assignment in the small a-c/d-c receivers.

a substitute, provided the heater string of the receiver is rewired so that 300 ma can be supplied to its heater, and the voltage distribution across the heater string is maintained at its original value. The first requirement may be met by shunting the three 12.6-volt 0.15-ampere tubes with a bypass resistor,  $R_1$ , that will allow the excess 0.15 ampere to flow through it, Fig. 5, and by shunting the heater of the 35Z5GT/G with a bypass resistor,  $R_2$ , that will allow the excess 0.15 ampere to flow through it. The resistance values and power dissipation in these resistors are:

$$R_1 = \frac{E}{I} = \frac{(12.6 + 12.6 + 12.6)}{0.15} = \frac{37.8}{0.15} = 252 \text{ ohms}$$

(a 250-ohm resistor would be satisfactory)

$$\text{and, } W_1 = E \times I = 37.8 \times 0.15 = 5.7 \text{ watts}$$

Similarly,

$$R_2 = \frac{E}{I} = \frac{35}{0.15} = 233 \text{ ohms}$$

(a 250-ohm resistor would be satisfactory)

$$\text{and } W_2 = E \times I = 35 \times 0.15 = 5.25 \text{ watts}$$

The sum of the voltages across all  
(Continued on page 30)

# RESISTORS IN TUBE SUBSTITUTIONS

(Continued from page 29)

of the heaters,  $12.6 + 12.6 + 12.6 + 25 + 35 = 97.8$  volts. Therefore, a series resistor,  $R_s$ , of such value that a voltage drop of 25 volts will be produced in it (the difference between the 50-volt drop that existed originally across the heater of the 50L6GT tube and the 25-volt drop that now exists across the heater of the 25L6GT/G replacement) must be added to the string. Since the full 300-ma (.3 ampere) heater current of the 25L6GT will flow through this resistor, its value should be

$$R_s = \frac{E}{I} = \frac{25}{0.3} = 83 \text{ ohms}$$

The power dissipated in it will be

$$W_s = E \times I = 25 \times 0.3 = 7.5 \text{ watts}$$

Actually, this resistor may be added in series at any place in the string, but it must be added in such a position that the total 300 ma flows through it.

If the tube which had to be replaced by a substitute type were located at either end of the filament string, such as the 12SQ7GT/G or the 35Z5GT/G in Fig. 5, then only one shunting resistor would be required, across all the rest of the heaters in the string.

Since the 0.3-ampere total current flowing through the heater circuit, changed over in the manner of (B) of Fig. 5, is double the 0.15 ampere that flowed in the original circuit at (A), the total power dissipated by all the components connected in the changed-over heater string is just double that which was dissipated in the original circuit. In the original heater string it was  $W = E \times I = 122.8 \times 0.15 = 18.4$  watts. In the changed-over heater string it is  $W = E \times I = 122.8 \times 0.3 = 36.8$  watts. Since all of this additional power is dissipated in the added resistors, precautions must be observed to prevent the concentrated heat developed in them from causing permanent damage to other parts of the receiver, such as fixed capacitors, composition resistors, r-f coils, cabinet, etc. Unfortunately, it is nearly always impossible to mount these added resistors in the open. For operation in the confined spaces of the usual compact a-c/d-c receiver (as under the chassis, etc.) a factor of safety of at least 2, and preferably about 3, is necessary in the wattage rating of the resistors selected. Accordingly, resistors  $R_1$ ,  $R_2$  and  $R_3$  in Fig. 5,

should have the following wattage ratings:

$$\begin{aligned} R_1 &= \text{approximately } 5.7 \times 3 = 15 \text{ watts} \\ R_2 &= \text{approximately } 5.25 \times 3 = 15 \text{ watts} \\ R_3 &= \text{approximately } 7.5 \times 3 = 20 \text{ watts} \end{aligned}$$

The greatest problem in the entire change-over may well be to find a suitable place in which to mount these resistors.

In view of the additional heat generated by these resistors it would be wise to provide additional ventilation within the receiver cabinet if possible, for the total heat now generated by the entire receiver within the cabinet will be almost twice that for which it was originally designed. Additional ventilation holes drilled in the bottom and rear of the cabinet, as well as in the chassis itself (wherever possible) will help.

## Summary

To summarize, when a 300-ma tube is used to replace a 150-ma tube in an a-c/d-c receiver, there are three steps to follow:

(1)—Shunt resistors of proper value must be added across the heaters of the 150-ma tubes in the receiver so that the heater of tube which is being used as the replacement can obtain its full 300 ma.

(2)—A series resistor which carries the full 300 ma must be added to the string to restore the original voltage distribution across the string.

(3)—The series and shunt resistors must be physically located in such a manner that the additional heat now developed by them within the receiver cabinet will not cause permanent damage to any of the receiver components.

## Substituting a 6.3-V 300-Ma Tube for a 12.6-V 150-Ma Type\*\*

The heater circuit modifications and resistor calculations necessary for this type of tube substitution are essentially the same as explained for the preceding problem (Fig. 5). All the heaters in the string, except that of the substitute tube, must be shunted by a resistor (or resistors) that will bypass 0.15 ampere of the heater-string current. A resistor must be added in series with the heater of the substitute tube. It should carry the full 300-ma heater current and be of such resistance value that a voltage

\*\*See footnote on page 29, covering line-drop resistors in receivers.

DESIGN COUNTS



COMPARE a modern sewing machine with the old-time model shown here. The difference is an example of how careful attention to design brings about a high level of efficiency.

Realizing this, design is one of the most carefully considered factors in the production of antennas at THE WARD PRODUCTS CORPORATION. It is only through superior design that the benefits of experience and the finest production facilities can be best brought to the user.

For the finest antennas for all applications... for home and automobile use... look to WARD.

# WARD



Antennas

THE WARD PRODUCTS CORPORATION  
1523 EAST 45TH STREET • CLEVELAND 3, OHIO

Export Dept.

C. D. BRANDES, Mgr.  
4900 Euclid Avenue  
Cleveland 3, Ohio

Canadian Office

ATLAS RADIO CORP.  
560 King Street, W.  
Toronto 1, Ont., Can.



drop of  $12.6 - 6.3 = 6.3$  volts will be produced in it.

#### Substituting a 12.6-V 150-Ma Tube for a 6.3-V 300-Ma Type

The original heater-string circuit would be of the type illustrated at (A) of Fig. 6, including a series line-dropping resistor,  $R_1 + R_2$ . This resistor is shown here as a tapped resistor, since in many such receivers ballast resistors with the tap for supplying voltage to the pilot lamp were used. In this case, the pilot lamp rating would be less than 300 ma. Many receivers were built in which a 300-ma pilot lamp was employed, and hence no resistance was shunted across it. For those cases,  $R_2$ , the part of the resistor shunting the pilot light in Fig. 6 may be considered to be open, or not present at all.

Let us assume that the  $6SK7GT/G$  supercontrol r-f amplifier tube is faulty and the only recommended substitute replacement type available is a  $12SK7GT/G$ . The heater of the former operates on 6.3 volts, 300 ma; that of the latter operates on 12.6 volts, 150 ma.

Since the heater of the  $12SK7GT/G$  substitute tube requires only 150 ma for its operation it will have to be shunted by a resistor,  $R$ , that must bypass 150 ma (0.15 ampere) of the string current. This is shown in (B). The value of this resistor will be

$$R = \frac{E}{I} = \frac{12.6}{0.15} = 84 \text{ ohms,}$$

and the calculated wattage is  $W = E \times I = 12.6 \times 0.15 = 1.9$  watts. To provide an adequate factor of safety a  $1.9 \times 3 = 5$ -watt resistor should be used.

Insertion of the 12.6-volt heater of the  $12SK7GT/G$  substitute increases the total voltage drop of the heaters in the string by  $12.6 - 6.3 = 6.3$  volts. Accordingly, if the heater string current is to be maintained at its proper value of 300 ma, some resistance in the circuit must be reduced sufficiently to compensate for this. The only resistance it is possible to reduce is that of  $R_1$ , the untapped portion of the series line-dropping resistor. The necessary reduction in

$$\text{resistance will be } R = \frac{E}{I} = \frac{6.3}{0.3} = 21 \text{ ohms.}$$

Now this line-dropping resistor may be in the form of a line-cord resistor, or a ballast tube mounted in the receiver itself. If it is a line-cord resistor, a resistor of the proper

(Continued on page 32)

# HICKOK

expands again

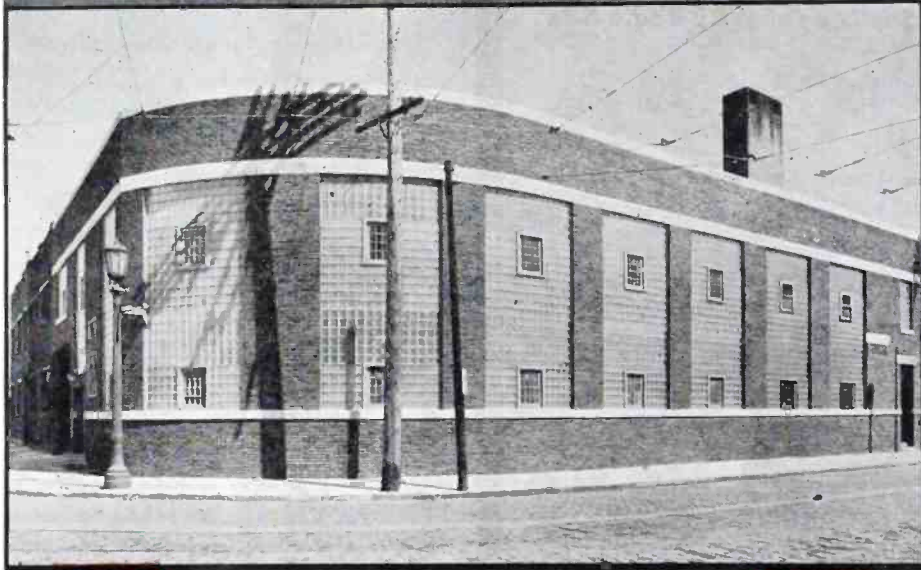

This is a new three-story addition to our Hickok Plant No. 1. It is designed with glass block and equipped with the latest fluorescent lighting equipment, as well as being dustproof and air-conditioned.

It is the home of Dynamic Mutual Conductance tube testers, radio service equipment and electrical indicating instruments. The Hickok line embraces many new innovations, including internal pivot meters, waterproof meters, electrical battery testers and many others.

We regret that the pressure of war production makes it impossible to take care of all your demands now; but when peace returns you can again have your first choice in instruments known for higher accuracy and longer life.

## THE HICKOK ELECTRICAL INSTRUMENT Company

10521 Dupont Ave. Cleveland 8, O.

**LEO'S SPECIAL!**

**Immediate Delivery**

Money Back Guarantee on this all-purpose



Model WRL 300 ONLY **\$18.75** Less Leads

**Multitester**

Handles AC and DC Voltmeter, DC Milliammeter, High and Low range Ohmmeter. Size 5 1/2 x 8 x 3 1/2" meter with sturdy D'Aronson movement. Write for priority information.

**See Leo for WRL Radio Kits** priority required



Phono Amplifier Kits Complete with tubes, instructions No. 1059... **\$9.50**

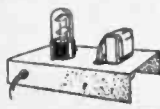

Code Oscillator Kits Complete with tube. Size 3" x 8" No. 66-200 **\$4.95**

**OUTPUT TRANSFORMERS**

15 watt P.P. 6LG output. To 4 ohm V.C. or 500 ohm line. Fully shielded. No. 9-649... **\$1.65**

**FIL. TRANSFORMERS Fully Shielded**

110 V. Tapped Primary. Secondary, 5 volt @ 3 amp. and 6.3 V.C.T. @ 4 amp. **\$2.25**

**We Feature HALICRAFTERS**

The "radio man's radio." Immediate delivery on priority. Write for full details today.

**EXCLUSIVE AT LEO'S!**

44 Page Parts Flyer... **FREE**  
Packed with hard-to-get items. Immediate delivery to radio repairmen. Usual priorities. Experimenters write Leo, W9GFQ, on how to get radio repair parts.  
Tube and Circuit Reference Book .....10c  
Handy Tube-Base Calculator .....25c  
Giant Radio Reference Map, Size 3 1/2 x 4 1/2 ft 15c



**MAIL TODAY**

Wholesale Radio Laboratories S-7  
744 West Broadway  
Council Bluffs, Iowa

- Please rush Multitester No. 300, \$18.75 is enclosed, or Enclosed is \$\_\_\_\_, Balance C.O.D.
- Here's 10c, Send "Tubes and Circuits" Book.
- I want a Tube-Base calculator. 25c enclosed.
- Ship me your radio map. 15c enclosed.
- Send me your free flyer of hard-to-get radio parts.

Name \_\_\_\_\_  
Address \_\_\_\_\_  
Town \_\_\_\_\_ State \_\_\_\_\_  
I am  an amateur;  experimenter;  service man.

**QUICK SERVICE**

Your order will receive my own personal attention. You'll get "same day" delivery service from the heart of the nation . . . on anything in radio.

*Sincerely,*  
*Leo S. Meijer*



**Wholesale RADIO LABORATORIES**

**RESISTORS IN TUBE SUBSTITUTIONS**

(Continued from page 31)

value may be shunted across the R<sub>1</sub> portion of the cord, provided room may be found to locate this added resistor within the receiver cabinet. This shunting resistor will, of course, generate quite a bit of heat, and must be placed in such a location that the added heat from it will not cause damage to adjacent fixed capacitors, etc. It is, of course, more satisfactory to use a new line cord if one of the proper new resistance value is available (which most probably will not be the case).

**Line-Dropping Resistor in Receiver**

If originally, the line-dropping resistor was of the type mounted in the receiver, and if a new resistor of the required wattage rating, new lower resistance value, and approximately the same or smaller physical size can be obtained, then it should be substituted for the one which was originally in the receiver.

The same general procedure must be followed if we wish to replace any one of the other tubes in the string with a 12.6-volt 150-ma tube.

**Substituting a 50-V 150-Ma Tube for a 25-V 300-Ma Type**

In this problem, we follow the same general procedure as in the preceding case, Fig. 6.

It should be observed that the practice of adding shunt resistors across the heaters of substitute tubes is recommended by the tube manufacturers only as an emergency measure, because the heater-string current during the warm-up period does not always divide proportionately between the heater and its shunt resistor. The reason for this is that since the shunt resistor does not heat up to the same temperature, nor at the same rate, as

does the tube's heater, and also since the temperature coefficient of resistance (change of unit resistance-per-unit change of temperature) of its material is different from that of the heater material, the proportion between the resistance of the heater and that of the shunt resistor does not remain constant during the warm-up period. Accordingly, during this period the currents do not divide exactly as we planned and the heater may be temporarily but seriously overloaded during the few-second warm-up period in some cases, with resulting decrease in tube life.

Fig. 6. Another a-c/d-c receiver heater string modification. In this circuit, however, a substitution tube of higher heater voltage and lower heater current is substituted.

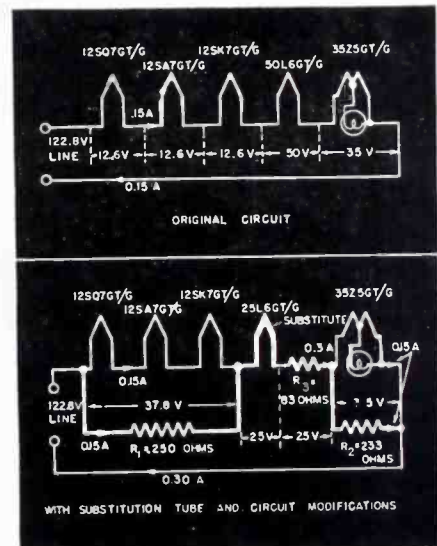

In the August issue of SERVICE, Mr. Ghirardi will discuss Volume and Tone Control Resistors; their design and application.

Get **EVERYTHING!**

Standardize on

**STANCOR**

Transformers

Call your nearest Stancor Jobber... or write us for his address

**STANDARD TRANSFORMER CORPORATION**  
1500 N. HALSTED STREET • CHICAGO



## DIRECT VIEWING TELEVISION

THE merits of direct-viewing television systems were set forth by Allen B. Du Mont at a recent meeting of The Institute of Radio Engineers, New York. Stated Dr. Du Mont:

"In the past, and also at the present time, the direct-viewing cathode-ray tube has been used almost universally in all kymograph, television and radar applications with very satisfactory results. The tubes that have been used previously in television ranged in size from 5" in diameter to 14" in diameter. Because of the desire on the part of television viewers for a larger picture, a 20" tube has been developed with a reasonably flat face. This tube utilizes a pressed face in order to economize on manufacture and insure uniformity of product. It is possible with this tube to obtain a picture 13½" x 18", which our experience has shown is of a satisfactory size for any ordinary home living room.

"The principal advantages obtained with the direct-viewing cathode-ray tube are: high light brilliance, better contrast range, wide angle viewing, lower accelerating voltage, longer life, better resolution, less alignment difficulty, and simplicity of the focusing system.

"The disadvantage of the direct-viewing cathode-ray system is a slight curvature of the screen and the need for a special mounting arrangement to reduce the depth of the television receiver in the larger bulb sizes.

"Taking up the various characteristics of the direct-viewing cathode-ray tube television receiver in detail, we find that the high light brightness of the 20" tube is in the order of 20 foot lamberts as compared with approximately 3.5 foot lamberts for the most efficient projection system now in use. In both cases the size of the picture is considered to be 13½" x 18".

"One of the big advantages of the higher light brilliance is the fact that the 20" tube receiver can be used satisfactorily in a quite brilliantly illuminated room and an ambient light level as high as 5 foot lamberts can be tolerated without seriously impairing the picture quality. On the other hand, with the projection system only about .5 foot lamberts average ambient light can be tolerated. It is interesting to compare the brilliance of the 20" picture with that of the normal commercial 35 mm screen, which averages between 6 and 10 foot lamberts.

"As regards the brightness ratio, or contrast range, the 20" tube has a contrast range of approximately 35 as compared with a contrast range of 17 for the projection system.

"As to directivity (maximum viewing angle from the normal=angle at which the apparent brightness decreases to 50% of its value in normal direction) we find that the 20" tube can be viewed from ±80° whereas the projection system screen can only be viewed from ±15°. It of course is possible to widen this angle somewhat in the projection system but in so doing the high light brightness will decrease from its already low value.

"In making these comparisons we have assumed an accelerating voltage on the 20" tube of 15 kilovolts, and 30 kilovolts

(Continued on page 34)

# These 2 GHIRARDI BOOKS Will help you to Diagnose, Locate and Repair Receiver Troubles EASIER • BETTER and FASTER



### COMPLETE DATA ON EVERY CONCEIVABLE SERVICE SUBJECT

Complete data on all essential service instrument types; How, when and why to use them; How to Build your own; Point-to-point testing; Preliminary trouble checks; Circuit analysis; Repairs; Obscure radio troubles; Aligning and neutralizing; Interference reduction; AVC and QAVC circuits, etc., etc.

### MODERN RADIO SERVICING

The finest, most complete book of its kind for the professional service man—bar none! Covers all phases of the work. Read from the beginning, it is a complete course in servicing by the most modern methods. Used as a reference volume by the busy serviceman it is an invaluable means of brushing up on types of work that may puzzle you. Its 1300 pages, 706 illustrations help you visualize every action. 720 self-testing review questions help you check your progress every step of the way. Get yours now! Only \$5 complete (\$5.50 foreign) while the present limited supply lasts!

**YOU CANNOT LOSE!** Every Ghirardi book is sold on a 5-day money back guarantee. If it isn't all that you expect—and more—send it back and every cent of your money will be cheerfully refunded.

### MONEY-SAVING COMBINATION OFFER

Save Money! Get BOTH Modern Radio Servicing and Radio Troubleshooter's Handbook—a complete service library of over 2,000 pages—for only \$9.50 (\$10.50 foreign). See coupon.

### CUT TIME IN HALF ON 4 JOBS OUT OF 5—Double Your Output of Work!

Ghirardi's RADIO TROUBLESHOOTER'S HANDBOOK isn't a "study" book. It rolls up its sleeves and goes to work for you the minute you get it. It will more than pay for itself the first time you use it! Simply look up the make, model, and the Trouble Symptom of the Radio you want to repair. The likely trouble and exact instructions for fixing it will be found listed. No useless testing! No lost time or motion!

### ELIMINATES USELESS TESTING

Over 400 pages include specific common Trouble Symptoms, their Causes and Remedies for OVER 4,800 RADIO MODELS. In addition, there are hundreds of pages more of time-saving material including i-f alignment peaks for over 20,000 superhets; a big section on i-f transformer troubles; an up-to-the-minute TUBE CHART with complete information in every type, and dozens of tips on tube substitutions plug-in and ballast resistor replacement charts; coil, transformer, wire, capacitor data, etc. A wealth of material to save you time and help you make more money. Only \$5 (\$5.50 foreign). Money-back guarantee.

### 5-DAY MONEY-BACK GUARANTEE

Technical Division, MURRAY HILL BOOKS, Inc., Dept. S-75, 232 Madison Ave., New York 16, N. Y.

Enclosed find \$..... for books checked or send C.O.D. (in U.S.A. only) for this amount plus postage. If not fully satisfactory, I may return the books at the end of 5 days and receive my money back.

MODERN RADIO SERVICING \$5 (\$5.50 foreign)  
RADIO TROUBLESHOOTER'S HANDBOOK \$5 (\$5.50 foreign)

Special MONEY-SAVING COMBINATION  
Both big books for only \$9.50 (\$10.50 foreign)

Name .....

Address .....

City & Dist. No. .... State .....

(Please print or write plainly)

# OHMITE RESISTORS

*for accurate trouble-free*

# SERVICE

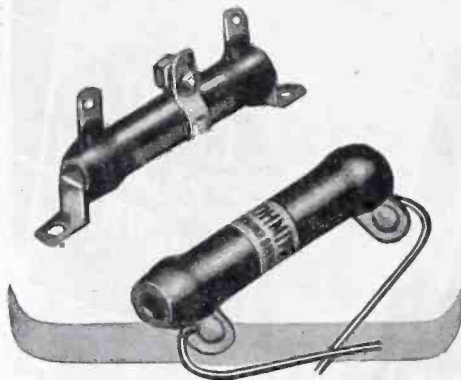

Time-proved, battle-proved, service-proved... Ohmite Brown Devils and Adjustable Divid-ohms are used today in critical war equipment. After Victory . . . these dependable units will again be the favorite of radio servicemen who want and use the best for resistor replacements.

For information about these and other Ohmite Resistors, write for Stock Unit Catalog 18.

## SEND FOR HANDY OHM'S LAW CALCULATOR

Figures ohms, watts, volts, amperes—quickly, accurately. Solves any Ohm's Law problem with one setting of the slide. Send only 10c in coin for handling and mailing. (Also available in quantities.)

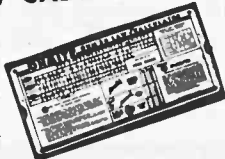

**OHMITE MANUFACTURING CO.**  
4877 Flournoy Street • Chicago 44, U.S.A.

Be Right with **OHMITE**  
RHEOSTATS • RESISTORS • TAP SWITCHES



## OLD TIMER'S CORNER

by **SERVICER**

**P**ERRY was in quite a jubilant mood when I met him some weeks ago. With the many problems that are facing Service Men today, I was frankly puzzled by this grand spirit. And I said as much to him.

"I've been working on an idea which I think will bring in some real present business today and even more after V-J day," Perry said cheerfully.

"You know, Joe," he said, "there are a lot of auto radios in this town. In fact most people have them, and there are at least 50 of them over at that trucking outfit at the edge of town in those big trailer trucks. The amount of servicing done in auto radios is too small, much too small.

"Why? Because its so darned hard to get anyone to leave their car to have their auto set repaired. They need the car for pleasure or for business, and they can't be letting it out of their sight for one or two weeks while you or I make the needed repairs. That's right, isn't it?"

I had to admit that that made sense to me.

"Well," continued Perry, "I have an answer to the problem.

"Where do people take their cars? At night they have their own garages, and the cars *sleep* there. And at least once or twice a week most people take the cars to a filling station for gas, water or air. Sometimes they leave them for greasing. That's when they can't use their cars and they don't mind leaving them."

"And that's where you propose to try your plan?" I interjected.

"Right. I have contacted all the filling stations and public garages in this town and the three nearest towns around here. And I've offered the proprietors this plan.

"If the garage or filling station owners will send their mechanics, or come himself to a *class* I am organizing, I will teach him or his men how to remove the receiver from a car and how to put it back. I will also show how some receivers can be repaired right in the car. Such items as replacement of some of the tubes for instance, or reconnecting up the antenna, tightening a knob, etc., are quite simple. And if these repairs do not help, the sets will have to be removed. I'll call for the sets, repair them and deliver them back to the garage or station attendant. They can then be reinstalled. The charge is made, out of which is allowed a substantial commission for their efforts. That

(Continued on page 39)

## DIRECT VIEWING TELEVISION

(Continued from page 33)

on the 5" flat face tube of the projection system.

"The anticipated life of the 20" direct-viewing tube should run considerably above 1,000 hours.

"With the 20" direct-viewing tube, the spot size is sufficiently small to resolve any 525-line television pattern or even higher with a well-designed deflection yoke."

# RADIO PARTS

and Sound Equipment  
IMMEDIATE DELIVERY

6 ft. cord sets—high grade—soldered—molded rubber plug at one end. 10 for \$2.75. Each . . . . . 29c  
Mike Cable—superior quality, single conductor, shielded pre-war quality natural rubber cover. Per ft., only . . . . . 8c  
Dual conductor as above. Per ft. . . . . 10c  
Carbon Resistor Kit No. 16, 100 RMA coded, ½ and 1 Watt, assorted. Our price, only . . . . . \$2.94  
Aerial Kit, containing aerial wire, insulators, rubber-covered lead-in, ground clamp, window strip, complete set, only . . . . . 89c  
10 MFD 50 WV Tubular Pigtail Electrolytic Condensers. Year guarantee. 10 for \$2.25. Each, only . . . . . 24c  
20 MFD 150 WV Tubular Pigtail Electrolytic Condensers. Guaranteed one year. 10 for \$3.30. Each . . . . . 35c  
10 MFD 450 WV Tubular Pigtail Electrolytic Condensers. Year guarantee. 10 for \$3.95. Each . . . . . 43c  
20-20 MFD 150 WV Tubular Pigtail Electrolytic Condenser. Year Guarantee. Each . . . . . 59c  
Bakelite Set-Screw Knobs. DeLuxe assortment of 50 for ¼ inch shaft . . . . . \$3.93

Write for latest bargain bulletin of hard-to-get parts, supplies and sound equipment.

*Lifetime*  
**SOUND EQUIP. CO., Dept. 61**  
1101 ADAMS ST., TOLEDO 2, OHIO

# RADOLEK

Radio-Electronic Service Parts

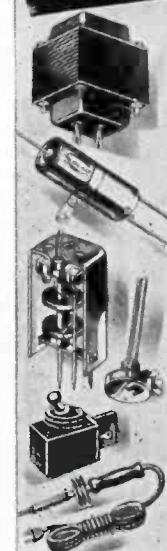

Large stocks assure the finest and most complete selections of all available items at lowest prevailing prices. Thousands of active buyers depend on us for their entire Radio repair and replacement requirements. Because we understand service problems, every order is expedited for delivery in double quick time. Everything we do is planned for convenience and satisfaction to our customers. You will find it profitable to make Radolek your buying headquarters.

## FREE BUYING GUIDES

Because of existing conditions we keep our customers right up to the minute on available merchandise by releasing supplements frequently instead of sending our regular Big Profit Guide once a year. Send the coupon now to get these Free Buying Guide Supplements as they are issued.

**FREE!**



## FAST SERVICE!

**RADOLEK CO., Dept. S-104**  
601 W. Randolph St., Chicago 6, Ill.

Please send FREE Buying Guide Supplements

NAME \_\_\_\_\_  
ADDRESS \_\_\_\_\_

**ORDER FROM RADOLEK**

## VOLUME CONTROLS

(Continued from page 22)

shown in Fig. 22. This control loads a tertiary winding in an i-f transformer, broadening the response which increases the frequency range accepted. It also reduces the gain. Thus some compensating control must be ganged to it if a constant gain is to be maintained.

### Dual Volume Controls

By ganging controls a variety of  
(Continued on page 36)

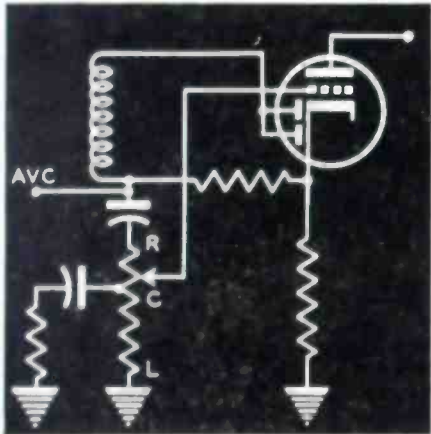

Figs. 21 (above) and 22 (below). . . In Fig. 21, we have a tone compensation method for bass control at low volume. Fig. 22 illustrates a method of increasing band acceptance in an i-f transformer by resistance control.

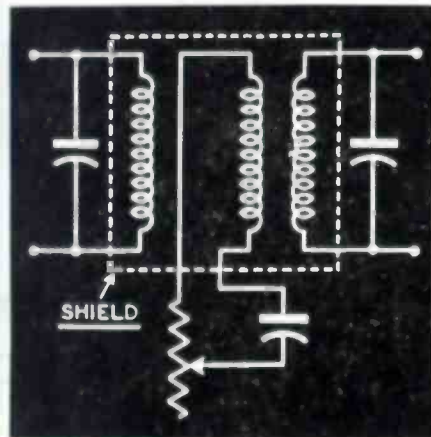
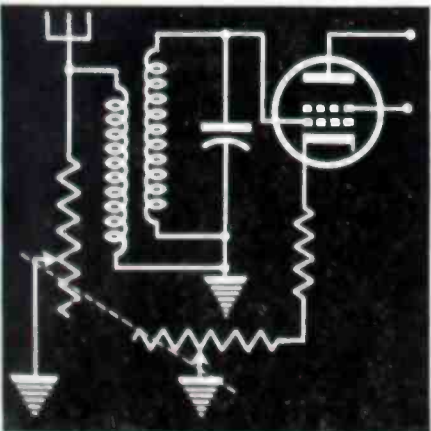

Fig. 23. Two controls ganged for smoother operation.



## SLIDE RULE or SCREWDRIVER

.. which will YOU be using 2 years from now?

Add CREI technical training to your present experience—then get that better radio job you want—make more money—enjoy security

Thousands of new men have joined the ranks of the radio industry during the war. But now, and after final peace, even more thousands will return from the armed forces. War production will settle down to supplying civilian needs. Where will you fit into this picture?

If you are wise, you will look ahead and prepare for the good-paying jobs in radio-electronics and industrial electronics. Every man in radio today has the opportunity to see the amazing developments that are taking place, as well as the unlimited opportunities available to men with modern technical training.

It is up to you to decide if you will be a "screwdriver" mechanic or a real technician in a responsible engineering position.

CREI can help you prepare by providing you with a proved program of home study training that will increase your technical ability and equip you to advance to the better-paying radio jobs that offer security and opportunity. The facts about CREI and what it can do for you are printed in a 36-page booklet. It is well worth your reading. Send for it today.



WRITE FOR  
FREE 36-PAGE  
BOOKLET

"Your Opportunity in the  
New World of  
Electronics

If you have had professional or amateur radio experience and want to make more money, let us prove to you we have something you need to qualify for a better radio job. To help us intelligently answer your inquiry—  
PLEASE STATE BRIEFLY YOUR BACKGROUND OF EXPERIENCE, EDUCATION AND PRESENT POSITION.

## CAPITOL RADIO ENGINEERING INSTITUTE

HOME STUDY COURSES IN PRACTICAL RADIO-ELECTRONICS  
ENGINEERING FOR PROFESSIONAL SELF-IMPROVEMENT

Dept. S-7, 3224—16th Street, N. W., Washington 10, D. C.

Contractors to U. S. Navy—U. S. Coast Guard—Canadian Broadcasting Corp.  
Producers of Well-trained Technical Radiomen for Industry.

MEMBER: NATIONAL COUNCIL TECHNICAL SCHOOLS

## VOLUME CONTROLS

(Continued from page 35)

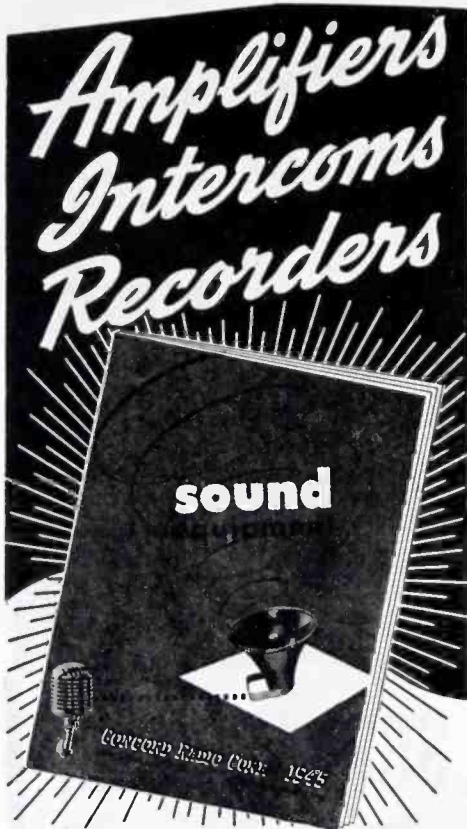

### Write for Important New CONCORD Presentation

"Sound Equipment"—ready now—a new up-to-the-minute Concord folder illustrating and describing our complete line of Amplifiers, Intercoms and Recorders AVAILABLE FOR IMMEDIATE SHIPMENT.

**Amplifiers**—ranging in output ratings of 17 watts to the largest requirements. Complete listing of speakers, microphones and essential equipment also included.

**Intercommunication Systems**—with master and sub-stations for every purpose and need.

**Recording Equipment**—professional type for microphone recording, radio recording, transcriptions, public address.

**Engineering Service**—Our engineering service is at your command, without charge, to answer any and all "Sound Equipment" questions.

Mail the coupon below for your copy of "Sound Equipment" now.

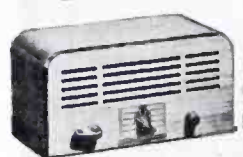

**CONCORD RADIO CORPORATION**  
*Lafayette Radio Corporation*  
CHICAGO 7, ILL. ATLANTA 3, GA.  
901 W. Jackson Blvd. 265 Peachtree Street

CONCORD RADIO CORP.  
901 W. Jackson Blvd., Dept. S-75  
Chicago 7, Illinois

Please send me at once copy of your new "Sound Equipment" folder.

Name.....  
Address.....  
City.....State.....



controlling effects may be obtained. Fig. 23 shows a combination antenna and cathode bias control, and in Fig. 24 we have an antenna and screen voltage gain control. In Fig. 25 we have an unusual circuit with an antenna shunt and an r-f rheostat adding resistance to the tuned plate circuit of the first r-f amplifier. The condenser C

serves as a blocking capacitor, an r-f choke keeping the signal confined to the first stage. The antenna section is a 10,000-ohm left-hand taper; the r-f rheostat is a 100,000-ohm right-hand taper. A combined antenna shunt and an r-f absorption circuit which extracts some energy from the r-f transformer is shown in Fig. 26. Both

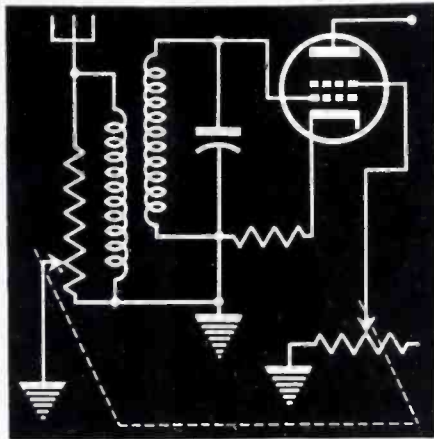

Figs. 24 (above) and 25 (below). In Fig. 24 we have another type of dual control, one in the antenna circuit and the other in the screen grid. This is an obsolete method. Fig. 25 illustrates a dual control in the antenna and grid circuit.

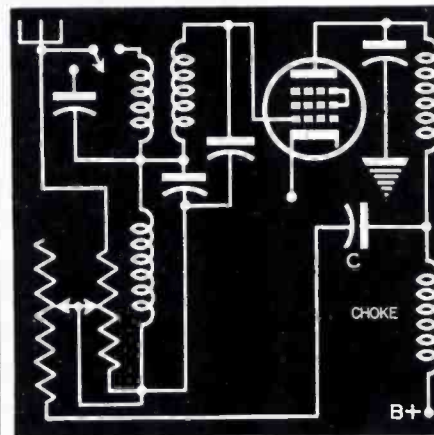
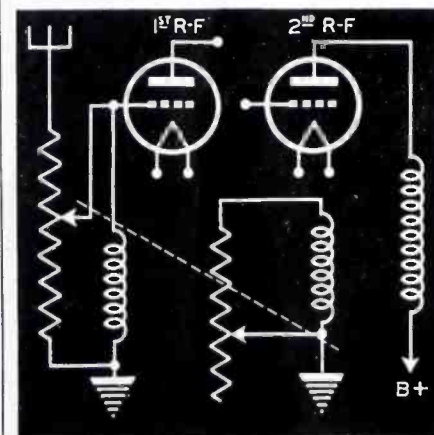

Fig. 26. Dual control for the antenna and r-f circuit; r-f control works on absorption principle.



## MUELLER



### CLIPS

For Quick Temporary  
Connections

- Made in 10 sizes—from the tiny wee-pee-wee to the 300 ampere Big Brute.
- Offered in both steel and sold copper.
- Red and black rubber insulators to fit each size.
- A complete line with

**A CLIP FOR EVERY PURPOSE**

Send for free samples and catalog 810

*Mueller Electric Co.*

1565 E. 31st St. - Cleveland, Ohio

## RADIO Wholesale REPAIR

THIS IS THE ANSWER  
TO YOUR RADIO REPAIR TROUBLES!

Just SEND us the SET via Railway Express. We REPAIR and RETURN. You ADD, MARK-UP AND DELIVER. That's all there is to it.

- Complete Stocks—We can fix 'em all
- 90 day guarantee
- Prompt service
- OUR LOW PRICES mean more Markup for you.

Send that set to

**SHEFFIELD RADIO CO.**

917 Belmont Ave., Chicago 14, Ill.

controls are 4,000-ohm left-hand tapers.

**Tone Controls**

Since tone controls are so allied with volume controls, a few typical circuits have also been included in this discussion. In Figs. 27 and 28 we have the most common type of bass tone control, cutting treble frequencies as resistance is cut out. Values used in the grid-control range from .0005 mfd to

(Continued on page 38)

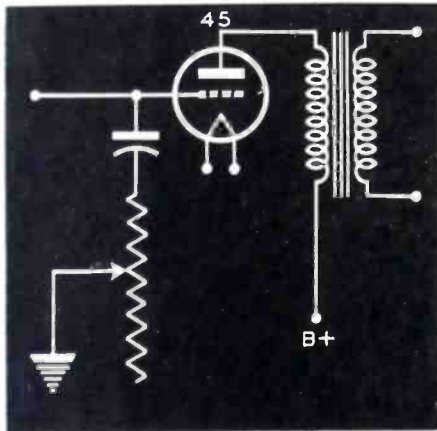

Figs. 27 (above) and 28 (below). Fig. 27 shows a tone control in the grid circuit of output stage. In Fig. 28 we have the same control in the plate circuit of the driver stage.

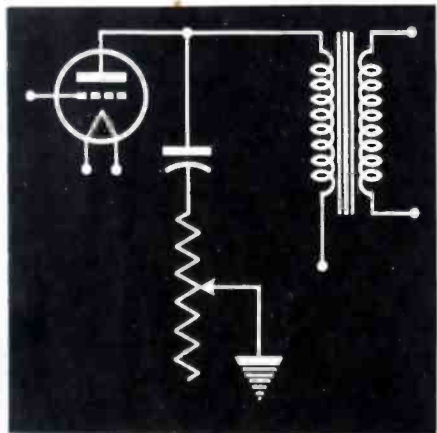
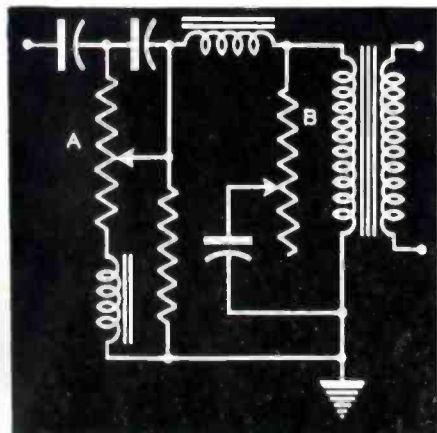

Fig. 29. A bass-boost/treble-boost system using separate controls for each.



**S**OUND is captured and imprisoned upon a phonograph record. Its release for entertaining, educational and commercial use has for years been made possible by The Astatic Corporation through Astatic Phonograph Pickups. Long favorites with most leading manufacturers and jobbers of phonographs and phonograph equipment, Astatic Pickups have supplied the highest degree of quality and fidelity to record reproduction. For the days ahead, Astatic promises even greater true-to-life tonal realism, improvements in pickup design, construction and operating efficiency that will contribute immeasurably to the clarity and beauty of reproduction from the new, fine-grain, noise-free, Vinylite recordings of tomorrow. Conversion to peacetime production, when such permission is given, will be prompt and Astatic's greatly increased manufacturing facilities will be ready to serve its great host of manufacturing and jobber customers.

**"You'll HEAR MORE  
from Astatic"**

ASTATIC Crystal Devices  
manufactured under Brush  
Development Co. patents.

**THE Astatic CORPORATION**  
CONNEAUT, OHIO  
IN CANADA. CANADIAN ASTATIC LTD., TORONTO, ONTARIO



★ Clarostat standard tapped controls, Series TCP, permit replacement of tapped units with the assurance that the total resistance value and tap satisfactorily match the original.

Twelve selected values in resistance ranges from 250,000 ohms to 2 megohms. One or two taps. These standard units are listed in the Clarostat Interim Line (essential wartime servicing items). These midget controls are equipped with the original Clarostat Ad-A Switch feature. List Price, \$1.50.



★ Ask Our Jobber . . .

Ask about these Series TCP controls and other replacement controls for your wartime servicing. Ask for your copy of the Clarostat Interim Line Catalog, or write us direct.



CLAROSTAT MFG. CO., Inc. • 285-7 N. 6th St., Brooklyn, N. Y.

(Continued from page 37)

.01 mfd and 1/4 to 2 megohms; in the plate control .002 mfd to .06 mfd and 5,000 to 100,000 ohms. Higher impedance audio tubes require higher resistance and lower capacitance. The bass attenuating systems are a bit more complex. Fig. 29 shows a separate bass and treble control method. The treble is *A*, bass booster, *B*. The audio choke acts as a shunt to bass frequencies, favoring the passage of highs.

**Circuit Notes**

In some instances a secondary detector action, causing distortion at certain settings, may occur in a control circuit. This may be cured by placing a .0001-mfd mica capacitor from the arm of the control to ground.

Wherever possible d-c should be kept out of the control. This will minimize noise problems.

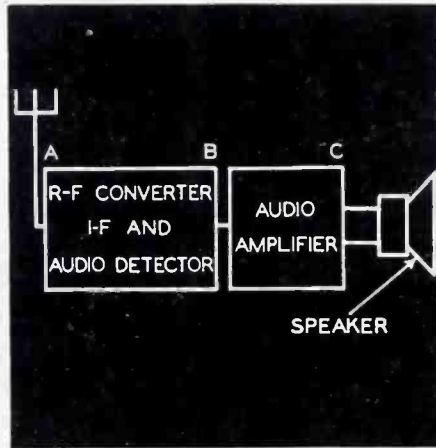

Fig. 30. Three basic points, *A*, *B* and *C*, for volume control installation are illustrated here. Most controls are used at point *B* for smoothest and simplest operation.

**AUTO SET CONVERSION**

(Continued from page 20)

external to the receiver, and the transformer cases grounded to the receiver.

In some cases it may be necessary to short out hash filters in the filament leg if the voltage drop across them is excessive.

Where the escutcheon plate formerly used in the car is obtainable, it may be used to enhance the appearance of the receiver when installed in a cabinet. Many homes have cabinets which formerly housed radios. A piece of beaverboard inserted where the dial face was formerly located, may be used as a mount for the control head, with cable control to the receiver proper. By converting in this manner, the set may be quickly and easily reconverted for use in the car.

One more point should be noted. Since the antenna coil is designed for a low-impedance input, a long antenna should not be used. A short piece of wire, about ten feet long, mounted around the window frame is sufficient.

*For Soldering in Tight Places . . .*

**DRAKE**

**No. 400 Soldering Iron**

*Smallest Industrial Iron Ever Designed*

60 Watts — 1/4 in. Tip  
Only 9 in. long. Wt. only 8 oz.

This mighty mite is backed by DRAKE's 25 years of soldering iron manufacturing experience. The high quality and long-service of DRAKE Soldering Irons have made them outstanding favorites with all types of radio men everywhere. The DRAKE No. 400 is an outstanding value at



Only \$4.50  
List

Drake Has an Iron for Every Purpose. Ask Your Radio Parts Jobber

**DRAKE ELECTRIC WORKS, INC.**  
3656 LINCOLN AVE., CHICAGO 13, ILL.

**FREE TO YOU**

**COLOR CODE and OHMS LAW CALCULATOR**

**Great Time Saver**

Burstein-Applebee of Kansas City offers you this great convenience FREE. Easy to work. Solves many problems in a jiffy. FREE to Radio men, electronic engineers and others in the business. Attach coupon to your letterhead.

**MAIL COUPON NOW**



BURSTEIN-APPLEBEE CO.  
1012 MCGEE ST.  
KANSAS CITY 6, MO.

Send me FREE Color Code and Ohms Law Calculator along with latest catalog.

I am \_\_\_\_\_  
STATE CONNECTION IN INDUSTRY

NAME \_\_\_\_\_

ADDRESS \_\_\_\_\_

TOWN \_\_\_\_\_ STATE \_\_\_\_\_



## OLD TIMER'S CORNER

(Continued from page 34)

allows a return to the garage or filling station owner and myself too. Simple, isn't it?

"Not only that, but on the tubes or knobs he might need, sales will be made at a profit, so that all profits revert to the garage folks. There is one important point though. If the job calls for a tube replacement or knob-tightening, OPA notices must be obeyed. In addition stickers are to be placed on the car, near the radio, or on the back of the mirror, advertising my service shop. That provides talking advertisements, really rolling ones, and I expect that many of the people will be coming in to my shop with their home radios to be repaired.

"Another feature of the plan provides for the posting of a sign reading:

**THIS IS AN AUTHORIZED AUTO RADIO REPAIR AGENCY OF PERRY STEWART RADIO SHOP**

**WE WILL FIX YOUR RADIO WITHOUT HOLDING UP THE USE OF YOUR CAR IF IT CAN BE DONE IN THE CAR WHILE YOU WAIT. IF EXTENSIVE REPAIRS ARE NEEDED WE WILL REMOVE THE RADIO WHILE YOU WAIT, AND YOU CAN CALL BACK TO HAVE THE RADIO INSTALLED AFTER REPAIRED. FOR DETAILS ASK OUR ATTENDANT OR THE MANAGER.**

"Many have indicated a willingness to go ahead with such a plan," said Perry.

"I'd like you to help me with the class. You're the oldest radioman, in time of service, in the town. They will listen to you. Tell them in one-syllable words how to change a tube on the average radio set. Show them how to remove one. Show them how to check the antenna connection, and tell them how they can discover when the vibrator is sticking and the set must be serviced in the shop. The whole lesson should not take more than three evenings of two hours each at the most.

"In return, I'll split the repairs with you fifty-fifty, if you'll help with the signs which I planned on having him print for me."

"Aren't you afraid that the auto mechanics will go into competition with you?" I asked, for his offer and idea were very tempting.

"I don't believe that they will. With auto parts so hard to get, and more repairs of that nature than they can handle, they will be too busy without trying to harness the wayward electron. I think that any business man would know that it's easier to be an agent for a repair agency than to buy instruments, train a technician and then go, effectively, into the radio servicing business. No, they'll do business with me, particularly in view of the following reason which will bring their customers back to the garage or filling station.

"Down at the shop, I have a mock-up of a car system. Got myself a car antenna, and a storage battery. With my instruments and training, I can repair car sets as well as anyone in the town, and all that I need is the business. There's no parking place in front of the shop except for one car at a time, and that blocks the customers driving in with their home radios to be fixed. No, this is the best way to break into the car radio set repair end of the servicing business."

Well, to make a long story very short, I went in with him.

Business is very, very good!

# Start with any **J** Jackson Instrument to Build a Balanced Testing **TEAM!**



**Condenser Tester**  
Model 650A—Measures Capacity, Power Factor and Leakage



**Sensitive Multimeter**  
Model 642—20,000 ohms per volt—complete ranges



**Electronic Multimeter**  
Model 645—A new Jackson instrument of advanced design

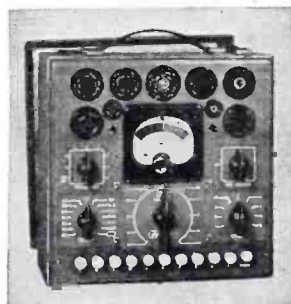

**Tube Tester**  
Model 634—Uses exclusive Jackson "Dynamic" Test Method

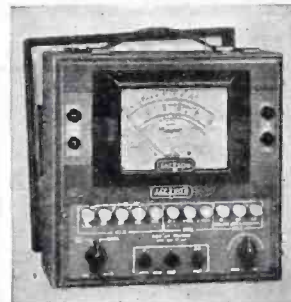

**Multimeter**  
Model 643—1000 ohms per volt. Push key range selection

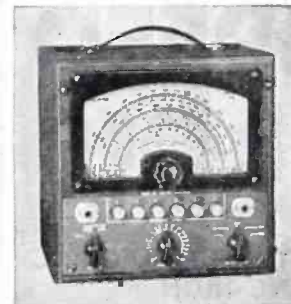

**Test Oscillator**  
Model 640—Accurate to 1/2%, covers full frequency range

It's a PLUS VALUE of the Jackson line. Each instrument is engineered and manufactured for long accurate life, as today's users know—but every one is carefully matched in appearance, dimensions and finish as well.

Start with whichever Jackson instrument you need first. Add to it as occasion demands. Your foresight will be repaid with a matched and balanced set of instruments built to give you testing results that you just can't get with hit-or-miss assemblies. Plan now to equip your shop with these Jackson instruments. See your distributor.

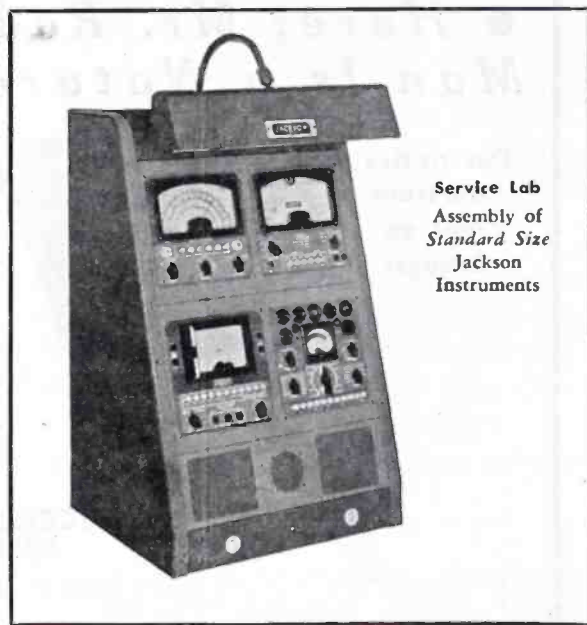

**Service Lab**  
Assembly of  
Standard Size  
Jackson  
Instruments

BUY WAR BONDS



AND STAMPS TODAY

# JACKSON

*Fine Electrical Testing Instruments*

JACKSON ELECTRICAL INSTRUMENT COMPANY, DAYTON, OHIO

SERVICE, JULY, 1945 • 39

# Announcing THE NEW\* SUPREME MODEL 565 VACUUM TUBE VOLTMETER!

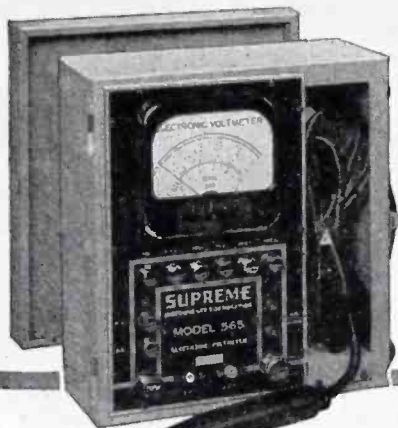

New type hand-fitting probe allows ease of measurements, handles just as any ordinary test lead. Probe incorporates new high-frequency diode giving best possible frequency response. Completely new, balanced, highly degenerative bridge circuit allows higher input impedances (less detuning on RF circuits) and greater stability than ever before.

**RANGES:**  
DC 0-1, 2.5, 10, 50, 250, 500  
AC 0-1, 2.5, 10, 50, 250  
EXTENDED TO 5000 VOLTS BY EXTERNAL MULTIPLIERS

**FREQUENCY RANGE:**  
Negligible frequency error from  
50 cycles to 100 megacycles.

**INPUT RESISTANCE:**  
DC—80 megohms on 1 volt range; 40 megohms on 500 volt range  
AC—40 megohms on 1 volt range; 20 megohms on 250 volt range  
**INPUT CAPACITY OF PROBE: 5 micro-micro farads**

**SUPREME INSTRUMENTS CORPORATION GREENWOOD MISSISSIPPI**

## ● Here, Mr. Radio Service Man Is a Natural for You

Descriptive Literature Sent on Request

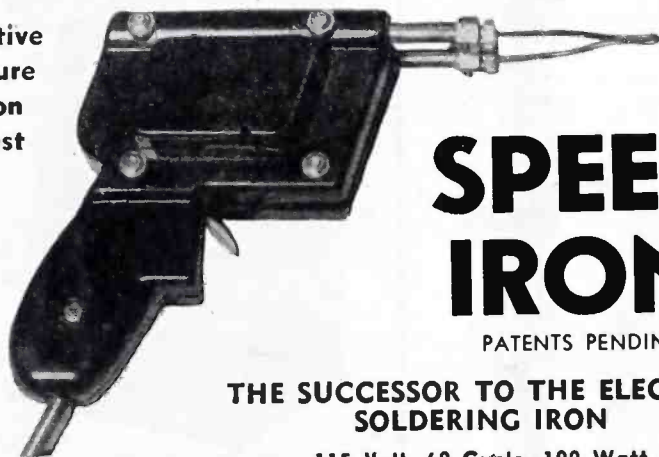

# SPEED IRON

PATENTS PENDING

THE SUCCESSOR TO THE ELECTRIC SOLDERING IRON

115 Volt, 60 Cycle, 100 Watt

### IT'S REALLY FAST!

Soldering Heat in 5 Seconds After Pressing the Trigger!

You don't wait for the SPEED IRON to heat. It waits on your bench, cold, for you. When you pick it up and press the trigger it goes to work with a surge of power and speed that is amazing. SPEED IRONS have been tested and used in hundreds of war plant applications over a four-year period and are now available to radio repairmen.

IF YOUR RADIO PARTS DISTRIBUTOR DOES NOT YET HAVE SPEED IRONS IN STOCK WRITE

**WELLER MANUFACTURING CO., DEPT. S, EASTON, PA.**

# SERVICING HELPS

**EMERSON 109, CHASSIS U4A**

*Weak reception on low frequencies:* Replace antenna coil with one that has a high-impedance primary winding.

*Distortion:* The screen voltage of the 6F7 detector is very critical and is usually the source of distortion in this set. With set in operation connect a test calibrated variable resistor in place of screen-grid resistor and adjust until distortion is eliminated. Note value of resistor required and connect proper value resistor in place of old resistor in the screen circuit.

**UNITED STATES RADIO & TELEVISION 28**

*Howl, no reception:* Interchange the two brown-wire speaker connections where they plug into the chassis. These two wires can easily be connected the wrong way since the color shade of both wires are identical.

*Crackling noise:* Caused by a corroded primary on one of the r-f coils. Replace with universal slip-on primary winding coil. Realign set after coil replacement. Voltage divider resistor also produces much noise in this set. Replace sections with individual 10-watt wire-wound resistors.

**COLUMBIA 5G8**

*Oscillation when volume control is turned up at low frequency portion of dial:* If filters and screen condensers check okeh then install a .1-mfd 600-volt condenser from one lead of the 110-volt line to chassis. The connections should be made right at the primary of the power transformer.

**ZENITH 85432, 85433, 85434, 85449, 85450, 85458, 85459, 85460, 85461, 85462; CHASSIS 5810**

*Oscillation on low frequency section of the broadcast band:* On the majority of these models this trouble seems to be quite common despite adequate filtering. Readjusting wave trap usually eliminates the trouble.

**ZENITH 705, 706, 707, 711, 750, 712; CHASSIS 2052**

*Volume control will not attenuate signal volume sufficiently:* Trouble is due to an open 5-mfd detector cathode electrolytic. Part indicated on diagram as 22-225.

Edward Goldschmidt.

## VIDEO I-F CIRCUITS

(See Front Cover)

THE video amplifier i-f system of the G. E. HM-225B/226-B television receiver appears on the cover this month.

Between the antenna and the first video i-f we have a single 6F8G dual triode acting as a first detector and oscillator. The iron core first i-f transformer connects from converter plate to an 1852 grid. To pass the entire 6-mc television band, this transformer is loaded very heavily, with 1,500 ohms on the secondary side ( $R_{10}$ ). The suppressor grid of the 1852 is used as a voltage pick-off for the audio i-f. The anode of the 1852 feeds a special broad-tuned, band-pass i-f transformer, with a primary loading resistor of 2,700 ohms and a secondary load of the same value. Wave traps are included in the interstage coupling circuits for rejecting the local and adjacent sound channels. The traps are tuned to 8.25 mc to eliminate the local channel and 14.25 mc for the adjacent channel.

### Second Video I-F

The second video i-f stage contains an extended cut-off 6AB7/1853 with combined avc and negative bias from a voltage divider. The interstage transformer is similar to the first, but has higher damping resistance loads; 2,200 ohms at the plate and 1,500 ohms at the following grid (secondary). The third stage is also an 1853, but an iron-core transformer is used. The primary is unloaded, but 2,200 ohms is shunted across the secondary. The fourth stage is similar to the third, and an 1852 is used.

### Detector-AVC

The fourth i-f feeds a 6H6 detector/avc tube with a 3,300-ohm shunt load. One diode sends the signal through the video and clipper stages to the grid of the picture tube. The other diode feeds a d-c bias (the same as avc bias) to the contrast control which is tied to a magnetic focussing coil on the picture tube. Each video i-f stage has an individual plate-supply filter for preventing feedback. This filter consists of a 2,200-ohm series resistor (acting as a choke) and a .005-mfd bypass capacitor. Avc is fed to the 1853 stages; second and third. The other stages are self-biased; first stage with 2,200 ohms, fourth with 180 ohms.

**Buy Your Share of  
War Bonds!**



is another phase of

# WAR . . .

THEY call it LOGISTICS in war . . . the difficult science of getting supplies to the fronts where they can be used. Post-War Reconversion will involve the same problems . . . just another phase of war itself.

CORWICO Wires, so long practically non-existent for American industry because of our national emergency, will figure importantly in the new Logistics of Reconversion. Soon you will be able to get these scientific strands for peacetime uses . . . and the world will stride into a new era of construction and expansion in which you'll no longer be *doing without* . . .



**cornish**  
WIRE COMPANY, INC.  
15 Park Row, New York City, New York  
*"Made by Engineers for Engineers"*



If your business is based on selling really good products . . . if your customers demand transformers of utmost dependability and service . . . then sell FREED — and you sell transformers of exceptional quality.

## FREED TRANSFORMER CO.

72A SPRING STREET  
NEW YORK 12, N. Y.



### MARSHALL JOINS AEROVOX SALES STAFF

Frank L. Marshall has become assistant sales manager of Aerovox Corporation, New Bedford, Mass. He will handle equipment manufacturers' sales. He was formerly assistant sales manager of Bundy Tubing Company of Detroit.



\* \* \*

### NEW YORK CHAPTER OF REPRESENTATIVES HOLDS ANNUAL DINNER

Eighty representatives, jobbers, manufacturers and members of their engineering and purchasing staffs attended the annual New York dinner of the New York Chapter of the Representatives recently.

The 23 members of the New York chapter acted as hosts.

Among those who attended were: Dan Bittan, Bob Breuer, Larry Braun, Ben Burns, Bill Carduner, Len Carduner, Charlie Cooper, Nels Case, Hy Davis, R. G. Brookfield, H. J. Dostal, Sam Egert, Irving Finkel, Bill Filler, Marty Camber, John Forshay, Adolph Friedman, Jack Fields, David Israel, H. J. Fairbanks, M. S. Feldman, Isador Golden, Bill Gold, S. W. Gross, Lester Hirtenstein, Milton

# Tone...

## Always a Deciding Factor

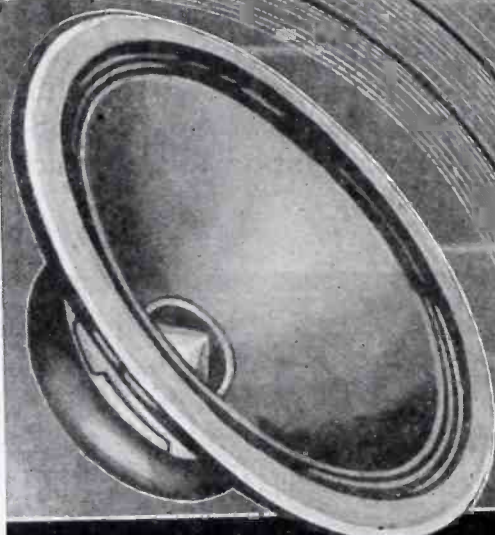

In the selection of any musical instrument, tone is of vital importance. Cinaudagraph Speaker Engineers have kept pace with every tone advancement — pioneered many new developments. That's why you'll want tomorrow's, better than ever, Cinaudagraph Speakers in every fine receiver — every quality sound unit.



### Cinaudagraph Speakers, Inc.

3911 S. Michigan Ave., Chicago  
Export Div., 13 E. 40th St., New York 16, N. Y.

"No Finer Speaker in all the World"

**F**OR a quarter of a century I have been browbeaten, bullyragged, and screamed at by a public that refused to pay me anything for my labor unless I hid the charge in the cost of parts—the same public that now offers me an illegal price for hard-to-get articles, hoping that I will accept it and lay myself open to legal action.

If I were of a vindictive nature I would take revenge on that public, but I don't. Instead I go on doing my work, ignoring criticism, charging a fair price for my labor when I could get a great deal more, confident that honesty and fair dealing will eventually win out.

*I am your radio Service Man.*

*(Contributed by Charles Middleton)*

ischer, Jung Herold, Arthur M. Harris, Tom Douglas, Ben Joseph, John Kopple, Jack Klein, Martin Kroll, Sam Kavesh, Kilpatrick, Ben Lehman, Adolph Anger, Charlie Lienan, Ben M. Moser, Pat Marks, Ben Miller, Charlie Newman, Jr. Lichter, Irv Nevins, J. L. Payne, Vol Predeger, Jack Ravdin, Milton Lanau, Rudolph F. Reinitz, Jack Rosenbaum, A. George Roger, Perry Saftler, Lee Sigmund, Max Stark, Mike Scott, Bill Sharp, Joseph Stantley, Leroy Schenck, Jules Sussman, M. H. Samm, Ben Singer, Tom Sewel, Joe Sprung, Hy teinberg, George Taylor, Jr., Al Wellington and Jack Weber.

**PRAGUE PULSE SERVICE CAPACITOR NOMOGRAPH**

A pulse service capacitor nomograph has been prepared by the engineering department of the Sprague Electric Company, North Adams, Mass.

Although the nomograph is primarily designed for determining the volt-amperes through a capacitor used in rectangular pulse service, it first, as an intermediate step, finds the d-c (unit pulse) energy content which, in some cases, may be sufficient.

In writing for the nomograph, ask for prague technical bulletin 11.

**BLAIR NOW WALKER-JIMIESON CHIEF SOUND ENGINEER**

J. Harold Blair has been named chief sound communications engineer of Walker-Jimieson, Inc. Mr. Blair comes to W-J from Operadio Manufacturing Company where he held the position of sales engineer.

**LAKE SALES NOW NEDA MEMBER**

Lake Radio Sales Co., 615 West Randolph Street, Chicago, Illinois, was recently elected a member of the National Electronic Distributors Association.

**SHERWOOD BECOMES S-M OF HALLICRAFTERS**

R. J. Sherwood has been appointed sales manager of the Hallicrafters Company, Chicago.

Mr. Sherwood was formerly assistant to the president of General Dry Battery, Inc., Cleveland.



**EXPERIMENTAL JAMAICA, L. I., TELEVISION STATION TO BEGIN OPERATION SOON**

Television station W2XJT, 148-18 Jamaica Avenue, Jamaica, Long Island, designed by William B. Still, will soon begin a series of tests on channel 13, 230-36 megacycles. Mr. Still, owner of Jamaica Radio and Television Manufacturing Co., operators of W2XJT, reports that his station will eventually include a completely equipped studio for live broadcasts, motion picture film equipment, control room containing three video monitors, two turntables and audio and video con-

*Convenient Pocket-Size*

*for*

**CONTINUITY TESTING**

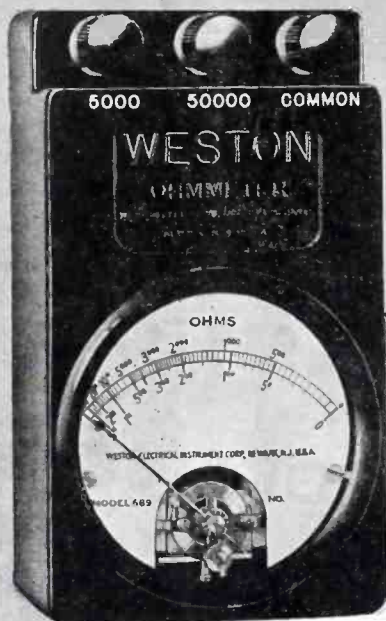

**WESTON  
MODEL 689  
OHMMETER**

Pocket-size but with typical WESTON dependability and ruggedness, Model 689 Ohmmeters are unequalled for checking circuits by resistance and continuity method. Available in two types . . . type 1E with double range of 0-5,000 ohms and 0-50,000 ohms, and type 1F with double range of 0-10 and 0-1000 ohms . . . ideal for motor maintenance. Entirely self-contained. Order through your local Weston representative, or direct from . . . Weston Electrical Instrument Corporation, 618 Frelinghuysen Ave., Newark 5, N. J.

**WESTON Instruments**

soles, a 600-watt (peak) video and 150-watt audio transmitter, and a 200' steel antenna tower.

**IRC SERVICE CATALOG**

A 12-page catalog, No. 50, describing types BTA (one watt) and BTS (one-half watt) resistors and entire BT and BW line in preferred RMA ranges has been released by International Resistance Company, Philadelphia, Pa. Also included are data on the I R C "Century Line" of controls.

**RADIO PRODUCTS AND RADIO SUPPLY TO DISTRIBUTE FOR HOFFMAN**

Radio Products Sales Co., operated by Walter Nettles, 1237 Sixteenth St., Denver, will represent Hoffman Radio in  
(Continued on page 44)

**PLASTIC METER CASE**

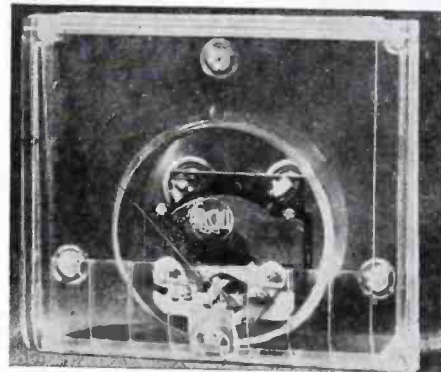

Transparent plastic meter case used in new RCA 195-A voltohmmst.

(Continued from page 43)

New Mexico, Colorado, Eastern Wyoming and Eastern Montana.

Radio Supply Co., operated by Harold Jones, 45 East 4th St., Salt Lake City, will cover Utah, Southern Idaho and Western Wyoming to Laramie for Hoffman.

\* \* \*

**ADDITIONAL MECK JOBBERS**

Additional jobbers who will distribute Meck equipment to radio service and sales shops were recently announced.

They are:

Curle Radio Supply, 825 Cherry Street, Chattanooga, Tennessee; Chemcity Radio & Electric Co., 408 North Gay St., Knoxville, Tennessee; Frost Electric Co., 1922 W. End Ave., Nashville, Tennessee; Amarillo Electric Co., 111 E. 8th St., Amarillo, Texas; All State Distributing Co., 2407 Ross Avenue, Dallas, Texas; United Appliance, 1009 Florence, Ft. Worth, Texas; R. C. & L. F. Hall, 1015 Caroline St., Houston, Texas; S. R. Ross, 1212 S. State St., Salt Lake City, Utah; Snyder & Snyder, 122-126 Church St., Norfolk, Virginia; Seattle Radio Co., 2117 Second Ave., Seattle, Washington; Roy R. White, West 908 First Avenue, Spokane, Washington; Sigmon Radio Supply, 708-10 Bigley, Charleston, West Virginia; Randle & Hornbrook, 536 Seventh St., Parkersburg, West Virginia; Appleton Radio Supply, 1217 North Richmond St., Appleton, Wisconsin; and Reed & Company, 1244 N. 6th Street, Milwaukee, Wis.

\* \* \*

**CHAMBERLAIN NOW ASS'T S-M AT CLAROSTAT**

Fran Chamberlain has been appointed assistant sales manager of the jobber division at Clarostat Mfg. Co., Inc., Brooklyn, N. Y.

\* \* \*

**J. J. CLUNE NAMED N. U. DISTRIBUTOR DIV. S-M**

J. J. Clune has been appointed sales manager of National Union's distributor



division. Mr. Clune will combine his new activities with those as head of the Na-

**PROJECTION TELEVISION**



Projection type 16" x 22" television receiver using the Schmidt optical system, recently demonstrated by G.E.

# Hi-Q

## CERAMIC CAPACITORS

## WIRE WOUND RESISTORS

## CHOKER COILS

The line to "get a line on" for your postwar sales.

**ELECTRICAL REACTANCE CORPORATION**  
**FRANKLINVILLE, N. Y.**

# UNIMETER

This unit fulfills an extremely important need for general utility portable service equipment. It has wide range coverage for both a-c and d-c measurements of voltage, current measurements on d-c and the popular ranges on resistance. The UM-3 is designed to clearly indicate all the functions which aid in the prevention of application of high voltages when preparing for current or resistance measurements.

Other G-E units for better servicing include: Tube Checker TC-3, Unimeter UM-4, and Oscilloscope CRO-3A.

Write: *Electronics Department, Specialty Division, General Electric, Syracuse, New York.*

*Electronic Measuring Instruments*

# UM-3 GENERAL ELECTRIC

ional Union war service, which department he has directed since the outbreak of the war.

\* \* \*

### BARRECA NOW AMALGAMATED RADIO PRESIDENT

Henry J. Barreca has been elected president of the Amalgamated Radio Television Corporation, New York. Mr. Barreca was formerly chief tool engineer of the American Radio Hardware Co., Inc., Mt. Vernon, N. Y.



\* \* \*

### STAY AWAY FROM SURPLUS GOODS, WARNS GOLENPAUL

Jobbers, dealers and Service Men should not buy surplus goods, warned Charley Golenpaul, of the Aerovox Corporation and chairman of the Sales Managers Club, Eastern Group, recently.

He said: "Surplus parts are usually of unknown quality. In fact, they are offered mainly as is with no real guarantee as to condition. In the case of military surplus, the radio components in many instances have been produced several years ago and stored in warehouses until now. In the case of components subject to deterioration through humidity or temperature or even age, the condition of such components can be very doubtful by the time of dumping.

"Speaking about capacitors, with which I am most familiar, my attention was called recently to some cardboard-tube electrolytics made by a reliable manufacturer as far back as 1941, sold to jobbers early in 1942, and subsequently picked up by Government-buying agencies. Later the military services decided against this type in favor of the midget metal-can type that became available to them. And so some of the cardboard-tube electrolytics were left in storage for approximately four years under varied conditions, deteriorating to varying degrees. Recently these same cardboard-tube electrolytics, unused, labeled the same as current production, presumably appearing as good as new, have been disposed of to surplus buyers by Government agencies. Some jobbers have purchased part of this lot.

"Naturally these jobbers have assumed that such cardboard-tube electrolytics were the same as items purchased directly from the given manufacturer, and in view of the serious shortage they have bought such electrolytics and sold them to their trade. Service Men and others have been finding out that some of these presumably 'new' electrolytics are really old, and deficient. Of course the Service Man may look to the jobber and even to the manufacturer to make good.

"The manufacturer of any reputable line has a fair guarantee policy. We stand behind our

### CENTRALAB REP MEETING



Jim Kay (left), Centralab Kansas City factory representative, discussing postwar products with W. S. Parsons and Al Tuttle of Centralab.

**UP FRONT...**

*Every Time*

You'll like our postwar line of *Smooth Power* motors, recorders and combination record - changer - recorders. They'll be right up in front with high-quality, velvety smooth operation, perfect fidelity in recording or reproduction.

They'll have the same fine design and built-in qualities that deliver complete satisfaction, as always. There'll be no skimping of details to give us fast production. You'll have a front seat in the postwar markets with General Industries phonograph mechanisms.

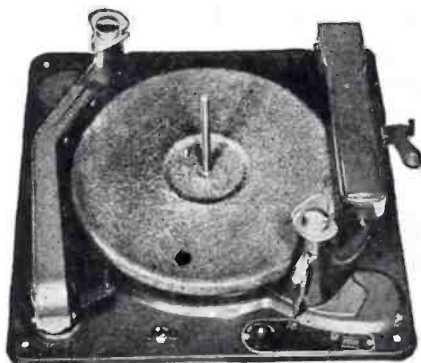

Combination record-changer and recorder Model GI-RC130

THE GENERAL INDUSTRIES CO.  
Dept. M • Elyria, Ohio



products for a reasonable length of time. But by no conceivable stretch of the imagination can any manufacturer be expected to stand behind cardboard-tube electrolytics already four or five years old and stored under unknown conditions. Consequently, the jobber and his customer can have no recourse. The jobber loses money and, more costly still, a lot of good will. It's a thoroughly costly transaction.

"Much the same story goes for other radio components subject to deterioration in time or through adverse conditions of storage.

"I'd be the last to deny that Government agencies have a perfect right to dispose of surplus radio components. Also, such goods have a perfectly legitimate place on the market. But my argument is that such goods be bought and sold for what they are—'bargains'—bought and sold 'as is'—the buyer buying at his own risk and without recourse should the goods fail to come up to expectations. Certainly such surplus goods should be in no direct competition with currently produced parts offered by the original manufacturer through regular jobbing channels. Let's not confuse these two propositions."

### SYLVANIA LOCK-IN'S

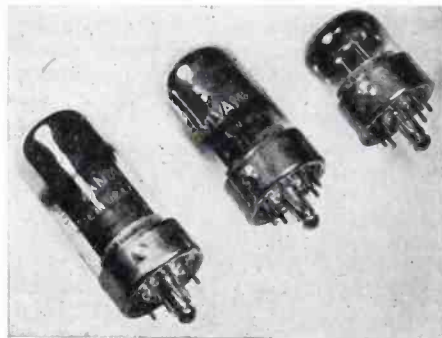

Assortment of Sylvania lock-in tubes used in u-h-f applications, featuring direct bonding of pins to glass.

## 10,000 RADIO MEN

are speeding up their work by using

# WARTIME RADIO SERVICE

75 pages — over 1500 detailed, tested tube substitutions and other information you can't be without.

PRICE \$3.00 POSTPAID

From your jobber or order from

## CITY RADIO COMPANY

East Washington at Fifth Street Phoenix, Arizona

## TUBES — PARTS

RADIO DEALERS—SERVICEMEN

Send for our list of available tubes and repair parts. Sylvania, Tung-Sol, Ken-Rad.

M. V. MANSFIELD CO.

937 LIBERTY AVE. PITTSBURGH 22, PA

### DU MONT MULTI-BAND C-R TUBE

A 5" multi-band cathode-ray tube, type 5RP, with a 17,500-volt accelerating potential, has been developed by Allen B. Du Mont Laboratories, Inc., Passaic, N. J. Tube is said to permit recording at writing rates in excess of 2,500 km/sec (using a 35-mm camera with an f:1.9 lens) corresponding to sine wave transients at 40 megacycles.

The new tube is of the hot-cathode, permanently-sealed, high-vacuum type. Constructed with deflection-plate leads brought out through the glass neck instead of the base.



\* \* \*

### LANGEVIN AUTOTRANSFORMERS AND POWER SUPPLIES

Three continuous duty autotransformers, and a new series of power supplies has been announced by the Langevin Company, Inc., 37 West 65th Street, New York, N. Y.

Autotransformers are 800-A, 801-A and 802-A. The type 800-A has a primary input of 220 volts, 60 cycles; secondary 110 volts, 250 watts; 5AS case, length 4 $\frac{1}{8}$ ", width 3 $\frac{1}{8}$ ", height 5"; weight 10 pounds. Type 801-A primary 220 volts, 60 cycles; secondary 110 volts, 500 watts; 6AS case, length 5 $\frac{1}{8}$ ", width 4 $\frac{1}{8}$ ", height 5"; weight 16 pounds. Type 802-A primary 220 volts, 60 cycles; secondary 100 volts, 1,000 watts; housed in No. 6 casting poured with humidity-proof compound,

## NEW PRODUCTS

length 9 $\frac{1}{4}$ ", width 7 $\frac{1}{4}$ ", height 6 $\frac{3}{4}$ "; weight 33 pounds.

Power supplies, 201-A, are designed to furnish filament and plate currents to line amplifiers, such as Langevin 102 series. Delivers 275 v at 75 ma/6.3 v at 8 a.

Length 10 $\frac{3}{8}$ "; width 5 $\frac{3}{8}$ "; maximum height 6 $\frac{1}{2}$ " (5 $\frac{1}{2}$ " above, 1" below mounting chassis).

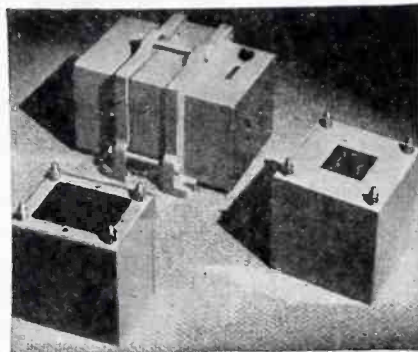

\* \* \*

### AMERLINE POCKET CIRCUIT TESTER

A vest pocket type all-purpose circuit tester has been announced by Amerline, 1753 North Honore St., Chicago 22, Illinois. Indicates voltages from 90 d-c, and 60 a-c, to 500 volts a-c or d-c. Neon lamp on the top glows in varying intensities indicating circuit conditions. No glow indicates a dead line; lamp is said to light on currents as low as one microampere.

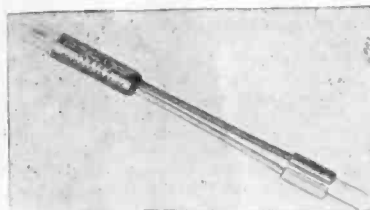

## ONE-STOP SERVICE

for all your parts requirements

# THE STANDARD RADIO

AND ELECTRONIC PRODUCTS CO.  
135 EAST SECOND ST., DAYTON, OHIO  
119 WEST MAIN ST., SPRINGFIELD, OHIO

• Ted McElroy

World's Largest Manufacturer of  
Wireless Telegraphic Apparatus

COMPLETE CENTRAL OFFICE EQUIPMENT

McElroy Manufacturing Corp.

32 Brookline Avenue • Boston, Massachusetts

## WHEN YOU CHANGE YOUR ADDRESS

Be sure to notify the Subscription Department of SERVICE at 52 Vanderbilt Ave., New York 17, N. Y., giving the old as well as the new address, and do this at least four weeks in advance. The Post Office Department does not forward magazines unless you pay additional postage, and we cannot duplicate copies mailed to the old address. We ask your cooperation.

### 6-WAY RCA VOLTOHMYST

A 6-way test unit, 195-A volt ohmyst, affording measurement of d-c or a-c voltages, resistances, audio levels, and f-m discriminator balance, has been announced by the RCA Victor division of RCA.

The volt ohmyst combines a 6-range d-c voltmeter, ohmmeter reading from .1 ohm to 1,000 megohms, 6-range a-c voltmeter, linear a-f voltmeter, audio-level meter, and an f-m discriminator balance indicator. Other features include a diode for a-c measurements, linear a-c scale for all ranges, plastic meter case and a shielded a-c cable and probe.



\* \* \*

### OPERADIO DUAL AMPLIFIER

A 40-watt dual amplifier designed for either plant broadcasting or public address service, has been introduced by Operadio Manufacturing Co., St. Charles, Illinois. Three models are available; Soundcasters 1335, 531 and 530.

Model 1335 is engineered for continuous use. Model 531 incorporates a 2-speed, manually-operated, record player for 10" or 12" commercial recordings, or 16" transcriptions. Model 530 features an automatic record-changing mechanism for either twelve 10" or ten 12" recordings.

Finished in blue-gray wrinkle case



and weighs approximately 45 pounds.



**MALLORY CAPACITOR MOUNTING CLIP**

A capacitor mounting clip that requires no tools for assembly has been announced by P. R. Mallory & Co., Inc., Indianapolis, Ind.

The clip, originated by Mallory and made by Prestole division of the Detroit Harvester Co., Toledo, Ohio, is now available in five sizes from 5/8" to 1 3/8". Catalog number is Mallory type TH, or Prestole series 500.

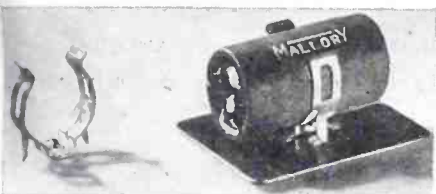

**TOBE BROAD-BAND FILTERS**

A power-line filter, for use with screen rooms, that is said to prevent entrance of objectionable line noise at frequencies from 150 kc to 400 megacycles, has been announced by the Filterette division of the Tobe Deutschmann Corporation, Canton, Mass. The unit is said to pro-

vide attenuation better than 60 db over the entire band.

Designed for continuous operation at 500 volts, d-c or a-c, at a full load current of 100 amperes. Filter is available for installation in two-wire and three-wire circuits. Three-wire filter is 23" long x 12" wide x 4 1/8" deep. Electrical connection is made to 3/8" studs at opposite ends of the internal assembly.



**QUICKCET VISE**

A 3" vice equipped with a trigger release pawl with 3/4" of thread which holds a screw under spring tension has been announced by Grand Specialties Co., Grand Avenue at Troy, Chicago 22, Ill.

The vice known as Quickcet, is said to open instantly to full 3" by pressure of thumb or finger on trigger release after tension has been eased by a turn of a looseproof handle.

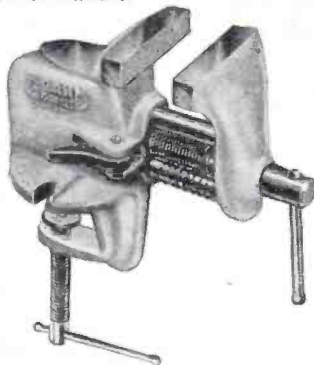

**Our G.I.'s  
are more important  
than our G's, our I's,  
our GL's-or anything  
else!**



● You'll agree that's the best policy — when we say that "Our G.I.'s come first!"

Of course we'd like to supply you with those Aerovox metal-can electrolytics (Types G, I, GL, etc.) you prefer for servicing and for initial-equipment needs. But so long as our armed forces require every metal-can electrolytic we can produce, we'll just keep supplying good cardboard-tube electrolytics that will see us through on the home-radio front until total victory is achieved.



● See Our Jobber . . . He can advise you as to available Aerovox types for your wartime requirements. Ask for current catalog. Or write us direct.

**AEROVOX**  
*Capacitors*  
INDIVIDUALLY TESTED

AEROVOX CORP., NEW BEDFORD, MASS., U. S. A.  
In Canada: AEROVOX CANADA LTD., HAMILTON, ONT.  
Export: 13 E. 40 ST., NEW YORK 16, N. Y. · Cable: 'ARLAB'

**SPEED UP REPAIRS WITH THESE G-C AIDS!**

**Get This New FREE Dial Belt-Drive Cable and Cabinet RepairGuide!**



**G-C Dial Belt Kits**

Exact replacement woven fabric belts. Easy to install — no stretching — no adjustments — a perfect fit every time. Kits come with 25, 50, 100, 200 or 300 belts.

Pocket-size, 68-page book contains thousands of listings, specifications and time-saving service instructions. Invaluable to every radio man. Get a copy from your jobber. If he cannot supply you, write us.



Immediate delivery on G-C Belts and Cables

Order From Your Radio Parts Jobber  
**ALWAYS ASK FOR G-C PRODUCTS**

**GENERAL CEMENT MFG. CO.**  
ROCKFORD, ILLINOIS



# JOTS AND FLASHES

# ADVERTISERS IN THIS ISSUE

## SERVICE INDEX—JULY, 1945

**F**INAL f-m, television frequency allocations have been announced by the FCC. . . . The 92-106 mc bands have gone to f-m. . . . Television will have 44-50 mc (No. 1), 54-60 mc (No. 2), 60-66 mc (No. 3), 66-72 mc (No. 4), 76-82 mc (No. 5), and 82-88 mc (No. 6) . . . Facsimile will be on the 106-108 mc bands. Later on, these bands will go to f-m and facsimile will move up to around 400 mc. . . . R. C. Cosgrove of Crosley has been reelected RMA president. . . . E. A. Nicholas of Farnsworth has also been reelected by RMA as vice president. . . . Another star has been added to the "E" flag of Hoffman Radio, Los Angeles. . . . Bendix Radio has won a white star. . . . RCA will continue to license under the Philips patents under a new agreement just signed. . . . Contract remains in force until December 31, 1954. . . . A standardization plan to cover 95% of vibrator replacements has been announced by Electronic Laboratories, Indianapolis. . . . Four vibrators are offered in the plan, according to Walter Peek, vice president in charge of sales. . . . District service managers of RCA Service Company held a ten-day conference recently to discuss newly developed test equipment, field servicing and other allied topics. . . . The C. L. Pugh Company have moved to 1670 Doone Road, Columbus, Ohio. . . . The Meissner Manufacturing Company has been bought by Maguire Industries. . . . James T. Watson and G. V. Rockey, Meissner execs, become Maguire officials. . . . Maguire has also purchased the plants of Ferrocarril and Micro Products. Harry A. Ford, founder of both plants, joined Maguire as vice president and general manager of the Micro-Ferrocarril products division. . . . Thordarson Electric purchased by Maguire some months ago is now a division of the company, with L. G. Winney, formerly Thordarson first vice president and treasurer, as a vice president and general manager of the Thordarson Electric Mfg. division. . . . E. H. Scott has resigned as president of E. H. Scott Labs. . . . Graybar will distribute Bendix radios in the Buffalo and Rochester areas. . . . Sprague Electric Company, North Adams, has won an "Approved Quality Control Rating" from the Air Service Technical Command. . . . Concord Radio will move soon to new quarters at 227-233 W. Madison Street, Chicago. . . . B. G. Erskine of Sylvania died recently. . . . Norman B. Neely Enterprises now located at 7422 Melrose Avenue, Hollywood 48, California. . . . Don't forget to buy your share of bonds!

AEROVOX CORPORATION	47
Agency: Austin C. Lescarboura & Staff	
THE ASTATIC CORPORATION	37
Agency: Wearstler Advertising, Inc.	
BURSTEIN-APPLEBEE CO.	38
Agency: Frank E. Whalen Adv. Co.	
CAPITOL RADIO ENGINEERING INSTITUTE	35
Agency: Henry J. Kaufman & Associates	
CINAUDAGRAPH SPEAKERS, INC.	42
Agency: Michael F. Maygor	
CITY RADIO CO.	46
CLAROSTAT MFG. CO. INC.	38
Agency: Austin C. Lescarboura & Staff	
CONCORD RADIO CORP.	36
Agency: E. H. Brown Adv. Agency	
CORNISH WIRE CO.	41
Agency: Hart Lehman, Advertising	
DETROLA RADIO DIV. INT'L DETROLA CORP.	7
Agency: Zimmer-Keller, Inc.	
DRAKE ELECTRIC WORKS, INC.	38
Agency: William Hoffman & Associates	
ELECTRICAL REACTANCE CORP.	44
Agency: Scheel Adv. Agency	
FREED TRANSFORMER CORP.	42
Agency: Franklin Adv. Service	
GENERAL CEMENT MFG. CO.	47
Agency: Turner Adv. Agency	
GENERAL ELECTRIC	17, 44
Agency: Mason, Inc.	
THE GENERAL INDUSTRIES CO.	45
Agency: Fuller & Smith & Ross, Inc.	
HICKOK ELECTRICAL INSTRUMENT CO.	31
Agency: White Adv. Co.	
INTERNATIONAL RESISTANCE CO.	19
Agency: The Lavenson Bureau	
JACKSON ELECTRICAL INSTRUMENT CO.	39
Agency: Kircher, Helton & Collett, Inc.	
KEN-RAD	1
Agency: Maxon, Inc.	
LIFETIME SOUND EQUIPMENT CO.	34
Agency: The Miller Agency Co.	
McELROY MFG. CORP.	46
Agency: Shappe-Wilkes Inc.	
M. V. MANSFIELD CO.	46
MARION ELECTRICAL INSTRUMENT CO.	5
Agency: Shappe-Wilkes Inc.	
JOHN MECK INDUSTRIES	11
Agency: The Fensholt Co.	
MEISSNER MFG. CO.	10
Agency: Gardner Adv. Co.	
MUELLER ELECTRIC CO.	36
NATIONAL UNION RADIO CORP.	Back Cover
OHMITE MFG. CO.	34
Agency: Henry H. Teplitz, Advertising	
RADIART CORPORATION Inside Front Cover	
Agency: Kenneth H. Kolplien	
RADIO CORPORATION OF AMERICA	23
Agency: Kenyon & Eckhardt, Inc.	
RADIO TUBE SERVICE CO.	34
Agency: Daniel DeKoren	
THE RADOLEK CO.	3
Agency: Turner Adv. Co.	
RAYTHEON MFG. CO.	3
Agency: Burton Browne, Advertising	
SHEFFIELD RADIO CO.	36
Agency: Sunder Rodkin Adv. Agency	
SOLAR CAPACITOR SALES CORP.	Inside Back Cover
Agency: O. S. Tyson & Co., Inc.	
SPRAGUE PRODUCTS CO.	4, 21
Agency: The Harry P. Bridge Co.	
STANDARD RADIO & ELECTRONIC PRODUCTS	46
Agency: Kircher, Helton & Collett, Inc.	
STANDARD TRANSFORMER CORP.	32
Agency: Burnet-Kuhn Adv. Co.	
SUPREME INSTRUMENTS CO.	40
Agency: O'Callaghan Adv. Agency, Inc.	
SYLVANIA ELECTRIC PRODUCTS, INC.	12
Agency: Newell-Emmett Co.	
TECHNICAL DIV. MURRAY HILL BOOKS, INC.	33
Agency: The Harry P. Bridge Co.	
TRIPLETT ELECTRICAL INSTRUMENT CO.	9
Agency: Western Adv. Agency, Inc.	
TUNG-SOL LAMP WORKS	6
Agency: E. M. Freystadt Associates	
U. S. TREASURY DEPT.	8
UNITED TRANSFORMER CO.	27
Agency: Shappe-Wilkes Inc.	
THE WARD PRODUCTS CORP.	30
Agency: Burton Browne, Advertising	
WESTON ELECTRICAL INSTRUMENT CORP.	43
Agency: G. M. Basford Co.	
WHOLESALE RADIO LABORATORIES	32
Agency: Pfeiffer Adv. Agency	

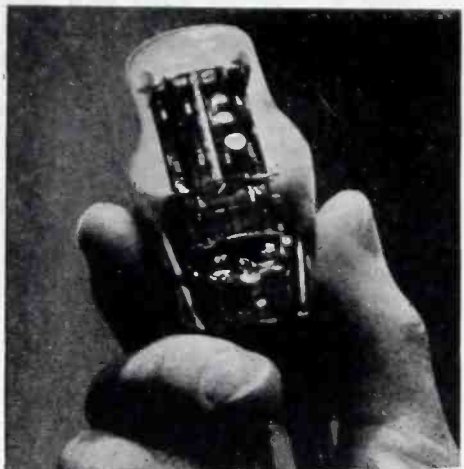

**STOP!** don't throw it away!

Let **RTS** reprocess your dead

# RADIO TUBES

*NEW Scientific Process*

**REACTIVATES THORIUM  
CONNECTS OPEN FILAMENTS  
CLEARS SHORTS and  
MICROPHONICS**

(NOT the old "flash" trick)

MINIMUM ORDER 6 TUBES

**SEND NO CASH**

**C. O. D. ONLY**

**30-Day Guarantee**

Every tube fully tested in checkers & sets before playing

50¢ EA.

Prices approved by O.P.A.  
1 volt & 3-Q5 \$1.00

Send itemized list with order

Make sure glass, base & prongs are intact . . . flashed, exploded or open cathodes **REJECTED** and **NOT RETURNED**

**RTS RADIO TUBE SERVICE CO. INC.**

6805 20th Avenue, Brooklyn 4, N.Y.

**you can't put the squeeze**  
**on SEALDTITE**  
**CAPACITORS**



Just try it . . . Take a genuine "Sealdtite" capacitor and try to *squeeze* it. No results. You'll find it has no soft spots, which in ordinary tubulars provide room for moisture, the capacitor's worst enemy, because the Solar capacitor has an internal winding of high quality paper and foil, skillfully *molded* into *solid* plastic.

No moisture can penetrate this protective case and its substantial construction permits rough handling, assures long and *reliable* service.

Use "Sealdtite" capacitors. Send for your copy of Catalog V-4.  
Any Climate - Any Atmosphere - Any Service.



 BAYONNE PLANT   
WEST N.Y. PLANT

A TOTAL OF EIGHT ARMY-NAVY  
EXCELLENCE AWARDS

SOLAR CAPACITOR SALES CORP.  
285 MADISON AVENUE, NEW YORK CITY

*Another*  
**N. U. SERVICE  
 FOR SERVICE  
 MEN**

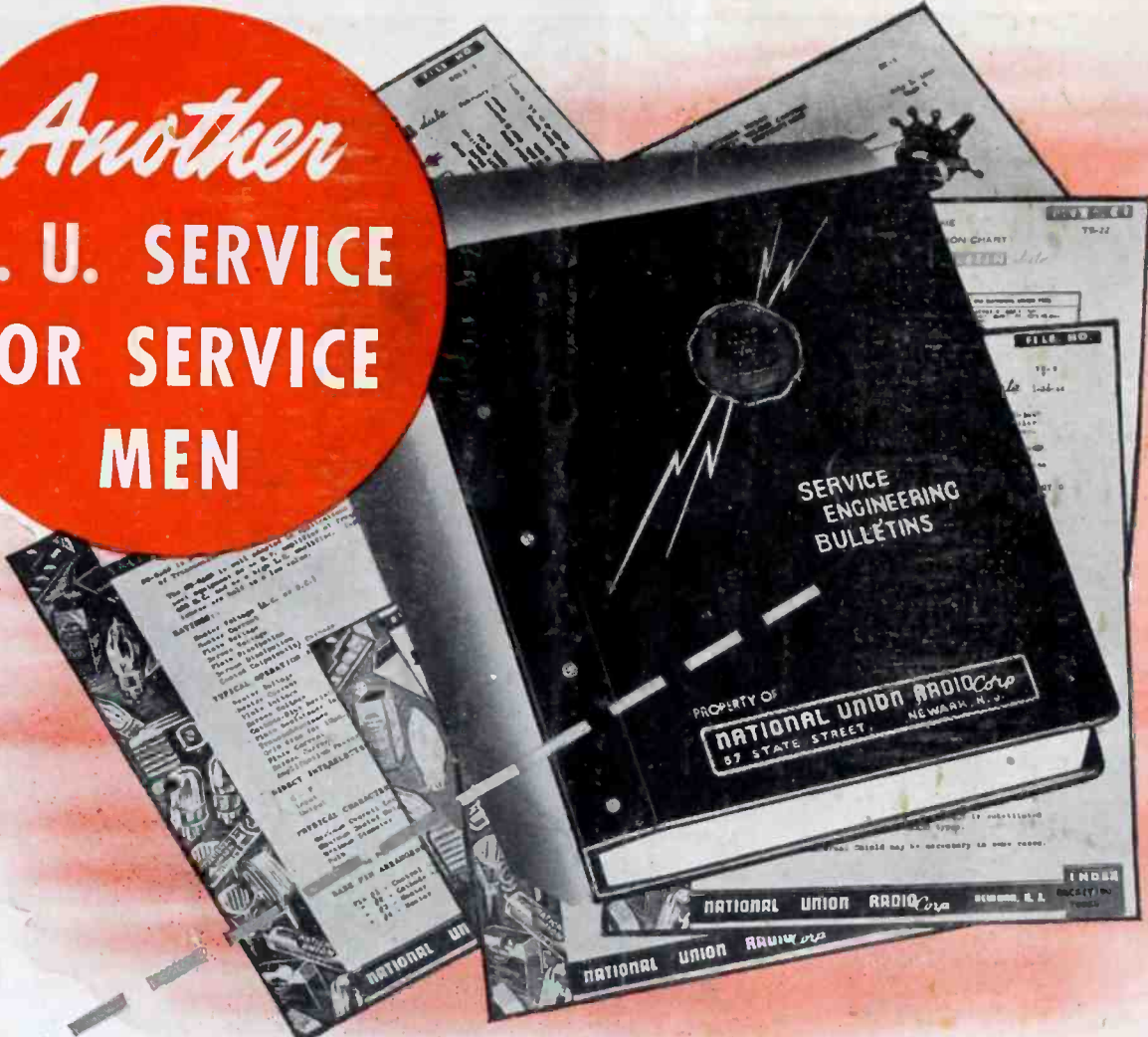

## UP-TO-THE-MINUTE TECHNICAL BULLETINS

Now available from coast to coast at National Union Distributors, is this big book of N. U. Service Engineering Bulletins. It is loaded with timely technical tips, troubleshooting short cuts and service suggestions, prepared by top notch N. U. engineers with all the newest radio facts at their finger tips. And all so easy to get at—arranged on handy separate bulletin sheets covering one subject at a time.

A ready reference file of N. U. Service Engineering Bulletins is now on hand at your National Union Distributor. You are invited to refer to it regularly. Bulletins in which you are particularly interested, may be obtained FREE from your N. U. Distributor. *National Union Radio Corporation, Newark 2, N. J.*

**Typical Bulletin subject matter**

- N. U. 7A4 as a high frequency oscillator
- 3B 7/1291 Ultra high frequency double triode
- 35Z5 filament burnouts
- A simple Loktal to Octal adapter
- Tube substitution data for 25B5
- Replacements for special purpose tubes

**After the War, MORE than Before!**

# NATIONAL UNION RADIO AND ELECTRON TUBES



*Transmitting, Cathode Ray, Receiving, Special Purpose Tubes • Condensers • Volume Controls • Photo Electric Cells • Panel Lamps • Flashlight Bulbs*