

# SERVICE

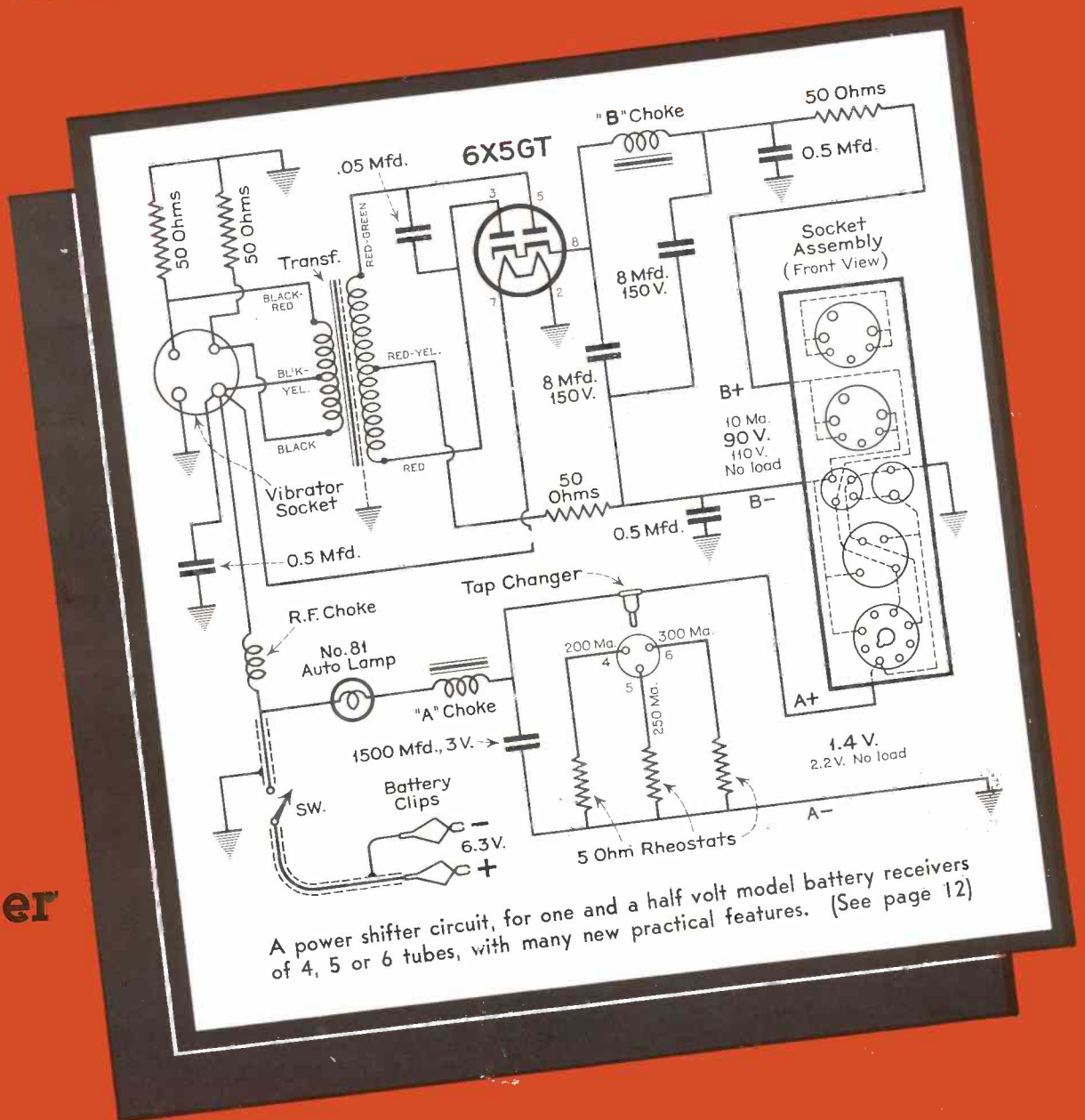

A power shifter circuit, for one and a half volt model battery receivers of 4, 5 or 6 tubes, with many new practical features. (See page 12)

September  
1942



## ← The Book of This Month . . .

The new MYE TECHNICAL MANUAL has received a hearty welcome from radio servicemen, amateurs, engineers, experimenters . . . and in training centers of the Army, Navy and Marine Corps.

But we're calling it "the book of this month," because September is when many business men start planning for the active autumn season ahead. In the radio business, alert men are thinking constructively and reading the best technical literature available. That's why, as you read over the list of chapter headings below, you'll put the MYE TECHNICAL MANUAL on your list of "must" reading . . . as thousands of others already have.

- 1 Loud Speakers and Their Use
- 2 Superheterodyne First Detectors and Oscillators
- 3 Half-Wave and Voltage Doubler Power Supplies
- 4 Vibrator and Vibrator Power Supplies
- 5 Phono-Radio Service Data
- 6 Automatic Tuning—operation and adjustment
- 7 Frequency Modulation
- 8 Television—suggestions for the postwar boom
- 9 Capacitors—how to overcome war shortages
- 10 Practical Radio Noise Suppression
- 11 Vacuum Tube Voltmeters
- 12 Useful Servicing Information
- 13 Receiving Tube Characteristics—of all American tube types

This manual is as valuable as a voltmeter, according to some of the outstanding servicemen who are using it daily. It contains 392 pages of down-to-earth, practical information. It bridges the gap between radio theory and actual practice. But the supply of MYE TECHNICAL MANUALS for civilian use is limited. Soon copies may be scarce. See your Mallory Distributor today—get your Manual now!

P. R. MALLORY & CO., Inc., INDIANAPOLIS, INDIANA

Cable—PELMALLO

P. R. MALLORY & CO. Inc.

# MALLORY

*Approved Precision Products*

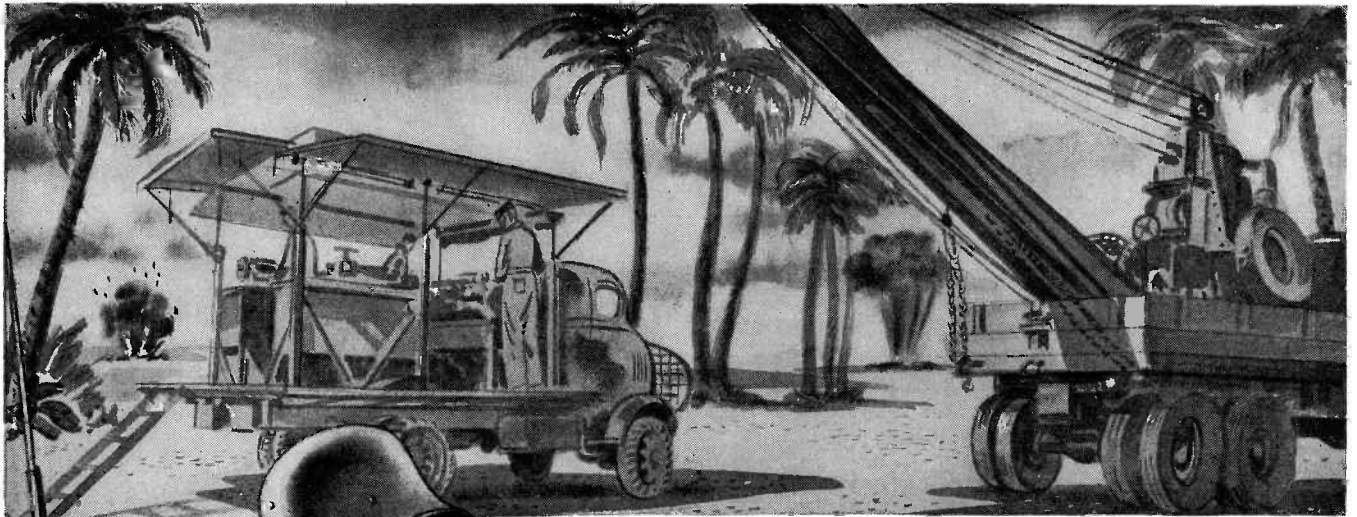

## *Tom is meeting familiar faces*

**EVEN 'OVER THERE'**

**T**OM'S background in radio now stands him in good stead in the Signal Corps. Starting as a "ham", then a communications engineer . . . he knows how to spot and correct trouble. From the day he "joined up" he's been thoroughly at home in his new job. Even the test instruments he works with are duplicates of those in the shop back home. They bear the same name he's always banked on for measurement dependability since he built his first "ham" transmitter. And now that he's abroad, he's surrounded by these same familiar instruments even on the equipment and in the repair depots of our allies. For throughout the allied countries, too, the mark WESTON is the accepted symbol for dependable electrical measurement. Weston Electrical Instrument Corporation, 604 Frelinghuysen Avenue, Newark, New Jersey.

Priority restrictions have necessarily greatly curtailed the supply of WESTON instruments for many industrial needs. *Uncle Sam stands firmly at the head of the instrument line!*

To the great majority of instrument users not now engaged in war production, however, this has meant little, if any, inconvenience. The WESTONS they now have in service will see them through for the duration and beyond. *Long-life dependability* is built into every instrument bearing this name.

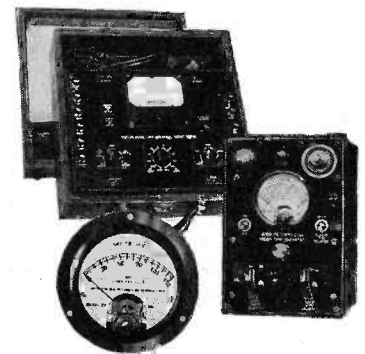

## **WESTON INSTRUMENTS**

Laboratory Standards • Precision D-C and A-C Portables • D-C, A-C, and Thermo Switchboard and Panel Instruments • Instrument Transformers • Sensitive Relays • Specialized Test Equipment • Light Measurement and Control Devices • Exposure Meters • Aircraft Instruments • Electric Tachometers • Dial Thermometers

# EDITORIAL

YOU remember the copy book adage about opportunity, taken at the flood that carries men to success. Today is the flood . . . tide time for servicers, and it behooves them to play their present opportunity to the hilt. The dearth of competent servicers has made the servicer a bit of a king and he can pick and choose his jobs and get what looks like important folding money for his time, labor and skill. But the greatest stroke of luck is the opportunity to rehabilitate the dog-eared, moth-eaten reputation of servicemen as a whole.

Haggling over prices should be out for the duration. The use of cheap, junky parts is no longer necessary. Cutting corners and shaving estimates have been outmoded by the current prosperity of the masses of set owners in this country. Should servicers adopt a policy of frankness; discard the apologetic attitude when giving a customer a quotation; tell the customer honestly what the trouble is with the set; endeavor to persuade him that complete reconditioning is more to be desired than a mere temporary 'patch up' job; explain proudly that a servicer is more than a common laborer; that he is a highly skilled technician and is entitled to be paid for his time and knowledge; they will be laying the groundwork for greater public respect and acceptance that has ever been the case heretofore.

ALTHOUGH the price ceiling rulings were announced some time ago, it was not until several weeks ago that the law with its new amendments, hits its full stride. The amended regulation now covers maximum prices of all repair, maintenance and rental services, at all levels, retail, wholesale and contract. Prices must not exceed the highest price charged in March for the same or similar service, even though prices for labor or material may have increased since then. All available information and records on this phase of the business must hereafter be kept.

(Continued on page 24)

# SERVICE

A Monthly Digest of Radio and Allied Maintenance

Reg. U.S. Patent Office

Vol. II. No. 9

September, 1942

**ROBERT G. HERZOG,**

Editor (On Leave)

**ALFRED A. GHIRARDI,**

Advisory Editor

	Page
Commutator Maintenance. By Ted Sterling	17
Farrell Says. By C. H. Farrell	20
Pickup, Motor and Record Changer Wartime Servicing. By Alfred A. Ghirardi	5
Ser-cuits. By Henry Howard	8
Servicing Power Supplies. By Mark Glaser	13
<b>Case Histories</b>	
Airline 62-301 (BRC 1170)	18
Airline 62-207	18
Airline 62-307	31
Emerson P-4B	18
DeWald 633	18
General Electric H639	18
General Electric G 95	18
Halsen O5	18
Majestic 210, 211, 214, 215	18
Motorola 50, 60, 80	18
Oldsmobile 982006 Auto Set	31
Philco 611	18
Philco 37-690	18
Philco 59	18
RCA 99K, 99T	18
RCA Schematics	29
RCA 9TX Series	29
RCA 86 K 7	29
RCA U-128, U-130	29
Westinghouse	29
Zenith	29
<b>Circuits</b>	
Crosley 96	12
RCA VHR-212	11
RCA Switch Positions V-135	29
Silvertone 7066	8
Silvertone 7168	8
Silvertone 7915	10
Silvertone 7134	10
Silvertone 7051	11
<b>Cover Diagram</b>	
A Power Shifter	12
<b>Short Item</b>	
Broken Dial Cords	31
<b>Index to Advertisers</b>	
	32
<b>Manufacturers</b>	
News	22
New Products	25
Jots and Flashes	32

Copyright, 1942, Bryan Davis Publishing Co., Inc.



**Bryan S. Davis, Pres.**  
**F. Walen, Secretary**



**Paul S. Weil, General Manager**  
**A. Goebel, Circulation Manager**

Published monthly by Bryan Davis Publishing Co., Inc.  
19 East 47th Street, New York City. Telephone PLaza 3-0483

Entered as second-class matter June 14, 1932, at the Post Office at New York, N. Y., under the Act of March 3, 1879. Subscription price: \$2.00 per year in the United States of America and Canada; 25 cents per copy. \$3.00 per year in foreign countries; 35 cents per copy.



# FOR'D MARCH

**For America!**  
**THROW YOUR SCRAP**  
**INTO THE FIGHT!**  
 AMERICAN INDUSTRIES  
 SALVAGE PROGRAM

with **METAL TUBES**

Metal radio tubes are in the forefront of the drive to keep the public informed of the war effort. Over 80,000,000 metal tubes are in use in the nation's radios. When there is no longer a wartime need, we will again make and recommend metal tubes for civilian use. At present, our entire production of metal tubes is reserved for our fighting forces.

*Handle Ken-Rad Radio Tubes and Be Sure of Satisfied Customers.*



# KEN-RAD

## *Metal Radio Tubes*

**KEN-RAD TUBE & LAMP CORPORATION, Owensboro, Kentucky**





# What about VOLUME CONTROL REPLACEMENTS?

*Knowing the importance of this question to you,  
IRC believes you are entitled to a straightforward answer  
divorced from evasions, empty promises and wishful thinking.*

**HERE ARE THE FACTS**—You can still obtain IRC VOLUME CONTROLS from most Jobbers! But, the chances are they will not be able to furnish exact duplicates in many instances. Due to War Production Board allocations of vital materials and because high-rated priority orders must be filled first, we of necessity have decreased our line for the duration—standardizing wherever possible. This means that you will be called upon more and more in the coming months to use your knowledge and ingenuity in making mechanical and electrical substitutions. IRC Standard Volume Controls, however, are so designed that you can easily adapt them to replace defective units.

**YOUR JOBBER WILL HELP YOU**—Many months ago we anticipated today's critical situation and adjusted our policies accordingly. Recently announced to Distributors, IRC's new Volume Control stock plan met with immediate approval and a practically 100% response.

This splendid cooperation enabled us to assemble Volume Controls from material on hand and make deliveries in substantial quantities without

sacrificing production of essential war orders.

We suggest you continue to use your IRC Volume Control Replacement Manual. Your Jobber has been advised how to make proper substitutions and will gladly help you with your problem if you will consult him whenever necessary.

**IRC QUALITY MAINTAINED**—You can rest assured that any IRC Volume Control, whether manufactured "before Pearl Harbor" or recently assembled, conforms to IRC Standards of Dependability, Stability, and Accuracy . . . and although IRC is operating 24 hours per day, 7 days a week, to meet urgent Army, Navy, Air-Force and War Industries requirements, we are ever mindful of your important function in keeping home radios in good working order.

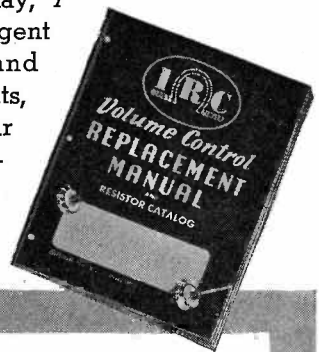

## INTERNATIONAL RESISTANCE COMPANY

401 N. BROAD STREET *Philadelphia*

## PICKUP, MOTOR AND RECORD CHANGER WARTIME SERVICING

By **ALFRED A. GHIRARDI**

Advisory Editor

IT'S vital today to insure the effectiveness of "Keep 'em playing" to the more than six million record players now in use in this country, as well as to the radio receivers with which they are associated. The servicing of record-playing equipment has developed great importance in the business of the radio service shop during the past few years. It involves electrical problems not unlike those encountered in ordinary receiver servicing; but, in addition to these problems, many mechanical and acoustical problems also enter. In fact, mechanical adjustments and repairs are the most frequent in this type of work. Servicing of pickups, motor repair, and record-changer adjustment and repair comprise the bulk of the jobs service men are called upon to do in this field of work.

### Servicing Crystal Pickups

There are a number of troubles directly and indirectly traceable to crystal pickups; hence, it is important that the service man recognize them and know the proper remedies for them.

Crystal pickup cartridges cannot bear excessive heat. They suffer permanent damage if they are subjected to temperatures above about 130 degrees Fahrenheit, even for a very short time. A source of heat seldom taken into account in home installations is the normal rays of the sun beating on an exposed crystal pickup (see Fig. 1), especially during hot summer weather. This, in time, will damage the crystal in the same manner as will the application of heat to the exposed pickup from any other source. Always advise your customer to close the lid of his record-player compartment when the player is not in use. (Instruct him to close it also while in use to minimize needle hiss.)

Crystal pickups are often the cause of "rumbles" or "growls." The crystal

can be replaced, but a simple cure that is usually effective is to wrap several thin rubber bands neatly around the pickup head. This dampens the mechanical resonance. It is effective also when the direct tone from the pickup is objectionable.

Rumble caused by the pickup may be cured often by mounting the pickup base on a soft-rubber cushion. Be sure that the rumble is not due to its being recorded on the record itself. Try several records to check this.

Another method of minimizing rumbling due to the pickup is to attenuate the low-frequency response by connecting a resistor across the pickup. The value of this resistor must be chosen by test, using a value of about 20% of the pickup load to start with, and then increasing or decreasing the value until best operation is obtained.

If the pickup produces so much excessive voltage that the input stage becomes overloaded, poor quality and distortion result. One method of remedying this condition is to shunt the pickup with a capacitor of approximately 0.001 mfd.

When the crystal pickup cartridge itself is found to be faulty, it is necessary

Fig. 1. Exposing the crystal pickup to the direct rays of sunshine will cause permanent damage. The cabinet lid should always be closed.

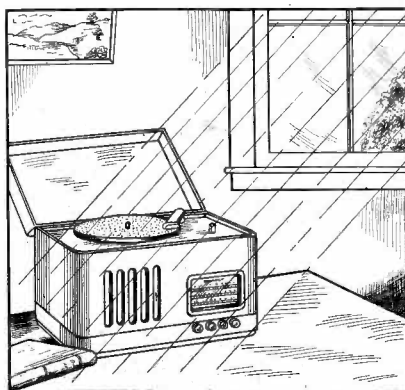

to replace it with a new one, as it is not practical for the service man to attempt a repair. Be sure that the replacement cartridge is exactly the same type as the original unit. Four typical types of replacement units are illustrated in Fig. 2.

It is important frequently to determine whether the correct weight or pressure is being exerted on the needle of the pickup, or the stylus of a recorder cutting head. To determine this with accuracy, a small weight scale can be used. One such unit, similar in appearance to a pocket pencil, is illustrated in Fig. 3. This little weight scale indicates the weight on phono pickup needles and phono cutting heads in ounces. It is small and compact and is provided with a small hook at one end, making it easy and convenient to use.

### Eliminating "Wow"

A "wow" sound may be caused by any one of several conditions. A warped turntable, a bent center pin, records with worn center holes, warped records, periodic variations in speed of the turntable will all cause "wow." Any of the first three mentioned causes can usually be detected by watching the pickup while the record is playing and the "wow" is present. If the pickup oscillates slightly back and forth, due to one of these off-center conditions, the "wow" will be timed with the oscillations when they are causing the trouble. The remedy is obvious.

"Wow" caused by periodic variations in the speed of the turntable is evidenced by distortion on long, sustained notes—especially on long-playing records. The first step toward eliminating this trouble is to check the speed of the turntable, with a stroboscope disc placed on the record *while it is being played*, and illuminated by a neon bulb connected to the a-c electric light line. If the lines appear to be traveling forward, the turntable speed is too *fast*; if the

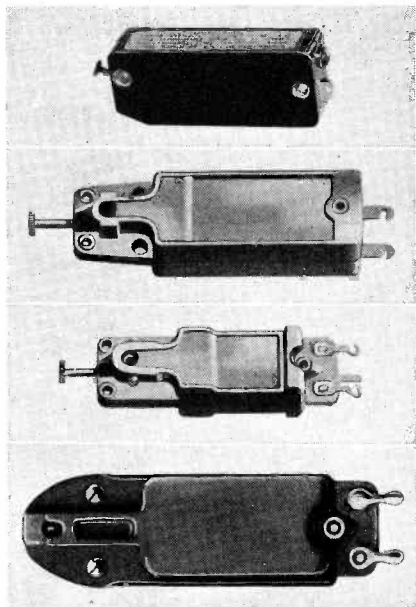

Courtesy The Astatic Corp.

Fig. 2. Four types of crystal cartridges designed especially for replacement in phono pickups.

lines appear to travel backward, the turntable is operating at too *slow* a speed. The speed adjustment provided should be regulated in either case.

Fluctuation in the turntable speed, causing "wow," is sometimes due to the hardening of the leather, soft rubber, or felt washer upon which the turntable rests. In such cases, replacement of the washer usually corrects the condition. Occasionally, the entire motor must be overhauled, oiled, greased, and each electrical connection checked and resoldered. When the motor is of the commutator-brush type, the commutator and brushes must be cleaned carefully with 00 sandpaper and fitted properly.

#### Phono Motor Repairs

Aside from electrical troubles in the windings, phono-motor troubles are usually due to gradually developing mechanical faults. When induction motors are encountered which cannot be made to operate at correct speed, or are sluggish in operation, the trouble may be traced to the turntable shaft, which has become slightly "frozen" at the bearing where it passes through the motor assembly. This condition may be rectified by easing the shaft loose with the aid of a few drops of light mineral oil. When the motor is sluggish, or has a tendency to stall or lose power, a drop or two of machine oil should be applied to the bearings. In the commutator-type motor, this latter condition may often be overcome merely by cleaning the commutator with 00 sandpaper and resurfacing and refitting the carbon brushes. Any loose parts in the mechan-

ism should be tightened. Any loose parts or shafts which bind should be freed, as they will overload the motor and may cause overheating and eventual damage to the insulation on the windings.

#### Servicing Rim-Driven Motors

The friction (rim-drive) phono-motor is used extensively in simple phonographs as well as in some record changers. It transmits the turning energy from the motor to the rim of the turntable by means of a rubber-tired *idler wheel*. The speed of the turntable is independent of any changes in the diameter of the idler wheel, being dependent upon the ratio of the diameters of the drive pulley, of the rotor shaft, and the rim of the turntable. Consequently, even appreciable wear of the idler rubber will not result in any change in turntable speed. However, the rubber deteriorates with age; it may become hard and crack, or oil (or grease) may be accidentally deposited on it causing deterioration. When a replacement is necessary, according to the type of idler wheel used, either the rubber tire or the entire idler wheel may be replaced. All rubber parts should be handled with clean hands only; grease, oil and dirt will shorten their life. A typical rim-drive phono motor and turntable are illustrated in Fig. 4. The various component parts likely to wear or cause trouble after long use are shown.

#### Eliminating "Rumble"

In addition to rumbling being caused by the pickup as already explained, it may also be due to *mechanical* coupling between the motor-turntable mechanism and the pickup, or between the motor and the high-gain low-level audio tubes. Such coupling is usually eliminated in the original design of the mechanism by mounting the player or record changer so it floats freely in shock-absorbing mountings. Where rubber, however, is used for such mountings, it will harden with age and its effectiveness in absorbing mechanical vibration may decrease consider-

Fig. 4. Cutaway view showing the main driving components of a typical rim-drive phonomotor.

Courtesy The Alliance Mfg. Co.

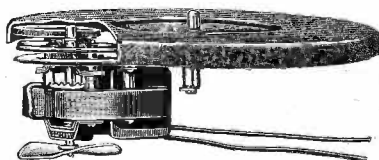

Courtesy Universal Microphone Co., Ltd.

Fig. 3. A small weight scale for determining the pressure exerted by a phono pickup or recorder head on the needle. A hook is provided for lifting.

ably after a time. Replacement is then necessary.

Rumble is sometimes caused also by the connecting wires between the chassis and the player or changer being too tight. The effectiveness of the shock-absorber mountings is thereby reduced, since the mechanism is prevented from floating freely on them as the original design intended.

#### Servicing Automatic Record Changers

In many instances, where unsatisfactory operation is blamed on the automatic record changer, the trouble is really due to the records instead. Before any attempt is made to service the record-changer mechanism, first check the records the customer is using. Warped records, chipped records, records of off-size diameter or center-hole, records that are just a shade too thick or too thin, all contribute to unsatisfactory automatic record-changer operation. They are illustrated in Fig. 5, and are especially troublesome in the types of changers which employ separating knives for feeding the records. Some of the early models of these machines are very critical in this respect. Get the customer to discard all records having these defects. Also some of the older records do not have the proper eccentric groove in the finish and therefore are not suitable for use in an auto-



Fig. 5. Warped records, chipped records, records of off-size diameter, etc., contribute to automatic record changer servicing problems.

matic record changer. However, they may be played manually one at a time. It is always well to have enough perfect records on hand to give the machine a fair test so that any troubles due to imperfect records may be immediately recognized and checked as such.

The mechanical parts of most automatic record changers are very similar to, and quite as delicate as, those found in typewriters. Most of these mechanisms consist of a multiplicity of levers, cams and gears (see Fig. 6). As most of the levers are made of thin metal, the mechanism, when working on it, should be handled carefully to avoid bending any of them. As all of the actions that take place with the mechanical parts are visible, a careful inspection of their movements during a few cycles of the mechanism will often reveal where the trouble lies and just what must be done to correct it.

When running the changer through its cycle for this purpose, be careful to keep it in its normal upright position, since in most types the correct action depends upon the downward weight of the pickup and the correct tracking of the needle in the record groove. If the mechanism sticks or jams at some point before the cycle has been completed, do not force it. Find out what is causing it to stick or jam and correct it. Check especially for bent or misaligned parts, loosened set-screws, etc.

If the mechanism is binding, inspect it for bent parts, misalignment, and excessive wear at points where cams and pushrods make contact. Levers and other parts should not be so loose at their pivoted points that they cause jamming by obstructing the movements of other parts. Hard running may also be caused by lack of proper lubrication, or by excessive friction between gears and between large sliding surfaces. Such parts should not bind when they

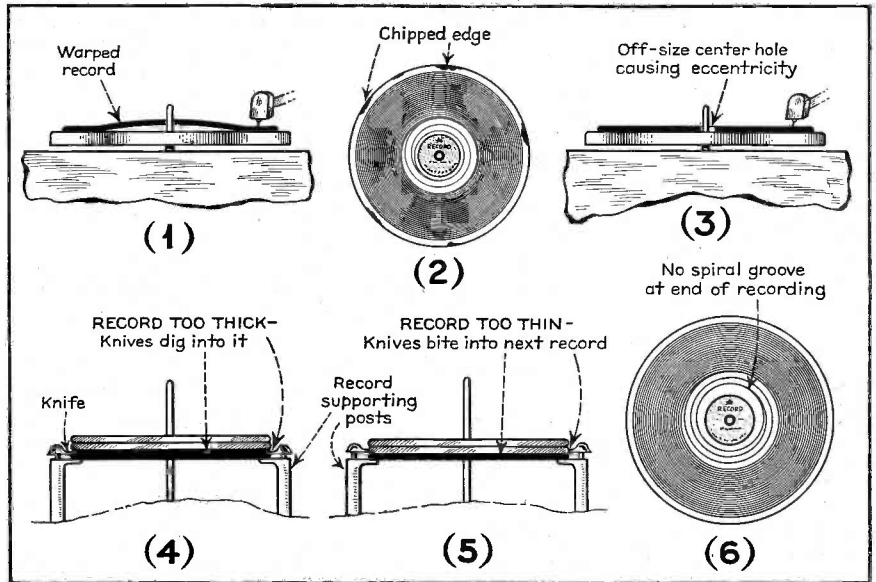

are operated by hand. If they do, it may be necessary to free them by adjusting their relative positions before applying lubrication.

The cams, levers, etc., are usually lubricated with a light grease, like petroleum jelly. The motors usually require oil. In all cases it is best to follow the lubrication recommendations specified by the manufacturer on the service sheet pertaining to the particular record changer.

If the mechanism has previously been overlubricated, a heavy collection of dust will probably be found on the parts—often sufficient to slow up and possibly stall the operation of the changer. In such cases, first clean off all dirt and oil with alcohol, kerosene or carbon tetrachloride, being careful not to get any into the motor windings or on any rubber surfaces. Then dry all the parts thoroughly, and apply the proper lubricants carefully—not to excess.

#### Phonograph Servicing Equipment

To service record players, recorders, record changers, etc., efficiently and successfully the service man should have

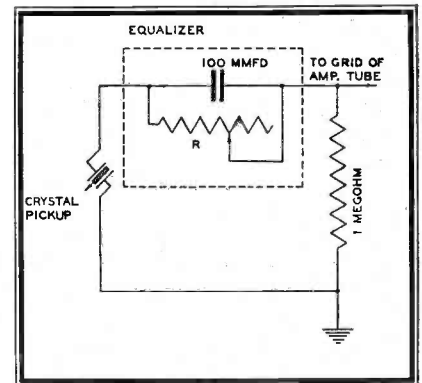

Fig. 7. An equalizer circuit for equalizing the response from a "boomy" phono-radio.

several pieces of special test equipment in addition to his regular units.

A compact record player is helpful as a check against doubtful pickups. This record player should have a good pickup with a known frequency response if possible, and a quiet, constant-speed motor and turntable. This unit can also serve double duty as a sample if the service man wants to try stocking and selling them.

Other equipment should include a stroboscope disc, a neon bulb, a record cleaner, one or more frequency test records, and a selected set of test recordings.

The stroboscope disc and neon bulb are used to check the speed of the turntable. The record cleaner is used to clean records before playing (dirt and grit wear records).

The frequency test records are used to test the frequency response of either the pickup or the entire audio system under test—or any part of it.

#### Use of Frequency Test Records

Commercial frequency-test records are useful and can be obtained from  
(Continued on page 28)

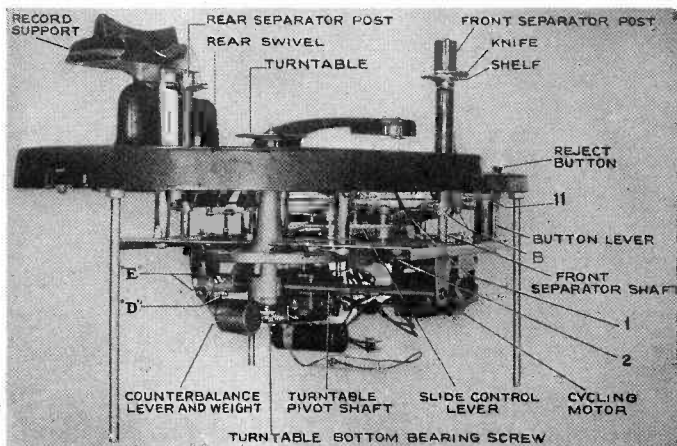

Fig. 6. Under-side view of a typical automatic record changer showing the multiplicity of cams and levers it contains.

Courtesy RCA

# SER-CUITS!

By HENRY HOWARD

**F**REQUENCY-modulation squelch systems and home recording and short wave receiver developments are among the features to be found in circuits discussed this month.

A phono model incorporating a home recorder is shown in Fig. 1. This is Silvertone model 7066, a 6 tube receiver including mike amplifier. The circuit is typical of the low-priced recorders and is very simple considering its versatility. Switch positions are as follows: Mike & Radio Recording, Mike Recording, Radio Recording, Radio Play, Phono Play, Mike, Mike & Radio—as many different functions as expensive combinations. An automatic record player, neon volume indicator and tone control are included. The recording level indicator operates from the output tube plate through a .01 condenser and 220,000 ohm resistor.

## Silvertone 7099

A more elaborate Silvertone is the model 7099, a 15 tube f-m/a-m com-

bination, with a 6SJ7 limiter and other refinements including a f-m squelch circuit with a 6J5. The audio end contains a pair of 6Y6Gs feeding a 12-inch woofer and 5-inch tweeter (haven't

seen many of these lately), both of which are electros.

In the squelch circuit the 6J5 squelch tube cathode and 6SQ7 audio tube cathode are tied together and returned to ground through a common 5,000 ohm resistor. If the heater to cathode leakage becomes excessive, only strong stations will be heard on f-m, in proportion to the false squelch action. This

Fig. 1. The Silvertone 7066 phono model, a moderate-priced 6 tube receiver that affords microphone and radio recording.

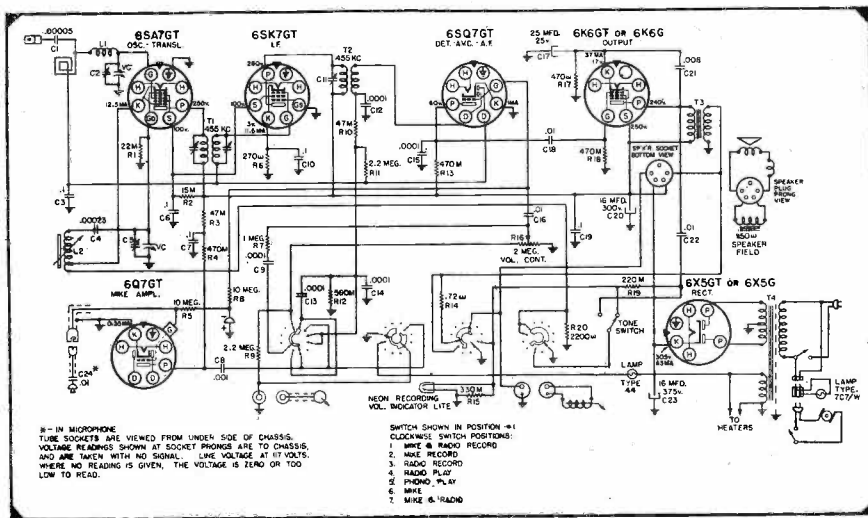
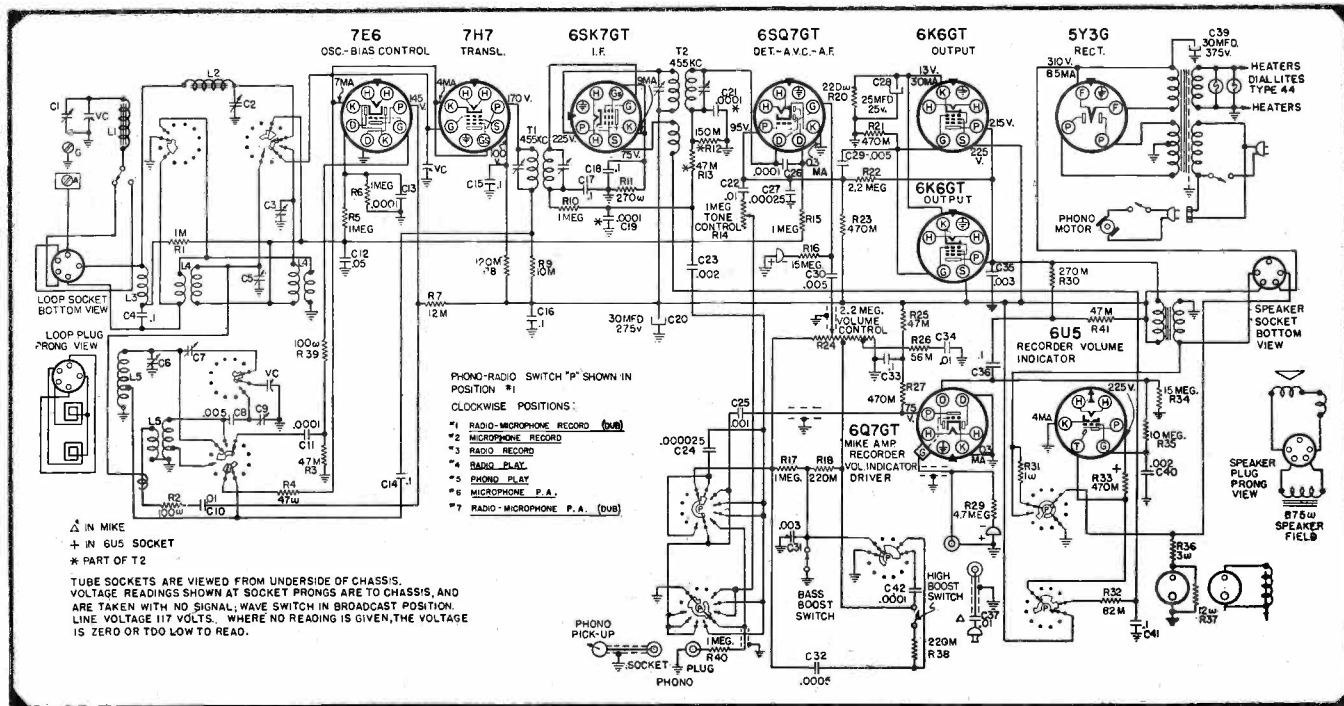
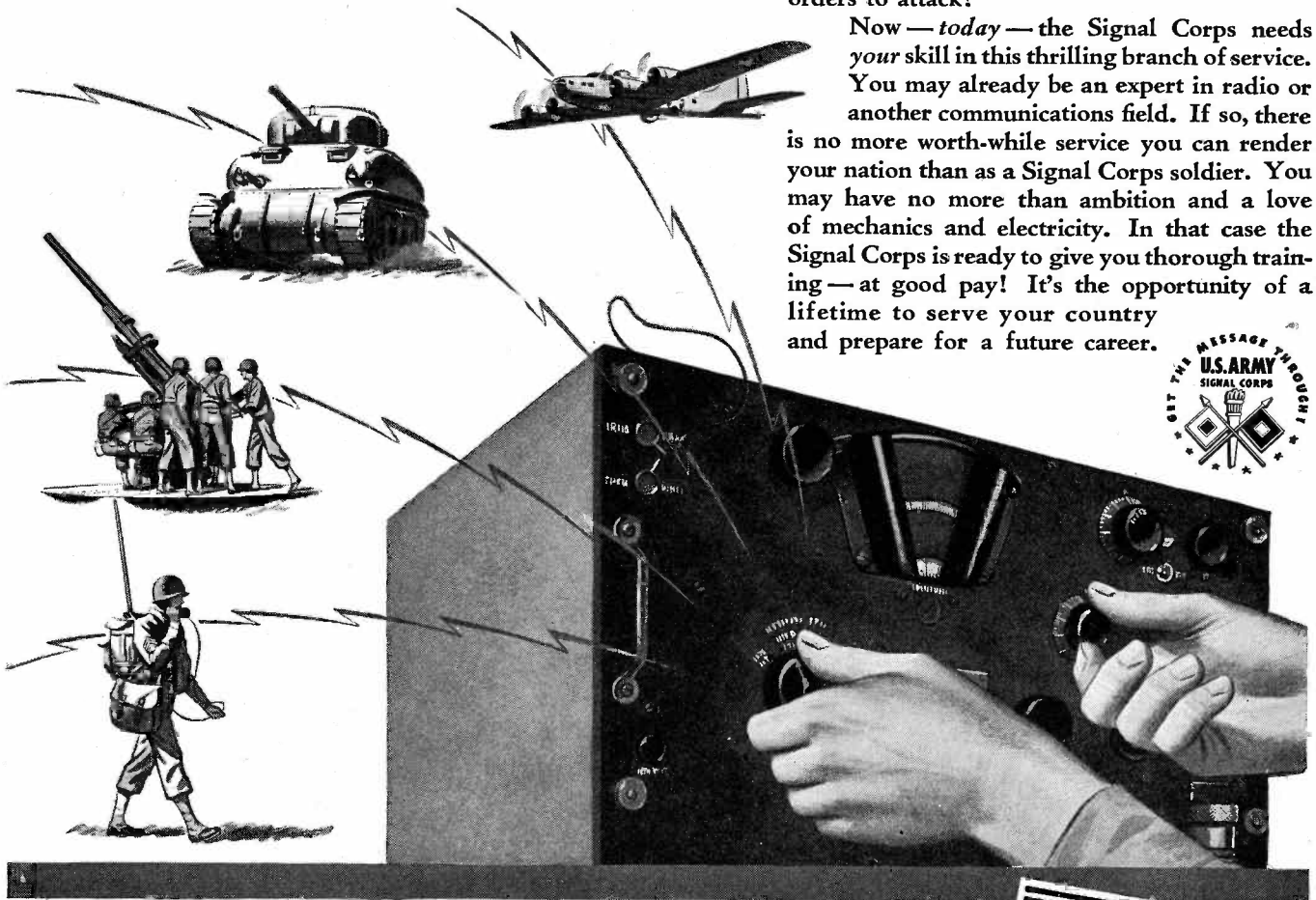

Fig. 2. The Silvertone 7168 with an unique preselection circuit that incorporates both loop tuning and translator tuning.



# The "Nerve Center of the Army" needs your skilled hands TODAY!



## HOW YOU CAN GET IN NOW

### 1. ENLISTMENT

If you are 18 to 45 and physically fit, you may apply for enlistment in the Signal Corps or in the Signal Corps Enlisted Reserve.

**DIRECT ENLISTMENT:** Experience as a licensed radio operator, a trained radio repairman, a telephone or telegraph worker, will qualify you for active duty at once. From Private's pay you can advance rapidly as you earn higher technical ratings—up to \$138 a month, with board, shelter and uniforms.

**ENLISTED RESERVE:** If you are skilled with tools but lack qualifying experience, you may enter the Enlisted Reserve. You will be given training, with pay, in one of the many Signal Corps schools, and ordered to active duty when you have completed the course.

**COMMISSIONS:** Graduate Electrical Engineers may apply for immediate commissions in the Signal Corps. And special opportunities for training and commissions are open to Juniors and Seniors in electrical engineering colleges.

### 2. CIVILIAN TRAINING

If you are over 16 years of age, and even though registered for Selective Service, have not received your order to report for induction, the Signal Corps offers you an outstanding opportunity.

If you have ability with tools—if you want to secure training in the vitally important field of communications—you may attend a school in or near your home city. You will be paid not less than \$1020 per year while learning. And when you have finished your training—in 9 months or less—you can advance to higher pay as your technical skill increases.

Even if you have a minor physical handicap, Signal Corps Civilian Training may give you the chance you've wanted to serve the Army of the United States.

**T**HIS is a war of speed—a radio war. Commands and messages must go through like lightning. Never have communications been so vital to victory, or have new devices meant so much.

The whole responsibility for "getting the message through" is in the hands of the U. S. Army Signal Corps. Hands that install and maintain countless thousands of radio sending and receiving sets—hands that adjust the marvelous mechanisms of America's newest and most secret weapons—hands that flash the orders to attack!

Now—*today*—the Signal Corps needs *your* skill in this thrilling branch of service. You may already be an expert in radio or another communications field. If so, there is no more worth-while service you can render your nation than as a Signal Corps soldier. You may have no more than ambition and a love of mechanics and electricity. In that case the Signal Corps is ready to give you thorough training—at good pay! It's the opportunity of a lifetime to serve your country and prepare for a future career.



**"KEEP'EM FLYING!"**

## U. S. Army

FOR FURTHER INFORMATION REGARDING ENLISTMENT—Call and talk this over at the nearest Army Recruiting and Induction Station. Or write to: "The Commanding General," of the Service Command nearest you:

- First Service Command ..... Boston, Massachusetts
- Second Service Command ..... Governors Island, New York
- Third Service Command ..... Baltimore, Maryland
- Fourth Service Command ..... Atlanta, Georgia
- Fifth Service Command ..... Fort Hayes, Columbus, Ohio
- Sixth Service Command ..... Chicago, Illinois
- Seventh Service Command ..... Omaha, Nebraska
- Eighth Service Command ..... Fort Sam Houston, Texas
- Ninth Service Command ..... Fort Douglas, Utah

Or write to: Enlisted Branch, AJ-1, A.G.O., Washington, D. C.

★ ★ ★

FOR CIVILIAN TRAINING INFORMATION—Call at any office of the U. S. Civil Service or U. S. Employment Bureau.

SERVICE, SEPTEMBER, 1942 • 9

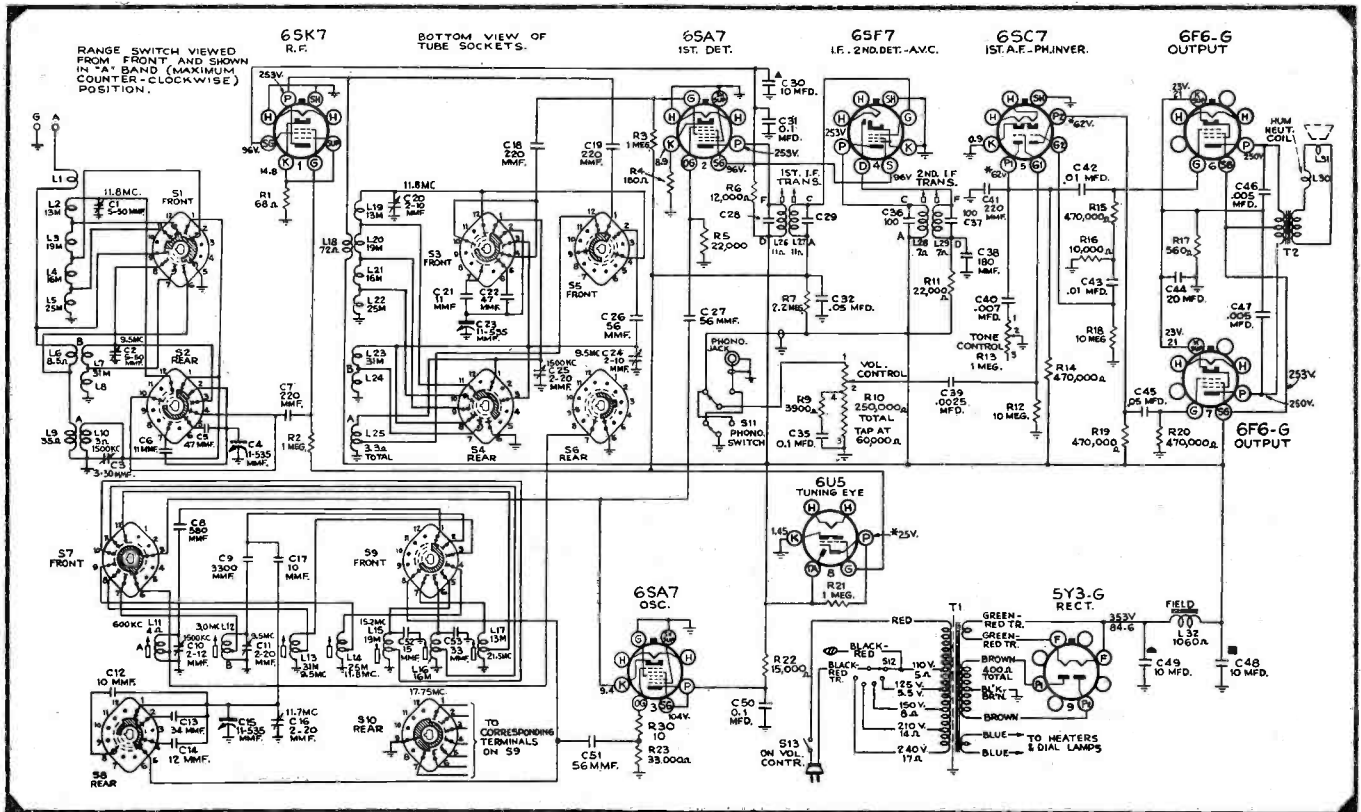

Fig. 3. The Silvertone 9 tube 7915, featuring five spread band operation.

low for developing avc voltage. Note that the output stage has two 6K6GTs in parallel. Screen grid regeneration is used in the 6SK7GT i-f stage and some sort of regeneration is used in the translator stage by feeding back from the low side of the i-f transformer primary to the cathode tap on the oscillator coil. All in all, this is an unusual receiver, really something to puzzle any service man without a circuit diagram.

#### Silvertone 7915

Fig. 3 shows a receiver which uses two 6SA7s, one as oscillator, the other as converter. This is model 7915 Silvertone, a 9 tube, 7 band superhet. Designed largely for short wave reception, it features five spread bands; 3.0-9.5 mc, medium wave band and broadcast. It has a tuning drive ratio of 25:1 and an r-f stage on all bands. The oscillator tube is connected essentially as a triode with screen grid and plate tied together. Note the grid suppressor to attenuate parasitic oscillations. Coupling to the 1st detector is effected by tying the oscillator grid (grid No. 1) of the detector to the cathode of the oscillator tube. The detector cathode resistor is un-bypassed. Magnetite-core i-f transformers and oscillator coils are used.

#### Silvertone 7134

In these days of conservative opera-

condition may be checked by removing the 6J5 from the socket and observing the performance; if not ok, a new low leakage 6SQ7 must be used.

#### Silvertone 7068 and 7168

In Silvertone models 7068 and 7168, we have phono-recorder combinations with 9 tubes, 3 bands. Seven modes of operating the receiver are the same as the small set previously described. Note the preselection circuit in Fig. 2 which incorporates both loop tuning and translator (1st detector) tuning with a 3 gang variable. A short wave loop is also provided. Another unusual feature is the iron cored loop loading coil

Fig. 4. The Silvertone 7134, 6 tube a-c/d-c receiver, with an effective pilot light circuit.

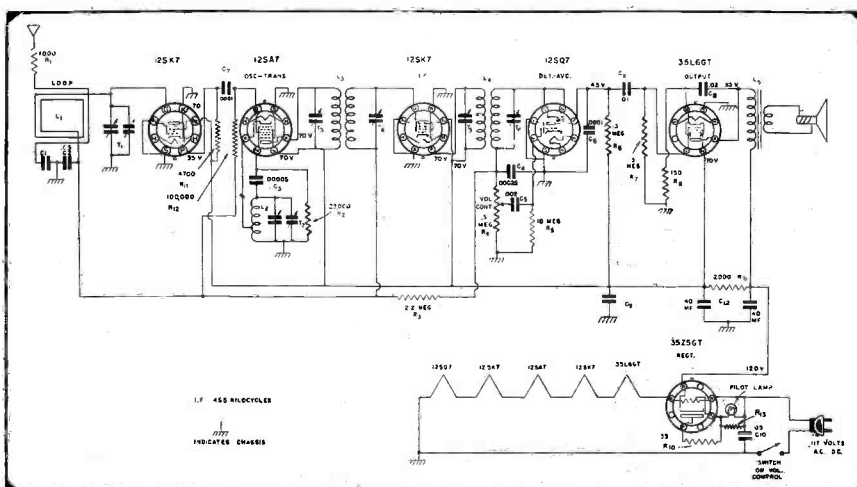

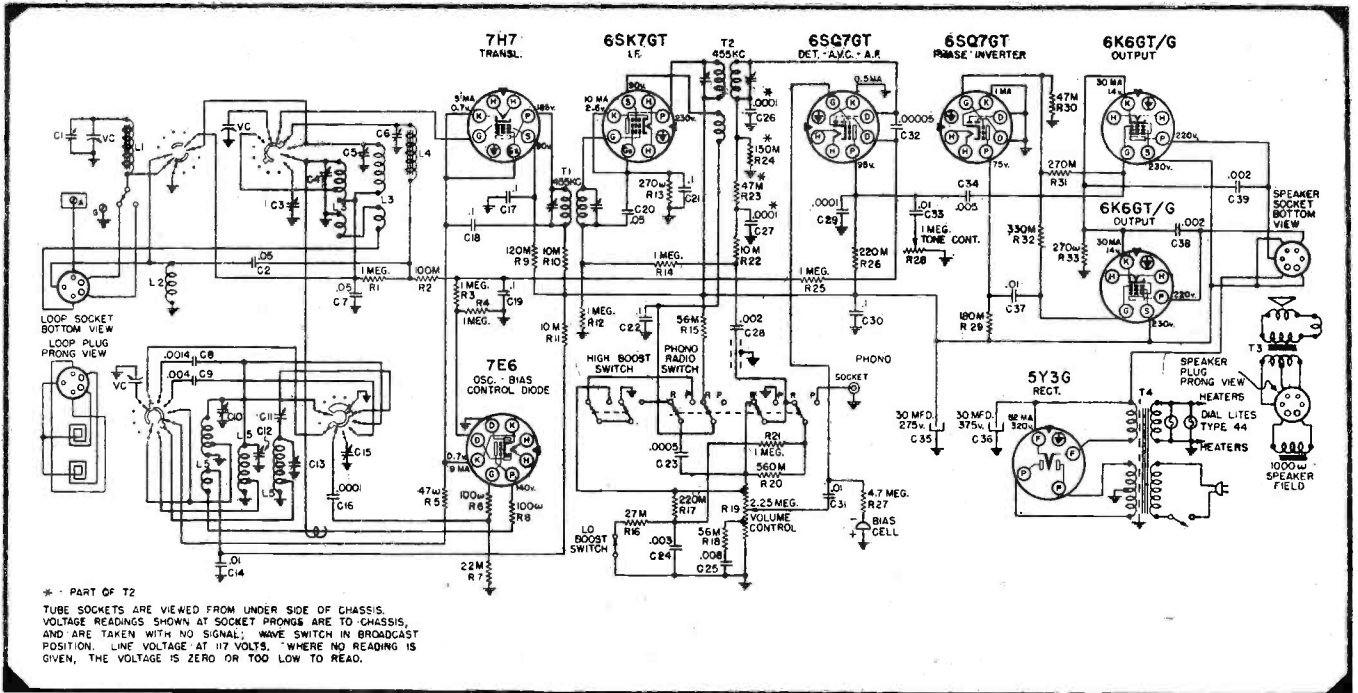
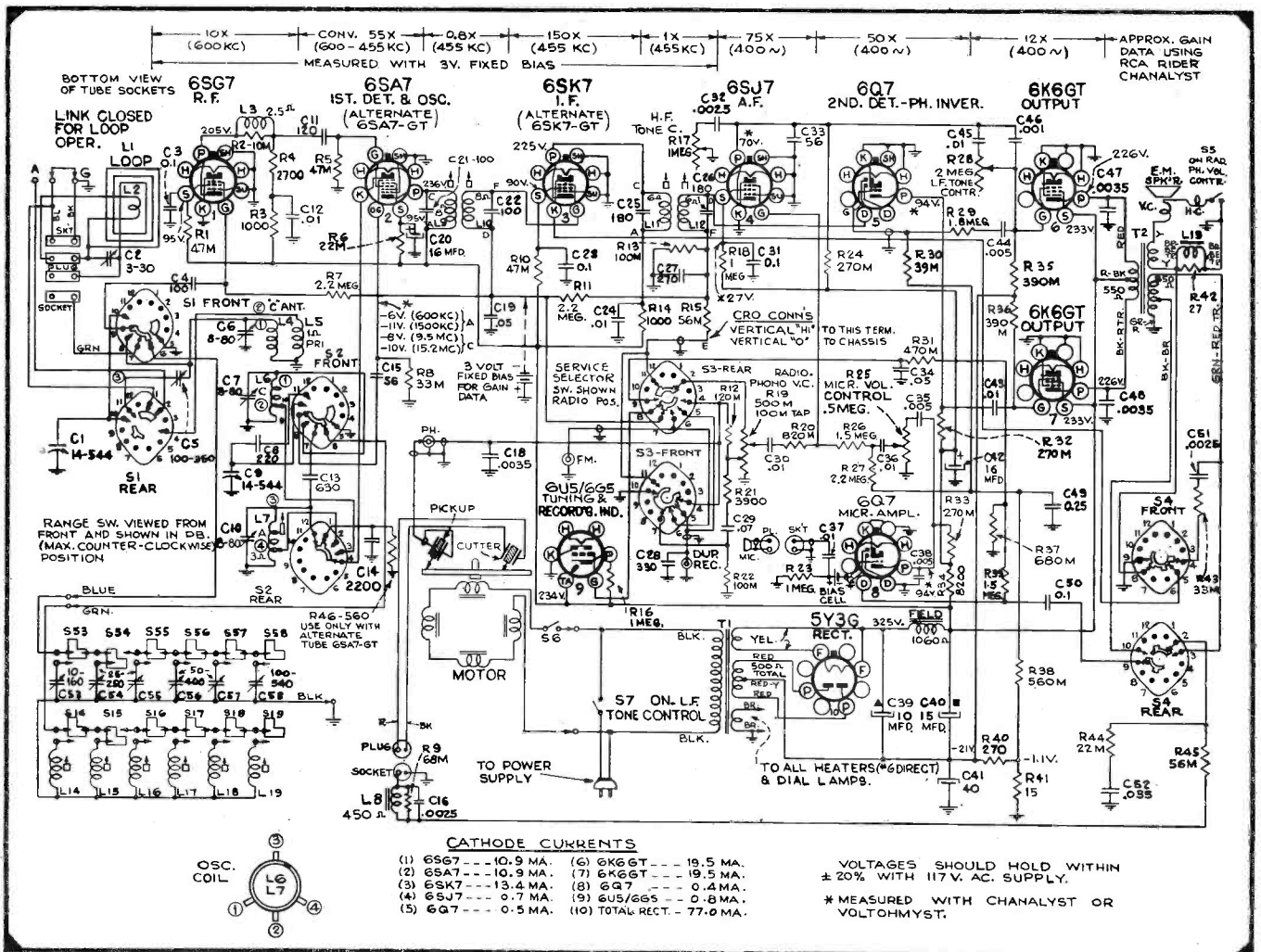

Fig. 5. The Silvertone 7051.

tion, the pilot lamp situation—unimportant as it may seem—comes in for a lot of attention. Silvertone model 7134, 6 tube a-c/d-c set, simply places a 200 to 400 ohm resistor in shunt with the

Fig. 6. The RCA VHR-212 home recording phono combination.

lamp, giving it considerable protection against burnout. See Fig. 4. In Sears model 7051, the loop primary winding is used as an open-ended short wave antenna. This model is an



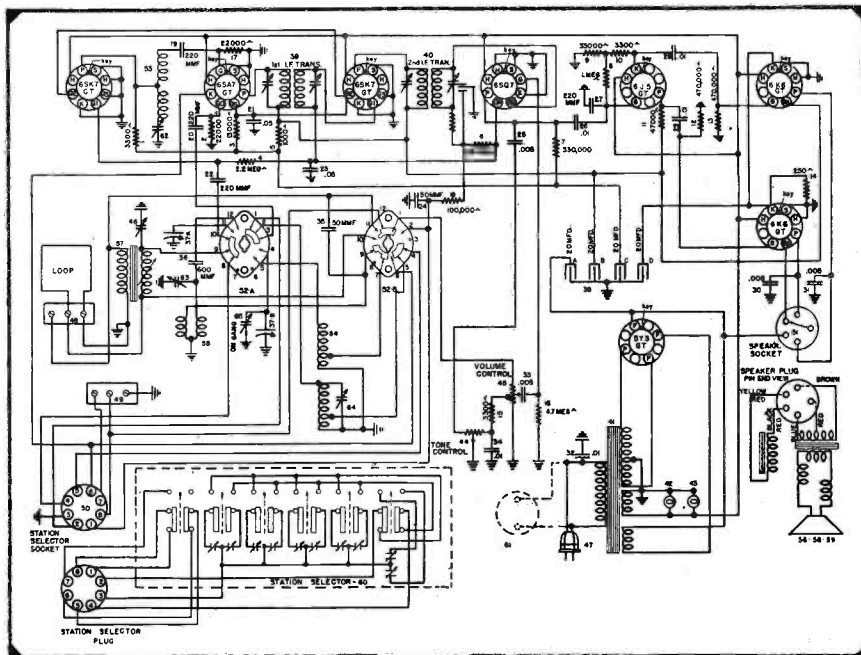

Fig. 7. The Crosley 96.

8 tube, 4 band job with low impedance loops and 3-gang tuning. See Fig. 5. A number of console receivers use a small open-ended aerial running around the cabinet for short wave reception but this is the first receiver we have noticed which uses part of the loop for the job. In good locations, free from man-made static, these small antennas are quite sufficient for foreign reception but provision is made for an external antenna, of course. Note the separate switch for selecting broadcast or short wave loop.

The RCA Victrola model VHR-212 home recording phono combination is a 10 tube job, with the usual recording facilities plus provision for plugging in an external record player for re-recording, or duplicating an existing record. The original record is played on the external record player and the copy is cut on the recorder. The circuit of this receiver is quite elaborate as we can see from Fig. 6. The audio amplifier has some unusual features. Note the 6SJ7 1st a-f stage with the high cutting tone control from plate to ground and the low cutting tone control (good for eliminating rumble in a record player) in the coupling circuit from 1st to power a-f.

The service data folder on this receiver is positively excellent for shooting trouble in the automatic player. First the entire cycle of operation is explained. Second, there is a quick reference chart for adjustments such as: mechanism jams, irregular operation, turntable not free, spacing between record posts, record shelf timing, point of landing of sapphire, height of pickup-arm in cycle, etc. Diagrams are shown

for the following troubles: fails to trip, trips early, trips continuously, repeats playing of last record, record stack unsteady, tone-arm returns to rest continuously, lands incorrectly, repeats grooves, jams records, slow speed, fails to track or distorts, sapphire strikes stud or motorboard, also replacement of sapphire. Three cheers to RCA for this folder.

Fig. 7 shows a very good antenna coupling system used in Crosley model 96 chassis. On loop operation, a low impedance loop is loaded by one winding of an iron core transformer. When an external antenna is connected, this loading coil acts as a transformer secondary; coupling being effected just as in a low frequency system.

## A POWER SHIFTER

(See Front Cover)

ON the cover is a circuit of the unique power model 4714 Silvertone Power Shifter—a power supply for operating 1.5 volt battery sets of 4 to 6 tubes, from a 6 volt storage battery. There are two separate supplies for "A" and "B" which are completely isolated so as not to short out the bias resistor of some sets, usually connected between "—B" and the filament battery.

### The "A" Supply

The 1.4 volt "A" supply consists of a r-f choke, a No. 81 auto lamp, an iron core choke, ½ mfd. paper con-

denser, a 1500 mfd. 3 volt electrolytic and three shunt 5 ohm rheostats.

### The R-F Filter

The r-f choke and ½ mfd. condenser constitute an r-f filter to combat "hash" due to the vibrator of the "B" supply. The auto lamp acts as a ballast resistor or voltage regulator, burning dimly on no load and fairly bright with load—the brilliance being proportional to the load. To you non-auto owners—type 81 lamp is a 6 candlepower single center contact standard bayonet base, 6-8 volt panel or dome light with a round bulb ¾ inch in diameter, normally drawing about an ampere.

### The A-F Choke and Condenser

The a-f choke and 1500 mfd. condenser form the low frequency filter for eliminating fluctuations due to the vibrator and battery charger, if such be used. The rheostats are set at the factory at 3.5 ohms for Q, 4.0 ohms for R and 4.67 ohms for S, but they may be easily reset when required with the aid of a small screwdriver. The no-load output is 2.2 volts and the storage battery drain varies from 1.9 amps at 6 volts to 2.4 amps at 8 volts.

The voltage regulation of this type of filament supply is usually pretty terrible, but this one is quite safe as long as the tap changer pin is not removed while in use. For instance, in a five tube receiver with the pin properly connected to R, the output voltage is 1.4 volts. If one tube burns out (assuming a 50 mil tube), the voltage will rise to only 1.445; if two tubes let go, the voltage will rise to 1.55. Hence, no catastrophe is likely to occur.

### The "B" Supply

The 90 volt "B" supply consists of a non-synchronous vibrator, transformer, .05 mfd. 600 volt buffer, 6X5GT rectifier, 50 ohm surge resistor, condenser input filter consisting of two 8 mfd. 150 volt 'lytics and a choke, and a ½ mfd. paper condenser and 50 ohm output resistor to help kill the hash. At 6 volts input, the output voltage is 90 with a 10 mil load. A ½ mfd. by-pass is connected from "B—" to chassis to aid stability in certain sets. As the vibrator is lightly loaded, the point should not become pitted for several thousand hours. To minimize hash and hum, it is expedient to keep the connecting leads to the receiver as short as possible. When a longer battery cable is required, it should be shielded. Also, if any parts are replaced, the same relative position as originally assembled must be kept to be on the safe side. Vibrator units are funny that way. Don't you be fooled!

# SERVICING POWER SUPPLIES

By MARK GLASER

OLD sets invariably use large, efficient filter chokes and small paper condensers, usually 1 or 2 mfd. and seldom exceeding 4 mfd. Around 10 years ago the wet, then dry electrolytics became popular, replacing the paper condensers and changing the whole power supply philosophy to one of brute force filtering. Chokes shrunk in size and were largely replaced by resistors in cheap receivers. This bit of history may seem superfluous but it gives several clues on handling power supply repairs.

## Replacing High Voltage Condensers

In replacing a high voltage paper condenser in an old timer (particularly the first filter section), two electrolytics may be used, series connected. It is recommended that similar condensers of the same manufacturer be used rather than different makes or ratings because the characteristics won't match. One section may have much more leakage than the other, which would greatly unbalance the voltage distribution. Fig. 1 shows a simple method of insuring proper voltage distribution by shunting each section with a resistor. This is recommended even for like condensers, but, in this case, the values may be much higher. Typical values may be 0.1 to 0.2 meg or lower for unlike condensers, while  $\frac{1}{4}$  to 1 megohm should suffice for like units known to be in first class condition. It is better to use the lower values and be sure the wattage is sufficient. In the higher values, 1 watt is sufficient, while 2 to 3 watt units may be required for low resistance shunts.

## Complicated Filter Systems

Many old-type receivers that have

Fig. 1. Methods of connecting electrolytics in series for even voltage distribution.

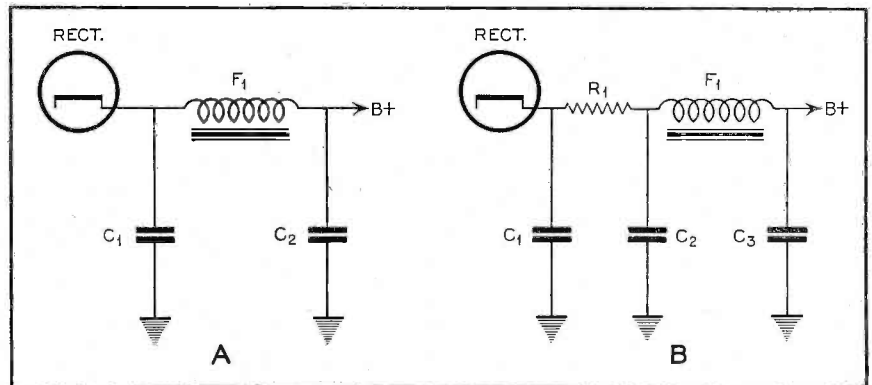
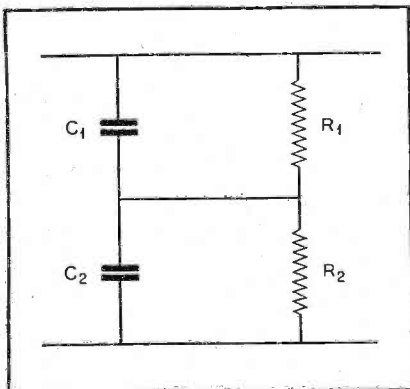

Fig. 2A (left). A conventional hum filter used in a majority of simple receivers.  
Fig. 2B (right). A resistance choke filter reducing hum level.

complicated filter systems consisting of two or three sections can often be repaired by brute force tactics—such as replacing a defective choke and condenser with a single large electrolytic. On the other hand, sets having large filter condensers may be serviced with low capacity sections if an additional filter section of resistance and capacity is added, as in Fig. 2A, showing original high capacity section using the speaker field as a choke converted to Fig. 2B. In some cases Fig. 3B should supplant Fig. 3A where smaller condensers must be used—and the hum will usually be lowered.

On the larger a-c receivers, an input choke may be used, permitting a lower voltage first condenser and smaller capacities than originally used, changing from the original circuit in Fig. 4A to that of 4B. Smaller condensers may also be used when an additional filter section is added for the more sensitive circuits, such as the resistance-capacity section shown in Fig. 5.

Fig. 6A shows a common filter circuit using the speaker field in the negative leg, the drop across it (or part of it) being used as bias for the final stage. A common positive condenser is indicated. For replacement, a condenser with common negative may be used provided that a new source of bias is provided and the series filter element is put in the positive leg, as in Fig. 6B. For bias, a cathode resistor of 150 to 600 ohms will do the job, depending upon the tube used as well as other circuit constants such as the output trans-

former design. Just a note on voltage-doubler circuits: you can't use a dual condenser with common negative for replacement purposes.

## Hum-Bucking Circuits

Hum-bucking circuits were mentioned in the August issue. Figs. 7A and 7B show two of the schemes in use. The first is a novel method using a tapped choke and trimmer condenser, the choke giving an out-of-phase voltage and the trimmer adjusting the magnitude to equal that of the hum voltage. The second method feeds the

Fig. 3A (top). A three-section resistance filter shown here is less efficient than the one shown in B.

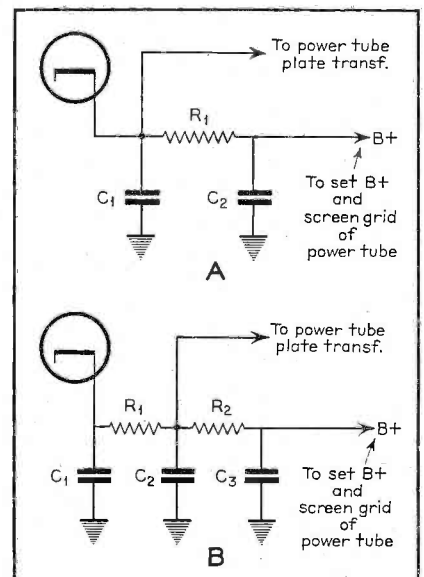

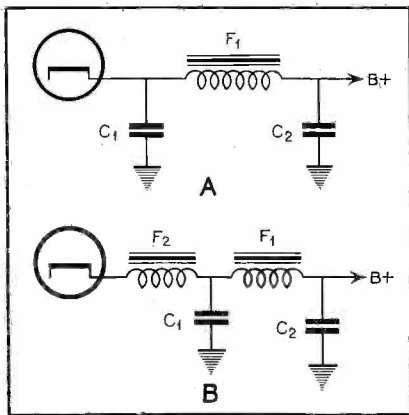

Fig. 4. A choke input system used in larger high power receivers.

phase opposition voltage into the power tube cathode using a resistor for adjustment. Some receivers utilize a phasing resistor in series with the first filter condenser which produces a similar voltage.

The introduction of audio degeneration a few years ago aided the hum-elimination program. Although its principal function was to flatten amplifier response by feeding back more voltage on the peaks than in the low spots, the amount of hum is often considerably reduced . . . approximately in proportion to the amount of feedback.

Another "hum-killer" is the tuned filter which, although never very popular, may be used in a pinch to produce very adequate filtering. One method of utilizing a tuned filter is to place various sizes of paper condensers across the choke, or speaker field acting as a choke, until the proper value is found . . . really a tuning process. This acts like an anti-resonant circuit, or wave trap, stopping the principal hum frequency (fundamental).

#### Bass Frequency and Hums

It is important to consider hum or ripple as a bass note. When the low frequency response is cut, so is the hum. Improve the bass and the hum appears to increase. The final filter condenser

(or the condenser tied to the audio circuits) because of its a-f by-pass action, has a large effect on the lows. All servicemen have surely noticed that, when a final dry electrolytic section dries up or otherwise becomes ineffective without shorting, there is a tinny quality to the set caused by the absence of bass. Replacing the condenser brings back the lows and also contributes to the filtering. It may well happen that the bass is brought up more than the hum is attenuated with the result that there is a net increase in hum. But try to convince an argumentative customer of this! When cone speakers started to replace horns in the "old days" one of the main drawbacks to a sale was the appearance of a hum that was not obvious with the old horn. The horn, of course, had almost no bass output.

#### Electrolytics and Forming Processes

When electrolytics, particularly wets, have remained on the shelf for many

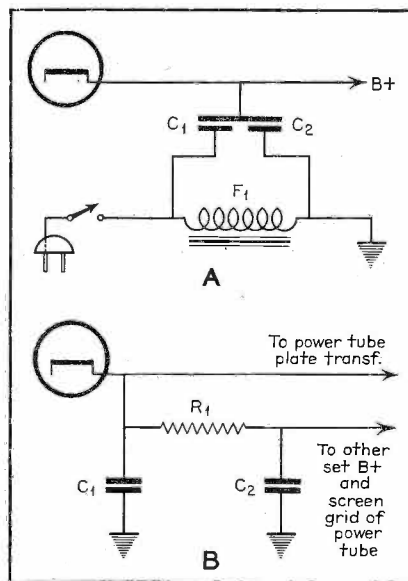

Fig. 6A (top). A conventional common positive filter system. In B (bottom) we have a conversion to common negative.

months, they become deformed. In this state, a severe surge takes place when

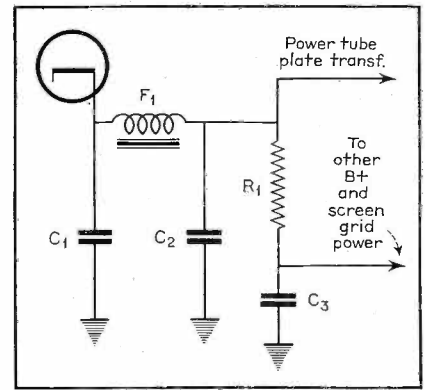

Fig. 5. A dual B plus distribution system.

they are connected in a high voltage circuit. To prevent damaging the rectifier or power transformer, the condenser should be re-formed before putting it into service. It may be placed in the circuit where it is to be used, but in series with a protective resistor. A better idea may be to construct a simple "B" supply out of parts from the "junk box" with facilities for measuring the voltage and current drain, so as to have an indication of the progress of the forming. The series resistor is an automatic regulating device, automatically increasing the voltage as the condenser forms. When the current has dropped to a reasonable value, the resistor should be removed, leaving the condenser ready for action.

We don't often talk of the power factor of a filter condenser in the servicing game, but we must bear in mind that a condenser with a poor power factor will not do a great deal of filtering although it may appear okay on a simple capacity test. Poor p-f will cause a condenser to run hot, which is usually the beginning of the end. In making condenser replacements, be careful not to place them in hot spots . . . keep 'em cool! They will live longer.

We'll bet that many a good Service Man in one of his weaker moments has applied an electrolytic with reversed polarity to a set under observation. The rectifier may not have given up, but it probably groaned. To avoid such a common mishap why not make up a test condenser by connecting a pair of condensers back-to-back in a bucking fashion so that the combination will serve equally well with either connection?

#### Filter Choke Replacements

In sizing up filter chokes for possible replacement use, don't forget that you have an adjustment in the amount of air gap. Where the d-c drain is large and you think the choke can take it in so far as heating is concerned, it often helps to open up the air gap which, un-

(Continued on page 31)

Fig. 7A (left). A novel hum neutralizing system for producing out-of-phase a-c voltage to the grid of the first a-f. In B (right), we have another method of producing hum bucking voltage to the final stage.

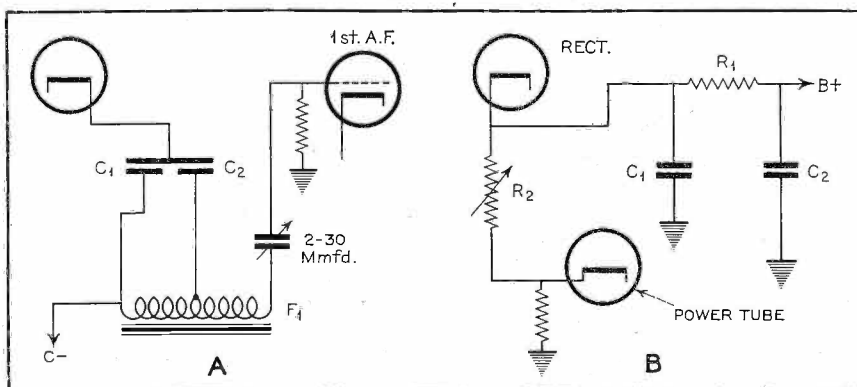





MACHINED ROD TO SPUN TUBING  
SAVING 50% BRASS



BRASS INSERT AND SCREW TO PH SCREW ONLY  
SAVING 100% BRASS



DRAWN ALUMINUM TO BAKELITE  
SAVING 100% ALUMINUM



DIECAST TO DRAWN  
SAVING 70% ALUMINUM

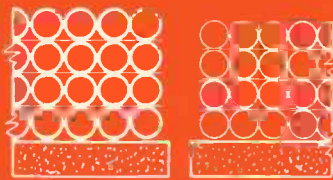

GLASS INSULATED TO FORMVAR  
SPACE FACTOR SAVING 10% COPPER



STAINLESS TO PLATED STEEL  
SAVING 18% NICKEL

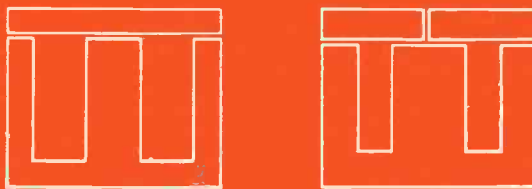

BLANKED LAMINATION TO SCRAPLESS  
SAVING 35% SILICON STEEL

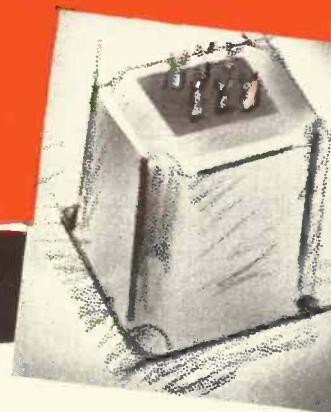

"and it can win or lose the war..."

We all know that our greatest problem today lies in material shortages. The bulk of this problem . . . and it can win or lose the war . . . lies in our hands. A waste of materials, particularly critical materials, in an engineering design today, is as damnable as sabotage.

**Here are a few cases in our organization:**

1. On one job our redesign combined two pieces of apparatus. The resultant unit, while more efficient, is smaller than either of the individual units. On the basis of projected requirements, the saving in aluminum alone is 500,000 lbs.
2. On this job our delivery schedule would have been delayed five months for the nickel iron core material and shielding cases required. Redesign made possible a unit using silicon core material and silicon shields with actually 10 DB less hum pickup than the original.
3. In this job substitution of a drawn aluminum housing for a die casting effected an aluminum saving of 70%.

Designs must be improved constantly. Take a look at that job you have been running and see whether an extruded rod or a spun bushing won't save the scrap involved in a screw machine part. Check with the Government Engineering Bureau involved as to whether they would not allow a change in material to something lower on the critical list. You will be surprised at their cooperation.

Only when you can say to yourself, "There isn't one of my designs left that can be reduced in amount of material or to less critical materials," can you feel that your share in the War Program is effective.

# UNITED TRANSFORMER CO.

150 VARICK STREET



NEW YORK, N. Y.

EXPORT DIVISION: 100 VARICK STREET NEW YORK, N. Y. CABLES: 'ARLAB

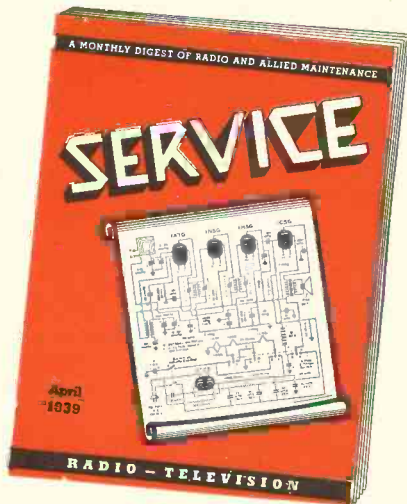

# Geared to the Wartime Needs of Radio Service

SERVICE—19 E. 47th St., N. Y. C.

Please enter annual subscription (12 issues) for each of the undersigned for which payment is enclosed at the rate of \$1.00 each; foreign \$2.00. (This rate applies only on 4 or more subscriptions when occupations are given.)

Name .....

Address .....

City-State .....

Occupation .....

Title (Service Mgr., etc.) .....

Employed by .....

State whether Employer is a Service Organization, Dealer, Jobber or Manufacturer.....

Name .....

Address .....

City-State .....

Occupation .....

Title (Service Mgr., etc.) .....

Employed by .....

State whether Employer is a Service Organization, Dealer, Jobber or Manufacturer.....

Name .....

Address .....

City-State .....

Occupation .....

Title (Service Mgr., etc.) .....

Employed by .....

State whether Employer is a Service Organization, Dealer, Jobber or Manufacturer.....

Name .....

Address .....

City-State .....

Occupation .....

Title (Service Mgr., etc.) .....

Employed by .....

State whether Employer is a Service Organization, Dealer, Jobber or Manufacturer.....

## —When Exact Duplicates are Unavailable

Data prepared by a group of leading receiver design engineers discussing various circuits and procedure necessary for making component substitutions.

## —When even Substitutes are Unavailable

Articles by Editor Herzog and engineers from parts companies and laboratories dealing with repairs of components and accessories.

## —When Industrial Electronic Service is Required

Technical discussions by Alfred A. Ghirardi and other engineers who specialize in electronic development—for industry, for control, for protective use.

## —When the latest Data on Circuits are Needed

Henry Howard's circuit analyses each month with diagrams and parts values.

## —Sound—Case Histories—Shop Notes . . . . .



Remember that until further notice the Group Rate (**\$1.00 Yearly instead of the regular \$2.00 Yearly**) is still in effect.

# COMMUTATOR MAINTENANCE

By TED STERLING

**P**ROBABLY the most important unit in a generator or motor is the commutator. It is quite a delicate section of the power unit, and thus requires similarly delicate handling in its maintenance.

One of the first steps in the maintenance schedule of the commutator is the inspection of its color and condition. They should be clean, smooth and have a polished-brown color on the brush contact area. A bluish color indicates overheating.

Cleaning of the commutator seems simple enough and is, provided the simple rules are followed. Troubles can pile up quickly enough if these simple rules are ignored for the sake of haste. For instance, dirty or oily commutators should always be cleaned with a lintless cloth. Don't pick up anything around the shop. The lint on a cloth,

small as it is, can cause irreparable damage.

If the commutator has to be smoothed, the roughness should be removed by sandpapering or stoning while running the machine at no load. In the case of a generator, the sanding should be done with no field excitation on the generator. Emery cloth or an emery stone should never be used, for the emery is conducting. The proper stone to use is a commutator stone. Actually it is a rectangular piece of grindstone. If it is found necessary to use sandpaper, it should be wrapped partly around a wood block in order to present a straight flat surface. The stone or sandpaper is then placed against the rotating commutator with moderate pressure, and moved back and forth across the commutator surface, as illustrated below. At all times, extreme

care should be exercised, particularly where there are live parts.

## *Using a Lathe*

The use of a lathe, if the commutator is very rough is quite a practice. An extremely delicate operation, it should be performed by an expert. In this process, it is necessary to undercut the commutator segments slightly. And after the commutator is turned down, its brushes should be carefully refitted. This refitting step is not necessary when light sanding or stoning has been used.

In maintaining the commutators, many have a habit of putting oil and other lubricants on them. This should never be done. Proper brushes will provide the commutator with all the lubrication required to prevent all undue wear and build up a smooth operating glazed surface on the copper.

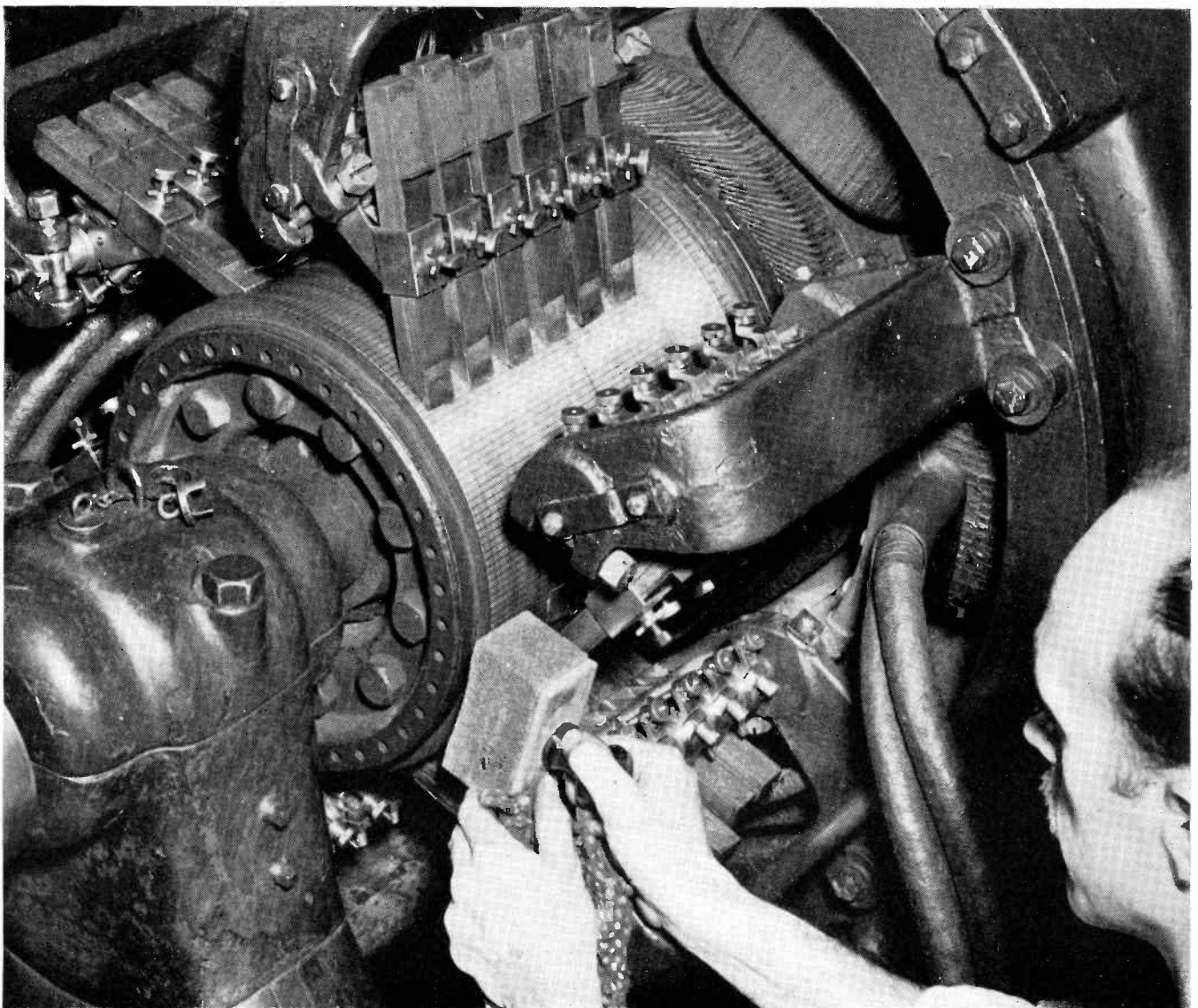

*Courtesy, General Electric*

SERVICE, SEPTEMBER, 1942 • 17

# CASE HISTORIES



## AIRLINE 62-207

*Very low volume:* Check with audio oscillator and oscillograph showed practically no gain in the first audio stage. This was due to the shunting effect of the dummy lug on the condenser block, used in this case as a tie point for the wiring. Moisture from within the condenser caused this lug to develop a leakage of about 40,000 ohms to ground. A new mounting post cleared the trouble.  
*Francis C. Wolven*

## AIRLINE 62-301 (BRC 1170)

*"Thin" tone at low volume levels:* Cause improper bass-compensation network. Replace volume control with 1 megohm tapped at 300,000 ohms from low side. Remove 5,000 ohm resistor and 0.05 mfd. condenser formerly used for bass compensation and replace with 30,000 ohm resistor and 0.008 mfd. condenser.

*Hum:* Often caused by cathode to heater leakage in 6F5 tube. Dress 6F5 grid lead from center contact on volume control away from heater connection and leads.  
*D. C. Sprong*

## EMERSON U-48

*Audio oscillation:* In cases where trouble is experienced with audio oscillation, check to see whether a condenser has been used from the plate of the 606 to the cathode to by-pass r-f voltages at this point. If such a condenser is not used it will be noticed that when the antenna lead is brought near the detector or output tube, oscillation will be evident. A 100 mmfd. condenser is suitable to connect across the 6C6 tube at this point.  
*Willard Moody*

## DE WALD 633

*Replacement of output tubes:* These sets use a type 25B5 output tube which few manufacturers make. Good results may be obtained by removing the ground connection to the cathode prong and connecting a 650 ohm, 1 watt resistor in parallel with a 10 mfd, 25-volt electrolytic from the cathode prong to ground and inserting a type 43 tube in the type 25B5 socket. The complete change can be made in a few minutes and at not much greater cost to the customer than replacement with type 25B5.  
*D. C. Sprong.*

## GENERAL ELECTRIC G 95

*Removing chassis and Beam-O-Scope from cabinet:* This 1939 'Radioforte' provides high fidelity and uses push button tuning exclusively for station selection. Push button tuning is essentially the same as that provided in the General Electric G 105 and G 106. In these receivers very little clearance is allowed, so that difficulty is experienced when re-connecting the Beam-O-Scope and when sliding the chassis into the cabinet. If the buttons, at the top of the selector rim, are moved to the left or right of center, an additional fraction of an inch clearance is gained. When the chassis is then raised, to slide the Beam-O-Scope connecting wires into place, is relatively easy. The button contacts generally require adjustment in every case, thus no time is lost by temporarily sliding them off center.  
*Willard Moody*

## GENERAL ELECTRIC H 639

*Intermittent:* Replace oscillator grid resistor with 50,000 ohm ½ watt resistor.  
*Willard Moody*

## HALSON 05

*Loss of sensitivity:* Lack of sensitivity in these models is often caused by the shorted or partially shorted volume control. Occasionally the short may be removed without replacing the control, although in most cases replacement is indicated.  
*Willard Moody*

## MAJESTIC 210, 211, 214, 215

*Insufficient volume on weak stations:* Cause insufficient audio gain. Remove 2,000 ohm resistor (R9) and replace with 4,500 ohm, ½ watt unit. Remove 20,000 ohm first audio plate load resistor (R5). Replace with 100,000-ohm, ½-watt unit. Remove 70,000-ohm diode-load resistor (R6) and replace with 100,000 ohm, ½ watt unit. Replace type 27 first audio tube with type 56.  
*D. C. Sprong*

## MOTOROLA 50, 60, 80

*Intermittent:* Set goes on and off while car is in operation. This may occur because the ground return lead inside the vibrator is broken. Replacing or resoldering this lead will eliminate the trouble.  
*Allen Siepman*

## PHILCO 37-690

*Crackling and popping; intermittent reception; or dead receiver:* May likely be caused by resistor No. 71 (1,000-ohm, ½ watt unit) intermittently opening. Replace with 1 watt unit as ½-watt unit heats considerably in operation. Also 6J5G tubes seem to suffer a high rate of mortality in these sets due to extreme sensitivity to microphonics, etc.  
*D. C. Sprong.*

## PHILCO 59

*Intermittent "cutting out" or fading:* Often caused by loose rivets in antenna and oscillator shields. Remove coils and shield cans. Tighten two rivets that fasten coil mounting strip to shields. These rivets become loose making a variable resistance ground connection for coils.

*Noisy, erratic:* If trouble is not a tube with loose elements tighten i-f transformer coils shield by tightening flange on bottom end of shield under chassis.  
*Poor sensitivity, instability:* Some individual sets were assembled with a red lead soldered to oscillator coil lug that goes to gang condenser and with free end wrapped approximately 1½ turns around lead from lug on antenna coil to antenna section of gang condenser. Remove this wire and resolder to terminal of oscillator coil that goes to 77 detector-oscillator tube and wrap approximately 1½ turns around lug on antenna coil which is connected to center terminal on volume control. Set can then be easily aligned and will be very stable.  
*D. C. Sprong*

## PHILCO 611

*Weak:* Weak reception in this model may be caused by an open 0.05 mfd. avc condenser connected to the grid return of the 6A7 mixer tube. Distortion either with or without hum modulation may be due to an open section in the filter condenser.  
*Willard Moody*

## RCA 99K, 99T

*Tone control action on these models is inadequate for some customers:* Replace 0.005 mfd. condenser (C22) with 0.01 mfd. 600-volt unit. After this change it will be noted that the greater part of control action is near bass end of rotation. To correct this trouble connect a 400,000 ohm, ½-watt resistor across tone control.  
*D. C. Sprong*

*(Continued on page 29)*

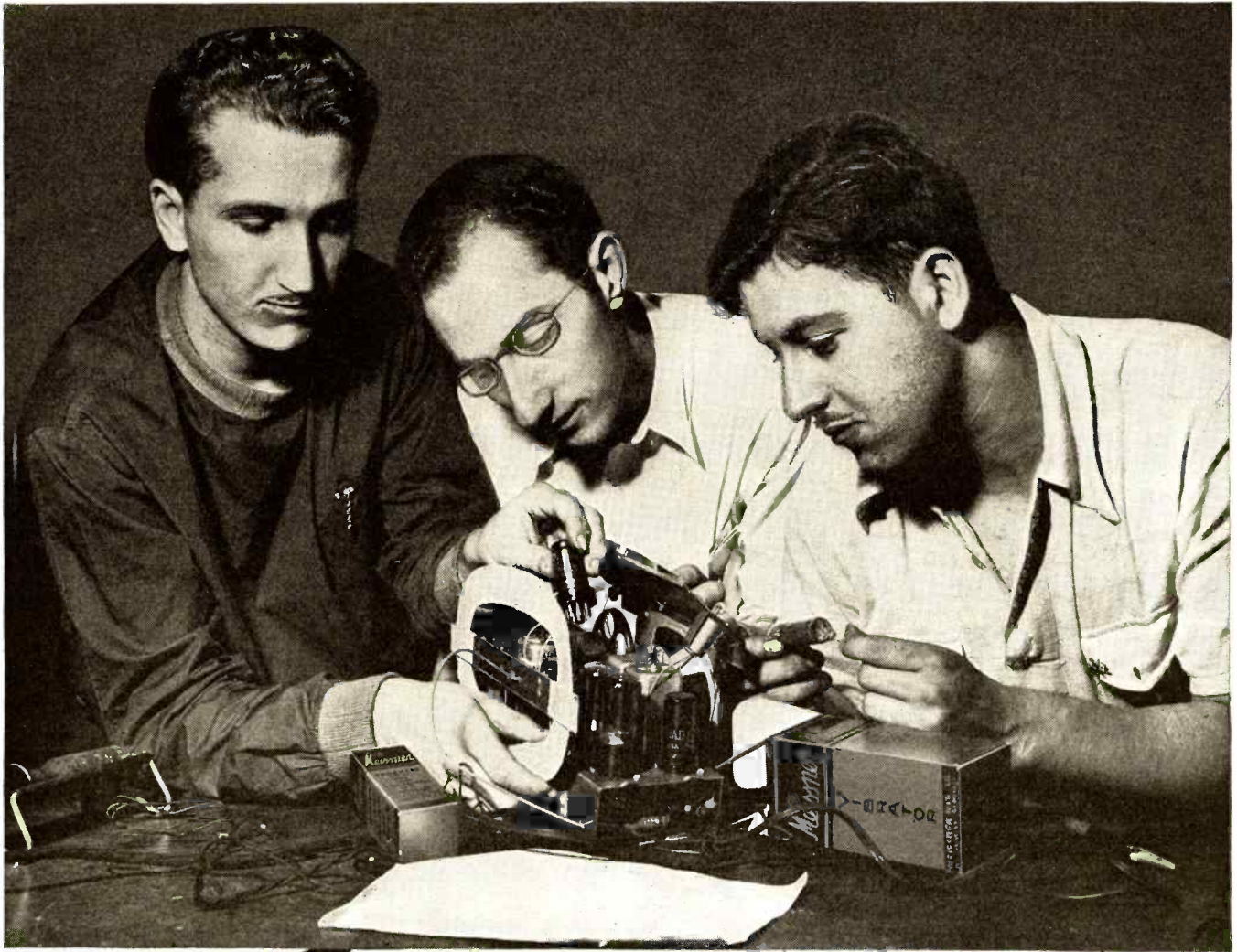

# Train 'em Faster with MEISSNER RADIO KITS

*Signal Corps Schools* know that in order to speed up radio training they must use kits that have been specially designed for student training purposes . . . Meissner radio kits are precision engineered for classroom use, saving valuable time for both instructor and student. Meissner pictorial Wiring diagrams simplify construction problems in basic radio training.

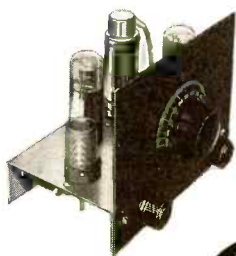

*Meissner* one, two and three tube add-on Kits are ideal for the beginner in classroom work . . . starting with a one tube Kit, students can, with the add-on features, construct two and three tube receivers—available for both AC and DC operations. Six and nine tube kits are available for the advanced student.

**See your Meissner distributor for special SCHOOL NET PRICES**

**Meissner**  
MT. CARMEL, ILLINOIS  
"PRECISION BUILT PRODUCTS"

# Farrell Says:

By C. H. FARRELL

EVERY so often a little, disquieting, bird-like voice, whispers bad news into my ear and I am duty bound to bring it to you whether I like it or not. Latest bit of chit chat is the news of a recent survey made in New England to ascertain the reactions of the citizens on the subject of radio servicing. The answers which the questioners received were enough to produce goose pimples as large as grape fruit on the individual and collective spines of the radio servicers of America.

Here, in a few thousand well chosen words, are the horrible details, and if you can get any consolation out of them, you're a dyed-in-the-wool optimist. Or a wishful thinker.

I cannot, for the life of me, figure out why anybody should start to get their vowels in an uproar about the way radio servicemen treat the set-owning public. Perhaps the recent *Reader's Digest* article on radio servicemen's methods has stirred up a hornet's nest among receiver manufacturers. There hasn't been a survey of servicemen's habits, practices or charges made in the last ten years that I couldn't have told in advance. In fact, I was once responsible for spending more than \$3,000 to conduct the most comprehensive survey of the American Servicer ever made and the answers to all of the questions were written down by me before the final compilations were arrived at. The estimate was so close to the final figures shown by the exhaustive survey that it was too bad the \$3,000 was spent.

And if the outfit which spent beaucoup bucks to ascertain the opinions of set owners in New England (or any other region) had asked me in advance, I could have told them the sad news. And it would have cost them a five cent telephone call. In addition, I could have told them that they were barking up the wrong tree. That would have been free, also.

It requires no crystal ball to divine the reaction of the average owner of a \$14.95 receiver to a servicing charge of \$5.00, which, in most cases, not only represents labor and replacement parts charges, but also the price of a tube or

two. John Q. Public can never understand the difference between costs on a mass produced article and the repair of single units of that article. Nor will Mr. Public, who is earning \$1.25 per hour in a war production plant ever concede that Johnny Servicer in a little hole-in-the-wall has justice or logic or plain common sense on his side when he charges \$2.00 or more per hour for his labor.

The genus homo is seldom given to thinking things through. He may have spent four years on relief or on the WPA and is only now beginning to know the feel of folding money in his pocket. He quite blandly accepts his fat pay envelope as though it were always his due, and, when the butcher or baker or restaurant owner is forced to tack a few pennies onto the price of everyday necessities, he cries: "Profiteer"! However justified the aforementioned repair charge of \$5.00 may be, it is almost a foregone conclusion that the customer will resent it. Let a serviceman do a "patch-up" job on a receiver which is coming apart at the seams; let another part or tube fail within two weeks, and the customer will immediately insist that the set be put in good working order again for the original charge. It would take the wisdom of a Solomon and the persuasiveness of a Churchill to make that customer understand that he or she is not being rooked when an additional charge for another "patch-up" job is made.

I know some service organizations which give dual estimates on all jobs which are brought in. They quote on "complete overhauls" and "patch up" jobs. The theory is that the customer must understand that when he orders a "patch up" job he is getting exactly what he pays for—and no more. But I know that not too many servicers are as wise as Solomon nor as rhetorically gifted as Churchill. They just try to calculate their charges to show them a profit and the customer is free to think the worst—and usually does.

It doesn't require a "survey" to establish the fact that the servicing fraternity—or at least a large part of it—does not bask in the sunshine of public

confidence. But a set manufacturer has just made this "startling discovery" and the future implications cannot be lightly laughed off.

## Manufacturers at Fault?

A FEW years ago I wrote a piece of advertising copy for a socket manufacturer who had suddenly been deluged with orders from parts jobbers. He was at a loss to understand the sudden demand for replacement sockets and launched an investigation. He called me to write the advertising copy based on the results of the investigation. The theme of the ad: "For Want of a Nail." The copy pointed out that a receiver manufacturer, penny wise and dollar foolish, had so cheapened his line of receivers that such obscure parts as tube sockets which were dielectrically valueless had been installed. The saving in socket costs per set would have amounted to less than two cents. Yet, this manufacturer staked his reputation on a line which was made up of junk parts.

Replacing tube sockets is not the toughest job in the world, but there must be a charge for it. Everybody who bought one of those receivers and was forced to spend good money to have new sockets installed was as sore as a boil. But NOT at the manufacturer! The servicers bore the brunt of public resentment.

This is not an isolated instance. Scores of thousands of mediocre (to put it mildly) receivers have been foisted on the public; receivers which should never have left the factory; receivers which were so poorly designed and manufactured that a manufacturer who had any pride would not have attached his trade mark to them. When they broke down; when they required re-wiring; who "took the rap?" Not the manufacturer!

When the questionnaires came around to the set owners, they cried out to the high heavens that the servicer was an incompetent profiteer!

## Scylla & Charybdis

ONE could hardly expect a manufacturer to concede that some of the faults prevalent in radio receivers originate on his own drawing boards and in his purchasing departments. It is so easy to "point the finger" at servicers and say "Something must be done about this servicing problem, and we are going to see to it that the public bring their sets only to those department stores and dealers whom we designate."

Such a move is in the mind of at least one manufacturer. And it is not

(Continued on page 31)

**Still YOUR BEST BET  
ON REPLACEMENTS!**



## **Centralab MIDGET RADIOHMS**

Servicemen recognize the "plus-performance" that these sturdy controls give on every replacement job... Old Man Centralab's good advice to "ALWAYS SPECIFY CENTRALAB" was never more timely than now . . . when it is so important to keep the "radio ears" of the nation properly tuned to the events of these critical moments in our history . . . For smooth, silent, sure attenuation, . . . specify CENTRALAB MIDGET RADIOHMS.

**CENTRALAB:** DIV. OF GLOBE-UNION INC.  
MILWAUKEE, WISCONSIN, U. S. A.



# ASK THE MAN WHO KNOWS



He's your Radio Parts Jobber! When you have an order that carries priority ratings or need some Astatic Product for replacement or repair of existing radio, public address or phonograph equipment, your Radio Parts Jobber is in a position to advise you concerning your requirements. Some products you desire may actually be immediately available in stock. Others may be procurable on order, and, of course, there will be those products in the Astatic line discontinued for the duration owing to the conversion of essential materials to wartime needs. Ask the man who knows . . . your Radio Parts Jobber!

## ASTATIC

### THE ASTATIC CORPORATION

YOUNGSTOWN, OHIO

Licensed Under Brush Development Co. Patents

In Canada Canadian Astatic Ltd Toronto, Ontario

*New, Handy*



## UNIVERSAL REPLACEMENT

*Capacitors*

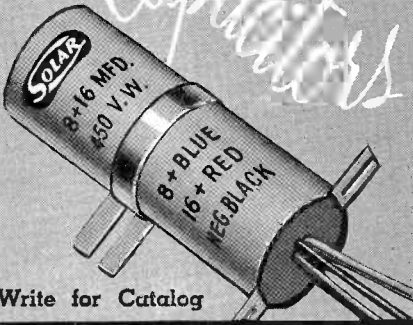

Write for Catalog

**SOLAR MFG. CORP.,  
Bayonne, N. J.**

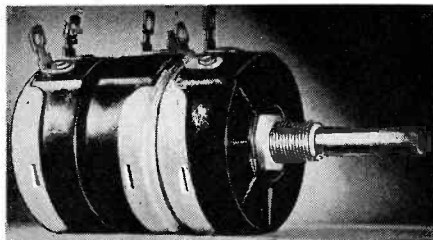

## P - A Controls

- ★ In servicing P-A and theatre sound installations, don't overlook that wide selection of sound-system controls offered by Clarostat. The wire-wound T-Pad constant-impedance series CIT-58 control here shown is typical. Also L-pads, mixers, faders, constant-impedance attenuators, etc. All are included in the Clarostat COMPLETE line of controls.
- ★ Likewise in servicing radio receivers, don't forget those Clarostat replacement controls, plug-in tube-type resistors, voltage-dropping power cords, etc.
- ★ Ask your local Clarostat jobber about these aids in your servicing. He's well equipped to take care of your usual and unusual needs.



### NATIONAL UNION RALLY

In recognition of the production achievements of the workers of National Union, a rally was held recently. More than 2,500 employees attended and listened to talks by Civic, Army and Navy leaders.

Below is a view of a section of the decorated stands. At the microphone is



S. W. Muldowney, president of National Union. At his left is Deputy Mayor Cozzolino of Newark, N. J. Seated are Capt. James Rhudy, U. S. A. and Walter Barry of CIO. A general view of the assemblage is seen below.

\* \* \*

### ARMY AND NAVY "E" TO HALLICRAFTERS

The Hallicrafters Inc., Chicago, Ill., have been notified by Under Secretary of War Robert P. Patterson that they have been awarded the Army and Navy "E" Banner.

The company was complimented in Mr. Patterson's notification letter for the "high achievement attained in the production of the war equipment."

"The high and practical patriotism of the men and women of The Hallicrafters Inc. is inspiring. Their record will be difficult to surpass, yet the Army and Navy have confidence that it was made only to be broken," continued the letter.

\* \* \*

### IRC WINS "E"

The International Resistance Company of Philadelphia, Pa., has been awarded the prized Army-Navy "E" award.

Official presentation of the pennant was made by Brigadier General A. A. Farmer, Commanding Officer in Charge of the Philadelphia Signal Corps Procurement District to Ernest Searing, president of the company. Sterling silver "E" pins to be worn by all IRC employees were presented by Lieutenant Commander Joseph L. Tinney, USNR, Public Relations Officer, Fourth Naval District.

To keep pace with the ever increasing demands of the war program, IRC in recent months has undertaken a vast expansion program, in which vital radio equipment is now being made.



**J. KAHN ELECTED SMC CHAIRMAN**

Jerome J. Kahn, president of Standard Transformer Corporation, has been elected chairman of the Sales Managers Club, Western Group, for the ensuing year. Mr. Kahn succeeds S. N. Shure of Shure Brothers, who has served for the past twelve months. Mr. Shure piloted the club through practically all of the initial priorities period, and during his administration the group prospered and expanded in educating jobbers and manufacturers on priorities developments.

Mr. Kahn who has been one of the most active manufacturers in the radio replacement parts field, was a member of the original Priorities Committee of the Radio Parts and Associated Industries. He was chairman of the Radio Victory Dinner held at the Stevens Hotel last June. Mr. Kahn was the original sponsor of the "Keep 'em Playing" campaign designed to bring pressure on the proper groups in Washington to make an allocation of critical materials for replacement parts for home receivers. He is now a member of the Radio Replacement Parts Industry Advisory Committee working with WPB, a director of the Radio Manufacturers Association, and chairman of the RMA Priorities Committee.

Paul H. Tartak, president of the Oxford Tartak Radio Corporation, was elected vice-chairman of the Group, while Miss H. A. Staniland of Quam-Nichols Company and Kenneth C. Prince, Chicago attorney, continue as treasurer and secretary respectively.

\* \* \*

**KEN-RAD DISPLAYS**

The Ken-Rad Tube & Lamp Corporation, Owensboro, Kentucky, is offering a new type of permanent plastic display in the form of an animated tube which ties in with the current merchandising program built around the theme "Ken-Rad on Parade."

The display is approximately 24" high and is reproduced in high relief and in full color. A slot is provided in the up-raised hand of the figure for insertion of a tube carton or display card.

A small charge covering only a portion of the cost of the display is made in order to insure its use by dealers who will give it proper space.

The first of a series of suggested window trims to utilize this display piece, as well



as other Ken-Rad displays to best advantage, is now also being offered to dealers. The display set consists of a large 19" x 24" easel card "Selected for Service," three window streamers illustrating the same theme, one cutout "Ken-Rad on Parade," a cutout "Tubes Tested Free," and two twin-tube cutouts to complete the set. Tube cartons and crepe paper trim are added to make a pleasing display high in attention value, yet easy for any dealer to construct with a minimum of effort or expense.

(Continued on page 24)

**YOU OUGHT TO BE MAKING REAL MONEY TODAY ...and here's how to do it!**

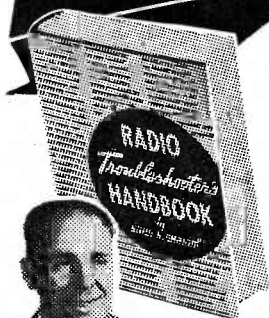

**ALFRED A. GHIRARDI**

**710 PAGES—NEW GREATLY ENLARGED!**

**The Data Book That Pays for Itself on a Single Job!**

**THESE MEN KNOW!**

"... paid for itself many fold. Contains more real, helpful information in less space than anything I've ever seen."

A. Colman, Johnson, Mich. "... most complete data book on the market. More than paid for itself the very first day."

E. Milton, Jr., New Orleans. To which others add: "A gold mine of technical information..." "Saves up to 25% of time to locate troubles..." "It paid for itself the first day."

✓ Save Time ✓ Cut Costs  
✓ Speed Up Your Work  
**... AND DO IT BETTER!**

With more radio service work to be done than ever before—but with fewer servicemen to do it—these are days when speed and efficiency count to the utmost. There's real money—BIG money—waiting for the man who can make every minute count—who is able to do two service jobs in the time formerly required for one—and here's the book to help you do exactly this...

**A. A. Ghirardi's famous**

**RADIO TROUBLE SHOOTER'S HANDBOOK**

The most practical, helpful, and inexpensive Handbook of on-the-job Servicing Data ever produced—now in the revised and enlarged new edition over 40% bigger than before, and containing over 400 pages of new, factory-checked material never before published—or a total of 710 pages in all. Gives common trouble symptoms for over 4,607 receivers. When a set comes in for repairs simply turn to the Handbook—and, in a great majority of cases your problem is solved—without lost time, effort, or extensive testing.

**THE HELP YOU NEED... When You Need It!**

Also contains I-F alignment "peaks" of 20,173 superhets; I-F transformer troubles, servicing and replacement; plug-in and ballast resistor replacement charts; 20-page tube chart; tips on modernizing old receivers, and a thousand and one other important tables, charts, and tips that will help you do almost every repair job *quicker and better.*

In short, the Handbook is chock-full of just the data you need for faster, more accurate, more profitable work. No other data book is so complete—none so genuinely helpful—none so widely used by successful servicemen. *Sold on a 5-Day Money Back Guarantee basis.* You be the judge!

**THE TRAINING BIBLE OF SUCCESSFUL SERVICEMEN**

*Ghirardi's*

**MODERN RADIO SERVICING**

How would you like to have Radio's foremost instructor always at your side to guide you in every phase of service work—answer your questions—show you short cuts—explain the theory and operation of instruments—tell you how to use your time to best advantage—help you solve problems as they arise? Actually, your ownership of Ghirardi's new 1300-page Modern Radio Servicing means just about that. To the beginner it is a complete,

practical course in radio repairing that is easily learned at home in spare time. To the veteran it is an "Open, Sesame!" of sound, intensely practical information on Test Equipment, Trouble-Shooting, Repairing, and Business Promotion. Contains over 706 illustrations, 720 review questions, 766 topics—the only single book that covers modern service procedure from beginning to end!

**BRUSH UP ON THEORY—IT PAYS!**

Primarily designed as a complete course of basic training in Radio, Sound, Television, Ghirardi's famous **RADIO PHYSICS COURSE** is proving tremendously popular with servicemen and others already in radio. Just the thing to brush up on technical facts that may be "foggy" in your mind—and, to those planning upon entering the Army and Navy it is an invaluable means of passing examinations that may mean better pay, faster

promotion, more pleasant duty. Actually, it is 36 different courses in one—a miracle of radio training packed into one book of almost 1,000 pages, and made understandable by more than 500 illustrations plus 856 self-testing review questions. Used by U. S. Army and Navy Schools, by civilian aviation schools—and by radio schools everywhere, more than any other radio textbook published. Literature free.

**MONEY-SAVING COMBINATION**—Get both Ghirardi's **RADIO TROUBLE-SHOOTER'S HANDBOOK** and **MODERN RADIO SERVICING**—a \$10.00 value—for only \$9.50. Save money—keep your library up to the minute.

**RADIO & TECHNICAL PUBLISHING CO.**  
Dept. S-92 • 45 Astor Place, New York, N. Y.

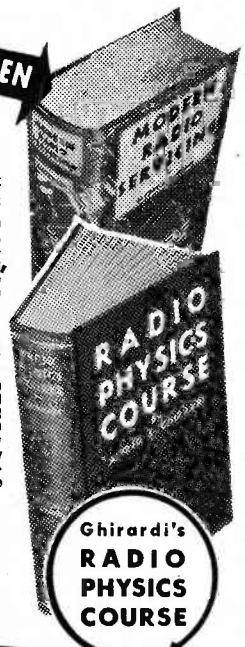

**Ghirardi's RADIO PHYSICS COURSE**

**THE 3 GREATEST VALUES IN MODERN RADIO TRAINING**

Sold at 1/10th the price you might expect to pay for such complete instruction.

**SEE GHIRARDI'S BOOKS AT YOUR LOCAL DEALER'S TODAY!**

# THERE'S A GROWING DEMAND for POLYMET

FOR VICTORY BUY UNITED STATES SAVINGS BONDS and STAMPS



Condenser replacements account for about 40% of all radio repair jobs. Dependable condensers are, therefore, essential for gaining and maintaining maximum customer satisfaction.

PROTECT that 40%



Now, more than ever, the jobber and service man must recognize the growing demand for POLYMET.

## CONTINUOUS DEPENDABLE SERVICE

For 21 years POLYMET ELECTROLYTIC and BY-PASS CONDENSERS have improved quality and service. Add to this a liberal and reasonable markup. No fly-by-night "bargain catalogs" can undersell you on POLYMET. You're protected, your customer is satisfied, your profits and volume increase. We're conserving vital defense materials by limiting sizes to those most universally used. These will serve practically every need. Complete listing of available types and prices will be forwarded upon request.



**POLYMET CONDENSER CO.**  
699 EAST 135th ST.  
NEW YORK N. Y.

## NEWS

(Continued from page 23)

### HALLICRAFTERS ISSUES PLANT PAPER

An interesting four page employee paper, temporarily entitled, "You Name It" has been issued by the employees of the Hallcrafters Inc., Chicago.

Featured in this initial issue is a story on William J. Halligan, Hallcrafters' president.

\* \* \*

### FRED TUERK, UTAH PRESIDENT

Effective September 1, 1942, Mr. Fred R. Tuerk became president of Utah Radio Products Company. G. Hamilton Beasley, president for the last five years, has been elected chairman of the board.

Mr. Beasley is also president of The Caswell-Runyan Company of Huntington, Indiana (wholly owned subsidiary of Utah Radio Products Company). Due to the serious illness of J. W. Caswell, Mr. Beasley will devote a greater portion of his time to the Caswell-Runyan Company.

He will continue to take an active part in the management of Utah, whose entire production facilities are and have been for some time past concentrated on war products.

Aside from the above changes the Utah executive roster remains as it has been for many years, with Henry S. Neyman, as vice president and treasurer, W. Dumke, vice president and secretary, W. A. Ellmore, chief engineer, and O. F. Jester, general sales manager.

\* \* \*

### N. U. DISTRICT MANAGER'S SON IN ARMY

William Hendrickson, Jr., son of Billy Hendrickson, the National Union District Manager for New England, is now a 1st Lieutenant in the U. S. Army.

Lieutenant Hendrickson, after completing college, entered the Army and was as-



signed to the 3rd Cavalry at Fort Myer, Virginia, then transferred to Fort Oglethorpe, Georgia and has now been transferred and is taking a special tank course in the Middle West.

\* \* \*

### FIRE PREVENTION WEEK

October 4-10 has been proclaimed Fire Prevention Week by the President. In his proclamation, the President called upon the nation for observance of this occasion as part of the war effort and charged the U. S. Office of Civilian Defense, which is responsible for civil protection in wartime, to assume leadership in the observance.

Fire is always serious, but now, as the President pointed out in his proclamation, every loss of life, every interference with production, every loss of critical materials delays victory. Fire Prevention Week affords an opportunity to impress all the people with the present urgency of protecting our resources against destruction by fire.

# BIG BOY

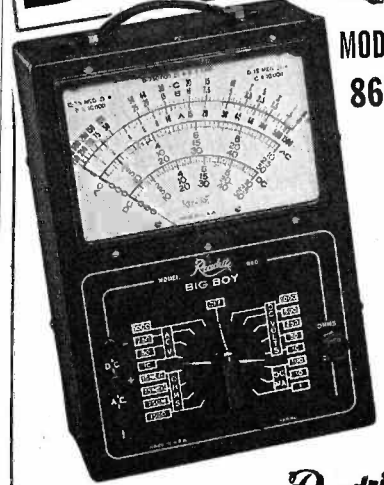

MODEL 860

Performance . . . Eye Appeal . . . Value . . . Sensationally Priced at \$19.65. Dealer Net Price.

Here is an AC-DC Volt-Ohm-Milliammeter with all the ranges you want . . . easily readable on the large 7" instrument with extra-long 6" scale, in a new up-to-the-minute three-tone case. DC Volts 0-10-50-250-500-1000 at 5000 Ohms per volt DC; 1000 ohms per volt AC. AC Volts 0-10-50-250-1000 at 400 ohms per volt; DC Ma. 0-1-10-100; Resistance ranges: 0-1500 Low Ohms; 0-150,000 Ohms and 0-7.5 and 0-15 Megohms. Maroon case with red and silver panel, attached handle.

Dealer Net Price, \$19.65

For Catalog Write — Section 917, College Drive

**READRITE METER WORKS, Bluffton, Ohio**

### C-D BULLETIN ON INCREASING OUTPUT

"Save Copper—Get More Capacity Quickly" headlines a 6-page folder on dykanol capacitors for power factor improvement, just issued by Cornell-Dubilier Electric Corporation. This bulletin weighs a familiar plant problem, overtaxed electrical systems, insufficient line, transformer and switching equipment capacity, and then presents a solution that boosts factory output while saving all-important time, materials and labor.

### EDITORIAL

(Continued from page 2)

Available for examination by any person during ordinary business hours must be the statements of the highest March prices. A duplicate of this statement should be on file with the War Price and Rationing Board.

Here is an important point . . . on any portion of a business which is not at retail, prices need not be made public, if it is claimed that substantial injury would result. This claim, however, must be made in an affidavit and attached to the statement that is filed with the local board. The OPA will keep such prices confidential, unless to do so, is contrary to the purpose of the regulation.

*Help beat the Axis by buying United States War Bonds and Stamps every pay day.*

# NEW PRODUCTS

Additional information and prices of the products described below may be obtained, without obligation, from the respective manufacturers.

## NON-WIRE-WOUND POTENTIOMETERS

A new non-wire stabilized element that is said to afford immunity to climatic conditions and long lasting wearing qualities has been developed by Clarostat Mfg. Co., 285 N. 6th St., Brooklyn, N. Y. This element takes the form of a resistive coating on a bakelite base, being practically as



smooth and hard as glass. The element is chemically-treated during processing to eliminate all further changes in its composition. It is likewise heat treated to stabilize its temperature and humidity characteristics.

The series 37 controls use this new stabilized element.

## THREE-IN-ONE MULTITESTER

A new vacuum tube multimeter, model 662, has been developed by Radio City Products Co., Inc., 127 W. 26th St., N. Y. C. It is said to furnish accurate and comprehensive capacity readings directly in microfarads, with a measurement

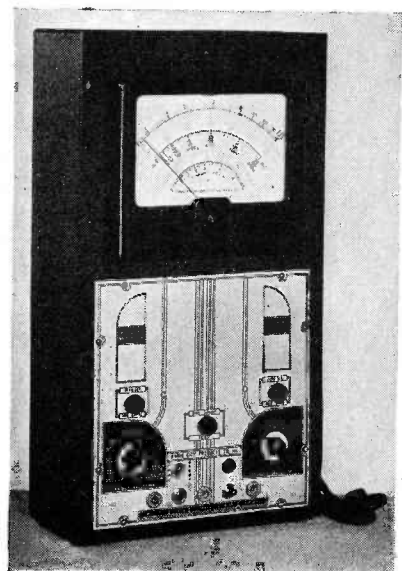

## "Sure, I'd Rather Drive 50"

... but until this war is won we all have to be satisfied with less in many things."

This is particularly true in the case of radio receivers, where the shortage of replacement parts is forcing more and more servicemen to improvise in order to get faulty sets into operation.

In so improvising it may be necessary to eliminate certain stages or find substitutes for certain resistors, condensers, or sockets, etc. While this may not produce the maximum in set performance, it will save a lot of jobs for you that would otherwise be lost. In addition, your customers will appreciate your licking a tough situation to get their sets into operation and, under the circumstances, be satisfied with less than perfection.

By this improvising, both you and your customer will be meeting your patriotic duty to free much needed replacement parts for use by the armed forces. At the same time, you will be contributing your share toward the building of public morale by keeping radio receivers in operation.

Of course, to improvise you have to know what's in the set. You can't spend hours "guessing out" the trouble and more hours experimenting with "probable" substitutions. You need RIDER MANUALS to tell you what is in the set—to supply you with all the facts you must have in order to find the trouble quickly and improvise the repair in the minimum of time. Speed is the essence today—reach for your RIDER MANUALS when you begin every job! It's your duty to work efficiently until "this thing" is over.

### RIDER MANUALS

Volumes XIII to VII.....\$11.00 each  
 Volumes VI to III..... 8.25 each  
 Volumes I to V Abridged.....\$12.50  
 Automatic Record Changers and Recorders... 6.00

### OTHER RIDER BOOKS YOU NEED

The Cathode Ray Tube at Work.....\$3.00  
 Frequency Modulation..... 1.50  
 Servicing by Signal Tracing..... 3.00  
 Meter at Work..... 1.50  
 Oscillator at Work..... 2.00  
 Vacuum Tube Voltmeters..... 2.00

AFC Systems..... 1.25  
 HOUR-A-DAY-WITH-RIDER SERIES — on "Alternating Currents in Radio Receivers" — on "Resonance and Alignments" — on "Automatic Volume Control" — on "D-C Voltage Distribution," 90c each

### JUST OUT!

A-C CALCULATION CHARTS—Two to five times as fast as a slide rule—and more fool-proof! All direct reading—operative over a frequency range of from 10 cycles to 1000 megacycles. 160 Pages—2 colors—9½x12 inches—\$7.50.

### FOR EARLY PUBLICATION

Inside the Vacuum Tube—complete elementary explanation of fundamentals of vacuum tubes.

**John F. Rider Publisher, Inc.**

404 Fourth Avenue - New York City

Export Division: Roeca-International Electric Corp.  
 100 Varick St., New York City Cable: ARLAB

## YOU NEED ALL THIRTEEN RIDER MANUALS TO "CARRY ON"

ratio of 40,000,000 to 1. In designing this multi-purpose instrument, RCP engineers forestalled all danger of shock on low capacity measurements. There are no test leads to short and no resetting is necessary when changing ranges.

The meter cannot be damaged by checking a live resistor or by using a low range on high readings. Error due to line voltage fluctuation is eliminated by a VR105-30 regulator tube and associated circuits.

This model employs a sloping panel and 4½-inch meter. There is also an upright-style companion model (No. 662-V-7) with a large 8½-inch rectangular meter, affording long scales for easy reading.

Both instruments have similar performance characteristics, and are complete with leads and large, readily accessible batteries, tubes and pilot light. It is described in Bulletin No. 126 which is free.

## INSTANT AUTOMATIC WIRE STRIPPER

The General Cement Manufacturing Company, Rockford, Illinois, announces a new wire stripping tool that is said to save time, money and trouble for electricians, maintenance engineers, service men, etc.

This new handy unit instantly strips

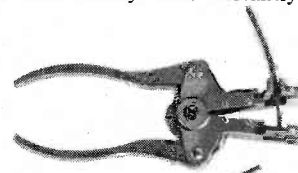

insulation from all types of wire easily and perfectly, by simply pressing a handle. It can also be used as a wire cutter.

(Continued on page 26)

Write for this  
interesting book

**"LONG LIVE YOUR  
MICROPHONE"**

**LONG LIVE YOUR  
MICROPHONE!**



**I**t is full of intimate facts concerning the life and care of your Microphone. Temperature and moisture effects on dynamic, crystal, carbon types. Points on Feedback. What to check in case of trouble such as cable-plug-output-response. In general—information to help you get the best possible service from your Microphone. A 16 page, 4 color illustrated booklet free. The data are based on statistics gathered in the Shure Service Dept. Send for it today!

**Bulletin 1735**

**SHURE BROTHERS**

*Designers and Manufacturers of Microphones  
and Acoustic Devices*

**225 W. Huron Street, Chicago, U. S. A.**

**SHURE**

## NEW PRODUCTS

(Continued from page 25)

### OHMITE FERRULE RESISTORS

Ferrule resistors, designed for easy interchangeability without the use of tools, are now being produced by Ohmite Manufacturing Company, 4835 Flournoy Street, Chicago, Ill.

An even winding of resistance wire on a ceramic core is protected by an Ohmite vitreous enamel coating. The wire is terminated on metal bands or ferrules

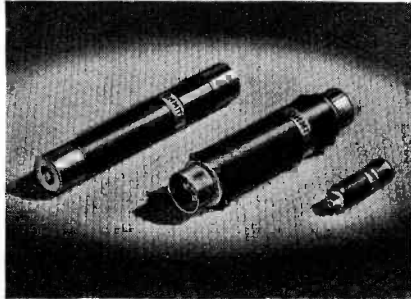

which permit mounting in fuse clips. Ferrules are cup, sleeve, or cartridge type.

Special ceramic cores are available which, with special coating, will, it is said, withstand the temperature shock test of repeated immersions alternately from ice cold water to hot water. Protective coatings which pass salt water immersion tests are also available.

The ferrule type of resistor available in a wide range of sizes is particularly applicable for use in the Navy, in the Signal Corps, on Army aircraft and on railroads.

\* \* \*

### DIMMER SIGNAL LAMP

A panel dimmer type signal lamp, the Dim-E-Roid, eliminating the incorporation of transformers and resistors in electrical systems for the purpose of dimming intensity of signal lights, is now being made by American Radio Hardware Co., Inc., 476 Broadway, New York City. Polarized discs, or a mechanical shutter, control the light emission intensity without interference with the electrical circuit proper.

Made entirely of nonferrous materials, this new device utilizes a plastic jewel in any color desired for differential signal purposes. Two models are available. Model 1920 is constructed with a mechanical shutter, and model 1874 operates by the use of two opposed polaroid discs. Both of these models, with the exception of the dimming mechanism, are identical in appearance, and mounting dimensions. A slight turn of the head of the lamp changes the light intensity from very bright to very dim. Model 1920, if desired, can be made to change light intensity from bright to total blackout.

The Army and Navy Air Corps are said to have accepted the Dim-E-Roid for use in the instrument panels of military aircraft for signal purposes.

\* \* \*

### TRIPLETT PORTABLE METERS

Two new instruments, model 625 d-c and 635 a-c have been added to the line of portables produced by the Triplett Electrical Instrument Co., Bluffton, Ohio.

These instruments, enclosed in molded cases, have long 4.58" hand calibrated mirror scales. A hinged cover closes when instrument is not in use, for added protection. The d-c instrument is enclosed

**TRIPLE UTILITY  
TRIPLE VALUE!**



**Speed Up With This  
New RCP Electronic  
MULTITESTER**

RCP Model  
No. 662  
Complete,  
only... \$47.50

You'll cover more ground—faster—with RCP's new vacuum tube multimeter! Here's an electronic voltmeter, ohmmeter and capacity-meter in *one* versatile, modern instrument—designed for maximum sensitivity, flexibility and utility to speed up wartime servicing. No useless frills, no costly gadgets—but all the features you need for faster, more accurate testing:

A genuine vacuum tube voltmeter on AC also— $4\frac{1}{2}$ " microammeter with measurement ratio of 40,000,000 to 1—measures all voltages without affecting circuit constants—errors due to line voltage fluctuations eliminated—no damage to meter by checking live resistor or by using low range on high readings—no resetting necessary when changing ranges—no danger of shock—no test leads to short—co-axial cable for high frequency measurements—matched pair multiplier resistors—thoroughly shielded, sturdy, welded steel case in crystalline gray finish—complete with leads, batteries, tubes and pilot light.

And that's only half the story! RCP—noted for value—tops all standards with this quality instrument. Get *all* the facts, the ranges and other features of RCP Model 662. Send for RCP Bulletin No. 126 TODAY.

RCP test instruments are available through your jobber. Consult him or write for latest RCP catalog. IT'S FREE.

**Radio City Products Company  
INC.**

127 WEST 26th STREET NEW YORK CITY

in a black molded case, and the a-c unit is in a red case. The size of the cases are 6" by 5 $\frac{1}{2}$ " x 2 $\frac{1}{2}$ ".

\* \* \*

### DE JUR-AMSCO INSTRUMENTS

Direct current voltmeters of 200 and 1,000 ohms per volt, d-c millivoltmeters, d-c ammeters and shunts, d-c galvanometers, d-c microammeters and milliammeters, a-c rectifier type meters and a-c rectifier voltmeters as well as thermo ammeters are described in a catalog, I-61, released by the manufacturer, De Jur-Amsco Corporation, Shelton, Connecticut.

Many of the instruments are illustrated full size. In addition, various type movements are also shown. Cross-section diagrams of the instruments are also shown.

\* \* \*

### TUBE CHECKERS

Two new radio tube checkers, one a portable model in a wood case with brown leatherette cover, the other a counter model enclosed in a metal case, grey in finish, have been announced by H. J. Mandernach of the Renewal Tube Sales Section, General Electric Co., Bridgeport, Connecticut. They are available only on orders carrying at least an A-1-J preference rating.

These new tube checkers, known as Models TC3 and TC3P, will take care of all present tubes and any tubes that may be announced in the future. This is made possible through the use of a special switching system that provides any voltages that may be necessary to test the tubes. The instruments also provide a triple test for output and a thorough check for short.

## TUBE NOISES ANALYZED IN TESTS

RECENT observations by Sylvania engineers have proven that in addition to the sharp impulse noises resulting from transients applied directly to a tube element when it makes intermittent contact with another conductor, an intermittent contact between two conductors in one tube results in a signal being picked up by a preceding high frequency stage. For example, if the getter support in an audio or even in a rectifier tube makes intermittent contact with the getter deposit upon the bulb it will sometimes cause a noise which will disappear if the first r-f tube is removed or if a shield is interposed between this tube and the offending tube.

Lint is, of course, still the major source of noisy tubes in spite of considerable progress made to eliminate it. Noise tests are not entirely reliable primarily because of the possibility of loose conductive particles shifting from positions where they can not cause noise during one test to position where they can cause noise prior to another test. (2)—Radio frequency disturbances resulting from intermittent contact between conductors are the fundamental source of sharp impulse tube noises. (3)—Radiated energy from intermittent contact between conductors to more sensitive parts of the receiver are frequently responsible for tube noises. (4)—Peak noise output voltages increase rapidly with the sensitivity of the receiver and the voltages to which the contacting conductors are charged and directly with the i-f band width. (5)—Normally isolated conductors or conductive deposits smaller than a pin head can cause noise if they make intermittent contact with "sensitive" electrodes.

\* \* \*

### WPB RADIO DIVISIONS CONSOLIDATED

All communication equipment requirements, civilian and military, have been consolidated under the direction of the Radio and Radar Branch of the Air-Craft Production Division, WPB. Formerly two groups covered this field, the Radio and Radar Branch which handled military requirements, and the radio section of the Communications Branch which handled civilian needs. The latter section has been transferred to the Radio and Radar Branch under the name, Civilian Radio Section.

Frank H. McIntosh, who was chief of the section under the Communications Branch, will continue as chief under the Radio and Radar Branch under the name, Civilian Radio and Radar Branch.

\* \* \*

### ELASTIC STOP NUT WALL CHART

A wall chart, 21 by 27 inches, explaining the uses of various types of self-locking nuts, is being distributed by Elastic Stop Nut Corporation, 2322 Vauxhall Road,



## Communications Must Be Kept

The intricate maze of modern radio equipment needs frequent servicing . . . and good tools to speed the work. Spintite, the wrench that works like a screw driver is on the job from assembly lines to air bases . . . on ship and ashore.

Originally developed by Stevens Walden, Spintite features drilled shank, non-slip handle, precision machining . . . a tool to do a better job.

To speed your production or to facilitate servicing, we offer these wrenches produced by a plant with over 36 years experience in building good tools. Send for catalog showing complete range.



T51 Set at left, is popular for quick repairs. Chuck type handle, 7 Spintites with sockets ranging from 3/16" to 1/2", Reamawl, three screw drivers in various sizes. All in compact leatherette roll.

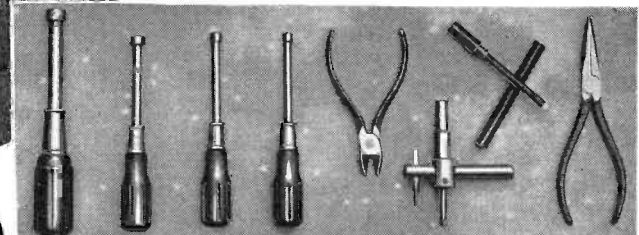

**STEVENS WALDEN, INC.**  
467 SHREWSBURY STREET  
WORCESTER, MASSACHUSETTS, U. S. A.

Union, New Jersey, to engineering departments, drafting rooms, maintenance shops, and schools.

The center of the chart is devoted to an illustrated description of the basic principle by which a self-locking action is obtained. This is followed by illustrations of some of the advantages to be obtained by the use of the nuts and, completing the presentation, there are cross-section drawings showing the method of application of the nine types most generally used, with corresponding photographs of these types.

Copies can be obtained from the manufacturer.

\* \* \*

### SPOKANE RADIO'S 15TH YEAR

The 15th anniversary of the Spokane Radio Co., Inc., 611 First Avenue, Spo-

kane, Washington, was recently celebrated. Morris H. Willis, radio veteran, is president of Spokane.

In addition to serving as a distributor, Spokane is also manufacturing equipment for the armed forces.

\* \* \*

### FLUORESCENT ACCESSORIES CATALOG

A new 16-page catalog on G-E fluorescent accessories has been announced by G. E., Bridgeport, Conn. Included with the catalog is a 2-page insert on the new G-E manual reset master no blink starter.

The catalog contains general and technical information on fluorescent lighting principles. It gives complete descriptions of the many G. E. fluorescent lampholders, starters, starter sockets, etc.

## WAR-TIME SERVICING

(Continued from page 7)

Columbia and R.C.A. Victor. The Columbia records are catalog listed as "Audio-Tone" No. 1, 10,001-M, 10,002-M and 10,003-M. The No. 1 record has a frequency range from 50 to 7,000 cycles, continuously variable, and has a 1,000-cycle reference tone at the start and finish of the record. It is a 12-inch disc, to be operated at *exactly* 78 rpm. Voice announcements give the frequency changes at 50, 60, 70, 80, 90, 100, 120, 140, 160, 180, 200, 250, 300, 350, 400, 500, 700, 1,000, 1,500, 2,000, 2,500, 3,000, 3,500, 4,000, 4,500, 5,000, 6,000, 6,500, and 7,000 cycles. The Columbia No. 10,001-M record has a "warbled" frequency recording from 100 to 10,000 cycles; the No. 10,002-M has a sweep-frequency band from 40 to 10,000 cycles (covered in 12 seconds), and the No. 10,003-M has a frequency range from 50 to 10,000 cycles.

The RCA Victor record is catalog-listed as No. 84,522. It is a 12-inch disc and has a frequency range on one side of from 30 to 10,000 cycles continuously variable. Buzzer signals are superimposed at 50, 100, 200, 500, 1,000, 2,000, 4,000, 5,000, 8,000, 9,000 and 10,000 cycles. The reverse side of the record contains two continuous recordings of 1,000 and 2,300 cycles at 78 rpm, or if played at 33 1/3 rpm the signals have frequencies of approximately 433 and 1,000 cycles.

A few test recordings are also useful as further aids to show up distortion, wow, resonance peaks, hang-over, insufficient power-handling capacity, improper action of record changer, etc., in the final check of the entire audio system. The recordings used for test purposes should be selected with some care. Obtain a good symphonic record (such as Victor's "Orpheus in Hades" overture), a good recording of a popular dance band that brings in both the

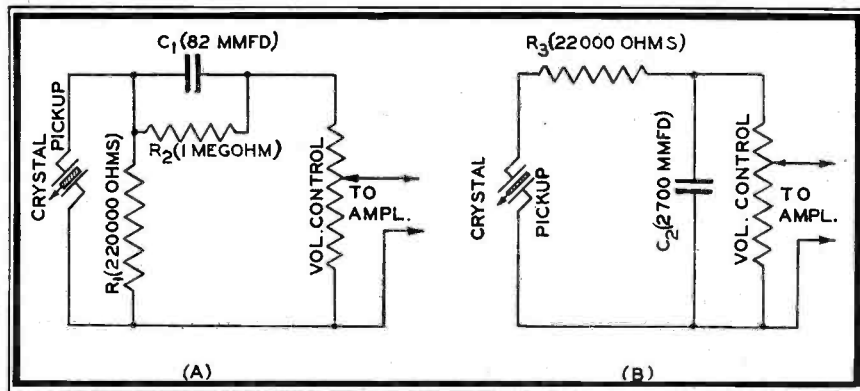

Fig. 8. Two simple equalizer circuits for altering the low- and high-frequency response of crystal pickups.

low and high note instruments, and a good piano solo. A recorded piano solo will show up the defects in a poor phonograph system very quickly and definitely.

### Altering Tone from Phono Pickups

A large percentage of radio set buyers have been educated to prefer excessive bass response. This fact accounts for the elevated bass response which is characteristic of most present-day phono combinations.

If a customer prefers high-quality music, equalization for a more flat response may be provided easily if the pickup is a crystal unit. As shown in Fig. 7, all that is required is a fixed condenser and a fixed, or preferably variable resistance  $R$  of about .3 megohms, connected as indicated. If a variable resistor is employed, any response curve between the fully equalized and the normal equalized can be obtained at will.

In connecting record players to run-of-the-mill audio systems it is frequently desirable to alter the crystal pickup circuit to compensate for certain performance characteristics of the amplifier. Illustrated in Fig. 8 are two circuits suggested by RCA for use

with the Model R103 S record player, and which servicemen can employ with the necessary variations in circuit constants to good advantage on many other crystal pickup phono attachments.

In the circuit arrangement at (A) the resistor  $R1$  controls the low-frequency response; larger values of  $R1$  give increased lows. For maximum low-frequency response remove  $R1$  altogether.  $R2$  controls the pickup output, smaller values giving increased output.  $C1$  controls the high-frequency response; to increase the highs, increase  $C1$ .

Where a decrease in high-frequency response is desired (for reducing needle scratch on worn records, etc.) the circuit shown at (B) may be employed. Here,  $C2$  acts as a load on the pickup and is also a controlling factor on the high-frequency response. Smaller values of  $C2$  give more pickup output and also more highs.  $R3$  gives a sharper high-frequency reduction; increasing  $R3$  decreases the highs.

The suggested circuit values shown here will serve as a basis from which slight changes may be made to suit individual cases. Variable controls may be employed in a trial circuit first in order to determine the proper values required. Then these may be replaced by more inexpensive and compact fixed components of the values determined.

# THANKS

# TO YOU, MISTER SERVICEMAN

From the first SUPREME instrument, and through the fourteen years since, the acceptance, loyalty and co-operation of servicemen everywhere are largely responsible for the excellence of SUPREME instruments today—and our ability to produce them in quantity for our armed forces. If you could not get the new equipment you wanted this year, just remember that it is now doing duty for us in some spot on the globe and represents part of your contribution to Victory.

Many Jobbers still have SUPREME Instruments in Stock. Tell us the instrument you want. We'll do our best to get it for you.

## SUPREME

INSTRUMENTS CORP.

GREENWOOD, MISSISSIPPI, U. S. A.

## WHEN YOU CHANGE YOUR ADDRESS

Be sure to notify the Subscription Department of SERVICE at 19 E. Forty-seventh St., New York City, giving the old as well as the new address, and do this at least four weeks in advance. The Post Office Department does not forward magazines unless you pay additional postage, and we cannot duplicate copies mailed to the old address. We ask your cooperation.

## CASE HISTORIES

(Continued from page 18)

### RCA SCHEMATICS

**Switch Positions:** Practically all of the larger RCA receivers have decals on the cabinet (or other means) to indicate the function of each position on the more complicated switches. In cases where only the chassis is brought in for service, the corresponding information about controls is given in a knob drawing printed in the service note. For example, the accompanying schematic

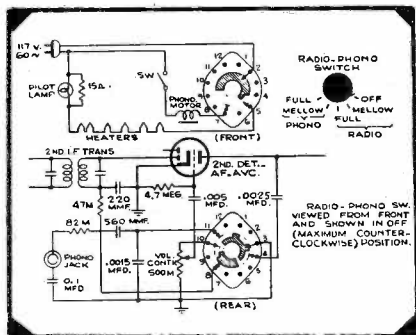

shows the radio-phono-tone control switch circuit in Model V133, drawn as usual in the extreme counter-clockwise position. The knob view shows the function of each position: 1) "Off" counter-clockwise; 2) Radio—mellow tone; 3) Radio—full tone; 4) Phono—mellow tone; 5) Phono—full tone (clockwise).

As a general rule, on RCA receivers, clockwise rotation of a control produces an increase. Thus on a range switch, the lowest-frequency band is counter-clockwise, and the highest-frequency band is clockwise. On tone controls, the narrowest audio range or deepest tone is counter-clockwise. The widest audio range or highest tone is clockwise.

### RCA 9TX SERIES

**Intermittent or continuous howling:** Cause undesirable feed-back from 25L6 plate to grid of 6SQ7. Dress lead from output transformer to plate of 25L6 as far as possible from 10 megohm 6SQ7 triode section grid resistor.

**Intermittent fading:** Cause defective 0.01 mfd. tubular condenser coupling rotating arm of volume control to grid of 6SQ7 tube. Some original units installed so as to put continual strain on leads of condenser, resulting in intermittent open. Install new unit carefully so that trouble will not reappear from same cause.  
D. C. Sprong

### RCA 86K7

**Receiver motoboats at high volume:** This fault can usually be corrected by re-routing the black lead connecting from the low side of the volume control,

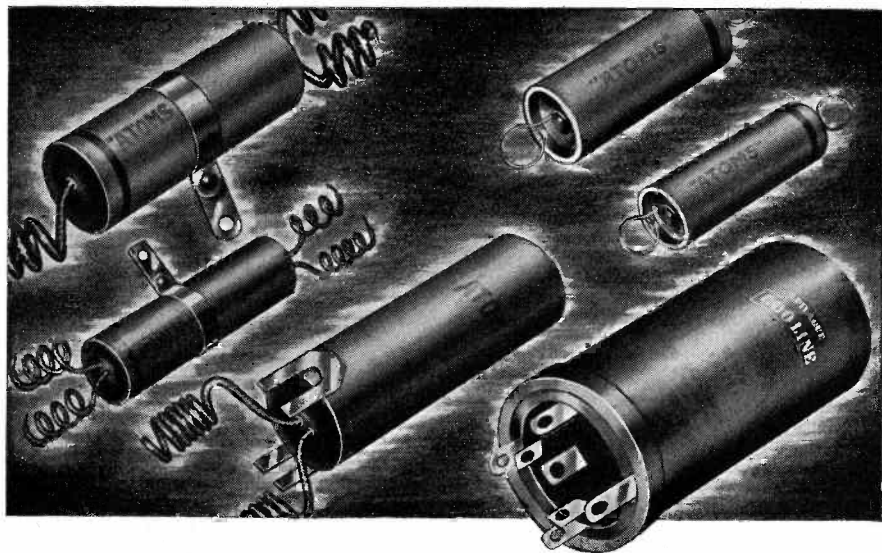

## WHO SAID ANYTHING ABOUT CONDENSER SUBSTITUTES?

Even if restrictions on metals hadn't eliminated aluminum can type electrolytic condensers . . .

Even if War demands on leading manufacturers such as Sprague hadn't made it necessary to simplify condenser lines and curtail many "exact duplicate" and other types . . .

The fact remains that leading servicemen would now be using Sprague Atom Midget Drys and Type EL Prong-Base Drys almost universally, anyhow. For these Condensers are definitely not substitutes. They're a big forward step in modern condenser construction. A small stock enables you to replace almost any condenser of equal rating—and do it in less space, at less cost, and with every assurance of better, more dependable performance. Drys or wets, low voltage or high voltage, single capacitors or duals or triples —Atoms and EL's handle them all.

As long as your Sprague jobber has these popular units, you've no need to worry about condenser replacements . . . and you won't be using substitutes. You'll be using condensers that are actually better—condensers that will set the style in efficient servicing for years to come!

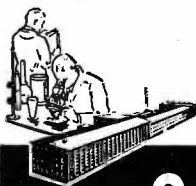

# SPRAGUE PRODUCTS COMPANY

North Adams, Mass.

in a short direct path to the bias strip through a 100,000 ohm carbon resistor. Alternately the paper condenser connected at the resistor to ground can be shifted to the volume control.

Willard Moody

### RCA U-128, U-130

**Dial sticks:** If the dial is noisy and sticks, align the gears that couple the driving motor to the dial mechanism under the chassis deck. They should be centered on their shafts and mesh smoothly. Suitable lubrication is also helpful.

Willard Moody

### WESTINGHOUSE 473

**Phonograph pick-up does not operate:** In this model the i-f transformer may be loose and shorting the crystal input wires beneath the chassis. The transformer should be thoroughly secured to the chassis, using lock nuts where possible.

Willard Moody

### ZENITH 7553, 5704

**Distortion:** Distortion on these models when the set is tuned to resonance can be corrected by a careful alignment of the intermediate frequency circuits.

Willard Moody

# FOR VICTORY TODAY AND SOUND BUSINESS TOMORROW

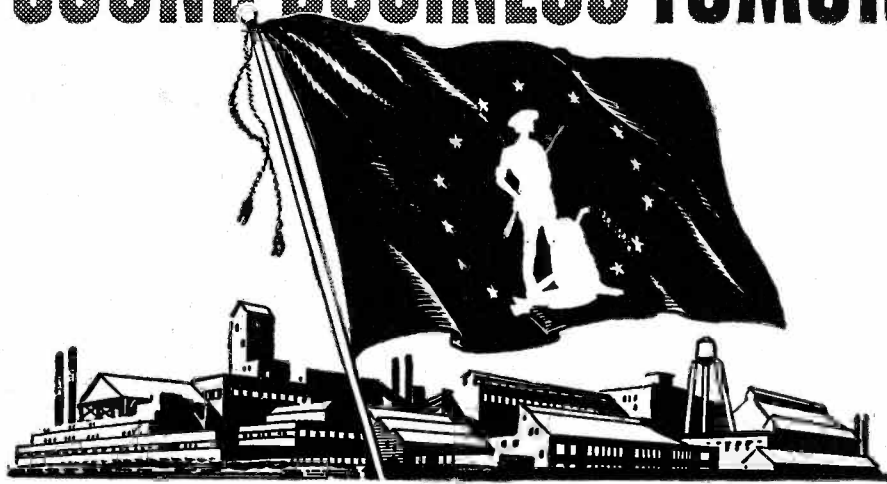

## *Get This Flag Flying Now!*

This War Savings Flag which flies today over companies, large and small, all across the land means *business*. It means, first, that 10% of the company's gross pay roll is being invested in War Bonds by the workers voluntarily.

It also means that the employees of all these companies are doing their part for Victory . . . by helping to buy the guns, tanks, and planes that America and her allies *must* have to win.

It means that billions of dollars are being diverted from "bidding" for the constantly shrinking stock of goods available, thus putting a brake on inflation. And it means that billions of dollars will be held in readiness for post-war readjustment.

Think what 10% of the national income, saved in War Bonds now, month after month, can buy when the war ends!

For Victory today . . . and prosperity *tomorrow*, keep the War Bond Pay-roll Savings Plan rolling in *your* firm. Get that flag flying now! Your State War Savings Staff Administrator will gladly explain how you may do so.

If your firm has not already installed the Pay-roll Savings Plan, *now is the time to do so*. For full details, plus samples of result-getting literature and promotional helps, write or wire: War Savings Staff, Section F, Treasury Department, 709 Twelfth Street NW., Washington, D. C.



Save With

## War Savings Bonds

This Space Is a Contribution to America's All-Out War Program by

### SERVICE



## POWER SUPPLIES

(Continued from page 14)

der these conditions, will increase the inductance.

Finally, a few words of caution. In replacing transformers and chokes, make sure the cores are well grounded. On metal chasses, the screws usually do a good grounding job, but not necessarily so. We have also seen replacement items mounted off the chassis, screwed to a wood console. Remember, it is very common for a wound coil to break down to the core, applying high voltage to the core. Play safe!

As rubber insulated wire becomes scarcer, we are apt to use cheap grades of insulation for high voltage leads. Don't chisel. If in doubt about the insulation, add some transparent Scotch tape—or even friction tape; lay the wire in, folding the tape.

## FARRELL SAYS

(Continued from page 20)

good news for independent service men. An advertising campaign directing the set owning public to patronize ONLY certain repair sources would carry the implication that any other sources of repair were less than the dust beneath the feet of the manufacturer.

Of course, such a plan would be a flop. But its failure could hardly be consoling to a servicer who lost business while it was in full swing.

Servicemen's organizations should take up this matter of restoring the confidence of the radio owning public in the American Service Man. For the servicer cannot afford to be caught between the Scylla of public opinion on one hand and the Charybdis of set manufacturer's condemnation on the other.

Thanks for listening . . . and I'll have a few thousand more well chosen and idea-ful words on the subject of "Good Will Stuff" in the next edition.

## AIRLINE 62-307

*Trouble with volume control and output transformer:* Both these parts are undersized and should be replaced with something better. This model is not listed under Montgomery Ward but can be found under Gamble-Skogmo on page 8-41 of Rider's Manual.

Francis C. Wolven

## OLDSMOBILE 982006 AUTO SET

*Blown filter condensers:* This block has an 8-8 mfd. 350 volt section and a 12 mfd. 20 volt section. Replace with 8-8 mfd. 450-volt and 10 to 25 mfd. at 25 volts. Connections to the block are as follows:

Two lugs at rear of block—8-8 mfd. 350 volts positive; black lead at front—common negative for above; white lead at front—positive 12 mfd. 20 volt; black lead with white tracer—negative for 12 mfd. 20 volt; lug at front—dummy lug used at tie point for B plus.

Francis C. Wolven

## BROKEN DIAL CORDS

A close and careful examination showed the cause plain enough. An exceedingly tiny lathe tool burr on the knob shaft, sufficient to gradually wear through the finest cord in short order, particularly when the careless user continued to turn the knob at the end of the dial travel, was the cause.

The cure was simple. A friend who owned a garage donated a little coarse valve grinding compound. The scrap box provided a few feet of heavy string. Wrapped around the troublesome shaft and coated with the grinding compound, the string put a fine finish on the steel shaft in a couple of minutes. (Just pull the string back and forth).

Coarse compound is necessary to get a "velvet" finish. A fine compound will give so fine a finish or polish that the dial cord will always slip.

R. G. Chrouch

Streamlining

# SYLVANIA SERVICEMAN SERVICE

by  
**FRANK FAX**



A lot of fellows tell me that replacing worn-out parts is a ticklish problem these days.

Duplicating tubes is particularly tough. Very often the entire circuit or the wiring setup of the chassis has to be changed.

That's why the new Sylvania Base Chart should be just what the doctor ordered. Like earlier editions, it provides a complete cross-index of all Sylvania tube types and bases.

But more than that—this handy and popular guide can now be used in three different ways: as a wall chart, a pocket booklet, or in the service kit.

You can get the Base Chart right away by writing to me, Frank Fax, Dept. S-9, Sylvania Electric Products Inc., Emporium, Pa. Remember, it's free.

There's no charge, either, for many of the invaluable sales helps on the list below. And the others are available at cost price. Select the ones you need and write for them now.

- |  |  |
|--|--|
| 1. Window displays, dummy tube cartons, timely window streamers, etc. (From your Sylvania jobber only) | 16. Technical manual                         |
| 2. Counter displays  | 17. Tube base charts                         |
| 3. Electric clock signs  | 18. Price cards                              |
| 4. Electric window signs   | 19. Sylvania News                            |
| 5. Outdoor metal signs   | 20. Characteristics sheets                   |
| 6. Window cards  | 21. Interchangeable tube charts              |
| 7. Personalized postal cards featuring timely topics   | 22. Tube complement books                    |
| 8. Imprinted match books   | 23. Floor model cabinet                      |
| 9. Imprinted tube stickers   | 24. Large and small service carrying kits    |
| 10. Business cards   | 25. Customer card index files                |
| 11. Doorknob hangers   | 26. Service garments                         |
| 12. Newspaper mats   | 27. 3-in-1 business forms                    |
| 13. Store stationery   | 28. Job record cards (with customer receipt) |
| 14. Billheads  | 29. "Radio Alert!" Post-cards                |
| 15. Service hints booklets   | 30. Radio Caretaking Hints to the Housewife  |

# SYLVANIA

RADIO TUBE DIVISION  
SYLVANIA ELECTRIC PRODUCTS INC.

SERVICE, SEPTEMBER, 1942 • 31

# STANCOR

## TRANSFORMERS

USED BY MOST SERVICEMEN . . . MOST!

## STANDARD TRANSFORMER

• CORPORATION •

1500 NORTH HALSTED STREET . . . CHICAGO

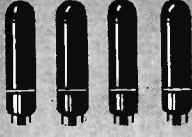

**4 STANDARD TYPES**  
of Amperite Regulators replace over 400 types of AC-DC Ballast Tubes now in use. Amperites are real REGULATORS . . . have patented Automatic Starting Resistor which prevents initial surge and saves pilot light's . . . Ask Your Jobber.

# AMPERITE

THE *Simplest*  
WAY TO REPLACE  
**BALLASTS**

WRITE FOR REPLACEMENT CHART  
**AMPERITE Co.** 561 BROADWAY, NEW YORK, N. Y.

# RADIART

*for*

# VIBRATORS AERIALS VIPOWERS

**THE RADIART CORP.**  
CLEVELAND, OHIO

## JOTS & FLASHES

Jerry Kahn, president of Standard Transformer, elected chairman of Sales Managers Club, Western Group, for the coming year. . . . Paul H. Tartak, of Oxford-Tartak Radio Corp., elected vice-president. . . . Vacum Tube Division of General Electric will now be designated as the Electronic Tube Division. . . . Jack Grand after 18 years with Sun Radio, New York, resigned to join Burlingame Associates, sales representatives . . . good luck, Jack . . . sorry to hear of death of Norton A. Mears, vice-president and General Purchasing Agent of RCA Manufacturing Co. . . . new fluorescent accessories catalog just announced by General Electric, Bridgeport . . . write for your copy. . . . Stofflet's, 331 Main St., Ann Arbor, Mich., appointed national sales agent for Kadette Radio Service. . . . Orchids to Hart Lehman, N. Y. adv. agent specializing in radio, 49 years young, veteran of World War 1, enlisted by preference as buck private in the infantry . . . congratulations to this month's Army-Navy "E" Production Award winners . . . included are Philco, Hallicrafters, Western Electric, Henry L. Crowley & Co., American Lava Corp., Galvin Mfg. Corp., International Resistance Co. . . . have you noticed RCA's institutional advertising campaign now running in leading mass circulation magazines . . . it's a corker. . . . General Electric reports 7,653 of their men now in armed services . . . buy bonds, save scrap, help beat Hitler and the Jap. . . . Belden's war bond-or-cash dividend plan honored by special citation from the U. S. Treasury Department . . . first of kind ever made. . . . SERVICE circulation upped substantially in August and early this month . . . thanks, boys. . . . Henry A. Pope, credit manager of National Union, elected chairman credit committee of RMA for ensuing year, succeeding Vic Mucher of Clarostat. . . . Fred R. Tuerk named president of Utah Radio Products Co. . . . G. Hamilton Beasley, former president, elected chairman of the board . . . attractive new booklet on phono needles and accessories available from Duotone Company, 799 Broadway, New York . . . great increase in amplifier sales to war industries by service men. . . . Rhythmic production is catching on in a big way and servicemen are cashing in. . . . Ohmite Manufacturing Co. have again expanded their factory space in a big way—many an Ohmite item in America's ships, tanks and planes . . . we are impressed with the number of rebuilt receivers being sold to radio-hungry customers. . . . Once again—Buy Bonds, Save Scrap.—P. S. W.

*Ask your jobber about this*

**absolutely FREE!**

**the AEROVOX**  
Research Worker

month after month . . .

- LATEST PRACTICAL DATA RIGHT FROM THE LAB. . . .
- NEW APPLICATIONS, CIRCUITS, TECHNIQUES. . . .
- CHARTS, FORMULAE, TABLES, REFERENCE DATA

For FREE Subscription ask us about the

**AEROVOX CORPORATION**

In Canada: AEROVOX CANADA LTD., Hamilton, Ont.  
EXPORT: 100 Varick St., N. Y., Cable "ARLAB"

## Index to Advertisers

	Page
A	
Aerovox Corp. . . . .	32
Amperite Co. . . . .	32
Astatic Corp. . . . .	22
C	
Centralab . . . . .	21
Clarostat Mfg. Co., Inc. . . . .	22
I	
International Resistance Co. . . . .	4
K	
Ken-Rad Tube & Lamp Corp. . . . .	3
M	
Mallory & Co., Inc., P. R. Inside Front Cover	
Meissner Mfg. Co. . . . .	17
N	
National Union Radio Corp. . . . .	Back Cover
P	
Polymet Condenser Co. . . . .	24
R	
Radiart Corp. . . . .	32
Radio City Products Co., Inc. . . . .	26
Radio & Technical Publishing Co. . . . .	23
Readrite Meter Works. . . . .	24
Rider Publisher, Inc., John F. . . . .	25
S	
Shure Brothers . . . . .	26
Solar Mfg. Corp. . . . .	22
Sprague Products Co. . . . .	29
Standard Transformer Corp. . . . .	31
Stevens Walden, Inc. . . . .	27
Supreme Instruments Corp. . . . .	28
Sylvania Electric Products Inc. . . . .	31
T	
Triplet Elec. Instr. Co. . . . .	Inside Back Cover
U	
U. S. Army. . . . .	9
United Transformer Co. . . . .	15
W	
Weston Electrical Instrument Corp. . . . .	1
Y	
Yaxley Mfg. Division. . . . .	Inside Front Cover

*When Space is at a Premium*

**TRIPLETT**

*Thin  
Line*

**INSTRUMENTS**

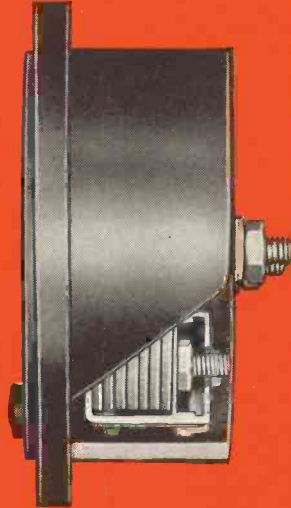

Full size of Instrument. Note deep shroud for glass protection—and "Quick-Look" Scale.

This molded case contains full size Triplet Mechanism. Rugged Construction—Compact Convenience.

**THIS IS THE INSIDE STORY**

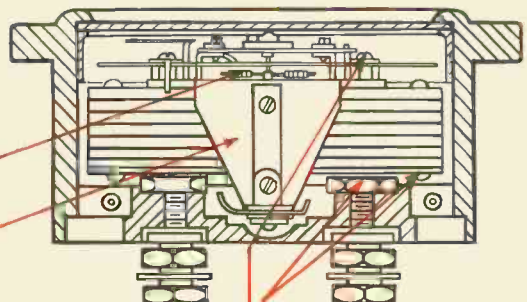
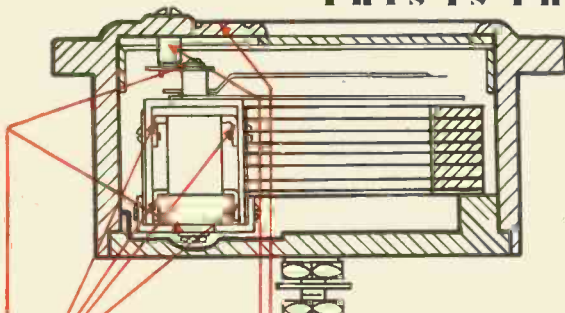

**1** Four-point Core Support

**3** Bezel Shroud Eliminates Unwanted Glare

**5** Balanced Frame Construction

**7** Four-point Rigid Magnet Clamping

**2** Full Metal Bridges on Top and Bottom

**4** One-piece Formed Spring Zero Adjustment

**6** Solid Balance Cross with Screw-type Balance Weights

**8** Separate Dial Mounting Independent of Top Bridge

Thin-Line Instruments also have Standard Large Coil Triplet Movements. Furnished with Osmium pivots for special requirements. All these features make for greater rigidity under vibration; greater permanence of calibration; greater user satisfaction.

**TRIPLETT**  
*Thin-Line*

memo

FOR CIRCULATION TO...

PLEASE INSERT INITIALS OF YOUR EXECUTIVES

Triplet Thin-Line Instruments meet rigid requirements for dependable performance. Though occupying minimum space they are *not* miniatures. Mechanisms are standard size with emphasis on excellent performance over long periods. Standardized installation. Made in three styles of cases — Molded, Metal Wide Rim and Metal Narrow Rim.

Triplet Thin-Line Instruments, available for many industrial applications, can be depended upon for precision performance in limited space. For full details write for "Triplet Thin-Line Bulletin".

**THE TRIPLETT ELECTRICAL INSTRUMENT CO., BLUFFTON, OHIO, U. S. A.**

# NATIONAL UNION *De Luxe* AMPLIFIER

**15 Watts Output . . . Less than 3% Distortion . . .**  
*at rated output . . .*

**Patented Circuit . . . Permits Extreme Compactness**

## **W15A-**

Amplifier includes set of 5 N U  
 Loktal Tubes.

## **W15A-C-**

Portable Case Only — Imitation  
 Leather (space for Amplifier  
 W15A, Two 8" P.M. Speakers,  
 Microphone and Cable).

## **W15A-CS-**

Portable Case with  
 2—8" P.M. Speakers

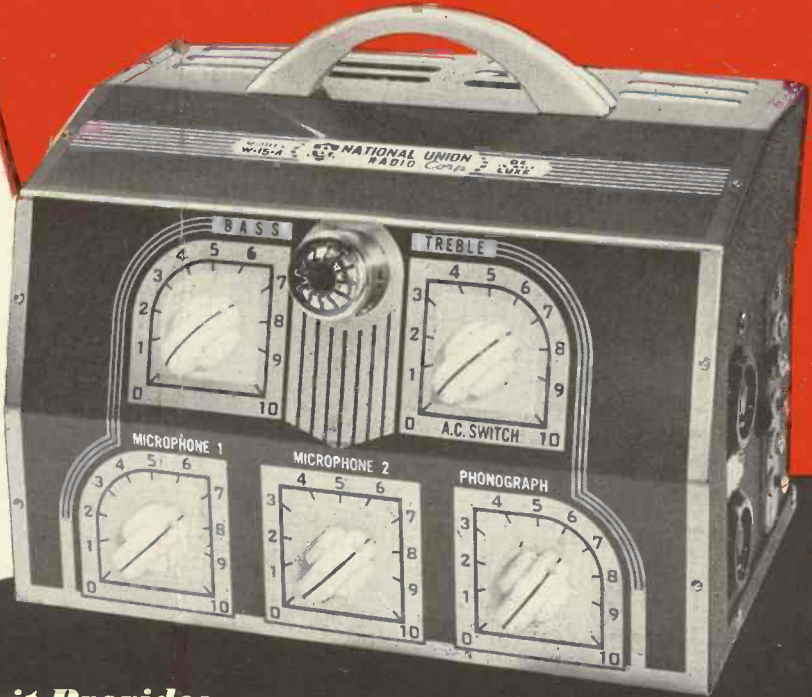

### **The Patented Circuit Provides...**

SMOOTH AND FLEXIBLE CONTROL OF BOTH VOLUME LEVEL AND TONE GRADATIONS OVER A WIDE RANGE . . . TWO MIKE INPUTS AND ONE PHONOGRAPH INPUT MAY BE SEPARATELY CONTROLLED OR MIXED FOR SIMULTANEOUS OPERATION . . . CONTINUOUSLY VARIABLE SEPARATE BASS AND TREBLE TONE CONTROLS. . . EASILY ACCESSIBLE FUSE . . . HOUSED IN COMPACT ATTRACTIVE GREEN CRACKLE FINISHED CABINET WITH PLASTIC IVORY KNOBS AND CARRYING HANDLE.

## **SPECIFICATIONS**

**Rated Output:** 15 Watts.

**Peak Power Output:** 25 Watts.

**Distortion:** Less than 3% at Rated Output

**Tone Controls:** 1—Bass Boost Control.  
 1—Treble Tone Control.

**Frequency Range:** ± 1 Db from 50 to 10,000 cycles

**Input Circuits:** Two high impedance microphones  
 One high impedance phonograph.

**Output Circuits:** Variable Impedance Output Two  
 Speaker Sockets. Each Socket  
 has Combination Voice Coil and  
 110 V A C Terminals

**Output Impedances:** 4-8-16-500 Ohms.

**Power Considerations:** 110-117 Volts 60 Cycle  
 A.C.

**Power Consumption:** 50 Watts.

**Circuit:** Special Patented Output and Bass Control  
 Circuits.

**Tubes:** National Union Loktal 2-7N7-2-7C5-1.7ZA.

**Size:** Extremely Compact 8<sup>5</sup>/<sub>8</sub> x 5<sup>5</sup>/<sub>8</sub> x 5<sup>5</sup>/<sub>8</sub>

**Weight:** 12 Pounds.

**Ask Your N.U. Distributor or Write**

**NATIONAL UNION RADIO CORP.**

57 STATE STREET, NEWARK, NEW JERSEY