

SERVICE

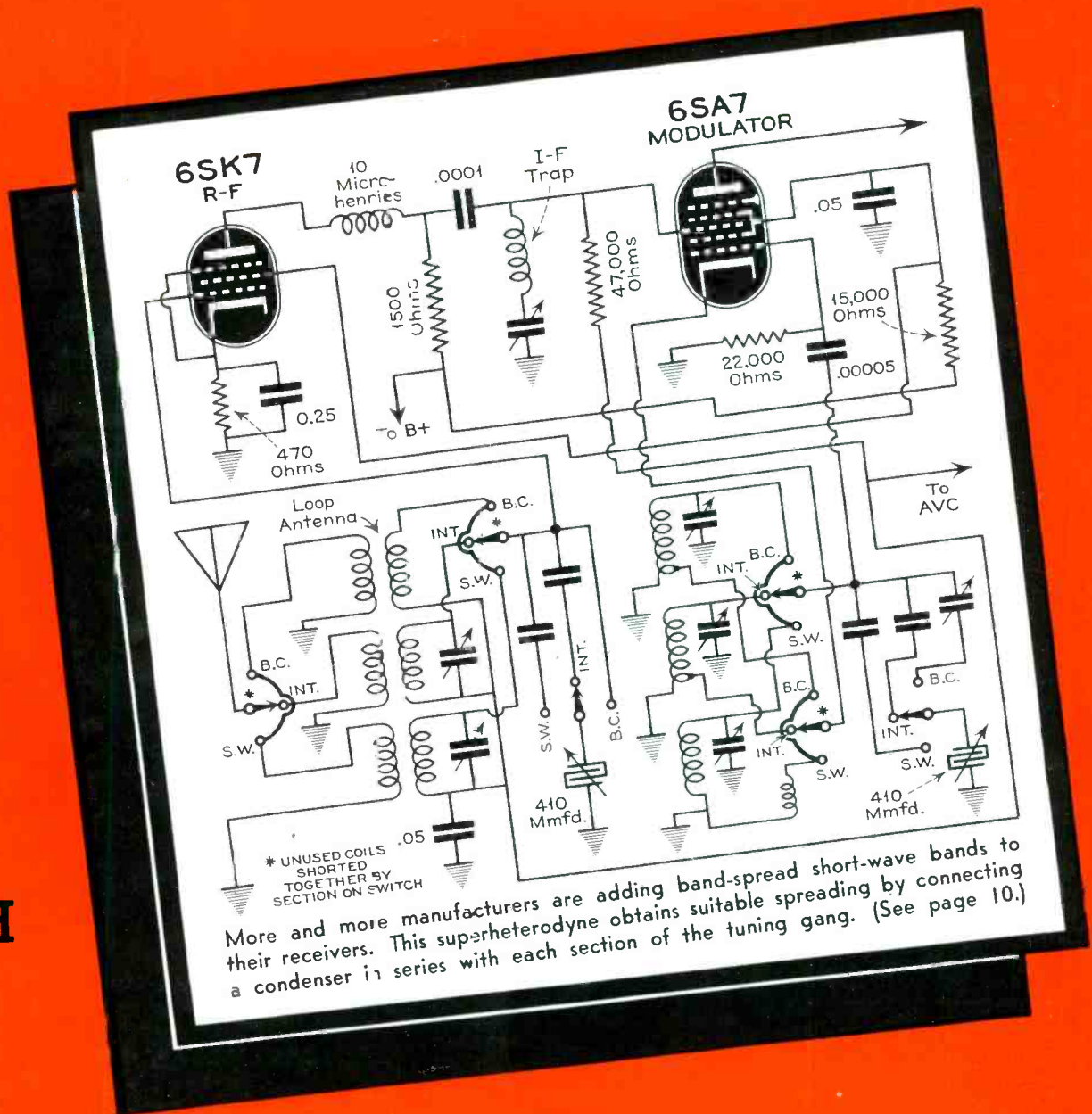

MARCH
1941

RADIO MOVING DAY MARCH 29

IT'S HERE! IT'S FREE!

ORDER
from your
distributor
TODAY!

MALLORY
1941 Replacement VIBRATOR GUIDE
with "Radio in 1941 Cars"

More Than Ever... Insist on Mallory

The Only
COMPLETE
Vibrator
Guide with
Exclusive Data
"Radio in
1941 Cars"

- Up-to-the-minute, completely accurate vibrator replacement chart for all makes and models of auto radios and battery operated home receivers.
- Complete cross-reference of Mallory Vibrators by make and model of receiver.
- Interference elimination, and auto radio installation in all 1941 cars. An exclusive Mallory feature.
- Vibrator connection charts.

P. R. MALLORY & CO., Inc., INDIANAPOLIS, INDIANA • Cable Address—PELMALLO

More
than ever
—INSIST ON

P. R. MALLORY & CO. Inc.
MALLORY
APPROVED
PRECISION PRODUCTS

VIBRATORS • VIBRAPACKS • CONDENSERS •
VOLUME CONTROLS • ROTARY SWITCHES •
SINGLE AND MULTIPLE PUSH BUTTON SWITCHES
• RESISTORS • RADIO HARDWARE



**MODEL 450
"TEST MASTER"**

Here the Model 300 is broadened to cover set testing. In addition to the tube tests of the No. 300 it has, as a set tester, 8 A.C. voltage ranges; 5 resistance ranges; 5 milliamp ranges; 5 Decibel ranges. Your net price..... **\$3975**

MODEL 300 TUBE TESTER

Here is a typical Simpson value. Tests locals, single ended tubes, bantams, midgets, miniature, ballast tube, gaseous rectifiers, Christmas bulbs, etc. Filament voltage from .5 to 120 V. Has three-way switching, neon short check, "good" and "bad" scale; percentage scale; tube charts in cover. Your net price..... **\$2650**

Who builds the best testers?

AFTER all, there can only be one *best* in any field. Who makes it? Who makes the best automobile—or screwdriver—or anything you need?

People are asking that question with more intensity today than they ever asked it before . . . and they *should*. Twenty years ago, when every manufacturer worked with practically the same materials and methods that everyone else in his field used, the best thing in any field was almost necessarily the highest priced thing available. But in recent years people have had their eyes opened.

Today, materials and methods and ideas are changing so rapidly that the manufacturer who held the lead *last* year may very easily *lose* it *this* year. You have seen makes of high priced automobiles pass into oblivion, not because they were not conscientiously built but because someone saw a "smart way" to make nine hundred dollar's worth of machinery do tricks that three thousand dollar's worth had failed to accomplish!

In the light of examples like that, we invite you to ask the question, "who builds the best testers?" In

seeking the answer forget manufacturers' names entirely and weigh basic worth against basic worth—idea against idea—workmanship against workmanship—record against record—straight through the list of radio testing equipment.

In such a comparison, we feel confident that you will find in Simpson Testers another one of those examples of smarter coordination of materials, methods and ideas that is re-shaping the trend of an industry.

Why? Because we came into the field with unsurpassed experience, but with a totally *fresh* viewpoint. That combination of advantages inspired the finer Simpson basic meter with bridge-type construction and soft iron pole pieces . . . the Roto-Ranger idea . . . the three-way switching idea . . . the "replaceable unit" idea . . . the countless other ideas that jolted testing equipment out of the rut into which it had fallen.

Three examples of this—but only three of the many—are illustrated here. Consider the *extra value* that these instruments represent and you have the answer to that vital question: "Who makes the best?"



**MODEL 400
TUBE TESTER**

A useful and impressive instrument. "Unit design" guards against obsolescence. Note visual guide tied in with new, Simpson speed-roll chart. Has three-way switching. Your name engraved free on panel at net price of..... **\$3600**

SIMPSON ELECTRIC COMPANY
5216-18 Kinzie Street, Chicago, Illinois

Simpson

INSTRUMENTS THAT STAY ACCURATE



Reg. U. S. Patent Office

BY THIS time every Service Man appreciates the opportunity staring him in the face to make definite tangible profits during the next few months. Several million push-button receivers, both in homes and in automobiles, will require resetting to conform with the new broadcast station wave lengths. Millions of listeners will be seeking information on where to find their favorite station. You will be called upon for this work and information. Of course, once inside the home you'll test all the tubes in the receiver and endeavor to sell replacements for those that are defective and weak.

TUBE replacement should provide a sizeable source for added profits. Make sure, however, that you take enough replacements with you to back up your sales effort. When you are through with the tubes don't stop and wait for your customer to make the next suggestion. Make an effort to check the antenna installation.

ANTEENNA installations are definitely the weakest link in the radio reproduction chain. It is estimated that over 70 per cent of those now in use are inadequate or improperly installed. New ones would certainly clear up a lot of noise interference. What a potential field for sales and service!

AUTO RADIO is another field for extensive sales and service. Recent U. S. Census figures show that over 80 per cent of all American families own at least one car; more than four out of every five. . . . It should prove very profitable, to say the least, to lead the conversation into this subject. If your customer has a set for his car it, too, may be in need of service as a result of reallocation. If his car is without a receiver make sure that you have his name and address written down somewhere handy, together with this fact, for future sales campaigns. Incidentally, it might also be wise to try to determine whether the customer is interested in any other equipment in this rapidly advancing field.

FREQUENCY MODULATION is in the limelight more and more each day. Newspaper and magazine columns are filled with news of the advances in this amazing new science of broadcasting. A wide-awake public is eagerly awaiting new developments of great promise. You can act directly or through a local set dealer to supply the ever increasing demand for these sets. Keep a record of prospects now.

HOME RECORDING and record reproducing equipment, discs and needles are other items that have been the subject of much advertising in the press throughout the country lately. There is no doubt but that some of the customers that you will visit within the next few weeks will be real live prospects for the sale of such equipment. There is no reason why you should not be able to cash in on this business.

REALLOCATION presents an exceptional opportunity. Make it serve not only to provide a few dollars of extra profit now, but to build up your business on a solid foundation for the next twelve months or more.

	Page
Circuits. <i>By Henry Howard</i>	10
Color Television	27
Communications Receivers. (Howard Progressive Series)	14
Gain Measurements and Signal Tracing. <i>By John H. Potts</i>	5
Sound Ideas. <i>By Robert G. Herzog</i>	18
Try Each Plan for Best Results. <i>By C. T. Kimberly</i>	13
Volume Controls. <i>By Edward M. and Mark Glaser</i>	8
Associations	30
Book Reviews	25
Case Histories	
RCA Little Nipper	12
RCA Phonograph Motors	20
RCA 15BP Series	12
RCA 16K, 16T3, 16T4, 17K, 18T, 19K, 110K, 111K	12
RCA 94BP1	12
RCA O-50, U-50	12
Wilcox-Gay A89, A91, A92, A93, A94, A101	20
Circuits	
Crosley 45 Personal Receiver	11
DeWald 670, 707	Front Cover
Farnsworth BK85, BK87, BK88, BK89, R-f and Oscillator	10
Farnsworth BT52, BT53, BT54, BT55, BT58	6
Farnsworth BT70, BT71, BT73, BT77, BT78 Oscillator and Converter	12
G. E. J51, J52, J54, J54W	5
Hallicrafters S29 Beat Oscillator and Noise Silencer	12
Howard 437A Communications Receiver	14
Motorola 35F, 43H, 44K A Filter	10
Motorola 40-60W	5
Philco AR40 Oscillator Mixer	11
RCA 11X1	6
Radio City 417 Appliance Tester	29
Volume Control Circuits	8 and 9
Weston 777 Tube Tester	16
Zenith 8F593, 8F594 (Chassis 8AO4)	7
Cover Diagram	
Band Spread Superheterodyne (DeWald)	10
Index to Advertisers	36
Manufacturers	
Catalogs and Bulletins	26
Displays	33
New Test Equipment	28
Parts, Etc.	35
Personnel	33
Sound News	24
Sound	
Sound Ideas. <i>By Robert G. Herzog</i>	18
Sound News	24
Test Equipment	
Gain Measurements and Signal Tracing. <i>By John H. Potts</i>	5
New Test Equipment	28
RCP 417 Appliance Tester	29
Weston 777 Tube Tester	16

Copyright, 1941, Bryan Davis Publishing Co., Inc.

BRYAN S. DAVIS
President

JAS. A. WALKER
Secretary

Chicago Office:
608 S. Dearborn Street
C. O. Stimpson, Mgr.
Telephone: Wabash 1903

Published Monthly by the
Bryan Davis
Publishing Co.
Inc.
19 East 47th Street
New York City

Telephone: PLaza 3-0483



PAUL S. WEIL
Advertising Manager

A. GOEBEL
Circulation Manager

Wellington, New Zealand:
Tearo Book Depot

Melbourne, Australia:
McGill's Agency

Entered as second-class matter June 14, 1932, at the Post Office at New York, N. Y., under the Act of March 3, 1879. Subscription price: \$2.00 per year in the United States of America and Canada; 25 cents per copy. \$3.00 per year in foreign countries; 35 cents per copy.

4 *New* EXTENDED RANGE COAXIAL SPEAKERS

ALL WITH THE SUPERIOR PERFORMANCE
INHERENT IN DUAL SPEAKER OPERATION

NEW! 4-POSITION HF RANGE CONTROL SWITCH

This new feature gives you finger-tip control of response, provides instant adjustment of high frequency range for best results on every record, every program — FM or AM.

(Extension cable permits convenient mounting of fully-wired, 4-point HF Range Control Switch on cabinet or panel.)

JAP-60 (15-Inch) Professional extended-range high efficiency model for broadcast monitoring, transcription playback, etc. Includes 4-Position HF Range Control Switch. Integral two-channel frequency dividing network ... **\$70.00**
List

JHP-52 (15-Inch) For high quality extended range phonograph, FM-AM receivers, etc. Includes 4-Position HF Range Control Switch. Integral two-channel frequency dividing network ... **\$46.50**
List

JHP-50 (15-Inch) For general high-quality extended-range reproduction. Accessory switching and HF Range Control may be added. **\$38.50**
Bridging network List

JCP-40 (12-Inch) New 12" size gives coaxial performance at a new low cost! Excellent replacement unit for phono and radio receiver modernizing. Bridging network **\$29.50**
List

ensen

6601 SOUTH LARAMIE, CHICAGO

FM • AM • PHONO REPRODUCERS



For Every Need
in EVERY Emergency



AXIAL LEAD RESISTORS
 TYPE 710 — size 1/8" x 3/8" rated 1/2 watt
 TYPE 714 — size 1/4" x 1" rated 1 watt

Centralab AXIAL LEAD RESISTORS

Under water... in the air... under ground... on every "front" these famous resistors are proving their fitness in routine as well as emergency work.

Due to more exacting conditions in the industry... the vogue of smaller plastic models; there is an even greater need for resistors that are both small in size and positively insulated. Centralab AXIAL LEAD resistors are designed to fit into limited space without danger of shorting. Moulded bakelite CAPS through which the end leads protrude... complete the positive insulation afforded by the non-conducting ceramic jacket. Will withstand five times rated load without permanent change.

For further information ask your jobber
 or write for Bulletin No. 606.

CENTRALAB: Div. of Globe-Union Inc.
 900 E. KEEFE AVE. • MILWAUKEE, WISCONSIN

Builders of the famous
CENTRALAB VOLUME CONTROLS ...
SWITCHES CERAMIC CAPACITORS ...

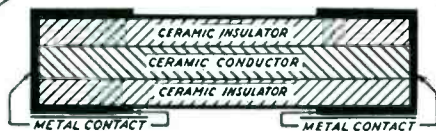

Magnified cross section shows center core of resistance material surrounded by a non conducting shock proof ceramic.

Both core and jacket are fired together at 2500 degrees F. into a solid unit—hard and durable as stone and impervious to moisture.

Pure copper spray at extreme ends gives positive electrical and mechanical contact.

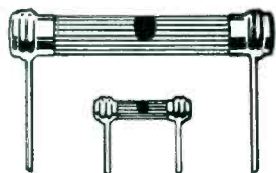

RADIAL LEAD RESISTORS

The radial leads where attached to the body of the resistor are uninsulated... making these resistors 90% insulated... in every other respect the electrical characteristics are the same as the AXIAL Lead units.

TYPE 310 — size 1/8" x 5/8" Rated 1/2 watt
 TYPE 314 — size 1/4" x 1" Rated 1 watt
 TYPE 316 — size 1/4" x 1 1/4" Rated 2 watts

GAIN MEASUREMENTS and Signal Tracing

By John H. Potts

SIGNAL tracing is now well out of its infancy. Having grown up, it is not strange that new and wider fields of application for this method of trouble shooting have been opened. No longer do we find its proponents engaged in poking an inquisitive probe into the vitals of an ailing receiver solely for the purpose of localizing the sore spot. With the new technical information which several large receiver manufacturers are now providing for their sets, it is possible to check over a receiver which is only slightly off color and determine just exactly which portion of the set is subnormal. Further,

Fig. 2. Motorola has been a pioneer in the presentation of gain data. The information given for Model 40-60W is the reverse of signal tracing.

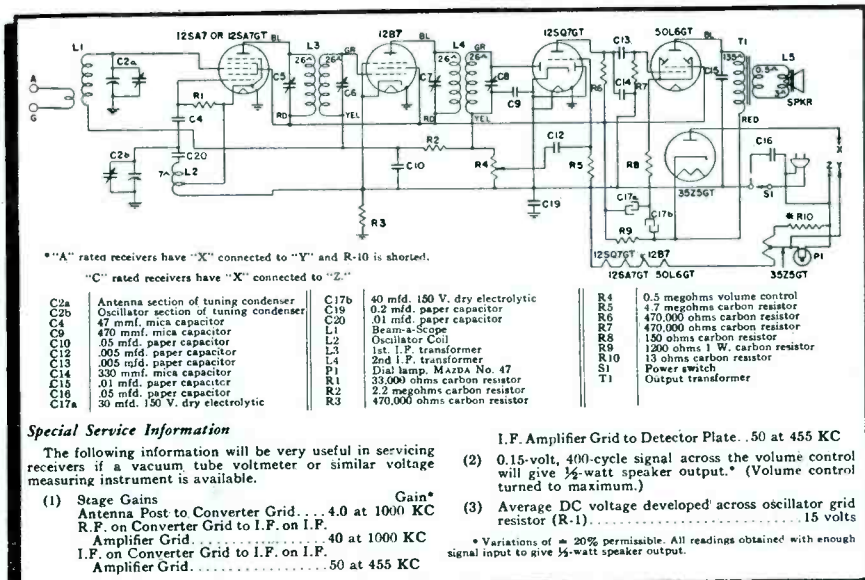
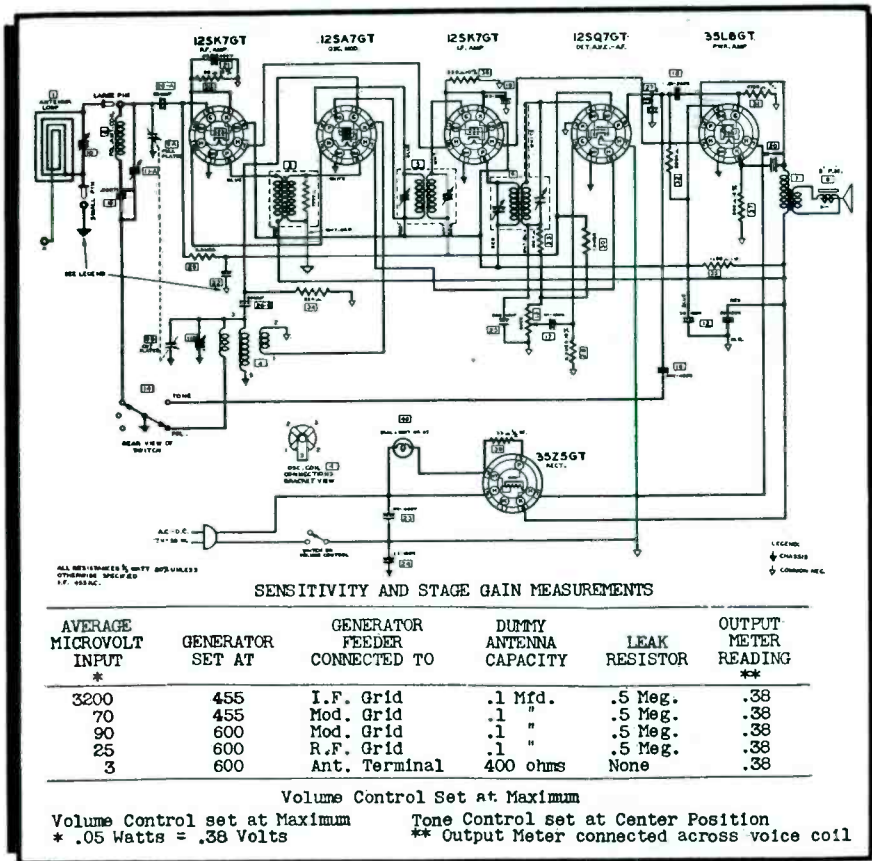

Fig. 1. General Electric tabulates the gain data in the service notes. The information given above is for the G.E. J51, J52, J54, and J54W receivers.

when a repair job is done on any of the receivers for which this new information is supplied, it is possible to determine definitely whether or not normal performance has been restored. This saves time, assures both the customer and the Service Man of that peace of mind which results from a job well done.

Most modern receivers have an excess of sensitivity which is seldom required. In checking an unfamiliar receiver in the shop, rather than in the customer's home, we are occasionally led to believe that the receiver has plenty of hop when actually, in the customer's home, it may be so much lacking in pep that a weak, desired station cannot be satisfactorily received. Often this condition may result from moisture absorption, either in the r-f, oscillator, or—and most frequently—in the i-f system. Such troubles are occasionally passed over, particularly when several transformers are affected but the stage gain has not been too greatly reduced in any one stage. In such cases, concrete specifications as to average gain in typical receivers of the identical model under test are especially valuable. And there is much of

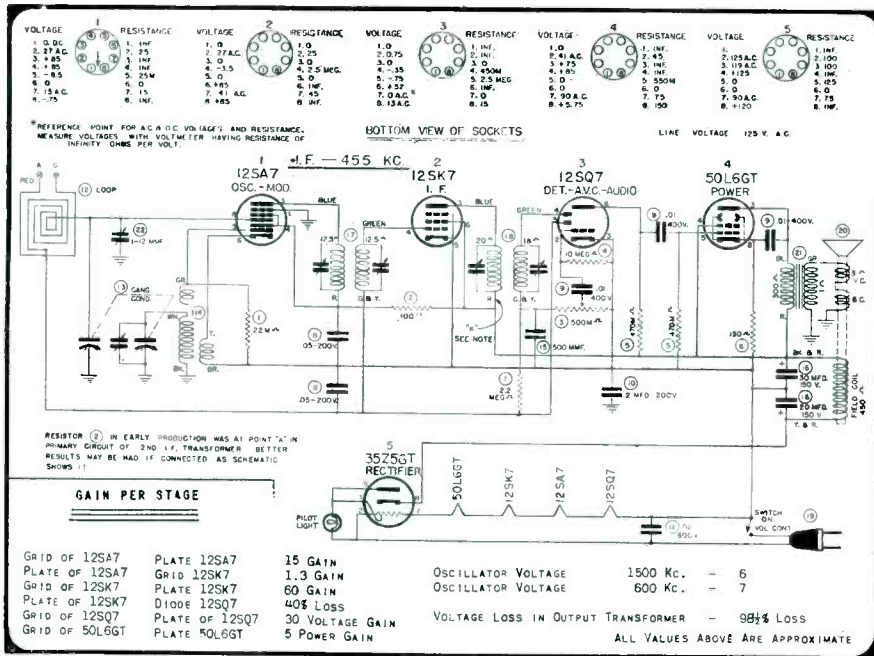

Fig. 4. Farnsworth has recently included gain measurements in their service notes. The circuit shown is used in their Models BT52, BT53, BT54, BT55 and BT58.

just this sort of information included in the service notes supplied by the manufacturers and the publishers of manuals.

This isn't all. Gain in antenna coils, audio amplifier sections, and in some cases avc voltages for a given signal input, are made available. Often we are supplied with data concerning the rectified voltage across the oscillator grid leak—a particularly valuable point—

which aids greatly in determining whether any obscure lack of pep in the receiver under test is due to insufficient oscillator voltage—so often caused by moisture absorption and other hard-to-find ailments.

As we run over the examples we are discussing in this article, we shall see that there is no uniformity in the presentation of this technical information—that is, insofar as the method of tabulation or, in fact, even the type of information supplied. Some manufacturers supply data which others omit: in some

cases, modification of the normal signal tracing test routine is required to take full advantage of the data furnished. However, no matter how the information is set forth, there's a way of making good use of it.

General Electric

Let us consider first the simple General Electric Model J51 (also for the H53, J54, and J54-W) receiver schematic, shown in Fig. 1, and the manufacturer's special service information directly below the schematic. The stage gain data embrace the entire r-f and i-f sections, from the antenna to the second detector. The audio amplifier is handled as a single unit; that is, as specified in (2) of the data, when the audio signal across the volume control at maximum setting is 0.15 volt, at 400 cycles, the speaker output should be 1/2 watt.

Insofar as measuring the gain from the antenna post to the converter grid, rated as 4.0 at 1000 kc, the procedure follows the normal signal tracing routine of feeding the signal generator signal to the antenna and ground terminals, and measuring the signal voltage at both the antenna post and the 12SA7 grid. The ratio of the signal voltage at the latter point to that at the antenna post should be at least 4.0. We might mention in passing that, if you can't get a

Fig. 3. RCA letters the gain measurements directly on the schematic diagram. The RCA 11X1 is shown.

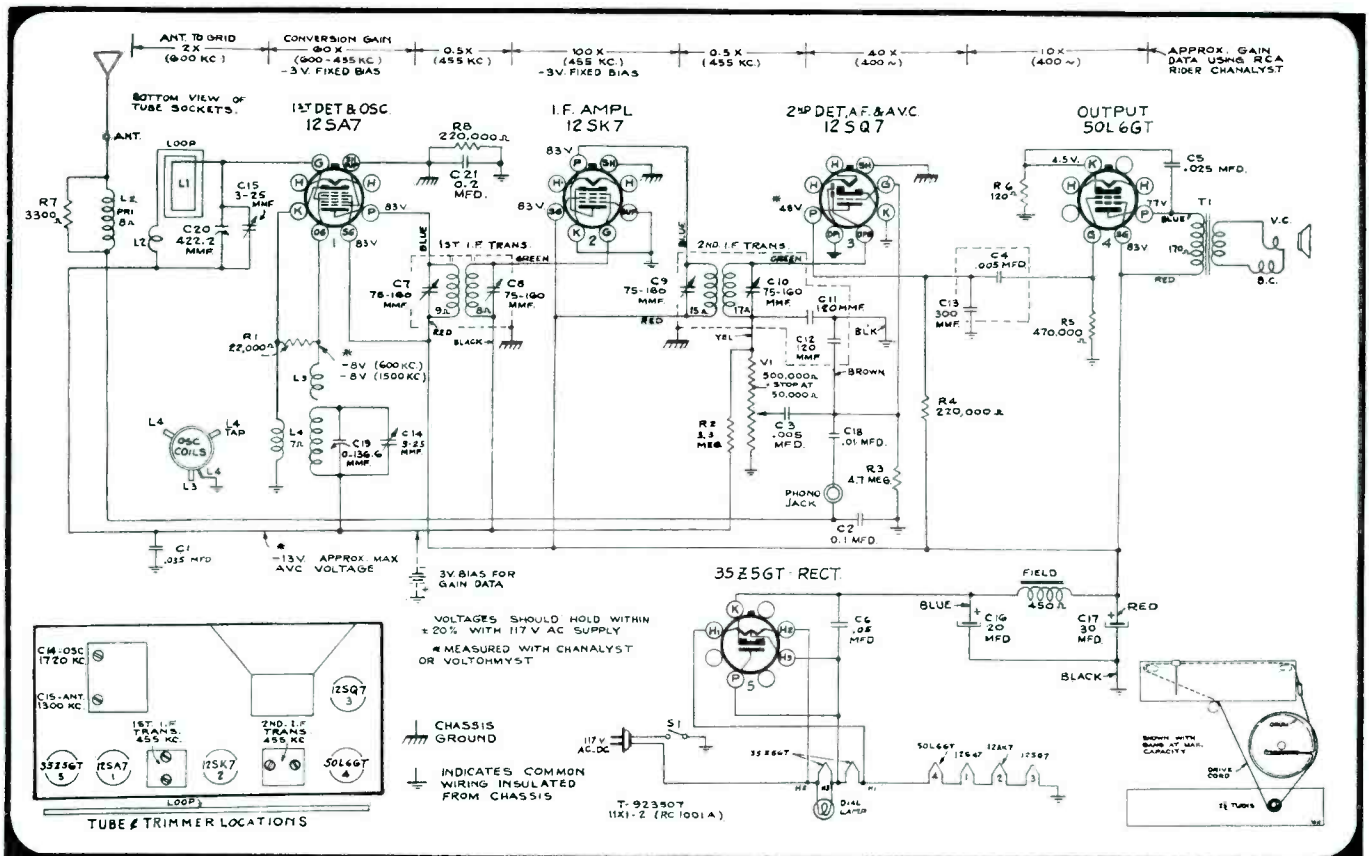

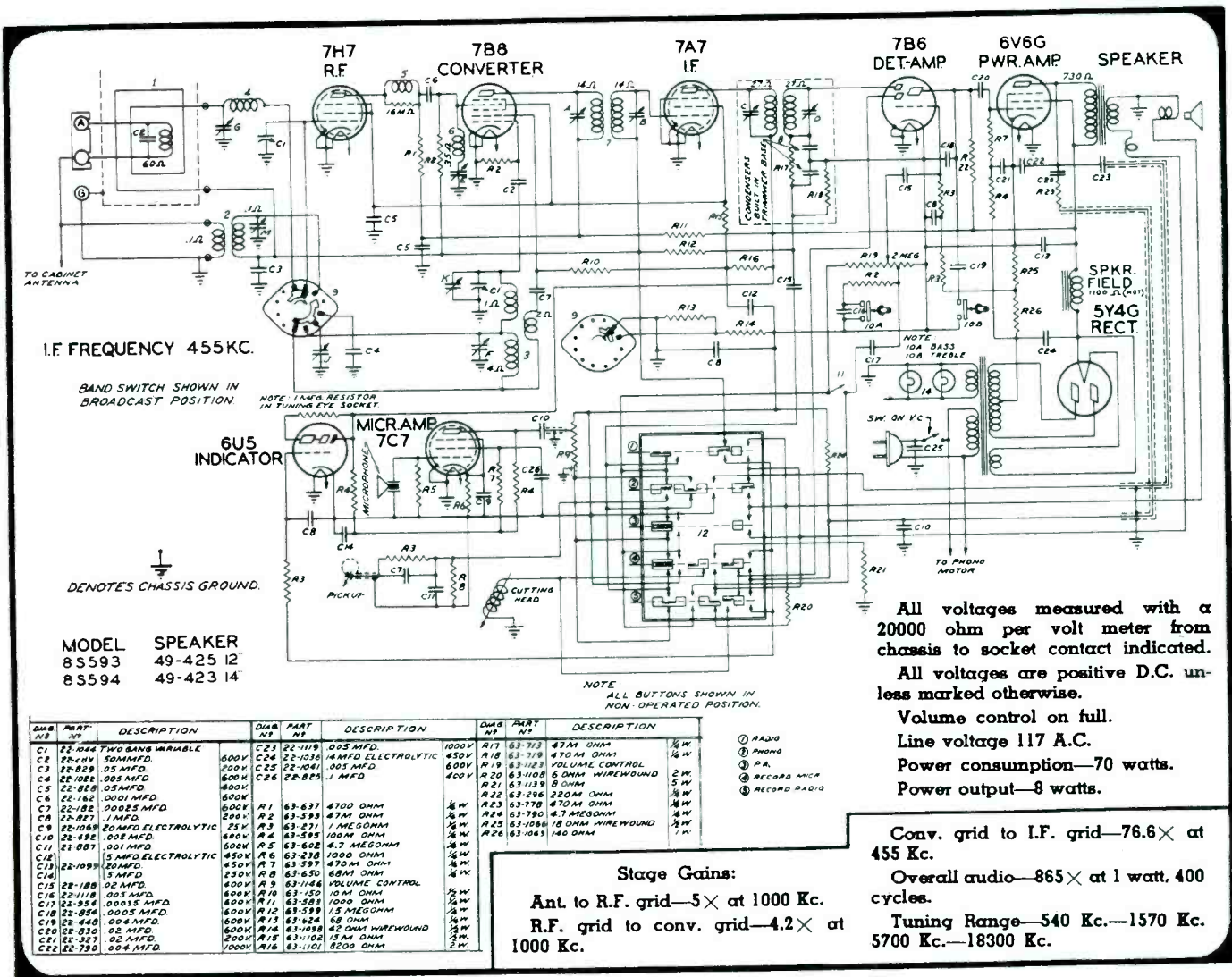

All voltages measured with a 20000 ohm per volt meter from chassis to socket contact indicated. All voltages are positive D.C. unless marked otherwise.

Volume control on full.

Line voltage 117 A.C.

Power consumption—70 watts.

Power output—8 watts.

Conv. grid to I.F. grid—76.6 × at 455 Kc.

Overall audio—865 × at 1 watt, 400 cycles.

Tuning Range—540 Kc.—1570 Kc. 5700 Kc.—18300 Kc.

Stage Gains:

Ant to R.F. grid—5 × at 1000 Kc.

R.F. grid to conv. grid—4.2 × at 1000 Kc.

reference indication on the signal tracing instrument when connecting the probe to the antenna post of the receiver, to which the signal generator has been connected, it is possible that the antenna coil is shorted. This may happen when the antenna is struck by lightning. The result is that the coil primary melts and forms such a low-resistance short across the signal generator output that no measurable signal can be produced. The check for this condition is to disconnect the test oscillator "hot" lead from the antenna post and then to note the signal output when the signal tracing probe is connected to the signal generator leads which would of course be very much greater than that which is obtained if the antenna coil is shorted.

The second specification in the G. E. J51 data reads "R-F on Converter Grid to I-F on I-F Amplifier Grid," which is, in effect, the conversion gain of the mixer. This is measured by checking the 1000-kc signal level at the 12SA7 grid and the resulting 455-kc i-f signal appearing at the grid of the 12B7. The ratio of the latter to former measured signal voltage represents the conversion gain to the i-f grid, which is rated at

40. Note that only the first measurement, at the converter grid, is at 1000 kc; the second measurement is at 455 kc. This is normal signal tracing routine.

The third specification, representing the ratio of the i-f signal at the 12B7 grid, to the i-f signal at the converter grid, represents the gain of the converter as an i-f amplifier. In fact, the rated gain of 50, in this mode of operation, could be obtained even if the oscillator section of the converter were inoperative. This test, while not normally a part of the customary signal tracing routine, is nevertheless useful. In the event that the converter section of the mixer is inoperative, this test permits a quick overall check of the balance of the receiver, if the oscillator section failure is the only fault. Thus this test is invaluable in making estimates.

To make this test, the dial of the receiver should be turned to the low-frequency end of the band and the signal generator should be connected from

control grid to ground in the 12SA7 input circuit. This can be conveniently done by connecting from the stator lug of C2a to ground, using an 0.1-mfd condenser (or thereabout) in series with each signal generator lead (since this is an a-c, d-c receiver). Tune signal generator to 455 kc. Then the ratio of the i-f signal level which appears at the 12B7 grid to that applied to the converter grid represents the gain of the 12SA7 as an amplifier. You may wonder why it is possible to connect the signal generator across an r-f circuit in this manner, and tune the instrument to 455 kc, without having the low resistance r-f circuit ground out the generator attenuator. When the r-f circuit is tuned to around 600 kc, as we mentioned earlier in this paragraph, the impedance of the tuned circuit is not only extremely high at 600 kc, but is also much higher than that of the signal generator output circuit, even though the signal frequency is 455 kc instead of 600 kc, so no appreciable loading results.

The specified gain of the i-f stage, from the i-f amplifier grid to the detector diode plate, is checked in the cus-

(Continued on page 31)

VOLUME CONTROLS

By EDWARD M. and MARK GLASER

THERE are two general systems of controlling volume: one decreasing gain in the r-f end of the receiver and the other controlling the voltage fed to the audio amplifier. Occasionally, the Service Man comes in contact with a set where the method of controlling volume is inadequate and some other means must be used to complement the original system or a radically different system must be installed. The latter is sometimes easier than locating an exact replacement part for some ancient model that is regarded as an heirloom or whose owner is awaiting \$25 television. With the exception of the replacement case, trouble is usually due to the presence of a strong local station. This may often be rectified by altering the antenna length or position, or by the use of wave traps or series condensers. When such methods fail some of the following data may be useful. We hope it may be useful on other occasions as well.

Filament Controls

The first volume controls were filament rheostats, either wire wound or carbon pile compression types. Some of the wire controls had a 1-turn vernier operated by a concentric knob. This knob was used for fine adjustment, imperative for controlling regeneration on the early sets.

Fig. 1. Bias control with a local-distance switch was employed in many early receivers. Before the advent of variable-mu tubes, however, this method caused detection in the r-f stages and produced cross modulation. The latter condition was evident when strong signals would ride in on any carrier.

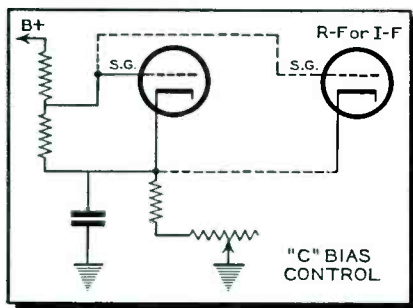

When neotradynes and other t-r-fs came along the same type of control was used but on more tubes—usually all the r-f tubes. Cutting filament voltage was one way to decrease the transconductance of the amplifier tubes, thereby reducing amplifier sensitivity. Cutting the filament drain was important, too, because storage batteries supplied the juice. The first all a-c sets tried to use the same filament control on 226s but the hum was terrible and the action would lag behind the adjustment. Nevertheless, filament control is still feasible on some battery sets.

Antenna

Antenna control was the next system introduced. To be effective, the receiver had to be perfectly shielded to eliminate pickup after the antenna stage input. No set, of course, is or was perfectly shielded so there was always some leakage; strong locals just wouldn't be controlled.

The greatest change in volume occurred at the very start of the curve making the action very critical. Attempts at a smooth logarithmic curve resulted in a variety of stunts, many of

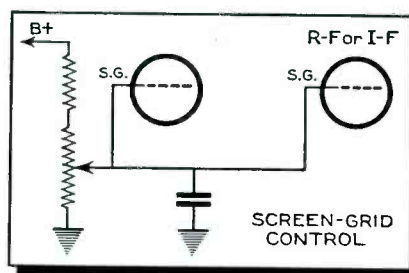

Fig. 2. Control of the screen voltage fed to the r-f stages was another early method used to control receiver volume. This method by itself was not entirely satisfactory.

which were beneficial. Some manufacturers had a single slide wire at the start followed by a heavy wound wire followed by a medium wound wire and ending with a wound fine wire. This type of control ranged from 1500 to 10,000 ohms and was not bad except

at the joints where a sudden jump occurred. They were quite noisy, too.

Bias

Bias control in conjunction with a local-distance switch was used in many sets. One, two or three t-r-f stages were controlled by varying the resistance between cathode and ground. Forced bleeders were used to push a small, fixed amount of current through the control; otherwise there was insufficient cut-off. (See Fig. 1.) A certain amount of resistance was left in the circuit at maximum volume setting to limit the r-f plate currents to the normal values. This was done by adding a fixed resistor in series with the cathode or by providing a stop in the control itself which left the required resistance. A principal disadvantage of this system was the local interference again, a strong signal rid-

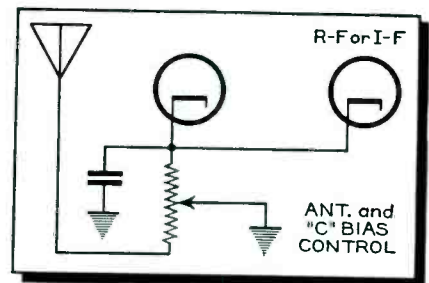

Fig. 3. While the antenna-C bias method of controlling the volume of a receiver was excellent from the standpoint of control, cross modulation difficulties were attendant before the introduction of variable-mu tubes.

ing in on any carrier due to non-linear amplifier operation with high C bias. Values of resistance used: 5,000 to 75,000 ohms.

Other Systems

With screen-grid tubes came screen control by means of a B-voltage potentiometer shown in Fig. 2. This method still had most of the disadvantages of the C bias idea. Values ranged from 50,000 ohms up.

Another scheme used variable capacity coupling between r-f stages. This was a very ticklish system, requiring very complete shielding of the entire r-f

end as well as between individual stages. Each stage, therefore, was a complete unit. The cost of such an outfit nowadays would make many a manufacturer faint.

Another system, introduced earlier, varied coupling between stages by using a potentiometer method of feeding the primary of an r-f interstage transformer from the plate; or by shunting the primary with a variable resistor. Most of these stunts produced some detuning, detracting from the set's selectivity when it was most needed.

Combined Antenna-Bias

This brings us to the combined antenna-bias control with the arm connected to ground, as in Fig. 3. These 5,000- to 25,000-ohm controls were very effective when the correct curve was used, especially when the antenna was

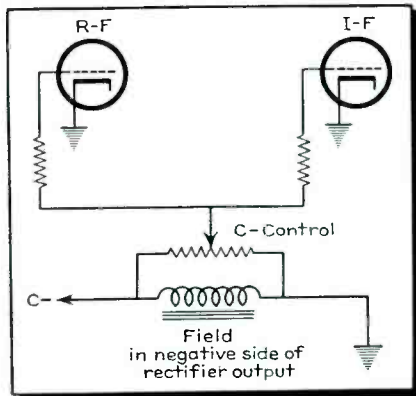

Fig. 4. In another method of C-bias control, the bias is obtained from a potentiometer connected across the field, in the negative return of the power supply.

of a proper length so as to deliver signals neither too strong nor too weak. Sometimes dual controls were used, each with its individual function. This, of course, provided even better control. They were often separated, one in front—the other in the rear, as in many Stromberg-Carlsons. The single control is the more interesting, cutting out antenna voltage as it increases the bias, producing smooth attenuation. When replacing this type of control the original should be duplicated as nearly as possible; otherwise action may be quite unsatisfactory.

When variable- μ tubes were introduced, there was no longer any need for local-distance switches for the tubes allowed less distortion on both powerful and weak signals. Tapers became more critical due to the extended range of signal levels—which led to a general introduction of logarithmic tapers.

A few sets used a potentiometer type of grid bias control where the negative bias was obtained from the drop across the speaker field located in the negative

high voltage lead. (Note Fig. 4.) This completes the r-f controls.

Audio Controls

When avc became popular, audio volume control became standard. Some sets, however, particularly the communication types, have an auxiliary r-f gain control which is very useful in certain in-

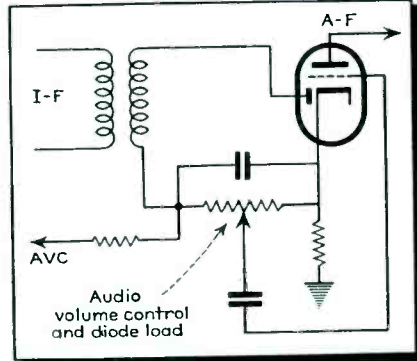

Fig. 5. Automatic volume control systems brought with them the audio control, which varied the amount of voltage fed to the a-f stages.

stances. This is sometimes known as a sensitivity or noise level control which is self-evident. It prevents overloading the r-f or i-f amplifier when strong signals are present. Before avc systems were standardized, the audio volume control was a separate item from the diode load resistor. Later, the two functions were combined and we had the present simple and very effective system which we all know. (See Fig. 5.) While several tapers are available for audio controls, they have practically been standardized permitting the Service Man to stock only a few types. No power is required for avc action or for the audio potentiometer but the diode load requirement does call for a small amount of power; not enough to cause any difficulty, however.

A New Method

Fig. 6 shows a new method of controlling volume on cheap midget sets which cuts down the hum as the volume is reduced. This allows the presence of more hum when strong signals are coming in, the hum being more or less masked by the program. As the control is turned down, the cathode of the r-f or i-f stage gets more bias while the audio grid is shunted to ground, cutting the incoming hum and also the low frequencies generally—which further cuts the hum. A trick taper is used in this application.

Bass Compensation

Many of the better sets have featured bass compensation in their audio volume-control systems. This is to compensate for the ear's variation of frequency response with different sound levels. As

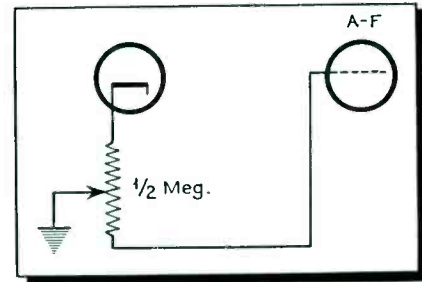

Fig. 6. The circuit shown above gives the connections of a new method for controlling the volume in inexpensive midgets.

the level is reduced, it seems that the very low and high frequencies are attenuated, or that the middle range is accentuated. So the object is to cut the middle frequencies while cutting volume. Fig. 7 shows the usual scheme employed; some controls have two taps providing more gradual action. A more perfect system uses combinations of L and C; a typical tuned circuit contains a choke of about 80 millihenries in series with a $\frac{1}{2}$ -mfd condenser and some resistance to broaden the effect.

Control Kits

Service Men get a real break in the new volume control kits put out by several manufacturers featuring plug-in shafts and interchangeable switches allowing a minimum number of controls with which to make all replacements. Controls now in use vary from 3-inch down to $\frac{3}{4}$ -inch diameter, practically all having some form of taper. The new controls have pigtailed which eliminate shaft contact noises.

New methods of control appear from time to time in the new patents issued but most are destined to collect the dust of the ages. Not that our present methods are perfect—not at all. We must be open-minded enough to expect something better tomorrow. One new idea changes the transconductance of a tube without changing quality by using a rotating magnet control which changes the element structure inside the tube: probably expensive but perhaps very good!

Fig. 7. In more expensive models bass compensation has been added to the audio volume control. Often a choke is used in series with the resistor and condenser shown below.

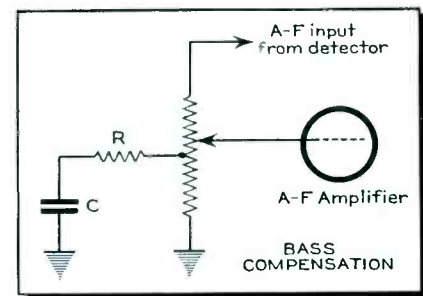

CIRCUITS

See Front Cover

By HENRY HOWARD

OUR medal of the month goes to Motorola for sticking to three-gang tuning condensers. In the old days, a three-gang tuning condenser cost as much as an entire compact today. But that was long, long ago. Many models are coming down the line today with a beneficial r-f stage, but with only a two-gang variable; the first detector is untuned. Some of these circuits have been shown in this series lately; several with straight resistance coupling, but most with a type of impedance coupling having a plate choke resonating at some point where the gain would otherwise be insufficient, often in a short-wave band. Such an arrangement, though welcome, sacrifices much of the benefits of the tuned r-f stage as we have known it.

With only a single tuned circuit at signal frequency, besides the oscillator, many annoying forms of interference become evident. Local stations of all types break through regardless of frequency; strong ones ride in on any carrier that happens to be tuned in; others beat with various harmonics creating enough birdies and squeaks to make one disgusted with supers—and long for good old t-r-fs, even with their "poor selectivity." Our sympathy goes out to those hams who have interference complaints lodged against them by neighbors with these non-preselective superheterodynes which permit amateur phone stations to appear on the broad-

cast band. The neighbor will, of course, swear that the amateur is usurping his rights in using broadcast station frequencies—he couldn't possibly be wrong—isn't the dial calibrated in frequency? Let us hope for a general return of three-gang condensers to eliminate this nuisance and, while we're at it, let's include portables in the deal, too.

Motorola 35F, 43H, 44K

Getting back to Motorola, we notice another good feature on Models 35F, 43H and 44K. This is an elaborate r-f filter in the A input lead to the vibrator and tube heaters, shown in Fig. 1. Note particularly the three separate types of by-pass condensers in parallel—a spark plate, a mica condenser and a paper tubular. Each type contributes toward improved noise filtering—which is one

Fig. 1. Motorola Models 35F, 43H, 44K use an elaborate input filter to the vibrator and tube heaters to prevent ignition noise from leaking through. Each condenser contributes toward this end.

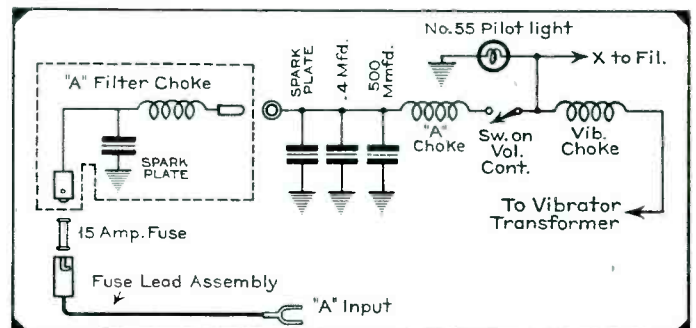
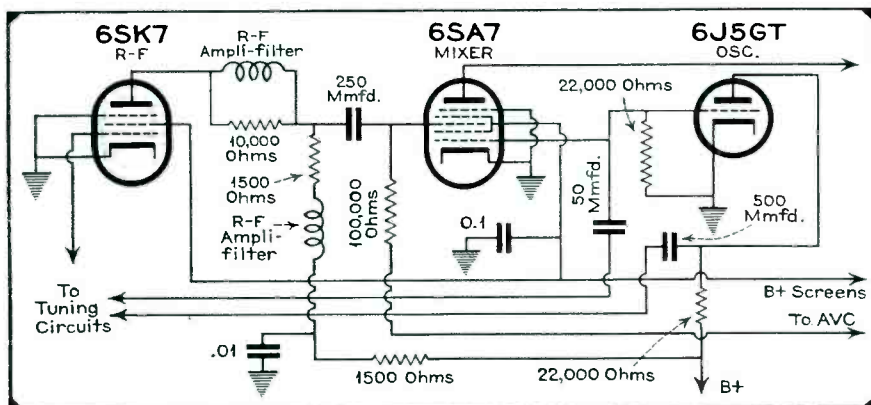

Fig. 2.)

Fig. 3. Farnsworth BK85, BK87, BK88, BK89 employ two trap circuits between the r-f and mixer stages.



of the odd and interesting facts about this game of ours called radio. We would be inclined to say, off-hand, that

Silvertone 5732, 7327

Silvertone Model 5732, an eight-tube single-band loop job with phonorecorder combination, uses push-pull 35L6GTs feeding a magnetic cutter. This is an a-c set with a 35-volt heater winding for the power tubes and 35Z6G rectifier. A 12.6 volt tap is brought out for the converter, i-f, avc-detector and inverter tubes and a 6-volt tap is used for the 6U5 eye. The eye serves as a recording level indicator in the recording positions.

Another Silvertone Model 7327, a 6-tube, 60-cycle, one-band superheterodyne, has a 25-volt heater winding,

the more perfect the condenser, the better the by-pass or filtering action. But, instead of air, or good quality mica, such things as fish paper are used as dielectrics in spark plates! It looks like a wide assortment of power factors is called for.

Another point of interest is a combined diode tuning condenser and filter condenser in the second detector circuit. These Motorolas, by the way, are designed for the new 1941 Ford and Mercury, Hudson, and Packard automobiles in order of model number.

Philco AR40, AR50

While on the subject of auto sets we have two Philco models with unusual features. Model AR50 uses a-f degeneration for high quality. The feedback voltage is taken from the voice coil and fed to the first-audio cathode through a series circuit of 1500 ohms and 0.07 mfd. This system of inverted feedback is usually found only on the better home receivers. This set uses a fixed-tune system of impedance coupling between the r-f and first detector.

Philco Model AR40 uses the same system of audio feedback, but uses a Colpitts type of oscillator circuit. In this circuit, the grid excitation is determined by the ratio of two condensers instead of by the mutual inductance between two coils as in other circuits. Straight resistance coupling is used between the r-f and detector stage. (See

feeding a 25L6 output tube and 25Z6 rectifier directly, and two sets of 12-volt tubes in series parallel. This one could be a puzzler to some Service Man not on the alert! The heater winding has a 6-volt tap for a pilot light.

Belmont 705

Belmont's Model 705 is a 4-band, 7-tube, a-c set that uses iron-core antenna coils and loop loading coil. A 6J5GT triode is used as a mixer fed by another 6J5 oscillator. A triode converter, especially with no r-f gain ahead of it, is beneficial in reducing noise generated during the process of conversion. The weaker the signal, the

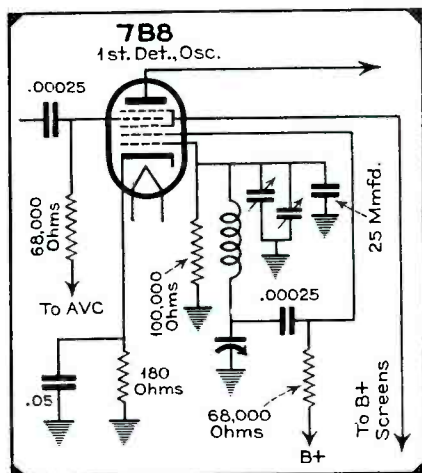

Fig. 2. Philco Model AR40 uses a Colpitts type of oscillator circuit, wherein the grid excitation is determined by the ratio of two condensers.

more noise created. Two high gain i-f stages are used in this receiver.

General Electric J1106, J1108

General Electric 11-tube combinations, Models J1106 and J1108, use push-pull, parallel 6K6GTs for the power end. Grid suppressors of 1000 ohms are used adjacent to each control grid to aid stability. The suppressor grid of the 6SK7 r-f stage is tied directly to the avc bus instead of returning to cathode or ground. The control grid is fed avc in the usual manner; also, the converter signal grid.

General Electric brings up an interesting point in their service notes cautioning against removal of the alnico magnet from the speaker. Although alnico is much more stable than older magnetic alloys, it can lose magnetism if the keeper is removed when disassembled. It will then have to be returned to the manufacturer to be remagnetized and reassembled. Otherwise the field may be too weak for good quality and sound conversion efficiency.

General Electric J614, J664

General Electric Models J614 and

Fig. 4. Crosley's Model 45 "Commuter" is a mid-gut personal receiver of rather small dimensions. Regeneration has been added, by running the B-plus side of the i-f transformer primary to the cold side of the oscillator tickler, to increase the i-f gain.

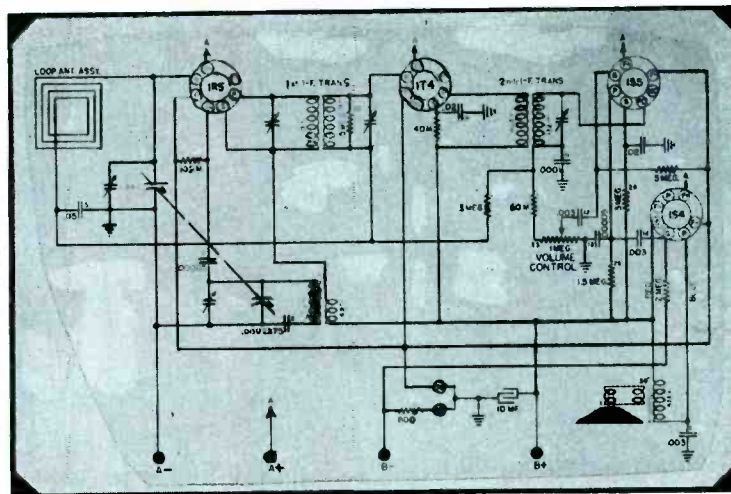

J664, 6-tube a-c, d-c superheterodynes, use a shorting link across the antenna coupling coil to the loop when no antenna is in use. This cuts out resonance points that would occur in the broadcast band due to the natural period of the high inductance primary. The r-f suppressor is run to the avc bus in these sets also.

Loops

When loops first became popular, separate loops were used for different bands, or, for an intermediate band, sometimes the broadcast loop was tapped. Lately, several set makers have turned to the built-in screen antenna because of better short-wave pick-up, and loops for short-wave reception are almost non-existent. Farnsworth 600 and 6000 series chassis use the screen. A number of console sets have a wire draped around the inside of the cabinet. Such an antenna is often featured as a "special built-in short wave aerial!"

Farnsworth BK85, BK87, BK88, BK89

Farnsworth Models BK85, -87, -88 and -89 are 8-tube two-band a-c supers with a 6J5GT separate oscillator tube coupled to the converter tube by connecting the oscillator grid to No. 1 of the 6SA7. The untunable coupling system between the r-f stage and detector has a second equalizer circuit—one more than most sets. (See Fig. 3.) When aligning these sets, two peaks are often found at 18 mc. The manufacturer denotes the peak found at the maximum setting of the oscillator trimmer to be the correct one.

Battery Sets

We haven't much on battery sets, but, by next month, we should be flooded. Farnsworth Model BT68 is one of the few a-c, d-c battery jobs with an i-f stage. The Crosley "Commuter" Model 45 chassis is a personal battery receiver with regeneration added to increase the i-f gain. Regeneration is ob-

tained by running the B-plus side of the i-f transformer primary to the cold side of the oscillator tickler instead of the B-plus battery terminal. (See Fig. 4.)

Hallicrafters S29

For those interested in multi-band portables, the Hallicrafters Sky Traveler, Model S29, has a self-contained telescopic antenna and a blinking neon lamp on-off indicator. The tube line-up includes an r-f amplifier, first detector-oscillator, two i-f stages, avc-detector-first a-f, a-f output, beat-frequency oscillator, automatic noise limiter and 50Y6 rectifier for line operation. Service Men should be acquainted with automatic noise limiting (anl). While not exactly a new development, it has never come into general use on broadcast receivers, although practically all communication type receivers include anl as a must. The type of anl used in this receiver is shown in Fig. 5, and consists of a 1G4GT serving as a diode whose plate is connected to the avc bus through a 1-meg resistor by-passed to ground through an 0.05-mfd condenser. The diode filament is connected to the high side of the volume control. Since this filament is "hot," a separate A battery must be used for this tube; a flashlight cell is ample. When a crash of static, or some form of peaked noise comes through, a high avc voltage momentarily appears. Due to the long-time constant of the diode plate circuit, the diode plate potential is unchanged, but the diode becomes a low-resistance conductor under this condition and virtually shorts the crash before it can get to the audio amplifier.

Farnsworth BT70, BT71, BT73, BT77, BT78

Farnsworth Models BT70, -71, -73, -77 and -78 are 7-tube, 2-band phono combinations for a-c only. The first a-f cathode is grounded; bias is obtained through a 10-meg grid-load re-

sistor. Inverted audio feedback is obtained by connecting a 2.2-meg resistor between the output 6K6GT plate and the 6SQ7 first audio plate. In phono position, the diode output is grounded, thus shorting the audio output of the detector. (Most radio cut-out systems that we have been showing work in the r-f end, usually opening the cathode or B circuit of one or more r-f tubes.) (See Fig. 6.)

The Crosley Model C35AK combination also uses the a-f shorting system for positive radio cut-off.

DeWald Model 670 and 707

This set, although of straightforward, conventional design, has a number of interesting features. A six-tube a-c, d-c job (plus an eye on Model 707), it has an r-f stage and 3 bands with bandspread on the two short-wave bands. The method used for spreading is simple, yet effective. (See front cover.) A fixed condenser (one for each band) is added in series with the tuning condenser. This spreads the low-frequency end of the band considerably, but the high-frequency end only slightly. Hence, the bands have to be carefully placed so the spreading will occur where it is most desirable. Note that the grid is connected across the coil and the spreading condenser is in series with the variable on the high side. The tube thus receives the full input voltage. This would not be the case if the condenser were in series with the coil and the grid were connected across the tuning condenser.

R-F Coupling

Note the coupling means between the r-f and modulator stages. A 10-microhenry plate choke in the r-f plate is included to boost the gain on the highest frequency band by resonating in the band (11.5 to 24 mc). Without this choke, or inductor, the r-f stage would have no gain at all and may even exhibit a loss over part of the band. There is no effect on the broadcast band or on the intermediate, 4.7 to 10 mc, range. Low values for plate and grid load resistors are used: 1500 ohms for the plate and 47,000 ohms in the grid circuit. The usual series wave trap is shunted across the converter input.

Another interesting point is the choice of a separate tickler coil for better control of feedback on the highest frequency band. This is especially important at the high-frequency end, since if the oscillator injection voltage is too high the conversion gain will be lowered considerably. The other bands used the more common tapped cathode coils for the oscillator.

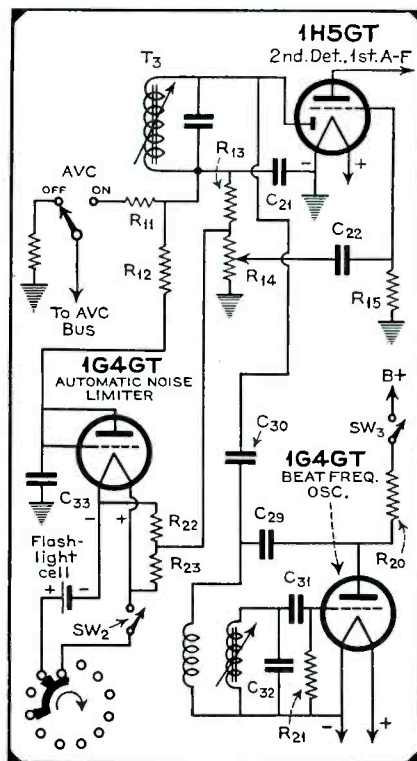

Fig. 5. Hallicrafters S29 employs an automatic noise limiter circuit.

RCA LITTLE NIPPER

Speaker adjustment: Certain cases of off center cones have been attributed to a binding between the speaker housing and chassis base as shown in the accompanying illustration. This should be checked wherever rattle is experienced and washers added as indicated if required.

RCA 15BP SERIES

Filament burnouts: Filament burn-outs may be caused by excessive voltage surges occurring when switching from "Power line" to "Battery" or vice versa. Whenever servicing receivers for this reason, the power switch should be replaced and wired as shown.

Note the addition of a 5-ohm resistor, and the necessity for installing a new indicator, both of which are included in the replacement power switch kit. The new

Fig. 6. Farnsworth BT70, BT71, BT73, BT77, BT78 employ a novel method of audio feedback.

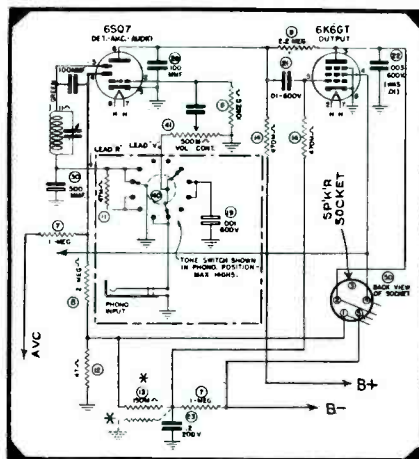

indicator is arranged "Battery-off-power line," necessitating that the switch pass through "Off" in going from line to battery, thereby discharging all filter capacitors.

Additional data: The following data should be added to the service note for model 15BP:

Power line consumption, 117 volts, 35 watts; total rectified B current, 117 volts, 60 cycles..56 mils.

Also, in some production, capacitor C15 on plate of 1H5GT is changed from 390 mmfd to 100 mmfd, to provide increased high-frequency response.

RCA 16K, 16T3, 16T4, 17K, 18T, 19K, 110K, 111K

Failure to oscillate on push-button tuning: Should a case of non-oscillation on any push-button range be experienced, check the oscillator grid leak to assure that it is 56,000 ohms. Some sets employed a 33,000-ohm leak which was occasionally found troublesome with low line voltage.

Low-frequency oscillator push-button coil: To ensure low-frequency coverage on the push-button oscillator coils in these models, a high-inductance coil is used for the 540-1,030-kc push-button oscillator ranges.

RCA 94BP1

Antenna attachment: Where few stations are receivable, two methods of using an external antenna may be used:

1) Five to ten turns of wire may be wrapped around the left end (loop end) of the cabinet attaching one end of the wire to a high antenna and the other to the ground.

2) One to two turns of insulation wire may be wrapped around one end of the loop in the cabinet, making connections to the end of an external antenna and ground. The wire may be fastened to the loop supports with scotch tape or string and the ends brought out through the rear of the cabinet making a permanent attachment for an outside antenna.

If care is taken in placing the wire around the loop (using small 22 gauge DCC wire spaced as far as possible from the loop winding) the receiver will not have to be realigned, and the directional effect of the loop will not be so prevalent.

RCA O-50, U50

Increasing phonograph gain: The over-all amplification of these models, when used for phonograph reproduction, is limited by the voltage divider circuit comprised of a resistor in series with, and a capacitor across, the pickup circuit. Values of these components are established on the basis of (1) average available voltage output from pickup under average climatic conditions, (2) degree of rumble likely with given amplification, (3) danger of microphonic howl with high amplification, and (4) possible consumer reaction to overload occurring at a low volume control setting with heavily cut records. If these points are kept in mind, additional gain may be obtained, wherever desired, by decreasing the value of the pickup shunt capacitor; C-1 in Model O-50 and C-32 in Model U50. The substitute capacitor should be approximately 1/4 to 1/2 the value of the original.

T R Y E A C H P L A N

for best results

By C. T. Kimberly

TO MAKE a good living in the radio service business you can't count on any one idea to keep the ball rolling. You've got to try everything. Each plan will do its share to bring in some customers. In the long run you hang on to those ideas which prove most profitable, that is those which produce the greatest return for a given expenditure in time and money, and you discard the others.

We started eleven years ago with a few tubes and a meter. In these eleven years we have built our business to a point where we are a recognized factor in the community. No single idea, however, can be credited for our success . . . we do the best work we can and guarantee every job that leaves our shop.

Each year without fail, we take a display booth at the local Pulaski County Fair. Here we show off by demonstrating the latest methods which we use in servicing radio sets with finely polished instruments and a neat looking service bench. In connection with our booth we run a public-address system, operating it from the booth inside the fair grounds with the loudspeakers mounted on top of the county building, plugging announcements and calling the public to visit our booth while at the fair. The job we use is quite powerful. It has four loudspeakers arranged for coverage of the midway and surrounding grounds. The population of

our city is only about 3,000, but you would be surprised how all this gets nosed around.

Public address work does boost business. In addition to a sound truck for street advertising, we have other systems ranging from 7 to 50 watts. Years ago we started with a single 8-watt job and one speaker . . . the 50-watt system we have today uses five aluminum trumpets, each four and a half feet long with four p-m pot units. This job is rented regularly for all day singing conventions in this territory, as well as for other outdoor events.

Starting with just one or two road signs, we now have at least two or more on each of the six state highways that lead into the city. This is of exceptional value in our case since we are RCA, Philco, Zenith and Stewart-Warner factory service stations for this territory. We render immediate service for all transient auto-radio trade.

Every service shop should cooperate with the local power company to try to eliminate radio interference. At one time every program in this city was hushed because of noise. In cooperation with the local power company we secured a service truck and crew and located the trouble by means of an auto-radio set. The source of the noise finally turned up as a tin can with hay wire dangling from one of the power transformers.

C. T. Kimberly's bench is not replete with colored knobs and shining chromium. He saves this type of eye appeal for the annual Pulaski County Fair, where he makes a big splash. Some of the instruments shown above the bench in the photo below can easily be recognized. Note the Precision Jumbo volt-ohm-milliammeter, the Supreme tube tester and the Philco a-f generator.

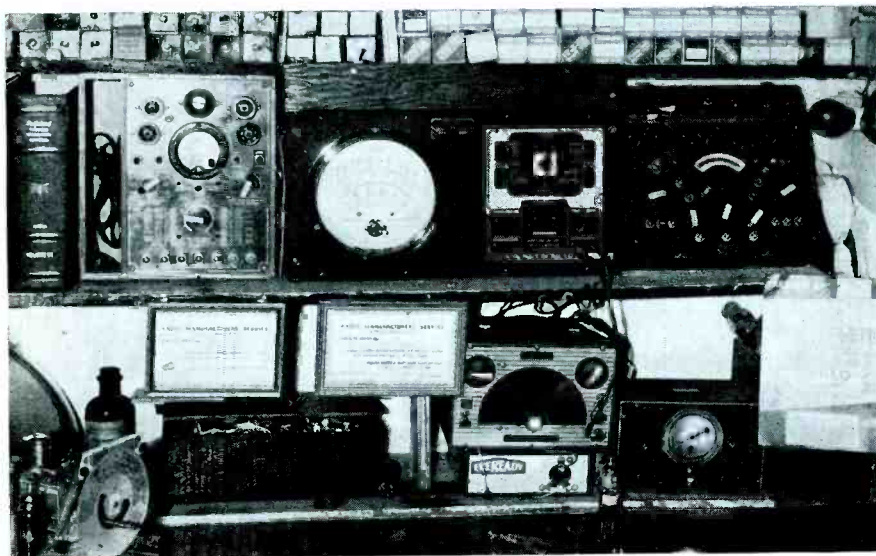

ATTENTION RADIO OWNERS?

IS HAWKINSVILLE THE NOISIEST CITY FOR
RADIO RECEPTION

We are cooperating with the Georgia Power Company by checking every residential district for Power Lines, sign flashers, etc., at no cost to you.
BETTER RADIO RECEPTION WILL BE THE OUTCOME OF THIS RADIO NOISE SURVEY.

PLEASE ANSWER THE QUESTIONS BELOW IN DETAIL AND RETURN TODAY IF POSSIBLE BUT NOT LATER THAN MONDAY MARCH 20TH.

MAIL THIS CIRCULAR OR BRING IT IN PERSON TO
KIMBERLYS RADIO SERVICE
(WE NEED YOUR COOPERATION!)

PLEASE ANSWER ALL QUESTIONS

KIND OF NOISE Bugging
TIME OF MOST NOISE Monday Early morn
CONSTANT Yes INTERMITTANT No
MAKE OF RADIO Crosley
AGE OF RADIO 10 or 12 years
YOUR NAME D. G. Henderson
STREET Co. 1st & Jackson St
REMARKS
Radio played clear until Monday 20th
March 13th. Noise started & continued since constantly

RETURN BEFORE MONDAY, MARCH, 20TH
KIMBERLYS RADIO SERVICE, PHONE NO. 8.

One of the ideas that proved quite profitable for Kimberly was the noise interference questionnaire shown above. This was sent out in cooperation with the local power company.

COMMUNICATIONS RECEIVERS

HOWARD PROGRESSIVE SERIES

THIS article continues SERVICE'S policy of supplying circuit diagrams and service information on communication type receivers which are being sold in large quantities to short-wave listeners. The desire of the American public to keep informed on events happening in foreign countries may account for a great number of the homes now using a ham receiver, but it is thought by the manufacturers that the thrill of real dx tuning accounts for most of the sales. There are no figures available on the exact number of these radios being used for other than communication purposes, but the volume of sales is so great that the amateur cannot be using more than 50 percent of those produced.

The Service Man has a big field here because the owner of a communication receiver wants 100 percent performance at all times. The amateur, too, although often capable of repairing his own radio, is usually employed outside

The 437A is a nine-tube receiver with all the trimmings. The 436A has one i-f stage less and the 435A has no noise limiter.



The Howard 435A (above) may be returned to the factory for conversion into the 436A or the 437A (below).



the radio field during the day and, without sufficient time to maintain the equipment, looks to the Service Man for repairs.

Progressive Series

The Howard Progressive Series is designed so that the user can purchase the smallest of the series, a seven-tube job, and then add to it in easy stages until he has a complete fifteen-tube amateur receiving station. It is necessary that the Service Man understands this conversion plan because his customer may desire to add to the receiver, or it may be that the customer's difficulty can be eliminated by adding to the receiver such circuits as the noise limiter, additional t-r-f stages, or loop tuning.

The model 435A can be returned to the factory at any time for conversion to the model 436A eight-tube or model 437A nine-tube receiver. There are also accessories which can be added at any time—a carrier level meter, monitor,

(Continued on page 21)

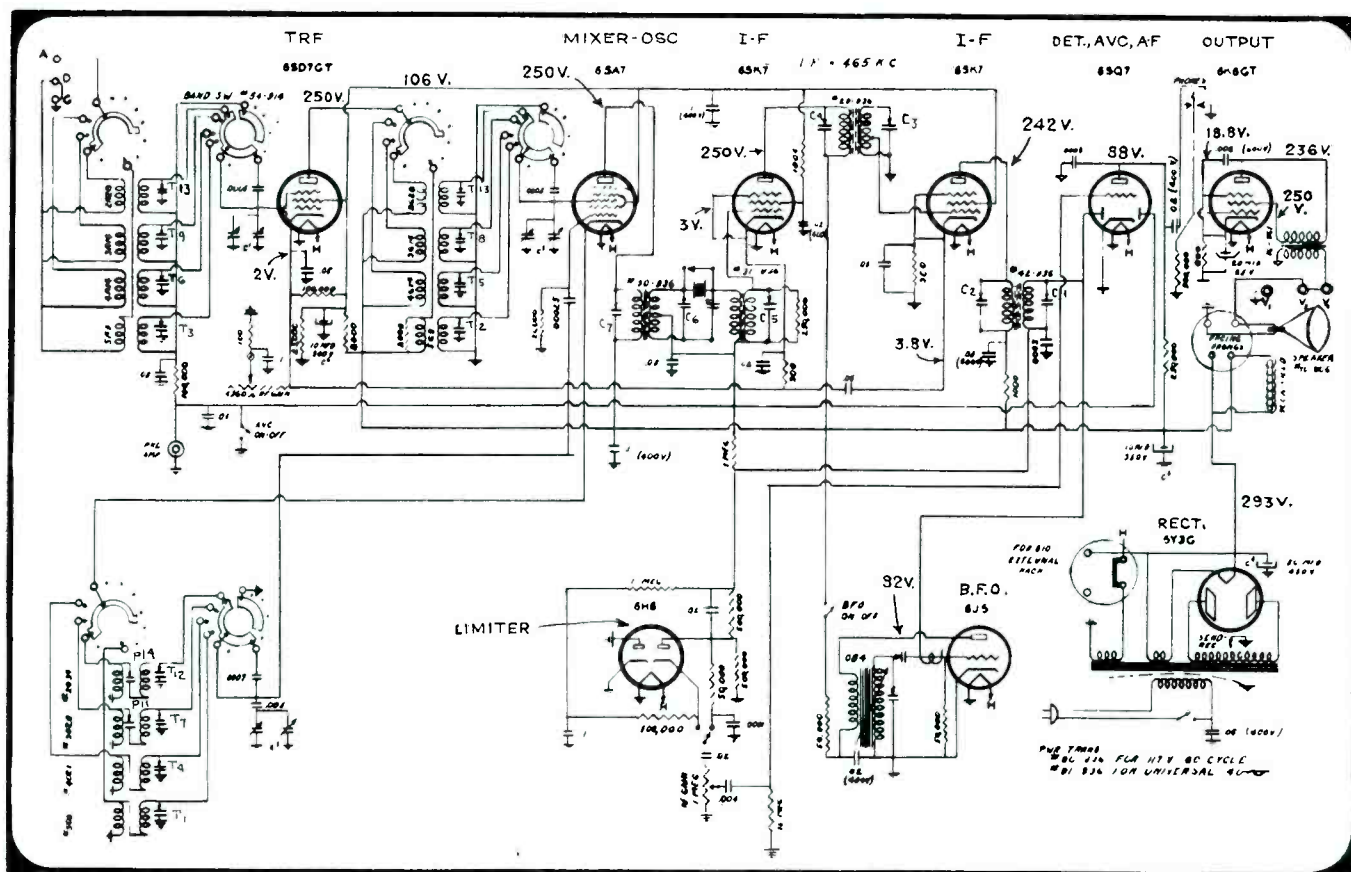

UTC OUNCER SERIES

of High Fidelity Transformer Components



The UTC OUNCER series represents the acme in compact quality transformer practice. These units weigh approximately one ounce and those which do not carry D. C. have high fidelity characteristics suitable for broadcast and similar applications. The OUNCER transformers are ideal for hearing aid, aircraft, glider, portable, concealed service, and similar applications.

The overall dimensions of these units are $\frac{7}{8}$ " diameter by $1\frac{3}{16}$ " height, including lugs. Mounting is effected by two screws, opposite the terminal board side, spaced $1\frac{3}{16}$ ".

The frequency response of these units is illustrated in the curves below, uniform response being obtainable from 40 to 15,000 cycles. The useful range of the 0-14 and 0-15 units is 150 to 4,000 cycles. Due to the very small size of the transformers, hum pickup is comparatively low.

OUNCER HIGH FIDELITY AUDIO UNITS

(MAX. LEVEL 0 DB)

200 ohm balanced winding may be used for 250 grms.

Type No.	Application	Pri. Imp.	Sec. Imp.	List Price
0-1	Mike, pickup or line to 1 grid	50, 200, 500	50,000	\$10.00
0-2	Mike, pickup or line to 2 grids	50, 200, 500	50,000	10.00
0-3	Dynamic mike to 1 grid	7.5/30	50,000	9.00
0-4	Single plate to 1 grid	8,000 to 15,000	60,000	8.00
0-5	Single plate to 1 grid, D.C. in Pri.	8,000 to 15,000	60,000	8.00
0-6	Single plate to 2 grids	8,000 to 15,000	95,000	9.00
0-7	Single plate to 2 grids, D.C. in Pri.	8,000 to 15,000	95,000	9.00
0-8	Single plate to line	8,000 to 15,000	50, 200, 500	10.00
0-9	Single plate to line, D.C. in Pri.	8,000 to 15,000	50, 200, 500	10.00
0-10	Push pull plates to line	8,000 to 15,000 each side	50, 200, 500	10.00
0-11	Crystal mike or pickup to line	50,000	50, 200, 500	10.00
0-12	Mixing and matching	50, 200	50, 200, 500	9.00
0-13	Reactor, 200 Hys.—no D.C.; 50 Hys.—2 MA. D.C.; 6,000 ohms			7.00
0-14	50:1 mike or line to 1 grid	200	$\frac{1}{2}$ megohm	10.00
0-15	10:1 single plate to 1 grid	8,300 to 15,000	1 megohm	10.00

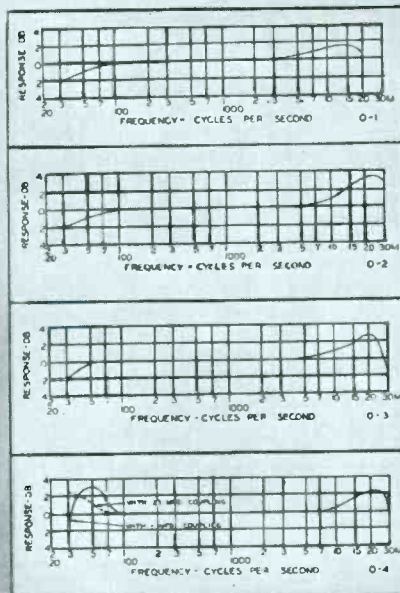

UNITED TRANSFORMER CORP.

150 VARICK STREET



NEW YORK, N. Y.

EXPORT DIVISION: 100 VARICK STREET NEW YORK, N. Y. CABLES: "ARLAB"

WESTON 777 TUBE TESTER

Circuit Selector

SEVERAL new features have been included in this tube tester to provide greater flexibility and wider coverage. These include a simplified switching arrangement wherein three main controls are used, a larger group of electrode switches providing means for checking of ballast tubes, provisions for accurately testing gas rectifiers such as the 0Z4, etc., under 300-volt potentials as required for satisfactory operation on automobile receivers, and complete filament voltage coverage up to and including 117-volt tubes. In addition, several mechanical developments have been incorporated, including a new type of molded electrode toggle switch of the knife type.

Filament Selector

This is a 17-position switch controlling the heater potential supplied to all sockets. The zero position is off and is

used for testing ballast tubes where the ballast resistance is across the normal heater pins. The setting of this switch should correspond to the number called for on the tube data card, and this switch should always be be set to the required position before placing the tube in the socket.

Tube Selector

This selector switch is located directly below the meter. It controls the shunt network that gives the English reading of Good-Weak-Bad for each particular tube type. The tube data chart indicates the proper setting for this selector for each tube type.

The Weston Model 777 tube tester provides for the checking of tubes with filament voltages up to 117 volts. Ballast resistors can also be checked on the instrument.

This is a master switch which sets up the correct circuits for the particular tube type for measurement to be taken. This also has an "Off" position for turning off the tube tester itself. When the device is not in use, this switch should be returned to the "Off" position at all times. When testing a tube this switch is first set to the "Line Short Check" position, and the tube is placed in the socket to correct the line voltage adjustment if necessary. The switch is then rotated to the required position for the type of tube being tested.

Electrode Switches

By using independent switches a high order of flexibility is available and individual element short and continuity tests are thus made available. These switches should be set in accord with

(Continued on page 22)

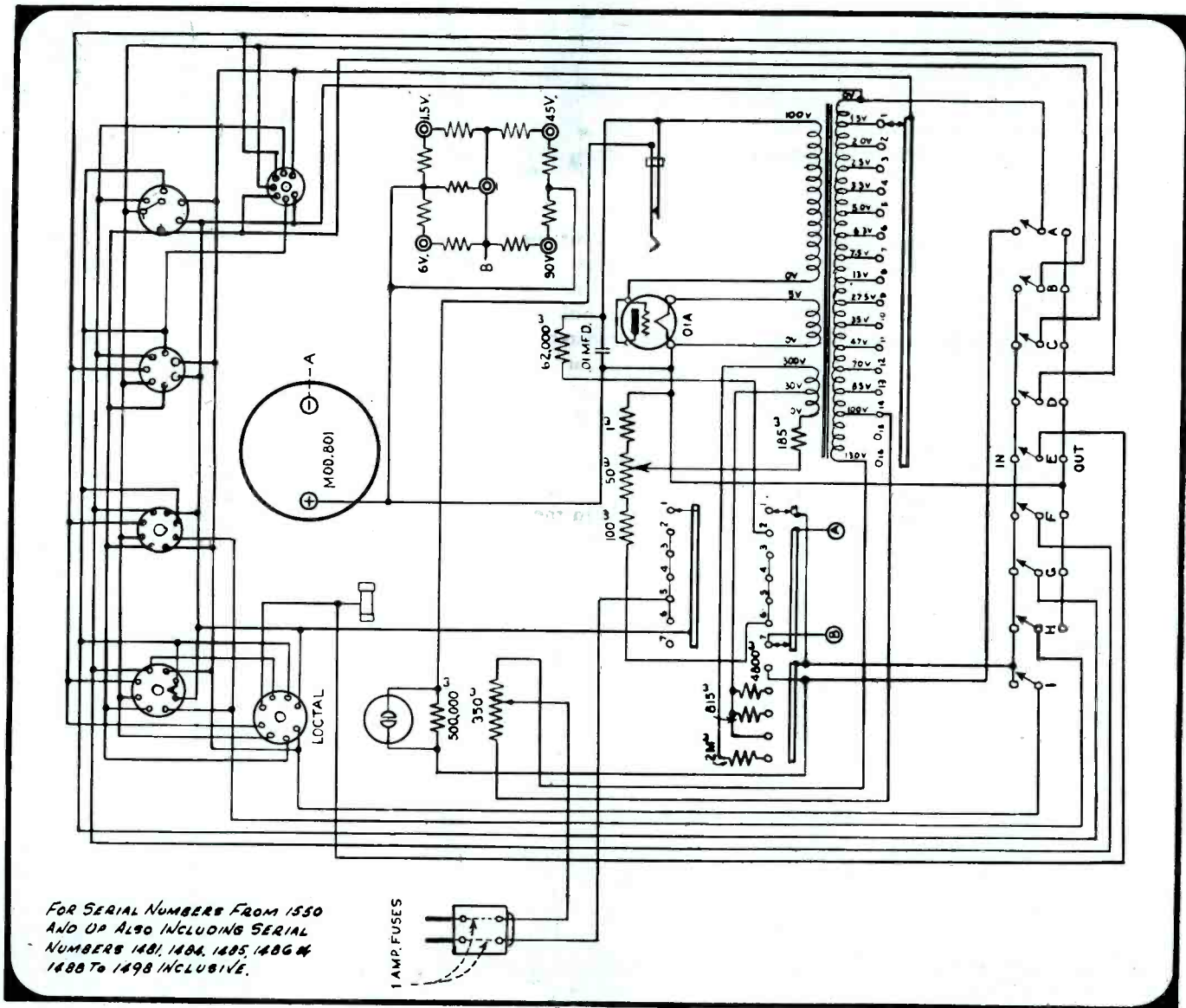

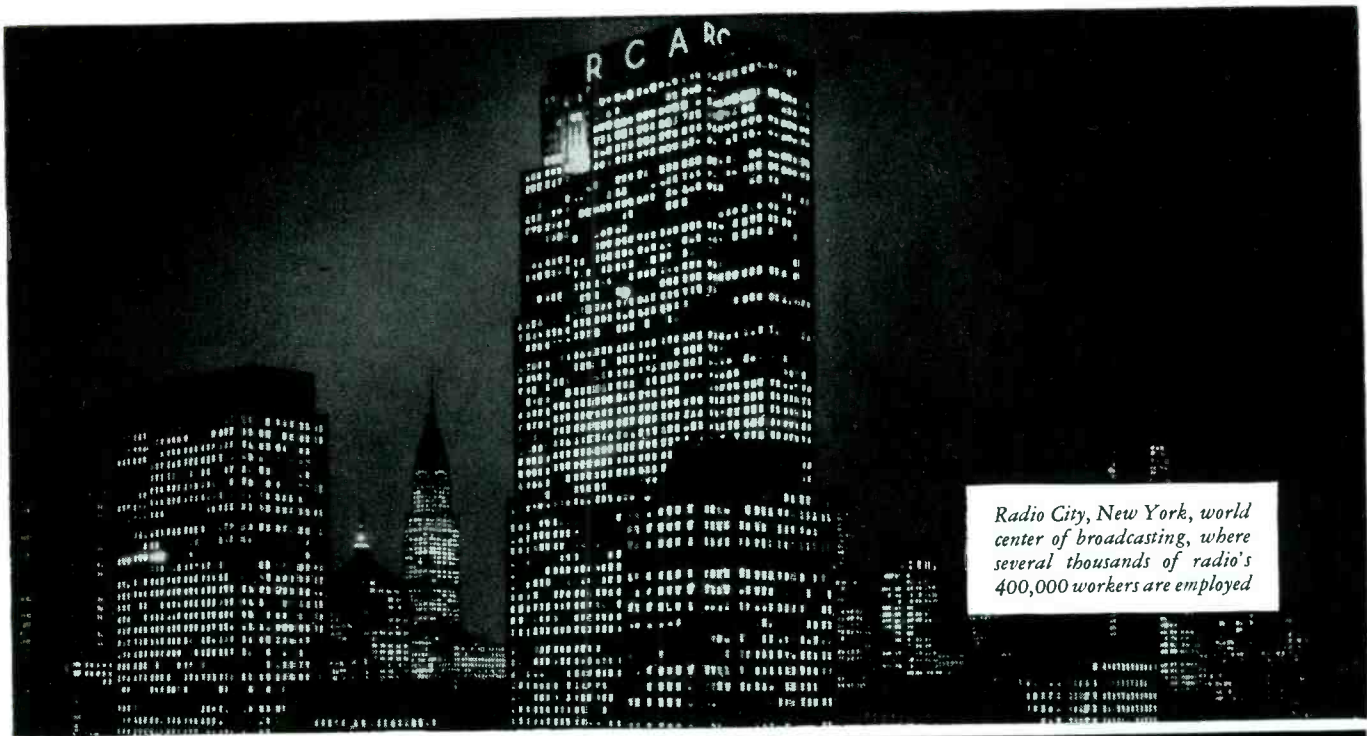

How Radio Helps Employ 400,000 People!

AS YOU SELL A RADIO SET, do you ever stop to think of the many thousands of people employed in the industry of which you are an important part?

The radio industry employs directly 400,000 persons, and indirectly hundreds of thousands of others. From the research laboratory to the song on the air, the employees of radio are at the listeners' beck and call. They earn their living in jobs which only two decades ago did not exist.

An Endless Procession of Workers

Long before the radio set "goes on the air" in the home of your customer it helps to give employment to an army of workers—from lumbermen to cabinetmakers, from miners who mined the copper and iron, to electrical engineers who designed the circuits that perform the magic. And, of course, there are those who fash-

ion the metal chassis; those who make the plastics and the vacuum tubes.

Radio employment is an endless procession—as endless as the production belts that constantly carry new instruments to the public, or the research that constantly plans improved instruments for the future. There are factory workers, salesmen, advertising men, artists, printers, wholesalers, retailers, and many others who work in radio because people in the United States have installed 50,000,000 radios in their homes and automobiles, and will want 10,000,000 more radios this year.

The People Behind the Programs

Each broadcast program has its actors, but behind every voice or song, behind every comedian, opera and drama, are the program planners, script writers, technicians, announcers, sound-effects men, control oper-

ators, and thousands of clerical helpers. Broadcasters alone employ many thousands of men and women in 850 stations, while radio-telegraph stations ashore and afloat, aircraft and police radio, add greatly to the roster of radio and to the payrolls of America.

New Gateways of Employment

Constantly developing new products and services through research, radio is ever widening the gateway of employment. Television holds the promise of another new industry developed by American enterprise, to create employment and raise the American standard of living.

Through the sale of a radio you do your bit as an employer of people unseen, and that role is always yours as long as you are in radio—while radio works for you it enables others to work, too.



RADIO CORPORATION OF AMERICA
RADIO CITY, N. Y.

RCA Manufacturing Co., Inc. • Radiomarine Corporation of America • RCA Laboratories
National Broadcasting Company, Inc. • R. C. A. Communications, Inc. • RCA Institutes, Inc.

SOUND IDEAS

By **ROBERT G. HERZOG**

EDITOR



Fig. 2. Carl Milles wood carved sculptural mural introduces sound and motion to the lobby of the Time and Life Building in Rockefeller Center, New York City, in the form of a singing nightingale.

the lobby of the Time and Life Building in Rockefeller Center, New York City.

Mr. Milles worked over a period of three years to complete the three parts of the mural, believed to be the first sculpture, introducing sound and motion, to be installed as a permanent decorative feature for the interior of any building in America. The section shown is 11½ feet high, 7½ feet wide and 3 feet deep, and was carved from hundreds of planks of northern Michigan pine glued together and held under great pressure for days to solidify them. It shows the figure of a hunter riding through a forest and suddenly halting his horse to listen to the voice of a bird in the branches above him. Milles' theme "Man and Nature" was furnished by a quotation from Goethe: "Where song is, pause and listen; evil people have no song."

The sound and motion of the mural is provided by a bird, carved in wood and then silver-leaved, which is motivated by a concealed mechanism. The bird sings for two minutes each hour daily, including Sundays, from 8 a.m. to 6 p.m. At the same time it moves its body, flutters its wings and opens and closes

PUBLIC address has invaded practically every field. It should, therefore, arouse no special surprise for us to find that it has taken over the old side show, lock, stock and barrel. In fact, since such a show is largely ballyhoo, public address should feel very much at home in this setting.

Charles T. Hulan, of Wartrace, Tennessee, a manufacturer of bridles and saddles used on the famous Tennessee walking horses, has installed a complete and powerful sound system in the trailer shown in Fig. 1. The trailer acts as a side show, traveling all over the south, at dog and horse shows. It is highly instrumental in building up a reputation for "Perfection" riding equipment and "Name-on-Plate" dog collars which Mr. Hulan manufactures. Needless to say, the sound system helps considerably toward this end.

The equipment installed in the trailer consists of two Shure Brothers microphones, a type 730A Uniplex crystal and a 55B Unidyne dynamic; a Bogen Model EX632 32-watt mobile amplifier; and four University Model LH 4½-foot trumpets equipped with type SAH permanent-magnet speaker units. It was installed by the Electra Distributing Company, 1603 Church Street, Nashville, Tennessee.

The trumpets are mounted, as shown in the photograph, on each of the four corners of the roof of the trailer. The amplifier and microphones are kept inside the trailer, except on occasions

where the system is utilized for other purposes.

Although the system is standard in every respect, it has been selected with an eye to the utmost in flexibility. The amplifier itself is equipped with a phono top to enable record reproduction during stand-by periods. The entire equipment is capable of operation from either 6-volt storage battery source or from the 110-volt a-c power lines. Both 6-volt and 110-volt power packs are built into the amplifier assembly.

Man and Nature

Fig. 2 shows the central and dominant unit of a group of three making up a wood-carved sculptural mural executed by Carl Milles, world-famous Swedish sculptor, for the west wall of

Fig. 1. A mobile amplifier, a pair of microphones and the four trumpets shown, furnish the trailer with a full complement of sound equipment to cover dog and horse shows throughout the south. The owner attributes a great many sales directly to the outfit.



2 more of NATIONAL UNION'S *50,000 Reasons Why!

POPULAR CONDENSER ASSORTMENT with TOOL SUPPORTER

2.75

TAKES BOTH

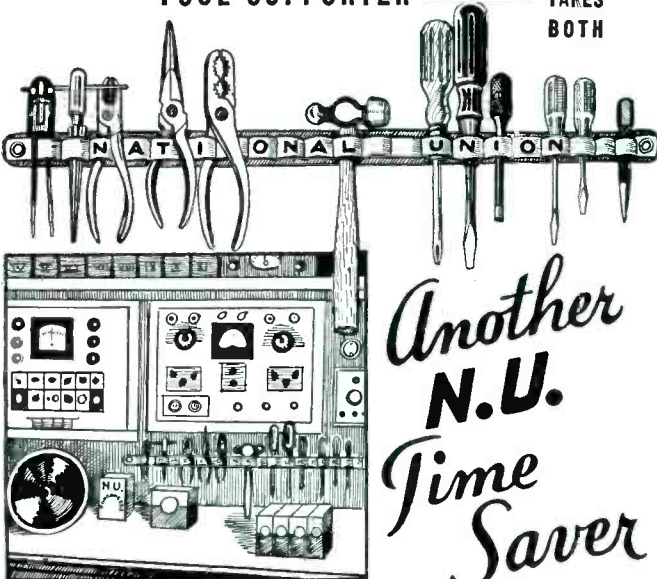

Another N.U. Time Saver

Tool Supporter is 24" long,—holds 20 tools,—sturdily constructed.

THE basic tools of your profession always at your finger-tips — No more hunting — no more wasted time — your tools are where you want them — when you want them.

FOR A LIMITED TIME ONLY

Get this POPULAR CONDENSER ASSORTMENT WITH TOOL SUPPORTER — \$5.25 LIST TOTAL VALUE \$6.10

This fine assortment of popular type N.U. Condensers will move fast, give you a good profit and insure the good will of your customers. If you're already using N.U. condensers, you'll be sure to snap up this offer in a hurry. If you don't know yet how really good N.U. condensers are, here's a great opportunity to try them! The assortment you get on this limited offer consists of:

- 1—AT1025 1—AT2015 2—AT8450 1—AT2215
- 2—T601 3—T605 3—T610 1—T625

See your N. U. Distributor or write

AND NOW

A BATTERY MERCHANDISER

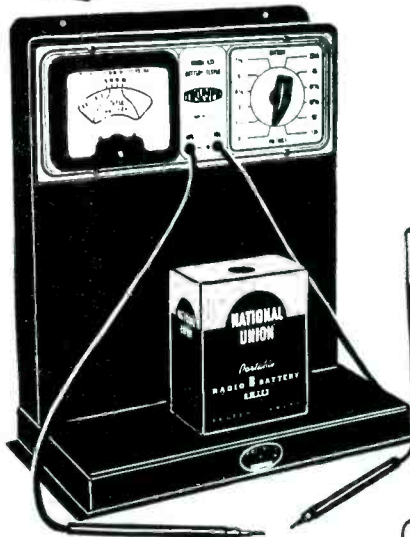

Sells More Batteries
•
Lets Your Customer See



win trade from drug stores and filling stations

Only \$8.00 Deposit

- Set Switch for Voltage
- Read condition of battery on percentage of useful life meter
- Made by TRIUMPH
- For Counter use or Can Be Mounted on Wall

Delivery made at once on \$8.00 deposit and order for \$10.00 worth of batteries, dealer prices. Deposit refunded on purchase of 430 points. All purchases of N.U. tubes, condensers and batteries count as points.

MAKE MORE MONEY WITH N.U. BATTERIES Sold Exclusively to Radio Service Dealers

The N.U. line of radio replacement batteries has been developed exclusively for radio service specialists. All popular types are included. Batteries are attractively packaged in rugged boxes incorporating the standard N.U. color scheme—black and two shades of green.

N.U. Batteries are carefully manufactured from the finest materials obtainable and are fully guaranteed against defects in workmanship and materials. All types equipped with standard plugs for quick and easy replacement installation.

Thoroughly moisture proof for satisfactory and reliable service under all climatic conditions.

Install N.U. replacement batteries for more hours of reliable service and satisfied customers.

N.U. brings you a line of replacement batteries on which you can

make your full radio service profit. It is not necessary now for you to test sets and install batteries without adequate compensation for your time and knowledge.

N.U. has been identified with the radio service dealer and his problems since the beginning. You can definitely make more money handling N.U. products.

SEE YOUR DISTRIBUTOR OR SEND COUPON

NATIONAL UNION RADIO CORPORATION
57 State Street, Newark, N. J.

I am interested in your new Battery Merchandiser calling for only \$8.00 deposit. Please send more information.

Please have salesman call. S. 3-41

Name

Street Address

City State



*Over a 10 year period Servicemen have earned through their purchases of N. U. tubes, batteries and condensers, in excess of 50,000 pieces of high calibre test equipment.

© 1941 N.U.R. Corp.

NATIONAL UNION RADIO

57 STATE STREET, NEWARK, N. J.

Corp



Fig. 3. The Master of Ceremonies of the 606 Club in Chicago waves his arms as a signal to the orchestra to start the overture. The sound system helps lure customers from the bar out front.

its beak. The song is from a special recording of the melody of an actual clarino or Mexican nightingale. The loudspeaker is located in the body of the man.

The sound equipment used to reproduce and amplify the special recording was purchased from Terminal Radio Corporation, 68 West 45th Street, New York City, and consists of a Type AC6G Garrard turntable and crystal pickup; a Model 30W1D Thordarson 30-watt amplifier and a LM12-15 12-inch Cinaudagraph p-m speaker. Accurate timing of the mechanism is secured through a very flexible arrangement designed and built in the laboratories of the Museum of Science and Industry, at Radio City, New York. This arrangement permits automatic functioning of the apparatus on any combination of one or more of the 48 half hour periods during the day. The design and construction of the bird and the special units of the sound and motion part of the mural, as well as the installation of the sound equipment itself was under the supervision of H. F. Meyer, who is in charge of engineering for the Museum.

Night Club

Modern microphones provide their own solution to feedback problems through their directional design. Such considerations make the speaker placement shown in Fig. 4 possible without feedback difficulties which might otherwise be encountered. Fig. 3 is a picture of the actual installation which was made in the famous 606 club, at the north edge of the Loop in Chicago. A Shure Brothers 730A Uniplex cardioid microphone is used to feed a stock 15-watt amplifier, which in turn feeds a pair of Jensen Bass-Reflex loudspeakers. One of the latter units can be seen be-

hind the air conditioning mechanism in the upper left corner of the illustration.

The system serves a dual purpose. It not only amplifies the whispered confidences of the master of ceremonies for the patrons surrounding the dance floor on which the entertainers strut their stuff, but also acts to lure the customers at the bar out front (from where they can get just a peek of the proceedings in the rear) to come closer and get an eyeful.

At the Races

Each year thousands of loyal fans flock to the annual motorcycle races held up Pike's Peak, near Colorado Springs, Colorado, and each year (for the past few at least) Sound Man E. O. Reinhardt, of the Radio Service and Supply Company, Colorado Springs, Colorado, covers the event with powerful amplifier equipment.

Fig. 5 shows the loudspeakers mounted on his car and on a portable tower at Mile Fourteen on Pike's Peak. The equipment serves to announce the names of the entrants, elapsed time during their run up the peak as well as to give a rolling commentary concerning the

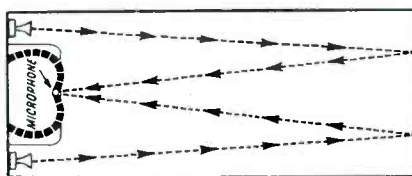

Fig. 4. Directional microphones were necessary in the 606 Club in Chicago to prevent feedback from the two speakers in the long narrow room.

progress of the race, who's who among the spectators, etc.

As can be seen in the illustration, Reinhardt uses two Atlas Sound DR42 projectors with PM25 permanent magnet units, mounted atop his car. Last year he also used six Atlas Sound RA72 trumpets with PM25 units mounted on the portable tower. Fourteen 15-watt cone speakers, mounted in Atlas Sound AM10 parabolic reflectors were used along the raceway. Three separate amplifier units (all fed from the same pre-amplifier) were used to feed the many speakers. For simplicity in installation all the equipment, except speakers, was installed inside Reinhardt's car.

Church Installation

The Demanbro Radio Supply Co., 1105 Commonwealth Avenue, Boston, Mass., have recently installed a modern Erwood sound system in the twin St. James Churches, at Haverhill, Mass. Four loudspeakers are concealed at points in the upper church. Another

sound system has been installed in the lower church. A single amplifier is used in each case. Although both systems can be used independently, wires have been run to permit interconnection so that the sound from either system can be made to cover both churches.

Another novel feature of the installation is the microphone placement. It is concealed in the pulpit and is so constructed that it will pick up sound from all directions.

RCA PHONOGRAPH MOTORS

Identifying colors: In order to facilitate identification in respect to frequency, phonograph motors are marked either on the bottom or side with a large spot of paint as follows: 60 cycles, no mark; 50 cycles, green; 25 cycles, white.

WILCOX-GAY A89, A91, A92, A93, A94, A101

Excessive hum: In the operation of Recordio Models A89, A91, A92, A93, A94 and A101, bearing serial numbers prior to No. 624060, if the residual hum, noted with the volume control turned to minimum position, appears to be abnormally high or objectionable, a correction may be effected by a rearrangement of the ground connections to the volume control and cathode by-pass condenser. These connections should be changed as follows:

(1) Disconnect the spiral shield covering of the volume control leads, from the volume control terminal and solder the shielding directly to the volume control switch cover.

(2) Remove the wire placed through the rubber grommet in the vertical shield fin, which connects the ground terminal of the volume control to chassis.

(3) Run a wire from the ground terminal of the volume control through the fibre grommet in the chassis base directly below the volume control, to the ground lug located near the electrolytic condenser in the approximate center of the underside of the chassis. (Note: R33 and C33 are already connected to this lug.) Do not permit the volume control ground terminal to contact the chassis through any other medium.

(4) Move the ground connection of the 6Q7 cathode by-pass condenser, C18, from its present location on the assembly lug of the electrolytic condenser, to the chassis ground lug to which the volume control has been grounded.

Fig. 5. A whole car full of p-a equipment was used to spread sound along the raceway at the motorcycle races on Pike's Peak. Six trumpets were fanned out in a circle on top of a portable tower.



COMMUNICATIONS RECEIVERS

(Continued from page 14)

two stage pre-amplifier and external speaker.

The amateur generally knows how he wants to build his receiving station, but the short-wave listener usually needs help. First of all, the short-wave lis-

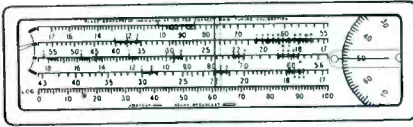

The Service Man should be able to walk up to a communications receiver and manipulate the right controls without experimenting.

tener will rarely ever require the carrier level meter or monitor. If he wants his receiver to have more signal strength the addition of the preamplifier is indicated. If he has the 435A and is troubled with auto ignition and other high frequency disturbances, the noise limiter may help, converting the 435A to a 436A. If the QRM is heavy in his locality he will want loop tuning which is possible after the preamplifier has been added.

Model 435A

The Model 435A is a seven-tube basic superheterodyne receiver with a stage of r-f on all bands. Separate coils are used for each band, and the band switch shorts out all coils except those tuning the band in use. The r-f, detector and oscillator coils are tuned by a three-gang condenser that has small trimmers for use as band-spread tuning condensers. The receiver tunes from 540 kc to 43 mc (556 to 7 meters) in four overlapping bands. The set may be operated from a six-volt storage battery through the use of the Howard Model 610 power pack. A receptacle is provided on the rear of the chassis to accommodate the pack connections.

Model 436A, 437A

The Model 436A is identical to the 435A, but has a noise limiter added employing a 6H6 tube. The 437A is identical to the 436A, but has an additional stage of iron-core i-f, employing a 6SK7 tube. Both the 436A and the 437A have heavy cast-metal inertia tuning knobs.

Tuning Communications Receivers

Although there is nothing mystical about bringing in stations with a ham set, if the Service Man cannot walk

(Continued on page 23)



HERE IS THE
Newest
REPLACEMENT

FOR ELECTRICAL
PHONOGRAPHS

ASTATIC LOW PRESSURE CRYSTAL PICKUPS are the "last word" in modern phonograph and radio-phonograph replacement parts . . . for three very important reasons.

* * *

First: ASTATIC LOW PRESSURE CRYSTAL PICKUPS, with only one ounce stylus pressure on records, keep valuable recordings LIKE NEW for years.

* * *

Second: ASTATIC LOW PRESSURE CRYSTAL PICKUPS are made with permanent, built-in, genuine SAPPHIRE STYLI, doing away with the necessity for buying or changing needles.

* * *

Third: ASTATIC LOW PRESSURE CRYSTAL PICKUPS improve tone quality by eliminating surface noise and needle talk.

* * *

Right now, or in the course of your "Moving Day" calls, servicemen may easily sell these advantages to phonograph owners and cash in on this modern replacement business. All Pickups are specially wired for quick and easy installation. Special literature is available upon request.

ASTATIC MICROPHONE LABORATORY, Inc.
YOUNGSTOWN, OHIO

In Canada:
Canadian Astatic, Ltd.,
Toronto, Ont.

ASTATIC

Licensed under Brush

Development Co. Patents

FREE

16-page Turner Vibrator Manual, containing a wealth of technical information; tells how the equal "push and pull" of Turner Vibrators means a harder, cleaner contact, better waveform, less R.F. hash and longer life. Cuts servicing costs!

TURNER PUSH PULL VIBRATORS



USE THE COUPON

THE TURNER COMPANY
906 17th St. N.E., Cedar Rapids, Iowa
Please send me, FREE, Turner Vibrator Manual for Radio Service Engineers.

NAME.....
ADDRESS.....
CITY..... STATE.....

Advanced engineering principles in Turner Vibrators are revolutionizing the industry. Learn how to cut servicing costs and give greater customer satisfaction. Send for your Free manual NOW!

TURNER MICROPHONES

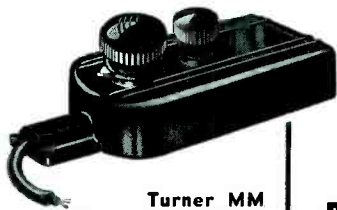

Turner MM
Magnetic Pick-Up

Instantly Installed; Novel Clamp for Fastening to Any Stringed Instrument

Gives immense volume without feedback. Continuously variable volume control built in. Rich brown enamel finish.

With 25 feet of cable.
List, \$12.50.



44X →
Selective
Directional

Let your customers choose the sound they want to amplify. 13-15 DB differential between front and rear pickup permits rear to be considered dead. Tilting head, satin chrome finish. With 7 ft. cable set. List, \$27.50. 44X Crystal with Off-On Switch, add \$2.00 list. Licensed under Patents of The Brush Development Co.
Write for FREE Catalog of Turner Microphones.

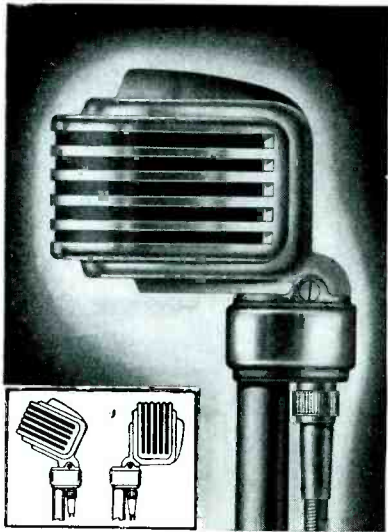

The TURNER COMPANY
906 17th St. N.E. - Cedar Rapids, Iowa

Where certain tubes are suspected of giving trouble, it may be advisable to allow these tubes to heat for a considerable time in the tester and then check the tube tapping it as mentioned above, watching the neon lamp for signs of intermittent shorts. Each of the toggle switches listed under the "In" position headings should be thrown one at a time to the "In" position, watching the neon lamp.

Noise Test

This tester is equipped with a noise test that may be operated with an ear phone or connected to an amplifier. A standard telephone jack on the lower left side of the instrument connects into this circuit. The noise check should be made in conjunction with the short test, with the operator listening to the tube while each of the red handled toggle switches are thrown to the "In" position for short testing. In addition, the tube should be tapped, preferably with a pencil, to give a sharp metallic effect and any sputtering noted in the ear phones will indicate a noisy tube. If the tube has an intermittent or continuous short, a loud hum will be heard in the earphones, also the neon tube will glow. A crackling noise noted when the tube is tapped, indicates a poor connection or a loose electrode inside the tube, and this will cause trouble in the average radio receiver.

Open Element Test

When checking for emission on any tube, some of the electrodes handle most of the emission current because of their proximity to the cathode, this occasionally causes the tube to check good, when one of the elements carrying only a very small current is open. Such a tube will not operate in a receiver. With the system of independent electrode switching, this type of fault can be located readily. First, set the tube up for the regular total emission check, and then throw each of the electrode switches used for the particular tube alternately from the "In" position to the "Out" position. If there is no change in meter indication, the tube should be rejected as bad due to open element. If satisfied that the particular element is not open, return its toggle switch to the "In" position and repeat the above procedure on each of the other electrode switches used in testing that tube shown on the tube data card. Note that certain electrodes in some tubes will give only about 1/2 division change in meter deflection, when a particular switch is shifted from the "In" position to the "Out" position. This is normal as it shows that the element under test is drawing current.

WESTON 777

(Continued from page 16)

the readings on the tube data card to the "In" position for tube test readings. For short test readings these switches should be operated one at a time while watching the neon lamp. For all cathode leakage indications, the "A" switch only is used. All switches not in use should be kept in the "Out" position.

Short Test

The 1/4-watt neon lamp operates in conjunction with the power supply to

provide a short testing circuit adjusted to the correct sensitivity. This circuit will indicate short or leakage that will cause trouble in receivers and all tubes should be short tested before proceeding with the tube tests. The short test is made in the regular test socket after the tube is hot. This is important in that where shorts occur due to expansion in the tube elements or in the cathode sleeve itself, these shorts will show up when the tube is properly heated. To be sure that there are no intermittent shorts, it is advisable to tap the tube with a pencil watching the neon lamp carefully for intermittent flicker.

COMMUNICATIONS RECEIVERS

(Continued from page 21)

right up to the set and manipulate the correct controls his customer loses confidence in him.

The off-on power switch is one of the slide switches. After you are sure the power is on and the send-receive switch is in the receive position, set the band-selector switch on the broadcast band and bring in a few stations to get the feel of the radio; after that get adventurous and go after short-wave broadcasts and amateur stations.

When tuning short waves it is usually wise to close the switch that cuts the beat-frequency oscillator into the circuit. A chattering whistle will indicate that a modulated signal is present. Throw the switch to take the bfo out of the circuit and the station can be tuned in easily because it has been located. Using the bfo on modulated signals will find many stations that might otherwise have been passed.

To facilitate band-spread tuning and logging, a special band-spread segment calibration is used. This calibration is the numbered red vertical lines found on all of the amateur and relay broadcast bands. The segments indicate the band-spread tuning limits and are also used as resetting positions in repeating logged stations' positions.

To illustrate the band-spread action, suppose we start with the tuning hand set at the red numeral 1, near 22 mc. When the band-spread indicator is rotated from 100 to 0, the effective tuning coverage will be to the red numeral 2 to the right. After resetting the main tuning hand to red numeral 2, as shown by dotted lines in accompanying diagram, start with the band spread at 100, rotate again to 9, at which point the spread will be a red 3. As will be noted, other bands have a different number of reset points, depending on the width and position of bands.

Since the band-spread tuning capacity becomes part of the main-tuning capacity, the main dial calibration will not be correct when band spread is advanced off the 100 position.

Specifications

Cabinet: Metal; black crinkle lacquer finish; oven baked.
Frequency range: 540 kc to 43 mc.
Number of bands: 4.
Range of each band: 540 to 1700 kc; 1.7 to 5.6 mc; 5.6 to 18 mc and 17 to 43 mc.
Power supply: 105 to 125 volts, 60 cycles, and/or 6-volts d-c.
Power consumption: 50 watts.
Audio output: $2\frac{3}{4}$ watts.
Speaker: Electrodynamic; 500-ohm field; 5-ohm voice coil.
I-f peak: 465 kc.



JOHN F. RIDER PRESENTS

"Clarified Schematics"

We have always sought to supply in Rider Manuals the information that would keep the servicing branch of the radio industry in step with the manufacturing division. As a result, we have in recent years given special attention to information on complicated circuits—whenever data were released by the manufacturers.

However, this available material has in many cases become so complicated—as the result of involved circuits and innovations—that the serviceman can only with difficulty, and at great expense of time, follow many of the schematics.

For months we have been working on a solution of this problem and are proud to announce "Clarified Schematics"—a new service beginning in Rider Manual Volume XII.

Bound right in the volume itself, these "Clarified Schematics" break down more than 200 models whose original schematics were so involved that they required hours of study to decipher.

Naturally, "Clarified Schematics" is a costly additional service for us to prepare and print. It requires the maintenance of a new department manned by competent technicians who are constantly breaking down the hard-to-read, complicated circuits and redrawing them so *you*—at a glance—can know everything about any section of the circuit.

In the establishment of this new service, which will be an increasingly important part of all Rider Manuals beginning with Volume XII, we have spared no expense in order that you may save time and decrease *your operating cost per hour*.

This new feature is fully explained with illustrations in the current issue of "Successful Servicing". If you do not have a copy, write and we will send one by return mail.

Order Rider Manual Volume XII today. Out on April 10th, it covers sets that are coming to your bench for repairs right now.

JOHN F. RIDER PUBLISHER, Inc.

404 Fourth Avenue - - - New York City

Export Division:

Rocke-International Elec. Corp.
100 Varick Street, New York City
Cable: ARLAB



VOL. XII RIDER MANUAL OUT APRIL 10th

SERVICE, MARCH, 1941 • 23

Big enough
to last...



Dry section in aluminum can. Inverted screw mounting. Two color-coded leads for each section. Slightly over actual size, 450 v. 4 mfd.

- Of course those midget metal-can electrolytics are O.K. So are cardboard-case electrolytics. But honestly, if you want an electrolytic that will last a mighty long, long time, by all means spend a bit more and use an AEROVOX GL. It's big enough to last and last and last.

AEROVOX TYPE GL ELECTROLYTICS	
Single Section:	
800 v. Surge Pk.—600 v. D.C.W. 4 and 8 mfd. \$1.11 and \$1.56, your net.	
600 v. Surge Pk.—475 v. D.C.W. 4, 8, 12 and 16 mfd. \$0.75 to \$1.38, your net.	
525 v. Surge Pk.—450 v. D.C.W. 4 to 80 mfd. \$0.51 to \$2.55, your net.	
Double Section:	
600 v. Surge Pk.—475 v. D.C.W. 8-8 mfd. \$1.44, your net.	
525 v. Surge Pk.—450 v. D.C.W. 4-4 to 20-20 mfd. \$0.78 to \$1.65, your net.	
Triple Section:	
525 v. Surge Pk.—450 v. D.C.W. 4-4-1 to 10-10-10 mfd. \$1.14 to \$1.59, your net.	
300 v. Surge Pk.—250 v. D.C.W. 8-8-8 to 8-16-16 mfd. \$1.26 to \$1.56, your net.	
Type GL 45025:	
10-10 x 450—20 x 25	\$1.59, your net.

Ask Your Jobber . . .

- Ask to see these popular GL electrolytics. Be sure to use them in building or servicing assemblies that must stand up under hard and steady going. Ask for catalog—or write direct.



Sound News . . .

Additional information on the products described below may be obtained, without obligation, directly from the respective manufacturers.

DUAL SPEAKER

Cinaudagraph Speakers, Inc., 2 Selleck St., Stamford, Conn., announced their Cinaxial dual speaker system, incorporating a 12" woofer, a 5" tweeter, and cross-over

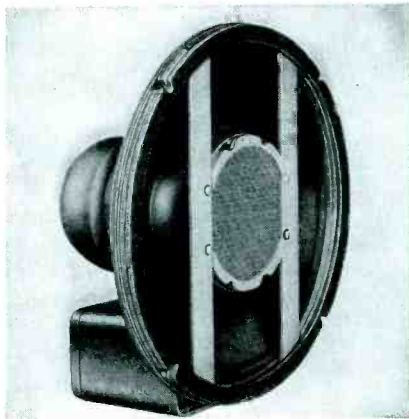

network. The system is designed for use in high-fidelity phonograph equipment for commercial, professional, and home use; also for f-m receivers. Frequency response is said to be flat from 30 to 12,000 cps.

HEARING AID

A vacuum-tube instrument for the hard-of-hearing has been announced by the Western Electric Co., 195 Broadway, New York City. The ortho-tronic audiphone, as the new instrument is called, uses two of the major developments of radio, the pentode vacuum tube and the stabilized feedback circuit. The vacuum tubes correspond in size with a peanut. They require a small amount of current and have an estimated life of several thousands of hours, it is said.

GENERAL UTILITY AMPLIFIER

Model 451T amplifier offered by the Lafayette Radio Corp., 100 Sixth Ave., New York City, is designed to fill the needs for sound equipment midway between the economy and deluxe classes. Providing 32-watts normal output, it has inputs that provide for two microphones and two pick-ups with provision for mixing and fading the two microphones and either of the phono inputs. Overall gain is 120 db; that of the phono channels, 92 db. Other controls include individual bass and treble equalizers and master mike gain control. The universal output transformer provides for loads of 2, 4, 8, 16, 250 and 500 ohms. Field supply is also included for two 2500-ohm speakers. An optional feature is the Type 566P volume indicator meter.

SOUND EFFECTS KIT

Wilcox-Gay Corp., Charlotte, Mich., has introduced an inexpensive sound effects kit

containing material and instructions to make many of the sound effects of interest to the Recordio owner. Made especially for amateur use, it will promote record sales and make recording more enjoyable, it is said.

NEW NEEDLE COMPANY

Stephen Nester, formerly with Recoton Corp., announces the formation of a new company at 799 Broadway, New York City, which will produce a line of American-made recording and playback needles for professional and lay use.

THEATRE AMPLIFIER

Transformer Corp. of America, 69 Wooster St., New York City introduces the Clarion Model A35K amplifier, designed for use in small theatres in conjunction with standard sound-on-film reproducing equipment. The A35K 21-watt amplifier features an equalizing control affording a maximum 10-db rise at 7,000 cps, to compensate for possible loss existing on high-frequency sound-track recording. Photo electric cell input gain, 120 db. Frequency response 80 to 10,000 cps. Hum level below zero level, -20 db. Input channel for two cells and two phono. Amplifier supplies 90 volts for the cells, as well as 4, 7, 8½ volts (each up to 4 amps.) for exciter lamps.

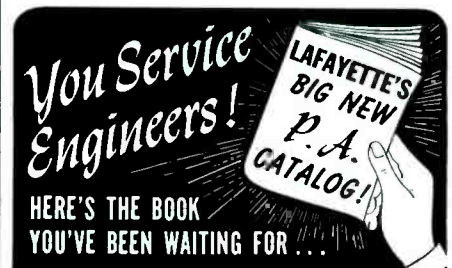

YOU CAN'T AFFORD to be without this great new book. Everything in the famous Lafayette Public Address line is here! Single and multiple channel amplifiers up to 100 watts . . . portable and rack-and-panel jobs . . . auto P.A. equipment . . . pre-amplifiers . . . boosters . . . mikes . . . speakers . . . record-players . . . phono-expanders . . . recorders—if it's P.A. equipment, you'll find it in this great new catalog, at prices that will make you bigger profits!

DON'T DELAY

mail this coupon NOW for the new FREE Lafayette P.A. Catalog.

Lafayette

SOUND SYSTEMS

Lafayette Radio Corp. Dept. 5C-1
100 Sixth Ave., New York, N. Y. or
901 W. Jackson Blvd., Chicago, Ill.

★ Rush Free Catalog.

NEW YORK, N. Y.
100 Sixth Ave.

CHICAGO, ILL.
901 W. Jackson Blvd.

ATLANTA, GA.
285 Peachtree Street

BOSTON, MASS.
BRONX, N. Y.

NEWARK, N. J.
JAMAICA, L. I.

Name

Address

City State

Book Reviews . . .

SERVICE rarely prints information which is easily available from other sources. From time to time, however, we review other sources and point out information of interest to the Service Man.

TOW TO MAKE GOOD RECORDINGS, prepared and published by Audio Devices, Inc., 1600 Broadway, New York City, 128 pages, illustrated, price \$1.25.

This little book is written in simple non-technical terms and while it is obvious that a complete treatise on the subject could not be given in 128 pages, nevertheless, a clear and practical picture of the fundamentals of sound recording is presented. Although written primarily for the layman; this book contains many realistic tips for anyone interested in making recordings.

The early chapters of the publication describe how the recorder itself works and give practical data on the selection of the proper type. Considerable space is devoted to the discussion of discs and cutting and playback needles. Various steps in preparing the recorder for use, i.e., adjusting the turntable drive, setting the cutting angle, adjusting the depth of cut, determining the correct recording volume and controlling the thread are also discussed. Data is given on the method of making recordings from the radio receiver, from direct pickup, etc. Especially interesting and instructive is the chapter devoted to microphone technique and placement. Sound effects, acoustically treating the studio, 33 1/3 rpm recording considerations, making copies, preserving the record, putting together a show, common recording difficulties and their remedies and a glossary of technical terms are items which complete the book.

The only criticism that this reviewer can make is that the book has been used to some extent to advertise the products of Audio Devices, Inc. This may give some readers the opinion that some of the statements are made with an ulterior motive. As for the rather high price set for such a small book, it is understood that Service Men can purchase it, in quantity, at a discount for sale to their clients. M. L.

UNDERSTANDING RADIO—A Guide to Practical Operation and Theory, by Herbert M. Watson, Herbert E. Welch and George S. Eby, published by McGraw-Hill Book Co., Inc., 330 West 42nd St., New York City, 603 pages, illustrated, price \$2.80.

Intended for the beginner in radio, this text treats the fundamentals of radio in a simple, clear and interesting non-mathematical manner. In addition to the lucid explanations each chapter suggests and outlines realistic methods for building, studying and operating simple practical equipment. It also contains numerous questions to be answered by the reader . . . a valuable aid in home study.

The author's explanation of radio waves and wave travel is especially good. This is followed by chapters on wave-form pictures; principles of the vacuum tube; tuning; receiving sets, using d-c tubes; phones and speakers; power supply; a-c tubes and receiving sets; short-wave sets; oscillators and transmitters; radiotelephone transmitters; aerials; and ultra-short-wave sets.

General Electric Introduces—

NEW Tube Checker

MODEL TC-2

The Model TC-2 includes all existing American sockets with some extra spares. Filament Voltage—complete coverage for 1 1/2 volts to 117 with five spare positions. Short Test—Standard RMA with rejection at .25 megohm. Two-color panel—beige and maroon. Weight—16 lbs.



NEW Unimeter

MODEL UM-1

A precision instrument for accurate service work. The large meter is calibrated and laid out so that the inclusion of the many ranges are very distinguishable to reduce the possibility of error in reading. Actually 29 meters in 1! Two-color panel—beige and maroon. Weight—9 1/4 lbs.

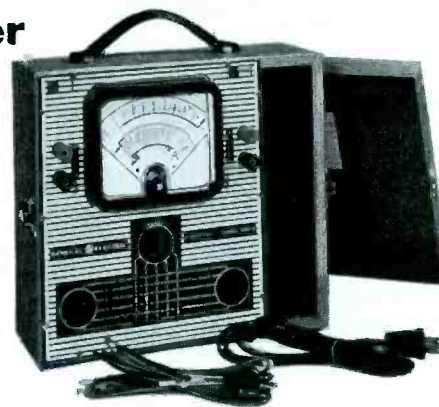

TECHNICAL MANUAL



FREE
VALUABLE
TECHNICAL
TUBE
MANUAL

Mail the Coupon!

General Electric Company, Tube Sales Section,
Radio and Television Department,
Bridgeport, Conn.

Please send me, without cost or obligation, the
new G-E Manual of Radio Tube Specifications.

Name

Address

GENERAL  ELECTRIC

The final chapter of the book is appropriately titled "Looking Ahead in Radio". . . a glossary of radio terms and a suggested reading list are also included.

"Understanding Radio" is highly recommended as a text for those interested in securing a non-mathematical understanding of the fundamentals of radio. R. D. R.

MEISSNER I-F — TRANSFORMER REPLACEMENT MANUAL, prepared and published by Meissner Manufacturing Co., Mt. Carmel, Ill., 254 pages, 4 by 7 1/4 in., paper covers, price 25c.

Prepared as a catalog of replacement i-f transformers for the receivers listed, this manual is exceptionally valuable to the

Service Man who makes his living repairing and aligning present day superheterodynes, because of the completeness of the incidental information included. The most useful of this incidental information is the column of intermediate frequencies for many thousands of superheterodyne receiver models. Another useful bit of information contained in the manual is the chassis-model number cross reference for a number of set manufacturers.

As an introduction to the listings the authors have included some 15 pages of instructive data on i-f transformers in general.

There is no question, in this reviewer's opinion, that the Meissner I-F Manual is worth many times the modest purchase price. R. H.

MORE THAN A "Station Setter"



As you know, more than 10 million push-button radios will need changing. Signal Generators will get a red hot workout. Chances are you will need a new one—or have to add another. When you do, don't get just a "Station Setter". Get a real Signal Generator! Choose the Jackson model 640 Test Oscillator and you have a standard type instrument for all general purpose work year after year. Direct reading from 100 KC up to 30 Megacycles. No skips or harmonics calibrated. All ranges are fundamental frequencies. Two circuit attenuator. Powerful signal output for either pure R.F. or Modulated R.F. Carrier. Accuracy guaranteed— $\frac{1}{2}$ of 1% on all ranges. Your net cost only \$29.95. Order from your jobber today.

"SERVICE LAB" UNIT

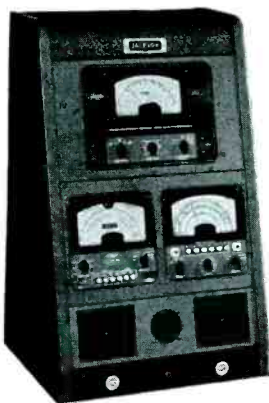

A well-equipped modern shop attracts customers, speeds work, earns extra profits by helping you obtain better prices. Jackson labs make your shop custom built. Unit illustrated is just one of 24. Every Jackson instrument is built to fit such a unit. Assembly shown includes Audio Oscillator, Condenser Tester and Oscillator.

Write for free information.

**THE JACKSON ELECTRICAL
INSTRUMENT COMPANY
DAYTON, OHIO**



26 • SERVICE, MARCH, 1941

Catalogs, Bulletins, etc...

Copies of the catalogs and bulletins discussed below may be obtained directly from the respective manufacturers mentioned. Write for them today!

• • • • Aerovox has compiled a 1941 general catalog in concentrated or tabloid form. The new catalog covers the general line of electrolytic, paper, oil, exact-duplicate replacements, transmitting and other condensers, together with such Aerovox instruments as the L-C checker, capacity-resistance bridge, and motor-starting capacitor selector.

• • • • The fourth edition of the Clarostat plug-in resistor replacement manual is now available. It contains all previous listings covering existing set replacements, together with many new listings bringing the data squarely up to date. Clarostat Mfg. Co., Inc., 285 N. Sixth St., Brooklyn, N. Y.

• • • • The Garrard Sales Corp., 296 Broadway, New York City, announce the release of their 1941 Catalog No. 41. The new catalog describes and illustrates the Garrard line of automatic record changers, phonograph turntables, motors, pick-ups and accessories.

• • • • Hallicrafters offers a 12-page illustrated booklet entitled "A Short Story on Short-Wave Radio Receivers" for listeners who are puzzled as to what type of receiving equipment will serve best for dependable European reception.

The booklet discusses the advantages claimed for communications type receivers and explains the purpose and functions of the various controls in non-technical language.

• • • • The Ken-Rad Tube & Lamp Corp., Owensboro, Ky., has just issued a 6-page folder titled "Selling Helps for Ken-Rad Dealers," which illustrates the merchandising material available to Ken-Rad outlets. Various display pieces are illustrated, together with mailing cards, price tags, technical data bulletins, etc.

• • • • National Union Radio Corp., 57 State St., Newark, N. J., is offering throw-away sheets listing the frequency changes as affected by reallocation March 29, 1941.

• • • • To help Service Men establish a disc business for themselves, Presto Recording Corp., 242 W. 55 St., New York City, is offering imprinted disc order cards which can be left with the set owner at the time his set is adjusted during reallocation.

The disc order cards list the prices of various types of Presto home recording discs and needles and require no postage for mailing. They are furnished to Service Men in quantities up to one hundred, free of charge.

• • • • To help Service Men cash in on reallocation, Hygrade Sylvania Corp., 500 Fifth Ave., New York City, is offering a special promotion in the form of window streamers, postcards, doorknob hangers and a new radio station finder.

A two-color Sylvania window poster, size 14" by 22", is free. The Sylvania radio station finder is the goodwill gift to set owners. It is printed in two colors, green and black, and lists the old and new frequencies for every United States station changing on March 29. Sylvania offers it free without

imprint through Sylvania jobbers, or imprinted at a nominal charge.

One Government stamped postal card tells the whole story of radio frequency change-over in a friendly personal way. Another repeats the window poster message; it is worded as a follow-up to the first card offering to the customer a free station finder. These Government postcards are offered imprinted at the price of postage only, 1¢ each.

The doorknob hanger also repeats the window poster copy. It is a house-to-house canvass follow-up to the direct mail and window display effort. It is offered imprinted at a nominal charge.

• • • • The Turner Co., 906 Seventeenth St., N.E. Cedar Rapids, Iowa, offers the Turner Vibrator Manual to readers of SERVICE.

This Tuner Manual discusses the new Turner vibrator and gives other technical information of interest to the Service Man. A full replacement chart is included, as well as a price list.

• • • • The 1941 Utah catalog supplies information on speakers, vibrators, transformers, and Carter parts now being distributed by Utah Radio Products Co., 816 Orleans St., Chicago. Well illustrated, the book gives a picture of the diversified Utah line. Tables and necessary data on the various products appear throughout the book.

FOR EVERYTHING IN RADIO



Free
New
Spring
180-page
Catalog

Reach for your
ALLIED CATALOG

When you get your copy of the latest ALLIED Catalog, you will have the most complete and reliable guide to Everything in Radio.

Whether you're a Dealer, Serviceman, Sound Man or Amateur, don't miss this new ALLIED Catalog. The new Spring Edition shows 57 new radio models that are real sales-builders—more than 15,000 items for all service needs—more than 25 new Sound Systems that surpass anything in the field—a full section devoted to Amateur gear—and a Special Bargain Section.

For Everything in Radio—at Radio's lowest Prices—reach for your ALLIED Catalog! Get your copy now!

Address Dept. 19-C-1 for Your Free Copy

ALLIED RADIO
833 W. JACKSON • CHICAGO

COLOR TELEVISION

THE first public showing of direct pickup of color television was made by the Columbia Broadcasting System before the members of the IRE on January 9. Operation of the direct pickup was explained by Dr. Peter C. Goldmark, CBS's chief television engineer, using slides and actual color television pictures.

The color pictures were picked up by a television camera in the CBS television laboratories on the fifth floor at 485 Madison Avenue, New York, transmitted by coaxial cable under 52nd Street, and reproduced on two different models of color receivers in Studio 21 of the new CBS studio building at 49 East 52nd Street.

Three receivers were used in the demonstration: a standard black-and-white receiver adjusted to receive color pictures in black and white, a standard black-and-white receiver that has been adapted for color, and a compact table model color receiver (which includes a standard broadcast radio receiver) especially designed and constructed in the CBS laboratories. This last receiver illustrates that color need not add bulkiness to the television receiver.

The color pickup is accomplished with an orthicon tube. The level of light required for direct color pickup is not particularly high by television standards. As a matter of fact, a satisfactory picture can be picked up with a lower level of illumination than is necessary for satisfactory black and white pictures when using the current type of studio pickup tube. Special orthicon tubes are now being developed which are expected to require even less light than the orthicon used in the demonstration.

The small, specially designed and constructed receiver incorporates two important features not previously demonstrated to the public. The first of these is a method of synchronizing the color disk in the receiver with the color disk in the studio by the synchronizing impulses ordinarily transmitted. This means it is not necessary to rely upon 60-cycle current for synchronizing the disks, and permits reception of color pictures when a receiver and transmitter operate from different power line circuits.

This receiver also has a simple, ingenious method of phasing the color disk so that the colors shown at the receiver can be "locked" to the colors being picked up. The viewer at home has only



INSULATED *Metallized* RESISTORS



They Stay PUT

WHY stake your reputation on unknown or doubtful, cheap resistors? It's easy to be safe—sure—right. Use only IRC Type BT Insulated Metallized Resistors—insulated from end to end—always dependable and definitely superior in such essential characteristics as stability, low noise level, low voltage coefficient, mechanical strength and moisture protection—and branded at the factory with the resistance value, type, color-coding and the well-known IRC trademark. IRC Resistors will insure you against trouble and safeguard your reputation. They work for you, not against you. They stay put!



THE KIT COSTS NOTHING EXTRA

Don't throw your resistors and other small parts into cigar boxes, jars or drawers! Keep them in this IRC All-Metal RESIST-O-CABINET made just for the purpose. Cabinet comes factory-packed with any one of three frequently-needed resistor assortments. You pay only for the resistors—the Cabinet is included. See it at your IRC jobbers or write for details.

INTERNATIONAL RESISTANCE COMPANY

401 N. Broad Street, Philadelphia, Pa.

to push a button on the cabinet's side until the picture appears in its proper colors, then release the button. The colors remain properly synchronized with those of the original scenes.

Some of the live subjects shown at the CBS demonstration were the same as those shown IRE during the film demonstration in October to facilitate comparison between film and direct pickup.

One impressive part of the demonstration emphasized dramatic effects possible with color television. Merely by turning a dial, Mr. Goldmark was able to create the effect of moonlight

on the face of a girl.

During the demonstration, a new system of low intensity fluorescent lighting was used. These lights eliminate most of the glare from the eyes of the person in front of the camera and are "cold light" so that no discomfort is experienced. They were developed in the Columbia Broadcasting System television laboratories.

The demonstration showed substantial progress along new fronts such as: direct pickup itself; synchronization of color disks; phasing of color disks, and new lighting methods for color television.

SOLAR CONDENSER
Quick-check Analyzer
MODEL QCA

- ✓ Measures Capacity
- ✓ Indicates Leakage
- ✓ Shows Insulation Resistance
- ✓ Indicates Power Factor
- ✓ Affords Dynamic Checking for

OPENS . . . SHORTS
INTERMITTENTS

- ✓ Acts as Continuity Meter
- ✓ Indicates R. F. Impedance



Model QCA-1-60
 Complete Analyzer, ready to operate . . . ONLY **\$18.90**
SOLAR MFG. CORP., Bayonne, N. J.

New Test Equipment . . .

Additional information and prices of the equipment described below may be obtained, without obligation, from the respective manufacturers.

STATION SETTER

Philco Corp., Tioga and C Sts., Philadelphia, Pa., have introduced their model 014 "wireless" station setter and signal generator. Equipped with 8 push buttons, the instrument is designed for setting the tuning buttons on broadcast receivers. An additional condenser (No. 30-1069) is also available to be used in instances where it is desired to have the device deliver an i-f signal as well as those covering broadcast frequencies.

IMPACT-EXCITATION GENERATOR

Radex Corp., 1733 Milwaukee Ave., Chicago, have introduced a new type of pocket tracer which can be used for all types of trouble shooting, it is said. This unit generates a universal frequency of the impact excitation type which can be used for test purposes. It is entirely self-powered and is similar in size and appearance to a pen-light type of flashlight.

ELECTRONIC MULTITESTER

The RCP Model 661 is an electronic volt-ohm-microfarad meter with an input resistance of 16 megohms (low) to 160 megohms; a-c and d-c voltage ranges from 0.1 to 6000 volts; resistance ranges from 0.1 ohm to 1000 megohms and capacity

test range from 0.00005 to 600 mfd. The instrument is enclosed in an all-metal case and employs a 4½" rectangular meter. Radio City Products Co., 88 Park Pl., New York City.

CHECK-A-LOOP

F. W. Sickles Co., 165 Front St., Chicopee, Mass., announce the "Check-A-Loop," a service instrument for checking loop antenna alignment. Operating on the same

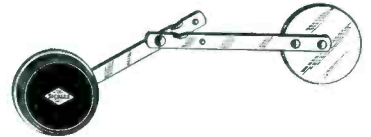

principles as the more familiar tuning wand, the Check-A-Loop raises or lowers the inductance of a loop and shows whether trimming capacity should be increased or decreased.

STATION ALLOCATOR

The RCA Model 171 Station Allocator is designed for operation from self-contained batteries or from the a-c power lines. It is equipped with 8 buttons for setting to the frequencies of an equal number of local broadcast stations. It will deliver either a 400-cycle modulated or a c-w signal. Weight with batteries 5½ lbs., RCA Mfg. Co., Inc., Camden, N. J.

We're Not Fooling, Mr. Serviceman!

→ **NATIONAL DUES IN THE RSA**
 → **ARE ACTUALLY ONLY \$1.00 A YEAR**



Yes—it seemed amazing . . . incredible . . . but Servicemen found it was true. Now hundreds of applications are pouring in from all parts of the country! Just think—a full year membership in the National RSA for only \$1.00 (that's less than 2c a week).

You get the RSA Membership Certificate and the RSA House Organ. You have access to RSA Technical Helps Bureau, and you can participate in all the other functions and benefits RSA offers.

RADIO SERVICEMEN OF AMERICA, INC.

"Reliable Service Assured"

JOE MARTY, JR., EXECUTIVE SECRETARY
 304 S. DEARBORN ST., CHICAGO, ILLINOIS

Get the RSA Push-Button Changeover Plan.

Are you ready to get your share of the Push-Button Changeover business? Join the RSA now and get the complete plan available to RSA Members.

Protected territories will be established as rapidly as local chapters are formed. Applicants in present chapter areas will be referred to the local chapter.

It's your big opportunity! Fill out the coupon, attach a \$1.00 bill and mail it in today.

RADIO SERVICEMEN OF AMERICA, INC.

304 S. Dearborn Street, Chicago, Illinois

\$1.00 enclosed for 1941 National Dues in RSA.

Name

Address

City..... State.....

Service—March

RADIO CITY 417 APPLIANCE TESTER

THIS is a low-price pocket type meter for checking of various appliances without the necessity of breaking into the line. For this function a receptacle, into which the plug of the appliance is inserted, is mounted on the face of the instrument. This automatically completes the necessary connections for voltage, current and power measurements when the tester itself is connected to power lines.

Its four scales provide a total of 18 measurements (9 a-c and 9 d-c) giving readings

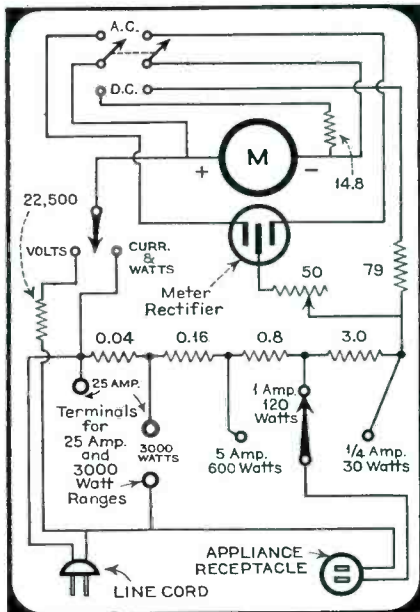

to 250 volts, 25 amperes and 3,000 watts in convenient ranges. Ranges are switch selected except that where the current measurement exceeds 6 amperes it is applied through separate binding posts rather than through the range selector. This also applies to wattage in excess of 660 watts at 120 volts or 1320 watts at 220 volts.

The wattage ranges are calibrated on the basis of 120-volt supply. If the line voltage is appreciably different from this value correction can be made by reference to a conversion chart which accompanies the instrument.

For power measurements the Model 417 functions as a volt-ammeter. In the case of d-c, power measurements, and a-c measurements where the load is of a pure resistive type, volt-amperes and watts are the same. For inductive loads operating from a-c lines the power consumption in terms of watts may be quite different from that expressed in volt-amperes. If the power factors is unity they will be the same but if less than unity the watts value will always be lower than the volt-amperes.

In the case of small motor-driven home appliances an average power factor of 0.8 may be assumed. This means that when measuring the power consumption of such devices by means of the instrument under discussion, or by means of any volt-ammeter arrangement, the resulting measurement multiplied by this figure of 0.8 will provide a fair indication of the actual watts consumed.

Because transformerless (a-c, d-c) sets represent substantially a pure resistive load their wattage will be correctly indi-

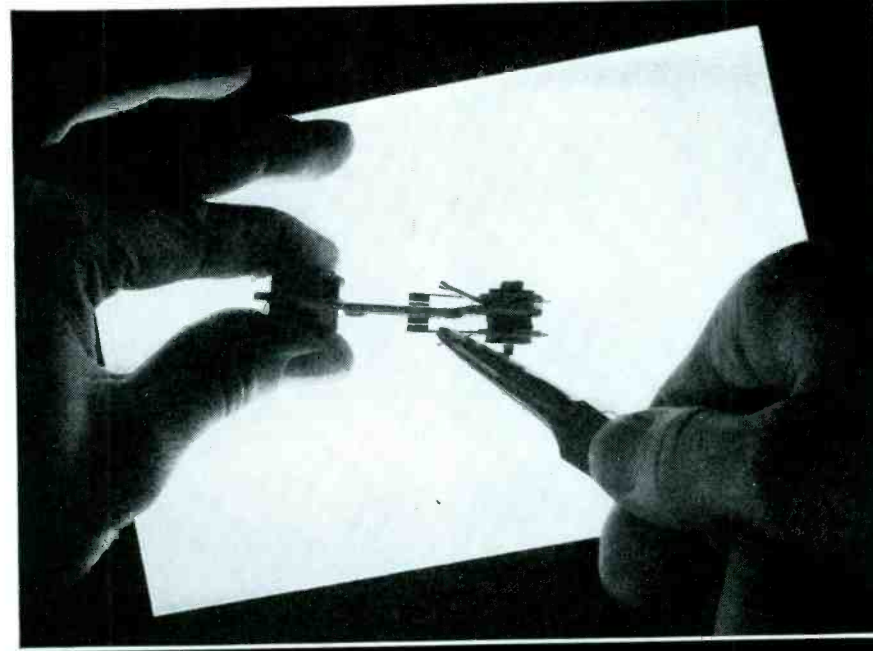

Heart Trouble Avoided by This Utah Operation

HANDS as skilled as any surgeon's perform this delicate operation in the Utah factory. This precision adjustment of the contact points in Utah Vibrators is responsible for their long life, correct electrical balance, current output and freedom from noise.

Because Utah contact points are adjusted to a specified clearance, with a variation of less than .0005 in., they eliminate the causes of failure so frequently found in ordinary vibrators. Pitted or locked points, unsatisfactory performance and short life are avoided.

Only high quality materials conforming to rigid standards are used in the manu-

facture of Utah Vibrators. The points, for example, are made of the best grade Tungsten, fully capable of standing up under the terrific punishment to which they will be subjected.

Write for information about the complete line of high-value, dependable Utah Vibrators. Utah Radio Products Company, 816 Orleans Street, Chicago, Illinois. Canadian Office, 560 King Street West, Toronto. In Argentina: Ucoa Radio Products Co., SRL Buenos Aires. Cable Address: Utaradio, Chicago.



VIBRATORS

SPEAKERS • TRANSFORMERS • UTAH-CARTER PARTS

cated by the instrument. Sets with line transformers have a power factor of approximately 0.9 and readings should therefore be multiplied by this factor to obtain true consumption in watts. Refrigerators operate at a power factor of about 0.8 to 0.85, fans at about 0.85, mixers between 0.8 and 0.85. Incandescent lamps constitute for the most part a pure resistive load. Neon, fluorescent and sun lamps, on the other hand, often operate at a power factor as low as 0.4 or 0.5. For small home-type fluorescent lamps a good average is 0.6. Toasters, irons, and various other electric heating devices constitute pure resistive loads. While these power factor figures are averages, they can be used for non-critical measurements. A reference chart supplied with the instrument gives a close approximation of the power factor that may be expected for the more common types of a-c

appliances.

The circuit is shown in Fig. 1. The meter includes a 5-ma movement with internal resistance of approximately 18 ohms. In the a-c positions the rectifier reduces the sensitivity to about 11 ma and for that reason a 14.8-ohm shunt is introduced for d-c, measurements. Likewise, because the rectifier introduces appreciable resistance in the meter circuit (around 50 ohms) and this value may vary considerably from one rectifier unit to another supposedly identical unit, a higher resistor is placed in series with the meter for d-c measurements and enough of the 50-ohm variable resistor added to the rectifier resistance to exactly balance this added value. As a result the meter branch of the circuit offers the same resistance value for both a-c and d-c measurements and the same shunts can be used for both.

The only low-priced
SIGNAL GENERATOR
that's really all-quality!

With reallocation of station frequencies on the broadcasting band, your service department is bound to receive an extraordinary number of calls. How many of them you turn into profitable future business depends on the ability and reliability of the test equipment you carry.

Right now is an excellent time to replace uncertain, obsolescent test instruments with advanced, economical and thoroughly dependable RCP equipment. Protect your profits and good will . . . invest in RCP. It will pay you dividends.

SIGNAL GENERATOR RCP Model 702



Here's the most economical, top-quality oscillator on the market. It is the only instrument of its kind offering all the latest improvements in circuit and mechanical design at this low price! Extremely wide all-wave coverage continuously variable from 95 KC. to 100 mc. Accurately calibrated direct reading. Output modulated or unmodulated at will. Effective accurate attenuation. Highly attractive appearance. Everything, in fact, a fine signal generator ought to be, except expensive. Good news, right now, just when you need such an instrument. AC operated. Dealer Net Price **\$22.95**



DE LUXE MULTITESTER RCP Model 414

You'll profit handsomely with RCP's sensational Multitester Model 414. Latest test features you never hoped to find in a single instrument — and certainly never expected in one priced so low! Meter fused against burn out. Sensitivity: 2000 ohms per volt. Measures current, voltage, resistance, capacity, power level, all at new higher and lower ranges than even more expensive instruments offer. If you have the time for new business and a vet for bigger profits, here's the instrument to help you hit your stride! Model 414 is ALL quality . . . the biggest test equipment value money can build or buy. Dealer Net Price . . . **\$21.95**

RCP
dependable
TEST
instruments

RADIO CITY

PRODUCTS COMPANY, INC.
88 PARK PLACE • NEW YORK, N. Y.

Associations . . .

Danville Chapter, RSA

The February meetings of the Danville Chapter of the Radio Servicemen of America have been very interesting. At the first meeting of the month, several new associate and qualified members were voted into the chapter. Doc McKinney led the discussion at the last meeting, using "Automatic Frequency Control" as his subject.

The local Chapter is conducting a training school for Sea Scouts, teaching them the fundamentals of radio and electricity. There are about 50 students enrolled in the school and it is proving very beneficial to those attending, as well as those teaching the classes.

A monthly party plan is being followed; each party is in keeping with the season. February we had a Valentine party, and in true Washington's birthday spirit the Hall was decorated in red, white, and blue.

The first public Bingo game was held at the Hall, 113 N. Vermilion St., on March 5, with a good crowd in attendance. Plans are now under way to hold regular games in the future.

Evard C. Welch, Secretary

Lawrence Chapter, RTG

On March 3, the following officers were elected for the coming year: John Sestini, president; Almeric Dussault, vice president; James A. Mulligan, secretary; Herbert Grosser, treasurer; Wallace Dill, sergeant-at-arms. The new Board of Directors are: Herbert Stadler, W. T. Nesbitt, Haven McCrillis, Robert Bingham, Howard C. Parker, James A. Mulligan, Almeric Dussault, and Herbert Grosser.

Since last July the local chapter has been receiving two spot Broadcasts daily recommending listeners to call an RTG member when in need of radio service. This has been very helpful in advertising the local chapter to the public and we expect to see more benefits when station reallocations are made. In return for these broadcasts we set one push button to Station WLAW and give them proper publicity.

The second year of the Radio Service Class at the Industrial School which was sponsored by the Lawrence Chapter RTG is near completion.

James A. Mulligan, Secretary

New Bedford Chapter, RTG

The regular meeting of the Whaling City Chapter was held Feb. 20 in Labor Temple, New Bedford, Mass. The meet-

ing opened with a few words of encouragement from our president, William Pedro, after which Professor Al Saunders gave an interesting lecture and demonstration showing how theory is used in conjunction with practical radio service.

Interesting experiments were performed showing effect of different voltages generated by the oscillator on strength and quality of the signal delivered to the i-f channel. Effects of open avc lines were also shown. Phase inversion in audio circuits was also on the program. A delegation from the Boston Chapter of RTG was present.

James L. Shepley, Secretary

Long Beach, Cal., RTA

Our organization is three and a half years young and meets twice a month. With nearly every meeting an instructive and technical lecture is given. So far this year we have had Lew Walton, of Philco Corp., who gave a fine instructive lecture on record changers. More recently, we had A. Barricks of Hickok Test Equipment; and then Delbert P. Hennes, a teacher from a local school, gave us an hour and a half lecture on selling. On the latter program, we were entertained by Dewey Schrago, an accomplished pianist. March 11 was under the direction of Bill Hitt of Aerovox.

The officers of our group are now Harry E. Ward, Jr., president (who replaced Oliver Colburn); Walt Rundquist, vice-president and treasurer; and Bob Hayden, secretary.

H. E. Ward, President.

Southeast Meetings

That Service Men are aware of the importance of fluorescent lighting was demonstrated during a series of service meetings held throughout the Southeast by Walter R. Jones and Frank Longstroth of Hygrade Sylvania Corp. In each of the meetings Mr. Jones offered his audiences a choice of several topics covering radio service problems. In addition, a ten-minute talk on special problems connected with fluorescent lighting was scheduled. So great was the interest in this subject that questions and answers extended this part of the program to an hour or more at each meeting.

Henry C. L. Johnson

PR SMA, Philadelphia

The February meeting of the Philadelphia Radio Service Men's Association was held on Feb. 4 with a program arranged by the Stewart-Warner jobbers in Philadelphia and the Ken-Rad Tube & Lamp Corp. A talk on "Noises in Radio Tubes" was given by E. V. Kesheimer, commercial engineer of Ken-Rad. A second talk was given by Max Schinke, service manager of Stewart-Warner on the subject "Equipment for Radio Servicing."

The meeting was attended by 150 members of the organization. After the talks, the balance of the evening was devoted to general discussion.

Detroit

A large group of Detroit amateurs and Service Men heard the story of amateur television experiments conducted in the New York area during the past year, and then took a trip, by proxy, through the RCA radio tube laboratory and factory, at a recent meeting in the auto city. D. Y. Smith, Power Tube Sales Manager for the RCA Manufacturing Co., was the speaker.

SAVE \$1.00 !!!

- The Group Subscription Plan for *Service* enables a group of service men, dealers or jobbers to subscribe at one-half the usual yearly rate.
- The regular individual rate is \$2.00 a year. In groups of 4 or more, the subscription rate is \$1.00 a year. (In foreign countries, \$2.00.)
- Each subscriber should print his name and address clearly and state his occupation—whether a dealer, jobber, independent service man, service organization, etc.

Remember this Group Plan when Your Subscription Expires

GAIN MEASUREMENTS AND SIGNAL TRACING

(Continued from page 7)

tomary manner. For the audio section, given in (2) above, it is not necessary to use an a-f oscillator to supply the 400-cycle audio signal. Instead, if a 400-cycle modulated r-f signal is fed to the antenna, the signal generator attenuator can be adjusted until the required 0.15-volt rectified a-f signal is developed across the volume control, as measured with an a-f channel. This signal voltage should produce 1/2-watt audio output at the voice coil. We don't measure the power directly; this is done by applying the formula $E^2/R = W$, which, when the resistance R of the voice coil is known, enables us to calculate the voltage across the voice coil representing 1/2 watt of electrical power. For this receiver, the voice coil impedance at 400 cycles (R) is 3.5 ohms. Then, for 1/2 watt, our equation will look as follows:

$$E^2 = 3.5 \times \frac{1}{2} = 1.75$$

and

$$E = \sqrt{1.75} = 1.32 \text{ volts.}$$

We don't have to be so precise about it, of course. It should be around 1.3 volts.

Note that the manufacturer emphasizes that variations of plus or minus 20 percent from any of these ratings is permissible. This should be kept in mind in making any of the gain measurements which we are describing.

The rectified d-c voltage across the oscillator grid leak is measured in the customary manner, using an electronic voltmeter with a resistor in the probe to avoid reaction on the oscillator.

Motorola

The Motorola technical information, shown in Fig. 2, shows the way the Galvin Company has been presenting their gain data. Incidentally, this company is perhaps the pioneer in presenting gain-per-stage information. The form of presentation is based on the use of the laboratory standard signal generator, feeding the signal from stage to stage, from the i-f grid back to the antenna—the reverse of the signal tracing routine. However, the data can be easily converted to fit the usual signal tracing procedure by converting the relative microvolt input levels into stage gain ratios. For instance, note that the signal specified for 0.05-watt output is, at the i-f grid, 3200 microvolts. At the modulator grid, the required value is 70 microvolts. The step-up or gain between these two points, at 455 kc, is therefore 3200/70 or 45.7. This represents the gain of the 12SA7GT as an amplifier, rather than as a converter, just as was considered in the G-E case. And the test has the same significance.

For the conversion gain, take the ratio of 3200 to 90, being the relative signal strengths required at the i-f grid and the modulator grid for the same output across the speaker voice coil. This comes to 34, approximately. And the r-f gain, obtained by dividing 90 by 25, figures out as 3.6. The antenna coil gain, calculated by dividing the signal level, 25 microvolts, at the r-f grid, by the 3-microvolt level applied to the antenna, is equal to 8.3. So we have converted the relative signal level tabulation to gain-per-stage data which, with most signal tracing instruments, is easier to handle and measure.

RCA

RCA enters their gain data directly on the schematic, as shown in Fig. 3. For the larger RCA receivers, even more complete data are included, but the example shown, representing that of the 11X1 receiver, shows the form of presentation. While the data follow rather closely conventional signal tracing routine practice, special mention is made of the departure in employing a fixed 3-volt bias for the gain measurements. This is an improvement over the meth-

*Proved Protection
against Breakdowns*

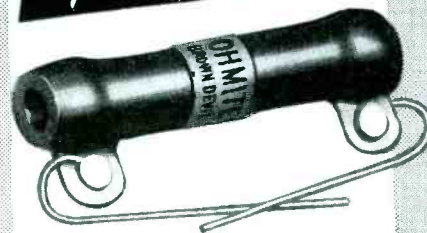

Brown Devils—Extra-sturdy vitreous enameled resistors for voltage dropping, bias units, bleeders, etc. 10 and 20 watt sizes. Many stock values.



Adjustable Dividohms—Handy for change of resistor value or quick replacement. Easily adjusted or tapped where needed. 7 sizes, 10 to 200 watts. Many stock resistances.

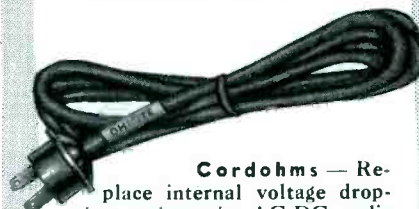

Cordohms—Replace internal voltage dropping resistor in AC-DC radio sets. Tapped cord for pilot light also available. Eliminates generated heat from set.

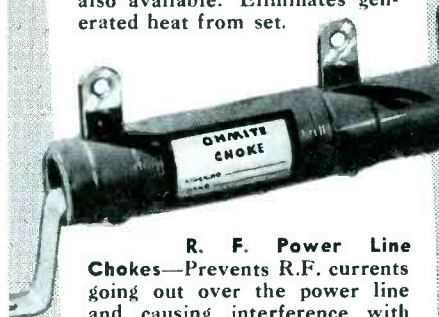

R. F. Power Line Chokes—Prevents R.F. currents going out over the power line and causing interference with radio receivers. 3 stock sizes, rated at 5, 10 and 20 amperes.

Send Coupon and 10¢ for New Ohmite Ohm's Law Calculator

OHMITE MANUFACTURING CO.
4879 Flournoy St., Chicago, Illinois
10¢ in Coin enclosed. Send Ohm's Law Calculator.

Name
Address
City State
Occupation Service—March

OHMITE
RHEOSTATS RESISTORS TAP SWITCHES

ATTENTION RADIO SERVICEMEN EXTRA PROFIT TO YOU!

On One Penny's Investment

RECOMMENDING NEW RADIOS TO YOUR CUSTOMERS OFTEN MEANS LITTLE OR NO EXTRA INCOME TO YOU—AND SOMETIMES A LOT OF WASTED TIME. Give your customer the value he expects at the price he wants to pay and make more money for yourself.

NORTH EASTERN RADIO COMPANY representing the fourth largest radio manufacturing organization in the world, offers to Radio Service Men an EXTRA PROFIT PLAN entailing no investment.

YOU DEAL DIRECTLY WITH THE MANUFACTURER. No jobbers; no middlemen. Because we are making our initial bid for retail business WE ARE OFFERING A NEW SALES PLAN WITH CONCESSIONS AND PRICES NO OTHER RADIO MANUFACTURER CAN DUPLICATE.

Paste the coupon below on a post-card for the details of North Eastern Radio Company's EXTRA PROFIT PLAN. No obligation. Mail the card TODAY!

NORTH EASTERN RADIO CO.
80 East 11th Street
New York, N. Y.

I certainly would like to know more about North Eastern's EXTRA PROFIT PLAN and its advantages to me.

NAME
ADDRESS
CITY, STATE

Now Available!
FAMOUS
HOWARD
REPLACEMENT
CHASSIS

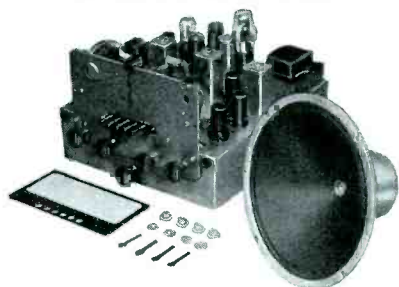

Precision Built by
America's Oldest
Radio Manufacturer

Now! The famous HOWARD Radios can be purchased in chassis form for installing in custom-built or old cabinets. Outstanding for foreign reception, superb tone and long life. Do your customer a favor by installing a modern HOWARD chassis instead of repairing an obsolete "has been".

MODEL 307 - 5 TUBES

5 tube, AC, 3 band chassis with 6½" Jensen electrodynamic speaker. Has phonograph and television connection and built-in loop. Size: 6½" high, 10" long, 6" wide.

MODEL 308 - 8 TUBES

8 tube, AC, 2 band (Broadcast and Foreign) with 8" or 12" Jensen electrodynamic speaker. Has phonograph and television connection and built-in loop. Size: 6½" high, 10" long, 6" wide.

MODEL 718 - 12 TUBES

12 tube, AC, 3 band chassis with 12" Jensen electrodynamic speaker. Has dual tone control and television and phono input. Has tuned R.F. on broadcast band and two I.F. stages. Size: 9" high, 12" long, 13¼" wide.

MODEL 568 - RECORDER CHASSIS

10 tube, AC, 3 band recorder chassis with T.R.F. on all bands. Has input for microphone, two inputs for phono pick-ups; mixes mike and radio or mike and phono music. Can be used as P.A. system and for duplicating recordings. Has mute switch on speaker. Size: 7½" high, 14" long, 8" wide.

SEND FOR COMPLETE DETAILS TODAY

HOWARD RADIO CO.
 1731-35 Belmont Ave., Chicago, Illinois

WHEN YOU CHANGE
YOUR ADDRESS

Be sure to notify the Subscription Department of SERVICE at 19 E. Forty-seventh St., New York City, giving the old as well as the new address, and do this at least four weeks in advance. The Post Office Department does not forward magazines unless you pay additional postage, and we cannot duplicate copies mailed to the old address. We ask your cooperation.

ods first used, and makes the gain measurements independent of signal level, which is not the case when the measure values are specified with the avc acting, unless all tests are made with a uniform signal input at each stage under avc control.

Note that RCA also specifies the rated oscillator voltage at both 600 kc and 1500 kc. This is useful since a decrease in Q of the oscillator circuit often causes a reduction in rectified oscillator voltage which is greater at one frequency than at another. Also, note that the maximum avc voltage is specified. This is useful in making a quick, overall check in that the maximum avc voltage cannot be obtained without overloading when either the r-f or i-f section is appreciably out of alignment.

Other Manufacturers

One of the more recent manufacturers to include gain-per-stage and other data is Farnsworth. For their Models BT52, BT53, etc., shown in the schematic of Fig. 4, the gain data beneath the circuit diagram applies. The tabulation is somewhat along the lines of the RCA data, though separated from the schematic. In addition, a useful bit of information is that concerning the output transformer. The voltage loss represents the change in signal level from the plate terminal of the primary winding to the high side of the voice-coil winding. In the example given, the loss is stated as 98½ per cent. This means that, if the measured signal at the 50L6GT plate is 10 volts, that across the voice coil should be 0.15 volt. The very low signal level shown results from the low-impedance voice coil (3 ohms), which the transformer secondary winding must match.

Zenith also tabulates their stage gain data, as shown beneath Fig. 5, the schematic of chassis 8A04 of present production. A departure from the usual practice is shown in the overall audio gain data. Note that the gain of the a-f system is specified as 865 at 1-watt output. This refers, not to the gain from the 7B6 grid to the speaker voice coil, but to the audio gain from the 7B6 grid to the 6V6G plate, at a power output level of 1 watt. The reason for specifying a 1-watt level is to provide a concrete figure, well within the range over which no overload of the a-f system can take place. A somewhat lower level could be used—not too low, or the presence of hum in the output circuit will affect the accuracy of the measurement.

Note also that the power consumption of the receiver is also tabulated with the Zenith gain data. This information is also furnished by the other manufacturers mentioned, either in the service notes or directly on the chassis.

Don't Miss the
Big Trade Show



IT'S a great show! . . .
 the big show of the year!
 It's the *only* chance to get together and discuss your **MUTUAL PROBLEMS**. It's your *opportunity* to get a world of ideas for your business.

Don't forget — 1941 is a *critical* year, because of the gigantic defense program.

Don't "miss the boat." Be on hand at the

Stevens Hotel

CHICAGO

JUNE 10-11-12-13

JOBBER DAYS

Tuesday, June 10 to Thursday, June 12

OPEN HOUSE

Thursday Eve., June 12 and Friday, June 13

Radio Parts
National Trade Show

Executive Office

53 West Jackson Boulevard • Chicago

MILLION ZERO CENTER



FOR ALL
STANDARD
RECEIVERS
and the
NEW
FM
SETS

VACUUM TUBE VOLTMETER

For streamlined, high speed servicing. A time saver on all types of receivers—and made to order for FM. Accurate, dependable. Features an oversize, easy to read meter with ZERO center.

- ★ Tests 1000 megohms insulation center.
- ★ Tests oscillator grid bias while in operation at 3,333.333 ohms per volt.
- ★ With 30 scales.

INDISPENSABLE FOR FM SETS

Model J
Special Net
Price, only **\$29.95**

MILLION RADIO AND TEL.
1619 No. Damon • Chicago, Ill.

BRACH Antennae

Automobile
Home — All types
F-M Systems
Television
Police • Marine
Multiple Systems
Complete Kits
Accessories

Made by World's Oldest and Largest
Manufacturers of Radio Aerial Systems

L. S. BRACH MFG. CORP.
55 DICKERSON STREET
NEWARK, N. J.

Personnel . . .

• • • • A. D. Davis, president and general manager of Allied Radio Corp., Chicago, announces the appointment of Charles S. Kiger as merchandise manager of the radio set division.

Robert M. Lachman, for the past six years in the radio set division, becomes assistant merchandise manager of that division.

• • • • The appointment of the H. E. Ransford Co., Fulton Building, Pittsburgh, Pa., as sales representative for Western Pennsylvania and the state of West Virginia is announced by Allen B. DuMont Laboratories, Inc.

• • • • H. T. Ziegler has joined Howard Radio Co., Chicago, as advertising manager.

Charles B. Shapiro, executive vice-president of Howard, has taken over the sales of Howard home receivers on the Pacific Coast, including California, Oregon, Wyoming, Utah, Washington, Arizona, Nevada, and Idaho.

• • • • The Russ Diethert Co., 7910 Drexel Ave., Chicago, has been appointed representative for Ken-Rad Radio Tubes in the southern part of Michigan, the Toledo territory and northern Indiana.

• • • • Milton Reiner, president of Radio City Products Corp., New York City, announces the appointment of the Herb Erickson Co., 14 Biltmore Ave., Asheville, N. C., to represent RCP for the territory including Florida, Alabama, Georgia, South Carolina and Eastern Tennessee. Herb Erickson will make his headquarters at his company's home office in Asheville, while his associate, Horace Russell, will work out of Atlanta.

• • • • J. I. Cornell, chief engineer of the Solar Manufacturing Corp., Bayonne, N. J., has been elected a director of that company.

Displays . . .

• • • • Alliance Manufacturing Co., Alliance, Ohio, are packing their line of "Even-Speed" phono-motors in individual cartons for the service trade. This offers the parts jobber and Service Man many convenient features, such as easier handling, easier storing, it is said.

• • • • A self-selling display is being distributed by the Electrovox Co., 424 Madison Ave., New York City, for their Walco Sapphire Needles.

• • • • Presto Recording Corp., 242 W. 55 St., New York City, are offering distributors an attractive 4-color counter display stand free of charge with the first order received for one or more Presto IIA tables. The stand mounts the turntable solidly on the counter where the customer operates it himself.

• • • • National Carbon Co., 30 E. 42 St., New York City, is launching a drive in behalf of Eveready Mini-Max B batteries for portable sets, using a free kit of sales helps. The kit is offered to all Service Men on a special battery deal.

Three items make up the kit. First is a mahogany plaque on which the name of the Service Men qualifying for the offer will be imprinted. Second is a window-piece designed to sell both portable radio sets and batteries. The third item in the kit is a portable battery replacement guide. Offer expires June 30, 1941.

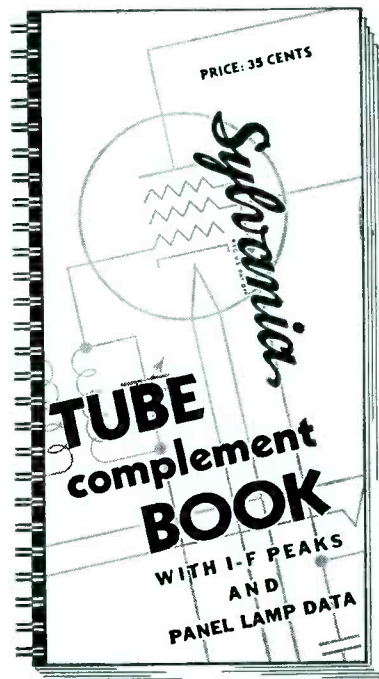

1941 EDITION

including
the first collection of
PANEL LAMP NUMBERS
ever attempted!

272 Pages—16,730 Radio Models shown—including data on '41 receivers. Tube replacement information for 100,380 Tubes or Sockets. 586 Trade Names of receivers. Names and Business Addresses of 190 Receiver Manufacturers. Patented, Hold-Tite, Wire-O Binding.

*The First and Only Compilation
of Panel Lamp Numbers.*

Every Radio Serviceman should own one of these Sylvania Tube Complement Books. All the information you'll need—from the oldest set up to and including the latest '41 models — is packed into those 272 pages. And the book is bound by the WIRE-O process. It opens flat and there's no danger of it falling apart or of the pages pulling out.

This valuable compilation, the only book of its kind in the field, is one of the 125 silent salesmen Sylvania has created to help you build a sounder, more profitable business. Write today for Sylvania's Tube Complement Book, enclosing 35c in stamps or coins, and for a full list of the surefire, tested, dealer aids. Some are free and some are available at a very nominal cost—all of them are designed to help you sell more, and *make more!*

SYLVANIA

Set-Tested Radio Tubes

Also makers of Hygrade Lamp Bulbs, Hygrade Fluorescent Lamps and Miralume Fluorescent Light Fixtures



ATR VIBRATORS

PROVEN UNITS
of the
HIGHEST QUALITY

Engineered to perfection, ATR Replacement Vibrators set high standards of performance and construction. Their greater life and reliability are made possible by new designs utilizing 3/16" diameter tungsten contacts with full wiping action. Other important features.

- Perforated Reed of highest quality Swedish spring steel.
- Highly Efficient Magnetic Circuit with formed base.
- Mica and Metal Stack Spacers with 2-bolt stack construction.
- Extra Flexible Leads with Tinned Clamp Supports.
- Highest Precision Construction and Workmanship.

ATR vibrators, the heart of vibrator-operated power supplies, are proven units of the highest quality, engineered to perfection. They are backed by more than ten years of vibrator design and research, development and manufacturing — ATR pioneered in the vibrator field. American Television & Radio Co. has consistently devoted its efforts and energies to the perfection and production of vibrators and associated equipment, and today, after ten years of painstaking, persistent and diligent work resulting in steady development and progress, is considered a leader in its field. All ATR Products incorporate only the best materials and workmanship and are carefully manufactured under rigid engineering inspection and tests, making them the finest that can be built.

ATR Vibrators Are Fully Guaranteed 1 Year. Insist Upon ATR.

AMERICAN TELEVISION & RADIO CO.
ST. PAUL, MINN., U. S. A.

Out April 15th! NEW VIBRATOR GUIDE

IT'S FREE — Write for it!

The most comprehensive and complete in the industry, covering ATR replacement vibrators for practically all standard vibrator-operated receivers, including Automotive, Aviation, Police and Household Sets.

YOU SAVE \$ 1 00

by using the
Group

Subscription Plan

OUR GROUP SUBSCRIPTION PLAN enables you and three or more of your co-workers to subscribe to SERVICE at one-half the regular yearly rate. In other words it will cost you and your friends only \$1.00 each for twelve issues of SERVICE. The G-S-Plan low rate only applies when 4 or more subscriptions are ordered at one time. (Foreign \$2.00.)

Speak to three or more of your friends . . . let them sign up with you and then you can remit for the whole group. (Renewals or extended subscriptions are acceptable as part of a group.)

TEAR OUT AND MAIL

SERVICE—19 E. 47th St., N. Y. C.

Please enter annual subscriptions (12 issues) for each of the undersigned for which payment is enclosed at the rate of \$1.00 each; foreign \$2.00. (This rate applies only on 4 or more subscriptions when occupations are given.)

Name

Address

City-State

Occupation

Employed by

State whether Employer is a Service Organization, Dealer, Jobber
or Manufacturer

Name

Address

City-State

Occupation

Employed by

State whether Employer is a Service Organization, Dealer, Jobber
or Manufacturer

Name

Address

City-State

Occupation

Employed by

State whether Employer is a Service Organization, Dealer, Jobber
or Manufacturer

Name

Address

City-State

Occupation

Employed by

State whether Employer is a Service Organization, Dealer, Jobber
or Manufacturer



KEN-RAD

DEPENDABLE
RADIO TUBES

Standardize on Ken-Rad Radio Tubes for your re-allocation business. You and your customers will be well pleased with their dependability.

KEN-RAD TUBE & LAMP CORPORATION
Owensboro, Kentucky

WHEN YOU CHANGE YOUR ADDRESS

Be sure to notify the Subscription Department of SERVICE at 19 E. Forty-seventh St., New York City, giving the old as well as the new address, and do this at least four weeks in advance. The Post Office Department does not forward magazines unless you pay additional postage, and we cannot duplicate copies mailed to the old address. We ask your cooperation.

Parts, etc. . . .

Additional information on the products described below may be obtained, without obligation, directly from the respective manufacturers.

EMERSON DEAL

Emerson Radio & Phonograph Corp., 111 Eighth Ave., New York City, is merchandising a package of 30 tubes in conjunction with a kit of standard parts consisting of volume controls, condensers and chokes frequently used in every day service work.

VOLUME CONTROL KIT

To help the Service Man capitalize on reallocation, the International Resistance Co., 401 N. Broad St., Philadelphia, Pa.,

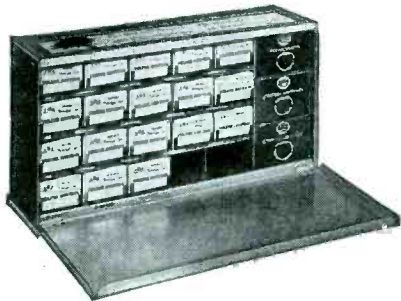

is featuring the IRC "Master Radiotriician's Volume Control Kit," packed in the IRC cabinet shown in the accompanying illustration. Eighteen type D controls with 6 switches and 5 extra tap-in shafts are included.

PREFERRED TYPE REPLACEMENTS

RCA's "Preferred Type" tube program which has been endorsed by many set manufacturers, is to be extended to embrace the renewal tube market as well, it has been announced by L. W. Teegarden, manager of the RCA Tube and Equipment Division. The "Preferred Type" program for renewal tubes centers on a list of 66 tube types, out of the more than 500 types now on the market, which account for 66% of the total renewal demand, Mr. Teegarden said.

A teaser campaign, utilizing the slogan "66/66," or 66 types for 66% of the market, takes the form of mailings in advance of the formal announcement. Cartoon-type drawings are featured and a large broadside has been prepared emphasizing demand and interchangeability of the Preferred Type Tube renewal list is being mailed to all RCA tube and equipment distributors and Service Men. The broadside may be used as an inventory control and ordering guide.

H-D PLUG-IN RESISTORS

For extra-heavy-duty service such as in sets employing both 300 and 150 milliamperes tubes served by a single voltage-dropping resistor, a new glass-insulated-element plug-in tube-type resistor, Type MTG is announced by Clarostat Mfg. Co., Inc., 285-7 N. 6 St., Brooklyn, N. Y. The glass-insulated element handles over three times the wattage of the usual bare winding, it is said. Some units are made with a combination of bare winding and glass-insulated winding, supported on the same mica form.



It's Got to be Right to be

TRIPLET



Model 1200-F
\$27.84
Dealer Net

Nobody "bosses" Cliff Elliott, chief of the Triplet inspection line.

Production is up,—way up, but nobody puts the heat on "Inspection" for the slightest variation from the most hardboiled inspection scrutiny in the Industry. For it is an axiom in the whole Triplet plant—regardless of position or the pressure of orders—"It's got to be right to be Triplet."

Under expanded Industrial demand there continues to be no compromise in those rigid Triplet standards which have become the International Hallmark of Precision and Quality. For more information write Section 173, Harmon Avenue.

THE TRIPLET ELECTRICAL INSTRUMENT COMPANY
Bluffton, Ohio



SERVICEMEN

who are

RADIO AMATEURS

buy a fresh copy today of the

RADIO AMATEUR CALL BOOK

The CALLBOOK is the only publication that lists all licensed radio amateurs in the United States and foreign countries.

Complete . . . Accurate . . . Up-to-Date

Issued Quarterly

MARCH . . . JUNE . . . SEPTEMBER
and DECEMBER

Annual subscription \$4.00
Single copies \$1.25

Buy your copy now from your radio jobber
or direct from:

Radio Amateur Call Book, Inc.
608 S. Dearborn St., Chicago, Ill., U. S. A.

PUBLIC ADDRESS HEADQUARTERS



RADOLEK De Luxe Public Address Systems offer the most for your money in Styling—Hi-Fidelity Performance—Reserve Power—fast, convenient, easy installation. Offered in 15, 30, 50 and 100 watt sizes—for permanent, portable or mobile use. They feature from 2 to 6 input channels, built-in input and mixing controls, AVC, and the newly developed "feedback" tone control circuit. Wide choice of microphones and speakers. Mail coupon for complete information.

RADOLEK'S NEW 1941 RADIO PROFIT GUIDE

FREE!

Indispensable to every serviceman, dealer and sound engineer. Send for big FREE Radolek Profit Guide now!



SEND TODAY! PASTE ON A PENNY POST CARD

RADOLEK CO., Dept. S-52
601 W. Randolph St., Chicago, Ill.

Please send information on Radolek Public Address equipment—also new 1941 Radio Profit Guide.

Name _____
Address _____
 DEALER SERVICEMAN ENGINEER

Simplest

WAY TO REPLACE
BALLASTS

- 4 STANDARD TYPES of Amperite Regulators replace over 200 types of AC-DC Ballast Tubes now in use.
- Not to be confused with ordinary dropping resistors. Amperite actually regulates.
- Amperite Regulators are equipped with a patented Automatic Starting Resistor which prevents initial surge and saves pilot lights.
- Amperite AC-DC Regulators; List \$1.00. Amperite Replacements for 2V Battery Set ballasts List \$1.25

WRITE FOR REPLACEMENT CHART "S"

AMPERITE Co. 561 Broadway, N. Y. C.

AMPERITE



Readrite
RANGER
MODEL 432-A

The Outstanding Tube Tester Value . . . Checks all type tubes including Loctals. Bantam Jr., 1.4 volt Miniatures, Gaseous Rectifier, Ballast, High Voltage Series, etc. Filament Voltages from 1.1 to 110 volts. Direct Reading GOOD-BAD Meter Scale. Professional-appearing case with accessory compartment large enough for carrying Model 739 AC-DC Pocket Volt-Ohm-Milliammeter, thereby giving the serviceman complete testing facilities for calls in the field. . . . Model 432-A with compartment, Dealer Net Price . . . \$18.85. Model 432-A in case less compartment . . . \$17.85. Model 739, Dealer Net Price . . . \$9.90.

WRITE FOR CATALOG—Section 317 College Avenue

READRITE METER WORKS, Bluffton, Ohio

Index to Advertisers

A	
Aerovox Corp.	24
Allied Radio Corp.	26
American Television & Radio Co.	34
Amperite Co.	36
Astatic Microphone Lab., Inc.	21
B	
Brach Mfg. Corp., L. S.	33
C	
Centralab	4
G	
General Electric Co.	25
H	
Howard Radio Co.	32
Hygrade Sylvania Corp.	33
I	
International Resistance Co.	27
J	
Jackson Elec. Instrument Co.	26
Jensen Radio Mfg. Co.	3
K	
Ken-Rad Tube & Lamp Corp.	34
L	
Lafayette Radio Corp.	24
M	
Mallory & Co., P. R. Inside Front Cover	
Million Radio & Television Lab., Inc.	33
N	
National Union Radio Corp.	19
North Eastern Radio Co.	31
O	
Ohmite Mfg. Co.	31
R	
RCA Mfg. Co., Inc. Back Cover	
Radio Corporation of America.	17
Radiart Corp., The. Inside Back Cover	
Radio Amateur Call Book, Inc.	35
Radio City Products Co., Inc.	30
Radio Parts Show.	32, 36
Radio Servicemen of America, Inc.	28
Radolek Co., The.	35
Readrite Meter Works.	36
Rider Publisher, Inc., John F.	23
S	
Simpson Electric Co.	1
Solar Mfg. Corp.	28
T	
Triplett Elec. Inst. Co., The.	35
Turner Co., The.	22
U	
United Transformer Corp.	15
Utah Radio Products Co.	29
Y	
Yaxley Mfg. Division. Second Cover	

**THE BIG SHOW
IS COMING AND
I'LL BE THERE!**



**JOBBERS, their Salesmen
and Countermen . . .**

**MANUFACTURERS, their
Engineers and Sales
Staffs . . .**

**THE TRADE PRESS and
its Writers . . .**

**ARMY AND NAVY Signal
& Ordnance Experts . . .**

**SERVICEMEN
and AMATEURS . . .**

They'll all get together at this one big show of the Radio Industry... Plan now to attend!

Stevens Hotel, Chicago
JUNE 10-11-12-13

JOBBER DAYS

Tuesday, June 10 to Thursday, June 12

OPEN HOUSE

Thursday Eve. June 12 and Friday, June 13

**Radio Parts
National Trade Show**

Executive Office

53 West Jackson Boulevard · Chicago

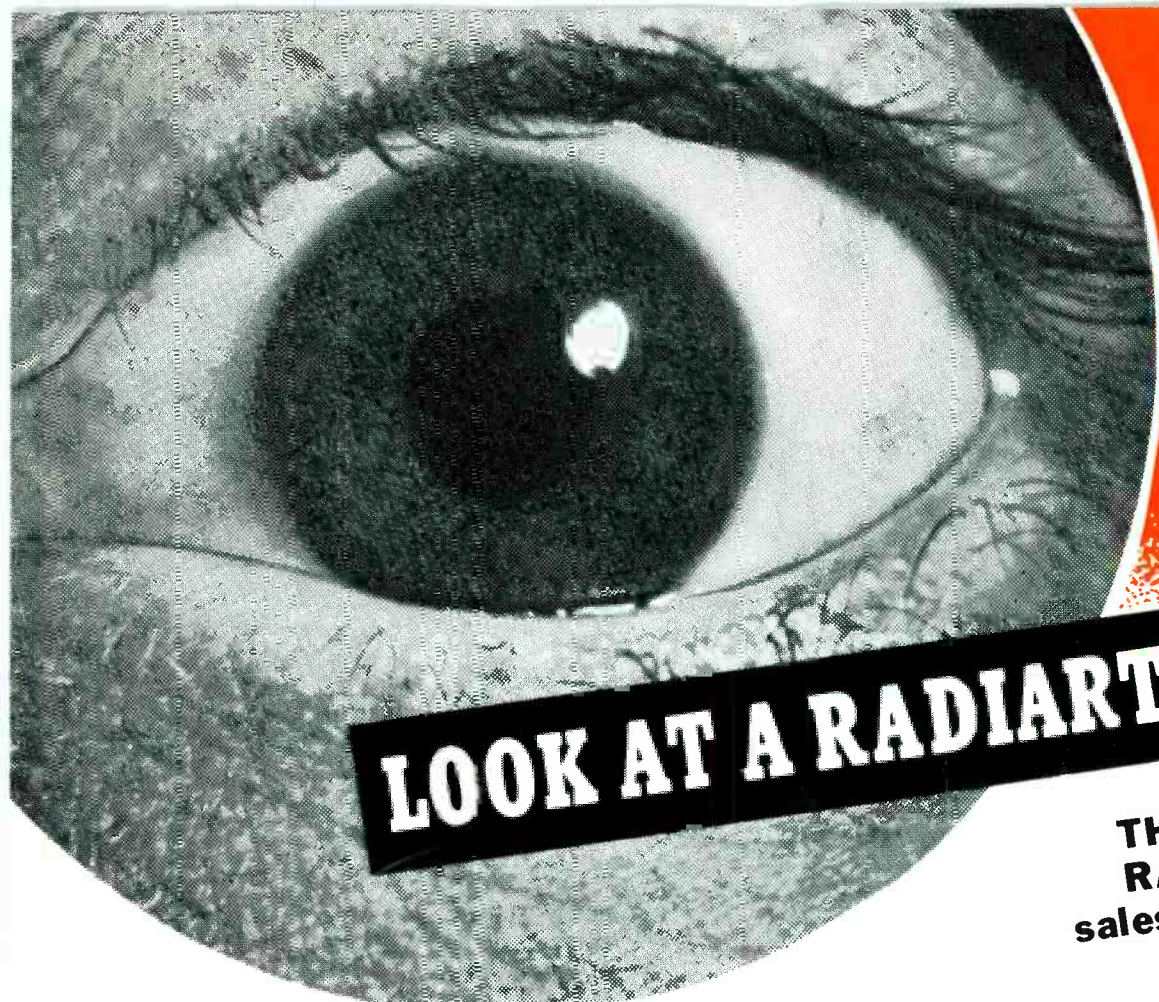

LOOK AT A RADIART VIBRATOR

**THIS MONTH, let a
RADIART JOBBER
salesman or counterman
SHOW you**

Why **RADIART VIBRATORS are BETTER**



**RADIART
AERIALS**
always a Year Ahead

Just out with a New Line that packs many powerful quick-selling features. Most Radiart Types **FIT ALL CARS** on Fender or Cowl, reducing your inventory and increasing your profit

SELECTICOIL
lets you "tailor-fit" a Radiart Aerial to the set.

- **RADIART VIBRATORS are EXACT DUPLICATE**
meaning, not merely size of can and prong arrangement, but load limit and frequency are engineered to work **RIGHT** with other components of the circuit.
- **RADIART VIBRATORS combine**
CLOSED FRAME
MICA STACK
MUCH LARGER POINTS
SWEDISH STEEL REEDS
RIVETED CONSTRUCTION
and other quality features
- **RADIART VIBRATORS are GUARANTEED**

NEW and **FREE**—the 1941 **RADIART VIBRATOR HANDBOOK**. It's complete, concise, correct. **GET YOUR COPY.**

WRITE for CATALOGS

THE RADIART CORP.
CLEVELAND, OHIO

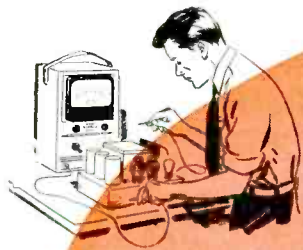

When You "Reset" or
Repair Their "Big Sets"

THESE RADIOLA MODELS

SELL
THEMSELVES



**RADIOLA "Extra" Radios
Mean Extra Sales... Extra Profits
for SERVICEMEN**

"JINX" FALKENBURG, America's Number 1 Model,
poses with America's Number 1 profit-opportunity for
servicemen... the new Radiola Model 515. Both
"Models" have plenty of eye-appeal!

SUCCESSFUL SERVICEMEN are smart salesmen. That's why we designed a line of small, fine sets specifically for *servicemen* to sell.

Look at the RADIOLA 515 above. Suppose you leave it in a customer's home while their regular set is in your shop—or even just demonstrate it when you retune their radio push-buttons.

While *their* set is in your hands, your customers are discovering the added pleasure such an "extra" radio can bring. A radio they can carry easily from room to

room... a radio they can listen to at will. A radio with such top-notch features as *foreign reception*... R. F. stage for greater sensitivity... *six* RCA Preferred Type Tubes... continental-style wrap-around cabinet of costly woods... the RADIOLA 515!

Try it—see for yourself. Remember that your best service *customers* are your best RADIOLA *prospects*. And that RADIOLA alone is especially designed to be sold by servicemen... by you.



All RADIOLA Models Are Equipped Exclusively with RCA Preferred Type Tubes

SUPER-SELLERS, Every One!



RADIOLA Model 510... 110-volt AC-DC. Striking cabinet of molded plastic, with tear-drop knobs and attractive clock-type dial. Highly efficient chassis embodies superheterodyne circuit, built-in tuned loop antenna, full AVC action. 5" Electrodynamic Speaker. 5 RCA Preferred Type Tubes.

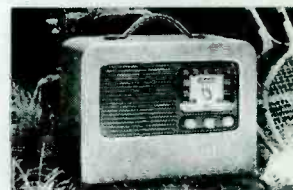

RADIOLA Model P-5... A 3-way portable that's a real eye- opener. Operates from self-contained batteries, or 110-volt AC or DC line. Durable, washable simulated-leather covering. Built-in tuned loop. 5 RCA Preferred Type Tubes.

**PLUS MANY OTHER
FAST-SELLING MODELS**

Radiola Preferred
Type Radios

Made by RCA Manufacturing Co., Inc., Camden, N. J., U. S. A.
A Service of the Radio Corporation of America
In Canada, RCA Victor Company, Ltd., Montreal