

SERVICE

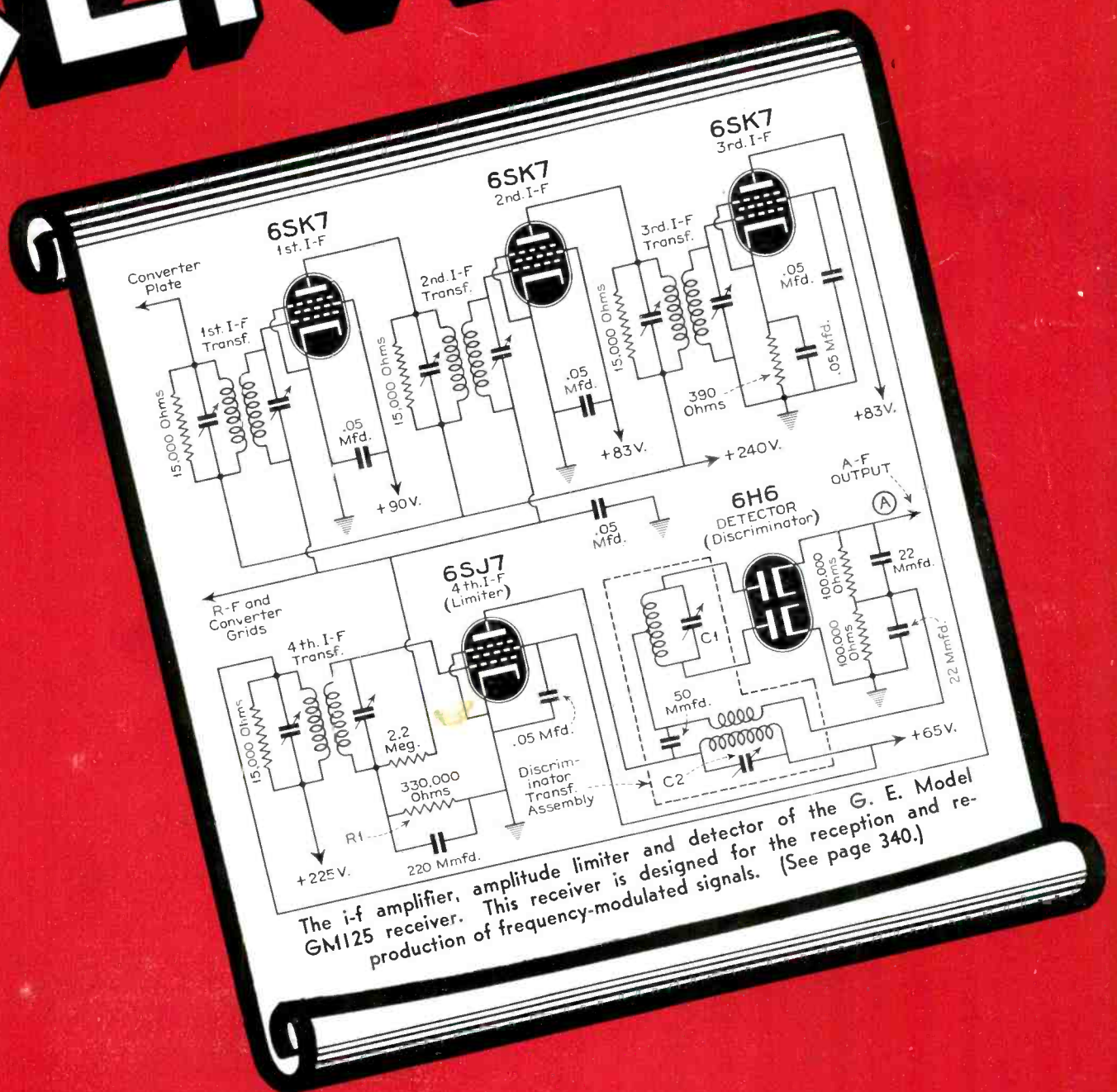

July
1939

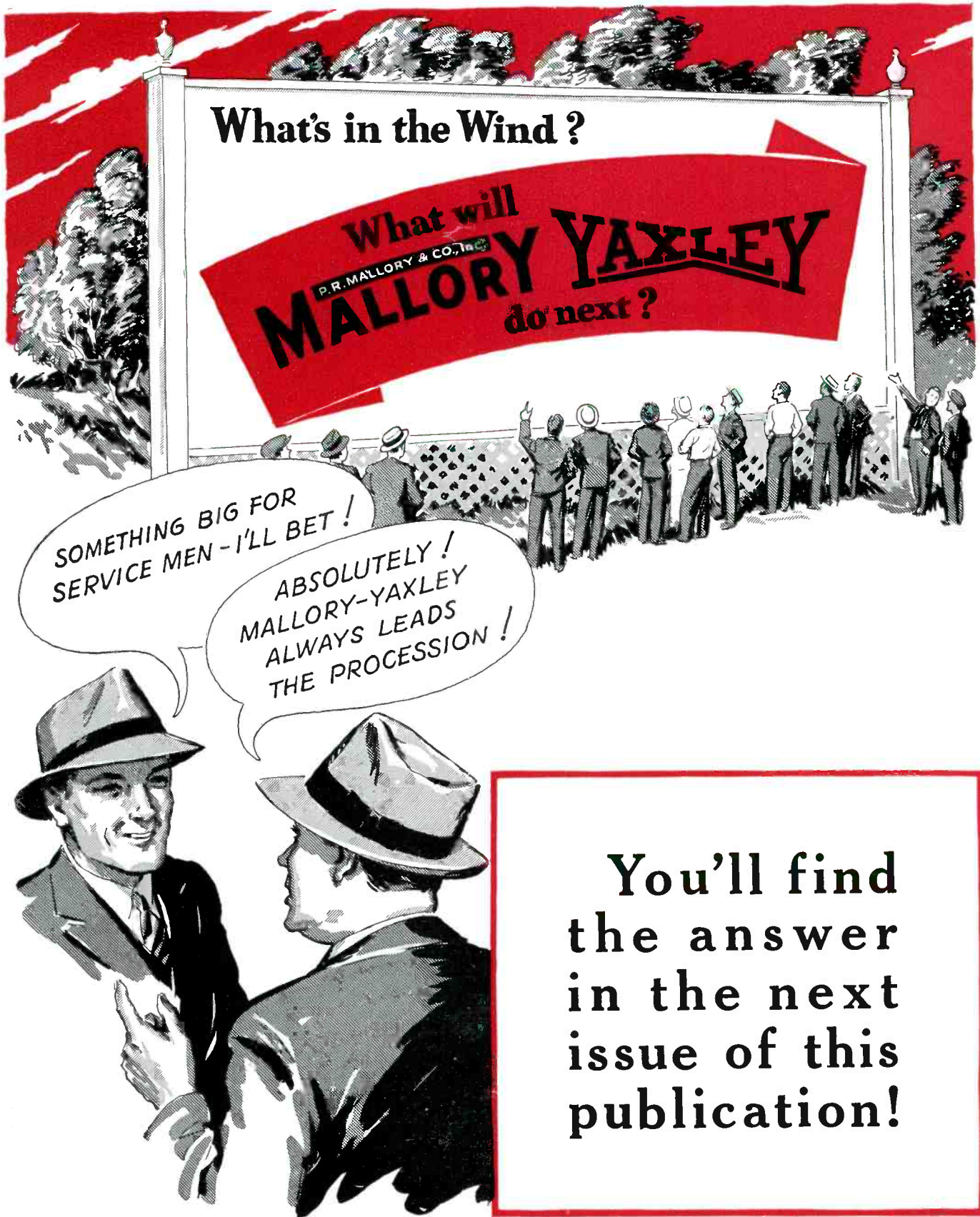

What's in the Wind ?

What will
P.R. MALLORY & CO., Inc.
MALLORY YAXLEY
do next ?

SOMETHING BIG FOR
SERVICE MEN - I'LL BET !

ABSOLUTELY !
MALLORY-YAXLEY
ALWAYS LEADS
THE PROCESSION !

You'll find
the answer
in the next
issue of this
publication!

Use
P.R. MALLORY & CO., Inc.
MALLORY
REPLACEMENT
CONDENSERS... VIBRATORS

P. R. MALLORY & CO., Inc.
INDIANAPOLIS INDIANA
Cable Address — PELMALLO

Use
YAXLEY
REPLACEMENT
VOLUME CONTROLS



SERVICE

A Monthly Digest of Radio and Allied Maintenance

Reg. U. S. Patent Office

Edited by
ROBERT G. HERZOG

Published Monthly
by the

**Bryan Davis
Publishing Co.**
Inc.

19 East 47 Street
New York City
Telephone PLaza 3-0483

BRYAN S. DAVIS
President

JAS. A. WALKER
Secretary

SANFORD R. COWAN
Manager

PAUL S. WEIL
Advertising Manager

A. GOEBEL
Circulation Manager

Chicago Office:
608 S. Dearborn Street
C. O. Stimpson, Mgr.
Telephone Wabash 1903

Wellington, New Zealand:
Tearo Book Depot

Melbourne, Australia:
McGill's Agency

Entered as second-class
matter June 14, 1932, at
the Post Office at New
York, N. Y., under the
Act of March 3, 1879.
Subscription price: \$2.00
per year in the United
States of America and
Canada; 25 cents per
copy. \$3.00 per year in
foreign countries; 35
cents per copy.

Contents

At the Trade Show	341		
Average Wind Velocities Throughout the U. S.	336		
Electrolytic Condensers <i>By Stanley Walters</i>	352		
Frequency Modulation <i>By J. Snivas</i>	340		
Loudspeaker Enclosures <i>By Maurice Apstein</i>	331		
RCA TRK5, TT5 Television Receiver	353		
Signal Tracing in Diode Detectors <i>By John F. Rider</i>	343		
Wind Chargers <i>By John H. Potts</i>	334		
Antenna	328	Highlights	362, 363
Associations	356	Index to Advertisers	366
Book Reviews	357	Manufacturers	358, 360, 365
Case Histories		On The Job	
G. E. G105		Noise Suppressor Condensers	364
<i>By Willard Moody</i>	338	R-C Filters	
		<i>By Alan S. Roberts</i>	347
Circuits		Sound Facts	
Diode Detector Circuits	343, 344, 345	Loudspeaker Enclosures	
G. E. GM125	Front Cover	<i>By Maurice Apstein</i>	331
Hickok TS50 Tester	350	Television	
Noise Suppressors	364	RCA TRK5, TT5 Television Receiver	353
R-C Filters	347	Test Equipment	
RCA TRK5, TT5 Television Receiver	353	Fox Radio Service Bench	361
Time Delay Circuit	352	Hickok TS50 Tester	
Wind Charger Connection	338	<i>By Bradley Thompson</i>	348
		Signal Tracing in Diode Detectors	
Cover Diagram		<i>By John F. Rider</i>	343
Frequency Modulation			
<i>By J. Snivas</i>	340		

Copyright 1939 Bryan Davis Publishing Co., Inc.

Also publishers of COMMUNICATIONS



A N T E N N A

• • • sound-motion picture film

THE Bryan Davis publication, COMMUNICATIONS, has, in the past few months, been featuring a series of articles on the probable importance of sound-motion picture film in television, by John A. Maurer of the Berndt-Maurer Corporation.

In this series Mr. Maurer says: "In television broadcasting the sound-motion picture film has a role that is analogous to that of the electrical transcription disc in sound broadcasting. It furnishes a convenient means of repeating a program, or of syndicating it to a number of stations. But the role of the sound-motion picture film in television is likely to be far more significant than is indicated by the above analogy. The electrical transcription merely repeats a program of sound entertainment as it was originally performed by the artists. A live broadcast would have been superior. There is nothing creative about the process of recording a sound program on a disc.

"By contrast, a television transcription on motion picture film can be a medium for the creation of effects that could not be produced in a live broadcast. On film it is possible to build a program of far greater entertainment value than can be achieved in the studio. Furthermore, the cost and effort of building such a program will be appreciably lessened by employing the medium of film.

"... Even in the field of sports the film transcription can furnish a desirable service. Certainly we would prefer to see a recast of a world series game on the evening of the day it was played rather than not see it at all because it occurs during business hours. At least, if this attitude is not shared by the public in general, newspapers would do well to discontinue their sporting pages.

"... Television will undoubtedly develop its own distinctive type of program material, which will not be that of the stage, the movie house, or the popular magazine and yet will derive some of its characteristics from each of these. But in seeking its own form of entertainment, television can ill afford to deny itself the freedom that the film technique has to offer. . . ."

In giving Mr. Maurer's opinions we, too, feel that sound-motion picture film will help television broadcasters solve many of their program and syndication headaches. Now that it is possible to project films about a minute and a half after taking them it would seem that film technique is made to order for television.

• • • use standard parts

WE CANNOT understand why some Service Men use cheap parts in making repairs and replacements on their customers sets. In the average four or five dollar repair call there is only about fifteen cents difference in cost between the cheapest parts obtainable and the very best. Aside from the gain in customer good will, which cannot be measured in dollars and cents, there is the actual saving in repeat calls which are necessitated through the breakdown of inferior parts. You will also get something out of the personal satisfaction you should feel after a job well done.

• • • tubes

WITH the multiplicity of types now on the market it takes an experienced Service Man to sell tubes. The corner drug clerk is no longer competent to test them or to recommend the proper replacement. By taking full advantage of the situation you can corner the entire replacement tube business. The galaxy of tube types thus bids fair to dump the whole thing in your lap.

Very good! It rightfully belongs to you. But don't let this opportunity catch you napping. Keep your tube stock up. Make sure that you can test every type. Know all about interchangeable types. Keep up-to-the-minute on new tube types.

In your customer's home talk tubes. Find out how old those in her set are. Recommend a complete new set if hers have been in use for more than 1,500 hours.

Tubes are something like spark plugs, that is, if one is replaced there is little noticeable improvement in the receiver's performance. If all are replaced, however, some change in reception should be evident. But dependability is an item that can be stressed even more than improvement in quality and efficiency. To make another analogy, the life of a tube is very much like that of a battery. Its efficiency goes down very slowly (it may even improve at first) until near the end of its useful life when the efficiency takes a sharp drop. A simple explanation of this to your customer should help convince her. If a single tube fails she will have to call you back. This will be considerably more expensive than early replacement. From your own standpoint, you cannot afford to guarantee a repair job where old tubes have not been replaced. Failure of a single tube in such a case will mean a repeat call on which you will definitely lose both money and prestige.

We repeat, make it a point to sell replacements for every tube that has been used for more than 1,500 hours.

Gift Merchandise added to **FREE EQUIPMENT**



**86 Piece
Rogers Silver Service**
Retail Value, \$60.00

86-Piece Embassy Chest Rogers Extra Silverware . . . made and guaranteed by Simon L. and George H. Rogers, famous Oneida Silversmiths. Retail value, \$60. . . . Dealer Deposit, \$12 . . . Immediate delivery.



Elgin Wrist Watch
Ladies' or Men's Style
Retail Value, \$37.50

Elgin wrist watch, DeLuxe Model, Ladies' or Men's Style. Retail Value, \$37.50 . . . Dealer Deposit, \$11 . . . Immediate Delivery.

**. . . . AND MANY
OTHER ITEMS!**

More reasons why it pays to handle **NATIONAL UNION TUBES AND CONDENSERS**

SERVICE DEALERS—

Do you want to increase your volume, give better satisfaction to your customers, protect yourself from cut price competition . . . THEN **WHY NOT WORK WITH N. U.** . . . All our policies and sales promotions are aimed to build up the service dealer and his business.

National Union offers a complete line of all (320) types of tubes. Quality is the finest that research skill and engineering can produce; backed by the most liberal replacement policy in the industry. The choice of leading service engineers everywhere . . . they've got to be good.



NEW LOKTAL TYPE

CERAMITE CONDENSERS

The only midget electrolytic enclosed in ceramic insulation. Can't short when jammed in tight places. Competitively priced. Available in all popular capacities and voltages.



What National Union is doing for others it can do for you. Thousands upon thousands of completed premium agreements prove the fairness of our proposition. Equipment or premium is obtained immediately on a small down deposit, no time payments to meet or exorbitant interest rates to pay. National Union can afford to do it because our selling costs are lower. Just try it for yourself and you'll see why it pays you to buy your tubes and condensers the National Union Way.

Both Tubes and Condensers Count on N. U. Premiums

**ASK YOUR JOBBER
OR WRITE ➡**

NATIONAL UNION RADIO CORPORATION
57 State Street, Newark, N. J.

Please send me more information on your Gift Merchandise. I am interested in the following Free Test Equipment:

.....
.....
Name
Address
City State..... S-739

Try this New and Improved I. F. TRANSFORMER

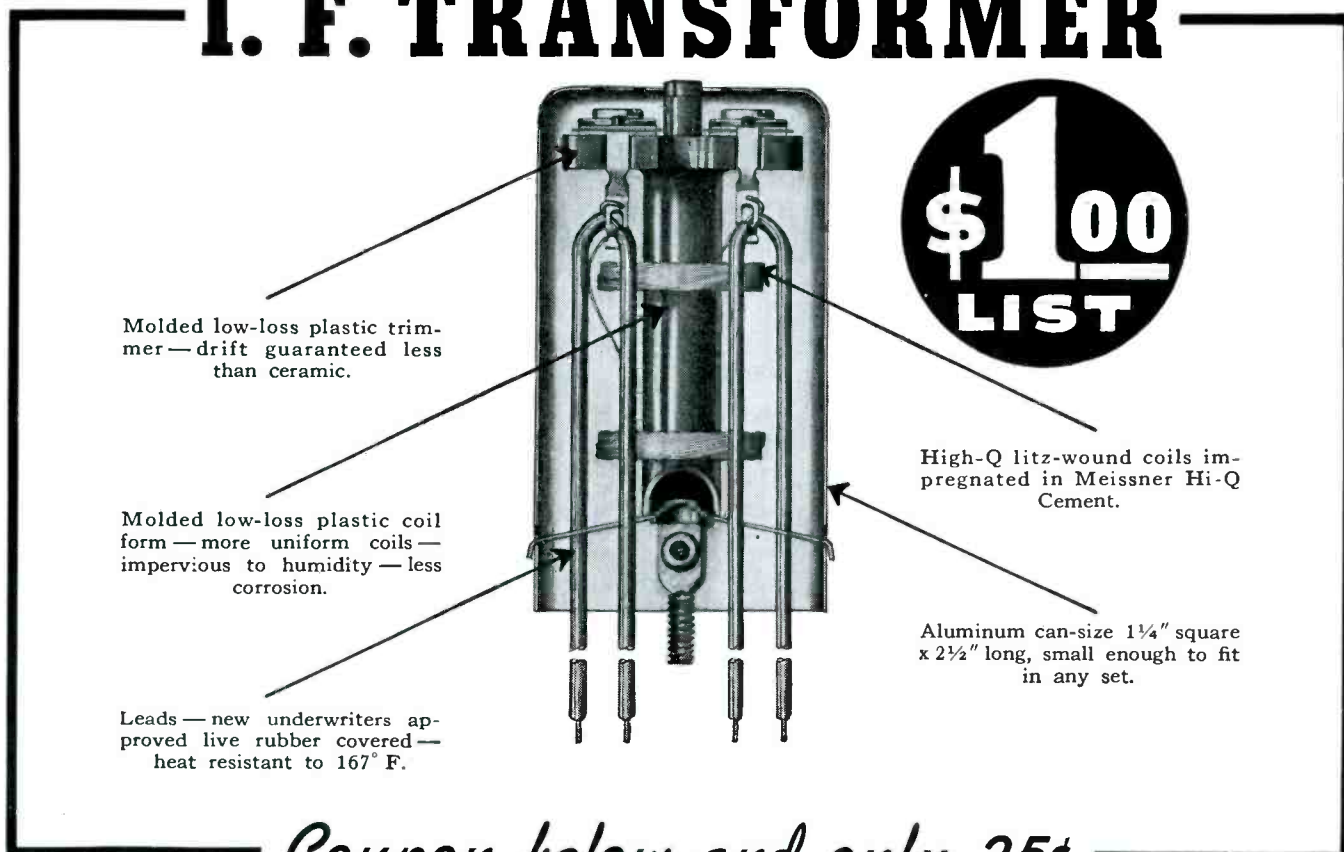

Molded low-loss plastic trimmer—drift guaranteed less than ceramic.

Molded low-loss plastic coil form—more uniform coils—impervious to humidity—less corrosion.

Leads—new underwriters approved live rubber covered—heat resistant to 167° F.

\$1.00
LIST

High-Q litz-wound coils impregnated in Meissner Hi-Q Cement.

Aluminum can-size 1¼" square x 2½" long, small enough to fit in any set.

Coupon below and only 25¢ brings you sample by return mail

Most sensational development in the radio parts industry! A real *midget* I. F. Transformer designed for superior performance in *any* type of receiver. High-dielectric winding form, integral with the trimmer base, provides a simplified construction that permits maximum space efficiency and a lower cost. Aluminum shield is only 1¼" square and 2½" long.

This new transformer is the result of years of engineering experience in the design of similar units for the manufacturer, serviceman and experimenter. It incorporates only the best materials from the high-quality molded coil form and trimmer base to the specially-served litz wire used for the windings. Manufacturing savings resulting from fewer parts and

simplified construction are passed on to you in the form of lowest possible prices.

Available in a complete range of operating frequencies and for input, inter-stage or output operation.

SPECIAL SAMPLE OFFER

See and try this new transformer for yourself. Send only 25¢ with the coupon below and we will send you a sample 456-kc input transformer for your examination and test.

Only one unit to each customer; no orders accepted on this basis without coupon. This offer is good for a limited time only so send in your coupon today.

NEW CATALOG FREE

Get your FREE copy of our New 1939-40 48 Page Catalog featuring 28 Radio Kits (1 to 14 tubes) and over 800 Meissner Products for Set Builders, Amateurs, and Experimenters.

NOTE: NO ORDERS FOR THIS SAMPLE WILL BE ACCEPTED WITHOUT THIS COUPON

ONLY ONE I. F. to a customer

Cable Address: "Meisnrcoil."



MEISSNER MANUFACTURING COMPANY
Mt. Carmel, Illinois, Dept. S-7

Enclosed find 25c for which please send me sample (456-KC INPUT) of your NEW IMPROVED I. F. TRANSFORMER (list \$1.00).

Name.....
Street.....
City..... State.....
Company.....
My Jobber is.....

LOUDSPEAKER ENCLOSURES

By **MAURICE APSTEIN**
MORLEN ELECTRIC CO.

AFTER spending the past two years in close association with both the engineering department and customers of one of the largest manufacturers of high fidelity speakers in the country, the writer has become firmly convinced that no component of a sound system is as completely misunderstood as the loudspeaker baffle. Particularly since the advent of the enclosed type speaker housing has much confusion arisen as to just how these devices function, and the manner in which to operate them to secure best results. Although the principle upon which the flat baffle operates; isolation of front radiation from that of the rear, seems to be well known in a general way, understanding of the proper handling of even this simplest of acoustic networks seems to be sadly lacking. At the risk of repeating what may seem to be familiar, a short review of the principle of operation of the flat baffle, seems to be not too much out of order. At the same time it will provide a basis for consideration of the more recent types of speaker enclosure.

• • • **purpose**

The purpose of any baffle is to insure

Fig. 1. At low frequencies a loudspeaker cone operates like a piston.

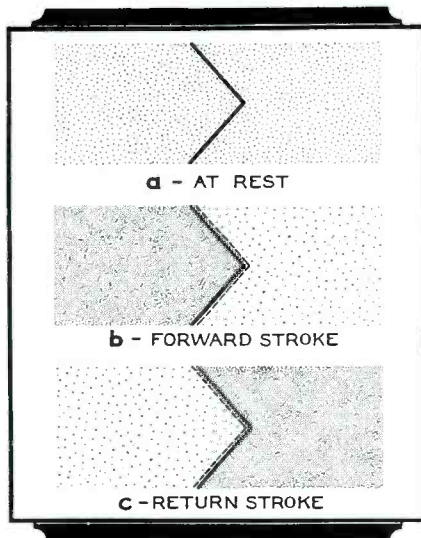

proper radiation of the low frequencies from the cone of a speaker. At these low frequencies the cone operates like a piston, that is, it moves back and forth as a whole, compressing the air in front of it on the forward stroke at the same time that it creates a partial vacuum or rarefaction at its rear. On its backward stroke the cone reverses this procedure, compressing the air behind the

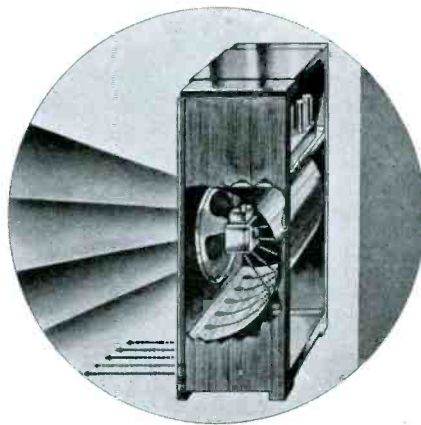

A variation of the RCA Magic Voice.

cone and creating the vacuum in front. This action may be seen very clearly in Fig. 1, where the dots are used to represent molecules of air. In 1(a) the cone is at rest and the air in front and back is at equal pressure. In 1(b) the cone has moved forward from the neutral position (shown as a dotted line) and compressed the air in front at the same time that it has rarefied the air behind. In 1(c) the cone has come back through neutral and has reversed the positions of the compressed and rarefied areas. It is apparent that in the area near the edge of the cone, the compressed and rarefied regions of air are adjacent, and that unless prevented from doing so, the air from the compressed area will flow around the edge of the cone into the rarefied area, and that the resultant alternate pressure or vacuum generated at the front of the cone will be materially reduced. A

baffle is a device for preventing this effect by isolating the pressure area in front of the cone from the vacuum in its rear and vice versa. In its simplest form it consists of a flat sound-proof partition which acoustically insulates the cone front from its rear. Fig. 2(a) illustrates the simple flat baffle and 2(b) shows how the sides may be bent back to form the conventional open back console cabinet. In each case the arrow shows the lengthened path that the sound must take in order to travel from the front of the cone to its rear, and thus cause interference.

It should be obvious that the longer the wavelength, or the lower the frequency of the sound to be isolated, the longer must be the path from the cone front to the cone rear. To completely isolate the front and rear radiations at all frequencies, the baffle would have to be infinite in extent. Conversely, for any baffle of finite size, there will be a particular frequency at which the distance from front to back will be just the length required for the front and rear radiation to meet exactly out of phase and cancel each other out. This critical frequency, common to all flat baffles, is known as the "cutoff fre-

Fig. 2. In its simplest form a baffle consists of a flat partition.

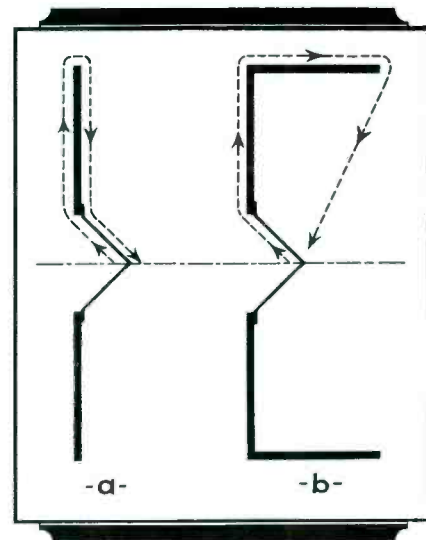

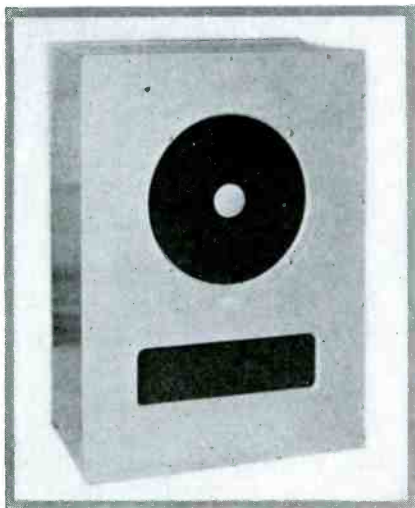

The Jensen Bass-Reflex type of enclosure.

quency," and may be very easily calculated, by the following relation:

$$D = \frac{V}{2}$$

where D is the distance from the cone front to cone rear (feet) and V is the velocity of sound in air (feet per second).

• • • square baffle

In the case of a square flat baffle, the distance from the cone to the edge and back is equal to the diameter of the baffle, so the formula may be said to give directly the diameter of a flat baffle for any cutoff frequency. Based on the above relationship, the required dimensions for square baffles of various cutoff characteristics are as follows:

Cutoff Frequency (cycles per second)	Baffle Diameter (path front to rear)
20	28 1/4 ft.
30	18 5/6 ft.
40	14 1/12 ft.
60	9 5/12 ft.
100	5 1/2 ft.

It is apparent that the dimensions given above are much greater than the usual dimensions for what is popularly considered a fair sized flat baffle. The term cutoff frequency is probably an un-

The Stromberg-Carlson Acoustic Labyrinth.

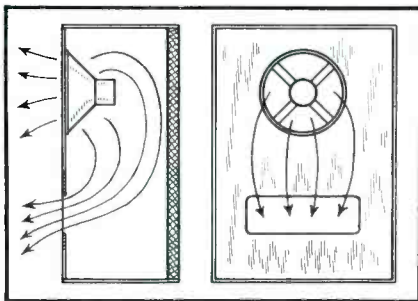
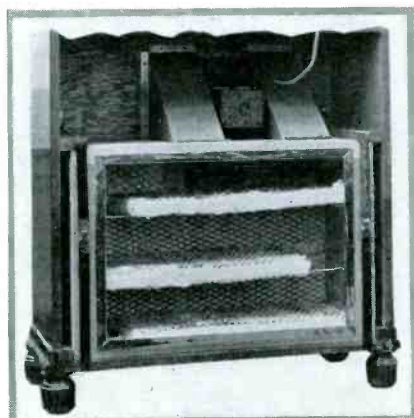

Fig. 7. The bass-reflex type of construction is a cross between an infinite baffle and an acoustic labyrinth.

fortunate one since it has led to the popular misconception that the baffle cuts off or ceases to be at all effective below this frequency in much the same way that an amplifier cuts off, and that no sound or very little, is radiated from the speaker below the baffle cutoff. This is not the case. Below the cutoff frequency of a baffle, the front and rear radiations approach an in phase condition again and the output begins to rise. This is the reason that small baffles three or four feet square which cut off at relatively high frequencies, sound much better than they would if there was actually no sound radiated below the cutoff frequency. This effect is shown in Fig. 3, which is the response curve of a high fidelity cone speaker mounted in a three-foot square baffle.

The deep valley at approximately 600 cycles indicates that at that frequency almost complete cancellation of front and rear radiation takes place. It can readily be appreciated how futile it is to talk about flat amplifier and speaker response, and then mount the speaker in such a way that there is a 20 db valley right in the middle of the response range.

Almost complete correction of this very grave defect in response can be obtained by a few very simple expedients. First of all, a square baffle is one of the worst shapes to use (in spite of its almost universal popularity). This is due to the fact that the path lengths around all four sides of the baffle are

Fig. 5. The labyrinth works on the principle of feeding the rear radiation into a long tube.

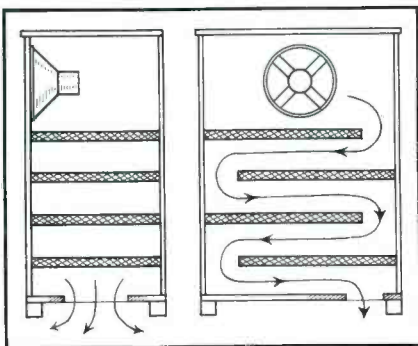

equal, and tend to create a valley at the same frequency. If an oblong baffle is used, there will be two paths of different length; one around the top and bottom, and the other around the sides and bottom. This will result in two valleys in the response, but neither valley will be as severe as before. If in addition, the speaker is located asymmetrically in the baffle, instead of in the center (the latter is also practically universal practice) still further improvement will result due to the fact that no two paths from front to rear will cause cancellation at the same frequency. If the lower edge of the baffle rests on the floor, and the speaker is located near the floor, cancellation 'round this edge is completely cut off, and this portion of the radiation will not suffer even at the very lowest frequencies. Mounting the speaker near the floor helps in another way. When a speaker is mounted in a flat baffle, it is radiating into a solid angle of 180 degrees. Mounting it near the floor puts the speaker in a corner, reducing this angle approximately 90

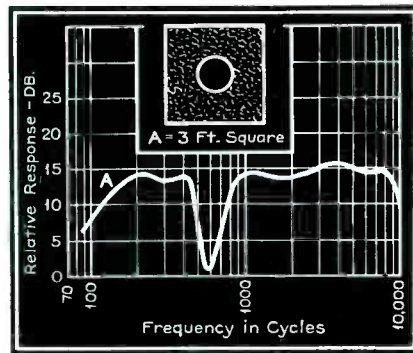

Fig. 3. The deep valley at 600 cycles indicates almost complete cancellation.

degrees with the result that the air in front of the cone is more restricted, loads the cone considerably better and the cone radiates more efficiently. If advantage is to be taken of this restricted solid angle, however, it is preferable to have the floor covered with a rug or some similar soft material; otherwise undesirable reflections may result.

• • • irregular baffles

Fig. 4 shows the startling improvement over Fig. 3 that results when the same speaker is mounted off center in an irregularly shaped baffle resting on the floor, to take advantage of the principles outlined above. This comparison of the same speaker, mounted differently, gives us a perfect example of how excellent electrical response may be completely nullified (and often is) by careless and improper baffling.

Another common error in speaker mounting occurs when two speakers are to be mounted on the same baffle. Here again it is almost universal practice to mount the speakers well separated from

each other, and symmetrically located with respect to the edges. Actually, best response and increased efficiency will be obtained if the two speakers are mounted as close together as physically possible. A little thought will make clear why this improvement takes place. Since both cones move in phase, the effect of the pressure area in the front of each cone is to act as a load on the other. The result is more efficient coupling from each cone to the air, with a corresponding increase in efficiency and response, particularly at the bass end where loading of the cone is a vital factor.

In spite of these improvements, however, Fig. 4 also illustrates the fundamental drawback of the flat baffle. Regardless of ingenuity in shape and placement, it is evident that in order to get efficient isolation at the low frequencies required for true high fidelity reproduction, the necessary dimensions are too great for ordinary use. This problem was not particularly acute as long as response down to 150 cycles was

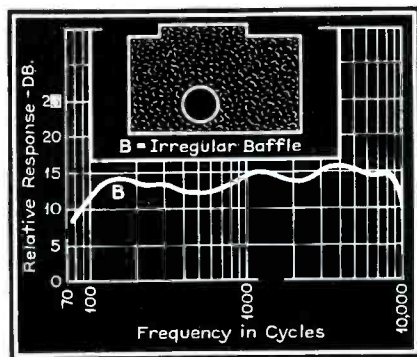

Fig. 4. A startling improvement in response is obtained by mounting the speaker off center on an irregular baffle.

considered good bass response. With the advent of really high-fidelity reproducers, however, which in baffles of infinite extent showed good reproduction characteristics to below 50 cycles, it became imperative to develop some form of baffle which would not be too bulky yet would allow complete advantage to be taken of these low frequency characteristics. It was this realization that caused speaker engineers to undertake the development of compact speaker enclosures that would provide sufficient baffling throughout the entire audible range of frequencies.

• • • acoustic labyrinth

One of the first of these developments was the acoustic labyrinth (Fig. 5). This cabinet works on the principle of feeding the rear radiation into a long tube, usually folded back upon itself several times to conserve space. The walls of the tube are lined with a highly absorbent material so as to rapidly attenuate all but the lowest frequencies,

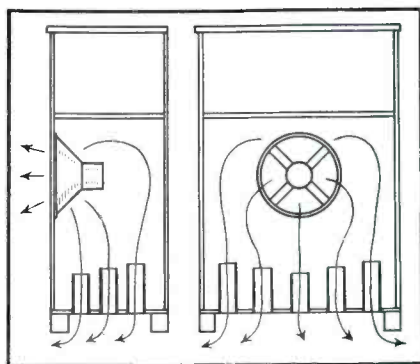

Fig. 8. The Magic Voice is also a cross between the infinite baffle and the acoustic labyrinth.

and the length of the tube is made great enough so that it will either resonate at the lower edge of the response range of the speaker or below the response range entirely. With a tube a half wavelength long at the lowest frequency it is desired to reproduce, sound at this frequency emerges from the tube in phase with the front radiation and thus re-inforces the bass notes to some extent. The actual increase in radiation from the rear is, however, of questionable value, as will be explained later. The real efficacy of the labyrinth lies in its excellent baffling action, which can be easily made equal in effectiveness to that of a flat baffle 12 or 15 feet square, without exceeding conventional cabinet size. Because the labyrinth does not build up high back pressures in the tube, there is little need for structural rigidity in the labyrinth itself, with the obvious result that very economical designs are possible.

• • • infinite baffle

The next high fidelity enclosure to appear was the infinite baffle cabinet. (Fig. 6.) This is perhaps the simplest device of all in both principle and construction. For a long time it had been considered very poor practice to completely enclose the rear of a cone speaker. Cabinets were always designed with either completely open backs or with some kind of air release, to avoid cabinet resonance and to prevent the building of appreciable pressure within the cabinet at high amplitudes of the cone. More recent investigation disclosed that if the cabinet were made large enough so that its natural period would fall below or at the lower edge of the response range of the speaker and if the walls are thickly lined with some highly absorbent material such as hair felt, that the performance was practically equivalent to a flat baffle of infinite extent; hence the name infinite baffle.

Such a baffle is very easy to construct since it merely consists of a solidly constructed box with well braced walls so

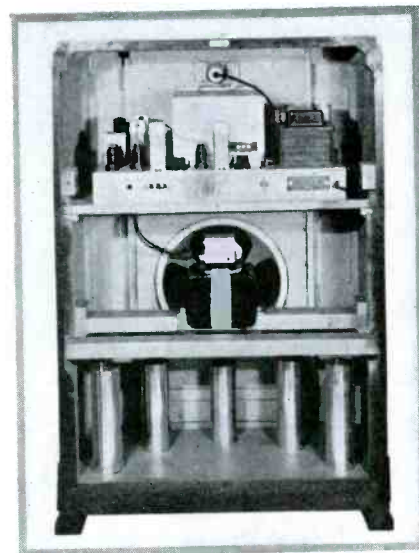

The RCA Magic Voice.

that there will be no tendency to vibration, the whole lined with felt about 1/2-in. thick. If the felt is not easily procurable, the very popular felt rug cushion of the "Ozite" type will serve admirably. The minimum size of the cabinet will depend somewhat upon the size of the speaker cone. For a 12- or 13-in., the interior should have a volume at least 8 cubic feet. If the walls are well padded against resonance, shape is not important; thus the above enclosure could be a cube 2 feet on a side, an oblong box 2 by 3 by 1 1/2 ft., or a shallow box 3 by 3 ft. by 11 in., all of which would give approximately the same results. Eighteen-inch cones, due to greater air displacement and somewhat better bass response, would require about 50 percent greater enclosed volume for optimum results but would deliver quite satisfactory performance even in the 8 cubic foot enclosure if not operated at too high volume levels. Ten-inch and smaller cones of course may be operated in correspondingly smaller cabinets with equivalent baffling action.

(Continued on page 354)

Fig. 6. An infinite baffle is perhaps the simplest baffle device both in theory and construction.

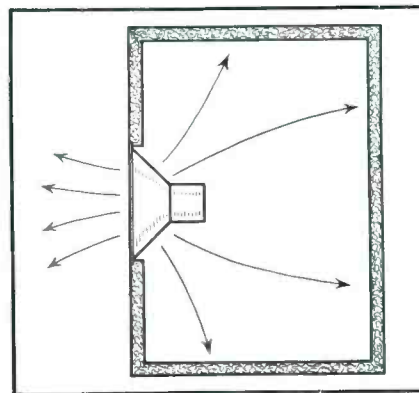

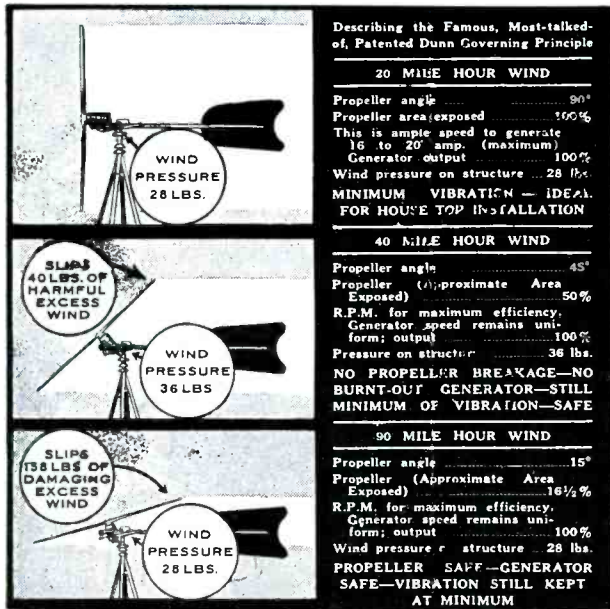

WIND CHARGERS

By JOHN H. POTTS

Fig. 2a. When the wind velocity is greater than twenty miles per hour, the speed at which the propeller turns must be limited to prevent overloading of the generator. The Parris-Dunn charger is mounted in a cradle which is arranged to tip backwards when the pressure is too great.

haps a few 25-watt bulbs, depending upon the average wind velocity in the neighborhood, the character of the installation and the capacity of the storage batteries used. The large units are designed to handle greater power loads under the same conditions.

• • • **installation**

For satisfactory service, the average wind velocity in the district where the device is to be used should be at least eight miles per hour. As shown on the accompanying maps (Fig. 3) this velocity is attained in most sections of the country. When the average wind velocity is low, the ampere hour rating of the storage batteries should be adequate to give service for long periods of calm. In other sections, it is possible to get along with less battery capacity or use a heavier battery drain. In any case, the propeller should be mounted as high as possible so as to have an unobstructed sweep of the wind. A good rule is to install the propeller at least fifteen feet higher than any wind obstructions within 400 feet. It is often found that an additional ten or fifteen feet in height will almost double the generator output when the wind velocity is low.

• • • **wire size**

The tower preferably should be located on a barn provided it is close to

HARNESSING the wind to generate electric power enables thousands of farmers throughout the accompanying maps (Fig. 3) this velocity-free operation of their radios. While the number of wind-operated battery chargers sold for this purpose has increased considerably during the past few years, there are still many dealers and Service Men in rural districts who are unfamiliar with this apparatus and thus pass over opportunities for profitable sales. Some idea of the extent of the market for such equipment may be gathered from the fact that less than 18 percent of the farm homes in this country are wired for electricity. Since there are approximately 6,800,000 such homes, this means that over five million of them are possible prospects for electric power generating plants. Most, but not all, are so situated that they can use wind-driven battery charging apparatus. For these, this method of generating electricity, when properly installed in a suitable location, has advantages in convenience, simplicity and economy of operation.

• • • **the generator**

A wind-driven battery charger consists essentially of a propeller fastened to the armature shaft of a d-c generator. This unit is mounted on a tower and installed well above all surrounding objects which might act as windbreakers. The output of the generator connects through an ammeter and cutout relay to a storage battery. The ammeter indicates the charging rate, which varies with the speed at which the propeller revolves. This in turn depends upon the wind velocity. When the wind speed is less than six miles per hour, the speed of the propeller revolutions is so low that the output voltage of the generator

becomes less than that of the battery; consequently it cannot charge the battery. Therefore the cutout relay is provided to disconnect the generator from the battery until the generator develops sufficient voltage to act as a charger. In a typical unit of this type, the generator develops this voltage and the relay closes when the propeller is turning at 350 rpm. This speed is reached when the wind velocity is approximately seven miles per hour. At higher wind velocities the charging rate increases, reaching a maximum at a wind velocity of approximately twenty miles per hour, as shown on the chart. (Fig. 1).

When the wind velocity is greater than twenty miles per hour, the speed at which the propeller turns is limited in various ways. This is necessary to prevent overheating of the generator. One way of doing this is to mount the generator in a cradle which is arranged to tip backward at various angles when the wind pressure is too high. This is illustrated in Fig. 2a. Other ways involve the use of extra propeller blade-governor (Fig. 2b), or braking mechanisms in the hub of the generator. A chain or other device is also employed to turn the propeller out of the wind when the battery is fully charged or during rain or sleet storms when the whirling propeller might be damaged by striking sleet. When the propeller is turning at 1000 rpm, as it usually does in strong winds, the propeller tips are traveling at the rate of 200 miles per hour so enormous force is exerted on anything it strikes.

Most wind chargers are designed to charge 6-volt storage batteries, though elaborate 32-volt and 110-volt charges are likewise available. The small units are suitable for radio operation and per-

Fig. 1. The charging rate of the average wind electric charger increases proportionately with the wind velocity until that velocity reaches approximately twenty miles per hour. At this point the governing action holds the rate constant.

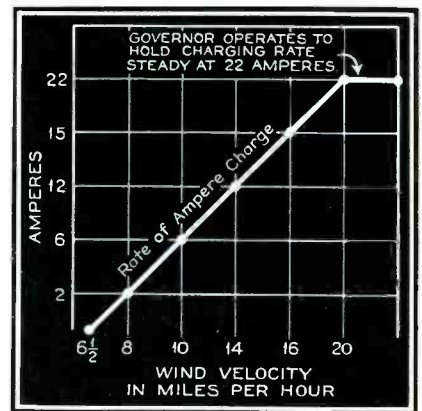

THEY'RE
DESIGNED
FOR THE
SERVICE
MAN!

THEY'RE
ENGINEERED
FOR THE
SERVICE
MAN!

THEY'RE
MANUFACTURED
FOR THE
SERVICE
MAN!

THEY'RE
PRICED
FOR THE
SERVICE
MAN!



Cunningham Radio Tubes **ARE THE SERVICE MAN'S SPECIAL!**

Cunningham Radio Tubes have enjoyed outstanding public acceptance for 24 years...are tubes that will help service men make more money! Ask your Cunningham Distributor why.

Over 95 million Cunningham Radio Tubes have been sold for replacement service work.

Trademark "Cunningham" Reg. U. S. Pat. Off. by RCA Mfg. Co., Inc.

Cunningham Radio Tubes

STANDARD SINCE 1915

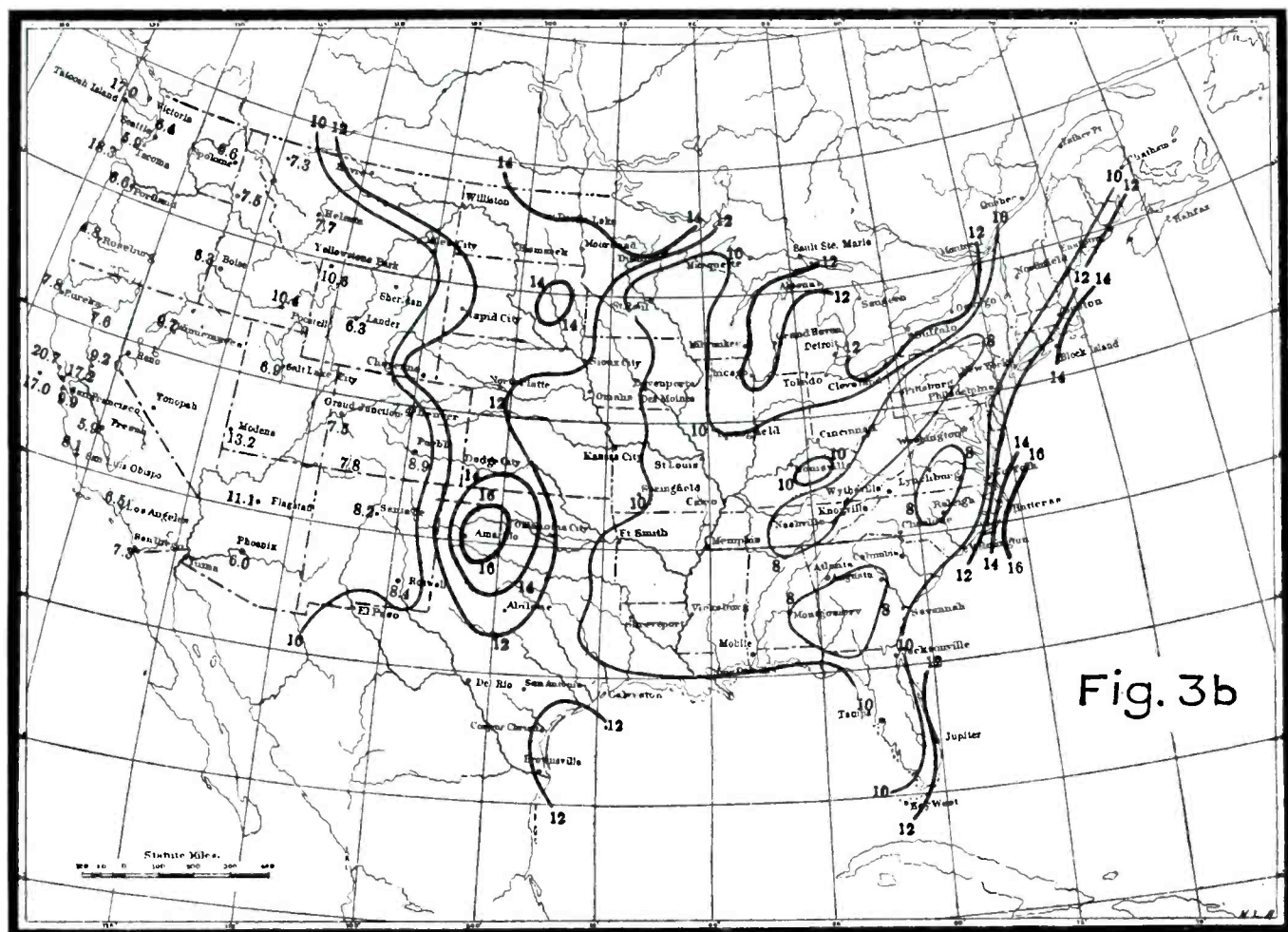
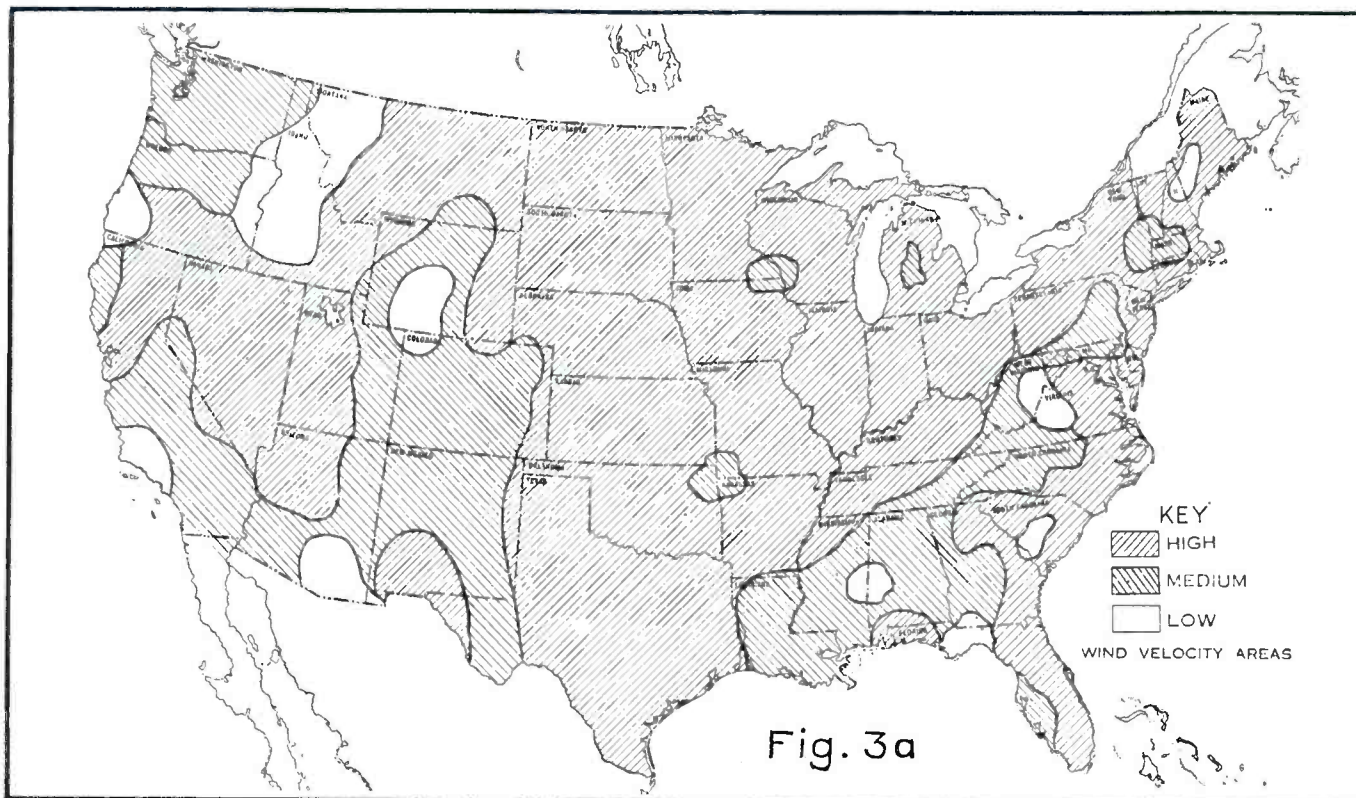

Average hourly velocity of the wind, daylight hours, 6 a. m. to 6 p. m., local standard time.
 Estimated for elevation of 100 feet.

OVER A MILLION BENDS

Without Conductor Breakage!

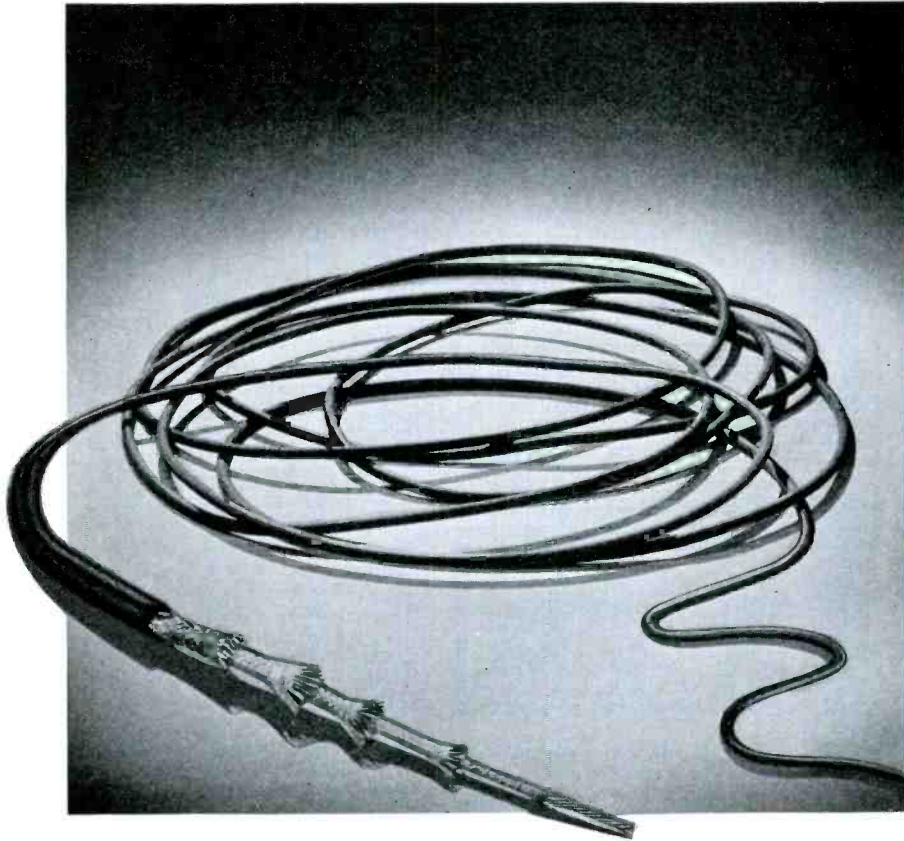

New **LENZ** Superflexible

MICROPHONE CABLE
*for Velocity, Crystal and
 Dynamic Mikes...*

- Conductor of Super Flexible Construction and great mechanical strength.
- Close tinned copper electrostatic shield.
- Non-Hygroscopic, high dielectric insulation.
- Tough, wear-resisting, rubber jacket.

LENZ ELECTRIC MANUFACTURING CO.
 1751 NO. WESTERN AVE. CHICAGO, U. S. A.



"IN BUSINESS SINCE 1904"

SEE YOUR
 NEAREST
 DISTRIBUTOR
 FOR FURTHER
 DETAILS

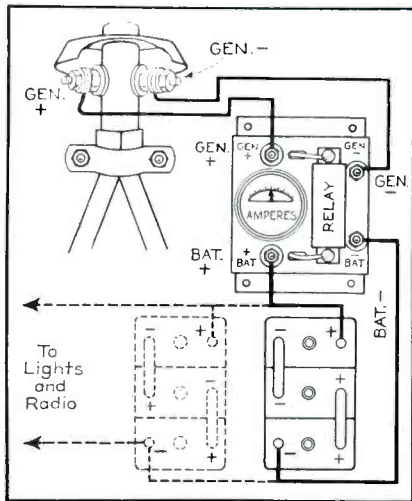

Fig. 4. Batteries should be installed as closely as practical to the generator and should be connected thereto with heavy wires to keep the resistance to a minimum.

the farm home. If not, the tower may be near the edge of the roof of the home, insulating the base with rubber or inner tube casings from tires to prevent rumble being transmitted to the dwelling.

Batteries should be installed as closely as practical to the generator in order to keep the resistance of the wires from the generator to a minimum. Heavy wire should be used, for the same purpose. This applies not only to the leads to the batteries, but also those to the radio and any lights which may be in the circuit. A table of recommended wire sizes is given below:

Distance from Charger to Battery	Wire Size
Less than 50 ft.	No. 8
50-100 ft.	No. 6
100-200 ft.	No. 4
200-300 ft.	No. 2

Only insulated weather-proof copper wire should be used. All joints should be spliced and soldered, then taped to avoid shorts.

A typical setup for charging is shown in Fig. 4. The batteries should preferably be of the glass-jar farm lighting type with a rated capacity of at least 160 ampere hours. In regions where the average wind velocity is low, it is desirable to use batteries having an ampere-hour rating of from 250-450. Two or more of lower rating may be connected together in parallel to provide the desired capacity.

The number of hours that the batteries will furnish satisfactory service without recharging may be determined by dividing 75 percent of the ampere-hour rating by the estimated drain. For a 160 ampere-hour battery operating on a 4-ampere drain, this amounts to 30 hours service. The average home radio of the 6-volt type draws about 2 to 3

amps per hour while a 25-watt bulb draws 4 amps. It is customary to provide sufficient battery capacity to operate the equipment over a period of ten days for the average number of hours per day it is normally used.

Prices for wind-operated 6-volt generators, complete with a tower, but not including wiring, batteries and accessories are low, ranging from \$13.50 up, net to Service Men. Complete installations can be made at a cost well within the means of a large majority of farmers and have proved outstandingly successful when properly installed. They require practically no attention, most generators having grease sealed ball bearings which do not have to be oiled during their entire life. The storage batteries require only the normal attention given an automobile battery.

Manufacturers of six-volt wind-driven generators are: Parris-Dunn Corporation, Clarinda, Iowa; Wincharger Corporation, Sioux City, Iowa; and Ruralite Engineering Co., Sioux City, Iowa. Manufacturers of 32-volt and 110-volt types are: Wincharger Corporation, Sioux City, Iowa; Ruralite Engineering Co., Sioux City, Iowa; Wind-impeller Electric Works, Ells-

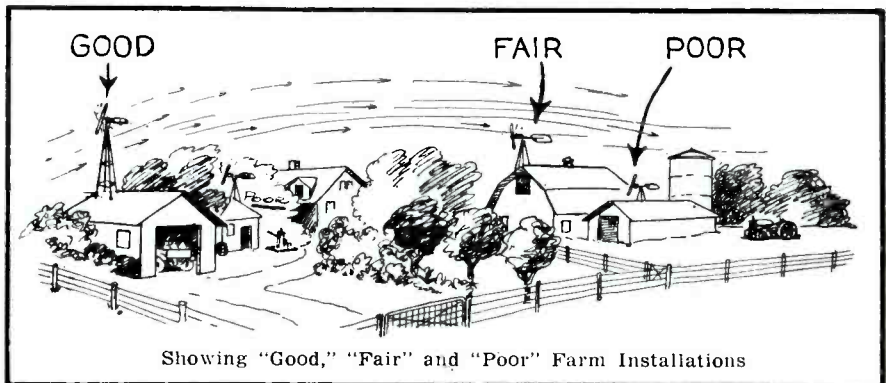

Fig. 2b. The Wincharger uses an extra blade-governor to control the unit when the wind pressure becomes too great.

worth, Iowa; and Breez-Electric Corporation, Chicago, Ill.

Much of the data upon which this article is based have been kindly supplied by the manufacturers listed above.

The arrows indicate the path of the wind as it is deflected up over the buildings and trees. The wind below and immediately above the level of these obstructions has little dependable power and a charger installed on a level with them cannot give good service.



Showing "Good," "Fair" and "Poor" Farm Installations

Electric tuning operation unsatisfactory: This receiver employs push-button tuning with the buttons referred to by the manufacturer as "piano keyboard type." This keyboard is in the top, front edge of the cabinet, held in place by wood screws that go through rubber grommets and the metal ends of the keyboard switch assembly. It will very often be found that at the factory the assembly was put into a position that prevents the buttons from working without sticking or rubbing against the cabinet. The wood screws should not be in too tight, or the purpose of the rubber grommets will be defeated. If a button works better when, after it has been pressed, it is pried up slightly with the finger nail or a screwdriver it is probably because there is a loose contact in the switch assembly. Take out the unit, observe the action of the other switches, then proceed to make any necessary adjustment on the faulty button switch.

If the receiver is said by the customer to work at times but not on some occasions check the off contact on the rear of the tuning condenser. When the dial pointer gets to about 600 kc, depending upon the individual receiver, the off-contact may stick and jam the system so that the motor stalls and hums or burns up if nothing is done to remedy the condition. Dial the receiver manually, if it is not jammed too much, and turn it to the point on the dial specified. It will be seen that when the off contact reaches an open or break in the contactor ring the receiver is shut off. If this off contact is jammed, it will not be possible to start the set, or drive motor, even when using the scan switch on the front of the set controls. Pry up the button contact slightly—not too much—relieving some of the excessive pressure. The set should then operate in a satisfactory manner. If the motor seems to be too highly loaded for smooth, quiet operation, check the large bakelite wheel on the rear of the tuning condenser which is a part of the contact assembly. It should not be too far forward on the shaft on which it is mounted. The hub of this bakelite wheel is of metal, with two screws set into it. Loosen these screws, move the wheel into proper position and retighten the screws. There is a brake adjustment at the front of the chassis which consists of a vertical machine screw with locknut attached for controlling the speed of rotation and tendency of the bakelite wheel already mentioned to overshoot the particular button contact in use at any given moment. This machine screw bears down on a metal brake with a felt underside that acts as a pressure load on the drive system, to reduce speed. If it is too tight, trouble from stalling will result. Willard Moody.

CAN YOU SEE Your Trouble?

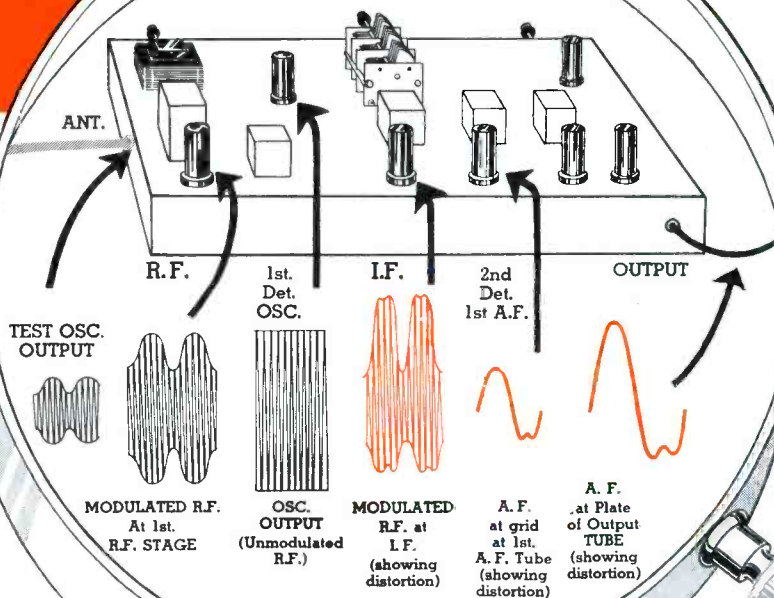

SUPREME 560 VEDOLYZER

A radically new and basically different Dynamic Test Instrument. Uses High Frequency 3" Scope with standard controls; wide range, high gain, television, video, vertical scope amplifier; multi-range, multi-function, push-button controlled, vacuum tube A.C., D.C., ohm and megohmmeter, and super-sensitive R.F. voltmeter; Broadcast, I.F. and Oscillator variable tuning section; push-button controlled multi-probe input circuit for checking intermittents.

561 SIGNAL GENERATOR

Includes (1) sinusoidal A.F. wave output from 15 to 15,000 cycles, (2) unmodulated R.F. from 65 K.C. to 20.5 M.C. on fundamentals and above 60 M.C. on harmonics, (3) variable audio modulated R.F. signal using internal 15-15,000 cycle audio oscillator, (4) metered, variable percentage of modulation control from 0 to 75%, (5) Frequency modulated oscillator for visual alignment and A.F.C. adjustments, (6) R.F. can be externally modulated. Continuously variable A.F. and R.F. controls on 6" illuminated dials. 1/2 to 1% accuracy on R.F. Less than 5% harmonic distortion on A.F.



Don't buy any instrument until you have the complete story on this new SUPREME equipment. Write today for literature.

SUPREME

SUPREME INSTRUMENTS CORP.
GREENWOOD, MISSISSIPPI, U. S. A.

WHY not get an "X-Ray" of what is happening in your receiver from Antenna post to speaker? Why not get a picture of the actual signal as it travels through your set by putting it under the magnifying power of the SUPREME VEDOLYZER? It is easy to use, rapid and efficient, because it is the **ONLY DYNAMIC TEST SYSTEM** that lets you **SEE THE SIGNAL** any place in every receiver! In this picture you see the 561 Signal Generator feeding an audio modulated signal into the receiver's input. By easy rapid use of the Vedolyzer, the actual signal in each stage is seen and studied.

EXPORT DEPT., Associated Exporters Co., 145 W. 45th Street, New York
Cable Address: LOPREH, N. Y.

FREQUENCY MODULATION

By J. SNIVAS

THE diagram on the front cover shows the i-f amplifier, limiter and detector of the G. E. Model GM125 receiver. This set is designed especially for the reception of frequency-modulated signals. Frequency modulation was introduced by Major Armstrong several years ago, and since that time it has been successfully demonstrated that transmissions of this type enable higher signal-to-noise ratios than are possible with present day amplitude modulation.

To understand the operation of the G. E. receiver the difference between a frequency-modulated signal and an amplitude-modulated signal must be kept in mind. In the latter type of modulation the amplitude of the carrier is varied in accordance with the modulation. The amplitude of a frequency-modulated carrier, however, is kept constant and modulation is effected at the transmitter by causing the frequency of the carrier to vary in direct proportion to the modulation.

As a simple illustration, an amplitude-modulated transmitter might radiate a steady carrier wave of say five amperes antenna current during the periods when there is no modulation. This antenna current, however, would vary between zero and ten amperes at a rate of 1,024 times per second if high C, as a pure tone, were played loud enough to give 100 per cent modulation.

If this same transmitter were using a frequency-modulated carrier instead of an amplitude-modulated one, it would continue to radiate the full-five-amperes antenna current regardless of the rate or amount of the modulation. However, if its normal carrier frequency were 42,800 kc, this would be varied approximately between 42,740 kc and 42,860 kc at a rate of 1,024 times per second in transmitting high C at 100 per cent modulation.

Because of this difference there are certain variations in the design of receivers which respond to these two types of signals. These are shown in the cover diagram.

In general the deviation in frequency from the carrier is of the order of plus or minus 100 kc. The r-f and i-f amplifier of a receiver designed for fre-

quency-modulated signals, must therefore be sufficiently broad to pass a band of frequencies within a range of approximately 100 kc on either side of a carrier frequency. The circuits of the G. E. GM125 are adjusted for a rated band width of 300 kc which is more than sufficient to cover the present requirements.

The r-f mixer circuits (not shown on the cover diagram) are similar to those used in a conventional short wave receiver of the same frequency range. Since the carrier frequency is high in comparison with the variation in frequency of the carrier (the tuning range of the receiver is from 37 to 44 megacycles) there is no frequency discrimination in these circuits and all the components in the signal are amplified equally. However, in order to obtain the required band pass, a comparatively high i-f peak (3000 kc) is used. To further reduce frequency discrimination, the primary winding of each of the i-f transformers is shunted with a 15,000-ohm resistor. The first three i-f stages are otherwise conventional in design and require no comment.

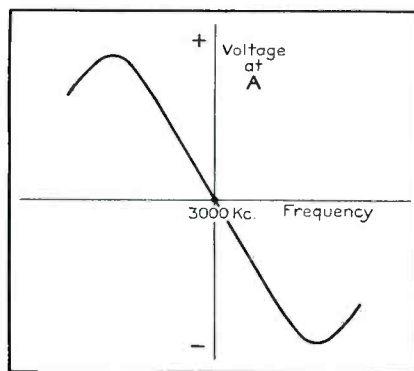

The procedure used in aligning the discriminator and i-f amplifier is not unlike that for aligning receivers equipped with afc. The type of characteristic which is obtained as the frequency of the signal generator is varied on either side of the i-f peak is shown.

The fourth i-f stage is arranged to function as a limiter stage, so as to provide a signal of constant amplitude (but varying frequency) at the input to the discriminator. The discriminator in turn converts the frequency variations

of the carrier into the original audio signal. The limiting action is effected by using a sharp cut-off tube, a 6SJ7, and operating it at zero bias and with only 65 volts on the plate and screen. As a result of these operating conditions the signal develops a rectified grid voltage across the 330,000-ohm resistor, R_1 . This negative voltage is used to provide an automatic bias control voltage at the r-f converter, first i-f and second i-f grids. In addition, the action of the 6SJ7 as a result of the negative voltage across R_1 functions to limit the output voltage of this stage.

The constant amplitude signal obtained at the output of the fourth i-f or limiter stage is applied to the detector or discriminator stage. As can be seen from the diagram this detector, which is essentially a frequency discriminator, bears a great resemblance to the circuits which have been used in receivers employing automatic frequency control. Essentially the detector converts the variations in frequency into variations in amplitude at point A. Since the modulation at the transmitter varies the frequency of the signal carrier in accordance with the modulation and since the output of the discriminator at A is proportional to the frequency of the carrier, it is apparent that the output of the discriminator will reproduce the original modulation.

The audio and power supply circuits of this receiver are not shown in the schematic since they are conventional and do not differ from the circuits used in present day receivers.

To obtain the quality reproduction of which receivers for handling frequency-modulated signals are capable, it is essential that the discriminator and i-f amplifier be accurately aligned. The procedure used is not unlike that for aligning receivers equipped with automatic frequency control. It is desirable that one stage at a time be aligned starting from the last i-f stage. The adjustment of C_1 and C_2 is especially important since these adjustments control the shape of the discriminator characteristic. When C_1 is adjusted properly, the output voltage at A will be zero at the intermediate frequency of 3000 kc; when C_2 is adjusted properly, the characteristic will be uniformly straight for approximately the same distance on either side of the zero voltage axis. The adjustment of C_1 is especially critical and should be very carefully made. The type of characteristic which is obtained as the frequency of the generator is varied on either side of the i-f peak is shown in the accompanying illustration. Note that the vertical reading is that which would be obtained by a high resistance voltmeter connected at point A.

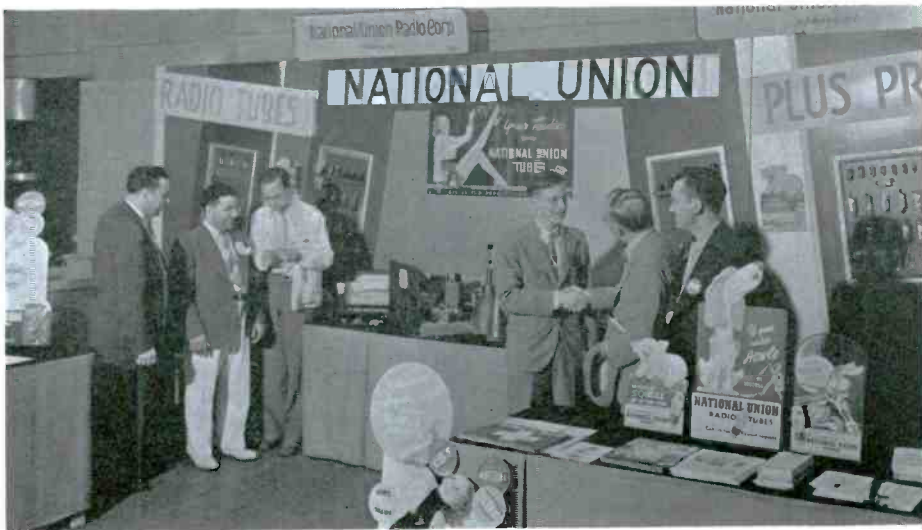

An atmosphere of good humor pervades the National Union booth at the Chicago Trade Show. Left to right are J. J. McBride, N. U. district manager; Joseph Demambro, Boston distributor; G. Ed. De-Nike, advertising manager; a Service Man; Billy Hendrickson, New England district manager, and Joe Clancy, N. U. Chicago salesman.



Albert Kahn (left) of Electro-Voice discusses microphones with a Service Man at the Chicago Trade Show.



(Left) Sam Poncher, Chicago jobber, chats with I. A. Mitchell of United Transformer Corporation.

(Right) Ed. Hughes (facing camera) of RCA invites a local Service Man to the RCA television demonstration.



(Left) W. F. Marsh of Meissner watches activities from the Meissner booth.

(Right) Sam Poncher, Chicago jobber, absorbs more information. This time his source is Murray Menzer (pointing) of Precision.



(Below) The annual get-together of the entire Thordarson sales group, presided over by W. S. Hartford, new sales chief, was held at the Stevens Hotel just before the show.

(Below) Henry Teplitz, Teplitz Advertising Agency, poses with Gene Berman of Shure Brothers.





Let the Thermometer
Boil and Bubble . . . or
Let It Rain and Pour !

P. R. MALLORY & CO., Inc.
MALLORY

**REPLACEMENT
CONDENSERS**
are **Heat-Proof**
and **Moisture-Proof**

Whether it's warm and sticky, or dry and hot . . . the performance of Mallory Condensers is unaffected. Mallory provides a heavy metal seal around the actual condenser unit inside the carton. Heat and humidity simply cannot change its characteristics.

This is just *one* point of superiority on which the leadership of Mallory Replacement Condensers has been built. The millions in use . . . both in replacement, and as original equipment testify to their many other points of superiority. Mallory Replacement Condensers cost no more . . . so why not insist on the best.

Use
MALLORY
P. R. MALLORY & CO., Inc.
REPLACEMENT
CONDENSERS . . . VIBRATORS

P. R. MALLORY & CO., Inc.
INDIANAPOLIS INDIANA
Cable Address—PELMALLO

Use
YAXLEY
REPLACEMENT
VOLUME CONTROLS

Signal Tracing in DIODE DETECTORS

By JOHN F. RIDER

PUBLISHER

THE average Service Man appreciates the fact that the various tubes in the receiver system are associated with the signal, but if you examine the usual service literature you will find that the general discussion of vacuum tubes is along the lines of certain specific static tests associated with operating voltages and a few dynamic tests such as emission and mutual conductance. All of these are made upon the tube external to its location in the receiver.

It is our belief that this is wrong, in that a test of a tube in a receiver is a routine part of the service test. However, to be able to make such tests it is imperative that you be familiar with where signals appear in the various tube circuits and how these signals, present or absent at certain places, can be employed to interpret the defective state existent in the system. In this article we consider the simplest of these tubes in structure. In reading this article you will note that we dwell but lightly upon the theory of the tube. Where theory is involved we speak of it in terms of the signal.

The simplest vacuum tube, yet a very commonly used tube is the two element tube known as the diode. This, consisting of an electron emitter and an anode or plate, does not utilize a control grid and is therefore incapable of amplification and hence finds general application as a detector or rectifier of alternating voltages. In this connection the terms "rectifier" and "detector" are used interchangeably, both being intended to signify the same function. In general it is possible to divide the two element or diode type tubes into two major classifications, namely, those used as power rectifiers in power-supply systems and those used as rectifiers or detectors of signal voltages in other places within the complete receiver. The power rectifier type of diode will be omitted in whatever discussion follows in the balance of this article.

The elementary operation of the diode is simple to comprehend. The tube is possessed of asymmetrical conduction properties, which means that it conducts current better in one direction than in another. Theoretically, that is,

*Abstracted from the book "Servicing by Signal Tracing," by John F. Rider, to be published shortly.

from the ideal viewpoint, the tube conducts current only in one direction. Thus, when the plate or anode is positive with respect to the cathode, electrons emitted by the cathode are attracted to the plate and current flows

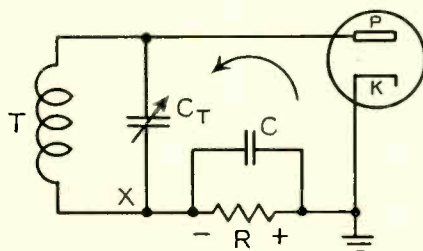

Fig. 1. In the diode rectifier circuit of a conventional superheterodyne an alternating voltage exists across the tuned transformer circuit during normal operation.

in the tube. On the other hand, if the plate becomes negative with respect to the cathode, the emitted electrons are repelled by the plate and there is no current flow through the tube. If the plate is alternately made positive and negative as the result of an alternating voltage applied to the tube, we find this alternating voltage is converted into a series of direct current pulses. Let us now examine a typical diode rectifier circuit and investigate the many items which are of interest to us.

Fig. 1 is a conventional diode rectifier circuit such as would be identified as a second detector circuit in a standard superheterodyne. T and C_T comprise a tuned transformer circuit, across which we shall assume the existence of an alternating voltage. This alternating

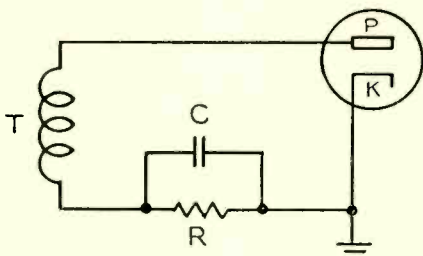

Fig. 6. In many instances the winding which feeds the diode is untuned.

voltage is a signal voltage, of say 470 kc and shall be referred to as the i-f signal. P is the plate and K is the cathode of the diode. One end of the tuned circuit, the high end is connected to the plate and the other end of the tuned

circuit is connected to the cathode of the diode via a load resistance R, which is shunted by the by-pass condenser C. The cathode of the diode is assumed connected to ground as shown.

What happens in this circuit? When an alternating voltage exists across the tuned circuit, the two ends of the circuit are alternately negative and positive. When the top end of the transformer is positive, the plate P of the diode is positive and electrons flow through the circuit in the direction shown by the curved arrow. For example, if the i-f signal voltage across the transformer winding is a modulated voltage like that shown in Fig. 2, wherein the carrier alternations above the zero line are assumed to be positive and those below the zero line are assumed to be negative, current flows through the diode circuit during the time that the plate is positive with respect to the cathode and rectification of this modulated carrier takes place. We say that rectification has taken place because the alternating voltage has been converted into a series of d-c pulses, which, for the sake of simplicity and since this is but a qualitative analysis, we can say is d-c which varies between certain maximum and minimum limits in accordance with the modulation of the carrier. You will note in Fig. 3 that the variation in instantaneous magnitude of the direct current is in accordance with the wave shape of the modulation component of the modulated i-f carrier shown in Fig. 2.

When the rectified current flows through the circuit of Fig. 1 it develops a d-c voltage across R. We speak in terms of a steady d-c voltage across the load resistance, although we know that this voltage is pulsating. The second significant detail relating to the rectified current is that it is proportional to the carrier intensity and not the modulation. This is so because the average value of a carrier is the same whether it is modulated or unmodulated, as shown in Figs. 4 and 5.

A third important item relates to the diode-load circuit consisting of the resistance R and the capacity C. This capacity C is of importance in many ways, but two facts are of special interest to us. These are: one, that this capacity provides a low reactance path across the load resistance R so that the maximum input i-f alternating voltage can be applied to the diode, thereby securing the maximum value of rectified current; and two: the value of the capacity C cannot be so great as to interfere with the performance of the circuit upon the modulation component of the rectified current. This is particularly true when the modulation

component embraces the higher audio frequencies.

A fourth general item of importance also associated with R and C in Fig. 1, is that since there are certain limitations imposed upon the value of C, perfect operating conditions cannot be achieved. This means that perfect by-passing of R is impossible and hence a certain input signal voltage drop takes place across RC. Since the reactance of C is very much less than the resistance of R, we can say that the signal voltage drop across the lead circuit is the drop across the reactance of C. Therefore, in the example cited, we can say that a 470 kc signal is available across RC. The exact magnitude of this voltage drop is a variable depending upon the constants of the circuit, but the important consideration is that it is present.

A fifth topic justifying mention is that the rectified current is in the form of pulses which occur at a rate equal to the frequency of the input signal voltage, in this case 470 kc, hence the rectified current contains an input signal frequency component. (This reference to a specific frequency of 470 kc is purely illustrative. If the input signal across the transformer had a frequency of 20 meg., the rectified current would then have a component of 20 meg.). At the same time, this rectified current, as a result of the process of rectification, also contains components whose frequencies are harmonics of the input signal frequency.

A sixth item relates to the polarity of the voltage developed across the load resistance R. As the consequence of the direction of the current flow, the cathode, although the source of the electrons, is positive with respect to the plate when the tube is rectifying and the plate end of the load resistor is negative with respect to the cathode end.

• • • other arrangements

While it is true that the diode circuit

Fig. 9. The a-c component of the rectified current becomes the audio signal and is usually fed to the audio tube as shown below.

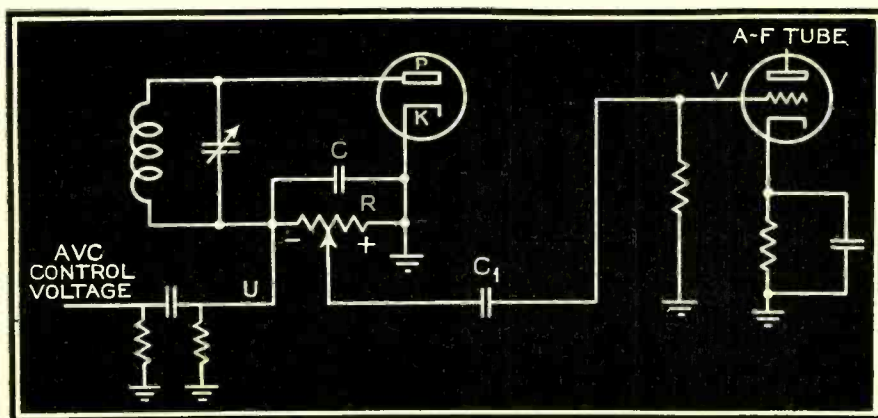

shown in Fig. 1 is not the only possible arrangement, we can discuss the subject using this circuit as our example, because what we say here will, in general, be found applicable to other types of circuit structure.

It is evident that the frequency of the input signal voltage across the transformer is of no consequence. It can just as readily be an audio frequency as an ultra-high frequency. It is only important to realize that during the process of signal tracing, variations in the frequency of the input signal voltage do not in any way influence the general operating details of the system. In the majority of old receivers where the diode rectifier is used as a second detector, the frequency of the i-f input signal voltage does not exceed 1000 kc but there is a tendency towards an increase in the frequency of this i-f voltage in some of the newer communication receivers. In television receivers this frequency is in the megacycle range. As to the application of the signal voltage, there is no rigid requirement that this input signal voltage must be secured from a tuned transformer. In many instances the winding which

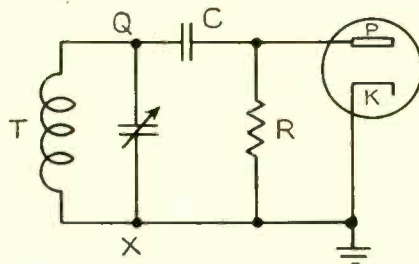

Fig. 7. In the second detector of some superheterodynes and in t-r-fs the load resistor is connected in shunt with the tube and the signal input circuit.

feeds the diode is untuned as shown in Fig. 6. This winding T in Fig. 6 may be the tertiary winding of a tuned i-f transformer.

Since proper operation of the diode requires that the input signal voltage

be available, there are certain places where the input signal can be checked in a diode circuit. One of these is the anode or plate P as shown in Fig. 1. The signal is checked at this point at the rated frequency of the input signal voltage. However, the presence of a signal at the diode anode does not necessarily mean that the signal is being properly applied to the diode, because the winding which supplies the signal to the diode also has a low or return connection, in this case the point X in Fig. 1, the junction between the input transformer and the load circuit RC.

Checking at the low end of the tuned circuit we can experience a number of different conditions. If, by chance, the tuned circuit is not connected to the load circuit, the signal at the low end of the tuned transformer will be almost as great as at the high end which joins the diode anode.

If, however, the transformer is correctly connected to the load circuit, the signal at X will depend upon a number of different circuit conditions. If C were sufficiently high so as to afford perfect by-passing of the load resistor R, then point X would be at ground potential with respect to the signal voltage, because the cathode K is shown connected to ground. Therefore the signal at X would be extremely small, depending upon the reactance of the capacity C at the signal frequency. However, in actual practice, this capacity does not offer zero reactance at the signal frequency, hence some value of signal will be found at X, although it is true that this signal will be much less than that available at the diode anode, P. The exact amount of signal, that is the relation between the signal level at P and at X differs in different receivers because of the values used for C. In the less expensive receivers economy is attained by employing large values of capacity for C, at least values greater than that which would be used in the more expensive receivers. As a general rule, the signal voltage at X for normal conditions, is but several percent of that prevailing at P. The better grade receivers C is smaller than in the cheaper receivers and voltage at X is higher. This is deliberate in order that the higher audio frequencies should not be reduced and because proper filtering is employed elsewhere to offset the higher value of signal voltage at X.

If on the other hand C is shorted, thereby shorting the load resistance R, virtually no signal will be available at X, because that point then is connected to the grounded cathode and therefore is at ground potential. Such a condition is, however, easily established by a simple d-c resistance test between X and ground or the cathode.

If C is open, the load resistor R is in the path of the signal voltage being applied to the tube and a high signal voltage drop will take place across R. Since such signal tests are usually made with respect to ground, the signal indicated at X is that representing the signal voltage drop across the load resistor.

As to the source of the signal voltage, that is, the transformer or winding which supplies this signal voltage, this must be intact as to circuit continuity in an untuned winding and both circuit continuity and resonance in a tuned winding. The presence of the proper signal at P indicates this condition, although the absence of a signal at P does not necessarily indicate a defect in the winding which supplies the signal voltage to the diode, because the circuit continuity between P and this winding may be imperfect.

The cathode K as a signal test point is not very satisfactory because it is grounded. However, if a signal does prevail at this point and this cathode is supposed to be grounded as shown in Fig. 1, it is an indication of either the absence of the ground connection or of an imperfect or high resistance connection to ground.

The conditions mentioned with respect to the signal will be found to be generally true irrespective of the type of diode circuit used or the application of the system. For example Fig. 7 shows another type of diode circuit employed in the second detector of a superheterodyne receiver and even in some t-r-f systems. In this system the load resistor R is connected in shunt with the tube and the signal input circuit, whereas in Fig. 1, the load circuit is in series with the tuned circuit and the tube.

The diode plate P (Fig. 7) still remains a signal test point, although another test point is Q, in the event that the signal does not appear at P. A signal test at X is possible only if the cathode K is disconnected from ground, although if a signal does appear at this point and cathode is supposedly connected to ground, it indicates either an open between X and the cathode, or that the cathode connection to ground is open or has an appreciable value of d-c resistance. In the circuit of Fig. 7 the signal voltage across R is greater than in Fig. 1.

Circuits such as shown in Figs. 1 and 7, generally are used as signal voltage detectors, although in some cases, Fig. 1, rather than Fig. 7 will also combine the function of producing the avc voltage. Of course, the diode circuits which develop the avc voltage likewise operate upon the signal and signal tests are like those already mentioned.

In some instances, the signal fre-

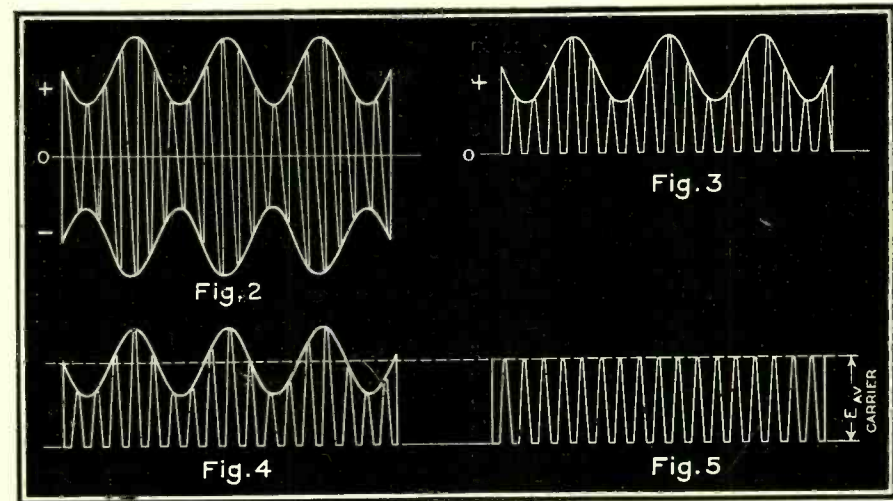

The variation in instantaneous magnitude of the d-c (Fig. 3) is in accordance with the wave shape of the modulation component of the modulated i-f carrier shown in Fig. 2. The average value of the carrier is the same whether it is modulated or unmodulated as shown in Figs. 4 and 5.

quency is within the audio range, in which case signal tests would be made at audio frequencies.

• • • d-c and control voltage

Let us again refer back to the same items we discussed earlier in this chapter as having great significance. The

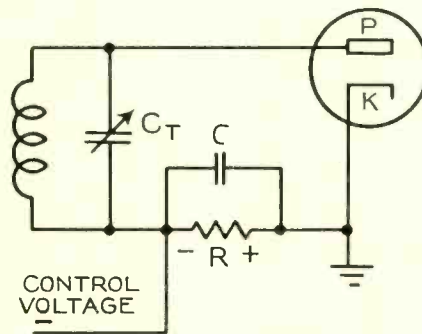

Fig. 8. Any point along R is negative with respect to the cathode.

first of these was the rectified current flow through the entire circuit of the system shown in Fig. 1. When rectification takes place, power is dissipated across the load circuit and the tuned circuit must supply this power. Also, the conducting diode in series with the load are in shunt with the tuned circuit so that the net result is loading or damping of this circuit, thereby reducing its selectivity and the possible amplification obtainable in the coupling device which is connected to the input circuit of the diode. This is quite important in connection with the process of tracing signals in conventional superheterodyne circuits which employ diode second detectors and separate afc diodes. There is a material decrease in signal voltage as one advances from the output circuit of the tube ahead of the diode to the diode plate. This decrease

in signal voltage varies between from 2 to 3 times.

The passage of the rectified current through the load resistor develops a voltage drop across this resistor. The end of R joined to the source of signal voltage is negative, so that if the grounded cathode K is the reference point, all other points along the circuit are negative with respect to the cathode and this includes the plate of the diode. This plate, Fig. 8, is substantially at the same d-c potential as that end of the resistor R, which joins the signal transformer T-C.

Any point along R is negative with respect to the cathode and if the full rectified voltage is developed across R, then we can secure various values of d-c voltage by tapping off R at whatever point may be required. Since the theoretical basis of operation of the diode is such that the rectified current, and therefore the d-c voltage, across R is proportional to the carrier voltage, we have the means of securing the negative control voltage required for avc systems.

From the viewpoint of signal tracing, the action taking place in the diode circuit affords a means of checking the automatic volume control action in a receiver. This applies equally well to the receiver wherein the avc voltage is developed by the detector and to the receiver wherein the voltage is developed by a separate diode, in a dual type tube or by a separate diode tube.

• • • contact potential

With respect to the d-c voltage developed across the load resistance of a diode, it is necessary at this time to introduce a phenomenon which seems contrary to the original description of the manner in which a diode functions. We said that rectification occurs when the plate is made positive by the signal

voltage. This would seem to indicate that current flow did not take place in the tube until a signal was applied and then only when the plate was positive. Essentially, the latter is true, but the former is not.

By this we mean that a certain amount of current flow takes place through the tube without any signal input to the diode. This current flow is due to the fact that some of the electrons boiled off the cathode reach the plate despite the fact that the plate does not attract these electrons. The random velocities of the electrons at the time they are emitted from the cathode is sufficient to enable them to reach the plate and current flows through the tube. This means that a d-c voltage is built up across the diode load resistor and this voltage is known as "contact potential." It represents the minimum d-c voltage found across the load resistor in a diode circuit. In practice this voltage approximates from 0.2 to 1.0 volt, depending upon the condition of the diode and the value of the load resistance. The usual current flow under such conditions is about 1 microampere. This point concerning the "contact potential" is of interest in connection with the signal tracing process of servicing because one routine in this procedure is the measurement of the control voltage and, unless the aforementioned condition is recognized, the presence of a d-c voltage across the diode load without any signal, will prove extremely confusing.

It is of further interest in establishing the condition of the diode. Gas within the tube will result in a decided increase in the value of this no input signal d-c voltage across the diode load. Measurement of this contact potential must be made in such a manner that the circuit conditions are not disturbed. Such measurement can be made at the plate end of the diode load, because the d-c potential difference between the cathode and the plate end of the load resistor is substantially the same as the potential difference between the cathode and the plate. The d-c voltage drop across the winding of the transformer T in the input circuit of the diode, is very small.

• • • audio pulsations

When the input signal is modulated the rectified current contains an a-c component representing the modulation voltage. This a-c component of the rectified current becomes the audio signal and is usually fed to the audio tube as shown in Fig. 9. In this instance we assume that the load resistor R is a potentiometer. The condenser C₁ prevents the d-c voltage across the diode load from reaching the control grid of the audio tube. By moving the slid-

er of the potentiometer, various values of audio voltage are made available. The maximum value of audio voltage is secured when the slider is moved to the most negative point along the load resistor, for then the audio voltage developed across the entire load resistor is fed to the audio tube.

Recognizing that the same value of d-c voltage will prevail across the load resistor for a modulated and an unmodulated signal input, the character of this d-c voltage will, however, be different. When the input signal is modulated the d-c voltage across the diode load appears as shown in Fig. 10,

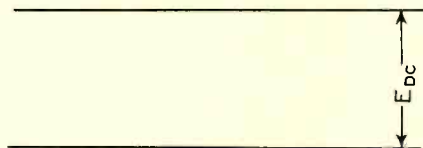

Fig. 11. For an unmodulated signal the d-c voltage across the diode load is as shown.

whereas for an unmodulated signal of the same carrier level, the equivalent d-c voltage will be like that shown in Fig. 11. Now the pulsating voltage as shown in Fig. 10 is that which prevails at point V in Fig. 9 and most certainly is unsuited for use as an a-c voltage. If such a pulsating control voltage were applied to an r-f or i-f amplifying tube, the amplification would vary at the audio rate and it would be the equivalent of applying an audio signal to the r-f and i-f tubes which are being controlled. This is, naturally, out of the question.

With this in mind, we note two paramount points. First is that filtering of the pulsating voltage across the diode load is necessary before that voltage

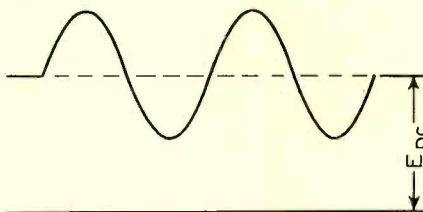

Fig. 10. When the input signal is modulated the d-c voltage across the diode is also modulated.

can be used as a control voltage. Second, that a signal test for such audio pulsations developed in the diode tube are possible in the a-c circuit. This is particularly necessary if some peculiar or fluctuating action seems to exist in the controlled tube circuits.

In practice, filtering of the control voltage is a definite fact. The usual receiver system employs a resistance capacity network of one or more sections to smooth out these audio pulsa-

tions and to deliver pure d-c to the points where the control voltage is to be applied. The various points along this control voltage supply circuit are the places where the audio pulsation test is made.

• • • carrier frequency pulsations

We stated that there existed across the diode load, a voltage at the input signal frequency. This voltage exists under normal conditions and consequently is present where the control voltage is taken off the circuit. In Fig. 9, it is a maximum at U, because this control voltage feed point is at the most negative point along the divider. The presence of the diode input signal voltage at some point ahead of that system is not desired for a number of reasons, all of which would impair the performance of the system, so that filtering of the control voltage is required. This is automatically accomplished by the filter system mentioned above which is employed to remove the audio pulsations. Since the audio pulsations are at a lower frequency, any arrangement which is effective at the audio frequencies to remove these signal voltages, will be more than effective at higher frequencies. The exception to this statement is the close proximity of the control voltage feed point U, Fig. 9, or a connection to this point to other portions of the receiver system. Such close proximity may result in coupling between the circuits and the introduction of this signal voltage into the circuits ahead of the diode. Thus various points along the control voltage circuit are subject to test for a signal voltage at the frequency of the signal voltage fed into the diode. Naturally, considering what has been said, these test points are at places along the control voltage feed circuit beyond the point U in Fig. 9.

Bearing in mind that the diode input signal voltage exists across the diode load and that a component of the rectified current has a frequency equal to that of the diode signal input, we must of necessity consider this signal voltage in connection with the audio pulsations present across the diode load resistor and fed to the audio system as the audio voltage. In other words, the circuit which feeds the audio voltage in the a-f amplifier also feeds a certain portion of the diode input signal voltage to the audio tube. Just what portion of the total input signal voltage present across C in Fig. 9 is fed to the a-f tube depends upon the position of the moving arm of the potentiometer R.

When the maximum a-f voltage is being fed to the a-f tube, the maximum diode signal voltage present across C also is being fed to the a-f tube. If

(Continued on page 350)

R-C FILTERS

PRACTICALLY every modern receiver has one or more resistance-capacity filters incorporated in its circuits. It is the purpose of this article to explain the action of these filters.

- • • fundamentals first

Before we tackle the explanation, how-

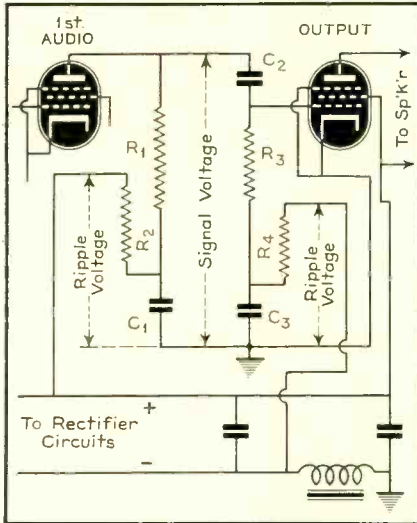

The R-C filters, R_2 , C_1 and R_4 , C_3 are used to keep most of the ripple voltage present in the plate and grid returns from the signal circuits. These filters are used effectively in practically every modern electronic device, radio receiver or power amplifier. In many cases they are the only type employed.

ever, let us refresh our memory on a few fundamentals.

A condenser offers a definite resistance to an a-c voltage which is called its capacitive reactance (X_c). The formula for this is

$$X_c = \frac{1}{2\pi f C}$$

where f is the frequency of the a-c applied to the condenser and C is the capacity in farads. Using this formula we find that a 0.25-mfd condenser has an impedance of 5,308 ohms to a 120-cycle a-c voltage (120 cycles is used because there will be 120 pulsations in the output of a full-wave rectifier working from a 60-cycle source). For simplicity let us call this impedance 5,000 ohms.

- • • grid return circuits

In the accompanying circuit the grid bias for the output stage is obtained from the d-c voltage drop across the speaker field or filter choke in the negative leg of the B power supply. In the grid circuit, beside the normal load resistor (R_3), there is another resistor (R_4) and condenser (C_3). These comprise the RC filter.

The voltage across the choke is not pure d-c but contains an a-c component, or ripple, which acts the same as an a-c voltage. If R_4 and C_3 were not in the circuit the total a-c ripple would be in series with the signal voltage and would be applied to the grid of the tube.

If we consider the condenser the same as a resistance (which it is to a-c) we see that the combination R_4 and C_3 is nothing more than a simple voltage divider. The

Hot off the Press....

THIS 56-PAGE CATALOG OF THE HOTTEST SOUND LINE IN HISTORY!



Here are the contents of this catalog

ACCESSORIES • AMPLIFIERS: Amplifier Units, Amplifier Cabinets (Metal), Cables for Amplifier Remote Controls, Input Transformer, Mixer and Mixer Pads, Panels for Amplifier Cabinet, Remote Control Devices, Signal Mixer Units • ANTENAPLEX (Multi-Wave) • ANTENAPLEX (Standard) • BAFFLES (see Loudspeakers) • COMPLETE SOUND SYSTEMS • CHIMES (Electric) • CONTROL CABINETS • HEARING AIDS • INTER-OFFICE COMMUNICATING SYSTEMS (Victor-Phones) • LOUDSPEAKERS: Baffles, Control Devices, Electro-Dynamic Speakers, Field Supply Units, Housings and Boxes, Matching Transformers, Permanent Field Speakers • MASTER CONTROL SYSTEMS (De Luxe) • MASTER CONTROL SYSTEMS (Junior), Typical Master Control Installations • MICROPHONES AND ACCESSORIES • MOBILE PUBLIC ADDRESS SYSTEM • PORTABLE PUBLIC ADDRESS SYSTEMS • PUBLIC ADDRESS SYSTEMS: Series Systems • RECORDING EQUIPMENT: Accessories, Recording Blanks • SOUND POWER TELEPHONES • TURNTABLES: Accessories and Records • VICTOR-PHONES • VOLUME CONTROLS • WIRE AND CABLE.

SEND FOR YOUR FREE COPY TODAY!



Get your free copy today from your RCA distributor, or mail this coupon.

Plan now to cash in on a huge market with

COMMERCIAL SOUND

RCA Mfg. Co., Inc., Camden, N. J.
A Service of Radio Corp. of America

Commercial Sound Section, Dept. VM-7
RCA Manufacturing Co., Inc.,
Camden, N. J.

Please send me my copy of the new
RCA Sound Equipment Catalog.

Name _____

Address _____

City _____

State _____

Any sound system sounds better equipped with RCA Radio Tubes

result is that only that small part of the ripple voltage which appears across the comparatively low resistance of the condenser is applied to the grid. For example, if R_4 has a value of 50,000 ohms and C_3 is 0.25 mfd, with a reactance of approximately 5,000 ohms, at 120 cycles, the ratio of ripple voltage applied to the grid compared to the total across the choke is 10 to 1. Increasing the capacity of the condenser or the value of the resistance would reduce the voltage applied to the grid still further.

- • • plate return circuits

In the B supply of the accompanying diagram a conventional brute force filter, consisting of a choke and two filter condensers, is used to smooth out most of the

a-c ripple. However, enough ripple may remain to cause hum in the speaker, especially if this ripple voltage is applied to the plate circuit of a tube which is followed by one or more high gain stages. The latter could easily amplify the ripple enough to make it audible in the speaker.

An RC filter can be used to advantage in series with the normal plate-load resistor. Here again the filter is nothing more than a voltage divider. If the value of resistor and condenser are the same as they were in the grid circuits the same ratio of hum reduction is obtained. Increasing the capacity of the condenser or the value of the resistance will again improve the filter action by reducing the amount of the drop in series with the signal circuit.

Alan S. Roberts.

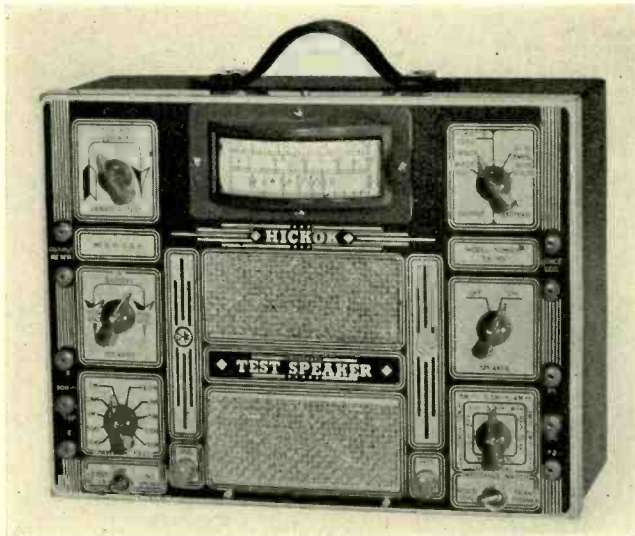

HICKOK TS50 TESTER

By **BRADLEY THOMPSON**
HICKOK ELECTRICAL INSTRUMENT CORP.

The Hickok Model TS50 tester is designed to incorporate many tests in a single instrument.

THERE is an excellent selection of test equipment on the market today designed to simplify the servicing of modern receivers. Much time and money have been well spent to develop the efficient circuits and the artistic appearance of modern service equipment. The improved design goes far to create a good first impression on your customers and the efficiency of the equipment helps to hold that impression. These good impressions help fill your cash register.

• • • features

The Hickok Model TS50 is designed to incorporate many tests in a single instrument. A three-range audio wattmeter can measure the receiver output in watts. The permanent magnet type dynamic speaker in conjunction with a multi-tapped transformer, to determine the proper output transformer ratio and the correct speaker impedance, and the filter choke with a variable resistance is available for use in place of the regular speaker. The resistance of the substitute field is calibrated in ohms and may be used to determine the field resistance of a speaker. An A battery circuit is provided for automotive and other battery operated radios. Included in this circuit is a suitable method of testing vibrators. A 15-volt, 15 amp d-c meter for automotive testing are also included. The above testers are combined in one medium sized case designed to harmonize with the rest of the test equipment in a modern service shop.

• • • output meter

Since most receiver and amplifier manufacturers give the output power in watts an output meter calibrated in watts is practical. A satisfactory method of measuring audio frequency power is by means of an a-c rectifier type voltmeter connected across a constant impedance circuit. Output transformers and speakers vary widely in impedance

so it is necessary to incorporate a matching circuit between the voltmeter and the output circuit. The diagram shows a matching transformer for this purpose. The speaker voice coil is connected through a rotary switch to a tapped voice coil winding on the matching transformer. The voice coil impedance will always be the same and can be matched to any output circuit by means of the matching transformer. If an a-c voltmeter of suitable range were connected directly across the voice coil it could be calibrated in watts. But the voltage across the voice coil is very low and rectifier type voltmeters of such a low range are not practical. It is therefore necessary to employ a potential transformer to step up the voice-coil voltage to a satisfactory value to operate the voltmeter. This can be done by means of an extra transformer or with a special meter winding on the matching transformer. The diagram shows the wattmeter and the special winding. The primary of the matching transformer is connected directly to the output tubes in place of the regular output transformer. The tap switch is adjusted for the proper impedance match to the speaker and the meter measures output directly in audio frequency watts.

• • • substitute speaker

The large majority of a-c receivers use the speaker field as a filter choke. If the correct speaker for a receiver is not available it is necessary to improvise a speaker field to connect into the power supply filter circuit. The exact inductance is usually not critical, but the d-c resistance often times is, as the voltage drop across this resistance may be used to supply the bias to one or more stages of the receiver. The substitute speaker field of the Model TS-50 consists of a 300-ohm filter choke of approximately 15 henries and a network of resistors which may be connected in series with this choke by means of a rotary switch to give any desired re-

sistance up to 10,000 ohms. If the proper resistance of the speaker field is not known this can readily be determined by adjusting the top on the rotary switch until the plate current of the output power tube has its proper value. This unit is universal in application and may be connected into practically any type of receiver, public-address system or similar apparatus within the power limits of the instrument.

• • • impedance matching

If the specifications on a transformer have been lost it is possible to determine these specifications. The proper connections are shown in Fig. 3. The transformer in question is connected to the output stage of any convenient receiver or audio amplifier. The voice-coil winding of the transformer is connected across the voice-coil connections of the Model TS50 to measure the voltage at that point. A 400-cycle audio signal is fed through the receiver or amplifier as indicated. Disconnect one lead of the voice coil (leaving the voltmeter connected across the transformer winding) and adjust the output of the 400-cycle signal generator to some arbitrary value, high up on the output meter scale, but easily read. Reconnect the voice coil and adjust the impedance matching switch on the TS50 until the output meter reading drops to exactly half of its previous value. The proper voice-coil impedance is then indicated by the designations on the impedance matching rotary switch. To determine

If the specifications of an output transformer are lost it is possible to determine these specifications.

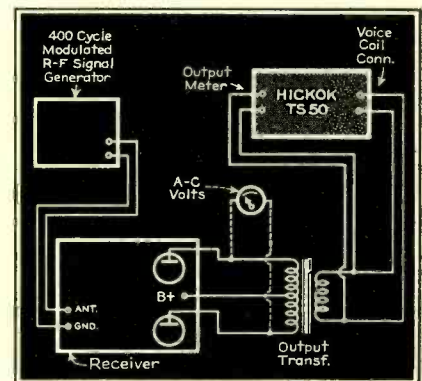

YOU SAVE \$ 1 00

by using the

**Group
Subscription Plan**

OUR GROUP SUBSCRIPTION PLAN enables you and three or more of your co-workers to subscribe to SERVICE at one-half the regular yearly rate. In other words it will cost you and your friends only \$1.00 each for twelve issues of SERVICE. The G-S-Plan low rate only applies when 4 or more subscriptions are ordered at one time. (Foreign \$2.00.)

Speak to three or more of your friends . . . let them sign up with you and then you can remit for the whole group. (Renewals or extended subscriptions are acceptable as part of a group.)

TEAR OUT AND MAIL

SERVICE—19 E. 47th St., N. Y. C.

Please enter annual subscriptions (12 issues) for each of the undersigned for which payment is enclosed at the rate of \$1.00 each; foreign \$2.00. (This rate applies only on 4 or more subscriptions when occupations are given.)

Name
Address
City-State
Occupation
Employed by
State whether Employer is a Service Organization, Dealer, Jobber
or Manufacturer

Name
Address
City-State
Occupation
Employed by
State whether Employer is a Service Organization, Dealer, Jobber
or Manufacturer

Name
Address
City-State
Occupation
Employed by
State whether Employer is a Service Organization, Dealer, Jobber
or Manufacturer

Name
Address
City-State
Occupation
Employed by
State whether Employer is a Service Organization, Dealer, Jobber
or Manufacturer



YOU'LL **CLICK**

WITH TUNG-SOL

If you operate an established radio service business . . . can turn over a price-protected tube stock at least three or four times a year . . . have the setup to cash in on helpful advertising displays . . . and a reputation for maintaining standard prices . . . you'll "CLICK" with Tung-Sol.

This means a *profitable* franchise—selling to a market free from conflict with already established Tung-Sol dealers—plus an adequate supply of tubes without buying them.

* * *

**IF YOUR BUSINESS FITS THIS
"PICTURE" WRITE US TODAY**

TUNG-SOL LAMP WORKS, Inc.
Dept. D Radio Tube Division

TUNG-SOL
V I B R A T I O N - T E S T E D
RADIO TUBES

SALES OFFICES: Atlanta • Chicago • Dallas • Denver • Detroit
Kansas City • Los Angeles • New York. General Offices: Newark, N. J.

SERVICE, JULY, 1939 • 349

the turns ratio of the transformer the primary voltage can be measured with a separate high-resistance a-c voltmeter as shown by the dotted lines in Fig. 3. The turns ratio is the same as the voltage ratio indicated by the two meters. The impedance ratio is the square of this value.

The following numerical example will help to visualize this explanation: We will assume that a certain output transformer is connected as shown in the diagram, Fig. 3, and the output of the signal generator is adjusted so that the output meter in the TS50 indicates 2 volts. The voltmeter connected across the primary of the output transformer indicates 120 volts. Then the voltage ratio between the two windings is 120/2 or 60 and the turns ratio is the same. The impedance ratio is the square of 60 or 3600. Now, if the output tubes in the receiver require a load impedance of 7000 ohms we will need a speaker having a voice coil impedance of 7000/3600 or 1.9 (approx.) ohms to properly match these tubes.

We can also measure the response characteristics of this transformer if we have a signal generator with a variable audio-frequency output. This is done by measuring the impedance ratio as described above for each frequency at which it is desired to check the fidelity of the transformer. Such measurements are usually made at 100, 400, 1000, 3000 and 6000 cycles. The test should be made with the transformer connections properly matched to the input and output circuits.

• • • **autc-radios**

When working on automobile radios

it is convenient to have a quick and simple check on the operation of the vibrator. A suitable vibrator test circuit is built into the Model TS50. The A battery circuit is connected through a polarity reversing switch, a vibrator testing rheostat and an overload relay to the hot and ground terminals. The polarity reversing switch is necessary to take care of auto radios having either a positive or a negative ground. This switch has an off position in the center, which is used to remove the voltage from the receiver while working on it. A 15-ampere meter is connected in series with the hot lead to indicate the A battery current drawn by the receiver and a 15-volt meter is connected across the terminals to measure the voltage at which the vibrator starts to operate. The overload relay is included in the circuit to protect the wiring in case of an accidental short. This relay is a self-resetting type and gives a loud warning signal when overloaded.

It is possible to check the vibrator without removing the receiver from the car. To do this the hot lead of the receiver is removed from the car ammeter and connected to the hot binding post of the Model TS50. The red (or black) battery lead is then connected to the car ammeter or, if more convenient, directly to the hot terminal of the car battery and the polarity reversing switch is set in the position which closes the circuit through to the hot terminal. (Referring to the diagram, it will be seen that if the red battery lead is connected to the battery the polarity reversing switch must be in the "Neg. Gnd." position, while if the black lead is connected to the battery the switch will be set in the

opposite position.) The other battery lead is grounded to the car frame. The "Gnd." post of the TS50 is not used. The vibrator is then tested in the usual manner by reducing the voltage with the vibrator testing rheostat to determine the voltage at which the vibrator will start operating. The polarity reversing switch is used to interrupt the circuit for this test. A good vibrator should start with less than 5 volts.

SIGNAL TRACING IN DIODES

(Continued from page 346)

the value of C is not so great as it should be to keep the signal voltage across the diode load at a low value, and no additional filtering is used in the a-f feed circuit, i-f signal fed to the a-f tube can be appreciable; in fact, enough to overload the a-f tube. . . . Hence, the control grid of the first audio tube immediately following the rectifier diode, point V in Fig. 9, is a signal test point at the frequency of the signal voltage fed into the diode. Thus, if in the example cited in connection with Fig. 9, the frequency of the diode input signal is 470 kc, a 470 kc voltage will be present at point V in Fig. 9. The level of this signal is a variable depending upon the factors mentioned in connection with the diode load.

With respect to this undesired signal at the a-f tube, experience has shown that in some of the better class receivers, this voltage seldom exceeds several percent of the maximum signal voltage fed to the diode. However, if a defect exists in the by-pass circuit across the diode load so that this low reactance path does not exist across the load resistor, a high signal voltage drop is developed across R and this signal in varying proportions, depending upon the position of the audio volume control, is applied to the a-f tube grid. In practice it has been found that this increase at the a-f grid is about five to ten times the normal signal.

• • • **other diode considerations**

We made the statement that the circuits shown thus far do not represent all of the applications of the diode. However, no matter what the final function of the rectified voltage, the manner in which it is developed is as has been described.

It might be well at this time to inject just one additional reference concerning diodes. A number of receivers employ a triode tube as a diode by joining the grid and plate or the plate and the cathode. Although the basic design of the tube is that of a triode such connection places its operating characteristics directly into the diode class.

A substitute speaker and an A battery circuit for auto-radio and vibrator testing are essential features of the Hickok Model TS50 tester.

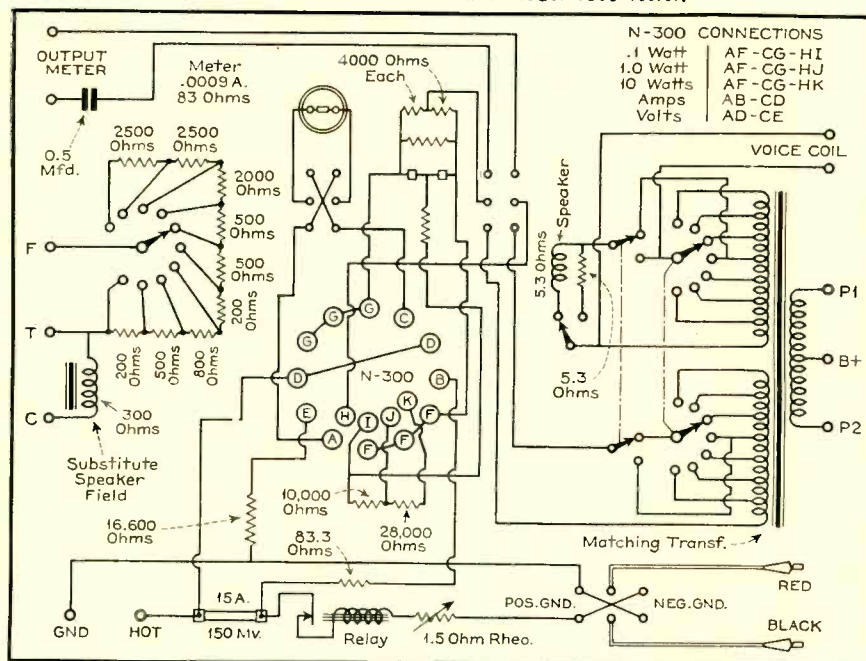

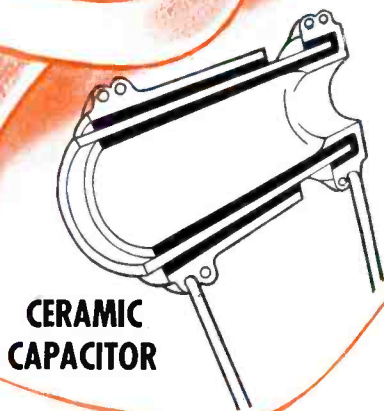
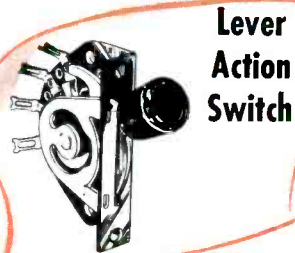
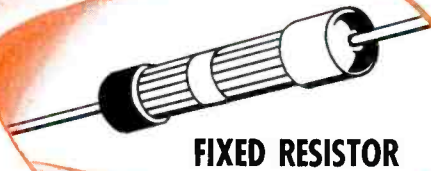

**THE ELECTRONIC INDUSTRY IS
LINKED WITH THESE FAMOUS
PRODUCTS by CENTRALAB**

New developments; some ephemeral and visionary; many sound and practical, are breaking on the horizon.

And today, as in the past, Centralab plays an impor-

tant part in the electronic industry—in the designing laboratories of manufacturers — on the benches of experimenters — in the “trouble-shooting” service-man’s kit

and in tiny ham shacks. For wherever Quality, Dependability and Reliability count . . . there Centralab serves supreme. For sound or sight . . . CENTRALAB.

CENTRALAB DIV. of GLOBE-UNION INC., Milwaukee, Wis.

ELECTROLYTIC CONDENSERS

By **STANLEY WALTERS**
CORNELL-DUBILIER ELECTRIC CORP.

AN ELECTROLYTIC condenser will not retain a charge since it always acts as if it had a resistor connected across it. An equivalent circuit of such a device is shown in Fig. 1, where C is the capacity (assumed to be of infinite resistance to d-c) and R is the d-c resistance in ohms which is associated with the electrolytic. This parallel resistance should not be confused with the equivalent series resistance. The latter is entirely different and can be neglected in this instance since it is only a few ohms whereas the parallel resistance is of the order of several hundred-thousand ohms.

For the purpose of calculating the rate of discharge of an electrolytic condenser, the following formula applies:

$$E = E_0 e^{-t/RC}$$

where E is the voltage across the condenser at any instant, E_0 is the initial voltage to which the condenser is charged, e is the natural logarithm base, t the time in seconds measured from the start of the discharge cycle, R is the resistance in ohms and C the capacity in farads. The current at any instant may be derived from the relation

$$E = iR$$

Then, by substitution

$$iR = E_0 e^{-t/RC}$$

or

$$i = \frac{E_0}{R} e^{-t/RC}$$

If it is desired to predict how long it will take for the condenser to discharge to some predetermined voltage, the equation may be solved for time (t).

$$\log_e E = \log E_0 - \frac{t}{RC}$$

or

$$t = RC \log_e \frac{E_0}{E}$$

The discharge of the condenser through its own inherent resistance cannot be too accurately predetermined because the resistance is variable and depends on the instantaneous voltage.

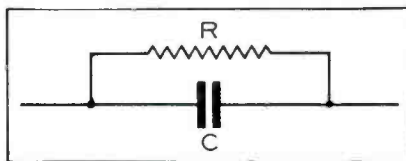

Fig. 1. An electrolytic condenser always acts as if it had a resistor connected across it.

For example, a properly designed 8-mfd, 450-volt unit will have a maximum leakage of 0.3 ma at its rated voltage. This corresponds to a parallel resistance of 1.5 meg. When the voltage has dropped to 300, the leakage current will be approximately 0.08 ma which corresponds to a resistance of 3.75 meg. These values are only very approximate since individual condensers will vary considerably.

Fig. 3. The discharge rate of an electrolytic depends upon its inherent resistance which varies with the instantaneous voltage.

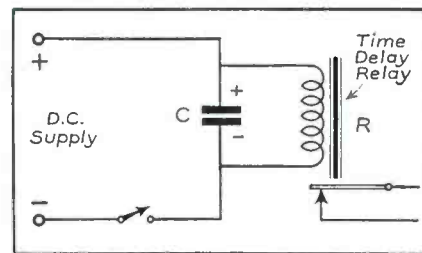
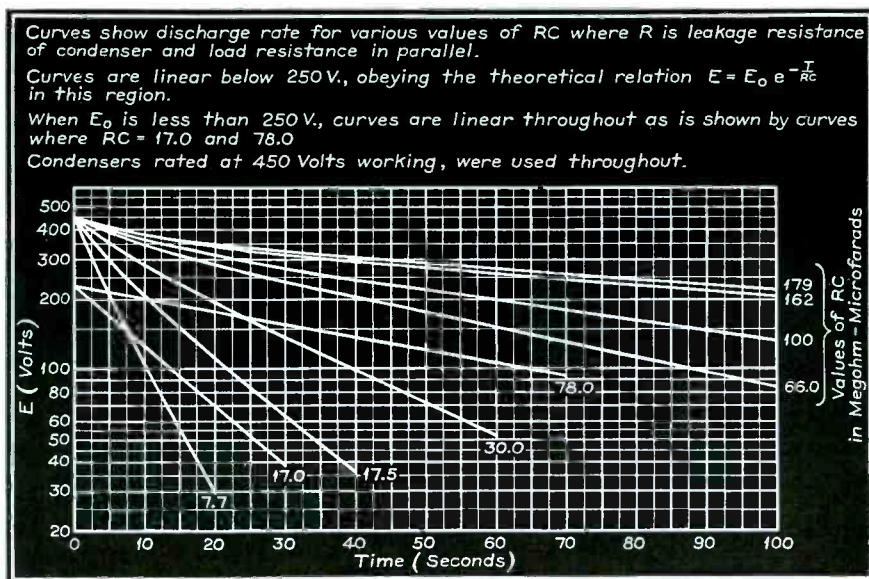

Fig. 2. A practical application of the discharge characteristics of a condenser is in time delay relay circuits.

When a condenser is to be used in this connection, there is generally an additional resistor connected in parallel with the unit of much lower value than the resistance of the condenser alone. This makes the over all resistance more nearly constant, and the discharge can be predicted with greater accuracy. The value of R then becomes the resultant of the added resistor and that of the electrolytic, using the relation:

$$R = \frac{R_1 R_2}{R_1 + R_2}$$

• • • practical application

A practical application of condensers in this connection is in a circuit where it is desired to hold a relay in the actuated position for a short period of time after the applied voltage to the relay is removed. A typical circuit is shown in Fig. 2. Many elaborations of this are possible.

In this case the additional resistance connected in parallel with the condenser is the d-c resistance of the coil of the relay, R.

A typical set of curves showing these discharge characteristics are given in Fig. 3. These curves are plotted on semi-logarithmic paper, since the logarithmic nature of the discharge makes the resulting curves straight line.

The deviation from the theoretical straight line is noted in the curves where the initial voltage is 450. The reason for this is that the inherent resistance of the condenser is changing. The curves which have a lower value of total resistance are more nearly straight line, since the resultant resistance is more nearly constant for this case. The curves starting at 232 volts are also straight-line. This shows that if the initial voltage is considerably below the rated voltage of the condenser the change in resistance with voltage is at a minimum and the discharge curve is more nearly straight-line.

The curves of Fig. 3 are drawn for various values of RC (the product of the resistance in ohms and the capacity in microfarads).

For most design purposes, a very good approximation for capacity can be made by neglecting the resistance
(Continued on page 355)



**So you can
build with
Confidence**

● This tiny electrolytic costs only 50 cents list. But it could cost many dollars to some serviceman, builder or manufacturer if it broke down and endangered tubes and other costly components. That's why the AERVOX guarantee really backing every AERVOX condenser with which it is packed, means so much to the radio industry today.

It is this sort of insurance against unwarranted failure that has built up supreme confidence in AERVOX products. They are bought by those who simply cannot afford failures. What more could be said?

*Are you getting
this?...*



● AERVOX issues this monthly bulletin of practical radio information. Free subscription copy can be obtained through your Aerovox jobber. Ask him about it.



LOUDSPEAKER ENCLOSURES

(Continued from page 333)

• • • bass reflex

The most recent modern baffle and perhaps the most obscure in principle is the bass reflex and Magic Voice cabinet. These types may be considered a cross between an infinite baffle and an acoustic labyrinth. They are similar and consist of an almost completely enclosed cabinet, partially lined with sound absorbing material, one of whose walls has an opening of definite size for air release and/or bass reinforcement. In the bass reflex variation, this opening is a rectangular port at the front of the enclosure and several inches below the cone of the speaker. In the Magic Voice version there are several openings at the bottom of the cabinet which connect to the interior through short tubes of varying length. The cabinet itself stands off the floor on short legs to allow any sound emanating from the tubes to be radiated into the room. Figs. 7 and 8 are simplified diagrams of the construction of these cabinets.

The design of this type enclosure, entails the treatment of the cabinet as a broadly resonant cavity at the low frequencies. The design of the opening is so handled that it acts as an acoustic phase inverter at these frequencies. These conditions are fulfilled by dimensioning the cabinet for proper resonance and by making the reflex opening approximately equal to the cone area. The simple open port does not invert the phase with quite the same effectiveness as the tubular passages of the Magic Voice design, but either method results in a more compact enclosure than the infinite baffle because the cabinet resonance falls within the response range rather than below it. Further economy is possible since complete absorption is not necessary within the enclosure and the padding need not be as elaborate as with the fully enclosed cabinet, nor is rigidity quite as important.

• • • performance

From the standpoint of performance there is little to choose between the rear port cabinet and the completely enclosed design. Although the completely enclosed unit is somewhat bulkier and more expensive, its simpler acoustic action tends to make it freer from accidental resonance effects such as the possibility that cone and cabinet resonance might occur at the same frequency which would result in undesirable accentuation of a narrow band of bass notes. It is a popular misconception that since the reflex cabinet makes use of rear radiation, a given speaker will deliver noticeably better bass response in this type of cabinet than could be ob-

JACKSON ANALYZER

TRACES THE SIGNAL
from ANTENNA TO SPEAKER
Shows All results instantly on Meters

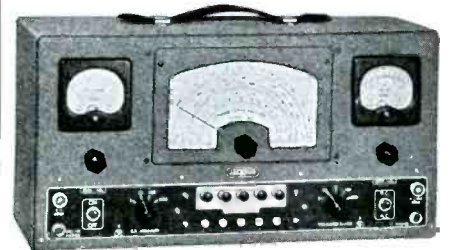

MODEL 660

The new Jackson Analyzer is a startling innovation that can save servicemen hours of work by quickly solving the toughest service problems. This new analyzer shows gain per stage, noise, hum, oscillator operation, AVC and AFC volts, antenna efficiency, etc., on DIRECT READING METERS. It gives results instantly. It will quickly pay for itself in the time it saves you. Also has complete built-in Vacuum Tube Voltmeter with AC and DC ranges to 500 V. \$79.50 COMPLETE.

WRITE TODAY for full information.

The Jackson Electrical Instrument Co.
DAYTON, OHIO



tained from a fully enclosed infinite baffle. A little reflection will make clear why this is not necessarily so. If the radiation from the rear of the cone were equal to that from the front; if the cone basket and magnet structure did not interfere with that radiation; if there were no absorption in the cabinet; if the phase inversion at the port were exactly 180 degrees, and if the radiation efficiency of the port were equal to the radiation efficiency of the cone front itself (then and only then) the gain due to rear radiation would be 3 db. Obviously, none of the above links in the chain from the rear of the cone to the front can be perfect, with the result that in practice the net gain, depending on design, runs between 1½ and 2 db., which is a negligible aural increase.

• • • true value

The true value of both the infinite baffle cabinet and the reflex cabinet lies in their common superiority over conventional flat baffles and open back cabinets rather than in any minor advantages one might hold over the other. In addition, frequency response does not tell the whole story of this common superiority. All of the above enclosures are superior to the usual flat baffle in bass radiation pattern, since they elim-

inate the out of phase area near the edge of the baffle in which area there is practically no bass response. Thus the extension of the cutoff frequency, plus improved radiation characteristics, make it possible to take advantage of the full capabilities of modern high fidelity speakers without resorting to extremely large dimensions.

• • • **summary**

A brief summary of the salient points discussed above may be helpful.

(1) Instead of the conventional practice of mounting a speaker in the center of a square flat baffle, definite improvement in performance may be obtained by irregular dimensioning and asymmetrical positioning of the speaker with respect to the baffle edges.

(2) Mounting the speaker near the lower edge of the baffle, and allowing this edge to rest on the floor, reduces the solid angle into which the cone radiates and provides increased effective baffle area from the floor, both effects contributing to higher efficiency at low frequencies. Care should be taken, however, to avoid excessive reflection from the floor.

(3) The acoustic labyrinth, although somewhat complicated structurally, provides an effective and compact method of duplicating the performance of very large flat baffles without resorting to resonant chambers.

(4) The infinite baffle cabinet, by virtually complete absorption of rear radiation, duplicates substantially the results obtained from a flat baffle of infinite extent.

(6) The full realization of the excellent capabilities of high fidelity speakers can only be obtained by proper baffling, and without such baffling the response obtained may easily ruin the response characteristics of an otherwise excellent reproducing system.

ELECTROLYTIC CONDENSERS

(Continued from page 352)

associated with the condenser. The ratio of initial to final voltage is first determined. Value of the initial voltage E_0 will be the operating voltage of the relay coil. E will be the voltage at which the relay releases. The desired time of delay (expressed in seconds), the resistance of the coil, and $\log_e E_0$ — are then substituted in formula and the latter solved for capacity in farads:

$$C = \frac{t}{R \log_e \frac{E_0}{E}}$$

This analysis is quite accurate if the values of R and C are such that their product (RC) is less than 90.

PROFITABLE SERVICING! *Faster!*

John F. Rider Announces!

Complete!

Easy TO USE!

- **ANSWER TO A NEED**
The great number of receiver models being produced by the manufacturers—have combined to create such a need—such a demand for servicing data that Volume X will be made available 4 months ahead of the usual date.
- **NEW SERVICE DATA**
Complete servicing data you need on the receivers now in your shop . . . The data you would ordinarily get in November, ready for you this year on August 19th. The information you have asked us for—in the form you asked for it—all in Rider's Volume X.
- **LATEST DEVELOPMENTS**
Television—Facsimile—Wireless Record Players—the servicing information on these important new developments for the servicemen will be found complete in Volume X. You must have the manufacturer's instructions when you install or service any of these new sets.
- **NEW "HOW IT WORKS"**
Easy-to-understand explanations on the theory of Television—Facsimile—Wireless Record Players, etc., are in the new, 64-page "HOW IT WORKS" section which is included at no extra cost. This is the type information you have always found so helpful. Volume X index covers all 10 Rider Manuals.

Volume X RIDER MANUAL OUT AUGUST 19th 1650 PAGES—\$10.00

✓ CHECK THIS LIST

Volume	Price	Covering
IX	\$10.00	1938-39
VIII	10.00	1937-38
VII	10.00	1936-37
VI	7.50	1935-36
V	7.50	1934-35
IV	7.50	1933-34
III	7.50	1932-33
II	7.50	1931-32
I	7.50	1920-31

ORDER TODAY **YOU NEED ALL 10 RIDER MANUALS**



"SERVICING BY SIGNAL TRACING"
by John F. Rider
Use the system of servicing which is proved and endorsed. The fast-modern system you can apply to all receivers regardless of age, type or make—independent of every limiting factor heretofore encountered. In this new book you learn what happens to the signal currents—the development of control voltages—and how all receivers are brought to a common servicing level. There is one thing which is common to every radio set—the signal. Read this book and you will be able to service the most complicated set with greater speed and less effort.
300 pages \$2.00

Out Soon! VOLUME II
THE CATHODE-RAY TUBE AT WORK
by John F. Rider
New applications of the cathode-ray tube require that the 1939 serviceman know more about its operation, characteristics and performance. The cathode-ray tube as the principal factor in television receiving sets is but one of the applications with which you will soon be faced. Use of the Oscillograph in industry is increasing every day in testing vibration, strength, engine pressure, etc. Industrial users need servicemen to maintain their oscillographs. Be up-to-date on this vital subject.



John F. Rider Publisher
404 Fourth Ave., New York City

ASSOCIATIONS

RADIO SERVICEMEN OF AMERICA

NEWLY elected national president George F. Duvall in his inaugural address to the members of RSA gathered at their Convention in Chicago June 16-17, said: "Our organization is the result of cooperation; cooperation between Service Men, cooperation with the Sales Managers Clubs, the RMA, the trade journals and other branches of the industry, and now cooperative action in the RMA-NAB campaign for the betterment of



George F. Duvall, newly elected national president of the Radio Servicemen of America, 8005 Third Ave., Brooklyn, New York, is a Service Man from 'way back before the World War. Duvall is 44 years old, is married and has three children. He served as president of the New York chapter of RSA in 1938 and was reelected in 1939. He is President of Television Technicians, Inc., New York City. Duvall succeeds T. P. Robinson, of Dallas, Tex., who served two terms as the first national president.

radio. Indeed, that word 'cooperation' is a grand word, a word of great potentiality, whereby Service Men gather together in mutual interest and for mutual benefit, and because of that cooperation between Service Men, are invited to participate in cooperation with other branches of the industry for mutual benefit. Cooperation, then, is the foundation of RSA."

Kenneth A. Vaughan, Johnstown, Pa., was elected vice-president for 1939-40. Donald H. Stover, Freeport, Ill., and Lee Taylor, Chicago, Ill., were reelected secretary and treasurer respectively.

New RSA directors seated during the convention were: Frank L. Clark, Nashville, Tenn.; Winston B. Jones, Washington, D. C.; Fred Olsen, Green Bay, Wis.; Ingvar Paulsen, Roxbury, Mass.; Norman W. Smith, Jamestown, N. Y.; Carl Williams, Phillipsburg, N. J.; and George D. Wooley, Rock Island, Ill.

Reelected directors and holdover directors are as follows: Joseph A. Cole, Detroit, Mich.; L. G. Dearing, Oklahoma City, Okla.; George F. Duvall, Brooklyn, N. Y.; Henry M. Lutters, Bronx, N. Y.; Carl A. Rauber, Somerville, N. J.; T. P. Robinson, Dallas, Tex.; Don H. Stover, Freeport, Ill.; Lee Taylor, Chicago, Ill.; Albert J. Theriault, Cleveland, Ohio; and Kenneth A. Vaughan, Johnstown, Pa.

convention notes

Closing service shops so that nary a tube could be tested in the whole city, Danville, Ill., chapter chartered a bus and attended the Second RSA Convention and the Trade Show in a body, thereby winning the prize as the RSA chapter within three-hundred miles of Chicago with the best record of attendance. Outside the three-hundred mile circle Johnstown, Pa., chapter showed the largest percentage and took home that attendance prize.

The RSA member traveling the furthest to attend was Hyman Leve,

Brighton, Mass. As there were three members from Boston registered, it took some figuring to decide which traveled the greatest distance through the devious Boston streets, but Hy finally took home the prize.

Radio Station WLS, Chicago, broadcast direct from the RSA booth Friday, June 16. Arranged by Ray Mason and Lowry Easley of the Chicago chapter, visiting Service Men participated in an interview program. The RSA booth, including the famous "Super Guberschucker," was described to listeners by the announcer.

Lectures and demonstrations at the Second RSA Convention were pronounced "the best ever" by the Service Men members and guests in attendance.

Facsimile and Television were ably described and demonstrated in a number of lectures giving the latest practical and theoretical information on these important subjects. Engineers of Radio Station WGN covered facsimile, while lectures by Morelock of Weston Electrical Instrument Corp., Preisman of RCA Institute and Cowan of Service Magazine brought a well rounded picture of Television.

Other lectures and demonstrations gave valuable data on radio interference, test equipment, crystals, etc. Rider of Service Instruments, Metcalf of Tobe Deutschmann, Burlingame of Supreme Instruments, McLaughlin of Wiley Electric and Cole of Hallcrafters each discussed a separate phase of these subjects.

An outstanding lecture was given by Connor of Hygrade Sylvania Corp. His practical hints were invaluable, and his method of servicing midgets by removing parts, but having a better radio when done, brought down the house!

binghamton

Wayne Shaw demonstrated a condenser tester that really works at our meeting of June 6. It is a very sensitive checker—the boys are planning to build one as a valuable addition to the shop equipment.

John Rose and Herb Snyder brought back glowing accounts of the Chicago Convention and Show. They told us all about it at our June 20 meeting.

Earl L. Pittsley, reporter

boston

A lecture with demonstration on the oscilloscope gave us some interesting information that will prove of value to us in our future service work was the feature of our meeting of June 6.

Three of our members made the long trip to Chicago to the Convention and Show.

Ingvar Paulsen, secretary

chicago

The highlight of the month was the Show and RSA Convention. One of the highlights of the Show was the RSA "Super Guberschucker" in the RSA Booth. Responsible for the idea is "Head Guberschucker" Mason. He promises a streamlined model with all the trimmings next year. The darn thing has a set of case histories all its own—but don't ask me. Ray is the doctor.

The planned lectures, meetings, tours and demonstrations were well attended. The tours through Underwriter's Laboratories and the Stancor factory had a special rating all their own. Our thanks to the "Ladies of RSA" (our ladies' auxiliary) for their part.

Brandex—the directory to service information on private brand and off brand sets—sold like hot cakes during the convention. No wonder, since the information Brandex gives is worth any Service Man's "quar-

ter" any old day. Only RSA men can get it, by ordering from chapter treasurer O. S. Dawson, 1031 E. 47 St., Chicago, price twenty-five cents.

Al Kilian, publicity

cleveland

A trip to the Radiart plant was the feature of the month. Lectures and demonstrations and a tour of the factory filled a very pleasant and profitable evening.

Thomas B. Holmes, secretary

danville

We are pleased to report a weekly radio program over station WDAN, entitled "Behind the Mike with RSA." This is a program to bring to the public the men and women putting on their programs and describe their duties and interesting facts in their life. We are planning to get representatives from every branch of the industry, since this program is donated to us as long as we can furnish material.

At our meeting of May 26 plans were completed for our trip to the RSA Convention and National Parts Show. Mr. McArdle conducted a round table discussion on business subjects and the importance of RSA to the Service Men.

Our trip to the Convention and Show was a success from every standpoint. Every man had a real time and most of them have already expressed a desire to go back again next year. At least part of the ladies will be there then, too—in fact, there has been certain laws laid down to us already that assures their presence!

Cal Stapp, secretary

fremont

This chapter has taken advantage of the Cleveland chapter's invitation to join them at several meetings of special interest. In fact, we were so eager to attend the meeting held at the Radiart factory that one car was forcefully restrained for speeding while passing through Dover Village!

At the May 24 meeting our new officers were installed, viz.: Ed Tarbox, chairman; H. C. Russell, vice-chairman; Donald Bruns, secretary-treasurer; and Frank Marx, sergeant-at-arms.

We hope for a big turn-out of Cleveland and Toledo members and families at our First Annual Picnic, to be held Sunday, July 16, at Twin Beaches.

Everett Ingles, reporter

lansing

Discussion of group advertising resulted in the decision to enter a thirteen-week contract for space in our local daily newspaper; costs to be shared by the group.

It was decided, after discussion, to provide copies of our Schedule of Service Charges to non-member Service Men of Lansing who are worthy and will cooperate.

L. W. Aubil, secretary

newark

The Newark chapter has changed its meeting nights from Tuesday to Wednesday at Hotel Douglas, Newark, so that those of our boys who are taking the GE television course may attend both meetings.

We are receiving plenty of good service information on radio and television from very competent factory engineers. Our director, Carl Rauber, and F. Andreatta are certainly giving their all to the chapter. Mr. Clark, also of our chapter, has been giving lectures on slide rule calculations and is planning talks on frequency modulation for future meetings.

Plans for a chapter outing are well under way. It is reported that our chairman has already located some one to donate the beer!

W. C. Pope, publicity

new york

Mr. Duvall opened our meeting of May 22 and introduced the lecturer, Mr. J. F. Miller, of the Re-

search and Engineering Department of RCA Manufacturing Co. Using slides and blackboard, Mr. Miller discussed design and recent improvements in receiving and television tubes.

A short business meeting followed. Service hints from the pamphlet of the Chicago chapter were read, and were well received.

S. Rosengarten, secretary

pittsburgh

A tour, the first of a series planned for the summer months, to the Colfax Power Station near Cheswick, Pa., provided an interesting and instructive Sunday afternoon June 18. The trip was of exceptional interest to both technically and non-technically minded men and women.

Technical details of the Beamoscope and Tone Monitor circuits of the new GE receivers were given to members and prospective members at our meeting of June 28.

Bill Irlam, secretary

scranton

One of the newest chapters, we meet the second and fourth Tuesday of each month. Our officers are: president, Adolph Oschman; secretary, Olin Van Fleet; treasurer, George Wilson, and sergeant-at-arms, Johnny Novak.

Olin Van Fleet, secretary

OTHER GROUPS

nriia

It's a little girl at the home of Carl Bromberg, Poultny, Va. Congratulations.

Melli C. Panday sends a cablegram from Bombay, India, offering anniversary congratulations. Thanks, Melli, for the unique message.

Cran Baldwin of Arthur, Tenn., gets special mention this month. Recovering from a severe illness of several years he is confined to a wheel chair most of the time, but he conducts his Radio service business without interruption.

Stewart Tyson of N. Transvaal, S. Africa, recently returned from a long honeymoon. Good luck.

A. Michaels of Emigh, Penna., got a real birthday gift on his anniversary—his wife presented him with a bouncing baby girl. Nice timing!

Menne attended a meeting of Baltimore Chapter on the day of his birthday. The fellows had a real surprise party for him. The Program Committee is to be congratulated.

Joseph J. Bouzek of Stewart, B. C. Canada, conducts the Radio column for his local newspaper.

Carl Carver of Lodi, Ohio, is the proud daddy of a son. Mr. and Mrs. Carver are extremely happy to have the stork drop in for the first time in nine years.

prsmia

The grass is getting awfully green out there in the pretty hills and vales . . . making us think of our Picnic. Whatsay?

Tough luck, boys! At the Radiart meeting Al Lynsky, Paul Freed and Bob McGrath's names were called out . . . but no answer. Better stick around next time, boys.

Bill Pool, with three new members in one night, won the space in the "News" for his picture. Let's go, fellows! Bring the new members in and you'll win a place in the Gallery of Distinguished PRSMA Workers.

A cordial "Thank You" to Mr. Higgins of Weston and Mr. Herzog, Editor of SERVICE for two interesting sessions last month.

Our little meeting patrolman says that if some of the statues would take chairs at the back of the room here would be room for everybody.

(Editor's Note: As usual, in spite of ardent promises, the news release concerning PRSMA activities was not received up to the present writing. The items published above were lifted from the PRSMA NEWS.)

BOOK REVIEWS

PRACTICAL TELEVISION, prepared by RCA Engineers, published by the Service Division of the RCA Manufacturing Co., Inc., Camden, N. J., 1939, 40 pages, self-covers, price 25c.

This booklet outlines the RCA television system and is divided into five sections, viz:

(1) A general discussion of the RCA television system as based on the RMA standard television signal.

(2) Outline technical description of receiving circuits with particular attention to the wide band i-f amplifying circuits, special a-v-c, d-c restoration, synchronizing separator and other circuits new to television.

(3) Details of television receivers, antenna and transmission line installation.

(4) A section devoted to general service problems, including 38 test patterns to assist the Service Man in recognizing receiving conditions and faults.

(5) A group of television definitions.

The book is highly recommended.

R. G. H.

POLICE COMMUNICATION SYSTEMS, by V. A. Leonard, published by University of California Press, Berkeley, California, 1938, 589 pages, price \$5.00.

As a review of available police communication systems this compact, carefully documented volume deserves high praise. Intended for the alert police official, it may well prove useful to the Service Man as an index to the types and varieties of equipment and devices employed in modern police communication.

E. A. M.

STANDARDS ON ELECTRONICS 1938, STANDARDS ON TRANSMITTERS AND ANTENNAS 1938, STANDARDS ON RADIO RECEIVERS 1938, STANDARDS ON ELECTROACOUSTICS 1938, published by the Institute of Radio Engineers, Inc., 330 West 42 Street, New York City, 1938, 59, 42, 58, and 37 pages respectively, paper covers, price 50 cents each.

The conveyance of information in clear and unambiguous terms, and not in a slipshod manner which can either be subject to a multiplicity of interpretations or else to a complete misunderstanding, is of extreme importance.

Fortunately, the publication of the four booklets on standards by the Institute of Radio Engineers should do much toward improving the Service Man's ability to correctly use the technical terms which he so frequently employs. This is particularly true in the field of electroacoustics. How many Service Men can distinguish among: "magnetic speaker," "moving-conductor speaker," "moving-coil speaker," "induction speaker," and "magnetic-armature speaker"? Or, again, can the Service Man engaged in public address work differentiate among: "pressure microphone," "velocity microphone," "magnetic microphone," "moving-conductor microphone," "moving-coil microphone" and "ribbon microphone"? Although the preceding examples are selected from the field of electroacoustics similar remarks apply in each of the other branches of radio.

The IRE booklets on standards also give standardized letter and graphical symbols as well as standardized measurement techniques.

Whether or not the Service Man already has a five-foot shelf of radio books the four IRE booklets on standards will prove an invaluable addition to his library.

D. B.

DACO

STOPS YOUR WISHING
FOR
OBSOLESCENCE PROOFED
INSTRUMENTS

Model 303
TESTS UP TO
FULL LINE
VOLTAGE

125 VOLTS

117 VOLT

TUBE TESTER
VOLT OHMMETER

DACO AND DAYRAD COMBINED EXPERIENCE
DELIVERS KNOCKOUT BLOW TO OBSOLESCENCE
WITH THIS NEW DACO CIRCUIT AT THE LOW
PRICE **\$29.90**

MODEL 303

Beautiful and It Has Remarkable Performance — Up-to-the-Minute and Into the Future.

- Tests all Tubes 1.4 to 117 Volts Single End — 9—Gt—M—M4—Octals—Loctals—Gaseous Rectifiers—Magic Eye—Ballast—Dial Light Battery and Xmas Tree Bulbs

- Provides Combined or Separate Tests on Each Element — Individual Tests on Each Section of All Multi-Purpose Tubes and Full Wave Rectifiers

- Practical Voltages and Resistance Ranges for General Testing

- Index Roller Chart With Obsolescence Protection and Four Spare Sockets

- Beautiful Streamlined Metal Case Finished in Black Morocco Blended in Silver and Red

- Simplicity—Light—Size 16" Long, 13" Wide, 3" Height Front, 5 3/4" Back

- Portable Model Black Leatherette Case At Same Price



ALL WAVE SIGNAL GENERATOR

ONE RANGE VISIBILITY

DACO FEATURE MODEL 421

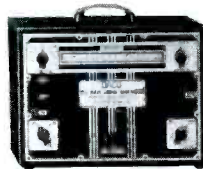

AC-DC VOLT OHMMETER 1000 OHMS PER VOLT Speaker Substitute

DACO FEATURE No Batteries Used MODEL 521

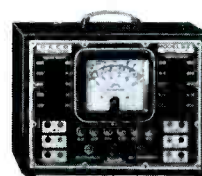

DACO EASY PAYMENT TERMS

Model 303. Tester Price, \$29.90. \$10.00 Down, 10 Months Balance.

Model 421. Zero Leakage Signal Generator. Price, \$29.90. \$10.00 Down, 10 Months Balance.

Model 521. AC-DC Volt Ohmmeter. Price, \$35.90. \$12.00 Down, 10 Months Balance.

Ask Your Jobber or Write Us

DAYTON ACME Co.

2339 Gilbert Ave., Cincinnati, Ohio

Let DAYRAD and DACO Combined Experience Modernize Your DAYRAD Instruments

DAYTON ACME CO.

- Please ship model _____ at once—check enclosed.
- Please send information on all new models.
- Please send information and forms for Easy Payment Plan.

Name

Address

City..... State.....

THIS NEW
Midget Bridge
DOES A MIGHTY BIG JOB

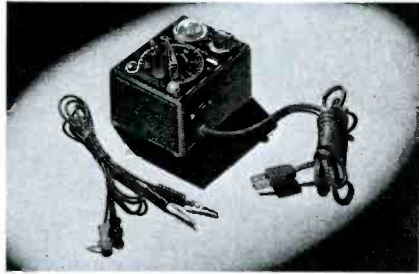

A big job of servicing and a big job of money-making. It's Cornell-Dubilier's new ultra-compact Capacitor Bridge. Quickly and accurately measures all types of capacitors between limits of .00001 mfd. and 50. mfd. Employs Wien Bridge circuit for all measurements. Operates on any 110 volt, 60 cycle power line . . . 12A7 tube acts as rectifier and amplifier, 6AF6-G for "visual eye" detector. Send today for new 1939-40 Catalog No. 167-A and complete feature story of Cornell-Dubilier's sensational Capacitor Bridge.

PRODUCT OF THE WORLD'S LARGEST MANUFACTURER OF CAPACITORS

CORNELL-DUBILIER
ELECTRIC CORPORATION
 1026 Hamilton Boulevard, South Plainfield, New Jersey
 Cable Address: "CORDU"

THORDARSON
TROPEX
TRANSFORMERS

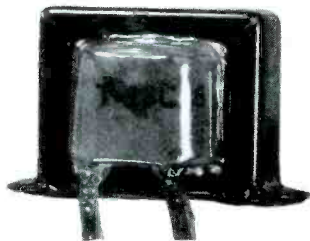

PROTECTED AGAINST EXCESSIVE MOISTURE SALT AIR TROPICAL CLIMATES

THORDARSON engineers developed the TROPEX process as the way to protect against the corrosive and destructive effects of moisture, high humidity and salt air which are found in tropical or coastal countries and regions with heavy rainfall. The TROPEX transformers give the serviceman who must fight these conditions the answer to transformer problems. TROPEX units include output transformers, replacement audios, and chokes. The process is adaptable to practically any Thordarson open mounting type transformer. For more complete information ask your parts distributor or write factory for free Catalog No. 400-D.

THORDARSON
ELECTRIC MFG. CO.
 500 W. HURON ST. CHICAGO, ILL.

358 • SERVICE, JULY, 1939

TACO TELEVISION ANTENNA

A television antenna with universal joint mounting, permitting adjustments in all directions, is now offered by *Technical Appliance Corp.*, 17 E. 16 St., New York City. The dipole antenna is constructed of duraluminum rods held together with a cen-

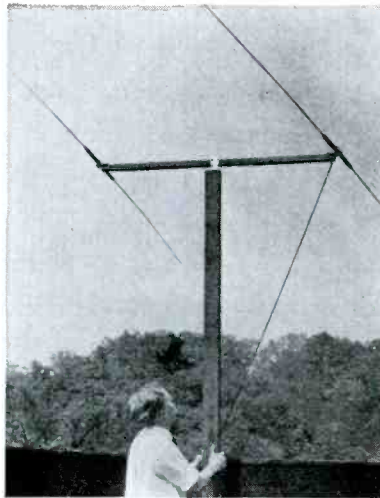

ter insulator. Two extension rods screw into the center rods for attaining the correct length of the dipole. Mounting straps are provided for mounting to an iron pipe or wooden mast. Adjustments are possible in both the horizontal and the vertical planes, simply by loosening a nut and tightening same after the correct position is obtained. A reflector is available wherever needed, and the same adjustments are provided for the full antenna-reflector assembly.

AMPERITE KONTAK STRAP

The new Amperite Kontak strap makes it easier to attach and detach the Kontak unit to any flat top guitar, such as is used

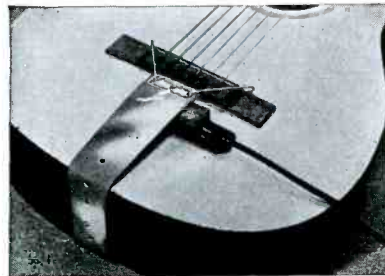

by some popular players and many concert players, it is said.

Additional details on this and other Amperite microphones and microphone accessories may be obtained directly from *Amperite Co.*, 561 Broadway, New York City.

RADIO CITY TUBE TESTER

Radio City Products Corp. announce the new Model 308 Dynoptimum tube testers. This new instrument will test all 35-, 45-, 50-, 70-volt tubes and provides for 40-, 75-, 80-, 115-volt tubes that tube manufacturers contemplate introducing shortly, it is said. It also contains provision for a noise-level test in addition to the regular RMA test under specified plate voltages and loads.

Additional details and prices may be obtained from *Radio City Products Corp.*, 88 Park Place, New York City.

SPRAGUE CONDENSERS

Type PC Sprague inverted screw can condensers have been designed for high gain amplifiers such as employed in television, etc., as well as for transmitters and p-a applications.

Like all Sprague high voltage condensers, the new units are both oil impregnated and oil filled. They are available in four ranges: 2 mfd., 600 d-c working voltage; 4 mfd, 600 d-c working voltage; 1 mfd, 1,000 d-c volts and 2 mfd, 1,000 d-c volts.

Additional information on these and other Sprague condenser products may be obtained directly from *Sprague Products Co.*, North Adams, Mass.

WESTON FILATROL

Service Men can now bring their old tube checkers up to date with the Filatrol unit announced by the *Western Electrical Instrument Corp.*, Newark, N. J., it is said. This unit, Model 767, can be used in construction with any early model tube checker for testing loktal, octal or other tubes of high filament voltages.

The Filatrol unit is equipped with two leads—one is plugged into any 110 volt a-c outlet, the other into the 4-prong socket



of the tube checker. A switch on the top of the unit can be turned to the proper position to provide the required voltage for the tube being tested. Switch settings range from 35 to 100 volts.

WEBSTER-CHICAGO RECORD CHANGER

The Webster-Chicago automatic record changer, Model W1260, is offered to the trade in a light, airplane cloth covered carrying case. The unit plays both 10 and 12-inch records. Push-button control is provided for rejecting and for changeover



to manual. A crystal pickup is employed. Additional information and prices may be obtained directly from *Webster Co.*, 5622 Bloomingdale Ave., Chicago.

AERIALS • STANDARD OF COMPARISON

SEE YOUR
RADIART JOBBER
GET YOUR COPY OF
R.V.M.
(RADIART VIBRATOR MANUAL)
ONLY **25¢**

RADIART

TEST NEW HIGH FILAMENT VOLTAGE TUBES WITH YOUR TUBE CHECKER!



Tiny device plugs into the tube checker and AC supply ... enables you to test high filament voltage tubes requiring from 35 to 117 volts! Complete test data with each unit. For use with most tube checkers having loktal sockets. Write, or ask your jobber for complete information. Weston Electrical Instrument Corporation, 604 Frelinghuysen Avenue, Newark, New Jersey.

"... but I have a Sylvania Tube Complement Book."

"Fine! Then keep it up-to-date by adding the 1938-39 Supplement!"

Which Do You Need?

IF you haven't the regular Complement Book, send for No. 1. All the contents of Sylvania's standard Tube Complement Book—plus a big, complete 56-page Supplement giving the tube complements and i-f peaks of all the new, recently-announced sets—bound right into the center of the regular book! 221 pages, all told . . . and it's yours for only 25c.

OR—if you already own a Sylvania Tube Complement Book—just send for No. 2. The 1938-39 Supplement will bring it completely up-to-date—and thus improve your servicing on new sets. The Supplement is 10c.

SYLVANIA

SET-TESTED RADIO TUBES

Also makers of famous Hygrade Lamp Bulbs.

DEPT. S-79, HYGRADE SYLVANIA CORP.
Emporium, Pa.

Please send me the Complement Book (No. 1) complete with 1938-39 Supplement @ 25c.

Send me the 1938-39 Supplement (No. 2) @ 10c.

Name

Address

City State

Name of Jobber

RUSH THIS COUPON TO DEPT. S-79, HYGRADE SYLVANIA CORP., EMPORIUM, PA.

RSA Membership is as Necessary to You as Your Test Equipment

RSA is the only organization of Servicemen that has the sponsorship of the Radio Manufacturers' Association and the Sales Managers' Clubs, as well as the endorsement of the entire industry.

RSA has sponsored over 200 service meetings the past year in cooperation with manufacturers and engineers.

RSA has members in every state in the union—and in most foreign countries.

RSA provides service diagrams, advanced circuit notes for members each month, technical help on service problems, access to its National Speakers Bureau, advanced

service courses to members at slight cost, a monthly RSA publication, and many other benefits.

RSA is constantly developing New Ideas—New Services—and expanding old services.

RSA will soon announce a plan to help members get more business.

Help yourself by joining RSA—Do It Now!

MAIL THIS COUPON NOW!

RADIO SERVICEMEN OF AMERICA, Inc.
304 S. Dearborn St., Chicago, Ill.

Please send advance copy of Convention Program.

Name

Address

City..... State.....

Please send advance copy of Convention Program.....

I am interested in RSA Membership. Tell me about it.....

I am enclosing \$4.00 for National dues and initiation.....

(Does not include Local Chapter dues where Local Chapters are organized.)

S-839

Let's Grow Together in 1939!



RADIO SERVICEMEN OF AMERICA, INC.

Joe Marty, Jr., Executive Secretary

304 S. DEARBORN ST., CHICAGO, U. S. A.

POWER TAP SWITCHES

Three new models, in addition to the 40-ampere tap switch recently announced, now completes the series of new Ohmite all-enclosed high-amperage tap switches. These new tap switches are multi-point, load-break, non-shorting, single-pole, rotary selectors particularly designed for alternating current use. They are compact and the ceramic construction provides good insulation. There are four sizes in this series: Model 212, 10 amperes, 240 volts

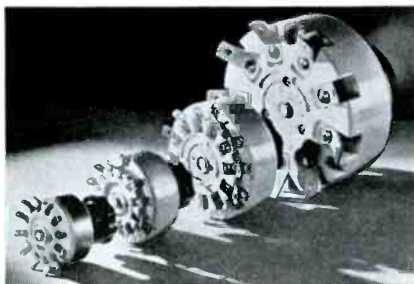

a-c, diameter 2 1/4". Model 312, 20 amperes, 240 volts a-c, diameter 3-5/16". Model 412, 40 amperes, 240 volts a-c, diameter 4-3/16". Model 608, 75 amperes, 240 volts a-c, diameter 6". Special tap switches with less than the maximum number of taps, special length shafts, etc., can be had on order. Tandem assemblies also available. *Ohmite Manufacturing Company*, 4835 Flournoy Street, Chicago, Ill.

SPEAKERS

Lansing has just placed on the market a new line of low-priced permanent-magnet

and replacement speakers. Sizes from 5 to 15 inches are now available. All models are said to be mechanically heavy and rugged. Full information may be obtained by writing direct to *Lansing Mfg. Co.*, 6900 McKinley Ave., Los Angeles, Calif.

DIAL LIGHTS

A line of eight radio dial lights, covering practically any replacement need, has been announced to the jobbing trade by *Arcturus*. The following types are now available: A40, A41, A42, A44, A46, A50, A51, A55.

The dial lights are packed in handy cartons of ten lamps each. *Arcturus Radio Tube Co.*, Newark, N. J.

CATHODE-RAY TUBES

Two recent DuMont designs in cathode-ray tubes have been announced. First, there is the new egg-shaped blank which is said to provide several times the struc-

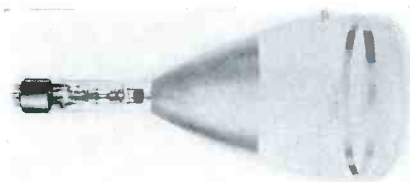

tural strength and hence a higher safety factor in larger tubes. The second DuMont development is the intensifier type tube, offering a direct means of lowering the cost of television sets and oscillo-

graphs of given image size. The introduction of one or two gold rings deposited on the inside wall adjacent to the screen, provides for the intensifier electrode which accelerates the electrons after deflection. *Allen B. DuMont Labs., Inc.*, 2 Main Ave., Passaic, N. J.

PAPER-WOUND CONDENSERS

To meet the demand for paper-wound replacements for metal-can and cardboard-

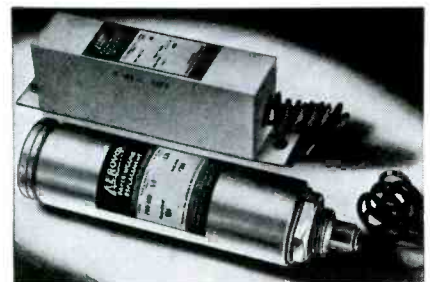

case dry electrolytics, two new condensers are announced by *Aerovox*. The PWC series, matching in size and shape the dry electrolytic metal-can condensers, is available in three types replacing the 4-600, 8-600 and 8-8-600 electrolytics, with actual capacities of 2.0, 2.75, and 1.75-1.75 mfd, respectively. The PWP series matches the cardboard-case dry electrolytics of 4-600, 8-600 and 8-8-600, with actual capacities of 2.0, 3.0, and 2.75-2.75 mfd. These paper replacement units have low power factor and leakage. No polarity need be observed. *Aerovox Corporation*, New Bedford, Mass.



**THE
HIT
of the
SHOW**



MODEL AP \$29.50

Everyone at the Radio Parts Show—
Especially the Service Men — liked
the new Brush Model AP Microphone.

The AP is an excellent Mike for the sound technician's service kit because:

- It can be connected for high or low impedance operation.
- It has a tone control which can be adjusted to minimize feedback.
- Its output is high—48 db.
- High crystal capacity permits the use of long leads.

See your jobber about the Brush AP microphone and get your copies of the three new Brush catalogs on the Brush Microphone, Headphone and Phonograph pickup lines.

THE BRUSH DEVELOPMENT CO.
3318 PERKINS AVE., CLEVELAND, OHIO

Laugh at obsolescence WITH
RCP TUBE TESTERS
- it's easy and economical

You've got to be able to test all the new tubes up to 115 volts on the heater to keep test instruments up-to-date. But take it easy. Modernize the economical and better way—with RCP tube testers. Check the features . . . then check RCP prices. You'll find RCP to be the most reliable and thrifty way to beat obsolescence.

HIGH in Reliability, LOW in Cost

**RCP
Model 308
NEW
DYNOP-
TIMUM
TEST**



How's this for performance! Tests up to 115 volt tubes, all metal, MG. glass, OZ4, cold cathode rectifiers, octal, locast, single end tubes and all ballast tubes. Test all pilot lights, Christmas tree lights, etc. Tests made under R.M.A. specified plate voltages and loads—finest co-relative test. Hot interelement short and leakage test between ALL INDIVIDUAL ELEMENTS. Audible test of noisy tubes. Spare socket for future tubes with new base arrangements. Adjustable for all line voltages. Counter type tube checker. Easier to operate than any other approved tube checkers, yet costs **\$16.95** only.

**Latest and Best—for the Least
RCP Model 701
MASTER SIGNAL GENERATOR**



All-wave, continuously variable from 125 kilocycles to 60 megacycles. Five bands on fundamentals 125 KC to 15 MC. Output may be modulated at will. Special triple shielding eliminates leakage. Supply double fused. Remarkably fine attenuation in approximate microvolt calibration. Many unusual quality features. An exceptional value at this thrifty price. **\$25.95**

Model 308 also available in combination portable counter model 308P. \$18.95

SEE YOUR JOBBER OR WRITE FOR CATALOG

RADIO CITY Products Co.
88 PARK PLACE NEW YORK CITY

The Fox Radio Service, 435 So. 5 St., Richmond, Ind., maintain their equipment in the fashion shown above. Jobs are completed the same day they are received. In the rack to the left the top panel contains a Clough Brengle OCX signal generator; the center panel a 120 Unimeter and the lower panel, a 79 beat-frequency audio oscillator. The center rack contains a Jackson 420 signal generator, a 680 analyzer and a 523 oscilloscope. The rack to the right contains an Oxford universal speaker, a Solar capacitor analyzer and an a-c voltage regulator. Between the left and center racks is a d-c voltage regulator with a self contained charger, for car radios. Between the center and right racks is a Rider Chanalyst. Portable equipment includes a Jackson 420 analyzer, Clough Brengle signal generator, Supreme analyzer, a volt-ammeter for car radios and a wattmeter.

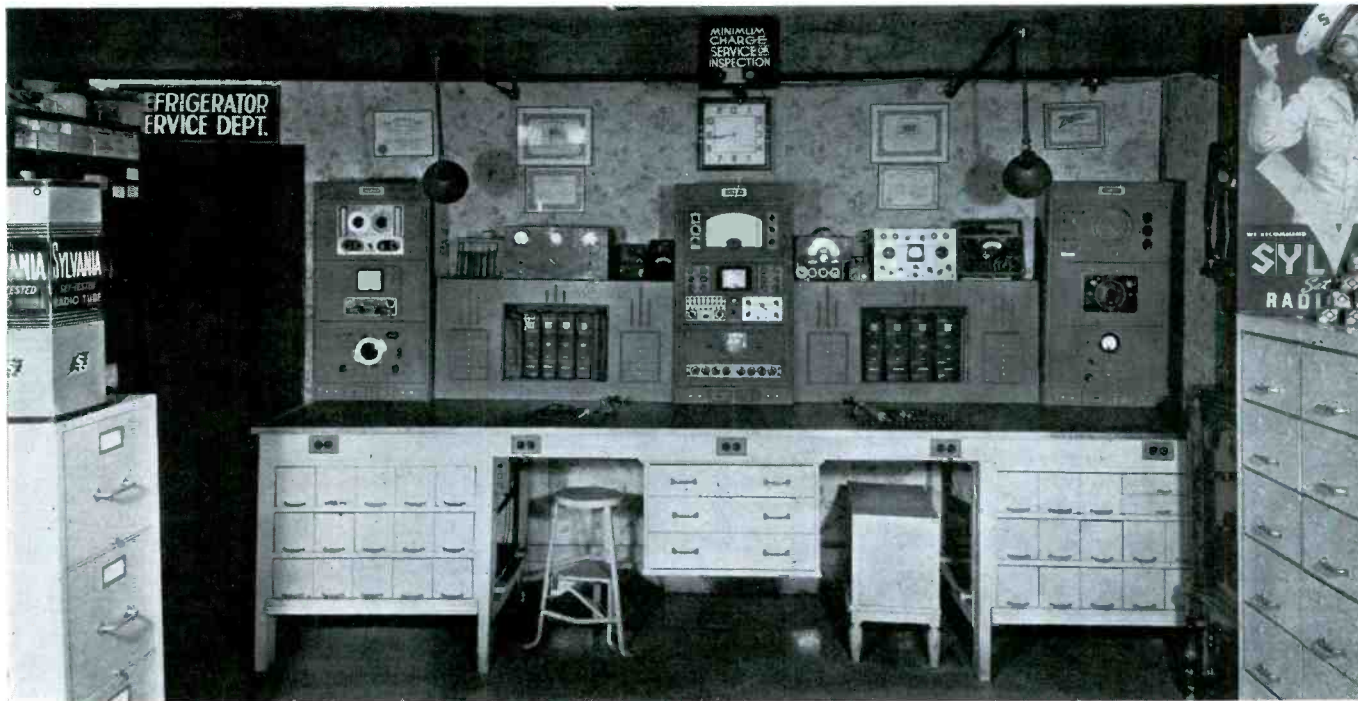

CORNELL-DUBILIER CATALOG

An 8-page, two-color catalog describing the line of C-D capacitor analyzer, bridge and decades has been released to the trade. Copies of catalog No. 167-A listing all the advantages of the analyzer, bridge and decades free on request. Inquiries should be addressed to the Cornell-Dubilier Electric Corporation, South Plainfield, New Jersey.

RCA ACQUIRES RIDER INSTRUMENTS

The manufacturing and sales rights to the Rider "Chanalyst" and the Rider "VoltOhmyst," introduced about a year ago by Service Instruments, Inc., have been acquired by the RCA Manufacturing Company, according to a joint announcement by John F. Rider, President of Service Instruments, and L. A. Goodwin, Jr., RCA Accessories and Test Equipment Sales Manager. At the same time, RCA announced a new policy of "Minimized Obsolescence" in the production of service test equipment.

MEISSNER CATALOGS

Meissner Manufacturing Co., Mt. Carmel, Ill., have issued their 1939-40 net price catalog and the Meissner Vibrator replacement guide. The former is a 48-page book illustrating and describing the Meissner kits, coils, tuning units, push-button assemblies, relays, knobs and accessories. The latter is a 12-page supplement listing vibrator replacements for popular auto-radio sets.

Copies may be obtained directly from Meissner.

HYTRONIC LABORATORIES CATALOG

A six-page folder giving the characteristics of the Hytronic products has been announced by the Hytronic Laboratories Division of the Hytron Corp., 76 Lafayette St., Salem, Mass. This bulletin lists transmitting tubes, diathermy types, high-frequency Bantams with ceramic base and also high-frequency types. It will be sent free upon request.

OPERADIO CATALOG

Operadio's latest catalog, No. 16, is a 24-page book illustrating and describing Operadio Unit Matched sound equipment and Operadio speakers.

Copies may be obtained directly from Operadio Manufacturing Co., St. Charles, Ill.

ARCTURUS DISPLAY

As the first unit in a new series of consumer display prices featuring Arcturus Radio Tubes for home radio use, the Arcturus Radio Tube Co., Newark, N. J., has just released four colorful eye-catching

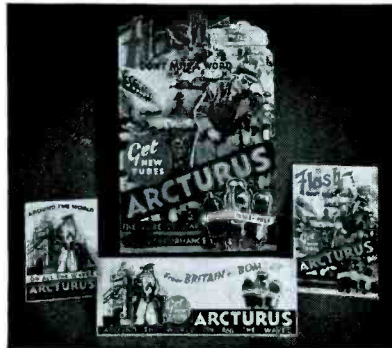

pieces which tie up with the widespread interest in current events.

SOLAR CONDENSER CATALOG

Installed entirely in its Bayonne, N. J., plant, Solar Mfg. Corp., makers of radio and television capacitors, present a new catalog, No. 10, which illustrates and describes the complete line, with special pages devoted to Solar's testing instruments. Various new capacitors expressly designed for television are also included.

Copies may be obtained by writing the manufacturer directly.

STANCOR CATALOG

Standard Transformer Corp., 1500 N. Halsted St., Chicago, have issued their summer and fall complete transformer catalog. The 32-page book lists the many items in the Stancor line.

Copies may be obtained directly from Stancor.

TRIPLETT BULLETINS

Triplett Electrical Instrument Co., Bluffton, Ohio, have issued three new bulletins. The first is a 12-page tester circular which illustrates and describes many new instruments in the Triplett line of service equipment. The second is a circular on wattmeters and the portable appliance tester. The third is called No. 52I and is an instrument price sheet.

Copies of these bulletins may be obtained directly from Triplett.

PREMAX BULLETINS

Premax Products, division of Chisholm-Ryder Co., Inc, Niagara Falls, N. Y., have issued a series of bulletins which illustrate and describe their line of Corulite tubular antenna elements, vertical steel radiators, rotary beam frame kits, wood towers, monel masts and mountings, insulators and accessories for radio receiver and transmitter antenna installations.

Copies may be obtained directly from Premax.

RCA SOUND CATALOG

A 56-page catalog containing a complete listing of all RCA sound equipment for a wide variety of applications in the industrial, entertainment and educational fields, has been announced by the Commercial Sound Section of the RCA Manufacturing Co.

All items are indexed and cataloged with photographs, prices, specifications and general descriptions, including possible uses. In addition, a compact guide for prospective buyers is included in a chart of six basic sound systems which, with extra equipment for special requirements, cover standard applications.

Copies may be obtained directly from RCA Mfg. Co., Inc., Commercial Sound Section, Camden, N. J.

SPRAGUE TABLOID

Service Men will find a great deal of helpful information in the Sprague Condenser News bulletin, a 4-page condenser newspaper issued by the Sprague Products Co., North Adams, Mass., it is said. Included in the bulletin are articles on interference elimination; condensers for television use; a simple method of testing condensers for intermittent shorts; a discussion of midjet dry electrolytic condensers and their uses; full details of a new condenser analyzer and many other articles.

Copies may be obtained directly from Sprague.

THORDARSON SALES MANAGER

Thordarson announces the appointment of W. S. Hartford as General Sales Manager. Mr. Hartford's experience in the industry dates from 1927 when he joined the radio sales division of Kellogg Switchboard in a sales promotional capacity. Now in his sixth year with Thordarson, he has made a close study of merchandising problems of mutual interest to distributor and manufacturer and is fully acquainted with Thordarson products and their distribution.

RECEIVER ALIGNMENT SIMPLIFIED



A Crystal Calibrator cannot be beat for rapid accurate receiver alignment—it is indispensable for a quick check of sensitivity and alignment. Your Bliley Distributor can supply the SMC100 Crystal Unit for only \$7.75. Bulletin E-7 (free) contains complete information. Bliley Electric Co., Erie, Pa.

BLILEY DUAL FREQUENCY CRYSTAL

A GOOD NAME GOES A LONG WAY



One of the outstanding superiorities of Ken-Rad Radio Tubes lies in the unusual skill in assembly, which makes for dependability in use.

KEN-RAD TUBE & LAMP CORPORATION
Owensboro, Ky.

KEN-RAD

DEPENDABLE RADIO TUBES

Just ask
for it..



Hot off the press. Right up to the minute. Lists control replacements for all standard sets under respective brand and model. Convenient. Accurate. Dependable. And backed by CLAROSTAT line of standard and exact-duplicate controls. Ask local CLAROSTAT jobber for your copy.

CLAROSTAT

MANUFACTURING CO.
Incorporated

285 North Sixth St.
Brooklyn, N. Y.

WHEN YOU CHANGE YOUR ADDRESS

Be sure to notify the Subscription Department of SERVICE at 19 E. Forty-seventh St., New York City, giving the old as well as the new address, and do this at least four weeks in advance. The Post Office Department does not forward magazines unless you pay additional postage, and we cannot duplicate copies mailed to the old address. We ask your cooperation.

CINAUDAGRAPH SPEAKERS

The eight 27-in. speakers used at the Lagoon of Nations in the New York World's Fair, 1939 are but one group in

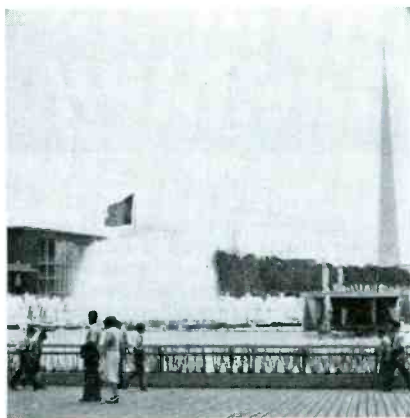

over 1,800 Cinaudagraph speakers in operation on the fair grounds. These range from the 6-in. type used in the General Motors Highways & Horizons exhibits to the 27-in. types mentioned.

CROWE BULLETINS

Two bulletins are announced by Crowe Name Plate & Manufacturing Co., 1775 Grace St., Chicago, showing many new products. Bulletin 225 shows components for receivers, transmitters, television, sound equipment and experimental work. Many new items shown, including a new line of knobs in distinctive shapes and colors. Bulletin 230 shows their line of remote controls, panel kits, colored knobs, etc.; also a check-chart with full control specifications for several hundred auto radios. Copies of these bulletins may be secured by writing directly to Crowe.

BLILEY BULLETIN

Bliley Electric Co., Erie, Pa., have just issued a bulletin that gives rather complete information on a dual-frequency crystal calibrator. Copies may be secured from the above organization. Write for Engineering Bulletin E-7.

AMERICAN MICROPHONE BULLETIN

American Microphone Co., Inc., 1915 S. Western Ave., Los Angeles, Calif., recently issued Special Bulletin No. 33, describing their Model D8T moving-coil dynamic microphone and the C6 crystal microphone. The above organization will send the bulletin free on request.

NEW Signal Generator

Model
1232-A



\$29.84 DEALER
NET
PRICE

- ★ **TRIPLE SHIELDING—**
and completely NEW design. Top panel is insulated from R. F. Main wiring is beneath double shielded panel. Coils and the band switch are individually shielded.
- ★ **IMPROVED ATTENUATION—**
Zero signal for all practical purposes.
- ★ **LARGE DIAL OPENING—**
180°—Improves readability. Scale is 345°. Dial is direct geared, permitting quick and accurate settings.
- ★ **SIX BANDS—**
cover frequencies from 115 Kc to 30.5 Mc. Total scale length over 50 inches. Direct reading.

Line Filter—Filters RF between oscillator and the line.

Six Trimmer Calibrated Coils—For accuracy well within servicing requirements on all bands.

400 Cycle Audio Note obtained from panel jacks.

This new model is made with full vision dial having six scales with total length of over 50 inches. Improved accuracy, shielding and attenuation equal to oscillators for which you would pay much more.

Model 1232-A, complete with accessories. Dealer Net Price.....\$29.84

TRIPLET
Precision

ELECTRICAL INSTRUMENTS

The Triplet Electrical Instrument Co.
177 Harmon Ave., Bluffton, Ohio

Please send me more information on

Model 1232-A.

Name

Address

City..... State.....

SENSATIONAL! NEW! PROFITS! PORTABLE SET OWNERS WANT

GTC PORTA-POWER

Shipping
Weight
5 Lbs.



Replaces batteries in sets using 1½ volt tubes. Operates on 110 v. 60 c. Current • As easily installed and removed as batteries • Fits all battery compartments.

List \$7.50 ea. Your cost \$4.50 ea.
F.O.B. Chicago 2% Cash Discount

ATTENTION SERVICE MEN
Use GTC PORTA-POWER for testing and cut battery cost. Representatives Wanted—Specify territory desired and trade contacts.

GENERAL TRANSFORMER CORP. 1256 W. VAN BUREN ST.
CHICAGO, ILLINOIS

if you're going to sell speakers SELL CINAUDAGRAPH

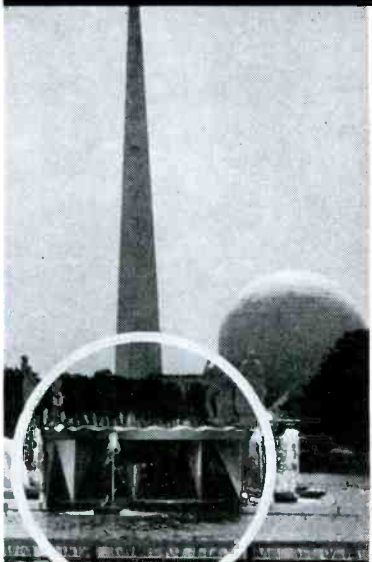

If you're going to sell speakers sell Cinaudagraph. It's easier to make money the Cinaudagraph way. For one thing, you've got a complete line of quality-built indoor and outdoor speakers to offer. For another, Cinaudagraph speakers are priced economically. Finally, you've got the speaker line that was specified for 76 World's Fair installations, (including the Lagoon of the Nations and General Motors installations).

Make your next P. A. job a Cinaudagraph installation and watch your customer's reactions.

Description of the Cinaudagraph 27" electro-dynamic speaker installation at the New York World's Fair available on request. Also complete catalog describing the entire line of Cinaudagraph electro-dynamic and permanent magnet speakers from 5 1/2 to 27".

We cordially invite you to visit our plant when you come to see the New York World's Fair. Call or write for guide.

CINAUDAGRAPH CORPORATION

Stamford
Connecticut



IT'S EASIER TO MAKE MONEY
the CINAUDAGRAPH way

BRACH COWL AERIAL

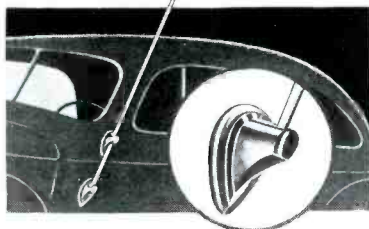

Radio's Smartest—

Made of Admiralty Brass, gleaming chrome plated. Handsome streamline design; smooth, noiseless action; permanently lubricated. Exclusive anti-rattle construction makes it vibrationless.

Approved and recommended by leading car manufacturers.

L. S. BRACH

MANUFACTURING CORPORATION

World's Largest Makers of Antenna Systems

55-67 DICKERSON STREET
NEWARK, N. J.

"PRECISION" SERIES 844

34 RANGE

AC-DC Volt-Ohm-Decibel-Milliammeter
including ranges of 6,000 Volts AC-DC
10 Megohms and 12 Amperes

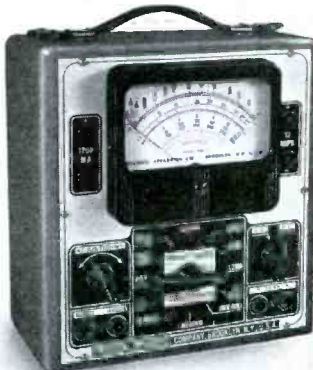

814L—Housed in walnut finished hardwood case with carrying handle. Compact in size 7x8x4. Code: Manse. NET PRICE (Less Batteries and test leads).....\$22.95

SPECIFICATIONS

- * SIX A.C. and D.C. VOLTAGE RANGES at 1000 ohms per volt: 0-12; 0-60; 0-300; 0-600; 0-1200; 0-6000 volts.
- * SIX D.C. CURRENT RANGES: 0-1.2; 0-12; 0-60; 0-300; 0-1200 MA; and 0-12 Amperes.
- * FOUR RESISTANCE RANGES: 0-400; 0-100,000; 0-1 Meg.; and 0-10 Megs.
- * Provisions for Mounting Ohmmeter Batteries (4 1/2 and 45 volts) on inside of case.
- * SIX DECIBEL RANGES from -12 to 70DB.
- * SIX OUTPUT RANGES: 0-12; 0-60; 0-300; 0-600; 0-1200; 0-6000 volts.

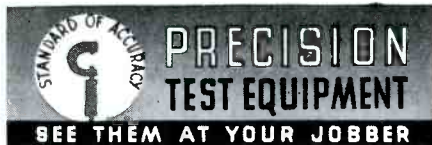

PRECISION APPARATUS CORP.
647 Kent Avenue, Brooklyn, N. Y.
Export Division—458 Broadway, New York City, U. S. A.
Cable Address: Morhanex

NOISE SUPPRESSOR CONDENSERS

THE Joint Coordination Committee on Radio Reception of the Radio Manufacturers Association, the Edison Electric Institute, and the National Electrical Manufacturers Association has studied the problems presented by the use of small capacitors for suppressing radio interference which may be generated at the brushes of commutator type motors, at the contacts of thermostats, and at the contacts of other types of electrical appliances.

In metal frame devices these capacitors frequently are connected between the ener-

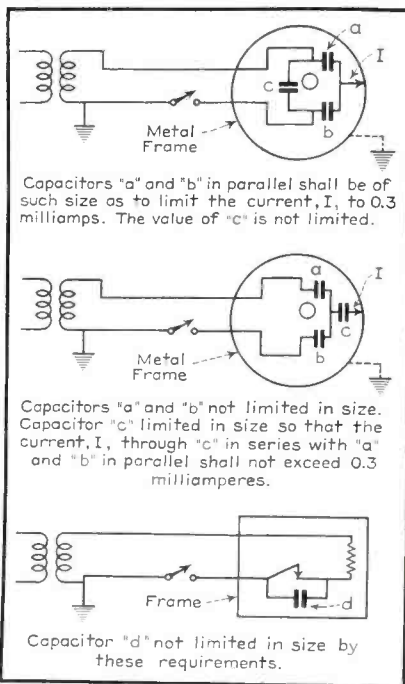

gized conductors of the device and the frame, thus giving rise to the possibility of objectionable shock. The choice of the suitable value of noise suppression capacitors is, therefore, a compromise between a desirably high value for purposes of noise suppression and a low value required for the avoidance of an appreciable possibility of sense of shock for the large majority of individuals under usual conditions.

As a result of the study of this problem, the Joint Committee has recommended, as tentative limits, that the maximum value of the capacitance to be connected between the windings and the case shall be such that the current to ground through this capacitance shall not exceed 0.3 milliamperes with the switch or switches of the device in any position. (Devices rated at 110 to 120 volts shall be assumed to operate at 120 volts and at rated frequency.) The accompanying diagrams illustrate the application of this limitation.

This study has not included consideration of devices where the frame is permanently grounded, as in oil burners, pump motors, etc., or where there is little likelihood of contact by an individual with the metal frame, as in the case of most radio sets. For such devices the limitation on size of capacitors for the avoidance of the possibility of shock does not, in general, apply. Nor has consideration been given to the make and break of switches which, as a rule, are operated infrequently.

It is recognized that the limiting value of current as here given may be subject to revision after further field experience.

C-D TELEVISION CAPACITORS

Cornell-Dubilier engineers have released a series of capacitors designed for use in television receivers. This series (Type PC) have been tested in actual television receivers in the C-D laboratories, and are now in use in models being produced by the trade. The type PC capacitors are impregnated and filled with Dykanol. They



are available in single, dual and multiple capacities at voltages between 2,000 and 10,000 volts d-c. Cornell-Dubilier Electric Corp., South Plainfield, N. J.

CONSOLIDATED ANTENNA

A new dipole type television antenna has been announced by Consolidated Wire & Associated Corps. It has two telescoping brass rods which allow for adjustment



to the exact frequency to be picked up by the television receiver. An especially designed transmission line is used. The impedance of this will match the input of the television receiver, which is approximately 100 ohms. The unit comes with 75 feet of transmission line.

Additional information may be obtained directly from Consolidated Wire & Associated Corps., 518 S. Peoria St., Chicago.

SHURE MICROPHONES

A new series of Streamliner crystal and dynamic microphones is announced by Shure Brothers. The series is intended for use in low-cost p-a, paging and call



systems, amateur phone and similar applications.

Additional information and prices may be obtained directly from Shure Brothers, 225 W. Huron St., Chicago.

IRC 50 WATT RHEOSTAT

The construction of the 50-watt all metal rheostats, IRC type PR50, results in a reduction of operating temperature to almost



Utah No. 8311
Universal Input

Utah No. 5999
Universal Output

Now Utah TRANSFORMERS for EVERY home or auto set replacement

You obtain the benefit of Utah's 10 years of experience in transformer engineering and manufacturing when you standardize on Utah transformers for all home and automobile replacement requirements. Because Utah designs and produces speakers, vibrators and transformers, Utah engineers have a decided advantage in "matching" the characteristics and in developing maximum performance features.

Utah Transformers, standard equipment in millions of receivers throughout the world, have proved the high

safety factor of their insulation. Precision manufacturing and the use of scientifically selected materials such as; the high silicon content steel used in all laminations, assure complete satisfaction. Because Utah Transformers are subjected to every conceivable test before shipment, they are uniformly dependable. These fully guaranteed transformers are individually boxed, with complete instruction sheets.

If you do not have your copy of the new Utah illustrated catalog containing complete information about the transformer line and other Utah products — write for it today — no obligation.



SPEAKERS — VIBRATORS — UTAH-CARTER PARTS



UTAH RADIO PRODUCTS CO.

CHICAGO, ILLINOIS

CABLE ADDRESS: UTARADIO — CHICAGO

half those obtained with rheostats of conventional design and of the same size, it is said.

The type PR50 is 2 $\frac{3}{8}$ in. in diameter 1 $\frac{3}{8}$ in. deep behind the panel. It is avail-

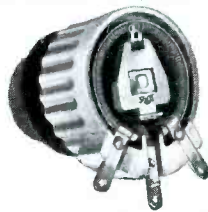

able in values from 0.5 to 10,000 ohms.

Catalogs describing this and other IRC products can be obtained directly from International Resistance Co., 401 N. Broad St., Philadelphia, Pa.

SOUND LEVEL METER

This new instrument has been designed to offer a convenient, portable means of measuring sound intensity in design and survey work. By means of a calibrated microphone and specially designed amplifier, all housed in a single portable carrying case, it is possible to measure the intensity of sounds or noises within the range of the human ear. The range of measurements is from plus 50 decibels to plus 125 decibels, in steps of one decibel each. A weighted response curve is employed, meeting the specifications set up by the American Acoustical Society. Complete information and bulletins describing the Pattern 15 Soundmaster may be secured by writing the manufacturer, John Meck Instruments, 164 N. May St., Chicago, Illinois.

Now..
5 VITAL FEATURES
 COMBINED IN
AMPERITE VELOCITY
 WITH ACOUSTIC COMPENSATOR



it's a VELOCITY
it's a DYNAMIC
UNI-DIRECTIONAL
NON-DIRECTIONAL
HIGH OR LOW PITCH

UNI-DIRECTIONAL PICK-UP FIELD COMPENSATOR UP

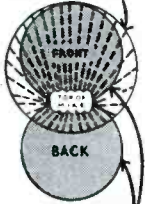

PICK-UP FIELD COMPENSATOR DOWN

By moving up the Acoustic Compensator, you change the Amperite Velocity Microphone to dynamic operation — without peaks. At the same time you reduce the back pickup, making the microphone practically UNI-DIRECTIONAL.

With the Acoustic Compensator down, the microphone is BI-DIRECTIONAL . . . 120 degrees front and back without frequency discrimination. Rotating the microphone until it parallels the ceiling makes the microphone NON-DIRECTIONAL.

THE ACOUSTIC COMPENSATOR is a regular feature of these models: RBHk (hi-imp); RBMk (200 ohms) LIST \$42.00. RSHk (hi-imp); RBSk (200 ohms) LIST \$32.00



Sell "Contact Mikes to Professional and Amateur Musicians

New high output model can be used in the home.

Professional musicians are buying Amperite "Contact Mikes" because "it makes an ordinary violin sound like a Strad". Now amateurs, too, can benefit by the "Contact Mikes". The new HIGH OUTPUT MODEL SKH can be used in the home. It operates on most radio sets made since 1935. It is connected to the phono-input, or to grid ground of detector tube, or across the volume control. Note new clamp, making the mike easy to attach to guitars, ukes, etc.

MODEL SKH (hi-imp); SKL (200 ohms) \$12.00 LIST. Any number up to 5 SKH's can be put in parallel and fed into one input. NEW FOOT PEDAL \$12.00 LIST. CLAMP for Contact Mike, \$1.00 LIST.



FOR TOP-NOTCH QUALITY AND AMAZING RUGGEDNESS, AT LOW COST SPECIFY MODEL RAH (OR RAL)

Here's why this popular Amperite Velocity Microphone leads the low-price field: (1) it is excellent for both speech and music; (2) has flat response without undesirable peaks; (3) reduces feedback; (4) stands up under rain, wind, heat, and rough handling . . . Frequency range 60 to 7500 CPS. Output, —68 db. MODEL RAH (hi-imp.), with 12' of cable; MODEL RAL (200 ohms) with 8' of cable. \$22.00 LIST

Write for Complete Illustrated Bulletins and Valuable Sales Helps

AMPERITE 561 BROADWAY, N. Y. Cable Address: Alkam, New York

AMPERITE Velocity MICROPHONES

Index to Advertisers

A	
Aerovox Corp.	354
Alden Mfg. Co.	366
Amperite Co.	366
B	
Bliley Electric Co.	362
Brach Mfg. Corp., L. S.	364
Brush Development Co., The.	361
C	
Centralab	351
Cinaudagraph Corp.	361
ClaroStat Mfg. Co., Inc.	365
Cornell-Dubilier Electric Corp.	358
D	
Dayton Acme Co.	357
G	
General Transformer Corp.	363
H	
Hygrade Sylvania Corp.	359
J	
Jackson Electrical Inst. Co.	354
K	
Ken-Rad Tube & Lamp Corp.	362
L	
Lenz Electric Mfg. Co.	337
M	
Mallory & Co., P. R. Second Cover	342
Meissner Mfg. Co.	330
N	
National Union Radio Corp.	329
P	
Precision Apparatus Corp.	364
R	
RCA Mfg. Co., Inc. 335, 351, Fourth Cover	
Radiart Corp., The.	359
Radio City Products Co., Inc.	361
Radio Servicemen of America, Inc.	360
Readrite Meter Works.	366
Rider, John F., Publisher.	355
S	
Solar Mfg. Corp. Third Cover	
Supreme Instruments Corp.	339
T	
Thordarson Elec. Mfg. Co.	358
Triplett Elec. Inst. Co., The.	363
Tung-Sol Lamp Works, Inc.	349
U	
Utah Radio Products Co.	365
W	
Weston Electrical Instrument Corp.	359
Y	
Yaxley Mfg. Division. Second Cover	342

PARALLEL PRECISION CONTACTS
INSURE QUALITY IN
NAALD SOCKETS
ADAPTERS and TEST EQUIPMENT

MOVEMENT HERE AVERAGES BUT .003"



THIS DISTRIBUTED FLEXING HERE IS INFINITESIMAL

This patented contact is the only one that has withstood life test of 1,750,000 insertions.

Contacts of other design regardless of shape or material start to fail upward of 5,000 insertions.

Why? Because at some point there is considerable flexing movement that sets up crystallization.

In the parallel precision contact, the contact floats to meet any bent or irregularly placed prongs. The open end moves on an average of but .003 of an inch. Because this movement is reduced by leverage to the fulcrum points and by the proper balance of thickness of the clip, the movement or flexing of the metal molecules at these points is microscopic; thus no crystallization can set up to cause failure.

Insist on these quality sockets in instruments you buy or make. Their price is not prohibitive for either you or manufacturers.

Write for a bulletin!

ALDEN PRODUCTS CO.
 DEPT. S7 BROCKTON, MASS.

FOR TUBES of TODAY and TOMORROW . . .

Readrite RANGER

MODEL 432-A RED-DOT



Lifetime Guaranteed Triplett Meter

ONLY \$17.85

- Sockets for All Tubes.
- Filament voltages from 1 to 110—A safeguard against obsolescence.
- Precision indicating instrument with two highest quality sapphire jewel bearings.
- Separate line control meter.
- Neon shorts test.
- Etched panel of outstanding new design.
- Approved RMA circuit.
- Portable rich black leatherette covered case—professional in appearance.

Today's outstanding tube tester value—a guaranteed quality portable tester at a price you can afford to pay. Checks Leetals, Single Ends, Bantam, Jr., Gaseous Rectifier, Ballast, the New High Voltage Series (including 11726G and others recently announced). Direct Reading GOOD-BAD Meter scale. Positively will not deactivate 1.4 volt or other type tubes.

Model 432-A-742—a combination Tube Tester and Volt-Ohm-Milliammeter, in similar case, but slightly larger. Dealer Net Price. \$26.85

Write for Information—Section 717

READRITE METER WORKS, Bluffton, Ohio



CAPACITORS OF TOMORROW

From Hell Gate to Golden Gate, faster than the wings of the wind, are the new Trade Routes of the air. Most of the United States is over-night from Solar. Ask your Jobber about Solar's prompt delivery service, which assures an adequate stock of all most-needed capacitors. For an emergency, rely on your Solar Jobber to use the telegraph and air-express — and your emergency is over tomorrow.

SOLAR MFG. CORP.

BAYONNE, NEW JERSEY

BUY FROM YOUR RELIABLE JOBBER

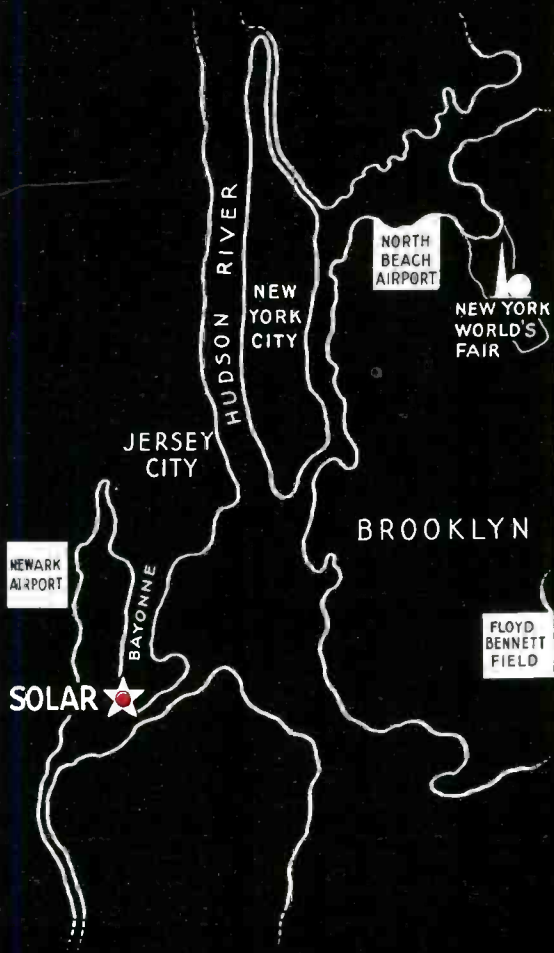

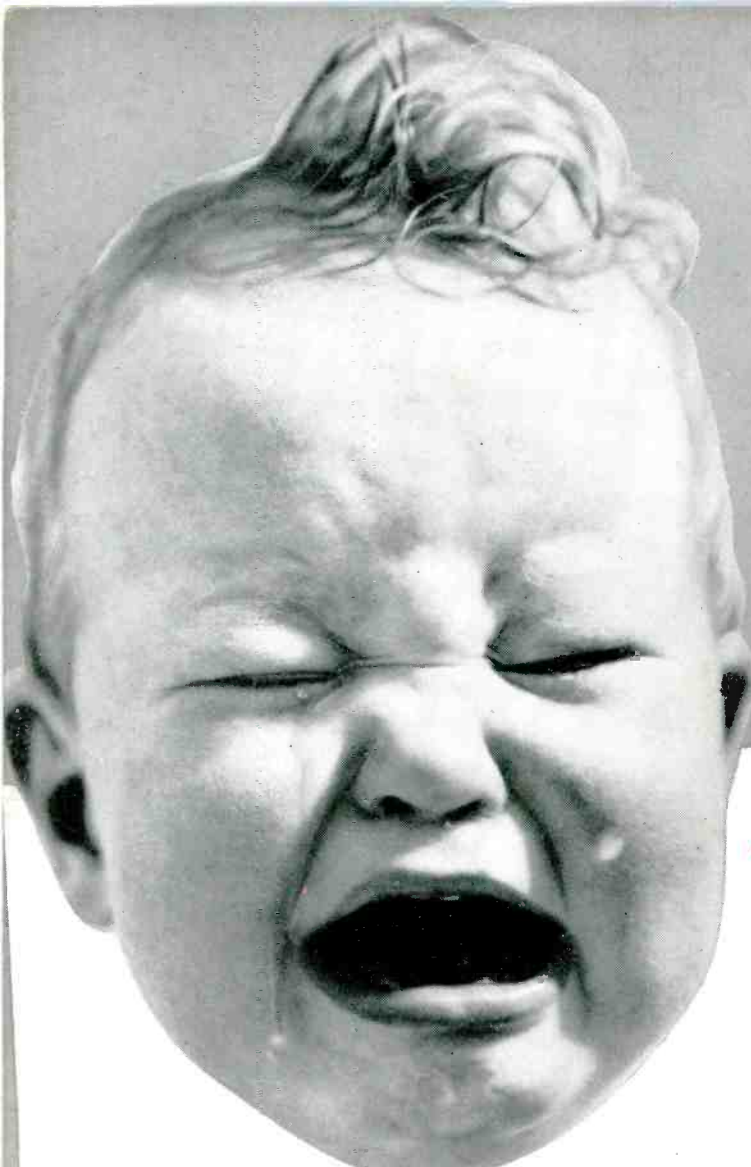

What's this picture got to do with you—and the **RIDER CHANALYST?**

Plenty!

... When babies start crying it's often-times pretty hard to locate the source of their distress. And in a radio receiver the story is pretty much the same . . .

Unless you own a Rider Chanalyst. You know from experience that locating the defect in a radio receiver is the major problem—a time consuming and costly operation. And the more complicated the receiver, the greater the time spent—time that means money to you and for which you can't collect.

The Rider Chanalyst solves this problem. With this modern service instrument you can work rapidly—accurately—profitably—on any one of the 40 million radio receivers now in use. Founded upon the most basic element in communication—the signal itself—the simplest and most complicated receivers are serviced with equal ease—quickly!

You can trace the signal—hear the signal—and, if you connect your oscillograph to the Rider Chanalyst, you can see the signal, any place in the receiver. The Rider Chanalyst is a proved service instrument. Ask the man who has used one.

Listen to the Magic Key, every Monday 8:30 to 9:30 P.M., E.D.S.T., on NBC Blue Network



Measure volts and ohms over very wide ranges with **THE RIDER VoltOhmyst**

It's new and it's different! Yes—and the Rider VoltOhmyst fulfills a real service need. It is an electronic d-c voltmeter-ohmmeter which is statically and dynamically balanced. Accurately independent of line voltage and tube variations. Operates from 100-130 volt, 25-60 cycle line supply.
WIDE RANGE . . . 0.05 volt to 5,000 volts in 9 overlapping ranges . . . 0.1 ohm to 1,000,000,000 in 7 decade ranges.
ADVANCED DESIGN . . . No readjustment of zero when changing ranges . . . highly stable push-pull circuit (patent pending) . . . balanced statically and mechanically.
PRECISION CONSTRUCTION . . . quality components throughout . . . built for years of trouble free service.
Price \$57.50

Over 335 million RCA Radio Tubes have been purchased by radio users . . . in tubes, as in parts and test equipment, it pays to go RCA All The Way.



*The Rider Chanalyst . . . \$107.50 net—
It will pay for itself by saving your time
—upping your profits!*



Test Equipment

RCA Manufacturing Co., Inc.
Camden, New Jersey
A Service of the
Radio Corporation of America