

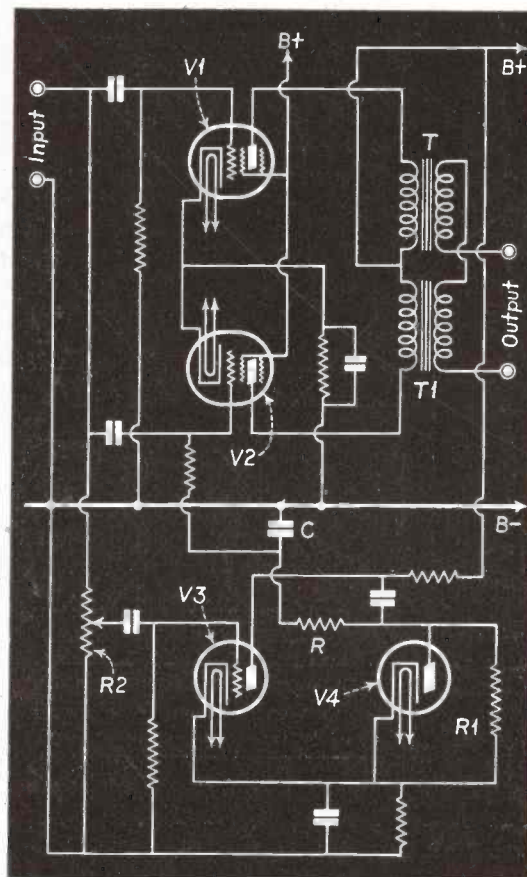

# SERVICE



## A MONTHLY DIGEST OF RADIO AND ALLIED MAINTENANCE



Volume Expander Circuit

(See Page 372)

PER COPY  
25 CENTS

OCTOBER  
1934

*The entire Schedule of List Prices of STANCOR Transformers for replacement . . . for Amateur Transmitting and Sound Amplification has been revised. Many sharp reductions have been effected. These new List Prices are effective as of September 25th, 1934.*

STANCOR



again helps you to  
get more business

*Complete price revisions*

Only a very little while back there was no reliable source from which a service man could secure transformers for replacement servicing. No set manufacturer had made any provision for keeping his product in satisfactory condition by making or buying stocks of parts for servicing. Transformer manufacturers made just so many transformers for an equal number of sets, to the specifications of the set maker.

Service men were blamed for things they couldn't help. They were doing their very best, working with what they could get and, altogether, doing as good a job as any group of men ever did with as little to help them.

Then STANCOR pioneered the EXACT-DUPLICATE Replacement Transformer and the whole job of servicing began to look up. Renewing original performance through transformer replacement became certain . . . the customer began to be completely satisfied; the standing of the service man in his community became that of any other good professional man, and in a short time other replacement parts makers began supplying him with sound, quality-made units.

This organization feels and we believe the fair-minded will agree with us that STANCOR has been of material help in helping the service man to get more business.

And now, the STANCOR line of Transformers for replacement having become accepted as standard . . . a great demand for them having become established, making it possible for more and more of each unit to be made every year, costs of production have gone down, in spite of increased costs of materials, higher wages and shorter hours.

The savings effected by these lowered costs are now being passed on to you in this sweeping price revision. In some instances the savings may not seem to amount to much, but in the total they are enough to make it possible for many an owner to have his set transformer-serviced when he couldn't before.

Your copy of this Price Revision is ready for you. You need it to bring your STANCOR 1934 Catalog "A COMPLETE TRANSFORMER SERVICE" up-to-date. All authorized STANCOR distributors have this list. Get your copy from your distributor or from here direct.

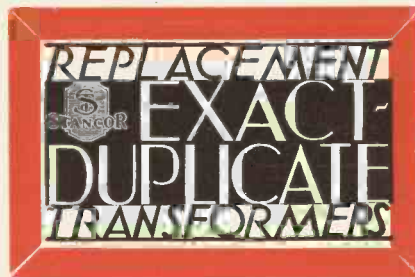

Every Radio Service Man  
should be a member of the  
Institute of Radio Service Men

STANDARD TRANSFORMER CORPORATION, 866 Blackhawk Street, Chicago, Ill.

# Consider all Points

## OHIOHM RESISTORS.

- Trade mark and value stamped on each piece in addition to being R. M. A. Color Coded.
- "Protect-O-Packed" so as to prevent bent or "kinked" wire-leads and to assist in easy selection of proper values.
- A type of container or kit for every type of business.
- Metal Stock Cabinet for jobbers — Counter Server for dealers—First-Aid Kits for service men.
- Spark Suppressor Sets for eliminating ignition interference on auto radios.
- Sales helps and advertising to popularize resistors.
- *Get the OHIOHM story and get started with real net profits.*



Display card for popularizing resistor importance—includes actual OHIOHM Resistor on card

OHM DIAL—for determining resistance value of resistors in sets, according to R. M. A. color code. Furnished Free with First-Aid kit.



Service labels furnished free with First-Aid Resistor Kit.

Radio Resistor Guide also furnished free with initial order.

# OHIOHM

## PROTECT-O-PACKED RESISTORS

THE OHIO CARBON COMPANY • 12510 Berea Rd. • CLEVELAND, OHIO

RESISTORS are made in Canada by C. C. Meredith & Co., Ltd., Toronto

# SERVICE

A Monthly Digest of Radio and Allied Maintenance

Vol. 3, No. 10  
OCTOBER, 1934

EDITOR  
M. L. Muhleman

ASSOCIATE EDITOR  
Ray D. Rettenmeyer

## EDITORIAL CONTENTS

### FEATURES

- DC Shunt Installations  
*By D. L. Van Lewen*..... 371
- P-A System with Velocity Mike  
*By H. Howard Rabe*..... 383
- Philco 200..... 376
- The Radio Service Man Becomes a Radio  
Service *Business Man*..... 373
- Versatile All-Wave Aerial System  
*By R. L. Haskins and R. T. Perron*..... 374
- Volume Expander Circuit..... 372

ANTENNA (Is Servicing a Business?)..... 368

ASSOCIATION NEWS..... 394

### AUTO RADIO

- Howard Highwayman..... 382

### CIRCUITS

- DC Shunt Installations..... 371
- Howard Highwayman..... 382
- Philco 200..... 376
- Test Meter Switching Unit..... 388
- Versatile All-Wave Aerial System..... 374
- Volume Expander Circuit..... Front Cover

FORUM..... 396

### GENERAL DATA

- Atwater Kent I-F Peaks..... 386
- Majestic 112..... 386
- Philco Compensating Condenser..... 381
- Philco Model 29 and "TX"..... 381
- Philco Model 95 Changes..... 375
- Philco Model 66..... 375
- Philco 200..... 376
- Silvertone Field-Coil Values..... 381
- Silvertone Model 1760 Hum..... 381
- Stewart-Warner Model-Chassis Numbers..... 381
- Stewart-Warner Wave-Trap Installation..... 380
- Volume Expander Circuit..... 372

HIGHLIGHTS..... 392

MANUFACTURERS..... 399-400

### ON THE JOB

- Argus Electric  
*By E. M. Prentke*..... 388
- RCA Victor Model 126-B Bias..... 388
- Test-Meter Switching Unit  
*By Al. Beers*..... 388

### PUBLIC ADDRESS

- P-A System with Velocity Mike  
*By H. Howard Rabe*..... 383

### SERVICE-MAN'S NOTEBOOK ("Voltage Relation"

and Its Application, Part I)..... 390

BRYAN S. DAVIS  
*President*

JAS. A. WALKER  
*Secretary*

Chicago Office—608 S. Dearborn St.—C. O. Stimpson, Mgr.  
Telephone: Wabash 1903  
Cleveland Office—10515 Wilbur Ave.—J. C. Munn, Mgr.

Published Monthly by the

Bryan Davis Publishing Co., Inc.  
19 East 47th Street  
New York City

SANFORD R. COWAN  
*Advertising Manager*

A. B. CARLSEN  
*Circulation Manager*

St. Louis Office—505 Star Bldg.—F. J. Wright, Mgr.  
Wellington, New Zealand—Tearo Book Depot.  
Melbourne, Australia—McGill's Agency.

Entered as second-class matter June 14, 1932, at the Post Office at New York, N. Y., under the Act of March 3, 1879. Subscription price \$2.00 per year in the United States of America; 25 cents per copy. \$3.00 per year in Canada and foreign countries; 35 cents per copy.



**Servicemen and Parts Dealers would profit by the new Clarostat Replacement Guide if it cost \$5.00 . . . . but IT IS FREE!**

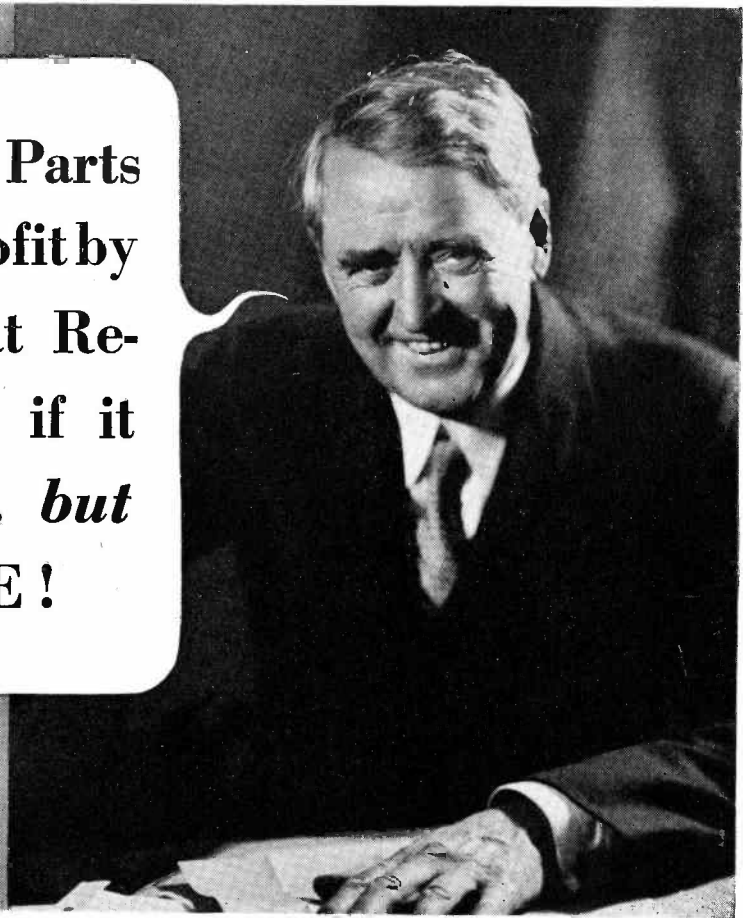

You'll find the components you need for all modern radio receivers listed in Clarostat's New Fall Replacement Guide and Catalog. It will help you quickly to pick the right values for all modern radio receivers.

Full data for parts replacement is given on Volume Controls, Tone controls, Clinch-Grip Flexible Resistors, Metal Cover Fixed Power Supply Resistors, Line Ballasts, L & T Pads, Series Mixers, Constant Impedance Devices and Standard Potentiometers.

*Write today for your Free Catalog—it will help you give your customers better service, and will help make your replacement parts business profitable.*

**MAIL COUPON TODAY**

CLAROSTAT MANUFACTURING CO., INC.  
287 NORTH 6TH STREET  
BROOKLYN, NEW YORK

Gentlemen:—Kindly send me a copy of the new Clarostat Replacement Guide and Catalog.

Name .....

Company .....

Address .....

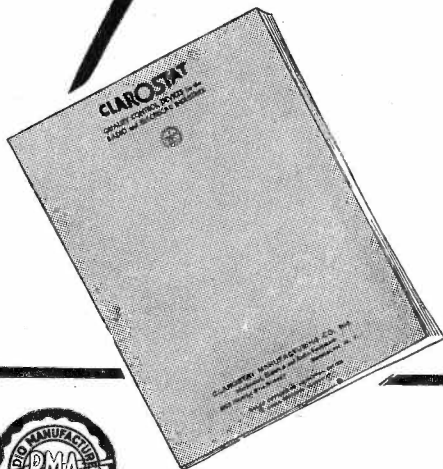

**CLAROSTAT MFG. CO., INC.**  
287 North 6th St., Brooklyn, N. Y.



# THE ANTENNA...

## IS SERVICING A BUSINESS?

A RECENT discussion between two men connected with radio publications resulted in some interesting conclusions. This discussion took place at the Rochester Convention of the Institute of Radio Service Men, and the subject was: "Will the Radio Dealer eventually restore his service department instead of, as at present, 'farming out' his repair work to an independent Service Man?"

Nine independent Service Men were interviewed in order to determine just what the situation might be. Of the nine men interviewed, *every one of them was a set dealer on the side*. Each had sold an average of one set a month to people who had called them in on repair jobs. They were all of the opinion that their "Service-Man identity" was their most valuable stock-in-trade, and none of these men have any idea of ever relinquishing this identity.

These nine men pointed out that their identity as bona-fide Service Men gave them entree into homes which the set dealer could never enter, and at a time when the prospect is *radio conscious*. The average procedure of these men is to point out to the prospect the expensive job that would be necessary on the ailing receiver in order to place it in perfect operating condition, and then to recite the advantages of having a new and up-to-date receiver capable of not only quality reception, high sensitivity and selectivity, but also capable of receiving police calls, airplane dispatches, foreign broadcasting, ship-to-shore telephony, etc. The appeal is too great for most prospects to turn down, particularly in view of the fact that these Service Men offer a trade-in allowance on the old receiver and deliver the new receiver on a strictly approval basis. The new receiver stays in the home!

None of the Service Men interviewed had direct dealer connections with any set manufacturer. All transactions are made through a local Radio Dealer who makes a commission allowance to the Service Man.

Time and again we have heard of similar arrangements between local Radio Dealers and Service Men and in each case both parties benefit, even though the Radio Dealer has to pay a commission. But if a Radio Dealer employs salesmen, he has to pay them a commission (or a salary—it amounts to much the same thing in the long run). If he doesn't employ salesmen, he is losing a lot of good business to the other fellow. Moreover, commissions paid to Service Men on the sale of radio receivers are not by a long shot commissions taken out of the pockets of the Radio Dealer's salesmen. The Service Man's sales are *extra sales*—sales that the Radio Dealer would never make, or make only in rare cases.

The Service Man can get to places the radio salesman can never get to . . . and he is doing it every day of

the week. He is doing it and coming back with orders from people who trust both his word and his ability to recommend—from people who, through past experiences, know better than to take the word of any type of salesman, not because the salesman may paint too brilliant a picture of his product but because the average salesman knows very little about the product he sells.

It's the old story of sales resistance. The radio salesman is up against it whereas the Service Man is not. The Service Man cannot afford to misrepresent a product for, in the event that he does, *his reputation as a Service Man is shot all to pieces*. A Service Man has got to tell the truth to protect his own interests and these interests are primarily servicing radio sets. His customers have sense enough to know this, the Service Man has sense enough, too—so, he clicks with his customer every time.

Let's take a common example: Mr. Jones has heard about all-wave reception and thinks maybe it's what he ought to have. He is all primed for someone to sell him and the local Radio Dealer seems to be the logical place for him to go. The salesman gives Mr. Jones a story on all-wave reception and sells him a set.

But, try as he may, there are many of the stations the salesman mentioned which Mr. Jones cannot receive, yet he gets plenty of distance. Mr. Jones complains, and eventually learns that his receiver is not an all-wave receiver at all, but a skip-band job! The salesman just didn't know. . . .

Now Mr. Smith, like Mr. Jones, is interested in all-wave reception. He had in a Service Man to take the whistle out of his set and then got right down to brass tacks. "You're an expert on radio," he says to the Service Man. "Now tell me—what's all this I hear about all-wave reception? Is it practical, or should I wait a year until they get all the kinks ironed out?"

So, in the course of his stay, the Service Man gives Mr. Smith a pretty good picture of all-wave reception, sells him completely and, moreover, *arranges to handle the deal because Mr. Smith wants to be sure that the new receiver is properly installed by someone who knows what's what*.

The idea of Service Men doing real *serviced* selling jobs is so logical, so matter-of-course, that it sticks out like a schnozzle. It's a "natural" for the Service Man, the Radio Dealer and *the radio set manufacturer*.

There are 20,000 real Service Men in the business. Each one selling just ten sets a year—which is the average for the Rochester boys—means an outlet for 200,000 sets a year! That's a market of worthwhile proportions, and not to be sneezed at. It's no dream, either.

Is Servicing a Business? You bet it is—but there are a lot of people who haven't awakened to the fact yet.

# RIDER'S MANUAL VOLUME V

READY NOVEMBER 20th

## VOLUME V FACTS

- 1200 pages (index not included)
- Products of more than 100 manufacturers
- No duplication
- Right up to the minute
- Separate index of 60 pages covering Volumes I, II, III, IV and V

Volume I, 1000 pages \$7.50  
Volume II, 800 pages \$6.50  
Volume III, 1000 pages \$7.50  
Volume IV, 1060 pages \$7.50  
Volume V, 1200 pages \$7.50  
Servicing Supers \$1.00  
MONEY BACK GUARANTEE

—◆—  
*Patronize your distributor*

## NONE BETTER

Rider's Manuals with 5,000 pages in the five volumes mean

- MORE MANUFACTURERS
- MORE RECEIVERS
- MORE ALIGNMENT DATA
- MORE I-F PEAKS
- MORE VOLTAGE DATA
- MORE ELECTRICAL VALUES
- MORE AND BETTER

**EVERYTHING**  
**THAN ALL OTHER MANUALS**

## SEND FOR

*Successful*  
**SERVICING**

the FREE monthly house-organ, that will keep your Rider Manuals up to date.

## MAIL THIS COUPON

JOHN F. RIDER, Publisher  
1440 Broadway, New York, N. Y.

..... Enclosed find \$7.50. Send me postpaid, when issued, Rider's Manual, Volume V.

..... Put my name upon your mailing list to receive FREE, your monthly house organ, "Successful Servicing."

Name .....

Address .....

City ..... State .....





**You Need the Kit  
You Need the Tool  
You Need the Book**



**Here is the Most Complete Manual For Service Men Ever Published**

Service men throughout America have heralded the appearance of a kit of six Yaxley Volume Controls that will service more than 2500 sets as *the greatest advance in volume controls* that the industry has ever seen. Service men in practically all States of the Union are saving time and making money with the beautifully finished Yaxley Wrench which is given FREE with every order for a Yaxley kit or in exchange for six tops from any Yaxley Control cartons.

You can't afford to be without the kit—you can't afford to be without the wrench. And you'll certainly want your free copy of the Yaxley Replacement Volume Control Manual—the most complete and authoritatively accurate service manual ever published, which tells all about the 30 new Yaxley Replacement Volume Controls that will service 98% of the 3200 set models now in existence. Mail the coupon now!

**YAXLEY MANUFACTURING COMPANY, INCORPORATED**  
 Division of P. R. Mallory & Company, Incorporated  
 Indianapolis, Indiana Cable Address: Felmallo

Please send free copy of Replacement Manual  
 I enclose 6 carton tops for FREE Wrench  
 I enclose \$3.60 (which is 40% less than regular list price of Individual Controls) for Kit of 6 volume controls which entitles me to FREE Wrench.

Name.....  
 Address.....  
 My Jobber's Name is.....



# SERVICE

A Monthly Digest of Radio and Allied Maintenance

FOR OCTOBER, 1934

## DC SHUNT INSTALLATIONS

Non-technical information on the application and use of shunts in connection with small meters having standard characteristics.

By D. L. VAN LEUVEN

SO many requests have been made of the writer for fundamental information concerning circuits and hook-ups for shunts that the following has been prepared:

### TEST METERS

The meter, as generally used by the radio and allied trades, is primarily a current-operated device. As the meter contains resistance (either in the moving coil or in series with it) it also becomes a voltmeter, and voltage will be necessary to overcome this resistance and cause the necessary current to actuate the meter. The meter, therefore, is current-operated but voltage driven. This explains what is called the voltage drop. According to a simple quotation of Ohm's Law, an electromotive force of 1 volt will cause a current of 1 ampere to overcome a resistance of 1 ohm. Now, by the same token, 1 millivolt (1/1000 volt) will cause 1 milliampere of current to flow through 1 ohm. The 1 milliampere meter has become the general standard and, according to the above calculations, there will be necessary to actuate this meter, 1 millivolt pressure for each ohm of internal resistance in the meter (contained in the moving coil or otherwise).

The most generally used meter is now one with 50 ohms internal resistance, which designates it as one having a 50-millivolt drop. Now if this meter were a one-half milliampere meter (500 microamperes) containing the same resistance the millivolt drop necessary would naturally be only 25 as the current has been cut in half. If the meter should be a 2-milliampere meter, with the same internal resistance, it would then need 100 millivolts for full-scale operation.

### METER MILLIVOLT VALUES

The most popular values in the 1-milliampere meters are as follows:

Approximately 27 millivolt, approximately 30 millivolt and 50 millivolt. It is a simple matter to raise the millivolt value by inserting the necessary amount of resistance, either externally or internally, to make 50 ohms, a standard value, or any value desired. The writer suggests this work be done in a meter repair shop or manufacturer's service station, if possible.

### METER SHUNTS

Shunts are just by-passes for part of the current flow. These shunts are also designated in millivolts and current. The 50-millivolt shunts are necessary to properly actuate 50-millivolt meters, etc. The amount of current necessary for full-scale operation and the internal resistance decides the millivolt drop of the meter (Ohm's Law).

A similar action is taken in regard to the determination of the millivolts created by the shunts. The millivolt rating of a shunt is arrived at through calculation of the current flow and the resistance, which is just another simple part of Ohm's Law.  $I \text{ times } R \text{ equals } E$ ; therefore, 1 milliampere multiplied

by the internal resistance, say 50 ohms, equals 50 millivolts.

Where a 10-milliampere shunt is properly used with a 1-milliampere instrument, say with 27 ohms internal, 27 millivolts, the current divides. The meter passing 1 milliampere and the shunt 9 milliamperes, makes it obvious that the voltage, 27 millivolts, divided by the current, 9 milliamperes, will give us 3 ohms, the resistance needed in the shunt.

### TYPES OF SHUNTS

The only difference between large and small shunts is the current-carrying capacity of the resistance element and its ohmic value. Shunts are generally known as current multipliers. There are two types generally in use; the multiple shunt—often called "parallel"—and the series shunt, each having their advantage and disadvantage, preference being given to parallel shunts for the following reasons: (See Fig. 1.) In parallel shunts it is possible to use a very low resistance, as it is independently used; it is not dependent upon any other shunt or connections. This means they can be mounted more compactly. Also individual shunts can easily be replaced, or different values substituted at one's desire. Another feature is that the current measured will be of a truer value because the lowest possible resistance is being inserted in the line under current test.

### SERIES SHUNTS

Series shunts are useful because of their simplicity in hook-up and the possibility of being able to use most any type of single-pole switch. (See Fig. 2.) This same switch can also be used for voltage measurements.

Fig. 1 is the schematic layout of the assembly shown in Fig. 3, which shows one of the many simple methods of mounting these small, light and effi-

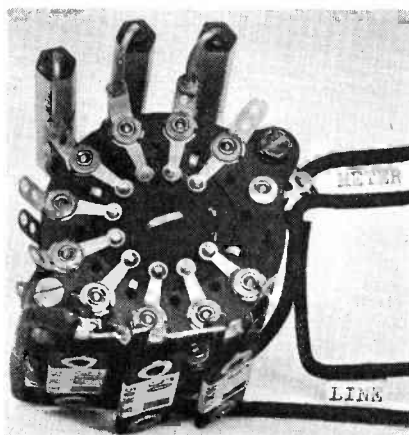

Fig. 3. View of the two-bank rotary switch, with resistors attached. (For circuit, see Fig. 1.)

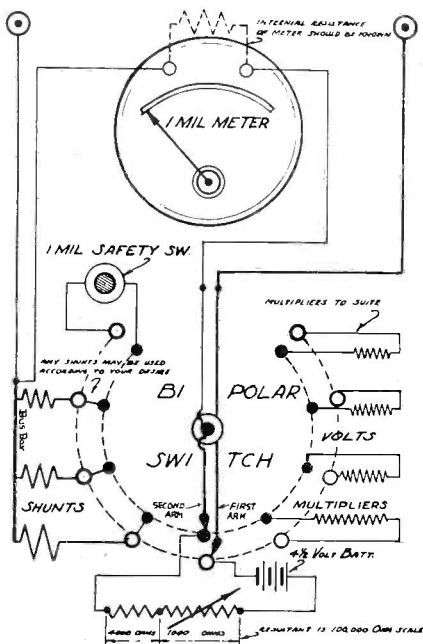

Fig. 1. Circuit of the switch system shown in Fig. 3. (Bi-polar switches should be used for connecting more than one shunt.)

cient current shunts and voltage multipliers. With the exception of the ohms circuit, the unit is complete and ready for the meter and line terminal posts. The bi-polar switch is a new type of a well-known make and lends itself perfectly to shunt circuits by reason of the positive wiping action of its heavily silvered contacts. Their distance from the lug connections prevents interference from solder, heat, rosin or flux.

#### PARALLEL SHUNTS

Speaking now of parallel connections, in Fig. 3 you will note that shunts are directly connected to the switch point terminals, no other support being necessary for this type of shunt. The other end of the above mentioned shunts are connected to a common wire, generally known as a buss-bar, one lead from this buss-bar going to the meter and another leading to the current source. Each must be connected separately to this buss-bar; in other words, all the necessary leads must terminate here separately, especially the one going to the meter terminal. If it were connected at some other point along the current-lead wire, the resistance of this wire would upset the values of the shunts.

#### SWITCH CONNECTIONS

The above information must be strictly adhered to if successful connections in parallel shunts are to be obtained. Now follow Fig. 1 and note that both contacts, one of each section of the switch, are wired together, this allowing the same arrangement as that at the buss-bar. The separate leads are connected by the two bi-polar switch arms, one a current circuit and the

other terminating at the remaining meter terminal post—thus furnishing the millivolts produced by the shunt directly to the meter having a corresponding millivolt rating.

In the use of switches for shunts, there is good reason to believe that the bi-polar types are the most fool-proof, giving more accurate readings and allowing contact resistance to interfere less with the proper operation of multiple current-multipliers (shunts). In explaining why the above mentioned bi-polar switch is more efficient, combined with more safety to the meter, it will be necessary to again note Fig. 1.

One of the switch arms of the bi-polar switch is the current lead through the first arm (lower section) to the switch point connected to the shunt. Now, if the first arm makes a bad contact or breaks completely at the contact terminal of the switch, little or no damage will occur, as considerable resistance would be necessary to affect the current circuit and will have no effect on the meter. Also, if the contact on the second arm should become bad, or be completely disconnected, the only result will be the disconnection of the meter. Considerable resistance (approximately  $\frac{1}{2}$  ohm for a 2% error) would be necessary in the second switch-arm contacts, including meter leads, before any appreciable error would result in the meter reading.

#### SEPARATE CONNECTION LEADS

All shunts, regardless of their type or system of connections, are to be connected by separate leads directly to the meter (through switches when necessary) with good terminal connections. Current to the shunts is also to be supplied by separate leads. Take the series shunt, for instance. Although the sev-

eral shunts are in series with each other, they also are in parallel with the meter. In case terminal posts are substituted for switches, the shunts may be placed anywhere, as several feet of good hook-up wire will not appreciably effect any amount of error. It will be the soldered joints one must be sure of.

#### CONCLUSION

In conclusion, the writer will say that shunts or current multipliers are just as simple to connect as voltage multipliers, and with a plentiful supply of shunts of the most popular millivolt ratings available one should find it simple to make shunt installations. It is sincerely hoped that this article will be of assistance to those in dire need of increasing the utility of meters to the greatest possible degree.

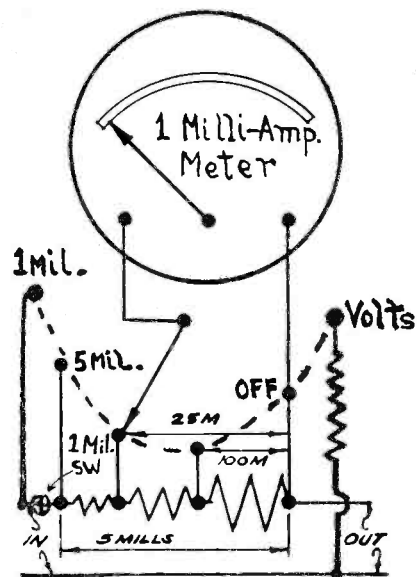

Fig. 2. Circuit of the series shunt arrangement.

## VOLUME EXPANDER CIRCUIT

(See Front Cover)

QUALITY is not the only point of importance in connection with high-fidelity transmission and reception. Of almost equal importance is volume range which, under common circumstances, is not very great.

#### WHAT IS VOLUME RANGE?

When we refer to volume range, we mean the ratio existing between the maximum and the minimum. The volume of an orchestra is often raised many millions of times above the softest musical passage, and this sort of volume range is what we are normally used to when listening to music direct.

It is impossible to give music any such volume range when broadcast. Ordinarily the loud passages transmitted by radio are no more than ten thousand times the volume of the softest passage,

and since this range does not come very near to comparing with the original volume swings, a certain naturalness is lost in the musical rendition.

#### NOISE DIFFICULTIES

When music bites into a carrier wave, the resultant picture of the modulated wave looks something like a series of Mae Wests strung end to end. The degree of the bite, or the percentage of modulation has quite an effect on the resultant reception of the music, aside from the possibility of distortion. For one thing, most broadcast-station carriers haul a certain amount of station hiss and hum with them, and if a very wide volume range is attempted, the soft passages of music are apt to be obliterated by the hiss and the hum, and

(Continued on page 380)

TOM HOGAN, WHOSE SLOGAN IS: "IF YOU CAN'T FIX IT, THROW IT AWAY," AND A VIEW OF HIS ESTABLISHMENT IN CHICAGO.



## The RADIO SERVICE MAN BECOMES A RADIO SERVICE BUSINESS MAN

NOT so very long ago, when the whole radio industry could think in no other terms save those of sets; when the sole effort of the manufacturer was to get as many sets across the production line as possible; when the dealer was only concerned in how many sets he could sell, the Service Man was a "pain in the neck."

But times changed, incomes shrunk like a piece of "shoddy" in a Spring rain; set manufacturers discovered people wouldn't junk a set only a year or two old for the new one they had designed; practically a saturation point was reached in the number of sets placed in homes of the American Public, and that same public began to demand that the sets they had bought be serviced—kept at the same level of performance that had induced their purchase.

And so, the Service Man came into his own, and instead of being kept in the back of the shop as a necessary evil, from which humble place he was ousted when the late depression caught the dealer with his trousers in a precarious state, the Service Man emerged as one of the most important elements in the entire radio industry.

"Tom Hogan" Southtown Radio and Electric shop, Chicago, is typical of the new order of service or rather of the dominant place the Service Man has taken in radio affairs. Tom's slogan is: "If you can't fix it, throw it away."

Tom, like many another Service Man, started as a Radio Amateur. For four years he worked as an independent Service Man from his home. Probably during this time he built a lot of those battery sets for people who knew him as a radio man, and of course he serviced a lot of those and other sets that were made when the battery set began

to be put out in production quantities by established manufacturers.

Then for three years he operated a service business catering to the new radio dealers who had sprung up with the introduction of the all-electric set.

His present business he has owned for the past three years.

To put all this in his own words, he



TOM HOGAN BEHIND THE COUNTER IN THE "PARTS DEPARTMENT," ALL SET TO TEST ANYTHING IN SIGHT.

"started on a shoestring," but, realizing that any business must be built on many things besides ability, he went out of his way to build up good-will. And, unlike the man who said to us only a few days ago that "the Service Man doesn't know how to take advantage of a business opportunity—he will never make any money," Tom has been most alive to every possible business chance.

He sells Sparton, Zenith and Atwater Kent receiving sets. He is the official service station for Stewart Warner, Zenith, Sparton and Motorola. In back of the store he has a garage capable of holding 50 cars and to date has installed 1,023 auto-radio sets.

Tom has a calling list of 1,800 customers—owners of home and auto-radio receiving sets with whom he keeps in constant contact either through mailings or by calling them on the telephone at regular intervals.

Nor has he overlooked any other opportunity for a profit in this business of servicing, for he handles all the service work for twelve dealers.

One policy is adhered to rigidly in this Southtown Radio & Electric shop, and that is a *charge for all testing*. In the experience of Mr. Hogan, which must be admitted to be considerable, this is the only way to handle this matter. It is his firm conviction that people



A VIEW OF THE SERVICING DEPARTMENT OF THE SOUTHTOWN RADIO AND ELECTRIC SHOP.

think a lot more of something they have to pay for than of something they get for nothing. Particularly is this true of any professional or semi-professional advice or counsel. Then, too, it quite positively eliminates that element in the business of servicing made up of the smart young fellow whose parents think he's a genius and who is touted to his friends as able "to fix" their radios.

To this and to the maintenance of a

live list of customers we want to call particular attention in closing this little story. The Service Man has become the Service Business Man and these two things are making his business a profitable one. He has come out of the basement and the attic onto Main Street and the dealer who couldn't waste time with servicing may find that the Service Man has taken his place in the retail selling scheme.

## VERSATILE ALL-WAVE AERIAL SYSTEM

By R. L. HASKINS and R. T. PERRON\*

SEVERAL unique features will be found in one of the latest all-wave antenna systems that has recently been announced and made available to the radio trade. This system is essentially designed for use in the average home where ideal antenna installations cannot be made because of space limitations, character of the structure, and other

\*Commercial Engineering Dept., Tohe Deutschmann Corp.

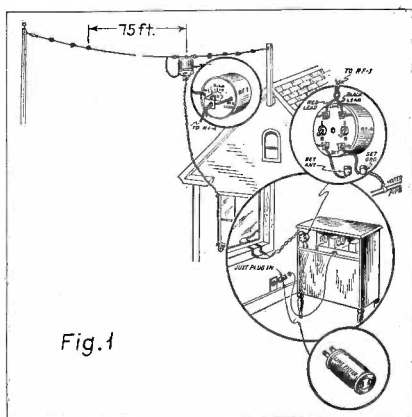

The all-wave aerial and filter system. The aerial is connected as a quarter-wave Marconi antenna.

local unfavorable conditions are concerned.

Expense of installation is kept at a minimum inasmuch as present flat-top aerials may even be used with this system if they were originally installed ruggedly and correctly.

### MARCONI AERIAL SYSTEM

The installation of the all-wave aerial as a quarter-wave Marconi antenna system is shown in Fig. 1. In this system the ground is an integral part of the aerial or open oscillatory circuit. The system consists of an average length flat-top aerial, approximately 75 feet for best results, connected to the aerial transformer which is suspended from the guy wire supporting the aerial, twisted-pair transmission line transfers the signal to the receiver transformer which cuts in different coil arrangements to properly match the transmission line to the input of the receiver at the various desired frequencies. The receiver in this case is grounded.

Fig. 2 shows the equivalent circuit diagram of the all-wave aerial connected as a quarter-wave Marconi system. Note the method of coupling from the

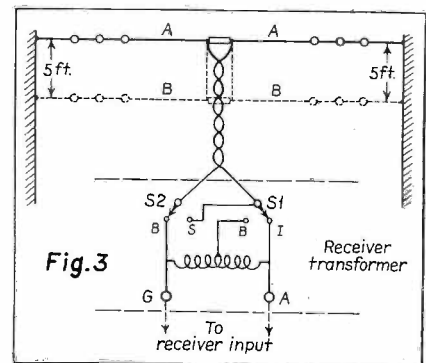

The antenna system connected as a half-wave Hertz doublet. Dotted lines show how this system may be adapted to a multiple doublet system.

aerial circuit to the receiver input circuit. Coil taps were so chosen that the system operates best with transmission lines of 50 feet or multiples thereof in length.

### BAND SELECTION

Note the switches S1 and S2 of the receiver transformer. The following positions of S1 and S2 respectively indicate the bands to which they will tune: B-B standard broadcast frequen-



TABLE NO. 1

The chart below shows suggested lengths for the two flat-top sections "A" and "B" (see Fig. 3) with the wavelengths at which highest efficiency will be obtained.

Meters	Megacycles	"A" or "B"
49	6.11	38.2 ft.
31	9.7	24.2 "
26	11.5	20.25 "
19	15.8	14.85 "

cies from 500 to 1,500 kilocycles; 1-B intermediate frequencies from 1,500 to 6,000 kilocycles; 1-S highest frequencies ranging from 6,000 to 15,000 kilocycles.

On position 1-S the transmission line is short circuited. In this position the entire system functions mainly as a straight pick-up aerial for the high-frequency signals. This is essential in order to get true all-wave performance from one antenna system. The use of the ground on the radio set adds great stability to the operation of the receiver.

DOUBLET AERIAL SYSTEM

This same system may readily be adapted for operation as a Hertz or half-wave antenna system. In this connection the doublet type of Hertz aerial is extremely popular for it is convenient and inexpensive. Here the installation is made as shown in Fig. 3. It is important that the aerial flat-top be as high above the ground as possible.

Table No. 1 indicates the length of the flat-top sections for different popular short-wave bands. Connected as a half-wave aerial, the aerial transformer is not used. The receiver is not grounded, of course, and neither is any part of the antenna system.

The settings of the switches S1 and S2 on the receiver transformer are the same as for the Marconi system. The use of the multiple doublet idea may be had by connecting additional flat-tops, as shown in dotted lines. These additional flat-tops should be at least 5 feet apart. Multiple doublets will assist in giving better sensitivity to the receiver over a wider range of frequencies, particularly those to which the flat-tops are purposely designed.

NOISE ELIMINATION FEATURES

One of the most vital problems confronting the successful operation of all-

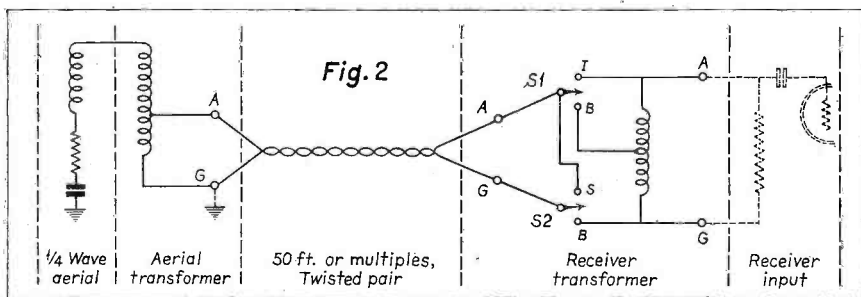

Equivalent analytical diagram.

wave and dual-wave receivers today is that concerning noise versus signal. As is commonly known, noise can be introduced into a well-shielded receiver through the aerial, ground, or power line or house-wiring system.

Basic precautions in installing the aerial will always insure most satisfactory elimination of noise pick-up. Such precautions consist of keeping the flat-top portion of the aerial at least 25 or 30 feet away from all buildings, wiring, poles, metallic objects, etc.

In this connection we greatly stress the use of several insulators in the guy wires supporting the flat-top of the aerial. This is positively essential where it is known that noise is present on house wiring, on the wiring of the building to which the aerial guy wire is connected. The use of twisted pair transmission line is for the purpose of "phasing out" noise pick-up on this portion of the antenna system.

The next consideration is noise on the ground system. Not any ground will do for good operation. It is necessary to use as direct a ground as possible, making a positive connection to the water pipe on the street side of the meter if possible. Few cases have been

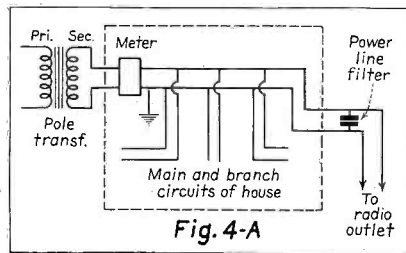

Fig. 4-A

Equivalent diagram of house wiring, showing resistance, inductance and capacity to ground of the wiring.

found where all grounds tried were noisy in which case it was better to leave the receiver ungrounded.

POWER-LINE NOISE

Perhaps one of the worst sources of noise trouble is due to power line or house wiring, particularly where old methods of wiring were used. Fig. 4-A illustrates roughly the wiring of a typical house showing branch circuits, etc. Open-circuit wiring is particularly bad and cases have been found where houses

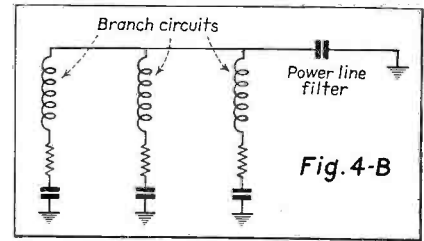

Fig. 4-B

By plugging in line filter, capacity to ground is introduced as shown. This detunes r-f circuit of house wiring as well as closing "open oscillatory circuits" radiating noise as small transmitting antenna.

wired with modern BX cable would be bothered by what is called power-line radiation. Radio noise created by electrical appliances within the house in which the all-wave receiver is located, or on the same secondary that the house wiring is connected to, may be fed to the receiver either by radiation to the antenna and lead-in or to the chassis of the receiver, and sometimes through the power transformer connected to the wall plug. The house wiring and its branches act as open oscillatory circuits and radiate noise at broad frequencies.

By connecting the power-line filter, a specially constructed radio-frequency condenser in a convenient socket, preferably the one to which the radio receiver is connected, at least two changes occur: first, the equivalent tuned circuits of the house wiring are detuned through introduction of the capacity of the line filter; secondly, the open oscillatory circuits are actually closed, that is, their free end is brought to ground through the line filter, as shown in Fig. 4-B. This greatly reduces the radiating properties of the house wiring and a substantial reduction of noise is generally brought about.

Philco Model 66

Starting July 10th, a 70-ohm wire wound resistor is being added to Philco Model 66, connected in series with condenser (14) on the oscillator-coil side. This will prevent oscillation at the extreme high-frequency end of the short-wave band.

Philco Model 45 Changes

Starting with Run No. 5, the cathode resistor on the 6A7 tube, number (21) on diagram, will be changed from Part No. 6977 (500 ohms) to 33-3016 (400 ohms). This is to prevent variation in output of sets due to a variation in 6A7 tubes.

Starting with Run No. 6, electrolytic condenser (62) and (63) (Part No. 30-2028) is replaced by No. 30-2079, same capacity but higher voltage rating.

# General Data . . .

## PHILCO MODEL 200 HIGH-FIDELITY RECEIVER

It is with pleasure that we offer the following data on the first high-fidelity receiver to be offered the American public. The information is necessarily lengthy, but warrants the space accorded it.

We have awaited with considerable interest for developments in this new phase of reception, and feel that the receiver to be outlined fully justifies its existence as a practical device. The engineers who were instrumental in its design did not lose sight of the fact that, though many broadcast stations lay down a high-fidelity signal at the receiver, it is not possible with present frequency allocations to obtain high-fidelity reception at all times. Consequently, the receiver is so designed that true high-fidelity reception may be had at those times when the station being received suffers no interference from one or more other stations operating on channels within 10 kilocycles of the selected carrier, and with slightly reduced fidelity reception at such times as there may be interference from an adjacent channel.

### VARIABLE ACCEPTANCE BAND

This practical arrangement is obtained by employing a variable acceptance band; that is, "Selectivity-Fidelity Control" with which the listener may "open up" the receiver for high-fidelity reception or "close it in" at such times when interference is present and better selectivity is required. The beautiful part of the system is that at all times the listener may be governed entirely by his ears, and he need increase selectivity only to the extent required for satisfactory reception.

As an example: The audio response of the Philco 200 is 30 to 7,500 cycles when "wide open." There might be slight interference which tended to put "chatter" on the fringe of the received carrier, in which case it would be necessary to increase the selectivity and thereby lop off some of the highs. But, if the interference were only slight, it might only be necessary to reduce the response 500 or 1,000 cycles, in which case the receiver would still be providing everything from 30 to 6,500 or 7,000 cycles—still quite a good deal in excess of what the average broadcast receiver is capable of reproducing.

The "Selectivity-Fidelity Control,"

therefore, provides a perfect method of adjusting the receiver to broadcasting conditions. One may have maximum fidelity and minimum selectivity, or vice versa. The control is variable from a 10-kc to 15-kc bandwidth.

Should the Federal Communications Commission decide in the future to provide more separation between stations, this same receiver could be operated "wide open" most, if not all, of the time. The variable bandwidth control prevents obsolescence in any event.

### CIRCUIT IN GENERAL

Now suppose we study the schematic diagram of Fig. 2 in order to determine just how the Model 200 functions. A hurried glance would suggest that the circuit is conventional in design, there being a stage of tuned radio-frequency amplification, combination mixer-oscillator, two stages of i-f, diode second detector—avc—first a-f, and a Class A Prime audio circuit with driver and 42 push-pull tubes connected to function as triodes, very much similar to the audio systems in other models of Philco receivers. The only striking difference is the shadow-meter control circuit, which we will cover in its turn.

But, as conventional as the circuit may appear at first glance, there are a number of kinks which do not appear in other receivers. Let's start at the beginning and work through.

### ANTENNA CIRCUIT

First of all, note that there is a 10,000-ohm resistor shunted across the primary of the antenna transformer. Without getting too involved, the resistor provides good damping at low frequencies and not such good damping of the coupled circuits at high frequencies, which is another way of saying that it serves to maintain constant wide bandwidth to all received signals throughout the broadcast band. The purely inductive transfer of energy from antenna to the first circuit is high at all times, and this helps to reduce the effects of first-circuit noise which can be very objectionable in any receiver, but particularly so in a high-fidelity receiver.

### BAND-PASS CIRCUIT

The antenna is coupled to the input of the 78 r-f tube through a band-pass circuit. This band-pass filter provides

a good degree of selectivity (with resultant elimination of image-frequency interference), but its resonance curve is flat-topped, with the result that there is no cutting of sidebands. The loss commonly introduced into a circuit by a band-pass filter is offset in this case by increased amplification and the effectiveness of the antenna coupling system.

The r-f stage is coupled to the mixer through an r-f transformer with tuned secondary. The damping in this secondary circuit is slightly decreased by the insertion of a 10-ohm resistor (13) so that here again there is no cutting of sidebands due to too sharp a resonance curve.

The frequency of the received signal is converted to 175 kc and fed to the first i-f transformer, thence to the first i-f tube, second i-f transformer, and second i-f tube.

### THE I-F TRANSFORMERS

Note that each i-f transformer has three windings. The first and second windings in each case are primary and secondary respectively. The third winding, to the extreme right, is a trap circuit tuned to the exact midpoint of the intermediate-frequency band, or 175 kc.

Let us center our attention on the first i-f transformer. Since the trap circuit is coupled to the secondary, and tuned to the same frequency, it will absorb energy from the secondary circuit. This is the same as placing a load on the secondary and it tends to broaden its resonance curve to a degree dependent upon the extent of the load. In this case the load is sufficient to provide a resonance curve 15-kc wide. The top of the curve is nearly flat but, due to the fact that the trap circuit is tuned to the midpoint of the i-f band, it absorbs the low frequencies, but not the highs. Therefore, there is a slight depression in the center of the i-f transformer resonance curve.

### VARIABLE I-F SELECTIVITY

It has been pointed out that the width of the i-f transformer resonance curve is dependent upon the amount of load placed upon the secondary by the trap circuit. Now note that there is a variable resistor (24) in series with the trap circuit. If the arm of this resistor is set so that there is no resistance in the trap circuit, then the condition we have outlined holds true. But, if resistance is added to the trap circuit its damping is decreased (its selectivity decreased) and it draws less energy from the secondary winding of the i-f transformer. This in turn places less of a load on the secondary with the result that the damping of the i-f transformer (its selectivity) increases. When all of the resistance is in the trap cir-

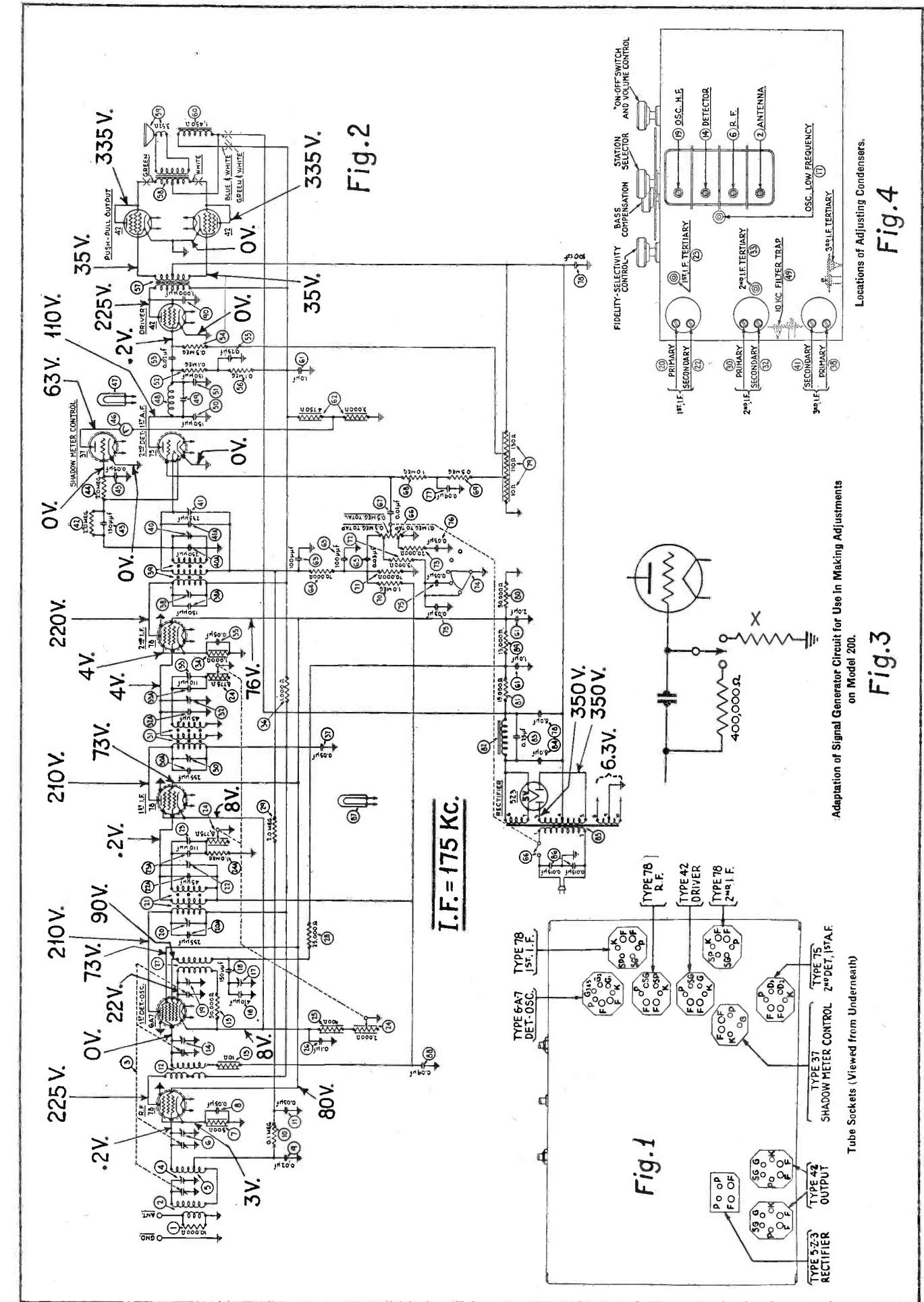

Fig. 2

Fig. 1

Fig. 4

Fig. 3

Adaptation of Signal Generator Circuit for Use in Making Adjustments on Model 200.

Tube Sockets (Viewed from Underneath)

Locations of Adjusting Condensers.

cuit, the trap draws little energy from the secondary and the load is almost entirely removed. Under these circumstances, the i-f transformer is highly damped (highly selective) and provides the 10-kc maximum selectivity desirable when interference prevails.

The operation of the second i-f circuit is identical to that of the first. The two variable resistors (24) in the trap circuits are connected in tandem so that the selectivity of both i-f amplifiers may be altered simultaneously.

### CONSTANT SENSITIVITY

This brings us to the point of sensitivity. Obviously, broadening of the resonance curves of the i-f transformers by absorbing energy from them results in a decrease in sensitivity. The result is that, were no means provided for correction, the sensitivity of the receiver would drop when the fidelity was increased and rise when the selectivity was increased. This is offset by connecting a third variable resistor in tandem with the Selectivity-Fidelity Control resistors. This resistor (24) is in the cathode circuit of the mixer tube. Its value increases and decreases with an increase and decrease of the values of the Selectivity-Fidelity Control resistors. Its effect is to reduce the bias on the mixer tube (increasing its sensitivity) when the i-f band is being opened out, and increasing the bias on the mixer tube (decreasing its sensitivity) when the i-f band is being closed in. The result is a signal of constant volume for any position of the Selectivity-Fidelity Control knob.

### SHADOW-METER CIRCUIT

Now let us turn our attention to the third i-f transformer. This also has a trap circuit tuned exactly to 175-kc. It is used principally for the purpose of providing an accurate shadow-meter indication.

Under circumstances of high degrees of selectivity, the usual type of tuning indicator circuit is satisfactory. In a high-fidelity receiver, however, it is essential that the listener tune the receiver to the exact center of a comparatively broad i-f band.

Because of the wide i-f band when the receiver is set for high-fidelity reception, and because of the double peak which is present in the circuit, it would be impossible to obtain an accurate indication of precise tuning if the shadow tuning meter were connected in the plate circuit of the i-f tubes, as commonly done, for then the tuning meter would give indication at two points, both of which would be incorrect, at all times the receiver were adjusted for

high-fidelity reception. It would be impossible, therefore, to determine when the receiver was tuned to the exact middle of the band.

In the Model 200 receiver this condition has been overcome by coupling a highly selective trap circuit to the third i-f transformer and utilizing the output of this selective circuit, rectified by one diode element of the type 75 tube, to operate the type 37 amplifier tube which in turn operates the shadow meter in its plate circuit. The voltage generated by this diode across the 2-megohm resistor (42) and the 150-mmfd condenser (43) is filtered by a 2-megohm resistor (44) and a .05-mfd condenser (45) before being applied to the grid of the type 37 tube. This prevents r-f and a-f voltages from reaching the plate circuit containing the shadow meter. Since the input of the type 37 tube is highly selective and accurately tuned to 175 kc by means of the compensating condenser (40), the shadow meter will indicate only at this frequency.

### THE AVC CIRCUIT

The secondary of the third i-f transformer is connected to the second diode of the type 75 tube. This diode serves as second detector and automatic volume control, the automatic bias voltages being placed on the grids of the r-f, mixer and first i-f tubes. The avc action on the r-f tube is made more extensive than on the other two tubes, the full avc voltage being applied to its grid.

### COMPENSATED VOLUME CONTROL

The detector diode circuit also contains the compensated volume control circuit to which the control grid of the 75 a-f triode is connected. It will be noted that the volume control is tapped at two places. When the variable point of the control is nearest the grounded end, minimum volume is obtained. It will be noted, however, that the resistance tapped at this low end is connected to a 20,000-ohm resistor (73) and a fixed condenser (76) of .03 mfd. This circuit constitutes a fixed bass compensation circuit for low volume, and when the volume control is set at a low point, bass compensation will always be present regardless of the setting of the tone control (74). At the next tapped point on the volume control, it will be seen that a connection is made through a 15,000-ohm resistor (72) and a .03-mfd condenser (75) to ground. It will also be noted that the tone control permits shorting out of the last-mentioned .03-mfd condenser at one point of the tone control, and also

permits cutting in an additional .03-mfd condenser at another point of the control. This makes it possible to have variable bass compensation, when desired, at the high volume level.

### LOW-PASS FILTER

Now, the triode section of the 75 tube functions as an intermediate a-f amplifier. In the plate circuit of this triode is a low-pass filter which cuts off very sharply at 10 kc. The purpose of this filter is to remove any sidebands of a signal which may be coming through from an adjacent channel and to provide clear audio reception up to 10,000 cycles. This means that the audio portion at this point is responsive to frequencies up to 10,000 cycles but will definitely not pass any signals of a higher frequency.

### CLASS A PRIME OUTPUT

The triode of the 75 tube is resistance coupled to a type 42 tube, triode connected, which functions as a driver for the triode-connected 42 tubes in the Class A Prime push-pull output circuit. All four of these tubes obtain their bias from taps on the dropping resistor (79) in the negative leg of the power-supply system. Since this is a semi-fixed bias, the output circuit may be worked at high volume without the creation of harmonic distortion.

### VOLTAGE TESTS

Voltage values are given in the diagram of Fig. 2. The voltages were obtained using a high resistance dc voltmeter for plate, grid and cathode tests, and an ac voltmeter for heaters. The readings are based on a line voltage of 115 and should be taken with the tuning dial set at 55, volume control at maximum and the fidelity control at middle position. The voltage of 350, indicated for the 5Z3 rectifier, should be taken from plate to ground.

### NOTES

Referring again to the diagram of Fig. 2, an 8,000-ohm resistor (33-3016) (gray-black-red) is added across the 2,000-ohm section of resistor (24) in the cathode circuit of the mixer tube.

The Model 200-A receiver is the 25-cycle version of the Model 200.

### MODEL 200 ADJUSTMENTS

The quality performance of this receiver depends to a great extent upon providing a wide channel through the r-f and i-f stages to permit the passage of a broadcast signal without cutting of the sidebands.

In order to produce this wide tuning band, the set must be carefully and accurately adjusted. These adjustments will be more critical than in the con-



ventional radio, and the procedure will be somewhat more complicated.

In making the adjustments, it is necessary to use an unmodulated signal generator. The Philco Model 048 Set Tester or the Model 024 Signal Generator can be readily adapted for this purpose by the installation of a single-pole double-throw switch, and an additional grid-leak resistor, as shown in Fig. 3. This switch will adapt the signal generator for either a modulated or an unmodulated signal.

With an unmodulated signal, it is not possible to obtain an indication of output by means of the usual form of output meter. An indirect indication can be obtained, however, through the automatic volume control system by connecting a high resistance voltmeter having a scale reading of 0-5 or 0-10 volts across the r-f cathode resistor (7), shown in the wiring diagram Fig. 2. This connection can be made conveniently through the use of leads equipped with test clips. With this arrangement, maximum output at the second detector will be indicated by a minimum reading of the meter, and vice versa. In other words, the action will be just the opposite of an output meter used to measure audio-frequency voltage at the power-output stage. With no signal applied to the receiver, the bias voltage indicated by the voltmeter, will be approximately 3 volts. This voltage will be reduced by the application of a signal to the r-f or i-f input circuits.

#### I-F ADJUSTMENTS

After preparing the unmodulated signal generator and connecting the voltmeter as directed, proceed as follows:

(1). Set the receiver tuning dial at its extreme low-frequency position. Remove the grid clip from the cap of the 6A7 detector-oscillator tube, and connect the signal generator antenna lead in its place. Connect the ground lead from the signal generator to the ground terminal of the chassis. Adjust the signal-generator frequency to exactly 175 kc. Turn the fidelity control of the receiver all the way to the left.

(2). Adjust the 6 i-f padding condensers (20), (22), (30), (32), (41), and (38) (see Fig. 4) in the tops of the 3 i-f cans, for maximum output (minimum meter reading), starting with the compensator or padder at the front of the chassis, and continuing with the adjustments toward the rear of the set. During these adjustments, the output of the signal generator should be regulated to maintain a voltmeter reading of approximately 2 volts.

(3). Connect a 250-mmfd condenser

from the plate of the 2nd i-f tube to ground. This will increase the voltmeter reading to approximately 2.5 volts.

(4). Readjust the 3rd i-f secondary padder (41) for maximum output.

(5). Readjust the 3rd i-f primary padder (38) for maximum output. Do not touch the grid padder (41) again.

(6). Turn the Fidelity Selectivity Control all the way to the right.

(7). Adjust the 1st and 2nd i-f tertiary padders (23) and (33) for *minimum* output (maximum voltmeter reading).

(8). Leaving the Fidelity Selectivity Control in the right hand position, it will be found, upon varying the frequency of the signal generator, that two definite dips will appear in the voltmeter reading—one at 167 kc and another at 182 kc. These dips in the voltmeter reading indicate peaks in the tuning curve. The amplitude of these peaks should be equal; that is, the same voltmeter reading should be obtained at both 167 kc and 182 kc. Any variations in these two readings can be corrected by a *slight* readjustment of the 3rd i-f primary padder (38). If the peak at 167 kc is higher than the one at 182 kc the primary padder will have to be turned out. If the reverse is true, the capacity of this padder must be increased. In any case, the voltmeter readings must be made equal by dividing the differences through readjustment.

#### R-F ADJUSTMENTS

The r-f portion of the receiver is adjusted as follows:

(9). Replace the grid clip on the detector-oscillator tube and connect the antenna terminal of the signal generator to the antenna terminal of the chassis. Turn the Fidelity Selectivity Control all the way to the left and set the receiver dial at 1,500 kc. The same type of output indication is employed as in the i-f adjustments.

(10). Adjust the signal generator for a frequency of 1,500 kc. Adjust the "oscillator" padding condenser (19) and the "detector" padding condenser (14) for maximum output and in the order mentioned. Regulate the signal-generator output control to maintain a voltmeter reading of 2 volts as before.

(11). Turn in padder (6) (r-f) until the voltmeter reads 2.5 volts and then adjust padder (2) (ANT.) for maximum output.

(12). Readjust padder (6) for maximum output. Do not touch padder (2) again.

(13). Set the receiver dial and the

signal generator at 600 kc. Adjust the "oscillator low frequency" padder (17) for maximum output. As the r-f tuning is rather broad, there will be a considerable range on the dial that will give about the same output when the oscillator LF padder is adjusted for maximum. The padder must be adjusted at the middle of this range. This point may be determined with accuracy in the following manner: Starting with the usual voltmeter reading of 2 volts, slowly turn the receiver dial toward the low-frequency end and, at the same time, readjust the padder (17) for maximum output until a point is reached where the maximum output is indicated by a voltmeter reading of 2.5 volts. Note carefully the exact dial reading at this point. Follow the same procedure while turning the dial in the opposite direction until the output reading decreases to the same value. Set the dial at the exact center of these two points and readjust padder (17) for maximum.

(14). Adjust the 3rd i-f tertiary padder (40) to give minimum width in the shadow-tuning meter in the receiver. This padder is reached from rear of chassis.

#### ADJUSTMENT OF 10-KC FILTER

The 10-kc filter in the audio circuit will rarely require readjustment. As the proper adjustment of this padder (49 on diagram) requires an accurately calibrated audio oscillator it should be reset only in the event that it has been tampered with.

An emergency adjustment of this filter can be made in the following manner:

(15). Connect the signal generator to the control grid of the type 6A7 tube, leaving the grid clip in place.

(16). Disconnect the voltmeter from resistor (7) and connect an output meter to the plates of the power-output tubes in the usual way.

(17). Set the receiver dial at 550 kc. At this point, the oscillator in the receiver will be tuned to 725 kc. The adjustment of the signal generator (switch in unmodulated position) to approximately this same frequency will cause an audible beat note to be heard in the speaker. By means of the signal-generator tuning control, reduce the frequency of this beat note until zero beat is reached, at which point the output-meter reading will decrease to 0. Turning the receiver dial in either direction will gradually increase the frequency of the audible note so that at 540 or 560 kc a 10,000-cycle note will be heard. At either of these points, the padder (49) should be adjusted for minimum reading of the output meter.

VOLUME EXPANDER CIRCUIT

(Continued from page 372)

other background noises which may appear at the receiving end. This, of course, cannot be tolerated, particularly in high-fidelity reception.

There happens to be a way around this. The system has been put to use by the Bell Telephone Company for special purposes, and it consists of what may be called a "volume contractor" and a "volume expander." Let's see what this amounts to:

VOLUME CONTRACTOR AND EXPANDER

Suppose that instead of attempting to take care of a very wide volume range in the usual manner, we *compress* this range within limits of volume which will neither over-modulate the carrier nor make the soft passages so low in volume that they are lost in noise. Such compression can be effected by amplifying the weak passages of music quite a good deal more than the loud passages. In this manner, soft passages are never lost in background noise.

Such volume compression at the transmitting end can be accomplished by employing a circuit very much like the automatic volume control circuits we use in modern receivers.

Now, if we compress our volume range at the transmitter, it is necessary to open it out at the receiver if we wish to take advantage of the desirable effects produced by a very wide range of volume without attendant noise. Therefore, we require at the receiver end some form of volume *expander* which will reverse the process at the transmitter; that is, we require a system which will amplify loud music more than weak music.

EXPANDER CIRCUIT

Though such circuits are used in this country, we are going to describe a similar expander circuit of British origin—a circuit which, we understand, is actually used in a modern English broadcast receiver.

We are indebted to *Wireless World* for the circuit of the volume expander. It is shown on the front cover. Let us see how it works:

EXPANDER OPERATION

The circuit is seen to employ four tubes. Tubes V-1 and V-2 are audio amplifier tubes having separate output transformers, the secondaries of which are opposed. The normal bias voltages placed on these tubes are such that should the gain of tube V-1 be 10 under normal conditions, the gain of tube V-2 is, say, 9. Since these two tubes do not

amplify to the same extent, and are connected in a sort of push-pull circuit, it becomes evident that since the secondaries of transformers T and T-1 oppose each other, the resultant amplification of a signal will be the *difference* between the actual amplification of the two tubes. Thus, if V-1 amplifies the signal 100 times and V-2 amplifies the signal 90 times, the resultant amplification is 10, because of cancellation in the output circuit.

WEAK-SIGNAL ACTION

If the difference in amplification between these two tubes is so adjusted that the signal in the output is equal to the signal at the input, then it is evident that this amplifier circuit will merely pass along the signal without either increasing or decreasing its volume. This is just what the circuit does for *weak signals*.

But the circuit operates in a different manner when strong signals are impressed on tubes V-1 and V-2. This brings us to the tubes V-3 and V-4.

AVC SYSTEM

It will be seen that tube V-3 is, after all, nothing more than a separate a-f amplifier which picks off a portion of the signal from the input, the level of which depends on the position of the arm of the potentiometer R-2. The signal is amplified by V-3 and then fed to V-4 which, it will be seen, is a diode rectifier. The amplified signal in the rectifier V-4 finally appears as a dc voltage across the load resistor R-1. This negative bias voltage is fed to the grid of the amplifier tube V-2 *only*, through the filter resistor R. Just like an amplified avc system. Now let us see what effect this has.

STRONG-SIGNAL ACTION

It has been stated that V-2 is given an initial bias of such value that it amplifies just slightly less than V-1. A weak signal is therefore really not amplified at all in passing through the amplifier. However, if a strong signal is fed to the input of the amplifier, a portion of it appears in the load circuit of the diode rectifier V-4 as a negative bias and this bias placed on the grid of V-2. The effect of this added negative bias voltage is to further decrease the gain of V-2 and, in doing so, increases the *difference* in gain between V-1 and V-2. Thus, the amplification of the signal by V-1 would still be 100 but possibly only 75 by V-2. The resultant gain is therefore 25 instead of 10 as it is with a weak signal. Consequently, weak signals are left "as is" while

strong signals are amplified considerably, with the result that the "compressed" volume range of the transmitted program has been opened out, or expanded. The stronger the signal, the greater the amplification.

DELAYED BIAS ACTION

No reason has been given as to why a weak signal would not also produce a negative bias voltage across the diode load resistor R-1. The answer is that the diode is negatively biased by the drop in voltage across the resistor common to the cathodes of both V-3 and V-4. Therefore, there is no diode current until the signal voltage is sufficient to overcome the diode bias.

The listener is able to adjust the volume range, or amount of volume expansion, by altering the position of the arm of the potentiometer R-2.

With an arrangement of this sort, it should be possible to obtain a volume range in a radio receiver in excess of the range of volume cut into modern phonograph records. It may be that this system, or one similar to it, may be put to use in the near future. It fits right in with high-fidelity transmission and reception.

Stewart-Warner Wave-Trap Installation

In some locations powerful commercial marine stations transmitting on some frequency near 456 kc may cause interference with broadcast reception in the Stewart-Warner series of 4-tube sets and in extreme cases, possibly in the 5- and 7-tube sets, carrying the following chassis and receiver model numbers:

Chassis	Receivers
R-123.....	1231 to 1239
R-125.....	1251 to 1259
R-126.....	1261 to 1269
R-127.....	1271 to 1279

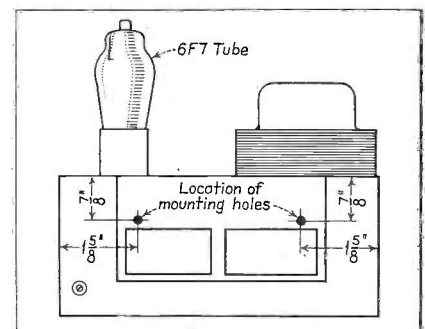

Details for mounting wave-trap on Stewart-Warner R-123 chassis.

To eliminate such interference, a simple wave-trap has been developed which may be fastened to the back of any of

## GENERAL DATA—continued

the receiver models of the R-123 listed above, and connected into the antenna circuit.

In the five- and seven-tube receivers, the wave-trap may be mounted on the inside of the cabinet.

### INSTALLATION OF TRAP

The trap is designed for use with any Stewart-Warner receiver employing an intermediate frequency of 456 kc. In the Model R-123, two holes for mounting it are provided on the rear of the chassis so that the wave-trap may be attached by means of two self-tapping screws which are included. These holes are normally covered by the paper name plate, but they can easily be found by punching through the paper sticker with a point at the positions shown in the accompanying diagram.

After mounting the trap, connect the blue antenna wire from the set to one of the wave-trap leads and connect the antenna lead-in to the other wave-trap lead.

### TRAP ADJUSTMENT

Usually the wave-trap will not require adjustment, but if some particular code station continues to cause excessive interference after installing the trap, it can be adjusted to diminish the unwanted signal. To make this adjustment, turn the slotted screw extending from the back of the wave-trap with a screwdriver. Turn it slowly, first in one direction and then in the other, until the interfering signal disappears or has minimum volume.

### Silvertone Model 1760 Hum

There are two versions of the Model 1760. Early models are rubber-stamped 206. Later models are stamped 206A or 206B.

If trouble from hum is encountered in any 206 chassis, they may be changed over to correspond to the chassis stamped 206A or 206B. The changes to be made as follows: Replace the 100,000-ohm, 0.5-watt, resistor in the grid circuit of the type 37 second a-f tube with one having a value of one megohm and same wattage; replace 100,000-ohm, 0.5-watt, plate resistor for the same tube with one having a value of 2 megohms, same wattage; replace the 20,000-ohm, 0.5-watt, grid resistor for the type 42 output tube with one having a value of 100,000 ohms, same wattage. Also replace the .02-mfd, 400-volt, coupling condenser between the first and second type 37 a-f tubes

with one having a value of .006 mfd, 400 volts.

The designations of the units listed are: R-9, R-10, R-11, and C-16, respectively, in the diagram.

### Silvertone Field-Coil Values

In the accompanying table are given the field-coil resistance values for the earlier models of the Silvertone (Sears-Roebuck) receivers.

Model	Resistance in Ohms
93	2500
94	2500
95	2500
98	2500
100	2500
109	2500
111	750-750
111-B	750-750
112	750-750
1150	9000
1152	1450
1154	1450
1170	9000
1174	1450
1250	2500
1260	9000
1310	1450
1312	1450
1320	1450
1322	1450
1324	1450
1326	1450
1330	1450
1370	2500
1420	1450
1420-X	1450
1430	1450
1450	1450

In the receivers employing 9000-ohm field coils, the coil is in shunt with the power supply.

H. G. D'ARCUS, JR.,  
1026 Monroe Ave.,  
Asbury Park, N. J.

### Philco Compensating Condensers

To prevent any tendency to frequency drifting in current Philco models, a bakelite washer and a metal washer are now being used on top of the compensating condenser, in place of the fibre washer previously used.

### RCA Victor Models 135-B and 235-B Trap Adjustments

A trap circuit, tuned to 460 kc (the i-f peak) is used in the antenna circuit to reduce interference from signals approximately the same frequency as that of the i-f amplifier. Two parallel trimmers are used and adjustment may be

made by means of either or both. Proceed as follows:

(1) Place the receiver in operation and connect the test oscillator output from the antenna to ground terminals of the receiver. Adjust the test oscillator frequency to 460 kc and connect the output meter or indicator across the voice coil of the speaker.

(2) Adjust either or both the trap circuit trimmers, accessible from the top of the chassis, until a *minimum* output from the receiver is obtained. The point of minimum output is the proper adjustment.

It should be remembered that the trimmers provide an adjustment over a small range. However, if constant interference is experienced at a slightly different frequency from 460 kc, adjusting the trap to the frequency of the interference will materially reduce the effect.

### Philco Model 29 and "TX"

The Model 29 (Code 123-TX) is the Model 29 with the addition of an output transformer, a speaker toggle switch and speaker Type P-22.

The Model 29-TX also includes a furniture-type speaker, HR-2, which is connected to the receiver by a 25-foot cable and plug assembly, attached to the speaker cabinet.

The ac cord on the Model 29-TX is a flat cable and contains an extra wire, which is for use as an antenna lead by connecting the antenna to the binding post mounted on the side of the special flat ac plug used. However, the antenna may be connected to the regular antenna clip terminal on the receiver chassis if desired and more convenient.

### Stewart-Warner Model—Chassis Numbers

The following data refers to the new series of Stewart-Warner receivers:

The R-123 Series chassis are used in receiver Models 1231 to 1239.

The R-125 Series chassis are used in receiver Models 1251 to 1259.

Chassis R-126 are used in receiver Models 1261 to 1269.

Chassis R-127 are used in receiver Models 1271 to 1279.

The Model R-117 chassis (auto radio) is used in receiver Models 1171 and 1172.

All of the above "home" receivers use an intermediate frequency of 456 kc. The Models 1171 and 1172 auto-radio receivers employ an intermediate frequency of 177.5 kc.

(Continued on page 386)

# Auto-Radio . . .

## Howard Highwayman

The diagram is shown in Fig. 1. There is an r-f stage using a 6D6. This is followed by a 6C6 used as modulator-oscillator. Both inductive and capacitive coupling are employed in the antenna and r-f transformers. This provides uniform gain over the complete wavelength range of the receiver.

A 78 tube is used in the i-f stage. Bias for the tube is supplied by the same resistor (R-4) which supplies bias for the r-f tube. The plate circuit of the i-f tube is transformer-coupled to the paralleled diode of the 75 tube. The diode functions both as second detector and avc. Bias control is placed on the r-f and i-f tubes only.

The a-f component of the i-f signal appears across the volume control potentiometer the arm of which connects to the control grid of the 75 a-f triode. The triode is resistance coupled to a 42 pentode which feeds a dynamic speaker. The tone control switch is in the plate circuit of the power tube. Bias for this tube is developed across a portion of the filter choke in the return lead of the power supply. The speaker field is energized by the storage battery.

### ADJUSTMENTS

A top view of the chassis is shown in Fig. 2. The locations of the trimmer condensers are given.

It may be well to first balance the set to the antenna. This is accomplished as follows:

With the receiver tuned to a very weak station, about 130 to 140 on the dial, adjust the antenna trimmer with a screwdriver until maximum volume is attained. To reach the antenna trimmer, remove the plug button from the top of the case.

If re-alignment is necessary, adjustments can be made with the receiver mounted in the cabinet, it being only necessary to remove the top cover.

Proceed as follows for i-f alignment: With gang condenser at its maximum capacity and with volume control full on, connect in series with a 0.1-mfd condenser an oscillator set at 175 kc to the grid cap of the 6C6 tube.

Adjust trimmer condensers of both input and output i-f transformers (see Fig. 2) to resonance with the oscillator, as indicated on an output meter connected across the primary of the speaker input transformer.

Each i-f transformer has two adjustments, one nut and one screw, both of which are adjustable through the top of the can.

Proceed as follows for frequency alignment:

(Continued on page 386)

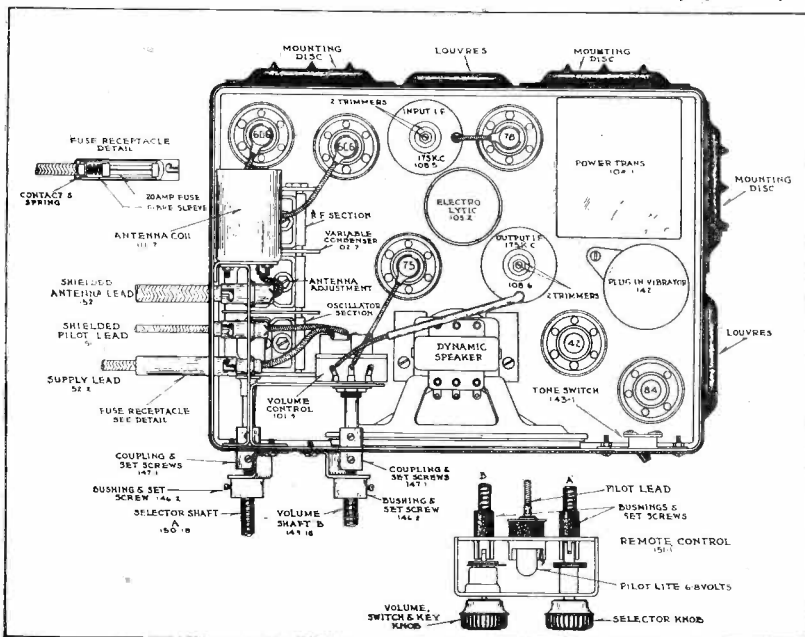
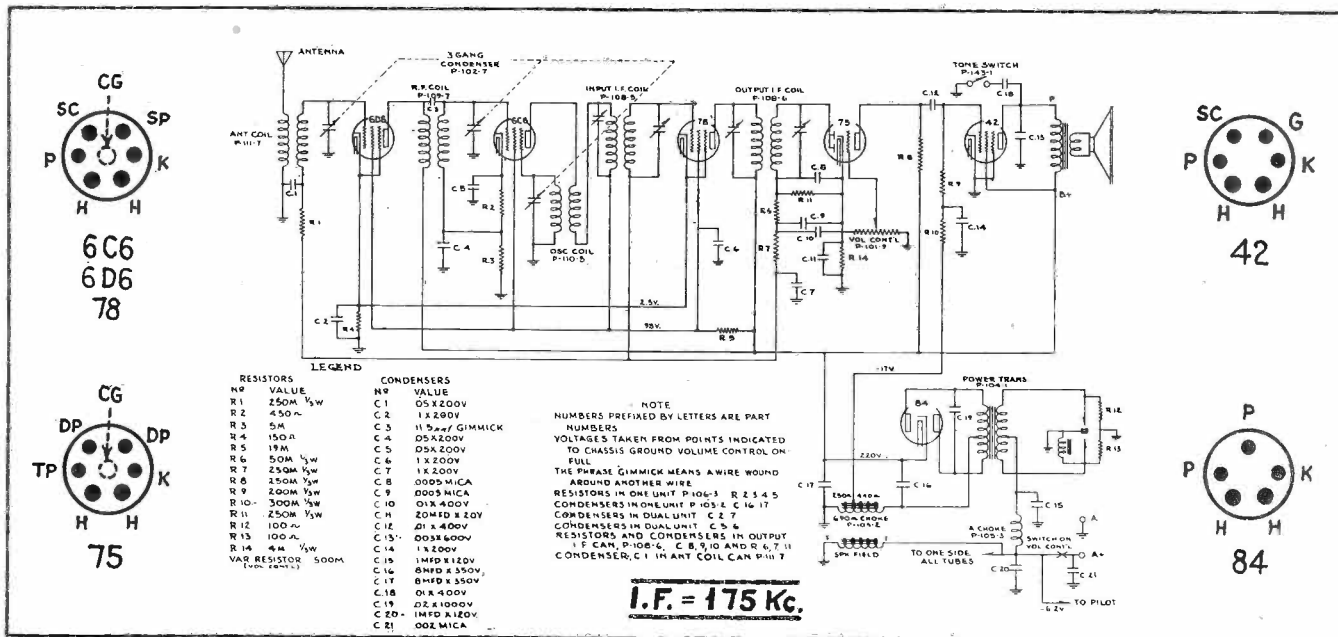

Fig. 2. (Above) A top view of the chassis of the Howard Highwayman receiver, showing location of tubes, trimmer condensers, etc. Fig. 1. (Below) Schematic diagram of the Howard Highwayman receiver, with values of all parts given. Note tone control switch in the plate circuit of the type 42 power tube.





# Public Address . .

## P-A SYSTEM WITH VELOCITY MIKE

By H. HOWARD RABE

Part I

FOR some types of p-a work it is highly desirable to have a good "distant-talking" microphone. In picking up church services and transmitting them to the auxiliary auditorium it is nice to be able to pick up the entire service instead of only the sermon at the pulpit. Feedback presents no problem for these "two-audience" setups and there is practically no limit to the amount of gain that may be used. Outdoor plays and presentations can be improved upon with a good distant-pickup microphone.

### MIKE WITH AC-OPERATED AMPLIFIER

When the publicity on the ribbon microphone first began coming out the

on the ribbon mike, but some of the faults of these units seem to have been overlooked.

The condenser microphone affords a good distance pickup, but the average p-a operator is not keen about packing any extra equipment around with him, especially on the low-priced or free jobs.

### MAGNETO MAGNETS USED

In order to get maximum output the microphone was built as large as conveniently possible. Four magneto permanent magnets were used for the "field." These had been formed from  $\frac{3}{4}$ -inch  $\times$   $1\frac{1}{2}$ -inch steel and the four had an area of  $2\frac{1}{4}$  square inches. The pole pieces were machined from  $\frac{3}{8}$ -in. angle iron. It is difficult to concentrate flux into a thin air gap, the lines have a tendency to spread out. Moving the ribbon  $1/16$ -inch out of the gap did not cut the volume to zero as might be expected, but to about a fourth. Therefore, the ribbon was made quite long and the pole faces were machined down to almost a sharp edge. The pole pieces were  $8\frac{1}{2}$  inches long and the total length over the magnets was  $12\frac{1}{4}$  inches. The ribbon clamps are shown at right angles to the ribbon but they should be in line with the ribbon.

The unit shown in Fig. 2 was tried but cavity resonance proved too detrimental. Not only did the ribbon have a peak, but at the beginning of every sound impulse the ribbon would first

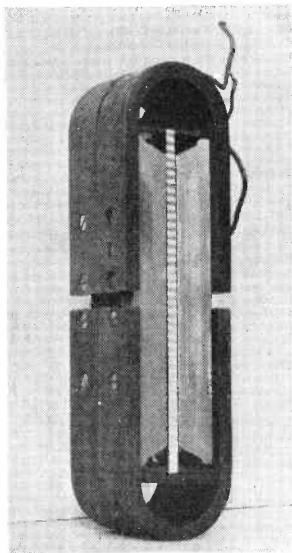

Fig. 1. The completed ribbon microphone. Magnets are grounded to shielding on cord.

writer decided to determine if it would be possible to build a good distant-talking velocity mike with an ac-operated amplifier, and at reasonable cost. The outfit proved very satisfactory and is described in the following paragraphs.

Several microphone kits are available on the market but this article is being written more for the dyed-in-the-wool experimenter who likes to build his own from the ground up. In recent months numerous articles have been published

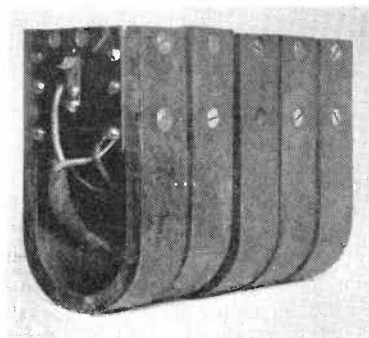

Fig. 2. This construction was tried but cavity resonance was detrimental. Note ribbon clamp.

try to resonate with the cavity before following the sound wave.

### THE RIBBON FOIL

Outside of the flux the ribbon is of course the heart of the microphone, the sensitivity being in proportion to the lightness of the ribbon. Many foils were tried. Candy bar foil is quite satisfactory. After tearing down several old, shorted, paper filter condensers some very good foil was found. The foils ranged in thickness from less than .5 mil to over one mil. Ribbons made from these foils ranged in weight from .5 grain to 1.5 grains. This ribbon has 2 square inches of active area; ribbons with a smaller area will naturally weigh less. Some foils have very little elasticity and the ribbon soon stretches out of shape and flops around. The crimp was put into the ribbon by running it through the gears of a small machine lathe (8 teeth to the inch).

Wind has a very detrimental effect on the ribbon, it flops around and makes lots of noise. If much crimp is left in the ribbon it may even stretch out of place in a strong wind. A narrow ribbon is less affected by wind, but a wide ribbon seems to be more sensitive to weak sounds. A quarter-inch ribbon in a  $5/16$ -inch gap was used.

Mounting the ribbon is quite a delicate job and the builder should figure on spoiling about a half dozen ribbons. Lay the foil on hard cardboard and with a sharp knife and a straight-edge, cut

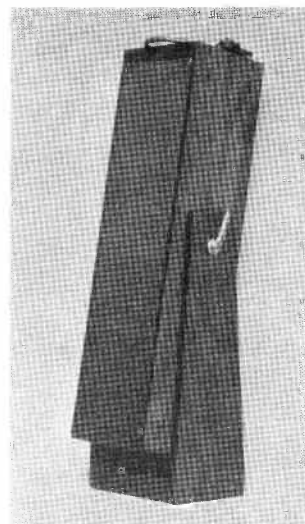

Fig. 3. The ribbon mike in its frame, for table mounting.

into ribbons. Lay the ribbon on glass or other hard surface and with the tips of the fingers smooth out any wrinkles. Crimp the ribbon. Smooth out one end and fasten under the clamp, pass the other end through the clamp and stretch out the ribbon until almost straight. Then allow the ribbon to spring back until almost slack, center, and clamp.

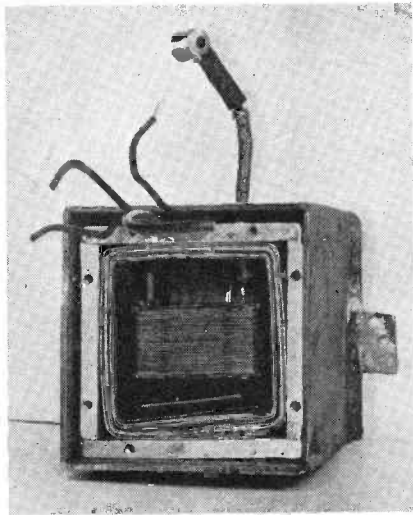

Fig. 5. The ribbon-to-grid transformer in its shielding box.

Re-center the first end. With the microphone placed in a horizontal position, the ribbon should not sag to the pole pieces.

#### MICROPHONE PROTECTION

Iron particles have quite a tendency to collect on the unit. These are best removed with a screwdriver which has been magnetized. To further protect the unit from wind and iron chips, it was wrapped in voile cloth (or cheese cloth) before being mounted in the wood frame. The two brass, pivot, thumb-screws screw into the iron pole pieces.

The mike weighs sixteen pounds, about the same as one heavy-duty B battery.

When used in a strong wind the mike must be covered with a hood. The ribbon will blow out of the gap and there will be little pickup until the ribbon returns to the gap.

#### DIRECTIONAL CHARACTERISTICS

The sensitivity was, of course, greatest at the front (and back) of the ribbon. At the sides of the ribbon it was considerably less, and was zero at the ends of the ribbon (top and bottom). However, this region or plane of sensitivity is not sharply defined; sounds striking at an angle will have a proportionate effect. If the microphone is placed below the level of the speaker's head, it must be tilted backward or else he will talk over it and there will be no pickup. If placed beside the tuba player with the bell of the horn above the mike, you would never know the tuba was there. When it is necessary to pick up sounds from several sources, the microphone should be so placed and rotated that all sounds lie in the plane of sensitivity.

#### THE HUM PROBLEM

The most serious problem was the hum picked up by the core of the input transformer. (This also applies to the dynamic microphone). When used for close-talking purposes this "core pickup" was not so serious; but then, when used for close-talking purposes the granule hiss of the carbon mike is not so bad. Most of this hum comes from the power transformer, but even with battery-operated amplifiers well removed from ac circuits there was excessive hum.

The shield for the input transformer is quite an elaborate affair. The outer box is made of one-eighth inch sheet iron with the corners welded together. A slip-over cover is provided which can be screwed down. Inside of this is a box made of one-fourth inch aluminum. The six pieces were accurately sawed to size, drilled, tapped, and screwed together. If a power saw is not available, a carpenter's nail saw works very good on aluminum, and a little cutting oil on the tools will keep the

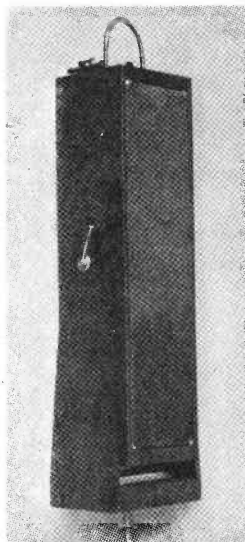

Fig. 4. The velocity mike on a stand. Front and rear of the frame are covered with copper screen.

aluminum chips from binding in them.

The four sides and bottom were then welded together in a few places. Inside of the aluminum box is a sort of laminated affair, consisting of four sheets of copper and four sheets of iron, alternated. The eight bottom squares were placed in the bottom of the aluminum box. The eight side strips were formed into a short square tube and forced into the aluminum box. To form this tube, place two pieces of 1½ or 2-

inch angle iron in a vice to form extension jaws for the vice. After the transformer has been put in place, the eight top squares are put in the aluminum box and then the aluminum and iron tops screwed down.

The reader may have the idea that all this shielding is superfluous; *it is not*. Part of the hum remaining in the output is "core pickup." The input transformer and the power transformer should be mounted at least a foot apart, and the input transformer should be rotated to the point of minimum hum pickup. The use of a power transformer with a low flux density in the core, and the use of a shield, will help matters. The first tube and the grid lead must also be shielded.

#### INPUT TRANSFORMER DESIGN

The design of the input transformer is not such a critical matter. If possible, obtain a small transformer with some unused winding space between the outside of the coil and the core, and connect the primary and secondary in series, assisting each other. To do this, connect the two windings in series to the 110-volt, ac line; measure the voltage across the larger or secondary coil and if it is higher than the line voltage the two windings are bucking.

There is no dc in the input transformer and a large core is not necessary. Or, cut the primary away from the secondary and use this winding space. The writer found an old discarded transformer (Fada, I think) in which the primary was wound on the outside of the secondary.

A very large ribbon winding results in a general loss of gain; a very small primary results in a loss of the very low frequencies. The final model contained 60 turns of No. 22 wire with a tap at 20 turns. The size of the wire is not critical, use the largest size space will permit. Under some conditions, it is desirable to have the ribbon winding grounded, either a center tap or one side. In this case the 20-turn tap is grounded. The full primary was used for regular work and the small winding where distance was most important. A dynamic speaker output transformer will also work. The different input transformers tried weighed from ½ to one pound; the shield weighs 7½ pounds.

#### RIBBON-TO-LINE TRANSFORMER

Present-day practice calls for an impedance raising (ribbon-to-line) transformer at the microphone. This transformer, if used, will require some shielding, but not as much as the set trans-  
(Continued on page 386)

# LATEST TECHNICAL INFORMATION

## YOURS FOR 10¢



The Hygrade Sylvania engineers have given you helpful books that cover general service data on both home and automobile radio receivers. Now available is a convenient 104-page technical manual containing the essential information every user of tubes must have to secure the optimum performance from any device employing vacuum tubes.

Complete data on over 90 types of receiving tubes is given along with base symbols, recommended operating conditions, circuit applications, amplifier classifications, receiver circuit diagrams, etc.—over 150 cuts and diagrams. Authoritative beyond question, because it was compiled after months of painstaking research by the famous Sylvania staff of tube and circuit engineers.

You need this new technical manual—it's as necessary as your voltmeter in service work. Just fill in the coupon below, attach 10 cents in stamps and mail today.

### YOURS for 10¢ in STAMPS

# Sylvania

REGISTERED U. S. PAT. OFF.

## THE SET-TESTED RADIO TUBE

Makers of  
Sylvania Tubes  
Hygrade Lamps  
Electronic Products



Factories  
Emporium, Pa.  
St. Mary's, Pa.  
Salem, Mass.  
Clifton, N. J. © 1934, H. S. C.

HYGRADE SYLVANIA CORPORATION  
Emporium, Pennsylvania (C-17)

Please send me the new Sylvania Technical Manual.  
I enclose 10¢ in stamps.

Name.....

Address.....

City..... State.....

former. If placed in a magnetic location, the iron circuit of the microphone itself will pick up some hum. This usually is not serious; but sometimes bell-ringing signal transformers are located in the speaker's stand, nor can the mike be used real close to the amplifier. Watches, especially wrist watches, worn by the operators or users of the ribbon microphone, soon become magnetized. It is practically impossible to magnetically shield the microphone, as any iron placed around it will rob much of the flux from the air gap.

**RIBBON LINE RESISTANCE**

Next it was necessary to determine the amount of resistance that could be tolerated in the ribbon line. Three ohms produced a noticeable drop in volume; one ohm produced a barely perceptible drop; one-half ohm apparently produced no loss at all. In order to simplify cordage stocks, all of the writer's p-a outfits are built up with similar circuits.

In this case a four-conductor No. 18 shielded cord was used. This provided five conductors (the shield at chassis potential) for use as a loudspeaker extension cord, and with two conductors, connected in parallel, to provide the equivalent of a No. 15 ribbon line. Seventy-five feet of this ribbon line has a little less than one-half ohm resistance. In this way it is possible to have either a long speaker or long microphone line.

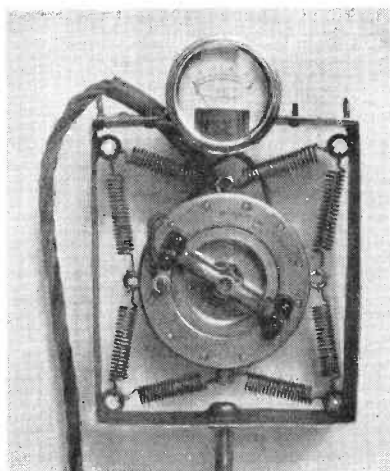

Fig. 6. Showing the double-button carbon mike in its mounting frame, with level indicator directly above. Two eyelets at the top of the frame permit the mike to be suspended.

**SENSITIVITY COMPARISONS**

In comparing the sensitivity and noise level of various microphones, a weak standard sound, such as the ticking of an alarm clock, is very useful. With the high grade, stretched diaphragm, highly damped, two-button carbon microphone, the ticking is lost in granule hiss at distances of 3 to 7 inches, depending upon the condition of the unit. With the low priced, sensitive, non-stretched diaphragm, two-button microphone, the ticking is lost

in granule hiss at distances of 1½ to 2 feet. The low-frequency response of these units is very poor and the output sounds tinny. With the velocity or ribbon microphone outfit described, the ticking is lost in noise and ac hum at distances of 3 to 4 feet. Using the small sensitive primary (20-turn) winding this distance is about doubled.

The hum level can be further reduced by the use of a battery-operated amplifier and further isolation from ac circuits, but this gets back to the difficulties surrounding the condenser microphones. On condenser microphones which the writer built several years ago, the ticking is just audible at distances of 10 to 12 feet.

In the amplifier used, the velocity microphone employs an extra stage of amplification over that for the carbon microphones. In order to obtain some semblance of distant pickup (with a lot of granule hiss) the carbon microphone circuit has more gain than is customary. Under the conditions described, the velocity microphone has twice the output of a good two-button carbon microphone for a given sound. A public speaker at a distance of 10 or 12 feet can develop full output on a pair of 45's push-pull. Because of reverberation and room noise, a further increase in gain is useless.

The p-a amplifier designed for use with the ribbon microphone will be described next month.

*(To be continued)*

**HOWARD HIGHWAYMAN**

*(Continued from page 382)*

Attach oscillator connected in series with a 200-mmfd condenser to the antenna lead and with the gang condenser at its minimum capacity setting, and with the oscillator set at 1550 kc, adjust condenser trimmer of oscillator section (shaft end) for maximum output.

Re-set oscillator to 1400 kc, rotate gang condenser to pick up signal, adjust antenna and r-f trimmers for maximum.

Now check alignment at 1200, 1000, 800, 600 and 530 kc, by setting oscillator to these frequencies and picking up signal by rotating gang condenser.

Bend slotted plates of antenna and r-f sections only if necessary. *Under no circumstances bend plates of oscillator section.*

**VOLTAGE READINGS**

Voltages from chassis to different points are indicated on the diagram of Fig. 1, and should be measured with

a voltmeter having a resistance of 1000 ohms per volt.

(Also see note on this receiver on page 264, July SERVICE.)

**GENERAL DATA**

*(Continued from page 381)*

**Atwater Kent I-F Peaks**

The intermediate frequencies used in the late models of the Atwater Kent receivers are as follows:

Model	I-F Peak
165	264
165Q	264
185	264
217	264
217D	264
275	264
310	130
387	264
425	264
427	264
427D	264
427Q	264
510	130
525	264

525Q	264
665	264
666	264
667	264
667D	264
708	472.5
711	472.5
711R	472.5
788J or T	472.5
788R	472.5
808	472.5
808A	472.5
816	264
926	264
936	264

The last three models listed are auto-radio receivers, as is also the Model 666.

**Majestic 112**

Shorted 0.1-mfd bypass condenser in i-f transformer can. Open 10,000-ohm resistor in same. Drill out rivets and lift off cover, or heat and remove. Unsolder condenser leads, replace with small 0.1-mfd, 400-volt tubular unit, or replace resistor with 1-watt type.

E. M. PRENTKE.



still  
**best!**



-by the  
**"blindfold test"**

Simple, easy and, boy, how smooth!

Whether you use the blindfold test to note its sure, smooth attenuation or hook it into the most complicated laboratory "third degree" the new RADIOHM will come up smiling.

And . . . a mere handful will give you practically any resistance value you'll ever need.

**Change to  
RADIOHMS**

Every Radio Service Man  
should be a member of the  
Institute of Radio Service Men

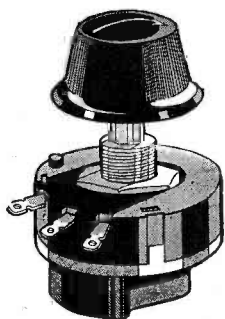

**Centralab**  
Central Radio Laboratories  
MILWAUKEE

**THORDARSON**  
the **LOWEST COST**  
Transformer Replacements  
for **FULL POWER** Performance  
**UNIVERSAL THORDARSON  
DUPLICATE** Replacement  
Transformers  
plus **FREE**  
Receiver Guide

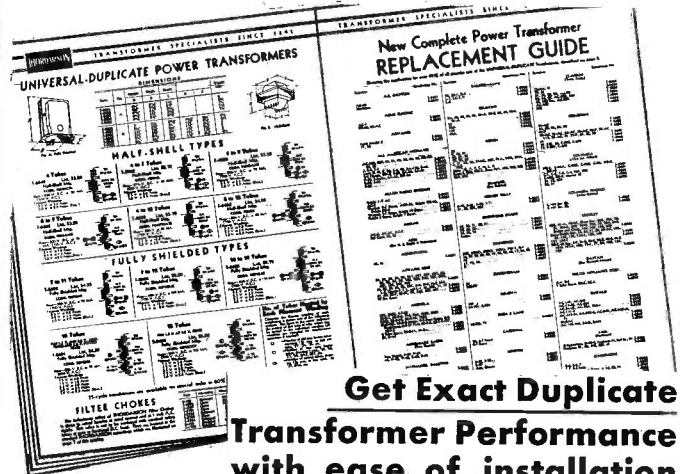
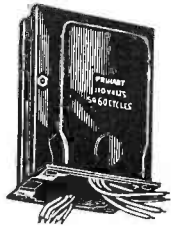

Get Exact Duplicate  
Transformer Performance  
with ease of installation  
—at **UNIVERSAL Transformer Cost**

Why take a chance by using a replacement transformer that is not designed for the set you are repairing?

The big new THORDARSON Transformer Replacement Guide lists transformers for 90% of all popular sets—each designed to the EXACT needs of the individual receiver. Yet through THORDARSON leadership in design, only eleven UNIVERSAL-DUPLICATE Transformers cover all sets. Thus your stocks are small—and quantity production has brought THORDARSON quality down to lowest price competition. Ask your jobber or write for a copy of this complete guide today!

Write for your  
**FREE** copy today



**THORDARSON ELECTRIC MFG. CO.**  
500 West Huron St., Chicago, Ill., Dept. J

Send us at once the NEW THORDARSON Receiver Replacement Transformer Guide—also new THORDARSON Bulletins checked below.

- Sound Amplifier Equipment Bulletin #345-A FREE. Name \_\_\_\_\_
- Sound Equipment Manual (25c). Address \_\_\_\_\_
- Transmitting Equipment Bulletin #343-A—FREE. City \_\_\_\_\_
- Transmitting Manual (10c). State \_\_\_\_\_

# ON THE JOB . . .

## Test-Meter Switching Unit

The accompanying diagram shows the schematic of a switching arrangement which permits simultaneous voltage and current measurements. Some of the advantages of this unit follow: It is fast, due to the fact that both volts and mils may be read simultaneously in the circuit desired; it is simple to operate, the operator selecting the circuits on which the test is to be conducted without swinging back and forth over dead contacts as is the case with a rotary switch; it is sturdy; and the contacts made are better than with a rotary switch.

### SWITCHES REQUIRED

An examination of the schematic will show 6 break-one, make-two contacts, push-button switches; 2 momentary switches; 2 double-pole, double-throw toggle switches, to reverse meters; a single-pole, double-throw 3-position key switch, for the reference switch; and a pin jack in series with each element, for reference point and substitution.

The schematic diagram is self-explanatory. However, a few brief remarks may be in order.

First, the meters are fully protected, being cut in the circuit only when one of the buttons is pressed.

### VOLTAGE AND CURRENT TEST

To make a voltage-current test, all one needs to do is set the meters for the proper range, set the reference switch, and then press the buttons in the various circuits called for in the

particular test . . . both volts and mils will read together. If the test calls for a negative reading on one or both meters, the reversing switch is simply thrown to negative. To read heater voltages, the reference switch is thrown to  $H\pm$  and the H switch is pressed. If the voltage reading to chassis is desired instead of to K or H, the reference switch is left in the off position and the negative side of the voltmeter is connected to the chassis. This permits a socket-to-chassis current and voltage test. If the reference point is other than K or H, the negative side of the voltmeter is connected to the reference point at the pin jacks.

For example, the reference point of a type 53 would be the G-1 pin jack, this being the position of the cathode in this tube. Now a voltage and current test on a 53 tube takes about 30 seconds. The procedure follows: Set the milliammeter on the 100 range, the voltmeter on the 500 range, and connect the negative side of the voltmeter to the G-1 pin jack. Press P button for one plate, press K button for two plates, reverse milliammeter, throw reference switch to  $H\pm$ , press G-1 button (this gives total current drawn by both plates along with K voltage), and with reference switch still on H, press H button for heater voltage. Then throw reference switch to the off position, reverse the voltmeter and press G-2 button for one control-grid voltage. G-3 button gives the second control-grid voltage.

### OTHER TESTS

To make a socket-to-chassis resistance

test, switch the meter (whichever one it happens to be) to ohms and connect the negative side of the unit to chassis. Then, pressing each button registers the resistance of that circuit. The momentary switch in  $H\pm$  lead is for resistance measurements and is not used for heater voltages.

A socket-to-chassis capacity test is taken in the same manner as a resistance test, with the capacity meter connected to the positive pin jack and chassis.

Condensers or resistors thought to be open are readily substituted between any element and chassis via the pin jacks of the unit and chassis.

The particular circuit arrangement used in this tester is easily incorporated in a complete analyzer through a suitable gang switch, or it can be made as a single unit to work with two universal meters.

There are several ways of obtaining simultaneous voltage and current readings, which, in the writer's opinion, are necessary since taking first volts and then mils is lost motion. The other methods require a certain amount of doctoring, but the switches are easily obtained on the market.

AL. BEERS,  
724 6th Ave.,  
San Francisco, Calif.

### Argus Electric

Argus Electric using 99's and 81's: Meter fails to come up to red mark, or comes up too slowly. This is caused by deterioration of old style electrolytic condenser which is found inside the small black metal case in power unit. Great improvement will result if a new type dry electrolytic condenser of 8-8-8-mfd, 500-volt rating is substituted.

E. M. PRENTKE.

### RCA Victor Model 126-B Bias

The Model 126-B is a 6-tube battery receiver. A 22½-volt "C" battery is used, and grid voltages are supplied through a high-resistance bleeder system of which the volume control is a part. The volume control varies the bias voltage supplied to the first detector and i-f tubes.

Since the high-resistance bleeder shunts the "C" battery, any desired bias voltages may be obtained through taps on the resistor.

The circuit is opened when the receiver is turned off so that there will be no constant drain on the "C" battery.

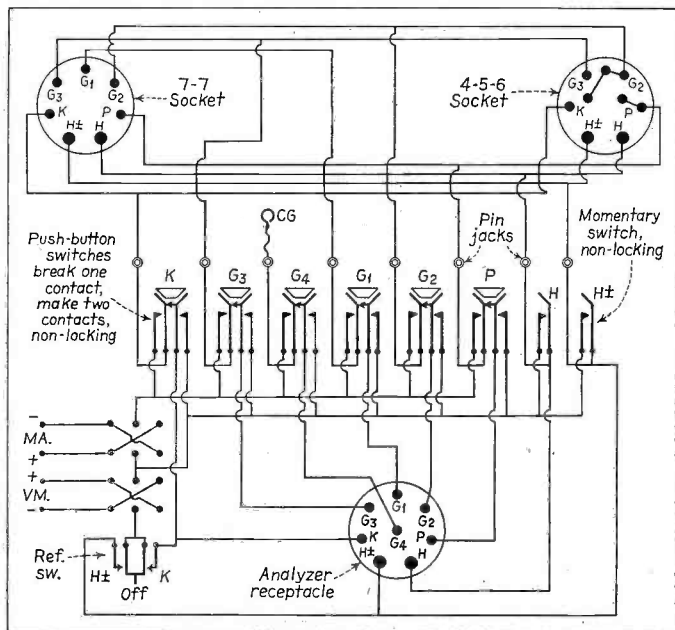

Detailed schematic diagram of the Test Meter Switching Unit.

KENYON

PRODUCTS

# NECESSARY

*... for profits!*

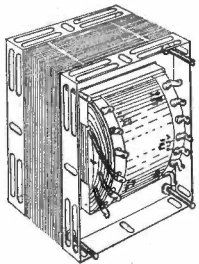

**5 KENYON TRANSFORMERS**  
now service over  
95% of STANDARD RECEIVERS

Yes, precisely so. With these 5 types in stock you can service practically any standard set—efficiently, economically, satisfactorily, profitably. Big inventory investment no longer required. Nor much storage space. Our transformer replacement chart tells you which of the 5 types to use for any standard receiver.

The KENYON line also includes audio transformers and chokes and flush type power transformers for radio set repairs and new assemblies.

### SERVICE DATA FREE

Ask for KENYON distributor for service data. He can show you our handy replacement units. Or write us giving us his name on your business letterhead.



**KENYON TRANSFORMER CO., Inc.**  
840 Barry Street New York City

## TACO—the pioneer manufacturer of the famous H.F. All-Wave Antenna System announces

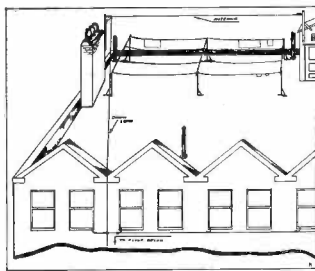

(Licensed A.A.K. Inc.)

### The TACO MULTIPLE RADIO OUTLET ALL-WAVE ANTENNA KIT SYSTEM

... a single antenna to serve many sets. ... Efficient. ... Easy to instal.

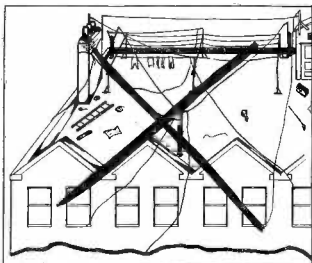

WRITE for DETAILS of the Complete TACO LINE.

Does away with this atrocity which has existed since radio began. ...

TECHNICAL

APPLIANCE TECHNICAL APPLIANCE CORP.  
27-26 Jackson Ave.  
Long Island City, N. Y.

# CORNELL-DUBILIER

# ONE BILLION CONDENSERS



One billion Cornell-Dubilier condensers manufactured and sold since 1910. A stupendous total. If laid end to end, they would form a chain, which could span seas, deserts and mountains, circling the globe nine times.

One billion ... in thousands of installations ... wherever and for whatever condensers are used.

One billion ... a silent guarantee that stands behind you whenever you use a C-D.

One billion ... and the total grows. The United States government, scientific expeditions, the leading 150 set manufacturers, demand Cornell-Dubilier: they can't take chances.

Remember, the Quality that has kept us in front, as the largest manufacturers of condensers in the world ... is still the same ... always the same ... while our prices are now the lowest in history. In justice to yourself and your customers use C-D condensers every time.

MAIL THIS

COUPON NOW

CORNELL-DUBILIER CORP.  
4375 Bronx Boulevard, N. Y.

Our catalog No. 125 gives you concrete facts and figures on the "Most Complete Condenser Line" Write for your copy.

Name

Address

**CORNELL-DUBILIER**  
CORPORATION  
4375 BRONX BOULEVARD  
NEW YORK

# "VOLTAGE RELATION" AND ITS APPLICATION

Last month we were discussing the none too well understood subject of voltage relations. Now, in order to gain a clearer conception of exactly what was meant, let us consider a few examples.

## VELOCITY ANALOGY

Off hand it would not appear that there was much in common between velocity and voltage, as the former represents motion and the latter is generally thought of as a form of electrical pressure. However, it is necessary to measure both voltages and velocities, and hence there must be some reference point from which to start these measurements. Voltage and velocity may, then, be said to be similar, in that they are both relative.

Fig. 1 shows three bodies, A, B and C, traveling at definite velocities and in definite directions. Perhaps it might

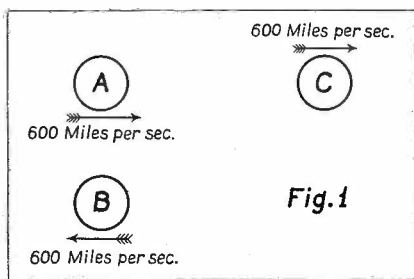

Fig. 1

Here are three planets in space whose speed and size is a matter of relativity—believe it or not!

be best to consider these bodies as planets traveling through space. Now to an observer on A, planet A would appear to have no motion . . . for the same reason that we observe no motion of the earth. Planet C would, also, appear to have no velocity for, due to their having the same velocities, the distance between A and C remains the same at all times. On the other hand B moving in the opposite direction would apparently be traveling at a rate just twice as fast as it is actually moving, namely, 1200 miles per second. Again, if the observer were on C, A would seem to be stationary, and B moving away at a rate of 1200 miles per second. Actually these bodies are all traveling at the same speed, though the direction of B is opposite to that of A and C. Further, if the velocity of C were 400 miles per second and the observer on A, C would appear to be approaching A at a velocity of 600—400 or 200 miles per second; and, if the observer were on B, C would seem to

## PART I

"Voltage Relationship" is an interesting as well as an important subject. The ways in which voltage relations are taken advantage of in receiver design will be covered.

be moving away from B at a rate of 400+600 or 1,000 miles per second.

While the actual velocities should, perhaps, be based on some one fixed point in space, it is neither convenient nor necessary. Imagine, for instance, the convenience of calculating the velocity of a train with reference to some fixed point in space. Not only would it be necessary to take into account the straight line movement of the earth away from or towards the point and the direction and speed of the train, but the angular movement of the earth or rotation about its own axis, must also be considered. Even having done this we probably would not have what we desired, namely, the velocity of the train with respect to ourselves or a particular point on the earth. It is desirable, then, to assume some particular reference point to fit the case.

The same thing is done with potentials. We base them on the most convenient reference point. Quite often this point is ground potential, the assumed zero of reference. With the above in mind, let us consider a simple resistance circuit.

## SIMPLE RESISTANCE CIRCUIT

In Fig. 2 there is shown a simple resistance, extending from a to e, across which is connected a battery having a terminal voltage of 100 volts. The plus terminal of the battery connects to a and the negative terminal to e (both the battery and leads are shown in dotted lines). The battery and leads will be assumed, for convenience, to have negligible resistance, so that the total 100 volts is effective only in sending current through the resistance ae; that is, there is a voltage drop in ae exactly equal to the voltage impressed across its terminals. Now let us further assume that the voltage drop from a to b is 10 volts, from b to c 20 volts, from c to d 30 volts, and from d to e 40 volts, making a total voltage drop of 10+20+30+40=100 volts. In other words the voltage drop from b to d is 20+30 or 50 volts. Also, if a tap were brought out from b (shown by the dash dot line), the voltage measured across it to the negative terminal of the battery, assuming no meter loss,

would be 90 volts. Similarly, the voltage measured from c to the negative terminal of the battery would be 70 volts. This shows that there is less voltage between the points b and e than between a and e . . . less by the amount of the voltage drop in the section ab.

## VOLTAGE-DROP TRIANGLE

Another and rather interesting way of illustrating how the voltage is used in this resistance makes use of the triangle shown in the upper part of Fig. 2. Assume that the resistance is a straight, homogeneous conductor in which the resistance in any one section of a given length is equal to the resistance in any other section of the same length, i. e., each inch length of the conductor might have a resistance of 10 ohms. The horizontal line is equal (or if it is more convenient it may be made proportional) to the length of ae. The vertical line can be made any desired length.

Since the total voltage impressed across ae is 100 volts, let us divide fj into 100 divisions. Now if we project vertically from b to the hypotenuse of the triangle and thence over to the left, this projected line will cut fj at i. This latter point will be ten divisions down from j, showing that there is a 10-volt drop from a to b. Similarly point d projects to g which is 60 units down or a voltage drop between a and d of 60 volts. Really the hypotenuse of the triangle is the voltage drop-length curve of the resistance for 100 volts impressed across it, the horizontal axis representing the length of resistance and fj the voltage drop. The line fj may be calibrated with f as zero and j as 100, if desired. However, in this case it should be remembered that the voltage read will be the voltage impressed on the remaining part of the resistance going from left to right.

(To be continued)

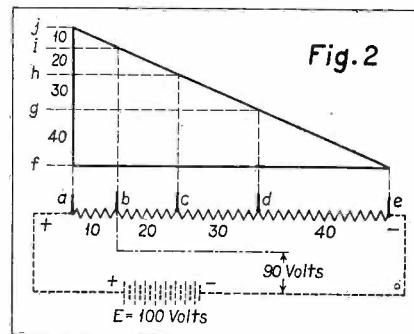

Here we have a voltage divider with a lot of lines indicating voltage relationships from point to point.



EXACT DUPLICATE

### Electrolytic Replacement Condensers are Designed for Modern 1934 Service

For Neatness  
Ease of Installation  
High Voltage Safety Factor  
Long, Satisfactory Service

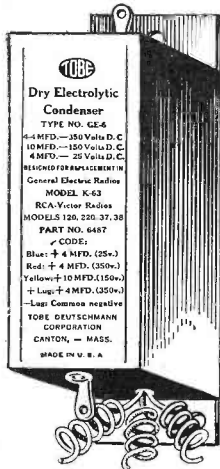

Insist Upon



### Replacement Condensers

Electrolytic condenser blocks like the one illustrated are available for all popular receivers.

Stocked by leading parts jobbers everywhere.  
Send for latest free condenser bulletins.

**TOBE DEUTSCHMANN CORP.**  
Canton, Massachusetts

### LATEST DEVELOPMENT IN ANTENNA SYSTEMS

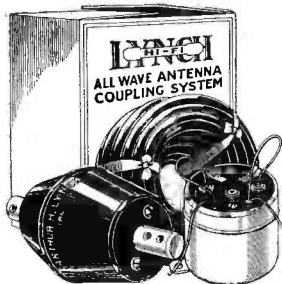

"No Radio  
Can Be Better  
Than Its  
Aerial"

# LYNCH

HI-FI  
(High Fidelity)

## ANTENNA SYSTEMS

are guaranteed to improve reception with any receiver, in any location. LYNCH "HI-FI" aeriels are necessary with the new High-Fidelity receivers. There are LYNCH "HI-FI" antenna kits for every purse and purpose. They're easy to install and they work like nobody's business.

From \$3.50 to \$7.90, list

Details appeared in "SERVICE" for September.  
Ideal for demonstration set-ups.  
Full Information on Request

**ARTHUR H. LYNCH, Inc.**  
227 Fulton Street New York, N. Y.

# POWERTONE Modulated Oscillators

## Hi-Quality TEST EQUIPMENT

### Deluxe Model 77 SIGNAL GENERATOR

Calibrated Frequency Range 115-3000 kc with a 1000 cycle Modulated Signal. Operates efficiently on A.C. or D.C. current. The ideal for simplicity and accuracy in service oscillators.

The radio frequency circuit uses an electron coupled type oscillator which is inherently extremely stable. This circuit generates powerful harmonics which are available down to 10 meters. The R.F. modulated signal can be employed for checking intermediate frequencies and for testing the general overall gain of All-Wave radio frequency circuits.



The audio frequency note generated by the 6A7 is fixed at 1,000 cycles and is brought out to tip jacks on the front panel. The new dial employed allows the serviceman to absolutely read accuracies as close as 500 cycles at any point of the broadcast band. This dial in conjunction with the electron coupled oscillator gives a standard as close as 1/10 of 1% of frequency.  
Size—6"x5"x9"  
Weight—4½ lbs. Net **\$10.50**

EXPERIENCE has shown us that one of the most pertinent testing instruments in the Servicemen's work-shop is a Signal Generator.

Powertone Laboratories have taken long strides in the testing field to finally announce a new line of Hi-Quality Test Oscillators.

Several of the models are illustrated below.

### Portable and Cabinet TEST OSCILLATORS

Accuracy better than 2%

Employs a frequency stabilized Hartley oscillator circuit, rigidly constructed of the finest component parts.

The primary scale is calibrated from 50 to 150 kc. The bars are 1 kc apart from 50 to 80 kc, and 2 kc apart from 80 to 150 kc. Therefore when used with TRF receivers (using the 10th harmonic) the separation, as registered by the calibration points, is 10 kc from 500 to 800 kc to 1500 kc.

On the upper on secondary scale the popular intermediate frequencies are clearly marked: 175, 280, 400 and 450 kc with 177.5—175—172.5 spotted. Frequencies not marked can be obtained by means of harmonics, by simply dividing the desired frequency by small whole numbers to obtain the nearest scale frequency.

String harmonics are present due to the character of the oscillator circuit employed. In actual practice sufficient signal is available for checking purposes up to the 50th harmonic and beyond. In many cases strong steady signals have been obtained up to the 150th harmonic.

#### Portable Model

Mounted in a neat imitation leather case similar to that used in high quality testing equipment. Supplied with genuine leather handle and removable cover.  
No. 66 .....Net

**\$6.75**

#### Cabinet Model

The oscillator is neatly mounted in a walnut finished cabinet which protects all parts from physical or electrical damage.  
No. 55 .....Net

**\$5.75**



Model 66



Model 55

## Great News for Servicemen

# FREE Catalog

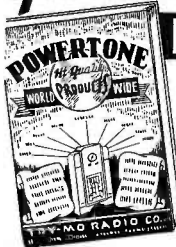

180 PAGES of the most versatile line of radio and equipment of any Mail Order concern in the country.

Short-Wave Equipment; Public Address Systems; Radio Replacement Parts; Broadcast Receivers; All-Wave Receivers; Radio and Electrical Hardware and thousands of other items.

SEND FOR YOUR COPY TODAY!

## More PROFITS for YOU!

The ink is still wet on these new 192 PAGE SHORT-WAVE AND PUBLIC ADDRESS MANUALS.

Tells how to make BIG MONEY in short-wave and public address paraphernalia. Bound in a sturdy Cardinal Red LEATHERETTE COVER.

An indispensable asset to your library.

If you are not satisfied with the Manual upon receipt, you may return it immediately and we will refund your money.



**50¢**

**TRY-MO RADIO CO., INC.**  
85-SE CORTLANDT ST. NEW YORK, N. Y.



# HIGHLIGHTS...

## HIGH-FIDELITY AGAIN

The usual period of peace which is ours directly after "putting to bed" an issue of SERVICE was shattered this last month by the arrival of some letters from a few of you fellows who misunderstood our little squib on "High-Fidelity Breaks", on page 346 of the September issue.

Some of our readers gained the impression from this item that we did not hold a high opinion of high fidelity in general—and after all we have printed on the subject, too!

Our aim in publishing the squib may appear obscure . . . we were attempting to indicate our belief that progress in the technical field of radio would far outstrip developments made in the actual programs broadcasted. In other words, we believe that the radio jokes of today will still be in evidence in the year 1936. The main difference will be not in the quality of the jokes but in the quality of the joker's voice.

## STANCOR ANNOUNCES COMPLETE PRICE REVISIONS

A four-page supplement to the Stancor 1934 Catalog in the form of a price revision list has just been published and released to the Service Men of the country. The official date for the effectiveness of this revision was September 25th to all Stancor authorized distributors.

This list affects every unit in the line of Stancor Exact-Duplicate Replacement Transformers, General Replacements, Audios, Chokes and Filters as well as the Universal Replacement Transformers and those for amateur transmitting and sound amplification.

## RADOLEK APPOINTED PHILCO PARTS AND TUBE DISTRIBUTOR

The Radolek Company has been appointed as Official Replacement Parts and Tube Distributor for Philco.

At a "family" dinner in the Palmer House in Chicago, September 28th, Mr. S. L. Capell, Chicago Division Manager of Philco, formerly presented the Philco

Authorization to Mr. W. C. Braun, president of the Radolek Company.

In a brief address, Mr. Braun stated, "We are blazing a new trail in parts distribution in making available to Service Men the genuine replacement parts of the leading radio manufacturer. Philco is recognizing the radio Service Man as an important factor in establishing good-will with the trade and has selected Radolek to supply Philco parts and tubes."

A special 32-page Philco parts catalog has been prepared for distribution to active Radolek customers. A complete stock of Philco parts, test instruments, and tubes is now available from the Radolek Company.

## THREE BOOKS BY GRANGER

Many of you fellows will remember the excellent series of articles on receiver design, by G. S. Granger, which appeared regularly in past issues of SERVICE. This series, and other similar articles dealing with the engineering features of antenna systems, audio amplifiers, etc., met with such widespread approval, that Mr. Granger decided it was high time to write books on design which would cover receivers more completely than possible in articles.

We have received advance proofs on the first three of his volumes and have had some decidedly interesting reading. We believe they should appeal to every Service Man, for whom the volumes were principally written.

Volume I, "Broadcast Receiver Design", is structurally patterned after Mr. Granger's original series in SERVICE, though it is completely rewritten and contains a great deal more than covered in the articles.

Volume II, "All-Wave Receiver Design", is brand new and contains much data which has never before, to our knowledge, appeared in print. The manner in which the data is presented makes it possible to apply the knowledge to actual servicing work.

Volume III, "High-Fidelity Receiver Design", is also brand new, as might be expected, and covers design data which so

far has not been put to use by manufacturers, as well as data on existing high-fidelity receivers. This is a particularly interesting book in that it provides concise explanations of high-fidelity problems and how they are being solved.

Some portions in all three volumes tend slightly toward mathematical interpretations which may be too deep for anyone but an engineer. However, such interpretations are, in most cases, explained in non-technical terms as well, so that little is lost.

These volumes are published by the Manson Publishing Company, 521 Fifth Ave., New York, N. Y. and cost fifty cents each.

## "THE SEALED CARTON CRUSADE"

The RCA Radiotron Company, Inc., Camden, N. J., have started a crusade against tube racketeers by developing a non-refillable sealed carton, which while effectively displaying the product, and is more practicable, makes it virtually impossible to substitute tubes. This ingenious device also permits the tube to be tested while still in the carton!

The RCA Radiotron Company are backing up their crusade by magazine advertising, by radio broadcasts over the NBC with a hook-up of 24 stations, and by window displays.

## NEW AUDIO AND ACOUSTICAL COURSE

The Capitol Radio Engineering Institute, Inc., Riggs Bank Building, Washington, D. C., have announced a completely new series of lessons, covering audio and acoustical work, which has been added to the regular extension courses.

All the work covered is taken up in actual practical problem form. Design of various types of audio amplifiers and studios, and other problems are discussed in detail, step by step. This series of lessons has been prepared directly from the notes and problems on this work as covered in the class room and laboratory of their residence school, it is stated.

In adding this new series of lessons no other lessons have been deleted. It will be available to all extension course students regardless of which course the student may select. These lessons are now being printed.

The Capitol Radio Engineering Institute, also, have a new catalog containing a detailed outline of the work covered in the new Audio and Acoustical lessons. This catalog contains, in addition, new photographs of equipment and much new data on the school and courses. Copies of the new catalog will be sent free on request.

## SHURE CATALOG SHEETS

We have just received a complete set of "Microphone Headquarters" catalog sheets from the Shure Brothers Company, 215 West Huron Street, Chicago, Illinois. These sheets give a rather complete coverage of their line of microphones and accessories in an up-to-date form. Further information may be obtained from the Shure Brothers Company.

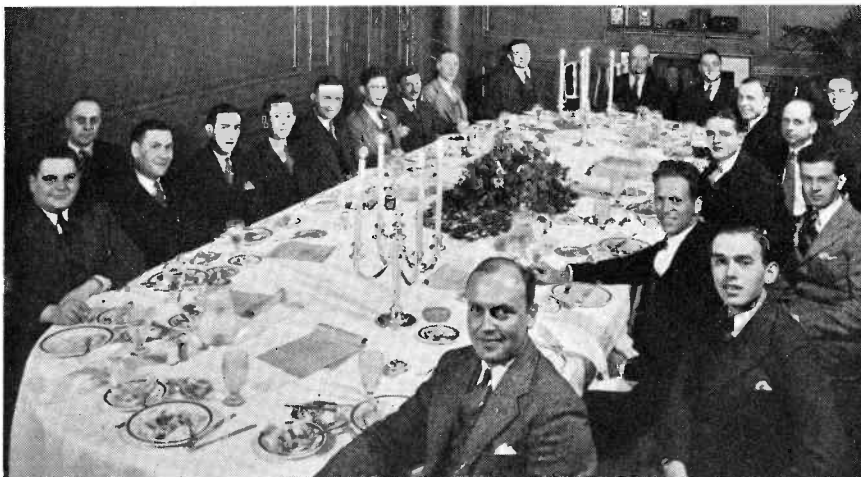

The broad smiles and empty plates visible in the picture are ample evidence of the good time enjoyed by the Philco officials and the Radolek department heads.



**Radio Engineering**—Covering the design, production, engineering and test of Radio Receivers, Tubes, Parts, Amplifiers, Recording and Sound Projection Equipment.

**Subscription, \$2.00 Yearly**  
(Foreign \$3.00)



**Communication and Broadcast Engineering**—Covering Radio Communication, Broadcasting, Police, Marine and Aeronautical Radio, Telephony and Telegraphy, Facsimile and Television.

**Subscription, \$3.00 Yearly**  
(Foreign \$4.00)

**BRYAN DAVIS PUBLISHING CO., Inc.**  
19 East 47th Street, New York City

## ATTENTION! SERVICE MEN!

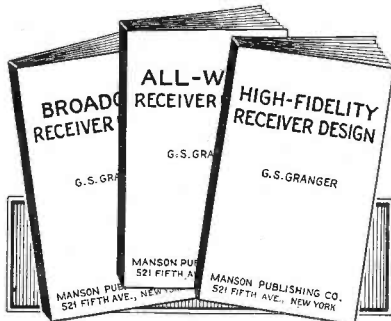

- Volume 1—Broadcast Receiver Design.
  - Volume 2—All Wave Receiver Design.
  - Volume 3—High Fidelity Receiver Design.
- One hundred pages. Forty-three diagram illustrations.

**SPECIAL TRADE DISCOUNT\***  
for  
**Accredited Service Men.**  
On complete set, **33 1/3% off**  
or 3 volumes for **\$1.00.**

## THREE NEW BOOKS

By  
**G. S. GRANGER**

Receiver Design has made tremendous advances in the last year and the Service Man who has not kept abreast with such developments is as handicapped as a 1920 mechanic trying to "trouble shoot" a 1934 car.

Constant advancement in radio construction and theory has created a demand for up-to-the-minute treatment of the subject.

### FIRST ANNOUNCEMENT

To meet this condition we have just published a series of booklets, convenient in size, written for YOU by G. S. Granger, known to every Service Man for his authoritative articles.

In addition to clear, concise explanations of all circuit functions, there are contained in these texts formulas and schematic diagrams essential in the calculation of circuit values, etc.

The knowledge essential to the success of every Service Man is presented in these volumes in a complete and readily understandable form.

*You cannot afford to be without these three volumes. They form an indispensable part of your kit.*

**Printing limited so order your copies today.**

### MANSON PUBLISHING COMPANY

521 Fifth Avenue

New York, N. Y.

Gentlemen:

- Send me postpaid volumes checked below, for which I enclose \$.....
- Broadcast Receiver Design..... 50c
  - All Wave Receiver Design..... 50c
  - High-Fidelity Receiver Design..... 50c
  - \*  Complete Set. Three Volumes..... \$1.00

Name .....

Address .....

# ASSOCIATION NEWS . . .

## P. R. S. M. A. PUTS ON RADIO SHOW

Despite the fact that there seems to be a consensus of opinion that the Philadelphia Radio Service Men's Association members should adjourn during the summer, meetings were held which were well attended, interesting, and last but not least, fruitful in accomplishment. Keep that last word in mind. Here is the story.

The Philadelphia Electrical Association—incidentally, the foremost electrical association in the country—puts on its annual Radio and Electric Show October 8th to 13th inclusive, and the P. R. S. M. A. will be there with bells on.

Thousands of people will pass the P. R. S. M. A. booth every day, to be made aware of the fact that here is an organization of Service Men of highest ethical standards who will lend their technical ability to assure the customer of 100 per cent performance from his receiver at a reasonably low cost. That is the story they will put over.

Folders containing an interesting article on the radio service business and having a directory of members listed as to localities contained in it, will be handed out at the booth. The Association was very fortunate in getting a most desirable location for their booth, which will be located on the center aisle not far from the doorways. Of interest to the visitor will be the display which is intended to educate the customer as to the desirability of patronizing an accredited Service Man who will use the proper materials in his work.

The writer is of the opinion that this one thing that the Association has done for its members is worth more to the membership individually and collectively than all the other forms of advertising put together. In fact, it is their estimation that every P. R. S. M. A. member received more for his dues in the form of lectures, advertising, service notes, employment service, and a great many other things too numerous to mention, than any other organization in the country, whether connected with radio or not.

There is another interesting happening in the offing and it is just what the doctor ordered so that all work won't make Jack a dull boy. The Association has a birthday in September which has not yet arrived at this writing, but which will be a happy memory when you read this. This FUN NIGHT will be held at the Stephen Girard Hotel Sept. 20. The evening will be filled with music and entertainment, dancing and refreshments. Between seven and eight hundred are expected to attend.

## A. R. S. E. (BUFFALO) EXHIBIT

The Association of Radio Service Engineers of Buffalo, N. Y. operated what was probably one of the most outstanding display booths at the Electrical and Radio Progress Exposition held at the Elmwood Music Hall from October 1st to 6th.

The important feature of the booth was two radio service benches. One was the haywire affair of days gone by with the miscellaneous lot of misfit meters and gadgets. The other was an up-to-date bench incorporating the latest in test equipment,

manned by members of the organization at all times doing actual repair work in full view of the public.

Men were in attendance to explain to the curious the how and why of modern radio set testing. Service calls from those attending the exposition were accepted and turned over to that member operating nearest to the person desiring service.

Close cooperation with the local electrical distributors and the fostering of public good-will toward the Service Man were the objectives of the Association of Radio Service Engineers in their participation in the exhibit. The Association boasts a membership of approximately 100 in representation of the more prominent Service Men in Buffalo and vicinity.

## N. Y. EXPOSITION HELD SUCCESS

Public and particularly dealer interest in the second annual National Electrical and Radio Exposition, which terminated its eleven-day run at Madison Square Garden September 29th, has given "every indication of marked confidence in the possibilities of considerable increased volume of business during the coming Fall and Winter months in electrical and radio merchandise," according to a statement issued by Ralph Neumuller, managing director of the Electrical Association of New York, sponsors of the show.

"The factors particularly contributing to this feeling of confidence are the possibilities presented through the National Housing Act for rewiring, refixturing, installation of air conditioning, oil burners, ranges and other appliances in the electrical field," Mr. Neumuller continued. "In the radio field, by the public's interest in all-wave receiving sets making available the world's best radio programs with remarkable perfection of clarity and volume, and the continued popularity of radios in automobiles."

"Advances in the electrical and radio arts during the past year, as shown by the products that have been displayed in the Show have been so marked," he added, "that replacement markets of considerable extent have been created for refrigeration, radio, appliances and other items."

## WASHINGTON (D. C.)

### I. R. S. M. MEETINGS

The September 14th meeting of the Washington Section was held with the help of the Weston Electrical Instrument Corporation. Messrs. Joralemon and Craig spoke on Modern Servicing and Equipment and the latest pieces of Weston equipment were effectively demonstrated.

The October 2nd meeting will feature a demonstration of the new Philco High-Fidelity Radio.

On October 16th the members will have the pleasure of hearing a technical talk by Mr. Crossland, one of G-E's outstanding engineers.

GERARD G. LARKIN,  
*Secretary.*

## BOSTON SECTION I. R. S. M. MEETING

Two hundred and seventy-five I. R. S. M. members and guests attended a meeting held at the Hotel Statler on Sept. 6.

Chairman A. R. La Haise presided. Mr. Alan Steinite, president of the Eastern Radio Co. welcomed the group and pointed out the importance of all Service Men becoming members of the I. R. S. M. Mr. Mouran, Manager of the Boston Office of the RCA Victor Co., was introduced. Mr. McGoy of the RCA Victor Co., described the methods of testing component parts at the factory of the RCA Victor Co., at Camden, N. J. Mr. Hollins, engineer of the RCA Radiotron Co., described the improvements in tube construction and described various methods of testing tubes. Mr. Aiken, engineer of the RCA Victor Co., described the theoretical design of the new all-wave receivers.

## SEPTEMBER ELEVENTH MEETING

On Sept. 11th members and guests held a meeting at the Hotel Statler. Vice Chairman, Ingvar Paulsen, who presided, introduced Mr. B. V. K. French, radio engineer of the United American Bosch Co., of Springfield, Mass. Mr. French gave an interesting technical description of super-heterodyne design. He described reasons for selecting various intermediate frequencies and testing methods for adjusting all-wave receivers. Mr. French was kept busy answering questions pertaining to servicing and installing all-wave receivers. Mr. Freeman, of the United American Bosch Co., told of the policies of the company in furnishing cooperation with radio service organizations.

## CLEVELAND I.R.S.M. TRADE SHOW

The Second Annual Cleveland Radio Trade Show, held under the auspices of the Cleveland Section of the I.R.S.M., will be held for one day only; Sunday, November 4th, in the Red Room and Auditorium at Hotel Cleveland.

There will be 30 or more displays of radio sets, parts, tubes, test equipment, etc.

There will be several attractive displays built up by the Cleveland members, among which will be one entitled, "The Evolution of Radio." This will show the progress of the set, tube, test equipment and advertising. There will be a working model of the photo-electric kidnap-proof baby. All of the speakers appearing in the auditorium will talk over a modulated light beam which will also be connected to a cathode-ray device.

## NEW TUBE BASE CHART

The Sylvania tube base chart has been revised to include base diagrams for the new line of Sylvania tubes for Majestic sets. The chart now shows 34 base diagrams, and includes tables of base arrangements by tube types, and tube types by base arrangement. It is available to any one addressing the Hygrade Sylvania Corporation at Emporium, Pa.

## NEW POLYMET CATALOG

Polymet Manufacturing Corporation, 829 East 134th St., New York, N. Y., announces its new 1934-35 Condenser and Resistor Catalog. Technical information regarding Polymet products will also be found in this booklet. Copies are available upon request.

## So SMALL yet So USEFUL

Here's the ultra-compact Type PM5 General Utility Unit alongside the usual electrolytic of same capacity and voltage rating. How's that for compactness—for use in midget set repairs? And note these PM5 features:



Universal voltage ratings—525 v. surge peak (450 v. operating) and 600 v. surge peak (475 v. operating). In all popular capacities.

A true Hi-Farad electrolytic in two wax-impregnated cardboard boxes. Flexible rubber-covered leads.

Sturdy. Not affected by temperature changes. May be mounted close together without electrostatic coupling.

Would have been introduced months ago but Aerovox engineers insisted on thorough life tests on thousands of samples.

Order an assortment today from your Aerovox jobber. Be prepared for that rising tide of radio repairs and experimental activities . . . with minimum stock and investment but maximum utility and profits.

SEND FOR DATA on these and other Aerovox products. Also free copy of Aerovox Research Worker . . . a monthly engineering service for practical radio men.



# AEROVOX

CORPORATION  
80 Washington St. : : Brooklyn, N. Y.

## RACON

The COMPLETE Line



4 1/2' Trumpet

Among the more than 35 types of *Racon* air-column sound projectors are ten models of 4 1/2-foot trumpets, available in regular and *Stormproof* construction, of the exclusive *Racon* acoustic cloth, or heavy-gauge aluminum. For especially severe operating conditions, the newly developed *unbreakable* projector can also be furnished.

Practically every large fair and road show this year is using *Racon P.A. Products*. Experienced rental companies know that the service and reliability of *Racon Horns and Units* is well worth their initial cost—which is usually as low as inferior products.

*Racon* electrodynamic units and horns are manufactured under 14 exclusive *Racon* patents.

Write Dept. S10 for catalog.

## RACON ELECTRIC CO. INC.

52 East 19th St., New York, N. Y.

London, Eng.

Toronto, Can.

## The TOBE CONDENSER ANALYZER

actually "X-Rays" Condensers

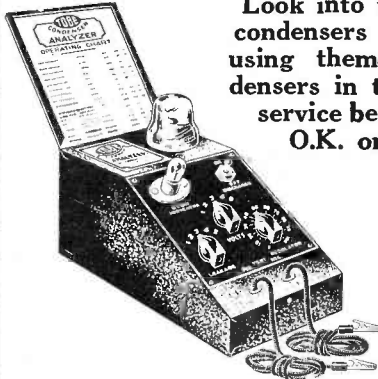

Look into the "heart" of the condensers you buy before using them. Test all condensers in the receivers you service before putting your O.K. on the job.

The TOBE CONDENSER ANALYZER instantly indicates if condensers of any type—paper, mica, oil, electrolytic—of any capacity from .00005 to 100 mfd.—are of low D.C. resistance or high current leakage and will soon break down or become "open"; are

operating intermittently (loose internal connections) or if they are "open" or "shorted."

Thousands of servicemen are now using this instrument.

110 volt, 60 cycle Model—\$11.40 Net

Available in 25 cycles, and 220 volt Models. Stocked by leading parts jobbers everywhere.

Send for latest free literature.

**TOBE DEUTSCHMANN CORP.**  
CANTON, MASSACHUSETTS

## FOUR REASONS WHY...

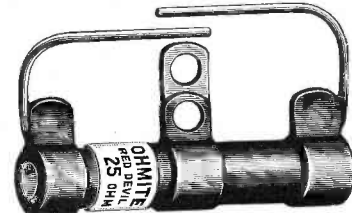

You, as a radio service man, are concerned chiefly with four things when considering replacement resistors—four things which have a great bearing on your ultimate profits. First—the replacement unit must easily fit in place of the old resistor. Second—the replacement unit must be reliable in order that you may guarantee your work. Third—the price of the replacement unit must be reasonable. Fourth—the resistor must be able to withstand severe overloads without failing.

Ohmite RED DEVIL RESISTORS, both standard and center-tapped, more than meet these requirements. For complete information about these handy units use the coupon below; a copy of the Ohmite Wattage Chart will also be sent free of charge.

## OHMITE

MANUFACTURING COMPANY  
627 N. Albany Ave., Chicago, Ill.

Please send me your No. 10 Catalog and one of the Ohmite Wattage Charts.

NAME .....  
ADDRESS .....  
CITY ..... STATE .....

# THE FORUM...

## A DUSTY LETTER

Editor, SERVICE:

When one thinks of the ounces of dust that a Service Man breathes into his system each day, while cleaning off a dust-laden radio, you would imagine he would do something about it.

Why doesn't a vacuum-cleaner manufacturer wake up and develop a small but strong suction cleaner to reach into the small places in a radio? It would save the Service Man much discomfort. What if a few bolts and nuts are sucked up by the cleaner?—they're cheap.

Possibly we live in the dustiest part of the U. S. If you don't believe it, come up and see us some time, but bring your vacuum cleaner with you.

EARLE J. BANCROFT,  
Fresno, Calif.

*(A vacuum cleaner would do the sets a lot of good, too. But, if you don't care about the sets, a better idea is to wear a gas mask. They're cheaper than vacuum cleaners.—THE EDITOR).*

## SIR TWIMBY CONVERSES

Editor, SERVICE:

You may fancy we English are not concerned with the turn of events in America. Really, though, we are, old chap, and I personally find your little bulletin SERVICE quite the thing in assisting in my experiments at Hatter's Castle-On-The-Downs.

My great grandmother twiddled cat-whiskers in her day and I fancy it got into my blood. Well, by Harry, the times change and these days find me twiddling hexode valves rather than hunting the fox.

I have some jolly ideas you might find of interest—they are really corking. Just say "toot toot" and your servant will dispatch them by the first carrier.

SIR TWIMBY,  
Hatter's Castle-On-The-Downs.

*(Sir Twimby. Sir: Fancy you off there in a Castle fiddling away with radio! What would the House of Commons say? By all means, let us have your jolly ideas—the jollier the better. Always glad to hear from a chum across the sea.—THE EDITOR).*

## CONSTRUCTIVE CRITICISM

Editor, SERVICE:

I seldom write letters merely to comment on the contents of publications. However, I feel a word of constructive criticism is never amiss.

Certain articles in SERVICE, otherwise understandable to a well-grounded Service Man, have been sketchily vague with regard to the arithmetical illustrations. Sometimes I have been able to work the problem from my own knowledge, but quite often I have not. I do not understand algebra; only straight arithmetic. I feel I am as well educated and as smart as the majority of men for whom SERVICE is intended. I used to get RADIO ENGINEERING and gave it up for much the same reason I have discussed above.

I certainly wish to continue with SERVICE, and, in fact, find it very worth while. I merely wish to point out a trait of engi-

neer-written articles which robs them of their full worth. A minor illustration just come to mind would be the calculations for resistances in parallel as given on page 300 of the August issue. I already know this calculation backwards, but would not have been able to learn it from that text. It is too vague in its arithmetic to awaken understanding. A chart is okay, but mostly as a sort of artificial limb.

A shorter and more definite illustration would have been, for instance:  $R_1 = 500$  ohms;  $R_2 = 1000$  ohms;  $R_3 = 2000$  ohms. Then:

$$R = \frac{1}{\frac{1}{500} + \frac{1}{1000} + \frac{1}{2000}} = \frac{1}{\frac{4}{2000} + \frac{2}{2000} + \frac{1}{2000}} = \frac{1}{\frac{7}{2000}} = 1 \div \frac{7}{2000} \text{ or } 1 \times \frac{2000}{7} = 2000 \div 7 = R$$

Perhaps you feel such specific detail to be unwarranted, but I feel there are many otherwise keen men who will need such detail in certain texts describing calculations new to their experience. I realize the example I have used is most elementary but it serves to make my point.

Another matter in mind is articles which describe possible test apparatus. I feel that the description of any test apparatus which does not permit an exact and definite test is a waste of paper and other things. The "Relaxation Oscillator" described in August SERVICE is a case in point. The article is well written but its subject is a piece of apparatus I would not care to use. There are too many chances of a poor guess.

I will say, though, the magazine has climbed up from a slump it hit when your outfit first took it over. My best wishes for the future.

J. G. HEACOCK  
Brown's Mills, N. J.

*(Perhaps you are right about the calculations. In any event, we shall be more specific in the future, for in no case can it do any harm. As to the Relaxation Oscillator, we believe you overestimate the uses of the device. There is chance of error, as you say, if the device is employed for the accurate readings required in a laboratory and in some cases required in certain branches of radio-receiver circuits. However, the device was designed for the purpose of providing a rapid and simple means of locating defective units, and for measurements where extreme accuracy is not necessary.—THE EDITOR).*

## INTERESTING P-A JOB

Editor, SERVICE:

You will recall my mentioning to you some time ago that I thought the Model 370 Bosch radio receiver, the circuit diagram of which appeared in the March issue of SERVICE, looked like a good propo-

sition for a public-address tuner. Perhaps you will be interested to know that I recently had an opportunity to install a public-address system where radio was called for, and that I used one of these tuners with very satisfactory results.

I found the particular type of AVC used in this receiver, together with the type 53 audio driver stage, made it very simple to feed the tuner into a high-power, public-address amplifier.

We opened one of the plate circuits of the 53 tube and inserted our line transformer. Although we have had some trouble with the tuner due to the method of mechanical assembly and several of the parts going bad, I am still well pleased with the reception and the facility with which the tuner can be applied to a public-address system.

This particular installation was made at the Manhattan Bathing Beach, Manhattan Beach, New York. We believe it is one of the outstanding outdoor installations in the country. The three sound sources taken care of are microphone, phonograph and radio. The radio is the Bosch tuner mentioned above, the phonograph a 10-record repeating machine.

The microphone set-up is exceptionally interesting. The microphone pick-up is made on a circular band stand, which is usually entirely surrounded by people... and they have as high as 60,000 in attendance on week-ends. This creates some crowd noise and, coupled with the sea breezes of fairly high velocity, gives a very considerable noise level against which to work. We were able to effectively handle this situation by using a combination of crystal and condenser microphones, the one type having non-directional pick-up and the other type being fairly directional.

Four microphones were fed into a four-position mixer. It is interesting to note that this mixer is placed in such a spot that the operator can watch the leader at all times and not only catch the solo numbers and the special effects called for by the leader, but also check the quality of reproduction with the headphone monitor.

The amplifiers are of the driver power-stage type. The power stages are each rated at 75 watts Class B. The entire system is in duplicate so that there cannot be any complete system failure other than the failure of the 110-volt, 60-cycle ac supply circuit. There are duplicate microphone power supplies, duplicate drivers, and duplicate power stages.

The loudspeakers are giant dynamic units driving 6-foot trumpets, eight of which are mounted circularly on top of the band stand. A special plug board was developed, to which the speaker leads are connected, of such a nature that quick change-over can be effected if it is necessary to cut out any particular loudspeaker and, when such changes are made, the proper impedance relation is still maintained.

In addition to the local service provided, there is also service via telephone line to another beach two miles distant, this line being fed from one of the drivers at proper level.

C. J. BROWN,  
RACON ELECTRIC CO.,  
New York, N. Y.



### Overize Universal Input and Output Transformers and Choke

Universal in every sense—especially designed for sets equipt with the new, stronger power tubes. Output type designed for coupling any combination of tubes in common use to any dynamic or magnetic speaker of any impedance. A universal choke in same design is available—275 ohms, nominal inductance, 20 henries, capacity 100 mils. Input type also recommended for straight audio service—center tap connection omitted for this service. Input, output, and choke units—all three—are assembled in universal brackets, coils machine wound for accuracy and uniformity and then vacuum treated. Can be mounted vertically or horizontally, on top or under chassis, or on panel. Silvered lugs and leads.



## Input and Output Transformers that Combine Highest Quality with Low Price

Successful service men don't wait for input, output, or audio transformers to actually open before replacing them. They demonstrate to the set owner how vastly improved the tone qualities of their sets can be made if Jefferson Transformers are installed. This leads to many additional sales because the set owner can note the improvement so decidedly.

The larger and more powerful Jefferson Transformers assure the uniform and full volume throughout the entire musical scale—something impossible to obtain heretofore except in transformers of much higher price.

Jefferson-engineered Transformers with larger cores and windings have carefully balanced component parts with the resultant equal amplification factor at all useful frequencies.

#### Jefferson Radio Products

- Input and Output Transformers and Chokes
- Line, Microphone and Phonograph Pick-up Transformers
- Power Transformers
- Audio Transformers
- Glass Fuses, Fuse Clips, Blocks and Bases
- Auto-Transformers

#### New Amplifier Diagram Free

A new 59 Class B Amplifier diagram is ready and will be mailed without charge. Snip out the reminder coupon and mail.

A New Amplifier Diagram **FREE** →

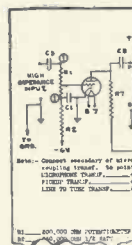

### Regular Universal Input and Output Transformers and Choke

These universal units incorporate the same features as the Oversize Group described above—universal mounting brackets, silvered lugs and leads, vacuum treated windings, and adaptability to all types of receivers. They are slightly more compact in size, resulting in lower cost. The input transformer can also be used as a straight audio type by omitting the center tap connection.

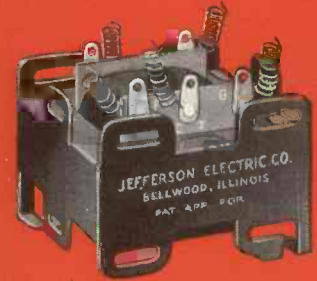

### No. 370A — quality at low price

A small, compact transformer for any A.C. or D.C. set using straight audio amplification. Low height makes it a favorite for sub-base installations. Brackets for horizontal or vertical mounting. High grade silicon steel core. Machine wound coil for accuracy. Best materials throughout. Supplied with flexible leads.



JEFFERSON ELECTRIC COMPANY  
Bellwood (Suburb of Chicago), Illinois

# JEFFERSON

## Radio Transformers

JEFFERSON ELECTRIC COMPANY  
Bellwood, Illinois

Please forward the new Class B Amplifier diagram and  copy of Catalog Sheet No. 343R.

Name \_\_\_\_\_ Address \_\_\_\_\_ City \_\_\_\_\_ State \_\_\_\_\_

(B-141)



# Introducing SPRAGUE

## Stars of the 1935 SEASON

As usual, Sprague Condensers hold the spotlight. And this year you'll see new units, important major developments and new designs coupled with prices which make the Sprague Line stand head and shoulders above any other condensers you might buy. Look 'em over . . .

### COMPARE THEIR QUALITY WITH THEIR PRICE. . . .

**SPRACO "RE" EXTRA SAFETY FACTOR 450 VOLT DRY ELECTROLYTICS** were designed by service men *for* service men. They fit anywhere and will replace much larger old style condensers of equal capacity.

Electrically they are better—physically they are smaller—self-supporting—absolutely universal in application—conservatively rated at 450 volts D.C. with **extra safety factor**. We guarantee you will use no others for this voltage and at these competitive prices.

Cat. No.	Cap. Mfds.	Dimensions	List Price	Your Price
RE-1	1	1 1/8" x 2 3/8"	\$ .55	\$ .33
RE-2	2	1 1/8" x 2 3/8"	.65	.39
RE-4	4	7/8" x 2 3/8"	.75	.45
RE-6	6	1 1/8" x 2 3/8"	.90	.54
RE-8	8	1 1/8" x 2 3/8"	.95	.57
RE-44	4-4	1 1/8" x 2 3/8"	1.20	.72
RE-88	8-8	1 1/4" x 4"	1.50	.90



**WE CALL 'EM "WORLD'S BEST"—and Mean it!**



That's a big claim. But try Sprague "TC" Tubulars for yourself and see if it isn't so.

Smallest, best looking cartridge by-pass tubulars on the market. One voltage—non-inductive winding—impregnated by a special process—moisture-proof tube—fer-ruled cap and secured leads.

Made in all popular capacities in sizes from 1 1/8" long x 3/8" diam. to 1 3/4" x 7/8".

.0001 to .01 incl., list 25c—Net 15c

.02 to .05 incl., list 30c—Net 18c

.06 and .1, list 35c—Net 21c

.25 list 45c—Net 27c      .5 list 60c—Net 36c

### MISSING SOMETHING?

If you haven't tried the improved Sprague "EC" Emergency Condensers lately, there's no question about it, you are missing plenty. These popular units are now **better than ever before** thanks to important major developments by Sprague engineers. Sold by prominent jobbers singly or in handy Emergency Kits. Will withstand the high surges common in a number of receivers. Far superior to our former popular EC condensers and other competitive makes. **Checked by their performance, there are no better condensers made.**

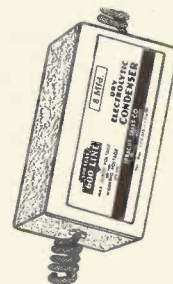

### VIBRATOR CONDENSERS—

Among other units featured in the complete Sprague Catalog you'll find the only real oil-impregnated Vibrator Condensers on the market to insure finest results in repairing defective condensers in motor vibrators. Small—metal encased—specifically designed for a specific job.



### THE COMPLETE CONDENSER ANALYZER \$8.90

Here you are, the **SPRAGUE CAPACITY INDICATOR** plus the 200 Mil. D.C. Millimeter which gives you the most complete Condenser Analyzer on the market—at less than the cost of the component parts. Quickly detects leaky paper, mica or dry electrolytic condensers—determines shorts or opens in paper filter blocks—tells the **correct** replacement capacity in a jiffy. Patented Sprague Surge-Arrestor "chirps" in warning against overloads. No manual can give all needed condenser information—no other service instrument will prove so helpful in condenser testing as the Sprague Capacity Indicator. Measures from .00025 to 16 mfd. Full Bakelite case 7" high, 4 1/2" wide and 3" deep. Complete with test leads and instruction folder.

net to servicemen  
Cowhide Carrying Case \$2.25 extra (optional)



**SPRAGUE PRODUCTS CO.,**



**North Adams, Massachusetts**



WRITE FOR THE COMPLETE SPRAGUE CONDENSER CATALOG



# THE MANUFACTURERS . . .

## NOISELESS ALL-WAVE ANTENNA

A single antenna with automatic frequency selector and impedance matching switch whereby broadcast or short-wave antenna circuit is provided for intercepted signals, with a minimum of background noise, is announced by the Technical Appliance Corp., 27-26 Jackson Ave., Long Island City. Known as the H-F (High-Fidelity) All-Wave Antenna System, the arrangement is available in complete kit form including wire and insulators, or as individual antenna and receiver units.

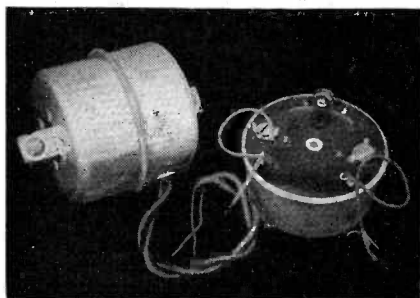

Two units comprise the heart of the system. The antenna unit, a compact aluminum-encased device with screw binding posts taking the ends of the aerial wire, is inserted at or near the center of a single-wire aerial. The unit automatically routes signals through the most desirable combination of aerial and downlead. The companion set unit, mounted near the receiver, is provided with a switch for impedance selection to obtain effective coupling between receiver and downlead. A twisted-pair cable for the down-lead cancels out inductive interference or background noise, including the usual troublesome automotive ignition interference. The new system is licensed under the A. A. K. antenna system patents.

## ALL-WAVE LINE NOISE FILTER

Keeping line noises out of present-day all-wave reception is the function of the new Taco H-F All-Wave Line Filter just announced by Technical Appliance Corp., 27-26 Jackson Ave., Long Island City, New York.

Housed in an attractive brown metal case with receptacle, ground binding post, attachment cord and non-breakable rubber



plug, the all-wave line filter comprises separate filter circuits for broadcast and short-wave bands. The circuits have been worked out over a considerable period by Amy, Aceves & King, Inc., well-known engineers specializing in antenna problems and radio noise elimination. The present device is made under license from them.

Filtering is thorough in both broadcast and short-wave bands. Only pure, noiseless ac or dc (device can be used on either supply) reaches the set, it is said. The device handles up to 250 watts. The installation is nothing more than plugging the usual set plug in receptacle of filter, inserting the filter plug in nearest electric outlet, and connecting binding post to convenient ground, grounded chassis or ground binding post of set. If preferred, the filter may be inserted between any electric appliance causing line noises, and its power supply, thus combating interference at the source.

## NEW TEST OSCILLATOR

A brand new item of interest to every radio Service Man or service department manager is the recently announced Burton-Weber All-Wave Test Oscillator Model 10.

The new unit's full-featured direct reading dial permits speedy, accurate settings without reference to graphs or tables, it is stated. Eight arcs provide a scale length of approximately 47 inches, covering from 90 kilocycles to 25 megacycles all on funda-

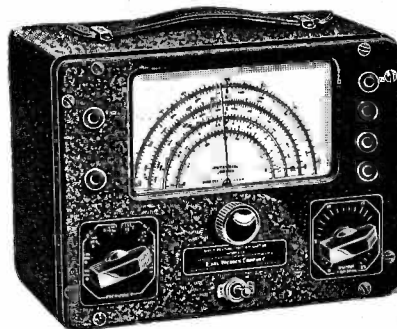

mental frequencies. Attenuation is of the ladder type with adjustable control on high, medium and low steps, permitting any signal voltage to be obtained from maximum to practically zero, and affording excellent attenuation on signals as high as 25 megacycles.

A 400-cycle note, approximately 35% modulated, is supplied by a separate modulator tube. The oscillator can be demodulated for adjusting radio receivers by the unmodulated method, and audio-frequency signal is available at panel jacks.

The new oscillator is manufactured and licensed under the approved circuits of the American Telephone & Telegraph Co., and each unit is carefully standardized with precision crystal-controlled frequency standards at 6 points on each band or arc, or at a total of 48 points, it is said.

Battery operated, this new testing device is fully portable. A one-piece aluminum case reduces leakage to a minimum, and the 6 to 1 vernier control aids in obtaining fine settings.

Full information may be had from the Earl Webber Company, Daily News Bldg.,

Chicago, Illinois, or from C. W. Burton, 755 Boylston St., Boston, Mass. Just ask for pamphlet No. RP11.

## NEW VELOCITY MICROPHONE

A new Velocity Microphone, Model RAE, which is especially designed for small studio work is shown in the illustration. The open construction obtained with the perforated case is used to prevent high- or low-frequency cut-off. A nickel alloy (permalloy) core transformer preserves the flat characteristic of the hand-hammered duraluminum (.00015") ribbon, it is stated.

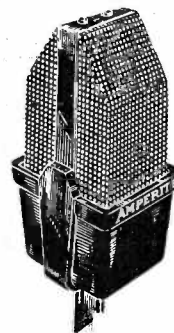

The microphone is of a rugged construction, not affected by temperature, humidity, or age. It can be used for both speech or music. One microphone is sufficient to "pick up" an entire orchestra.

The unit is a product of the Amperite Corporation, 561 Broadway, New York.

## MORRILL PRECISION MULTIPLIER

The Morrill Six-Range Precision Multiplier, Model A, is a device which in connection with a suitable milliammeter provides a safe and convenient method of making accurate and dependable voltage measurements covering all values generally encountered in electronic work, it is stated.

When used with an 0-1 milliammeter the unit is capable of making voltage measurements from 0.1 volt to 1,000 volts, dc or ac, at 1,000 ohms per volt in six ranges, name-

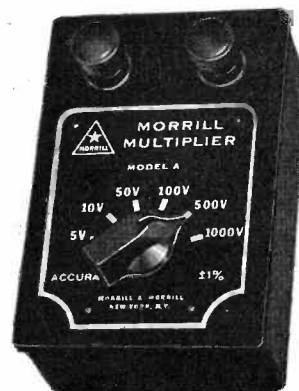

ly, 5-10-50-100-500-1,000 volts. The desired range is obtained by simply turning the selector switch to the proper setting, the accuracy of the multiplier being within plus or minus one percent.

This unit can also be used with 100, 200 and 500 microampere meters, the vol-

## MANUFACTURERS—continued

tage ranges being 0.5-1-5-10-50-100, 1-2-10-20-100-200, and 2.5-5-25-50-250-500 volts, respectively.

As the multiplier is non-capacitive it is said to induce no appreciable error into ac voltage measurements up to 50,000 cycles. The unit is built into a sturdy, compact bakelite case measuring 3 inches by 4½ inches by 1½ inches. The manufacturers are Morrill and Morrill, 30 Church Street, New York, N. Y.

### CLOUGH-BREngle TEST OSCILLATOR

To afford rapid and accurate servicing of all-wave and short-wave receivers, as well as all superheterodynes employing the wide variety of intermediate frequencies now in use, engineers of the Clough-Brengle Co., 1134 W. Austin Ave., Chicago, Illinois, have developed a new combination radio-frequency and audio-frequency signal generator.



The radio-frequency output on fundamental signals only, is continuously variable without any skips from 50 kc to 30 mc (6,000 to 10 meters).

A panel snap switch gives the choice of an unmodulated r-f signal, or 400-cycle modulation from the separate audio-oscillator stage. The 400-cycle output of the audio oscillator is also available for making audio-circuit tests.

A jack allows the r-f output to be modulated externally by a phonograph pick-up or calibrated audio oscillator if desired.

The new Model OC is completely operated from ac or dc line, eliminating battery weight and expense. Fluctuation of line voltage does not affect output frequency assuring a far more uniform signal than with battery power, it is stated.

An entirely new type tuning dial has been developed, that provides full 25 inches of dial for each of the 6 frequency bands, divided into 400 divisions, each 1/16-inch wide, making possible reading to 1/10 of 1% accuracy. Each instrument is hand calibrated with crystal oscillators, it is said.

The full frequency range is covered without use of harmonics, eliminating the frequent confusion and inaccuracy resulting from this cause. A descriptive bulletin is available on request.

### NEW PRECISION RESISTOR

The Precision Resistor Company, 334 Badger Ave., Newark, N. J., have recently announced their new Type M non-



inductive unit, shown in the illustration, which has been designed to meet the requirements of a resistor with soldering lug terminals and a unit that could be purchased rough wound to be calibrated to meet meter requirements.

This unit is manufactured as a complete unit of standard accuracy or may be purchased rough wound to an accuracy of approximately 3 percent of its rated resistance. The resistor is so constructed that the purchaser may calibrate it to his requirements and connect the wire to the terminal again without the use of insulating paper. Type M is a 1-watt unit having a resistance range from 0.25 to 500,000 ohms.

A copy of the new Precision Resistor catalog may be had on request.

### CROWE REPLACEMENT COMPONENTS

The Crowe Name Plate and Manufacturing Company, 1749 Grace Street, Chicago, Illinois, manufacturers of tuning controls, remote controls, dials, grilles, metal cabinets, name plates, and escutcheons for all types of radio receivers, are featuring many of these numbers as replacements on a number of the well-known types of radio receivers. For further information see Crowe Bulletin No. 55, their complete catalog of radio components.

### VIBRATOR REPLACEMENT CONDENSER

To take care of condenser replacements in auto-radio vibrators, a line of tiny units specifically designed for the purpose is announced by the Aerovox Corporation, Brooklyn, N. Y. These replacement units comprise oil-impregnated, oil-filled, pure



linen paper sections in hermetically-sealed metal containers, with mounting lug and pigtail lead. The units are designed to withstand heat, vibration, moisture and climatic conditions, as well as exceptional peak loads, without breakdown, it is stated. They are available in several standard capacities.

### NEW TYPE 80 TUBE

National Union has just perfected a new type 80 rectifier tube which is said to be a marked improvement on the type 80 as previously used in the dome shaped S-14 envelope.

Since the elements of the 80 tube had to be inserted from the bottom the plate area was increased by corrugating them, thus permitting the lowering of the operating temperature. The result is a tube that is different in design and operation. It will replace any 80 in any set.

It is said that the new National Union corrugated plate 80 will give equally as long life at 150 milliamperes drain as the old one at 125 milliamperes.

### J-M-P "CHECKATUBE"

The J-M-P Manufacturing Company, Milwaukee, Wis., have a tube tester, known

as the "Checkatube," which indicates poor or good tubes, shorts or leaks, and the meter of which reads line voltage. This unit is shown in the accompanying illustration.



The 4, 5, 6, 7, and a possible 8-prong tube can be accommodated in the four sockets. There are 96 popular and present-day tube numbers on the panel chart, segregated under four, five, six and seven-prong groups with dial setting for each tube. The information on this chart is so arranged that anyone can easily recognize amplifiers, half or full-wave rectifiers, cathode or filament tubes, etc.

Shorts are indicated on a sensitive neon pilot light. Cathode leaks up to one megohm are clearly shown.

By pressing the Tube Value button the meter reads "Poor" or "Good" tube. The meter is of the D'Arsonval type and has sapphire bearings. It is said that the circuit employed prevents any damage to the meter if a shorted tube is tested.

### YAXLEY MANUAL AND REPLACEMENT CONTROLS

The Yaxley Manufacturing Company announces the publication of a new, complete Replacement Control Manual. It is said to be the first complete publication of this nature. It is a 120-page volume, so arranged as to enable the Service Man to tell the proper control at a glance. It also contains much valuable reference information and instruction. It is free and may be secured by writing the Yaxley Manufacturing Company, Indianapolis, Indiana.

It is said that the new Yaxley universal line of replacement volume controls, embodies many features that greatly improve volume controls and at the same time simplify stocks necessary to service most radio sets:—fifteen controls will service 90% of all sets; 4 controls will service 1398 sets; one control services 618 sets.

Some sets using antenna cathode circuits require a fixed resistance varying from 100 to 500 ohms. The new Yaxley controls are equipped with an adjustable stop, permitting them to be set at the desired value. The adjustable stop makes it possible to decrease residual bias, increasing the sensitivity of the set.

A new design in switch attachment with bayonet and slot, assures definite locking to hold the switch in position.

**STATEMENT OF THE OWNERSHIP, MANAGEMENT, CIRCULATION, ETC., REQUIRED BY THE ACT OF CONGRESS OF MARCH 3, 1934**

Of SERVICE—A Monthly Digest of Radio and Allied maintenance published monthly at New York, N. Y., for Oct. 1, 1934.  
State of New York, } ss.  
County of New York, }

Before me, a Notary Public, in and for the State and County aforesaid, personally appeared Bryan S. Davis, who, having been duly sworn according to law, deposes and says that he is the Business Manager of the SERVICE—A Monthly Digest of Radio and Allied Maintenance, and that the following is, to the best of his knowledge and belief, a true statement of the ownership, management, (and if a daily paper, the circulation), etc., of the aforesaid publication for the date shown in the above caption, required by the Act of March 3, 1933, embodied in section 537, Postal Laws and Regulations, printed on the reverse of this form, to wit:

1. That the names and addresses of the publisher, editor, managing editor, and business manager are: Publisher, Bryan Davis Publishing Co., Inc., 19 East 47th Street, New York, N. Y.; Editor, M. L. Muhleman, Mt. Vernon, N. Y.; Managing Editor, Ray D. Rettenmeyer, Madison, N. J.; Business Manager, Bryan S. Davis, Scarsdale, N. Y.

2. That the owners are: John F. Rider Publications, Inc., 1440 Broadway, New York, N. Y.; John F. Rider, 1440 Broadway, New York, N. Y.; Florence Rider, 1440 Broadway, New York, N. Y.

3. That the known bondholders, mortgagees, and other security holders owning or holding 1 per cent or more of total amount of bonds, mortgages, or other securities are: None.

4. That the two paragraphs next above, giving the names of the owners, stockholders and security holders, if any, contain not only the list of stockholders and security holders as they appear upon the books of the company but also, in cases where the stockholder or security holder appears upon the books of the company as trustee or in any other fiduciary relation, the name of the person or corporation for whom such trustee is acting, is given; also that the said two paragraphs contain statements embracing affiant's full knowledge and belief as to the circumstances and conditions under which stockholders and security holders who do not appear upon the books of the company as trustees, hold stock, and securities in a capacity other than that of a bona fide owner; and this affiant has no reason to believe that any other person, association, or corporation has any interest direct or indirect in the said stock, bonds, or other securities than as so stated by him.

5. That the average number of copies of each issue of this publication sold or distributed, through the mails or otherwise, to paid subscribers during the . . . months preceding the date shown above is . . . (This information is required from daily publications only.)

BRYAN S. DAVIS, Business Manager.  
Sworn to and subscribed before me this 1st day of October, 1934  
[SEAL] J. A. WALKER, Notary Public.  
Queens Co. Clk's No. 2982, Reg. No. 7176. New York Co. Clk's No. 655, Reg. No. 5-W-424. My commission expires March 30, 1935.

**Hurry! Hurry!!!**

Still Time...

**\$10.00**  
Deposit

**Supreme 35 Tube Tester**



Look! Act! . . . on this remarkable offer. A Supreme Model 35 Tube Tester . . . yours for only \$10.00 deposit and a National Union tube purchase agreement. You get the \$10.00 back as a merchandise credit as soon as you complete the agreement.

This Supreme tester is a brand new model . . . sturdy, efficient, great big easy reading dial. Imagine, this fine tester which would cost you \$29.95 is all yours FREE on this startling National Union offer for the month of October only.

Get full details at once from your jobber or write NATIONAL UNION. OCTOBER ONLY!

**Look At All N. U. Offers You!**

**MORE PROFIT:** The 10 cent higher list price of National Union tubes gives you most profit margin. (Send for Profit Comparison Chart). **PRICE DECLINE PROTECTION:** Complete unlimited protection against list price declines on all shelf stock. **FREE SHOP EQUIPMENT:** Meters, manuals, tube testers, oscillators given with tube purchases. Get details! **FREE SALES AIDS, SERVICE AIDS, CHARTS AND DATA:** You can't afford not to tie up with National Union!

National Union Radio Corporation of N. Y.  
400 Madison Avenue,  
New York City.

S 10-34



Tell me more about . . .

Name . . .

Street . . .

City . . .

State . . .

**REFRIGERATOR REPAIRS**

**Opens Up Big Money-Making Opportunity for RADIO SERVICEMEN**

**A**FTER months of research and investigation in the field of Refrigeration, we announce the creation of a Refrigerator Parts Department . . . which will double the profits of far sighted Radio Servicemen!  
There are few better qualified in ability, skill and experience to service refrigerators than the Radio Serviceman. Why not cash in on this ability and on your contacts with hundreds of homes? This year 'round business is wide open—and there are no "slack times"!

**5 Million Homes Are Waiting for RELIABLE REFRIGERATOR SERVICE**

The field is BIG! 4,960,000 homes have refrigeration. The "live wire" Radio Serviceman will give this field serious thought and study for now each home can be made a 2-way source of Profit—Radio and Refrigeration!

Here at Wholesale Radio Service Company you will find all parts for every leading make of refrigerator at lowest **WHOLE-SALE prices!** You can be assured, too, of the same high quality and service as you have been accustomed to receiving on Radio Supplies. Get all the facts today—as well as our great new Catalog No. 56 (described on another page) which contains a big Refrigeration section.

Wholesale Radio Service Co.,  
100 Sixth Ave., Dept. SX-104  
New York, N. Y.

I am interested in Refrigeration. Please send me details.

NAME . . .  
ADDRESS . . .  
CITY . . . STATE . . .

**WHOLESALE RADIO SERVICE CO. INC.**

**NEW YORK ATLANTA**  
100 Sixth Avenue 430 W. Peachtree St. N.W.  
Local Branch 219 Central Ave., Newark, New Jersey.

**MULTI-TAP UNIVERSAL OUTPUT and INPUT Audio TRANSFORMERS**

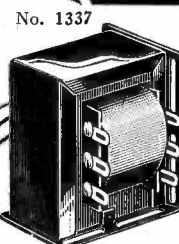

No. 1337

**"MULTI-TAP" OUTPUT**  
The Universal primary and the tapped secondary, from 2 to 30 ohms in 2 ohm steps, makes it possible to feed practically any straight or push-pull output stage to any dynamic speaker. **Universal—Physically** may be mounted on end or side. Slots in base allow wide range of adaptability without redrilling panel. Overall dimensions: 2" x 2 3/8" x 1 3/8". Mtg. Centers: 1 1/4" x 1/2" to 1-9/16" or 1 1/4" x 1/2" to 1 7/8". Indispensable for Service Engineer's Emergency Stock.

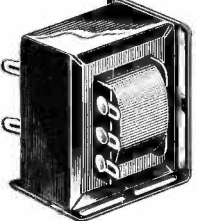

No. 3205

**UNIVERSAL INPUT AUDIO**

can efficiently feed any straight or push-pull audio stage on either A.C. or D.C. sets. A wide range of adaptability physically is made possible through the slotted end and side mounting bracket. Service Engineers should always have one or more in their emergency stock. Dimensions same as Output Transformer.

**Free for the Asking!**

"GENERAL" illustrated and fully descriptive BULLETIN! with complete list of 1898 models of radios on which you can replace power supply units out of a stock of only 5 models Multi-tap Universal Power Transformers with Multi-tap Output and universal input unit.

**MAIL THIS COUPON TODAY**  
GENERAL TRANSFORMER CORP.,  
502 S. Troop St., Chicago, Ill.  
Send me, without charge, Multi-tap Bulletin No. 3, listing 1898 models of radios in which one of the 5 Multi-tap power transformers can be used to restore original performance in case of transformer trouble.  
NAME . . .  
ADDRESS . . .  
TOWN . . . STATE . . .





# TOBE UNIVERSAL ALL WAVE ANTENNA SYSTEMS

Designed by pioneer specialists in  
**RADIO NOISE ELIMINATION**

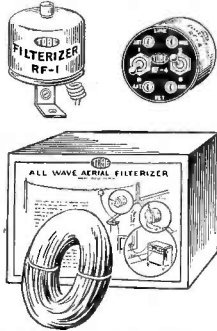

- Outstanding Features:**
1. Adapted to simple inverted "L" flat tops and to single or multiple half-wave doublets.
  2. Wave band switches tune antenna system to listening band, assuring maximum signal strength.
  3. Ample noise reduction.
  4. Rugged weather-proof materials.

Model 34 (illustrated) \$4.95 list

Model 34 listing at \$6.95 is the most complete system ever offered. In addition to the two couplers and transmission line, you get one LINE FILTER, 75 ft. aerial wire, 25 ft. ground wire, two window lead-in strips, ground clamp, insulators, etc.

Stocked by leading parts jobbers everywhere.  
Send for latest free bulletin.

**TOBE DEUTSCHMANN CORP.**  
Canton, Massachusetts

# Halldorson Replacement Transformers

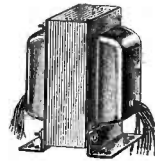

**INVISIBLE QUALITIES** — When you buy transformers you rely upon the manufacturer for the invisible qualities that give them merit. Outwardly one brand may look the same as another, but in operation one may fail while the other gives perfect results. Halldorson Transformers not only look their part, but in addition excel in such invisible qualities as insulation, regulation and reserve against overload.

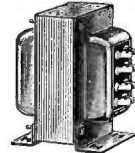

**ADAPTABILITY** — Halldorson line of Replacement Transformers fits the requirements of the serviceman and jobber. One electrical design fits the maximum set models that convenience and economy permit. It neither multiplies beyond limit nor contracts beyond common sense the number of designs a jobber must keep in stock.



**REPUTATION** — The name "Halldorson" has long been associated with high quality products. It is the label of merit on the carton.

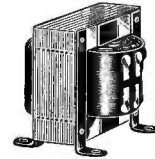

Ask your jobber. If he hasn't the line, send his name with your request for catalog.

**The Halldorson Company**  
4500 Ravenswood Ave., Chicago

## "A SHIFT TO THE RIGHT"

Microphone Cables for Public  
Address Systems at Football Games

SHIELDED-COTTON  
BRAID OVERALL



Conductors consist of Flexible tinned copper, rubber covered, color-coded braid. Braid on the individual conductors **MOISTURE-PROOFED**. **TINNED COPPER** shield over cable can be grounded to avoid pick-up. Durable brown cotton braid applied overall. Especially adaptable for inside permanent or portable PA systems.

### Shielded Rubber Jacketed Cables

Conductors all color-coded. Braided with tinned copper shield. Heavy Jacket Tough Black Polished Rubber applied overall. Will withstand severe service. Adaptable to carbon condenser, and moving coil microphones. **POSITIVELY WATERPROOF**—excellent for field microphones.



### Investigate Now

Be prepared for emergencies.  
Make certain you have ample  
stock on hand.

Send coupon today for illustrated catalog No. 20.

## LENZ ELECTRIC MFG. CO.

1751 No. Western Avenue Chicago, Ill.  
Please send without obligation your new Lenz Radio Products  
Catalog No. 20.

NAME .....  
ADDRESS .....  
CITY ..... STATE .....

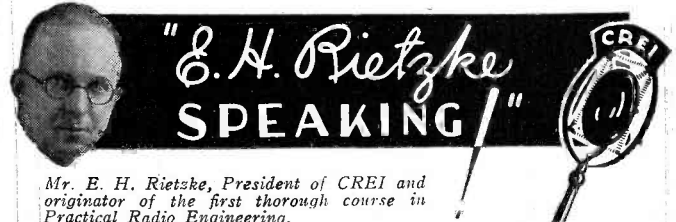

Mr. E. H. Rietzke, President of CREI and  
originator of the first thorough course in  
Practical Radio Engineering.

**Mr. Service Man! If you're "sold" on  
studying... why not take the BEST?**

Although CREI is a nationally accredited school, known and recommended throughout the industry, it is not "out of reach" of any service man! Our home study courses in Practical Radio Engineering are written in "service man" language, and are practical right from the beginning. After the first few lessons, you can start capitalizing on the information you have learned... but you'll see real results after you have finished the thorough technical training CREI offers. Terms may be arranged to meet your own needs.

First Time Offered!

### "Audio & Acoustical Engineering"

A new series of lessons now included as a part of all courses. These new lessons will prepare the engineer to handle practical problems arising in the design and installation of audio and acoustical systems.

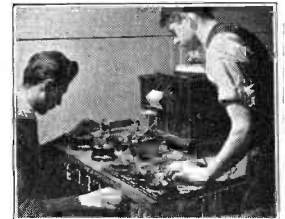

### New 44-Page Catalog Just Off the Press

Send for this new booklet today. It gives in complete detail everything you'll want to know about CREI, together with scores of pictures of our school and array of equipment.

Students preparing to study the wave form of modulated transmitter output. The Oscillograph is one of the most important pieces of equipment in the CREI laboratories.



## Capitol Radio Engineering Institute

Dept. S-10

14th & Park Rd., N.W., WASHINGTON, D.C.

## The ORD-O-PAM System



*Wall or Counter Mike*

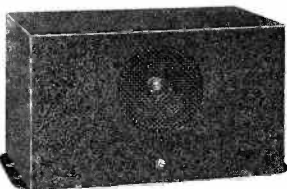

*Speaker-Amplifier*

Talk in a normal voice and your message is reproduced by the **SPEAKER-AMPLIFIER** in a **LOUD, CLEAR** voice. Ideal for restaurants, warehouses, public garages, etc., where an announcing system will save time and wasted footsteps.

—Manufacturers—

### S. H. COUCH COMPANY, INC.

NORTH QUINCY, MASS.

Sales Offices in Principal Cities. WRITE FOR BULLETIN PAM-20

## *Radiart*

### VIBRATORS FOR AUTO RADIOS

Exact Duplicate Replacement

Every electric auto radio in use means a vibrator replacement eventually. Only with Radiart can you cash in on this market completely. Only Radiart makes a **COMPLETE EXACT DUPLICATE** line. Only Radiart has the experience of furnishing initial equipment to more than 70% of the auto set manufacturers. Look for the orange and black label on the box and on the vibrator, if it isn't there it isn't a genuine Radiart vibrator. In making replacements choose the vibrator the set manufacturers themselves prefer—you will be sure of a satisfied customer. Available at all good jobbers. Write for catalog sheet.

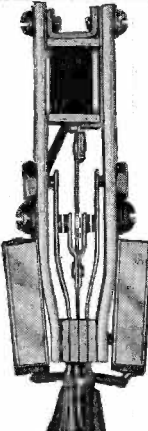

### THE RADIART CORP.

13229 Shaw Ave. Cleveland, O.

## SERIES "S"

### HIGH FIDELITY GENERAL PURPOSE AMPLIFIERS

PA 100 Voltage Amplifier  
PA 101 Output Amplifier

Ask for Bulletin No. 10

## Sound Systems, Inc.

1311 TERMINAL TOWER  
CLEVELAND, OHIO

## UPCO PRODUCTS

*Offer the last word in Sound Equipment*

Balanced Pick-Up Plays both the OLD (78 R.P.M.) records and the NEW (33 1/3 R.P.M.) records. We also manufacture a complete line of Upco Pick-Ups to meet manufacturers' special requirements. Special types for portable combinations as well as radio and phonograph console styles.

We build Special Recording Equipment for Aluminum or Celluloid Recording. We produce Recording Heads for both processes.

*Write for Catalog and full details on the UPCO line of Acoustic Products*

### UPCO ENGINEERING LABORATORIES

254 Canal St. ANTON BORSUK, President New York

# FREE The BIGGEST Latest, Most Complete 1935 RADIO CATALOG



**THIS** amazing new 1935 Radio Catalog is the last word . . . the greatest Bargain Book of Radio ever published by us or any other company. There are more pages, more items listed, more nationally known lines, more Specialized Departments. Over 50,000 items have been assembled in this great 192-page book to make it the outstanding book of the Radio Industry.

There is a Special Department on the latest Broadcast and All-Wave Receivers from 2 to 10 tubes. You'll find an entirely new Department on **REFRIGERATION PARTS** and accessories . . . a new money-making field for Servicemen. A whole section on **PUBLIC ADDRESS** is the most complete and all-inclusive thing of its kind.

### SHORT WAVE HEADQUARTERS

Then there is our matchless **SPECIALIZED SHORT WAVE DEPARTMENT** which in itself is a complete catalog listing everything the Ham, Brasspounder and Experimenter will ever need. Sets, Kits, Transceivers, Pre-selectors, Converters, as well as other Short Wave parts and accessories. Practically every nationally known manufacturer is listed here. The complete list reads like a Who's Who of Radio . . . and everything is at **LOWEST WHOLESALE PRICES!**

For 13 years the "Wholesale" catalog has been the Serviceman's "Bible." Today the greatest Radio Catalog ever printed—backed by the resources of the greatest organization of its kind in the world—is yours for the asking. Get yours to-day!

**WHOLESALE RADIO SERVICE CO.**

NEW YORK ATLANTA

100 Sixth Avenue 430 W. Peachtree St. N.W.  
Local Branch 219 Central Ave., Newark, New Jersey

Name .....

Address .....

City .....

State .....

Please send me your FREE Catalog No. 56 of 192 pages.

## NEW... *Burton-Webber*

### ALL WAVE TEST OSCILLATOR

Full Vision Direct Reading



47 inch scale. No confusing graphs or charts. Continuously variable range. Eight bands cover from 90 kilocycles to 25 megacycles. *All on fundamental frequencies.* Dial Standardized at 48 points with Crystal Controlled Frequency Standards. Knife edge pointer with vernier drive. Licensed American Telephone & Telegraph circuit. High, Medium and Low steps afford perfect attenuation control throughout entire range. 400 cycle note, approximately 35% modulated, obtained by separate modulator tube. A. F. signal available at panel jacks. One piece aluminum case prevents strays. Light weight, compact—carry it anywhere; battery operated—use it anywhere; A.C. or D.C. districts, auto radios, farm radios, etc.

## BURTON-WEBBER

755 Boylston Street  
BOSTON, MASS.

Daily News Building  
CHICAGO, ILL.

---

BURTON-WEBBER,  
(use address nearest you)

Gentlemen: Please send catalog No. 1733 on Burton-Webber All-Wave Test Oscillator.

Name .....

Address .....

City .....

State .....

# BUY THIS new DAYRAD

## TUBE TESTER

before you wish you HAD!

We needn't tell you that this is a real price on a tester of this quality . . . a portable job, tests all tubes, selector switch method, combination sockets, Cathode Release Short Tests, English reading dial. You KNOW the price is right, but our advice is BUY NOW. Price levels are rising, modernize your testing equipment at present prices. ORDER NOW! You will find this new tester the most accurate, versatile and convenient tube tester you have ever used. More information on request. Operates on 100 to 135 volts, 50 cycle. Cover, hinging at top, not shown here. Size: 9 3/4" x 8 3/4".

ONLY \$24.75

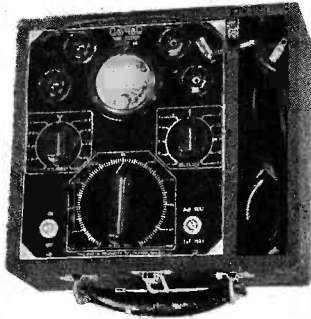

The RADIO PRODUCTS CO., 125 Sunrise Place, Dayton, Ohio

# YOU—IN or OUT?

Many good service men are actually out of business, but won't admit it! They're stale—inert to the modern method of selling radio service at professional prices. Guess-work-mechanics have treated set-owners so badly, that you also are mistrusted! BUT—today progressive radio men everywhere, Chuckkerize the customer to inspire confidence. They isolate radio faults quickly with a Chuckker compiled, cross-indexed trouble-chart. Then they explain, to the set-owner, the Chuckker repair-pricer feature which publishes the fee for that repair job. They must use a Chuckker because it is professional, looks official, and gets them that job at a price based upon a \$1.50 hourly labor rate, plus list-priced parts. Eliminate guesswork in What is Wrong and What to Charge! A Chuckker will keep you in business! We'll rush you a Chuckker postpaid for a \$1 bill.

SEND DOLLAR BILL NOW!

FREED'S RADIO CO. Publishing Division S.  
5053 Baltimore Avenue Philadelphia, Pa.

Don't Miss It . . . .

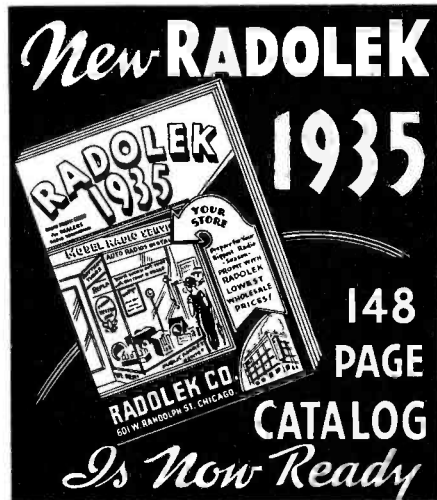

If you've changed your address since receiving our 1933 Catalog, or if you have not received a catalog from Radolek recently, send us your business card or letter-head immediately.

THE RADOLEK CO.  
617 W. Randolph Street  
CHICAGO

## DEPENDABLE

SHUNTS and MULTIPLIERS for Test Equipment

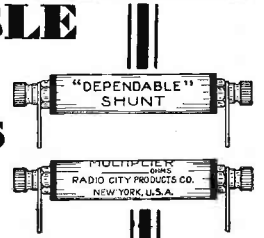

ABSOLUTELY noiseless and guaranteed accurate within 1% or 2%. Shunts for all meters in all ranges:—2% accuracy, 75c each, net. 1% accuracy, 84c each, net.

Multipliers in all standard ranges; accurate within 1% or 2%, 5,000 to 10 million ohms, 45c to \$2.55 each, net. Special values to order.

Write Dept. S-10 for FREE Data Sheets

RADIO CITY PRODUCTS  
48 West Broadway, New York City

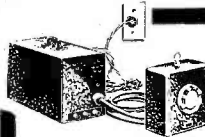

## UNIVERSAL MODEL "G"

A completely assembled, ready-to-use condenser microphone unit—All A.C. operated—Nothing to add—No batteries or battery expense; yet guaranteed as silent as batteries. Just plug into 110 v. AC. 50-60 cycle socket and be assured of trouble-free, full satisfaction performance—2 stage amplifier with No. 230 tubes—barometric adjustment—temperature compensator—shielded diaphragm—Frequency response 70 to 7,000 cycles—Engineered by Universal to guarantee maximum results at the lowest price consistent with Universal standards.

Dealers Net Cash \$49.39

UNIVERSAL MICROPHONE CO., LTD.  
424 Warren Lane Inglewood, Calif., U. S. A.

### INDEX TO ADVERTISERS

Aerovox Corp. . . . . 395  
Alan Radio Corp. . . . . 405  
Allied Radio Corp. . . . . 405  
Amperite Corp. . . . . 405  
Burgess Battery Co. . . . . 406  
Burton-Webber . . . . . 403  
Capitol Radio Eng. Inst. . . . . 402  
Central Radio Labs. . . . . 387  
Clarostat Mfg. Co., Inc. . . . . 367  
Continental Carbon Co. . . . . 406  
Cornell-Dubilier Corp. . . . . 389  
Couch Co., Inc., S. H. . . . . 403  
Freed's Radio Co. . . . . 404  
General Transformer Corp. . . . . 401  
Halldorson Co., The . . . . . 402  
Hygrade Sylvania Corp. . . . . 385  
Insuline Corp. of America. . . . . 405  
Jefferson Electric Co. . . . . 397

Kenyon Transformer Co., Inc. . . . . 389  
Lenz Elec. Mfg. Co. . . . . 402  
Leotone Radio Co. . . . . 405  
Lynch, Inc., Arthur H. . . . . 391  
Mallory & Co., P. R. . . . . 370  
Manson Publishing Co. . . . . 393  
National Union Radio Corp. of N. Y. . . . . 401  
Ohio Carbon Co., The. . . . . 365  
Ohmite Mfg. Co. . . . . 395  
RCA Institutes, Inc. . . . . 405  
RCA Radiotron Co., Inc. . . . . 404  
Racon Elec. Co., Inc. . . . . 395  
Radiart Corp., The. . . . . 403  
Radio City Products Co. . . . . 404  
Radio Products Co., The. . . . . 404

Rider, John F. . . . . 369  
Solar Mfg. Corp. . . . . 405  
Sound Systems, Inc. . . . . 403  
Sprague Products Co. . . . . 398  
Standard Transformer Corp. . . . . 391-395-402  
Technical Appliance Co. . . . . 389  
Thordarson Elec. Mfg. Co. . . . . 387  
Tobe Deutschmann Corp. . . . . 391-395-402  
Try-Mo Radio Co., Inc. . . . . 391  
Universal Microphone Co., Ltd. . . . . 404  
Upco Engineering Labs. . . . . 403  
Van Leuven, D. L. . . . . 405  
Weston Electrical Instrument Corp. . . . . 370  
Wholesale Radio Service Co., Inc. . . . . 401-403  
Yaxley Mfg. Co., Inc. . . . . 370

# WATCH—

for important announcement covering P. A. Equipment in the November issue. » »

**ALAN RADIO CORP.**  
83P CORTLANDT ST., NEW YORK, N. Y.  
Western Branch: 1028 So. Olive St., Los Angeles, Calif.

## SMALL METER SHUNTS—

  
Low Resistance Multiple Shunt  
2/5ths actual size.

for all standard milliamp. meters of 50, 30 and 27 millivolt drops. Meters having a low millivolt rating can be adjusted to the standard (50 m.v.) where desired. Ship Parcel Post.

  
5 - 25 - 100 Mil. Series Shunt  
2/5ths actual size.

MULTIPLE SHUNTS, all millivolt ratings, in 5 - 10 - 25 - 50 - 100 and 500 milliamps. These values correspond to readings on No. 1 and No. 4 VAN dials.

Order VAN Shunts and Dials through your dealer or distributor.  
Folder on request.

SILVERED, ETCHED METAL DIALS of multiple readings with 100,000 ohm scale and voltage current readings as follows: Type I, 0 to 50 - 250 - 1,000; Type II, 0 to 150 - 300 - 600; Type IV, 0 to 50 - 250 - 1,000 for A.C., D.C. Universal rectified, with A.C. current density error correction. Can be used with external connected rectifiers if special resistors are employed for A.C. voltage. For models 301, 88, 321, 324.

D. L. VAN LEUVEN, 410 E. 15th St., New York, N. Y.



WET AND DRY ELECTROLYTIC PAPER AND MICA CONDENSERS

RECOGNIZED FOR SUPERIOR QUALITY IN ALL CLIMATES THE WORLD OVER

SOLD BY LEADING JOBBERS EVERYWHERE

SOLAR MFG. CORP.  
599 BROADWAY  
NEW YORK

**BEST BY TEST!**  
ASK FOR CATALOG OF EXTREMELY COMPACT TYPES HANDY FOR SERVICE

## A FEW GOOD TERRITORIES STILL OPEN

REPRESENT US — THERE IS GOOD MONEY IN IT!

MAKERS OF

FREE EDGE  
CONE AND VOICE  
COIL ASSEMBLIES

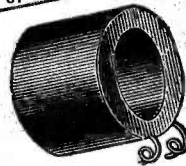
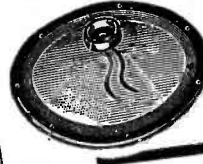

BAKELITE BOBBINS  
FIELD COILS FOR  
ALL DYNAMIC SPEAKERS

We also Manufacture Various Types of Magnetic Speakers  
We can Supply and Remedy Your Speaker Needs  
SPEAKER MANUFACTURERS SINCE 1921  
LEOTONE RADIO CO. 63 Dey Street, New York City

## When Choosing a Radio School

Consider the advantages afforded by the long-established RCA Institutes

The beginner or the experienced man who seeks instruction in any branch of radio will find courses designed for him . . . either at the resident schools in New York and Chicago or in the RCA Institutes Extension Courses for Home Study.

Following Units Especially Recommended to Readers of "Service":  
Elementary Radio Mathematics—Advanced Radio Mathematics—Advanced Radio Servicing—Sound Amplification

Resident schools are fully equipped, conveniently located, low weekly tuition rates. Home Study Courses are on the "no obligation" plan. Free post-graduate practical training period at a resident school.



Catalog on Request

RCA INSTITUTES, Inc.  
Dept. SV-34

75 Varick Street, New York  
1154 Merchandise Mart, Chicago

## DOES the WORK of 3 MIKES



Because of its wider area of coverage, one Amperite Velocity Microphone replaces a plurality of other types of microphones. Most highly perfected means of translating sound energy into electrical energy. Easiest, least expensive way to improve any studio installation. Write for illustrated Bulletin SR-80.

AMPERITE Corporation 561 BROADWAY NEW YORK

AMPERITE Velocity MICROPHONE

## MAKES THE RIGHT TOOLS For the Right Radio Repair Job!

LOCK SOCKET WRENCH AND SCREW DRIVER SET

Consists of 11 parts. Hi-grade steel, cadmium plated. Screw driver and handle, hex handles and extensions and socket wrenches: 3/16", 1/4", 5/16", 11/32", 3/8", 7/16". Also 1 knurled wrench to fit 3/16" to 3/8" double hex nuts. List price, \$2.00

RADIO SCREW DRIVER KIT WITH INSULOID HANDLE

Five special radio screw drivers. Hi-Grade carbon steel and Insuloid shock-proof handles. Sizes 4 1/2" to 10 1/4" long and blades of 3/16" to 3/8". For all radio needs. List price

\$1.75



FREE CATALOG Just off the press! Hundreds of latest developments for servicemen. Big selection of S.W. Parts, Kits, etc. Get your FREE copy today!



DISCOUNT of 40% applies on above when purchased from your Jobber or Mail Order House . . . or write us direct and we will see that you are supplied.

INSULINE CORPORATION OF AMERICA  
23-25 PARK PLACE Dept. V-104 NEW YORK, N. Y.

NEW

## SERVICE GUIDE FREE

A New ALLIED Catalog for 1935, packed with values for every Radio Serviceman, will be ready shortly. Reserve your copy at once and meet your autumn and winter business with confidence. You'll be able to give better service with equipment from ALLIED, and your margins of profit will be bigger than ever. Over 100 pages of highest quality standard radio equipment in the new 1935 ALLIED book! Thousands of exact duplicate parts—all leading makes of test instruments. Before you buy, consult your new 1935 ALLIED Catalog. It leads the field.



ALLIED RADIO CORPORATION

833 W. JACKSON BLVD., CHICAGO, Dept. N.

Gentlemen:

Send me FREE your New 1935 Radio Catalog which is packed with thousands of highest quality radio parts selected especially for the Radio Serviceman.

Name .....

Address .....



# WORLD'S FINEST RESISTOR



now stepped up still higher

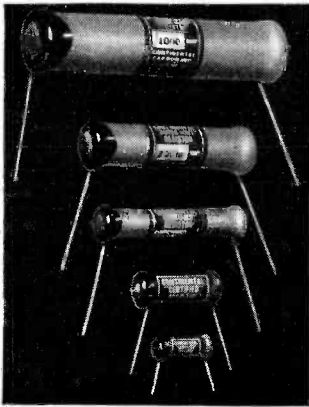

### *in Value*

New low prices just announced on CONTINENTAL Molded CARBORITE Resistors make them the outstanding value of the replacement parts field.

### *in Performance*

New automatic manufacturing and testing machines eliminate every possibility of human variation or error. Permanently accurate, absolutely noise-free, proof against effects of moisture and heat—are all features that mean extra performance!

### *in Quality*

All sizes now coated with the exclusive CONTINENTAL 1000-volt Ceramic. An extra feature that you get only in Certified CONTINENTALS at no extra cost.

## New LOW RESISTANCE Suppressors provide full noise elimination—yet do not affect ignition

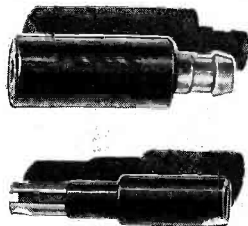

CONTINENTAL engineers have just developed a new resistance element that completely suppresses all ignition noise, yet has only one-half the customary suppressor resistance. Made in all standard types and the two new UNIVERSAL styles shown on the right. Write for descriptive bulletin today.

## Replace Filter Condensers with CONTINENTAL Paper Dielectric Replacement Units



Don't take chances with repeated condenser failures where operating conditions are severe. Replace all troublesome filter condensers with this exclusive new CONTINENTAL PAPER DIELECTRIC Filter Condenser. Provides increased filtering action and the ability to withstand high temperatures. May be used on A.C. circuits.

Write for New FALL Bulletins

**CONTINENTAL CARBON Inc.**

13912 LORAIN AVENUE

CLEVELAND, OHIO

Send us the new Fall CONTINENTAL Resistor, Condenser, and Suppressor Bulletins.

Name .....

Address .....

SERVICE MEN SAY



YOU DON'T HAVE TO "BABY" BURGESS BATTERIES

You Can Use Them 7 or 8 Hours a Day and Get FULL Service!

It is no longer necessary to use battery operated sets only a few hours a day to get full service from your batteries. BURGESS engineers have proved—by many tests in our laboratory and in actual use—that you can operate a set equipped with BURGESS Batteries seven or eight hours a day and get the same number of hours of service!\* You don't have to "baby" BURGESS Batteries. They are built to stand the gaff!

## Dependable DRY "A" Power at Less than 1¢ an Hour!

Distinctly a BURGESS development, the POWER HOUSE is a 100% DRY "A" battery designed for use with 2-volt sets. It costs only \$3.20 and delivers 400 hours of dependable service. It is compact, weighs only 14 lbs., requires no attention, is not affected by weather. The POWER HOUSE will deliver every hour of service we've built into it even when used for long periods each day.

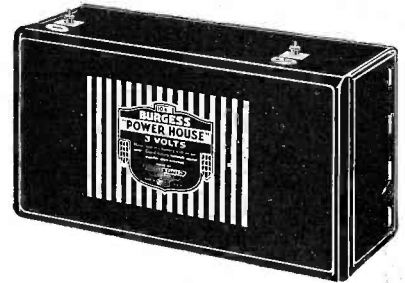

## World-Famous BURGESS "B" and "C" Batteries

BURGESS Batteries have been taken to the North and South Poles and all around the world by explorers who would have only batteries built to "take it" hour after hour without any decrease in the total hours of service delivered. Recommend BURGESS Batteries, and as owners of battery operated sets enjoy more programs per day they will thank you. BURGESS BATTERY COMPANY, Freeport, Ill.



\* Economical operation of 7 to 8 hours a day depends, of course, on the set being powered by batteries of the proper capacity.

**BURGESS**  
BATTERIES AND FLASHLIGHTS



*Undisputed Leaders!*



**WESTON**  
Standardized  
Service Units

The aggressive service man recognizes that good instruments are business builders. With such instruments he can quickly and surely get at the root of the trouble . . . do a thorough job in shorter time. This builds confidence . . . and holds trade. And the good instrument is a *permanent* partner in his business . . . for it defies obsolescence, remaining dependable and serviceable throughout the years. In the field of portable test instruments, Weston Standardized Service Units hold undisputed leadership. They represent, by far, the greatest value ever offered in the servicing field. Weston Standardized Service Units consist of Model 663 Volt-Ohmmeter . . . Model 664 Capacity Meter . . . Model 665 Selective Analyzer and Model 694 Test Oscillator. Return the coupon for complete details . . . Weston Electrical Instrument Corporation, 604 Frelinghuysen Avenue, Newark, New Jersey.



**WESTON**   
*Radio Instruments*

WESTON ELECTRICAL INSTRUMENT CORPORATION, 604 Frelinghuysen Ave., Newark, N. J.  
Send bulletin on Weston Radio Instruments.

Name

Address

City and State

# And now . . . the

## SEALED CARTON CRUSADE



And now..

THE SEALED CARTON CRUSADE, backed by the most powerful concentration of advertising in radio tube history, and spelling the doom of that profit thief and arch enemy of all honest dealers—the Used Tube Racketeer.

★ Get behind the Sealed Carton Crusade. Win back the 3,000,000 tube sales per year that have gone to the racketeers at the expense of honest service men and dealers. ★

## RCA Radiotron Company, Inc.

A RADIO CORPORATION OF AMERICA SUBSIDIARY

Camden, New Jersey

Always the leader in sales, RCA Radio Tubes during the past six months have enjoyed an increase in popularity among the 30,000 Authorized Agents handling them that is truly amazing. Indeed, the feeling has become widespread that RCA Radio Tubes are the only tubes to handle for a substantial, steady, protected volume of compensation.

Unquestionably this feeling has come about as the result of the adoption of the RCA Radio Tube Agency Plan, and the steps the RCA Radiotron Company has since taken to reinforce it. Here are a few of the advantages that make Agents enthusiastic:

**Agency Plan Features:**

- Adequate stock without investment.
- Assured profits.
- Protection against unfair trade practices.
- Complete inventory price protection.
- Protection against losses from dead stock.

### Steps Taken to Protect Compensation

1. Agent-owned stock bought back by RCA Radiotron Company. This enabled the Company to assure every Agent of equal opportunity from a price standpoint.
2. List price reduction . . . putting Agents in a better position competitively and setting the stage for more sales of complete complements of RCA Tubes.
3. Withdrawal by Company of RCA Tubes not in Sealed Cartons — enabling every Agent to take full advantage of the merchandising features of this superb packaging advance.