



SERVICE



A MONTHLY DIGEST OF RADIO AND ALLIED MAINTENANCE



VICTORY — ACHIEVEMENT

"To GUGLIELMO MARCONI in Grateful Recognition of his Enduring Contribution to the Enrichment of Human Life"—A Tribute from the Radio Industry of America presented by the Radio Manufacturers Association at the Century of Progress Exposition—Chicago—October 2, 1933.

PER COPY
20 CENTS

OCTOBER
1933

A Tip for SERVICE MEN

THE name "ELECTRAD" on a replacement Resistor, Volume Control or Amplifier has always meant the HIGHEST QUALITY at the LOWEST POSSIBLE PRICE. ELECTRAD products were the best obtainable when radio was young, and they are the best today—the result of pioneering and specialization.

TRUVOLT—The Only RESISTOR of Its Type



TRUVOLT design is patented. No other resistor gives you these combined features:—Open-air cooling and large wire for long life; double-spiral winding for better electrical contact; sliding clips for exact adjustments; 1,000 volt insulation; full-length fibre guard for protection. All standard sizes.

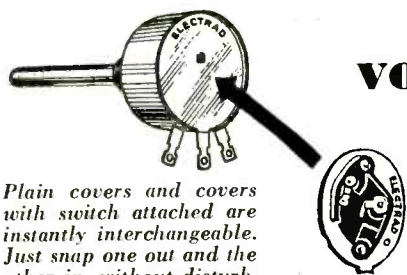

Plain covers and covers with switch attached are instantly interchangeable. Just snap one out and the other in, without disturbing the control connections.

The Handiest VOLUME CONTROL

Only five types required for the replacement needs of 799 standard receiver models. Saves time, labor and money. All types instantly convertible to use a power-switch. Long aluminum shafts are easier to cut to desired length.



VEST-POCKET Volume Control Guide

A handy 44-page Vest-Pocket Manual on Replacement Volume Controls.

FREE

Mail Coupon for FREE VEST-POCKET VOLUME CONTROL GUIDE and GENERAL CATALOG.



175 Varick St., New York, N.Y.
ELECTRAD
INC.

10-Watts of Resistor Perfection

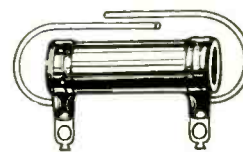

IN THIS resistor ELECTRAD has combined mechanical and electrical advantages which distinguish it from all others, in uniqueness of design, quality of workmanship, and practical usefulness.

(1)—Monel Metal contact bands and lugs mean: (a) low coefficient of expansion which eliminates strains at junction of resistance wire and lugs; (b) high resistance to oxidation under firing prevents high resistance contacts between resistance wire and lugs; (c) Monel Metal does not crystallize or lose its strength under firing.

(2)—Vitreous Enamel insulation. Capable of withstanding high temperature—non porous—does not absorb moisture.

(3)—Rapid heat dissipation. (4)—Positive lug contact. (5)—Long life and permanent resistance value. (6)—High quality—low cost. (7)—Pigtails and soldering lugs. (8)—3 sizes and 67 values.

3/8" x 1 3/4" Ceramic Tube, Monel Metal Lugs—10 Watt Rating

Electrad Part No.	Ohms	Electrad Part No.	Ohms
H-875	1	H-896	300
H-876	2	H-897	400
H-877	3	H-898	500
H-878	4	H-899	600
H-879	5	H-900	750
H-880	7.5	H-901	1000
H-881	10	H-902	1200
H-882	12	H-903	1500
H-883	15	H-904	2000
H-884	20	H-905	2500
H-885	25	H-906	3000
H-886	30	H-907	4000
H-887	35	H-908	5000
H-888	40	H-909	6000
H-889	50	H-910	7500
H-890	75	H-911	10000
H-891	100	H-912	12000
H-892	125	H-913	15000
H-893	150	H-914	20000
H-894	200	H-915	25000
H-895	250		

List Price, \$0.35 each

1/2" x 2"—20 Watt Rating

Values to 10,000 ohms, List Price, \$0.50 ea.
12,500 to 75,000 ohms, List Price, 0.65 ea.
80,000 to 100,000 ohms, List Price, 0.75 ea.

ELECTRAD, INC., 175 Varick St., New York

Please send me your FREE complete catalog. Check here for FREE copy of VEST-POCKET VOLUME CONTROL GUIDE.

Name

Address

..... S-10

SERVICE

A Monthly Digest of Radio and Allied Maintenance

OCTOBER, 1933
Vol. 2, No. 10

EDITOR
John F. Rider

MANAGING EDITOR
M. L. Muhleman

Editorial Contents

FEATURES

A Professional Standard Analyzer By D. L. VAN Leuven.....	346
New York I.R.S.M. Convention.....	366
Variable-Mu Pentodes as A-F Amplifiers.....	356

ANTENNA (Service Associations)	344
--------------------------------------	-----

ASSOCIATION NEWS	362
------------------------	-----

AUTO-RADIO

A.K. Models 756 and 756-B.....	360
Auto-Radios and Chargers.....	368
Eliminating Vibrator Hash in Stewart-Warner Model 112.....	360
G.E.-40 and RCA-40 Note.....	368
G.E. Model A-90	368
Majestic Model 66 (Twin Six) Super.....	358

CIRCUITS

A Professional Standard Analyzer.....	346
A.K. Models 756 and 756-B.....	360
Echophone Model 4 and 44.....	355
G-E K-106 Color Radio.....	350
Gulbransen Model 322 Super.....	353
Majestic 460 Delayed AVC.....	351
Majestic Model 66 (Twin Six) Super.....	358
Noiseless Pre-Amplifier Gain Control.....	356
Stromberg-Carlson Nos. 52 and 54 Receivers.....	349
Weston 664 Capacity Meter	352

FORUM (The Reader's Page)	368
---------------------------------	-----

GENERAL DATA

A.K. Model 246 Changes	352
Atwater-Kent Peak Frequencies	351
Bosch Model 60 Inoperation	364
Crosley Peak Frequencies, New.....	355
Echophone Model 4 and 44	355
Equivalent Tube Tests	354
G-E K-106 Color Radio.....	350

Gulbransen Model 322 Super.....	353
Majestic 460 Delayed AVC.....	351
Philco 71 Shadow Tuning Meter Installation.....	352
Philco Models 35 and 36.....	354
Philco Model 54	352
RCA Model R-7-LW	351
RCA Victor I-F Peaks	355
Stromberg-Carlson Nos. 52 and 54 Receivers.....	349
Stromberg-Carlson No. 55 Te-lek-tor-et.....	351
Universal Receiver Servicing	355
Victor R-32 and RE-45 Short.....	364
Weston 664 Capacity Meter	352
Weston Tube Base Chart.....	354

HIGHLIGHTS	366
------------------	-----

INDEX OF MONTHLY LITERATURE	374
-----------------------------------	-----

MANUFACTURERS

Continental Super-Watt Resistors	372
I.R.C. Dual Resistance Indicator.....	372
Racon High-Frequency Unit	372
Radolek Megohm Indicator	372
Tau-Rex Meter Rectifier	372
Tobe Auto-Radio Filterizer	372
Webster Amplicall System	372

ON THE JOB

AVC Correction	364
Bosch Model 60 Inoperation	364
Cure for Slipping Dial Drives.....	364
Finding the Ground	364
Handy Shop Device	364
Handy Trouble Light	364
Saving Large-Iron Tip	364
Victor R-32 and RE-45 Short	364

PUBLIC ADDRESS

Noiseless Pre-Amplifier Gain Control	356
Variable-Mu Pentodes as A-F Amplifiers.....	356

Published monthly by

BRYAN DAVIS PUBLISHING CO., Inc.
19 EAST 47th STREET
NEW YORK, N. Y.

Entered as second-class matter June 14, 1932, at the Post Office at New York, N. Y., under the Act of March 3, 1879. Subscription price \$2.00 per year in the United States of America; 20 cents per copy. \$3.00 per year in Canada and foreign countries; 35 cents per copy.

THE ANTENNA...

SERVICE ASSOCIATIONS

THIS issue of SERVICE introduces a new department. For quite some time, we have been deliberating about the allocation of a certain amount of space within this magazine to news concerning various radio service association activities. There are many reasons why space should be devoted to such information. The most important is that close co-operation between different associations fosters closer co-operation between the many Service Men located in all parts of the nation. A feeling of friendliness among all Service Men is vital to the success of the industry.

If associations pull together, their members will pull together. Interchange of communications between associations—intersectional visits of groups and individuals—all tend to stimulate and uplift the morale of the members. Today, we have a national service organization known as the Institute of Radio Service Men, with headquarters in Chicago. We have numerous state-wide Service Men's associations with sections in different towns within the same state, and we have separate, strictly local, service associations.

Some groups are affiliated with the national organization. Others are not. However, the important thing is that the associations exist. It is vital that greater activity be carried on in connection with such associations. Every man affiliated with the radio service industry should be a member of a Service Man's association. Every town, city, county and state in the Union should have its own association or be affiliated with a state-wide or national group. It is vital to the earning power of its members, the conduct of the art of servicing, the success of the industry at large, and the establishment of a voice in national affairs.

The association department of SERVICE will be open to all associations, large and small. No attempt is being made to make SERVICE the official organ of any one particular Service Men's association. Hence every organized group of Service Men is at liberty to forward news concerning activities to SERVICE for publication. However, in order to include as much varied information as possible, make your association news brief and to the point. That which you believe will be of interest to other association members or to future members of your own association, will be welcome for publication.

This association news department should prove of immense value in securing enrollments—in the formation of new groups. No doubt many hundreds, if not thousands, of Service Men not as yet members of any Service Men's association will receive copies of the magazine. They will read and learn about your activities. The result will be new members—solidifying your own group and the industry at large.

Generally speaking, Service Men's associations can perform one great function; the overcoming of personal animosities. To remove hard feelings between townsmen and to establish cordial relations, constitutes a prime mover in establishing fair practices and removing unfair competitive tactics. Association meetings make it possible for total strangers to meet and become fast friends. Association meetings offer the much-desired opportunity of amicably ironing out competitive difficulties.

Mention this association news department at your next association meeting. Make definite arrangements to forward news concerning your activities on a regular schedule. You men who are not members of associations—follow this department closely. Communicate with the officers of the association closest to you. Attend the open meetings. . . . Become a member. . . . Every Service Man should be a member!

• • •

WHAT is wrong with auto-radio service? We have spoken to many radio Service Men who embarked upon auto-radio service, only to abandon it after a short period of activity. We know that it is not the lack of work—plenty of work is available. The men we have met have told us so. They seem to complain that the amount of work required is too great for the remuneration received. Is it that the normal fees are basically not sufficient, or is it that the peculiarities of auto-radio systems are so numerous that much time is spent on the finishing touches? We do not know, but sure would like some information about these points.

• • •

WITH the advent of wide-range transmission, recording and reproduction, the public-address field has taken on a new color. So far, wide-range equipment is not being used to any great extent, but with wide-range equipment going into movie theatres and auditoriums, the public may well experience a change of ear and demand something better than the present public-address jobs now offer.

Here is a chance for you. If you have anything at all to do with public-address equipment—if you rent, install or sell—start going places with wide-range equipment. In some cases you will have to relegate present equipment used for rental to a secondary place and replace it with completely new equipment. In other cases, a bit of revamping and the addition of a few more units will give you a real fine job capable of handling a very wide range of audio frequencies and producing something decidedly more life-like.

You can't imagine what the ear is missing unless you have heard a good wide-range job. Radio men, as well as the public, have gotten in the habit of enjoying "radio" speech and music devoid of many of their natural harmonics. We get our music and speech "through the neck of a bottle" so to speak. Now that the trend is towards opening out the neck and attempting to reproduce naturally, the swing into wide-range is going to be rapid and extensive.

We have noted many times that Service Men are progressive—probably because they have to be. That's why we think a good many Service Men are going to look into this wide-range business and make it pay handsomely. You may expect to find wide-range data in future issues of SERVICE . . . the kind of data which will really help you progress with the idea.

John F. Rider.

A Complete REPLACEMENT CONDENSER STOCK

for only
\$8.94



FORGET your replacement condenser headaches! You no longer have to carry a large and costly stock of condensers of different voltages. Here at last is a single, *universal voltage* line. Units of various standard capacities can be used singly or grouped for any required value. And when installed, these units stay put. You can bank on them.

Put one of these kits in your service bag. You are then ready for any repair job or emergency. Any capacity, any working voltage, any combination—well, it's just like pulling rabbits out of a silk hat!

CORNELL - DUBILIER Handy Mike Condenser Kit

Contains ten units, namely: two 1 mfd.; two 2 mfd.; two 4 mfd.; two 6 mfd. and two 8 mfd. Packed in attractive orange and blue carton. Compact. Fits in smallest tool bag. Can be set up as shown for counter or window display. Complete kit is offered to service men for only \$8.94. Ten condensers—five to ten potential repair jobs—with a big profit for you because of utmost convenience, efficiency and no make-good calls. That's the way to make money out of radio servicing!

Each Handy Mike is rated for maximum surge voltage of 600 D.C., or working voltage of 475 D.C. Encased in attractive aluminum-finished cardboard case. Dry electrolytic type of most advanced design. Extremely compact. Long insulated pigtail leads of push-back wire, sufficiently rigid to support unit in any position. Easily mounted and wired. Metal clamp to hold two or more units together. Heat and moisture proof, due to impregnation. Connected in parallel for multiple capacities.

Order Now! Send your order to your jobber, if he handles the Cornell-Dubilier Complete Condenser Line, or order direct from us. Also, be sure to write for our new 1933 catalog, covering the combined Cornell and Dubilier lines.



CORNELL-DUBILIER CORPORATION
4377 Bronx Boulevard » » » » » New York City

A Professional Standard Analyzer

By D. L. VAN LEUVEN

THIS analyzer was designed with the new tubes in mind. For this reason advantage was taken of the use of numbers to supplant element or prong designations. The standard RMA prong numbers are used, and this system of designation is a considerable convenience because of the various uses to which grids are put in modern tubes.

In this analyzer then, the meter looks to the tube element as a number, and any value or kind of test can be applied to any said number, using any other number as a reference point. This means that one can test between any elements (by their number designation) the gradient voltage, a-c component, d-c voltage, current, etc.



Fig. 2. Panel view of the special analyzer described in this article

• This article describes and gives construction details for a new point-to-point tester of the three-wire, two circuit type, comprising three main controls. The first controls the ranges of the meter. The second selects the circuit. The third for point of reference or return. This analyzer permits testing through the sockets of a receiver or by means of test prods through external connections. Aside from permitting the usual forms of testing—including the measurement of resistance—it also provides a complete transconductance test for tubes. The analyzer has great flexibility.

The automatic telephone dial furnishes an apt comparison to this number system, and the tests are limited only to the amount of numbers, and the numbers are limited only by the number of elements that may appear in future tubes. Spare contacts are provided to take care of this. As new elements are developed, or as one element of a tube is supplanted by another, the number system takes care of these alterations without the necessity for any changes whatsoever in the analyzer.

ELEMENTS OF DESIGN

While this analyzer was designed primarily for making tests directly from the sockets of a radio set, it will be seen from the accompanying illustrations, and from the diagram of Fig. 1, that three external connections are provided so that any desired external test may be made as well. Five sockets are provided on the panel of the tester so that no

complications in contacts may arise. Looking at the panel (Fig. 2), the three main switches will be found at the bottom. The switch at the left, which is Switch No. 1 in the diagram, is the meter control switch, which covers the milliampere ranges on the left side and voltage ranges on the right side. The use of but one switch to take care of both the current and voltage ranges of the meter makes for compactness and convenience and is a perfectly practical arrangement as there is no possibility of wrong switching.

The switch at the center of the panel and directly under the meter is Switch No. 2 in the diagram. It will be seen that there are number designations from 1 to 8, and one spare—the latter to be used in the event of new tubes with a greater number of elements. This switch is surrounded by push buttons of the non-locking type, and these are used for making current readings in any of the eight circuits. The external test posi-

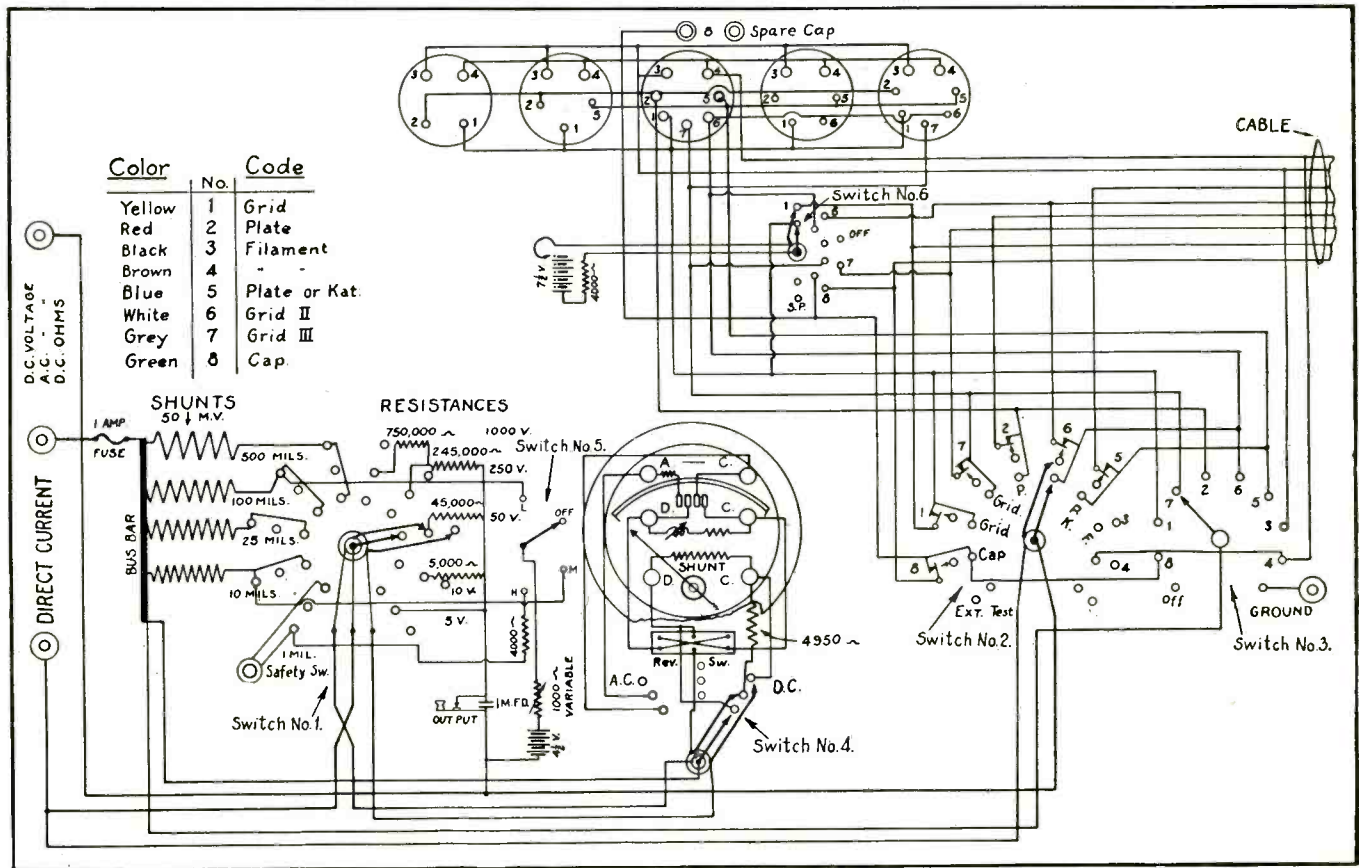

Fig. 1. Complete schematic diagram of the Professional Standard Analyzer

tion of this switch permits making measurements externally through the jacks or binding posts provided at the upper left corner of the panel.

Switch No. 3 at the extreme lower right, in Fig. 2, with numbers 1 to 8, is the reference point switch, and its contacts are connected with the same contacts as Switch No. 2. It will be seen that this switch permits the testing between any tube elements or receiver circuits desired.

Returning to the push-button above Switch No. 1 at the extreme left, this is marked "Safety." This is the safety switch for the 1-milliampere position of Switch No. 1. To the right of this is the regular toggle reversing switch, used in case the meter shows a reversed reading, which is many times the case.

Above the reference-point Switch No. 3 at the extreme right, there are two switches; one is marked "output" and is used for output tests or any a-c component test, such as hum, etc. This switch should always be closed when making other tests. To the right is the ohmmeter switch, marked "Off, L, M, and H." This switch should always be in the "Off" position when the analyzer is in use. It is to be used only when the radio set under test is entirely disconnected from the power line. The "L" marking on this switch designates the low-resistance position, "M" the intermediate position—up to 10,000 ohms using the 10 mil. shunt position, and "H" the high-resistance position for the 100,000-ohm range. When this switch is in the "H" position, Switch No. 1 should be in the 1-mil. position.

Above the ohmmeter switch is the rheostat for adjusting all the resistance ranges for full-scale reading on the meter. This is a 1,000-ohm variable resistor.

There is one other important switch at the left of the panel and directly to the right of the three external jacks or terminals. This

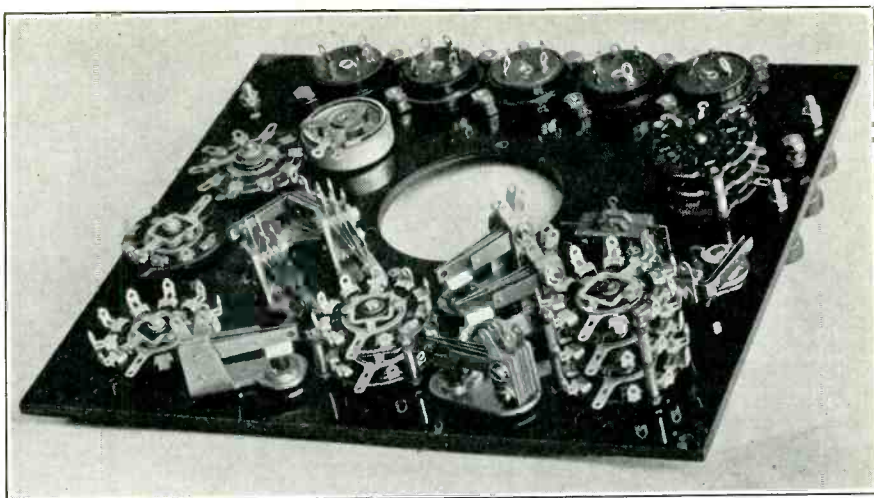

Fig. 5. A rear view of the analyzer panel with all parts, with the exception of the meter, mounted in place. Drilling details are given below

is Switch No. 4 in the diagram and is marked "A.C. OFF, and D.C." This is for the purpose of changing to a-c or d-c readings on the meter.

And now we come to the small switch at the extreme right of the panel, above the ohmmeter switch. This switch is used entirely for transconductance tests. This switch (No. 6 in diagram) has numbers for each of the various grids in the new tubes. The code for these numbers will be found along with the diagram of Fig. 1. This switch connects to a 7½-volt battery and permits the placing of most any desired voltage on any desired grid. Switch No. 6, of course, selects the proper grid.

Now take note that there is a special connector just above the rheostat on the panel which is marked "G." This is to be connected to any desired point on the chassis of the radio set, or ground, for point-to-point testing.

OPERATION

It is suggested that the code numbers and their designations be memorized. These are given in the table accompanying the schematic diagram of Fig. 1. Once you have a clear memory of this coding, any form of testing can be carried out with unusual rapidity.

The analyzer connects to a receiver in the usual way—by means of the cable and plug. Now in operation the first thing to do is set the a-c, d-c switch properly, providing whether an a-c or d-c reading is desired. From then on, all ordinary tests will be carried on by the use of Switch No. 1, which controls the meter ranges, Switch No. 2, which selects the desired circuit, and Switch No. 3, which provides the desired reference point.

Suppose a plate reading is necessary. Set Switch No. 1 at 1,000 volts, Switch No. 2 at point 2 (plate) and Switch No. 3 at point 5 (cathode). Then it will be possible to obtain a voltage reading between the plate and the cathode of the tube. If the a-c component is desired, the a-c, d-c switch is set at a-c, the proper voltage range selected by the voltage selector switch (No. 1) and with Output switch in the closed position. In this position, hum and output tests can be carried out.

Where current readings are desired, Switch No. 3 should be set to the "Off" position. Then the circuit desired is selected by Switch No. 2. Let us say that Switch No. 2 is set to position 2. This is a plate circuit. Then by pressing the button corresponding to this number, a current reading may be had. Since there is a button for each circuit, current readings can be taken between any two desired points.

TRANSCONDUCTANCE TESTS

Switch No. 6 is used for transconductance tests as mentioned before. The knob of this switch is marked "Mu," as will be seen from the panel view of Fig. 2. Numbers 1, 6, 7 and 8 are used for these tests. It will be seen from the code in Fig. 1 that these numbers correspond to grids only.

Now Switch No. 6 is really used only for connecting a variable voltage (7½-volt battery and resistor) in series with the desired grid lead. The test therefore provides for a wide variation of grid voltage in any desired grid circuit.

Now, to make a transconductance test, first take a current reading on the tube by setting

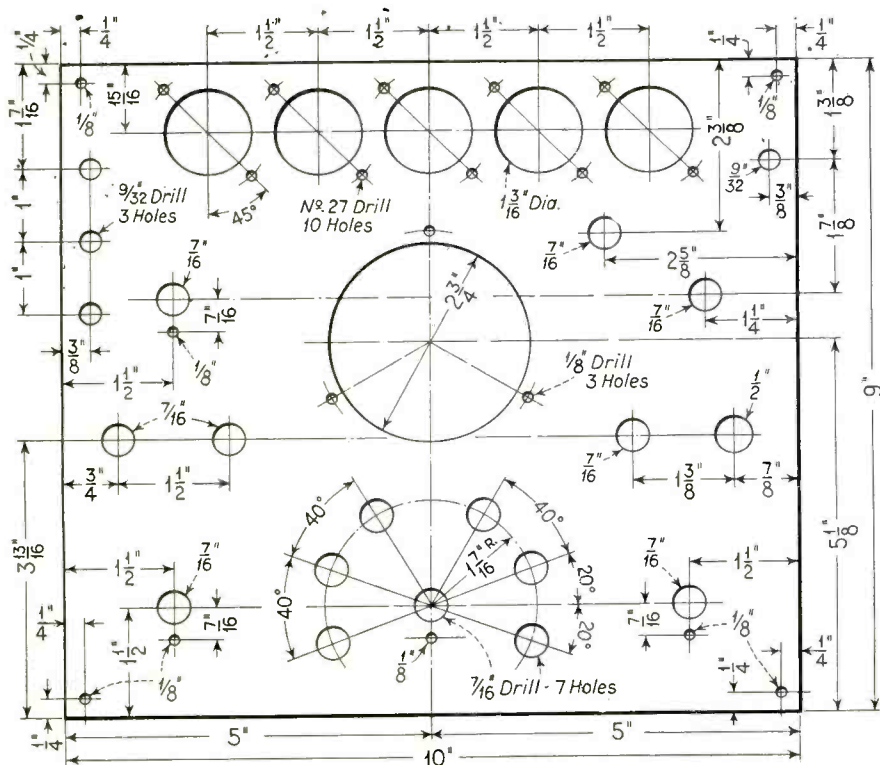

Fig. 3. Complete measurements and drilling details for the analyzer panel

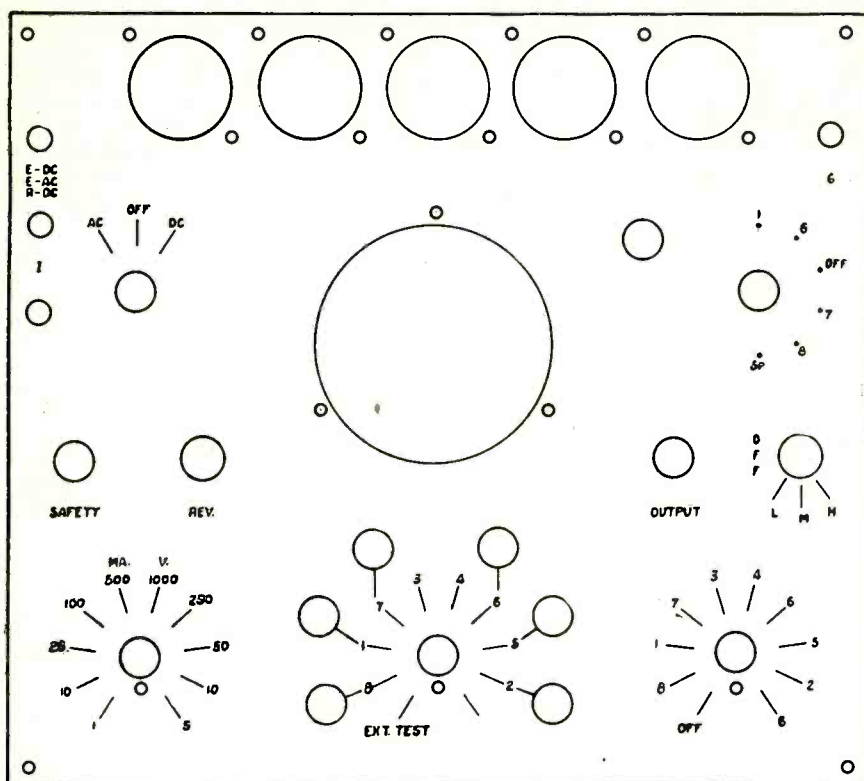

Fig. 4. In this drawing are given all the engraving details. The letters are one-eighth inch high

Switch No. 1 at "Mils." position. Switch No. 2 to the plate (position 2) and pushing button 2, as explained before. This will give the normal plate-current reading. Then, by placing Switch No. 6 to the grid position—say to 8 and then pushing button 8, a voltage will be placed on the grid and the corresponding change in plate current will give the transconductance of the tube. That is, since the current drop is known for a corresponding change in grid voltage, the result may be calculated into micromhos.

CONSTRUCTION DETAILS

The necessary measurements and drilling details for the panel are given in Fig. 3, and the engraving details in Fig. 4. A rear view of the panel, with the parts mounted, is shown in Fig. 5.

The meter and the sockets should be mounted first. The four-prong socket is mounted at the left—then the five, the six, then the small seven and finally the medium seven. Next the three jacks or binding posts are mounted at the left of the panel, with the red jack at the top, the black in the center and the green at the bottom. The black jack for the ground is mounted on the right side of the panel, as shown in Fig. 2. It is marked "G." Next, the a-c, d-c switch is mounted at the left, and the 1,000-ohm rheostat with its knob at the right. The various other switches may be mounted in any convenient order as desired. Care should be taken to refer constantly to the illustrations and schematic diagram, so that no mistake can occur.

After all the units are mounted on the panel, the analyzer is ready for wiring. A good grade of wire should be used for this purpose, and it is desirable to wire up the sockets first.

The following procedure is recommended: First, start with the sockets and complete their wiring as far as possible, to whatever

the points these wires may lead. Then start with the selector switch and complete this wiring in the same manner. Continue in this manner with each switch and end up with the binding posts and the meter. In order that there may be no confusion, the internal wiring of the meter is shown in the diagram of Fig. 1. The six meter posts are clearly shown, so that there should be no difficulty in wiring this correctly.

The shunt and multiplier resistors should be attached directly to the contacts on Switch No. 1. The leads to these resistors should be

as short as possible, and the far leads should be connected to a bus bar, as shown in Fig. 1. Furthermore, all wires leading to the bus bar must be connected directly and not to some other wire leading to the bus.

The external cable is colored according to the RMA coding, and is connected to the various points on the switches as shown in the schematic diagram. The 4,000-ohm series resistor is soldered directly to the ohmmeter switch contact "H" without using any other form of mounting. However, a mounting will probably be necessary for the 1-mfd condenser across the output switch. The analyzer cable comes in from either side, and is carried around close to the meter, entering at the approximate center line of the panel, following around the meter and being wedged in place so that it needs no additional anchoring.

THE METER

The meter used in this analyzer is of a new type with a knife-edge pointer. It is a 50-millivolt a-c, d-c type with 5 volts as its lowest a-c reading. The meter dial has five different scales. The voltage ranges are 0-5-10-50-250-1,000 volts. The current ranges are 0-1-10-25-100-500 ma. These of course are obtained by the use of four separate shunts. The multiplier resistors and shunts employed in the analyzer are of standard 50-millivolt type.

It will be noted from the schematic diagram that a one-ampere fuse is used as a protective device for the meter. This is a worthwhile addition.

If any other information is desired, Mr. Van Leuven will be pleased to supply it. Address him at 410 East 15th Street, New York, N. Y.

Philco Plug-Battery

Philco have out a new battery for their battery-operated receivers. The "B" and "C" battery are in the same case and all connections lead to a regular plug. So, all you do is plug the set into the battery. And if that isn't a new experience!

LIST OF PARTS REQUIRED

- 1—Three pole, three-position switch (Switch No. 4)
- 1—Single pole, six-position switch (Switch No. 5)
- 1—Single pole, ten-position switch, non-shorting (Switch No. 3)
- 2—Double pole, ten-position switch (Switch No. 2)
- 1—Triple pole, ten-position switch, non-shorting (Switch No. 1)
- 6—Single pole, double throw, push-button switches, non-locking (Current Switches)
- 1—Single pole, break-contact switch (Output Switch)
- 1—Single pole, single throw, push-button switch, break contact, locking (Safety Switch)
- 1—Double pole, double throw, toggle switch (Reversing Switch)
- 1—Four-prong socket
- 1—Five-prong socket
- 1—Six-prong socket
- 1—Seven-prong (small) socket
- 1—Seven-prong (medium) socket
- 1—Red insulated tip jack
- 1—Green insulated tip jack
- 2—Black insulated tip jacks
- 1—Insulated grid cap and lead
- 1—Variable 1,000-ohm resistance
- 1—Set of multipliers, 5,000 ohms, 4,950 ohms, 45,000 ohms, 245,000 ohms, 750,000 ohms
- 1—Set of 50-mv. shunts; 1-10 ma., 1-25 ma., 1-100 ma., 1-500 ma.
- 1—Eight-wire cable with plug
- 1—Set of four adapters
- 1—Continuity test resistor, 4,000 ohms
- 1—Weston or Hickok Universal A-C, D-C Meter
- 1—Littelfuse 1-amp. fuse and mounting clip
- 5—Instrument knobs
- 1—"C" battery, 7½ volts, for transconductance tests
- 1—"C" battery, 4½ volts, for continuity and resistance tests
- 1—Bakelite panel, 9" by 10" by 3/16"
- 1—Hardwood cabinet

General Data . . .

Stromberg-Carlson Nos. 52 and 54 Receivers OPERATION OF "Q" CIRCUIT

The complete diagram is shown on this page. Note that three type 35 tubes are used as r-f. amplifier, mixer and i-f. amplifier, while a type 27 is used as oscillator. Also note that a type 55 tube is used in the first audio stage. The diodes in this tube are not used.

Special attention should be given to the 2B7 tube. Note that the i-f. signal is fed to the pentode portion of this tube, this portion functioning as an i-f. amplifier only. Then the output of the pentode portion is fed to the diodes, one of which is used for audio rectification and the other for AVC.

The resistor unit of the volume control potentiometer R-14 forms part of the load of the "audio" diode of the 2B7 tube and the audio voltage is applied to the triode portion of the type 55 tube. The potentiometer is double (actually R-13 and R-14), the rear unit (R-13) being used in the low level tone compensation circuit, which increases the response to bass frequencies and high frequencies in proper proportion as the volume level is reduced. The output of the type 55 tube is fed through a transformer to the push-pull first audio stage. The "Bass Control" circuit apparatus (R-36, L-14, C-33, C-34, C-35) is connected across the primary of this transformer.

The AVC voltage secured from the other diode of the 2B7 is fed back to the first three tubes in the receiver, through a suitable filter network made up of resistors and condensers.

The "Q" circuit for providing quiet operation for tuning between stations, consists of the type 57 tube connected to the AVC diode of the 2B7. When there is no carrier coming in, the action of this circuit is to put high negative potentials on the "audio" diode and the grid of the type 55 triode, thus preventing reception of inter-carrier noise. When a carrier of suitable strength comes in, these negative potentials are removed and the signal is received. This is accomplished by the change in plate current in the type 57 tube circuit. The "Q" circuit can be rendered inoperative when the maximum sensitivity of the receiver is desired, by the "Q" switch, shown in the diagram.

The power supply employs two choke-type stages of filter, the second one using the speaker field as the choke. The first choke is resonated in order to increase the filtering properties. The plate supply for the 2A3 power tubes is tapped off between these two chokes, while the remainder of the voltages are supplied from the voltage divider resistor, R-30.

ALIGNMENT

Realignment of the r-f. and oscillating tuning circuits, when necessary, may be accomplished in the following manner:

If a test oscillator and output meter are used, the signal strength applied to the receiver should be low enough so that the automatic volume control is not operated in order to avoid apparent broad adjustment. If broadcast signals are used, moderately strong signals which swing the meter pointer about half the distance back toward the "off" position should be used.

With whichever method is used, the receiver should be tuned to a 1,400-kc. signal first, and the antenna, r-f. and oscillator

CONTINUITY TEST DATA

Socket	Heater	Plate	Screen	Suppressor	Cathode	Control Grid
R-F.	0	4,080	24,040	450	1,600,000
Mixer	0	4,080	24,040	6,500	1,600,000
Osc.	0	23,440	6,500	600
1st I-F.	0	3,480	23,440	450	1,600,000
2nd I-F.	0	18,480	33,440	1,264	1,264	664
Relay (57) ...	0	100,520	101,164	*	*	1,500,000
2nd Det.	0	8,840	664	664	664	2,100,520
1st A-F. No. 1.	0	14,940	1,200	5,500
1st A-F. No. 2.	0	14,315	1,200	4,200
2nd A-F. No. 1	750	3,670	830
2nd A-F. No. 2	750	3,590	750
Rectifier	3,510	30	28

* No reading when either Q switch is open or when phono-switch is operated. Zero ohms when Q switch is closed and phono-switch is not in operated position.

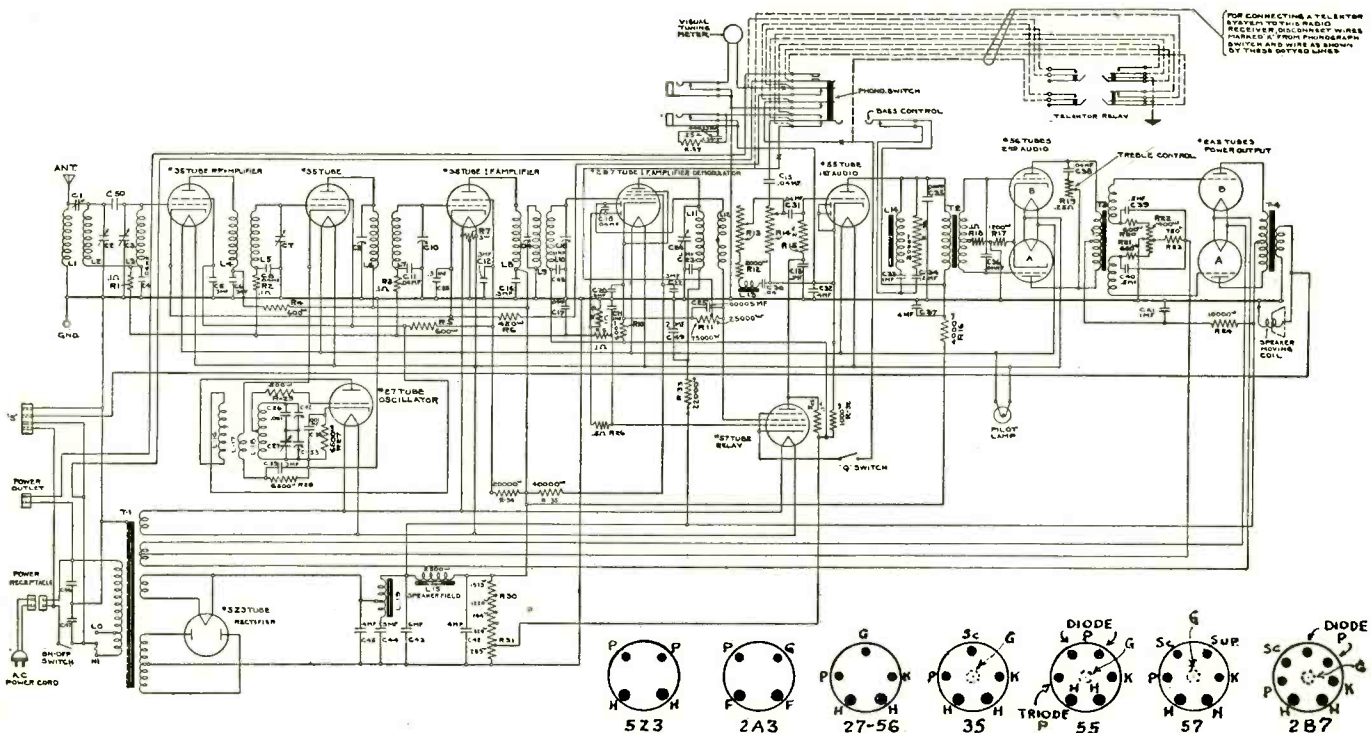

Schematic diagram and socket connections for Stromberg-Carlson Nos. 52 and 54

GENERAL DATA—continued

shunt aligners adjusted for best setting. Next the receiver should be set at 600 kc. on the dial, and the oscillator series aligner *only* adjusted for best position for maximum background noise. After this is done recheck the oscillator shunt aligner at 1,400 kc., using same dial setting as previously. The receiver should be left turned on for about 15 minutes before aligning.

The i-f. amplifier circuits should not be adjusted, as it is not possible to peak them properly with the usual equipment.

Warning regarding changing position of cable wires in base of chassis—re-arrangement may cause mis-alignment, tweets, hum, etc.

Because of the complicated wiring of this receiver and the inability of satisfactorily checking some circuits by the voltage method, we are providing the continuity test data in the accompanying table.

G-E K-106 Color-Radio

This is a 10-tube super with a number of new features. Colored illuminated indicators are used for all operating controls. Their main usefulness is found in the tone control, as the shading of the colors is made to follow the shading of tone.

A glance at the accompanying diagram of the K-106 will show that there are two tone controls, one for bass response and the other for treble response. The treble or high-frequency tone control consists of a variable resistor (R-23) and a condenser shunted across the grids of the output tubes. This is the usual form of tone control and is well understood. The bass or low-frequency tone control is more complicated. It consists of the network of units between the type 56 second detector and the push-pull stage. The control itself is the variable resistor R-17 which, together with the impedance L-16 and the condensers, forms a parallel resonant circuit.

ACOUSTICALLY-COMPENSATED VOLUME CONTROL

Immediately following the bass tone control is the volume control, R-19. It should be noted that this is of the acoustically-compensated type; that is, as volume is decreased the bass response is automatically built up with the result that good bass response may be had at low volume. This is accomplished by the use of a group of resonated circuits which are connected to taps on the variable resistor R-19.

The variable resistor R-3 in the cathode circuit of the type 56 r-f. amplifier is the noise suppressor, or silent tuning control. This can be adjusted from the front panel. In the plate circuit of the same tube is the tuning meter. This is shown in the diagram.

Four adjustable condensers are provided for aligning the r-f. circuits and adjusting the oscillator frequency. Poor quality, poor sensitivity, poor AVC action and possible in-operation of the receiver may be caused by these condensers being out of adjustment.

R-F. ALIGNMENT

In the alignment work, a dummy type 56 tube (with one heater prong removed) should be substituted for the one normally used in the AVC socket. Then the chassis should be checked to see that the dial pointer reads exactly at the first line on the scale when the gang condenser plates are fully meshed.

Then place oscillator in operation at 1,400 kc. and couple its output to the antenna. Set the dial scale at exactly 1,400. Connect up the output meter and then place the volume control and suppressor control, if noise level will permit, at its maximum position. Adjust the oscillator input so that an excessive reading on the output meter is not obtained.

With a socket wrench—the adjusting nuts are at ground potential—adjust the oscillator,

first detector and r-f. line-up condensers until a maximum deflection is obtained in the output meter.

Now set the oscillator at 600 kc. and tune in signal with the receiver until maximum deflection is had in the output meter. Then adjust the 600-kc. series condenser. This will be found by the gang condenser. Rock the gang condenser back and forth while making this adjustment as the tuning condenser and oscillator series condenser adjustments interlock.

Then set the oscillator at 1,400 kc. and make the same adjustments at 1,400 kc.

I-F. ADJUSTMENTS

The i-f. transformers should be adjusted to 175 kc. Note that there are three i-f. transformers, but only two are tuned by adjustable condensers. The third or AVC i-f. transformer is broadly tuned and requires no adjustment.

Use a modulated oscillator set at 175 kc. and couple its output from the control grid of the first detector to ground. Leave the dummy tube in the AVC socket and also remove the receiver oscillator tube.

Now adjust the secondary and primary condensers of the second and then the first i-f. transformer for maximum deflection in output meter.

The AVC and second i-f. transformers are mounted at the rear of the chassis, the one to the right being the second i-f. transformer. The first i-f. transformer is mounted nearer to the front and slightly to the left of the second i-f. transformer.

THE AVC SYSTEM

A word about the AVC system. It will be seen from the diagram that two tubes are really involved in this function; i.e., a type 58 i-f. amplifier, marked "AVC I-F." in the diagram, and a type 56 tube. The 58 tube picks the i-f. signal off the secondary of the

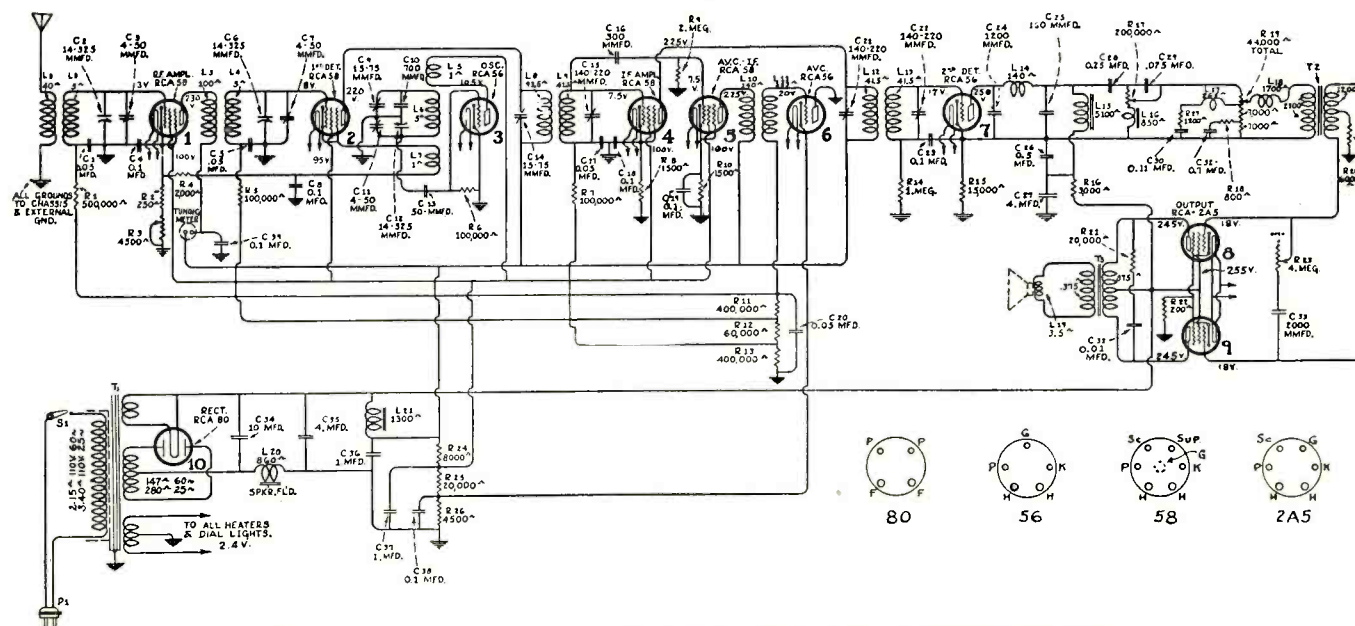

Diagram, socket connections and all values for General Electric K-106 Color Radio

GENERAL DATA—continued

first i-f. transformer, amplifies this signal and then feeds it into the AVC i-f. transformer which is untuned. This then feeds the actual AVC tube, whose operation controls the bias voltages on the r-f., i-f. and second detector.

The AVC i-f. transformer is broadly tuned so that it will not reject a signal slightly off 175 kc., which might happen if there was any oscillator drift or if the first i-f. transformer was not peaked exactly at 175 kc. In other words, if the AVC i-f. transformer was also sharply tuned to 175 kc., it would reject any signal other than one of 175 kc. with the result that the AVC would not function.

The diagram shown herewith carries all voltage, resistance and capacity values, as well as socket connections. Resistance values are also given for the coils so that it is possible to carry out a true point-to-point analysis if desired.

Atwater Kent Peak Frequencies

The i-f. peak frequencies of recent A.K. supers are given in the table below.

Model	I-F. Peak
155	262.5
165	262.5
217	264.0
217D	264.0
275	264.0
310	130.0
387	264.0
424	264.0
427	264.0
427D	264.0
427Q	264.0
448	130.0
510	130.0
534	450.0
555	262.5
667	264.0
667D	264.0
636	262.5
708	472.5
711	472.5
756	262.5
808	472.5

The 636 and 756 are auto-radio receivers. There is also a 756-B, which uses the same i-f. peak as the 756.

Stromberg-Carlson No. 55 Te-lek-tor-et

This receiver, in two separate and distinct units, provides remote tuning and volume control. It is of particular interest in that only two tubes of the superheterodyne receiver are included in the remote tuning unit, so that this device is a departure from the other types of two-unit receivers in which the entire receiver, and in most cases the a-f. amplifier as well, is contained in one small cabinet.

In the Te-lek-tor-et only a type 78 tube and a type 6A7 tube are contained in the small tuning and volume-control cabinet. In other words, all variable-frequency units are in the cabinet and all fixed-frequency units are contained in the main large chassis in the speaker cabinet. Thus, there is very little heat generated in the small cabinet. At the

same time, this unique method of splitting the receiver so that the r-f. pre-selector circuit and the mixer-oscillator circuit only are contained in the small cabinet, permits an expansion of the equipment over that used in other forms of two-unit sets. That is, a "large" set, having all the features of any other multi-circuit job, plus real power output.

GENERAL CIRCUIT ARRANGEMENT

Though we do not have complete information on the Te-lek-tor-et as yet, it appears that the small remote tuning cabinet contains a type 78 tube used in a stage of tuned r-f., and a type 6A7 tube used as combination mixer and oscillator. The small cabinet con-

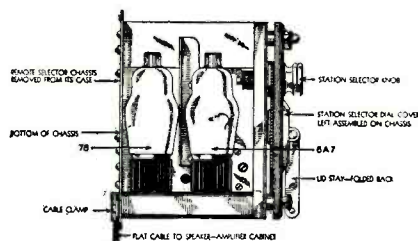

Fig. 2. Side view of remote tuning unit of Te-lek-tor-et

nects to the large speaker-amplifier cabinet through a flat cable. In the speaker-cabinet chassis there appears to be a type 58 tube in the first i-f. stage, a type 2B7 as combination 2nd i-f. amplifier, automatic volume control and second detector, a type 55 tube used as an a-f. amplifier feeding two type 2A5 tubes in push-pull in the output. A type 5Z3 full-wave rectifier is used. A similar circuit appears in this issue. It is the Stromberg-Carlson Nos. 52 and 54. Of course, this chassis uses a separate tube as oscillator and also uses type 35 tubes in the r-f. and i-f., but nevertheless there is a great deal of similarity.

The Te-lek-tor-et includes all the features of the other Stromberg-Carlson receivers, such as automatic volume control, "Q" circuit, pre-selector circuits, as well as bass and treble control.

A top view of the main chassis is shown in Fig. 1. A side view of the remote-unit chassis is shown in Fig. 2.

RCA Model R-7-LW

This receiver is a combination broadcast and long-wave job and was manufactured principally for export. The frequency range is 550 to 1500 kc. and 150 to 300 kc.

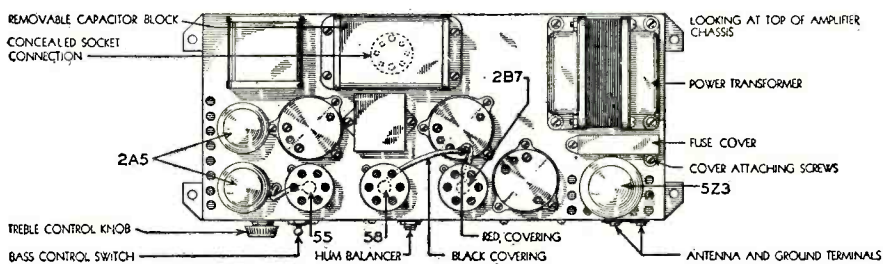

Fig. 1. A top view of the main chassis used in the Te-lek-tor-et

Majestic 460 Delayed AVC

The new Majestic Model 460 receiver, using Model G-24-C speaker, has a new AVC circuit incorporated in it which follows the modern trend of having an improved overload and AVC action, but without the customary disadvantages of the more conventional circuits. Referring to the circuit of Fig. 1, which is the AVC circuit of the Model 460, the above advantages are accomplished by utilizing one diode plate of the type 55 tube for audio development only, and the other for AVC voltage only. It is therefore possible to design an audio circuit and an AVC circuit of optimum constants without any sacrifice of one to aid the other as has been the case in previous receivers. The result of this is a much greater power output for very weak, as well as strong, signals and a very constant output level over an extremely wide range of signal inputs, which, of course, effectively overcomes fading.

MANNER OF OPERATION

The diagram of Fig. 1 shows just how this complete independence of audio and AVC circuits is accomplished. It will be seen that the secondary of the second i-f. transformer is in two sections, the upper section being employed in the audio circuit and the lower

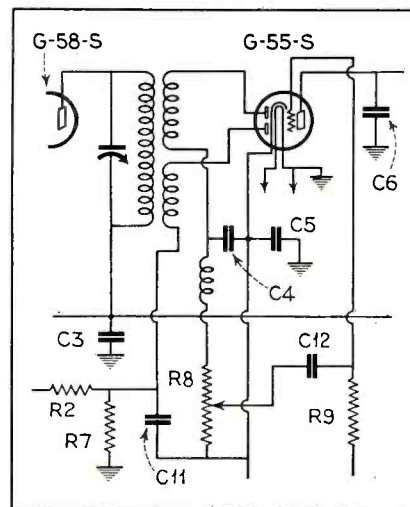

Delayed AVC circuit used in Majestic Model 460 chassis

section in the AVC circuit. The choke CH and the condenser C-4 keep i-f. voltages out of the grid circuit of the triode portion of the 55 tube, the audio voltage for the grid being picked off the potentiometer R-8.

The AVC action in this receiver controls the r-f. tube, first detector and i-f. tube.

Philco 71 Shadow Tuning Meter Installation

The mechanical part of the installation of the tuning meter in the Philco Model 71 receiver is accomplished by means of two brackets supplied with the kit which are to be fastened to the tuning dial bracket with the two small screws provided for this purpose. The dial bezel on the set is to be replaced with the new bezel which will require the enlarging of the hole in the control panel to accommodate the opening for the shadow screen.

In some of the later Model 71 chassis the wiring at the terminal board of the choke

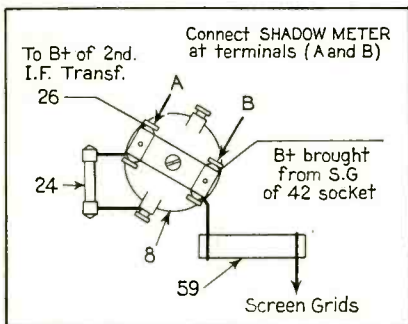

Connections for Philco Shadow Tuning Meter

No. 8, will be arranged as shown in the accompanying sketch and with a short piece of wire connecting terminals A and B. In these sets it is only necessary to remove the link and to connect the tuning meter leads to these terminals.

INSTALLATION IN OLD CHASSES

The earlier chassis which are not already wired for the tuning meter in the above manner will require the following changes.

If the terminal strip at the top of choke No. 8 has only a single terminal, remove the strip and replace with the double terminal strip furnished with the kit. In other chassis equipped with the double terminal strip, a common lead from resistor 27, 28 and 17, and condensers 31 and 32 will be found connected to terminal A. In this case the common lead should be removed and connected to the corresponding terminal of by-pass condenser 32. After making either of these changes, the wiring at the terminal strip should be rearranged as illustrated.

The B + lead coming from the screen grid contact of the type 42 tube socket must be broken at this point and connected at terminal B as shown. When the changes have been properly made, the B + lead will be connected to the screen grids of the r-f., i-f. and detector-oscillator tubes through resistor 59, and to the plates of these three tubes through the shadow tuning meter.

To complete the changes, remove resistor 23 and wire the terminal on the first i-f. transformer from which the resistor was removed to the terminal on by-pass condenser 5 to which resistor 17 is connected. This change will connect the grid returns of the r-f. and i-f. tubes to a common point and through resistor 17 to the automatic volume control circuit.

Weston 664 Capacity Meter

The schematic diagram of the Weston 664 Capacity Meter is shown in the accompanying sketch. The unit itself provides a means of measuring all values of capacity from .0002 to 200 microfarads. A group of a-c. volt ranges makes possible the measurement of voltage up to 800 volts with a sensitivity on all ranges of 1,000 ohms per volt. Any of the low ranges connected through a series condenser from the plate of an output tube to ground, provide a sensitive output meter to be used in aligning a radio receiver with an oscillator.

OPERATION OF UNIT

The operation of the Capacity Meter can be understood by referring to the accompanying diagram. For example, to measure capacity the unit is plugged into an a-c. outlet (105-125 volts, 60 cycles) and the switch turned to "Check" position. Then the 4,000-ohm line adjuster is rotated until the meter pointer just comes to the right hand end of the scale.

Then place test leads in "Capacity" jacks, and turn the main switch to the capacity range desired. Only the "C" range is shown on the instrument scale. The other four ranges are obtained by using the factor indicated on the switch (see diagram), i.e., multiply the microfarad reading by 10 for the high range (C×10), or divide by 1,000 for the low range (C÷1,000).

The voltage applied to the Capacity jacks on the C×10, C, and C÷10 ranges is 4 volts a-c. This covers with ample leeway all low-voltage electrolytic condensers with peak ratings as low as 6 volts.

The potential on the C÷100 range is 40 volts, and on the C÷1,000 is 92.5 volts. The current passing through the condenser is 100 ma on the C×10 range, 10 ma on the C range, 1 ma on the C÷10 and the C÷100

ranges, and 250 microamperes on the C÷1,000 range. These are all maximum values, and occur only at the top division on each range. The current at center scale is one-half of the maximum value.

In general, capacity readings are most accurate when taken between 1 and 10 on the microfarad scale, and the range selected should be chosen with this fact in mind.

To measure volts, the switch is turned to the volts position. The volt jacks are then connected and the instrument will read full scale according to the jack markings. All volt ranges are based on a resistance of 1,000 ohms per volt.

Regarding the test leads used for capacity measurement; it is important that the leads be in good condition, their tips clean and their points sharp.

Philco Model 54

The correct resistance value of the speaker field coil (39) in the Model 54 receiver is 2600 ohms.

A.K. Model 246 Changes

The following changes have been made in the Model 246 a-c. receiver: The gray-yellow screen resistor (15,000 ohms) is replaced by two 1.5-watt black-red resistors (each 20,000 ohms) connected in parallel. This increases the screen voltage slightly.

The electrolytic filter condensers are reversed, the 8 mfd. condenser being connected to the rectifier end of the field coil of the speaker.

In late sets, the first detector bias resistor is changed from 2,000 ohms (flexible) to 5,000 ohms (blue-yellow, 0.5 watt). When replacing this resistor, use the same value as the one you remove. In a few sets that use the 2,000-ohm resistor, a flexible 48-ohm resistor is connected in series with the oscillator plate.

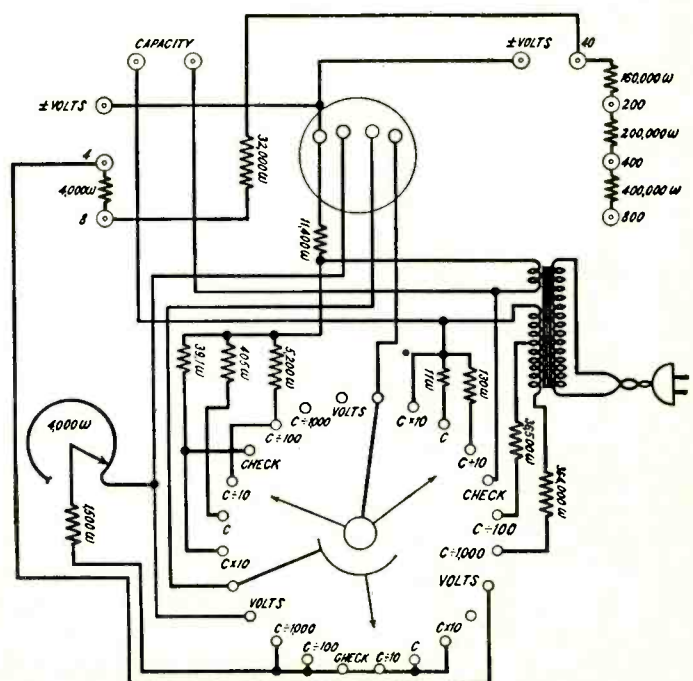

Schematic diagram of the Weston Model 664 Capacity Meter. All the actual resistor values are given. The range designations are explained in the article

GENERAL DATA—continued

Gulbransen Model 322 Super

The Model 322 super is peaked at 175 kc. The second detector tube is connected as a diode and supplies the automatic volume control voltage. The noise suppressor tube operation will be described later.

A capacity winding in the third i-f. transformer serves as a bypass condenser to ground. This condenser, in conjunction with the two chokes in the grid-plate circuit of the second detector tube acts as an i-f. filter. The volume control is in the grid circuit of the first audio tube and the tone control in the input circuit of the push-pull amplifier.

THE NOISE SUPPRESSOR

Noise suppressing action, when tuning between stations, is obtained in this receiver by controlling the screen voltage of the type 57 first audio tube.

Referring to Fig. 1, consider the movable arm of the noise suppressor potentiometer, R-16, at the extreme left (knob at extreme clockwise position). Assume no signal being received, which would bring the control grid of the noise suppressor tube to ground potential. The cathode of this tube is sufficiently positive at this setting of the noise suppressor knob to cause cut-off in the tube. No plate current flows. The screen voltage of the type 57 first audio tube is not reduced and the tube amplifies normally. Additional bias voltage impressed on the noise suppressor tube due to a signal has no further effect, as the tube is already at cut-off.

Now consider the movable arm of the noise suppressor potentiometer, R-16, at the extreme right (knob at extreme counter-clockwise position). At this setting the noise suppressing action is at maximum. The cathode of the noise suppressor tube is now negative, relative to the grid. Plate current flows in this tube and the plate voltage drops due to the drop across resistor R-9. The screen voltage of the type 57 first audio tube also drops, as it feeds through the same line. The screen voltage of this tube differs from the plate voltage of the noise suppressor tube only by the drop across resistor R-23. Under "no signal" conditions the screen voltage of the 57 first audio tube is sufficiently low to prevent this tube from amplifying.

When a weak signal (noise) is received, the control voltage applied to the grid of the noise suppressor tube makes this grid more negative. Less plate current flows and the voltage of the plate of the noise suppressor tube and the screen of the first audio tube rises. If the signal is weak, the screen voltage will not be raised sufficiently to allow the first audio tube to amplify.

When a strong signal (station) is received, there is sufficient control voltage to bring the noise suppressor tube to cut-off. This allows the screen voltage of the first audio tube to rise to its full amount and the tube amplifies fully.

The signal once amplified in the first audio tube is fed into a second audio stage coupled to two type 46 tubes in push-pull

GULBRANSEN 322 VOLTAGE DATA

Tube	Fil.	Plate	Screen	Grid	Plate MA.
R-F.	2.4	242	90	4.0 (1)	4.0
1st Det.	2.4	250	86	7.0 (1)	2.0
Osc.	2.4	24	..	0.0	8.0
1st I-F. (2)	2.4	252	90	4.0 (1)	4.0
2nd I-F. (2)	2.4	254	91	3.0	5.7
2nd Det.	2.4	0	..	0.0	0.0
1st A-F.	2.4	65	55	4.0 (3)	0.4
Noise Sup.	2.4	55	20	3.0 (1)	0.0
2nd A-F.	2.4	255	..	14.0 (4)	3.3
Power	2.4	260	260	34.0	23.0
Rect.	2.4	880 volts plate to plate			53.0 (5)

- (1) Read from cathode to ground.
- (2) If i-f. readings are made with a cord and plug, ground the control grid through a condenser to prevent oscillation and motorboating.
- (3) Read across 30-ohm section of voltage divider.
- (4) Read across 30-ohm and 100-ohm section of voltage divider.
- (5) Per plate.

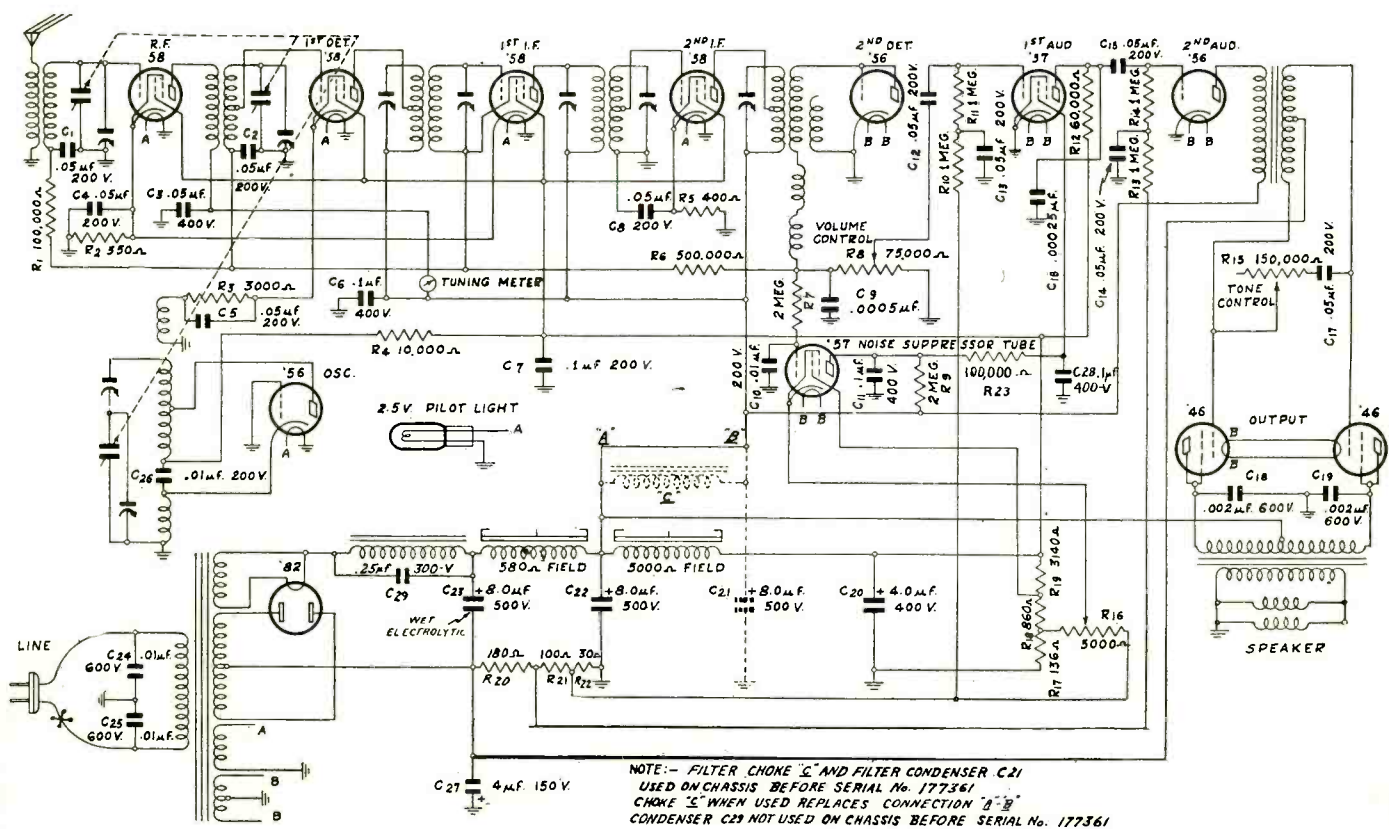

Fig. 1. Schematic diagram of the Gulbransen Model 322 superheterodyne

GENERAL DATA—continued

in Class A connection. Connected in this manner the tubes provide a semi Class B state, at low volume the amplification being Class A under which conditions the harmonic distortion is much less, and at large volume the output changes to Class B in order to get large power output.

VOLTAGE READINGS

Check the voltages at the sockets to see if the power unit is delivering the correct voltages. The antenna and ground should be disconnected and the antenna and ground leads from the set connected together. The noise suppressor knob should be set at maximum while taking these readings.

All of the d-c. voltage readings given in the accompanying table should be taken with a 1,000 ohms-per-volt meter. As high a range as possible should be used.

The voltage table gives the voltages with all tubes in, the speaker connected and the set in operating condition. The readings are based on a line voltage of 115.

CONDENSER ALIGNMENT

For alignment, if necessary, there will be required a signal generator that will provide an accurately calibrated 175-kc. signal as well as accurate signals over the broadcast band. Also an output meter. The procedure is as follows:

Set the signal generator for 175 kc. Connect the signal lead from the signal generator to the grid of the first detector tube through a .05 mfd. condenser. Turn the tuning condenser rotor until the plates are completely out. The ground lead from the signal generator goes to the ground lead of the receiver. Then adjust the five intermediate-frequency condensers for maximum output. The adjusting screws for these con-

densers are reached from the bottom of the chassis.

Next set the signal generator for a signal of exactly 1,400 kc. The antenna lead from the signal generator is in this instance connected to the antenna lead of the receiver. Set the tuning dial of the receiver on 1,400 kc. and adjust the three trimmer condensers on the gang tuning condenser for maximum output, adjusting the oscillator trimmer first. The location of these condensers are shown in Fig. 2.

Next set the signal generator at 600 kc. and adjust the oscillator 600 kc. trimmer. This trimmer is shown in Fig. 2 by the side of the oscillator tuning condenser. A non-metallic screwdriver is necessary for this adjustment. Turn the condenser rotor until maximum output is obtained. Then turn the rotor slowly back and forth over this setting, at the same time adjusting the 600-kc. trimmer screw until the highest output is obtained.

Then set the signal generator again at 1,400 kc. and check the adjustment of the tuning condenser trimmers at this frequency for maximum output.

SETTING NOISE SUPPRESSOR

The action of the noise suppressor is to establish a certain signal strength level below which signals are cut out, and above which all signals come through without being reduced in intensity.

The general method of using the noise suppressor is to first turn the knob to the "Power" or right hand position. At this point there is usually considerable noise received. Turn the knob to the left until the noise is eliminated and then continue to tune the set in the regular manner to whatever stations are wanted.

For distance reception, turn knob towards

"Power." For local reception the knob may be turned well toward the "Quiet" position as the station signals are usually strong.

If the signal of a station is distorted, turn the noise suppressor knob to the right until the signal becomes clear.

Weston Tube Base Chart

The new Weston Model 665 Selective Analyzer employs the standard numbering system for tube-connection reference. The accompanying Tube Base Chart gives all

TUBE BASE CHART FOR USE WITH THE WESTON METHOD OF SELECTIVE ANALYSIS

Tube Base	Tube Base	Tube Base	Tube Base
1 4-7	38 5-2	68 5-2	2A6 6-4
1V 4-7	39 5-2	69 6-2	2A7 7-2
00A 4-1	40 4-1	71A 4-1	2B7 7-3
01A 4-1	41 6-3	75 6-4	5Z3 4-5
10 4-1	42 6-3	76 5-1	6A4 5-3
12A 4-1	43 6-3	77 6-1	6A7 7-2
14 5-2	44 5-2	78 6-1	6B7 7-3
15 5-2	45 4-1	79 6-5	6C6 6-1
17 5-1	46 5-4	80 4-5	6C7 6-4
18 6-3	47 5-3	81 4-6	6D6 6-1
19 6-6	48 6-3	82 4-5	6D7 5-2
20 4-1	49 5-4	83 5-5	6E7 5-2
22 4-2	50 4-1	84 5-5	6F7 7-5
24 5-2	51 5-2	85 6-4	6Z4 5-5
26 4-1	52 5-3	89 6-1	6Z5 6-8
27 5-1	53 7-4	90 6-2	12Z3 4-7
29 6-2	55 6-4	92 6-2	25Z5 6-7
30 4-1	56 5-1	95 6-3	LA 5-3
31 4-1	57 6-1	96 4-7	KR1 4-7
32 4-2	58 6-1	98 5-5	KR2 4-7
33 5-3	59 7-1	99 4-1	182B 4-1
34 4-2	64 5-2	1A6 6-9	183 4-1
35 5-2	65 5-2	2A3 4-1	485 5-1
36 5-2	67 5-1	2A5 6-3	864 4-1
37 5-1			

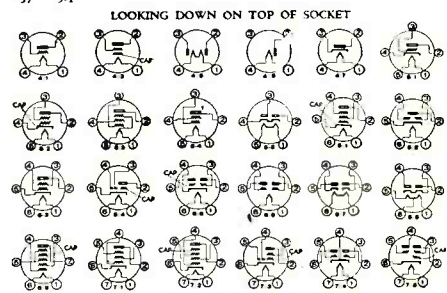

the necessary data on these connections. Note that the connections in each case are those as viewed from the top of the tube socket.

Equivalent Tube Tests

In checking up on tubes in tube testers, the following list of tubes may be considered as equivalent for test purposes. That is, their characteristics under the usual forms of tube testing procedure are so similar that the same values may be used as a check in all cases of tubes listed below as being equivalent.

1V = 1	95 = 2A5
44 = 39	98 = 84
51 = 35	77 = 6C6
64 = 36	85 = 6C7
65 = 39	78 = 6D6
67 = 37	36 = 6D7
68 = 38	39 = 6D7
90 = 29	1 = KR1
92 = 69	LA = 6A4

This is the list as given by Weston in connection with the data on the Model 673 Tubechecker.

Philco Models 35 and 36

Philco receivers Models 35 and 36 are identical. These are battery-operated sets.

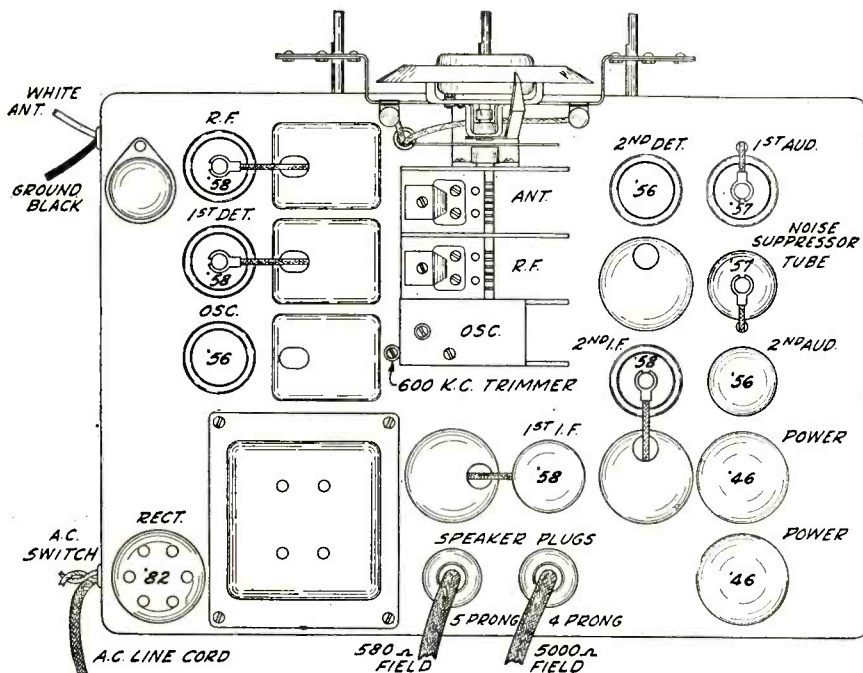
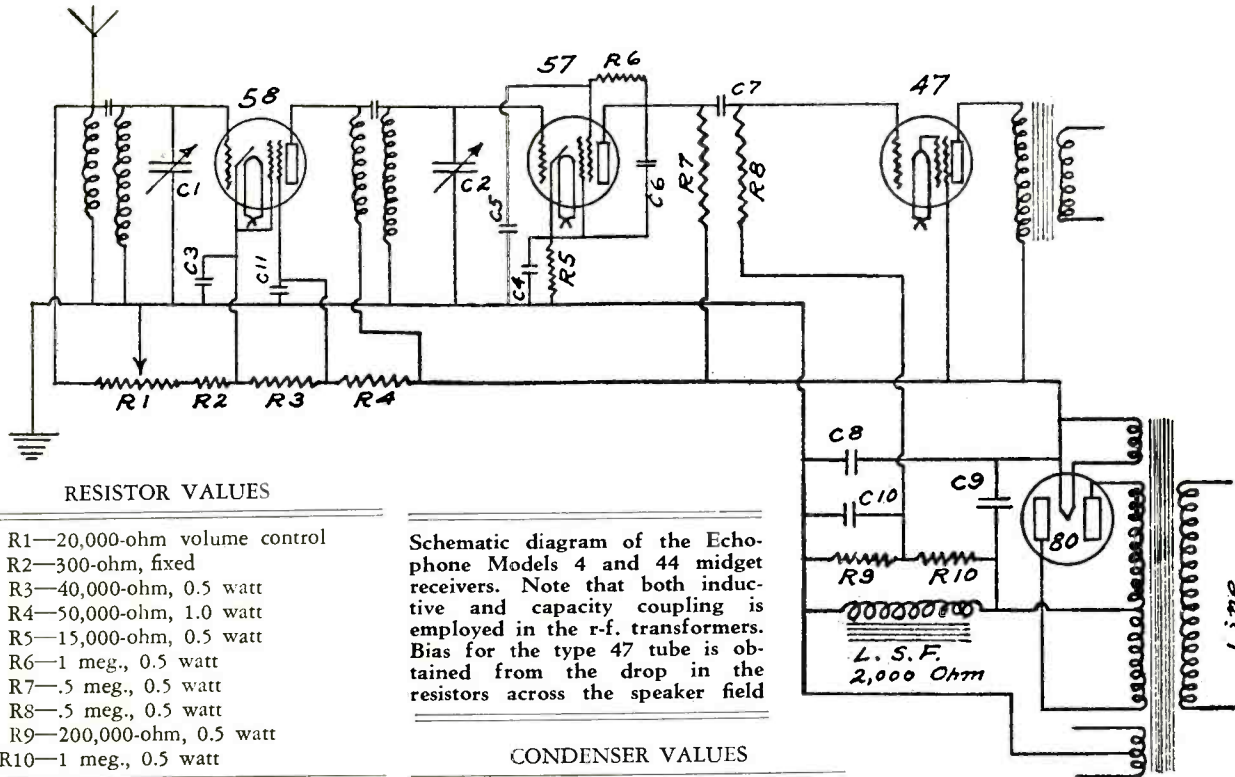

Fig. 2. Chassis of Gulbransen Model 322, showing location of adjusting condensers



RESISTOR VALUES

- R1—20,000-ohm volume control
- R2—300-ohm, fixed
- R3—40,000-ohm, 0.5 watt
- R4—50,000-ohm, 1.0 watt
- R5—15,000-ohm, 0.5 watt
- R6—1 meg., 0.5 watt
- R7—.5 meg., 0.5 watt
- R8—.5 meg., 0.5 watt
- R9—200,000-ohm, 0.5 watt
- R10—1 meg., 0.5 watt

Schematic diagram of the Echo-Phone Models 4 and 44 midget receivers. Note that both inductive and capacity coupling is employed in the r-f. transformers. Bias for the type 47 tube is obtained from the drop in the resistors across the speaker field

CONDENSER VALUES

- C1—.00036 mfd., variable
- C2—.00036 mfd., variable
- C3—.25 mfd., 200 volt
- C4—.25 mfd., 200 volt
- C5—.1 mfd., 200 volt
- C6—.001 mfd., mica
- C7—.01 mfd., 400 volt
- C8—4 mfd., 400 volt
- C9—8 mfd., 400 volt
- C10—.1 mfd., 200 volt
- C11—.1 mfd., 200 volt

Echophone Model 4 and 44

The same chassis is used in both the Model 4 and the Model 44. The circuit is shown herewith and is seen to consist of one stage of high-gain r-f. impedance coupled to the detector. There is a small coupling condenser fastened on the lower end of the r-f. coil. If the set lacks volume, or oscillates at the high-frequency end of the band, a slight adjustment of this condenser will remedy the trouble. After adjusting this condenser the gang condenser should be checked for alignment with the rotor plates nearly open.

The volume control (R-1 and R-2) works by varying the bias on the r-f. tube and at the same time controlling the antenna input to the r-f. tube. R-2, of course, is the bias limiting resistor and is not variable.

The filter consists of an 8 mfd. and a 4 mfd. electrolytic condenser and the 2,000-ohm speaker field. The speaker field is in the negative lead and a part of the voltage drop across it is used to bias the grid of the type 47 tube.

The values of the condensers and resistors are given in the accompanying tables. Tol-

ECHOPHONE VOLTAGE DATA

58 plate to gnd.	245-250	v.
58 screen to gnd.	85-95	"
58 cathode to gnd.	2-3	"
47 plate to gnd.	235-245	"
47 screen to gnd.	245-250	"
57 plate to gnd.	50-75	"
57 screen to gnd.	20-40	"
57 cathode to gnd.	2-5	"
Across spkr. field.	85-95	"
All heaters	2.4-2.6	"
80 filament	4.8-5.2	"
80 plate to gnd.	340-360	"

erances in both cases are plus or minus 10%. The voltage data is also given in a table shown on this page. All d-c. voltages given were tested on a 250-volt, 1,000 ohms per volt meter, with volume control full on and no signal.

New Crosley Peak Frequencies

The i-f peak frequencies for the new Crosley receivers are given in the table below.

Model	I-F Peak
102	181.5
143	181.5
159	456.0
166	456.0
168	181.5
169	456.0
170	181.5
171	181.5
172	456.0
173	456.0
173-5	456.0
174	456.0
175	181.5

The Model 102 listed above is an auto receiver. This receiver is used in conjunction with the Crosley Synchronode "B" Power unit.

It might be added that the same circuit is used in both the Model 173 and Model 173-5 receivers. The Model 173 is for operation on 110 volts d-c. or 60-cycle a-c. The Model 173-5 is for operation on 110 volts d-c. or 25 to 60-cycle a-c. and has a slightly different filter system.

The Model 166 and Model 172 receivers are also identical except that Model 172 is a dual band receiver, covering a portion of the short-wave band as well as the broadcast band.

RCA Victor I-F Peaks

The RCA Victor Models 110, 111, 120, 310, 330 and 331 receivers all employ an intermediate frequency of 175 kc. RCA Victor Model 300 is a tuned radio-frequency job.

Model 330 and 331 employ Class B audio in the output, a type 53 tube being used in each case.

Universal Receiver Servicing

When you service an a-c, d-c. receiver, it is a good idea to place the chassis on a wood board or some insulated surface. Also disconnect the antenna and ground leads to avoid the possibility of any external ground contacts with the chassis.

And, if you don't like shocks—keep yourself ungrounded.

Correction

The example given in the calculation of the formula for tube power output, on page 328 of the September issue of SERVICE is incorrect. Upon calculation it will be found that the answer should be 1.86 watts rather than 2.16 watts, as stated.

Public Address . . .

Variable-Mu Pentodes As A-F Amplifiers

Special Noiseless Gain Control Made Possible

It is well known that the principal advantage of variable-mu tubes generally is that the amount of distortion for a constant output is constant and independent of the grid bias. Let us see what this means. Suppose we wished a given tube to deliver 10 volts of audio signal and that as we increased the signal voltage fed to the tube we simultaneously decreased its amplification so that the output level remained constant at 10 volts. One very simple way of doing this would be to increase the control-grid bias of a variable-mu tube as we increased the input. Since the variable-mu tube has an approximately exponential characteristic, the percentage of harmonic distortion will remain constant in the output.

VARIABLE BIAS GAIN CONTROL

This suggests the possibility of using a variable bias to control the gain of an amplifier instead of employing mixer potentiometers. Let us examine the characteristics of the type 58 tube, which is a variable-mu pentode, to see whether they will fit the conditions. In the first place, we know that since the plate resistance of this tube is almost one megohm and the normal plate current about 8 milliamperes, that we must have a fairly low load impedance if the tube is resistance coupled, since there is a voltage drop in the plate resistor of 8 volts per 1,000 ohms. If we set the maximum d-c. voltage drop in the plate resistor at say 200 volts, then the load resistor would be only 25,000 ohms. We might of course use a choke coil to supply the plate voltage to relieve this condition, but even with a 400-henry choke the loss at 50 cycles would be 2.5 db. for a load resistor of 25,000 ohms.

Considering all points, resistance coupling, such as shown in Fig. 1, or a load resistance shunted by a step-up interstage transformer,

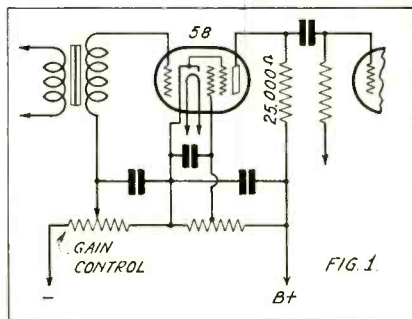

A type 58 used as an a-f. amplifier. Note that the gain control is in the cathode circuit

as shown in Fig. 2, would give best results. From the practical standpoint, the circuit of Fig. 2 is to be desired.

CHARACTERISTICS OF TUBE

The gain of a tube operated into a load impedance small compared to its plate impedance is proportional to its mutual conductance. Now for small inputs we would operate at high gain and therefore at high mutual conductance, and at large inputs at low gain and low mutual conductance. We need a tube in which the mutual conductance changes rapidly with grid voltage at small grid biases and more slowly at large grid biases. If the tube were truly exponential, then the mutual conductance plotted in db.—which would give the same shaped curve as gain plotted in db.—plotted against grid bias would be a straight line. From the curves of the type 58 it will be found that this is nearly true for this tube. Actual tests show that the second and third harmonics are negligible when the grid bias of the type 58 tube is varied over a range of about 2.5

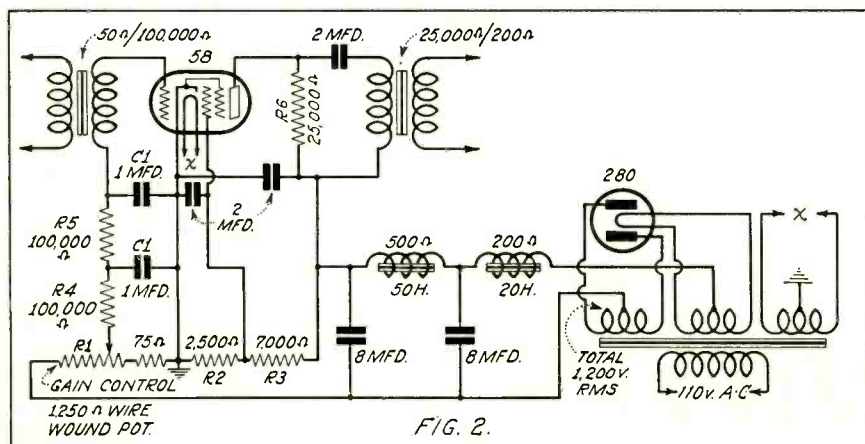

Here is the complete circuit of an excellent pre-amplifier, using the noiseless gain control described in the accompanying article

volts to 35 volts. Over this same range we may change the gain some 40 db. As a matter of fact, the total harmonic content of the output when the signal voltage applied to the grid is not over 3 volts, is less than 3 per cent for a constant output when the grid bias is varied from 2.5 to 50 volts. This corresponds to a change in gain of nearly 60 db. These figures of course only hold when the applied signal is small and the load impedance applied to the plate of the tube is less than 30,000 ohms. We have previously shown however that a 25,000-ohm load resistor is about as large as we can use from other considerations. Even under these conditions a voltage gain of about 32 db. can be realized at a grid bias of 2.5 volts (i.e., $\frac{1,600 \times 25,000}{1,000,000} = 40$ or 32 db.)

$$\frac{1,600 \times 25,000}{1,000,000} = 40 \text{ or } 32 \text{ db.}$$

DESIGN OF PRE-AMPLIFIER

Now let us design a pre-amplifier to operate from a high-quality microphone such as the ribbon mike, and to have a gain of 30 db. Let us suppose that a level of 30 db. (6 watts) is to be delivered to the loudspeakers. The usual main amplifier for public-address work has a gain of 80 db. and about 5 per cent harmonic distortion at full load. In an article on page 322 of the September issue of SERVICE, it is shown that if the total root mean square harmonic output of a system is less than 7 per cent for a system having a frequency range of 8,000 cycles, no one is the wiser. Therefore, if the harmonic content of the pre-amplifier does not exceed 4 per cent, the total will be less than 7 per cent (i.e., $\sqrt{4^2 + 5^2} = \sqrt{41} = 6.4$ per cent). We know that the output of ribbon and other high-quality mikes is about minus 80 db. Therefore, the pre-amplifier must have a gain of over 30 db. Such an amplifier is shown in Fig. 2. The total gain of this pre-amplifier is 38.5 db.

ADVANTAGES OF BIAS CONTROL

A precaution we must observe in this pre-amplifier is that a large current flows through R-1, R-2 and R-3 so that the change in plate current of the tube flowing through R-1 will not prevent a linear potentiometer from having a linear characteristic. With this taken care of we can thus arrange for one type 58 tube to replace two type 56 tubes which are normally used for a pre-amplifier, and in addition include the mixer potentiometer in the pre-amplifier proper. This latter feature has one decided advantage aside from the fact that it is a much cheaper arrangement. It is that since the variable gain element is removed from the program circuit (the actual amplifier circuit handling a-f.) it can cause no clicks or other noise. All such noise is effectively filtered out by the two-section resistance-capacity grid filter (R-4, R-5, C-1, C-2). Moreover, the contact resistance of the potentiometer arm to the wire is of no importance (unless it is open) since no current flows through this contact. Therefore the potentiometer requires practically no maintenance. The usual mixer potentiometer however, being directly in the program circuit, must be carefully chosen and carefully maintained to prevent noise since the slider does carry signal current, and small

(Continued on page 368)

FREE!

New 64-PAGE HANDBOOK

*of Servicing facts and
Short-cuts!*

Here's a new free booklet every service man will find invaluable! Contains practical information and servicing tips that service men all over the country have sent to us. Shows how to solve many tough problems... saves you time and money!

Mail the coupon today and get your copy. We'll also put your name on the mailing list for Sylvania's free monthly Service Bulletin. It gives additional service tips each month... and tells how you can earn free tubes for your own suggestions!

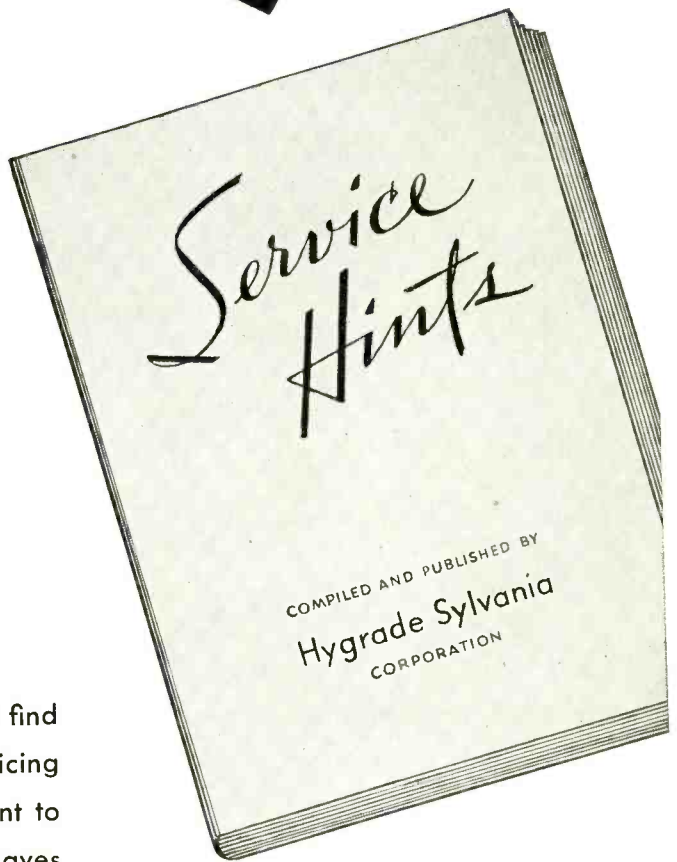

HYGRADE SYLVANIA CORPORATION

Makers of
Sylvania Tubes Hygrade Lamps Electronic Devices
FACTORIES
Emporium, Pa. St. Marys, Pa. Salem, Mass. Clifton, N. J.



Sylvania
REGISTERED U.S. PAT. OFF.
THE SET-TESTED RADIO TUBE

Hygrade Sylvania Corporation C 5
500 Fifth Avenue, New York, N. Y.
Please send me your free booklet "Service Hints"
and your free monthly Service Bulletin.
Name.....
Address.....
City.....State.....

Auto-Radio

Majestic Model 66 (Twin Six) Super

Here is a very good example of a modern auto-radio. It is a good reflection of the general trend in design by set manufacturers. In the first place, advantage is taken of two distinct types of dual-purpose tubes, one being the 6A7, which is modulator and oscillator combined in one envelope, and the other being a combination diode second detector and intermediate audio amplifier.

Two other points of considerable interest are the delayed automatic volume control, which does not detract from the sensitivity of the receiver except when actual control is required, and second the dual tip jacks which make possible the addition of a magnetic speaker without in any way reducing volume or affecting the operation of the dynamic speaker. Thus a magnetic speaker may be used in the back of the car or brought out by long leads to a camping spot, etc.

THE CIRCUIT

The i-f amplifier is peaked at 175 kc. A stage of r-f preceding the modulator (making a three-gang tuning condenser) assists in eliminating the possibility of image reception. Even response over the broadcast band is obtained by the use of both inductive and capacitive coupling between antenna and r-f stage and between r-f stage and modulator, as indicated by the open-end coils.

It should be noted that full automatic

volume control takes place on three tubes; i.e., the r-f, the modulator section of the 6A7 and on the i-f tube.

DELAYED AUTOMATIC VOLUME CONTROL

The audio detection and automatic volume control are obtained from the diode circuit by the "delayed rectification method." In this method the diode plates operate at somewhat negative bias so that no AVC results until a certain signal level has been reached. This results in much higher outputs at low signal levels (important in auto-radio receivers) than in the ordinary meth-

ods of AVC, since the set is left in its most sensitive condition until reasonable power output has been obtained. In the old methods of AVC any input signal at all starts to decrease the sensitivity of the set.

On Model 66 receivers bearing serial number 16,000 and up a switch is located above the tone control which is connected across the 10,000-ohm resistor, R-9 and the 0.25-mfd condenser, C-14. To bring in distant or low-powered stations the switch is turned to the right, in which position R-9 and C-14 are shorted out and an apparent increase in sensitivity will be noted.

SERVICING

The accompanying schematic diagram includes tables of resistor and condenser values. Voltage readings are in a separate table. Undervolt socket connections are also given.

The voltage values given are based on a storage battery voltage (under load) of 6.3 (Continued on page 360)

MAJESTIC 66 VOLTAGE VALUES

	Plate Volts			Screen Volts			Cathode Volts			Grid Volts		
	5.5	6.3	7.5	5.5	6.3	7.5	5.5	6.3	7.5	5.5	6.3	7.5
Battery Volts	5.5	6.3	7.5	5.5	6.3	7.5	5.5	6.3	7.5	5.5	6.3	7.5
R-F (6E7)	182	217	256	88	99	109	8.0	9.3	12.5	8.0	9.3	12.5
Mod. (6A7)	182	217	256	88	99	109	2.7	3.4	4.2	2.7	3.4	4.2
Osc. (6A7)	88	99	109	—	—	—	—	—	—	7.0*	8.0*	8.0*
I-F (6E7)	182	217	256	88	99	109	8.0	9.3	12.5	8.0	9.3	12.5
A-F (6C7)	51	60	61	—	—	—	7.5	9.2	9.5	1.8	2.2	2.3
Power (89)	177	209	248	184	218	257	—	—	—	23.0	27.0	35.0

*Measured with 300,000 ohm meter.
All voltages measured with no input signal.

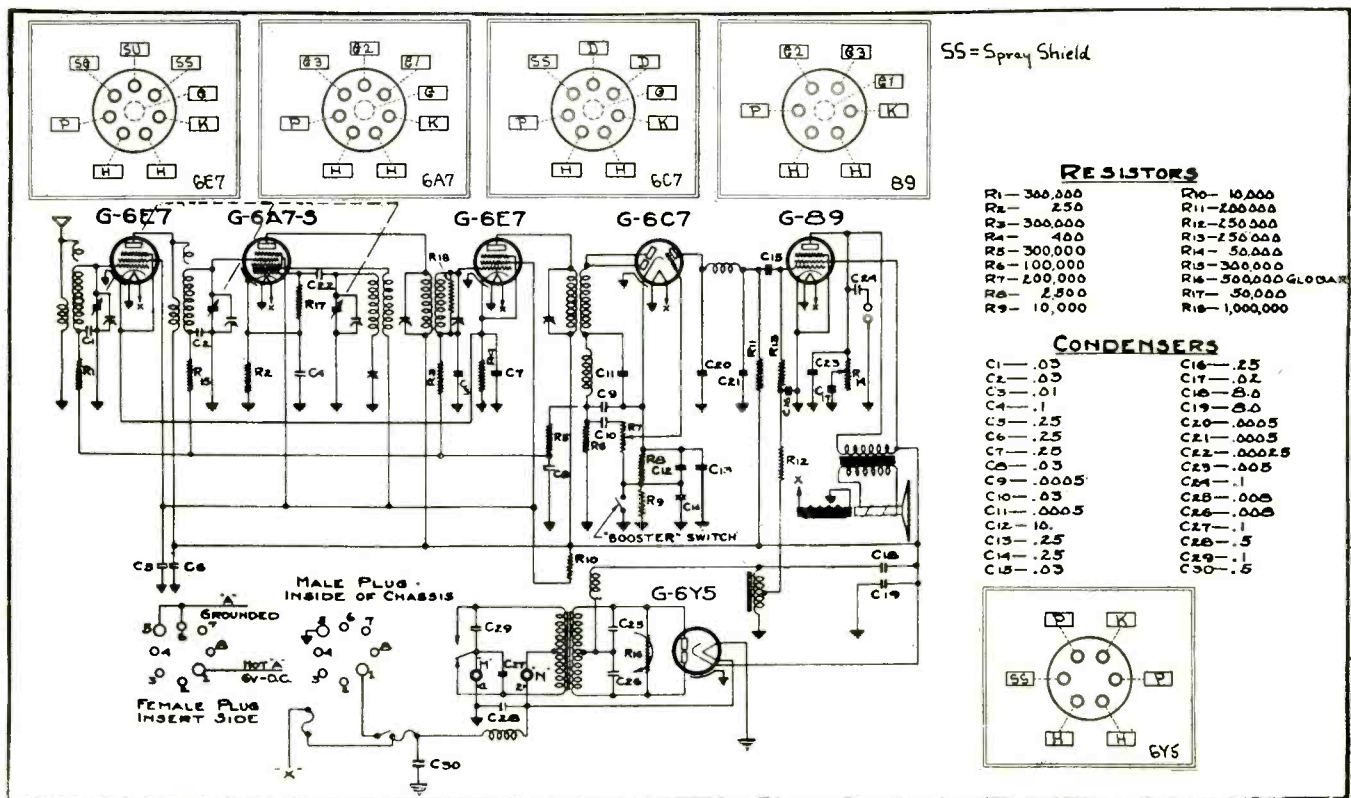

BROAD-BAND

Finer quality now practical in radio receivers with the new Racon Reproducers designed to cover the broad audio spectrum up to 12,000 cycles.



The Dynamic High-Frequency Loudspeaker illustrated is intended for use with a suitable low-frequency loudspeaker and the Racon Filter Network, to obtain broad-band reproduction. The response level of the H.F. unit is correct for acoustic balance with all commercial types of low-frequency reproducers. It does not accentuate or peak the upper band but faithfully reproduces all high-frequency components in the source.

This new unit can be effectively used in high quality radio receivers. Correspondence is invited.

Write for descriptive data S10.

RACON ELECTRIC CO. INC.

52 East 19th St., New York, N. Y.
London, Eng. Toronto, Can.

POINT to POINT



DAYRAD

Order this Dayrad Series 71 Test Box from your regular jobber . . . the price to service men is only \$13.60.

Write for our new catalogue of service instruments, tube checkers, test oscillators, Volt Ohmmeters, etc.

We use the Octo Connector. . . Your best assurance against obsolescence.

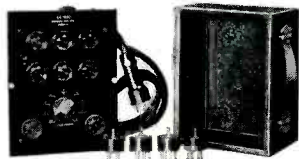

The RADIO PRODUCTS CO.
FIFTH AND NORWOOD DAYTON, OHIO

TESTING with your old ANALYZER

The Dayrad Series 71 Test Box permits point to point testing with your present equipment . . . no need to discard old analyzers.

This Series 71 Test Unit furnishes an auxiliary test instrument which permits point to point testing as well as voltage-current analysis on all types of circuits . . . used with your present analyzer or test set.

AN OPEN LETTER to the SERVICE MEN of AMERICA:

Dear Fellow Collaborators:

Please pardon the familiarity and that four dollar word, "collaborators," but we feel that we have a lot in common and that your success and ours depends on working together.

We have got to promote work for you and supply you with the finest products that engineering skill and manufacturing facilities can produce. It is our duty to simplify your task of servicing radio receivers so that your profit is not reduced in the least.

We have been told that OHIOHM RESISTORS are giving service men the ultimate satisfaction. They tell us they like the uniform quality, the clear markings, the protect-o-packed feature. They are equally pleased with OHIOHM SPARK SUPPRESSOR SETS for eliminating ignition interference on auto radios. We have been commended for our FIRST AID RESISTOR KITS.

We could perhaps afford to rest on our laurels. But we will not let a day pass without attempting to improve product and service.

We are dependent on you and your goodwill. We hope that by aiming to promote your success we will promote our own. If that's a selfish attitude, let's both be more selfish.

Sincerely yours,

THE OHIO CARBON COMPANY,
12508 Berea Rd., Cleveland, Ohio.

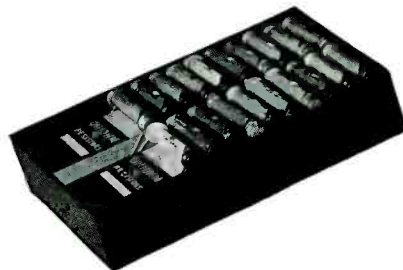

OHIOHM RESISTORS

volts. Thus, the plate reading for the r-f 6E7 tube should be approximately 217 volts when the storage battery voltage is 6.3 volts. With the storage battery voltage at 5.5 the approximate reading would be 182 volts, and 256 volts for a storage battery potential of 7.5 volts. The grid volts on the oscillator section of the 6A7S should be read with a 300,000-ohm meter.

In reference to the vibrator power unit, when the A+ of the storage battery is grounded, vibrator lead No. 1 (blue) should connect to terminal "M" (vibrator armature) and lead No. 2 (black) should connect to transformer primary center tap (terminal "N"). When A — is grounded reverse above connections.

In some of the earlier models of the 66 receiver, resistor R-2 has a value of 400 ohms and resistor R-4 a value of 120 ohms. There are also two resistors, each with a value of 69 ohms, in series with each side of the vibrator circuit. Some of the earlier models—below serial numbers 16,000—do not have the booster switch.

layed AVC in this issue). The diode plate D-1 is used for AVC only, the i-f. voltage being picked off the plate of the i-f. tube. The diode plate D-2 is in the audio circuit which also includes a choke to keep i-f. out of the grid circuit of the triode portion of the type 85 tube. The plate circuit of the triode feeds an input push-pull transformer which is in circuit with two type 41 pentodes.

The volume control is in the grid circuit of the triode portion of the type 85 tube. This can be traced through the chassis connector socket, the speaker plug, and thence through the speaker connector socket and remote control plug.

The control unit, of course, contains the on-off switch, pilot light and volume control. The speaker unit contains not only the entire speaker assembly but also the tone control switch which throws condensers in and out of the output transformer circuit.

The power-supply unit consists of a dynamotor and a filter system comprising filter chokes and capacities for both the "A" and "B" circuits.

has but one condenser adjustment, this being the condenser A-6 shown in the diagram.

All testing values are given on the diagram. Socket connections are also included.

Eliminating Vibrator Hash in Stewart-Warner Model 112

Occasionally a Model 112 auto-radio chassis may be found in which the vibrator creates electrical interference known as "vibrator hash". This type of interference is similar in character to that caused by the ignition system but can be readily distinguished from the latter since it is present *when the engine is not running*. Vibrator hash may be eliminated as follows:

- (1) Remove the chassis from the metal cabinet.
- (2) With a heavy soldering iron, solder the top of the transformer-vibrator housing to the sides, making sure that you run a complete ring of solder clear around all four sides.
- (3) Check to see that bottom cover is soldered to the side at least at one point.

ALIGNMENT DATA

A.K. Models 756 and 756-B

As will be seen from the accompanying diagram, these receivers are composed of four sections; the receiver proper, the volume control unit, the speaker unit and the power supply unit. These four units are interconnected by plugs and special terminal strips.

Referring to the diagram, the receiver unit consists of a stage of tuned r-f., detector-oscillator, i-f. stage, a type 85 tube which functions as second detector, automatic volume control and a-f. amplifier. Note that the plates of the diode portion of this tube are used separately (also see Majestic 460 De-

This receiver may be aligned and peaked in the usual manner. The intermediate frequency employed is 262.5 kc. The trimmer condensers A-1, A-2 and A-3 are adjusted from the top of the gang condenser unit. When facing the gang condenser shaft, trimmer condenser A-1 is nearest the front, A-3 the next and A-2 to the rear. The i-f. adjusting condensers A-4, A-5 and A-6 are mounted in the i-f. transformer shields and are reached from underneath the chassis. The i-f. transformer T-4 has both primary and secondary adjustments but the other unit is an i-f. plate choke, or impedance, and

USE OF CONDENSERS

These steps should eliminate practically every complaint of this trouble. However, an occasional set may be found where soldering the cover fails to completely cure the trouble. In such cases the addition of two .25-mfd. 100-volt condensers connected across the vibrator contacts will eliminate the noise. These condensers may be installed in the chassis as follows:

- (1) Remove the two self-tapping screws used to hold the transformer-vibrator housing to the bottom cover.

(Continued on page 368)

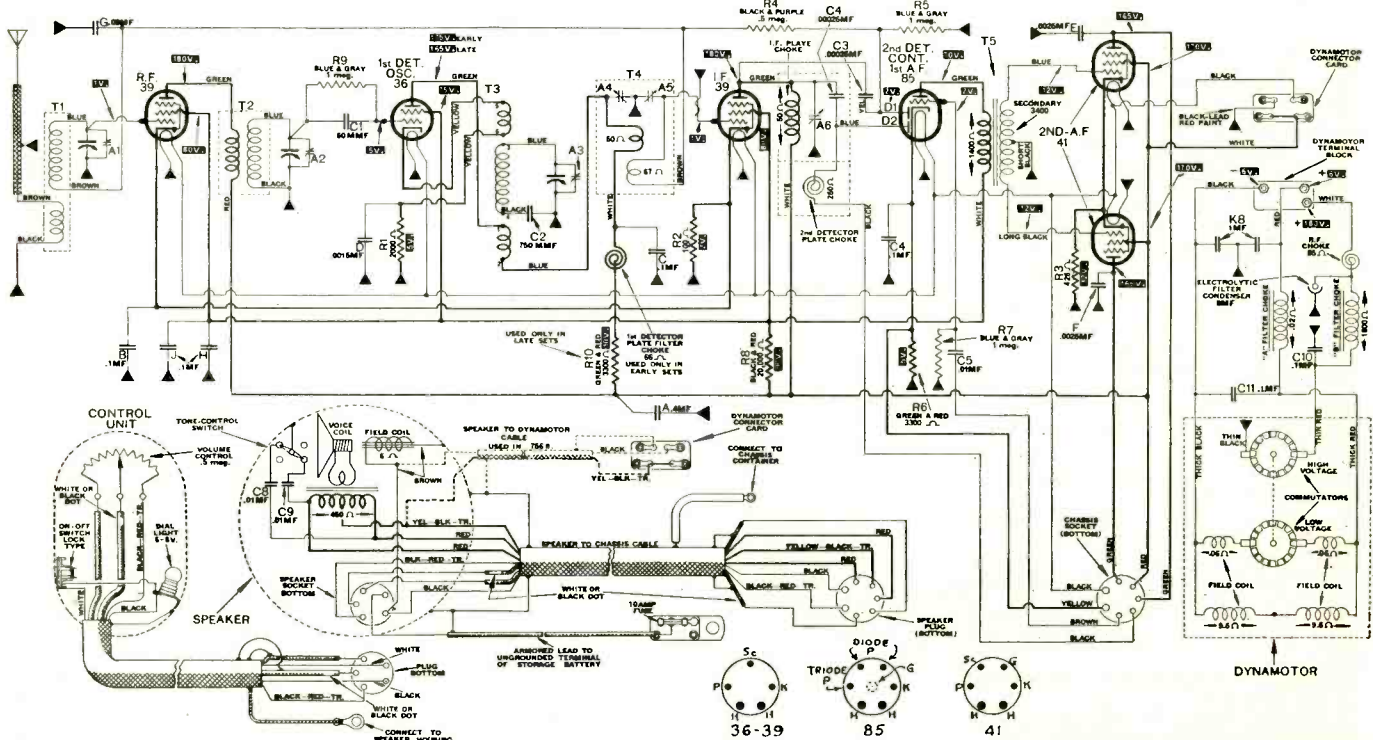

Complete diagram of the Atwater-Kent Models 756 and 756-B receivers

MULTI-TAP UNIVERSAL OUTPUT and INPUT Audio TRANSFORMERS

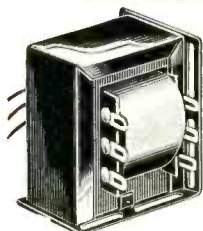

No. 1337

MULTI-TAP OUTPUT

The Universal primary and the tapped secondary, from 2 to 30 ohms in 2 ohm steps, makes it possible to feed practically any straight or push-pull output stage to any dynamic speaker.

Universal—Physically may be mounted on end or side. Slots in base allow wide range of adaptability without redrilling panel. Overall dimensions: 2" x 2 3/8" x 1 5/8". Mtg. Centers: 1 1/4" x 1/2" to 1-9/16" or 1 1/4" x 1/2" to 1 1/8". Indispensable for Service Engineer's Emergency Stock.

UNIVERSAL INPUT AUDIO

can efficiently feed any straight or push-pull audio stage on either A. C. or D. C. sets. A wide range of adaptability physically is made possible through the slotted end and side mounting bracket. Service Engineers should always have one or more in their emergency stock. Dimensions same as Output Transformer.

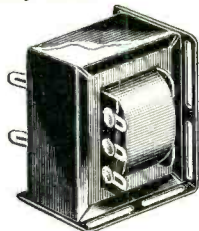

No. 3205

FREE! "GENERAL" Illustrated and fully descriptive BULLETIN!

with complete list of 1,377 models and makes of radios on which you can replace power units out of a stock at an investment of only \$23.25 (list) in 4 models Multi-tap Universal Power Transformers with Multi-tap Output and Input unit.



GENERAL TRANSFORMER CORP.

502 So. Throop Street

Chicago, Illinois

Make More Calls
at LOWER Cost . . .

with the *Readrite*

No. 710
Tester



THIS popularly priced tester is just what you have been looking for! It fills every need of both the expert serviceman and the radio beginner. It is designed to operate accurately under the hardest kind of service.

The No. 710 Tester is designed for the testing of both new and old radios. It handles the most advanced circuits and newest tubes. It is equipped with a practical selector switch for checking all parts of tube circuits by connecting to the set sockets. Selection for testing voltage of plate, grid, cathode, suppressor grid and screen grid is quickly and accurately done. Plate current, filament volts, line and power supply volts, resistance and continuity are measured. Battery is used for continuity testing of transformers, chokes, etc.

The No. 711 Tester is the same as the No. 710 except that it is equipped with the new Triplett D'Arsonval Volt-Ohmmeter, which has 1000 ohms per volt resistance.

Your Jobber Can Supply You

. . . with the No. 710 Tester at the Dealer's Net Price of only \$16.50 See him today.

READRITE METER WORKS

87 College Avenue

Bluffton, Ohio



SEND COUPON FOR FACTS!

READRITE METER WORKS
87 College Avenue, Bluffton, Ohio

Gentlemen:

Send me catalog on Readrite No. 710 Tester, as well as folder giving proofs of Readrite Leadership.

Name

Street Address

City

State

Have you tried the NEW
CONTINENTAL SUPER-WATT?

The SAFE replacement for all resistor failures!

Don't take needless risks with units of doubtful quality—look for the GREEN Continental Label.

Now all Continental jobbers are stocking the new SUPER-WATT. The three-watt rating, negligible voltage and temperature coefficients and exclusive noise-free one-piece construction assure dependable performance.

Continental SUPER-WATTS are available in values up to 5 megohms, and are pressure molded to produce everlasting "Carborite" units. 1000-volt insulation eliminates danger of sub-panel shorts. Cellophane wrapped to reach you in perfect condition.

Write for free literature and a name of nearest jobber.

ELIMINATE AUTO RADIO IGNITION INTERFERENCE

CONTINENTAL SUPPRESSORS
New Continental Flexo-Terminal Spark Plug Suppressor fits all cars and eliminates the need for carrying numerous types in stock. Isolantite housings withstand most severe service without breakdown.

NOISE-FILTER CONDENSERS
These vibration and heat-proof condensers filter out noise at the generator and breaker points. Many manufacturers suggest placing these filter units across lighting wires running near roof and under-car antennas.

CONTINENTAL CARBON Inc.
13912 LORAIN AVE. CLEVELAND, OHIO
Canadian factory Toronto, Ontario

Please send literature on the complete Continental Line. Name Address City State

ASSOCIATION NEWS . . .

Radio Dealers and Servicemen's Association (Calif.)

This association is in San Francisco, California, and was organized in March of 1933. They now boast of a membership of 70 per cent of the men engaged in radio in that city.

The slogan of the "R.D.S.A." is simple and to the point: "For the Betterment of the Ethics of the Radio Profession."

Address all communications to Mr. A. V. Tobey, Secretary, R.D.S.A., 238 Gough St., San Francisco, Cal.

Radio Service Association (Iowa)

The Radio Service Association, of Sioux City, Iowa, was organized in August and already has 30 members. Just another proof that associations are desirable.

Address all communications to Mr. T. J. Morris, President, 1305 South Cornelia St., Sioux City, Iowa.

Akron Radio Service Men's Association (Ohio)

Here is an association formed last January with a membership of 25 Service Men who represent the largest radio stores and radio departments in Akron.

Another association whose members are exchanging information. This is a fine idea and should be of great help to members in any association.

Address all communications to Mr. C. D. Gahagan, 1021 North Main St., Akron, Ohio.

Radio Technicians' Guild (Mass.)

The Radio Technicians' Guild was formed in 1931 and chartered in 1933. They have an emblem representing an oscillatory circuit traveling over the earth's surface on the wings of Mercury.

This association has a membership of 50. Meetings are held in the Hotel Lenox, Boston, Mass., on the fourth Monday of every month, and all Service Men are cordially invited to attend. Meetings generally include a lecture and an open forum where the boys discuss their particular problems for the interest and education of everyone.

While headquarters are in Boston, the association has members in Everett, Medford, Arlington, Cambridge, Hudson, Worcester, Revere, Malden, Lynn and Salem.

Address all communications to the secretary, Mr. Howard W. Stockbridge, 26 Reed Ave., Everett, Mass.

Associated Radio Craftsmen (Texas)

This association has been in existence for the past two years. It was originally formed in Houston, Texas, but is now practically a state-wide organization. Address all communications to Mr. John Wiley, Jr., 1401 Heights Blvd., Houston, Texas.

A NEW DEPARTMENT

ASSOCIATION NEWS is to be a regular feature in SERVICE from now on. New radio service associations are springing up all over the country—many through the general influence of the NRA.

If you are not a member of the group in your locality, you will want to join up. This department will assist you. If you are already a member, you will want to know what the other groups are doing to better conditions in the radio service field. This department will tell you.

We earnestly desire all associations, and chapters of associations, to keep us informed on meetings, new regulations and trade practices adopted, etc., for publication in this department. This form of editorial cooperation will help everyone.—THE EDITORS.

Associated Radio Craftsmen have two membership classifications. There are members and associate members. The men are graded according to their knowledge which is determined by an examination with a passing mark of 80 per cent.

Mr. Wiley informs us that trade abuses have been corrected in a great many cases, that giving trade discounts to those not entitled to them has been practically stopped, and a true information exchange for members set up. He says, "Cooperation among our members is something we are very proud of."

Saginaw Radio Service Association (Mich.)

There are 24 full-time Service Men already members. Officers are: Dale Hoag, President; Bertram Nederveldt, Vice-President; Truman Radke, Treasurer.

Address all communications to Wallace A. Youmans, Secretary, Saginaw Radio Service Association, 413 Gallagher Street, Saginaw, Mich.

Radio Service Men's Association (Ind.)

The Radio Service Men's Association, of Evansville, Indiana, was organized in August, 1931. A very progressive group. Address all communications to E. Lloyd Whitmer, Secretary, Radio Service Men's Association, 10 N.W. Second St., Evansville, Ind.

Mr. Whitmer has this to say about the R. S. M. A.

"Local organizations are the only solutions to local problems confronting radio Service Men. Accomplishments of this association have been: a booth at the local radio show, a unit in local parades, recognition of Radio Service as a profession, obtaining standard discounts on parts from local distributors, terminating "cut-throat" competition in tube sales, obtaining recognition and statements of cooperation from manufacturers, obtaining recognition also from the head of the local

NRA committee by having a member appointed as a representative of the Service Men.

"The days of 'fist-shaking' at each other are nearly over in Evansville, for now members even call each other for information."

Mr. Whitmer adds a good pointer. . . "A tip in organizing such a group—in the interest of the profession, keep it above the level of a labor union."

Associated Radio Servicemen

Covers a number of counties in South Carolina. Headquarters located at Greenville. Will the secretary kindly give us full particulars and address?

Radio Service Dealers of Southern California

This association is made up of members who derive their chief source of income from service work. The association cooperates fully with the organized jobbers and distributors in their area.

Communications should be addressed to Melvin O. Kappler, President, Red Man Radio Service, 9732 Santa Monica Blvd., Beverly Hills, California.

Philadelphia Service Men's Association

A newly formed association and already going strong. Communicate with Harry R. DeLong, Philadelphia Service Men's Association, Philadelphia School of Wireless, 1533 Pine Street, Philadelphia, Pa.

RCA Victor Schools

RCA Victor Co., Inc., is conducting schools throughout the country during the latter part of October. The schools are for the purpose of familiarizing Service Men with the products of the Camden plant and for creating a better understanding of the problems involved. Close cooperation is being maintained with the local parts of the I. R. S. M.

I. R. S. M. Chicago Convention

The Chicago convention of the Institute of Radio Service Men is being planned. Dates will be selected in the near future and will quite likely fall either the last part of January or the last of February.

I. R. S. M. Cleveland Show

An announcement has been received from the Cleveland Section of the Institute of Radio Service Men that that group is holding a Trade Show on the evening of October 23. The information available indicates that the show will be open from 6:00 p.m. to midnight at the Hotel Statler.

GIVE SERVICE *with a*

Here is the Best **SMALL INVENTORY**
Volume Control Proposition on the Market : : :

Here are the reasons why!

1. Over 400 "exact duplicate" controls in the "X" SERIES.
2. Yet with SIX controls in the original AD-A-SWITCH SERIES 477 sets can be serviced.
3. By combining controls in both lines any requirement can be met with minimum stock investment.
4. CLAROSTAT with its two separate lines offers the widest range of controls to choose from.
5. CLAROSTAT CONTROLS are inseparable from Quality Service Work.

CLAROSTAT "X" line has over 400 controls to choose from—exact as to electrical overall resistance, taper, bushing, shaft length, and will fit into exact space in set.

CLAROSTAT AD-A-SWITCH line comprises the maximum utility with minimum stock investment. Series W (Wire Wound) obtainable from 50 to 50,000 ohms. Series C (new composition element) obtainable from 10,000 to 5,000,000 ohms. Both lines obtainable in all tapers—insulated shaft 1½" long. Wide use is indicated as follows: W-28 will service 128 sets; C-28, 106 sets; W-29, 77 sets; C-59, 66 sets, etc., etc.



NEW CONTROL REPLACEMENT GUIDE UPON REQUEST.

CLAROSTAT Mfg. Co., Inc.

287 North 6th Street, Brooklyn, N. Y.

"AD-A-SWITCH" was originated by Clarostat

TAU-REX Meter RECTIFIER

Converts any D. C. Milliammeter into a Sensitive A. C. Meter

Will Pay for Itself Many Times!

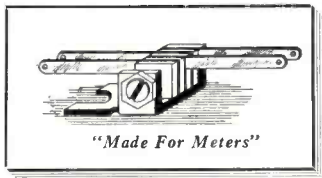

Can be used in Set Testers, Analyzers and for many other purposes. Specified for the Universal Analyzer in October issue of Radio-Craft. Size only ¼ in. by ¾ in. FULLY GUARANTEED. Furnished complete with diagrams and instructions. Price \$3 postpaid. Send money-order, check or pay postman.

MASTERDIAL installed on any 0-1 D.C. Milliammeter permits one to read Sixteen A.C. and D.C. Voltage, Resistance and Capacity ranges instantly and accurately. The first really important improvement in meters in many years. Price \$2.75 postpaid.

Engineers, Service Men, Dealers: Send for interesting, useful free data.
LEO TAUSSIG, 32-45 37th St., Long Island City, N. Y.

VAN Shunts and Dials

EXTEND RANGE of YOUR METERS

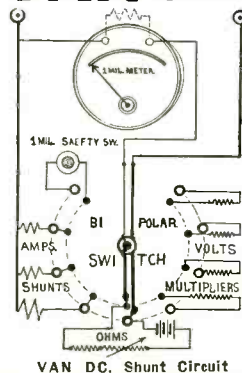

By using the VAN DC. circuit, shunts, multipliers and dials many combinations of current resistance and voltage values can be measured. Thus you can very economically broaden the scope of and increase the efficiency of your present meters.

A VAN AC-DC. blue print gives you a wide combination such as series multipliers, 3 ranges of DC. ohms, high, medium and low; and AC. voltages, output and components. Capacity can be measured by use of charts. (VAN Pocket Meter.)

VAN accessories are very light and accurate. Circuit diagram with every shunt and dial. Much valuable data covering these subjects is included in our descriptive literature. Write for your free copy today.

D. L. VAN Leuven

410 E. 15th Street New York City

THE

SOURCE of SUPPLY

FOR

SOUND AMPLIFYING

EQUIPMENT

Everything from the small Portable Public Address outfits to large Rack and Panel combinations for theaters, auditoriums and schools.

All types, sizes and prices of units for indoor and outdoor fixed or movable installations—many of them carried regularly in stock ready for immediate delivery.

Mixing Panels, Transformers, Booster Devices, Centralized Control Assemblies, Radio and Phonograph, Screen Grid Audio, Pentode Amplifiers—and special equipment built to order.

Whatever the requirements of the radio dealer, service man or engineer, he can usually fill them here; at a fair price and *immediately* without wasting time tinkering or hunting around.

Back of every unit in this wide, well balanced line is the Webster laboratory and the Webster guarantee.

Therefore when in the market for sound amplifying equipment save yourself time and "grief" by coming or writing direct to Webster.



NOTE Send for our complete catalog so you will have it handy for reference. Mailed on request.

THE WEBSTER COMPANY

3825 West Lake Street
CHICAGO, ILLINOIS

ON THE JOB . . .

Handy Trouble Light

Trouble inside of a radio receiver can often be located by the use of a trouble light of the type shown in the accompanying illustration. Shorted variable condensers and broken connections are especially easy to find by the use of a light.

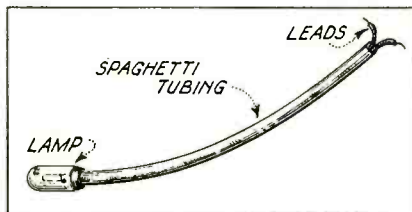

For seeing in dark places . . .

To make this useful trouble-finder, a flashlight or pilot lamp of the same voltage rating as the filament supply in the set is connected to two long, flexible leads. A six-inch length of large-size spaghetti tubing is slipped over the leads and down to the lamp. The spaghetti serves the double purpose of acting as a protection to the wires and as a handle for moving the lamp to different positions in the set.

The lamp should be soldered to the wires, and then the tubing slipped down to cover the metal base of it. A bit of tape will hold it in place. The ends of the two leads should be connected to the terminals of the filament supply in the set. For the sake of convenience, small spring battery clips can be attached to the free ends of the leads.

The trouble light can be placed in any position without the danger of its short-circuiting any leads in the set.

George Mark.

AVC Correction

In the article, "Adding AVC to Sets", by R. H. Koch, appearing on page 330 of the September issue of SERVICE, the AVC lead in the diagram of Fig. 1 is incorrect. The diagram shows this lead as coming from the grid circuit of the detector tube. Instead of connecting to the right side (grid side) of the 1-megohm resistor, it should connect to the left side. Thus, this lead would connect in between the resistor and the condenser.

Finding the Ground

When taking a chassis from the customer's house to the shop we usually tie a knot in the ground lead in order to be able to identify it easily when the set is returned. In case this is forgotten, or one is not reasonably sure which connection is the ground, the following method may be used.

Connect your test leads to an a-c voltmeter which reads 100 volts or more. Place one of the test prods in one of the slots in the female a-c outlet, touch the other test prod to one of the two wires from the receiver under question. If there is no deflection on the meter, touch the other wire.

If you still get no reading place test prod in other slot of the a-c outlet and repeat above process. As soon as you get a reading you know you have located the ground lead.

If no a-c meter is available an ordinary 110-volt lamp in series with two pieces of wire may be used.

C. King.

Victor R-32 and RE-45 Short

With ground wire disconnected and switch on, the tubes would not light. Set went into perfect operation when ground wire was replaced. Set would also operate with ground wire removed if the a-c. plug was reversed.

The trouble was traced to a shorted section of the double 0.1-mfd. by-pass condenser block which is across the primary of the power transformer.

F. C. Underwood, Jr.

Handy Shop Device

The device shown in the accompanying illustration gives the Service Man an extra hand so to speak. It is used to hold the gang condenser shaft of a receiver rigid while installing a new drive cable or belt, or while shifting rotors for alignment purposes on those receivers not employing trimmers.

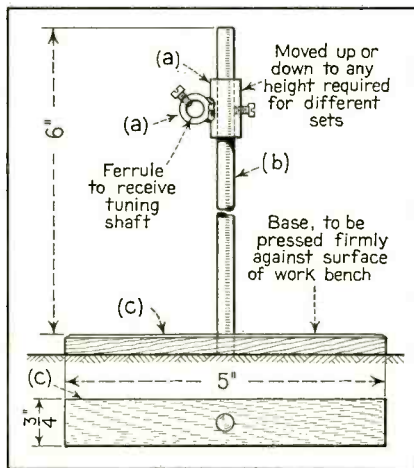

This will hold the gang-condenser shaft . . .

Referring to the sketch, "a" indicates ferrules and set screws taken from an old tuning knob and soldered at right angles to each other, "b" rod, or spike with head cut off, and "c" the base, made of wood or metal.

Charles F. Machin.

Bosch Model 60 Inoperation

A voltage check on this set with a 1000 ohms per volt meter showed everything up to par but still the set was silent. Next part by part was checked until finally a very small by-pass condenser was found to be leaking. It was hooked between plate and ground

on the AVC tube and was a .006-mfd., 500-volt condenser which when checked on the ohmmeter read approximately 100,000 ohms. With this condenser out of the circuit the set had full volume yet the plate voltage on the AVC increased by only 2 volts. Replacement of this condenser was all that was necessary.

F. C. Underwood, Jr.

Cure for Slipping Dial Drives

My tool kit at all times contains a small bottle containing a saturate solution of rosin and alcohol; I use the denatured kind but presume that if it were not for our now almost defunct "Eighteenth Amendment" the "good-natured" kind would do as well.

This solution applied to dial drive cords with a pipe cleaner is almost a sure cure for slipping, also it comes in mighty handy at times as a soldering flux.

One more use that is quite valuable is to prevent the end-fraying of insulation by applying a tiny bit of the solution to the end of the insulation. The alcohol evaporates pronto, leaving the good old rosin right where it will do the most good.

Geo. Harold.

Saving Large-Iron Tip

The writer has found a 50-watt soldering iron too small and too slow for general radio repairing, and a 75- or 100-watt iron satisfactory but with the disadvantage that the tip would burn unless the iron were in constant use.

Desiring to use a 100-watt iron, and finding turning it on and off was inconvenient and a waste of time, the following arrangement has been made. Two 60-watt lamps and a "Mark Time" switch connected up to short them, were connected in the line circuit, as shown in the accompanying diagram.

The advantage gained is that the 100-watt iron will heat up in 3 minutes and that a uniform heat is maintained which will not burn the iron tip. This heat is sufficient for regular connections; however, when full heat is required for a short time (3 to 30 minutes) the Mark Time switch is set, and the heat automatically reduced at the end of the time set.

This system will save the iron from being overheated, and the cost of the switch will be made up in a few months use in the saving on iron tips.

Marius A. Rousseau.

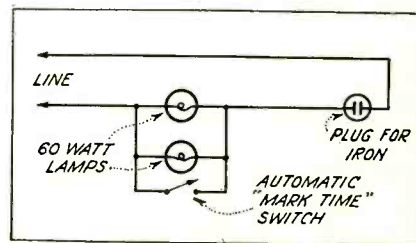

Automatic soldering iron regulation . . .



"Whata-Man"

Holder of ALL records—takes the cup for superior performance on Every Test.
No wonder they out-perform and out-wear so-called "just-as-good" fixed resistors. Service men take note: SPECIFY CENTRALAB.

CENTRAL RADIO LABORATORIES—MILWAUKEE, WIS.

Centralab **FIXED RESISTORS**

SPRAYBERRY

has done it!

• A 28-Lesson Radio Service Course FOR ONLY \$10.00!

- And it isn't the usual form of stereotyped course. This complete modern training, "PRACTICAL MECHANICS OF RADIO SERVICE" covers the actual points of present-day servicing very seldom found in other courses.
- F. L. Sprayberry has found through actual contact with thousands of Service Men, and through his own practical experience in servicing and teaching, just what you *want* to know and *should* know about servicing. It's in the course—written simply and effectively—stripped of all superfluous material . . . one reason why the course can be priced so low.
- Write immediately for the complete prospectus. This will also tell you about the *Grading and Consultation Services*—and how you can start right in with the lessons by making only a small down payment.

MAIL COUPON TODAY!

F. L. SPRAYBERRY
132 Bryant Street, N.W.
Washington, D.C.

S-10

Gentlemen:

Please rush to me the complete details of your new course "PRACTICAL MECHANICS OF RADIO SERVICE" of 28 lessons.

NAME

ADDRESS

CITY STATE



Announcing

The **TRIPLET**
Perpetual Tester
No. 1177



THIS finer tester is built for a lifetime of service. It has every feature you need to diagnose and remedy set troubles. Tests tubes while operating in the set socket. Tests set circuits and aligns tuning condensers. Fulfills every testing requirement in the home or in the shop. Contains a direct reading Ohmmeter, Output meter, A.C.-D.C. Voltmeter and Milli-ammeter. Meter is 3½" in size.

PRECISION BUILT

The single meter, when used as either an A.C. or D.C. Voltmeter has 1000 ohms resistance per volt. Voltage readings are 15-150-750. The D.C. milliampere readings are 1.5-15-150. The A.C. milliampere readings are 15-150. The direct reading Ohmmeter, with the easy reading scale, has red and black figures which make possible accurate readings from 3 megohms down to 1 ohm. All readings are controlled by a selector switch. Point to point continuity tests are made with this part of the instrument. The meter is also used for indicating output when set is connected with the oscillator for aligning condensers and measuring gain in tube values.

A switch on the oscillator permits its use for generating either a stabilized modulated or unmodulated signal of constant level. Extremely accurate scale divisions cover fractional frequencies on the individually hand-made chart from 110 to 1600 KC.

YOUR JOBBER CAN SUPPLY YOU

Net price to dealer in oak case.....\$26.67

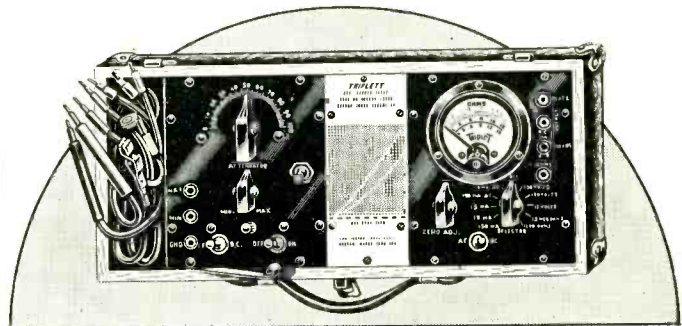

SEND COUPON FOR FACTS!

TRIPLET ELECTRICAL INSTRUMENT CO.
22 Main St., Bluffton, Ohio

Gentlemen:
Send me literature on Triplet No. 1177 Perpetual Tester.

Name

Street Address

City State

HIGHLIGHTS . . .

NEW YORK I. R. S. M. CONVENTION

SOMETHING new for New York—that convention of the Institute of Radio Service Men at the Hotel Pennsylvania during October 2, 3, and 4. Something out of the ordinary; institutional, promotional, and conservative. Exhibits of Service Men's equipment and things for Service Men to sell. Technical lectures by engineers familiar with the problems of the Service Man. Good fellowship and congeniality were evident.

It was the first attempt on the part of the national association to stage a convention and exhibit in the New York area. It was recognized that difficulties would be encountered; that there would be a reticence to accept the progressive ideas as represented by the Institute. Nevertheless, the Institute took the reins and came out with flying colors—successful in every respect. The ice is broken in the New York area, and there is no doubt that the next convention in this eastern metropolis will be an even greater success.

The convention was held on the 18th floor of the hotel. The Roof Garden was used for exhibits and the lectures were conducted in the *Salle Moderne* (ha-cha!), high above the noise of the street.

IMPORTANT PAPERS DELIVERED

Louis Martin now Technical Director of *Short Wave Radio* (a new magazine) gave a fine talk on "Problems in Short-Wave Installations and Servicing." E. H. Rietzke, President of Capitol Radio Engineering Institute, covered the very important subject of "Quiet Automatic Volume Control Systems." This was followed by a very detailed talk on "Auto-Radio Interference," by E. O. Johnson of RCA Victor.

Another very important subject covered was that of "New Tubes and Their Applications," ably dealt with by Walter Jones, of Hygrade Sylvania. John F. Rider, Editor of *SERVICE*, spoke on the question, "Should a Service Man Remain a Service Man."

The "Test Equipment Symposium" was dealt with by C. W. Burton and V. S. Church of the Apparatus Design Co., F. E. Wenger of Readrite Meter Works, Bruce O. Burlingame of Supreme Instruments Corp., and John H. Miller of Weston-Jewell Electrical Instrument Corp.

F. L. Horman, of RCA Institutes, spoke on "The Decibel—How to Use It—What It Should Be to the Radio Service Man." This was followed by a melody cruise into the intricacies and simplicities of radio servicing by David Grimes of RCA Licensing Labs. The title he gave to the comedy was "Music, if any"—and after having demonstrated his ability as a complete, self-contained concert orchestra, by playing a great variety of instruments all at once, the majority of the audience, and Mr. Grimes himself, still felt that the title, "Music if any" was apt enough.

After Mr. Grimes finished playing his harmonica, Arthur Lynch, of the Lynch Manu-

facturing Co., brought the audience back to its senses with a grand talk on "Noise-Reducing Antenna Systems for Broadcast and Short-Wave Bands." Then Ken Hathaway, Executive Secretary of the Institute of Radio Service Men, gave out the dope on the subject of the moment—"Last-minute Information about the NIRA Code for Radio Service Men." This left no doubt in the minds of the audience that things are moving for the Service Man "down in Washington."

Then back to technical subjects, with a talk by E. W. Temple, of Raytheon Products Corp., on "Tube Characteristics as Viewed by Tube Manufacturers, Set Manufacturers, and Radio Service Men." The lectures were completed by a paper delivered on "Public Address; Fundamental Circuits—Line Balancing," by Clifford E. Denton, of Federated Purchaser, Inc.

THE EXHIBITORS

The following manufacturers and distributors occupied spaces in the Exhibit Hall: Aerovox, Inc., B. & O. Radio, Inc., Burton-Weber Co., Tobe Deutschmann Corp., H. H. Eby Mfg. Co., Federated Purchaser, Inc., Galvin Mfg. Co., General Transformer Co., Hygrade-Sylvania Corp., P. R. Mallory Co., Inc., National Union Radio Co., Ohmite Manufacturing Co., Radio Engineering, Radio Merchant, Radio News, Radio Retailing, Raytheon Products Co., RCA Victor Co., Inc., Readrite Meter Works, John F. Rider Publications, Rossiter, Inc., *SERVICE*, Short-Wave Radio, Supreme Instruments Corp., Weston Electrical Instrument Co., and Wholesale Radio Service Co. Quite a list!

One of the highlights of the I. R. S. M. convention was the meeting called by the National Association of Radio Parts and Accessories Distributors, an association created July 31, 1933, in Chicago.

FAIR PRACTICE CODE

The purpose of the meeting was to discuss further the plans of the association to establish equitable practices in the parts distribution field. Those attending the meeting who had not already taken membership in the new association, signified their intention to do so and thereby support the move to clean up inequities that exist within that part of the industry and which have an effect upon the radio industry as a whole.

The contents of a code of fair competition to govern the distribution of parts and accessories was discussed also. Mr. Chas. Golenpaul, of Aerovox, Inc., attended the meeting unofficially and lent his support to the move that has been undertaken.

New Service Course

F. L. Sprayberry, at one time connected with the National Radio Institute, and more recently on his own, has been making quite

a splash with his radio data sheets. Being a practical man himself, he has managed to hit the nail on the head when it came to data for Service Men.

Now he's branching out a bit and has instituted a 28-lesson course on radio servicing which appears to be more than well up-to-date in-so-far as the subjects are concerned. It has the added advantage of being practical—and that's of particular value to any Service Man. After all, how far can a man get on theory in this game?

Self-Reading Diagrams

Many thanks to you fellows who told us what you thought about the experimental self-reading diagrams we published in the last two issues.

The opinion seems to be that these diagrams are a great improvement over past ones. We think so too. However, when it comes to the socket connections, the boys don't care so much for the diagrams which show the tube and socket together. When drawn in this manner it lends confusion—the diagrams are hard to read "at sight".

The answer is separate socket connections, and that's the way they are going to be by popular vote. Take a look at the ones in this issue. We think they fill the bill.

Radio Pains

B. H. Kyger, of Overton, Texas, sent us a news clipping about the man in Tacoma, Washington, who suffers severe pains from radio waves. This man subsequently got quite a spread in newspapers all over the country.

Some engineer claims to have hooked up a couple of condensers to the sufferer and brought instant relief to the man.

If this radio pain business spreads, it's going to be tough on the Service Men. It's bad enough servicing radio sets without having to service the listeners as well. What say?

Carrier Telephone

Dame Rumor, that old megaphone, says there is a little carrier telephone unit ready for the market which is about the size of a box of fifty (50) Corona-Coronas. Has a little mike perched atop the box and the idea of the thing is to plug it into the light line and talk to the guy in the next office.

We haven't all the dope so can't say for sure whether an r-f. carrier is used or whether the a-f. is impressed right on to the light wires. In any event, it sounds like a swell arrangement for inter-office communication, for friends living in the same apartment building and . . . well, you think up other uses.

Here is another possible chance for the Service Man (meaning, you and *you* and *YOU*) to sell the equipment, installation and maintenance service. More dope when the whole cat is out of the bag.

RCA Victor Automatic REMOTE CONTROL is a Profit Maker for Service Men Who Sell!

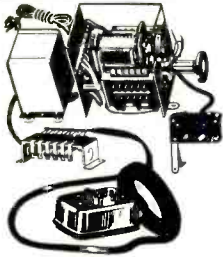

It's a bargain that comes once in a lifetime! Attach this full automatic remote control to present chassis. Turns radio "on" or "off" from a distance up to 75 feet. Accurately selects 6 different stations as well as adjusts volume. Service men—you will find this a profit making item to sell. The present great interest in remote control makes sales come easily. Of course you'll want to sell only the best—and that's the **\$ 12.50** RCA-Victor Automatic SENSATIONALLY LOW AT **12.**

MERSON Electrolytic Condensers

SPECIAL! 8MFD Single. Capacity 8; Peak Voltage 455. A BARGAIN 27c AT



DRY Electrolytic Condensers Single 8 MFD

Used in new installations and replacements. Not injured by current surges. Can be insulated from condenser sections. Guaranteed. OUR LOW PRICE IS ONLY **49c**



RCA-Victor Radio Speaker

For natural reproduction with plenty of volume—you cannot beat this Speaker. Equipped with Channel selection switch and volume control. Size 13½ x 11½ x 1¼ ins.



SPECIAL **\$ 1.85** AT

SERVICE MEN! DEALERS!!

You need this Great New Book of more than 10,000 Radio Bargains! Make this your Headquarters! We carry the largest stock of replacement parts in the entire world—replacement parts for every known radio set! Save time by asking us first!

Our Technical Department is made up of trained men who are ready and willing to clear up difficulties for you! Our Public Address Department with its staff of technicians will assist you in designing P.A. systems to meet your particular requirements. If you have a Radio Problem bring it to us . . . !"



FREE!

In the meantime get our New Catalog listing thousands of Bargains in Sets, Tubes, Speakers, Replacement Parts, Kits, Etc. It also features Public Address, Short Wave, Lafayette Receivers, Trutest Parts . . . and anything and everything in Radio at lowest wholesale prices! The four Bargains listed to the left will give you an idea of the values to be found here . . . Send TODAY for your Copy!

No connection whatsoever with any other company

MAIL COUPON TODAY!

WHOLESALE RADIO SERVICE Dept. S-103
100 Sixth Avenue, New York, N. Y.

PLEASE SEND ME YOUR BRAND NEW CATALOG No. 55.

Name
Address
City State

WHOLESALE RADIO SERVICE CO., INC.
100 SIXTH AVE.
CORNER GRAND ST. (ONE BLOCK ABOVE CANAL) NEW YORK, N.Y.

How Do You Do It?

How do you solve the many servicing problems with which you have to contend . . . what special kinks have you worked out which help you in servicing receivers . . . have you developed short-cut schemes for testing, or built test devices that do the work better and faster?

No matter what the scheme or the device, there are many, many Service Men who would like to know the how's and why's—just as you would like to know about the schemes and devices employed by others.

SERVICE WANTS TO KNOW!

If you have clever ideas and clever devices, we want to know about 'em as much as do our readers. Regular space rates are paid for all material accepted for publication.

All you have to do is give us the outstanding points, and a rough pencil sketch of the device if it happens to be such—and we will do the rest.

Come on, now, and kick in. Write up those ideas now and send them in to the . . .

ON THE JOB DEPARTMENT



NEW PROFITS FOR SERVICE MEN IN LEDERER ULTRA VIOLET LAMPS

The Lederer Ultra Violet Lamp Kit and Parts announced by National Vita Lite Corporation, affiliated with National Union Radio Corporation, opens up a broad field of profit possibilities for service men making Ultra Violet installations in the home. These new lamps provide an adequate range of vital ultra violet for health, beauty, strength and vitality. They can be purchased in complete kit form or individual parts necessary for home installations can be procured at low cost.

Installations are easy to make with Lederer parts and no live service man can afford to ignore the "dollars and cents" possibilities offered by this new ideal in Ultra Violet for the home. Send coupon for complete details.

FREE EQUIPMENT OFFERS CONTINUE

The free offers with National Union tube purchases of a Hickok Simplex Tube Tester, Supreme 333 Set Analyzer, an Oscillator and Output Meter, three Service Manuals, an Auto Radio Service Manual, A.B.C. Unameter and Readrite Tube Tester continue in effect although subject to withdrawal without notice. Write for details. Small deposit on some items.

National Union Radio Corporation of N. Y.
400 Madison Avenue, New York, N. Y.

Gentlemen: Tell me more about Lederer Ultra Violet S11
Give me details of free equipment



Name
Address
City State

THE FORUM . . .

Diagram Service

Editor, SERVICE:

Technical data pertaining to the newer type receivers is fairly easily obtained, due no doubt to the realization of the larger manufacturers that the Service Man is entitled to such data. But the data pertaining to the old timers is very hard to secure. Many of the manufacturers of these receivers have passed out of existence. But someone, somewhere, has that data. Why not devote a small amount of space in SERVICE each month to a listing of diagrams which are desired by your readers, and which you cannot supply yourself? Readers having the diagrams would drop a postcard to the reader desiring it, stating price, etc., for furnishing it.

Alvin F. Braeking,
749 North 21st Street,
Milwaukee, Wis.

(This is an excellent idea. We would be pleased to devote the necessary space for such listings. However, there are a few points to consider in connection with such an arrangement. First of all, it appears that there should be a standard charge for such diagrams, as well as a clear understanding as to whether or not the diagrams include parts values, etc. Secondly, should the owner of a diagram send his original diagram without some form of deposit to assure its return? Let's have your ideas both on the value of the service and the best manner of conducting it.—THE EDITORS.)

Service Guarantees

Editor, SERVICE:

Your new service on diagrams by adding the voltages at the tube elements is a great improvement over the old method. We are in favor of it and hope you will continue.

About service guarantees; we agree with Mr. Peran in some respects, but we use only parts that are guaranteed for 90 days by the factory and stand back of that guarantee with our work also. But we do not stand back of a part that has been replaced in the set by someone else.

We do no free service and tell the public so. We have standard charges fixed on all repairs and on all makes of sets.

H. H. Snyder,
Greer Radio Service,
Greer, S. C.

Story of Receiver Design

Editor, SERVICE:

I feel it necessary to write you extending due praise to you and Mr. Granger for his most excellent series on "The Story of Receiver Design".

I read practically every important radio publication, but I have never read (studied) anything which contained so much real "meat" for the progressive Service Man as the series referred to here.

Isn't it possible to continue these articles as a regular feature? Enlarge upon them, and go into things even more deeply, covering developments as they are put on the market.

Incidentally, I wish you would double the size and the price of your magazine.

L. W. Van Slyck,
Ironwood, Mich.

(After a short breathing space, we intend to continue publishing material of much the same nature as contained in "The Story of Receiver Design." We hope to double the size of SERVICE in time, but we shan't double the price.—THE EDITORS.)

NOISELESS GAIN CONTROL

(Continued from page 356)

variations in contact resistance or contact potential will cause noise.

This same pre-amplifier may be used as the first stage of the main amplifier, either with its own rectifier and filter circuit as shown in Fig 2, or it may be operated from the rectifier for the main amplifier if it has sufficient capacity.

REMOTE VOLUME CONTROL

For small systems requiring only a single mike, it is usually a simple matter to replace the first amplifier tube with a type 58 tube having variable grid bias. The bias potentiometer may of course be located away from the amplifier in almost any location since the circuit is well filtered and therefore not subject to noise pickup. This bit of flexibility may often be of considerable value.

AUTO-RADIO

(Continued from page 360)

(2) Break the solder seal at the bottom of the housing by means of a hammer and screwdriver. Do not attempt to use a soldering iron. Any bending or distortion of the housing in breaking the solder seal can be disregarded, since the metal is very soft and can easily be bent back to shape.

(3) Force a screwdriver between the housing and bottom cover at the two screw holes to break away any burr formed by the self-tapping screws.

(4) Place a block of wood against the upper edge of the transformer-vibrator housing and knock it loose with a hammer.

(5) Now connect the two .25-mfd., 100-volt condensers, one across each of the outside terminal strips of the vibrator, connecting the other end of each condenser to ground. One of the condensers is to be placed in a vertical position alongside the transformer winding directly opposite the r-f. choke. The other condenser should be placed in a horizontal position between the bottom of the transformer winding and the legs of the transformer bracket.

(6) Straighten out and replace the trans-

former-vibrator housing, soldering it securely at one corner to the bottom cover.

These two changes should absolutely eliminate any vibrator hash that exists.

Model 112 chasses with the rubber vibrator housing already have the top soldered and the condensers connected into the circuit.

Auto-Radios and Chargers

The Fansteel Products Co., Inc., report that there has been an increasing sales activity of their new home garage model Fansteel Balkite Automotive Battery Charger. A certain amount of such activity can be attributed to cold weather, but it's a bit too early in the season for anything like that. Our guess is that many car owners, realizing the increased drain their auto radios place on the storage battery, and not wishing a continual recharging at some local garage, have started to purchase their own little chargers (they work while you sleep, you know).

GE-40 and RCA-40 Note

Quite often the cable sheath picks up interference and passes it to the tuning cable which is connected to the variable condenser rotors.

This interference can usually be cleaned up if the triangular plate which is mounted on rubber to which the tuning control sheath is attached, is grounded to the side of the set by a piece of flexible copper sheath.

A. L. HISSONG.

The Quality Group

They say that a product is more or less a reflection of what the public wants. We wonder. Has anyone heard people crying for better tone in their radio receivers?

Anyhow, there is a definite movement towards better tone (we aren't referring to cigar box sets) and since a number of manufacturers are doing things in this respect, we are getting to call them the "Quality Group."

Things are popping in this line, and before frost appears on the landscape, there will be many a new device on the market for those who are after realism in radio.

Television

Don't ask us if television is just around the corner—we don't know. All we do know is that there are several practical systems already for immediate sale when, as, and if the good old buying power of the people takes a turn for the better.

So, you see how it is . . . maybe tomorrow or maybe not for a year. But, when it comes you fellows are going to have a new set of headaches. Some television fan will phone you and say Kate Smith's face is all out of wack and come up right away and do something about it. Maybe it will be due to a leaky condenser or the need of a new ten-watt resistor . . .

Announcement . . .

SERVICE is now being published by the Bryan Davis Publishing Co., Inc.—publishers of the monthly journal *Radio Engineering*.

To you as readers of the publication, this means added facilities for the gathering and selection of the most important and timely information on the problems of radio servicing, sound installations, and related subjects.

JOHN F. RIDER continues as Editor of **SERVICE**, and *M. L. MUHLEMAN* as Managing Editor.

The high standards of past numbers of **SERVICE** is attested by its present paid circulation of over 9,000 enthusiastic subscribers. Our organization, editorial facilities and experience of more than twelve years of publishing in the radio field—all are dedicated to making **SERVICE** even more valuable to you than it has been in the past. We'll welcome your continued comments, criticisms and suggestions.

BRYAN DAVIS PUBLISHING CO., INC.

19 East 47th Street

New York, N. Y.

STATEMENT OF THE OWNERSHIP, MANAGEMENT, CIRCULATION, ETC., REQUIRED BY THE ACT OF CONGRESS OF MARCH 3, 1933

Of **SERVICE**—A Monthly Digest of Radio and Allied maintenance published monthly at New York, N. Y., for Oct. 1, 1933.

STATE OF NEW YORK }
COUNTY OF NEW YORK } ss.

Before me, a Notary Public, in and for the State and county aforesaid, personally appeared John F. Rider, who, having been duly sworn according to law, deposes and says that he is the Editor of the **SERVICE**—A Monthly Digest of Radio and Allied Maintenance, and that the following is, to the best of his knowledge and belief, a true statement of the ownership, management, (and if a daily paper, the circulation), etc., of the aforesaid publication for the date shown in the above caption, required by the Act of March 3, 1933, embodied in section 537, Postal Laws and Regulations, printed on the reverse of this form, to wit:

1. That the names and addresses of the publisher, editor, managing editor, and business manager are: Publisher, Bryan Davis Publishing Co., Inc., 19 East 47th Street, New York, N. Y.; Editor, John F. Rider, 1440 Broadway, New York, N. Y.; Managing Editor, M. L. Muhleman, 1440 Broadway, New York, N. Y.; Business Manager, Bryan Davis, 19 East 47th Street, New York, N. Y.

2. That the owners are: John F. Rider Publications, Inc., 1440 Broadway, New York, N. Y.; John F. Rider, 1440 Broadway, New York, N. Y.; Florence Rider, 1440 Broadway, New York, N. Y.

3. That the known bondholders, mortgagees, and other security holders owning or holding 1 per cent or more of total amount of bonds, mortgages, or other securities are: None.

4. That the two paragraphs next above, giving the names of the owners, stockholders and security holders, if any, contain not only the list of stockholders and security holders as they appear upon the books of the company but also, in cases where the stockholder or security holder appears upon the books of the company as trustee or in any other fiduciary relation, the name of the person or corporation for whom such trustee is acting, is given; also that the said two paragraphs contain statements embracing affiant's full knowledge and belief as to the circumstances and conditions under which stockholders and security holders who do not appear upon the books of the company as trustees, hold stock, and securities in a capacity other than that of a bona fide owner; and this affiant has no reason to believe that any other person, association, or corporation has any interest direct or indirect in the said stock, bonds, or other securities than as so stated by him.

5. That the average number of copies of each issue of this publication sold or distributed, through the mails or otherwise, to paid subscribers during the . . . months preceding the date shown above is . . . (This information is required from daily publications only.)

JOHN F. RIDER,
Editor,

Sworn to and subscribed before me this 29th day of September, 1933.
[SEAL] JACOB B. HOFFMAN,
(My commission expires March 30, 1934).

WHICH "RED DEVIL" OR "WIREWATT?"



10 watt Size—1 ohm through 25,000 ohms.
20 watt Size—30,000-100,000 ohms.

Wise service men everywhere are using RED DEVIL and WIREWATT resistors for a large part of their replacement work. The addition of the one watt WIREWATTS in values through 25,000 ohms makes it possible to service about 80% of all resistor troubles with wirewound units which have no voltage or temperature characteristics and which remain absolutely quiet under all conditions. Use the coupon for further details about the RED DEVILS and WIREWATTS.

1 watt Size—100 ohms through 25,000 ohms.

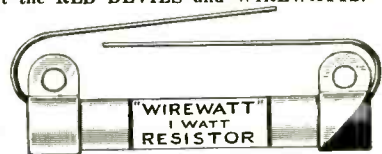

OHMITE

MANUFACTURING COMPANY

637 N. Albany Avenue Chicago, Ill.

Please send me further details about the RED DEVIL and WIREWATT Resistors.

NAME
ADDRESS
CITY..... STATE.....
JOBBER'S NAME.....

A NEW Rider Manual

The *Specialized Auto Radio Manual* NOW AVAILABLE

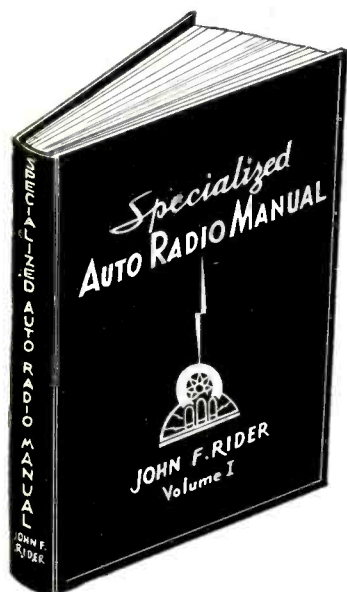

"In the Brown Cover"

HERE is the manual auto radio specialists have been awaiting for a long time.

PREPARED with the effort to make it the most complete and comprehensive in the industry.

Rider's *Specialized Auto Radio Manual*.

- has about 60% more pages than any other auto manual
- has more old auto radio receivers
- has more new auto radio receivers
- has more complete information about the receivers
- has a complete and useful index
- has 350 pages
- is actually bound in imitation leather
- letter press printed

EVERY page in the *Specialized Auto Radio Manual* is devoted to auto radio receivers. The production of the industry since the very earliest auto receiver to the very latest is included. You will find this Manual, like other Rider Manuals, to contain complete information about the various receivers included.

IN addition to the schematic wiring diagrams—chassis layouts—photographic views—electrical values—voltage data—point-to-point data—resistance and condenser values—peak frequencies—location of trimmers—alignment data—Rider's *Specialized Auto Radio Manual* also contains full and complete installation instructions.

SPECIAL attention has been paid to the publication of information about the installation of antenna systems in automobiles—how to install the respective chassis in various makes of cars with specific information about these cars.

YOU will find special and very valuable hints about ignition interference elimination and means of securing best performance of the receivers—as furnished by the receiver manufacturers.

YOU will find in this *Specialized Auto Radio Manual*—special instructions about the installation of the control units—speaker units, etc. Really, there is no other auto radio manual the equal of Rider's *Specialized Auto Radio Manual*.

Price \$3.50 Postpaid. Sold with a Money Back Guarantee.

Buy it from your dealer or from us direct.

155 Tube Types!

in the—MODERN TUBE INDEX

BIGGER because it lists all the tubes announced right up to the very last moment, such as the 1A6, 2B6, 6D6 and 6Z5!

BETTER because *illustrated* base layouts and connections are given for all tubes—both the old and the new!

FINER because of the new added feature of complete listing of tubes which are similar or interchangeable!

AN INDISPENSABLE ITEM—GET YOURS NOW

Price 25 Cents Post Paid

(Add 5 Cents For Foreign Mailings)

JOHN F. RIDER

1440 Broadway

New York, N. Y.

370

SAY YOU SAW IT IN SERVICE

• SERVICE FOR

BEWARE of the Bridge Table

MANY successful service organizations are built on a foundation of word-of-mouth advertising by the satisfied customers.

THEN again—many service organizations have been ruined by just that. . . . In one case the advertising is favorable and in the other case—it is very unfavorable.

PROTECT yourself against unfavorable advertising across the bridge table. Your present and past customers have friends. . . . They converse across the table. . . . Will they help you or will they harm you?

ARE you prepared to render rapid, efficient and accurate service on any receiver? Therein lies the means of establishing an enviable reputation—of building a successful business.

PROPERLY equipped with service apparatus and fortified with the technical background—the ownership of Rider's Manuals will complete the three requirements for rendering good, reliable and rapid service.

SERVICE equipment—the technical background—and Rider's Manuals provide the wherewithal to build a good reputation in the service field—so that your customer's word-of-mouth advertising will be beneficial and remunerative.

YOU cannot secure finer service data than is to be found in Rider's Perpetual Trouble Shooter's Manuals. Ample proof of this is the offering of these Manuals by the world's most famous tube manufacturers in connection with tube sales.

E. T. Cunningham, Inc.
RCA Radiotron Co.

National Union Radio Corp.
Raytheon Products Corp.

USE, sell and recommend Rider's Manuals to the service and dealer industry. There is no higher form of recommendation. . . . It establishes absolute superiority of Rider's Manuals.

WESTON recommends Rider's Manuals in the instruction pamphlets which accompany their test equipment. Hickok, Readrite, Supreme, and other famous test instrument manufacturers use and recommend Rider's Manuals. Thousands of Service Men the country over have told other thousands about these Manuals, until today Service Men feel that they cannot get along without Rider's Manuals.

VOLUME I
\$7.50



*See them
at
your dealers*

VOLUME III \$7.50

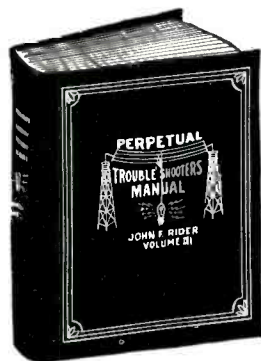

*Sold with a
money-back
guarantee*

VOLUME II
\$6.50

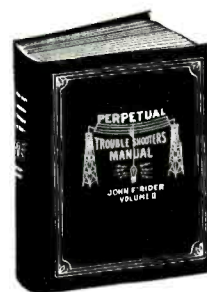

Buy from your dealer or order direct.

JOHN F. RIDER

1440 BROADWAY



NEW YORK CITY

THE MANUFACTURERS . . .

Racon High-Frequency Unit

Racon Electric Co., Inc., 52 East 19th St., New York City, has developed a special dynamic high-frequency loudspeaker to meet the demands for wide-range reproduction. This speaker is composed of a dynamic unit and horn, and is designed to cover the frequency band from 3,000 to 12,000 cycles, with uniform response up to 18,000 cycles.

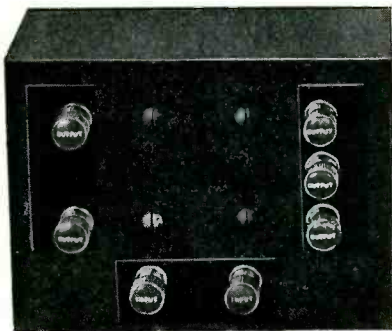

The speaker weighs 3 pounds, and has a voice-coil impedance of 15 ohms. The unit may be obtained with a field rating of either 6 volts or 110 volts, as desired.

Racon has also developed a special coupling transformer for the high-frequency speaker, as well as an exciter for the field coil when the rating is 110 volts.

Wide-range equipment requires the use of a filter network for low- and high-frequency transmission. Racon has designed a unit of this type with one range up to 3,000 cycles provided for low-frequency transmission and the other range from 3,000 cycles up for high-frequency transmission. This filter network, as illustrated, is used between the amplifier and speakers and is made for either 500 or 4,000-ohm line (source) impedances.

Continental Super-Watt Resistors

Continental Carbon, Inc., have brought out a new replacement resistor called the Super-Watt. This unit will handle three times the power of the ordinary one-watt resistor, yet is but a fraction of an inch longer.



An insulating coating capable of standing over 1,000 volts eliminates all possibility of shorts to metal chassis or adjacent wiring. The unit is non-inductive and is available in all resistance values from 100 ohms to 5 megohms.

The resistance material is a new pressure-moulded substance called "Carbolite" which the makers state does not change in resistance value with age and is entirely free from noise.

Tau-Rex Meter Rectifier

Leo Taussig, 3245 37th Street, Long Island City, N. Y., is marketing a very compact rectifier measuring only $\frac{1}{4}$ " by $\frac{3}{8}$ ", for use in connection with meters. This unit will convert any d-c milliammeter into a sensitive a-c meter.

This rectifier finds its main use in set testers, tube testers and universal analyzers.

I. R. C. Dual Resistance Indicator

A new I.R.C. Dual Resistance Indicator announced this month by the International Resistance Co., of Philadelphia, incorporates a number of improvements. These include unique design with resistance rods wound with the heaviest wire possible and enclosed in a sturdy metal case; ball-bearing slider insuring smooth, uniform pressure on the resistance rods and a permanently attached slider knob that frees the user's hands and permits him to work elsewhere after an adjustment has been made.

The new Indicator has two scales—0 to 10,000 ohms and 10,000 to 100,000 ohms. Quick reading from 100 to 100,000 ohms may thus be made. The one slider serves for both scales.



In determining resistor values, the Indicator will give good results either used alone or with a voltmeter. Other practical uses to which the Indicator may be put range from its use as a calibrated rheostat for adjusting voltage or limiting current; calibrated potentiometer or voltage divider; temporary heavy-duty resistor up to 100,000 ohms, measuring unknown resistance by the substitution method, and many others.

Tobe Auto-Radio Filterizer

The Tobe Deutschmann Corp. have brought out a special Filterizer kit for cutting out noise in auto-radio receivers. The complete kit includes one combination dome light or tail light Filterette, one ammeter Filterette and one special receiver Filterizer with a 10-foot Filterized shielded aerial lead.

This kit may be used in conjunction with any type auto-radio broadcast receiver and is equally effective for use with a roof aerial or an under-car aerial.

Radolek Megohm Indicator

The Radolek Co., 601 W. Randolph St., Chicago, are manufacturing a decade style 1,000,000-ohm resistance box, as illustrated. Ten resistance values are available in 100,000-ohm steps from 0.1 megohm to 1 megohm. An etched aluminum dial plate marked 1 to 10 identifies the value of resistance employed at any position of the selector switch. All resistors and the selector switch are contained

in a polished brown bakelite, pocket-size box. Connections are made through insulated pin jacks.

This unit may be used in conjunction with the Radolek Resistance Indicator (see this section in September SERVICE) for determining values of resistors and as a multiplier for voltmeters.

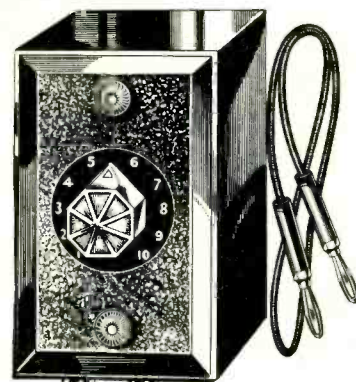

The Megohm Indicator is supplied with 24-inch spring-tipped cord for use with the Resistance Indicator.

Webster Amplicall System

The Webster Company, 3825 West Lake Street, Chicago, has brought out a special factory and office call system which is composed of a self-contained amplifier—the Webster Type K—a carbon microphone which may be located at a distance from the amplifier unit, and from one to five speakers.

The entire system is very easy to install, and the units may be placed at any desirable point. The power consumption of the amplifier is low, making it an inexpensive item for general use.



The input impedance of the amplifier is 200 and 5,000 ohms. The output impedance is variable. Hum rating is minus 55 db. and the hiss level is low. The frequency range is 60 to 5,000 cycles which is considered in excess of requirements for work of this type.

Group Subscriptions at SUBSTANTIAL SAVINGS!

● The Regular Subscription price for SERVICE is now \$2.00 per year.

You, no doubt, know many other Service Men who would like to receive SERVICE every month. Probably several other Service Men in your acquaintance are already subscribers.

Here are two plans whereby you can save money for yourself and your friends:

- 1—Subscriptions (new or renewals) can be purchased in groups of ten or more for \$1.00 per year each.
- 2—Subscriptions (new or renewals) can be purchased in groups of five to ten for \$1.50 per year each.

If your subscription is about to expire show SERVICE to five or ten of your friends. They, too, will want it. If they are already subscribers, they will want to renew or extend their subscriptions.

If you wish to extend your subscription at these savings, get five or ten others to subscribe at the same time.

Be sure to print clearly the name and address of all the subscribers, and send a check or money order covering the exact amount, noting in each case whether the subscription is a new one or a renewal.

All Offers are Subject to Withdrawal Without Notice

Bryan Davis Publishing Co., Inc.

19 East 47th Street

New York, N. Y.

INDEX TO ADVERTISERS

Central Radio Laboratories.....	365
Clarostat Manufacturing Co.	363
Continental Carbon, Inc.	361
Cornell-Dubilier Corp.	345
Electrad, Inc.	Second Cover
General Transformer Corp.	361
Hickok Electrical Instrument Co.	Third Cover
Hygrade Sylvania Corp.	357
National Union Radio Co.	367
Ohio Carbon Co.	359
Ohmite Manufacturing Co.	369
Racon Electric Co., Inc.	359
Radolek Co., The	373
Radio Products Co.	359
Readrite Meter Works	361
Rider, John F.	370, 371
Sprayberry, F. L.	365
Taussig, Leo	363
Triplet Electrical Instrument Co.	365
VAN Leuven, D. L.	363
Webster Co.	363
Weston Electrical Instrument Corp.	Back Cover
Wholesale Radio Service	367

Best SELECTION Lowest PRICES Quickest SERVICE

THE RADOLEK CO. (Dept. 709)
601 West Randolph Street, Chicago, Illinois

Please send me, without obligation, the NEW Radolek Profit Guide.

Name

Street

City..... State.....

Do you do Service Work? Yes No

Do you operate from Store Shop Home (Check which, please.)

Index of Monthly Literature

AUTO-RADIO

Eliminating Auto-Radio Noises
R. L. Dougherty, Radio-Craft, pp 288, November, 1933

BROADCAST

Amplifiers, A-F.

Duo-Channel A-F Amplifier (Using 2B6's)
Radio Retailing, pp 43, September, 1933

Resistance-Coupled Push-Pull (Circuit)
Radio Retailing, pp 43, September, 1933

Using Midgets With External Speakers (Circuits)
B. S. Trott, Radio Engineering, pp 16, September, 1933

Amplifiers, R-F.

Constant-Gain R-F Transformer (Circuit design)
J. E. Anderson, Radio World, pp 8, October 21, 1933

New I-F Transformer Design (Design)
K. Clough, Radio News, pp 285, November, 1933

General

Complete Broadcast Station List (Freq. & Pwr.)
Radio-Craft, pp 284, November, 1933

Using Midgets With External Speakers (Circuits)
B. S. Trott, Radio Engineering, pp 16, September, 1933

Receivers

Silver Masterpiece II (Design details)
McMurdo Silver, Radio News, pp 287, November, 1933
Also Radio-Craft, pp 276, November, 1933

PUBLIC-ADDRESS

26-Watt P-A System, Part III (Construction)
L. Gancher, Radio-Craft, pp 282, November, 1933

Maintenance of Carbon Mikes
A. R. Kahn, Radio-Craft, pp 287, November, 1933

Mixing Circuits for P-A Systems (Circuits)
G. E. Fleming, Radio News, pp 271, November, 1933

Push-Pull 2A3 Amplifier (Circuit)
Radio, pp 27, October, 1933

Wired-Radio P-A System (Construction)
D. R. Freeling, Radio-Craft, pp 272, November, 1933

SHORT WAVE

Alphabetical S.W. Station List
Short Wave Radio, pp 34, November, 1933

Improved Code Heterodyne Receiver (Construction)
F. C. Jones, Radio, pp 12, October, 1933

Improving Regeneration Control (Circuits)
C. E. Malsberger, Short Wave Craft, pp 410, November, 1933

International Nine S.W. Receiver (Circuit)
W. C. Dorf, Radio News, pp 277, November, 1933

Modernizing Short-Wave Receivers (Circuits)
Short Wave Radio, pp 27, November, 1933

Short-Wave Antennas (Construction)
Don C. Wallace, Short Wave Craft, pp 409, November, 1933

Tuned Doublet for S.W. Receivers
Radio, pp 25, October, 1933

TESTING SYSTEMS

Capacity Bridge (Circuit)
W. A. Edson, Radio-Craft, pp 289, November, 1933

Measuring Percentage of Modulation (Circuits)
J. E. Anderson, Radio World, pp 10, October 7, 1933

Radio Noise—Causes and Cures
E. H. Scott, Radio News, pp 278, November, 1933

Short-Circuited Turn Indicator (Circuit)
T. Martel, Radio News, pp 317, November, 1933

Using Standard Frequency Transmissions
CQ, pp 18, September, 1933

TUBES

2B6 Tubes in Duo-Channel Amplifier (Circuit)
Radio Retailing, pp 43, September, 1933

84 Rectifier Characteristics
Radio World, pp 4, October 21, 1933

Diode-Triode Results (Circuits)
W. L. Hemstreet, Radio World, pp 12, October 7, 1933

Replacing 80 with 5Z3
Radio, pp 14, October, 1933

MISCELLANEOUS

Converting A-C, D-C Sets for Dry-Cell Tubes (Circuits)
R. Silberstein, Radio-Craft, pp 278, November, 1933

Converting Battery Sets for 32-Volt D-C (Circuits)
M. Chernow, Radio Retailing, pp 51, September, 1933

Radio Noise—Causes and Cures
E. H. Scott, Radio News, pp 278, November, 1933

Servicing Sound-Picture Equipment, Part I
A. Nadell, Radio-Craft, pp 274, November, 1933

Using Midgets With External Speakers (Circuits)
B. S. Trott, Radio Engineering, pp 16, September, 1933

Voltage-Divider Design (Details)
Radio Retailing, pp 47, September, 1933

All articles listed on this page are cross-indexed for your convenience. Titles given are not necessarily the titles of the original articles, but in each case serve to determine the substance of the article. Listings marked with an asterisk (*) are abstracted in this issue. The material in each issue of SERVICE is alphabetically indexed on the Contents Page.

SIMPLEX PORTABLE TUBE TESTER

•
SIMPLE TO OPERATE

•
TESTS ALL NEW TYPE TUBES
ANNOUNCED TO DATE

•
*Accurate limit of values for all tubes
on two color meter dial. Readily un-
derstood by any one for maximum
tube sales.*

•
*Customer confidence is immediately
established as there are a minimum of
operations, and no multiplicity of push
buttons, reset knobs and switches to
cause confusion.*

A LOW PRICED PRACTICAL TUBE MERCHANDISER
FOR THE SERVICEMAN

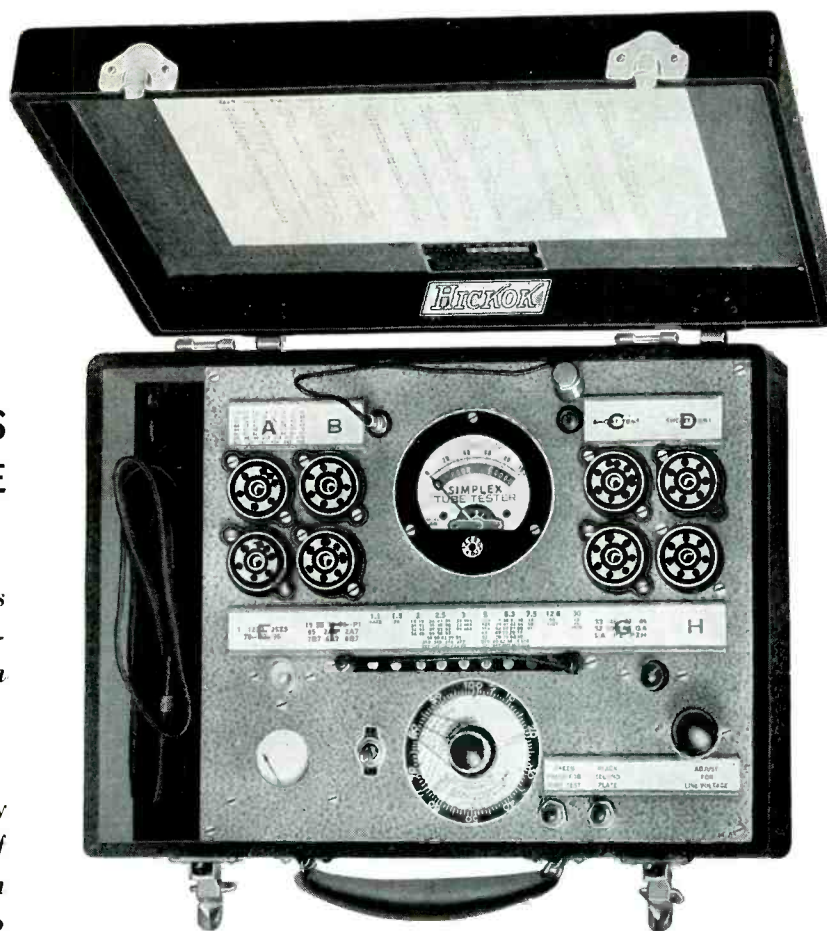

Size 14 $\frac{1}{4}$ " x 10 $\frac{1}{4}$ " x 5 $\frac{3}{8}$ "—In Carrying Case as Shown

This tester is the direct result of the universal demand for a more flexible Portable Tube Tester. One that exemplifies Simplicity in the eyes of Radio Owners, and vastly enhances the sale of Tubes by the simple indication—on one meter—of GOOD or BAD in two colors—red and green.

DESIGNED RIGHT—BUILT RIGHT

- Rugged construction for Portable Service
- Mounted complete in removable cover type case
- Compact size
- Attaches to A. C. line—no batteries
- Has line voltage indicator
- Has line voltage regulator
- Equipped with Hickok 3 $\frac{1}{2}$ " Meter—two color dial—in red and green
- Approved—Guaranteed

THIS TESTER HAS BEEN DESIGNED TO AVOID FUTURE OBSOLESCENCE

With years of Tube Tester Engineering Practice behind us, we offer this Tester as the lowest priced, practical unit possible to build, consistent with Tube Manufacturers' Standards of Values from which there must be no deviation.

Dealers Net Price, \$34.50. West Coast Prices Somewhat Higher.

THE HICKOK ELECTRICAL INSTRUMENT CO.

10514 Dupont Avenue

Cleveland, Ohio

SAY YOU SAW IT IN SERVICE

OBSOLESCENCE WORRIES ARE ENDED

*with this new
test equipment*

Here is new test equipment that will never gather cobwebs because of obsolescence. Never cost you real money in order to keep it up-to-date. The reasons are obvious:

The Weston Model 665 Selective Analyzer contains all the necessary voltage, current and resistance ranges. Separate Socket Selectors are provided to accommodate all 4, 5, 6 and 7 prong tubes. You merely attach the proper Socket Selector to the Analyzer, and insert the plug into the tube socket of the radio set. Then, by plugging into the proper jacks, voltage, current and resistance may be read in any part of the entire network leading to the tube socket. *New tube bases merely mean a new, inexpensive Socket Selector.*

The Weston Model 674 Tube Checker is a real tube merchandiser. It shows good tubes as "GOOD", and is beautifully finished in three distinct tones of brown. Provides for testing all present tubes; and has seven spare sockets which can be quickly wired in to test some fifty-odd additional tubes when and if offered. All reference to or knowledge of tube characteristics is avoided. Quick and accurate indication is obtained by simply following the few concise steps on the tube limit chart. Other features make it the outstanding value today.

Weston Model 666 Socket Selectors can be used with any and all makes of Analyzers. Your present Analyzer can be brought up-to-date, and kept that way, with these simple, inexpensive units.

These and other Weston radio instruments are illustrated and described in the new bulletin RA. Send the coupon today, and receive your copy . . . Weston Electrical Instrument Corporation, 604 Frelinghuysen Avenue, Newark, New Jersey.

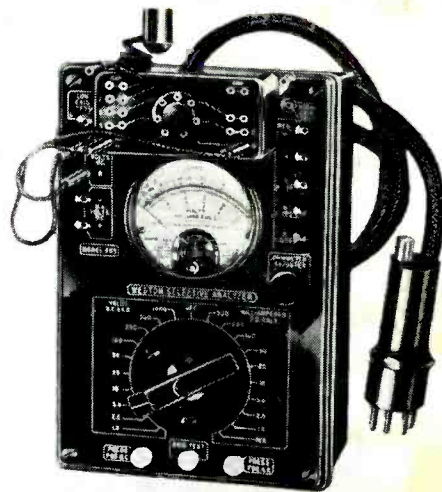

MODEL 665
SELECTIVE ANALYZER



MODEL 674
TUBE CHECKER

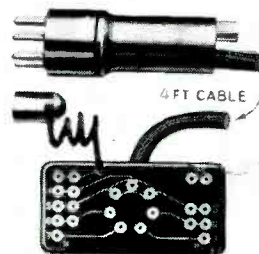

MODEL 666
SOCKET SELECTOR

WESTON

Radio Instruments



WESTON ELECTRICAL INSTRUMENT CORPORATION
604 Frelinghuysen Avenue, Newark, New Jersey

Please send circular RA containing full information on Weston Radio Instruments.

Name _____

Address _____