



# SERVICE



A MONTHLY DIGEST OF  
**RADIO**  
AND ALLIED MAINTENANCE



Get on the move!  
(See page 296)

PER COPY  
20 CENTS

AUGUST  
1933

# You GIVE Service, How Would You Like to RECEIVE Some?

“NEW Deal,” old deal—  
it doesn't matter—  
Electrad gives the service  
man a SQUARE DEAL,  
every time, all the time.

Electrad's great business  
has been built on giving  
*service to service men.*

That isn't just a slogan—it  
is a *principle*. Electrad not  
only manufactures the  
highest grade Resistors,  
Volume Controls and Am-  
plifiers for every purpose  
—they are designed to  
simplify installation and  
to save time and money.

More than 12,000 busy  
service men know how  
helpful Electrad service  
can be. DO YOU?

## TRUVOLTS Are Unlike Ordinary Resistors

- 1 TRUVOLT patented construction permits air-cooling, larger wire, greater radiation and longer life.
- 2 TRUVOLT double-spiral winding gives better electrical contact.
- 3 TRUVOLT sliding clips permit accurate adjustment to exact voltages.
- 4 TRUVOLTS have 1,000 volt insulation.
- 5 TRUVOLTS have a full-length fibre guard to prevent injury from contact with tools or hands.

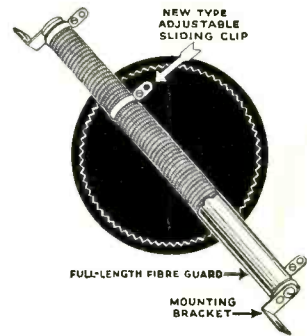

Use TRUVOLTS and Be SURE!

## Time-Saving VOLUME CONTROLS

An outstanding feature of these volume controls is their adaptability. Only five types are required to service 799 standard receiver models. End covers are interchangeable with power-switch assembly. Long aluminum shafts are easier to cut to desired length.

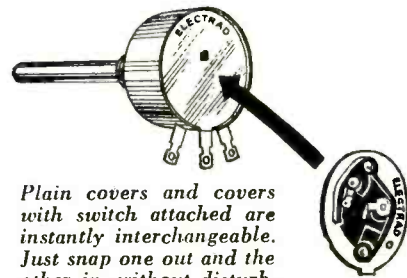

Plain covers and covers with switch attached are instantly interchangeable. Just snap one out and the other in, without disturbing the control connections.

## AMPLIFIERS For Every Purpose

ELECTRAD Amplifiers are world-famous for high output, rich tone and economical operation. Four models cover every private and public amplifier need, from 1.6 watts to 21.9 watts of undistorted power. List price, \$32.50 to \$195.00, less tubes.

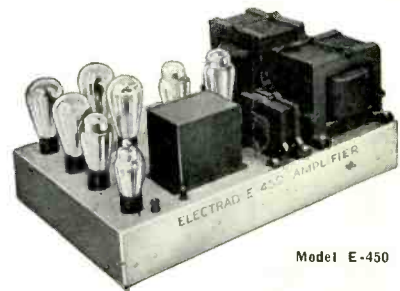

## 122 Pages of SERVICE DATA You Need Every Day

Now in its second edition, this helpful book has won the praise of thousands of service men. 122 pages of up-to-the-minute service data. Sold on a 10-day trial, money-back guarantee.



\$1  
a year

including 3 supplements

Mail Coupon for your copy of the new  
1933 ELECTRAD catalog and circular  
describing the 1933 Hand Book.

ELECTRAD, INC., 175 Varick St., New York

Please send me your complete 1933 catalog.  
..... Check here for circular describing the 1933  
Resistor Replacement Hand Book.

Name .....

Address .....

..... S-8

175 Varick St., New York, N.Y.  
**ELECTRAD**  
INC.

SAY YOU SAW IT IN SERVICE



# SERVICE ENGINEERS' POWER UNIT EMERGENCY STOCK

**Only Four Models FOR 90% OF ALL RADIOS**

**Easily Installed!**  
FULL DIRECTIONS WITH EACH UNIT

For any 110-120 V., 50-60 cy. use No. 1804-6-8-10 type "F" or 1814-16-18-20 type "U." For 220-240 V., 60 cy. use 1924-26-28-30 type "U" or "F." For 115 V., 25 cy. use 1914-16-18-20 type "U" or "F" as follows:

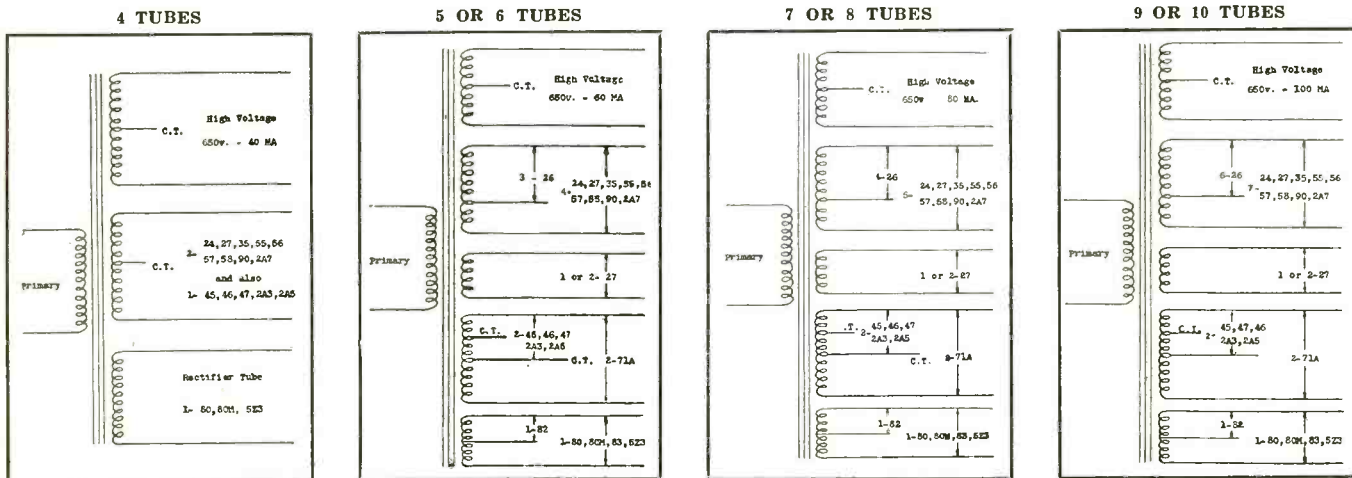

## "GENERAL" MULTI-TAP UNIVERSAL POWER TRANSFORMERS

These replacement transformers from an electrical standpoint, may be installed as permanent equipment; but if the set owner insists on an Exact-duplicate, physically as well as electrically, the "GENERAL" Multi-tap Universal may be installed temporarily to give immediate re-

newal of original performance until an Exact-duplicate can be obtained through a "GENERAL" distributor; or while the defective unit is returned to our factory to be remanufactured. (See "GENERAL" catalog No. 1.)

### UNIVERSAL ELECTRICALLY

The wide range of adaptability of only four models Multi-tap Universal Power Transformers is made possible through various taps in these units, as shown above, which may be used singly or in combinations. With this variety of combinations in the four models, the required current values can be delivered to each of the several leads in the set for any

combination of tubes used in 4- to 10-tube receivers, as accurately as the original power units—considering the variation in the lighting current of different localities. The important consideration in replacing power units is how many tubes in the set and their current requirements—not what tubes or what make of radio.

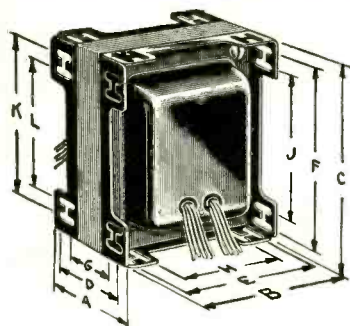

Type "U"  
Pat. Applied For

### DIMENSIONS—MULTI-TAP UNIVERSAL POWER UNITS

No.	A	B	C	D	E	F	G	H	J	K	L
1814	2- 9/16	3-13/16	3- 3/16	2- 1/8	2-11/16	3- 5/16	1- 1/2	1-15/16	2- 9/16	2-15/16	2- 3/16
1816	2-13/16	3- 3/16	3-13/16	3- 3/8	2-11/16	3- 5/16	1- 3/4	1-15/16	2- 9/16	2-15/16	2- 3/16
1818	3- 3/8	3- 3/4	4- 1/2	3- 1/4	3- 1/4	4	1- 7/8	2- 1/2	3- 1/4	3-11/16	2-15/16
1820	3- 5/8	3- 3/4	4- 1/2	3- 1/4	3- 1/4	4	2- 1/8	2- 1/2	3- 1/4	3-11/16	2-15/16
1914	3-11/16	3- 3/16	3-13/16	3- 1/4	2-11/16	3- 5/16	2- 5/8	1-15/16	2- 9/16	2-15/16	2- 3/16
1916	4- 1/8	3- 3/4	4- 1/2	3- 3/4	3- 1/4	4	2- 5/8	2- 1/2	3- 1/4	3-11/16	2-15/16
1918	4- 1/2	3- 3/4	4- 1/2	4- 1/8	3- 1/4	4	3	2- 1/2	3- 1/4	3-11/16	2-15/16
1920	4- 3/4	3- 3/4	4- 1/2	4- 3/8	3- 1/4	4	3- 1/4	2- 1/2	3- 1/4	3-11/16	2-15/16
1924	2- 9/16	3- 3/16	3-13/16	2- 1/8	2-11/16	3- 5/16	1- 1/2	1-15/16	2- 9/16	2-15/16	2- 3/16
1926	2-13/16	3- 3/16	3-13/16	2- 3/8	2-11/16	3- 5/16	1- 3/4	1-15/16	2- 9/16	2-15/16	2- 3/16
1928	3- 3/8	3- 3/4	4- 1/2	3- 1/4	3- 1/4	4	1- 7/8	2- 1/2	3- 1/4	3-11/16	2-15/16
1930	3- 5/8	3- 3/4	4- 1/2	3- 1/4	3- 1/4	4	2- 1/8	2- 1/2	3- 1/4	3-11/16	2-15/16
1804	2- 3/8	2- 9/16	3- 1/16	2	2	2					
1806	3- 3/8	3- 3/8	4- 1/2	2- 3/8	2- 7/8	2- 7/8					
1808	3- 1/2	3- 3/8	4- 1/2	2- 5/16	2- 7/8	2- 7/8					
1810	3- 7/8	3- 3/8	4- 1/2	2- 3/4	2- 7/8	2- 7/8					

Type "U" overall dimension through the shells is measurement "A" plus 1/4".

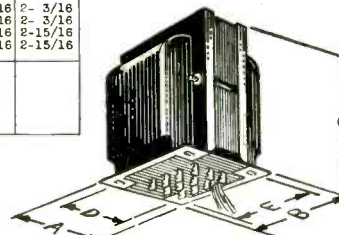

TYPE "F"

**UNIVERSAL AUDIO TRANSFORMER—Model 3205**—For push-pull or straight Audio, Universal Mounting Bracket.

**MULTI-TAP UNIVERSAL OUTPUT TRANSFORMER—Model 1337**—Combination of various taps provided in this unit makes it possible:

To feed from single or push-pull output stage.  
To any voice coil from 2 to 30 ohms in 2 ohm steps:—Universal electrically as well as physically.



**FREE!** "GENERAL" Illustrated and fully descriptive BULLETIN!

with complete list of 1377 models and makes of radios on which you can replace power units out of a stock at an investment of only \$23.25 (list) in "GENERAL" Multi-tap Universals.

**MAIL THIS COUPON NOW!**

GENERAL TRANSFORMER CORPORATION  
502 So. Throop Street,  
Chicago, Ill.

Please send free Bulletin of "GENERAL" Multi-tap Universals and list of Radios on which they can be used for replacements.

Name .....

Address .....

My Jobber is.....

Address .....

**GENERAL TRANSFORMER CORPORATION**

502 So. Throop Street Chicago, Illinois

---

# SERVICE

---

A Monthly Digest of Radio and Allied Maintenance

AUGUST, 1933  
Vol. 2, No. 8

EDITOR  
John F. Rider

MANAGING EDITOR  
M. L. Muhleman

---

## Editorial Contents

### FEATURES

Last Word in Auto-Radio Test Equipment By Franklin King .....	276	Radio Manufacturers Service By J. R. Jackson .....	284
Multi-Tap Transformers By G. McL. Cole .....	286	RCA Victor R-73's and R-75 .....	286
New Method of Selective Analysis By John H. Miller .....	278	Story of Receiver Design, Part VI By G. S. Granger .....	281
Radio Manufacturers Service By J. R. Jackson .....	284	Wells-Gardner 05A Universal .....	285
Radio Progress Week .....	296	Why Self Bias? .....	288
Story of Receiver Design, Part VI By G. S. Granger .....	281	Zenith Models 705, 706, 707, 711 and 750 .....	287
ANTENNA (National Service Codes) .....	274	HIGHLIGHTS .....	296
AUTO-RADIO		INDEX OF MONTHLY LITERATURE .....	302
Last Word in Auto-Radio Test Equipment By Franklin King .....	276	MANUFACTURERS	
United Motors Model 4037 Super .....	290	Alden Adapters .....	300
FORUM (The Reader's Page) .....	294	Eby Universal Adaptor .....	300
GENERAL DATA		Hickok Tubeless Oscillator .....	300
Crosley Model 163 Universal .....	284	IRC Volt-Ohmmeter .....	300
Crosley Names and Chasses .....	280	New Deal in Condensers .....	300
Eveready Series 50 Notes .....	287	ON THE JOB	
Franklin Model 53 Universal .....	283	Boosting A. K. Battery Sets By W. C. Ward .....	292
L. Tatro Models F913, F923, E83, D73 and D76 .....	280	Break-In Adapter System By George Jehle .....	292
Multi-Tap Transformers By G. McL. Cole .....	286	Eliminating Dynacone Rattle By A. V. Ditty .....	292
New Method of Selective Analysis By John H. Miller .....	278	Self-Reading Diagrams .....	292
Philco Condenser Identifications .....	280	PUBLIC ADDRESS	
Philco Model 9 as Interference Locator .....	283	Importance of Working an Amplifier Out of Its Designated Impedance .....	288
Philco Model 17 Notes .....	283	Load Impedance for Triodes .....	288
		Noise in Condenser Microphones .....	288
		Why Self Bias? .....	288

---

### Advertising Director

FRANK TIBBITTS  
1440 Broadway, N. Y. City  
Telephone: CHickering 4-4542

Published monthly by

John F. Rider Publications, Inc.  
1440 BROADWAY  
NEW YORK, N. Y.

### Officers

JOHN F. RIDER,  
President and Treasurer  
M. L. MUHLEMAN,  
Vice-President  
J. SCHNEIDER,  
Secretary

---

Entered as second-class matter June 14, 1932, at the Post Office at New York, N. Y., under the Act of March 3, 1879. Copyright, 1933, by John F. Rider Publications, Inc. Contents must not be reproduced without permission. Subscription price \$2.00 per year in the United States of America; 20 cents per copy. \$3.00 per year in Canada and foreign countries; 35 cents per copy.

---



**HICKOK****TUBELESS****NEW  
METHOD****OSCILLATOR**

• CONTINUOUS  
FREQUENCY ALIGNMENT  
105 TO 1500 KILOCYCLES  
WITHOUT  
USE OF HARMONICS

• Utilizes pure radio-frequency  
unmodulated signal for aligning  
R.F. and I.F. stages—all receivers

• APPROVED—GUARANTEED

• NEW SALIENT FEATURES:

Employs one of the tubes in the Receiver for generating Radio Frequency Oscillations. Equipped with R. F. Milliammeter and D. C. Milliammeter with self-contained Rectifier System to indicate A. C. or D. C. Milliamperes.

Each stage of R. F. or I. F. can be independently aligned if desired without introducing any other stages into the circuit being tested. Eliminates previous method of feeding signal into first stage and reading final output at last Audio Stage.

The Tuning System enables extremely close settings for any given Frequency. Adjustable R. F. Output from Zero to Maximum by means of Continuous Variable Output Potentiometer. Provided with very efficient vibrator for A. F. Oscillations where desirable to test Audio sections of receivers independent of R. F. Stages—Continuously Variable from Zero to Maximum.

No A. C. Line Connections or External Voltages necessary. Merely connect to Receiver.

*List Price \$80. Liberal Trade Discounts Upon Application*

**THE HICKOK ELECTRICAL INSTRUMENT CO.**

10514 Dupont Avenue

Cleveland, Ohio

AUGUST, 1933 •

SAY YOU SAW IT IN SERVICE

273



With Input  
and  
Output Meters

SIZE  
11 $\frac{1}{4}$ " x 8 $\frac{3}{4}$ " x  
5 $\frac{3}{4}$ "

*Greatest Contribution  
to the Art of  
Radio Service  
Since Its  
Inception*

MEMBER R.M.A.

Sponsoring

"A REBUILD PROSPERITY CAMPAIGN"

For the Radio Industry.

# THE ANTENNA...

## NATIONAL SERVICE CODES

**T**HE nation is agog with fair practice codes, being established in conformity with President Roosevelt's National Recovery Administration. The radio service field is not exempt. This is being realized the country over and many local service organizations are working upon such codes.

The last thirty days have witnessed the arrival of many communications concerning such codes. No doubt more will follow. In order to clarify the situation, we have the following to say: In order to realize fully the benefits of the NRA, it is essential that a service men's organization be existent in every community—small or large. It is further essential that every Service Man now operating as such be a member of some such organization. This status is required in order that concerted effort in the proper direction be achieved. Men not affiliated with a service men's organization of some kind will find themselves roaming wildly—guessing at what is being done and being forced into line at a disadvantage. Men who are members of an organization, be it a national or a purely local association, will find it of very definite advantage.

In the first place, the lone rider will have no voice in deciding upon policies and tactics. In the second place, the decision of the association may be definitely disadvantageous to non-members. To protect yourself, join an association. If none is existent in your section and enough men are not available for a local group, join the association nearest to you.

As to fair practice codes, many are being formulated. The I.R.S.M. is working upon such a code. They have registered themselves with the NRA at Washington to that effect. At the same time many local groups not affiliated with the aforementioned national group are also working upon codes applicable to their community. This is vital. No one code established by any one group can be equitable to as greatly a diversified field as that of radio service unless the requirements of the various parts of the country are considered. Recognition of sectionalization is imperative. Living conditions and servicing conditions differ in different parts of the country; consequently, the men in these parts of the nation should have a voice in matters.

However, there is no time for dilly-dallying. Be it a national association, a state association or purely a local association—action is imperative. As yet there is no National Fair Practice Code for the service field. The blanket code offered to the nation is quite confusing to the service industry because of the nature of the work involved and because of the classification of the members. The only solution is the establishment of a code by the members of the service group.

It is not our intention to establish such a code. However, we have been asked by numerous associations who are forming codes to make suggestions relative to the contents of such codes. That is what we shall do now. Once more we remind you that what is to follow is purely suggestive—to

be changed or modified to suit the requirements of your group, community and locality. More than likely this list of suggestions will not include every item which can come to the minds of thousands of men. If so, you are to add whatever you think should be added.

1. The term "Service Man" or "Service Technician" is to mean an individual who, by virtue of technical training and practical experience, is capable of effecting a diagnosis and repair of a major defect in a radio receiver of any type.

2. The term "Installation Man" is to mean an individual who is sufficiently familiar by virtue of limited electrical and mechanical training or practical experience to erect antenna systems, and to install completely finished and operating radio receivers, in accordance with the usual interpretation of the term.

3. No one man should work more than eight hours in any one working day, or a maximum of 48 hours in any one week. (This applies equally as well to men who must work at night because many calls cannot be made at any other time. This group of men would work a number of hours at night and a number of hours during the daytime, the total not to exceed eight hours).

4. Minimum wage scale for permanent Service Men employees of 50 cents per hour, exclusive of car maintenance and sales commissions.

5. Minimum wage scale for Installation Men employees of 40 cents per hour.

6. If completion of 48-hour week is impossible because of the desires of the employer, the minimum wage scale for Service Men should be 50 cents per hour exclusive of car maintenance.

7. Car maintenance on mileage basis to be worked out.

8. Commission on the sale of all merchandise not specifically required to complete the installation or service call.

9. To meet with emergency demands for installation or service work during national events or broadcasts, no employee shall be allowed to work more than 10 per cent more than the aforementioned time limitation in any one week.

10. The minimum base pay for emergency overtime shall be one and one-half.

11. Full service and sales records to be kept by every service organization.

12. No service organization shall sell its product or products at such a price or terms that it will cost the customer less than the seller.

13. Each service organization shall submit to its affiliated association a list of its charges for classifications of service, said list to become known to the other members of the association. List of customers is not required.

14. Each service organization shall maintain a cost and sales accounting system which will be open to investigation by authorized government parties. The purpose of this stipulation is to definitely establish that cut price sales tactics are not being used.

15. Exchange of confidential information among service groups relative to delinquent customer accounts.

16. Definite statements in advertising. No trick phraseology or subterfuge employed to gain entry into the home of the set owner and to take the receiver out of the home.

17. No misleading statements in advertising relative to the work offered.

18. Establishment of a supervisory group for the purpose of deciding upon violations of the code.

One of the problems of this code is related to the functions of the service group. The modern Service Man is also a salesman, inasmuch as he is continually called upon to make sales of items not necessarily affiliated with the specific service call. Since we are concerned with increasing employment, increasing buying power, etc., it might be best if the function of the Service Man was considered solely in the field of service and not also as a salesman.

*John F. Rider.*



# Announcing..

## the WESTON METHOD of SELECTIVE ANALYSIS



### ANALYZER OBSOLESCENCE IS BANISHED!

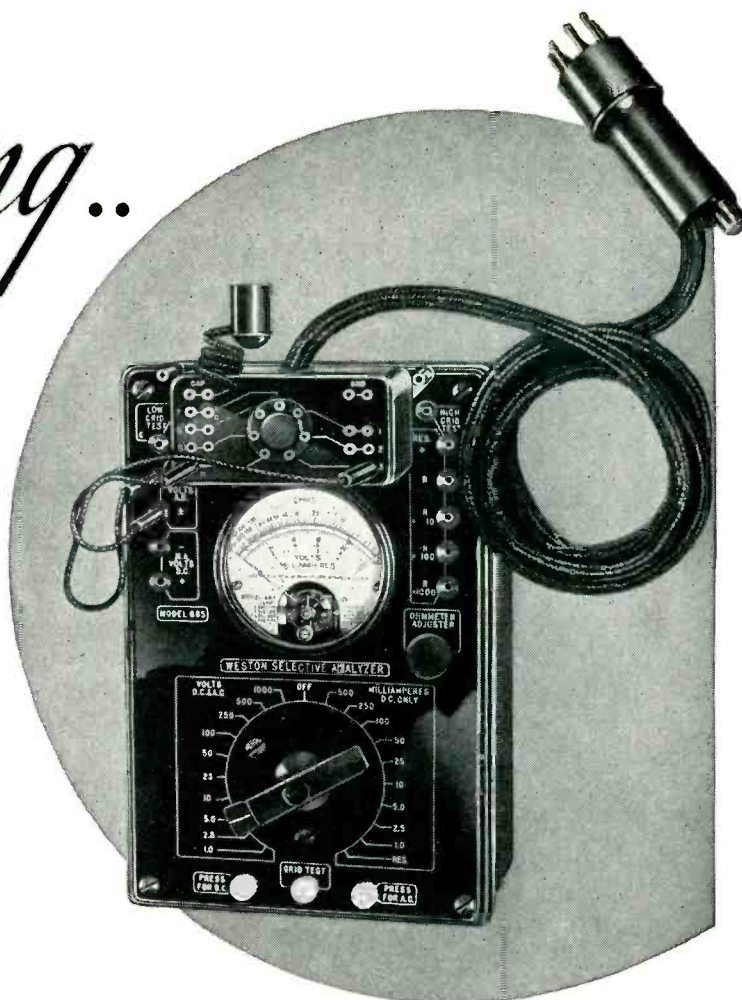

No LONGER is there the slightest need for worrying about Analyzer obsolescence. Weston has found the solution, providing a design which is always up-to-date regardless of tube developments. It's a method of Selective Analysis involving the new Weston Model 665 Selective Analyzer and suitable Tube Selectors.

Weston Model 665 Selective Analyzer contains all the necessary voltage, current and resistance ranges. Tube Selectors to accommodate 4, 5, 6 and 7 prong tubes are provided. You merely attach the proper Tube Selector to the Selective Analyzer. Next insert the plug into the tube socket of the radio set. Then by plugging into the proper jacks, voltage, current and resistance may be read in any part of the entire network leading to the tube socket.

The Weston Model 665 Selective Analyzer with Tube Selectors truly is universal in its capacity to analyze radio receivers. New tubes merely mean a new, inexpensive Tube Selector. That's how obsolescence is eliminated. Return the coupon today for complete information . . . Weston Electrical Instrument Corporation, 604 Frelinghuysen Avenue, Newark, N. J.

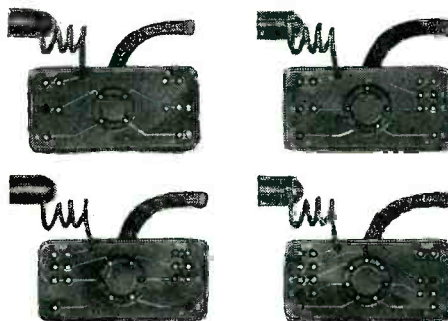

#### MODERNIZE YOUR ANALYZER

with Weston Socket Selector Units

Your present Analyzer can be brought up-to-date and kept that way by means of the new, inexpensive Weston Tube Selectors which can be used with all models and makes of Analyzers. Return the coupon for descriptive bulletin.

# WESTON *Radio Instruments*

Weston Electrical Instrument Corporation,  
604 Frelinghuysen Avenue, Newark, N. J.  
Please send bulletin describing Model 665 Selective Analyzer and  
Tube Selectors.

Name \_\_\_\_\_

Address \_\_\_\_\_

# The Last Word In AUTO-RADIO TEST EQUIPMENT

## • The Screened Room in Practical Use

By FRANKLIN KING

**F**OR a number of years, the screened or shielded room has been confined to the better equipped laboratories of radio manufacturers and independent research companies to permit accurate measurements to be made on highly sensitive radio receivers, with complete freedom from interference set up by foreign and undesired radio frequencies generally classed under the heading of "man-made" static.

This idea has at last been put to practical use in a comparatively new field, that of automobile radio receiver service and installation.

### THE SERVICING PROBLEMS

The problems which presented themselves to us and led to the construction of a first-class shielded room were as follows:

(1) We desired to make accurate comparative tests of competing makes of auto-radio receivers, so as to have available definite information upon which to base our selection of the makes of receivers we should decide to sell, and to establish standards by which to check other sets of the same model.

(2) We wish to be able to test other receivers of the same model as the sample originally tested at any time, under practically identical conditions.

(3) For these tests to be of definite value, the sample set should be checked and balanced—i.e., all r-f. and i-f. adjustments properly made.

(4) We wished to use standard testing equipment which could also be used as our standard service layout.

(5) We planned to check each set on the bench before installation and compare the results with those obtained from the sample set, particularly the overall sensitivity and selectivity, so as to be sure the set we installed was up to standard.

(6) It also seemed desirable to check the pick-up of the car aerial and general performance of the set after the installation was complete.

(7) It was our desire to be able to reduce ignition interference to the vanishing point.

### COPPER-LINED ROOM

It was immediately obvious that every one of these items would be well-nigh impossible in our building. In addition to various motors, elevators, etc., in the building our own

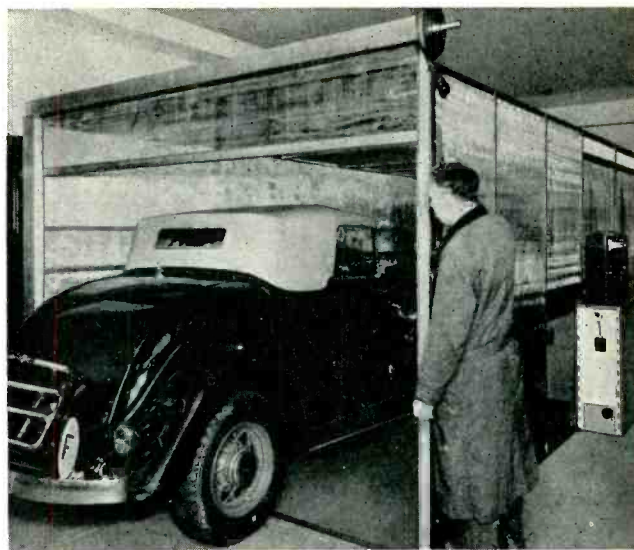

elaborate equipment for testing the entire electrical equipment of the automobile was a source of considerable interference.

So, we decided to construct the room shown in the accompanying illustration, which is completely copper lined. The dimensions are approximately 26' long by 10' 3" wide and 7' 6" high. The floor of sheet copper was laid first, and then a skeleton construction of brass tees and angles was set up in such a way as to permit the insertion of removable screens. The screening is standard 16-mesh copper and is soldered to  $\frac{3}{4}$ " x  $\frac{3}{4}$ " brass angle frames made to fit exactly between the brass "T Studs" and bolted to the frame.

The entrance is closed by a rolling screen door 10' 3" wide and 7' 6" high, hand-operated by a bronze cable which connects to a counter weight, housed against the wall on the floor below. A piece of flexible bronze weather strip is attached to the bottom bar of the door, making a tight electrical contact when the screen is lowered.

Two additional rolling screens give access to a bench convenient for tools, meters, etc., when checking a car in the enclosure. The entire structure is heavily bonded to the water pipe system.

### THE TEST BENCH

At the end of the room is the test bench, upon which are mounted a set of standard instruments, which have been somewhat modified to suit our requirements. They are, in order from left to right in the illustration—

(1) Weston Model 664 Capacity Meter, having ranges covering from .002 to 200 mfd. This instrument is mounted into a 12" x 15" engraved bakelite panel, which also carries an ammeter to check current drain of sets and a voltmeter to check the condition of the bench "A" and "B" batteries. Binding posts permit the use of these batteries, which are carried on a half shelf below the bench.

(2) Weston Model 663 Ohmmeter: This instrument covers resistance measurements from 0.5 ohm to 10 megohms and in addition is connected so that rapid continuity tests can be made by three different methods, as follows:

(a) A lead connected from ohms—to chassis. A cable with analyzer plug plugged into any socket. Rotating left hand lower switch gives the resistance from chassis to any terminal of the socket.

(b) With analyzer plug in a socket, the resistance be-



tween any two terminals is read by rotating right and left hand switches to desired position. For instance, left hand switch on 1, right hand switch on 4, gives resistance between filament and plate contacts.

(c) By using two cables plugged into any two sockets of the set the resistance between any terminal of one socket and any terminal of the other can be read by setting the two lower switches to appropriate positions.

(3) Jewell No. 538 Tube Checker: This well-known checker has been rebuilt and a new circuit designed to permit checking all types of tubes used in auto radio without the use of any adapters.

(4) Weston Model 660 Analyzer: This is a standard analyzer with the addition on the panel of a d-c. filament voltmeter and a d-c. plate milliammeter permanently connected so as to permit the three major readings to be made simultaneously—pin jacks on the panel permit the use of the various voltage, current and ohm ranges and also the use of the a-c. ranges of the meter for output measurements.

(5) Weston Model 662 Oscillator: This instrument furnishes calibrated fundamental frequencies covering all broadcast and high and low intermediate frequencies. The additional apparatus mounted on the panel permit greater signal attenuation than is possible with the standard job and is particularly useful for selectivity measurements.

#### TESTS AT MAXIMUM SENSITIVITY

In practice, this installation has worked out very well, as we find it possible to balance a set with sensitivity and volume controls at maximum settings, by using a weak oscillator signal and a low range on the output meter, and we find practically no interference other than that inherent in the set under conditions of maximum sensitivity with no signal and hence no AVC action. Unless all openings in the room are closed, and the a-c. outlet covered, however, precise balancing becomes difficult due to the fluctuations of the output meter as the set picks up interference.

A dummy aerial, supported on insulators about six inches clear of the screening, runs the length of the room and can be plugged into either the oscillator or to a jack connecting to an AKAformer antenna, which is brought into the cage at the right hand side of the bench. This antenna has a grounding switch, so that no signals are introduced into the

cage while the oscillator is in use for balancing the set or checking it on the car.

In practice, the car with the radio installed is driven into the cage, and all doors, etc., are closed. The dummy antenna is plugged into the oscillator, set for about 1,000 kc. This signal is tuned in on the set, to check both the condition of the set and the efficiency of the aerial. As we are concerned chiefly with practical and comparative measurements, and not with the precision required in a laboratory, we can judge aerial efficiency reasonably well by listening to the oscillator signal as picked up by the set at maximum sensitivity. Where necessary, more accurate measurements can be made if an output meter can be conveniently connected, without disturbing the shielding of the set. Sometimes the leads from the meter can be connected through air holes in the case, and one or two sets have external speaker connections which are accessible and into which the output meter can be connected. On the particular set for which we are distributors and with which we are most familiar, we have found that we can judge the overall installed efficiency very well by attenuating the oscillator signal to inaudibility and noting the setting of the attenuation controls.

The final test on the set is made with the dummy antenna connected to the outside aerial. As this aerial is remarkably efficient, the pickup of a good set, properly installed and having a good roof antenna is very excellent, and as the car owner hears broadcast music on his set before it is driven out of the cage he usually leaves in a pleasant frame of mind.

Incidentally, the difficult job of ignition interference suppression is made much easier as within the cage the only noise in the set at maximum sensitivity is that set up by the ignition of the car itself and there is no outside interference to complicate matters.

To carry off exhaust gas fumes, a blower system connected to the exhaust pipe through flexible Greenfield tubing has been installed, so the engine can be run indefinitely without risk.

The writer will be glad to furnish any details as to circuits, materials and construction that anyone may desire—and all interested visitors are welcome.

*(Any inquiries should be addressed to Mr. King, P. J. Durham Company, Inc., 17 West 60th St., New York, N. Y. —THE EDITORS.)*

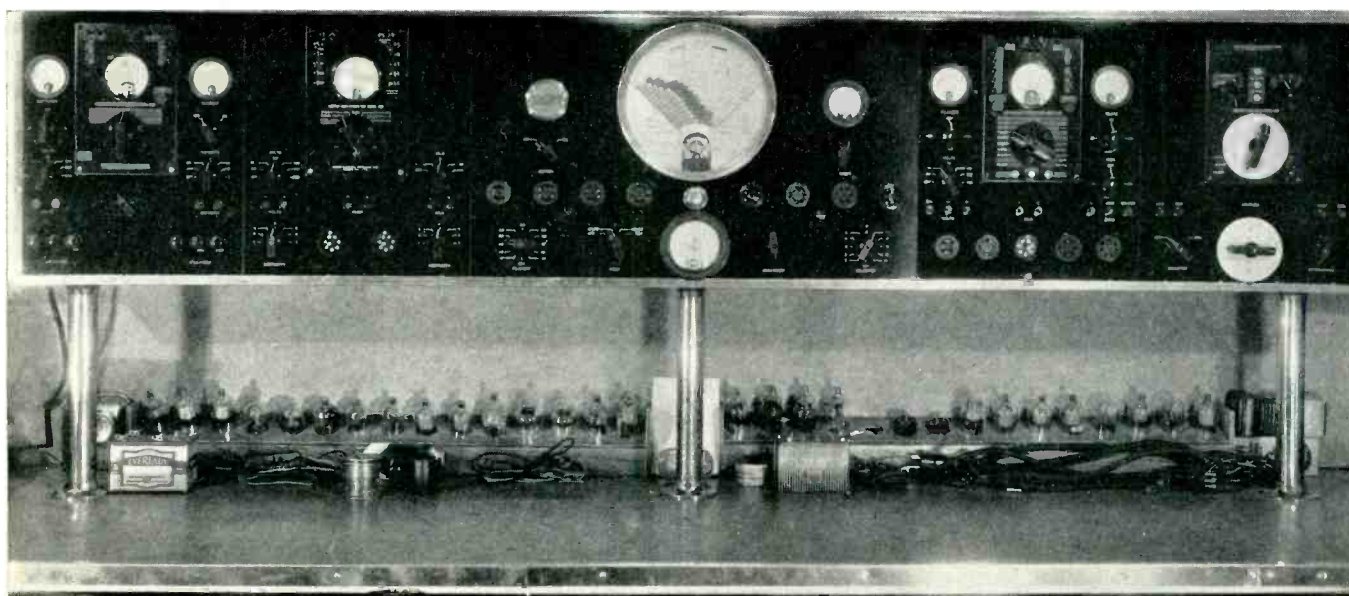

# General Data . . .

## NEW METHOD OF SELECTIVE ANALYSIS

By JOHN H. MILLER\*

OVER the last ten years the servicing of radio receivers has largely been handled through the medium of a combination testing instrument arranged for plugging into the vacuum tube socket. Such a device known under various trade names, has been invaluable in locating such troubles as will occur in any complicated electrical assembly.

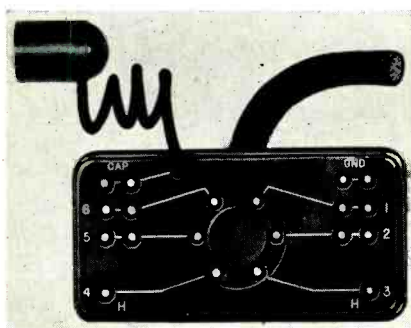

The 6-prong tube selector, with grid cap connection. The white lines indicate the actual internal connections

Of late the complexities in the tube situation, particularly as to the allocation of the various electrodes, has been such as to complicate matters to the point where the analyzer has seemed to be on its way to extinction.

### MEASUREMENT COMBINATIONS

Going back into what now seems ancient history, the first tube that was used in any quantity was a simple triode with 4 pins. The only measurements that could be made were filament voltage, plate voltage, grid voltage and plate current, a total of four possible measurements. Further, the battery voltages were fairly well standardized and two or three ranges sufficed to take care of all requirements. With three ranges for each measurement, except the filament, we have a total of ten possibilities. This simply means that a 10-point switch would cover all such possibilities.

Then the screen grid tube came into the picture with its added electrode and several more measurements were necessary. The 5-prong, indirectly-heated cathode tube followed it very shortly and heater voltages began to expand in numbers. Additional requirements of testing to the cathode instead of the heater added to the problem and the analyzer switch began to require upwards of 20 to 25 positions with auxiliary switches for reversing, for making readings to one or another return electrode, and so on.

But by exercising all of his ingenuity the instrument manufacturer was able to keep up with the procession by supplying instruments

with multiple ranges, switches with many contacts, and a wiring assembly much more complex than the radio set of today.

Over this entire period the heater terminals remained fixed. The cathode terminal remained fairly stable with the exception of the pentode where the screen was connected to this pin. The top cap in general has always been the control grid.

### ALTERED TUBE ELEMENT CONNECTIONS

This year's tubes, however, have completely upset all preconceived ideas as to standards of connection and we now have tapped heaters with the requirement for measuring filament voltage to other than the normal heater pins. The cathode wanders around among the other pins and may take any position. It has also multiplied itself and we may have two or possibly three cathodes to which certain voltages must be measured. We have two complete tubes in one envelope and there seems to be no end to the possibilities of multiplying the number of electrodes brought out on a single base.

As a concrete example of the requirements, assume a 7-prong tube with a top cap. This

gives us 8 electrodes. We may be required to measure voltage from any electrode to any other electrode and with 8 electrodes this gives us 28 possible pairs. If we have 10 voltage ranges to cover all possibilities, and we must measure direct or reversed on any range and on any pair of electrodes, we have a total of 560 possible combinations of polarity, range and position. And to measure current, we are required to go into each circuit with the exception of the filament circuit and this means that we will make measurements in any of 6 electrodes, and if we assume 9 possible ranges and also the possibility of either polarity, we have 108 more possible combinations.

The total is 668 possible d-c. measurements. If we add the possible a-c. measurements of filament and rectifier supply voltages we reach a grand total of something like 700 possibilities and to follow the matter through in the old way, we would require a 700-point switch if we were to proceed with a single switch. To be sure, we can break this up into a group of switches and reduce the number of possibilities but the total still remains a formidable figure.

We are also faced with the fact that whatever is done, we are likely to see more and more pins on a base as the tendency is consistently to get more elements into a single tube and the requirement of extreme flexibility of a system is still paramount.

We have, therefore, after much study of the situation, decided that it is necessary to divorce completely the switching to socket terminals and the measuring device itself.

### ELIMINATION OF OLD SWITCHING ARRANGEMENT

The new Weston Method of Selective

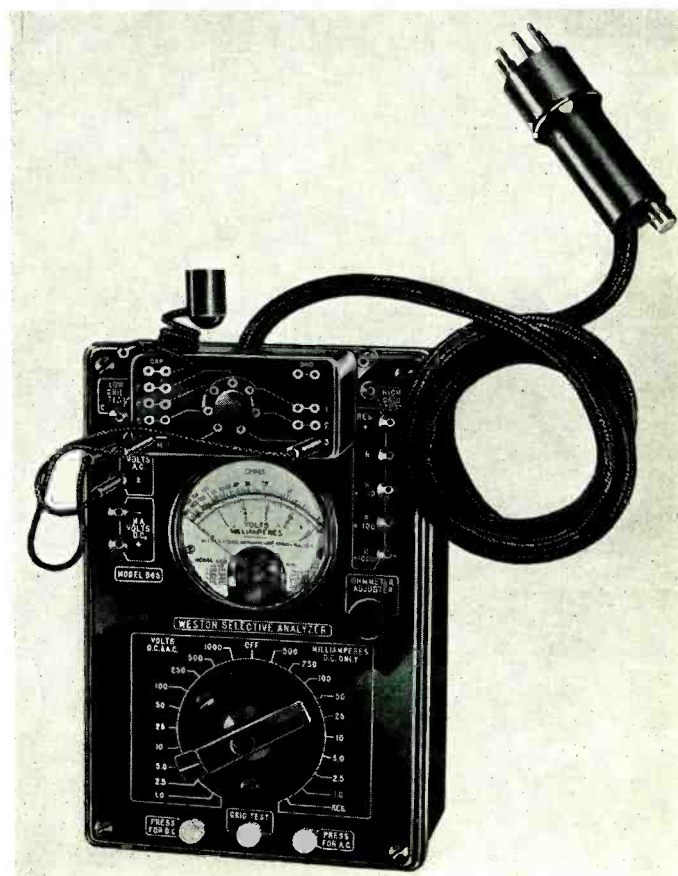

Front view of the new Weston Selective Analyzer Model 665 showing the 7-prong Model 666 Tube Selector plugged into position. Note the individual patch cords connected between jacks on the tube selector and jacks on the analyzer

\*Radio Engineer, Weston Electrical Instrument Corp.









# THE STORY OF RECEIVER DESIGN

## Part VI

**B**EFORE we plunge into the details of commercial power-supply systems, it will be advisable to get a clear picture of the relations of the various quantities involved in rectifier and filter circuits.

### HALF-WAVE RECTIFIER CIRCUIT

Let us start by considering the arrangement of Fig. 1. In this discussion let "e" be the voltage across the transformer secondary at any instant, let "Ep" be the peak value of "e," let "Ee" be the r.m.s. or effective value of "e," let "Ea" be the average value of "e" over one cycle, and let "Edc" be the d-c. voltage across R, which represents the load.

Now current will flow in the secondary circuit only when terminal (a) becomes positive with respect to (b). Since (a) will be positive for one-half of each cycle, a series of half waves spaced a half cycle apart will flow in the circuit. This is also shown in Fig. 1.

Now suppose a shunt condenser is added across the load, as shown by the dotted lines in the circuit of Fig. 1. By using a value of condenser sufficiently high (its value depends on the d-c. drain and the value of R), it is possible to increase the d-c. voltage (Edc) almost to the value of the peak value (Ep). This is due to the fact that the condenser acts as a storage tank, absorbing energy during one half cycle and discharging during the next half cycle. The average direct potential is obviously equal to the average between the charged and discharged condenser voltages. With electrolytic condensers it is often possible to construct a satisfactory filter of this type with reasonable economy. The principal disadvantage of this filter is the large charging current drawn by the condenser during the interval before the next cycle peak. This current is limited only by the transformer and rectifier regulation. If it is too large it may materially shorten the life of the rectifier, even causing it to overload or lose emission in a few minutes if improperly designed. The higher the d-c. voltage (Edc), the larger the condenser must be, and the larger the charging current.

More filtering may be obtained after the limiting value of the condenser is obtained

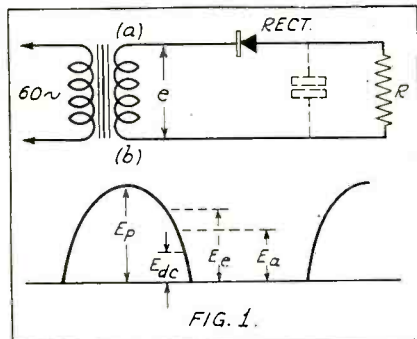

Simplified diagram of half-wave rectifier, and waveform with voltage references

by adding a series choke, as shown in Fig. 2-A. This arrangement when properly used will insure long life to the rectifier and must be used to prevent immediate failure with certain types of gaseous rectifiers.

The circuit of Fig. 2-A is used when the total value of R is relatively high. Now the

amplitude of ripple across R is  $\frac{ZC}{ZL - ZC}$

times the ripple produced by rectification at each frequency. Consequently ZL should be large compared to ZC at all ripple frequencies.

If a relatively high current is to be drawn from the rectifier the circuit of Fig. 2-B is generally used, in which the condenser is on the rectifier side of the choke. Here the amplitude of ripple across R is  $\frac{R}{ZL}$

that obtained with the filter of Fig. 1 with the condenser.

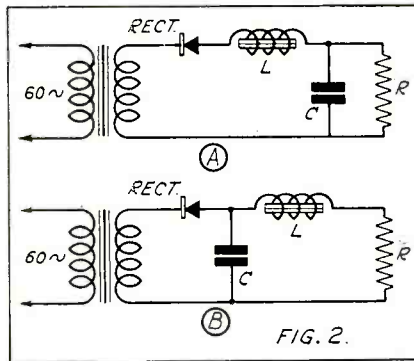

Half-wave rectifier supply circuits with (A) choke input and (B) condenser input

Half-wave rectifiers are used only in circuits which require a relatively small amount of filtering.

### FULL-WAVE RECTIFIER CIRCUIT

When a greater degree of ripple suppression is required the full-wave rectifier is usually employed. It is shown in its simplest arrangement in Fig. 3. It is of interest to note that with the full-wave rectifier the first harmonic is balanced out, and therefore filtering is somewhat easier than it is with a half-wave rectifier wherein the first harmonic is not balanced out. Moreover, the d-c. component is twice that of the half-wave rectifier. These features have resulted in the development of inexpensive full-wave rectifiers and their almost universal use in radio receivers.

The full-wave rectifier uses only one-half the secondary voltage at any one time, therefore twice the voltage step-up is required. Now the same reasoning as that given previously for filtering of half-wave rectifiers applies to full-wave rectifiers, and need not be repeated. However, for a given total value of choke coil inductance L and shunt capacity C, better filtering will be obtained when they are split up into the greatest number of

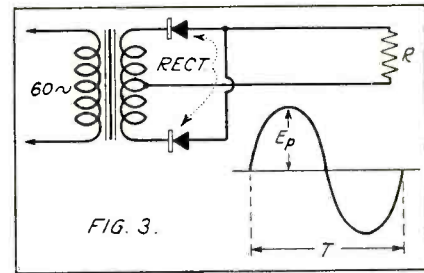

Simplified version of full-wave rectifier system, and waveform

sections. Thus, the filter shown in Fig. 4 is better than the filter in A or B of Fig. 2. A three-section filter would be even more effective than the two-section one shown in Fig. 4.

However, two chokes are more expensive than one, even though the total reactance is the same. Consequently it is usual to use one choke and as many condensers as required to get the necessary degree of filtering.

### FILTERING HARMONICS

Since the lower harmonics are stronger, we need more filtering at low frequencies than at high frequencies. As a result some of the circuits shown in Fig. 5 are often used. All of these circuits are intended to give progressively less filtering at higher harmonics. In Fig. 5-A, L and C are chosen to resonate at the lowest frequency to be filtered. In Fig. 5-B a single choke is used and C resonates the mutual inductance between those portions of the choke on either side of the tap. In Fig. 5-C the shunt circuit resonates at the lowest frequency to be filtered.

Now the first choke in a circuit, such as that shown in Fig. 5-A, has limited filtering action. Its principal function is to reduce the peak value of rectified current to a safe value. It is therefore desirable to use as small a choke as possible in this location. It happens however that there is a value of inductance for this choke above which it is unnecessary to go and below which it is unsafe to go—with gaseous rectifiers for example. This value is 0.1 per cent of the total resistance of the load and chokes. Thus, assume that 100 milliamperes at 400 volts were required across R in Fig. 5-A. Then

$$R = \frac{400}{.1} = 4,000 \text{ ohms, and let the d-c.}$$

resistance of both chokes be 1,000 ohms. Then  $L = 1 = .001 \times 5,000 = 5$  henrys. A larger inductance for the first choke would of course do no harm but neither would it do any particular good.

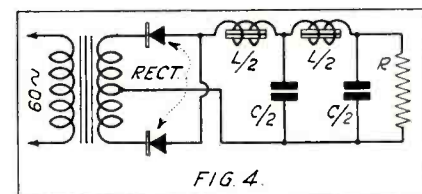

Full-wave supply system with double filter

## GENERAL DATA—continued

Consider the circuit of Fig. 4. The best value for the condenser between the two chokes is say  $\frac{C}{2}$  if the last condenser is  $\frac{C}{4}$ .

In other words the condenser in the center of the filter should be twice that of the end condenser for optimum filtering. The cut-off frequency of the filter must also be well below the lowest frequency to be filtered. Cut-off frequency can be determined from:

$$f = \frac{1000}{\pi \sqrt{LC}}$$

If 120 cycles is the lowest frequency to be filtered, then the cut-off should be 80 cycles or less. If the lowest frequency to be filtered had been 60 cycles, then the cut-off frequency should be 40 cycles or less. The above criteria are generally followed by designers, although they are altered to conform to standard sizes of condensers and chokes to form the most economical design.

### RESISTANCE-CAPACITY FILTERS

Resistance-capacity filters are also frequently used because of cheapness when regulation does not prevent. This type of filter has one decided advantage and that is, it offers appreciable attenuation to very low frequencies which occur when the receiver has a tendency to motorboat. It is often desirable to use a separate resistance-capacity filter for each of a number of tubes and thus reduce interaction as well as suppress ripple. A number of these filters feeding in parallel from the output of the main filter is an excellent as well as an inexpensive means of insuring low hum level and good stability. Filters of this sort are used in many commercial receivers.

### HIGH-FREQUENCY FILTERING

Very high frequency interference will often find its way into the receiver via the power supply. This may be introduced

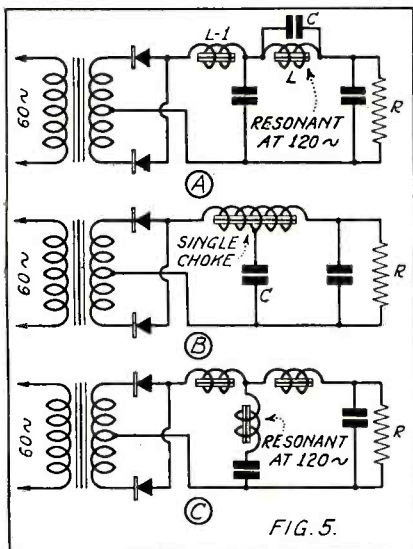

Three general arrangements for filtering out harmonics from full-wave rectifier

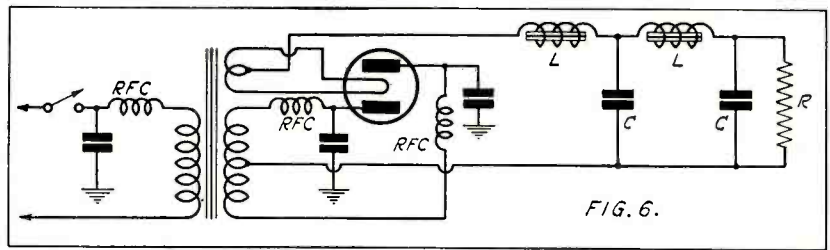

Full-wave rectifier circuit with chokes and condensers for high-frequency filtering

through the capacity existing between the primary and secondary windings of the power transformer and thence by any one of a number of routes to the receiver. This may be eliminated by inserting a static shield between the primary and the secondaries of the transformer and this is the manner usually employed in modern receivers.

It is particularly important that such interferences be kept out of the filament leads. Buffer condensers and power line filters, although usually less effective than a static shield, are also occasionally employed. Thus, 0.1 mfd. condensers are sometimes used from the plates of the rectifier to ground.

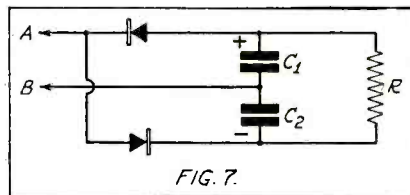

Simplified circuit of a voltage doubler

Occasionally r-f chokes are used in these leads or in the primary of the power transformer, as shown in Fig. 6. Condenser and choke filters of this type are also being employed in auto-radio receivers for the elimination of r-f interference.

In general such chokes should be shielded, although frequently they are not. Shielding might improve matters in some cases of trouble. Gaseous and mercury-vapor rectifiers, due to their sudden breakdown, may cause radio-frequency interference. The proper use of r-f chokes and buffer condensers will often prevent this interference from being picked up by the receiver. Gaseous rectifiers usually require that their cathodes be heated before plate voltage is applied. With the type used in broadcast receivers, however, the life is satisfactory when both filament and plates are energized simultaneously. Longer life would result even with these tubes if the filament were allowed to heat up before voltage were applied to the plates.

### VOLTAGE DOUBLING

Voltage doubling tubes are now being used quite extensively in universal receivers although the general principle of their operation has been known and applied in other fields for many years. You all know the general circuit arrangement. A simplified diagram is shown in Fig. 7. This arrangement works as follows: When terminal A of the line becomes positive, condenser C-1

is charged positive at about line voltage on its resistance side, as indicated. Likewise, when A becomes negative C-2 is charged negatively to line voltage on its resistance side. The sum of these two charges of course add up to twice the line voltage and the voltage across R, if the drain is small, is about twice the line voltage.

Filter circuits for doubler tubes are identical with those discussed previously. In this circuit the first harmonic of the line frequency is balanced out and its output is essentially the same as that of the full-wave rectifier. Electrolytic condensers of 8- to 16-mfd. are usually employed at C-1 and C-2. (Also see page 241, July SERVICE.)

By connecting the plates and cathodes of this tube in parallel it may of course be made to function as a simple half-wave rectifier, just as it is employed in many of the a-c., d-c. receivers. Or the tube may be used as two separate half-wave rectifiers, which is also done in many universal receivers—in this case one of the rectifiers is used for supplying the speaker field and the other for supplying the tubes in the receiver.

The chief advantage of the voltage doubler tube lies in the possibility of omitting the power transformer and still have a sufficiently high voltage for good receiver operation.

### HEATER-SUPPLY RIPPLE

Hum or ripple from the filaments of direct-heater type of tubes may sometimes rise to undue proportions. Usually the electrical center of filament and heater windings is grounded. A center-tapped winding is best although a center-tapped resistance connected across the winding may be used provided its resistance is not sufficiently high to affect tube bias. Both sides of the filament should be by-passed to ground with condensers when necessary. Grid filters, such as the types shown in Fig. 8, may frequently be

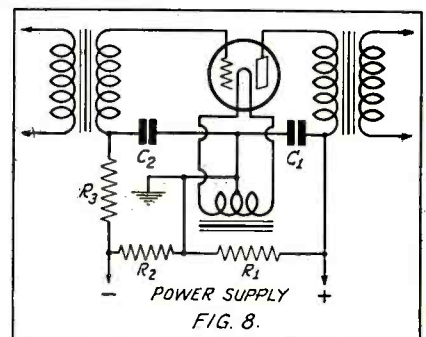

Circuit with grid filters for the reduction of a-c. ripple or hum



## GENERAL DATA—continued

used to advantage. When necessary, the grid condenser and resistor may be adjusted for minimum noise by the following formula:

$$C_2 = \frac{\mu R_2 C_1}{R_2 + R_3}$$

Where  $\mu$  is the amplification factor of the tube and the other designations are evident from the figure.

Hum reduction may often be effected by the use of a condenser and variable resistance in series connected between the proper points in the system. This consists in feeding ripple of the proper phase and amplitude back into one of the bias or plate leads of the amplifier. Several sizes of condenser ranging from 0.1 mfd. to 2.0 mfd. should be tried in series with a variable resistor of about 10,000 ohms. Any convenient point in the power supply may be chosen as the source and one terminal of this series circuit connected to it. The other terminal of the circuit may be applied to various points of the detector and audio amplifier and the resistance varied each time over its entire range until suitable cancellation is obtained.

G. S. GRANGER.

(To be continued)

### Using Philco Model 9 as Interference Locator

There are many Philco Transitone Receivers being used by power companies and Service Men for locating the sources of power leaks and radio interference. While most of these receivers are being used just as they were received from the factory, there have been numerous requests for information as to the best method of removing the automatic volume control feature from the receivers. Others have desired a switching arrangement, appreciating the value of automatic volume control for broadcast reception,

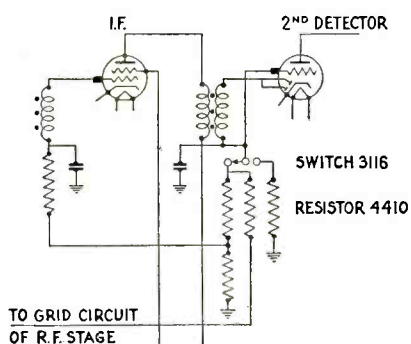

Switching arrangement for cutting in and out the AVC in Philco Model 9

but realizing that without it, the receiver will pick up more interference.

Philco has supplied the following data for those who wish to use the Model 9, or similar models, for locating interference.

#### SWITCHING OUT AVC

In the accompanying diagram the i-f. and detector stages of the Model 9 are depicted, with the switch for controlling automatic volume control. Similar changes can be made to any Philco Transitone Receiver since all models use the same automatic volume control principle. The single-pole, double-throw switch in the normal position connects the r-f. and i-f. grid circuits and the resistor network to the second detector stage. In the other position, these circuits are disconnected from the second detector while the detector stage is terminated with another resistor.

The connections can be broken at the bypass condenser (27) and the switch connections made to the condenser and resistors at this point.

For best operation in locating interference, a small enclosed loop should be used. This can be conveniently mounted on a pipe stand

on the left running board forward of the front corner post. The upper section of the loop should be free to rotate so that it can be turned toward the source of interference and in this manner be easily located.

With the automatic volume control connected in the circuit, it is difficult to get a good location of the source of interference because of the action of the automatic volume control in holding the output of the receiver to the same volume level over such a wide range of varying signal strength. With this control cut out, the least change in signal strength will be noticeable in the receiver output.

### Philco Model 17 Notes

The type 42 power pentode tubes used in the push-pull stage of the Model 17 are not used as pentodes. They are connected up as triodes and function in a Class A circuit.

The receiver is made in two types. The early Model 17-121 employs a type 80 tube as rectifier. The late Model 17-122 employs a 5Z3 tube as rectifier.

Both types use an intermediate frequency of 175 kc.

### Franklin Model 53 Universal

The schematic diagram of the Franklin Model 53 is shown on this page. It is a five-tube superheterodyne for operation on either a-c. or d-c. and tunes from 1,715 kc. to 540 kc. The intermediate peak frequency is 456 kc.

It will be noted that the antenna transformer and oscillator coils are marked "Ins." and "Outs." These markings refer to the inside and outside windings of the coils.

The voltage at the output of the filter choke is 100 volts. Though other voltage values are not at present obtainable, this power unit voltage value will assist in approximating other terminal voltages.

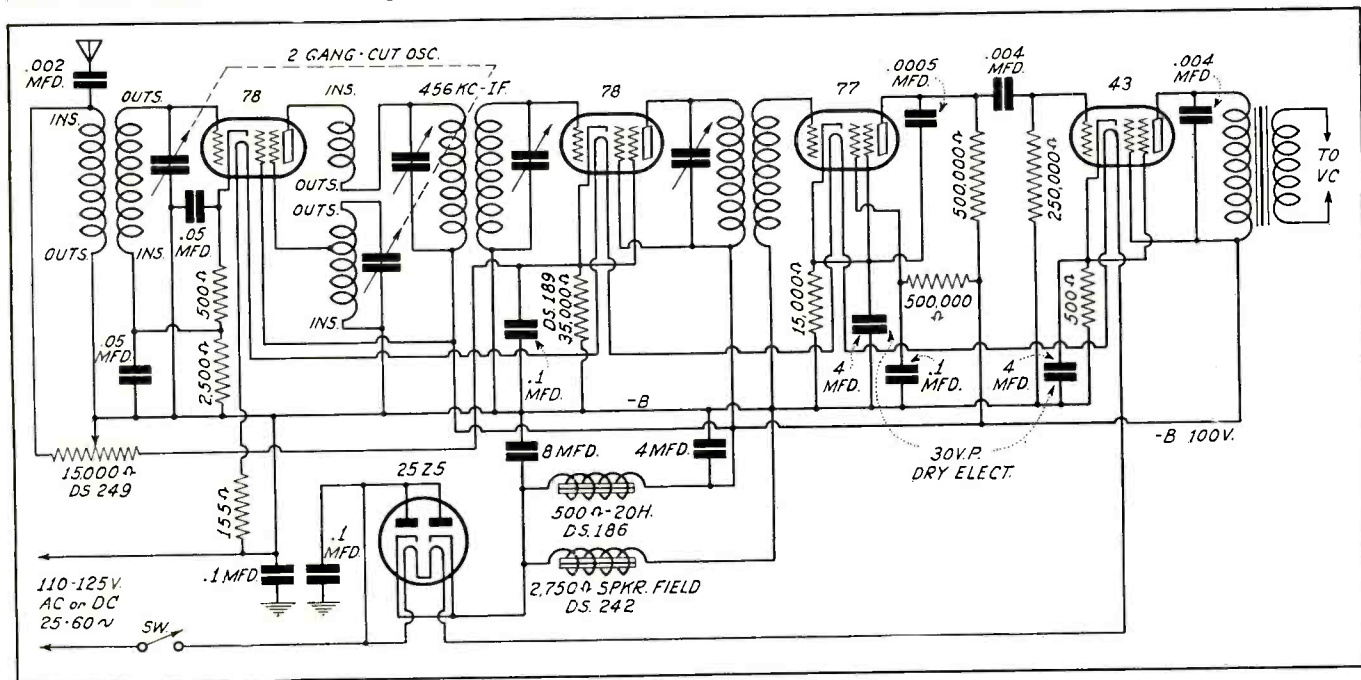

Schematic diagram of the Franklin Model 53 Universal superheterodyne receiver

## RADIO MANUFACTURERS SERVICE

By J. R. JACKSON\*

**S**OMETHING new in service has recently been announced by Philco in sponsoring the formation of a National Organization known as *Radio Manufacturers Service (RMS)*. This organization comprises a membership of the best Service Men in the country. It is national and has many plans for the assistance and improvement of the radio service industry. Local units are now being organized by the Philco Distributors in each territory throughout the country.

### TO IMPROVE SERVICE CONDITIONS

During the past several years Philco has cooperated in the development of Service Men's associations in many parts of the country. Now there will be local units of the RMS group organized by the Philco Distributor in each territory. The 25,000 best Service Men in this country are being selected and asked to join in building up a service organization which will accomplish the following purposes: *Give the Service Man the backing of tremendous Philco merchandising and advertising of Radio Manufacturers Service.*

The Philco Distributor in each territory is cooperating in organizing each local group. Only one qualification is necessary to become a member—the man must be a capable Service Man with sufficient experience to carry out the guarantee. Application must be made to the Philco Distributor's Service Manager, who will forward it to the Philco Service Engineer at the factory for formal acceptance. The accepted member will receive from the Philco factory a signed Certificate of Membership suitable for framing for display in the service shop.

Service calls which come into Philco Distributors will be turned over to members of

RMS at absolutely no cost. Philco plans to advertise *Radio Manufacturers Service* nationally in many ways which will actually bring business into the member's shop.

### ADVERTISING PROGRAM

As soon as sufficient members have been secured throughout the country, Philco will advertise *Radio Manufacturers Service* organization to the public nationally and will cooperate through the Distributor with local groups to secure service work for members. Detailed plans of this advertising campaign will be worked out with the individual Distributor. Where local advertising is run in newspapers it will be over members' names and will give the phone number of the Philco Distributor who will turn over calls received to the nearest member in the neighborhood. At the present time, the instruction sheet which accompanies every Philco Radio shipped from the factory tells the customer to look for members of *Radio Manufacturers Service* for expert service work should this be needed.

### TO MEET SERVICE PROBLEMS

The most serious problem confronting the Service Man is the unfair competition of "gypps" in the radio business. Hard times have forced many thousands of men to call themselves radio Service Men in spite of the fact that they have no training and little or no experience in this highly technical field. These men depend on cutting repair prices to secure business. *Radio Manufacturers Service* will help members to earn a fair price for high quality work well done. Each member will receive with his Membership Certificate a printed chart of Standard *Radio Manufacturers Service* labor charges which he is entitled to collect for the standard

of work he has completed. This chart can be shown to service customers in explanation of the bill. *Radio Manufacturers Service* members are entitled to collect the labor charge established for members plus the list price of the part used on the service job.

### PARTS GUARANTEE

A serious result of poor workmanship has been the loss of public confidence in Service Men and organizations. Members will be selected because of their ability as Service Men. Philco will advertise that the work and the parts used in servicing receivers carry a standard *Radio Manufacturers Service* guarantee for ninety days after the job has been completed. This guarantee will be maintained on a cooperative basis. Philco parts are guaranteed for ninety days. *Radio Manufacturers Service* members will enforce the terms of this ninety-day warranty and supply the labor that will be required in those few cases where such warranty adjustments are necessary. Service work which is not satisfactorily completed and which is not remedied by the Service Man will result in loss of membership in the RMS. High quality workmanship will be rewarded with additional work given out by the Philco Distributors.

(Continued on page 285)

### Crosley Model 163 Universal

Model 163 (Companion and Travette), the circuit for which is shown on this page, is a five-tube superheterodyne designed to operate on either a-c. or d-c. The intermediate frequency is 456 kc.

Note that all condenser, resistance and voltage values are given on the diagram. The voltage measurements are those to be expected when the set is operated from an a-c. line with a potential of 117.5 volts. Voltages with d-c. operation are about 10 per cent lower than those with a-c. operation. These readings should be taken with no signal to the antenna circuit.

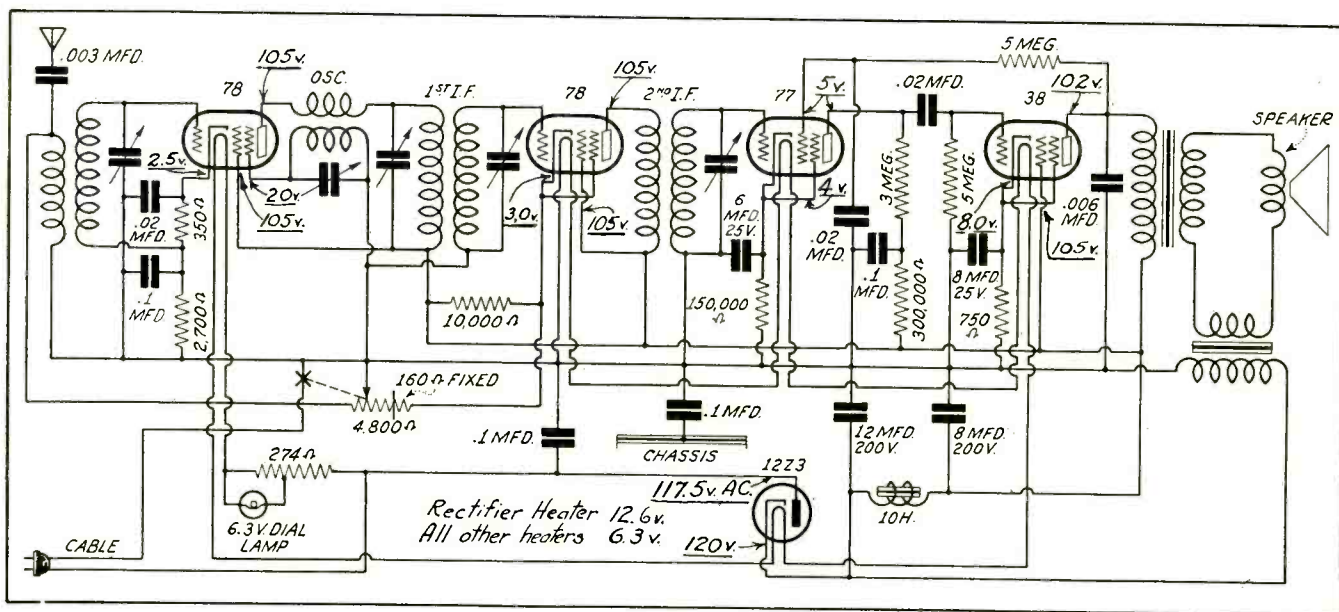

Diagram of the Crosley Model 163 Universal superheterodyne. Test voltage readings are given in the diagram



# GENERAL DATA—continued

## Radio Manufacturers Service (Continued from page 284)

### TECHNICAL INFORMATION

Members will receive from the Philco Distributor a copy of the monthly *Radio Manufacturers Service News*—the "PHILCO SERVICEMAN." They will receive bulletins on service work giving as many helpful suggestions as possible which will assist in working on radio sets of all types. They will receive complete technical information on tubes and service bulletins dealing with general service problems. When present plans are completed, all RMS members will receive lessons dealing with radio servicing prepared by the Philco Engineering Department. They will receive instructions on cabinet repairing and touch-up, complete listing of Philco general replacement parts and all technical information released by Philco for the use of Service Men.

With each Membership Certificate there is given an attractive 8 by 11-inch sign for display in the window, advertising membership in RMS. A copy of "Standard Radio Manufacturers Service Labor Charges" is also supplied at this time.

### HOW TO BECOME A MEMBER

The Philco Distributor in your territory has been supplied with Membership Applications. His Service Manager will explain in detail the requirements necessary for membership. When membership applications are accepted by the Philco factory the Membership Certificate and the equipment described above is forwarded promptly to the address on the application. It costs absolutely nothing to join. There are no membership dues,

no initiation fee and no costs connected with *Radio Manufacturers Service*.

### Wells-Gardner 05A Universal

The No. 05A Series, Wells-Gardner receiver is an a-c., d-c. job, as the accompanying diagram indicates. All tube heaters are, of course, connected in series.

The circuit consists of an r-f. transformer with tuned secondary feeding into a type 77 triple-grid tube which functions both as first detector and oscillator. The primary and secondary of the r-f. transformer are each made up of two sections. For short-wave reception, one portion of the primary and the secondary are shorted out with the broadcast-short-wave switch, as shown in diagram.

The remaining portions, in combination with the r-f. section of the tuning condenser and trimmer can then be tuned to the short-wave band of from 1,450 to 4,000 kc. An adjusting condenser, connected across the short-wave portion of the secondary is used in tracking the oscillator and r-f. circuits for the short-wave band.

For short-wave reception, the upper oscillator winding is shorted out as well as the 600-kc. trimmer condenser, when the switch is in the short-wave position.

### TRACKING

In order to provide satisfactory tracking with the r-f. tuned circuit for broadcast reception, the oscillator is provided with a 600-kc. and a 1,400-kc. trimmer condenser. Alignment should be made at these frequencies. The short-wave trimmer condenser previously referred to should be aligned at 3,000-kc.

The intermediate frequency used in this

receiver is 262-kc.—but take note of the fact that the two i-f. transformers have no trimmers, being self tuned. There are, therefore, no peaking operations to go through.

The type 78 tube functions as the i-f. amplifier. A second type 77 tube is used as second detector. When grid current flows in the second detector, a voltage is developed across a resistor which provides additional bias voltage on the i-f. and second detector tubes, thus giving overload control.

The type 43 power pentode receives its bias from the drop in voltage across the filter choke in the power unit.

The 25Z5 acts as a double rectifier, one cathode supplying the tubes in the receiver and the other cathode supplying the speaker field.

### TEST READINGS

Note that voltage readings are given on the diagram. Values are given for both a-c. and d-c. operation. Such readings should be taken with a high-resistance voltmeter. The antenna and ground should be disconnected and the antenna and ground leads in the receiver connected together. Volume control should be set at maximum. If a cable and plug are used to read the voltages, when making the readings at the i-f. socket, ground the control grid through a condenser to prevent oscillation.

The early models of this receiver did not have a 4-mfd. condenser connected between the second detector cathode and ground, as shown in the diagram. If the second detector tube has cathode to heater leakage, the set will hum excessively. This can be corrected in the earlier models by connecting a 4-mfd. electrolytic condenser between the points mentioned above.

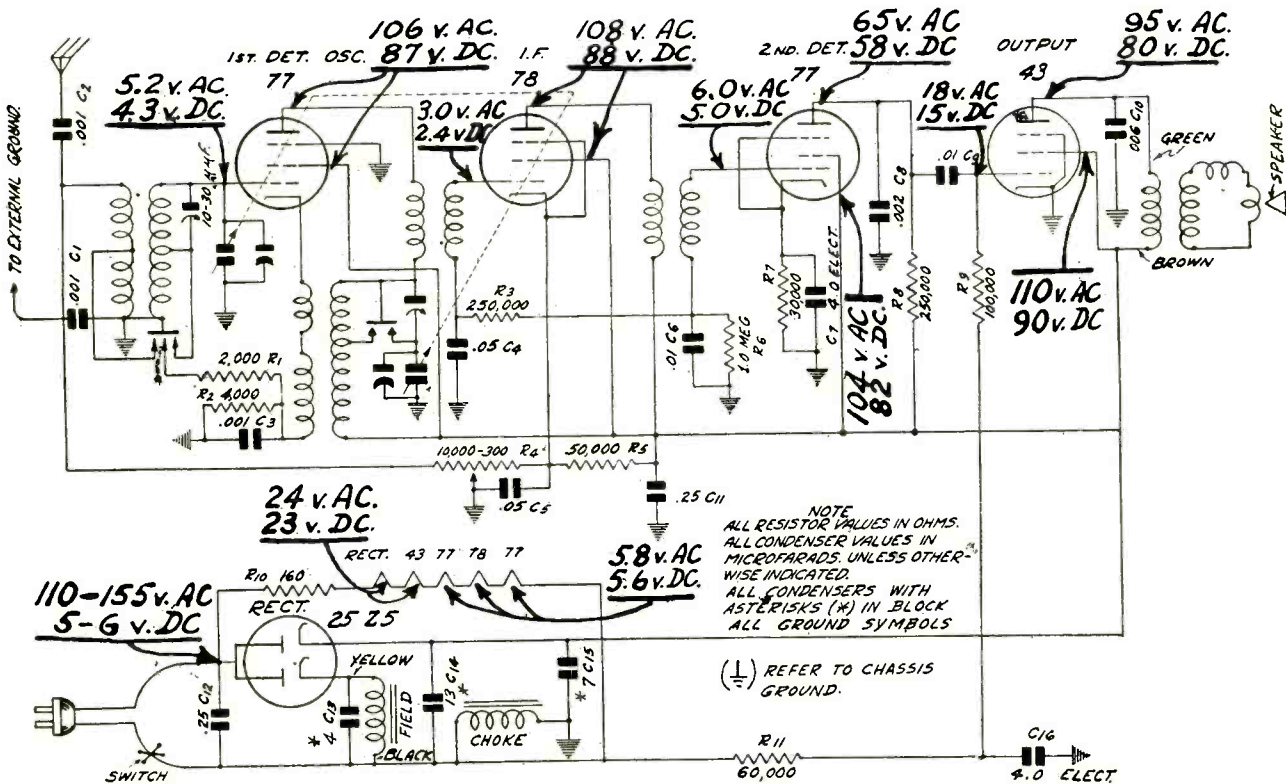

Wells-Gardner 05A Universal superheterodyne. Both a-c. and d-c. voltage values are given

## MULTI-TAP TRANSFORMERS

By G. McL. COLE\*

(A paper presented before the Institute of Radio Servicemen, July 24, 1933)

THE amount of success attending the art of servicing a radio receiving set is largely dependent upon the promptness with which the set is restored to its original performance. Immediate service—to get that World's Series ball game—means a very pleasant jingle in the pocket of the Service Man. It was with this thought in mind that the multi-tap universal transformer was developed.

Noah Webster, father of the dictionary, defined universal as "adaptable to various uses." He was by no means limiting himself to the mechanical. Universal-type transformers have heretofore been equipped with mountings whose range of mechanical adaptability has been quite satisfactory. But, electrically they were useful for one type of set, and only one. The truly universal transformer must be suitable electrically as well as mechanically. Since universal type mountings are well known we will consider the electrical features only of such a transformer.

### COMMON TUBE COMPLEMENTS

The first step is to determine what types of sets are most likely to be encountered in service. This is another way of saying, what are the most popular set types on the market today—from the Service Man's standpoint?

Below is a list of set types showing tubes only, arranged according to the filament windings required on the transformer. This list considers only the type of tubes and not the total number of tubes in any particular set.

- A—26, 27, 71A, 80.
- B—26, 27, 45, 80.
- C—24, 71A, 80.
- D—24, 45, 80.
- E—24, 50, 80.
- F—24, 27, 71A, 80.
- G—24, 27, 45, 80.
- H—24, 45, 82.
- J—24, 45, 83.
- K—6.3-v. tubes, 80.

Where a type 24 is designated it is to be understood that this represents any 2.5-volt heater tube, and likewise the type 45 as any amplifier tube with the same filament or heater voltage. To the list of set types can be added 6.3-volt tubes with type 82 or 83 rectifiers in place of the type 80. Also combinations of 6.3-volt tubes with type 45 amplifiers and a type 80, 82 or 83 rectifier. Though many more such set types are readily brought to mind, the above list serves to illustrate the following points and so is sufficient.

### TRANSFORMER FILAMENT WINDINGS

A transformer wound to take care of type A set is of no use for type B or type F, nor can type K be used in place of E or H, etc. Obviously, then, one transformer is required

\*Chief Engineer, General Transformer Corp.

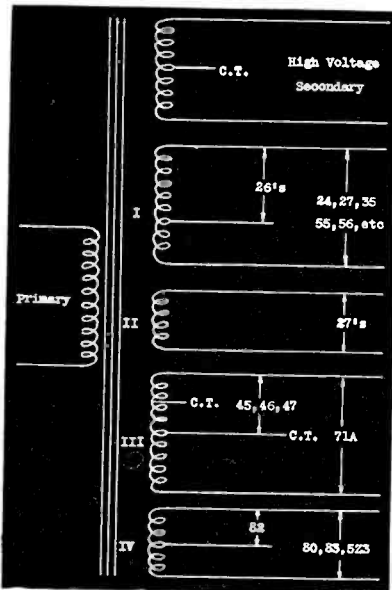

Fig. 1. Schematic of a typical multi-tap transformer. Its uses are explained in the text

for every set type for any given number of tubes.

Now, the list below shows the set types classified according to the number of tubes in the set, from 4 to 10 tubes, and the number of transformers required.

Tubes	Set Type	Transformers
4	D, H, K	3
5	A to K incl.	9
6	A to K incl.	10
7	A to K incl.	10
8	A to K incl.	10
9	A to K incl.	10
10	A to K incl.	10
Total		62

Since, as it was shown above, that A, B, C, etc., represent separate and different transformers, the numbers to the left are in actuality the number of transformers required to service these sets. Remember, too, that this is only a partial listing. The difference in any two adjacent groups is such that they may be very safely combined making for:

Tubes	Transformers	
4	3	
5-6	10	
7-8	10	
9-10	10	
Total		33

The number of transformers is now reduced to 33. Look through any of your catalogs—you'll find them all there with several additions.

Fig. 1 shows the general schematic of a

multi-tap universal transformer. Naturally, the primary and secondary windings are required for all of the transformers, no matter what the tubes or the set type.

Consider the set types given in the first table in relation to the diagram of Fig. 1. The tubes for set type A (26, 27, 71A, 80) are supplied with filament voltage as follows: the 26's from the 1.5-volt portion of winding I. The 2.5-volt tap on this winding remains dead. The type 27 detector receives its filament supply from winding II, the 71A from III and the 80 from IV. For the B type set, the 26, 27 and 80 are taken care of in the same manner as in the A type. The type 45 amplifiers use only half of the III winding, 1.25 volts being the center tap (C.T.). Sets of type C use all of winding I for the 24's, the 71A on III, the 80 on IV. Types F and G represent sets requiring two separate filament windings for the heater tubes, with additional windings for the amplifier and rectifier tubes. The 24's are supplied from winding I, the additional 24's or 27's from II, and the amplifiers and rectifier from III and IV respectively. The 7.5 volts for the 50's (type E) may be gotten by connecting II and III. This gives 7.5 volts with the C.T. at the 1.25-volt tap on the III winding.

### COMBINED WINDINGS

There are several ways of connecting the windings for the 6.3-volt tubes. The simplest is to connect winding II to the 1.25-volt tap of winding III. The resulting voltage is obtained from the start of winding II and the 5.0-volt end of III. This leaves I free to be used with type 45 tubes if necessary.

Wherever type 82 tubes are encountered, either windings II or one-half of winding IV, may be used. In the same manner it can be shown that the transformer takes care of not only every set type from A to K, but many more combinations. Inasmuch as the transformer satisfies the conditions of A and B, also C, D, E, etc., the last table becomes for:

Tubes	Transformer	
4	1	
5-6	1	
7-8	1	
9-10	1	
Total		4

Only four transformers, universal electrically and mechanically solve the power problem in over 90 per cent of all sets on the market.

### RCA Victor R-73's and R-75

There are two versions of the R-73 receiver. The first model employs a pair of type 47 pentodes in push-pull in the output and has no Silent Tuning Control. The second model employs a pair of type 2A5 tubes in push-pull in the output and has a Silent Tuning Control located on the left hand side panel.

The Model R-75 receiver is the same as the second model of the R-73, using the 2A5 tubes, but has the Silent Tuning Control knob mounted on the front, directly above the station selector dial.





# Public Address . . .

## Load Impedance for Triodes

In the March, 1924, issue of the *Journal of the Institute of Electrical Engineers* (British), Mr. W. J. Brown proved that maximum distortionless output of a power triode is obtained when the tube operates into an impedance about *double* that of the tube. However, we know that maximum power output (where distortion is disregarded) will be obtained when the tube is operated into an impedance *equal* to its plate resistance. As a result, there has been some disagreement among designers ever since the above publication appeared as to the best load impedance for triodes.

This may not strike you as being very important. Nevertheless, for those who design and construct amplifiers and public-address systems the data should prove of considerable value.

## REDUCTION IN HARMONICS

A number of papers have appeared in recent years showing that experiment verifies Mr. Brown's analytical predictions. These publications have shown that as a rule there is a considerable reduction in harmonics when the tube works into twice its plate resistance. Moreover, the power output of the tube is reduced only one db by this impedance mismatch of two to one (as may be seen by referring to Fig. 2, page 216, *JUNE SERVICE*). This amounts to a reduction in power of about 20 per cent and is not a particularly serious matter. It can be said with certainty therefore that for high fidelity work, the two to one impedance mismatch is best. The power loss is negligible.

## Why Self Bias?

Since the operating characteristics of vacuum tubes vary over fairly wide limits, the plate currents will likewise vary considerably. Consequently the grid bias is usually adjusted for the "average" tube. This is the reason that the plate currents of power tubes operated at fixed bias (from C batteries or C power unit) may be widely different for different tubes. For large tubes this may be a matter of some importance.

With self bias, the grid bias is of course

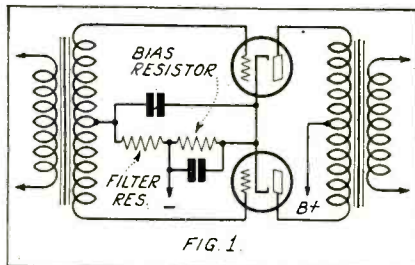

**In this push-pull stage the bias resistor is common to both tubes. This does not guarantee the correct bias for either one or both of the tubes due to possible differences in plate current, the controlling factor**

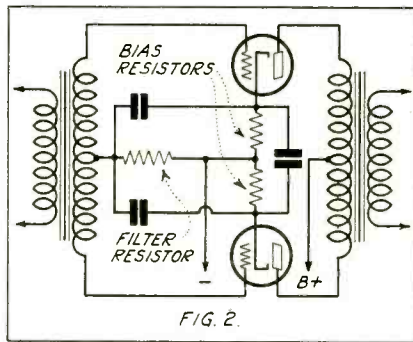

**In this push-pull stage, separate bias resistors are employed—one for each tube. Since bias is directly proportional to plate current, each tube is supplied with the proper bias with a resultant reduction of distortion near the overload point**

directly proportional to the plate current so that low current tubes tend to operate at nearer average plate current (i.e., higher than with fixed bias) and high current tubes due to higher bias tend to operate at lower current. As a result the plate current varies less from tube to tube with self bias than with fixed bias.

## OVERLOADING AND BIAS

Suppose the power stage of an amplifier with self bias is overloaded. This will either cause an increase or a decrease in normal plate current, usually the former. Since the bias is proportional to the plate current, a certain amount of stabilization will take place so that the change in plate current will be considerably less than if fixed bias had been used. As a result a self-biased amplifier can be overloaded to a greater degree than a fixed-bias amplifier before noticeable distortion takes place.

## SEPARATE SELF-BIASING

From the previous discussion it becomes apparent that in the usual form of push-pull amplifier it would be desirable to have each tube biased separately by its own plate current. When both tubes are biased by the voltage drop in a single resistor, as shown in Fig. 1, the bias for one tube with respect to its plate current may not be at all satisfactory. The condition would be correct only in the event that the two tubes were matched. However, if the tubes are separately biased, as shown in Fig. 2, each tube is biased in direct proportion to its plate current. This tends to preserve balance and reduce distortion.

## Noise in Condenser Microphones

In some floor model condenser microphones, a shielded lead from the amplifier is run down the stem of the cable connection. Usually the sheath of this lead is carefully bonded to the metal stand at several places. If the lead becomes loose and the remaining connections between stand and sheath are

oxidized, the stand becomes ungrounded and may pick up a static charge. This charge may break down the oxide at intervals and spark, or it may discharge to the sheath when the stand is moved so that momentary contacts are formed between sheath and stand. This will usually cause loud clicks and scratching noises similar in sound to poor connections. The remedy of course is a careful rebonding of cable to stand.

## Importance of Working an Amplifier Out of Its Designated Impedance

You have probably noticed that an amplifier connected across a 200-ohm circuit does not produce the same effect as a 200-ohm resistance, although the amplifier is intended to work out of a 200-ohm circuit. This immediately indicates that the input impedance of amplifiers do not match the circuits from which they work. As a matter of fact, they don't. The input impedance of most high-quality amplifiers is five or ten times as high as the impedance from which they work. The reason for this is that maximum voltage step-up for good quality is obtained by so doing.

## IMPEDANCE AND FREQUENCY

Let us attempt to find the reason for this. In the first place the input impedance of a Class A amplifier is a small capacity. A transformer terminated only in a small capacity is for all practical purposes working into an open circuit—except at the upper end of the audio spectrum. The input impedance of a perfect transformer with open-circuited secondary is an infinitely high inductance.

We know that the reactance of an inductance increases as the frequency is increased, that is, if it is 1,000 ohms at 50 cycles, it is 2,000 ohms at 100 cycles, etc. The voltage applied to the grid circuit of the tube, which is that appearing across the secondary terminals, is proportional to the voltage across the primary. If the impedance of the primary is increasing with frequency, it will absorb more and more of the total input voltage so that instead of a flat frequency characteristic, we should have one in which response increases with frequency. Suppose, however, that at the lowest frequency in which we are interested that the input impedance is ten times the circuit impedance, i.e., for a 200-ohm circuit an input impedance of 2,000 ohms.

Then  $\frac{10}{11}$  of the total voltage would appear

across the transformer primary. At twice this frequency the input impedance would be 4,000 ohms and the voltage across the primary would be  $\frac{20}{21}$  of the total voltage,

etc. (See page 22, *JANUARY SERVICE*.) That is, the difference between the two above frequencies would be about 0.5 db. Had the input impedance been higher the difference would have been less. It is thus evident that by making the amplifier input impedance very high the amplifier gain becomes more nearly independent of the circuit impedance provided it is always low. Of course, copper and iron loss in the transformer, both of which increases with frequency, tend to reduce this difference and in practical cases a compromise is affected that results in a more nearly equal voltage step-up.



# Get **FREE SERVICE BULLETINS!**

Keep up-to-date on new facts and methods discovered every month by other service men

- "Sylvania News" brings all the latest news of radio sets and servicing. In every issue, there's a full page of useful servicing tips from other men in your business.

Fill in and mail the coupon and you'll get this valuable service **FREE** each month. No obligation . . . it's a complimentary service offered by the makers of Sylvania Tubes.

And here's a chance to cash in on *your* experience, too! Send in your own servicing tips. For every one that's printed in "Sylvania News," you get a free Sylvania Tube (any type you select up to \$3.00 in value!)

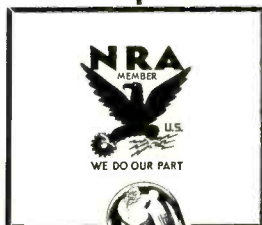

**Sylvania**  
RECOMMENDED BY R.F.A. PAT. OFF.  
**THE SET-TESTED RADIO TUBE**

● A Product of Hygrade Sylvania Corporation

## MAIL COUPON TO-DAY!

HYGRADE SYLVANIA CORP.  
 Emporium, Pa.

C-3

Dear Sirs:

Please put my name on the mailing list for your free radio bulletin, "Sylvania News."

Name .....

Address .....

City..... State.....





(Continued from page 287)  
 diagram of the R-F. Unit as originally published:

**PARTS ADDED**

No.	Item
2406	Volume control insulating washer
2407	Volume control insulating bushing
3514	35-ohm wire wound resistor
3515	Volume control; wire wound
3516	1,150-ohm carbon resistor
3517	260-ohm carbon resistor
3518	50,000-ohm carbon resistor

**PARTS OMITTED**

No.	Item
2338	2,500-ohm wire wound resistor
2835*	4,000-ohm carbon resistor
2917	Volume control
3004	200-ohm carbon resistor

\* One part No. 2835 remains in R-F Unit.

In Fig. 2 is the schematic diagram of the Series 50 R-F Unit with the following list of parts added to and omitted from the schematic diagram of Fig. 1:

**PARTS ADDED**

No.	Item
2154-D	Trimming Condenser
3515-A	Volume control

**PARTS OMITTED**

No.	Item
2154-B	Trimming condenser
2406	Volume control insulating washer
2407	Volume control insulating bushing
3515	Volume control

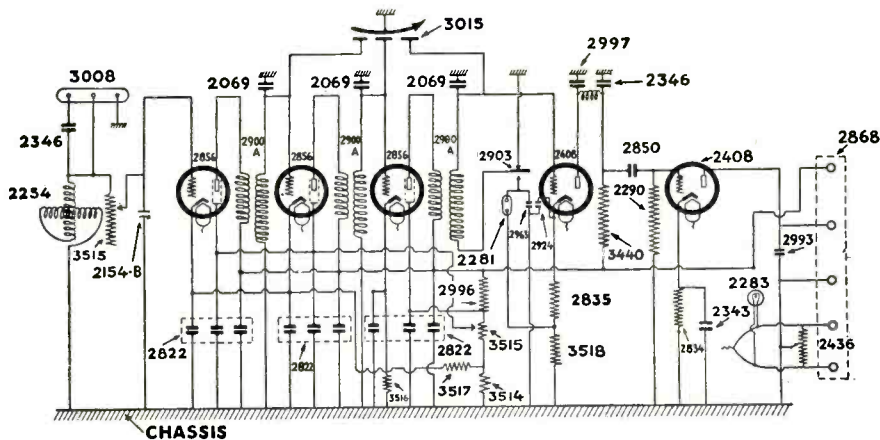

Above: Fig. 1. Circuit of the second Model 50 Eveready tuned r-f. receiver.

Below: Fig. 2, the third Model 50

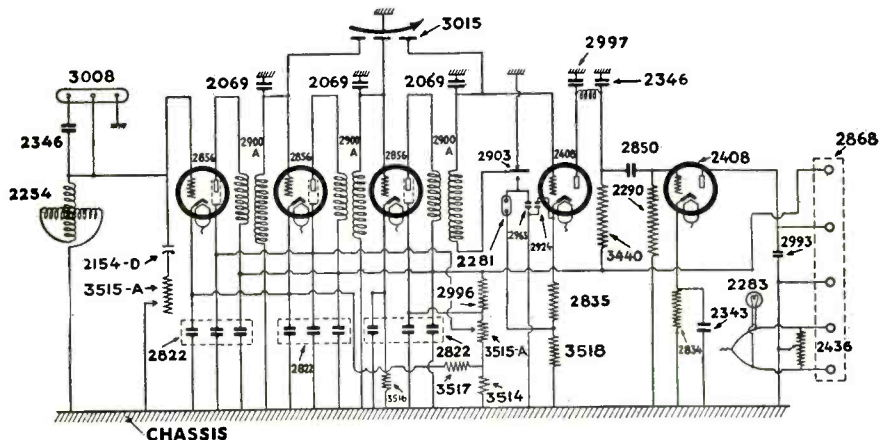

# NOW—the New

## MODERN TUBE INDEX

**BIGGER** because it lists all the tubes announced right up to the very last moment, such as the 1A6, 2B6, 6D6 and 6Z5!

**BETTER** because *illustrated* base layouts and connections are given for all tubes—both the old and the new!

**FINER** because of the new added feature of complete listing of tubes which are similar or interchangeable!

WE EXPECT TO BE SWAMPED WITH ORDERS—SO GET YOUR COPY TODAY

Price 25 Cents Post Paid  
 (Add 5 Cents For Foreign Mailings)

JOHN F. RIDER PUBLICATIONS, INC.

1440 Broadway

New York, N. Y.

# ON THE JOB . . .

## Self-Reading Diagrams

For some time we have been toying with the idea of making schematic diagrams more complete. We have felt that it would be a great convenience to the Service Man if we were to put voltage values right on to the diagrams along with resistance and condenser values. One could then work directly from the diagram without having to turn to a voltage table.

The first few diagrams made up in this manner appear in this issue. We hope you will like them. We intend to make up all diagrams in this manner in the future.

We are most anxious to have your criticisms. Do you like the idea? Does it suit your needs? Do you feel that it could be done more effectively in some other manner? Should we continue with this system?

The new tubes make it practically a necessity to have socket connections with diagrams. We are attempting to work out a simple and foolproof method of doing this. Hope to have these included in the diagrams next month.

## Break-In Adapter System

Various types of socket break-in adapters have been suggested, the majority of them employing a switch between two tip jacks for current measurements. The milliammeter contact leads are plugged into the proper tip jack circuit, and after selecting the proper current range, the switch is opened and the current reading for that particular circuit is the result.

The break-in adapter system shown in the accompanying diagram (with apologies to Supreme 333 and Weston 566 type 3) eliminates these switching arrangements by permanently connecting meter shunts in each lead, with the exception of the heater or filament connections. The resistance of these meter shunts, for a one-milliamper d-c., 27-millivolt meter, is very small and will not seriously vary the applied operating voltages.

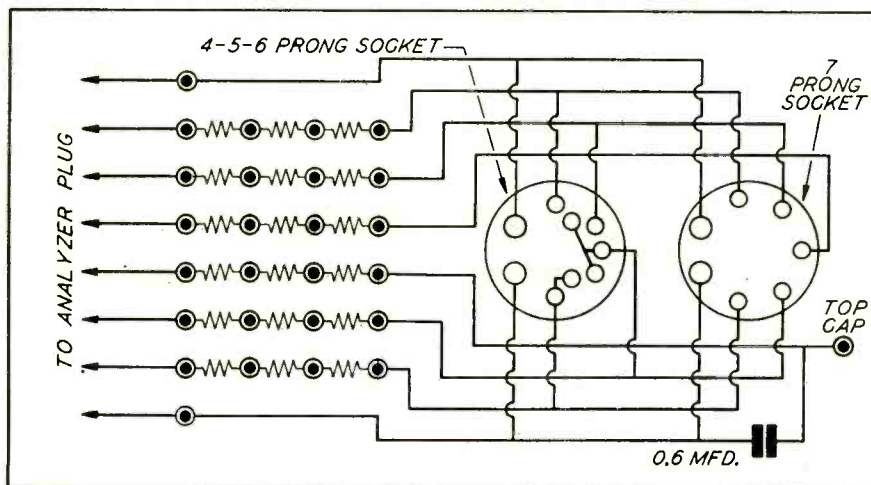

Complete diagram for the break-in adapter system described on this page

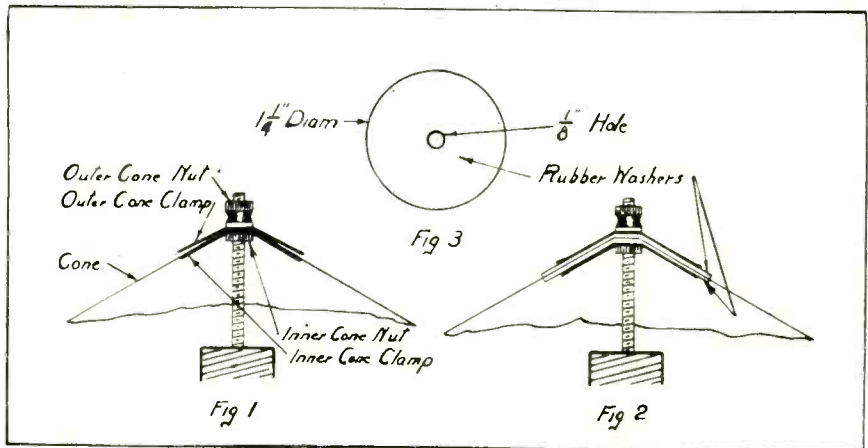

Showing placement of washers for eliminating rattle in Dynacones

Shunts are commercially available for the various types of commonly used instruments, but any Service Man can construct and calibrate these shunt resistances without much effort, and a small cash outlay. A Truvolt wire-wound resistor, made to carry about 200 milliamperes, can be unwound and cut into proper lengths to supply the required shunt resistance. Insulating tubing slipped over these lengths of wire will prevent short-circuits between adjacent shunts or contact points.

Tip jacks are not necessary, for counter-sunk, flat-head machine screws can be used for the contact points.

Shunt values to give the meter a range of 5, 25 and 150 milliamperes will be found adequate to cover practically all circuit current tests.

When making resistance measurements, use the set of contacts connected directly to the analyzer plug cable.

George Jehle.

## Eliminating Dynacone Rattle

The following service kink has been found through actual use to be a very effective method of taking the rattle out of the Cros-

ley Dynacone and similar speakers, as well as a means of disposal of old auto inner tubes.

Upon investigating the cause of the rattle in said speakers, it was found that the outer cone clamp (See Fig. 1) has a tendency to flatten out through the tightening of the outer cone nut, allowing the cone to vibrate in the small space between the inner and outer cone clamps. This causes the rattle.

To cure this trouble, make up two rubber washers, as per Fig. 3, from an old inner tube (or a piece of felt will serve the same purpose) and insert as shown in Fig. 2.

To do this, remove outer cone nut, outer cone clamp, cone, inner cone clamp and then run the inner cone nut down a few threads on the screw. Re-assemble in the following order: Inner cone clamp, one rubber washer, cone, one rubber washer, outer cone clamp, and the outer cone nut. Make necessary adjustment on the speaker adjustment screw.

A. V. Ditty.

## Boosting A.K. Battery Sets

We are frequently called upon to service the old model A.K. battery sets, such as the 10, 20 and 30 series. Upon making the usual routine tests we usually find nothing wrong but weak reception.

I recently made an interesting experiment on a Model 20 by removing the r-f. coils and baking them for about two hours in an oven at about 200 degrees. While the baking was being done, I removed all variable condensers and completely tore them down, carefully cleaning the aluminum plates and washers, shaft bearings, etc., and when the job was re-assembled the set performed to my entire satisfaction.

I have also inserted an antenna transformer (A.K. Part No. 13668) in place of the antenna choke with remarkable results. If the set is thrown into oscillation by this change, slip a small piece of metal of a size that will fit inside the coil, under the primary winding, and the set is as good as new.

W. C. Ward.



# Binders for SERVICE

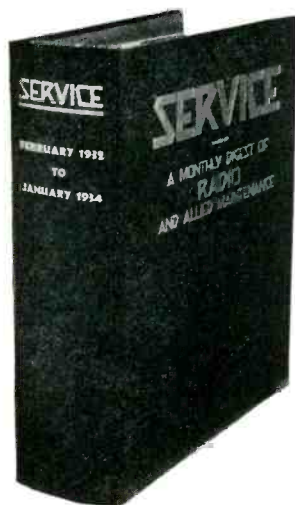

**Holds  
24  
Copies**  
•  
**2  
YEARS'  
ISSUES**

Every issue of SERVICE contains many articles which are not only valuable today but will be worth many dollars to you at some future date. Preserve your copies of SERVICE in this handsome, practical binder. You'll never regret this purchase.

This handsome, two-tone blue, imitation leather binder is of De Luxe library construction, stamped in gold. It is the most secure method of holding your copies of SERVICE. The individual issues, once bound, cannot fall out or be pulled out and yet it takes less than half a minute to insert or remove the contents.

You know the value of having this information at your finger-tips. The magazines are kept clean and ready for instant reference. With the index and this binder you have the year's most important service information filed and in perfect condition. This SERVICE binder will protect your copies permanently.

Price \$2.00 Postpaid

**John F. Rider Publications, Inc.**

1440 Broadway

New York, N. Y.

**H**ERE is a practical and flexible three-meter instrument that serves every possible analyzing requirement. It makes servicing easier, quicker, more profitable. It gives all the information any service man or dealer needs to know for servicing sets.

Furnished with a practical selector switch, the Readrite No. 711 instrument tests voltages and resistances at set sockets. In addition, voltage, resistance and capacity tests are available through the meter jacks. This unit will handle the most advanced circuits and the newest tubes. Sturdily and accurately built, it will give long, accurate, trouble-free service.

Equipped with the new Triplet D'Arsonval Voltmeter, which has 1000 ohms per volt resistance. The readings are 0-15-60-300-600 volts—0 to 300,000 ohms covering a complete range for testing control grid, screen grid, cathode and plate voltages. The ohm-meter reading is secured with a 4½ volt battery. Additional resistors can be furnished, which, with additional batteries will bring readings up to any desired range.

### YOUR JOBBER CAN SUPPLY YOU

... at the dealer's net price of \$22.50. See him today, or send coupon for descriptive catalog.

### READRITE METER WORKS

77 College Avenue

Bluffton, Ohio

## Send Coupon for Quick Facts!

READRITE METER WORKS  
77 College Ave. Bluffton, Ohio.

Gentlemen:—Please send me catalog on Readrite Tester No. 711, as well as information concerning your other servicing instruments.

NAME.....

STREET ADDRESS.....

CITY..... STATE.....

# THE FORUM . . .

## Oscillograph Servicing

Editor, SERVICE:

I have read with interest your comment on oscillograph servicing of radios and would like to offer my three-cents worth.

It is very evident that this would eliminate some of the trouble in finding hidden faults which are, as you state, the curse of the Service Man. But, remember his bread and butter also.

For my part, the spice and attraction in radio work is hunting for some fault that is hard to find. The ability to find some "elusive" bug is what puts the real Service Man above the ordinary "fusser." Any counter radio clerk can locate a blown condenser, the ordinary open resistor, or test a tube, and the point-to-point system has simplified matters still more.

But mark my word, if we get too much of this "machine age" in our service work, the delivery boy will be doing the job. Of course, we cannot stay the wheels of progress, and if the oscillograph can be worked up into a simple set-up which simplifies the work, it will come in spite of the number of Service Men which it would eliminate. We see this illustrated in the complicated machines for locating automotive troubles. If the grease monkey can read the indicators, he can locate any trouble for ten dollars a week.

E. D. GILPIN.

*(We do not believe that any one but a trained man could possibly analyze the indications of an oscillograph. After all, it takes a medico, and a good one, to properly "read" an X-ray photo. Both call for a specialized form of knowledge. Nevertheless, we appreciate your viewpoint—and we like your "servicing philosophy." The same type of man hunts bears with a bow and arrow—to him a rifle is not sporting. Ah, well . . .)*  
THE EDITORS.)

## From a "Handy Man"

Editor, SERVICE:

This is from one of the much-despised "handy men." No technical education whatever. Even have to hunt up Ohm's Law sometimes. But, in self defense let me say that I did not "crash" the radio service business—I was forced into it.

Back in '25 (had built several hookups and they all worked) I started selling Browning-Drake 5R's and didn't even know that factory-built receivers ever went wrong. We sold for cash those days, and after putting out a dozen or so, one went wrong.

There were no Service Men here at that time and I was afraid if I shipped the set back to the factory the owner would get cold feet and want his money back—so we "fixed" it.

Some time later the technically-trained Service Men (they had arrived) advised an owner to ship a five-tube Magnavox back to the factory. Said it tested O.K. but wouldn't work. One of my customers who had more confidence in me than I had, sent the owner

in. It took about ten minutes to locate the trouble, so I was "high" on myself for a while. I've sat up 'til the "wee sma" hours with some since, but service information makes that unnecessary now.

Your organization scheme and letters from Service Men, published in SERVICE, bring strongly to mind the condition in auto service in 1914. Seven years as mechanic, besides some driving, had made me an old timer. Then some of the old timers decided that too many butchers, shoemakers and painters were getting into the business, so they started a Union. I joined but was too much interested in a certain young lady just at that time to attend the meetings. In about three months I did attend a meeting and found the butchers and painters running the Union, so I quit paying my dues.

There was never a time, until this "compression" started, that I haven't had more work than I could do. I believe we are where we are because of what we are. We are what we are because of what we think. So if we don't like it where we are, we must change our thinking. Above all things, let us not think that someone is taking away from us something that belongs to us. Our time can be more profitably used.

THOMAS LLEWELLYN,  
Okmulgee, Okla.

*(We have a hunch that you earned your salt years back. Call yourself a "handy man" if you wish—we think different.—THE EDITORS.)*

## About Service Guarantees

Editor, SERVICE:

With reference to your question on the status of guarantees on service calls; why should a Service Man guarantee for six months a replacement unit of reliable make when the manufacturer gives a guarantee for only three months? Whether it is a complete receiver or simply a transformer or filter pack, it has always been my understanding the guarantee is ninety days.

Based on the above, such repair jobs have always carried the same guarantee as that of the manufacturer on work performed by me.

If you will notice the general trend of the gyms and cut-throats, they are about the only ones who guarantee their work for six months.

If I use any parts that call for a guarantee, I make it a practice to mark right on the bill, "Transformer guaranteed for sixty or ninety days from date," or whatever the part may be. Outside of this part, the customer has no comeback.

I have been in the game for eleven years and have yet to have the first argument on my system of giving guarantees.

FREDERIC H. PERAN,  
Buffalo, N. Y.

*(Your practice seems fair enough and it would probably be a good idea if other Service Men worked out a similar plan. But we should like to hear more on this subject.—THE EDITORS.)*

## Addresses Wanted!

Will Mr. Ralph L. Bowers and Mr. Carl Keppler, Jr., kindly forward their addresses to the Managing Editor of SERVICE and greatly oblige. Thanks.

## We Blush

Editor, SERVICE:

Having just received the June number of SERVICE and reveled in the wealth of material contained in those few crowded pages, I could not resist writing you a few words of appreciation.

At last we have a real Service Man's magazine; as near perfect as it possibly can be. When it arrives here everything must wait, until the latest developments in circuit design, the information on new tubes, the Auto-Radio section, have been pored over and each circuit worked out mentally to the minutest detail.

The Story of Receiver Design has been very good, and we hope for more. Please do not change SERVICE. We are not beginners and are for a magazine that keeps us posted, just a little ahead of the parade. Thank you.

A. L. LEE,  
RADIO SERVICE SHOP,  
Rensselaer, Ind.

*(Many thanks for your kindness and consideration in writing us.—THE EDITORS.)*

## Service Organizations

Editor, SERVICE:

As the general consensus of opinion seems to be that there is something wrong with the service end of the radio industry, and that the best way to approach the problem is through cooperative organization, let us try some action along these lines.

The least that can be done is to try some method of solving the problem. If that method fails, then we can try another. But action is necessary in order that we may have some idea of what we may accomplish through cooperative effort.

Therefore, if you would publish a list of all the cooperative organizations which you know to be in existence today, it would help those who are interested to find the nearest existing group and in the absence of such a group, steps could be taken to get together with other interested Service Men in order to start a local organization.

The burden may rest with the organizations, to find the Service Men who are worthy of membership, and persuade them to cooperate. In that case, they could secure a list of your subscribers and work on them as a starter.

RICHARD P. ROBERTS,  
Philadelphia, Pa.

*(We think this a very good idea. Will all existing service organizations be good enough to acquaint us with their addresses? A list will appear in an early issue.—THE EDITORS.)*





wouldn't) on using CENTRALAB FIXED RESISTORS, for ALL replacement jobs.

**Centralab**  
Central Radio Laboratories  
Milwaukee, Wis.

You'll be happy—the customer will be happy . . . and the set will “perk” again with new pep . . . that is if you insist (and who

A IT'S  
WOW!

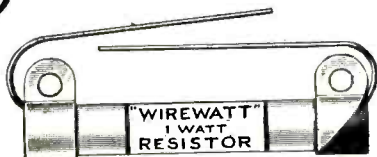

Not only has the WIREWATT been pronounced a success by the radio service men who have tried it, but it has also received immediate acceptance by manufacturers of radio sets, service apparatus and sound equipment.

The WIREWATT is now being used to replace one watt composition units because it guarantees complete freedom from noise and change in resistance value. Tests made by prominent engineers show that inductive effect of these units is negligible in all broadcast receiver circuits.

WIREWATTS may be secured from your jobber in resistance values through 25,000 ohms. The price is the same as that of first line composition units. Try some on your next job!

USE THE COUPON BELOW FOR YOUR COPY OF THE NEW OHMITE CATALOG NUMBER 9.

**OHMITE**

MANUFACTURING COMPANY

637 N. Albany Avenue Chicago, Ill.

Please send me a copy of your new Catalog Number 9.

NAME .....

ADDRESS .....

CITY..... STATE.....

JOBBER'S NAME.....

# AT LAST— The Service Problem SOLVED!

## EBY

Universal  
Analyzer  
Adaptor



Model  
No. 733

EBY ENGINEERING SCORES AGAIN IN PRESENTING THE FIRST REALLY CONSTRUCTIVE CONTRIBUTION TO THE SERVICE FIELD

There has long been great need for a radio and electronic test device which must be universally applicable in spite of the ever more complicated situation developing not only in circuit engineering but vacuum tube engineering as well. Since the advent of multi-electrode tubes and the inclusion of the functions of several tubes in a single bottle, circuit methods have become more complicated until the service man has found himself in the position of being obliged to invest more and larger sums of money in newer test instruments—or less satisfactorily—rebuild existing test equipment.

### ADVANTAGES

The New EBY Universal Analyzer Adaptor is simple in operation. The method of use is obvious without intensive study of a complicated array of switches, selectors, etc.

The New EBY Universal Analyzer Adaptor in combination with a good multi-range meter performs all the functions of the modern analyzer or tube checker and is not restricted to any circuit or tube limitations whatever.

The New EBY Universal Analyzer Adaptor is arranged for point to point tests, circuit break-in tests for checking voltage or current to any element or for short circuits between elements of any tube having up to seven base prongs and cap contact.

The New EBY Universal Analyzer Adaptor is not made obsolete in any respect in the event a new tube with additional prongs, elements, internal connections or special arrangements for new uses is presented to the market.

The New EBY Universal Analyzer Adaptor is the only tube or circuit analyzer that is always up to date—never requiring circuit alterations—devoid of complication—universally flexible.

The EBY Universal Analyzer Adaptor is sold as follows:

1. Complete with high grade imitation leather covered carrying case ..... List Price \$15.75
2. Case, long handled moulded bakelite plug with cable and short type moulded bakelite plug, test panel and instruction chart ..... List Price \$13.00
3. Special EBY Moulded bakelite Adaptors, singly or in sets. List Price, each .65
4. Long handled plug with cable, short plug and grid clip. List Price \$3.75

Send coupon TODAY for complete technical data

THE H. H. EBY MANUFACTURING CO., INC.  
21st and Hunting Park Ave., Philadelphia, Pa.

Gentlemen:—Please rush to me the complete data on the new EBY Universal Analyzer Adaptor.

NAME.....

ADDRESS .....

CITY..... STATE.....

# HIGHLIGHTS . . .

## Radio Progress Week

The Rebuild Radio Prosperity Campaign, the forerunner of Radio Progress Week, moves steadily on. Special committees have already been formed in the major cities and it should not be long now before the necessary campaign connections will reach into every small town.

### WHAT TO DO

The thing to do is to get in touch with your local jobber or distributor. He will provide you with the very latest information regarding the campaign and at the same time arrange to provide you with the special folders, posters, etc., which you can use personally. One of the posters, and the folder that will be of most value to you, are illustrated on this page. There are also available other folders, poster stamps which can be used on your letterheads, etc., and a large window display

card. Your local distributor should have all of this material.

### SPECIAL ADVERTISEMENTS

You can order any number of nine different mats for your newspaper advertising. These may be obtained at a cost of three cents apiece (send money order) direct from Campaign Headquarters, Radio Manufacturers Association, 330 West 42nd Street, New York, N. Y. Two of these advertising mats are illustrated on this page and are the ones you would want as they deal exclusively with servicing. Order them by the number indicated, such as "Adv. No. 4," etc.

An illustration of one of the Emblem mats also appears on this page. You can use this with your advertising, or for specially printed

Below: Circular No. 2—Made up specifically for use by the Service Man



Above: An emblem you can use on your stationery or in your advertisements

folders. The one shown is exact size. Emblem No. 8 measures approximately 1" by 1½", and Emblem No. 9 approximately ¾" by 1". Order the size you wish, referring to the Emblem number given.

### GET GOING

If the local Campaign Committee, or your local distributor have not as yet gotten in touch with you, by all means get in touch with them, as they have a great number of suggestions for you as to how the Campaign can best be put over locally. Cooperation in this respect will be mutually beneficial.

Above all, learn your part in the program. Then get your hat and get out and hustle.

Adv. No. — 3

Adv. No. — 4

### I.R.S.M. Convention

Plans for the "Rebuild Prosperity" Convention of the Institute of Radio Service Men, to be held at the Hotel Pennsylvania in New York City, October 2 to 4 are under way. Hope all of you who can make it will be there.

### Attention—Service Organizations!

The *Radio Servicemen's Association of Pittsburgh*, in order to cooperate with other radio service organizations throughout the country, would like to receive identifying communications from their Secretaries. These letters should be mailed to William Irlam, Executive Secretary, 514 Station Street, Wilmerding, Pa.

(Will Secretaries communicate at the same time with the Managing Editor of SERVICE. We wish a complete list of all service associations with a view towards publication of the names of such groups for the convenience of such readers who might care to join.—THE EDITORS.)

### New Ohmite Catalog

Ohmite Manufacturing Company, 636 North Albany Ave., Chicago, Ill., have out a new catalog dealing with their complete line of rheostats, fixed resistors, etc. The mechanical and electrical details for each device are extensive.

Write to Ohmite for Catalog Number 9.



FOR STATE AND COUNTY FAIRS

# RACON

WIDE - RANGE  
LOUDSPEAKERS



Are specified this year, for public address service, at the greatest number of fairs and race meets in RACON history. Fair Executives know that they get super-service and super-quality from RACON horns and dynamic units. See that they are specified at your fair.

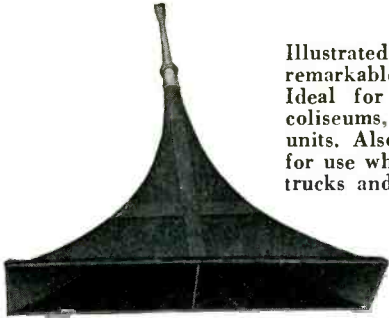

Illustrated: The Radial Horn, remarkable "Circle Projector." Ideal for judges' stands and coliseums, for two and four units. Also the flat bell trumpet for use where height is limited, trucks and windows.

Racon products are covered by U. S. Patents Nos. 1,507,711; 1,501,032; 1,577,270; 73,217; 73,218; 1,722,448; 1,711,514; 1,781,489; 1,832,608; 1,834,327; 1,835,739; 1,845,210; 1,878,360; 1,888,442; 1,918,366.

Write for detailed catalog S8

**RACON ELECTRIC CO. INC.**

52 East 19th St., New York, N. Y.

London, Eng.

Toronto, Can.

What's New IN RADIO TUBES

TIE UP FOR PROFIT WITH NATIONAL UNION RADIO TUBES

## N.U. DEALERS PROFIT IN PRICE RISE

In a move to protect the profit margin of its service dealers and assure the continued superiority of the National Union Tubes, a list price advance of 10¢ per tube over the general level has been announced by National Union Radio Corporation. Regular dealer discounts of 40-10%, shop equipment offers and other sales features are retained.

H. A. Hutchins, General Sales Manager, states that the majority of National Union tube replacement sales are made by Radio Service Men and Service Dealers, who must maintain a decent profit margin to cover operating expenses and at the same time be assured of high quality to be able to fully guarantee their work. The price rise is designed to help these dealers protect their position.

National Union offers you free with tube purchases an Oscillator and Output Meter, Four Service Manuals, Unameter (Tube Tester), Supreme Model 333 set analyzer and point to point resistance tester, Bench Kit Box and Hickok Ohm Capacity Voltmeter. Equip your shop the easy National Union way. Send coupon.



National Union Radio Corp., of N. Y.  
400 Madison Avenue, New York City S9

Gentlemen: Send me details of your free equipment offers.

Name .....

Street .....

City ..... State .....

# SPEND YOUR TIME IN Selling!

THAT'S WHERE THE MONEY IS!

● Instead of wasting your time tinkering around the shop, buy dependable, serviceable and guaranteed amplifying equipment from a reliable manufacturer who knows his business—neat, professional looking equipment that makes a favorable impression on your customers and prospects—equipment that's ready to install. Spend your time looking for business—selling. You'll find it *pays bigger returns* for your time.

## Webster the Best Source of Supply

The Webster Company, Chicago, manufactures standard amplifying equipment for practically every requirement. Standard or special, every unit in the Webster line is accurately engineered, manufactured exactly to specifications, thoroughly tested before being released, and fully guaranteed.

## Statements Dependable

You'll find, too, that when Webster describes a unit in technical terms, the equipment can be depended upon to perform as claimed and meet its specifications. When Webster says that an amplifier has a gain of 96 DB at 1,000 cycles—it means 96 DB, not 80 nor 100, but 96. Such dependability means more than ever today.

## SEND FOR OUR CATALOG

● In it are shown all types and various price ranges of modern equipment, described fully in conservative accurate terms. This catalog is indispensable. Every radio engineer and service man should have a copy. Sent on request.



# THE WEBSTER COMPANY

3825 West Lake Street

CHICAGO, ILLINOIS, U. S. A.

# AN INCREASE IN PRICES

## (An open letter)

We voiced the warning in the July, 1933, issue of SERVICE that there was a likelihood of a price increase for Volumes I and II of the Perpetual Trouble Shooter's Manual.

Inasmuch as the list price of \$5.00 had been established for a period of years, it was our intention to carry on at this price as long as possible. However, no one run of books lasts forever and we shall soon require another printing.

We sincerely regret the necessity of announcing this price increase. We have tried hard to avoid such a step but find it impossible to do so. In the face of the fact that Volumes I and II were under-priced during the cheap production era of 1931 and 1932, today's production costs make a price increase an imperative step.

However, we realize that it would be an injustice to increase prices without warning. Consequently, we have established September 15th, 1933, as the day when the new prices go into effect. Our dealers and ourselves will accept orders for Volumes I and II at the old prices up to the close of September 14th. Effective September 15th, 1933, Volume I will sell for \$7.50 and Volume II will sell for \$6.50.

We are extremely sorry that we cannot extend this old price period beyond the date named. We feel that by that time our present supply will have been exhausted and the new printing will involve greatly increased printing, binder, and labor costs.

May we suggest that you take advantage of today's prices and save money.

Signed:

JOHN F. RIDER,  
1440 Broadway, New York, N. Y.

The Dealers listed below have been informed of the impending increase in prices. They will honor your orders at the present prices up to September 15th.

<b>Alabama</b> Auto Elec. Service Co. . . . . Montgomery	<b>Iowa</b> S. S. Kresge Store . . . . . Davenport S. S. Kresge Store . . . . . Sioux City S. S. Kresge Store . . . . . Waterloo Sitles-Duda-Myers Co. . . . . Des Moines Iowa Radio Co. . . . . Des Moines	<b>Nebraska</b> S. S. Kresge Store . . . . . Lincoln S. S. Kresge Store . . . . . Omaha Sitles-Duda-Myers . . . . . Lincoln Sitles-Duda-Myers . . . . . Omaha H. C. Noll Co. . . . . Omaha	<b>Oklahoma</b> Kay Radio Co. . . . . Tulsa
<b>Australia</b> McGill's . . . . . Melbourne	<b>Kansas</b> S. S. Kresge Store . . . . . Topeka Stimpson Sales & Inv. Co. . . . . Wichita	<b>New Hampshire</b> Radio Service Labs. . . . . Manchester John B. Varick Co. . . . . Manchester	<b>Oregon</b> Wedel Company . . . . . Portland
<b>Brazil</b> Agencia Soave . . . . . Sao Paulo	<b>Kentucky</b> P. I. Burks Co. . . . . Louisville S. S. Kresge Store . . . . . Lexington	<b>New Jersey</b> Bennetts Radio Supplies . . . . . Perth Amboy B & O Radio . . . . . Newark Aaron Lippman . . . . . Newark S. S. Kresge Store . . . . . Morristown	<b>Pennsylvania</b> Cameradio Co. . . . . Pittsburgh S. S. Kresge Store . . . . . Allentown S. S. Kresge Store . . . . . Butler S. S. Kresge Store . . . . . Erie S. S. Kresge Store . . . . . Oil City S. S. Kresge Store . . . . . Philadelphia S. S. Kresge Store . . . . . Pittston S. S. Kresge Store . . . . . Pottsville S. S. Kresge Store . . . . . Reading S. S. Kresge Store . . . . . Scranton S. S. Kresge Store . . . . . Warren Radio Electric Service Co. . . . . Philadelphia Radio Service Co. . . . . Wilkes Barre Radio 437 Store . . . . . Philadelphia M & H Sporting Goods . . . . . Philadelphia
<b>California</b> Offenbach Electric Co. . . . . San Francisco Radio Supply Co. . . . . Los Angeles Radio Television & Supply . . . . . Los Angeles Warner Brothers . . . . . San Francisco	<b>Louisiana</b> Shuler Supply Co. . . . . New Orleans	<b>New York</b> American Sales . . . . . New York City Blair the Radio Man . . . . . New York City Coast to Coast Radio . . . . . New York City H. L. Dallas . . . . . New York City Federated Purchaser, Inc. . . . . New York City Fort Orange Radio . . . . . Albany S. S. Kresge Store . . . . . Dunkirk S. S. Kresge Store . . . . . Buffalo S. S. Kresge Store . . . . . Olean S. S. Kresge Store . . . . . Schenectady S. S. Kresge Store . . . . . Troy Kronson Service . . . . . Buffalo Maurice Schwartz & Son . . . . . Schenectady Roy C. Stage . . . . . Syracuse Sun Radio Co. . . . . New York City Try-Mo Radio Corp. . . . . New York City Wholesale Radio Service Co. . . . . New York City J. F. Distributing Co. . . . . Brooklyn Vaeth Electric Co. . . . . Utica	<b>Rhode Island</b> W. H. Edwards . . . . . Providence S. S. Kresge Store . . . . . Pawtucket
<b>Canada</b> T. Eaton Co. . . . . Toronto T. Eaton Co. . . . . Winnipeg Edwin J. Galloway . . . . . Vancouver Taylor, Pearson, Carson . . . . . Edmonton Taylor, Pearson, Carson . . . . . Calgary	<b>Maine</b> Frank M. Brown Co. . . . . Portland S. S. Kresge Store . . . . . Lewiston S. S. Kresge Store . . . . . Portland	<b>North Carolina</b> Shaw Distributing Co. . . . . Charlotte	<b>South Dakota</b> S. S. Kresge Store . . . . . Aberdeen
<b>Colorado</b> Inter-State Radio . . . . . Denver	<b>Maryland</b> A. R. Spartana . . . . . Baltimore Mattson Radio Supplies . . . . . Baltimore Radio Elect. Service Co. . . . . Baltimore	<b>Ohio</b> Altken Radio Corp. . . . . Toledo Burns Radio Co. . . . . Dayton Goldhamer, Inc. . . . . Cleveland Hughes-Peters Elec. Corp. . . . . Columbus Kladag Radio Labs. . . . . Kent S. S. Kresge Store . . . . . Akron S. S. Kresge Store . . . . . Cincinnati S. S. Kresge Store . . . . . Cleveland S. S. Kresge Store . . . . . Columbus S. S. Kresge Store . . . . . Lancaster S. S. Kresge Store . . . . . Marion S. S. Kresge Store . . . . . Newark S. S. Kresge Store . . . . . Toledo S. S. Kresge Store . . . . . Sandusky S. S. Kresge Store . . . . . Zanesville Progress Elec. Co. . . . . Cleveland Radio Servicemen's Supply . . . . . Cleveland Ross Radio . . . . . Youngstown United Radio . . . . . Cincinnati	<b>Tennessee</b> J. L. Perry Co. . . . . Nashville Southern Wholesale Supply . . . . . Knoxville
<b>District of Columbia</b> Star Radio Co. . . . . Washington	<b>Massachusetts</b> T. F. Cushing . . . . . Springfield H. Jappe Co. . . . . Boston S. S. Kresge Store . . . . . Boston S. S. Kresge Store . . . . . Malden S. S. Kresge Store . . . . . Quincy S. S. Kresge Store . . . . . Springfield Radio Shack . . . . . Boston	<b>Texas</b> Service Parts Co. . . . . Abilene Straus-Frank Co. . . . . Houston Straus-Frank Co. . . . . San Antonio Walter Tips Co. . . . . Austin Wilkinson Bros. . . . . Dallas McLendon Co. . . . . Waco The Shield Co. . . . . Fort Worth	<b>Virginia</b> Johnston-Gasser Co. . . . . Richmond S. S. Kresge Store . . . . . Norfolk S. S. Kresge Store . . . . . Richmond
<b>Connecticut</b> Hatry & Young . . . . . Hartford S. S. Kresge Store . . . . . New Haven S. S. Kresge Store . . . . . Stamford S. S. Kresge Store . . . . . New London	<b>Michigan</b> S. S. Kresge Store . . . . . Bay City S. S. Kresge Store . . . . . Detroit S. S. Kresge Store . . . . . Grand Rapids S. S. Kresge Store . . . . . Highland Park S. S. Kresge Store . . . . . Jackson S. S. Kresge Store . . . . . Muskegon S. S. Kresge Store . . . . . Saginaw Rissi Brothers . . . . . Detroit Radio Distributing Co. . . . . Detroit Radio Specialties . . . . . Detroit Reno Radio Stores . . . . . Detroit Radio Equipment Sales . . . . . Detroit Shand Radio . . . . . Flint	<b>Utah</b> O'Loughlins . . . . . Salt Lake City	<b>West Virginia</b> S. S. Kresge Store . . . . . Charleston S. S. Kresge Store . . . . . Wheeling
<b>Illinois</b> Allied Radio Corp. . . . . Chicago Chicago Radio Apparatus . . . . . Chicago Grant Radio . . . . . Chicago S. S. Kresge Store . . . . . Chicago S. S. Kresge Store . . . . . Champaign S. S. Kresge Store . . . . . Springfield S. S. Kresge Store . . . . . Peoria S. S. Kresge Store . . . . . Freeport S. S. Kresge Store . . . . . Belleville S. S. Kresge Store . . . . . Danville S. S. Kresge Store . . . . . Decatur The Lukko Company . . . . . Chicago Mid-West Radio Mart . . . . . Chicago Newark Elect. Co. . . . . Chicago Radolek . . . . . Chicago	<b>Minnesota</b> Lew Bonn Co. . . . . St. Paul Radio Maintenance . . . . . Minneapolis Belmont Corp. . . . . Minneapolis	<b>Washington</b> Seattle Radio Co. . . . . Seattle Spokane Radio Co. . . . . Spokane Wedel Company . . . . . Seattle	<b>Wisconsin</b> S. S. Kresge Store . . . . . Milwaukee Radio Parts Co. . . . . Milwaukee
<b>Indiana</b> S. S. Kresge Store . . . . . Evansville S. S. Kresge Store . . . . . Fort Wayne S. S. Kresge Store . . . . . Gary S. S. Kresge Store . . . . . Kokomo S. S. Kresge Store . . . . . Lafayette S. S. Kresge Store . . . . . South Bend S. S. Kresge Store . . . . . Terre Haute S. S. Kresge Store . . . . . Vincennes Kruse Radio . . . . . Indianapolis State Radio Co. . . . . Indianapolis	<b>Missouri</b> Walter Ashe Radio Co. . . . . St. Louis Burstein-Applebee Co. . . . . Kansas City S. S. Kresge Store . . . . . Hannibal S. S. Kresge Store . . . . . Joplin S. S. Kresge Store . . . . . St. Louis S. S. Kresge Store . . . . . University City Geo. W. Van Sickle Co. . . . . St. Louis		

Note:—All S. S. Kresge Stores are Green Front

If there is no dealer near you, order direct from us

JOHN F. RIDER

1440 Broadway

New York, N. Y.



# Don't Let Him Get FAT



## On YOUR Time!

### He'll Soon Eat You Out of Your Service Business

The proper kind of service information will kill that animal. Rider's Manuals give you the service information which will banish waste and loss of time during service operations. No longer is it necessary to hunt—guess—experiment and hope that you are right. *Hunting and guessing costs you money.*

Sets with whiskers are as easily serviced as the very new ones. Nothing is a secret in a commercial receiver when you own Rider's Manuals. Upside-down servicing (chassis turned upside-down) is as easy as you want it to be. You don't have to be a Sherlock Holmes when you have these Manuals because the hard-to-get and seldom-heard-of circuits which cause so much trouble for the service field are in these Manuals.

No more guessing at peak frequencies—or hunting for trimmers and tracing of power transformer leads. All of this material is in the Manuals. No more wishing you had the circuits. They ARE there! Right in the Manuals. You don't have to gaze into a crystal ball to learn what units are in sealed cans and the circuit. This information is shown in Rider's Manuals.

Banish waste and loss of time! Make every minute on the job a *paying minute*. Get Rider's Manuals—they will pay for themselves many times over.

The fact that these Manuals are the finest in every respect and will be of tremendous aid, is proved by their use and recommendation by such famous tube companies as RCA Radiotron, E. T. Cunningham, Inc., National Union Radio Corp.—such famous instrument manufacturers as Weston, Hickok, Readrite, etc., and such famous set manufacturers as Stromberg-Carlson, Fada, All-American, Grigsby-Grunow, etc.

Rider's Manuals, Volumes I, II and III cover receiver production from 1919 right up to the minute. Volume III contains the receivers produced during the last year, inclusive of about June, 1933. Volume II contains the earlier productions. Volume I contains the receivers from 1919 to about May, 1931. ABSOLUTELY NO DUPLICATION OF CONTENTS IN THESE MANUALS!

Start your Rider's Manual library today. Each volume is self-contained and does not duplicate. Each has a complete index. Each is available with a *money-back guarantee!*

See these Manuals at the finest Radio Dealers. If they do not stock them, do not take substitutes. Only Rider's Manuals are "standard" in the industry. You can buy Rider's Manuals directly from us.

*Send for descriptive literature*

### AUTO RADIO

If you specialize in automobile radio, you will find practically every job and every major manufacture in Rider's Manuals Volumes II and III. It pays you to buy Rider's Manuals for auto radio data because in addition to the auto radio material contained in these two Manuals, you have about 1600 additional pages of service information—and you are buying the "standard" of the industry . . . the finest there is.

Volume I, \$5.00

Volume II, \$5.00

Volume III, \$7.50

*SPECIAL NOTE: We have on hand a number of Volumes I and II, enough to last up to about September 15, 1933. These are being offered at the prices shown above. Because of increased production costs all along the line, we are forced to announce a price increase on Volumes I and II effective September 15th. See the opposite page.*

## JOHN F. RIDER

1440 Broadway

New York, N. Y.

AUGUST, 1933 •

SAY YOU SAW IT IN SERVICE

299

# THE MANUFACTURERS . . .

## Eby Universal Adaptor

The H. H. Eby Manufacturing Company, 21st and Hunting Park Ave., Philadelphia, Pa., has brought out a new type of Universal Analyzer Adaptor which, with the use of a good multi-range meter, performs all the functions of the modern analyzer or tube checker and is not restricted to any circuit or tube limitations.



This new instrument consists of a long handled plug with grid connector, cable and small plug, a test panel having two seven-prong sockets and twenty-one jacks with insulated jumpers, and a set of eight special adaptors. These parts are fitted into a neat imitation leather-covered carrying case.

In use, the tube for the receiver stage being tested is replaced by the long handled plug, the tube being placed in one of the test panel sockets and the small plug end of the cable is plugged into the remaining socket of the test panel. Now, to test any series circuit conditions for any element of the tube in question, the jumper is removed for any particular element according to the pin number indicated by the chart which comes with the Adaptor, and a suitable meter inserted into the circuit through the use of pin jacks and leads. For testing a condition between elements, they are chosen according to number and a test made between jacks connected to the respective elements.

For other than seven-prong tubes, the adaptors are used in pairs in conjunction with the long-handled plug and the socket of the test panel into which the tube is to be placed.

The new Eby Universal Analyzer Adaptor is known as Model No. 733.

## Hickok Tubeless Oscillator

After two years of research, The Hickok Electrical Instrument Co., Cleveland, Ohio, have developed a tubeless oscillator which has a number of interesting features and permits more accurate servicing.

This new oscillator employs one of the tubes in the receiver for the purpose of generating radio-frequency oscillations. The receiver at the same time supplies the normal operating voltages for the tubes.

The oscillator is equipped with two

meters, one being the radio-frequency milliammeter, and the other a d-c. milliammeter, operating in connection with a rectifier so as to indicate either a-c. or d-c. milliamperes.

The circuit employed allows the use of a pure radio-frequency, unmodulated signal for use in aligning r-f. and i-f. stages. This method eliminates the harmonics present in a modulated signal, thus permitting greater accuracy in alignment.

The construction of the oscillator is such that each stage of radio frequency or intermediate frequency can be independently aligned, if desired, without introducing any other stages into the circuit being tested. In the usual type of oscillator it is necessary to feed the signal into the first stage or antenna circuit, and read the final output at the last audio stage.

The use of two meters, one as input meter and the other as output meter, enables the operator to apply a designated value of signal to the receiver by means of the output meter, determine the efficiency of each stage independently, and also determine the increase in efficiency when new tubes are installed.

As this oscillator uses the power supplied by the radio receiver, it is effective in testing any type receiver, whether battery operated, a-c., or d-c.

The range of frequencies obtained without the use of harmonics covers the complete broadcast and intermediate-frequency range, extending from 1,500 kc. continuously to 105 kc.

The radio frequency output is adjustable from zero to full amount by means of a continuously variable output potentiometer.

The oscillator also contains an efficient vibrator for producing audio frequency where it is desired to test the audio portion of the receiver independently of the r-f. stages. The output of this a-f. signal is also continuously variable from zero to maximum.

A special cable is used for making the connections between receiver and oscillator.

## New Alden Adapters

The Alden Manufacturing Co., 715 Center St., Brockton, Mass., have brought out a series of seven-to-seven transposition adapters, as follows:

The No. 977SM which has the small-pin diameter socket and the medium-pin diameter base, is used in the 59 socket of analyzers for receiving the small-base, seven-prong tube, such as the 2A7.

The No. 977MS has a medium-pin diameter socket and small-pin diameter base



977SM 977MS 975-AB7

for attaching to analyzer plugs with the type 59 base so that they may be inserted in the small seven-contact sockets.

The internal connections for these adapters are straight through.

The No. 975-AB7 adapter, when used in the 24 socket of a tube tester, tests the 2A7, 2B7 and also checks the 6A7, 6B7, 6C7, 6D7 and 6F7 tubes in the 36 checker socket.

## New IRC Volt-Ohmmeter

To meet the rapidly growing need resulting from increased use of point-to-point service methods, International Resistance Co., Philadelphia, Pa., has brought out the IRC Volt-Ohmmeter.

An interesting feature of this new instrument is its automatic vacuum relay which prevents burn-outs of meters or circuits resulting from accidental overloads. When an overload occurs, the relay automatically throws the circuit open, then closes it when the overload is removed.

The IRC Volt-Ohmmeter weighs 2½ lbs. It is 7" long by 3" deep. Voltage ranges are 3, 30, 300 and 600. Resistance ranges are 0 to 1,000; 0 to 100,000 and 0 to 1 megohm.



With minor wiring changes and the addition of IRC Precision Resistors, various d-c. current readings can be made. The basic meter used is an 0-1 milliammeter.

Other features of the IRC Volt-Ohmmeter include extra large 3" etch scale with double strength glass cover; full bakelite case either black or mahogany finish; one set of pin jacks for all readings; rotary switch, and convenient compensation for battery variations on ohmmeter.

## New Deal in Condensers

The Sprague Sales Co., headed by Harry Kalker, has what we consider a swell idea. It's this; one standard voltage rating for all capacities. The rating is 600 volts . . . that's why they call it the "600-Line" group. Which means that so long as you pick up one of these condensers with the right capacity, you don't have to think about its voltage rating, because the rating is more than high enough for all general purposes.

We still appreciate things which are convenient, time-saving and trouble-saving. We think the above is a good example.



# Officially Accepted!

"A CHRONOLOGICAL SET CATALOG AND INDEX"

of all American radio receivers manufactured and sold between 1923 and 1933 has been accepted by the HARTFORD and TOLLAND COUNTIES' RADIO RETAIL DEALERS ASSOCIATION as the authority for the original list price used in determining age and value of radios for trade in.

No wonder! More than 50,000 facts were collated under the personal supervision of the famous consulting radio engineer Ralph Langley in order to produce this 115-page volume. Each page is 8½ x 11 inches and printed letter press from plates.

Approximately 3000 different models are catalogued showing the

- manufacturer's name
- model number and name of model
- year of production
- number of tubes
- number of controls
- type of circuit
- type of power supply
- number of stages.

For the receivers sold between 1931 and 1933, the above mentioned data is supplemented by a listing of the types of tubes used in the receivers.

This information should be of immense value to—

Radio Receiver Manufacturers—Parts Manufacturers—Tube Manufacturers—Radio Dealers—Radio Jobbers—Service Men—Statistical Organizations—Libraries—Technical Schools—Patent Attorneys—Instrument Manufacturers.

LIST PRICE \$2.00 POSTPAID  
BOUND IN PAPER COVER

NOTE: This catalog is given with Volume III of Rider's Perpetual Trouble Shooter's Manual. If you own this volume of Rider's Manual you already have this Set Catalog and Index.

Published by

**JOHN F. RIDER**

1440 Broadway

New York City

## GIVE SERVICE with a Here is the Best Volume Control Proposition on the Market

**SMALL INVENTORY**

Here are the reasons why!

1. Over 400 "exact duplicate" controls in the "X" SERIES.
2. Yet with SIX controls in the original AD-A-SWITCH SERIES 477 sets can be serviced.
3. By combining controls in both lines any requirement can be met with minimum stock investment.
4. CLAROSTAT with its two separate lines offers the widest range of controls to choose from.
5. CLAROSTAT CONTROLS are inseparable from Quality Service Work.

CLAROSTAT "X" line has over 400 controls to choose from—exact as to electrical overall resistance, taper, bushing, shaft length, and will fit into exact space in set.

CLAROSTAT AD-A-SWITCH line comprises the maximum utility with minimum stock investment. Series W (Wire Wound) obtainable from 50 to 50,000 ohms. Series C (new composition element) obtainable from 10,000 to 5,000,000 ohms. Both lines obtainable in all tapers—insulated shaft 1½" long. Wide use is indicated as follows: W-28 will service 128 sets; C-28, 106 sets; W-29, 77 sets; C-59, 66 sets, etc., etc.



**NEW CONTROL REPLACEMENT GUIDE UPON REQUEST.**

**CLAROSTAT Mfg. Co., Inc.**

287 North 6th Street, Brooklyn, N. Y.

"AD-A-SWITCH" was originated by Clarostat

**Best SELECTION Lowest PRICES Quickest SERVICE**

THE RADOLEK CO. (Dept. 708)  
601 West Randolph Street, Chicago, Illinois

Please send me, without obligation, the NEW Radolek Profit Guide.

Name .....

Street .....

City..... State.....

Do you do Service Work? Yes  No

Do you operate from Store  Shop  Home  (Check which, please.)

# Index of Monthly Literature

## AUTO-RADIO

- Auto Antennas (Installation, Types)  
*Radio*, pp 27, August, 1933
- Car Set Troubles (Aerial & Ignition)  
*Radio World*, pp 6, August 19, 1933

## BROADCAST

### Amplifiers, A-F.

- Circuit Design of 2A3 Amplifier  
*C. H. W. Nason, Radio Engineering*, pp 20, July, 1933
- Direct Coupled A-F. Amplifiers, Part II  
*L. M. Barcus, Radio-Craft*, pp 154, September, 1933
- Quality in Audio Amplifiers (Circuits with 2B6 Tubes)  
*W. H. Hollister, Radio-Craft*, pp 150, September, 1933

### General

- Quality in Audio Amplifiers (Circuits with 2B6 Tubes)  
*W. H. Hollister, Radio-Craft*, pp 150, September, 1933
- Rewiring A.K. 70-Q for 2-Volt Operation  
*A. A. Janszen, Radio-Craft*, pp 165, September, 1933
- Shielded Lead-in System (Construction)  
*H. J. Adler, Radio News*, pp 148, September, 1933

## PUBLIC-ADDRESS

- 26-Watt Dual Channel P.A. System (Construction)  
*L. Gancher, Radio-Craft*, pp 146, September, 1933
- Circuit Design of 2A3 Amplifier  
*C. H. W. Nason, Radio Engineering*, pp 20, July, 1933
- Condenser vs. Carbon Mikes  
*Radio*, pp 32, August, 1933
- Direct Coupled A-F. Amplifier, Part II (Construction)  
*L. M. Barcus, Radio-Craft*, pp 154, September, 1933
- Low-Hum A-C. Operated Pre-Amplifier (Circuit)

*M. C. Bartlett, QST*, pp 36, August, 1933

### Mixer Circuits

- H. H. Scott, Radio Engineering*, pp 14, July, 1933
- Portable A-C., D-C. P.A. System (Construction)  
*L. Littman, Radio News*, pp 156, September, 1933

### Push-Pull Amplifiers with 2A3 Tubes (Construction)

*S. L. Baraf and I. A. Mitchell, Radio News*, pp 146, September, 1933

### Quality in Audio Amplifiers (Circuits with 2B6 Tubes)

*W. H. Hollister, Radio-Craft*, pp 150, September, 1933

## SHORT WAVE

"Acratone Discoverer" (Circuit)  
*C. E. Denton, Short Wave Craft*, pp 276, September, 1933

Patterson Amateur S.W. Super (Circuit Analysis)  
*R. Gudie, Radio*, pp 22, August, 1933

Superheterodyne with Coil Switching System  
*H. B. Allen, QST*, pp 12, August, 1933

Wallace S.W. Receiver (Circuit)  
*Short Wave Craft*, pp 287, September, 1933

## TESTING SYSTEMS

Accessor Unit for Receiver Testing (Construction)  
*H. Bernard, Radio World* pp 8, August 5, 1933

Adapters for Test Equipment (Circuits)

*F. L. Sprayberry, Radio-Craft*, pp 152, September, 1933

Analyzer Switching (Circuit)  
*J. W. Davies, Radio News*, pp 155, September, 1933

Decade Condenser Unit (Construction)  
*H. S. Kenyon, Radio-Craft*, pp 163, September, 1933

Frequency Meter (Design)  
*W. P. Hughes, Radio*, pp 10, August, 1933

### Meter Rectifiers (Circuits)

*F. Fausett, Radio News*, pp 150, September, 1933

### Modern Servicing Equipment, Part II

*J. Kaufman, Radio News*, pp 153, September, 1933

### Resistor-Condenser Calculation Chart

*L. B. Sklar, Radio-Craft*, pp 164, September, 1933

### Supreme Master AAA-1 (Circuit)

*F. Fausett, Radio-Craft*, pp 148, September, 1933

### Testing Electrolytic Condensers (Circuit)

*M. Chernow, Radio News*, pp 154, September, 1933

### Testing Resistors (Methods)

*Radio-Craft*, pp 186, September, 1933

### Testing Transformers & Chokes

*O. A. Pearson, Radio Retailing*, pp 37, August, 1933

### Vacuum Tube Voltmeter Design

*A. R. Haidell, Radio*, pp 19, August, 1933

## TUBES

### New Metal Tubes (English)

*F. E. Henderson, Radio News*, pp 138, September, 1933

### Type 2B6 Details and Characteristics

*L. Van Der Mel, Radio-Craft*, pp 142, September, 1933

Uses of Type 53 Tube (Circuits)  
*Radio World*, pp 10, July 29, 1933

## MISCELLANEOUS

Photo-Cell Relays (Construction)  
*M. L. Wendel, Radio News*, pp 144, September, 1933

### Rewiring A.K. 70-Q for 2-Volt Operation

*A. A. Janszen, Radio-Craft*, pp 165, September, 1933

### Shielded Lead-in System (Construction)

*H. J. Adler, Radio News*, pp 148, September, 1933

All articles listed on this page are cross-indexed for your convenience. Titles given are not necessarily the titles of the original articles, but in each case serve to determine the substance of the article. Listings marked with an asterisk (\*) are abstracted in this issue. The material in each issue of SERVICE is alphabetically indexed on the Contents Page.



# **STRIKE**

## *While It's*

# **HOT**



●

### **Group Subscriptions at Substantial Savings!**

The Regular Subscription price for SERVICE is now \$2.00 per year.

You, no doubt, know many other Service Men who would like to receive SERVICE every month. Probably several other Service Men in your acquaintance are already subscribers.

Here are two plans whereby you can save money for yourself and your friends:

- 1—Subscriptions (new or renewals) can be purchased in groups of ten or more for \$1.00 per year each.
- 2—Subscriptions (new or renewals) can be purchased in groups of five to ten for \$1.50 per year each.

If your subscription is about to expire, show SERVICE to five or ten of your friends. They, too, will want it. If they are already subscribers, they will want to renew or extend their subscriptions.

If you wish to *extend* your subscription at these savings, get five or ten others to subscribe at the same time.

Be sure to print clearly the name and address of all the subscribers, and send a check or money order covering the exact amount, noting in each case whether the subscription is a new one or a renewal.

*All Offers are Subject to Withdrawal Without Notice*

**John F. Rider Publications, Inc.**  
1440 Broadway New York, N. Y.

SAY YOU SAW IT IN SERVICE

# S E R V I C E B O O K S

by

## Smack on the Button!

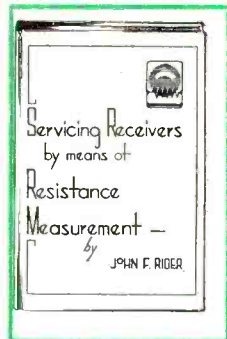

203 Pages; Type Set; Cloth Bound; Profusely Illustrated; PRICE \$1.00.

### SERVICING RECEIVERS by means of RESISTANCE MEASUREMENT

The number of radio receiver manufacturers who are furnishing point-to-point resistance data or continuity test data expressed in specific values of resistance, is mounting daily.

More and more of the radio service managers and engineering staffs in the large receiver manufacturing plants concur in the statement made by Rider that modern receivers with their tricky circuits require resistance measurement method of servicing.

*Servicing Receivers by means of Resistance Measurement* by Rider is the only clear and concise exposition of this method of servicing. It was the first to discuss point-to-point methods and is the best.

If you are interested in operating along the most modern lines—along lines which recognize the fewest limitations—get this volume. Its contents hit present-day servicing interest and requirements “right smack on the nose!”

Not only is *Servicing Receivers by means of Resistance Measurement* a clear explanation of actual application of the point-to-point system, but it also gives you a clear insight into resistance problems as experienced in radio receiver design.

A thorough understanding of this book will not only give you the information you require about today's receiver, but you will be prepared for whatever changes are made upon future receivers.

Don't delay! Get your copy today. . . . Your competitor who is keeping abreast of the latest developments—who employs the most modern equipment—the most modern systems—has a definite advantage over you . . . unless you too fall in line.

*Now is the time! . . . Send for your copy today.*

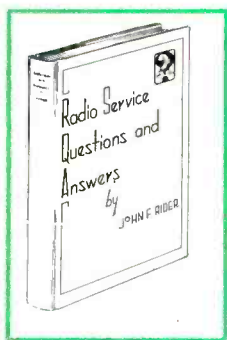

Type Set; Well Illustrated; Cloth Bound; PRICE \$1.00.

### RADIO SERVICE QUESTIONS AND ANSWERS

*Radio Service Questions and Answers* is a compilation of radio service problems prepared over a period of years by Rider. Your problems and the solutions, and the problems and solutions submitted by thousands of other Service Men, are placed at your disposal.

*Radio Service Questions and Answers* covers all types of radio receivers, speakers, tubes, amplifiers, power packs, public address systems—everything with which you come in contact in your daily work.

*Radio Service Questions and Answers* contains only practical information—no theory. All the information is boiled down to the essential facts which are clearly explained.

You will use *Radio Service Questions and Answers* the day this book gets into your hands. It will never become obsolete. Year after year you will find data of current interest—information which will save you time and effort and bring you immediate financial returns. One answer to a perplexing problem will repay the cost of the book.

*Radio Service Questions and Answers* covers old and new systems. It is an essential reference book for Service Men.

### ALL BOOKS SOLD WITH A MONEY BACK GUARANTEE

RADIO TREATISE CO.,  
1440 Broadway,  
New York, N. Y.

NAME .....

ADDRESS .....

CITY .....

STATE .....

Enclosed find \$.....

Please rush, post paid, the following books.

.....SERVICING RECEIVERS BY MEANS OF RESISTANCE MEASUREMENT.

.....RADIO SERVICE QUESTIONS AND ANSWERS.

J  
O  
H  
N  
F  
R  
I  
D  
E  
R