

SERVICE



A MONTHLY DIGEST OF
RADIO
AND ALLIED MAINTENANCE



He pounds brass . . .
(see page 230)

PER COPY
15 CENTS

SEPTEMBER
1932

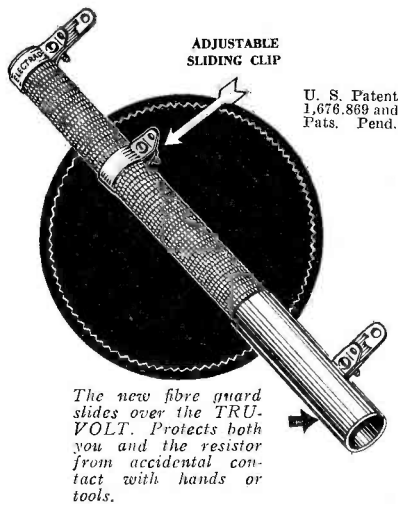

TRUVOLT Resistors

Electrad TRUVOLT Resistors, *alone*, offer several distinct advantages:

- 1—Patented construction permits larger wire, giving longer life and greater heat radiation.
- 2—TRUVOLT construction gives a better electrical contact.
- 3—TRUVOLT construction offers finer adjustment, due to its method of spirally winding the resistance wire.
- 4—Adjustable sliding clips may be added, removed or set for any desired voltages.
- 5—Every TRUVOLT Resistor has a full-length fibre guard. Prevents injury from accidental contact with tools—or hands, when under load.
- 6—Because of these *exclusive* features, TRUVOLTS are the most economical and adaptable of all resistors for replacement or experimental work.

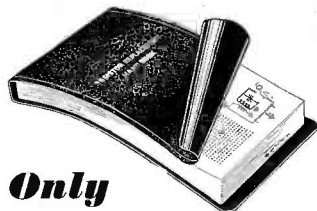

Only
\$1.00 a Year
Including 4
Supplements

ELECTRAD RESISTOR Replacement Hand Book

The most valuable hand book ever compiled for the service man. An accurate, loose-leaf guide to resistor values in all receivers. Kept up-to-date by four supplements a year. Hundreds of enthusiastic service men use this book daily, and have written to us praising its time, labor and money - saving helpfulness. Sold on a 10-day trial money-back guarantee. Mail coupon for your copy.

175 Varick St., New York, N.Y.
ELECTRAD
INC.

ELECTRAD Consistently Improves Its Products to Simplify the Service Man's Work

Radio knowledge is constantly advancing, and Electrad engineering has kept in the forefront since the beginning of broadcasting. The quality of Electrad Products is of so high a standard that they are *unqualifiedly guaranteed to give complete satisfaction*. That fact means that, notwithstanding their moderate cost, you are assured of proper performance when you rely on Electrad Products for replacement work.

Your every need in resistors, volume controls and amplifiers, for service or experimental work, can be supplied from the new Electrad Catalog. *Mail coupon for your copy.*

STANDARD VOLUME CONTROLS

Instantly Changed to Power-Switch Type

The new Electrad line of Replacement Volume Controls is the most complete now available. Economical too—for just five types will fit the replacement requirements for 799 modern and obsolete receiver models. Think what that means in convenience and saving of time and labor. All standard types are instantly convertible to use a power-switch, merely by removing the end cover and snapping the cover, with switch attached, in its place. All Electrad Replacement Volume Controls are now equipped with long aluminum shafts—easy to cut to any desired length—less time—less trouble.

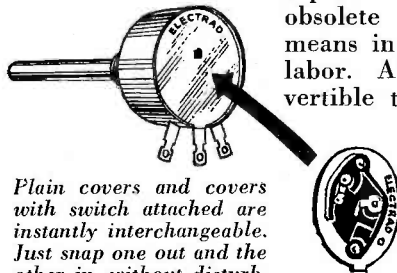

Plain covers and covers with switch attached are instantly interchangeable. Just snap one out and the other in, without disturbing the control connections.

Direct-Coupled AMPLIFIERS

Widely praised for high output, rich tone and economical operation. Four models, covering every private and public amplifier need, from 1.6 watts to 21.9 watts of undistorted power output. List price, \$32.50 to \$195.00, less tubes. Write for complete catalog.

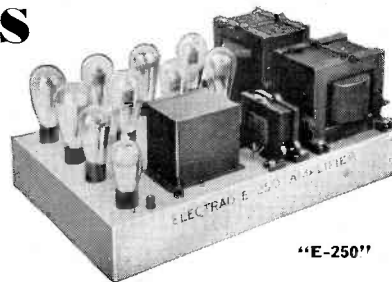

ELECTRAD, INC., 175 Varick St., New York
.....Check here for general catalog.

Enclosed \$1.00 (*check, currency or money-order*) for ELECTRAD REPLACEMENT HAND BOOK, including four supplements, (*as published*).

Name

Address



“Hop aboard our ‘Magic Carpet’
 for a thrill-ride ‘round the globe”
LONDON · PARIS · ROME · MADRID

JUST turn a switch and—z-i-p! we’re off on a world tour via radio. Because it’s a new **SCOTT ALLWAVE DELUXE** there’ll be no fussing and fumbling about—only one dial to tune, no coils to plug in, no trimmers to adjust carefully. Just use the convenient log furnished with the set and the foreign station you want—maybe 10,000 miles or more away—comes in on the dot.

Let’s Start to Merrie England!

Let’s try G5SW, Chelmsford, England. Get it any day between 3:00 and 6:00 P.M. Hear peppy dance music from the Hotel Mayfair in London (Yes, those Britishers furnish music that’s as “hot” as any orchestra in the States!). Then, too, there are world news broadcasts that tell listeners all over the far-flung British Empire the news of the day in the homeland. At 6:00 P.M. (Midnight London time) it’s thrilling to hear “Big Ben,” in the House of Parliament, strike the hour of midnight in a sonorous voice.

Foreign Reception Every Day in the Year

Tired of the English program, eh? Like something French? That’s easy—let’s go to gay Páree.

Here’s Radio Colonial, Paris, France, and it is on the air for the **SCOTT ALLWAVE DELUXE** any day between 3:00 and 6:00 P.M. Hear those dulcet tones of a spirited Mademoiselle? What, you can’t understand French? Never mind, here’s an orchestra and a song. Music is a universal language. This is Monday—that’s lucky, for there’ll be an hour’s talk in English today about the encampment of the Veterans of Foreign Wars to be held in Paris in 1935.

10,000-Mile Distant Stations Guaranteed

Unusual to get such reception? Not at all for this receiver. This new **SCOTT ALLWAVE DELUXE** is guaranteed to bring it in like that—yes, absolutely guaranteed to bring in foreign stations 10,000 miles or more away, every day of every week in the year, with loud speaker volume.

How can they make such a guarantee? Well, chiefly because the **SCOTT ALLWAVE DELUXE** is a custom-made receiver. It is built with as much care and

precision as a fine watch. There’s skilled designing and engineering behind it too—as well as parts good enough to carry a five-year guarantee against failure.

Most Perfect Tone Quality in Radio

Want to hear some more? Sure! Where do you want to go? Germany? All right. Here’s Zeesen. It can be **SCOTT**-ed any morning between 9:30 and 11:00. From it you will hear about the grandest symphony concert put on the air any place. You’ll be glad your **SCOTT ALLWAVE DELUXE** has such exquisite tone. And it is exquisite tone! So perfect that, in a studio test, observers were unable to distinguish between the actual playing of a pianist and the **SCOTT** reproduction of a piano solo from a broadcasting station when the set and the pianist were concealed behind a curtain.



Tired of Germany? Then let’s jump to Spain on our “Magic Carpet.” Here’s EAQ, Madrid. Hear the castanets and guitars? Always typically Spanish music from this station between 7:00 and 9:00 P.M. You’ll enjoy EAQ doubly because they thoughtfully make their announcements in both English and their native tongue.

Opera Direct from the Eternal City

Want a quick trip farther south? Here’s Rome—12RO. The lady announcer’s voice is saying, “Radio Roma, Napoli.” From here, between 3:00 and 6:00 P.M. daily, you’ll hear grand opera with its most gorgeous voices and with the finest accompaniments.

So you want to hear what’s doing on the other side of the world now? That’s easy, let’s get up early and pick up VK2ME, from Sydney, Australia, any Sunday morning between 5:00 and 8:30 A.M., or VK3ME, Melbourne, any Wednesday or Saturday morning, between 4:00 and 6:30 A.M. Hear the call of the famous bird of the Antipodes—the Kookaburra. There’ll be

an interesting and varied program, music, and always a talk on the scenic or industrial attraction of the country.

Australian Stations Sound Close as Home

Can I get Australia easily? Why, of course you can! In a test didn’t one **SCOTT ALLWAVE** pick up every regular program from VK2ME in Chicago, 9,500 miles away, over a whole year’s time? Quite a record? You bet! And what’s more, the programs received were recorded on phonograph records, and one was even played back to Australia over long distance telephone, and they heard it clear as a bell! That’s performance!

These are but a few of the more than 200 foreign stations that may be heard by **SCOTT** owners.

Tired of foreign travel? Well, let’s jog about the STATES—or Canada or Mexico—on the regular broadcast frequencies. Wonderful? You bet! There was never finer reception. Or you can eavesdrop on police calls, international phone transmission, gabbing amateur wireless telephony fans. Your fun with a **SCOTT ALLWAVE DELUXE** is unlimited.

New Values! Prices Lowest Ever!

Too expensive for you? Not at all! A **SCOTT ALLWAVE DELUXE** won’t cost you more than any good model of an ordinary receiver. And it gives so much more in pleasure and satisfaction!

You’d like to know more about it—the technical details, and proofs of those wonderful performances? Easy! Just tear out the coupon below, fill in your name and address, and mail it TODAY.

THE E. H. SCOTT RADIO LABORATORIES, INC.
4450 Ravenswood Ave., Dept. S92, Chicago, Ill.

Tell me how I can have a **SCOTT ALLWAVE DELUXE** for a “Magic Carpet” of my own, and send me complete technical details, proofs of performance, and complete information.

Name.....
 Address.....
 City..... State.....

SERVICE

A Monthly Digest of Radio and Allied Maintenance

SEPTEMBER, 1932
Vol. 1, No. 8

EDITOR
John F. Rider

MANAGING EDITOR
M. L. Muhleman

Editorial Contents

FEATURES

- Rider's Condenser Tester..... 229
Biography: F. E. Smolek..... 230
Resistance Measurement Method of Service
Analysis—Part IV, By John F. Rider..... 231

ANTENNA (Is Servicing Justified?)..... 226

AUTO-RADIO

- Curing Hiss in Transitone..... 242
Dodge and Plymouth Installations..... 242
Ford Ignition Systems..... 242

FORUM (The Reader's Page)..... 248

GENERAL DATA

- Adjusting Peerless Speaker..... 238
Aligning All-Wave Receivers..... 241
Amrad 81 Electrical Values..... 238
Atwater-Kent 46, 47 and 53..... 235
Balanced Aerial System*..... 236
Brand Line RCA Victor Models..... 236
Carbon Type Resistors Used in Fada Receivers..... 238
Crosley Pickup Connections..... 235
Curing Oscillation When Checking Receivers... 238
Eliminating Radio Reception When Pickup is Used 233
Fada "RE" Chassis..... 232
Kennedy Model 63..... 237
Musette Models 52 and 53..... 235
Philco Peak Frequencies..... 238
Radiola 30-A..... 236
Servicing is not for the Color Blind..... 238
Superheterodyne Harmonics..... 233
Tube Variations in Colonial 62..... 237
Tube Variations in Silvertone 1580, 1582 and 1584 238

- Type 59 Tube..... 233
Up and Going..... 238
Wire Type Resistors Used in Fada Receivers..... 238
Zenith Parts Numbers and Values..... 237

HIGHLIGHTS..... 244

INDEX OF MONTHLY LITERATURE..... 254

MANUFACTURERS

- Electrad V.C. and Switch Assembly..... 250
Herst "Laiz-Flat Radiolet"..... 250
I.R.C. Grid Bias Kit..... 250
Lynch Aerial Products..... 250
NA-ALD Adapters and Sockets..... 250
Sampson Stiktape Aerial..... 250
Tobe Filterizer Kit..... 250

ON THE JOB

- Cooperative Advertising, By W. Kenneth Jeffords 246
Handy Reference Charts, By B. W. Freid..... 246
Sell Them an '80, By Wells G. Arnold..... 246
Temporary Sets, By Joseph Vicari..... 246

PUBLIC ADDRESS

- Class "A" to Class "B"..... 239
Grounding Shielded Cable..... 239
Multi-Speaker Coupling..... 239
PAM-110 Class B Amplifier..... 239

SHORT WAVES

- Aligning All-Wave Receivers..... 241
Converters With '27 Detectors..... 240
C.W. on Converters..... 241
Hammarlund Comet "Pro"..... 240
Kennedy Model 53 Converter..... 241

Advertising Director

ROBERT N. MANN
1440 Broadway, N. Y. City
Telephone: CHickering 4-4542

Published monthly by

John F. Rider Publications, Inc.
1440 BROADWAY
NEW YORK, N. Y.

Officers

JOHN F. RIDER,
President and Treasurer
M. L. MUHLEMAN,
Vice-President
J. SCHNEIDER,
Secretary

SERVICE, Sept., 1932. Volume 1, No. 8. Published monthly at New York, N. Y. Copyright, 1932 by John F. Rider Publications, Inc. Contents must not be reproduced without permission. Subscription price \$1.00 per year in the United States of America; 15 cents per copy. \$2.00 per year in Canada and foreign countries; 25 cents per copy. Application for entry as second-class matter is pending

HICKOK

STATIKTESTER
INDIVIDUAL UNIT MEASUREMENT

Laboratory Accuracy

**The First
ALL NEW
Set Tester Development
IN YEARS**

- THE ONLY SERVICE DEVICE MEASURING EVERY UNIT IN A RADIO RECEIVER.
- THE ONLY TESTER WHICH LOCATES EVERY DEFECTIVE RECEIVER UNIT when—
- THE RECEIVER IS ENTIRELY INOPERATIVE.

A NEW METHOD

Rapid—
Accurate—
Modern

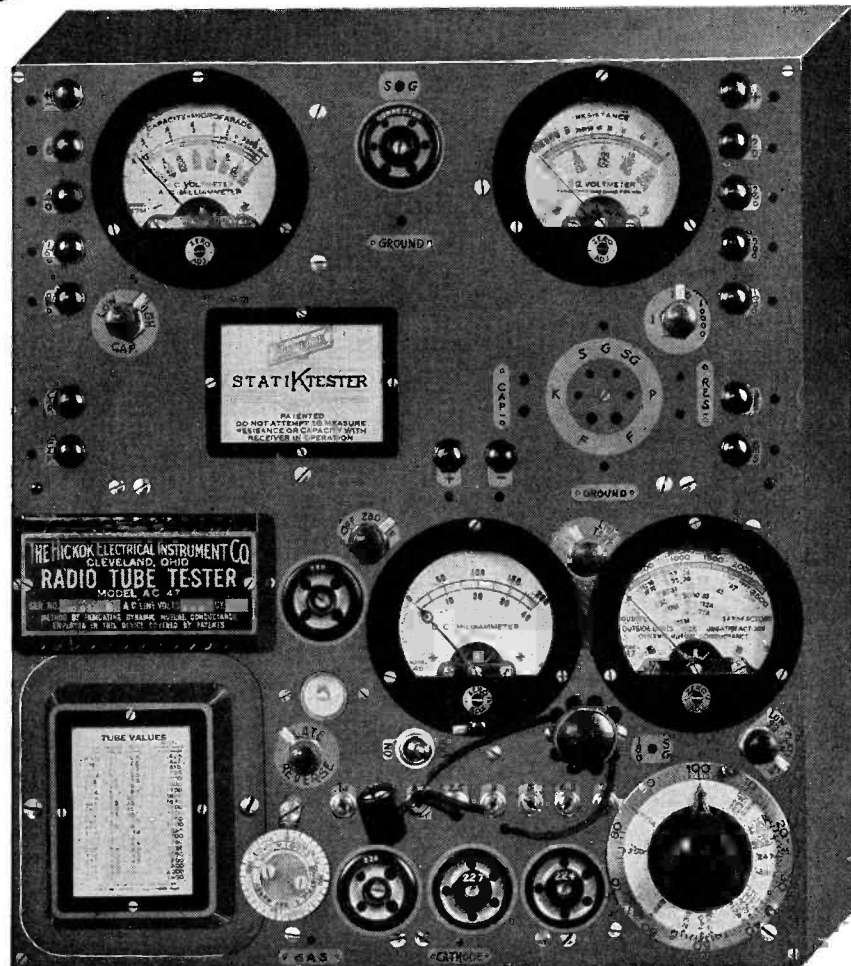

Size: 12 1/16 x 13 1/2 x 3 inches

WHAT IT MEASURES

- All Values of D. C. Volts on Quadruple Range Voltmeter from 0 to 1000 Volts—High Sensitivity Voltmeter, 1666 Ohms per Volt. Ranges 0 to 20, 0 to 200, 0 to 500, 0 to 1000 Volts.
- All Values of A. C. Volts on Quadruple Range A. C. Voltmeter 0 to 800 Volts. Ranges 0 to 8, 0 to 40, 0 to 160, 0 to 800 Volts.
- All Values of D. C. Milliamperes on Double Range Milliammeter from 0 to 200 Milliamperes. Ranges 0 to 40, 0 to 200 Milliamperes.
- All Values of A. C. Milliamperes on Double Range Milliammeter from 0 to 200 Milliamperes. Ranges 0 to 40, 0 to 200 Milliamperes.
- All Values of Resistance on Triple Range Ohmmeter from 1/4 Ohm to 20 Megohms. Ranges 1/4 to 1000, 200 to 200,000 Ohms, and 2000 Ohms to 20 Megohms.
- All Values of Capacity on Double Range Capacity Meter from .05 to 15 Micro Farads. Ranges .05 to 1 M.F., 1/4 to 15 M.F. Capacities from .0005 to .05 measured on Megohmmeter. Tests. ELECTROLYTIC CONDENSER LEAKAGE AND CAPACITY UNDER OPERATIVE CONDITIONS. OUTPUT OF RECEIVERS MEASURED ON MILLIAMMETER.
- All Values of Inductance on Double Range Inductance Meter from 1/2 to 50 Henries.
- TESTS RADIO TUBES BY THE MOST ACCURATELY KNOWN METHOD BY APPLYING STANDARD VALUES OF D. C. VOLTAGE TO PLATE AND GRID, READING STANDARD VALUES OF PLATE CURRENT, MUTUAL CONDUCTANCE AND GAS CONTENT.
- All measurements without use of Auxiliary Apparatus. Instructions include Loose Leaf Book in Leatherette Binder covering. Point-to-Point Resistance Measurements on Receivers.

List Price - - - - \$250.00 Carrying Case - - - - \$15.00 Subject to Regular Discounts

SERVICE MEN—WRITE NOW TO

THE HICKOK ELECTRICAL INSTRUMENT CO.

10516 DUPONT AVENUE

CLEVELAND, OHIO

THE ANTENNA...

IS SERVICING JUSTIFIED?

A RATHER vitriolic editorial made its appearance in a recent issue of a weekly trade paper catering to the talking machine and radio dealers. The sum and substance of the presentation was aimed to show that service work is generally harmful to the merchandising of radio receivers. Further, that Service Men are unfairly competing with the established radio dealer.

A great wail is raised about the glorification of service, and the warning is given that service work interferes with sales. One is not to be surprised that in a merchandising publication, merchandising is uppermost. That is to be expected, but at the same time let it also be recognized that you can't eat your cake and have it, too.

Let us consider some facts in general. The accumulation will be the bulk answer to the editorial in question. SERVICE is wholeheartedly for the Service Man as a Technician and for the Service Man as a Merchandiser. For years this branch of the radio industry has been considered a necessary evil. Now that his position has been tremendously strengthened and his efforts are being felt, the merchandising group are beginning to wail. It is said that the servicing of old receivers is curtailing the sale of new receivers. We would like to ask one question. There are about 30,000,000 families in the United States. About 16,000,000 receivers have been sold up to the end of the last season. Where are the sales to the remaining 14,000,000 families?

Why should the merchandising group bellyache on the grounds that Service Men are interfering with sales by repairing what are termed to be old receivers? Is it the wail of the man who loses an opportunity to another and cries, "foul" or "unfair competition?" Every city in the United States shows concrete evidence of the fact that Service Men at large are making an effort to sell themselves and their time. On the other hand, how many dealers are making an honest effort to sell? We purchased a radio receiver in October, 1929. Not since the moment we paid for the receiver and carted it home, have we seen a sign or heard a word from the dealer. However, we have had at least 100 cards, letters, notices, etc., offering to repair the receiver we own—keep it in good condition, etc., from Service Men in the neighborhood. Would it not be natural to consult one of these men who may have created a good impression and interest in their activities when a new receiver is to be purchased? Is it reasonable to expect that a customer who purchased a radio receiver from a radio dealer should call upon that dealer or recommend that dealer for a new sale, when the said dealer has shown total neglect during three years? If dealers throughout the nation made an effort to really sell radio receivers there would be no need to cry about the fact that obsolete receivers were being serviced by a group of men who represent the backbone of the industry.

The suggestion is made in the editorial that efficiently operated Service Departments should produce a substantial portion of dissatisfied rather than satisfied set owners. Such a suggestion is ridiculous in the face of statements that are made when the receiver is sold. Such high pressure tactics just don't work. When the receiver is sold, it is said to be the finest—the ultimate in perfection, which it may be at the time.

The receiver is said to be good for several years. Within two or three years the picture changes. The receiver is no longer perfect. It no longer offers the finest in tone quality. We are willing to grant that a receiver two or three years old is no longer as good as new, but it can be made almost as good as new. The comparison in the editorial between the radio set and the automobile is entirely out of proportion. The mechanics of the two are not the same. It is actually unsafe to operate an old car.

However, plenty of service is rendered upon an automobile between its time of purchase and the time when replacement of the entire car is required. Can the automobile industry decry the fact that a car is good for three years and that service rendered during the three years curtails the sale of a new automobile? Not by a long shot! How many people who have purchased a certain make of car will buy another of the same make if the service department upon checking the car after two years of normal use, and perhaps 25,000 miles upon the speedometer, tells the customer that the car

is unfit for further repairs? Is any industry justified in stimulating its sales by limiting service, or by having its service groups make misleading statements?

The editorial in question bemoans the fact that Service Men are servicing receivers, three, four and five years old. Such service operations are purported to be limiting sales of new receivers. It is further stated that if the owners of these receivers were taught to be dissatisfied with their possessions, receiver sales would be stimulated. Once again we ask, why must the sales branch of the radio industry depend upon present-day receiver owners, be the receivers old or new? Where are the sales to the group who have never owned receivers?

The fact that the economic situation of the country limits the sale of new receivers to new customers—so does the same condition cause a man to have his receiver repaired. Receivers three, four and five years old were quite expensive. The owners of these receivers feel that they are entitled to a reasonable period of utility. Are they not entitled to a decent life for their investment?

Let it be known that the service branch of the radio industry does not consist of the group of men pictured by merchandising organizations. Let it be known that there are many thousands of Service Men who render honest opinions concerning the utility of a radio receiver and whether or not the repair is justified. There is nothing wrong with stating honest opinions. Service Men and groups are building upon a solid foundation for future business. There are some few who will sacrifice future possibilities for the present dollar, but the majority—those men who have helped increase the prestige of the industry—will and do render an honest opinion.

In very many instances there is nothing but repair open to some people in the United States. For instance, about 2,000,000 receivers are used on farms. With depressed farm prices, what can these people do other than to have their old receivers repaired? If the types of receivers used on these farms are classed as obsolete, and it is said that 4,500,000 obsolete receivers are in use, here is about 45 per cent of all of the obsolete receivers which actually cannot be replaced. There is no alternative but service.

It is a very simple matter to state that service is interfering with sales and thus avoid any reflection upon sales ability on the part of the established radio dealer. How many obsolete sets have been taken in in trade during the past five years? How many of these receivers were destroyed and thus removed from the market? Even a conservative estimate will reduce the total number of obsolete receivers to very definitely less than 4,500,000. Then again, there are hundreds of thousands of instances where more than one receiver is used in a home. This reduces the number of families who have receivers and increases the number who do not have receivers. Let us quote Mr. J. Rose, Service Manager of Davega, one of the largest radio receiver outlets in the United States. The Service Department under his guidance showed a profit in excess of \$100,000 during the last year without any curtailment of receiver sales. "We do not feel," says Mr. Rose, "that the success of the Davega Service Department was made at a sacrifice of sales. As a matter of fact our Service Department is of direct benefit and value to our sales department, by furnishing leads to our salesmen. These leads are made possible by the fact that we service any and all makes of radio receivers; not only those sold through our organization. Our Service Men render an honest opinion when called upon to service an old receiver and if the customer—who knows his economic condition better than we do—feels that it pays to repair the old receiver, rather than to purchase a new one, because he does not have the purchase price, we do our best to give him a serviceable receiver. We have gained a friend and a future customer."

Another part of the editorial claims that Service Men are unfairly competing with the established radio dealer. The competition we admit—but that it is unfair we deny. Is it unfair because the Service Group are making an effort to sell, without much needed co-operation from the dealer? The lack of co-operation between the dealer and the service fraternity is responsible for the competition

(Continued on page 230)

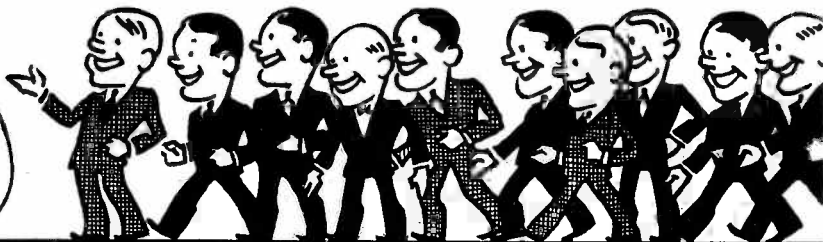

NATIONAL UNION meets the service man MORE THAN HALF WAY!

No other manufacturer of radio tubes offers more to help the service man and the dealer.

Radio men everywhere are telling us what National Union means to them. All appreciate that National Union helps the service man to help himself. And the reason why National Union does all this for service men and dealers is because National Union understands and does something about the service man's problems—

FIRST . . . National Union sells him only High-Quality Tubes.

SECOND . . . National Union offers him FREE the finest, most efficient shop equipment.

THIRD . . . National Union gives the latest and correct data on all radio equipment.

FOURTH . . . National Union assures him a real profit . . . because there is *no price cutting*.

Just look at all the valuable free equipment in this advertisement. And then ask yourself what tube manufacturer does more for service men.

Decide today to tie up with National Union for profit. Decide what equipment you want . . . and mail coupon below!



Oscillator and Output Meter

The only way to service super hets properly! Absolute necessity for modern servicing. Free with small purchase of National Union Tubes.

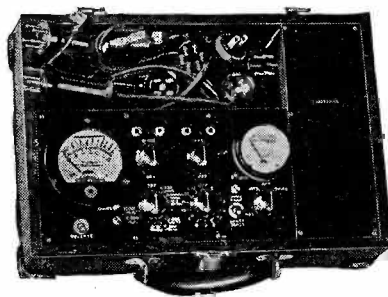

Readrite Resistance Tester

The new Readrite continuity, capacity, and resistance tester. No more chassis pulling! With the new Readrite Tester you can make every test—continuity, capacity, and resistance . . . without taking the set apart!

Operates easily, efficiently. And that means you can service more sets better and quicker than ever. Yours free with small purchase of National Union Tubes and small deposit.



The Readrite Tube Tester

Here's a valuable tester! Easily carried, convenient. An illuminated dial enables you to read tests in even the darkest corners! Send for it today!



Two Service Manuals

Here are two instructive, valuable service manuals written by John F. Rider, well known radio scientist and lecturer.

Volume 1 has over 2,000 diagrams on voltage, electrical values, color coding, etc.

Volume 2 has over 700 pages of valuable information. Point-to-point resistance data furnished for the first time enables operation of continuity, capacity, and resistance tester above at the right. Either one or both of these manuals free with small purchase of tubes.



NEW! NEW! NEW! Latest Method of Servicing

At the left is the new, sensational Unameter. Now offered to service men for the first time!

This Unameter Tester is very easy to operate. Turn the selector, then place tube in the socket, and watch the reading on the meter in English.

It is a compact, easily carried, sturdy meter. An aluminum chassis, with all panels made of bakelite. And attractively finished in gold, red and black. This Unameter is undoubtedly one of the finest pieces of radio equipment ever offered to service men. So don't miss this opportunity. It is yours free with moderate purchase of tubes and a small deposit.

FREE! Tube Base Layout Chart compiled by John F. Rider. No obligation. Write for one!

ASK YOUR JOBBER'S SALESMEN

NATIONAL UNION RADIO CORPORATION 400 MADISON AVENUE · NEW YORK CITY

Dear Sirs: I am checking the equipment in which I am interested:

READRITE TUBE TESTER OSCILLATOR AND OUTPUT METER VOL. I VOL. II
RESISTANCE TESTER UNAMETER

NAME _____

ADDRESS _____ CITY _____ STATE _____

Locate Set Troubles Quicker and More Precisely *with the New*

Readrite

No. 1000 Resistance, Continuity and Capacity Tester

TESTS

- Voltages
- Milliamperes
- Resistances
- Continuities
- Short Circuits
- Capacities

Here's the new Readrite Tester that will make money for you—an instrument that will give you a new conception of speed and accuracy—an instrument that makes possible a new method of servicing. Because sets are becoming more complicated every day, testing socket voltages only, is not enough to determine and locate set troubles. This new tester will enable you to quickly and precisely make a complete analysis of the set circuit from the set socket—including resistances, continuities, capacities, and short circuits. It will enable you to test

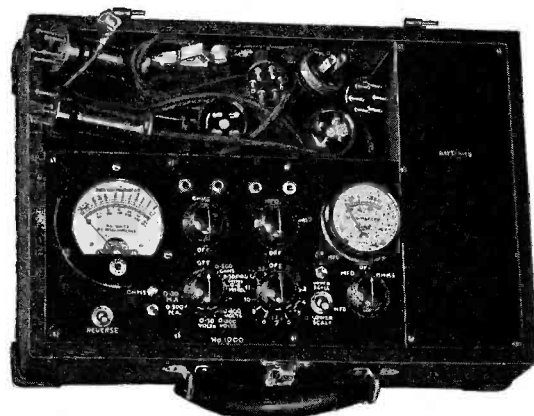

any receiver no matter how complicated the circuit . . . without removing the chassis from the cabinet!

The 3¾" D. C. precision meter has full scale deflection of 1 ma. The lower scale is divided into 60 divisions of 0-30, 0-300 and 0-600 D. C. Volts and 0-30, 0-300 D. C. Milliamperes. The upper scale reading is in ohms and megohms. Three scale readings are available for resistance measurements, 0-500 and 0-50,000 ohms, and 0-3 megohms. Can also be equipped to test up to 6 megohms. This scale arrangement insures easy reading and enables resistance tests to be quickly made with extreme accuracy.

The A. C. meter is calibrated for reading directly in microfarads. The lower scale reading is .008 mfd. to .25 mfd. The upper scale reading is .1 mfd. to 10. mfd. Line voltage is also checked with the A. C. meter. The instrument is calibrated for use on 60 cycles at 110 volts. The rheostat regulates the correct voltage to be applied.

Two plug-in cables and two separate cords are provided, enabling testing through the set socket, the resistance of voltage dividers, series resistors, transformer primaries and secondaries,

filter chokes, shorts, opens, speaker fields—also capacities of paper and mica type condensers. Jacks are provided for individual tests separate from the plug connection for all the above, and, in addition, milliampere and voltage readings.

The case is strong and covered with fabricoid. The cover is removable. Battery compartment has separate panel. It contains two 22½-volt batteries and one small flashlight cell. There is very small drain on the "B" batteries.

Cash in on this newest method of set analysis. Bring your equipment up-to-date. Order the Readrite No. 1000 Tester today!

PRICE

Only \$33.00
Net
to Dealers
and
Service Men

Mail
This
Coupon
NOW!

READRITE METER WORKS,
25 College Ave.,
Bluffton, Ohio.

Gentlemen:

Please send me information about Readrite No. 1000 Resistance, Continuity and Capacity Tester. Also catalog of other servicing instruments.

Name

Street Address.....

City..... State.....

READRITE METER WORKS

25 College Avenue

Bluffton, Ohio

Rider's Condenser Tester

HERE'S something to fool with. It's experimental, yet, it is for the Service Man. If you go about it in the proper way, I believe that you will find it worthwhile and the forecast is made that there are commercial possibilities to this device.

For a long time past it has been the custom to disconnect condensers from the receiver chassis in order to test the condenser for a short or open. Well, here is something which so far has shown itself to be applicable to solid-dielectric and air-type condensers, variable and fixed, without requiring that the condenser be disconnected. This means that an r-f. transformer connected across a tuning condenser need not be disconnected to check the condenser. The same is true if a fixed condenser is connected across a bias resistor, or across an a-f. or output transformer.

Unfortunately the range of operation as determined up to this period of development extends down to about .00025 mfd. The upper limit is several microfarads. Nothing definite is as yet available concerning electrolytic condensers, but its application to solid and air-dielectric condensers is sufficiently extensive to justify its construction. It's been used on electrolytics, but the entire range has not been covered. It's perfect for variable condensers used to tune broadcast receivers. In fact, anything between .00025 mfd. and about .008 mfd. can be checked to perfection.

The device has one limitation present when checking high values of capacity, but this limitation is one related to critical reading of the meter indication. Actually the limitation is present only when checking one value of capacity; namely, 1. mfd. Above and below this value it is easily applied.

The circuit is shown in Fig. 1. The constants of the parts are quoted at the end of this article. The coils L, L1, L2 and L3 are shown in Fig. 2. L and L1 are wound upon the outer form and L2 and L3 are wound upon the inner form. L and L1 are separate windings, whereas L2 and L3 is a continuous winding with a tap at the junction between L2 and L3. The winding L2 is used for the high range of capacities from about .005 mfd. to several microfarads. The complete winding of L2 and L3 is used for the low range of from .00025 mfd. to .008 mfd. The two ranges overlap slightly. With about half of C in the circuit and about half of the total capacity of C1 in the circuit, and the tube oscillat-

Schematic diagram of the Condenser Tester

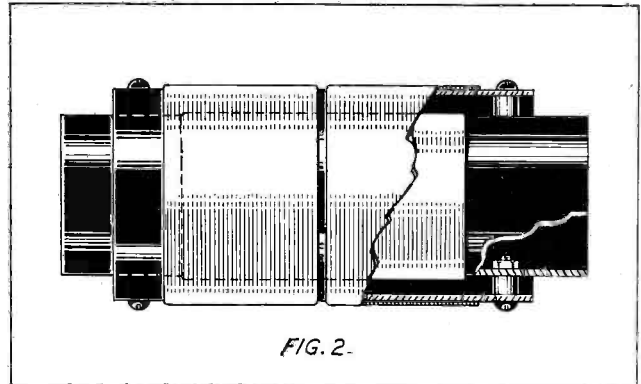
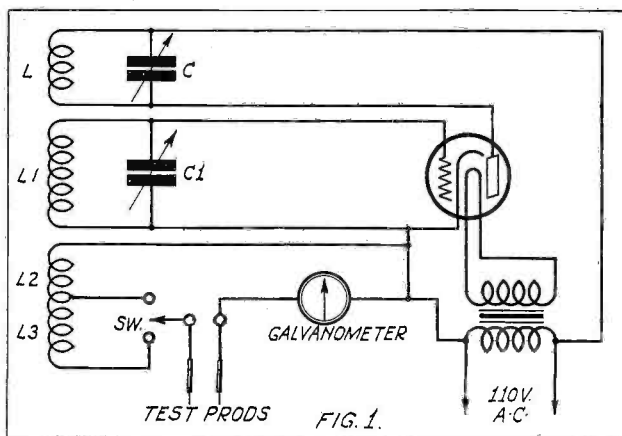

Details of coil assembly for Condenser Tester

ing, and the switch set for the low range, shorting the test prods should show no indication upon the galvanometer. However, when a condenser of from .00025 mfd. to about .008 mfd. is connected across the test prods, current will be shown upon the galvanometer. The lower the value of the condenser, the lower the indication, but even the lowest value in the range quoted will cause about quarter scale reading. If the condenser under test is shunted by a coil or resistor, and the condenser is intact, the meter will indicate about 1/10th scale.

The higher the value of the capacity being tested within the low range, the higher is the indication upon the meter, irrespective of what unit is shunted across the condenser, be it a coil or resistor, provided that the condenser is intact or the shunted unit is not wholly shorted. Since shorted coils and resistors are checked by means of an ohmmeter, the function of this condenser tester is only to show whether or not the condenser is intact—which it does. Just so long as the condenser is intact, the meter will indicate current. Short the prods or short the terminals of the condenser and no current will be indicated upon the galvanometer. If the condenser is open the meter will show no current.

When making the initial adjustment, connect a .001 mfd. fixed condenser across the test prods. If the meter goes off scale, vary C slightly until the current indicated is within the scale range of the meter. Another adjustment to secure this type of operation is to vary the position of the inner coil with respect to the outer coil. The proper setting is obtained when shorting the prods shows no meter indication, and when a .001 mfd. condenser is connected across the prods, the meter indicates about 80 percent of full scale.

As to the high range of capacities, the method of judging the condition is somewhat different. With only L2 in the circuit, shorting the prongs will cause an indication upon the meter. If the prongs are connected across a condenser which is open, there will be no indication. If the condenser in the circuit is shorted, the indication will be the same as if the prongs were shorted. You are now wondering about the practicability of the device, inasmuch as it may appear difficult to judge condensers. Nay, nay, my friend. With one exception, that is, one value of capacity, all other values will cause readings which will differ from that obtained with the prongs shorted or the condenser shorted. The presence of a coil or resistor of high or low value in shunt

with the condenser being tested will cause a change in reading, but current will be indicated, thus showing that the condenser is intact.

The only time when a misleading current indication may be encountered is when the condenser being tested is in shunt with a resistor of less than about 10 ohms and the condenser is open. However, even in this instance, a small amount of experience with the unit will teach the proper indications to be expected when certain values are being checked. The presence of a 10-ohm resistor in the circuit is sufficient to cause a very low reading, not more than about 1/10th of full scale.

When you play with this unit, you will note that a condenser of about 1. mfd. will cause a current indication which is approximately the same as that noted when the prongs are shorted. This is the limitation previously referred to.

With respect to the constants, L and L1 are wound upon the same form. Each winding consists of 90 turns of No. 28 silk-enamel wire wound upon a 1-3/4 inch form with 1/8 inch separation between the coils. The inside diameter of this form is 1-5/8 inches. L2 and L3 are also wound with the same size wire. L2 has 3 turns and L3 has 70 turns. The tap is taken off at the 3rd turn. The galvanometer is a Weston 425. The tube is a '27 and the transformer is any ordinary filament transformer capable of supplying the voltage and current. The condenser C is of 100-mmfd. and is of the midget type. C1 is a 50-mmfd. condenser, also of the midget type. Coils L2 and L3 are wound upon a 1-1/2 inch form and so arranged that the entire winding, form and all, may be slipped within the outer coil. The approximate position of L2 and L3 is such that the major portion of L3 is within the grid coil L1 and the 3-turn winding L2 is just within the plate winding L. No separation is required between L2 and L3.

This tester supersedes the one described in Volume II of the Perpetual Trouble Shooter's Manual. The coupling in the former tester was too critical.

Future issues will show adaptations for 110-volt d-c. and battery operation.

(Continued from page 226)

Instead of working hand in hand, the established radio dealer hangs his Service Man out on a limb. He wants him to be a salesman for him, without compensation or recognition for his services. Instead of co-operating with the independent Service Man, he makes it necessary for that man to go on his own. As a possible mover of merchandise, the dealer's floor salesman does not compare with the Service Man. How can there be any such comparison when we consider that the Service Man is on the job when the receiver is bad? Is any one in a better position to sell tubes, accessories or even new receivers, than the Service Man on the job? Certainly the Service Man is competing with the dealer, because he can get no co-operation from the established dealer. How many dealers have equipped a car with an auto radio receiver or are contacting customers for such sales? Not a great many if we are to judge by the experiences of acquaintances. On the other hand, many Service Men have equipped their service cars with auto radio receivers and are selling auto radio sets by talking them during service calls, and even demonstrating. Is this unfair competition? Again, not by a long shot!

The glorification of radio repair work is ridiculed. Comparisons are offered. Not a single comparison quoted stands close analysis. The radio industry cannot survive without radio maintenance for the very simple reason that the nature of the merchandise being sold, namely the radio receiver, is one which is subject to failure at any moment through no fault of the manufacturer of the receiver or its components. The very finest of radio receivers is apt to fail the day it is delivered. No amount of tolerance allowed in engineering design is sufficient to make a receiver wholly free of trouble. Any suggestion on the part of a merchandising group to the effect that service should be curtailed is devastatingly dangerous to the industry. There is no parallel to such a condition. There can be no paral-

lel. It has been said that the radio receiver manufacturer would benefit greatly if there were no service, that the dealer would benefit, that there would be no need for a service department. But *would* these people benefit thereby?

Would John Public buy a receiver if he were told that its normal life was two years? Not if we are to judge by comments pertaining to parallels where the investment is short-lived. The radio industry cannot produce a receiver which can be guaranteed to produce satisfaction for two years without any need for service work of any nature, and then suddenly fall apart. Just so long as this is an impossibility, just so long will there be need for radio maintenance. And if our personal knowledge of matters pertaining to radio is of any value, it is our statement that as long as radio receivers will be sold to the public, just so long will there be need for radio service facilities.

Let us remind the merchandising group in the radio industry that placing the blame of reduced sales upon the Service Group is a definite sign of weakness. If it were possible for the Service Branch of the radio industry to service every one of the 16,000,000 receivers which have been sold, and to keep these receivers in use for the next 10 years, there still remains room for a great many more radio receivers. Every room in every hotel, every cabin upon a ship, every maid's room, every room in college dormitories, every home in the United States, every automobile, etc., should have a radio receiver.

Let us further remind the merchandising groups that it is the Service Man who keeps the customer sold upon the receiver he owns by the satisfactory repair of that receiver. It is the Service Man who is the cause for repeated purchases of the same brand of receiver because he shows that the defect—whatever it may be—is something which can be rectified and the previously obtained performance continued.

Let us also remind the merchandising groups that the radio industry at large does not consist solely of sales. A branch of the radio industry is the Service Group, with manufacturers who are part and parcel of the radio industry catering to these men. Furthermore, radio receiver manufacturers have found that their service departments and their parts business can be handled at a profit. So have dealers and independent Service Men. No one branch of the industry can be sacrificed on a false altar.

John F. Rider.



The Man on the Cover

F. E. Smolek

Service Manager, Zenith Radio Corp.

HE has had a long and diversified experience in the radio field that began prior to the boom days of broadcasting. After completing his technical education, in 1920 he entered the service of the C. C. Wright Radio Company as designing engineer. During that time he did considerable development work in connection with several now well-known radio devices.

In 1924 he became Service Manager for the Electrical Research Laboratories, manufacturers of Erla products. It was here that he gained his knowledge of the service problems confronting the retail trade.

During the Fall of 1928 he entered the employ of the Zenith Radio Corporation, where he continues to unravel the service problems which are encountered in a large radio organization. Mr. Smolek has spent a great deal of time in actual contact with dealers and distributors in the field where he has become very well known.

Radio authorities attribute a great deal of the present-day success of broadcasting to the amateur and experimenter of whom Smolek was one of the early few. For many years he has been licensed under W9BAG in Chicago. He has designed and now operates one of the most elaborate short-wave transmitters in the middle west. Pounding brass in spare time is his principal diversion.

Resistance Measurement Method of Service Analysis

By JOHN F. RIDER

PART IV

THE application of the electrolytic condenser is of course dependent upon the polarity of the voltages present in the circuit during the operation of the receiver. This polarity remains unchanged when the receiver is not in operation. By realizing that the chassis is, as a general rule, negative with respect to all other points in the system, and by connecting the negative prod of the ohmmeter to chassis and probing with the positive prod, trouble from the presence of electrolytic condensers will be minimized. In the event that the test is made between two points which involve an electrolytic condenser but which are not connected directly to ground, connect the positive prod of the ohmmeter to that point which is known to be positive when the receiver is in operation. Thus, when operating between the rectifier filament as the common terminal and some other point, the positive prod of the ohmmeter should always be connected to the rectifier filament.

The effects of voltage upon electrolytic condensers is related to its resistance because of the variable leakage current. This factor is of importance as far as the measurement of voltage-divider circuits is concerned. Filter condensers of the electrolytic variety are usually of high capacity and as such have appreciable leakage and offer comparatively low resistance. However, the test voltage required for the ohmmeter to test these resistors is not very great—actually, only a small portion of the usual voltage applied to the condensers during operation. Consequently, the leakage current is much smaller and the resistance effect upon the balance of the circuit is much less because the resistance is high. The only possible exception to this general statement is the low-voltage rated bypass condenser connected across the pentode bias resistor in certain circuits. With the low value of this resistor, a very low test voltage is required for the ohmmeter. Hence the leakage is again minimized.

ELECTROLYTIC CONDENSER DETERIORATION

There is one item related to electrolytic condensers which deserves special mention. Although due precautions may be exercised in relation to polarity, trouble will undoubtedly be encountered when checking the resistance of a circuit which is paralleled by an electrolytic condenser which has been inoperative for several months. This is due to a characteristic of such units. When inactive for a period of time, there occurs a deterioration of the film with the result that the condenser action is greatly reduced and the internal resistance in the proper direction is very low.

However, trouble due to the presence of such a condenser—which, incidently, can be restored to its original state by being placed into operation for several hours—is native not only to resistance measurement, but also to voltage tests across such a circuit. As far as resistance measurement is concerned, the presence of the condenser will be productive

of an indication which will result in investigation. The first step will naturally be an isolation of the condenser from the rest of the circuit in order to enable a test of the components of that circuit. Once the condenser has been disconnected and the remainder of the system is perfect, the fact will become evident when the resistance is tested. Further tests upon the condenser will show its condition and the remedy will follow in due course.

Solid dielectric fixed condensers introduce no such complications. Polarity of the ohmmeter is of no consequence when checking resistors or circuits shunted by solid dielectric fixed condensers. Naturally, the same is true of air dielectric types of capacitors. It is therefore possible to dismiss these condensers without further discussion.

KNOWLEDGE OF OHM'S LAW NEEDED

A knowledge of Ohm's law and its application to series, parallel and series-parallel circuits is essential in the resistance measurement method of servicing. However, this requirement is not native solely to resistance measurement methods of analysis, so that no one can say it is a detriment when resistance and voltage measurement methods are compared. The greater the knowledge of Ohm's law as applied to d-c. circuits, the more rapidly can one operate in any service analysis which is predicated upon resistance measurement. The greater the knowledge of various types of d-c. circuit networks, the more readily will it be possible to detect troubles and their approximate locations. This is particularly true when actual tabulated point-to-point resistance data is not available and an analysis of the circuit is required. In this connection, we can only say that the deeper your knowledge of Ohm's law as applied to d-c. and a-c. circuits—the former in particular—the easier will you find it to service any and all receivers. Thus, the knowledge of this law is a service requirement.

CONCLUSION

Notwithstanding the fact that resistance measurement methods of service analysis have been used in many instances for quite a long time, there has been no definite and concerted effort to prepare service data in tabulated form concerning the point-to-point resistance (d-c.) to be expected between two separate points in a receiver. As previously stated, a few manufacturers in the past have prepared their manuals along such lines. All indications point to a more abundant use and presentation of such data.

Tabulated point-to-point resistance measurement data for commercial radio receivers will become a regular feature of SERVICE and will appear in every issue. Comments and criticism, pertaining to resistance measurement methods of analysis as outlined in this series of articles, will be welcomed.

General Data . . .

Fada "RE" Chassis

The "RE" chassis is used in the Fada Models 73 and 85. Note that a type 55 tube is used as second detector and automatic volume control.

In order to accurately adjust the various trimmer condensers of the receiver in accordance with the following instructions, it is essential to use a shielded signal generator capable of giving a modulated carrier frequency which can be accurately attenuated at 175 kc., 600 kc., and 1,400 kc.

Since this receiver is equipped with an automatic volume control, it is necessary to set the manual volume control at maximum position to assure accuracy in alignment. To control the signal output of the receiver it will be necessary to use the attenuator of the signal generator.

ADJUSTMENT OF I-F. CONDENSERS

The four i-f. condensers are located in the rear and side of the chassis itself. For adjustment, proceed as follows:

1. Disconnect the outside antenna system from the receiver and connect a lead wire from the dummy antenna system of the signal generator to the control grid of the first detector tube. Do not disconnect the control grid connector from the tube, nor remove the tube shield. Connect the ground (slate) lead of the receiver to the ground post of the signal generator. In the event

that the signal generator being used does not have a dummy antenna system, connect a 250-mfd. condenser in series with the lead wire.

2. Remove the 56 oscillator tube from the receiver socket. Place an output meter across the secondary of the receiver output transformer (which is mounted on the speaker) so that the variations in signal output can be noted.

3. Place the signal generator in operation and adjust the frequency output to 175 kc. Regulate the attenuator control so that the output signal is low enough to insure accuracy in adjusting the i-f. condensers of the receiver.

4. With the aid of a No. 4 socket wrench adjust the four i-f. condensers to resonance

TABLE 2

Tube Position	Plate Volts	Plate Current	Control Grid Volts	Screen Grid Volts
R-F.	267	8.0	4.8	90
1st Det.	263	1.0	10.0	85
I-F.	267	8.0	4.8	90
Osc.	72	4.0
2nd Det.
1st A-F.	94	2.5	6.2
Power	236	32.0	15.0	258
Rectifier		64.0 total		

Note: Bias readings are to be taken across each respective bias resistor. Correct readings cannot be obtained at control grids due to use of series resistors.

Schematic diagram of the Fada "RE" Chassis, or Models 73 and 85 Receivers

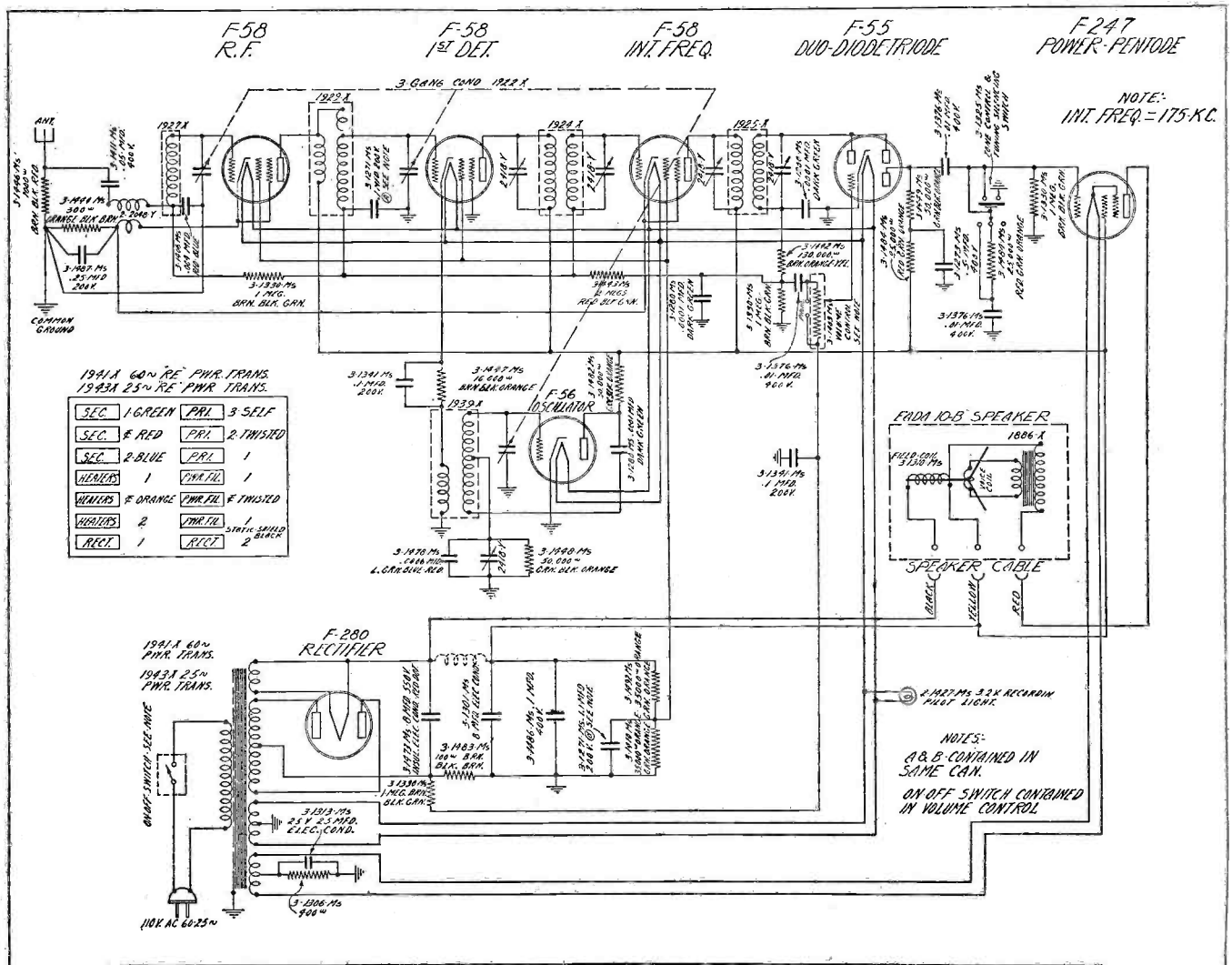

TABLE 1

The measurements below should be made with all tubes removed from their sockets, the speaker disconnected, silencing switch off and pilot light removed. Unless otherwise clearly indicated, all resistance values are measured between chassis and point stated.

Reference Points	Value in Ohms	Reference Points	Value in Ohms
Aerial to ground	1,000	2 Det. diode plate to plate	0
R-F. control grid	4 megs.	2 Det. diode plates	1,130,097
R-F. grid winding only	3.5	2 Det. input coil only	97
R-F. suppressor coil pri. only	15.5	2 Det. cathode	0
R-F. cathode	301.47	2 Det. control grid (V.C. all out)	1 meg.
R-F. suppressor coil sec. only	1.47	2 Det. triode plate to 47 screen	75,000
R-F. screen grid	35,000	Osc. control grid	50,000
R-F. plate to 47 screen	71	Osc. grid coil only (complete)	3.5
Suppressor grid to r-f. cathode	0	Osc. cathode	0
		Osc. plate to 47 screen	50,000
1 Det. control grid	3 megs.	47 control grid	1 meg.
1 Det. grid coil only	3.5	47 filament	400
1 Det. cathode	10,000.8	47 screen grid	70,000
1 Det. cathode-osc. coil only	.8	47 plate to 80 fil.	3,208
1 Det. suppressor grid	0	47 plate to screen	708
1 Det. screen grid	35,000	80 filament	72,500
1 Det. plate to 47 screen	97	80 anode to anode	350-400
I-F. control grid	3 megs.	80 anode	225-250
I-F. grid coil only	97	Across speaker field only	2,500
I-F. cathode	301.47	Across output trans. sec. only	1,003
I-F. suppressor to i-f. cathode	0		
I-F. screen grid	35,000		
I-F. plate to 47 screen	97		

as indicated by the greatest swing of the output meter.

ADJUSTMENT OF GANGED CONDENSERS

The compensators for the ganged condensers are located at the top of their respective tuning condensers, and can be adjusted with the aid of a screw driver. For adjustment, proceed as follows:

1. Remove the lead wire which is connected to both the control grid of the first detector and also to the dummy antenna system of the signal generator.

2. Connect the antenna (red) wire of the receiver to the dummy antenna system of the signal generator. The ground (slate) wire of the receiver is to remain connected to the ground post of the signal generator.

3. Adjust the carrier frequency output of the signal generator to 1,400 kc., and set the calibrated dial of the receiver to read 1,400 kc.

4. Starting with the compensator nearest the rear of the receiver, adjust each compensator in turn for maximum signal output as indicated on the output meter. Do not disturb the setting of the gang condenser during these operations. Leave the manual volume control on full and regulate the signal output with the attenuator control of the signal generator as before.

ADJUSTMENT OF OSCILLATOR

The oscillator series condenser can be adjusted through the hole in the side of the chassis, near the first i-f. transformer. Proceed as follows:

1. Adjust the carrier frequency output of the signal generator to 600 kc., and set the

calibrated dial of the receiver to read 600 kc.

2. With the aid of a No. 4 socket wrench adjust the oscillator series condenser until a maximum output signal is indicated on the output meter. To insure perfect adjustment it is necessary to "rock" the ganged variable condenser in order to follow the maximum signal output.

3. After the oscillator series condenser is properly adjusted turn the calibrated dial of the receiver to 1,400 kc., and adjust the signal generator to the same frequency, then readjust all variable condenser compensators as outlined in the foregoing instructions.

The resistance measurement data for the Fada "RE" chassis is given in Table 1.

The Type 59 Tube

We are indebted to the National Union Radio Corporation for the following tentative characteristics and details of the new type 59, seven-pin tube.

The type 59 tube is similar in a few respects to the type 47 pentode, but is of the

Connections for the type 59 tube. The suppressor grid is not necessarily used as a suppressor and is so indicated only to distinguish it from the other grids

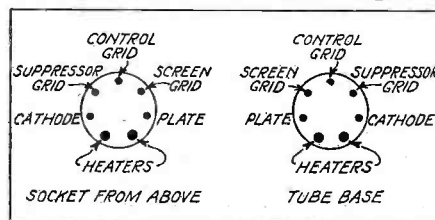

indirectly-heated type and has an external connection for the suppressor grid. With external connections for each one of the elements, it is possible to employ connections permitting operation of the tube as a triode, a pentode, or as a triode for Class B operation. The tube base and socket connections are shown in the accompanying illustration.

The tentative characteristics are as follows:

Filament Voltage	2.5
Filament Current	2.0
Base	Large 7-pin
Bulb	ST-16

TRIODE OPERATION

Screen and suppressor grids connected to plate

Control Grid Volts	-28
Plate Volts	250
Plate Current	30 ma.
Load Res.	5,000
Power Output*	1.25 watts
*(at 5% 2nd harmonic distortion)	
Amplification Factor	6

PENTODE OPERATION

Suppressor grid connected to cathode

Control Grid Volts	-18
Screen Grid Volts	250
Plate Volts	250
Plate Current	35 ma.
Load Res.	7,000
Power Output*	3 watts
*(At 7½% 3rd harmonic distortion)	
Power Output*	2.5 watts
*(At 5% 3rd harmonic distortion)	

CLASS B OPERATION

Control grid and screen grid connected together and operated at zero bias.

Suppressor grid connected to plate and operated at plate voltage of 400.

Plate current at zero bias	15 ma.
Nominal Load Res.	1,500 ohms per tube
Max. Continuous Output	20 watts (2 tubes)

Eliminating Radio Reception When Pickup is Used

A very effective method of eliminating radio reception during the time that the audio amplifier in the receiver is being used for the amplification of music secured from a record is to short circuit the antenna coil by means of an ordinary single pole, single throw switch. In a-c. receivers the aerial and ground posts can be shorted. In d-c. receivers, however, it is imperative to short only the aerial coil and not to include the ground and aerial isolating condensers.

Superheterodyne Harmonics

One of the most important parts of the superheterodyne receiver, at least as far as satisfactory operation is concerned, is the plate-filter system in the 2nd detector circuit. It is at this point where a great deal of the "whistling" originates—at least its presence in the speaker is due to some flaw at this point.

One of the seldom considered items to be found in superheterodyne receivers is the presence of harmonics of the i-f. frequency. When the i-f. signal is produced by beating the oscillator against the incoming signal, harmonics are also developed. If these harmonics are allowed to beat against broadcast r-f. carriers, heterodyne beats are produced and are audible as whistles when the tuning dial is manipulated over its range.

It is essential that no aerial or ground leads be in the proximity of the r-f. choke in the 2nd detector plate circuit, or near any of the leads which connect to the various associated bypass condensers. It is likewise important that the r-f. choke and its associated condensers be intact. As a rule, the d-c. resistance of this choke is so low that the choke can be shorted without ever manifesting any influence upon the operating potentials. The same is true if any of the condensers are open circuited.

In many superheterodyne receivers this choke is located in a shielded can which is also grounded; that is, it is hoped that it is grounded. The fact that this ground connection is imperfect is the reason for some of the heterodyne trouble. It might be well to supplement the previous statement concerning the proximity of other leads by saying that no leads other than those actually connected to the choke should be near the winding. If for some reason service has been rendered upon the receiver, it will be worthwhile to definitely establish that the position of the plate-voltage supply lead between the 2nd detector tube plate and the r-f. choke has not been changed. It should be in the position originally determined by the manufacturer.

If a long aerial lead is used, it should not run the length of the chassis from the aerial post, pass the 2nd detector tube, etc. Keep the aerial lead and also the ground lead far removed from everything but the antenna post. It is surprising to note how much difference even a small amount of separation will make.

BEAT NOTES

With respect to beat notes, particularly the undesired ones, the following is an idea of the possible sources of such annoyances. One can very readily realize the need for care.

1. With the receiver adjusted to a station rated at from 550 to about 700 kc., there is always the possibility of a beat note between the second harmonic of the oscillator and some broadcasting station operating upon a frequency between 1,100 and 1,500 kc. At the same time there also exists the possibility of a beat note between the second harmonic of the oscillator and an undesired station, in which case the beat is equal to the i-f. frequency. This is unlikely with receivers wherein the i-f. frequency is an odd multiple of 5, but quite a few receivers use an i-f. frequency which is an even multiple of 5. Such as 180, 130, 260 kc., etc. This example has nothing to do with the image frequency type of interference.

The interference due to some undesired

condition in the 2nd detector plate circuit is recognized by the fact that there is a sudden development of whistles with respect to satisfactory freedom from such a state, until the time of the entry of the trouble, upon broadcast frequencies which represent harmonics of the intermediate frequency. As a matter of fact, such beats are to be expected in superheterodynes, even under ideal conditions, but fortunately they are so weak as to be barely audible. The reason for this is that it is fairly impossible to secure perfect shielding against such coupling. Thus, a receiver with an i-f. peak at 175 kc. is apt, if the 2nd detector plate circuit is imperfect, to have such marked whistles or beats at 700 kc., 875 kc., 1,025 kc., 1,225 kc., and 1,400 kc. A receiver tuned to 130 kc. is apt to show, under similar conditions, marked beats at 650 kc., 780 kc., 910 kc., 1,040 kc., 1,170 kc., 1,300 kc., and 1,430 kc. A receiver with an i-f. peak at 260 kc. is apt to show under similar conditions beats at 780 kc., 1,040 kc., 1,300 kc. Of course, in each of the cases named the frequencies mentioned are only those which appear in the broadcast band. If this broadcast band is extended by some means, such as a converter, beats will appear at higher frequencies. Complete isolation of the 2nd detector plate circuits with respect to coupling with any preceding circuit is the only means of minimizing this trouble.

Of course, there are other possible efforts which can be made. One of them is to prevent overloading of any of the tubes preceding the 2nd detector tube and to take care during the operation of the volume control system to avoid altering the operating characteristics of all amplifying tubes ahead of the 2nd detector, from amplifiers to detectors.

IMAGE FREQUENCY

Image frequency is an item unfortunately related to the location of the receiver; that is, as far as its presence is concerned in a perfect receiver. Of course the problem is one associated with the technical aspects of the receiver, but this type of interference may exist despite the manufacturer's effort to eliminate it by means of special circuit arrangements. It is due to the fact that the beating signal (produced by the local oscillator in the receiver) is capable of beating with a carrier frequency lower or higher than itself—that is, in numerical value. If the desired station carrier is less than the frequency of the signal being produced by the oscillator (which is the usual arrangement in the modern superhet.) it can also produce a beat signal with some other undesired carrier which is sufficiently powerful to find its way into the receiver system. If the undesired carrier differs from the oscillator frequency by the value of the i-f. peak, both the desired and undesired signals will pass into the i-f. amplifier and will be audible. Many men call this type of trouble "over-riding." The only means of eliminating the trouble is to so arrange the receiver and its tuned circuit that none other than the desired carrier can get into the receiver. If some local station is extremely

powerful, the best remedy is to employ a wavetramp in the aerial circuit which is operated when some other station is desired. This trap is tuned to the frequency of the very powerful and interfering station. When that station is desired, the trap is detuned or shorted out of the circuit. This suggestion may appear old-fashioned, but the fact remains that many perfect receivers are oftentimes bothered by such interference and no remedy can be applied to the set itself. Consequently, that which may appear plebian is still much desired when no other remedy is available.

DOUBLE-POINT RECEPTION

There are times when one or more stations are received at more than one point upon the dial. As a rule, this condition occurs more frequently when some powerful local station is operating upon some frequency between 540 and 750 kc. If this condition is true, then the trouble may be attributed to either of the following: Either the station is very powerful and its second harmonic forces its way into the receiver and is beating against the correct oscillator frequency for that frequency adjustment, or due to overloading in the receiver the low-frequency wave gets into the receiver and its second harmonic is developed in the amplifying system. Once more the remedy lies in the attainment of a receiving state wherein none but the desired signal may find entry, and also distortionless r-f. and 1st detector operation.

Double - point reception may also occur when the r-f. or mixer circuits are not tracking correctly with the oscillator. However, such cases, in contrast to the former, will show double-spot reception at points close together, and not far removed as in the case of the presence of the second harmonic.

Image frequency trouble may also cause double-spot reception. At one spot the receiver is tuned to the carrier of the powerful station and at the other spot the station is the image frequency for some other station which may be located at a distant point and is consequently too weak to be audible, or is heard in conjunction with the undesired station.

AIRCRAFT STATION INTERFERENCE

Aircraft station interference from stations operating upon carrier frequencies of from 175 to 260 kc. is due to direct pickup by the i-f. amplifier. Power supply leads, speaker cords, aerial leads or ground leads, adjacent to the i-f. system will function as pickup surfaces for the i-f. amplifier and thus convey the signal into the amplifier. Location of the receiver in such position that the i-f. system may be near power or light wires running through the wall, telephone cables, etc., may result in pick-up of long-wave station interference. Imperfect shielding of a sensitive i-f. amplifier followed by a powerful audio amplifier may be productive of such long-wave interference. An i-f. system which is operating close to the point of oscillation will possess undue sensitivity for such signals.

Musette Models 52 and 53

It should be noted from the accompanying circuit diagram that tuned impedance coupling is employed, with parallel plate feed through r-f. chokes. This circuit is known as a constant gain impedance coupled system, the "constant gain" referring to the gain in the radio-frequency amplifier which is practically constant at all frequencies, with the result that the sensitivity of the set does not drop off at either the high or low settings of the dial. It would be a good idea to take a good look at the circuit before attempting to shoot trouble.

CIRCUIT CONSTANTS

Each unit in the accompanying diagram carries a serial number. The values of these units are as follows:

Condensers: A-203, 8 mfd. electrolytic; A-304, .0001 mfd.; A-305, special coupling; A-306, .25 mfd.; A-307, .006 mfd.; A-308, .002 mfd.

Chokes: C-102, 505 turns; C-104, 1,200 turns.

Resistors: R-102, volume control, 6,400 ohms with 200 ohms fixed; R-103, tone control resistor, special; R-203, center tapped, 15 ohms; R-310, 25,000 ohms; R-311, one megohm; R-312, 200 ohms; R-313, .5 megohm; R-314, 100,000 ohms; R-315, 50,000 ohms; R-316, 3 megohms.

VOLTAGE DATA

The ordinary set analyzer will not give correct voltage readings on the Musette due to so many readings having to be taken through high resistance. Even a high-resistance voltmeter will not give a correct reading for the following circuits: C bias for '45 tube; detector plate voltage; screen grid voltage and grid bias; first audio plate and first audio C bias. A voltmeter with from 800 to 1,000 ohms resistance per volt should give a deflection on these circuits, but the reading will be reduced by the high resistances.

In checking to determine there are no open circuits, see that at least some reading is had on the above circuits, being sure the volume control is turned to maximum volume position. Then read the following

voltages which vary according to a-c. line voltage, being sure the antenna is disconnected and condenser shield is in position.

Reading from:

Chassis to plate prongs of the 1st and 2nd r-f. tubes and '45 output tube, from 190 to 210 volts.

Chassis to screens of 1st and 2nd r-f. tubes, from 75 to 110 volts.

Chassis to cathodes of 1st and 2nd r-f. tubes, should not exceed 5 volts.

Filament to filament of all tubes except '80, from 2.3 to 2.5 volts.

Between chassis and '80 filament, from 190 to 210 volts. Should this read 250 volts or more, indications are that the electrolytic condenser on rectifier side is shorted to chassis.

Across speaker field, from 100 to 110 volts. This reading checks the filter condenser and indicates that the speaker field is not shorted.

If all the above voltages are correct and some meter deflection is had on the other mentioned circuits, you can assume other voltages to be correct and look for the trouble elsewhere.

ADJUSTING

It will be seen from the circuit diagram that the tone control is made up of the condenser A-307 and the variable resistor R-103. If variation of this control has no effect, the condenser is open. If a variation of this control to maximum low note position cuts out the received signal, the condenser is shorted.

If an exceedingly long antenna is used with the Musette it may well effect the tracking of the first r-f. circuit. A 50-foot antenna is recommended.

When adjusting for resonance, use the trimmers only at the bottom end of the dial and make the necessary adjustments with the trimmers open as much as possible. If they are screwed down tightly, there is a constant added capacity to the tuned circuit which might not allow the set to tune down low enough. The adjustment of the detector tuned circuit is quite critical and great care should be taken in this adjustment.

Adjust at the top of the dial by bending the split fins on the rotor plates of the condensers. When making these, as well as the

trimmer adjustments, select a weak signal to work on.

HUM ELIMINATION

In case of excessive hum, first determine whether it is in the chassis or the speaker by removing the '45 tube. If the hum stops, the trouble is most likely in the chassis. If the hum continues, it is probably in the speaker.

Hum in the chassis is usually due to either a defective '24 detector tube or electrolytic condensers either shorted, open, or not properly "formed."

Hum in the speaker may be due to the hum bucking coil being connected up in the reverse manner. Therefore, first try reversing the bucking coil leads. These wires come out of the pot coil and go to the output transformer mounted on the side of the speaker. Looking from the back, with the transformer at the left, the yellow upper inside connection and the black lower center connection are the leads which should be reversed.

Crosley Pickup Connections

When connecting a phono. pickup to many of the older Crosley receivers it is necessary to open the circuit between the pickup terminals. These are usually closed with a piece of wire. In order to enable a choice of either radio or phonograph operation, the installation of a single pole, double throw switch is required. These switches are not furnished with the receiver. As a general rule, when operating the phonograph pickup, it is necessary to detune the receiver.

Atwater-Kent 46, 47 and 53

The Model 46 is similar to the Model 43 except that the power unit is larger due to the type '71A tubes in the output stage. Also that the voltage regulator resistance is not used, and the condensers are in a replaceable can. Model 53 is the same as the 46 except for the use of a type F-2C dynamic speaker. Model 47 is the same as Model 46 with the exception of the use of four r-f. stages with double r-f. transformers.

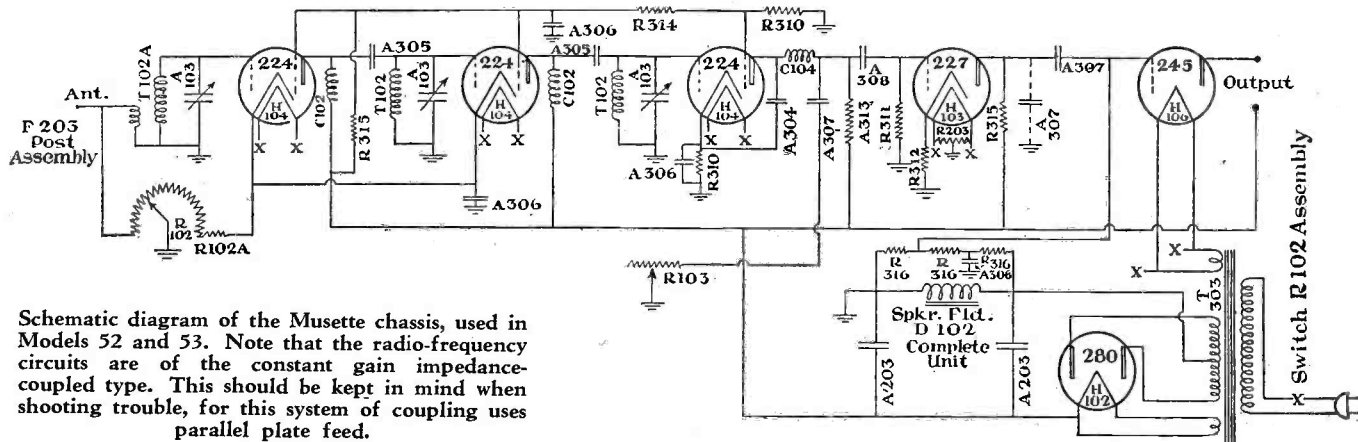

Schematic diagram of the Musette chassis, used in Models 52 and 53. Note that the radio-frequency circuits are of the constant gain impedance-coupled type. This should be kept in mind when shooting trouble, for this system of coupling uses parallel plate feed.

GENERAL DATA—continued

Balanced Aerial System

The Engineers of the General Motors Radio Corporation introduced some time ago a balanced aerial system for the elimination of man-made noise. The system actually employs two aeriels, one being suspended from ten to fifteen feet beneath the other and running parallel to it. These two wires are of exactly the same mechanical length.

There is a lead-in wire connected to each of the two aerial wires. These leads are brought together at a point equidistant from both aerial wires, and from thereon are twisted together or, in other words, transposed.

The twisted lead terminates in an impedance-matching transformer, the output of which feeds into the input of the radio receiver. The purpose of this transformer is to electrically adjust the impedance at the input of the receiver to the impedance of the aerial proper. This matching of impedances results in a voltage at the input of the receiver equivalent to the voltage developed in the aerial. The impedance of the aerial varies but little in the broadcast range and, as odd as it may seem, the impedance of the transposed lead-in is practically constant for all normal frequencies.

It will be seen that the system is quite similar to others which have been described heretofore, but it has one difference, and this difference is the function of the two aerial wires.

Since one of the aerial wires is some ten to thirty feet above the other, it is clear that a signal wave will not induce the same voltage in each. Therefore, with the phase displacement afforded by the transposed lead-in, a portion of the voltage developed in each aerial wire will be cancelled out, the remaining voltage being the difference between the two. On the other hand, any local noise of an electrical nature will produce an equal field in the vicinity of both aerial wires, and therefore an equal voltage in each wire. Since these voltages are equal, they will cancel each other in the transposed lead-in. The result, therefore, is a signal without noise.

Practically, of course, the effects are not quite so elaborate, for total cancellation cannot be expected in the transposed lead any more than an equal noise voltage can be expected to develop in each aerial wire. However, the system is to be recommended on an equal basis with the other systems recently publicized.

(Review of article in *Radio News* for October).

Radiola 30-A

Although specifically designated for one receiver, the following notes apply to the majority of Radiola catacomb superhet. assemblies.

If the antenna coupler neutralizing condenser connected across terminals 7 and 8 of the catacomb assembly is out of adjustment, the receiver will oscillate. The equipment required to neutralize this unit is a dummy '99, made by cutting off one filament prong

from a perfect tube, a modulated r-f. oscillator, a 50-ohm resistor rated at 10 watts, and a long non-metallic screw-driver.

Facing the front of the receiver, count the tubes from left to right and remove the third tube. Place the dummy tube into this socket. Now tune the oscillator to 1,000 kc. and place it in some position so that it is coupled to the receiver. Tune the receiver to 1,000 kc. and adjust all controls for maximum signal. Connect the 50-ohm resistor across terminals 3 and 4 of the catacomb assembly.

With the tubes in the receiver lighted—with the exception of the dummy tube—and the oscillator in operation, the signal from the receiver (that of the oscillator) should be very weak, if heard at all. If it is heard, break the wax seal upon the neutralizing condenser and vary the adjustment until the minimum signal is heard in the receiver. This adjustment must be made with the receiver volume control "full" on. If read-

justment of the volume control subsequent to minimum adjustment of the neutralizing condenser causes the signal to disappear, the proper neutralizing adjustment has been reached. Now restore the original tube to its proper place.

The sequence of the tubes is as follows: Counting from left to right, while facing the front of the cabinet; tube 1 is the 1st detector or mixer; tube 2 is the 1st i-f.; tube 3 is the r-f. amplifier; tube 4 is the 2nd i-f. amplifier; tube 5 is the oscillator; tube 6 is the 2nd detector; tube 7 is the 1st a-f. amplifier.

It is possible that oscillation difficulties cannot be cured by adjustment of the antenna coupler neutralizing condenser. It is then necessary to investigate the neutralizing condenser within the catacomb. The cheapest and best method of making this adjustment is to secure a new catacomb rather than make an attempt to open the one at hand, make adjustments and re-seal it.

Brand Line Models Comparable to RCA Victor Models

1930 MODELS

RCA VICTOR MODEL	GEN. ELEC. MODEL	WESTINGHOUSE MODEL	GRAYBAR MODEL
R 42	None	None	None
A 48	T 41	WR 4	GB 678
R 80	H 31	WR 5	GB 700
R 82	H 51	WR 6	GB 770
R 86	H 71	WR 7	GB 900

1931 MODELS

T 5	E 52	WR 9	None
R 5	T 12	WR 14	GB 4
R 7	S 22	WR 10	GB 8
R 7A	S 22A	WR 10A	GB 8A
R 9	S 42	WR 12	None
R 10	S 132	None	GB 989
R 11	K 62	WR 15*	GB 9
R 43	S 42B	None	None
R 50	H 32	None	None
R 55	None	None	GB 100
RAE 59	H 72	None	None
None	S 22X*	None	None
None	H 91*	None	None
None	K 82*	None	None
None	None	WR 8*	None

1932 MODELS

R 4	J 70	None	GT 7
R 6	J 75	None	GG 13
R 8	J 80	None	GT 8
R 12	J 85	None	GC 14
M 30	A 90	None	None
R 71	J 82	None	GT 8-56
R 72	J 86	None	GC 8-69
R 74	J 100	None	GC 10-69
R 76	J 105	None	GC 10-88
R 77	J 107	None	GC 10-99
A 81	P 31	None	None
None	J 88	None	None
RE 81	J 109	None	None
R 78	J 125	None	None
RE 83	None	None	None

*Clock Models

GENERAL DATA—continued

Tube Variations in Colonial 62

Some of the Colonial Model 62 receivers employed a '24A tube as the mixer and a '57 as the 2nd detector. Other chassis of the same model number employ a '57 as the mixer tube and a '24A as the 2nd detector.

Kennedy Model 63

This receiver, as will be seen from the accompanying diagram, employs a combination oscillator and first detector. This looks into a single stage of i-f. which in turn feeds a type 55 duo-diode-triode, the diode portion acting as detector and providing automatic volume control by acting on the grid of the i-f. tube. The triode portion of the second detector is operated as an individually-biased a-f. amplifier.

The first two variable tuned circuits are not electrically coupled. They are mutually coupled by being placed close together and left unshielded.

In aligning, it is first desirable to see that the i-f. transformers are properly set. The first i-f. transformer is on top of the base and has two adjustments. The second is inside the base, but its single adjustment may be reached through a hole in the rear center of the base. The intermediate frequency is 175 kc.

The tuning condenser may be adjusted for alignment or tracking of the tuned circuits by means of an oscillator and output meter. The oscillator should cover the band from

550 to 1,500 kc. The energy from the oscillator is coupled weakly into the antenna circuit—a simple means being to place the oscillator near the antenna wire. The receiver and oscillator are first tuned to approximately 1,500 kc., and by watching the output indicator, the three condenser trimmers are adjusted for maximum output. These three trimmers must then be left untouched for all further aligning.

The next step is to tune both receiver and oscillator to some point near 550 kc. Here the alignment is made by adjusting the oscillator padding condenser for maximum response. The adjusting screw for this condenser is on top of the base. If it is necessary to adjust the two r-f. condenser sections, it may be done by bending the condenser end plates. If necessary to align at points other than the end of the band, it may be done by bending portions of the slotted end plates of the condenser rotor sections. Alignment of the two ends of the scale is usually quite sufficient.

It is desirable to move the dial back and forth across the signal while making the above alignments. This is particularly necessary when altering any capacities connected with the oscillator circuit. Use an insulated or bakelite screw driver. No aligning, other than the i-f. transformers, is necessary for the short-wave band (75 to 200 meters) as no attempt has been made to tune more than the oscillator.

Be certain that a good 57 tube is used in the mixer-oscillator socket.

Zenith Parts Numbers and Values

The following are parts numbers and values of resistors and condensers employed in some of the Zenith receivers produced during 1930 and early 1931. These resistors are not RMA color-coded.

MODEL 52 AND 53

63-108	50,000 ohms	Green
63-109	100,000 ohms	Red ²
63-110	400 ohms	Yellow
63-111	2,000 ohms	Black
63-112	4,000 ohms	Blue
63-113	250,000 ohms	White
63-121	100,000 ohms	Pink

¹In some productions of this model the 100,000-ohm red resistor is replaced by 63,121, a pink resistor of 100,000 ohms.

63-105 is a voltage divider tapped at 850 ohms from one end and at 2,800 ohms from the other, leaving 2,350 ohms in the center.

Some parts numbers and values used in some of the a-c. power packs are as follows:

63-67	600 ohms
63-69	2,700 ohms
63-70	22,500 ohms
63-71	1,600 ohms
63-72	22,500 ohms
63-85	22,700 ohms

The parts numbers and values specified for the 52 and 53 will also be found in other receivers in the 60 and 70 series.

Schematic diagram of the Kennedy Model 63 Superheterodyne. The type 57 tube is used as both mixer and oscillator

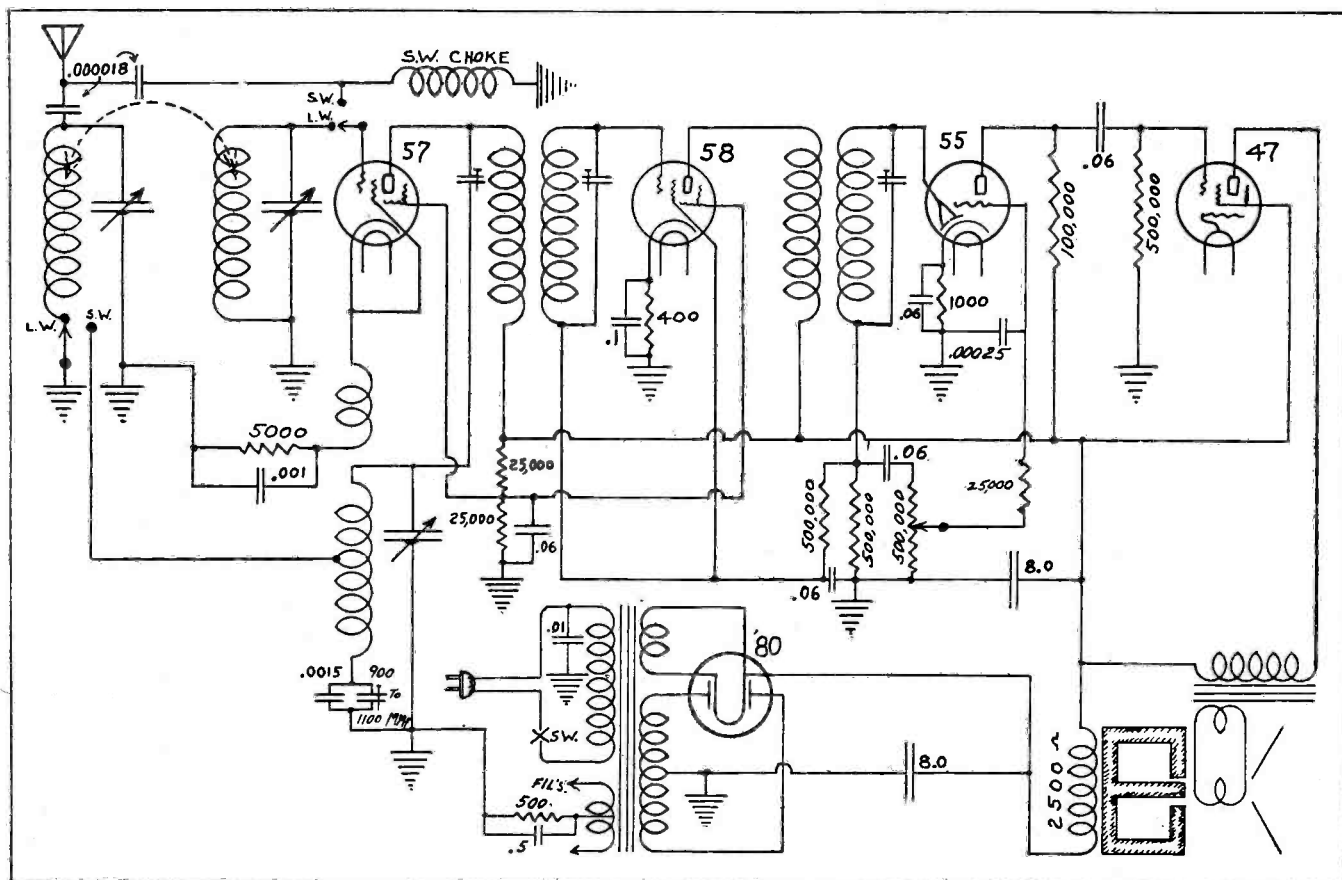

GENERAL DATA—continued

Amrad 81 Electrical Values

The diagrams of the Amrad 81 receiver available from various sources do not show the electrical values of the various parts. The following is the list of the parts used in this receiver. Also the d-c. resistance of the various windings. The values and designations listed correspond to the designations shown upon the diagram, particularly in the Perpetual Trouble Shooter's Manual.

CONDENSERS

C	1.	mfd.
C2	.002	mfd.
C3	1.	mfd.
C4	.5	mfd.
C5	.25	mfd.
C6	1.	mfd.
C7	1.	mfd.
C8	1.	mfd.
C9	.5	mfd.
Grid	.00025	mfd.

RESISTORS

Grid Leak	1.5 megohms
R2	31 ohms
R4	2,250 ohms orange
R6	100,000 ohms yellow
R7	20 ohms
R8	200,000 ohms
R9	5,000 ohms brown
R10	60 ohms
R12	860 ohms
R13	1,500 ohms purple
R14	50,000 ohms
R15	21,000 ohms green
R16	12,500 ohms black

The d-c. resistance of the various windings is as follows: A-F. choke number 1 has a d-c. resistance of 500 ohms and a-f. choke number 2—150 ohms. The d-c. resistance of the field coil used with the RCA or Peerless speakers is 7,500 ohms. The output transformer for the RCA 106 speaker has a primary resistance of 410 ohms total and a secondary resistance of 0.8 ohm. For the Peerless speaker, the primary resistance is 550 ohms total. The secondary resistance is a few hundredths of an ohm, being a single copper band. The d-c. resistance of the 1st a-f. transformer is as follows, when working between the grounded terminal and the balance of the system: Between ground and grid, 12,000 ohms. Between ground and the detector plate tap, 2,000 ohms, and between ground and the phono. tap, 20 ohms. The ground lead is silver and red. The grid lead is the copper braid. The detector tap is the silver braid, and the phono. tap is silver and copper.

The d-c. resistance of the primary winding of the second a-f. transformer is 1,600 ohms. The total resistance of the secondary of the second a-f. transformer is 10,600 ohms, divided into two windings of 4,800 and 5,800 ohms. The primary winding of each r-f. transformer has a d-c. resistance of 80 ohms, and the r-f. choke in the detector plate circuit has a d-c. resistance of 100 ohms.

The values of the Mershon condenser sections are as follows: M-1, 18 mfd.; M-2, 8 mfd.; M-3, 18 mfd.; M-4, 8 mfd.

Up and Going

A brother Service Man reports a healthy racket in his district for noise-reducing aeriels and ditto equipment. It turns out, however, that he drummed up the trade on his own hook by a well-planned house-to-house campaign—or better said, "noise quest."

This fellow is doing his bit in combating the bum aerial plague, and making a profit in the bargain. And whether or not he realizes it, he is assisting both the set owners and the radio manufacturers, by rubbing out just another bit of the discontent lots of people find in radio.

Servicing Is Not For The Color Blind

We don't know if the people who originated the color schemes for resistors were peeved at the color blind—but heaven help such an individual if he tries to locate RMA color-coded resistors in a chassis by checking according to colors.

WIRE TYPE RESISTORS USED IN FADA RECEIVERS

Number	Resistance In Ohms	Color Coding (Not R-M-A.)
1414	250	Yellow-White
1458	75	Red-White
1459	500	Blue-Green
1460	600	Red-Blue
1461	750	Red-Green
1462	6,000	Red-Yellow
1463	10,000	Blue-White
1328	1,000	Yellow
1415	2,000	Green-White
1416	3,000	White-White
2-1218	2,500	Blue-White
2-1219	1,200	Green-Yellow
2-1249	65	Red
2-1250	65 *	Blue
2-1251	10	Yellow
2-1311	20	White
2-1312	200 **	Green
2-1379	1,500	Red-Red
2-1390	5,000	Blue-Blue

* tap at 40.

** taps at 10 and 160.

CARBON TYPE RESISTORS USED IN FADA RECEIVERS

Two arrangements of color coding were used. One in which the resistor was black and had colored dots. The others did not employ black as the basic color.

Number	Resistance In Ohms	Black Units	Other Units
1265	3,000	White-Yellow	White-White
1311	250,000	Gray-Yellow	Yellow
1341	20,000	Red-Green	Green
1375	125,000	Gray-Green	Gray
1394	500,000		Brown
1408	2,000,000		Red
1417	50,000		Blue
1467	2,000	Heavy Duty	No color
2-1207	2,000		Black
2-1299	250		Light Brown
2-1300	1,000	Heavy Duty	Green Ends
2-1308	4,000		Orange

Just as an incidental thought, the color of the illumination under which you are working has an effect upon the visible color upon the resistor. In other words, blue or purple lights will cause apparent changes in the color code marking upon the resistors.

Tube Variations in Silvertone 1580, 1582 and 1584

See notes on the Colonial Model 62 receiver in this issue.

Curing Oscillation When Checking Receivers

One of the bugaboos to voltage measurement upon sensitive receivers is that the effect of the plug-cable attachment of the tester causes excessive coupling in the circuits and sustained oscillation is the result. Such excessive regeneration causes a change in readings. It is possible to stop oscillation in such circuits by touching the control grid of the tube with the finger tip.

Adjusting Peerless Speaker

The single copper band type of Peerless speaker used in some old receivers had three bolts which secured the copper band secondary in position. To center the cone and voice coil in this speaker, it is necessary to loosen the three securing bolts and to move the cone by hand to a free position. Then the securing bolts are again tightened.

Philco Peak Frequencies

Two values of peak frequency are to be found in the Model 90 and 90-A Philco receivers. The early production 90 and 90-A with the '45 output, and the early production with the single pentode output, designated as "above Serial 237,001," are adjusted to an intermediate peak frequency of 175 kc. In the later Models 90 and 90-A receivers which bear serial numbers with the letter "B" as the prefix, and stated as between B-32,001 and B-35,000 and above B-53,100, the intermediate transformers are peaked at 260 kc. The Model 70 receivers marked above Serial B-22,000 are also peaked at 260 kc.

Public Address . . .

Multi-Speaker Coupling

The following data was courteously supplied by the Thordarson Electric Manufacturing Company.

Where speakers are to be used at some distance from the amplifier a considerable loss of power will result if long leads are run from the output transformer to the voice coils. In order to obviate this loss a separate transformer should be used which will couple the line to the voice coils. An output transformer couples the power stage to a 500-ohm line, and at the speaker end of the line another transformer couples the 500-ohm line to the voice coils. This is shown in Fig. 1.

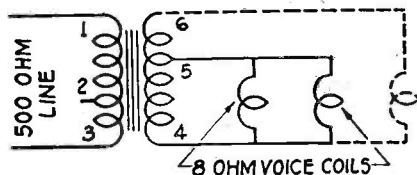

Fig. 1. Manner of connecting voice coils to impedance-adjusting transformer. The impedance between terminals 4 and 5 is 4 ohms

The primary of this transformer is, of course, designed to match the 500-ohm line, and also has a tap for 250-ohms. The secondary is designed for an 8-ohm voice coil (which is almost standard for dynamic speakers) and has a tap at 4 ohms if two voice coils are to be used in parallel. Fig. 1 shows the circuit for two speakers with the connections for one speaker dotted in. The 4- and 8-ohm taps should not both be used at the same time.

Fig. 2 shows the method of coupling recommended where it is desired to operate two groups of speakers which may be some distance apart. Two line-matching transformers are used and these should be placed as close as possible to the speakers. Using the 250-ohm

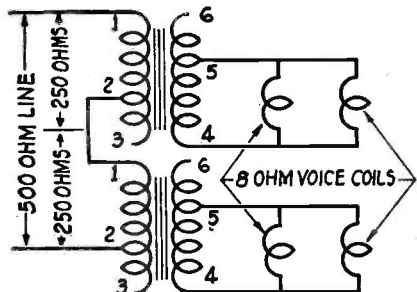

Fig. 2. Manner of connecting up two groups of speakers which may be operated some distance apart. The 250-ohm leads of the two transformer primaries are connected in series to match the line

taps, as indicated, the primaries of the two transformers are connected in series to match the 500-ohm line. Either one or two voice coils may be connected to the secondaries, as explained in connection with Fig. 1.

If four speakers are to be used, they should be connected in series-parallel to the 8-ohm terminals of the transformer.

Class "A" to Class "B"

Class "A" amplification looks like Class "B" when you view the wiring diagram. However, in actual practice, the changeover is quite extensive. Changes are required in the rectifier so as to produce a unit which will provide substantially constant output voltage over quite a variation in load current. It is also necessary to change the stage preceding the output stage and the complete output system inclusive of the input and output transformers.

Grounding Shielded Cable

When a ground connection is required to a shielded microphone cable, proceed as follows: Remove sufficient insulation so as to expose the required amount of bare connecting surface. Then remove about one-half inch more of the outside insulation so as to expose the shielding braid or material, whatever kind it may be. Now place a length of bare copper wire along the shielding surface. Then wind a length of bare No. 28 or No. 30 B & S wire over the combined shielding and the length of grounding wire. Make the turns very tight. Then place a coat of solder around the entire connection to the shielded surface and wind with rubber insulation. Around the rubber insulation wind one or two layers of insulation tape.

PAM-110 Class B Amplifier

The Samson PAM-110 Class B Amplifier employs a type '57 tube in the first stage, a type '46 in the Class A second stage and two type '46s in push-push in the Class B output stage. The rectifier is an '82 mercury-vapor tube.

This amplifier has a power consumption of 43 watts with no signal, and with a signal to cause full power output, 93 watts. The maximum power output of the amplifier is 26 watts.

The amplifier is designed to work with source impedances up to 500,000 ohms. The maximum source volts required for maximum power output is 0.2, root mean square. The load impedance for which the amplifier is designed is 4- to 4,000-ohms, accomplished by an adjustable switch control.

Fig. 1 is a diagram for radio set connection. The condenser, C, and resistor, R, vary with tubes used, and conform roughly to the following table:

Tube	C	R
Screen Grid	.02 mfd.	500,000 ohms
3 Element	.2 mfd.	50,000 ohms

The tube should be the detector (second detector of superheterodyne) and the lead to condenser C should be attached to the plate circuit after any radio-frequency filter that may be incorporated in the set. The resistor R serves to reduce the output (and, incidentally, hum) by an amount comparable to the additional gain of this amplifier over the usual radio set audio system. Tuning and volume control should be accomplished with the set controls once R is satisfactorily adjusted.

In Fig. 2 are shown the recommended values and connections for phonograph pick-up operation. Tapered volume controls are designed to give a more uniform change of volume than straight controls, and will be found superior for this purpose. A control having an attenuation characteristic of about 5 decibels for each ten per cent of rotation is best.

When a microphone connection is to be used, a microphone unit should precede the amplifier.

In order to approximate more closely ideal load conditions, the amplifier is equipped with an adjustable output transformer with taps, permitting operation over the normal range of load impedances. Load impedances must be known, and the switch set accordingly, if full volume and quality are to be realized and if tubes and supply units are to be protected.

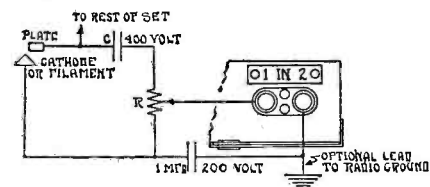

Fig. 1. Suitable method of connecting the PAM-110 to the second detector output of a super.

In all cases, if load component units are to be switched in or out of the circuit, or to be controlled in volume individually, the circuit must be arranged so that the effective load on the amplifier remains unchanged. This presupposes constant-impedance switching and volume-control devices, if loads are to be unaffected in quality and volume when adjustments or changes are made in other loads. When using the amplifier with different loads, the output switch may be used to secure proper adjustment.

TESTING DATA

The following list gives readily obtained currents and voltages (such as would be indicated by a conventional set tester). Attempts to measure currents and voltages not given will be unsuccessful, as a rule, because of circuit peculiarities.

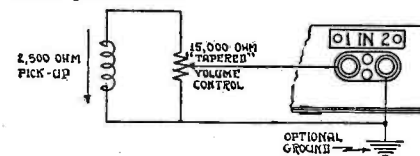

Fig. 2. Connections for a phonograph pick-up and volume control to the PAM-110

1st Stage—'57
Heater Volts—2.5
2nd Stage—'46
Filament Volts—2.5
Plate Volts—240
Plate Milliamperes—20
3rd Stage—'46s
Filament Volts—2.5
Plate Volts—400
Plate Milliamperes:
No signal—5
With signal—to 68
Rectifier—'82
Filament Volts—2.5
Plate Milliamperes:
No signal—17
With signal—to 80

Short Waves

voltage readings from element to chassis are given in Table 1.

Converters With '27 Detectors

Some of the early short-wave converters use a '27 tube as the first detector. The sensitivity of these units can be increased considerably by replacing the '27 with a '24 screen-grid tube. Since the voltages on the elements of the tubes in these converters are not critical, the change is not difficult.

Feed the screen grid of the '24 tube from the high-voltage connection, through a resistor of approximately 50,000 ohms, and connect a bleeder resistor of about 30,000 ohms from the screen grid to ground. The bleeder should be by-passed to ground with a 0.1 mfd. condenser.

No other changes are actually necessary, though a change in the value of the grid leak may show added improvement.

Hammarlund Comet "Pro"

The Hammarlund Comet "Pro" is a-c. operated, and the power supply is an integral part of the chassis. A power amplifier is not included, as the accompanying circuit diagram will indicate, nor are provisions made to supply voltage for an external amplifier. This unit comes separately and has its own power supply unit and dynamic speaker.

This receiver covers the frequency range from 20,000 kc. to 1,500 kc. A change of frequency band is accomplished by four pairs of plug-in coils rather than a switching arrangement.

The receiver employs a first detector or mixer, short-wave oscillator, two stages of i-f., detector and one stage of a-f. A separate long-wave oscillator is included for the reception of c.w. signals. A small part of the output of this oscillator is fed to the grid circuit of the second detector through a .000001-mfd. coupling condenser, where it beats with the 465 kc. output of the i-f. amplifier, thus producing an audible note. Actually, the frequency of this oscillator is also 465 kc., but due to unavoidable though slight inaccuracies in tuning a beat note is created.

It should be noted from the diagram that there are three sets of tuning condensers—three for the oscillator and three for the mixer. Two of the sets are ganged to the main tuning dial, which is used for band spreading and also to overcome image interference. One condenser in each of these

sets comes into play only in the 5 mc. to 1.5 mc. range covered by two of the plug-in coils. These two condensers are automatically connected into the circuit when plugging in the coils for the ranges mentioned above. The other set of condensers—one in the mixer circuit and the other in the oscillator circuit—each have a capacity of 138 mfd. and are independently controlled by separate dials, one to each side of the band-spread drum dial. Wide-range tuning is done with these two controls.

The values of the various units are given in the schematic diagram. The approximate

TABLE 1

Element	Volts
Top terminal of voltage divider	175
Second terminal of voltage divider	80
Third terminal of voltage divider	0
Bottom terminal of voltage divider	0
K terminal of 1st Det.	5
K terminal of H-F. Osc.	30
K terminal of 1st and 2nd I-F. (Max.)	32
(Varies with volume control setting) (Min.)	2
K terminal of 1st A-F.	12
K terminal of 2nd Det.	8
K terminal of I-F. Osc. (Oscillator turned on)	12
P terminal of 2nd Det.	110
P terminal of H-F. Osc., 1st and 2nd I-F., 1st Det. and 1st A-F. (With phones or speaker connected)	75
P terminal of I-F. Osc.	80
G terminal of 1st Det.	55
G terminal of 1st and 2nd I-F. and 2nd Det.	75

Schematic diagram of the Hammarlund Comet "Pro." Note that two oscillators are used, one being used for c.w. reception

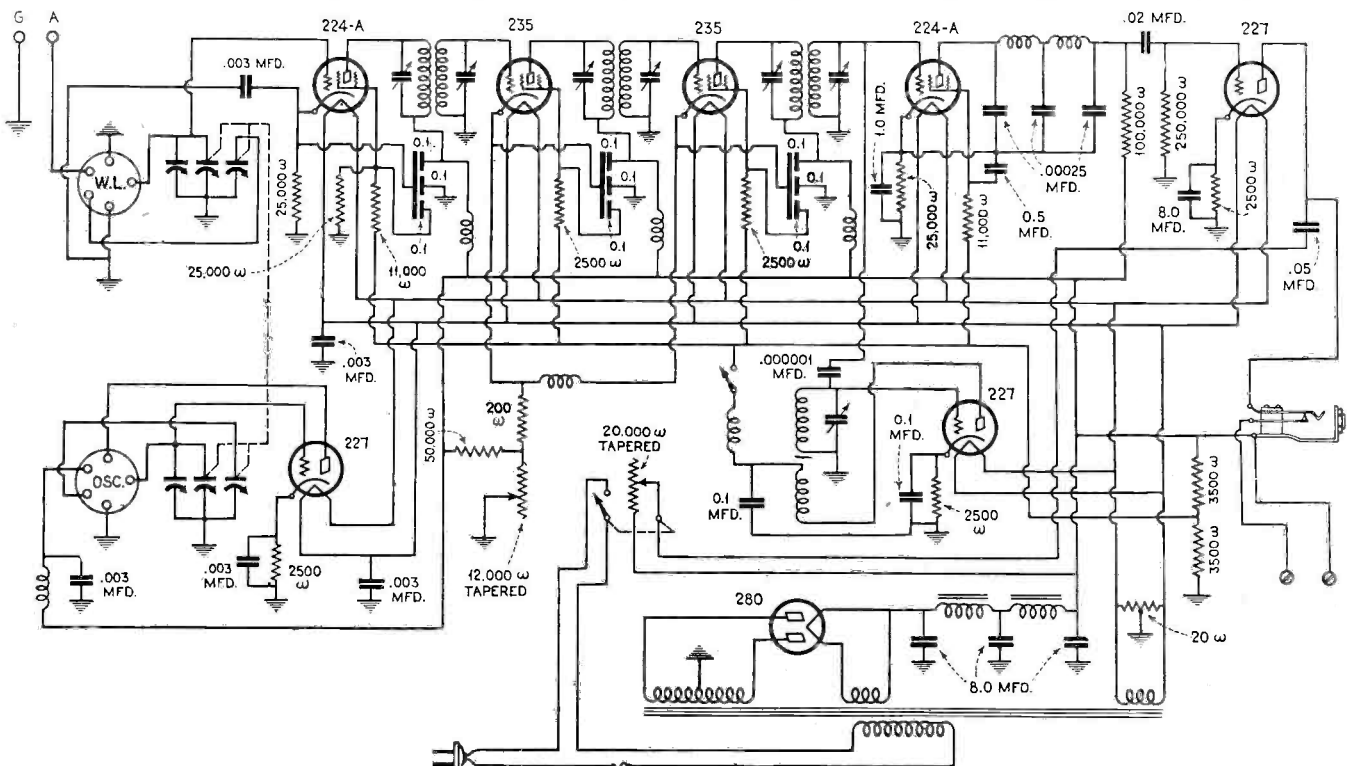

Aligning All-Wave Receivers

The recent crop of all-wave superheterodyne receivers brings forth new service considerations. At the present time there are two types of all-wave receivers. One type consists of a short-wave converter feeding into a broadcast superheterodyne. The other consists of a wave-changing-switch-controlled receiver wherein all of the tubes in the receiver are utilized at all times that is, for short-wave or broadcast wave reception. In the first named arrangement, two separate oscillators are used. One is for the conversion of the short-wave signal to some intermediate frequency which is fed into the broadcast receiver just as any ordinary signal. The second oscillator is located in the broadcast receiver part of the system and is used to produce the beating signal for the changing of the output signal from the short-wave converter to one of the proper intermediate frequency for the i-f. system in the broadcast receiver.

In the second type of all-wave receiver, but one oscillator is used and this tube produces the beating signal for both short- and long-wave signals.

Troubles due to alignment may be different in these two types of receivers. In the first named receiver, it is a very simple matter to separate the units to check whether the broadcast receiver or the short-wave receiver oscillator is out of alignment, and then make the repair. In the receiver which uses but one oscillator, a very confusing condition may be experienced. Such a condition consists of an apparent case of mis-alignment upon the short waves and perfect alignment upon the complete broadcast band. As a general rule this is a sign of incorrect alignment of the oscillator condenser upon the broadcast band. However, the discrepancy may be so small as to pass unobserved upon the broadcast band, but when tuned to the short-wave band, the same discrepancy creates a very great difference in the i-f. frequency produced. The following is an illustration of what we have in mind.

Let us suppose that the intermediate frequency in the receiver is 175 kc. Let us further suppose that the oscillator adjustment is high by about .1 per cent in excess of the rated frequency difference required to produce the intermediate-frequency signal. When tuned to a 600-kc. carrier, the intermediate frequency produced would have a value of about 175.775 kc., which of course is negligible. At 1,400 kc., assuming the same variation in oscillator adjustment, the intermediate frequency would be about 176.575 kc. Once more this variation is negligible. However, when we are tuned to a carrier of, say, 15,000 kc. a similar variation of .1 per cent would produce an intermediate frequency of about 190.175 kc., and it is very possible that the signal would not be heard or the receiver would lack sensitivity.

A variation of .1 per cent must be acknowledged to be very small and is an indication of the extreme accuracy of alignment which must be obtained in receiver of this type. A warning is therefore given against any attempt to align such receivers at the broadcast frequencies. Alignment is required at the high-frequency end of the scale; namely,

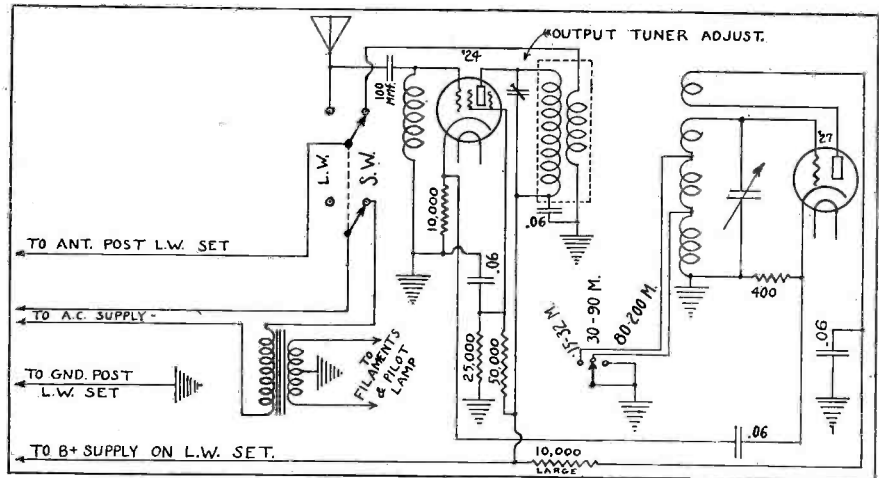

Schematic diagram of the Kennedy Model 53 Short-Wave Converter. Note that the antenna circuit is untuned. Therefore, the only tuning control is the oscillator variable condenser

between the 10,000-kc. and 6,000-kc. ranges.

However, alignment at this high frequency is something more easily said than done, particularly when very few high-frequency oscillators are available. A possible source of signal is the fifth harmonic of a modulated radio-frequency oscillator which is tuned to 1,500 kc. and which is known to be accurate. The fifth harmonic of this fundamental would be 7,500 kc.

In view of the fact that the broadcast frequency range adjustment is satisfactory, it is best to attempt alignment by working upon the short-wave coils rather than upon the oscillator condenser. Select the coil used for the short-wave band upon which the receiver appears to lack sensitivity, or is out of alignment. With the testing oscillator in operation, move one of the outside turns of the short-wave oscillator winding towards or away from the other turns upon the coil. A great amount of variation may not be required to create perfect alignment of the system for that waveband. By adjusting this coil, the alignment upon the other wave bands is not interfered with.

Under no circumstances should you alter the adjustment of the i-f. transformers so as to produce satisfactory response upon the short waves with the oscillator condenser in its original condition. If this is done, the receiver will lack sensitivity upon the broadcast band.

Kennedy Model 53 Converter

As will be noted from the accompanying diagram, the Model 53 Converter employs a type '24 tube as first detector or mixer. The input or antenna circuit is untuned (an r-f. choke being used) while the output circuit feeds into an r-f. transformer, with a tuned primary, which is adjusted to a frequency of 1,000 kc.

There are three leads from the converter. The black lead should connect to the ground post on the broadcast receiver, and the white lead to the antenna post. The red lead should be connected to the most appropriate voltage source in the broadcast receiver, preferably in the speaker or filter

system. Any voltage from 150 to 250 is suitable.

The values of the units are given in the diagram. Tube voltages of course depend on the source voltage which is obviously a variable factor.

If by chance the output frequency of the converter has shifted, it may be retuned by setting the dial of the broadcast receiver to 1,000 kc., and with a signal tuned in on the converter, adjust the output tuner condenser with a bakelite screwdriver for maximum volume. This adjustment screw will be found to the right of the aerial and ground binding posts at the rear of the converter chassis.

Should a local broadcast station at or near 1,000 kc. interfere with the operation of the converter, set the broadcast receiver dial to some other point near 1,000 kc. and readjust the output tuner condenser for maximum signal.

C.W. On Converters

A simple and effective way of picking up continuous-wave signals on a short-wave converter is to use the carrier of some local broadcast station as the frequency with which to produce the necessary audible beat.

If the converter is of such type that a specific intermediate frequency must be used, and if the broadcast station at or near said intermediate frequency setting is not of sufficient intensity to function as the "local oscillator" then it is simple to resort to a separate antenna, attached to the antenna post on the broadcast set, in order to increase the pick-up of this station's carrier to such a point where it will create the audible beat. A few feet of wire will usually do the trick.

More than likely you will run into few people who may wish to listen to code on the short waves. However, the method described above is of considerable utility when fishing for DX, for each short-wave broadcast station will produce a whistle when reached on the dial. When the station has been picked up in this manner, then the broadcast set may be tuned off the carrier of the local broadcast station—or the extra pick-up antenna switched out.

Auto-Radio

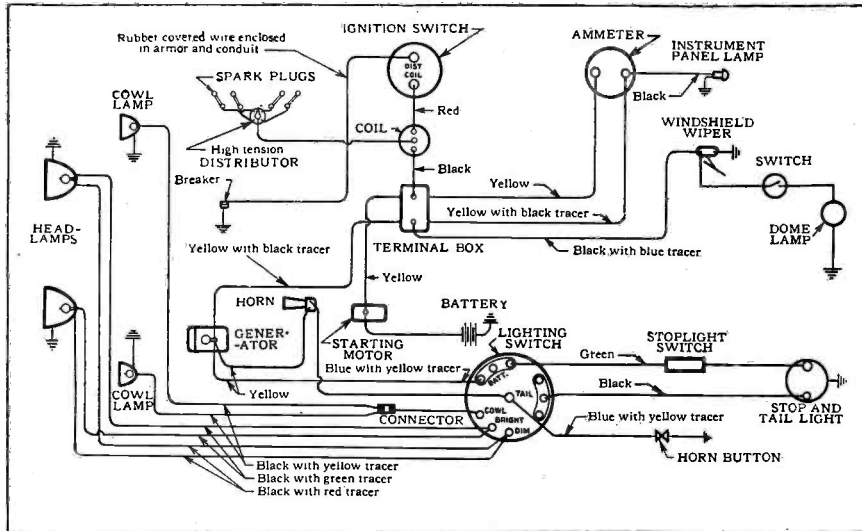

Fig. 1. Diagram of the wiring system used in the Model A Ford. The distributor is mounted above the engine and is comparatively easy to get at for installing a suppressor resistor. It is an easy matter to trace all the wiring under actual conditions, as this diagram provides the color-coding

Ford Ignition Systems

The ignition system diagrams for the Model A Ford, and the Ford V-8, are shown in Figs. 1 and 2 respectively. These should be of distinct help when making radio installation jobs in these cars.

(The diagrams of the ignition systems used in other cars will be published in forthcoming issues, as well as special installation notes.—EDITOR.)

Dodge and Plymouth Installations

When installing auto radios in Dodge or Plymouth cars (Model No. 7 Philco Transitone is standard) the following operations should be carefully executed, when thereafter there should be little or no noise evident in the loudspeaker with the volume control full on and the set tuned off signal:

- (1) Connect one interference condenser from the battery terminal of the generator to ground.
- (2) Install the spark plug interference suppressors; one on each spark plug.
- (3) Install the distributor interference suppressor in the center lead of the distributor as close to the center outlet as possible.
- (4) Close the gap between the rotor electrode and the stationary electrodes in the distributor cap. This operation requires the utmost care in execution. Remove cap and chalk the inside faces of the stationary electrodes. Remove the rotor and extend the electrode by carefully peening about .005 inch, then replace in distributor and put on the cap, turn the engine over by hand a few times, remove the cap and examine for indications of contact on the chalk. Repeat this operation until there is evidence of the rotor sweeping the stationary electrodes; then file off about .002 inch and re-assemble. Start

the engine and run for a minute, then re-examine the cap. If there is evidence of the rotor contacting with the stationary electrodes, file off another thousandth of an inch and recheck for evidence of contact.

- (5) Install the shielded loom over the high-tension wire from the coil to the point where the high-tension wire enters the tube on the engine. Securely bind the oil line and temperature indicator tube together at the dash, and then ground the same by means of the ground lead supplied as part of the shield. Install the end of loom that is not shielded for one inch toward the coil outlet.

- (6) Coil the primary wire from the coil to the distributor around the shielding as many times as its length will permit between the dash and the coil. This has a tendency to neutralize radiation from the metallic braid.
- (7) Install one interference condenser on the dome light lead as close as possible to the point where the wire enters the left front "A" pillar. This operation is performed by stripping the insulation for about one inch and connecting the condenser lead. This splice must be properly taped. Drill the instrument board flange and mount the condenser by means of an 8-32 bolt and nut.
- (8) Connect the shielded antenna lead from the set to the antenna lead wire as close as possible to the point where it leaves the "A" pillar where the antenna lead comes out.

Curing Hiss in Transitone

The following refers to a Transitone receiver installed in a closed Cadillac with factory-equipped aerial. In many cases, however, the same data may well hold true with other installations.

The particular installation referred to had a bad hiss and was inclined to be directional in reception. Common methods were of no avail, and it was not until the aerial installation was investigated that any improvement was brought about.

This was a roof antenna, and consisted of 6 or 7 strands of Litz wire in the roof of the car. The down-lead was shielded and ran through one of the corner posts.

The size of the antenna was not sufficient for requirements, and an extra antenna was added beneath the car. This was of three strands. At the same time, the shielded lead-in was removed from the corner post and a new one inserted, as the old one appeared to be inefficient.

The added size of the antenna, plus the new shielded lead-in, eliminated the hiss and also removed the greater part of the directional properties

W. P. Horne.

Fig. 2. Diagram of the wiring system used in the Ford V-8. This diagram includes the color coding. The distributor in the V-8 is mounted between the engine and radiator, and it is mechanically impossible to install a suppressor resistor, as the distributor is entirely enclosed in a housing. An "A" choke may be necessary

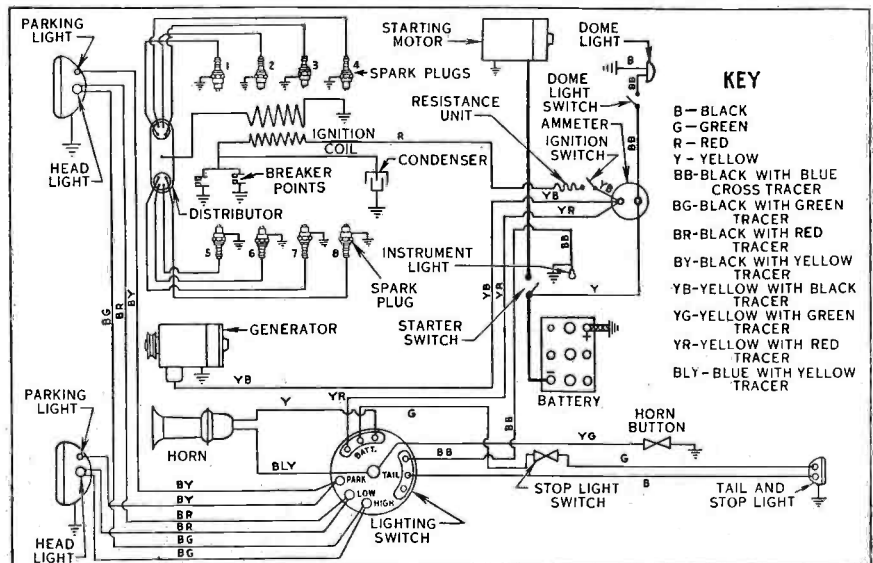



FIRST-AID
KIT

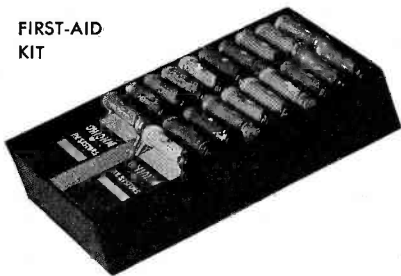

OHM-DIAL



FREE
With Initial Order

LABELS

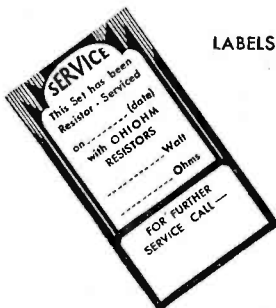

SPARK SUPPRESSOR SET

YOU Win the Business of the Radio Fans who Want their Sets in Order

POLITICALLY SPEAKING, the bray of the Democratic donkey with its powerful kick, and the trumpet of the Republican elephant challenging competition, make radio listeners attentive to every word. And, sets must be serviced to be in condition for the presidential battle of the air.

That much neglected—and often overlooked—item, the resistor, needs replacing in countless sets. Hundreds of thousands of resistors will be installed. You, the service man, should be prepared for this business.

Your Platform is Safe the OHIOHM Way

With OHIOHM Resistors as your stock in trade, and with the aid of the servicing helps given you free, you are always well qualified to give prompt, accurate and profitable service.

Ohiohm First-Aid Resistor Kit . .

pocket size, furnished in 1-watt and 2-watt types, supplies you with the right resistors for the job. Free with initial order, we give a supply of Service Labels for placing in the back of sets to record the job and as reminder advertising; an Ohm-Dial for determining resistance values of the resistors you wish to replace; and, a Guide for ready reference in servicing the set.

Ohiohm Spark Suppressor Sets

for Eliminating Ignition Interference on Automobile Radios.

Furnished in sets for 4, 6 and 8 cylinder cars, consisting of condenser and the necessary suppressors to meet all usually encountered conditions of automobile radio installations. High grade in every respect—protected against "shorting" and made to last the life of the car.

• Write for prices and details •

THE • OHIO • CARBON • COMPANY
12508 BEREA ROAD CLEVELAND, OHIO

OHIOHM RESISTORS are made in Canada by C. C. Meredith & Co., Ltd., 67 Bay St., Toronto

OHIOHM

HIGHLIGHTS . . .

Greetings

Just another department to keep you awake nights. May you enjoy its ramblings.

We have long felt the need for a department such as this . . . a section of the magazine where we could speak of such matters as defy classification, and of such matters as strike our fancy. Now that the department is a fact, you may expect to find an astonishing array of unrelated items.

There is no saying where the thing will end, but we start off with great optimism and extend greetings and salutations.

Try Blotters

The Scientific Radio Service, of Rutherford, N. J., has had printed up a combination advertisement and coupon (good for a free inspection), the back of which is nothing less than a nice, blue blotter.

Advertising authorities say people never throw away blotters; it's the Scotch in them, we suppose. At any rate, it is reasonable to believe that both the advertisement and coupon worked up by the Scientific Radio Service will receive more than the usual attention, and will prove itself a business getter, if it has not already done so. We recommend the idea.

Tubes and Stuff

Both RCA Radiotron Co., Inc., and E. T. Cunningham, Inc., have brought out Tube Manuals containing just the sort of information we are usually looking for but can never find. All tubes from the UX- and

UY-199 up to and including the new type 55 duo-diode are given full consideration in the way of operating data and characteristic curves.

The forepart of each of these Manuals is given over to really understandable explanations of the operation of diodes, triodes, tetrodes and pentodes. There follows in each a chapter on the actual manufacture of vacuum tubes which is very interesting, and thereafter two lengthy chapters on the application of all types of tubes and installation considerations.

Each Manual contains 83 pages in all, and each sells for 25 cents. However, being a Service Man, you can obtain one free by sending a written request to RCA Radiotron Company, Inc., Harrison, N. J., or E. T. Cunningham, Inc., 415 South Fifth Street, Harrison, N. J. You can't lose.

High-Low

Central Radio Laboratories, 900 E. Keefe Ave., Milwaukee, Wis., have published a fine 64-page Manual on volume controls. The name of this Manual, to be exact, is Centralab Volume Control Guide for Servicemen.

In thumbing through the pages, we find good dope on fundamental circuits used for volume and tone control; twin volume control circuits; T-pad and fader attenuation circuits for broadcast, recording and sound work; control of multiple speaker installations; and a replacement guide, just to mention a few of the subjects covered.

The Manual sells for 50 cents and may be ordered direct from the manufacturer.

A REAL SERVICE LABORATORY, maintained by William H. Hobbs, of Radio Engineering and Service, Louisville, Ky. This Company serves over 300 dealers in Kentucky and southern Indiana. The left panel contains a Wheatstone Bridge, grid-dip meter, oscillation tube tester, ohmmeter, etc. The center panel is a Jewell 581 job. The right panel carries a V.T. voltmeter, 0 to 50-ohm Ohmmeter, tube short checker and switching system. Mr. Hobbs is a Ham, and operates W9DK

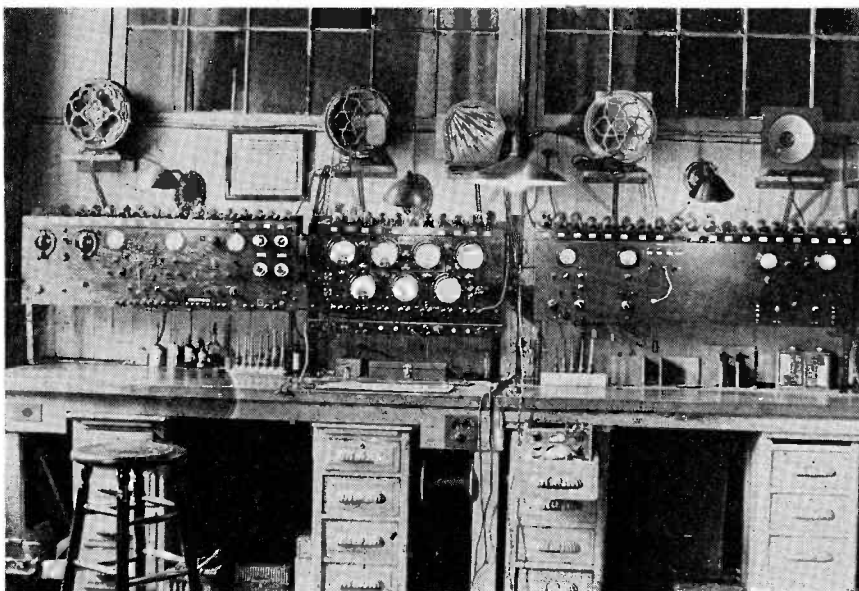

Peas in a Pod

We have received gratis—and it's gratis to you, too, if you wish one—a neat catalog listing a myriad of replacement transformers for most any model receiver you can think of. This catalog comes from the Standard Transformer Corporation, of Chicago, and it "makes" this page because it discloses what might well be termed the "neatest trick of the year."

The trick is this: Every transformer listed is an exact duplicate, both mechanically and electrically, of the transformer it is made to replace. To us, that's a swell idea. No more need of attempting to fit square pegs in round holes, so to speak.

After thinking about the matter, we have decided that the original job of collecting a complete and authentic batch of all those modern and antique transformers must have been about as easy as hunting needles in a haystack . . . and at that, there is an advantage to the latter in that you at least know where the needles are.

Noise-Reducing Aerials

The above reminds us of a little-known fact—aerials employing transposed lead-ins or transmission lines usually pump more into the receiver than does an aerial using a regular lead-in. The reason for this is that the transposed lead or transmission line is not a part of the aerial itself and does not function as a pick-up. On the other hand, the usual lead-in may be considered as a portion of the aerial, as it is exposed and consequently functions as a collector. If this lead is run at some angle to the aerial—and there are very few cases where it is parallel—the voltage in the lead will be out of phase with the voltage in the aerial. The resultant effective voltage will, therefore, be less, as the lead voltage tends to cancel a portion of the aerial voltage. When a transposed lead or transmission line is employed the resultant effective voltage is that of the aerial only, with no subtractions except small transmission losses.

S.W. Converters

This short-wave converter business is getting serious. It's the thorn in the side of many a manufacturer, and do you wonder? Sometimes they work—and many times they don't. They require an extreme amount of coddling, and the average radio dealer does not appear to be in the mood to act as a mother to these erring pups.

The fact remains that a good converter can supply an immense amount of enjoyment, while a bad one is next to worthless. But even with a good converter, results may be downright rotten because of improper voltages or connections, antennas squat in the center of noise areas, or absolute ignorance on the part of the owner as to how to handle the new gadget.

Believe it or not, it is up to the Service Man to correct these many faults. No one else is in a position to do it.

AN EXACT DUPLICATE REPLACEMENT TRANSFORMER SERVICE

for 16,000,000 Radio Receiving Sets

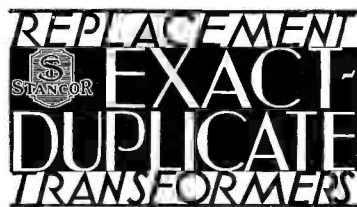

These Stancor EXACT-DUPLICATE Replacement Transformers represent a partial list, available for prompt shipment from stock.

THE new Stancor Catalog-Bulletin of *Exact-Duplicate* Replacement Transformers presents to the service man a service of profit and convenience impossible for him to find elsewhere.

In this new bulletin he will find every possible transformer service necessary for his use in renewing the original performance of any of the 16,000,000 radio receiving sets now in operation.

Stancor *Exact-Duplicate* Replacement Transformers are made and guaranteed by the same organization and in the same plant that has produced so many of the transformers specified by discriminating manufacturers as original equipment for their sets.



ALL-AMERICAN MOHAWK
Models—Lyric 90, (25 cycle); Lyric 90, Lyric D & H.

APEX
Models: (Superheterodyne) 10; 20, 26, 32, 36, 37.

ATWATER-KENT
Models: 37, 38, 55, 55-C, (late model); 55, 55-C (early model); 60, 60-C, H-1, H-2, L-1, L-2, 82, 85, 82-F, 85-F; (early and late type) 84-F; 80, 83, 80-F, 87, 89, 89-P, 89-F, 66.

BOSCH
Models: 29, 825.

BELMONT
Models: 41, 41-A, 47, 50, 51, 51-A, 51-B, 70, 71, (25 cycle) 42, 42-A, 48, 72.

BRUNSWICK
Models: (60 cycle) 14, 21, 81, 82, S-14, S-21, S-81, S-82; (Chassis D) 12, 12-A, 16, 16-A, 18, 18-A, 33, 33-A, 10; (25 cycle) 14, 21, 81, 82, S-14, S-21, S-81, S-82, 2-KRO, 3-KRO, 3-KR-6, 5-KR-6, 5-KR.

COLUMBIA
Models: SG-8.

CROSLEY
Models: (Chassis 73) 40-S, 41-S, 42-S, 82-S.

EARL
Models: 31, 32, 32-S, 41.

EDISON
Models: (Chassis JR & JC) R-1, R-2, C-2.

EVEREADY
Models: Series 30, 40, 50.

FREED
Models: 65, 78, 79, 79-S, 90, 95.

FREED-EISEMAN
Models: NR-85.

FRESHMAN
Models: Q-15, Q-16, 3-Q-15, 3-Q-16, QD-16-S.

GENERAL ELECTRIC
Models: H-31, 51, 71, T-41, T-41-C.

GENERAL MOTORS
Models: Chassis S-9-A.

GRAYBAR
Models: 310, 311, 700, 770, 900, 500, 550, 340, 600, 678.

KELLOGG
Models: 523, 533, 534, 535, 536.

KENNEDY
Models: 10, 20.

KOLSTER-BRANDES
Models: K-20, 22, 25, 27, 24, 36, 43, B-15, 16.

KOLSTER-COLUMBIA
Models: 950.

MAJESTIC
Models: 90, 9-P-6; (plate) 70, 7-P-6; (filament) 70, 7-P-6; (plate) 180, 8-P-6; (filament) 15, 15-A, 90-B, 100-B; (Chassis 20 unmounted) 21, 22, 23, 130-A, 230-A; unmounted 25, 25-B.

PHILCO
Models: 20, 65, 76, 77, 86, 87, 95, 96, 296, 11, 211; for 245 tubes, 112, 212; for 247 tubes 112, 212; 70, 270; (60 cycle) 511; (25 cycles) 521.

RCA RADIOLA
Models: 80, 82, 60, 62, 44, 46, 47; (60 cycle) 17, 18, 33, 50; (25 cycle) 17, 18, 33, 50, 51; 66; (25 cycle) 42, 48, 64, 67.

RCA-VICTOR
Models: R-32, R-52, RE-45, RE-75, R-35, R-39, RE-57, R-15, 7-11, 7-25, R-15, (25 cycle); 9-18, 9-54.

SILVER-MARSHALL
Models: Sheridan 750.

SPARTON
Models: 931, 589, 89-A, 301, 410, 420, 25, 26, 26-AW.

STEINITE
Models: 40, 50, 102, 40-C, 41-C, 60-C, 102-C.

STEWART-WARNER
Models: Series A & B 60 cycle 801, 801-A, 802. Series A & B 25 cycle 811, 811-A.

STROMBERG-CARLSON
Models: 641, 642, 652, 654, 846, 848, 10, 11.

TEMPLE
Models: 8-60, 8-80, 8-90, 8-61, 8-81, 8-91.

TRAV-LER
Model: B.

UNITED AIR CLEANER
Models: 108, 108-B, 108-A, 110, Silvertone (Sentinel) 104.

WESTINGHOUSE
Models: WR-5-6-7, WR-4; (25 cycle) WR-4.

ZENITH
Models: (Series) 50, 60, 70; Models 10 11, 12.

STANDARD TRANSFORMER CORPORATION

862 BLACKHAWK STREET CHICAGO, ILL.

STANDARD TRANSFORMER CORP.,
862 Blackhawk St., Chicago, Ill.

Gentlemen:

Send me by return mail, your catalog of Exact-Duplicate Replacement Transformers, together with price schedule and name of distributor nearest me. Also put my name on your list to receive Catalog-Bulletin No. 3.

Name.....
Address, Street & No.....
City & State.....
Firm and Position.....

ON THE JOB . . .

FIRST PRIZE

COOPERATIVE ADVERTISING

By W. Kenneth Jeffords

In the vicinity of my Electrical Service Shop there is nearly every kind of business, such as Dry Goods, Drugs, Hardware, Plumbing, Grocery and Auto Supply.

We as a group have banded together in an attempt to stimulate business in our territory and have been very successful. We employ a coupon book which is worth to the holder about eight dollars in cash, providing the coupons are used in trade. These coupon books are given out by sales girls who are hired to solicit each housewife. These girls explain the use to which the coupons may be put, and in each case obtain the name, address and phone number of the person accepting the book.

The names and addresses so gained form an excellent mailing list, and the people respond because of the value they can receive through the coupons.

The page in the coupon book is about 2½" by 6", only a part of which is given over to the coupon proper. The main portion of the page is used to carry an advertisement, so that this portion always remains in the book and only the coupon torn out.

We make our coupon good for one service call, which is otherwise one dollar. I have received calls from different parts of the city by this method which I would not have received otherwise.

When the coupon is honored, it is charged to advertising. The one dollar spent for advertising in this manner will average a net profit of \$2.50. This method of advertising has increased my service work from 50 to 75 percent.

This coupon idea also opens up unusual opportunities for the demonstration of electrical and radio equipment.

SECOND PRIZE

TEMPORARY SETS

By Joseph Vicari

I carry with me on all service calls a modern midget receiver which I connect up and leave with the customer in the event that

ENTER THIS CONTEST

Every month SERVICE awards prizes for the three best merchandising, sales or management ideas used by Service Men to improve or increase their business. First Prize, \$7.00. Second Prize, \$5.00. Third Prize, \$3.00. Your idea may win. Send it in now!

I must take his own receiver back to my shop for repairs.

This idea has done a great deal for my business and has a two-fold advantage. In the first place, people get used to certain programs and hate to miss them. Leaving with them a temporary set is, therefore, a great convenience, and it creates good will. In the second place, some of the people who own old receivers come to realize what a difference there is between their sets and a modern one. Particularly so when they are having a demonstration of the superiority of one over the other right in their own homes. This results in extra sales which ordinarily would never take place.

I might also add that in numerous cases I have gotten service jobs for the very reason that the customers knew that they could still listen in while their own receivers were being repaired in my shop, whereas in another case they would have let the servicing go.

THIRD PRIZE

SELL THEM AN '80

By Wells G. Arnold

Sell them an '80 whether they need it or not! That sounds like a racket but it really isn't.

The majority of power transformer troubles are due to the burning out and shorting of the '80 tube. Not all sets have fuses, and while some have line ballasts which will sometimes burn out first, '80 tubes are cheaper.

We make it a practice to explain the facts to every customer, and make it plain to him that though the rectifier tube may test okay, replacing it with a new one is pretty good insurance against transformer trouble.

We have replaced many power transformers and it is interesting to note that in two

years' time, since we started on our '80 campaign, we have not had to replace transformers for any customers to whom we had sold a new '80 tube.

Another idea we have put into practice is a plan of sending letters to all customers from whom we have not heard for a period of eighteen months, and suggesting that they put in a call for one of our Service Men and perhaps save themselves from considerable expense later on.

This is especially advantageous to us in such cases where we have sold the radio to the customer. It keeps us in contact with him and helps to keep his friendship.

A new '80 tube once a year does avoid a lot of trouble, and the carelessness of the occasional customer who does not answer our letter is an excellent alibi for us when he does have some grief, and sends for us.

HONORABLE MENTION

HANDY REFERENCE CHARTS

There are many charts and lots of special data which are constantly needed by the Service Man near where he works. Find-

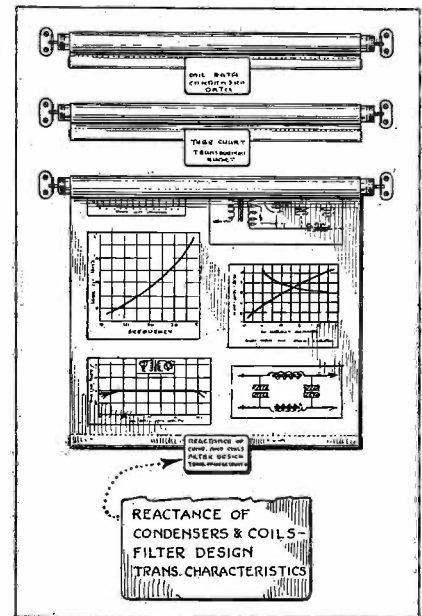

ing it inconvenient to look through a lot of magazines each time I wished to refer to some chart or special data, I struck upon the idea of tracing directly on to tracing cloth, measuring three or four feet in length, such charts and tables I found of constant use, and then mounting the tracing cloth on window shade rollers. These I have fastened to the wall directly over my test bench (see accompanying sketch) and I can unroll any one at will.

A wooden slat is fastened to the bottom of each tracing-cloth roll, just like the wooden slat at the end of a window shade. To each of the rolls there is attached a tab upon which I have printed a description of each of the charts, tables, etc., on that particular roll.

B. W. Freid.

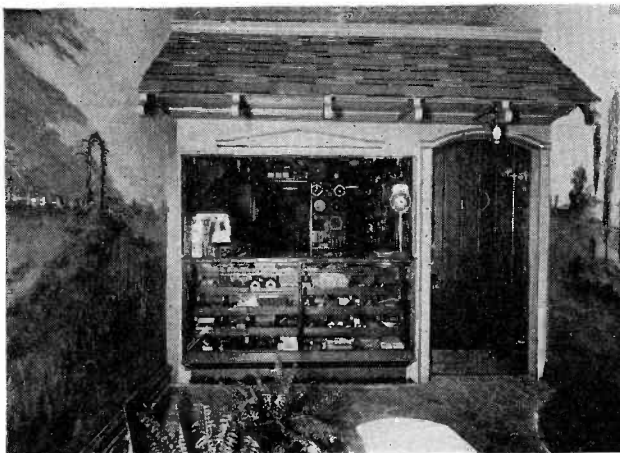

A SHOP WITHIN A SHOP. This bungalow amidst a beautiful landscape is in reality the Service Department in the rear of the store of the Kronson Service Co., Buffalo, N. Y. The scenery is painted on the walls. Note the "path" leading up to the door

Essential to
MODERN RADIO!
and a MONEY-MAKER
for the SERVICE MAN

AMPERITE is the only self-regulating line voltage control that successfully compensates for line voltage variations, up and down. Greatly improves reception and adds life to tubes and filter equipment.

AMPERITE can be installed in any radio in five minutes. It is so easy to sell that service men are averaging from \$60 to \$110 *extra profit* each month.

R. Gordon, service man at 2504 Olinville Ave., New York, averages more than 40 AMPERITE sales a month. S. Commadore, 200 E. 104th St., New York, sells 60.

Get in on this live-wire money-maker. Those *extra* dollars are worth having.

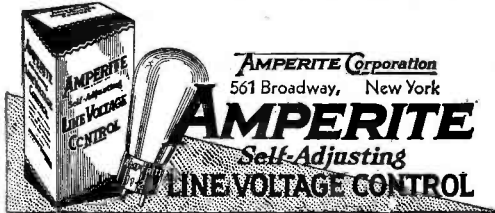

AMPERITE Corporation
 561 Broadway, New York
AMPERITE
 Self-Adjusting
 LINE VOLTAGE CONTROL

Send \$1.40 to Dept. S-9 for dealers' sample and sales helps.

RADOLEK

The Radio Serviceman's Supply House
 WHERE
QUALITY · SERVICE
 Lowest Wholesale Prices
 Are Combined

Complete lines of finest quality, new radio and electrical merchandise—carefully selected for you from the offerings of the most reliable, standard manufacturers. Test Equipment, Tubes, Batteries, Repair Parts, Accessories of all Kinds, Public Address, Lighting Fixtures, Electrical Supplies, and many other items to make money for you, are carried in stock—always ready for you.

Fastest, Most Reliable Service
 Practically every mail order shipped same day.
VERY PROMPT, COURTEOUS COUNTER SERVICE
 Our Store is convenient—Plenty of parking space.
 Get your copy of our 1932 Serviceman's Price Guide.
SEND FOR IT NOW!

SERVICE-MEN
 SEND FOR THIS BOOK
 YOU NEED IT **FREE!**

Coupon

Chicago, Ill.
 Radolek Company
 706 Canal Station.
 Please send me without obligation your Serviceman's Supply Book.
 Name
 Address
 City..... State.....

RADOLEK CO.
 601 W. RANDOLPH ST.
 CHICAGO, ILL.

FREE Brass-Fitted, Leatherette-Covered SERVICE KIT

JUST the thing every service man needs! Easy to carry!—and provides ample space for tools, small parts, 20 assorted tubes, a coil of wire, literature, etc. This kit is sturdily constructed, handsomely finished. It's planned by radio experts for radio experts! Speeds up work, impresses customers with your neatness, efficiency and professional standards.

Get the Sylvania Service Kit **FREE!** All you do is send us your purchase order for 75 assorted Sylvania tubes—any 75

you want—to be billed through your regular jobber. You will receive your Free Sylvania Service Kit at once.

If you want—order 25 tubes at a time—when you've placed 3 such orders you will receive your kit!

Your customers know that Sylvania tubes have been "tested for a set like yours." When you use Sylvania tubes steady consistent newspaper and radio advertising helps you make quick easy sales!

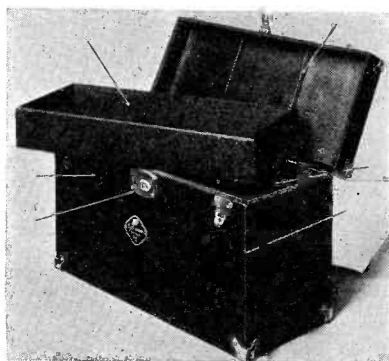

- 6 IMPORTANT FEATURES**
1. Convenient Too Tray—plenty of room for aerial wire, etc.
 2. Heavy Brass Finished Lock.
 3. Finished in Black Leatherette.
 4. Elastic Straps for Advertising Material.
 5. Capacity up to 20 Tubes.
 6. Rugged Construction, Professional Appearance, Large Capacity.

Sylvania

REGISTERED U.S. PAT. OFF.

THE SET-TESTED TUBE

Hygrade Sylvania Corporation,
 Sylvania Division,
 Emporium, Penna. Date.....

We are anxious to have a Sylvania Service Kit, and attach our purchase order for 75 25 assorted Sylvania Radio Tubes to be billed through

.....
 Jobber's Name Address
 Name..... Signed.....
 Address..... S-91

THE FORUM . . .

About Resistance Measurement

Editor, SERVICE:

It was with more than ordinary interest that I read Part I of your article, "Resistance Measurement Method of Service Analysis" in the June issue of your magazine, SERVICE. I, personally, am thoroughly in accord with your thought on the advantages of resistance analysis in comparison with voltage analysis to quickly and definitely locate the fault in a receiver that does not function properly.

We are contemplating the preparation of a chart on each of our models that will be sold this season showing the value of resistance obtained from point-to-point.

K. E. BROOKS,
Assistant Service Manager.
THE SPARKS-WITHINGTON CO.

About Testing Instruments

Editor, SERVICE:

Your publication SERVICE touches on several of the most important subjects to the Service Man, but one subject—a very important one—has been omitted; that is, testing instruments used in service work.

If you could and would introduce a department dwelling on tube testers, oscillators and analyzers, the construction of workable models and the remodeling of past commercial models and adapters in order to bring them up to date, and at the same time give diagrams and data on the changes necessary to test newly developed tubes and circuits, it would be a real "SERVICE" to the Service Man, as well as a real money saver.

Another service of real value would be to show the detailed construction of a good tube tester, and whenever new tubes came out, to show the changes necessary to bring the tester up to date.

NEIL C. BETHEL,
RADIO SERVICE CO.,
Wheeling, W. Va.

(Your suggestions are greatly appreciated. We have had this subject in mind for some time, and fully intend to offer our readers the essential details of various forms of testing equipment for general and special purposes.—EDITOR.)

Aerials to Ohmmeters

Editor, SERVICE:

I always hesitate to write the busy editor of a technical magazine, because having had similar personal experience in a different line, I realize how little time he has to read lengthy correspondence.

However, the excellence that SERVICE is rapidly approaching, prompts me to compliment its editors for filling a long felt need in radio servicing and at the same time offer a few suggestions which may have merit.

My first suggestion is that you publish a general index in the issue that finishes your first volume. Your method of indexing is

excellent, but after receiving twelve issues, the task of looking through each index can be greatly lessened by having a general index covering past numbers.

I was gratified to see an article on aerials in the June number. The lowly aerial has been receiving scant attention lately, and there is no doubt that a special aerial will do much to reduce the noise-to-signal ratio.

Radio salesmen, especially those working on a commission basis, have gradually unsold the public on the necessity of having a good aerial. Four years ago, our customers were anxious to know that their aerials were properly installed; to-day, if we suggest a better aerial we are invariably told that the salesman said the set would play just as well on a piece of wire hung out the window. If we could reduce noise-to-signal ratio with a little magic box to be attached to the set, we would be overwhelmed with orders, but when we suggest an aerial installation that will accomplish the same results, we are looked upon as being primarily interested in lightening their pocketbooks.

It is up to the Service Man to re-educate the public to the necessity for having good aerials, and articles along the lines of Mr. Fausett's recent article should be encouraged. The aerial situation in this city is deplorable and I imagine the same holds true all over the country.

In popularizing analysis by resistance measurements, we believe you have done more for the Service Man than any other one thing since radio servicing came into existence. We have used this system for nearly four years, the writer having developed a resistance analyzer somewhat similar to the one described on page 156, and having used it constantly day in and day out for more than three years. In the beginning it was very useful, but as the values of resistances in use increased, it has become more of a continuity-indicating device rather than an accurate measuring instrument—and here comes the rub.

There does not seem to be a single, suitable ohmmeter on the market to-day having a flexible enough range to cover radio service needs. It is true we could build such an instrument but the small scale radio meters which are within our means have such a short scale that the deflections on the high-resistance range are entirely too crowded. What we need is an accurate meter with longer scales. Somewhere between the usual miniature meters and the elaborate laboratory models, it seems that a suitable meter could be manufactured.

I think the second step in your commendable movement to popularize resistance measurement would be to prevail upon the meter manufacturers to market such an instrument. As for ourselves, we have bought our last set analyzer and are saving our money toward buying better meters, as a good ohmmeter will never be obsolete.

I feel that I am voicing the sentiments of all brother Service Men when I state that articles on service equipment, such as your

last description of a condenser tester in the July *Radio Merchant*, which we can build cheaply ourselves are waited for and welcomed by the entire service fraternity.

H. B. DUNCAN,
DUNCAN RADIO LABORATORY,
Wilmington, Del.

(We have no doubt that ohmmeters of the type you mention will be placed on the market in the very near future. Thank you for the suggestion pertaining to a general index. We shall have one, you may be sure.—Editor.)

Re Inspection Charges

Editor, SERVICE:

Since the magazine is for the benefit of service and since a standard practice and standard recognized "ethics" are as desirable in our profession as in the medical and dental professions, I am pleased to give my own views on the question of service charges.

Mr. Walker, of Great Falls, Montana, asks why a charge should be made for an inspection. Consider the case of the doctor who calls on you and says you need some common pill, or who possibly approves of some you are already taking; he collects his charge for a call just the same. Then consider the many service calls where a loose connection or a single tube is the cause of the trouble. Are we to content ourselves with the profit on an article the list price of which has fallen below a dollar? I say no. Let us have a minimum charge for the time required to travel to and from a job, for in the end, after we have determined the trouble, if the cost appears too high to the customer you may get no compensation whatsoever.

Another point along this line that I think we could well begin to standardize on is this: I can see no reason why standard rates should not be established to cover all kinds of repairs. I mean a flat rate. I will repair any radio brought to my shop for two dollars labor charge plus the list price of the part. Or, if it is necessary for me to bring the set or a part of the set from the field to the shop and return it, the charge is four dollars plus the price of the part.

Although competitive conditions force me to charge only one dollar for routine inspection and minor service calls in the home, I feel that such calls are worth two dollars. Just as long as the Service Men continue to make the inspection charge one dollar in large cities, just so long are we "cutting our own throats."

By all means, in large cities at least where the established Service Man has to compete against even the apartment building janitors, let us uphold the service inspection charge.

CARL D. SHORT,
Bronx, New York.

The WEDGE ▼

▼
THE SERVICE MAN is the focal point in modern radio merchandising. His word is taken without skepticism - - his recommendations are crystallized sales.

▼
HE IS THE WEDGE in the heart of the consumer merchandising problem. He, with his sincerity, born of his pride of profession, cuts through the resistance of consumer doubt and timidity—prescribes, and leaves behind him a good-will. Upon this is he building his future.

▼
THE SERVICE MAN is the logical outlet for your products. Gain his faith in the merits of your merchandise and he will accomplish the rest.

SERVICE

1440 Broadway

New York City

A New Tube-Seller



Weston
Model
677

— with proven profit-making features

The new Weston Model 677 Tube-Seller makes the exclusive features of Weston-Jewell design available at a cost so low no dealer can afford to be inadequately equipped.

Such proven features as the direct reading three-color tube performance meter, zero-reset test circuit, line voltage indicator, and compensating control are combined in the Model 677 with compact design and Weston high standards of workmanship. Furthermore your investment is protected by a unique arrangement of spare sockets for use as new tubes are developed.

Ask your jobber to show you one of these new Weston Tube-Sellers.

Jewell Pattern 675 Tube-Checker



A compact, light weight tube-checker that is popular for both portable and counter use. Test limits are etched on the instrument panel for quick reference. All present tubes are tested without the use of adapters. Models available for 25 and 60 cycle supplies.

WESTON JEWELL

Weston Electrical Instrument Corp. } 604 Freylinghuysen Ave.
Jewell Electrical Instrument Co. } Newark, N. J.

Please send me information concerning the complete Weston-Jewell line of tube merchandising and set servicing instruments.

Name.....
 Address.....
 City..... State.....

THE MANUFACTURERS . . .

Tobe Filterizer Kit

The Tobe Deutschmann Corporation announces the "Filterizer," a new product for the elimination of radio noises which may enter a radio receiver from three different points: namely, the light line, the ground wire and the aerial.

The Filterizer Kit is shown in the accompanying illustration. Reading from left to right, we have a roll of shielded wire, a light line filter and a special impedance-matching transformer.



The light line filter connects in between the light socket and the power plug of the radio receiver, and prevents noise from entering via this path. The impedance-matching transformer is connected directly to the aerial and the lead-in wire (with a third terminal connecting to the shielding on the lead-in wire) and tends to match the aerial with the input of the receiver. The shielded wire is used for both the lead-in and the ground connection, as an exposed ground wire can also pick up considerable noise.

I.R.C. Grid Bias Kit

The International Resistance Company has just placed on the market a Grid Bias Kit of resistors containing the necessary units for properly biasing '24-'26-'27-'71A-'10-'45-'50 and '47 tubes.



There is an information folder enclosed with each kit which gives the proper resistance value for the correct biasing of the tubes mentioned.

More NA-ALD Adapters and Sockets

The Alden Manufacturing Company, of Brockton, Mass., have brought out two new seven-prong latch lock analyzer plug adapters. One is made with a center post connected to the control grid prong so that it may be used with the No. 906WL Latch Lock Analyzer Plug in which the latch is

connected to the control grid. The other type brings the control grid out to a clip which can be slipped over the control grid insert of the six-prong analyzer plug. An associate adapter holds the seven-prong tubes in the six-prong sockets of the analyzer.

The new line also includes three new six-prong sockets and two new seven-prong sockets. And a composite socket which will take a four-, five-, or six-prong tube.

The Alden Company now makes some 93 sockets and adapters, all of which are listed on a convenient Adapter Chart for Tube Checkers and Set Analyzers. If you wish a copy of this chart, send 3 cents in postage to the Alden Company, 715 Center St., Brockton, Mass.

Sampson Stiktape Aerial

A bright fellow in Missouri got together with himself and doped out what would make a real good indoor aerial . . . then made it. With his "model" under his arm he hiked over to see Professor Glasgow, at Washington University, to find out how the aerial stacked up. Professor Glasgow put the "model" through its paces and found that such an aerial, 48 feet long, when stretched diagonally across the radio laboratory, midway between floor and ceiling, had an actual



capacity of 110 micro-microfarads and a natural period of 91.1 meters. When fastened to the walls and ceiling the same aerial had a capacity of 265 micro-microfarads and a natural period of 156.6 meters. Which means that this "model" had the inductance and capacity of an aerial of much larger dimensions.

These nice attributes were gained by employing an adhering facing composed of a rubber base, the rubber of course acting as insulation as well. And also by the use of an alloy tape whose surface area is equivalent to approximately four No. 14 copper wires in parallel.

So the bright fellow went home with his "model" and there now blooms the Sampson Industries, Inc., St. Louis, Mo., who will sell these aerials to you if you're interested.

Electrad V.C. and Switch Assembly

The new Snap-On Volume Control Switch Assembly here illustrated will be standard for all Electrad Replacement Volume Controls. By simply removing the standard



cover which is incorporated in each standard control and snapping in place the switch assembly a standard switch type control is available. All standard controls without switch will incorporate the necessary switch arm throw lever when shipped. In this way the necessity for carrying a separate stock of switch controls is eliminated.

New Lynch Aerial Products

The Lynch Manufacturing Company, of New York City, have placed on the market a number of new noise-reducing-antenna products designed especially for short-wave work.

Heading the list is the Lynch Transposition Block, a number of which are used to space and permit the transposition of the double lead-ins from a quarter-wave Hertz or similar antenna. These blocks are also convenient for spacing straight-line leads. In both cases the blocks prevent the twisting of the leads, which is a common occurrence when employing the usual form of spreaders.

An antenna coupler, for use in connection with Hertz aerials, is also produced by this Company. The coupler is used to balance the antenna system.

The list of products includes as well two types of aerial insulators for short-wave receiving aerials, and cage aerial spreaders for use with folded aerials in restricted locations.

Herst "Laiz-Flat Radiolet"

The William Herst Company, of Chicago, has brought out a new surface-type outlet which contains the power line leads and a lead each for aerial and ground. The four-



wire cable is flat and therefore may be run under rugs, or easily tacked along the wall baseboard. It's a nice way of running leads to an out-of-the-way radio (or vice versa). The receptacle is polarized, which eliminates a continuity test!

SERVICE MEN!



NEW 1933 CATALOG
Just off the Press! Be sure to write for **FREE COPY**

REMARKABLE VALUES ON REPLACEMENT PARTS!

Make "Wholesale Radio" your replacement parts headquarters! We maintain a huge stock of **REPLACEMENT PARTS FOR ALL SETS**. Brand new factory merchandise at lowest wholesale prices. A guarantee of satisfaction on every purchase. Immediate service.

New Catalog READY!

Write for *Free Copy* of our latest catalog, featuring **LAFAYETTE SETS, TRUTEST PARTS**, nationally-advertised tubes, kits, speakers, amplifiers, public address systems, etc. Keep in touch with the newest developments in radio by sending us your name and address. *Write today!*

WHOLESALE RADIO SERVICE CO.



100 SIXTH AVE.
NEW YORK, N.Y.

Lafayette Radio

NATIONAL DISTRIBUTORS

MR. SERVICE MAN:

... **FREE**

28-Page Brochure, "Practical Radio and Television Engineering."



Mr. E. H. Rietzke, Pres. Capitol Radio Eng. Inst.

Address a letter to me personally and I will see that you receive a copy of this handsome booklet. It describes a course of instruction through which you can advance out of the wage earner classification of Service Men.

To digest the information described in this booklet you do not have to be a college man—but there is also a great deal of advanced material of interest to the college graduate.



This booklet is intended for Service Men who know enough to realize that the better jobs are held by trained minds. I can train you as I have many other experienced Radio Service Men and qualify you for the technical field where the real money is made.

Address your inquiry to Mr. E. H. Rietzke, President

CAPITOL RADIO ENGINEERING INSTITUTE
14th and Park Road, N. W., Dept. S-9, Washington, D. C.



Insure YOUR WORK

with

CLAROSTAT Replacement VOLUME CONTROLS



CLAROSTAT Replacement Volume Controls are "Custom-made" to exactly suit the receivers for which they are offered. Not a makeshift job lot idea.

The resistance, taper, shape and shaft are made according to the proper specifications.

There is no delay in installing them. There are no comebacks when you use CLAROSTAT products.

See the new CLAROSTAT CONTROL HANDBOOK AND CATALOG for 32 pages of dope for servicemen. Send for your **FREE** copy.



CLAROSTAT Mfg. Co.
285-287 N. 6TH ST. BKLYN. N.Y.

More Capacity At Less Cost

Latest electro-chemical research by the oldest and largest exclusive condenser manufacturer is reflected in the present large and varied line of



DUBILIER ELECTROLYTICS

Available in all types—round and square metal cans, cardboard containers, tubular paper wrappings, high-voltage, low-voltage, tapped units, etc. Positively guaranteed for quickest reforming time, lowest leakage, highest working voltage, longest life. And they cost less!

Write for literature on Dubilier Electrolytics as well as all other types of condensers for every radio need.



DUBILIER CONDENSER CORP.
4377 BRONX BLVD. NEW YORK CITY

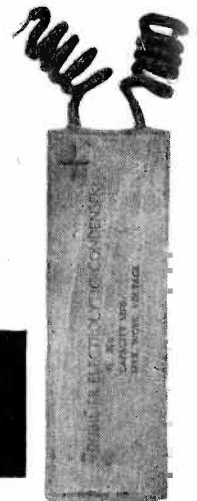

"I WANT A COPY OF VOLUME 1"

Say the Owners of RIDER'S "PERPETUAL TROUBLE SHOOTER'S MANUAL," VOLUME II . . .

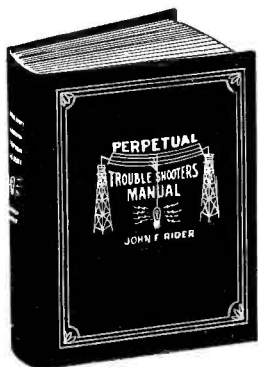

*Every Service Man and Service Department
Need These Manuals*

Volume I is the Manual which was originally issued during 1931 and contains the wiring diagrams of the commercial receivers, power packs, power amplifiers, analyzers, short-wave receivers, etc., which were announced between 1919 and the time that Volume II was issued.

Volume I is the basic Manual for the "Perpetual Trouble Shooter's Manual" series. It contains about 1152 pages of wiring diagrams, chassis layouts, color-coding data, voltage data, electrical values, socket layouts, etc., for most of the old receivers.

There is no duplication of material between Volume I and II. When you have both of these volumes you have a service information library with a total of about 1,900 pages.

Can you afford to be without the most reliable source of service data—the Manuals which are to be found in the service shops of the nation's finest service stations—department stores—dealers—schools, etc.? Of course not!—Not if you really want time-saving information—the kind of infor-

mation that is really worth having—really worth money!

No matter what other manuals you may have—it will pay you to switch to Rider's "Perpetual Trouble Shooter's Manual"—right now—because it is the standard in the business and because you want the best—and it will always be the best.

When you have Volume I and Volume II of the "Perpetual Trouble Shooter's Manual"—you have all of the service material which Rider has issued thus far.

Price \$5.00 Postpaid

You can get your copy from the dealer who sold you Volume II. If you do not have Volume II of this series, see the list of dealers on the adjoining page. They will be pleased to show you Volume I and also Volume II. If there is no dealer near you, write direct to us.

RIDER'S \$1.00 BOOKS

The following \$1.00 books are available for distribution. Each of these covers its subject with greatest accuracy and each is right up-to-the-minute in contents.

There are several other \$1.00 books being printed. They will be ready for distribution in a very short time. We regret the delay, but it was unavoidable. You will find that they are worth while waiting for.

PRACTICAL TESTING SYSTEMS

Describes various kinds of testing systems for tubes, condensers, coils, transformers, oscillators, ohmmeters, etc. 149 pages, 99 illustrations. Price \$1.00.

SERVICING SUPERHETERODYNES

A real honest-to-goodness explanation in simple easy-to-read and easy-to-understand language of the superheterodyne receiver. It contains actual specific

references to types of superhets—intermediate frequency—alignment and trouble shooting. 163 pages. Type set. Bound in cloth. A real book. Well illustrated. Right up-to-the-minute. Price \$1.00.

SERVICING RECEIVERS BY MEANS OF RESISTANCE MEASUREMENT

This is the only book upon the market which explains the latest method of Point-to-Point Resistance Measure-

ment Method of Servicing a receiver. It explains Ohm's law and its application to the many different kinds of circuits used in modern and old receivers, and shows you just how circuits are broken down for rapid and accurate servicing with an ohmmeter and a tube checker. This book, just published, will show you how you can locate troubles in receivers without removing the chassis from the cabinet. It is timely and just what you want. 203 pages. Type set. Bound in cloth. More than 100 illustrations. Price \$1.00.

You can secure all of these books from the dealers listed on page 253

Radio Treatise Co., Inc.

1440 Broadway

New York City

THIS VOLUME SHOULD SELL FOR \$10.00

— BUT —

IT SELLS FOR ONLY \$5.00

Compare it with any other Manual offered and you will agree that it is worth twice the price we ask

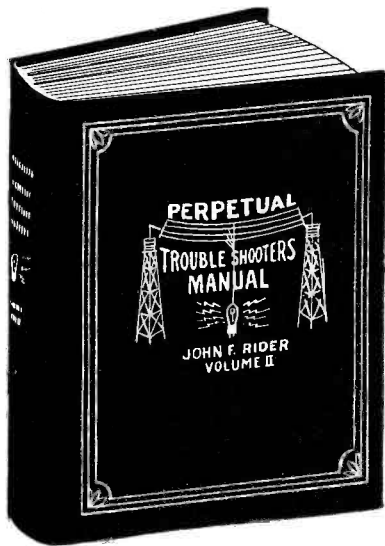

Volume II is the companion Manual to Volume I. Volume II contains all new information, none of which appeared in Volume I and most of which will not be found in any other Manual published today.

If you own a copy of Volume I, you will want Volume II immediately. Volume II shows diagrams of sets produced since the publication of Volume I and the two Manuals together represent a complete diagrammatic history of radio receivers since the beginning.

Volume II fulfills the demands made by Service Men for full electrical values of resistors and condensers. For instance, THE ELECTRICAL VALUES OF ATWATER KENT RECEIVERS ARE GIVEN IN COMPLETE DETAIL.

Volume II has been prepared on the basis of the results of a comprehensive survey, made to determine exactly what Service Men want and need in a Manual. It includes wiring diagrams, chassis layouts, socket layouts, alignment data, peak frequencies, location of trimmers, color coding, electrical continuity of units sealed in cans, special notes, circuit peculiarities, voltage data and other important information. Special attention has been given to auto-radio, automatic record changers, superheterodyne converters—everything necessary to the successful operation of a service business.

SPECIAL—More Than 50 Pages of Point-to-Point Resistance Data

Buy it from Your Dealer. Sold with a Money-Back Guarantee

- Alabama**
Auto Elec. Service Co. Montgomery
- Australia**
McGill's Melbourne
- California**
Radio Mfg. Supply Co. Los Angeles
Radio Supply Co. Los Angeles
Offenbach San Francisco
Warner Bros. San Francisco
- Canada**
T. Eaton Co. Winnipeg
Edwin J. Galloway Vancouver, B. C.
- Colorado**
Vreeland Radio Corp. Denver
- District of Columbia**
Star Radio Co. Washington
- Connecticut**
Hatry & Young Hartford
S. S. Kresge New Haven
S. S. Kresge Stamford
S. S. Kresge New London
- Illinois**
Chicago Radio Apparatus Chicago
Electric & Radio Supply Co. Chicago
Grant Radio Co. Chicago
Klaus Radio Company Peoria
S. S. Kresge Chicago
S. S. Kresge Champaign
S. S. Kresge Springfield
S. S. Kresge Peoria
S. S. Kresge Freeport
S. S. Kresge Belleville
S. S. Kresge Danville
S. S. Kresge Decatur
Mid-West Radio Mart Chicago
Newark Elect. Co. Chicago
Pioneer Auto Supply Co. Chicago
The Swords Company Rockford
- Indiana**
S. S. Kresge Evansville
S. S. Kresge Fort Wayne
S. S. Kresge Gary
S. S. Kresge Lafayette
S. S. Kresge South Bend
S. S. Kresge Terre Haute
S. S. Kresge Vincennes
Kruse Radio Co. Indianapolis
- Iowa**
S. S. Kresge Davenport
S. S. Kresge Sioux City
S. S. Kresge Waterloo
- Kansas**
S. S. Kresge Topeka

- Kentucky**
P. O. Burkes & Co. Louisville
S. S. Kresge Lexington
- Louisiana**
Shuler Supply Co. New Orleans
- Maine**
S. S. Kresge Lewiston
S. S. Kresge Portland
- Maryland**
A. R. Spartana Baltimore
Mattson Radio Baltimore
- Massachusetts**
T. F. Cushing Springfield
H. Jappe Co. Boston
S. S. Kresge Boston
S. S. Kresge Malden
S. S. Kresge Quincy
S. S. Kresge Springfield
Mutt's Radio Labs Boston
R. C. A. Institutes Boston
Trade Contact Corp. Boston
- Michigan**
S. S. Kresge Bay City
S. S. Kresge Detroit
S. S. Kresge Grand Rapids
S. S. Kresge Highland Park
S. S. Kresge Jackson
S. S. Kresge Muskegon
S. S. Kresge Saginaw
Rissi Brothers Detroit
R. & M. Radio Co. Detroit
Radio Distributing Co. Detroit
Radio Specialties Detroit
Reno Radio Stores Detroit
Wedemeyer Radio Co. Ann Arbor
- Minnesota**
Les Bonn Co. St. Paul
Radio Maintenance Co. Minneapolis
Southern Minn. Supply Co. Mankato
- Missouri**
Walter Ashe Radio Co. St. Louis
Bursteln-Applebee Co. Kansas City
S. S. Kresge Hannibal
S. S. Kresge Joplin
S. S. Kresge St. Louis
S. S. Kresge University City
Van Ashe Radio Co. St. Louis
- Nebraska**
S. S. Kresge Lincoln
S. S. Kresge Omaha

- New Jersey**
Bennetts Radio Supply Perth Amboy
Ferry & Smith Newark
Jacksonfield Radio Camden
S. S. Kresge Morristown
- New York**
American Sales Co. New York City
Baltimore Radio Co. New York City
Blair, the Radio Man New York City
Coast to Coast New York City
H. L. Dalis Co. New York City
Federated Purchaser, Inc. New York City
Ft. Orange Radio Dist Corp. Albany
S. S. Kresge Dunkirk
S. S. Kresge Buffalo
S. S. Kresge Olean
S. S. Kresge Schenectady
S. S. Kresge Troy
Kronson Buffalo
Maurice Schwartz & Son Schenectady
Radio Circular New York City
R. C. A. Institutes New York City
Roy C. Stage Syracuse
Sun Radio Co. New York City
Wholesale Radio Service, New York City
- New Zealand**
Te Aro Book Depot Wellington
- North Carolina**
Shaw's Charlotte
- Ohio**
Aitken Radio Corp. Toledo
Bergman Tool Cleveland
Burns Radio Co. Dayton
Goldhamer, Inc. Cleveland
Hughes-Peters Elec. Corp. Columbus
Madag Radio Labs Kent
S. S. Kresge Akron
S. S. Kresge Cincinnati
S. S. Kresge Cleveland
S. S. Kresge Columbus
S. S. Kresge Marion
S. S. Kresge Newark
S. S. Kresge Toledo
S. S. Kresge Sandusky
S. S. Kresge Zanesville
Lew Stores Toledo
Progress Elec. Co. Cleveland
Ross Radio Co. Youngstown
Steinberg's Cincinnati
United Radio, Inc. Cincinnati
Uncle Sam Stores Akron
- Oregon**
J. K. Gill Co. Portland
Johnson-Weiler Co., Inc. Portland

- Pennsylvania**
Cameradio Pittsburgh
Hall's Harrisburg
S. S. Kresge Allentown
S. S. Kresge Butler
S. S. Kresge Erie
S. S. Kresge Oil City
S. S. Kresge Philadelphia
S. S. Kresge Pottsville
S. S. Kresge Reading
S. S. Kresge Scranton
S. S. Kresge Warren
Keystone Radio Co. Philadelphia
Radio Elec. Service Co. Philadelphia
Radio Service Co. Wilkes-Barre
M. & H. Sporting Goods, Philadelphia
- Rhode Island**
W. H. Edwards Radio Svc., Providence
S. S. Kresge Pawtucket
- South Dakota**
S. S. Kresge Aberdeen
- Tennessee**
J. L. Perry Nashville
- Texas**
Service Parts Co., Inc. Abilene
Southwest Radio Svc. Dallas
Straus-Frank Co. Houston
Walter Tips Co. San Antonio
Walter Tips Co. Austin
Wilkinson Bros. Dallas
- Virginia**
Johnston-Gasser Co. Richmond
S. S. Kresge Norfolk
S. S. Kresge Richmond
- West Virginia**
Foster-Thornburg Hardware Co. Huntington
S. S. Kresge Charleston
S. S. Kresge Wheeling
- Washington**
General Radio, Inc. Seattle
Spokane Radio Co. Spokane
Wedel Co. Seattle
- Wisconsin**
Harriman Radio Svc. Appleton
S. S. Kresge Milwaukee
Radio Parts Co. Milwaukee

Note:—All S. S. Kresge Stores are Green Front

If there is no dealer near you, order direct from us

Radio Treatise Co., Inc.

1440 Broadway

New York City

Index of Monthly Literature

AUTO-RADIO

Improved Auto "B" Eliminator
W. W. Garstang, Electronics, pp. 254, August, 1932

Type 89 Power Tube
L. Martin, Radio-Craft, pp 204, October, 1932

BROADCAST RECEIVERS

Amplifiers, A-F.

A-F. Transformer Impedance Estimation by Use of A-C. Voltmeter
Modern Radio, pp 13, September, 1932

Automatic Volume Control Systems
W. S. Williams, Radio-Craft, pp 211, October, 1932

Crystal Loudspeakers
C. B. Scott, Radio News, pp 214, October, 1932

Noise-Reducing Balanced Aerial System*
T. C. McClary, Radio News, pp 212, October, 1932

Tubes 55, 85, 29, 69, 83
L. Martin, Short Wave Craft, pp 290, September, 1932

Amplifiers, R-F.

Automatic Volume Control Systems
W. S. Williams, Radio-Craft, pp 211, October, 1932

Noise Interference Elimination
John F. Rider, Radio Merchant, pp 24, August, 1932

Tubes 55, 85, 29, 69, 83
L. Martin, Short Wave Craft, pp 290, September, 1932

Receivers

Lincoln DeLuxe SW-33, Part II
W. C. Dorf, Radio News, pp 228, October, 1932

Midwest Allwave Receiver
W. A. Smith, Short Wave Craft, pp 276, September, 1932
W. A. Smith, Radio News, pp 216, October, 1932

Scott Allwave DeLuxe, Part III
S. G. Taylor, Radio News, pp 224, October, 1932

PUBLIC-ADDRESS SYSTEMS

A-F. Transformer Impedance Estimation by Use of A-C. Voltmeter
Modern Radio, pp 13, September, 1932

Crystal Microphones and Speakers
C. B. Scott, Radio News, pp 214, October, 1932

Dynamic Microphone; Construction, Part II
Zolnier and Selliken, Radio News, pp 218, October, 1932

Servicing Sound Equipment
J. Mauran, Journal S.M.P.E., pp 260, September, 1932

SHORT WAVE

Lincoln DeLuxe, SW-33, Part II
W. C. Dorf, Radio News, pp 228, October, 1932

Midwest Allwave Receiver
W. A. Smith, Short Wave Craft, pp 276, September, 1932
W. A. Smith, Radio News, pp 216, October, 1932

Scott Allwave DeLuxe, Part III
S. G. Taylor, Radio News, pp 224, October, 1932

Short-Wave Aerial Design
A. H. Lynch, Short Wave Craft, pp 275, September, 1932

Simplified Inductance Charts
R. R. Batcher, Modern Radio, pp 3, September, 1932

Tester for Short-Wave Sets
H. Harrison, Radio-Craft, pp 230, October, 1932

Tubes 55, 85, 29, 69, 83
L. Martin, Short Wave Craft, pp 290, September, 1932

TESTING SYSTEMS

A-F. Transformer Impedance Estimation by Use of A-C. Voltmeter
Modern Radio, pp 13, September, 1932

Capacity and Inductance Bridge
Short Wave Craft, pp 279, September, 1932

Inductance Charts, Simplified
R. R. Batcher, Modern Radio, pp 3, September, 1932

Measuring Electrolytic Condensers
B. Brunn, Radio World, pp 8, August 20, 1932

Ohmmeters; Construction
L. W. Hatry, Modern Radio, pp 9, September, 1932

Resistor Requirements in Radio Circuits
A. G. Ostrand, Journal I.R.S.M., pp 220, June-July, 1932

Servicing Sound Equipment
J. Mauran, Journal S.M.P.E., pp 260, September, 1932

Tester Adapters; Construction
F. L. Sprayberry, Radio-Craft, pp 216, October, 1932

Tester for Short-Wave Sets
H. Harrison, Radio-Craft, pp 230, October, 1932

Testing Condenser Leakage
J. H. Sandidge, Radio World, pp 9, August 20, 1932

TUBES

Audio Output Tube Table
Modern Radio, pp 16, September, 1932

Complete Tube Tabulation
QST, pp 36, September, 1932

Tube Type 89
L. Martin, Radio-Craft, pp 204, October, 1932

Tubes 55, 85, 29, 69, 83
L. Martin, Short Wave Craft, pp 290, September, 1932

All articles listed on this page are cross-indexed for your convenience. Titles given are not necessarily the titles of the original articles, but in each case serve to determine the substance of the article. Listings marked with an asterisk (*) are abstracted in this issue. The material in each issue of SERVICE is alphabetically indexed on the Contents Page.

IRC Service helps

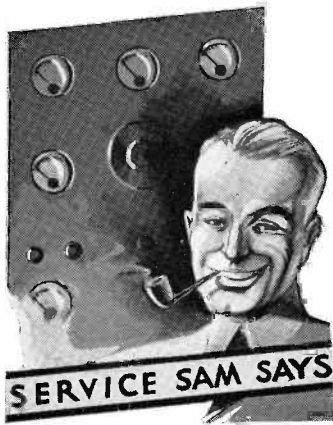

PLENTY of Service Men are having grief with auto radio sets—and the regular broadcast receivers, too, you can bet—but from what I hear, the most grief comes with the many breeds of short-wave converters in the hands of inexperienced and unadvised "set owners."

I know that a well-designed short-wave converter can stack up flocks of DX of a kind worth listening to, IF the converter is given an even break . . . just as I know that there are a pile of converters that aren't worth their weight in horse feathers.

Now, it seems to me that we fellows ought to help the set owner get an even break out of his converter, because it's a sure thing he isn't sufficiently "in the know" to humor the outfit into decent perking.

When I think of converter trouble, the first thing I connect up with is the necessary "general design" of these gadgets. They have to be made to (somehow) meet all conditions, and it is quite a common thing to find excessive voltage on all the converter tubes, with a consequent load on a number of resistors and condensers, when the voltage is picked up from the '80 in the broadcast receiver. I venture to say that the average converter will, in any case, perk a darn sight better if one or more voltage-reducing resistors are added, or the existing resistors replaced with new ones of higher value, to meet the proper voltage requirements. After all, you can't slap 250 to 280 volts on most of these converters and expect peace to prevail. If it does nothing else, it will slam-bang the tubes for a goal.

It's always a good idea to first test the voltages on the converter and then test the tubes. Bet you a microphone to a burnt-out tube, the next time you shoot one of these jobs you'll find plenty of room for improvement.

And now the noise problem. That's a big rub in itself, and where's the set owner who appreciates that some noise must be tolerated? Well, you can help him to some extent by going over the wave-changing switch for rotten contacts, and by re-positioning his aerial in an area as free from electrical obstructions as possible. And then use a transposed lead-in to phase out noise pickup.

Service Sam

Make Your Own Set Analyzer

**FROM THE INSTRUCTIONS
WHICH WE WILL
GLADLY SEND
TO YOU FREE**

F. L. Sprayberry, one of the country's foremost radio engineers, designed this analyzer which has attracted nation-wide attention because of its simplicity and effectiveness.

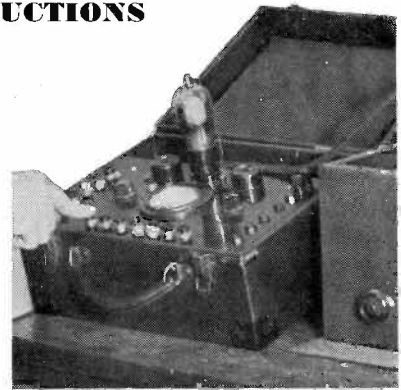

Sprayberry Set Analyzer

Plate voltage, plate current measurements and filament voltage, sometimes hard to determine, are easily arrived at with a set analyzer. If the filament voltage is low, for instance, the complete circuit may be shorted or grounded (the ground may be to the core of the transformer, or to the chassis of the receiver) and a continuity test between filament and core of the transformer and chassis will quickly establish where the ground exists.

A set analyzer is a short cut to trouble finding. Many Servicemen, owing to conditions, have trouble in buying one—but the difficulty is easily solved with the IRC Precision Wire Wound Kit and instruction folder.

It makes profits—it is better to spend a few dollars extra for a good analyzer and insure your profits than to lose money through a wrong estimate because of a faulty diagnosis of the set.

With the introduction of new tubes, it is practically impossible to keep your set analyzer up to date. The building of your own analyzer will automatically help you to keep your test equipment up to date at all times.

IRC will show you how to convert voltmeters and current meters into ohmmeters and to extend the ranges of these instruments. Write us for complete information. We will send you FREE, full constructional details and an ohmmeter scale which you can use on Weston and Jewell 0—1 milliammeters.



IRC WIRE WOUND POWER RESISTORS

are available in 3- and 5-watt sizes with ranges up to 5,000 and 15,000 ohms respectively.

Is Your Name on Our Mailing List?

Here are some of the Free services which are yours for the asking: RMA Color Code Chart; Booklets on Suppression of Motor Radio Noises, Grid Biasing of New Tubes.

*They're better
because they're*

Metallized

Resistors for Replacements

Precision Wire Wound Resistors For Meters and Test Equipment

INTERNATIONAL RESISTANCE COMPANY

2006 Chestnut Street, Philadelphia

74 Wellington Street, West, Toronto, Canada

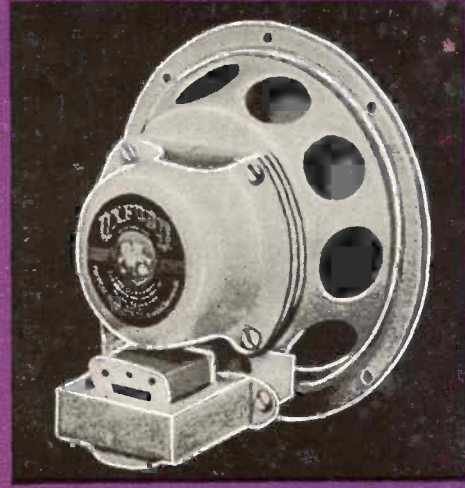
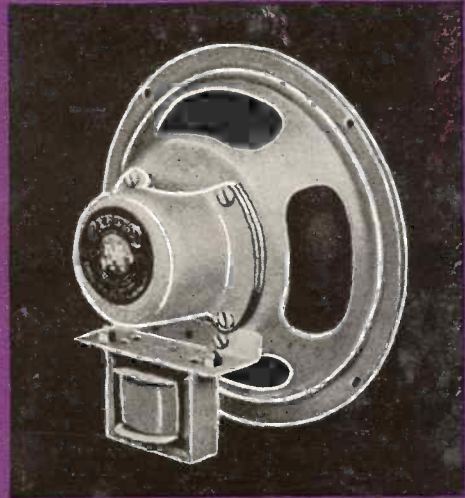
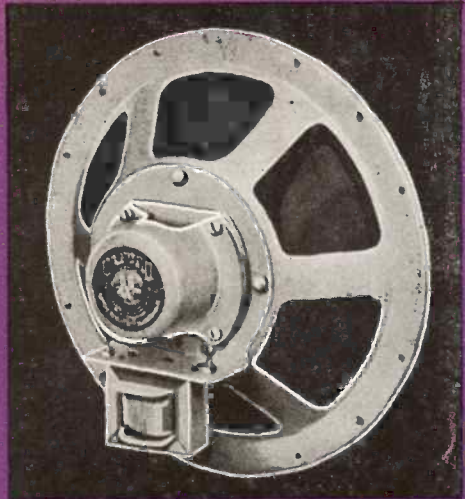

SPEAKER

BY

TONE SELLS RADIOS—and in an Oxford Speaker, you will find the rich, clear, undistorted tone that persuades eloquently for the set employing it.

Every requirement of every speaker application is met by Oxford with a full line of sizes and types.

The sizes are:

6", 8", 11" and 12",

Made under the patents and designs of Frank Reichmann, oldest speaker manufacturer in America.

Write for our complete Bulletins

Manufactured by

OXFORD PRODUCTS COMPANY

Division of THE POTTER COMPANY

North Chicago, Illinois

CONDENSERS

BY

THOUSANDS of specifications to choose from—distinctive Potter high quality in every one—when desired, shipment the day your order is received. That is the brief story of Potter Condensers—and the reason why they are so favorably known throughout America.

Last year, we shipped to parts jobbers 7650 different specifications of Condensers—and 97% were shipped within 48 hours!

Don't gamble with quality when Potter Condensers are so easily available. All Potter Condensers are made of the finest materials we can buy.

Write for our free Replacement Chart

THE POTTER COMPANY

NORTH CHICAGO, ILLINOIS

OXFORD POTTER

