

# SERVICE

A Monthly Digest of Radio and Allied Maintenance

Edited by John F. Rider

COPYRIGHT 1932 BY JOHN F. RIDER PUBLICATIONS.

Vol. 1 Number 1

February 1932

## Editorial Contents

### ABSTRACTS

Auto Radio Problems.....	16
A Sales Stunt.....	14
Beat Frequency Oscillator.....	16
Carrier Wave Hum Elimination.....	15
Noise Elimination.....	14
Ohmmeters .....	15
Output Meters.....	15
Testing Plug (Auto Radio).....	16
Tube Testing.....	14
Vacuum Tube Voltmeter.....	15
Voltage Doubler System.....	14

### AUTOMOBILE RADIO

Auto-Radio Problems.....	16
RCA M-30 Installation Notes.....	17
Removing Upholstery.....	17
Spark Plug Interference.....	17
Testing Plug.....	16

### GENERAL DATA

Audio Howl in Philco 270.....	8
Automatic Volume Control.....	9
Class "B" Amplifiers.....	9
Detector Tube Plate Current.....	10
Fluttering Reception.....	8
Hum and Fading.....	8
IF Peaking.....	8
Image Suppression.....	7
Lighting Circuit Interference.....	7
Light Terms and Definitions.....	10
Loftin-White Amplifier Servicing.....	5

Noise .....	9
Open Bypass Condenser Effect.....	9
Optimum Load Impedance.....	9
Pentode Tube Circuit.....	7
Pentode Tube Bias Condenser.....	7
Pentode Tube Operation.....	8
Phileo Power Consumption.....	8
Phonograph Needle Life.....	10
Push-Pull Detectors .....	10
Relay Interference Filter.....	7
Resistance In Pentode Circuit.....	8
RF and IF Alignment.....	8
Simple Output Meter.....	10
Test Block for Condensers.....	8
Tone Control.....	6
'24 and '51 Tubes.....	9
'39 Tube.....	9
'80 and '81 Tube Efficiency.....	8

### INDEX OF MONTHLY LITERATURE 18

### PUBLIC ADDRESS

Public Address System Notes.....	13
----------------------------------	----

### REFRIGERATION

Electric Refrigerator Data.....	12
---------------------------------	----

### SHORT WAVES

RCA Short Wave Converter SWA-2.....	11
Short Wave Notes.....	11
Short Wave Hints.....	11

### TUBE SOCKET CONNECTIONS 19

Published by

John F. Rider Publications

1440 Broadway

New York City

Sold Only By Subscription

# The Antenna . . . editorially speaking -

## SERVICE NEWLY DRESSED

**T**his issue starts SERVICE in a new suit of clothes. For the benefit of all, we feel that it may be a good idea to outline our platform or policy. SERVICE shall be for the Service Man ONLY and we shall encompass the radio and allied fields. There are several other excellent magazines which present news and engineering information. Our aim shall be the dissemination of service data in brief, but informative manner, so that he who does not have much time to read, will still be able to secure the required service information. The man now recognized as a radio service technician is a sufficiently important branch of the industry to warrant a magazine of his own. SERVICE shall function as such.

You will note upon examination of the contents of this issue, that the scope of the publication is quite broad with respect to kinds of service, but that its primary interest is the Service Man. This policy shall exist as long as the magazine exists. This is a flat footed statement, but it is an honest statement of policy. If you will closely examine the contents of this issue, you will find that radio manufacturers as well as radio magazines are represented. In forthcoming issues, we shall give space to the service man as an individual. At least, a page in each issue shall be devoted to a FORUM for service discussions.

One of the aims of this publication shall be to do away with cut-rate service. It benefits no one and causes great harm to every man associated with service work. Another aim shall be the clarification of certain supposedly difficult service problems as related to the design of radio receivers. Certain forms of design introduce definite complexities. The veil of mystery shall be removed.

We want you to know that SERVICE will do all in its power to be of aid to the service man, be he interested in radio, public address, refrigeration, short waves, etc.

The makeup of SERVICE shall be of the following order. The various fields of interest to the service man shall be classified as "auto-radio", "refrigeration", "short waves", "home talking movies", etc. Abstracts taken from other radio magazines shall be found in "Abstracts". The index of articles of interest to service men which have appeared in other magazines and periodicals shall be found under "Index of Monthly Literature". Irrespective of the location of the text, the table of contents in each issue of SERVICE shall contain mention of every article, be it brief or lengthy, presented in that issue of SERVICE.

## REFRIGERATOR SERVICING

**E**lectric refrigerator servicing represents more than just another service job. An electric refrigerator, while not a very complex unit, still requires a certain amount of study in order to comprehend the actual workings and ramifications of such units. We have had the opportunity of examining a fairly large number of refrigerator manuals which were furnished to us by the various electric refrigerator manufacturers.

This type of service work differs greatly from radio service. It requires study. It requires tools. It is unlike a radio receiver in as much as there can be no halfway measures. The job is done well or not at all. Unlike a radio receiver you cannot take the refrigerating unit back to the shop for a minor repair. All of the trouble shooting must be done right in the home. There are certain similarities to be found between boxes of different manufacture, but there are also sufficient variations to make each brand of refrigerator a separate field. Refrigeration involves terms not found in radio work and it will be necessary to become familiar with these terms and just what they mean; the location of the unit in the complete assembly, etc. You will have to become familiar with motors of various types. An electrician's license would do no harm. It will be necessary to learn as much as you can about compressors, terminology, parts and actions. You will find good use for whatever information you can gather about the vaporization of liquids, such as sulphur dioxide, methyl chloride, ethyl chloride, iso-butane and other refrigerants. SERVICE shall devote as much space as possible to supply some of this data, but the recommendation is made that you study a good text book upon electric refrigeration. If you can lay your hands upon the manufacturer's service manual, read it thoroughly several times.

## SERVICE PROGRESS

**P**rogress in servicing covers a good deal of ground. Each issue of SERVICE will contain some material relative to information to stimulate progress. We now are working upon a series of charts and tables which will be of inestimable value to the service man in various fields. We shall not divulge the substance of these tables, other than to say that you will find them handy and valuable because they shall give you the information you have been seeking in books and magazines and could never find. We want to assure you that SERVICE will help Service Man progress in his chosen field.

Everything considered, we feel that you will like SERVICE and that it will aid you in your work. If you are a Service Man, SERVICE is YOUR magazine.

*John F. Rider.*

**Service for**

# Servicing the Loftin-White Amplifier

The Loftin-White amplifier has been a thorn in the side of many a service man called upon to service one of these audio amplifiers. So much so that certain receiver manufacturers have ceased the production of this type of amplifier in their radio receivers and have gone back to the conventionally coupled arrangements. The great difficulty arises in that the regular set analyzer test is of no utility. The distribution of voltages in this installation differs radically from that to be found in ordinary circuits and many service men have admitted utter confusion when called upon to analyze symptoms. Let us attempt a simple breakdown of this type of amplifier.

A wiring diagram of a simple Loftin-White amplifier as used in some commercial radio receivers and in some power amplifiers is shown below. Several pertinent facts must be noted. The first is that the most negative point upon the power pack goes to ground. This is the centre tap upon the high voltage rectifier winding. All other points along the voltage distributing system are naturally positive.

Suppose that we start with the most positive part of the rectifier, the midtap upon the rectifier filament winding. The plate voltage for the output tube is secured through the conventional type of filter system. Now, in any type of AC operated audio amplifier, the filament, or for that matter the cathode, are as a rule positive with respect to ground. By virtue of the return of the grid to the

The most negative point is ground and the output tube plate current reflects circuit conditions.

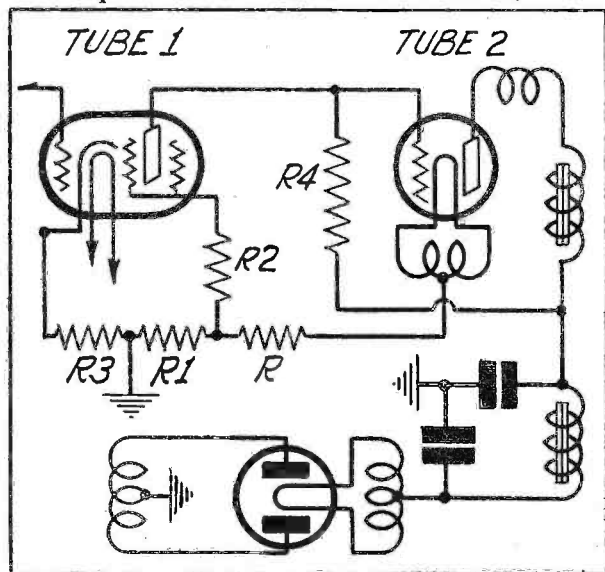

grounded side of the circuit, the control grid becomes negative with respect to its associated filament or cathode. If you trace the path of the plate current for the output tube, you will note that this current is to be found in the output tube filament system and in the two resistances R and R1. The sum of the two voltages developed across these two resistances represents the potential difference between the output tube filament and ground, with the latter negative, and the filament positive. Since grounded end of R, R1 is the most negative part of entire system, all other points along either R or R1 are positive. Therefore a tap at the junction between R and R1 will provide a positive potential, which can be applied to the screen grid of the input tube. This voltage is applied to the screen grid through the resistor R2. As is evident the control grid bias for the output tube is secured by means of the cathode resistance R3, between the cathode and ground of this tube. This circuit is quite conventional and requires no special discussion.

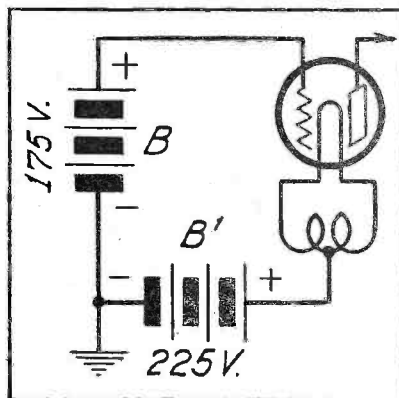

The batteries represent the voltages in the circuit. B is the voltage across R4 and B1 is the voltage across tube 2 filament to ground.

Now for the common coupling resistance R4. According to its position it is common to both the plate of the first tube and the control grid of the output tube, or for that matter the next amplifying tube, whatever it may be. By virtue of the common connection of R4 to the high voltage lead, a positive voltage is applied to the plate of tube 1. At the same time a positive voltage is also applied to the grid of tube 2. However don't be alarmed. This positive potential is only relative to the grounded point in the circuit. When we consider the relation between the control grid of tube 2 and ground and the filament circuit of tube 2 and ground, the true state of affairs relative to the potential difference between the filament and control grid of tube 2 becomes evident.

A simple explanation of this is shown below. The battery B represents the voltage developed across the control grid to ground system. The Battery B' represents the voltage developed between the output tube filament and ground. According to the polarity of these differences and their numerical values, the grid is 50 volts negative with respect to the filament of tube 2. This is the normal condition. The fact that the grid of tube 2 is at a certain positive potential with respect to ground is due to the flow of plate current through R4, which causes a certain

voltage drop across R4 and establishes the potential difference between the common junction of tube 1 plate and tube 2 grid with R4 and ground.

The first important service consideration is that a routine test between control grid and ground of tube 2 will show a high positive potential upon the grid, as against a zero value when checking a conventional output tube control grid circuit. The second major deviation from conventionalism is that a routine test between filament and ground will show a very high positive filament or a very high negative ground.

Don't stop. There are a few more important considerations. In a way, the major item during service work is the plate current of the output tube. This value reflects the status of the system, because all of the items in the amplifier have a bearing upon this value. The condition of tube 1 is an important item. If the plate current of this tube is very low because of a defective screen grid circuit or plate circuit, the drop across R4 will become negligible and the potential upon the control grid of tube 2 will increase, thus reducing the resultant bias. Of course a sort of compensating condition occurs due to the fact that the potential difference between the output tube filament and the ground is dependent upon the output tube plate current, but this does not interfere with the establishing of a value of current in this plate circuit which is in excess of the normal. Naturally, any defect in R4, as for example an open will increase the output tube plate current. The same is true if this resistance becomes shorted; if tube 1 is deactuated; if its plate element is open; if its cathode is open, etc.

### Short Circuits

A short circuit across any one of the output tube bias resistances R or R1 will raise the output tube plate current because the resultant bias upon the output tube will be reduced. With this information at hand, and a close study of the structure of any conventional amplifier of this type, the service man should not experience very much difficulty rendering service upon Loftin-White amplifiers.

As a last thought it might be well to mention that voltage tests must be made from point to point. It is also significant to note that the voltage from output tube filament to ground must be higher than the voltage from output tube control grid to ground by the value of the grid bias. This may vary from about 16 to perhaps 80 volts, depending upon the type of tube used for tube 2. It is also significant to remember that service work includes the analysis of the power pack, in as much as a defect in this system will influence operating voltages, hum etc. At the same time, some Loftin-White amplifiers are equipped with hum balancing circuits, in the form of a series capacity-resistance circuit between the voltage divider and the cathode of the input tube or tube 1 in the wiring diagram.

# Tone Control

The accompanying sketch shows the two most popular types of tone control circuits now employed in radio receivers.

The range of values employed for the resistance extends from about 10,000 ohms maximum perhaps 1,000,000 ohms maximum. However there exists a definite preponderance of units with a maximum value less than 300,000 ohms. The average large number of units used to do have a maximum resistance in excess of 100,000 ohms, but a safe replacement unit, in the event that the actual value is unknown would be about 250,000 ohms. An examination of receiver manufacturers' literature shows that the higher than value of resistance, the lower is the value of capacity used. The approximate range of capacities used with resistances up to about 100,000 ohms is from .015 mfd to about .1 mfd. Capacity values used with resistances from .1 meg to 1. meg range from about .001 mfd to about .01 mfd.

Style B tone control is also used in fairly large numbers but not in equal proportion to that shown at A. Once again there exists a range of capacities and also a range of the number of condensers used in the control. In so, instances only one condenser is utilized. In others, two are used and in still others, three are used. The selection of the capacities is based upon the circuit and also upon the degree of high frequency bypass desired. The condensers used range from about .0002 mfd to about .01. Where two or three condensers are employed, the one which tends to make the music most mellow (?) is the highest capacity.

*(Continued on Page 12)*



### THE MAN ON THE COVER

**CHARLES CAFFALL** (General Service Manager A. H. Grebe Company, Richmond Hill, L. I.) Born in St. Louis, Mo., Oct. 27th. (Will not divulge year.)

Left home town for the Navy. Completed training at the Naval Radio School at Great Lakes and was put to work as an instructor. Finally got to Bar Harbor for active duty (NBD was the prize then). Re-enlisted in 1921 for duty at New York (NAH) but wound up at San Juan, P.R. (NAU). Came with present concern in June of that year as a tester.

Mechanically inclined and is always happiest when he is 'making something'. Thinks a radio is a fascinating game but claims the service end is a headache. Blames this on the nonsensical questions asked by set-owners. Contends that service men of today are better fitted for their jobs than ever before.

Two hobbies:—Fishing and reading breath taking murder mysteries. Great at spinning yarns and not overly particular whether they are true or not. Just so they are interesting.

# General Data . . .

When lighting circuits seem to affect the operation of a receiver, consider the following: The power plug may not be making good contact with the house supply system and a change in line voltage caused by the manipulation of some light or other switch causes a fluctuation of the line voltage and the contact of the socket. Increasing the load upon the line by connecting some other unit across the circuit may reduce the line voltage and thus reduce the volume output of the receiver. Reducing the load upon the line may cause an increase in tube operating potentials and thus cause tube overloading, excessive heater voltage and possibly gas emission from one of the cathodes in the receiver. Both of these effects may be manifest in reduction of the volume; the latter may even cause fading upon local signals. In the event that excessive regeneration trouble develops under these con-

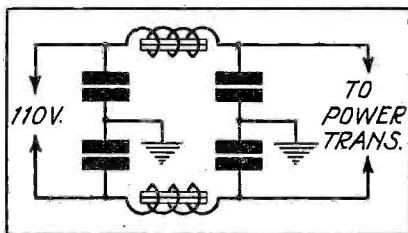

The chokes do not have iron cores.

ditions, it is a sign of normal operation of that receiver too close to the point of oscillation. As a rule the state of excessive regeneration develops when the load upon the line is removed or decreased. The usual condition created in such cases in an increase in line voltage and operating potentials, with oscillation as the final result.

## Tuning Effect

A tuning effect is noted at times. That is, increasing the load or decreasing the load upon the line seems to change the tuning of the receiver. The exact cause of phenomenon is not definitely known but it is assumed to be due to a resonance condition in the power line circuit and some sort of an RF link between the receiver tuned circuits and the power system. This has been found to be particularly true in a number of cases where the "Local Antenna" terminal is joined to one side of the power line through a fixed condenser. One remedy is to remove this condenser, although it should be understood that this sug-

gestion is NOT a positive remedy. Another possible remedy is the use of an inductive-capacity filter in the power cable which joins the power transformer with the power line. 100 turns of No. 18 DCC wire wound upon a 1 inch form in each leg will make up the RF chokes. The usual capacity filter of .1 mfd with the midtap joined to ground is connected each side of these chokes. See illustration.



Pentode tubes with high resistance in the grid circuit are apt to be troublesome. Generally speaking the total resistance in the grid circuit of this type of output tube should not exceed between 300000 and 500000 ohms. A buzzing sound in the loud speaker is oftentimes due to just this trouble. Of course there may be a dozen or two other reasons but if the set being checked is of the pentode output type and the trouble is not due to local interference, much trouble and time can be saved by examining this part of the receiver first.



Electrical interference from relays of various types can be subdued by connecting a series combination of a 1. mfd condenser and about 50 ohms across the relay contacts. Another suggested method is the use of high RF impedance but low DC resistance windings in the relay leads. The RF chokes should present a high impedance at broadcast frequencies and have a DC resistance sufficiently low so as not to interfere with the operation of the relay. They should be connected into the circuit with very short leads. Wherever possible filter windings should be excased in metal containers. This is true in the case of all types of filters.



The bias resistance bypass condenser used in pentode output tube circuit can be increased to 20 mfd instead of the usual 8 mfd and improvement in operation will be noted. The usual voltage rating of such condensers is about 25 volts.



Image suppression in some superheterodyne receivers is accomplished by means of a tapped mixer tube input coil. The position of this tap is determined during the design of the receiver and is dependent upon the image frequency to be rejected, which means that the intermediate fre-

quency is the paramount item. The image frequency is at all times equal to a value higher than the desired carrier by twice the intermediate frequency. The statement that it is higher than the desired carrier is based upon the present status of design wherein the oscillator frequency is higher than the desired carrier. If the oscillator frequency is lower than the desired carrier than, the image frequency is lower than the desired carrier by twice the IF.

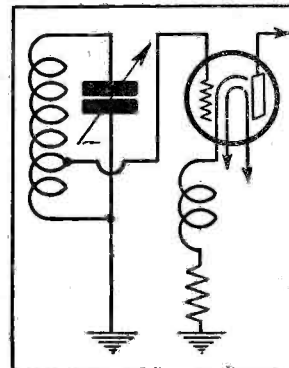

The tap upon the coil is not a mistake.

Quantity production of receivers does not mean that mistakes do not happen. Thus it is possible that the grid lead connection in receivers which use such systems, (U.S. Radio and Television, Deforest-Crosley) may not be to the tap; it may be to the normal top of the coil. This may cause interference of the image frequency variety. On the other hand, if a service man finds a connection such as shown in the accompanying sketch, IT IS NOT AN ERROR. Do not remove the grid lead from this tap in the hope that it will remedy whatever trouble is existant.



Any service man can service any receiver! All he needs is a set analyzer or a set tester or a diognometer (They're all our friends) an oscillator an output meter pliers (many) cutters (more) screw drivers (left and right hand) dummy tube other tubes socket wrenches . . . . . ad infinitum Oh, yes, also a knowledge of radio. Yea bo—we're laughing too.



And sopranos still sing over the air. Fortunately tone control helps stifle them.

**Pentode tubes** in which the steady grid current is higher than normal overload easily when the control grid circuit contains a resistance as shown in the illustration. The symptom is a harsh buzzing sound and sometimes fluttering reception after the tube warms up. By transposing this suppressor resistance so that it is con-

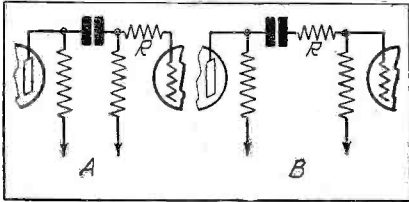

The resistance R should be rewired as shown in B. Its usual position is as shown in A.

nected between the blocking condenser and the grid leak as shown, the trouble will be eliminated. (Ed. This type of circuit is also used in some Majestic receivers and such troubles are remedied in the same way.) In the Stewart-Warner line this circuit is used in the R 102A, B and E sets. (Ed. In the Majestic line, such a circuit is used in the 15 and 15B receivers. Also Sentinel 108-B and 109)

**Pentode tubes** operated without plate voltage will be damaged beyond repair. Never make any tests upon a pentode unless the control grid bias is applied. If any control grid bias changes are to be made, shut off the power supply. If pentode tubes seem to go bad at a too rapid rate, check the control grid bias circuit and see that the connections to the control grid are intact and that the grid leak in the control grid circuit is perfect.

**Fluttering reception** is an affliction of some older receivers equipped with single turn capacity coupled RF transformers. Old age loosens the joints and this coupling link has a tendency to vibrate when the speaker is in operation; thus affecting the tuning and causing fluttering reception.

**Hum and fading** of signals may be due to any one of a number of reasons, but one unusual cause is a defective RF coupling condenser in capacity coupled and sometimes combination capacity-inductive coupled RF transformers. The signal will gradually fade out a short time after the receiver is placed into operation. Switching the receiver off momentarily will restore the signal—only to fade away again within a very short time.

**Power consumption** of Philco models is as follows:

**AC Receivers**

- 75 watts 511, 20
- 80 watts 70
- 90 watts 86
- 95 watts 65, 76, 77, 87, 90
- 100 watts 220, 270
- 105 watts 95, 96, 111, 112
- 135 watts 211, 212
- 145 watts 296

**DC Receivers**

- 42 watts 46
- 85 watts 46-E
- 210 watts 40, 41, 42
- 420 watts 41-E, 42-E

**Audio howl** in the Philco 270, assuming that the chassis is floating properly upon its rubber supports, may be stopped by placing a metal shield over the detector tube. (Ed. Such a remedy is applicable to many other radio receivers.)

**Do not attempt RF or IF alignment** with the set analyzer plugged into the tube socket. The capacity of the long cable will upset the balance of the receiver. If the receiver oscillates when the cable is plugged into the socket, it is not a sign of a defect. More than likely when the cable-plug is removed the receiver will resume normal operation.

The Service Man must be neat.  
The Service Man must be punctual.  
The Service Man must be accurate in his work.  
The Service Man must not annoy the maid.  
'Nuff said.

The type '80 and '81 tubes are about 60 to 65 percent efficient and the mercury vapor tube, type '66 is about 95 percent efficient. The difference is attributed to the fairly high wattage dissipation across the plate resistance of the first two named rectifiers and the fairly low drop across the mercury vapor rectifier.

**A rapid condenser test block** can be made out of five 1. mfd filter condensers of the non-inductive type. This test box will serve a multitude of purposes, least of which is the good old fashioned orthodox method of checking poor condensers by replacement. The five condensers are placed within a wood box upon which may be fastened a bakelite cover. The size of this container need not be larger than is necessary to house the condensers. A somewhat greater depth is required in order to accommodate the pin jacks mounted upon the bakelite cover. Two pin jacks are required for each condenser. Upon the underside of the

cover, the condensers are connected in series as shown by the dotted line. All external connections are made by means of short insulated leads which terminate in pin plugs which may be inserted into the pin jacks.

The capacity variation is secured by interconnecting the respective terminals. Various series, parallel and series-parallel combinations are possible. Eight such combinations are listed and the respective capacities are mentioned. Where more than one letter is shown as one terminal, it means that these terminals are joined externally by means of the short leads. Thus between A-B, the capacity is 1. mfd. Between A-D the two condensers are in series and the resultant capacity is .5 mfd. Between A-F, three condensers are in series and the resultant capacity is .33 mfd. By the

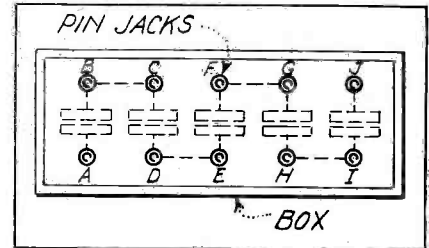

The dotted lines show the internal series connections.

same method of progression, the capacity between A-H is .25 mfd and between A-J, .2 mfd. With A and D joined, between AD-B we have two condensers in parallel and the resultant capacity is 2 mfd. Between AD-FC, it is 3 mfd.; between ADEH-BCFG it is 4 mfd.; between ADEHI-BCFGJ it is 5 mfd. This range of condensers will cover practically every value being for bypass work. A .2 mfd can well be used to check the condition of a .1 mfd unit.

By utilizing series-parallel combinations, various intermediate values are available.

Numerous Service men seem to report that satisfactory operation is secured by simple peaking of the IF transformers which are supposed to be adjusted for a flat top. Such adjustment is contrary to the service instructions of the receiver manufacturers who make such receivers, namely RCA, Westinghouse, Graybar, General Electric. Fortunately flat top adjustment is required in only a few of their receivers and at that upon but a few IF transformers.

Radiotrician,  
Service man,  
Radio expert,  
Service expert,  
Service technician,  
What makes who a what?



The '24 and the '51 type tubes will handle input signal voltages equally well as their bias voltages are increased—up to a certain point. Then the advantage of the '51 comes to the fore. At low values of mutual conductance, the condition created when the control bias is increased and the other operating potentials remain normal, the '51 is capable of handling signals about 20 times as large as that which may be passed into the '24 without distortion. However, this does not mean that the variable mu tubes do not have limits. Even with the greater signal handling ability of the variable mu tube, it may still be necessary to reduce the signal voltage into the tube as a supplementary control of volume. The '35 and the '51 represent two types of variable mu tubes and while there are some minor differences, they are interchangeable in receivers originally designed for variable mu tube.

The primary difference between the conventional screen grid amplifier tube and the variable mu tube is that the amplifying ability of the latter tubes does not decrease as rapidly as that of the conventional screen grid tubes as the volume control adjustment (usually the control grid bias voltage) is increased to reduce volume. This is a function of the physical structure of the control grid.

The '39 RF pentode is in a way like the '47 pentode except for the fact that its design is changed so that the tube is operative at low values of plate voltage and satisfactory values of plate resistance are secured at a plate voltage range around 90 volts. This is of definite advantage in connection with DC operated receivers. The variable mu feature of this tube affords the required freedom from cross talk and modulation distortion.

Of course the '39 can be operated at plate voltages in excess of 90 volts, with about 180 volts as a maximum. Raising the plate voltage applied to the '39 from 90 to 180 volts increases the plate resistance about 2.5 times and the amplification constant about the same amount. However there is very little difference in the mutual conductance, the plate current and the screen current. These values remain substantially the same. The normal range of mutual conductance of this tube is from about 1000 micromhos down to about 10 micromhos with an increase in control grid bias (negative) from about 3 to 30 volts. The screen grid current is equal to about one third of the plate current.

Noise is often due to poor power circuit installation in the home. The mere fact that a licensed electrical organization made the installation is not proof of its perfection. There have been several instances where a separate line from the fuse box in the apartment to the radio receiver cleared up all troubles due to overloaded lines, voltage fluctuation, etc. It should be understood that such wiring is not within the realm of the service man, that it must be done by a licensed electrician. However an experimental line will show whether or not such a permanent installation is worthwhile. If it is of value have an electrician put one in.

◆ ◆ ◆  
**Open bypass condenser** connected across a dual acting volume control of the RF bias and antenna circuit type shown below will have a tendency to cause oscillation and to have an effect upon the tuning as the control is manipulated. Associating this effect with the state of oscillation should be an indication of the trouble.

An open bypass condenser may cause an effect upon the tuning.

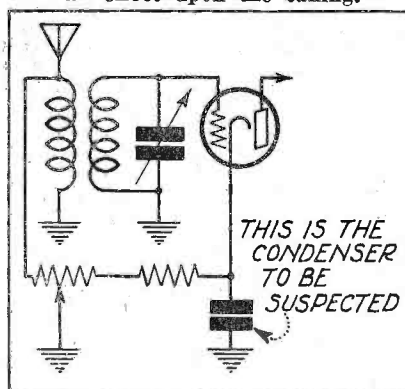

Class B amplifiers have not been used to any extent in radio receivers, but with this wave of economy which has engulfed us, there is very great likelihood of such systems in audio amplifiers. Particularly so in battery receivers such as autoradio units. The amplifier systems usually used in radio receivers are of the Class "A" type, meaning that the output is essentially an amplified reproduction of the input. In the face of possibilities, certain facts about Class "B" systems should be known. As a matter of fact one receiver manufacturer employs such output systems and unless this fact is recognized, confusion during service is apt to result.

The Class "B" amplifier is one wherein the tube is heavily biased so that plate current flows only during the time that a signal is applied to the grid. The normal no signal input value of plate current is zero or substantially so. The circuits of

Class "A" and Class "B" amplifiers are identical. They differ solely in the value of the control grid biasing potential and in the plate current. The advantage of the Class "B" system is that it affords much greater output at lower cost, a condition of great benefit in battery operated receivers. The method of overcoming the distortion present when a single tube is used in this manner is to use tubes in push-pull fashion, which is the way that the output tubes previously referred to are used in the RCA R-43 a battery operated receiver, utilizing two 230s in push-pull in the output stage. Also in the RCA auto radio receiver MB-30. The low normal value of plate current during the state of no signal input is what causes the confusion during a service analysis. Bear these facts in mind when you encounter low output tube plate current and high grid bias in battery sets.

◆ ◆ ◆  
The automatic volume control tube in some receivers can be found by adjusting the receiver so that it is operating in normal fashion and then removing one tube at a time and noting the effect. In receivers which employ a tube solely as an automatic volume control, this tube when removed will increase the signal output of the receiver. Any other tube removed from this receiver will interfere with reception. However in the case of receivers which utilize the combination detector and automatic volume control tube, it will be necessary to work backwards, to locate all the other tubes first; bearing in mind the dual role of the AVC tube and then by subtracting the other tubes from the total, locate the AVC tube. Such isolation is not simple, but a half loaf is better than none.

◆ ◆ ◆  
The optimum load impedance for the pentode is equal to one quarter of its plate impedance. On the other hand, the optimum load impedance for the conventional three element output tube of the '45 or the '50 type is 2 times the tube plate impedance. For oscillators, where maximum power output is desired, the load impedance should be equal to the tube plate impedance. Because of the appreciable difference in plate resistance values of the type '47 pentode and the conventional '45, the out transformer used with the latter is not suitable for the former. The '47 has a plate impedance of about 35000 ohms and requires a load of about 9000 ohms. The '45 has a plate impedance between 1600 and 1900 ohms and requires a load of about 3200 to 4000 ohms, depending upon the plate voltage and of course upon the number of tubes in the output system.

**Detector tube plate current** with resistance as the plate circuit load, as in the case of many commercial receivers, will usually be of such low value as not to register or cause an appreciable deflection upon high current meters. When checking the plate current of screen grid detector tubes or when it is known that the first audio stage is resistance-capacity coupled, use the lowest possible milliamperage range. A DC meter with a maximum range of about 5 milliamperes is ideal for such measurements.

A very simple output meter applicable to power detector circuits is shown below. The complete system consists of a high resistance ohmmeter connected across the bias resistance in the cathode circuit. The plate current flowing through this re-

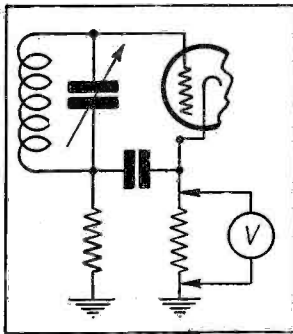

sistor develops a voltage across the terminals of the unit. The voltage varies in accordance to carrier signal voltage and can be read on any good grade instrument. In the normal biased detector, the greater the signal voltage input, the greater will be the voltage developed across this resistance. This form of measurement is not interpretable in actual signal voltage input, but it lends itself very well to alignment adjustments and obviates the need of break-in adapters. (Ed. See "Vacuum tube output meters" among the abstracts elsewhere in this issue.)

**Ordinary needles** are not satisfactory for use with the automatic record changing devices. Some sort of long life needle should be used.

Some of the present crop of midget cabinets make very good housings for some of the smaller dynamic speakers. The front panel of the cabinet constitutes the baffle. If this speaker is made a supplementary unit, the holes can be covered by a bakelite plate upon which is mounted the control switch.

The dealers who at one time said that "service is a necessary evil" now are realizing that the service man is a pretty important individual. Any body can sell a receiver but it takes a good man to fix one.

**Push-pull detectors** are now used in some of the latest radio receivers. Whether or not true push-pull action is obtained is not the important item. It is of much greater importance that the man who is called upon to service one of these receivers recognize that two tubes are used as detectors (2nd detectors or demodulators) and that such systems are in existence. A list of the manufacturers who use such tubes is not as yet very long. As a matter of fact Grigsby-Grunow (Majestic) and Silver-Marshall are the two major exponents, but it is more than likely that the list will grow rapidly.

The use of such systems is not general in the lines produced by the two organizations named. According to their statements, the purpose is the ability to handle greater input and greater freedom from distortion.

Color Coding as set forth by the RMA is not as yet used by all radio receiver manufacturers. The editors of SERVICE are now compiling a list of those manufacturers who are using RMA color coding.

**Light sensitive cells**, known by whatever names the manufacturers decide upon shall find application in the home. What with the combination of musical instruments, radio receivers, and electric refrigerators as items to be sold by radio dealers, it is quite logical to assume that when photoelectric devices become saleable in the home in one or many forms, the service man will have his finger in the pie. Even today the prospects of sound on film home talking movies are not very far in the offing. What other devices used in the home will employ a photoelectric cell, only the future knows.

Accordingly, the time is ripe for details relating to light and light sensitive devices. In view of the fact that most of the literature accompanying such devices and descriptions contain certain technical terms, the following definitions should find extended utility as references.

**Candle Power** is the unit of intensity of a luminous source, and is the luminous intensity of a light source known as the International Candle. The candle power rating of any lamp represents the number of times that that source of light provides an illuminating power greater than that of the standard candle. Thus a 50 candle power lamp has an illuminating power 50 times as great as the standard candle. In view of the fact that the intensity of light varies according to the direction from which it is viewed and also the

distance from the source, any reference to candle power is usually allied with a definite standard of distance and direction.

The **Foot-candle** is the intensity of illumination upon a surface, perpendicular to the light rays at that point, and which is held 1 ft. distant from a source of 1 candle.

The **Lumen** is the unit used to denote the quantity of light falling upon a surface which has an area of 1 square ft. and when every point upon that surface is 1 ft. away from a light source of 1 candle power.

The **Inverse Square Law** denotes the variation of the intensity of illumination produced by a point source with distance. For example the illumination upon a surface varies inversely as the square of the distance. If a light has a rating of 1 candle power and produces an intensity of illumination of 1 ft-candle upon a surface 1 ft. distant from the source of light, and that surface is moved 2 feet distant from the light source, the intensity of illumination is decreased to  $\frac{1}{4}$  ft-candle.

If the surface is moved to a distance of 3 feet, the intensity of illumination becomes one-ninth ft-candle.

The inverse square law is of direct interest in connection with home moving talkies with respect to the projection of the image. The greater the distance between the projector and the screen, the larger is the image, but the less the light. Naturally as the intensity of light is decreased, the detail of the picture is lost.

The **Angstrom** is the unit of length employed in connection with light rays. The usual units employed in connection with other waves, as for example the shortest radio waves, are entirely too large for use with light wave radiations. The production of a radio wave of 1 centimeter is an accomplishment, whereas a wave of this length is equal to 100,000,000 angstrom units, which means that a wave 1 angstrom long is equal to 1/100,000,000th of a centimeter. The range of wavelengths from the ultra-violet to the infra-red extends from 2500 to 8000 angstrom units. Thus yellow light is said to have a wavelength of about 6000 angstroms, which means that its wavelength is .00006 centimeter. The eye can see colors within a range of from about 4000 to 7500 angstroms, which is the equivalent of a wavelength range of about .00004 to .000075 centimeter. (It would be kind of difficult to tune a circuit to this wave.) The shorter wavelength has violet as its limit and the upper limit is red.



# Short Waves

The new RCA Superheterodyne Short Wave converter has an intermediate frequency of 1075 KC. This is important information because most of the commercial short wave superhet converters have an IF of about 1000 KC. This converter utilizes three tubes and covers a range of from 13.8-200 meters. A '24 is used as an RF amplifier, a '24 as the detector and a '27 as the oscillator. The plate voltage for the tubes in the converter is secured from the receiver by means of a wafer contact adapter and lead.

there is no doubt about the fact that such an oscillator is imperative.

Some more short wave notes. They apply to short wave converter systems. An important consideration is recognition of the fact that short wave broadcasting stations do not operate over the entire dial. They have certain definite wavelengths and a great deal of time will be saved and disappointment avoided if the owner of such a receiver is told to study the short wave station tabulations and adjust

hand don't tune below 25 meters after dark. After all, some people sleep some time, so that you cannot expect to hear very many European stations after about 8 or 9 PM in the eastern part of the U.S. or after 6 PM until about 4 AM in the western part of the U.S. There exists a certain relation between the frequency of the transmission and the daylight or dark hours. This condition must be recognized. Stations between about 14 and 25 meters can be heard best during the hours between daybreak and about 3 or 4 P.M.

The number of short wave broadcast stations are not too plentiful. They are limited to certain portions of the tuning dial and you must learn just where they are located upon the dial. As a rule, all of these with the ex-

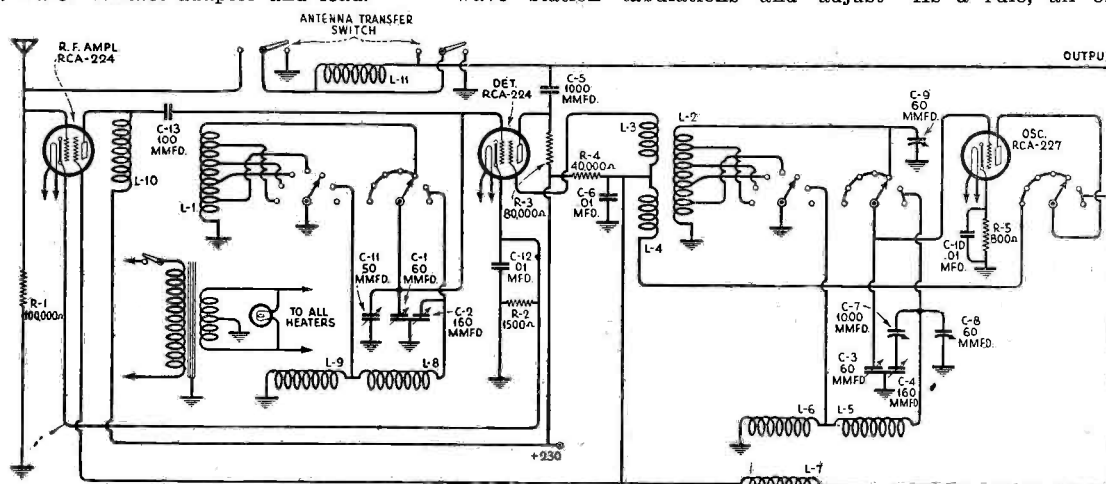

This is the wiring diagram of the new RCA SWA-2 short wave converter.

Short wave test oscillators are becoming a necessity. The ever increasing crop of short wave converters makes necessary some sort of test system whereby alignment of the converter circuits becomes possible. The possibility of employing harmonics of intermediate frequencies for short wave work is very unlikely, although the system is suitable for the broadcast band alignment. What with the possible need for alignment at say 7000 KC, it would require the 40th harmonic of a 175 KC signal. A crystal oscillator with a fundamental of say 1000 KC would supply the required harmonics up to about the 7th for converter alignment. A simple switching arrangement would allow the use of the crystal for the converter alignment and the IF winding for the intermediate and broadcast band alignment. The dynatron oscillator is a possibility for the entire band. A simple switching arrangement would allow the use of the short wave oscillator circuit or the IF oscillator circuit. This type of oscillator is quite constant, is rich in harmonics and shows but a very small variation in frequency for operating potential changes. Whatever type of oscillator shall become popular is as yet unknown, but

his receiver to operate over the required wavebands to listen to these stations. Broadcasting stations heard upon other wavelengths should be viewed with skepticism unless it is definitely proved to be a regular short wave broadcasting station and not a higher harmonic of a local broadcaster. One experience of waiting 15 minutes for an announcement should be sufficient.

There are no short wave broadcasting stations, other than police and aircraft upon the 90-200 meter band. Broadcasting stations heard within this band, other than police, aircraft or possibly the sound for television programs, can be considered to be harmonics of local broadcasting stations, which as a rule may be heard with better quality of speech upon their regular waves.

Noisy short wave receivers can be (maybe) silenced by resoldering every joint. Tough job, but it works.

A few short wave tuning hints. Maybe you can use them. Don't expect distant stations above 35 meters during daylight hours. On the other

reception of ships, police, aircraft and other such organizations operate upon wavelengths below 70 meters. Tuning must be done slowly, because short wave stations are very sharp. Furthermore, short wave stations fade and fade badly. This applies equally to local and distant stations. Fading upon the short waves is far more common than upon the broadcast wavelengths. Unlike broadcast stations, consistency is something unknown in short wave work, that is, for general reception. You can expect good reception today and poor reception tomorrow.

Short wave reception requires an aerial. This is true irrespective of the receiver you have, whether it is a short wave receiver or a converter combination. There is no specified length for this aerial. In some places 20 feet will do. In others 150 feet are required.

Aircraft stations conversation is brief. So is a police alarm announcement. With respect to police alarms, you may hear several at one time. Don't be surprised. Our government has allotted similar wavelengths to many police broadcasting stations in different parts of the country. No amount of fine tuning will separate these stations

# Refrigeration

Refrigeration manufacturers report that certain changes are being instituted, whereby the 1932 line will differ from the boxes offered in 1931. However, the following is a tabulation of pertinent facts relating to the different electric refrigerators available at the present time. All of the information contained herein has been secured from the service manuals submitted by the organizations whose products are named.

As far as refrigerants are concerned, all manufacturers of ice boxes intended for domestic or home use, do not employ the same chemicals. This list is by no means complete and more will follow in subsequent issues. Sulphur Dioxide is used in the Cavalier, Frigidaire, General Electric, Icyball, Majestic, Kelvinator, Sparton and Starr-Freeze and Zerozone re-in the Icemaster, Iceberg, Mohawk, Servel, boxes. Ethyl Chloride under the trade name Alcozol is used in the Welsach refrigerator. The Copeland unit employs Freezol (Iso-Butane) and the Devon unit employs Air.

Considering the prevalent use of liquid refrigerants, a good deal of interest cannot be avoided in the use of Air for such purposes. Unfortunately detailed information concerning the methods of utilizing this gas (for after all the air that we breath is gas) is not available.

Household refrigerating systems are usually divisible into two classes namely compression and absorption. All of the above named refrigerators are of the compression type. Gas refrigerators such as the Electrolux are of the absorption type. Generally speaking each type has its advantages. The primary difference between the compression and absorption systems may be expressed by stating, that the former has moving parts and operates at low pressures, whereas the latter has no moving parts and operates at high pressure.

There are certain similarities to be found among compression type electric refrigerators which utilize similar refrigerants. For that matter the same is true even when different refrigerants are used. In view of the fact that this subject is quite extensive, we shall devote this issue to those boxes which employ sulphur dioxide as the refrigerant.

An important service item is the discovery of leaks. The odor of sulphur dioxide is not the most pleasing so that it is easily detectable. Fur-

thermore, when this gas combines with the fumes of strong ammonia (aquammonia) it produces a white smoke. This chemical reaction affords a very easy means of actually discovering the leak and a supplementary operation after the service man's nose advises him that a leak exists somewhere in the system. Dip a flat brush or a rag wound around a stick into strong ammonia. Hold this brush or stick wound with rag near the various joints. If a leak is present, a white smoke will be visible.

The Welsbach refrigeration manual makes a very excellent suggestion relative to leak searches, etc. A mirror, (Ed. preferably attached to heavy piece of wire) makes a very good searcher because it enables an examination of the reverse side of joints and pipes. The front is visible to the eye, and the reverse side of this joint can be seen through the mirror. By attaching the mirror, which may be small, 1 or 2 inches square is sufficient, to a piece of heavy yet flexible wire, it may be placed into the most out of the way positions.

While it is true that sulphur dioxide is not inflammable and some of the other refrigerants are slightly inflammable and only when in certain critical concentrations with air, it is still the wisest thing to keep all flames away from the various piping systems. When searching for leaks use a FLASHLIGHT, never a lighted match, candle or torch.

Fuses suitable for electrical refrigerator installations are quite standard and are based upon the horsepower rating of the motor and the voltage of the power circuit. The lower the line voltage the higher must be the rating of the fuse. The higher the horsepower rating of the motor, the higher the current rating of the fuse. A horsepower is equal to 746 watts.

Motor H.P.	Single phase 60 cycle		
	110 V	220 V.	
1-8 to 1-4	6 amp	3 amp	
1-3 to 1-2	10	5	
3-4	15	10	
1. to 1.5	20	10	
Motor H.P.	Direct Current		
	32 V	110 V	220V
1-8	10	3amp	3amp
1-6 to 1-3	10	6	3
1-2 to 3-4	20	10	6

According to the Copeland manual, a fuse of 10 amperes should be used for 1-6 horse power induction (split phase) motors on 110 volt circuits and

of 5 amperes on 220 volt circuits. For 1-4 horse power induction (split-phase) motors use 20 amperes on 110 volt circuits and 10 amperes for 220 volt circuits.

Motors used in some of the electric refrigerators are as follows:

Sparton 1-5 H.P. For DC circuits a compound wound motor is used and for AC circuits a repulsion-induction unit is employed. The speed is 1750 r.p.m.

In the Iceberg unit, the motor is of the repulsion-induction or capacitor type for AC circuits.

The Zerozone AC box utilizes a General Electric KC capacitor motor.

The Copeland domestic line is quite extensive. The 1928 model F and 1929 model G employ 1-6 H.P. repulsion-induction, single phase motors. The 1929 models N, I and O, use 1-6 H.P. repulsion-induction, single phase brush lifting motors. The same type of motor is used in the 1930-1, 1930-1-L, 1930-2 and 1930-2-L models.

The 1931-1 and 1931-2 models make use of a 1-6 H.P. repulsion induction, single phase motor of the brush lifting type, but are equipped with Thermal safety cutouts instead of fuse boxes. All of the motors listed under the Copeland name, although of like horse power rating are not necessarily identical motors, inasmuch as the r.p.m. values differ. The 1928 N-5 model has a rating of 390 r.p.m. The 1928 F, 1929 G, 1929 I, 1929 O, 1930-1, and 1930 1-L are rated at 440 r.p.m.

A resume of troubles and symptoms in different types of electric refrigerators is now being prepared and will be published in serial form in subsequent issues.

## Tone Control

Assuming three condensers, the first adjustment utilizes condensers within a .0002 mfd—.001 mfd range. The second adjustment utilizes condensers within a .0005 mfd range. The third adjustment utilizes a range of from .002 mfd to about .01 mfd. It is significant to note that the aforementioned range is used across the grid circuits of the audio amplifiers. When this type of tone control is used in the plate circuit, as for example across the primary or the output transformer, the values used range from about .01 mfd to about .05 mfd.

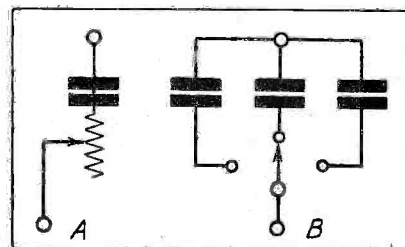

# Public Address . . .

Public address system installation now is becoming a part of the field served by the modern radio service man. Not only is he called upon to service such systems, but he is often called upon to develop and install a public address amplifier. The following paragraphs present some of the paramount items which should be borne in mind when work of this character is being considered.

In public address work the choice of an amplifier depends on many factors, and these factors are so important that each and every one of them must be taken into consideration and weighed carefully. The size of the room to be served, the shape and the acoustical treatment of the room, and whether the installation is to be used for outdoor or indoor work are examples of important points in the design.

Frequency discrimination means that certain frequencies are suppressed to some extent in relation to other frequencies within the audio frequency range. Experience has shown that, in general, a good response characteristic embraces a frequency range of from 40-8000 cycles per second with a total difference of not more than 3DB. An amplifier response characteristic conforming to these limits might be called commercially good. No doubt this amplifier would be ideal for all types of work, but the man who is choosing this piece of apparatus usually has some particular installation in view which gives him an advantage in the proper selection to suit the particular requirements. If the installation is to be used solely for voice amplification, then it is not wise to choose a highly efficient amplifier, because the maximum frequency that the apparatus would be called upon to pass would be about 3500 cycles. A less expensive and efficient amplifier would be more than sufficient.

On the other hand, if music is to be picked up, a quality amplifier would be in order, but it would be useless to use such an apparatus if the input and output apparatus are not also highly efficient. A poor microphone or a poor speaker would offset any advantage that might have been gained by a good amplifier. Too many people choose an amplifier first, and supplement it with inferior apparatus to their sorrow.

## Overall Gain

The next item that should be considered is that of overall gain and power required. Here the design must

be guided by the use to which the equipment is to be put. Too low an overall gain may mean that the full power output of the amplifier may never be realized, with consequent dissatisfaction on the part of the purchaser, who has equipment to fulfill definite power output requirements. Too high an overall gain may also be a disadvantage, especially if the amplifier is to be used by a person unaccustomed to the operation of amplifying systems, as the tendency of such an operator is to overload the system in practically all cases. Of necessity, high-gain amplifiers introduce a greater element of instability into audio frequency systems than amplifiers of lower, though adequate gain, inasmuch as the coupling necessary for overall feedback is less in the case of the former.

In the matter of power required the amplifier is governed solely by the area to be served. The table shown has been prepared to facilitate the work of the estimator. The figures given are all taken from practical installations and while they may not be accurate in all jobs, they are close enough to give the service man a good idea of the amplifier needed. Certain peculiarities may make it necessary to use a larger or smaller amplifier. The acoustic properties of a room are very important and many times unusual acoustics have been the cause of unsatisfactory sound service.

If the room is heavily draped there will be considerable sound absorption and since the table has been prepared for rooms having average sound absorption, greater power will be needed

to serve this particular room.

The seating capacity of the room is also an important consideration. If the room has very narrow aisles and most of the floor area is covered with seats, the sound absorption due to the clothing worn by the audience will be considerably greater than that provided for in the table which was made for a hall equipped with spaced aisles and a generous space between audience and the rear of the hall. Therefore if it is evident that the seating capacity covers the entire floor area, it will be necessary to choose an amplifier of slightly greater power.

If the height of a room is considerably greater than its width an amplifier of considerable less power than that recommended in the table may often be used. This is due to the fact that the higher the room of a given cubical content the smaller the floor area, and consequently, the smaller the audience. This knowledge will often enable the estimator to reduce his estimate considerably by including a small amplifier in his specifications. In such an installation directional baffle speakers can be set so that the reproduced sound is directed solely to the audience and not broadcast equally to all parts of the room.

## Prevention of Extraneous Noises

In public address installations protection must be provided against interference of an electrical nature which would give rise to extraneous noises within the system. This is absolutely necessary where extremely high amplification is employed. The complete protection of any electrical circuit from outside interference requires that it shall not have currents induced in it by either electrostatic or electro-magnetic fields such as may be set up by wiring or electrical machines located near by. Electromagnetic induction is caused by varying

(Continued on Page 16)

Cubical Content of Room	TYPICAL CIRCUITS	Voltage Gain at 1000 cys.	Undistorted Power output in watts
25,000 - 50,000 or less	2 Stage Trans. Coupled - 250	42 D. B.	2.5
	Output Direct Coupled 1-224 - 1-245	50 D. B.	2.0
25,000 Cu. ft. Cu. ft.	2 Stage Coupled 245 Push Pull Output Transformers Coupled	31 D. B. 68 D. B.	4.3 4.4
	2 Stage Transformer Coupled 210 Output in Combination With One Push Pull 250 Stage	48 D. B.	11.5
	3 Stage Transformer Coupled 1-227 - 2-226 - 2-250	75 4 D. B.	12.
125,000 - 175,000 Cu. Ft.	3 Stage With 250 Push Pull Output Transformer and Resistance Coupled 1-224 - 1-245 - 2-250	53 D. B. 72 D. B.	14.0 14.0
	175,000 Cu. Ft. and up	Transformer Coupled 2-224 - 4-250 or 1-227 - 2-245 - 4-250 or 1-227 - 226 - 4-250	66 D. B. 64 D. B. 75 D. B.

# Abstracts

Voltage doubling from AC systems now is secured by means of transformer and in the majority of cases by means of tube rectifier. There appears in the offing a means of securing high plate voltages by "double:"

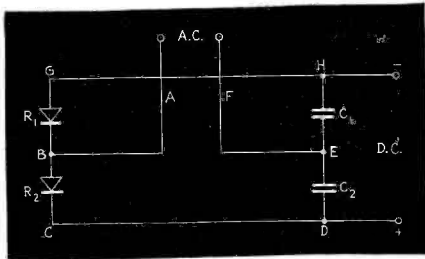

C1 and C2 are charged alternately upon each half cycle. Thus upon one alternation the path of the current would be A B C D E F and upon the other half cycle it would be A B G H E F. The two condensers C1 and C2 discharge in series. One rectifier operates upon one half cycle and the other rectifier operates upon the other half cycle.

and 'quadrupler' circuits which do not use transformers or tube rectifiers. Rectifiers are used but they are not of the tube type. This new type of power pack, for that is what it is, operates upon 110 volt AC. Essentially it is based upon that ever present idea in the mind of the engineer, to charge condensers in parallel and discharge them in series. In the voltage doubler, two dry disc rectifiers are used. One rectifier operates upon one half of the incoming AC cycle and charges the other condensers. See diagram—(add description). With respect to the filter system and voltage divider connected to the rectifier circuit, the two condensers subjected to individual charges, discharge in series. While it is true that the ideal condition of a DC voltage equal to twice the impressed peak AC voltage is not obtained, the output voltage is about twice the impressed effective AC voltage, about 220 volts at about 30 milliamperes for an input voltage of 110 volts AC.

The system has the advantage of being applicable to all power lines irrespective of frequency. Just what its applications will be is as yet unknown, but no doubt some will be found. Four such rectifiers are used in a quadrupler circuit, which supplies about 440 volts at 50 mils from a 110 volt AC line.

—Garstang, *Electronics*, February 1932

Tubes may still be tested in the good old fashioned way. A receiver chassis known to be good, a modulated oscillator, an output meter and a number of good tubes make a very satisfactory tube testing system. (Of course with limitations due to the fact that all types of tubes are not applicable to any one set). The oscillator is connected to the receiver and the output meter is also connected to the receiver. For a certain adjustment of the oscillator output, the indication upon the output meter is noted. The tubes to be tested are now used to replace the good tubes in the receiver. One tube is tested at a time. The output indication is noted and compared with the standard reading. (This is a qualitative rather than a quantitative test but furnishes information which is handy when you need it.)

—Philco Service Bulletin 99

Noise, noise—and then more noise. There are cases where the noise level compared with the signal strength of the station desired may be such that the station cannot be received without an objectionable background. The noise may have no radio frequency peak or it may have a broad peak. This noise condition may be divided into the following three general classes.

(A) Where the noise level is zero with no antenna or ground, but is equally great on either an indoor or outdoor aerial.

(B) Where the noise is equally great with the antenna and ground either connected or disconnected.

(C) Where the noise level is greater with an outdoor than indoor antenna, but the indoor antenna does not provide sufficient pickup.

In (A) the interference does not enter through the power line. In such cases the receiver should be located close to the point where the outside antenna lead-in enters the building. If impractical, the receiver may be located at the best spot and a copper braid placed over the inside portion of the lead-in wire. The ground

lead should be as short as possible. A shield over the grounded wire but not grounding the shield may help.

In (B) the noise enters the receiver through the power lines. (Ed. See "Carrier wave hum" abstract in this issue.)

In (C) the pickup is probably in the lead-in wire between the receiver and the antenna. Copper braid should be placed over the entire lead-in from the receiver to the flat portion of the antenna. Whether or not this shielding braid should be grounded must be determined by experiment. The same is true of changing the position of the aerial. (Switching an aerial is no joke, but listening to a noisy receiver is even worse.)

RCA Service Bulletin

Try and beat this one! Bill Whalen, owner of Whalen Radio Service, Alamo, Texas had tried every possible means of stimulating business, good will and what have you. Practically every channel was exhausted. Good will means business but it is even better to get both. Bill sells and services Atwater-Kent receivers and Frigidaire boxes. He figured that his old customers represented the best bet, no matter how much they owed on old accounts. So Bill went to work pronto. He made arrangements with a local theatre to purchase tickets for ten cents each. Then he wrote a letter to each of his customers, in which he enclosed what appeared to be a personal check, except that "pay to" was altered to read "admit" and instead of the bank, he drew the check upon the local theatre. At the same time, the name was filled in as "Mr. . . . and one" and the numerical valuation of the check was shown to be 80 cents.

This idea was a knockout in every respect. It satisfied the theatre owner because he received publicity which made up for the reduced admission fee. It satisfied Whalen, because he made several sales traceable directly to this campaign. Further some of his delinquent accounts had a change of heart and sent in remittances to cover the overdue accounts. It was a collection letter as well as a good will builder

—Radio and Music Merchant, Feb. 1932

This wiring diagram shows the circuit of a complete voltage doubler power pack.

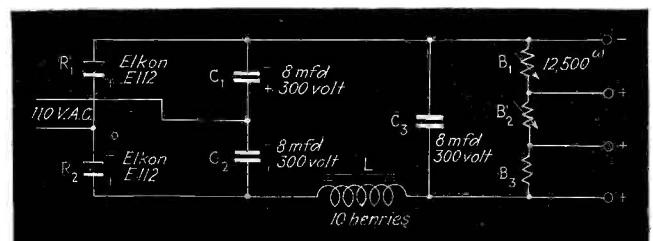

**Vacuum tube voltmeters** have been used for general measurement of voltage. The author shows the application of a tube voltmeter for inductance and capacity testing and matching. For inductance testing the input circuit of the tube voltmeter is connected across the resonating condenser. For capacity matching the input circuit of the voltmeter is connected across two taps upon the two ratio arms of the bridge. Instructions for the use of and construction details of the tube voltmeter are given with particular reference to the use of resistances in the plate circuit of the voltmeter tube in order to increase its sensitivity. This type of instrument fills a definite purpose because it enables measurement at radio frequencies. (Ed. Vacuum tube voltmeters must be constructed with great care and arranged in such fashion that they are free of all extraneous disturbances, as for example coupling between the test voltage generator and the input circuit of the voltmeter.)

—Fiske, *Radio News*, March, 1932

**Carrier wave hum** and power line noises have been nuisances for a long time. Their elimination has been the subject of many articles. The suggestion is made that the antenna ground system be isolated entirely from the balance of the receiver and that while the tuned circuits and tuning condensers may be grounded to the chassis, the chassis itself should not be grounded to the regular ground or in anyway joined to the aerial-ground system. It is this connecting lead between the ground and the chassis which seems to be the basis for such troubles. Experiments conducted in the effort to minimize supposed line noises and carrier hum showed that when this lead was removed, thus limiting the coupling between the aerial and the remainder of the receiver to purely inductive coupling between the antenna and secondary coils, a great deal of the noise was eliminated. So much so that this action is suggested as a remedy. (Ed. As a point of information all recent receivers manufactured by RCA isolate the aerial circuit from the balance of the receiver. The external ground connects to the ground end of the aerial circuit only, while the remainder of the receiver is grounded to the chassis. The power pack ground lead joins the chassis and not the external ground.)

With respect to carrier hum, investigation shows that this trouble is present only in certain cases, with certain receivers and that it is not consistent with a change in locations. Tests indicate that the hum is loudest when the reactance of the normal ground and the power path ground are alike. It is on account of this condition that the trouble is more pre-

valent upon certain frequencies than upon others. The usual capacity filter across the power transformer primary minimizes this effect because of the

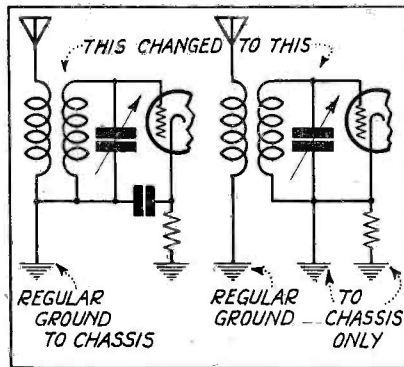

**Isolate the antenna circuit by using the regular ground for the antenna system only.**

low impedance path to ground across the rectifier system. (Ed. See example of such power path to ground across filter in "lighting circuit interference" note.)

—Teachmann, *Radio Engineering*, 1932

**An ohmmeter** consisting of a 0-100 milliamper DC meter and 4.5 or 6 volt battery can be used for resistance measurements up to and including 500 ohms. About 50 percent of the current range is available for resistance measurements between 0 and 50 ohms, so that low values of resistance may be measured with very little trouble. Herein is found a very definite advantage. A simple method of multiplying the resistance scales of these ohmmeters is suggested, so that any one calibration curve can be employed for several ranges. Calibration tables designating resistance and current indication accompany the text, thus eliminating a great deal of calculation.

*Service Sheet, Radio World, February 13-20, 1932*

**The output meters** being advertised for use by service men and consisting of the conventional rectifier meters are not the only ones suitable for the checking of receivers. Various types of output indicating systems were used in

years gone by in connection with received signal intensity measurements. As a rule, these output meters were of the vacuum tube type, very similar to the present day vacuum tube voltmeter.

As a matter of fact any detector tube and circuit can be employed as a signal intensity indicator. All that is necessary is the insertion of a current meter in the plate circuit so as to indicate the increase or decrease in plate current as a consequence of the signal voltage applied to the control grid of the tube. The action of the plate current, whether it will increase or decrease with applied signal voltage depends upon the structure of the grid circuit.

The use of a tube as a volume indicator is not limited to the detector tube. The power output tube inclusive of the pentode as used in any radio receiver is suitable for application as an output indicator. True that certain circuit changes are required, but these are easily available by means of various adapter systems.

The tube output indicator system utilizing the output tube in the receiver consists of two sockets, a four and five prong, so as to accommodate the standard four prong output tubes like the '45, '71, etc., and the five prong socket is used for pentode tubes. A plug is provided whereby the required heater, grid and plate potentials are secured for the output meter system. The tube used in the receiver is transferred from the receiver to the output meter, and the adapter plug is inserted into the vacant output tube socket in the receiver. A filament transformer is provided in the output meter. The primary winding of this transformer secures its voltage from the heater or filament terminals of the output tube socket within the receiver. The output meter circuit contains the plate current meter and also the means of increasing the bias voltage applied to the control grid of the tube. Wiring diagrams of several types are shown.

(Ed. The Class B type of audio amplifier utilized in some auto radio receivers lends itself admirably to the

**This is the output indicating system evolved from the regular output stage. The terminals G, S, H, H2 and P constitute a plug.**

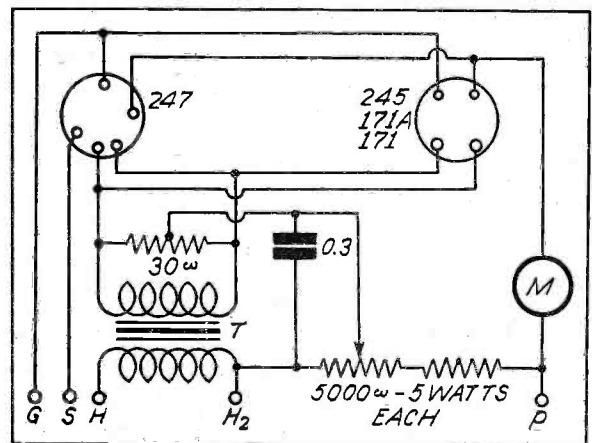



use of the complete circuit as is, as an output meter. All that is required is the insertion of a suitable current meter into the plate circuit of the output tube. This type of amplifier is heavily biased and the plate current will show an increase as the signal voltage is applied. See "Class B amplifier" notes elsewhere in this issue.)

*Anderson, Radio World, Jan. 30, 1932*

◆ ◆ ◆  
**Coil data** for plate and grid coils to be used in a simple regenerative short wave receivers are as follows: All coils are wound with No. 22 double silk covered wire upon a 2 inch form. The turns are not spaced and separate coils are used for the grid and plate coils. The grid coils are intended to be tuned with a .0001 mfd variable condenser. For the 100-190 meter band, the grid coil has 45 turns and the plate coil has 12 turns. For the 60-130 meter band, the grid coil has 18 turns and the plate coil has 8 turns. For the 42-70 meter band, the grid coil has 12 turns and the plate coil has 8 turns. For the 25-50 meter band, the grid coil has 8 turns and the plate coil has 6 turns. For the 18-28 meter band, the grid coil has 4 turns and the plate coil has 6 turns. A simple short wave receiver of the two tube type, one stage audio is also discussed.

◆ ◆ ◆  
*Q S T October, 1931*

◆ ◆ ◆  
**Many auto-radio problems** must be faced during 1932. One of the requirements of a radio receiver is to supply between 1 and 2 watts of output so as to overcome the absorption due to the upholstery within the average car. Such output requires a receiver of from 7 to 8 tubes and a fairly high plate voltage.

As a rule many tubes and high plate voltage means higher plate current consumption. Such cannot be satisfactory supplied from batteries. (Ed. See notes on "Class B amplifiers" for battery receivers elsewhere in this issue.) Accordingly there is a trend towards B eliminators for use in automobiles. Several such devices have been developed. Several installations have been made but these are more in the nature of experiments to determine the kinds and troubles rather than actual exploitation of the units. (Ed. One manufacturer of such a device admits that such installations are not as simple as in the case of stationary receivers used in the home. In some instances the eliminator functions in perfect manner and in other cases, for no accountable reason, unless it is a variation of tubes used in the receiver or receiver design, the operation of the eliminator is exceedingly poor.)

The contemplated eliminators are of

varied type. Some are of the mechanical interrupter type or commutator type whereby an interrupted signal is fed into a transformer and there stepped up to the required 110 volts AC. Others are of the permanent magnet-dynamotor type and still others are generators driven by the motor or by the car battery.

It seems as if the rotating type of machinery such as the dynamotor or generator is meeting with greatest approval on the part of the automotive industry, due perhaps to the fact that these people are more familiar with the trials and tribulations of this type of equipment rather than of the other types which are wholly new to them. However these devices secure their primary power from the storage battery and this increased load involves changes in charging rate, the relation between charging rate and car speed, the possible need for larger sized batteries, which means greater cost, etc.

There are two other obstacles in the way of complete and immediate popularization of the automobile radio receiver. One is the high list price of auto receiver, that is, when compared with the price asked for a receiver to be used in the home. The other is service. The first no doubt is a matter of demand and production. The second is a matter of being a virgin field. The automotive people are not as yet prepared to service these receivers.

(Ed. Herein lies a field for the radio service man. There are certain limitations it is true, as for that related to upholstery, but actual service upon the receiver can be carried out without association with the aerial system, which as it happens is the only part of the entire system related to the upholstery. Why not tie up with the local auto dealer to do his radio service and with a local upholsterer to do that part of the work. It is just a suggestion.)

—*Electronics, February, 1932*

◆ ◆ ◆  
When testing auto-radio receivers it is sometimes desirable to have the A battery voltage accessible. This can be accomplished by utilizing a bayonet plug that fits into the lampsocket upon the instrument panel or dashboard. (Ed. A regular two wire cable is connected to this plug and if desired this cable can terminate in a test bulb). The testing of an auto-radio receiver prior to actual mounting of the receiver.

*Vera, Radio World, Feb. 6, 1932*

### ◆ ◆ ◆ Public Address

(Continued from page 13)

magnetic fields and is dependent on the current in the disturbing circuit. Electrostatic induction is caused by voltage fields generally acting through capacity and is dependent on the volt-

age of the disturbing circuit. In order to protect against electrostatic induction it is necessary that metallic shields be used that more or less surround the system to be protected and they must be connected to the ground point of the system. This method of shielding has the effect of altering the magnetic shield so that the system to be shielded is no longer exposed to the field. The use of a ground on the midpoint of a transformer connected in a circuit, thereby balancing the circuit to ground, is also effective in protecting against electrostatic induction in certain types of circuits.

Protection against electromagnetic induction is ordinarily obtained by keeping close together two conductors which are associated as a pair, such as by twisting them, in order to eliminate the effects of loops of large area in which circulating currents may be induced. The use of a shield of very low resistance completely surrounding the system to be protected is also effective against electromagnetic induction in certain cases. If this shield is grounded its effectiveness against electro-magnetic fields is not increased, but it may act also as an electrostatic shield.

Shielding against electromagnetic fields must in general be made fairly thick in order to have sufficiently low resistance, and the lower the frequency against which the shield is to protect, the thicker it must be made. Against fields having a frequency greater than about 100 cycles a copper or lead shield is usually more effective. In ordinary amplifier work the frequencies that are most annoying are 60 and 120 cycles. The power transformer due to its large winding creates a very powerful 60 cycle field, and it is usually necessary to encase any audio transformers which are in the near vicinity of this field in heavy iron cases. The input transformer due to its high impedance and low level is usually the one that is most susceptible to hum pickup, and besides putting it in an iron case, it is placed as far away from the power transformer as is possible. In the filter section of the power supply the field generated is 120 cycles and while not as powerful as the power transformer is equally as annoying. The same precautions are also here observed. In the layout of the amplifier, it is usually good policy to analyze the different fields set up by the different transformers and to try as much as possible to have each filed at right angles to its neighbor. In electromagnetic shielding it is desirable to have the shield as thick as possible, but in shielding against electrostatic fields, the shield is equally effective, whether thick or thin.

GEORGE J. SALIBA

# Auto-Radio

Removing upholstery in auto radio installations is the work of an organization specializing in such operations. The service man equipped with the proper tools can install the receiver but it is best if he refrains from tampering with the upholstery.



**Spark Plug Interference** suppressors may or may not have to be used upon some Buick models. While it is true that most of the automobile receiver manufacturers who have made installations in this brand of car recommend the use of suppressors, there have been cases where the pan which covers the spark plugs was found to function as an effective shield. However both should be tried. The remainder of the usual ignition interference equipment must be used. Pipes which make intermittent contact with the chassis should be electrically grounded thereto.



## Installation Notes for RCA M-30 Auto-Receiver, Continued from January 1932 Issue

### STUDEBAKER COUPE 1930 8 Cylinder

**BATTERY TERMINAL GROUNDED** +  
(Make internal change in receiver).  
**LOCATION OF RECEIVER**—Close to right side of car under cowl, and as high as possible.  
**LOCATION OF LOUDSPEAKER**—As high as possible, over steering column.  
**LOCATION OF "B" BATTERY BOX**—  
In left side of rear compartment.  
**LOCATION OF ANTENNA PLATE**—On left frame channel, front hanger just back of storage battery.  
**APPLICATION OF IGNITION SUPPRESSORS**—

Distributor: Splice-in type, near distributor.

Plugs: Mount vertically on plugs.

**APPLICATION OF FILTER CAPACITORS**—

Generator: Fasten under inside cut-out mounting screw, connect pigtail to rear cut-out terminal.

Coil: Fasten under left bolt of coil bracket, connect pigtail to switch wire terminal of coil.

Ammeter: Fasten to bottom edge of instrument panel, try pigtail connection for best results.

**SPECIAL NOTES**—If roof antenna is used, it may be necessary to bond to the bulkhead pipes and control rods that pass through the engine

compartment. Also the lead-in should be shielded and come down right windshield column. Avoid running antenna lead-in or any connecting cables through engine compartment.

### STUDEBAKER 1932 6 Cylinder

**BATTERY TERMINAL GROUNDED** +  
(Make internal change in receiver).  
**LOCATION OF RECEIVER**—6" from left side of car under cowl, 16" above floor board, 4" from bulkhead.  
**LOCATION OF LOUDSPEAKER**—Right side of bulkhead, as high as possible.  
**LOCATION OF "B" BATTERY BOX**—  
Under right rear floor, ahead of crossmember, ½" from drive shaft, plug ahead.  
**LOCATION OF ANTENNA PLATE**—  
On left frame channel, front hanger just behind storage battery.  
**APPLICATION OF IGNITION SUPPRESSORS**—

Distributor: Plug-in type.

Plugs: Mount vertically on plugs.  
**APPLICATION OF FILTER CAPACITORS**—

Generator: Fasten under inside cut-out mounting screw, connect pigtail to rear cut-out terminal.

Ammeter: Bolt hole provided in bottom edge of instrument panel, connect pigtail for best results.

**SPECIAL NOTES**—Roof antenna installed at the factory, lead-in down right windshield column. Test for ground before using. If roof antenna is used it may be necessary to bond to the bulkhead pipes and control rods that pass through from the engine compartment. Avoid running antenna, lead-in or any connecting cables through the engine compartment. Shield secondary wire from coil to distributor and bond shield to bulkhead.

### STUDEBAKER DICTATOR 1932 8 Cylinder

**BATTERY TERMINAL GROUNDED** +  
(Make Internal change in receiver).  
**LOCATION OF RECEIVER**—Same as 6 cylinder model 1932.  
**LOCATION OF LOUDSPEAKER**—Same as 6 cylinder model 1932.  
**LOCATION OF "B" BATTERY BOX**—  
Same as 6 cylinder model 1932.  
**LOCATION OF ANTENNA PLATE**—  
Same as 6 cylinder model 1932.  
**APPLICATION OF IGNITION SUPPRESSORS**—

Distributor: Splice-in type distributor.

Plugs: Mount vertically on plugs.

**APPLICATION OF FILTER CAPACITORS**—

Generator: Fasten under gear case nut at base of No. 1 cylinder pigtail to inside cut-out terminal.  
Coil: Fasten under screw in bottom of circuit breaker, connect pigtail to right coil terminal.

Ammeter: Bolt hole provided in bottom edge of instrument panel. Use two capacitors, one on each side of ammeter.

**SPECIAL NOTES**—Same as 6 cylinder model 1932.

### STUDEBAKER COMMANDER 1932 8 Cylinder

**BATTERY TERMINAL GROUNDED** +  
(Make internal change in receiver).  
**LOCATION OF RECEIVER**—Same as 6 cylinder model 1932.  
**LOCATION OF LOUDSPEAKER**—Same as 6 cylinder model 1932.  
**LOCATION OF "B" BATTERY BOX**—  
Same as 6 cylinder model 1932.  
**LOCATION OF ANTENNA PLATE**—  
Same as 6 cylinder model 1932.  
**APPLICATION OF IGNITION SUPPRESSORS**—

Distributor: Splice-in type distributor.

Plugs: Mount vertically on plugs.

**APPLICATION OF FILTER CAPACITORS**—

Generator: Fasten under gear case nut at base of No. 1 cylinder, pigtail to inside cut-out terminal.

Coil: Fasten under screw in bottom of circuit breaker, connect pigtail to right coil terminal.

Ammeter: Bolt hole provided in bottom edge of instrument panel, connect pigtail for best results.

**SPECIAL NOTES**—Same as 6 cylinder model 1932.

### STUDEBAKER PRESIDENT 1932 8 Cylinder

**BATTERY TERMINAL GROUNDED** +  
(Make internal change in receiver).  
**LOCATION OF RECEIVER**—Same as 6 cylinder model 1932.  
**LOCATION OF LOUDSPEAKER**—Same as 6 cylinder model 1932.  
**LOCATION OF "B" BATTERY BOX**—  
Same as 6 cylinder model 1932.  
**LOCATION OF ANTENNA PLATE**—  
Same as 6 cylinder model 1932.  
**APPLICATION OF IGNITION SUPPRESSORS**—

Distributor: Splice-in type distributor.

Plugs: Mount vertically on plugs.

**APPLICATION OF FILTER CAPACITORS**—

Generator: Fasten under gear case nut at base of No. 1 cylinder, pigtail to right coil terminal.

Coil: Fasten under screw in bottom of circuit breaker, connect pigtail to right coil terminal.

Ammeter: Bolt hole provided in bottom edge of instrument panel, connect pigtail for best results.

**SPECIAL NOTES**—Same as 6 cylinder model 1932.

# Index of Monthly Literature

## AUTOMOBILE RADIO

### Improvements on,

Block, Radio Craft, March, 1932

### Problems for 1932

Electronics, p. 12, January, 1932\*\*\*

### Police

Lampkin, Electronics, January, 1932

### Receivers (Marquette)

Berge, Radio News, January, 1932

Berge, Radio News, March, 1932

## PRACTICAL THEORY AND TABLES

### Coil winding data

Radio World, January 30, 1932

### Filter design

Johnson, Radio News, January, 1932

Johnson, Radio News, February 1932

Johnson, Radio News, March, 1932

### Ohm's Law

Radio Call Book, pp. 31, February, 1932

## TESTING EQUIPMENT

### Meters

#### AC and DC multi-range

Radio Call Book, pp. 28, January, 1932

Radio News, pp. 769, March, 1932

#### Multipliers and shunts

Radio Craft, pp. 406, January, 1932

### Set Testers

Radio Craft, pp. 465, February, 1932

Radio Craft, pp. 537, March, 1932

Radio News, pp. 774, March, 1932

Radio Retailing, pp. 40, February, 1932

### Oscillators

#### Beat frequency

Radio News, pp. 580, aJanuary, 1932

#### Dynatron

Q.S.T. pp. 32, February, 1932

#### Dynatron with amplifier

Q.S.T. pp. 37, February, 1932

#### RF Pentode

Radio News, pp. 680, February, 1931

### Voltmeter, (Vacuum Tube)

Radio News, pp. 762, March, 1932

Bryant, Radio Craft, February, 1932

## BROADCAST RECEIVER OPERATION

### Air Cell Battery

Bowditch, I.R.E., February, 1932

Fox, Q.S.T., September, 1931

### Amplifier (direct-coupled)

Fishberg, Radio Craft, aJanuary, 1932

Fleming, Radio News, January, 1932

### Automatic Volume Control

Radio Call Book, pp. 41, January, 1932

### Adjustments

#### RF trimmers for Superhet

Anderson, Radio World, February 13, 1932

#### AF and RF stabilization

Tully Radio, World, January 2, 1932

### Coils

#### Antenna for Radiola 28

Radio Retailing, pp. 41, January, 1932

### Hum

#### Elimination methods

Fitzalan, Radio World, February 20, 1932

### Current

#### Grid, in oscillators

Brunn, Radio World, January 9, 1932

### Interference

#### Elimination, antenna circuit

Radio Call Book, pp. 38, January, 1932

### Receivers

#### Principles of superhets

Sprayberry, I.R.S.M., January, 1932

#### Lincoln, All-wave

Hollister, Radio Craft, January, 1932

#### Silver-Marshall 12 tube

Radio News, pp. 768, March, 1932

## TUBES

### Mercury Vapor Tube

Schwerin, Radio Craft, March, 1932

### RF Pentode ('39)

Radio Call Book, pp. 40, February, 1932

Q.S.T. pp. 34, February, 1932

Ritter, Electronics, January, 1932

### Triple-Twin (295)

Radio News, pp. 758, March, 1932

Radio Retailing, pp. 42, February, 1932

### Photo-Tube (868)

Radio Call Book, pp. 30, March, 1932

Radio World, pp. 8, January 9, 1932

### Voltage Amplifier (841)

Radio World, pp. 3, January 16, 1932

Radio World, pp. 11, January 23, 1932

# Tube Socket Connections

*As seen from beneath sub-panel*

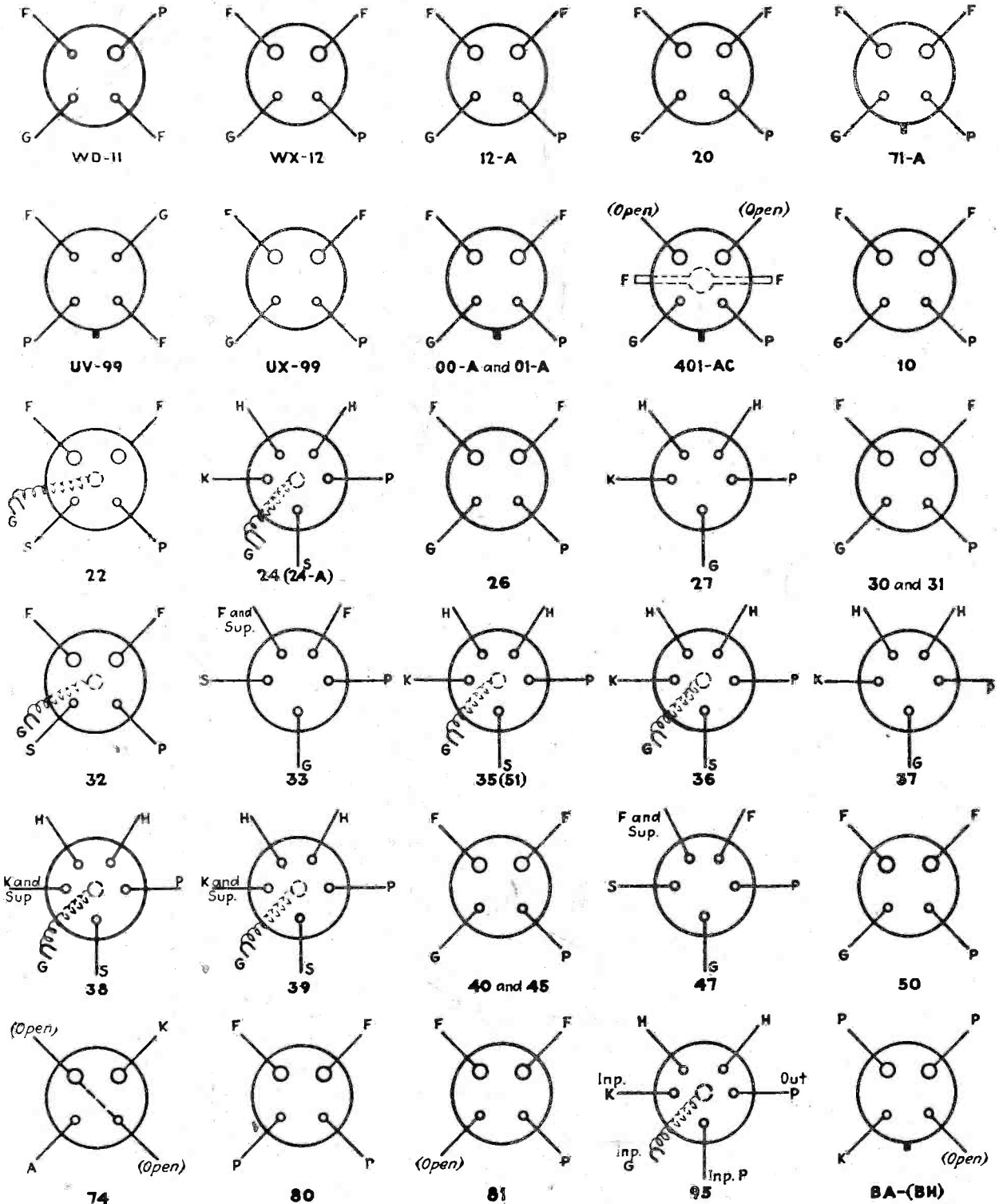

- Symbols —
- F — Filament
  - H — Heater
  - K — Cathode
  - G — Grid
  - P — Plate
  - S — Screen
  - Sup. — Suppressor Grid

JOHN F. RIDER'S

## Perpetual Trouble Shooter's Manual

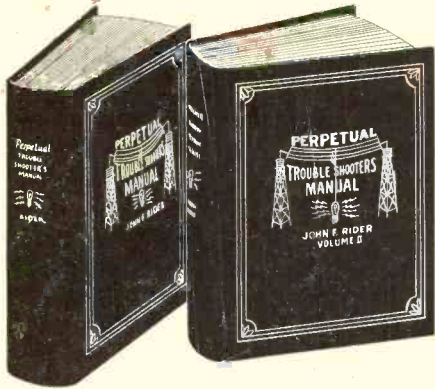

is recognized as the standard in the radio industry. Every service man who has need for wiring diagrams of commercial receivers should consider well when buying a manual which is supposed to give him all of the required service data.

The first Trouble Shooter's Manual by Rider was published in 1929. It received very excellent response from the service industry. The Perpetual Trouble Shooter's Manual was received with even greater approval.

There are many reasons why this loose leaf manual of more than 1000 pages has been accepted by the radio service industry—why it has been found to be the greatest aid to the practicing service man.

Having been prepared with the co-operation of the radio receiver manufacturers, the material presented is accurate in every detail.

Recognition in and the co-operation of the radio manufacturing industry has made possible the presentation of electrical values—color coding—chassis layouts—transformer color coding—voltage data—socket layouts—pictorial views of the chassis—changes made in receivers—etc. **EVERYTHING** the service man requires so that he can service rapidly and accurately.

### A Supplementary Service to Rider's Perpetual Trouble Shooter's Manual

**Guaranteed minimum of 96 pages per month - 288 pages per quarter -  
1152 pages per year** of up-to-the-minute Radio Service Data available  
in "Monthly" or "Quarterly" mailings.

**2300 PAGES BY SEPTEMBER**

Every owner of Rider's Perpetual Trouble Shooter's Manual and subscriber to Rider's Supplementary Service will by September, 1932, have a two volume manual of at least 2300 pages of the most accurate, valuable and time-saving service data available in the radio industry.

In days gone by, radio receivers were simple circuits. Today they are complex. Radio receivers are continually changing. . . . A few years ago the average service man could get along. . . . Today you must be better than average to get by. . . . Modern service must be rapid and accurate. . . . Nothing but the proper amount of service data will enable you to work accurately and rapidly—to meet competition and make more money.

### MONEY BACK GUARANTEE

You risk nothing in subscribing to this service. At any time if you are not satisfied that you are receiving more than full value, merely return the supplements and any premiums and we shall willingly and promptly return your money. . . . No questions. . . . No reservations. . . . You can't lose.

Price for the Manual only \$5.00 postpaid.

Price for the "Quarterly" Service \$ .50 per month.

Price for the "Monthly" Service \$ .75 per month.

The Manual and Supplementary Service are available upon the Easy Payment Plan. Send for descriptive literature.

## **RADIO TREATISE CO., INC.**

1440 BROADWAY

NEW YORK CITY