

# SUCCESSFUL

# Servicing

JANUARY 1952

## Using the 'Scope for

# TV SERVICING

by Walter Boiko and Joseph J. Roche

The oscillograph is one of the most useful instruments available for servicing television receivers. The purpose of this article is to help those who are now using the instrument to obtain maximum value from it.

The utility of the oscillograph is greatly increased if a crystal probe and a voltage calibrator are available. To observe the signals in the r-f and i-f stages of a tv receiver the signal must be detected before it is applied to the vertical input terminals of the oscillograph. The crystal probe performs this function.

### Using the Probe

To observe the signals in these stages the output leads of the probe should be connected to the vertical input terminals of the instrument, the ground lead of the probe connected to the chassis, and the positive lead of the probe connected to the circuit to be investigated.

The usual procedure in troubleshooting the r-f and i-f stages of a receiver is to observe the signal at the grid and then the plate of each stage. The probe detects with the same polarity at all times and the 180° phase shift, which occurs between the input and output of each stage, is not observed on the oscillograph screen—a point which often confuses the beginner.

### Probe Loading

When the probe is connected to a high-Q tuned circuit it loads the circuit, changing its response characteristics. If this point is not kept in mind, the information appearing on the oscillograph screen can be misleading.

An example of the effect of probe loading occurs in the narrow-band sync amplifier (Fig. 1) of current production Du Mont Telesets. The narrow-band sync transformer, Z209, is sharply tuned. When a probe is ap-

(Continued on page 6)

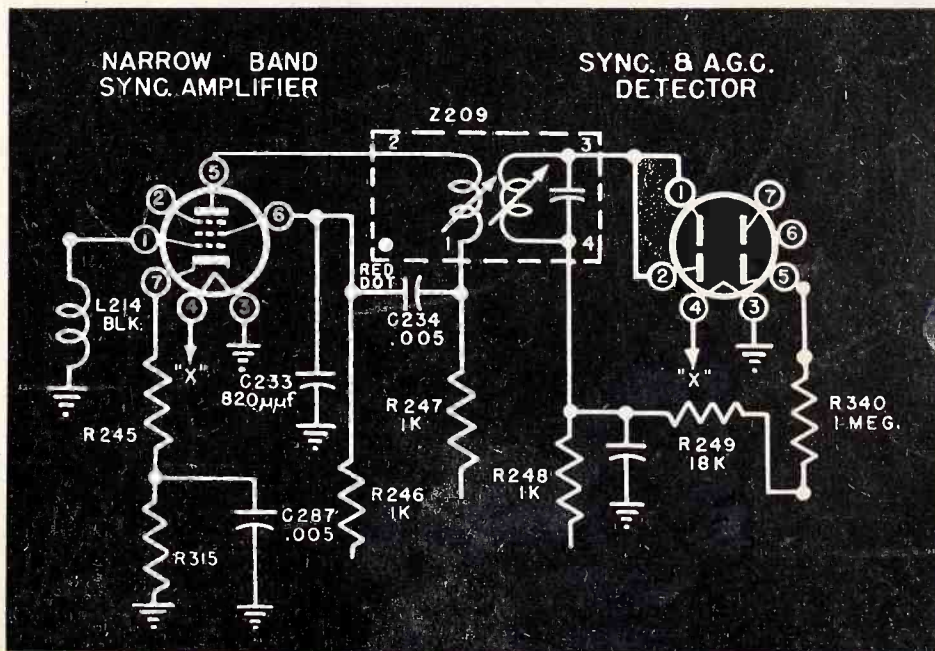
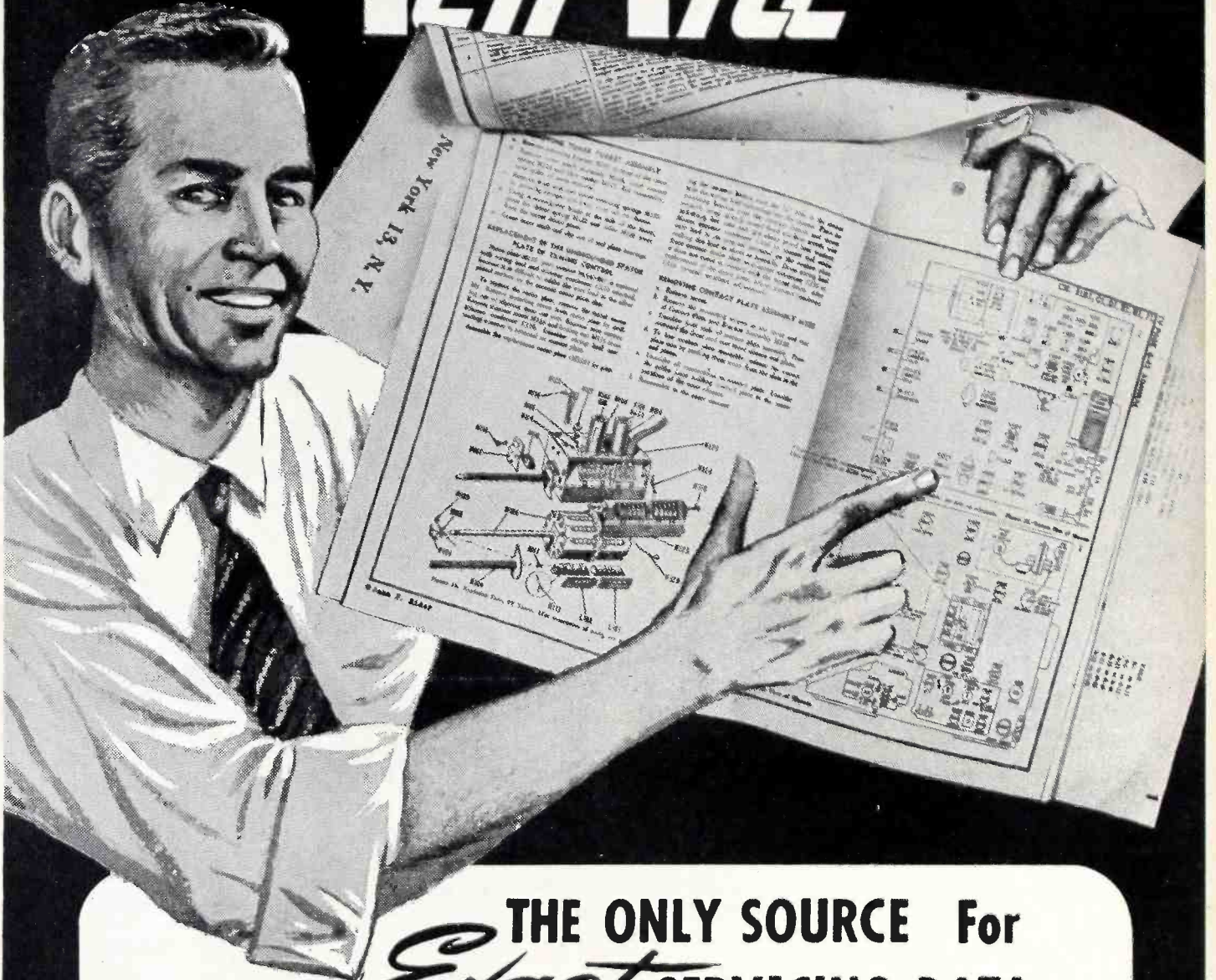

Fig. 1. Narrow-band sync amplifier of television receiver.



# TEK-FILE



## THE ONLY SOURCE For *Exact* SERVICING DATA

Make your servicing job faster — easier — and more profitable by using the new Tek-File: The only monthly service that gives you complete, factory-authorized data which exactly matches the set you're working on

You buy only what you need — when you need it. Each Tek-File pack has at least 128, 8½ x 11" pages bound in one or more file folders — containing *complete* servicing data for the manufacturer's sets you specify. Easy to file, easy to use in shop or field. See your jobber today.

**THE MAN WHO USES  
RIDER TEK-FILE — MANUALS  
MAKES MORE MONEY.**



**JOHN F. RIDER**

PUBLISHER, INC.  
480 Canal St., N. Y. 13, N. Y.

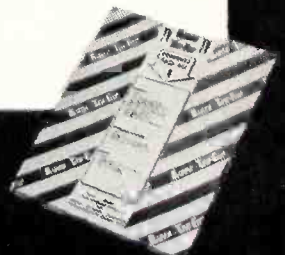



# What's Tek-File?

The complete story on the new companion to the Rider Manuals.

For over 20 years, radio and television technicians have found Rider Manuals to be the most dependable source of accurate, factory-authorized servicing data on all models of radio, public address, and television receivers. These data were available in completely collated and indexed manual form. The manuals appeared periodically at intervals of 4 to 5 months. This service is being continued, but in addition, and as an aid to the radio and tv servicing industry, there has come into being a new arrangement whereby these authentic and accurate data are made available to the industry. This is RIDER TEK-FILE.

## Packaged Service Data

RIDER TEK-FILE answers the needs of many radio and television technicians. It is packaged service information, representative of the data which the manufacturer uses in his own factory. The specialist on certain brands of receivers, the part-time worker, the engineer, the technician who repairs receivers in the home—their needs are satisfied by the packaged RIDER TEK-FILES because they can procure the data they need as they require it. This applies to current models and old models. Each RIDER TEK-FILE pack sells for only two dollars (\$2.00) and contains all the features which have made Rider Manuals the standby of the servicing industry for more than 20 years.

As new receiver models are made available by the manufacturers, the service data is

Fig. 1. Contents of a typical Tek-File pack. Note the waveform diagrams in the service data. Not shown here are the Handies and Binder Coupon included in this pack.

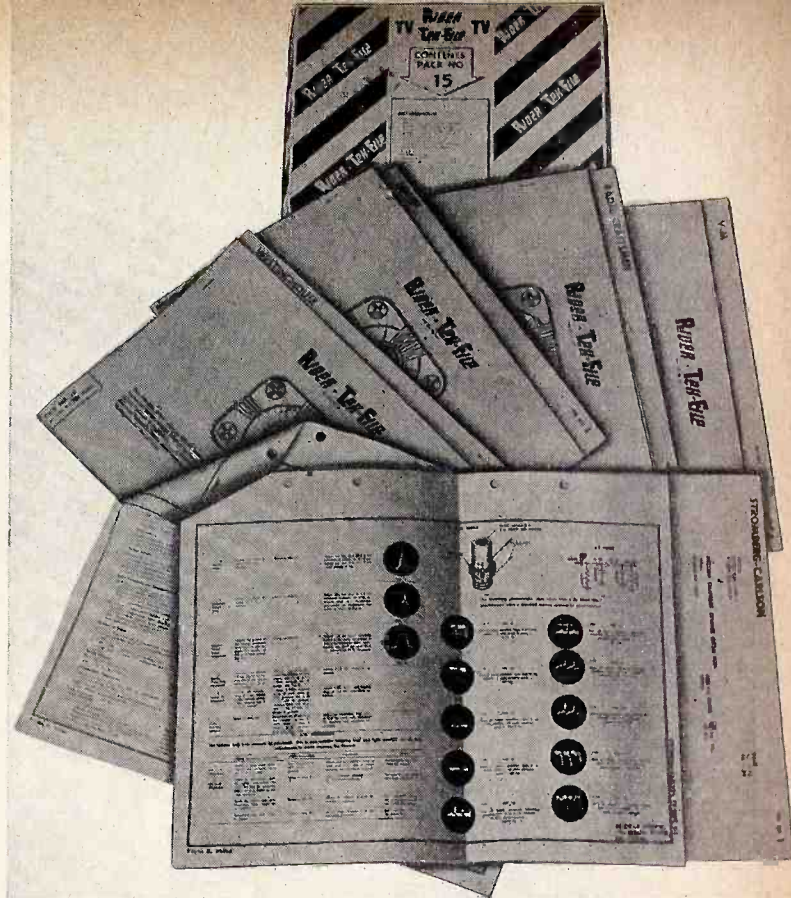

incorporated into new RIDER TEK-FILE packs. In this way, the technician has his manufacturer-authorized service data in his shop, ready for the first set to come in for repair. The serviceman's data is up-to-date, up-to-the-minute.

Figure 1 shows part of the contents of a single RIDER TEK-FILE package. This pack contains four file folders, each 9½ x 12 inches. The Westinghouse folder contains all of the factory-tested service data (the equivalent of 104 8½ x 11 inch pages) for 26 different Westinghouse tv receiver models manufactured in 1951. Similarly, the Zenith, Stromberg-Carlson, and Radio Craftsmen file folders in this pack contain the unabridged servicing data for late model television re-

ceivers manufactured by these firms. The V-M folder contains all of the data for the popular model V-M 950 record changer.

Each file folder contains a wealth of factual installation and service data. Included are step-by-step procedures for repairing and correcting actual circuit faults. The Stromberg-Carlson folder (shown open in Fig. 1) contains, for example:

1. A complete physical and electrical description of the Stromberg-Carlson models 317TM and 317RPM television receivers.
2. Factory-tested and recommended installation adjustments.
3. Complete step-by-step alignment procedures for tuner, i-f, and audio stages.
4. The actual oscilloscope waveforms which should be observed at every relevant checkpoint in the chassis are included for faster and more accurate troubleshooting alignment.
5. A tube location diagram.
6. A complete chart of the normal voltages which should be found at the pins of all tubes.
7. A complete parts list giving values and tolerances.
8. Large size, easily followed schematic diagram.

All of this in a convenient folder, with the manufacturer's name clearly marked on the top. This folder is so designed that it can be brought by the technician to his customer's home on a service call. He will therefore have the information he needs right there with him when he needs it. The folder can also be filed in any standard 11½ x 13½ inch file cabinet for quick and easy reference in the shop.

(Continued on page 24)

### STROMBERG-CARLSON

MODEL 317 Series

#### Noise in Picture (Improvement for Fringe Area)

White noise spots appearing in the picture in fringe areas, caused by video amplifier overshoot, may be reduced by the following changes:

1. In the L-12 position, the video detector load, peaking coil Part No. 114641 replaces old Part No. 114716.
2. In the L-25 position, the video amplifier grid, peaking coil Part No. 114725 replaces old Part No. 114715.
3. In the L-14 position, the video amplifier plate, peaking coil Part No. 114691 replaces old Part No. 114714.
4. In the L-13 position, the picture tube cathode, peaking coil Part No. 114726 replaces old Part No. 114713.
5. Capacitor C-101 in the contrast circuit becomes 1,000mmf (Part No. 110599) instead of 750mmf.
6. Capacitor C-153, 33mmf, in the Noise Reference-Blanking Amplifier section, is removed.
7. Capacitor C-151, in the same section, is changed from .1mf to .047mf (S-C Part No. 110722).
8. Resistor R-150, in the same section, is changed from 680K to 1 meg (S-C Part No. 149119).
9. Resistor R-152, in the same section, is changed from 10K to 18K (S-C Part No. 28173).
10. Resistor R-160, in the Keyed AGC section, is changed from 18K to 22K (S-C Part No. 149109).

NOTE: These changes have been made in receivers date-coded 51-18-3 and later.

Fig. 2. A typical Tek-File Handy.



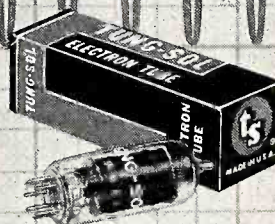
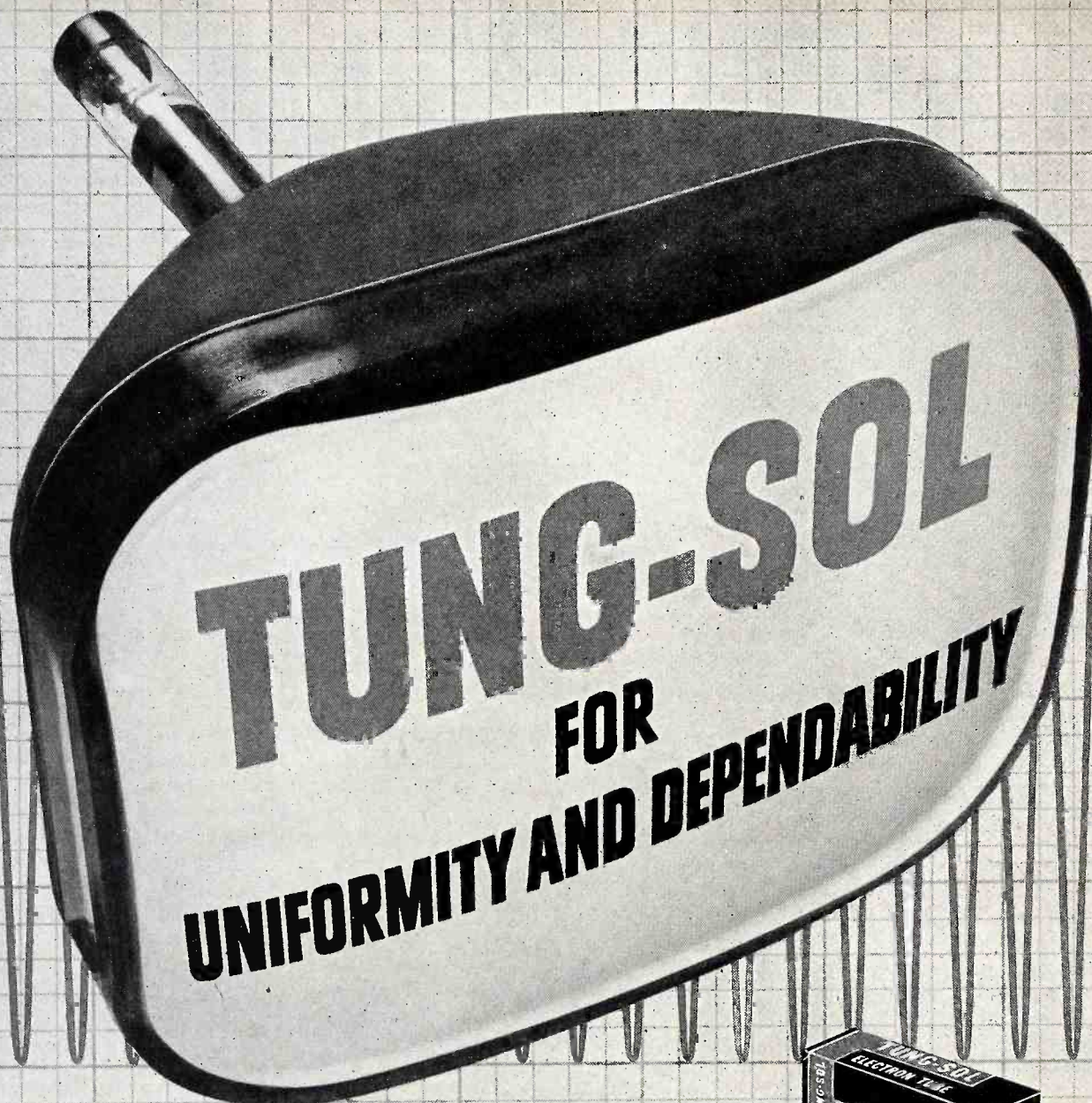

**REPLACEMENT:**

Tung-Sol Tubes keep service standards up to set manufacturers' specifications.

**INITIAL EQUIPMENT:**

Tung-Sol Tubes meet the highest performance requirements of set manufacturers.

TUNG-SOL ELECTRIC INC., Newark 4, N. J. Sales Offices: Atlanta  
Chicago • Dallas • Denver • Detroit • Los Angeles • Newark

**TUNG-SOL**  
RADIO, TV TUBES, DIAL LAMPS



# Successful SERVICING

REG. U.S. PAT. OFF.

Dedicated to the financial and technical advancement of electronic maintenance personnel

Volume 14 Number 3

January, 1952

JOHN F. RIDER, *Publisher*

Charles Tepfer, *Editor*

Annette M. Tricarico, *Assoc. Editor*

*Advertising Representative*

H. J. Oslow & Co.

3951 Grand Central Terminal

New York 17, N. Y.

Murray Hill 6-4670



MEMBER



## Curtain Time

### How About Your Radio Receiver?

It is safe to say that not one out of one hundred servicemen who call in a home to repair a tv receiver, or to pull a tv chassis, ask the owner about possible radio receiver service. More than likely every home equipped with a tv receiver has one or more radio receivers. The interest in tv reception takes the play away from the radio receiver with the result that its repair, assuming it to be defective, is put off. But the power of suggestion is very great; bring the radio receiver to the attention of the set owner and, having just had his tv receiver repaired properly, he will be prone to have the defective radio set repaired.

The tv servicing industry is missing a good bet in radio receiver servicing. Not only is it a source of added income, but the cost of traveling to and possibly from the home is already paid for by the repair charge for the tv receiver. It is just as easy to return a tv receiver and a radio receiver, as the former only. The solicitation for the radio repair business is made very easy by a good

tv repair job. The confidence is established and this means a great deal.

Statistics show that more than 65,000,000 radio receivers have been sold during the last six years. Add these to those already in the home before 1946, and a pool of at least 100,000,000 radio receivers is potentially available for service. Isn't it an awful waste of income not to do a little selling job on the use of radio and tv in the average home? Make the public conscious of their radio equipment and they will have their defective receivers repaired. Whatever may be the percentage of success in this direction, it is added income with relatively little selling expense.

Vendors of all kinds cook up all sorts of tactics to enable their salesmen to get their foot in the door. Here is the tv service technician who not only gets his foot in the door, but is very welcome because his services are needed—only to overlook his sales and income opportunities.

### TV Courses for Servicemen

We have from time to time expressed our belief that many servicemen could further advance in radio and tv theory to the point where it increases their servicing ability. Servicemen's organizations could perform a necessary service to their members by instituting classes on this subject. In fact, this has already been done by a number of such organizations.

The Blair County Association of Radio Service Engineers in Altoona, Pennsylvania, has been running a television school for its members which can very well serve as a model for all similar organizations. The course itself is designed to give the serviceman a solid background primarily in tv theory because during the daytime they work at tv servicing. The course covers all types of receivers, and is given twice weekly from 8 to 10:30 in the evening. The student pays \$5 a month, out of which \$1 is deducted for monthly dues, if the student attends every course session. For the past fifteen months, a class of 40 servicemen have been taking the course in Altoona.

One locality where the local school board has cooperated with a servicemen's organization educational program is New York City, where the Associated Radio and Television Servicemen of New York present a program of radio and tv instruction in cooperation with the New York City Board of Education. The Board furnishes the instructors and classrooms, and the Association furnishes the students.

Besides this program of instruction, the Association operates at its clubrooms, a servicemen's clinic where, during any night of the week, a member may bring up a tv or radio receiver which has been of particular trouble to him in his shop. The other servicemen members discuss the chassis and work out its repair together.

*John F. Rider*



Using the 'Scope

# IN TV SERVICING

(Continued from page 1)

plied directly to the primary or secondary of the transformer, the waveforms observed are distorted, as shown in Fig. 2. The loading can be minimized by connecting a small capacitor (approximately 1mmf) in series with the positive input lead of the probe. A short length of miniature 75-ohm twin lead, connected as shown in Fig. 3, can serve as a capacitor for this purpose. The series capacitor should be used when checking the signal at the primary or secondary of the NBS transformer.

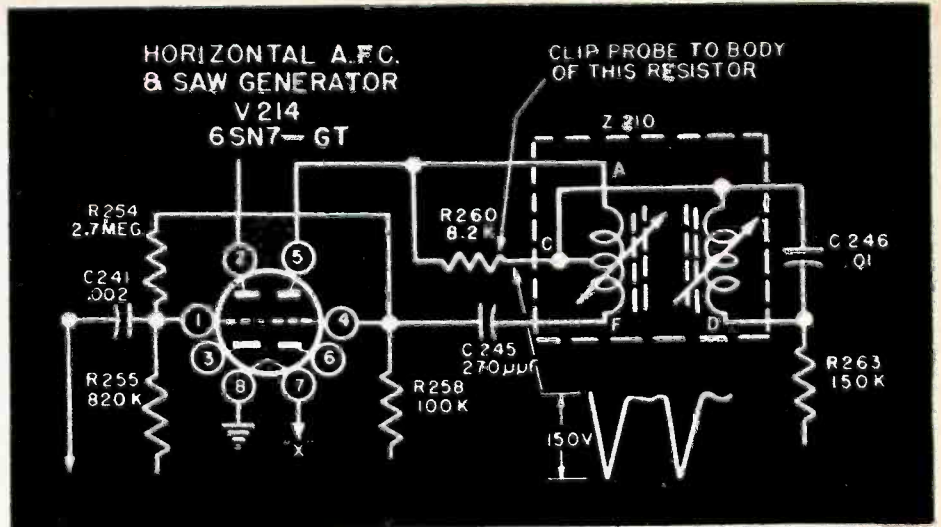
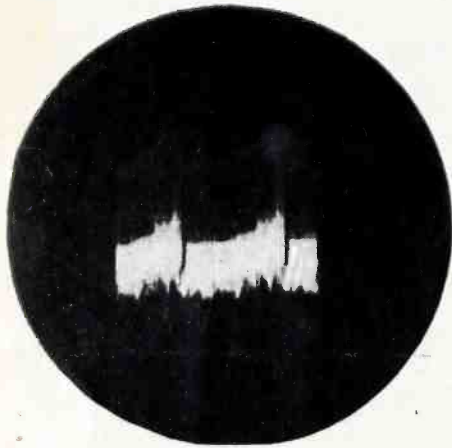
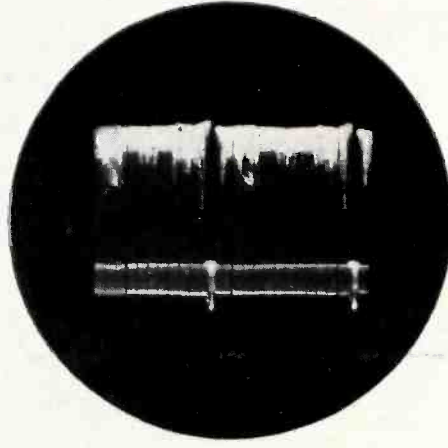

Fig. 4. Horizontal oscillator circuit of typical television receiver.



(A)



(B)

Fig. 2. (A) Waveform at NBS transformer distorted by probe loading, and (B) normal NBS waveform.

of R260, the 8.2K resistor connected between terminals A and C of Z210. This minimizes loading of the circuit, eliminates the waveform distortion, and enables the technician to secure the proper waveform, as shown in Fig. 5B.

### Troubleshooting

In troubleshooting a television receiver with an oscillograph, the waveforms of the signals in suspected stages are examined and compared to waveforms which are known to be correct. When a distorted waveform is discovered it is analyzed to determine which components or adjustments could be the cause of the distortion. The components which may be at fault are then checked with a suitable voltmeter and ohmmeter, or by substitution.

The procedure to be followed in troubleshooting can best be described by giving actual examples. Several typical receiver faults and the methods used to locate the defective components are described in the following paragraphs.

Another example of the effect of circuit loading occurs in the horizontal oscillator (Fig. 4) of RA-111A, RA-112A, RA-113 and RA-117A Du Mont Telesets. When adjusting the horizontal oscillator transformer, the oscillator signal is observed on an oscillograph connected between terminal C of the transformer and ground. Since the signal at this point in the circuit has already been detected (by the sync detector) the crystal in the probe is not used. If the ungrounded vertical input terminal of the oscillograph is connected directly to terminal C of the transformer, a distorted waveform similar to that shown in Fig. 5A will be obtained. The distorted waveform is identical to that which

is obtained when the transformer is improperly adjusted, and may lead the unsuspecting technician to assume that readjustment is required. The loading effect can be eliminated by clipping the positive probe lead to the body

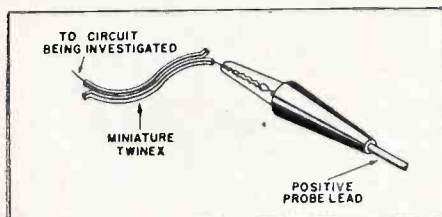
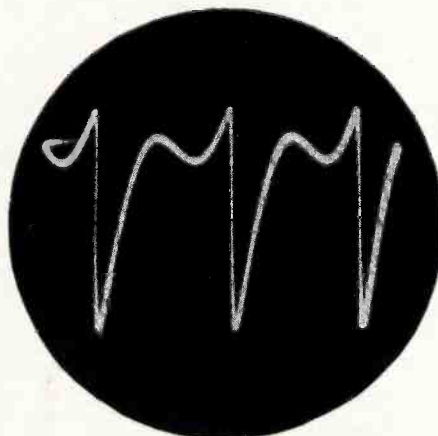
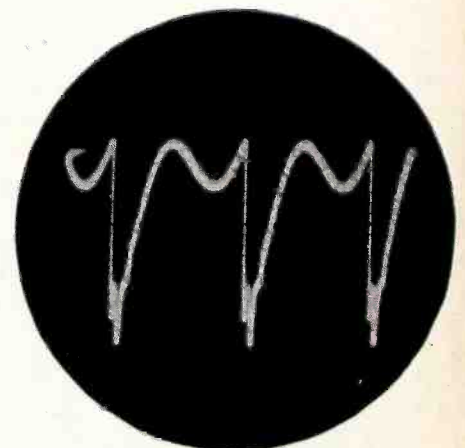

Fig. 3. Method for minimizing loading effect of probe on high-Q tuned circuit.



(A)



(B)

Fig. 5. (A) Waveform at horizontal oscillator transformer distorted by loading and (B) normal waveform at horizontal oscillator transformer.



**Sync-Pulse Compression**

Compression of the sync pulses accompanying the composite video signal is a common fault occurring in television receivers. It results in poor horizontal and/or vertical stability.

Sync compression is a reduction in the relative amplitude of the sync signals with respect to other information in the composite video signal. An oscillograph pattern of a composite video signal (oscillograph synchronized at vertical sweep frequency) exhibiting sync compression is shown in Fig. 6A. A normal pattern is shown in Fig. 6B. Note the difference in the amplitude of the sync pulses in these signals.

Compression of the vertical and/or horizontal sync signals can be caused by the following.

1. Improper alignment of one or more video i-f stages.
2. Overload resulting from insufficient agc voltage.
3. Improper adjustment of the narrow-band sync transformer.
4. A defective component affecting the frequency response or amplitude linearity of one of the stages through which the signal passes.

When a case of horizontal and/or vertical instability is encountered a check should be made for sync compression. This may be accomplished by examining the output of the sync-detector stage with the oscillograph controls adjusted to observe one or two vertical fields.

If sync compression is observed at the output of the sync detector, the stage in which the compression is taking place may be isolated by working toward the front end of the receiver, checking the signal at the plate and grid of each stage. When compression is observed at the plate but not the grid of a stage, the compression is obviously occurring in that stage. Voltage and resistance measurements, and an alignment check in i-f stages, should then be made to determine the exact cause of the trouble.

**Hum**

The oscillograph is useful when attempting to locate the cause of hum in the video signal. The first step is to determine whether the frequency of the hum is 60 cycles or 120 cycles. This can be accomplished by setting the oscillograph controls to observe two fields (30-cycle sweep) and examining the signal at the output of each video i-f stage, each video amplifier stage, and at the grid of the picture tube. A normal signal, a signal containing 60-cycle hum and a signal containing 120-cycle hum are shown in Fig. 7. Note that there is one cycle of hum per field when the frequency of the hum is 60 cycles (Fig. 7B), and two when the hum is 120 cycles (Fig. 7C). The frequency of the hum may be identified in this way.

60-cycle hum is usually the result of coupling between the filament supply and the signal circuits. The most common cause is filament-to-cathode leakage in one of the r-f,

terminal to the cathodes of each of the suspected tubes in turn. The cathode at which the largest 60-cycle signal appears will usually be that of the faulty tube. The above applies only to tubes using cathode bias.

60-cycle hum can also enter the r-f and video i-f stages through the agc line. The agc line should be checked in the manner described above. If 60-cycle hum is discovered on the line, the tubes in the agc, sync detector and associated stages should be checked.

120-cycle hum is usually the result of a filter capacitor failure. The B+ lines should be checked using the method described for 60-cycle hum. The amplitude of the hum at various points in the B+ voltage-divider circuit will give some clue as to the location of the faulty component. Voltage, resistance and substitution checks may then be used to identify the defective component.

Some 120-cycle hum and 60-cycle ripple—from the vertical-sweep circuits—normally

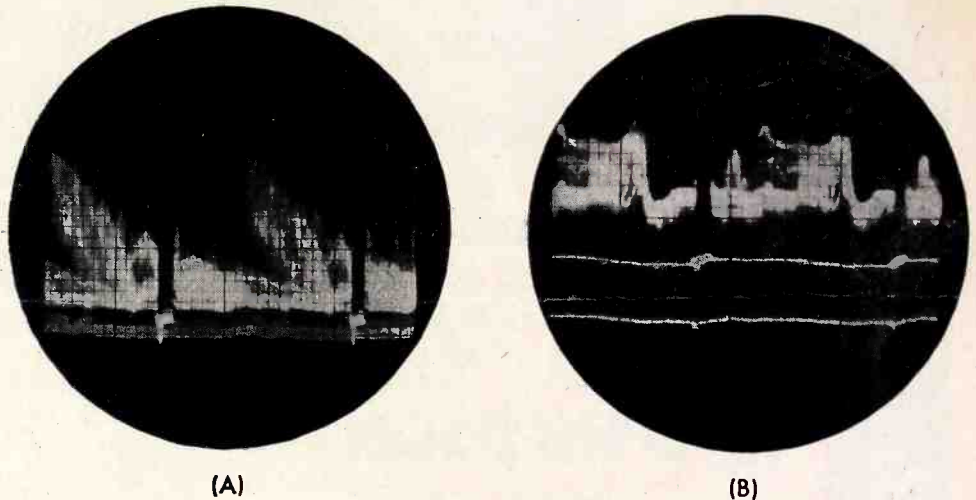

Fig. 6. (A) Composite video signal exhibiting sync compression. (B) Normal composite video signal.

video i-f, or video-amplifier tubes, or the picture tube. To locate the faulty stage, connect the ground terminal of oscillograph to the Teleset Chassis, set the instrument for 30-cycle sweep, and connect the vertical-input

appears in the B+ circuits. In order to avoid being misled the technician should familiarize himself with normal conditions by examining the B+ circuits of a properly operating receiver.

(Continued on page 11)

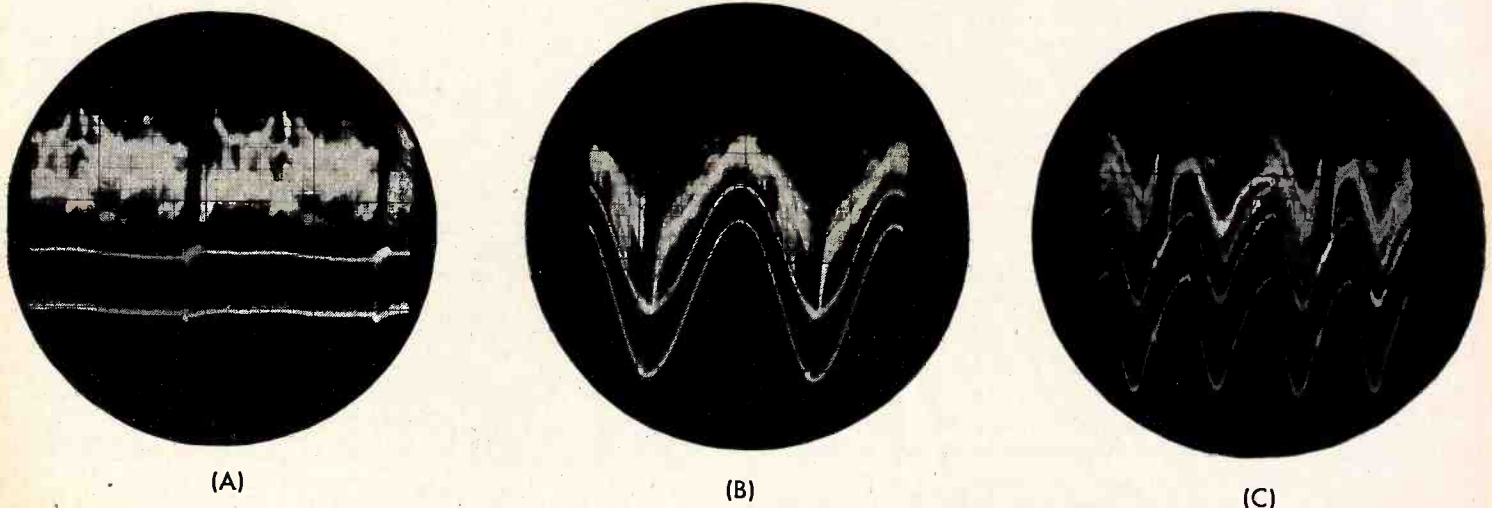

Fig. 7. (A) Normal video signal, (B) video signal with 60-cycle hum, and (C) video signal with 120-cycle hum.





for greater speed and  
accuracy of TELEVISION INSTALLATIONS  
in any locality use the new

# Simpson

MODEL 488

## TV FIELD STRENGTH METER

In addition to location of maximum signal areas, the Simpson Model 488 Television Field Strength Meter is also ideal for antennae orientation, comparison of antennae systems, adjustment of TV signal boosters and checking antennae and lead-in installations to list but a few of the many functions available . . . THE 50 MICROVOLT FULL SCALE RANGE IS AN OUTSTANDING FEATURE FOR THOSE CONCERNED WITH FRINGE AREA INSTALLATIONS WHERE MAXIMUM EFFICIENCY MUST BE ATTAINED . . . The 500, 5,000 and 50,000 microvolt ranges extend the usefulness of the Simpson Model 488 into areas of higher signal strength. The large 4½-inch modernistic meter is easily read from a considerable distance and all controls and connections are arranged for greatest accessibility. Model 488 is housed in a beautiful gray hammerloid finished case for greater portability. LINE VOLTAGE: 105-125 volts, 50-60 cycles. SIZE: 8" x 11" x 8½".

WEIGHT: 11½ lbs. Shipping weight 15 lbs.  
DEALER'S NET PRICE, including operating instructions and shoulder strap . . . \$89.50

### SIMPSON ELECTRIC COMPANY

5200 WEST KINZIE STREET, CHICAGO 44, ILLINOIS

Phone: COLUMBUS 1-1221

In Canada: Bach-Simpson, Ltd., London, Ontario



# ASSOCIATION NEWS

From National Alliance of Television and Electronic Service Associations (NATESA) headquarters comes news of the results of the elections in various member groups. . . . The Associated Radio and Television Service Dealers, Columbus, Ohio affiliate, elected Fred Colton President, The Television and Electronics Service Association (formerly the Nebraska-Iowa Television and Electronic Service Association) elected Jim Hustad President. Jim is also Secretary General of NATESA. Edmund Trefari has been elected to a directorship in NATESA by the Radio and Television Servicemen of New Jersey.

The Television Installation Service Association (TISA), Chicago affiliate of NATESA, is making available to its members a little pamphlet on the care of tv receivers for distribution to their customers. The pamphlet is called "Why Service," and does a clever job of informing the tv set owner of the need for periodic service to keep the set in good shape.

A forum on tv servicing, designed to clear up many of the questions on servicing in the minds of industry and the public, was held on January 24th in Detroit, Michigan. Sponsored by the Television Service Contractors Association, Inc., of Detroit, the audience consisted of representatives of manufacturers, set distributors, parts jobbers, manufacturers agents, tv dealers, tv contractors, members of

the Detroit press, and tv stations. Special speakers at this forum were Paul V. Forte, Albert M. Haas, and Paul Wendel.

Servicemen in the Columbus, Ohio area will have an opportunity to hear John F. Rider, well-known radio and tv author and lecturer, and publisher of RIDER MANUALS and Tek-File, on February 13. This talk will be sponsored by Whitehead Radio Company of Columbus, Ohio.

The National Appliance and Radio Dealers Association (NARDA) held its annual convention at the Conrad Hilton Hotel in Chicago on January 13-15. Forty-nine of its members were honored at the annual banquet held in the Grand Ballroom on Monday, January 14, for "playing a leading part in the crusade for higher standards in their industry by working for better understanding and fuller cooperation among the nation's retailers."

Radio Servicemen's Association of Trenton, New Jersey . . . In order to promote a more progressive and active program within the association for the benefit of its members, a series of technical and business lectures have been arranged for and will be held in the studios of the local broadcasting stations. Gibson Grandly, Chairman of the membership committee announced that membership in the Association is open to all radio and tv tech-

nicians and service dealers in the Metropolitan area of Trenton.

The Blair County Radio Service Engineers Association and the Mid-State Radio Servicemen's Association of Harrisburg among other groups report a rise in membership as a result of the lecture series they have been running. The lectures are not only well attended, but bring many servicemen into the fold after they realize that the local associations are on their toes.

Due to the rapid growth of membership in the Radio and TV Technicians Guild of Florida, it was felt necessary to increase the number of members on the board of directors. The following members were elected to the board for a period of one year: Samuel Kessler, Thomas M. Middleton, and John C. Ryan. This makes a total of eleven men on the board.

The Southern Pennsylvania Radio Servicemen's Association of York, Pennsylvania, became the 10th chapter in that state of the Federation of Radio Servicemen's Association of Pennsylvania. Incidentally, the 50 point program on servicing, as compiled by representatives of the Federation to the Joint Electronic Radio Committee on Service in Philadelphia, is being presented by all chapters to their local distributors and manufacturer's representatives for action.

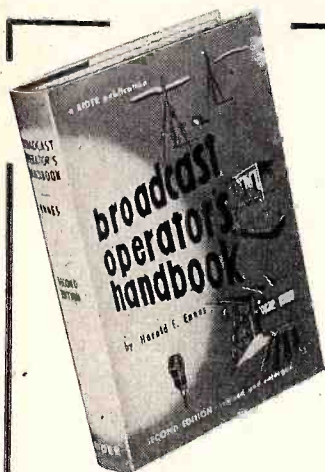

**BROADCASTING-TELECASTING** magazine says:

"There have been many changes in the broadcasting art . . . the new volume brings these to the attention of veteran and newcomer alike in work-a-day, how-to-do-it fashion."

## BROADCAST OPERATOR'S HANDBOOK

Second Edition by Harold E. Ennes

COMPLETELY REVISED and brought up to date, the book deals with the practical considerations of radio broadcasting and its equipment. The first four parts of the book cover actual operating practice in control rooms, the master control, remote controls, and the transmitter; the fifth and sixth parts discuss technical data for operators and technicians, including vital maintenance instructions. The author, a practicing broadcast operator, takes you inside and outside the studio, while explaining all the why's and wherefore's of daily studio routine.

Written in the operator's language, the text is intended not only for students of broadcasting techniques, but veteran operators also, who wish to keep abreast of current techniques in the field.

THE NEW EDITION FEATURES a completely new chapter on meeting emergencies in the control room, and how to cope with transmitter troubles. Modern methods of studio transcription are discussed with emphasis on magnetic tape recordings. FM broadcasting is treated as well as AM practices. *This is the most up-to-the-minute book on broadcast operating practice.*

Order from your jobber or —  
**JOHN F. RIDER PUBLISHER, INC.**  
 480 Canal St., New York 13, N. Y.

### CONTENTS

**Part I: Operating in the Control Room**—1. What You're Up Against; 2. Are Mechanical Operations Apparent?; 3. Keeping Sound "Out of the Mud"; 4. You're Often a Producer Too; 5. Studio and Control Room;  
**Part II: Operating the Master Control**—6. Where Split Seconds Count;  
**Part III: Operating Outside the Studio**—7. Remote Control Problems; 8. Remote versus Studio Pickups; 9. Remote Musical Pickups; 10. Eye-Witness Pickups and Mobile Transmitters; 11. Field Facilities; **Part IV: Operating the Transmitter**—12. Operator's Duties; 13. Programs Are Entertainment; 14. Measuring Noise and Distortion; **Part V: We're Off the Air**—15. Emergency Shutdowns; 16. Why Preventive Maintenance; 17. Preventive Maintenance Instructions; **Part VI: Technically Speaking**—18. Control-Room and Studio Equipment; 19. The Broadcast Studio; 20. Selecting the Broadcast Transmitter Location; Bibliography. Index.

440 pages

226 illus.

Only \$5.40



# NOW



## the greatest improvement in vibrators

### in 17 years\*

**RADIART**  
**Seal-Vent**  
**RED SEAL VIBRATORS**

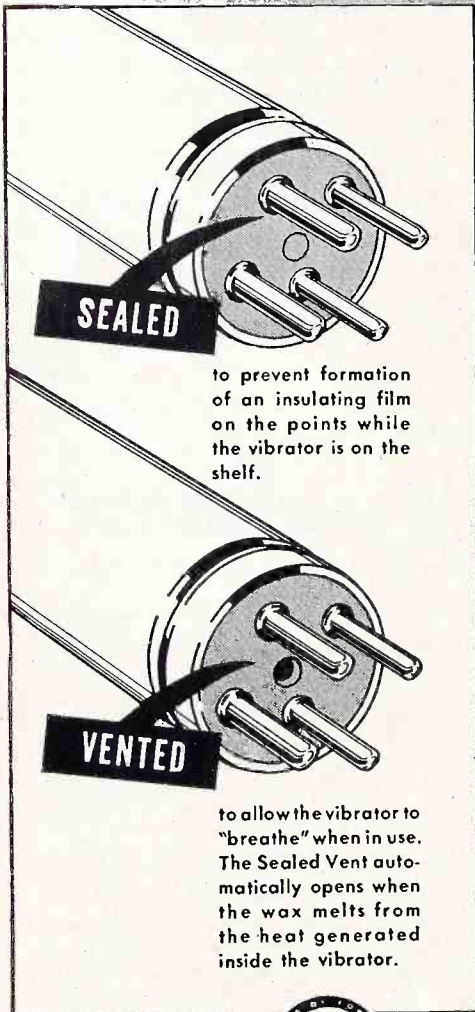

Who said you can't have your cake and eat it, too? WE'VE FOUND A WAY! The famous RADIART "RED SEAL" Vibrator that has been the standard of comparison of the industry for decades now is better than ever! The RED SEAL sandwich of rubber and bakelite NOW has a vent that is wax-sealed at the factory to prevent oxidation of the points. When the vibrator is put into use, the wax melts out and permits air circulation for EVEN GREATER PERFORMANCE AND STILL LONGER LIFE! Unquestionably, this is the GREATEST ADVANCEMENT IN VIBRATORS SINCE THE CHANGE TO PLUG-IN DESIGN . . . get yours NOW!

\*in our opinion the greatest improvement since the change from a permanently-wired-into-the-set vibrator to the plug-in design.

for additional literature and catalog sheets, see your jobber or write



**THE RADIART CORPORATION** CLEVELAND 2, OHIO

VIBRATORS • AUTO AERIALS • TV ANTENNAS • ROTATORS • POWER SUPPLIES

Please mention Successful Servicing when answering advertising.



## Using the 'Scope IN TV SERVICING

(Continued from page 7)

### Horizontal Nonlinearity

The oscillograph is also useful in locating the cause of foldover and other forms of horizontal nonlinearity.

Horizontal nonlinearity results from improper operation of one of the stages between the horizontal oscillator and the deflection coils. By examining the waveforms in these stages it is usually possible to isolate the fault to a few components.

While a complete discussion of the procedure used to troubleshoot the horizontal sweep circuits is beyond the scope of this article, an example of the manner in which the waveform at one point in the circuit may be interpreted to secure a clue to the fault, will serve as a guide.

Three examples of the manner in which the signal at the grid of the horizontal deflection amplifier is affected in cases of nonlinearity are illustrated in Fig. 8.

Figure 8A illustrates the appearance of the waveform when the linearity-coil bypass capacitor is open. The ripple on the waveform is due to improper filtering of the damper circuit and is thus a clue to the location of the fault. Some ripple of this type is normal

in RA-109A, RA-112A and RA-117A Tele-sets, as shown in Fig. 8D, and does not affect the picture. This type of fault sometimes occurs in earlier chassis such as the RA-103 and RA-105.

Figure 8B illustrates the effect of a shorted drive control potentiometer on the waveform at the grid of the 6BG6. This waveform results in the appearance of a white vertical line in the picture. Note the absence of the negative pulse which results in a reduction in the amplitude of the signal and delays the conduction of the 6BG6, producing the white line in the picture.

A change in the time constant of the horizontal differentiating network produces the waveform shown in Fig. 8C. The fault may be isolated by observing the waveforms at the grid of the sawmaker and the plate of the horizontal oscillator. A normal waveform at the plate of the horizontal oscillator and a distorted waveform at the grid of the sawmaker would indicate that the faulty component was located between these points, or in the differentiating network.

Only a few of the uses of the oscillograph have been described. They are representative of the application of the oscillograph to troubleshooting and when the technician has mastered them he will find little difficulty in expanding his ability to use this valuable instrument.

(Reprinted from *DuMont Service News*; a monthly publication of Allen B. DuMont Labs., Inc.)

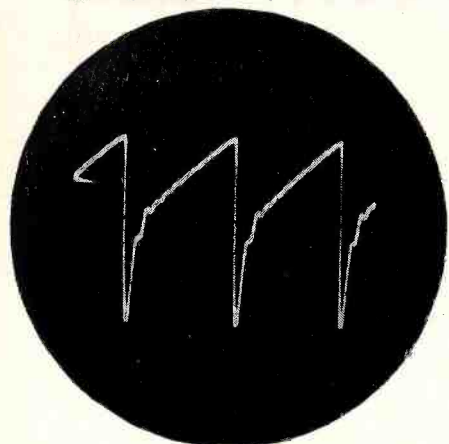

(A)

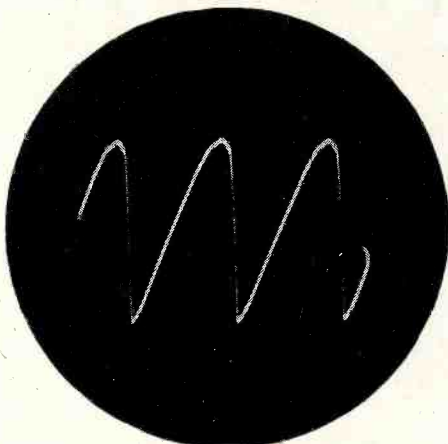

(B)

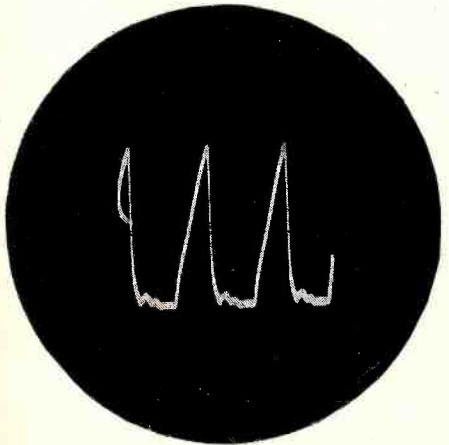

(C)

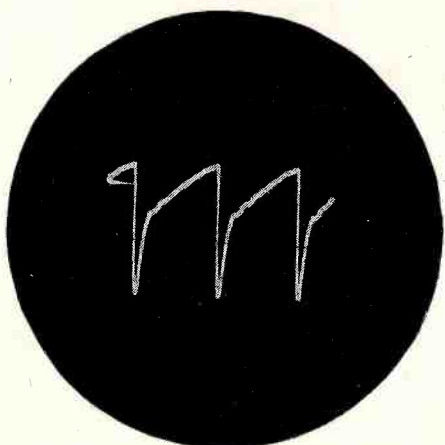

(D)

Fig. 8. (A, B, C) Waveforms at the grid of horizontal-sweep amplifier for various circuit defects; (D) normal waveform for this checkpoint.

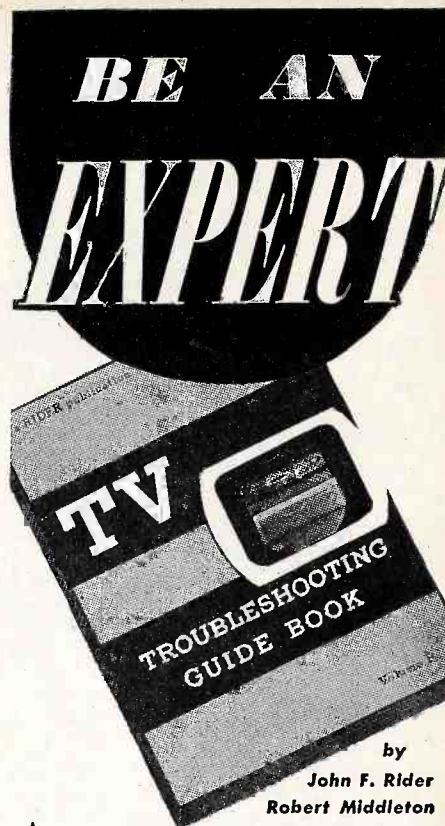

A new, practical, easy-to-use book for the TV service technician. It tells you how to spot receiver troubles and correct them. Contains factual information right from the manufacturer, things you must know to be a TV troubleshooting and repair expert. The contents include: explanation of split-circuit and intercarrier receivers, circuit variations and how they affect operating waveforms, simplified TV receiver troubleshooting by scope and picture tube screen display analysis, remedies for circuit troubles, rapid methods of alignment and recognition of alignment problems. Not a theory book—but a practical, down-to-earth troubleshooting and repair guide. 200 pages, 8½" x 11", durably bound.....\$3.90

### ENCYCLOPEDIA ON CATHODE-RAY OSCILLOSCOPES AND THEIR USES

By John F. Rider and Seymour D. Uslan



This practical book tells you everything you should know about an oscilloscope! WHAT it is — what it can do... and HOW to use it properly! They say — "Invaluable." S. F. Patton, General Mgr. Allen B. DuMont Labs., Inc. "...most elaborate treatment..." F. E. Smolek, Service Mgr., Zenith Radio Corp. "...most complete..." Radio Television Service Dealer. 992 pp., 8½" x 11", durably bound, \$9.00

### FIRST SUPPLEMENT RECEIVING TUBE SUBSTITUTION GUIDE BOOK

By H. A. Middleton



An indispensable addition to your service library. Illustrates 650 completely new AM-FM-TV tube substitutions with socket wiring instructions. 48 pp., 8½" x 11".....\$3.99  
FIRST EDITION — 225 pp., 8½" x 11".....\$2.40

---MAIL THIS COUPON — TODAY!---

JOHN F. RIDER, Publisher, Inc. Dept. RE 2  
480 Canal St., New York 13, N. Y.

Please send me book(s) checked. I understand, if not satisfied, I may return them within 10 days and receive full refund.

TV TROUBLE SHOOTING GUIDE BOOK, \$3.90  
 ENCY. ON C-R SCOPES AND USES, \$9.00  
 RECEIVING TUBE SUB. GUIDE, \$2.40  
 1st SUPPLEMENT, \$3.99

NAME.....  
(PLEASE PRINT)

ADDRESS.....

CITY.....ZONE.....STATE.....





# SYLVANIA NATIONAL ADVERTISING

**5 Stars Endorse Your Business in these Smashing Magazine ads**

**Jane Russell says:**

"For the finest radio and television service, I advise my friends to depend on the man who displays the Sylvania sign. Believe me, he's a past master at keeping sets in splendid shape."



**RADIO TELEVISION SERVICE**  
SYLVANIA RADIO TUBES

**SYLVANIA RADIO AND TELEVISION PICTURE TUBES**

Sylvania Electric Products Inc., 1740 Broadway, New York 19, N. Y.

**June Hawco says:**

"I've made a wonderful discovery. When I have trouble with my radios or TV set, I simply call the man who displays the Sylvania service sign. He gives me prompt, courteous and competent repair service. Try him and see if you don't agree."



**RADIO TELEVISION SERVICE**  
SYLVANIA RADIO TUBES

**SYLVANIA RADIO AND TELEVISION PICTURE TUBES**

Sylvania Electric Products Inc., 1740 Broadway, New York 19, N. Y.

**Says Leo Durocher:**

"Laraine and I don't fool around with just any radio and TV service. We like an expert who knows how to call things right. That's why we call the man who shows the Sylvania sign."



**RADIO TELEVISION SERVICE**  
SYLVANIA RADIO TUBES

**SYLVANIA RADIO AND TELEVISION PICTURE TUBES**

Sylvania Electric Products Inc., 1740 Broadway, New York 19, N. Y.

**Says Ann Blyth**

"I've found a man who knows all the answers at least to radio and TV troubles. He's the man who displays the Sylvania radio and television service sign. So whether I'm in Hollywood or in New York, I look for this sign for dependable service."



**RADIO TELEVISION SERVICE**  
SYLVANIA RADIO TUBES

**SYLVANIA RADIO AND TELEVISION PICTURE TUBES**

Sylvania Electric Products Inc., 1740 Broadway, New York 19, N. Y.

**Every one of your prospects will see and read these appealing ads in famous national magazines. These ads recommend your service . . . when you display the Sylvania Service Emblem, shown above. So, make sure these emblems are on your doors, your windows, and trucks. They're FREE from your Sylvania Tube Distributor NOW!**

**These ads will appear in the 4 famous magazines your prospects read most!**





# Will Sell Your RADIO-TV SERVICE in '52

Nation-wide weekly TV Show "BEAT THE CLOCK" will sell your service to every TV set owner

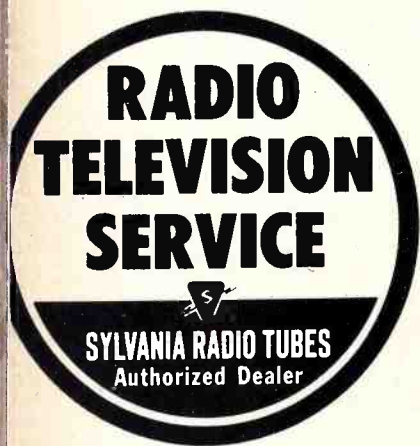

You're an "expert, reliable service-man who does a tough job well," Bill Shipley, crack CBS-TV announcer, tells your prospects. And, he adds: "Always look for that Sylvania Service Emblem." That's how the hard-hitting, full-minute commercials on Sylvania's CBS-TV show, "Beat the Clock," put Bill Shipley, Roxanne, and Bud Collyer in your sales staff.

Roxanne and Bud Collyer are seen weekly over CBS-TV in 35 cities... selling your service... when you display the Sylvania Service Emblem.



**Make this great national ad campaign pay off in your store**

Mail the coupon below for FREE, full-color folder giving complete details about Sylvania's compelling Spring Service Dealer Advertising Program. It contains everything to identify you unmistakably as the dealer advertised in Sylvania's magazine and TV advertising. If you want more business, you can't afford to miss it. But, time's awastin'... get that coupon in the mail NOW!



# SYLVANIA

RADIO TUBES; TELEVISION PICTURE TUBES; ELECTRONIC PRODUCTS; ELECTRONIC TEST EQUIPMENT; FLUORESCENT TUBES, FIXTURES, SIGN TUBING, WIRING DEVICES; LIGHT BULBS; PHOTOLAMPS; TELEVISION SETS

Sylvania Electric Products Inc.  
Dept. R-3401, Emporium, Pa.

Please send me full details about Sylvania's powerful business-building campaign for Service Dealers.

Name \_\_\_\_\_

Street \_\_\_\_\_

City \_\_\_\_\_ Zone \_\_\_\_\_ State \_\_\_\_\_





**RCA 8T270, 8TC270, 8TC271,  
Ch. KCS29, KCS29A**

The following production changes have been made. Resistor R102 has been changed to 68 ohms. Resistor R236 has been changed to 100,000 ohms. In some receivers, the phono-switch, S105, and jack, J110, were omitted. In this case, R195 was connected directly to C184, and R224 was connected to -50 volts. The accompanying figure shows the changes that have been made.

Rider TV Manual	Page
From	Thru
3-15	3-28

**Interstate Stores (Plymouth) 250, 350,  
750**

The schematic for AROTO5 tuner, type 2, is shown in Fig. 1.

The following material on oscillator alignment should be added to the information already contained in the service notes for the above models (tuner AROTO4, type 1).

Set generator and tuner to Channel 12 and observe on the oscilloscope the position of the picture carrier. If the picture carrier cannot be centered on response curve by plus or minus one-eighth turn rotation of the fine tuning shaft, adjust L449. (This loop is difficult to see since it is positioned around the switch wafer support rod.) In adjusting L449,

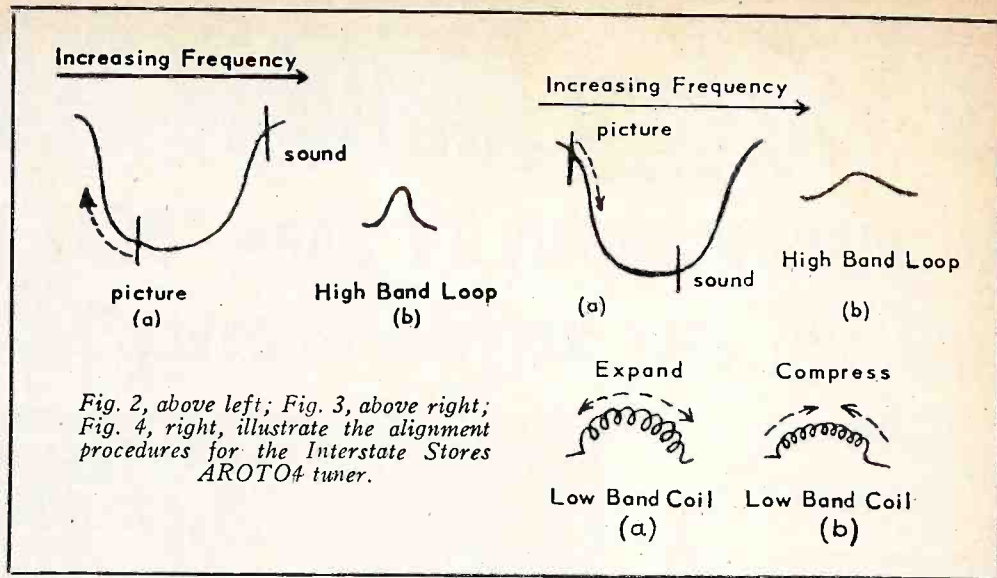

first note position of picture carrier (fine tuning at mid range). If picture carrier is as shown in Fig. 2a, distort loop toward the shape in Fig. 2b. This will move picture carrier down on the response curve. If picture carrier is as shown in Fig. 3a, distort the loop toward the shape as shown in Fig. 3b. This will move picture carrier up on the response curve. The above procedure is also used in the adjustment of L448, L447, L446, L445, and L444.

To adjust the low band channels from two through six, set tuner and sweep generator to channel six, set fine tuning to mid range and adjust the lower screw, the slug for L443, until the picture carrier is 50% down on the response curve.

Set sweep generator and tuner for Channel 5 and observe position of picture carrier on the response curve. If it cannot be centered by plus or minus one-eighth turn rotation of the fine tuning shaft, adjustment to L422 is necessary. If picture carrier is as shown in

Fig. 2a, expand coil with insulated tool as shown in Fig. 4a; this will move picture carrier down on the response curve. If picture carrier is as shown in Fig. 3b, compress coil with insulated tool as shown in Fig. 4b; this will move picture carrier up on the response curve. The above procedure is also used in the adjustment of L441, L440 and L439.

Rider TV Manual	Page
From	Thru
5-1	5-11
C8-5	—

**Crosley Service Hint**

To reduce sweep radiation which interferes with radio reception, the following steps should be undertaken:

1. With glass type picture tubes, make sure that the tube has a good coating of aquadag. If the tube has no coating, it may be necessary to replace the tube. If the aquadag is peeling or is missing from some portion where it is required, repair the aquadag with "Television Tube Coat - No. 49-2," manufactured by General Cement Mfg. Co., Rockford, Illinois. Also, be sure the aquadag is grounded to yoke with ground clip.

2. With Scotch tape, fasten one end of a sheet of aluminum foil (approximately 10" x 10") to the aquadag on the top area of the picture tube. Ground the other end of the foil under the tube strap.

3. Line the inside of the cabinet (area surrounding chassis) by cementing foil to the cabinet and grounding it to the sides of the chassis. Be sure to cut the foil away from any ventilation opening in the cabinet. In some cases it may be necessary to also place the foil completely across the chassis mounting shelf, underneath the chassis. After lining the cabinet with foil the built-in antenna is no longer effective and should be grounded to the chassis. Therefore, it will be necessary to use either an external indoor or outdoor type antenna.

4. Sometimes it may be necessary to make a shield, out of copper screen, to fit over the horizontal output and damper tubes.

*Rider Ten-File gives you*  
**Circuit action descriptions**

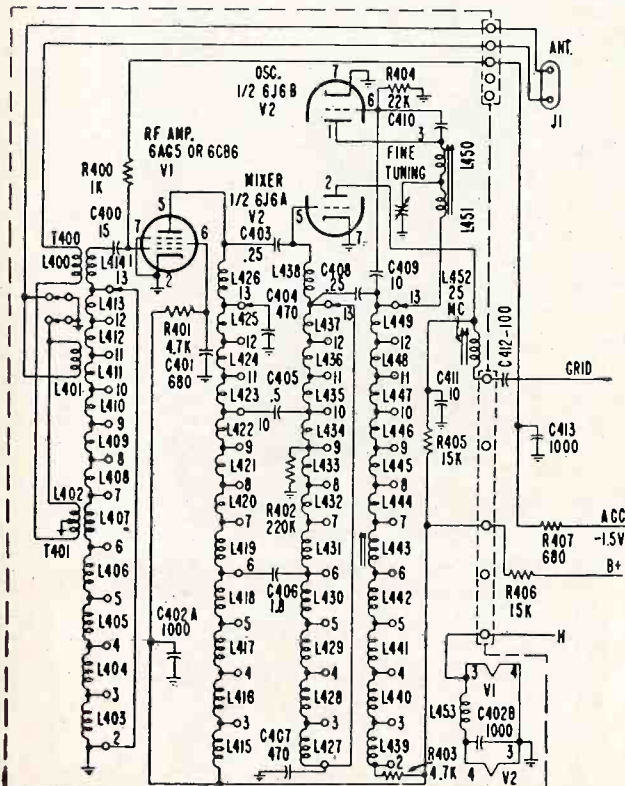

Fig. 1. Schematic diagram for the Interstate Stores AROTO5 tuner.



# Competence

is the word for Model 3432

Take it at face value, and you can't be wrong! The big, BIG no-glare illuminated dial, the fine control Output Attenuator, the wide frequency range, improved shielding to control radiation, and other performance features—all proved for action and accuracy. Give it the bench test—you'll find more competence packed in its handsome metal case than any test oscillator you ever used. It's double-copper shielded and individually calibrated against precise crystal standards. It is competent every step of the way.

**Extra-Large Dial**  
Seven long 330° scales for easy reading at any spot on the dial. All Illuminated—no glare. Top scale is 16" long. Dial has 10 to 1 ratio vernier tuning.

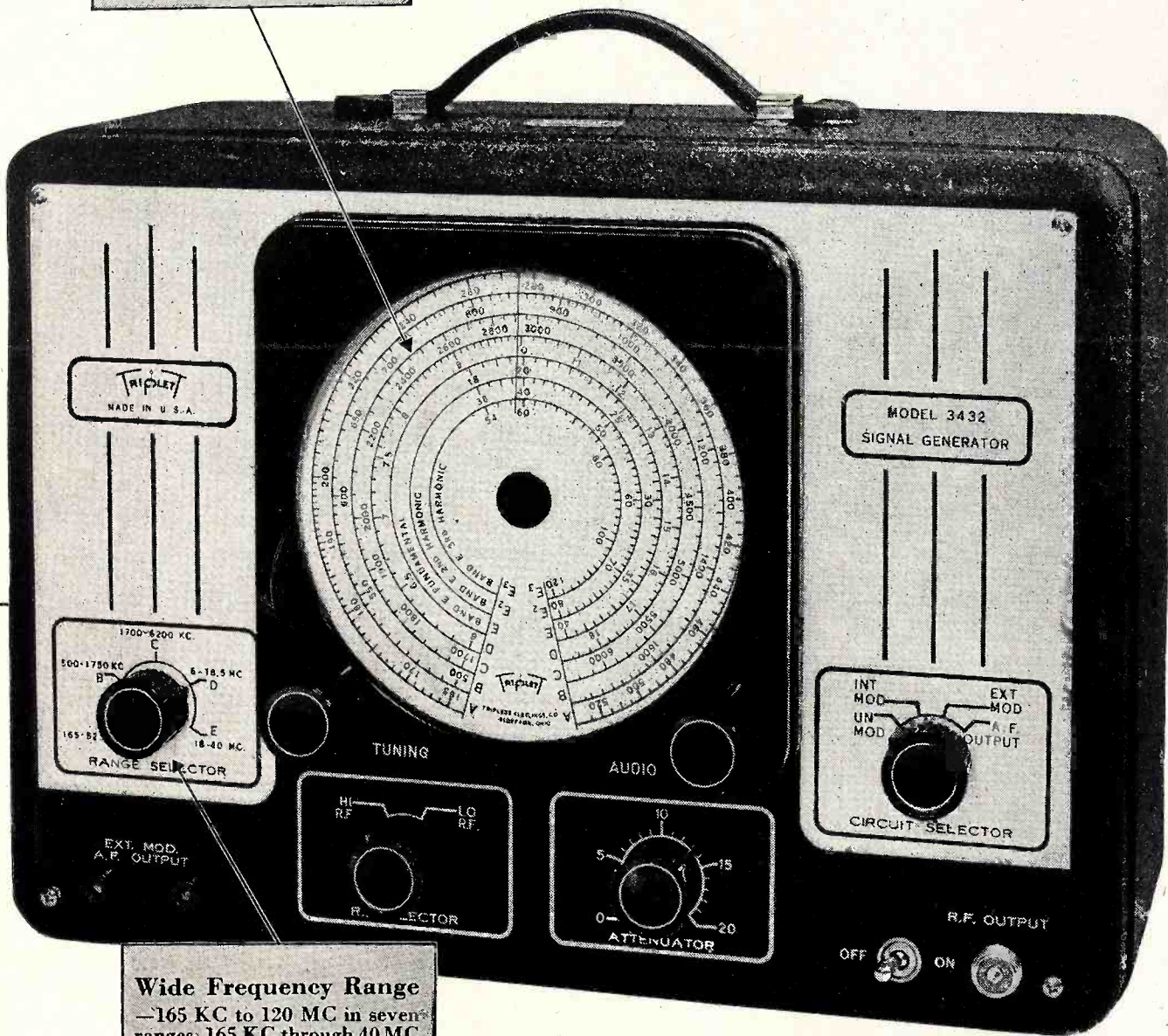

**Wide Frequency Range**  
—165 KC to 120 MC in seven ranges: 165 KC through 40 MC fundamentals; through 120 MC by strong harmonics.

**ONLY \$79.50 at your Distributor**  
(Price subject to change)

FOR THE MAN WHO TAKES PRIDE IN HIS WORK

# Triplet

TRIPLET ELECTRICAL INSTRUMENT CO. BLUFFTON, OHIO, U.S.A.



# Television Changes

(Continued from page 14)

## Du Mont RA113

With the substitution of a 6BC5 for the 6AK5 tube V102 in the mixer stage of the Inputuner, it has been necessary to change the mixer circuit in order to maintain high band sensitivity. The new tuner is listed on the parts list as: Inputuner assembly; part number, 8900395. The first chassis so modified at the plant was RA113, serial 1356435, code AK.

In replacing the old tuner with the new, the procedure is as follows:

Connect the red, black-yellow, and solid yellow leads as before.

Remove the lead running from the 20  $\mu$ f capacitor C103 (in the cathode circuit of the 6J6 tube V101) to ground and connect the formerly grounded side of the capacitor to the tinned side of the twinex lead from the tuner.

Connect the bare side of the twinex to the other side of capacitor C103.

Realign the first video i-f stage.

Rider TV Manual	Page
From	Thru
6-1	6-26

## Emerson Service Hints

**Conditions:** No high voltage, no horizontal sync, insufficient width or horizontal non-linearity.

1. Determine whether the horizontal output tube (6BG6, 6CD6, or 19BG6) is fed with a sufficient sawtooth voltage. This can be checked by the amount of grid rectification taking place. The d-c voltage on the grid should be about minus 20 volts, measured with a vtvm from grid to cathode. The best check is to observe the sawtooth on an oscilloscope. It should measure from 40 to 50 volts, peak to peak (about three times bigger than a 6.3-volt a-c wave). Check the linearity of the sawtooth (see Fig. 1). (The wave shape shown in Fig. 1 has more or less damped oscillations superimposed, depending upon the pickup of the leads.)

Caution: The Emerson probe should be used for making this check. If one is not available, use unshielded leads from the oscilloscope, one ground lead and one probe lead. Connect a 20,000-ohm insulating resistor at the test point end of the probe lead.

2. If the above conditions are correct, the trouble is in the horizontal output tube. If they are not, check the oscillator and control tube (6SN7 or 12SN7) outlined in steps (a) to (d) below.

a. Check voltages and resistances at the tube socket.

b. Check to see that the oscillator grid goes sharply negative with respect to cathode. This indicates the amount of oscillation. The voltage on this grid should change as the tuner is switched to off-channel positions. The voltage on the control grid and the control cathode should also change with switching of the tuner.

c. Check to see if the voltage on the control plate varies when varying the horizontal hold control.

d. Check the pulses arriving at the control grid. With the oscillator coil shorted

(short any two of the three terminals on the oscillator coil with a clip lead or metal tool), the sync pulse should be seen on the oscilloscope. With the short removed and the tuner switched to off-channel position, the sawtooth fed back from the output should be seen. Under normal working conditions these pulses are superimposed on each other.



Fig. 1. Sawtooth voltage with damped oscillations.

Caution: A slight leakage in any of the capacitors associated with the circuit will completely upset the operation. This should be the first thing to suspect. Check all capacitors carefully and replace the leaky ones with capacitors of a 600-volt rating.

Note: The alignment procedure outlined in the Manual should be carefully followed. This is the only way to properly align the circuit, and it also gives a good indication as to whether the circuit performs normally.

3. If the sawtooth presented at the grid of the horizontal output tube checks correctly, the trouble is in the horizontal output circuit or in the deflection system.

a. Check voltages and resistances at the tube socket.

b. Check continuity through the deflection system. Very often a partly shorted coil is encountered. This is difficult to find in a continuity check. The symptom is usually insufficient high voltage. A small arc can be drawn from the high-

voltage rectifier plate but the anode cap on the kinescope carries no voltage.

## Du Mont RA117A

In some chassis it has been found that inductive feedback from the audio amplifiers to the tuner (through pickup in the red B+ tuner lead) has lead to "motorboating." That is, the resulting variation of voltage on the plate of the local oscillator modulates the oscillator frequency and thereby the sound i-f beat frequency, causing the sound discriminator to deliver the transmitted audio signal plus a feedback audio signal.

To eliminate such feedback, the capacitor C303 connecting the tie point of the red B+ tuner lead to ground, has been changed from a 0.1- $\mu$ f paper capacitor to a 10- $\mu$ f electrolytic one. The new capacitor (still C303) is listed on the parts list as: capacitor, FE, 10  $\mu$ f, 450v; parts number 03 019 410.

The first chassis to be so modified at the plant is RA-117A, serial number 1723060, code 9K.

Rider TV Manual	Page
From	Thru
7-1	7-9

## Federal Video 209, 309, 409

The tube layout for these models is shown in the accompanying diagram (Fig. 2).

Rider TV Manual	Page
From	Thru
3-1	—

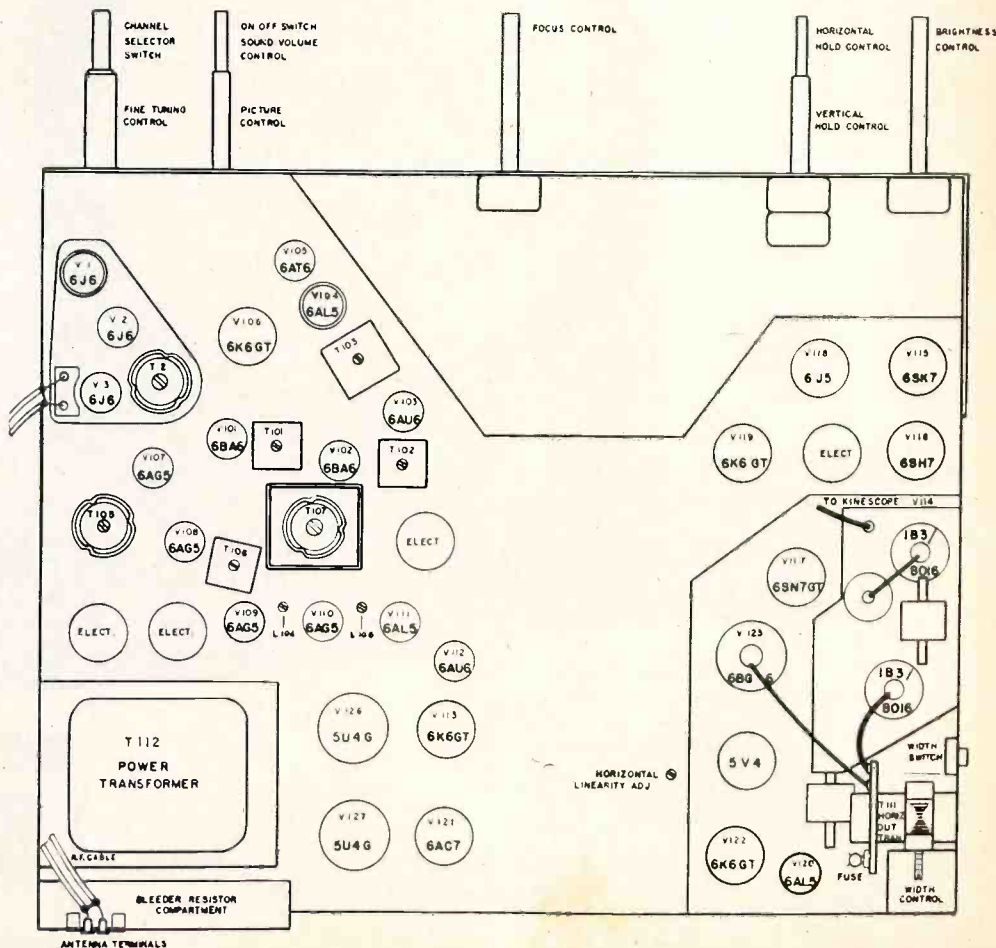

Fig. 2. Tube layout for Federal Video models 209, 309, and 409.



# Television Changes

(Continued from page 16)

## Westinghouse H-605T12, Ch. V-2150-101, V-2150-106

The schematic diagram of the V-2150-101 chassis should be altered to include later production changes as follows:

1. A 100-ohm resistor R469 has been added between pins 3 and 8 of the 12AU7 horizontal multivibrator, and the upper end of R424 should be connected to pin 3 rather than pin 8. This change improves the horizontal sync stability.

2. The value of R428, located in the pin 1 plate circuit of the 12AT7 1st sync amplifier, has been changed from 5600 ohms to 22,000 ohms.

3. The value of R433, located in the pin 6 plate circuit of the 12AT7 sync separator, has been changed from 33,000 ohms to 22,000 ohms. This and the preceding change help to eliminate vertical jitter in weak signal areas.

4. The value of R439, in the 12AU7 phase inverter grid circuit, has been changed from 100,000 ohms to 2.2 megohms. This change helps eliminate horizontal jitter.

5. The value of R446, located in the grid circuit of the 7A5 horizontal output tubes, has been changed from 470,000 ohms to 100,000 ohms.

6. The value of C430, in the 7A5 grid circuit, has been changed from 47  $\mu\text{f}$  to 270  $\mu\text{f}$ . This and the preceding change help to eliminate foldover.

7. The value of R419, in the pin 3 cathode circuit of the 12AU7 2nd amplifier, has been changed from 220 ohms to 330 ohms. This change improves the vertical hold action.

8. The value of C438, which is connected between pins 1 and 7 of the 12AU7 2nd sync amplifier and phase inverter, has been changed from 390  $\mu\text{f}$  to 0.05  $\mu\text{f}$ . This improves the horizontal sync action.

9. The value of R430, in the pin 1 plate supply circuit of the 12AU7 horizontal multivibrator, has been changed from 10,000 ohms to 33,000 ohms. This improves the stability of the horizontal sweep circuit.

Rider TV Manual Page	From	Thru
	5-55	5-63
	C7-4	—

### Stromberg-Carlson Service Hint

Both the EM-PM and PM type focus assemblies used on current receivers can easily be damaged if proper care is not exercised in handling them both within the receiver and in parts stock.

A slight jar or striking with a metallic tool may cause the assembly to lose its magnetism thereby affecting its focusing ability. When working on the receiver chassis, extreme care should be used to prevent damage to the focus assembly. In making any adjustments of this assembly, it is advisable to use a brass or non-metallic screw driver.

When storing these assemblies in parts stock, they should not be left in contact with each other or permitted to rest on metal shelves nor should they be subjected to serious jars or vibration.



## YOU POINT TO GREATER PROFITS

when you have a complete set of RIDER MANUALS, with their up-to-date factory authorized service data, on your shelves. When you have the *complete* information on every set in every manufacturer's line, you take less time per call . . . and do a better job. RIDER MANUALS tell you everything, from complete waveform data to factory parts lists and changes.

Ask your jobber to show you RIDER MANUALS — today!

### RIDER TELEVISION AND RADIO MANUALS

TELEVISION VOLUME 8 Equivalent of 2688 pages (8½x11) .....	\$24.00	VOLUME XXII, 1520 pages.....	\$18.00
TELEVISION VOLUME 7 Equivalent of 2352 pages (8½x11).....	24.00	VOLUME XXI, 1648 pages.....	21.00
TELEVISION VOLUME 6 Equivalent of 2320 pages (8½x11).....	24.00	VOLUME XX, 1776 pages.....	21.00
TELEVISION VOLUME 5 Equivalent of 2320 pages (8½x11).....	24.00	VOLUME XIX, 2122 pages.....	22.50
TELEVISION VOLUME 4 Equivalent of 2296 pages (8½x11).....	24.00	VOLUME XVIII, 2036 pages.....	22.50
TELEVISION VOLUME 3 Equivalent of 2032 pages (8½x11).....	24.00	VOLUME XVII, 1648 pages.....	19.80
TELEVISION VOLUME 2 Equivalent of 1896 pages (8½x11).....	24.00	VOLUME XVI, 768 pages.....	9.90
TELEVISION VOLUME 1 Equivalent of 2000 pages (8½x11).....	19.80	VOLUME XV, 2000 pages.....	22.50
PA EQUIPMENT VOLUME 1 2024 pages .....	18.00	VOLUME XIV, 1376 pages.....	19.80
		VOLUME XIII, 1672 pages.....	19.80
		VOLUME XII, 1648 pages.....	19.80
		VOLUME XI, 1652 pages.....	19.80
		VOLUME X, 1664 pages.....	19.80
		VOLUME IX, 1672 pages.....	19.80
		VOLUME VIII, 1650 pages.....	19.80
		VOLUME VII, 1600 pages.....	19.80
		VOLUME VI, 1240 pages.....	15.00
		VOLS. I-V ABRIDGED, 2000 pages.....	19.80



**JOHN F. RIDER Publisher, Inc.**

480 Canal Street, New York 13, N. Y.



set 'em...  
forget 'em!

Fully Automatic  
**AUTOBOOSTERS**



**NO Tuning NO Switching  
Necessary**

**COMPLETELY AUTOMATIC  
HIGH UNIFORM GAIN  
SINGLE OR DUAL INPUT  
FULL, 5 MC BANDWIDTH  
CLEARER PICTURES  
CONCEALED INSTALLATION**



LIST  
PRICE  
**39.<sup>95</sup>**

IT-75A Fully Automatic, All-Channel AUTOBOOSTER—Up to 19 db (9 times) gain • Separate inputs for high and low band antennas or single high-low antenna • May be peaked in the field for maximum performance on any channel • Installed at rear of receiver.



LIST  
PRICE  
**69.<sup>95</sup>**

IT-90A Fully Automatic, All-Channel Cascade AUTOBOOSTER—Up to 30 db (30 times) gain • Extremely low signal-to-noise Cascade input circuit • Ideal for sub-fringe areas, community antenna systems • 2 stage amplification • Separate controls for independent gain adjustment on high and low channels (set by installer) • Automatic on-off • By-pass switch removes unit from line but does not alter impedance • Installed at rear of receiver.

WRITE FOR SPECIFICATION SHEETS.  
AUTOBOOSTERS ARE AVAILABLE AT JOBBERS  
EVERYWHERE. ORDER  
THE ONES YOU  
NEED TODAY!

Are you using the

**Tenna-Clip**

Write for  
FREE sample

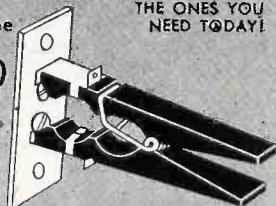

**Industrial Television, Inc.**

359 LEXINGTON AVENUE CLIFTON, N. J.  
GRegory 3-0900

**Television Changes**

(Continued from page 17)

**Steward Warner Service Hint, Models  
9120, 9121**

On some of the 26-tube chassis, it is sometimes difficult to obtain correct horizontal linearity through adjustment of the horizontal linearity, horizontal drive and width controls. When such cases are encountered, the .1- $\mu$ f capacitor C280 in the return lead (from pin 6) of the horizontal sweep transformer T275 should be changed from 0.1- $\mu$ f to 0.25- $\mu$ f.

Rider TV Manual	Page
From	Thru
7-1	7-17
7-18	7-36

**Air King Series 700 Service Hint**

Some chassis of the 700 series have been troubled with an audio buzz or hum due to poor contact of the aquadag coating of the Hytron 16RP4 tubes with the grounding strap. It has been found that under certain conditions of humidity, the binder used in the aquadag will form a calky coating which prevents proper contact between the aquadag and the grounding strap.

This can be corrected by carefully washing the area around and under the contact spring, using a cloth moistened with water. After the area around the grounding spring has been washed and dried, it should be blacked by the application of graphite from a very soft pencil.

**Caution:** This set must be shut off and the high voltage supply discharged when this is done. No other type of picture tube should be washed in this manner because most standard aquadag coatings are water soluble and would be removed if washed.

When the afc control is correctly adjusted in the chassis of the 700-10 and later series, the picture should fall into horizontal sync instantly when changing from station to station and it should be stable. Sometimes this cannot be done without causing a foldover on either the right or the left side of the picture. This condition is an indication of unstable horizontal hold due to incorrect phasing from the transmitter. At certain adjustments of the afc control the picture will jitter violently. To correct this condition, the 2,700-ohm phasing resistor R52 will have to be increased to approximately 5,000 ohms if the foldover is on the left side of the picture or decreased to about 1,000 ohms if the foldover is on the right side of the picture.

**RIDER TV TEK-FILE**

**Packs 1-32**

1240 Models

Now Available  
At Your Jobber!

**PLAN for TOMORROW  
TODAY  
THESE BOOKS  
TELL HOW!**



**TV and ELECTRONICS AS A CAREER**

by Ira Kamen & Richard H. Dorf

Interesting! Informative! Only this book, written by top authorities of the industry, tells newcomers and veterans what to expect from a career in electronics. All phases... engineering, broadcasting, manufacturing, servicing, parts and receiver distributing, selling... are clearly discussed in this easy-to-read book... designed to help you plan your future now. Handsomely bound with 326 pages, 130 illustrations, it is priced at \$4.95.

**RADIO OPERATOR'S LICENSE Q  
AND A MANUAL**

by Milton Kaufman, Third Edition

This "best seller's" revised, enlarged edition contains new elements 2, 5, 7 and 8 and revised elements 3 and 6. Lists all questions and answers for FCC examinations... plus, an exclusive feature—a thorough, yet simplified discussion of the answer to every technical question. Useful appendices include Small Vessel Direction Finders and Automobile Alarms. Easy-to-read, a "must" for anyone interested in securing a new or higher-rated or additional license. Contains 734 pages, 243 explanatory diagrams and is priced at \$6.60.

Order today from your Jobber or mail this coupon with your check or money order!

JOHN F. RIDER, Publisher, Inc.  
480 Canal St., Dep't. 55 N. Y. 13, N. Y.  
Please send me book (s) checked below. It is understood, if not satisfied, I may return book (s) within 10 days and receive full refund.  
( ) TV and ELECTRONICS AS A CAREER, \$4.95  
( ) RADIO OPERATOR'S LICENSE Q AND A MANUAL, \$6.60 (Please Print)

Name \_\_\_\_\_  
Address \_\_\_\_\_  
City \_\_\_\_\_ Zone \_\_\_\_\_ State \_\_\_\_\_

**RIDER** **JOHN F. RIDER**  
PUBLISHER, INC.  
480 Canal Street, New York 13, N. Y.



January, 1952

# March of Dimes Month

**150,000 DIMES**

*Buy*



**1 Electron MICROSCOPE**

**GIVE *Voluntarily* TO**

**MARCH OF DIMES**

**JANUARY 2-31**

For the fourth time in four years, the swelling tide of polio has engulfed the nation — bringing hardship and tragedy to the families of over 28,000 victims. The disease strikes year after year in the heavily populated centers as well as in low population areas. Annually the spectre of crippled and bed-ridden children haunts the nation.

But wherever polio struck—on the farm, in the mining town, on the reservation, or in the nation's teeming centers of population—the means of resisting its onslaught were close at hand—through the MARCH OF DIMES.

*The disease has been stripped of one of its most terrifying allies — the element of surprise.*

In hard hit communities everywhere, MARCH OF DIMES money helped families of an estimated 67,000 polio patients struggling with the heavy financial burden that the disease carries with it. Chapters paid all or part of bills for hospitalization and medical care; furnished iron lungs, beds, cribs, and special equipment to cover emergency needs; were instrumental in bringing sufficient nurses, physical therapists and other skilled personnel to the bedside of the stricken.

The great need now is for facilities with which to carry out research to find a reliable cure for polio. To this end, electron microscopes, centrifuges, and other type of equipment is vital. The cost of this equipment, in many cases, runs into thousands of dollars, and your contributions must meet the demands.

Your community could fight back at polio in 1951, and fight back hard because there was a MARCH OF DIMES! Let us be prepared in 1952.

HELP YOUR CHAPTER  
HELP YOUR COMMUNITY  
JOIN THE MARCH OF DIMES

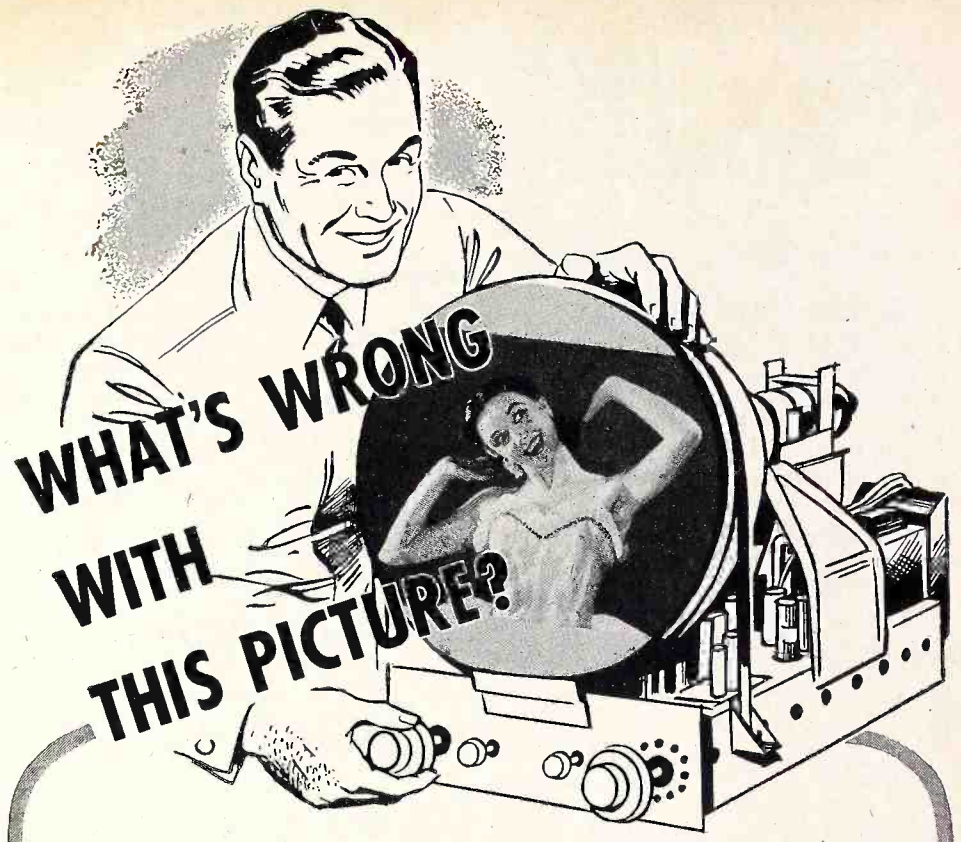

There's nothing wrong, *yet*. The set's just out of the shop and everything *seems* A-1 . . . but wait until chassis heat goes to work on the paper tubulars. Then it's "out of sync" and another costly call-back for the service technician.

Sprague Black Beauty Telecap Molded Tubulars are a positive guarantee against this sort of trouble. Made by the same "dry process" as expensive metal-encased oil capacitors, they are stable and retrace consistently, unlike ordinary cardboard-cased or "wet process" molded tubulars. And this extra quality is yours at no extra cost!

Black Beauty Telecaps are a *must* for every TV replacement job.

Write for Catalog C-607

**SPRAGUE**  
Black Beauty  
**TELECAPS**<sup>®</sup>

*Ask for them by name*

**SPRAGUE**

**SPRAGUE PRODUCTS COMPANY**

(Distributors' Division of Sprague Electric Co.)  
North Adams, Massachusetts

**PIONEERS**

**IN ELECTRIC AND ELECTRONIC DEVELOPMENT**





### United Motors, 980797, 980798, Buick

In the Service Parts List, the service part number for Illustration No. 39, which is the 8" permanent magnet speaker, should be changed from 7255895 to 6105.

The spring pointer coil tension which carried the production part and the service part number 7238860 is no longer available.

Rider Radio Manual Page	
From	Thru
18-20	18-21

### Philco 51-538

Circuitwise this model is identical to model 51-537.

Sets coded 122 use a 12BA6 tube in place of the 14A7 as an i-f amplifier. A miniature socket (part no. 27-6203-1) replaces the local socket and a new 68-ohm,  $\frac{1}{2}$  resistor (part no. 66-0688340) is added in series to the connection from the cathode (pin 7) of the 12BA6 i-f amplifier tube.

Rider Radio Manual Page	
From	Thru
21-49	21-52

### RCA BX55, Ch. 1088-B

The circuits of chassis 1088-B are the same as those for chassis 1088.

Rider Radio Manual Page	
From	Thru
21-31	21-34
C22-5	

### Emerson 702B, Ch. 120136-B

With the exception of the chassis parts list and the addition of a 220,000-ohm resistor from B— to chassis ground, all technical information pertaining to the above model is the same as that covering model 653B using chassis 120136-B.

The new chassis parts list is as follows:

Part No.	Description
140435	Cabinet
520157	Dial Glass
525022-2	Pointer
410904	Dial backplate
460162S	Knob
180045	Speaker
583032	Line cord
575848	Baffle
700063	Loop antenna and back

Rider Radio Manual Page	
From	Thru
22-1	22-4

### RCA BX57, Ch. 1088-C

The circuits of chassis 1088-C are the same as those for chassis 1088-A.

Rider Radio Manual Page	
From	Thru
21-35	21-38
C22-5	

### Jewel, Model 980

The Replacement Parts List is as follows:

Symbol No.	Part No.	Description
C1	5 32-17	Tubular Paper Condenser, .002 $\mu$ f, 200v
C2	7 35-4	Mica Condenser, 100 $\mu$ f, 500v
C3	4 32-4	Tubular Paper Condenser, .05 $\mu$ f, 200v
C6	8 32-29	Tubular Paper Condenser, .01 $\mu$ f, 200v
C9	32-47	Tubular Paper Condenser, .15 $\mu$ f, 200v
C10	32-5	Tubular Paper Condenser, .05 $\mu$ f, 400v
C11	31-18B	Electrolytic Condenser, 35x35 $\mu$ f, 150v
C12	30-16	Variable Condenser, 2 Gang, 420 & 420 $\mu$ f
R1	20-53	Resistor, 4.7 meg, $\frac{1}{4}$ w, 20%
R2	20-123	Resistor, 120,000 ohms, $\frac{1}{2}$ w, 20%
R3	50-14A	Resistor, Volume Control, 100,000 ohms
R4	20-10	Resistor, 270 ohms, $\frac{1}{2}$ w, 10%
R5	20-57	Resistor, 10 meg, $\frac{1}{4}$ w, 20%
R6, 7	20-92	Resistor, 470,000 ohms, $\frac{1}{4}$ w, 20%
R8	20-80	Resistor, 3,300 ohms, 1 w, 20%
R9	20-93	Resistor, 22 ohms, $\frac{1}{2}$ w, 20%
R10	20-96	Resistor, 22 ohms, 1 w, 20%
R11	20-81	Resistor, 150 ohms, $\frac{1}{2}$ w, 20%
T1	62-18	Antenna Coil
T2	60-11	R. F. Coil
	80-14C	4" P.M. Speaker With Output Transformer
	47-3	Antenna Hank, 15 Ft.
	120-36	Cabinet
	122-15	Volume Knob
	122-25	Selector Knob
	140-4	Clock

To align this model, put the output meter across the voice coil, 3.2 ohms; have the volume control at maximum for all adjustments; align for maximum output but reduce input as needed to keep output near 1.28 volts (0.5 watt).

Rider Radio Manual Page	
From	Thru
20-9	

## ATTENTION! RADIO SERVICEMEN

THERE ARE THOUSANDS OF OUT-MODED RADIOS IN YOUR "BACK YARD" JUST WAITING TO BE REPLACED . . . AT YOUR SUGGESTION

Here is the custom-built AM-FM chassis that means **BIGGER PROFITS** for you!

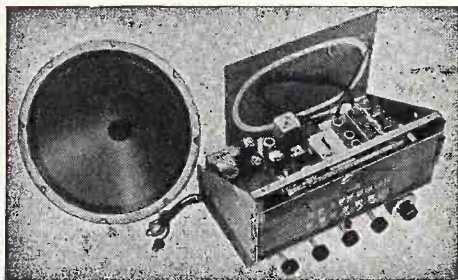

### SPECIFICATIONS

Supplied ready to operate, complete with tubes, antennas, speaker and all necessary hardware for mounting in a table cabinet or console, including escutcheon. Power consumption—105 watts.

Chassis Dimensions: 13 $\frac{1}{2}$ " wide x 8 $\frac{1}{2}$ " high x 10" deep.

Carton Dimensions: (2 units) 20 x 14 $\frac{1}{2}$  x 10 $\frac{3}{4}$  inches.

Net Weight: 17 pounds each.

Sold through your favorite parts distributor.

WRITE FOR CATALOG KD12 AND NAME OF NEAREST DISTRIBUTOR.

### The NEW ESPEY model 511-C FEATURES

1. AC Superheterodyne AM-FM Receiver.
2. Improved Frequency Modulation Circuit, Drift Compensated.
3. 12 tubes plus rectifier and Pre-Amp Tubes.
4. 4 dual purpose tubes.
5. Treble Tone control.
6. 6-gang tuning condenser.
7. Full-range bass tone control.
8. High Fidelity AM-FM Reception.
9. Automatic volume control.
10. 10 watts (max.) Push-Pull Beam Power Audio Output.
11. 12-inch PM speaker with Alnico V Magnet.
12. Indirectly illuminated Slide Rule Dial.
13. Smooth, flywheel tuning.
14. Antenna for AM and folded dipole antenna for FM Reception.
15. Provision for external antennas.
16. Wired for phonograph operation with switch for crystal or reluctance pick-up.
17. Multi-tap output trans., 4-8-500 ohms.
18. Licensed by RCA and Hazeltine.
19. Subject to RMA warranty, registered code symbol #174.

Makers of fine radios since 1928.

**ESPEY** TEL. Trafalgar 9-7000  
**MANUFACTURING COMPANY, INC.**  
 528 EAST 72nd STREET, NEW YORK 21, N. Y.

### Firestone 4-A-99, 4-A-100

The above models are similar to models 4-A-86 and 4-A-95 except for the additions to the parts lists and the use of a 12AT7 as the r-f amplifier and mixer tube instead of two 6AB4 tubes.

Additions to the parts list are:

Part No.	Description
12A5058	8" PM speaker
3A443	12AT7 tube socket
58-1127A	Hinges
61-3313	Catches
61-3314	Baffle
A1560-A276	Door pull
79X12	Grille cloth
79X13	Grille cloth
79X8	Metal grill
79X22	Phono bottom
79X31	Cabinet back
79X36	Cabinet back

Rider Radio Manual Page	
From	Thru
21-13	21-16
22-1	22-4

### Vacuum-Tube Voltmeter

Hickok Electrical Instrument has announced a new vacuum-tube voltmeter of laboratory quality providing the sensitivity and ranges for accurate measurement of sine or complex waves of tv or industrial devices.

The new model 215 features a new design dual-purpose a-c, d-c probe in a single unit with a built-in switching arrangement. It measures a-c and d-c volts, rms or peak-to-peak, and resistances in seven different ranges.



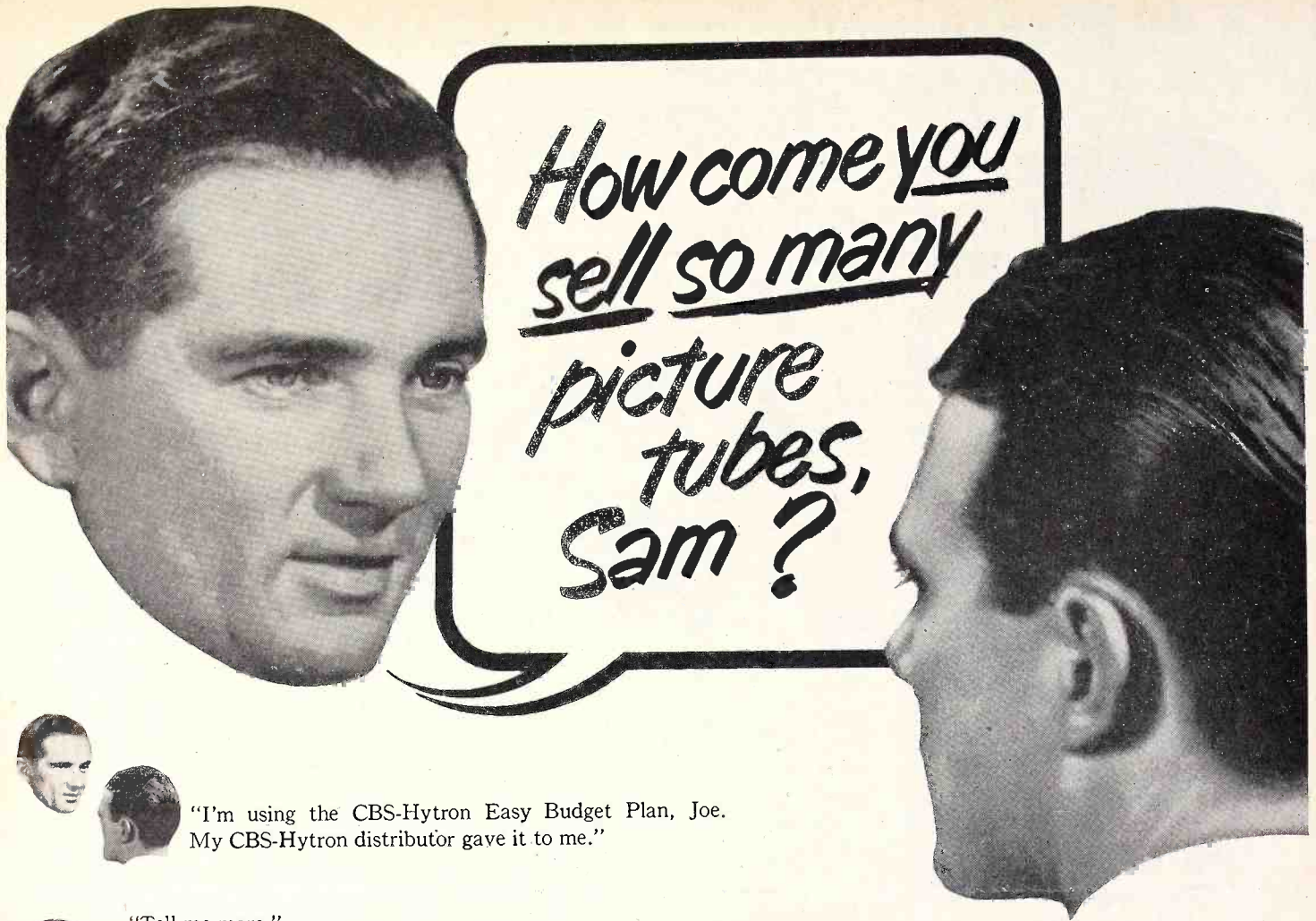

"I'm using the CBS-Hytron Easy Budget Plan, Joe. My CBS-Hytron distributor gave it to me."



"Tell me more."

"Well, CBS-Hytron's Plan helps me sell TV picture tubes and service to many a customer who just doesn't have \$50 cash. My customer now pays for the job painlessly a few dollars a month. Yet I get my cash right away."



"Fine! How does it work, Sam?"

"Simple. I introduce my customer to the finance company authorized by CBS-Hytron. The finance company does the rest . . . acts as my credit department . . . arranges all details. My customer gets his tube and I get my cash — at once."



"That's swell, Sam! I've sure been losing sales I shouldn't. I need that CBS-Hytron Easy Budget Plan. CBS-Hytron tubes are tops, too. Thanks for the tip. I'll see my CBS-Hytron distributor today."

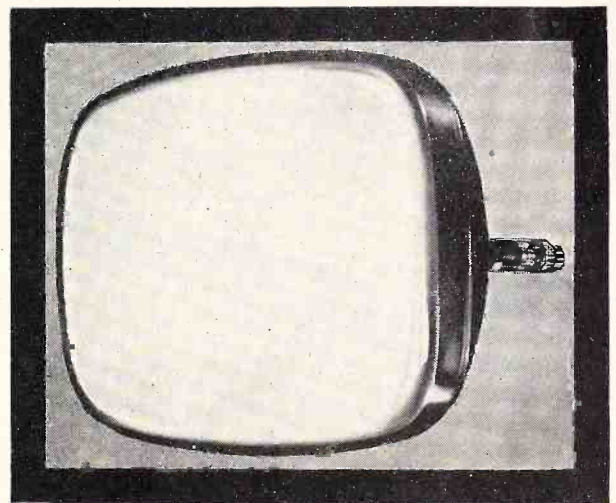

**SAVE THE SALE** No need for you to miss a single profitable picture-tube sale . . . just because your customer does not have the cash. Get the details on this original CBS-Hytron service for you. See your CBS-Hytron jobber . . . or write us . . . today!

**ANOTHER  
HELPFUL SERVICE FOR YOU  
FROM . . .**



MAIN OFFICE: SALEM, MASSACHUSETTS

Please mention Successful Servicing when answering advertising.



It's no trick to make 'em fit . . . fast!

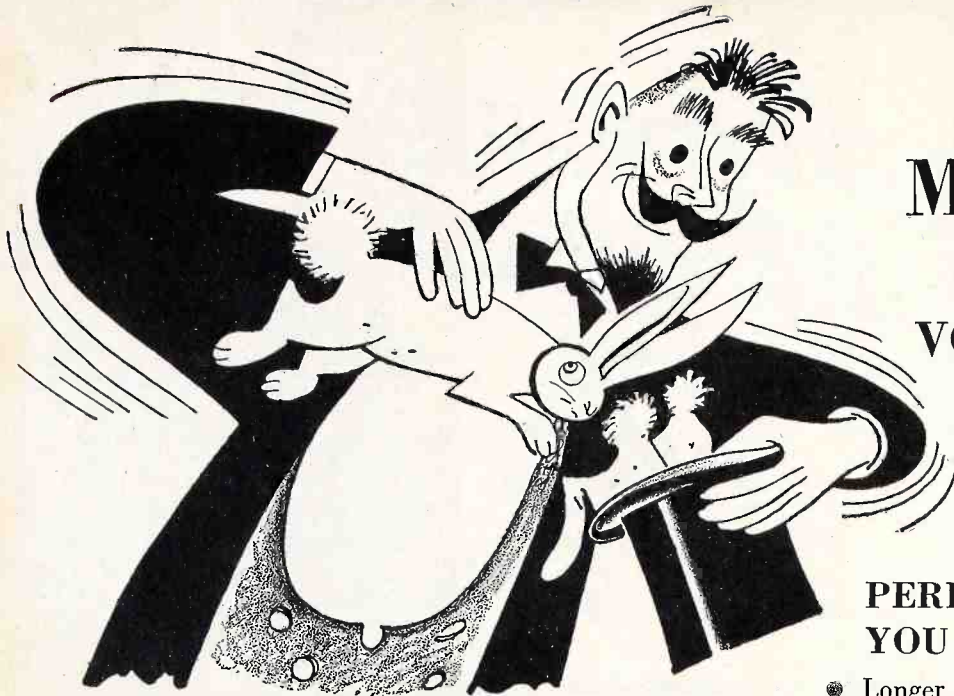

# MALLORY MIDGETROL®

## ROUND-SHAFT VOLUME CONTROLS

### FAST, EASY INSTALLATION

- Because of the wide and easy adaptability of Mallory Midgetrols, it's easy to stock—or get fast from your distributor—just what you need to do your job.
- Round tubular shaft designed and built for fast, easy and accurate cutting.
- Factory-tested AC switch may be attached instantly without disassembling control.
- Speedy adaptability to both split-knurl and flatted type knobs.

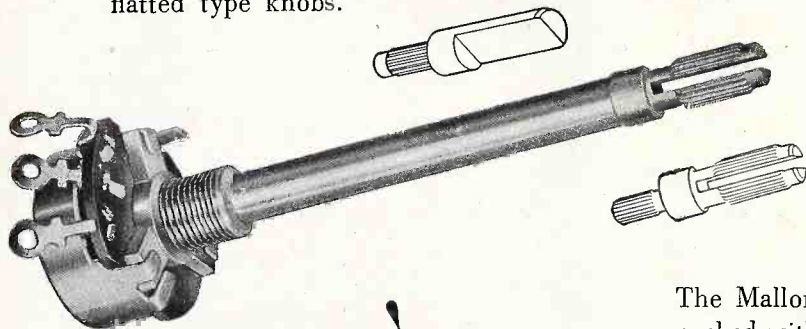

**Make Sure!  
Make it Mallory!**

### PERFORMANCE YOU CAN COUNT ON

- Longer lasting resistance elements even in extremes of temperature and humidity.
- Better and more accurate taper curves resulting from precision processing methods.
- No pigtail connections to break, thanks to Mallory's exclusive sliding contact which gives EXTRA quiet operation.
- Minimum wobble with Mallory's exclusive 2-point shaft suspension.

So versatile are Mallory Midgetrols—both standard and dual—that they reduce by 40% the cost of inventory needed to service the 10 most popular makes of radio and TV sets.

The Mallory Midgetrol is shown with the two shaft ends packed with every control to permit easy use of split-knurl or flatted type knobs. The Mallory Midgetrol line, in addition to round shaft standard controls, includes dual concentric controls that offer fast, easy assembly in five steps *without* special tools. Front and rear sections are factory assembled and inspected. AC switch attachment is easy.

R. MALLORY & CO. Inc.  
**MALLORY**

CAPACITORS • CONTROLS • VIBRATORS • SWITCHES • RESISTORS  
• RECTIFIERS • VIBRAPACK\* POWER SUPPLIES • FILTERS

\*Reg. U. S. Pat. Off.

**APPROVED PRECISION PRODUCTS**

**P. R. MALLORY & CO., Inc., INDIANAPOLIS 6, INDIANA**





A monthly summary of product developments and price changes of radio, electronic, and television parts and equipment, supplied by United Catalog Publishers, Inc., New York City, publishers of RADIO'S MASTER.

These REPORTS will help you to buy and sell to best advantage. They will also help you to keep your inventory up to date. A complete description of most products will be found in the Official Buying Guide, RADIO'S MASTER, available through local parts distributors.

**Price Increases**

- ARRL—Increased prices on "The Radio Amateur's Handbook" to \$3.00.
- BRITISH INDUSTRIES—"Loudspeaker" publication increased to \$1.60.
- KESTER SOLDER CO.—Increased price \$.02 per pound of their 1 pound, 5 pound and 20 pound spools of acid-core, plastic-core and "Resin-Five" core of solder spools.
- RAYTHEON MFG. CO.—Rectifier type RFR-1043-AR increased to \$150.00 user price.
- SIMPSON ELECTRIC—Model 381 Capacity Bridge increased to \$28.50 net.

**Price Decreases**

- BARKER & WILLIAMSON, INC.—Reduced prices on Coaxial Connectors CC50 to \$5.85 net and CC51 to \$6.45 net.
- CROWN CONTROLS CO.—Reduced prices on their line of antenna rotators.
- ELECTRO-VOICE INC.—Model T-10 High Frequency Driver decreased to \$36.00 net.
- SYLVANIA—Picture tubes 16AP4B decreased to \$38.00 net along with 16GP4B to \$30.00 net, 16GP4C to \$30.00 net and 19AP4B to \$45.00 net. Also reduced 6BQ7 to \$3.20 list.
- TECH-MASTER—Plastic Sleeve & Ring Sets Nos. PL-4, PL-4S, PL-17R, PL-19 and PL-24 reduced in price.
- WRIGHT, INC.—Reduced prices on most of their line of speakers & cabinets; grilles; baffles and transformers.

**New Items**

- ASTRON—Introduced type BT series of electrolytic motor starting capacitors; types MX and ME series of metallized paper capacitors and type AQ series of subminiature paper capacitors. Also added additional electrolytics and capacitors to their line.
- BOGEN, DAVID, INC.—Added R604 AM-FM Tuner at \$97.35 net. Also Model H010 Power Amplifier at \$95.70 net; Model RXPX, Remote Controller and Pre-amplifier at \$54.45 net and EXT-20, 20 ft. Extension Cable for RXPX at \$9.90 net.
- BRACH MFG. CO.—TV antenna 466 added at \$11.44 net.
- BRUSH DEV. CO.—Added Model BA-206, Double Headphone at \$16.80 net; Model BA-207, Single Headphone at \$9.60 net and Model BA-208, Long-needle Phone at \$13.77 net.
- CLAROSTAT MFG. CO.—RTV 315 to 322 inclusive (tv replacement controls) added to their "RTV" series.
- CORNELL-DUBILIER — Communication Vibrator No. S-8050 added at \$4.62 net.
- ELECTRO-VOICE—Introduced Aristocrat 1,2 and Royal 2, Two way Sound Systems; Models 108-111-114, Two way Speaker Component Package; Model X-825, Crossover Network; Model 8-HD Horn; Model 12BW, Low Freq. Drive; and Royal Speaker Enclosure.
- G. E.—Added G7 series of 7 Germanium products and G10 series of 1 Germanium Power Rectifier and 3 General Purpose Rectifiers available in limited quantities within 2 months. "At this time, G. E. does not encourage your stocking these rectifiers until they have reached full production."

- HICKOK—Introduced Models 533 ADM, Special Tube Merchandiser; 533 AP, 533 B and 600 A Tube Testers; 605, Combination Tube Tester and Set Analyzer; 670 Cathode Ray Oscillator; 680, Marker Generator and Crystal Calibrator; 700, Lab. Tube Tester; 7001 null reading accessory for Model 700; and 7002, short tester accessory for Model 700.

- La POINTE (VEE-D-X)—Now marketing 2 new "Rocket" Boosters; also "LJ" series of 6 new "Long John" 8 element Yagis; the JM-45 Yagi for channels 4 & 5, and Thermo Switch SW-T-1 used in boosters.

- MASTER MOBILE MOUNTS—Introduced new series of 12 Junior Mounts.
- MERIT TRANSFORMER—Introduced their new series of if-rf coils which include items for television, fm, short wave and broadcast units. Also introduced A-3080-1, Vertical Output Transformer; MWC-2, Horizontal Output and Hi-Voltage Transformer, and A-4003, Vertical Blocking Oscillator Transformer. Added TV Kit No. 1000 at \$13.63 net.
- PERMOFLUX CORP.—Marketing 18 new items of headsets, earphones and cushions. Also introduced new baffle model.
- RADIO KITS, INC.—Added 1 new model tv kit and 6 new 3 & 4 band radio receiver kits.
- RAYTHEON—Immediately available from your serving warehouse is Raytheon's tv picture tube 21EP4A. 17HP4, also a new tv tube will be available the latter part of December.
- RIDER, JOHN F.—Second printing of "Encyclopedia on Cathode-Ray Oscilloscopes and their Uses" now available from jobbers. Also TEK-FILE packs 17 through 32 available this month.
- SARKES TARZIAN INC.—Added 17 new tv picture tubes in 10, 12, 14, 17, 19, 20 and 21 inch size. Also added new line of Universal Replacement Tuners TTSR21 and TTSR41.
- SUPERIOR INSTR. CO.—Introduced Junior Super Meter at \$21.40 net and TV Bar Generator at \$39.95 net.
- SYLVANIA—Added radio receiving tube 6BK7 at \$3.20 list; special purpose tube 5932/6L6WGA at \$8.60 net; transmitting tube 5933/807W at \$12.85 and Electroflash tube R-4330 at \$12.50 net.
- TALK-O-PRODUCTS INC.—Added CW-1, Cabinet Station at \$18.00 list and S1 Surface Remote at \$15.00 list with quantity discounts on both.
- V-M CORP.—Added No. 3950, Pre-cut Mounting Board for the Model 950 record changer at \$1.46 net.

**PERFORMANCE Not Size IS WHAT COUNTS**

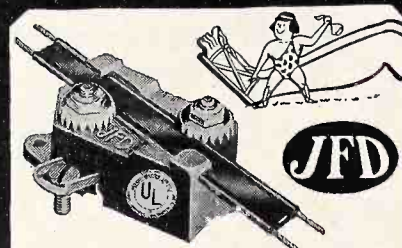

**"LITTLE GIANT" LIGHTNING ARRESTER**

PROTECTS Against Lightning Hazards

No. AT 105 For ribbon-type and oval jumbo twin lead. **\$1.25 LIST**

ONLY JFD Lightning Arresters offer you these exclusive patented features...

1. Strain-relief Retaining Lip prevents pulling or straining of lead against contact points.
2. You actually see positive contact made with lead-in wire.
3. No wire stripping or cutting.

Write for Form No. 84 showing the damage lightning can do to a Television Installation.



**JFD MANUFACTURING CO., Inc.**  
6127A 16th AVENUE, BROOKLYN 4, N. Y.  
FIRST in Television Antennas and Accessories

Please mention Successful Servicing when answering advertising.

**Discontinued Items**

- CARTER PARTS CO.—Withdrew electrical controls No. 6 and No. 9.
- EDITORS & ENGINEERS, LTD. — Withdrew "World's Radio Tubes," 8th Edition and advised 9th Edition to be published about February 1952.
- J F D—Tandem Yagi Antenna TY-7 to TY-13 withdrawn.
- PERMOFLUX CORP.—Withdrew their "H" series of transformers.
- PHILLIPS MFG. CO.—5 parts in their "VT" series for Model LW Soldering Gun withdrawn.
- PICKERING & CO. — Withdrew No. 180L loud-speaker.
- RADIO CITY PRODUCTS CO.—Sweep Generator Marker No. TV-80 withdrawn.
- RIDER, JOHN F. — Discontinued "Oscillator At Work" (Catalog No. 112) and "The Meter at Work" (Catalog No. 116).
- TACO—Discontinued No. 862, Mast Standoff Insulator; 863, Mast Coupling and 888, Guy Wire Thimble.
- TELEX INC.—Withdrew 3 items from their line of headsets.

**Miscellaneous Changes**

- DuMONT A. B.—Replacement parts for DuMont Telesets are now available to servicemen through jobber channels.
- MERIT TRANSFORMER—Replaced Transformers HVO-6 with HVO-7 and MD-70 with MDF-70.
- SCHAUER MFG. CO.—Rectifier Units AR-1-2-3 replaced by AR-4-5-6.
- UNIVERSITY LOUDSPEAKERS, INC.—Withdrew "C" bell and incorporated it as standard equipment in Model B-6 and B-12 with corresponding price increase.

The man who uses

**RIDER Ten-Files & MANUALS**

makes more money!

**63,500**

There are 63,500 references to pertinent electronic and allied engineering articles published from 1925 through 1949 in the five editions of the

**ELECTRONIC ENGINEERING MASTER INDEX**

- 1925-1945 edition—  
(15,000 entries).....\$17.50
- 1935-1945 edition—  
(10,000 entries).....\$10.00
- 1946 edition—  
(7,500 entries).....\$14.50
- 1947-1948 edition—  
(18,500 entries).....\$19.50
- 1949 edition—  
(12,500 entries).....\$17.50

Electronics Research Publishing Company, Inc.  
Dept. 55 480 Canal St., New York 13, N. Y.



## Radio Changes

(Continued from page 20)

### General Electric 422, 423

Stage gain measurements by a vacuum tube voltmeter or similar measuring device may be used to check circuit performance and isolate trouble. The gain values may have tolerances of  $\pm 20\%$ . Readings are taken with low signal input so that the AVC is not effective.

#### 1. I-f gain.

12SA7 grid to 12BA6 grid, 50 @ 455 kc.  
12BA6 grid to 12SQ7 diode plate,  
50 @ 455kc.

2. *Audio Gain.* An input of 0.15 volts at 400 cycles across the volume control R6 with the control set at maximum will develop approximately  $\frac{1}{2}$  watt output across the speaker terminals.

3. *Oscillator grid bias.* D-c voltage developed across the oscillator grid leak resistor R4 averages 4 volts at 1,000 kc.

Rider Radio Manual Page	From	Thru
	22-4	22-6

### United Motors 984688, Pontiac

The r-f coupling capacitor on those radios using miniature type tubes has been changed from a .000005  $\mu$ f to a .000010  $\mu$ f molded mica capacitor (part no. G 100). This change should be made whenever failure necessitates replacement of this component. (Note that this model may use either octal, loctal, or miniature type tubes which necessitate several minor circuit changes).

Rider Radio Manual Page	From	Thru
	22-23	22-30

### General Electric 414, 415, 416, 430

Five groups of transformers, each having a slight difference in specifications, were used throughout production of the above models. Receivers employing transformers marked M77J602-3 use a 68-ohm resistor R12 in the cathode (pin 7) circuit of the 12BA6 i-f amplifier tube V2, while those using transformers M77J460-2, M77J460-3, M77J602-1, M77J602-2 have a 47-ohm resistor.

For this latter group of four transformers the connections for T3 are as follows:

Terminal 1 to diode plate,  
Terminal 2 to diode load.

Rider Radio Manual Page	From	Thru
	22-1	22-3

## What's Tek-File?

(Continued from page 3)

### Tek-File Handies

As an additional aid for radio and television servicemen using Tek-File, John F. Rider Publisher, Inc. is furnishing a perpetual source of service hints and receiver changes absolutely free. This information is furnished on convenient 3 x 4 $\frac{1}{8}$  inch cards, known as HANDIES, suitable for filing in a 3 x 5 inch card file. Eight different cards are printed on a sheet, perforated for easy separation into individual cards. These sheets are part of the Tek-File pack.

All of the information supplied on the HANDY is manufacturer-authorized, factory tested. A typical HANDY, one of the sixteen included in the Tek-File pack shown in Fig. 1, is reproduced in Fig. 2. This HANDY gives the step-by-step procedure for improving the television receiver models of the Stromberg-Carlson 317 series for fringe area reception. Other HANDIES included in this pack give in detail methods and circuit changes (where necessary) for the elimination of ringing, improvement of vertical and horizontal hold, and suppression of retrace lines and sound bars, and many more. This form of servicing aid is an exclusive feature of RIDER TEK-FILE.

In order to keep radio and television technicians up to date on production changes made by manufacturers on their radio and television receiver models already on the market, these production changes are written up and included in Tek-File packs as Handies. These Handies are inserted in the Tek-File pack pertaining to the receiver manufacturer to which they refer. Wherever possible, however, production changes are included directly in the Tek-File service data for each particular model. In this way, the buyer of Tek-File not only gets the complete service data on the receiver models he needs, but also, he gets all the pertinent production changes.

For the convenience of the users of RIDER TEK-FILE who wish to bind their Tek-File folders together so as to keep them on a shelf or in a bookcase, Rider Manual Binders are supplied. To obtain one of these loose-leaf, large-size binders, the serviceman merely sends to John F. Rider Publisher, Inc. fifteen coupons, one of which is included in each Tek-File pack, and a small fee to cover handling.

### Cumulative Index

A specially prepared cumulative index for all Rider TV Tek-File packs is available

## RIDER Books Cover The Field

Encyclopedia on Cathode-Ray Oscilloscopes and Their Uses	992 pages	\$9.00
Vacuum-Tube Voltmeters, 2nd Ed.	432 pages	\$4.50
TV and Other Receiving Antennas (Theory and Practice)	606 pages	\$6.00
TV Installation Techniques	336 pages	\$3.60
TV Master Antenna Systems	356 pages	\$5.00
Receiving Tube Substitution Guide Book, 1st Ed.	224 pages	\$2.40
First Supplement, Receiving Tube Substitution Guide Book	48 pages	\$ .99
TV Picture Projection and Enlargement	192 pages	\$3.30
Television—How It Works	203 pages	\$2.70
FM Transmission and Reception, 2nd Ed.	460 pages	\$3.60
Radio Operator's License Q & A Manual, 3rd Ed.	734 pages	\$6.60
Broadcast Operator's Handbook, 2nd Ed.	440 pages	\$5.40
Radar—What It Is	80 pages	\$1.00
Understanding Vectors and Phase in Radio	160 pages	Cloth cover \$1.89 Paper cover \$ .99
Installation and Servicing of Low Power Pa Systems	208 pages	\$3.00
Servicing by Signal Tracing	360 pages	\$4.00
Inside the Vacuum Tube	424 pages	\$4.50
Servicing Superheterodynes	288 pages	\$2.00
Servicing Receivers by Means of Resistance Measurement	203 pages	\$2.00
The Business Helper	134 pages	\$2.00

WE GUARANTEE your satisfaction! Make these books PROVE their value to you. Examine them at your favorite jobber. If he does not have them — order from us.

### Order Your Copy Now!

JOHN F. RIDER PUBLISHER, INC.  
480 Canal Street, New York 13, N. Y.

FREE at radio and tv parts distributors all over the country. It is an 8 $\frac{1}{2}$  x 11 inch booklet listing the tv receiver manufacturers and models in Tek-File with their pack and file numbers, and is just as easy to use as the Rider radio and tv manual indexes.

RIDER TEK-FILE packs 1 through 32 are now available at Rider distributors. Ask your distributor to let you examine one, and see for yourself if it doesn't answer all your tv service data needs.

Sec. 34.66, P. L. & R.  
U. S. POSTAGE  
PAID  
NEW YORK, N. Y.  
PERMIT No. 9427

JOHN F. RIDER  
437 NEVIN ST.  
LANCASTER, PENN.

From  
JOHN F. RIDER PUBLISHER, Inc.  
480 CANAL ST., NEW YORK 13, N. Y.  
Forwarding and Return Postage Guaranteed



# SUCCESSFUL

# Servicing

FEBRUARY 1952

Checking Your

## TV SWEEP GENERATOR

by Milton S. Snitzer

### Use of TV Sweep Generator

A tv sweep generator is used in conjunction with an oscilloscope for the visual alignment of the tuned circuits in a television receiver. The sweep generator supplies a frequency-modulated signal which is centered at the intermediate frequency or the input radio frequency of the tv set. When the i-f stages of a television receiver are to be aligned, the sweep generator is usually connected to the grid of the mixer stage. An oscilloscope is then connected to the video detector or sound discriminator. When the r-f stages are to be aligned, the sweep generator is connected to the antenna terminals and the scope is connected to the mixer.

The sweep voltage for the scope is commonly obtained from the tv sweep generator and is usually a 60-cycle sine wave. This sine-wave sweep causes the electron beam of the cathode-ray tube to move back and forth horizontally as the frequency of the sweep generator is swept back and forth below and above the center frequency. During this sweeping process, the amplitude of the detector output in the receiver varies in accordance with the response of the tuned circuits preceding the stage. Consequently, the spot of light on the scope screen moves horizontally

in synchronization with the changes in frequency and, at the same time, it moves vertically in accordance with the response of the tuned circuits involved. A graph is produced then in which frequency is plotted on the horizontal axis and amplitude is plotted on the vertical axis. This, of course, is the response curve of the circuit being checked.

### Common Controls and Terminals

Although no two tv sweep generators produced by different manufacturers are identical, all such generators perform about the same functions and have much in common. The controls and terminals may have different names in different units but there is enough similarity in what these controls do to make the following breakdown.

There are four major types of control and two terminal connections on most sweep generators.

First, one or more controls are used to select the center frequency of the f-m output signal. Sometimes a single control which permits continuous tuning is used. In other cases, the single control is actually a range switch which sets a number of fixed frequency ranges. These may be the 12 tv channels plus some additional lower frequency

ranges for i-f alignment. Sometimes a frequency vernier control is used in conjunction with a range switch as a fine frequency control. Depending on the particular sweep generator you have, these controls may be called Range Selector, Frequency, Band, Tuning, Vernier, etc.

Second, some type of control is used to determine the amount of frequency deviation of the f-m output signal. With this control, you are able to vary the swept bandwidth from 0 to 20 mc depending on the unit used. A common maximum bandwidth output is 10 mc. Controls used for this purpose may be called Sweep Width, Megacycle Sweep, Dev. Mc, etc.

Third, one or more controls are used to regulate the amplitude of the output signal. This regulation may be accomplished by a single continuous control or by a step attenuator switch in conjunction with a continuous vernier control. These controls may be called Attenuator, Output Multiplier, Fine Attenuator, R. F. Amplitude, etc.

Fourth, a control is usually provided to determine the phase of the signal used as the horizontal sweep on the scope. This signal is shifted with respect to the signal used to frequency modulate the sweep generator output

(Continued on page 6)



# RIDER TV **TEK-FILE** RELEASES for FEBRUARY, 1952

### ADMIRAL

Model Pack 40  
4H15A, 4H15B, 4H16A, 4H16B (CH. 20A1); 4H17A, 4H17B (CH. 20A1); 4H18C, 4H18CN, 4H19C, 4H19CN (CH. 20B1); 4H126A, 4H126B, 4H126C, 4H126CN (CH. 21A1); 4H137A, 4H137B (CH. 21A1); 4H145A, 4H145B, 4H145C, 4H145CN (CH. 20B1); 4H146A, 4H146B, 4H146C (CH. 20B1); 4H147A, 4H147B (CH. 20B1); 4H156C, 4H156CN (CH. 20B1); 4H157A, 4H157B (CH. 20B1); 4H165A, 4H165B (CH. 20B1); 4H166A, 4H166B, 4H166C, 4H166CN (CH. 20B1); 4H167A, 4H167B, 4H167C, 4H167CN (CH. 20B1); 12X11, 12X12 (CH. 20Z1); 20X11, 20X12, 20X122 (CH. 20X1); 20X136 (CH. 20Y1); 20X145, 20X146, 20X147 (CH. 20Y1); 22X12, 22X25, 22X26, 22X27 (CH. 20Z1); 24A12, 24A125 (CH. 20A1); 24A125AN (CH. 20X1); 24C15, 24C16 (CH. 20B1); 24X15, 24X155 (CH. 20X1); 24X16, 24X165, 24X175 (CH. 20X1); 25A15, 25A16, 25A17 (CH. 21A1); 30F15, 30F15A, 30F16, 30F16A (CH. 20B1); 30F17, 30F17A (CH. 20B1); 32X15, 32X16 (CH. 20Z1); 32X26, 32X27 (CH. 20Z1); 32X35, 32X36 (CH. 20Z1).

### ADMIRAL

Model Pack 48  
26R25, 26R26 (CH. 24H1); 26R35, 26R36, 26R37 (CH. 24H1); 26X35, 26X36, 26X37 (CH. 24D1); 26X45, 26X46 (CH. 24H1); 26X55, 26X56, 26X57 (CH. 24D1); 26X65, 26X66 (CH. 24D1); 26X67, 26X75, 26X76 (CH. 24D1); 29X16, 29X17 (CH. 24F1); 29X25, 29X26, 29X27 (CH. 24F1); 36X35, 36X35A, 36X36, 36X36A, 36X37 (CH. 24E1); 36X37A (CH. 24E1); 39X16, 39X16A, 39X16B (CH. 24G1); 39X17A, 39X17B (CH. 24G1); 39X25, 39X26 (CH. 24G1).  
Rcd. Ch. RC500, RC550.

### AFFILIATED RETAILERS (ARTONE)

Model Pack 40  
AR-16-CD, AR-16-CD-3CR, AR-16-CX, AR-16-3CR, AR-216, AR-316, AR-316-3CM, AR-816, AR-816-3CM, AR-816-3CR, AR-819, AR-819-3CM, AR-919.  
Model Pack 48  
AR-MST-14, AR-MST-16, AR-14-TR, AR-16-ATR, AR-16-CR, AR-16-RO, AR-16-TR, AR-17-CD, AR-17-CR, AR-17-RO, AR-17-3D, AR-112X, AR-114A.

### AIR KING

Model Pack 43  
12C1, 12T1, 12T2 (CH. 700); 14T1 (CH. 700-30); 16C1 (CH. 700-1, 700-10, 700-90); 16C2, 16C3 (CH. 700-10); 16C5 (CH. 700-10, 700-90); 16K1 (CH. 700-2, 700-50, 700-92); 16M1 (CH. 700-10, 700-90); 16T1 (CH. 700-1, 700-10); 16T1B (CH. 700-1, 700-10, 700-90); 19C1 (CH. 700-40, 700-91); 20C1, 20C2 (CH. 700-93); 20K1 (CH. 700-95); 20M1 (CH. 700-90, 700-93); 700-5, 700-20, CH.

### AIR MARSHALL

Model Pack 43  
B-17-T.

### ALLIANCE

Model Pack 43  
AB, Booster.

### ANCHOR

Model Pack 43  
ARC-101-75, ARC-101-100.

### ANDREA

Model Pack 43  
C-VL16, Sutton (CH. VL16)  
C-VL17, Brewster (CH. VL17)  
CO-VL16, Fleetwood (CH. VL16)

CO-VL19, Caronia (CH. VL19)  
T-VL12, Saybrook (CH. VL12)  
T-VL16, Mayfield (CH. VL16)  
T-VL17, Gotham (CH. VL17)  
2C-VL17, Warwick (CH. VL17).

### ARVIN

Model Pack 43  
2120, 2121 (CH. TE289-3); 2122TM (CH. TE289); 2123, 2124, 2126 (CH. TE289-3); 2160, 2161, 2162, 2164 (CH. TE290); 3100TB, 3100TM, 3101CM (CH. TE272-1); 3120CB, 3120CM, 3121TM (CH. TE272-2); 3160CM (CH. TE276); 4080T (CH. TE282); 5204, 5206 (CH. TE300); 5210, 5211, 5212 (CH. TE315, TE315-1, TE315-2).

### BELMONT (RAYTHEON)

Model Pack 48  
C-1614A, The Marquis (CH. 16AY211); C-1615A, The Mayfair (CH. 16AY211); C-1616A, The Mozart (CH. 16AY211); C-1614B, The Marquis (CH. 16AY28); C-1615B, The Mayfair (CH. 16AY28); C-1616B, The Mozart (CH. 16AY28); C-1714A, The Marquis (CH. 17AY24); C-1715A, The Mayfair (CH. 17AY24); C-1716A, The Mozart (CH. 17AY24); C-1714B, The Marquis (CH. 17AY21); C-1715B, The Mayfair (CH. 17AY21); C-1716B, The Mozart (CH. 17AY21); C-1724A (CH. 17AY21); M-1611A, The Rocket (CH. 16AY211); M-1612A, The Rancho (CH. 16AY211); M-1613A, The Revere (CH. 16AY211); M-1611B, The Rocket (CH. 16AY28); M-1612B, The Rancho (CH. 16AY28); M-1613B, The Revere (CH. 16AY28); M-1711A, The Rocket (CH. 17AY24); M-1712A, The Rancho (CH. 17AY24); M-1713A, The Revere (CH. 17AY24); M-1711B, The Rocket (CH. 17AY21); M-1712B, The Rancho (CH. 17AY21); M-1713B, The Revere (CH. 17AY21); RC-1618B, The Savoy (CH. 16AY211); RC-1619A, The Santung (CH. 16AY211); RC-1618B, The Savoy (CH. 16AY28); RC-1619B, The Santung (CH. 16AY28); RC-1718A, The Savoy (CH. 17AY24); RC-1719A, The Santung (CH. 17AY24); RC-1718B, The Savoy (CH. 17AY21); RC-1719B, The Santung (CH. 17AY21).

### BENDIX

Model Pack 48  
C172, Belair; C200, Guilford.

### DUMONT

Model Pack 33  
RA-109-A1, Winslow; RA-109-A2, Hanover; RA-109-A3, Sherbrooke; RA-109-A5, Winslow; RA-109-A6, Hanover; RA-109-A7, Sherbrooke; RA-111-A1, Putnam; RA-111-A2, Guilford; RA-111-A4, Putnam; RA-111-A5, Guilford; RA-112-A1, Ardmore; RA-112-A2, Westerly; RA-112-A3, Mt. Vernon; RA-112-A4, Ardmore; RA-112-A5, Westerly; RA-112-A6, Mt. Vernon; RA-113-B1, RA-113-B2, Brookville; RA-113-B3, RA-113-B4, Revere; RA-113-B5, RA-113-B6, Burlingame; RA-113-B7, RA-113-B8, Tarrytown; RA-119A, Royal Sovereign.

### EMERSON

Model Pack 39  
699B (CH. 120148-B); 700B, 701B (CH. 120153-B).  
Rcd. Ch. VM-950.

### EMERSON

Model Pack 39  
699B (CH. 120148-B); 700B, 701B (CH. 120153-B).  
Rcd. Ch. VM-950.

### GENERAL INSTRUMENT

Model Pack 35  
44, Tuner.  
HALLCRAFTERS  
Model Pack 35  
716, 717 (CH. C919120); 730, 731 (CH. C919120); 740, 741 (CH. C919120).

### HERTNER (PRECISION)

Model Pack 35  
L-10.

### HOFFMAN

Model Pack 35  
600 (CH. 154); 601 (CH. 155); 610 (CH. 140, Rev.); 612, (CH. 142, Rev.); 613 (CH. 149); 620, 621 (CH. 155); 622, 623 (CH. 149); 830, 831, 832 (CH. 151); 841, 842, 843 (CH. 158); 846 (CH. 151); 850, 851, 852 (CH. 151); 914, 915, 916 (CH. 150); 917, 918, 920 (CH. 152); 921, 930, 931, 932 (CH. 150); 936, 937, 938 (CH. 152).

### INTERSTATE STORES (PLYMOUTH)

Model Pack 35  
250, 350, 750; P1650T, P1652, P1653, P1751, P1752, P1753, P2052.

### MACY'S

Model Pack 47  
HP-21B, HP-21M, HP-71B, HP-71M, HPC-21B, HPC-21M, HPC-22X, HPC-71B, HPC-71M; HPD-21.

### MECK

Model Pack 45  
MM-510T, MM-512C, MM-512T; MM-516C, MM-516T; MM-614C, MM-614T (CH. 9018); MM-616C, MM-616T (CH. 9018); MM-617C, MM-617T (CH. 9018); MM-619C (CH. 9018); X0B, X0A, X0R, XRA, XRP, XRP, XSA, XSB, XSC, XSD (CH. 9018); XSPS, XSPT, XTA, XTR.

### MIDWEST

Model Pack 45  
K-19, KR-19 (CH. DJ-19); KX-19 (CH. DX-19); KXA-19 (CH. DXA-19); P-16, PR-16 (CH. DR-16); PX-16 (CH. DM-16); PXA-16 (CH. DMA-16).

### MITCHELL

Model Pack 45  
T16-2KB, T16-2KM; T16-B, T16-M.

### MONTGOMERY WARD (AIRLINE)

Model Pack 45  
05GCB-3019A, 16K1/63-3019; 94GCB-3023A, 94GCB-3023B, 94GCB-3023C; 94WG-3008A, 94WG-3016A, 94WG-3016B, 94WG-3016C; 94WG-3028A.

### MOTOROLA

Model Pack 36  
12K1, 12K1B, 12K2, 12K2B (CH. TS-53); 12K3, 12K3B (CH. TS-53); 12T1, 12T1B, 12T2, 12T3 (CH. TS-53); 14K1, 14K1B (CH. TS-88); 14K18B, 14K1H (CH. TS-115); 14T1, 14T1B (CH. TS-88); 14T3 (CH. TS-114); 16K2, 16K2B (CH. TS-74).

### MOTOROLA

Model Pack 47  
16F1, 16F1B (CH. TS-60); 16F1BH, 16F1H (CH. TS-89); 16K2BH, 16K2H (CH. TS-94); 16T1, 16T1B (CH. TS-60); 16T1BH, 16T1H (CH. TS-89); 17F1A, 17F1BA (CH. TS-89); 17F2WA, 17F3BA (CH. TS-89); 17F4A, 17F5A, 17F5BA (CH. TS-89); 17K1A, 17K1BA (CH. TS-95); 17K3A, 17K3BA (CH. TS-89); 17K4A (CH. TS-95); 17T1A, 17T1BA (CH. TS-89); 17T2A, 17T2BA (CH. TS-89); 17T3A (CH. TS-89); 17F1, 17F1B

(CH. TS-118); 17F2W, 17F3B, 17F4 (CH. TS-118); 17F5, 17F5B (CH. TS-118); 17F6, 17F6B, 17F7B (CH. TS-118); 17F8, 17F9, 17F9B (CH. TS-118); 17K1BE, 17K1E (CH. TS-172); 17K2BE, 17K2E (CH. TS-172); 17K3, 17K3B (CH. TS-118); 17K4E (CH. TS-172); 17K5, 17K6, 17K7, 17K7B (CH. TS-118); 17T1, 17T1B (CH. TS-118); 17T2, 17T2B, 17T3 (CH. TS-118); 17T4 (CH. TS-118); 19K2, 19K2B (CH. TS-101); 19K3, 19K4, 19K4B (CH. TS-101).

### MUNTZ

Model Pack 36  
M31 (CH. TV17A2); M31R (CH. TV17A3); M32, M32R (CH. TV17A3); M33 (CH. TV17A4); M34 (CH. TV17A4); M41, M42 (CH. TV17A3A); M46, M49 (CH. TV17A7).

### NORTH AMERICAN PHILLIPS (NORELCO)

Model Pack 38  
PT200, The Irvington (CH. PT200); PT300, The Mt. Vernon (CH. PT200).

### OLYMPIC

Model Pack 44  
DX-214, DX-215, DX-216; DX-619, DX-620; DX-621; DX-622; DX-931, DX-932, DX-950; XL-210, XL-211, XL-612, XL-613; 752, Riviera; 752U; 753, Monte Carlo; 753U; 755, Challenger; 755U; 762, Riviera Deluxe; 764, Broadmoor; 764U; 766, Catalina; 766U, 767; 769, Prince George; 783; 967, Windsor; 968, Lancaster; 970, Marlborough.

### PACKARD-BELL

Model Pack 44  
2001-TV, 2002-TV; 2091-TV, 2092-TV; 2101, 2102 (CH. 2101-2); 2105, 2105A (CH. 2101-2); 2202-TV, 2204-TV; 2601-TV; 2602; 2692-TV; 2801-TV, 2801A-TV.

### PHILCO

Model Pack 34  
50-T1104 (CODES 121, 122); 50-T1105 (CODES 121, 122); 50-T1106; 50-T1403 (CODE 125); 50-T1404 (CODES 123, 124, 125); 50-T1406 (CODES 123, 124, 125); 50-T1432 (CODE 124); 50-T1600, 50-T1632, 50-T1633 (CODE 121).

### PHILCO

Model Pack 37  
50-702 (CODE 122); 50-T1443 (CODES 122, 123); 50-T1476, 50-T1477, 50-T1478, 50-T1479, 50-T1481, 50-T1482, 50-T1484; 76-4402, 76-5411, 76-5433, Series; Tuners.  
Rcd. Ch. M-20.

### PILOT

Model Pack 37  
TV-127, TV-164, TV-167A, TV-191.

### RADIO CRAFTSMEN

Model Pack 38  
RC100A.

### RCA

Model Pack 34  
T100 (CH. KCS38); T120 (CH. KCS34C); T121 (CH. KCS34C).  
Model Pack 37  
T164 (CH. KCS40); TC165, TC166, TC167, TC168 (CH. KCS40A).

### RCA

Model Pack 46  
T251 (CH. KCS45); T260 (CH. KCS45A); T281 (CH. KCS46); 6T53, 6T54 (CH. KCS47, KCS47T); 6T64, 6T65 (CH. KCS47A, KCS47AT); 6T71 (CH. KCS47A, KCS47AT); 6T72 (CH. KCS40B); 6T74, 6T75, 6T76 (CH. KCS47A, KCS47AT).

### SENTINEL

Model Pack 38  
1U416, 1U419, 1U420, 1U424; 1U425, 1U428, 1U432 (CH. YA, YB, YC); 1U435 (CH. YB, YC); 1U438, 1U439, 1U440 (CH. YA, YB, YC); 1U441, 1U443, 1U444 (CH. YA, YB, YC); 1U446 (Series XD); 416; 419, 420; 420B; 423, 424; 425, 428, 432 (CH. YA, YB, YC); 435 (CH. YB, YC); 438, 439, 440 (CH. YA, YB, YC); 441, 443, 444 (CH. YA, YB, YC).

### TELE KING

Model Pack 41  
K-21, K-21B, K-22 (CH. TVJ); K-71, K-72, K-72B, K-73L, K-74 (CH. TVJ); KC-21, KC-21B, KC-71, KC-71B (CH. TVJ); KD-21M, KD-22B, KD-71, KD-72B (CH. TVJ); 172L0, 172M (CH. TVG); 174L0, 174M (CH. TVG); 202L0, 202M, 203, 205 (CH. TVG); 916, 916CAF (CH. TVG); 919, 919CAF (CH. TVG); 1014, 1016 (CH. TVG).

### TELEQUIP

Model Pack 41  
12TR, 14T, 14TR, 16T, 16TR, 19T, 19TR.

### TELE-TONE

Model Pack 41  
TV-284 (CH. TT); TV-286 (CH. TH, TJ, Rev.); TV-287, TV-288 (CH. TT); TV-300, TV-301 (CH. TW, TX); TV-304, TV-305 (CH. TW, TX); TV-306 (CH. TZ); TV-307 (CH. TX); TV-314 (CH. TAJ); TV-315 (CH. TAA, TAB); TV-316 (CH. TZ); TV-317 (CH. TAG); TV-318, TV-322, TV-323 (CH. TAM); 324, 325, 326, 328, 329 (CH. TAP-2); 335, 336, 340, 345 (CH. TAP-2).

### WESTINGHOUSE

Model Pack 42  
H-606K12, H-607K12 (CH. V-2150-111); H-609T10 (CH. V-2150-94C); H-610T12 (CH. V-2150-136); H-611C12 (CH. V-2192-16); H-613K16 (CH. V-2150-146); H-614T12 (CH. V-2150-136); H-615C12 (CH. V-2152-16); H-617T12, H-619T12 (CH. V-2150-176); H-619T12U (CH. V-2150-176U, V-2150-177U).

### ZENITH

Model Pack 42  
H2226E, H2226R, Warton; H2226RQ (CH. 22H20); H2227E, Garland; H2227EQ, H2227R, Walpole; H2227RQ (CH. 22H20); H2250R, Lowell; H2250RQ (CH. 22H20); H2255E, Morley; H2255EQ (CH. 22H20); H2328E, H2328R, Walton; H2328RQ (CH. 23H22); H2328EZ, H2328RQZ, H2328RZ (CH. 23H22Z); H2329R, Burton; H2329RQ (CH. 23H22); H2352R, Mansfield; H2352RQ (CH. 23H22); H2352RZ, H2352RZ (CH. 23H22Z); H2353E, Meredith; H2353EQ (CH. 23H22); H2353EQZ, H2353EZ (CH. 23H22Z); H2437E, Fielding; H2437EQ (CH. 24H20); H2437R, Irving; H2437RQ (CH. 24H20); H2438R, Aldrich; H2438RQ (CH. 24H20); H2439R, Coleridge; H2439RQ (CH. 24H20); H2445R, Tennyson; H2445RQ (CH. 24H21); H2447R, Byron; H2447RQ (CH. 24H21); H249E, Churchill (CH. 24H20); H3267, Hawthorne; H3267R, H3267RQ (CH. 24H20); H3469E, Wordsworth; H3469EQ (CH. 24H20); H3475R, Kilmer; H3475RQ (CH. 24H20); H3477R, Thackeray; H3477RQ (CH. 24H21); H3478E, Shelley; H3478EQ (CH. 24H21).



# HOW TO ORGANIZE YOUR RESISTOR STOCK FOR SPACE ECONOMY AND EASY USE WITH IRC ALL-METAL KITS AND CABINETS

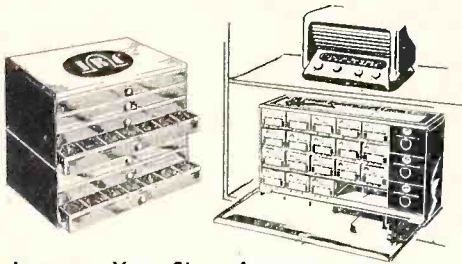

### Improve Your Shop Appearance and Efficiency—End Cigar Box Confusion

Tired of taking time out to go and buy parts? Want a neater, better looking, more efficient shop? Then buy your resistors, chokes and controls in convenient, all-metal IRC kits and cabinets. *At no extra cost*, these compact units put the parts you use most right at your finger tips! And at the same time, you get a neat stocking arrangement that saves space and gives your shop an attractive, business-like appearance.

### Pay Only the Price of the Parts

### Get Kits and Cabinets at No Extra Cost!

*It costs nothing extra* to buy the resistors, chokes and controls you need in these handy Resist-O-Kits and Resist-O-Cabinets. You actually pay only the standard net price of the parts. IRC provides the complete selection of assortments tailor-made to your requirements. And prices begin as low as \$4.50.

Beautifully  
Lithographed  
Resist-O-  
Cabinets



with any of 3  
Fast-Moving Assortments

IRC supplies the popular Resist-O-Cabinets in three wanted assortments— $\frac{1}{2}$  watt, 1 watt, and Combination, including ranges most widely used in television. The Combination assortment also includes IRC deposited carbon, close-tolerance PRECISTORS. Four-drawer cabinets have 28 separate compartments—each with range identification. Drawers have special non-spill feature and cabinets are designed for handy stacking. Beautifully lithographed in blue, yellow and silver. Dimensions  $5\frac{3}{8}'' \times 5\frac{1}{16}'' \times 10\frac{7}{8}''$ . Dealer Prices:  $\frac{1}{2}$  watt Assortment No. 4, \$10.00. 1 watt Assortment No. 5, \$12.45. Combination Assortment No. 6 ( $\frac{1}{2}$  to 2 watts), \$14.95.

### Flat, Pocket-Size Resist-O-Kits for Service Calls and Small Bench Stocks



This handy, all-metal kit slides easily into your pocket—takes up scant room on your bench. A real convenience for service calls! Ten compartments keep ranges from mixing and lid snaps securely shut. Each resistor in kit has range clearly marked on body. Resist-O-Kits measure  $\frac{1}{16}'' \times 3\frac{7}{8}'' \times 6\frac{3}{8}''$ . Price:—\$4.50. Your Choice of Two Assortments— $\frac{1}{2}$  watt (Assortment No. 7) or 1 watt (Assortment No. 8)—in No-Extra-Cost Resist-O-Kits.

### Get the Types of Resistors You'll Need for Most Radio and Television Servicing

#### IRC Advanced



**Type BT Fixed Composition Resistors**, used in all assortments, easily meet the stiff requirements of television. Compact, lightweight, fully insulated BT's combine extremely low operating temperature and superior power dissipation—actually beat Army-Navy specs in most characteristics.

#### IRC Type BW



**Insulated-Wire Wound Resistors**, used in Resist-O-Kits and Resist-O-Cabinets, are unusually stable and inexpensive units for low-range requirements. They have an excellent record in TV circuits and high stability attenuators. Molded bakelite housing seals out moisture and eliminates any possibility of grounding.

#### IRC Deposited



**Carbon PRECISTORS**, included in the Combination Resist-O-Cabinet Assortment, combine accuracy and low cost in close-tolerance applications. They are ideally suited to critical television circuits and other applications where stability over long periods of time is important. Low voltage coefficient and low capacitive and inductive impedance make them outstanding in high frequency applications.



### New Convenience in Volume Control Stocks with IRC's Volume Control Cabinet

What Resist-O-Cabinet does for your resistors, IRC's Volume Control Cabinet does for your Type Q Controls. Each IRC Volume Control Cabinet is stocked with 18 new Type Q Controls plus switches and special shafts. With this stock, you can handle

over 90% of all AM, FM and TV Single Carbon Control replacements. Individually marked compartments contain controls—3 special drawers hold shafts, switches and spare parts. The Volume Control Cabinet *costs you nothing extra*; you pay only for its contents. Cabinet measures  $4\frac{1}{2}'' \times 7\frac{3}{8}'' \times 14\frac{1}{2}''$ . Price:—\$18.54.

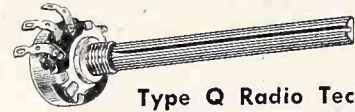

### Type Q Radio Technician's Volume Control Covers More than 90% of

**Replacement Needs.** Special Knob Master Fixed Shaft Feature and Interchangeable Fixed Shafts give you the widest possible coverage of replacement needs with a nominal control stock. The Knob Master Fixed Shaft handles most knob requirements—gives all the adaptability of a Tap-in shaft with the security of a permanent or fixed shaft. Interchangeable Fixed Shafts convert the Type Q Control to a "special" in just a few moments. Type Q Control, itself, features small  $\frac{15}{16}''$  size, short  $\frac{1}{4}''$  bushing, rugged construction. It fits smaller sets easily—yet handles the requirements of large receivers without trouble.

### Handy Bench Supply of Insulated Chokes in 4-Drawer Metal Cabinet



This assortment contains 140 IRC Chokes—5 each of 28 different units, in two sizes from 0.47 to 10 microhenries. Each value is in a separate, identified compartment. Cabinets are compact, all-metal, handsomely lithographed—and may be stacked with IRC Resist-O-Cabinets. Price:—\$29.40—the cost of the Chokes alone. No extra charge for the Cabinet.

### IRC Insulated Chokes Make



### Accurate Replacement Easy

Available in a wide range of size-and-characteristic combinations, IRC Chokes make it easy to meet space and electrical requirements. You can get them in two sizes—both types fully insulated in molded phenolic housings for protection against high humidity, abrasion or physical damage, and possibility of shorting to chassis.

### GET NEW CATALOG BULLETIN OF IRC ALL-METAL CABINETS AND KITS

Your name and address on a post card brings you our new Catalog Bulletin DC2A—with details of Resist-O-Kits, Resist-O-Cabinets, Volume Control Cabinets and Choke Cabinets. If you want to make your servicing more efficient and more profitable, get the full story today. There's no obligation.



Wherever the Circuit Says 

**INTERNATIONAL  
RESISTANCE CO.**

423A N. Broad Street, Philadelphia 8, Pa.



# It's Tung-Sol for radio and tv



**Quality** -that keeps pace with the growth of the electronic industry  
 -that meets fully the performance requirements of all  
 radio and tv set manufacturers  
 -that safeguards dealer service work

**TUNG-SOL**  
 RADIO, TV TUBES, DIAL LAMPS



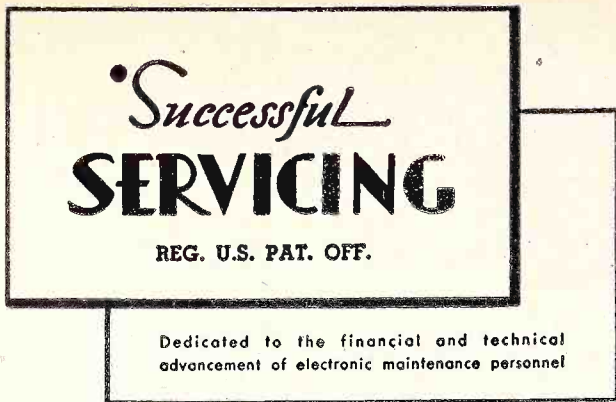

Volume 13 Number 4

February, 1952

JOHN F. RIDER, *Publisher*  
Charles Tepfer, *Editor*  
Annette M. Tricarico, *Assoc. Editor*

*Advertising Representative*

H. J. Olsow & Co.  
3951 Grand Central Terminal  
New York 17, N. Y.  
Murray Hill 6-4670



MEMBER



## Curtain Time

### TV Owner Service

A number of advertisements are appearing on TV station programs offering service books to the TV receiver owner. The selling organizations make the claim that from 65 to 70 percent of the troubles in TV receivers can be corrected by the receiver owners and it is unnecessary to always call upon the TV service technician. Advertisements appearing in New York newspapers claim that the set owner can repair 90 percent of all his TV troubles. The advertisers safeguard themselves, however, by either saying or implying that expert service is still required for major faults.

It goes without saying that a number of troubles occurring in TV receivers can be corrected by the set owner—even the nontechnical man. In the main, these are tube replacements in nonresonant circuits, and possibly linearity and picture size adjustments, PROVIDED that the need for tube replacement or adjustment does not stem from a defect which has developed in the circuit. In that event, tube replacement is only a tem-

porary cure, as are the adjustments. The amount of subsequent damage which may occur because circuit malfunctioning has not been corrected, is in the lap of the gods.

Be that as it may, trouble corrections by the nontechnical TV set owner is something which bodes ill for the set manufacturer and the TV broadcast station. No matter what boundaries are set on the repairs that may be done by the set owner, once he starts to tamper with his receiver he will attempt more and more difficult repairs. There is no limit to the amount of damage he may do.

This situation warrants serious consideration from the service departments of receiver manufacturers, parts manufacturers, part and set distributors, and broadcast stations. They should advise the nontechnical set owner not to attempt repairs on his TV set, for in the long run it will be more costly than calling the TV service technician at the beginning.

### \$1.00 Service Calls

Whatever may be the technique used to accomplish the end result — namely profitable operation — it is inconceivable to reconcile TV service advertisements which offer from \$1.00 to \$3.00 service (parts extra) with the everyday cost of operation. Add to this the offer of day or night service, and it becomes even more incomprehensible.

What motivates an individual to run an advertisement offering service for \$1.00 when he sees others asking \$3.00 for the same operation? Since these ads run day after day and week after week, it is obvious that the \$3.00 guy is getting his fee. Even the \$3.00 price is questioned inasmuch as national cost figures justify from \$4.50 to \$5.00 per hour charge. If this is true, why offer the same service for \$1.00?

Another point to be remembered by people who are selling on a price basis is that with cigarettes slightly less than 25 cents per pack, lipsticks selling for \$1.00, magazines selling from 35 cents to 50 cents a copy, and bus and other transportation fares going from 10 to 15 cents, the public looks with suspicion on an offer of technical service for only \$1.00. It just seems too cheap in the light of all other costs. Everything else tied to the sale of time also is suspected. The public realizes that the service technician is desirous of earning a livelihood and when they receive an offer of technical know-how at a ridiculously low price, the natural conclusion is that the cheap price is going to be made up somehow — in this case, in the sale of the parts which are tied to the deal.

Summarizing the whole thing — there is a limit to how cheaply a service can be offered. It can be too cheap and for that reason, it will not sell!

*John F. Rider*



# TV SWEEP GENERATOR

(Continued from page 1)

signal. This control is required in order to superimpose the response curve traced on the scope screen while the electron beam is moving from left to right with the response curve traced while the beam is moving from right to left. Such controls may be referred to as Phasing, Phase Shifter, Scope Phasing, etc. depending on your particular equipment.

In addition to the above major controls, some auxiliary controls may be provided. One such control is a blanking switch. This is used to cut off the sweep generator oscillator for one-half of a sweep cycle. With no r-f output from the generator, there will be no output from the circuit being aligned. As a result, a horizontal base line is superimposed on the scope screen. If your sweep generator has marker generator circuits built into it, there will be additional controls associated with these circuits.

There are two groups of output terminals. These may take the form of binding posts or shielded cable connectors. The first group consists of one or more terminals at which the f-m output signal is taken. These may be called Output, R. F., R. F. Out, etc. Second, there is a terminal where the modulating signal can be taken off to feed the horizontal input terminals of the scope. This may be referred to as Horizontal Sweep, Sync, Scope, 60 cps, etc.

For the tv sweep generator to operate correctly, each of the controls described above must be in proper operating condition. To determine whether these controls are in good condition the checks described in the rest of this article should be used. However, before making any operational checks on your sweep generator, be sure to allow it to warm up thoroughly. This must be done so that any check made will reflect the normal stable operating conditions of the equipment.

## Output Amplitude Control

You can check the operation of the output amplitude control quite simply. Connect your sweep generator and scope to a television receiver. Set up both instruments to produce a response curve on the scope screen. Now operate the output amplitude control from minimum to maximum setting while you observe the scope. The height of the response curve should vary smoothly. At minimum setting, only a horizontal line should appear on the screen. Then as the control is advanced, the height of the curve should increase as shown in Fig. 1.

If only a horizontal line appears on the scope then this may indicate no output. Check both the fixed and frequency-modulated oscillator tubes, any isolating stage tubes (such as a cathode follower), and the rectifier. Change the frequency setting to determine whether or not an output is obtained at other fre-

quencies. Also check the coupling circuit to and from the output signal amplitude control. Finally, check this control itself.

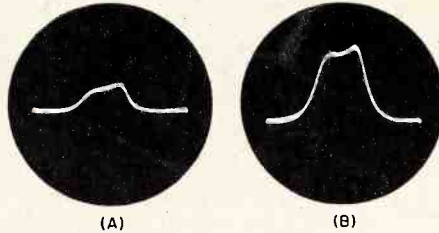

Fig. 1. Response curves at two settings of the output amplitude control.

## Frequency Deviation Control

In order to check the frequency deviation control, you need an accurate marker generator. This should be crystal controlled in order to obtain exact readings. The required markers can be obtained from a separate marker generator or, if the sweep generator has internal marker circuits, these can be used.

Assume that an external crystal calibrated marker generator is available. This is loosely coupled through a small capacitor (20  $\mu\text{mf}$ )

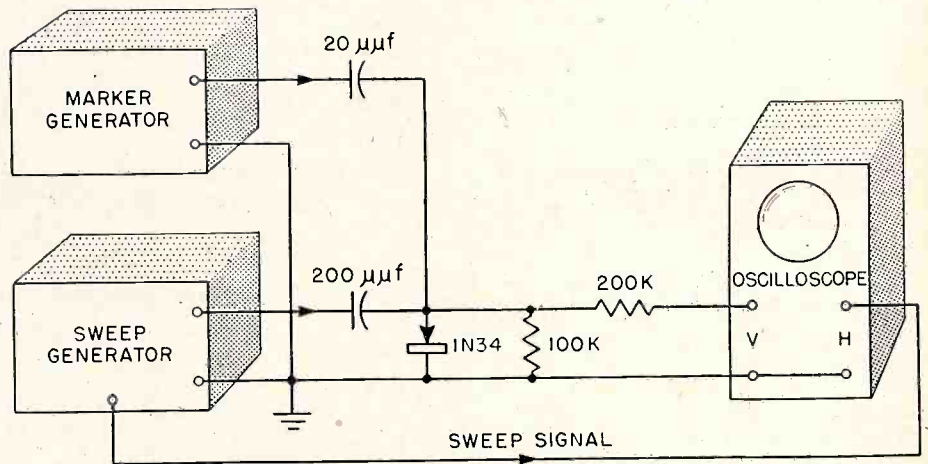

Fig. 2. Crystal detector circuit for mixing marker generator and sweep generator outputs.

to a crystal detector such as is shown in Fig. 2. The sweep generator is also connected to the detector. Adjust the marker generator to the center frequency of the sweep generator. When the pattern is properly phased, a single marker should appear at the center of the horizontal baseline on the scope. This is shown in Fig. 3. Now the marker is moved to the extreme right end of the trace as shown in the figure. Note the frequency of the marker under these conditions. Next, adjust the marker generator so that the marker is placed at the extreme left end of the baseline. Note the setting of the marker generator here. The difference between the two frequencies is the amount of frequency deviation.

It is a good idea to use the above method to check the deviation at various settings of the frequency deviation control and at various frequencies. In this way you are able to check the calibration of this control.

If the sweep width does not check with the specifications for your particular sweep generator, this circuit must be checked. To do this in most sweep generators, check the voltage applied to the loudspeaker-like arrangement used to produce the frequency modulation. It is a good idea to familiarize yourself with the normal sound made by the electro-mechanical arrangement. If this unit buzzes excessively, a mechanical fault may be indicated or perhaps excessive voltage is being applied to the unit. Check the low-ohmage series resistor and the control itself for proper valves. In some generators, an internal adjustment is provided to produce correct deviation. If the components are satisfactory, it may be necessary to investigate the mechanical arrangement itself. As this may involve a special or elaborate mechanical set-up, check the sweep generator instruction book for exact details.

## Phasing Control

The proper operation of this control may be easily seen when the equipment is set up for normal response curve observation. With

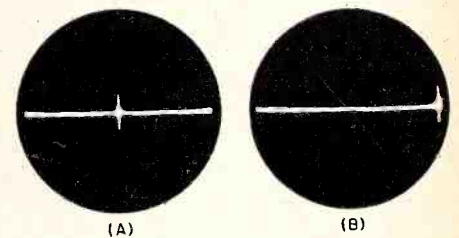

Fig. 3. Determining frequency deviation with marker.

a normal response curve on the scope as shown in Fig. 1, vary the phasing control. You should be able to phase the two response curves so that they are superimposed to form a single pattern as described earlier. Then check to determine whether the control has sufficient range. You should be able to sep-

(Continued on page 20)



# TROUBLESHOOTING tv afc circuits

by Richard Blitzer

Automatic frequency control (AFC) is used in horizontal sweep circuits of television receivers to keep the horizontal oscillator running at the correct frequency. A failure of any part of the AFC circuit such as a tube, a capacitor, a resistor, or a coil could cause the horizontal oscillator to operate at a wrong frequency or not to operate at all.

A knowledge of how the AFC circuit works is helpful if the trouble is to be remedied in the shortest possible time. The servicing equipment, as usual, should include an oscilloscope and a VTVM. An ordinary 1,000-ohms/volt meter may not suffice, since small voltages will have to be measured across very large resistors. The resistance of the voltmeter, if small, could upset the circuit across which it is placed. This could give an erroneous reading.

In this article two common AFC circuits will be discussed. The operation of each will be briefly reviewed, and each circuit discussion will be followed by troubleshooting information.

## Sine-Wave Oscillator-Discriminator AFC Circuit

One common circuit is the horizontal AFC used in the RCA type 630 chassis. This circuit is shown in Fig. 1.

The horizontal oscillator is a Hartley type, producing a sine-wave output. The frequency is mainly determined by the variable inductance (the primary of T1) and the tube V4, which is an inductive reactance tube circuit.

The sine waves from the oscillator are coupled through the transformer T1 to the plates of V1 and V2. The sine waves which appear at the plates of the duo-diode are 180 degrees out of phase with each other.

A positive-going sync pulse from the sync amplifier is coupled through C9 to the center tap of the secondary winding of transformer T1. This pulse appears exactly the same at each diode plate and adds to the sine waves already there. The resultant waveforms are as shown in Fig. 1.

The diode load resistors R1 and R2 are so situated that voltages of opposing polarities are produced across them when the diodes V1 and V2 conduct. These voltages and the directions of electron flow through R1 and R2 are indicated in the figure.

When the frequency of the horizontal oscillator and the sync pulses are the same and the phase relationship is as shown in Fig. 1, then V1 and V2 will conduct equally. Since R1 and R2 have the same values, the voltages produced across each resistor are equal. Because these

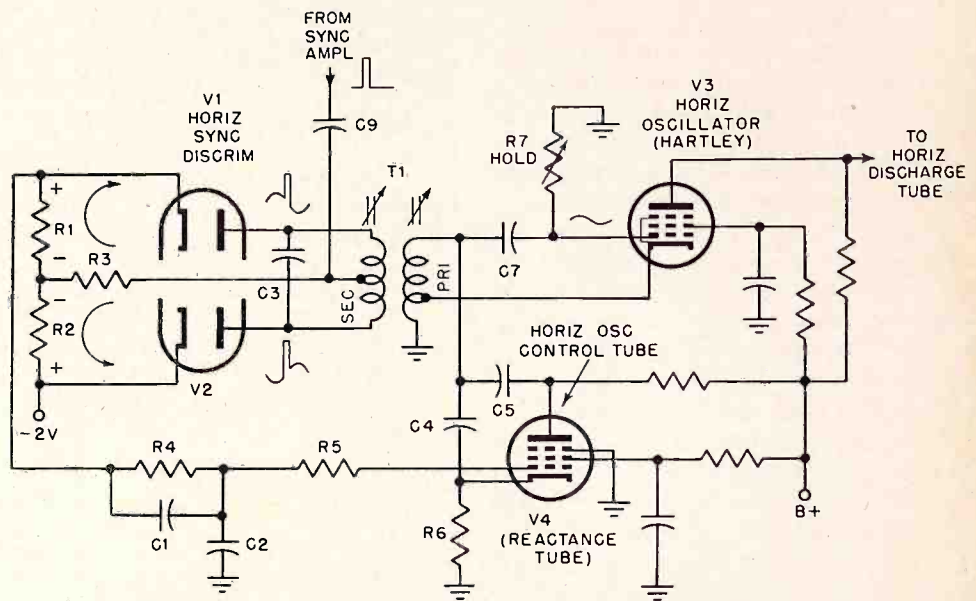

Fig. 1. Sine-wave oscillator-discriminator afc circuit.

voltages oppose and cancel, the output from the discriminator, taken from the top of R1, is the same potential as that at the bottom of R2, or -2 volts. This voltage is used as the normal bias on V4, the inductive reactance control tube.

If the horizontal oscillator frequency changes, say it attempts to increase, then the phase relationship between the sine waves and the stable sync pulses also changes. The sync pulses are now lower in frequency than the sine waves. This results in V1 conducting more heavily than V2. As a result, the voltage across R1 is larger than that across R2. The discriminator's output is now the -2 volts added to the net voltage developed across R1 and R2. This results in a smaller negative voltage being applied to the grid of the control tube. Consequently, the plate current of V4 rises. This causes a change in the amount

of injected reactance so that the oscillator's frequency is reduced.

Under opposite conditions, when the oscillator frequency tends to decrease, V2 conducts more heavily than does V1. The net output voltage of the discriminator is then negative. This increases the negative bias on the reactance tube which causes the oscillator frequency to increase.

## Causes For Circuit Failure

Most troubles in the AFC circuit of Fig. 1 cause the horizontal oscillator frequency to change with subsequent effect on the picture. The picture may be either completely torn out as shown in Fig. 2A or it may consist of repeated overlapping pictures as shown in Fig. 2B. Some defects in the AFC circuit could

(Continued on page 8)

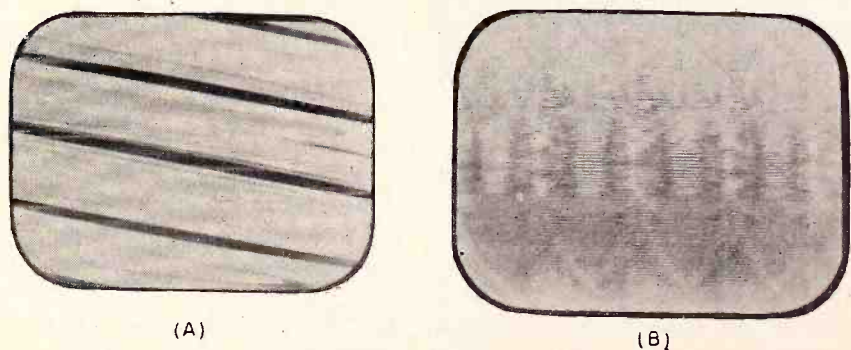

Fig. 2. Results of faulty afc circuits.



## TROUBLESHOOTING

## tv afc circuits

(Continued from page 7)

prevent the oscillator from operating at all. Since the high voltage is usually derived from the flyback portion of the horizontal sawtooth signal, there would be no raster on the picture tube under these conditions.

The most common trouble is tube failure. If the duo-diode, V1 and V2, becomes defective, the oscillator would lose synchronization easily and change its frequency. Adjustment of the horizontal hold control usually holds the picture stationary for a moment but then it will again tear out as the frequency starts to drift or if noise pulses occur.

Failure or weak emission of only one half of the duo-diode results in an incorrect bias fed to the reactance control tube, V4. This completely alters the oscillator frequency so that the hold control has no effect in properly synchronizing the torn out picture.

Failure or weak emission of the reactance control tube V4 likewise alters the frequency and nullifies the effect of the hold control. In servicing, the first thing to do, is to substitute new tubes in place of suspected faulty ones.

The transformer T1 is slug tuned. The primary is adjusted to bring the oscillator to its correct frequency, and as such it has the same effect as the hold control. A short or open circuit here, either stops the oscillator completely or radically alters its frequency. An ohmmeter check is used to indicate faults in this winding.

The secondary or discriminator side of T1 is tuned to give proper phasing of the picture. Incorrect adjustment of the secondary or a few shorted turns causes the picture to slide across the screen. Under these conditions, the right-hand edge of the picture falls off the screen and starts to reappear at the left side as shown in Fig. 3. The black vertical bar appearing between the two sections of the picture is the horizontal blanking bar.

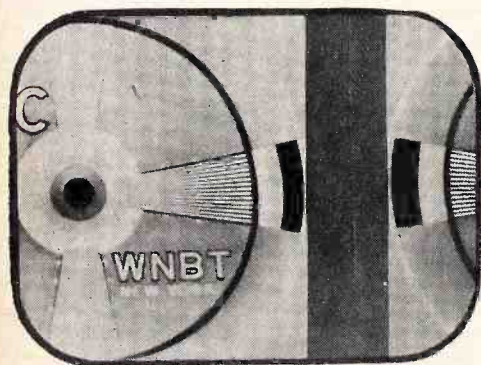

Fig. 3. Result of incorrect phasing adjustment.

If capacitor C3 opens, then the same effect as was just described occurs.

The loss of sync pulses, such as occur if C9 opens, allows the oscillator to become unsynced. An oscilloscope connected between

either diode plate and ground would indicate the presence or lack of sync pulses.

If R1 or R2 change resistance, an incorrect output voltage is obtained from the discriminator. This alters the oscillator frequency so that the hold control has no appreciable effect. A VTVM connected from the cathode of V1 to ground can be used to measure this voltage to determine if it is correct.

Capacitor C2 helps filter the discriminator's output voltage. If this capacitor opens, this causes the oscillator to become more easily unsynced at low contrast control settings. If capacitor C4 develops an open or short, this stops the oscillations with subsequent loss of

not be obtained. This changes the current in V4 which alters the oscillator frequency. When the discriminator's output does not indicate -2 volts with a voltmeter check, measure the voltage at the bottom of R2 before checking the AFC circuit components. If this voltage is not correct then check the power supply for the trouble.

## Pulse-Time AFC

Another very popular AFC circuit is shown in Fig. 4. The horizontal oscillator is a blocking oscillator circuit with L1 acting as the primary and L2 as the secondary of the feed-

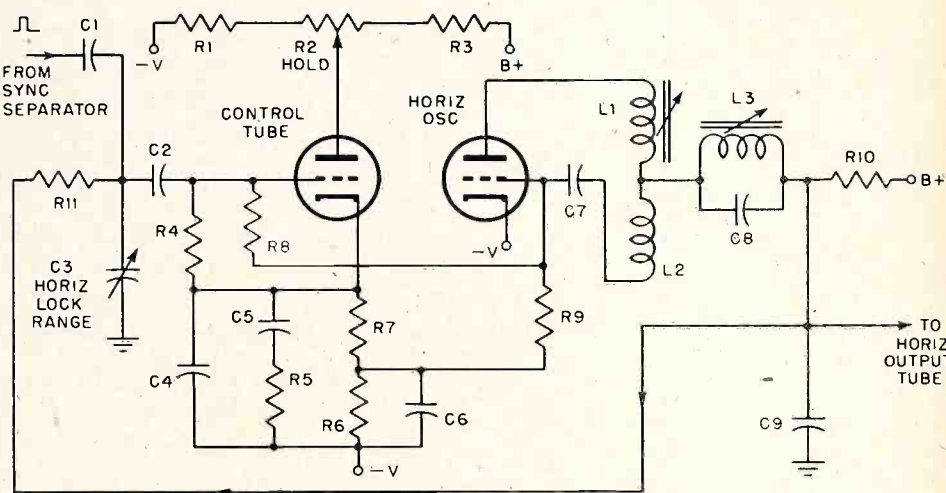

Fig. 4. Pulse-time afc circuit.

high voltage and raster. If resistor R6 or C5 become defective or change value, this alters the oscillator frequency. A shorted capacitor C5 places d.c. across the primary of T1 and immediately stops oscillations. Damage to the coil would take place.

C7 and R7 make up the grid-leak bias components for the oscillator. Trouble in these units causes oscillations to stop or to change frequency considerably. The presence of oscillations can be checked with either a VTVM or an oscilloscope. The meter indicates a negative d-c voltage when connected from the

back transformer. The grid-leak bias circuit consists of C7, R9 and R6. The frequency of the blocking oscillator can be varied either by changing the size of the grid-leak resistor (R9 and R6), or by varying the bias. Here, the bias is varied by the control tube. Plate current flowing through the control tube produces a voltage across R6 which affects the bias on the oscillator.

The conductivity of the control tube is determined by its grid signals and its plate voltage. The plate voltage can be varied manually by the hold control R2.

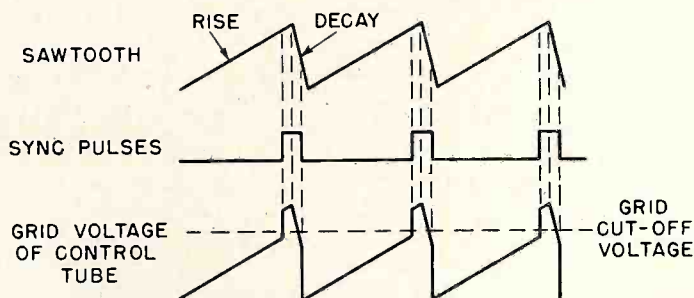

Fig. 5. Combined sawtooth and sync pulses.

oscillator grid to ground. The scope permits actual observation of the sine waves.

Sometimes a trouble in another circuit causes symptoms similar to those given above. For example, the -2 volts is developed by means of a voltage divider circuit across the low-voltage power supply. If one of these resistors changes value, then -2 volts would

The operation of the AFC is as follows. Sync pulses and the horizontal sawtooth sweep signal are both fed into the grid of the control tube. Here they combine to form the grid voltage signal shown in Fig. 5. In practice, the sawtooth voltage is integrated so that a parabolic waveform is produced. For simplic-

(Continued on page 13)



# The Path to Easier & Better TV Servicing

by John F. Rider

It is an open secret that the daily life of the tv service technician is not an easy one; that the process of accomplishing a *complete* and *effective* repair job on a tv receiver is not a bed of roses. Many reasons are advanced to account for this situation and, in our estimation, the most important of the lot is the matter of service literature.

Effective repair of a tv receiver consists of two major phases—diagnosis and repair. . . . Diagnosis is founded on knowledge and information, both of which are also associated with test equipment. Repair on the other hand is built on knowing what to do and using the most suitable parts, that is refraining from indiscriminate use of repair parts. Both diagnosis and repair can be time consuming, and unless properly accomplished, can be incomplete. The former makes operating costs high, and the second feeds the dissatisfaction of the public. Both requirements can, however, be satisfied to the advantage of the service technician, and to the public, by proper use of the set manufacturer's service literature.

## Knowledge of Changes Essential

The problems of television receiver design and construction are numerous and varied. Receivers must be suitable for use in both high- and low-signal level areas as well as high- and low-humidity locations, and thus must be manufactured with a variety of components as determined by the adequacy of supply. Use in different localities of the nation and under varying conditions develops peculiarities in performance. These dictate corrections. Without information to guide the service technician, the diagnosis of the fault and the *proper* remedy can be an awful headache. These are being experienced by tv service technicians all over America. And strangely enough the problem can be greatly minimized to the best interests of the service technician if he will fully utilize the set manufacturer's service literature. A great many men and organizations are not taking full advantage of all the benefits which accrue from using the information developed by the people who *originally made the receiver*. No one—and we repeat no one, knows his receiver as well as the guy who designed and built it.

Proper use of the set manufacturer's service literature not only reduces diagnosis time in a great many instances—but it actually *indicates* the most effective repair. It actually tells the service technician *what to do* in the form of the *permanent* repair, it states the kind of repair which minimizes repeat

calls and assures satisfaction to the public. . . . If you are a service technician who has not been using the set manufacturer's service information—try what we say and you will be gratified with the result!

Isn't it natural that the people who built the receiver should know the most about it? . . . Isn't it natural that when weaknesses develop in the receiver, that the sales and service organizations of the manufacturer notify him of what is happening in the field, and that the design engineers' service departments then determine the correction—the complete correction? Information of this kind received from the field is of the utmost importance to every set manufacturer because it enables him to change parts, circuit designs and other details inside the receiver on the subsequent production runs so as to avoid the repetition of the weakness which appeared in the early runs.

Frequently these corrective measures are simple—other times they are elaborate, but whichever it may be, the data is vital to every service technician. Let me give you a few examples. The manufacturer shall be nameless because mentioning him here serves no purpose. It's sufficient to say that the chassis we have in mind was produced in quantities approximating 1,000,000.

For instance, distortion due to the ratio detector misalignment in some models can be corrected by realignment. But the manufacturer found that this is only a temporary remedy, that the distortion will reappear a short time later (*a repeat call for the service technician*), so he developed a permanent cure—the addition of a certain capacitor at a specific point in the sound discriminator system.

Here's something else. It relates to vertical foldover. . . . The manufacturer found that one source of trouble was the 6S4 tube used as the vertical output tube. Some brands of 6S4 give greater output than others, for that matter even tubes of the same brand may do the same. The manufacturer therefore recommended a tube change. The same trouble may be solved by increasing the *horizontal width* by adding a capacitor across the width control. This increased the vertical height without causing foldover, but would you know this without being told. . . . The manufacturer who made the receiver established it and it is one of the cures. There still is another possibility. . . . Maybe it's the deflection yoke, and we quote the manufacturer—"inspect the iron cores in the yoke to see that the air gap is a minimum. If it exceeds  $\frac{3}{2}$ ", tighten the collar. If this does

not reduce the gap, remove the collar and the iron cores, and smooth the insulation between the cores so that the gap will be at a minimum. . . . Some yokes are made so that the fibre sleeve must be clipped away with a pair of diagonal cutters before the collar and iron cores may be removed." Would you normally know these things?

If you were an expert, the answer might be yes—but generally speaking, the answer is in the negative. That is why the set manufacturer releases this kind of information. . . . He wants to make servicing operations as *easy* as possible for the service technician. No one knows his receiver as well as he does. Let's stop kidding ourselves on that score. But we're not yet finished with possible cures for this one trouble of vertical foldover. . . .

Another recommendation made by the set manufacturer is the change in value of the grid leak in the vertical output tube. It's a change from 1.0 megohm to 3.3 megohms, and a change in the decoupling resistor between the horizontal and vertical output tubes plate supply from 1000 ohms to 560 ohms. . . . Would the average service technician know these changes without being told about them? . . . Definitely not and he can't be expected to! . . . But the manufacturer knows the proper remedies. . . . And strangely enough, more than one of these many have to be applied in order to solve the problem completely.

## Manufacturer Knows His Set Best

How did he establish these answers? . . . It's simple. It's his baby and he is told about the peculiarities of the child, so he goes to work on the remedy. Having made about 1,000,000 of these receivers, he is faced with variables, so he establishes all of the possible cures. . . . No independent laboratory can establish these facts. They can't afford to do so, but the set manufacturer can and he does. He does so in his service notes! That is why we say that working with the set manufacturer's service notes is the key to easiest and fastest diagnosis and repair. Nothing else equals it.

Let's give you just one more interesting example. This is another product. This time setting the receiver on the *unused* channels results in a high pitched squeal. Peculiar isn't it! . . . Well, the trouble is a half-frequency squeal at about 7.5 kc in the horizontal oscillator when the tube operates without sync-signal input. Some sort of a parasitic. So the manufacturer gives the

(Continued on page 11)



# These Books Make Servicing Easier!

This practical book tells you everything you should know about an oscilloscope! WHAT it is . . . what it can DO . . . and HOW to use it properly!



## ENCYCLOPEDIA ON CATHODE-RAY OSCILLOSCOPES AND THEIR USES

by John F. Rider and Seymour D. Usian

The **FIRST** and **ONLY** book that so fully and clearly describes the 'scope . . . its construction . . . its capabilities . . . its applications in communications, engineering, research . . . with thousands of time-saving

and labor-saving references, charts, waveforms, etc. All oscilloscopes produced during the past ten years, a total of more than 70 different models, are accurately described—with specifications and wiring diagrams.

Planning to buy or build a 'scope? This book will help you select the type best suited to your needs! If you already own one, the book will show you how to increase your instrument's usefulness in a thousand and one ways.

**992 Pages • 500,000 Words • 3,000 Illustrations**  
**8½ x 11" Size • 22 Chapters • Completely Indexed**  
**Easy to Read • Cloth Bound . . . . . And only \$9.00**

## Solve Your Tube Problems!

### RECEIVING TUBE SUBSTITUTION GUIDE BOOK

by H. A. Middleton

For **AM-FM-TV Receivers and Allied Equipment!**

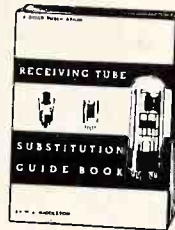

- 2500 Radio and TV Tube Substitutions Are Listed!
- TV Receiver Filament Wiring!
- Heater Substitution Wiring Instructions!
- Tube Types Classified By Functions!
- And A Wealth Of Other Priceless Data!

**EXTRA!** In addition to tube information . . . this sensational book contains material on Cathode-Ray Tube Characteristics, Complete Tube Characteristics Chart, Ballast Tube Data, Pilot Light Information, Resistors—Capacitors—Transformer Color Codes, Transformer Substitution, Fixed Condenser Substitution, etc. . . .

**224 Pages in Heavy Durable Paper Cover. 8½ x 11" Only . . . . . \$2.40**

**New! First Supplement, RECEIVING TUBE SUBSTITUTION GUIDE BOOK . . . 750 new tube substitutions . . . 99¢**

## TV and OTHER RECEIVING ANTENNAS

(Theory and Practice)  
by Arnold B. Bailey



Tells you . . . **WHAT** each type can do . . . **HOW** to use it . . . and **WHICH** is best!

This is a text book on all types of receiving antennas. If you have any questions—you'll find the answers in this book! Manufacturer, engineer, student, teacher, service technicians — all can use

this text. **WE GUARANTEE IT!** Antenna data never before published anywhere will be found in it. And it's readable—because mathematics has been translated into charts and graphs.

**606 Pages . . . 310 Illustrations . . . . . And only \$6.00**

Order this **RIDER** book, the **ONLY** text that gives you complete information on all the mechanical and electrical considerations.

## TV INSTALLATION TECHNIQUES

by Samuel L. Marshall



**KNOW** the absolute facts about such things as ice loading, wind surface, and mounting requirements—whether for short chimney-attached mast or an 80 ft. tower, including foundation.

**HAVE** at your fingertips, accurate data on receiver adjustments in the home . . . municipal regulations governing the installation of TV antennas and masts in all of the major television areas in the U.S.

**SURE** to help you wherever and whenever any part of the installation requires "doping out"! A **TIMELY** and **IMPORTANT** book!

**336 Pages • 270 Illustrations • 5½ x 8½ Size**  
**Cloth Bound . . . . . And only \$3.60**

## FM TRANSMISSION AND RECEPTION

by John F. Rider and Seymour D. Usian



The entire system of frequency modulation is explained thoroughly . . . all types employed in amateur radio, television, broadcast, railroad, aviation, marine, police, point-to-point and mobile receivers. Basic theory, transmission, reception, circuit design and servicing are covered, with mathematics kept to a minimum. Almost all of the presently used FM commercial transmitters are described in detail.

**460 Pages, Profusely Illustrated . . . . . \$3.60**

## New . . . Revised . . . Enlarged

### VACUUM-TUBE VOLTMETERS

2nd Ed. by John F. Rider

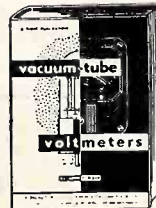

This is the only book that deals exclusively with all types of vacuum-tube voltmeters, their design, construction, calibration, testing, applications, and maintenance instructions. Get the most use and value out of your vacuum-tube voltmeter. Learn how

this versatile instrument can save you valuable hours in your everyday servicing operations.

Here you find operating characteristics for more than 40 commercial vacuum-tube voltmeters now in use, with schematics and parts values. New, valuable chapters on D-C and R-F probes make this a completely up-to-the-minute book.

**432 pages • 210 illustrations • Only \$4.50**

## TV MASTER ANTENNA SYSTEMS

by Ira Kamen and Richard H. Dorf



50 million dollars will be spent in 1952 for TV Master Antenna Systems installed in apartment buildings, hotels, hospitals, etc. . . . in both new and old buildings. In **TV MASTER ANTENNA SYSTEMS**, the authors provide a practical working manual which deals with installation, maintenance, usage, etc. This book shows how the Master Antenna is installed, how it works, and how you can capitalize on this fast-growing field.

**368 pages • 234 explanatory illustrations.**  
**Cloth bound . . . . . Only \$5.00**

**WE GUARANTEE** your satisfaction! Make these books **PROVE** their value to you. Examine them at your favorite jobber. If he does not have them — order from us.

**JOHN F. RIDER PUBLISHER, Inc.**  
 480 Canal Street, New York 13, N. Y.



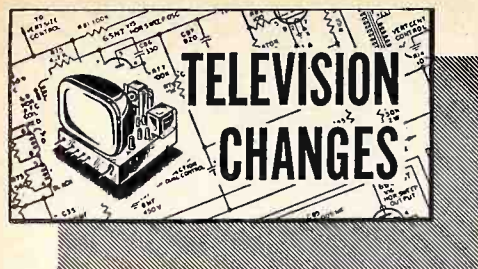

**Belmont Radio Corporation**

Due to procurement difficulties, replacements of HV Deflection transformers may be unobtainable, forcing the use of substitutions. The chart below should be used as a guide, together with the proper schematic diagram, when the exact replacement transformer is unavailable.

T-6 Transformer to be replaced	Substitute	Necessary Circuit Changes
12M-18286	12M-18563	None
12M-18563	None	—
12M-17967	12M-18285	None
201-18530	12M-18285	None
12M-18285	None	—
12M-18689	12M-18689-1	None
	12M-18689-2	Replace 6BG6 with 6BQ6 plate clip
	201-18562	Add 3,900-ohm, 2-watt resistor and connect agc lead to terminal 7.
	201-18562-1	Add 3,900-ohm, 2-watt resistor and connect agc lead to terminal 7.
12M-18689-1	12M-18689	None
	12M-18689-2	Replace 6BG6 with 6BQ6 plate clip
	201-18562	Add 3,900-ohm, 2-watt resistor and connect agc lead to terminal 7.
	201-18562-1	Add 3,900-ohm, 2-watt resistor and connect agc lead to terminal 7.
12M-18689-2	12M-18689	Replace 6BQ6 with 6BG6 plate clip.
	12M-18689-1	Replace 6BQ6 with 6BG6 plate clip.
201-18562	201-18562-1	None
	12M-18689	Remove 3,900-ohm, 2-watt resistor and connect agc lead to terminal 5.
	12M-18689-1	Remove 3,900-ohm, 2-watt resistor and connect agc lead to terminal 5.
	12M-18689-2	Remove 3,900-ohm, 2-watt resistor and connect agc lead to terminal 5. Replace 6BG6 with 6BQ6 plate clip.
201-18562-1	201-18562	None
	12M-18689	Remove 3,900-ohm, 2-watt resistor and connect agc lead to terminal 5.
	12M-18689	Remove 3,900-ohm, 2-watt resistor and connect agc lead to terminal 5.
	12M-18689-2	Remove 3,900-ohm, 2-watt resistor and connect agc lead to terminal 5. Replace 6BG6 with 6BQ6 plate clip.
201-18418	None	—
201-18843	None	—
12M-19407	12M-19407-1	None
	12M-19407-2	None
12M-19407-1	12M-19407	None
	12M-19407-2	None
12M-19407-2	12M-19407	None
	12M-19407-1	None
201-19533	201-19533-1	None
	201-19817	Add 2.2-ohm or choke coil in series with 1X2 filament.

201-19817-1		Add 2.2-ohm or choke coil in series with 1X2 filament and replace 3,600-ohm, 5-watt with 5,600-ohm 3-watt.
201-19533-1	201-19533	None
	201-19817	Add 2.2-ohm or choke coil in series with 1X2 filament.
	201-19817-1	Add 2.2-ohm or choke coil in series with 1X2 filament and replace 3,600-ohm, 5-watt with 5,600-ohm 3-watt.
201-19817	201-19817-1	Replace 3,600-ohm, 5-watt with 5,600-ohm, 3-watt.
201-19817-1	201-19817	Replace 5,600-ohm, 3-watt with 5,600-ohm, 5-watt.
201-19874	None	—
201-19999	None	—

We can cite thousands of such examples, but space will not permit it. It is our sincere feeling that while many problems face the servicing industry, and no doubt will do so for years to come, this one phase of it, namely diagnosis and repair, can be solved rapidly and effectively through the use of the set manufacturer's service literature. We have felt so for more than 20 years. That is why we have tried for more than this number of years to expose the radio servicing industry of America and the world to the set manufacturer's service data. That is why we publish only the official, factory-prepared and factory-authorized tv and radio service information in Rider Manuals and Tek-Files. These data reflect everything the set manufacturer knows about his product.

Do you realize how important it is to be able to tell the public of America that you are using the original set manufacturer's service techniques, recommendations and practices? You can do this if you are actually applying his suggestions as contained in the set manufacturer's service literature.

**The Path to Easier & Better TV Servicing**

(Continued from Page 9)

answer. A change in resistance from 5600 ohms to 3900 ohms. . . Finding the answer for this trouble without having the manufacturer's data would be time consuming and costly. But with the information which the set manufacturer furnishes about his product—which he knows like a father knows his child—the cure is a matter of minutes.

*The man who uses  
RIDER **Tek-Files** & MANUALS  
makes more money!*

# SUPERCHARGED TV!

when results count...

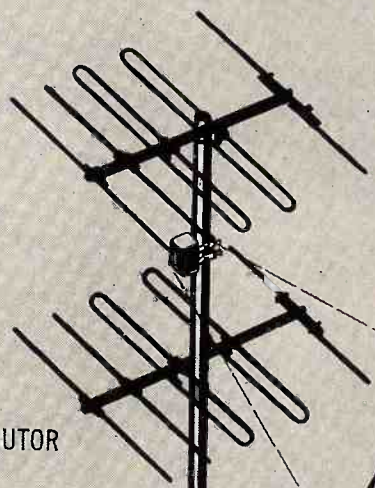

For the highest signal-to-noise ratio try this winning combination. Taco Super 980 Yagi and Taco Antenna Supercharger provide 25db gain plus rejection of noise due to sharp directivity of the antenna and sharp frequency tuning of the combination. (For high-band channels use the Taco 5-element Yagi)

ASK YOUR DISTRIBUTOR



**TECHNICAL APPLIANCE CORPORATION,**  
ONE TACO AVE., SHERBURNE, N. Y.  
Manufacturers of Tacoplex Master Antenna Systems  
In Canada: Stromberg-Carlson Co., Toronto 4, Ont.

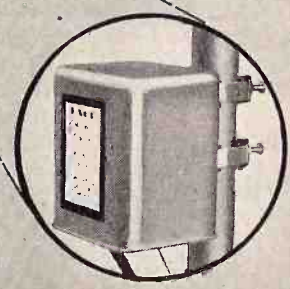



Life-like window displays and counter cards!



Bright exciting streamers!

Personalized postal cards. Giant mailers! Radio announcements and reminder stickers!

# STOP! DON'T PASS THIS PAGE

... until you've read about SYLVANIA'S power-packed Service-Dealer Campaign

Talk about an exciting, sales-building Radio-TV Service Dealer campaign! Mister, this is it!

Featuring personal endorsements of some of the most glamorous and newsworthy people in the entire country, this campaign ties you in with big-space ads in *Life*, *The Saturday Evening Post*, *Collier's* and *Better Homes and Gardens*.

Just see what you get: . . . brilliant life-like cut-outs of the celebrated stars . . . counter cards, streamers, appealing mailers . . . also radio spot announcements, and reminder stickers. You pay only two cents per prospect per month for the mailers. The rest is FREE. Don't delay! Call your Sylvania distributor or mail coupon N-O-W!

SEND COUPON NOW FOR DETAILS ON THIS BIG CAMPAIGN



Sylvania Electric Products Inc. Dept. R-3402, Emporium, Pa.

I'd like full details about Sylvania's big 1952 Campaign for Service Dealers.

Name \_\_\_\_\_  
 Street \_\_\_\_\_  
 City \_\_\_\_\_ Zone \_\_\_\_\_ State \_\_\_\_\_

# SYLVANIA

RADIO TUBES; TELEVISION PICTURE TUBES; ELECTRONIC PRODUCTS; ELECTRONIC TEST EQUIPMENT; FLUORESCENT TUBES, FIXTURES, SIGN TUBING, WIRING DEVICES; LIGHT BULBS; PHOTOLAMPS; TELEVISION SETS

Please mention Successful Servicing when answering advertising.



## TROUBLESHOOTING tv afc circuits

(Continued from page 9)

ity, a sawtooth is shown.

When the two signals, sync and sawtooth, are in the correct phase, the leading or left half of the sync pulse occurs during the rise portion of the sawtooth and the trailing or right half of the sync pulse occurs during the decay portion of the sawtooth. The left half thus rides up high on the sawtooth, while the right half slides down lower as is shown in Fig. 5.

The left half of the sync pulse drives the control tube above cut-off, since it occurs high up on the sawtooth. Therefore, the tube conducts for the duration of this portion of the sync pulse.

Figure 6 illustrates what takes place when the oscillator frequency drifts too low or too high. If the oscillator frequency goes down, the sync pulses move to the left of their original positions on the sawtooth. Now, more of

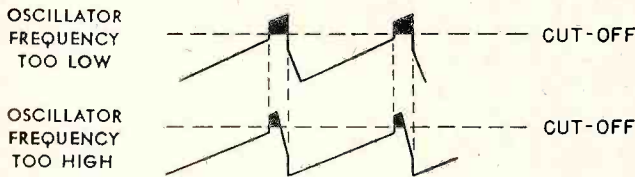

Fig. 6. Control-tube grid voltage for incorrect oscillator frequency.

the sync pulse occurs during the rise time of the sawtooth so that the control tube conducts for a longer time than before. This increases the voltage across R6 and C6, which decreases the amount of negative bias on the oscillator. A smaller bias results in a higher oscillator frequency, thus pulling the frequency back to its correct value.

An increase in oscillator frequency has the reverse effects, with the control tube conducting for a shorter time.

### Troubleshooting Pulse-Time AFC

As usual, the first troubleshooting step consists of tube substitutions for the suspected stages. As stated before, troubles in the AFC could cause loss of horizontal sync or complete loss of raster.

If C1 (Fig. 4) opens, then no sync pulse gets into the control tube and the horizontal oscillator frequency may change. The picture loses sync horizontally and it resembles that shown in Fig. 2. If C1 shorts, then the negative voltage (not shown in the diagram) on the left side of C1 is shorted through R11 and R10 to B+. This lowers the oscillator plate voltage and stops all oscillations. With no driving signal, the horizontal output stage and high-voltage rectifier cannot produce the high voltage necessary for a visible raster.

An open or shorted transformer winding L1 or L2 produces the same effect and no raster would be seen. This same fault could also be caused by any one of the following:

- A shorted or open capacitor C9. This is the discharge capacitor, across which the sawtooth is developed.
- A shorted or open capacitor C7. This is the oscillator's grid-leak bias capacitor.
- A shorted or open inductor L3 or capacitor C8. This resonant tank is used to add a sine wave to the blocking oscillator's grid wave to make it more stable. If this circuit becomes defective, the oscillator will not operate.
- A shorted capacitor C3, which could be caused by tightening the adjusting screw excessively. This shorts B+ to ground through R10 and R11, with resultant decrease in oscillator plate voltage.
- An open or increased value of R10. This removes or lowers the oscillator plate voltage.

Adjustments L1, L3, and R2 can change the oscillator frequency enough to cause it to lose sync. Other causes of this condition are:

- A changed value of R1, R2 or R3. This changes the plate voltage of the control tube.

- An open capacitor C2. This prevents the sync pulses from reaching the control tube.
- A shorted capacitor C4. This changes the bias on the control tube.
- An open or shorted R6 or R7.
- A shorted capacitor C6. This removes the control bias of the oscillator.
- A changed value of C7 or R9.
- A small change in the inductance of L1, L2 or L3.

A peculiar condition occurs in which the picture waves horizontally. Straight vertical objects such as a flag pole appear snaky or wobbly. This can be caused by heater-to-cathode leakage of one of the AFC tubes.

Another trouble in the AFC circuit of Fig. 4 could also produce this effect. When the control tube first begins to control the frequency of the horizontal oscillator, there may be some over control, that is, when the frequency is too high, the control tube may reduce it. In so doing, however, the control tube may pull it down too low. Then the control tube would pull the frequency back up, but in so doing, may increase it too much. This electrical hunting action continues until the correct frequency and phase relation of sync to sawtooth is obtained. The result of this hunting by the control tube is shown in Fig. 7. The amplitude of the waviness can be varied by the horizontal hold control.

In the cathode of the control tube there is a circuit, C5 and R5, used to prevent the hunt-

ing action. It is called an error correction circuit. Any trouble with C5 or R5 produces the effect shown in Fig. 7.



Fig. 7. Hunting by control tube produces this effect.

### Stromberg-Carlson Receiver Models Service Hint

Most models specify a 5000-ohm potentiometer (part no. 145079) for the vertical linearity control R217. When potentiometers of Mallory manufacture are used, they must be connected in reverse from normal operation so that maximum size is obtainable in the full counter-clockwise direction. Mallory potentiometers can be identified by referring to the RMA date coding which will begin with the digits "235—."

Compare!

PROVE  
**EMC**  
SUPERIORITY!



MODEL  
106  
VACUUM TUBE  
VOLTMETER

- Specially designed for field alignment of TV and radio sets
- All functions completely electronic — meter cannot burn out
- 5 DB ranges
- Full scale deflection of 1½ volts for both AC-DC volts.

**SPECIFICATIONS**

DC VOLTAGE: Input resistance 16.5 megs or 1/3 megohms per volt. Ranges: 0 to 1.5, 10, 100, 300, 1000 up to 30,000 v. (with accessory probe.)

AC VOLTAGE: Input resistance 2 megohms. Ranges: 0 to 1.5, 10, 100, 300, 1000. Frequency response flat from: 25 to 100,000 cycles.

OHMS: 1000 — 10,000 — 100,000 — 10 megohms, 1000 megohms.

Compact, portable bakelite case measures 4¼ x 5¼ x 2⅞".

**MODEL 106 .....\$35.90**

**Write Dep't SS-2 for latest FREE catalog.**



Electronic  
Measurements Corp.

280 Lafayette St., New York 12, N. Y.  
Export Dept., 303 W. 42nd St., N. Y. C.

Please mention Successful Servicing when answering advertising.



more than

# 2,000,000

set owners use

jfd panorama

indoor tv antennas

*triple-chrome plated dipoles*

MODEL TA135 DELUXE 6.95 list  
 MODEL TA136 STANDARD COMPANION 5.95 list  
 MODEL TA137 ECONOMY COMPANION 5.50 list  
 COMPLETE WITH TWIN LEAD

*absolutely tip-proof*



JFD MFG. CO.  
 BENSONHURST 6-9200  
 BROOKLYN 4, N. Y.

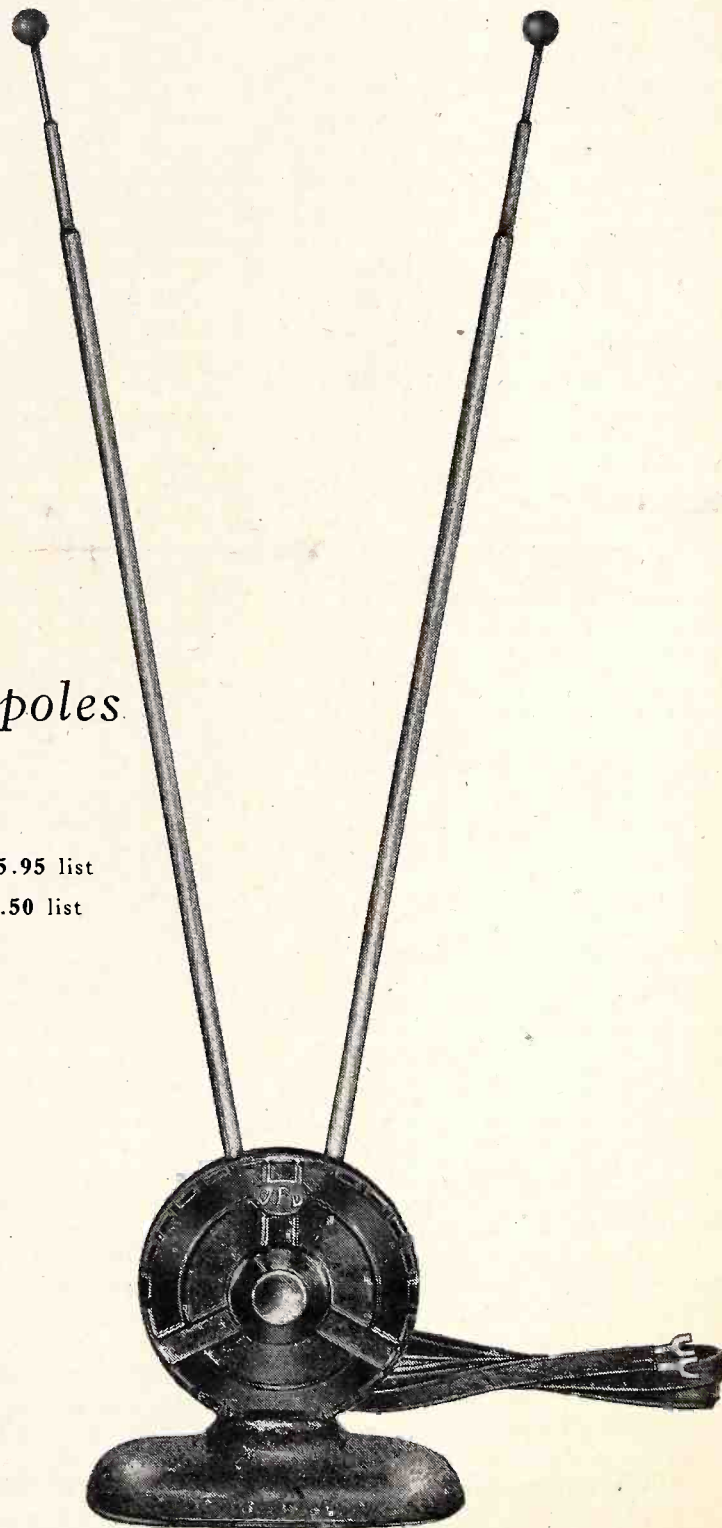

Please mention Successful Servicing when answering advertising.



# TRIPLETT

## Load-Chek

introduces  
**Servicing**  
 by  
**Power**  
**Consumption**

**MODEL 660**

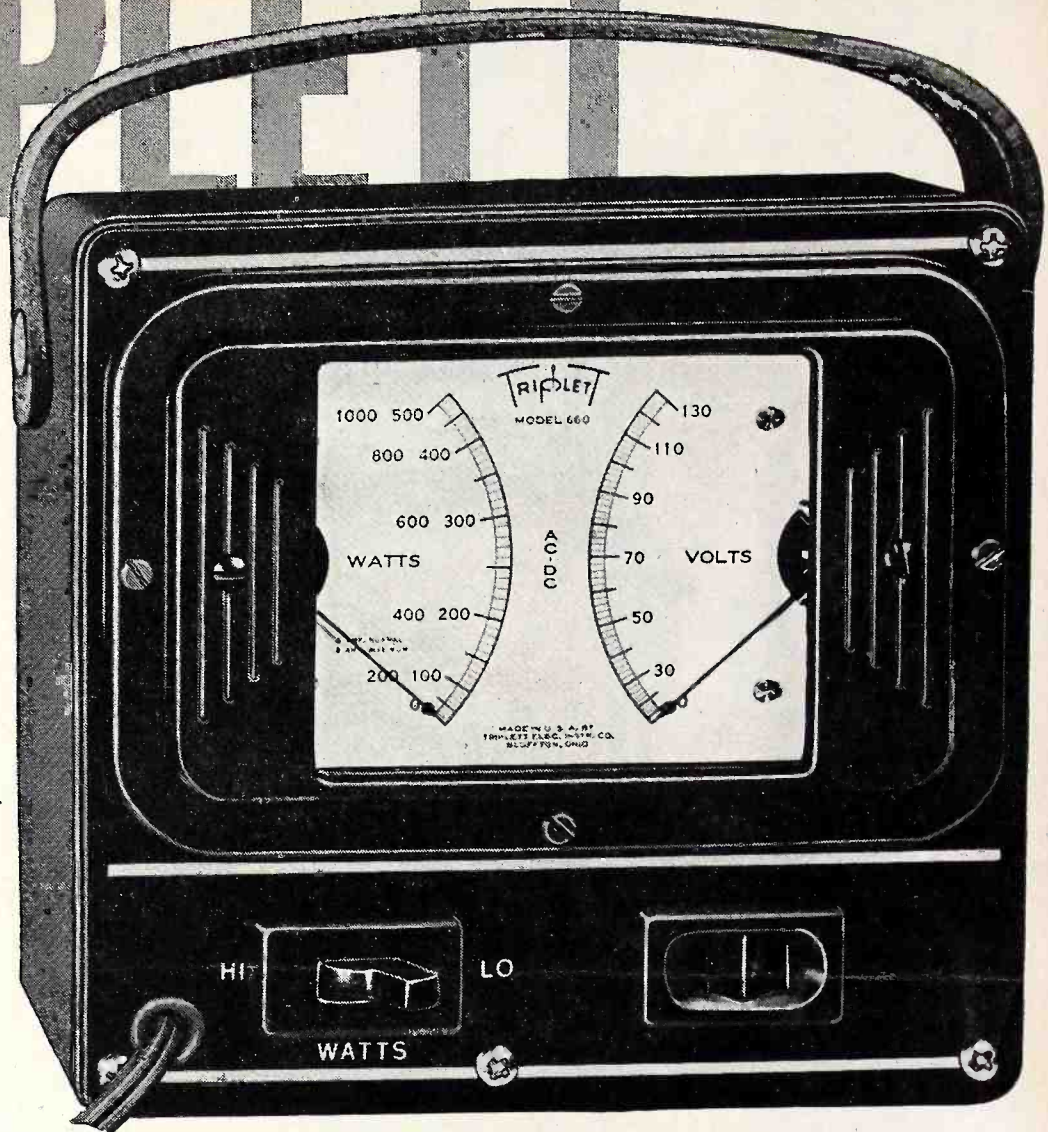

**LOAD-CHEK** for the first time makes it possible for every technician to utilize what is perhaps the simplest and quickest of all service methods—Servicing by Power Consumption Measurements.

Power consumption measurement has long been proved by auto-radio servicemen as a rapid method of localizing troubles in auto radios. But Triplett's new **LOAD-CHEK** is the first Wattmeter to be produced at moderate cost, and with the proper ranges, to bring this short-cut method within the reach of every radio and TV service man.

Basis of the **LOAD-CHEK** method is the tag or label on every radio and TV chassis which shows the normal power consumption. The following examples are only two of many time-saving uses of this new instrument.

**LOCATING A SHORT**—The chassis tag may show a normal consumption of 225 Watts. Simply plug the power cord of the chassis into **LOAD-CHEK** (there are no loose ends to connect or be in the way). Note the reading—which should be possibly 350 Watts. By removing the

rectifier tube you can determine at once which side of the tube the short is on. With a soldering iron and long-nosed pliers you can check through the chassis, locate and correct the trouble without having to lay down tools or to check with lead wires!

**REPLACING BURNED OUT RESISTORS**—With the chassis to be repaired plugged into a **LOAD-CHEK** MODEL 660, note the wattage reading with the burned out resistor circuit open. Now replace the resistor. Should the increase in watts be greater than that of the resistor rating being installed, it indicates that an extra load has caused the trouble which has not been cleared.

**LOAD-CHEK** is made-to-order for the busy service man and can help stop costly "come back" repair jobs. It's a profit-maker because it's a Time-Saver. And at its moderate cost **LOAD-CHEK** can be standard equipment on every service bench. *By all means*, inspect this versatile instrument at your distributor and place your order, for under present conditions we must fill all orders on a basis of "First Come, First Served."

SEE MODEL 660 **LOAD-CHEK** AT YOUR DISTRIBUTOR'S

FOR THE MAN WHO TAKES PRIDE IN HIS WORK

# Triplet

TRIPLETT ELECTRICAL INSTRUMENT COMPANY · BLUFFTON, OHIO, U. S. A.



**★ Build Your Service-Sales Future on a Firm Foundation with . . . .**

**PRECISION TEST EQUIPMENT**

*Standard of Accuracy...*

**...These 5 Matched "Precision" Instruments provide a Complete MODERN SERVICE LABORATORY for TV-FM-AM at only moderate cost.**

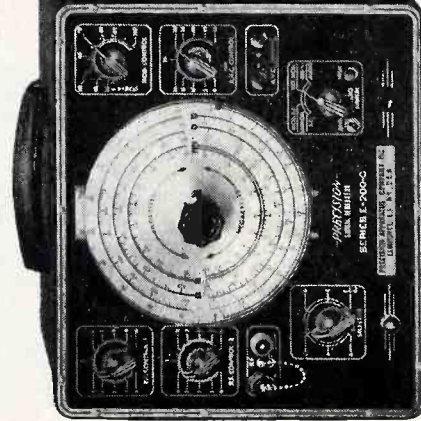

**SERIES E-200-C**—Modern Multi-Band SIGNAL and MARKER GENERATOR for A.M., F.M., and TV alignment.

Exceptional Accuracy and Stability! 1000 pt. vernier calibrating scale 0-100% Modulation! A.V.C. — A.G.C. substitution-override network! Direct reading 88KC to 120 MC! Complete with Coaxial output cable and technical manual! In matched, heavy gauge steel case 10½" x 12 x 6".

Net Price: \$71.25



**SERIES E-400**—Wide Range H.F. SWEEP SIGNAL GENERATOR Direct Reading from 2 to 480 MC.

Narrow and Wide Band Sweep for F.M. and TV, 0-1MC and 0-15MC • 1500 pt. vernier calibrating scale • Multiple Crystal Marker • 8 tubes including V.R. and rectifier • RG/62U Coaxial Terminated Output cable • Complete with 2 crystals • In matched copper-plated case 10½" x 12 x 6".

Net Price: \$134.50

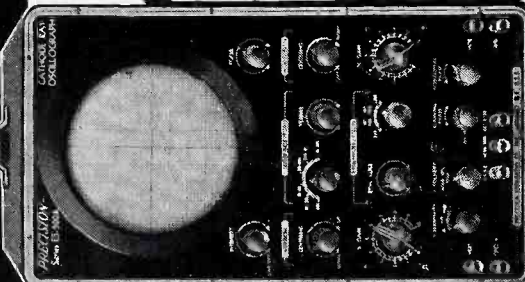

**SERIES ES-500A**—20 MV. High Sensitivity Wide Range 5" C.R. OSCILLOGRAPH.

Push-Pull "V" and "H" amplifiers • 1 MC Band Width • High impedance, compensated "V" input Step Attenuator • Z axis modulation • 12 tubes incl. V.R. and 2 rect. • Light Shield and Mask • Heavy Steel Case 8¼" x 14½" x 18".

Net Price: \$169.50



**SERIES EV-10A**—High Sensitivity True Zero-Center VTVM—MEG OHMMETER — with large 7" meter.

58 ranges to 6000 Volts, 2000 Megs. +70DB, 12 Amps • Direct Reading R.F. VTVM scales via optional RF-10A High Freq. probe • Voltage Regulated bridge type circuit • Constant 13½ Megs input resistance to 600 V. 133½ Megs at 6000 V • Complete with test cables and manual • Matched heavy gauge steel cabinet 10½" x 12 x 6".

Net Price: \$94.50



**SERIES 612**—Modern Free-point Cathode Conductance TUBE TESTER, and dynamic A-B-C Battery Tester.

Incorporates RTMA recommended circuit principles! 10 lever free-point element selection! Built-in roller chart! Dual short-check sensitivity! Noise, Ballast and Pilot Tests! Free replacement tube test data chart service! Complete, ready to operate! In matched heavy gauge steel cabinet 10½" x 12 x 6".

Net Price: \$69.75

**BUY PERFORMANCE—NOT SPECIFICATIONS!—BUY "PRECISION"**

"PRECISION" PERFORMANCE, ACCURACY, WORKMANSHIP and VALUE have been setting a standard of comparison for over 15 years. . . . . DO NOT BE MISLED . . . . . It is not "PRECISION" test equipment unless it is manufactured by Precision Apparatus Co., Inc., Elmhurst, L. I., N. Y.

"Precision" Performance—Engineered Instruments are on display at leading radio parts and equipment distributors.

AM • FM • TV • AM • FM • TV

**OTHER MATCHED COMBINATIONS**

The instruments shown above illustrate one of many possible MATCHED COMBINATIONS of diversified "PRECISION" Test Equipment for TV-FM-AM. Each combination provides a selected and basic, modern, efficient Laboratory at moderate cost.

**SERIES TV-4**—Super-High Voltage Safety Test Probe.

Extends range of Series EV-10A (above) to 60 KV direct reading, with full safety to operator and equipment. Multiplier cartridges also available to match most VTVM's and 20,000 ohms/v. test sets.

Series TV-4: — Complete, for use with EV-10A.

Net Price: \$14.75



**PRECISION APPARATUS CO., INC.**

92-27 Horace Harding Boulevard, Elmhurst 14, New York  
Export Division: 458 Broadway, New York, U.S.A. • Cables—Manhattan  
In Canada: Atlas Radio Corp., Ltd., Toronto, Ontario

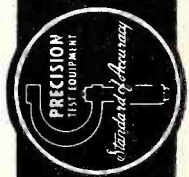

Convenient "Precision" Purchase Terms can be arranged with your favorite authorized Precision Distributor.

AM • FM • TV • AM • FM • TV

Please mention Successful Servicing when answering advertising.



# ASSOCIATION NEWS

Local organizations of retail appliance, radio and television dealers will receive specially compiled reports for their exclusive use on the cost-of-doing-business in their areas as a part of the nation-wide annual survey conducted by the *National Appliance and Radio-TV Dealers Association* announced D. E. Urner, Chairman of the NARDA Costs-of-Doing-Business Survey Committee. This is the first time in the five years that the surveys have been made that individualized studies will be conducted. Mr. Urner pointed out that there will be no charge for these special studies, but it is necessary that at least 20 dealers in each area participate in order to get an adequate sampling of that territory. The survey will again be under the direction of NARDA's Economist Consultant Richard E. Snyder, who has been in charge of the project since its inception.

Mr. Seymour D. Uslan, Managing Editor of the John F. Rider Publishing Co., Inc., delivered a talk on antennas, transmission lines, r-f tuners, and the sound system of TV receivers. This lecture, given on January 28th, was one of a series of talks sponsored by the AIEE and was held at the RCA Institutes, 350 West 4th St., New York City. A large audience, composed primarily of civil, power, mechanical, chemical, and electrical engineers interested in TV servicing fundamentals, received the lecture most enthusiastically. The talk was illustrated with slides and drawings.

The *Southern Penna. Radio and Television Technicians* (York), as well as other groups are arranging to have service dealers and distributors service managers speak to the membership.

The *Federation of Radio Servicemen's Association of Pennsylvania* is now compiling a course on "Business Management and What Is Your Labor Worth" and will soon be featured at each Chapter meeting for its members. It will be tried for the first time in Reading by the *Reading Radio Servicemen's Assn.*

This year, for the first time NEDA will participate with the manufacturers as a full-fledged partner in the May Trade Show in Chicago.

The *Blair County Radio Service Engineers* (Altoona, Pa.) announces a very great increase in membership since the use of Federation sponsored programs and meetings were adopted. The Educational Committee has completed their new TV and Radio Course which will be held weekly for their membership.

# WHAT is TEK-FILE

- 1** Tek-File is Rider service data in package form.
- 2** New Tek-File packs are available every month.
- 3** Tek-File's contents are grouped according to manufacturers.
- 4** All Tek-File data is the official, complete factory-issued data direct from the manufacturer.
- 5** Tek-File folders are packed one or more to a box . . . a minimum of 128 (8½ X 11") pages for only \$2.00. The cumulative index covering all issued Tek-Files is available *free* from your distributor.
- 6** With Tek-File you buy only the servicing data you need to match the set you're working on . . . and it's complete data! Includes chassis views, voltages, resistance readings, troubleshooting test patterns, complete alignment procedures, waveforms, circuit action descriptions, complete parts lists and values, coverage of all models and circuit changes, plus all unpackaging and installation data . . . and much, much more.
- 7** Tek-File gives you extras! A free coupon, 15 of which entitle you to a free hard-cover, permanent Rider manual binder for Tek-File shelf use . . . plus Tek-File Handies, 3 X 5" index cards containing trouble cures based on manufacturer's changes for his set.

Remember all this for only \$2.00 — buy it from your jobber today!



The man who uses Tek-File finds servicing easier

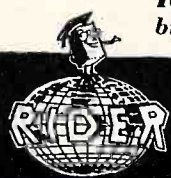
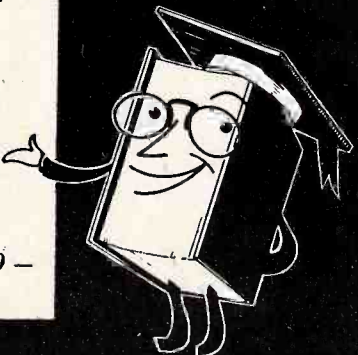

## JOHN F. RIDER

PUBLISHER, INC.  
480 Canal St., N. Y. 13, N. Y.



The "Fittingest" thing you ever saw . . .

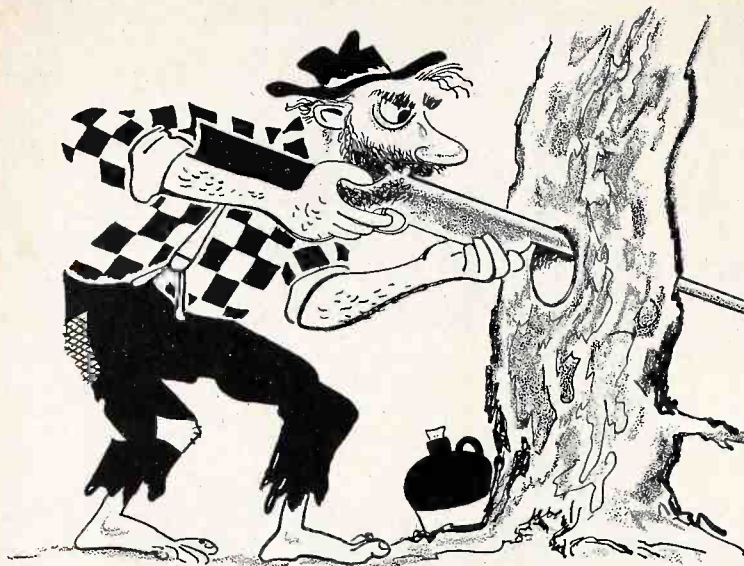

## MALLORY MIDGETROL®

Dual Concentric Volume Controls

### MAKE YOUR CUSTOMERS HAPPY

#### FIT 'EM FAST . . . FIT 'EM EASY

- In just five steps that take less than five minutes, you assemble a dual control that gives you the precise resistance values you need.
- Directions are short, easy to follow and you need no special tools . . . no soldering.
- Front and rear sections are factory-assembled and inspected.
- Instant AC switch attachment without control disassembly.

- Longer lasting resistance elements even in extremes of temperature and humidity.
- Better and more accurate taper curves resulting from precision processing methods.
- No pigtail connections to break—thanks to Mallory's exclusive sliding contact that gives EXTRA quiet operation.
- Minimum wobble with Mallory exclusive two-point shaft suspension.

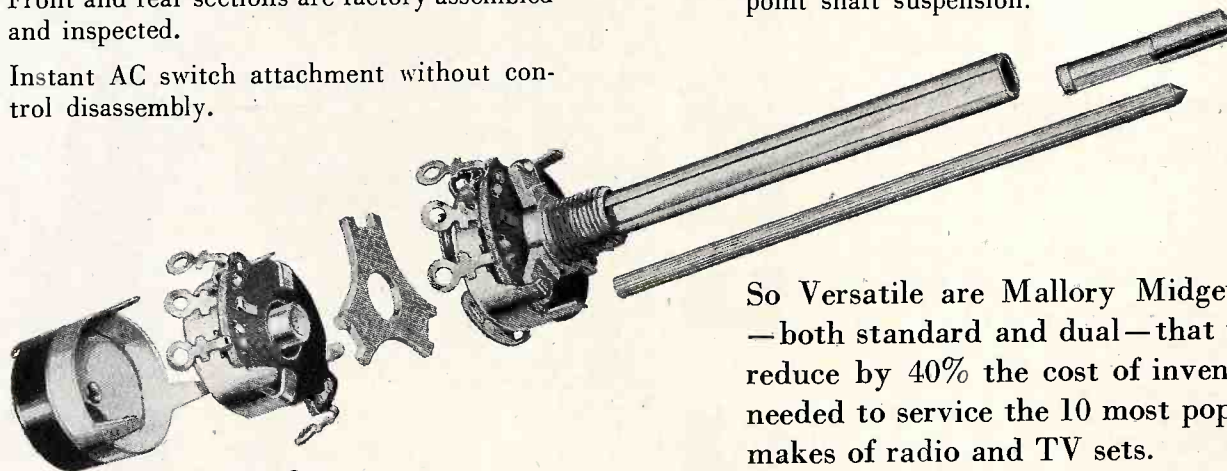

So Versatile are Mallory Midgetrols —both standard and dual— that they reduce by 40% the cost of inventory needed to service the 10 most popular makes of radio and TV sets.

**Make Sure!  
Make it Mallory!**

You can build more than 10,000 different combinations with Mallory Midgetrols and do it fast . . . easily. Each dual control you build duplicates exactly the control it replaces. The Mallory Midgetrol Line, in addition to dual concentrics, includes round shaft, standard controls with the advantages of stable, two-point shaft suspension, instant AC switch attachment. Ready adaptability to split-knurled and flatted type knobs.

P. R. MALLORY & CO. Inc.  
**MALLORY**

CAPACITORS • CONTROLS • VIBRATORS • SWITCHES • RESISTORS  
• RECTIFIERS • VIBRAPACK\* POWER SUPPLIES • FILTERS

\*Reg. U. S. Pat. Off.

**APPROVED PRECISION PRODUCTS**

**P. R. MALLORY & CO., Inc., INDIANAPOLIS 6, INDIANA**

Please mention Successful Servicing when answering advertising.



Coming In April...

# RIDER TELEVISION MANUAL VOLUME 9.

- Makes TV Servicing Easy
- Do TV Servicing Faster
- Do More Profitable Servicing
- Keep Up-To-Date
- Watch For It At Your Jobber!

For Faster, Better,  
More Profitable  
Servicing  
Use

## RIDER MANUALS

ORDER THE MANUALS YOU  
NEED FROM YOUR JOBBER  
TODAY!

VOLUME XXII, 1520 pages.....	\$18.00
VOLUME XXI, 1648 pages.....	\$21.00
VOLUME XX, 1776 pages.....	21.00
VOLUME XIX, 2122 pages.....	22.50
VOLUME XVIII, 2036 pages.....	22.50
VOLUME XVII, 1648 pages.....	19.80
VOLUME XVI, 768 pages.....	9.90
VOLUME XV, 2000 pages.....	22.50
VOLUME XIV, 1376 pages.....	19.80
VOLUME XIII, 1672 pages.....	19.80
VOLUME XII, 1648 pages.....	19.80
VOLUME XI, 1652 pages.....	19.80
VOLUME X, 1664 pages.....	19.80
VOLUME IX, 1672 pages.....	19.80
VOLUME VIII, 1650 pages.....	19.80
VOLUME VII, 1600 pages.....	19.80
VOLUME VI, 1240 pages.....	15.00
VOLS. I-V ABRIDGED, 2000 pages.....	19.80

TELEVISION VOLUME 8  
EQUIVALENT of 2688 pages  
(8½x11) .....\$24.00

TELEVISION VOLUME 7 Equivalent of 2352 pages (8½x11).....	24.00
TELEVISION VOLUME 6 Equivalent of 2320 pages (8½x11).....	24.00
TELEVISION VOLUME 5 Equivalent of 2320 pages (8½x11).....	24.00
TELEVISION VOLUME 4 Equivalent of 2296 pages (8½x11).....	24.00
TELEVISION VOLUME 3 Equivalent of 2032 pages (8½x11).....	24.00
TELEVISION VOLUME 2 Equivalent of 1896 pages (8½x11).....	24.00
TELEVISION VOLUME 1 Equivalent of 2000 pages (8½x11).....	19.80
PA EQUIPMENT VOLUME 1 2024 pages .....	18.00

IT'S GOT **everything**  
FOR **profitable servicing--**

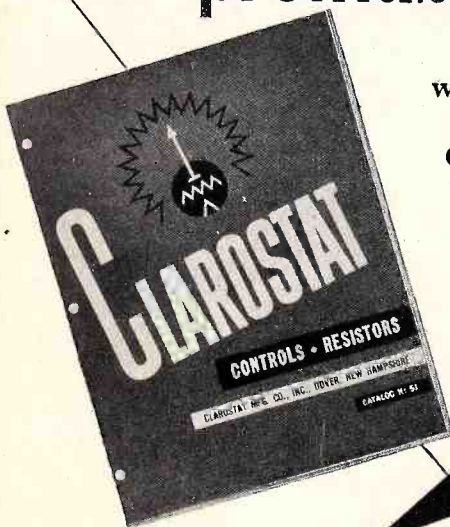

Your time is money! That's why Clarostat's latest catalog gets right down to what's-what in **CONTROLS and RESISTORS**. Instead of lengthy sales blurb, you get better listings of more values to meet the greatest range yet for servicing and initial-equipment needs. Proved easier, faster, safer and more profitable to work with this latest Clarostat catalog.

Ask for your copy...

Your Clarostat distributor has your copy waiting for you. Ask for it. Or if you prefer, write us directly.

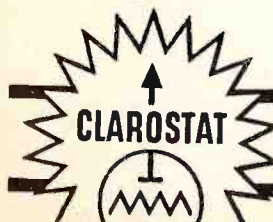

### Controls and Resistors

CLAROSTAT MFG. CO., INC., DOVER, NEW HAMPSHIRE

In Canada: Canadian Marconi Co., Ltd., Toronto, Ontario

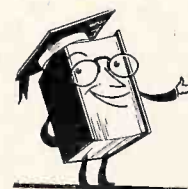

"The World's  
Greatest Compilation  
of  
AM-FM-TV-PA  
Servicing Data."

JOHN F. RIDER PUBLISHER, Inc.  
480 Canal St. • New York 13, N. Y.



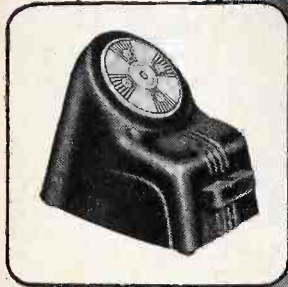

**the MOST  
POWERFUL  
TV ROTATOR  
on the market**

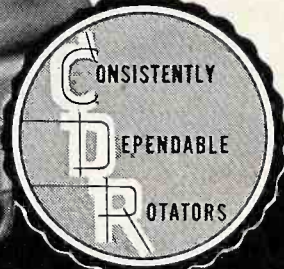

**TELE-ROTOR**

-  YAGI ANTENNAS
-  HI-LO ANTENNAS
-  INDOOR ANTENNAS
-  FM ANTENNAS
-  SUPER-VEE ANTENNAS
-  LAZY-X CONICAL
-  STRATE-LINE ANTENNAS

**Power When And Where You Need It...To Turn Any TV Antenna Array Under All Weather Conditions**

When your customers want an antenna-turning device, it is YOUR RESPONSIBILITY to sell them one that will do the job best day in and day out... night in and night out! This covers considerable ground... but the TELE-ROTOR fills the bill! STURDY enough to hold any array... POWERFUL enough to rotate it under all weather conditions... DEPENDABLE because it offers long-lasting, uninterrupted service! Give them the best... they'll thank you for your recommendation!

**MODEL TR-2**... complete rotator with "COMPASS CONTROL" cabinet having illuminated "perfect pattern" dial... (uses 8 wire cable) . . . . . \$49.95

**TELE-ROTOR**



**Second Only In Power To The Heavy Duty TELE-ROTOR**

Featuring the same powerful motor that has helped to make the 'heavy duty' TELE-ROTOR so famous, the "CUB" incorporates a sensitive meter for utmost accuracy in tuning.

**MODEL 502B**... complete rotator with indicating meter control cabinet for "hairline" tuning... (uses 5 wire cable) . . . \$44.95



**THE RADIART CORPORATION**  
CLEVELAND 2, OHIO



**CORNELL-DUBILIER**  
SOUTH PLAINFIELD, N.J.





A monthly summary of product developments and price changes of radio, electronic, and television parts and equipment, supplied by United Catalog Publishers, Inc., New York City, publishers of RADIO'S MASTER.

These REPORTS will help you to buy and sell to best advantage. They will also help you to keep your inventory up to date. A complete description of most products will be found in the Official Buying Guide, RADIO'S MASTER, available through local parts distributors.

**Price Increases**

- J F D—Antenna Models SW 2 to 13 increased to \$14.37 net.
- NATIONAL UNION—Videotron 21FP4A increased to \$45.00 net.
- RAYTHEON—Increased price of Rectfilter RFR-1044 GR to \$130.00 User Price.
- VAN NOSTRAND—Price of publication "Elementary Radio Servicing" increased to \$4.00 net.

**Price Decreases**

- ATLAS SOUND—Reduced prices on AD-11 and AD-12 (Female & Male) Flanges to \$3.36 net each; MS-10C, Mike Stand to \$5.85 net; MS-12C, Sleeve Action Stand to \$6.30 net; SS-3, Speaker Stand to \$20.55 net; St-8, Saddle Fixture and Base to \$3.60 net.
- AUDIO DEVELOPMENT CO.—Output Transformers 314F reduced to \$23.64 net and 314G to \$23.58 net.
- CHICAGO TRANSFORMER—Reduced prices approximately 10% on their entire line of Transformers and Reactors.
- CORNELL-DUBILIER—Decreased prices about 10% on "Lazy-X" antenna models, LZX, MA, 2L, 2, 4, 6B, 6BE, and 6BQ.
- G. E.—8 Picture tubes in 10", 16" and 19" size reduced in price along with 6 Pilotrons.
- J F D—AT-107 Lightning Arrestor reduced to \$2.10 net.
- MASCO—MHP-110 and MA-10-HF, High Fidelity Amplifiers reduced to \$35.93 and \$51.24 net respectively. MHP-110X and MA-10EX, High Fidelity Amplifiers with expander circuit reduced to \$46.55 and \$61.26 net respectively.
- NATIONAL CO.—Condensers PSE, PSL and PSR 25, 50 and 100 reduced in price along with Bushings XS-3, 4, 5F and 7.
- NATIONAL UNION—Decreased Videotrons 10BP4 and 10BP4A to \$23.00 net and 16AP4 to \$38.00 net.
- PHILMORE MFG. CO.—Decreased price of DPK, Voltage Doubler Unit to \$26.75 net and H109E, 6 Ft. Power Supply cord to \$4.48 net.
- RADELCO MFG. CO.—Reduced prices in following categories of their line: FM Dipoles, TV Dipoles, Dipole Accessories and TV Stacking Arrays.
- RADIART CORP.—Decreased prices about 10% on "Lazy-X" Antenna Models, LZX, M, MA, 2L, 2, 4, 6B, 6BE, and 6BQ.
- RAULAND CORP.—Prices reduced approximately 15% on 13 Picture Tubes.
- SIMPSON ELECTRIC—Decreased prices of AC Voltmeters Models 155, 156 and 157 to \$7.50 net for ranges 0-1.5 to and including 0-100 and AC Voltmeters Models 55, 56 and 57 to \$8.10 net for identical ranges. Also reduced prices on DC Voltmeters Models 125, 126 and 127 to \$7.65 net for ranges 0-3 to and including ranges 0-25.

**New Items**

- AMPHENOL—300 Ohm Twin Lead No.'s 184-803 introduced at \$2.28 net and No. 184-804 at \$2.91 net.
- APPROVED ELECTRONIC—Added A-800 Pre-Amplifier at \$37.50 and A-850, 10 watt Amplifier at \$34.50 net resale.
- BAKER MFG. CO.—Introduced Antenna Mast No. 10AM, 10' section of 18 gauge tubing with special Baker joint for stacking at \$2.28 net and 20AM, 2 section 20' telescoping mast for 1 man straight up vertical erection at \$9.30 net.
- BELDEN MFG. CO.—Added transmission line cables 8242 to 8245 inclusive to their line of RGU cables.
- CLAROSTAT MFG.—(CORRECTION from previous Reports), 2 and 3 watt wire wound controls No. 43-1500, 43-2500 at \$1.25; No. 43S-1500, 43S-2500 at \$1.85; No. 58-1500, 58-2500 at \$1.25; No. 58S-1500, 58S-2500 at \$1.85 are all LIST prices and not net as reported.
- CLEVELAND ELECTRONICS—Model 18, Automobile Rear Seat Speaker added at \$5.37 net.
- CORNELL-DUBILIER—Added LZX-AA, All Aluminum Antenna at \$5.58 net and LZX-2LAA, All Aluminum Antenna at \$11.82 net. Also introduced Yagi No. 4YG45 for Channels 4 and 5.
- G. E.—Now marketing 15 new replacement Cone and Voice Coil Kits. Also added Picture tube 16DPA4 at \$38.20 net, and 4 new Welded Germanium Diodes, G8, 8A, 8B and 8C.
- KENT PRODUCTS—CB-100 and CB-106, metal changer bases for the Webster record changer added at \$4.08 net each.
- LEAK AMPLIFIER (British Industries)—Added Model TL/25A, 25 watt Amplifier with RC/PA/U, Remote Control Preamplifier complete at \$249.00 net and Model TL/25A, 25 watt Amplifier only, at \$210.70 net.
- MALLORY & CO.—5 new Carbon and Wire Wound Controls, 3 new "LA" series Jacks and 17 other products added.
- NUCLEAR INSTR. & CHEM. CORP.—Introduced Model 1613A "Classmaster" at \$139.50 net and MRM1 Meter at \$31.50 to their line of Geiger Counters.
- RADELCO MFG. CO.—Introduced a number of new items on their line which include Mobile and Police Equipment, TV Stacking Arrays and Dipole Accessories.
- RADIART CORP.—Added LZX-AA, All Aluminum Antenna at \$5.58 net and LZX-2LAA, All Aluminum Antenna at \$11.82 net. LDX-1 is now available on a quantity discount basis.
- RAULAND CORP.—Added Picture Tubes 17LP4A at \$27.20 net and 21EP4A at \$45.00 net.
- RIDER, JOHN F.—TEK-FILE Packs 33-48 available at jobbers this month at \$2.00 per Pack.
- SCOTT, HERMON HOSMER—Added new relay-rack type Laboratory Amplifier No. 221-A at \$148.50 net (rated power output, 20 watts), and 221-A1 Amplifier at \$165.00 net, available on special order (output impedances of 4, 8, 16, and 500 Ohms).
- SMITH, HERMAN H., INC.—Added 12 new items of Electronic Components and Hardware to their line.
- THORDARSON-MEISSNER—Added following replacements: 14 Peaking Coils at \$3.36 each net; 2 Ratio Detectors at \$1.80 each net; Type 20-1026, Horizontal Linearity at \$6.60 net; Type 20-1010, Focus Coil at \$4.80 net; and Type 19-1575 at \$1.35 net.
- UNGAR ELECTRIC TOOLS—No. 535 Heating Unit introduced at \$1.10 list. Due to the lack of Tellurium replace the following items with 1/8" ELKALOY-A tips: No. 331 (straight pencil tip to replace No. 537S), No. 332 (curved tip to replace No. 537) and No. 333 (chisel tip to replace No. 538) at \$1.15 list.

UNIVERSITY LOUDSPEAKERS—Added Diffusor cone 8 at \$21.00 net; MMZTC-T, and MSR-T Railroad and Marine type speakers with transformer and volume control (underwriter approved) at \$47.10 net each. Reinstated transformer model 5420 at \$3.00 net.

**Discontinued Items**

- APPROVED ELECTRONIC—Withdrew No. A-600 AC/DC, AM Tuner.
- ATLAS SOUND—Discontinued MS-11S, Mike Stand and MS-12S, Sleeve Action Stand.
- RIDER, JOHN F.—Discontinued "A.C. Calculation Charts" (Catalog No. 106).
- UNIVERSITY LOUDSPEAKERS—Withdrew RBP-8 and RBP-12, Radial cone-speaker projectors.

**Miscellaneous Changes**

- GENERAL ELECTRIC—Type 20LP4 redesignated to type 20HP4A. G. E. tubes will be branded type 20HP4A/20LP4 to indicate that they may be used as direct substitutes for 20LP4 tubes. Type 21LP4 redesignated to 21FP4A. Type 17HP4 redesignated to 17RP4. In view of the fact that these tubes are directly interchangeable, G. E. will continue to brand its tubes 17RP4/17HP4.
- MALLORY—42 items throughout their line withdrawn.
- PAR-METAL—Revised their entire price line of products which consist of Racks, Chassis and Cabinets for Electronic Apparatus.
- PREMAX PRODUCTS—Prices on their entire line of products which include Antennas and Accessories have been revised.
- STANDARD TRANSFORMER—Redesignated P-6441 thru P-6444 (Line Adjusters) to PV-6441 thru PV-6444 at same prices.
- TRIAD TRANSFORMER—Prices on D-1 and D-2, Horizontal Output (Flyback) Transformers reverted back to old price of \$6.27 net each.

**63,500**

There are 63,500 references to pertinent electronic and allied engineering articles published from 1925 through 1949 in the five editions of the

**ELECTRONIC ENGINEERING MASTER INDEX**

- 1925-1945 edition—  
(15,000 entries).....\$17.50
- 1935-1945 edition—  
(10,000 entries).....\$10.00
- 1946 edition—  
(7,500 entries).....\$14.50
- 1947-1948 edition—  
(18,500 entries).....\$19.50
- 1949 edition—  
(12,500 entries).....\$17.50

**RIDER TV TEK-FILE**  
**Packs 1-32**  
1240 Models  
Now Available  
At Your Jobber!  
See February Releases on Page 2

Electronics Research Publishing Company, Inc.  
Dept. 55 480 Canal St., New York 13, N. Y.



# FRSAP NAMES JOHN F. RIDER FOR 1951 AWARD

The Federation of Radio Servicemen's Associations of Pennsylvania has voted to award the 1951 plaque to John F. Rider. The presentation will be made on March 16th at a luncheon meeting to be held at the Hotel Harrisburger in Harrisburg, Pa.

This is the fifth year that the Federation and the servicemen of the state of Pennsylvania have honored an individual, company, organization, or publication which they consider to have done an outstanding job on behalf of technicians and their associations. Mr. Rider was nominated this year for his many achievements in the electronic servicing industry. The plaque for 1951 will be presented to him by Carl W. Smith, Chairman of the Delegate Committee of the Associated Radio Service of Central Pennsylvania (one of the Federation's chapters).

All service dealers, technicians, and servicemen's associations from the New York, New Jersey, Ohio, Maryland, Virginia, and West Virginia areas have been invited to attend. Sandy Cowan, winner of last year's award, is also expected to attend along with such notables in the industry as Max Liebowitz, President of NETSDA, Mal Parks, Editor of "What's New in Television," Edward C. Cahill, President of the RCA Service Co., Inc., El Merriam, Service Manager of Sylvania Electric Products, Inc., Lou Winner, Editor of "Service Magazine," Ray Yeranko, Chairman of the RTMA Service Committee, Albert Coumont, Service Manager of RTMA, and many others.

Additional information on the award and its presentation will be given in more detail in a following issue.

## WE NEED YOUR HELP!

We want to make **SUCCESSFUL SERVICING** of greater value to all its readers. We plan to reorganize the contents to best suit your requirements. *We need your help!*

In order to plan a magazine that is most useful to you, we need to know how many of our readers own **RIDER TV MANUALS**. Please indicate on the coupon below *whether or not* you own **RIDER TV MANUALS**. Just paste the coupon on a penny postcard and return it to us. Regardless of how you fill it in, you will continue to receive **SUCCESSFUL SERVICING**.

This is *your* magazine. Help us make it most useful to *you*. Our sincere thanks for your past cooperation.

### MAIL THIS COUPON NOW

**JOHN F. RIDER PUBLISHER, INC.**  
480 Canal Street — Dept. 55  
New York 13, N. Y.

Gentlemen:

I have the following **RIDER TV MANUALS** in my servicing library (please circle those you own)

RIDER TV MANUAL    1    2    3    4    5    6    7    8

I do not own **RIDER TV MANUALS**

NAME.....

ADDRESS.....

CITY..... ZONE..... STATE.....

## There's a RIDER Book For Every Phase of Radio — Television

- Encyclopedia on Cathode-Ray Oscilloscopes and Their Uses  
992 pages .....\$9.00
- Vacuum-Tube Voltmeters, 2nd Ed.  
432 pages .....\$4.50
- TV and Other Receiving Antennas (Theory and Practice)  
606 pages .....\$6.00
- TV Installation Techniques  
336 pages .....\$3.60
- TV Master Antenna Systems  
356 pages .....\$5.00
- Receiving Tube Substitution Guide Book, 1st Ed. 224 pages...\$2.40
- First Supplement, Receiving Tube Substitution Guide Book  
48 pages .....\$ .99
- TV Picture Projection and Enlargement 192 pages .....\$3.30
- Television—How It Works  
203 pages .....\$2.70
- FM Transmission and Reception, 2nd Ed. 460 pages .....\$3.60
- Radio Operator's License Q & A Manual, 3rd Ed. 734 pages.....\$6.60
- Broadcast Operator's Handbook, 2nd Ed. 440 pages.....\$5.40
- Radar—What It Is 80 pages.....\$1.00
- Understanding Vectors and Phase in Radio  
160 pages .....Cloth cover \$1.89  
Paper cover \$ .99
- Installation and Servicing of Low Power Pa Systems 208 pages.....\$3.00
- Servicing by Signal Tracing  
360 pages .....\$4.00
- Inside the Vacuum Tube  
424 pages .....\$4.50
- Servicing Superheterodynes  
288 pages .....\$2.00
- Servicing Receivers by Means of Resistance Measurement  
203 pages .....\$2.00
- The Business Helper  
134 pages .....\$2.00

WE GUARANTEE your satisfaction! Make these books PROVE their value to you. Examine them at your favorite jobber. If he does not have them — order from us.

### Order Your Copy Now!

**JOHN F. RIDER PUBLISHER, INC.**  
480 Canal Street, New York 13, N. Y.

Sec. 34.66, P. L. & R.  
**PAID**  
U. S. POSTAGE  
NEW YORK, N. Y.  
PERMIT NO. 9427

JOHN L. GIGL  
437 NEVIN ST.  
LANCASTER, PENN.

From  
JOHN F. RIDER PUBLISHER, Inc.  
480 CANAL ST., NEW YORK 13, N. Y.  
Forwarding and Return Postage Guaranteed



# SUCCESSFUL

# Servicing

MARCH 1952

## HORIZONTAL OUTPUT TRANSFORMERS

### *Their Use and Replacement*

by Albert Friedman and Victor Markosian\*

In the early days of radio, one of the first problems to face the industry was one of parts replacement. Initially, the manufacturer of radio receivers was the only source for replacement parts for his receivers and complete anticipatory inventories of all types of items were maintained. However, as the industry grew and radio receiver distribution became nation wide, a sharply defined need for additional sources of replacement parts manifested itself. This need gave birth to replacement manufacturers whose sole function consisted of supplying related components that could be used in all types of radio equipment and still satisfy individual manufacturer's specifications.

The advent of television again brings the replacement situation into focus. In some cases the original parts are easily available; in others, deliveries are slow or they are no longer available. To further amplify this problem, there is still no manufacturer-authorized, centralized source to designate which manufacturer of replacement parts makes units correctly and exactly designed to fill the requirements of each of the various tv receivers.

In allied industries, such as the automotive trade, a factory-authorized index lists the approved exact replacement parts for each manufacturer and thereby eliminates the confusion that exists in our industry. Until some

recognized authority in our field publishes this type of information, the serviceman has no choice but to use any information indiscriminately made available to him. There are agencies in our industry whose basic function qualifies them to compile and prepare this information. Until exact replacement information is made available, however, the conscientious serviceman, who wants to do a good replacement job and reduce costly callbacks, must know how to determine what replacement parts to use in various receiver circuits.

In this and subsequent articles we are going to cover the replacement of some of the more

important replaceable parts of a tv receiver. The series will discuss the following topics:

1. use and replacement of horizontal output transformers
2. use and replacement of deflection yokes
3. use and replacement of width and linearity coils
4. proper use and application of conversion units.

In this article, we will discuss the replacement of horizontal output transformers used in flyback high-voltage supplies. First, however, it may be helpful to review the operation of a typical flyback circuit.

#### Operation of Flyback Circuit

In Fig. 1 is shown a block diagram of a conventional flyback circuit. This circuit supplies the sweep voltage to the horizontal deflection system of the receiver cathode-ray tube, as well as the high-second anode voltage for the crt.

The output amplifier (A) receives a signal from the horizontal oscillator and amplifies it. This signal is impressed across part of the primary of the horizontal output transformer. One secondary draws high current variations by means of step-down turns ratio. This current operates the deflection coils of the yoke

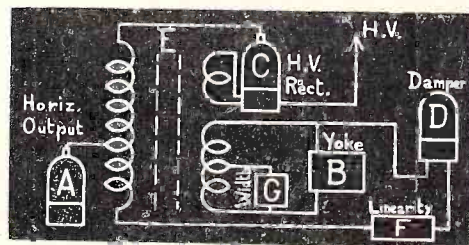

Fig. 1. Block diagram of a typical flyback horizontal output circuit.

\*Albert Friedman is National Sales Engineer and Victor Markosian, Chief Engineer of Ram Electronics, Inc. All figures for this article are through the courtesy of Ram Electronics.

(Continued on page 7)



# Fast Fit for the Job at Hand . . .

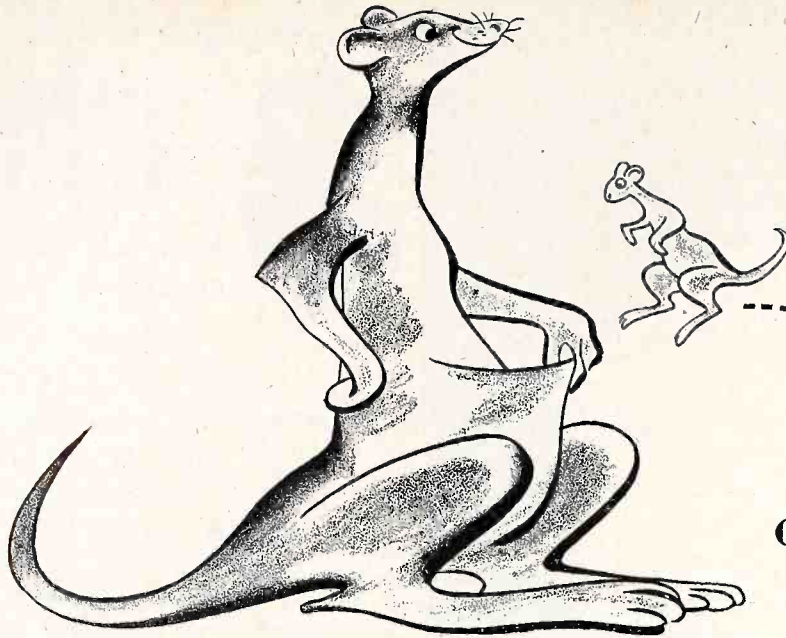

## MALLORY MIDGETROL®

Round-Shaft Volume Controls

### START FAST . . . FINISH FAST . . .

- Because of the wide and easy adaptability of Mallory Midgetrols, it's easy to stock—or get fast from your distributor—just what you need to do your job.
- Round tubular shaft designed and built for fast, easy and accurate cutting.
- Factory-tested AC switch may be attached instantly without disassembling control.
- Speedy adaptability to both split-knurl and flatted type knobs.

### CUSTOMER-PLEASING RESULTS . . .

- Longer lasting resistance elements even in extremes of temperature and humidity.
- Better and more accurate taper curves resulting from precision processing methods.
- No pigtail connections to break—thanks to Mallory's exclusive sliding contact that gives EXTRA quiet operation.
- Minimum wobble with Mallory exclusive two-point shaft suspension.

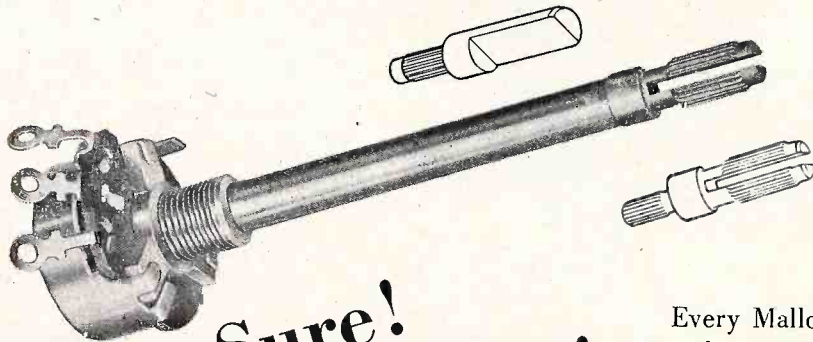

**Make Sure!  
Make it Mallory!**

So Versatile are Mallory Midgetrols—both standard and dual—that they reduce by 40% the cost of inventory needed to service the 10 most popular makes of radio and TV sets.

Every Mallory Midgetrol is packed with two shaft ends to make it easy for you to use either split-knurl or flatted type knobs. The Mallory Midgetrol line, in addition to round shaft standard controls, includes dual concentric controls that offer fast, easy assembly in five steps *without* special tools. Front and rear sections are factory assembled and inspected. AC switch attachment is easy.

R. MALLORY & CO. INC.  
**MALLORY**

CAPACITORS • CONTROLS • VIBRATORS • SWITCHES • RESISTORS  
• RECTIFIERS • VIBRAPACK\* POWER SUPPLIES • FILTERS

\*Reg. U. S. Pat. Off.

**APPROVED PRECISION PRODUCTS**

**P. R. MALLORY & CO., Inc., INDIANAPOLIS 6, INDIANA**

Please mention Successful Servicing when answering advertising.



# Successful SERVICING

REG. U.S. PAT. OFF.

Dedicated to the financial and technical  
advancement of electronic maintenance personnel

Volume 13 Number 5

March, 1952

JOHN F. RIDER, *Publisher*  
Annette M. Tricarico, *Editor*

*Advertising Representative*  
H. J. Olsow & Co.  
3951 Grand Central Terminal  
New York 17, N. Y.  
Murray Hill 6-4670



## Curtain Time

### Open Letter to Mr. Albert Coumont RTMA Service Manager

Dear Al,

First of all, let me take this opportunity of wishing you the best of success in your new assignment as Service Manager of RTMA. Having had the pleasure of spending a substantial number of hours with you, I feel certain that you will do a grand job for the servicing industry as a whole, and for the RTMA. Heavens knows that the TV servicing industry needs an individual like yourself to carry the ball on many issues!

For example, here is something which deserves serious consideration by you, the RTMA, and the Better Business Bureau. For many years past, the public has been uninformed on a very important matter — the differential between the *list price* of a radio or tv receiver and the *cost* of having it serviced properly.

The public is aware of the fact that the ability to buy a tv receiver for only \$199 or \$295 stems from mass production. If a manufacturer produced only one set a day, or even a dozen, the list price conceivably could be \$500 or perhaps \$1,000. Certainly it would be several times the list price now being charged.

Assuming mass production at the factory, what happens when a tv (or radio) receiver comes into the service shop? Now it is a single item no longer entitled to the advantages of mass production. The service technician *must* treat that receiver the same way he would a custom-made set. The parts used may be similar to parts used in thousands of other receivers, but as far as he is concerned, whatever he replaces in the defective receiver must be handled on

an *individual* basis. The public must realize that mass production techniques in receiver manufacturing cannot be applied in repair activity. There is no production line for the diagnosis of the fault or for the accomplishment of the repair. If a service shop handles a dozen or even two dozen receivers a day, production line techniques cannot be applied, because these receivers may be of varied model and circuit designs.

The mass purchasing power of the factory is reflected in the cost of the parts which go into the assembly of the receiver, affecting the list price, but *does not exist* in the service shop. Many parts used in tv receivers are singular, that is only one of a kind is used — but the manufacturer can buy these items in tens of thousands or even million quantities. The service shop owner on the other hand buys singular items individually, because he does not know how many of the same model will come into his shop for repair — and even if a dozen come in for service, the same fault will not be present in all of them. Therefore, his cost per item is higher.

The sum and substance of the whole thing is that the cost of parts to the service shop is substantially higher than the cost of parts at the set manufacturing level. This is reflected in the repair charge, and the advantages accruing to the public because of mass manufacturing should not, and cannot be expected at the servicing level!

There is another extremely important point which must be brought to the attention of the public. . . . You are the man to do this through the RTMA and every other possible medium. I am referring to the relation between the cost of items which are frequently replacements in a receiver and the overall service charge.

The public and some of the investigating bodies have criticized the servicing industry for charging five dollars for time and labor when replacing an item which costs only pennies — say 15 or 20 cents, as for example, a resistor. The same could be true of a tube which costs \$2.00 or a capacitor which costs 80 cents.

What the public loses sight of is the fact that the replacement of a part, no matter how small, involves a number of operations prior to the actual replacement — diagnosing the fault, making measurements to determine the precise part gone bad, etc. This all consumes time, and the end result may be merely the replacement of a cheap resistor. Also, time can be spent waiting for the receiver to heat up, tuning the receiver and noting the fault; making minor adjustments here and there.

Also involved is the expenditure of traveling time to the home, examination there, pickup, and eventual delivery to the home. Even disregarding the pickup and delivery time, the fact remains that the effort and time required for the replacement of a cheap item is not based on the cost of the item.

It is entirely possible that it is no more time consuming to replace a \$15.00 item than a 50 cent item. But the rent paid by the service shop owner, or the equipment he must buy, or the insurance he must pay is not based on the list price of an item. These factors, and *many others* which are related to time and overhead, are responsible for the disproportionate charge for time and parts in many instances, and it cannot be helped.

Now Al, what the servicing industry needs from you and RTMA, is the publication of a booklet for the public which tells the story of mass production. A booklet of this kind has been needed for many years. It would help make the public understand why a \$6.95 midget used tubes which listed for \$7.50, or why a \$19.95 or even \$29.95 receiver may cost \$10.00 to service. Today, the public evaluates the *justice* of a service charge, especially the time charge, on the basis of the cost of the part replaced. This is wrong and we hope that you will be able to correct it. . . . We know that it is going to be difficult to do so, but I trust that you, the RTMA and the Better Business Bureau will try. Thanks!

*John F. Rider*



guaranteed  
for

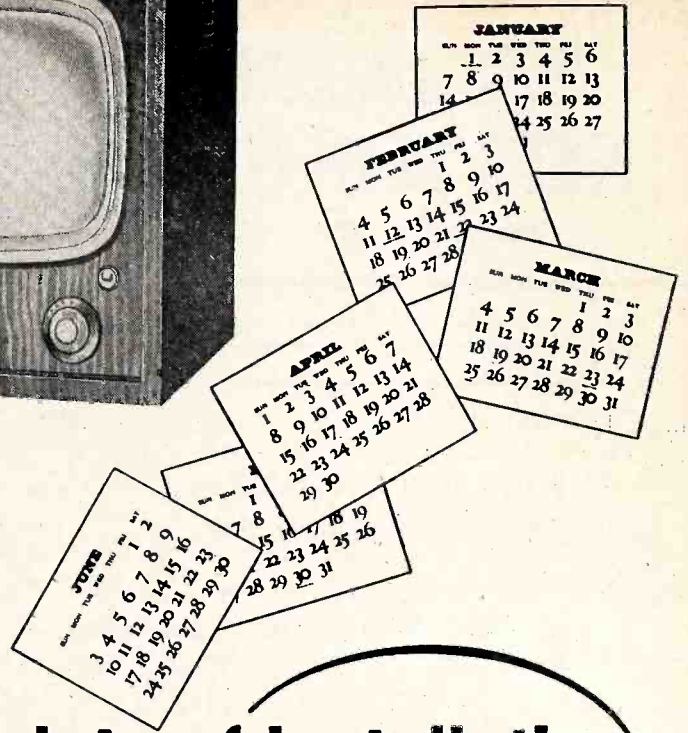
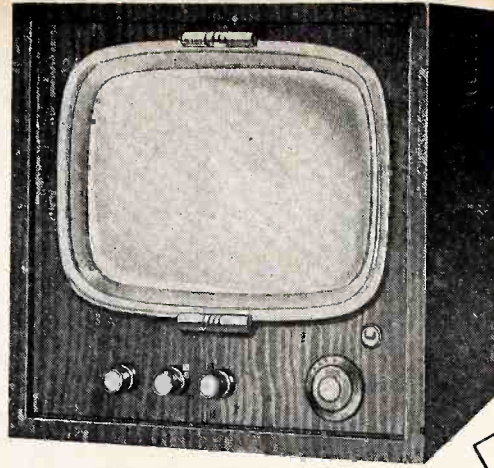

**6** months from date of installation

REGISTRATION  
No. 10861

**USER'S REGISTRATION**  
**REPLACEMENT TELETRON WARRANTY**

Teletron Serial Number: \_\_\_\_\_  
Purchased From: \_\_\_\_\_ (Name of dealer)  
User's Signature: \_\_\_\_\_  
Street Address: \_\_\_\_\_  
City: \_\_\_\_\_  
State: \_\_\_\_\_  
Teletron purchased for repair replacement  conversion replacement  Indicate one.

**USER—COMPLETE. SIGN AND MAIL THIS SECTION IMMEDIATELY AFTER YOUR PURCHASE. UNLESS YOU DO SO YOUR WARRANTY IS NOT VALID.**

Write for complete information  
on the Du Mont tube line.



\*TRADE MARK

Here is a warranty with sales appeal—with your customer participating in the registration of his Teletron. A series of three cards are supplied with each Teletron. One copy is retained by you, a second is retained by the set owner and the third is sent to Du Mont providing complete protection for the set owner for a period of six months from the date of installation against any defects in the Teletron.

CATHODE-RAY TUBE DIVISION, ALLEN B. DU MONT LABORATORIES, INC., CLIFTON, N. J.

Please mention Successful Servicing when answering advertising.



# Horizontal Output Transformers

## Their Use and Replacement

(Continued from page 1)

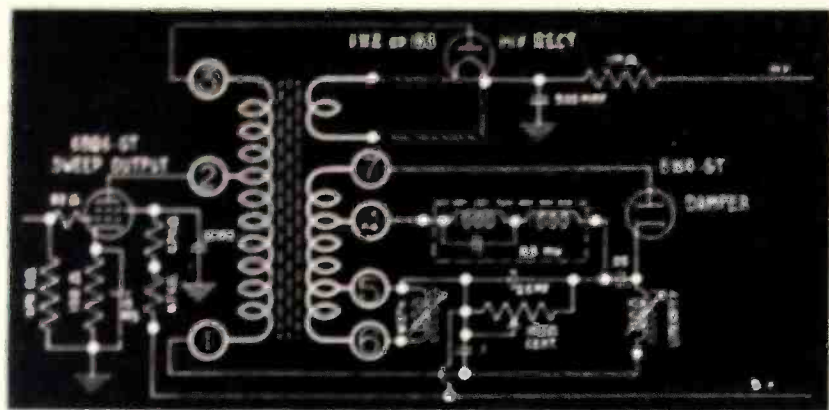

Fig. 2. Schematic of a horizontal flyback circuit using a Ram type X066 transformer.

(B) At the same time, the transformer matches the low impedance value of the yoke to the horizontal-output circuit.

The transformer primary also acts as an auto-transformer; the high potential developed across the entire primary is half-wave rectified and used to supply the second anode of the cathode-ray tube (C).

When the horizontal-output tube stops conducting, due to the drop in signal voltage fed to it, a breakdown of lines of force in the transformer induces a pulse of voltage in the transformer secondary. This pulse tends to set up transient oscillations in the yoke secondary circuit. To avoid these oscillations, the damper tube (D) is used. This tube absorbs the power in these oscillations which otherwise would appear as vertical bars on the picture information. This extra power is rectified and filtered through a network consisting of a linearity coil (F) and two filter condensers. Since this rectified voltage is in series with the B+ of the driver tube it adds to it and, therefore, is called boost voltage.

The linearity coil as part of a tuned filter circuit has a direct adjustable function on the linearity of the waveform in that circuit. The width coil (G) is wired in shunt with a portion of the transformer secondary and therefore provides some adjustment of its output. This adjustment is in direct relation to the resultant width of the sweep.

For purposes of clarity we will condense a wide variety of actual flyback transformers and circuits into three basic groups. These are the ones which find the widest use in present day tv receivers.

A general description of all flyback transformers will note that they are all of the ceramic-core, high-efficiency type. Since the advent of large-screen television tubes, powdered iron cores were found to be inadequate. As a result, to simplify production and increase the efficiency of older chassis, modified ceramic-core units have been developed for

use as replacement with smaller size tubes. Figure 2 shows a transformer used in conjunction with an 8.3 mh deflection yoke. This diagram shows a 6BQ6 as the driver tube, however, it is also common to use either a 6BG6 or a 6AU5 in such circuits. For purposes of maximum damping, the damper tube

is connected to the highest tap on the transformer while the deflection coil is connected to the next lowest tap. Under these conditions, the voltage at the output of the linearity coil will be about 500 volts with a B+ voltage of only 320 volts.

Figure 3 illustrates a somewhat different circuit. This is an early type of high-efficiency flyback unit. Its principle of operation is similar to that of the circuit in Fig. 2. The transformer shown works well with horizontal deflection coils having inductances from 8 to 30 mh and will deflect a 21" picture tube. It produces about 14KV with a B+ supply of 325 volts. The insertion of the HV filter capacitor on the highest tap of the secondary helps to produce this high voltage. Pin 4 tap on the HV flyback has a sharp negative pulse of about 3KV at the same instant that the positive pulse is delivered to the 1B3. The addition of this voltage across the high voltage filter boosts the HV to 14KV.

The width and linearity coils used in this circuit differ from those used with the previous transformer. Whereas that circuit employs the same type coils as used in early TS-630

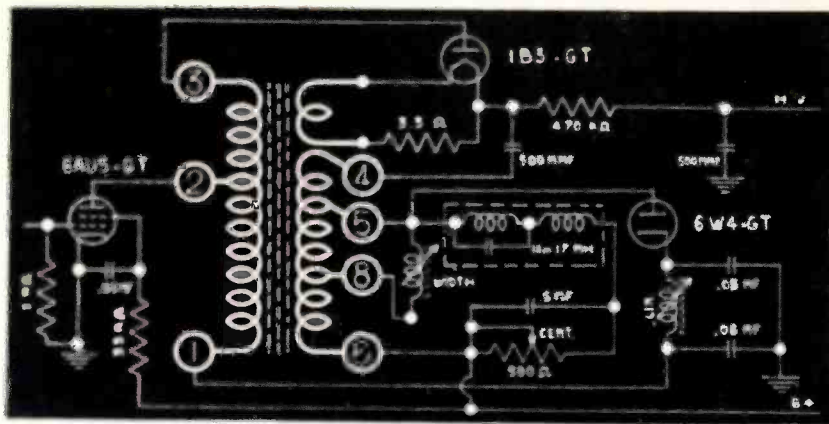

Fig. 3. Early type, high-efficiency flyback circuit. (Ram X045 transformer)

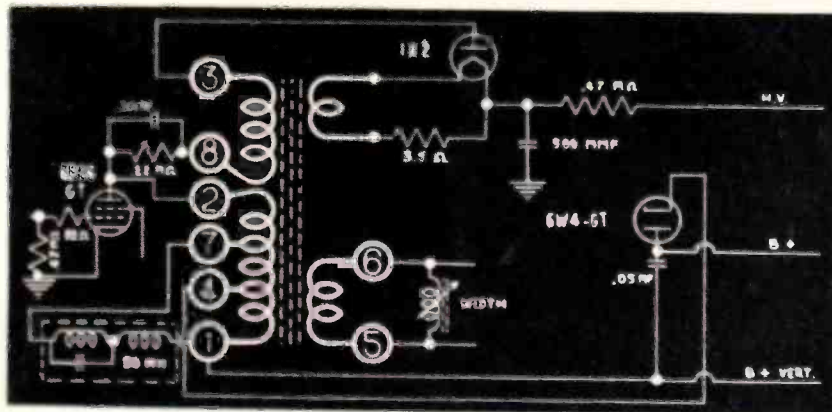

Fig. 4. The Ram X054 autotransformer flyback circuit. This type is useful in large-tube circuits.

type circuits, the width coil used with the transfer shown in Fig. 3 has much higher inductance because of greater voltage between taps.

The third basic type of flyback transformer is illustrated in Fig. 4. Employing the principles of an autotransformer, it still retains



the function of a regular flyback transformer. Because of its autotransformer design, the horizontal deflection yoke must be reversed. Therefore, the pulse on the "hot side" of the yoke will be positive. In conformance with this reversal in polarity, the damper tube must also be inverted. B+ is applied to the plate of the damper and the developed boost voltage appears on Pin 1 of the transformer. The deflection yoke used in this circuit has a 30 mh horizontal winding.

The autotransformer design reduces leakage reactance and distributed capacitance resulting in lower retrace time and ultimately, in fewer foldover problems. The resistor-capacitor combination connected between Pins 2 and 8 on the transformer is a current limiting device to reduce HV danger and is required by Underwriters Laboratories. The circuit shown will sweep up to a 24" tube and supply 14 to 15KV with a B+ supply of approximately 320 volts.

There are many variations of the three types of transformers we have discussed. Basically they all perform the same functions. Some have additional windings for keyed automatic gain control, feedback voltages, additional filament windings and other such variations including a separate winding for the width coil. With the latter arrangement, the width coil can be operated with one side connected to ground.

We cannot stress too strongly the fact that one of the most important functions of the flyback transformer is to match the deflection yoke to the plate impedance of the driver tube. A mismatch of these components can be evidenced in many ways. One very frequent result of mismatch between these units is non-linearity or crowding at one side of picture information. This condition can also be caused by a mismatch between output tube and transformer. Before a transformer replacement is considered therefore, correct impedance, turns ratio and current capacity for the transformer must be determined.

### Replacement Considerations

If a flyback transformer is found to be defective, the following points should be considered to obtain the correct replacement:

1. Check the receiver circuit diagram to determine the type and size of windings on the transformer to be replaced. In many cases, the receiver schematic found in manufacturer-authorized service data (such as Rider Manuals or TEK-FILES) shows not only the impedance values for the transformer windings but also the color coding.
2. Determine the tube type, and the impedance of the yoke used, from the receiver schematic or parts list.
3. Be sure to check whether the unit has special windings for AGC, width control or feedback purposes.
4. Consult a catalog listing horizontal output transformers for a transformer with the windings required. The terminal arrangement may vary but if

the winding data per section is within 15-20% of that required, the unit can be used.

5. *We emphasize at this point that the driver plate winding should be held as close as possible to required value in order to assure proper impedance match.* Also, the taps used for the width coil should have the proper impedance to match the coil, as should the windings used for the yoke. All of these impedance values may be obtained from the schematic given with manufacturer-authorized service data.
6. Examine the outline characteristics of the transformer replacement, to be sure that the new unit can be mounted in the space available, and will fit onto the bracket already in place.
7. Do not under any circumstances select a transformer designed to operate with a tube having a lower current rating than the one used in the set. If the current drain on the transformer is too high its operating life will be shortened due to overheating.
8. Some original equipment is made with a resistance wound filament. It usually appears wound on the sleeving of the filament lead. In replacement, connect a 3.3 to 3.9 ohm, 1 watt resistor in series with the filament circuit.

### Trouble-Shooting Replacements

If all the foregoing considerations are made, the receiver should operate satisfactorily. However, due to circuit disturbances or slight mismatches, certain adjustments may have to be made. Following are some of the variances and the remedies for them.

#### Insufficient Width

Use one, two, or all of the following:

1. Shunt the width coil a .05 mf capacitor.
2. Adjust the drive trimmer to provide more drive on the grid of the output tube.
3. Increase the screen voltage of the output tube by replacing the screen resistor with one of lower value. This is a trial and error process, try successively smaller values until the one giving the best results is found.

**CAUTION!!!** Increase voltage in steps of no higher than 10% by change of resistance value.

#### Low Second Anode Voltage

1. Remove or reduce capacitance across width coil.
2. Replace or remove width coil.
3. Increase boost voltage by connecting the vertical sweep to another B+ source. Increasing the drive or screen voltage will also increase HV.
4. Connect the cold or ground side of the HV capacitor to the top of the flyback secondary. This is usually where the damper plate is connected.

#### Excessive HV

1. Reduce drive on grid of output tube

by adjustment of driver trimmer.

2. Reduce driver screen voltage by replacing the existing resistor with one of higher value.
3. Shunt the width coil with various sized mica capacitors, selecting the one rendering best results. Shunt the damper tube with a 15K ohm, 10 watt resistor.
5. Reduce B+ voltage to flyback with a series 500 ohm, 10 watt resistor.

#### HV Arcing or Corona

Check for sharp points on soldered connections. Dirt, excessive rosin flux or dust near HV coils will also cause this condition.

1. Clean all soldered connections in HV section with carbon tetrachloride.
2. Smooth and round all connections.
3. Insulate core side from coil with high-frequency vinyl tape. Use anti-corona dope on spots where tape cannot be applied.

#### Non-Linearity

1. Substitute shunt condensers on linearity coil. Use lower or higher value to effect desired result.
2. Adjust drive trimmer for desired linearity, then readjust to proper width.
3. Non-linearity is also a condition of mismatch between flyback and yoke. Check to determine whether variations in taps on secondary of transformer can be used to correct this condition. If this cannot be accomplished, a matching yoke replacement is necessary.

#### Foldover

Before any component replacement is made be sure that the horizontal oscillator coils are properly adjusted. Special emphasis is made regarding syncrolock or syncroguide circuits. Tune both coils carefully to prevent lock-in action. This condition can be blanked out by connecting the negative side of the yoke to the first anode of the picture tube by means of a voltage divider between the "hot" side of the yoke and the normal source of first anode potential.

#### Damping Bars

This condition appears as vertical bars on the screen. It is usually caused by component mismatch, excessive drive, or failure in the damper circuit.

1. Check the damper tube for efficiency of operation.
2. Check adjustment of drive trimmer.
3. The value of the capacitor in the deflection yoke may have changed in value. Replacement with one of higher value may correct this condition. Yoke and transformer matching is of course the basic check before any rewiring is attempted.

Careful consideration should be given to all aspects before the replacement of a flyback transformer is made. We have purposely avoided related effects of deflection circuits as much as possible. This will be treated in the next article.



# TV

versus

# Radio Repair

by John F. Rider

How much time can a tv service technician afford to lose? The answer is none. The reason is simple: time is money in the servicing business. All of us know that it is impossible to make every minute of the day pay off; but if we're given the job of taking the bugs out of a tv receiver it just doesn't make sense to plunge into it without looking around a little bit.

TV receiver diagnosis and repair is vastly different from radio-receiver diagnosis and repair. Most a-m radio receivers produced during the past six years are table models and contain 5 or 6 tubes; diagnosis of these is simple in comparison to the 22-30 tube tv receivers. The same can be said about

the repair. Radio-receiver repair is replacement or adjustment; occasionally it entails modification in the circuitry as the means of effecting permanent cures of performance peculiarities. These radio repairs still mean recourse to service information of course—for, after all, differences do exist in these receivers; and it is to the distinct advantage of the service technician to know everything possible about the receiver being repaired.

On the other hand, TV receiver diagnosis and repair is much more complicated. It's not that the video receiver contains circuitry which is beyond understanding by the service technician, but it is a case of taking advantage of every bit of known art. By "known art"

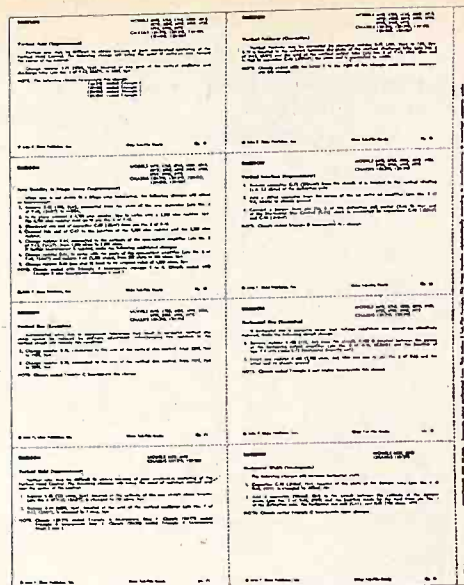

Fig. 1. Layout of a typical HANDY sheet which is included in various TEK-FILE packs.

we mean what the receiver manufacturer knows. Utilizing this information is the difference between making every minute on the job produce results—or wasting a lot of time on a job and in repeat calls.

The issue at the moment is not one of profit. We take it for granted that every service operator does everything he can to earn a profit. What we are talking about is a practice which is followed by every engineering outfit which has occasion to work on electronic equipment, to develop or modify equipment to fit a need. These organizations make life easy for themselves by first determining the *known art*—and known art means information relating to what already has been done. The bigger these organizations are, the more they do this.

The tv service technician can well afford to follow the practices of electronic engineering outfits. Why waste time and money pondering and trying to locate cures for tv receiver troubles when specific information is at hand? It's bad enough when this has to be done because the necessary information is not available, but when the information is available—it is throwing money away not to use it.

We are referring specifically to the HANDIES contained in many Rider TEK-FILES, and the CHANGES in the Rider Manuals. Beginning with Volume 9, each Rider TV Manual will contain the HANDIES applicable to the receivers in the manual. Earlier Rider TV Manuals contained these as change notices. Rider TV Manual Volume 9 will be released in late April.

Several HANDIES are shown on this page. They are the equivalent of 3" x 5" cards, which can be filed in a card file. Each is identified with a manufacturer, a receiver model and a trouble symptom and fault—and each card states the permanent cure as described by the set manufacturer.

Examine the cards shown on this page. They are just a few of the 240 Handies which  
(Continued on page 24)

**WESTINGHOUSE** **MODELS H-640T17, H-641K17**  
**CHASSIS V-2192, V-2192-1,**  
**V-2192-2, V-2192-3**

**Sound Bars (Elimination)**

Sound bars in the picture may be eliminated when caused by adjacent channel interference in the following manner:

1. Obtain slug-tuned reactor L-308 (adjacent channel sound trap).
2. Connect one end of L-308 to chassis ground.
3. Connect other end of L-308 through capacitor C-320 (1.5mmf) to pin no. 1 of the 2nd i-f amplifier (6CB6).
4. Connect capacitor C-321 (12mmf) in parallel with L-308.
5. Turn the TV receiver on and tune it accurately to the station on which the adjacent channel interference occurs.
6. Turn L-308 to its extreme counterclockwise position; then rotate slowly clockwise until sound bars disappear.

NOTE: The alignment of T-302 may be affected. If so, it will have to be realigned. Later production chassis incorporate this change.

© John F. Rider Publisher, Inc.
Rider Tek-File Handy
No. 7

---

**WESTINGHOUSE** **MODEL H-630T14**  
**CHASSIS V-2176**

**Circuit Changes (Deflection Yoke)**

1. a. In chassis using a deflection yoke (Z-402) marked V-10045-3, the 110 ohm resistor (R-453), which is shown on the schematic shunting the width control, is omitted. This is done to obtain correct picture width.
- b. In most of these chassis, the low-potential lead of the high-voltage filter capacitor (C-431, 500mmf) is connected to ground rather than to terminal 7 of the high-voltage transformer (T-402) as shown.
2. a. In chassis using a deflection yoke marked V-10045-1, resistor R-453 will be omitted in some cases for correct width.
- b. In these chassis, the lead from the horizontal winding of the yoke goes to terminal 7 of the high-voltage transformer (T-402), instead of to terminal 5, as shown.
3. When it becomes necessary to replace a yoke, it is recommended that an assembly bearing the same Part number is used.

© John F. Rider Publisher, Inc.
Rider Tek-File Handy
No. 19

Fig. 2. A couple of TEK-FILE HANDIES (actual size) showing two explicit type changes written up.





\$10.00

**FOR YOUR  
CARTOON IDEA**

Have a pet peeve about service customers and their peculiarities? Help us keep the above "SERVICEMAN'S DIARY" cartoon series going by sending in your idea. No need to draw it—just write it out. Sprague will pay \$10.00 for every idea that is used.

**Unequaled  
Dependability**

Actual service records prove that Sprague Twist-Lok dry electrolytic capacitors are tops for keeping you out of trouble with service customers—by keeping their TV sets working right!

And Sprague has the *most* complete listing of *every type* of television electrolytic. Ask your Sprague distributor for a catalog or write to: SPRAGUE PRODUCTS COMPANY, 55 Marshall St., North Adams, Mass.



**TWIST-LOK\* 'LYTICS**

*The easiest to use, most reliable electrolytics  
for television replacement use*

★ T.M. (Sprague Products Company is the Distributors' Division of the Sprague Electric Company)

Please mention Successful Servicing when answering advertising.



(A)

Fig. 1A. Picture distortion observed when stray-capacitance balancing capacitor across horizontal deflection coil is too large.

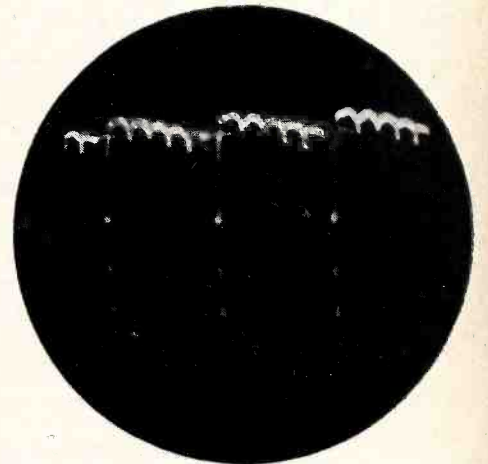

(B)

Fig. 1B. Voltage across horizontal deflection coil displays four troughs, each corresponding to a foldover in the picture.

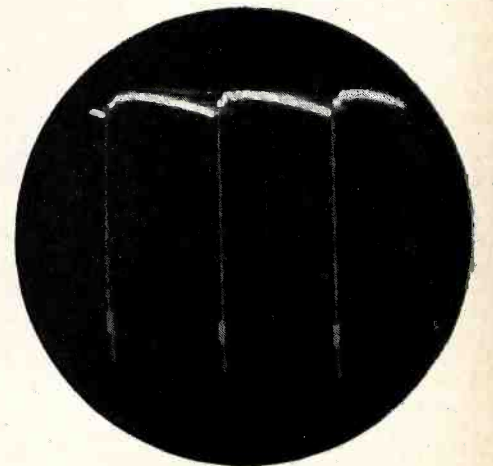

(C)

Fig. 1C. Normal voltage waveform across horizontal deflection coil. A certain tendency to ring at the end of retrace appears, due to tolerances of circuit components.



# Interpreting Scope Waveforms in TV Servicing

by Bob Middleton

The importance of knowing how to interpret waveforms seen on a service oscilloscope is not fully appreciated by most tv service technicians. There is a tieup between the picture observed on the screen and the oscilloscope waveforms observed at various test points on a chassis. Knowing how to interpret these waveforms will cut service time to a minimum and make for better servicing.

As an example of the relationship between the picture on the tv screen and the waveforms in the circuit, refer to Fig. 1, which shows the picture and voltage and current

waveforms resulting from distortion introduced by the horizontal deflection circuit. The various waveforms and the circuit conditions causing them are described in the captions.

The shape of the sync pulse of a tv receiver is closely related to picture reproduction. If the picture rings, the sync pulse will also ring. Ringing is increased as the bandwidth of the amplifier is narrowed and as the picture carrier is run further down on the response curve. The various scope patterns reproduced in Fig. 2 show the effects of ringing on the picture tube as well as on the chassis waveforms.

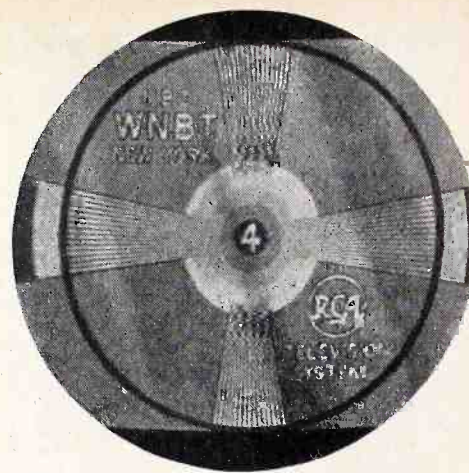

(C)

Fig. 2C. Ringing produced in test pattern when i-f amplifier bandwidth is narrowed. (See Fig. 2D)

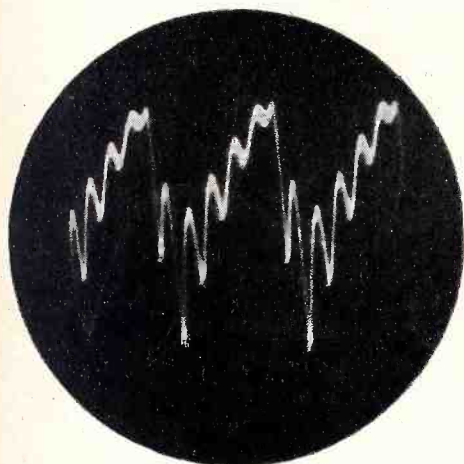

(D)

Fig. 1D. Current through the horizontal deflection coils when excessive balancing capacitance is used. Four troughs are displayed, as in the voltage waveform (Fig. 1B), but the waveform details differ, due to current and voltage association with a reactive (inductive) circuit.

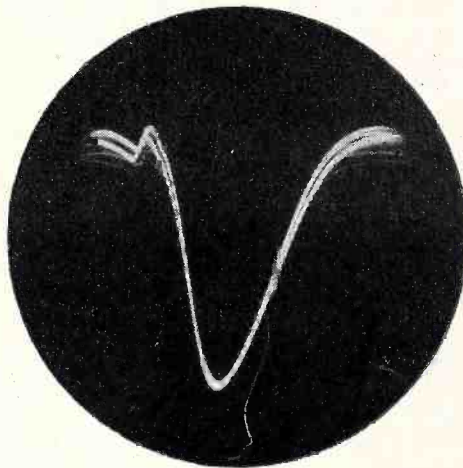

(A)

Fig. 2A. I-f amplifier bandwidth wide enough to avoid ringing. Picture carrier is seen halfway up curve.

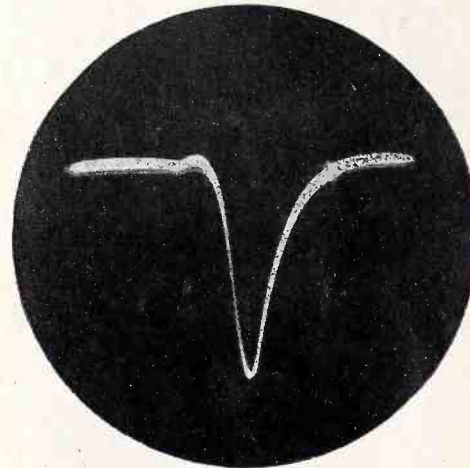

(D)

Fig. 2D. Narrowed i-f amplifier bandpass which produces ringing in test pattern, as well as overshoot and ringing in sync pulse. Picture carrier, seen very low on curve, aggravates the distortion.

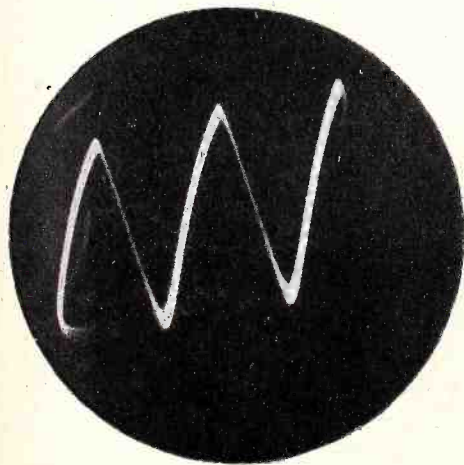

(E)

Fig. 1E. Normal sawtooth. The sawtooth is somewhat non-linear, due to misadjustment of the drive and linearity controls.

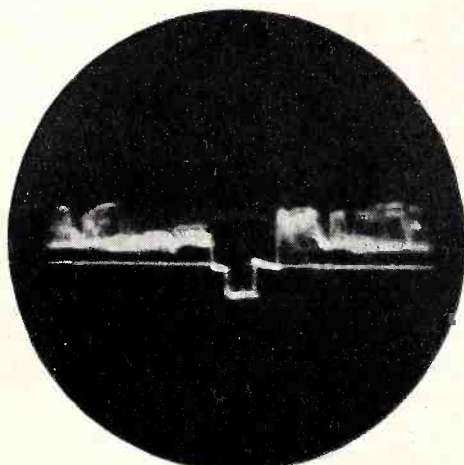

(B)

Fig. 2B. Sync-pulse waveform produced by response curve of Fig. 2A.

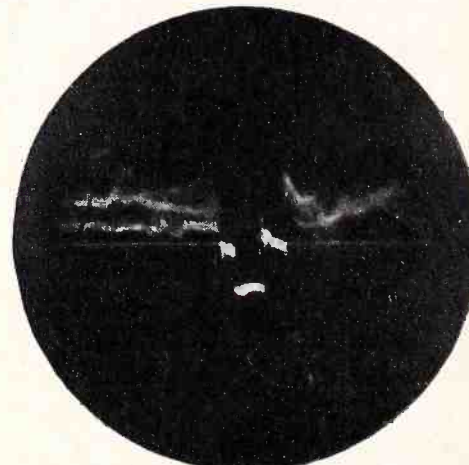

(E)

Fig. 2E. Distorted sync pulse produced by response curve of Fig. 2D. Low placement of picture carrier attenuates sync pulse, and causes instability of sync action in many cases. Scope gain was advanced to obtain sufficient height of display on screen.



# TUNG-SOL<sup>®</sup>

for  
Uniformity  
and  
Dependability

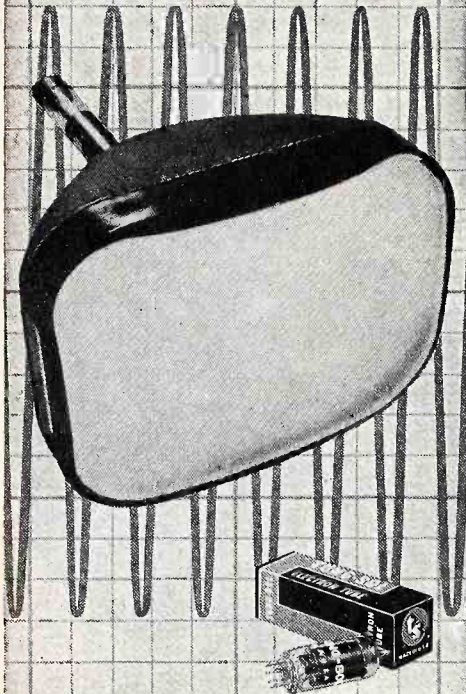

## REPLACEMENT:

Tung-Sol tubes keep service standards up to set manufacturers' specifications.

## INITIAL EQUIPMENT:

Tung-Sol tubes meet the highest performance requirements of set manufacturers.

**TUNG-SOL**  
RADIO, TV TUBES, DIAL LAMPS

TUNG-SOL ELECTRIC INC., NEWARK 4, N. J.  
Sales Offices: Atlanta • Chicago • Dallas • Denver  
Detroit • Los Angeles • Newark

ALSO AUTO LAMPS, ALL-GLASS SEALED  
BEAM LAMPS AND SIGNAL FLASHERS

Please mention Successful Servicing when answering advertising.

## Chassis Coding

How does the radio and tv receiver manufacturer code his chassis? Some use the RTMA numbering, others use letters, numbers, triangles, etc. This information is very important to every service technician because it is the best means for correlating the service data which appears in RIDER MANUALS, TEK-FILES, and other of our literature with the actual chassis at hand. It is especially important in the association of circuit changes and trouble cures applied to different production runs of a receiver.

We are surveying the manufacturers for such information and shall print this data in SUCCESSFUL SERVICING. Make certain that you keep these data on hand. File them with your Rider Manuals or Tek-File Folders.

Alliance Mfg. Co. rubber stamps the bottom plate of their tv booster with an AB or AB-1 if the booster is the original Tenna-Scope design or AB-2 and AB-5 for later production models.

It is the practise of the Altec Lansing Corp. to include a schematic diagram with each tuner, and this drawing indicates the serial numbers to which the drawing applies. The schematic is changed every time any principal change is made in the circuit and the identification of serial numbers is put in the lower right-hand corner.

Any major change in circuit or mechanical design which would render original drawings obsolete, is accomplished with a change in Model No., advises the Anchor Radio Corp. Minor substitutions or changes in mechanical parts, that still leave all components of a particular unit interchangeable, are not indicated in an original Model No. or a particular serial no. Only the individual part is so identified (A, B, C, etc.) and the replacement parts shipped will always be of the latest type.

Arvin Industries, Inc. identifies changes of consequence in production runs by a dash (—) number following the chassis no. For example, take the TE 302 chassis. On the schematics applying to the different production runs of this chassis, changes are outlined showing how they differ from the preceding dash number. The added number (now TE 302-1) is "impressed stamped" on the back flange of the chassis.

Motorola, Inc. rubber stamps their chassis for the initial runs with a plain chassis number, such as TS-314. When subsequent changes are made, a letter is added behind the chassis number, such as TS-314A, TS-314B, etc.

The Crosley Division of the Avco Mfg. Corp. indicates major changes by a change in the suffix number of the chassis model. For example, 356-1 used 17" rectangular glass picture tube. When a 17" rectangular metal tube was used, the chassis number became 356-2 and when a 17" rectangular glass tube with electrostatic focusing was used, the chassis number became 356-3. On minor changes, such as changing resistor values or other changes that affect the wiring diagram, the change is

indicated by a code letter rubber stamped on the top of the chassis at the right-hand corner as viewed from the rear of the set.

The Fada Radio and Electric Co., Inc. identifies their radio receiver models by a white licensee label or tube layout label. These labels are glued on either the bottom or inside wall of the cabinet and have the Model No. printed on them. Circuit changes are indicated by a large alphabetical letter stamped on either the Rear Chassis Apron or Loop Backing. Their tv receiver models are identified by a white model and licensee label glued on the Rear Apron of the tv chassis. Circuit changes are indicated by a large alphabetical letter (or double lettering if more than one circuit change has been made) on the Rear Apron of the tv chassis. Serial numbers on both radio and tv chassis only serve to individualize the chassis.

As of January 1, 1951, the Tele-Tone Radio Corp. has been using a new system for coding their receiver chassis. The 7000 series of chassis numbers indicate tv receiver chassis with no power transformer and the 8000 series indicate tv receivers with power transformers. Prior to this date, a letter system (TAO, TAH-UL, TAP-2-UL, etc.) was used. The new, rubber-stamped series can be found on the rear apron of the chassis or next to the power transformer.

In order to indicate a major change, such as substitution of a tube and associated circuits, the Zenith Radio Corp. adds a Z, Z1, Z2 or even double Z's to their model numbers. A corresponding service note is printed and sent out to the field. These numbers would definitely allow the service man to be able to identify a chassis for its original design and subsequent modifications.

Western Auto Supply's principal method of coding is by the use of letters following the Truetone Model No., that is, original production runs will be identified by the Model No. followed by either no letter designation or the letter "A." Any changes in design or circuitry which would make service literature as originally published no longer correct, will result in the changing of the Model No. by adding the letter "B." An example of this would be as follows: 2D2052A would be the original production run. 2D2052B would be a suppliance production run in which major changes have been incorporated. Each of these would have its own set of serial numbers. Minor changes in any given Model are handled by issuing a supplement to the original manual.

The method of coding used by Gamble-Skogmo, Inc., is to have the Stock No. attached to the base on the back of the chassis. The initial run of a given set carries their regular Stock No. such as 43-1000. Any subsequent changes in circuits or parts are designated with alphabetical suffixes such as "A" for the first change, "B" for the second change, etc.



# Another Rider 'First'

## "TELL-A-FAULT"

### RIDER

ION VOLUME 8	
ent of 2688 pages (8½x11)	24.00
ION VOLUME 7	
ent of 2352 pages (8½x11)	24.00
ION VOLUME 6	
ent of 2320 pages (8½x11)	24.00
ION VOLUME 5	
ent of 2320 pages (8½x11)	24.00
ION VOLUME 4	
ent of 2296 pages (8½x11)	24.00
ION VOLUME 3	
ent of 2032 pages (8½x11)	24.00
ION VOLUME 2	
ent of 1896 pages (8½x11)	24.00
ION VOLUME 1	
ent of 2000 pages (8½x11)	19.80
LEMENT VOLUME 1	
res	18.00
XII, 1520 pages	18.00
I, 1648 pages	21.00
1776 pages	21.00
2122 pages	22.50
2036 pages	22.50
1648 pages	19.80
XVI, 768 pages	9.90
XV, 2000 pages	22.50
XIV, 1376 pages	19.80
XIII, 1672 pages	19.80
XII, 1648 pages	19.80
E XI, 1652 pages	19.80
E X, 1664 pages	19.80
E IX, 1672 pages	19.80
VIII, 1650 pages	19.80
VII, 1600 pages	19.80
E VI, 1240 pages	15.00

YOU SHOULD OWN ALL OF THESE RIDER MANUALS — so vital to profitable and successful tv-radio-pa servicing! If you own only a few, you're cutting down on your daily income. Each volume is complete in its entirety and does not duplicate servicing data published in companion volumes. All data is direct from the receiver manufacturers — and it's complete data, not abridged or prepared by an independent laboratory. It contains the manufacturer's knowledge about his receiver, his research in troubleshooting the set and in

finding the permanent cures for peculiarities in the operation of his receiver . . . all of this means successful servicing. It is the difference between a temporary repair, which is troublesome — or a permanent one and a prestige builder. Schematics, chassis views, tube layouts, parts lists and values, voltages, circuit changes . . . it's all in RIDER TV-AM-FM-PA MANUALS. Buy them at your favorite parts jobber and prove to yourself that you can service easier, faster, and more profitably.



# I.R.E. SHOW AT PALACE HUGE SUCCESS

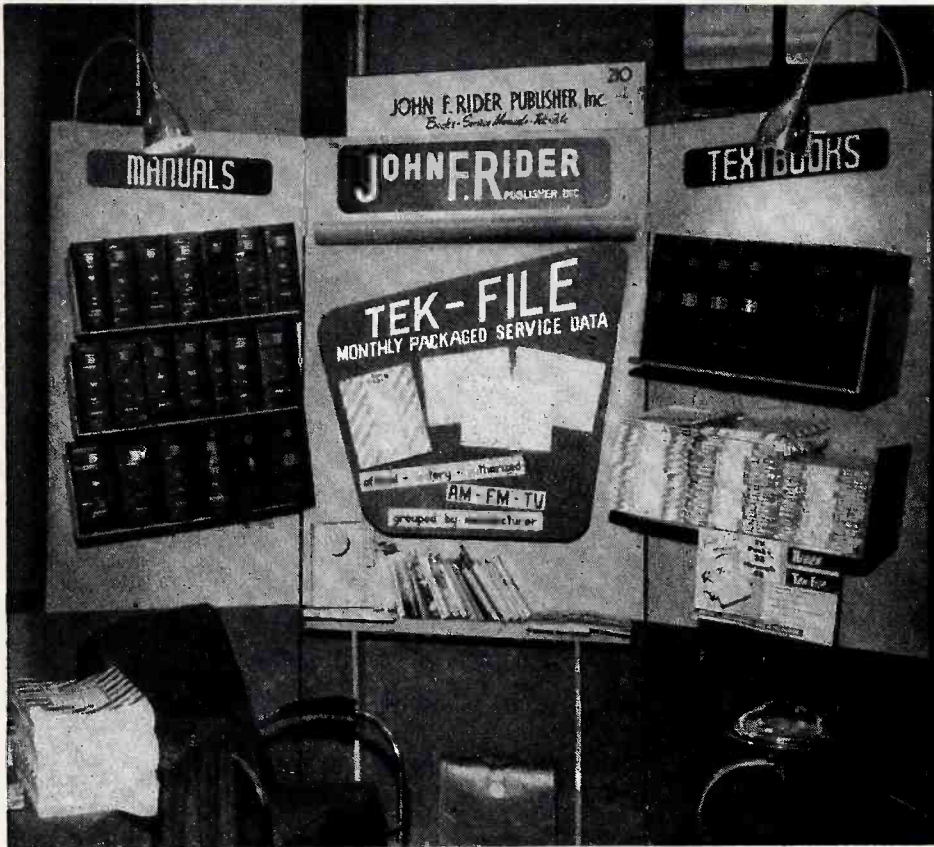

The John F. Rider Booth at the I.R.E. convention, showing Rider Manuals and TEK-FILE in background.

Over 27,500 members of the Institute of Radio Engineers, including scientists, engineers and executives from nearly every country of the world, attended the I.R.E. annual convention from March 3-6. The forty year old I.R.E. is the world's most influential and fastest growing organization devoted to radio, television and allied sciences.

The convention enabled over 350 companies to exhibit and demonstrate more than ten million dollars worth of radio and electronics apparatus on four floors at Grand Central Palace. The Radio Engineers' show featured exhibitions of special military radio equipment, including atomic radiation detection devices and guided missile trajectory plotters. Demonstrations from the countries leading electronics manufacturers and research laboratories included items ranging from small "transistors," which someday may replace vacuum tubes, to full sized television transmitters.

Another major feature of the I.R.E. convention was the extensive series of technical sessions and forums on research, production and design in the radio and technical fields. Over two hundred papers, covering nearly every phase of the radio electronics field, were presented in meetings at the Waldorf-Astoria. Color television was discussed and an emphasis given to UHF transmitters and receivers with the description of a new, compact UHF receiver tuner to be assembled in new sets at the factory and a forum on new UHF antennas and experimental amplifiers. Other meetings included discussions on instrumentation, information theory, circuits and microwave-guides.

All in all, the convention was pretty terrific, and if an editorial note may be added, the staff at the John F. Rider booth certainly enjoyed "meeting you at the show."

## ATTENTION! RADIO SERVICEMEN

THERE ARE THOUSANDS OF OUT-MODED RADIOS IN YOUR "BACK YARD" JUST WAITING TO BE REPLACED . . . AT YOUR SUGGESTION

Here is the custom-built AM-FM chassis that means **BIGGER PROFITS** for you!

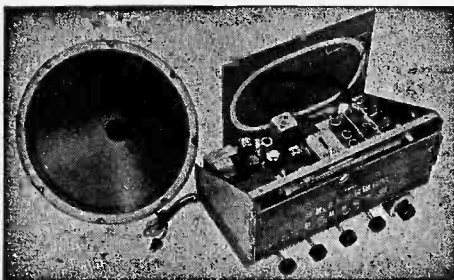

### SPECIFICATIONS

Supplied ready to operate, complete with tubes, antennas, speaker and all necessary hardware for mounting in a table cabinet or console, including escutcheon. Power consumption—105 watts.

Chassis Dimensions: 13½" wide x 8½" high x 10" deep.

Carton Dimensions: (2 units) 20 x 14½ x 10¾ inches.

Net Weight: 17 pounds each.

Sold through your favorite parts distributor.

WRITE FOR CATALOG KD12  
AND NAME OF NEAREST DISTRIBUTOR.

### The NEW ESPEY model 511-C FEATURES

1. AC Superheterodyne AM-FM Receiver.
2. Improved Frequency Modulation Circuit, Drift Compensated.
3. 12 tubes plus rectifier and Pre-Amp Tubes.
4. 4 dual purpose tubes.
5. Treble Tone control.
6. 6-gang tuning condenser.
7. Full-range bass tone control.
8. High Fidelity AM-FM Reception.
9. Automatic volume control.
10. 10 watts (max.) Push-Pull Beam Power Audio Output.
11. 12-inch PM speaker with Alnico V Magnet.
12. Indirectly illuminated Slide Rule Dial.
13. Smooth, flywheel tuning.
14. Antenna for AM and folded dipole antenna for FM Reception.
15. Provision for external antennas.
16. Wired for phonograph operation with switch for crystal or reluctance pick-up.
17. Multi-tap output trans., 4-8-500 ohms.
18. Licensed by RCA and Hazeltine.
19. Subject to RMA warranty, registered code symbol #174.

Makers of fine radios since 1928.

**ESPEY** TEL TRafalgar 9-7000  
**MANUFACTURING COMPANY, INC.**  
528 EAST 72nd STREET NEW YORK 21, N. Y.

*Rider Tek-File gives you*

**Complete alignment data**

Attention TV Service Technicians!

Please bear with us a little longer. The publication of the TV TROUBLESHOOTING AND REPAIR GUIDEBOOK is being delayed because we are making it the most complete possible. It is a broad subject and filled with variations. We'll be off the press very shortly.



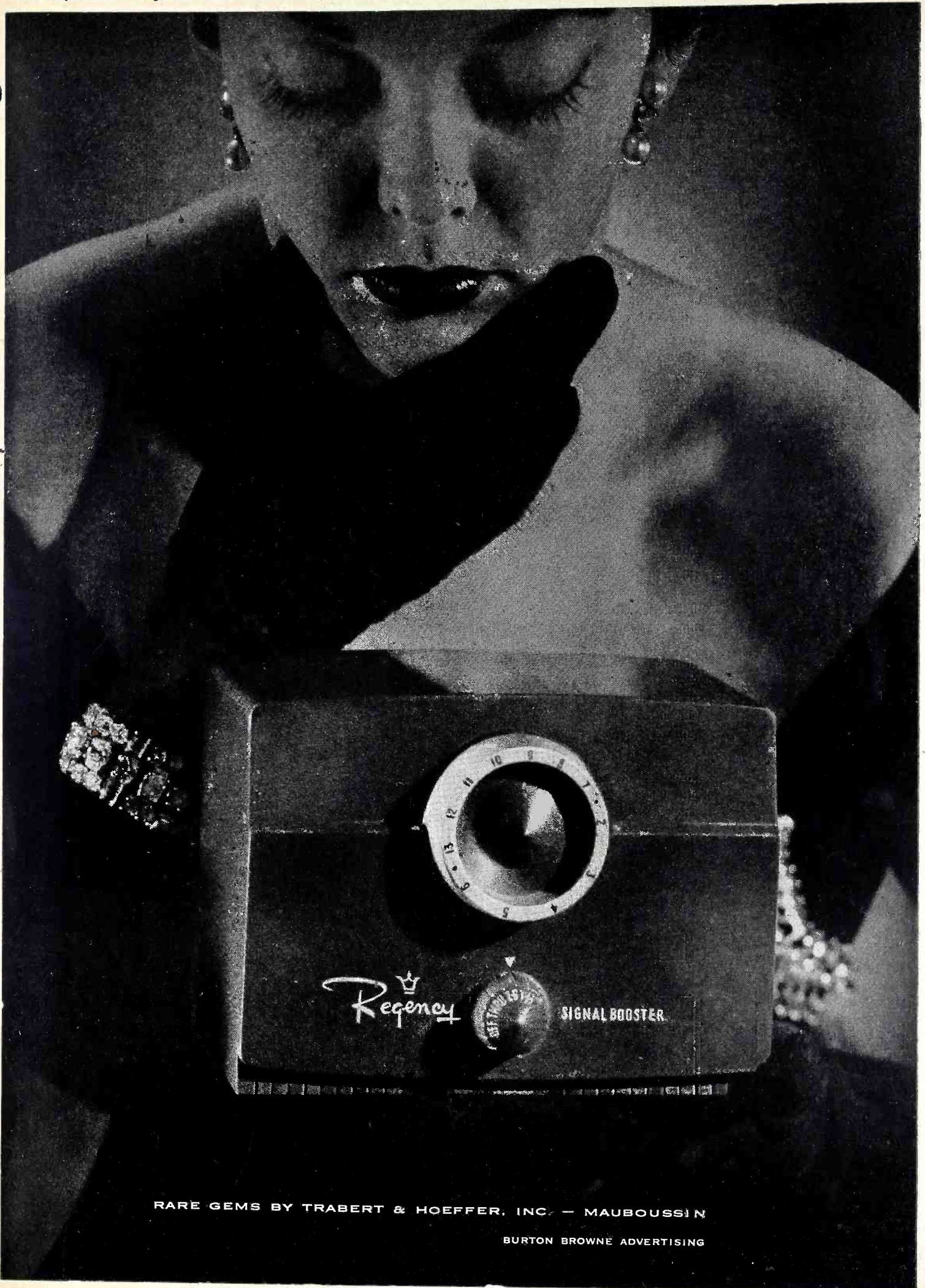

RARE GEMS BY TRABERT & HOFFER, INC. — MAUBOUSSIN

BURTON BROWNE ADVERTISING





**IMPORTANT ANNOUNCEMENT TO SERVICE DEALERS!**

Your used  
**PICTURE TUBES** are  
 now worth **\$2.25 to \$5.25**

Sylvania Tube Distributors offer trade-in allowance on more than 40 picture tube types . . . of any make.

Here's the best picture tube news you ever heard. It's the Sylvania GLASS ALLOWANCE PROGRAM. You can make \$2.25 to \$5.25 more on every picture tube you sell.

You also protect your reputation by installing only new, fully guaranteed Sylvania Picture Tubes in your customers' sets. The process is simple! No strings attached!

**Here's all you do!**

1. Return old picture tubes to your Sylvania tube distributor. Sylvania has made it possible for him to give you a GLASS ALLOWANCE CREDIT of from \$2.25 to \$5.25 per used tube on the purchase of any new Sylvania picture tube.
2. Return tubes may be of ANY MAKE but must be types shown on the suggested Sylvania Glass Allowance Price List. (See list below.)
3. Returned tubes must be under vacuum and free from chips, scratches, etc.
4. New tubes purchased need not be the same as those returned. You may choose any type Sylvania has for sale.

Sylvania reserves the right to change cash values or tubes shown on the suggested Glass Allowance Price List. SO ACT NOW. Take your used picture tubes to your Sylvania Dis-

tributor . . . TODAY! For further details call your Sylvania Representative or Sylvania Electric Products Inc., Glass Department, Seneca Falls, New York.



**Here's your Suggested Glass Allowance PRICE LIST**

*(Clip this list and keep it handy)*

12KP4A	\$2.25	17AP4	\$2.25	20CP4	\$4.25
12LP4A	2.25	17BP4	2.25	20CP4A	4.25
12VP4A	2.25	17BP4A	2.25	20DP4	4.25
		17BP4B	2.25	20DP4A	4.25
16JP4A	3.25	17FP4	2.25	20FP4	4.25
16KP4	3.25	17FP4A	2.25	20GP4	4.25
16KP4A	3.25	17HP4	2.25	20HP4	4.25
16LP4A	3.25	17JP4	2.25	20HP4A	4.25
16QP4	3.25	17KP4	2.25	20JP4	4.25
16RP4	3.25	17LP4	2.25		
16TP4	3.25	17QP4	2.25	21EP4	5.25
16UP4	3.25	17RP4	2.25	21EP4A	5.25
16XP4	3.25	17SP4	2.25	21FP4	5.25
16ZP4	3.25			21FP4A	5.25
				21KP4	5.25
				21KP4A	5.25

**SYLVANIA**



RADIO TUBES; TELEVISION PICTURE TUBES; ELECTRONIC PRODUCTS; ELECTRONIC TEST EQUIPMENT; FLUORESCENT TUBES, FIXTURES, SIGN TUBING, WIRING DEVICES; LIGHT BULBS; PHOTOLAMPS; TELEVISION SETS



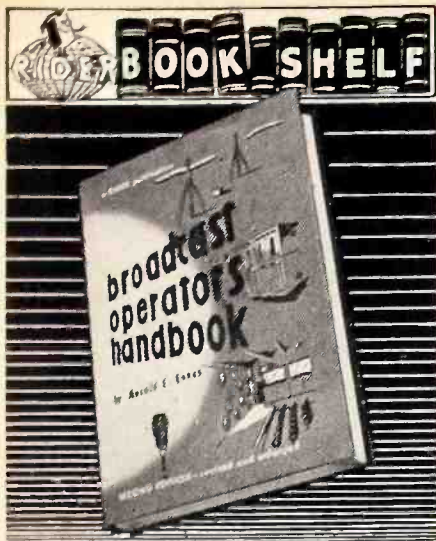

**1. BROADCAST OPERATOR'S HANDBOOK** Second Edition, by Ennes

Keep up with the industry . . . so many new broadcasting techniques, together with new equipment, have been developed in the past few years that the author of the original "best seller" has revised and enlarged it for this Second Edition. H. E. Ennes, staff engineer at WIRE, Indianapolis, covers all practical operations in and out of the studio. Typical chapters: You're Often a Producer Too; Studio and Control Room; Where Split Seconds Count; Remote Versus Studio Pickups; Emergency Shutdowns. Ideal for newcomers and veterans alike. Cloth bound with 440 pp., 226 ill.

\$5.40

**2. RADIO OPERATOR'S LICENSE Q AND A MANUAL**, Third Edition, by Kaufman.

Revised and enlarged edition includes new Elements 2, 5, 7 and revised Elements 3 and 6 plus Element 8; Ship Radar Techniques. Contains questions and answers to FCC exams, plus a thorough discussion of the subjects covered. 734 pp. (5½ x 8½") 243 ill.....\$6.60

**2a. ELEMENT 8: SHIP RADAR TECHNIQUES**, available separately bound. 32 pp. (5½ x 8½") ill.....\$1.78

**3. UNDERSTANDING VECTORS AND PHASE IN RADIO**, by Rider & Uslan.

Covers scalars, vectors, vector analysis and their application to radio. " . . . an excellent book for any engineer who has allowed his vectors to grow rusty through lack of use!" —Tele-Tech. 160 pp. (5½ x 8½") ill.....\$1.89

**4. FM TRANSMISSION AND RECEPTION**, Second Edition, by Rider & Uslan.

Covers operating principles of wide and narrow band FM-PM transmitters. Typical chapters: Transmitters of Today; The Transmission of FM Signals; The FM Receiver. 460 pp. (5½ x 8½") ill. .... \$4.95

Buy these books now at leading bookstores . . . or



--- MAIL THIS COUPON—TODAY ---

JOHN F. RIDER Publisher, Inc.  
480 Canal Street, New York 13, N. Y.

Please send me book(s) circled. I understand, if not satisfied, I may return them within 10 days for full refund.

1    2    2a    3    4

NAME \_\_\_\_\_

ADDRESS \_\_\_\_\_

CITY \_\_\_\_\_

ZONE \_\_\_\_\_ STATE \_\_\_\_\_

Please Print

Could we say more?

SIMS ELECTRONIC SERVICE

Radio & Television Repairs

12A Bellevue Ave. • Oceanside, N. Y.

John F. Rider Publisher, Inc.  
480 Canal Street, Dept. SS  
New York 13, New York

Gentlemen:

I would like to take this opportunity to thank you for making SUCCESSFUL SERVICING available to us independent service men. The articles are of the utmost interest to me, and the world of help.

I'd like also to congratulate you on the wonderful job you are doing for service men through the use of TEK-FILES. I used TEK-FILE #1 on an Admiral. It contained such a wealth of information that I completed the repairs in one fourth the usual time. The owner of the Admiral was so pleased that through his recommendation I received several more Admirals for factory—recommended changes listed in TEK-FILE. Now I use TEK-FILE on every set I repair if the model is available. I anxiously watch for the new releases each month.

Thank you sincerely.

Respectfully,  
HENRY E. SIMS

**Please Pardon Us . . .**

*Our apologies to Mr. Richard Blitzer. Through no fault of his own, a technical error occurred in his article, "Troubleshooting TV AFC Circuits," which ran in the March issue of SUCCESSFUL SERVICING. Two paragraphs dealing with Fig. 1 and beginning with "If the horizontal oscillator frequency changes . . ." should have read as follows:*

If the horizontal oscillator frequency changes, say it attempts to decrease, then the phase relationship between the sine waves and the stable sync pulses also changes. The sync pulses are now higher in frequency than the sine waves. This results in V1 conducting more heavily than V2. As a result, the voltage across R1 is larger than that across R2. The discriminator's output is now the -2 volts added to the net voltage developed across R1 and R2. This results in a smaller negative voltage being applied to the grid of the control tube. Consequently, the plate current of V4 rises. This causes a change in the amount of injected reactance so that the oscillator's frequency is increased.

Under opposite conditions, when the oscillator frequency tends to increase, V2 conducts more heavily than does V1. The net output voltage of the discriminator is then negative. This increases the negative bias on the reactance tube which causes the oscillator frequency to decrease.



The newest Rider TV Manual covering the very latest complete, factory-issued TV receivers servicing data for all prominent manufacturers. Make sure you get your copy. Order from your jobber — today!

**TV8 and Vol. 22**

TV8. The largest TV manual ever published by Rider. Covers the products of 52 TV manufacturers. Contents include chassis views, voltages, resistance readings, troubleshooting test patterns, waveforms, complete parts lists and values plus coverage of all models and circuit changes . . . and much, much more. Equivalent of 2694 pp. 8½x11" . . . \$24.

Vol. 22. Covers all AM-FM production runs of 62 manufacturers. Contents include all factory-issued servicing data on AM-FM receivers, auto radios, record changers, tuners and recorders . . . plus a cumulative index for vols. 16 through 22. 1520 pp. 8½x11" . . . \$18.

Make all your servicing easier — be sure your Rider Manual library is complete. Now available, Rider TV Manuals 1 through 8. AM-FM Manuals up to 22.

Get them from your jobber—today!

**JOHN F. RIDER**  
PUBLISHER, INC.  
480 Canal St., N. Y. 13, N. Y.





by servicemen and electronics experts . . .

as the **GREATEST** Improvement in Vibrators in 17 Years

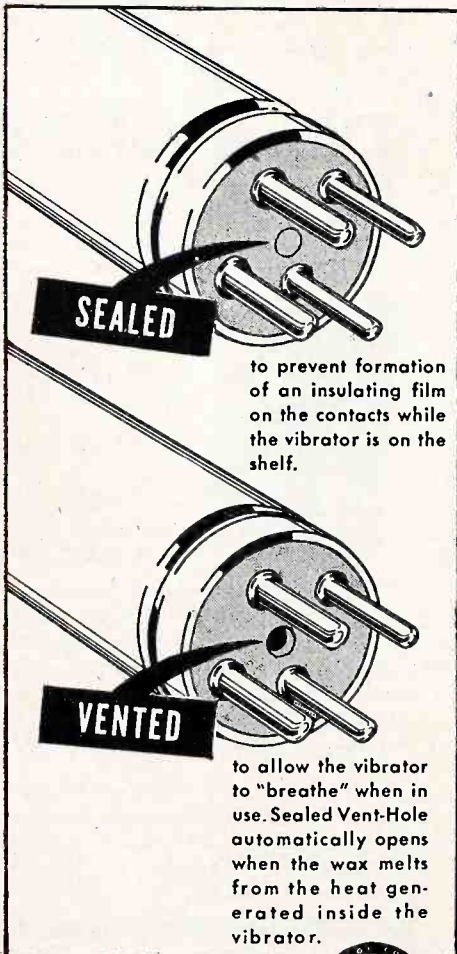

**SEALED**

to prevent formation of an insulating film on the contacts while the vibrator is on the shelf.

**VENTED**

to allow the vibrator to "breathe" when in use. Sealed Vent-Hole automatically opens when the wax melts from the heat generated inside the vibrator.

**RADIART**  
**Seal-Vent**  
**RED SEAL VIBRATORS**

Experts everywhere agree that this is the greatest advancement in vibrator design in the last 17 years! That's because NOW . . . with the RADIART SEAL VENT . . . the vibrator is sealed BEFORE it is used . . . and VENTED after it is put into use! The RED SEAL rubber-faced bakelite plug prevents insulating film formation on contacts. Heat generated when the vibrator is put into service melts the wax out of the sealed vent-hole and permits air circulation . . . FOR LONGER LIFE AND EVEN GREATER PERFORMANCE! Give your customers the best . . . give them RADIART . . . the STANDARD OF COMPARISON.



**THE RADIART CORPORATION CLEVELAND 13, OHIO**

**VIBRATORS • AUTO AERIALS • TV ANTENNAS • ROTATORS • POWER SUPPLIES!**

Please mention Successful Servicing when answering advertising.





How come you sell so many picture tubes, Sam?



"I'm using the CBS-Hytron Easy Budget Plan, Joe. My CBS-Hytron distributor gave it to me."



"Tell me more."

"Well, CBS-Hytron's Plan helps me sell TV picture tubes and service to many a customer who just doesn't have \$50 cash. Now I make sales I'd lose otherwise. My customer pays for the job painlessly a few dollars a month. Yet I get my cash right away — and can discount my bills with my distributor."



"Fine! How does it work, Sam?"

"Simple. I introduce my customer to the finance company authorized by CBS-Hytron. The finance company does the rest. Acts as my credit department to secure me against losses. Takes care of all the details . . . paper work, collections, etc. My customer gets his tube and I get my cash — at once."



"That's swell, Sam. Now I can see why you always have plenty of working capital."

"That's right. And talk about service! This CBS-Hytron Easy Budget Plan has even brought me immediate cash from old accounts I'd written off as bad debts. CBS-Hytron is perfectly willing, too, that my regular budget loans include my service work and other components besides CBS-Hytron tubes. I owe my CBS-Hytron distributor a vote of thanks for letting me in on this wonderful Plan."



"Fair enough! I've sure been losing sales I shouldn't, Sam. I need the CBS-Hytron Easy Budget Plan. CBS-Hytron tubes are tops, too. Thanks for the tip. I'll see my CBS-Hytron distributor today."

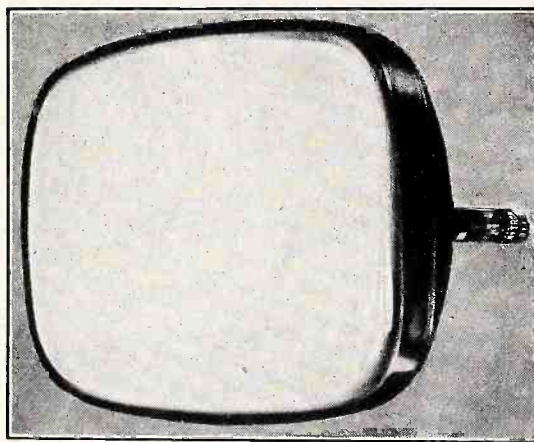

**SAVE THE SALE** No need for you to miss a single profitable picture-tube sale . . . just because your customer does not have the cash. Get the details on this original CBS-Hytron service for you. See your CBS-Hytron jobber . . . or write us . . . today!

ANOTHER HELPFUL SERVICE FOR YOU FROM . . .

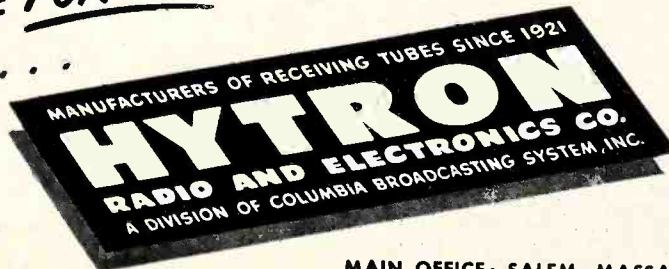

MAIN OFFICE: SALEM, MASSACHUSETTS

Please mention Successful Servicing when answering advertising.



# HOW TO FIX YOUR OWN TELEVISION SET

We know of no better way of indicating the status of home TV service by the set owner than this cartoon by Dowling of the *N. Y. Herald Tribune*. It appeared in the aforementioned newspaper. We think it's terrific!

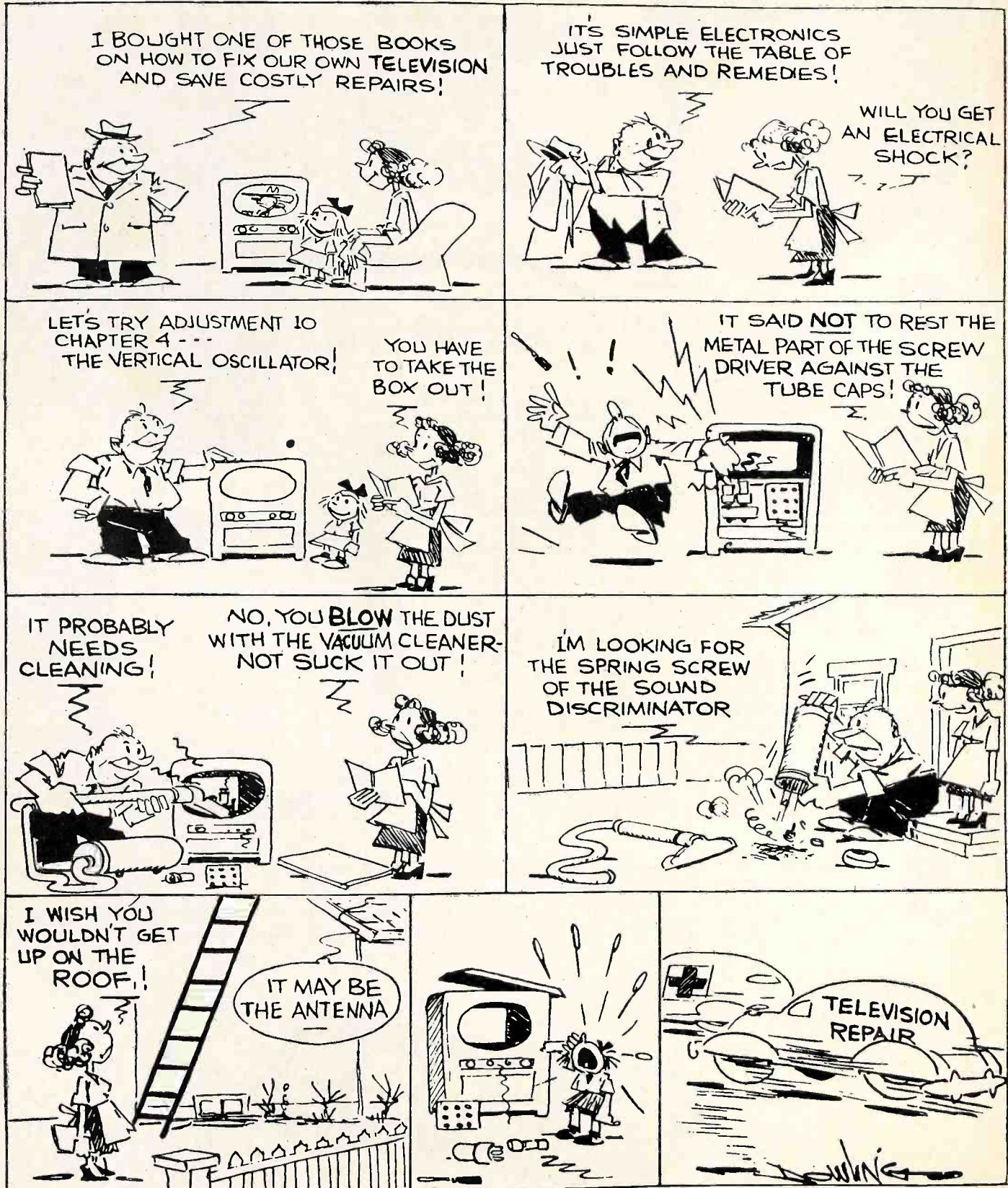





Frank J. Moch says—  
 "there is no other **OSCILLOSCOPE**  
 like the **NEW Simpson MODEL 476**  
**MIRROSCOPE"**

FRANK J. MOCH,  
 president of the  
 National Alliance of Television and  
 Electronics Service Associations.

**Simpson's** new and completely advanced type of oscilloscope—Model 476 **MIRROSCOPE**—is designed to eliminate certain inherent disadvantages found in the conventional type of oscilloscope by use of the "Mirroscope principle." In this kind of construction the 5-inch cathode ray tube is mounted in a vertical position, thus reducing bench space requirements to an area of only 9" x 8" thereby permitting better concentration of associated equipment for any type of test procedure. The cathode ray image is reflected from an optical type front surfaced mirror mounted in the adjustable cover at the top of the cabinet bringing the viewing surface of instrument near eye level when instrument is used on benches of normal height. The mirror angle is quickly and easily adjusted to any position of the operator. The cover with integral side wings forms an effective shield against external light sources or may be closed down for protection of the tube and mirror when the instrument is not in use. The upright construction permits location of controls and connections for maximum convenience and allows for internal cathode ray tube connections at the front of the panel instead of the rear.

**SENSITIVITY:**

Vertical direct.....12 volts rms per in.  
 Vertical amplifier.20 millivolts rms per in.  
 Horizontal direct.....14 volts rms per in.  
 Horizontal amplifier.....38 millivolts rms per in.

**INPUT IMPEDANCE:**

Vertical direct.....10 megohms, 15 mmf.  
 Horizontal direct...10 megohms, 15 mmf.  
 Vertical amplifier.300,000 ohms, 30 mmf.  
 Horizontal amplifier.....500,000 ohms, 15 mmf.

Horizontal trace expansion is over 4 times tube diameter. This makes it possible to examine minute portions of a response pattern for finer detail. Linear Sweep frequency is continuously adjustable in five overlapping ranges from 15 cycles to 60,000 cycles. Internal, external or line frequency synchronization with variable amplitude is available.

Means for intensity or "Z axis" modulation is provided. Approximately 14 volts peak will blank a trace of normal intensity.

The vertical amplifier frequency response is within 3 DB from 20 cycles to over 300,000 cycles and is usable to well over three megacycles. Square wave slant and over-shoot is held to less than 5 per cent of amplitude. This response will be found adequate for all phases of television receiver service including observation and diagnosis of Sync. signals.

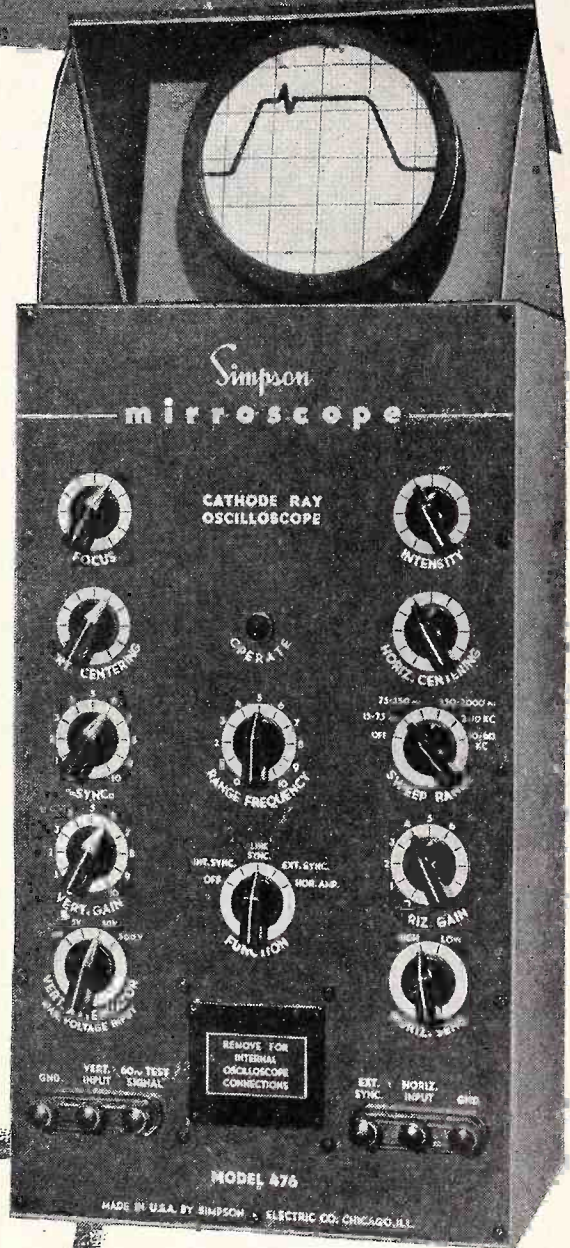

**TUBE COMPLEMENT:**

- SUP4 Cathode Ray Tube.
- 4-6J6 Horizontal and Vertical Amplifiers.
- 1-12AU7 Vertical pre-amplifier.
- 1-6J6 Linear Sweep oscillator and Sync. injector.
- 2-6X4 High voltage rectifiers.

LINE VOLTAGE: 105-125 volts, 50-60 cycles.  
 SIZE: Height 16 1/4"; Width 9 1/8"; Depth 8" over all  
 WEIGHT: 25 lbs.; Shipping weight 30 lbs.  
 High Frequency Crystal Probe... \$7.50  
 DEALERS NET PRICE including operators manual .....\$179.50



**SIMPSON ELECTRIC COMPANY**  
 5200 W. Kinzie St., Chicago 44, Ill.  
 Phone: Columbus 1-1221  
 In Canada:  
 Bach-Simpson Ltd., London, Ontario

BURTON BROWNE ADVERTISING

Please mention Successful Servicing when answering advertising.









A monthly summary of product developments and price changes of radio, electronic, and television parts and equipment, supplied by United Catalog Publishers, Inc., New York City, publishers of RADIO'S MASTER.

These REPORTS will help you to buy and sell to best advantage. They will also help you to keep your inventory up to date. A complete description of most products will be found in the Official Buying Guide, RADIO'S MASTER, available through local parts distributors.

**New Items**

ASTATIC CORP.—Introduced Carbon Hand Microphone Model 10M5 at \$17.70 net.  
 CHANNEL MASTER—Added 14 new models to their line of Television Antennas and Accessories.  
 DUOTONE CO.—36 new Diamond Replacement Needles added.  
 EDITORS & ENGINEERS—"World's Radio Tubes," 9th Edition now available.  
 ELECTRONIC MEASUREMENTS CORP.—Models 205 and 205P Tube Testers and HVP, High Voltage Probe added.  
 ELECTRONIC TRANSFORMER CO.—Added 4 new items to their line of Step-Down Auto Transformers.  
 JENSEN INDUSTRIES—Added 6 new "Jensen" Replacement Needles (Shure Bros.) for Standard, All Purpose and Micro-Groove. Also added Jensen cutting needles No. WG-65, Wilcox Gay (Stellite) cutter playback combination for 78 RPM records . . . and WG-652, Wilcox Gay (Stellite) cutter playback combination for 33-1/3, 45, and 78 RPM records.  
 J F D—Added 2 Indoor Antennas . . . 7 Zoom-up Masts . . . 3 Screw Eye Standoffs #NUT 350-550-750 . . . Screw Eye Standoff Insulators #DNUT 350-550-750 . . . Pre-Amplifying Coupler EC4 and Open Line Wire Lead In OL-100 and OL-250.  
 OXFORD ELECTRIC—Added 16 new items to their line of Loudspeakers.  
 PERMOFLUX—Added 3 new Speakers, #4CM and 45CM to their "Champion" line and 15WP-8-1 to their "Royal" line.  
 PRESTO RECORDING—Added #CS-10 at \$52.00 net to their line of Recording Equipment.  
 RADIART CORP.—Lightning Arrestors TA-5-DP and TA-5WS added at \$.75 and \$.81 net . . . added Yagi 4YG45 for Channels 4 and 5.  
 R. C. A.—21 Electron Tubes and 4 Kinescopes added.  
 RECOTON CORP.—Recoton Replacement Phoneedle Kits #150 and 550 added . . . also 11 "Recoton" Replacement Needles.  
 RIDER, JOHN F.—TEK-FILE Packs 49 thru 56 available at jobbers this month (\$2.00 per pack).  
 SHELDON ELECTRIC—Added TV Tubes 16AP4A and 21KP4A to their Blue Label and White Label series.  
 TELREX INC.—Added 1/4 wave and 1/2 wave Transmission Line Coupler and E-Z Rig "Clover-V-Beam." Also TVB-1 and TVB-2, Telrex "V-Beam" w/Hi-V Reflector, and "Hi-V-Reflector" Adapter added to their line of "Conical-V-Beams."  
 THORDARSON-MEISSNER—23 TV Replacement Coils added.  
 TRIPLETT—Introduced Model 650 at \$69.50 net to their series of Test Equipment.

VACO PRODUCTS—Added Lynn Lightning Solderless Terminals #2600 at \$1.00 net per pack of 50 and #3300 at \$1.00 net per pack of 50.  
 VAN CLEEF—Added line of Dutch Brand Rubber Bonding Cement . . . Dutch Brand Rub'r Shim and Dutch Brand .010 Plastic Electrical Tape.

**Discontinued Items**

AMPHENOL—Withdrew 4 Steatite "CP" Type Plugs 49-245, 255, 265, and 285 . . . also packaged 300 Ohm Twin Lead #184-803 and 184-804.  
 CHANNEL MASTER—Withdrew 7 models from their line of Television Antennas and Accessories.  
 E. F. JOHNSON CO.—Temporarily discontinued 97 items on their line of Radio-Electronics Products.  
 OXFORD ELECTRIC—Withdrew 15 items from their line of Loudspeakers.  
 PERMOFLUX—Withdrew 17 Permoflux Speakers.  
 RAM ELECTRONICS—Withdrew X052 and X055 Horizontal Output Transformers.  
 T-V PRODUCTS CO.—Withdrew MJ-1, Mast Joiner Mount and RM-5, Roof Mount.  
 UTICA DROP FORGE—Tools #43-5", Wire Stripping Diagonal Cutting Pliers . . . 49-5", Plastic Cutting End Nippers . . . 52-7", Side Cutting Pliers . . . 26-7", End Cutting Nippers withdrawn.

**Price Increases**

BEAM INSTRUMENT CO.—Increased prices on Loading Cassettes and Receiving Cassettes in their series of Cossor Oscillographs and Accessories.  
 ELECTRO-VOICE—Increased prices on 24 items on their line of Mikes, Phonograph Pickups and Cartridges.  
 GARRARD SALES CORP.—5 items on their line of Record Playing Equipment increased.  
 KENYON TRANSFORMER—Revised their entire price line up in accordance with CPR 22 Sup. Reg. 17.  
 KESTER SOLDER CO.—Increased prices on 1 lb., 5 lb., and 20 lb., spools of Rosin Core, Acid Core and "Resin-Five" core Solder Spools.  
 PERMOFLUX—Increased prices on Monaural Headsets #DHS-1B, DHS-15B, DHS-17B and DHS-28B.  
 R. C. A.—52 Electron Tubes and 191 Receiving Tubes increased.  
 RAYTHEON—15 Special Purpose tubes increased "due to higher material and manufacturing costs."  
 RIDER, JOHN F.—Increased price on "FM Transmission and Reception" to \$4.95, March 1st. April 1st increases: "TV Installation Techniques" to be \$4.50; "TV and Other Receiving Antennas" to be \$6.60; "Receiving Tube Substitution Guide Book" to be \$3.00.  
 SHELDON ELECTRIC—Increased prices on TV Tubes 19AP4A, 19AP4B and 19AP4D in their Blue Label and White Label series.  
 SYLVANIA—51 Receiving tubes increased in price.  
 WINCHARGER CORP.—Increased price of Roof Mount Towers 15805 to \$8.95 net and 15810 to \$17.90 net.

**Price Decreases**

ELECTRONICS, INC.—Decreased prices on 26 items on their line of Rectifier Tubes and Grid Control Rectifiers (Thyratrons).  
 ELECTRO-VOICE—22 items on their line of Mikes, Phonograph Pickups and Cartridges have been decreased in price.  
 GARRARD SALES CORP.—Decreased prices on #RC80-C and RC80-DC on their line of Record Playing Equipment.  
 G. E.—Two 10" TV Tubes, two 12" TV Tubes and two 16" TV Tubes decreased in price.  
 PERMOFLUX—14 Speakers on their line decreased in price.  
 PHILSON MFG. CO.—Decreased prices on #101, 102 and TWM 4 in their line of antennas.  
 PRECISE DEVELOPMENT CORP. — Reduced #999-R to \$2.80 net on their line of Electronic Test Equipment.  
 R. C. A.—19 Receiving Tubes, 8 Electron Tubes and 13 Kinescopes reduced in price.  
 RECOTON CORP.—Decreased prices on 4 "Recoton" Replacement Needles #305, 6, 7, and 10.

SARKES TARZIAN—Reduced prices approximately 20% on Universal Replacement Tuners TTSR2J and TTSR41.  
 SHELDON ELECTRIC—Decreased prices on 4 TV Picture Tubes in their Blue Label series, and 5 TV Picture Tubes in their White Label series. . . . also price of Microphone Replacement Cart- Cartridge (carbon) #101C and 102C to \$16.50 net . . . also price of Microphone Replacement cart- ridge (carbon) #R10 to \$4.80 net.  
 SOLA ELECTRIC—Added quantity discount for 5 and up on 31 items on their line of Constant Volt- age Transformers.  
 SYLVANIA—Decreased prices on 7 Subminiature Tubes, 7 Radio Receiving Tubes and Special Pur- pose Tubes OD3 and 6X5WGT.  
 TRIO MFG. CO.—Towers 101-A-B and 101-CUC re- duced to \$7.50 net.  
 UTICA DROP FORGE—91 Series of Adjustable Wrenches (7 Wrenches) reduced approximately 5% list.  
 VIBRALOC CORP.—Decreased prices on 8 items on their line of Loudspeaker Baffles.

**Miscellaneous Changes**

SYLVANIA—Announced that 41 TV Tubes are now subject to Dealer Glass Allowance on purchases of new Sylvania TV Tubes.

*Coming in April...*

**RIDER TV MANUAL  
VOLUME 9**

**63,500**

There are 63,500 references to pertinent electronic and allied engineering articles published from 1925 through 1949 in the five editions of the

**ELECTRONIC ENGINEERING  
MASTER INDEX**

1925-1945 edition—	
(15,000 entries).....	\$17.50
1935-1945 edition—	
(10,000 entries).....	\$10.00
1946 edition—	
(7,500 entries).....	\$14.50
1947-1948 edition—	
(18,500 entries).....	\$19.50
1949 edition—	
(12,500 entries).....	\$17.50

Electronics Research Publishing Company, Inc.  
Dept. 55 480 Canal St., New York 13, N. Y.





# C-D's Tiny Mike

—the ceramic with the  
million dollar body!

Never before such uniformity, such dependability in ceramic capacitors! TINY MIKE is C-D through and through. Even the ceramic body is made by C-D, in its brand new ceramic body plant, electronically controlled at every stage!



ONSISTENTLY DEPENDABLE  
**CORNELL-DUBILIER**  
CAPACITORS

Plants in South Plainfield, N. J., New Bedford, Worcester and Cambridge, Mass.; Providence, R. I.; Indianapolis, Indiana; Fuquay Springs, North Carolina, and subsidiary, The Radiart Corporation, Cleveland, Ohio.  
Please mention Successful Servicing when answering advertising.

**RIDER TV TEK-FILE PACKS 1-48**

Now Available At Your Jobber!

(If Not — Call or Write to Us Directly)

## TV versus Radio Repair

(Continued from page 9)

have been released in Rider TEK-FILE PACKS 1-48. Thousands more are coming. Wouldn't it be a horrible waste of time, money and effort to ponder and experiment in an attempt to cure these faults when you run into them in these receivers? All you have to do is to get the proper TEK-FILE or Rider Manual, and these examples of *known art* are ready to serve you. They'll make your whole servicing job easier—they'll make your whole day better.

TEK-FILE HANDIES reflect what the receiver manufacturer has learned about troubles in his receiver. It is the kind of known art which helps the man who is not thoroughly familiar with tv receiver design. It is the kind of known art which saves hours of effort and aggravation. It is the difference between making a TV receiver repair job temporary and troublesome—or making the repair permanent, and a prestige builder.

Make Rider Manuals and TEK-FILES your background, your technical know-how. They'll serve you day after day, month after month, and year after year—and with exactly the same information as the receiver manufacturer uses in his own plant and in the shops of his distributors.

## Association News

(Continued from page 22)

their "retail" service calls over to ARTSD members with good results.

On its second anniversary, the *Radio and TV Technicians Guild of Florida* was unanimously accepted into the NETDSA this month.

NETSDA itself, at its regular monthly meeting in Harrisburg, acted upon the matter of its own incorporation, moving to make an application as a non-profit corporation with the State of N. Y. National Headquarters of the association have been moved from Washington to New York City. At the annual election of officers, Max Liebowitz was re-elected president and Roger Haines V.P. At an earlier meeting, in Philadelphia, a report was made on the progress of Radio-TV Licensing in New York City and the State of Pennsylvania.

Have you written your Congressmen expressing your opposition to House Bill #HR 6219? This bill would require all electrical appliance manufacturers to include a repair booklet with each sale of a radio or tv set. Such a bill would license all set owners to attempt to repair their own receivers; it would endanger set value by causing the general public to attempt repair without qualification; it would cause untold loss to dealers selling sets on time to tampering customers. For the set owner, radio and TV receivers are conveniences to be enjoyed, not jig-saw puzzles to be played with.

Sec. 34.66, P. L. & H.  
U. S. POSTAGE  
**PAID**  
NEW YORK, N. Y.  
PERMIT NO. 9427

JOHN L. GIGL  
437 NEVIN ST.  
LANCASTER, PENN.

From  
JOHN F. RIDER PUBLISHER, Inc.  
480 CANAL ST., NEW YORK 13, N. Y.  
Forwarding and Return Postage Guaranteed



# SUCCESSFUL

# Serviceing

APRIL 1952

## TROUBLESHOOTING TV RECEIVERS\*

### with Special 'Scope Probes

by R. G. (Bob) Middleton

#### Types of Probes

The value of oscilloscope probes, long recognized in the laboratory, has begun to impress itself upon the service field. Many service technicians are extending the field of application of their scopes by means of suitable probes. Some of these probes are as follows:

1. The *low-capacitance probe*, otherwise known as the high-impedance or the attenuating probe, makes possible effective testing in high-impedance circuits without disturbing circuit operation. For example, such a probe make possible various tests in sync circuits without throwing the receiver out of sync during tests.

2. The *demodulator probe*, otherwise known as a crystal or signal-tracing probe, makes possible effective testing in high-frequency circuits which would otherwise be closed to a service scope. For example, a demodulator probe can be used to localize a weak or dead i-f stage immediately, by applying a modulated signal to the receiver, and tracing stage-by-stage with the probe.

3. The *capacitance-divider probe*, otherwise known as the high-voltage probe, makes possible waveform tests in high-voltage sections of the receiver, such as the plate of the hori-

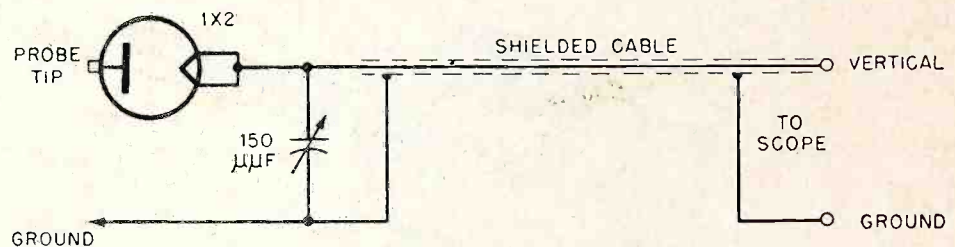

Fig. 1. Typical voltage-doubler crystal probe.

zontal-output tube and the plate of the h-v rectifier tube.

4. The *tuned signal-tracing probe* makes possible the exclusion of one signal during the display of another, such as the removal of a picture signal during the inspection of the sound signal in tracing a buzz pulse through the video amplifier or through the picture i-f amplifier. These probes are further divided into the inductively-coupled and the capacitively-coupled types.

5. The *voltage-doubler probe*, which is a type of crystal probe that permits double deflection on a scope screen for a given input voltage.

*Voltage-doubler Probe.* In Fig. 1 is shown the circuit diagram of a voltage-doubler crystal probe. This is perhaps the most useful general-purpose probe. Construction is straightforward, provided usual consideration

is given to high-frequency factors, such as the use of short leads, carbon resistors, suitable capacitors, and minimizing of stray capacitance in mounting the components in the probe case. Since the input impedance of this probe is low, it has a tendency to load down the circuits to which it is applied. A great advantage of this probe is that it produces twice the scope deflection that would be produced by a simple crystal probe using a single crystal diode.

*Demodulator Probe.* The demodulator probe shown in Fig. 2 is closely related to the voltage-doubler probe. It has certain advantages however. The input impedance is higher, and this probe will not load down the test circuit to as great an extent. The frequency response is somewhat better, and if careful construction is employed, this probe will be flat

(Continued on page 7)

\*This is Part I of a two-part article by Bob Middleton, Senior Engineer at Precision Apparatus Co., Inc.



Fast . . . easy replacement for any set



# MALLORY MIDGETROL®

Dual Concentric Volume Controls

## DO THE JOB WITH SMALL STOCKS

- You can match 10,000 combinations of resistance values, taps and tapers with a minimum inventory of Mallory Dual Concentrics.
- Assembly involves just five simple steps. Takes less than five minutes. You need no special tools . . . do no soldering.
- Front and rear sections are factory-assembled and inspected.
- Instant AC switch attachment without control disassembly.

## PERFORMANCE THAT PAYS OFF

- Longer-lasting resistance elements even in extremes of temperature and humidity.
- Better and more accurate taper curves resulting from precision processing methods.
- No pigtail connections to break—thanks to Mallory's exclusive sliding contact that gives EXTRA quiet operation.
- Minimum wobble with Mallory exclusive two-point shaft suspension.

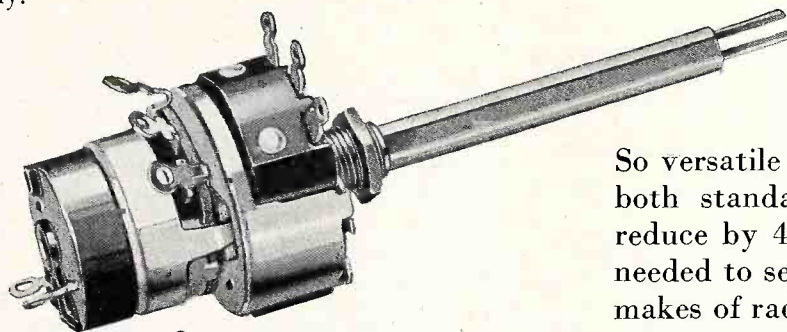

So versatile are Mallory Midgetrols—both standard and dual—that they reduce by 40% the cost of inventory needed to service the 10 most popular makes of radio and TV sets.

**Make Sure!  
Make it Mallory!**

Shown here is the Mallory Dual Concentric Midgetrol with a wire wound front section, available for such uses as TV focus controls. The Mallory Midgetrol line, in addition to dual concentrics, includes round shaft, standard controls with the advantages of stable, two-point shaft suspension, instant AC switch attachment, ready adaptability to split-knurl and flatted type knobs.

P. R. MALLORY & CO. Inc.  
**MALLORY**

CAPACITORS • CONTROLS • VIBRATORS • SWITCHES • RESISTORS  
• RECTIFIERS • VIBRAPACK\* POWER SUPPLIES • FILTERS

\*Reg. U. S. Pat. Off.

**APPROVED PRECISION PRODUCTS**

**P. R. MALLORY & CO., Inc., INDIANAPOLIS 6, INDIANA**

Please mention Successful Servicing when answering advertising.



# deflection yokes

## their use, application and replacement

by albert friedman  
victor markosian

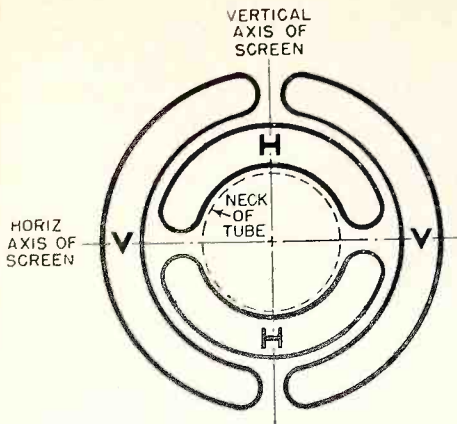

Figure 1

This is the second in a series of articles by Albert Friedman and Victor Markosian of Ram Electronics.

Almost all cathode-ray tubes in tv receivers are swept by magnetic deflection of the electron beam both horizontally and vertically. This is the function of the deflection yoke. It is a single part which contains the horizontal deflection coil and the vertical deflection coil. As a unit it is positioned on the CR tube at a point just behind the flare; usually as far forward on the neck as it can go. The magnetic fields, both horizontal and vertical, are passed at right angles through the neck of the tube. In order to cause the electron beam to sweep across the face of the picture tube, then return almost instantly to the starting point, and to repeat this process a sawtooth wave of current is passed through the two sets of deflection coils. By virtue of the frequency of the horizontal sawtooth current (15.750 cps), the beam moves horizontally from one edge of the CR tube to the other in a period of 53.3 microseconds. In the vertical direction the frequency is 60 cps and the forward sweep time is about 16,000 microseconds. A quick return of the beam to the original starting point is desired in both cases. Distributed capacitance and leakage resistance in the associated circuits make this impossible. The time allowed for the horizontal retrace is 10.2 microseconds. This period being very low, it is desirable to keep the distributed capacitance and leakage reactance of the horizontal deflection coils within specific limits. This is accomplished, in part, by properly designing the horizontal deflection coils and also by such physical construction that it is as close as possible to the electron beam, that is, hugging the neck of the picture tube.

The retrace time for the vertical sweep is 400 microseconds. This large allowance for the forward trace and retrace time in the vertical deflection coils permits considerably more design leeway. Relatively high distributed capacitance and leakage reactance can be tolerated in this circuit. Since the design of the vertical deflection coils is less critical they can be placed further away from the electron beam than the horizontal deflection coils. Therefore, in a deflection yoke, the horizontal coil is assembled with the vertical

coils mounted on the horizontal coils. An end view is shown in fig. 1.

ment part. Finally that the "high" and "low" sides of the windings are properly coded.

### Location of Yoke on Tube Neck

In order to obtain vertical deflection, the vertical deflection coils must be positioned horizontally, and therefore are located on the sides, rather than above and below the tube neck. Similarly for horizontal deflection of the electron beam the horizontal deflection coils are located above and below the neck of the tube.

### Center of Deflection

A very important consideration in the deflection yoke design is the exact center of the deflecting field developed between the coils of each pair relative to the beam in the picture tube. If the center is placed nearer to the flange of the picture tube, the beam can be made to oversweep the edges of the face of the tube as illustrated in fig. 2. If the center

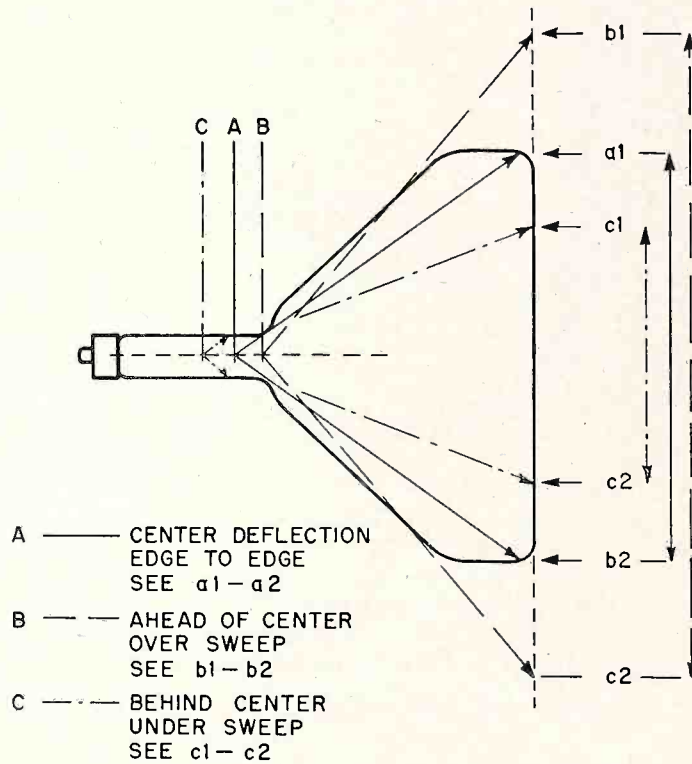

Figure 2

### Direction of Deflection

The direction of deflection of the electron beam is dependent on the polarity of the field which is induced by the deflection coils. Therefore, if this polarity is reversed, the direction of the electron beam is reversed. Reversal of polarity must be avoided, which means that care must be exercised by the service technician when he connects a new yoke in place. It also is a responsibility of the part manufacturer to make certain that the proper direction of winding is maintained in the replace-

of the deflection field of the yoke is in exact position with relation to the electron stream in the tube, edge to edge sweep across the picture tube screen will result. However, if the field center is too far behind the flange, the beam will be deflected by the glass edge of the tube flange and full sweep will not be obtained. This too is shown in fig. 2. How well the yoke manufacturer accomplishes his design is a function of knowledge and care in manufacture. The shadow or lack of bright-



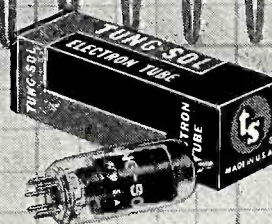
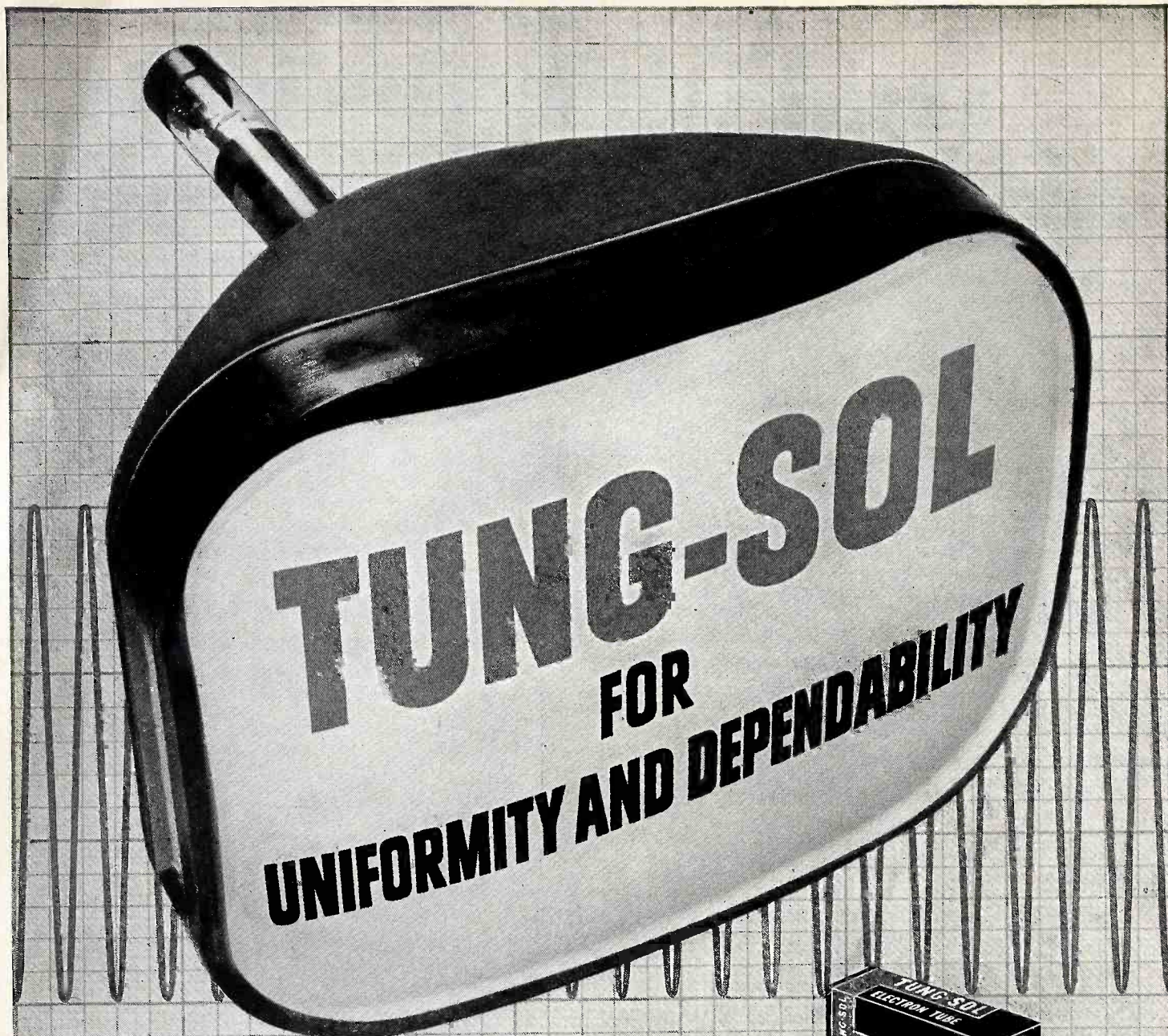

**REPLACEMENT:**

Tung-Sol Tubes keep service standards up to set manufacturers' specifications.

**INITIAL EQUIPMENT:**

Tung-Sol Tubes meet the highest performance requirements of set manufacturers.

TUNG-SOL ELECTRIC INC., Newark 4, N.J. Sales Offices: Atlanta  
Chicago · Dallas · Denver · Detroit · Los Angeles · Newark

**TUNG-SOL**  
RADIO, TV TUBES, DIAL LAMPS



# Successful SERVICING

REG. U.S. PAT. OFF.

Dedicated to the financial and technical advancement of electronic maintenance personnel

Volume 13 Number 6

April, 1952

JOHN F. RIDER, *Publisher*  
Annette M. Tricarico, *Editor*

*Advertising Representative*  
H. J. Olso & Co.  
3951 Grand Central Terminal  
New York 17, N. Y.  
Murray Hill 6-4670



MEMBER



## Curtain Time

### Rebuilt Picture Tubes

The "rebuilt" picture tube business is growing. The rebuilders are hungry for glass; they are offering all sorts of premiums to receiver manufacturers in the attempt to secure old and useless picture tubes. As for us, we know that the set manufacturers are not falling for the gimmick. The standard sources of picture tubes are feeling the pressure of the rebuilders in the replacement market. Being a free enterprise system nothing can be done to prevent individuals from going into the picture tube rebuilding business.

But there is another side to the "rebuilding" program. That is the quality of the "rebuilt" tubes and the sale of rebuilds. If a rebuilder makes an effort to do a good job and has the required equipment he can produce a tube which will be backed by a proper guarantee. And when that tube is sold to a customer, it will perform satisfactorily. But how about the rebuilt tube which uses the original gun; the original, and well-worn screen phosphor, and to cap it all, a new tube neck which is bumpy and will not properly accept a yoke?

It is said that merchandise is sold on the basis of "caveat emptor," which simply means, let the buyer beware. But how wary can an uninformed buyer be. In this connection we are not speaking about the service man — we have the public in mind. Many people are getting rebuilt tubes and do not know it, at least the tubes are not so identified to the receiver owners who are buying them as replacements from service facilities. This is not a blanket indictment of all rebuilt tubes, for as we said before, a so-called rebuilt job can be the equivalent of a brand new one, as for example when it contains a new screen and a new gun. On the other hand many rebuilt tubes are not what they are said to be; many of them fail within a very

short period — a month or so after installation. Those with the old screens and old guns never should be sold. To make matters worse some rebuilders leave the original tube manufacturer's name on the blank. When the public gets one of these tubes, they are under the impression that it is a new one and of reputable manufacture.

Now can the sale of inferior rebuilds be stopped? . . . It is in the hands of the servicing industry. It is the intermediary between the rebuilders and the public. The servicing industry is screaming about unfair press. It has a right to do this, because much of it is undeserved. But what is the good element in the industry doing about preventing the sale of rebuilt picture tubes, as new picture tubes for replacement, by the bad element?

The servicing industry does not want regimentation by outside authorities — municipal or state. To fend off such actions it must always be on the alert to keep its own house clean. If it sells a rebuilt tube, it should be known to the public. . . . The tube should be identified in that manner. . . . In fact it is entirely proper for all authorities, city and state to enact regulations which demand by law that anything which is rebuilt be identified in that fashion. That is the second way in which the sale of inferior products to the unwary public can be stopped.

Isn't it high time that the regular picture tube manufacturers did something about having regulations enacted concerning the identification of rebuilt picture tubes? As far as we know such laws exist in many states concerning rebuilt furniture, pianos, vacuum cleaners and numerous other items bought by the public. They should cover television picture tubes, also!

### The Fringe Area TV Technician

Hats off to the fringe area tv service technician. He has a much tougher job than the guy in the big city. It's always more difficult to satisfy the tv set owner when the signal level is low than when it is substantial. The antenna problem also is more acute. It is positively fascinating to look at the tv antenna skyline in a fringe tv area. It looks like the redwood forest in California. Almost every house or yard or back lawn supports a tower which may be from 40 to 100 feet high. These are construction jobs which do not as a rule face the big city technician. In addition to being a tv technician he also must be a rigger.

The criticalness of tv service in a fringe area is another feature of these operations. There is little room for neglect or carelessness. Not only because many receivers operate with little sensitivity to spare, but also because a man's reputation can go down so darn fast. All his neighbors know him; more than likely they even knew his grandfather. When you live under conditions such as these, a job must be done well. There are no transients around the next block for new customers. Lip service can increase trade — but it can decrease it much faster. With that kind of a sword hanging over a fellow's neck, hats off to the tv technician in the fringe area.

### About Rider Tek-File

Many service technicians have wanted Rider Manuals for a long time, but were not in a position to plunk down the cost of the manual all at once — or they specialized in certain brands only. Well, we have Tek-File as the answer. It's the same data as appears in Rider Manuals. . . . It is not abridged in any way. . . . It is official set manufacturer's information. . . . Some parts jobbers, however, do not carry the line. . . . If this happens to be the case, when you want a Rider Tek-File, don't be sold a substitute. Insist on Tek-File! If your jobber does not have the Rider Tek-File you want, don't buy something else. Write to me and I'll see to it that it's sent to you the day your order arrives. Thanks for your support by buying our products.

*John F. Rider*



# It's Here!

# TV9

The latest Rider Television manual designed to make your TV servicing easy. Large, easy-to-follow schematics — lots of photos — troubleshooting test patterns — waveforms — complete factory parts lists — enlarged chassis views — circuit changes — everything you need to do a fast, easy and thorough servicing job!

With a Rider TV Manual you eliminate call-backs and repairs are positive and final . . . because for each set you service, Rider provides you with all the factory-issued data direct from the manufacturer. No one knows his receiver better than the manufacturer who made it. Nothing cut — nothing edited . . . everything is organized and indexed for speed and accuracy.

Rider's TV9 contains more than 2,000 pages (8½ x 11") covering new models .....\$24.

**BUY IT AT YOUR JOBBER'S**

*Note: A complete Rider TV manual and radio manual shelf is the solution for all your servicing problems. They make servicing easy! Get these vital editions at your jobber's . . . today.*



# JOHN F. RIDER

PUBLISHER, INC.  
480 Canal St., N. Y. 13, N. Y.





# TROUBLESHOOTING TV RECEIVERS

## with Special 'Scope Probes

(Continued from page 1)

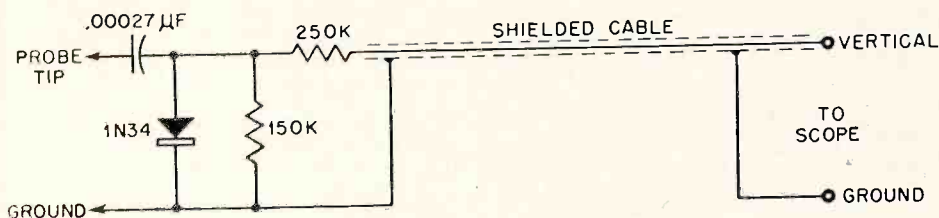
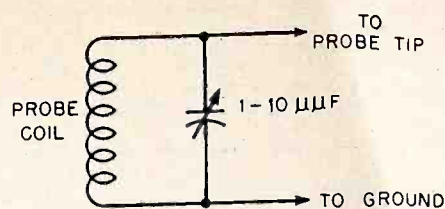
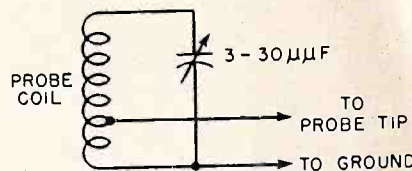

Fig. 2. Crystal signal-tracing (demodulator) probe.



(A)



9 TURNS ON 1/2" FORM.  
TAPPED AT 3 TURNS  
NO 18 WIRE, CLOSE WOUND

(B)

Fig. 3 A, B. Tuned heads used with crystal probe for buzz tracing.

to about 100 mc. The time constant is adjusted to pass a good 60-cycle square wave. This is essential when the probe is used to demodulate a 0-4.5 mc sweep-generator signal that is utilized in adjusting a video amplifier.

**Tuned Signal-tracing Probes.** When either of the crystal probes shown previously are used in conjunction with a tuned head, then a tuned signal-tracing probe results. Both tuned heads shown in Fig. 3 are used for the tracing of buzz pulses in intercarrier to receivers.

The probe coil shown in part A may be a peaking coil similar to those used in the receiver being traced. The tuned circuit is resonated at 4.5 mc so that it will respond to the a-f modulation on the 4.5 mc (inter-carrier) but not to the video information. The probe coil is held close to one of the peaking coils in the video amplifier so that energy is picked up by induction. The circuit shown in part B is used in the i-f amplifiers of the receiver. The circuit is resonated to the sound i.f. of the particular receiver being traced. The probe coil is held close to one of the i-f coils in the receiver so that energy is picked up by induction. Both tuned heads are used to eliminate the video information which would mask the buzz waveform. In the event that the i-f coils are shielded so that inductive coupling cannot be used, a small capacitor (1-10 μμf) can be connected between the top of the probe coil and the proper i-f tube pin. This provides capacitive coupling to the tuned head.

**Low-capacitance Probe.** In Fig. 4 is shown a 10-to-1 low-capacitance high-impedance probe. The required values of resistors are indicated in the diagram. This probe raises the input impedance of the cable by a factor of ten and attenuates the a-c input signal by a factor of ten. The probe also attenuates any d-c component which may be present, and thereby reduces the d-c voltage stress across the series blocking capacitor in the input circuit of the scope.

The 10-to-1 low-capacitance probe requires compensation before use. This compensation is best accomplished with a square-wave gen-

erator. If such a generator is available, connect it to the probe and adjust the trimmer capacitor for optimum square-wave reproduction at 20 cycles per second, and also at 20,000 cycles per second. A satisfactory compromise adjustment can usually be effected.

In case a square-wave generator is not available, a tv receiver which is known to be in good adjustment can be used instead. Apply the probe to the grid terminal of the picture tube, and display the composite video signal on the screen of the scope. The trimmer capacitor can then be adjusted by observing the relative heights of the equalizing pulses and of the vertical sync pulses. The proper adjustment is made when the tops of the equalizing pulses line up at the same level as the tops of the vertical sync pulses. As an independent check, the scope sweep can be speeded up to the picture-line rate (15,750 cps), and the horizontal sync pulse observed for rounding and tilt.

**High-voltage Capacitive-divider Probe.** Fig. 5 illustrates a high-voltage capacitive-divider probe. The 1X2 tube is not used as a rectifier, but as an inexpensive high-voltage capaci-

tor with a value of about 1 μμf. The capacitance of the tube is connected in series with the input capacitance of the scope plus the cable capacitance. Precise 100-to-1 attenuation is obtained by adjustment of the trimmer capacitor shown in conjunction with a previously calibrated attenuator. A method of doing this is given below with a scope having a 100 to 1 attenuator.

Connect the scope by means of a direct cable to a low-impedance circuit of the tv receiver. Turn the coarse attenuator of the scope to its lowest-sensitivity position (100 to 1 attenuation), and note the vertical deflection obtained on the scope screen. Next, plug in the 100-to-1 probe and advance the coarse attenuator of the scope to a position 100 times as sensitive (1 to 1 attenuation). Finally, adjust the trimmer capacitor of the

(Continued on page 19)

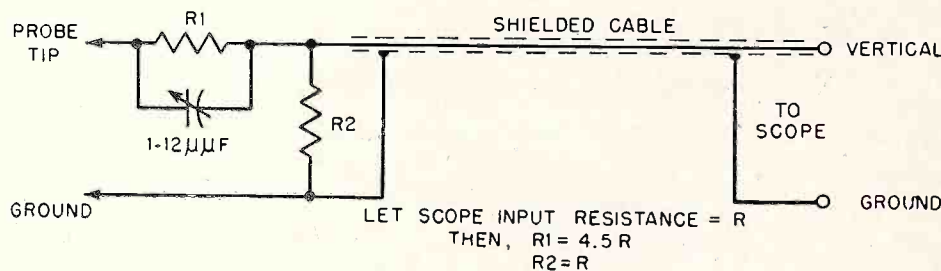

Fig. 4. Low-capacitance 10-to-1 attenuator probe.

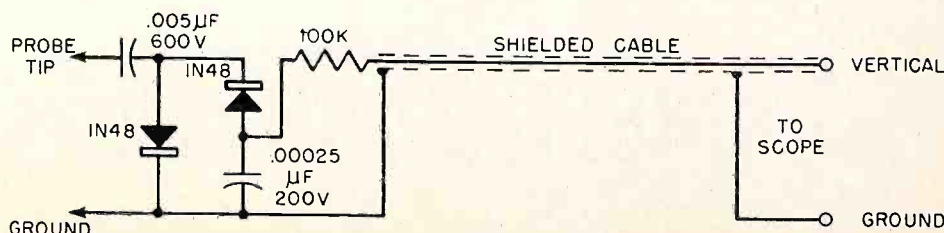

Fig. 5. High-voltage capacitive-divider probe.



## ASSOCIATION NEWS

In a meeting of the Memphis Appliance Dealers Association, Mort Farr, President of the *National Appliance and Radio-TV Dealers Association*, made a plea for hardhitting, intensive, clean selling by established appliance and tv dealers to combat the series of rackets and fact-distorting advertising that have arisen in the field. In his talk he said, "We're getting discredited and our profession is becoming insulted by promoters who advertise . . . television service at \$1 a call."

At a later talk before the *Canadian Association of Radio and Appliance Dealers* in Toronto, Farr said that Canadian retailers should take steps to master tv and be its master from the start. He traced the history of tv merchandising in the U. S. and outlined a program for Canadian dealers to profit by U. S. experience.

In Chicago, Al Robertson, owner of his own appliance store in Oklahoma City, was featured speaker at the *Annual Edison Electric Institute Meeting* on April 1. He spoke on "As Appliance Dealers See Us," as the E.E.I. Dealer Coordination Committee contribution to the program.

The March meeting of the Chicagoland Chapter of the REPS heard Sam Poncher

speaking on "We Need the REPS." He credited the REPresentatives with a substantial contribution to the growth and accomplishments of his own Newark Electric organization. Activities of the group helped him in maintaining merchandise stocks, maintaining fair discount schedules and obtaining technical information.

The Chicagoland REPS have recently inaugurated a new service for Midwestern Jobbers and Manufacturers by compiling and making available a complete listing of lines and products handled by the Chicago chapter. This service is a continuation of the successful educational and service program of last year.

TISA announces that the Chicagoland area now has approximately 1,100,000 tv and 10,000,000 radio sets. In 1952 at least \$40,000,000 will be spent by owners to maintain these receivers. There is actually a lack of good service operators as there is enough work at legitimate rates for all professional shops. TISA called an open forum on March 26 to discuss mutual problems and means of working together. Topics discussed included: licensing, parts warranties, cut-rate service rackets, "fix-it-yourself" books and derogatory newspaper and magazine articles. The forum was to give TISA a background of its members' regional problems and ideas to take to the FIRST NATIONAL INTRA-INDUSTRY CONFERENCE planned by NATESA for May. TISA's special Fraudulent Practices Committee is also carrying on an intense investigation with cooperation from Better Business Bureaus and the Illinois State Attorney.

The NATESA Bulletin announces that NATESA has sent out over 75 telegrams to manufacturers, Better Business Bureaus, papers, magazines, tv and radio stations, etc. on the problem of phoney "fix-it-yourself" books and advertising. Among those "who have offered positive support" to combat the problem is John Rider. RTMA is in favor of local action to curb these books and advertisements, NATESA favors action on a national level.

Vince Lutz of ATSC of St. Louis and "Rosey" Rosenberg of RSA-Wichita were among those who spoke at the regional meeting of the Television Service Engineers Inc. of Kansas.

The Association of TV Service Companies of Greater St. Louis has announced a grand meeting to be held from May 10-12. A Miss TV will be selected and the Governor has proclaimed a TV week.

The Radio-Television Service Association of Minneapolis has elected new officers: Charles Ecklon, President; John Hemak, Vice President. The new Code of Ethics of this group is expected to reinforce customer confidence.

J. Palmer Murphey, Executive Secretary of the Radio and Television Servicemen of New Jersey, advises that the association is critically watching the N. J. trend toward licensing and can be relied upon to prevent any harmful action to service.



# C-D's Champion PUP

—from a long line of winners!

Just introduced—already rated "best in its class"! It's C-D's PUP, the new and advanced metallized capacitor. *Saves space*—half the size of conventional paper tubulars. *Saves trouble calls*—unique self-healing feature means extra long service life.



Write for Bulletin N142. Dept. R-42  
Cornell-Dubilier Electric Corp.  
South Plainfield, N. J.

CONSISTENTLY DEPENDABLE  
**CORNELL-DUBILIER**  
CAPACITORS

Plants in South Plainfield, N. J., New Bedford, Worcester and Cambridge, Mass.; Providence, R. I.; Indianapolis, Indiana; Fuquay Springs, North Carolina, and subsidiary, The Radiart Corporation, Cleveland, Ohio.  
Please mention *Successful Servicing* when answering advertising.





New CBS-Hytron  
cylindricals  
17LP4 and 21FP4A low-  
voltage electrostatics  
17QP4 and 21EP4A  
electromagnetics

## Facts

# YOU'LL WANT TO KNOW ABOUT NEW CBS-HYTRON Cylindricals

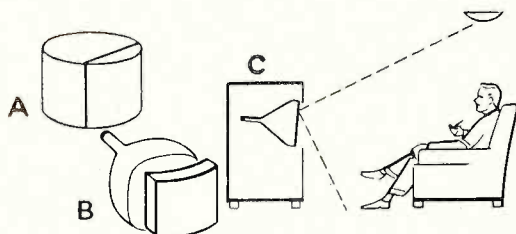

### WHY CBS-HYTRON CYLINDRICAL?

To eliminate reflected glare? How? Simple as ABC: A. Imagine a cylinder; slice it vertically. B. You now have the shape of the face plate of a cylindrical tube: curved horizontally; straight, vertically. C. Light falling on this surface at an angle from above is reflected at the same angle... downward. Tilting the tube directs glare downward even more, away from the viewer's eyes.

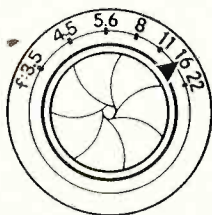

### WHY CBS-HYTRON SHIELDED LENS?

With this shielded lens in the electron gun, greater depth of field and better definition are achieved. Just as when you stop down the diaphragm of a large, fast camera lens (f/3.5) to a small aperture (f/16). Distortion caused by interaction of external electrostatic fields used to focus and accelerate the electron beam is avoided. Focusing is easier, less critical. Slight changes in voltages and currents do not cause drift.



### WHY CBS-HYTRON BLUE-WHITE SCREEN?

Ever notice how a shirt laundered with bluing appears whiter? With the CBS-Hytron blue-white screen, whites appear whiter; blacks, blacker. Picture definition is crisper. In fringe areas, the expanded gray scale of the blue-white screen gives noticeably clearer pictures. No wonder CBS-Hytron's original blue-white screen is fast becoming the standard preferred by consumers for best definition.



MAIN OFFICE: SALEM, MASSACHUSETTS

These are just a few reasons why it's smart to demand CBS-Hytron... original studio-matched rectangulars. Try the new CBS-Hytron cylindricals yourself. Discover for yourself why 9 out of 10 leading set manufacturers pick CBS-Hytron.







## deflection yokes

(Continued from page 3)

ness around the edge of the tube face due to improper location of the center of the deflecting field is commonly referred to as neck shadow.

The replacement of deflection yokes cannot be a happenstance affair. Tv receiver manufacturers are very much concerned with the yoke replacement problem. Receiver performance to the satisfaction of the customer is greatly influenced by it. Therefore, it stands to reason that every tv service technician must make certain that the correct deflection yoke is used, and by correct is meant that it is not a compromise, rather it is intended specifically for operation in the receiver in question. The following are offered for guidance:

1. Picture size is proportional to the amount of sawtooth current flowing through the yoke coils. This simply means that as the amount of horizontal drive is increased the picture width will increase to within the limits permitted the circuit elements. In the vertical circuit, when the height and linearity controls are advanced, the height is increased. Conversely, if the controls are retarded the picture size is reduced. However, if a yoke with incorrect inductance is used for replacement the load impedance reflected back to the driver tube will be incorrect. This will result in low load-current, smaller picture size and *extreme* non-linearity conditions.

2. Deflection is proportional to the length of the deflection coils. In order to attain proper characteristics for the deflection coils it is necessary that proper care, material and construction be used. In early 630 type chassis all of the manufacturers used similar components particularly in the horizontal and vertical deflection circuits. It was then and still is, in some instances, a relatively simple matter to replace one of these components. The development changes which have taken place since the appearance of the 630 chassis appear as more elaborate systems of deflection are employed.

a. Where cost is not too great a governing factor, fairly high B+ voltages are used and components are not pushed to maximum output. In this type of receiver ferrite cores are used on the yokes. These are the shorter sized cores, generally 15/16" long. Neck shadow problems are not usually encountered with this type of design. A longer ferrite core in the replacement will not usually be satisfactory.

b. Moderately priced sets, where costs are reduced with lower B+ supplies, employ yokes with ferrite, flaked iron or powdered iron cores. These cores are up to 1 1/8" in length. Here the greater deflecting ability of the yoke is used for greater horizontal sweep. Replacement of this yoke with one using a shorter ferrite core may effectively reduce width. However, in some receivers, replacement with a yoke having a shorter core is

possible, provided that the choice is a proper one.

c. When B+ voltages are obtained from metallic rectifiers and similar sources, maximum utilization of the horizontal sweep components is necessary to produce the necessary width requirements. The length of the core on the yokes used in these circuits vary from 15/16" to 1 1/4" in length.

Yokes used in these receivers cannot be replaced with ones designed to perform a lesser sweep function. It is necessary to use extreme caution when replacing not only the yoke but the picture tube as well, because both can be critical relative to minimizing neck shadow problems.

3. As the second anode potential is increased, less deflection will occur in a given deflection field. If the anode voltage were doubled, the deflective field current would have to be increased 1.4 times to accomplish the same amount of electron beam deflection. Simple application of this statement means that, when the second anode potential is increased, a yoke which is designed to operate at a lower potential will probably not have enough sweep. When replacing the horizontal output transformer or otherwise boosting the second anode voltage you must bear in mind that the deflection current too must be increased, and a properly matching yoke must be selected if proper width is to be maintained.



Figure 3 and 4.

4. The deflection yoke is one of the most important parts of the electron-optical system of the tv set. An important consideration in replacement is *insulation* design to prevent voltage breakdown. This can occur between windings or from windings to grounded framework. A yoke can be fully insulated against breakdown at room temperature but it can fail at the relatively high operating temperatures reached in operation receivers.

When tv receiver manufacturers order their parts they specify voltage breakdown tests in order to assure themselves of proper operation; also voltage tests at specific temperatures. For example, set manufacturers' specifications for deflection yokes may stipulate:

1. Operation at from 80°C to 90°C and sometimes higher.
2. 3,000 volts insulation between horizontal winding and ground.
3. 3,000 volts insulation between the horizontal and vertical windings.
4. 1,500 - 2,500 volts insulation between vertical winding and ground.

The tv service technician is not expected to make such tests, but he can expect that whatever part is recommended for use in a tv receiver will meet every requirement set by the receiver manufacturer for the original equipment.

Set tv receiver manufacturers also specify inductance values for deflection yoke windings when they purchase parts for their sets. While it is true that each inductance specification bears a tolerance figure expressed in percentage, usually plus or minus 5%, it never is so high as to allow indiscriminate selection of deflection yokes. This dictates that every receiver requires a deflection yoke of a specific electrical design, and when a replacement of a defective yoke is made it should conform with the specification of the required equipment. When such parts are used customer satisfaction is assured; the set manufacturer's product name is enhanced, and the service technician is building a good reputation and a good business.

The balance of this article will be devoted

to a discussion of certain types of conditions which we have photographed or illustrated for greater clarification.

Figure 3 illustrates the result of a replacement yoke wherein the inductance of the horizontal deflection coil exceeded the original equipment specification. Rollover (rolling over of picture) and distortion of width is evident. The mismatch resulted in lower coil currents and linearity can no longer be corrected by waveform adjustment in the linearity coil circuit.

Figure 4 shows a yoke with too low horizontal inductance. In this instance, the effect of stray capacitance and reduced coil currents

(Continued on page 17)



# This Amazing MAGNA-TIP SCREW DRIVER!

*4 Screw Drivers in 1*

*Yours  
FREE!*



...with every 100 Sylvania  
Receiving Tubes or 4 Picture Tubes  
purchased between April 1st and May 15th

"SAVES HOURS  
IN RADIO  
AND TV WORK!"

It's the greatest time-saving tool you ever saw! Just slip the right-sized bit in place and a permanent Alnico magnet charges the bit... holds both your bit and screw in place for fast, easy, one-hand operation.

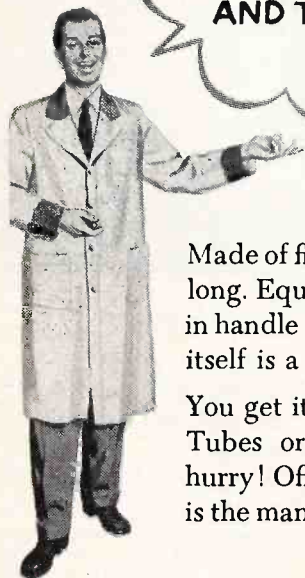

*Lifetime quality*

Made of fine tool steel, this slim-shaft driver is 8½ inches long. Equipped with 2 Phillips and 2 slotted bits, (3 bits in handle compartment and one in shank). And the shank itself is a power driver for ¼-inch hex-head screws.

You get it FREE when you buy 4 Sylvania TV Picture Tubes or 100 Sylvania receiving tubes. But, better hurry! Offer closes May 15th. Your Sylvania Distributor is the man to see... TODAY!

"NEVER LOSES  
ITS MAGNETIC  
GRIP!"



**SYLVANIA**



# TELL-A-FAULT

*the most unique SERVICE  
ever made available to  
TV-radio service technicians*

Every month **TELL-A-FAULT**  
gives you detailed information on:

- TV trouble symptoms as they appear on picture tubes — also fault locations
- Short cuts to easier servicing — trouble isolation and construction of troubleshooting speed-up devices for TV and radio
- Circuit guides showing different kinds of TV receiver circuits
- Explanations of test oscilloscope patterns for each type of circuit found in TV receivers
- How to use test equipment — all kinds by brand names — for TV, radio, and other servicing

**and much, much more**

**TELL-A-FAULT**

**does your troubleshooting for you!**

**READ THE COMPLETE DETAILS**



you'll service  
receivers  
equipment  
and more products  
complete service

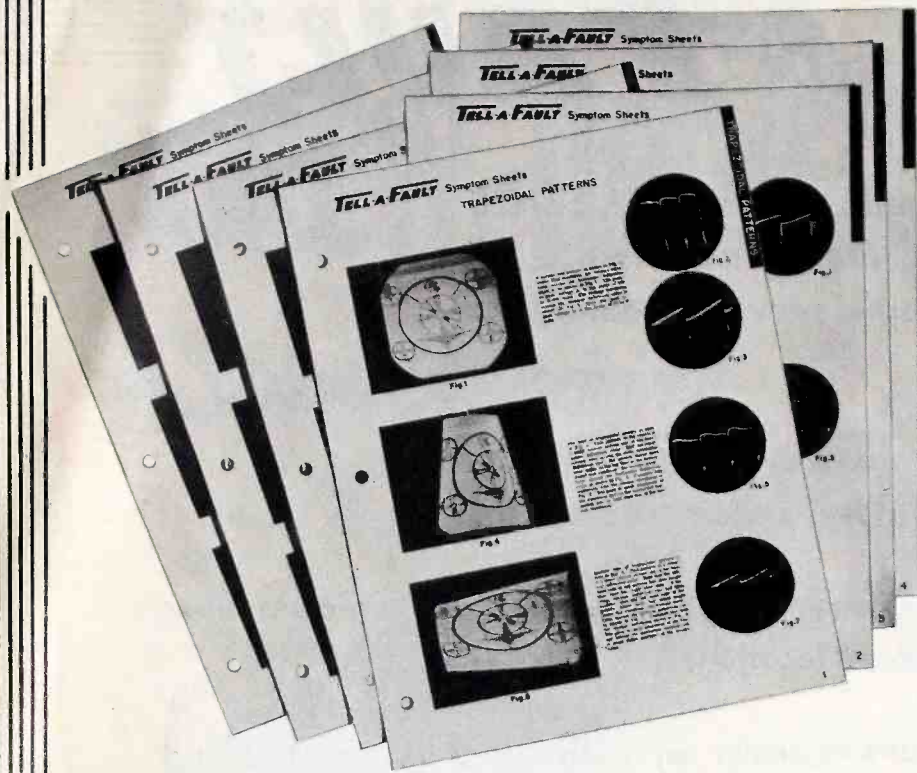

## TELL-A-FAULT SYMPTOM SHEETS

TELL-A-FAULT symptom sheets do your troubleshooting for you! These time-saving, easy-to-use sheets actually catalog receiver symptoms for you. Pictures, pictures, and more pictures — all set up for you to compare with symptoms on picture tube screens and scope screens on your service bench. The Rider service laboratory did the troubleshooting on a wide variety of receivers. The receivers were not hand-picked to bring to light a specific fault. They represent the same receivers *you* service every day in your shop. Every month you will receive between 64 and 96 symptom pictures to make your servicing easier (from 768 to 1,152 pictures per year). They will be presented on handy 8½ x 11" pages, three-hole punched, ready for filing in your binder, which we furnish. They will be correlated with various kinds of circuits used in TV and other receivers. The greatest emphasis is on TV.

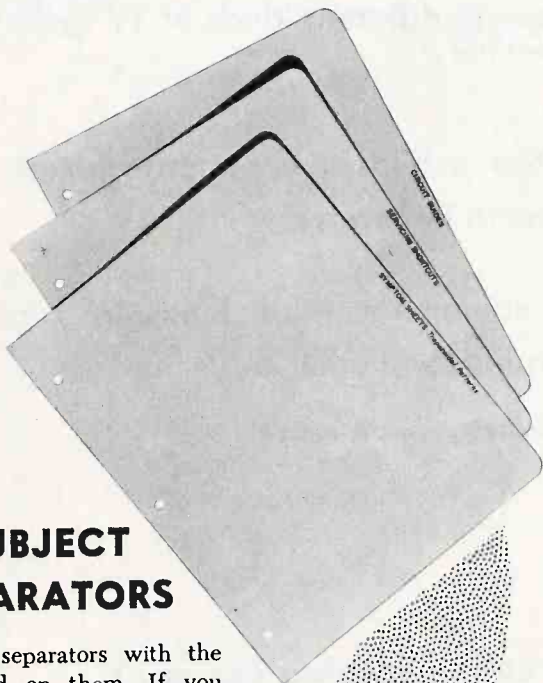

## SUBJECT SEPARATORS

We give you separators with the symptoms printed on them. If you have trouble with buzz, ringing in the picture, vertical jitter, horizontal tearing, low brightness, or any one of the many possible faults, you'll know exactly where to look. Merely lift the 9 x 11" separator, with the symptom listed on it, and the pages that follow contain the information you need. It's as easy as pressing a button to locate the troubles responsible for a symptom, to say nothing of the time you save.



## TELL-A-FAULT BINDER

File all your TELL-A-FAULT information for instant reference in this handsome, simulated-leather, flexible, loose-leaf ring binder. It will accommodate a full year's TELL-A-FAULT troubleshooting data and the other information we send you monthly. You receive this binder with your first month's issue of TELL-A-FAULT troubleshooting data.



# does your troubleshooting for you!

and radio  
of allied  
easily, faster  
ably with this

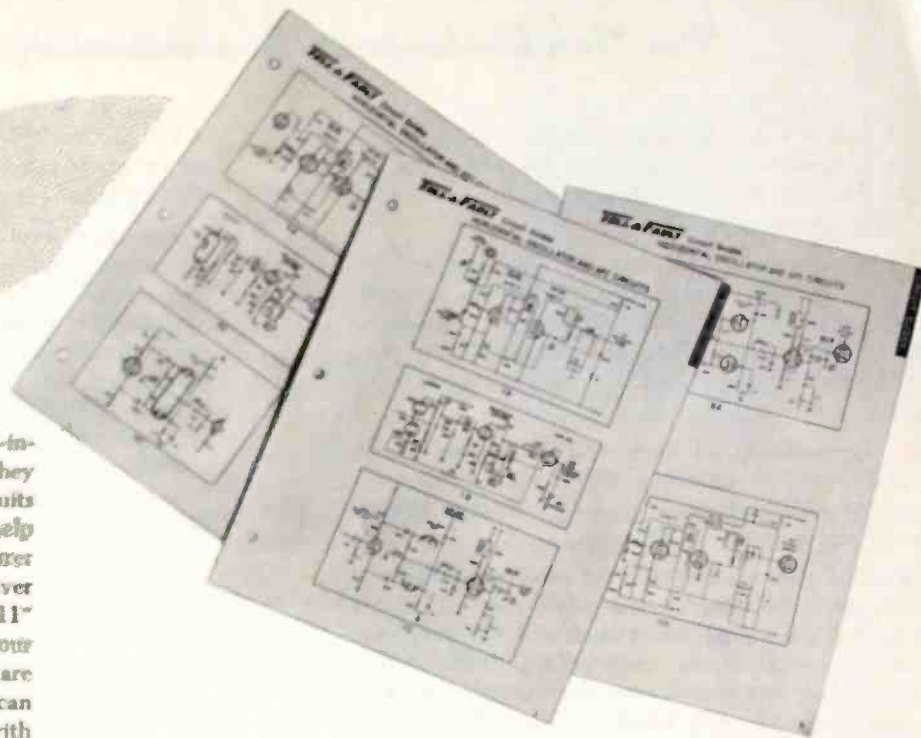

TELL-A-FAULT Circuit Guides work hand-in-hand with TELL-A-FAULT symptom sheets. They are examples of the great many different circuits used in various TV receivers. The circuit guides help you to localize faults. Each time a manufacturer incorporates one or more new circuits in his receiver you will receive a breakdown on them on 8 1/2 x 11" pages to place in the circuit-guide section of your binder. The TELL-A-FAULT symptom sheets are correlated with the circuit guides so that you can immediately identify the symptom and trouble with the particular kind of circuit. TELL-A-FAULT is planned to work with your service data - your Rider Manuals and TEK-FILE, etc. In a matter of seconds you can pinpoint the trouble - especially an obscure one.

## TELL-A-FAULT CIRCUIT GUIDES

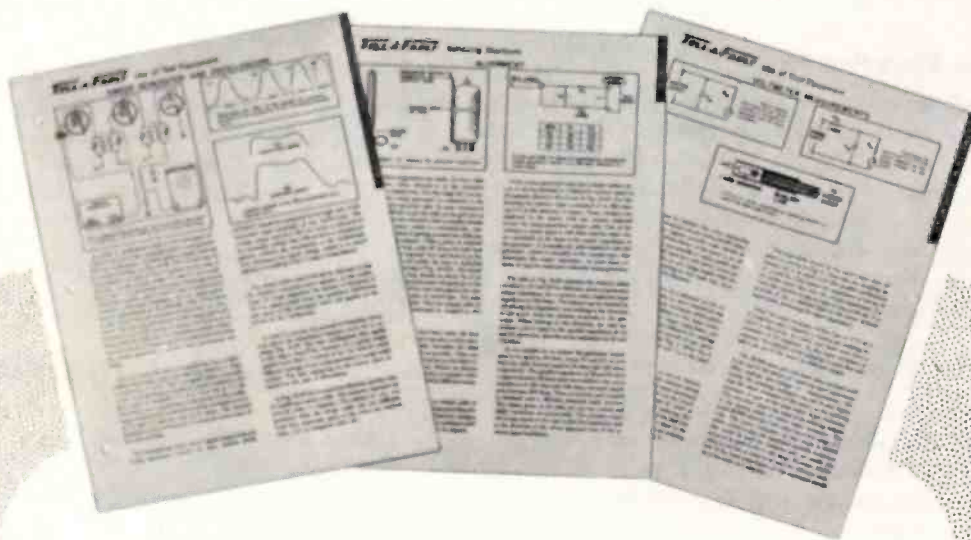

Time is money. The more you save, the greater your income. This section shows you how to save time. For instance, it tells you the fastest techniques for isolating faults, how to make measurements more rapidly, how to construct devices that eliminate wasted time in servicing.

## SERVICING SHORT CUTS and HOW TO USE TEST EQUIPMENT

Since most of your servicing is done with test equipment, TELL-A-FAULT tells you how to use your scope, vtvm, signal generator, etc., to get the most use and value from them. This section alone is worth the price of the entire service! Pages in this section are 8 1/2 x 11".

will save you hours of time! As few as one or two symptom sheets  
can save you enough time to pay for the entire year's cost of **TELL-A-FAULT**



# TELL-A-FAULT

## The Troubleshooter's Troubleshooting Service

TELL-A-FAULT is a completely new troubleshooting service for electronics technicians. Nothing like it has ever been attempted in the servicing industry. *It is practical information for the practical man. No theory!*

In addition to today's TV problems, the lifting of the TV freeze — the contemplated increase in radiated power from TV stations — the approach of UHF — all will combine to make the daily life of the TV service technician more complicated. Let TELL-A-FAULT relieve you of this burden. Let experts work for you!

Specifically, TELL-A-FAULT deals with the troubleshooting (symptoms and cures) of all types of television receivers — also radio receivers, record changers and recorders. Special emphasis, however, is given to television.

TELL-A-FAULT is a quadruple-threat service consisting of (1) time-saving, pictorial, symptom and cure sheets, (2) circuit guides, (3) servicing-technique short cuts, and (4) the usage of all sorts of test equipment. All information is practical. It is developed by working with and on everyday receivers and other equipment, just like those with which you have had trouble.

Working under the same conditions you work under, the Rider service laboratory analyzes receiver symptoms and determines the faults and cures. It is these analyses and cures that are available to you. *You profit by the experience of experts* who are working daily in a service clinic to assist you. This is the reason TELL-A-FAULT will save you hours and many dollars.

### Make Every Hour Pay

From now on you won't have to work many hours diagnosing a fault — and then charge for only an hour or two. You'll have the information in TELL-A-FAULT service. Because the Rider laboratory deals with a wide cross section of TV and radio receivers and allied equipment, in nine cases out of ten your problem will have already been diagnosed. Merely by flipping through the practical, time-saving TELL-A-FAULT symptom sheets, you'll find your problem *and its cure*.

### TELL-A-FAULT Does Not Duplicate

The servicing information in TELL-A-FAULT is available nowhere else. Nor does TELL-A-FAULT duplicate data that has been published in Rider Manuals, TEK-FILE or in other sources. It is copyrighted information that is made available to TELL-A-FAULT subscribers.

### TELL-A-FAULT Pays For Itself

One or two TELL-A-FAULT symptom sheets in one year can save you enough time to pay for the entire year's subscription cost. During the course of a year we mail to you in TELL-A-FAULT service between 768 and 1,152 symptom pictures *plus* the circuit guides, *plus* servicing short cuts, *plus* valuable information on how to use your test equipment. This comes to you monthly.

### Available at Low Cost

Most specialists charge a high fee for consultation. But all findings of the Rider laboratory will be available to you monthly

in TELL-A-FAULT service at an extremely low price in comparison to the value you will receive. Obtain the skilled services of SPECIALISTS at the modest fee of a General Practitioner!

*How much does a subscription cost you?* We estimate that you can save anywhere from 50 to 200 hours in servicing time by using TELL-A-FAULT. A quick computation on your part tells you how much this means to you in dollars. We are certain your estimate comes to many, many times the cost of a year's subscription to TELL-A-FAULT. Twelve months of the *complete* TELL-A-FAULT troubleshooting service, including all features shown, costs you only \$10.00 — less than twenty cents a week! In fact, we're so sure you'll profit every day from using the TELL-A-FAULT service, we want to make the following attractive offer.

### Special One Year Introductory Offer

The regular yearly rate is \$10.00. But if you act now and mail us your subscription by May 20, 1952 . . . we'll send you TELL-A-FAULT for *two additional months*. 14 months in which TELL-A-FAULT does your troubleshooting for you . . . for the price of 12 months. Just fill in and return the coupon you see below with your remittance.

You have the opportunity of becoming a charter subscriber to the TELL-A-FAULT service. In future months you will receive special offers to which *only* TELL-A-FAULT subscribers will be entitled. The first issue of TELL-A-FAULT will be out in June, 1952.

REMEMBER! TELL-A-FAULT pays for itself if you use only one or two symptom sheets during the year. Save time and eliminate guesswork in troubleshooting — use TELL-A-FAULT! The information you use comes from troubleshooting EXPERTS! Whether you have one year's experience or twenty years' experience, TELL-A-FAULT can serve you equally well!

### MAIL THIS COUPON TODAY

John F. Rider Publisher, Inc.  
480 Canal Street  
New York 13, N. Y.

Gentlemen:

TELL-A-FAULT is the direct answer to the service technician's needs. As a service technician it will save me many hours of troubleshooting time. I am enclosing ten dollars (\$10.00) to cover the cost of a one year subscription (14 months mailed before May 20, 1952). Send me my TELL-A-FAULT binder, separate cards, and the first month's issue of symptom sheets, circuit guides, and other information as soon as it is published.

Name.....

Address.....

City.....

Zone.....

State.....

Cash

Check

Money Order



# A SERVICING LAB is announced by

John F. Rider

One of the most serious handicaps from which the alert and enterprising tv and radio technician suffers is his inability, on an individual basis, to afford the laboratory facilities he would like to have. His facilities are restricted to applying information to commonplace situations, and he is severely limited in the case of unique servicing situations and particular pieces of equipment. If, as frequently occurs, this information is not adequate or not geared to his approach as a serviceman, he is not in a position to arrive at a rapid conclusion which will enable him to sell his time profitably.

The best solution to his problem is a servicing clinic, geared to his needs, which acts as a clearing house of information for himself and the tens of thousands of other technicians that share his position. At last, such a central agency exists. The equipment capabilities of the John F. Rider Laboratories have been substantially expanded from what they have been in years past. The most modern testing devices of laboratory character have been procured.

## New Equipment Installed

Outstanding among them is the full complement of Monoscope picture generating equipment — the standard equipment used at tv broadcast stations to generate the test pattern and all synchronizing, blanking, and control pulses. With equipment of this kind it is unnecessary to depend on received tv signals for testing; also it is possible to set up conditions frequently encountered at television broadcasting stations. This enables us to publish pictorial information which allows ready identification of receiver performance while eliminating variables in the transmitted signal.

*Fig. 1. A view of the shielded room containing the Monoscope (Indian Head) picture generator and the monitor. The video signal from the Monoscope generator is distributed to 5 test positions. The different r-f signal generators modulated by the Monoscope signal are located at the test positions.*

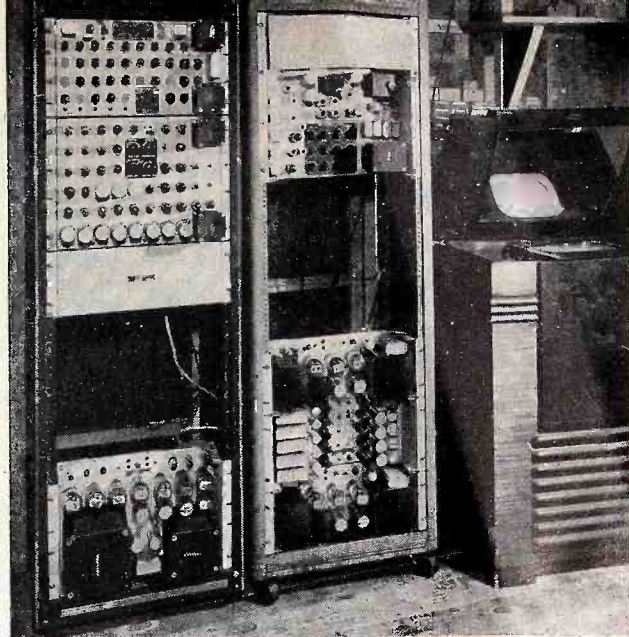

Moreover, and most important, it provides the means whereby the most complete variety of troubleshooting tests can be made on receivers of all kinds. By generating our own picture in the laboratory we can tailor-make the necessary test conditions which will assure users of our information of the greatest accuracy and authenticity.

At the same time, bearing in mind that tv and radio service technicians active in the nation are using commercial test equipment rather than precise laboratory apparatus, we have on hand a great variety of commercial test equipment used by tv and radio service technicians. All service information is developed ultimately through their use. This procedure is not haphazard. It is being followed so that information sold to the servicing industry through our various media, although developed by trained personnel under laboratory-controlled conditions, can be used directly. There is no necessity for translation into practical methods.

Our facilities allow operation on all frequencies from zero (d-c) to 1,500 mc, thus embracing all radio channels, vhf-tv channels and the forthcoming UHF channels. We have signal generators which cover this frequency band, pulse generators, harmonic

analyzers, waveform analyzers, high voltage testing sources up to 35,000 volts, and very many other devices. We are awaiting the arrival of a humidity chamber as well as several other special units. The multitude of problems which will be created by the advent of UHF television, and which will be added to the burdens already being carried by the servicing industry of the nation, were responsible in great measure for the expansion of our present laboratory facilities.

These problems are numerous. Parts replacement and the suitability of suggested substitutions, test equipments and their suitability to servicing needs, troubleshooting techniques as applied to tv, radio receivers and other devices, and the manner in which service test equipment can be put to best use by the service industry, are but a few of the questions of vital concern to the service technicians of the nation. We intend to provide the answers through the media of our laboratory.

The "TELL-A-FAULT" data, described elsewhere in this issue, will originate in the John F. Rider Laboratories, as will information which will make Rider Manuals and TEK-FILES better than they have ever been. In addition, information for forthcoming practical books will also be obtained through our labs. The expansion of our laboratory facilities is the final answer to this goal.

We also foresee the possibility of serving, in a broader way, the entire radio and television industry — the manufacturers of sets, test equipment, and parts, etc. This, however, is a long-range aim; our first and foremost concern continues to be the electronic servicing industry of the nation.

Using this concern as our guide, we expect to consider every type of equipment that comes within the province of the service technician. If his lot is to be made easier, our emphasis must be on maintenance and repair. We aim to make our laboratory a central agency for technical aid at a nominal fee — to make it the kind of organization the servicing industry has never had available before but has needed for a long time.

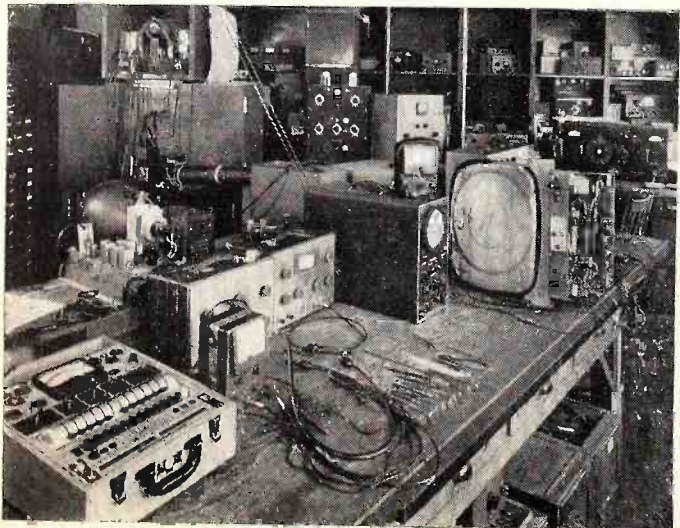

*Fig. 2. A view of the lab showing one of eight vhf test positions. The Indian Head pattern on the tv receiver is a signal from a channel 6 signal generator which receives it modulating signal from the Monoscope picture generator.*



you'll service  
receivers  
equipment  
and more products  
complete service

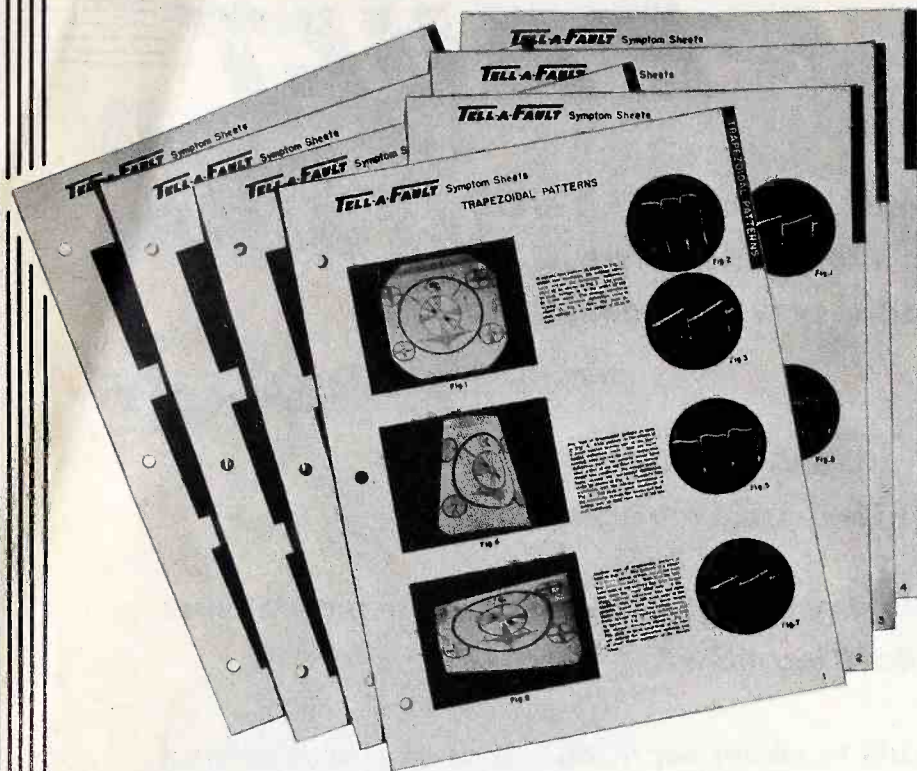

## TELL-A-FAULT SYMPTOM SHEETS

TELL-A-FAULT symptom sheets do your troubleshooting for you! These time-saving, easy-to-use sheets actually catalog receiver symptoms for you. Pictures, pictures, and more pictures — all set up for you to compare with symptoms on picture tube screens and scope screens on your service bench. The Rider service laboratory did the troubleshooting on a wide variety of receivers. The receivers were not hand-picked to bring to light a specific fault. They represent the same receivers *you* service every day in your shop. Every month you will receive between 64 and 96 symptom pictures to make your servicing easier (from 768 to 1,152 pictures per year). They will be presented on handy 8½ x 11" pages, three-hole punched, ready for filing in your binder, which we furnish. They will be correlated with various kinds of circuits used in TV and other receivers. The greatest emphasis is on TV.

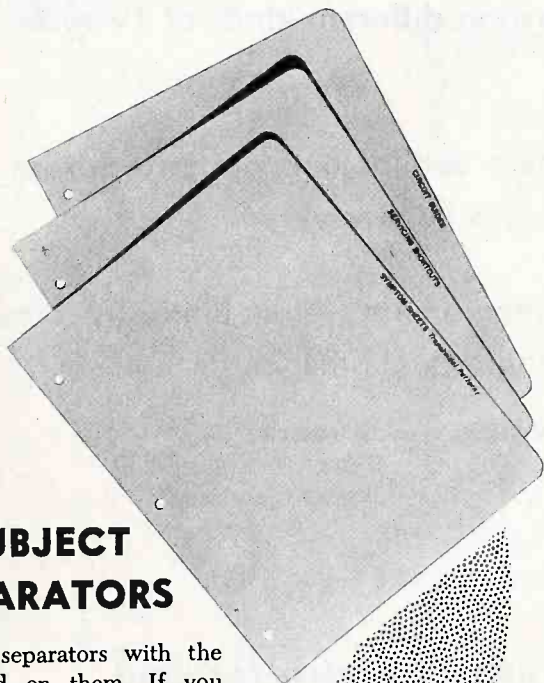

## SUBJECT SEPARATORS

We give you separators with the symptoms printed on them. If you have trouble with buzz, ringing in the picture, vertical jitter, horizontal tearing, low brightness, or any one of the many possible faults, you'll know exactly where to look. Merely lift the 9 x 11" separator, with the symptom listed on it, and the pages that follow contain the information you need. It's as easy as pressing a button to locate the troubles responsible for a symptom, to say nothing of the time you save.

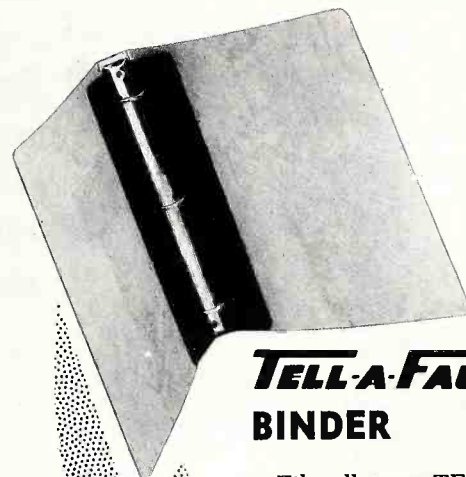

## TELL-A-FAULT BINDER

File all your TELL-A-FAULT information for instant reference in this handsome, simulated-leather, flexible, loose-leaf ring binder. It will accommodate a full year's TELL-A-FAULT troubleshooting data and the other information we send you monthly. You receive this binder with your first month's issue of TELL-A-FAULT troubleshooting data.



# Does your troubleshooting for you!

and radio  
of allied  
easily, faster  
ply with this

TELL-A-FAULT Circuit Guides work hand-in-hand with TELL-A-FAULT symptom sheets. They are examples of the great many different circuits used in various TV receivers. The circuit guides help you to localize faults. Each time a manufacturer incorporates one or more new circuits in his receiver you will receive a breakdown on them on 8½ x 11" pages to place in the circuit-guide section of your binder. The TELL-A-FAULT symptom sheets are correlated with the circuit guides so that you can immediately identify the symptom and trouble with the particular kind of circuit. TELL-A-FAULT is planned to work with your service data — your Rider Manuals and TEK-FILE, etc. In a matter of seconds you can pinpoint the trouble — especially an obscure one.

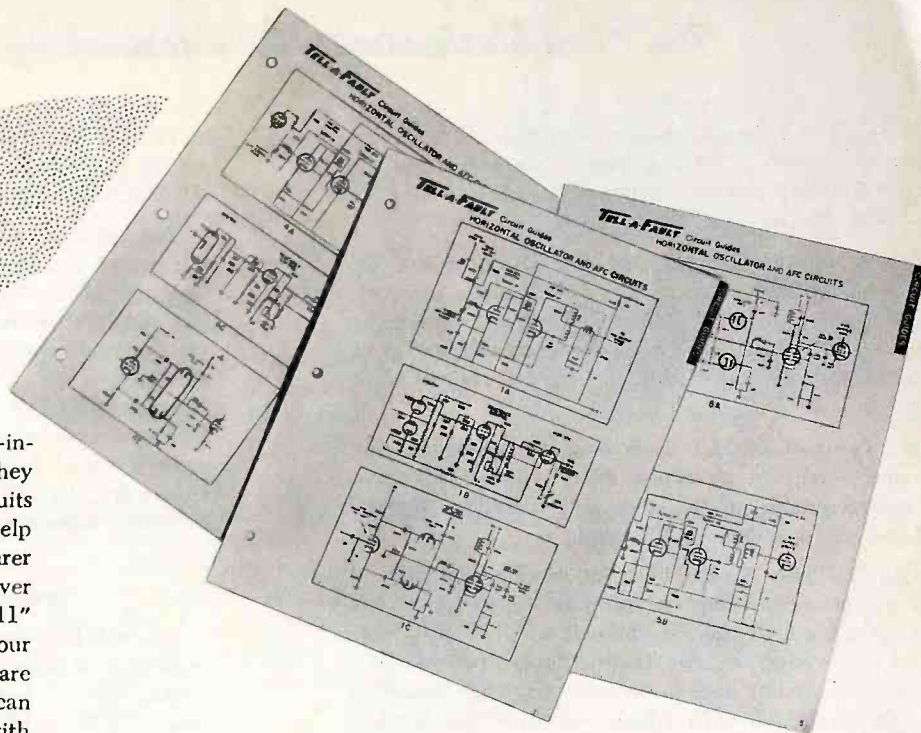

## TELL-A-FAULT CIRCUIT GUIDES

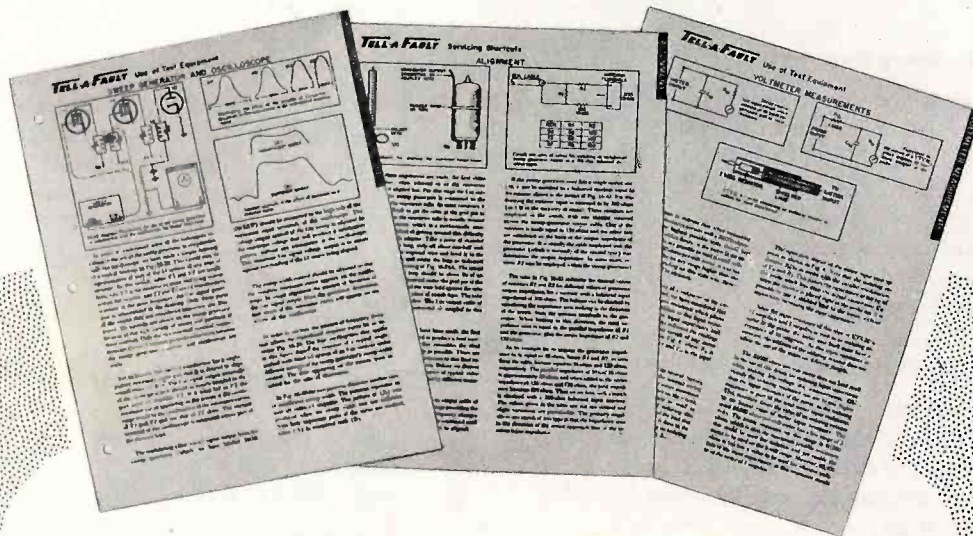

Time is money. The more you save, the greater your income. This section shows you how to save time. For instance, it tells you the fastest techniques for isolating faults, how to make measurements more rapidly, how to construct devices that eliminate wasted time in servicing.

## SERVICING SHORT CUTS and HOW TO USE TEST EQUIPMENT

Since most of your servicing is done with test equipment, TELL-A-FAULT tells you how to use your scope, vtvm, signal generator, etc., to get the most use and value from them. This section alone is worth the price of the entire service! Pages in this section are 8½ x 11".

will save you hours of time! As few as one or two symptom sheets  
can save you enough time to pay for the entire year's cost of **TELL-A-FAULT**



# TELL-A-FAULT

## The Troubleshooter's Troubleshooting Service

TELL-A-FAULT is a completely new troubleshooting service for electronics technicians. Nothing like it has ever been attempted in the servicing industry. *It is practical information for the practical man. No theory!*

In addition to today's TV problems, the lifting of the TV freeze — the contemplated increase in radiated power from TV stations — the approach of UHF — all will combine to make the daily life of the TV service technician more complicated. Let TELL-A-FAULT relieve you of this burden. Let experts work for you!

Specifically, TELL-A-FAULT deals with the troubleshooting (symptoms and cures) of all types of television receivers — also radio receivers, record changers and recorders. Special emphasis, however, is given to television.

TELL-A-FAULT is a quadruple-threat service consisting of (1) time-saving, pictorial, symptom and cure sheets, (2) circuit guides, (3) servicing-technique short cuts, and (4) the usage of all sorts of test equipment. All information is practical. It is developed by working with and on everyday receivers and other equipment, just like those with which you have had trouble.

Working under the same conditions you work under, the Rider service laboratory analyzes receiver symptoms and determines the faults and cures. It is these analyses and cures that are available to you. *You profit by the experience of experts* who are working daily in a service clinic to assist you. This is the reason TELL-A-FAULT will save you hours and many dollars.

### Make Every Hour Pay

From now on you won't have to work many hours diagnosing a fault — and then charge for only an hour or two. You'll have the information in TELL-A-FAULT service. Because the Rider laboratory deals with a wide cross section of TV and radio receivers and allied equipment, in nine cases out of ten your problem will have already been diagnosed. Merely by flipping through the practical, time-saving TELL-A-FAULT symptom sheets, you'll find your problem *and its cure*.

### TELL-A-FAULT Does Not Duplicate

The servicing information in TELL-A-FAULT is available nowhere else. Nor does TELL-A-FAULT duplicate data that has been published in Rider Manuals, TEK-FILE or in other sources. It is copyrighted information that is made available to TELL-A-FAULT subscribers.

### TELL-A-FAULT Pays For Itself

One or two TELL-A-FAULT symptom sheets in one year can save you enough time to pay for the entire year's subscription cost. During the course of a year we mail to you in TELL-A-FAULT service between 768 and 1,152 symptom pictures *plus* the circuit guides, *plus* servicing short cuts, *plus* valuable information on how to use your test equipment. This comes to you monthly.

### Available at Low Cost

Most specialists charge a high fee for consultation. But all findings of the Rider laboratory will be available to you monthly

in TELL-A-FAULT service at an extremely low price in comparison to the value you will receive. Obtain the skilled services of SPECIALISTS at the modest fee of a General Practitioner!

*How much does a subscription cost you?* We estimate that you can save anywhere from 50 to 200 hours in servicing time by using TELL-A-FAULT. A quick computation on your part tells you how much this means to you in dollars. We are certain your estimate comes to many, many times the cost of a year's subscription to TELL-A-FAULT. Twelve months of the *complete* TELL-A-FAULT troubleshooting service, including all features shown, costs you only \$10.00 — less than twenty cents a week! In fact, we're so sure you'll profit every day from using the TELL-A-FAULT service, we want to make the following attractive offer.

### Special One Year Introductory Offer

The regular yearly rate is \$10.00. But if you act now and mail us your subscription by May 20, 1952 . . . we'll send you TELL-A-FAULT for *two additional months*. 14 months in which TELL-A-FAULT does your troubleshooting for you . . . for the price of 12 months. Just fill in and return the coupon you see below with your remittance.

You have the opportunity of becoming a charter subscriber to the TELL-A-FAULT service. In future months you will receive special offers to which *only* TELL-A-FAULT subscribers will be entitled. The first issue of TELL-A-FAULT will be out in June, 1952.

REMEMBER! TELL-A-FAULT pays for itself if you use only one or two symptom sheets during the year. Save time and eliminate guesswork in troubleshooting — use TELL-A-FAULT! The information you use comes from troubleshooting EXPERTS! Whether you have one year's experience or twenty years' experience, TELL-A-FAULT can serve you equally well!

### MAIL THIS COUPON TODAY

John F. Rider Publisher, Inc.  
480 Canal Street  
New York 13, N. Y.

Gentlemen:

TELL-A-FAULT is the direct answer to the service technician's needs. As a service technician it will save me many hours of troubleshooting time. I am enclosing ten dollars (\$10.00) to cover the cost of a one year subscription (14 months mailed before May 20, 1952). Send me my TELL-A-FAULT binder, separate cards, and the first month's issue of symptom sheets, circuit guides, and other information as soon as it is published.

Name.....

Address.....

City..... Zone..... State.....

Cash

Check

Money Order



# A SERVICING LAB is announced by

John F. Rider

One of the most serious handicaps from which the alert and enterprising tv and radio technician suffers is his inability, on an individual basis, to afford the laboratory facilities he would like to have. His facilities are restricted to applying information to commonplace situations, and he is severely limited in the case of unique servicing situations and particular pieces of equipment. If, as frequently occurs, this information is not adequate or not geared to his approach as a serviceman, he is not in a position to arrive at a rapid conclusion which will enable him to sell his time profitably.

The best solution to his problem is a servicing clinic, geared to his needs, which acts as a clearing house of information for himself and the tens of thousands of other technicians that share his position. At last, such a central agency exists. The equipment capabilities of the John F. Rider Laboratories have been substantially expanded from what they have been in years past. The most modern testing devices of laboratory character have been procured.

## New Equipment Installed

Outstanding among them is the full complement of Monoscope picture generating equipment — the standard equipment used at tv broadcast stations to generate the test pattern and all synchronizing, blanking, and control pulses. With equipment of this kind it is unnecessary to depend on received tv signals for testing; also it is possible to set up conditions frequently encountered at television broadcasting stations. This enables us to publish pictorial information which allows ready identification of receiver performance while eliminating variables in the transmitted signal.

*Fig. 1. A view of the shielded room containing the Monoscope (Indian Head) picture generator and the monitor. The video signal from the Monoscope generator is distributed to 5 test positions. The different r-f signal generators modulated by the Monoscope signal are located at the test positions.*

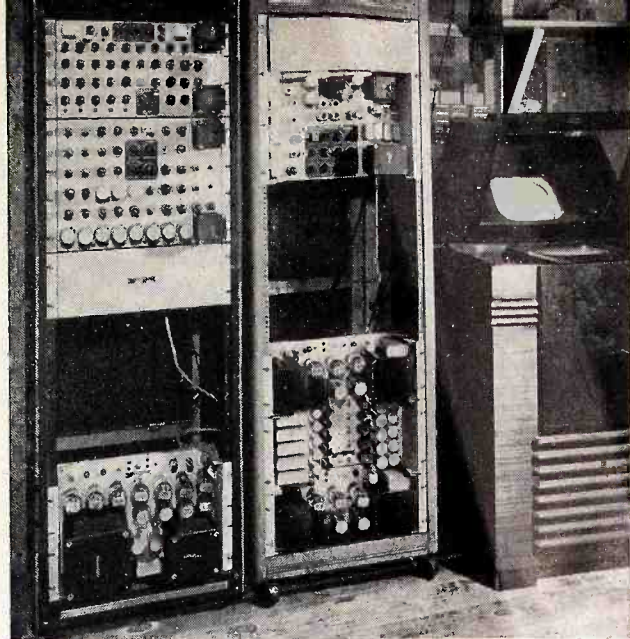

Moreover, and most important, it provides the means whereby the most complete variety of troubleshooting tests can be made on receivers of all kinds. By generating our own picture in the laboratory we can tailor-make the necessary test conditions which will assure users of our information of the greatest accuracy and authenticity.

At the same time, bearing in mind that tv and radio service technicians active in the nation are using commercial test equipment rather than precise laboratory apparatus, we have on hand a great variety of commercial test equipment used by tv and radio service technicians. All service information is developed ultimately through their use. This procedure is not haphazard. It is being followed so that information sold to the servicing industry through our various media, although developed by trained personnel under laboratory-controlled conditions, can be used directly. There is no necessity for translation into practical methods.

Our facilities allow operation on all frequencies from zero (d-c) to 1,500 mc, thus embracing all radio channels, vhf-tv channels and the forthcoming UHF channels. We have signal generators which cover this frequency band, pulse generators, harmonic

analyzers, waveform analyzers, high voltage testing sources up to 35,000 volts, and very many other devices. We are awaiting the arrival of a humidity chamber as well as several other special units. The multitude of problems which will be created by the advent of UHF television, and which will be added to the burdens already being carried by the servicing industry of the nation, were responsible in great measure for the expansion of our present laboratory facilities.

These problems are numerous. Parts replacement and the suitability of suggested substitutions, test equipments and their suitability to servicing needs, troubleshooting techniques as applied to tv, radio receivers and other devices, and the manner in which service test equipment can be put to best use by the service industry, are but a few of the questions of vital concern to the service technicians of the nation. We intend to provide the answers through the media of our laboratory.

The "TELL-A-FAULT" data, described elsewhere in this issue, will originate in the John F. Rider Laboratories, as will information which will make Rider Manuals and TEK-FILES better than they have ever been. In addition, information for forthcoming practical books will also be obtained through our labs. The expansion of our laboratory facilities is the final answer to this goal.

We also foresee the possibility of serving, in a broader way, the entire radio and television industry — the manufacturers of sets, test equipment, and parts, etc. This, however, is a long-range aim; our first and foremost concern continues to be the electronic servicing industry of the nation.

Using this concern as our guide, we expect to consider every type of equipment that comes within the province of the service technician. If his lot is to be made easier, our emphasis must be on maintenance and repair. We aim to make our laboratory a central agency for technical aid at a nominal fee — to make it the kind of organization the servicing industry has never had available before but has needed for a long time.

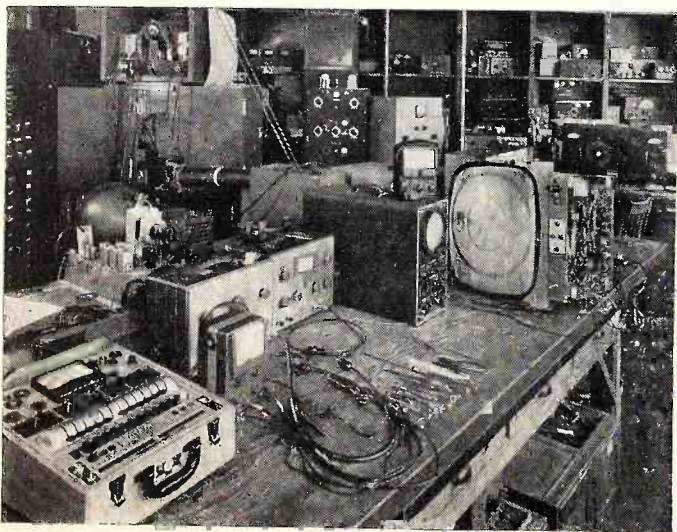

*Fig. 2. A view of the lab showing one of eight vhf test positions. The Indian Head pattern on the tv receiver is a signal from a channel 6 signal generator which receives it modulating signal from the Monoscope picture generator.*



# Now, The Plain Truth about easy tv servicing

Learn how official service data direct from the set manufacturer's own engineering and testing laboratories can solve the most difficult tv repairs, quickly and permanently!

No one knows his receiver better than the manufacturer.

Isn't it common sense that the men who design and build the receiver know the most about it? They are responsible for the receiver's performance and when a weakness is discovered, they are the first to determine the necessary permanent correction. The servicing information issued by the manufacturer's engineering department is certainly the most complete; because it contains not only the whole story on each model but includes *changes* in the receiver which the service technician must know in order to make a permanent repair!

For example: A major set manufacturer found that a capacitor overheated and broke down. A conventional replacement of the defective capacitor would mean repeat calls and customer dissatisfaction because the overheating and eventual breakdown would reoccur. So he developed a permanent cure—rearrangement of the circuit wiring. You couldn't possibly know that by looking at the original schematic. The only way you could repair this manufacturer's set containing this trouble would be to have the *complete* factory data! When faced with these facts, and there are many, many more, isn't it surprising that some servicemen are still not taking advantage of the wealth of data developed by the manufacturer?

How to get this vital information.

There are only two ways to get the complete unabridged manufacturers' servicing data: one way is to write the manufacturers direct. However, by doing this you run the risk of mail delay while your customer's set gathers dust, plus the difficulty of organizing the material once it's received.

The other way—the only practical way—is to buy this data in complete, easy-to-read published form. **THIS MEANS RIDER SERVICING DATA!** For 22 years Rider, and Rider alone, has been the only source for getting the whole story—the complete story, including all manufacturers' production changes—in accurate, organized, un-

edited form. You get large, easy-to-follow schematics . . . explanation of circuits . . . stage by stage alignment curves . . . page after page of trouble-shooting test patterns . . . waveforms . . . *complete* factory parts lists and values . . . clear, enlarged chassis views . . . circuit changes . . . and much, much more, all guaranteed to match the set you're working on. This has made servicing *easy* for countless thousands of service technicians.

Rider servicing data designed to meet your needs.

Whether you are a part-time or full-time service technician — independent or employed — you can afford Rider servicing data; Because it's available two ways:

*Rider Manuals.*

Volumes 1 through 9.

The greatest collection of manufacturers' servicing data ever published. Each volume covers all production runs for a certain period. The newest Rider Manual (TV9) contains servicing data for sets produced between October 1951 and February 1952. Each Rider manual contains an index listing the contents for all Rider manuals. The average volume contains more than 2000 (8½ x 11") pages bound in a permanent, heavy-duty binder. Perfect for shop use and permanent reference. Price \$24.00 each.

*Rider Tek-File.*

Packs 1 through 56.

The newest way to get complete Rider servicing data. The *only* difference between Rider manuals and Tek-File is the package. In manuals you buy the data of many manufacturers in one volume. In Tek-File packs you buy the same data—but only for one, two, or a few manufacturers at a time according to your needs. Each numbered Tek-File pack contains standard file folders with all servicing data for the manufacturer's models printed on the pack's

tamper-proof label. These folders are designed for house calls and easy bench use in the shop. Perfect for the specialist on certain brands of receivers . . . the part-time service technician . . . the engineer and the independent or employed serviceman. Price only \$2.00 per pack.

As an additional Tek-File service, many packs contain Tek-File Handies. These are 3 x 5" index cards giving manufacturer-tested trouble cures plus production changes made by the manufacturer's own engineering department . . . Each Tek-File pack contains a coupon, 15 of which, plus a small handling charge, get you a permanent manual binder for Tek-File shelf use.

**DON'T BE SWITCHED!**

There is only one Rider Tek-File. It is *not* the same as any other publisher's service. If your jobber doesn't carry Rider Tek-File **DON'T BE SWITCHED** . . . write us direct—we'll sell you! Please include your jobber's name.

Combat unfair press . . . combat national ads that say "fix your own set"! You can do this if you use Rider Manuals and Tek-Files because then you can tell your customers that you are using *factory-prepared, official, authorized, complete servicing information.*

**TRY A PACK!** Once you've tried Rider Tek-File we are convinced you'll never use any other service. Make this simple test. Use Tek-File for seven days—if you're not convinced, return it to us and receive full refund!

*Free Rider Tek-File Index.*

Rider Tek-File indexes covering all issued packs are available at your jobbers. If your jobber doesn't have Rider Tek-File Indexes—write us direct . . . it's free.

John F. Rider Publisher, Inc. 480 Canal St. New York 13, N. Y. West Coast office: 4216-20 W. Jefferson Blvd. Los Angeles, Calif.



**Bill Clemens says—**

Midget Radio Service (a 3-Man Shop)  
129 S. Elizabeth St., Lima, Ohio

*"TRIPLITT 660 saves us  
50 to 100 man hours  
per month."*

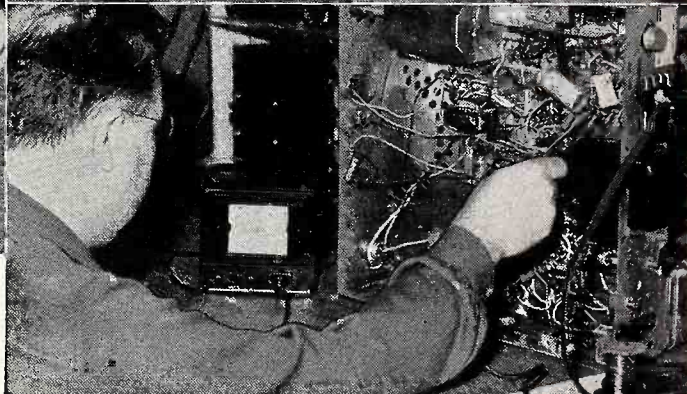
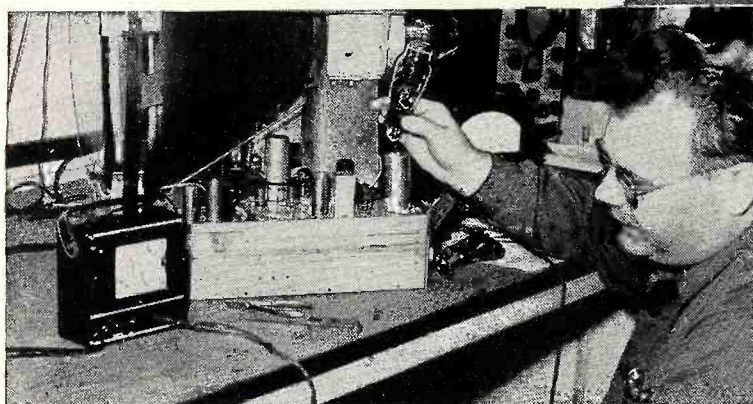

**1. ISOLATING THE TROUBLE**—Plug the power cord of the chassis into LOADCHEK and note the reading. With your eye on the large meter remove the rectifier tube and you can tell immediately which side of the tube the trouble is on. You have already eliminated 50% of your probing time.

**2. LOCATING THE SHORT**—With Loadchek you can quickly check the shorted side, part by part, without laying down tools or picking up test leads. Here, the trouble was a short in the transformer, spotted without having to warm up set. Overloads are found the same way.

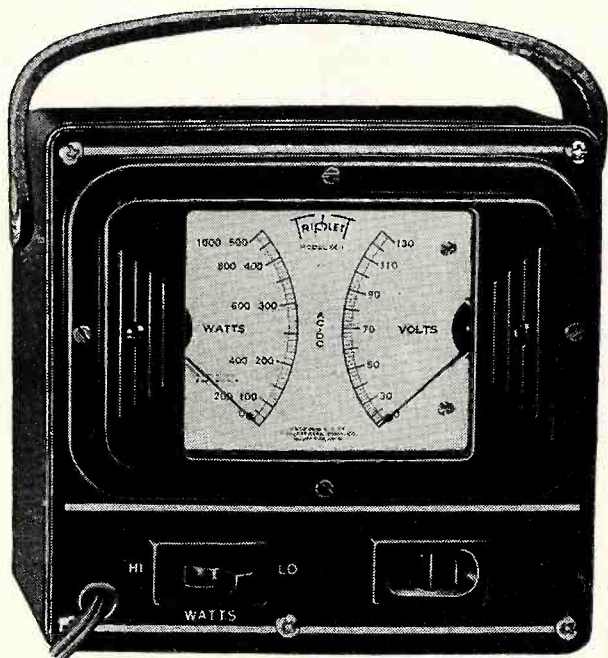

**Locates trouble in a hurry**

The above pictures illustrate but one of the many time-saving uses of Triplitt 660 Loadchek. This versatile instrument accurately measures power consumption, enables you to see instantly any deviation from normal load, without disconnecting a single part... finds trouble in a hurry.

For Radio and TV servicing—for almost any kind of electrical trouble-shooting—LOADCHEK saves hours of painstaking work every day. At its moderate cost no service technician can afford to be without it. Try one today—and see! Write for free booklet.

TRIPLITT ELECTRICAL INSTRUMENT CO., BLUFFTON, OHIO, U.S.A.

**SEE TRIPLITT 660 LOADCHEK AT YOUR DISTRIBUTOR**



**Triplitt**



← there's something missing here



but the RADIART ANTENNA LINE has EVERYTHING

From conicals to yagis . . . from indoor "rabbit-ears" to hi-los and strate-lines — RADIART has everything good to be had in antennas! There's nothing missing in your antenna "picture" when you handle RADIART because there is a type and model for every need . . . quality engineered for peak performance . . . and made to outlast them all! GET RADIART — because it means you've got the best!

AND . . . don't forget our quality antenna accessories . . . like the "hottest" lightning arrestor on the market . . . the "SPEE-DEE" chimney mount . . . and our famous TELE-ROTORS!

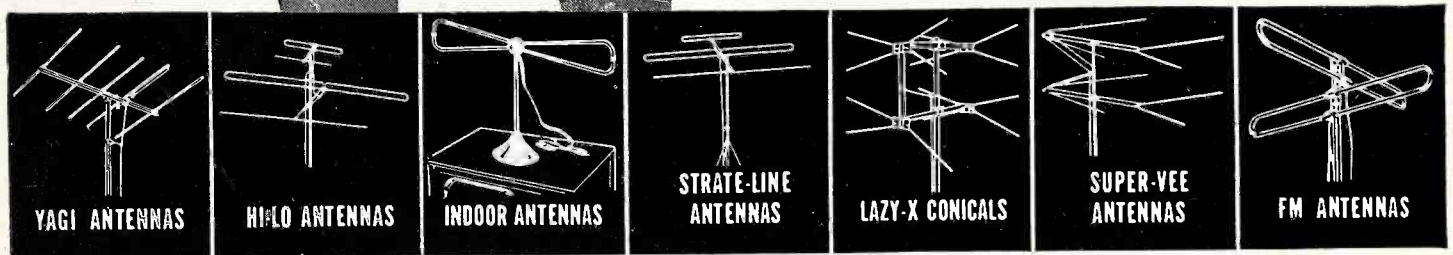

SUBSIDIARY OF



THE RADIART CORPORATION CLEVELAND 13, OHIO

VIBRATORS • AUTO AERIALS • TV ANTENNAS • ROTATORS • POWER SUPPLIES

Please mention Successful Servicing when answering advertising.



## deflection yokes

(Continued from page 11)

produce a waveform distortion and hence the resulting foldover and non-linearity.

Figure 5 shows the result of a non full-focus yoke used on a CR tube requiring one. You will note that edge-to-edge focus cannot be accomplished, therefore the center of the picture is in focus while the edges are definitely out of focus or vice-versa. This is a direct result of an incorrectly formed deflection field.

Figure 6 shows a yoke with a lower value damper resistor on the vertical deflection coils. Reduction of Q (figure of merit of the winding) resulted in power dissipation across the resistor and ultimately in less coil currents. This accounts for the absence of required height.

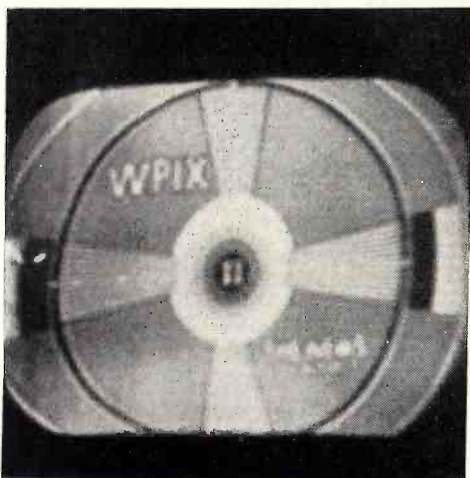

Figure 5.

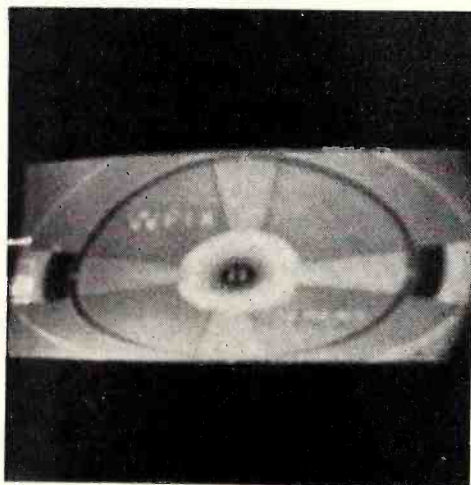

Figure 6.

*Thanks for your  
patience...*

The TV Troubleshooting Guidebook is on press and will be delivered to your jobber the latter part of May.

**PUT IN YOUR ORDER NOW!**

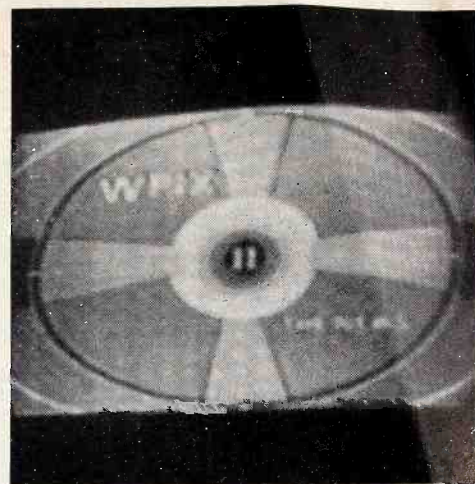
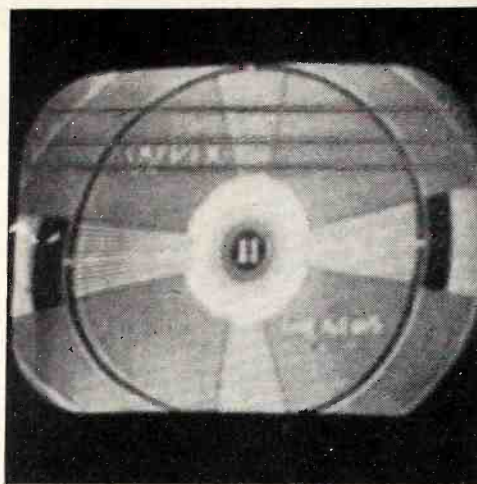

Figure 7 and 8.

Figure 7 illustrates a yoke having an unduly high value damping resistor across the vertical deflection coils. The load current tends to have damped oscillations due to the collapse of the transformer field at retrace time. Since this resistor is not of the proper size to damp these oscillations, they are reflected in the load current of the vertical deflection coils. On the CR tube this condition appears as horizontal bars across the picture face.

Figure 8 illustrates a condition wherein the capacitor connected across the yoke to prevent interaction between windings is too high in value. This causes the resulting

smaller picture. This excessive capacity tends to reduce a portion of the current flow through the coils. In addition to affecting picture size, a ripple is introduced with a resultant change in the normal waveform. Extreme cases of ripple will cause vertical distortion bars to appear.

We hope that what has been said and shown will prove of value to tv service technicians; that careful selection of replacement components and thorough observation of all results after installation is the only guide to optimum performance. In a subsequent article we shall discuss the relationship between linearity and width coils and other related components.

**FREE TO READERS OF  
SUCCESSFUL SERVICING**  
*TV Servicing made easier than before!*

**RAM NEW TV  
REPLACEMENT MANUAL** List Price \$1.00

- 80 MANUFACTURERS
- OVER 5000 LISTINGS
- LATEST CONVERSION DATA
- 32 PAGES
- SCHEMATIC DIAGRAMS
- COMPONENT CO-RELATION INDEX

**Cross-Indexed with RIDER MANUAL  
and TEK-FILE References**

**WRITE FOR IT NOW!**

CLIP HERE AND  
PASTE TO POST-  
CARD FOR FREE  
RAM CATALOG

**Ram**  **ELECTRONICS SALES CO.**  
SOUTH BUCKHOUT STREET  
IRVINGTON-ON-HUDSON, N. Y.  
IRvington 9-5700  
**TEST-PATTERN TESTED COMPONENTS FOR TV**

Please mention Successful Servicing when answering advertising.





# ANNOUNCING — NEW IRC BROAD-COVERAGE TV REPLACEMENT CONTROL LINE

**Features Both Exact Duplicate Controls and  
Amazing New CONCENTRIKITS with Exact Duplicate Shafts**

Whether you prefer the convenience and simplicity of factory-assembled Exact Duplicate Controls, or the wide coverage and faster servicing at lower stock cost afforded by Universal Replacements—the new IRC-TV Control Line gives you what you want! On either type, you have full coverage of 295 different concentric dual controls handling 416 Manufacturers' Part Numbers specified in over 5,000 TV models.

## **NEW** IRC UNIVERSAL REPLACEMENTS

Two new, four-piece CONCENTRIKITS of improved, simplified design plus a full line of Exact Duplicate Shafts and an expanded series of IRC Base Elements feature:—

- "Less-than-a-minute" assembly—in shop or home!
- No filing, slotting, soldering, hammering or cutting of shafts!
- Assembly of both carbon and wire-wound concentric duals!
- New reduced prices!

No special tools or skills are needed to assemble these new, simplified CONCENTRIKITS. Easy-to-follow pictorial instruction sheet shows you how to make actual assembly in less than a minute. Assembled CONCENTRIKIT Controls are *Exact Duplicates*.

New IRC Exact Duplicate Shafts take the labor and complexity out of control assembly. Absolutely no alterations needed. Shafts are supplied in proper lengths and with factory-tooled ends for complete satisfactory fit. Accurate specifications are assured.

One CONCENTRIKIT assembles carbon concentric duals. The other assembles wire-wound/carbon controls.

New reduced prices. Wide replacement coverage at low stock cost. CONCENTRIKITS enable service technicians to save time and money—to give faster service on TV controls.

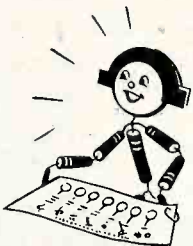

## THREE **NEW** IRC CONCENTRIPAKS COVER MAJOR TV SETS

IRC CONCENTRIPAKS are selected assortments of CONCENTRIKITS, Exact Duplicate Shafts and Base Elements, providing big replacement coverage of specific makes of TV sets. Housed in large, sturdy partitioned plastic stock box, with full replacement data. Cover RCA, Admiral or Philco concentric duals. Prices start at \$7.44.

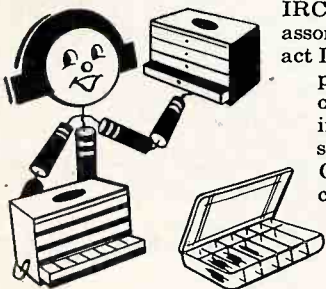

## **NEW** IRC EXACT DUPLICATE CONTROLS

295 new IRC Exact Duplicate Concentric Dual Controls provide satisfactory mechanical fit and electrical operation for over 90% of TV Controls. They feature:—

- Accurate, dependable specifications!
- Factory assembly under rigid quality control!
- Both carbon and wire-wound types!
- Easy installation—no modification required!

IRC Exact Duplicate Controls are made to carefully prepared specifications. Shaft lengths have not been compromised. Shaft ends are accurately machined for good knob fit. Electrical characteristics are carefully engineered for satisfactory operation.

Easy installation is assured with IRC Exact Duplicates. No need to improvise—to reverse connections—to alter controls in any way.

Both carbon and wire-wound concentric duals are included. IRC now supplies the broadest line of Exact Duplicate Concentric Duals—covers more part numbers with greater accuracy.

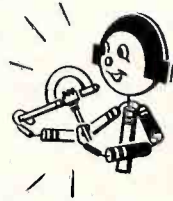

## IRC STANDARD CONTROLS FOR TV

IRC Type Q Carbon Controls and Type W Wire-Wound Controls provide wide coverage of TV single controls. Full standard line includes 61 Type Q Controls featuring the exclusive IRC Knob Master Shaft for easy fit to knurled or spring-type knobs—plus 39 Type W and Type WK Wire-Wound Controls. Wide selection of resistance values, taps and tapers.



### Send for Full Details and Free Replacement Data

Full information on new IRC TV Control Line is yours for the asking. Specify Catalog DC1C. Complete replacement data by Manufacturers' Parts Numbers also is yours at no charge. Specify Form SO12. Ask your IRC Distributor or send post card to us for your copies.



Your IRC Distributor  
is Your ONE-STOP  
source for TV Controls



**INTERNATIONAL  
RESISTANCE CO.**  
423 N. Broad Street—Philadelphia 8, Pa.  
*Wherever the Circuit Says* —



# Compare!

PROVE  
**EMC**  
SUPERIORITY!

## EMC MODEL 206

Tube Tester

- Mutual Conductance
- Uses lever-type switches.
- Checks mutual conductance on calibrated microhmo scale
- Detects both shorted and open elements
- Tests all tubes from .75 v to 117 filament volts
- Built-in roll chart
- 4 1/2" meter

Model 206 P

\$83.50

## MODEL 204

Tube-Battery-Ohm  
Capacity Tester

- Tests all tubes including Noval and sub-miniature
- Tests resistance to 4 megohms
- Tests condensers from .01 to 1 mfd.
- Tests all batteries under rated load.

Model 204 (oak case) \$55.90

Write Dep't. 55-4 for FREE catalog.



Please mention Successful Servicing when answering advertising.

## "We find Rider Manuals most helpful . . .

particularly when we come across some of the lesser known brands," says I. J. Saltzman of the Globe Radio and Sound Service of 95-41 Sutphin Blvd. "The biggest thing we sell is 'time.' Any time saved through adequate test equipment, service manuals and well-stocked parts' bins saves money for our customers and assures us of a better profit and a well earned reputation for fast, efficient service at nominal prices.

"When I first started in radio service in 1930, service manuals were something to be ashamed of, for the use of them denoted lack of knowledge to the uninformed. However, I still have Rider's Service Manual #1 which I bought about that time and now I display our manuals and am as proud of them as a lawyer showing off his fine reference library."

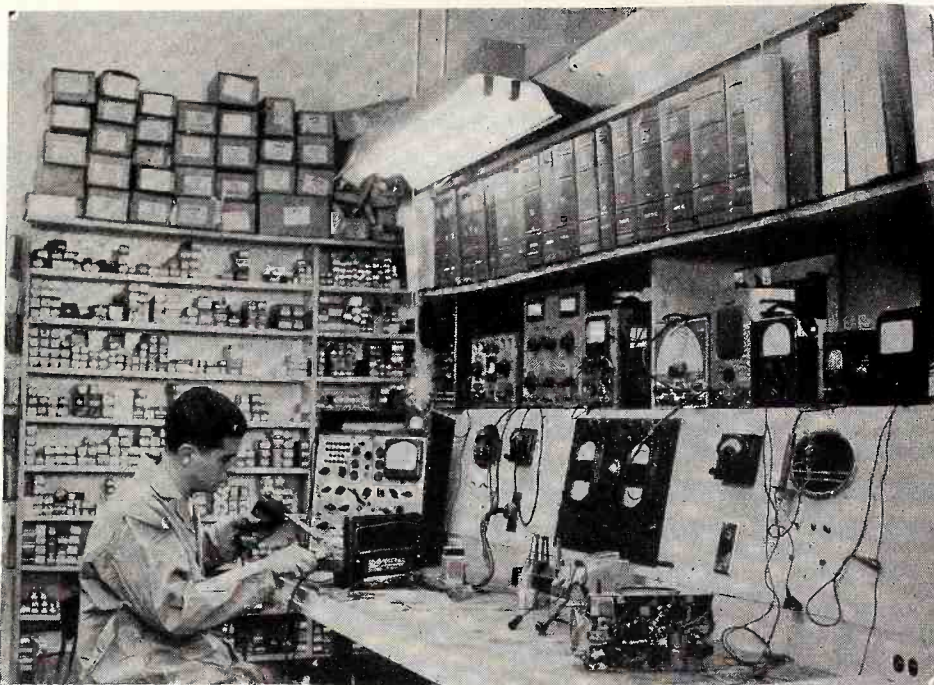

Figure shows technician at work — separated from customers by a glass partition similar to that used in the prescription department of a modern drug store. (Note complete set of Rider Manuals in background.)

## TROUBLESHOOTING TV RECEIVERS

(Continued from page 7)

probe to obtain the same deflection as before. The probe is then in adjustment.

Capacitive-divider probes can be used in the horizontal-sweep and high-voltage sections of a tv receiver without encountering much waveform distortion. However, do not attempt to use this probe in the vertical-sweep circuits of the tv receiver, as these 60-cps waveforms will be severely distorted by the probe. Fortunately, the use of a capacitive-divider probe is usually required only in the high-voltage horizontal circuits of the receiver.

## RCA INSTITUTES FORM ALUMNI ASSOCIATION

The Radio Corporation of America has announced the election of Herman C. Belderok as the first President of the newly formed Alumni Association of RCA Institutes. The purpose of this Association is to create closer ties between the graduates of RCA Institutes, and to further their common educational, social and technical interests. All graduates of RCA Institutes, one of the oldest radio technical training schools in the country, are eligible to become members.

# ATTENTION! RADIO SERVICEMEN

## THERE ARE THOUSANDS OF OUT-MODED RADIOS IN YOUR "BACK YARD" JUST WAITING TO BE REPLACED . . . AT YOUR SUGGESTION

Here is the custom-built AM-FM chassis that means **BIGGER PROFITS** for you!

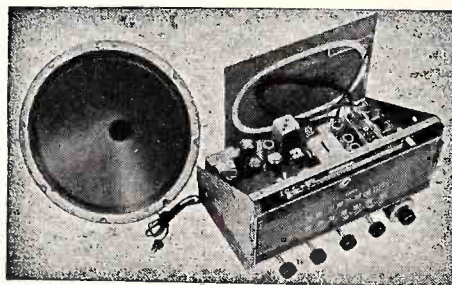

### The NEW ESPEY model 511-B FEATURES

1. AC Superheterodyne AM-FM Receiver.
2. Improved Frequency Modulation Circuit, Drift Compensated.
3. 12 Tubes plus rectifier and Pre-Amp Tubes.
4. 4 dual purpose tubes.
5. Treble Tone control.
6. 6-gang tuning condenser.
7. Full-range bass tone control.
8. High Fidelity AM-FM Reception.
9. Automatic volume control.
10. 10 watts (max.) Push-Pull Beam Power Audio Output.
11. 12-inch PM speaker with Alnico V Magnet.
12. Indirectly illuminated Slide Rule Dial.
13. Smooth, flywheel tuning.
14. Antenna for AM and folded dipole antenna for FM Reception.
15. Provision for external antennas.
16. Wired for phonograph operation with switch for crystal or reluctance pick-up.
17. Multi-tap output trans., 4-8-500 ohms.
18. Licensed by RCA and Hazeltine.
19. Subject to RMA warranty, registered code symbol #174.

Makers of fine radios since 1928.

**ESPEY** TEL. TRafalgar 9-7000  
**MANUFACTURING COMPANY, INC.**  
528 EAST 72nd STREET, NEW YORK 21, N. Y.

### SPECIFICATIONS

Supplies ready to operate, complete with tubes, antennas, speaker and all necessary hardware for mounting in a table cabinet or console, including escutcheon. Power consumption — 105 watts.

Chassis Dimensions: 13 1/2" wide x 8 1/2" high x 10" deep.

Carton Dimensions: (2 units) 20 x 14 1/2 x 10 3/4 inches.

Net Weight: 17 pounds each.

Sold through your favorite parts distributor.

WRITE FOR CATALOGUE KD12  
AND NAME OF NEAREST DISTRIBUTOR.

Please mention Successful Servicing when answering advertising





for greater speed and  
accuracy of TELEVISION INSTALLATIONS  
in any locality use the new

# Simpson

MODEL 488

## TV FIELD STRENGTH METER

In addition to location of maximum signal areas, the Simpson Model 488 Television Field Strength Meter is also ideal for antennae orientation, comparison of antennae systems, adjustment of TV signal boosters and checking antennae and lead-in installations to list but a few of the many functions available . . . THE 50 MICROVOLT FULL SCALE RANGE IS AN OUTSTANDING FEATURE FOR THOSE CONCERNED WITH FRINGE AREA INSTALLATIONS WHERE MAXIMUM EFFICIENCY MUST BE ATTAINED . . . The 500, 5,000 and 50,000 microvolt ranges extend the usefulness of the Simpson Model 488 into areas of higher signal strength. The large 4½-inch modernistic meter is easily read from a considerable distance and all controls and connections are arranged for greatest accessibility. Model 488 is housed in a beautiful gray hammerloid finished case for greater portability. LINE VOLTAGE: 105-125 volts, 50-60 cycles. SIZE: 8" x 11" x 8½".

WEIGHT: 11½ lbs. Shipping weight 15 lbs.  
DEALER'S NET PRICE, including operating instructions and shoulder strap . . . \$89.50

### SIMPSON ELECTRIC COMPANY

5200 WEST KINZIE STREET, CHICAGO 44, ILLINOIS

Phone: COlumbus 1-1221

In Canada: Bach-Simpson, Ltd., London, Ontario



# Like a Better Paying Job in TV and Electronics?

Man-to-Man Guidance Book Puts You On The Right Track

A quick backward glance at the development of this country shows that from time to time in our history one or another field of endeavor opened up a new world of possibilities and was responsible for a forward spurt in our progress. An example of this was the introduction of the steam engine in America—the new businesses and careers that this force made available became a powerful influence in the development of the country.

Today the new field is electronics. That it is here to stay is attested by the basic importance it has attained in industry, in the military, and in the home. The opportunities in electronics for men already in one branch of the field, as well as newcomers, are unlimited. However, as in any other type of work, not all jobs are suited for all individuals.

Where do you get such information? Well, if you know about five men, each of whom has been engaged in one particular field of electronics for over fifteen years, knows his field from every angle, and has become a leader in his profession, you can get the information you need from them. Unfortunately, most of us do not know such men. However, just such a group of successful career men in electronics have gotten together and written TV AND ELECTRONICS AS A CAREER, a new factual guide to the field, published by John F. Rider Publisher, Inc.

ELECTRONICS calls TV AND ELECTRONICS AS A CAREER —“A comprehensive book size answer to the perennial question fired at the electronics industry, ‘How can I get into television or electronics.’”

JOBBER NEWS says—“This volume is the first to outline in detail the careers available in the electronics industry.”

The five authors of TV AND ELECTRONICS AS A CAREER are well qualified to offer guidance in this field. Each of the five has risen to the top of his chosen branch in electronics. Each tells you clearly what is available in his branch and how to get a good job in it.

W. HOLLANDER BOHLKE, who wrote the Chapter on tv and electronic servicing, is Manager of the Custom Service Division, RCA Service Company, Inc. He has been active in electronic servicing since its inception.

RICHARD H. DORF (AM-FM Broadcasting and Communications), has been an announcer and technician for stations WNYC, WOR, and WMGM in New

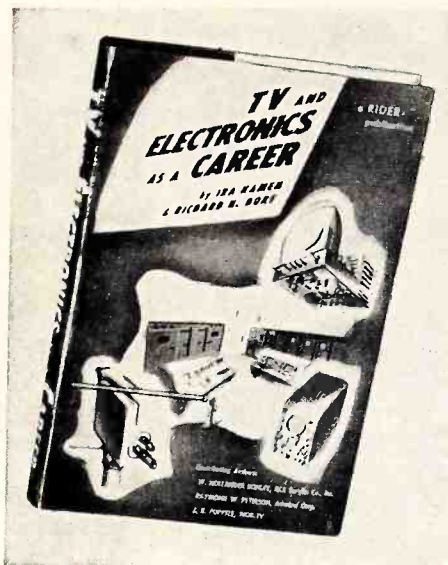

TV AND ELECTRONICS AS A CAREER (shown above) . . . “is an authoritative, graphically presented account of the workings of a greatly expanding field—electronics. The chapters are clear and well written.” — RADIO AND TELEVISION NEWS

York. He is thoroughly familiar with every phase of broadcasting.

IRA KAMEN, author of the chapter on Distribution of Radio and Television Receivers and Components, is Director of TV Development and Promotion, Branch Division of General Bronze Corporation. He has been closely associated with the radio and tv business—both retailing and engineering—for a great many years.

RAYMOND W. PETERSON (TV and Electronic Manufacturing and Engineering), is Assistant Manager of the Electronics Division of the Admiral Corporation where he helped set up the production of tv receivers, and has done important engineering work on electronic instruments and equipment.

J. R. POPPELE, author of the chapter on Television Broadcasting, is Vice President in charge of engineering for station WOR in New Jersey. He was a pioneer in the development of regular f.m. and tv broadcasting and is now President of the Television Broadcasters Association.

TV AND ELECTRONICS AS A CAREER is available through radio and tv parts distributors and book stores all over the country. It is popularly priced at \$4.95 for 326 pages. Go into your local store and ask to see a copy or, write directly to John F. Rider Publisher, Inc.

Let it put you on the right track!



A monthly summary of product developments and price changes of radio, electronic, and television parts and equipment, supplied by United Catalog Publishers, Inc., New York City, publishers of RADIO'S MASTER.

These REPORTS will help you to buy and sell to best advantage. They will also help you to keep your inventory up to date. A complete description of most products will be found in the Official Buying Guide, RADIO'S MASTER, available through local parts distributors.

## New Items

- ASSEMBLY PRODUCTS—Added 15 “Simplytrol Pyrometers” and also #4539 and #4549, “Simplytrol Large Scale Controls.”
- BRITISH INDUSTRIES (Wharfedale)—Introduced new Speaker, Super 5 at \$20.95 net.
- EITEL-McCULLOUGH—Added 3 new Vacuum Tubes: 3W5000A3, 3W5000F3, and 3X3000A1 all at \$198.00 net each.
- ELECTRONIC MEASUREMENTS — Added new Models 206 and 206P, Mutual Conductance Tube Testers.
- ERIE RESISTOR—Added #413 (500 mmm), completely universal Hi-Voltage Ceramicon at \$1.35 net and extra terminals for above at \$.06 net.
- GON-SET CO.—Added VHF Adaptor with Squelch at \$79.50 net.
- J F D—3 new Jet-enna Conicals, JT-116 at \$7.50 net . . . JT-161 at \$15.84 net . . . and JT-164 at \$34.08 net added.
- MASCO—Added MA-77, Amplifier . . . MA-77R, Remote Control Amplifier . . . MCO-77, Outdoor System . . . MB-77, Booster Amplifier and MB-77P, Booster Amplifier with Panel.
- MERIT TRANSFORMER—Correction: Introduced MWC-2, Horizontal Output and Hi-Voltage Transformer and A-3080-1, Vertical Output Transformer. Corrected to read: Introduced MWC-2, Width Control and A-3080 and A-3081, Vertical Output Transformers.
- NATIONAL CARBON—Added #729, “Eveready” “A-B” packs for portable receivers, 4351, “Eveready” Flashlight and 715, “Eveready” Lantern battery and emergency lighting battery.
- NATIONAL ELECTRONICS—NL-249C, Half-wave Rectifier added at \$12.75 net, and Ignitron type #NL-1001 at \$37.50 net.
- PANSTIEHL CHEM. CO.—Added PA-62A, PA-63MG and PA-66U Panstiehl Replacement needles. (Shure Whisker-type for Std. groove, Micro-groove and All Purpose.)
- PRECISE DEV. CORP.—Added to their line of Electronic Test Equipment #K-630, R.F. — A.F. — TV and Marker Generator . . . KA-630, same as K-630 with pre-assembled and pre-calibrated R.F. head . . . K-635, Universal A.F. sine, square and Pulse generator . . . W-630, as K-630, but wired and W-635, as K-635, but wired.
- QUAM-NICHOLS—Introduced #AS-1, Rear seat auto speaker at \$5.97 sugg'd resale and #AS-2, Rear seat auto speaker at \$8.37 sugg'd resale.
- R.C.A.—Added Electron tubes type 6146, 6159 VHF Beam Power Amplifiers and 6161, UHF Power Triode. Also added TV components 212R1, Width Control; 213R1, Hor. Linearity Control; 230T1, Hor. Defl. Output and HV Transformer for 21AP4 . . . added PM type Speakers 446S2 and 269S1.
- RADIO MFG. ENGINEERS—Added new Mobile Converter for 2, 6, and 10-11 meters at \$66.60 net.

(Continued on page 23.)



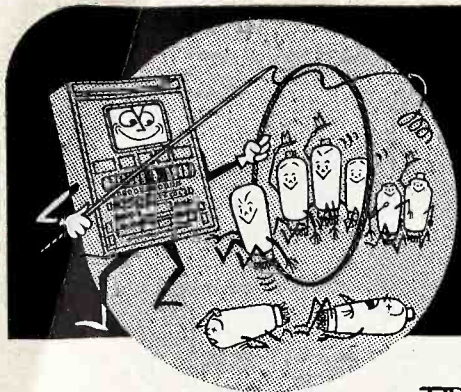

# THE INSTRUMENT THAT DEMANDS OVERALL PERFORMANCE FROM THE TUBE UNDER TEST!

*-PRECISION-* SERIES 10-12

## Electronamic\* Tube PERFORMANCE Tester

with 12 element free-point Master Lever Selector System

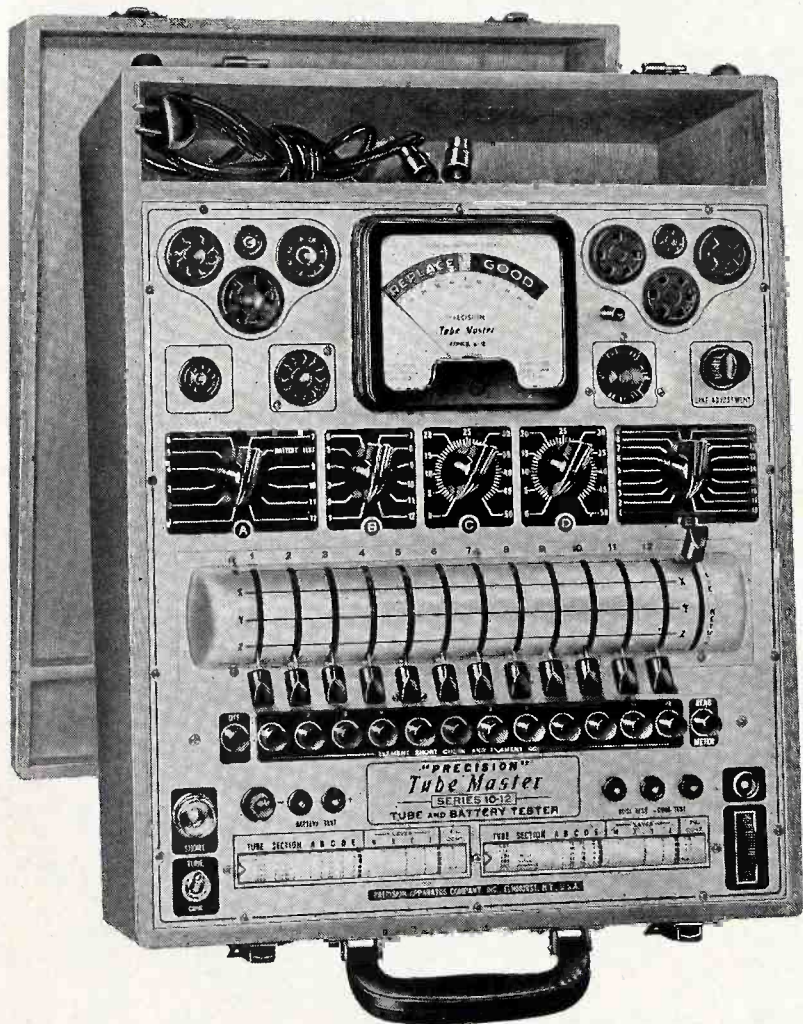

To test modern tubes for only one characteristic will not necessarily reveal **OVERALL PERFORMANCE CAPABILITIES**. Modern tube circuits look for more than just mutual conductance or other single factor.

It has been conclusively proven that even though a tube may work well in one circuit, it might fail to work in another—simply because different circuits demand different relative performance characteristics, such as amplification factor, plate resistance, power output, emissive capability, etc.

In the PRECISION "ELECTRONAMIC" Circuit, the tube under test is made to *perform* under appropriately phased and selected individual element potentials, encompassing a wide range of plate family characteristic curves. This COMPLETE PATH OF OPERATION is electronically integrated by the indicating meter circuit in the positive performance terms of Replace-Weak-Good.

The efficiency of this "Electronamic" test results from encompassing several fundamental tube characteristics, NOT JUST ONE. Accordingly, when a tube passes this demanding OVERALL PERFORMANCE test, it can be relied upon, to a very high degree, to work satisfactorily.

\*REG. U.S. PAT. OFF. T.M. 439,006

### Compare these features

- ★ Facilities to 12 element prongs.
- ★ Filament voltages from  $\frac{3}{4}$  to 117 V.
- ★ Tests Noval 9 pins; 5 and 7 pin acorns; double-capped H.F. amplifiers; low power transmitting tubes, etc., regardless of filament or any other element pin positions.
- ★ Isolates each tube element regardless of multiple pin positions.
- ★ Dual Hi-Lo short check sensitivity for special purpose tube selection.
- ★ Simplified, High Speed, 12 element Short-Check system, uses consecutive push-button switching.
- ★ Battery Tests under dynamic load conditions.
- ★  $4\frac{1}{2}$ " Full Vision Meter.
- ★ Built-in Dual-Window, high speed, geared roller chart.
- ★ Free Replacement Roll Charts & supplementary tube test data service.

MODEL 10-12-P (illustrated): in sloping, portable hardwood case with tool compartment and hinged removable cover. Sizes  $13\frac{3}{4}$ " x  $17\frac{1}{4}$ " x  $6\frac{3}{4}$ ".....\$101.75

MODEL 10-12-C (Counter Type) \$106.50

MODEL 10-12-PM (Panel Mount) \$106.50

See the "Precision" Master "Electronamic" Tube Testers at leading Radio Equipment Distributors. Write for new, 1952 "Precision" catalog.



## PRECISION APPARATUS CO., INC.

92-27 Horace Harding Boulevard, Elmhurst 14, New York  
Export Division: 458 Broadway, New York 13, U.S.A. • Cables—Morhanex  
In Canada: Atlas Radio Corp., Ltd., 560 King Street, W., Toronto 2B

Convenient "PRECISION" Purchase Terms can be arranged with your local and favorite authorized "PRECISION" Distributor.

AM • FM • TV •

AM • FM • TV



### Radio's Master Reports

(Continued from page 21)

**RAYTHEON**—Added Receiving tubes 6BK7 at \$3.20 list, a twin-triode of miniature construction designed primarily for use as a cascade amplifier at freq. below 300 megacycles . . . also 6V3 at \$3.90 list, a nine pin miniature, heater cathode type diode, designed for use as a damper diode in television sweep circuits.

**RECOTON** — Added Replacement needles #380 (Standard), 381 (Micro-Groove) and 382 (All Groove) at \$.90 net each.

**SANGAMO**—Added approximately 263 new TV replacement capacitors.

**SCHOTT (Walsco)**—Added #4100, Double VEE Dual stack no Mast at \$7.50 list, and #4102, Double VEE, Dual stack no mast at \$17.75 list. Both subject to quantity discount.

**SIMPSON ELECTRIC**—Added series 45, 47 and 49 of Rectifier type Voltmeters, Microammeters and Milliammeters.

**TALK-O-PRODUCTS**—Introduced CW-5, Cabinet Station at \$36.00 list and FW-5, Flush Station at \$25.00 list.

**TAYLOR TUBES**—Added Rectifier Tubes TR40M at \$20.00 list . . . 8013A at \$10.30 list . . . and 8020 at \$22.00 list.

**TECHNICAL APPLIANCE CORP. (TACO)** — Added #1511, 1512 and 1513 to their series of TV Master Antenna Distribution Systems.

**TRICRAFT PRODUCTS**—Introduced Model #TB 400, "Tenna-Boat" at \$12.95 list.

**UNITED TRANSFORMER**—Added Miniature Audio Units types H-1 to H-11 . . . Compact Audio Units types H-20 to H-24 . . . Subminiature Audio Units types H-30 to H-35.

**UTICA DROP FORGE**—Added 2 new compound-leverage parallel-action pliers #402-6½" (with cutter) and #400-6½" (without cutter) . . . added new Plier-Snip #101-4½" and added #2001-8".

### Discontinued Items

**ELECTRO-MECHANICAL INSTR. CO.**—Withdrew A.C. Ammeters #6106 and 6206.

**PERMOFLUX CORP.**—Withdrew Baffle, #CB-8-M from their line.

**PICKERING**—Withdrew #161L and 161M, 78 RPM Pick-ups and #165L, Equalizer Pre-Amplifier unit.

**POTTER & BRUMFIELD**—Withdrew Synchronous Utility Timer and Signal Indicator.

**RADIO MFG. ENGINEERS**—Discontinued Model NBF-4, Ratio Detector.

**RAULAND CORP.**—Picture Tubes 10RP4 and 16AP4B withdrawn.

**WILCOX-GAY**—Withdrew their series of Recordio Tape.

**WIRT CO.**—Withdrew #SW 711 and SW 711A from their line of Dim-A-Lite Sockets and Resistors.

### Price Increases

**BEAM INSTRUMENTS**—Increased their prices on Standard Thermo-Couples (Vacuo-Junction) 5 M.A. — 1000 M.A. to \$11.00 ea., 2.5 M.A. to \$31.50 ea., and U.H.F. Thermo-Couples from 5 M.A. up, to \$16.50 ea. Prices are net.

**J F D**—Correction: SW 2 to 13 increased to \$14.37 net are Boosters, not Antennas as reported.

**PHILMORE MFG. CO.**—Increased price of 7001A, "Supertone" Radio Crystal set kit to \$2.94 net.

**R.C.A.**—Increased price of 4E27A/5-125B to \$35.75 sugg'd user . . . and also prices on 2 items in their Phono Accessories series and 40 items in their Television Components series.

**SYLVANIA**—Increased prices of 12 Special Purpose tubes, 8 Transmitting Tubes and 6 Subminiature Tubes, and 189 Receiving Tube types.

### Price Decreases

**ACOUSTI-CRAFT**—Decreased prices on "Deluxe" Base Reflex Cabinets #512 and #515 to \$60.00 net each.

(Continued on page 24)

**FASTER  
STURDIER  
Lower Installed Cost**

**SPEE-DEE  
CHIMNEY MOUNT**

**Model AK 85** The fastest-installed chimney mount ever devised for TV antennas! Rugged in design—simple to install. Simply thread strapping through ratchet, around chimney and back through ratchet—wind up ratchet tight—and the job's done! Heavy gauge, zinc-plated steel with large "U" bolt for up to 1¼" O.D. mast and full length galvanized steel strapping.

THE **RADIART CORPORATION**  
CLEVELAND 13, OHIO

**TV SERVICING SIMPLIFIED**

Use this big Clarostat TV Control Replacement Manual! Almost 3000 control listings of all the popular TV set models and chassis. You can spot the correct replacement for any wornout or defective TV control.

Best of all, your Clarostat jobber has that right replacement in stock. No delay. And it fits — electrically and mechanically — without fussing or cussing. Stays put, too, for a profitable job.

**GET THAT TV CONTROL REPLACEMENT MANUAL NOW!**

Supply is running out. Send your dollar bill and start saving time, trouble, money, in TV servicing. Or get your copy from your Clarostat jobber.

**CLAROSTAT**

*Controls and Resistors*

CLAROSTAT MFG. CO., INC. • DOVER, NEW HAMPSHIRE

IN CANADA: CANADIAN MARCONI CO. LTD., TORONTO, ONTARIO

Please mention Successful Servicing when answering advertising.

**GREATER COVERAGE PER POUND**

Perfect joints in less time with less solder — when you use Ersin MULTICORE Solder, the original 3-core solder and the only solder in the world made with non-corrosive, extra-active Ersin Flux! Eliminates "dry" joints! Bonds difficult metals! See for yourself! Send for FREE SAMPLE — Multicore Sales Corp., Dep't S., 164 Duane St., New York 13, N. Y.



### Radio's Master Reports

(Continued from page 23)

**BEAM INSTRUMENTS**—Reduced prices on Oscillograph Model 1035 to \$599.50 . . . Oscillograph Model 1049 to \$889.50 and Pre-Amplifier Model 1430 DC to \$390.45. Prices are net.

**CHICAGO TRANSFORMER**—Correction: reduced prices on their entire line amounting in most cases to less than 2%. Erroneously reported as a 10% reduction.

**DRAKE ELECTRIC WORKS**—Decreased price of #900 "Instant Heat" Solder Gun to \$9.00 net.

**NATIONAL UNION**—Prices on two 10", two 12", one 14" and two 16" NU Videotron Picture Tubes decreased.

**PLYMOUTH RUBBER CO.**—Decreased prices on their Slipknot Friction Tapes, Double Rubber Tape and their Splicing Compounds . . . also Slipknot Friction in Display Cartons.

**R.C.A.**—Decreased prices of 5 items in their series of PM type Speakers . . . also decreased two 10", two 12", one 14" and three 16" Kinescopes . . . decreased prices of Electron Tubes 2BP11, 2C43 and 931A.

**RAULAND CORP.**—Decreased price of Picture Tube 21EP4A to \$43.50 net.

**SARKES-TARZIAN**—17 TV Tubes decreased in price.

**SYLVANIA**—Decreased prices on 35 Receiving Tube types . . . also prices on two 10", two 12" and five 16" TV Picture Tubes.

**TEL-O-TUBE CORP.**—Decreased prices on 8 TV Picture Tubes.

**TRIO MFG. CO.**—Rotator #TR-2M decreased to \$26.97 net.

**VAN CLEEF BROS.**—Reduced prices on Dutch Brand Friction Tapes . . . Dutch Brand Rubber Insulating Tape and Dutch Brand "Hippo" shop package Rubber Tape.

**VIBRALOC CORP.**—Decreased prices on "G," "E," and "K" series of Loudspeaker Baffles.

#### Miscellaneous Changes

**AMPHENOL**—Resumed production on 300 OHM Tubular Twin-lead #14-271.

**HALLDORSON CO.**—Revised their entire line of Transformers to include 114 new items, 70 price decreases and withdrew 141 other items. Also their part numbering system has been revised.

**RADIO MERCHANDISE SALES**—To their line of Television Antennas and Accessories added 69 new items, withdrew 26 items, decreased prices on 79 items and increased price of TR-372, Matching Transformer to \$.65 list.

**SYLVANIA**—Added 3 ten-inch tinted-face Picture tube types to Sylvania's Glass Allowance program, 10BP4A and 10MP4A.

### There's a RIDER Book For Every Phase of Radio — Television

Encyclopedia on Cathode-Ray Oscilloscopes and Their Uses 992 pages .....	\$9.00
Vacuum-Tube Voltmeters, 2nd Ed. 432 pages .....	\$4.50
TV and Other Receiving Antennas (Theory and Practice) 606 pages .....	\$6.60
TV Installation Techniques 336 pages .....	\$4.50
TV Master Antenna Systems 356 pages .....	\$5.00
Receiving Tube Substitution Guide Book, 1st Ed. 224 pages..	\$3.00
First Supplement, Receiving Tube Substitution Guide Book 48 pages .....	\$ .99
TV Picture Projection and Enlargement 192 pages .....	\$3.30
Television—How It Works .203 pages .....	\$2.70
FM Transmission and Reception, 2nd Ed. 460 pages .....	\$4.95
Radio Operator's License Q & A Manual, 3rd Ed. 734 pages.....	\$6.60
Broadcast Operator's Handbook, 2nd Ed. 440 pages.....	\$5.40
Radar—What It Is 80 pages.....	\$1.00
Understanding Vectors and Phase in Radio 160 pages .....	Cloth cover \$1.89 Paper cover \$ .99
Installation and Servicing of Low Power Pa Systems 208 pages.....	\$3.00
Servicing by Signal Tracing 360 pages .....	\$4.00
Inside the Vacuum Tube 424 pages .....	\$4.50
Servicing Superheterodynes 288 pages .....	\$2.00
Servicing Receivers by Means of Resistance Measurement 203 pages .....	\$2.00
The Business Helper 134 pages .....	\$2.00

WE GUARANTEE your satisfaction! Make these books PROVE their value to you. Examine them at your favorite jobber. If he does not have them — order from us.

**Order Your Copy Now!**

**JOHN F. RIDER PUBLISHER, INC.**  
480 Canal Street, New York 13, N. Y.

**PERFORMS THE BEST IN EVERY TEST!**

**THE TACO ANTENNA**

**Supercharger**

Proven in installations all over the country.

TV, FM, AND AM ANTENNAS

**TACO**

TECHNICAL APPLIANCE CORP.

SHERBURNE, N. Y. • IN CANADA: STROMBERG-CARLSON CO. LTD. TORONTO 4, ONTARIO

**NOW . . .**

**NEW MODEL No. 1628-4½ RECEIVES CHANNELS 4 and 5!**

Please mention Successful Servicing when answering advertising.

PHILADELPHIA 45, PENN.  
3144 PASSYUNK AVE.  
THE ATLANTIC REFINING CO.  
ARTHUR F. MILLER

Sec. 34.66, P. L. & R.  
U. S. POSTAGE  
**PAID**  
NEW YORK, N. Y.  
PERMIT No. 9427

From JOHN F. RIDER PUBLISHER, Inc.  
480 CANAL ST., NEW YORK 13, N. Y.  
Forwarding and Return Postage Guaranteed



# SUCCESSFUL

# Serviceing

MAY 1952

## linearity and width coils

*their use, application and replacement*

by **albert friedman\***  
**victor markosian**

*\*This is the third in a series of articles by Albert Friedman, National Sales Engineer and Victor Markosian, Chief Engineer of Ram Electronics, Inc.*

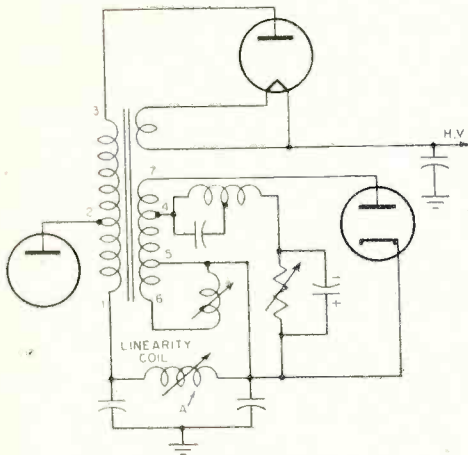

Fig. 1. Conventional linearity control; Ram type 201R3.

When the RCA TS-630 type circuit was the basis for tv receiver design, there was little difference, if any, between the linearity coils used by one manufacturer and those used by another. The same was true for width controls. Progressive receiver design since that time has resulted in variations of design and applications for these components. These variations have been resolved by replacement parts manufacturers into a grouping of replacement units.

Important differences in operation, replacement, and servicing of both linearity and width controls are discussed in this article. The operation of each of the most commonly used types is considered first.

The most common application of the linearity coil is illustrated in Fig. 1. It is essentially a tuned filter circuit. Thus it has an adjustable effect on the waveform in that circuit, making possible the correct waveform for required linearity. The inductive range of this coil is 5 to 20 millihenrys. The resistance value of the coils is approximately 32 ohms. This value has little application in circuit analysis unless checked against values as specified in a factory-approved service manual. The d-c resistance can vary 20 percent to wire size and still have the proper inductance range if proper winding technique and core permeability are used. The use of a tapped linearity control, as illustrated in

Fig. 2, is another popular practice. The range of adjustment in this control, 0.4 to 2.5 millihenrys, is much less than that shown in Fig. 1. Closer fixed tuning of this type of circuit results in a broader response when the core is moved. Finer adjustments can be made with this arrangement since the wave-

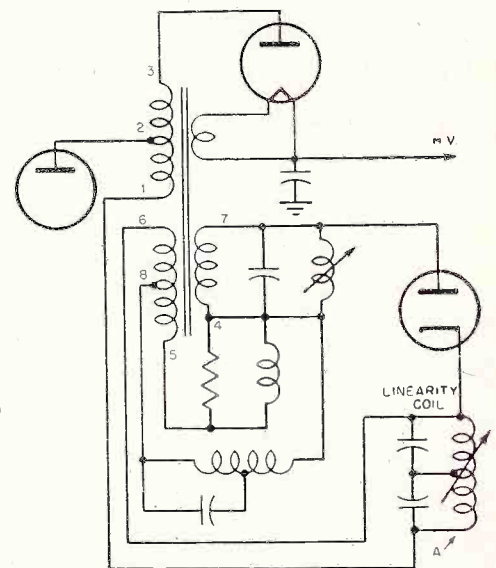

Fig. 2. Tapped linearity control; Ram type 201R5.

(Continued on page 6)



# HOW EASY

## can YOU make tv servicing?



Try this simple rule used successfully by thousands of service technicians.

**Take advantage of the set manufacturer's service literature.**

This is the key to easy, successful servicing which is overlooked by a surprising number of service technicians. They believe, strangely enough, that the more oversimplified the data they purchase the less their servicing problems. They think that because the servicing information on a set is condensed, that data will be easier to work with. How wrong this approach can be measured by the fact that servicing data *in itself* is worthless. Its only value comes from its use as a guide to receiver diagnosis and repair. Doesn't it make sense then that the most complete data will be the best because it makes your diagnosis and repair job easier?

**Rider data is complete data with a bonus!**

For 22 years Rider has been the only publishing source for complete, factory issued, official servicing data. From large, easy to follow schematics... circuit explanations... stage by stage alignment curves... page after page of troubleshooting test patterns... waveforms...

clear, enlarged chassis views... circuit changes... to complete unpacking instructions; Rider gives you the complete story including all manufacturer's production changes... in accurate, organized, unedited form. PLUS A NEW FEATURE: A LISTING OF ABSOLUTELY GUARANTEED REPLACEMENT PARTS. The parts listed must meet the physical and electrical performance ratings of the original equipment used in the receiver... or you get your money back. (Look for this new Rider feature beginning with Rider TV Manual 10 and Rider TV TEK-FILE Pack 57.)

**Rider Servicing data available two ways!**

**Rider TV Manuals Vols. 1 to 9**

Complete data for manufacturer's receivers produced during a certain period. (The newest, TV 9, (just published) covers October 1951 through February 1952.) Each manual contains over 2000 (8½ x 11) pages in permanent binder, with an index covering the contents of all manuals. Manuals are perfect for shop use and permanent reference. Price \$24.00 each.

**Rider TV TEK-FILES  
Packs 1 to 56**

The contents of a typical TEK-FILE Pack are pictured below. In TEK-FILE Packs you buy complete Rider servicing data for only one, two, or a few manufacturers according to your needs. Notice that each pack is made up of standard file folders for easy use. Only \$2.00 each pack.

**TEK-FILE EXTRA.**

Many packs contain TEK-FILE Handies... 3 x 5" index cards giving manufacturer's trouble cures plus production changes. Vital data for permanent repairs!

**DON'T BE SWITCHED!**

Rider TEK-FILE is *Not* the same as any other publisher's service. If your jobber doesn't carry them **DON'T BE SWITCHED.** Write us direct... We'll sell you. (Please include your jobber's name.)

**TRY A PACK**

To judge TEK-FILE'S superiority, buy one pack for the next receiver you service. If you don't agree it's best... return

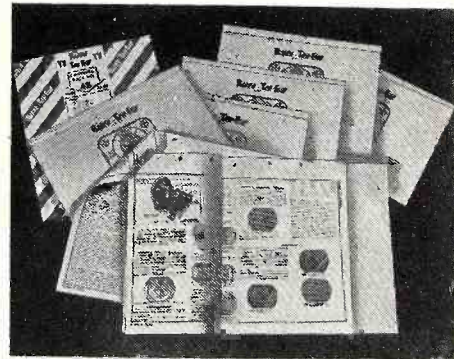

the pack to us within seven days and we'll send you a full refund. **TRY ONE TODAY!**

FREE Rider TEK-FILE indexes are at your jobber's. If he's out, write us.

**OUT SOON!**

Rider **RADIO** TEK-FILES! Same style as TV TEK-FILES. Now, get your complete radio servicing data this easy, economical package way. Ask your jobber.

John F. Rider Publisher, Inc. 480 Canal St. New York 13, N. Y. West Coast office: 4216-20 W. Jefferson Blvd. Los Angeles, Calif.



# WAS . . . and IS . . .

## and FREEDOM from CONFUSION

by John F. Rider

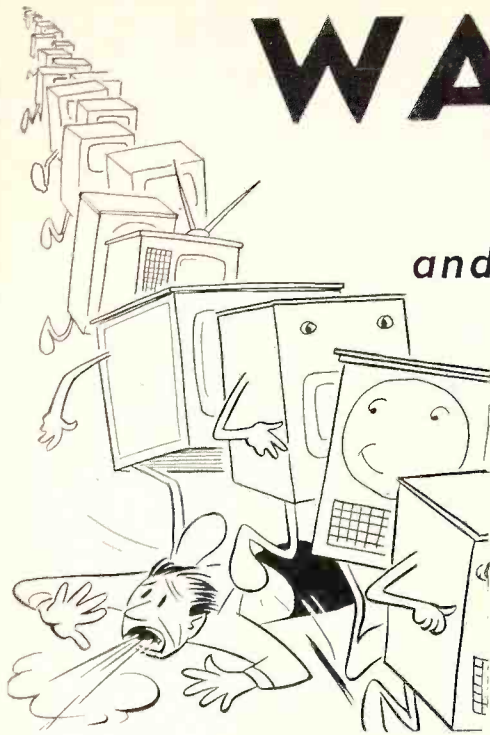

The title of this short piece is not a puzzle or an attempt to be facetious. "Was" and "is" is simply an approach to a situation which has been experienced by almost all tv service technicians at one time or another. We are referring to the discrepancies between receiver circuit wiring and service manual wiring diagrams. These discrepancies are often noted by service technicians, and the first impulse is to become angry. Well try to control it, because there are explanations, and sometimes the matter is not as aggravating as it seems to be at first.

### Circuit Wiring vs. Wiring Diagrams

To begin with, differences in receiver wiring and in schematic wiring diagrams are due to a number of possible causes. Let us examine the first of these, a quite common cause. Parts shortages develop in the set manufacturing plant during a production run and substitutions must be made. Substitutions of resistors, causing changes in values, are the most common.

If you exercise patience you will find that when this is the case, the substitute resistor usually has a value which is within the tolerance limits of the original. In other words, if a resistor R176 is rated at 48,000 ohms plus or minus 20 percent, it is possible to substitute another of from 39,000 to as high as 57,000 ohms, still being within the tolerance of the original and not interfering too much with the performance of the circuit. These two resistance values are the minus 20 percent and plus 20 percent limits of the original 48,000 ohm unit.

Whether the manufacturer's substitute, used until the correct original value is received in quantities for use once more in the receiver, is on the high side or the low side of the tolerance limits is a matter of the circuit arrangement and of how other resistors asso-

ciated with the substitute part are related to the tolerance. If the tolerance of the other units runs toward the plus side, then the substitute usually will be toward the minus side. Of course the reverse is true if the original circuit resistance tends to lean toward the minus side, in which case the manufacturer will usually choose a substitute part approaching the plus tolerance limit of the original resistor. In this way substitutions are made which tend to keep the overall circuit resistance, and possibly the tube voltage, reasonably unchanged.

In a similar manner, resistive components which are rated at plus or minus 5 percent will be found replaced by others which approximate values equal to the resistive limits set by the original tolerance. For instance, a resistor rated at 330,000 ohms, plus or minus 5 percent, may be replaced by another (with suitable wattage) of a value as low as 315,000 ohms, or as high as 345,000 or even 350,000 ohms. The last named figure would represent about 6 percent plus tolerance, and in many cases would do no harm.

### Replacements and Parts Lists

Thus it is necessary to consult the parts list first, when a discrepancy of this kind is found, before declaring that the receiver constants differ greatly from the constants shown on the circuit diagram. Of course, if a difference in excess of the tolerance stated in the parts list is experienced, such as a 40 or 50 percent discrepancy, then it becomes necessary to check the service information very closely for any possible information given in the data as an explanation for the circuit constant differences. Quite frequently, depending on the kind of service information being used, the component constant discrepancies are explained.

Usually changes of the kind mentioned are, as previously stated, the consequence of parts shortages and the desire to keep a production line going. If the trouble is not related to the circuit wherein the discrepancy exists, it matters little anyway, even if the difference in resistance values exceeds the tolerance of the original several fold. However, if the trouble is related to these circuits in which the receiver part differs substantially from that part shown in the schematic, the replacement part should be that which is indicated in the schematic.

Quite frequently a change in parts value is a manufacturer's production change, made in order to effect an improvement in circuit action. Invariably such changes in constants exceed by far the tolerance stated for the original part. Such might be a change from 680,000 ohms to 1,300,000 ohms — almost a 100 percent increase in resistance — when perhaps the tolerance limit for the original resistor was only 20 percent.

However, a distinction can be drawn between a discrepancy in ohmic value equal to the limits set by the tolerance of the original part, as shown in the schematic, and one which far exceeds the tolerance limits. The latter is either a production change for a deliberate purpose other than a short supply of the original value, or it represents trouble. There are rare exceptions to this statement, but since they do exist we will mention them

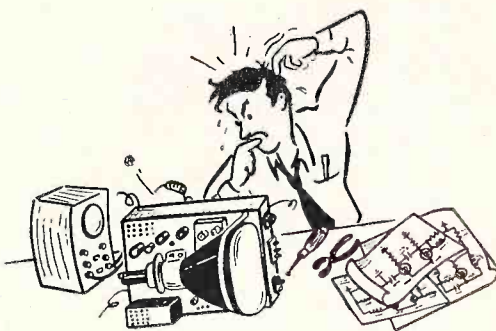

here. They become significant if the trouble in the receiver is related to them. If the fault is elsewhere and not associated with the circuit in which the discrepancy is found (as demonstrated by normal circuit action) it is needless to worry about it.

But if the discrepancy remains a source of mental aggravation, and a reason for the difference is sought, it is well to examine the service information. Usually a reference to "was" will be found in the service information, indicating that the manufacturer has deliberately made a production change to accomplish a purpose. Where this information may be found differs in the different presentations of the set manufacturers. Sometimes this information appears as notes on the schematic. As a matter of fact, all notes on a schematic should be read. They should not be taken for granted as being unimportant because they often explain the discrepancy

(Continued on page 13)



## He'll know better next time . . .

When it comes to making your customers happy, there's no "next time". You have to do the job right the first time. That's why it isn't good business to order capacitors by rating alone instead of specifying rating *and* brand. You can avoid customer trouble when you order capacitors if you . . .



## Make Sure! Make it Mallory!

You can build a reputation for dependable service and really satisfy your customers by specifying Mallory capacitors.

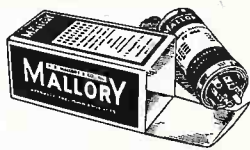

Rating-for-rating and size-for-size Mallory FP's give longer life even at higher temperatures and greater ripple current. You get trouble-free operation at 185°F. (85°C.). And Mallory FP's won't "die" on your shelves.



Mallory Plascaps† are the first completely engineered plastic tubular capacitors. They eliminate premature shorting . . . leakage . . . unsoldered leads . . . off-center cartridges. And Plascaps are priced right! Count on them as you do on Mallory FP's.

Mallory pioneered capacitor development . . . produced the first dry electrolytic capacitors . . . showed the way in making capacitors smaller, longer-lasting, more heat resistant, more uniform.

So, when you order capacitors, specify Mallory—always. Mallory capacitors are best for you . . . best for your customers. And they cost no more.

*Depend on your Mallory Distributor for quality products at competitive prices.*

P. R. MALLORY & CO. Inc.

# MALLORY

CAPACITORS • CONTROLS • VIBRATORS • SWITCHES • RESISTORS  
• RECTIFIERS • VIBRAPACK\* POWER SUPPLIES • FILTERS

\*Reg. U. S. Pat. Off.

## APPROVED PRECISION PRODUCTS

**P. R. MALLORY & CO., Inc., INDIANAPOLIS 6, INDIANA**

†Reg. U. S. Pat. Off.

Please mention *Successful Servicing* when answering advertising.



# Successful SERVICING

REG. U.S. PAT. OFF.

Dedicated to the financial and technical advancement of electronic maintenance personnel

Volume 13 Number 7

May, 1952

JOHN F. RIDER, *Publisher*  
Annette M. Tricarico, *Editor*

*Advertising Representative*

H. J. Olsow & Co.  
3951 Grand Central Terminal  
New York 17, N. Y.  
Murray Hill 6-4670



## Curtain Time

### The Lifting of the Big Freeze

It would be unforgivable not to say something about the lifting of the tv freeze. Everybody had been waiting for it and it finally happened. 'Tis said that about 40,000,000 tv receivers will be in use within five years, if not sooner. Good — the servicing industry needs the business. However, let's not look for hectic activity during 1952; things won't start rolling until 1953. That's not bad either because it gives each service technician the opportunity to become familiar with uhf.

The uhf side of television servicing will introduce a few new things of concern to the service technician. It will hit his pocket-book by requiring new sweep generators and markers. These will be more expensive than corresponding vhf units. Whether we like it or not, the cost of test equipment rises with each increase in operating frequency.

Circuit techniques used in uhf front ends are interesting. We've seen some of the devices and they're humdingers. However, like everything else which has come within the province of the service technician, uhf front ends eventually will become completely understandable. Nothing in these units is beyond the acceptance capabilities of a serious minded serviceman. Given time, even the resonant hole (the cavity) will be looked upon in the same way by the service technician as is the present day vhf front end. Uhf, like everything else before it, will be taken in stride.

### The Coumont Letter

Thanks for the volume of mail concerning the open letter to Al Coumont which appeared in the March, 1952 issue of SUCCESSFUL SERVICING. Our belief is that something will be done about it. It may not happen as soon as all of us would like it to, but we feel reasonably certain that the idea is sufficiently sound so that it will not be ignored. Service managers of tv receiver manufacturers have expressed favorable comment concerning the communication. The main problem in this whole affair is to convince the sales departments of the tv receiver manufacturers that there is no shame in admitting that electronic devices are subject to failure. Since all sales managers do not think alike, it makes more sense to have an impartial body such as the RTMA carry the ball. In this way all brands of receivers receive equal treatment.

Now for the \$64 question. Have *you* backed up our letter by affirming it to Al Coumont? Maybe the guy needs convincing that the servicing industry agrees with our stand. An open letter has merit, but thousands of letters saying the same thing carry more weight. Write to Al Coumont. He'll get your message through to Glen McDaniel, President of RTMA. The address is RTMA, 14th St. N.W., Washington, D. C. You must be heard if you want to get something done. Mail is one way of expressing yourself. Remember that you get only as much out of something as you put into it!

Also many of the letters requested reprints of the editorial. These reprints will be prepared, but we'd like to know in what form you would like them. Drop us a line and let us know *immediately* how you would like the reprints, in brochure form or as a display "blow-up" for your store window. The way you decide is the way it will be done. The sooner we know how the majority wants it, the sooner the reprint of the Coumont letter will be ready.

### Manufacturers' Change Notices and Trouble Cures

We have received letters asking about the omission of this data from SUCCESSFUL SERVICING. We published such information for almost 12 years, skipping only the World War II years. They're being omitted from the magazine because they now appear in Rider TEK-FILE Handies on 3 x 5 inch cards. Tek-File Handies appear in groups of eight per page in Rider TV Manuals beginning with TV 9, in place of the change pages which appear in earlier volumes. Form the habit of examining these Handies; they'll save you hundreds of diagnosing hours each year.

### TELL-A-FAULT Responses

The May issue of SUCCESSFUL SERVICING contained our first announcement of the completely new troubleshooting TELL-A-FAULT service. It seems that the idea of making the findings of the Rider laboratory available to service technicians on a monthly basis through TELL-A-FAULT service was well liked. Nothing like this trouble-shooting service has ever been offered before, and we're glad to see that practical servicemen are receptive to this new, unique and time saving service. For more details on TELL-A-FAULT see the four page insert in the centerfold of the magazine.

*John F. Rider*



# linearity and width coils

## their use and replacement

(Continued from page 1)

form change in relation to the movement of core in or out of the coil form is considerably less than that in the circuit shown in Fig. 1.

In certain circuits great variations in waveform adjustments are desired. This is accomplished by the use of a linearity control with relatively high inductance, as illustrated in Fig. 3. This coil is used in GE and similar type circuits. The inductance variation is from 3.5 to 29.5 and the d-c resistance is approximately 32 ohms. The linearity and

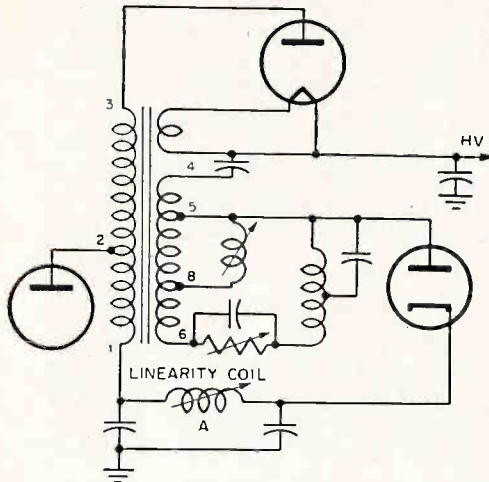

Fig. 3. High-inductance linearity control; Ram type 201R10.

width controls used in this type of circuit are alike.

### Width Controls

The width control, when wired across a portion of the horizontal-output transformer secondary, has a direct effect on the output efficiency of the transformer. At maximum inductance, maximum width is obtained. Reduction of inductance in this control results in corresponding reduction of picture width. In order to prevent what would amount to shorting out that portion of the transformer secondary, a range of adjustment is established. Variations from  $\frac{1}{4}$  to  $\frac{3}{4}$  of an inch on each side of the picture are sometimes desired. The proper maximum inductance and variations are accordingly determined by the amount of voltage produced across the portion of the transformer secondary used for this purpose.

In Fig. 4 we see the most conventional type of width-control. The inductive range of this coil is from 0.5 to 0.25 millihenry and the d-c resistance is approximately 0.5 ohm. Essentially the inductance of the width control (across the windings on terminals 5 and 6 of the horizontal output transformer) is made high enough to maintain maximum voltage distribution in the secondary when at full

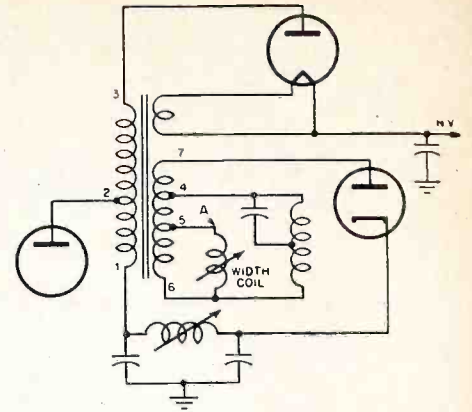

Fig. 4. Conventional width control; Ram type 201R1.

inductance. When the inductance is lowered, the voltage drop across this portion of the secondary (terminal 5 and 6) increases. This results in an overall drop in the distribution of secondary voltages and ultimately in less width. The inductive range of this control is not large, therefore the change in width is fairly sharp when the coil core is vertical.

In certain applications, a broader tuning effect is desired. Although the connections are essentially the same as those shown in Fig. 4, the horizontal-output transformer is designed to accommodate a width coil of higher inductance. The range is 0.17 to 0.61 millihenry. Both broad tuning and greater range of width adjustment is accomplished with this arrangement.

Figure 5 shows a circuit in which the voltage between taps is considerably higher, therefore a higher inductance is used to maintain a balance of voltage distribution across the secondary of the horizontal-output transformer. The inductive variation in this con-

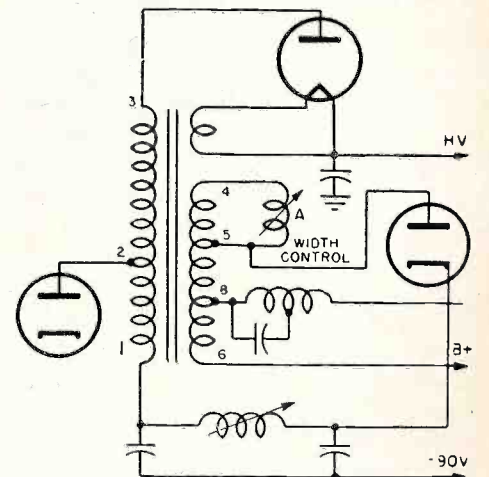

Fig. 5. High-inductance width control; Ram type 201R10.

rol is from 3.5 to 29.5 millihenrys, and the d-c resistance is approximately 32 ohms.

Certain horizontal-output transformers are designed with a completely separate width-coil winding, as opposed to the use of taps. In this arrangement, shown in Fig. 6, the width control can be operated with one side grounded since there is no d-c potential on this winding; the inductive effect on width

(Continued on page 8)

## ATTENTION! RADIO SERVICEMEN

THERE ARE THOUSANDS OF OUT-MODED RADIOS IN YOUR "BACK YARD" JUST WAITING TO BE REPLACED... AT YOUR SUGGESTION

Here is the custom-built AM-FM chassis that means **BIGGER PROFITS** for you!

### The NEW ESPEY model 511-C

#### FEATURES

1. AC Superheterodyne AM-FM Receiver.
2. Improved Frequency Modulation Circuit, Drift Compensated.
3. 12 Tubes plus rectifier and Pre-Amp 12AT7 Tube.
4. 4 dual purpose tubes.
5. Treble Tone control.
6. 6-gang tuning condenser.
7. Full-range bass tone control.
8. High Fidelity AM-FM Reception.
9. Automatic volume control.
10. 10 watts (max.) Push-Pull Beam Power Audio Output.
11. 12-inch PM speaker with Alnico V Magnet.
12. Indirectly illuminated Slide Rule Dial.
13. Smooth, flywheel tuning.
14. Antenna for AM and folded dipole antenna for FM Reception.
15. Provision for external antennas.
16. Wired for phonograph operation with switch for crystal or reluctance pick-up.
17. Multi-tap output trans., 3.2-8-500 ohms.
18. Licensed by RCA and Hazeltine.
19. Subject to RMA warranty, registered code symbol #174.

Makers of fine radios since 1928.

**ESPEY**  
MANUFACTURING COMPANY, INC.  
258 EAST 72nd STREET, NEW YORK 21, N. Y.  
TEL. TRafalgar 9-7000

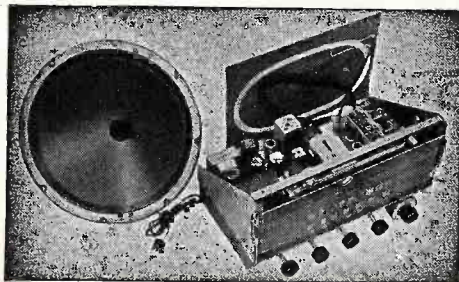

#### SPECIFICATIONS

Supplied ready to operate, complete with tubes, antennas, speaker and all necessary hardware for mounting in a table cabinet or console, including escutcheon. Power consumption - 105 watts.

Chassis Dimensions: 13 1/2" wide x 8 1/2" high x 10" deep.

Carton Dimensions: (2 units) 20 x 14 1/2 x 10 3/4 inches.

Net Weight: 17 1/2 pounds each.

Sold through your favorite parts distributor.

WRITE FOR CATALOGUE KD12  
AND NAME OF NEAREST DISTRIBUTOR.



# "Let Me Tell You How It Happened..."



Carl Vineglass,  
Al's Radio,  
Lawrence, Mass.

"FOR YEARS I'VE BEEN BUYING TUBES... A LOT OF THEM CBS-HYTRON. But I didn't know too much about CBS-Hytron. Sure, I'd seen their ads. Read about their original rectangular tube. Their IX2A, 6BQ6GT, 12BH7, 12BY7, etc. Their handy service tools. (I just couldn't get along without my Soldering Aid.) Their Budget Plan. And so on.

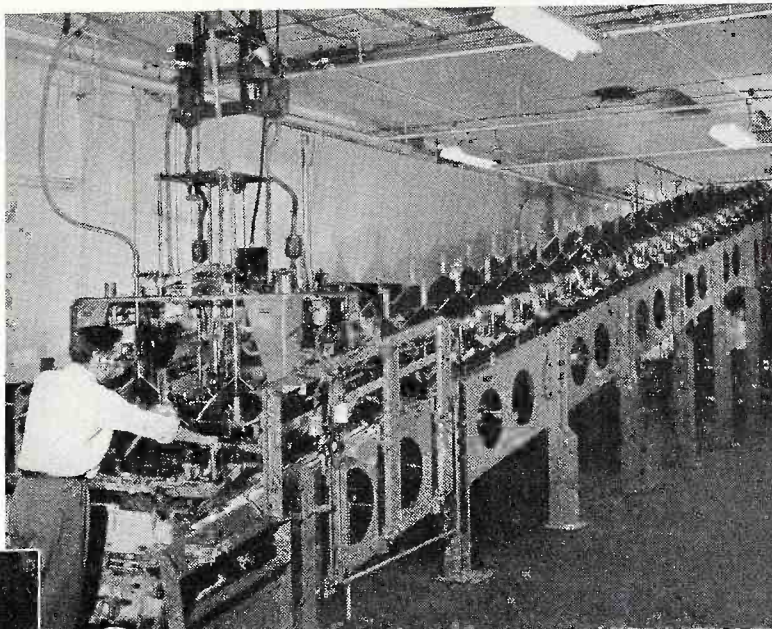

"CBS-Hytron has a saying, 'Tubes are known by the company they keep.' In their shipping rooms, I saw tubes being rushed out to most of the top manufacturers and jobbers I ever heard of... and lots I don't even know.

"The reason for all the popularity wasn't hard to find. I never saw such painstaking manufacturing and testing in my life. From raw materials to finished tube. Every single tube gets the works.

"And is making tubes complicated! That ingenious machinery does everything but talk. The flying fingers of the girls assembling the tubes, though, are what caught my eye. I just couldn't believe you could get that watch-like precision with that amazing speed. And talk about engineers! I saw electronic, mechanical, chemical, metallurgical, production, industrial engineers by the score.

"I've read that CBS-Hytron's picture-tube plant is the most modern in the world. I believe it. It's really something the way that push-button, automatic plant handles those big bottles. And that new Danvers receiving-tube plant is more of the same. Floor space covers approximately five acres. Main production floor is longer (500 feet) than the longest home run ever hit by Babe Ruth. That plant has everything. They tell me the whole idea was to produce at economical top speed the finest receiving tubes in the world. To my way of thinking, they succeeded.

"Believe me, I'm glad I made that trip to CBS-Hytron. They're a real on-their-toes outfit. Before I never was too fussy what standard brand of tube I bought. But now I want CBS-Hytron, and that's that! You would, too, if you'd seen what I have."

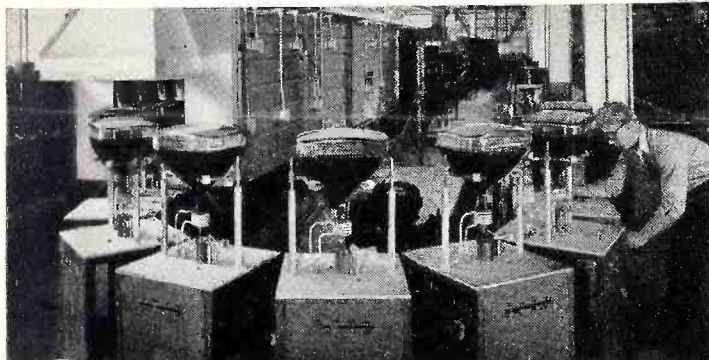

"I like to know the fellows I buy from though. So last week I drove over to Salem. The CBS-Hytron gang, from President Bruce A. Coffin down, gave me a real welcome. Also the low-down on CBS-Hytron tubes, and what's behind them.

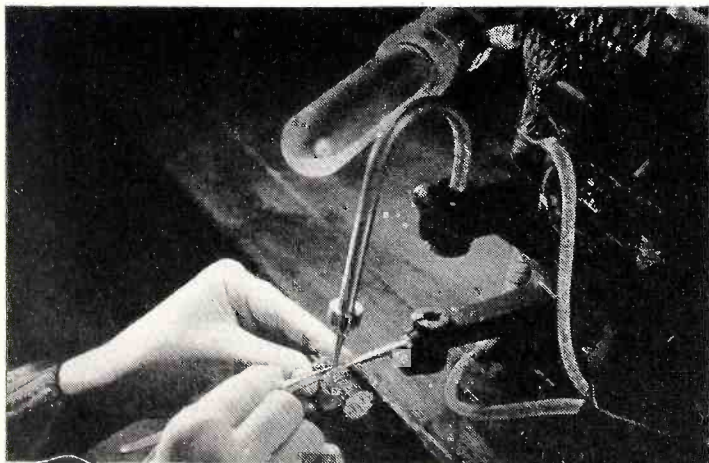

"First off, I discovered that CBS-Hytron is big... and getting bigger fast. I saw receiving tubes rolling out of their combined Salem and Newburyport plants at 300 a minute. With their new Danvers plant, it'll be 600 a minute! And their picture tubes run at 5000 a day! You may already know that CBS-Hytron is now a division of Columbia Broadcasting System, Inc.

### AN OPEN INVITATION . . .

to all service-dealers and their distributors. You are mighty welcome to drop in at CBS-Hytron any time. How about this summer?



MAIN OFFICE: SALEM, MASSACHUSETTS

Please mention Successful Servicing when answering advertising.



## linearity and width coils

(Continued from page 6)

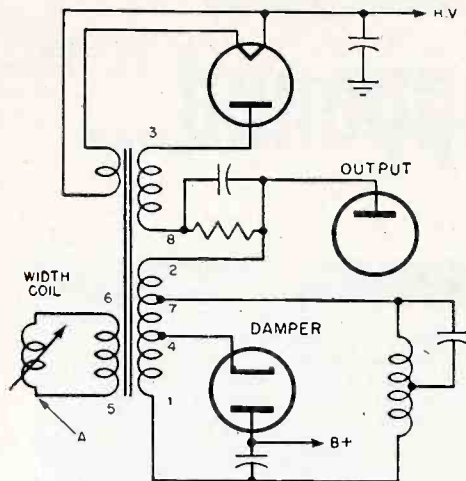

Fig. 6. Grounded width control on separate winding of flyback transformer; Ram type 201R1.

will be the same, but this will give additional protection against shorting.

Although keyed-age voltages are usually supplied from special windings on the horizontal output transformer, this pulse voltage is sometimes obtained by use of an adjunct winding on the width control, as illustrated in Fig. 7. This is done to simplify design variation for manufacturers who incorporate keyed age in some models but not in others. It is simpler and less costly to change the design of the width control alone than to change that of the entire transformer. The inductance range of this control is approximately 3 to 29 millihenrys, and the range of the keyed-age winding is 0.16 to 0.7 millihenry. The approximate d-c resistance of the width-control winding is 28 ohms.

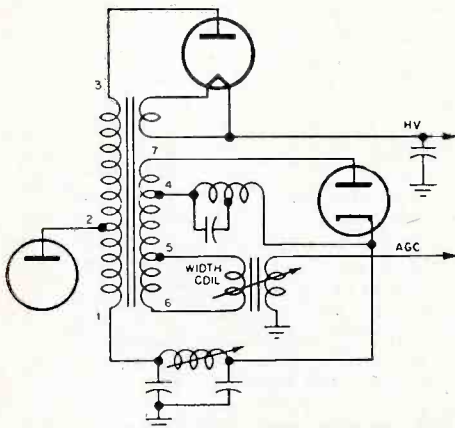

Fig. 7. Width control with added winding for keyed age; Ram type 201R11.

### Design Factors Helpful in Servicing

Width and linearity controls must be designed to withstand the high-peak pulse voltages that appear in the circuits in which they are used. To obtain higher Q or merit, universal winding is used rather than random winding. This technique introduces the danger of shorting if some of the insulation is scraped off where wires cross. The manufacturer's standard test for these coils, which

duplicates operating conditions, is to apply a high-peak pulse in the order of 2,000 volts to the coil terminals. Shorted turns will show up in this way. In a tv receiver a shorted coil drains excessive current from the high-voltage transformer, absorbing power and reducing the other secondary voltage.

High test voltages in the order of 3,000 volts rms are applied between the core and coil windings. This potential will break down as inferior coil form. In circuits of the type shown in Fig. 6, this capability is important. Effectively, the width coil shown

here appears across terminals 4 and 5 of the transformer secondary, where the pulse potential is the highest. In tv-receiver operation, the breakdown of the coil to ground (the core) will burn out the coil. Under sustained breakdown the transformer will burn up.

Since the normal ambient operating temperature of the receiver is 40° C, the design of the component must be such that its temperature rise does not exceed 50° C. This is a specification of the Underwriters Labora-

(Continued on page 16)



★ You'll agree that this is the greatest advance in vibrator design in the past 17 years. This new CORNELL-DUBILIER vibrator is SEALED until used, to prevent oxidation of the vibrator contacts, and VENTS itself when needed! Heat generated when the vibrator is put into service melts the wax out of the sealed vent and permits air circulation... for LONGER LIFE and EVEN GREATER PERFORMANCE!

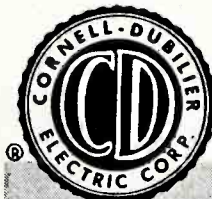

CONSISTENTLY DEPENDABLE  
**CORNELL-DUBILIER**  
SOUTH PLAINFIELD, NEW JERSEY



• CAPACITORS • ANTENNAS  
• ROTATORS • VIBRATORS • CONVERTERS

Please mention Successful Servicing when answering advertising.



*Another Rider 'First'*

# TELL-A-FAULT

*the most unique SERVICE  
ever made available to  
TV-radio service technicians*

Every month **TELL-A-FAULT**  
gives you detailed information on:

- TV trouble symptoms as they appear on picture tubes — also fault locations
- Short cuts to easier servicing — trouble isolation and construction of troubleshooting speed-up devices for TV and radio
- Circuit guides showing different kinds of TV receiver circuits
- Explanations of test oscilloscope patterns for each type of circuit found in TV receivers
- How to use test equipment — all kinds by brand names — for TV, radio, and other servicing

**and much, much more**

**TELL-A-FAULT**

**does your troubleshooting for you!**

READ THE COMPLETE DETAILS

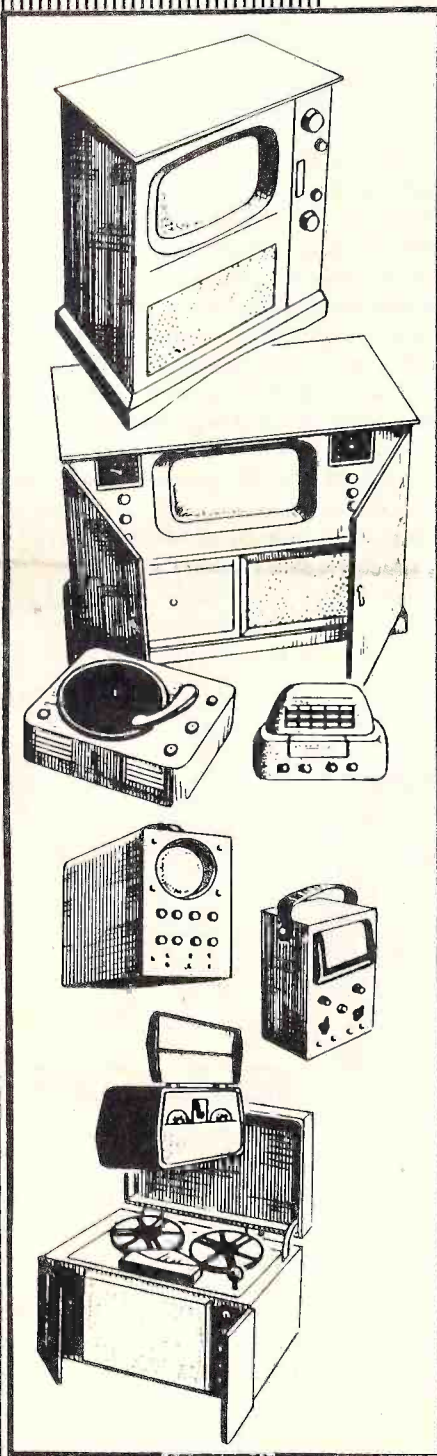



# TELL-A-FAULT

you'll see  
receivers and  
equipment in  
and more pr  
complete serv

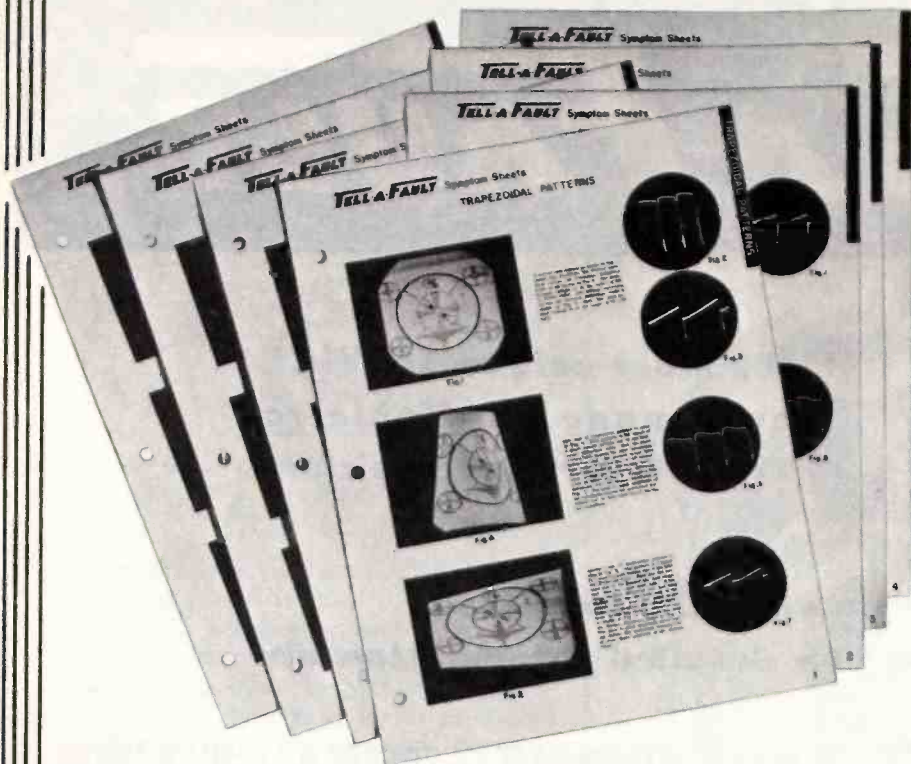

## TELL-A-FAULT SYMPTOM SHEETS

TELL-A-FAULT symptom sheets do your troubleshooting for you! These time-saving, easy-to-use sheets actually catalog receiver symptoms for you. Pictures, pictures, and more pictures — all set up for you to compare with symptoms on picture tube screens and scope screens on your service bench. The Rider service laboratory did the troubleshooting on a wide variety of receivers. The receivers were not hand-picked to bring to light a specific fault. They represent the same receivers *you* service every day in your shop. Every month you will receive between 64 and 96 symptom pictures to make your servicing easier (from 768 to 1,152 pictures per year). They will be presented on handy 8½ x 11" pages, three-hole punched, ready for filing in your binder, which we furnish. They will be correlated with various kinds of circuits used in TV and other receivers. The greatest emphasis is on TV.

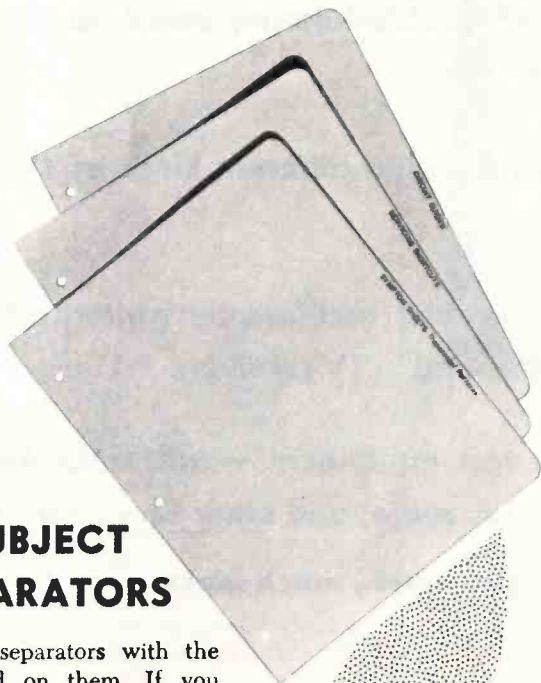

## SUBJECT SEPARATORS

We give you separators with the symptoms printed on them. If you have trouble with buzz, ringing in the picture, vertical jitter, horizontal tearing, low brightness, or any one of the many possible faults, you'll know exactly where to look. Merely lift the 9 x 11" separator, with the symptom listed on it, and the pages that follow contain the information you need. It's as easy as pressing a button to locate the troubles responsible for a symptom, to say nothing of the time you save.



## TELL-A-FAULT BINDER

File all your TELL-A-FAULT information for instant reference in this handsome, simulated-leather, flexible, loose-leaf ring binder. It will accommodate a full year's TELL-A-FAULT troubleshooting data and the other information we send you monthly. You receive this binder with your first month's issue of TELL-A-FAULT troubleshooting data.

# TELL-A-FAULT



# Does your troubleshooting for you!

and radio types of allied easily, faster ly with this

TELL-A-FAULT Circuit Guides work hand-in-hand with TELL-A-FAULT symptom sheets. They are examples of the great many different circuits used in various TV receivers. The circuit guides help you to localize faults. Each time a manufacturer incorporates one or more new circuits in his receiver you will receive a breakdown on them on 8 1/2 x 11" pages to place in the circuit-guide section of your binder. The TELL-A-FAULT symptom sheets are correlated with the circuit guides so that you can immediately identify the symptom and trouble with the particular kind of circuit. TELL-A-FAULT is planned to work with your service data — your Rider Manuals and TEK-FILE, etc. In a matter of seconds you can pinpoint the trouble — especially the obscure one.

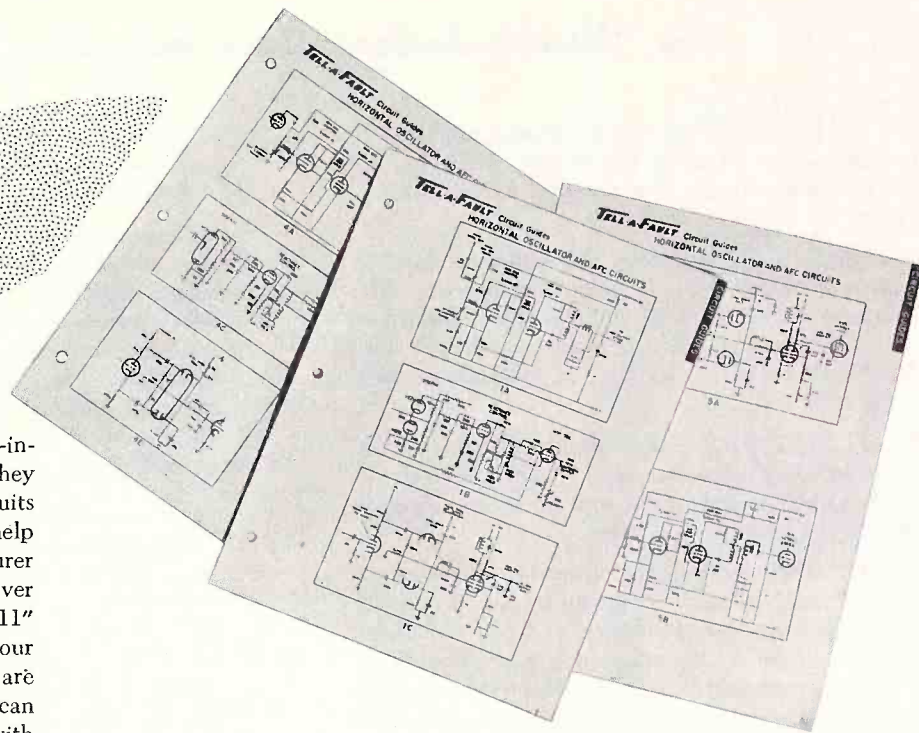

## TELL-A-FAULT CIRCUIT GUIDES

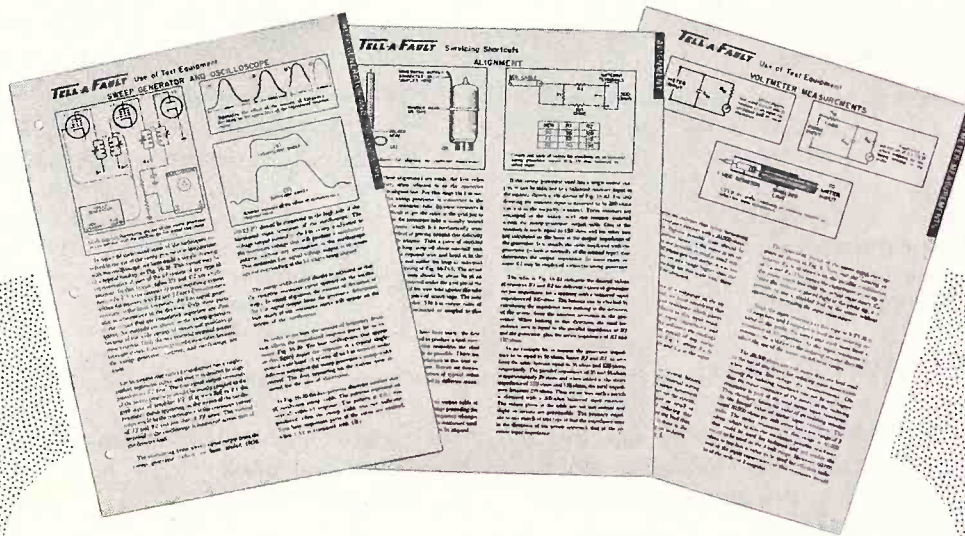

Time is money. The more you save, the greater your income. This section shows you how to save time. For instance, it tells you the fastest techniques for isolating faults, how to make measurements more rapidly, how to construct devices that eliminate wasted time in servicing.

## SERVICING SHORT CUTS and HOW TO USE TEST EQUIPMENT

Since most of your servicing is done with test equipment, TELL-A-FAULT tells you how to use your scope, vtvm, signal generator, etc., to get the most use and value from them. This section alone is worth the price of the entire service! Pages in this section are 8 1/2 x 11".

will save you hours of time! As few as one or two symptom sheets can save you enough time to pay for the entire year's cost of TELL-A-FAULT



# TELL-A-FAULT

## The Troubleshooter's Troubleshooting Service

TELL-A-FAULT is a completely new troubleshooting service for electronics technicians. Nothing like it has ever been attempted in the servicing industry. *It is practical information for the practical man.* No theory!

In addition to today's TV problems, the lifting of the TV freeze — the contemplated increase in radiated power from TV stations — the approach of UHF — all will combine to make the daily life of the TV service technician more complicated. Let TELL-A-FAULT relieve you of this burden. Let experts work for you!

Specifically, TELL-A-FAULT deals with the troubleshooting (symptoms and cures) of all types of television receivers — also radio receivers, record changers and recorders. Special emphasis, however, is given to television.

TELL-A-FAULT is a quadruple-threat service consisting of (1) time-saving, pictorial, symptom and cure sheets, (2) circuit guides, (3) servicing-technique short cuts, and (4) the usage of all sorts of test equipment. All information is practical. It is developed by working with and on everyday receivers and other equipment, just like those with which you have had trouble.

Working under the same conditions you work under, the Rider service laboratory analyzes receiver symptoms and determines the faults and cures. It is these analyses and cures that are available to you. *You profit by the experience of experts* who are working daily in a service clinic to assist you. This is the reason TELL-A-FAULT will save you hours and many dollars.

### Make Every Hour Pay

From now on you won't have to work many hours diagnosing a fault — and then charge for only an hour or two. You'll have the information in TELL-A-FAULT service. Because the Rider laboratory deals with a wide cross section of TV and radio receivers and allied equipment, in nine cases out of ten your problem will have already been diagnosed. Merely by flipping through the practical, time-saving TELL-A-FAULT symptom sheets, you'll find your problem *and its cure*.

### TELL-A-FAULT Does Not Duplicate

The servicing information in TELL-A-FAULT is available nowhere else. Nor does TELL-A-FAULT duplicate data that has been published in Rider Manuals, TEK-FILE or in other sources. It is copyrighted information that is made available to TELL-A-FAULT subscribers.

### TELL-A-FAULT Pays For Itself

One or two TELL-A-FAULT symptom sheets in one year can save you enough time to pay for the entire year's subscription cost. During the course of a year we mail to you in TELL-A-FAULT service between 768 and 1,152 symptom pictures *plus* the circuit guides, *plus* servicing short cuts, *plus* valuable information on how to use your test equipment. This comes to you monthly.

### Available at Low Cost

Most specialists charge a high fee for consultation. But all findings of the Rider laboratory will be available to you monthly

in TELL-A-FAULT service at an extremely low price in comparison to the value you will receive. Obtain the skilled services of SPECIALISTS at the modest fee of a General Practitioner!

*How much does a subscription cost you?* We estimate that you can save anywhere from 50 to 200 hours in servicing time by using TELL-A-FAULT. A quick computation on your part tells you how much this means to you in dollars. We are certain your estimate comes to many, many times the cost of a year's subscription to TELL-A-FAULT. Twelve months of the *complete* TELL-A-FAULT troubleshooting service, including all features shown, costs you only \$10.00 — less than twenty cents a week!

### Start Your Subscription Right Now!

Get TELL-A-FAULT service from the first issue. Use it every day at your service bench. Take it with you when you make home service calls. Use it whenever a time-consuming problem faces you. Watch it whittle down your troubleshooting time!

TELL-A-FAULT is another Rider 'first' that will revolutionize the servicing industry. Other Rider 'firsts' — Rider's Radio, Television, PA, Record Changer service manuals, have proved through the years that Rider has consistently met the needs of the industry with the best information available. TELL-A-FAULT carries on this high tradition.

You have the opportunity of becoming a charter subscriber to the TELL-A-FAULT service. In future months you will receive special offers to which *only* TELL-A-FAULT subscribers will be entitled. The first issue of TELL-A-FAULT will be out in June, 1952.

REMEMBER! TELL-A-FAULT pays for itself if you use only one or two symptom sheets during the year. Save time and eliminate guesswork in troubleshooting — use TELL-A-FAULT! The information you use comes from troubleshooting EXPERTS! Whether you have one year's experience or twenty years' experience, TELL-A-FAULT can serve you equally well!

### MAIL THIS COUPON TODAY

John F. Rider Publisher, Inc., Dept. TF  
480 Canal Street  
New York 13, N. Y.

#### Gentlemen:

TELL-A-FAULT is the direct answer to the service technician's needs. As a service technician it will save me many hours of troubleshooting time. I am enclosing ten dollars (\$10.00) to cover the cost of a one year subscription. Send me my TELL-A-FAULT binder, separator cards, and the first month's issue of symptom sheets, circuit guides, and other information as soon as it is published.

Name.....

Address.....

City.....

Zone.....

State.....

Cash

Check

Money Order



# USE OF 'SCOPE PROBES\*

by R. G. (Bob) Middleton

\*This is Part Two of a two-part article on Special Scope Probes by Bob Middleton, Senior Engineer at Precision Apparatus Co., Inc. Our apologies to the author. In Part One of this article, which ran in the April issue of Successful Servicing, Figure 1 and Figure 5 were reversed. The captions, however, are correct.

Scope probes are powerful tools in the hands of the experienced technician. With a suitable complement of probes, the following jobs can be done quickly, and guesswork can be supplanted by real know-how.

1. Locating Source of Buzz: As illustrated in the September and October issues of Successful Servicing, buzz appears on the scope screen as a narrow pip. This pip can be traced through the audio circuits by use of a direct cable to the scope. However, since a service scope will not usually respond directly to a 4.5-mc signal, a simple untuned crystal probe is required to trace buzz through the 4.5-mc amplifier. The probe develops the wave envelope, to which the scope can respond.

Furthermore, since the 4.5-mc sound signal is mixed with the 0.4 mc picture signal in the video amplifier, a crystal probe tuned to 4.5 mc is required to trace buzz through the video amplifier. Otherwise, the vertical sync pulse will mask the buzz pulse.

Likewise, since the i-f sound signal is mixed with the i-f picture signal, a crystal probe tuned to the sound i-f frequency is required to trace buzz through the i-f amplifier. As before, the tuned probe eliminates the vertical sync pulse from the display on the scope screen.

2. Making Marker Visible on F-M Detector Response Curve: Because some f-m detectors have a high degree of a-m rejection, the technician finds that best markers may be invisible on the visual-response curves. This difficulty is easily overcome by substituting a simple crystal probe for the tv receiver for marker location. Because the probe has no a-m rejection, the marker will then appear clearly at some point along the base line of the scope. Now, as long as the sweep and horizontal controls are untouched, the position of the marker will remain unchanged along the baseline of the scope trace. Accordingly, the tv receiver can then be re-

placed in the test circuit, and the location of the marker is known. Any necessary alignment adjustments can now be made and the vertical-gain control of the scope can be varied as desired without changing the location of the marker.

3. Calibration of Marker Generator: The easiest and quickest way to calibrate any marker generator is to beat the output from the generator against the harmonics from a 1-mc or 2-mc crystal oscillator. Here again, the simple crystal probe is required to make the beat envelope of the mixed signal visible on the scope screen. Outputs of the marker generator and crystal oscillator can be paralleled, and then fed through the crystal probe to the vertical amplifier of the scope as shown in Fig. 1.

The internal sweep of the scope is used and its frequency is adjusted to any convenient audio rate. When there is no harmonic relation between the frequency of the crystal oscillator and the marker generator, only a horizontal baseline appears on the scope screen. As the marker-generator frequency is changed so that a beat-note is produced that is within the frequency range of the scope, some vertical deflection occurs. The waveform of the beat-note appears on the screen. When the marker-generator is at exactly the same frequency as the crystal oscillator (or one of its harmonics) so that zero-beat occurs, no vertical deflection occurs on the screen and a horizontal line appears once more. As the marker-generator frequency is varied to the other side of zero-beat so that a beat-note is produced within the frequency range of the scope, some vertical deflection occurs again. The waveform of the beat-note appears on the screen. Hence, as the marker-generator frequency is varied through the frequency of the crystal oscillator (or its harmonic), the difference frequencies and the zero-beat produced in the probe circuit are clearly visible on the scope screen. In this manner, the exact zero-beat indication is seen

(Continued on page 11)

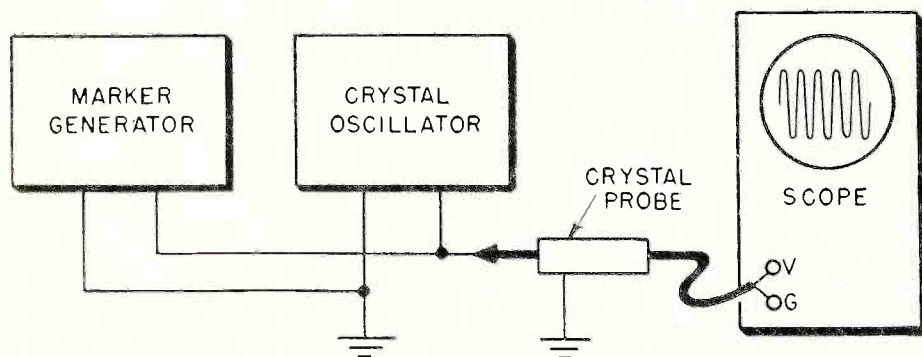
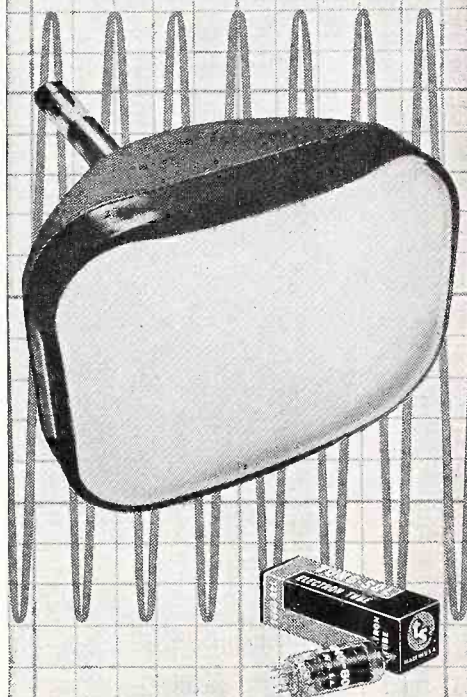

Fig. 1. Calibrating marker generator against crystal oscillator.

# TUNG-SOL®

for  
**Uniformity  
and  
Dependability**



### REPLACEMENT:

Tung-Sol tubes keep service standards up to set manufacturers' specifications.

### INITIAL EQUIPMENT:

Tung-Sol tubes meet the highest performance requirements of set manufacturers.

**TUNG-SOL**  
RADIO, TV TUBES, DIAL LAMPS

TUNG-SOL ELECTRIC INC., NEWARK 4, N. J.  
Sales Offices: Atlanta • Chicago • Dallas • Denver  
Detroit • Los Angeles • Newark

ALSO AUTO LAMPS, ALL-GLASS SEALED  
BEAM LAMPS AND SIGNAL FLASHERS

Please mention Successful Servicing when answering advertising.



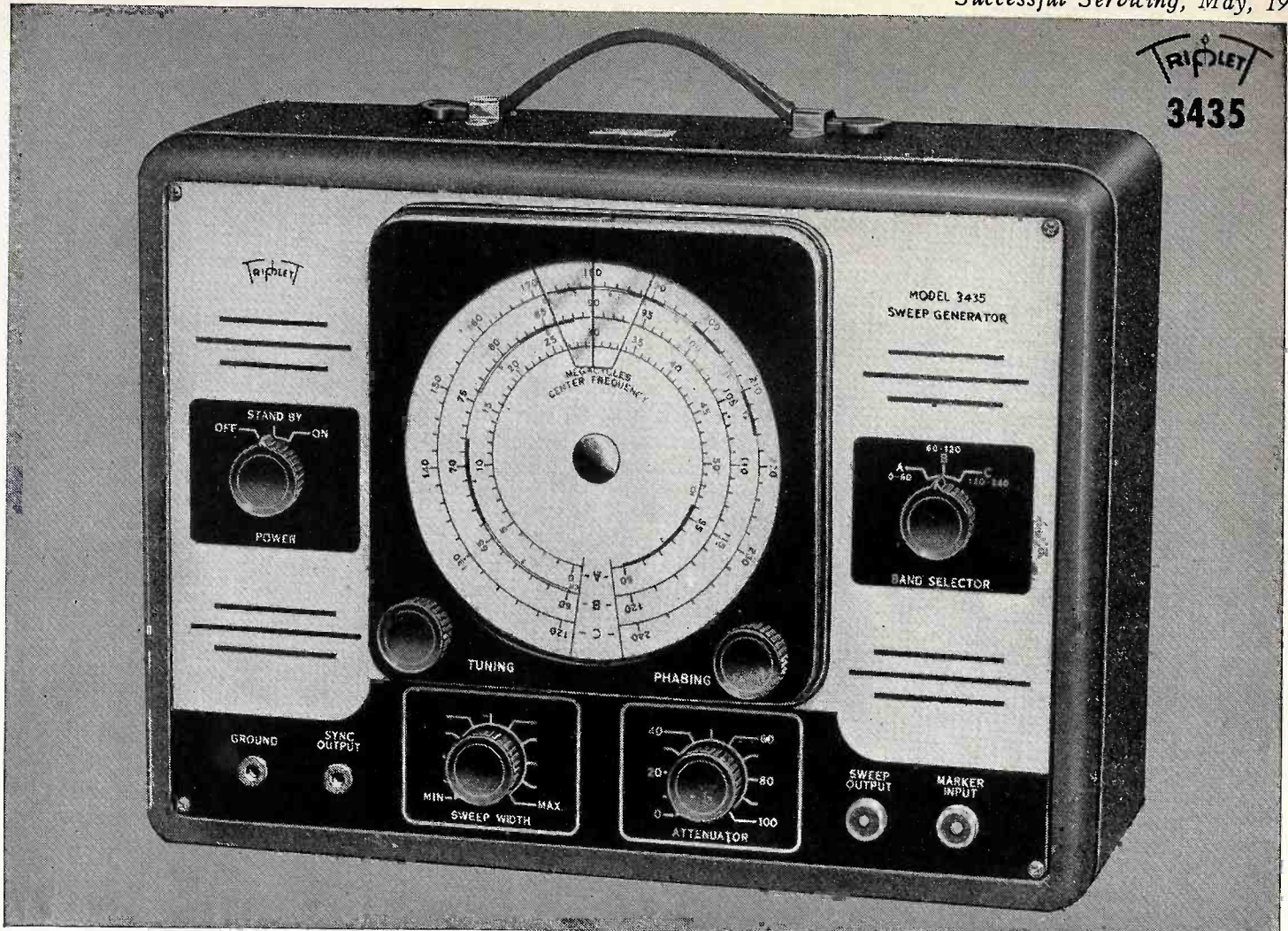

## Only \$114.50 and you're in Profitable TV Testing

Value-wise you can't make a smarter buy. For if you have a good Signal Generator to use as a marker with 3435, this new Triplet Sweep saves you real money! Performance-wise it's Triplet Engineering at its best. There are no complications in use. Continuous range coverage to 240 MC for all TV carrier and IF frequencies. There are no gaps in frequency, and continuous tuning is provided over all TV and FM bands. Note MAIN frequency dial, marked with channels as well as frequencies; continuously variable sweep width, effective from 500 KC to 12 MC; the PHASE controlled sweep voltage for scope horizontal input; the STAND-BY switch for temporary silencing of generator during other testing. These and many other features make Triplet 3435 an outstanding "buy." See it today at your distributor's.

TRIPLET ELECTRICAL INSTRUMENT COMPANY, BLUFFTON, OHIO



### YOU CAN USE ANY A.M. SIGNAL GENERATOR

...but if you are critical you'll appreciate this Wide Range Test Oscillator — Triplet 3432. Five fundamental ranges—165 KC to 40 MC. Two Harmonic ranges—36-120 MC, directly calibrated. Completely Shielded. Seven directly calibrated 330° scales. Illuminated Dial. Try it today.

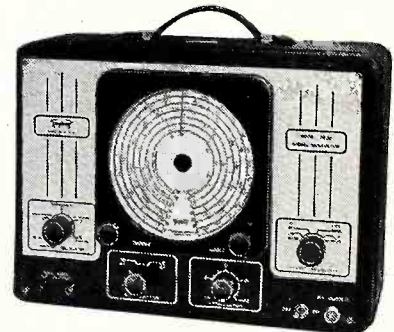

Triplet 3432

FOR THE MAN WHO TAKES PRIDE IN HIS WORK

# Triplet



## USE OF 'SCOPE PROBES

(Continued from page 9)

on the scope and exact calibration of the marker generator is possible.

As the marker-generator frequency is varied throughout its entire range, zero-beat indications occur at the fundamental frequency of the crystal oscillator and at its harmonic frequencies. Zero-beat indications may also be produced at frequencies that are between the crystal oscillator harmonics. These are inter-harmonic beats and are the result of marker-generator harmonics beating with the crystal-oscillator harmonics.

4. Troubleshooting High-Impedance Circuits: Various tv circuits have sufficiently high-impedance that the waveforms become distorted by application of a direct cable to the scope. Such distortion is caused by capacitive loading of the high-impedance circuit.

Distortion is avoided in such cases by use of a low-capacitance probe, which raises the effective input impedance of the input cable. In obtaining the increased input impedance, the probe attenuates the signal proportionately.

In many tv circuits, such signal attenuation is actually desirable. For example, the 1,300 volts (peak-to-peak) typically found across the horizontal-deflection coils is sufficient to overload the vertical amplifiers of many scopes, and thereby cause distortion for this reason. Evidently, the attenuating probe eliminates this source of waveform distortion.

5. Troubleshooting High-Voltage Circuits: As is well known, application of the scope to the plate of the horizontal-output tube or to the plate of the high-voltage rectifier tube, will usually damage the scope input system. However, a capacitive-divider probe can be used to observe the waveshapes in these circuits, and to measure peak-to-peak voltages.

The same probe is very useful in checking the high-voltage system for the presence of 60-cycle buzz components.

6. Signal-Tracing the High-Frequency Amplifiers: A modulated signal can be traced from the antenna posts of the receiver through the r-f and mixer circuits, and through the i-f amplifiers to the picture detector by use of a crystal probe. In this manner, the technician can locate dead or low-gain stages in much the same manner as a conventional signal-tracer locates similar trouble in a broadcast receiver.

7. Stage-by-Stage Alignment: Stage-by-stage alignment is easily accomplished by use of a crystal probe. Since the effectiveness of the technique is dependent upon specified waveshapes at each stage, the manufacturers' service data should be consulted to perform an accurate alignment job.

8. Video-Amplifier Adjustment: When used with a low-frequency sweep generator, a crystal probe makes it possible to display the response curve of a video amplifier on the scope screen, thereby facilitating adjustments of peaking coils, load resistors, low-frequency compensating circuits, and lead dress.

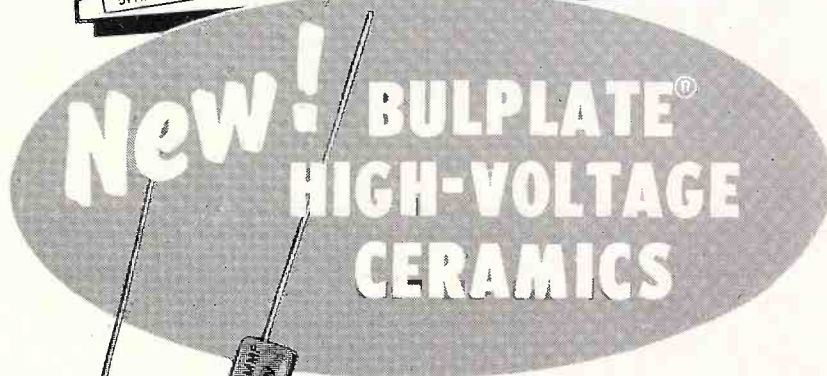
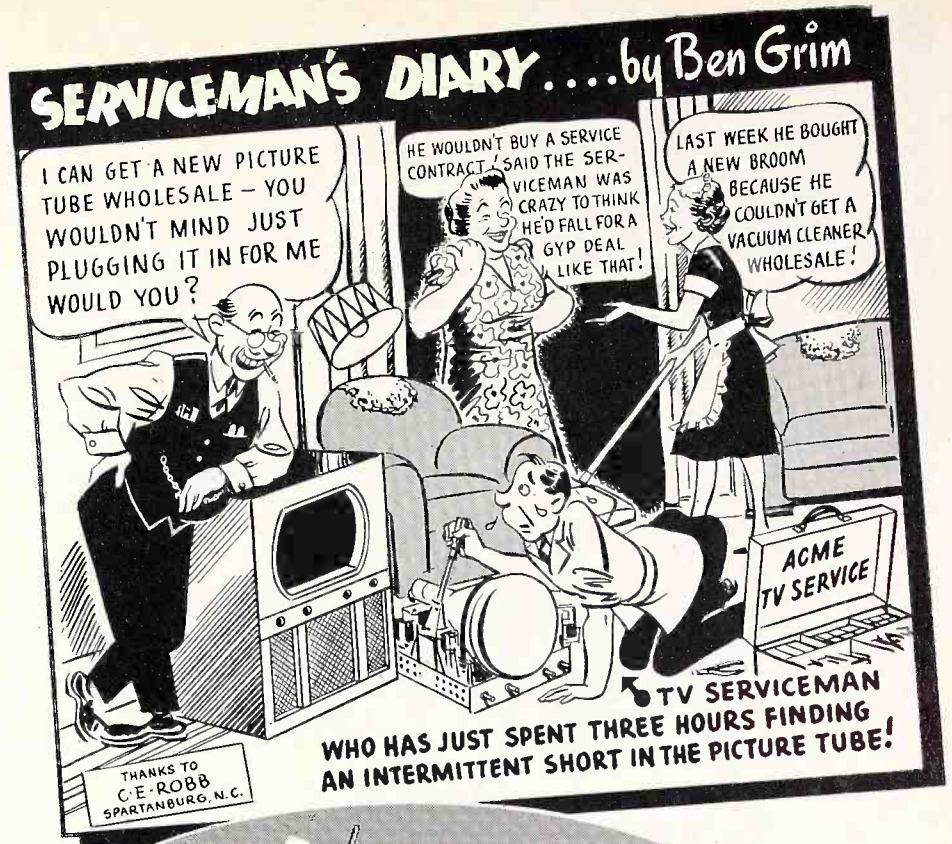

**Complete Ratings for  
1,000, 1,500 and 6,000 Volts  
at all Sprague distributors**

Your Sprague distributor now has these tiny, high-voltage flat plate ceramics in all popular capacitance ranges needed in TV sets. They're absolute tops in dependability. Small size, extra heavy moisture-resistant insulation coating, and conservative ratings for 85°C. operation are just what the doctor ordered for TV and other tough jobs.

Write for Bulletin M-479.

Another

**SPRAGUE** first!

SPRAGUE PRODUCTS COMPANY • 55 Marshall St., North Adams, Mass.  
(Distributors' Division of Sprague Electric Company)

Please mention Successful Servicing when answering advertising.



Assured Balanced  
Performance On  
Both Audio and  
Video Signals

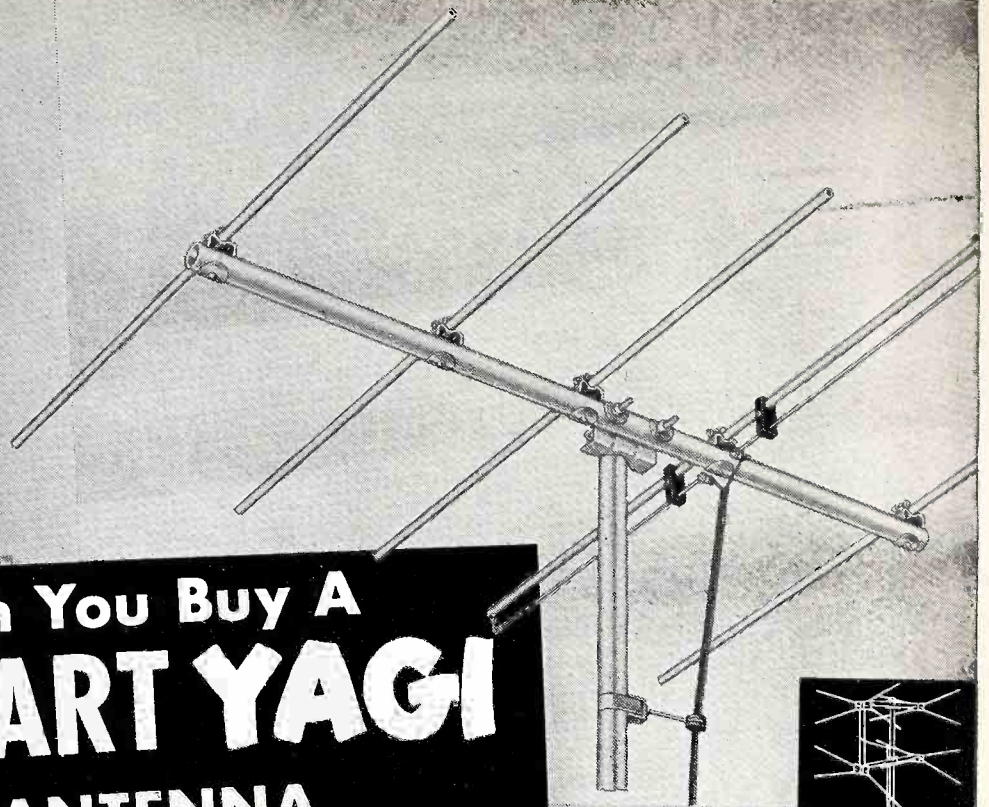

When You Buy A  
**RADIART YAGI**  
TV ANTENNA

You **KNOW** it covers the entire  
6 Megacycle Band width in the  
specific channel for which it  
was designed

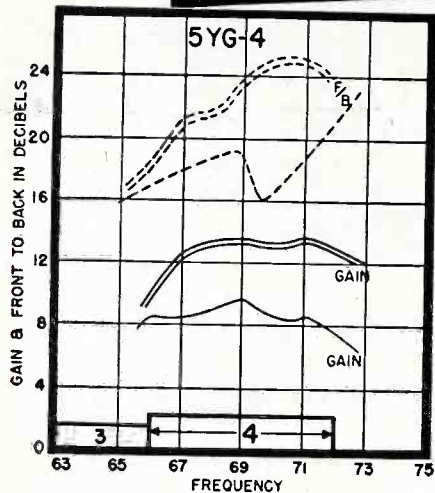

The perfect answer to the need for maximum signal pickup in "fringe" areas. Each YAGI is cut for a specific channel and may be used singly or doubly stacked. Nothing skimpy or shortcut in their manufacture either —each RADIART YAGI covers the full band width of its channel.

**CHECK THESE FEATURES:**

- Pre-assembled Fold-out Design for FAST Installations
- Over 8 lb. Forward Gain
- Excellent Front-to-Back Ratio
- Narrow Beam Width That Develops High Signal-to-Noise Ratio
- Low Standing Wave Ratio
- Sturdy Construction For Lasting and Dependable Performance.

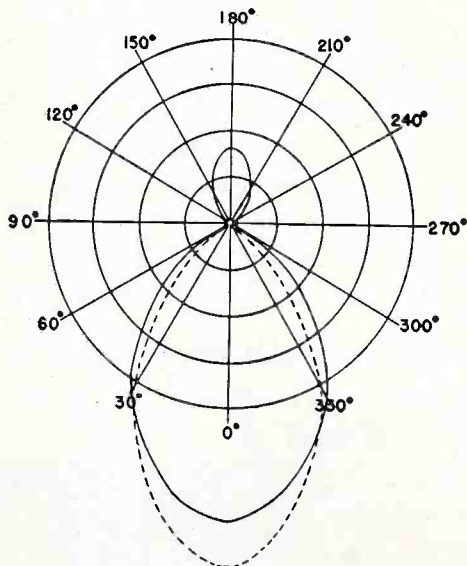

YAGI response curves for all channels available from your RADIART distributor... or write direct to us... Specify Form F885.



**THE RADIART CORPORATION**

CLEVELAND 2, OHIO

VIBRATORS • AUTO AERIALS • TV ANTENNAS • ROTATORS • POWER SUPPLIES  
Please mention Successful Servicing when answering advertising.





**WAS  
and  
IS**

(Continued from page 3)

between the circuit diagram and the receiver. Sometimes discrepancies are explained under the headings stating cures for peculiarities in operation or performance; when this information appears it is of the utmost benefit, for it greatly reduces the time required for diagnosis. When a discrepancy is described as a corrective measure for specific troubles, then the change from "was" to "is" should be made in the receiver, if it does not already exist. To determine the latter, it is necessary to check the chassis coding with the information given in the service notes.

**Receiver and Service Information**

When the discrepancy between the schematic and the receiver is one of circuit construction, it is an entirely different matter. Then it is important to determine which is the later of the two, the receiver or the schematic. This too is shown in the service information, or should be shown, to say the least. That such discrepancies between receivers and schematics occur is quite natural, because very few manufacturers of tv receivers complete a series of production runs without making circuit changes in order to improve performance, or to satisfy the needs of the different areas where their receivers are used.

If the circuit label indicates that the schematic is of a later version of the receiver than the receiver on hand, then the logical thing to do is to make the circuit corrections indicated on the schematic (provided, of course, that the fault is related to the circuit discrepancy). As a matter of fact, this particular point is debatable if the fault in the receiver stems from trouble somewhere else in the circuit. Our feeling is that the change from "was" to "is" should be made and sold to the customer as a forward step in keeping his receiver in best operating condition. Some do not agree, on the ground that the public desires service at the least cost; however, we feel that a good salesman will sell the public on the higher cost — which is fully justified. But this point warrants a discussion of its own — let's continue with the subject at hand.

If, on the other hand, the label shows the receiver to be a later production than the schematic, the service data should be checked for information which may refer to the difference. Naturally, set manufacturers will not produce completely new schematics each time they make circuit changes. Instead they note the differences in their service information; sometimes they include small sectionalized schematics indicating the change, sometimes they tabulate the circuit modifications. Assuming that the receiver is a later version than the schematic, and no change data exists, the receiver circuitry should not be restored to

that shown in the schematic. If corrective remedies are needed in that particular part of the circuit, the guide should be the receiver wiring and not the schematic wiring.

Concerning dating of schematic and receiver chassis, these require attention. Nothing can be taken for granted. The few minutes required to examine the schematic and the receiver is well spent, including the tube type designation. This can save a great deal of time and help avoid confusion.

The words "was" and "is," as related to tube types, occur quite frequently in service manuals. As in the case of resistors and capacitors, tube types are subject to changes. Sometimes they are made without any changes in the circuit wiring, but the presence of different tubes in the receiver from those shown on the schematic or top view can be confusing. At other times changes in tube types require slight changes in socket wiring, changes in bias resistors or even changes in grounding of the shield. These are minor changes when identified and known, but major jobs if first noted without any prior information which indicates the possible presence of any one of several tube types.

Set manufacturers try to make such details clear by doing one of several things. They may show a variety of tube types associated with one or more sockets on the schematic or top view of the chassis. Some go so far as to show alternate pin numbering for the different types (the alternate type being shown in brackets, and both types being labeled next to the socket). But such data is not printed in scare-headline type; it is on the schematic or top view for all to see, but a simple, casual glance will not bring to light the "was" and "is" or "either" references. The function of schematics, top views and other data is important enough to warrant a complete inspection, as is the reading of all service information.

**How to Avoid Confusion**

Summarizing the whole subject, there can be no doubt about the possibility of confusion arising out of differences between receivers and service information. It always will exist because service information cannot be held up for many months until the last copy of a model comes off the production line. Service manuals always appear before completion of a season's production, hence some differences will always exist. The goal, of course, is to keep these to a minimum. Every set manufacturer is striving to accomplish this. In fact he is the only one who can achieve it, because he is the source of the receivers and the information. He and he alone knows what his design engineers and production engineers did to his receivers during a season's production.

As to the service technician, his aim is to minimize confusion due to the differences between receivers and service data. . . . The less the confusion the easier the job — the faster the repair and the more profitable. All this he can accomplish by using the proper

kind of service information — the set manufacturer's information — the same kind of information that is used by the set manufacturer's own service department and by the service department of his distributors. . . . This is the information which appears in Rider Manuals and in Rider TEK-FILES. . . . The tv service technician who uses Rider Manuals and Rider TEK-FILES makes more money — finds servicing easier, faster and more profitable. . . . He has all the data — all the accurate data. . . . And he buys with double assurance because of Rider's TEK-FILE money-back guarantee . . . and the more than twenty years of know-how in the preparation of service data.

**RIDER Books Cover  
The Field**

- Encyclopedia on Cathode-Ray Oscilloscopes and Their Uses  
992 pages .....\$9.00
- Vacuum-Tube Voltmeters, 2nd Ed.  
432 pages .....\$4.50
- TV and Other Receiving Antennas (Theory and Practice)  
606 pages .....\$6.60
- TV Installation Techniques  
336 pages .....\$4.50
- TV Master Antenna Systems  
356 pages .....\$5.00
- Receiving Tube Substitution Guide Book, 1st Ed. 224 pages.....\$3.00
- First Supplement, Receiving Tube Substitution Guide Book  
48 pages .....\$ .99
- TV Picture Projection and Enlargement 192 pages.....\$3.30
- Television—How It Works  
203 pages .....\$2.70
- FM Transmission and Reception, 2nd Ed. 460 pages.....\$4.95
- Radio Operator's License Q & A Manual, 3rd Ed. 734 pages.....\$6.60
- Broadcast Operator's Handbook, 2nd Ed. 440 pages.....\$5.40
- Radar—What It Is 80 pages.....\$1.00
- Understanding Vectors and Phase in Radio  
160 pages.....Cloth cover \$1.89  
Paper cover \$ .99
- Installation and Servicing of Low Power Pa Systems 208 pages.....\$3.00
- Servicing by Signal Tracing  
360 pages .....\$4.00
- Inside the Vacuum Tube  
424 pages .....\$4.50
- Servicing Superheterodynes  
288 pages .....\$2.00
- Servicing Receivers by Means of Resistance Measurement  
203 pages .....\$2.00
- The Business Helper  
134 pages .....\$2.00

WE GUARANTEE your satisfaction! Make these books PROVE their value to you. Examine them at your favorite jobber. If he does not have them — order from us.

**Order Your Copy Now!**

**JOHN F. RIDER PUBLISHER, INC.  
480 Canal Street, New York 13, N. Y.**



**UHF** is just around the corner for TV SERVICEMEN now that the TV FREEZE has been lifted!

Prepare for it NOW with

**UHF PRACTICES AND PRINCIPLES**

by Allan Lytel, Instructor, Temple U. Tech. Inst.

LEARN NOW about the uhf principles and practices that will soon affect you in your everyday work. Because ultra-high frequencies do not behave like the lower frequencies, a knowledge of the special techniques, concepts, and circuits is necessary. This means the TV serviceman must keep abreast of such developments if he is to operate successfully and profitably.

Designed to provide a fundamental background for an understanding of uhf transmitting and receiving equipment, this book applies to the various services using uhf. Much of the emphasis is on practical applications to television. Converters, oscillators, developmental vacuum tubes, test equipment, receiving antennas, transmission lines and waveguides, etc., are just a few of the subjects thoroughly discussed.

TV service technicians and students will find all the information they need to achieve a complete working knowledge of the subject. Engineers, seeking the latest practices in this specialized field, will want to add this book to their technical library.

Available in July from your distributor — or write to us.  
Approximately 400 pages — \$6.60

John F. Rider Publisher, Inc., 480 Canal St., New York, N. Y.

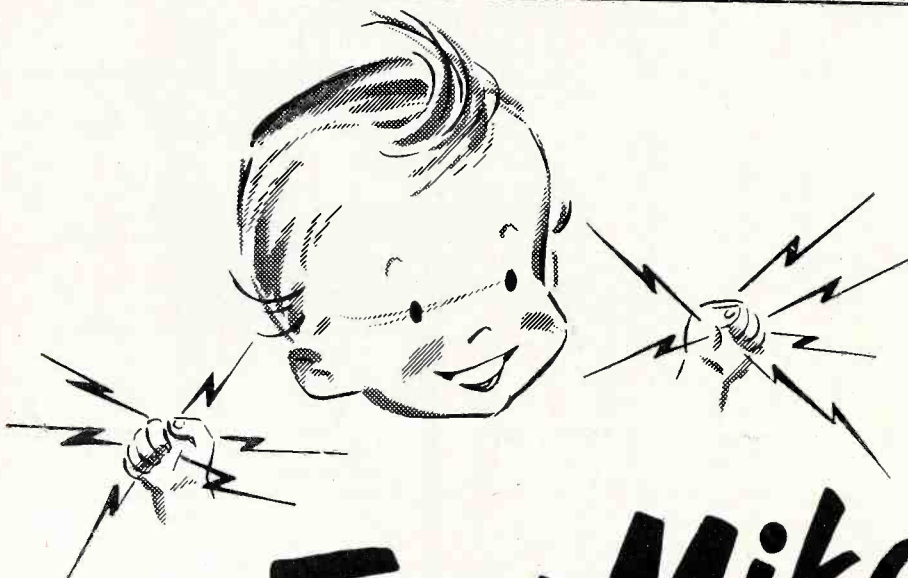

# GD's Tiny Mike

takes 30,000 volts with a grin!

The famous ceramic body made by C-D with an original engineering job inside and out! More dependable, longer lasting than any previous TV high-voltage ceramic capacitor! Can be used at full rated voltage, because it's conservatively rated for DC flash test up to 2x rated working voltage!

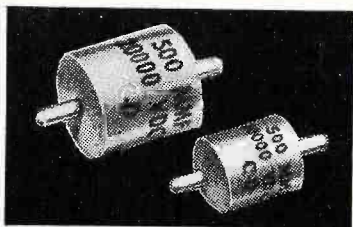

Send for Bulletin 2-614  
Department R52  
Cornell-Dubilier Electric Corp.  
South Plainfield, N. J.



CONSISTENTLY DEPENDABLE  
**CORNELL-DUBILIER**  
CAPACITORS

Plants in South Plainfield, N. J.; New Bedford, Worcester, and Cambridge, Mass.; Providence, R. I.; Indianapolis, Ind.; Fuquay Springs, N. C.; and subsidiary, The Radiant Corp., Cleveland, Ohio

Please mention Successful Servicing when answering advertising.

**SO IMPORTANT** — it was  
Featured in Special Article  
in

**The New York Times**

Jan. 28, 1952  
FREE copy  
of article on request

**UNIT REACTIVATES  
TV PICTURE TUBES**

Small Electronic Device Tests  
Sets at Home and May Add  
Year or More of Use

By T. R. KENNEDY Jr.

A small electronic device that can be applied to home television receivers to test and reactivate the picture tube without removing the tube from the set, resulting in renewed brightness in many and considerably longer useful life, has been placed on the market for the first time by a New York manufacturer.

In some cases, it was said, the picture tube may be made almost as good as new and given as much as a year's useful life before replacement is necessary. The instrument is small and compact. It weighs three pounds, is as large as the average lunch box, costs little and is simple to operate. Picture tubes, some of them new and never in a receiver, have shown remarkable improvement in brilliance and definition after a few minutes of reactivation here in the last few days.

Although the principle of its operation is not new—cathode-ray tube manufacturers have used it for years in the initial making of picture tubes—its incorporation in a small instrument is a new development.

The almost immediate urgent need for such an instrument, which also soon may be produced in kit form for home assembly, is apparent. Eight to ten million TV picture tubes, Transvision engineers estimate, have now been in use for three to four years or more, and "probably are in need of test and reactivation to 'renew' their brightness." Unfortunately, test and reactivation is a time-consuming and costly procedure. It was pointed out, addition can be detected short of comparing the old tubes with new ones in lately produced sets.

Furthermore, picture tubes in their original cartons in stores may have lost some of their brightness, which has been described as a "kind of aging process" to which all large cathode-ray tubes and similar devices are subject. Such tubes, in the current sizes most in use today, cost from \$25 to \$65. New picture tubes can be tested and reactivated without removing them from their cartons, and tubes in TV sets without removing the tubes from the receivers. It is done by attaching a standard picture-tube socket to the tube, turning a switch on the instrument, and noting the glow of an ammeter neon bulb as the tester-reactivator is watched. The dial on the tester is watched. The condition of the tube is indicated directly on a dial of the tester, which is plugged into an AC home electric socket. The receiver, meanwhile, is not turned on.

In some cases the test and reactivation is accomplished in less than a minute.

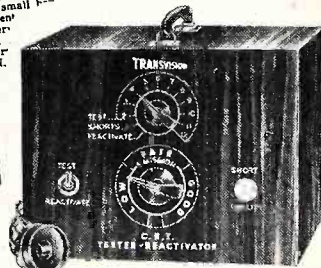

## TRANSVISION CR TUBE TESTER - REACTIVATOR

performs 2 vital functions:

- Tests Picture Tubes
- Renews Brightness of Dim Picture Tubes

It's a **TESTER**:

Without removing picture tube from set, you apply this precise instrument to:—

- Measure Cathode emission
- Locate shorts between elements
- Locate high resistance shorts or leakage as high as 3 megohms

It's a **REACTIVATOR**

for dim CR Picture Tubes

Revives dim TV Picture Tubes, without removal of tubes from set. Reactivation works on a great many tubes with low light output, if there's no mechanical break in tube. 110 V—60 cycles. Weighs only 3 lbs. One or two applications pays for instrument.

**SATISFACTION GUARANTEED**  
or money refunded if you return the instrument in 10 days in good condition. **\$19.95 NET**

—RUSH THIS COUPON—  
TRANSVISION, INC.  
DEPT. S55 NEW ROCHELLE, N. Y.  
( ) Send me CR Tube Tester-Reactivator(s).  
( ) Enclosed find \$ deposit. Balance C.O.D.  
( ) Enclosed find \$ in full. Send prepaid.  
Name \_\_\_\_\_  
Address \_\_\_\_\_  
City \_\_\_\_\_ State \_\_\_\_\_

Please mention Successful Servicing when answering advertising.



**"PACKAGED ENGINEERING"  
at Its Best!  
For the TV Technician**

**The B-T  
MIXER-AMPLIFIER  
SYSTEM**

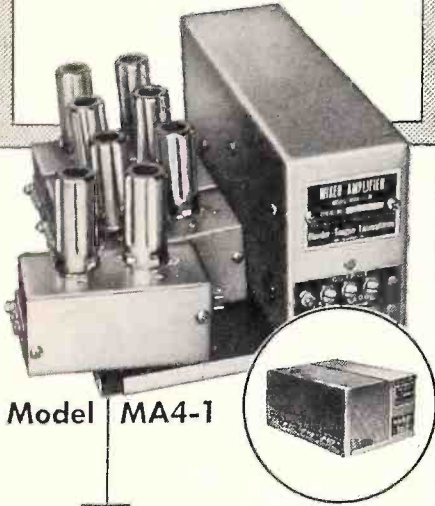

Model MA4-1

**For All VHF and UHF  
Multi-Antenna Problems**

Designed for the Service Technician to enable him to plan and make any installation . . . whether a single receiver or a complete 2000-set Master Antenna System . . . at lower cost, and without outside engineering.

The B-T MA4-1 is a wide-band, all-channel TV signal mixer for feeding 5 antennas to 1 TV receiver or distribution system. One input is broad-band for signals requiring no pre-amplification, and the remaining 4 accommodate separate plug-in strip assemblies. All terminals have 75 and 300 ohm connections. Several units may be ganged to serve any number of antennas.

**B-T PLUG-IN STRIPS**

Channel Strip CS-1 is a 2-tube (6AB4-6CB6), single channel, highly selective amplifier with a gain of at least 17 db., one strip for each TV channel.

The UHF Converter, UC-1 is designed for lowering UHF signals to existing TV frequencies, permitting UHF reception on present TV receivers.

*Eliminates all need for rotators, separate boosters, converters, and other costly projects.*

*Once connected the MA4-1 performs without further attention . . . no switching . . . no adjustments.*

**LIST PRICES:**

Model MA4-1 (less plug-in strips) **\$52.50**  
Channel Strip CS-1 (specify channel) **19.50**  
UHF Converters UC-1 . . . . . to be announced  
*Standard RTMA Warranties Apply.*



For the Complete 'Packaged Engineering' story, ask about B-T Signal Amplifiers and B-T Distribution Amplifiers at your local Distributor, or write to Service Department, E

**BLONDER-TONGUE LABS. inc.**  
Mount Vernon 8, New York



A monthly summary of product developments and price changes supplied by RADIO'S MASTER, the Industry's Official Buying Guide, available through local parts distributors.

**New Items**

**BLONDER-TONGUE LABS**—Added MA4-1 at \$31.50 net, Basic Mixer Amplifier. As stated, a complete, self-contained master antenna system for UHF as well as VHF TV reception and provided with 4 socket receptacles to accommodate plug in strip assemblies for specific channels . . . also added CS1 series of 12 individual fixed tuned channel strips which can be used in tandem with basic mixer at \$11.70 net each.

**INTERNATIONAL RESISTANCE (I. R. C.)**—295 TV concentric dual controls for replacement in over 5000 TV models added . . . also added 47 outer shafts in type P1, P2, P3 and P4 . . . 44 inner shafts in types R1, R2, R3 and R4 . . . added 20 base elements for panel or rear carbon sections and 13 base elements for wire wound panel sections . . . 2 Concentrikits . . . 3 Concentrikpacks for Philco, RCA and Admiral . . . 2 universal shaft kits for Concentrikit.

**R. C. A.**—Added radio batteries VS057W and VS064 at \$4.03 net each . . . VS073 at \$.05 net, VS084 at \$.80 net, VS085 at \$.96 net, VS0119 at \$6.20 net, VS216 at \$2.78 net and VS236 at \$.26 net . . . added RCA master volt ohmyst WV-87A at \$112.50 net . . . electron tubes 6082 at \$530.00 net and 6166 at \$780.00 net . . . receiving tubes 6BL7GT, 12BH7 and 25BQ6GT.

**R. C. A.**—Withdraw radio batteries #VS007, VS018, VS027 . . . also PM type speakers #23S1 . . . TV components 201D1, 201D3, 201D75, 201S1, 202X1 and antenna accessory 213A1.

**STANDARD TRANSFORMER** — Added WC-5 Width Control with AGC winding at \$1.14 net.

**SYLVANIA**—Withdraw 10 radio receiving tubes . . . TV picture tube 8BP4 . . . general purpose cathode ray tubes 3JP7 and 5NP1 . . . subminiature 5897, 5898, 5900 and 5901.

**TECHNICAL APPLIANCE CORP.** — Withdraw #1555 from their series of TV master antenna distribution systems.

**Price Increases**

**G. E.**—Increased prices on 51 radio receiving tubes and 9 transmitting & industrial type tubes.

**MALLORY & CO.**—Increased prices on 22 replacement magnesium-copper sulfide rectifier stacks.

**RADIART CORP.**—Increased prices on #2S, 3S and 4S, two insulator side mount type auto aerials . . . also 3D, disappearing mount auto aerial and 4BX2, 2 section "Superior Standard" auto aerial and 4BX3, 3 section "Deluxe Model" auto aerial. Also increased prices on #8BD and 8BDL.

**R. C. A.**—Increased prices on 30 receiving tubes . . . electron tubes 5946, Power Triode to \$115.00 net and 6161, UHF Power Triode to \$115.00 net.

**Price Decreases**

**AKRO-MILS, INC.**—Reduced prices of Jiffy Metal Storage unit J-8 to \$3.95, J-12 to \$5.25 and J-16 to \$6.95. Prices are "Minimum resale to dealer for own use."

**SYLVANIA**—Decreased prices on 16 TV picture tubes in 16", 17", 20" and 21" sizes . . . 9 radio receiving tubes and general purpose cathode ray tube 7JP1 to \$23.50 net.

**TECHNICAL APPLIANCE CORP.** — Decreased prices of #1700L, stacked twin-driven corner antenna to \$10.80 net . . . #1703, single bay twin driven corner antenna to \$4.80 net.

**Laughs in the Life of a TV Serviceman**



*"I know nothing about the repair job — besides I'm shampooing — please come back when my husband's home"*

**W**HEN you do see the lady of the house about her Raytheon you'll find, like thousands of other servicemen, that Raytheon TV receivers are easy to service.

One reason is that you are sure of a steady flow of replacement parts and tubes from your Raytheon distributor. The factory usually ships distributor orders in 24 hours;

complete stocks are carried for both in-warranty and out-of-warranty sets.

With Raytheon TV you know you can keep the set in operation three or four years later, and not have it sitting in your shop waiting for parts . . . Raytheon Manufacturing Co. (Belmont Radio Corp., 5921 West Dickens Avenue, Chicago 39, Ill.)



# REPLACEMENT PARTS

In case you have not seen the advertisements, Rider Manuals, beginning with TV 10 and with Rider TV TEK-FILE Pack 57, will show replacement parts. Each of these parts listings will be guaranteed to fit the receiver without fabrication, match the performance and test specifications of the original part, or your money back. Within a relatively short period we shall release to the servicing industry, replacement parts guides on Rider TV Manuals prior to Volume 10. By the end of the year we hope to have covered Rider TV Manuals 5, 6, 7, 8, and 9. At least that's what we're shooting for!

We are going to do the same thing for Rider Radio Manuals. In fact, Rider Radio TEK-FILES, beginning with Pack R1 (starting Volume 23), will begin in June 1952, if not in May. These too will bear replacement parts listings. Watch for announcements in the magazines.

The John F. Rider Laboratories are receiving shipments of television and radio receivers daily. We work on these receivers and make up parts location charts which we add to the set manufacturer's service information — if they do not already contain them. Hence, Rider Manuals and TEK-FILES will show more parts locations than ever before. AND LIKE HERETOFORE, RIDER MANUALS AND TEK-FILES WILL SHOW THE ORIGINAL SET MANUFACTURER'S SERVICE DATA—COMPLETE—UNABRIDGED—ACCURATE AND COVERING ALL PRODUCTION RUNS AND CHASSIS OF A MODEL!

THE USERS OF RIDER MANUALS AND TEK-FILES WORK EASIER, FASTER, AND MAKE MORE MONEY.

## linearity and width coils

(Continued from page 8)

tories. Another standard requirement, set forth by manufacturers, is that the coil should be wax- or lacquer-impregnated. This prevents moisture seepage between windings. Such seepage may cause a change in inductance or Q, and will ultimately result in a dielectric breakdown.

### Service Notes

**Poor Linearity.** This is due to a partially shorted coil, resulting in inability to adjust to correct waveform. The condition can also be caused by a defective input condenser in the linearity filter network.

**Poor Width.** This is usually caused by a defective width coil or leakage to core, due to poor insulation provided by coil form.

**No Width.** This is usually caused by a shorted width coil or a complete breakdown to ground.

**Low Boost Voltage.** An open linearity coil or open linearity filter condenser can cause this condition.

**Poor Control of Width.** If inductance of the width control is too low at minimum setting, large amounts of current will flow through the width coil. This usually results in breakdown of the coil. A low value of inductance in this circuit can also cause the right side of the picture to be crowded.

**Poor Control of Linearity.** If the inductance value of the linearity control is too low, the tuning range becomes critical and a stable setting cannot be achieved.

It is the desire of replacement manufacturers to provide satisfactory replacements for all receivers. We caution you to check the replacement guide to assure yourself that the part is correct. It should meet all physical and electrical requirements. Besides saving time and work, proper parts replacement eliminates costly call-backs.

In a subsequent article we are going to deal with the subject of converting tv receivers with 10-12 inch picture tubes to larger screens. In this coverage we shall deal with specific problems that can be handled with the use of matched components.

## CURING 15-METER BAND INTERFERENCE

"Effective on May 1, 1952, the 15-meter band was opened for use by radio amateurs. Although this is sure to make quite a few hams happy, their neighbors who own television receivers may not share their enthusiasm. . . ."

For the rest of this very topical article see the next issue of SUCCESSFUL SERVICING.

**FREE TO READERS OF SUCCESSFUL SERVICING**  
*TV Servicing made easier than before!*

**RAM NEW TV REPLACEMENT MANUAL** List Price \$1.00

- 80 MANUFACTURERS
- OVER 5000 LISTINGS
- LATEST CONVERSION DATA
- 32 PAGES
- SCHEMATIC DIAGRAMS
- COMPONENT CO-RELATION INDEX

**Cross-Indexed with RIDER MANUAL and TEK-FILE References**

**WRITE FOR IT NOW!**

CLIP HERE AND PASTE TO POST-CARD FOR FREE RAM CATALOG



**RAM ELECTRONICS SALES CO.**  
 SOUTH BUCKHOUT STREET  
 IRVINGTON-ON-HUDSON, N. Y.  
 IRVINGTON 9-5700

**TEST-PATTERN TESTED COMPONENTS FOR TV**

Please mention Successful Servicing when answering advertising.

JOHN L. GIGL  
 437 NEVIN ST.  
 LANCASTER, PENN.

From JOHN F. RIDER PUBLISHER, Inc.  
 480 CANAL ST., NEW YORK 13, N. Y.  
 Forwarding and Return Postage Guaranteed

Sec. 34.66, P. L. & R.  
 U. S. POSTAGE  
**PAID**  
 NEW YORK, N. Y.  
 PERMIT No. 9427



# SUCCESSFUL

# Servicing

JUNE 1952

Effective as of May 1, 1952, the 15-meter band was opened for use by radio amateurs. Although this is sure to make quite a few hams happy, their neighbors who own television receivers may not share their enthusiasm. The reason for this difference in reaction is that the new amateur band is uncomfortably close or, in some cases, right in the i-f pass band of a good many tv receivers. As a result, the ham who operates in this new band may find that his neighbors with television sets can tell quite easily when he goes on the air. It is more than possible that their screens will look like Fig. 1, or even Fig. 2,

radiation in this frequency band, because the low-frequency end of their i-f pass band is located within it. For example, consider the receiver with a video i.f. of 25.75 mc which is operating near an amateur transmitter on 21.40 mc. The amateur signals could be picked up by the tv antenna and transmission line, ride through the r-f and mixer circuits, and then find themselves in the i-f circuits. The 21.40-mc amateur signal mixes with the 25.75-mc video i.f. and the 21.25-mc sound i.f., in the picture detector to produce 4.35-mc and 150-kc beat frequencies. These beat frequencies pass through the detector and

Fig. 2, below. Typical pattern produced by lower frequency beat interference.

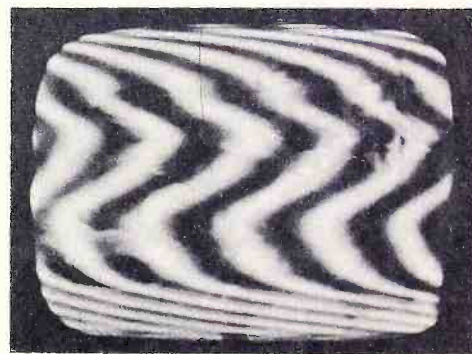

## Curing 15-Meter Band Interference



Fig. 1. Typical pattern produced by r-f beat interference.

by Milton S. Snitzer, W2QYI

video amplifiers onto the signal electrode of the picture tube. As a result, beat-interference patterns appear on the screen.

Most of the interference will be produced on those receivers which are aligned so that the low end of the i-f pass-band or sound i.f. falls in or extends below the frequencies from 21 to 21.45 mc. It should be pointed out that even those receivers that use the newly recommended 40-mc i.f. may experience 15-meter band interference; however, since the harmonic is invariably lower in amplitude than the fundamental, the interference thus produced will usually not be as severe. If a strong second harmonic signal is being generated by the amateur transmitter, it is the ham's obligation to minimize it. However, when the second harmonic is gen-

erated by nonlinear operation of the circuits in the tv receiver, the amateur is relieved of all responsibility.

Since the 15-meter amateur band has been opened first for c-w operation, the beat interference is intermittent and follows the keying of the transmitter. Thus, every time the key is depressed at the transmitter, the beat pattern will appear; when the key is released, the interference pattern will disappear. As a result, an annoying "blinking" type of interference shows up on the picture-tube screen, along with interference in the tv sound. Later, when modulation is permitted in the 15-meter band, the beat pattern will be more or less steady, but then fluctuating sound bars may be present in the pattern.

The exact nature of the receiver interference is determined by many factors. Some of these are the frequencies involved,

(Continued on following page)

### Nature of the Interference

The 15-meter band was allocated for amateur use by the International Radio Conference in 1947; it extends from 21 to 21.45 megacycles. A good many television receivers will respond quite nicely to ra-



# REPLACEMENT PARTS

In case you have not seen the advertisements, Rider Manuals, beginning with TV 10 and with Rider TV TEK-FILE Pack 57, will show replacement parts. Each of these parts listings will be guaranteed to fit the receiver without fabrication, match the performance and test specifications of the original part, or your money back. Within a relatively short period we shall release to the servicing industry, replacement parts guides on Rider TV Manuals prior to Volume 10. By the end of the year we hope to have covered Rider TV Manuals 5, 6, 7, 8, and 9. At least that's what we're shooting for!

We are going to do the same thing for Rider Radio Manuals. In fact, Rider Radio TEK-FILES, beginning with Pack R1 (starting Volume 23), will begin in June 1952, if not in May. These too will bear replacement parts listings. Watch for announcements in the magazines.

The John F. Rider Laboratories are receiving shipments of television and radio receivers daily. We work on these receivers and make up parts location charts which we add to the set manufacturer's service information — if they do not already contain them. Hence, Rider Manuals and TEK-FILES will show more parts locations than ever before. **AND LIKE HERETOFORE, RIDER MANUALS AND TEK-FILES WILL SHOW THE ORIGINAL SET MANUFACTURER'S SERVICE DATA—COMPLETE—UNABRIDGED—ACCURATE AND COVERING ALL PRODUCTION RUNS AND CHASSIS OF A MODEL!**

**THE USERS OF RIDER MANUALS AND TEK-FILES WORK EASIER, FASTER, AND MAKE MORE MONEY.**

## linearity and width coils

(Continued from page 8)

tories. Another standard requirement, set forth by manufacturers, is that the coil should be wax- or lacquer-impregnated. This prevents moisture seepage between windings. Such seepage may cause a change in inductance or Q, and will ultimately result in a dielectric breakdown.

### Service Notes

**Poor Linearity.** This is due to a partially shorted coil, resulting in inability to adjust to correct waveform. The condition can also be caused by a defective input condenser in the linearity filter network.

**Poor Width.** This is usually caused by a defective width coil or leakage to core, due to poor insulation provided by coil form.

**No Width.** This is usually caused by a shorted width coil or a complete breakdown to ground.

**Low Boost Voltage.** An open linearity coil or open linearity filter condenser can cause this condition.

**Poor Control of Width.** If inductance of the width control is too low at minimum setting, large amounts of current will flow through the width coil. This usually results in breakdown of the coil. A low value of inductance in this circuit can also cause the right side of the picture to be crowded.

**Poor Control of Linearity.** If the inductance value of the linearity control is too low, the tuning range becomes critical and a stable setting cannot be achieved.

It is the desire of replacement manufacturers to provide satisfactory replacements for all receivers. We caution you to check the replacement guide to assure yourself that the part is correct. It should meet all physical and electrical requirements. Besides saving time and work, proper parts replacement eliminates costly call-backs.

In a subsequent article we are going to deal with the subject of converting tv receivers with 10-12 inch picture tubes to larger screens. In this coverage we shall deal with specific problems that can be handled with the use of matched components.

## CURING 15-METER BAND INTERFERENCE

"Effective on May 1, 1952, the 15-meter band was opened for use by radio amateurs. Although this is sure to make quite a few hams happy, their neighbors who own television receivers may not share their enthusiasm. . . ."

For the rest of this very topical article see the next issue of **SUCCESSFUL SERVICING.**

From JOHN F. RIDER PUBLISHER, Inc. 480 CANAL ST., NEW YORK 13, N. Y.  
Forwarding and Return Postage Guaranteed

# FREE TO READERS OF SUCCESSFUL SERVICING

## TV Servicing made easier than before!

# RAM NEW TV REPLACEMENT MANUAL

List Price \$1.00

- 80 MANUFACTURERS
- LATEST CONVERSION DATA
- SCHEMATIC DIAGRAMS
- OVER 5000 LISTINGS
- 32 PAGES
- COMPONENT CO-RELATION INDEX

**Cross-Indexed with RIDER MANUAL and TEK-FILE References**  
**WRITE FOR IT NOW!**

CLIP HERE AND PASTE TO POST-CARD FOR FREE RAM CATALOG

**Ram** ELECTRONICS SALES CO.  
SOUTH BUCKHOUT STREET  
IRVINGTON-ON-HUDSON, N. Y.  
Irvington 9-5700  
**TEST-PATTERN TESTED COMPONENTS FOR TV**

Please mention Successful Servicing when answering advertising.

JOHN L. GIGL  
437 NEVIN ST.  
LANCASTER, PENN.

Sec. 34.66, P. L. & R.  
U. S. POSTAGE  
**PAID**  
NEW YORK, N. Y.  
PERMIT No. 9427



# SUCCESSFUL

# Servicing

JUNE 1952

Effective as of May 1, 1952, the 15-meter band was opened for use by radio amateurs. Although this is sure to make quite a few hams happy, their neighbors who own television receivers may not share their enthusiasm. The reason for this difference in reaction is that the new amateur band is uncomfortably close or, in some cases, right in the i-f pass band of a good many tv receivers. As a result, the ham who operates in this new band may find that his neighbors with television sets can tell quite easily when he goes on the air. It is more than possible that their screens will look like Fig. 1, or even Fig. 2.

Interference in this frequency band, because the low-frequency end of their i-f pass band is located within it. For example, consider the receiver with a video i.f. of 25.75 mc which is operating near an amateur transmitter on 21.40 mc. The amateur signals could be picked up by the tv antenna and transmission line, ride through the r-f and mixer circuits, and then find themselves in the i-f circuits. The 21.40-mc amateur signal mixes with the 25.75-mc video i.f. and the 21.25-mc sound i.f. in the picture detector to produce 4.35-mc and 150-kc beat frequencies. These beat frequencies pass through the detector and

Fig. 2, below. Typical pattern produced by lower frequency beat interference.

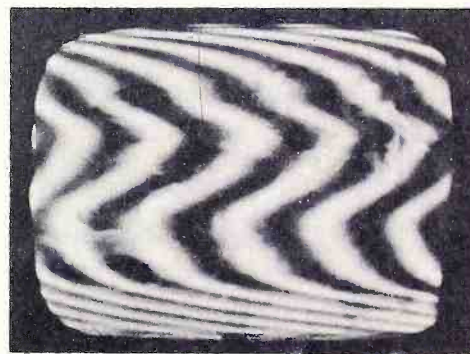

## Curing 15-Meter Band Interference

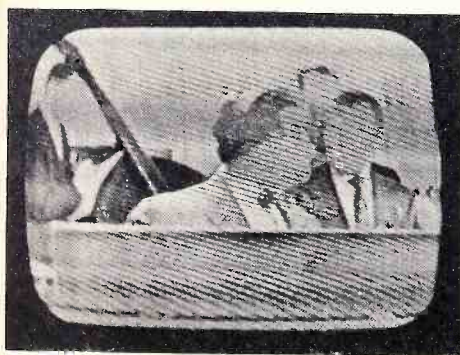

Fig. 1. Typical pattern produced by r-f beat interference.

by Milton S. Snitzer, W2QYI

video amplifiers onto the signal electrode of the picture tube. As a result, beat-interference patterns appear on the screen.

Most of the interference will be produced on those receivers which are aligned so that the low end of the i-f pass-band or sound i.f. falls in or extends below the frequencies from 21 to 21.45 mc. It should be pointed out that even those receivers that use the newly recommended 40-mc i.f. may experience 15-meter band interference; however, since the harmonic is invariably lower in amplitude than the fundamental, the interference thus produced will usually not be as severe. If a strong second harmonic signal is being generated by the amateur transmitter, it is the ham's obligation to minimize it. However, when the second harmonic is gen-

erated by nonlinear operation of the circuits in the tv receiver, the amateur is relieved of all responsibility.

Since the 15-meter amateur band has been opened first for c-w operation, the beat interference is intermittent and follows the keying of the transmitter. Thus, every time the key is depressed at the transmitter, the beat pattern will appear; when the key is released, the interference pattern will disappear. As a result, an annoying "blinking" type of interference shows up on the picture-tube screen, along with interference in the tv sound. Later, when modulation is permitted in the 15-meter band, the beat pattern will be more or less steady, but then fluctuating sound bars may be present in the pattern.

The exact nature of the receiver interference is determined by many factors. Some of these are the frequencies involved,

(Continued on following page)

### Nature of the Interference

The 15-meter band was allocated for amateur use by the International Radio Conference in 1947; it extends from 21 to 21.45 megacycles. A good many television receivers will respond quite nicely to ra-



# Curing 15-Meter Band Interference

(Continued from page 1)

the magnitude and type of the interfering signal, and the i-f alignment and response of the receiver. A small amount of interference may produce a beat pattern that is hardly noticeable and not objectionable. A somewhat larger amount of interference may produce the "blinking" interference mentioned above. The alternate appearance and disappearance of the interference pattern changes the average brightness of the picture observed on the tv screen. A still greater amount of interference may produce a negative picture in which all dark tones are converted to light tones and vice versa. It is obvious that this does not make for very pleasant viewing. Finally, an extremely high value of interference can wipe out the picture completely by causing loss of horizontal and vertical sync.

## Use of Traps to Eliminate Interference

At this point it should be emphasized that transmission by radio amateurs within the 15-meter band represents a legally constituted operation. Little can be done at the amateur transmitter to reduce interference on tv receivers, other than reducing output power or curtailing operation. Neither of these represents a solution to the problem, because the amateur is legally authorized both by federal regulations and international agreements to use the 15-meter band. Therefore, all remedies for this type of interference must be applied at the receiver itself.

Probably the simplest method of reducing or eliminating 15-meter band interference is to install a wavetraps at the receiver. One such circuit which the author has used successfully consists of a 7-45  $\mu\mu\text{f}$  trimmer capacitor used with an inductor constructed of 20 turns of No. 20 enameled wire close-wound on a one-half inch form. This circuit is resonated to the 15-meter band at a capacitance setting of about 25 to 30  $\mu\mu\text{f}$ , with the final adjustment of capacitance being made after trap is installed. If a coil of fewer turns is desired, a larger diameter winding should be used. For example, a dozen turns of wire wound to a one-inch diameter can be used.

The resonant circuit so produced may be connected to the tv receiver in a number of ways, as shown in Fig. 3. The simplest method is shown in part A of the figure. Here the coil and capacitor are connected in series, then the combination is tied between the antenna terminals of the tv receiver. At resonance, the series circuit shunts the antenna terminals with a low impedance which effectively shorts out the signal to which the circuit is tuned. The coil and capacitor may also be connected in parallel and the combination then connected in series with one side of the lead-in, as shown in part B of the figure. At resonance, the high impedance of the parallel combination blocks the signal to which the circuit is tuned.

If either of these arrangements unbalances the transmission line to such an ex-

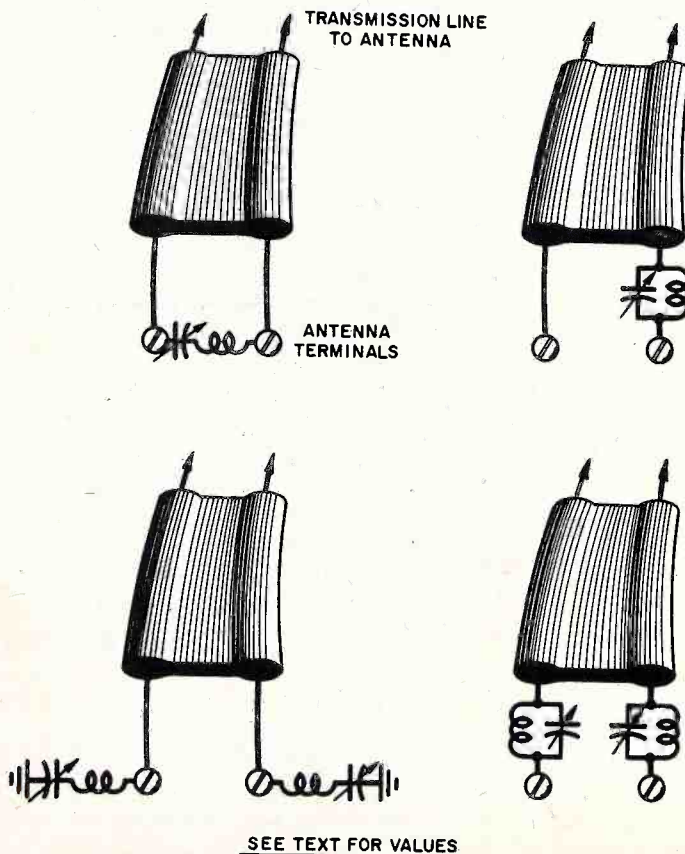

Fig. 3.  
Methods of  
connecting  
wavetraps.

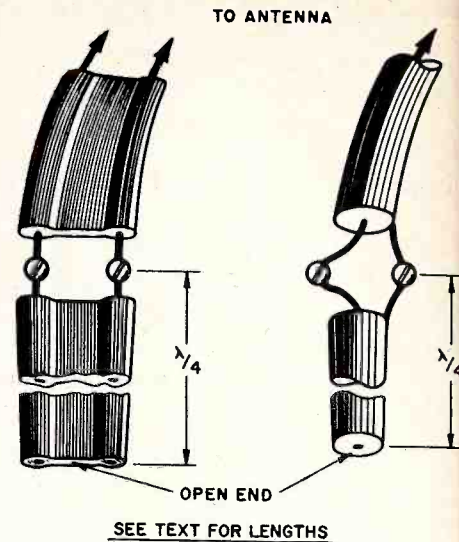

Fig. 4. Use of quarter-wave open stubs.

tent that the signal-to-noise ratio is reduced or so that a degradation of picture quality occurs, the balanced arrangements shown in C and D may be more satisfactory. Here, two similar tuned circuits must be employed.

Although the wavetraps discussed are easier to install at the antenna terminals of the receiver, they will be somewhat more effective if they can be installed in the receiver at the point where the antenna lead-in connects to the tuner. In this way, the foot or more of lead-in between the antenna terminals and the connection to the tuner will not inject an interfering signal into the receiver.

Since 15-meter band interference can also enter the receiver through the power line and power-wiring circuits, the wavetraps may be installed at the power-line connection. To be effective for signals that may be picked up by the line cord itself, the traps should be connected at the point where the line cord enters the receiver rather than at the electrical outlet. The parallel arrangements are to be preferred here so that a breakdown in the capacitor will not produce a power-line short circuit.

The use of sections of transmission line as wavetraps should not be overlooked. Because of the relatively low frequencies involved, which would make a half-wave line inconveniently long, it is recommended that a quarter-wave open stub be used. Such a stub shunts its input terminals with a low impedance at the resonant frequency just as the series resonant circuit does. The stub is connected as shown in Fig. 4. The quarter-wave stubs should be cut to the center of the 15-meter band, which is close to 21.22 mc.

If the stub is to be made of the 2-wire ribbon line, the length is calculated as follows: the length in feet of a free-space quarter wavelength is equal to 246 divided by the frequency in megacycles, in this case

(Continued on page 29)



Part I

# Improvement of

# fringe area reception

## by Proper Antenna Installation

by J. C. Spindler\*

\*Part I is an excerpt taken from the book "Compendium on Improving Fringe Area T.V. Performance," published by the Zenith Radio Corp., and compiled by J. C. Spindler. The article and its illustrations are reprinted through the courtesy of the publisher.

### Antenna Location and Elevation

**Level Terrain.** In level terrain the signal field strength increases proportionately with antenna elevation above ground. That is, doubling the antenna height doubles the signal intercepted by the antenna. For this reason adjacent roofs and towers, or other nearby high locations, should be kept in mind as ideal antenna locations. However, additional height away from the house will require additional lead-in, and since there is some signal loss in the extra lead-in, it is advisable to estimate both the extra height that can be obtained and the extra length of lead-in that will be required before deciding on such a location.

At an antenna elevation of 50 feet, the signal increase obtained from one extra foot of height, i.e., going to 51 feet, is cancelled out by 10 extra feet of 300 ohm ribbon line on channels 2-6, while only 5 extra feet of this line will nullify the improvement on channels 7-13. Table 1 below gives the approximate percentage of the signal remaining after a specified length of transmission line is inserted. That is, it denotes the ratio  $\frac{\text{signal out of line.}}{\text{signal into line.}}$

Table 1 indicates that there is an ultimate limit in benefits realized from increasing antenna height because the lead-in also increases. As an example of how this table may be used, let us suppose that we have a choice of two locations. No. 1 will give us an overall elevation above ground of 30 ft. and requires 50 ft. of ribbon line to the receiver. No. 2 will give us an elevation of 70 ft., but being away from the house re-

quires 250 ft. of lead-in. Thus No. 2 requires 200 extra feet of lead-in. The signal at the receiver obtained from location No. 2 can be compared to that obtained from location No. 1 by means of the following:

$$\frac{\text{Signal from \#2}}{\text{Signal from \#1}} = \frac{\text{Height \#2}}{\text{Height \#1}}$$

× Ratio from Table 1 for difference in line length.

Application of this formula, and the ratios from Table 1 for 200 feet, gives the following results if 300 ohm ribbon lead is to be used:

$$\frac{\text{Ch 2-6 \#2}}{\text{\#1}} = \frac{70}{30} \times .68 = 1.6 = 160\%$$

$$\frac{\text{Ch 7-13 \#2}}{\text{\#1}} = \frac{70}{30} \times .43 = 1.0 = 100\%$$

This indicates a distinct improvement in signal to the receiver on channels 2-6, but none whatever on channels 7-13.

If open wire lead-in were to be used instead of ribbon line, then the comparison would be as follows:

$$\frac{\text{Ch 2-6 \#2}}{\text{\#1}} = \frac{70}{30} \times .90 = 2.1 = 210\%$$

$$\frac{\text{Ch 7-13 \#2}}{\text{\#1}} = \frac{70}{30} \times .78 = 1.8 = 180\%$$

This indicates a substantial improvement on channels 2-6 and also the superiority of location No. 2 on channels 7-13.

Use of Table 1 will aid in determining the best location and elevation of the antenna where the terrain is flat and variations in signal strength are comparatively small.

**Hilly or Mountainous Terrain.** In terrain of this type the signal amplitudes may vary rapidly and the best signals are often obtained by an antenna location which is neither the highest nor the nearest. Considerable care should be exercised, keeping in mind that extra lead-in length results in additional signal loss. A good procedure to follow is to try several of the most likely locations and then select the best. If the country is very mountainous try several elevations at each location, for in such terrain it is not necessarily true that the higher the antenna the more signal is obtained. Occasionally a lower elevation will prove superior to a higher one. Be sure to check antenna orientation each time.

### Man-Made Electrical Interference

The most commonly used lead-in is the 300 ohm ribbon type, because it is both economical and reasonably efficient. If moderate man-made electrical noise (automobile ignition, electric motors, power lines, etc.) is present, it is advisable to twist this lead about once around every foot. If the electrical noise is severe, and the origin is known, it may help to choose an antenna location away from the noise source. On the other hand it may be advisable to use coaxial lead-in plus matching transformers at the antenna and receiver. If coaxial line is used, the proper balance transformers *must* also be used, as without them coaxial line may be inferior to twisted balanced ribbon line with regard to both signal transmission, efficiency and noise rejection. A third possibility, which is useful if the source of interference is directly (or nearly directly) under the antenna is to use a vertical stack of two antennas, spaced  $\frac{1}{2}$  wave length apart, if a single antenna has previously been used. This will increase the tv signal level and decrease the noise pickup from beneath the antenna. If the source of interference is known, it is also advisable to route the lead-in as far away

TABLE 1

Percentage of Signal Available after Line Loss Deduction

Ratio:  $\frac{\text{Signal Out of Line}}{\text{Signal Into Line}}$

Line Length (feet)	3000 ohm ribbon or RG8/U		300 ohm open wire line	
	Ch 2-6	Ch 7-13	Ch 2-6	Ch 7-13
20	.97	.92	.99	.97
40	.92	.84	.98	.94
60	.89	.77	.97	.92
80	.85	.71	.96	.90
100	.82	.65	.95	.88
120	.79	.59	.94	.86
140	.76	.54	.93	.84
160	.73	.50	.92	.82
180	.70	.46	.91	.80
200	.68	.43	.90	.78

(Continued on page 6)



# It's Tung-Sol for radio and tv



**Quality** -that keeps pace with the growth of the electronic industry  
 -that meets fully the performance requirements of all  
 radio and tv set manufacturers  
 -that safeguards dealer service work

**TUNG-SOL**  
 RADIO, TV TUBES, DIAL LAMPS

TUNG-SOL ELECTRIC INC., Newark 4, N. J. — Sales Offices: Atlanta • Chicago • Culver City (Calif.) • Dallas • Denver • Detroit • Newark

Please mention *Successful Servicing* when answering advertising.



# Successful SERVICING

REG. U.S. PAT. OFF.

Dedicated to the financial and technical  
advancement of electronic maintenance personnel

VOLUME 13 NUMBER 8

JUNE, 1952

**JOHN F. RIDER, Publisher**

**Annette M. Tricarico, Editor**

**Advertising Representative**

H. J. Oslow & Co.

3951 Grand Central Terminal

New York 17, N. Y.

MURRAY HILL 6-4670



MEMBER



## Curtain Time

### RTMA and the Servicing Industry

We have before us a résumé of items related to the servicing industry, its relations with the public, and the responsibility of the tv receiver industry to the servicing industry and to the public. These are to be discussed at a forthcoming RTMA Service Committee meeting. We mention these facts at this time in order to advise the tv servicing industry that its comments are not going unheeded by the manufacturing industry.

It is significant to note that the RTMA Service Manager, Mr. Al Coumont, has worked up a plan of action which, if implemented by the industry, will be a great step forward. It may not answer every single problem in the minds of the nation's service technicians, but it will take care of many of them. In the meantime, let's hope that top level management in the RTMA will see their way clear to take the recommendations of its service manager and of the Service Committee.

### Service Associations

The move to organize local service technician organizations is rapidly gaining momentum. We are very delighted to note interest in this direction. Perhaps it is due to the ever increasing threat of licensing, or it may be due to any one of numerous actions or reactions in the individual areas. It matters not what is responsible for it—just so long as the association comes into being, and having been born is nurtured by those who are its members.

There is every reason for the existence of service associations. Whether it is to fight against or for licensing—an association can do much more than individual voices. Whether it be to register a complaint or to deliver favorable comment—an association's voice is strong—whereas the individual's is weak. However, associations have been attempted in the past and many of them failed. They did not hurdle the obstacles, so we hasten to express words of caution. These are directed towards the membership:

1. You can't get more out of an association than you put into it. If you want your association to grow, you must attend meetings—you must think about its welfare and express yourself. You can't be too busy to attend meetings. Let

the service job wait. You owe it to yourself and to your set customers to set up a local association which will make every effort to end abuses, therefore neither you nor the public suffers too much because the jobs you might complete during the servicing meeting night must be held over until the following day. Nothing is so disheartening to those members who appear at meetings and to the officers of the association as poor attendance.

2. Don't expect your officers to carry the entire burden. They need your help. Few, if any new service associations are rich enough to afford paid secretarial help, yet the lack of it has caused many to fall apart. This is why it is recommended that dues be set at a level which will allow hiring someone to take care of mailings. This seems like biting off a big chew, but it is true, and the larger the membership, the more difficult it is for unpaid officers to sacrifice their time and income to carry on their association duties. The matter of dues is not an easy one to resolve, but it is very important because it determines to a great extent the possible growth of the association. The lower the dues the greater must be the individual desire of every member to make the association grow.
3. Don't expect the officers to run the association without making mistakes and without failing to satisfy the desires of each member. If they do something which is not to your liking, don't feel that the answer is to leave the association. Try to find a solution inside the organization; you'll never rectify a mistake by being outside looking in. If there is need for the organization then there is a need for you to stay in and do your part in making it grow.
4. If you don't agree with what the officers are doing, discuss it in open meeting; let them convince you, or you convince them, but don't assume the attitude that whatever is happening is a personal affront; or that the actions taken are aimed at you. That is the first crack in the structure; the next is absence from meetings—and soon, no more association.
5. Try to remember that it is easy to criticize, and that officers who are not being paid for their efforts and who are trying to do the best they can, are doing so only at some sacrifice to themselves—either in free time or in income. They're human and can't take too much abuse. If you feel that you must criticize, don't do so on a personal basis. Above all criticism should be constructive—you should present an alternative approach to whatever may be the action you don't like; simply saying you don't like something is not sufficient.
6. Try to see the other man's point of view. Remember that the servicing industry is composed of full-time and part-time service technicians. The part-time man requires recognition. This is a country of free enterprise. No matter what may be your present complaints about the part-time worker, you'll never give him your religion concerning operations unless he is given the opportunity of full participation in the local service technicians association.
7. Don't found the association as a means of controlling or eliminating competition. This has been attempted and has always failed. It just will not work; that is not an association's purpose.

Rome wasn't built in a day. Neither can we list all of the possible pitfalls in one issue. The thought that bothers us most is that insufficient heed may be paid to these suggestions. Not that they become important because they are expressed here, but because twenty-five or so years of direct contact with the servicing industry has demonstrated that the simplest things—obvious things, when ignored, can be productive of very bad results. So it is with some of the thoughts we have listed. . . . They warrant serious attention—especially in the formative stages of a service association. . . . But the possibility of many obstacles should not be a deterrent to the effort. The service industry needs local service associations—then statewide affiliations and finally a national group. . . . If correction is needed within the servicing industry—it should come from within. These and other benefits can be the goal of every service association.

*John F. Rider*



## Improvement of fringe area reception

(Continued from page 3)

from it as is practical. The list below presents the foregoing measures in their approximate order of efficiency in minimizing electrical noise effect.

1. Stacked antennas plus coaxial line in best available location.
2. Single antenna plus coaxial line in best available location.
3. Stacked antennas with twisted 300 ohm line in best available location.
4. Single antenna with twisted ribbon line in best available location.
5. Twisted ribbon line with antenna at existing location.

In steps 4 and 5 the line is to be routed as far away from the noise source as practical. It is recommended that if the amount of noise pickup is not known that the initial installation be made as per item 5. If it is found that considerable noise interference is still present, proceed further with steps in the reverse order listed.

It is of extreme importance in selecting the antenna site and lead-in that noise interference pickup, as well as signal strength, be given consideration, as picture quality can be seriously impaired by noise, as well as by the amount of "snow". In extremely noisy locations it may be necessary to reach a compromise between conditions resulting in minimum "snow" and those giving the least noise interference pickup.

### Selection of Antenna

There are many types of antennas on the market today, but it is advisable to choose one which, performance-wise, has been generally accepted in the field for use in similar locations. Three general types, each made by numerous manufacturers have established themselves throughout the country for fringe area reception. These are the In-line, the Conical, and the Yagi. The In-line and Conical are broad band, being designed to receive channels 2-13. The Yagi is high gain, but narrow band and is designed for reception of signals emanating from one general direction.

Preference for the In-line or Conical varies from one locality to another. The In-line has slightly better pickup efficiency on channels 3 and 4. The Conical is superior on channels 5, 6, 12, and 13. The In-line or Conical antennas are recommended wherever it is desired to receive a number of stations located in approximately the same direction, with some stations in the low band (2-6) and others in the high band (7-13).

The Yagi is usually found in fringe areas where it is possible to receive only one or two channels, in which case a separate Yagi is used for each channel.

The discussion below lists some of the more frequently encountered conditions and recommends the antennas generally found to be most helpful in each case:

**A Number of Channels Available on Both High and Low Bands.** If all signals arrive from the same direction, use either the In-line or Conical, single or stacked. Except in a few instances, double stacking (4 antennas) is not recommended. The extra benefit obtained in going from a stack to a double stack is small in comparison to that obtainable from either (a) increased antenna height (except as previously mentioned) (b) use of open wire 300 ohm line or (c) a separate Yagi antenna for each of the desired channels.

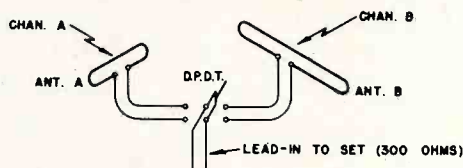

Fig. 1. Switch connection of two antennas.

If the signals arrive from different directions, it is possible to use either the In-line or Conical, single, or stacked, plus an antenna rotator. A practical, and frequently more flexible alternative, if there are only two directions involved, is to orient a first antenna (or stack) in one direction and a second antenna (or stack) in the second direction, then run a separate lead from each antenna to a switch located near the tv receiver, so that either one of the antennas may be connected to the receiver, as shown in Fig. 1.

The increased flexibility of the latter method can be illustrated by the following example: Let us assume channels 2, 4, and 5 arrive from direction A and channel 10 from B. Then the antenna for A need only contain low band elements and the antenna

for B only high band elements. Furthermore, if stacking is used, it will not be necessary to compromise the stock spacing between that which is best for the low band channels and that which is best for the high band. Antenna A can utilize the stacking distance which is optimum for the low band and antenna B that which is optimum for the high band. In fact, for this particular example, it would be best to use a channel 10 Yagi (or stack of two) for antenna B.

There are many more possibilities of course, but using individual antennas for each signal direction (as shown in Fig. 2) results in greater flexibility than using one antenna plus a rotator, and frequently careful study of the situation can result in better performance at comparable cost.

**Only Two Channels Available.** Generally the best results are obtained by using a separate Yagi antenna for each channel, running a separate lead-in to a switch near the tv set and selecting the antenna as desired. While it is possible to make the antenna connections in such a way as to use only one lead-in, the matching stub lengths are different for each pair of channels, and unless this is done accurately, considerable signal loss can result. Use of separate lead-ins and a selector switch avoids this possibility.

However, where it is still desired to use a single lead-in from two antennas, the following procedure may be employed. Referring to Fig. 3, connect lead-ins LA and LB to each antenna and form a common junction (J) with the lead-in to the receiver. Make LA and LB long enough so that if necessary 10 feet can be cut from both and the overall length will still be sufficient to make the connection. Then, observing channel A, disconnect LB from J. If the removal of LB improves channel A, cut down LB progressively until it is of such length that its connection to the junction (J) makes

(Continued on page 27)

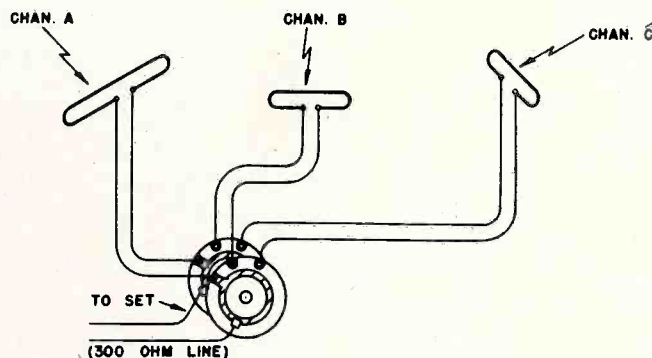
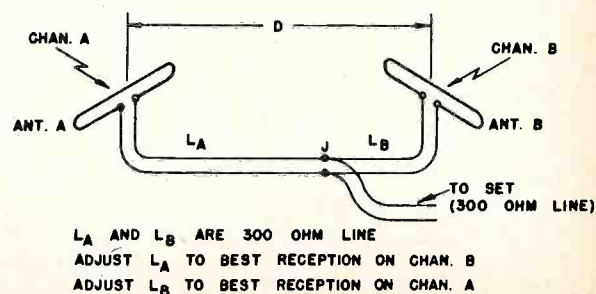

Fig. 2. Switch connection of three antennas.

Fig. 3. Feeding two antennas to one line.





# Preventive Maintenance

by John F. Rider

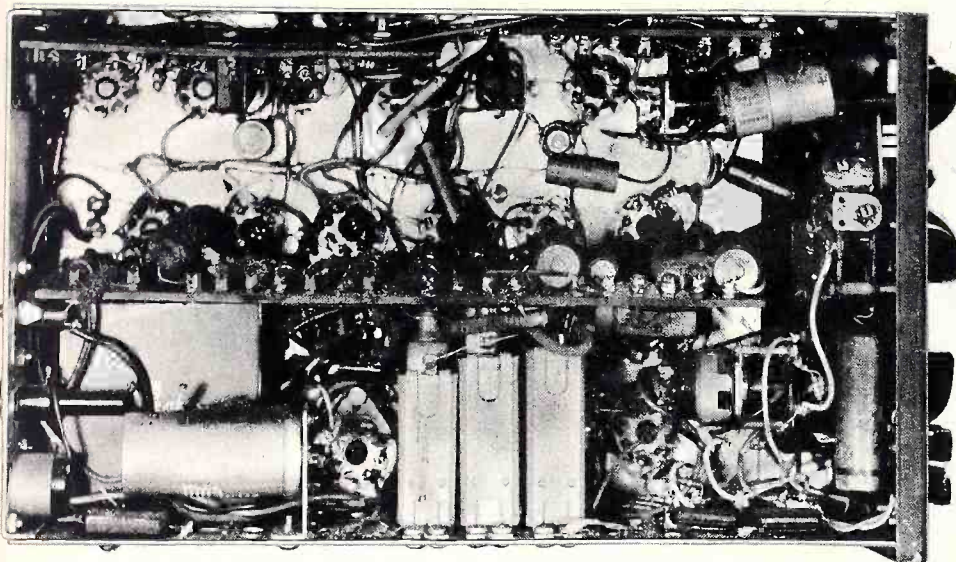

Fig. 1. If given time, dirty equipment will function poorly.

Preventive maintenance is not unknown to tv and radio service technicians who served in the Armed Forces during World War II. It was the means of keeping weapons, vehicles, electronics equipment and other devices in good working order so they would be ready for proper use and good performance when needed. This was used by all branches of the service, whether on the ground, in the air or on or below the surface of the sea.

But the application of preventive maintenance is not limited to the Armed Forces. It is practiced in civilian life too. When you take your car in for a spring check-up, for tire pressure, tightening, lubrication, new spark-plugs, points, etc., the sum and substance of the whole thing is preventive maintenance. You are preparing your car for summer use; you want to make certain that it is in proper running order. When you paint a scratch on a fender to prevent rusting — or oil the hinges of a door, tighten it on the frame and check the lock — all of this is preventive maintenance. In other words preventive maintenance is a series of operations which are periodic and are intended to keep equipment in correct working order — thus assuring longest life and, even more important, making sure that the

equipment is ready to do its job when needed — and to do it well.

Every service technician who is connected with radio transmitting station operation knows the meaning of preventive maintenance. Regardless of the kind of signal being transmitted, each installation performs

preventive maintenance as religiously as you wash your face. That is SOP every day, week and month — and in case you've forgotten the meaning of SOP, it is "Standard Operating Procedure." Whatever good record a broadcasting station may develop for uninterrupted service is attributable only to the preventive maintenance which is performed on a regular schedule. Neglect preventive maintenance and equipment suffers. The more expensive your equipment, the more it needs preventive maintenance if the cost of replacement is to be kept to a minimum . . . and maximum performance is to be achieved.

## Service Equipment is Expensive

The test equipment and other devices used in tv and radio service shops are no longer cheap. They may have been considered relatively inexpensive in the days of radio receivers only, that is prior to 1940, but since that time costs have been rising . . . and are destined to go higher. Such being the case, it stands to reason that each service facility is interested in getting the most out of its test equipment while keeping repair and replacement at the lowest possible figure. Preventive maintenance is one way of achieving this; it is the most effective

*(Continued on page 12)*

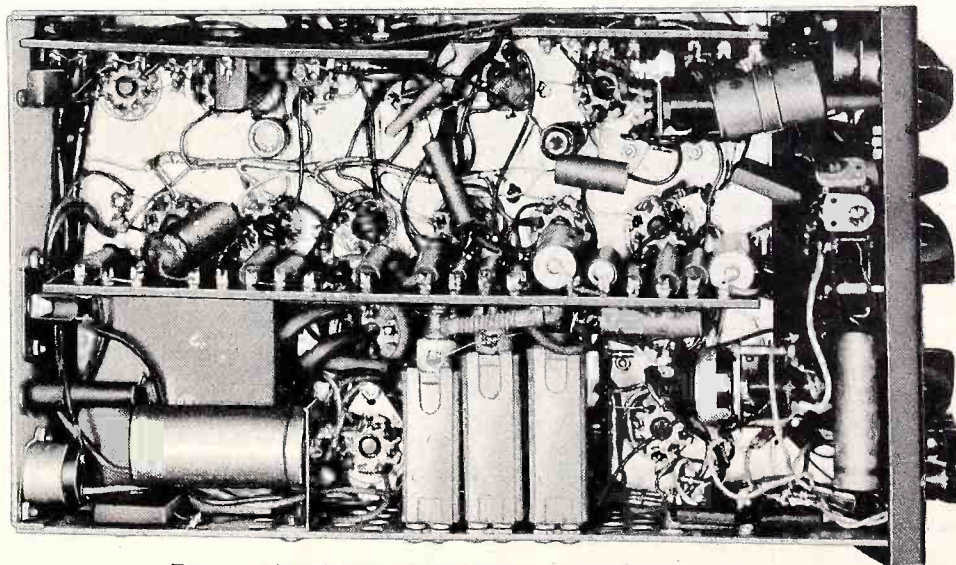

Fig. 2. Clean equipment lasts longer and operates better.



**Bill Clemens says—**

Midget Radio Service (a 3-Man Shop)  
129 S. Elizabeth St., Lima, Ohio

**"TRIPLITT 660 saves us  
50 to 100 man hours  
per month."**

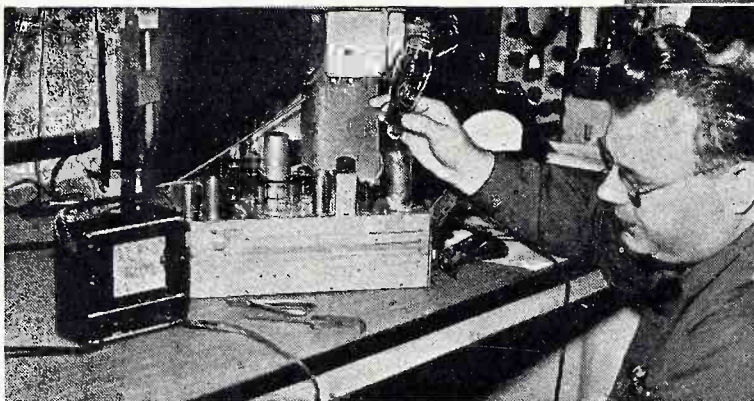

- 1. ISOLATING THE TROUBLE**—Plug the power cord of the chassis into LOADCHEK and note the reading. With your eye on the large meter remove the rectifier tube and you can tell immediately which side of the tube the trouble is on. You have already eliminated 50% of your probing time.

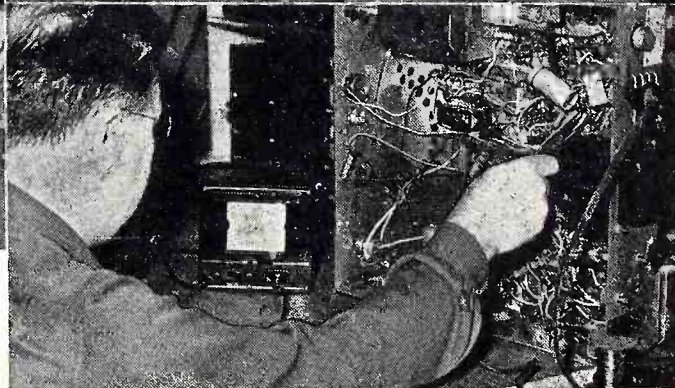

- 2. LOCATING THE SHORT**—With Loadchek you can quickly check the shorted side, part by part, without laying down tools or picking up test leads. Here, the trouble was a short in the transformer, spotted without having to warm up set. Overloads are found the same way.

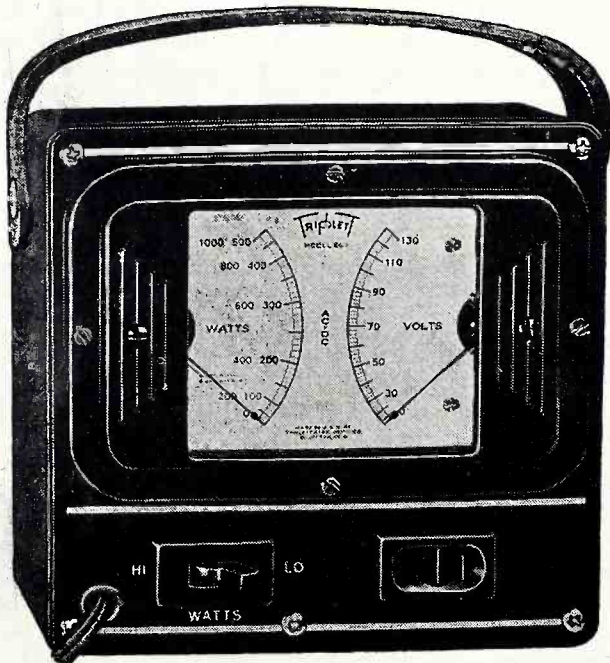

**SUGGESTED U.S.A. DEALER NET \$29.50**

Price subject to change without notice.

### *Locates trouble in a hurry*

The above pictures illustrate but one of the many time-saving uses of Triplitt 660 Loadchek. This versatile instrument accurately measures power consumption, enables you to see instantly any deviation from normal load, without disconnecting a single part... finds trouble in a hurry.

For Radio and TV servicing—for almost any kind of electrical trouble-shooting—LOADCHEK saves hours of painstaking work every day. At its moderate cost no service technician can afford to be without it. Try one today—and see! Write for free booklet.

TRIPLITT ELECTRICAL INSTRUMENT CO., BLUFTON, OHIO, U.S.A.



# Triplitt



# UHF television converters

by Allan Lytel\*

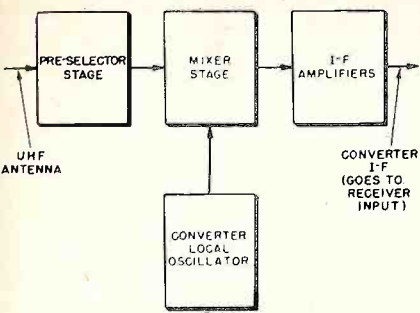

Fig. 1. Typical block diagram of uhf converter.

radio receiver was used when the converter was attached. The radio receiver supplied only the audio amplifier and speaker section to be used with the converter.

Uhf television converters involve a situation entirely different from that which exists with the f-m converters. The amplifiers and detectors of the television receiver can be used with the converter. A television converter needs only to receive the signal and mix it with a local oscillator signal to produce an i-f output. However, this output is not fed to the i-f amplifier of the associated television receiver for several reasons. First, there is the mechanical difficulty in feeding a signal into the amplifier since some method of separate coupling involving an individual connection would be needed.

Second, a less complicated system is required if the uhf converter has signal output which is within the tuning range of the front end of the existing television receiver. If the converter puts out a signal which is, for example, between 210 mc and 216 mc, it can be picked up by an ordinary television receiver tuned to channel 13.

In this manner, the converter output, while it is an intermediate frequency in relation to the converter itself, represents an r-f input signal as far as the television receiver is concerned. When it is used in this manner, the converter actually changes the receiver into a double superheterodyne; that is, the uhf signal is received and mixed with the converter local oscillator to pro-



Courtesy G. E.

Fig. 2. General Electric uhf converter.

duce what is, for the converter, an intermediate frequency. This is often called the converter i.f. Experimental uhf television converters use one or two stages of i-f amplification to compensate for the loss in signal in the mixer circuit. A typical converter uses a tuned input stage feeding a tuned mixer stage, as in Fig. 1. The local oscillator also feeds into the mixer stage. The mixer may be a crystal diode because of the low inherent noise figure. The output of the converter is fed into the antenna terminals of the conventional television receiver.

Output from the converter is thus applied to the r-f amplifier of the television receiver.

(Continued on page 11)

\*NOTE: The following material was taken from the new Rider publication *UHF PRACTICES & PRINCIPLES* by Allan Lytel. Although only a few converters are touched on in this brief excerpt from the chapter dealing with Receivers and Converters, much additional information as well as material dealing with converters produced by other manufacturers are to be found in the book.

## General Principles Involved in Conversion

When a system of broadcasting is being used by many people, as is presently the case with television broadcasting, any change in the operating frequency always brings the inevitable problem of frequency conversion. For example, frequency-modulation broadcasts could not be received on ordinary a-m broadcast receivers for several reasons. First, the radio receivers obviously could not tune in the programs since the a-m band ranges from 550 kc to 1,600 kc and the present f-m band goes from 88 mc to 108 mc. The local oscillator of the ordinary broadcast receiver would have to be modified to operate at a very high-frequency if the receiver were going to be used to pick up f-m programs. The bandwidth in a.m. is normally only 10 kc while the bandwidth in fm is almost 200 kc. In addition, the detection system in ordinary a-m broadcasting is different from the frequency-modulation detectors. These are special detectors which are responsive to variations in frequency rather than in amplitude.

As a natural consequence of these factors, converters were designed, built, and sold to many people in areas which have frequency-modulation broadcasting. These converters usually consisted of a local oscillator, mixer, several stages of intermediate-frequency amplification, a special type of detector, and an audio output jack. In some cases, converters use a stage of radio-frequency amplification for its advantages of image suppression and greater selectivity. A converter of this type was ordinarily attached to the grid of the first audio amplifier of the standard broadcast radio receiver. No part of the radio-frequency section of the

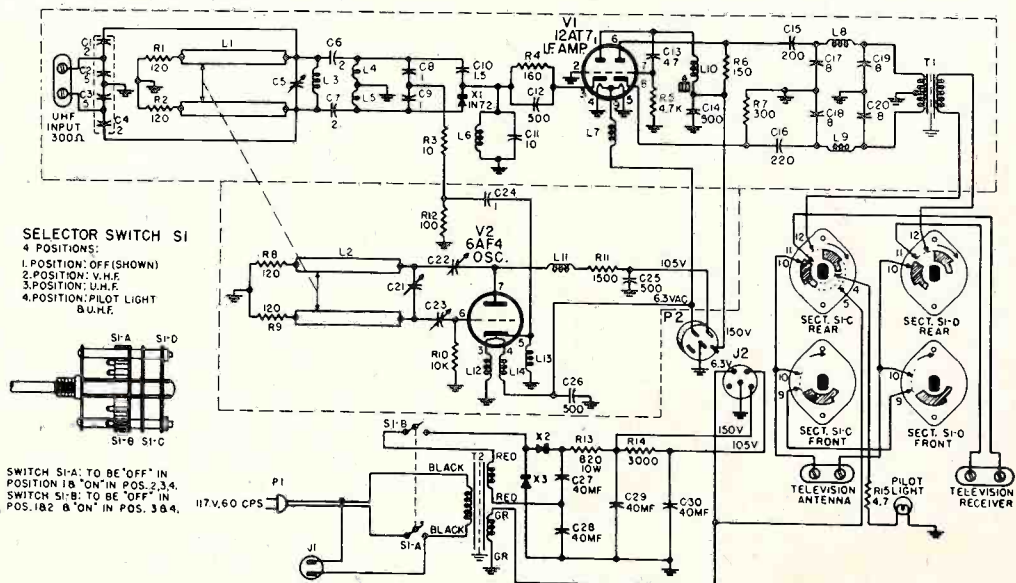

Fig. 3. General Electric uhf-101 schematic diagram.

Courtesy G. E.



# Why take a chance?

Some people make their living by taking chances. But you must make your living by earning customer satisfaction—so why take chances by ordering capacitors by rating only? Order by rating *and* brand!



## Make Sure! Make it Mallory!

Customer satisfaction with your service pays off in repeat business . . . word-of-mouth advertising . . . cash in the bank. You can build it by using Mallory capacitors on all your service work.

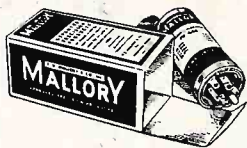

Top-notch TV and radio set makers accept Mallory FP's as *the* standard of capacitor quality. You get longer life even with higher temperatures and greater ripple current . . . dependable operation even at 185° F. (85° C.).



Mallory Plascaps\* leave ordinary plastic tubulars far behind! Dependable performance . . . no leaks . . . no premature "shorts" . . . no off-center cartridges . . . and no unsoldered leads. It will pay you to use Mallory Plascaps—the first completely engineered plastic tubular!

Back of every Mallory capacitor is the knowledge and experience gained in 25 years of research and development work. Mallory produced the first dry electrolytic capacitor . . . pioneered in making smaller, longer-lasting capacitors with outstanding heat-resistant qualities. There's just no sense in taking chances on capacitor performance. Always be sure . . . always order Mallory capacitors for all your service work.

*Depend on your Mallory Distributor for quality products at competitive prices.*

P. R. MALLORY & CO. Inc.  
**MALLORY**

CAPACITORS • CONTROLS • VIBRATORS • SWITCHES • RESISTORS  
• RECTIFIERS • VIBRAPACK\* POWER SUPPLIES • FILTERS

\*Reg. U. S. Pat. Off.

**APPROVED PRECISION PRODUCTS**

**P. R. MALLORY & CO., Inc., INDIANAPOLIS 6, INDIANA**



# UHF television converters

(Continued from page 9)

This stage feeds into the mixer where the signal frequency is mixed with the television set's local oscillator output to provide the i.f. for the receiver. This method represents maximum utilization of the existing components in the receiver itself.

## Sample UHF Television Converters

Nearly all television receiver manufacturers have announced models of uhf television converters. A few of these are discussed briefly in the following paragraphs.

*The General Electric Translator UHF-101.* Figure 2 is the General Electric uhf television converter. As in common practice, in the vhf position of the front panel control, the standard television antenna is connected directly to the television receiver. In the uhf position, the uhf antenna is used and the converter is connected to the receiver antenna terminals. Converter output at a frequency between 79 and 85 mc is fed into the receiver which is tuned to either channel 5 or 6. Frequency adjustments are provided for the channel which is to be used.

Figure 3 is a schematic diagram of this converter. Two adjustable tuned lines are used that are ganged. One line is the tuned input for the mixer and the other is for oscillator tuning. The 6AF4 local oscillator is capacitively coupled into the crystal mixer

circuit. A 12AT7 is used as a two-stage i-f amplifier whose output frequency may be adjusted. The first section of this tube uses a tuned cathode input with a grounded grid and the second stage has the signal input to the grid with the output taken between plate and cathode.

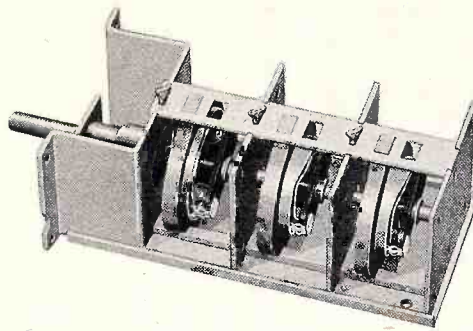

Courtesy Mallory & Co.

Fig. 4. Mallory uhf inductuner.

This unit has a self-contained selenium rectifier in a transformer-type power supply. This allows it to be used without deriving its power from the receiver.

*The Mallory UHF Television Converter.* The P.R. Mallory Company manufactures both a separate uhf Inductuner<sup>1</sup> as well as a complete converter. The tuner itself is similar in theory and operation to their model designed for vhf operation and it is available in one, two, three, or four sec-

<sup>1</sup>Reg. U. S. Pat. Off.

tions. Figure 4 shows a three-unit model. The required tuning is accomplished in 270° of rotation. The preselector or tuned input elements are shaped differently from each other. These are different from the oscillator tuning element so as to provide proper tracking. Output frequencies are obtainable at approximately 40, 80, and 130 mc. The r-f tuning range is from 460 to 910 mc. A special antenna coupling input circuit is used to match the 300-ohm line.

The tuning elements cover the entire uhf range with approximately 10 mc over travel at either end with an external tank capacitance of 1 μmf. The grid-to-plate capacitance of the oscillator tube, which is approximately 1.5 μmf resonates with the oscillator tuning element.

Figure 5 is a schematic diagram of the complete converter. Note the balanced input and the capacitive coupling to the pre-selector. This unit has a preselector tuned circuit, a crystal mixer, a local oscillator and an i-f amplifier. This amplifier uses a grounded cathode triode as input section with neutralization. This is coupled to a grounded grid triode output section. The output circuit uses a double-tuned transformer with a 12-mc bandwidth having a gain of approximately 6. Because of the conversion loss, however, the overall unit gain of the converter is approximately 1.

*The Stromberg-Carlson Converter.* Another example of the use of the Mallory uhf tuning is found in the Stromberg-Carlson converter shown in Fig. 6. The cabinet is 8 by 4 by 6 inches. The circuit for this unit closely resembles that shown in Fig. 5 ex-

(Continued on page 32)

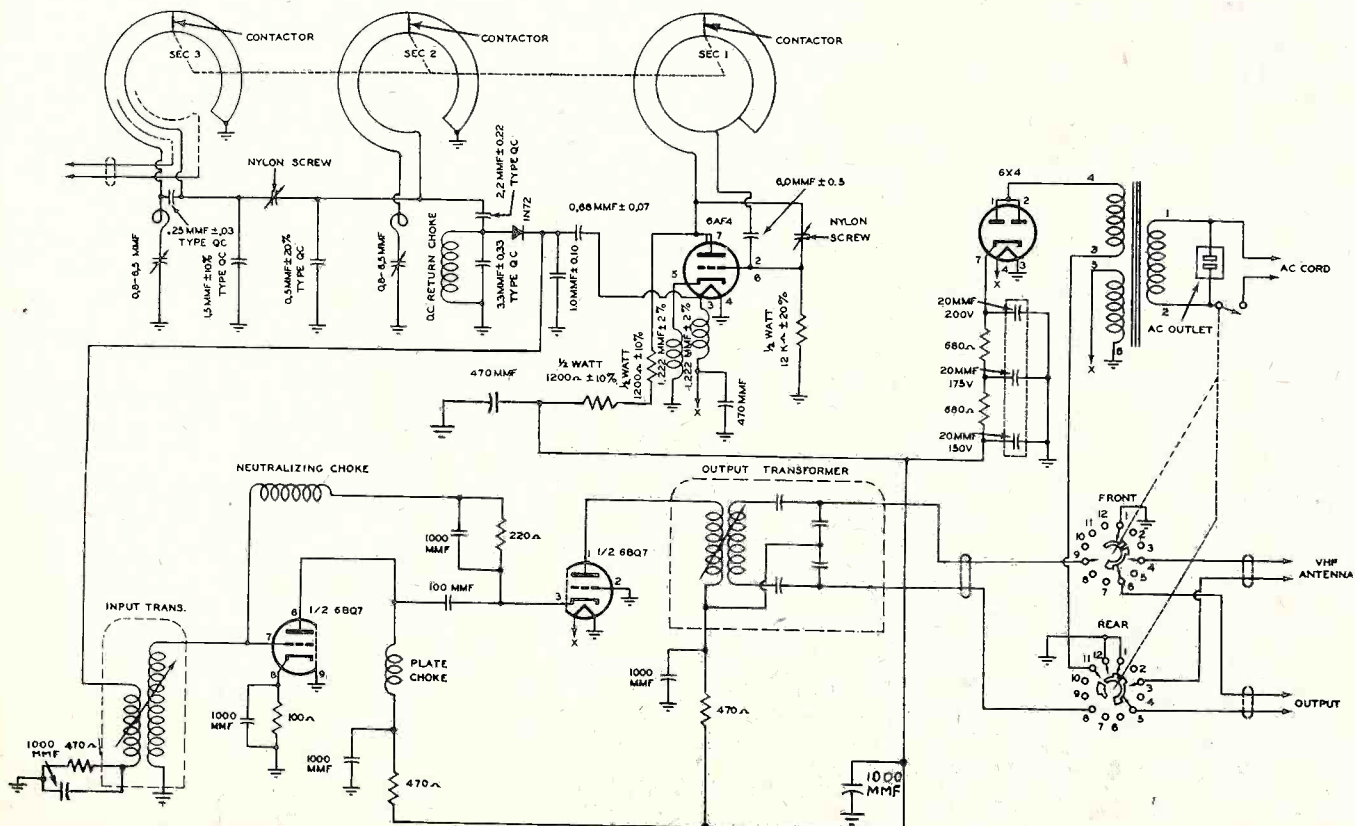

Fig. 5. Mallory uhf converter schematic diagram.

Courtesy Mallory & Co.



# Preventive

# Maintenance

(Continued from page 7)

means of prolonging the life of equipment and keeping it in the best operating condition at the same time.

## Preventive Maintenance of Electronic Equipment

Specifically what is preventive maintenance on electronic equipment? Let us say right at the outset that it is simple to perform and is not time consuming. From this point on, it is keeping the equipment clean — seeing to it that everything is always in proper operating condition — and doing these things *regularly*. And by regularly we mean according to a preset schedule.

Preventive maintenance of electronic equipment can be divided into three groups of operations. The first of these includes everything that can be done from the outside of the equipment. This means keeping the front panel clean and free from dust and dirt. It means keeping control and tuning knobs functioning properly, replacing broken meter and dial windows, and seeing to it that terminals are clean and free from corrosion and are tight so that proper connections can be made to them. Connecting cables should be clean and not oil soaked, and should not have frayed or torn insulation. Alligator clips attached to these cables should be clean and capable of making good contact, so that they do not introduce noise into the circuits they interconnect and can allow the transfer of the full signal with minimum loss. The same goes for bayonet contacts, plugs and phone tips.

The screws holding panels to the cabinet should be tight, ground contacts should be tight and free from corrosion, and covers should be on tight. Voltage, frequency and other dial markings should be clean and easily readable. All in all it means keeping the appearance of the equipment nice and clean and presentable.

If anything on the panel is broken it should be replaced; if scratches exist on the panel they should be painted over to prevent rusting and subsequent damage.

The preventive maintenance performed on the outside of the equipment should be set on a regular schedule. Believe it or not, making it daily is not too frequent. Once the operation has been started, keeping it clean is only a matter of a few minutes work each day, of course if you want to make it twice a week that's ok too. This is worthwhile because it saves far more money and time in the long run than is spent caring for your equipment each day.

## Preventive Maintenance on the Inside

What is preventive maintenance inside the equipment? Again it is simple. The tubes should be tight in their sockets. The top of the chassis should be clean and free from dirt and dust. Most equipments have louvres cut in the cabinets for ventilation, dust and dirt enter the unit through these openings. In high humidity areas, a film of moisture on the top of the chassis is quite common. Of course if the equipment housing has no such openings, the need for cleaning inside is reduced; but if the equipment is handled quite a lot and its location changed so as to suit the different operations each day, it still is necessary to make certain that tubes are tight in their sockets.

Dirt and dust don't gather only on the top of the chassis, but underneath as well. However, the complete check of the chassis is something else, as is the testing of the tubes in the device to make sure they are functioning properly. This means checking the tubes with a tube checker, or whatever other

means is decided upon . . . but some sort of check should be made.

Some tv generators contain vibrating devices. These impart vibration to the tubes and other components, hence these require more attention than those which do not use such units for generating frequency modulation. These references do not reflect adversely on the design of the apparatus, but such vibrating devices warrant attention.

How frequently the inside is cleaned and the tubes checked is determined by the design of the equipment. Devices which have louvres and covers require it more often than units which are completely sealed. The former may be once a month, whereas the latter can be as infrequently as every three months or even once every six months. If the top of the chassis is cleaned once a month, then the bottom of the chassis, and everything mounted on it, should be cleaned every three or every six months. In the final analysis local conditions are the determining factors. In some towns the air is loaded with dirt, dust and soot; in others the air is much cleaner. In some locations, such as near the seashore, the air is moist and loaded with salt. This can damage equipment rapidly unless cleaning is frequent.

Set whatever preventive maintenance schedule you feel is best for your location and the kind of equipment you have — but

(Continued on page 25)

## ATTENTION! RADIO SERVICEMEN

THERE ARE THOUSANDS OF OUT-MODED RADIOS IN YOUR "BACK YARD" JUST WAITING TO BE REPLACED . . . AT YOUR SUGGESTION

Here is the custom-built AM-FM chassis that means **BIGGER PROFITS** for you!

### The NEW ESPEY model 511-C

#### FEATURES

1. AC Superheterodyne AM-FM Receiver.
2. Improved Frequency Modulation Circuit, Drift Compensated.
3. 12 Tubes plus rectifier and Pre-Amp 12A7 Tube.
4. 4 dual purpose tubes.
5. Treble Tone control.
6. 6-gang tuning condenser.
7. Full-range bass tone control.
8. High Fidelity AM-FM Reception.
9. Automatic volume control.
10. 10 watts (max.) Push-Pull Beam Power Audio Output.
11. 12-inch PM speaker with Alnico V Magnet.
12. Indirectly illuminated Slide Rule Dial.
13. Smooth, flywheel tuning.
14. Antenna for AM and folded dipole antenna for FM Reception.
15. Provision for external antennas.
16. Wired for phonograph operation with switch for crystal or reluctance pick-up.
17. Multi-tap output trans., 3.2-8-500 ohms.
18. Licensed by RCA and Hazeltine.
19. Subject to RMA warranty, registered code symbol #174.

Makers of fine radios since 1928.

**ESPEY**  
EL. Trafalgar 9-7000  
**MANUFACTURING COMPANY, INC.**  
528 EAST 72nd STREET, NEW YORK 21, N. Y.

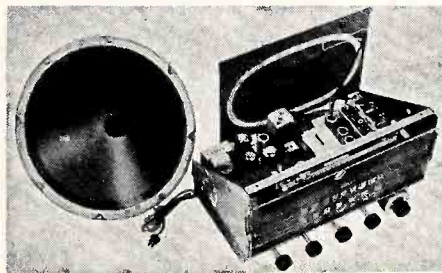

#### SPECIFICATIONS

Supplied ready to operate, complete with tubes, antennas, speaker and all necessary hardware for mounting in a table cabinet or console, including escutcheon. Power consumption — 105 watts.

Chassis Dimensions: 13 1/2" wide x 8 1/2" high x 10" deep.

Carton Dimensions: (2 units) 20 x 14 1/2 x 10 3/4 inches.

Net Weight: 17 1/2 pounds each.

Sold through your favorite parts distributor.

WRITE FOR CATALOGUE KD12  
AND NAME OF NEAREST DISTRIBUTOR.



ANOTHER CBS-HYTRON FIRST YOU'LL BE BUYING SOON



# CBS-HYTRON 1AX2

**NEW HEAVY-DUTY TV HIGH-VOLTAGE RECTIFIER CAN TAKE IT!**

TV high-voltage rectifiers take a beating: Terrific variations occur in applied filament voltage... 0.8 to 2.4 volts! Sudden arcs in the rectifying system place destructive electromechanical stresses on the filament. And the increasingly larger TV picture tubes demand peak emission and peak inverse voltage simultaneously. The new CBS-Hytron 1AX2 was especially designed to take such rough treatment and come up smiling.

### 1AX2 DATA

The CBS-Hytron 1AX2 is a compact, 9-pin miniature TV pulse rectifier. Plate is brought out to top cap and filament is oxide-coated. Absolute maximum ratings are: peak inverse plate voltage, 25,000 volts; d-c load current, 1.0 ma.; and steady-state peak plate current, 11.0 ma.

### Typical Operation — TV Pulse Rectifier

Filament voltage	1.4 v ± 10%
Filament current	650 ma
Positive-pulse plate voltage	20,000 v
Negative-pulse plate voltage	5,000 v
Peak inverse plate voltage	25,000 v
D-c output voltage	20,000 v
D-c load current	300 μa

### ADVANTAGES OF NEW CBS-HYTRON 1AX2

- 1 Rugged, high-wattage filament of CBS-Hytron 1AX2 has adequate peak emission for the new, larger TV picture tubes. 1AX2 may be run simultaneously at both its peak inverse voltage and maximum d-c current.
- 2 Higher load of 1AX2 filament on transformer tends to regulate filament voltage. Eliminates need for limiting resistor. Yet lower plate-to-filament capacitance (0.7 μμf) of 1AX2 prevents loss of high voltage.
- 3 Insulated tension bar (patent applied for) through center of 1AX2 coiled filament limits destructive movement of filament by electromechanical stresses.
- 4 Filament of 1AX2 is located in base and shielded to eliminate bombardment of cool ends of filament by gas molecules.
- 5 An overloaded 1X2A may be replaced with its big brother, the CBS-Hytron 1AX2, by simply removing the limiting resistor. In rare cases, it may be necessary to add another turn to the secondary of the filament transformer to obtain the required 1.4 volts for the 1AX2.

BOTTOM VIEW OF SOCKET

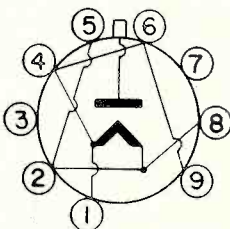

MAIN OFFICE: SALEM, MASSACHUSETTS



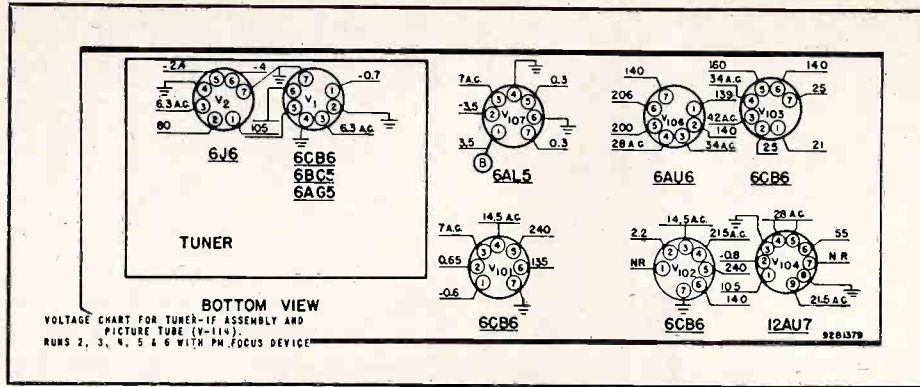

# WHAT to do and HOW to do it!

## What was it the atom bomb spies stole from this nation?

Briefly, what to do, and how to do it information . . . What it is that a surgeon learns? . . . Many things, but foremost among them is what to do and how to do it! Have you ever assembled some piece of equipment for yourself or for your youngster? What information did you follow—the simple instructions which told you what to do and how to do it. Many things which you have done, and which had no association with tv servicing were made easy and accomplished *successfully* only because you knew what to do, and how to do it.

Television servicing is no different. The key to easy tv servicing—and, at the same time, the open door to public good will and successful operation is knowing what to do and how to do it. And when we say this we're not thinking about theory; we are speaking about out and out practical things; we are referring to definite and specific servicing instructions. That and only that is what can make tv servicing easy.

Ever since the first radio receiver was built in 1920, and the first commercial tv receiver with a cathode-ray tube made its appearance in 1938, the place of origin of what to do and how to do it information about radio and tv servicing has been the set manufacturer's service department and his engineering department. Every set manufacturer is very much interested in having his receiver repaired properly. Having sold his product to the public, he wants it to stay sold. To help in this effort, the set producer prepares service information for use by the servicing industry. To make it most useful, he puts into it, among other facts, what to do, and how to do it—as applied to troubleshooting and repair. Following these instructions is what makes television and radio servicing easy.

## And where do we come into all this?

We compile and publish this information in Rider Manuals and Tek-Files. It appears in complete, unabridged form—

rich in information—rich in what to do and how to do it instructions. This is the kind of information that makes servicing easy. If a service technician has been in business one year or twenty-five, Rider information fills the bill. This is true because it is accurate, complete and dependable.

To illustrate just what we mean, here is a sample case. The receiver manufacturer is Hallicrafter, the receiver models are 805, 806, 810 and 810C and the chassis number is M800S (this appears in Rider TV Manual, Volume 8 and in Rider Tek-File Pack 6). The set manufacturer's service literature on these receivers amounts to 32 8½ x 11 inch pages. That is what we published. Now for the pertinent details.

These models were manufactured in 7 production runs. To present this data properly and to give the service technician *all* the information about the receivers, so that he can work competently on any one of the production runs which may come into his shop, individual bottom views are given for runs 1, 2 and 3 and for runs 4, 5, 6 and 7.

To make servicing easy and to show the differences between the receivers properly, the manufacturer prepared, and we reprinted, four different schematics. One of these is for run 1, another shows the receiver as produced in runs 2 and 3. Still another schematic shows the runs 4, 5, 6 and 7, but this schematic applies

to the receivers using EM (electromagnetic) focus coils used in these runs. The fourth schematic applies to production runs 4, 5 and 6 for receivers which used PM (permanent magnetic) focus coils.

The variations introduced by different runs are indicated in two bottom socket views showing the operating voltages. These are illustrated in Figs. 1 and 2. Note carefully the great variations in the operating voltages at the different tube pins. Imagine having one set of voltage data, that for runs 4, 5 and 6 with the EM focus coil, and applying it to a receiver from runs 1, 2, 3, 4, 5 or 6 with a PM focus coil!

For example, compare the operating voltages used for V 101 in both cases. The tube is the same, a 6CB6. In one case the screen voltage is 135 volts; in the other it is 180 volts. The operating voltages on pins 1 and 2 differ by more than 100 percent in the two cases. Compare the operating voltages applied to tube V 103 in the video amplifier. In each case it is a 6CB6—but the operating voltages differ greatly. They differ so much that if a serviceman lacks the correct information he will draw the wrong conclusions. Without full information time would be lost in determining if the operating conditions were right or wrong, but with the *full* service data at hand, you know exactly what is right and what is wrong. There is little left to the imagination and guesswork is eliminated . . . All of this makes servicing easy . . . But you must have all the facts! You must have the set manufacturer's accurate and complete service information. . . . There is no substitute for completeness and accuracy in service information. . . . It is the foundation of easy, rapid tv servicing.

Room does not permit a full presentation to show how complete this information is. Receivers produced by other manufacturers are covered in similar detail. When you know what to do and how to do it—as stated by the receiver manufacturers and as contained in Rider Manuals and Tek-Files—servicing becomes as easy as falling off a log.

## Free Rider Tek-File Index.

Rider Tek-File indexes covering all issued packs are available at your jobbers. If your jobber doesn't have Rider Tek-File Indexes—write us direct . . . it's free.

John F. Rider Publisher, Inc. 480 Canal St. New York 13, N. Y. West Coast office: 4216-20 W. Jefferson Blvd. Los Angeles, Calif.

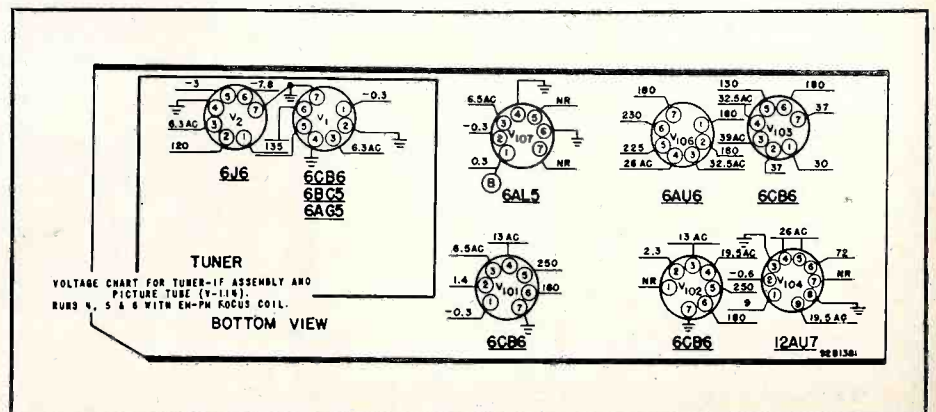



**Advance comments from service technicians on**

# **TELL-A-FAULT**

*The Troubleshooter's Troubleshooting Service*

it contains as much information as your  
successful Servicing, it will still be worth  
more than the price

will be the best investment I ever made

*Long needed in our trade*

Will without doubt be tops in the TV field today

*fills a definite gap*

if it's Rider's, it's bound to be good

How can we go wrong with all this info for only ten bucks

looking forward to much help in our servicing

SIGHT UNSEEN **TELL-A-FAULT** has completely captured the fancy of the servicing industry. Thousands of progressive service technicians showed strong faith in Rider's reliability by putting their cash on the line for the most unique SERVICE ever made available to TV-radio service technicians. The next two pages show reproductions of a typical symptom sheet and circuit guide.

**TELL-A-FAULT** does your troubleshooting for you!



**TELL-A-FAULT**

## Symptom Sheets LOSS OF HORIZONTAL SYNC (HOR. OSC.-PULSE-WIDTH AFC)

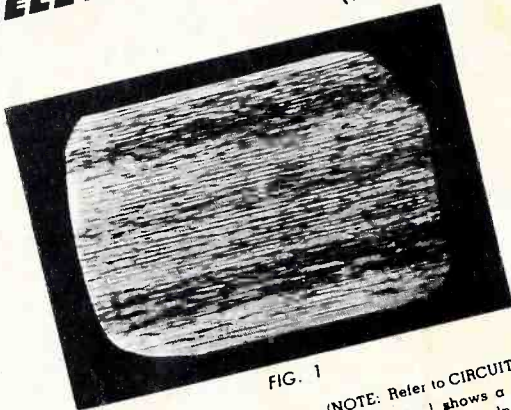

FIG. 1

(NOTE: Refer to CIRCUIT GUIDE-1 for identification of components.)  
Figure 1 shows a faulty picture-tube pattern indicating loss of horizontal sync. In order to determine whether the controls and adjustments were set properly, the horizontal-lock control (C7), the horizontal-frequency control (L1), the horizontal stabilization control (L2), and the horizontal-hold control (R2) were all adjusted. Improper horizontal synchronization still existed, as shown by the multiple-image pattern in Fig. 2.

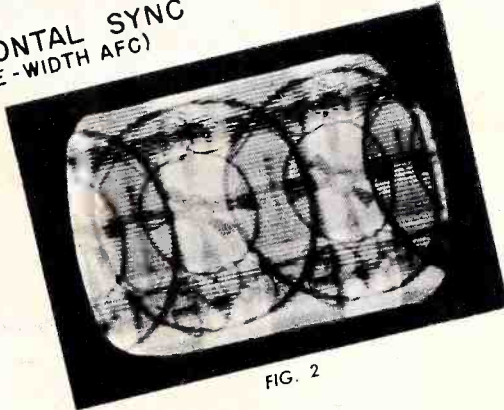

FIG. 2

LOSS OF HOR SYNC  
(HOR. OSC.-PULSE-WIDTH AFC)

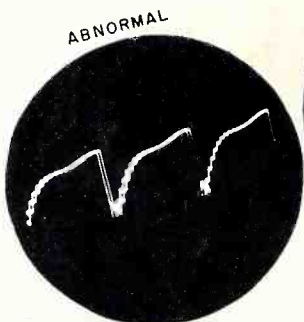

FIG. 3

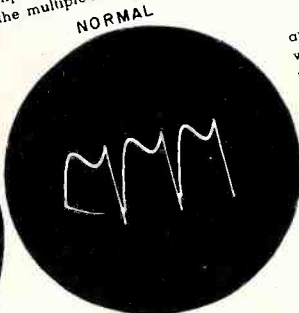

FIG. 4  
NORMAL

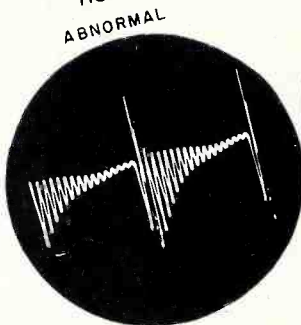

FIG. 5

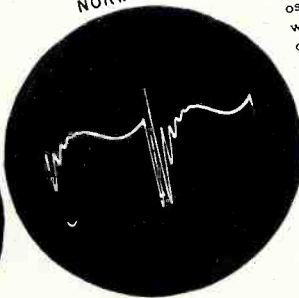

FIG. 6

An oscilloscope was connected between the center-top of L1 and ground through a high-impedance probe. The scope sweep was adjusted for  $\frac{1}{2}$  of the horizontal-sweep rate. The resultant waveform is shown in Fig. 3. This waveform was very jittery and was held stationary by critical adjustment of the horizontal-hold control (R2). For comparison, the normal waveform at this same point in the circuit is shown in Fig. 4. Note the low-amplitude damped oscillations that are superimposed on the fundamental frequency in this abnormal waveform, as well as the deterioration in shape. There was a slight increase in the peak-to-peak amplitude as compared with normal voltage value at the same point. The d-c voltage, as measured by VTVM, decreased by about 10% of the normal value.

The scope was then connected to the plate of the horizontal-oscillator stage (V2) through a high-impedance probe, and sweep was adjusted for  $\frac{1}{2}$  of the horizontal-sweep rate. The resultant abnormal waveform is shown in Fig. 5. High-frequency damped oscillations appear which recur at the horizontal-oscillator normal waveform at the plate of the horizontal-oscillator is shown in Fig. 6 for comparison. Note that high-frequency damped oscillations also occur in the normal waveform but are damped out rapidly after a few cycles. In the case of the entire interval between (Fig. 5), these oscillations continue for the entire interval between horizontal-oscillator pulses. The peak-to-peak amplitude of the oscillator plate voltage, under these conditions, was over 2 times the normal value. The d-c voltage, as measured by VTVM, decreased by about 10% of the normal value.

The receiver fault which was responsible for the patterns and abnormal waveforms shown was an open damping resistor in the horizontal-oscillator circuit. This resistor, designated as R13, is shunted across the plate winding of the blocking-oscillator transformer. Its purpose is to provide damping for the shock-excited oscillations which occur in the blocking-oscillator circuit.

(70% of original size)

I-A-1

**TELL-A-FAULT**

SYMPTOM SHEET

The unbeatable  
TELL-A-FAULT  
and circuit  
easier, more  
profitable to  
work hand-  
other. The  
light the trou-  
guides help  
TELL-A-FAULT  
work with  
Rider Manual  
etc. In a con-  
period of time  
a fault and  
Troubleshooting  
time-consuming  
ities is a  
cialty! During  
year you receive  
1,152 symptoms  
form pictures  
plus servicing  
valuable  
use your  
receive this



Time! As few as one or two symptom sheets  
 Time to pay for the entire year's cost of **TELL-A-FAULT**

mination of  
 tom sheets  
 the key to  
 and more  
 eting. They  
 with each  
 sheets spot-

**TELL-A-FAULT** Circuit Guides

HORIZONTAL

FC (PULSE-WIDTH) CIRCUIT

HOR OSC - PULSE-WIDTH AFC

o continue receiving  
**SUCCESSFUL SERVICING . . .**  
 and return this card to us! Otherwise this is

CING will be bigger and better  
 ast. Don't miss this opportunity  
 our mailing list.  
 in receiving future issues of  
 CING because it helps you in  
 erations—then please fill in and  
 Be sure to affix a 2-cent stamp.

**Check the following:**

- I am a **SERVICEMAN**
- DEALER**
- ENGINEER**
- HAM**
- Other** .....

(PLEASE PRINT)

Zone State

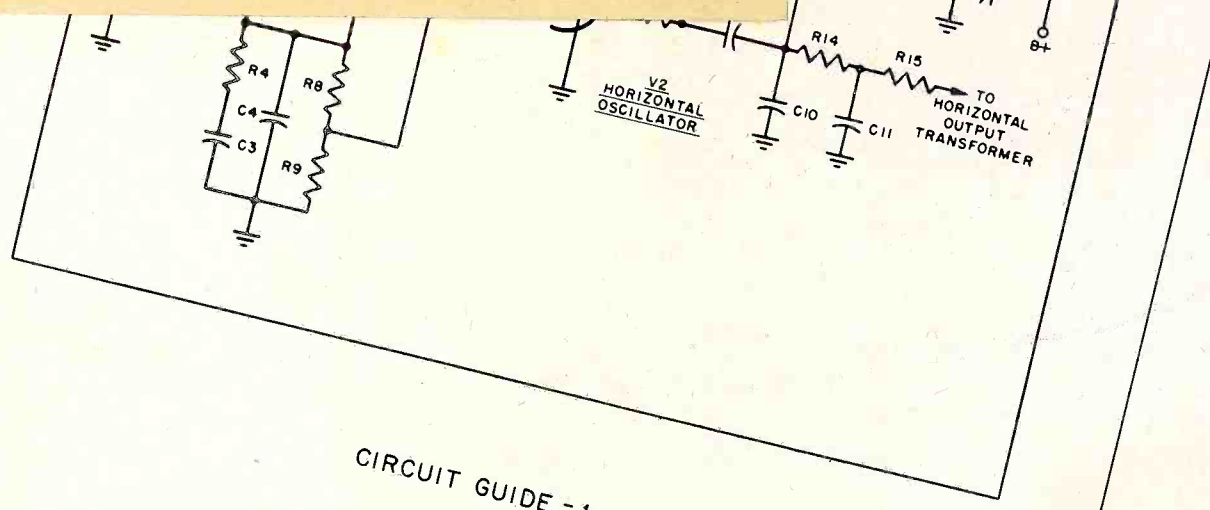

CIRCUIT GUIDE -1

**TELL-A-FAULT** CIRCUIT GUIDE

(70% of original size)

CG-1

**troubleshooting for you!**



## TELL-A-FAULT

### Symptom Sheets LOSS OF HORIZONTAL SYNC (HOR. OSC.-PULSE-WIDTH AFC)

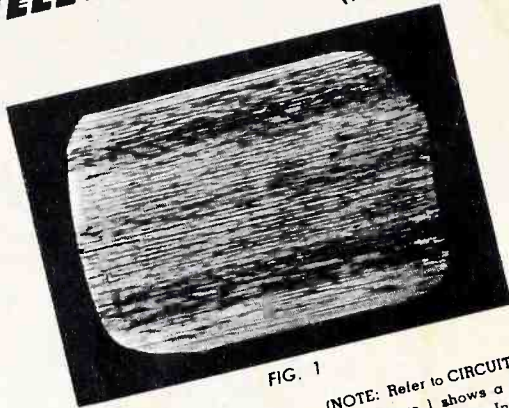

FIG. 1

(NOTE: Refer to CIRCUIT GUIDE-1 for identification of components.)  
Figure 1 shows a faulty picture-tube pattern indicating loss of horizontal sync. In order to determine whether the controls and adjustments were set properly, the horizontal-lock control (C7), the horizontal-frequency control (L1), the horizontal-stabilization control (L2), and the horizontal-synchronization still existed, as shown by the multiple-image pattern in Fig. 2.

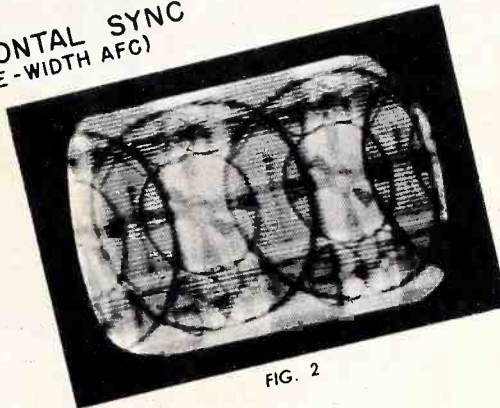

FIG. 2

LOSS OF HOR. SYNC  
(HOR. OSC.-PULSE-WIDTH AFC)

ABNORMAL

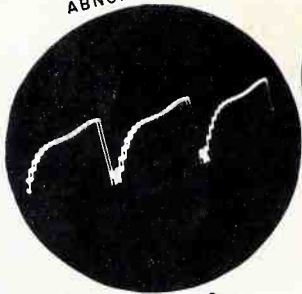

FIG. 3

NORMAL

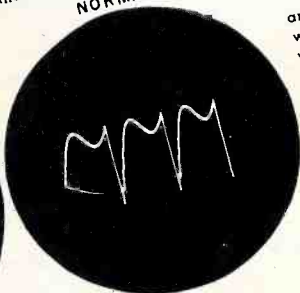

FIG. 4  
NORMAL

An oscilloscope was connected between the center-tap of L1 and ground through a high-impedance probe. The scope sweep was adjusted for 1/2 of the horizontal-sweep rate. The resultant waveform is shown in Fig. 3. This waveform was very jittery and was held stationary by critical adjustment of the horizontal-hold control (R2). For comparison, the normal waveform at this same point in the circuit is shown in Fig. 4. Note the low-amplitude damped oscillations that are superimposed on the fundamental frequency in this abnormal waveform, as well as the deterioration in shape. There was a slight increase in the peak-to-peak amplitude as compared with normal voltage value at the same point. The d.c. voltage, as measured by VTVM, decreased by about 10% of the normal value.

ABNORMAL

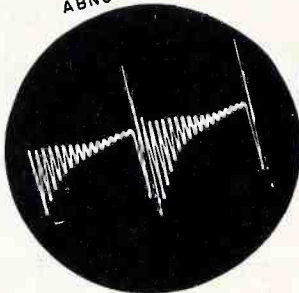

FIG. 5

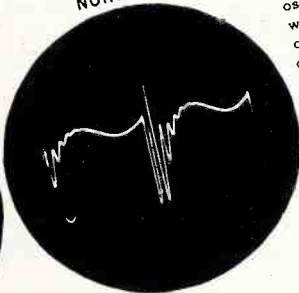

FIG. 6

The scope was then connected to the plate of the horizontal-oscillator stage (V2) through a high-impedance probe, and sweep was adjusted for 1/2 of the horizontal-sweep rate. The resultant abnormal waveform is shown in Fig. 5. High-frequency damped oscillations appear which recur at the horizontal sweep rate. The normal waveform at the plate of the horizontal oscillator is shown in Fig. 6 for comparison. Note that high-frequency damped oscillations also occur in the normal waveform but are damped out rapidly after a few cycles. In the case of the entire interval between (Fig. 5), these oscillations continue for the entire interval between horizontal-oscillator pulses. The peak-to-peak amplitude of the oscillator plate voltage, under these conditions, was over 2 times the normal value. The d.c. voltage, as measured by VTVM, decreased by about 10% of the normal value.

The receiver fault which was responsible for the patterns and abnormal waveforms shown was an open damping resistor in the horizontal-oscillator circuit. This resistor, designated as R13, is shunted across the plate winding of the blocking-oscillator transformer. Its purpose is to provide damping for the shock-excited oscillations which occur in the blocking-oscillator circuit.

(70% of original size)

I-A-1

## TELL-A-FAULT

### SYMPTOM SHEET

The unbeatable TELL-A-FAULT and circuit guides help you work with your Troubleshooter's Manual, etc. In a period of time a fault and Troubleshooter's Manual is a specialty! During the year you receive 1,152 symptom forms picture plus service use your receive this in



time! As few as one or two symptom sheets  
 time to pay for the entire year's cost of **TELL-A-FAULT**

combination of  
 symptom sheets  
 the key to  
 and more  
 spotting. They  
 with each  
 sheets spot-

**TELL-A-FAULT** Circuit Guides

HORIZONTAL

FC (PULSE-WIDTH) CIRCUIT

HOR OSC - PULSE-WIDTH AFC

to continue receiving  
**SUCCESSFUL SERVICING . . .**  
 and return this card to us! Otherwise this is

SERVICING will be bigger and better  
 fast. Don't miss this opportunity  
 our mailing list.

in receiving future issues of  
 CING because it helps you in  
 operations—then please fill in and  
 Be sure to affix a 2-cent stamp.

**Check the following:**

- I am a **SERVICEMAN**   
**DEALER**   
**ENGINEER**   
**HAM**   
**Other** .....

(PLEASE PRINT)

Zone State

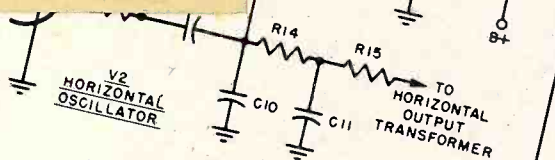
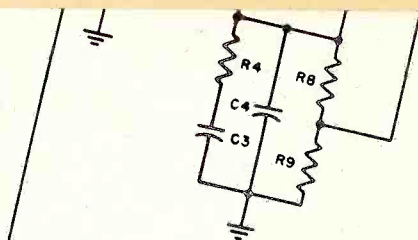

CIRCUIT GUIDE - 1

**TELL-A-FAULT** CIRCUIT GUIDE

(70% of original size)

CG-1

**troubleshooting for you!**



The unbeatable  
TELL-A-FAULT  
and circuit guide  
easier, more  
profitable trouble  
work hand-in-hand  
other. The symptoms

## TELL-A-FAULT Symptom Sheets LOSS OF HORIZONTAL SYNC (HOR. OSCILLATOR PULSE - WIDTH AFC)

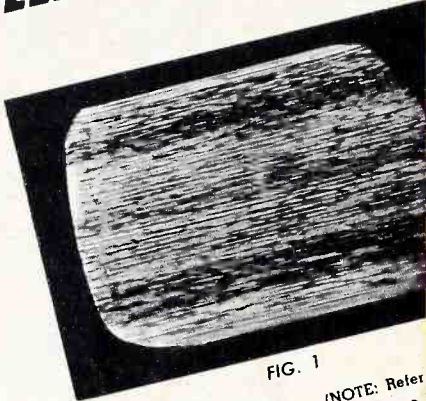

FIG. 1

(NOTE: Refer to Figure of horizontal sync and adjust (C7), the horizontal sync control adjusted as shown in the diagram.)

ABNORMAL

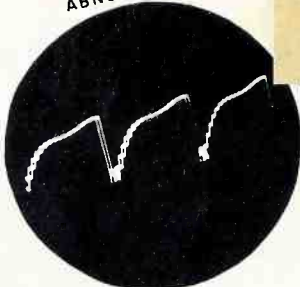

FIG. 3

ABNORMAL

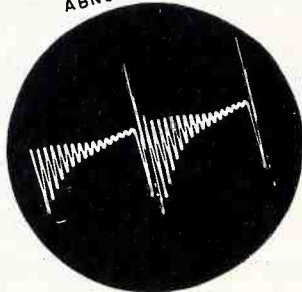

FIG. 5



FIG. 4  
NORMAL

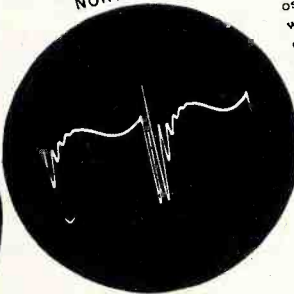

FIG. 6

The scope was then connected to the plate of the horizontal oscillator stage (V2) through a high-impedance probe, and sweep was adjusted for 1/4 of the horizontal-sweep rate. The resultant abnormal waveform is shown in Fig. 5. High-frequency damped oscillations appear at the plate of the horizontal oscillator is shown in Fig. 6 for comparison. Note that high-frequency damped oscillations also occur in the normal waveform but are damped out rapidly after a few cycles. In the case of the abnormal waveform (Fig. 5), these oscillations continue for the entire interval between horizontal-oscillator pulses. The peak-to-peak amplitude of the oscillator plate voltage, under these conditions, was over 2 times the normal value. The d-c voltage, as measured by VTVM, decreased by about 10% of the normal value.

The receiver fault which was responsible for the patterns and abnormal waveforms shown was an open damping resistor in the horizontal-oscillator circuit. This resistor, designated as R13, is shunted across the plate winding of the blocking-oscillator transformer. Its purpose is to provide damping for the shock-excited oscillations which occur in the blocking-oscillator circuit.

### SUCCESSFUL SERVICING

480 CANAL STREET

NEW YORK 13, N. Y.

PLACE  
TWO  
CENT  
STAMP  
HERE

(70% of original size)

# TELL-A-FAULT

## SYMPTOM SHEET

I-A-1



time! As few as one or two symptom sheets  
time to pay for the entire year's cost of **TELL-A-FAULT**

combination of  
symptom sheets  
is the key to  
and more  
troubleshooting. They  
come with each  
symptom sheet spot-  
light the circuit  
to localize faults.  
A planned to  
provide data —  
TEK-FILE,  
concisely short  
to determine  
the pinpoint it.  
The otherwise  
peculiar-  
TELL-A-FAULT spe-  
cial course of a  
between 768 and  
trouble wave-  
form circuit guides,  
short cuts, plus  
information on how to  
troubleshoot. You re-  
ceive monthly.

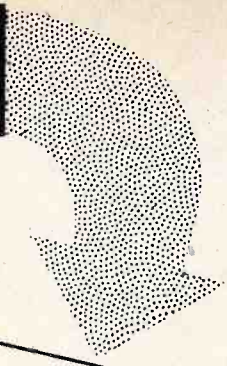

**TELL-A-FAULT** Circuit Guides

HORIZONTAL OSCILLATOR AND AFC (PULSE-WIDTH) CIRCUIT

HOROSC - PULSE-WIDTH AFC

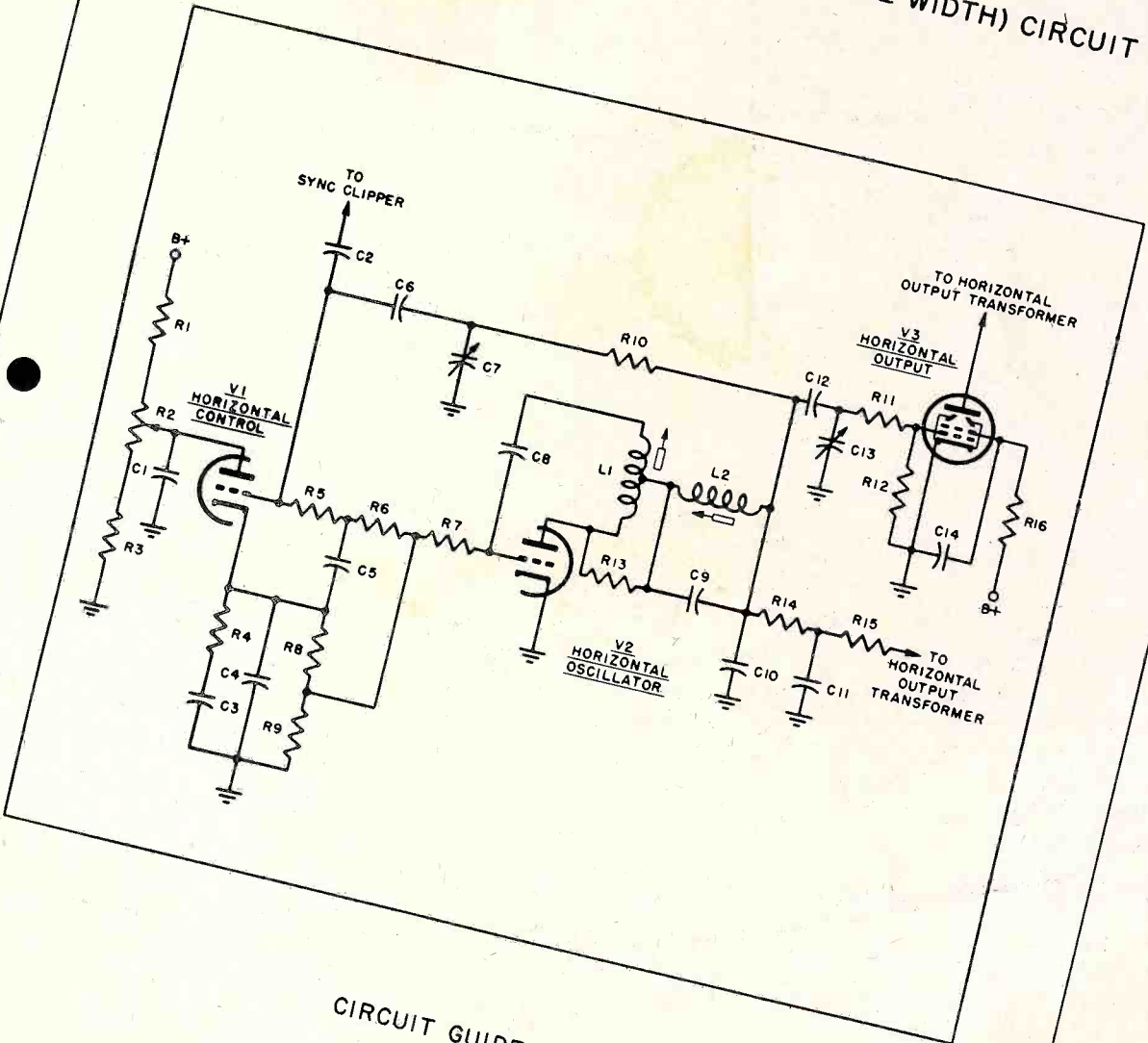

**TELL-A-FAULT** CIRCUIT GUIDE

(70% of original size)

CG-1

**troubleshooting for you!**



**IT'S ALL NEW**

**the Rotor of Tomorrow  
HERE TODAY!**

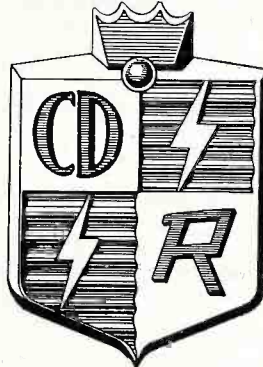
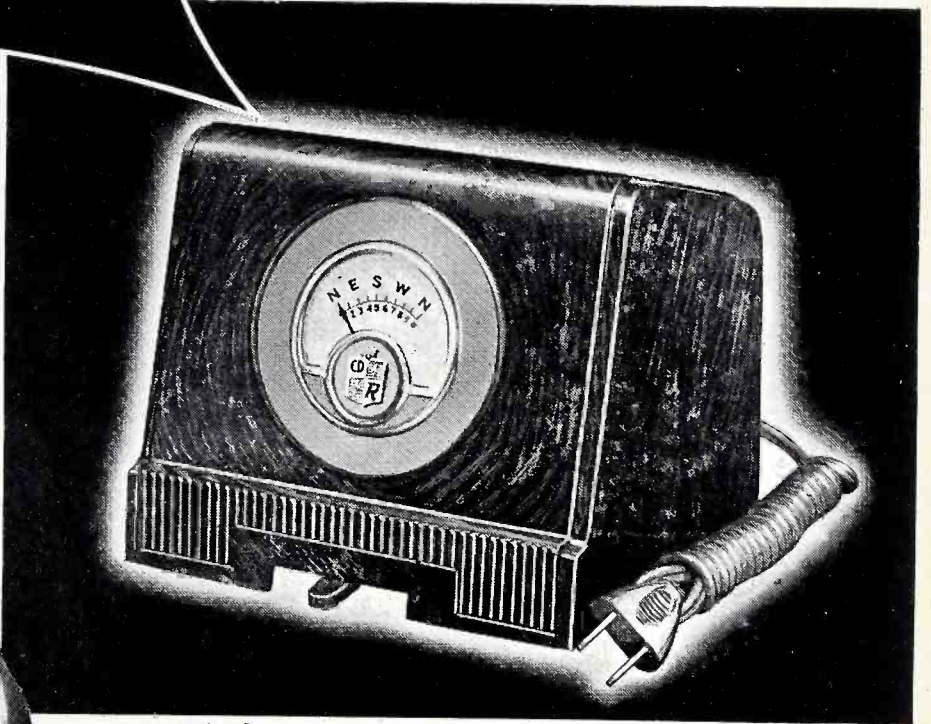
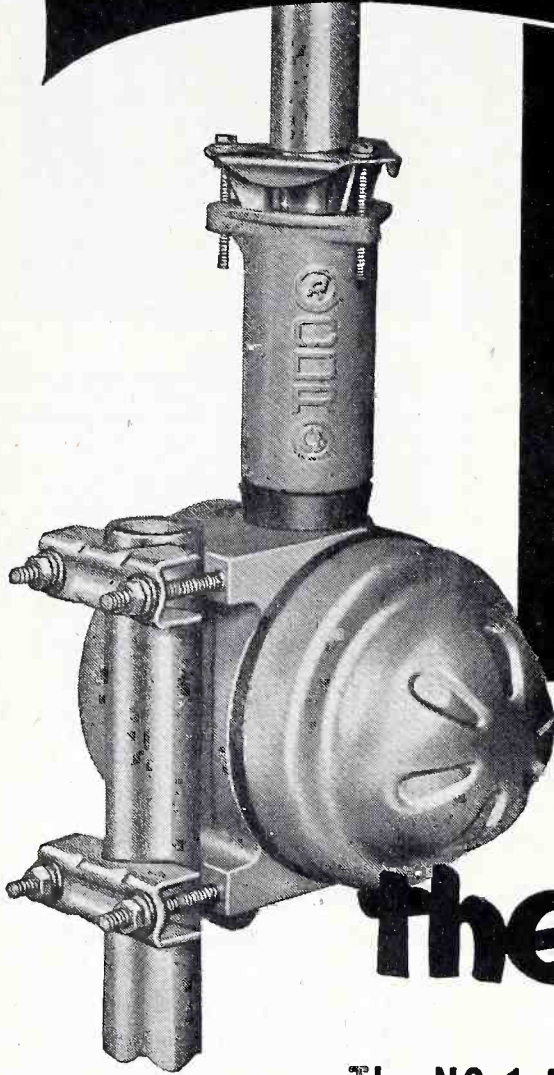

# the Rotor

**The NO.1 ALL-PURPOSE ROTOR *That Has Everything!***

Designed to give the trade everything they've asked for. To do this, it's taken time . . . lots of time and money and engineering skill . . . and NOW WE HAVE IT . . . the best possible ALL-PURPOSE ROTOR! It's TOPS! Order them at your jobber NOW . . . be the FIRST with the BEST in your area!

**MODEL TR-11** Complete rotor with handsome modern design plastic cabinet and meter control dial . . . fingertip lever . . . using 4-wire cable . . . . . \$44.95

- ★ Quick Mounting Antenna Mast Collet
- ★ Speedy Installation—No Loose Parts to Assemble
- ★ Takes Antenna Masts up to 1½" OD
- ★ High Torque
- ★ Instant Locking—will not drift
- ★ Instantly Reversible—makes complete revolution in 45 seconds
- ★ Completely Weather-proofed—Thoroughly Water-proofed
- ★ Less wind resistance
- ★ High strength with low weight
- ★ Fits standard towers

THE **RADIART** CORPORATION  
CLEVELAND 13, OHIO



SUBSIDIARY OF  
**CORNELL-DUBILIER**  
SOUTH PLAINFIELD, NEW JERSEY



# ASSOCIATION NEWS

On May 28 some 200 Texas dealers met in Fort Worth at the *Texas Appliance and Television Dealers Clinic*. Speakers at the meeting included representatives from several large manufacturing firms and from *NARDA*; topics included "The Value of Dealer Meetings and the Value of Your Association," and "What to Expect When the Coaxial Cable Comes to Texas." It is the hope of many of the members that the clinic will become a regular affair to improve the member's knowledge of the most recent developments in their industry.

The new Charleston *NARDA* chapter is beginning to grow. A.R. Dilley of South Charleston has assumed the temporary Chairmanship, with Ralph Haynes and R.S. Baer serving with him. Harold Frankel, of Huntington, a member of the national association's Board of Directors, is acting as West Virginia's State *NARDA* Chairman.

From Iowa . . . Television dealers of Waterloo met recently to form a local *NARDA* chapter and establish the association's Certified Television Installation and Service program. The local committee is developing this program to alleviate a pending city ordinance to regulate the trade . . . In Des Moines, Earl Holst, of Beaverdale Radio Sales and Service, was elected President of the newly formed Des Moines *NARDA* group. R.D. O'Callaghan is the association's State Chairman of Iowa . . . A meeting of the *Nebraska-Iowa Electrical Council* heard Mort Farr speak on credit policies for dealers, on May 20. He told the meeting that the selling advantages resulting from the government's lifting of Regulation W should be used imaginatively and with responsibility, and that dealers should not merely transfer the responsibility for their consumer credit actions from the government to their banks. Since consumer credit is a joint problem of dealers and banks, *NARDA* is establishing a special Associate Membership category for financial institutions.

Russell C. Hanson, of the Motorola Service Department, spoke on "Don't Be Afraid of UHF," at the *Elkhart, Indiana TV Council* on May 15. In discussing and demonstrating the design of UHF antennas, low-loss transmission lines and tuners, he emphasized that if servicemen are properly trained and have adequate test and installation equipment that UHF will become a quite normal part of the service industry's work. Russell also stressed the fact that the three basic needs of a good service company are equipment, well chosen parts, and up-to-date information of the tv industry. The *Elkhart TV Council* has played a large part in bringing about professional quality tv service standards in its area, without the need of municipal legislation.

*TISA*, Illinois affiliate of *NATESA*, is really doing something about the tv service problems in the Chicago area. Acting against the \$3 service fee entry scheme by some alleged technicians who attempt to pull every set into a highly questionable "shop," and then ransom the set back to the owner with an exorbitant non-itemized bill, *TISA* has obtained hundreds of sworn statements from bilked set owners and past employees of the companies involved. Sets were set-up with very obvious, natural type defects, witnessed and sworn to by the owners and qualified experts. The sets were then submitted to suspected companies, whose "service" confirmed some of *TISA's* worse suspicions. The Chicago Better Business Bureau, States Attorneys office and some newspapers gave full cooperation. The first suspected company has been subpoenaed before the Grand Jury with other complaints pending, several companies under investigation have closed shop. The investigation is still proceeding and a permanent Grievance Committee is functioning to continue policing service operations and to expose service rackets in order to protect the legitimate service technician in the tv business.

Despite the necessity of keeping the industry on its guard against racketeers, the service industry as a whole can be proud of a recent Roper Poll which shows that the vast majority of the public considers technicians competent, prompt and polite. This nationwide public opinion pool was conducted for RCA Victor by Elmo Roper, one of the country's leading market research experts. 86 percent of all tv set owners had a high opinion of the quality of the work of service technicians, and the great majority thought them prompt, fair and reasonable in their charges. Thus it seems that the public has not judged the service industry on the unfair and misleading impressions created by a few firms. 68 percent of the people polled called service work "really good," with only 7 percent showing any dissatisfaction. Two-thirds of the people described service charges as "entirely reasonable," with only one-tenth considering the bills "too high." Less than one percent of the public considered the technician discourteous, with the rest being well satisfied. 75 percent considered the work done "in a reasonable length of time."

(Continued on page 32)

## Laughs in the Life of a TV Serviceman

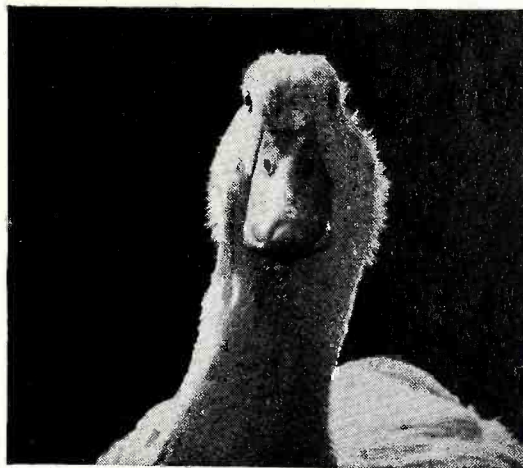

"That sounds serious—do I need a new tuner?"

"NO MA'M, it isn't serious, your tuner's OK—and you're lucky you own a Raytheon TV receiver. They're well engineered and an easy set to service. Their tuner is one of the best on the market."

Raytheon's Ray-Dial tuner is one of the few tuners you can service 100% while it is in the chassis. All tuner parts and circuits are easy to

get at for test, repair or alignment. This eliminates the necessity for complete tuner replacement and new tuner alignment.

Raytheon designs and builds its own tuner for stability, fringe performance and long life . . . Raytheon Manufacturing Company (Belmont Radio Corporation, 5921 West Dickens Avenue, Chicago 39, Ill.)



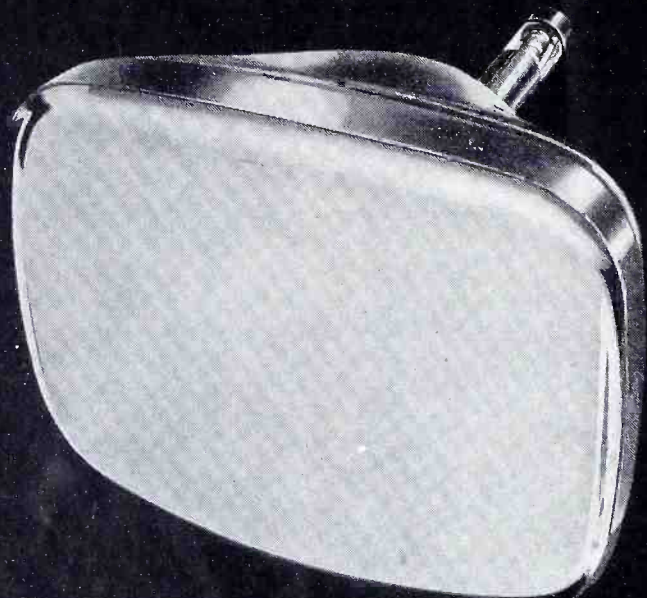

THERE'S ALWAYS ONE LEADER...

**DU MONT**

*Fine receivers can be  
made finer through the use of Du Mont Teletrons.\**

*Available in all popular screen sizes.*

Cathode-ray Tube Division, Allen B. Du Mont Laboratories, Inc., Clifton, N. J.

\*trade mark

Please mention *Successful Servicing* when answering advertising.



# Cutting Down TV Repeat Calls

Many television technicians have been faced with the dilemma of determining why a TV receiver performs well in the service shop but is unreliable when returned to the customer's home. Here are some thoughts on the subject as determined in the field.

The antenna in the service shop may be a very good one; it is only natural that a service shop will operate with a better than average tv antenna installation . . . Is this good or bad? . . . The answer is determined by the relative effectiveness of the antennas owned by the customers served by the service facility. If the signal pickup at the service shop is very much greater than at the customer's location, it becomes a problem to judge the performance of the receiver — for that matter even the condition of the receiver. When the signal level is high the overall gain of the receiver is knocked down very substantially. Practically this means that less than required receiver gain will not be noted in the service shop unless special efforts are made to detect it.

On the other hand, less than normal receiver gain will materially affect the operation of the receiver when it is installed in the home where signal pickup is substantially below that in the service shop . . .

What is the solution? The first step necessary in every service shop is the use of attenuators whereby the signal level fed into the receiver can be reduced in steps so as to determine the behavior of the receiver with varying levels of signal input. A defective condition resulting in insufficient sensitivity and which would cause unstable operation at the home would then become evident.

In addition to noting the action of the receiver with reduced signal input, it also is necessary to establish the receiver action with less than normal power line voltage. This too must be correlated with the power line voltage in the customer's home. If the line voltage in the customer's home is less than that in the service shop, the adjustments made in the shop should be accomplished at the line voltage available in the customer's home. This requires the use of a variac or other line voltage control device in every service shop and proper monitoring of the line voltage.

Speaking in generalities 117 volts may be the average line voltage, but many receiving locations are subject to less than this voltage in the evening. Under the circum-

*(Continued on page 25)*



it's the new  
**TANCO**  
 twin-driven  
**Silver Streak**

send for complete technical information

TECHNICAL APPLIANCE CORPORATION  
 SHERBURNE, N. Y.

In Canada: Stromberg-Carlson Co., Ltd.  
 Toronto 4, Ont.

## Use the Same Complete Data the Set Manufacturer uses with **RIDER MANUALS**

A complete chronological history of FACTORY-AUTHORIZED American circuits and data on radio receiver design and operation.

<b>VOLUME XXII, 1520 pages.....</b>	<b>\$18.00</b>
VOLUME XXI, 1648 pages.....	\$21.00
VOLUME XX, 1776 pages.....	21.00
VOLUME XIX, 2122 pages.....	22.50
VOLUME XVIII, 2036 pages.....	22.50
VOLUME XVII, 1648 pages.....	19.80
VOLUME XVI, 768 pages.....	9.90
VOLUME XV, 2000 pages.....	22.50
VOLUME XIV, 1376 pages.....	19.80
VOLUME XIII, 1672 pages.....	19.80
VOLUME XII, 1648 pages.....	19.80
VOLUME XI, 1652 pages.....	19.80
VOLUME X, 1664 pages.....	19.80
VOLUME IX, 1672 pages.....	19.80
VOLUME VIII, 1650 pages.....	19.80
VOLUME VII, 1600 pages.....	19.80
VOLUME VI, 1240 pages.....	15.00
VOLS. I-V ABRIDGED, 2000 pages.....	19.80

<b>TELEVISION VOLUME 9</b>	
Equivalent of 2136 pages (8 1/2 x 11) .....	<b>24.00</b>
<b>TELEVISION VOLUME 8</b>	
Equivalent of 2688 pages (8 1/2 x 11).....	24.00
<b>TELEVISION VOLUME 7</b>	
Equivalent of 2352 pages (8 1/2 x 11).....	24.00
<b>TELEVISION VOLUME 6</b>	
Equivalent of 2320 pages (8 1/2 x 11).....	24.00
<b>TELEVISION VOLUME 5</b>	
Equivalent of 2320 pages (8 1/2 x 11).....	24.00
<b>TELEVISION VOLUME 4</b>	
Equivalent of 2296 pages (8 1/2 x 11).....	24.00
<b>TELEVISION VOLUME 3</b>	
Equivalent of 2032 pages (8 1/2 x 11).....	24.00
<b>TELEVISION VOLUME 2</b>	
Equivalent of 1896 pages (8 1/2 x 11).....	24.00
<b>TELEVISION VOLUME 1</b>	
Equivalent of 2000 pages (8 1/2 x 11).....	19.80
<b>PA EQUIPMENT VOLUME 1</b>	
2024 pages .....	18.00

"The World's Greatest Compilation of AM-FM-TV-PA Servicing Data"



# "It pays to replace with the BEST" Federal-

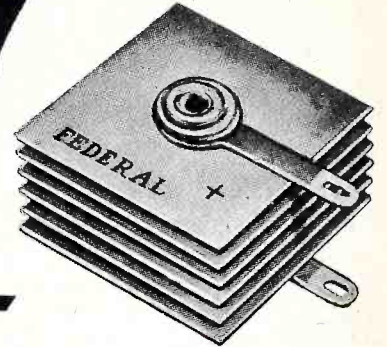

## The Original Miniature Selenium Rectifier!

**IT PAYS YOUR CUSTOMERS** in finest quality and dependable, long-life performance—proved by over 30,000,000 units shipped to the field!

**IT PAYS YOU, Mr. Serviceman,** in customer satisfaction and goodwill—and a good profit on every job!

### Here Are Other Specific Reasons Why "Federal" Is Your No. 1 Choice for Servicing the Big, Growing Radio-TV Replacement Market:

- Tests by receiver manufacturers show a life expectancy of well over RTMA guarantee.
- Over 250,000 tests prove superior immunity to shelf-aging.
- Federal's synthetic barrier layer stops change during long storage.
- Quality rigidly controlled. All units fully tested before release.
- Units available either packed in the attractive Federal resale box or in bulk.
- Constant research keeps you up-to-date on rectifier progress.

**SAVE TIME—SERVE YOURSELF**  
from *Federal's* **NEW**

# RECTIFIER DISPENSER



**LOOK FOR IT  
ON YOUR  
DISTRIBUTOR'S  
COUNTER!**

America's Oldest and Largest Manufacturer of Selenium Rectifiers

## Federal Telephone and Radio Corporation



SELENIUM-INTELIN DIVISION  
100 KINGSLAND ROAD, CLIFTON, NEW JERSEY

In Canada: Federal Electric Manufacturing Company, Ltd., Montreal, P. Q.  
Export Distributors: International Standard Electric Corp., 67 Broad St., N. Y.



Please mention *Successful Servicing* when answering advertising.



## Preventive

## Maintenance

(Continued from page 12)

don't fail to have a preventive maintenance schedule and to live up to it religiously.

### Operational Checks

Preventive maintenance does not consist only of cleaning and tightening. It includes periodic operational tests. Check the frequency of signal generators against known signals every so often. Check the voltage readings of voltmeters against known voltages, and the resistance readings against known values. In this way you are certain that the equipment is performing properly. If discrepancies are found they should be corrected. The time spent in this way is much less costly than faulty diagnosis or completing a repair job only to discover that frequencies are wrong, voltage values incorrect, etc. In fact all of the constants of a signal being generated by a device should be checked periodically. As to frequencies, it is well to check generators at the beginning of each day to make certain that the device is on frequency. Allow time for the unit to reach a stable temperature and then make the frequency checks; it requires only a minute or so for several frequencies.

### Summary

Preventive maintenance is the simplest way of keeping down repair costs and keeping up equipment operating efficiency. Individuals who have had no experience with preventive maintenance may view it as a waste of time, but those who have practiced it know that an ounce of prevention is worth a dollar of cure. If you have a lot of loose money in boxes that isn't doing anything, then you don't need preventive maintenance; but if money is not too plentiful and the cost of tv and radio test equipment is a factor in your life, then you should apply preventive maintenance to equipment in your shop.

### Attention Philanthropists!

If any of you have any old vacuum tubes that might be contributed to a fixed, permanent collection, where due credit will be given to the donors, Les' Rucker, of Rucker Radio Wholesalers in Washington, D. C., would be pleased to hear from you. The collector's home address is: Leslie C. Rucker, 3139 18th Street, North, Arlington, Virginia.

## Cutting Down TV Repeat Calls

(Continued from page 23)

stances it is logical to consider receiver adjustments with power line voltages of from 112 to perhaps 114 volts, especially the adjustments which determine picture dimensions.

Fall-off in output of the low-voltage rectifier tube need not be too great in order to influence the stability of receiver action. Add to this a reduction in line voltage of a few volts and an unsatisfactory operation receiver is the result. This is especially true in areas where relatively low signal strength prevails even if it is not strictly fringe area. Testing such a receiver at more than 117

volts line voltage can give misleading results, that is create the impression that the receiver is in perfect shape whereas, actually, it is subject to correction. The use of a new low voltage rectifier tube may not be the answer. It may require a specially good tube, one which affords 5 to 10 volts more output than the average tube.

The use of signal attenuators is a very interesting item. It is not too effective if signal pickup by the antenna feed system in the receiver is permitted. The higher the signal level at the test point, the more important it is to prevent direct signal pickup by the antenna feed between the input terminals at the input to the front-end.

(Continued on page 32)



# C-D's Tiny Mike

takes 30,000 volts with a grin!

The famous ceramic body made by C-D with an original engineering job inside and out! More dependable, longer lasting than any previous TV high-voltage ceramic capacitor! Can be used at full rated voltage, because it's conservatively rated for DC flash test up to 2x rated working voltage!

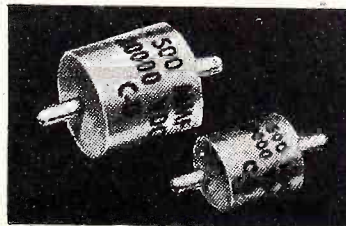

Send for Bulletin 2-614  
Department R62  
Cornell-Dubilier Electric Corp.  
South Plainfield, N. J.

1910 - 1952



CONSISTENTLY DEPENDABLE  
**CORNELL-DUBILIER**  
CAPACITORS

Plants in South Plainfield, N. J.; New Bedford, Worcester, and Cambridge, Mass.; Providence, R. I.; Indianapolis, Ind.; Fuquay Springs, N. C.; and subsidiary, The Radiart Corp., Cleveland, Ohio

Please mention *Successful Servicing* when answering advertising



EIGHTH IN A SERIES OF **IRC** TECHNIC-AIDS

## HOW TO SAVE TIME AND MONEY THROUGH YOUR IRC DISTRIBUTOR...YOUR ONE-STOP REPLACEMENT CONTROL SOURCE

### Full Replacement Control Coverage without Shopping or Waiting

Here's a new convenience that's going to save you hours of time—and some dollars too. For now there's a replacement control line so complete that no technician need shop or wait for the units he wants. *One* stop at your IRC Distributor covers *all* your replacement needs.

### 295 New Factory Assembled Exact Duplicate Controls...



2 New

Simplified  
CONCENTRIKITS

with Exact Duplicate Shafts

Maybe you prefer the convenience and simplicity of factory-assembled Exact Duplicate Controls. Or maybe you like the wide coverage and faster servicing at lower stock cost you get with Universal Replacements. Either way, IRC gives you just what you want. The new IRC Replacement Line includes 295 new factory assembled Exact Duplicate Controls *and* 2 new, simplified CONCENTRIKITS with Exact Duplicate Shafts.

### Full Coverage of 295 Different Concentric Duals Handling 416 Manufacturers' Parts Numbers Specified in over 5,000 TV Models

This is what you get with either IRC Factory-Assembled Exact Duplicates or IRC improved CONCENTRIKITS. 295 new IRC Exact Duplicate Controls provide satisfactory mechanical fit and electrical operation for over 90% of TV controls. And 2 new, four-piece IRC CONCENTRIKITS with Exact Duplicate Shafts and versatile Base Elements give you the same broad, dependable control coverage.

### Guaranteed Reliable Fit and Operation or Double Your Money Back

Every IRC Factory-Assembled Exact Duplicate *and* every IRC new Universal Replacement—employing K-2 or K-3 CONCENTRIKITS—*must* operate and fit satisfactorily! If it fails to do so—*double your money back!* This is IRC's guarantee of dependability.

### New IRC Exact Duplicate Controls Feature:

- Accurate Dependable Specifications.
- Factory assembly under rigid quality control.
- Both carbon and wire-wound types.
- Easy installation—no modification needed.

We build these new IRC Exact Duplicates to carefully prepared specifications. Shaft lengths have not been compromised—so there's no need to improvise, to reverse connections or to alter controls in any way. Shaft ends are accurately machined for good knob fit. And electrical characteristics are carefully engineered to assure satisfactory operation. IRC Exact Duplicates are easy to install and they operate efficiently.

### New Four-Piece IRC CONCENTRIKITS Feature:

- "Less-than-a-minute" Assembly in Shop or Home.
- No filing, slotting, hammering, soldering or cutting of shafts.
- Assembly of both Carbon and Wire Wound Concentric Duals.
- New reduced prices.

You'll need no special tools or skills to assemble these new, simplified CONCENTRIKITS. With each one, we furnish easy-to-follow pictorial instructions that show you how to make actual assembly in less than a minute. No alterations are needed; shafts are supplied in proper lengths and with factory-tooled ends for accurate fit.

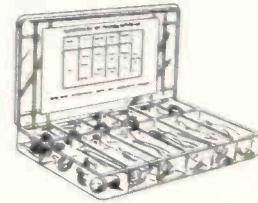

New, Dealer  
Assortments  
for Widest  
Coverage  
at Lowest Cost

You'll have less money tied up in inventories—and you'll lose fewer parts through obsolescence—when you buy IRC's new CONCENTRIKITS in low-cost, convenient CONCENTRI-PAKS. These handy assortments include Base Elements, Exact Duplicate Shafts and Switches for specific brands of TV controls. Contained in large, sturdy, partitioned plastic stock boxes, with full replacement data. CONCENTRI-PAKS give you wide coverage at a fraction of the cost of factory-assembled controls.

### Make Your IRC Distributor Your One-Stop Source of TV Replacement Controls

You'll save time and cash by scheduling your trips to your IRC Distributor—and buying *all* your Replacement Concentric Duals from him. And you'll be sure of Concentric Dual efficiency, too. For IRC's guarantee protects you on Universal Replacements or Factory Assembled Exact Duplicates. Remember—Double your money back if fit or operation is unsatisfactory!

### Full Details and Free Replacement Data Yours for the Asking

For full information on IRC's new Replacement Control Line, get new Catalog Data Bulletin DC1C. Complete replacement data by Manufacturers' Parts Numbers also is yours at no charge. Specify Form SO12. Just send post card to us for your copies—or get them from your IRC Distributor.



Wherever the Circuit Says 

**INTERNATIONAL  
RESISTANCE CO.**

423A N. Broad Street, Philadelphia 8, Pa.







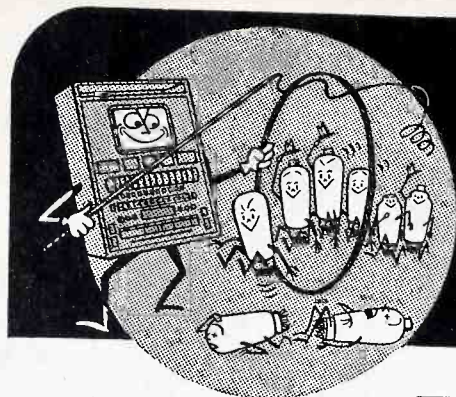

# THE INSTRUMENT THAT DEMANDS **OVERALL PERFORMANCE** FROM THE TUBE UNDER TEST!

*-PRECISION-* SERIES 10-12

## Electronamic\* Tube PERFORMANCE Tester

with 12 element free-point Master Lever Selector System

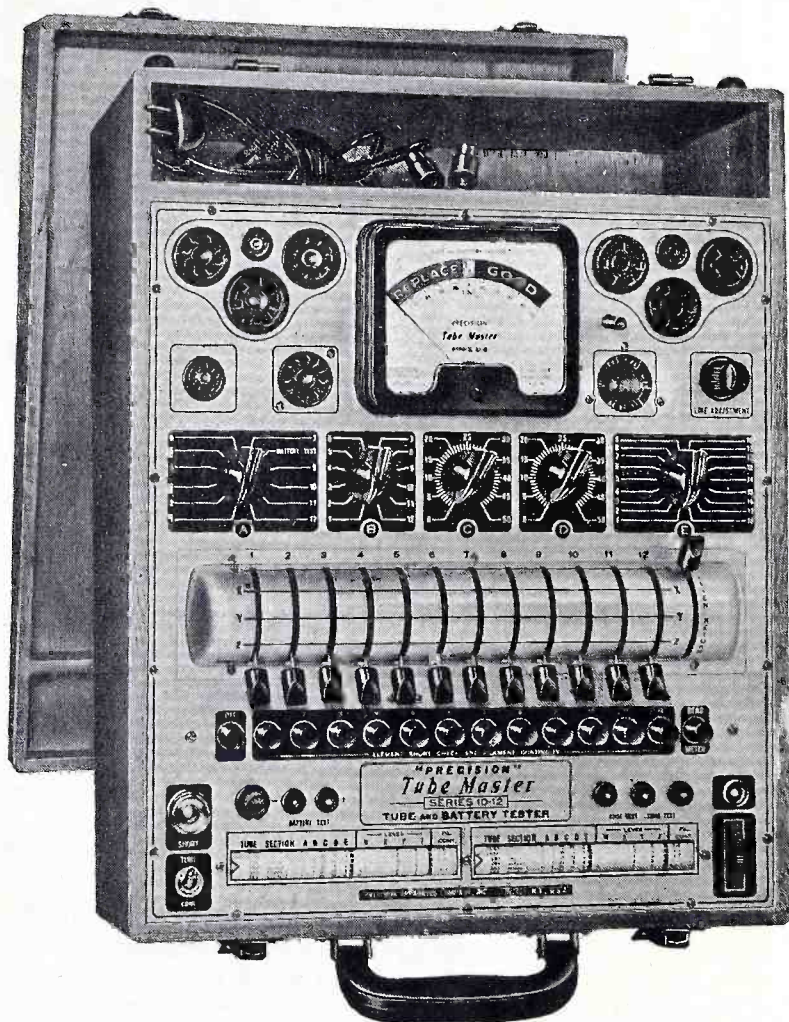

To test modern tubes for only one characteristic will not necessarily reveal **OVERALL PERFORMANCE CAPABILITIES**. Modern tube circuits look for more than just mutual conductance or other single factor.

It has been conclusively proven that even though a tube may work well in one circuit, it might fail to work in another—simply because different circuits demand different relative performance characteristics, such as amplification factor, plate resistance, power output, emissive capability, etc.

In the PRECISION "ELECTRONAMIC" Circuit, the tube under test is made to perform under appropriately phased and selected individual element potentials, encompassing a wide range of plate family characteristic curves. This COMPLETE PATH OF OPERATION is electronically integrated by the indicating meter circuit in the positive performance terms of *Replace-Weak-Good*.

The efficiency of this "Electronamic" test results from encompassing several fundamental tube characteristics, NOT JUST ONE. Accordingly, when a tube passes this demanding **OVERALL PERFORMANCE** test, it can be relied upon, to a very high degree, to work satisfactorily.

\*REG. U.S. PAT. OFF. T. M. A38,006

### Compare these features

- \* Facilities to 12 element prongs.
- \* Filament voltages from 3/4 to 117 V.
- \* Tests Noval 9 pins; 5 and 7 pin acorns; double-capped H.F. amplifiers; low power transmitting tubes, etc., regardless of filament or any other element pin positions.
- \* Isolates each tube element regardless of multiple pin positions.
- \* Dual Hi-Lo short check sensitivity for special purpose tube selection.
- \* Simplified, High Speed, 12 element Short-Check system, uses consecutive push-button switching.
- \* Battery Tests under dynamic load conditions.
- \* 4 1/2" Full Vision Meter.
- \* Built-in Dual-Window, high speed, geared roller chart.
- \* Free Replacement Roll Charts & supplementary tube test data service.

MODEL 10-12-P (illustrated): in sloping, portable hardwood case with tool compartment and hinged removable cover. Sizes 13 3/4" x 17 1/4" x 6 3/4" — \$101.75  
 MODEL 10-12-C (Counter Type) \$106.50  
 MODEL 10-12-PM (Panel Mount) \$106.50

See the "Precision" Master "Electronamic" Tube Testers at leading Radio Equipment Distributors. Write for new, 1952 "Precision" catalog.



## PRECISION APPARATUS CO., INC.

92-27 Horace Harding Boulevard, Elmhurst 14, New York  
 Export Division: 458 Broadway, New York 13, U.S.A. • Cables—Morhanex  
 In Canada: Atlas Radio Corp., Ltd., 560 King Street, W., Toronto 2B

Convenient "PRECISION" Purchase Terms can be arranged with your local and favorite authorized "PRECISION" Distributor.

AM • FM • TV

AM • FM • TV



# Curing 15-Meter Band Interference

(Continued from page 2)

(246/21.22) 11.6 feet. This figure must be reduced to 82 percent of its value because of the reduced velocity of energy propagation along this type of line. Thus, the actual length of stub required is 82 percent of 11.6 feet, or 9.5 feet. If coaxial lead-in is used, then the stub should be made of coaxial line. In this case, the free-space quarter wavelength should be reduced to 66 percent of its value to compensate for the reduced velocity of propagation. The actual length of stub then required is 66 percent of 11.6 feet, or 7.7 feet. Quarter-wave open stubs may also be connected across the line cord to prevent power-wiring pickup of interfering signals.

## Other Methods of Reducing Interference

The wave traps discussed above will reduce or eliminate 15-meter band interference which is picked up by the antenna and lead-in or by the power lines. However, some interference will undoubtedly be picked up directly by the i-f stages themselves. This condition occurs when the receiver is located quite close to the interfering transmitter. In this case, improved receiver shielding will often reduce or eliminate the interference.

Copper screening is frequently used for this purpose. The screening is tacked or stapled to the inside of the receiver cabinet and backboard. The underside of the receiver chassis should also be covered with screening, though this may alter the i-f alignment slightly and reduce the high-frequency video response. All shielding should be bonded together thoroughly at several points and connected to the receiver chassis.

Aluminum foil is occasionally used also. However, such shielding may reduce ventilation and reflect much of the heat that is produced by the receiver back to the chassis. If aluminum is employed, be sure the ventilating louvers are not obstructed.

The use of a high-pass filter at the receiver input terminals will often eliminate interference picked up by the tv antenna and transmission line; in fact some progressive manufacturers already have such filters built into their receivers. These filters attenuate all signals below 40 or 50 mc, including those in the 15-meter band, and have practically no effect on the tv channels. They can be purchased commercially or constructed by the user. One such filter, designed for use with a 300-ohm balanced line, is shown in Fig. 5. The capacitors are about 10  $\mu\text{f}$  and the coils constructed of 14 turns of No. 12 enameled wire with a coil diameter of one-half inch wound to a length of one and three-quarter inches.

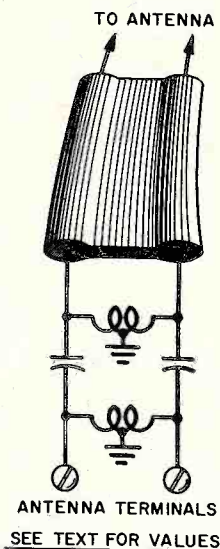

Fig. 5. Simple high-pass filter for tv receiver.

An advantage of the high-pass filter over the simple wavetraps is that the filter rejects all frequencies below 40 to 50 mc while the wave-trap rejects only the frequency to which it is tuned. Hence, it might be thought that the wavetraps would not be effective in eliminating interference from amateur stations using variable-frequency oscillators. In the case of 15-meter band interference, however, the Q's of many tuned circuits are low enough to make the

use of a trap tuned to the center of the band worth trying.

Finally, probably the most effective method of reducing 15-meter band interference is to realign the receiver so that the sound i.f. or the low end of the i-f pass band is moved above the frequency of the interfering signal. For example, it has been found that raising the i-f pass-band by as little as .25 mc will noticeably reduce the effect of 15-meter band interference. This means that the sound i.f. should occur at a frequency of 21.7 mc, which is 21.45 mc (the highest frequency in the band) plus .25 mc. If the i-f pass band is raised by .50 to .75 mc or more, the interference is eliminated in almost all cases.

## Two more RIDER books comin' off the press —

TV TROUBLESHOOTING AND REPAIR GUIDEBOOK and UHF PRACTICES AND PRINCIPLES

### Order Your Copy Now!

JOHN F. RIDER PUBLISHER, INC.  
480 Canal Street, New York 13, N. Y.

# 63,500

There are 63,500 references to pertinent electronic and allied engineering articles published from 1925 through 1949 in the five editions of the

## ELECTRONIC ENGINEERING MASTER INDEX

1925-1945 edition— (15,000 entries) .....	\$17.50
1935-1945 edition— (10,000 entries) .....	\$10.00
1946 edition— (7,500 entries) .....	\$14.50
1947-1948 edition— (18,500 entries) .....	\$19.50
1949 edition— (12,500 entries) .....	\$17.50

Electronics Research Publishing Company, Inc.  
Dept. 55 480 Canal St., New York 13, N. Y.

Please mention *Successful Servicing* when answering advertising.

A Full Size  
LIGHTNING ARRESTER  
at the Price of a Midget



## LIGHTNING ARRESTER

**MODEL TA5** Real protection against lightning and static charges — the RADIART Lightning Arrestor has all the features! Fits anywhere... inside or out... handles standard or jumbo leads... no wire stripping necessary... does not unbalance the line... low internal capacity... no loss of signal... internal resistance "leaks off" static discharges! UNDERWRITERS LABORATORIES APPROVED.

THE RADIART CORPORATION  
CLEVELAND 13, OHIO

Please mention *Successful Servicing* when answering advertising.



**SIMPSON MODEL 480 GENESCOPE FOR ACCURATE TESTING**

approved by  
service managers of:

*admiral*

*zenith*

*motorola*

*emerson*

*hoffman*

*hallicrafters*

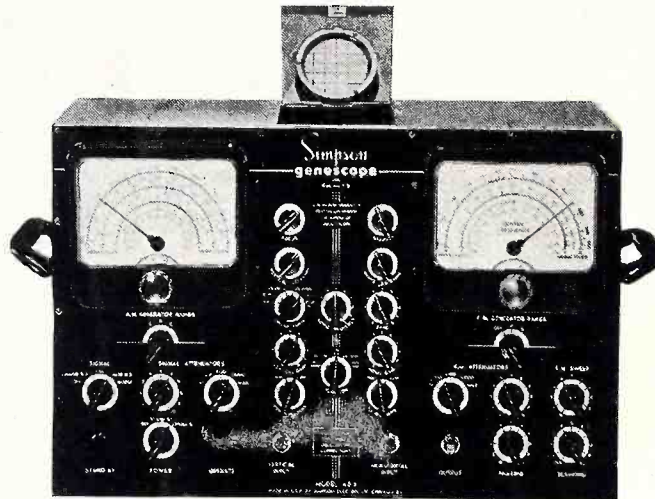

Provides all the necessary signal sources for proper alignment and servicing of FM and TV receivers • Includes the Simpson High Sensitivity Oscilloscope, complete in every detail and equipped with a high frequency crystal probe for signal tracing • Independent, continuously variable attenuators and step attenuators for both AM and FM units offer complete control of output at all times—from the high level required for front end adjustment to extremely low levels for fringe area peaking operations • Multiple shielding, generous bypassing and adequate line filtering reduces signal leakage to a negligible factor • A 0-15 megacycle sweep is provided by means of a noiseless specially designed sweep motor based on the principles of the D'Arsonval meter movement for fine control and lasting accuracy • The exclusive Simpson output cable (illustrated on the right) includes a variable termination network which is quickly adapted to provide open, 75 or 300 ohm terminations—the addition of a pad provides attenuation and isolation. The use of appropriate resistors across certain terminals will provide any other termination required. A .002 MFD blocking condenser can be added on any termination for use on circuits containing a DC component • The FM generator output voltage is constant within .2 DB per MC of sweep.  
Model 480 \$395.00

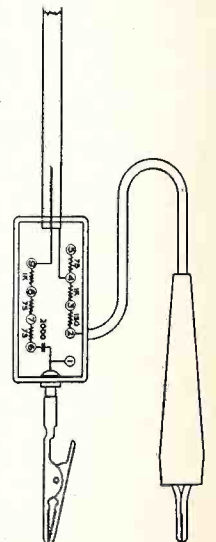

Also available without the oscilloscope as Simpson Model 479 TV-FM Signal Generator. Model 479 \$269.00

Simpson Instruments That Stay Accurate Are Available From All Leading Electronic Distributors

SIMPSON ELECTRIC COMPANY

5200 W. Kinzie St., Chicago 44, Illinois • Phone: COlumbus 1-1221 • In Canada: Bach-Simpson, Ltd., London, Ont.

Please mention *Successful Servicing* when answering advertising.





A monthly summary of product developments and price changes of radio, electronic, and television parts and equipment, supplied by United Catalog Publishers, Inc., New York City, publishers of RADIO'S MASTER.

These REPORTS will help you to buy and sell to best advantage. They will also help you to keep your inventory up to date. A complete description of most products will be found in the Official Buying Guide, RADIO'S MASTER available through local parts distributors.

**New Items**

**DUOTONE**—Added series of solid blue and solid amber Kolor-Vision screens . . . added Nos. 34 through 39, Duotone display with card of Cactus needles #18; and No. 40, Duotone display with card of "Lifetone" Osmium tipped needles.

**EBY SALES**—Added K-302 kit at \$3.69 net and 49-13 DD, electrostatic TV socket at \$.48 net.

**ELECTRO-VOICE**—Model 430 utility floor stand added at \$10.20 net along with model 423-G desk stand. Electro-Voice advises that the restriction on the use of zinc are off and that manufacturing is now underway on their full line of stands. Also added "Baronet" folded horn corner loudspeaker enclosure for 8" speakers at \$35.70 net in mahogany and \$37.80 net in blonde.

**G. E.**—New Oscilloscope ST-2B added at \$495.00 suggested user price.

**JAMES VIBRAPOWR** — Added new vibrator, J-74 which is, as stated, equivalent to Raytheon #B-21A-12291, mobile communications.

**J F D**—Added pre-assembled "Vee-Beam" single array antenna #Q800 at \$4.50 net, delivering a gain of 7½ db. and Q801 stacked array "Vee-Beam" at \$11.40 net, delivering a gain of over 11 db.

**MALLORY**—Added a number of the following items in the various categories named through out their line: cardboard tubular dry electrolytic capacitor; bench power supply and kit; grid bias cells; midgetrol accessory part; 91 new FP series dry electrolytic capacitors; vibrator; industrial noise filters; AC motor starting capacitor; plastic tubular paper capacitors; UHF converter and kit; carbon front section controls; carbon rear section controls; single tapped midgetrols.

**MARKEL ELECTRIC**—Added model 74-P at \$72.00 net and 75-P at \$78.66 net, both Playmaster 3 speed record changer equipped with Pfan-tone standard and micro-groove high fidelity pick-ups.

**MILLER MFG. CO.**—Added 3 new replacement cartridges for Astatic . . . 1 for Electro-Voice . . . 1 for Magnavox . . . 3 for Shure Bros.

**NATIONAL CO.**—Added a number of items to their line which include: knobs, dials; transformers; dial pointers; miniature tube clamps; turret socket assemblies; condensers.

**NATIONAL UNION**—Added 11 radio receiving tubes.

**PRESTO RECORDING**—Y-5 Recorder added (for low impedance mike) at \$771.00 list . . . also T-99-H, dynamic microphone at \$32.50 list . . . A-15-S floor stand at \$10.00 list and L-2 Transcription player at \$290.00 list.

**RADELCO**—Added R-118, yagi low band stacking kit at \$1.26 net and R-119, yagi high band stacking kit at \$.45 net.

**RAYTHEON**—Advised of 50 new special purpose tubes and 2 radio receiving tubes.

**STANDARD TRANSFORMER**—Added 19 new items to their line.

**SIMPSON ELECTRIC**—Added 11 current transformers which are, as stated, of the inserted one turn primary type for use with switchboard and panel ammeters where external transformers are required.

**TUNG-SOL ELECTRIC**—Added 120 radio receiving tubes and 4 CR tubes.

**WEB ELECTRONICS**—Added new Web converter for 10, 11 meters, with J6J and OB2 tubes at \$29.95 amateur net.

**WHARFEDALE (British Industries)** — Added 3000 cycle crossover at \$13.50 net.

**WRIGHT INC.**—#12A flush mounting grille added for 12" speakers at \$7.50 net.

**XCELITE, INC.**—Added #49, midget snip at \$2.47 net.

**RAYTHEON**—231 radio receiving tubes and 17 special purpose tubes increased.

**SYLVANIA**—Increased price of Strobotron SA-309 to \$2.95 net.

**TUNG-SOL ELECTRIC**—Increased 167 radio receiving tubes in price.

**WEB ELECTRONICS**—Web converter for 6, kO and 11 meters with 6J6 and OB2 tubes increased to \$39.95 amateur net.

**WILCOX GAY**—Increased price on #2A10, 2 speed tape recorder to \$159.95 retail price.

**Discontinued Items**

**BELL SOUND SYSTEMS**—Withdrew #2075, portable record player.

**CLEAR BEAM**—Window and indoor antennas WA2 and WA100 withdrawn.

**EDITORS & ENGINEERS**—Withdrew "Radio-Television Question and Answers."

**MILLER MFG. CO.**—Withdrew diamond stylii M213 and M513 for Magnavox cartridges and PH413 (D) and PH413 (DS) for Philco cartridges.

**R.C.A.**—Withdrew 6 electron tubes . . . 2 radio batteries (VS007 and VS018) . . . phonograph accessory 210X1 . . . 8 television components . . . antenna and accessory #213A1 . . . 3 crystal pick-ups.

**RAYTHEON**—Discontinued 54 special purpose tubes and 37 radio receiving tubes.

**SANGAMO ELECTRIC**—Discontinued type 13 television paper tubular capacitors . . . type FM, 15 electrolytic capacitors.

**SIGNAL INDICATOR**—Withdrew #1005 and #1005N, pilot light assemblies.

**STANDARD COIL**—Withdrew B-50 booster parts (25B-001; 31C-013; 31C-026; 31C-202) and B-51 booster and parts (25B-002; 31C-500; 31C-524; 31C-537).

**Price Increases**

**MALLORY**—Increased prices on their VA series power supplies.

**NATIONAL UNION**—Increased price of 263 radio receiving tubes.

**Price Decreases**

**DUMONT**—Decreased prices on 12 Teletron tubes.

**G. E.**—10 TV picture tubes decreased in price.

**NATIONAL UNION**—Decreased price of 27 radio receiving tubes.

**R. C. A.**—Decreased prices on six 17" kinescopes and two 21" kinescopes . . . also electron tubes 5946 and 6161.

**RAYTHEON**—22 radio receiving tubes and 83 special purpose tubes decreased in price.

**SARKES-TARZIAN**—16 TV picture tubes decreased.

**SUPREME INC.**—Decreased prices of DC Microammeters models 2100, 2400, 3100, 3400, 4100, in ranges 0-50, 0-100, 0-200, 0-500 . . . also model 3100 and 3400 DC Voltmeters ranges 0-1, 0-3, 0-5, 0-10, 0-25, 0-50 to \$9.25.

**SYLVANIA**—Reduced prices on 29 TV picture tubes . . . 9 silicon crystal diodes . . . 7 germanium crystal diodes . . . 2 TR and ATR tubes (1B35 and 1B63A) . . . 2 klystrons (SD 1103 and SD 1104).

**TECHNICAL APPLIANCE CORP.** — #873-3, change-over switch (2 or 3 circuit) reduced to \$1.80 net.

**THOMAS ELECTRONICS**—Decreased prices on 20 cathode-ray tubes.

**TUNG-SOL ELECTRIC**—Reduced prices on 10 radio receiving tubes and 6 cathode-ray tubes.

**VAN CLEEF BROS.**—Decreased prices on 60 yard rolls of Dutch Brand masking tape available in "bulk case packing."

IT'S GOT **everything**  
FOR **profitable servicing**

Your time is money! That's why Clarostat's latest catalog gets right down to what's-what in **CONTROLS and RESISTORS**. Instead of lengthy sales blurb, you get better listings of more values to meet the greatest range yet for servicing and initial-equipment needs. Proved easier, faster, safer and more profitable to work with this latest Clarostat catalog.

**Ask for your copy...**  
Your Clarostat distributor has your copy waiting for you. Ask for it. Or if you prefer, write us directly.

**CLAROSTAT**

**Controls and Resistors**  
CLAROSTAT MFG. CO., INC., DOVER, NEW HAMPSHIRE

In Canada: Canadian Marconi Co., Ltd., Toronto, Ontario



## ADEQUATE PROTECTION

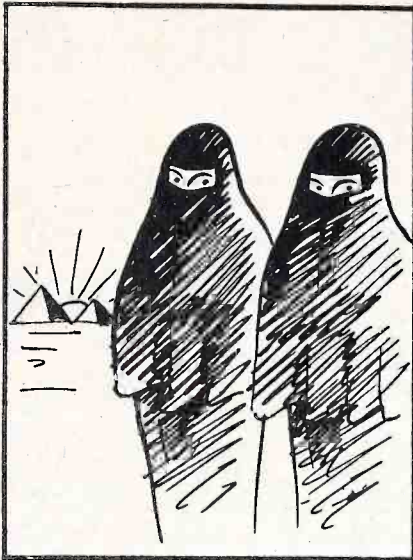

Ersin MULTICORE—the original 3-core solder and the only solder made with non-corrosive, extractive Ersin Flux—protects your reputation! Melts rapidly! Wets metals faster! Prevents "dry" joints that cause customer complaints. Works rapidly and reliably on difficult metals and on oxidized parts! Write for FREE SAMPLE today! Multicore Sales Corp., Dept. S., 164 Duane St., New York 13, N. Y.

Please mention *Successful Servicing* when answering advertising.

## Association News

(Continued from page 22)

When announcing the results of this poll, E.C. Cahill, President of the RCA Service Company, pointed out that few people realize the size and scope of the service industry, which has installed and kept in good repair over 16,000,000 tv sets and which owns test equipment, tools, etc. worth over \$200,000,000. Mr. Cahill probably expressed what should be the serviceman's attitude toward the results of the poll when he said, "While we are proud of the industry's record of competence and integrity, as shown by the survey, neither we nor the service associations will be content until the small percentage of undesirable practices is completely eliminated."

## UHF television converters

(Continued from page 11)

cept that a selenium rectifier is used rather than a vacuum tube.

The function switch has three positions: In one, both the converter and the television receiver are turned off. In the vhf position, the television receiver is turned on with the vhf antenna going directly to the receiver through the converter switch. In this position, although the converter is not in use, its heaters have power applied to them in order to minimize the drift time when the converter is actually turned on. In the uhf position, both units are turned on and the input to the converter may be a separate outdoor uhf antenna, the built-in cabinet antenna, or the vhf antenna.



Courtesy Stromberg-Carlson

Fig. 6. Stromberg-Carlson uhf converter.

By means of a selector switch on the converter chassis, the i-f amplifier has its frequency shifted by 6 mc. In this manner, either channel 5 or 6 of the television receiver may be used. Since the preselector tuned circuit has a bandwidth of 12 mc, this does not interfere with tracking.

*Sarkes Tarzian UHF Converter.* The Sarkes Tarzian organization has several answers to the problem of allowing coverage of the uhf band and still permitting the operation of the television receiver on all twelve present vhf channels. Their new 15-position vhf tuner has, in addition to the 12 vhf channels, three new positions. Between channels 6 and 7 there is an input position for a 130 mc signal, and ahead of the channel 2 position there are two additional positions for uhf reception.

The uhf converter made by this company tunes over the entire band with an output

going into either channel 2 or 3 of the vhf tuner. A single channel device is also available, which is pretuned for one uhf channel. This unit can be connected to the vhf tuner in any of the three uhf positions mentioned above.

## Cutting Down TV Repeat Calls

(Continued from page 25)

This may mean a shielded room, but it is not unreasonable that such a need exist, especially with modern day television receivers with sensitivities ranging from 10 to perhaps 20 microvolts. Tv receiver servicing is much more critical than radio receiver servicing. It need not be complicated, but it does demand the application of common sense engineering practices—none of which are beyond the capabilities of the modern-day tv technician.

**Compare!**

PROVE  
**EMC**  
SUPERIORITY!

**MODEL 106**  
**VACUUM TUBE**  
**VOLTMETER**

• Specially designed for field alignment of TV and radio sets • All functions completely electronic—meter cannot burn out • 5 DB ranges • Full scale deflection of 1½ volts for both AC-DC volts.

**SPECIFICATIONS**

DC VOLTAGE: Input resistance 16.5 megs or 12½ megohms per volt. Ranges: 0 to 1.5, 10, 100, 300, 1000 up to 30,000 v. (with accessory probe.) AC VOLTAGE: Input resistance 2 megohms. Ranges: 0 to 1.5, 10, 100, 300, 1000. Frequency response flat from: 25 to 100,000 cycles.  
OHMS: 1000 — 10,000 — 100,000 — 10 megohms, 1000 megohms.  
Compact, portable bakelite case measures 4¼ x 5¼ x 2⅞".

**MODEL 106 ..... \$35.90**

Write Dept. 55-6 for latest FREE catalog.

**EMC** Electronic Measurements Corp.  
280 Lafayette St., New York 12, N. Y.  
Export Dept., 302 W. 42nd St., N. Y. C.

Please mention *Successful Servicing* when answering advertising.

PERMIT NO. 9427  
NEW YORK, N. Y.  
**PAID**  
U. S. POSTAGE  
Sec. 34.66, P. L. 8. R.

JOHN L. GIGL  
437 NEVIN ST.  
LANCASTER, PENN.

Forwarding and Return Postage Guaranteed  
480 CANAL ST., NEW YORK 13, N. Y.  
JOHN F. RIDER PUBLISHER, Inc.  
From



# SUCCESSFUL

# Servicing

JULY 1952

*\*This is a continuation of an article by the same name which was started in the June issue of SUCCESSFUL SERVICING. It is reprinted from the book "Compendium on Improving Fringe Area T.V. Performance," published by the Zenith Radio Corp., and compiled by J. C. Spindler. The article and its illustrations are reprinted through the courtesy of the publisher and will be concluded next month.*

## Improvement of

# fringe area reception

## by Proper Antenna Installation

by J. C. Spindler\*

### Single Stacked Antenna Spacing for Multi-Channel Reception

In stacking antennas vertically for increased gain, the optimum spacing will vary for different channel combinations. If the spacing is incorrect, or too severe a compromise is made, no noticeable improvement may be made in going from a single antenna to a stacked array. Table 3 outlines the permissible range of vertical spacing for each channel for In-line or Conical type antennas. Reference to this table will enable one to choose optimum vertical spacing for any channel combination.

For example, if you are to receive channels 3, 6, and 10, and channel 10 is the weakest, about 91" is a good compromise. Likewise if your channel requirements are 4, 5, 7, and 9 and 9 is weakest while 4 is strongest, about 98" is a good compromise.

### Double Stacked (4 Bays) Antenna Spacing for Multi-Channel Reception

Table 4 lists the useful range and optimum spacings to be observed in double stacking antennas if the use of such is being considered. However, prior to arriving at a definite decision, due consideration should be devoted to the often superior results to be gained by (A) increasing antenna height, (B) use of open wire line, or (C) use of separate Yagi antennas.

Comparison of Tables 3 and 4 indicates that when antennas are double stacked the frequency acceptance range is narrowed. Therefore a compromise spacing will not be possible over as wide a range of channels as

with a single stacked array. As an example, if the problem was the reception of channels 3, 6, and 10, double stacking may help channels 6 and 10 but reception of channel 3 may be impaired. For this reason careful study should be made of the circumstances before a final decision is reached.

### Stacking Antennas for Reception of One Channel

In vertically stacking antennas, (including Yagis) for reception of one channel it is possible to use the true optimum spacing for the particular channel. Table 5 lists the optimum spacing for each channel.

### Impedance Matching (Antenna to 300 ohm Line)

In the following paragraphs frequent reference will be made to the use of impedance matching sections of 75, 150 and 300 ohm line. Particular attention is called to the fact that all lengths tabulated in Tables 6, 7, 8, 9 and 10 are for commercially available ribbon lines with propagation

TABLE 3

Vertical Spacing for Single Stack of In-line or Conical Antennas

Channel	Maximum Range Providing Stability and Sufficient Gain	
	Sufficient Gain	Best
2	65" — 141"	131"
3	59" — 127"	118"
4	54" — 116"	108"
5	47" — 101"	94"
6	43" — 94"	88"
7	88" — 113"	105"
8	85" — 109"	101"
9	83" — 105"	98"
10	80" — 102"	95"
11	77" — 99"	92"
12	75" — 96"	89"
13	73" — 93"	87"

(Continued on page 8)



# COMMON SENSE about easy tv servicing

## Make your servicing job easier than you ever thought possible

### Complete Servicing Facts Method Proved Outstanding Success

Tens of thousands of service technicians throughout the country have learned this key to fast, easy, profitable servicing: They *insist* on having the complete servicing facts for every receiver they repair! They know that by having the complete story . . . and only by having the complete story . . . can they spot trouble quickly and do an easy, permanent servicing job.

Here's an example: On Philco models 52-P-1810, 52-P-1812, 52-P-1840, 52-P-1842, 52-P-1844, 52-P-1882, 52-P-2110, 52-P-2142, codes 122 and 123, the manufacturer released 32 pages (8-1/2 x 11") of official service data. (That is what we published in Rider TV Manual Vol. 9 and in Rider TV Tek-File Pack 22.)

These models were made in a variety of production runs; using three different chassis . . . each with its own schematic. These chassis are identical in many respects . . . but the vital differences can make servicing a real headache. For instance, three types of power transformers are used. Each has different electrical constants—and a different part number. In the C2 deflection chassis, the power transformer has one high voltage winding of 635 volts, center-tapped, and four low voltage windings: one 5 volts, two 6.8 volts and one 6.4 volts. In the CP1 deflection chassis, the power transformer has one high voltage winding of 635 volts, center tapped, but only three low voltage windings: one 5 volts, one 6.8 volts and one 6.4 volts. In the F2 chassis, the power transformer has one high voltage winding of 675 volts, center-tapped, and four low voltage windings: one 5 volts, two 6.8 volts and one 6.4 volts.

Suppose you were the service technician faced with one of these receivers. A single schematic showing just *one* of these chassis and *one* of these power transformers certainly would not be coverage for all production runs. If you were lucky, the single schematic might happen to match the receiver you had before you. But—and it's a very big but—you might also be unlucky and be faced with a receiver not described by the schematic! This is only one example in thousands of why you need *complete*, factory-prepared and factory-issued data for every set you service.

Here is how you can get this vital information. Insist on Rider Servicing Data. For 22 years Rider Servicing Data has been the *only* publishing source for the complete servicing facts: Exactly as issued by the manufacturer who made the set. Unabridged facts . . . everything is here to make your diagnosis and repair EASY. You get page after page of troubleshooting test patterns . . . large, easy-to-follow *complete* schematics . . . circuit explanations . . . stage by stage alignment curves . . . clear, enlarged chassis views . . . all circuit changes . . . and much, much more. For example: Rider tv servicing data has shown 'scope waveforms in tv receivers ever since the first tv receiver was made!

*To meet your individual needs, Rider Servicing Data comes in two forms . . . both with these important, new features:*

### Manufacturers' Trouble Cures

These 3" x 5" standard index cards called Rider Handies contain vital manufacturer-issued permanent trouble cures plus production changes. Each Handy is identified with a manufacturer and a receiver model. With Rider Handies you save countless hours of diagnosis and repair time . . . because Handies contain the data you *must* have to make *permanent repairs* on many manufacturers' models. (Rider Handies information appears in Rider TV Tek-File packs, and Rider TV Manuals beginning with Vol. 9.)

### Guaranteed Replacement Parts Listings

Beginning with Rider T.V. Manual 10 and Rider T.V. Tek-File Pack 57, replacement parts listings are included. All the replacement parts listed in Rider tv servicing data meet the physical and electrical performance ratings of the original equipment!

### Rider T.V. Manuals Vols. 1 to 9 (covering more than 4,200 models)



Each contains full data for manufacturers' receivers produced during a certain period. (The latest, T. V. 9, recently published, covers October 1951 through February 1952.) Each manual has over 2,000 (8-1/2" x 11") pages in permanent binder, with an index covering the contents of all manuals. Rider manuals are perfect for shop use and permanent reference. Price—\$24 each.

### Rider T.V. Tek-Files (Packs now cover 2,200 models)

A typical T.V. Tek-File pack is shown below. In Rider Tek-File packs you buy complete Rider servicing data for whatever receivers you want . . . when you want it. You buy according to your needs with the assurance of getting the *complete servicing facts* for every repair. Notice that each pack consists of handy, standard file folders for easy use. Only \$2 each pack.

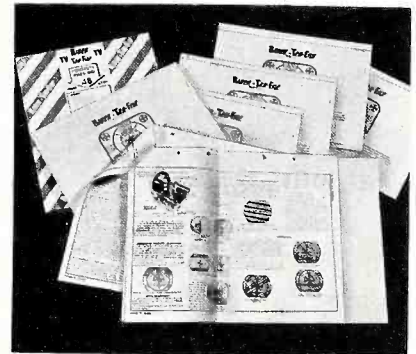

**FREE** Rider T.V. Tek-File indexes covering the contents of all published packs are at your jobber's. If he doesn't have them, write us.

### DON'T BE SWITCHED!

Rider Tek-File is DEFINITELY NOT the same as any other publisher's service. If your jobber doesn't carry them, DON'T BE SWITCHED. Write us direct . . . we'll sell you. (Please include your jobber's name.)

### TRY A PACK

Prove to yourself that Rider Tek-File makes tv servicing easy. Buy one pack for the next receiver you service. If you don't agree it's better than anything you ever used, return the pack to us within seven days . . . we'll send you a full refund.

**Rider Radio Manuals. Vols. 1 to 22.** Contain complete, factory-issued, official AM, FM radio servicing data . . . plus auto radios, record changers, tuners and recorders.

### OUT SOON!

Rider RADIO Tek-Files! Same style as T.V. Tek-Files. Now, get your complete radio servicing data this easy economical package way. Ask your jobber.

**John F. Rider Publisher, Inc., 480 Canal St., New York 13, New York. West Coast Office: 4216-20 W. Jefferson Blvd., Los Angeles, California.**



If a service technician were asked to state his greatest single problem relative to the public, the answer would be the difficulty in making the public understand the time and labor charge. It seems impossible to justify a \$10 to \$12 time and labor fee for the correction of a fault which involves perhaps a dollar in replacement parts . . . What can be done about it?

In order to find the answer, or rather to try to arrive at an answer, we must look at everything associated with the operation. But before we say anything specific it might be well to go on record as being wholly against the falsification of the charge for parts. We are against raising the list price, or charging for parts which never were installed. These malpractices are being carried on by a comparatively few on the grounds that there are no alternatives. Let's see if this is so.

Suppose we assume an ordinary diagnosis and repair operation. If what we say fits the simple case, it will fit the complex one even better. The ultimate repair consists of re-

Now, examining the list above, it is clear to see that a bill which shows only a charge for time and labor as a single lump sum, and a charge for the part as a single lump sum, certainly does not reflect all that went into the repair. All that the customer sees on the invoice are two amounts—possibly three, if the service shop separates travel time from repair time. It is not unnatural that the first impulse demonstrated by the customer is to complain if the ratio between the time and repair charge and the list price of the part is high.

Psychologically, rendering a bill which does not reflect the full operation is wrong, if for no other reason than that the customer cannot be expected to understand all that enters into a repair job. He can't assign the proper weight to the proportions of the respective dollar amounts listed. Is this his fault? After all, a bill which shows nothing more than a time charge and the list price

Everyone may think of the tv serviceman as being only a technician. Of course, he is that at heart, but in his dealing with the public he must be a salesman also . . . He must employ sales psychology whenever and wherever possible. Believe it or not, the invoice requires this approach because we know that tv and radio servicing is something which the public does not understand. We in the industry know why a \$10 or \$12 service charge must be made for the repair of a tv receiver even though the list price of the part replaced is relatively little. It is because of the travel and operational items listed above. But the public doesn't know it and we don't tell them anything when all the operations are lumped into a single dollar item, or perhaps into two items.

What do we suggest here? . . . Simply this: itemize the travel time separately. Then itemize the time required to remove and install the chassis. Itemize the diagnosis

# Selling Time

Invoice I  
July 1, 1952

Services rendered		
Time and labor	\$11	55
Parts 1 .25 mfd paper tubular		60
1 1.0 meg 1/2 watt resistor		20
	\$12	35

Invoice II  
July 1, 1952

Services rendered		
Traveling time 1 1/4 hrs at \$3.50 per hr		40
Removing and installing chassis 1/3 hr at \$4.50 per hr		50
Diagnosis and repair time 1 hr at \$4.50 per hr		50
Parts replaced 1 .25 mfd condenser		60
1 1.0 mg resistor		20
Air Check and Adjustment 1/4 hr at \$4.50 per hr		15
Cleaning chassis (no charge)		
Cleaning safety glass in cabinet (no charge)		
	\$12	35

Fig. 1 above, Fig. 2 right: Two examples of invoicing a service job. In every instance, the recipient responded favorably to the detailed invoice and unfavorably to the abridged listing of charges.

# and Labor

by John F. Rider

- placing a capacitor and a resistor. The list price for the parts involved is 80 cents.
- Now let's examine the major items in the complete service call:
1. The service technician goes to the home to examine the receiver.
  2. The receiver is inspected and the chassis is removed from the cabinet.
  3. The chassis is taken to the shop.
  4. The trouble is diagnosed in the shop and the faulty parts located.
  5. The defective parts are removed and the good ones are inserted.
  6. The receiver is given an air check and appropriate voltages are measured.
  7. Slight adjustments are made while the picture or pattern is viewed.\*
  8. The chassis is returned to the customer.
  9. The chassis is placed within the cabinet.
  10. The receiver is given an air check in the home.
  11. The technician returns to the shop.\*\*

of the part replaced, does not truly reflect all that was done by the service shop. So in a sense, the average shop actually belittles its own activity by the nature of the invoice.

Perhaps you have in mind a bill from a doctor or a lawyer for "services rendered"—and an amount. But why should we make comparisons with such people who do not face the same problems we do? What must be done is to employ every normal, reasonable and honest technique which tells the whole story. Of course, it must be done in the fewest words possible—but if it takes a detailed listing of items performed to show clearly why a certain charge is being made, and all that the repair job entailed, then it should be done.

\*That such adjustments should be made is only natural since almost every tv receiver requires some adjustments after a period of use.  
 \*\*Whether or not the technician returns directly to the shop or goes to the next service job is secondary to the fact that time charges are based usually on shop to job and back to shop.

and repair time. Also itemize separately the parts replaced, referring to "replacement" rather than installed. Itemize the air check and adjustments. These comprise five items, each with its own dollar value. (Examine the two invoice listing in Figs. 1 and 2.) The ratio between the parts cost and the aggregate of the remaining items has not been changed, but the invoice as a whole "looks" different. This is not kidding the public, it's simply showing them the justice of the charge. Moreover, the bill tends to educate the public into all of the operations involved. Little by little they will learn that service is more than just time as one item, and parts as another.

And if you wish to display your consideration for the customer, clean the chassis and list the item as "no charge." If you wish to go further, make certain to clean the safety glass of the tv receiver cabinet and generally clean the cabinet. List these items as "no charge." They can see that the glass is clean and that the cabinet has been polished.

(Continued on page 14)



# What's your unlucky day?

Bad luck—in the form of dissatisfied customers—can come your way any day in the month if you buy capacitors by rating only rather than by rating *and* brand. But . . . you can make every day a lucky day if you . . .



## Make Sure! Make it Mallory!

Repair work that insures satisfied customers is yours every time if you always specify Mallory capacitors, because outstanding performance is built into *all* Mallory capacitors.



Mallory FP's are the only fabricated plate capacitors available to the replacement trade. And they are accepted as *the* top-notch capacitors by the makers of TV and radio sets. Mallory FP's give long-lasting service even at 185° F. (85° C.).



Mallory Plascaps\* are the first completely engineered plastic tubular capacitors. Always use them and avoid leakage . . . premature shorting . . . unsoldered leads . . . off-center cartridges. Count on Mallory Plascap as you do on Mallory FP's.

In the past 25 years, Mallory research and engineering work has resulted in a series of developments that give you capacitors which are smaller . . . more uniform . . . longer-lasting . . . more resistant to heat. Look to Mallory for future capacitor improvements. Order Mallory capacitors today and be sure.

*Depend on your Mallory Distributor for quality products at competitive prices.*

P. R. MALLORY & CO. Inc.  
**MALLORY**

CAPACITORS • CONTROLS • VIBRATORS • SWITCHES • RESISTORS  
• RECTIFIERS • VIBRAPACK\* POWER SUPPLIES • FILTERS

\*Reg. U. S. Pat. Off.

**APPROVED PRECISION PRODUCTS**

**P. R. MALLORY & CO., Inc., INDIANAPOLIS 6, INDIANA**



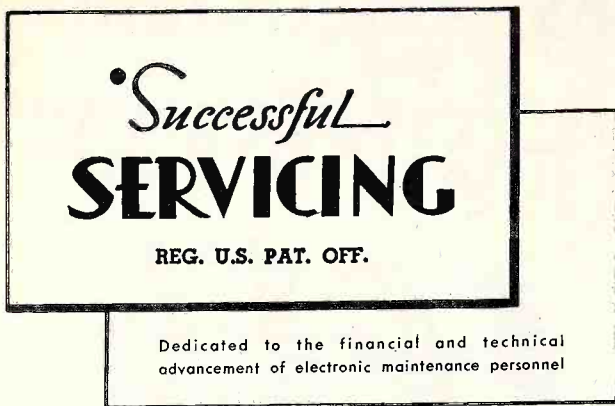

VOLUME 13 NUMBER 9

JULY, 1952

**JOHN F. RIDER, Publisher**  
Annette M. Tricarico, Editor

Advertising Representative  
H. J. Olsow & Co.  
3951 Grand Central Terminal  
New York 17, N. Y.  
MUrray Hill 6-4670



## Curtain Time

### The RCA-Roper Survey

Recently the RCA Service Co. commissioned the Roper organization to conduct a nationwide poll among 5000 tv receiver owners to determine public reaction to the operations of the nation's tv service technicians. (See June 1952 Successful Servicing, page 21.) To say the least tv service technicians fared well on all counts. In this connection it is important to bear in mind that the survey was impartial and related to all service facilities.

Summarizing the findings for purposes of discussion they were as follows:

- 68% said that the work was really good
- 18% said that the work was fairly good
- 7% did not reply.

Under the circumstances it can be concluded that 7 percent of those polled expressed disfavor of the tv service technicians activities. If we feel that "fairly good" is a half-hearted expression of approval, then better than two-thirds of the people were satisfied with what they bought for their money in the way of tv service. This is not a bad figure. Of course it is not what all of us would like to see, but we know that perfection is not attained in any field. However, even with only 68% being completely satisfied, it makes the numerous sensational "exposes" look a little bit

silly. Of course we are aware of the fact that the public eats up the unfavorable and forgets all about the favorable, which means simply that negative comments always will be expressed no matter what, because one malpractitioner will be written about whereas 100 honest guys go ignored.

Looking at this survey from a dispassionate point of view, the acceptance by the public of the tv service technician's efforts is not sufficient to justify a feeling of complacency on the part of the industry. There is no doubt about the effectiveness of the service industry's efforts to improve its technical status during the past four years. It is paying off, but the goal has not yet been reached. In fact it never can reach its objective because the technical developments never stop. Tv servicing is a unique business — it is always in a state of flux. Just about the time an individual decides that he is familiar with a television receiver — a new crop of ideas see daylight in modified circuits and the work starts all over again.

Please understand that the foregoing comments do not attempt to take one iota of credit away from the service technicians who were responsible for creating the public attitude developed by the survey. It is simply that public acceptance must be built higher and higher, day by day and week by week.

There is, however, something else that the service industry might gain from this survey. It can take heart from its findings; it can become more confident of its ability. . . . Many individuals who are part of the servicing industry would do well to change some of their ideas that the public is down on the tv technician. Here is positive evidence that it is not so. Many men have become discouraged and disheartened. Some have felt so badly about the reputed attitude of the public and the blanket indictments because of a relatively few men that they left the ranks of the servicing industry. Many of these men were old-timers whom the industry could not afford to lose.

Perhaps it is necessary to become thicker-skinned about the whole affair. This does not deny the responsibility of the tv service technician to the public, but the ultra sensitive man can be made very unhappy by adverse comment — especially when it is not warranted. So let's become less sensitive. Each man does the best he can, improving a little every day. Give this kind of mental approach an opportunity to expand and the next survey among the nation's tv receiver owners will show better than 68% as considering tv service to be "really good." Let's try to change the 18% who said that it was "fairly good" to "really good," and all will be well. When 86% of an industry's personnel activities are considered really good in the mind of the public, that is an accomplishment of which everyone can be proud.

Before we conclude these comments we would like to suggest that every service technicians' association in every tv area would serve its interests to the utmost by securing a copy of this survey and getting it into the hands of every local and state legislative body. Let them know how the preponderant majority of tv receiver owners feel about tv service. . . . If you desire a copy write to Edward C. Cahill, Pres. RCA Service Co., Gloucester, N. J.

*John F. Rider*



# Don't miss Sylvania's unbeatable 3-way Service Helper—"SIT-'N-FIXIT"

# FREE

## WITH 16 SYLVANIA PREMIUM TOKENS



Entire kit folds into a neat compact carrying case.



Sylvania now offers you the world's handiest and most complete servicing kit. Nothing else like it! It'll speed your work, spare your back, impress your customers!

Here, in a neat sail-cloth carrying case, is a sturdy, aluminum and canvas, folding stool. Equipped with zippered pocket for tools and parts. Also open pockets for Sylvania Wrench Kit and Pliers Kit. And get this! The unzipped case opens out to a broad, turned-up-edge drop-cloth.

### How to get your "Sit-'N-Fixit"

You get this complete servicing kit FREE for only 16 Sylvania Premium Tokens shown above. One of these tokens is yours free with every Sylvania Picture Tube or with every 25 Sylvania Receiving Tubes purchased from your distributor. When you have 16 tokens, take them to this distributor and pick up your "Sit-'N-Fixit." *Note, these tokens will be honored only by the one distributor where you buy all your tubes.*

### Don't delay

This is a special summer offer. Good only from July 1st to August 31st. So, call your Sylvania Distributor and get in those tube orders TODAY!

# SYLVANIA



RADIO TUBES; TELEVISION PICTURE TUBES; ELECTRONIC PRODUCTS; ELECTRONIC TEST EQUIPMENT; FLUORESCENT TUBES, FIXTURES, SIGN TUBING; WIRING DEVICES; LIGHT BULBS; PHOTOLAMPS; TELEVISION SETS



# "WHY you should not try to fix your own TV!"

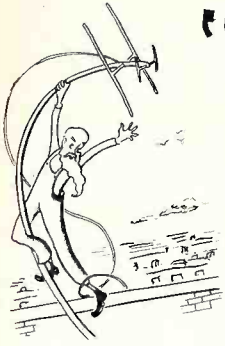

by John D. Burke\*

own television. He got several "fix-it" books. He bought 8 tubes; about \$20.

He put in four tubes.

Now his set stopped altogether. Before he started, the set had just been acting up.

When he called me in, my bill came to \$20.

I also had to replace four tubes.

One of these four was one of his *new tubes*. Probably defective from the factory.

Besides — he had a shorted capacitor.

Besides — he had a very noisy tuner.

Besides — his sound circuit was out of adjustment.

Since then, he has had still another tube go bad. It was *not* one of the eight types he bought previously. The set is just over a year old. That sort of thing can happen to *any television set*, no matter what brand.

Another man who finally came to me for service had done a very ridiculous thing — and yet it was exactly what the "fix-it" book had told him to do. He lives in a six-story apartment house. His aerial was up on the roof, and worked very well when he got the set. One day the set stopped. The book said that perhaps his lead-in wire was defective — and also that perhaps his aerial was in the wrong position. So first he bought a hundred feet of wire, and ran a new lead-in. No good. No picture.

Then this old man, taking his life in his hands, went up on that roof, and raised his antenna another ten feet. Still no picture.

When he finally came to me — came to my "den of thievery" — I repaired his set within two hours. He had a shorted capacitor in the set. The repair and service came to \$10.

## What to Expect From Your Set

Let me now try to advocate a sensible approach to the question of TV repair. Just an off-hand attack on the problem.

As a TV set owner, you naturally would like your set to work *all the time*.

You must face it — it won't.

No television set can possibly be free from trouble.

You can cite all the cases you please about sets which go years without trouble.

\*Book of the same title written and published by the John D. Burke Co.

I'm prepared to prove to you that those sets are going to require major replacements one of these days — that some day they may have to be thrown out as not worth repairing, even if the cabinet is still highly polished and beautiful, and even if they have any highly advertised manufacturer's name on them.

Somehow, people expect TV and radio tubes to last indefinitely. It is true that some tubes in radio sets built twenty and thirty years ago are still working today. Again and again I hear the complaint from people that "They don't build things as well now as they used to." I shall not try to enter that argument — but, you must understand that the tubes used in the *early types* of radios were very simple structures, internally, and very *big*. Ask a repairman to show you, side by side, a 45 tube, and a 6AQ5. Both have been used for the same purpose, to drive loudspeakers. The first is much bigger than the second.

Furthermore, to be able to work as television tubes, some of your tubes *must be small and fragile*.

All of your tubes start to wear out, the first time they are turned on. Some day, just as we do, they must die.

And, like us, they also may have a *very short life* if —

1. They have any defect at all when manufactured.

2. They are damaged in any way — in shipment, in use, or as a result of *other defects* in other parts of your set.

(For example — a shorted "coupling capacitor" may ruin the tube to which it is connected — just like that!)

It is a *gamble*, no matter whose tubes you buy, how long they will last!

All sorts of *other parts* in your TV set wear out.

They go bad from *heat*.

They go bad from *wear and tear*.

They go bad, in a few instances, from *dirt and dust*. (But — do not try to clean the inside of your TV.)

They go bad, as a result of electrical tension voltage — constantly pounding at their insulation.

They go bad from *age*.

*Expect your set to give trouble.*

Be surprised if it does not!

## Mr. Service Technician:

*It is suggested that you read the following taken from the above titled book. Better still, let your customers glance at it. Perhaps it will help promote a better understanding between you.*

## Some Examples of Amateur Tinkering

Anyone who tells you he knows all about television — take it with a big portion of salt.

It's really funny — the professional TV repairman has a hard time convincing people that he knows his business.

But the same people will believe anyone else — who is not working in TV repair — if they claim to be experts.

When your car needs a valve-grinding job, you probably give the job to an automobile repair shop.

Why then should you let any Tom, Dick or Harry fool around with your television set?

Throughout my years and years of work in radio repair, and now in television as well — it is a fact that I have been presented with some awful messes created by these home-grown "experts."

One time I had to charge some people \$15 to fix a radio, where the real job should have been about \$3.

Why?

Because an "expert" had turned *one screw*. Unfortunately, that screw was in a *porcelain base*, and was mounted way down inside the set, in among dozens of capacitors, resistors, and behind the whole bandswitch. I had to remove all these other things to reach the broken porcelain, broken by a screw driver wielded by a *friend of the family*. He had told them he was an "engineer."

Just recently an auto mechanic — who should have known better — tried to fix his



## Improvement of fringe area reception

(Continued from page 1)

velocities of .68, .77, and .82 respectively. Lines whose propagation velocities differ from these will deviate from the tabulated lengths.

**Matching Multi-Channel Single In-Line or Conical Antennas (Both High and Low Channels).** Since these antennas are designed for 300 ohms impedance they should be fed directly into 300 ohm line, or if coaxial line is used, through a suitable impedance matching transformer.

**Matching Single Stacked (2 Bays) In-Line or Conical Antennas.** Equal lengths of 300 ohm line from each antenna should be joined, as in Fig. 4. This will result in an impedance of 150 ohms at the junction, and a 2 to 1 mismatch (150-300) results if the lead-in is connected to this junction. However, as a practical matter, it may be advisable to allow such a mismatch, rather than attempt impedance matching measures, as use of some transformers may result in an attenuation greater than that resulting from a 2 to 1 mismatch.

**Matching Double Stacked In-Line or Conical Antennas.** Two procedures are suggested. Equal lengths of 300 ohm line from each of the four antennas may be joined together as in Fig. 5.

A second arrangement is illustrated in Fig. 6.

In the latter case, a third line of 150 ohms impedance should join the midpoints of the pair of lines. The output then should tie in at the midpoint of this third line.

In either case the stack impedance at the common junction is approximately 75 ohms and this should be matched to the 300 ohm lead-in by a suitable transformer. A simple transformer for accomplishing this can be made from a specific length of 150 ohm ribbon twin lead, which is inserted between the feed junction and the 300 ohm lead-in. Since this transformer has a definite frequency characteristic, there may be some

Channel	Spc'g in Inches	Channel	Spc'g in Inches
2	131"	2	66"
3	118"	3	59"
4	108"	4	54"
5	94"	5	47"
6	88"	6	43"
7	41"	7	21"
8	39"	8	20½"
9	38"	9	19½"
10	36½"	10	19"
11	35½"	11	18½"
12	34½"	12	18"
13	33½"	13	17½"

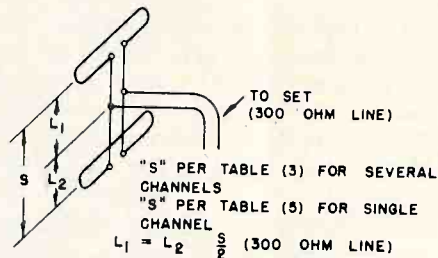

Fig. 4. Single Stacking 300 Ohm Antennas.

cases where it will not be satisfactory on all channels. Its suitability for any particular case can be predicted from Table 6.

For example in referring to Table 6 it can be determined that for channels 4, 5, 7 and 9 a length of 36 inches would probably be the most satisfactory. On the other hand for channels 3, 6 and 10 a length of 33 inches would probably be most effective.

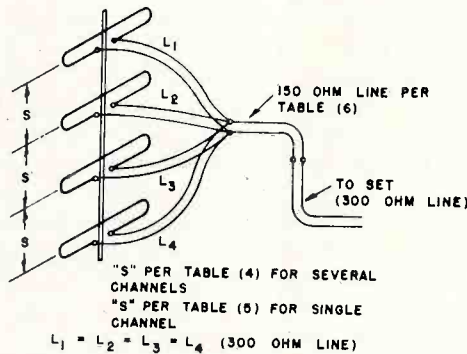

Fig. 5. Double Stacking 300 Ohm Antennas.

**Matching Stacked, Single Channel, Antennas of 300 Ohm Impedance.** In this case, single or double stacking can be quite beneficial, using the optimum spacing specified in Table 5. In either case equal lengths of 300 ohm lead are to be run from each antenna to a junction point, as shown in Fig. 4 or 5. For a single stack the 300 ohm lead-in should connect directly to this junction.

For a double stack a matching section with the optimum length given in Table 6 should be inserted between the common junction and the 300 ohm lead-in. Care should be taken that all leads be so supported away from the mast that they cannot tangle, whip in the wind, or twist about each other.

**Matching Yagi Antennas.** The Yagi Antenna is fundamentally of low impedance (15-30 ohms). However, some Yagi anten-

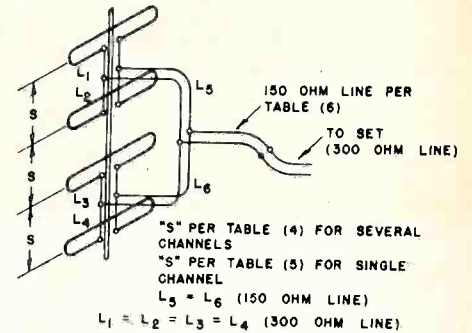

Fig. 6. Double Stacking 300 Ohm Antennas.

nas on the market have been designed so as to bring the terminal impedance up to 300 ohms. If using Yagi antennas designed to match 300 ohm impedance, treat them exactly the same as any other single channel 300 ohm antenna, in accordance with the preceding section (d). If the antenna has not been designed for 300 ohm match, proceed as outlined in 1, 2 and 3 below.

1. Single Low Impedance Yagi  
Connecting an unmatched low impedance Yagi directly to 300 ohm line, results in an average loss of approximately half of the signal voltage available from the antenna. Adding a proper impedance matching transformer usually results in as much more signal as could be gained by transferring from an In-Line or Conical to the single Yagi (without impedance matching). A simple trans-

(Continued on page 11)

**TABLE 4**

Vertical Spacing for Double Stack (4 Bays) of In-line or Conical Antennas

Channel	Maximum Range Providing Stability and Sufficient Gain	Best
2	46" — 86"	66"
3	41" — 77"	59"
4	38" — 70"	54"
5	33" — 61"	47"
6	30" — 56"	43"
7	45" — 51"	48"
8	43" — 49"	46"
9	42" — 48"	45"
10	40" — 46"	43"
11	39" — 45"	42"
12	38" — 43"	40"
13	37" — 42"	39"



# 102 BILLION

## FREE SALES BOOSTS A YEAR

and REQUEST!  
Do you  
want to  
continue  
receiving  
SUCCESSFUL  
SERVICING  
?  
Fill in and return  
this Post Card

★ SECOND REQUEST ★  
Continue receiving **SUCCESSFUL SERVICING** . . .  
and return this card to us! Otherwise this is your  
only ignore this card if you returned the first one.

SERVICING will be bigger and better  
next. Don't miss this opportunity  
on our mailing list.  
in receiving future issues of  
SERVICING because it helps you in  
decisions—then please fill in and  
Be sure to affix a 2-cent stamp.

(PLEASE PRINT)  
.....  
Zone ..... State .....

**Check the following:**

I am a  SERVICEMAN  
 DEALER  
 ENGINEER  
 HAM  
 Other .....

I subscribe to or read the following  
magazines regularly.

RADIO ELECTRONICS  
 RADIO NEWS  
 RADIO SERVICE DEALER  
 SERVICE



### Acceptance



100,000,000 times a year! The magic letters "CBS" are seen and heard on radio and TV station breaks. Impact is terrific. An average of 13 sales impressions weekly for every man, woman and child in the country. Every one of your customers knows CBS. Knows he can depend upon CBS. Consumer acceptance of your CBS-Hytron brand grows hourly.

### Engineering



As a division of the Columbia Broadcasting System, Inc., CBS-Hytron commands tremendous engineering resources for you. Because CBS embraces the field of electronic entertainment: Radio broadcasting. TV broadcasting. Radio, television, and phonograph sets. Records. Electronic research laboratories. And CBS-Hytron tubes.

### Leadership



For example, CBS-Hytron originated: the GT tube . . . the subminiature tube . . . the rectangular picture tube . . . specialized, low-cost TV receiving tubes. CBS-Hytron's new picture-tube and miniature-tube plants are the most modern in the world. Such aggressive leadership guarantees you the newest and best in tubes.

### YOU CAN'T BUY BETTER

Demand the CBS-Hytron brand. You get the finest electron tubes that progressive engineering skill and craftsmanship can make. You get the brand known and respected by every one of your customers. You get the brand they see and hear the most . . . CBS-Hytron.



MAIN OFFICE: SALEM, MASSACHUSETTS

Please mention *Successful Servicing* when answering advertising



## Improvement of fringe area reception

(Continued from page 1)

velocities of .68, .77, and .82 respectively. Lines whose propagation velocities differ from these will deviate from the tabulated lengths.

*Matching Multi-Channel Single In-Line or Conical Antennas (Both High and Low Channels).* Since these antennas are designed for 300 ohms impedance they should be fed directly into 300 ohm line, or if coaxial line is used, through a suitable impedance matching transformer.

*Matching Single Stacked (2 Bays) In-Line or Conical Antennas.* Equal lengths of 300 ohm line from each antenna should be joined, as in Fig. 4. This will result in an impedance of 150 ohms at the junction, and a 2 to 1 mismatch (150-300) results if the lead-in is connected to this junction. However, as a practical matter, it may be advisable to allow such a mismatch, rather than attempt impedance matching measures, as use of some transformers may result in an attenuation greater than that resulting from a 2 to 1 mismatch.

*Matching Double Stacked In-Line or Conical Antennas.* Two procedures are suggested. Equal lengths of 300 ohm line from each of the four antennas may be joined together as in Fig. 5.

A second arrangement is illustrated in Fig. 6.

In the latter case, a third line of 150 ohms impedance should join the midpoints of the pair of lines. The output then should tie in at the midpoint of this third line.

In either case the stack impedance at the common junction is approximately 75 ohms and this should be matched to the 300 ohm lead-in by a suitable transformer. A simple transformer for accomplishing this can be made from a specific length of 150 ohm ribbon twin lead, which is inserted between the feed junction and the 300 ohm lead-in. Since this transformer has a definite frequency characteristic, there may be some

Channel	Spc'g in Inches	Channel	Spc'g in Inches
2	131"	2	66"
3	118"	3	59"
4	108"	4	54"
5	94"	5	47"
6	88"	6	43"
7	41"	7	21"
8	39"	8	20½"
9	38"	9	19½"

PLACE  
TWO  
CENT  
STAMP  
HERE

## SUCCESSFUL SERVICING

**480 CANAL STREET**

**NEW YORK 13, N. Y.**

ably be the most satisfactory. On the other hand for channels 3, 6 and 10 a length of 33 inches would probably be most effective.

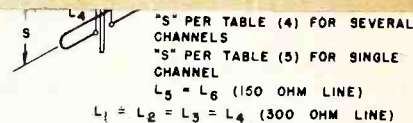

Fig. 6. Double Stacking 300 Ohm Antennas.

nas on the market have been designed so as to bring the terminal impedance up to 300 ohms. If using Yagi antennas designed to match 300 ohm impedance, treat them exactly the same as any other single channel 300 ohm antenna, in accordance with the preceding section (d). If the antenna has not been designed for 300 ohm match, proceed as outlined in 1, 2 and 3 below.

1. Single Low Impedance Yagi  
Connecting an unmatched low impedance Yagi directly to 300 ohm line, results in an average loss of approximately half of the signal voltage available from the antenna. Adding a proper impedance matching transformer usually results in as much more signal as could be gained by transferring from an In-Line or Conical to the single Yagi (without impedance matching). A simple trans-

(Continued on page 11)

Channel	Maximum Range Providing Stability and Sufficient Gain	
	Sufficient Gain	Best
2	46" — 86"	66"
3	41" — 77"	59"
4	38" — 70"	54"
5	33" — 61"	47"
6	30" — 56"	43"
7	45" — 51"	48"
8	43" — 49"	46"
9	42" — 48"	45"
10	40" — 46"	43"
11	39" — 45"	42"
12	38" — 43"	40"
13	37" — 42"	39"

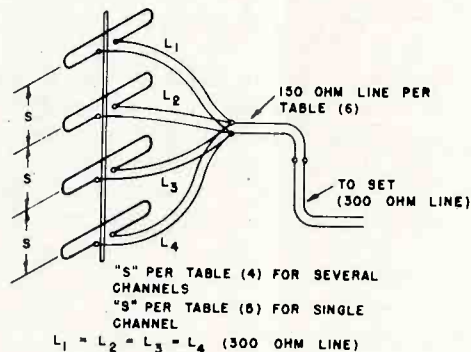

Fig. 5. Double Stacking 300 Ohm Antennas.

*Matching Stacked, Single Channel, Antennas of 300 Ohm Impedance.* In this case, single or double stacking can be quite beneficial, using the optimum spacing specified in Table 5. In either case equal lengths of 300 ohm lead are to be run from each antenna to a junction point, as shown in Fig. 4 or 5. For a single stack the 300 ohm lead-in should connect directly to this junction,



# 102 BILLION

## FREE SALES BOOSTS A YEAR FOR YOU!

**NEW  
CBS-HYTRON  
BRAND  
gives you:**



### Acceptance



1,973,326,000 times a week! 102,612,952,000 times a year! The magic letters "CBS" are seen and heard on radio and TV station breaks. Impact is terrific. An average of 13 sales impressions weekly for every man, woman and child in the country. Every one of your customers knows CBS. Knows he can depend upon CBS. Consumer acceptance of your CBS-Hytron brand grows hourly.

### Engineering



As a division of the Columbia Broadcasting System, Inc., CBS-Hytron commands tremendous engineering resources for you. Because CBS embraces the field of electronic entertainment: Radio broadcasting. TV broadcasting. Radio, television, and phonograph sets. Records. Electronic research laboratories. And CBS-Hytron tubes.

### Leadership



For example, CBS-Hytron originated: the GT tube . . . the subminiature tube . . . the rectangular picture tube . . . specialized, low-cost TV receiving tubes. CBS-Hytron's new picture-tube and miniature-tube plants are the most modern in the world. Such aggressive leadership guarantees you the newest and best in tubes.

### YOU CAN'T BUY BETTER

Demand the CBS-Hytron brand. You get the finest electron tubes that progressive engineering skill and craftsmanship can make. You get the brand known and respected by every one of your customers. You get the brand they see and hear the most . . . CBS-Hytron.



MAIN OFFICE: SALEM, MASSACHUSETTS



# Here's Why - the CDR Rotor

**...Is the NO. 1  
all-purpose Rotor!**  
*It has EVERYTHING!*

And it does have EVERYTHING ... as you can plainly see! Just check over this impressive list of features — and you'll see why ... ALREADY THE NEW CDR ROTOR is acclaimed as the outstanding unit in the field! No other rotor boasts all these features ... that's why it's the best ALL-PURPOSE rotor money can buy.

**MODEL TR-11** Complete rotor with handsome modern design plastic cabinet and meter control dial ... finger-tip lever—using 4 WIRE CABLE.. \$44.95

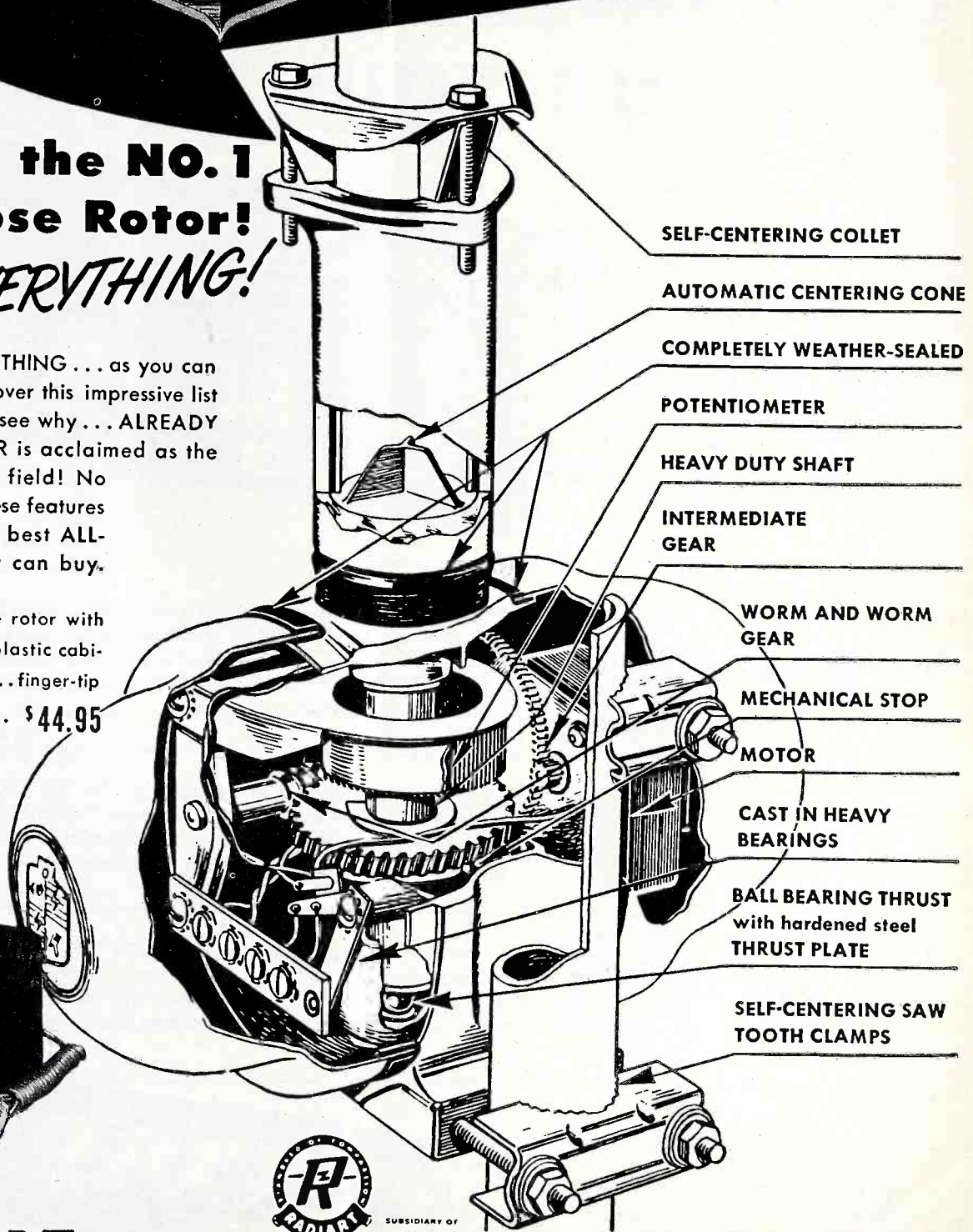

- SELF-CENTERING COLLET
- AUTOMATIC CENTERING CONE
- COMPLETELY WEATHER-SEALED
- POTENTIOMETER
- HEAVY DUTY SHAFT
- INTERMEDIATE GEAR
- WORM AND WORM GEAR
- MECHANICAL STOP
- MOTOR
- CAST IN HEAVY BEARINGS
- BALL BEARING THRUST with hardened steel THRUST PLATE
- SELF-CENTERING SAW TOOTH CLAMPS

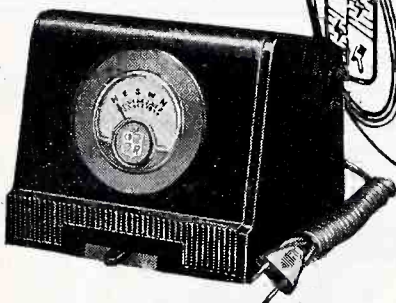

SUBSIDIARY OF



**THE RADIART CORPORATION**  
CLEVELAND 13, OHIO

**CORNELL-DUBILIER**  
SOUTH PLAINFIELD, NEW JERSEY

Please mention *Successful Servicing* when answering advertising.



## Improvement of fringe area reception

(Continued from page 8)

**TABLE 6**

Length of 150 Ohm Ribbon Line Required for Matching Multi Channel In-line or Conical Antenna Arrays Having a 75 Ohm Balanced Impedance to a 300 Ohm Line.

Channel	Optimum Length (inches)	Useful Range (inches)
2	40½	30½ — 50½
3	36½	27½ — 45½
4	33	25 — 41½
5	29	22 — 36½
6	27	20 — 33½
7	39	35½ — 42
8	37½	34½ — 40½
9	36½	33½ — 39½
10	35½	32½ — 38
11	34	31½ — 37
12	33	30½ — 36
13	32½	29½ — 35

provided in the original design of the antenna, equal lengths of 75 ohm line (in accordance with Table 8) should be run from the antennas to a junction point (J), and an impedance matching transformer, as outlined in Table 7, inserted between this point and the 300 ohm line as shown in Fig. 8.

All leads are to be supported away from the mast, in such a manner that they can-

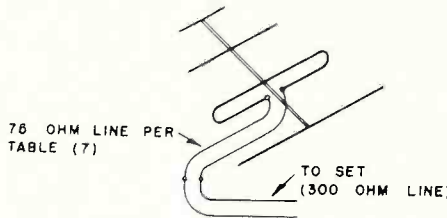

Fig. 7. Matching the Low Impedance Yagi.

**TABLE 7**

Optimum Lengths of 75 Ohm Ribbon Line Required in Matching Impedance of a Single Yagi Antenna (19 to 300 Ohms)

Channel	Length in Inches
2	35½
3	32
4	29½
5	25½
6	24
7	11½
8	11
9	10¾
10	10½
11	10
12	9¾
13	9½

former is made by inserting a piece of 75 ohm balanced ribbon transmission line (which is available commercially), of the optimum lengths specified in Table 7, between the antenna and the 300 ohm lead-in, as shown in Fig. 7.

2. Single Stacked Low Impedance Yagi (2 Bays)

Vertical spacing should be optimum as specified in Table 5. Unless means of impedance matching have been

not tangle, whip in the wind, or twist around each other.

3. Double Stacked Low Impedance Yagis (4 Bays)

Vertical spacing should be optimum as specified in Table 5. Unless means of impedance matching have been provided in the original antenna design, the upper two antennas should be joined by two equal lengths of 75 ohm

(Continued on page 16)

**TABLE 8**

Lengths of 75 Ohm Ribbon Line (1:1 ratio) Required In Matching the Single Stacked (2 Bay) Yagi

Channel	Length in Inches	Channel	Length in Inches
2	71½	8	22
3	65½	9	21½
4	59	10	20½
5	51½	11	20
6	47½	12	19½
7	23	13	19

Tung-Sol "Quality Control" recognizes but one standard. All Tung-Sol Tubes meet the highest original equipment requirements of leading radio and tv set manufacturers! Use Reliable Tung-Sol Tubes.

TUNG-SOL ELECTRIC INC.  
Newark 4, N. J.

Sales Offices: Atlanta • Chicago • Culver City  
Dallas • Denver • Detroit • Newark

**TUNG-SOL MAKES:**

All-Glass Sealed Beam Lamps, Miniature Lamps, Signal Flashers, Picture Tubes, Radio, TV and Special Purpose Electron Tubes.

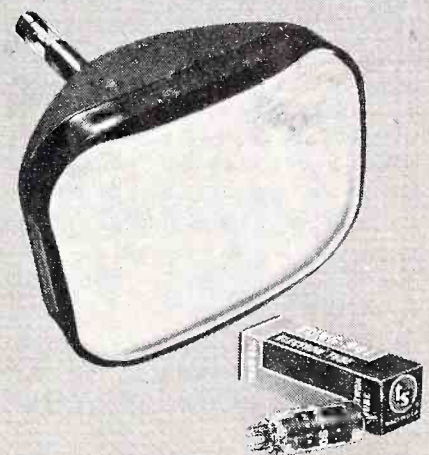

**TUNG-SOL®**  
RADIO, TV TUBES, DIAL LAMPS



Here's a real lively "stopper" to attract attention to your place of business and emphasize the quality of your service. Colorful—bright red and two shades of blue. 15 inches high. Your jobber salesman will tell you how to get one.



*Now Available!*

# TELL-A-FAULT

## The Troubleshooter's Troubleshooting Service

The first issue of TELL-A-FAULT, Rider's completely new troubleshooting service, has been sent to all subscribers. There's still time for you to receive the big first issue of troubleshooting information — but you must hurry as the supply is limited.

**Nothing like TELL-A-FAULT has ever before been attempted in the servicing industry. It is practical information for the practical man. No theory!**

Specifically, TELL-A-FAULT deals with the troubleshooting (symptoms and cures) of all types of television receivers — also radio receivers, record changers, and recorders. Special emphasis, however, is given to television.

**This quadruple-threat service consists of:**

- (1) time-saving pictorial, symptom and cure sheets
- (2) circuit guides
- (3) servicing-technique short cuts
- (4) the usage of all sorts of test equipment

You profit by the experience of experts who are working daily in the Rider service laboratory. They analyze receiver symptoms and determine the faults and cures. TELL-A-FAULT saves you many hours of profit-consuming diagnosis time.

During the course of a year you receive between 768 and 1,152 symptom pictures (between 64 and 96 pictures each month) plus circuit guides, servicing short cuts, and information on how to use test equipment.

TELL-A-FAULT will save you hours of time! As few as one or two symptom sheets can save you enough time to pay for the entire year's cost of the service.

**The entire service costs you less than twenty cents a week! You receive a full 12 month's TELL-A-FAULT for only \$10.00.**

Become a charter subscriber to the TELL-A-FAULT service. Start with the very first issue!

Write today for complete information on the most unique SERVICE ever made available to TV-radio service technicians.

### TELL-A-FAULT

**does your troubleshooting for you!**



**JOHN F. RIDER**  
PUBLISHER, INC.  
480 Canal St., N. Y. 13, N. Y.  
DEPT. TF 4

# About Increasing TV Receiver Sensitivity

As an operation it is relatively simple to increase the sensitivity of a tv receiver. One recommended procedure is to modify the AGC system by removing the AGC voltage from the r-f tube. An example of this is shown in Fig. 1. The correction consists of disconnecting the grid lead RI from the AGC bus and joining it to ground as indicated by the dotted lines. The extra lead remaining in the AGC bus from the last AGC feed point (A in Fig. 1) is cut off.

The extent to which the sensitivity is increased is a function of the individual receiver design, but it has been found that in many instances such a change is the difference between making a receiver usable and having an unhappy customer.

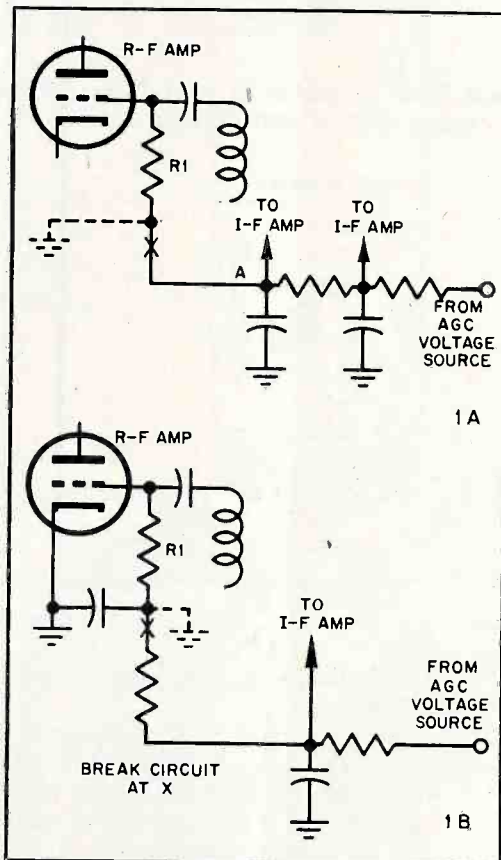

Figure 1

But there are several other matters which must be taken into account. The first of these relates to the advisability of making a permanent change of this kind, which immediately sets a definite limit on the signal acceptance capability of the r-f stage. Having removed the AGC voltage, there is no control over the gain of the r-f stage. This means that a strong signal will overload the r-f stage and from that point on can cause a variety of troubles.

Bearing in mind that a receiver in a certain location will not behave in the same manner for all stations which can be picked up at the point, making a fixed modification in the AGC system so as to

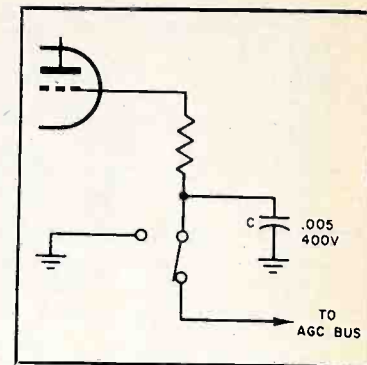

Figure 2.

increase the sensitivity for one station is taking a chance with overloading on other stations. This assumes that some of the stations received are of satisfactory signal strength but that one or perhaps two stations are of insufficient strength. If all stations are of low level, then the change we are discussing can be made with very little concern.

If there are different signal levels from different stations at any one receiving point, this is easily determined and it should be done before any changes are made in the wiring of the AGC system. If such changes do exist, then it is recommended that the break in the AGC system to the r-f tube be controlled by means of a single-pole, double-throw toggle switch. In one position, this switch connects the AGC bus to the r-f tube grid leak, and in the other, it disconnects the control voltage line from the r-f tube grid leak and grounds the latter. This gives the set owner the opportunity of adjusting his receiver to suit the signal need. If such a switch is connected into the system, it should be located as close as possible to the circuit controlled, although accessible to the set owner. At the same time the low end of the grid leak should be bypassed to ground (C in Fig. 2) to minimize pickup by the extra long AGC bus which connects to the switch.

Although removal of the control voltage from the r-f system is recommended, it is preferable not to remove it, even with the switch arrangement shown in Fig. 2, if other reasonable steps can be taken to increase the sensitivity. These may not be possible or may not be satisfactory, but they should be tried. For instance, an increase of as little as 5 volts on the plates of the r-f, video i-f and video-amplifier tubes may be sufficient to improve the overall performance of the receiver to the point where tampering with the control voltage may not be required.

The possibility of increasing the plate voltages lies in the rectifier used in the low-voltage power supply. This should be checked by substitution. It is possible that when trying several low voltage rectifiers, one or two may be found which afford a higher output than the one in the receiver. Whether or not the increased voltage is sufficient to produce an increase in sensitiv-

(Continued on page 14)



## SHUNT CAPACITOR ACROSS HORIZONTAL YOKE WINDING

To reduce ringing in the horizontal winding of the deflection yoke, a capacitor is connected in shunt with one half of the winding, as shown by C in Fig. 1. A value of 47  $\mu\text{mf}$  is commonplace and appears on the majority of schematics. This value is set by the distributed capacitance to ground of the coil.

As a rule, the construction of these windings is kept to close tolerances, but even so, variations occur in the distributed capacitance to ground of the horizontal windings. The result is that more than one value of shunt capacitance may be used in a production run of receivers. These vary from a low of about 20  $\mu\text{mf}$  to a high of perhaps 50 to 60  $\mu\text{mf}$ . Changes in the shunt capacitor may be necessary when making a replacement if the ringing is excessive.

When ringing seems to be excessive, it might pay to check the shunt capacitor and to change the value. This is so even if the capacitor found on the yoke conforms with the value shown on the schematic. Moreover, some manufacturers have used different values without indicating the change on the schematic.

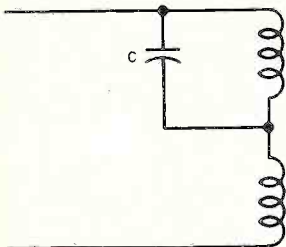
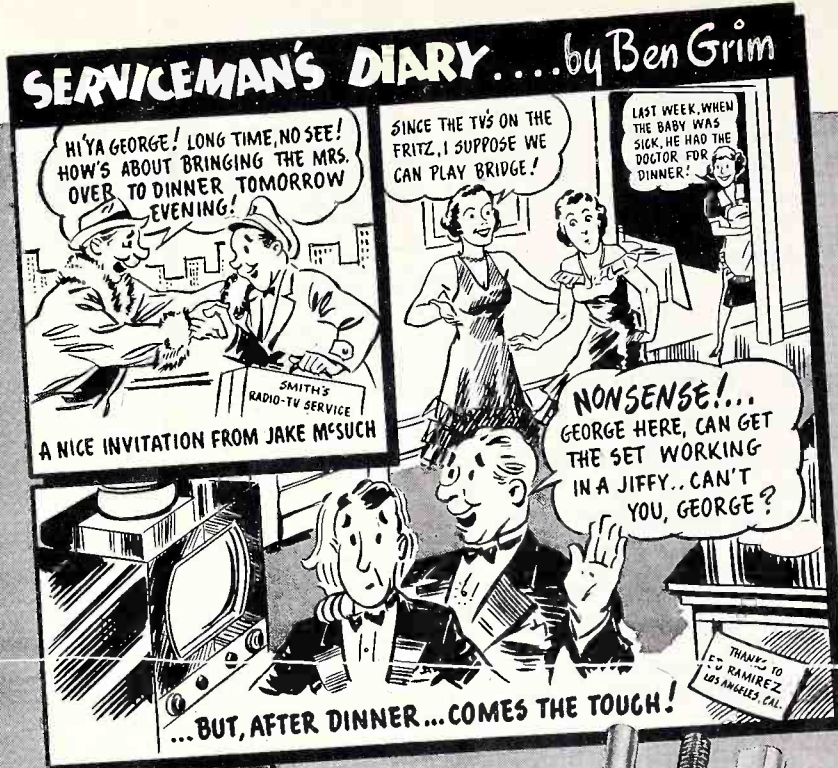

Figure 1.

Since the shunt capacitor across the horizontal winding has an effect on the resonant frequency of the circuit, there is a limit to the amount of capacitance which can be used. Increasing the value beyond reason as determined by the general design of the yoke will make the ringing worse. In other words, the amount of capacitance needed seldom exceeds from 50 to 60  $\mu\text{mf}$ ; usually it is less. If it is made too high on the erroneous basis that the capacitor is a by-pass, the ringing will be aggravated.

Inasmuch as the average service shop does not have means for determining the correct shunt capacitance, it may be worthwhile to have on hand various fixed capacitances beginning with 20  $\mu\text{mf}$  and ending with 60  $\mu\text{mf}$ , in steps of about 5  $\mu\text{mf}$ . The voltage rating of these capacitors is determined by the data in the set manufacturer's service manual. Some set manufacturers are now adding a variable trimmer across the winding so that an exact adjustment can be made.



# NEW!

## UNIVERSAL REPLACEMENT HI-VOLTAGE "DOORKNOB" CERAMIC...



### FURNISHED WITH SCREW-IN TERMINALS TO MEET EVERY NEED!

An ingenious screw-in terminal system makes Sprague's new type 20DK-T5, 500 mmf, 20,000 volt molded case ceramic capacitor fit most every TV set. All you have to do is select the proper set of terminals, two twists of the wrist, and there you are!

With this new Sprague development, you need only one capacitor in your kit to service sets up to 21" tubes.

Sprague's 20DK-T5 "Doorknob" ceramic is molded in genuine thermosetting plastic, non-flammable and moisture-resistant. Guard rings are molded in both faces to lengthen the surface leakage path. Write for complete catalog C-608 to Sprague Products Co., 55 Marshall St., North Adams, Mass.



Don't Be Vague!  
Insist On Sprague

WORLD'S LARGEST CAPACITOR MANUFACTURER

Rider **TEX-FILE** gives you

Unpacking and installation data



" . . . an excellent text for every TV owner—if he could be persuaded to read it."

Says RADIO-ELECTRONICS

- - - Let us persuade them - - -

THE minds of people have been poisoned against us. This book is an antidote. More than an answer to the fix-it books, it is straight-from-the-shoulder, written in anger.

LET them read it while you work. Carry several copies in your tool box. You will be repaid—in money, and in relief from arguments!

**- RUSH THIS COUPON -**

**ALERT MULTIGRAPH SERVICE**  
54 Dey St. New York 7, N. Y.

Send me.....copies "WHY You Should NOT TRY To Fix Your Own TV" By John D. Burke. 44 pages

Enclosed \$.....50¢ postpaid

Name.....

Address.....

City.....State.....

**Selling Time and Labor**

(Continued from page 3)

If ever the servicing industry is going to find a solution for the problems it faces in connection with charges, it better take advantage of every form of sales angle. *Keep it honest — but use it.* It is done in all other industries, why not in radio and tv service?

You may have even more elaborate ideas on this subject than are treated here. Good, try them out. At any rate, we hope that you'll give the thoughts outlined a trial; they have been found very successful by those who have used them.

**About Increasing TV Receiver Sensitivity**

(Continued from page 12)

ity depends on the local conditions, but the trial is warranted.

Realignment of the r-f and i-f system frequently increases sensitivity to the point that circuit changes are unnecessary. Peaking of the front end and video i-f transformers is another method of increasing gain, except that it degrades the picture. This is not too bad if reception overall requires increased sensitivity, but if some stations are received well, the loss in picture quality will be noted, and the results of the operation may not meet with approval.

**RIDER BOOK SHELF**

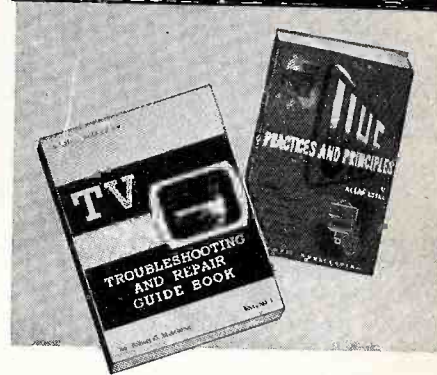

**1 TV TROUBLESHOOTING AND REPAIR GUIDE BOOK**

by R. G. Middleton

A new practical book designed to make your tv servicing *easy*. It tells—in easy-to-read language—how to spot receiver troubles . . . and how to correct them permanently. You'll find enough practical data in one chapter to repay the low cost of this book many times over. Typical chapters include: Receiver Differences and Waveforms; Visual Alignment; Troubleshooting Sync Circuits; Locating Sweep Troubles; Causes and Cures of Receiver Buzz; Test Equipment Kinks. Indexed and illustrated with over 190 (8½ x 11") pages bound in durable art cover -----\$3.90

**2 UHF PRACTICES AND PRINCIPLES**

by A. Lytel

A new, up-to-the-minute book that clears away the confusion and misunderstanding most people have about UHF. Written in clear, easy-to-understand terms, this book covers both fundamental theory and practical, working applications with special emphasis on television. Present-day brand name converters are thoroughly covered, including circuit descriptions and schematics. Here is profitable and practical reading for anyone who will be working with UHF. Typical chapters include: UHF Receiving Antennas; Electromagnetic Radio Waves; Transmission Lines; Waveguides. Illustrated and indexed with approx. 400 (5½ x 8½") pages bound in cloth cover. -----\$6.60

Buy these books now at your jobbers . . . leading bookstores . . . or—

**MAIL THIS COUPON — TODAY —**

**JOHN F. RIDER, Publisher, Inc.**  
480 Canal Street, New York 13, N. Y.

Please send me book(s) circled. I understand, if not satisfied, I may return them within 10 days for full refund. 1 2

NAME \_\_\_\_\_

ADDRESS \_\_\_\_\_

CITY \_\_\_\_\_ ZONE \_\_\_\_\_

STATE \_\_\_\_\_ SS-7

(Please Print)

**Laughs in the Life of a TV Serviceman**



"I don't think I touched any of the knobs in the back . . ."

**A**ND EVEN if he did, or if something else is wrong, you'll find that Raytheon TV receivers are well constructed and easy to service. The Raytheon TV service manuals are complete in every detail, such as showing wave forms and operating voltages, as well as condensed service tips that help you do your

job quickly and well. Every Raytheon TV receiver comes with a complete schematic that shows all part values. This helps on service calls because you don't have to haul along a complete service encyclopedia . . . Raytheon Manufacturing Company (Belmont Radio Corporation, 5921 West Dickens Ave., Chicago 39, Ill.)





A monthly summary of product developments and price changes of radio, electronic, and television parts and equipment, supplied by United Catalog Publishers, Inc., New York City, publishers of RADIO'S MASTER.

These REPORTS will help you to buy and sell to best advantage. They will also help you to keep your inventory up to date. A complete description of most products will be found in the Official Buying Guide, RADIO'S MASTER available through local parts distributors.

**New Items**

- ALPROD CO. INC.—Added No. ALP80HD, complete tower erection, signal testing and demonstration mobile unit (less tires) at \$393.50 net and ALP 68HD, assembled telescoping tower unit only, at \$233.50 net.
- CLAROSTAT MFG. CO.—Added TV replacement controls RTV 326 through RTV 344.
- ELECTRO-VOICE—Microphone model 715 added at \$6.75 net and model 3012, TV booster at \$35.70 net.
- GENERAL CONTROL CO.—Added ETC timer (electronic) at \$35.00 resale price.
- G. E.—Industrial & transmitting tube types GL-6135, GL-6136 and GL-6137 added. Also added radio receiving tubes 6V3 at \$3.55 list and 12AV7 at \$2.90 list which are currently being used by some VHF set infrgrs.
- INDUSTRIAL CONDENSER CORP.—Added 5 new type GA oil filled capacitors.
- JENSEN INDUSTRIES—Added Jensen sapphire needle J25LP at \$2.50 list . . . added 3 replacement needles for Electro-Voice . . . 2 for Webster Electric . . . added No. 80, Jensen replacement needle combinations at \$27.88 net.
- MERIT TRANSFORMER—Added type P-3097, TV isolation filament transformer at \$2.22 net . . . P-3098, TV autotransformer at \$1.65 net . . . 4 new TV power transformers . . . type MWC width/linearity control at \$1.14 net and 6 new IF RF coils.
- PENN BOILER & BURNER—Added 30' telescopic tower at \$3.75 net . . . adjustable base at \$4.65 net and hoisting mech. at \$13.25 net.
- PERMOFLUX CORP.—Added baffles CH-8M at \$45.87 net and CH-8B at \$50.70 net.
- PRECISE DEV. CORP.—Introduced signal generators K-610 at \$22.95 net . . . KA-610 at \$27.95 net and W-610 at \$38.95 net. Prices are East Coast.
- RACON ELECTRIC CO.—Added CHU, high frequency driver unit . . . COB-15 and COB-16, paging speaker . . . RE 32, horn . . . and XP-1 and XP-2, explosion-proof driver units. (both will handle 30 watts continually with peaks up to 60 watts).
- R.C.A.—Added 6V6-Y, beam power amplifier with micaol base at \$4.25 sugg'd user price.
- RADIO MERCHANDISE SALES—Added 22 new items to their line of TV antennas and accessories.
- RADIO RECEPTOR CO.—Added series of 10 germanium diodes to their line.
- ROGAN BROS.—Added escutcheons RB-1000-1 to RB-1000-10.
- SHURE BROS.—Added 21 new tape recording heads . . . 1 new Bifurcated needle . . . 2 new cartridges . . . 1 new cutter-cartridge . . . 2 tinsel coiled cords . . . 3 new carbon mikes . . . 1 new controlled reluctance mike.
- SUPREME PUBLICATIONS—Added volume 12, Radio Diagram Manual, to their series of publications.
- TUNG-SOL ELECTRIC—Added radio receiving tubes 6BK7 and 6BQ7 at \$3.05 list; 6F6GT at \$1.65 list, 6X8 at \$2.75 list, 117Z6GT at \$2.50 list and special purpose tube 6AS7G at \$4.53 net.



**ATTENTION!  
RADIO  
SERVICEMEN**

THERE ARE THOUSANDS  
OF OUT-MODED RADIOS  
IN YOUR "BACK YARD" JUST  
WAITING TO BE REPLACED  
... AT YOUR SUGGESTION

*Makers of  
fine radios  
since 1928.*

**ESPEY**  
TEL. TRafalgar 9-7000  
**MANUFACTURING COMPANY, INC.**  
528 EAST 72nd STREET, NEW YORK 21, N. Y.

**Here is the custom-built  
AM-FM chassis that means  
BIGGER PROFITS for you!**

**The NEW ESPEY model 511-C**

**FEATURES**

1. AC Superheterodyne AM-FM Receiver.
2. Improved Frequency Modulation Circuit, Drift Compensated.
3. 12 Tubes plus rectifier and Pre-Amp 12AT7 Tube.
4. 4 dual purpose tubes.
5. Treble Tone control.
6. 6-gang tuning condenser.
7. Full-range bass tone control.
8. High Fidelity AM-FM Reception.
9. Automatic volume control.
10. 10 watts (max.) Push-Pull Beam Power Audio Output.
11. 12-inch PM speaker with Alnico V Magnet.
12. Indirectly illuminated Slide Rule Dial.
13. Smooth, flywheel tuning.
14. Antenna for AM and folded dipole antenna for FM Reception.
15. Provision for external antennas.
16. Wired for phonograph operation with switch for crystal or reluctance pick-up.
17. Multi-tap output trans., 3.2-8-500 ohms.
18. Licensed by RCA and Hazeltine.
19. Subject to RMA warranty, registered code symbol #174.

**SPECIFICATIONS**

Supplied ready to operate, complete with tubes, antennas, speaker and all necessary hardware for mounting in a table cabinet or console, including escutcheon. Power consumption—105 watts.

Chassis Dimensions: 13½" wide x 8½" high x 10" deep.

Carton Dimensions: (2 units) 20 x 14½ x 10¾ inches.

Net Weight: 17½ pounds each.

Sold through your favorite parts distributor.

WRITE FOR CATALOGUE KD12  
AND NAME OF NEAREST DISTRIBUTOR.

Please mention *Successful Servicing* when answering advertising.

- UTAH RADIO PRODUCTS—Added 2 new speakers SE5725 and SE6910.
- WESTON ELEC. INSTR. CO.—Added models 633 VA-1, 633 A-1, 633 A-2, 633 A-3, clamp volt-ammeters and clamp-ammeters . . . 564, 681 I-E, 689 I-F, 697, pocket size testers. (volt-ohm-milliammeter).
- XCELITE, INC.—Added No. 49, midget snip at \$2.49 net.

**Discontinued Items**

- APPROVED ELECTRONIC INSTR. CO.—Withdrew A 220 K, vacuum tube volt ohmmeter kit . . . A 410 K, push-pull 5" oscilloscope kit . . . A450, marker generator . . . A610, 4 watt AC amplifier . . . A TVB, fixed frequency TV booster.
- AUDIO DEV. CO.—Withdrew 11 items in their PJ series.
- EDITORS & ENGINEERS—Withdrew electronic publication "Two-way Radio."
- GARRARD SALES CORP.—Withdrew crystal cartridge from 3 speed-record changers RC-80C and RC80C-DC. However, the cartridge is still obtainable in a Garrard shell as a separate item entirely.
- RECORDING WIRE & TAPE CO.—Discontinued their series of Magna-Wire & Accessories.
- SUPREME, INC.—Model 660, deluxe wide range TV oscilloscope withdrawn.
- WEBSTER ELECTRIC CO.—Withdrew replacement cartridges A7-1, A7M1, C2, C8 and C9X.

**Price Increases**

- FEILER ENGINEERING—Advised of a price increase on their line of test equipment.
- PRESTO RECORDING—Increased prices on Presto double sided Master No. 621-A to \$1.53 net and 623-A to \$1.95 net and Presto single sided Master No. 821-B to \$1.20 net and 823-B to \$1.44 net.
- SIMPSON ELECTRIC CO.—Increased price of model 488 field strength meter to \$98.50 net.
- SYLVANIA—Rocket tubes 2C36 and 2C37 (pulse-modulated and C.W. oscillators) increased to \$40.65 sugg'd resale each.
- WARD PRODUCTS CORP.—Increased the prices on communication antennas SPP-94, 95, 96 and 97.

**Price Decreases**

- INSULINE CORP.—Decreased prices on No. 2383, pin plug to \$5.00/c and No. 2385, socket and shield for R.C.A. recording units, receivers and auto sets to \$7.00/c dealer cost . . . also No. 6136 to \$3.93 and 6139 to \$5.91 dealer cost, both multi-position antenna mounting brackets.

- KESTER SOLDER CO.—Reduced the list price per pound of their Kester plastic rosin . . . Kester acid and Kester "Resin-Five" core solder.
- MALLORY & CO.—URF converter No. 101 reduced to \$31.88 net.
- R.C.A.—Decreased prices on 20 Kinescopes in 14", 16", 17", 19", 20" and 21" sizes.
- RAYTHEON—14 TV picture tubes reduced in price.
- SYLVANIA—Subminiature tubes 5903, 04, 05, 06, 07, 08, and 5916 reduced to \$13.00 net.
- TUNG-SOL ELECTRIC—Radio receiving tube types 14F7 reduced to \$2.20 list and 14F8 reduced to \$3.00 list . . . also reduced CR tubes 17BP4A, 17HP4, 17LP4 to \$26.25 net each.
- UTAH RADIO PRODUCTS—Decreased prices on 112 speakers on their line.

**RIDER Books May Now Be  
Purchased with  
TEK-FILE Coupons!**

You can now buy Rider books from your favorite parts distributor and pay him with TEK-FILE binder coupons.

The TEK-FILE binder coupon, included with each TEK-FILE pack you buy, has a purchase value of five cents when you purchase Rider books.

Of course, you can still use the coupons to get TEK-FILE binders, but you now have the alternative of applying them toward your purchase of Rider books. This special offer does not apply to Rider Manuals or TEK-FILE.

Do you want to own a copy of the TV TROUBLE-SHOOTING AND REPAIR GUIDE BOOK, ENCYCLOPEDIA ON CATHODE-RAY OSCILLOSCOPES AND THEIR USES, etc? Start saving your TEK-FILE binder coupons today. They're redeemable at all TEK-FILE distributors.



## Improvement of fringe area reception

(Continued from page 11)

ribbon line as outlined in Table 7 and shown in Fig. 9.

The lower two antennas should also be connected by two equal pieces of 75 ohm ribbon line of the same length as was used to join the upper pair. From the upper junction (J) and from the lower junction (K), two equal length sections of 150 ohm line (as specified in Table 9), should be joined to form a third junction (M).

Between junction (M) and the 300 ohm lead-in, a matching section of the length specified in Table 10 should be inserted.

All leads are to be supported away from the mast, in such a manner that they cannot tangle, whip, or twist around each other.

4. Correction of Sound Attenuation Resulting from Use of Yagi Antenna. Because Yagis are relatively narrow band antennas and because they are

usually cut to the picture carrier frequency, sometimes on the lowest channels the sound carrier is attenuated in relation to the picture carrier. This condition can frequently be improved by shortening the front director approximately 4%.

TABLE 9

Lengths of 150 Ohm Ribbon Line (1:1 ratio) Required In Matching the Double Stacked Yagi.

Channel	Lgth in Inches	Channel	Lgth in Inches
2	81	7	26
3	72½	8	25
4	66½	9	24½
5	58	10	23½
6	54	11	22½
		12	22
		13	21½

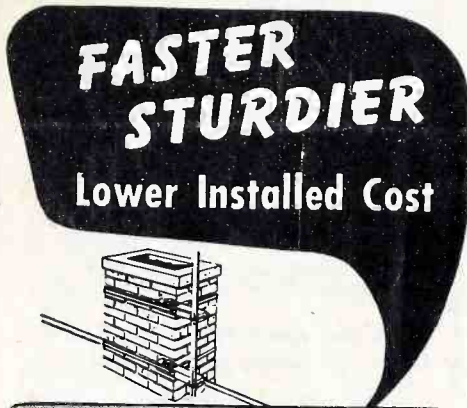

**FASTER  
STURDIER**  
Lower Installed Cost

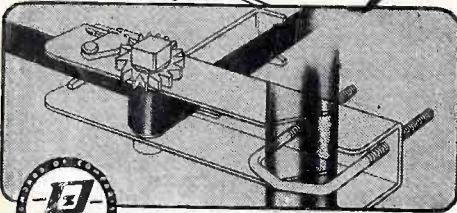

**RADIART SPEED-DEE  
CHIMNEY MOUNT**

**Model AK 85** The fastest-installed chimney mount ever devised for TV antennas! Rugged in design—simple to install. Simply thread strapping through ratchet, around chimney and back through ratchet—wind up ratchet tight—and the job's done! Heavy gauge, zinc-plated steel with large "U" bolt for up to 1¾" O.D. mast and full length galvanized steel strapping.

**THE RADIART CORPORATION  
CLEVELAND 13, OHIO**

Please mention *Successful Servicing* when answering advertising.

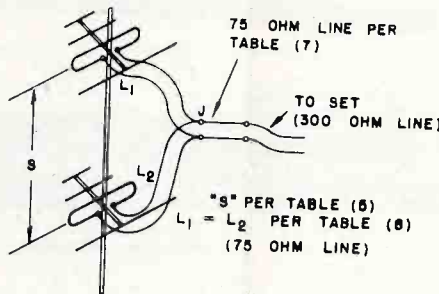

Fig. 8. Matching the Single Stacked Low Impedance Yagi.

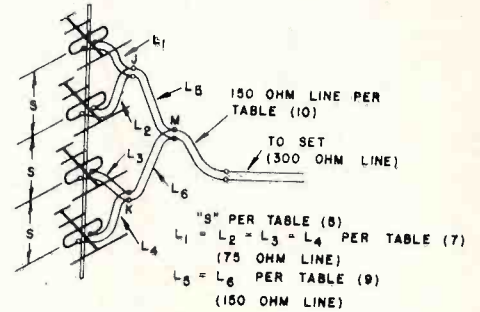

Fig. 9. Matching the Double Stacked Low Impedance Yagi.

TABLE 10

Lengths of 150 Ohm Balanced Ribbon Line Required to Match 75 to 300 Ohms (Double Stacked Yagis)

Channel	Lgth in Inches	Channel	Lgth in Inches
2	40½	8	12½
3	36½	9	12
4	33	10	11¾
5	29	11	11½
6	27	12	11
7	13	13	10¾

Sec. 3466, P. L. & R.  
U. S. POSTAGE  
**PAID**  
NEW YORK, N. Y.  
PERMIT NO. 9427

A. J. S. CERINO  
5310 OVERBROOK ST.  
DOUGLASSON, L. I., NEW YORK

From  
JOHN F. RIDER PUBLISHER, Inc.  
480 CANAL ST., NEW YORK 13, N. Y.  
Forwarding and Return Postage Guaranteed



# SUCCESSFUL

# Servicing

AUGUST 1952

TABLE 11

Comparison of Average Antenna Efficiencies Using the Single In-Line or Conical Broad Band Antenna as a Reference.

	Average (Over all channels)	Peak (Best channel)
a) Single In-line or Conical (broad band—channels 2-13)	100%	140%
b) Single Stacked In-line or Conical (broad band)	150%	210%
c) Double Stacked In-line or Conical (broad band)		
(without impedance matching)	200%	280%
(with impedance matching as per Table 6)	230%	320%
d) Single Yagi (one channel)		
(without impedance matching)		175%
(with impedance matching)		300%
e) Single Stack Yagi (one channel)		
(with impedance matching)		425%
f) Double Stack Yagi (one channel)		
(with impedance matching)		600%

\*This completes the article by the same name which was started in the June issue of SUCCESSFUL SERVICING. It is reprinted from the book "Compendium on Improving Fringe Area T.V. Performance," published by the Zenith Radio Corp., and compiled by J. C. Spindler. The article and its illustrations are reprinted through the courtesy of the publisher.

## Evaluation of Antenna Efficiencies

The above table (11) lists gain ratios of common antenna types percentagewise, so that a direct comparison can be made as to their relative efficiency.

## Evaluation of Antenna Height to Signal Gain Ratios

The following table (12) is included in order that the average gain in signal with a given increase in antenna height may be pre-determined. It lists the approximate percentage increase in signal amplitude to be expected in relatively level terrain. It is sometimes not applicable in hilly or mountainous fringe areas, or where an intervening hill lies in the line of sight to the transmitter, or in locations beyond the line of sight. In such circumstances the best elevation can only be

determined experimentally. However, in many of these cases it will still be found that the higher the antenna, the more signal it will pick up.

Thus, as an example, it is seen that in an average non-mountainous fringe area, (neg-

TABLE 12

Relative Signal at Antenna Terminals to be Expected with Various Antenna Heights

Elevation	
25 ft.	25%
50 ft.	50%
75 ft.	75%
100 ft.	100%
200 ft.	200%

lecting differences in line losses), about as much benefit is obtained by elevating a single In-line from 25 ft. to 50 ft. as would be obtained by allowing the antenna to remain at 25 ft. and double stacking. Also, a single Yagi (with impedance matching) would, on the average, be as effective for one channel reception at 25 ft., as an In-line at 75 ft.

## Guy Wires

Guy wires and the antenna lead-in should be kept as far apart as possible, otherwise possible line loading and coupling to the lead-in of unbalanced signals and/or interference pickup will result. If the guy wires are within 6 feet or less of the lowest antenna element, it is recommended that the

## improvement of Fringe Area Reception by proper antenna installation

by J. C. Spindler\*

guy wire run be broken with insulators placed at a distance of 45 inches and perhaps at 90 inches from the top in order to eliminate possible undesirable coupling between the antenna and guy, which may adversely affect the antenna directivity, gain, and noise pickup. Guy wires should also be kept away from known sources of noise, such as motors or power lines.

## Selection of Lead-In

In general, 300 ohm twin lead is satisfactory. Under extreme man-made noise conditions coaxial line may be used to advantage,

(Continued on page 10)





**MAXIMUM STRENGTH**

In the PARALLELOGRAM OF FORCES featuring built-in thrust bearing to take up down thrust

**Sturdy**

...to support any antenna array

**Power**

...more than you'll ever need

all yours in the **MODEL TR-12**

the **CDR ROTOR**

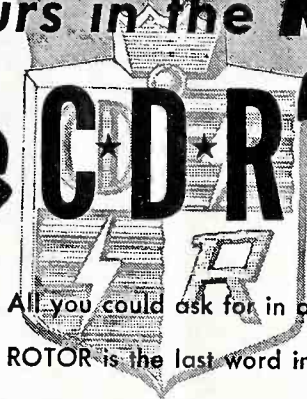

All you could ask for in an antenna-turning device... the TR-12 CDR ROTOR is the last word in streamlined efficiency! It will support and turn with ease any antenna array—even 4-stack designs... you just can't beat it! Some of the features include: speedy installation, no loose parts to assemble—quick-mounting antenna mast collet—dependable, trouble-free, fool-proof operation!

**MODEL TR-12**... Complete rotor with handsome modern design plastic cabinet and meter control dial — fingertip lever — using 4-wire cable **\$47.95**

**MODEL TA6**... thrust-bearing accessory, separately . . . . . **\$4.95**

**MODEL TR-11**... same as TR-12 without thrust-bearing . . . . . **\$44.95**

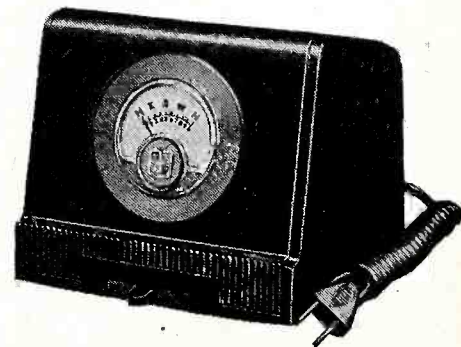

**THE RADIART CORPORATION** CLEVELAND 13, OHIO

VIBRATORS • AUTO AERIALS • TV ANTENNAS • ROTATORS • POWER SUPPLIES

Please mention *Successful Servicing* when answering advertising.



Some Notes on:  
**Point-to-Point D-C  
 Resistance Measurement  
 in TV Receivers**  
 John F. Rider

IT is a well established fact that time is of the essence in all servicing operations. Therefore, every approach to servicing techniques must be made with this in mind. It is in this connection that we examine the value of point-to-point d-c resistance measurement as a technique for the diagnosis of troubles in tv receivers.

About twenty years ago, we wrote a book entitled "Servicing Receivers by Means of Resistance Measurement." At that time voltage and d-c resistance measurement were the two most prominent methods of trouble localization in radio receivers. Signal injection also was used, but signal tracing had not yet appeared. In sum and substance, d-c resistance measurement between receiver ground or some other reference point and pins on the tube sockets was regularly used. In view of the relatively few resistance elements which constituted the chain between the test points, the technique was rapid and the conclusions were fairly definite. Finally the choice between voltage and d-c resistance measurement as the first step in the diagnosis was a matter of individual preference. Obviously, in the case of *dead* receivers, d-c resistance measurement was applied first.

Today, twenty years later, d-c resistance measurement is still being used — now applied to tv and radio receivers. Analyzing the suitability of the technique in these days of scopes, voltmeters and signal tracing as well as substantial differences in circuit design, especially in tv receivers, we cannot help but arrive at certain conclusions. It is completely suitable to radio receivers, just as it always has been, but it has limited utility in tv receivers. Lest anyone develop

the wrong conclusion from these references, we are *not* speaking about the benefits of knowing the d-c resistance of components such as transformers, coils, etc. These comprise an entirely different subject to be dealt with in a subsequent article. Right now we are concerned with point-to-point d-c resistance measurements between specified points in a tv receiver; for example from the plate or grid of a tube and ground or some other reference point.

The majority of radio receivers sold during the past five or six years are of the table kind. The tubes are few in number as are the resistors and capacitors. However, the number of resistive elements in any circuit chain are relatively few. Also, and this point is very important, the range of resistance values present in any chain is not too great. Finally, the number of circuits which are isolated from a d-c resistance test because of the presence of series capacitors are very limited.

**Limitations in TV Servicing**

But when we look at a television receiver, we see something different. Not that point-to-point d-c resistance measurement is not applicable; it is a suitable technique with reservations. For instance, consider Fig. 1. This shows the video detector and the video amplifier in a receiver. A point-to-point d-c resistance measurement between the anode of the detector and ground shows approximately 3.3 K ohms. This is the value of R3. The presence of resistors R1 and R2 has little effect on the overall circuit resistance because these resistors are shunted by the low d-c resistance coils L1 and L2, respectively.

Admittedly, an open in either L1 or L2 will display an effect on the total circuit resistance and so call attention to the presence of a defect, but a partial short or a complete short in either or both of these coils will cause virtually no change in total circuit resistance, but circuit operation will be faulty. Such conditions can have a great effect on the picture. The same is true if either or both R1 and R2 are open, have

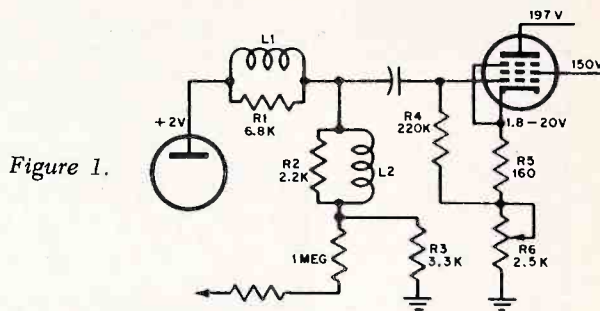

Figure 1.

increased or decreased in value and so alter the loading on the individual coils, or if they become shorted between the terminals. In other words, the number of possible troubles which are not detectable by means of the point-to-point d-c resistance measurement so outnumber the possible troubles which are detectable in this fashion, as to severely limit the usefulness of the process.

The same is not true in the input circuit of the video amplifier. Here the number of elements in any chain are few and the circuit structure is simple. The d-c resistance measurement between the cathode and ground is informative relative to the condition of the fixed and variable bias resistors. But it is not as definite in its findings as measurement of the voltage between cathode and ground, which is supposed to be from 1.8 to 20 volts, depending on the setting of the variable 2.5 K contrast control. On the other hand, the measurement between the control grid and ground is useful only for the measurement of the 220 K ohm grid leak, since the tolerance for that part far exceeds the maximum value of the variable control R6 which is in the same chain. In this connection, the possible tolerance in R6 may exceed the total value of R5, which means that two readings are required between cathode and ground. One of these is with R6 set to zero and other is with it set to maximum.

Before making any conclusions, let us consider another case. This is Fig. 2, the horizontal multi-vibrator circuit. The measurement from control grid (1) to ground involves R4 and R3, each being 330 K ohms. This test harbors no difficulty, nor does the measurement between the cathode (3) and ground. The performance of the system, however, is not determined solely by the components which make up the d-c resistance paths between grid and ground and cathode and ground. The C1, C2, C3, and R1 also play very important roles, although

(Continued on page 16)



# USE TUNG-SOL TUBES FOR TROUBLE-FREE SERVICE!

TUNG-SOL "QUALITY CONTROL" recognizes but one standard. All Tung-Sol Tubes meet the highest original equipment requirements of leading radio and tv set manufacturers.

TUNG-SOL ELECTRIC INC., Newark 4, N. J.  
Sales Offices: Atlanta · Chicago · Culver City · Dallas  
Denver · Detroit · Newark

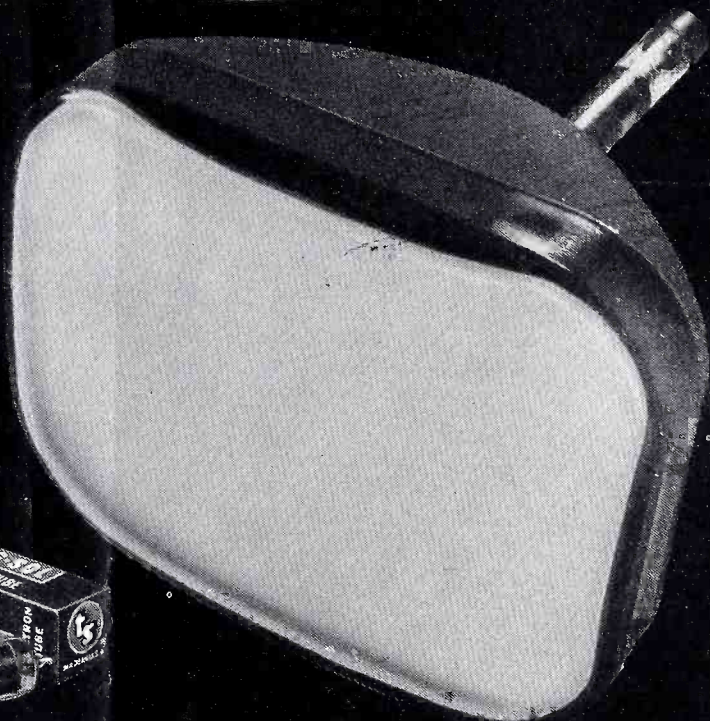

**RADIO  
TELEVISION  
SERVICE**

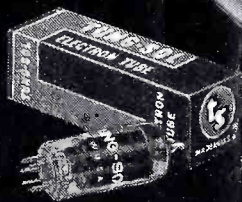

No Call-Backs for me, pal

Here's a real lively "stopper" to attract attention to your place of business and emphasize the quality of your service. Colorful—bright red and two shades of blue. 15 inches high. Your jobber salesman will tell you how to get one.

TUNG-SOL MAKES ALL-GLASS SEALED BEAM LAMPS, MINIATURE LAMPS, SIGNAL FLASHERS, PICTURE TUBES, RADIO, TV AND SPECIAL PURPOSE ELECTRON TUBES

Please mention *Successful Servicing* when answering advertising.



# Successful SERVICING

REG. U.S. PAT. OFF.

Dedicated to the financial and technical  
advancement of electronic maintenance personnel

VOLUME 13 NUMBER 10

AUGUST, 1952

**JOHN F. RIDER, Publisher**  
Annette M. Tricarico, Editor

Advertising Representative  
H. J. Olsow & Co.  
3951 Grand Central Terminal  
New York 17, N. Y.  
MUrray Hill 6-4670



## Curtain Time

We are very much intrigued by some market data which was developed by the Sales Research Division of Sylvania Electric Products, Inc. We feel that some of these data are of interest to the servicing industry, hence we'll deal with them in this editorial. The servicing business is big business, and is destined to become much bigger. In fact, we don't think that the service technicians of this nation realize the extent of their dollar activity.

For instance, in 1948 the value of receiving tubes and tv picture tubes used in the replacement market at service technician cost amounted to \$44,760,000. By 1952, a tremendous increase took place. The annual value of receiving tubes and picture tubes at serviceman cost grew to \$121,500,000.

Let us look at some other figures, those related to other parts used for replacement purposes. Stated in terms of the service industry's purchase price, the parts market amounted to slightly more than \$140,000,000 in 1948 and \$381,000,000 in 1952. If we total the tube replacement and parts replacement sales at serviceman prices we find that the annual dollar value grew from \$185,000,000 in 1948 to \$502,000,000 in 1952. To say the least, an industry which deals with more than a half billion dollars worth of products per year is no small potato.

In terms of what is the normal profit that should be realized on these parts and tubes, assuming that they are purchased at 40% below list and sold to the public at list, the serviceman's share in dollars is not an insignificant figure. The markup amounts to 66% gross on cost; on a half billion dollars it is roughly \$330,000,000. If we further assume the sale of these replacement items at list to the public, the service industry's sales volume represents approximately \$800,000,000.

We realize, of course, that the premise set forth here may not always apply; that is, all servicemen are not selling the replacement parts and tubes at list prices. Failure to do so can dig in very seriously to the overall profit earned by the industry. These figures, produced by Sylvania, prove how important it is to the servicing industry as a whole, to charge list prices — to stop giving away their profits.

Continuing with the projection of the service market, the servicing industry can gain courage from the possibilities of the future. So much so that it merits the utmost effort on the part of every service facility to stay in business and carry on regardless of the trials and tribulations which it is undergoing at the present time.

The tremendous upsurge of television receiver sales is past. However, it is felt by the researchers who developed this information that from this point on there will be a relatively steady sale of receivers each year, at least up to about 1961. While the figures do not show the increase each year between 1952 and 1956, the figures given for 1956 clearly indicate an expanding market every single year, and more and more dollar income to the servicing industry from the sale of replacement tubes and parts. For instance, it is projected that by 1956 the annual dollar volume of replacement tubes and parts at serviceman prices will reach approximately \$660,000,000 and in terms of resale at list price this figure rises above one billion dollars. That's a lot of money! The same figure is expected to reach two billion dollars annually by 1961.

With these dollar amounts as a background, it isn't surprising that an industry such as the servicing group will have problems, but certainly it is worth while to make every effort to find solutions. When an industry looks into the future and sees itself handling possible profits of hundreds of millions of dollars, it cannot lose hope, or become discouraged — it cannot expect that these profits will be acquired without growing pains.

## The Capehart President's Service Cup

An idea propounded by Capehart Farnsworth merits reference on this page. They have started a contest among their set distributors in the effort to upgrade service activity. The prize is a large sterling silver trophy which is to be awarded annually to the Capehart set distributor who does the most effective job service-wise. But the deal does not relate only to service activity in the distributor's shop. It involves his dealers and the service industry in his community. It calls for all-around effort, including the most effective service shop layout, greatest cooperation with set dealers and local service technicians.

The trophy is a merit reward for outstanding direction and achievement in the television and radio service field. While it is true that the effort revolves around one band of receiver, the fact remains that if the set distributors' service department managers in each community could become better acquainted with the service technicians in their area — if they would make the service technician see their problems—and they in turn see the service technicians problems, it would aid the attempt which the parts jobbers and set manufacturers are making to raise the general standard of television and radio servicing. While it is true that some set distributors have had contact with the servicing industry through occasional service meetings, they have been one-shot affairs—once a year . . . Perhaps contests and awards of this kind run by many set manufacturers may help get set distributor's service managers to work more closely with each other and with the servicing industry.

Congrats to Ted Ostman, Service Manager of Capehart Farnsworth!

*John F. Rider*



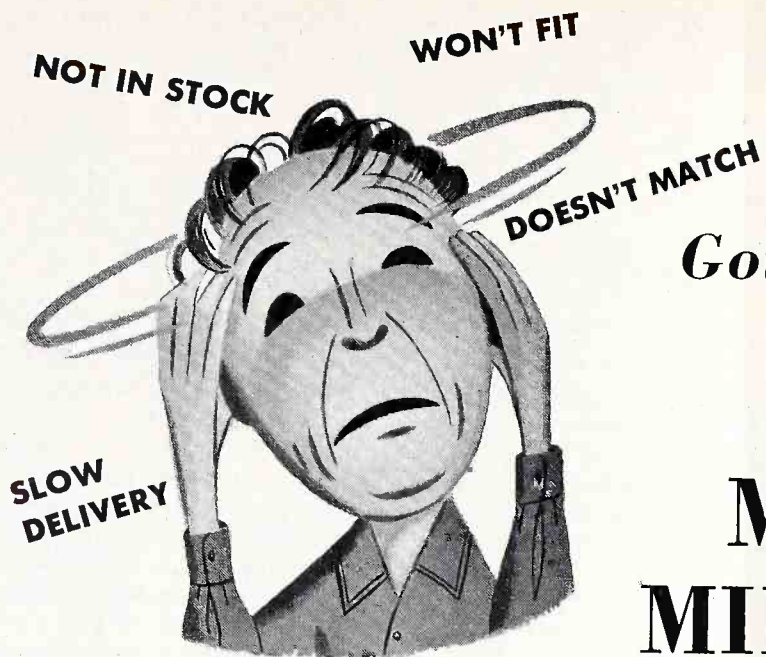

Got "Dual Control  
headaches?"

## MALLORY MIDGETROLS® will cure them!

Why wait for delivery—why scour distributors' stocks for special controls? You can replace *any* dual control in only a few minutes, by assembling the *exact* combination you need with Mallory Midgetrol Companion Units.

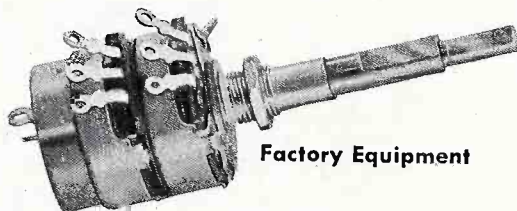

Factory Equipment

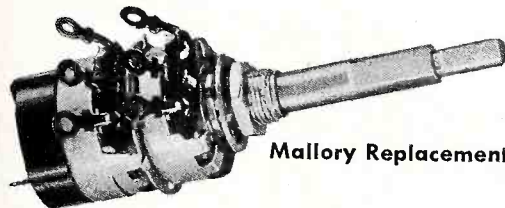

Mallory Replacement

Here's how easy it is to get an *exact replacement* for the original control. You just combine the Mallory factory-assembled front and rear control sections... add the easily attached switch... insert the shaft tip. The job takes less than five minutes. No soldering, no special tools.

**Quick—sure—economical.** Here's the way to get the control you need, with these features:

- **Exact match**, electrically and mechanically, for original components.
- **Highest quality**—quiet, drift-free resistance elements, accurate tapers, wobble-free, two-point suspension.

Best of all, you won't have to carry big inventories. A small selection of standard sections will equip you to service all the popular radio and TV sets. Your Mallory distributor has a complete stock of control sections, switches and hardware ready for immediate delivery. See him today!

<b>P. R. MALLORY &amp; CO. Inc.</b> <b>MALLORY</b>	CAPACITORS... CONTROLS... VIBRATORS... SWITCHES... RESISTORS... RECTIFIERS... VIBRAPACK* POWER SUPPLIES... FILTERS
	*Reg. U.S. Pat. Off.
<b>APPROVED PRECISION PRODUCTS</b>	
<b>P. R. MALLORY &amp; CO., Inc., INDIANAPOLIS 6, INDIANA</b>	

*Make Sure...  
Make it Mallory*



# The TV Serviceman Meets the Family

by John D. Burke

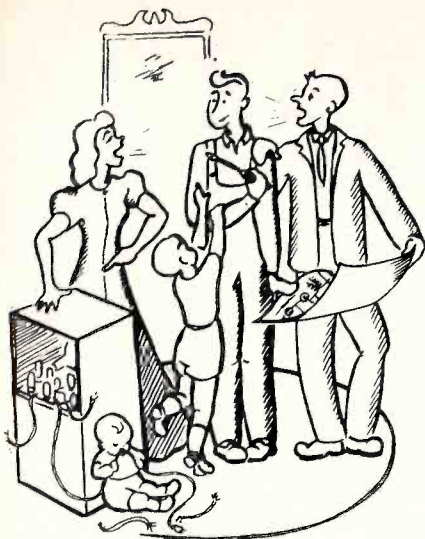

Here are a few more excerpts from the book entitled "Why You Should Not Try to Fix Your Own TV," written and published by the John D. Burke Co. We hope you took our suggestion last month and showed a copy of it to your customers!

## Find a Repairman You Can Trust

By all means, make an effort to establish a good, friendly relationship with some neighborhood repairman.

Go to his shop. Look at his instruments. Watch him at work. Talk to him. Listen to his other customers. Glance in his reference books. Make friends.

Establish such a relationship and your troubles are over.

All except money — you will have to pay a good price for his services.

There's no getting away from that fact. Good workers in TV are able to earn around \$100 per week.

Honest mechanics must charge substantial hourly rates, and the list price for tubes and parts to make up that weekly income.

Look around now for a shop you can have confidence in.

You will probably be surprised — but the repairman also *must have confidence in you!* *That's right.*

Every so often I refuse jobs.

Why? A few examples:

The owner of a \$600 set had "vertical jitters" — and "ghosts."

When I asked her, on the phone, whether she was prepared for the possibility that her set might require about \$20 in repair, and that her "ghosts" might be in the aerial, and therefore another problem — she replied that she was *sure* that there was only a "loose wire" as her set is a humdinger, and there could never be anything wrong with it. . . .

That was the end of it. I, an honest man, did not even go to look at her set.

I spent an hour in a house trying to locate an obscure trouble. All the time I worked an old man sat watching me like a hawk. Obvious distrust on his face. A



line of chatter about us repairmen being a lot of swindlers. I quit.

A man came in with his boy, of high school age. The father raved against his children for playing the TV rather than doing their home work. Said he did not know whether to fix the set, or throw it out. All this was for my benefit, so I should persuade him to fix his set at a very low price.

People come around with tales about having been badly treated by other repair shops. I ask for details. It turns out that their experience has been the normal thing in relation to TV headaches.

I refuse to look at their sets. They show no ability to understand what we repairmen are up against — why should my name be added to the list of those whom they are cursing?

Some people are chronic grumblers. They are *sure* that "life" is against them, that no matter what they buy, there is always something wrong with it. They curse the stores, the salespeople, and later the repairmen.

How would you like to try to solve complex, scientific problems while people are hovering over you with two positive opinions: First, that you do not know what you are doing; and second, that you are only concerned with how to swindle them!

## How to Keep the Repairman Happy!

Therefore — *if you have had the good sense to find a repairman with a good reputation* —

Let the man alone!  
Let him work undisturbed!  
Leave the room — find something else to do!

Ask him no more questions than he seems to welcome!

Give him a chance to swear — as he undoubtedly will when he gets shocked or burned!

Let him smoke. Give him an ashtray!

Clear away all the bric-a-brac and other breakables from the vicinity of the set — let him be free to spread out!

If he decides to take the set to his shop — he is right!

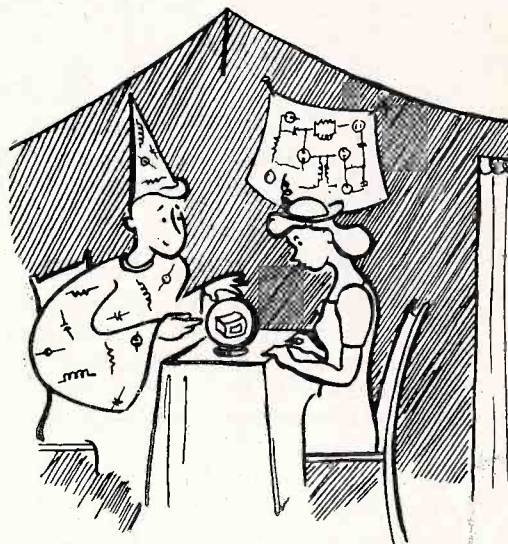

Please try to understand!

Ask him to let you see *under the chassis*. He will very likely be glad to show you the *jungle* of parts and wires through which he has to search for your troubles.

After the repair is done — try to understand that the replacement of this or that capacitor, or resistor, or coil, or tubes — *does not mean that your set has been "overhauled."*

If the man says he "guarantees" his work — this means he guarantees *only* those few parts or tubes he has replaced.

Anything else can happen to your set — at any time,

For example, if an elderly person has all his or her teeth pulled out by a dentist, and artificial teeth put in —

Such a person would *not* blame the dentist if soon thereafter he came down



# TV SERVICING

## is easier than you think

How many times have you asked yourself this question: "What can I do to make my servicing job easier?" Chances are you ask it every time you get a "stickler" in the shop. But have you ever stopped to consider that *all* your servicing . . . from the real headaches to the simplest repair . . . can be easier than you ever thought possible if you GET THE COMPLETE SERVICING INFORMATION ON A RECEIVER BEFORE YOU START TO REPAIR IT. Let's take a closer look to see why. *All* servicing data must originally come from the receiver manufacturer. He made the product, so he knows all about it. His information is not based on a single receiver but on hundreds, which are sampled. If you are using this kind of information, servicing is easy; but if you are using abridged data — information which does not originate with the set manufacturer — you do *not* have all the data required to do easy — permanent — prestige-building servicing.

Here's a typical example: For Stewart-Warner model 9122-A the set manufacturer prepared the equivalent of 35 pages (8½ x 11") of servicing data. The complete data is published in Rider TV Manuals Vol. 8 and in Rider TV Tek-File pack 12. The reason was that the production runs covered seven different codings (from A to G) plus 16 important changes in the receivers. Some of these changes were made to eliminate such actions as component resonance in the I-F system . . . horizontal sync instability . . . and the possibility of arcing in the high voltage system. Other changes were in tubes and parts. But *all* of the changes are vitally important to you when you're faced with a repair on this Stewart-Warner model. This is only one case in thousands of why it is absolutely necessary for you to have the complete, official, manufacturer-prepared servicing information for every set you repair.

There are two ways for you to get complete, official, factory prepared servicing information. One way is to write the set manufacturer directly. However, this takes time when you

need it most: While the customer's set is in the shop. So the easy way is to buy this data in complete published form. This means Rider Servicing Data! For 22 years Rider Servicing information has been the only publishing source for factory authorized and prepared servicing information: Exactly as issued by the manufacturer who made the set . . . organized into indexed, easy-to-follow style. In Rider Servicing Data you get all of the manufacturer's troubleshooting test patterns . . . schematics of all his productions . . . stage by stage alignment curves . . . clear, enlarged chassis views . . . the manufacturer's circuit changes . . . circuit explanations . . . voltage data, disassembly information and much, much more. For example: Rider Servicing Data has shown scope waveforms in TV receivers ever since the first TV receiver was made!

And Rider Servicing Data now has these important new features: manufacturers' trouble cures and guaranteed replacement parts listings. The manufacturers' trouble cures are standard (3 x 5") index cards, called Rider Handies, containing vital manufacturer-issued permanent trouble cures plus production changes. Each Handy is identified with a manufacturer and receiver model. With Rider Handies you save countless hours of diagnosis and repair time . . . because Handies contain the data you *must* have to make permanent repairs on many receivers. The replacement parts listings are included in the latest Rider Servicing Data. All these replacement parts must meet the physical and electrical performance ratings of the original equipment.

To meet your individual requirements, Rider TV Servicing Data comes in two forms. The Manual form; volumes covering the complete data on receivers manufactured during a certain period, and Tek-File form; separate packs containing complete data for specific models.

The TV Manual form has nine volumes covering more than 4,200 models of television receivers. Each vol-

ume has over 2,000 (8½ x 11") pages of servicing data with an index covering the contents of all volumes. Each volume is attractively bound in a permanent hard cover. The Manual form is ideal for shop use and as a permanent reference.

The Tek-File form now covers more than 2,200 models. Each Tek-File pack contains complete data for several of the most popular models . . . the ones you are called to work on every day. (Contents are clearly marked on the cover of each pack.) These models are bound in handy, standard file folders for easy home and shop use. In each Tek-File pack you get a special coupon. 15 of these coupons plus a small handling charge entitles you to a permanent, hard-cover manual binder for Tek-File shelf use. Or if you prefer, each coupon is worth five cents toward the purchase of any Rider book. Note: Get your free Tek-File indexes covering the contents of all packs at your jobber's. If he doesn't have them, write us.

For the complete servicing facts on *radio*, get Rider Radio Manuals. In 22 volumes Rider Radio Manuals give you the complete, factory-authorized, official AM, FM radio servicing data for receivers manufactured over the past 22 years! Plus complete data on auto radios, record changers, tuners and recorders. Everything is organized and indexed to make radio servicing easy.

### DON'T BE SWITCHED

Remember, Rider Manuals and Tek-Files are the *only* source for complete published servicing data. If your jobber doesn't have them, **DON'T BE SWITCHED!** If he doesn't have Rider Manuals, write to us . . . we'll tell you where to get them. If he doesn't have Rider Tek-Files, write to us . . . we'll fill your order directly. (Please include your jobber's name.) Why not prove to yourself that Rider Servicing Data really makes servicing easy. Try one Rider TV Tek-File pack *at our risk!* Try a pack for the next receiver you repair . . . if you don't agree that it makes your servicing easier than anything you've ever used **RETURN THE PACK TO US WITHIN SEVEN DAYS AND WE'LL SEND YOU A FULL REFUND!** So act now . . . you have absolutely nothing to lose! John F. Rider, Publisher, Inc., 480 Canal Street, New York 13, N. Y. West Coast Office: 4216-20 W. Jefferson Blvd., Los Angeles, California.



# 102 BILLION

## FREE SALES BOOSTS A YEAR FOR YOU!

**NEW**  
**CBS-HYTRON**  
BRAND  
gives you:

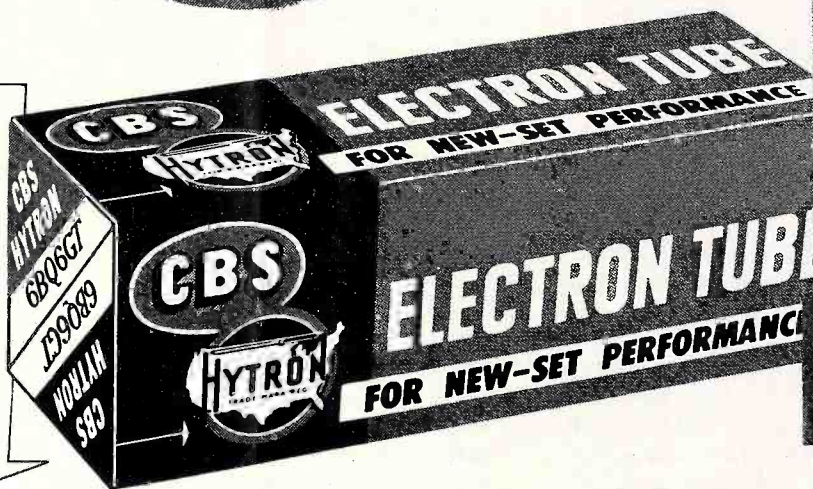

### Acceptance



1,973,326,000 times a week! 102,612,952,000 times a year! The magic letters "CBS" are seen and heard on radio and TV station breaks. Impact is terrific. An average of 13 sales impressions weekly for every man, woman and child in the country. Every one of your customers knows CBS. Knows he can depend upon CBS. Consumer acceptance of your CBS-Hytron brand grows hourly.

### Engineering



As a division of the Columbia Broadcasting System, Inc., CBS-Hytron commands tremendous engineering resources for you. Because CBS embraces the field of electronic entertainment: Radio broadcasting. TV broadcasting. Radio, television, and phonograph sets. Records. Electronic research laboratories. And CBS-Hytron tubes.

### Leadership



For example, CBS-Hytron originated: the GT tube . . . the subminiature tube . . . the rectangular picture tube . . . specialized, low-cost TV receiving tubes. CBS-Hytron's new picture-tube and miniature-tube plants are the most modern in the world. Such aggressive leadership guarantees you the newest and best in tubes.

### YOU CAN'T BUY BETTER

Demand the CBS-Hytron brand. You get the finest electron tubes that progressive engineering skill and craftsmanship can make. You get the brand known and respected by every one of your customers. You get the brand they see and hear the most . . . CBS-Hytron.



MAIN OFFICE: SALEM, MASSACHUSETTS



## Improvement of fringe area reception

(Continued from page 1)

in which case proper impedance matching transformers should be placed at each end of the line. In cases where an extremely long lead-in is necessary (over 150 feet) it may be advantageous to use an open wire twin line. This may be made by using any of the combinations of wire sizes and spacings (between centers) given in Table 13. However, it is also available commercially.

Wire Size	Wire Dia. (Inches)	Spacing Between Wire Centers (Inches)
4	.204	1.02
5	.182	.91
6	.162	.81
7	.144	.72
8	.128	.64
9	.114	.57
10	.102	.51
12	.081	.40

In constructing open wire line, insulators and spacers used must be of good quality material, such as polyethylene, polystyrene, lucite, or glazed ceramic. The number of supports should be limited in number to that absolutely necessary to provide adequate and permanent spacing. The approximate increase in signal pickup at the receiver terminals obtained by using open line in place of standard 300 ohm ribbon is listed in Table 14.

Line Length (feet)	Relative Signal (% Microvolts)	
	Chan 2-6	Chan 7-13
50	106%	114%
100	112%	135%
200	125%	180%
300	140%	240%
400	160%	315%
500	180%	420%

There is a tubular dielectric 300 ohm line, available commercially, which has substantially lower losses when wet than the regular ribbon line under similar conditions. When clean and dry, however, the losses of the tubular and ribbon types are merely comparable. One of the main disadvantages of the tubular lead-in is that it cannot be twisted readily, and therefore is subject to greater interference pickup than twisted ribbon in noisy areas.

### Routing the Lead-In

**Coaxial Line.** This line should be routed in as short and direct a path as practical from antenna to receiver. Bends should not

have a radius of less than 1" for RG-58/U and RG-59/U and a radius of not less than 3" for RG-8/U, RG-9/U, and RG-11/U. Fastening clamps should be snug, but should not flatten the cable. The shield braid should be grounded to the antenna mast at one end and to a suitable ground at the receiver end. In the case of "hot" chassis, the connection to the chassis may be made through a 100 mmf isolating capacitor.

**Ribbon Type 300 Ohm Line.** This line should be routed in as short and direct a path as is consistent with the following conditions:

1. Never place in direct contact with any metallic object.
2. Do not place in direct contact with any material which absorbs moisture or is a poor r-f insulator.
3. Keep as far away from guy wires as practical.
4. If run parallel to a metallic surface, such as the mast, gutters, drain pipes, etc., space at least 3" and preferably 6" or more from them by means of standoff insulators. Spacing of over 6" is desired on Ch 7-13 if the length of run is 50 feet or more.
5. Use only as many standoffs as is necessary to insure permanent spacing under conditions of wind, rain, etc.
6. Use standoff insulators of good quality with metallic parts mounted away from the lead-in.
7. Never bunch up or coil excess lead-in. Where some slack is desired (probably near the tv receiver) it must be kept to a minimum and supported.
8. Avoid routing antenna lead-in between

installation and after every cleaning. This compound causes the water to form into globules which are easily shed, resulting in less signal loss during rainy weather. This also helps to preserve the line.

10. If an exact match does not exist between the tv receiver and the transmission line, the signal on at least one, and possibly more channels, can be improved by wrapping a piece of tin-foil about 3" wide around the line near the receiver and sliding it back and forth until the point where the best picture is obtained is located. Caution must be exercised in using this device, since when it is best for one channel, it may be harmful to others. Thus other channels received must be checked at the time, and the best compromise position found. If no apparent improvement in signal is realized by the use of the foil, it is best to leave it off. If a position is found, that is of overall benefit, tape the foil securely in position with cellulose (Scotch) tape. If subsequently it becomes necessary to lengthen or shorten the lead-in to the set, it will also be necessary to shift the position of the foil along the line until it is the same distance from the receiver terminals as it was previously.

**Open Wire 300 Ohm Line.** The same precautions should be used as for 300 ohm ribbon line, except that even greater care should be exercised to prevent accidental contact of the line with metallic or wet objects. Spacing and standoff insulators should be periodically cleaned.

**Tubular 300 Ohm Line.** The same precautions should be used as for 300 ohm ribbon line.

### Tropospheric Reception

In areas well beyond the line of sight, tv reception is still possible because of refraction of the signals from the tropospheric region of the atmosphere. However, the quality of reception varies over a very wide range with time, changing from excellent at one time to no reception at another. Usually the signal arriving at the receiver antenna, in such locations, comes in at varying and sometimes considerable angles above the horizontal, and this change in the vertical angle of arrival, plus actual changes in signal strength, results in considerable fading. In locations where tropospheric reception is obtained, the two measures described below may help to reduce the effects resulting from changes in the vertical angle of the received signal and variance in signal level.

**Tilting the Antenna.** During tropospheric reception the signal almost always arrives at a substantial angle above the horizontal. Due to their vertical directivity, conventionally mounted antennas do not intercept as much energy as they would if pointed

a window and its frame, particularly if metal frames are used. It is recommended whenever possible, that line be routed in through bushings in the window pane, or through an insulating tube through the wall. In the latter case the tube is to be sealed with an insulating plate inside and out.

9. It is beneficial to clean the line, matching stubs, standoffs and all feed-through points at intervals of 3 to 6 months, as dirt on the line results in considerable signal loss, especially in rainy weather. It is also a good idea to apply a commercially available silicone compound to the outside of the line at time of



**Comments from service technician subscribers to**

**RIDER'S  
TELL-A-FAULT**

*The Troubleshooter's Troubleshooting Service*

The time saved using this system will pay me more than one hundred times the price I paid

TELL-A-FAULT is as essential as test equipment and tools

TELL-A-FAULT is a much needed aid on the TV service bench

*It is really a very good bargain*

Congratulations on TELL-A-FAULT. It ought to be a "must" just as Rider Manuals

Not only valuable to the beginner serviceman, but the experienced serviceman as well

*I can hardly wait for the succeeding issues*

There isn't anyone more capable of furnishing us servicemen with this information than Rider

The above comments are just a handful of the enthusiastic responses from service technicians who have received TELL-A-FAULT. TELL-A-FAULT is truly the most unique SERVICE ever made available to TV-radio service technicians. The next two pages show reproductions of a typical symptom sheet and circuit guide. Use the coupon on the last page to subscribe to this completely practical troubleshooting service.

**TELL-A-FAULT** does your troubleshooting for you!



## TELL-A-FAULT Symptom Sheet HORIZONTAL FOLDOVER

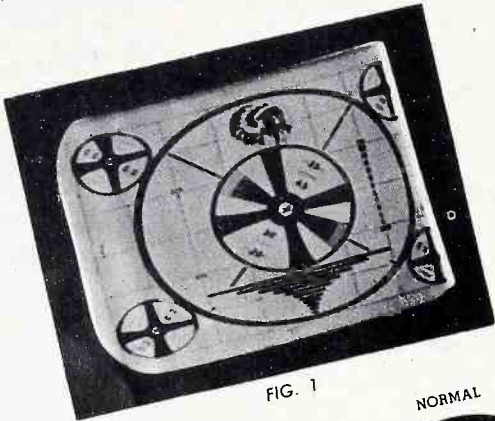

FIG. 1

(NOTE: Refer to CIRCUIT GUIDE IV-3 for identification of components.)

Fig. 1 shows a faulty picture-tube pattern which displays horizontal foldover. Note the picture compression and the bright vertical bar at the extreme right-hand side.

HORIZONTAL FOLDOVER

ABNORMAL



FIG. 2

NORMAL

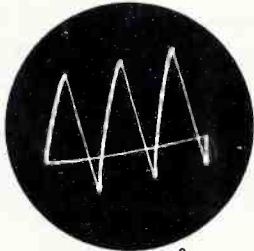

FIG. 3

The waveform at the input to the horizontal-sweep generator (multivibrator) was normal. The scope was then connected to the output plate of the horizontal-sweep generator (second plate of the multivibrator) with  $F=H/3$ . Under these conditions, the abnormal waveform in Fig. 2 appeared. Compare this with the normal voltage waveform shown in Fig. 3 which appeared at this point after the fault was corrected. The P-P amplitude here was normal as were the d-c voltage and resistance readings to ground.

The scope was then connected to the grid of the horizontal-output tube (V1), at which point the abnormal waveform of Fig. 4 occurred with  $F=H/3$ . The normal waveform is shown in Fig. 5 for comparison. The P-P value of the abnormal waveform was slightly above normal. The normal negative d-c bias of V1 was removed; instead, the grid voltage was actually slightly positive. Were it not for the protective cathode bias provided by R3, the horizontal-output tube would probably be damaged under these conditions. The resistance from the grid of V1 to ground was only about 1/4 of the combined value of R2 and R1, which was the expected reading from this point to ground.



FIG. 4

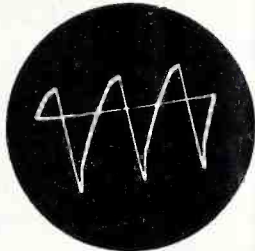

FIG. 5

With the scope connected to the plate of V1 through a capacitance-divider probe, the abnormal waveform of Fig. 6 occurred ( $F=H/3$ ). Compare this with the normal waveform shown in Fig. 7. The P-P value of the abnormal waveform was about 2/3 of normal. The d-c voltage at the same point was about 10% below normal. The P-P value of the voltage at the plate of the high-voltage rectifier tube was also about 2/3 of normal.

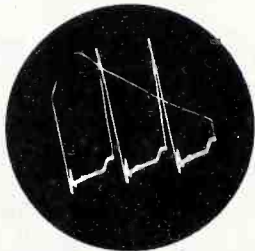

FIG. 6

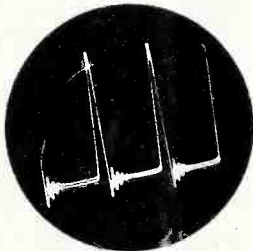

FIG. 7

The receiver fault that was responsible for the above effects was high leakage in feedback capacitor C3.

II-E-2

PRINTED IN U.S.A.

ALL RIGHTS RESERVED

# TELL-A-FAULT

## SYMPTOM SHEET

(70% of original size)

© 1957 JOHN F. RIDER

# TELL-A-FAULT

does you

The unbea  
TELL-A-FA  
and circuit  
easier, mo  
profitable  
work hanc  
other. The  
light the tr  
guides help  
TELL-A-FA  
work with  
Rider Man  
etc. In a c  
period of ti  
a fault an  
Troublesho  
time-consum  
ities is a  
cialty! Dur  
year you rec  
1,152 sympt  
form pictur  
plus servic  
valuable  
use your  
ceive this i



time! As few as one or two symptom sheets  
 time to pay for the entire year's cost of **TELL-A-FAULT**

combination of  
 symptom sheets  
 is the key to  
 and more  
 spotting. They  
 with each  
 sheets spot-  
 ded the circuit  
 localize faults.  
 planned to  
 vice data —  
 TEK-FILE,  
 tively short  
 an determine  
 pinpoint it.  
 otherwise  
 ure peculiar-  
 FAULT spe-  
 course of a  
 ven 768 and  
 trouble wave-  
 circuit guides,  
 t cuts, plus  
 on how to  
 nt. You re-  
 on monthly.

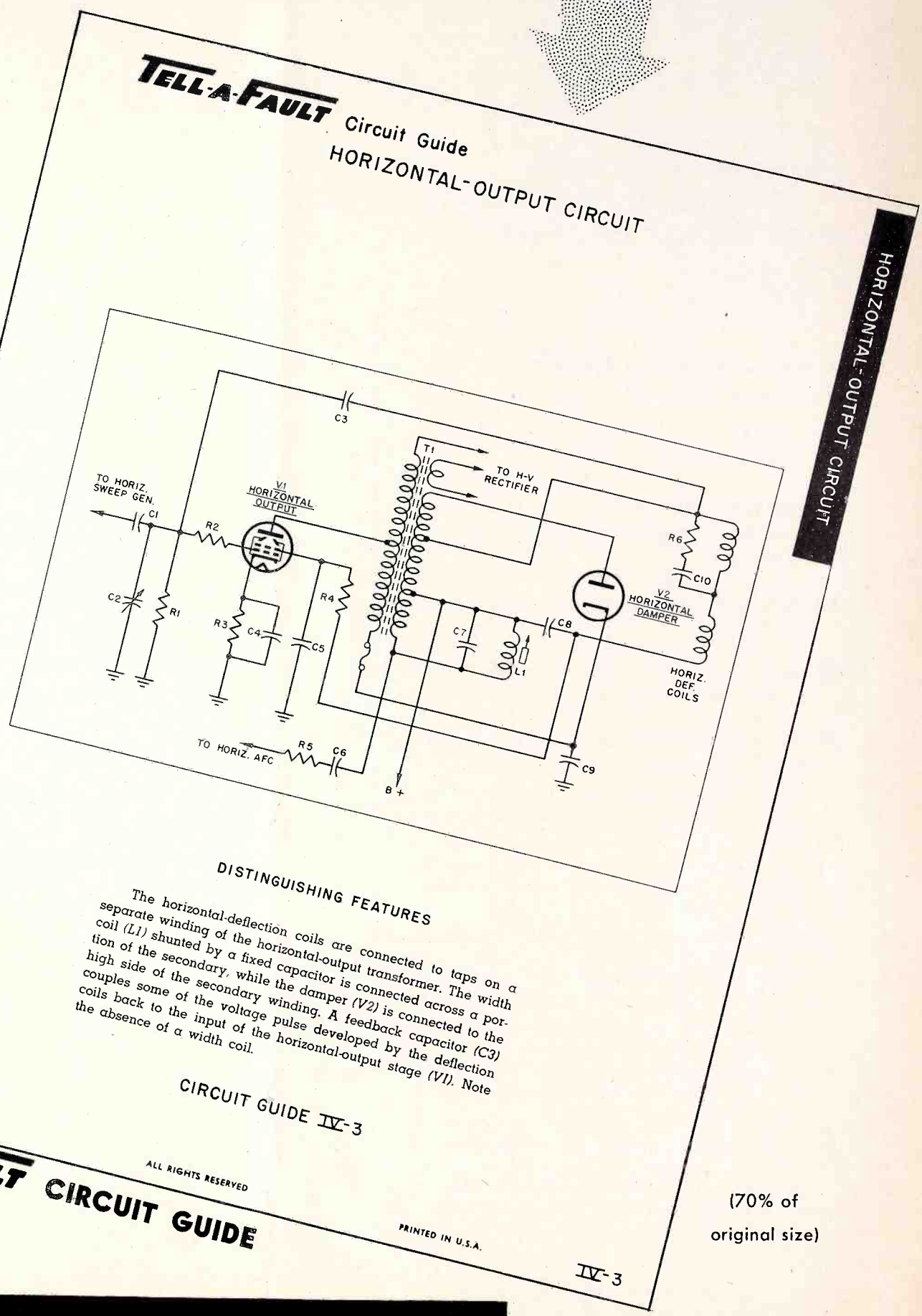
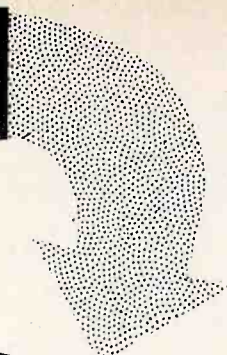

(70% of original size)

**troubleshooting for you!**



and you also receive . . .

**TELL-A-FAULT** BINDER

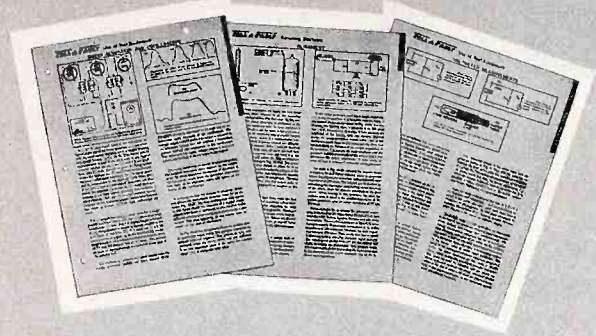

**SERVICING SHORT CUTS  
and  
HOW TO USE TEST EQUIPMENT**

*plus*

**SUBJECT  
SEPARATORS**

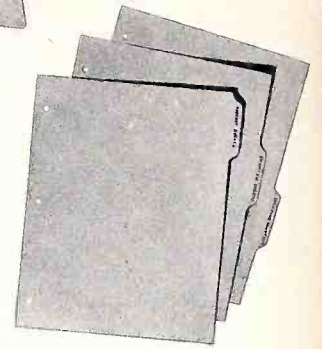

Every month **TELL-A-FAULT**  
gives you detailed information on:

- TV trouble symptoms as they appear on picture tubes — also fault locations
- Short cuts to easier servicing — trouble isolation and construction of troubleshooting speed-up devices for TV and radio
- Circuit guides showing different kinds of TV receiver circuits
- Explanations of test oscilloscope patterns for each type of circuit found in TV receivers
- How to use test equipment — all kinds by brand names — for TV, radio, and other servicing

and much, much more

TELL-A-FAULT is a completely new troubleshooting service for electronics technicians. Nothing like it has ever been attempted in the servicing industry. *It is practical information for the practical man. No theory!*

Specifically, TELL-A-FAULT deals with the troubleshooting (symptoms and cures) of all types of television receivers — also radio receivers, record changers and recorders. Special emphasis, however, is given to television.

TELL-A-FAULT is a quadruple-threat service consisting of (1) time-saving, pictorial, symptom and cure sheets, (2) circuit guides, (3) servicing-technique short cuts, and (4) the usage of all sorts of test equipment. All information is practical.

Working under the same conditions you work under, the Rider service laboratory analyzes receiver symptoms and determines the faults and cures. It is these analyses and cures that are available to you. *You profit by the experience of experts who are working daily in a service clinic to assist you.* This is the reason TELL-A-FAULT will save you hours and many dollars.

**Make Every Hour Pay**

From now on you won't have to work many hours diagnosing a fault — and then charge for only an hour or two. You'll have the information in TELL-A-FAULT service. Merely by flipping

through the practical, time-saving TELL-A-FAULT symptom sheets, you'll find your problem and *its cure*.

**Available at Low Cost**

*How much does a subscription cost you?* We estimate that you can save anywhere from 50 to 200 hours in servicing time by using TELL-A-FAULT. A quick computation on your part tells you how much this means to you in dollars. We are certain your estimate comes to many, many times the cost of a year's subscription to TELL-A-FAULT. Twelve months of the *complete* TELL-A-FAULT troubleshooting service, including all features shown, costs you only \$10.00 — less than twenty cents a week!

**Start Your Subscription Right Now !**

You have the opportunity of becoming a charter subscriber to the TELL-A-FAULT service. In future months you will receive special offers to which *only* TELL-A-FAULT subscribers will be entitled.

REMEMBER! TELL-A-FAULT pays for itself if you use only one or two symptom sheets during the year. Save time and eliminate guesswork in troubleshooting — use TELL-A-FAULT! The information you use comes from troubleshooting EXPERTS! Whether you have one year's experience or twenty years' experience, TELL-A-FAULT can serve you equally well!

**—MAIL THIS COUPON TODAY—**

**John F. Rider Publisher, Inc., Dept. TVT  
480 Canal Street  
New York 13, N. Y.**

Gentlemen:

TELL-A-FAULT is the direct answer to the service technician's needs. As a service technician it will save me many hours of troubleshooting time. I am enclosing ten dollars (\$10.00) to cover the cost of a one year subscription. Send me my TELL-A-FAULT binder, separator cards, and the first month's issue of symptom sheets, circuit guides, and other information.

Name.....

Address.....

City..... Zone..... State.....

Cash       Check       Money Order



# *Notice to All Service Technician Readers of Successful Servicing*

Beginning with this issue, we are modifying the program of distributing SUCCESSFUL SERVICING to our readers as follows:

1. As of August, 1952 and the alternate months following (October, December, February, April, etc.) the magazine will be mailed directly to our readers.
2. Beginning with September, 1952 and the alternate months following (November, January, March, May, etc.) the magazine will be available only through your parts' distributor. Therefore, DO NOT expect to receive the September issue through the mail. During these alternate months the Rider TEK-FILE index will be included with SUCCESSFUL SERVICING. If you want to make certain of getting the magazine and the TEK-FILE index during these alternate months, be sure to make arrangements with your distributor.
3. However, you can receive all twelve issues (starting with September, 1952) directly at your mailing address by simply sending us one dollar (\$1.00) to cover the cost of handling.

We would have preferred to continue our former policy of direct-to-your home distribution of SUCCESSFUL SERVICING to service technicians; but rising costs in production and mailing have caused us to resort to the solution outlined above.

Thank you for your cooperation.

*John F. Rider,  
Publisher*





## You can double your fall service business with this **NEW SYLVANIA CAMPAIGN**

Two gorgeous movie stars, Ann Blyth and June Havoc, feature their personal endorsements of your service in this brand new Sylvania advertising campaign for service dealers. On life-like window displays and streamers, they recommend *you* just the way they will in the big Sylvania ads in *Collier's*, *Life*, *Look*, and *The Saturday Evening Post*, which will appear this Fall.

In addition, the Sylvania Campaign offers you four sets of personalized mailings imprinted

with your name, address and phone number. All of the mailing pieces have stamps already attached. You pay **NO POSTAGE!** Radio spot announcements, and reminder stickers for your customers' sets round out this sure business-attracting kit!

And all you pay is just **2 cents per prospect per month** for the mailers. All the rest is absolutely **FREE . . .** even the postage on the mailers! Call your Sylvania Distributor today, or mail the coupon below.



# SYLVANIA



RADIO TUBES; TELEVISION PICTURE TUBES; ELECTRONIC PRODUCTS; ELECTRONIC TEST EQUIPMENT; FLUORESCENT TUBES, FIXTURES. SIGN TUBING, WIRING DEVICES; LIGHT BULBS; PHOTOLAMPS; TELEVISION SETS

Sylvania Electric Products Inc.  
Dept. R-3408 Emporium, Penna.

Please send me full details on Sylvania's big Fall Campaign for Radio-TV Service Dealers.

Name \_\_\_\_\_  
Street \_\_\_\_\_  
City \_\_\_\_\_ Zone \_\_\_\_\_ State \_\_\_\_\_



# Improvement of fringe area reception

(Continued from page 10)

upward at an angle corresponding to the direction from which the signal is received, as is shown in Fig. 10.

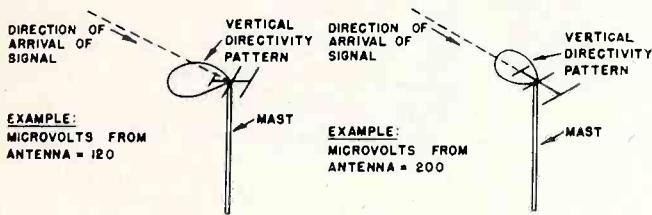
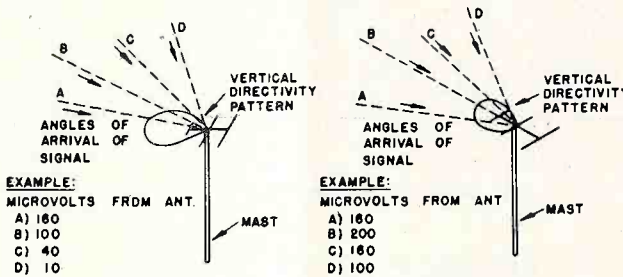

Fig. 11. Variation in Angle From Which Signals Are Received



When conventional antenna mounting the fading that occurs due to variation of the arrival angle of tropospheric signals is much more severe than if the antenna is mounted at an angle corresponding to the average angle from which the signal is coming, as shown in Fig. 11.

As previously stated, due to the vertical directivity pattern of antennas, aiming the antenna upward from the horizontal is beneficial for tropospheric reception; however, there are limitations as to how great this angle may be for optimum results. The narrower the vertical lobe of an antenna, the greater the maximum benefit, but it will be more critical in regard to fading with changes in the vertical angle of the received signal. Table 15 lists average optimum angles of antenna tilt above the horizontal for improved tropospheric reception.

Antenna	Angle Above Horizontal
Single Antennas	
In line or Conical	35°
Yagi	25°
Single Stacked (2 Bay)	
In line or Conical	20°
Yagi	15°
Double Stacked (4 Bay)	
In line or Conical	15°
Yagi	15°

While tilting of single antennas is simple, with stacked arrays it becomes somewhat of a mechanical problem. But, where possible, vertically tilting the antenna should be given careful consideration in tropospheric reception areas.

It is because single antennas have much broader vertical lobes than stacked arrays

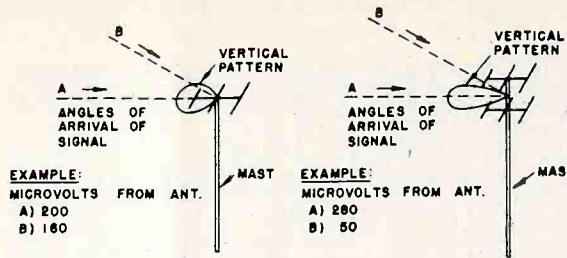

Fig. 12. Effect of Vertical Lobe Variations on Tropospheric Reception

Fig. 10. Angular Arrival of Tropospheric Signals

that conventionally stacking antennas in tropospheric reception areas sometimes result in little or no improvement in signal, and perhaps may result in a loss. The reason is that while the stack has higher gain

than the single antenna in a horizontal direction, it may have only comparable, or even less gain than the single antenna at large angles above the horizontal. This condition is illustrated in Fig. 12.

**Use of Two Spaced Antennas.** It has often been observed in tropospheric reception areas that at a given time one viewer will get good reception while his neighbor does not and at another time the reverse may be true. This is because the signal at the antennas is formed by the vector sum of the various tropospheric signal components which may tend to have an additive effect in one location and cause cancellation at another. It is because of this effect that, if two identical antennas are installed 100 feet apart, at various times one or the other will deliver more signal. If two such spaced antennas are installed therefore, with separate lead-ins to the receiver, it is possible to select the one giving the best results at any given time by means of a simple DPDT switch.

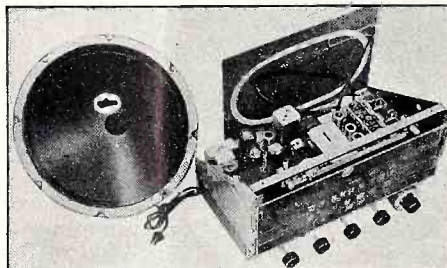

Here is the custom-built AM-FM chassis that means **BIGGER PROFITS** for you!

The **NEW ESPEY** model 511-C

**FEATURES**

1. AC Superheterodyne AM-FM Receiver.
2. Improved Frequency Modulation Circuit, Drift Compensated.
3. 12 Tubes plus rectifier and Pre-Amp 12AT7 Tube.
4. 4 dual purpose tubes.
5. Treble Tone control.
6. 6-gang tuning condenser.
7. Full-range bass tone control.
8. High Fidelity AM-FM Reception.
9. Automatic volume control.
10. 10 watts (max.) Push-Pull Beam Power Audio Output.
11. 12-inch RM speaker with Alnico V Magnet.
12. Indirectly illuminated Slide Rule Dial.
13. Smooth, flywheel tuning.
14. Antenna for AM and folded dipole antenna for FM Reception.
15. Provision for external antennas.
16. Wired for phonograph operation with switch for crystal or reluctance pick-up.
17. Multi-tap output trans., 3.2-8-500 ohms.
18. Licensed by RCA and Hazeltine.
19. Subject to RMA warranty, registered code symbol #174.

**SPECIFICATIONS**

Supplied ready to operate, complete with tubes, antennas, speaker and all necessary hardware for mounting in a table cabinet or console, including escutcheon. Power consumption - 105 watts.

Chassis Dimensions: 13 1/2" wide x 8 1/2" high x 10" deep.

Carton Dimensions: (2 units) 20 x 14 1/2 x 10 3/4 inches.

Net Weight: 17 1/2 pounds each.

Sold through your favorite parts distributor.

**ATTENTION!**  
**RADIO**  
**SERVICEMEN**

THERE ARE THOUSANDS  
OF OUT-MODED RADIOS  
IN YOUR "BACK YARD" JUST  
WAITING TO BE REPLACED  
... AT YOUR SUGGESTION

Makers of fine radios since 1928.

**ESPEY**  
TEL. TRafalgar 9-7000  
**MANUFACTURING COMPANY, INC.**  
528 EAST 72nd STREET, NEW YORK 21, N. Y.

WRITE FOR CATALOGUE KD12 AND NAME OF NEAREST DISTRIBUTOR.



EIGHTH IN A SERIES OF **IRC** TECHNIC-AIDS

# HOW TO SAVE TIME AND MONEY THROUGH YOUR IRC DISTRIBUTOR... YOUR ONE-STOP REPLACEMENT CONTROL SOURCE

## Full Replacement Control Coverage without Shopping or Waiting

Here's a new convenience that's going to save you hours of time—and some dollars too. For now there's a replacement control line so complete that no technician need shop or wait for the units he wants. *One* stop at your IRC Distributor covers *all* your replacement needs.

## 317 New Factory Assembled Exact Duplicate Controls...



Maybe you prefer the convenience and simplicity of factory-assembled Exact Duplicate Controls. Or maybe you like the wide coverage and faster servicing at lower stock cost you get with Universal Replacements. Either way, IRC gives you just what you want. The new IRC Replacement Line includes 317 new factory assembled Exact Duplicate Controls *and* 2 new, simplified CONCENTRIKITS with Exact Duplicate Shafts.

## Full Coverage of 317 Different Concentric Duals Handling ~~452~~ Manufacturers' Parts Numbers Specified in over 5,000 TV Models

This is what you get with either IRC Factory-Assembled Exact Duplicates *or* IRC improved CONCENTRIKITS. 317 new IRC Exact Duplicate Controls provide satisfactory mechanical fit and electrical operation for over 90% of TV controls. And 2 new, four-piece IRC CONCENTRIKITS with Exact Duplicate Shafts and versatile Base Elements give you the same broad, dependable control coverage.

## Guaranteed Reliable Fit and Operation or Double Your Money Back

Every IRC Factory-Assembled Exact Duplicate *and* every IRC new Universal Replacement—employing K-2 or K-3 CONCENTRIKITS—*must* operate and fit satisfactorily! If it fails to do so—*double your money back!* This is IRC's guarantee of dependability.

## New IRC Exact Duplicate Controls Feature:

- Accurate Dependable Specifications.
- Factory assembly under rigid quality control.
- Both carbon and wire-wound types.
- Easy installation—no modification needed.

We build these new IRC Exact Duplicates to carefully prepared specifications. Shaft lengths have not been compromised—so there's no need to improvise, to reverse connections or to alter controls in any way. Shaft ends are accurately machined for good knob fit. And electrical characteristics are carefully engineered to assure satisfactory operation. IRC Exact Duplicates are easy to install and they operate efficiently.

## New Four-Piece IRC CONCENTRIKITS Feature:

- "Less-than-a-minute" Assembly in Shop or Home.
- No filing, slotting, hammering, soldering or cutting of shafts.
- Assembly of both Carbon and Wire Wound Concentric Duals.
- New reduced prices.

You'll need no special tools or skills to assemble these new, simplified CONCENTRIKITS. With each one, we furnish easy-to-follow pictorial instructions that show you how to make actual assembly in less than a minute. No alterations are needed; shafts are supplied in proper lengths and with factory-tooled ends for accurate fit.

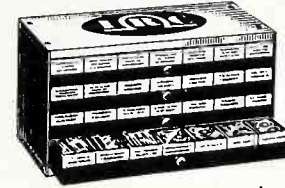
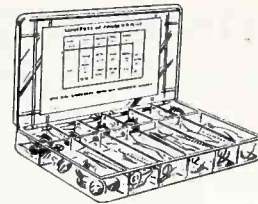

## New, Dealer Assortments for Widest Coverage at Lowest Cost

You'll have less money tied up in inventories—and you'll lose fewer parts through obsolescence—when you buy IRC's new CONCENTRIKITS in low-cost, convenient CONCENTRI-PAKS. These handy assortments include Base Elements, Exact Duplicate Shafts and Switches for specific brands of TV controls. Contained in large, sturdy, partitioned plastic stock boxes, with full replacement data. CONCENTRI-PAKS give you wide coverage at a fraction of the cost of factory-assembled controls.

## Make Your IRC Distributor Your One-Stop Source of TV Replacement Controls

You'll save time and cash by scheduling your trips to your IRC Distributor—and buying *all* your Replacement Concentric Duals from him. And you'll be sure of Concentric Dual efficiency, too. For IRC's guarantee protects you on Universal Replacements *or* Factory Assembled Exact Duplicates. Remember—Double your money back if fit or operation is unsatisfactory!

## Full Details and Free Replacement Data Yours for the Asking

For full information on IRC's new Replacement Control Line, get new Catalog Data Bulletin DC1C. Complete replacement data by Manufacturers' Parts Numbers also is yours at no charge. Specify Form SO12A. Just send post card to us for your copies—or get them from your IRC Distributor.



# IRC

Wherever the Circuit Says

## INTERNATIONAL RESISTANCE CO.

423A N. Broad Street, Philadelphia 8, Pa.



## Point-to-Point D-C Resistance Measurement

(Continued from page 16)

undue load seems to exist on the power supply, thus indicating the presence of some kind of short, or when fuses blow as soon as power is applied. In these cases d-c resistance tests between points are sensible, quick tests which protect the equipment from additional damage if power is applied. But do these limited advantages warrant the attitude that if it is good for some checks, it is good for all. We doubt this, especially in tv receivers. We doubt it because a voltage measurement leads to conclusions concerning the location of the fault, and in many instances it is still necessary to check every resistive element in a chain. If this could be avoided by an overall point-to-point test, it would be worthwhile, but it is not, specifically because of what we stated earlier. This is that a chain of resistors of high and low values, some of which may be shunted by low d-c resistance elements can well mask the defect in a part. Also because of the tolerance condition which we mentioned earlier.

The main objection to the continued use of point-to-point d-c resistance measuring techniques in tv receivers is that it can cause a great waste of time, except in a number of instances which we will mention later. But even more important than this is the influence of what is supposed to be the simplest of all measurements, on the thinking of the individual who is not thoroughly familiar with the more modern testing devices — the kind of devices which are becoming more and more pertinent to rapid trouble diagnosis. The ohmmeter is a very important servicing tool — but the scope likewise is daily increasing in utility, as is the vacuum tube voltmeter and the sweep generator and the calibrator.

### New Techniques

Like everything else service techniques must advance with the times. We must recognize the strong points and the weak points of each method, and use each where it best fills the bill. Point-to-point d-c resistance measurement has seen its day . . . Its usefulness is on the decline, even though it is still applicable under special circumstances. This is not just one man's opinion . . . This is the opinion of many experienced tv service technicians who consider diagnosis time as being very important. Fewer and fewer of these men are resorting to point-to-point d-c resistance measurement as a means of locating faults throughout the chassis. They are restricting its application. They are depending more and more on scope analysis — voltmeter analysis and interpretation of the picture tube display.

We appreciate that expounding one technique against another is a debatable point; that all kinds of qualifications are present in the ranks of the servicing industry and that all individuals must be served. In the final analysis each man selects that technique which serves him best, or which he can best apply; but like everything else which is happening in the world, it is necessary to call attention to changes which are taking place. That is why we are highlighting the 1952 ideas of the experienced tv service technician relative to point-to-point d-c resistance measurement. In 1952 they look at point-to-point resistance measurements in tv receivers as limited in value to perhaps a half-dozen tests. These relate to the input and output of the low-voltage rectifier, thus establishing circuit shorts and load conditions on the rectifier as a whole; picture-tube cathode and grid to ground, and circuit conditions related to the bias supply systems. In the light of the other tests made on tv receivers with scopes, generators and voltmeters, a preference is indicated for individual component tests rather than point-to-point d-c resistance tests.

### Erratum

In the article "Linearity and Width Coils" which appeared in the May, 1952 issue of SUCCESSFUL SERVICING, the following should be substituted for the two sentences which immediately precede Fig. 7 on page 8:

*"The inductance range of the width-control winding is 0.16 to 0.7 millihenry, and the range of the keyed-agc winding is 3.2 to 9 millihenrys. The approximate d-c resistance of the width-control winding is 1 ohm and the resistance of the keyed-agc winding is 28 ohms.*

### Pratt Offers Course in TV Technology and Servicing

The Evening School of Science and Technology at Pratt Institute will offer an intensive course in Television Technology and Servicing as part of its training program for men and women in industry this fall.

The course, conducted on a technical level, will be broken into three 12-week units. More than half of the class time will be spent in the television laboratory, as the course is intended for radio and TV service men who wish to extend their present knowledge.

Each applicant will be personally interviewed by the program supervisor at the School Office, 195 Grand Avenue. Tuition for each 12 week unit is \$60.

## ASSOCIATION NEWS

Attention all secretaries of Servicemen's Associations! Keep your association's news (its members, meetings and events) up to date, and make it available to other servicemen and associations by making sure that SUCCESSFUL SERVICING receives all of your news letters and releases.

The *Federation of Radio Servicemen's Association of Pennsylvania* is keeping up its good work in getting the Pa. servicemen to unite in associations to work together and solve mutual problems. Dave Krantz of Philadelphia is President of this organization; Milan Krupa of Kingston is V.P.; and W. J. Lansberry of Altoona is Secretary.

The *Southern Pennsylvania Radio and Television Technician Association*, gave a series of lectures to give repairmen better knowledge of equipment which they may be called on to fix, and is carrying out an advertising program to benefit all members of the association. In upstate Pa., the *Radio Servicemen's Association of Luzerne County* has made progress in its efforts to establish an ethical basis for distributor relationships.

Following a survey of dealers in the industry which showed that a large majority favored the Fair Trade bill approved by Congress, NARDA wired an appeal to President Truman to sign the bill into law. The association felt that the bill would protect small dealers and help them give the public better value and service. (Ed. Note: The President did sign the bill.)

New membership dues brackets were set by the NARDA Board of Directors at its recent mid-year meeting, broadening the basis of the association's membership. The new dues scale will mean less dues for some members in the lower annual volume group, and higher dues for some in the higher annual volume group. With the members receiving industry directories, business surveys and newsletters, becoming eligible for group insurance and special rates on tv servicing training, and being able to receive help with their problems from fellow members and the association, NARDA illustrates the benefits to be gained from any business association.

The Montreal Town Meeting, sponsored by all branches of the Canadian Radio Television Industry, recently was conducted in the form of a four-day elementary training school. Classes in setting up, installation, diagnosis and troubleshooting were included. The introduction of tv into Montreal brought about the problem of creating an adequate number of trained servicemen; this meeting was a part of the training program and, at the same time, demonstrated to the public how efficient and modern tv servicing can be.



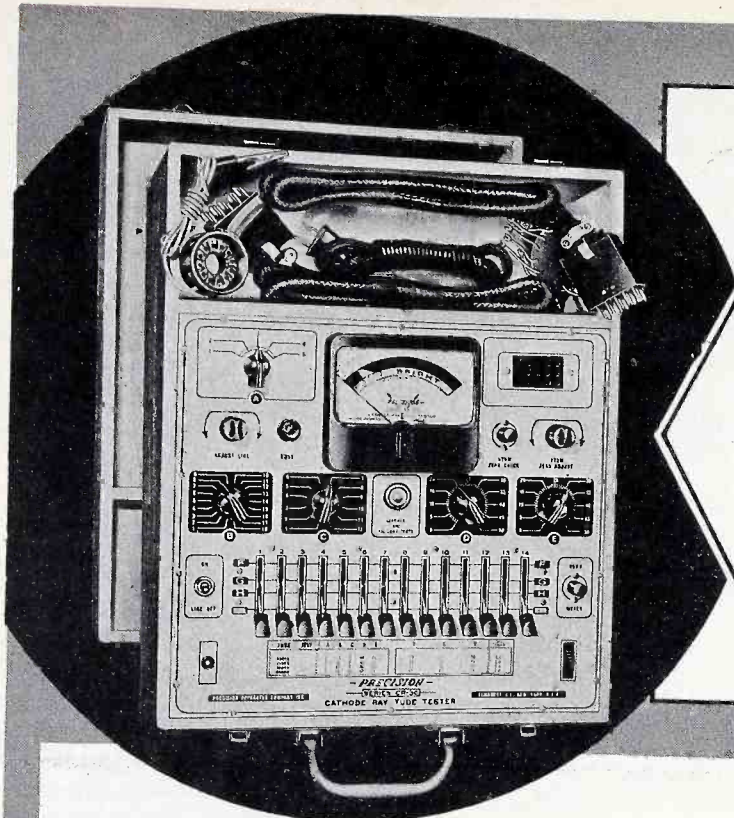

# PRECISION CR-30 CATHODE RAY TUBE TESTER

**TESTS ALL TV PICTURE TUBES**  
(MAGNETIC AND ELECTROSTATIC)  
**'SCOPE TUBES AND INDUSTRIAL CR TYPES**  
for True Beam Current (Proportionate Picture Brightness)  
Tests ALL CR Tube Elements—Not Just a Limited Few

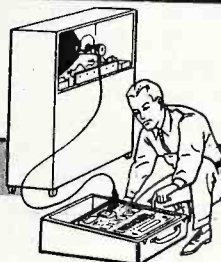

**IN FIELD OR SHOP**  
Tests CR Picture Tubes  
Without Removal from  
TV Set or Carton!

The Precision CR-30 fills an obvious gap in the test equipment facilities employed by TV service and installation technicians.

Because of the absence of a reliable cathode ray tube tester, up to 50% of so-called "rejected tubes" are found to be fully serviceable and should rightfully never have been "pulled out."

Proven product of extended development, the CR-30 has been

specifically engineered to answer the question, "Is It the TV Set or is it the Picture Tube?"

The Precision CR-30, a complete and self-contained *Electronic Instrument*, incorporates a TRUE BEAM CURRENT Test Circuit. The CR-30 checks overall electron-gun performance for proportionate picture brightness as well as additional direct testing facilities for accelerating anodes and deflection plate elements.

The Precision CR-30 should not be confused with mere adapters connecting to ordinary receiving tube testers which were never designed to meet the very specialized needs of CR tube checking. Similarly, it is not to be confused with neon-lamp units or similar devices of limited technical merit and which do not check all CR tubes or all tube elements.

## GENERAL AND TECHNICAL SPECIFICATIONS

- ★ Tests All Modern Cathode Ray Tubes:—Magnetic and Electrostatic, 'Scope Tubes and Industrial Types.
- ★ Tests All CR Tube Elements:—Not just a limited few.
- ★ Absolute Free-Point 14 Lever Element Selection System, independent of multiple base pin and floating element terminations, for Short-Check, Leakage Testing and Quality Tests. Affords maximum anti-obsolescence insurance.
- ★ True Beam Current Test Circuit checks all CR Tubes with Electron-gun in operation. It is the Electron Beam (and NOT total cathode emission) which traces the pictures or pattern on the face of the CR tube.
- ★ Voltage Regulated, Bridge Type VTVM provides the heart of the super-sensitive tube quality test circuit. Such high sensitivity is also required for positive check of very low current anodes and deflection plates.
- ★ Micro-Line Voltage Adjustment Meter-monitored at filament supply.
- ★ Accuracy of test circuits closely maintained by use of factory adjusted internal calibrating controls; plastic insulated, telephone type cabled wiring; highest quality, conservatively rated components.
- ★ Built In, High Speed, Roller Tube Chart.
- ★ Test Circuits Transformer Isolated from Power Line.
- ★ 4½" Full Vision Meter with scale-plate especially designed for CR tube testing requirements.
- ★ Heavy Gauge Aluminum Panel etched and anodized.
- ★ PLUS many other "PRECISION" details and features.

Total cathode emission can be very high and yet Beam Current (and picture brightness) unacceptably low. The CR-30 will reject such tubes because it is a true Beam Current tester. Conversely, total cathode emission can be low and yet Beam Current (and picture brightness) perfectly acceptable. The CR-30 will properly pass such tubes because it is a true Beam Current tester. The significance of the above rests in the fact that Beam Current (and picture brightness) is primarily associated with the condition of the center of the cathode surface and not the overall cathode area. (See illustration below)

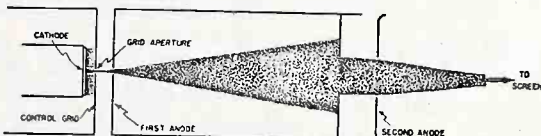

**SERIES CR-30**—In hardwood, tapered portable case, with hinged removable cover. Extra-Wide Tool and Test Cable Compartment. Overall Dimensions 17¼ x 13¾ x 6¾". Complete with standard picture tube cable, universal CR Tube Test Cable and detailed Instruction Manual.

Shipping Weight:—22 lbs. Code: Daisy  
NET PRICE:—\$99.75

See the CR-30 on display at leading electronic equipment distributors. Place your orders now to assure earliest possible delivery.



## PRECISION APPARATUS CO., INC.

92-27 Horace Harding Boulevard, Elmhurst 14, New York  
Export Division: 458 Broadway, New York, U.S.A. Cables—Morhanex  
In Canada: Atlas Radio Corp., Ltd., Toronto, Ontario





A monthly summary of product developments and price changes supplied by RADIO'S MASTER, the Industry's Official Buying Guide, available through local parts distributors.

**New Items**

**ALTEC LANSING CORP.**—Added No. 730A, driver unit at \$29.50 net . . . 15037-X, transformer at \$12.00 net . . . 30A, horn at \$29.50 net . . . 40A, horn at \$33.75 net . . . M14, microphone system at \$395.00 net . . . 21BR-200, microphone at \$125.00 net . . . 157A, base and cable at \$125.00 net . . . P524A, power supply at \$145.00 net . . . 159A, probe tube at \$21.00 net.

**AMERICAN TELEVISION & RADIO CO.**—Added 2 standard and 4 super heavy duty radio and television inverters . . . 12 new standard and heavy duty industrial inverters (with built-in filter) . . . 28-LID, low power inverter.

**ASTATIC CORP.**—CT-1, TV booster added, (A balanced cascaded circuit used with a neutralized 6J6 driving a 6BQ7. Both tubes used over entire TV freq. range. Either 72 or 300 ohm impedance input and output) at \$19.50 net.

**BEAM INSTRUMENTS**—Barker duode reproducer added at \$59.50 net.

**BIRNBACH RADIO**—Added series of 100' and 1000' spools of extruded nylon jacket hook-up wire . . . high voltage & cathode-ray tube lead cable . . . thermoplastic hook-up wire . . . thermoplastic insulated hook-up wire (600-volt rating UL approved) . . . hook-up wire shielded. (tinned copper)

**BOGEN DAVID**—Added TV booster BB1-A (for mahogany & walnut sets) at \$19.50 net and BB1-B (for blonde sets) at \$20.10 net; separate 6J6 triodes operate in independent push-pull circuits to provide maximum gain and bandwidth with measurable superior signal to noise characteristics . . . Model TWIN, a two station wireless system employing the power line and ground as the transmitting medium at \$57.00 net . . . CW-1, additional single stations at \$30.00 net . . . Models TP17 and TP17X, 3 speed transcription players with crystal and magnetic pickups at \$126.00 and \$138.00 net respectively . . . FM 801, FM tuner with a freq. response of 50-15000 cps  $\pm$  1 db at \$69.00 net . . . AM 901, AM tuner with a freq. response of 50-7500 cycles in high fidelity position and 50-3500 cycles in high selectivity position at \$57.00 net.

**CLAROSTAT MFG. CO.**—Constant impedance controls CIL 4, (wire-wound L-pads) and CIT 4, (wire-wound T-pads) added at \$2.55 net.

**CLEVELAND ELECTRONICS**—Added PM-5CR, tweeter at \$2.87 net . . . PM-8FR, hi fi speaker at \$5.10 net . . . public address speakers PM-8JR at \$7.26 and PM-12LR at \$11.97 net . . . PM-12JR, coaxial at \$16.59 net.

**DRAKE CO., R.L.**—Added TV-300-15HW, a 15 meter half-wave harmonic filter. Uses specially constructed capacitors with extremely low inductance for maximum attenuation of high freq. harmonics, at \$10.95 net.

**DUOTONE CO.**—Added 45 rpm adaptors, 5 to an envelope at \$.125 net.

**ELECTRO-VOICE**—T-35, super tweeter added at \$29.70 net . . . X-36, crossover for T-35 at \$6.75 net . . . peage equipment console in mahogany at \$78.00 net and blonde at \$84.00 net . . . regency speaker enclosure mahogany at \$114.00 net and blonde at \$120.00 net.

**GENERAL CEMENT**—Added approximately 134 new items to their line.

**G.E.**—Oscilloscopes ST-2B2 using 5UP7 CR tube added at \$497.50 net and St-2B3 using 5UP11 CR tube at \$499.25 net.

**HYTRON RADIO & ELEC. CO.**—Added receiving tubes 1AX2 at \$2.55 list . . . 6AH4GT at \$2.20 list and 5642 at \$2.20 list.

**LECTROHM, INC.**—Added solder pots No. 200 and 250 at \$2.99 net each and spare replacement elements at \$.85 net each.

**LOWELL MFG. CO.**—Added rear seat speaker kit model No. R7 at \$2.70 net . . . long corridor baffles LCB6 at \$9.00 net, LCR8 at \$10.80 net and LCB10 at \$12.60 net . . . Hi-Fi decorative grille H-24 at \$13.50 net . . . 6 metal recessed perforated square ceiling grills . . . model SUELX, semi-recessed wall type angular baffle at \$13.80 net.

**MALLORY & CO.**—Added 8 mercury-type batteries for instrument and industrial use.

**Discontinued Items**

**AMERICAN MICROPHONE CO.**—Withdrew model CH, carbon hand microphone . . . DH and DHT, dynamic hand-held microphones.

**MALLORY & CO.**—Withdrew a number of resistors and controls throughout their line.

**MILLEN, JAMES MFG. CO.**—Temporarily withdrew No. 90201, regulated power supply and No. 90810, crystal controlled transmitter.

**NATIONAL CO.**—Withdrew their HRO series except HRO-50XCU-2 and HRO-650-S.

**TACO**—No. 894 and 895, aluminum sectional masts withdrawn.

**Price Increases**

**GENERAL CEMENT**—Increased price on 8732-G to \$8.70 net.

**G.E.**—Increased prices on transmitting and industrial tubes GL-5691 and GL-5692 to \$8.55 net and GL-5693 to \$6.95 net.

**HYTRON RADIO & ELECTRONICS CO.**—Special purpose tube OB3 increased to \$3.35 list.

**JOHNSON CO., E.F.**—Advises of an increase in price on most of their line.

**Price Decreases**

**ALTEC LANSING**—Decreased prices on A-322C, amplifier to \$338.00 net . . . P-511, power supply to \$108.00 net . . . TI-401, generator to \$34.00 net . . . TI-402, analyzer to \$450.00 net and 10425, cabinet to \$54.00 net.

**ASTRON CORP.**—Type "E" screw base dry electrolytic capacitors No. E-8-600 decreased to \$1.89 net and E-16-600 to \$2.25 net.

**G. E.**—Reduced prices on 4 TV picture tubes and 9 transmitting and industrial types.

**MASCO ELECTRONIC SALES**—Reduced the price of model MC-25N, mobile amplifier with plain cover, without phono-top with tubes to \$129.00 net.

**MILWAUKEE RECORD CHANGER**—Reduced prices on the 3 speed automatic record changer 12300 to \$25.25 net and 12300 GE to \$26.50 net . . . also metal base to \$2.75 net.

**RAULAND CORP.**—Reduced prices on 14 TV picture tubes in 14", 16", 17", 20" and 21" sizes.

**WIRT PRODUCTS**—Suppressors S-914 to S-926 reduced to \$.17 each.

(Continued on page 24)

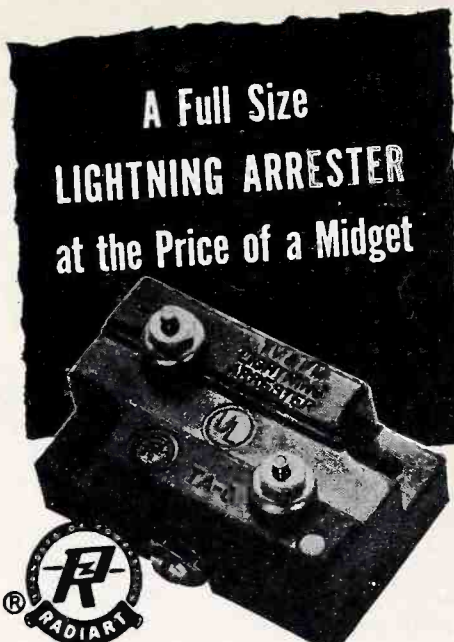

A Full Size  
**LIGHTNING ARRESTER**  
at the Price of a Midget



**LIGHTNING ARRESTER**

**MODEL TA5** Real protection against lightning and static charges — the RADIART Lightning Arrester has all the features! Fits anywhere . . . inside or out . . . handles standard or jumbo leads . . . no wire stripping necessary . . . does not unbalance the line . . . low internal capacity . . . no loss of signal . . . internal resistance "leaks off" static discharges! **UNDERWRITERS LABORATORIES APPROVED.**

THE **RADIART** CORPORATION  
CLEVELAND 13, OHIO

**PERFORMANCE** for customer satisfaction

The reason most fringe area installations are **TACO-EQUIPPED**

Ask your distributor for your Taco Cat. No. 38 — the Antenna Handbook.

**TUTAN** TECHNICAL APPLIANCE CORPORATION  
Sherburne, N. Y.

In Canada: Stromberg-Carlson Co., Ltd., Toronto 4, Ont.



# The TV Serviceman Meets the Family

(Continued from page 9)

with heart trouble, or their livers, or what not!

But—you people certainly do blame us repairmen. You even expect us—

To be able to prophesy future troubles!

You are angry because we have not anticipated which tube or part is going to give trouble next!

Here is a case which just happened to me today. This customer is about to be put on my refusal list for the way he acted:

About 3 or 4 months ago I sold him a used picture tube. He was pleased to get one so cheaply—and all was well.

About six weeks later—no picture. He brought in the set—somewhat belligerently. It was *not* the picture tube. Another trouble—small trouble. Small repair bill. He went away satisfied.

Yesterday the set came in again. Very weak picture, and “ticking” sounds.

This morning I phoned him, quite pleased with myself, to say that his bill was only \$7, that I had replaced 2 small tubes—

Was he pleased? Was he grateful?

No! Instead, he said to me, in a very annoyed voice, that the last time he had the set in I had mentioned, just before he left with his set, that he seemed to have a weak tube somewhere else in the set—but I had added—“Let it go!”

Now—remember, there were about 20 tubes in the set. Of the two tubes I replaced today, one had a burned-out heater (it was *cold*). The other had become noisy. Sparks would jump across inside the tube. Neither of these two troubles has anything to do with *weakness*. Weakness simply means that not enough electrons are flowing through the tube, from the hot cathode to the plate.

But a perfectly strong tube can burn out its filament (or heater) wire *anytime*. A weak one might not burn out its filament for 10 or 15 years, or more!

No one—no one—not even if he has the best equipment science has developed, can predict when a tube filament will open up.

No one—no one—can predict when a tube may become noisy.

No one—no one—can anticipate *any* of the troubles your set will develop at *any* time.

If you ask a repairman—“How long do you think my set will be alright this time?”—if he says anything but “I don’t know!”—he is a liar!

Perhaps—to soothe you—he will say something like, “It should work all right for quite a while now.” Soft soap!

In my honest way I tell people it could act up anytime. Some people think that proves I do not know my business. On the contrary, it proves that I do!

## Radio's Master Reports

(Continued from page 23)

### Miscellaneous Changes

**CROWN CONTROLS**—Revised their sugg'd re-sale price schedule from approximately 1/3 off list to a straight 40% off the list price.

**R. C. A.**—Kinescope exchange allowance discontinued on 16AP4, 16GP4-A, 16GP4C, 19AP4 and 19AP4D . . . reduced the exchange allowance on 16LP4A and 16WP4A to \$3.00 each and 20CP4 and 20MP4 to \$7.00 each.

**SYLVANIA**—Advised of a general increase in prices on 47 of the 53 previously listed types of tubes subject to glass allowance, ranging up to \$2.00 increase per tube . . . added 8 more tubes subject to glass allowance . . . 14BP4, 14CP4, 14DP4, 14EP4, 14GP4 at \$2.75 each and 16WP4, 16WP4A, 17VP4 at \$3.25 each.

**COMMENT:** Activity in the Electronic Industry continues to center upon the introduction of new products with antenna and audio manufacturers being the most active. Price increases and decreases remain quite minor with revision occurring among tube manufacturers.

## TRY CLAROSTAT'S RTV PROGRAM!

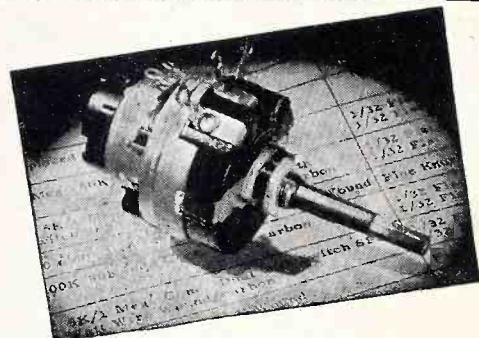

By all means, TRY IT! Because, when it comes to those tricky TV control replacements, you can save time, trouble, money and even reputation with Clarostat's RTV program. It means exact-duplicate replacements that positively match initial equipment. In many cases the RTV replacements cost less than any makeshift or “kit” assembly. Prove it for yourself.

And of course where standard controls, plus Ad-A-Switches and Pick-A-Shafts, can do the trick, Clarostat has them too.

Ask your Clarostat distributor for the *Clarostat TV Control Replacement Manual* (with supplements). Also for the latest *Clarostat Catalog*.

### Controls and Resistors

CLAROSTAT MFG. CO., INC., DOVER, NEW HAMPSHIRE  
In Canada: Canadian Marconi Co., Ltd., Toronto, Ontario



Please mention *Successful Servicing* when answering advertising.

Sec. 34.66, P. L. L. & R.  
U. S. POSTAGE  
**PAID**  
NEW YORK, N. Y.  
PERMIT No. 9427

A. J. S. CERINO  
5310 OVERBROOK ST.  
DOUGLASSON, L. I., NEW YORK

From  
JOHN F. RIDER PUBLISHER, Inc.  
480 CANAL ST., NEW YORK 13, N. Y.  
Forwarding and Return Postage Guaranteed



# SUCCESSFUL Servicing

SEPTEMBER 1952

with **TEK-FILE** index

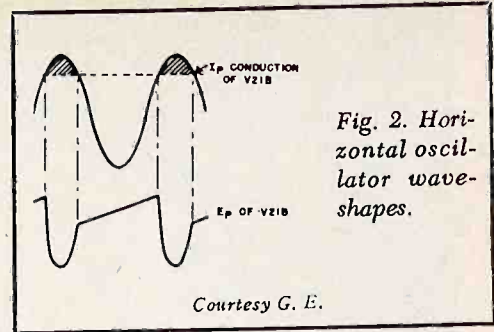

Fig. 2. Horizontal oscillator wave-shapes.

Courtesy G. E.

A COMBINED horizontal sweep generator and AFC circuit used by G.E. makes use of a sine-wave oscillator, a phase discriminator, and a "variable-resistance" reactance-control tube. Circuit details are shown in Fig. 1. The frequency of the oscillator is controlled by the plate resistance of the reactance tube. This plate resistance varies with changes of grid bias on the control tube, the bias being

portion of its exponential charging path, through resistors R396 and R395. When the tube conducts, the capacitor discharges through it and through R395, which serves as a linearity control. The effect of R395 in series with the capacitor is to peak the sawtooth waveshape and thus provide the required trapezoidal waveform necessary in electromagnetic deflection circuits.

increase in the oscillator frequency. Thus the frequency of the oscillator may be controlled by the voltage applied to the grid of the reactance tube.

Since the initial bias on the reactance-tube grid determines the pull-in sensitivity of the system, an optimum value is obtained by means of a voltage divider connected between the oscillator grid and ground. As shown in Fig. 1, the voltage divider consists of resistors R401 and R386. The voltage developed across R386 is inserted in series with the ground-return of the discriminator, and applied as bias to the grid of V21A through resistors R385, R384, R387 and R388.

As previously stated, any change in voltage at the grid of the reactance tube will produce a change in the frequency of the sweep oscillator. Therefore, the output of discriminator V22 is fed to the reactance-tube grid, the output being a d-c correcting

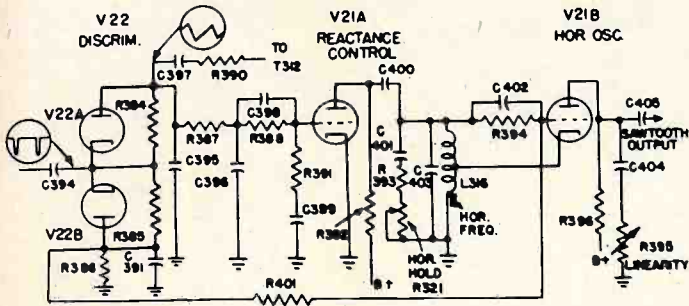

Fig. 1. Schematic diagram of horizontal sweep oscillator and AFC circuit.

Courtesy G. E.

obtained from the output of the discriminator. The discriminator circuit develops a d-c output which is dependent upon the phase difference between the incoming synchronizing pulse and the sawtooth output of the oscillator.

The horizontal oscillator, V21B, functions as a sine-wave oscillator and discharge tube to provide a sawtooth output wave. The tube is connected as a modified grounded-plate Hartley oscillator. A tuned circuit consisting of coil L316 and capacitor C403 resonates near 15,750 cps, which is the horizontal sweep frequency. An additional small capacitor, C401, is shunted across the tuned circuit in series with resistor R393 and the horizontal hold control, R321. (In the discussion to follow, fixed resistor R393 will be considered as being a part of R321.) Varying the resistance of R321 controls the capacitive shunting effect of C401, and so provides a means of adjusting the oscillator frequency about some center value. When the hold control is set for minimum resistance, the effect of C401 is increased, which lowers the oscillator frequency. With the hold control set at maximum resistance, the shunting capacitive reactance of C401 is minimized, and the frequency increases.

Normal oscillator feedback through coil L316 causes the grid of V21B to draw current, developing sufficient bias across R394 and C402 to keep the tube cut off for the greater portion of the sine-wave cycle. This is shown in Fig. 2. During this interval, capacitor C404 charges along the linear

## REACTANCE-TUBE AFC SYSTEMS

In addition to the frequency-adjusting network, C401 and R321, the plate circuit of the reactance-control tube, V21A, is also connected across the oscillator tank circuit. Although this tube is called a reactance tube, it differs from the conventional phase-quadrature reactance tube in that the tube itself does not show reactance to the external circuit. Referring to the simplified circuit diagram of Fig. 3, it can be seen that the plate resistance of V21A, in series with capacitor C400, shunts the tuned circuit, L316-C403. Resistor R392 is high in value as compared to the plate resistance, and may be disregarded. Changes in the plate resistance will vary the capacitive effect of C400 in the same manner as changes in the setting of R321 affect the apparent reactance of C401. When the reactance tube conducts heavily as would happen when the grid-bias voltage is low, the plate resistance is lowered; the capacitive effect of C400 is increased, lowering the oscillator frequency. An increase in bias reduces the plate current and produces the opposite effect — an

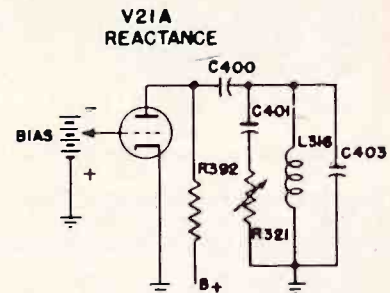

Courtesy G. E.

Fig. 3. Simplified schematic of reactance-control tube.

voltage obtained by comparing the phase between the horizontal sync pulses and the output sawtooth waveshape.

Fig. 4 shows a simplified schematic of the phase discriminator. The synchronizing signal is applied as a negative pulse to V22 through capacitor C394. Both diodes function as peak rectifiers, developing voltage across load resistors R384 and R385 of equal magnitude but of opposite polarity, with

(Continued on page 7)



*More POWER to you...*

*with the Radiart TV Booster*



- ★ High signal-to-noise ratio for less "snowy" pictures.
- ★ Wide band amplification for sharp pictures free from "smear".
- ★ Complete neutralization for stable operations.
- ★ Large, handsome dial face for easy reading.
- ★ Operates on 115 V. A. C., 60 cycle current.
- ★ Attractively styled cabinet with mahogany grained polished finish . . . matching the rotor control cabinet . . . together making the TV TWINS . . . the ideal combination for the MOST in TV reception.

Here's the power boost needed to get the MOST from any TV set! It improves the picture because it increases contrast . . . minimizes ghosts, snow and interference and actually STRENGTHENS the signal! Easily installed — simple in operation — a welcome addition to any home.

*The Perfect Partner to the CDR Rotor...they go together*



**THE RADIART CORPORATION** CLEVELAND 13, OHIO

VIBRATORS • AUTO AERIALS • TV ANTENNAS • ROTATORS • POWER SUPPLIES

Please mention *Successful Servicing* when answering advertising.



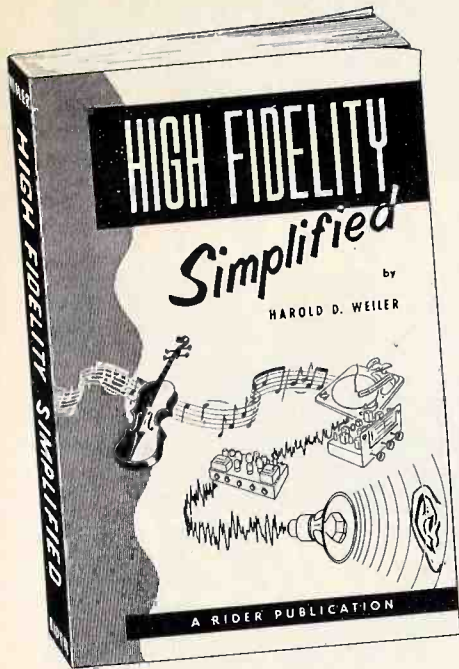

The following is excerpted from Chapter 10 of the book *HIGH FIDELITY SIMPLIFIED*, by Harold D. Weiler (jacket of book shown above). This newest Rider publication will be available next month at your jobber.

# Stylus - Wear in Hi-Fi Reproduction

by Harold W. Weiler

dust and also the stylus and record dust, from normal operation. A photomicrograph of one of these records is shown in Fig. 1(D). Compare these grooves with the ones shown in Fig. 3(A), and the reasons for the additional abrasive action of used records becomes obvious.

The results of the second test, after 48 playings, showed marked wear, completely beveled edges and chisel shape on the osmium and sapphire, and still no discernible wear on the diamond.

From these and other tests, we can safely state that on microgroove records, osmium and sapphire styli should not be used for more than 35 plays for osmium and 75 plays for sapphire, preferably less, if we

are to obtain the utmost in high-fidelity reproduction. The diamond can be used for more than 1,000 plays.

With standard groove records, the wear on the stylus is less. The average, on the usual home type of equipment, is approximately 100 plays for osmium, 250 plays sapphire and over 2,000 plays for diamond. Diamond styli, though the initial cost is higher, are actually the least expensive when the cost per playing is compared. Not only is the diamond styli more economical per playing, but the reduction in record wear, as a result of its use, also contributes to the economy of this type. Our next group of photomicrographs will illustrate this fact.

(Continued on page 12)

... Our interest in stylus wear is three-fold. The first reason is the effect of a worn stylus on reproduction. The second is the effect of stylus wear on our records and last, but not least, the effects of stylus wear on our pocketbooks. Record styli tips are today made from three different materials: osmium, sapphire, and diamond. It is our intention, through actual tests, to discover which of the three materials is best suited for our purpose — the high-fidelity reproduction of commercial records.

Figure 1 (A, B, and C) illustrate three different styli tips: "A" is an osmium tip, "B" is a sapphire tip, and "C" is a diamond tip. Each of these tips were photographed after being played 48 times on new record surfaces. At no time, did any stylus tip touch a groove played more than two times.

The records used in this and succeeding tests, were all 12" vinylite microgroove records of various manufacture and were played on a Webster 3 speed changer, with a pick-up arm weight of exactly 8 grams. At the end of 48 playings, both the sapphire and the osmium have, as can be seen, flats worn on the sides of the tips. The diamond tip shows no signs of wear. This test, it is important to note, was conducted on brand new records, an ideal situation, which is not likely to occur in actual practice. The test was made to show the difference in wear, even under ideal conditions.

Another series of tests was run, this time, under conditions which more closely approximated the actual wear of a stylus under normal conditions. All factors were the same, with the exception of the fact, that the records utilized were slightly used. These records had in the grooves atmospheric

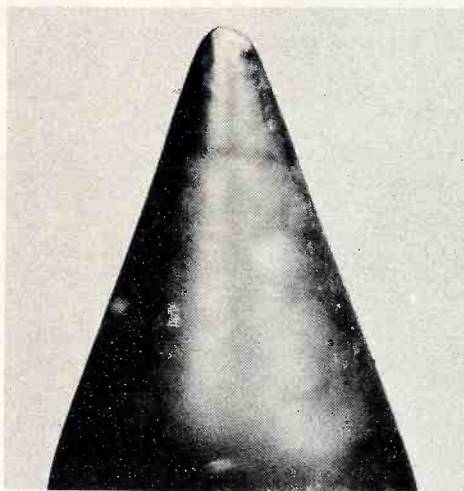

Courtesy Tetrad Corp.  
Fig. 1(A)

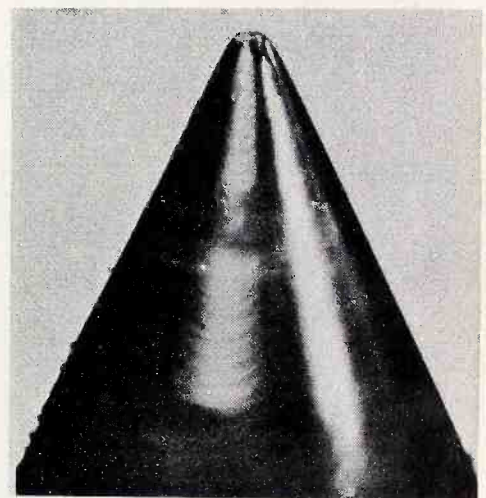

Courtesy Tetrad Corp.  
Fig. 1(C)

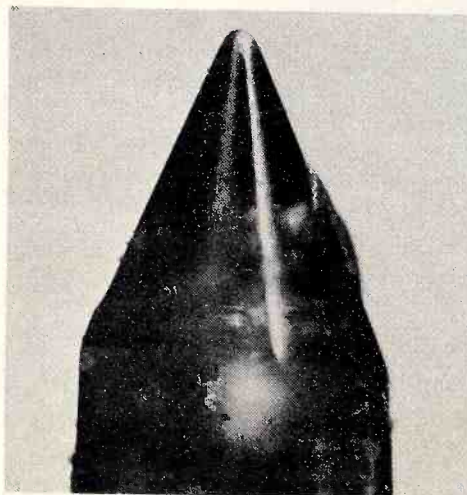

Courtesy Tetrad Corp.  
Fig. 1(B)



Courtesy Tetrad Corp.  
Fig. 1(D)



# USE TUNG-SOL TUBES FOR TROUBLE-FREE SERVICE!

TUNG-SOL "QUALITY CONTROL" recognizes but one standard. All Tung-Sol Tubes meet the highest original equipment requirements of leading radio and tv set manufacturers.

TUNG-SOL ELECTRIC INC., Newark 4, N. J.  
Sales Offices: Atlanta • Chicago • Culver City • Dallas  
Denver • Detroit • Newark

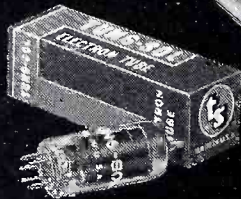
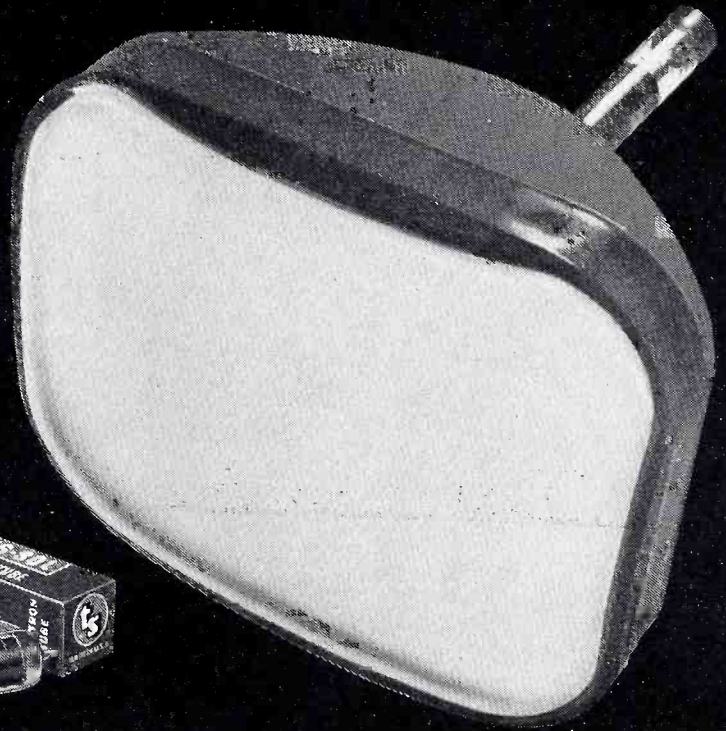

No Call-Backs for me, pal

Here's a real lively "stopper" to attract attention to your place of business and emphasize the quality of your service. Colorful—bright red and two shades of blue. 15 inches high. Your jobber salesman will tell you how to get one.

TUNG-SOL MAKES ALL-GLASS SEALED BEAM LAMPS, MINIATURE LAMPS, SIGNAL FLASHERS, PICTURE TUBES, RADIO, TV AND SPECIAL PURPOSE ELECTRON TUBES

Please mention *Successful Servicing* when answering advertising.



# Successful SERVICING

REG. U.S. PAT. OFF.

Dedicated to the financial and technical  
advancement of electronic maintenance personnel

VOLUME 13 NUMBER 11

SEPTEMBER, 1952

**JOHN F. RIDER, Publisher**  
**Annette M. Tricarico, Editor**  
**Stuart Flexner, Assistant Editor**

Advertising Representative  
H. J. Olsow & Co.  
3951 Grand Central Terminal  
New York 17, N. Y.  
MUrray Hill 6-4670



## Curtain Time

### Front End Tuner Service

Two schools of thought are active concerning the servicing of the tuner in a television receiver. One school prefers those devices which lend themselves to a ready assembly and disassembly, with the set manufacturer presenting complete service notes. These people assume that the service technician will make whatever repairs are necessary.

On the other hand there is the group which feels that repairs on the front end are too tedious and time consuming to warrant servicing by the service technician . . . and that the complete tuner should be replaced. In this school of thought the service notes are generally limited to a schematic, voltage data and alignment information.

Which camp you're in is not known, but this is an attempt to present both sides. After it's all over we'll tell you which side we're on.

The widespread distribution of tv receivers, and the location of service technicians at substantial distances from a source of replacement supply, strengthens the idea that service on front ends should be rendered by the service technician . . . that this gives the least delay and inconvenience to the public. As a whole the public just doesn't understand the delays occasioned by mail or phone orders and the time required for delivery of the part. You can't blame them too much . . . they own a tv receiver and want to enjoy it.

Another reason is one of simple principle; the basic character of a tuner is such that many parts which may fail are subject to replacement by the local technician himself. Under these circumstances it seems most fitting and proper for the service technician to effect as many repairs as he can. The front end as a whole is generally not comparable to a horizontal-output transformer,

a power transformer, or any one of the other inductor type components which must be replaced as a unit. Therefore it seems that the argument for local repair of front ends is valid.

But having read this far don't jump to a hasty conclusion as to whether you agree or disagree with what has been said.

Let's look at the other viewpoint . . . that tuners should be replaced instead of repaired. The present day types of tuners are critical items. They function over a frequency range which, while representing only a small ratio of about  $4\frac{1}{2} : 1$ , still involves frequencies higher than 200 mc. If you examine the majority of tuners in use today you will find them fairly full of very small coils. Some of these are related to more than one channel, and so affect the operation of all of the channels with which they are associated.

The capacitors and resistors used are selected to display certain particular characteristics; to perform in a certain prescribed manner over the full frequency range. Believe it or not, all resistors which display a certain ohmic value at d-c or low frequencies present very much lower resistance at 100 or 200 mc.

The wiring of the capacitors is critical. Whereas lead length is critical in a video i-f system the degree doesn't even remotely approach that encountered in a front end. As we said before, the inductors are tiny and not easy to handle. But even more important than that is the matter of being able to adjust a faulty coil when the tuner shield is not in place, and then to have the coil behave in the same fashion after the shield is in place.

Then there is the matter of having proper signal generator equipment for work of this kind. Some men have it and others don't, yet that doesn't necessarily dictate the conclusion to the technician.

Getting back to the matter of wiring, present day tuners do not behave as they do on all hands because someone put one together; they represent the results of many hundreds of hours of experimentation. Change the lead lengths or positions of coils and capacitors, or solder a connection improperly, and performance is adversely affected.

Finally there is the matter of time . . . how much does it cost a customer for the repair of a tuner in comparison to what it would cost him for a new one? The answer to this question is not easy because it depends on the kind of tuner and what is wrong with it. Of course there is the matter of determining what is wrong before the repair is made, and the variations in price of different kinds of tuners.

As a matter of fact the last condition is the most important one. That is where the public is hit hardest and the service technician can be hurt most. By rights the service technician should be paid for all the time he spends on a receiver . . . but this doesn't happen when several hours are spent trying to locate a fault.

As we see it, the whole thing boils down to the following . . . Certain tuners on the market are complete entities and are sold as such. If the price is reasonable, it is better to replace the whole thing rather than mess with faults which can't be located or repaired rapidly. If a whole tedious alignment process is involved because of repairs which have to be made, it's better to get a new one than fuss with the old one. If you can't charge for all the time that it takes to fix the old one, then you're better off selling a new one. Compare both dollar amounts . . . that will help you arrive at an answer.

All of this does not mean that service notes on tuners should be reduced. Not by any means. All the information now being supplied and as much more as possible should be given. The service industry needs all of it, if for no other reason than to be able to determine what is wrong and, when necessary, to complete the alignment properly and rapidly.

By the way how about giving us your opinion about front end repairs . . . Thanks.

*John F. Rider*





Preferred by Servicemen everywhere . . .

## MALLORY VIBRATORS

There are three big reasons why servicemen prefer Mallory vibrators over all other brands combined. They count on Mallory vibrators for long dependable service because they give . . .

- 1— Slow contact impact for minimum wear
- 2— High contact pressure for low resistance
- 3— Fast contact break for reduced arcing, pitting

That combination—available only from Mallory, with its patented, tuned mechanism—means real performance for you and your customers. That's why more Mallory vibrators are used as original equipment than all other makes combined. Put these features to work for you. When you order vibrators . . .

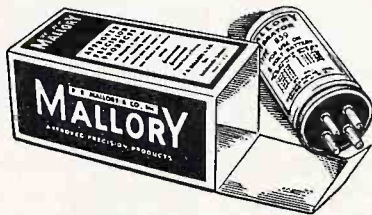

**Service 47 Radio Makes  
With ONE of Mallory's  
Special Vibrator Deals**

Ask your distributor about these Mallory specials. They help keep your inventory down. You can service 47 radio makes with the 6 Mallory vibrators in one of these deals. And you get a handy parts cabinet at no additional cost when you buy at your regular discount price. Call your distributor today for details.

## Make Sure! Make it Mallory!

P. R. MALLORY & CO. Inc.  
**MALLORY**

CAPACITORS • CONTROLS • VIBRATORS • SWITCHES • RESISTORS  
• RECTIFIERS • VIBRAPACK\* POWER SUPPLIES • FILTERS

\*Reg. U. S. Pat. Off.

**APPROVED PRECISION PRODUCTS**

**P. R. MALLORY & CO., Inc., INDIANAPOLIS 6, INDIANA**



# Reactance-Tube AFC Systems

(Continued from page 1)

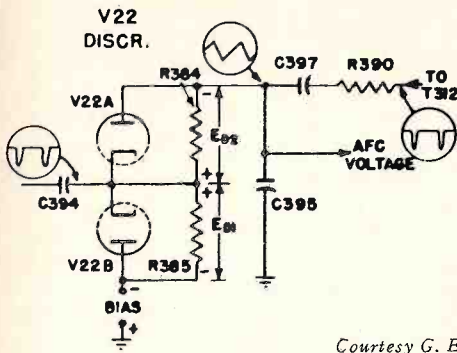

Courtesy G. E.

Fig. 4. Simplified schematic of phase discriminator.

respect to the common cathode point. As a result, there will be no voltage across capacitor C395, measured with respect to ground, other than the steady-state bias in the circuit. A negative pulse, obtained from the horizontal sweep output transformer, T312, is applied to the discriminator load circuit through an integrating network composed of resistor R390 and capacitors C397 and C395. This network shapes the negative pulse so that the voltage developed across C395 is a sawtooth, having the same phase and frequency as the output of the horizontal oscillator. The resultant voltages across R384 and R385 consist of a sawtooth

the sync pulse falls on the trailing edge of the sawtooth wave as it crosses the a-c axis. Therefore,  $E_{D1}$ , the peak voltage across R385, equals  $E_{D2}$ , the peak voltage across R384; the net d-c output is zero, and there is no change in bias at the reactance-control-tube grid.

If the sweep oscillator lags the incoming sync pulse, as a result of its decrease in its natural frequency, the pulse will move up on the slope, as in Fig. 5(B). The peak voltage,  $E_{D2}$ , will increase, while  $E_{D1}$  decreases. Therefore,  $E_A$ , the net voltage across C395, will be negative. This voltage is applied to the grid of V21A as additional bias, and causes the sweep oscillator frequency to increase to that of the synchronizing signal.

Should the sweep oscillator frequency run higher than that of the sync pulses, the sawtooth output will lead the pulses in phase. The pulse will then move down on the slope, as shown in Fig. 5(C). Thus,  $E_{D1}$  increases and  $E_{D2}$  decreases, resulting in a positive output correction voltage. Applied to the reactance-tube grid this voltage reduces the bias and so lowers the frequency of the oscillator.

The low-pass filter in the grid circuit of the control tube - C395, C396, and R387

- has a relatively long time constant, so that random noise and interference do not affect the bias circuit. C398, C399, R388, and R391 prevent hunting of the sweep generator.

## Multivibrator AFC Circuit

A circuit which has been used to control the frequency of a multivibrator-type sweep oscillator is shown in Fig. 6. The particular circuit is that used in the Hallicrafters model T-64, 509, and 510 receivers; a similar system is used in the Westinghouse model H-223 television set. The grid bias on the first section of a multivibrator is controlled by the d-c output of a phase discriminator. The d-c voltage depends on the phase difference between the synchronizing pulses and the sweep sawtooth output, and is so polarized that, as bias applied to the multivibrator grid, it results in a change of frequency in the desired direction.

The horizontal oscillator tube, V13, is connected as a cathode-coupled multivibrator, with an L-C circuit in series with the plate-load resistor of the first triode. This type of oscillator combines the pull-in sensitivity of the multivibrator with the stability of a sinusoidal circuit. The operating frequency is set at 15,750 cps by adjusting the slug in coil L30, with potentiometer R86A at its mid-range setting. Adjustment of R86A then permits a limited control of the sweep speed.

A negative-pulse synchronizing signal is fed to the grid of V11B, which acts as a split-load phase inverter. Sync pulses of equal amplitude and opposite polarity are developed across load resistors R71 and R74, in the plate and cathode circuits, respectively. These pulses are applied to the input of the phase discriminator, as shown in Fig. 6.

The positive pulse applied to the plate of V12A causes the diode to conduct through its load circuit, which consists of resistors R77, R118, and R79. As the electron flow is from the junction of R77 and R118 to

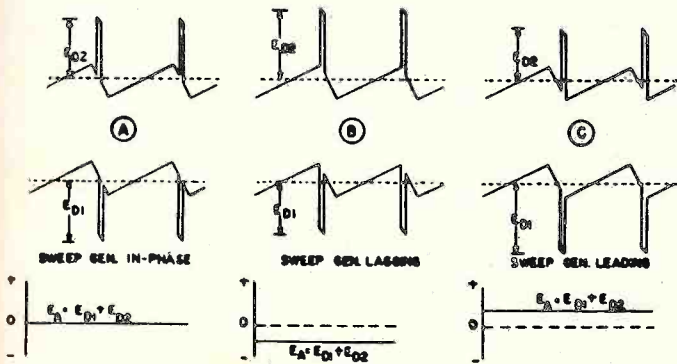

Fig. 5. Composite waveforms at output of discriminator, shown for in-phase and out-of-phase conditions.

Courtesy G. E.

(Continued on page 8)

and sync pulse, the pulse having approximately twice the amplitude of the sawtooth wave.

The composite waveforms across the diode loads are shown in Fig. 5, where  $E_{D1}$  is the peak voltage across R385 and  $E_{D2}$  is the peak voltage across R384. The sawtooth voltages across the resistors are equal in magnitude and of the same polarity, while the rectified sync pulses are equal in magnitude, but opposite in polarity. The waveforms are drawn so that  $E_{D1}$  shows the direction of the pulse at the plate of V22A with respect to the cathode, while  $E_{D2}$  shows the pulse direction at the cathode of V22B, relative to the plate. Note that the pulse falls on the steep or discharge slope of the sawtooth, since the pulse must normally occur at the end of each scanning line. The condition for synchronization of the pulses and the oscillator is illustrated in Fig. 5(A). Here

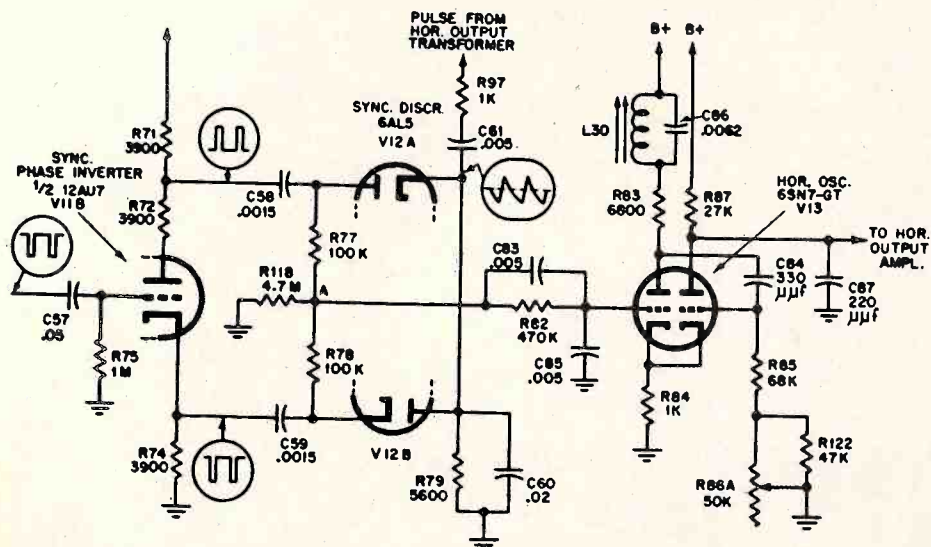

Fig. 6. Schematic diagram of horizontal oscillator and AFC circuit used in Hallicrafters receivers.

After Hallicrafters



## Reactance-Tube AFC Systems

(Continued from page 7)

ground, a d-c voltage will appear at the junction side of  $R118$  (point A) which is negative with respect to ground. At the same time, the negative-going pulse applied to the cathode of  $V12B$  causes this diode to conduct, its load circuit being resistors  $R78$ ,  $R118$ , and  $R79$ . Since the electron flow in this circuit is opposite to that of the upper diode, and since  $R118$  is common to both diodes, an equal and opposite voltage appears across this resistor, cancelling that potential caused by the conduction of  $V12A$ . Thus, there will be zero d-c output at point A, considering the synchronizing signal alone.

In addition to the synchronizing pulses, a sawtooth voltage is applied to the discriminator. This wave is obtained by integrating a pulse from the horizontal output transformer, and then reducing it to approximately the amplitude of the sync pulse; capacitors  $C60$  and  $C61$  and resistor  $R97$  serve as the integrating and attenuating network. This voltage causes  $V12A$  to conduct during the negative half-cycles and  $V12B$  to conduct during the positive half-cycles of the sawtooth. As in the case of the sync pulses,  $R118$  is common to both diode load circuits; therefore, the voltage across the resistor due to conduction of  $V12A$  is equal

and opposite to that due to  $V12B$ . Although the two diodes do not conduct simultaneously, as indicated in Fig. 7, the time constant of  $R79$  and  $C60$  is sufficiently long so that, considering only the sawtooth signal, the net d-c voltage at point A remains zero.

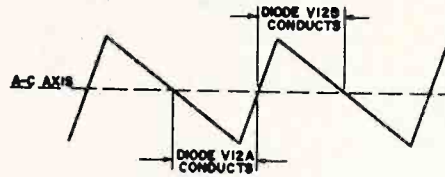

Fig. 7. Sawtooth across discriminator load circuit, with conduction period indicated for each diode.

Considering the combined effect of the sync pulse and the sawtooth, three conditions of phase difference are shown in Fig. 8.  $E_1$  represents the peak voltage applied to diode  $V12A$ , and  $E_2$  represents the peak voltage applied to  $V12B$ . Thus the d-c voltage developed across resistor  $R118$  by

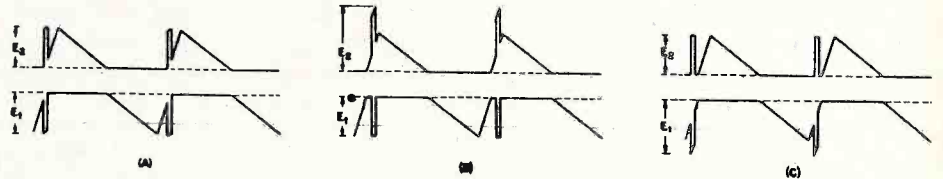

Fig. 8. Composite waveforms applied to synchronizing discriminator when sawtooth and sync pulse are in phase (A), when sawtooth is higher in frequency than sync pulse (B), and when sawtooth is lower in frequency (C).

conduction of  $V12A$  is directly proportional to  $E_1$ , and the voltage appearing across  $R118$  due to current flow through  $V12B$  is proportional to  $E_2$ . In Fig. 8(A), the pulse and sawtooth voltages are in phase, with the sync pulse arriving at the instant the steep slope of the sawtooth crosses the a-c axis. Since  $E_1$  and  $E_2$  are equal in this case, the two voltages developed across resistor  $R118$  are equal in amplitude and of opposite polarity. Hence, there is no change of potential at point A, and no change in grid bias at the first half of the oscillator tube.

If the oscillator frequency increases, the sync pulse will move up on the slope, as shown in Fig. 8(B). As a result of this phase displacement, the amplitude of  $E_2$  will increase. The greater voltage applied to diode  $V12B$  causes the resultant voltage at point A to become positive. This will decrease the bias at the first grid of  $V13$ , which will lower the operating frequency of the oscillator.

If the oscillator frequency decreases, the

sync pulse will move down on the slope. As seen from Fig. 8(C), the amplitude of  $E_1$  will increase, causing  $V12A$  to conduct more heavily than  $V12B$ . The larger current due to the conduction of  $V12A$  makes point A negative with respect to ground. This voltage is transmitted to the first grid of  $V13$ , effectively raising the bias which increases the operating frequency.

Capacitors  $C83$  and  $C85$  and resistor  $R82$ , in the grid circuit of the first section of the oscillator, prevent hunting and also form a low-pass filter. The long time constant of this circuit eliminates control of the oscillator by any source other than the discriminator output.

**Greater Coverage  
per pound**



**World's Finest  
3-Core Solder**

Now in one-pound  
"Handi-feed" cartons!

ON YOUR JOBBER'S COUNTER

**Take One!**

Multicore Sales Corp., 164 Duane Street, N. Y. Dept. S-9

Please mention *Successful Servicing* when answering advertising.

Perfect joints in less time with less solder—when you use Ersin MULTICORE Solder, the original 3-core solder and the only solder in the world made with non-corrosive, extra-active Ersin Flux. Eliminates "dry" joints! Bonds difficult metals!



### MAIL THIS COUPON TODAY

John F. Rider Publisher, Inc., Dept. C9  
480 Canal Street  
New York 13, N. Y.

Gentlemen:

Rather than take the chance of missing the alternate copy of **SUCCESSFUL SERVICING** at my jobber's, I am enclosing one dollar (\$1.00) to cover the cost of direct-to-my-home mailing every month.

Name.....

Address.....

City..... Zone.....

State.....

Cash  Check  Money Order



**TRIPPLET**  
**650 VTVM**

There's Nothing finer for

*Television*

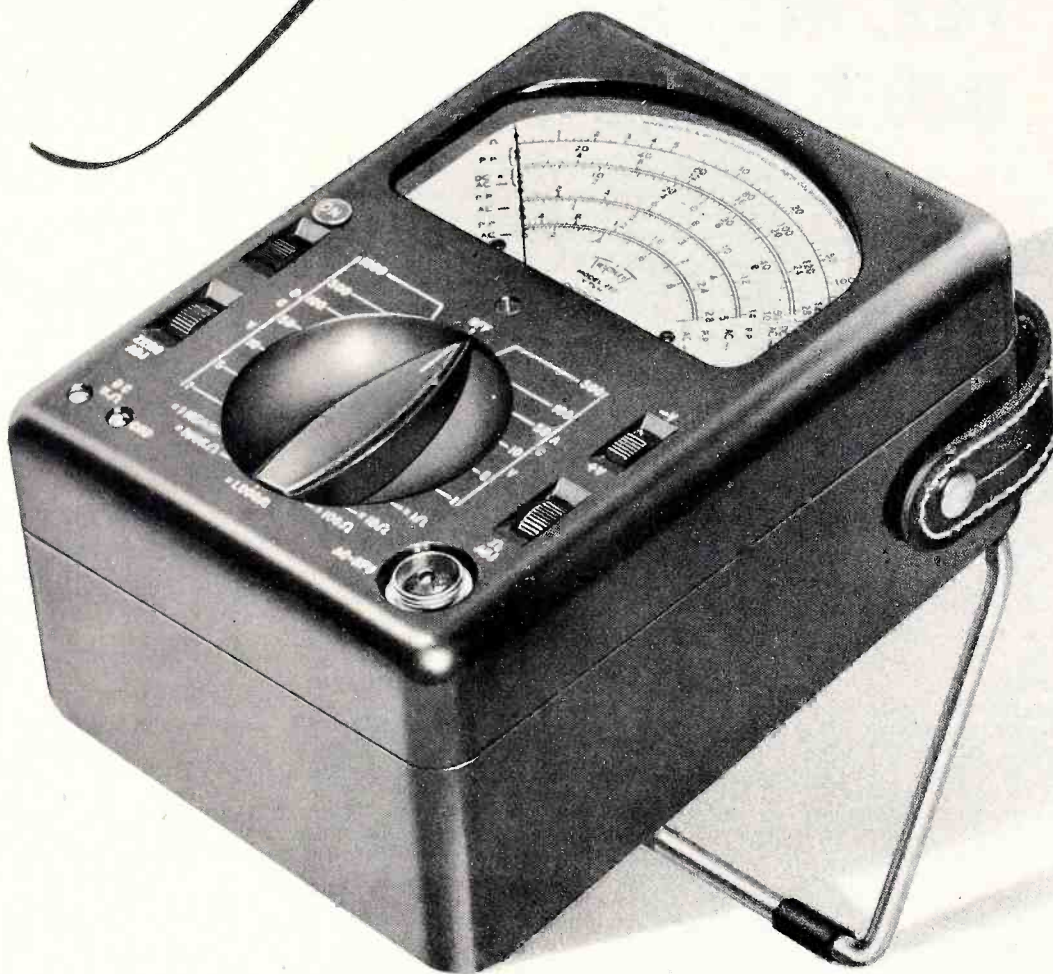

**This combination of features explains why**

- Complete frequency coverage with one probe, 20 cps to over 110-mc. Insulated and shielded RF tube probe, found usually only with laboratory instruments, is included.
- Peak to Peak ACV and RF with one probe.
- One volt full scale reading on AC & DC.
- One main selector switch, all ranges.
- ACrms—Peak to Peak
- 32 Ranges
- Zero center mark for FM discriminator alignment plus any other galvanometer measurements.
- High input impedance 11 megohms on DC.

Suggested U.S.A. Dealer Net \$69.50 • Prices subject to change without notice.

TRIPPLET ELECTRICAL INSTRUMENT CO., BLUFFTON, OHIO

**Triplet**





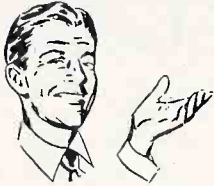

## YES, RIDER SERVICING DATA DOES MAKE TV SERVICING EASY!

Read what these satisfied Rider users say. These are men like yourself: professional service technicians who are faced with the same servicing problems as you. They found, just as you will, that tv servicing can be easy. Here's what they say:

"... 3 weeks ago I had a receiver in my shop for which there seemed to be no repair possible. According to the one schematic I had for this receiver, it should have operated perfectly. I was on the verge of returning the receiver to the customer and admitting defeat, when a technician friend suggested I check the receiver with Rider servicing data. I did; with the result that I found the trouble to be a production change which was not explained in the data I had been using. Needless to say, I'm a Rider user from now on!" John Ottenheimer, Radio Television Clinic, 137 Main St., Hempstead, L. I., N. Y.

"... and as a result of using your data, I haven't had a single callback in 9 months!" J. W. Scatchard & Co., 7135 Germantown Avenue, Philadelphia 19, Pennsylvania.

### WHAT'S THE SECRET?

It's simple! The one thing that Rider gives you is *all the facts*. That's the one big difference between Rider Servicing Data and any other kind. Rider Servicing Data is official, complete, factory-authorized data. Exactly as issued by the manufacturer who made the set . . . with all of his changes and modifications . . . organized into indexed, easy-to-follow style. This means that when you repair a set with Rider Servicing Data, you have everything in front of you. Everything that you must know in order to do a fast, accurate diagnosis and make a prestige-building, permanent repair!

In Rider Servicing Data you get all of the manufacturer's troubleshooting test patterns . . . schematics of all his productions . . . stage by stage alignment curves . . . clear, enlarged chassis views . . . the manufacturer's circuit changes . . . circuit explanations . . . voltage data, disassembly information and much, much more. For example: Rider Servicing Data has shown scope waveforms in TV receivers ever since the first TV receiver was made!

And Rider Servicing Data now has these important new features: manufacturers' trouble cures and guaranteed replacement parts listings. The manufacturers' trouble cures are standard (3 x 5") index cards, called Rider Handies, containing vital manufacturer-issued permanent trouble cures plus production changes. Each Handy is identified with a manufacturer and receiver model. With Rider Handies you save countless hours of diagnosis and repair time . . . because Handies contain the data you *must* have to make permanent repairs on many receivers.

The replacement parts listings are included in the latest Rider Servicing Data. All these replacement parts must meet the physical and electrical performance ratings of the original equipment.



### RIDER TV SERVICING DATA COMES IN TWO FORMS.

**MANUALS** ■  
The TV Manual form has nine volumes covering more than 4,200 models of television receivers. Each volume has over 2,000 (8½ x 11") pages of servicing data with an index covering the contents of all volumes. Each volume is attractively bound in a permanent hard cover. The Manual form is ideal for shop use and as a permanent reference.



### TEK-FILE

The Tek-File form now covers more than 2,200 models. Each Tek-File pack contains complete data for several of the most popular models . . . the ones you are called to work on every day. (Contents are clearly marked on the cover of each pack.) These models are bound in handy, standard file folders for easy home and shop use. In each Tek-File pack you get a special coupon. 15 of these coupons plus a small handling charge entitles you to a permanent, hard-cover manual binder for Tek-File shelf use. Or if you prefer, each coupon is worth five cents toward the purchase of any Rider book. Note: Get your free Tek-File indexes covering the contents of all packs at your jobber's. If he doesn't have them, write us.

For the complete servicing facts on radio get Rider Radio Manuals. In 22 volumes Rider Radio Manuals give you the complete, factory-authorized, official AM, FM radio servicing data for receivers manufactured over the past 22 years! Plus complete data on auto radios, record changers, tuners and recorders. Everything is organized and indexed to make radio servicing easy.

### DON'T BE SWITCHED

Remember, Rider Manuals and Tek-Files are the *only* source for complete published servicing data. If your jobber doesn't have them, **DON'T BE SWITCHED!** If he doesn't have Rider Manuals, write to us . . . we'll tell you where to get them. If he doesn't have Rider Tek-Files, write to us . . . we'll fill your order directly. (Please include your jobber's name.) *Why not prove to yourself that Rider Servicing Data really makes servicing easy? Try one Rider TV Tek-File pack at our risk! Try a pack for the next receiver you repair . . . if you don't agree that it makes your servicing easier than anything you've ever used RETURN THE PACK TO US WITHIN SEVEN DAYS AND WE'LL SEND YOU A FULL REFUND! So act now . . . you have absolutely nothing to lose!*

### RIDER "HOW-TO-DO-IT" BOOKSHELF.

#### 1. TV Troubleshooting and Repair Guide Book.

Save time! Loaded with troubleshooting charts and waveform pictures. 10 vital chapters. 204, 8½ x 11" pages. Paper cover \$3.90

#### 2. Ency on CR 'Scopes and Uses.

Most complete work on 'scopes! What they are, what they do, construction and capabilities. 992 pages 8½ x 11". 3000 ill. Cloth cover \$9.00

#### 3. Vacuum Tube Voltmeters.

All the facts! Design, construction, testing, maintenance, applications, etc., of all types of VTVM's. 432 pages 5½ x 8½". 210 ill. Cloth cover \$4.50

#### 4. TV and Other Receiving Antennas

No mathematics! Easy to read facts. Complete data on 50 basic antenna types. 606 pages 5½ x 8½". 310 ill. Cloth cover \$6.60

### IT'S NEWS! TELL-A-FAULT

It's Rider's new monthly tv troubleshooting service. Save countless hours of diagnosis time. Rider experts do your trouble-shooting for you . . . in pictures, charts, and symptom and cure sheets. Monthly bulletins. Send coupon for complete story — no obligation.

**BE SHARP!  
MAIL THIS COUPON  
TODAY!**

JOHN F. RIDER, Publisher, Inc.  
480 Canal Street, New York 13, N. Y.

Please send me book(s) circled. I understand, if not satisfied, I may return them within 10 days for full refund.

Send Free Data on Tell-A-Fault.

NAME \_\_\_\_\_

ADDRESS \_\_\_\_\_

CITY \_\_\_\_\_

ZONE \_\_\_\_\_ STATE \_\_\_\_\_ S-9

(Please Print)





MODEL	PACK-FILE	PAGES
<b>ADMIRAL CORP</b>		
4H15A, 4H15B, Ch. 20A1	40-2	4=1-37
4H16A, 4H16B, Ch. 20A1	40-2	4=1-37
4H17A, 4H17B, Ch. 20A1	40-2	4=1-37
4H18C, 4H18CN, Ch. 20B1	40-2	4=1-37
4H19C, 4H19CN, Ch. 20B1	40-2	4=1-37
4H126A, 4H126B, Ch. 21A1	40-2	4=1-37
4H126C, 4H126CN, Ch. 21A1	40-2	4=1-37
4H137A, 4H137B, Ch. 21A1	40-2	4=1-37
4H145A, 4H145B, Ch. 20B1	40-2	4=1-37
4H145C, 4H145CN, Ch. 20B1	40-2	4=1-37
4H146A, 4H146B, Ch. 20B1	40-2	4=1-37
4H146C, Ch. 20B1	40-2	4=1-37
4H147A, 4H147B, Ch. 20B1	40-2	4=1-37
4H156C, 4H156CN, Ch. 20B1	40-2	4=1-37
4H157A, 4H157B, Ch. 20B1	40-2	4=1-37
4H165A, 4H165B, Ch. 20B1	40-2	4=1-37
4H166A, 4H166B, Ch. 20B1	40-2	4=1-37
4H166C, 4H166CN, Ch. 20B1	40-2	4=1-37
4H167A, 4H167B, Ch. 20B1	40-2	4=1-37
4H167C, 4H167CN, Ch. 20B1	40-2	4=1-37
12X11, 12X12, Ch.20Z1	40-2	4=38-62 5=8-9
14R12, 14R16, Ch. 20T1, Rev.	1-1	8=1-22
16R11, 16R12, Ch. 21B1	1-1	8=23-46
20A1, 20B1, Ch.	40-2	4=1-37
20T1, 20V1, Ch., Rev.	1-1	8=1-22
20X1, Ch.	40-2	4=38-62
20X11, 20X12, Ch. 20X1	40-2	4=38-62
20X122, Ch. 20X1	40-2	4=38-62
20X136, Ch. 20Y1	40-2	4=38-62
20X145, 20X146, 20X147, Ch. 20Y1	40-2	4=38-62
20Y1, Ch.	40-2	4=38-62
20Z1, Ch.	40-2	5=8-9
21A1, Ch.	40-2	4=1-37
21B1, 21C1, 21D1, 21E1, Ch.	1-1	8=23-46
21H1, 21J1, Ch.	1-1	8=23-46
22X12, Ch. 20Z1	40-2	4=38-62 5=8-9
22X25, 22X26, 22X27, Ch. 20Z1	40-2	4=38-62 5=8-9
24A12, Ch. 20A1	40-2	4=1-37
24A125, Ch. 20A1	40-2	4=1-37
24A125AN, Ch. 20X1	40-2	4=38-62
24C15, 24C16, Ch. 20B1	40-2	4=1-37
24D1, 24E1, 24F1, 24G1, 24H1, Ch.	48-3	7=1-24
24R12, Ch. 20T1, Rev.	1-1	8=1-22
24X15, 24X15S, Ch. 20X1	40-2	4=38-62
24X16, 24X16S, Ch. 20X1	40-2	4=38-62
24X17S, Ch. 20X1	40-2	4=38-62
25A15, 25A16, 25A17, Ch. 21A1	40-2	4=1-37
26R12, Ch. 21B1	1-1	8=23-46
26R25, 26R26, Ch. 24H1	48-3	7=1-24
26R25A, 26R26A, Ch. 21B1	1-1	8=23-46
26R35, 26R36, 26R37, Ch. 24H1	48-3	7=1-24
26R35A, 26R36A, 26R37A, Ch. 21B1	1-1	8=23-46
26X35, 26X36, 26X37, Ch. 24D1	48-3	7=1-24
26X45, 26X46, Ch. 24H1	48-3	7=1-24
26X55, 26X56, 26X57, Ch. 24D1	48-3	7=1-24
26X55A, 26X56A, 26X57A, Ch. 21D1	1-1	8=23-46
26X65, 26X66, 26X67, Ch. 24D1	48-3	7=1-24
26X65A, 26X66A, 26X67A, Ch. 21D1	1-1	8=23-46
26X75, 26X76, Ch. 24D1	48-3	7=1-24
26X75A, 26X76A, Ch. 21D1	1-1	8=23-46
29X16, 29X17, Ch. 24F1	48-3	7=1-24
29X25, 29X26, 29X27, Ch. 24F1	48-3	7=1-24
29X25A, 29X26A, Ch. 21H1	1-1	8=23-46
30F15, 30F15A, Ch. 20B1	40-2	4=1-37
30F16, 30F16A, Ch. 20B1	40-2	4=1-37
30F17, 30F17A, Ch. 20B1	40-2	4=1-37
32X15, 32X16, Ch.20Z1	40-2	4=38-62 5=8-9
32X26, 32X27, Ch. 20Z1	40-2	4=38-62 5=8-9

**INDEX  
PACKS 1-56**

MODEL	PACK-FILE	PAGES	ADMIRAL AFF. RETAILERS
<b>ADMIRAL CORP. (Cont'd)</b>			
32X35, 32X36, Ch. 20Z1	40-2	4=38-62 5=8-9	
34R15, 34R15A, 34R16, 34R16A, Ch. 20V1, Rev.	1-1	8=1-22	
Record Changer ADMIRAL RC500	1-RC1	RCH21=1-8	
36R37, 36R45, 36R46, Ch. 21C1	1-1	8=23-46	
Record Changer ADMIRAL RC500	1-RC1	RCH21=1-8	
ADMIRAL RC550	1-RC2	RCH21=9-16	
36X35, 36X35A, Ch. 24E1	48-3	7=1-24	
Record Changer ADMIRAL RC500	1-RC1	RCH21=1-8	
ADMIRAL RC550	1-RC2	RCH21=9-16	
36X36, 36X36A, Ch. 24E1	48-3	7=1-24	
Record Changer ADMIRAL RC500	1-RC1	RCH21=1-8	
ADMIRAL RC550	1-RC2	RCH21=9-16	
36X36AS, 36X36S, Ch. 21E1	1-1	8=23-46	
Record Changer ADMIRAL RC550	1-RC2	RCH21=9-16	
36X37, 36X37A, Ch.24E1	48-3	7=1-24	
Record Changer ADMIRAL RC500	1-RC1	RCH21=1-8	
ADMIRAL RC550	1-RC2	RCH21=9-16	
39X16, 39X16A, 39X16B, Ch. 24G1	48-3	7=1-24	
Record Changer ADMIRAL RC500	1-RC1	RCH21=1-8	
ADMIRAL RC550	1-RC2	RCH21=9-16	
39X17A, 39X17B, Ch. 24G1	48-3	7=1-24	
Record Changer ADMIRAL RC500	1-RC1	RCH21=1-8	
ADMIRAL RC550	1-RC2	RCH21=9-16	
39X17C, Ch. 21J1	1-1	8=23-46	
Record Changer ADMIRAL RC550	1-RC2	RCH21=9-16	
39X25, 39X26, Ch. 24G1	48-3	7=1-24	
Record Changer ADMIRAL RC550	1-RC2	RCH21=9-16	
39X25A, 39X26A, Ch. 21J1	1-1	8=23-46	
Record Changer ADMIRAL RC550	1-RC2	RCH21=9-16	
39X35, 39X36, Ch. 21J1	1-1	8=23-46	
Record Changer ADMIRAL RC550	1-RC2	RCH21=9-16	
320R17, Ch. 21J1	1-1	8=23-46	
Record Changer ADMIRAL RC550	1-RC2	RCH21=9-16	
320R25, 320R26, Ch. 21J1	1-1	8=23-46	
Record Changer ADMIRAL RC550	1-RC2	RCH21=9-16	
<b>AFFILIATED RETAILERS, INC. (ARTONE)</b>			
AR-MST-14, AR-MST-16	48-3	6=1-9	
AR-14-LG, AR-14-P	1-1	8=1-12	
AR-14-TR	48-3	6=1-9	
AR-16-ATR	48-3	6=1-9	
AR-16-CD, AR-16-CD-3CR	40-2	5=1-8	
AR-16-CR	48-3	6=1-9	
AR-16-CX	40-2	5=1-8	
AR-16-RO, AR-16-TR	48-3	6=1-9	
AR-17-3D	48-3	6=1-9	
AR-17-3DG	1-1	8=1-12	
AR-17-CD	48-3	6=1-9	
AR-17-CDG	1-1	8=1-12	
AR-17-CR	48-3	6=1-9	
AR-17-CRG	1-1	8=1-12	
AR-17-LG, AR-17-P	1-1	8=1-12	
AR-17-RO	48-3	6=1-9	
AR-17-ROG	1-1	8=1-12	
AR-20-3DG, AR-20-CDG, AR-20-CRG, AR-20-TRG	1-1	8=1-12	
AR-112X	48-3	6=10-16	
AR-114A	48-3	6=1-9	
AR-163-CR	40-2	5=1-8	
AR-216	40-2	5=1-8	
AR-316, AR-316-3CM	40-2	5=1-8	



**AFF. RETAILERS  
BELMONT**

MODEL PACK-FILE PAGES

AFFILIATED RETAILERS, INC. (Cont'd)

AR-816	40-2	5=1-8
AR-816-3CM, AR-816-3CR	40-2	5=1-8
AR-819, AR-819-3CM	40-2	5=1-8
		7=1
AR-919	40-2	5=1-8
		7=1

AIR KING PRODUCTS CO., INC.

12C1, Ch. 700	43-1	7=1-24
12T1, 12T2, Ch. 700	43-1	7=1-24
14T1, Ch. 700-30	43-1	7=1-24
16C1, Ch. 700-1, 700-10, 700-90	43-1	7=1-24
16C2, 16C3, Ch. 700-10	43-1	7=1-24
16C5, Ch. 700-10, 700-90	43-1	7=1-24
16K1, Ch. 700-2, 700-50, 700-92	43-1	7=1-24
16M1, Ch. 700-10, 700-90	43-1	7=1-24
16T1, Ch. 700-1, 700-10	43-1	7=1-24
16T1B, Ch. 700-1, 700-10, 700-90	43-1	7=1-24
19C1, Ch. 700-40, 700-91	43-1	7=1-24
20C1, 20C2, Ch. 700-93	43-1	7=1-24
20K1, Ch. 700-95	43-1	7=1-24
20M1, Ch. 700-90, 700-93	43-1	7=1-24
700, 700-1, 700-2, 700-5, Ch. 700-10, 700-20, 700-30, 700-40, 700-50, Ch.	43-1	7=1-24
700-90, 700-91, 700-92, 700-93, 700-95, Ch.	43-1	7=1-24

AIRLINE  
See MONTGOMERY WARD

AIR MARSHAL CORP.

B-17-T	43-1	7=1-4
--------	------	-------

ALLIANCE MFG. CO.

AB, Booster	43-1	7=1
-------------	------	-----

ANCHOR RADIO CORP.

ARC-101-75, ARC-101-100	43-1	7=1-3
-------------------------	------	-------

ANDREA RADIO CORP.

Brewster	43-1	9=1-4
Caronia, Fleetwood	43-1	6=1-10
Gotham	43-1	9=1-4
Mayfield	43-1	6=1-10
Saybrook, Sutton	43-1	6=1-10
Warwick	43-1	9=1-4
C-VL16, Ch. VL16, Sutton	43-1	6=1-10
C-VL17, Ch. VL17, Brewster	43-1	9=1-4
CO-VL16, Ch. VL16, Fleetwood	43-1	6=1-10
CO-VL19, Ch. VL19, Caronia	43-1	6=1-10
T-VL12, Ch. VL12, Saybrook	43-1	6=1-10
T-VL16, Ch. VL16, Mayfield	43-1	6=1-10
T-VL17, Ch. VL17, Gotham	43-1	9=1-4
VL12, VL16, Ch.	43-1	6=1-10
VL17, Ch.	43-1	9=1-4
VL19, Ch.	43-1	6=1-10
2C-VL17, Ch. VL17, Warwick	43-1	9=1-4

ARTONE  
See AFFILIATED RETAILERS, INC.  
Also See MACY'S

ARVIN INDUSTRIES, INC.

TE272-1, TE272-2, Ch.	43-2	6=1-9
TE276, Ch.	43-2	6=1-9
TE282, Ch.	43-2	6=13-18
TE 286, Ch.	1-1	8=4-6
TE289, Ch.	43-2	6=10-12
TE-289-2, Ch.	1-1	8=1-3

MODEL PACK-FILE PAGES

ARVIN INDUSTRIES, INC. (Cont'd)

TE289-3, Ch.	43-2	7=1-4
TE290, Ch.	43-2	7=5-8
TE300, Ch.	43-2	9=1-8
TE-302, Ch.	1-1	8=6-8
TE-302-1, Ch.	1-1	8=6
		8=9-10
		9=1-8
TE315, TE315-1, TE315-2, Ch.	43-2	7=1-4
2120, 2121, Ch. TE289-3	43-2	7=1-4
2120CM, 2121TM, Ch. TE-289-2	1-1	8=1-3
2122TM, Ch. TE289	43-2	6=10-12
2123, Ch. TE289-3	43-2	7=1-4
2123TM, Ch. TE-289-2	1-1	8=1-3
2124, Ch. TE289-3	43-2	7=1-4
2124CCM, Ch. TE-289-2	1-1	8=1-3
2126, Ch. TE289-3	43-2	7=1-4
2126CM, Ch. TE-289-2	1-1	8=1-3
2160, 2161, 2162, 2164, Ch. TE290	43-2	7=5-8
3100TB, 3100TM, Ch. TE272-1	43-2	6=1-9
3101CM, Ch. TE272-1	43-2	6=1-9
3120CB, 3120CM, Ch. TE272-2	43-2	6=1-9
3121TM, Ch. TE272-2	43-2	6=1-9
3160CM, Ch. TE276	43-2	6=1-9
4080T, Ch. TE282	43-2	6=13-18
4162, Ch. TE 286	1-1	8=4-6
5170, Ch. TE-302	1-1	8=6-8
5170, Ch. TE-302-1	1-1	8=6
		8=9-10
		8=6-8
5171, Ch. TE-302	1-1	8=6
5171, Ch. TE-302-1	1-1	8=6
		8=9-10
		8=6-8
		8=6
		8=9-10
		9=1-8
5172, Ch. TE-302	1-1	8=6-8
5172, 5173, Ch. TE-302-1	1-1	8=6
		8=9-10
		9=1-8
5204, 5206, Ch. TE300	43-2	
5210, 5211, 5212, Ch. TE315, TE315-1, TE315-2	43-2	9=1-8

ASTORIA  
See MACY'S

BELMONT RADIO CORP.  
(RAYTHEON)

Adams	2-1	8=1-13
The Belmont	27-2	5=1-8
Catalina, Clayton	2-1	8=1-13
The Console	27-2	5=1-8
Constellation	2-1	8=1-13
The Evanston, The Marquis	48-3	7=1-16
The Mayfair, The Mozart	48-3	7=1-16
The Revere, The Rancho	48-3	7=1-16
The Rocket	48-3	7=1-16
The Rover	27-2	5=1-8
The Savoy, The Santung	48-3	7=1-16
The Starlight	2-1	8=14-25
The Suburban	27-2	5=1-8
C-1104B, Ch. 12AX27, The Console	27-2	5=1-8
C-1401, Ch. 14AX21	27-2	5=9-18
C-1602, Ch. 16AX23, 16AX25, 16AX26	27-2	5=21-29
C-1602, Series C, Ch. 16AX29	27-2	5=21-29
C-1614A, Ch. 16AY211, The Marquis	48-3	7=1-16
C-1614B, Ch. 16AY28, The Marquis	48-3	7=1-16
C-1615A, Ch. 16AY211, The Mayfair	48-3	7=1-16
C-1615B, Ch. 16AY28, The Mayfair	48-3	7=1-16
C-1616A, Ch. 16AY211, The Mozart	48-3	7=1-16
C-1616B, Ch. 16AY28, The Mozart	48-3	7=1-16
C-1714A, Ch. 17AY24, The Marquis	48-3	7=1-16
C-1714B, Ch. 17AY21, The Marquis	48-3	7=1-16



MODEL	PACK-FILE	PAGES
<u>BELMONT RADIO CORP. (Cont'd)</u>		
C-1715A, Ch. 17AY24, The Mayfair	48-3	7=1-16
C-1715B, Ch. 17AY21, The Mayfair	48-3	7=1-16
C-1716A, Ch. 17AY24, The Mozart	48-3	7=1-16
C-1716B, Ch. 17AY21, The Mozart	48-3	7=1-16
C-1724A, Ch. 17AY21, The Evanston	48-3	7=1-16
C-2001A, Ch. 20AY21, Clayton	2-1	8=1-13
C-2002A, Ch. 20AY21, Catalina	2-1	8=1-13
C-2006A, Constellation	2-1	8=1-13
M-1105B, Ch. 12AX27, The Suburban	27-2	5=1-8
M-1106, Ch. 12AX27, The Rover	27-2	5=1-8
M-1107, Ch. 12AX27, The Belmont	27-2	5=1-8
M-1402, M-1403, M-1404, Ch. 14AX21	27-2	5=9-18
M-1601, Ch. 16AX23, 16AX25, 16AX26	27-2	5=21-29
M-1611A, Ch. 16AY211, The Rocket	48-3	7=1-16
M-1611B, Ch. 16AY28, The Rocket	48-3	7=1-16
M-1612A, Ch. 16AY211, The Rancho	48-3	7=1-16
M-1612B, Ch. 16AY28, The Revere	48-3	7=1-16
M-1613A, Ch. 16AY211, The Revere	48-3	7=1-16
M-1613B, Ch. 16AY28, The Revere	48-3	7=1-16
M-1711A, Ch. 17AY24, The Rocket	48-3	7=1-16
M-1711B, Ch. 17AY21, The Rocket	48-3	7=1-16
M-1712A, Ch. 17AY24, The Rancho	48-3	7=1-16
M-1712B, Ch. 17AY21, The Rancho	48-3	7=1-16
M-1713A, Ch. 17AY24, The Revere	48-3	7=1-16
M-1713B, Ch. 17AY21, The Revere	48-3	7=1-16
*M-1725A, Ch. 17AY21	48-3	7=1-16
P-301, Series B, Ch. 7DX22P	27-2	5=31-34
RC-1405, Ch. 14AX21	27-2	5=9-20
RC-1618A, Ch. 16AY211, The Savoy	48-3	7=1-16
RC-1618B, Ch. 16AY28, The Savoy	48-3	7=1-16
RC-1619A, Ch. 16AY211, The Santung	48-3	7=1-16
RC-1619B, Ch. 16AY28, The Santung	48-3	7=1-16
RC-1718A, Ch. 17AY24, The Savoy	48-3	7=1-16
RC-1718B, Ch. 17AY21, The Savoy	48-3	7=1-16
RC-1719A, Ch. 17AY24, The Santung	48-3	7=1-16
RC-1719B, Ch. 17AY21, The Santung	48-3	7=1-16
RC-1720A, Ch. 17AY27, The Starlight	2-1	8=14-25
Record Changer VM-950	2-RC1	RCH22=1-16
RC-2005A, Ch. 20AY21, Adams	2-1	8=1-13
Record Changer VM-950	2-RC1	RCH22=1-16
6J6, 12AT7, Tuners	2-1	8=26-31
7DX22P, Ch.	27-2	5=31-34
12AX27, Ch.	27-2	5=1-8
14AX21, Ch.	27-2	5=9-20
16AX23, 16AX25, 16AX26, Ch.	27-2	5=21-29
16AX29, Ch.	27-2	5=21-29

MODEL	PACK-FILE	PAGES
<u>BELMONT RADIO CORP. (Cont'd)</u>		
16AY28, Ch.	48-3	7=1-16
16AY211, Ch.	48-3	7=1-16
17AY21, 17AY24, Ch.	48-3	7=1-16
17AY27, Ch.	2-1	8=14-25
20AY21, Ch.	2-1	8=1-13

BENDIX RADIO DIV.

Belair, Guilford	48-2	7=1-9
C172, Belair	48-2	7=1-9
*C182	48-2	7=1-9
C200, Guilford	48-2	7=1-9
T170	27-1	5=1-11
*T171	48-2	7=1-9
2051	27-1	5=1-11
2060, 2070	27-1	5=1-11
3051	27-1	5=1-11
6001, 6003	27-1	5=1-11
6100	27-1	5=1-14
7001	27-1	5=1-11

GADILLAC ELECTRONICS CORP.

F-16	2-1	8=1-8
------	-----	-------

CAPEHART - FARNSWORTH CORP.

C-278, C-279, Ch.	27-1	7=1-13
C-281, Ch.	27-1	5=1-12
CT-27, Ch. CX-33DX	27-1	9=1-4
CT-37, CT-38, CT-39, Ch. CX-33DX	27-1	9=1-4
CT-45, Ch. CX-33DX	27-1	9=1-4
CX-32, Ch.	27-1	7=1-13
CX-33, Ch.	27-1	5=1-12
CX-33DX, Ch.	27-1	9=1-4
3005-M, Ch. C-279, CX-32	27-1	7=1-13
3008-M, Ch. C-278, CX-32	27-1	7=1-13
3011-B, 3011-M, Ch. C-281, CX-33	27-1	5=1-12
3012-B, 3012-M, Ch. C-281, CX-33	27-1	5=1-12

CONRAC, INC.

27-M-40, 27-W-40, Ch. 40, 44	2-1	8=1-3
28-B-40, 29-P-40, Ch. 40, 44	2-1	8=1-3
30-M-40, 30-W-40, Ch. 40, 44	2-1	8=1-3
31-P-40, Ch. 40, 44	2-1	8=1-3
40, 44, Ch.	2-1	8=1-3

CORONADO

See GAMBLE-SKOGMO, INC

COVIDEO, INC.

T-1400	2 1	8=1-4
--------	-----	-------

CROSLLEY DIV.  
AVCO MFG. CORP.

DU-17CDB, DU-17CDM, DU- 17CHM, DU-17CHN, DU- 17COB, DU-17COM, Ch. 356-1	2-1	8=13-17
DU-17PDB, DU-17PDM, Ch. 359	17-3	9=5-10
Record Changer CROSLLEY V-950	17-RC1	RCH 9=1-16
DU-17PHB, DU-17PHM, DU-17PHN, DU-17PHN1, Ch. 359	17-3	9=11-16
Record Changer CROSLLEY V-950	17-RC1	RCH 9=1-16
DU-17TOB, DU-17TOL, DU-TOM, CH. 356-1	2-1	8=13-17

\* See HANDY.

\* See HANDY.



**CROSLY  
DUMONT**

MODEL PACK-FILE PAGES

**CROSLY DIV. (Cont'd)**

DU-20CDM, DU-20CHB, DU-20CHM, DU-20COB, DU-20COM, Ch. 357	17-3	9=1-4
DU-20PDM, Ch. 363 Record Changer CROSLY V-950	17-3	9=17-22
S11-442M1U, Ch. 331-4	17-RC1	RCH 9=1-16
S11-444MU, Ch. 331-4 Record Changer CROSLY V-950	2-1	8=18-23
S11-447MU, Ch. 321-4	2-1	8=18-23
S11-453MU, Ch. 331-4	2-1	8=18-23
S11-459MU, Ch. 321-4	2-1	8=24-29
S11-472BU, Ch. 331-4	2-1	8=18-23
S11-474BU, Ch. 331-4 Record Changer CROSLY V-950	2-1	8=18-23
S17-CDC1, S17-CDC3, S17-CDC4, Ch. 331-4	2-RC1	RCH 9=1-16
S17COC1, S17COC2, S17COC3, Ch. 331-4	2-1	8=18-23
S20-CDC1, S20-CDC2, S20-CDC3, Ch. 323-6	2-1	8=18-23
9-422M-LD	17-2	8=30-35
9-423M-LD Record Changer CROSLY 700F-33/45	17-2	5=1-13
10-401	17-RC2	RCH 9=17-24
10-404MU, 10-404M1U	17-2	5=25-36
10-412MU	18-4	6=1-4
10-414MU	18-4	6=1-4
10-416MU, 10-416M1U	17-2	5=37-41
10-418MU	17-2	5=37-41
10-418MU	18-4	6=1-4
10-419MU	17-2	5=42-46
10-421MU	18-4	6=5-9
10-428MU	18-4	6=10-14
10-429MU	17-2	5=37-41
11-441MU, Ch. 320	18-4	6=15-26
11-442M1U, Ch. 331	18-4	6=27-34
11-443MU, Ch. 323	18-4	6=35-40
11-444MU, Ch. 331 Record Changer CROSLY V-950	18-4	6=27-34
11-453, Ch. 331	18-RC1	RCH 9=1-16
11-454MU, Ch. 323	18-4	6=27-34
11-458MU, Ch. 323	18-4	6=35-40
11-460MU, Ch. 331	18-4	6=35-40
11-461WU, Ch. 320	18-4	6=27-34
11-470BU, Ch. 331	18-4	6=15-26
11-471BU, Ch. 320	18-4	6=27-34
11-472B1U, Ch. 331	18-4	6=15-26
11-473BU, Ch. 323	18-4	6=27-34
11-474BU, Ch. 331 Record Changer CROSLY V-950	18-4	6=35-40
11-476BU, Ch. 325, 325-1, 325-2	18-RC1	RCH 9=1-16
11-483BU, Ch. 331	18-4	6=21-27
11-484MU, Ch. 323	18-4	6=27-34
17CDC1, 17CDC2, 17CDC3, 17CDC4, Ch. 331, 331-1, 331-2	18-4	6=35-40
17COC1, 17COC2, 17COC3, Ch. 331, 331-1, 331-2	2-1	8=1-6
20CDC1, 20CDC2, 20CDC3, Ch. 323-3, 323-4	2-1	8=1-6
320, Ch.	2-1	8=7-12
321-4, Ch.	18-4	6=15-26
323, Ch.	2-1	8=24-29
323-3, 323-4, Ch.	18-4	6=35-40
323-6, Ch.	2-1	8=7-12
325, 325-1, 325-2, Ch.	2-1	8=30-35
331, Ch.	18-4	6=21-27
331, 331-1, 331-2, Ch.	18-4	6=27-34
331-4, Ch.	2-1	8=1-6
356-1, Ch.	2-1	8=18-23
357, Ch.	2-1	8=13-17
359, Ch., DU-17PDB	17-3	9=1-4
359, Ch., DU-17PHB	17-3	9=5-10
363, Ch.	17-3	9=11-16
	17-3	9=17-22

MODEL PACK-FILE PAGES

**ALLEN B. DUMONT LABORATORIES, INC.**

Andover	18-1	7=1-9
Ardmore	33-3	6=1-26
Bradford	39-4	4=5-14
Brookville	33-3	6=1-26
Burlingame	33-3	6=1-26
Canterbury	39-4	1=31-42
		3=1-4
		4=1-4
Carlton	18-1	7=1-9
Chatham	39-4	1=31-42
Fairfield	39-4	1=31-42
		3=1-4
		4=1-4
Guilford, Hanover	33-2	5=1-25
Hastings	39-4	1=31-42
		3=1-4
		4=1-4
Mansfield	39-4	4=5-14
Mt. Vernon	33-3	6=1-26
Park Lane	18-1	7=1-9
Putnam	33-2	5=26-43
Revere	33-3	6=1-26
Royal Sovereign	33-2	5=1-25
		8=1-12
Rumson	39-4	1=31-42
		3=1-4
		4=1-4
Savoy	39-4	1=31-42
Sheffield	39-4	1=31-42
		3=1-4
		4=1-4
Sherbrooke	33-2	5=1-25
Strathmore, Sumter	18-1	7=1-9
Sussex	39-4	4=5-14
Tarrytown	33-3	6=1-26
Wellington	39-4	1=31-42
		3=1-4
		4=1-4
Westerly	33-3	6=1-26
The Westminster	39-4	9=1-24
Westwood	39-4	1=31-42
		3=1-4
		4=1-4
Winslow	33-2	5=1-25
Winthrop	39-4	1=31-42
RA-103, Chatham, Savoy	39-4	1=31-42
RA-103C, Winthrop	39-4	1=31-42
RA-103-D, Canterbury, Rumson, Sheffield	39-4	1=31-42
		3=1-4
		4=1-4
RA-104-A, Hastings, Wellington	39-4	1=31-42
		3=1-4
		4=1-4
RA-105-B, Sussex	39-4	4=5-14
RA-108-A, Bradford, Mansfield	39-4	4=5-14
RA-110-A, Fairfield, Westwood	39-4	1=31-42
		3=1-4
		4=1-4
RA-109-A1, Winslow	33-2	5=1-25
RA-109-A2, Hanover	33-2	5=1-25
RA-109-A3, Sherbrooke	33-2	5=1-25
RA-109-A5, Winslow	33-2	5=1-25
RA-109-A6, Hanover	33-2	5=1-25
RA-109-A7, Sherbrooke	33-2	5=1-25
RA-111-A1, Putnam	33-2	5=26-43
RA-111-A2, Guilford	33-2	5=26-43
RA-111-A4, Putnam	33-2	5=26-43
RA-111-A5, Guilford	33-2	5=26-43
RA-112-A1, Ardmore	33-3	6=1-26
RA-112-A2, Westerly	33-3	6=1-26
RA-112-A3, Mt. Vernon	33-3	6=1-26
RA-112-A4, Ardmore	33-3	6=1-26
RA-112-A5, Westerly	33-3	6=1-26
RA-112-A6, Mt. Vernon	33-3	6=1-26
RA-113-B1, RA-113-B2, Brookville	33-3	6=1-6



MODEL	PACK-FILE	PAGES
<b>ALLEN B. DUMONT LABORATORIES, INC. (Cont'd)</b>		
RA-113-B3, RA-113-B4, Revere	33-3	6=1-26
RA-113-B5, RA-113-B6, Burlingame	33-3	6=1-26
RA-113-B7, RA-113-B8, Tarrytown	33-3	6=1-26
RA-116A, The Westminster, Series II	39-4	9=1-24
Record Changer WEBSTER 100	39-RC1	RCH21=1-10
RA-117-A1, Sumter	18-1	7=1-9
RA-117-A3, Carlton	18-1	7=1-9
RA-117-A5, Strathmore	18-1	7=1-9
RA-117-A6, Andover	18-1	7=1-9
RA-117-A7, Park Lane	18-1	7=1-9
RA-119A, Royal Sovereign	33-2	5=1-25 8=1-12

**ELECTRO-TECHNICAL INDUSTRIES  
(TELEKIT)**

19C	3-1	8=1-10
-----	-----	--------

**ELECTRO-VOICE INC.**

3000, Booster	26-1	7=1-2
---------------	------	-------

**EMERSON RADIO & PHONO. CORP.**

609, Ch. 120084-B	3-1	8=1-13
614D, Ch. 120095-B	26-2	6=1-4
637A, Ch. 120095-B	26-2	6=1-4
649A, Ch. 120094A	26-2	6=5-10
650B, Ch. 120118B	26-2	6=11-19
654B, Ch. 120118B	26-2	6=11-19
661B, Ch. 120134-B, 120134-G	26-3	7=1-10
662B, 663B, Ch. 120127-B, 120128-B	26-3	7=11-19
665B, Ch. 120131-B	26-3	7=20-27
666B, Ch. 120135-B	26-3	7=28-35
667B, 668B, Ch. 120134-B, 120134-G	26-3	7=1-10
669B, Ch. 120129-B	26-3	7=36-44
674B, Ch. 120134-G	26-3	7=1-10
675B, Ch. 120129-B	26-3	7=36-44
676B, Ch. 120140-B, 120140-G, 120140-H	26-3	7=45-57
676D, Ch. 120144-B, 120144-G, 120144-H	3-1	8=16-30
*676F, Ch. 120143-B, 120143-H, similar to 681F, 686F, 687F, 696F	3-1	8=31-39
677B, 678B, Ch. 120134-B	26-3	7=1-10
680B, Ch. 120144-B, 120144-G, 120144-H	3-1	8=16-30
680D, 681B, Ch. 120140-B, 120140-G, 120140-H	26-3	7=45-57
681D, Ch. 120144-B, 120144-G, 120144-H	3-1	8=16-30
681F, Ch. 120143-B, 120143-H	3-1	8=31-39
683B, Ch. 120141-B	3-1	8=40-45
684B, 685B, Ch. 120134-B	26-3	7=1-10
686B, Ch. 120144-B, 120144-G, 120144-H	3-1	8=16-30
686D, Ch. 120140-B, 120140-G, 120140-H	26-3	7=45-57
686F, Ch. 120143-B, 120143-H	3-1	8=31-39
686L, Ch. 120142-B	3-1	8=46-55
687B, Ch. 120144-B, 120144-G, 120144-H	3-1	8=16-30
*687D, Ch. 120140B, similar to 680D, 686D	26-3	7=45-57
687F, Ch. 120143-B, 120143-H	3-1	8=31-39
687L, Ch. 120142-B	3-1	8=46-55
688B, 689B, 690B, Ch. 120129-B	26-3	7=36-44

MODEL	PACK-FILE	PAGES
<b>EMERSON RADIO &amp; PHONO. CORP. (Cont'd)</b>		
*692B, 693B, 694B, Ch. 120129-D, similar to 688B, 689B, 690B, Ch. 120129-B	26-3	7=36-44
696F, Ch. 120143-B, 120143-H	3-1	8=31-39
696L, Ch. 120142-B	3-1	8=46-55
*697B, Ch. 120129-D, similar to 688B, 689B, 690B, Ch. 120129-B	26-3	7=36-44
699B, Ch. 120148-B	39-4	9=9-16
Record Changer VM-950	39-RC1	RCH22=1-16
700B, 701B, Ch. 120153-B	39-4	9=1-8
Record Changer VM-950	39-RC1	RCH22=1-16
700D, 701D, Ch. 120158-B	50-5	9=17-24
120084-B, Ch.	3-1	8=1-13
120094A, Ch.	26-2	6=5-10
120095-B, Ch.	26-2	6=1-4
120118B, Ch.	26-2	6=11-19
120127-B, 120128-B, Ch.	26-3	7=11-19
120129B, 120129D, Ch.	26-3	7=36-44
120131-B, Ch.	26-3	7=20-27
120134-B, 120134-G, Ch.	26-3	7=1-10
120135-B, Ch.	26-3	7=28-35
120140-B, 120140-G, 120140-H, Ch.	26-3	7=45-57
120141-B, Ch.	3-1	8=40-45
120142-B, Ch.	3-1	8=46-55
120143-B, 120143-H, Ch.	3-1	8=31-39
120144-B, 120144-G, 120144-H, Ch.	3-1	8=16-30
120148-B, Ch.	39-4	9=9-16
120153-B, Ch.	39-4	9=1-8
120158-B, Ch.	50-5	9=17-24
470651, Tuner	3-1	8=56-62
470662, Tuner	3-1	8=63-69

**FADA RADIO & ELECTRIC CO., INC.**

R7C15, R7C25	4-1	8=1-8
Tuner 42.51 for all 'R' Series	4-1	9=1-2
R-1025, R-1050	32-2	5=1-7
S6C55, S6C70, S6T65	32-2	7=1-12
S7C20, S7C30	32-2	7=1-14
S7C20, S7C30, Rev.	32-2	9=11-18
S7C70, S7T65	32-2	7=1-12
S-1015, S-1020, S-1030	32-2	5=8-12
S-1055	32-2	5=10-14
		7=1-12
S-1055X	32-2	7=1-12
S-1060, S-1065	32-2	5=10-14
		7=1-12
S20C10, S20T20	32-2	9=11-18
42.55, 42.64, Tuners used with 'S' Series	32-2	9=3-10

**THE FIRESTONE TIRE & RUBBER CO.**

13-G-44, 13-G-45	4-1	8=10-24
13-G-51, 13-G-52	4-1	8=25-39
13-G-53, 13-G-54, Ch. 700-90, 700-96	4-1	8=40-51
13-G-55, Ch. 700-93	4-1	8=40-51
13-G-56	4-1	8=52-59
13-G-57	4-1	8=1-9
Record Changer VM-950	4-RC1	RCH22=1-16
13-G-58, 13-G-59, 13-G-79, Ch. 700-96	4-1	8=60-70
700-90, 700-93, Ch.	4-1	8=40-51
700-96, Ch., 13-G-53, 13-G-54	4-1	8=40-51
700-96, Ch., 13-G-58, -59, -79	4-1	8=60-70

**FRANKLIN AIRLOOP CORP.**

500-A-10, Tuner	4-1	8=1-2
-----------------	-----	-------

**FREED-EISEMANN  
See FREED RADIO CORP.**



**FREED HALLICRAFTERS**

MODEL	PACK-FILE	PAGES
<u>FREED RADIO CORP.</u> (FREED-EISEMANN)		
54, 55, 56, 68, Ch. 1620C	32-1	5=1-7
101, 102, 103, 104, Ch. 1900	32-1	5=8-10
110, 111, 112, Ch. 700-120	50-2	9=1-8
121	50-2	9=9-14
700-120, Ch.	50-2	9=9-14
1620C, Ch.	32-1	5=1-7
1900, Ch.	32-1	5=8-10

GAMBLE-SKOGMO, INC.  
(CORONADO)

05RA4-43-8935A	31-2	6=1-6
05TV1-43-9014A, Ch. 16AY210	31-2	6=7-16
05TV2-43-8950A	31-2	6=17-26
05TV2-43-9010A	31-2	6=17-26
05TV6-43-8935A	31-2	6=1-6
15RA2-43-9105A, Ch. 16AY210	31-2	6=7-16
15TV1-43-8957A	5-1	8=1-8
15TV1-43-8958A	31-2	9=1-8
15TV1-43-9008A	5-1	8=9-18
15TV1-43-9015A,		
15TV1-43-9016A	5-1	8=1-8
15TV1-43-9020A,		
15TV1-43-9021A	31-2	9=1-8
15TV2-43-9101A,		
15TV2-43-9102A	5-1	8=19-27
Record Changer VM-950	5-RC1	RCH22=1-16
15TV2-43-9025A	5-1	8=28-35
15TV2-43-9025B	5-1	8=28-38
15TV2-43-9026A	5-1	8=28-35
15TV2-43-9026B	5-1	8=28-38
15TV4-7003U, Ch.	5-1	8=39-46
15TV4-43-8948A,		
15TV4-43-8949A, Ch.		
15TV4-7003U	5-1	8=39-46
16AY210, Ch.	31-2	6=7-16
94TV2-43-8972A,		
94TV2-43-8973A	32-3	5=1-8
94TV2-43-8987A	32-3	5=1-8
94TV2-43-8993A, 94TV2-		
43-8994A, 94TV2-43-8995A	32-3	5=1-8
94TV6-43-8953A	32-3	5=9-14

GAROD RADIO CORP.

12C4, 12C5; 94 Series	19-1	5=1-14
12T2, 12T3, 12T6; 94 Series	19-1	5=1-14
14C4, 94 Series	19-1	5=1-14
14CT4, 97, 98 Series	19-1	5=1-20
14T2, 14T6; 94 Series	19-1	5=1-14
16C4, 16C5, 16C6; 94 Series	19-1	5=1-14
16CT4, 16CT5; 97, 98 Series	19-1	5=1-20
16T2, 16T3; 94 Series	19-1	5=1-14
19C6, 19C7; 97, 98 Series	19-1	5=1-20
1042, 1042G Late	19-1	5=1-14
1042GU, 1042T Late	19-1	5=1-14
1043, 1043G Late	19-1	5=1-14
1043GU, 1043T Late	19-1	5=1-14
1142 Late, 1143 Late	19-1	5=1-14
1244, 1244G Late, 1244GU	19-1	5=1-14
1244T Late, 1244TX	19-1	5=1-14
1245, 1245G Late, 1245GU	19-1	5=1-14
1245T Late, 1245TX	19-1	5=1-14
1344 Late, 1345 Late	19-1	5=1-14
1348	19-1	5=1-14
1546, 1546G Late, 1546GU	19-1	5=1-14
1546T Late	19-1	5=1-14
1547, 1547G Late, 1547GU	19-1	5=1-14
1547T Late	19-1	5=1-14
1548, 1548G Late, 1548GU	19-1.	5=1-14
1548T Late	19-1	5=1-14
1549, 1549G Late, 1549GU	19-1	5=1-14
1549T Late	19-1	5=1-14
1646, 1647, 1648, 1649; Late	19-1	5=1-14
1671, 97, 98 Series	19-1	5=15-17
1672, 1673, 1674, 1675;		
97, 98 Series	19-1	5=18-20
1900, 97, 98 Series	19-1	5=1-20
1974, 1975; 97, 98 Series	19-1	5=18-20

MODEL	PACK-FILE	PAGES
<u>GAMBLE-SKOGMO, INC. (Cont'd)</u>		
2042T Late, 2043T Late	19-1	5=1-14
2546T, 2547T, 2548T, 2549T;		
Late	19-1	5=1-14

GENERAL ELECTRIC CO.

10C101, 10C102	19-2	5=1-11
10T1, 10T4, 10T5, 10T6	19-2	5=1-11
12C101, 12C102, 12C105	19-2	5=25-34
12C107, 12C108, 12C109,		
B Version	19-2	5=35-47
12K1	19-2	5=12-24
Record Changer GE P14	19-RC1	RCH21=5-12
12T1	19-2	5=25-34
12T3, 12T4	19-2	5=25-44
12T3, 12T4, B Version	19-2	5=35-47
12T7	31-4	6=1-11
14C102, 14C103	31-4	6=12-21
14T2, 14T3	31-4	6=12-21
16C110, 16C111	31-4	6=35-44
16C113	19-3	7=1-10
16C115	31-4	6=35-44
16C116	19-3	7=1-10
16K1, 16K2	31-4	6=22-34
16T1, 16T2	31-4	6=35-44
16T3, 16T4	19-3	7=1-10
17C101, 17C102	19-3	7=1-12
17C103, 17C104, 17C105	5-1	8=21-32
17C107, 17C108, 17C109	5-1	8=21-32
17C110, 17C111	5-1	8=1-20
17C112	50-5	9=1-8
17C113	50-5	9=9-24
17C114	50-5	9=1-8
17C115	50-5	9=9-24
17C117	50-5	9=9-24
17C120	50-5	9=9-24
17T1, 17T2, 17T3	5-1	8=21-32
17T4, 17T5, 17T6	50-5	9=1-8
17T7	50-5	9=9-24
19C101	5-1	8=33-44
815	19-3	7=13-22

GENERAL INSTRUMENT CORP.

44, Tuner	35-2	5=1-4
45, Electuner	31-1	6=1-6

THE HALLICRAFTERS CO.

B919120, Ch.	49-5	9=17-24
C919120, Ch.	35-4	5=1-10
D919120, Ch.	28-2	6=1-8
E800D, Ch.	49-5	9=25-36
G900S, Ch.	49-5	9=67-84
J800D, Ch.	49-5	9=25-36
K800D, Ch.	49-5	9=25-36
L800D, Ch.	49-5	9=53-66
L900D, Ch.	49-5	9=37-52
L919120, Ch.	28-2	6=21-28
M800S, Ch.	6-1	8=1-16
M900D, Ch.	49-5	9=37-52
P800S, Ch.	49-5	9=67-84
R900D, Ch.	49-5	9=37-52
U800S, Ch.	49-5	9=67-84
680, 681, Ch. B919120, Run 3	49-5	9=17-24
690, Ch. B919120, Run 3	49-5	9=17-24
715, 715A, Ch. B919120, Run 3	49-5	9=17-24
716, 717, Ch. C919120	35-4	5=1-10
730, 731, Ch. C919120	35-4	5=1-10
740, 741, Ch. C919120	35-4	5=1-10
745, Ch. D919120	28-2	6=1-8
747, 748, Ch. D919120	28-2	6=1-8
750, 751, Ch. D919120	28-2	6=1-8
760, 761, Ch. D919120	28-2	6=1-8
805, 806, Ch. M800S	6-1	8=1-16
810, Ch. M800S	6-1	8=1-16
810A	28-3	9=1-14
810C, Ch. M800S	6-1	8=1-16
811	6-1	8=17-28
811, Ch. E800D, Runs 2-8	49-5	9=25-36



MODEL	PACK-FILE	PAGES
<u>THE HALLICRAFTERS CO. (Cont'd)</u>		
815	28-3	7=1-11
818	28-2	6=9-20
818, Ch. K800D, Runs 2-8	49-5	9=25-36
820, 821	6-1	8=17-28
820, 821, Ch. E800D, Runs 2-8	49-5	9=25-36
822	28-3	7=12-22
832, 833, Ch. L919120	28-2	6=21-28
860, 861	6-1	8=17-28
Record Changer GENERAL INSTRUMENT 700F	6-RC1	RCH19=1-10
860, 861, Ch. E800D, Runs 2-8	49-5	9=25-36
Record Changer GENERAL INSTRUMENT 700F	49-RC1	RCH19=1-10
870, 871	28-3	7=1-11
880	28-3	9=1-14
14808, Ch. R900D, Runs 1, 2	49-5	9=37-52
14808B, Prelim.	28-3	9=15-16
17804C, Ch. L800D, Runs 1-3	49-5	9=53-66
17810C, 17810M, 17810MG, Ch. G900S, P800S, U800S, Run 1	49-5	9=67-84
17812, 17813, Ch. L800D, Runs 1-3	49-5	9=53-66
17815-H, Ch. L800D, Runs 1-3	49-5	9=53-66
17819, Ch. L800D, Runs 1-3	49-5	9=53-66
17824, 17825, Ch. L800D, Runs 1-3	49-5	9=53-66
17838, Ch. L800D, Runs 1-3	49-5	9=53-66
17848, 17849, 17850, Ch. L800D, Runs 1-3	49-5	9=53-66
20823, Ch. M900D, Run 1	49-5	9=37-52
20823B, Ch. L900D, Run 1	49-5	9=37-52
20872, Ch. G900S, P800S, U800S, Run 1	49-5	9=67-84
20990, 20990S, Ch. J800D	49-5	9=25-36
Record Changer GENERAL INSTRUMENT 700F	49-RC1	RCH19=1-10
20994, Ch. J800D	49-5	9=25-36
Record Changer GENERAL INSTRUMENT 700F	49-RC1	RCH19=1-10

THE HERTNER ELECTRIC CO.  
(PRECISION)

L-10	35-1	5=1-12
------	------	--------

HOFFMAN RADIO CORP.

Tuner	29-2	6=1-4
RF-6, RF-7, RF-8, Tuners	29-3	9=11-16
24B707, 24M708, Ch. 187, 187B, 187C	29-3	9=1-10
140, 142, Ch., Rev.	35-4	5=8-16
149, Ch.	35-4	5=8-16
150, Ch.	35-4	5=7-16
151, 152, Ch.	35-4	5=17-24
153, Ch.	29-3	7=1-5
154, Ch.	35-4	5=1-5
155, Ch.	35-4	5=1-5
		5=7
156, 157, Ch.	29-3	7=3
		7=6-21
158, Ch.	35-4	5=1-7
159, 160, Ch.	29-2	6=5-14
164, Ch.	29-3	7=3
		7=6-21
170, 171, Ch.	29-2	6=15-28
172, Ch.	29-3	7=22-30
173, Ch.	29-2	6=15-28
174, Ch.	29-3	7=22-30
175, Ch.	29-2	6=15-28
176, Ch.	29-3	7=22-30
180, Ch.	6-1	8=26-34
183, 184, 185, 186, Ch.	6-1	8=8-25
187, 187B, 187C, Ch.	29-3	9=1-10
600, Ch. 154	35-4	5=1-15
601, Ch. 155	35-4	5=1-5
		5=7
610, Ch. 140, Rev.	35-4	5=8-16
612, Ch. 142, Rev.	35-4	5=8-16
613, Ch. 149	35-4	5=8-16

MODEL	PACK-FILE	PAGES
<u>HOFFMAN RADIO CORP. (Cont'd)</u>		
620, 621, Ch. 155	35-4	5=1-5
		5=7
622, 623, Ch. 149	35-4	5=8-16
630, 631, Ch. 159	29-2	6=5-14
630, 631, Ch. 170	29-2	6=15-28
632, 633, Ch. 160	29-2	6=5-14
632, 633, 634, 635, Ch. 171	29-2	6=15-28
636, 637, Ch. 183	6-1	8=8-25
638, 639, Ch. 180	6-1	8=26-34
830, 831, 832, Ch. 151	35-4	5=17-24
836, 837, 840, Ch. 153	29-3	7=1-5
841, 842, 843, Ch. 158	35-4	5=1-7
846, Ch. 151	35-4	5=17-24
847, 848, 849, Ch. 156	29-3	7=3
		7=6-21
850, 851, 852, Ch. 151	35-4	5=17-24
856, 857, 858, Ch. 153	29-3	7=1-5
860, 861, 862, Ch. 157	29-3	7=3
		7=6-21
866, 867, 868, Ch. 171	29-2	6=15-28
866A, 867A, 868A, Ch. 173	29-2	6=15-28
870, 871, 872, Ch. 170	29-2	6=15-28
876, 877, 878, Ch. 171	29-2	6=15-28
876A, 877A, 878A, Ch. 173	29-2	6=15-28
880, 881, 882, 883, 884, 885, 886, 887, Ch. 183	6-1	8=8-25
890, 891, 892, Ch. 175	29-2	6=15-28
893, 894, 895, Ch. 185	6-1	8=8-25
Record Changer VM-950 or WEBSTER 100	6-RC1	RCH22=1-16
	6-RC1	RCH21=1-10
896, 897, Ch. 185	6-1	8=8-25
914, 915, 916, Ch. 150	35-4	5=7-16
917, 918, 920, Ch. 152	35-4	5=17-24
921, Ch. 150	35-4	5=7-16
930, 931, 932, Ch. 150	35-4	5=7-16
936, 937, 938, Ch. 152	35-4	5=17-24
946, 947, 948, Ch. 164	29-3	7=3
		7=6-21
950, 951, 952, Ch. 172	29-3	7=22-30
950A, 951A, 952A, Ch. 174	29-3	7=22-30
953, 954, 955, Ch. 184	6-1	8=8-25
Record Changer VM-950 or WEBSTER 100	6-RC1	RCH22=1-16
	6-RC1	RCH21=1-10
960, 961, 962, Ch. 176	29-3	7=22-30
963, 964, 965, Ch. 186	6-1	8=8-25
Record Changer VM-950 or WEBSTER 100	6-RC1	RCH22=1-16
	6-RC1	RCH21=1-10

HYDE PARK  
See MACY'S

INTERSTATE STORES BUYING CORP.  
(PLYMOUTH)

AR-21, AR-21B	50-2	9=1-16
AR-71, AR-71B	50-2	9=1-16
AR-73L	50-2	9=1-16
ARC-21, ARC-21B	50-2	9=1-16
ARC-71, ARC-71B	50-2	9=1-16
ARD-21M, ARD-22B	50-2	9=1-16
ARD-72, ARD-72B	50-2	9=1-16
250, 350	35-1	5=1-11
750	35-1	5=1-11
P1650T	35-1	7=1-8
P1652, P1653	35-1	7=1-8
P1751, P1752, P1753	35-1	7=1-8
P2052	35-1	7=1-8

JACKSON INDUSTRIES, INC.

114G, 116G, 117G, 120G, Ch.	6-1	8=1-8
1400T, Ch. 114G, 116G, 117G, 120G	6-1	8=1-8
1700C, 1700T, Ch. 114G, 116G, 117G, 120G	6-1	8=1-8
2000C, Ch. 114G, 116G, 117G, 120G	6-1	8=1-8



**JACKSON  
MAJESTIC**

MODEL	PACK-FILE	PAGES
<b>JACKSON INDUSTRIES, INC. (Cont'd)</b>		
3170C, Ch. 114G, 116G, 117G, 120G Record Changer VM-950	6-1 6-RC1	8=1-8 RCH22=1-16
5120C, Ch. 114G, 116G, 117G, 120G Record Changer VM-950	6-1 6-RC1	8=1-8 RCH22=1-16

**KAYE-HALBERT CORP.**

Cambridge, Hideaway	30-2	6=1-7
Normandy, Windsor	30-2	6=1-7
014, 024, Ch. 253	6-1	8=1-6
044, 045, 046, Ch. 253	6-1	8=1-6
074, 076, 077, Ch. 253	6-1	8=1-6
231, Ch.	30-2	6=1-7
231, 232, 233, Ch. 231, 242	30-2	6=1-7
234, Ch. 231, 242, Hideaway	30-2	6=1-7
235, Ch. 231, 242, Windsor	30-2	6=1-7
236, Ch. 231, 242, Normandy	30-2	6=1-7
237, Ch. 231, 242, Cambridge	30-2	6=1-7
238, Ch. 231, 242	30-2	6=1-7
239, Ch. 231, 242, Hideaway	30-2	6=1-7
240, Ch. 231, 242, Windsor	30-2	6=1-7
242, Ch.	30-2	6=1-7
253, Ch.	6-1	8=1-6
424, Ch. 253	6-1	8=1-6
714, 724, Ch. 253	6-1	8=1-6
731, 733, Ch. 231, 242	30-2	6=1-7
744, 745, Ch. 253	6-1	8=1-6
777, Ch. 253	6-1	8=1-6
914, Ch. 253	6-1	8=1-6

**MACY ASSOCIATES  
See MACY'S**

**MACY'S**

AR14L, Ch. TVG, Artone, Hyde Park	7-1	9=21-30
AR-16 T-68, Artone	7-2	9=31-38
AR17L, Ch. TVG, Artone, Hyde Park	7-1	9=21-30
AR-23TV-1, Artone	7-2	9=31-38
HP-21B, HP-21M	47-3	9=57-72
HP-71B, HP-71M	47-3	9=57-72
HPC-21B, HPC-21M, HPC-22X	47-3	9=57-72
HPC-71B, HPC-71M	47-3	9=57-72
HPD-21	47-3	9=57-72
MST12, Artone, Astoria, Hyde Park	7-2	9=45-52
Q-2617, Q-2617-1, Ch. 260-FM, 260-V, Macy Associates, Supremacy	7-2	9=53-56
Q-2619, Q-2619-1, Q-2620, Q-2620-1, Ch. 260-FM, 260-V, Macy Associates, Supremacy	7-2	9=53-56
S-20, Ch. 260-FM, 260-V, Macy Associates, Supremacy	7-2	9=53-56
S-210, S-211, S-212, S-213, Ch. 260-FM, 260-V, Macy Associates, Supremacy	7-2	9=53-56
TVG, Ch.	7-1	9=21-30
10C, 12X, Artone, Astoria, Hyde Park	7-2	9=45-52
16CD, Artone, Astoria, Hyde Park	7-1	9=1-8
16TR, Artone, Hyde Park	7-1	9=11-20
17CD, Ch. TVG, Artone, Hyde Park	7-1	9=21-30
17CR, Artone, Hyde Park	7-1	9=11-20
17CR, 17CRR, Ch. TVG, Artone, Hyde Park	7-1	9=21-30
17RDG, Ch. TVG, Artone, Hyde Park	7-1	9=21-30
17RO, Artone, Hyde Park	7-1	9=11-20
17ROR, Ch. TVG, Artone, Hyde Park	7-1	9=21-30
19CD, Artone, Hyde Park	7-1	9=1-9
19CX, Artone, Hyde Park	7-1	9=1-10

MODEL	PACK-FILE	PAGES
<b>MACY'S (Cont'd)</b>		
20CD, 20TR, Ch. TVG, Artone, Hyde Park	7-1	9=21-30
112, 112X, Artone, Astoria, Hyde Park	7-2	9=45-52
114, Artone, Hyde Park	7-1	9=11-20
203D, 204CAF, Ch. TVG, Artone, Hyde Park	7-1	9=21-30
260-FM, 260-V, Ch.	7-2	9=53-56
312, Artone, Astoria, Hyde Park	7-2	9=45-52
316, Astoria, Hyde Park	7-1	9=1-8
516, Artone, Hyde Park	7-1	9=11-20
816-3CR, Artone, Astoria, Hyde Park	7-1	9=1-8
819, Artone, Hyde Park	7-1	9=1-8 9=10
819, 819-3CM, 920, Ch. TVG, Artone, Hyde Park	7-1	9=21-30
1000, 1001, Ch. TVG, Artone, Hyde Park	7-1	9=21-30
1920, Ch. TVG, Artone, Hyde Park	7-1	9=21-30
2400, 4620, Ch. 260-FM, 260-V, Macy Associates, Supremacy	7-2	9=53-56

**THE MAGNAVOX CO.**

CT-232, CT-236, Ch.	30-1	6=1-14
CT-239, CT-240, Ch.	30-1	6=1-14
CT-244, CT-245, CT-246, Ch.	30-1	6=1-14
CT-247, CT-248, CT-249, Ch.	30-1	6=15-28
CT-250, CT-251, Ch.	30-1	6=1-14
CT-252, CT-253, CT-255, Ch.	30-1	6=15-28
CT-257, CT-258, CT-259, CT-260	30-1	7=1-13
CT-262, CT-263, CT-264, CT-265, CT-266, CT-267, CT-269, Series 103 Ch.	30-1	6=29-38
CT-270, CT-271, CT-272, CT-273, CT-274, CT-275, CT-276, CT-277, CT-278, CT-279, CT-280, CT-281, CT-282	30-1	7=14-28
CT-283, CT-284, CT-285, CT-286, CT-287, CT-288, CT-289, CT-290, CT-291, CT-293, CT-294, Series 103 Cn.	30-1	6=29-38
CT-295, CT-296	30-1	7=1-13
CT-297, Series 103 Ch.	30-1	6=29-38

**MAJESTIC RADIO & TELEVISION  
DIV. OF WILCOX-GAY CORP.**

A-70, Ch. 106A	6-1	8=1-7
A-712, Ch. 106A	6-1	8=1-7
7P1, 7P2, 7P3, Ch. 101A	30-2	7=1-16
7P10, 7P11, Ch. 101A	30-2	7=1-16
7PR12, 7PR13, Ch. 101C	30-2	7=1-16
9P4, 9P5, Ch. 103	30-2	7=1-16
9PR8, 9PR9, Ch. 103A	30-2	7=1-16
17DA, Ch. 101D	30-2	7=1-16
17FA, Ch. 106A	6-1	8=1-7
17GA, 17HA, Ch. 101D	30-2	7=1-16
17JA, 17K, Ch. 106A	6-1	8=1-7
20K, Ch. 108C	6-1	8=1-7
20KA, 20LA, Ch. 108A	6-1	8=1-7
20UAT, Ch. 108B	6-1	8=1-7
20UC, 20UT, Ch. 108D	6-1	8=1-7
20X, Ch. 108B	6-1	8=1-7
70, 72, 73, Ch. 106	6-1	8=1-7
99, 100, 101, 101A, 101B, 101C, 101D, 102, 103, 103A, Ch.	30-2	7=1-16
105, Ch.	30-2	7=1-16
106, 106A, Ch.	6-1	8=1-7
108, 108A, 108B, 108C, 108D, Ch.	6-1	8=1-7
120, 121, 121B, Cn. 99	30-2	7=1-16
141, 141B, Ch. 100	30-2	7=1-16
141C, Ch. 101B	30-2	7=1-16
142, 142B, Ch. 100	30-2	7=1-16



MODEL	PACK-FILE	PAGES
<b>MAJESTIC RADIO &amp; TELEVISION (Cont'd)</b>		
143	30-2	7-1-16
160, 160B, Ch. 101	30-2	7-1-16
162, 163, Ch. 101	30-2	7-1-16
170, Ch. 101A	30-2	7-1-16
173	30-2	7-1-16
700, 701, Ch. 106	6-1	8-1-7
712, 715, 717, 718, 719, Ch. 106	6-1	8-1-7
800, 801, 802, 803, 804, Ch. 108	6-1	8-1-7
902, 903, Ch. 103	30-2	7-1-16
910, 911, Ch. 103	30-2	7-1-16
1400, 1400B, Ch. 100	30-2	7-1-16
1401, Ch. 105	30-2	7-1-16
1600, 1600B, Ch. 101	30-2	7-1-16
1605, 1605B, Ch. 102	30-2	7-1-16
1610, 1610B, Ch. 102	30-2	7-1-16
1700C, 1701C	30-2	7-1-16
1710, Ch. 101A	30-2	7-1-16
1720, 1721	30-2	7-1-16

**JOHN MECK INDUSTRIES, INC.**

JM-717C, JM-717T, Ch. 9021	7-1	8-1-11
JM-720C, JM-720T, Ch. 9023	7-1	8-1-11
MM-510T, MM-512C, MM-512T	45-2	6-1-5
MM-516C, MM-516T	45-2	6-1-5
MM-614C, MM-614T, Ch. 9018	45-2	7-1-11
MM-614TL, Ch. 9022, 9024	7-1	8-1-11
MM-616C, MM-616T, Ch. 9018	45-2	7-1-11
MM-617C, MM-617T, Ch. 9018	45-2	7-1-11
MM-617C, MM-617TL, Ch. 9022, 9024	7-1	8-1-11
MM-619C, Ch. 9018	45-2	7-1-11
XOB, XQA, XQR	45-2	6-1-5
XRA, XRPS, XRPT, XSA	45-2	6-1-5
XSB, XSC, XSD, Ch. 9018	45-2	7-1-11
XSPS, XSPT, XTA, XTR 9018, Ch.	45-2	7-1-11
9021, 9022, 9023, 9024, Ch.	7-1	8-1-11

**MIDWEST RADIO & TELEV. CORP.**

BT-20, Ch.	7-1	8-1-6
CV-20, Ch.	7-1	8-7-11
DJ-19, Ch.	45-2	6-1-6
DM-16, DMA-16	45-2	7-1-7
DR-16, Ch.	45-2	6-1-6
DX-19, DXA-19, Ch.	45-2	7-1-7
K-19, KR-19, Ch. DJ-19	45-2	6-1-6
KX-19, Ch. DX-19	45-2	7-1-7
KXA-19, Ch. DXA-19	45-2	7-1-7
N-20, NC-20, Ch. BT-20	7-1	8-1-6
Record Changer VM-950	7-RC1	RCH22=1-16
NV-20, Ch. CV-20	7-1	8-7-11
P-16, PR-16, Ch. DR-16	45-2	6-1-6
PX-16, Ch. DM-16	45-2	7-1-7
PXA-16, Ch. DMA-16	45-2	7-1-7

**MITCHELL MFG. CO.**

T16-2KB, T16-2KM	45-2	6-1-4
T16-B, T16-M	45-2	6-1-4
T17-B, T17-M	7-1	8-1-4

**MONTGOMERY WARD  
(AIRLINE)**

05BR-3034A, 05BR-3041A	8-1	8-1-10
05GCB-3019A	45-4	6-1-10
05WG-3038A	8-1	8-11-20
Record Changer VM-950	8-RC1	RCH22=1-16
05WG-3045A	8-1	8-21-30
Record Changer GENERAL INSTRUMENT 700F	8-RC1	RCH19=1-10
15BR-3035A	8-1	8-31-40
Record Changer VM-950	8-RC1	RCH22=1-16
15BR-3048A	51-5	9-1-8
15BR-3053A, 15BR-3053B	8-2	8-41-51
15GSE-3047A, 15GSE-3047B	8-2	8-52-62
15WG-3046A	8-3	8-63-70

MODEL	PACK-FILE	PAGES
<b>MONTGOMERY WARD (Cont'd)</b>		
15WG-3049A	51-5	9-9-16
15WG-3046B	8-3	8-63-73
15WG-3050A	8-3	8-74-83
Record Changer WEBSTER 100	8-RC1	RCH21=1-10
15WG-3050B	8-3	8-74-83
Record Changer VM-950	8-RC1	RCH22=1-16
15WG-3051A	8-3	8-63-70
15WG-3051B	8-3	8-63-73
16K1/63-3019	45-4	6-1-10
94GCB-3023A, 94GCB-3023B, 94GCB-3023C	45-4	6-1-10
94WG-3008A	45-4	6-11-20
94WG-3106A, 94WG-3016B, 94WG-3016C	45-4	6-11-22
94WG-3028A	45-4	6-23-32

**MOTOROLA INC.**

TS-53, Ch.	36-3	6-1-15
TS-60, Ch.	47-4	7-1-16
TS-74, Ch.	36-3	6-51-64
TS-88, Ch.	36-3	6-29-41
TS-89, Ch.	47-4	7-17-34
TS-94, Ch.	47-4	7-17-34
TS-95, Ch.	47-4	7-17-34
TS-101, Ch.	47-5	7-57-65
TS-114, Ch.	36-3	6-42-50
TS-115, Ch.	36-3	6-16-28
TS-118, Ch.	47-5	7-35-45
		7-66-68
		9-25-32
TS-118A, TS-118B, Ch.	51-6	
TS-119, TS-119A, TS-119B, TS-119C, Ch.	9-1	8-25-38
TS-172, Ch.	47-5	7-46-56
TS-174, TS-174A, TS-175B, Ch.	9-1	8-1-15
TS-214, Ch.	51-6	9-33-40
TS-216, Ch.	9-2	9-1-8
TS-221, Ch.	9-1	8-16-24
TS-236, Ch.	9-2	9-9-16
TS-314, Ch.	51-6	9-17-24
TS-314A, Ch.	51-6	9-41-44
TS-315, Ch.	51-6	9-17-24
TS-315A, Ch.	51-6	9-41-44
12K1, 12K1B, Ch. TS-53	36-3	6-1-15
12K2, 12K2B, Ch. TS-53	36-3	6-1-15
12K3, 12K3B, Ch. TS-53	36-3	6-1-15
12T1, 12T1B, Ch. TS-53	36-3	6-1-15
12T2, 12T3, Ch. TS-53	36-3	6-1-15
14K1, 14K1B, Ch. TS-88	36-3	6-29-41
14K1BH, 14K1H, Ch. TS-115	36-3	6-16-28
14T1, 14T1B, Ch. TS-88	36-3	6-29-41
14T3, Ch. TS-114	36-3	6-42-50
14T4, 14T4B, Ch. TS-216	9-2	9-1-8
16F1, 16F1B, Ch. TS-60	47-4	7-1-16
16F1BH, 16F1H, Ch. TS-89	47-4	7-17-34
16K2, 16K2B, Ch. TS-74	36-3	6-51-64
16K2BH, 16K2H, Ch. TS-94	47-4	7-17-34
16T1, 16T1B, Ch. TS-60	47-4	7-1-16
16T1BH, 16T1H, Ch. TS-89	47-4	7-17-34
17F1, Ch. TS-118A, TS-118B	51-6	9-25-32
17F1, 17F1B, Ch. TS-118	47-5	7-35-45
17F1A, 17F1BA, Ch. TS-89	47-4	7-17-34
17F2W, Ch. TS-118	47-5	7-35-45
17F2W, Ch. TS-118A, TS-118B	51-6	9-25-32
17F2WA, Ch. TS-89	47-4	7-17-34
17F3B, Ch. TS-118	47-5	7-35-45
17F3B, Ch. TS-118A, TS-118B	51-6	9-25-32
17F3BA, Ch. TS-89	47-4	7-17-34
17F4, Ch. TS-118	47-5	7-35-45
17F4, Ch. TS-118A, TS-118B	51-6	9-25-32
17F4A, Ch. TS-89	47-4	7-17-34
17F5, Ch. TS-118	47-5	7-35-45
17F5, Ch. TS-118A, TS-118B	51-6	9-25-32
17F5A, Ch. TS-89	47-4	7-17-34
17F5B, Ch. TS-118	47-5	7-35-45
17F5BA, Ch. TS-89	47-4	7-17-34
17F6, Ch. TS-118	47-5	7-35-45
17F6, Ch. TS-118A, TS-118B	51-6	9-25-32



MODEL	PACK-FILE	PAGES
<u>MOTOROLA INC. (Cont'd)</u>		
17F6B, Ch. TS-118	47-5	7=35-45 7=66-68
17F6BC, 17F6C, Ch. TS-174 TS-174A, TS-174B Record Changer MOTOROLA RC-36A	9-1 9-RC1	8=1-15 RCH21=1-16
17F7, Ch. TS-118A, TS-118B	51-6	9=25-32
17F7B, Ch. TS-118	47-5	7=35-45 7=66-68
17F7B, Ch. TS-118A, TS-118B	51-6	9=25-32
17F7BC, Ch. TS-174, TS-174A, TS-174B Record Changer MOTOROLA RC-36A	9-1 9-RC1	8=1-15 RCH21=1-16
17F8, Ch. TS-118	47-5	7=35-45
17F8, Ch. TS-118A, TS-118B	51-6	9=25-32
17F8C, Ch. TS-174, TS-174A, TS-174B Record Changer MOTOROLA RC-36A	9-1 9-RC1	8=1-15 RCH21=1-16
17F9, Ch. TS-118A, TS-118B	51-6	9=25-32
17F9, 17F9B, Ch. TS-118	47-5	7=35-45 7=66-68
17F9BC, 17F9C, Ch. TS-174, TS-174A, TS-174B Record Changer MOTOROLA RC-36A	9-1 9-RC1	8=1-15 RCH21=1-16
17K1A, 17K1BA, Ch. TS-95	47-4	7=17-34
17K1BE, 17K1E, Ch. TS-172	47-5	7=46-56
17K2BE, 17K2E, Ch. TS-172	47-5	7=46-56
17K3, Ch. TS-118	47-5	7=35-45
17K3, Ch. TS-118A, TS-118B	51-6	9=25-32
17K3A, 17K3BA, Ch. TS-89	47-4	7=17-34
17K3B, Ch. TS-118	47-5	7=35-45
17K4A, Ch. TS-95	47-4	7=17-34
17K4E, Ch. TS-172	47-5	7=46-56
17K5, Ch. TS-118	47-5	7=35-45 7=66-68
17K5, Ch. TS-118A, TS-118B	51-6	9=25-32
17K5C, Ch. TS-174, TS-174A, TS-174B	9-1	8=1-15
17K5E, Ch. TS-221	9-1	8=16-24
17K6, Ch. TS-118	47-5	7=35-45 7=66-68
17K6, Ch. TS-118A, TS-118B	51-6	9=25-32
17K6C, Ch. TS-174, TS-174A, TS-174B	9-1	8=1-15
17K7, 17K7B, Ch. TS-118	47-5	7=35-45 7=66-68
17K7, Ch. TS-118A, TS-118B	51-6	9=25-32
17K7BC, 17K7C, Ch. TS-174, TS-174A, TS-174B	9-1	8=1-15
17K8, 17K8B, Ch. TS-236	9-2	9=9-16
17K10E, Ch. TS-314	51-6	9=17-24
17K10E, Ch. TS-314A	51-6	9=41-44
17K11, 17K11B, 17K11C, Ch. TS-236	9-2	9=9-16
17T1, 17T1B, Ch. TS-118	47-5	7=35-45
17T1A, 17T1BA, Ch. TS-89	47-4	7=17-34
17T2, Ch. TS-118A, TS-118B	51-6	9=25-32
17T2, 17T2B, Ch. TS-118	47-5	7=35-45
17T2A, 17T2BA, Ch. TS-89	47-4	7=17-34
17T3, Ch. TS-118	47-5	7=35-45
17T3, Ch. TS-118A, TS-118B	51-6	9=25-32
17T3A, Ch. TS-89	47-4	7=17-34
17T3G, Ch. TS-221	9-1	8=16-24
17T3X1, Ch. TS-118A, TS-118B	51-6	9=25-32
17T4, Ch. TS-118	47-5	7=35-45 7=66-68
17T4, Ch. TS-118A, TS-118B	51-6	9=25-32
17T4C, Ch. TS-174, TS-174A, TS-174B	9-1	8=1-15
17T4E, Ch. TS-221	9-1	8=16-24
17T5A, 17T5CA, Ch. TS-214	51-6	9=33-40
17T5D, Ch. TS-236	9-2	9=9-16

MODEL	PACK-FILE	PAGES
<u>MOTOROLA INC. (Cont'd)</u>		
17T5E, Ch. TS-314	51-6	9=17-24
17T5E, Ch. TS-314A	51-6	9=41-44
17T5F, Ch. TS-315	51-6	9=17-24
17T5F, Ch. TS-315A	51-6	9=41-44
17T6BD, 17T6C, 17T6D, Ch. TS-236	9-2	9=9-16
17T6G, Ch. TS-314A	51-6	9=41-44
19K2, 19K2B, Ch. TS-101	47-5	7=57-65
19K2BE, 19K2E, Ch. TS-119, TS-119A	9-1	8=25-38
19K3, Ch. TS-101	47-5	7=57-65
19K4, 19K4B, Ch. TS-101	47-5	7=57-65
20F1, 20F1B, Ch. TS-119, TS-119A	9-1	8=25-38
Record Changer MOTOROLA RC-36A	9-RC1	RCH21=1-16
20F2, 20F2B, Ch. TS-119B, TS-119C	9-1	8=25-38
Record Changer MOTOROLA RC-36A	9-RC1	RCH21=1-16
20K1, 20K1B, 20K2, Ch. TS-119B, TS-119C	9-1	8=25-38
20T1B, Ch. TS-119B, TS-119C	9-1	8=25-38

M. P. TELEVISION

16T503, 17T504	9-1	8=1-4
----------------	-----	-------

MULTIPLE TELEV. MFG. CO.

EC20, Ch. 630K3B	9-1	8=1-2
HFD17, HFD20, Ch. 630K3B	9-1	8=1-2
LFD17, LFD20, Ch. 630K3B	9-1	8=1-2
OF17, OF20, OF20R, Ch. 630K3B	9-1	8=1-2
630K3B, Ch.	9-1	8=1-2

MUNTZ T-V, INC.

M31, Ch. TV17A2	36-1	6=1-12
M31R, Ch. TV17A3	36-1	6=1-12
M32, M32R, Ch. TV17A3	36-1	6=1-12
M33, M34, Ch. TV17A4	36-1	6=1-12
M41, M42, Ch. TV17A3A	36-1	6=1-12
M46, M49, Ch. TV17A7	36-1	6=1-12
TV17A2, Ch.	36-1	6=1-12
TV17A3, TV17A3A, Ch.	36-1	6=1-12
TV17A4, TV17A7, Ch.	36-1	6=1-12
WG2060	51-2	9=13-20
17B1, 17B2, 17B3, 17B4, 17B5, 17B6, Ch.	51-2	9=1-12
*1750, 1751, 1752, Ch. TV17A3A	36-1	6=1-12
*2053, 2054, 2055, 2056, Ch. TV17A7	36-1	6=1-12
2053-A, 2054-A, 2055-A, Ch. 17B1, 17B2	51-2	9=1-12
2055-B, Ch. 17B2	51-2	9=1-12
2056-A, Ch. 17B1, 17B2	51-2	9=1-12
2158-A, 2159-A, Ch. 17B5,		
2162-A, Ch. 17B5, 17B6	51-2	9=1-12
2457-A, Ch. 17B3, 17B4	51-2	9=1-12

NORELCO

See NORTH AMERICAN PHILLIPS CO., INC.

NORTH AMERICAN PHILLIPS CO., INC.  
(NORELCO)

The Irvington	38-1	6=1-11
The Mt. Vernon	38-1	6=1-11
PT200, Ch.	38-1	6=1-11
PT200, Ch. PT200, The Irvington	38-1	6=1-11
PT300, Ch. PT200, The Mt. Vernon	38-1	6=1-11

\* See Muntz HANDY No. 8, Pack 36



MODEL	PACK-FILE	PAGES	MODEL	PACK-FILE	PAGES
<u>OLYMPIC RADIO &amp; TELEV. INC.</u>			<u>PHILCO CORP. (Cont'd)</u>		
Broadmoor	44-1	6=1-12	50-T1105, Codes 121, 122	34-4	5=1-6 6=19-20
Catalina	44-1	6=1-15	50-T1106	34-4	5=1-6 6=19-20
Challenger	44-1	6=1-12	50-T1403, Code 125	34-4	5=7-16 6=29-32
Lancaster, Marlborough	44-1	7=1-8	50-T1404, Codes 123, 124, 125	34-4	5=7-16 6=29-32
Monte Carlo	44-1	6=1-12	50-T1406, Codes 123, 124, 125	34-4	5=7-16 6=29-32
Prince George	44-1	6=1-15	50-T1432, Code 124	34-4	5=7-16 6=29-32
Riviera	44-1	6=1-12	50-T1443, Codes 122, 123	37-5	6=33-43
Riviera Deluxe	44-1	7=1-8	50-T1476, 50-T1477	37-5	6=44-54
Windsor	44-1	7=1-8	50-T1478, 50-T1479	37-5	6=44-54
DX-214, DX-215, DX-216	44-1	4=1 5=1-6	Record Changer PHILCO M-20	37-RC1	RCH20=1-16
DX-619, DX-620	44-1	5=1-7	50-T1481, 50-T1482	37-5	6=44-54
DX-621	44-1	5=1-7 6=13-15	Record Changer PHILCO M-20	37-RC1	RCH20=1-16
DX-622	44-1	5=1-7	50-T1483	22-2	7=1-10
DX-931, DX-932	44-1	5=1-7	50-T1484	37-5	6=44-54
DX-950	44-1	5=1-7	50-T1600, Code 121	34-4	5=17-23
XL-210, XL-211	44-1	5=8-14	50-T1600, Code 122	22-2	7=11-17
XL-612, XL-613	44-1	5=8-14	50-T1630, Code 121	22-2	7=18-21
752, Riviera	44-1	6=1-12	50-T1630, Code 122	22-2	5=17-23
752U	44-1	6=1-12	50-T1632, 50-T1633, Code 121	34-4	7=18-32
753, Monte Carlo	44-1	6=1-12	50-T1632, 50-T1633, Code 122	22-2	5=17-23
753U	44-1	6=1-12	50-702, Code 122	37-5	7=11-17
755, Challenger	44-1	6=1-12	51-PT1207, 51-PT1208	10-1	6=9-17
755U	44-1	6=1-12	51-PT1234	10-1	5=17-23
762, Riviera Deluxe	44-1	7=1-8	51-PT1282	10-1	8=5-12
764, Broadmoor	44-1	6=1-12	Record Changer PHILCO M-22	10-RC2	8=5-12
764U	44-1	6=1-12	51-T1443B, 51-T1443L, 51-T1443M	10-RC2	RCH22=1-12
766, Catalina	44-1	6=1-15	51-T1443PL, 51-T1443PM, 51-T1443PW	22-2	7=33-40
766U, 767	44-1	6=1-12	51-T1443X, 51-T1443XL	22-2	7=41-50
769, Prince George	44-1	6=1-15	51-T1601, 51-T1601T, 51-T1602, Codes 121, 122	22-2	7=33-40
783	44-1	7=1-8	51-T1634, Codes 123, 124	22-2	7=51-58
967, Windsor	44-1	7=1-8	51-T1836, 51-T1836L, Code 123	10-1	7=51-58
968, Lancaster	44-1	7=1-8	51-T1838, Code 124	10-1	8=14-31
970, Marlborough	44-1	7=1-8	51-T1870, 51-T1872, Code 121	10-1	8=14-31
<u>PACKARD-BELL CO.</u>			Record Changer PHILCO M-22	10-RC2	RCH22=1-12
2001-TV, 2002-TV	44-2	5=1-8	51-T1874, 51-T1874L, Code 121	10-1	8=14-31
2091-TV, 2092-TV	44-2	5=3-8	Record Changer PHILCO M-22	10-RC2	RCH22=1-12
2101, 2102, Ch. 2101-2	44-2	7=1-9	51-T1875, Code 121	10-1	8=14-31
2101-2, Ch.	44-2	7=1-9	Record Changer PHILCO M-20	10-RC1	RCH20=1-16
2105, 2105A, Ch. 2101-2	44-2	7=1-9	51-T2134, 51-T2136, 51-T2138, Code 124	10-1	8=14-31
2202-TV, 2204-TV	44-2	7=10-16	51-T2175, 51-T2176, Code 124	10-1	8=14-31
2111, Ch. 2111-2	52-3	9=15-20	Record Changer PHILCO M-20	10-RC1	RCH20=1-16
2111-2, Ch.	52-3	9=15-20	52-T1810, 52-T1812, Codes 122, 123	22-3	9=1-16
2112, 2113, Ch. 2111-2	52-3	9=15-20	52-T1840, 52-T1842, 52-T1844, Codes 122, 123	22-3	9=1-16
2114, Ch. 2114	52-3	9=15-20	52-T1882, Codes 122, 123	22-3	9=1-16
2114, Ch.	52-3	9=15-20	Record Changer PHILCO M-22	22-RC2	RCH22=1-12
2301, 2302	9-1	8=1-13	52-T2100, 52-T2144, Code 121	52-6	9=17-32
2311	52-3	9=1-14	52-T2110, Codes 122, 123	22-3	9=1-16
2601-TV	44-2	5=9-14	52-T2142, Codes 122, 123	22-3	9=1-16
2602	44-2	7=1-9	52-T2145X, Code 125	52-6	9=17-32
2611	52-3	9=21-24	52-T2182, 52-T2182L, Code 121	52-6	9=17-32
Record Changer VM-950	52-RC1	RCH22=1-16	Record Changer PHILCO M-22	52-RC2	RCH22=1-12
2692-TV	44-2	5=9-14	52-T2182, 52-T2182L, Code 121	52-6	9=17-32
2801-TV, 2801A-TV	44-2	6=1-7	Record Changer PHILCO M-22	52-RC2	RCH22=1-12
2803	9-1	8=1-13	52-T2100, 52-T2144, Code 121	52-6	9=17-32
Record Changer WEBSTER 100	9-RC1	RCH21=1-10	52-T2110, Codes 122, 123	22-3	9=1-16
2811	52-3	9=1-14	52-T2142, Codes 122, 123	22-3	9=1-16
Record Changer WEBSTER 100	52-RC1	RCH21=1-10	52-T2145X, Code 125	52-6	9=17-32
2811, Late	52-3	9=1-14	52-T2182, 52-T2182L, Code 121	52-6	9=17-32
<u>PATHE TELEVISION CORP.</u>			Record Changer PHILCO M-22	52-RC2	RCH22=1-12
TAP, Ch.	10-1	8=1-5	52-T2182, 52-T2182L, Code 121	52-6	9=17-32
14-PT	10-1	8=6-11	Record Changer PHILCO M-22	52-RC2	RCH22=1-12
17-N25, Ch. TAP	10-1	8=1-5	52-T2100, 52-T2144, Code 121	52-6	9=17-32
17-PC	10-1	8=6-11	52-T2110, Codes 122, 123	22-3	9=1-16
17-RPC, 17-RPT, Ch. TAP	10-1	8=1-5	52-T2142, Codes 122, 123	22-3	9=1-16
<u>PHILCO CORP.</u>			52-T2145X, Code 125	52-6	9=17-32
RC-1 Remote Control Unit	10-1	8=1-4	52-T2182, 52-T2182L, Code 121	52-6	9=17-32
50-T1104, Codes 121, 122	34-4	5=1-6 6=18-20	Record Changer PHILCO M-22	52-RC2	RCH22=1-12
			76-4402, 76-5411, 76-5433, Series; Tuners	37-5	6=1-8



# PHILHARMONIC SCOTT

MODEL	PACK-FILE	PAGES
-------	-----------	-------

## PHILHARMONIC RADIO & TELEV. CORP.

C-6161, T-616	22-1	7=1-5
1116, 5816	22-1	7=1-5

### PILOT RADIO CORP.

TV-125	20-1	5=1-12
TV-127	37-2	6=1-10
TV-161	20-1	5=1-12
TV-163	20-1	5=1-14
TV-164	37-2	6=1-10
TV-165	20-1	5=1-14
TV-167A	37-2	6=1-10
*TV-167B, TV-168	37-2	6=1-10
TV-191	37-2	6=1-10
*TV-191	37-2	6=1-10
TV-271, TV-273, TV-274	53-3	9=1-14
TV-293, TV-294	53-3	9=1-14

### PLYMOUTH

See INTERSTATE STORES BUYING CORP.

### PRECISION

See THE HERTNER ELECTRIC CO.

### RADIO CORP. OF AMERICA

Bently	16-3	9=1-16
Bristol	16-5	9=73-80
Clarendon, Donley	16-4	9=45-52
Fairfield, Final	16-5	9=53-72
Hampton	16-5	9=73-80
Haywood	16-3	9=17-30
Highland, Final	16-5	9=53-72
Hillsdale	11-2	8=62-76
Kendall	16-5	9=73-80
Kent, Modern, Newport; Final	16-5	9=53-72
Preston	16-5	9=73-80
Provincial	11-2	8=62-76
Provincial, Regency; Final	16-5	9=53-72
Rockingham	16-4	9=45-52
Rutland	10-1	8=31-48
Somerville	10-1	8=1-16
Suffolk	16-4	9=45-52
Talbot	16-4	9=31-44
Winston, Final	16-5	9=53-72
York	11-2	8=62-76
KCS31-1, Ch., S1000	20-6	5=48-64
KCS31-1, Ch., 9TW390	20-6	5=32-47
KCS34C, Ch.	34-7	5=80-110
KCS38, Ch.	34-7	5=65-79
KCS38C, Ch.	20-6	5=1-15
KCS40, KCS40A, Ch.	37-8	6=1-15
KCS40B, Ch.	46-10	7=50-64
KCS41-1, Ch.	20-6	5=16-31
KCS45, KCS45A, Ch.	46-9	7=1-16
KCS46, Ch.	46-9	7=17-32
KCS47, KCS47A, KCS47AT, Ch.	46-10	7=33-49
KCS47B, KCS47C, KCS47D, Ch.; Final	16-5	9=53-72
KCS47E, Ch.	16-4	9=31-44
KCS47F, KCS47G, Ch.; Final	16-5	9=53-72
KCS47GF-2, Ch.	16-3	9=17-30
KCS47T, Ch.	46-10	7=33-49
KCS48A, Ch.	10-1	8=31-48
KCS49B, KCS49C, Ch.	11-2	8=62-76
KCS60A, Ch.	11-2	8=77-94
KCS61, Ch.	16-3	9=1-16
KCS62, Ch.	10-1	8=1-16
KCS66, KCS66A, Ch.	16-5	9=73-80
KCS68C, Ch.	16-4	9=45-52
S1000, Ch. KCS31-1	20-6	5=48-64
T100, Ch. KCS38	34-7	5=65-79
T120, Ch. KCS34C	34-7	5=80-94
T121, Ch. KCS34C	34-7	5=95-110
T164, Ch. KCS40	37-8	6=1-15
TC165, TC166, TC167, TC168, Ch. KCS40A	37-8	6=1-15

MODEL	PACK-FILE	PAGES
-------	-----------	-------

## RADIO CORP. OF AMERICA (Cont'd)

2T51, Ch. KCS45	46-9	7=1-16
2T60, Ch. KCS45A	46-9	7=1-16
2T81, Ch. KCS46	46-9	7=17-32
4T101, Ch. KCS61, Bently	16-3	9=1-16
4T141, Ch. KCS62, Somerville Record Changer	10-1	8=1-16
RCA 960282-4, 960282-5	10-RC2	RCH21=19-34
RCA RP-190-2	10-RC1	RCH21=1-12
6T53, 6T54, Ch. KCS47, KCS47T	46-10	7=33-49
6T64, 6T65, Ch. KCS47A, KCS47AT	46-10	7=33-49
6T71, Ch. KCS47A, KCS47AT	46-10	7=33-49
6T72, Ch. KCS40B	46-10	7=50-64
6T74, 6T75, 6T76, Ch. KCS47A, KCS47AT	46-10	7=33-49
7T103, Ch. KCS47B, Newport, Final	16-5	9=53-72
7T104, Ch. KCS47B, Kent, Final	16-5	9=53-72
7T104B, Ch. KCS47F, Final	16-5	9=53-72
7T111B, Ch. KCS47GF-2, Haywood	16-3	9=17-30
7T112, Ch. KCS47C, Highland, Final	16-5	9=53-72
7T112B, Ch. KCS47G, Final	16-5	9=53-72
7T122, Ch. KCS47C, Fairfield, Final	16-5	9=53-72
7T122B, Ch. KCS47G, Final	16-5	9=53-72
7T123, Ch. KCS47C, Regency, Final	16-5	9=53-72
7T123B, Ch. KCS47G, Final	16-5	9=53-72
7T124, Ch. KCS47C, Modern, Final	16-5	9=53-72
7T125B, Ch. KCS47G, Provincial, Final	16-5	9=53-72
7T132, Ch. KCS47D, Winston, Final	16-5	9=53-72
7T143, Ch. KCS48A, Rutland Record Changer	10-1	8=31-48
RCA 960284	10-RC3	RCH21=35-50
RCA RP-190	10-RC1	RCH21=1-12
9T105, Ch. KCS49B, York	11-2	8=62-76
9T126, Ch. KCS49C, Hillsdale	11-2	8=62-76
9T128, Ch. KCS49C, Provincial	11-2	8=62-76
9T147, Ch. KCS60A Record Changer	11-2	8=77-94
RCA 960284	11-RC3	RCH21=35-50
RCA RP-190	11-RC1	RCH21=1-12
9T256, Ch. KCS38C	20-6	5=1-15
9TW309, Ch. KCS41-1	20-6	5=16-31
9TW390, Ch. KCS31-1	20-6	5=32-47
16T152, Ch. KCS47E, Talbot	16-4	9=31-44
17T153, Ch. KCS66, Bristol	16-5	9=73-80
17T155, Ch. KCS66, Preston	16-5	9=73-80
17T160, Ch. KCS66, Hampton	16-5	9=73-80
17T174, Ch. KCS66A, Kendall	16-5	9=73-80
21T176, Ch. KCS68C, Suffolk	16-4	9=45-52
21T177, Ch. KCS68C, Donley	16-4	9=45-52
21T178, Ch. KCS68C, Rockingham	16-4	9=45-52
21T179, Ch. KCS68C, Clarendon	16-4	9=45-52

### RADIO CRAFTSMEN

RC101	15-1	8=1-5
RC100A	38-2	5=1-6
RC201	15-1	8=6-9

### RAYTHEON

See BELMONT RADIO CORP.

### SCOTT RADIO LABS., INC.

Ashly, Chippendale, Cressy, Croydon, Ravenswood, Waverly, Wellington	54-1	9=1-16
--	------	--------



MODEL	PACK-FILE	PAGES
<u>SCOTT RADIO LABS., INC. (Cont'd)</u>		
AC-17, AT-17, Ch. 720, Ravenswood	54-1	9=1-16
Record Changer WEBSTER 100	54-RC1	RCH21=1-10
310, Ch. 720, Croydon	54-1	9=1-16
Record Changer MILWAUKEE 11600	54-RC1	RCH 9=1-4
320, Ch. 920, Croydon	54-1	9=1-16
Record Changer MILWAUKEE 11600	54-RC1	RCH 9=1-4
510, Ch. 720, Cressy	54-1	9=1-16
Record Changer WEBSTER 100	54-RC1	RCH21=1-10
520-TA, Ch. 920, Ashly	54-1	9=1-16
Record Changer WEBSTER 100	54-RC1	RCH21=1-10
720, Ch.	54-1	9=1-16
910, Ch. 920, Waverly	54-1	9=1-16
Record Changer WEBSTER 100	54-RC1	RCH21=1-10
920, Ch.	54-1	9=1-16
924, Ch. 924, Wellington	54-1	9=1-16
Record Changer WEBSTER 100	54-RC1	RCH21=1-10
924, Ch.	54-1	9=1-16
1000-TC, Ch. 924, Chippendale	54-1	9=1-16
Record Changer WEBSTER 100	54-RC1	RCH21=1-10

SEARS, ROEBUCK & CO.  
(SILVERTONE)

100.112, Ch.	11-1	8=1-14
100.120, Ch.	55-4	9=57-72
102-A, Ch. 549.100-7	55-4	9=49
110.111, Ch.	11-1	8=15-31
128-16, Ch. 478.337	55-3	9=13-20
132.014, Ch.	55-4	9=53-56
132.890, 132.890-1, 132.890-2, Ch.	12-2	8=53-66
143, Ch. 100.111	11-1	8=15-31
Record Changer SEARS 100.211-20	11-RC1	RCH 9=1-16
143A, Ch. 100.111	11-1	8=15-31
Record Changer VM-950	11-RC1	RCH22=1-16
150-14, Ch. 478.338	11-1	8=32-39
153-16, Ch. 478.341	55-3	9=9-12
161-16, Ch. 100.112	11-1	8=1-14
163-16, Ch. 478.319	55-3	9=1-8
165-16, Ch. 100.120	55-4	9=57-72
166-16, Ch. 478.339	55-3	9=21-36
166-17, Ch. 478.339-A	55-3	9=21-36
167-16, Ch. 549.101	11-1	8=40-52
167-16A, Ch. 549.101-1	11-1	8=40-52
168-16, Ch. 549.100-7	55-4	9=49
175-16, 175-16A, Ch. 549.100-5, 549.100-8, 549.100-9	55-4	9=37-48
176-19, Ch. 549.100-6	55-4	9=50-52
179-16, 180-16, Ch. 132.890, 132.890-1, 132.890-2	12-2	8=53-66
185-16, Ch. 549.101-2	11-1	8=40-52
186-19, Ch. 549.101-3	11-1	8=40-52
194-16, Ch. 132.890, 132.890-1, 132.890-2	12-2	8=53-66
195-16, Ch. 132.890, 132.890-1, 132.890-2	12-2	8=53-66
Record Changer VM-950	12-RC1	RCH22=1-16
478.319, Ch.	55-3	9=1-8
478.337, Ch.	55-3	9=13-20
478.338, Ch.	11-1	8=32-39
478.339, 478.339-A, 478.339-B, Ch.	55-3	9=21-36
478.341, Ch.	55-3	9=9-12
478.361, 478.361-A, Ch.	55-3	9=21-36
478.375, 478.376, Ch.	55-3	9=13-20
549.100-5, Ch.	55-4	9=37-48
549.100-6, Ch.	55-4	9=50-52
549.100-7, Ch.	55-4	9=49

MODEL	PACK-FILE	PAGES
<u>SEARS, ROEBUCK &amp; CO. (Cont'd)</u>		
549.100-8, 549.100-9, Ch.	55-4	9=37-48
549.101, 549.101-1, 549.101-2, 549.101-3, Ch.	11-1	8=40-52
1132-17, Ch. 478.376	55-3	9=13-20
1146-20, Ch. 132.014	55-4	9=53-56
1150-14, Ch. 478.361, 478.361-A	55-3	9=21-36
1163-17, Ch. 478.375	55-3	9=13-20
1166-17, Ch. 478.339-B	55-3	9=21-36

SENTINEL RADIO CORP.

YA, YB, YC, Ch.	38-1	7=1-13
		9=1-12
1U416	38-1	5=1-8
1U419, 1U420	38-1	5=9-16
		6=1-8
		6=1-8
1U424	38-1	
1U425, 1U428, Ch. YA, YB, YC	38-1	7=1-13
1U432, Ch. YA, YB, YC	38-1	7=1-13
1U435, Ch. YB, YC	38-1	7=1-13
1U438, 1U439, 1U440, Ch. YA, YB, YC	38-1	9=1-12
1U441, 1U443, 1U444, Ch. YA, YB, YC	38-1	9=1-12
1U446, Series XD	38-1	9=1-12
416	38-1	5=1-8
419, 420	38-1	5=9-16
420B	38-1	6=1-8
423, 424	38-1	6=1-8
425, 428, Ch. YA, YB, YC	38-1	7=1-13
432, Ch. YA, YB, YC	38-1	7=1-13
435, Ch. YB, YC	38-1	7=1-13
438, 439, 440, Ch. YA, YB, YC	38-1	9=1-8
441, 443, 444, Ch. YA, YB, YC	38-1	9=1-8

SHERATON TELEV. CORP.

260-DX, 260-FM	54-1	9=1-6
260-S, 260-V	54-1	9=1-6

SILVERTONE  
See SEARS, ROEBUCK & CO.

SKYRIDER

519, 520	12-1	8=1-7
----------	------	-------

SONORA RADIO & TELEV. CORP.

323, 324	54-1	9=1-4
----------	------	-------

SPARTON RADIO-TELEVISION  
DIV. OF  
THE SPARKS-WITHINGTON CO.

Berkeley	56-2	9=1-10
Del Mar	56-2	9=22-24
Gramercy	56-2	9=17-21
Hanover	56-2	9=11-16
Rochelle, Sheffield	56-2	9=22-24
The Sparcraft	24-1	7=3-10
		8=1-6
The Westmont	24-1	7=3-10
		8=1-6
Whitney	56-2	9=1-10
		9=17-21
25RD190, Ch.	24-1	7=10
		8=7-13
25SD201, Ch.	24-1	7=10
		8=14-20
25SD201A, Ch.	56-2	9=11-16
26SD160, Ch.	24-1	7=3-12
26SD170, Ch.	24-1	7=3-10
		8=1-6
		8=21-25



**SPARTON  
STROMBERG**

MODEL	PACK-FILE	PAGES
<u>SPARTON RADIO-TELEVISION (Cont'd)</u>		
26SD170, DeLuxe, Ch., 5078BB	24-1	7=3-10 8=6 8=31
26SD170, DeLuxe, Ch., 5079B	24-1	7=3-10 8=22 8=25-26
26SD170P, Ch.	24-1	7=3-10 8=2 8=21-25
26SD170X, 26SD170XP, Ch.	24-1	7=3-10 8=2 8=21-25 9=22-24
26SD171, Ch.	56-2	
26SS160, 26SS160B, 26SS160L, Ch.	24-1	7=3-12
26SS170, Ch.	24-1	7=3-10 8=23-24 8=27-31
26SS170D, 26SS170DD, Ch.	56-2	9=1-10
26SS170D, 26SS170DP, Ch.	24-1	7=5-10 8=23-24 8=27
26SS170P, Ch.	24-1	7=5-10 8=23-24 8=27
26SS171, 26SS171A, Ch.	56-2	9=17-21
5025, Ch. 26SS160	24-1	7=3-12
5025BA, Ch. 26SS170	24-1	7=3-10 8=28-31
5026, Ch. 26SS160	24-1	7=3-12
5029, 5030, Ch. 26SD160	24-1	7=3-12
5035, 5036, 5037, Ch. 26SS160L	24-1	7=3-12
5075BA, Ch. 26SS170	24-1	7=3-10 8=28-31
5076, Ch. 26SS160	24-1	7=3-12
5076BA, Ch. 26SS170	24-1	7=3-10 8=28-31
5076BB, Ch. 26SS160B	24-1	7=3-12
5077, Ch. 26SS160	24-1	7=3-12
5077B, Ch. 26SS160B	24-1	7=3-12
5077BA, Ch. 26SS170	24-1	7=3-10 8=28-31
5078BB, Ch. 26SD170, DeLuxe	24-1	7=3-10 8=6 8=31
5079, Ch. 26SD160	24-1	7=3-12
5079B, Ch. 26SD170, DeLuxe	24-1	7=3-10 8=22 8=25-26
5079BB, Ch. 26SD170, DeLuxe	24-1	7=3-10 8=6 8=31
5080, Ch. 26SD160	24-1	7=3-12
5080BB, Ch. 26SD170, DeLuxe	24-1	7=3-10 8=6 8=31
5082, 5083, Ch. 26SD170	24-1	7=3-10 8=1-6
5082, 5083, Ch. 26SD170X, 26SD170XP	24-1	7=3-10 8=2 8=21-25
5085, 5086, Ch. 25RD190	24-1	7=10 8=7-13
5088, Ch. 26SD170, The Westmont	24-1	7=3-10 8=1-6
5089, Ch. 26SD170	24-1	7=3-10 8=1-6
5090, Ch. 26SD170, The Sparcraft	24-1	7=3-10 8=1-6
5101, 5102, 5103, Ch. 26SS170, 26SS170P	24-1	7=5-10 8=23-24 8=27

MODEL	PACK-FILE	PAGES
<u>SPARTON RADIO-TELEVISION (Cont'd)</u>		
5104, 5105, Ch. 26SS170D, 26SS170DP	24-1	7=5-10 8=23-24 8=27
5107X, Ch. 26SS170D, Whitney	56-2	9=1-10
5107X, Ch. 26SS171, Whitney	56-2	9=17-21
5108, Ch. 26SS170D, Whitney	56-2	9=1-10
5110, Ch. 26SS170DD, Berkeley	56-2	9=1-10
5125, Ch. 26SS170DD	56-2	9=1-10
5152, 5153, 5154, Ch. 26SS170, 26SS170P	24-1	7=5-10 8=23-24 8=27
5155, 5156, 5157, Ch. 26SD170X, 26SD170XP	24-1	7=3-10 8=2 8=21-25
5158, Ch. 26SD170, 26SD170P	24-1	7=3-10 8=2 8=21-25
5162X, 5163X, Ch. 26SS171A, Gramercy	56-2	9=17-21
5165X, 5166X, Ch. 26SD171, Sheffield	56-2	9=22-24
5170, 5171, Ch. 25SD201	24-1	7=10 8=14-20
5175X, Ch. 26SD171, Rochelle	56-2	9=22-24
5178X, Ch. 26SD171, Del Mar	56-2	9=22-24
5182, 5183, Ch. 26SD170, 26SD170P	24-1	7=3-10 8=2 8=21-25
5188, 5189, Ch. 26SD170, 26SD170P	24-1	7=3-10 8=2 8=21-25
5191, 5192, Ch. 25SD201A, Hanover	56-2	9=11-16

SPENCER-KENNEDY LABS., INC.

212TV, Booster	12-1	8=1-3
----------------	------	-------

STANDARD COIL PRODUCTS CO. INC.

B-51, Booster	12-1	8=1
---------------	------	-----

STEWART-WARNER ELECTRIC  
DIV. OF  
STEWART-WARNER CORP.

9120-A, 9120-B, 9120-C, 9120-D, 9120-E, 9120-F	24-2	7=1-17
9121-A, 9121-B	24-2	7=18-36
9122-A	12-1	8=1-19
9125-A	56-4	9=19-36
Record Changer STEW. - WARNER VM-509032	56-RC1	RCH 9=1-16
9126-A, 9126-B	56-4	9=37-41
9127-A	56-4	9=42-46
9200-A, 9200-C, 9200-D, 9200-FA, 9200-G	12-1	8=20-36
9202-C, 9202-DA, 9202-DB, 9202-DD, 9202-E, 9202-F	12-1	8=37-53
9203-A	25-3	9=1-18

STROMBERG-CARLSON CO.

Cavalier, Futura	23-2	9=1-8
24C, 24CM, Ch. 112126	23-2	7=1-8
24RP, 24 Series, Ch. 112119	23-2	7=1-8
24RPM, 24 Series, Ch. 112119 Record Changer WEBSTER 100	23-2	7=1-8
119CDM, 119CM, Ch. 112107	23-RC1	RCH21=1-10
119M5A, 119M5D, 119M5G, 119M5I, 119M5M, 119M5R, Ch. 112114	23-2	7=9-20
119RPM, 119RPM2, Ch. 112114	23-2	7=9-20



MODEL PACK-FILE PAGES

STROMBERG-CARLSON CO. (Cont'd)

317RPM, Ch. 112120	15-1	8=1-8
Record Changer VM-950	15-RC1	RCH22=1-16
317TM, Ch. 112121	15-1	8=1-8
321CD2M, 321CD2O, 321		
Series, Ch. 112127, Futura	23-2	9=1-8
321CF, 321C2M, Ch. 112127,		
Cavalier	23-2	9=1-8
112107, Ch.	23-2	7=9-20
112114, Ch.	23-2	7=9-20
112119, Ch.	23-2	7=1-8
112120, 112121, Ch.	15-1	8=1-8
112126, Ch.	23-2	7=1-8
112127, Ch.	23-2	9=1-8

SUPREMACY  
See MACY'S

SYLVANIA ELECTRIC PRODUCTS INC.

1-197-2, Ch. 1-227	13-1	8=53-63
1-227, Ch.	13-1	8=53-63
1-231, Ch.	13-2	8=105-117
1-245-2, Ch. 1-227	13-1	8=53-63
1-247-1, Ch. 1-231	13-2	8=105-117
1-260, 1-261, Ch.	23-3	7=1-23
1-329, Ch.	13-1	8=64-82
1-356(CO5), Ch.	13-2	8=160-173
1-366, Ch.	23-3	7=1-23
1-366(CO8), Ch.	13-2	8=140-153
1-366-66, Ch.	23-3	7=1-23
1-381, Ch.	13-1	8=64-81
1-387, Ch.	13-1	8=83-98
1-387(CO7), Ch.	13-2	8=118-131
1-387-1, Ch., 22M-1	13-2	8=118-139
1-387-1, Ch., 25M	25-4	9=15-30
1-437, Ch.	23-3	7=24-37
1-437-1, Ch.	25-4	9=1-14
		9=41-52
1-441, Ch.	23-3	7=1-23
		8=99-104
1-441(CO2), Ch.	13-2	8=140-159
1-442, Ch.	23-3	7=24-37
1-502-1, Ch.	25-4	9=31-40
22M, Ch. 1-387(CO7)	13-2	8=118-131
22M-1, 23B, 23M, 24M-1,		
Ch. 1-387-1	13-2	8=118-139
25M, Ch. 1-387-1	25-4	9=15-30
Record Changer VM-950	25-RC1	RCH22=1-16
71M, Ch. 1-441(CO2)	13-2	8=140-153
71M-1, 72B-1, Ch. 1-502-1	25-4	9=31-40
72M, Ch. 1-366	23-3	7=1-23
72M, Ch. 1-366(CO8)	13-2	8=140-153
72M-1, Ch. 1-502-1	25-4	9=31-40
73B, Ch. 1-366(CO8)	13-2	8=140-153
73M, Ch. 1-366	23-3	7=1-23
73M, Ch. 1-366(CO8)	13-2	8=140-153
74B-1, Ch. 1-437-1	25-4	9=41-52
74M, Ch. 1-356(CO5)	13-2	8=160-173
74M-1, Ch. 1-437-1	25-4	9=41-52
75B, 75M, Ch. 1-437-1	25-4	9=1-14
Record Changer VM-950	25-RC1	RCH22=1-16
1110X, Ch. 1-329	13-1	8=64-82
1210X, Ch. 1-381	13-1	8=64-81
2221M, Ch. 1-387	13-1	8=83-98
4120M, 4130B, Ch. 1-260,		
1-261	23-3	7=1-23
4130E, Ch. 1-260	23-3	7=1-23
4130M, 4130W, Ch. 1-260,		
1-261	23-3	7=1-23
6110X, Ch. 1-261	23-3	7=1-23
6120B, 6120M, 6120W,		
Ch. 1-260, 1-261	23-3	7=1-23
6130B, 6130M, 6130W,		
Ch. 1-260, 1-261	23-3	7=1-23
7110X, Ch. 1-366	23-3	7=1-23
7110XB, Ch. 1-441	23-3	7=1-23
		8=99-104
7110XF, Ch. 1-366-66	23-3	7=1-23
7110XFA, Ch. 1-442	23-3	7=24-37

MODEL PACK-FILE PAGES

SYLVANIA ELECTRIC PRODUCTS INC. (Cont'd)

7111M, Ch. 1-441	23-3	7=1-23
		8=99-104
7111MA, Ch. 1-366	23-3	7=1-23
7120B, 7120M, 7120W,		
Ch. 1-366	23-3	7=1-23
7120BF, 7120MF,		
Ch. 1-366-66	23-3	7=1-23
7120MFA, Ch. 1-442	23-3	7=24-37
7120WF, Ch. 1-366-66	23-3	7=1-23
7130, 7130M, 7130W,		
Ch. 1-366	23-3	7=1-23
7130BF, 7130MF, Ch.		
1-366-66	23-3	7=1-23
7130MFA, Ch. 1-442	23-3	7=24-37
7130WF, Ch. 1-366-66	23-3	7=1-23
7140MA, 7140WA, Ch. 1-437	23-3	7=24-37

TECH-MASTER PRODUCTS CO.  
(VIDEOLA)

17U-A, Ch.	14-1	8=1-9
5116, Ch. 17U-A	14-1	8=1-9

TELE KING CORP.

K-21, K-21B, K-22, Ch. TVJ	41-1	9=1-16
K-71, K-72, K-72B, Ch. TVJ	41-1	9=1-16
K-73L, K-74, Ch. TVJ	41-1	9=1-16
KC-21, KC-21B, Ch. TVJ	41-1	9=1-16
KC-71, KC-71B, Ch. TVJ	41-1	9=1-16
KD-21M, KD-22B, Ch. TVJ	41-1	9=1-16
KD-71, KD-72B, Ch. TVJ	41-1	9=1-16
TVG, Ch.	41-1	7=1-11
TVJ, Ch.	41-1	9=1-16
172LO, 172M, Ch. TVG	41-1	7=1-11
174LO, 174M, Ch. TVG	41-1	7=1-11
202LO, 202M, Ch. TVG	41-1	7=1-11
203, 205, Ch. TVG	41-1	7=1-11
916, 916CAF, Ch. TVG	41-1	7=1-11
919, 919CAF, Ch. TVG	41-1	7=1-11
1014, 1016, Ch. TVG	41-1	7=1-11

TELEKIT

See ELECTRO-TECHNICAL INDUSTRIES

TELEQUIP RADIO CO.

C517, C517B, Ch. 5050, 5050A	14-1	8=1-8
C617, C617B, Ch. 5050, 5050A	14-1	8=1-8
C720, C720B, Ch. 5050, 5050A	14-1	8=1-8
C820, C820B, Ch. 5050, 5050A	14-1	8=1-8
T417, T417B, T620,		
Ch. 5050, 5050A	14-1	8=1-8
12TR	41-2	6=1-8
14T, 14TR	41-2	6=1-8
16T, 16TR	41-2	6=1-8
19T, 19TR	41-2	6=1-8
5050, 5050A, Ch.	14-1	8=1-8

TELE-TONE RADIO CORP.

TAA, TAB, Ch.	41-2	6=9-17
TAG, Ch.	41-2	6=18-26
		7=4-6
TAJ, Ch.	41-2	6=18-26
TAM, Ch.	41-2	7=7-12
TAO, Ch.	14-1	8=4-10
TAP-2, Ch.	41-2	7=1-12
		8=1-3
TH, TJ, Rev., Ch.	41-2	6=1-8
TT, Ch.	41-2	6=1-8
TV-284, Ch. TT	41-2	6=1-8
TV-286, Ch. TH, TJ, Rev.	41-2	6=1-8
TV-287, TV-288, Ch. TT	41-2	6=1-8
TV300, TV301, Ch. TW, TX	41-2	6=9-14
TV304, TV305, Ch. TW, TX	41-2	6=9-14
TV306, Ch. TZ	41-2	6=18-26
TV307, Ch. TX	41-2	6=18-26
TV314, Ch. TAJ	41-2	6=18-26
		7=1-3



**TELE-TONE  
WESTINGHOUSE**

MODEL	PACK-FILE	PAGES
<u>TELE-TONE RADIO CORP. (Cont'd)</u>		
TV315, Ch. TAA, TAB	41-2	6=9-17
TV316, Ch. TZ	41-2	6=18-26
TV317, Ch. TAG	41-2	6=18-26
		7=4-6
TV318, Ch. TAM	41-2	7=7-12
TV322, TV323, Ch. TAM	41-2	7=7-12
TV324, TV325, TV326, Ch. TAP-2	41-2	7=1-12
		8=1-3
TV328, TV329, Ch. TAP-2	41-2	7=1-12
		8=1-3
TV330, TV331, TV332, TV333, Ch. TAO	14-1	8=4-10
TV335, TV336, Ch. TAP-2	41-2	7=1-12
		8=1-3
TV340, TV345, Ch. TAP-2	41-2	7=1-12
		8=1-3
TW, Ch.	41-2	6=9-14
TX, Ch.	41-2	6=9-14
		6=18-26
TZ, Ch.	41-2	6=18-26

TELEVISION EQUIPMENT CORP.

S505, Booster	14-1	8=1
---------------	------	-----

TRAD TELEVISION CORP.

C-2020, C-2420, CD-2020, Series T-20E	54-1	9=1-16
T-1720, Series T-20E	54-1	9=1-16

TRANS-VUE CORP.

1700C, 1700CD, 1700T	14-1	8=1-6
----------------------	------	-------

TRUETONE

See WESTERN AUTO SUPPLY CO.

VIDAIRE TELEVISION CO.

501	14-1	8=1-6
-----	------	-------

VIDEOLA

See TECH-MASTER PRODUCTS CO.

JOHN WANAMAKER

C1720T, C1720T, See TRAD Ch. T-20E	54-1	9=1-16
T-1720, Series T-20E	54-1	9=1-16
C2020T, C2020V, See TRAD Ch. T-20E	54-1	9=1-16
C2420D, CD2020W, See TRAD Ch. T-20E	54-1	9=1-16

WESTERN AUTO SUPPLY CO.  
(TRUETONE)

2D1091, Ch. 12AX27	53-2	9=41-48
2D1092	53-2	9=37-40
2D1094A	14-1	8=1-9
Record Changer GENERAL INSTRUMENT 700F	14-RC1	RCH19=1-10
2D1095A, Ch. 16AX27	53-2	9=1-8
2D1185A	14-1	8=20-27
2D1194A	14-1	8=10-19
Record Changer GENERAL INSTRUMENT 700F	14-RC1	RCH19=1-10
2D1190A	14-1	8=28-35
2D1190B	14-1	8=28-38
2D2043A, 2D2047B, Ch. 12AX27	53-2	9=41-48
2D2049A, Ch. 16AY210	53-2	9=9-20
2D2052A, 2D2052B, Ch. 16AY210	53-2	9=9-20
2D2052C, Ch. 17AY23	53-2	9=21-28
2D2052D, 2D2052E, Ch. 17AY28	53-2	9=29-36
12AX27, Ch.	53-2	9=41-48

MODEL	PACK-FILE	PAGES
<u>WESTERN AUTO SUPPLY CO. (Cont'd)</u>		
16AY210, Ch.	53-2	9=9-20
16AX27, Ch.	53-2	9=1-8
17AY23, Ch.	53-2	9=21-28
17AY28, Ch.	53-2	9=29-36

WESTINGHOUSE ELECTRIC CORP.

Carlyle	54-4	9=17-24
H-606K12, H-607K12, Ch. V-2150-111	42-3	6=1-9
H-609T10, Ch. V-2150-94C	42-3	6=10-17
H-610T12, Ch. V-2150-136	42-3	6=18-24
H-611C12, Ch. V-2152-16	42-3	6=25-32
H-613K16, Ch. V-2150-146	42-3	6=33-40
H-614T12, Ch. V-2150-136	42-3	6=18-24
H-615C12, Ch. V-2152-16	42-3	6=25-32
H-617T12, Ch. V-2150-176	42-3	6=41-47
H-618T16, Ch. V-2150-186, V-2150-186A, V-2150-186C, V-2150-186CA	21-2	7=1-8
H-619T12, Ch. V-2150-176	42-3	6=41-47
H-619T12U, Ch. V-2150-176U, V-2150-177U	42-3	6=41-48
H-620K16, H-622K16, Ch. V- 2150-186, V-2150-186A, V-2150-186C, V-2150-186CA	21-2	7=1-8
H-625T12, Ch. V-2150-197	21-2	7=9-15
H-626T16, Ch. V-2172	21-2	7=16-24
H-627K16, H-628K16, H-629K16, Ch. V-2171	21-2	7=16-24
		7=34-35
H-630T14, Ch. V-2176	21-2	7=16-24
H-633C17, H-634C17, Ch. V-2173	15-1	8=4-13
H-636T17, Ch. V-2175	21-2	7=16-25
		7=34-35
H-637T14, Ch. V-2177	21-2	7=16-26
H-638K20, Ch. V-2178	21-2	7=27-35
H-639T17, Ch. V-2192, V-2192-1	15-1	8=14-23
H-640T17, Ch. V-2175-3, V-2175-4	15-1	8=14-21
		8=28-30
H-640T17, Ch. V-2192, V-2192-1, V-2192-2, V-2192-3	15-1	8=14-26
H-640T17A, Ch. V-2192	15-1	8=14-24
H-641K17, Ch. V-2175-1, V-2175-5	15-1	8=14-21
		8=28-30
H-641K17, Ch. V-2192, V-2192-1, V-2192-2, V-2192-3	15-1	8=14-26
H-641K17A, Ch. V-2192-1	15-1	8=14-24
H-642K20, Ch. V-2178-1, V-2178-3	15-1	8=32-39
H-642K20A, Ch. V-2194, V-2194-1	15-1	8=32-43
H-643K16, Ch. V-2179, V-2179-1	21-2	7=36-42
H-646K17, H-647K17, Ch. V-2175-3, V-2192	15-1	8=14-30
H-648T20, Ch. V-2201-1	21-2	9=9-16
H-649C17, Ch. V-2200-1	15-1	8=45-52
H-649T17, Ch. V-2192-4	15-1	8=14-27
H-650T17, Ch. V-2192-4	15-1	8=14-27
H-650T17, Ch. V-2200-1	15-1	8=45-52
H-651K17, Ch. V-2200-1, V-2204-1	15-1	8=45-52
H-652K20, Ch. V-2194-2, V-2194-3	15-1	8=32-44
H-652K20, Ch. V-2201-1	21-2	9=9-16
H-653K24, Ch. V-2202-2, V-2202-3, V-2210-1, Carlyle	54-4	9=17-24
H-654T17, Ch. V-2175-3, V-2175-4, V-2192, V-2192-1	15-1	8=14-31
H-655K17, H-656K17, H-657K17, Ch. V-2200-1	15-1	8=45-53



MODEL	PACK-FILE	PAGES
<b>WESTINGHOUSE ELECTRIC CORP. (Cont'd)</b>		
H-658T17, Ch. V-2192, V-2192-1	15-1	8=14-31
H-659T17, Ch. V-2204-1	15-1	8=45-54
H-660C17, H-661C17, Ch. V-2203-1	21-2	9=1-8
H-662K20, Ch. V-2201-1	21-2	9=9-16
H-663T17, Ch. V-2192, V-2192-2	15-1	8=14-26
H-664K17, Ch. V-2200-1	15-1	8=45-54
V-2150-94C, Ch.	42-3	6=10-17
V-2150-111, Ch.	42-3	6=1-9
V-2150-136, Ch.	42-3	6=18-24
V-2150-146, Ch.	42-3	6=33-40
V-2150-176, Ch.	42-3	6=41-47
V-2150-176U, V-2150-177U, Ch.	42-3	6=41-48
V-2150-186, V-2150-186A, V-2150-186C, V-2150- 186CA, Ch.	21-2	7=1-8
V-2150-197, Ch.	21-2	7=9-15
V-2152-16, Ch.	42-3	6=25-32
V-2171, Ch.	21-2	7=16-24
		7=34-35
V-2172, Ch.	21-2	7=16-24
V-2173, Ch.	15-1	8=4-13
V-2175, Ch.	21-2	7=16-25
		7=34-35
V-2175-1, V-2175-3, V-2175-4, V-2175-5, Ch.	15-1	8=14-31
V-2176, Ch.	21-2	7=16-24
V-2177, Ch.	21-2	7=16-26
V-2178, Ch.	21-2	7=27-35
V-2178-1, V-2178-3, Ch.	15-1	8=32-39
V-2179, V-2179-1, Ch.	21-2	7=36-42
V-2192, V-2192-1, V-2192-2, V-2192-3, Ch.	15-1	8=14-31
V-2194, V-2194-1, V-2194-2, V-2194-3, Ch.	15-1	8=32-44
V-2200-1, Ch.	15-1	8=45-54
V-2201-1, Ch.	21-2	9=9-16
V-2202-2, V-2202-3, Ch.	54-4	9=17-24
V-2203-1, Ch.	21-2	9=1-8
V-2204-1, Ch.	15-1	8=45-54
V-2210-1, Ch.	54-4	9=17-24

**ZENITH RADIO CORP.**

Aldrich	42-3	6=1-20
Barrett, Barrie	21-2	9=1-16
Burton, Byron	42-3	6=1-20
Carlyle, Chesterton	21-2	9=1-16
Churchill	42-3	6=1-20
Coleridge, J2051E	21-2	9=1-16
Coleridge, H2439R	42-3	6=1-20
Conrad	21-2	9=1-16
Fielding, J2030R	21-2	9=1-16
Fielding, H2437E	42-3	6=1-20
Galsworthy	21-2	9=1-16
Garland	42-3	6=1-20
Hawthorne, J2026R	21-2	9=1-16
Hawthorne, H3267	42-3	6=1-20
Irving, Kilmer	42-3	6=1-20
Kipling	21-2	9=1-16
Lowell	42-3	6=1-20
Mansfield	42-3	6=1-20
Markham	21-2	9=1-16
Meredith, Morley	42-3	6=1-20
Shelley	42-3	6=1-20
Tennyson	42-3	6=1-20
Thackeray, J2054R	21-2	9=1-16
Thackeray, H3477R	42-3	6=1-20
Walpole	42-3	6=1-20
Walton, J2044R	21-2	9=1-16
Walton, H2328R	42-3	6=1-20
Warton	42-3	6=1-20
Wordsworth, J2043R	21-2	9=1-16
Wordsworth, H3469E	42-3	6=1-20
H-2029R, H 2030E, H-2030R, Ch. 20H20	15-1	8=1-8
H-2041R, Ch. 20H20	15-1	8=1-8

MODEL	PACK-FILE	PAGES
<b>ZENITH RADIO CORP. (Cont'd)</b>		
H-2052R, H-2053R, Ch. 20H20	15-1	8=1-8
H2226E, Ch. 22H20	42-3	6=1-20
H2226R, Ch. 22H20, Warton	42-3	6=1-20
H2226RQ, Ch. 22H20	42-3	6=1-20
H2227E, Ch. 22H20, Garland	42-3	6=1-20
H2227EQ, Ch. 22H20	42-3	6=1-20
H2227R, Ch. 22H20, Walpole	42-3	6=1-20
H2227RQ, Ch. 22H20	42-3	6=1-20
H2250R, Ch. 22H20, Lowell	42-3	6=1-20
H2250RQ, Ch. 22H20	42-3	6=1-20
H2255E, Ch. 22H20, Morley	42-3	6=1-20
H2255EQ, Ch. 22H20	42-3	6=1-20
H2328E, Ch. 23H22	42-3	6=1-20
H2328EZ, Ch. 23H22Z	42-3	6=1-20
H2328R, Ch. 23H22, Walton	42-3	6=1-20
H2328RQ, Ch. 23H22	42-3	6=1-20
H2328RQZ, H2328RZ, Ch. 23H22Z	42-3	6=1-20
H2329R, Ch. 23H22, Burton	42-3	6=1-20
H2329RQ, Ch. 23H22	42-3	6=1-20
H2329RZ, Ch. 23H22Z	42-3	6=1-20
H2352R, Ch. 23H22, Mansfield	42-3	6=1-20
H2352RQ, Ch. 23H22	42-3	6=1-20
H2352RQZ, H2352RZ, Ch. 23H22Z	42-3	6=1-20
H2353E, Ch. 23H22, Meredith	42-3	6=1-20
H2353EQ, Ch. 23H22	42-3	6=1-20
H2353EQZ, H2353EZ, Ch. 23H22Z	42-3	6=1-20
H2437E, Ch. 24H20, Fielding	42-3	6=1-20
H2437EQ, Ch. 24H20	42-3	6=1-20
H2437R, Ch. 24H20, Irving	42-3	6=1-20
H2437RQ, Ch. 24H20	42-3	6=1-20
H2438R, Ch. 24H20, Aldrich	42-3	6=1-20
H2439R, Ch. 24H20, Coleridge	42-3	6=1-20
H2438RQ, Ch. 24H20	42-3	6=1-20
H2445R, Ch. 24H21, Tennyson	42-3	6=1-20
H2445RQ, Ch. 24H21	42-3	6=1-20
H2447R, Ch. 24H21, Byron	42-3	6=1-20
H2447RQ, Ch. 24H21	42-3	6=1-20
H2449E, Ch. 24H20, Churchill	42-3	6=1-20
H-2868R, Ch. 20H20	15-1	8=1-8
H-3074R, Ch. 20H20	15-1	8=1-8
H3267, Ch. 24H20, Hawthorne	42-3	6=1-20
H3267R, H3267RQ, Ch. 24H20	42-3	6=1-20
H3469E, Ch. 24H20, Wordsworth	42-3	6=1-20
H3469EQ, Ch. 24H20	42-3	6=1-20
H3475R, Ch. 24H20, Kilmer	42-3	6=1-20
H3475RQ, Ch. 24H20	42-3	6=1-20
H3477R, Ch. 24H21, Thackeray	42-3	6=1-20
H3477RQ, Ch. 24H21	42-3	6=1-20
H3478E, Ch. 24H21, Shelley	42-3	6=1-20
H3478EQ, Ch. 24H21	42-3	6=1-20
J2026R, Ch. 20J22, Hawthorne	21-2	9=1-16
J2027E, Ch. 20J21, Barrett	21-2	9=1-16
J2027R, Ch. 20J21	21-2	9=1-16
J2029E, J2029R, Ch. 20J21, Markham	21-2	9=1-16
J2030E, Ch. 20J21	21-2	9=1-16
J2030R, Ch. 20J21, Fielding	21-2	9=1-16
J2040E, Ch. 20J21, Conrad	21-2	9=1-16
J2042R, Ch. 20J21, Galsworthy	21-2	9=1-16
J2043R, Ch. 20J21, Wordsworth	21-2	9=1-16
J2044E, Ch. 20J21	21-2	9=1-16
J2044R, Ch. 20J21, Walton	21-2	9=1-16
J2051E, Ch. 20J22, Coleridge	21-2	9=1-16
J2053R, Ch. 20J22, Chesterton	21-2	9=1-16
J2054R, Ch. 20J22, Thackeray	21-2	9=1-16
J2055R, Ch. 20J22, Carlyle	21-2	9=1-16
J2126R, Ch. 21J21	21-2	9=1-16
J2127E, J2127R, Ch. 21J20	21-2	9=1-16
J2129E, J2129R, Ch. 21J20	21-2	9=1-16
J2130E, J2130R, Ch. 21J20	21-2	9=1-16
J2140E, J2142R, J2143R, Ch. 21J20	21-2	9=1-16
J2144E, J2144R, Ch. 21J20	21-2	9=1-16



MODEL	PACK-FILE	PAGES	MODEL	PACK-FILE	PAGES
<b>ZENITH RADIO CORP. (Cont'd)</b>			<b>ZENITH RADIO CORP. (Cont'd)</b>		
J2151E, J2153R, J2154R, J2155R, Ch. 21J21	21-2	9=1-16	J3069E, Ch. 20J21, Barrie Record Changer ZENITH S14029	21-2	9=1-16
J2868R, Ch. 20J21, Kipling Record Changer ZENITH S14029	21-2	9=1-16	J3169E, Ch. 21J20 Record Changer ZENITH S14029	21-RC1 21-2	RCH21=9-24 9=1-16
J2968R, Ch. 21J20 Record Changer ZENITH S14029	21-RC1	RCH21=9-24	20H20, Ch.	21-RC1	RCH21=9-24
	21-2	9=1-16	20J21, 20J22, 21J20, 21J21, Ch.	15-1	8=1-8
	21-RC1	RCH21=9-24	22H20, 23H22, 23H22Z, Ch.	21-2	9=1-16
			24H20, 24H21, Ch.	42-3	6=1-20
				42-3	6=1-20

## HOW TO USE THIS INDEX

To locate service data instantly, all you need to know is the manufacturer's name and the model or chassis number of the set.

The index is compiled alphabetically, according to manufacturer. Note the column headings at the top of each page: **MODEL**, **PACK-FILE**, **PAGES**.

Model numbers run in numerical sequence, starting with the smallest number under a manufacturer's name. This applies also to model numbers using letters. (i.e. model AR precedes model CG). Model numbers starting with letters precede model numbers starting with numbers.

Under the column **PACK-FILE**, the first number is the TEK-FILE Pack number, and the second number is the File number.

Under the column headed **PAGES**, the first and second numbers indicate the page where the information starts; the last number shows where the data is concluded.

As an example, let's look up *ADMIRAL model 36X36AS*. It shows that the information is in (1-1) Pack No. 1, *ADMIRAL*, File No. 1. The data (8 = 23-46) starts on page 8-23 and runs through page 8-46. There is also data on the *ADMIRAL* record changer model RC 550. It's in (1-RC2) *TEK-FILE* Pack No. 1, in *ADMIRAL* Record Changer File No. 2. The data begins on page 21-9 and ends on page 21-16.

If you remove the pages from the TEK-FILE Files and insert them in the TEK-FILE binder, you can disregard the **PACK-FILE** column and refer to the **PAGES** only.

## REPLACEMENT PARTS LISTINGS

TO BE INCLUDED IN RIDER MANUALS AND RIDER TEK-FILE



RIDER'S TELEVISION MANUAL VOLUME 10, which is scheduled for November, 1952 publication will contain replacement parts listings. The names of the manufacturers you see listed here are participating in this new Rider program. The Rider organization declares to the TV-radio servicing industry that the replacement parts listed conform with the physical and electrical requirements of the original equipment used in the receiver. The original manufacturer's parts lists and values will continue to be listed as heretofore. All servicing information will as thorough-

ly complete as it has been in the past — no abridgement.

This is a completely new program for John F. Rider Publisher, Inc., and as such we intend to expand its utility from month to month. Starting with TV TEK-FILE Pack No. 57, the Rider monthly packaged service data will also contain replacement parts listings. Regardless of what form you choose to buy Rider servicing data — Manual or TEK-FILE — you are assured the best in servicing information. Remember — You're Always Right with Rider!



MALLORY & CO Inc.  
**MALLORY**



**Jensen**







A monthly summary of product developments and price changes supplied by RADIO'S MASTER, the Industry's Official Buying Guide, available through local parts distributors.

**COMMENT:** As previously noted, product activity in the Electronic Industry continues to center upon the introduction of new items. At the same time manufacturers are withdrawing products at almost the same pace. Price increases and decreases are quite spotty with no apparent trend at this time.

**New Items**

- AKRO-MILS—Added adapter kit model AK-8 and jiffy cannister model JC-5.
- ARGOS PRODUCTS CO.—Model PC-1A, record changer carrying case and 8" and 12" corner base reflex baffles models CB-8 and CB-12 added.
- CHANNEL MASTER CORP.—Introduced their Challenger series 550 of 5 element yagi antennas producing over 7 DB gain on the single bay with a 5 to 1 front to back ratio which matches 300 ohm lines.
- CLEAR BEAM—Added YSD and YSD-2 series of super director yagis, and multi-yagi #MY900 at \$20.93 list.
- ELECTRONIC INSTRUMENT CO.—Introduced CRA, TV picture tube test adapter for models 625 (tube tester) and 625K (tube tester kit) at \$4.50 net.
- ELECTROVOX—Added model W-52TPS, Magnavox replacement needle at \$2.10 net.
- ERIE RESISTOR CORP.—Added additional disc ceramic capacity values . . . series of 1500, 3000 and 6000 volt high voltage ceramicons . . . series of standard printed circuits.
- HALLICRAFTERS CO.—Added models ST-83, hi-fi AM/FM tuner at \$129.95 net . . . A-84, amplifier, power output 15 watts maximum, freq. range 3 to 200,000 cps at \$99.50 net and HT-20 at \$449.50 net.
- MILLER, M. A.—Added 7 diamond styli replacement needles for Astatic cartridges, 1 for Electro-Voice, 4 for Philco and 3 for Webster-Electric cartridges.
- MORROW RADIO MFG. CO.—Introduced 3 generator filter chokes, GC-6, GC-10 and GC-20 at \$3.75 net each.
- NATIONAL ELECTRONICS—Added Thyatron NL-760 at \$30.90 net . . . Half-wave rectifier NL-5558/FG-32 at \$14.00 net and Ignitron NL-5882 at \$143.00 net.
- NATIONAL UNION—Added 7 new receiving tubes and 6 new transmitting tubes.
- OLIN INDUSTRIES INC.—Added No. 4812 and 6715, lantern batteries and L-1045, flashlight lens assortment.
- PERMOFLUX CORP.—Telephone pickup No. M-53A added at \$10.50 net.
- OXFORD ELECTRIC CORP.—Added 5PAMS, 5PBMS, 5PCMS, pin cushion type magnet replacement speakers . . . drive-in theatre speakers 5CM-51 at \$3.19 net, employing a 1.47 oz. Alnico V magnet; 5BA-3, with a .68 oz. Alnico V at \$2.67 net; 4CM-13, employing a 1.47 oz. Alnico V at \$3.49 net and 4AM-65, employing a .68 oz. Alnico V magnet.
- RADIO CITY PRODUCTS CO.—Introduced their TV "do-all" generator model 740 which combines a signal generator, an audio generator, a marker generator and a pattern generator at \$69.50 net . . . model 808 which combines a tube tester, a CR tube tester, a CR tube reactivator, a vacuum tube voltmeter (AC & DC) and an ohmmeter at \$99.95 net . . . model 533M midgetscope, a miniaturized oscilloscope weighing 9 lbs. at \$99.50 net . . . TV series 8000 which includes models 740, 808 and 533M at \$279.50 net in one portable case . . . series 8010, as 8000 plus 730 signalizer at \$299.50 net.
- R.C.A.—Added receiving tubes 6CL6, a power pentode of the 9 pin miniature type designed especially for use in the final video-amplifier stage of TV receivers. Also useful as a wide-band amplifier in lab equipment at \$3.00 list. Also added 12AX4-GT, a half-wave vacuum rectifier tube of the heater-cathode type. It is intended for use as a damper tube in horizontal deflection circuits of TV receivers utilizing series-heating strings at \$2.25 list . . . added WR-40A at \$1450.00 net and WR-41A at \$595.00 net, UHF sweep generators.
- RIDER, JOHN F.—Added catalog No. 140, "TV Troubleshooting and Repair Guide Book" at \$3.90 net.

(Continued on page 17)

\*\*\*\*\*  
 \* Get window-size \*  
 \* reprints of this ad \*  
 \* free from your \*  
 \* Sprague distribu- \*  
 \* tor, or send 10c to \*  
 \* Sprague to cover \*  
 \* handling costs. \*  
 \*\*\*\*\*

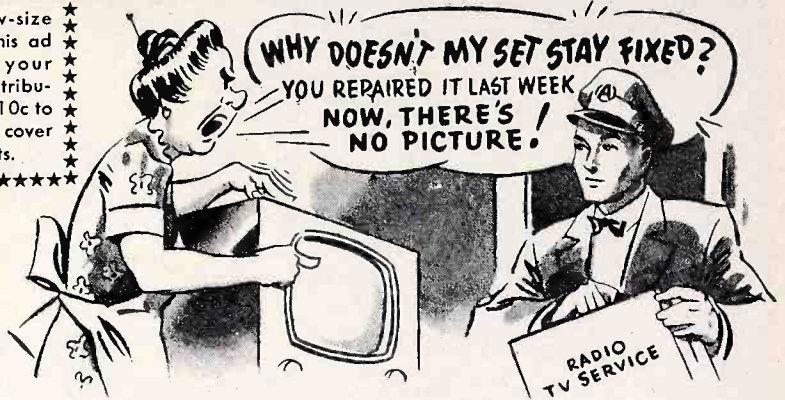

**HERE'S YOUR ANSWER, MR. AND MRS. SETOWNER!**

999 times out of a thousand, when this happens . . . *don't blame your service technician!*

The repair to your television receiver made several days ago or even several months ago probably had no relation to the new trouble that developed today.

Actually, there are more than 300 electrical parts in even a small table model television receiver. Trouble in any one of them might cause the picture or sound to disappear or to be received poorly.

Take your automobile for instance. Tuning up the motor today is no guarantee against a tire blowout tomorrow!

Such a thing is easier to understand because most of us are more familiar with automobiles than with today's highly complicated TV and radio sets. But such unconnected troubles occur in TV and radio nevertheless—and because they are so

hard to explain in non-technical terms, it is always embarrassing to your service technician when they do.

His continued business existence is based on gaining the full confidence of you and other set owners like you. He isn't in business to "gyp" you or to overcharge you. His success is based on doing each and every job to the level best of his ability, at a fair price for his skilled labor. It's only when you patronize the shops that feature "bargains" at ridiculously low prices that you need worry. Good radio and TV service can't be bought on the bargain counter! Set owners who recognize this aren't likely to get "gypped."

Sincerely yours,

(HARRY KALKER, President)

**SPRAGUE PRODUCTS COMPANY**

(Distributors' Division of the Sprague Electric Company)

55 Marshall Street

North Adams, Massachusetts



**WORLD'S LARGEST MANUFACTURER OF ELECTRIC CONDENSERS**

Please mention *Successful Servicing* when answering advertising.



# Say It\* With Service!

\*For All Applications—33 $\frac{1}{3}$ , 45, or 78 R.P.M.—These Shure Replacement Cartridges Assure Superior Performance



W 42 BH

78

This "Dual Voltage" cartridge is an excellent all-around replacement for old-style 78 r.p.m. cartridges. It guarantees improved performance in many cases. A unique "Slip-On" condenser harness provides choice of output voltage—1.5 with condenser harness installed and 3.75 without condenser. For fine quality at low cost your best bet is the Model W42BH at only \$4.95 list.



W 31 AR

WC 31 AR

33 $\frac{1}{3}$

45

This high output (2.1 volts!) "Direct Drive" cartridge was specifically designed for use with all fine-groove records. Universal mounting bracket provides quick, easy installation in RCA-type 45 r.p.m. changers. (Fits  $\frac{1}{2}$ " and  $\frac{3}{8}$ " mounting centers.) Has easy-to-replace needle. For maximum quality, highest output, and low cost, specify Model W31AR at the low list price of only \$6.50

33 $\frac{1}{3}$

45

Also available as ceramic cartridge (same price)—Model WC31AR. Highly recommended in areas where heat and humidity make use of conventional crystal cartridges impractical. List price.....\$6.50



W 26 B

33 $\frac{1}{3}$

45

78

This "Vertical Drive" "all-purpose" cartridge provides superlative reproduction for all types of records. Low tracking pressure (only 6 grams) and high needle compliance guarantee faithful tracking and longer record life. Uses exclusive Shure "Unipoint" needle, scientifically designed for maximum performance and long life. List price.....\$7.50



W 22 AB

33 $\frac{1}{3}$

45

78

This "Vertical Drive" "turnover-type" cartridge provides extended frequency response (50 to 10,000 c.p.s.) at extremely low needle point pressure—only 8 grams. One of the most popular, widely used cartridges in original equipment. Highly recommended as replacement in phonographs equipped with turnover mechanism. Individual needles—one for fine-groove and the other for standard records—guarantee maximum results. List price...\$9.50

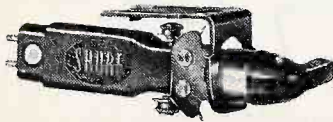

W 22 AB-T

33 $\frac{1}{3}$

45

78

Offers all the advantages provided by the Model W22AB, plus a long-life turnover mechanism. Furnishes replacement of old, worn-out turnover mechanisms as well as cartridges. Also an excellent replacement for converting all-purpose phonographs into turnover type. List price.....\$10.00

Patented by Shure Brothers, Inc., and Licensed under Patents of the Brush Development Co.



**SHURE BROTHERS, Inc.** ☆  
225 W. HURON ST., CHICAGO 10, ILL.

Manufacturers of Microphones  
and Acoustic Devices  
Cable Address: SHUREMICRO

# Stylus-Wear

Figure 2 illustrates the results of our third test. Brand new styli of osmium, sapphire and diamond were played 48 times each on slightly used records. The diamond stylus was then continued in play, until 1,000 plays were completed. All styli were then photographed, as shown in Figs. 2(A) for the osmium, 2(B) for the sapphire, and 2(C) for the diamond. From Fig. 2(A) we can see the large flats and sharp edges. Fig. 2(A) shows the chisel shape previously mentioned. Fig. 2(C) shows the smooth contours maintained even after 1,000 plays.

The same styli after being photographed were then used on brand new records and played 50 times for each styli. Then the photomicrographs shown in Figs. 2(D), (E), and (F) were made of sections of the grooves of each record. Fig. 2(D)



Courtesy Tetrad Corp.  
Fig. 2(A)

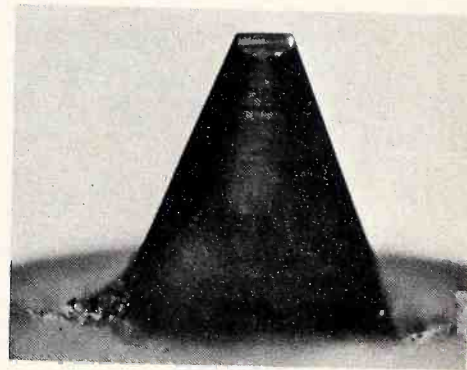

Courtesy Tetrad Corp.  
Fig. 2(B)

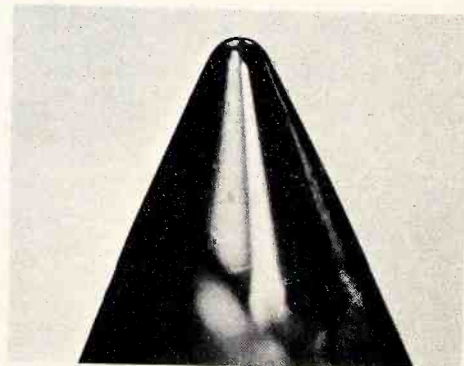

Courtesy Tetrad Corp.  
Fig. 2(C)



# Hi-Fi Reproduction

(Continued from page 3)

is a section of the record played by the osmium stylus, shown in Fig. 2(A). Fig. 2(E) is a section of the record played by the sapphire stylus, shown in Fig. 2(B). Fig. 2(F) is a section of the record played by the diamond stylus, shown in Fig. 2(C).

The difference in the condition of the grooves of the three brand new records after 50 playings is obvious. We can easily see how the diamond stylus imposed less wear on the record grooves, by comparing each of these photographs to Fig. 3(A), depicting a brand new record.

Since we have discovered the damage to records that can be caused by worn styli, it may be interesting to our readers to find out just how this damage is caused. From Fig. 3(B) we discovered that the contact

between a new stylus and the record walls, occurred at two microscopically small points, on each side of the tip. When we discovered that these points travel over one half mile of surface, with each playing of a 12" microgroove record, at pressures of up to 26 tons per inch, we agreed it was not at all surprising that these small contact surfaces started to wear and to flatten out. It is these flats, such as illustrated in Figs. 4(A) and 2(A), which are responsible for practically all of the damage to the record grooves.

As the flats on the stylus grow larger with wear, the edges become progressively sharper. When the flats on each side of the stylus eventually meet, the tip starts to look like a miniature chisel. A stylus tip worn to this condition is illustrated in Fig. 2(B). This chisel tip, while swinging from side to side in the groove, cuts and actually chisels into the groove walls, cutting minute particles as it travels. These particles cut from the walls of the groove combined with the particles worn from the stylus remain in the groove, as shown in Fig. 1(D), and help grind the flats on the stylus to a still sharper edge.

We have, thus far, confined our discussions to the economical aspect of stylus wear, both on the stylus itself and on the record. Despite the fact that these are both important to the author's mind, there is an equally important factor—the effect of stylus wear on high-fidelity reproduction. We will, in our succeeding paragraphs attempt to explain just how worn styli affect reproduction.

Chapter Eight (not reprinted here) explained how the cutting head, when recording, transformed electrical impulses into mechanical side to side or lateral motion, thus forcing the cutting stylus to engrave minute impressions into the walls of the record groove. These impressions are in proportion to the frequency and intensity of the signal being recorded.

We also explained that a sound wave with a frequency of 10,000 C.P.S. caused the cutting stylus to vibrate 10,000 times per second. When the playback stylus transmitted this recorded sound, it was forced by the impressions engraved upon the walls of the groove, to vibrate at 10,000 times per second.

The length of a recorded wave on a groove is dependent upon the frequency and amplitude of the sound, upon the diameter of the record and the speed of the recording. A low-frequency note will cause the formation of a wave such as is shown in Fig. 4(B), with a comparatively long distance between crests. A high frequency note will produce waves, as shown in Fig. 4(C), with a short distance between crests.

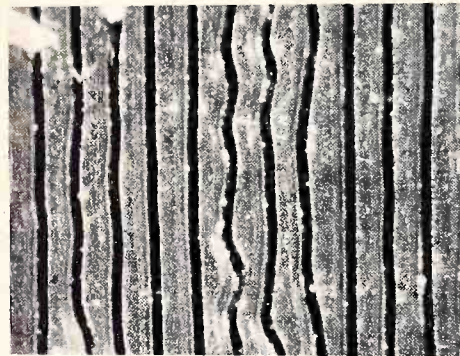

Courtesy Tetrad Corp.  
Fig. 2(D)

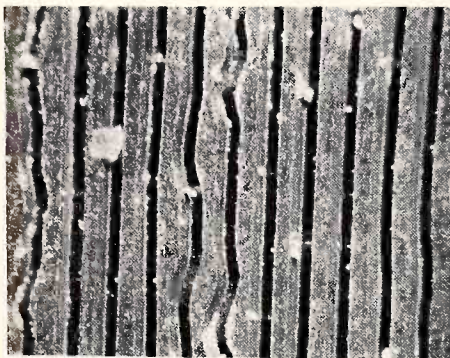

Courtesy Tetrad Corp.  
Fig. 2(E)



Courtesy Tetrad Corp.  
Fig. 2(F)

(Continued on page 14)

## RIDER BOOK SHELF

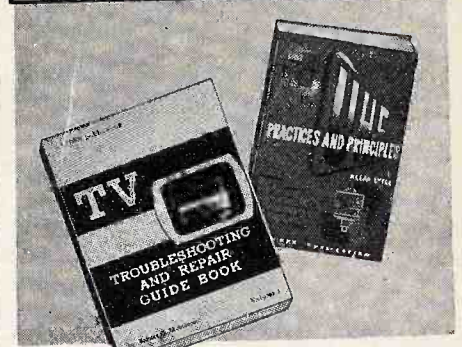

### 1 TV TROUBLESHOOTING AND REPAIR GUIDE BOOK by R. G. Middleton

A new practical book designed to make your tv servicing easy. It tells—in easy-to-read language—how to spot receiver troubles... and how to correct them permanently. You'll find enough practical data in one chapter to repay the low cost of this book many times over. Typical chapters include: Receiver Differences and Waveforms; Visual Alignment; Troubleshooting Sync Circuits; Locating Sweep Troubles; Causes and Cures of Receiver Buzz; Test Equipment Kinks. Indexed and illustrated with over 190 (8½ x 11") pages bound in durable art cover -----\$3.90

### 2 UHF PRACTICES AND PRINCIPLES by A. Lytel

A new, up-to-the-minute book that clears away the confusion and misunderstanding most people have about UHF. Written in clear, easy-to-understand terms, this book covers both fundamental theory and practical, working applications with special emphasis on television. Present-day brand name converters are thoroughly covered, including circuit descriptions and schematics. Here is profitable and practical reading for anyone who will be working with UHF. Typical chapters include: UHF Receiving Antennas; Electromagnetic Radio Waves; Transmission Lines; Waveguides. Illustrated and indexed with approx. 400 (5½ x 8½") pages bound in cloth cover. \$6.60

Buy these books now at your jobbers  
... leading bookstores ... or—

---MAIL THIS COUPON--- TODAY---

JOHN F. RIDER, Publisher, Inc.  
480 Canal Street, New York 13, N. Y.

Please send me book(s) circled. I understand, if not satisfied, I may return them within 10 days for full refund. 1 2

NAME \_\_\_\_\_

ADDRESS \_\_\_\_\_

CITY \_\_\_\_\_ STATE \_\_\_\_\_ ZONE \_\_\_\_\_

STATE \_\_\_\_\_ (Please Print) 55-9

Please mention *Successful Servicing* when answering advertising.



## Stylus Wear, Etc.

(Continued from page 13)

A recorded combination of a high and a low-frequency will produce a complex wave, as shown in Fig. 4(D).

As the record speed is constant on a single record, the length of a recorded wave of a specific frequency decreases with the diameter of the groove in use. For example, a 10,000 C.P.S. note has a length along the groove of .002" at the starting grooves of a 12" microgroove record; the same frequency recorded 6" from the center has a length of .001". At a point 3" from the center the length decreases to .0005". From these figures, we can easily see why a stylus cannot have a flat greater than .0005" if we



Fig. 3(A) Left  
Courtesy Tetrad Corp.

Fig. 3(B) Right  
Reprinted from June '52 issue of Service.

are to reproduce a frequency of 10,000 C.P.S. When the flat is greater, the stylus will bridge the crests of the recorded wave, consequently it will not reproduce this frequency. As the flat becomes larger, the lower becomes the frequency that the stylus can reproduce.

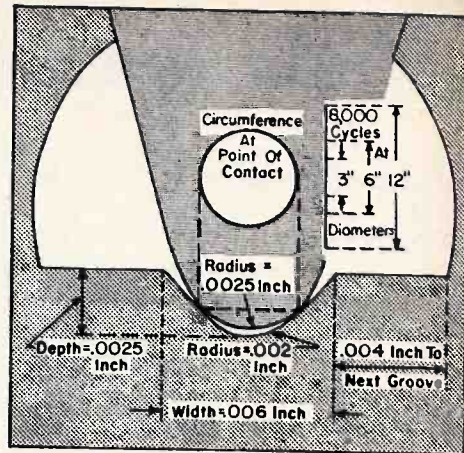

We have also discovered that even a diamond stylus is not permanent. When should it be replaced? Unfortunately, there is no simple, direct answer to this question. When wear has progressed to a point where there is a clearly defined flat, "under a microscope," on either side of the tip, it is then time to replace that stylus. Unfortunately, checking a stylus by this method requires the use of a good 150-200 power microscope. Obviously most individuals do not possess such an instrument and, therefore, this answer is unsatisfactory, except to a professional.

However, a rapidly increasing number of reputable music dealers are installing microscopes of this type, in order to provide this essential service for their record customers, therefore we would suggest you call on your local dealer first. The best possible suggestion we can offer, is to be sure to present for examination "under a microscope" any diamond stylus that has been used for 1,000 plays or more.

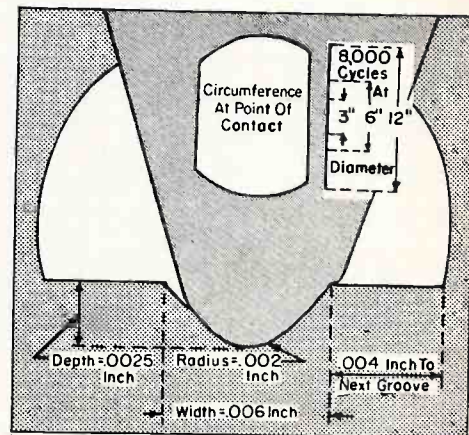

Reprinted from June '52 issue of Service  
Fig. 4(A)

Many record collectors seem to have the erroneous impression that the time to replace a stylus is when the quality has deteriorated to a point, at which it becomes obvious, that something is wrong with record reproduction. This is a rather dangerous and expensive misconception, as a stylus that sounds bad has been damaging records for quite some time. A good preliminary check can be obtained with the Sonafax 60 power microscope, illustrated in Fig. 4(E).

(Continued on page 18)



# No Searching

with C-D's line of "UP" electrolytics

... simplifies your TV replacement problems



- The only twist-prong electrolytic line with complete replacement coverage!
- Saves you hours of "hunting time".
- Follow the C-D TV Guide, and you automatically meet and beat the manufacturer's requirements for every TV set.
- See your local C-D jobber today (he's in your local Classified Phone Directory) for C-D's Television Replacement Guide TVR 7A or write to Dept. R92, Cornell-Dubilier Electric Corp., South Plainfield, N. J.



CONSISTENTLY DEPENDABLE  
**CORNELL-DUBILIER**  
CAPACITORS

PLANTS IN SO. PLAINFIELD, N. J. • NEW BEDFORD, WORCESTER AND CAMBRIDGE, MASS. • PROVIDENCE, R. I.  
INDIANAPOLIS, IND. • FUYQUAY SPRINGS, N. C. • SUBSIDIARY, RADIART CORP., CLEVELAND, OHIO

Please mention *Successful Servicing* when answering advertising.





# New CBS-HYTRON Germanium Diodes Guaranteed Moisture-Proof!

## GENERAL PURPOSE TYPES

- 1N48
- 1N51
- 1N52
- 1N63
- 1N64
- 1N65
- 1N69\*
- 1N70\*
- 1N75
- 1N81\*

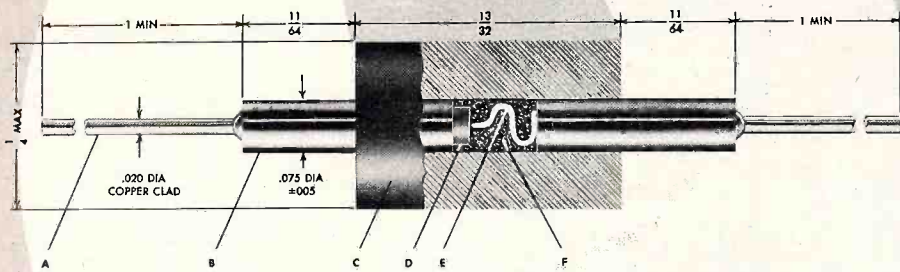

### Mechanical Specifications

- A. .020" copper-clad wire
- B. Nickel-silver "clip-in" pin
- C. Glass-filled plastic case
- D. Germanium crystal soldered directly to base
- E. .005" tungsten cat whisker
- F. Moisture-resistant impregnating wax

\*JAN TYPES

### WHY CBS-HYTRON GERMANIUM DIODES ARE BETTER RECTIFIERS

1. **MOISTURE-PROOF** . . . eliminates humidity and contamination problems
2. **SELF-HEALING** . . . self-recuperating from temporary overloads
3. **SUBMINIATURIZED** . . . only 1/2 inch long, 1/4 inch in diameter
4. **SOLDERED WAFER** . . . omission of plating eliminates flaking
5. **LOW SHUNT CAPACITY** . . . 0.8  $\mu\mu\text{fd}$  average
6. **SELF-INSULATING CASE** . . . mounts as easily as a resistor
7. **EXCEPTIONAL LIFE** . . . 10,000 hours minimum under rated conditions
8. **NO FILAMENTS** . . . low drain, no hum

Vital germanium wafer in a CBS-Hytron diode is *guaranteed moisture-proof*. Sealed against deadly moisture . . . fumes . . . and contamination, a CBS-Hytron diode keeps moisture where it belongs . . . out! First, by a chemically and electrically inert impregnating wax. Second, by a glass-filled phenolic case. With *moisture-proof* CBS-Hytron germanium diodes, you can be sure of maximum trouble-free life.

Superior techniques also permit CBS-Hytron to omit plating of the germanium wafer. Soldering is directly to the base. Thus flaking is eliminated and quality improved. Universal design of CBS-Hytron diodes follows Joint Army-Navy specifications. "Clip-in" feature gives you versatility, ruggedness, and electrical stability. Flexible pigtailed of copper-clad steel welded into sturdy nickel pins also insure you against damage by soldering heat.

Check the eight important-to-you reasons why CBS-Hytron *moisture-proof* germanium diodes are better rectifiers. Send today for complete data and interchangeability sheets. Specify CBS-Hytron *guaranteed moisture-proof* diodes for superior, trouble-free operation.



SALEM, MASSACHUSETTS



# Here's Why - the CDR Rotor

**...Is the NO. 1  
all-purpose Rotor!**

*It has EVERYTHING!*

And it does have EVERYTHING... as you can plainly see! Just check over this impressive list of features—and you'll see why... ALREADY THE NEW CDR ROTOR is acclaimed as the outstanding unit in the field! No other rotor boasts all these features... that's why it's the best ALL-PURPOSE rotor money can buy.

**MODEL TR-11** Complete rotor with handsome modern design plastic cabinet and meter control dial... finger-tip lever—using 4 WIRE CABLE.. \$44.95

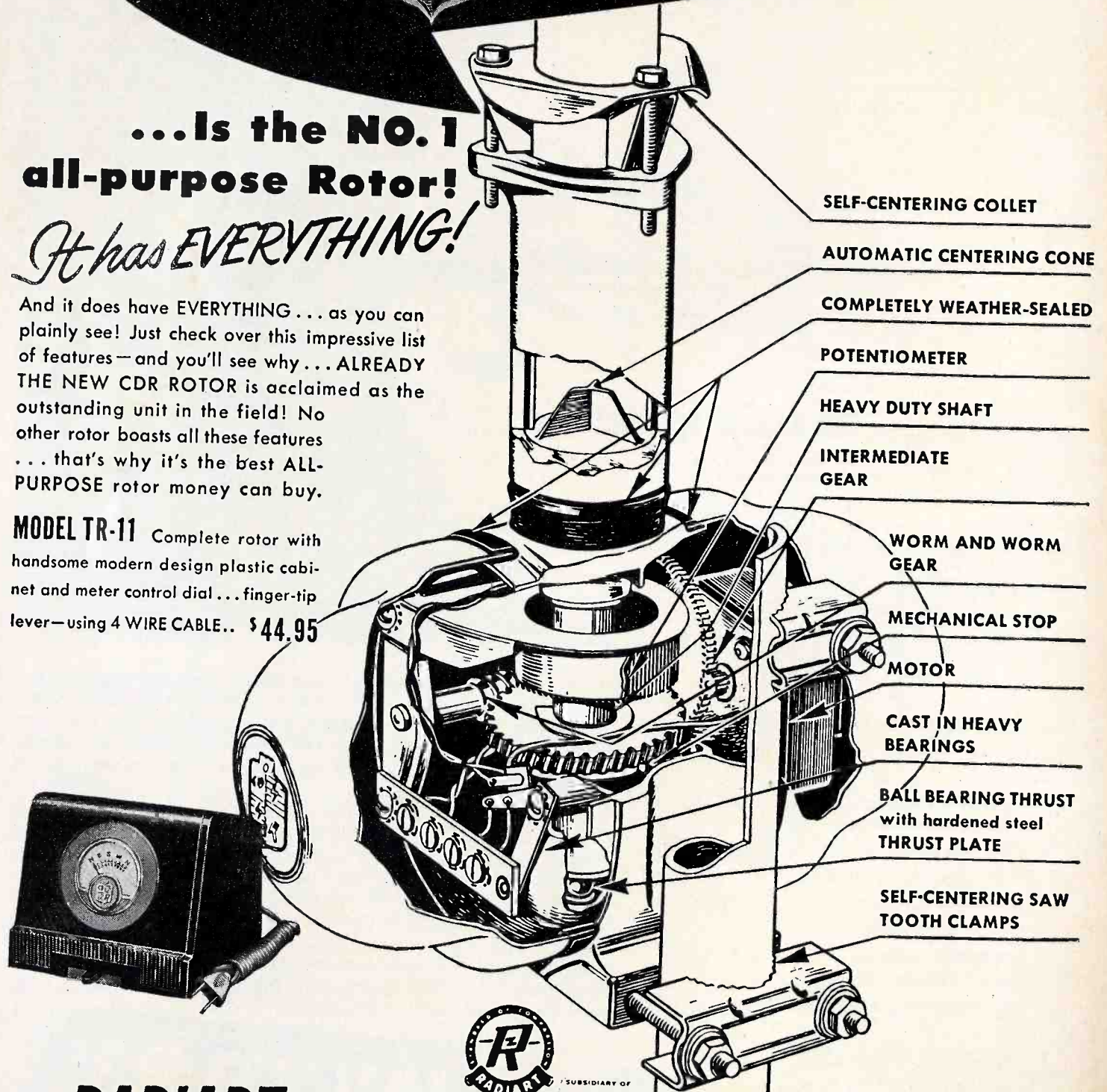

- SELF-CENTERING COLLET
- AUTOMATIC CENTERING CONE
- COMPLETELY WEATHER-SEALED
- POTENTIOMETER
- HEAVY DUTY SHAFT
- INTERMEDIATE GEAR
- WORM AND WORM GEAR
- MECHANICAL STOP
- MOTOR
- CAST IN HEAVY BEARINGS
- BALL BEARING THRUST with hardened steel THRUST PLATE
- SELF-CENTERING SAW TOOTH CLAMPS

THE **RADIART** CORPORATION  
CLEVELAND 13, OHIO



SUBSIDIARY OF



**CORNELL-DUBILIER**  
SOUTH PLAINFIELD, NEW JERSEY

Please mention *Successful Servicing* when answering advertising.



# CONGRATULATIONS!

on

## TELL-A-FAULT

"it ought to be a 'must'."

John C. Pyle  
Simplex Radio Service  
1511 Alton  
Denver, Colorado

"you have started the ideal service for all of us who service TV receivers."

Horace L. Graham  
1006 N. Buffalo St.  
Cleburne, Texas

"the time saved using this service will pay more than 100 times its price."

Frank Tomaszewski  
455 Pearl St.  
Pittsburgh, Penna.

### NEED WE SAY MORE!

These comments are from servicemen just like yourself who are using TELL-A-FAULT in their everyday servicing work. They have found that TELL-A-FAULT does their troubleshooting for them. It can do the same for you!

This quadruple-threat service consists of:

- (1) time-saving pictorial, symptom and cure sheets
- (2) fault pinpointing circuit guides
- (3) servicing-techniques short cuts
- (4) how to use all sorts of test equipment

Save anywhere from 50 to 200 hours of troubleshooting time per year by using this practical service based on symptoms rather than circuitry. It completely removes the guesswork in locating receiver troubles by rapidly locating the faults and giving you the proper cures.

TELL-A-FAULT is only a few months old, but the idea has caught on with thousands of progressive service technicians throughout the country.

The entire service costs you less than twenty cents a week. You receive a full 12 month's TELL-A-FAULT for only \$10.00.

Start your subscription today! We'll send you your TELL-A-FAULT binder, subject separators and all the installments that have been released to date. For full information on the most unique SERVICE ever made available to TV and radio service technicians — write to Dept. TF 5.



**JOHN F. RIDER**  
PUBLISHER, INC.  
480 Canal St., N. Y. 13, N. Y.

## Radio Master's Reports

(Continued from page 11)

### Discontinued Items

**ADVANCE ELECTRIC**—Withdrew 32 relays from their line.  
**BELL SOUND SYSTEMS**—Withdrew amplifiers 3715A, 3725A, 3750A, 3750A-R; mobile amplifier 3723-M; PA systems PA-3715A, PA-3725A, PA-3750A; Phono PA system 2078; record player 2075; microphone DY-11 and recorder RC-47.  
**BRIDGEPORT BRASS**—#605 withdrawn from their line of plastic sprays.  
**DECIMETER, INC.**—"Professional" TV pre-amplifier models 300 and 400 withdrawn.  
**DUMONT LABS**—Withdrew series of 5 Y2 deflection yokes.  
**EBY SALES CO.**—Withdrew No. 140, alarm annunciator and No. 150, heavy duty universal unit, with built-in light source.  
**JACKSON ELECTRICAL INSTR. CO.**—HV, high voltage probe discontinued.  
**OXFORD ELECTRIC CORP.**—Withdrew 5CM-WS, weatherproof speaker.  
**R.C.A.**—Withdrew WG-211, cable and probes for WO-58A (individual parts may be ordered by catalog number from service parts stock); WG-263, crystal probe (superseded by WG-264 & WG-218) . . . WG-265, testpoint adapter . . . WO-57B, oscilloscope (will be superseded by WO-88A).  
**RADIO MERCHANDISE SALES**—Corner array antennas models COR-4 to 10 and COR-FM withdrawn along with their LN8 series.

### Price Increases

**AMERICAN ELECTRIC HEATER CO.**—Increased price of No. 3798 copper soldering iron tip to \$1.995 net.  
**AMERICAN PHENOLIC**—RF connectors 82-814 and 82-815 increased in price.  
**BENDER CO., L. M.**—Net price of box chassis model 00Z increased to \$.54.

### Price Decreases

**AMERICAN PHENOLIC**—Reduced prices on remote control wire #14-316 (100)(500)(1000), also on a number of items in their RG/U type transmission lines, series 21.  
**GOLDRING GRAMAPHONE**—Stylus models 260 and 270 reduced to \$1.50 net each.  
**NATIONAL UNION**—Decreased prices on two 16" and two 19" videtron tubes.  
**RADIO CITY PRODUCTS CO.**—Reduced price on No. 488A, deluxe multi-tester to \$61.50 net.

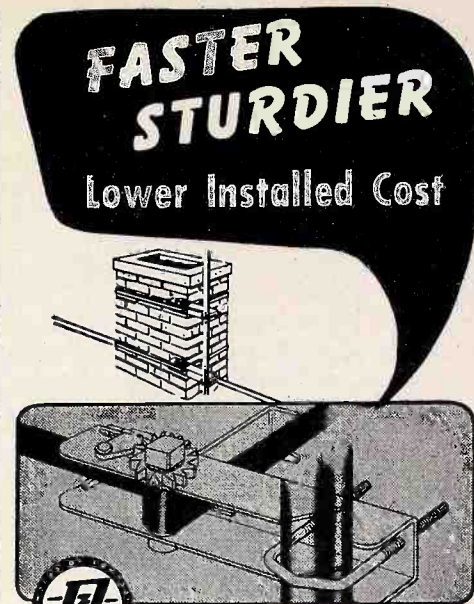

## SPEE-DEE CHIMNEY MOUNT

**Model AK 85** The fastest-installed chimney mount ever devised for TV antennas! Rugged in design—simple to install. Simply thread strapping through ratchet, around chimney and back through ratchet—wind up ratchet tight—and the job's done! Heavy gauge, zinc-plated steel with large "U" bolt for up to 1 3/4" O.D. mast and full length galvanized steel strapping.

**THE RADIART CORPORATION**  
CLEVELAND 13, OHIO



Here is the custom-built AM-FM chassis that means **BIGGER PROFITS** for you!

### The NEW ESPEY model 511-C

#### FEATURES

1. AC Superheterodyne AM-FM Receiver.
2. Improved Frequency Modulation Circuit, Drift Compensated.
3. 12 Tubes plus rectifier and Pre-Amp 12AT7 Tube.
4. 4 dual purpose tubes.
5. Treble Tone control.
6. 6-gang tuning condenser.
7. Full-range bass tone control.
8. High Fidelity AM-FM Reception.
9. Automatic volume control.
10. 10 watts (max.) Push-Pull Beam Power Audio Output.
11. 12-inch PM speaker with Alnico V Magnet.
12. Indirectly illuminated Slide Ruler Dial.
13. Smooth, flywheel tuning.
14. Antenna for AM and folded dipole antenna for FM Reception.
15. Provision for external antennas.
16. Wired for phonograph operation with switch for crystal or reluctance pick-up.
17. Multi-tap output trans., 3.2-8-500 ohms.
18. Licensed by RCA and Hazeltine.
19. Subject to RMA warranty, registered code symbol #174.

#### SPECIFICATIONS

Supplied ready to operate, complete with tubes, antennas, speaker and all necessary hardware for mounting in a table cabinet or console, including escutcheon. Power consumption—105 watts.

Chassis Dimensions: 13 1/2" wide x 8 1/2" high x 10" deep.

Carton Dimensions: (2 units) 20 x 14 1/2 x 10 3/4 inches.

Net Weight: 17 1/2 pounds each.

Sold through your favorite parts distributor.

WRITE FOR CATALOGUE KD12 AND NAME OF NEAREST DISTRIBUTOR.

## ATTENTION! RADIO SERVICEMEN

THERE ARE THOUSANDS OF OUT-MODED RADIOS IN YOUR "BACK YARD" JUST WAITING TO BE REPLACED . . . AT YOUR SUGGESTION

Makers of fine radios since 1928.

**ESPEY**

MANUFACTURING COMPANY, INC.  
528 EAST 72nd STREET, NEW YORK 21, N. Y.



## A Window Display as a Market Generator

The *Radio and Television Technicians Guild of Florida, Inc.* — Dade County Chapter, has prepared a window in Miami to show the public the complicated equipment needed by the modern serviceman. The *R&TTG* did all work necessary for the display, and all the distributors in the city contributed the equipment used. Along with the 'scopes and probes, VTVM and tube tester in the window, the Guild included Rider Manuals as an important part of a modern tv service shop. It's nice to be appreciated. But, even without the Rider Manuals, we think the window is well done and a fine idea. Congratulations!

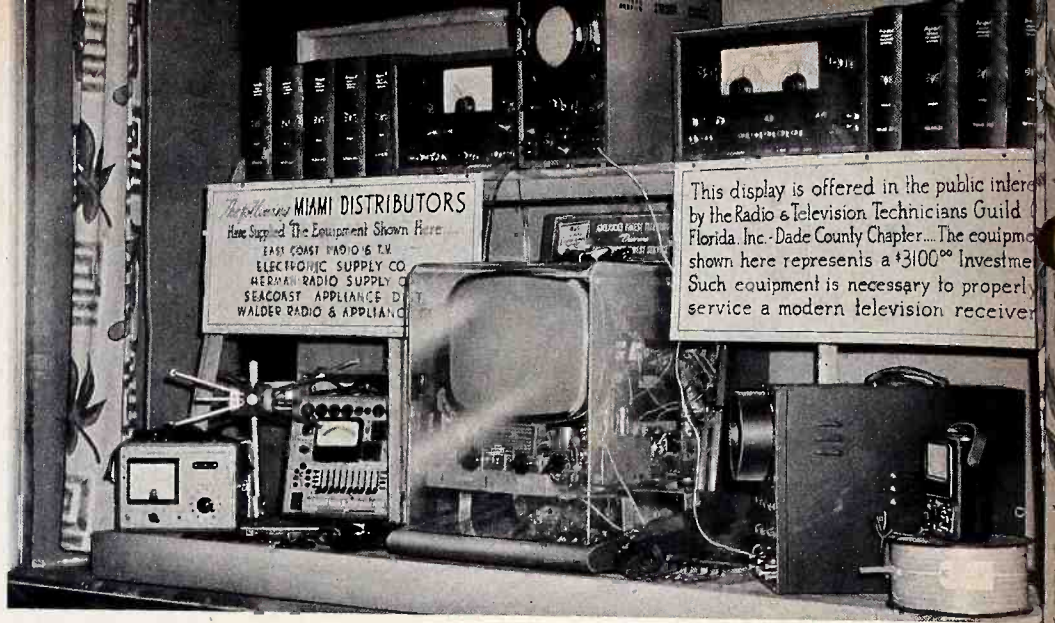

## Laughs in the Life of a TV Serviceman



**"The \$30 I'll save by installing my own antenna ought to cover the hospital bill..."**

**T**HAT's just one of the problems TV servicemen sometimes run into! Some of the problems you *don't* run into when you service Raytheon TV are lack of schematics and technical information, or lack of help from our Field Service Representatives.

Every Raytheon TV set comes with schematics showing all part values. Our Field Service engineers

make regular calls, and through our distributors there's a free factory course in advanced TV service. Then there's the successful "How to Interpret What You See" program — write for details. All this helps you service Raytheon TV and other brands, too... Raytheon Manufacturing Company (Belmont Radio Corporation, 5921 West Dickens Ave., Chicago 39, Ill.)

Please mention *Successful Servicing* when answering advertising.

## Stylus Wear, Etc.

(Continued from page 14)

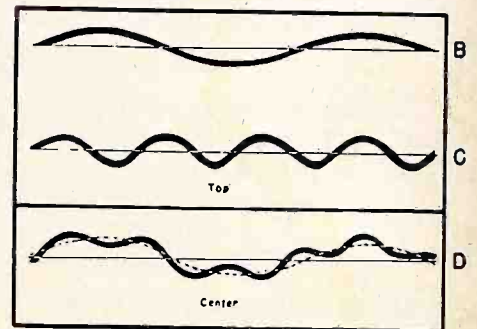

Reprinted from June '52 issue of *Service*  
Fig. 4(B, C, D)



Courtesy Sonafax Co.  
Fig. 4(E)

When a cartridge with a built-in stylus, such as Pickering, Fairchild or Weathers, is used and returned to the manufacturer for styli replacement, the customer can always be certain of a high quality replacement. When a cartridge with a replaceable stylus, such as G.E. or Audak is used, equally high quality styli are available from these manufacturers or your local music dealer.

From  
JOHN F. RIDER PUBLISHER, Inc.  
480 CANAL ST., NEW YORK 13, N. Y.  
Forwarding and Return Postage Guaranteed



# SUCCESSFUL Servicing

OCTOBER 1952

This is Part 1 of a two-part article on the use of "gimmicks" in radio and TV. The former is discussed in this article and the latter will be discussed next month.

THE TITLE HEADING of this page will probably arouse the curiosity of many a reader. The word "gimmick" has been used so widely throughout the radio industry (besides being used in ordinary everyday life) that an exact meaning of the word becomes difficult. We have found reference given to gimmicks by many receiver manufacturers and analyzing all the cases, we have set up an arbitrary definition of what a gimmick is. Any piece of wire or coil that has been inserted purposely in a circuit in such a manner that one end is connected in the circuit with the other end open, or both ends open, and serves the purpose of a small capacitance, is termed a "gimmick". In other words, a certain amount of capacitance exists between the wire or coil and some other part of the circuit.

An illustration will help explain the full extent of a gimmick. In Fig. 1(A) is shown a coil on wire L1 with one end tied to the control grid of a tube and the other end open. Near this open end of the coil there is an inductance L2. The inductance L2 is part of a 1000-kc resonant tank circuit of which C2 is the variable capacitor and the tank circuit is excited by a 1000-kc signal. Due to this excitation, a circulating alternating current exists within the tank circuit and energy is available from this tank. Placed very close to the inductance of the tank is the open end of L1, which forms, effectively, one "plate" of a capacitor. The high side of L2 represents the other "plate" of a capacitor and together both "plates" form an effective capacitance, which is small in value, some of the energy from the tank circuit being fed into the grid of the tube through the L1 gimmick.

An equivalent circuit with the gimmick replaced by a capacitor is shown in Fig. 1(B). Since it may not be evident exactly how a capacity is formed between L1 and L2, it will be best to study the formation of a capacity from the physical point of view.

Two conductors separated by some type of dielectric can be called a capacitor; the dielectric may be air, paper, mica, oil, or a number of other materials. The many

different insulating materials used as a dielectric between two conducting plates are capable of exhibiting electric charges on the outer surface of the material facing the conducting plates. How capable these insulating materials are in exhibiting electric charges is dependent upon the type of dielectric used. In the case of gimmicks, the dielectric is the insulating material which covers the wires.

With the understanding of how a capacity does exist and of what is arbitrarily de-

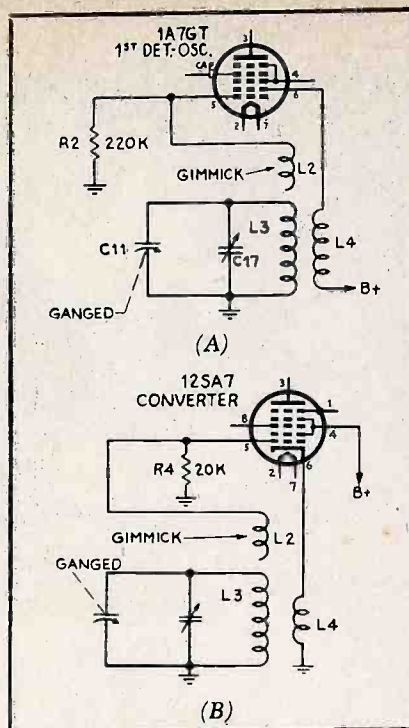

Figure 2

## "GIMMICKS" in Radio and TV

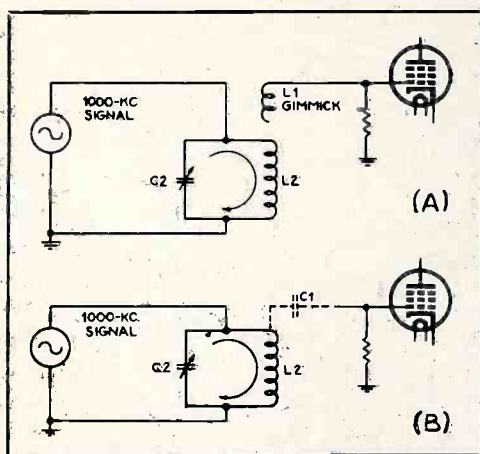

Figure 1

defined as a "gimmick", the next thing to do is to study the various different arrangements of gimmicks.

One type of gimmick used in the oscillator circuits to provide the necessary capacitance to couple the oscillator-tank circuit voltage to the grid of the oscillator is shown in Fig. 2. Both models have a form of tickler-coil oscillator but seem to have their tank circuit "floating". That is to say, the oscillatory tank circuit has only one end going to ground and the other end unconnected. At a first glance one would believe that there is no means of conductively coupling

the oscillator high-tank voltage to the grid of the oscillator section of the tube. Notice the coil L2 placed above the tank inductance L3; hence an effective capacitance exists between the open end of L2 gimmick and coil L3 so that some oscillatory voltage is fed through this effective capacitance, formed by the gimmick and high side of L3, to the grid of the oscillator tube. These gimmicks usually are wound around the same coil form as the rest of the oscillator coils and how close they are wound or coupled to the other coils determines the amount of capacity introduced between the gimmick and tank coil and hence the amount of oscillatory voltage fed to the grid.

The serviceman will probably not be able to notice from looking at the chassis that a gimmick does exist in the oscillator circuit since most of these gimmicks are on one oscillator coil form and the form is completely wax impregnated.

Another type gimmick arrangement is used to accomplish the coupling of some of the oscillator tank voltage to the oscillator grid. The circuit is shown in Fig. 3. It will be noticed that one end of coils L1 and L2 are open and the other ends attached, each to respective parts of the circuit. Each coil L1 and L2 according to our

(Continued on page 11)



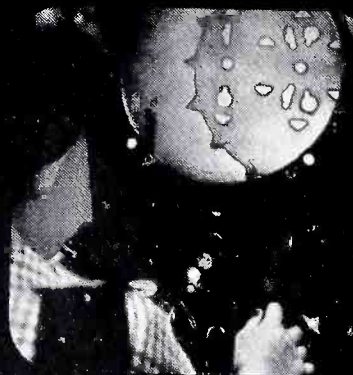

Mica specifications checked to thousandth-inch accuracy.



Completed mounts are inspected for visual defects.

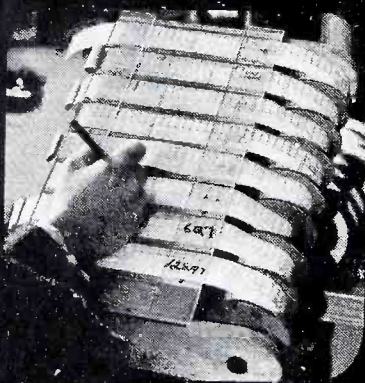

Statistical control assures uniformity of quality and performance.

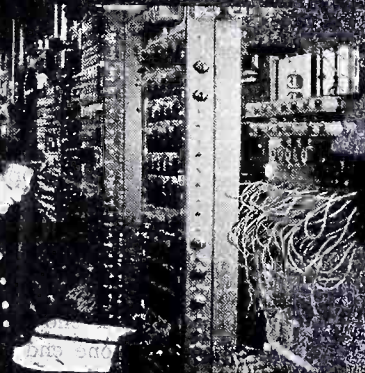

Life tests prove Tung-Sol Tubes can take it.

# Complete control of materials and manufacturing procedures makes Tung-Sol Tubes dependable!

## You can build a reputation on Tung-Sol Quality

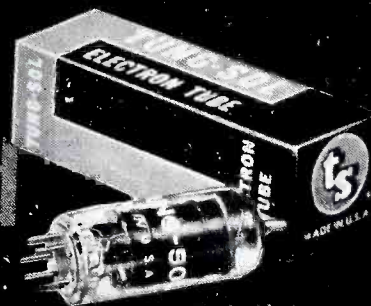

TUNG-SOL ELECTRIC INC., Newark 4, N. J.

Sales Offices: Atlanta, Chicago, Culver City, Dallas, Denver, Detroit, Newark

TUNG-SOL MAKES All-Glass Sealed Beam Lamps, Miniature Lamps, Signal Flashers, Picture Tubes, Radio, TV and Special Purpose Electron Tubes.



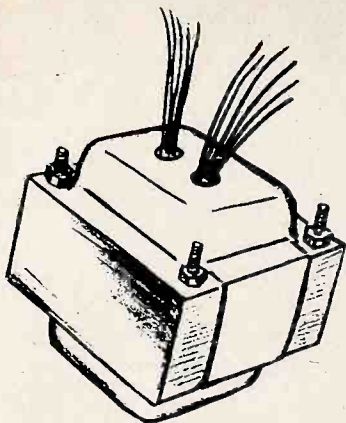
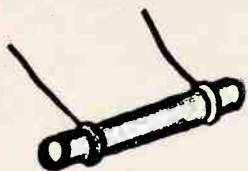
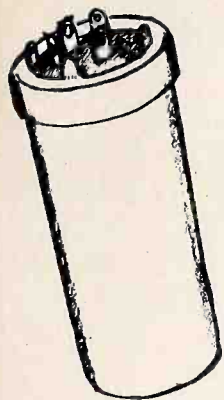

# The RIDER

## Replacement Parts

### Program

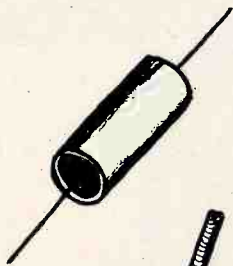
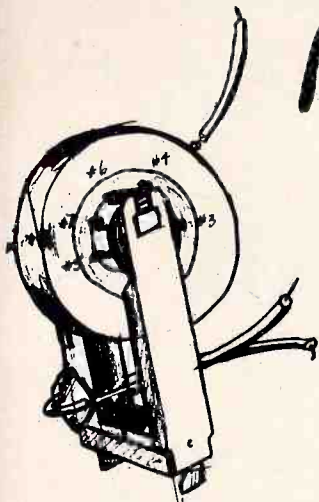

RIDER TV MANUAL VOLUME 10 will be published in November, 1952. It will be the first of the Rider Manuals to contain replacement part listings. These listings will be in addition to the complete set manufacturer's parts list so, for the first time in the history of the radio and television industry, a single volume will give the servicing industry the unabridged parts list for all the parts used in the receiver and, in addition, a dependable listing of equivalent replacement parts for many of the components.

This program differs from all other existing programs in that listings of replacement parts is based on the results of a comparison of the performance specifications of the replacement part suggested with the specifications set by the receiver manufacturer for the original part. This is positive assurance to the service technician that whatever suggested replacement he finds listed in Rider TV Manual Volume 10, and forthcoming Rider Tek-Files, will fit the receiver's need in all respects.

The examination of the specifications of

a suggested replacement part and the comparison with the specifications covering the original part is done for a number of reasons. It is vital that the part used as a replacement by the service technician perform properly in the receiver in which it is installed. If this is achieved, the result is a satisfied customer and an increase in public confidence in the service technician. Moreover, it is assurance to the set manufacturer that his receiver has been serviced properly . . . that it will continue functioning and give the product the longest life in the hands of the public. The Rider Replacement Parts Program is a three pronged affair . . . it aims to protect the service technician, the public, and the set manufacturer. This is why it has the support of the tv receiver manufacturing industry.

#### It's a Serious Matter!

The choice and listing of replacement parts cannot be a haphazard affair . . . it is an extremely serious matter. Properly carried out, it means greater freedom from costly, profitless, time-consuming repeat calls

on the part of the service technician. It means elimination of frustration when something does not fit the receiver properly . . . or function in the receiver properly. It means the elimination of time spent for major fabrication effort in order to adapt the part . . . time for which the service technician cannot charge . . . or if he does, meets great opposition in collecting.

Merely satisfying the physical needs of a receiver when choosing a replacement part is not sufficient . . . satisfying the d-c resistance needs of an inductor type component is not sufficient . . . in fact, quite frequently, it is meaningless. Satisfying the stated capacitance ratings when selecting a replacement is not sufficient . . . a-c constants must be satisfied also.

All yokes which are rated at the same deflection angle are not equally suitable for all receivers which use that deflection angle for the picture tube . . . the inductance of the vertical and horizontal windings of the yoke must satisfy the conditions set by the vertical and horizontal output transformers.

Every vertical output transformer does not suit every tv receiver . . . or every vertical deflection coil. Every horizontal output transformer does not work equally well with any horizontal winding in a deflection yoke . . . or with any width coil. These are companion components . . . they must complement each other in their electrical constants and in their performance.

All capacitors are not equally suitable for use in all places in a receiver simply because their stated capacitance values are alike . . . this is so even if the working voltage ratings are the same. Too little attention has been paid to tolerance in capacitance ratings . . . in the ratings of inductor type components. Speaking about capacitors at the moment, receiver manufacturers stipulate the capacitance tolerance for the capacitors which they use in their receivers — also the temperature characteristics. These requirements *must* be satisfied in the replacement. Capacitors rated at 5% and 10% tolerance should be replaced by capacitors of like tolerance rating and not by 20% tolerance units. Temperature compensating capacitors cannot be replaced by ordinary units and result in proper circuit action.

Many circuits are far more critical in design requirements than generally assumed. This is so because the conditions under which a tv receiver is used vary widely. A liberal combination of components which may function properly in one high signal area may not work the same way in another, simply because all tv broadcasting stations are not holding to transmitting standards equally well. The receiver manufacturers know this and stipulate component values which are much closer in tolerance than the normal everyday standard, because they want their receivers to function correctly under all transmitting conditions . . . under even the most trying conditions.

(Continued on page 8)





Here's The NEW Smart Way To Buy Vibrators

# RADIART Seal-Vent VIBRATORS

In A Re-Usable Clear Plastic Box

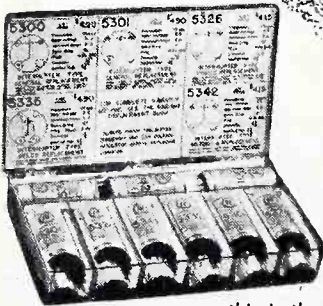

this is the way it looks fully packed



here is the re-usable box with dividers for a hundred uses at home or work

★ The BEST Vibrator Money Can Buy.

★ A "BONUS" For Your Customers in the re-usable Plastic Box.

★ BIGGER Unit Sales... Sell NINE at a time instead of 2 or 3.

★ MORE Sales Faster... MORE PROFITABLY for you.

Here's an unusual merchandising plan that means EXTRA volume and FASTER profits for you! RADIART vibrators sell fast and well on their own... NOW... with this KIT PLAN... you will sell even MORE vibrators... FASTER, and with a bigger UNIT SALE! Each kit contains 9 vibrators, the 5 basic types that serve 60% of replacement applications... 2,5300... 2,5301... 2,5326... 2,5342 and 1,5335. The original supply is limited... so act fast and get your order in now to protect your allocation. This is too good to miss!



**THE RADIART CORPORATION** CLEVELAND 13, OHIO  
VIBRATORS • AUTO AERIALS • TV ANTENNAS • ROTORS • POWER SUPPLIES

Please mention *Successful Servicing* when answering advertising.



# Successful

# SERVICING

REG. U.S. PAT. OFF.

Dedicated to the financial and technical advancement of electronic maintenance personnel

VOLUME 13 NUMBER 12

OCTOBER, 1952

**JOHN F. RIDER, Publisher**  
**Annette M. Tricarico, Editor**  
**Stuart Flexner, Assistant Editor**

*Advertising Representative*  
**H. J. Olso & Co.**  
 3951 Grand Central Terminal  
 New York 17, N. Y.  
 MUrray Hill 6-4670



MEMBER



## Curtain Time

### TV Advertising Can Be Funny . . . . .

For instance there is the scene wherein the beautiful lady is sitting on a divan in a living room, sipping coffee. She remarks that she is so sorry that we cannot have the pleasure of being with her to enjoy this coffee. She knows doggone well that we haven't been asked . . . no one in my family has been asked. If she feels so sorry that people can't be with her to enjoy the coffee, she's had plenty of time to do something about it. If she really meant what she says, she could have loaded that dining room time and again. Having watched her for a long time, I'm beginning to think that she's not sorry at all . . . in fact she must like solitude, because she's always alone.

Then there's the guy who peddles dishes during the wee hours of the morning . . . you know, during the movie intermission. Last night he said that we'll have a busy season at my house during the coming winter, and should buy extra dishes since we'll have a lot of people coming and going. My wife was listening too, she looked at me in a funny way . . . she wanted to know if I had made some special plans about which she knew nothing . . . did I intend to hold service meetings at home and ask everybody for dinner? If not, where did this guy get the idea that we would be so busy entertaining that we would need an extra supply of crockery?

I've been a cigarette smoker for years . . . now I'm getting ready to quit smoking altogether . . . I'm confused. I don't know if I should buy one brand by the carton, try another for thirty days, or get away from the commonplace with a third brand. I'm fond of horses and confess that I'm very much intrigued by the cigarette ad which shows the horses taking the fences and then a hunt breakfast afterwards. But I also like the sexy movie star who smokes another brand, and if it's good enough for her it should be good enough for me.

All of these cigarettes claim to be the best . . . no hot spots, firmly packed, easy on the draw . . . they keep the flavor in and

the irritants out . . . and every one uses the world's best tobaccos. Maybe so, but why do I cough . . . and why does my doctor tell me to stop smoking? I know that he has a television set too . . . because I got it for him wholesale.

Are you intrigued by the man who wants to put us in the greeting card business, sell them in our spare time? You should be interested since you can make more money in no time whatsoever. I wish the guys who sell these cards would get together on how much money we can make . . . one of them says about \$20 to \$50 . . . another one goes as high as 150 bucks. In how long? . . . in no time whatsoever. If this is true it sounds better than the servicing business, that's for sure!

One beer is brewed so that chill can't kill the flavor; another has very little nonfermented sugar, a third has two extra steps in the brewing process. I've tried them all and like them all . . . but can't decide between them because they all give me the hiccups.

### Advertising Can Be Not So Funny

As a change of pace let's look at a printed ad which is presently appearing in some newspapers. This ad is aimed at the public and offers a device to eliminate tv interference.

The ad says that the device is a wavetrap; it can be installed at the antenna terminals in less than one minute. It has three connections: one for ground and two to be joined to the antenna terminals of the receiver. According to the ad this is a *newly invented bypass filter* . . . It is a *new miracle of modern science*. If this is a new invention it no doubt is or will be covered by one or more patents. This we would like to see.

It's a grand thing that paper is patient and ink is very willing . . . all sorts of statements can be made in ads. Unlike lots of other ads, this one doesn't take a crack at the service technician, but it does use some words and pictures quite loosely. For example, a ghost pattern is shown and identified as distortion caused by outside telephone lines or by neighborhood tv sets and antennas which compete with your receiver for the same channel. The trap is supposed to eliminate this kind of *interference*. This we would like to see too.

Now hear this . . . the addition of this trap across the antenna terminals adds new life to the picture in fringe areas . . . even in weak reception zones . . . even on channels you could never pick up before. In other words the trap increases the gain of the receiver, or the antenna pickup, so that stations which were not received before now result in a picture. I'm sure everyone in the television industry would like to see this claim demonstrated. It would be a real miracle!

It is claimed that this trap eliminates *diathermy* interference before it reaches the receiver. How about those frequencies in the interference which fall within the received signal frequency band? . . . how about those frequencies which fall within the video i-f band and get right into the i-f amplifiers? . . . how about pickup hum by the antenna lead inside the receiver, or between the antenna terminals and lead-in connection to the tuner input?

The newspapers always are concerned with protecting their readers. They are supposed to check the claims made in the advertising they carry. Are they doing this? It's true that it would be a bad practice to make each newspaper and magazine a censor of advertising copy, but isn't it within the realms of possibility for them to request proof of performance on some claims?

The ad sells the product with a money-back guarantee. This is a redeeming feature, but is it a license to make claims which every responsible engineer in the television industry would question?

Is it too far-fetched to imagine the different chapters of the Institute of Radio Engineers setting up committees which might work with local newspapers in major cities, so as to check the claims made in ads which are selling devices of various kinds related to radio and television? Would it not be worthwhile to ask these groups to act as advisors to local Better Business Bureaus? Maybe this is not the right answer, but something should be done.

John F. Rider





'Way Out Front with Servicemen . . . everywhere !

## MALLORY VIBRATORS

Servicemen know they get dependable, trouble-free performance from Mallory vibrators. That's why a recent survey showed Mallory vibrators the choice of servicemen by a 2 to 1 margin. Count on Mallory vibrators for . . .

- 1—Slow contact impact for minimum wear.
- 2—High contact pressure for low resistance.
- 3—Fast contact break for reduced arcing, pitting.

Mallory *alone* gives you that three-way vibrator combination because of its patented, tuned mechanism. It's your assurance of long-lasting service that beats the comeback problem. Set makers count on Mallory, too . . . they use more Mallory vibrators as original equipment than all other brands combined. When you order vibrators . . .

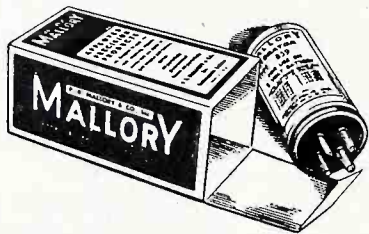

You get a Handy Parts Cabinet at no additional cost with Mallory's Special Vibrator Deals

You keep your inventory down . . . and get the parts cabinet, too . . . with these Mallory deals you can service 47 different makes of radios with the assortment of 6 Mallory vibrators. All this is yours at *your regular discount price*. See your distributor today.

## Make Sure! Make it Mallory!

P. R. MALLORY & CO. Inc.

# MALLORY

CAPACITORS • CONTROLS • VIBRATORS • SWITCHES • RESISTORS  
• RECTIFIERS • VIBRAPACK\* POWER SUPPLIES • FILTERS

\*Reg. U. S. Pat. Off.

### APPROVED PRECISION PRODUCTS

**P. R. MALLORY & CO., Inc., INDIANAPOLIS 6, INDIANA**

Please mention *Successful Servicing* when answering advertising.



# Oscillator Frequency and Overmodulation Effects in Intercarrier Receivers

## Local Oscillator Tuned Above and Below Incoming Signal

In the conventional-type television receiver the local oscillator is usually tuned above the incoming r-f signal for all channels. The same tuning for all channels is necessary in order to maintain the same video and sound i-f signals for each channel. If the oscillator were tuned below the incoming r-f signal for any one channel, the i-f's produced at the output of the mixer tube will be different from those required by the i-f tuned circuits of the receiver.

In the intercarrier type of television receiver it is possible to have the oscillator signal tuned both *above* and *below* the incoming r-f signals. For best results, the oscillator should be tuned above the incoming r-f signals for the low-frequency channels (channels 1 through 6), and tuned below the incoming r-f signals for the high-frequency channels (channels 7 through 13.) For this reason, the design of the oscillator is simpler since it tunes over a smaller range of frequencies than in the conventional receiver.

The reason that intercarrier receivers can have the local oscillator tuned above or below the incoming signal is that the resultant video and sound i-f carriers will always be 4.5 mc apart. Upon application of both of these i-f signals to the video detector, the output beat-signal will always be equal to 4.5 mc. There is an important requirement in the design of the pass band for intercarrier receivers in order to have the oscillator tuned above and below the incoming signal. The i-f pass band *must* have a symmetrical response curve so that regardless of which side the video or sound i-f signal appears on, the required ratio between the sound and video i-f carriers will remain approximately the same.

An idealized i-f pass band for the situation under discussion is illustrated in Fig. 1. Note that in the symmetrical shape of this curve we have included the same small plateau on either side for the sound i-f carriers and that the video carriers are each the same height. The sound i-f carrier at A and the video i-f carrier at B represent the intermediate frequencies when the oscillator is tuned above the incoming r-f signal and

those at C and D represent the video and sound i-f carriers, respectively, when the oscillator is tuned below the incoming r-f signal.

The typical case as mentioned previously has the oscillator tuned above the signal for channels 1 through 6 and below the signal for channels 7 through 13. This means that the sound and video i-f outputs from the front-end mixer tube for the lower channels should all be the same, but different from the i-f outputs for the higher channels. As a typical example let us figure out what the i-f and oscillator signals should be for one low channel and one high channel. For this problem we will use channel 6 (82-88 mc), to represent the low-frequency band and channel 7, (174-180 mc), for the high-frequency band.

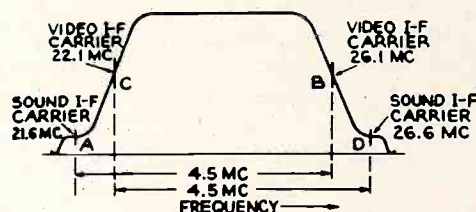

Fig. 1. An idealized over-all video i-f response for an intercarrier receiver where the local oscillator is tuned above and below the incoming signal.

The video carrier for channel 6 is 83.25 mc and the sound carrier 87.75 mc. If we choose a video i-f. equal to 26.1 mc, the sound i-f. would be equal to 21.6 mc and the local oscillator being tuned above the incoming signal would be equal to 109.35 mc ( $83.25 + 26.1 = 109.35$  or  $87.75 + 21.6 = 109.35$ .) The i-f values are indicated in the drawing of Fig. 1 next to points A and B. In order for channel 7, and hence the high-frequency channels, to utilize this pass band when the local oscillator is tuned below the incoming r-f signals, the sound i-f signal should be higher and the video i-f signal lower than the respective i-f signals of the low-frequency channels. The video and sound i-f carriers for channels 7 through 13 appear at points C and D, respectively, in the drawing of Fig. 1. These two i-f carriers are also 4.5 mc apart. Exactly what

their frequencies will be depends upon a number of factors, the principal one being the limitation in the bandwidth of the circuit. The over-all bandwidth of the r-f response cannot be greater than 6 mc or it will overlap into an adjacent channel. For the high-frequency channels, the sound i-f carrier is higher than the video i-f carrier because the local oscillator is tuned below the incoming r-f signal.

The video i-f carrier for the high-frequency channels, for example, can be made 0.5 mc higher than the sound i-f. of the low-frequency channels. For the example under discussion this means that the video i-f carrier for the high-frequency channels will be equal to 22.1 mc as shown at C in Fig. 1. The accompanying sound i-f carrier is 4.5 mc higher than the 22.1 mc video carrier and, therefore, will have a frequency equal to 26.6 mc as illustrated at D in the drawing.

The two sound i-f carriers in this drawing are shown ideally situated in the center of their small plateaus. Although such a level response is only ideal, the symmetry of the curve near the sound intermediate frequencies can be approached by employing traps. Two traps would be needed, one tuned slightly higher than 21.6 mc and the other slightly lower than 26.6 mc. These traps should be sharply tuned so as not to decrease the response near the video i-f carriers.

The video r-f carrier for channel 7 is 175.25 mc and the sound r-f carrier is 179.75 mc. This means that for the case under discussion the local oscillator for channel 7 will be tuned to 153.15 mc ( $175.25 - 22.10 = 153.15$  or  $179.75 - 26.6 = 153.15$ .)

## Faults of the Intercarrier System

The majority of faults with this system are directly attributable to operation at the transmitting end of the system. These faults will become evident as the discussion progresses.

This intercarrier sound system is predicated upon the fact that the video r-f carrier must be present in order to obtain sound output from the receiver. In other words, the sound carrier has to beat against the video carrier



# The RIDER Replacement Parts Program

(Continued from page 3)

The possible use of a tv receiver in a high or low signal area—in areas of different power line voltage—as determined by where the receivers are sold, requires a design which suits all conditions. This is why the replacement parts used must match the original, not only physically, but also the capacitance or inductance constants must fall within the tolerance limits of the original part.

All set manufacturers do not allow similar leeway in the electrical constants of complementary components. Some design their parts with very close tolerance, which means that the permissible limits of variations from the ratings are relatively small. Therefore replacements parts used in their receivers must conform more closely with the needs of such design than in other receivers which allow greater leeway. Such facts must be taken into account in the identification or selection of replacements . . . Later articles will prove these points.

It is because of these facts, and many more which shall be described in the pages of SUCCESSFUL SERVICING, that the Rider Replacement Parts Program is founded on the examination of the specifications of both the original parts and the replacement

parts. This is why the replacement parts listings which will be seen in Rider publications are dependable listings.

The Rider Replacement Parts Program is getting under way . . . It is a big program. It will begin with Rider's TV Volume 10 and move forward with each succeeding Rider Manual . . . it will eventually cover all the old Rider TV Manuals as well. In time there will be a separate dependable Rider Replacement Parts Guide for use by the servicing industry.

Because the program is elaborate, and every effort is being put forth to make it dependable, all possible replacement parts cannot be listed at one time. Substantially all receivers in Rider TV Manual Volume 10, and Tek-File packs beginning with Pack 57, will show replacement parts . . . not for all parts, but for many, as many as time allows to meet the publication date of TV Manual Volume 10 . . . yet enough to be of tremendous aid to the servicing industry. As time passes, more and more replacement parts listings will be made available to the servicing industry.

Some parts used in tv receivers are unique . . . singular in physical shape, electrical constants or tolerance values . . . so that

nothing but another of the original part is suitable for replacement. This is a situation which each service technician must understand. It is a situation which is destined to exist for many years. This means that service technicians will use two avenues of replacement parts supply: the parts jobber and the set manufacturers' channels. The latter may not be the most convenient . . . but it must be used, when necessary, if the service technician is going to protect his interests by making certain that he uses parts which will work properly in the receiver being repaired. The public has the right to expect such performance, and so does the set manufacturer.

No doubt, parts manufacturers will produce a more widely diversified line of parts. Parts jobbers will carry these and 2%, 5%, 10%, and 20% capacitors to meet the service technician's needs. This is the way it should be—service will be better and everybody, including the public, will be happier.

Many parts in tv receivers are special in one way or another and critical in function. Replacements for these are equally critical. To serve the best interests of the servicing industry . . . Rider Replacement Parts Listings will show the information which will help servicing technicians procure exactly what they need in the form of proper replacements.

## A "Part Number for Part Number" Program

The Rider Replacement Parts Program is "a part number for part number" program . . . the set manufacturer's part number and the replacement manufacturer's part number. This is in addition to the unabridged presentation of the set manufacturer's parts list in its entirety. The parallel listing of the set manufacturer's part number and the replacement manufacturer's part number is the most comprehensive form. It eliminates a great deal of duplication because many receiver manufacturers use the same part and part number in many different receivers. It means a replacement parts list which is the easiest to use . . . a replacement parts list which is the least voluminous and has the longest life.

This article is the first gun in the Rider Replacement Parts Program. Watch SUCCESSFUL SERVICING for articles each month on circuit components and replacement parts. Beginning with November, SUCCESSFUL SERVICING will contain articles which will explain the meaning of the specifications which tv receiver manufacturers establish for their components. These will tell you what to look for in replacement parts . . . the relationship between exact duplicates and suitable replacements . . . the kinds of parts which are needed for different sections of the receiver and the factors which determine the suitability of a part as a replacement.

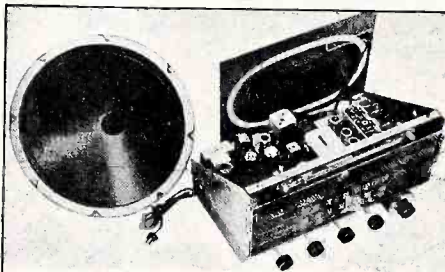

Here is the custom-built  
AM-FM chassis that means  
**BIGGER PROFITS for you!**

### The NEW ESPEY model 511-C

#### FEATURES

1. AC Superheterodyne AM-FM Receiver.
2. Improved Frequency Modulation Circuit, Drift Compensated.
3. 12 Tubes—plus rectifier and Pre-Amp 12AT7 Tube.
4. 4 dual purpose tubes.
5. Treble Tone control.
6. 6-gang tuning condensar.
7. Full-range bass tone control.
8. High Fidelity AM-FM Reception.
9. Automatic volume control.
10. 10 watts (max.) Push-Pull Beam Power Audio Output.
11. 12-inch PM speaker with Alnico V Magnet.
12. Indirectly illuminated Slide Rule Dial.
13. Smooth, flywheel tuning.
14. Antenna for AM and folded dipole antenna for FM Reception.
15. Provision for external antennas.
16. Wired for phonograph operation with switch for crystal or reluctance pick-up.
17. Multi-tap output trans., 3.2-8-500 ohms.
18. Licensed by RCA and Hazeltine.
19. Subject to RMA warranty, registered code symbol #174.

#### SPECIFICATIONS

Supplied ready to operate, complete with tubes, antennas, speaker and all necessary hardware for mounting in a table cabinet or console, including escutcheon. Power consumption—105 watts.

Chassis Dimensions: 13½" wide x 8½" high x 10" deep.

Carton Dimensions: (2 units) 20 x 14½ x 10¾ inches.

Net Weight: 17½ pounds each.

Sold through your favorite parts distributor.

WRITE FOR CATALOGUE KD12  
AND NAME OF NEAREST DISTRIBUTOR.

**ATTENTION!  
RADIO  
SERVICEMEN**

THERE ARE THOUSANDS  
OF OUT-MODED RADIOS  
IN YOUR "BACK YARD" JUST  
WAITING TO BE REPLACED  
... AT YOUR SUGGESTION

Makers of  
fine radios  
since 1928.

**ESPEY**

TEL. 1 Jafalgar 9-7000

**MANUFACTURING COMPANY, INC.**

528 EAST 72nd STREET, NEW YORK 21, N. Y.





"WHY SHOULD I INSIST ON CBS-HYTRON?"

"YOU PROFIT MORE! HERE ARE 5 BIG REASONS WHY"



**1. CBS-HYTRON IS FAMOUS . . . EASY TO SELL.** The magic letters "CBS" are plugged for you on radio and TV station breaks . . . 102 BILLION times a year! CBS is known and respected by *all* your customers. CBS-Hytron is the profitable brand with endless sales assistance.



**2. CBS-HYTRON SPECIALIZES IN RECEIVING TUBES.** Since 1921, CBS-Hytron has concentrated on receiving types. Practice makes perfect. Put those years of know-how to work for you. Let time-proved CBS-Hytron dependability cut call-backs . . . make more money for you.



**3. CBS-HYTRON LEADS IN TV TUBES.** You know them. CBS-Hytron TV originals: 1AX2, 1X2A, 6BQ6GT, 12A4, 12B4, 12BH7, 12BY7, 12BZ7, 25BQ6GT, and the original rectangular 16RP4. Even CBS-Hytron standard TV tubes are designed-for-TV . . . tested-for-TV . . . to give you peak performance and profit.

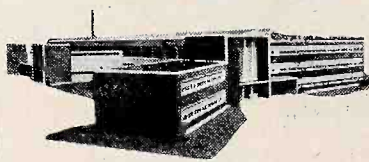

**4. CBS-HYTRON IS ULTRAMODERN.** CBS-Hytron is the tube of the future. Made in the world's most modern plants. On manufacturing equipment years ahead of the rest of the industry. CBS-Hytron advanced design and precision construction keep you always ahead. Give you tomorrow's trouble-free performance today.

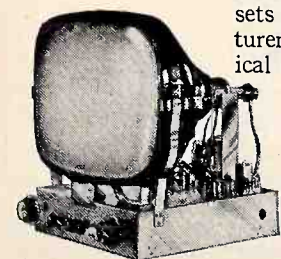

**5. CBS-HYTRON IS MATCHED-TO-THE-SET.** Combined engineering skills of leading set makers and CBS-Hytron work hand in glove for you. CBS-Hytron tubes are originally set-engineered right into the sets of 9 out of 10 leading set manufacturers. No wonder CBS-Hytron is your logical matched-to-the-set replacement tube.

**IT PAYS TO BE FUSSY!** Just any standard brand won't do. If you want: Trouble-free, advanced performance. Maximum customer satisfaction. Minimum call-backs. More profit. Five big reasons point the way: Insist on CBS-Hytron!

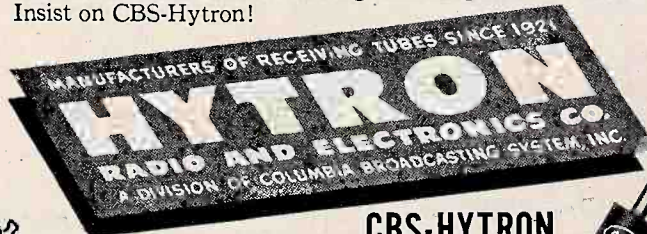

**CBS-HYTRON**  
Germanium Diodes

Complete data yours for the asking. Write CBS-Hytron, DANVERS, MASS., today.





# HOW TO REDUCE YOUR INVESTMENT IN TV REPLACEMENT CONTROLS WITH IRC'S #14 DEALER ASSORTMENT

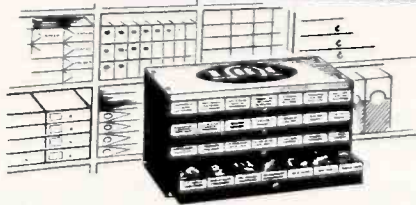

## This Compact Assortment— Or Shelves Full of Controls?

If you service television sets, you'll use a great number of exact duplicate concentric duals. Chances are you'll keep a lot of them *on hand*—to meet the requirements of dozens of TV models and manufacturers' parts numbers. So your investment in exact duplicate controls can amount to several hundred dollars—*unless you use IRC's #14 Dealer Assortment of concentric dual replacements.*

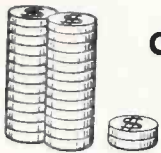

**Compare the Cost—  
\$26.76 versus  
\$331.74**

IRC's #14 Dealer Assortment of concentric dual replacements costs only \$26.76 (dealer wholesale price). Yet with it you can cover any of 157 different concentric duals—used as exact duplicate replacements for 254 different manufacturers' parts numbers among 57 trade names! Equivalent coverage in factory-assembled exact duplicate controls would require an investment of \$331.74.



## And Compare the Convenience

You can keep a bushel of factory-assembled controls on your shelves and still not be sure of having the one you're going to need. Or you can keep a #14 Dealer Assortment handy and supply almost any exact duplicate control that's called for—*at once!* That's real convenience and economy—and it means prompter servicing and more satisfied customers.



**Why Invest 90%  
More in Factory-  
Assembled Controls?**

All concentric dual controls contain many common parts. The #14 Dealer Assortment provides a generous stock of these basic parts and gives wide interchangeable coverage at low cost. Compared to factory-assembled concentric duals, you save as much as 90% of your control stock investment cost.

## All-Metal, 4-Drawer Cabinet Keeps Stock Straight



Each #14 Dealer Assortment is housed in a goodlooking, all-metal, 4-drawer cabinet. This cabinet provides a total of 28 compartments—each identified as to contents—to keep parts safe where you can find them in a hurry. Cabinet measures 5 $\frac{3}{8}$ " x 5 $\frac{1}{4}$ " x 10 $\frac{1}{8}$ " and is attractively finished in blue, yellow and silver. It stacks compactly with the popular IRC Resist-o-Cabinets. Cabinet costs you nothing extra; you pay only the price of the parts.

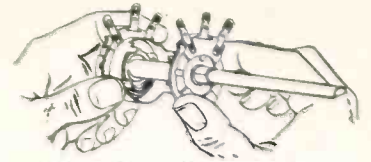

## You Can Assemble Almost Any Concentric Dual In Less Than A Minute!

It's a fact—*actual assembly*, with the simplified parts in the #14 Dealer Assortment, can be made in less than 60 seconds! And you'll need no special tools or skills. Each #14 Assortment contains a variety of IRC Base Elements, Exact Duplicate Shafts and Switches—which you can easily assemble into specific Exact Duplicate Controls. No filing, slotting, soldering, hammering or cutting of shafts. And easy-to-follow pictorial instructions show you how to make actual assembly without trouble.

## See the New #14 Assortment At Your Distributor

Your IRC Distributor has the new #14 Dealer Assortment in stock and will be glad to show it to you. If you're really interested in cutting control inventories as they've never been cut before, visit him today. Let him demonstrate the convenience, compactness and ease-of-use of this new kit of concentric dual replacement parts. It's going to mean money in your pocket!

### HERE'S THE COVERAGE YOU GET IN THE #14 DEALER ASSORTMENT

Trade Name	Part Nos.	Trade Name	Part Nos.
Admiral	15	Motorola	1
Air King	7	Muntz	1
Airline	9	National	1
Andrea	1	Olympic	3
Ansley	2	Packard Bell	6
Artone	1	Pathe	2
Arvin	3	Philco	12
Automatic	3	RCA	12
Belmont	2	Radio & Television	2
Bendix	1	Raytheon	1
Brunswick	4	Regal	4
Capehart-Farnsworth	2	Silvertone	6
Coronado	5	Skyrider	1
Crosley	9	S.M.A. TV	1
Delco	3	Sonora	1
Dewald	1	Sparton	3
Dumont	4	Starrett	5
Emerson	13	Stromberg-Carlson	5
Fada	5	Sylvania	1
Firestone	5	Techmaster	2
Garod	4	Tele King	1
General Electric	18	Tele-Tone	1
Hallcrafters	10	Trad	3
Hoffman	2	Transvue	1
Interstate Stores	1	Truetone	8
Jackson	4	Video Corp.	2
Majestic	2	Wells-Gardner	7
Meck	4	Westinghouse	10
Mitchell	1		
		Total	254

Plus Concentric Dual Coverage for Auto Sets, Home Radios and Future Model TV Sets



**INTERNATIONAL RESISTANCE CO.**

423A, N. BROAD STREET, PHILADELPHIA 8, PA.

*Whenever the Circuit Says*



# "GIMMICKS" in Radio and TV

(Continued from page 1)

definition, represents an individual gimmick. Since the coils of  $L1$  and  $L2$  are closely coupled and also since the common surface area between them is great, then a higher effective capacitance exists between both gimmicks and more oscillator voltage will be coupled to the oscillator grid.

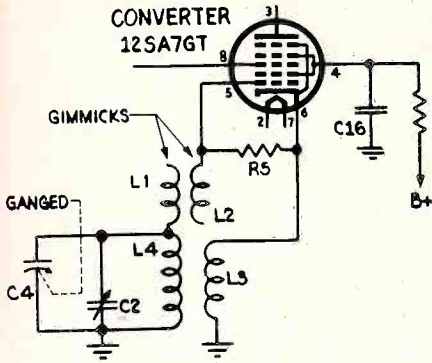

Figure 3.

The usual method of coupling the oscillator tank voltage to the oscillator grid is through a fixed mica capacitor which is connected between the grid and high side of the tank circuit. This capacitor is anywhere from 50 to 100 mmf in value. The higher the value of the capacitance, the greater would be the coupling between the oscillator tank and the oscillator grid of the tube. The previous gimmick arrangements produced a satisfactory enough capacitance, but another gimmick arrangement in the form of a *bifilar winding* is used to give a high capacitance. It is shown in Fig. 4.

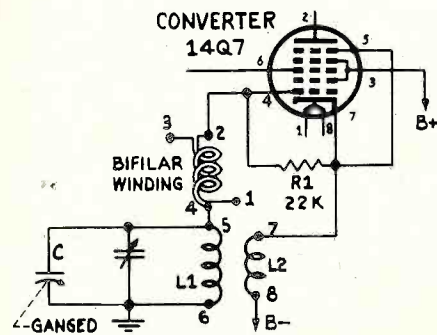

Figure 4.

What is meant by a bifilar winding? Originally it was a method of winding non-inductive resistances. The way of forming a bifilar winding is to double the necessary wire to be used on itself; then take the loop end of the wire (i.e., that end of the wire not open) and wind the doubled wire around a form.

In the circuit of Fig. 4, a bifilar type winding is used but one end is open on each side of the winding (terminals 1 and 3).

There is a definite purpose for doing this and it will become evident as the complete oscillator coil is analyzed. Coils  $L1$  and  $L2$  represent the necessary transformer inductances incorporated with the usual tickler-coil oscillator. The bifilar winding together with  $L1$  and  $L2$  are all wound on one coil form. A drawing of the actual coil form with all the coils wound on it is shown in Fig. 5(A) and a schematic representation of the coils is shown in Fig. 5(B). The numbers from 1 to 8 on Figs. 4, 5(A) and 5(B) are all related to one another and represent the connecting ends of the coils.

### Antenna Input Circuit Gimmicks

The application of gimmicks has found a wide variety of uses in the antenna and input circuits of many radio receivers. Use is made of two gimmicks to form the necessary capacitance in completing the antenna output circuit to ground. The input circuit and

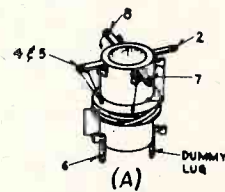

Figures 5A, B.

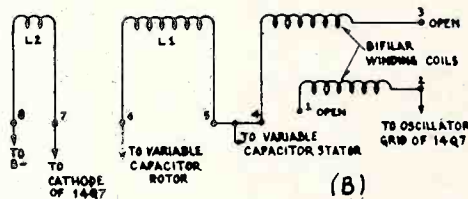

its equivalent are shown in Fig. 6. The two gimmicks in the antenna circuit are wired with gimmick No. 1 having one end connected to ground with the other end open and gimmick No. 2 having one end connected to the hank antenna and the other end open. Both open ends of the gimmick lie near each other and an effective capacity exists between them, this being shown in the equivalent drawing of the input circuit by the dotted capacitor. Gimmick No. 2 is closely coupled to the permeability-tuned ganged tank circuit coil for the necessary

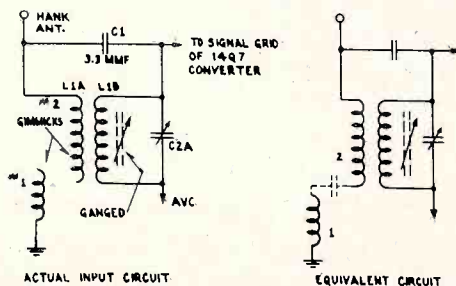

Figure 6.

amount of transformer coupling from the antenna circuit to the r-f circuit of the 14Q7 converter. The two gimmicks together serve the purpose of forming a complete L-C circuit from hank antenna to ground without d-c circuitry.

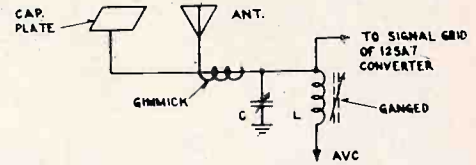

Figure 7.

In another case use is also made of a gimmick arrangement in the antenna circuit but only one gimmick is employed. The antenna circuit of this receiver is shown in Fig. 7. The gimmick here is a coil of wire wrapped around the lead going from the capacity plate to the L-C r-f tuned circuit. The capacity plate serves the purpose of an indoor antenna. The gimmick in this circuit serves the purpose of capacitively coupling the outside antenna to the L-C tank circuit for the r-f input signals. The amount of capacity is determined by how many turns the gimmick is wound around, and how closely it is wound, the lead going to the L-C circuit.

Still another gimmick in the antenna circuit to obtain a good frequency response of the input r-f signal is shown in Fig. 8. Part No. 37 is the broadcast antenna coil assembly and consists of all the coils enclosed in the dashed box. All these coils are wound on one coil form with  $L_p$  and  $L_s$  representing the primary and secondary inductances respectively of the antenna input transformer for the broadcast band. The gimmick coil is attached at one end of the high side of the secondary  $L_s$  of the input transformer and open at the other end. The open end is drawn schematically as being coupled to

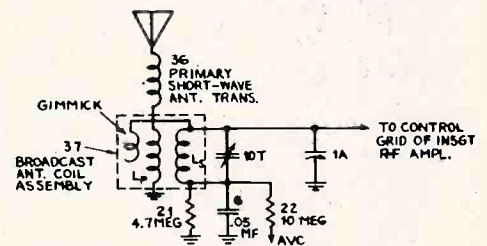

Figure 8.

the primary  $L_p$  of the antenna input transformer. The primary coil 36 is from the short-wave antenna transformer and it remains in the broadcast position of the set because the switching arrangements within the set can be made more economically—and furthermore, it has a negligible effect in this position.

Two more gimmicks utilized in the antenna circuit are shown in Fig. 9, to increase the input response characteristics of the set

(Continued on page 32)



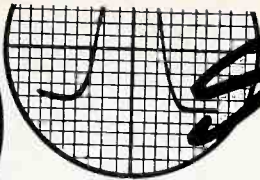
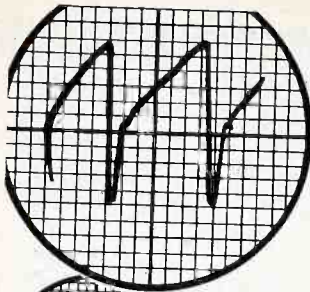

See YOUR ANSWER

WITH THE

## PRECISION ES-500A

HIGH SENSITIVITY—WIDE RANGE

# 5" OSCILLOSCOPE

PUSH-PULL VERTICAL AND HORIZONTAL AMPLIFIERS

20 MV PER INCH "V" SENSITIVITY—150 MV PER INCH "H" SENSITIVITY

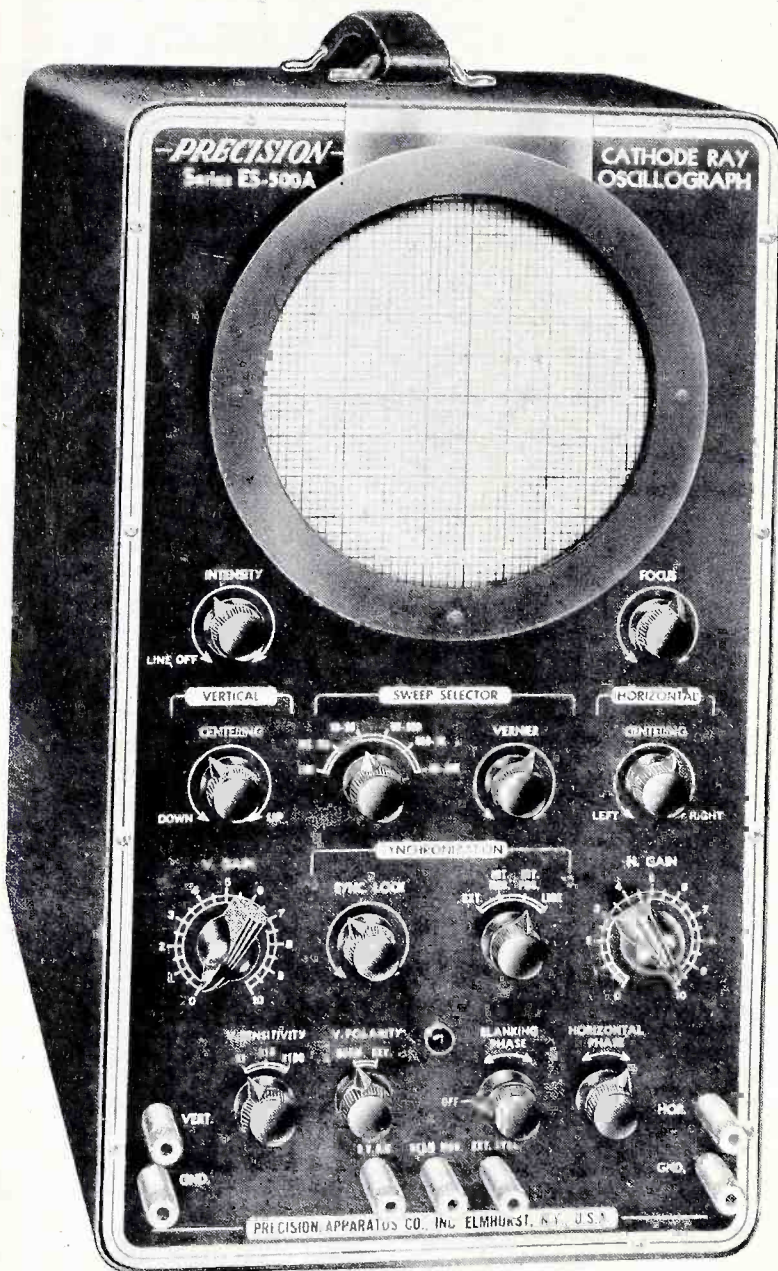
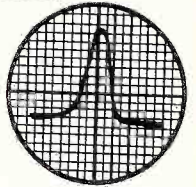
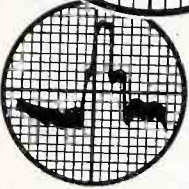
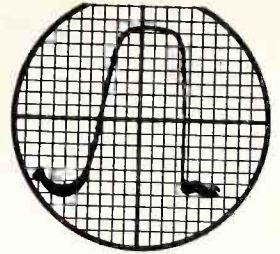

**SERIES ES500A** affords the ultimate in performance, visibility and operational flexibility at moderate cost. "Precision" engineers have incorporated every necessary basic feature which they have found to be required to meet the needs of the rapidly advancing art of electronics, A.M., F.M., and TV.

Series ES-500A provides an unparalleled combination of high sensitivity, extended frequency range and other essential operating features specifically desired for experimental and commercial visual circuit analysis.

### SUMMARY OF IMPORTANT FEATURES

- \* High Sensitivity, Extended Range, Voltage Regulated Push-Pull Vertical Amplifier—20 MV (.02 V) per inch deflection sensitivity. 10 cycles to 1 MC response. 2 megohms input resistance. Approx. 22 mmfd. input capacity.
- \* Frequency Compensated Vertical Input Step Attenuator—X1, X10, X100 plus continuous variable gain control in cathode follower input stage.
- \* Vertical Phase-Reversing Switch permits inversion of all patterns at will. Non-frequency discriminating.
- \* Extended Range, High Sensitivity Push-Pull Horizontal Amplifier—150 MV (.15 V) per inch high deflection sensitivity adequate for most all "H" drive purposes. 10 cycles to 1 MC response at full gain. 1/2 megohm input resistance. Approx. 20 mmfd. input capacity.
- \* Linear Multi-Vibrator Sweep Circuit—10 cycles to 30 KC plus line and external sweep.
- \* Amplitude Controlled, 4-Way Synch. Selection—Internal Positive, Internal Negative, External and Line.
- \* "Z" Axis Modulation input facility for blanking, timing, etc.
- \* Internal, Phasable 60 cycle Beam Blanking for elimination of alignment retrace; clean display of synch. pulses etc.
- \* Sweep Phasing Control for sinusoidal line sweep usage. Wide angle bridge circuit.
- \* Direct H and V Plate Connections and Audio Monitoring phone jacks at rear. All four plates accessible.
- \* High Intensity CR Patterns through use of adequate high voltage power supply with 2X2 rectifier.
- \* The Circuit and Tube Complement—6C4 Vertical input cathode follower. 6CB6 first "V" amplifier. 6CA "V" phase inverter. Push-Pull 6AU6's vertical CR driver. 7N7 first "H" amplifier and phase inverter. Push-Pull 6AU6's horizontal CR driver. 7N7 Multi-vibrator internal linear sweep oscillator. 5Y3 low voltage rectifier. 2X2 high potential rectifier, VR-150 voltage regulator. SCPI/A CR Tube.
- \* 7 Four-Way Lab. Type Input Terminals—Take banana plugs, phone tips, bare wire or spade lugs.
- \* Light Shield and Mask removable and rotatable.
- \* Extra Heavy-Duty Construction and components to assure "Precision" performance.
- \* Heavy Gauge, Etched-Anodized, No-Glare, Aluminum Panel.
- \* Fully Licensed under Western Electric Co. patents.

\* **Series ES-500A** In louvered, black ripple, heavy gauge steel case. Size 8 1/4" x 14 1/2" x 18". Complete with light shield, calibrating mask and instruction manual.

Net Price.....\$173.70

See the ES-500A Oscilloscope on display and available at leading Radio Parts & Equipment Distributors.

AM • FM • TV



## PRECISION APPARATUS CO., INC.

92-27 Horace Harding Boulevard, Elmhurst 14, New York

Export Division: 458 Broadway, New York, U.S.A. • Cables—Morhanex  
In Canada: Atlas Radio Corp., Ltd., Toronto, Ontario

Convenient "PRECISION" Purchase Terms can be arranged with your local favorite authorized "PRECISION" Distributor.

AM • FM • TV



## Oscillator Frequency and Overmodulation Effects in Intercarrier Receivers

(Continued from page 7)

in order to produce the 4.5-mc f-m signal which is to be fed to the sound section of the receiver. Inoperation of the video transmitter would obviously result in no video carrier at the receiver. This condition, of course, is most unlikely to occur and if it did it would be just as detrimental to the operation of the conventional receiver as it would be to the intercarrier type. When the video transmitter undergoes over 100-percent modulation, there will be no r-f signal output from the transmitter. This condition will result in no sound output from intercarrier-type television receivers. Let us briefly analyze why this is so.

The video signal in the transmitter amplitude-modulates the carrier. This means that if the strength of the peak white parts of the video signal during downward modulation is sufficient to just cut off the carrier, the resulting video modulated a-m signal is said to be 100-percent modulated.

### Overmodulation of the Video Carrier

When the strength of the peak white portions of the video signal exceeds this value, the video carrier is said to be overmodulated. If the downward modulation of the video carrier is such that the peak white parts of the video signal do not cut off the carrier, the video-modulated a-m signal is said to be less than 100-percent modulated.

Basic drawings of a 50-percent modulated, 100-percent modulated, and an overmodulated a-m wave are illustrated in Fig. 2. The video-modulating signal is assumed to be sinusoidal for the sake of illustration, the envelopes of the signals, therefore, are drawn sinusoidal. In the wave at (A) the video signal amplitude modulates the carrier to about 50 per cent. From this drawing it can be readily seen that the modulated wave is continuous along its time axis. The troughs of this 50-percent modulated wave, as well as the others, represent the peak white portions of the video signal. The signal at (B) portrays 100-percent modulation. Such a signal is said to be the turning point of the continuity of the modulated wave. By this we mean that as an a-m signal increases its degree of modulation toward 100 percent, the wave will always be continuous along its time axis. The moment the degree of modulation becomes greater than 100 percent, the video signal modulates its carrier in such a manner that the resulting a-m wave will no longer be continuous. This is illustrated by the overmodulated wave at (C). What has happened is that the instantaneous amplitudes of the video-modulating signal when adding and subtracting from the carrier to produce the a-m wave has resulted in a partial cancelling out of the carrier and, hence, the a-m wave.

In television broadcasting this overmodulation of the video carrier may occur as mentioned previously, when modulating during a white part of the picture information. It should be remembered that in television broadcasting the negative peaks of the video signal represent the white portions of the picture and the positive peaks the black portions. Thus overmodulation will occur when the picture is brightest.

When the video overmodulated signal is heterodyned down to an i-f signal in the receiver this new signal will contain the

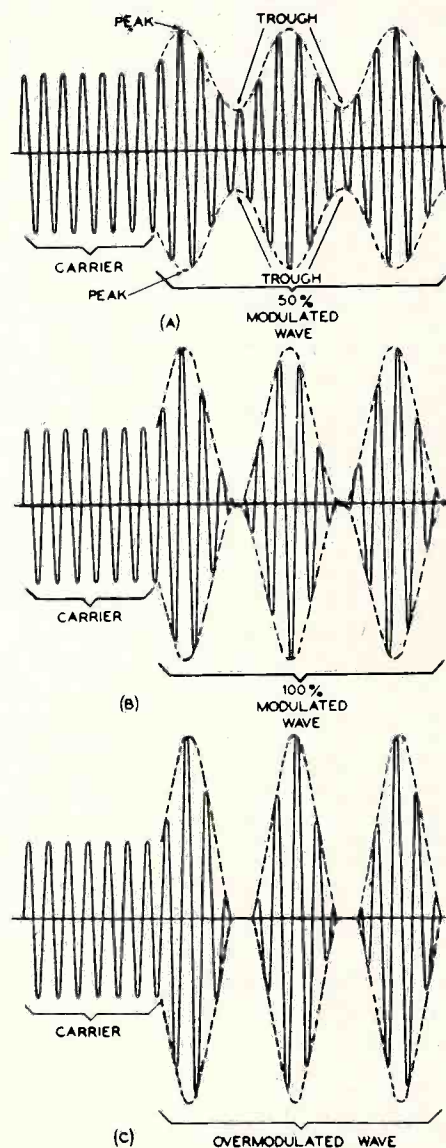

Fig. 2. Basic a-m signals of a 50-percent modulated, 100-percent modulated, and overmodulated wave at (A), (B), and (C) respectively. If the waves at (B) and (C) represent video modulated signals, they will cause distortion in the sound output of intercarrier television receivers.

same intelligence as the input and, hence, will be overmodulated in the same manner. Under this circumstance, the input to the video detector in an intercarrier receiver will be an overmodulated video i-f signal and also an f-m sound i-f signal. In the mixing process of these two i-f signals to obtain the 4.5-mc signal output, the f-m sound i-f will not be beating against any signal during the overmodulated portions of the video i-f. If we consider the illustration of Fig. 2 (C) to be the video-overmodulated i-f signal, it can be readily seen that during that portion of the wave where there is no signal along the base line, the f-m sound i-f signal will have no signal to beat against. The result of this mixing process will not produce any 4.5-mc f-m sound output during the overmodulated portions of the video i-f signal.

In effect then, the output from the video detector will be a 4.5-mc f-m sound signal which is not continuous. When this signal is fed to the f-m sound detector and hence to the audio section no sound output is heard during those instants when there is no 4.5-mc signal.

The effect of overmodulation and near overmodulation of the video carrier has been known to cause interference in the sound output of intercarrier receivers. This interference is primarily in the form of a 60-cycle hum and lasts as long as the periods of overmodulation occur. What happens is that the loss of the sound is actually repeated 60 cycles a second (due to the nature of the television signal) and this effectively acts as an additional frequency change in the 4.5-mc f-m wave and therefore shows up in the sound output of the receiver. This interference is at the vertical scanning rate. The 15,750-cycle horizontal scanning signal also causes interference in the sound output of the receiver. The interference is at the repetition rate of 15,750 cycles per second but this signal is usually too high to be passed by the audio amplification stages of the receiver.

We have mentioned that 60-cycle and perhaps 15,750-cycle interference may also occur when the video carrier is near overmodulation. By this we mean when the video carrier is nearly 100-percent modulated. This situation, of course, also occurs during very bright parts of the picture being televised. When the video carrier is modulated to this strong degree, the carrier will always be present. However, the relative amplitude of the video-modulated signal (r.f. and i-f.) at these points of high modulation (that is, troughs) is quite small compared to that of the f-m sound signal. Consequently, the 4.5-mc beat-note output from the detector-mixer will be continuous but will vary in signal strength, being weak during those moments of high modulation of the video a-m signal. This weak signal output from the detector is repeated 60 cycles a second and effectively causes a

(Continued on page 18)



**SIMPSON MODEL 480 GENESCOPE FOR ACCURATE TESTING**

approved by  
service managers of:

- admiral*
- zenith*
- motorola*
- emerson*
- hoffman*
- hallicrafters*

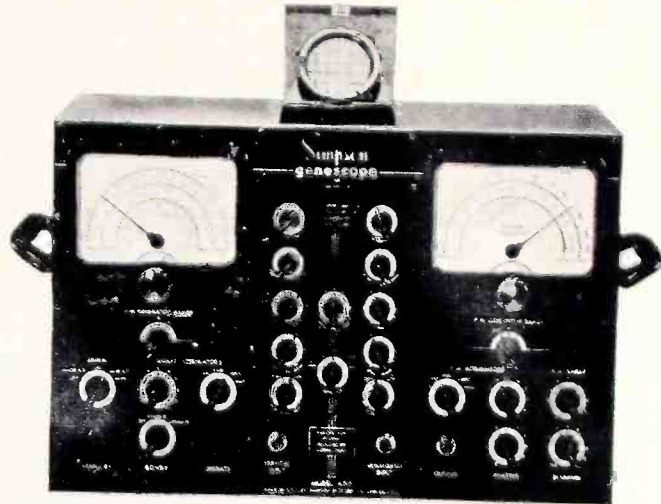

Provides all the necessary signal sources for proper alignment and servicing of FM and TV receivers • Includes the Simpson High Sensitivity Oscilloscope, complete in every detail and equipped with a high frequency crystal probe for signal tracing • Independent, continuously variable attenuators and step attenuators for both AM and FM units offer complete control of output at all times—from the high level required for front end adjustment to extremely low levels for fringe area peaking operations • Multiple shielding, generous bypassing and adequate line filtering reduces signal leakage to a negligible factor • A 0-15 megacycle sweep is provided by means of a noiseless specially designed sweep motor based on the principles of the D'Arsonval meter movement for fine control and lasting accuracy • The exclusive Simpson output cable (illustrated on the right) includes a variable termination network which is quickly adapted to provide open, 75 or 300 ohm terminations—the addition of a pad provides attenuation and isolation. The use of appropriate resistors across certain terminals will provide any other termination required. A .002 MFD blocking condenser can be added on any termination for use on circuits containing a DC component • The FM generator output voltage is constant within .2 DB per MC of sweep. Model 480 \$395.00

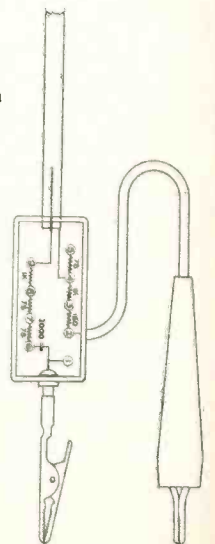

Also available without the oscilloscope as Simpson Model 479 TV-FM Signal Generator. Model 479 \$269.00

Simpson Instruments That Stay Accurate Are Available From All Leading Electronic Distributors

SIMPSON ELECTRIC COMPANY

5200 W. Kinzie St., Chicago 44, Illinois • Phone: COlumbus 1-1221 • In Canada: Bach-Simpson, Ltd., London, Ont.

Please mention *Successful Servicing* when answering advertising.



# CONGRATULATIONS!

on

## TELL-A-FAULT

"it ought to be a 'must'."

John C. Pyle  
Simplex Radio Service  
1511 Alton  
Denver, Colorado

"you have started the ideal service for all of us who service TV receivers."

Horace L. Graham  
1006 N. Buffalo St.  
Cleburne, Texas

"the time saved using this service will pay more than 100 times its price."

Frank Tomaszewski  
455 Pearl St.  
Pittsburgh, Penna.

### NEED WE SAY MORE!

These comments are from servicemen just like yourself who are using TELL-A-FAULT in their everyday servicing work. They have found that TELL-A-FAULT does their troubleshooting for them. It can do the same for you!

This quadruple-threat service consists of:

- (1) time-saving pictorial, symptom and cure sheets
- (2) fault pinpointing circuit guides
- (3) servicing-techniques short cuts
- (4) how to use all sorts of test equipment

Save anywhere from 50 to 200 hours of troubleshooting time per year by using this practical service based on symptoms rather than circuitry. It completely removes the guesswork in locating receiver troubles by rapidly locating the faults and giving you the proper cures.

TELL-A-FAULT is only a few months old, but the idea has caught on with thousands of progressive service technicians throughout the country.

The entire service costs you less than twenty cents a week. You receive a full 12 month's TELL-A-FAULT for only \$10.00.

Start your subscription today! We'll send you your TELL-A-FAULT binder, subject separators and all the installments that have been released to date. For full information on the most unique SERVICE ever made available to TV and radio service technicians — write to Dept. TF 5.



**JOHN F. RIDER**  
PUBLISHER, INC.  
480 Canal St., N. Y. 13, N. Y.

## Attention:

# All Service Association Members

The following should interest not only all service association members, but also all those who have been thinking about joining a servicing group. There is nothing we could add to the letter below. Read it through and decide for yourself!



SAN DIEGO COUNTY ELECTRONIC ASSOCIATION INC.

P. O. BOX B • OLD SAN DIEGO STATION • SAN DIEGO 10, CALIFORNIA

September 15, 1952

Mr. John F. Rider  
Publisher's, Inc.  
480 Canal Street  
New York 13, New York

Dear Mr. Rider:

We feel that members of associations throughout the nation who may sometimes wonder just what benefit their organization is to them, may be interested in the following experience of a member of San Diego's enterprising technician's association - San Diego County Electronic Association, Inc.:

Jim Tilley, an active SDCEA member, was recently assaulted by a hoodlum who was attempting to rob the shop where Jim is employed. Hit over the head with an electric drill, Jim was confined to the hospital for an extended period with a fractured skull. As Jim is alone on his bench, he was naturally worried about the back-log of work that was constantly piling up. Needless to say, so was his employer who couldn't find a solution until he appealed to the SDCEA for help. Immediately, SDCEA members rallied to his aid and formed a committee who soon had Jim's work up-to-date. Thus, both a fellow association member and a busy dealer were served by the unified efforts of sincere SDCEA members.

We would also like to add that two SDCEA members who went to a new area to open a service shop related that their membership cards were the means of their establishing a business and the good-will of the civic leaders in this area which is being flooded with wild-cat technicians of dubious character. They added that they were treated cordially and with utmost respect as soon as they produced their Certification cards.

Another member said that he was asked to produce his Association Membership Card here in San Diego before he was granted an interview by a prospective dealer-employer. This indicates growing interest and trust in the technician's associations and their reliability.

We appreciate also the wonderful cooperation the trade magazines have given these expanding associations in bringing their stories to interested readers.

Very truly yours,

*Georgia Mather*

Georgia Mather  
Director of Public Relations

GM:mw



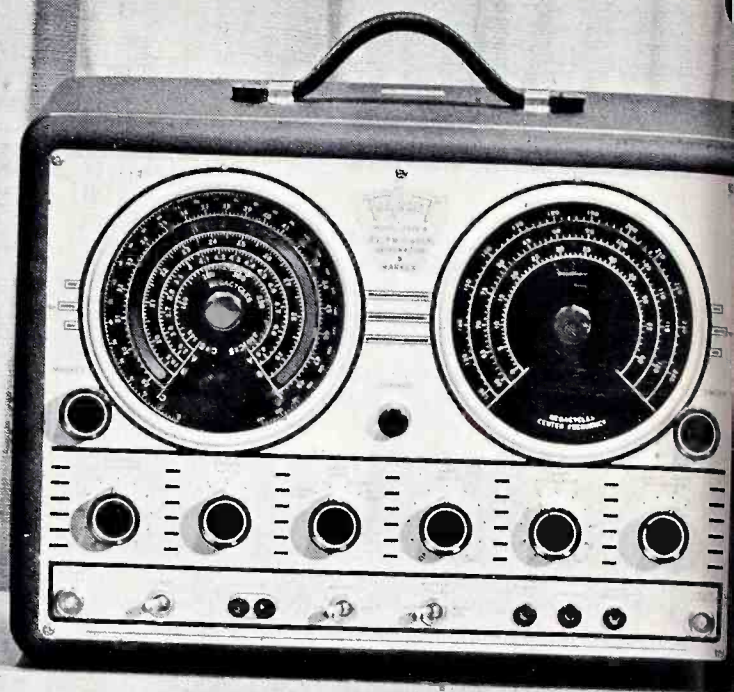
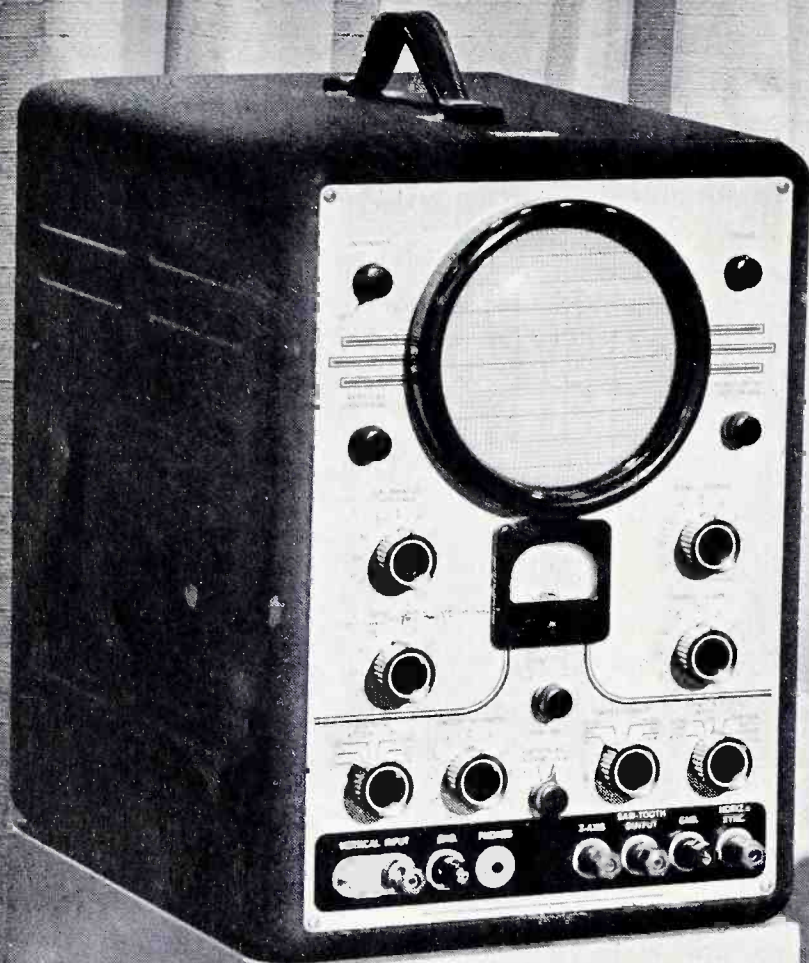

## PUT *Yourself* IN THIS PICTURE

If Service is your business, this could be your shop. And, because it is *completely Triplet*, you can be sure it can quickly meet your TV and AM servicing requirements. More than that, it can change for you, as it has for countless service men and service dealers, the whole profit picture of your business.

For with this shop so equipped — so modernized — you can meet any service need with complete confidence. And, what is just as important, *complete* equipment shortens

the whole testing cycle, keeps your charges within the reasonable expectations of your customers, prevents call-backs, and contributes substantially to the profitable operation of the shop. Indeed, good equipment, *complete* equipment, pays for itself, and the lowered cost of servicing made possible is the best guarantee of staying in business.

*This matched equipment is ready for your inspection at your Triplet distributor's. See it now.*

TRIPLET ELECTRICAL INSTRUMENT COMPANY • BLUFFTON, OHIO

A complete related line of tech





**IN THE PICTURE**

*Prices are Suggested U.S.A. Dealer Net*

Model 3441 5" Oscilloscope, \$199.50 · Model 3434-A Sweep Signal Generator, \$199.50 · Model 3432 Illuminated Dial Test Oscillator, \$79.50 · Model 650 Vacuum Tube Voltmeter, \$69.50 · Model 660 Load—Chek, \$29.50 · Model 630 Volt-Ohm-Mil-Ammeter, \$39.50 · Model 3413-A Tube Tester, \$79.50. Prices subject to change without notice.

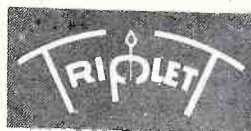

**Triplet**

ly advanced testing equipment



## Just Out!

bigger  
17<sup>TH</sup> edition  
better

# Radio's MASTER

**The right part when you need it for service**

This permanent, hard cover Official Buying Guide of the electronic-TV parts and equipment industry with its comprehensive detailed index, eliminates the need for maintaining files of small catalogs and manufacturers' literature. Radio's Master catalogs 90% of TV and electronic equipment. Not merely part number listings — complete descriptions, specifications and illustrations written and compiled by each manufacturer. Enables you to make comparisons or substitutions right now!



No More Files of Small Catalogs and Loose Literature

• 1220 pages  
• 80,000 items  
• 8,000 illustrations  
• 8" x 11" — 5 lbs.

*Publisher's price \$6.50—your price through your regular parts distributor \$1.95.*

**UNITED CATALOG PUBLISHERS, INC.**  
110 Lafayette St., New York 13

### Classroom TV at Cornell

Cornell University students will see basic physics' experiments by television beginning this fall. An RCA midget tv camera and two 21" viewers will televise the experiments from the instructor's desk to students in the same room. This method will give the instructor more opportunity to explain the work since all students will see a close-up of the experiments without having to wait in line to use microscopes or other equipment.

### Three to Go

By November of this year, tv stations in Miami, New Orleans, Houston, Dallas, Fort Worth, San Antonio, Oklahoma City and Tulsa will be able to carry nationwide broadcasts. At that time 60 out of the 63 tv areas, or 105 of the 108 tv stations in the country, will be able to receive direct network programs; Phoenix, Albuquerque and Seattle then being the only stations without simultaneous network coverage.

### Laughs in the Life of a TV Serviceman

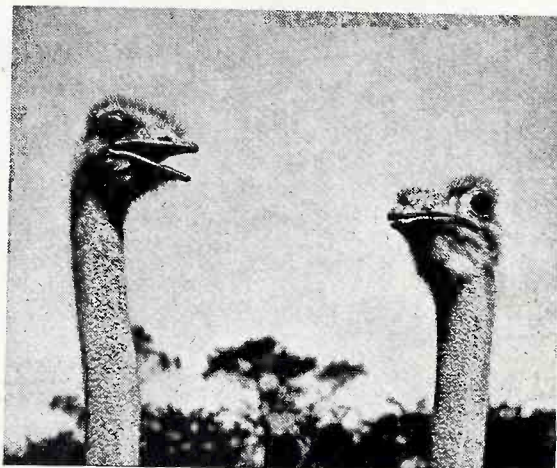

**"That's funny, we get Channel 4 perfectly  
—and to think you're right next door to us!"**



**Y**ES, when customers compare their pictures it often means a call for a TV serviceman.

Like thousands of other servicemen, you'll like the ease of servicing Raytheon TV receivers. Not only the tuner but the entire chassis is easily accessible for test, repair, or part replacement. It's not necessary to unsolder or remove parts or wir-

ing to get at any part. That means quicker service and more profits. Raytheon TV service manuals show wave forms and voltages, give condensed service tips, help you do your job quickly and well . . . Raytheon Manufacturing Company (Belmont Radio Corporation, 5921 West Dickens Avenue, Chicago 39, Illinois.)

Please mention *Successful Servicing* when answering advertising.

## RIDER BOOK SHELF

**RADIO OPERATOR'S LICENSE Q & A MANUAL**, 3rd Edition by Kaufman. Revised and enlarged edition includes new Elements 2, 5, 7 and revised Elements 3 and 6 . . . plus Element 8: Ship Radar Techniques. Contains questions and answers to FCC Exams, plus a thorough discussion of the subjects covered. 7 Chapters in all. 734 pages (5½ x 8½") 243 illustrations, cloth bound . . . . . \$6.60

**BROADCAST OPERATOR'S HANDBOOK**, 2nd Edition by Ennes. Covers all practical operations in and out of the studio. Typical chapters: You're often a Producer, Too; Studio and Control Room; Where Split Seconds Count. Ideal for veterans and newcomers alike. 7 Chapters in all. 440 pages (5½ x 8½") 226 illustrations, cloth bound . . . . . \$5.40

**UNDERSTANDING MICROWAVES**, by Young. This book provides foundation for understanding microwave radio and radar. Mathematics are confined to footnotes wherever possible. Covers theory and operation. Typical chapters: The Ultra High Frequency Concept; Alternating Current and Lumped Constants; Transmission Lines; Waveguides. 11 Chapters in all. 385 pages (5½ x 8½") illustrated, cloth bound . . . . . \$6.00

**UNDERSTANDING VECTORS AND PHASE IN RADIO**, by Rider and Uslan. Covers scalars, vectors, vector analysis and their application to radio by students and practicing technicians. 8 Chapters in all. 160 pages (5½ x 8½") illustrated, cloth bound . . . . . \$1.89

John F. Rider Publisher, Inc.  
480 Canal Street, N. Y. 13

### Oscillator Frequency and Overmodulation Effects

*(Continued from page 13)*

similar type of interference in the sound output as mentioned previously.

This disadvantage of too high a video modulation can be corrected at the transmitter by special monitoring precautions. The video signal should never be allowed to modulate its carrier to the point where the resultant a-m signal will cause the interference mentioned above. It has been determined that the amplitude of the video-modulated signal during moments of strong downward modulation should always be greater than approximately 10-percent of the maximum peak amplitude of the modulated signal to prevent this type of interference. Operators of transmitting stations are well aware of this condition of over-modulation and it is believed that some stations are already controlling the degree of modulation of their video carriers to the point where it will not interfere with the sound output of the intercarrier television receiver. The FCC has been approached with the idea of making such control of the percentage of video modulation a requirement.



# ANOTHER RIDER

# SMASH HIT

is on its way!

## RIDER TV MANUAL VOL. 10

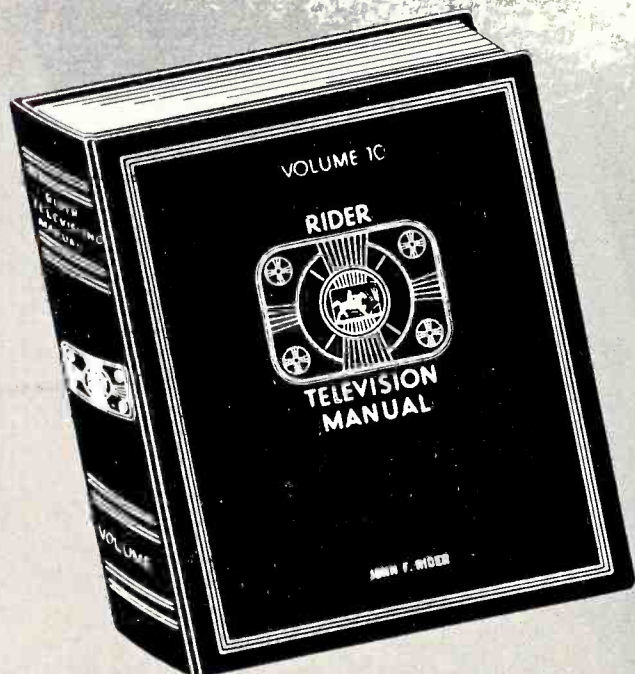

with replacement parts

Featuring a listing of dependable replacement parts. A FEATURE THAT CAN'T BE BEAT! Here's why—all parts listed check with the physical and electrical requirements of the original equipment used in the receiver. This means fewer callbacks . . . reduced servicing time . . . and faster repairs because of the reduced number of changes on the parts replaced. Make servicing easier with Rider's TV 10.

Rider's TV 10 is scheduled for November deliv-

ery. It contains approximately 2,000 (8½" x 11") pages of complete, official, factory-issued servicing data . . . covering TV receivers manufactured from March to September, 1952.

Order your copy today from your jobber . . . it's only \$24.00.

John F. Rider Publisher, Inc., 480 Canal Street, New York 13, N. Y. West Coast Office: 4216-20 W. Jefferson Blvd., Los Angeles, Calif.



# FREE TELE-MIRROR

... an amazing  
**one-two** offer  
 with your next purchase  
 of three Teletrons

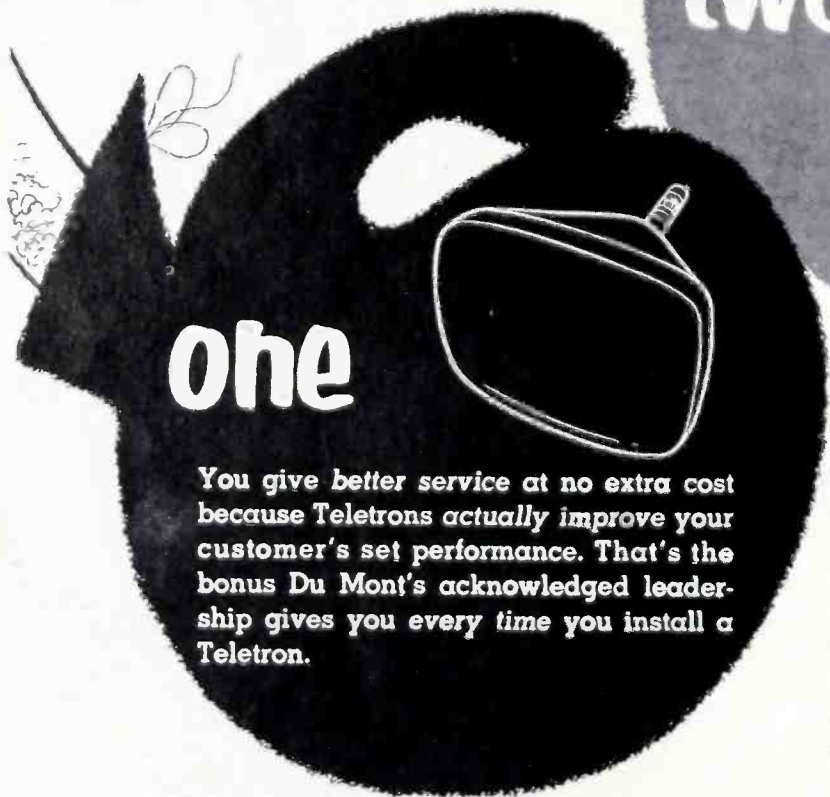

You give better service at no extra cost because Teletrons *actually improve* your customer's set performance. That's the bonus Du Mont's acknowledged leadership gives you every time you install a Teletron.

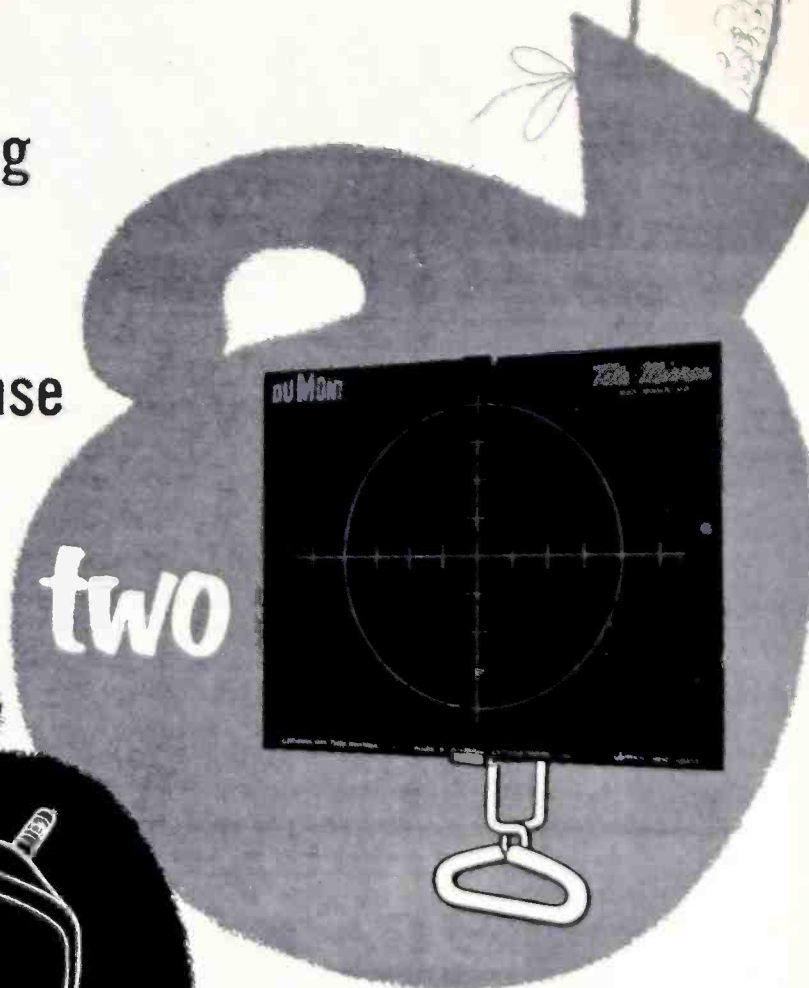

You get the TELE-MIRROR FREE... as an added bonus for better service.

It's the service tool you've wanted most... needed most... and haven't been able to buy anywhere!

A self-clamping, 8" x 10" BLACK MAGIC mirror, target-lined for accurate picture alignment.

This offer is limited, so act fast! See your Du Mont Jobber today!



ANOTHER  
*Teletron*\*

SERVICE AID

\*TRADE MARK

# DU MONT

CATHODE-RAY TUBE DIVISION • ALLEN B. DU MONT LABORATORIES, INC. • CLIFTON, N. J.

Please mention *Successful Servicing* when answering advertising.



# ASSOCIATION AND INDUSTRY NEWS

The General Electric Tube Department has scheduled the first consumer magazine advertisements to explain the work, problems, and accomplishments of television servicemen. The full page ads (see *Life*, September 8 and *Collier's*, October 4) will reach an estimated 35,000,000 readers and point out to them how well the service technician has met the challenge of the rapid growth of tv, the average investment of more than \$3,000 which the serviceman has in equipment, and the training which the technician has undergone. The ads should help the average set owner appreciate the general high caliber of the service industry.

The G. E. Tube Department also announced the establishment of an award in recognition of "outstanding public service" by amateur radio operators. This award, *The Edison Radio Amateur Award*, will be presented for meritorious public service on behalf of a group or individual in a disaster area, civil defense zone, or like situation. Nominations will be judged by E. R. Harri-man, President of the American Red Cross, G. E. Sterling, Commissioner for the FCC, and G. L. Dosland, President of the American Radio Relay League. Nominations for the 1952 award may be made by any individual or group familiar with the service performed while the candidate was pursuing his hobby as "ham" within the continental limits of the U. S. Nominations should be addressed to the Edison Award Committee,

Tube Department, General Electric Company, Schenectady 5, New York.

The *Television Service Association of Michigan* has voted unanimously to take on the maintenance of 24 tv sets in the Veterans Hospital at Dearborn. TSA members will do all servicing and furnish parts free of charge out of their own recreation funds. This is a fine idea, and TSA is to be congratulated on its thoughtfulness and true spirit of service.

A new course for tv technicians has been announced by the International Correspondence School of Scranton, Pa. The course will acquaint technical workers, students, sales engineers, etc., with all components of transmitting and receiving equipment.

New uses of television in railroading were explored last month in Chicago in joint tests by RCA and the B & O Railroad. Officials of 28 railroads saw three of RCA's newly developed pint-sized Vidicon industrial tv systems perform operations which saved much time and movement of yard workers and rolling stock. The disposition and movement of all cars and switch engines in the yard, and the listing of freight car numbers on incoming trains, were all seen by two small tv cameras on the yardmaster's tower.

The Office of Price Stabilization has suspended price controls on all radio and tv sets, phonographs, recorders and all their components.

RTMA has forwarded copies of two model ordinances recently released by the

National Institute of Municipal Law Officers and distributed to all its members. This organization comprises City Attorneys in many large cities in most of the country, and thus the two ordinances will receive wide circulation. One ordinance provides for the licensing and regulating of persons engaged in selling, distributing and servicing radio and tv equipment. The other ordinance regulates the installation, repair and maintenance of tv and radio receiving antennas. It is stated that the purposes of these ordinances is to protect the public against incompetent, unqualified, unreliable and financially irresponsible persons who operate their business in such a manner as to cause damage or injury to set owners, to protect the health and safety of the public and workers in the field, and to protect property from fire and other damages. Al Coumont, RTMA service Coordinator, points out that this is the first time he has noted any proposal to license retailers and distributors. RTMA has taken a firm stand in opposition to the licensing of servicemen earlier, and is very much against these two ordinances.

The first commercial UHF station to go on the air was station KPTV in Portland, Ore. Broadcasts began with the opening of the World Series on October 1st.

The nation's first multiple-outlet antenna system designed for reception of both UHF and VHF signals was also installed in Port-

(Continued on page 25)

## TV TROUBLESHOOTING AND REPAIR GUIDE BOOK

by Robert G. Middleton



LONG NEEDED in this specialized field, here is a complete down-to-earth book that offers practical information on troubleshooting and repairing television receivers.

Taking into consideration all possible problems that may arise in servicing television receivers, this book is a thorough presentation of TV receiver troubles and cures. It tells the reader how to recognize TV receiver trouble symptoms and remedy them. This is accomplished through the use of pictures taken directly from TV receiver picture tubes and oscilloscopes. Troubleshooting charts are also given.

Much valuable information is presented on troubleshooting with test

equipment — special emphasis on using oscilloscopes. Visual troubleshooting techniques, also very important, are covered with amazing completeness.

This is not a theory book — but a practical troubleshooting and repair guide guaranteed to save the user hours of time-consuming labor!

Here are all the facts that must be known to be a troubleshooting expert! Service technicians will value the book for its thoroughly practical approach. Instructors and students will use it because it puts all the answers to television troubleshooting at their fingertips.

### 10 Fact-Packed Chapters

1. Receiver Differences and Waveforms
2. Handy Hints in Visual Alignment Procedures
3. Troubleshooting Sync Circuits
4. Locating Sweep Troubles
5. Faults in Video Amplifiers
6. Checking High-Voltage Power Supplies
7. Test Equipment Kinks
8. Troubleshooting in the Home
9. Receiver Buzz: Causes and Cures
10. External Interference

INDEX

204 pages  
8 1/2 x 11"

Durable art cover  
illus. Only \$3.90

JOHN F. RIDER, PUBLISHER, Inc., 480 Canal St., New York 13, N. Y.



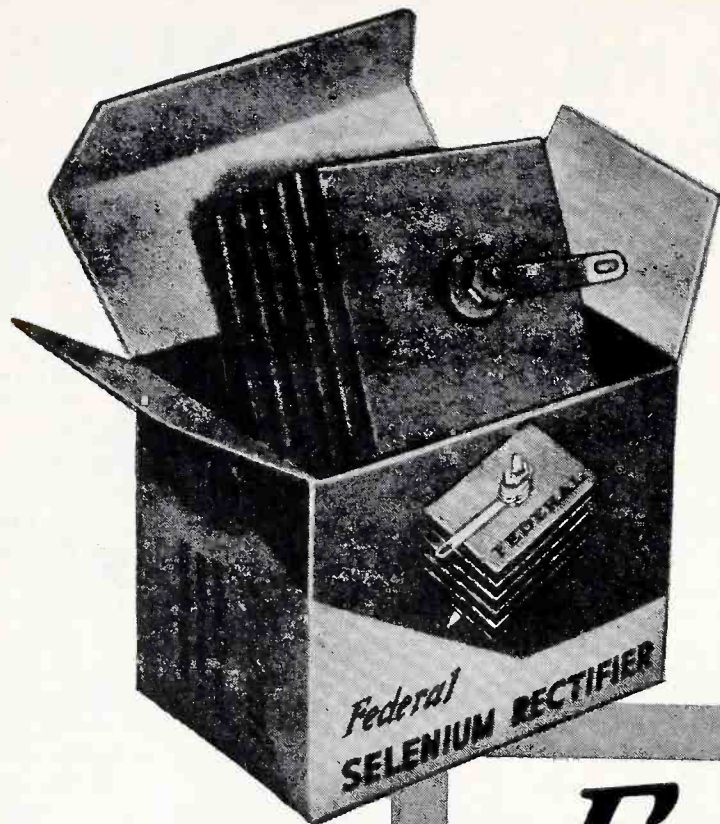

# There's PROFIT in Every Package...!

That's why, Mr. SERVICEMAN,  
it pays to make radio-TV  
replacements with—

## Federal MINIATURE SELENIUM RECTIFIERS

**Federal QUALITY** assures set owners the dependable, long-life performance that keeps your job profits **INTACT!**

QUALITY that *clicks*...profit that *sticks*! No wonder servicemen everywhere rely on Federal—the *original* miniature—for *money-making* replacements!

Every step of the way—from raw materials to finished, packaged unit—Federal selenium rectifier production is under *rigid quality control*. According to tests by receiver manufacturers, Federal miniatures show a life expectancy of well over RTMA guarantee. Hundreds of thousands of factory tests prove superior immunity to shelf-aging.

Be sure of your replacement profits, Mr. Serviceman. Depend on Federal...backed by a record of over 35,000,000 units in the field. Remember: "*It pays to replace with the BEST!*"

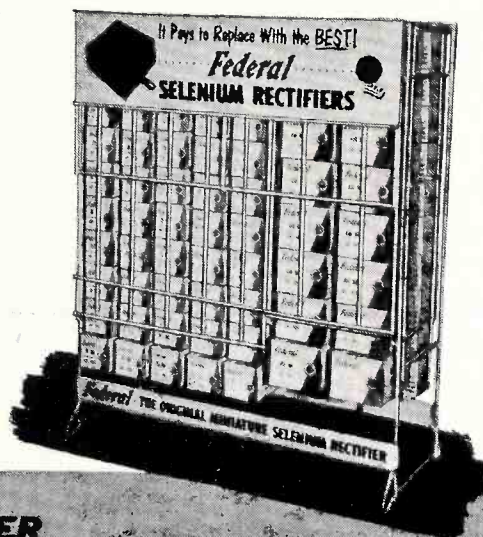

Save Time—Serve Yourself  
from Federal's new

**RECTIFIER DISPENSER**

Look for it on your distributor's counter

America's oldest and largest manufacturer of selenium rectifiers

# Federal Telephone and Radio Corporation

SELENIUM-INTELIN DIVISION

100 KINGSLAND ROAD, CLIFTON, NEW JERSEY

In Canada: Federal Electric Manufacturing Company, Ltd., Montreal, P. Q.  
Export Distributors: International Standard Electric Corp., 67 Broad St., N. Y.

Please mention *Successful Servicing* when answering advertising.





# New Channels and Frequency Allocations

Most service men realize the importance of the FCC lifting its freeze on the authorization and construction of new tv stations, but more important than that unfreezing will be the resulting number of new stations and tv areas which will be opened up to the service technician.

By its thaw the FCC allowed additional VHF stations to be built. Since a tv station channel requires 6 mc (see the chart below), crowding would have taken place in the VHF range of 30 to 300 mc (which is from channel 2 to 13). To prevent crowding, the FCC also released part of the ultra-high frequency band (300 to 3,000 mc), allowing that part of it from 470 to 890 mc to be used for UHF stations. These are channels 14 through 83 in the chart below.

Until the FCC unfreezing on April 14th, there were 108 stations on 12 VHF channels; now 498 more stations can be added to these channels. These, with the 70 new UHF channels, will bring the possible total of new tv stations to 2,053. The stations will be spread over 1,291 separate receiving areas. Thus, the importance of the FCC

thaw will be in the number of new stations that eventually will bring tv installation and repair work to your community, no matter in what section of the country you are employed.

Of course the allocation of these recently released frequencies will not mean that new stations will develop overnight. It is taking time for stations to apply for the new VHF and UHF frequencies, for the FCC to allocate them, and finally it takes time for the stations to be built.

The FCC is giving priority to applications from communities which have no tv as yet, and favouring communities in the 100,000 population group. On its first day of hearings, July 1st, the FCC granted 18 construction permits; it has since granted 22 more, but will need many more months to review all applications. New stations are already being built and, if winter conditions don't interrupt construction of aerials, perhaps 15 of them will be on the air by January, perhaps a hundred more within the following year. Transmitters and other equipment are

readily available; one firm alone sold 32 transmitters in the few weeks around the FCC non-freezing announcement.

The channel frequencies listed below are being put to use rapidly. 730 new tv station applications from 47 states are now pending FCC consideration (and Vermonters still have time to apply). At last count 40 new stations, both VHF and UHF, had been approved (33 of these are commercial and 7 are for educational use only). Among the first stations to receive an FCC go-ahead was KFEL-TV in Denver, which probably set a record by going on the air just 8 days after receiving its permit. In Reading, Pa., WHUM-TV plans the world's largest UHF transmitter. Its effective power of 26 kilowatts will also cover parts of Delaware, New Jersey and Maryland. Other tv-less cities to receive FCC station grants include Springfield and New Bedford, Mass.; Bridgeport and New Britain, Conn.; York, Pa.; Youngstown, Ohio; Flint, Mich.; Fort Lauderdale, Florida; Austin and El Paso, Texas; Portland, Oregon, and Spokane, Washington.

## COMPLETE LIST OF TV CHANNEL FREQUENCIES

CHANNEL NO.	FREQUENCY RANGE MC	PICTURE CARRIER MC	SOUND CARRIER MC	CHANNEL NO.	FREQUENCY RANGE MC	PICTURE CARRIER MC	SOUND CARRIER MC
2	54-60	55.25	59.75	43	644-650	645.25	649.75
3	60-66	61.25	65.75	44	650-656	651.25	655.75
4	66-72	67.25	71.75	45	656-662	657.25	661.75
5	76-82	77.25	81.75	46	662-668	663.25	667.75
6	82-88	83.25	87.75	47	668-674	669.25	673.75
7	174-180	175.25	179.75	48	674-680	675.25	679.75
8	180-186	181.25	185.75	49	680-686	681.25	685.75
9	186-192	187.25	191.75	50	686-692	687.25	691.75
10	192-198	193.25	197.75	51	692-698	693.25	697.75
11	198-204	199.25	203.75	52	698-704	699.25	703.75
12	204-210	205.25	209.75	53	704-710	705.25	709.75
13	210-216	211.25	215.75	54	710-716	711.25	715.75
14	470-476	471.25	475.75	55	716-722	717.25	721.75
15	476-482	477.25	481.75	56	722-728	723.25	727.75
16	482-488	483.25	487.75	57	728-734	729.25	733.75
17	488-494	489.25	493.75	58	734-740	735.25	739.75
18	494-500	495.25	499.75	59	740-746	741.25	745.75
19	500-506	501.25	505.75	60	746-752	747.25	751.75
20	506-512	507.25	511.75	61	752-758	753.25	757.75
21	512-518	513.25	517.75	62	758-764	759.25	763.75
22	518-524	519.25	523.75	63	764-770	765.25	769.75
23	524-530	525.25	529.75	64	770-776	771.25	775.75
24	530-536	531.25	535.75	65	776-782	777.25	781.75
25	536-542	537.25	541.75	66	782-788	783.25	787.75
26	542-548	543.25	547.75	67	788-794	789.25	793.75
27	548-554	549.25	553.75	68	794-800	795.25	799.75
28	554-560	555.25	559.75	69	800-806	801.25	805.75
29	560-566	561.25	565.75	70	806-812	807.25	811.75
30	566-572	567.25	571.75	71	812-818	813.25	817.75
31	572-578	573.25	577.75	72	818-824	819.25	823.75
32	578-584	579.25	583.75	73	824-830	825.25	829.75
33	584-590	585.25	589.75	74	830-836	831.25	835.75
34	590-596	591.25	595.75	75	836-842	837.25	841.75
35	596-602	597.25	601.75	76	842-848	843.25	847.75
36	602-608	603.25	607.75	77	848-854	849.25	853.75
37	608-614	609.25	613.75	78	854-860	855.25	859.75
38	614-620	615.25	619.75	79	860-866	861.25	865.75
39	620-626	621.25	625.75	80	866-872	867.25	871.75
40	626-632	627.25	631.75	81	872-878	873.25	877.75
41	632-638	633.25	637.75	82	878-884	879.25	883.75
42	638-644	639.25	643.75	83	884-890	885.25	889.75



# NOW

## MORE TV SET OWNERS ENJOY BETTER TELEVISION with B-T UNIT SYSTEMS



More and more SERVICE TECHNICIANS are using the B-T UNIT SYSTEM to plan and install Master TV Systems for VHF and UHF, for 1 Set or for 2000, and without outside engineering assistance. And today hundreds of thousands of set owners enjoy the benefits of Better Television

The B-T UNIT SYSTEM was designed expressly for the Service-Technician to help him meet the various problems which arise in his work. The B-T UNITS are intended for use wherever the Technician finds any one or all of the following requirements to exist: Amplifying Weak Signals . . . Handling Multi-directional Signals without a Rotator . . . Multi-set Distribution from a Single or Multiple Antenna Installation. (See Typical Applications)

### B-T UNITS include:

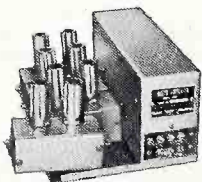

- MIXER AMPLIFIER MA-4**
- Basic Chassis and Power Supply \$52.50
  - Individual Channel Plug-in Amplifier Strips \$19.50
  - UHF Conversion Strip To be announced

**DISTRIBUTION AMPLIFIER DA-8**  
No Loss Distribution to 8 Sets \$87.50

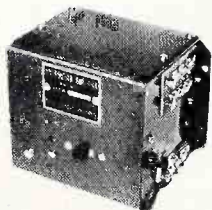

**DISTRIBUTION AMPLIFIER DA-2**  
No Loss Distribution to 2 Sets \$39.50

**COMMERCIAL ANTENSIFIER CA-1**  
All Channel Line Amplifier—27db Gain \$77.50



The B-T UNIT SYSTEM is the result of exhaustive study projects conducted by Blonder-Tongue Laboratories, whose research facilities are entirely and continuously devoted to Better Television. All B-T UNITS are broad band, and require no channel tuning or band-switching.

### TYPICAL APPLICATIONS

FOR USE	MA-4 plus Individual Channel Strips	CA-1 All Channel Line Amplifier	DA-8 Each Feeds 8 Sets	DA-2 Each Feeds 2 Sets
WEAK SIGNALS	✓	OR ✓		
MULTI-SET DISTRIBUTION			✓	✓
MULTI-ANTENNA INSTALLATIONS	✓			
COMMUNITY TV SYSTEMS	✓	✓	✓	✓

NOTE: These Units may be used alone or in any number of combinations. See Your Distributor, or Write to B-T Service Department for full specifications of B-T Units and Accessories.

Standard RTMA Warranties Apply



**BLONDER-TONGUE LABORATORIES, INC.**  
Westfield, New Jersey



**Association and Industry News**

(Continued from page 21)

land; the RCA Master-Tenna system brings in local and network programs to receivers throughout the city's large retail appliance store. Two antenna masts atop the store support UHF corner reflector antennas, with a separate antenna and transmission line for VHF fastened below one corner reflector. Signals are fed to a main amplifier and then to outlets throughout the store.

"Old radio men never die — they just keep on fighting," writes Ira Kamen from St. Lukes Hospital in Chicago, Ill, where he is recovering from a serious illness. Even a hospital bed can't take away the usual "Kamen spirit".

Mr. Kamen, co-author of "TV Master Antenna Systems" and "TV and Electronics as a Career", is vice-president of the Brach Mfg. Corp., division of the General Bronze Corp. He is also well-known in the field as a sales official, writer, and lecturer.

Keep fighting, Ira — we're all pulling for you in your corner!

**Taco Announces National "Oldest Taco Antenna" Contest**

Servicemen and installers throughout the country are being canvassed by the Technical Appliance Corporation, and it is all in the interest of locating the oldest operating Taco tv antenna.

This is all because Fred Voorhaar of Taco started wondering just how long an antenna will stand up and give service. Many figures have been given as to the life of an antenna, none of these figures apparently being based on anything other than a wild guess.

Here is a case where the serviceman or installer who locates the oldest operating Taco antenna will receive \$100 as a reward for his time and trouble, and the customer who owns the antenna will receive a new Taco installation absolutely free of charge.

Complete details of the contest are available in printed form obtainable at all Taco distributors.

The contest will close early in 1953 so that the winner can receive his reward prior to March 15th.

Photo of the winning entry and verification of the installation date will be checked by Taco representatives.

**MAIL THIS COUPON TODAY**

John F. Rider Publisher, Inc.,  
Dept. C9  
480 Canal Street  
New York 13, N. Y.

Gentlemen:

Rather than take the chance of missing the alternate copy of **SUCCESSFUL SERVICING** at my jobber's, I am enclosing one dollar (\$1.00) to cover the cost of direct-to-my-home mailing every month.

Name .....

Address .....

City ..... Zone .....

State .....

Cash  Check  Money Order

# A Brand New RIDER Book

## UHF PRACTICES AND PRINCIPLES

by Allan Lytel, Instructor, Temple Univ. Tech. Inst.

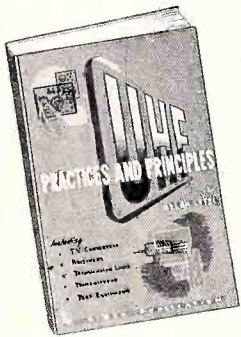

UHF is just around the corner for the service technician. Prepare now by learning about uhf and how to apply it in your everyday work. Because ultra-high frequencies do not behave like the lower frequencies, a knowledge of the special techniques, concepts, and circuits is necessary. Once you know them you can operate with greater success and more profitably. UHF PRACTICES AND PRINCIPLES is designed to provide a fundamental background for an understanding of uhf transmitting and receiving equipment as it applies to the various services using it. Much of the emphasis is on practical appli-

cations to television. Many presently available converters are discussed along with circuit descriptions and schematics. UHF oscillators are treated with examples of practical circuits used in equipment. Separate sections are devoted to uhf developmental vacuum tubes and test equipment.

You will find here all the information you need to achieve a complete working knowledge of the techniques employed in this potentially profitable field of operation. UHF will mean added income for you. Learn about it now!

### CONTENTS

- |  |   |
|--|---|
| Chapter 1. Introduction to UHF               | Chapter 8. Receivers and Converters                   |
| Chapter 2. What's Different about UHF        | Chapter 9. Transmitters                               |
| Chapter 3. Electromagnetic Radio Wave        | Chapter 10. Developmental Vacuum Tubes                |
| Chapter 4. Receiving Antennas                | Chapter 11. Test Equipment and Techniques             |
| Chapter 5. Transmission Lines and Waveguides | Appendix; Bibliography; Index; Chapter-end questions. |
| Chapter 6. New Types of Tuned Circuits       |   |
| Chapter 7. Oscillator Tubes and Circuits     |   |

Approx. 400 pages  
5½" x 8½"

List \$6.60

Cloth bound  
285 illustrations

John F. Rider Publisher, Inc.  
480 Canal Street, N. Y. 13



FROM MANUFACTURER...

TO JOBBER... TO

SERVICEMAN TO CONSUMER

**ASTRON CAPACITORS**

MEAN A LONG LINE  
OF RELIABILITY & SATISFACTION.

You can *depend on* ASTRON Capacitors! They've earned a reputation for outstanding performance and reliability—a reputation that means something to YOU. When you replace with ASTRON, you build your reputation for high-quality service. Every step of the way, ASTRON means reliability . . . reliability that pays off in more satisfied customers, less call-backs, better earnings for you. Talk to your jobber about ASTRON Capacitors today, or write us for the name of the Astron Distributor nearest you.

DEPEND ON . . .  
INSIST ON



**ASTRON**

255 Grant Avenue East Newark, N.J.



# The Autronic-Eye\*

The Autronic-Eye is an electronic device that automatically switches the headlamps between the upper and lower beams on the car to which it is installed, in response to light from an approaching car. It consists of four individual units: Phototube Unit, Amplifier Unit, Power Relay, and Auxiliary Foot Switch. (See Fig. 1.) Autronic-Eye units are factory installed in the 1952 Cadillacs and Oldsmobiles.

The Phototube Unit is an optical device containing a phototube and receives power from the Amplifier Unit by cable. The lens of the Phototube Unit picks up light from approaching headlamps and focuses it through a filter and mask to the phototube within the unit. This light is then converted into an electrical signal and returned by cable to the Amplifier Unit. The Phototube Unit is mounted on the top left side of the instrument panel. The sensitivity of the Phototube Unit is adjusted to accommodate the clear or tinted windshields on the car to which it is installed. The mounting bracket will fit only the instrument panel of the car for which it is designed.

The Amplifier Unit is an electronic device which supplies voltage to the Phototube Unit and the Power Relay. The Amplifier Unit operates the Power Relay in response to a signal from the Phototube Unit caused by the headlamps from an approaching car. The Amplifier Unit is mounted under the hood. Serial number is six digit number on end of the base.

The Power Relay is a heavy duty relay, with special alloy contacts, for switching the headlamps between the upper and lower beams. The Power Relay is operated by the Amplifier Unit in response to a signal from the Phototube Unit. The Power Relay is mounted under the hood.

The Auxiliary Foot Switch is a normally open, plunger type switch which is mounted on the toe pan just above the Standard Foot Dimmer Switch. When the Autronic-Eye is controlling the headlamps, the Auxiliary Foot Switch when pressed down and held, provides an upper beam regardless of light on the Phototube Unit.

## Functional Operation

The headlamps are controlled automatically in only one position of the Standard Foot Dimmer Switch. The other position of the Standard Foot Dimmer Switch is for the lower beam.

The Autronic-Eye is disconnected from its vehicle headlamps in the "Lower Beam" position of the Standard Foot Dimmer Switch; however, the Autronic-Eye is not turned off. It continues to function as long as the headlamps are turned on, and is

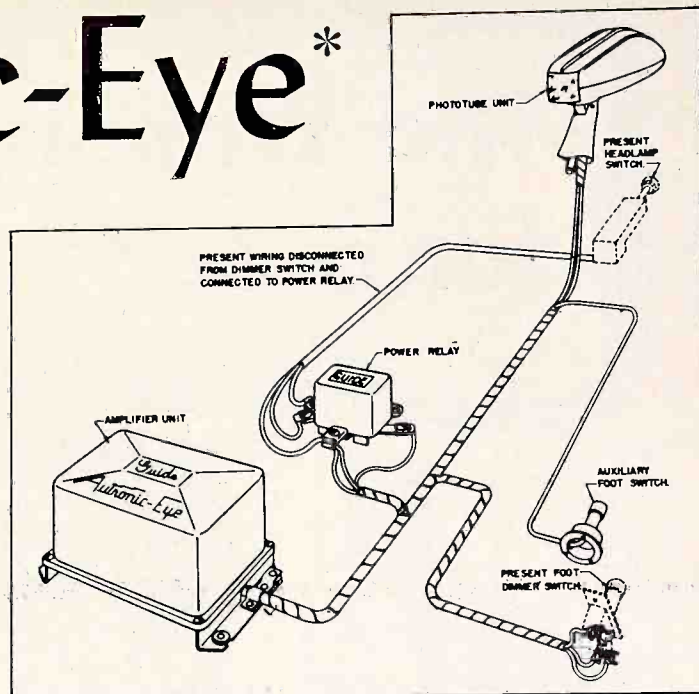

Figure 1.

ready at all times to provide automatic control whenever the Standard Foot Dimmer Switch is returned to the "Automatic" position.

The Auxiliary Foot Switch functions only in the "Automatic" position of the Standard Foot Dimmer Switch. When pressed down and held, it provides the upper beam regardless of light on the Phototube Unit. This arrangement permits signalling if desired and provides a simple test for the "Automatic" position of the Standard Foot Dimmer Switch.

## Block Diagram

The battery supplies voltage through the ballast tube to the vibrator. The vibrator supplies voltage for the amplifier stage and through the high voltage rectifier to the phototube. When light strikes the phototube, a signal is transmitted to the amplifier stage which operates the Power Relay to switch headlamps between upper and lower beam. (See Fig. 2.)

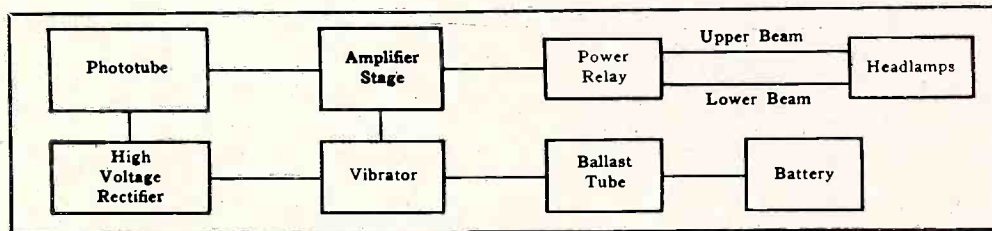

Figure 2.

## Circuit Description

As shown in Fig. 3, a 6 volt supply for the Autronic-Eye is received from the main light switch through the standard car wiring harness. This voltage is supplied through the red wire with natural tracer, the fuse and

\*This article and its illustrations are reprinted through the courtesy of Western Auto Supply Co.

the ballast tube to the primary winding of the transformer. Rheostat (16) is adjusted to produce 4 volts at transformer center tap, thus, requiring a 4 volt vibrator. The transformer has two secondary windings, one producing approximately 1100 volts A.C. and the other approximately 150 volts A.C. The higher voltage is rectified to produce approximately 1000 volts D.C. across the load resistor network (19, 13 and 14). A high voltage control (19) in the Amplifier Unit is adjusted to supply the necessary voltage for the Phototube Unit. The sensitivity control (18) in the Phototube Unit adjusts the high voltage supplied to the phototube.

The 150 volt winding is used as the power supply for the amplifier tube and sensitive relay. When the Standard Foot Dimmer Switch is in the "Automatic" position, the sensitive relay operates the power relay which in turn switches the headlamps between upper and lower beam. When the Standard Foot Dimmer Switch is in the "Lower Beam" position, the power relay

will be energized, holding the headlamps on a lower beam.

When light strikes the Phototube Unit, current flows from the phototube to the control grid (G1) of the amplifier tube. The control grid regulates the current flow through the amplifier tube. The voltage of the control grid is varied by the flow of current from the Phototube Unit through resistor (11), and in the closed position of

(Continued on page 29)



# The Winning *COMBINATION* for a perfect *TV* picture!



## THE TV TWINS

Here's What You Get — ALL YOU NEED  
TO GET THE MOST OUT OF ANY TV SET!

- ★ CDR Rotor, Model TR-11 . . . . . \$44.95
- ★ Thrust Bearing, Model TA-6 . . . . . 4.95
- ★ Radiart Booster, Model TVB-1 . . . . . 29.95
- ★ Connecting Kit, Model TA-7 . . . . . 1.00

If Bought Separately . . . \$80.85

**SPECIAL RETAIL  
COMBINATION PRICE...** \$ **74<sup>95</sup>**  
Model RAC-4497...  
*Regular Trade  
Discount Applies*

Here's a rare opportunity to really get the most out of any TV set—putting it to work at peak possible performance... and at a real savings! We have combined these 4 Radiart units into one package and at real savings! The quality can't be beat... and the two cabinets form a handsome piece of furniture for any home. Will handle any antenna array... meter dial on remote control cabinet... and the booster improves picture quality beyond compare! **ACT NOW!**



**THE RADIART CORPORATION CLEVELAND 13, OHIO**

VIBRATORS • AUTO AERIALS • TV ANTENNAS • ROTORS • POWER SUPPLIES

Please mention *Successful Servicing* when answering advertising.



# The Autronic - Eye

(Continued from page 27)

the sensitive relay through its contact points, to the 6 volt supply and through car battery to ground. In the open position of the sensitive relay, the flow of current from the phototube passes through resistor (11), resistor (20), and rheostat (17), to the 6 volt supply and through the car battery to ground. A given flow of current from the Phototube Unit produces a smaller voltage change at the control grid (G1) of the amplifier tube when the sensitive relay is closed, as compared to when it is open. In the closed position, the current flows through resistor (11) only, while in the open position, the current flows through resistor (11), resistor (20), and rheostat (17). When no current flows from the Phototube Unit, there is no voltage change across the resistors (11), (20), or (17), so the control grid is at the same voltage as its cathode because they are connected together at the 6 volt supply. In this condition, section (1) of amplifier tube will conduct current and cause sensitive relay to be closed. As previously mentioned, a negative voltage is supplied to the Phototube Unit, therefore, any flow of current from the Phototube Unit through resistors (11), (20), or (17), is in a direction to produce a negative voltage change at the control grid (G1) of the amplifier tube. A small amount of current from the Phototube Unit flowing through resistor (11) and sensitive relay points produces a small negative voltage at the control grid (G1) causing the current through the sensitive relay to be reduced. An increase in current from the Phototube Unit causes the current through the sensitive relay to be further reduced until the relay opens. When the relay opens, current from the Phototube Unit passes through resistors (11), (20), and (17) and may be greatly reduced before the voltage of the control grid (G1) loses its negative voltage to the point where section 1 of the amplifier tube passes enough current to close sensitive relay again.

A small smoothing capacitor (8) is connected between the control grid (G1) and the 6 volt supply to remove the voltage ripple from the grid. A capacitor (5) is connected across the coil of the sensitive relay to smooth the current flow through it. A second triode section of the amplifier tube is connected between the sensitive relay and through the Auxiliary Foot Switch to ground. The control grid (G2) is connected directly to the cathode (K2) so that section (2) will pass current to close sensitive relay whenever the Auxiliary Foot Switch is closed. A capacitor (4) is connected across the 150 volt secondary winding of the transformer to protect vibrator (1). Capacitor (7) and resistor (12) are connected from sensitive relay contact to the 6 volt supply to protect the points of the sensitive relay. Current in the Phototube Unit flows from the high

voltage supply through potentiometer (18) and resistor (15) to ground. Current also flows from the potentiometer (18) through the resistor network (21) to ground. Resistor network (21) divides the voltage evenly for each dynode of a multiplier type

phototube. Each dynode is connected to the resistor network (21) through a protective resistor. The multiplier phototube passes current to the Amplifier Unit in response to light. No current flows when the phototube is dark.

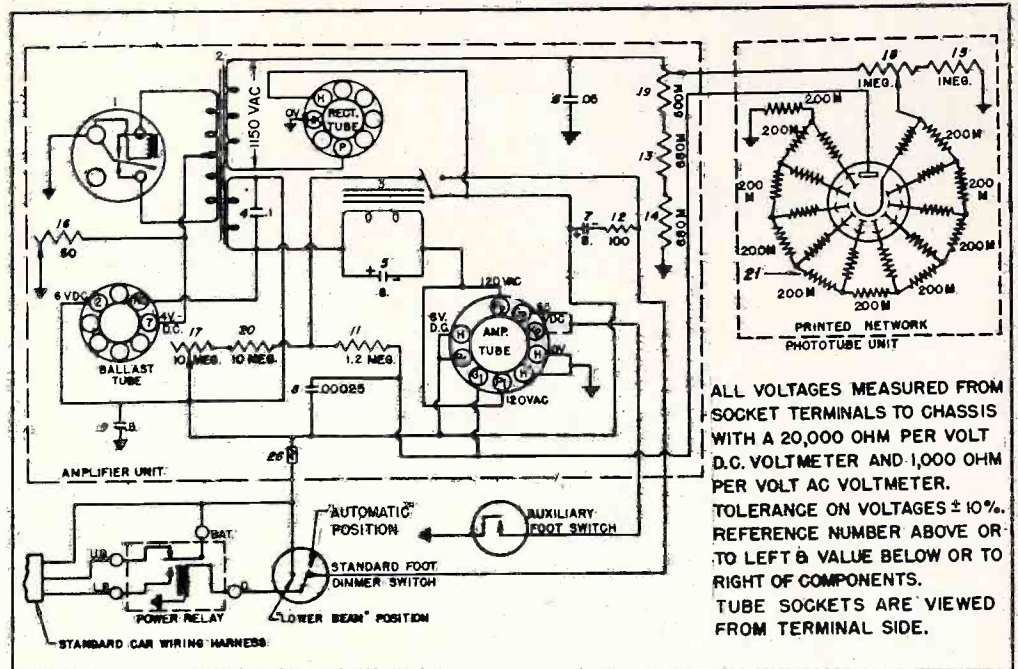

ALL VOLTAGES MEASURED FROM SOCKET TERMINALS TO CHASSIS WITH A 20,000 OHM PER VOLT D.C. VOLTMETER AND 1,000 OHM PER VOLT AC VOLTMETER. TOLERANCE ON VOLTAGES  $\pm 10\%$ . REFERENCE NUMBER ABOVE OR TO LEFT & VALUE BELOW OR TO RIGHT OF COMPONENTS. TUBE SOCKETS ARE VIEWED FROM TERMINAL SIDE.

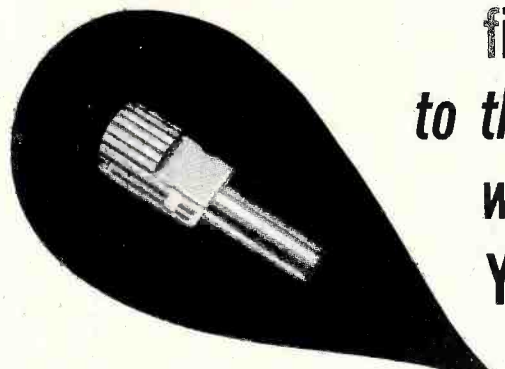

fit the right shaft  
to the right  
wire-wound control—  
YOURSELF!

Immediately, conveniently, correctly, economically.

Just select the Clarostat wire-wound control for your electrical needs. Then select any one of 12 Pick-A-Shaft types (or even a high-voltage coupler or nylon shaft) meeting your shaft needs. A slight tap joins them together—rigidly, permanently, satisfactorily. Ideal for radio-TV and industrial purposes.

It's another Clarostat first! These new Clarostat A43, A58 and A10 wire-wound controls take field-attached shafts. And remember, only Clarostat offers 2-, 3- and 4-watt wire-wound controls.

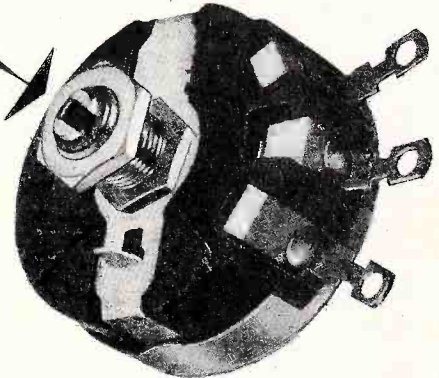

ASK YOUR CLAROSTAT DISTRIBUTOR for these new Pick-A-Shaft wire-wound controls. Ask for new catalog—or write us.



## Controls and Resistors

CLAROSTAT MFG. CO., INC., DOVER, NEW HAMPSHIRE

In Canada: Canadian Marconi Co., Ltd., Toronto, Ontario



# the PERMO Line

**MADE TO ORDER FOR THE COMPONENT PARTS TRADE**



The Permo Line gives you everything you need to make needle replacements fast, easy and profitable. You get (1) Handy and accurate service data, (2) Individual needle packages complete with (3) Installation tools and accessories with instructions, and (4) Stock-display and re-order case. See your jobber for fast-moving assortments or individual needles.

**Developed Scientifically**

**Engineered Specifically**

**Made Precisely**

**Priced Competitively**

**Packaged Practically**

**Simple Inventory Control**

**Installation Tools, Accessories and Instructions Supplied**

**Complete Service Data**

**National Distribution**

**PERMO, INC.**

6415 Ravenswood, Chicago 26, Illinois

MANUFACTURERS OF FIDELITONE PERMO-POINT AND PERMO PRODUCTS  
LONG-LIFE PHONOGRAPH NEEDLES • RECORDING TAPE AND WIRE • RECORD BRUSHES





A monthly summary of product developments and price changes of radio, electronic, and television parts and equipment, supplied by United Catalog Publishers, Inc., New York City, publishers of RADIO'S MASTER.

These REPORTS will help you to buy and sell to best advantage. They will also help you to keep your inventory up to date. A complete description of most products will be found in the Official Buying Guide, RADIO'S MASTER available through local parts distributors.

**COMMENT:** The trend, as previously noted, continues to center upon the introduction of new products, with leaders in all replacement fields taking part. This has been in evidence now for the past four months. Price increases and decreases remain quite spotty.

**New Items**

**ASTATIC CORP.**—Added model 54M3 microphone at \$7.65 net . . . also models DR-11 and DR-11-S microphones at \$40.80 and \$41.70 net respectively.

**BEAM INSTR. CORP.** Added model 1039, portable service oscillograph weighing 9¼ lbs., at \$167.50 net. Also added motor drive, model 1431 at \$306.00 net to replace model 1429 which is discontinued.

**BLONDER-TONGUE LABS.**—Added model HA-3 at \$23.70 net, a 3-tube, 3 stage cascade push-pull circuit, fully automatic booster with all-channel gain in excess of 16db.

**CHICAGO TRANSFORMER**—Added a number of normal reactance type (NCF) and high reactance type (HCF) control transformers . . . PCB, PCC and PCF power circuit transformers . . . hi-voltage fly-back transformers (TFB) . . . vertical scanning output transformers (TSO) . . . width and linearity coils (TL, TW and TWL) and deflection yokes (TY).

**CORNELL DUBILIER**—20 dual common negative capacitor units added . . . also 7 dual separate section units . . . 23 triple common negative units and 2 quadruple common negative units. Added vibrator kit containing 9 vibrators; 2—#5300, 2—#5326, 2—#5301, 2—#5342 and 1—#5335 at \$24.66 net . . . also added 6 capacitor kits.

**CREST TRANSFORMER CORP.**—Added 4 power transformers for capacitor input filter circuits . . . 2 power transformers for reactor input filter circuits . . . 4 filament transformers . . . 4 filter reactors . . . 2 universal output audio transformers and 2 heavy duty output audio transformers.

**G. E.**—Added model ST-12A, a portable germanium diode checker at \$169.50 net. Useful as general resistance checker (10 ohms to 6 megohms); accurately-metered power supply; forming electrolytic capacitors and checking DC leakage current. Also introduced 27EP4, a magnetic-focus and magnetic-deflection, direct-view all-glass picture tube at \$97.50 net.

**J F D**—Introduced series of 5 element Baline yagis and series of 5 element stacked Baline yagis.

**MASTER MOBILE MOUNTS**—Added model 214, deluxe 2 meter antenna at \$15.95 net.

**MINNESOTA MINING & MFG. CO.** — Added "scotchfil", a putty-type insulating compound designed to fill voids in irregular shaped electrical connectors and to pad or cushion sharp edges, thus allowing a smooth and easy to tape surface . . . also "scotchkote", an electrical coating for use as an outer seal on splices, underwater cables, etc. . . . and "scotchlok", electrical spring connectors.

**PFANSTIEHL CHEM. CO.**—Added 4 new Pfan-tone pickup kits.

**QUAM-NICHOLS**—Added "tweeters", 3A15T at \$3.45 net and 5A15T at \$3.90 net.

**R.C.A.** — Added 12AY7, medium-mu twin triode, miniature type at \$3.00 net.

**RADELCO**—Added model MB-2H, swivel base and heavy duty spring for mobile antennas . . . model MM-60, chrome silicon steel mobile antenna . . . model PL-259, coaxial connector (JAN approved) and model US-102, UHF pre-assembled, stacked V-type aerial.

**RADIO CRAFTSMEN INC.**—Added C800, FM-AM tuner with record equalizer at \$159.50 net . . . WM-1 mahogany wood cabinet (will accommodate either RC10, C10 or C800 tuners) at \$18.00 net . . . WB-3 (blonde) and WM-3 (mahogany) wood cabinets at \$7.50 net each.

**RAYTHEON**—Introduced tube types 1AX2, a 9 pin miniature diode designed for pulse rectifier service in television at \$2.65 list . . . also 6AH4GT, a high permance triode designed to be used as a vertical deflection amplifier in TV receivers at \$2.20 list. Added TV picture tube 17LP4, a rectangular-face picture tube with magnetic deflection and electrostatic focus at \$25.50 net.

**RIDER, JOHN F.** — Added Catalog No. 141, "UHF Practices and Principles" at \$6.60.

**SIMPSON MFG. CO.** — Added Wirelessfone at \$57.00 net and single stations at \$28.50 net to their series of intercom equipment.

**THORDARSON-MEISSNER** — Added audio inter-stage transformer No. T-20A19 at \$2.46 net.

**TRICRAFT PRODUCTS CO.**—Introduced model TB-400-L, tenna-boat with light at \$14.95 list.

**TRIO MFG. CO.**—Added 8 zig-zag antennas . . . a controlled pattern antenna system . . . 4 stacking kits . . . 1 phasing strip and 1 phasing harness for the zig-zag antennas.

**VAN CLEEF BROS., INC.**—No. 121, Jr. shop package of plastic electrical tape added . . . also series of DB wire connectors available in 4 standard sizes.

**Discontinued Items**

**EITEL-McCULLOUGH INC. (EIMAC)** — Withdrew triodes 3X12500A3, 3X10000A3 and 3C24 . . . also tetrode 4X100A.

**JENSEN MFG. CO.**—Bass reflex cabinet stock #ST-743 withdrawn.

**NATIONAL CO.** — CORRECTION — Erroneously reported HRO series as withdrawn in previous issue. This should have read . . . HRO-50 series redesignated HRO-60 with corresponding price changes.

**Price Increases**

**COPPERWELD STEEL CO.**—Advised of a slight increase in prices on their antenna wire, guy strand, grounding wire, and radio and television ground rods.

**JENSEN MFG. CO.**—Increased price slightly of stock No. ST-875, coaxial speaker with horn-loaded compression-driver "tweeter" to \$47.70 net.

**J F D**—Boosters SB increased to \$15.87 net and VB to \$13.47 net.

**WARD PRODUCTS CORP.** — Increased prices slightly on their ME series of "zip-hi" masts.

**Price Decreases**

**BRITISH INDUSTRIES** — Decreased price on KT-66, power amplifying tube to \$3.50 net.

**DRAKE ELECTRIC WORKS** — Decreased net prices on soldering "tips" models 225, 325, 326, 400, 450, 600, 600-10 and 600-S.

**FEDERAL TELEPHONE & RADIO CORP.**—RG series of coaxial lead-in cables reduced in price.

**HICKOK ELECTRICAL INSTR. CO.**—Decreased price of model 380, CR oscilloscope to \$215.00 net.

**JONTZ MFG. CO.**—Decreased prices in their series of Kwick-up telescoping masts and their series of roof mounts.

**R.C.A.**—Decreased tube type 3B28, Xenon rectifier to \$8.55 net.

**RADELCO** — YS-502 thru 506, pre-assembled 5 element yagis decreased in price. Also MM-72, MM-84, MM-96, steel masts . . . MB-1, swivel base . . . MB-2, swivel base and spring . . .

ME-60, mast extension . . . R-102, standoff insulator and R-105, chimney mount.

**PERFORMANCE** for customer satisfaction

The reason most fringe area installations are **TACO-EQUIPPED**

Ask your distributor for your Taco Cat. No. 38 — the Antenna Handbook.

**TACO** TECHNICAL APPLIANCE CORPORATION  
Sherburne, N. Y.

In Canada: Stromberg-Carlson Co., Ltd., Toronto 4, Ont.



# "GIMMICKS"

(Continued from page 11)

at the high frequencies. By the use of these gimmicks an effective capacitance is added between the high sides of the primary  $L_p$  and secondary  $L_s$  of the antenna input transformer.

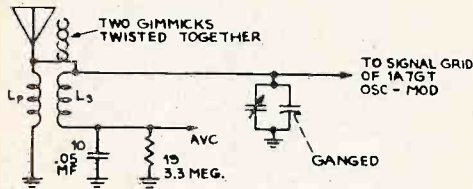

Figure 9.

Two gimmicks in the form of a twisted pair are used to give an effective capacitance across the secondary of the loop. The schematic representation and the actual circuit is shown in Fig. 10. The so-called twisted pair is shown schematically in Fig. 10(A) to be a trimmer capacitor  $C1$ . This  $C1$  actually consists of two separate twisted gimmicks. One gimmick is attached to the high side of the secondary of the loop, as shown in Fig. 10(B), and the other gimmick has one end attached to the low side of the same loop secondary, which goes to the avc circuit. Both the other ends of the gimmicks

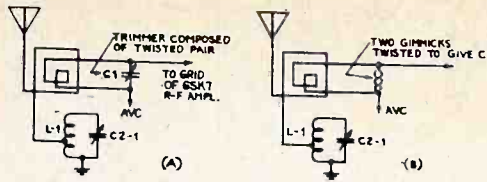

Figure 10.

are open and both wires imposing the gimmicks are twisted together as stated above. The capacitance formed by these two twisted gimmicks is about 2 or 3 mmf. It is shown as a trimmer because by varying the degree of twist, the capacitance between both gimmicks can be changed.

A gimmick arrangement also is used in the r-f transformer assembly to increase the response at the high-frequency end of the band. In this circuit, shown in Fig. 11, the r-f transformer assembly  $L2$  is enclosed in a shielded can and the gimmicks are considered as a part of the transformer network.

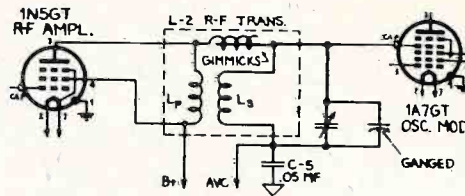

Figure 11.

Without these gimmicks, the r-f transformer, with its untuned primary  $L_p$  and its tuned secondary  $L_s$ , has a frequency-response characteristic such that at the high frequencies the response drops. The gimmicks incorporated in the  $L-2$  assembly effectively increase this undesired drop in response at the high frequencies.

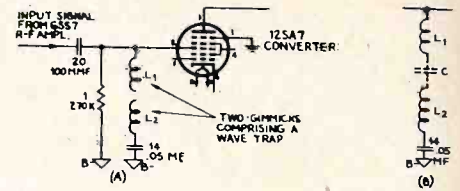

Figure 12.

Two gimmicks in the signal-grid circuit of the 12SA7 converter tube in the broadcast band are used to serve the purpose of an i-f wave trap. The circuit is shown in Fig. 12(A), coils  $L1$  and  $L2$  are the two gimmicks comprising the wave trap of this set. One end of the coil  $L1$  is attached to the signal-grid circuit of the 12SA7 tube and one end of coil  $L2$  is attached to one side of a .05-mf capacitor. (This capacitor is part of the avc filter network). Both the open ends of the gimmicks are facing each other and between these open ends a certain amount of capacity exists.

## What Every Hi Fi Enthusiast Should Know!

Just Off the Press

### HIGH FIDELITY SIMPLIFIED

by Harold D. Weiler

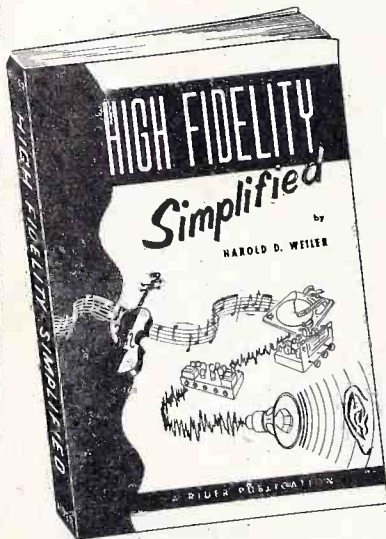

HIGH FIDELITY SIMPLIFIED is written for those who now own, intend to purchase or improve a high fidelity music system. It is the complete story of high fidelity from the point of origin, through the tuner, into the amplifier, and then into the loudspeaker. The author provides a thorough explanation of the characteristics required for high fidelity reproduction.

HIGH FIDELITY SIMPLIFIED has over 100 illustrations, blueprints and photographs of the latest equipment available.

HIGH FIDELITY SIMPLIFIED provides for the first time the minimum requirements for each component

and explains in simple language the terminology used by the manufacturers in their specifications.

The problems encountered in housing a high fidelity system are discussed in detail and many suggested installations are illustrated. The Nova Wall Units are described in detail with complete dimensional drawings. Audio hobbyists, record collectors, and all who enjoy lifelike reproduction will find this book authentic and practical.

HIGH FIDELITY SIMPLIFIED contains 160 pages in a handsome paper binding, provides information which will save its purchaser hundreds of dollars, in building and selecting a home music system.

John F. Rider Publisher, Inc., 480 Canal Street, New York

Forwarding and Return Postage Guaranteed  
480 CANAL ST., NEW YORK 13, N. Y.  
JOHN F. RIDER PUBLISHER, Inc.  
From

JOHN L. GIGL  
437 NEVIN ST.  
LANCASTER, PENN.

Sec. 3466, P. L. & R.  
U. S. POSTAGE  
PAID  
NEW YORK, N. Y.  
PERMIT No. 9427



# SUCCESSFUL Servicing

NOVEMBER 1952

## with **TEK-FILE INDEX**

### The Crosley UHF Converter

The Crosley Ultratuner, model DU-UHFP is an Ultra-High Frequency (UHF) Converter Unit specifically designed for use with Crosley Television Receivers. It may also be used with any television receiver that operates on 105 to 125 volts, 50 to 60 cycle, alternating current and has 122 to 132 megacycle amplification available.

The purpose of the unit is to extend the frequency range of the VHF Television Receiver to make possible the reception of local stations in the Ultra-High Frequency Band.

The tuning range of the unit is continuous from Channel 14 to 83 inclusive (470 to 896 megacycles).

Tuning Range: Channel 14 to 83 (470 to 896 mc.).

Power Consumption: 25 watts.

Voltage Rating: 105-125 volts.

Power Supply: 50-60 cycle, AC.

Position of TV Receiver Dial Pointer: Approximately 127 mc.; late Model Crosley TV Receivers have the letters "UHF" on the dial at this point.

Tube Complement:

Sym. No.	Type	Function
V1	6AF4	Oscillator
V2	6X4	Rectifier
V3	6BQ7	I-F Amplifier

### Circuit Description

The tuner assembly consists of three variable (tuned line) inductors mounted on a common shaft. The first two inductors tune the antenna preselector circuit. This circuit passes the signal to which the converter dial is set and attenuates all other signals, thus acting to reduce interference. The first two inductors in conjunction with the associated capacities, tunes to any desired frequency between 465 to 902 megacycles, while the third inductor, is used to tune the local oscillator and covers a range of approximately 338 to 775 megacycles.

The antenna preselector circuit is shunted by the choke L14. This provides additional attenuation to unwanted signals and acts as a high-pass radio-frequency filter to suppress broadcast and other low frequency

cross-modulation interference that may be encountered when the television receiver is located in an extremely intense field of a local AM broadcast station or other radiator.

Each of the variable inductors has an end inductor (L1, L2 and L3). The end inductors and the variable capacitors, C2, C7 and C8, provide a means for aligning the tuner at the high and low end. The UHF oscillator utilizes a 6AF4 tube. Feedback voltage from the plate to the grid of the

local oscillator signal are applied to the crystal mixer.

The antenna preselector is capacity coupled through C3 to the 1N72 crystal mixer and the local oscillator which is tuned to approximately 127 megacycles below the signal and is coupled to the mixer through the capacitors C17 and C13.

The crystal mixer is inductively coupled, through the IF input transformer, T2 to the grid of a cascode IF amplifier. The IF amplifier employs a 6BQ7 low noise duo triode, V3. The high impedance output of the cascode IF amplifier is transformed to a low impedance to match the input impedance of the Crosley RF Tuner in the television receiver. The output of the cascode IF amplifier is at a nominal frequency of 127 megacycles and has an approximate band width of 10 megacycles. Proper operation of the television receiver on the UHF Channels requires that the VHF receiver be tuned to approximately the center frequency (127 mc.) of the IF output.

A 6X4 half-wave rectifier tube with a resistance-capacity filter is used in the power supply.

Power consumption of the Ultratuner is

## Some Notes on uhf converters

tube is obtained by means of capacity coupling. The oscillator circuit is tuned to frequency by movement of a shorting contact on the tuned line inductance. Position of this contact determines the resonant frequency of the inductance. Both the tuned incoming signal from the antenna and the

twenty-five watts at 117 volts, 50 to 60 cycles.

### The Mallory UHF Inductuner

The Mallory UHF Inductuner is a compact assembly of variable inductances avail-

(Continued on page 7)

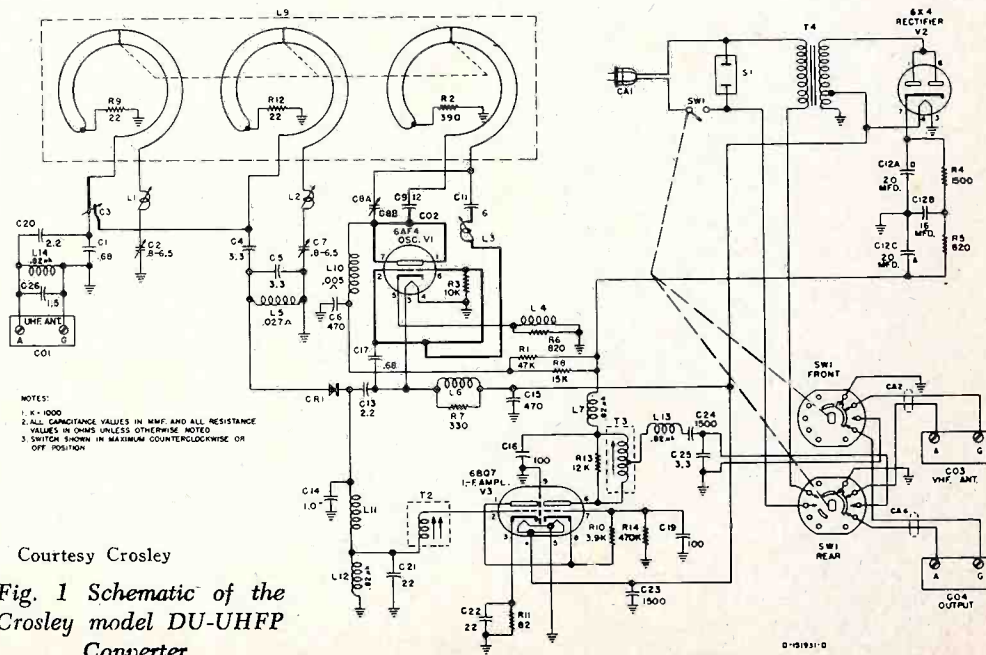



# It's Here!

## TV 10

Now — in Rider's latest Television Manual . . . TV 10 . . . you'll find a feature that can't be beat... **DEPENDABLE REPLACEMENT PARTS LISTINGS!** Every replacement part listed meets the physical and electrical performance ratings of the original equipment! And, like everything Rider publishes, TV 10 is *complete* . . . large, easy-to-follow schematics — lots of photos — troubleshooting test patterns — waveforms — enlarged chassis views — circuit changes — different production runs — *everything* you need to do a fast, easy and thorough servicing job! Remember, with a Rider Manual you do the job right the first time . . . because all Rider data is complete, factory-issued, direct from the set manufacturer. You get all the facts — organized and indexed for speed and accuracy. TV 10 contains more than 2,000 (8½ x 11") value-packed pages . . . **SEE IT . . . BUY IT . . . AT YOUR JOBBER'S — NOW. \$24.**



### JOHN F. RIDER

PUBLISHER, INC.  
480 Canal St., N. Y. 13, N. Y.

West Coast Office: 4216-20 W. Jefferson Blvd.  
Los Angeles, California



# Replacement Parts in TV Receivers

## Part I - Capacitors

by John F. Rider

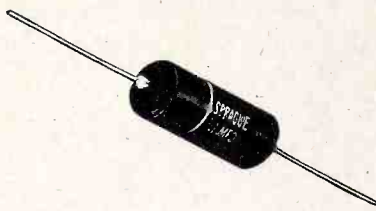
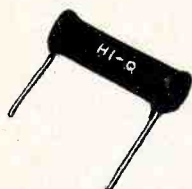
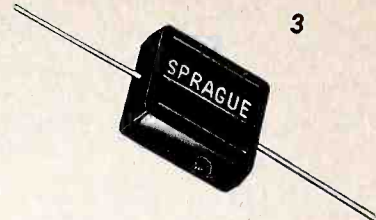
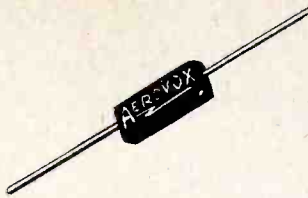

All component illustrations are reprinted through the courtesy of the Aerovox Corp., Cornell Dubilier, P. R. Mallory & Co. and Sprague Products Co.

Among the circuit components which are subject to replacement in TV receivers, the fixed capacitor occupies a very prominent place. This is no reflection on the part manufacturer. Many capacitors are used in a TV receiver, and failure is the result of the ravages of temperature, humidity and voltage. In the attempt to fortify against failure, or at least to reduce capacitor failures to the lowest practicable extent, the TV receiver manufacturer establishes definite standards of performance. These details form the specifications which govern the procurement of capacitors by the maker of the receiver. Capacitor manufacturers produce units that conform with these specifications.

Fixed capacitors used in TV receivers are of four varieties. These are

- Mica
- Ceramic
- Paper
- Electrolytic.

Each of these terms denotes the kind of dielectric used in the component. This is the insulating material between the active surfaces (on which the charge is stored) of the capacitor. The dielectric sets many of the performance capabilities of the units, as well as the physical dimensions necessary to meet voltage requirements. Physical dimensions for any one working voltage rating also differ because of the varied requirements for capacitance. As a general rule, a range of capacitance values for any one value of working voltage rating is encompassed by a certain physical dimension.

While it is true that some applications in a TV receiver demand capacitors of minimum size, as for instance, when a unit is

housed inside a transformer can or within a yoke, the problem of physical size is generally not too acute because of the ample space available on the underside of the chassis. However, as will be shown later, this does not afford limitless latitude in the selection of components. Fortunately, the usual run of replacement capacitors of the kinds which may be used inside cans are of the type that fit properly.

The standardization programs that exist in the television and radio industry, or for that matter in the electronic industry in general, have resulted in fairly uniform physical dimensions for capacitors of different makes which satisfy the same constants and characteristics. This is truer in the case of micas, ceramics and electrolytics than in paper tubulars. Although, even in the latter case, the effort to meet space requirements in electronic equipment has forced capacitor manufacturers to stick fairly close to like dimensions for similarly rated units. Moreover, they are trying hard to make the parts jobbers' stock of capacitor replacements as complete as possible, in that way offering the utmost in procurement convenience.

All specifications for capacitors do not revolve around the minimization of component failure. In other words, when we speak about performance, it means more than just the ability to withstand a certain voltage, or to continue functioning at a certain temperature, or at a certain percentage of humidity. Equally important are such details as capacitance value, capacitance stability, degree of efficiency expressed as power factor, increase or decrease in capacitance with changes in temperature, insulation resistance, physical size, cost and others. Most of these are performance requirements which relate to the suitability of a capacitor to perform a specific function in a receiver. A capacitor need not be leaky or punctured to be unfit for duty at one or a number of points in a receiver.

The dielectric used and the kind of impregnation material employed establishes the operating characteristics mentioned in the preceding paragraphs. This condition sets the mica and ceramic dielectric types apart from the paper dielectric and electrolytic capacitors. While it is true that some degree of interchangeability exists between micas and ceramics, on the one hand, as compared with paper capacitors, it is not a bi-directional road without reservations. The same can be said when it is desired to interchange micas for ceramics.

The behavior of all capacitors under different temperature and humidity conditions is not the same. The variations in capacitance under such conditions can be set readily for micas and ceramics, which permit the replacement of one by the other, provided that the performance constants are alike. But this cannot be done too well for paper tubulars: the simple figure stating the capacitance alone is not the complete story governing interchangeability. There is much more to it.

As to the paper capacitor versus the mica and ceramic, the former is not ordinarily

(Continued on page 9)

**5 new RIDER TEK-FILE Packs with Replacement Parts Listings available this month!**

Pack 57. Admiral, Aimcee

Pack 58. Andrea, Arvin, Automatic, Belmont, Bendix

Pack 59. CBS-Columbia, Capehart, Crosley

Pack 60. Du Mont, Emerson

Pack 61. Emerson, Fada, Firestone

For the individual models included in these Packs, refer to the TEK-FILE INDEX in this issue.



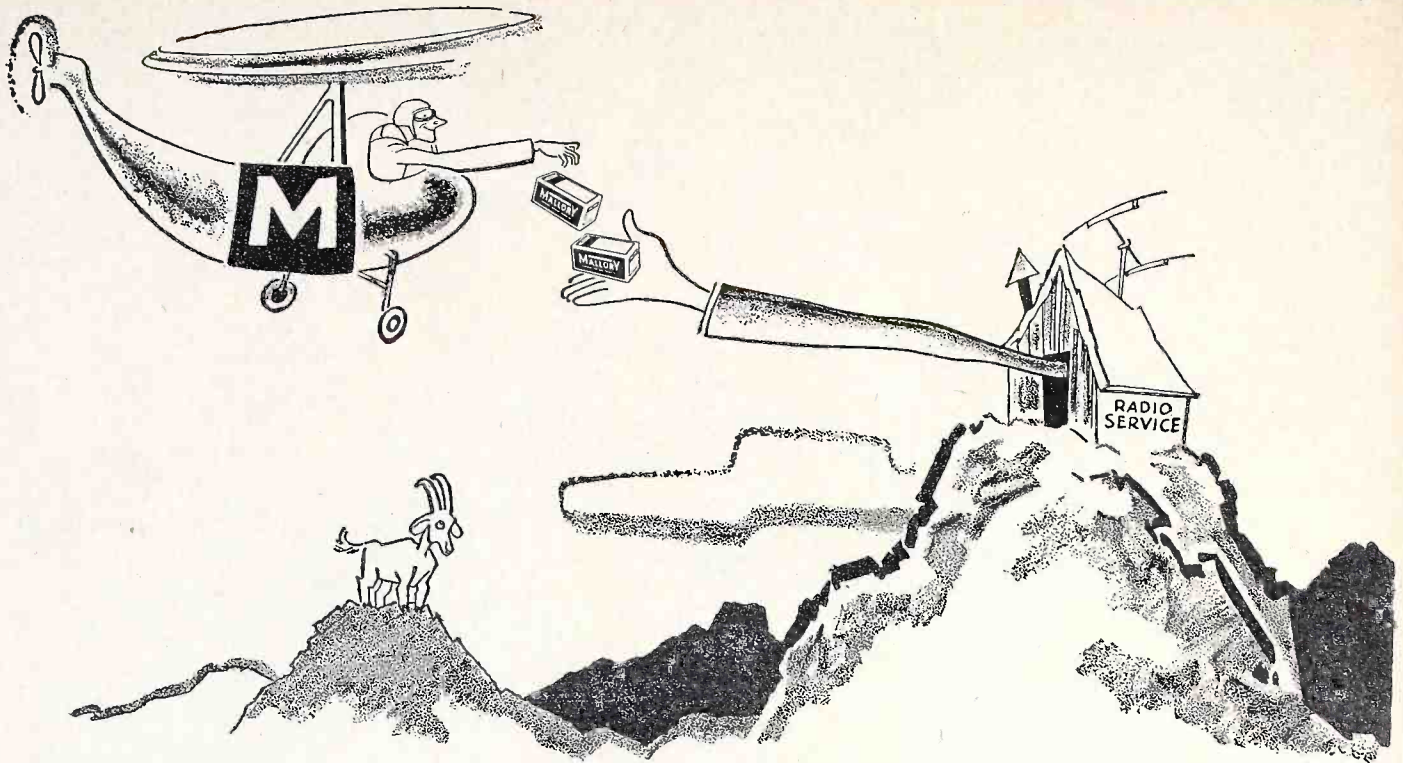

TOPS with Servicemen Everywhere . . .

## MALLORY VIBRATORS

That's right! In a recent survey, more servicemen preferred Mallory vibrators than all other brands combined. And manufacturers use more Mallory vibrators as original equipment than all other brands combined. Here are the reasons . . .

- 1— Slow contact impact for minimum wear
- 2— High contact pressure for low resistance
- 3— Fast contact break for reduced arcing, pitting

You get that vibrator combination *only* from Mallory—thanks to a patented, tuned mechanism. That's why Mallory vibrators give you and your customers long, trouble-free service. When you order vibrators, always . . .

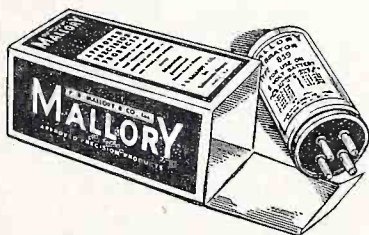

**With Just ONE of Mallory's Special Vibrator Deals You Can Service 47 Different Makes of Radios**

Think what that means from the standpoint of fast service for your customers . . . and smaller inventory for you—6 Mallory vibrators are all it takes to fix 47 radio makes. When you purchase one of these Mallory vibrator deals at your regular discount price, you get a handy parts cabinet at no additional cost. See your distributor today.

## Make Sure! Make it Mallory!

P. R. MALLORY & CO. Inc.

# MALLORY

CAPACITORS • CONTROLS • VIBRATORS • SWITCHES • RESISTORS  
• RECTIFIERS • VIBRAPACK\* POWER SUPPLIES • FILTERS

\*Reg. U. S. Pat. Off.

### APPROVED PRECISION PRODUCTS

P. R. MALLORY & CO., Inc., INDIANAPOLIS 6, INDIANA

Please mention *Successful Servicing* when answering advertising.



# Successful SERVICING

REG. U.S. PAT. OFF.

Dedicated to the financial and technical  
advancement of electronic maintenance personnel

VOLUME 13 NUMBER 13

NOVEMBER, 1952

**JOHN F. RIDER, Publisher**  
**Annette M. Tricarico, Editor**  
**Stuart Flexner, Assistant Editor**

Advertising Representative  
H. J. Olsoy & Co.  
3951 Grand Central Terminal  
New York 17, N. Y.  
MUrray Hill 6-4670



## Curtain Time

### The DA Steps In

The following appeared in the *New York World-Telegram and Sun* under the dateline of October 17th, 1952.

"Two television repairmen were arrested today as the Queens district attorney's office disclosed what was believed to be the first attempt in the metropolitan area to be a trap for TV gyps. The two men were accused of charging \$34.13 to fix a perfectly operating decoy TV set, into which one faulty tube had been deliberately placed."

We do not know the full details of the case or the nature of the bill for services rendered. It is possible that out-and-out fraud was practiced by the service facility. More than likely they claimed making repairs or replacements which were never done. We are under the impression that such an act constitutes accepting money under false pretenses, or possibly some other interpretation of the word fraud. If such were the case, then the district attorney's action is warranted.

But we can't lose sight of the possible injustices which may arise from setting a trap of this kind. For example, it is well known that troubles in TV receivers can appear when the receiver is turned on after a period of inoperation. In other words a receiver performs properly — then it is turned off. Up to the moment that the primary power was removed, everything seemed fine. Then to the great consternation of the owner, the receiver does not function properly when it is turned on an hour later, the next day or the following week.

No one tampered with it from the moment it was last turned on; yet it is faulty. How come? . . . This has confused many TV receiver owners and has caused many a child to be blamed for things he never did. It just seems to be a peculiarity of electronic equipment that weak spots give way more frequently the instant primary power is turned off than when power is turned off. A possible answer is the momentary surge in voltage and current which follows the opening of the primary power supply

switch. Maybe the fault isn't due to this, but a part may fail, and the action is no respecter of new receivers or old ones — it occurs in both.

We are not saying that this happened in the case of the two individuals who were taken in tow by the police. As we said before, we don't know how the service bill was worded. What we are concerned with is the possible suspicion which may fall on someone who is baited in this fashion and who might make honest repairs on a receiver that failed the instant after the trappers turned off the power. That some failure, in addition to the fault which they introduced, existed in the receiver would be unknown to them. As far as they are concerned, the receiver was perfect except for the minor trouble they introduced.

Verification of the presence of such a fault is difficult after the repair has been made. The part or parts removed from the receiver can be checked to see if they are defective, but even if found so, it would not necessarily be conclusive evidence in the minds of the baiters, because the parts could have come from some other receivers of similar make. Much depends on whether or not the repair was made while others were looking on, or if the receiver was left in the shop. In other words, variables in how the whole thing is handled can complicate the matter very much.

Numerous operations may be performed on a TV receiver — testing and adjustments which do not show up in physical form. It is within the jurisdiction of the service technician to check the related circuitry and components when a bad tube is found in a socket. Perhaps the tube failure was due to some fault in the circuitry. This should be determined.

We take for granted that the output for which the trap was set was already under suspicion. Being a realist we can understand that laying bait is one way of catching a culprit. But it is bad business, unless all possibilities of being wrong have been closed off. Proving a TV service technician innocent in court is fine, but unfortunately it does not get the same newspaper space as being arrested.

### The OPS Regulation on TV Service

It is reported that the office of Price Stabilization will reinstate controls on service parts and service activity. This is aimed at TV more than anything else. Each of these controls warrant separate consideration. Were it not so tragic, it would be funny to contemplate regulation to prevent gouging of the TV public by the TV service technician in connection with the sale of replacement parts. If a law is necessary, then it should be one which would prohibit the serviceman from selling replacement parts below list. It should penalize him when he does not make the full markup to which he is entitled. TV service technicians have made it a practice to sell replacement parts below list, especially if it amounted to a significant sum relative to the charge for time and labor.

As to limiting price rises in replacement parts at the manufacturer's level it would be a good thing if the OPS could show the industry how it is possible to produce 800 or 500 or even 1000 pieces of a part for the same price per unit as when 10,000 or 50,000 are produced in a production run. This is an issue in its own right and is too detailed for discussion here.

The proposal to regulate TV service activity is a humdinger. We do not know all the details, but we understand that the basic objective is to set maximum time limits for various repair jobs; then to make the TV technician stay within these limits when billing a customer. The entire TV industry was against licensing — what are they going to do about this? It's worse than licensing!

It is not too difficult to set time limits for the physical operation of replacement — but how about the time spent tracking down the basic causes underlying the need for replacement — namely, intermittents, or finding hidden coupling troubles, buzz and hum causes, reasons for picture jitter and instability, and other obscure faults.

We don't know all the details of this regulation, hence we will refrain from further comments. With fingers crossed we await promulgation of this edict.

*John F. Rider*



# It's Here!

## TV 10

Now — in Rider's latest Television Manual . . . TV 10 . . . you'll find a feature that can't be beat... **DEPENDABLE REPLACEMENT PARTS LISTINGS!** Every replacement part listed meets the physical and electrical performance ratings of the original equipment! And, like everything Rider publishes, TV 10 is *complete* . . . large, easy-to-follow schematics — lots of photos — troubleshooting test patterns — waveforms — enlarged chassis views — circuit changes — different production runs — *everything* you need to do a fast, easy and thorough servicing job! Remember, with a Rider Manual you do the job right the first time . . . because all Rider data is complete, factory-issued, direct from the set manufacturer. You get all the facts — organized and indexed for speed and accuracy. TV 10 contains more than 2,000 (8½ x 11") value-packed pages . . . **SEE IT... BUY IT... AT YOUR JOBBER'S — NOW. \$24.**



### JOHN F. RIDER

PUBLISHER, INC.  
480 Canal St., N. Y. 13, N. Y.

West Coast Office: 4216-20 W. Jefferson Blvd.  
Los Angeles, California



# Replacement Parts in TV Receivers

## Part I - Capacitors

by John F. Rider

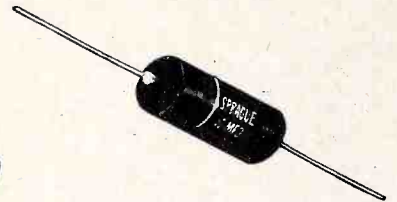
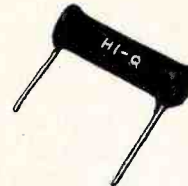
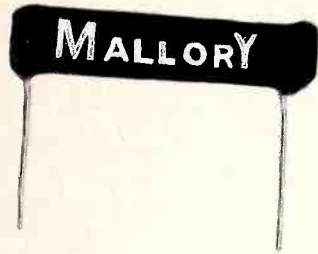

All component illustrations are reprinted through the courtesy of the Aerovox Corp., Cornell Dubilier, P. R. Mallory & Co. and Sprague Products Co.

Among the circuit components which are subject to replacement in TV receivers, the fixed capacitor occupies a very prominent place. This is no reflection on the part manufacturer. Many capacitors are used in a TV receiver, and failure is the result of the ravages of temperature, humidity and voltage. In the attempt to fortify against failure, or at least to reduce capacitor failures to the lowest practicable extent, the TV receiver manufacturer establishes definite standards of performance. These details form the specifications which govern the procurement of capacitors by the maker of the receiver. Capacitor manufacturers produce units that conform with these specifications.

Fixed capacitors used in TV receivers are of four varieties. These are

- Mica
- Ceramic
- Paper
- Electrolytic.

Each of these terms denotes the kind of dielectric used in the component. This is the insulating material between the active surfaces (on which the charge is stored) of the capacitor. The dielectric sets many of the performance capabilities of the units, as well as the physical dimensions necessary to meet voltage requirements. Physical dimensions for any one working voltage rating also differ because of the varied requirements for capacitance. As a general rule, a range of capacitance values for any one value of working voltage rating is encompassed by a certain physical dimension.

While it is true that some applications in a TV receiver demand capacitors of minimum size, as for instance, when a unit is

housed inside a transformer can or within a yoke, the problem of physical size is generally not too acute because of the ample space available on the underside of the chassis. However, as will be shown later, this does not afford limitless latitude in the selection of components. Fortunately, the usual run of replacement capacitors of the kinds which may be used inside cans are of the type that fit properly.

The standardization programs that exist in the television and radio industry, or for that matter in the electronic industry in general, have resulted in fairly uniform physical dimensions for capacitors of different makes which satisfy the same constants and characteristics. This is truer in the case of micas, ceramics and electrolytics than in paper tubulars. Although, even in the latter case, the effort to meet space requirements in electronic equipment has forced capacitor manufacturers to stick fairly close to like dimensions for similarly rated units. Moreover, they are trying hard to make the parts jobbers' stock of capacitor replacements as complete as possible, in that way offering the utmost in procurement convenience.

All specifications for capacitors do not revolve around the minimization of component failure. In other words, when we speak about performance, it means more than just the ability to withstand a certain voltage, or to continue functioning at a certain temperature, or at a certain percentage of humidity. Equally important are such details as capacitance value, capacitance stability, degree of efficiency expressed as power factor, increase or decrease in capacitance with changes in temperature, insulation resistance, physical size, cost and others. Most of these are performance requirements which relate to the suitability of a capacitor to perform a specific function in a receiver. A capacitor need not be leaky or punctured to be unfit for duty at one or a number of points in a receiver.

The dielectric used and the kind of impregnation material employed establishes the operating characteristics mentioned in the preceding paragraphs. This condition sets the mica and ceramic dielectric types apart from the paper dielectric and electrolytic capacitors. While it is true that some degree of inter-changeability exists between micas and ceramics, on the one hand, as compared with paper capacitors, it is not a bi-directional road without reservations. The same can be said when it is desired to interchange micas for ceramics.

The behavior of all capacitors under different temperature and humidity conditions is not the same. The variations in capacitance under such conditions can be set readily for micas and ceramics, which permit the replacement of one by the other, provided that the performance constants are alike. But this cannot be done too well for paper tubulars: the simple figure stating the capacitance alone is not the complete story governing interchangeability. There is much more to it.

As to the paper capacitor versus the mica and ceramic, the former is not ordinarily

(Continued on page 9)

### 5 new RIDER TEK-FILE Packs with Replacement Parts Listings available this month!

- Pack 57. Admiral, Aimcee
- Pack 58. Andrea, Arvin, Automatic, Belmont, Bendix
- Pack 59. CBS-Columbia, Capehart, Crosley
- Pack 60. Du Mont, Emerson
- Pack 61. Emerson, Fada, Firestone

For the individual models included in these Packs, refer to the TEK-FILE INDEX in this issue.



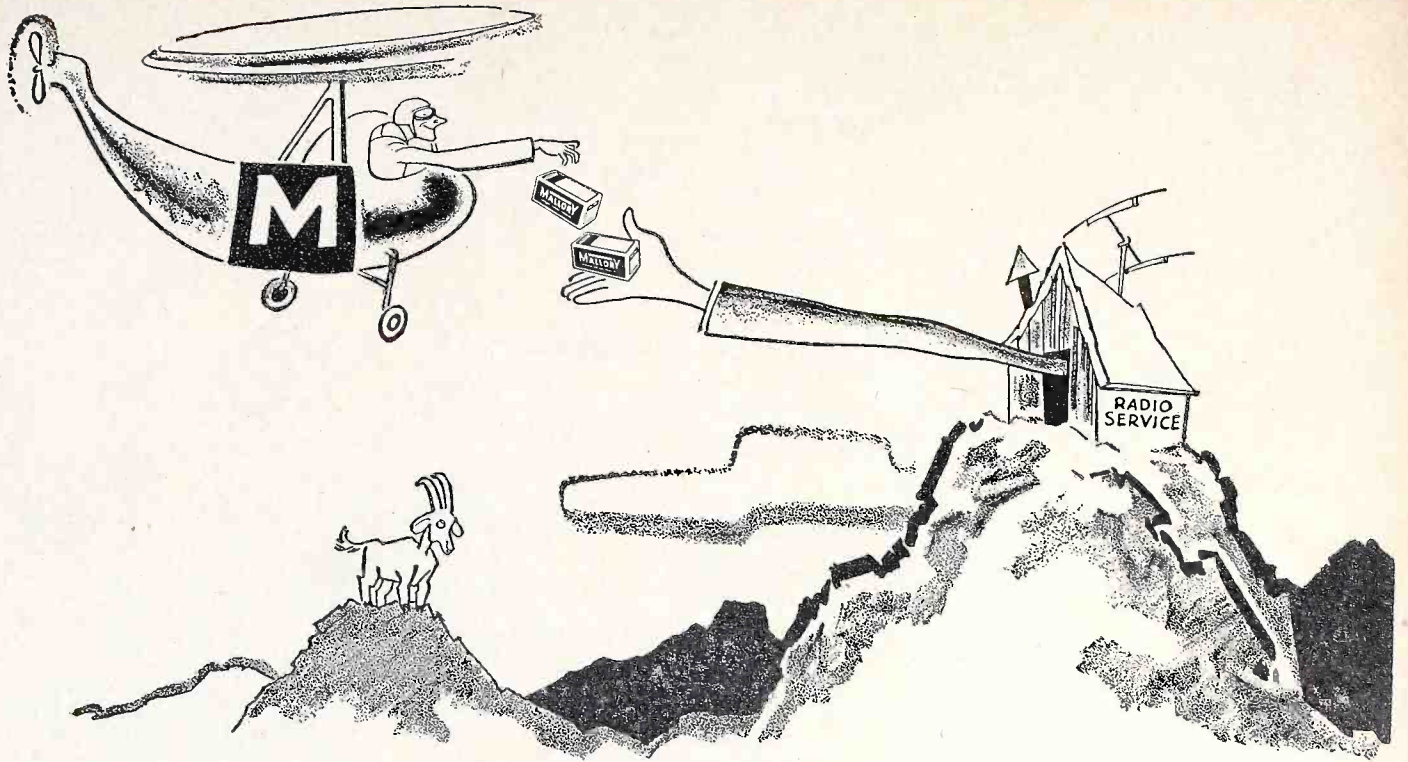

TOPS with Servicemen Everywhere . . .

## MALLORY VIBRATORS

That's right! In a recent survey, more servicemen preferred Mallory vibrators than all other brands combined. And manufacturers use more Mallory vibrators as original equipment than all other brands combined. Here are the reasons . . .

- 1— Slow contact impact for minimum wear
- 2— High contact pressure for low resistance
- 3— Fast contact break for reduced arcing, pitting

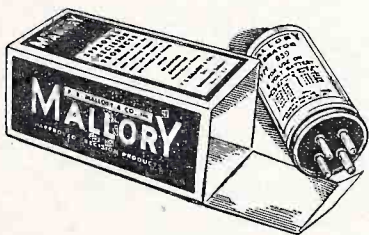

With Just ONE of Mallory's Special Vibrator Deals You Can Service 47 Different Makes of Radios

Think what that means from the standpoint of fast service for your customers . . . and smaller inventory for you—6 Mallory vibrators are all it takes to fix 47 radio makes. When you purchase one of these Mallory vibrator deals at your regular discount price, you get a handy parts cabinet at no additional cost. See your distributor today.

You get that vibrator combination *only* from Mallory—thanks to a patented, tuned mechanism. That's why Mallory vibrators give you and your customers long, trouble-free service. When you order vibrators, always . . .

## Make Sure! Make it Mallory!

P. R. MALLORY & CO. INC.

# MALLORY

CAPACITORS • CONTROLS • VIBRATORS • SWITCHES • RESISTORS  
• RECTIFIERS • VIBRAPACK\* POWER SUPPLIES • FILTERS

\*Reg. U. S. Pat. Off.

### APPROVED PRECISION PRODUCTS

**P. R. MALLORY & CO., Inc., INDIANAPOLIS 6, INDIANA**

Please mention *Successful Servicing* when answering advertising.



# Successful SERVICING

REG. U.S. PAT. OFF.

Dedicated to the financial and technical  
advancement of electronic maintenance personnel

VOLUME 13 NUMBER 13

NOVEMBER, 1952

**JOHN F. RIDER, Publisher**  
**Annette M. Tricarico, Editor**  
**Stuart Flexner, Assistant Editor**

Advertising Representative  
H. J. Olsow & Co.  
3951 Grand Central Terminal  
New York 17, N. Y.  
MUrray Hill 6-4670



## Curtain Time

### The DA Steps In

The following appeared in the *New York World-Telegram and Sun* under the dateline of October 17th, 1952.

"Two television repairmen were arrested today as the Queens district attorney's office disclosed what was believed to be the first attempt in the metropolitan area to be a trap for TV gyps. The two men were accused of charging \$34.13 to fix a perfectly operating decoy TV set, into which one faulty tube had been deliberately placed."

We do not know the full details of the case or the nature of the bill for services rendered. It is possible that out-and-out fraud was practiced by the service facility. More than likely they claimed making repairs or replacements which were never done. We are under the impression that such an act constitutes accepting money under false pretenses, or possibly some other interpretation of the word fraud. If such were the case, then the district attorney's action is warranted.

But we can't lose sight of the possible injustices which may arise from setting a trap of this kind. For example, it is well known that troubles in TV receivers can appear when the receiver is turned on after a period of inoperation. In other words a receiver performs properly — then it is turned off. Up to the moment that the primary power was removed, everything seemed fine. Then to the great consternation of the owner, the receiver does not function properly when it is turned on an hour later, the next day or the following week.

No one tampered with it from the moment it was last turned on; yet it is faulty. How come? . . . This has confused many TV receiver owners and has caused many a child to be blamed for things he never did. It just seems to be a peculiarity of electronic equipment that weak spots give way more frequently the instant primary power is turned off than when power is turned off. A possible answer is the momentary surge in voltage and current which follows the opening of the primary power supply

switch. Maybe the fault isn't due to this, but a part may fail, and the action is no respecter of new receivers or old ones — it occurs in both.

We are not saying that this happened in the case of the two individuals who were taken in tow by the police. As we said before, we don't know how the service bill was worded. What we are concerned with is the possible suspicion which may fall on someone who is baited in this fashion and who might make honest repairs on a receiver that failed the instant after the trappers turned off the power. That some failure, in addition to the fault which they introduced, existed in the receiver would be unknown to them. As far as they are concerned, the receiver was perfect except for the minor trouble they introduced.

Verification of the presence of such a fault is difficult after the repair has been made. The part or parts removed from the receiver can be checked to see if they are defective, but even if found so, it would not necessarily be conclusive evidence in the minds of the baiters, because the parts could have come from some other receivers of similar make. Much depends on whether or not the repair was made while others were looking on, or if the receiver was left in the shop. In other words, variables in how the whole thing is handled can complicate the matter very much.

Numerous operations may be performed on a TV receiver — testing and adjustments which do not show up in physical form. It is within the jurisdiction of the service technician to check the related circuitry and components when a bad tube is found in a socket. Perhaps the tube failure was due to some fault in the circuitry. This should be determined.

We take for granted that the output for which the trap was set was already under suspicion. Being a realist we can understand that laying bait is one way of catching a culprit. But it is bad business, unless all possibilities of being wrong have been closed off. Proving a TV service technician innocent in court is fine, but unfortunately it does not get the same newspaper space as being arrested.

### The OPS Regulation on TV Service

It is reported that the office of Price Stabilization will reinstate controls on service parts and service activity. This is aimed at TV more than anything else. Each of these controls warrant separate consideration. Were it not so tragic, it would be funny to contemplate regulation to prevent gouging of the TV public by the TV service technician in connection with the sale of replacement parts. If a law is necessary, then it should be one which would prohibit the serviceman from selling replacement parts below list. It should penalize him when he does not make the full markup to which he is entitled. TV service technicians have made it a practice to sell replacement parts below list, especially if it amounted to a significant sum relative to the charge for time and labor.

As to limiting price rises in replacement parts at the manufacturer's level it would be a good thing if the OPS could show the industry how it is possible to produce 800 or 500 or even 1000 pieces of a part for the same price per unit as when 10,000 or 50,000 are produced in a production run. This is an issue in its own right and is too detailed for discussion here.

The proposal to regulate TV service activity is a humdinger. We do not know all the details, but we understand that the basic objective is to set maximum time limits for various repair jobs; then to make the TV technician stay within these limits when billing a customer. The entire TV industry was against licensing — what are they going to do about this? It's worse than licensing!

It is not too difficult to set time limits for the physical operation of replacement — but how about the time spent tracking down the basic causes underlying the need for replacement — namely, intermittents, or finding hidden coupling troubles, buzz and hum causes, reasons for picture jitter and instability, and other obscure faults.

We don't know all the details of this regulation, hence we will refrain from further comments. With fingers crossed we await promulgation of this edict.

*John F. Rider*



# Your dollar buys more "instrument" ... in our Model



# # 630

by R. L. Triplett  
PRESIDENT

Because we build every major part of our instruments the quality is carefully controlled. For example, we know we have more torque driving our pointers because we designed and built the complete instrument. We know we have sustained dependence in the shafts and switch contacts of our test equipment for the same reason. Cycle tests for switches exceed several times the rigid requirements of the armed forces.

There is another important value to you. Because we make our own components we eliminate the profit another manufacturer would make in selling them to us. And this "profit" is passed on to you.

Consider these features of Model 630 V.O.M., for example—

**One Hand Operation**—One switch with large recessed knob has a single position setting for each reading. Leaves one hand free. Eliminates switching errors, trouble, saves time.

**Ranges**—AC-DC Volts: 3-12-60-300-1200-6000 (AC, 5000 Ohms/Volt; DC, 20,000 Ohms/Volt). 60 Micro-Amps. 1.2, 12, & 120 Mil Amps. DB scales at 1.73V on 500 Ohm line, 0-66 DB output.

**Highest Ohm Reading**—To 100 Meg. in steps of 1000-10,000-100,000 Ohms—100 Megohms.

Yes, with us it's a matter of personal pride to make "Triplett" stand for better construction and more service for your test equipment dollar.

*R. L. Triplett*

PRESIDENT  
TRIPLETT ELECTRICAL INSTRUMENT CO.  
Bluffton, Ohio

**630 V.O.M. only \$39.50**

Suggested U. S. A. Dealer Net  
Price subject to change without notice.



**For service, accuracy, highest dependability, buy**



# Triplett



# uhf converters

(Continued from page 1)

able in one, two, three or four sections in the same case. It has the same mounting dimensions as the Spiral Tuner. The tuner has been engineered to fit into a small space for two reasons: first, to minimize stray circuit parameters essential at ultra high frequencies; and second, to make increased cabinet size unnecessary for UHF television receivers.

Features of the Spiral Inductuner incorporated in the Mallory UHF Inductuner include: reduction in overall capacitance while maintaining the same compact case as used for the Spiral Tuner; complete shielding between sections; shaping of the various sections for oscillator tracking at various I-F frequencies; rugged contacts, and positive, uni-control range coverage in 270° of rotation by means of non-slipping, insulated shaft.

The antenna circuit is designed to work with a 300-ohm, balanced antenna. Antenna matching is more difficult to evaluate in UHF receivers than in VHF receivers because often the receiver operator prefers use of the VHF antenna, particularly in areas where signal strengths are high.

The antenna-coupling method used by Mallory engineers was developed while attempting to obtain a reasonably low noise-figure. The circuit represents a compromise between energy transfer (from various types of antennas or lines), alignment problems, oscillator radiation and noise-figure. The R-F chokes across the antenna terminals to ground reduce the static pick-up. These chokes act as capacitors in the UHF band, and their capacitance to ground serves as an impedance tap-in on the first tuned circuit.

The band-pass coupling arrangement, represented by C<sup>1</sup> and L<sup>1</sup> in the schematic diagram, contains an automatic adjustment of bandwidth across the range of the con-

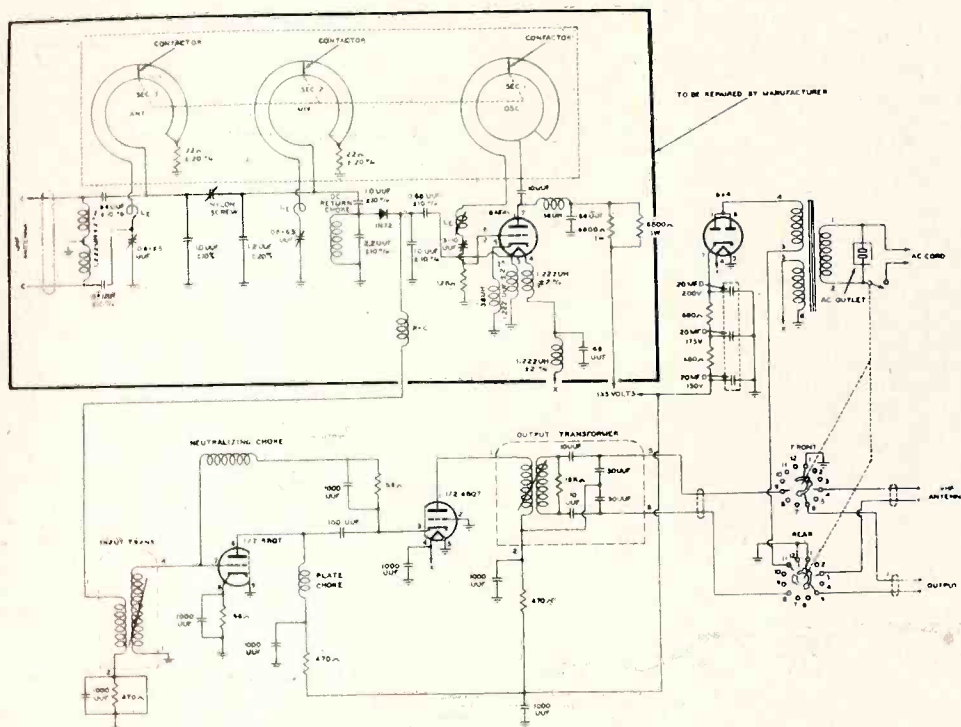

Fig 2. Schematic of the Mallory UHF Inductuner.

The converter consists of a preselector, a crystal mixer, an oscillator and a single I-F stage. The input impedance is 300 ohms nominal, balanced or unbalanced line, and the output impedance is 75 or 300 ohms. The gain of this converter is approximately 2.0 when used with the 300-ohm output connection and a 300-ohm receiver input.

**Preselector.** The preselector utilizes two tuning elements. These provide double-tuned selectivity and an impedance match ahead of the mixer. Each has spurious resonance below the band at approximately 370 megacycles. A single, oscillator-tuning element, which has spurious resonance above 900 megacycles, is employed. Preselector elements are shaped to track the oscillator.

verter. When properly aligned, it is possible to maintain TV-channel bandwidths in the UHF range at approximately 16 to 24 megacycles.

## The Raytheon UHF Tuner

The UHF Tuner is a single conversion, continuous tuning device which mechanically mounts directly over the VHF tuner in the receiver. The tuner is coupled to the VHF tuner by drive gears which thus provides tuning of both UHF and VHF by the same tuning knob. The tuner obtains its filament and plate supply voltages from the TV chassis and a switch is provided to select the desired tuner for operation. Signal points and filament leads are not switched.

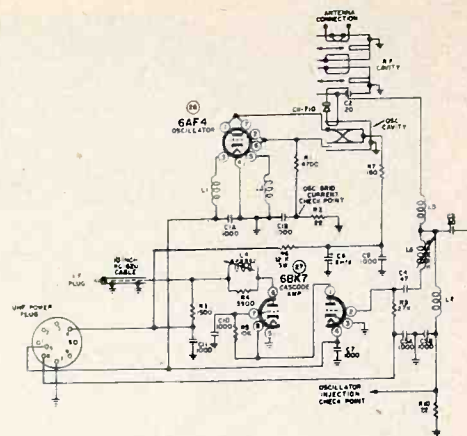

Courtesy Raytheon TV & Radio Corp.

Fig. 3. Schematic of the Raytheon UHF Converter.

The UHF Tuner selects the UHF stations video and sound carriers and converts them to the carrier IF frequency of 26.75 MC for video and 22.25 MC for sound which is coupled to the IF amplifiers in the receiver by 10 inches of RG-62U cable.

Two methods of coupling the power cable of the UHF Tuner to the receiver have been used. Direct coupling is employed in the 21T3 chassis and a plug and socket arrangement is used on the 17T1, 21T1 and all receivers modified by the UHF-100P kits.

## Circuit Description

The UHF Tuner employs a double tuned coaxial line RF cavity pre-selector. The coaxial line arrangement has the advantages of high selectivity, low insertion losses, uniform band-width and good shielding against oscillator radiation. The coaxial cavity is basically a one-quarter wave shorted tuned stub. The electrical length of the cavities is varied by a ribbon which is attached to the dial cord and pulley arrangement. In this manner tuning is accomplished similar to varying the length of a tuned stub which would change the resonant length for various frequencies. The dial cord is of a special material which is not affected by temperature or moisture and is locked to the pulleys which eliminate the possibility of slippage. Tracking screws are provided in the cavities to obtain uniform band-width and sensitivity. The tracking screws vary the capacity between the ribbon and the cavity wall and thus vary the electrical length of the ribbon.

The oscillator tube used is a 6AF4 which is similar to the 6F4. The oscillator tuning is accomplished by a one-quarter wave shorted parallel wire transmission line arrangement. It differs from the RF cavities, in that a shorting bar is used to vary the electrical length of the lines. This method provides very stable operation.

Inductive or link coupling is employed to transfer the signal between stages. The arrangement of link coupling gives maximum selectivity and constant band-width

(Continued on page 15)

Courtesy P. R. Mallory & Co.



*More POWER to you...*  
*with the Radiart TV Booster*

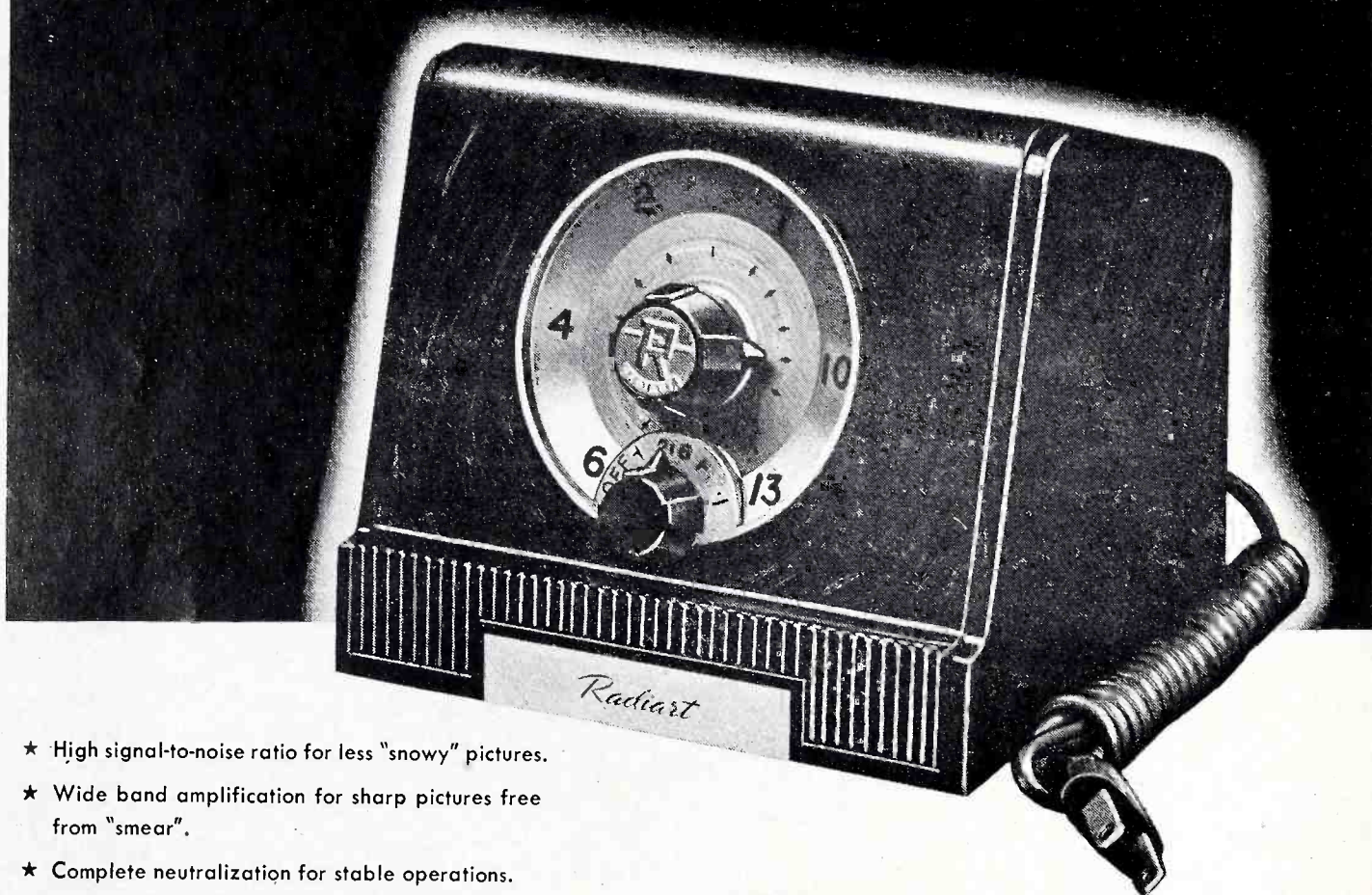

- ★ High signal-to-noise ratio for less "snowy" pictures.
- ★ Wide band amplification for sharp pictures free from "smear".
- ★ Complete neutralization for stable operations.
- ★ Large, handsome dial face for easy reading.
- ★ Operates on 115 V. A. C., 60 cycle current.
- ★ Attractively styled cabinet with mahogany grained polished finish . . . matching the rotor control cabinet . . . together making the TV TWINS . . . the ideal combination for the MOST in TV reception.

Here's the power boost needed to get the MOST from any TV set! It improves the picture because it increases contrast . . . minimizes ghosts, snow and interference and actually STRENGTHENS the signal! Easily installed — simple in operation — a welcome addition to any home.

*The Perfect Partner to the CDR Rotor...they go together*



**THE RADIART CORPORATION** CLEVELAND 13, OHIO

VIBRATORS • AUTO AERIALS • TV ANTENNAS • ROTATORS • POWER SUPPLIES

Please mention *Successful Servicing* when answering advertising.



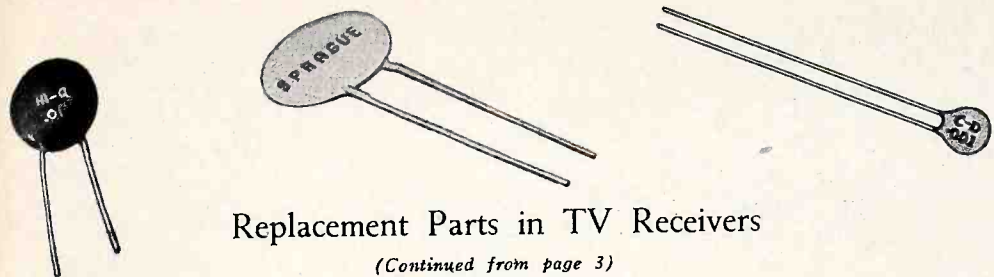

## Replacement Parts in TV Receivers

(Continued from page 3)

used as a replacement for the last two named, even though some cases will be found, especially in the early TV receivers where paper tubulars were used where ceramic is found today.

There was a time in the not too distant past, when the servicing industry was primarily concerned with radio broadcast receivers. Then the fixed capacitor was only of casual concern. If its working voltage rating was satisfactory and its capacitance rating within reason for a variety of general applications, a type of component might see duty in a variety of places.

Various types of capacitors and ranges of capacitance were associated with various kinds of duties. Any value from perhaps .05  $\mu\text{f}$  as high as 1.0  $\mu\text{f}$  were used for bypass purposes; micas from perhaps .01  $\mu\text{f}$  to .25  $\mu\text{f}$  were used as blocking and parallel feed capacitors; micas with values from 50  $\mu\text{f}$  to several hundred  $\mu\text{f}$  appeared in r-f, oscillator, i-f and tone control sections. Of course specific values were used in fixed tuned systems and these had to be replaced by similar values, but even here the requirements relating to the values were fairly liberal. Papers and electrolytics were the bypass units. As far as the servicing industry was concerned there didn't seem to be any particular need for special consideration in the replacements, as long as the general pattern was followed. The results pretty much substantiated such thinking; there didn't seem to be too much difference in the performance of the broadcast receiver after repair when one or another value of capacitance was used in a number of places. Critical measurements would have shown performance variations, but such measurements weren't necessary, and hence were not made.

The climb in operating frequencies and bandwidths dictates different thinking. Now we are dealing with frequencies from about 20 mc to perhaps 250 mc in vhf television. With the advent of uhf television the frequencies involved will go up to around 900 mc. Both of these frequency regions demand closer attention to details that hitherto were treated only casually. At the moment we are concerned with capacitors, but the same applied to resistors and inductor type components.

The above considerations are not new to receiver design engineers or to the capacitor manufacturer. Both were involved in radar equipment design in World War II, wherein operating frequencies embraced not only the

vhf and uhf television channels, but went much higher. It is at the service level that capacitor types, characteristics and constants become a subject for discussion.

What are the different approaches in the use of capacitors which reflect themselves in television receiver parts replacement? They are not too evident when one examines a schematic. On paper, the capacitors seem to be just where they always were, and still are, in a radio broadcast receiver; that is, r-f against r-f, i-f against i-f and sound against sound systems. They are connected to and between similar elements of the vacuum tube and to similar terminations of coils, transformers and resistors.

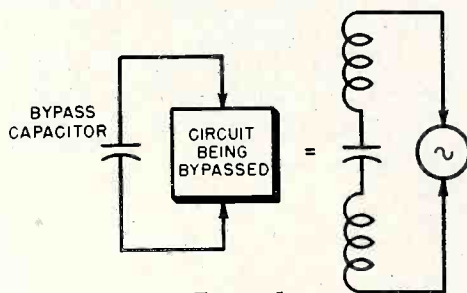

Figure 1.

For instance consider the matter of bypassing in tv front-end and video i-f systems, where high frequencies are involved and most effective bypassing is desired at a single frequency. The usual idea about a capacitor is that it is a reservoir of electricity. Another is that it is a variable reactance device, whose reactance varies inversely with frequency. Extending the latter idea makes the capacitor a sort of variable frequency filter whereby voltages of certain frequency can be kept out of circuits which are paralleled by the capacitor; the capacitor acting as a low reactance path around those circuits.

The modern approach in high frequency circuits where selective bypassing is needed sees the capacitor in a different light. It takes advantage of a condition known to be present in capacitors, but which becomes far more important at vhf frequencies and higher than at radio broadcast and intermediate frequencies. This is the inductance

present in all capacitors to a greater or lesser degree. The L component may be considered to appear in the metallic surface inside the capacitor and also in the leads attached to the part. As far as electrical properties of a capacitor are concerned, the capacitance, inductance and resistance are all present. For the moment let's ignore the resistance, and we see the capacitor as a combination of inductance (the lead on one side), capacitance, and again inductance, (the lead on the other side - Fig. 1).

If an alternating voltage is applied across the extremities of this combination of circuit elements, as would exist across the signal circuit being bypassed by the capacitor, the component would be the equivalent of a series L-C circuit across a signal voltage source (Fig. 2). Theoretically, such a circuit presents zero reactance at resonance, at which frequency it would act as a most effective bypass. This is known as *series resonance bypassing*.

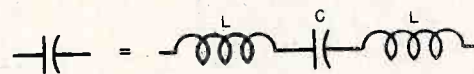

Figure 2.

Now the interesting thing is that various types of capacitors resonate at different frequencies as determined by the type, the value of capacitance, and the lead lengths. For example, a .005  $\mu\text{f}$  mica capacitor with a total lead length of 2 inches for both leads (#20 tinned copper wire), displays series resonance at slightly above 20 mc. With the total lead length reduced to about three-quarter inch, the resonant frequency climbs to about 40 mc. On the other hand, a .005  $\mu\text{f}$  capacitor of the same kind resonates at 10 mc with a total lead length of 2 inches, and at about 12 mc with a total lead length of three-quarter inch.<sup>1</sup>

Phenomena of this kind have been analysed and resonance at any desired frequency within a very wide range and with different values of capacitance can be accomplished. Being an effective method of bypassing, it may be employed in TV receivers, although not necessarily labeled so in each case. But it does account for some of the numerous statements that capacitance values, lead lengths and lead dress should be duplicated when a replacement is made.

If the capacitance is increased too much, it may be impossible to attain resonance at the desired frequency because the lead length would have to be reduced to an unusable minimum. For example, a .001  $\mu\text{f}$  mica with a total lead length of 1.0 inch resonates at 30 mc. Doubling the capacitance would require a reduction of the total lead length to 0.5 inch, and increasing the capacitance to .005  $\mu\text{f}$  would require that the total lead length be less than 0.1 inch, an unusable length.

<sup>1</sup>Green and McComb, "Resonance in Mica Capacitors," *Electronics*, March, 1944.

### Our apologies to:

United Motors Service, Div. of General Motors Corp., who should have been given credit for the article entitled "The Autronic Eye" which appeared in the October issue. Credit was given to Western Auto Supply Co. in error.



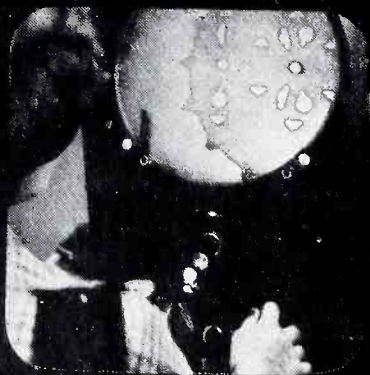

Mica specifications checked to thousandth-inch accuracy.



Completed mounts are inspected for visual defects.

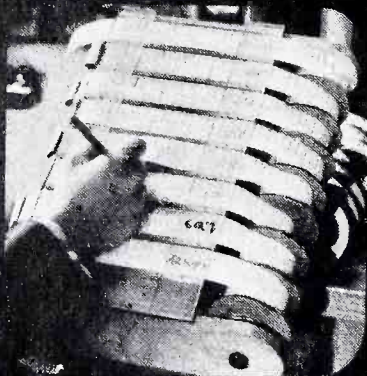

Statistical control assures uniformity of quality and performance.

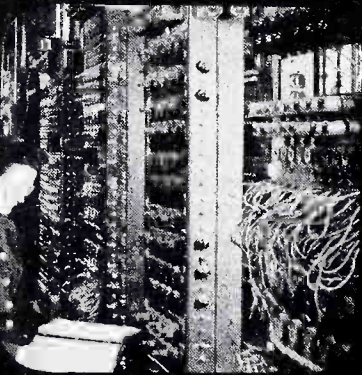

Life tests prove Tung-Sol Tubes can take it.

# Complete control of materials and manufacturing procedures makes Tung-Sol Tubes dependable!



## You can build a reputation on Tung-Sol Quality

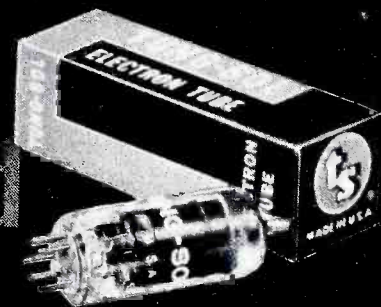

TUNG-SOL ELECTRIC INC., Newark 4, N. J.

Sales Offices: Atlanta, Chicago, Culver City, Dallas, Denver, Detroit, Newark

TUNG-SOL MAKES All-Glass Sealed Beam Lamps, Miniature Lamps, Signal Flashers, Picture Tubes, Radio, TV and Special Purpose Electron Tubes.



# RIDER · TEK-FILE INDEX

PACKS 1-61

## HOW TO USE THIS INDEX

To locate service data instantly, all you need to know is the manufacturer's name and the model or chassis number of the set.

The index is compiled alphabetically, according to manufacturer. Note the column headings at the top of each page: MODEL, PACK-FILE, PAGES.

Model numbers run in numerical sequence, starting with the smallest number under a manufacturer's name. This applies also to model numbers using letters. (i.e. model AR precedes model CG). Model numbers starting with letters precede model numbers starting with numbers.

Under the column PACK-FILE, the first number is the TEK-FILE Pack number, and the second number is the

File number.

Under the column headed PAGES, the first and second numbers indicate the page where the information starts; the last number shows where the data is concluded.

As an example, let's look up ADMIRAL model 36X36AS. It shows that the information is in (1-1) Pack No. 1, ADMIRAL, File No. 1. The data (8-23-46) starts on page 8-23 and runs through page 8-46. There is also data on the ADMIRAL record changer model RC 550. It's in (1-RC2) TEK-FILE Pack No. 1, in ADMIRAL Record Changer File No. 2. The data begins on page 21-9 and ends on page 21-16.

If you remove the pages from the TEK-FILE Files and insert them in the TEK-FILE binder, you can disregard the PACK-FILE column and refer to the PAGES only.

MODEL	PACK-FILE	PAGES	MODEL	PACK-FILE	PAGES
<b>ADMIRAL CORP</b>			<b>ADMIRAL CORP. (Cont'd)</b>		
4H15A, 4H15B, Ch. 20A1	40-2	4=1-37	26R35A, 26R36A, 26R37A,		
4H16A, 4H16B, Ch. 20A1	40-2	4=1-37	Ch. 21B1	1-1	8=23-46
4H17A, 4H17B, Ch. 20A1	40-2	4=1-37	26X35, 26X36, 26X37, Ch. 24D1	48-3	7=1-24
4H18C, 4H18CN, Ch. 20B1	40-2	4=1-37	26X45, 26X46, Ch. 24H1	48-3	7=1-24
4H19C, 4H19CN, Ch. 20B1	40-2	4=1-37	26X55, 26X56, 26X57, Ch. 24D1	48-3	7=1-24
4H126A, 4H126B, Ch. 21A1	40-2	4=1-37	26X55A, 26X56A, 26X57A,		
4H126C, 4H126CN, Ch. 21A1	40-2	4=1-37	Ch. 21D1	1-1	8=23-46
4H137A, 4H137B, Ch. 21A1	40-2	4=1-37	26X65, 26X66, 26X67, Ch. 24D1	48-3	7=1-24
4H145A, 4H145B, Ch. 20B1	40-2	4=1-37	26X65A, 26X66A, 26X67A,		
4H145C, 4H145CN, Ch. 20B1	40-2	4=1-37	Ch. 21D1	1-1	8=23-46
4H146A, 4H146B, Ch. 20B1	40-2	4=1-37	26X75, 26X76, Ch. 24D1	48-3	7=1-24
4H146C, Ch. 20B1	40-2	4=1-37	26X75A, 26X76A, Ch. 21D1	1-1	8=23-46
4H147A, 4H147B, Ch. 20B1	40-2	4=1-37	27M12, Ch. 21X2	57-4	10=29-46
4H156C, 4H156CN, Ch. 20B1	40-2	4=1-37	29X16, 29X17, Ch. 24F1	48-3	7=1-24
4H157A, 4H157B, Ch. 20B1	40-2	4=1-37	29X25, 29X26, 29X27, Ch. 24F1	48-3	7=1-24
4H165A, 4H165B, Ch. 20B1	40-2	4=1-37	29X25A, 29X26A, Ch. 21H1	1-1	8=23-46
4H166A, 4H166B, Ch. 20B1	40-2	4=1-37	30F15, 30F15A, Ch. 20B1	40-2	4=1-37
4H166C, 4H166CN, Ch. 20B1	40-2	4=1-37	30F16, 30F16A, Ch. 20B1	40-2	4=1-37
4H167A, 4H167B, Ch. 20B1	40-2	4=1-37	30F17, 30F17A, Ch. 20B1	40-2	4=1-37
4H167C, 4H167CN, Ch. 20B1	40-2	4=1-37	32X15, 32X16, Ch. 20Z1	40-2	4=38-62
12X11, 12X12, Ch. 20Z1	40-2	4=38-62			
		5=8-9	32X26, 32X27, Ch. 20Z1	40-2	5=8-9
		8=1-22	32X35, 32X36, Ch. 20Z1	40-2	4=38-62
14R12, 14R16, Ch. 20T1, Rev.	1-1	8=1-22			5=8-9
16M12, Ch. 21X1	57-4	10=29-46	34R15, 34R15A, 34R16, 34R16A,		
16R11, 16R12, Ch. 21B1	1-1	8=23-46	Ch. 20V1, Rev.	1-1	8=1-22
20A1, 20B1, Ch.	40-2	4=1-37	Record Changer		
20T1, 20V1, Ch., Rev.	1-1	8=1-22	ADMIRAL RC500	1-RC1	RCH21=1-8
20X1, Ch.	40-2	4=38-62	36R37, 36R45, 36R46, Ch. 21C1	1-1	8=23-46
20X11, 20X12, Ch. 20X1	40-2	4=38-62	Record Changer		
20X122, Ch. 20X1	40-2	4=38-62	ADMIRAL RC500	1-RC1	RCH21=1-8
20X136, Ch. 20Y1	40-2	4=38-62	ADMIRAL RC550	1-RC2	RCH21=9-16
20X145, 20X146, 20X147,			36X35, 36X35A, Ch. 24E1	48-3	7=1-24
Ch. 20Y1	40-2	4=38-62	Record Changer		
20Y1, Ch.	40-2	4=38-62	ADMIRAL RC500	1-RC1	RCH21=1-8
20Z1, Ch.	40-2	4=38-62	ADMIRAL RC550	1-RC2	RCH21=9-16
		5=8-9	36X36, 36X36A, Ch. 24E1	48-3	7=1-24
21A1, Ch.	40-2	4=1-37	Record Changer		
21B1, 21C1, 21D1, 21E1, Ch.	1-1	8=23-46	ADMIRAL RC500	1-RC1	RCH21=1-8
21H1, 21J1, Ch.	1-1	8=23-46	ADMIRAL RC550	1-RC2	RCH21=9-16
22X12, Ch. 20Z1	40-2	4=38-62	36X36AS, 36X36S, Ch. 21E1	1-1	8=23-46
		5=8-9	Record Changer		
22X25, 22X26, 22X27, Ch. 20Z1	40-2	4=38-62	ADMIRAL RC500	1-RC2	RCH21=9-16
		5=8-9	36X37, 36X37A, Ch. 24E1	48-3	7=1-24
24A12, Ch. 20A1	40-2	4=1-37	Record Changer		
24A125, Ch. 20A1	40-2	4=1-37	ADMIRAL RC500	1-RC1	RCH21=1-8
24A125AN, Ch. 20X1	40-2	4=38-62	ADMIRAL RC550	1-RC2	RCH21=9-16
24C15, 24C16, Ch. 20B1	40-2	4=1-37	37M25, 37M26, 37M27,		
24D1, 24E1, 24F1, 24G1, 24H1, Ch.	48-3	7=1-24	Ch. 21Z1	57-4	10=29-46
24R12, Ch. 20T1, Rev.	1-1	8=1-22	39X16, 39X16A, 39X16B, Ch. 24G1	48-3	7=1-24
24X15, 24X15S, Ch. 20X1	40-2	4=38-62	Record Changer		
24X16, 24X16S, Ch. 20X1	40-2	4=38-62	ADMIRAL RC500	1-RC1	RCH21=1-8
24X17S, Ch. 20X1	40-2	4=38-62	ADMIRAL RC550	1-RC2	RCH21=9-16
25A15, 25A16, 25A17, Ch. 21A1	40-2	4=1-37	39X17A, 39X17B, Ch. 24G1	48-3	7=1-24
26R12, Ch. 21B1	1-1	8=23-46	Record Changer		
26R25, 26R26, Ch. 24H1	48-3	7=1-24	ADMIRAL RC500	1-RC1	RCH21=1-8
26R25A, 26R26A, Ch. 21B1	1-1	8=23-46	ADMIRAL RC550	1-RC2	RCH21=9-16
26R35, 26R36, 26R37, Ch. 24H1	48-3	7=1-24	ADMIRAL RC500	1-RC1	RCH21=1-8
			ADMIRAL RC550	1-RC2	RCH21=9-16



ADMIRAL  
ANDREA

MODEL	PACK-FILE	PAGES
<u>ADMIRAL CORP. (Cont'd)</u>		
39X17C, Ch. 21J1 Record Changer ADMIRAL RC550	1-1	8=23-46
39X25, 39X26, Ch. 24G1 Record Changer ADMIRAL RC550	1-RC2 48-3	RCH21=9-16 7=1-24
39X25A, 39X26A, Ch. 21J1 Record Changer ADMIRAL RC550	1-RC2 1-1	RCH21=9-16 8=23-46
39X35, 39X36, Ch. 21J1 Record Changer ADMIRAL RC550	1-RC2 1-1	RCH21=9-16 8=23-46
47M15, Ch. 21W1	1-RC2	RCH21=9-16
47M15A, Ch. 21Z1	57-4	10=14-28
47M16, 47M17, Ch. 21W1	57-4	10=29-46
47M35, 47M36, 47M37, Ch. 21Z1	57-4	10=14-28
57M10, 57M11, 57M12, Ch. 21Z1A	57-4	10=29-46
57M16, 57M17, Ch. 21Z1	57-4	10=29-46
121K15, 121K16, 121K17, Ch. 21M1	57-4	10=14-28
121K15A, 121K16A, 121K17A, Ch. 22M1	57-4	10=1-13
121M10, Ch. 22M1	57-4	10=1-13
121M11, 121M12, Ch. 21M1	57-4	10=14-28
121M11A, 121M12A, Ch. 22M1	57-4	10=1-13
221K45, 221K46, 221K47, Ch. 21M1	57-4	10=14-28
221K45A, 221K46A, 221K47A, Ch. 22M1	57-4	10=1-13
320R17, Ch. 21J1 Record Changer ADMIRAL RC550	1-1 1-RC2	8=23-46 RCH21=9-16
320R25, 320R26, Ch. 21J1 Record Changer ADMIRAL RC550	1-1 1-RC2	8=23-46 RCH21=9-16
321F65, 321F66, 321F67, Ch. 21N1	57-4	10=14-28
321K65, 321K66, 321K67, Ch. 21N1	57-4	10=14-28
321M25, 321M26, 321M27, Ch. 21Y1	57-4	10=14-28
321M25A, 321M26A, 321M27A, Ch. 22Y1	57-4	10=1-13
421M15, 421M16, Ch. 21Y1	57-4	10=14-28
421M35, 421M36, 421M37, Ch. 22Y1	57-4	10=1-13
520M11, 520M12, Ch. 22A2A	57-4	10=1-13
520M15, 520M16, 520M17, Ch. 22A2	57-4	10=1-13
521M15, 521M16, 521M17, Ch. 21Y1	57-4	10=14-28
521M15A, 521M16A, 521M17A, Ch. 22Y1	57-4	10=1-13

AFFILIATED RETAILERS, INC.  
(ARTONE)

AR-MST-14, AR-MST-16	48-3	6=1-9
AR-14-LG, AR-14-P	1-1	8=1-12
AR-14-TR	48-3	6=1-9
AR-16-ATR	48-3	6=1-9
AR-16-CD, AR-16-CD-3CR	40-2	5=1-8
AR-16-CR	48-3	6=1-9
AR-16-CX	40-2	5=1-8
AR-16-RO, AR-16-TR	48-3	6=1-9
AR-17-3D	48-3	6=1-9
AR-17-3DG	1-1	8=1-12
AR-17-CD	48-3	6=1-9
AR-17-CDG	1-1	8=1-12
AR-17-CR	48-3	6=1-9
AR-17-CRG	1-1	8=1-12
AR-17-LG, AR-17-P	1-1	8=1-12
AR-17-RO	48-3	6=1-9
AR-17-ROG	1-1	8=1-12
AR-20-3DG, AR-20-CDG, AR-20-CRG, AR-20-TRG	1-1	8=1-12
AR-112X	48-3	6=10-16
AR-114A	48-3	6=1-9

MODEL	PACK-FILE	PAGES
<u>AFFILIATED RETAILERS, INC. (Cont'd)</u>		
AR-163-CR	40-2	5=1-8
AR-216	40-2	5=1-8
AR-316, AR-316-3CM	40-2	5=1-8
AR-816	40-2	5=1-8
AR-816-3CM, AR-816-3CR	40-2	5=1-8
AR-819, AR-819-3CM	40-2	5=1-8
AR-919	40-2	7=1
		5=1-8
		7=1

AIMCEE WHOLESALE CORP.  
(AMC)

117C, 117CD, 117T	57-1	10=1-10
-------------------	------	---------

AIR KING PRODUCTS CO., INC.

12C1, Ch. 700	43-1	7=1-24
12T1, 12T2, Ch. 700	43-1	7=1-24
14T1, Ch. 700-30	43-1	7=1-24
16C1, Ch. 700-1, 700-10, 700-90	43-1	7=1-24
16C2, 16C3, Ch. 700-10	43-1	7=1-24
16C5, Ch. 700-10, 700-90	43-1	7=1-24
16K1, Ch. 700-2, 700-50, 700-92	43-1	7=1-24
16M1, Ch. 700-10, 700-90	43-1	7=1-24
16T1, Ch. 700-1, 700-10	43-1	7=1-24
16T1B, Ch. 700-1, 700-10, 700-90	43-1	7=1-24
19C1, Ch. 700-40, 700-91	43-1	7=1-24
20C1, 20C2, Ch. 700-93	43-1	7=1-24
20K1, Ch. 700-95	43-1	7=1-24
20M1, Ch. 700-90, 700-93	43-1	7=1-24
700, 700-1, 700-2, 700-5, Ch. 700-10, 700-20, 700-30, 700-40, 700-50, Ch. 700-90, 700-91, 700-92, 700-93, 700-95, Ch.	43-1	7=1-24

AIRLINE  
See MONTGOMERY WARDAIR MARSHAL CORP.

B-17-T	43-1	7=1-4
--------	------	-------

ALLIANCE MFG. CO.

AB, Booster	43-1	7=1
-------------	------	-----

ALLIED PURCHASING CORP.  
(AMBASSADOR)

C1720, C2020, C2420, CD2020, See TRAD T-20E Series	54-1	9=1-16
T1720, T2020, See TRAD T-20E Series	54-1	9=1-16

ANCHOR RADIO CORP.

ARC-101-75, ARC-101-100	43-1	7=1-3
-------------------------	------	-------

ANDREA RADIO CORP.

Brewster	43-1	9=1-4
Caronia, Fleetwood	43-1	6=1-10
Gotham	43-1	9=1-4
Mayfield	43-1	6=1-10
Saybrook	43-1	6=1-10
Stratford	58-2	10=1-8
Sutton	43-1	6=1-10
Warwick	43-1	9=1-4
C-VL16, Ch. VL16, Sutton	43-1	6=1-10
C-VL17, Ch. VL17, Brewster	43-1	9=1-4
CO-VL16, Ch. VL16, Fleetwood	43-1	6=1-10
CO-VL19, Ch. VL19, Caronia	43-1	6=1-10
T-VL12, Ch. VL12, Saybrook	43-1	6=1-10
T-VL16, Ch. VL16, Mayfield	43-1	6=1-10



MODEL	PACK-FILE	PAGES
<b>ANDREA RADIO CORP. (Cont'd)</b>		
T-VL17, Ch. VL17, Gotham	43-1	9=1-4
VL12, VL16, Ch.	43-1	6=1-10
VL17, Ch.	43-1	9=1-4
VL19, Ch.	43-1	6=1-10
VL-20, Ch.	58-2	10=1-8
2C-VL17, Ch. VL17, Warwick	43-1	9=1-4
2C-VL20, Ch. VL-20, Stratford	58-2	10=1-8

**ARTONE**  
See **AFFILIATED RETAILERS, INC.**  
Also See **MACY'S**

MODEL	PACK-FILE	PAGES
<b>ARVIN INDUSTRIES, INC.</b>		
TE272-1, TE272-2, Ch.	43-2	6=1-9
TE276, Ch.	43-2	6=1-9
TE282, Ch.	43-2	6=13-18
TE 286, Ch.	1-1	8=4-6
TE289, Ch.	43-2	6=10-12
TE-289-2, Ch.	1-1	8=1-3
TE289-3, Ch.	43-2	7=1-4
TE290, Ch.	43-2	7=5-8
TE300, Ch.	43-2	9=1-8
TE-302, Ch.	1-1	8=6-8
TE-302-1, Ch.	1-1	8=6
		8=9-10
TE315, TE315-1, TE315-2, Ch.	43-2	9=1-8
TE 331, Ch.	58-3	10=1-4
2120, 2121, Ch. TE289-3	43-2	7=1-4
2120CM, 2121TM, Ch. TE-289-2	1-1	8=1-3
2122TM, Ch. TE289	43-2	6=10-12
2123, Ch. TE289-3	43-2	7=1-4
2123TM, Ch. TE-289-2	1-1	8=1-3
2124, Ch. TE289-3	43-2	7=1-4
2124CCM, Ch. TE-289-2	1-1	8=1-3
2126, Ch. TE289-3	43-2	7=1-4
2126CM, Ch. TE-289-2	1-1	8=1-3
2160, 2161, 2162, 2164, Ch. TE290	43-2	7=5-8
3100TB, 3100TM, Ch. TE272-1	43-2	6=1-9
3101CM, Ch. TE272-1	43-2	6=1-9
3120CB, 3120CM, Ch. TE272-2	43-2	6=1-9
3121TM, Ch. TE272-2	43-2	6=1-9
3160CM, Ch. TE276	43-2	6=1-9
4080T, Ch. TE282	43-2	6=13-18
4162, Ch. TE 286	1-1	8=4-6
5170, Ch. TE-302	1-1	8=6-8
5170, Ch. TE-302-1	1-1	8=6
		8=9-10
5171, Ch. TE-302	1-1	8=6-8
5171, Ch. TE-302-1	1-1	8=6
		8=9-10
5172, Ch. TE-302	1-1	8=6-8
5172, 5173, Ch. TE-302-1	1-1	8=6
		8=9-10
5204, 5206, Ch. TE300	43-2	9=1-8
5210, 5211, 5212, Ch. TE315, TE315-1, TE315-2	43-2	9=1-8
6175TM, 6179TM, Ch. TE 331	58-3	10=1-4

**ASTORIA**  
See **MACY'S**

**AUTOMATIC RADIO MFG. CO., INC.**

TV-5217, TV-5217T	58-1	10=1-6
-------------------	------	--------

**BELMONT RADIO CORP.**  
(RAYTHEON)

Adams	2-1	8=1-13
The Belmont	27-2	5=1-8
Catalina, Clayton	2-1	8=1-13
Commander	58-4	10=1-10
The Console	27-2	5=1-8
Constellation	2-1	8=1-13
The Evanston	48-3	7=1-16
Highland	58-4	10=11-20
Linden	58-4	10=1-10

MODEL	PACK-FILE	PAGES
<b>BELMONT RADIO CORP. (Cont'd)</b>		
The Marquis	48-3	7=1-16
The Mayfair, The Mozart	48-3	7=1-16
Raleigh	58-4	10=11-20
The Rancho, The Revere	48-3	7=1-16
The Rocket	48-3	7=1-16
Roseland	58-4	10=1-10
The Rover	27-2	5=1-8
The Savoy, The Santung	48-3	7=1-16
Sensation	58-4	10=11-20
The Starlight	2-1	8=14-25
The Suburban	27-2	5=1-8
Vogue	58-4	10=11-20
C-1104B, Ch. 12AX27, The Console	27-2	5=1-8
C-1401, Ch. 14AX21	27-2	5=9-18
C-1602, Ch. 16AX23, 16AX25, 16AX26	27-2	5=21-29
C-1602, Series C, Ch. 16AX29	27-2	5=21-29
C-1614A, Ch. 16AY211, The Marquis	48-3	7=1-16
C-1614B, Ch. 16AY28, The Marquis	48-3	7=1-16
C-1615A, Ch. 16AY211, The Mayfair	48-3	7=1-16
C-1615B, Ch. 16AY28, The Mayfair	48-3	7=1-16
C-1616A, Ch. 16AY211, The Mozart	48-3	7=1-16
C-1616B, Ch. 16AY28, The Mozart	48-3	7=1-16
C-1714A, Ch. 17AY24, The Marquis	48-3	7=1-16
C-1714B, Ch. 17AY21, The Marquis	48-3	7=1-16
C-1715A, Ch. 17AY24, The Mayfair	48-3	7=1-16
C-1715B, Ch. 17AY21, The Mayfair	48-3	7=1-16
C-1716A, Ch. 17AY24, The Mozart	48-3	7=1-16
C-1716B, Ch. 17AY21, The Mozart	48-3	7=1-16
C-1724A, Ch. 17AY21, The Evanston	48-3	7=1-16
C-1729A, Ch. 17AY21A, Roseland	58-4	10=1-10
C-1731A, Ch. 17AY21A, Linden	58-4	10=1-10
C-2001A, Ch. 20AY21, Clayton	2-1	8=1-13
C-2002A, Ch. 20AY21, Catalina	2-1	8=1-13
C-2006A, Constellation	2-1	8=1-13
C-2103A, Ch. 21AY21, Raleigh	58-4	10=11-20
C-2105A, Ch. 21AY21, Highland	58-4	10=11-20
M-1105B, Ch. 12AX27, The Suburban	27-2	5=1-8
M-1106, Ch. 12AX27, The Rover	27-2	5=1-8
M-1107, Ch. 12AX27, The Belmont	27-2	5=1-8
M-1402, M-1403, M-1404, Ch. 14AX21	27-2	5=9-18
M-1601, Ch. 16AX23, 16AX25, 16AX26	27-2	5=21-29
M-1611A, Ch. 16AY211, The Rocket	48-3	7=1-16
M-1611B, Ch. 16AY28, The Rocket	48-3	7=1-16
M-1612A, Ch. 16AY211, The Rancho	48-3	7=1-16
M-1612B, Ch. 16AY28, The Revere	48-3	7=1-16
M-1613A, Ch. 16AY211, The Revere	48-3	7=1-16
M-1613B, Ch. 16AY28, The Revere	48-3	7=1-16
M-1711A, Ch. 17AY24, The Rocket	48-3	7=1-16



BELMONT  
CROSLEY

MODEL	PACK-FILE	PAGES
<u>BELMONT RADIO CORP. (Cont'd)</u>		
M-1711B, Ch. 17AY21, The Rocket	48-3	7=1-16
M-1712A, Ch. 17AY24, The Rancho	48-3	7=1-16
M-1712B, Ch. 17AY21, The Rancho	48-3	7=1-16
M-1713A, Ch. 17AY24, The Revere	48-3	7=1-16
M-1713B, Ch. 17AY21, The Revere	48-3	7=1-16
*M-1725A, Ch. 17AY21	48-3	7=1-16
M-1726A, Ch. 17AY21A, Commander	58-4	10=1-10
M-1728A, Ch. 17AY21A, Vogue	58-4	10=1-10
M-2101A, Ch. 21AY21, Sensation	58-4	10=11-20
P-301, Series B, Ch. 7DX22P	27-2	5=31-34
RC-1405, Ch. 14AX21	27-2	5=9-20
RC-1618A, Ch. 16AY211, The Savoy	48-3	7=1-16
RC-1618B, Ch. 16AY28, The Savoy	48-3	7=1-16
RC-1619A, Ch. 16AY211, The Santung	48-3	7=1-16
RC-1619B, Ch. 16AY28, The Santung	48-3	7=1-16
RC-1718A, Ch. 17AY24, The Savoy	48-3	7=1-16
RC-1718B, Ch. 17AY21, The Savoy	48-3	7=1-16
RC-1719A, Ch. 17AY24, The Santung	48-3	7=1-16
RC-1719B, Ch. 17AY21, The Santung	48-3	7=1-16
RC-1720A, Ch. 17AY27, The Starlight	2-1	8=14-25
Record Changer VM-950	2-RC1	RCH22=1-16
RC-2005A, Ch. 20AY21, Adams Record Changer VM-950	2-1	8=1-13
	2-RC1	RCH22=1-16
6J6, 12AT7, Tuners	2-1	8=26-31
7DX22P, Ch.	27-2	5=31-34
12AX27, Ch.	27-2	5=1-8
14AX21, Ch.	27-2	5=9-20
16AX23, 16AX25, 16AX26, Ch.	27-2	5=21-29
16AX29, Ch.	27-2	5=21-29
16AY28, Ch.	48-3	7=1-16
16AY211, Ch.	48-3	7=1-16
17AY21, Ch.	48-3	7=1-16
17AY21A, Ch.	58-4	10=1-10
17AY24, Ch.	48-3	7=1-16
17AY27, Ch.	2-1	8=14-25
20AY21, Ch.	2-1	8=1-13
21AY21, Ch.	58-4	10=11-20

BENDIX RADIO DIV.

Belair, Guilford	48-2	7=1-9
C172, Belair	48-2	7=1-9
OAK3	58-3	10=1-12
*C182	48-2	7=1-9
C200, Guilford	48-2	7=1-9
T170	27-1	5=1-11
*T171	48-2	7=1-9
21K3, 21KD, 21T3, 21X3	58-3	10=1-12
2051	27-1	5=1-11
2060, 2070	27-1	5=1-11
3051	27-1	5=1-11
6001, 6003	27-1	5=1-11
6100	27-1	5=1-14
7001	27-1	5=1-11

BENRAY ELECTRONICS CORP.  
(SURREY)

621-20, 621-16, See TRAD T-20E Series	54-1	9=1-16
--	------	--------

\* See HANDY.

MODEL	PACK-FILE	PAGES
<u>CADILLAC ELECTRONICS CORP.</u>		
F-16	2-1	8=1-8

CBS-COLUMBIA INC.  
Also See AIR KING PRODUCTS CO., INC.

17C18, 17M18, 17T18, Ch. 817	59-1	10=1-5
20M18, 20M28, 20T18, Ch. 820	59-1	10=1-5
817, 820, Ch.	59-1	10=1-5

CAPEHART-FARNSWORTH CORP.

C-278, C-279, Ch.	27-1	7=1-13
C-281, Ch.	27-1	5=1-12
CT-27, Ch. CX-33DX	27-1	9=1-4
CT-37, CT-38, CT-39, Ch. CX-33DX	27-1	9=1-4
CT-45, Ch. CX-33DX	27-1	9=1-4
CT52, CT57, CTR68, Ch., Prelim.	59-2	10=1-10
CX-32, Ch.	27-1	7=1-13
CX-33, Ch.	27-1	5=1-12
CX-33DX, Ch.	27-1	9=1-4
CX-36, Ch., Prelim.	59-2	10=1-10
1T172M, 2C172M, Ch. CT52, CX-36, Prelim.	59-2	10=1-10
3C212B, 3C212M, Ch. CT57, CX-36, Prelim.	59-2	10=1-10
4H212B, 4H212M, Ch. CT57, CX-36, Prelim.	59-2	10=1-10
5F212M, 6F212B, 7F212M, 8F212B, 9F212M, Ch. CT57, CX-36, Prelim.	59-2	10=1-10
10W212M, Ch. CTR68, CX-36, Prelim.	59-2	10=1-10
3005-M, Ch. C-279, CX-32	27-1	7=1-13
3008-M, Ch. C-278, CX-32	27-1	7=1-13
3011-B, 3011-M, Ch. C-281, CX-33	27-1	5=1-12
3012-B, 3012-M, Ch. C-281, CX-33	27-1	5=1-12

CONRAC, INC.

27-M-40, 27-W-40, Ch. 40, 44	2-1	8=1-3
28-B-40, 29-P-40, Ch. 40, 44	2-1	8=1-3
30-M-40, 30-W-40, Ch. 40, 44	2-1	8=1-3
31-P-40, Ch. 40, 44	2-1	8=1-3
40, 44, Ch.	2-1	8=1-3

CORONADO  
See GAMBLE-SKOGMO, INCCOVIDEO, INC.

T-1400	2-1	8=1-4
--------	-----	-------

CROSLEY DIV.  
AVCO MFG. CORP.

DU-17CDB, Ch. 356-1	2-1	8=13-17
DU-17CDB, Ch. 356-3, 356-4	59-5	10=1-4
DU-17CDM, Ch. 356-1	2-1	8=13-17
DU-17CDM, Ch. 356-3, 356-4	59-5	10=1-4
DU-17CHB, Ch. 356-3, 356-4	59-5	10=1-4
DU-17CHM, Ch. 356-1	2-1	8=13-17
DU-17CHM, Ch. 356-3, 356-4	59-5	10=1-4
DU-17CHN, Ch. 356-1	2-1	8=13-17
DU-17CHN, DU-17CHN1, Ch. 356-3, 356-4	59-5	10=1-4
DU-17COB, Ch. 356-1	2-1	8=13-17
DU-17COB, DU-17COL, DU-17COLa, Ch. 356-3, 356-4	59-5	10=1-4
DU-17COM, Ch. 356-1	2-1	8=13-17
DU-17COM, Ch. 356-3, 356-4	59-5	10=1-4
DU-17PDB, DU-17PDM, Ch. 359	17-3	9=5-10
Record Changer CROSLEY V-950	17-RC1	RCH 9=1-16







DUMONT  
EMERSON

MODEL	PACK-FILE	PAGES
<u>ALLEN B. DUMONT LABORATORIES, INC. (Cont'd)</u>		
Rumson	39-4	1=31-42 3=1-4 4=1-4
Savoy	39-4	1=31-42
Sheffield	39-4	1=31-42 3=1-4 4=1-4
Shelburne	60-5	10=35-42
Sherbrooke	33-2	5=1-25
Somerset	60-5	10=1-34
Strathmore, Sumter	18-1	7=1-9
Sussex	39-4	4=5-14
Tarrytown	33-3	6=1-26
Wakefield	60-5	10=35-42
Wellington	39-4	1=31-42 3=1-4 4=1-4
Westerly	33-3	6=1-26
The Westminster	39-4	9=1-24
Westwood	39-4	1=31-42 3=1-4 4=1-4
Whitehall II	60-5	10=1-34
Wickford	60-5	10=1-34
Wimbledon	60-5	10=1-34
Winslow	33-2	5=1-25
Winthrop	39-4	1=31-42
RA-103, Chatham, Savoy	39-4	1=31-42
RA-103C, Winthrop	39-4	1=31-42
RA-103-D, Canterbury, Rumson, Sheffield	39-4	1=31-42 3=1-4 4=1-4
RA-104-A, Hastings, Wellington	39-4	1=31-42 3=1-4 4=1-4
RA-105-B, Sussex	39-4	4=5-14
RA-108-A, Bradford, Mansfield	39-4	4=5-14
RA-110-A, Fairfield, Westwood	39-4	1=31-42 3=1-4 4=1-4
RA-109-A1, Winslow	33-2	5=1-25
RA-109-A2, Hanover	33-2	5=1-25
RA-109-A3, Sherbrooke	33-2	5=1-25
RA-109-A5, Winslow	33-2	5=1-25
RA-109-A6, Hanover	33-2	5=1-25
RA-109-A7, Sherbrooke	33-2	5=1-25
RA-111-A1, Putnam	33-2	5=26-43
RA-111-A2, Guilford	33-2	5=26-43
RA-111-A4, Putnam	33-2	5=26-43
RA-111-A5, Guilford	33-2	5=26-43
RA-112-A1, Ardmore	33-3	6=1-26
RA-112-A2, Westerly	33-3	6=1-26
RA-112-A3, Mt. Vernon	33-3	6=1-26
RA-112-A4, Ardmore	33-3	6=1-26
RA-112-A5, Westerly	33-3	6=1-26
RA-112-A6, Mt. Vernon	33-3	6=1-6
RA-113-B1, RA-113-B2, Brookville	33-3	6=1-26
RA-113-B3, RA-113-B4, Revere	33-3	6=1-26
RA-113-B5, RA-113-B6, Burlingame	33-3	6=1-26
RA-113-B7, RA-113-B8, Tarrytown	33-3	6=1-26
RA-116A, The Westminster, Series II	39-4	9=1-24
Record Changer		
WEBSTER 100	39-RC1	RCH21=1-10
RA-117-A1, Sumter	18-1	7=1-9
RA-117-A3, Carlton	18-1	7=1-9
RA-117-A5, Strathmore	18-1	7=1-9
RA-117-A6, Andover	18-1	7=1-9
RA-117-A7, Park Lane	18-1	7=1-9
RA-119A, Royal Sovereign	33-2	5=1-25 8=1-12
RA-160-A1, Devon	60-5	10=1-34
RA-162-B1, Wickford	60-5	10=1-34

MODEL	PACK-FILE	PAGES
<u>ALLEN B. DUMONT LABORATORIES, INC. (Cont'd)</u>		
RA-162-B4, Banbury	60-5	10=1-34
RA-162-B5, Flanders	60-5	10=1-34
RA-162-B6, Wimbledon	60-5	10=1-34
RA-162-B7, Whitehall II	60-5	10=1-34
RA-162-B10, Flanders	60-5	10=1-34
RA-162-B11, Newbury	60-5	10=1-34
RA-162-B12, Somerset	60-5	10=1-34
RA-162-B13, Banbury	60-5	10=1-34
RA-162-B14, Dynasty	60-5	10=1-34
RA-162-B21 -- RA-162-B26, Banbury	60-5	10=1-34
RA-164-A1, Clinton	60-5	10=35-42
RA-165-B1, Milford	60-5	10=35-42
RA-165-B2, Beverly	60-5	10=35-42
RA-165-B3, Wakefield	60-5	10=35-42
RA-165-B4, Ridgewood	60-5	10=35-42
RA-165-B5, Shelburne	60-5	10=35-42

ELECTRO-TECHNICAL INDUSTRIES  
(TELEKIT)

19C	3-1	8=1-10
-----	-----	--------

ELECTRO-VOICE INC.

3000, Booster	26-1	7=1-2
---------------	------	-------

EMERSON RADIO & PHONO. CORP.

609, Ch. 120084-B	3-1	8=1-13
614D, Ch. 120095-B	26-2	6=1-4
637A, Ch. 120095-B	26-2	6=1-4
649A, Ch. 120094A	26-2	6=5-10
650B, Ch. 120118B	26-2	6=11-19
654B, Ch. 120118B	26-2	6=11-19
661B, Ch. 120134-B, 120134-G	26-3	7=1-10
662B, 663B, Ch. 120127-B, 120128-B	26-3	7=11-19
665B, Ch. 120131-B	26-3	7=20-27
666B, Ch. 120135-B	26-3	7=28-35
667B, 668B, Ch. 120134-B, 120134-G	26-3	7=1-10
669B, Ch. 120129-B	26-3	7=36-44
674B, Ch. 120134-G	26-3	7=1-10
675B, Ch. 120129-B	26-3	7=36-44
676B, Ch. 120140-B, 120140-G, 120140-H	26-3	7=45-57
676D, Ch. 120144-B, 120144-G, 120144-H	3-1	8=16-30
*676F, Ch. 120143-B, 120143-H, similar to 681F, 686F, 687F, 696F	3-1	8=31-39
677B, 678B, Ch. 120134-B	26-3	7=1-10
680B, Ch. 120144-B, 120144-G, 120144-H	3-1	8=16-30
680D, 681B, Ch. 120140-B, 120140-G, 120140-H	26-3	7=45-57
681D, Ch. 120144-B, 120144-G, 120144-H	3-1	8=16-30
681F, Ch. 120143-B, 120143-H	3-1	8=31-39
683B, Ch. 120141-B	3-1	8=40-45
684B, 685B, Ch. 120134-B	26-3	7=1-10
686B, Ch. 120144-B, 120144-G, 120144-H	3-1	8=16-30
686D, Ch. 120140-B, 120140-G, 120140-H	26-3	7=45-57
686F, Ch. 120143-B, 120143-H	3-1	8=31-39
686L, Ch. 120142-B	3-1	8=46-55
687B, Ch. 120144-B, 120144-G, 120144-H	3-1	8=16-30
*687D, Ch. 120140B, similar to 680D, 686D	26-3	7=45-57
687F, Ch. 120143-B, 120143-H	3-1	8=31-39
687L, Ch. 120142-B	3-1	8=46-55
688B, 689B, 690B, Ch. 120129-B	26-3	7=36-44

\* See Emerson HANDY No. 16, Pack 26



MODEL PACK-FILE PAGES  
EMERSON RADIO & PHONO CORP. (Cont'd)

*692B, 693B, 694B, Ch. 120129-D, similar to 688B, 689B, 690B, Ch. 120129-B	26-3	7=36-44
696F, Ch. 120143-B, 120143-H	3-1	8=31-39
696L, Ch. 120142-B	3-1	8=46-55
*697B, Ch. 120129-D, similar to 688B, 689B, 690B, Ch. 120129-B	26-3	7=36-44
699B, Ch. 120148-B	39-4	9=9-16
Record Changer VM-950	39-RC1	RCH22=1-16
699D, Ch. 120160-B	60-6	10=1-8
700B, Ch. 120153-B	39-4	9=1-8
Record Changer VM-950	39-RC1	RCH22=1-16
700D, Ch. 120158-B	50-5	9=17-24
700L, Ch. 120153-D	61-7	10=18-27
701B, Ch. 120153-B	39-4	9=1-8
Record Changer VM-950	39-RC1	RCH22=1-16
701D, Ch. 120158-B	50-5	9=17-24
709A, Ch. 120162-A	61-7	10=9-17
711B, 712B, Ch. 120164-B	61-7	10=28-39
714B, Ch. 120153-B	61-7	10=18-27
714D, 715D, Ch. 120153-D	61-7	10=18-27
720B, Ch. 120164-B	61-7	10=28-39
120084-B, Ch.	3-1	8=1-13
120094A, Ch.	26-2	6=5-10
120095-B, Ch.	26-2	6=1-4
120118B, Ch.	26-2	6=11-19
120127-B, 120128-B, Ch.	26-3	7=11-19
120129B, 120129D, Ch.	26-3	7=36-44
120131-B, Ch.	26-3	7=20-27
120134-B, 120134-G, Ch.	26-3	7=1-10
120135-B, Ch.	26-3	7=28-35
120140-B, 120140-G, 120140-H, Ch.	26-3	7=45-57
120141-B, Ch.	3-1	8=40-45
120142-B, Ch.	3-1	8=46-55
120143-B, 120143-H, Ch.	3-1	8=31-39
120144-B, 120144-G, 120144-H, Ch.	3-1	8=16-30
120148-B, Ch.	39-4	9=9-16
120153-B, Ch.	39-4	9=1-8
120153-B, Ch., Late	61-7	10=18-27
120153-D, Ch.	61-7	10=18-27
120158-B, Ch.	50-5	9=17-24
120160-B, Ch.	60-6	10=1-8
120162-A, Ch.	61-7	10=9-17
120164-B, Ch.	61-7	10=28-39
470651, Tuner	3-1	8=56-62
470662, Tuner	3-1	8=63-69

FADA RADIO & ELECTRIC CO., INC.

R7C15, R7C25	4-1	8=1-8
Tuner 42.51 for all 'R' Series	4-1	9=1-2
R-1025, R-1050	32-2	5=1-7
S6C55, S6C70, S6T65	32-2	7=1-12
S7C20, S7C30	32-2	7=1-14
S7C20, S7C30, Rev.	32-2	9=11-18
S7C70, S7T65	32-2	7=1-12
S-1015, S-1020, S-1030	32-2	5=8-12
S-1055	32-2	5=10-14
S-1055X	32-2	7=1-12
S-1060, S-1065	32-2	5=10-14
S20C10, S20T20	32-2	9=11-18
7C42, 7C52, 7T32	61-3	10=1-11
721, 775T	61-3	10=1-11
42.55, 42.64, Tuners used with 'S' Series	32-2	9=3-10

THE FIRESTONE TIRE & RUBBER CO.

13-G-44, 13-G-45	4-1	8=10-24
13-G-51, 13-G-52	4-1	8=25-39
13-G-53, 13-G-54, Ch. 700-90, 700-96	4-1	8=40-51

\* See Emerson HANDY No. 16, Pack 26

MODEL PACK-FILE PAGES  
THE FIRESTONE TIRE & RUBBER CO. (Cont'd)

13-G-55, Ch. 700-93	4-1	8=40-51
13-G-56	4-1	8=52-59
13-G-57	4-1	8=1-9
Record Changer VM-950	4-RC1	RCH22=1-16
13-G-58, 13-G-59, 13-G-79, Ch. 700-96	4-1	8=60-70
13-G-110, Code 334-2-MS31C/A	61-2	10=1-10
13-G-115, 13-G-116, 13-G-119, 13-G-120, Code 334-2- MS31C/A	61-2	10=1-10
700-90, 700-93, Ch.	4-1	8=40-51
700-96, Ch., 13-G-53, 13-G-54	4-1	8=40-51
700-96, Ch., 13-G-58, -59, -79	4-1	8=60-70

FRANKLIN AIRLOOP CORP.

500-A-10, Tuner	4-1	8=1-2
-----------------	-----	-------

FREED-EISEMANN  
See FREED RADIO CORP.

FREED RADIO CORP.  
(FREED-EISEMANN)

54, 55, 56, 68, Ch. 1620C	32-1	5=1-7
101, 102, 103, 104, Ch. 1900	32-1	5=8-10
110, 111, 112, Ch. 700-120	50-2	9=1-8
121	50-2	9=9-14
700-120, Ch.	50-2	9=9-14
1620C, Ch.	32-1	5=1-7
1900, Ch.	32-1	5=8-10

GAMBLE-SKOGMO, INC.  
(CORONADO)

05RA4-43-8935A	31-2	6=1-6
05TV1-43-9014A, Ch. 16AY210	31-2	6=7-16
05TV2-43-8950A	31-2	6=17-26
05TV2-43-9010A	31-2	6=17-26
05TV6-43-8935A	31-2	6=1-6
15RA2-43-9105A, Ch. 16AY210	31-2	6=7-16
15TV1-43-8957A	5-1	8=1-8
15TV1-43-8958A	31-2	9=1-8
15TV1-43-9008A	5-1	8=9-18
15TV1-43-9015A, 15TV1-43-9016A	5-1	8=1-8
15TV1-43-9020A, 15TV1-43-9021A	31-2	9=1-8
15TV2-43-9101A, 15TV2-43-9102A	5-1	8=19-27
Record Changer VM-950	5-RC1	RCH22=1-16
15TV2-43-9025A	5-1	8=28-35
15TV2-43-9025B	5-1	8=28-38
15TV2-43-9026A	5-1	8=28-35
15TV2-43-9026B	5-1	8=28-38
15TV4-7003U, Ch. 15TV4-43-8948A, 15TV4-43-8949A, Ch. 15TV4-7003U	5-1	8=39-46
16AY210, Ch.	31-2	6=7-16
94TV2-43-8972A, 94TV2-43-8973A	32-3	5=1-8
94TV2-43-8987A	32-3	5=1-8
94TV2-43-8993A, 94TV2- 43-8994A, 94TV2-43-8995A	32-3	5=1-8
94TV6-43-8953A	32-3	5=9-14

GAROD RADIO CORP.

12C4, 12C5; 94 Series	19-1	5=1-14
12T2, 12T3, 12T6; 94 Series	19-1	5=1-14
14C4, 94 Series	19-1	5=1-14
14CT4, 97, 98 Series	19-1	5=1-20
14T2, 14T6; 94 Series	19-1	5=1-14
16C4, 16C5, 16C6; 94 Series	19-1	5=1-14
16CT4, 16CT5; 97, 98 Series	19-1	5=1-20
16T2, 16T3; 94 Series	19-1	5=1-14
19C6, 19C7; 97, 98 Series	19-1	5=1-20
1042, 1042G Late	19-1	5=1-14
1042GU, 1042T Late	19-1	5=1-14



GAROD  
HOFFMAN

MODEL	PACK-FILE	PAGES
<u>GAROD RADIO CORP. (Cont'd)</u>		
1043, 1043G Late	19-1	5-1-14
1043GU, 1043T Late	19-1	5-1-14
1142 Late, 1143 Late	19-1	5-1-14
1244, 1244G Late, 1244GU	19-1	5-1-14
1244T Late, 1244TX	19-1	5-1-14
1245, 1245G Late, 1245GU	19-1	5-1-14
1245T Late, 1245TX	19-1	5-1-14
1344 Late, 1345 Late	19-1	5-1-14
1348	19-1	5-1-14
1546, 1546G Late, 1546GU	19-1	5-1-14
1546T Late	19-1	5-1-14
1547, 1547G Late, 1547GU	19-1	5-1-14
1547T Late	19-1	5-1-14
1548, 1548G Late, 1548GU	19-1	5-1-14
1548T Late	19-1	5-1-14
1549, 1549G Late, 1549GU	19-1	5-1-14
1549T Late	19-1	5-1-14
1646, 1647, 1648, 1649; Late	19-1	5-1-14
1671, 97, 98 Series	19-1	5-15-17
1672, 1673, 1674, 1675; 97, 98 Series	19-1	5-18-20
1900, 97, 98 Series	19-1	5-1-20
1974, 1975; 97, 98 Series	19-1	5-18-20
2042T Late, 2043T Late	19-1	5-1-14
2546T, 2547T, 2548T, 2549T; Late	19-1	5-1-14

MODEL	PACK-FILE	PAGES
<u>GENERAL ELECTRIC CO.</u>		
10C101, 10C102	19-2	5-1-11
10T1, 10T4, 10T5, 10T6	19-2	5-1-11
12C101, 12C102, 12C105	19-2	5-25-34
12C107, 12C108, 12C109, B Version	19-2	5-35-47
12K1	19-2	5-12-24
Record Changer GE P14	19-RC1	RCH21=5-12
12T1	19-2	5-25-34
12T3, 12T4	19-2	5-25-44
12T3, 12T4, B Version	19-2	5-35-47
12T7	31-4	6-1-11
14C102, 14C103	31-4	6-12-21
14T2, 14T3	31-4	6-12-21
16C110, 16C111	31-4	6-35-44
16C113	19-3	7-1-10
16C115	31-4	6-35-44
16C116	19-3	7-1-10
16K1, 16K2	31-4	6-22-34
16T1, 16T2	31-4	6-35-44
16T3, 16T4	19-3	7-1-10
17C101, 17C102	19-3	7-1-12
17C103, 17C104, 17C105	5-1	8-21-32
17C107, 17C108, 17C109	5-1	8-21-32
17C110, 17C111	5-1	8-1-20
17C112	50-5	9-1-8
17C113	50-5	9-9-24
17C114	50-5	9-1-8
17C115	50-5	9-9-24
17C117	50-5	9-9-24
17C120	50-5	9-9-24
17T1, 17T2, 17T3	5-1	8-21-32
17T4, 17T5, 17T6	50-5	9-1-8
17T7	50-5	9-9-24
19C101	5-1	8-33-44
815	19-3	7-13-22

MODEL	PACK-FILE	PAGES
<u>GENERAL INSTRUMENT CORP.</u>		
44, Tuner	35-2	5-1-4
45, Electuner	31-1	6-1-6

MODEL	PACK-FILE	PAGES
<u>THE HALLICRAFTERS CO.</u>		
B919120, Ch.	49-5	9-17-24
C919120, Ch.	35-4	5-1-10
D919120, Ch.	28-2	6-1-8
E800D, Ch.	49-5	9-25-36
G900S, Ch.	49-5	9-67-84
J800D, Ch.	49-5	9-25-36
K800D, Ch.	49-5	9-25-36
L800D, Ch.	49-5	9-53-66

MODEL	PACK-FILE	PAGES
<u>THE HALLICRAFTERS CO. (Cont'd)</u>		
L900D, Ch.	49-5	9-37-52
L919120, Cn.	28-2	6-21-28
M800S, Ch.	6-1	8-1-16
M900D, Ch.	49-5	9-37-52
P800S, Ch.	49-5	9-67-84
R900D, Ch.	49-5	9-37-52
U800S, Ch.	49-5	9-67-84
680, 681, Ch. B919120, Run 3	49-5	9-17-24
690, Ch. B919120, Run 3	49-5	9-17-24
715, 715A, Ch. B919120, Run 3	49-5	9-17-24
716, 717, Ch. C919120	35-4	5-1-10
730, 731, Ch. C919120	35-4	5-1-10
740, 741, Ch. C919120	35-4	5-1-10
745, Ch. D919120	28-2	6-1-8
747, 748, Ch. D919120	28-2	6-1-8
750, 751, Ch. D919120	28-2	6-1-8
760, 761, Ch. D919120	28-2	6-1-8
805, 806, Ch. M800S	6-1	8-1-16
810, Ch. M800S	6-1	8-1-16
810A	28-3	9-1-14
810C, Ch. M800S	6-1	8-1-16
811	6-1	8-17-28
811, Ch. E800D, Runs 2-8	49-5	9-25-36
815	28-3	7-1-11
816	28-2	6-9-20
818, Ch. K800D, Runs 2-8	49-5	9-25-36
820, 821	6-1	8-17-28
820, 821, Ch. F800D, Runs 2-8	49-5	9-25-36
822	28-3	7-12-22
832, 833, Ch. L919120	28-2	6-21-28
860, 861	6-1	8-17-28

Record Changer GENERAL INSTRUMENT 700F	6-RC1	RCH19=1-10
860, 861, Ch. E800D, Runs 2-8	49-5	9-25-36
Record Changer GENERAL INSTRUMENT 700F	49-RC1	RCH19=1-10
870, 871	28-3	7-1-11
880	28-3	9-1-14
14808, Ch. R900D, Runs 1, 2	49-5	9-37-52
14808B, Prelim.	28-3	9-15-16
17804C, Ch. L800D, Runs 1-3	49-5	9-53-66
17810C, 17810M, 17810MG, Ch. G900S, P800S, U800S, Run 1	49-5	9-67-84
17812, 17813, Ch. L800D, Runs 1-3	49-5	9-53-66
17815-H, Ch. L800D, Runs 1-3	49-5	9-53-66
17819, Ch. L800D, Runs 1-3	49-5	9-53-66
17824, 17825, Ch. L800D, Runs 1-3	49-5	9-53-66
17838, Ch. L800D, Runs 1-3	49-5	9-53-66
17848, 17849, 17850, Ch. L800D, Runs 1-3	49-5	9-53-66
20823, Ch. M900D, Run 1	49-5	9-37-52
20823B, Ch. L900D, Run 1	49-5	9-37-52
20872, Ch. G900S, P800S, U800S, Run 1	49-5	9-67-84
20990, 20990S, Ch. J800D	49-5	9-25-36
Record Changer GENERAL INSTRUMENT 700F	49-RC1	RCH19=1-10
20994, Ch. J800D	49-5	9-25-36
Record Changer GENERAL INSTRUMENT 700F	49-RC1	RCH19=1-10

MODEL	PACK-FILE	PAGES
<u>THE HERTNER ELECTRIC CO. (PRECISION)</u>		
L-10	35-1	5-1-12

MODEL	PACK-FILE	PAGES
<u>HOFFMAN RADIO CORP.</u>		
Tuner	29-2	6-1-4
RF-6, RF-7, RF-8, Tuners	29-3	9-11-16
24B707, 24M708, Ch. 187, 187B, 187C	29-3	9-1-10
140, 142, Ch., Rev.	35-4	5-8-16
149, Ch.	35-4	5-8-16
150, Ch.	35-4	5-7-16
151, 152, Ch.	35-4	5-17-24
153, Ch.	29-3	7-1-5
154, Ch.	35-4	5-1-5



MODEL	PACK-FILE	PAGES	MODEL	PACK-FILE	PAGES
<u>HOFFMAN RADIO CORP. (Cont'd)</u>			<u>INTERSTATE STORES BUYING CORP. (Cont'd)</u>		
155, Ch.	35-4	5=1-5 5=7	ARC-21, ARC-21B	50-2	9=1-16
156, 157, Ch.	29-3	7=3 7=6-21	ARC-71, ARC-71B	50-2	9=1-16
158, Ch.	35-4	5=1-7	ARD-21M, ARD-22B	50-2	9=1-16
159, 160, Ch.	29-2	6=5-14	ARD-72, ARD-72B	50-2	9=1-16
164, Ch.	29-3	7=3	250, 350	35-1	5=1-11
170, 171, Ch.	29-2	7=6-21	750	35-1	5=1-11
172, Ch.	29-3	6=15-28	P1650T	35-1	7=1-8
173, Ch.	29-2	7=22-30	P1652, P1653	35-1	7=1-8
174, Ch.	29-3	6=15-28	P1751, P1752, P1753	35-1	7=1-8
175, Ch.	29-2	7=22-30	P2052	35-1	7=1-8
176, Ch.	29-3	6=15-28			
180, Ch.	6-1	8=26-34	<u>JACKSON INDUSTRIES, INC.</u>		
183, 184, 185, 186, Ch.	6-1	8=8-25	114G, 116G, 117G, 120G, Ch.	6-1	8=1-8
187, 187B, 187C, Ch.	29-3	9=1-10	1400T, Ch. 114G, 116G,		
600, Ch. 154	35-4	5=1-15	117G, 120G	6-1	8=1-8
601, Ch. 155	35-4	5=1-5	1700C, 1700T, Ch. 114G,		
610, Ch. 140, Rev.	35-4	5=7	116G, 117G, 120G	6-1	8=1-8
612, Ch. 142, Rev.	35-4	5=8-16	2000C, Ch. 114G, 116G,		
613, Ch. 149	35-4	5=8-16	117G, 120G	6-1	8=1-8
620, 621, Ch. 155	35-4	5=1-5	3170C, Ch. 114G, 116G,		
622, 623, Ch. 149	35-4	5=8-16	117G, 120G	6-1	8=1-8
630, 631, Ch. 159	29-2	6=5-14	Record Changer VM-950	6-RC1	RCH22=1-16
630, 631, Ch. 170	29-2	6=15-28	5120C, Ch. 114G, 116G,		
632, 633, Ch. 160	29-2	6=5-14	117G, 120G	6-1	8=1-8
632, 633, 634, 635, Ch. 171	29-2	6=15-28	Record Changer VM-950	6-RC1	RCH22=1-16
636, 637, Ch. 183	6-1	8=8-25	<u>KAYE-HALBERT CORP.</u>		
638, 639, Ch. 180	6-1	8=26-34	Cambridge, Hideaway	30-2	6=1-7
830, 831, 832, Ch. 151	35-4	5=17-24	Normandy, Windsor	30-2	6=1-7
836, 837, 840, Ch. 153	29-3	7=1-5	014, 024, Ch. 253	6-1	8=1-6
841, 842, 843, Ch. 158	35-4	5=1-7	044, 045, 046, Ch. 253	6-1	8=1-6
846, Ch. 151	35-4	5=17-24	074, 076, 077, Ch. 253	6-1	8=1-6
847, 848, 849, Ch. 156	29-3	7=3	231, Ch.	30-2	6=1-7
850, 851, 852, Ch. 151	35-4	7=6-21	231, 232, 233, Ch. 231, 242	30-2	6=1-7
856, 857, 858, Ch. 153	29-3	5=17-24	234, Ch. 231, 242, Hideaway	30-2	6=1-7
860, 861, 862, Ch. 157	29-3	7=1-5	235, Ch. 231, 242, Windsor	30-2	6=1-7
866, 867, 868, Ch. 171	29-2	7=3	236, Ch. 231, 242, Normandy	30-2	6=1-7
866A, 867A, 868A, Ch. 173	29-2	6=15-28	237, Ch. 231, 242, Cambridge	30-2	6=1-7
870, 871, 872, Ch. 170	29-2	6=15-28	238, Ch. 231, 242	30-2	6=1-7
876, 877, 878, Ch. 171	29-2	6=15-28	239, Ch. 231, 242, Hideaway	30-2	6=1-7
876A, 877A, 878A, Ch. 173	29-2	6=15-28	240, Ch. 231, 242, Windsor	30-2	6=1-7
880, 881, 882, 883, 884, 885,			242, Ch.	30-2	6=1-7
886, 887, Ch. 183	6-1	8=8-25	253, Ch.	6-1	8=1-6
890, 891, 892, Ch. 175	29-2	6=15-28	424, Ch. 253	6-1	8=1-6
893, 894, 895, Ch. 185	6-1	8=8-25	714, 724, Ch. 253	6-1	8=1-6
Record Changer VM-950	6-RC1	RCH22=1-16	731, 733, Ch. 231, 242	30-2	6=1-7
or WEBSTER 100	6-RC1	RCH21=1-10	744, 745, Ch. 253	6-1	8=1-6
896, 897, Ch. 185	6-1	8=8-25	777, Ch. 253	6-1	8=1-6
914, 915, 916, Ch. 150	35-4	5=7-16	914, Ch. 253	6-1	8=1-6
917, 918, 920, Ch. 152	35-4	5=17-24	<u>MACY ASSOCIATES</u>		
921, Ch. 150	35-4	5=7-16	See MACY'S		
930, 931, 932, Ch. 150	35-4	5=7-16	<u>MACY'S</u>		
936, 937, 938, Ch. 152	35-4	5=17-24	AR14L, Ch. TVG, Artone,		
946, 947, 948, Ch. 164	29-3	7=3	Hyde Park	7-1	9=21-30
950, 951, 952, Ch. 172	29-3	7=6-21	AR-16 T-68, Artone	7-2	9=31-38
950A, 951A, 952A, Ch. 174	29-3	7=22-30	AR17L, Ch. TVG, Artone,		
953, 954, 955, Ch. 184	6-1	8=8-25	Hyde Park	7-1	9=21-30
Record Changer VM-950	6-RC1	RCH22=1-16	AR-23TV-1, Artone	7-2	9=31-38
or WEBSTER 100	6-RC1	RCH21=1-10	HP-21B, HP-21M	47-3	9=57-72
960, 961, 962, Ch. 176	29-3	7=22-30	HP-71B, HP-71M	47-3	9=57-72
963, 964, 965, Ch. 186	6-1	8=8-25	HPC-21B, HPC-21M, HPC-22X	47-3	9=57-72
Record Changer VM-950	6-RC1	RCH22=1-16	HPC-71B, HPC-71M	47-3	9=57-72
or WEBSTER 100	6-RC1	RCH21=1-10	HPD-21	47-3	9=57-72
<u>HYDE PARK</u>			MST12, Artone, Astoria,		
See MACY'S			Hyde Park	7-2	9=45-52
<u>INTERSTATE STORES BUYING CORP.</u>			Q-2617, Q-2617-1, Ch.		
(PLYMOUTH)			260-FM, 260-V, Macy		
AR-21, AR-21B	50-2	9=1-16	Associates, Supremacy	7-2	9=53-56
AR-71, AR-71B	50-2	9=1-16	Q-2619, Q-2619-1, Q-2620,		
AR-73L	50-2	9=1-16	Q-2620-1, Ch. 260-FM,		
			260-V, Macy Associates,		
			Supremacy	7-2	9=53-56
			S-20, Ch. 260-FM, 260-V,		
			Macy Associates, Supremacy	7-2	9=53-56



MACY'S  
MIDWEST

MODEL	PACK-FILE	PAGES
<b>MACY'S (Cont'd)</b>		
S-210, S-211, S-212, S-213, Ch. 260-FM, 260-V, Macy Associates, Supremacy	7-2	9=53-56
TVG, Ch.	7-1	9=21-30
10C, 12X, Artone, Astoria, Hyde Park	7-2	9=45-52
16CD, Artone, Astoria, Hyde Park	7-1	9=1-8
16TR, Artone, Hyde Park	7-1	9=11-20
17CD, Ch. TVG, Artone, Hyde Park	7-1	9=21-30
17CR, Artone, Hyde Park	7-1	9=11-20
17CR, 17CRR, Ch. TVG, Artone, Hyde Park	7-1	9=21-30
17RDG, Ch. TVG, Artone, Hyde Park	7-1	9=21-30
17RO, Artone, Hyde Park	7-1	9=11-20
17ROR, Ch. TVG, Artone, Hyde Park	7-1	9=21-30
19CD, Artone, Hyde Park	7-1	9=1-9
19CX, Artone, Hyde Park	7-1	9=1-10
20CD, 20TR, Ch. TVG, Artone, Hyde Park	7-1	9=21-30
112, 112X, Artone, Astoria, Hyde Park	7-2	9=45-52
114, Artone, Hyde Park	7-1	9=11-20
203D, 204CAF, Ch. TVG, Artone, Hyde Park	7-1	9=21-30
260-FM, 260-V, Ch.	7-2	9=53-56
312, Artone, Astoria, Hyde Park	7-2	9=45-52
316, Astoria, Hyde Park	7-1	9=1-8
516, Artone, Hyde Park	7-1	9=11-20
816-3CR, Artone, Astoria, Hyde Park	7-1	9=1-8
819, Artone, Hyde Park	7-1	9=1-8
819, 819-3CM, 920, Ch. TVG, Artone, Hyde Park	7-1	9=21-30
1000, 1001, Ch. TVG, Artone, Hyde Park	7-1	9=21-30
1920, Ch. TVG, Artone, Hyde Park	7-1	9=21-30
2400, 4620, Ch. 260-FM, 260-V, Macy Associates, Supremacy	7-2	9=53-56

**THE MAGNAVOX CO.**

CT-232, CT-236, Ch.	30-1	6=1-14
CT-239, CT-240, Ch.	30-1	6=1-14
CT-244, CT-245, CT-246, Ch.	30-1	6=1-14
CT-247, CT-248, CT-249, Ch.	30-1	6=15-28
CT-250, CT-251, Ch.	30-1	6=1-14
CT-252, CT-253, CT-255, Ch.	30-1	6=15-28
CT-257, CT-258, CT-259, CT-260	30-1	7=1-13
CT-262, CT-263, CT-264, CT-265, CT-266, CT-267, CT-269, Series 103 Ch.	30-1	6=29-38
CT-270, CT-271, CT-272, CT-273, CT-274, CT-275, CT-276, CT-277, CT-278, CT-279, CT-280, CT-281, CT-282	30-1	7=14-28
CT-283, CT-284, CT-285, CT-286, CT-287, CT-288, CT-289, CT-290, CT-291, CT-293, CT-294, Series 103 Ch.	30-1	6=29-38
CT-295, CT-296	30-1	7=1-13
CT-297, Series 103 Ch.	30-1	6=29-38

**MAJESTIC RADIO & TELEVISION  
DIV. OF WILCOX-GAY CORP.**

A-70, Ch. 106A	6-1	8=1-7
A-712, Ch. 106A	6-1	8=1-7
7P1, 7P2, 7P3, Ch. 101A	30-2	7=1-16
7P10, 7P11, Ch. 101A	30-2	7=1-16
7PR12, 7PR13, Ch. 101C	30-2	7=1-16
9P4, 9P5, Ch. 103	30-2	7=1-16

MODEL	PACK-FILE	PAGES
<b>MAJESTIC RADIO &amp; TELEVISION (Cont'd)</b>		
9PR8, 9PR9, Ch. 103A	30-2	7=1-16
17DA, Ch. 101D	30-2	7=1-16
17FA, Ch. 106A	6-1	8=1-7
17GA, 17HA, Ch. 101D	30-2	7=1-16
17JA, 17K, Ch. 106A	6-1	8=1-7
20K, Ch. 108C	6-1	8=1-7
20KA, 20LA, Ch. 108A	6-1	8=1-7
20UAT, Ch. 108B	6-1	8=1-7
20UC, 20UT, Ch. 108D	6-1	8=1-7
20X, Ch. 108B	6-1	8=1-7
70, 72, 73, Ch. 106	6-1	8=1-7
99, 100, 101, 101A, 101B, 101C, 101D, 102, 103, 103A, Ch.	30-2	7=1-16
105, Ch.	30-2	7=1-16
106, 106A, Ch.	6-1	8=1-7
108, 108A, 108B, 108C, 108D, Ch.	6-1	8=1-7
120, 121, 121B, Ch. 99	30-2	7=1-16
141, 141B, Ch. 100	30-2	7=1-16
141C, Ch. 101B	30-2	7=1-16
142, 142B, Ch. 100	30-2	7=1-16
143	30-2	7=1-16
160, 160B, Ch. 101	30-2	7=1-16
162, 163, Ch. 101	30-2	7=1-16
170, Ch. 101A	30-2	7=1-16
173	30-2	7=1-16
700, 701, Ch. 106	6-1	8=1-7
712, 715, 717, 718, 719, Ch. 106	6-1	8=1-7
800, 801, 802, 803, 804, Ch. 108	6-1	8=1-7
902, 903, Ch. 103	30-2	7=1-16
910, 911, Ch. 103	30-2	7=1-16
1400, 1400B, Ch. 100	30-2	7=1-16
1401, Ch. 105	30-2	7=1-16
1600, 1600B, Ch. 101	30-2	7=1-16
1605, 1605B, Ch. 102	30-2	7=1-16
1610, 1610B, Ch. 102	30-2	7=1-16
1700C, 1701C	30-2	7=1-16
1710, Ch. 101A	30-2	7=1-16
1720, 1721	30-2	7=1-16

**JOHN MECK INDUSTRIES, INC.**

JM-717C, JM-717T, Ch. 9021	7-1	8=1-11
JM-720C, JM-720T, Ch. 9023	7-1	8=1-11
MM-510T, MM-512C, MM-512T	45-2	6=1-5
MM-516C, MM-516T	45-2	6=1-5
MM-614C, MM-614T, Ch. 9018	45-2	7=1-11
MM-614TL, Ch. 9022, 9024	7-1	8=1-11
MM-616C, MM-616T, Ch. 9018	45-2	7=1-11
MM-617C, MM-617T, Ch. 9018	45-2	7=1-11
MM-617C, MM-617TL, Ch. 9022, 9024	7-1	8=1-11
MM-619C, Ch. 9018	45-2	7=1-11
XOB, XQA, XQR	45-2	6=1-5
XRA, XRPS, XRPT, XSA	45-2	6=1-5
XSB, XSC, XSD, Ch. 9018	45-2	7=1-11
XSPS, XSPT, XTA, XTR	45-2	6=1-5
9018, Ch.	45-2	7=1-11
9021, 9022, 9023, 9024, Ch.	7-1	8=1-11

**MIDWEST RADIO & TELEV. CORP.**

BT-20, Ch.	7-1	8=1-6
CV-20, Ch.	7-1	8=7-11
DJ-19, Ch.	45-2	6=1-6
DM-16, DMA-16	45-2	7=1-7
DR-16, Ch.	45-2	6=1-6
DX-19, DXA-19, Ch.	45-2	7=1-7
K-19, KR-19, Ch. DJ-19	45-2	6=1-6
KX-19, Ch. DX-19	45-2	7=1-7
KXA-19, Ch. DXA-19	45-2	7=1-7
N-20, NC-20, Ch. BT-20	7-1	8=1-6
Record Changer VM-950	7-RC1	RCH22=1-16
NV-20, Ch. CV-20	7-1	8=7-11
P-16, PR-16, Ch. DR-16	45-2	6=1-6
PX-16, Ch. DM-16	45-2	7=1-7
PXA-16, Ch. DMA-16	45-2	7=1-7



MODEL	PACK-FILE	PAGES	MODEL	PACK-FILE	PAGES
<u>MITCHELL MFG. CO.</u>			<u>MOTOROLA INC. (Cont'd)</u>		
T16-2KB, T16-2KM	45-2	6=1-4	17F1, Ch. TS-118A, TS-118B	51-6	9=25-32
T16-B, T16-M	45-2	6=1-4	17F1, 17F1B, Ch. TS-118	47-5	7=35-45
T17-B, T17-M	7-1	8=1-4	17F1A, 17F1BA, Ch. TS-89	47-4	7=17-34
<u>MONTGOMERY WARD (AIRLINE)</u>			17F2W, Ch. TS-118	47-5	7=35-45
05BR-3034A, 05BR-3041A	8-1	8=1-10	17F2W, Ch. TS-118A, TS-118B	51-6	9=25-32
05GCB-3019A	45-4	6=1-10	17F2WA, Ch. TS-89	47-4	7=17-34
05WG-3038A	8-1	8=11-20	17F3B, Ch. TS-118	47-5	7=35-45
Record Changer VM-950	8-RC1	RCH22=1-16	17F3B, Ch. TS-118A, TS-118B	51-6	9=25-32
05WG-3045A	8-1	8=21-30	17F3BA, Ch. TS-89	47-4	7=17-34
Record Changer GENERAL INSTRUMENT 700F	8-RC1	RCH19=1-10	17F4, Ch. TS-118	47-5	7=35-45
15BR-3035A	8-1	8=31-40	17F4, Ch. TS-118A, TS-118B	51-6	9=25-32
Record Changer VM-950	8-RC1	RCH22=1-16	17F4A, Ch. TS-89	47-4	7=17-34
15BR-3048A	51-5	9=1-8	17F5, Ch. TS-118	47-5	7=35-45
15BR-3053A, 15BR-3053B	8-2	8=41-51	17F5, Ch. TS-118A, TS-118B	51-6	9=25-32
15GSE-3047A, 15GSE-3047B	8-2	8=52-62	17F5A, Ch. TS-89	47-4	7=17-34
15WG-3046A	8-3	8=63-70	17F5B, Ch. TS-118	47-5	7=35-45
15WG-3049A	51-5	9=9-16	17F5BA, Ch. TS-89	47-4	7=17-34
15WG-3046B	8-3	8=63-73	17F6, Ch. TS-118	47-5	7=35-45
15WG-3050A	8-3	8=74-83	17F6, Ch. TS-118A, TS-118B	51-6	9=25-32
Record Changer WEBSTER 100	8-RC1	RCH21=1-10	17F6B, Ch. TS-118	47-5	7=35-45
15WG-3050B	8-3	8=74-83	17F6BC, 17F6C, Ch. TS-174 TS-174A, TS-174B	9=1	8=1-15
Record Changer VM-950	8-RC1	RCH22=1-16	Record Changer MOTOROLA RC-36A	9-RC1	RCH21=1-16
15WG-3051A	8-3	8=63-70	17F7, Ch. TS-118A, TS-118B	51-6	9=25-32
15WG-3051B	8-3	8=63-73	17F7B, Ch. TS-118	47-5	7=35-45
16K1/63-3019	45-4	6=1-10	17F7B, Ch. TS-118A, TS-118B	51-6	9=25-32
94GCB-3023A, 94GCB-3023B, 94GCB-3023C	45-4	6=1-10	17F7BC, Ch. TS-174, TS-174A, TS-174B	9=1	8=1-15
94WG-3008A	45-4	6=11-20	Record Changer MOTOROLA RC-36A	9-RC1	RCH21=1-16
94WG-3106A, 94WG-3016B, 94WG-3016C	45-4	6=11-22	17F8, Ch. TS-118	47-5	7=35-45
94WG-3028A	45-4	6=23-32	17F8, Ch. TS-118A, TS-118B	51-6	9=25-32
<u>MOTOROLA INC.</u>			17F8C, Ch. TS-174, TS-174A, TS-174B	9=1	8=1-15
TS-53, Ch.	36-3	6=1-15	Record Changer MOTOROLA RC-36A	9-RC1	RCH21=1-16
TS-60, Ch.	47-4	7=1-16	17F9, Ch. TS-118A, TS-118B	51-6	9=25-32
TS-74, Ch.	36-3	6=51-64	17F9, 17F9B, Ch. TS-118	47-5	7=35-45
TS-88, Ch.	36-3	6=29-41	17F9BC, 17F9C, Ch. TS-174, TS-174A, TS-174B	9=1	8=1-15
TS-89, Ch.	47-4	7=17-34	Record Changer MOTOROLA RC-36A	9-RC1	RCH21=1-16
TS-94, Ch.	47-4	7=17-34	17K1A, 17K1BA, Ch. TS-95	47-4	7=17-34
TS-95, Ch.	47-4	7=17-34	17K1BE, 17K1E, Ch. TS-172	47-5	7=46-56
TS-101, Ch.	47-5	7=57-65	17K2BE, 17K2E, Ch. TS-172	47-5	7=46-56
TS-114, Ch.	36-3	6=42-50	17K3, Ch. TS-118	47-5	7=35-45
TS-115, Ch.	36-3	6=16-28	17K3, Ch. TS-118A, TS-118B	51-6	9=25-32
TS-118, Ch.	47-5	7=35-45	17K3A, 17K3BA, Ch. TS-89	47-4	7=17-34
TS-118A, TS-118B, Ch.	51-6	9=25-32	17K3B, Ch. TS-118	47-5	7=35-45
TS-119, TS-119A, TS-119B, TS-119C, Ch.	9=1	8=25-38	17K4A, Ch. TS-95	47-4	7=17-34
TS-172, Ch.	47-5	7=46-56	17K4E, Ch. TS-172	47-5	7=46-56
TS-174, TS-174A, TS-175B, Ch.	9=1	8=1-15	17K5, Ch. TS-118	47-5	7=35-45
TS-214, Ch.	51-6	9=33-40	17K5C, Ch. TS-118A, TS-118B	51-6	9=25-32
TS-216, Ch.	9=2	9=1-8	17K5C, Ch. TS-174, TS-174A, TS-174B	9=1	8=1-15
TS-221, Ch.	9=1	8=16-24	17K5E, Ch. TS-221	9=1	8=16-24
TS-236, Ch.	9=2	9=9-16	17K6, Ch. TS-118	47-5	7=35-45
TS-314, Ch.	51-6	9=17-24	17K6, Ch. TS-118A, TS-118B	51-6	9=25-32
TS-314A, Ch.	51-6	9=41-44	17K6C, Ch. TS-174, TS-174A, TS-174B	9=1	8=1-15
TS-315, Ch.	51-6	9=17-24	17K7, 17K7B, Ch. TS-118	47-5	7=35-45
TS-315A, Ch.	51-6	9=41-44	17K7, Ch. TS-118A, TS-118B	51-6	9=25-32
12K1, 12K1B, Ch. TS-53	36-3	6=1-15	17K7BC, 17K7C, Ch. TS-174, TS-174A, TS-174B	9=1	8=1-15
12K2, 12K2B, Ch. TS-53	36-3	6=1-15	17K8, 17K8B, Ch. TS-236	9=2	9=9-16
12K3, 12K3B, Ch. TS-53	36-3	6=1-15	17K10E, Ch. TS-314	51-6	9=17-24
12T1, 12T1B, Ch. TS-53	36-3	6=1-15	17K10E, Ch. TS-314A	51-6	9=41-44
12T2, 12T3, Ch. TS-53	36-3	6=1-15			
14K1, 14K1B, Ch. TS-88	36-3	6=29-41			
14K1BH, 14K1H, Ch. TS-115	36-3	6=16-28			
14T1, 14T1B, Ch. TS-88	36-3	6=29-41			
14T3, Ch. TS-114	36-3	6=42-50			
14T4, 14T4B, Ch. TS-216	9=2	9=1-8			
16F1, 16F1B, Ch. TS-60	47-4	7=1-16			
16F1BH, 16F1H, Ch. TS-89	47-4	7=17-34			
16K2, 16K2B, Ch. TS-74	36-3	6=51-64			
16K2BH, 16K2H, Ch. TS-94	47-4	7=17-34			
16T1, 16T1B, Ch. TS-60	47-4	7=1-16			
16T1BH, 16T1H, Ch. TS-89	47-4	7=17-34			



MOTOROLA  
PACKARD-BELL

MODEL	PACK-FILE	PAGES
<u>MOTOROLA INC. (Cont'd)</u>		
17K11, 17K11B, 17K11C, Ch. TS-236	9-2	9-9-16
17T1, 17T1B, Ch. TS-118	47-5	7-35-45
17T1A, 17T1BA, Ch. TS-89	47-4	7-17-34
17T2, Ch. TS-118A, TS-118B	51-6	9-25-32
17T2, 17T2B, Ch. TS-118	47-5	7-35-45
17T2A, 17T2BA, Ch. TS-89	47-4	7-17-34
17T3, Ch. TS-118	47-5	7-35-45
17T3, Ch. TS-118A, TS-118B	51-6	9-25-32
17T3A, Ch. TS-89	47-4	7-17-34
17T3G, Ch. TS-221	9-1	8-16-24
17T3X1, Ch. TS-118A, TS-118B	51-6	9-25-32
17T4, Ch. TS-118	47-5	7-35-45
17T4, Ch. TS-118A, TS-118B	51-6	9-25-32
17T4C, Ch. TS-174, TS-174A, TS-174B	9-1	8-1-15
17T4E, Ch. TS-221	9-1	8-16-24
17T5A, 17T5CA, Ch. TS-214	51-6	9-33-40
17T5D, Ch. TS-236	9-2	9-9-16
17T5E, Ch. TS-314	51-6	9-17-24
17T5E, Ch. TS-314A	51-6	9-41-44
17T5F, Ch. TS-315	51-6	9-17-24
17T5F, Ch. TS-315A	51-6	9-41-44
17T6BD, 17T6C, 17T6D, Ch. TS-236	9-2	9-9-16
17T6G, Ch. TS-314A	51-6	9-41-44
19K2, 19K2B, Ch. TS-101	47-5	7-57-65
19K2BE, 19K2E, Ch. TS-119, TS-119A	9-1	8-25-38
19K3, Ch. TS-101	47-5	7-57-65
19K4, 19K4B, Ch. TS-101	47-5	7-57-65
20F1, 20F1B, Ch. TS-119, TS-119A	9-1	8-25-38
Record Changer MOTOROLA RC-36A	9-RC1	RCH21=1-16
20F2, 20F2B, Ch. TS-119B, TS-119C	9-1	8-25-38
Record Changer MOTOROLA RC-36A	9-RC1	RCH21=1-16
20K1, 20K1B, 20K2, Ch. TS-119B, TS-119C	9-1	8-25-38
20T1B, Ch. TS-119B, TS-119C	9-1	8-25-38
<u>M. P. TELEVISION</u>		
16T503, 17T504	9-1	8-1-4
<u>MULTIPLE TELEV. MFG. CO.</u>		
EC20, Ch. 630K3B	9-1	8-1-2
HFD17, HFD20, Ch. 630K3B	9-1	8-1-2
LFD17, LFD20, Ch. 630K3B	9-1	8-1-2
OF17, OF20, OF20R, Ch. 630K3B	9-1	8-1-2
630K3B, Ch.	9-1	8-1-2
<u>MUNTZ T-V, INC.</u>		
M31, Ch. TV17A2	36-1	6-1-12
M31R, Ch. TV17A3	36-1	6-1-12
M32, M32R, Ch. TV17A3	36-1	6-1-12
M33, M34, Ch. TV17A4	36-1	6-1-12
M41, M42, Ch. TV17A3A	36-1	6-1-12
M46, M49, Ch. TV17A7	36-1	6-1-12
TV17A2, Ch.	36-1	6-1-12
TV17A3, TV17A3A, Ch.	36-1	6-1-12
TV17A4, TV17A7, Ch.	36-1	6-1-12
WG2060	51-2	9-13-20
17B1, 17B2, 17B3, 17B4, 17B5, 17B6, Ch.	51-2	9-1-12
*1750, 1751, 1752, Ch. TV17A3A	36-1	6-1-12
*2053, 2054, 2055, 2056, Ch. TV17A7	36-1	6-1-12
2053-A, 2054-A, 2055-A, Ch. 17B1, 17B2	51-2	9-1-12

\* See Muntz HANDY No. 8, Pack 36

MODEL	PACK-FILE	PAGES
<u>MUNTZ T-V, INC. (Cont'd)</u>		
2055-B, Ch. 17B2	51-2	9-1-12
2056-A, Ch. 17B1, 17B2	51-2	9-1-12
2158-A, 2159-A, Ch. 17B5,		
2162-A, Ch. 17B5, 17B6	51-2	9-1-12
2457-A, Ch. 17B3, 17B4	51-2	9-1-12
<u>NORELCO</u>		
See NORTH AMERICAN PHILLIPS CO., INC.		
<u>NORTH AMERICAN PHILLIPS CO., INC.</u> (NORELCO)		
The Irvington	38-1	6-1-11
The Mt. Vernon	38-1	6-1-11
PT200, Ch.	38-1	6-1-11
PT200, Ch. PT200, The Irvington	38-1	6-1-11
PT300, Ch. PT200, The Mt. Vernon	38-1	6-1-11
<u>OLYMPIC RADIO &amp; TELEV. INC.</u>		
Broadmoor	44-1	6-1-12
Catalina	44-1	6-1-15
Challenger	44-1	6-1-12
Lancaster, Marlborough	44-1	7-1-8
Monte Carlo	44-1	6-1-12
Prince George	44-1	6-1-15
Riviera	44-1	6-1-12
Riviera Deluxe	44-1	7-1-8
Windsor	44-1	7-1-8
DX-214, DX-215, DX-216	44-1	4-1
DX-619, DX-620	44-1	5-1-6
DX-621	44-1	5-1-7
		6-13-15
DX-622	44-1	5-1-7
DX-931, DX-932	44-1	5-1-7
DX-950	44-1	5-1-7
XL-210, XL-211	44-1	5-8-14
XL-612, XL-613	44-1	5-8-14
752, Riviera	44-1	6-1-12
752U	44-1	6-1-12
753, Monte Carlo	44-1	6-1-12
753U	44-1	6-1-12
755, Challenger	44-1	6-1-12
755U	44-1	6-1-12
762, Riviera Deluxe	44-1	7-1-8
764, Broadmoor	44-1	6-1-12
764U	44-1	6-1-12
766, Catalina	44-1	6-1-15
766U, 767	44-1	6-1-12
769, Prince George	44-1	6-1-15
783	44-1	7-1-8
967, Windsor	44-1	7-1-8
968, Lancaster	44-1	7-1-8
970, Marlborough	44-1	7-1-8
<u>PACKARD-BELL CO.</u>		
2001-TV, 2002-TV	44-2	5-1-8
2091-TV, 2092-TV	44-2	5-3-8
2101, 2102, Ch. 2101-2	44-2	7-1-9
2101-2, Ch.	44-2	7-1-9
2105, 2105A, Ch. 2101-2	44-2	7-1-9
2202-TV, 2204-TV	44-2	7-10-16
2111, Ch. 2111-2	52-3	9-15-20
2111-2, Ch.	52-3	9-15-20
2112, 2113, Ch. 2111-2	52-3	9-15-20
2114, Ch. 2114	52-3	9-15-20
2114, Ch.	52-3	9-15-20
2301, 2302	9-1	8-1-13
2311	52-3	9-1-14
2601-TV	44-2	5-9-14
2602	44-2	7-1-9
		8-14-19
2611	52-3	9-21-24
Record Changer VM-950	52-RC1	RCH22=1-16
2692-TV	44-2	5-9-14



MODEL	PACK-FILE	PAGES
<u>PACKARD BELL CO. (Cont'd)</u>		
2801-TV, 2801A-TV	44-2	8=1-7
2803	9-1	8=1-13
Record Changer WEBSTER 100	9-RC1	RCH21=1-10
2811	52-3	9=1-14
Record Changer WEBSTER 100	52-RC1	RCH21=1-10
2811, Late	52-3	9=1-14

PATHE TELEVISION CORP.

TAP, Ch.	10-1	8=1-5
14-PT	10-1	8=6-11
17-N25, Ch. TAP	10-1	8=1-5
17-PC	10-1	8=6-11
17-RPC, 17-RPT, Ch. TAP	10-1	8=1-5

PHILCO CORP.

RC-1 Remote Control Unit	10-1	8=1-4
50-T1104, Codes 121, 122	34-4	5=1-6 6=18-20
50-T1105, Codes 121, 122	34-4	5=1-6 6=19-20
50-T1106	34-4	5=1-6 6=19-20
50-T1403, Code 125	34-4	5=7-16 6=29-32
50-T1404, Codes 123, 124, 125	34-4	5=7-16 6=29-32
50-T1406, Codes 123, 124, 125	34-4	5=7-16 6=29-32
50-T1432, Code 124	34-4	5=7-16 6=29-32
50-T1443, Codes 122, 123	37-5	6=33-43
50-T1476, 50-T1477	37-5	6=44-54
50-T1478, 50-T1479	37-5	6=44-54
Record Changer PHILCO M-20	37-RC1	RCH20=1-16
50-T1481, 50-T1482	37-5	6=44-54
Record Changer PHILCO M-20	37-RC1	RCH20=1-16
50-T1483	22-2	7=1-10
50-T1484	37-5	6=44-54
50-T1600, Code 121	34-4	5=17-23
50-T1600, Code 122	22-2	7=11-17
50-T1630, Code 121	22-2	7=18-21 5=17-23
50-T1630, Code 122	22-2	7=18-32
50-T1632, 50-T1633, Code 121	34-4	5=17-23
50-T1632, 50-T1633, Code 122	22-2	7=11-17
50-702, Code 122	37-5	6=9-17 5=17-23
51-PT1207, 51-PT1208	10-1	8=5-12
51-PT1234	10-1	8=5-12
51-PT1282	10-1	8=5-12
Record Changer PHILCO M-22	10-RC2	RCH22=1-12
51-T1443B, 51-T1443L, 51-T1443M	22-2	7=33-40
51-T1443PL, 51-T1443PM, 51-T1443PW	22-2	7=41-50
51-T1443X, 51-T1443XL	22-2	7=33-40
51-T1601, 51-T1601T, 51-T1602, Codes 121, 122	22-2	7=51-58
51-T1634, Codes 123, 124	22-2	7=51-58
51-T1836, 51-T1836L, Code 123	10-1	8=14-31
51-T1838, Code 124	10-1	8=14-31
51-T1870, 51-T1872, Code 121	10-1	8=14-31
Record Changer PHILCO M-22	10-RC2	RCH22=1-12
51-T1874, 51-T1874L, Code 121	10-1	8=14-31
Record Changer PHILCO M-22	10-RC2	RCH22=1-12
51-T1875, Code 121	10-1	8=14-31
Record Changer PHILCO M-20	10-RC1	RCH20=1-16
51-T1876, Code 124	10-1	8=14-31
Record Changer PHILCO M-20	10-RC1	RCH20=1-16

MODEL	PACK-FILE	PAGES
<u>PHILCO CORP. (Cont'd)</u>		
51-T2134, 51-T2136, 51-T2138, Code 124	10-1	8=14-31
51-T2175, 51-T2176, Code 124	10-1	8=14-31
Record Changer PHILCO M-20	10-RC1	RCH20=1-16
52-T1810, 52-T1812, Codes 122, 123	22-3	9=1-16
52-T1840, 52-T1842, 52-T1844, Codes 122, 123	22-3	9=1-16
52-T1882, Codes 122, 123	22-3	9=1-16
Record Changer PHILCO M-22	22-RC2	RCH22=1-12
52-T2100, 52-T2144, Code 121	52-6	9=17-32
52-T2110, Codes 122, 123	22-3	9=1-16
52-T2142, Codes 122, 123	22-3	9=1-16
52-T2145X, Code 125	52-6	9=17-32
52-T2182, 52-T2182L, Code 121	52-6	9=17-32
Record Changer PHILCO M-22	52-RC2	RCH22=1-12
76-4402, 76-5411, 76-5433, Series; Tuners	37-5	6=1-8

PHILHARMONIC RADIO & TELEV. CORP.

C-6161, T-616	22-1	7=1-5
1116, 5816	22-1	7=1-5

PILOT RADIO CORP.

TV-125	20-1	5=1-12
TV-127	37-2	6=1-10
TV-161	20-1	5=1-12
TV-163	20-1	5=1-14
TV-164	37-2	6=1-10
TV-165	20-1	5=1-14
TV-167A	37-2	6=1-10
*TV-167B, TV-168	37-2	6=1-10
TV-191	37-2	6=1-10
*TV-191	37-2	6=1-10
TV-271, TV-273, TV-274	53-3	9=1-14
TV-293, TV-294	53-3	9=1-14

PLYMOUTH

See INTERSTATE STORES BUYING CORP.

PRECISION

See THE HERTNER ELECTRIC CO.

RADIO CORP. OF AMERICA

Bently	16-3	9=1-16
Bristol	16-5	9=73-80
Clarendon, Donley	16-4	9=45-52
Fairfield, Final	16-5	9=53-72
Hampton	16-5	9=73-80
Haywood	16-3	9=17-30
Highland, Final	16-5	9=53-72
Hillsdale	11-2	8=62-76
Kendall	16-5	9=73-80
Kent, Modern, Newport; Final	16-5	9=53-72
Preston	16-5	9=73-80
Provincial	11-2	8=62-76
Provincial, Regency; Final	16-5	9=53-72
Rockingham	16-4	9=45-52
Rutland	10-1	8=31-48
Somerville	10-1	8=1-16
Suffolk	16-4	9=45-52
Talbot	16-4	9=31-44
Winston, Final	16-5	9=53-72
York	11-2	8=62-76
KCS31-1, Ch., S1000	20-6	5=48-64
KCS31-1, Ch., 9TW390	20-6	5=32-47
KCS34C, Ch.	34-7	5=80-110
KCS38, Ch.	34-7	5=65-79
KCS38C, Ch.	20-6	5=1-15
KCS40, KCS40A, Ch.	37-8	6=1-15
KCS40B, Ch.	46-10	7=50-64
KCS41-1, Ch.	20-6	5=16-31

\* See Pilot HANDY No. 1, Pack 37.



MODEL	PACK-FILE	PAGES
<u>RADIO CORP. OF AMERICA (Cont'd)</u>		
KCS45, KCS45A, Ch.	46-9	7=1-16
KCS46, Ch.	46-9	7=17-32
KCS47, KCS47A, KCS47AT, Ch.	46-10	7=33-49
KCS47B, KCS47C, KCS47D, Ch.; Final	16-5	9=53-72
KCS47E, Ch.	16-4	9=31-44
KCS47F, KCS47G, Ch.; Final	16-5	9=53-72
KCS47GF-2, Ch.	16-3	9=17-30
KCS47T, Ch.	46-10	7=33-49
KCS48A, Ch.	10-1	8=31-48
KCS49B, KCS49C, Ch.	11-2	8=62-76
KCS60A, Ch.	11-2	8=77-94
KCS61, Ch.	16-3	9=1-16
KCS62, Ch.	10-1	8=1-16
KCS66, KCS66A, Ch.	16-5	9=73-80
KCS68C, Ch.	16-4	9=45-52
S1000, Ch. KCS31-1	20-6	5=48-64
T100, Ch. KCS38	34-7	5=65-79
T120, Ch. KCS34C	34-7	5=80-94
T121, Ch. KCS34C	34-7	5=95-110
T164, Ch. KCS40	37-8	6=1-15
TC165, TC166, TC167, TC168, Ch. KCS40A	37-8	6=1-15
2T51, Ch. KCS45	46-9	7=1-16
2T60, Ch. KCS45A	46-9	7=1-16
2T81, Ch. KCS46	46-9	7=17-32
4T101, Ch. KCS61, Bently	16-3	9=1-16
4T141, Ch. KCS62, Somerville Record Changer	10-1	8=1-16
RCA 960282-4, 960282-5	10-RC2	RCH21=19-34
RCA RP-190-2	10-RC1	RCH21=1-12
6T53, 6T54, Ch. KCS47, KCS47T	46-10	7=33-49
6T64, 6T65, Ch. KCS47A, KCS47AT	46-10	7=33-49
6T71, Ch. KCS47A, KCS47AT	46-10	7=33-49
6T72, Ch. KCS40B	46-10	7=50-64
6T74, 6T75, 6T76, Ch. KCS47A, KCS47AT	46-10	7=33-49
7T103, Ch. KCS47B, Newport, Final	16-5	9=53-72
7T104, Ch. KCS47B, Kent, Final	16-5	9=53-72
7T104B, Ch. KCS47F, Final	16-5	9=53-72
7T111B, Ch. KCS47GF-2, Haywood	16-3	9=17-30
7T112, Ch. KCS47C, Highland, Final	16-5	9=53-72
7T112B, Ch. KCS47G, Final	16-5	9=53-72
7T122, Ch. KCS47C, Fairfield, Final	16-5	9=53-72
7T122B, Ch. KCS47G, Final	16-5	9=53-72
7T123, Ch. KCS47C, Regency, Final	16-5	9=53-72
7T123B, Ch. KCS47G, Final	16-5	9=53-72
7T124, Ch. KCS47C, Modern, Final	16-5	9=53-72
7T125B, Ch. KCS47G, Provincial, Final	16-5	9=53-72
7T132, Ch. KCS47D, Winston, Final	16-5	9=53-72
7T143, Ch. KCS48A, Rutland Record Changer	10-1	8=31-48
RCA 960284	10-RC3	RCH21=35-50
RCA RP-190	10-RC1	RCH21=1-12
9T105, Ch. KCS49B, York	11-2	8=62-76
9T126, Ch. KCS49C, Hillsdale	11-2	8=62-76
9T128, Ch. KCS49C, Provincial	11-2	8=62-76
9T147, Ch. KCS60A Record Changer	11-2	8=77-94
RCA 960284	11-RC3	RCH21=35-50
RCA RP-190	11-RC1	RCH21=1-12
9T256, Ch. KCS38C	20-6	5=1-15
9TW309, Ch. KCS41-1	20-6	5=16-31
9TW390, Ch. KCS31-1	20-6	5=32-47
16T152, Ch. KCS47E, Talbot	16-4	9=31-44
17T153, Ch. KCS66, Bristol	16-5	9=73-80
17T155, Ch. KCS66, Preston	16-5	9=73-80
17T160, Ch. KCS66, Hampton	16-5	9=73-80
17T174, Ch. KCS66A, Kendall	16-5	9=73-80
21T176, Ch. KCS68C, Suffolk	16-4	9=45-52

MODEL	PACK-FILE	PAGES
<u>RADIO CORP. OF AMERICA (Cont'd)</u>		
21T177, Ch. KCS68C, Donley	16-4	9=45-52
21T178, Ch. KCS68C, Rockingham	16-4	9=45-52
21T179, Ch. KCS68C, Clarendon	16-4	9=45-52

RADIO CRAFTSMEN

RC101	15-1	8=1-5
RC100A	38-2	5=1-6
RC201	15-1	8=6-9

RAYTHEON  
See BELMONT RADIO CORP.

SCOTT RADIO LABS., INC.

Ashly, Chippendale, Cressy, Croydon, Ravenswood, Waverly, Wellington	54-1	9=1-16
AC-17, AT-17, Ch. 720, Ravenswood Record Changer	54-1	9=1-16
WEBSTER 100	54-RC1	RCH21=1-10
310, Ch. 720, Croydon Record Changer	54-1	9=1-16
MILWAUKEE 11600	54-RC1	RCH 9=1-4
320, Ch. 920, Croydon Record Changer	54-1	9=1-16
MILWAUKEE 11600	54-RC1	RCH 9=1-4
510, Ch. 720, Cressy Record Changer	54-1	9=1-16
WEBSTER 100	54-RC1	RCH21=1-10
520-TA, Ch. 920, Ashly Record Changer	54-1	9=1-16
WEBSTER 100	54-RC1	RCH21=1-10
720, Ch.	54-1	9=1-16
910, Ch. 920, Waverly Record Changer	54-1	9=1-16
WEBSTER 100	54-RC1	RCH21=1-10
920, Ch.	54-1	9=1-16
924, Ch. 924, Wellington Record Changer	54-1	9=1-16
WEBSTER 100	54-RC1	RCH21=1-10
924, Ch.	54-1	9=1-16
1000-TC, Ch. 924, Chippendale Record Changer	54-1	9=1-16
WEBSTER 100	54-RC1	RCH21=1-10

SEARS, ROEBUCK & CO.  
(SILVERTONE)

100.112, Ch.	11-1	8=1-14
100.120, Ch.	55-4	9=57-72
102-A, Ch. 549.100-7	55-4	9=49
110.111, Ch.	11-1	8=15-31
128-16, Ch. 478.337	55-3	9=13-20
132.014, Ch.	55-4	9=53-56
132.890, 132.890-1, 132.890-2, Ch.	12-2	8=53-66
143, Ch. 100.111 Record Changer	11-1	8=15-31
SEARS 100.211-20	11-RC1	RCH 9=1-16
143A, Ch. 100.111 Record Changer VM-950	11-1	8=15-31
150-14, Ch. 478.338	11-RC1	RCH22=1-16
153-16, Ch. 478.341	11-1	8=32-39
161-16, Ch. 100.112	55-3	9=9-12
163-16, Ch. 478.319	11-1	8=1-14
165-16, Ch. 100.120	55-3	9=1-8
166-16, Ch. 478.339	55-4	9=57-72
166-17, Ch. 478.339-A	55-3	9=21-36
167-16, Ch. 549.101	55-3	9=21-36
167-16A, Ch. 549.101-1	11-1	8=40-52
168-16, Ch. 549.100-7	11-1	8=40-52
175-16, 175-16A, Ch. 549.100-5, 549.100-8, 549.100-9	55-4	9=49
176-19, Ch. 549.100-6	55-4	9=37-48
179-16, 180-16, Ch. 132.890, 132.890-1, 132.890-2	55-4	9=50-52
	12-2	8=53-66



MODEL	PACK-FILE	PAGES	MODEL	PACK-FILE	PAGES
<u>SEARS, ROEBUCK &amp; CO. (Cont'd)</u>			<u>SPARTON RADIO-TELEVISION (Cont'd)</u>		
185-16, Ch. 549.101-2	11-1	8=40-52	Rochelle, Sheffield	56-2	9=22-24
186-19, Ch. 549.101-3	11-1	8=40-52	The Sparcraft	24-1	7=3-10
194-16, Ch. 132.890, 132.890-1, 132.890-2	12-2	8=53-66	The Westmont	24-1	8=1-6
195-16, Ch. 132.890, 132.890-1, 132.890-2	12-2	8=53-66	Whitney	56-2	7=3-10
Record Changer VM-950	12-RC1	RCH22=1-16	25RD190, Ch.	24-1	8=1-6
478.319, Ch.	55-3	9=1-8	25SD201, Ch.	24-1	9=1-10
478.337, Ch.	55-3	9=13-20	25SD201A, Ch.	56-2	9=17-21
478.338, Ch.	11-1	8=32-39	26SD160, Ch.	24-1	7=10
478.339, 478.339-A, 478.339-B, Ch.	55-3	9=21-36	26SD170, Ch.	24-1	8=7-13
478.341, Ch.	55-3	9=9-12	26SD170, DeLuxe, Ch., 5078BB	24-1	7=10
478.361, 478.361-A, Ch.	55-3	9=21-36	26SD170, DeLuxe, Ch., 5079B	24-1	8=14-20
478.375, 478.376, Ch.	55-3	9=13-20	26SD170P, Ch.	24-1	9=11-16
549.100-5, Ch.	55-4	9=37-48	26SD170X, 26SD170XP, Ch.	24-1	7=3-12
549.100-6, Ch.	55-4	9=50-52	26SD171, Ch.	56-2	7=3-10
549.100-7, Ch.	55-4	9=49	26SS160, 26SS160B, 26SS160L, Ch.	24-1	8=6
549.100-8, 549.100-9, Ch.	55-4	9=37-48	26SS170, Ch.	24-1	8=31
549.101, 549.101-1, 549.101-2, 549.101-3, Ch.	11-1	8=40-52	26SS170D, 26SS170DD, Ch.	56-2	7=3-10
1132-17, Ch. 478.376	55-3	9=13-20	26SS170D, 26SS170DP, Ch.	24-1	8=25-26
1146-20, Ch. 132.014	55-4	9=53-56	26SS170P, Ch.	24-1	7=3-10
1150-14, Ch. 478.361, 478.361-A	55-3	9=21-36	26SS171, 26SS171A, Ch.	56-2	8=2
1163-17, Ch. 478.375	55-3	9=13-20	5025, Ch. 26SS160	24-1	8=21-25
1166-17, Ch. 478.339-B	55-3	9=21-36	5025BA, Ch. 26SS170	24-1	9=22-24
<u>SENTINEL RADIO CORP.</u>			5026, Ch. 26SS160	24-1	7=3-12
YA, YB, YC, Ch.	38-1	7=1-13	5029, 5030, Ch. 26SD160	24-1	8=23-24
1U416	38-1	9=1-12	5035, 5036, 5037, Ch. 26SS160L	24-1	8=27-31
1U419, 1U420	38-1	5=1-8	5075BA, Ch. 26SS170	24-1	9=1-10
1U424	38-1	5=9-16	5076, Ch. 26SS160	24-1	7=5-10
1U425, 1U428, Ch. YA, YB, YC	38-1	6=1-8	5076BA, Ch. 26SS170	24-1	8=23-24
1U432, Ch. YA, YB, YC	38-1	7=1-13	5076BB, Ch. 26SS160B	24-1	8=27
1U435, Ch. YB, YC	38-1	7=1-13	5077, Ch. 26SS160	24-1	7=5-10
1U438, 1U439, 1U440, Ch. YA, YB, YC	38-1	9=1-12	5077B, Ch. 26SS160B	24-1	8=23-24
1U441, 1U443, 1U444, Ch. YA, YB, YC	38-1	9=1-12	5077BA, Ch. 26SS170	24-1	8=27
1U446, Series XD	38-1	9=1-12	5078BB, Ch. 26SD170, DeLuxe	24-1	9=17-21
416	38-1	5=1-8	5079, Ch. 26SD160	24-1	7=3-12
419, 420	38-1	5=9-16	5079B, Ch. 26SD170, DeLuxe	24-1	7=3-10
420B	38-1	6=1-8	5079BB, Ch. 26SD170, DeLuxe	24-1	8=28-31
423, 424	38-1	6=1-8	5080, Ch. 26SD160	24-1	7=3-12
425, 428, Ch. YA, YB, YC	38-1	7=1-13	5080BB, Ch. 26SD170, DeLuxe	24-1	7=3-12
432, Ch. YA, YB, YC	38-1	7=1-13	5082, 5083, Ch. 26SD170	24-1	8=6
435, Ch. YB, YC	38-1	7=1-13	5082, 5083, Ch. 26SD170X, 26SD170XP	24-1	8=31
438, 439, 440, Ch. YA, YB, YC	38-1	9=1-8			7=3-10
441, 443, 444, Ch. YA, YB, YC	38-1	9=1-8			8=28-31
<u>SHERATON TELEV. CORP.</u>					7=3-10
260-DX, 260-FM	54-1	9=1-6			8=6
260-S, 260-V	54-1	9=1-6			8=31
<u>SILVERTONE</u>					7=3-10
See SEARS, ROEBUCK & CO.					8=22
<u>SKYRIDER</u>					8=25-26
519, 520	12-1	8=1-7			7=3-10
<u>SONORA RADIO &amp; TELEV. CORP.</u>					8=6
323, 324	54-1	9=1-4			8=31
<u>SPARTON RADIO-TELEVISION</u>					7=3-12
DIV. OF					7=3-10
<u>THE SPARKS-WITHINGTON CO.</u>					8=6
Berkeley	56-2	9=1-10			8=31
Del Mar	56-2	9=22-24			7=3-10
Gramercy	56-2	9=17-21			8=2
Hanover	56-2	9=11-16			8=21-25



**SPARTON  
SYLVANIA**

MODEL	PACK-FILE	PAGES
<u>SPARTON RADIO-TELEVISION (Cont'd)</u>		
5085, 5086, Ch. 25RD190	24-1	7=10 8=7-13
5088, Ch. 26SD170, The Westmont	24-1	7=3-10 8=1-6
5089, Ch. 26SD170	24-1	7=3-10 8=1-6
5090, Ch. 26SD170, The Sparcraft	24-1	7=3-10 8=1-6
5101, 5102, 5103, Ch. 26SS170, 26SS170P	24-1	7=5-10 8=23-24 8=27
5104, 5105, Ch. 26SS170D, 26SS170DP	24-1	7=5-10 8=23-24 8=27
5107X, Ch. 26SS170D, Whitney	56-2	9=1-10
5107X, Ch. 26SS171, Whitney	56-2	9=17-21
5108, Ch. 26SS170D, Whitney	56-2	9=1-10
5110, Ch. 26SS170DD, Berkeley	56-2	9=1-10
5125, Ch. 26SS170DD	56-2	9=1-10
5152, 5153, 5154, Ch. 26SS170, 26SS170P	24-1	7=5-10 8=23-24 8=27
5155, 5156, 5157, Ch. 26SD170X, 26SD170XP	24-1	7=3-10 8=2 8=21-25
5158, Ch. 26SD170, 26SD170P	24-1	7=3-10 8=2 8=21-25
5162X, 5163X, Ch. 26SS171A, Gramercy	56-2	9=17-21
5165X, 5166X, Ch. 26SD171, Sheffield	56-2	9=22-24
5170, 5171, Ch. 25SD201	24-1	7=10 8=14-20
5175X, Ch. 26SD171, Rochelle	56-2	9=22-24
5178X, Ch. 26SD171, Del Mar	56-2	9=22-24
5182, 5183, Ch. 26SD170, 26SD170P	24-1	7=3-10 8=2 8=21-25
5188, 5189, Ch. 26SD170, 26SD170P	24-1	7=3-10 8=2 8=21-25
5191, 5192, Ch. 25SD201A, Hanover	56-2	9=11-16
<u>SPENCER-KENNEDY LABS., INC.</u>		
212TV, Booster	12-1	8=1-3
<u>STANDARD COIL PRODUCTS CO. INC.</u>		
B-51, Booster	12-1	8=1
<u>STEWART-WARNER ELECTRIC DIV. OF STEWART-WARNER CORP.</u>		
9120-A, 9120-B, 9120-C, 9120-D, 9120-E, 9120-F	24-2	7=1-17
9121-A, 9121-B	24-2	7=18-36
9122-A	12-1	8=1-19
9125-A	56-4	9=19-36
Record Changer STEW. WARNER VM-509032	56-RC1	RCH 9=1-16
9126-A, 9126-B	56-4	9=37-41
9127-A	56-4	9=42-46
9200-A, 9200-C, 9200-D, 9200-FA, 9200-G	12-1	8=20-36
9202-C, 9202-DA, 9202-DB, 9202-DD, 9202-E, 9202-F	12-1	8=37-53
9203-A	25-3	9=1-18

MODEL	PACK-FILE	PAGES
<u>STROMBERG-CARLSON CO.</u>		
Cavalier, Futura	23-2	9=1-8
24C, 24CM, Ch. 112126	23-2	7=1-8
24RP, 24 Series, Ch. 112119	23-2	7=1-8
24RPM, 24 Series, Ch. 112119	23-2	7=1-8
Record Changer WEBSTER 100	23-RC1	RCH21=1-10
119CDM, 119CM, Ch. 112107	23-2	7=9-20
119M5A, 119M5D, 119M5G, 119M5I, 119M5M, 119M5R, Ch. 112114	23-2	7=9-20
119RPM, 119RPM2, Ch. 112114	23-2	7=9-20
317RPM, Ch. 112120	15-1	8=1-8
Record Changer VM-950	15-RC1	RCH22=1-16
317TM, Ch. 112121	15-1	8=1-8
321CD2M, 321CD2O, 321 Series, Ch. 112127, Futura	23-2	9=1-8
321CF, 321C2M, Ch. 112127, Cavalier	23-2	9=1-8
112107, Ch.	23-2	7=9-20
112114, Ch.	23-2	7=9-20
112119, Ch.	23-2	7=1-8
112120, 112121, Ch.	15-1	8=1-8
112126, Ch.	23-2	7=1-8
112127, Ch.	23-2	9=1-8
<u>SUPREMACY See MACY'S</u>		
<u>SURREY See BENRAY ELECTRONICS CORP.</u>		
<u>SYLVANIA ELECTRIC PRODUCTS INC.</u>		
1-197-2, Ch. 1-227	13-1	8=53-63
1-227, Ch.	13-1	8=53-63
1-231, Ch.	13-2	8=105-117
1-245-2, Ch. 1-227	13-1	8=53-63
1-247-1, Ch. 1-231	13-2	8=105-117
1-260, 1-261, Ch.	23-3	7=1-23
1-329, Ch.	13-1	8=64-82
1-356(CO5), Ch.	13-2	8=160-173
1-366, Ch.	23-3	7=1-23
1-366(CO8), Ch.	13-2	8=140-153
1-366-66, Ch.	23-3	7=1-23
1-381, Ch.	13-1	8=64-81
1-387, Ch.	13-1	8=83-98
1-387(CO7), Ch.	13-2	8=118-131
1-387-1, Ch., 22M-1	13-2	8=118-139
1-387-1, Ch., 25M	25-4	9=15-30
1-437, Ch.	23-3	7=24-37
1-437-1, Ch.	25-4	9=1-14
		9=41-52
1-441, Ch.	23-3	7=1-23
		8=99-104
1-441(CO2), Ch.	13-2	8=140-159
1-442, Ch.	23-3	7=24-37
1-502-1, Ch.	25-4	9=31-40
22M, Ch. 1-387(CO7)	13-2	8=118-131
22M-1, 23B, 23M, 24M-1, Ch. 1-387-1	13-2	8=118-139
25M, Ch. 1-387-1	25-4	9=15-30
Record Changer VM-950	25-RC1	RCH22=1-16
71M, Ch. 1-441(CO2)	13-2	8=140-153
71M-1, 72B-1, Ch. 1-502-1	25-4	9=31-40
72M, Ch. 1-366	23-3	7=1-23
72M, Ch. 1-366(CO8)	13-2	8=140-153
72M-1, Ch. 1-502-1	25-4	9=31-40
73B, Ch. 1-366(CO8)	13-2	8=140-153
73M, Ch. 1-366	23-3	7=1-23
73M, Ch. 1-366(CO8)	13-2	8=140-153
74B-1, Ch. 1-437-1	25-4	9=41-52
74M, Ch. 1-356(CO5)	13-2	8=160-173
74M-1, Ch. 1-437-1	25-4	9=41-52
75B, 75M, Ch. 1-437-1	25-4	9=1-14
Record Changer VM-950	25-RC1	RCH22=1-16
1110X, Ch. 1-329	13-1	8=64-82
1210X, Ch. 1-381	13-1	8=64-81
2221M, Ch. 1-387	13-1	8=83-98
4120M, 4130B, Ch. 1-260, 1-261	23-3	7=1-23



MODEL	PACK-FILE	PAGES	MODEL	PACK-FILE	PAGES
<u>SYLVANIA ELECTRIC PRODUCTS INC. (Cont'd)</u>			<u>TELE-TONE RADIO CORP. (Cont'd)</u>		
4130E, Ch. 1-260	23-3	7=1-23	TAP-2, Ch.	41-2	7=1-12 8=1-3
4130M, 4130W, Ch. 1-260, 1-261	23-3	7=1-23	TH, TJ, Rev., Ch.	41-2	6=1-8
6110X, Ch. 1-261	23-3	7=1-23	TT, Ch.	41-2	6=1-8
6120B, 6120M, 6120W, Ch. 1-260, 1-261	23-3	7=1-23	TV-284, Ch. TT	41-2	6=1-8
6130B, 6130M, 6130W, Ch. 1-260, 1-261	23-3	7=1-23	TV-286, Ch. TH, TJ, Rev.	41-2	6=1-8
7110X, Ch. 1-366	23-3	7=1-23	TV-287, TV-288, Ch. TT	41-2	6=1-8
7110XB, Ch. 1-441	23-3	8=99-104	TV300, TV301, Ch. TW, TX	41-2	6=9-14
7110XF, Ch. 1-366-66	23-3	7=1-23	TV304, TV305, Ch. TW, TX	41-2	6=9-14
7110XFA, Ch. 1-442	23-3	7=1-23	TV306, Ch. TZ	41-2	6=18-26
7111M, Ch. 1-441	23-3	8=99-104	TV307, Ch. TX	41-2	6=18-26
7111MA, Ch. 1-366	23-3	7=1-23	TV314, Ch. TAJ	41-2	6=18-26 7=1-3
7120B, 7120M, 7120W, Ch. 1-366	23-3	7=1-23	TV315, Ch. TAA, TAB	41-2	6=9-17
7120BF, 7120MF, Ch. 1-366-66	23-3	7=1-23	TV316, Ch. TZ	41-2	6=18-26
7120MFA, Ch. 1-442	23-3	7=24-37	TV317, Ch. TAG	41-2	6=18-26 7=4-6
7120WF, Ch. 1-366-66	23-3	7=1-23	TV318, Ch. TAM	41-2	7=7-12
7130, 7130M, 7130W, Ch. 1-366	23-3	7=24-37	TV322, TV323, Ch. TAM	41-2	7=7-12
7130BF, 7130MF, Ch. 1-366-66	23-3	7=1-23	TV324, TV325, TV326, Ch. TAP-2	41-2	7=1-12
7130MFA, Ch. 1-442	23-3	7=1-23	TV328, TV329, Ch. TAP-2	41-2	8=1-3
7130WF, Ch. 1-366-66	23-3	7=1-23	TV330, TV331, TV332, TV333, Ch. TAO	14-1	8=4-10
7140MA, 7140WA, Ch. 1-437	23-3	7=24-37	TV335, TV336, Ch. TAP-2	41-2	7=1-12
<u>TECH-MASTER PRODUCTS CO. (VIDEOLA)</u>			TW, Ch.	41-2	8=1-3
17U-A, Ch.	14-1	8=1-9	TX, Ch.	41-2	7=1-12
5116, Ch. 17U-A	14-1	8=1-9	TZ, Ch.	41-2	8=1-3
<u>TELE KING CORP.</u>			<u>TELEVISION EQUIPMENT CORP.</u>		
K-21, K-21B, K-22, Ch. TVJ	41-1	9=1-16	3505, Booster	14-1	8=1
K-71, K-72, K-72B, Ch. TVJ	41-1	9=1-16	<u>TRAD TELEVISION CORP.</u>		
K-73L, K-74, Ch. TVJ	41-1	9=1-16	C-2020, C-2420, CD-2020, Series T-20E	54-1	9=1-16
KC-21, KC-21B, Ch. TVJ	41-1	9=1-16	T-1720, Series T-20E	54-1	9=1-16
KC-71, KC-71B, Ch. TVJ	41-1	9=1-16	<u>TRANS-VUE CORP.</u>		
KD-21M, KD-22B, Ch. TVJ	41-1	9=1-16	1700C, 1700CD, 1700T	14-1	8=1-6
KD-71, KD-72B, Ch. TVJ	41-1	7=1-11	<u>TRUETONE</u>		
TVG, Ch.	41-1	9=1-16	See WESTERN AUTO SUPPLY CO.		
TVJ, Ch.	41-1	7=1-11	<u>VIDAIRE TELEVISION CO.</u>		
172LO, 172M, Ch. TVG	41-1	7=1-11	501	14-1	8=1-6
174LO, 174M, Ch. TVG	41-1	7=1-11	<u>VIDEOLA</u>		
202LO, 202M, Ch. TVG	41-1	7=1-11	See TECH-MASTER PRODUCTS CO.		
203, 205, Ch. TVG	41-1	7=1-11	<u>JOHN WANAMAKER</u>		
916, 916CAF, Ch. TVG	41-1	7=1-11	C1720T, C1720T, See		
919, 919CAF, Ch. TVG	41-1	7=1-11	TRAD Ch. T-20E	54-1	9=1-16
1014, 1016, Ch. TVG	41-1	7=1-11	T-1720, Series T-20E	54-1	9=1-16
<u>TELEKIT</u>			C2020T, C2020V, See		
See ELECTRO-TECHNICAL INDUSTRIES			TRAD Ch. T-20E	54-1	9=1-16
<u>TELEQUIP RADIO CO.</u>			C2420D, CD2020W, See		
C517, C517B, Ch. 5050, 5050A	14-1	8=1-8	TRAD Ch. T-20E	54-1	9=1-16
C617, C617B, Ch. 5050, 5050A	14-1	8=1-8	C2020T, C2020V, See		
C720, C720B, Ch. 5050, 5050A	14-1	8=1-8	TRAD Ch. T-20E	54-1	9=1-16
C820, C820B, Ch. 5050, 5050A	14-1	8=1-8	C2420D, CD2020W, See		
T417, T417B, T620, Ch. 5050, 5050A	14-1	8=1-8	TRAD Ch. T-20E	54-1	9=1-16
12TR	41-2	6=1-8	C2020T, C2020V, See		
14T, 14TR	41-2	6=1-8	TRAD Ch. T-20E	54-1	9=1-16
16T, 16TR	41-2	6=1-8	<u>WESTERN AUTO SUPPLY CO. (TRUETONE)</u>		
19T, 19TR	41-2	6=1-8	2D1091, Ch. 12AX27	53-2	9=41-48
5050, 5050A, Ch.	14-1	8=1-8	2D1092	53-2	9=37-40
<u>TELE-TONE RADIO CORP.</u>			2D1094A	14-1	8=1-9
TAA, TAB, Ch.	41-2	6=9-17	Record Changer GENERAL		
TAG, Ch.	41-2	6=18-26	INSTRUMENT 700F		
TAJ, Ch.	41-2	7=4-6	2D1095A, Ch. 16AX27	14-RC1	RCH19=1-10
TAM, Ch.	41-2	6=18-26	2D1185A	53-2	9=1-8
TAO, Ch.	14-1	8=4-10			



WESTERN AUTO  
ZENITH

MODEL	PACK-FILE	PAGES	MODEL	PACK-FILE	PAGES
<u>WESTERN AUTO SUPPLY CO. (Cont'd)</u>			<u>WESTINGHOUSE ELECTRIC CORP. (Cont'd)</u>		
2D1194A	14-1	8=10-19	H-651K17, Ch. V-2200-1, V-2204-1	15-1	8=45-52
Record Changer GENERAL INSTRUMENT 700F	14-RC1	RCH19=1-10	H-652K20, Ch. V-2194-2, V-2194-3	15-1	8=32-44
2D1190A	14-1	8=28-35	H-653K24, Ch. V-2201-1	21-2	9=9-16
2D1190B	14-1	8=28-38	H-654T17, Ch. V-2175-3, V-2175-4, V-2192, V-2192-1	54-4	9=17-24
2D2043A, 2D2047B, Ch. 12AX27	53-2	9=41-48	H-655K17, H-656K17, H-657K17, Ch. V-2200-1	15-1	8=14-31
2D2049A, Ch. 16AY210	53-2	9=9-20	H-658T17, Ch. V-2192, V-2192-1	15-1	8=45-53
2D2052A, 2D2052B, Ch. 16AY210	53-2	9=9-20	H-659T17, Ch. V-2204-1	15-1	8=14-31
2D2052C, Ch. 17AY23	53-2	9=21-28	H-660C17, H-661C17, Ch. V-2203-1	21-2	9=1-8
2D2052D, 2D2052E, Ch. 17AY28	53-2	9=29-36	H-662K20, Ch. V-2201-1	21-2	9=9-16
12AX27, Ch.	53-2	9=41-48	H-663T17, Ch. V-2192, V-2192-2	15-1	8=14-26
16AY210, Ch.	53-2	9=9-20	H-664K17, Ch. V-2200-1	15-1	8=45-54
16AX27, Ch.	53-2	9=1-8	V-2150-94C, Ch.	42-3	6=10-17
17AY23, Ch.	53-2	9=21-28	V-2150-111, Ch.	42-3	6=1-9
17AY28, Ch.	53-2	9=29-36	V-2150-136, Ch.	42-3	6=18-24
<u>WESTINGHOUSE ELECTRIC CORP.</u>			V-2150-146, Ch.	42-3	6=33-40
Carlyle	54-4	9=17-24	V-2150-176, Ch.	42-3	6=41-47
H-606K12, H-607K12, Ch. V-2150-111	42-3	6=1-9	V-2150-176U, V-2150-177U	42-3	6=41-47
H-609T10, Ch. V-2150-94C	42-3	6=10-17	V-2150-186A, V-2150-186C, V-2150-186CA	21-2	7=1-8
H-610T12, Ch. V-2150-136	42-3	6=18-24	H-619T12, Ch. V-2150-176	42-3	7=9-15
H-611C12, Ch. V-2152-16	42-3	6=25-32	H-619T12U, Ch. V-2150-176U, V-2150-177U	42-3	6=41-47
H-613K16, Ch. V-2150-146	42-3	6=33-40	H-620K16, H-622K16, Ch. V- 2150-186, V-2150-186A, V-2150-186C, V-2150-186CA	21-2	7=16-24
H-614T12, Ch. V-2150-136	42-3	6=18-24	H-625T12, Ch. V-2150-197	21-2	7=34-35
H-615C12, Ch. V-2152-16	42-3	6=25-32	H-626T16, Ch. V-2172	21-2	7=16-24
H-617T12, Ch. V-2150-176	42-3	6=41-47	H-627K16, H-628K16, H-629K16, Ch. V-2171	21-2	7=34-35
H-618T16, Ch. V-2150-186, V-2150-186A, V-2150-186C, V-2150-186CA	21-2	7=1-8	H-630T14, Ch. V-2176	21-2	7=27-35
H-619T12, Ch. V-2150-176	42-3	6=41-47	H-633C17, H-634C17, Ch. V-2173	15-1	8=32-39
H-619T12U, Ch. V-2150-176U, V-2150-177U	42-3	6=41-48	H-636T17, Ch. V-2175	21-2	7=36-42
H-620K16, H-622K16, Ch. V- 2150-186, V-2150-186A, V-2150-186C, V-2150-186CA	21-2	7=1-8	H-637T14, Ch. V-2177	21-2	8=14-31
H-625T12, Ch. V-2150-197	21-2	7=9-15	H-638K20, Ch. V-2178	21-2	8=14-31
H-626T16, Ch. V-2172	21-2	7=16-24	H-639T17, Ch. V-2192, V-2192-1	15-1	7=16-24
H-627K16, H-628K16, H-629K16, Ch. V-2171	21-2	7=16-24	H-640T17, Ch. V-2175-3, V-2175-4	15-1	7=16-26
H-630T14, Ch. V-2176	21-2	7=16-24	H-640T17, Ch. V-2192, V-2192-1, V-2192-2, V-2192-3	15-1	7=27-35
H-633C17, H-634C17, Ch. V-2173	15-1	8=4-13	H-640T17A, Ch. V-2192	15-1	8=32-39
H-636T17, Ch. V-2175	21-2	7=16-25	H-641K17, Ch. V-2175-1, V-2175-5	15-1	7=36-42
H-637T14, Ch. V-2177	21-2	7=34-35	H-641K17, Ch. V-2192, V-2192-1, V-2192-2, V-2192-3	15-1	8=14-31
H-638K20, Ch. V-2178	21-2	7=16-26	H-641K17A, Ch. V-2192-1	15-1	8=14-26
H-639T17, Ch. V-2192, V-2192-1	15-1	7=27-35	H-642K20, Ch. V-2178-1, V-2178-3	15-1	8=14-24
H-640T17, Ch. V-2175-3, V-2175-4	15-1	8=14-23	H-642K20A, Ch. V-2194, V-2194-1	15-1	8=32-39
H-640T17, Ch. V-2192, V-2192-1, V-2192-2, V-2192-3	15-1	8=14-26	H-643K16, Ch. V-2179, V-2179-1	21-2	9=1-16
H-640T17A, Ch. V-2192	15-1	8=14-24	H-646K17, H-647K17, Ch. V-2175-3, V-2192	15-1	9=1-16
H-641K17, Ch. V-2175-1, V-2175-5	15-1	8=14-21	H-648T20, Ch. V-2201-1	21-2	9=1-16
H-641K17, Ch. V-2192, V-2192-1, V-2192-2, V-2192-3	15-1	8=28-30	H-649C17, Ch. V-2200-1	15-1	9=1-16
H-641K17A, Ch. V-2192-1	15-1	8=14-26	H-649T17, Ch. V-2192-4	15-1	6=1-20
H-642K20, Ch. V-2178-1, V-2178-3	15-1	8=14-24	H-650T17, Ch. V-2192-4	15-1	6=1-20
H-642K20A, Ch. V-2194, V-2194-1	15-1	8=32-39	H-650T17, Ch. V-2200-1	15-1	6=1-20
H-643K16, Ch. V-2179, V-2179-1	21-2	8=32-43	<u>ZENITH RADIO CORP.</u>		
H-646K17, H-647K17, Ch. V-2175-3, V-2192	15-1	7=36-42	Aldrich	42-3	6=1-20
H-648T20, Ch. V-2201-1	21-2	8=14-30	Barrett, Barrie	21-2	9=1-16
H-649C17, Ch. V-2200-1	15-1	9=9-16	Burton, Byron	42-3	6=1-20
H-649T17, Ch. V-2192-4	15-1	8=45-52	Carlyle, Chesterton	21-2	9=1-16
H-650T17, Ch. V-2192-4	15-1	8=14-27	Churchill	42-3	6=1-20
H-650T17, Ch. V-2200-1	15-1	8=14-27	Coleridge, J2051E	21-2	9=1-16
		8=45-52	Coleridge, H2439R	42-3	6=1-20
		8=45-52	Conrad	21-2	9=1-16
		8=45-52	Fielding, J2030R	21-2	9=1-16
		8=45-52	Fielding, H2437E	42-3	6=1-20
		8=45-52	Galsworthy	21-2	9=1-16
		8=45-52	Garland	42-3	6=1-20
		8=45-52	Hawthorne, J2026R	21-2	9=1-16
		8=45-52	Hawthorne, H3267	42-3	6=1-20
		8=45-52	Irving, Kilmer	42-3	6=1-20
		8=45-52	Kipling	21-2	9=1-16
		8=45-52	Lowell	42-3	6=1-20
		8=45-52	Mansfield	42-3	6=1-20
		8=45-52	Markham	21-2	9=1-16
		8=45-52	Meredith, Morley	42-3	6=1-20
		8=45-52	Shelley	42-3	6=1-20



MODEL	PACK-FILE	PAGES	MODEL	PACK-FILE	PAGES
<b>ZENITH RADIO CORP. (Cont'd)</b>			<b>ZENITH RADIO CORP. (Cont'd)</b>		
Tennyson	42-3	6=1-20	H-3074R, Ch. 20H20	15-1	8=1-8
Thackeray, J2054R	21-2	9=1-16	H3267, Ch. 24H20, Hawthorne	42-3	6=1-20
Thackeray, H3477R	42-3	6=1-20	H3267R, H3267RQ, Ch. 24H20	42-3	6=1-20
Walpole	42-3	6=1-20	H3469E, Ch. 24H20, Wordsworth	42-3	6=1-20
Walton, J2044R	21-2	9=1-16	H3469EQ, Ch. 24H20	42-3	6=1-20
Walton, H2328R	42-3	6=1-20	H3475R, Ch. 24H20, Kilmer	42-3	6=1-20
Warton	42-3	6=1-20	H3475RQ, Ch. 24H20	42-3	6=1-20
Wordsworth, J2043R	21-2	9=1-16	H3477R, Ch. 24H21, Thackeray	42-3	6=1-20
Wordsworth, H3469E	42-3	6=1-20	H3477RQ, Ch. 24H21	42-3	6=1-20
H-2029R, H 2030E,			H3478E, Ch. 24H21, Shelley	42-3	6=1-20
H-2030R, Ch. 20H20	15-1	8=1-8	H3478EQ, Ch. 24H21	42-3	6=1-20
H-2041R, Ch. 20H20	15-1	8=1-8	J2026R, Ch. 20J22,		
H-2052R, H-2053R, Ch. 20H20	15-1	8=1-8	Hawthorne	21-2	9=1-16
H2226E, Ch. 22H20	42-3	6=1-20	J2027E, Ch. 20J21, Barrett	21-2	9=1-16
H2226R, Ch. 22H20, Warton	42-3	6=1-20	J2027R, Ch. 20J21	21-2	9=1-16
H2226RQ, Ch. 22H20	42-3	6=1-20	J2029E, J2029R, Ch. 20J21,		
H2227E, Ch. 22H20, Garland	42-3	6=1-20	Markham	21-2	9=1-16
H2227EQ, Ch. 22H20	42-3	6=1-20	J2030E, Ch. 20J21	21-2	9=1-16
H2227R, Ch. 22H20, Walpole	42-3	6=1-20	J2030R, Ch. 20J21, Fielding	21-2	9=1-16
H2227RQ, Ch. 22H20	42-3	6=1-20	J2040E, Ch. 20J21, Conrad	21-2	9=1-16
H2250R, Ch. 22H20, Lowell	42-3	6=1-20	J2042R, Ch. 20J21,		
H2250RQ, Ch. 22H20	42-3	6=1-20	Galsworthy	21-2	9=1-16
H2255E, Ch. 22H20, Morley	42-3	6=1-20	J2043R, Ch. 20J21, Wordsworth	21-2	9=1-16
H2255EQ, Ch. 22H20	42-3	6=1-20	J2044E, Ch. 20J21	21-2	9=1-16
H2328E, Ch. 23H22	42-3	6=1-20	J2044R, Ch. 20J21, Walton	21-2	9=1-16
H2328EZ, Ch. 23H22Z	42-3	6=1-20	J2051E, Ch. 20J22, Coleridge	21-2	9=1-16
H2328R, Ch. 23H22, Walton	42-3	6=1-20	J2053R, Ch. 20J22, Chesterton	21-2	9=1-16
H2328RQ, Ch. 23H22	42-3	6=1-20	J2054R, Ch. 20J22, Thackeray	21-2	9=1-16
H2328RQZ, H2328RZ,			J2055R, Ch. 20J22, Carlyle	21-2	9=1-16
Ch. 23H22Z	42-3	6=1-20	J2126R, Ch. 21J21	21-2	9=1-16
H2329R, Ch. 23H22, Burton	42-3	6=1-20	J2127E, J2127R, Ch. 21J20	21-2	9=1-16
H2329RQ, Ch. 23H22	42-3	6=1-20	J2129E, J2129R, Ch. 21J20	21-2	9=1-16
H2329RZ, Ch. 23H22Z	42-3	6=1-20	J2130E, J2130R, Ch. 21J20	21-2	9=1-16
H2352R, Ch. 23H22, Mansfield	42-3	6=1-20	J2140E, J2142R, J2143R,		
H2352RQ, Ch. 23H22	42-3	6=1-20	Ch. 21J20	21-2	9=1-16
H2352RQZ, H2352RZ,			J2144E, J2144R, Ch. 21J20	21-2	9=1-16
Ch. 23H22Z	42-3	6=1-20	J2151E, J2153R, J2154R,		
H2353E, Ch. 23H22, Meredith	42-3	6=1-20	J2155R, Ch. 21J21	21-2	9=1-16
H2353EQ, Ch. 23H22	42-3	6=1-20	J2868R, Ch. 20J21, Kipling	21-2	9=1-16
H2353EQZ, H2353EZ, Ch.			Record Changer		
23H22Z	42-3	6=1-20	ZENITH S14029	21-RC1	RCH21=9-24
H2437E, Ch. 24H20, Fielding	42-3	6=1-20	J2968R, Ch. 21J20	21-2	9=1-16
H2437EQ, Ch. 24H20	42-3	6=1-20	Record Changer		
H2437R, Ch. 24H20, Irving	42-3	6=1-20	ZENITH S14029	21-RC1	RCH21=9-24
H2437RQ, Ch. 24H20	42-3	6=1-20	J3069E, Ch. 20J21, Barrie	21-2	9=1-16
H2438R, Ch. 24H20, Aldrich	42-3	6=1-20	Record Changer		
H2439R, Ch. 24H20, Coleridge	42-3	6=1-20	ZENITH S14029	21-RC1	RCH21=9-24
H2438RQ, Ch. 24H20	42-3	6=1-20	J3169E, Ch. 21J20	21-2	9=1-16
H2445R, Ch. 24H21, Tennyson	42-3	6=1-20	Record Changer		
H2445RQ, Ch. 24H21	42-3	6=1-20	ZENITH S14029	21-RC1	RCH21=9-24
H2447R, Ch. 24H21, Byron	42-3	6=1-20	20H20, Ch.	15-1	8=1-8
H2447RQ, Ch. 24H21	42-3	6=1-20	20J21, 20J22, 21J20, 21J21, Ch.	21-2	9=1-16
H2449E, Ch. 24H20, Churchill	42-3	6=1-20	22H20, 23H22, 23H22Z, Ch.	42-3	6=1-20
H-2868R, Ch. 20H20	15-1	8=1-8	24H20, 24H21, Ch.	42-3	6=1-20

# TELL-A-FAULT does your troubleshooting for you!

TELL-A-FAULT is a completely new troubleshooting service for electronics technicians. Nothing like it has ever been attempted in the servicing industry. *It is practical information for the practical man.* No theory!

Specifically, TELL-A-FAULT deals with the troubleshooting (symptoms and cures) of all types of television receivers — also radio receivers, record changers and recorders. Special emphasis, however, is given to television.

TELL-A-FAULT is a quadruple-threat service consisting of (1) time-saving, pictorial, symptom and cure sheets, (2) circuit guides, (3) servicing-technique short cuts, and (4) the usage of all sorts of test equipment. All information is practical.

### Available at Low Cost

*How much does a subscription cost you?* We estimate that you can save anywhere from 50 to 200 hours in servicing time by using TELL-A-FAULT. A quick computation on your part

tells you how much this means to you in dollars. We are certain your estimate comes to many, many times the cost of a year's subscription to TELL-A-FAULT. Twelve months of the *complete*, TELL-A-FAULT troubleshooting service, including all features shown, costs you only \$10.00 — less than twenty cents a week!

REMEMBER! TELL-A-FAULT pays for itself if you use only one or two symptom sheets during the year. Save time and eliminate guesswork in troubleshooting — use TELL-A-FAULT! The information you use comes from troubleshooting EXPERTS! Whether you have one year's experience or twenty years' experience, TELL-A-FAULT can serve you equally well!

write to Dept. TF 6

John F. Rider Publisher, Inc. 480 Canal St. New York 13, N. Y.



**The Automatic Answer  
to Your Booster Problems...**

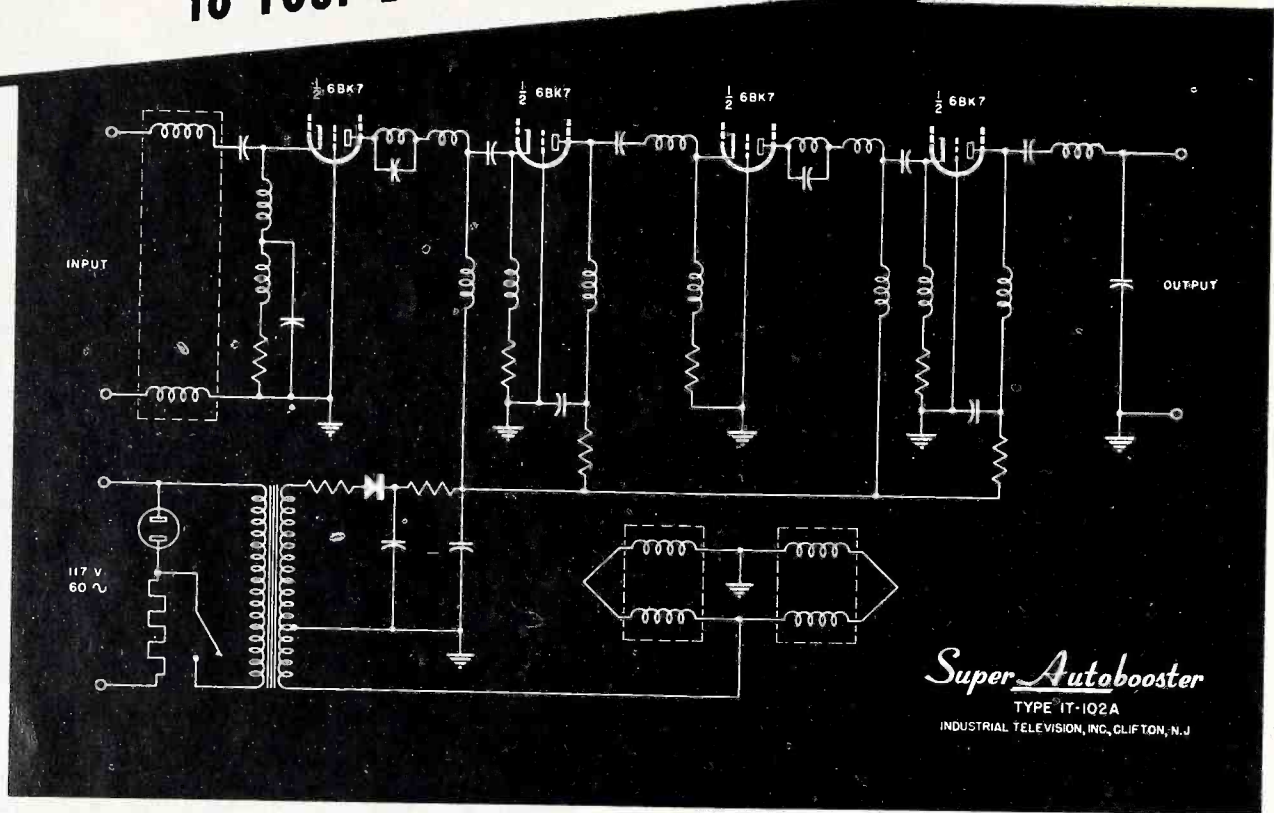

*Super Autobos*  
TYPE IT-102A  
INDUSTRIAL TELEVISION, INC., CLIFTON, N. J.

**the NEW IT-102A Super AUTObooster**

**4 Stage  
Amplification**

**9 db  
Noise  
Factor**

**19 db  
Gain**

**Guaranteed (Parts and Alignment) for 1 Full Year**

Using the new 6BK7A dual triode in a unique\* multiple resonant circuit, the IT-102A Super Autoboster provides a minimum of 19 db gain over both bands.

Because of its low noise factor, the IT-102A delivers uniform high useable gain at moderate cost even with the newest "low noise" TV receivers.

- Wide Band—No Tuning
- Automatic Thermal Relay
- High Useable Gain
- Heavy Duty Dual Transformer Power Supply
- Low Noise
- Fully Guaranteed

**Order Today From Your Jobber On Money Back Guarantee**  
Write today for specifications on all Industrial fringe area products.

\*Licensed under Allen B. Du Mont Laboratories, Inc., Patent Rights

**Industrial Television, Inc.**  
369 LEXINGTON AVE., CLIFTON, NEW JERSEY





# Radio's MASTER REPORTS

A monthly summary of product developments and price changes supplied by RADIO'S MASTER, the Industry's Official Buying Guide, available through local parts distributors.

**COMMENT:** The trend toward introducing new items continues as it has for the past 5 months. It is noticeable at this time that there are a greater number of manufacturers involved than in the past. Tube and antenna manufacturers are showing more activity than in the past 4 months.

### New Items

- ALTEC LANSING—Added 2 amplifiers . . . 2 mikes . . . 2 loudspeakers and model 606 cabinet and model 20607 replacement head assembly.
- AMERICAN ELECTRICAL HEATER — Introduced model 571A, soldering stand . . . model 3128A, an angle-type soldering iron . . . model 3907A, wooden soldering handle and model 9272A, a new heating element.
- AMERICAN MICROPHONE—Added model CL-3, crystal lapel microphone.
- BARKER & WILLIAMSON — Introduced No. 3975, Balun coils (which will match 75 ohm unbalanced transmitter outputs to 75 and 300 ohm balanced feed lines) at \$4.65 net each coil, and added dip meter model 600 at \$48.00 net.
- BLONDER-TONGUE LABS.—Added model WH-1, weather-proof housing for outdoor installation model RC-1, remote control unit for automatic on-off operation of B-T units . . . model LLE-1, line loss equalizer for graduated attenuation from 17 db. to less than 1 db. on channel 13 . . . models LS4-1 through LS4-4, line splitters for dividing 75 ohm and 300 ohm lines . . . and model AT-1, attenuator for reducing signal level 0-42 db. in 6 db. steps on all channels.
- BURGESS BATTERY—Introduced a new 1½ volt portable radio "A" battery, model 21 at \$1.75 net and model P45, a 67½ volt portable radio "B" battery at \$2.06 net.
- CREST LABS.—Introduced series MT, SMT, and MMT transistor transformers . . . also 3 CR tube rejuvenators.
- ELECTRONICS MEASUREMENT—Added high voltage lead, HVT at \$7.95 net.
- FISHER RADIO CORP.—Introduced model 50-C, master audio control at \$94.50 net and model 50-A, a laboratory standard amplifier at \$159.50 net.
- G. E.—Added GL-6183, an air cooled version of the GL-6019, at \$680.00 net available in December . . . 22 new transmitting and industrial type tubes and 3 new mercury switches.
- GUARDIAN ELECTRIC MFG.—Added No. 200-5 to their contact switch assembly series at \$3.35 net.
- HEXACON ELECTRIC—Introduced model P-25, pin-point instrument soldering iron at \$5.00 net. (weight 3 oz., less cord.)
- INDUSTRIAL TELEVISION—Added model IT-105R, field strength meter (VHF-UHF) at \$89.95 net and model IT-116B, battery pack for IT-105R at \$29.95 net.
- JACKSON ELECT. INSTR.—Added CR tube analyzer model 707 at \$149.50 net.
- JFD—Introduced "Formvar" open-line all copper lead-in wire, available in 100, 200, 250, and 500 foot spool lengths at \$19.80 net/M'.
- KENWOOD ENGINEERING—Added model S40, Kenco sky strut at \$2.17 net.
- LITELFUSE—Added No. 312.187 to their 3AG fuse series.
- MILLER CO., J. W.—Introduced model 522, a phono-oscillator coil at \$1.98 net . . . model 112-H6, an air core midget transformer at \$1.59 net. Also added 4 other air core transformers.
- MOODY MACHINE—Added No. SH-2, a screw holding screw driver set at \$7.20/12 net.
- NATIONAL CARBON—Added No. 776, "Eveready" A-B packs for portable receivers.
- PERMA-POWER—Introduced C-Brite (TV Tube Britener) at \$3.90 list.
- R. C. A.—Introduced 6BQ7-A at \$3.05 list, a medium-mu twin triode of the 9-pin miniature type designed for use as the first RF amplifier tube in VHF television-receiver tuners or as a low-noise IF pre-amplifier tube in UHF television receivers employing a crystal mixer. It can replace the older 6BQ7 in existing sockets.
- RADIO MUSIC CORP.—Introduced model TP-12E, turntable chassis with 12" platter-synchronous at \$100.50 net.

(Continued on page 21)



You're always right with Sprague's 85°C (185°F) smaller, versatile and dependable

# ATOMS

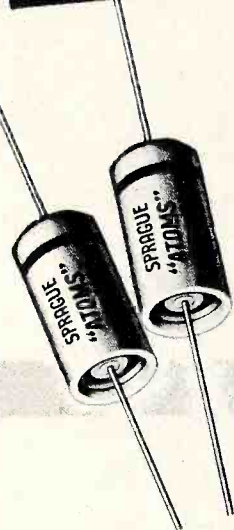

You only need to stock one lytic tubular for every application when you buy Sprague Atoms . . . whether it be an auto radio set . . . a home radio-phonograph combination . . . or a television receiver. Sprague Atoms, the smallest dependable electrolytics, are always right size-wise to fit the most crowded chassis. And they're right temperature-wise to fit the hottest TV receiver!

Write for Catalog C-608 to Sprague Products Company, 55 Marshall St., North Adams, Mass.

## INSIST ON ATOM® ELECTROLYTICS

MADE BY



THE WORLD'S LARGEST CAPACITOR MANUFACTURER

Please mention Successful Servicing when answering advertising.



In a Class.  
by Itself

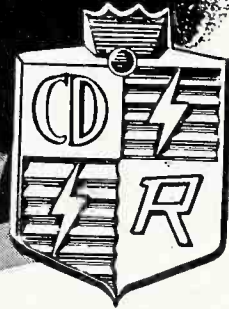

# the C·D·R Rotor

**Speedy Installation** ... the servicemen's dream come true! No loose parts to assemble ... no kits with loose washers, nuts and bolts ... quick mounting antenna mast collet plus four wire cable hookups!

**Dependable** ... experience has proven that once a CDR ROTOR is up ... it's THERE TO STAY! No costly call-backs! Completely weather-sealed and streamlined ... it's the outstanding value in the field!

**Powerful** ... sturdy in design to support and TURN ANY TV ANTENNA array ... never a worry about the CDR rotor working! Locking instantly it will not drift! Instantly reversible ... makes a complete revolution in 45 seconds!

**MODEL TR-12** A special combination value consisting of complete rotor including thrust bearing ... handsome modern design plastic cabinet with meter control dial, only ..... **\$47.95**

**MODEL TA-6** Thrust bearing accessory, separately .... **\$4.95**

**MODEL TR-11** Same as TR-12 without thrust bearing.. **\$44.95**

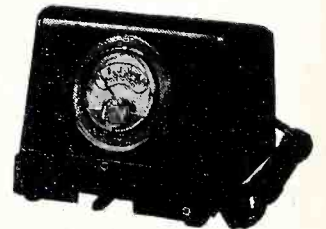

SUBSIDIARY OF



THE **RADIART** CORPORATION  
CLEVELAND 13, OHIO

**CORNELL-DUBILIER**  
SOUTH PLAINFIELD, NEW JERSEY

Please mention *Successful Servicing* when answering advertising.



# uhf converters

(Continued from page 7)

over the entire UHF band. The signal from the output coupling link is mixed and detected by a CK-710 crystal detector and then applied to the tuned input of the cascode amplifier. A 6BK7 tube is used as a cascode Pre-IF amplifier which is tuned to a center frequency of 25 MC and has the features of low noise and broad band-width. The signal is amplified by the cascode amplifier and then coupled to the IF amplifier section in the receiver through 10 inches of RG-62U coaxial cable.

The UHF tuner maintains a fairly constant antenna input impedance of 300 ohms, has an overall band-width of 6 to 8 megacycles and has an oscillator injection current ratio of approximately 2 to 1. The only amplification of the signal takes place in the cascode amplifier. The signal is not amplified in the RF cavities, therefore, the sensitivity of the receiver on UHF will not quite equal that of VHF. A receiver equipped with a UHF tuner will have an overall UHF sensitivity of approximately 150 microvolts.

## The RCA UHF Selectors

**Models U1A and U1B.** UHF Selector Models U1A and U1B permit the reception of any one UHF television station within receiving range when employed with a VHF television receiver.

The unit employs one tube and a crystal rectifier. Filament and plate power is obtained from the receiver to which it is attached. The two models are identical except for power cables. The UHF Selector units may be mounted on the back of the receiver cabinet or other convenient location, as long as the selector switch is accessible.

### Television R-F Frequency Range

All 70 UHF television channels .....470 mc. to 890 mc.

I-F Output Frequency.....Channel 5 or 6

### Power Supply Rating

Filament .....6.3 volts, .225 amps.  
Plate .....Approx. 10 ma at 70 to 370 volts

### Antenna Input Impedance

72 ohms unbalanced.

### Tube Complement

Tube Used	Function
RCA 6AF4	R-F Oscillator
CK 710	Crystal Mixer

### Use on Other Makes of Receivers

The U1A and U1B UHF Selectors will provide satisfactory UHF reception on other makes of receivers provided that the proper voltages for operation of the selector can be obtained from the receiver.

The U1A and U1B UHF Selectors were designed for use on receivers in which the

(Continued on next page)

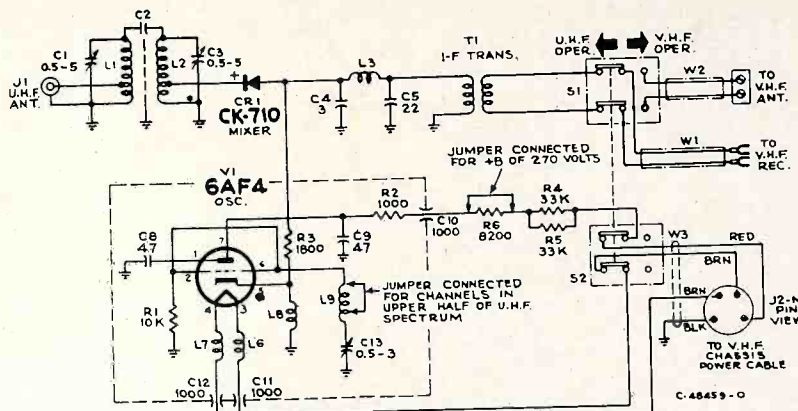

Courtesy RCA

Fig. 4. Schematic of the RCA UHF selector models U1A and U1B.



1. ENCYCLOPEDIA ON CATHODE-RAY OSCILLOSCOPES and THEIR USES, by Rider and Usilan. The most complete source of practical, usable knowledge concerning the oscilloscope ever published. Complete, detailed treatments of auxiliary equipment, measurements and waveforms. Typical chapters: The Basic Oscilloscope; Deflection Systems; Linear Time Bases; Non-Linear Time Bases; Electrical Measurements and Error-bearing Applications. 22 Chapters in all. Completely indexed. 992 pages (8 1/2 x 11") 500,000 words, 3000 illustrations, cloth bound. \$.90
  2. VACUUM-TUBE VOLTMETERS, by Rider. Completely revised and up-to-date, this book covers theory, functions, operation and applications of the modern VTVM in detail. Typical chapters: Triode Vacuum-Tube Voltmeters; Probes for DC & RF; Calibrations and Testing of VTVM's. 14 Chapters in all. 432 pages (8 1/2 x 8 1/2") illustrated, cloth bound .....\$4.50
  3. TV and OTHER RECEIVING ANTENNAS, by Bailey. A comprehensive source book on antennas of all types. Typical chapters: The Center Fed Zero DB Half-Wave Antenna; Parasitic Element Antennas; The TV Signal and Its Bandwidth; Vertically Polarized Antennas. 12 Chapters in all. 606 pages (5 1/2 x 8 1/2") illustrated, cloth bound .....\$6.90
  4. TV INSTALLATION TECHNIQUES, by Marshall. A timely, practical "how-to-do-it" text book on antenna installation and receiver adjustment. Typical chapters: Materials and Methods Used in Installation; High Mast and Tower Installations; Municipal Regulations Governing TV Installations. 9 Chapters in all. 336 pages (5 1/2 x 8 1/2") 270 illustrations, cloth bound .....\$4.50
  5. FM TRANSMISSION AND RECEPTION, 2nd Edition by Rider and Usilan. Covers operating principles of wide and narrow band FM-PM transmitters. Typical chapters: The Transmission of FM Signals; The FM Receiver. 10 Chapters in all. 460 pages (5 1/2 x 8 1/2") illustrated, cloth bound...\$4.95
  6. RADIO OPERATOR'S LICENSE Q & A MANUAL, 3rd Edition by Kaufman. Revised and enlarged edition includes new Elements 2, 5, 7 and revised Elements 3 and 6... plus Element 8: Ship Radar Techniques. Contains questions and answers to FCC Exams, plus a thorough discussion of the subjects covered. 7 Chapters in all. 794 pages (8 1/2 x 8 1/2") 241 illustrations, cloth bound .....\$6.60
  - 6a. ELEMENT 8: SHIP RADAR TECHNIQUES, available separately bound. 32 pages (5 1/2 x 8 1/2") illustrated, paper bound .....\$1.78
  7. RECEIVING TUBE SUBSTITUTION GUIDE BOOK, by Middleton. Lists 2,500 radio, TV and electronic tube substitutions in numerical order for quick reference. Gives performance ratings and any necessary wiring changes. Has tube base diagrams and characteristics chart. 226 pages (8 1/2 x 11") paper bound .....\$3.00
  - 7a. FIRST SUPPLEMENT to original GUIDE lists 650 completely new and different tube substitutions. Includes wiring instructions and illustrations of original and substitute tube sockets. 48 pages (8 1/2 x 11") paper bound .....\$3.99
  8. UNDERSTANDING VECTORS AND PHASE IN RADIO, by Rider and Usilan. Covers scalars, vectors, vector analysis and their application to radio by students and practicing technicians. 8 Chapters in all. 160 pages (5 1/2 x 8 1/2") illustrated, cloth bound .....\$1.89
  9. BROADCAST OPERATOR'S HANDBOOK, 2nd Edition by Ennes. Covers all practical operations in and out of the studio. Typical chapters: You're often a Producer, Too; Studio and Control Room; Where Split Seconds Count. Ideal for veterans and newcomers alike. 7 Chapters in all. 440 pages (5 1/2 x 8 1/2") 226 illustrations, cloth bound .....\$5.40
  10. TV AND ELECTRONICS AS A CAREER, by Kamen and Dorf. The only authoritative vocational guide ever written for the electronics industry. Top authorities tell what career possibilities are offered by the seven basic branches of the industry. Typical chapters: Selecting A Career in TV and Electronics; Television Broadcasting; Electronic Engineering; Electronics in the Armed Forces. 9 Chapters in all. 326 pages. (5 1/2 x 8 1/2") 130 illustrations, cloth bound. \$4.95
  11. INSIDE THE VACUUM TUBE, by Rider. Covers in plain and understandable language the fundamental theory of the vacuum tube and its operation. Typical chapters: The Cathode Circuit; Power Amplifiers; Dynamic Transfer Characteristics; Electron Emission. 15 Chapters in all. 424 pages (5 1/2 x 8 1/2") illustrated, cloth bound .....\$4.50
  12. UNDERSTAND MICROWAVES, by Young. This book provides foundation for understanding microwave radio and radar. Mathematics are confined to footnotes wherever possible. Covers theory and operation. Typical chapters: The Ultra High Frequency Concept; Alternating Current and Lumped Constants; Transmission Lines; Waveguides. 11 Chapters in all. 386 pages (5 1/2 x 8 1/2") illustrated, cloth bound .....\$6.00
- RIDER TEK-FILE. Packs 1 through 56. Covers complete TV servicing data arranged according to manufacturer. \$2.00 per pack. Send for free TEK-FILE index.
- RIDER MANUALS  
Television Vols. 1 through 9. Covers all manufacturers' official servicing data issued through March 1952. \$24. ea. vol. (Vol. 1 \$19.80).  
Radio Vols. 1 through 22. Covers all manufacturers' official servicing data issued through September 1951.
- Available at leading bookstores or mail this coupon.
- JOHN F. RIDER** 480 CANAL STREET  
PUBLISHER, INC. NEW YORK 13, N. Y.

Please send me book (s) circled. I understand that I may return them within 10 days if not satisfied for full refund.

1 2 3 4 5 6 6a 7 7a 8 9 10 11 12

Name \_\_\_\_\_

Address \_\_\_\_\_

City \_\_\_\_\_ Zone \_\_\_\_\_ State \_\_\_\_\_

Please Print **SS-11**



tube filaments are fed in parallel from a 6.3 volt transformer winding. Since the black lead of the selector power cable is connected to the selector chassis, the U1 series selectors should not be employed with any receiver in which a direct connection exists between the a-c power line and the receiver d-c power supply.

The plate voltage available from the receiver may not be optimum for operation of the selector as wired. It is very important that between 60 and 90 volts should be present at the junction of R2 and R6 in order to obtain optimum crystal current. The voltage at the junction of R2 and R6 should be measured with a "VoltOhmyst" and with the UHF Selector shield in place. To obtain proper voltage at R2 and R6, shunt R4, R5 and R6 as necessary with resistors of adequate wattage to obtain the desired voltage.

The television receiver operating voltages should not be materially altered by the installation of the UHF Selector.

In some makes of receivers it may be necessary to rewire the adapter socket and cable to suit the particular type of audio output tube. In some instances where filament wiring difficulties are encountered, it may be necessary to remove the adapter socket and wire the power cable into the television receiver.

**The Sylvania UHF Converter**

Sylvania UHF converter chassis 1-506-1 is a compact tuner and converter chassis

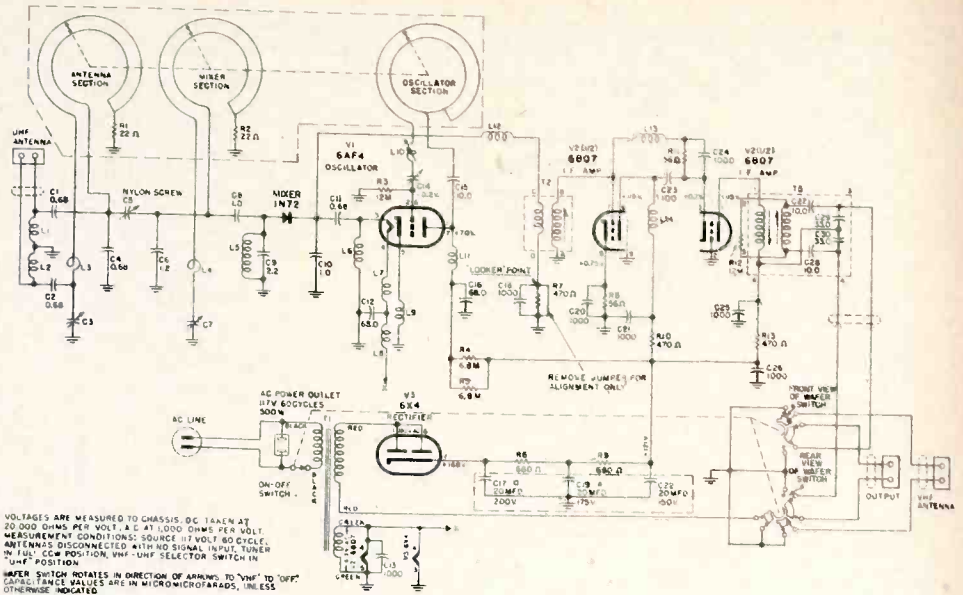

Fig. 5. Schematic of the Sylvania UHF converter chassis 1-506-1.

Courtesy Sylvania Electric Prods.

developed to receive the ultra-high frequency range of television channels. It is designed to tune continuously the UHF signals and convert them to a frequency within the range of present VHF receivers. Terminals are provided for VHF and UHF antenna connections. A multiple switch allows the viewer a choice between VHF or UHF bands, the VHF signals being relayed directly to the receiver.

The 1-506-1 chassis is used in Sylvania model C31M, a UHF converter unit in its own cabinet. The C31M is designed to convert most existing television receivers for UHF reception without any extensive changes to the receiver.

**SPECIFICATIONS**

- Frequency Range:  
Channels 14 to 83 .....470 mc. to 890 mc.
- IF Frequency:  
Channels 5 & 6 centering at .....82 mc.
- Power Supply:  
105 to 128 volts 60 cycle AC .....45 watts
- Input & Output Impedances:  
Antenna input ..... 300 ohms  
Output ..... 300 ohms

Tube Complement:

Symbol	Function	Type
V1	Oscillator	6AF4
V2	IF Amplifier	6BQ7
V3	Rectifier	6X4
	Mixer	IN72 Crystal

**Circuit Description**

The Sylvania 1-506-1 UHF converter chassis operates with a three-section tuner of the variable inductance type. It utilizes two tubes as oscillator and IF amplifier, and a crystal as the mixer. The oscillator operates on the low side of the carrier frequency; thus maintaining the original relationship of the video and audio carriers. This is necessary for use of the converter with a conventional VHF receiver.

Two metal strips pressed edgewise into an element of molded phenolic material comprise the individual tuner sections. Circuit inductance is varied by a dual contactor that slides between the conductor strips.

The antenna or first preselector section, coupled to a balanced 300 ohm input signal,

(Continued on page 22)

**Laughs in the Life of a TV Serviceman**

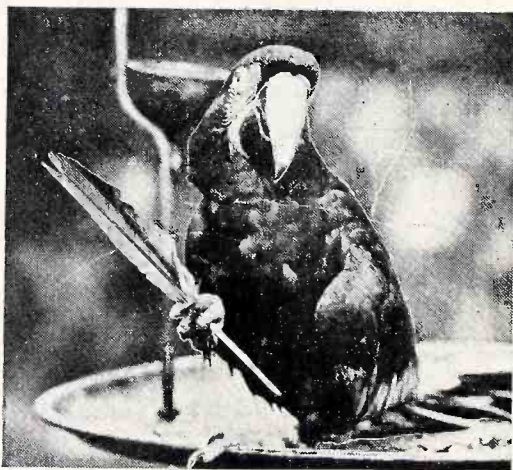

**"I wrote for a fix-it-yourself TV book and did exactly what it said—my set hasn't worked since!"**

SOME people think repairing a TV set is as easy as fixing a leaky faucet. They'd save time and money by calling a serviceman right away—whether or not their set is a Raytheon.

Most servicemen like to take service contracts on Raytheon TV receivers. They find Raytheon has fewer part and tube failures than

most sets. That means extra profits, more satisfied customers.

Then there's Raytheon's famous service clinic that helps you spot, and fix, 98% of TV set troubles. Write for popular FREE booklet, *How to Interpret What You See*. No obligation. Address Raytheon Television and Radio Corp., 5921 West Dickens Avenue, Chicago 39, Illinois.



# CBS-HYTRON NEWS FOR YOU...

## ABOUT NEW CBS-HYTRON DIODES

CBS-Hytron guarantees its new germanium diodes *moisture-proof* . . . trouble-free. Germanium wafer is soldered directly to the base . . . no plating to flake. Universal design follows joint Army-Navy specifications. You can clip or solder these diodes into circuit. Ten popular CBS-Hytron types are ready for you. See your CBS-Hytron jobber. Or write direct for catalogue and interchangeability chart.

Type No.	Min. Forward Cur. (mA) + IV	Max. Inv. Cur. (mA)		Peak Inv. Voltage 25° C
		-10V	-50V	
1N448	4.0		850	85
1N51	2.5		1 667	50
1N52	4.0		15	85
1N63	4.0		05	125
1N64	Special video detector tested at 44 mc. Complete data on request			
1N65	2.5		20	85
1N69	5.0	05	85	75
1N70	5.0	025	30	125
1N75	2.5		.05	125
1N81	3.0	01		50
-1AR TYPES				

Permanent X molded into end of case marks connection to germanium . . . which corresponds to cathode of vacuum tube.

New, attractive tuck-away carton fully protects CBS-Hytron germanium diodes. Note un bent leads and convenient data on inside cover.

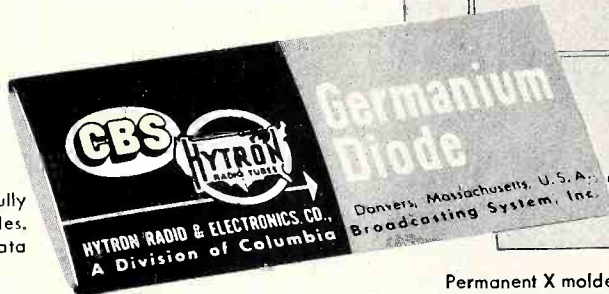

## ABOUT CBS-HYTRON GOLDEN GRIDS

Hidden gold in CBS-Hytron tubes? Yes, since 1944. CBS-Hytron first used gold-plated grids in the 6AK5. Later in many transmitting types: 2E25A, 2E30, 3B4, 5516, etc. Now you will find them also in the 6BZ7, 6BQ6GT, 12A4, 12BY7, etc.

Why? Gold kills unwanted emission. Even mounted very close to a hot cathode, a CBS-Hytron gold-plated grid does not give *primary* emission. Like a sponge the gold also soaks up stray electrons. Wipes out *secondary* emission too. And foreign material vaporized onto the grid during exhaust is absorbed harmlessly by the gold plating.

Such deluxe processing costs money. But it gives you better tubes. That is why CBS-Hytron has ignored the cost. Has specified gold-plated grids for years.

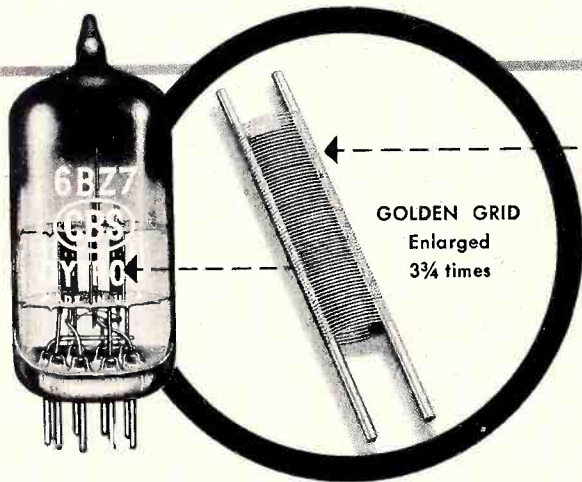

## ABOUT NEW, FREE CBS-HYTRON TV GUIDE

Like the popular CBS-Hytron Miniature Guide, the new CBS-Hytron Reference Guide for Television Picture Tubes is *complete*. Gives all important data . . . as well as basing diagrams . . . for 164 types. Includes *all* magnetically deflected picture tubes . . . regardless of make. Also shows electrical interchangeability of similar types.

You need this complete . . . accurate . . . helpful Guide. Keep abreast of today's confusing variety of TV picture tubes. Get the new CBS-Hytron TV Guide now. It's *free*. At your CBS-Hytron jobber's. Or write direct today.



DANVERS, MASSACHUSETTS



# SUCCESSFUL SERVICING

by John F. Rider



**RAY RILING, Service Mgr.**  
 J. W. Scotchard & Co.  
 Philadelphia, Penn.

## "I HAVEN'T HAD A SINGLE CALL BACK IN NINE MONTHS!"

### WHAT'S THE SECRET?

It's simple! The one thing that Rider gives you is *all the facts*. That's the one big difference between Rider Servicing Data and any other kind. Rider data is official, complete, factory-authorized data. Exactly as issued by the manufacturer who made the set... with *all* of his changes, and trouble cures organized into indexed, easy-to-follow style. This means that when you repair a set with Rider Servicing Data, you have *everything* in front of you. Everything that you must know to do a fast, accurate diagnosis and make a prestige-building, permanent repair. Rider Manuals make servicing easy!

### NEW FEATURE ADDED!

Now, in Rider's latest Servicing Data, beginning with TV Manual Vol. 10, you'll find a feature that can't be beat—a listing of *dependable* replacement parts. All listed parts check against the physical and electrical requirements of the original parts used in the receiver. This means reduced servicing time and faster repairs because of less changes on parts replaced.

### RIDER TV SERVICING DATA COMES IN TWO FORMS.



#### MANUALS

The TV Manual form has ten volumes covering more than 4,650 models of television receivers. Each volume has over 2,000 (8½ x 11") pages of servicing data with an index covering the contents of all volumes. Each volume is attractively bound in a permanent hard cover. The Manual form is ideal for shop use and as a permanent reference.



#### TEK-FILE

The Tek-File form now covers more than 2,200 models. Each Tek-File pack contains complete data for several of the most popular models... the ones you are called to work on every day. (Contents are clearly marked on the cover of each pack.) Get your free Tek-File indexes covering the contents of all packs at your jobber's. If he doesn't have them, write us.

For the complete servicing facts on radio get Rider Radio Manuals. In 22 volumes Rider Radio Manuals give you the complete, factory authorized, Official AM, FM radio servicing data for receivers manufactured over the past 22 years! Plus complete data on auto radios, record changers, tuners and recorders. *Everything is organized and indexed to make radio servicing easy.*

### DON'T BE SWITCHED.

Remember, Rider Manuals and Tek-Files are the only source, for complete factory-authorized servicing data. If your jobber doesn't have them, **DON'T BE SWITCHED!** If he doesn't have Rider Manuals, write to us...we'll tell you where to get them. If he doesn't have Rider Tek-Files, write to us...we'll fill your order directly. (Please include your jobber's name.) *Why not prove to yourself that Rider Servicing Data really makes servicing easy? Try one Rider TV Tek-File pack at our risk! Try a pack for the next receiver you repair...if you don't agree that it makes your servicing easier than anything you've ever used RETURN THE PACK TO US WITHIN SEVEN DAYS AND WE'LL SEND YOU A FULL REFUND! So act now...you have absolutely nothing to lose!*

### RIDER "HOW-TO-DO-IT" BOOKSHELF.

#### 1. TV Troubleshooting and Repair Guide Book.

Save time! Loaded with trouble-shooting charts and waveform pictures. 10 vital chapters. 204, 8½ x 11" pages. Paper cover \$3.90.

#### 2. Ency on CR'Scopes and Uses.

Most complete work on 'scopes! What they are, what they do, construction and capabilities. 992 pages 8½" x 11". 3,000 ill. Cloth cover \$9.00.

#### 3. Vacuum Tube Voltmeters.

All the facts! Design, construction, testing, maintenance, application, etc., of all types of VTVM's. 432 pages 5½" x 8½". 210 ill. Cloth cover \$4.50.

#### 4. Receiving Tube Substitution Guide Book.

Lists 2,500 radio, TV and electronic tube subs in numerical order. Gives ratings, wiring changes, tube base diagrams and characteristics chart. 224 pages. 8½" x 11". Paper cover \$3.00.

#### 4a. First Supplement to Original Guide.

Lists 750 completely new and different tube substitutions. 48 pages 8½" x 11". Paper cover \$9.99.

#### 5. UHF Practices and Principles.

The complete, up-to-the-minute story on UHF told in a clear, down-to-earth style. Covers practical, working applications and equipment including brand-name converters. 400 pages. 5½" x 8½". Cloth cover \$6.60.

### IT'S NEWS! TELL-A-FAULT

It's Rider's new monthly TV trouble-shooting service. Save countless hours of diagnosis time. Rider experts do your trouble-shooting for you...in pictures, charts, and symptom and cure sheets. Monthly bulletins. Send coupon for complete story—no obligation.

**BE SMART...MAIL THIS COUPON TODAY!**

**JOHN F. RIDER, Publisher, Inc.**  
 480 Canal Street, New York 13, N. Y.

Please send me book(s) circled. I understand, if not satisfied, I may return them within 10 days for full refund.

1  2  3  4  4a  5  
 Send Free Data on Tell-A-Fault.

NAME \_\_\_\_\_  
 ADDRESS \_\_\_\_\_  
 CITY \_\_\_\_\_  
 ZONE \_\_\_\_\_ STATE \_\_\_\_\_ SS-11  
 (Please Print)



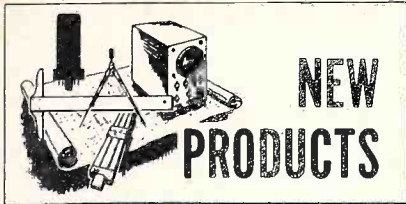

Additional literature on each of the products described in these columns may be obtained from SUCCESSFUL SERVICING. See the coupon in column three.

**New Sound Equipment Console**

A new sound equipment console, called the Peerage, has been created by Electro-Voice, Inc. It is expressly designed to house, in one compact unit, virtually any combination of the popularly-known tuners, amplifiers, and record changers. The Peerage makes it simple to install, with ordinary tools, all the components needed for High Fidelity sound reproduction.



Item 1.

Pivoted, tilting top panel opens with brass pull and mounts all conventional tuners. In open position, controls are at easy-to-read 65 degree angle. Amplifier is mounted on back panel which is readily removed. Changer drawer is directly below tuner panel and is mounted on roller slides for smooth operation.

**Low Resistance — High Accuracy Instrument Resistor**

Type 245S, a new 1-watt precision wire-wound resistor for decades and other appli-



Item 2.

cations requiring low resistance values with close tolerances, low temperature rise and low inductance, has been announced by the Shallcross Mfg. Co. The new resistor can be calibrated to a tolerance of  $\pm 0.1\%$  or better and is available in values from 0.1 ohm to 1000 ohms. A single layer bifilar winding protected by a moisture resistant lacquer coating is used for all values. The Steatite bobbin and axial wire leads at the same end make it easy to mount the resistor directly on decade switch decks or other similar equipment. Size is  $\frac{1}{8}$ " long by  $\frac{3}{8}$ " diameter.

**Cascade Auto booster**

Industrial Television has announced a new sub-fringe TV booster, the IT-90AB cascade auto-booster.



Item 3.

Successor to the IT-90A, the IT-90AB provides a uniform gain of 26 db. on the high band and 34 db. on the low band. It has been designed for use with modern low-noise, high-sensitivity receivers. Fully automatic, the IT-90AB retains all the functional advantages of the predecessor model, including wide-band (automatic) tuning, on-off relay, separate high and low-band input, independent gain controls for each band, and by-pass switch.

**Full-Wave, High-Vacuum Rectifier**

G.E.'s Tube Department has designed a full-wave, high-vacuum rectifier for use in aircraft power supply units of moderate current requirements.

The tube, type number GL-6087, has been added to the company's "Five Star"

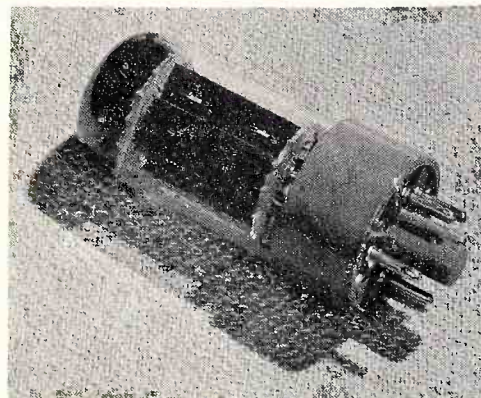

Item 4.

high-reliability tube line and may be used as a replacement for the 5Y3GT. The tube may be used in applications which are subject to altitudes as high as 60,000 feet. It will withstand a peak impact acceleration of 700 G in any direction.

In typical operation, the GL-6087 has a d-c output current of 125 milliamperes. Measured with applied d-c at 125 ma per plate, the tube voltage drop is 50 volts.

**High-Voltage Ceramic Capacitors**

Voltage ratings of from 1 to 20 KV are now made available in Hi-Q ceramic capacitors of the slug, disk, plate and tubular types offered by the Hi-Q Division of the Aerovox Corp.

In the new slug type utilizing thick disk dielectrics, the strength of the capacitor is greatly increased by an exacting jacketing procedure in conjunction with a newly developed plastic that provides excellent arc-resistant properties. Terminals are silvered brass integrally soldered to silver electrodes fired directly to the ceramic dielectric. Insulation resistance is of the order of 50,000 megohms. Working voltage is 20,000 V.D.C., and flash test 27,000 V.D.C.

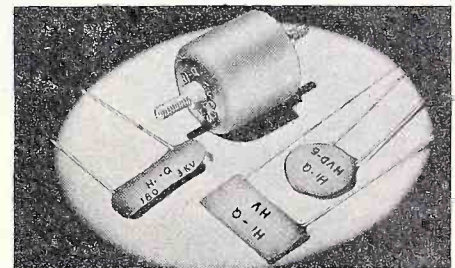

Item 5.

Hi-Q High Voltage disks are available in many capacities and voltage ratings. The high-voltage tubulars have been developed specifically for use in horizontal sweep and deflection sections of TV receivers, and come in standard capacitances from 4.7 to 1000 mmf., voltage pulse ratings of 1 to 7 KV and capacity tolerances of  $\pm 5\%$ . Physical sizes are contingent on operational specifications or application requirements.

To obtain additional literature on any of the items described in this section encircle the number of the product (number appears under picture) on the coupon below, cut the coupon out and mail it to SUCCESSFUL SERVICING, 480 Canal Street, New York 13, N. Y.

Cut Here

**SUCCESSFUL SERVICING**  
480 Canal Street, New York 13, N. Y.

Please send me additional literature on the items circled below appearing in the NEW PRODUCTS column of the November, 1952 issue of SUCCESSFUL SERVICING:

1                      2                      3  
4                      5

Name.....  
Address.....  
City.....Zone.....State.....  
Company.....



## UNSTABLE PIECRUST PATTERN

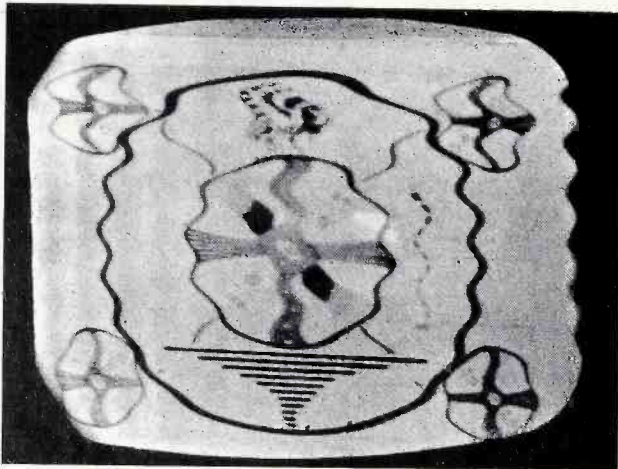

FIG. 1

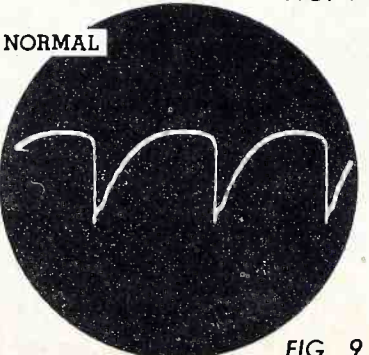
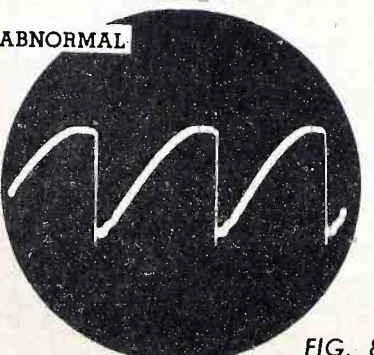
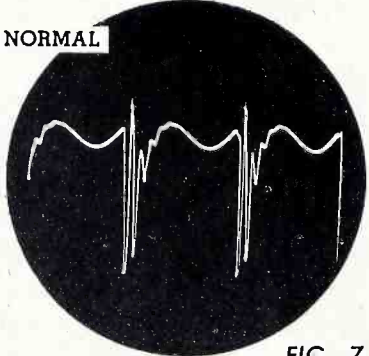
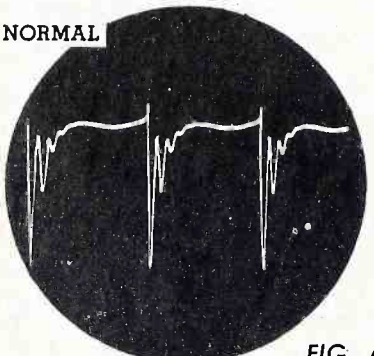
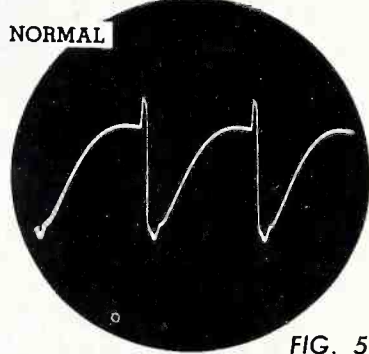
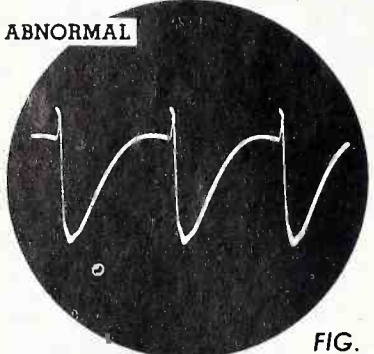
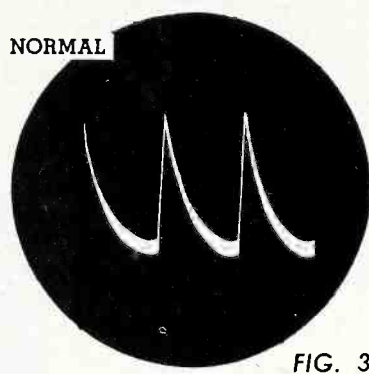
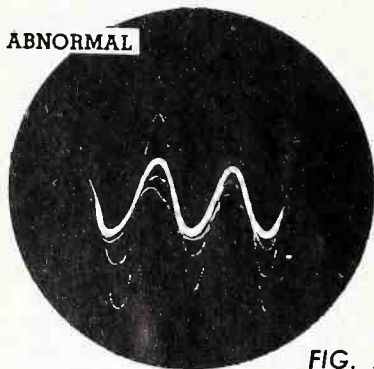
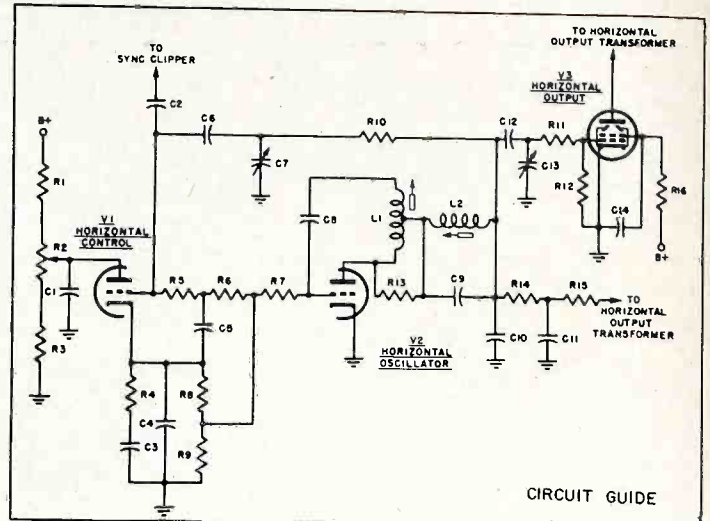

Fig. 1 shows an unstable piecrust picture-tube pattern. There was a tendency for parts of the picture to lose sync intermittently, breaking into diagonal lines.

A check at the horizontal-sync take-off showed no irregularities. The scope was then connected directly to the cathode of the control stage, V1. To obtain the three cycles shown in Fig. 2, scope F had to be set at a very low frequency. Note the grassy, unstable display obtained, as compared to the normal waveform at this point shown in Fig. 3. The latter was taken with the scope set at H/3.

The abnormal waveform shown in Fig. 4 was observed at the grid of the same stage with F equal to H/3. Its amplitude was nearly 50% greater than the P-P value of the normal waveform, shown in Fig. 5, but there was no change in d-c voltage. Although there is no change in waveform shape, note that the abnormal display was slightly fuzzy in appearance.

Normal waveforms only are shown for the grid (Fig. 6,  $F=H/3$ ) and plate (Fig. 7,  $F=H/3$ ) of the oscillator, V2. Once more, the abnormal indications were properly shaped displays that could not be brought to the best focus of which the test instrument was capable. All d-c and resistance readings are normal.

With the scope at the grid of the horizontal-output stage, V3, the same inability to obtain good focus was noted in the abnormal waveform, Fig. 8. Compare this with the normal display in Fig. 9. There was no change in P-P value, but the d-c voltage rose slightly during the presence of the fault.

The receiver fault responsible for the above abnormal indications was an open resistor in the cathode circuit of the control stage. This resistor, R4, is part of a filter-delay network (anti-hunt circuit) which serves to stabilize the operation of the control stage and, therefore, also stabilizes its regulation of the oscillator.

<sup>\*</sup>See last page of Tek-File Index for information on TELL-A-FAULT, the most unique monthly service ever made available to TV and radio service technicians.

UNSTABLE PIECRUST PATTERN



## Radio Master's Reports

(Continued from page 13)

**RECOTON**—Added No. 650, phonocone kit at \$163.30 net. . . . No. 383 and 384, replacement needles at \$2.10 net each . . . series of 3 diamond replacement needles . . . No. 3050, steel needle at \$5.63 net and No. 3112, osmium needle at \$6.00 net.

**TECH-MASTER PRODUCTS**—Introduced model TM-15P, four channel pre-amplifier kit at \$19.95 net and model TM-15A, ultra-linear Williamson-type amplifier kit at \$49.95 net.

**TECHNICAL APPLIANCE** — Added No. 862, mast standoff insulator . . . No. 954A, stacking transmission lines for 2-bay lazy-X antennas . . . No. 1323, single-bay 5-element two diameter Yagi antenna.

**THOMAS ELECTRONICS** — Introduced 27GP4 and 27NF4, CR tubes with rectangular gray faces.

**UNITED TECHNICAL LABS.** — Added model CB-101, cross bar generator at \$29.50 and Plastik-707, spray-on insulation at \$1.25.

**WEBSTER ELECTRIC**—Added replacement cartridge model BX at \$3.60 net . . . Ekotape model 114 and 116 at \$179.50 list each.

### Discontinued Items

**ARGOS PRODUCTS**—Discontinued model PC-1, a record changer carrying case.

**ASTATIC CORP.** — Discontinued pickup models B-10, B-16, S-8, and S-12-B-2 . . . booster models BT-2 and BT-1.

**ATLAS SOUND** — Discontinued speaker support stand model HM-2 and marine midget projector model WX-5.

**BROWNING LABS.**—Discontinued models RJ-20B and RJ-12C, FM-AM tuners and model RV-10B, FM tuner.

**CROWN CONTROLS CO.**—Model CAR-7, an electric eye indicating antenna rotator discontinued.

**DRAKE ELECTRIC WORKS**—Discontinued soldering iron models 55, 700, 701, 703, 804.

**EBY SALES**—Model S-20-11, a magal type television socket withdrawn.

**HICKOK ELECTRICAL INSTR. CO.**—Discontinued the leads and carrying case for model 465, a double range dc kilovoltmeter.

**JOHNSON CO. E. F.**—Discontinued model 23.986, tube kit for Viking 1.

**MOSLEY ELECTRONICS**—Withdrew No. 331, tap sockets and No. 341, base socket.

**PENN BOILER & BURNER**—Discontinued their 20' Thriftower.

**RADIO CITY PROD. CO.** — Discontinued No. 322AK, tube tester . . . No. 322APK, portable tester . . . No. 323M, tube merchandiser . . . No. 450A, hi-megohm multimeter and No. 450AP, portable multimeter.

**R. C. A.** — Discontinued crystal pick-ups No. 34307 (superceded by No. 9890) and No. 74625 (superceded by No. 75575.)

**SCHAUER MFG.**—Discontinued model DX-2, 1-2-3-battery charger and model FX-2, 20 amp. size battery charger. These items have been superceded by model DX-3 at \$47.95 retail and model FX-3 at \$42.95 retail.

**SOLA ELECTRIC**—Discontinued 5 constant voltage transformers.

**TAYLOR TUBES**—Discontinued 803 transmitting tube . . . 872-A and 8008 rectifying tubes.

**WEBSTER ELECTRIC**—Crystal cartridge model F19 . . . Ekotape models 109 and 111 discontinued.

### Price Increases

**AMERICAN ELECTRICAL HEATER**—Increased price on soldering cord set, model 877 to \$.665 net.

**DRAKE ELECTRIC WORKS**—Solder dip pot models 100 and 200 increased in price to \$7.00 and \$9.00 list respectively.

**G. E.**—Increased prices on three 16" and two 19" TV picture tubes . . . industrial tube analyzer YTW-3 to \$528.97 net and Marker Generator to \$15.00 net.

**HICKOK ELECTRICAL INSTR.**—Model 465, double range dc kilovoltmeter increased in price.

**MILLEN MFG. CO., JAMES**—Octal socket plug and shield, model 74400 increased to \$1.08 net.

**SNAP-ON DRAW**—Increased prices on No. 1, "small" Snap-On drawer . . . No. 2, "junior" Snap-On drawer . . . No. 2-D, "junior" divider . . . No. 3, "senior" Snap-On drawer and No. 3-D, "senior" divider.

### Miscellaneous Changes

**R. C. A.**—Discontinued picture tube 17CP4A from their dealer return allowance schedule.

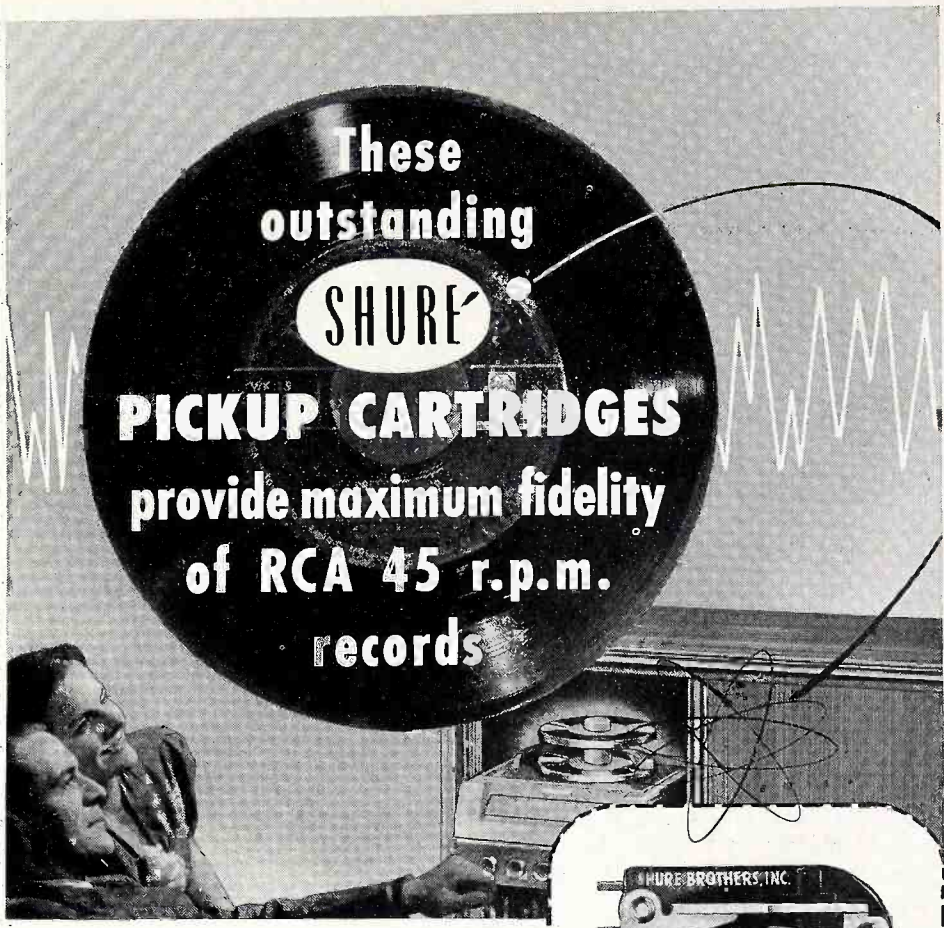

**Superlative "Direct Drive" and "Vertical Drive" cartridges reproduce all the recorded music on these modern wide-range high-fidelity records.**

These Shure "Direct Drive" and "Vertical Drive" Cartridges have been perfected to meet the greater requirements of high needle point compliance and fidelity demanded by the fine-groove recordings. The cartridges provide extended frequency response, high output, and high needle point compliance. They also feature the famous "Muted Stylus" and "Simple Mount" needles designed for longer record and needle life, faithful tracking and clear full tone qualities. These individually replaceable needles are easy to remove and insert.

Patented by Shure Brothers, Inc., and Licensed under Patents of the Brush Development Co.



**SHURE BROTHERS, Inc.**

Microphones and Acoustic Devices

225 W. Huron St., Chicago 10, Ill.

Cable Address: SHUREMICRO

Please mention *Successful Servicing* when answering advertising.



**"DIRECT DRIVE" CRYSTAL (W31AR)** High output (2.1 volts!) "Direct Drive" cartridge specifically designed for use with all fine-groove records. Universal mounting bracket provides quick, easy installation in RCA-type 45 r.p.m. changers. (Fits 1/2" and 5/8" mounting centers.) Has easy-to-replace needle. For maximum quality, highest output, and low cost, specify Model W31AR at the low list price of only \$6.50.



**"DIRECT DRIVE" CERAMIC (WC31AR)** Same as Model W31AR, except for ceramic element and .65 volts output. Highly recommended in areas where heat and humidity make use of conventional crystal cartridges impractical. List price . . . \$6.50



**"VERTICAL DRIVE" (W21F)\*** High-fidelity cartridge. Provides superlative reproduction for 33 1/3 and 45 r.p.m. records. Extended frequency response (50 to 10,000 c.p.s.). Low tracking pressure (only 6 grams) and high needle compliance guarantee faithful tracking and longer record life. Uses quiet tracking Shure "Muted Stylus" needle, scientifically designed for maximum performance and long life. List price . . . \$7.75

\*Cartridge with .453 Mount for Oak Changer

**FREE**

Write today for "How to Service T-V Receivers" with the HICKOK VIDEO GENERATOR.

**The Hickok Electrical Instrument Co.**

10820 Dupont Ave., Cleveland, Ohio



# uhf converters

(Continued from page 16)

is located at the rear of the tuner. The mixer or second preselector section occupies the center of the tuner, and the oscillator section occupies the front. Although all sections of the tuner are composed of metallic strips spaced evenly, the two preselector elements are shaped differently from the oscillator section for tracking purposes.

The two tuned circuits in the preselecting network select the signal and pass it to the crystal. Here, the local oscillator signal is injected into the incoming signal, and mixer action takes place. The heater-cathode capacity of the oscillator tube constitutes the sole coupling between mixer and oscillator circuits.

The IF amplifier circuit was specifically chosen for its low noise contribution at high IF frequencies, such as that used in this converter. This circuit utilizes a dual-triode tube, one section of which is operated as a grounded-cathode input system, and the other as a grounded-grid amplifier output system. The IF output transformer is a double-tuned circuit designed for a center frequency of 82 megacycles with a minimum bandwidth of 12 megacycles at the half-power points.

A self-contained power supply is employed using a 6X4 rectifier tube. The B+ filtering is accomplished by a conventional RC filter network.

Further notes on the new UHF converters will be continued next month.

Please mention *Successful Servicing* When answering advertising.

# "GIMMICKS" in Radio and TV

The use of gimmicks is not as widespread in television receivers as in radio receivers. No doubt this is due to the manufacture of very low, odd value ceramic capacitors. These range from about .75  $\mu\text{f}$  (0.00000075  $\mu\text{f}$ ) to several micromicrofarads. Under the circumstances it is not necessary to resort to twisted wire gimmicks, except when it is convenient to do so.

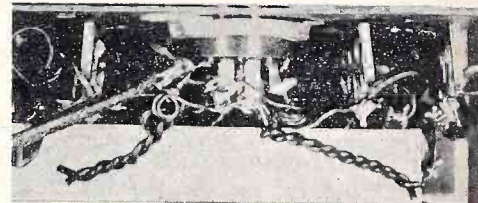

Figure 1.

But gimmicks are used. Occasionally tv boosters employ them for neutralization. By being able to twist the wire until the desired operating condition is achieved, one finds that they offer easy adjustment over a range of tube capacitance values. The gimmicks are connected between the plate of one tube and the control grid of another, in dual-triode r-f amplifiers. Two such gimmicks appear in each r-f stage. The physical appearance of the device is shown in Fig. 1.

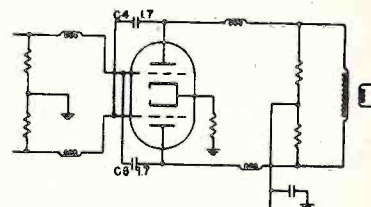

Figure 2.

Another use for the twisted wire gimmick in some tv receivers is between the horizontal deflection yoke winding and the grid circuit of the horizontal output tube. In appearance it resembles Fig. 1 (and hence need not be shown here.) It appears schematically in Fig. 2. We'll describe more of these in later issues of **SUCCESSFUL SERVICING**.

This completes the two-part article on use of "gimmicks" in radio and tv. All illustrations are courtesy of Electro-Voice, Inc.

**Just Out!**

bigger

17<sup>TH</sup> edition

Radio's MASTER

better

- 1220 pages
- 80,000 items
- 8,000 illustrations
- 8" x 11" — 5 lbs.

Publisher's price \$6.50—your price through your regular parts distributor **\$1.95**

**The right part when you need it for service**

This permanent, hard cover Official Buying Guide of the electronic-TV parts and equipment industry with its comprehensive detailed index, eliminates the need for maintaining files of small catalogs and manufacturers' literature. Radio's Master catalogs 90% of TV and electronic equipment. Not merely part number listings — complete descriptions, specifications and illustrations written and compiled by each manufacturer. Enables you to make comparisons or substitutions right now!

No More Files of Small Catalogs and Loose Literature

**UNITED CATALOG PUBLISHERS, INC.**  
110 Lafayette St., New York 13

Sec. 3466, P. L. & R.  
 U. S. POSTAGE  
**PAID**  
 NEW YORK, N. Y.  
 PERMIT NO. 9427

From  
 JOHN F. RIDER PUBLISHER, Inc.  
 480 CANAL ST., NEW YORK 13, N. Y.  
 Forwarding and Return Postage Guaranteed



# SUCCESSFUL Servicing

DECEMBER 1952

## The Philco UHF Conversion Kits

Part No. 43-6473 and 43-6474. UHF conversion kit Part No. 43-6473 permits the reception of UHF channels 14 through 83 when installed in the Philco R-F Chassis 91 or 94. This also holds true for kit No. 43-6474 when installed in the Philco R-F Chassis 81 and 84. The kit consists of a UHF tuner, a change-over switch, adapter cables and plugs, a planetary tuner driving assembly, and mounting hardware.

The UHF tuner converts the UHF signals to the intermediate frequencies of the r-f chassis 91 or 94, and converts the UHF signals to the frequency of either channel 2 or 3, and after amplification in the pre-amplifier, feeds into the VHF tuner antenna terminals.

In either case the incoming UHF signal is coupled to the antenna tank of the converter through a 150-ohm matching section. The antenna tank is coupled to the mixer tank by means of the mutual coupling of L2 and L3 and the stray capacitance (C5). The antenna tank and mixer tank select the desired channel signal and feed this signal to the crystal mixer circuit. The local-oscillator signal is generated by a 6AF4 tube, V1. The oscillator signal is coupled to the crystal

mixer circuit by the 300-ohm transmission line and the mutual coupling of L7 to L5 and L8 to L6.

Mixing of the r-f signal and oscillator signal in the mixer circuit produces a 45.75-mc. video carrier intermediate frequency in R-F Chassis 91 and 94, which is coupled to J500 on the VHF tuner. In UHF operation the local oscillator of the VHF tuner is inoperative, and the r-f amplifier and mixer circuits of the VHF tuner operate as i-f amplifiers.

# uhf converters

Mixing of the r-f signal and oscillator signal in the mixer circuit in R-F Chassis 81 and 84 produces an output signal at frequency of either Channel 2 or Channel 3. This signal is amplified by the 6BQ7 tube and its associated wide-band amplifier, and is then fed to the antenna input of the VHF tuner. If a station operates on either Channel 2 or Channel 3 in the area where the receiver is to be used, the UHF station

must be received on the unused channel. If no station operates on either Channel 2 or 3 either channel may be used for reception of the UHF station.

Conversion Kit Part No. 43-6473 for R-F Chassis 91 and 94. The change-over switch supplied with the kit is installed on the back of the VHF tuner, and is operated by the actuator on the VHF tuner shaft. When the Channel Selector of the VHF tuner is turned to the UHF position, the switch is thrown to its UHF position. In the UHF position of the switch a 150,000-ohm resistor is placed in series with the VHF mixer plate, thus dropping the voltage applied to this tube. This permits the mixer circuit to operate as an i-f amplifier. The change-over switch also turns off the VHF pilot light and turns on the UHF pilot light. When the receiver is connected for single-antenna operation, the switch also connects the antenna to the UHF tuner input. When the Channel Selector of the VHF tuner is turned to any channel from 2 through 13, the above procedure is reversed and a 150,000-ohm resistor is placed in series with the UHF local-oscillator plate circuit, thus

dropping the voltage applied to the circuit and putting the UHF oscillator out of operation.

The adapter plugs shown in the schematic diagram are not used in factory-installed units, and the cables are wired directly into the chassis at the required points. The adapter plugs are used in field-installed units. The octal adapter fits into the audio output tube socket, with the tube inserted into the socket of the adapter. This adapter supplies B plus, B minus, and filament power connections for the UHF converter. The single-conductor disconnect assembly is connected in series with the B plus supply for the VHF mixer circuit. The twin-lead disconnect assembly is used to connect the VHF tuner antenna input to the change-over switch.

The UHF tuner is tuned by means of a 3-gang tuning condenser, which is driven through a specially designed planetary drive. The planetary drive is constructed so that fine tuning and coarse tuning can be accomplished with one control knob. The tuning shaft is coupled to the driving shaft through three balls which form a planetary drive for fine tuning. After rotating 180 degrees with the tuning shaft, a pin engages the driving shaft, and the two shafts are direct-coupled, for coarse tuning. To re-engage the planetary drive for fine tuning, it is only necessary to reverse the direction of rotation. The dial pointer is connected to the tuning gang through a cord drive, and indicates the channel number to which the tuner is tuned.

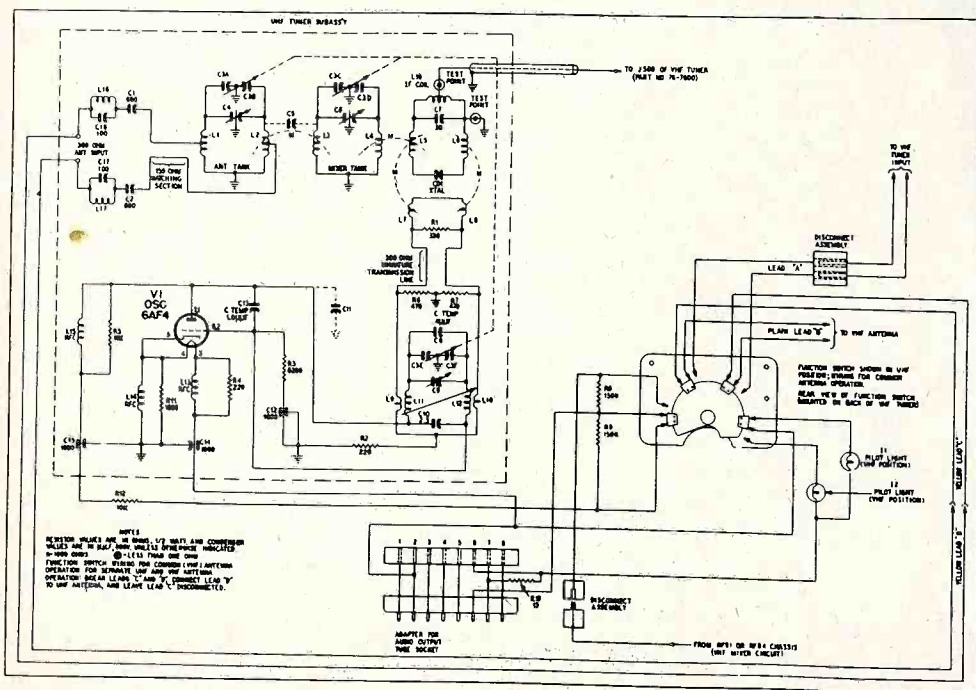

Fig. 1. Schematic Diagram, Philco UHF Tuner for R-F Chassis 91 and 94.

Courtesy Philco

(Continued on page 13)



**It's New!**

**It's Better!**

**Here's Proof!**

Now, we have finally found the answer in your V8 antenna. Servicemen tell us its the best antenna we have ever had. It really does the job because it pulls in stations we could not get before.

**Here's How  
the new RADIART  
TELEVISION  
V\*8 ANTENNA  
Solved Mr. Hartong's  
Fringe Area Headaches**

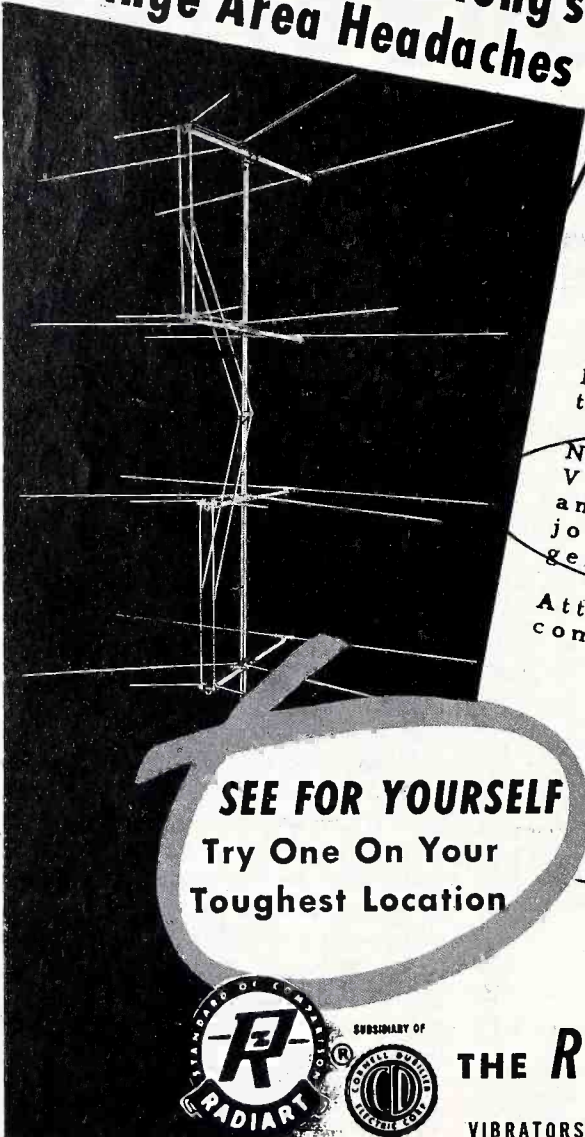

**SEE FOR YOURSELF  
Try One On Your  
Toughest Location**

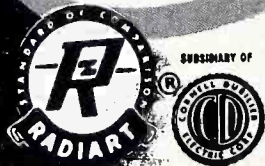

**THE RADIART CORPORATION CLEVELAND 13, OHIO**

VIBRATORS • AUTO AERIALS • TV ANTENNAS • ROTORS • POWER SUPPLIES

Please mention *Successful Servicing* when answering advertising.

*Burroughs*

TELEPHONE 5-0273

*Radio, inc.*

DISTRIBUTORS OF  
ELECTRONIC EQUIPMENT  
WHOLESALE ONLY  
711 SECOND STREET, NW CANTON 3, OHIO

October 7, 1952

Mr. William Schoneberger  
Jobber Sales Manager  
Radiart Corporation  
3455 Vega Avenue  
Cleveland, Ohio

Dear Bill,

Just a word to let you know how we feel about your new V8 antenna.

As you know, our reception problem down here is difficult because of the fringe area position. Believe me, when I tell you almost everything that has come along has been tried.

Now, we have finally found the answer in your V8 antenna. Servicemen tell us its the best antenna we have ever had. It really does the job because it pulls in stations we could not get before.

Attached is another reorder, please keep them coming.

Sincerely yours,  
BURROUGHS RADIO INC.

*D. R. Hartong*  
D. R. Hartong

drh/iw



# Right Near the School\*

by John D. Burke

Everything about the house seemed right. Especially the price.

To bargain a little was the natural thing, even without hope of gaining more than a concession here or there—perhaps just that new deep freezer thrown in. How short that discussion was—no tussle at all! Martha went crazy over the freezer—and did not seem to mind Mrs. Corwin's evident sorrow over giving it up.

Corwin made a showing of bravado—promised his wife an even better one. What a pretender!

How else could that additional \$500 off the purchase price be explained—even without being asked . . .

They really must be anxious to sell! Short of cash—perhaps. Simple enough!

As a buyer of anything at all, Sturgeon had always prided himself on being a careful man. "Never been swindled yet!" he always told his children, urging like behavior on their part.

Of course, this time the bargain was so evident he paid his deposit on the spot. No use looking any further; this was it.

Beautiful house, lovely garden, good street, near the stores, far from noise—good neighbors.

Matter of fact, it was the neighbors who first came under suspicion. Sturgeon remembered a case where a man bought a house like this, and woke up one morning to the crash of a window pane. It happens often enough—bought next to a "Dennis the Menace."

The title closing was put off a week while Sturgeon prowled the streets nearby—corralled every chance acquaintance; cross-examined the children; bought copy after copy of the same paper—asking, and asking . . .

No one knew of any menace to his peace on Ludlow Street.

No windows showed recent replacement.

There was no sign of hysteria—not even a little weentsie bit. No signs of compulsion to move.

Queer fellow, that Corwin, thought Sturgeon. Seems a sporting type—kind that likes to watch the fights. Yet, whenever I mention my favorite wrestlers, or fighters, he manages to change the subject. Oh well, must have plenty on his mind. Forced to sell . . .

But why? What kind of double-talk did he give . . . ? Why do Mrs. Corwin and

their kids sort of fade out whenever we ask their plans?

Sturgeon fully expected an argument when the second title closing delay was proposed. Corwin did mumble a bit—but then agreed.

Surely there is something wrong—thought an even more cautious Mr. Sturgeon. For he *knew* now that the house was worth an easy two thousand more than he was about to pay!

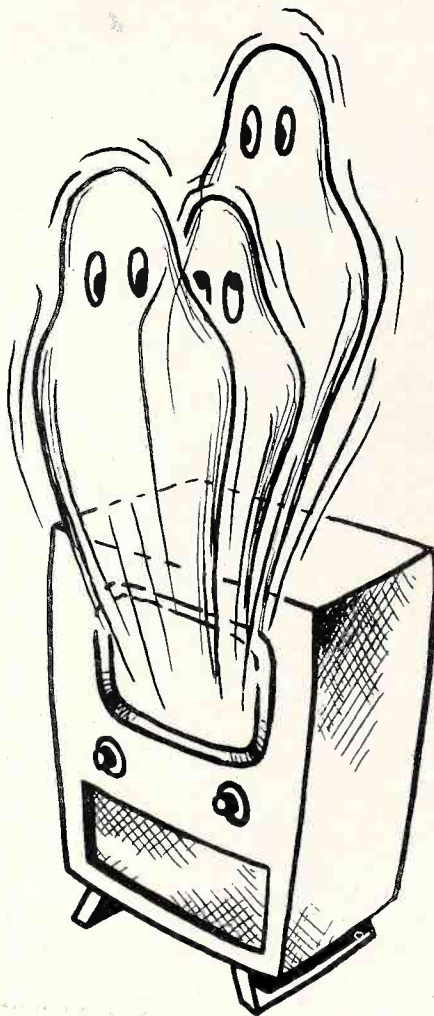

An appraiser had said so. Another agreed. Not Corwin's appraisers—no, his own. Friends of his for years. Said he was making an excellent buy.

Right near the school, too.

Again Sturgeon prowled. On the pretext that he wanted to figure out what furniture they would need to buy for the playroom, he prowled the basement.

Looking for rats—and other things.

Nothing.

—Looking for moles, tree blight, the seven-year-itch (who knows what!)—he prowled the garden.

The closets—the attic—looking for ghosts? (Little he knew!)

The week passed, and the title changed hands.

Afterwards they had a little party—the sellers and the sold clinked glasses and wished each other well. In the best of spirits, Sturgeon exulted—even expressed his condolences to Corwin for his bad luck in having to sell . . .

One thing marred the party for Sturgeon. It seems that Corwin's television had still not come back from that TV shop. He had so wanted to see Mauler Joe . . . Such service!

\* \* \*

The answer came suddenly—all too plainly. There was no quarrelling with life. No doubt about it. This house had ghosts!

They flitted about—they sang—they danced—they played ball.

Sometimes they came singly—again they multiplied. And if that were not enough, sometimes they reversed themselves, as if seen on a photograph negative.

The worst of all were the fights. The fighters came in pairs—facing other pairs. And tank team fights were staged by eight men in this house!

Where Sturgeon had poked about for things in the dark—in the basement, under ground, in closets, cobwebby places—these men probed in the air. A finger—extendable, retractable, poking, turning—probed the air overhead. Higher—lower, here—there.

Now plans, specifications, consultations—experts, amateurs, amateurs who knew more than the experts—all the kids joined in.

Three alternatives:

Do nothing and accept the ghosts.

Give up television. (No one dared suggest this to a modern family.)

Erect—at considerable expense—an elaborate back screen fence on one side of the roof. (*No guarantee* that this would completely end the ghosts.)

Then the most obvious solution came to Sturgeon's mind. He whispered it to himself, and while saying it, knew that the words had been spoken before, "Sell the house and move away!"

\*May not be reprinted without written permission of the author.



**TRIPLETT**  
**650 VTVM**

There's Nothing finer for

*Television*

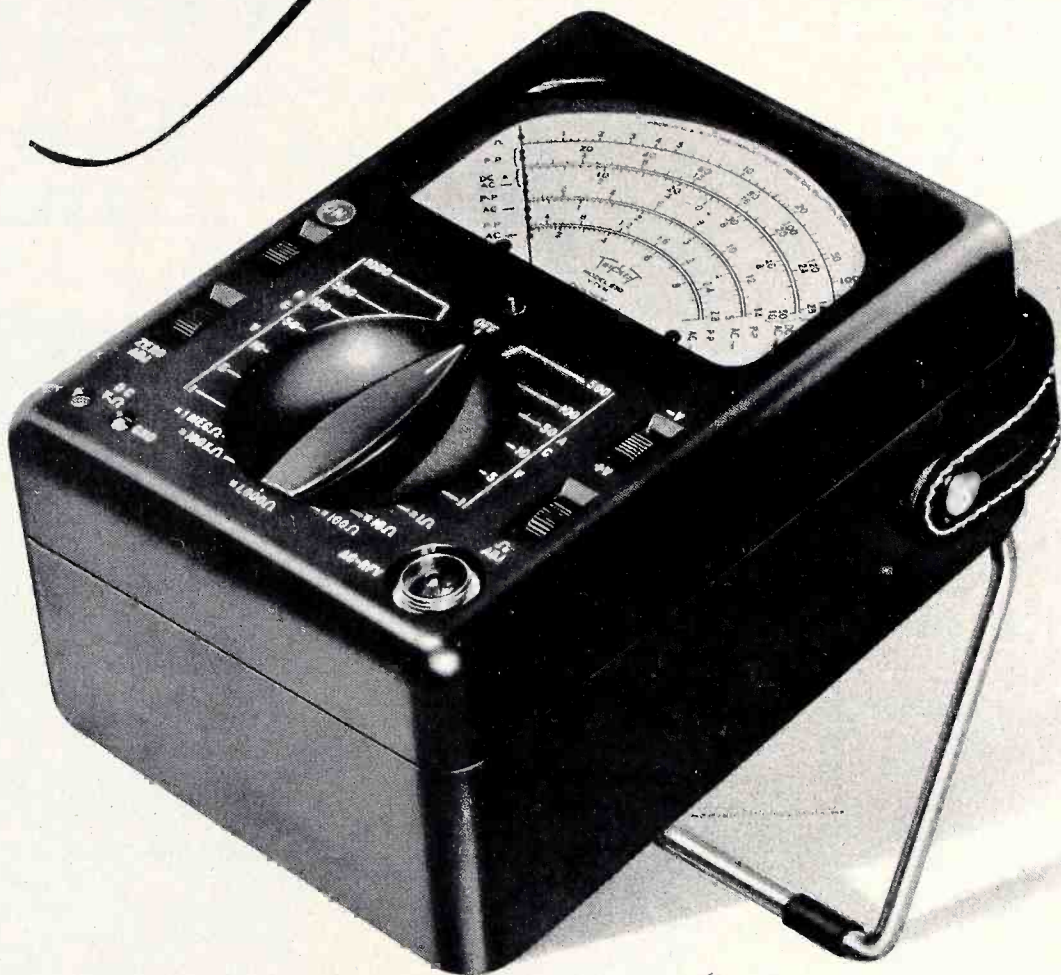

**This combination of features explains why**

- Complete frequency coverage with one probe, 20 cps to over 110-mc. Insulated and shielded RF tube probe, found usually only with laboratory instruments, is included.
- Peak to Peak ACV and RF with one probe.
- One volt full scale reading on AC & DC.
- One main selector switch, all ranges.
- ACrms—Peak to Peak
- 32 Ranges
- Zero center mark for FM discriminator alignment plus any other galvanometer measurements.
- High input impedance 11 megohms on DC.

Suggested U.S.A. Dealer Net \$69<sup>50</sup> • Prices subject to change without notice.

TRIPLETT ELECTRICAL INSTRUMENT CO., BLUFFTON, OHIO

**Triplet**





# Successful SERVICING

REG. U.S. PAT. OFF.

Dedicated to the financial and technical advancement of electronic maintenance personnel

VOLUME 13 NUMBER 14

DECEMBER, 1952

**JOHN F. RIDER, Publisher**  
**Annette M. Tricarico, Editor**  
**Stuart Flexner, Assistant Editor**

Advertising Representative  
H. J. Olsow & Co.  
3951 Grand Central Terminal  
New York 17, N. Y.  
MUrray Hill 6-4670



MEMBER



## Curtain Time

### UHF Test Equipment

The entrance of UHF television presents a challenge to the test equipment manufacturers who cater to the servicing industry. It is a well known fact that the higher the frequency of operation, the higher the price of test equipment. It makes sense, since the problems of design are much more complex.

This is where the rub is. The UHF part of a television receiver is small in comparison to the rest of the unit. It includes one or two tubes and, dollarwise, represents a relatively small portion of the complete receiver price. Servicing the UHF tuner or converter calls for a suitable signal source. Measurement of the operating voltages is taken care of by the voltage measuring devices which are bound in every service shop. The types of troubles which may be encountered in UHF tuners and converters are not too numerous since the device contains relatively few components. In saying this we are not belittling the ingenuity required on the part of the receiver design engineer to give birth to a good, stable unit.

But regardless of what may be involved in the UHF portion of a TV receiver, how much can the average service shop afford to spend for the equipment he must buy to service this portion? Frankly speaking, it can't be too much. UHF equipment is expensive, but too much expense is not warranted when one considers the nature of the application, that is, in the TV service shop.

No one can deny that a sweep generator is a convenient tool, but is a UHF sweep generator necessary as a signal source if it makes the cost high? The average service shop already possesses a VHF sweep generator. Isn't it possible to work with carrier frequencies which are *not* swept to check the few UHF channels

which may be in operation in a certain area by using several spot frequencies? The device must be continuously variable so as to cover the entire band, and that is all. Two such signal sources, one for the carrier signal and the other for the marker, are all that are needed.

We realize that even this much can be expensive, but test equipment manufacturers possess the know-how to come up with something for less than \$400 or \$500. After all, UHF tuners designed for VHF-TV receiver use can be a source of ideas.

We have heard some rumors about an inexpensive UHF signal source for service technicians. More power to the designers. It is true that the best device is the cheapest in the long run, but there are times when the best may be too rich for the blood, and this seems to be the case with a UHF signal generator for the TV servicing field. Who'll be the first to lick this problem? We wonder.

### Why Not More Standardization?

Every test equipment manufacturer knows that a better understanding of testing devices by the servicing industry will result in greater sales. Such understanding is hindered by the lack of standardization of nomenclature assigned to portions of test equipment which perform similar functions. We commented about this in our scope encyclopedia several years ago, but the practice is still rampant. We never entertained the idea that our comment would bring immediate action, but we did feel that the expressions of approval which we received from different test equipment manufacturers might bear some fruit in the long run.

Every attempt to describe the functioning of test equipment in general terms is hindered by the necessity of using a variety of identifications. And it makes it more difficult for the owner of a unit to apply what he reads to what he sees. Using similar nomenclature for similarly functioning controls may remove the individuality from different units, but it certainly will not lessen the unit's salability or its operating capabilities. After all, the individuality is found in brand names and capabilities, *not* in what the control is called. Hence it would be of great benefit to all concerned if the test equipment group would get together and do something about nomenclature.

### Preventive Maintenance

Some time ago we spoke about PM (Preventive Maintenance) in the TV service shop. Recently we spoke with a large scale TV operator who declared that he instituted the practice. He noted that since he started Preventive Maintenance there had been a definite decline in the frequency of test equipment failure in his shop. The bigger the investment in test equipment the more vital is such a program, and the greater the ultimate savings. And, on the other hand, the guy who doesn't have too much to put out for test equipment replacement needs preventive maintenance even more.



*John F. Rider*





First Choice with Servicemen Everywhere . . .

## MALLORY VIBRATORS

Servicemen know Mallory Vibrators give long, dependable performance—performance that keeps their customers happy. In fact, servicemen prefer Mallory Vibrators by a 2 to 1 margin, according to a recent survey. Mallory Vibrators give you . . .

- 1—Slow contact impact for minimum wear
- 2—High contact pressure for low resistance
- 3—Fast contact break for reduced arcing, pitting

Only from Mallory—with its patented, tuned vibrator mechanism—do you get this important three-way performance combination. It helps you beat the comeback problem. It's the reason manufacturers use more Mallory Vibrators as original equipment than all other brands combined. Follow their lead . . .

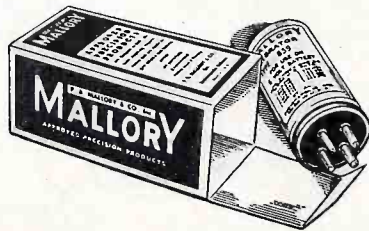

**Mallory Vibrator Deals Help Keep Inventory Down . . . Include Parts Chest At No Additional Cost**

You can service 47 different radio makes with the 6 vibrator types in these Mallory special deals. And you get a handy parts chest at no additional cost when you buy at your regular discount price. Ask your distributor for details today.

## Make Sure! Make it Mallory!

P. R. MALLORY & CO., INC.

# MALLORY

CAPACITORS • CONTROLS • VIBRATORS • SWITCHES • RESISTORS  
• RECTIFIERS • VIBRAPACK\* POWER SUPPLIES • FILTERS

\*Reg. U. S. Pat. Off.

### APPROVED PRECISION PRODUCTS

**P. R. MALLORY & CO., Inc., INDIANAPOLIS 6, INDIANA**



# Replacement Parts in TV Receivers

## Part I - Capacitors (cont'd)

by John F. Rider

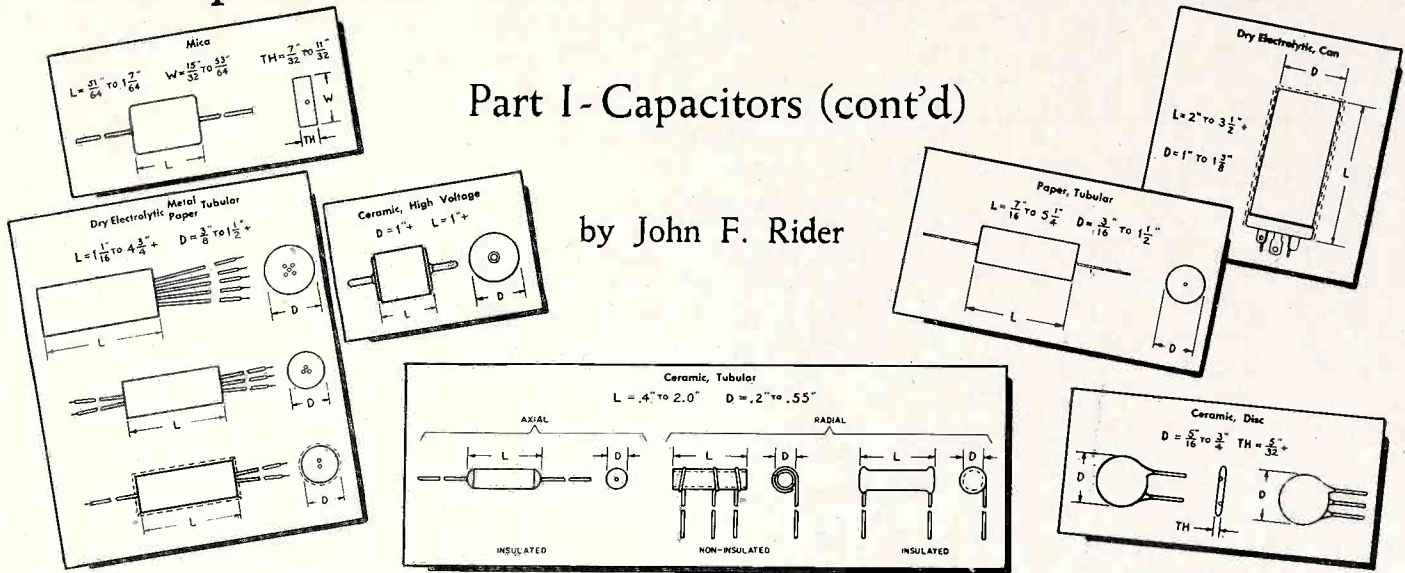

Moving down the scale of capacitance values for mica capacitors raises the series resonant frequency. Values from 500  $\mu\text{mf}$  down to about 10  $\mu\text{mf}$  result in self-resonant frequencies from about 25 mc up to as high as 280 mc. Depending on capacitance and connecting lead length self-resonance may occur at frequencies high up in the hundreds of megacycles range.

The same phenomenon is experienced with ceramic capacitors and paper dielectric tubulars. The former displays resonance at somewhat higher frequencies than the micas, whereas in the case of the paper dielectric tubulars, the frequency is somewhat lower.

These references to self-resonance should not be construed as expressions of comparative merit. They should be viewed as the basis for comments which appear in TV service literature stating the importance of maintaining capacitance values, lead lengths and lead dress when making replacements in front-end and i-f systems. The number of times that a TV receiver engineer makes use of series resonance phenomena for bypassing is not known because it is not indicated or labeled on a receiver or parts list. But since it is an effective method, the likelihood of it being used is high, and it is to the best interests of the service technician to pay more than just casual attention to these details when effecting a capacitor replacement. Adhering to this approach will neither complicate servicing nor make the procurement of replacement parts more difficult. Virtually every capacitor which may be used in this fashion is available from parts jobbers.

Two other items are of interest in connection with self-resonance effects in capacitors. Again they relate to high frequency circuits. It has been established that certain ratios of inherent L and C in a capacitor and its lead lengths can be used for filtering or bypassing purposes. This time, however, to accomplish varying degrees of filtering over a band of frequencies each

side of the self-resonant frequency. The frequency bandwidth over which the filtering is effective is determined by the L/C constant. The higher the ratio between L and C, the less the bypassing effect (or filtering) each side of the resonant frequency.

The final item of interest concerning self-resonance is when the prescense of the action can be undesirable. Capacitors, especially micas and ceramics, are used in different ways in high-frequency circuits. Some of the applications are in circuits through which a band of frequencies are passed. In order to minimize the possibility of undesirable signal absorption effects or shunting due to self-resonance, set manufacturers frequently stipulate the low frequency limit of series resonance when they order their capacitors. As a further safeguard, the lead lengths are kept as short as possible when the capacitor is wired into the receiver.

Capacitors in TV receivers do not bear labels stating the engineering considerations. However, it is easy to take care of them when making replacements by using, as was stated before, the correct value of capacitance, the type and tolerance stipulated, and by duplicating the lead lengths used with the original part that is being replaced. We reiterate once more that doing this does not necessarily mean troublesome procurement, it simply means using the proper part and exercising care when replacing a defective capacitor.

### Applications of Capacitors

Having discussed an inherent feature of capacitors and ways in which it is used, it is still necessary to describe the general manner in which capacitors of all kinds are employed. Understandably it is impossible in the limited space which we have available to describe each individual application, hence it is necessary to treat the subject broadly by categorizing the uses to which

capacitors are put, also the kinds of capacitors used for these functions.

**Tuning.** The use of a capacitor for tuning purposes includes many uses. It includes resonating a coil (individually, or as a part of a transformer) to a given frequency, or to reject or accept a band of frequencies. Then there is the application with resistors to control the rise of signal voltage relative to time. These are the time constant circuits. Remotely it is a form of tuning in that the system can be made frequency selective to the extent that the circuit allows the build-up of a signal voltage at one or more frequencies to a substantially greater extent than at some other frequencies.

These uses appear in front-ends, video i-f amplifiers, sound i-f amplifiers, multi-vibrator circuits, deflecting systems, sweep systems, phase discriminator systems, tone controls, audio amplifiers, etc.

The kinds of capacitors which are employed in this fashion are mica and ceramic dielectric types in the main, and on occasion, paper and dielectric tubulars. The paper unit is not used for tuning in r-f or higher frequency circuits. Distinctions are to be found in the specific classifications of these general categories of capacitors which are used in this manner. That is to say, all classifications of micas or ceramics are not used in the same circuits of a section of the receiver. Some of the functions required for proper operation of the receiver are not available in all varieties of a single category of capacitor, hence the distinctive type within a general category is chosen. For example, and this is only a capsule review, many tuned circuits require temperature compensation in order to assure frequency stability. This special action can be accomplished by certain kinds of mica and ceramic capacitors - the temperature compensating kind. Generally speaking, the ceramic type unit is used preponderantly in these cases. More will be said about this later.

(Continued on next page)



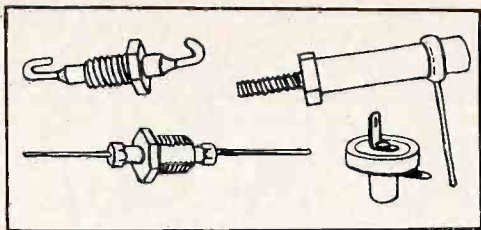

Feed-through and button type capacitors.

**D-C Blocking.** The isolation of a d-c voltage applied to one point from another point which is electrically connected to the first is another application of capacitors. Sometimes this function is performed simultaneously with coupling, or transferring energy from one point to another, but for the sake of clarity we distinguish between the two.

Mica, ceramic and paper dielectric capacitors are used in this way. (The first two at picture and sound carrier frequencies, at the video and sound i-f frequencies, in the majority of sweep circuits and even in the audio amplifiers.) The paper dielectric capacitor on the other hand is used mostly for d-c blocking (and coupling) in the audio amplifier, although even here it has been replaced by the ceramic in many instances.

**Coupling.** The transferring of energy from one circuit to another where a direct connection cannot be used because of d-c voltages, is accomplished by capacitors in most instances. Of course electromagnetic coupling is a common method where transformers are used, but on occasion the action of the electromagnetic coupling between windings is complemented by capacitive coupling in order to secure the required frequency response.

Mica and ceramic capacitors are used throughout the TV receiver as a signal transfer component, although the paper dielectric unit divides the function with ceramics. There was a time when micas were very popular as coupling capacitors in all r-f circuits, and the paper dielectric unit was used in the low frequency systems; today the ceramic is replacing both kinds.

**Bypassing.** Bypassing is a fluid word. Fundamentally it is the process of keeping signal currents out of undesired paths by providing a separate low impedance path around them. Another viewpoint, which perhaps is even more basic, is that bypassing is a means for minimizing voltage fluctuations at a point in the circuit. Oftentimes this is expressed as keeping a point in a circuit at ground potential by connecting a suitable amount of capacitance between that point and ground (or chassis).

All four main categories of capacitors are used for bypassing. The type is determined by the frequencies involved. Mostly ceramic dielectric capacitors are used for bypassing in signal circuits operating at frequencies higher than the audio range. In audio and lower frequency circuits, paper dielectric and

electrolytic capacitors see service. On occasion two capacitors may be connected across the same circuit element, an electrolytic and a ceramic. The former is intended to bypass the low frequencies and the latter serves for the higher frequencies.

The choice of paper dielectric and electrolytic types is based on the impedance of the path being bypassed. The lower its impedance, the higher must be the capacitance of the bypassing capacitor, and this is most readily available in electrolytic types. The operating voltage involved also is a factor; electrolytic capacitors are available at various voltage ratings up to about 450 volts d-c, whereas paper dielectric units are available at much higher voltage ratings.

**Filtering.** Filtering is another broad function. Common usage has given it a singular meaning; namely, the process of removing the ripple frequencies from the output of rectifier tubes in a power supply, thereby providing a d-c output from the unit. Simultaneous with this action of the capacitor in a power supply is its behavior as a reservoir of electricity thereby affording a steady supply of d-c voltage and current.

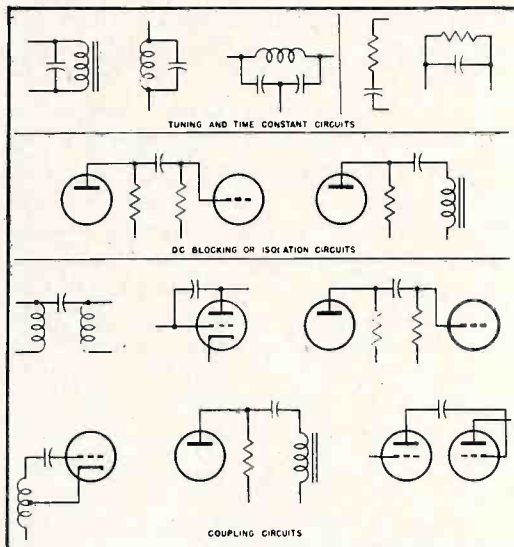

Filtering has other interpretations as well. One or more capacitors used in conjunction with either inductors or resistors, as the case may be, accept, reject, attenuate or accentuate one or more frequencies; or allow all frequencies below a limit value to pass through a circuit, or allow all frequencies above a limit value to pass through the circuit. Such are low-pass filters, integrator networks, etc.

As to the kinds of capacitors which are used for filtering purposes, the power supply filter capacitors are mainly of the electrolytic variety at least at working voltages up to 450 volts. At higher voltages, paper dielectric units are used. At very high voltages, such as in the picture-tube, second-anode power supply, ceramic capacitors rated at from 10,000 to 20,000 volts working voltage are employed.

In circuits which are intended to control the passage of bands of frequencies, higher

than perhaps 500 cps, mica and ceramic, especially the latter see most service. Paper dielectric capacitors are used in great numbers for this function at audio frequencies.

**Summary of Applications.** These references to applications are of necessity very brief. Elaborations will appear at different places in this text, as the discussion of the different kinds of capacitors warrants.

### Identification of Capacitors

How are capacitors identified? Identification is by means of the basic types first, then by the subdivisions of these types, and then finally by constants. Some constants are general in application, that is, will be found applied to all capacitors, whereas others are native only to certain specific varieties.

The family of main categories of capacitors and their subdivisions as applied to TV receivers is the following:

#### Air Dielectric

- Tuning capacitors (variable)
- Trimmer capacitors (variable)

#### Mica

- Foil, (fixed, postage stamp)
- Foil, (variable trimmers)
- Temperature compensating
- Foil, button
- Silver mica (fixed, postage stamp)
- Silver mica, button

#### Ceramic

- Tubular (fixed)
  - insulated
  - non-insulated
  - stand-offs
  - temperature compensating
  - feed-through
  - dual
- Disc (fixed)
  - single
  - dual
  - temperature compensating

#### Plates

- single
- multiple
- Door Knob (thick disc)
- Trimmers (variable)
  - tubular
  - flat (round)

#### Composition (fixed)

#### Paper Dielectric

- Tubular
  - Wax impregnated and cardboard case, wax sealed
  - Oil impregnated, cardboard case, wax sealed
  - Oil impregnated and molded case
  - Special impregnation, cardboard tube, molded seal
  - Metal cased (wax impregnated or oil impregnated)
  - Metal cased, hermetically sealed

#### Metalized Paper

#### Electrolytic

- Tubular (etched foil and plain)
- cardboard case or metal case

(Continued on page 17)





"WHY SHOULD I INSIST  
ON CBS-HYTRON?"

"YOU PROFIT MORE!  
HERE ARE  
5 BIG REASONS WHY"

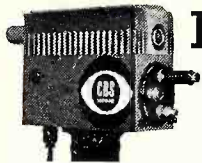

**1. CBS-HYTRON IS FAMOUS . . . EASY TO SELL.** The magic letters "CBS" are plugged for you on radio and TV station breaks . . . 102 BILLION times a year! CBS is known and respected by all your customers. CBS-Hytron is the profitable brand with endless sales assistance.



**2. CBS-HYTRON SPECIALIZES IN RECEIVING TUBES.** Since 1921, CBS-Hytron has concentrated on receiving types. Practice makes perfect. Put those years of know-how to work for you. Let time-proved CBS-Hytron dependability cut call-backs . . . make more money for you.



**3. CBS-HYTRON LEADS IN TV TUBES.** You know them. CBS-Hytron TV originals: 1AX2, 1X2A, 6BQ6GT, 12A4, 12B4, 12BH7, 12BY7, 12BZ7, 25BQ6GT, and the original rectangular 16RP4. Even CBS-Hytron standard TV tubes are designed-for-TV . . . tested-for-TV . . . to give you peak performance and profit.



**4. CBS-HYTRON IS ULTRAMODERN.** CBS-Hytron is the tube of the future. Made in the world's most modern plants. On manufacturing equipment years ahead of the rest of the industry. CBS-Hytron advanced design and precision construction keep you always ahead. Give your tomorrow's trouble-free performance today.

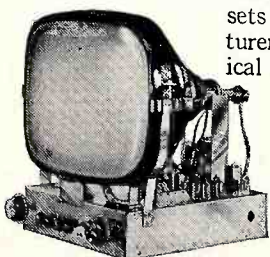

**5. CBS-HYTRON IS MATCHED-TO-THE-SET.** Combined engineering skills of leading set makers and CBS-Hytron work hand in glove for you. CBS-Hytron tubes are originally set-engineered right into the sets of 9 out of 10 leading set manufacturers. No wonder CBS-Hytron is your logical matched-to-the-set replacement tube.

**IT PAYS TO BE FUSSY!** Just any standard brand won't do. If you want: Trouble-free, advanced performance. Maximum customer satisfaction. Minimum call-backs. More profit. Five big reasons point the way: Insist on CBS-Hytron!



**CBS-HYTRON**  
Germanium Diodes

Complete data yours for the asking. Write  
CBS-Hytron, DANVERS, MASS., today.





# HOW TO PLAN FAST-MOVING INVENTORIES AND REDUCE OBSOLESCENCE WITH IRC "BEST SELLERS"

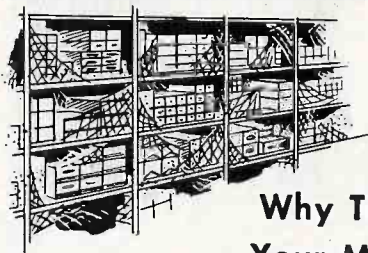

## Why Tie-up Your Money in Stagnant Stocks?

Resistors on your shelves won't bring you a cent—until you put them to use. If they're lazy movers they tie-up your money and your shelf space. And if they're shelf-squatters—gathering dust month after month until they become obsolete—they're actually money wasted. Yet a lot of servicemen continue to stock slow-moving parts because they haven't thought about the advantages of IRC "Best Seller" Resistors and Controls.

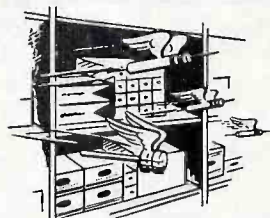

## For Fast Stock Turnover

### Invest in IRC "BEST SELLERS"

It's just as easy—easier in fact—to stock fast-moving, money-making parts as it is to load up with shelf-squatters. And it's certainly a lot more profitable. All you have to do is tell your Distributor's salesman that you want a realistic, commonsense inventory based on IRC "Best Sellers". He'll know what you mean, because ten-to-one your Distributor's own inventory is based on those very fast-moving parts.

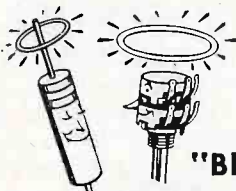

## What Do We Mean by "BEST SELLERS"?

"Best Seller" Resistors and Controls are those you use most often in radio and TV servicing. They're the indispensables—the ones you'll want on hand at all times. Of course there are others you'll need on occasion. But the great majority of parts essential in radio and TV divides into relatively few classifications regardless of brands or models of sets. Although IRC makes resistors and controls for every replacement need, careful analysis shows the greatest movement among a limited number of types and ranges. These "Best Sellers", listed here, provide a realistic base for establishing your parts inventory.



## IRC Advanced BT Filament Type Resistors

In television sets you'll find more IRC Type BT's than any other types or makes of resistors. Fully insulated, they combine extremely low operating temperature and superior power dissipation. Not only do they easily meet the stiff requirements of television, they also beat Army-Navy Specifications in most characteristics. IRC supplies Advanced Type BT Resistors in a complete variety of ranges and sizes to meet every servicing need.

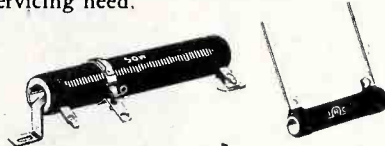

## IRC Fixed and Adjustable Power Wire Wound Resistors

These rugged, long-life resistors are specially engineered for dependable heavy-duty performance. Unlike ordinary resistors, IRC PWW's need no derating; they carry full wattage in any range. Special coating gives faster heat dissipation, and special lead-lug arrangement permits easier installation in crowded chassis. IRC Power Wire Wounds are available in a full range of sizes and resistance values and terminal types.

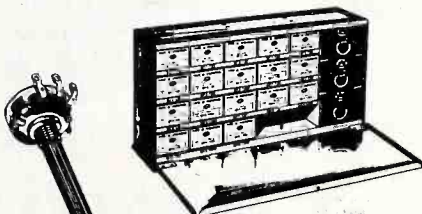

## Widest Replacement Coverage with Minimum Control Stocks

Most adaptable of all radio-TV technicians' volume controls, IRC Type Q Controls give you full replacement coverage with only nominal control stocks. IRC's exclusive Knob Master Shaft fits most push-on knobs without alteration except cutting to length. And IRC's Interchangeable Fixed Shaft feature allows fast control conversion to suit almost any radio or TV set. Handy IRC Volume Control Cabinet is the ideal way to buy and stock Q Controls. Cabinet stock of 18 controls handles over 90% of your single carbon control replacements.

## Here are Your IRC "BEST SELLER" Resistors and Controls listed in order of popularity

TYPE BT RESISTORS	
Type	Value
BTS 1/2 watt	0.1 meg.
BTS 1/2 watt	0.47 meg.
BTS 1/2 watt	22,000 ohms
BTS 1/2 watt	1.0 meg.
BTS 1/2 watt	1000 ohms
BTS 1/2 watt	10,000 ohms
BTS 1/2 watt	1500 ohms
BTS 1/2 watt	0.22 meg.
BTS 1/2 watt	4700 ohms
BTS 1/2 watt	100 ohms

POWER WIRE WOUND RESISTORS	
Type	Value
1 3/4A 10 watts	10,000 ohms
1 3/4A 10 watts	5000 ohms
1 3/4A 10 watts	1000 ohms
1 3/4A 10 watts	200 ohms
1 3/4A 10 watts	100 ohms
1 3/4A 10 watts	75 ohms
1 3/4A 10 watts	15,000 ohms
1 3/4A 10 watts	2000 ohms
1 3/4A 10 watts	1500 ohms
1 3/4A 10 watts	2500 ohms

REPLACEMENT CONTROLS		
Stock No.	Ohms	Taper
Q13-133	0.5 meg.	C
Q13-137	1.0 meg.	C
Q11-133	0.5 meg.	A
Q11-137	1.0 meg.	A
Q13-139	2.0 meg.	C
Q11-123	50 K	A
Q13-137X	1.0 meg.	H
Q11-128	0.1 meg.	A
Q13-139X	2.0 meg.	H
Q13-130	0.25 meg.	C

## Cash in on IRC "BEST SELLERS"



Ask your IRC Distributor to set up a sensible inventory for you, based on these fast-moving units. Also, get Catalog Bulletins DC1, DC5 and DC8 on these parts from your IRC Distributor—or send postcard to us for your copies. IRC "Best Sellers" can save you money!



Wherever the Circuit Says 

# INTERNATIONAL RESISTANCE CO.

423A N. Broad Street, Philadelphia 8, Pa.



---

*Notice to All Purchasers of:*

## **RIDER'S TV 10**

We have always prided ourselves on the accurate information we have made available to the servicing industry. To live up to this tradition we wish to correct certain discrepancies that crept into the replacement parts listings published in TV 10. Because we are anxious to give you thoroughly accurate replacement parts listings, which include additions that arrived after the publication of TV 10, we ask you to do the following:

Please fill in the registration coupon on the first page of your Rider TV 10 Manual and send it to us. We will forward the replacement parts listing corrections direct to your address. Also, by returning this coupon to us, you will be assured of having your name on our mailing list for exclusive information that will be available to TV 10 owners. Do Not send us the replacement parts pages!

Look to future issues of SUCCESSFUL SERVICING for the newest additional replacement parts listings.

*John F. Rider,  
Publisher*



# DOWN GO CALL-BACKS

# UP GO PROFITS

That's why...

## Federal TV PICTURE TUBES

... ARE THE REPLACEMENT  
CHOICE OF MORE AND MORE  
SERVICEMEN

**Federal tubes are designed right, made right, factory-tested to the hilt... and BACKED BY A YEAR'S GUARANTEE!**

FEDERAL is fast-growing in demand as a *profitable* picture tube replacement, because Federal goes the limit to assure your customers *steady satisfaction!*

Every Federal tube must measure up to exacting standards of efficiency for breakdown and stray emission (at max. ratings), ion trap current, central grid cut-off, zero bias beam current, focus voltage current, highlight brightness, leakages, shorts, gas ratio, screen and glass quality... plus other characteristics. Tests include the tough 500-hour operation run.

Moreover, a unique, prior-to-shipment check-up follows a 24-hour minimum storage period—an *extra provision for trouble-free performance!*

Start now to protect your replacement profits with Federal picture tubes... the tubes backed by decades of experience in producing highest-quality vacuum tubes for broadcast, military communications and other major uses.

Consult your Federal distributor for full information and prices.

**FEDERAL POPULAR-SIZE TUBES INCLUDE:** 12½ and 16-inch round; 14, 16, 17, 20 and 21-inch rectangular. Write for your free copy of Federal's Television Picture Tube Data Book.

**Federal**  
Telephone and Radio Corporation

VACUUM TUBE DIVISION • 100 KINGSLAND ROAD, CLIFTON, NEW JERSEY  
In Canada: Federal Electric Manufacturing Company, Ltd., Montreal, P. Q.  
Export Distributors: International Standard Electric Corp., 67 Broad St., N. Y.

"Federal always has made better tubes"

Please mention *Successful Servicing* when answering advertising.



# uhf converters

(Continued from page 1)

Conversion Kit Part No. 43-6473 for R-F Chassis 81-84. The change-over switch supplied with the kit is installed on the back of the VHF tuner, and is operated by the actuator on the VHF tuner shaft. When the Channel Selector of the VHF tuner is turned to either Channel 2 or Channel 3 (see adjustment of the actuator below), the switch is thrown into the UHF position. In the UHF position of the switch the antenna input of the VHF tuner is switched to the output of the UHF tuner and, if a single antenna is used, the antenna is switched to the input of the UHF tuner. In this position the VHF pilot light is turned off and the UHF pilot light is turned on. When the Channel Selector is set to a channel other than the one on which the switch is thrown by the actuator, the switch returns to the VHF position. In this position the antenna is connected to the VHF tuner input, the VHF pilot light is turned on, and a 150,000-ohm resistor is connected in series with the B plus supply for the UHF oscillator. The resistor lowers the plate voltage of the UHF oscillator and puts the oscillator out of operation.

The adapter plug fits into the socket of the audio output tube, with the tube inserted into the socket of the adapter. This adapter supplies B plus, B minus, and filament power connections for the UHF converter. The adapter plug and socket is used in field-installed kits only. In factory-installed kits the cable is wired directly into the r-f chassis.

The UHF tuner is tuned by means of a 3-gang tuning condenser, which is driven through a specially designed planetary drive. The planetary drive is constructed so that fine tuning and coarse tuning can be accomplished with one knob. The tuning shaft is coupled to the driving shaft through three balls which form a planetary drive for fine tuning. After rotating 180 degrees with the tuning shaft, a pin engages the driving shaft, and the two shafts are direct-coupled, for coarse tuning. To re-engage the planetary drive for fine tuning, it is only necessary to reverse the direction of rotation. The dial pointer is connected to the tuning gang through a cord drive, and indicates the channel number to which the tuner is tuned.

## The RCA UHF Selectors

Model U2. UHF Selector Model U2 permits the reception of any two UHF television stations within receiving range when employed with a VHF television receiver.

The unit employs two tubes, a crystal rectifier and a selenium power rectifier. The unit is housed in a small metal cabinet and is operated by a single control knob.

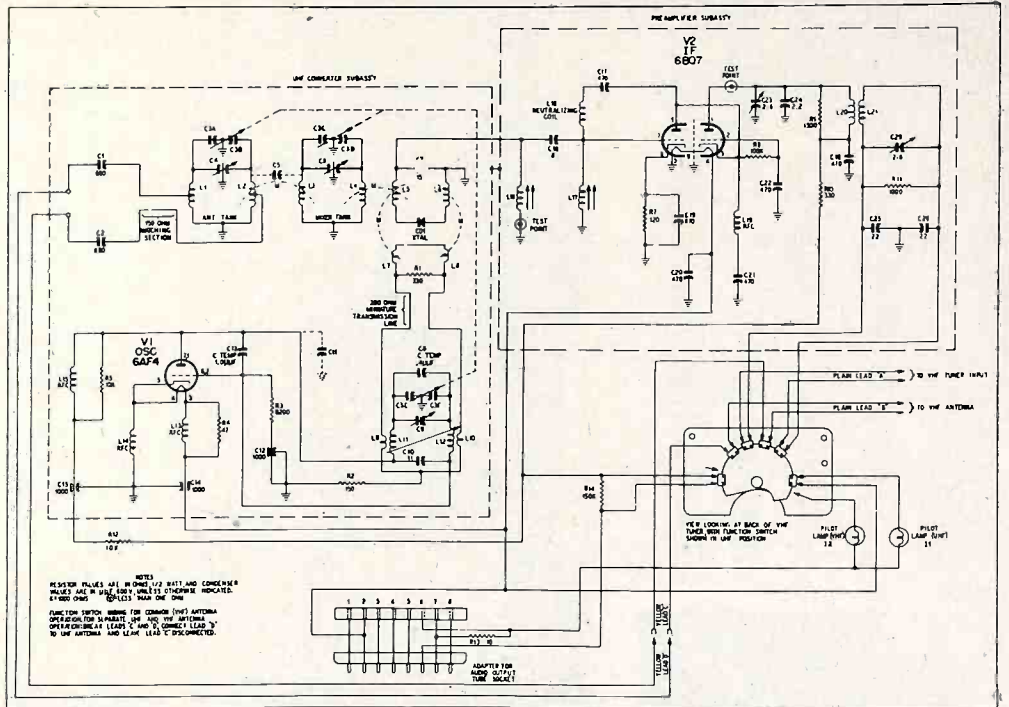

Courtesy Philco

Fig. 2. Schematic Diagram, Philco UHF Converter for R-F Chassis 81 and 84.

### Television R-F Frequency Range

All 70 UHF television channels ..... 470 mc.  
to 890 mc.

I-F Output Frequency ..... Channel 5 or 6

### Power Supply Rating

### Weight and Dimensions

Net Weight	Shipping Weight	Width Inches	Height Inches	Depth Inches
5	6½	8⅝	4⅞	7¾

(Continued on page 23)

## Laughs in the Life of a TV Serviceman



"... just as he caught a right to the jaw the picture started rolling and didn't stop till the commercial!"

IF HE'D only adjusted the vertical hold control—that's all it was. And anyway, if it had been serious, Raytheon TV is easy to service.

Besides furnishing complete Service Manuals with condensed service tips, Raytheon originated the famous "How to Interpret What You See" program, seen by over 40,000 servicemen. This popular 90-minute

show uses two slide films—one shows defective TV pictures, the other schematics of affected circuits. An experienced technician explains how to fix the trouble. Write for FREE copy of *How to Interpret What You See*, which gives you basic clinic material. Address Raytheon Television and Radio Corp., 5921 West Dickens Ave., Chicago 39, Ill.



**★ Build Your Service-  
Sales Future on a Firm  
Foundation with . . . .**

**PRECISION  
TEST EQUIPMENT**

*Standard of Accuracy...*

**...These 5 Matched "Precision"  
Instruments provide a Complete  
MODERN SERVICE LABORATORY for  
TV-FM-AM at only moderate cost.**

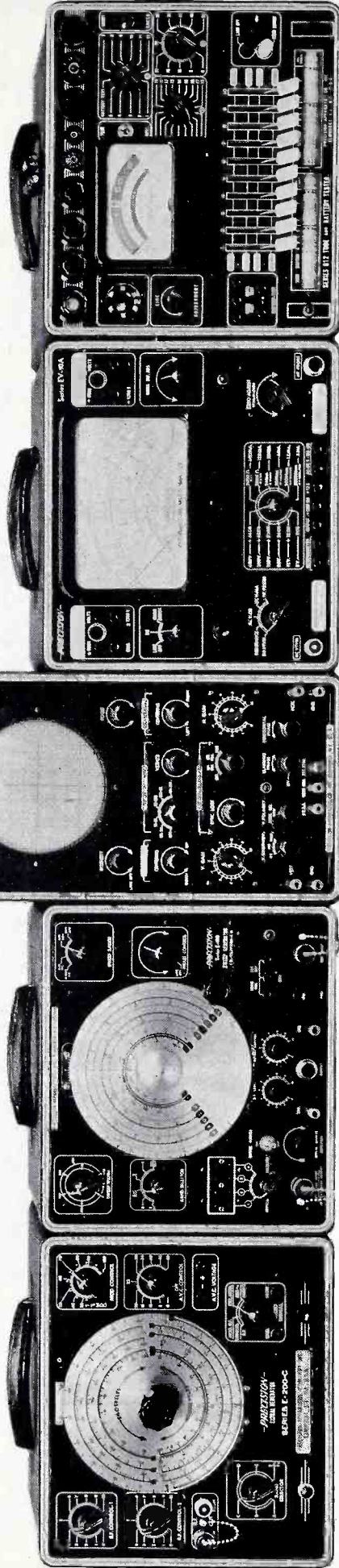

**SERIES E-200-C**— Modern Multi-Band SIGNAL and MARKER GENERATOR for A.M., F.M., and TV alignment.

Exceptional Accuracy and Stability! 1000 pt. vernier calibrating scale! 0-100% Modulation! A.V.C. — A.G.C. substitution-over-ride network! Direct reading 88KC to 120 MC! Complete with Coaxial output cable and technical manual! In matched, heavy gauge steel case 10½ x 12 x 6".

**Net Price: \$73.25**

**SERIES E-400**— Wide Range H.F. SWEEP SIGNAL GENERATOR Direct Reading from 2 to 480 MC.

Narrow and Wide Band Sweep for F.M. and TV. 0-1MC and 0-15MC • 1500 pt. vernier calibrating scale • Multiple Crystal Marker • 8 tubes including V.R. and rectifier • RG/62U Coaxial Terminated Output cable • Complete with 2 crystals • In matched copper-plated case 10½ x 12 x 6".

**Net Price: \$135.75**

**SERIES ES-500A**— 20 MV. High Sensitivity, Wide Range 5" C.R. OSCILLOGRAPH.

Push-Pull "V" and "H" amplifiers • 1 MC Band Width • High impedance, compensated "V" input Step Attenuator • Z axis modulation • 12 tubes incl. V.R. and 2 rect. • Light Shield and Mask • Heavy Steel Case: 8¼ x 14½ x 18".

**Net Price: \$173.70**

**SERIES EV-10A**— High Sensitivity True Zero-Center VTVM—MEGOhmmETER — with large 7" meter.

58 ranges to 6000 Volts, 2000 Megs. ±70DB, 12 Amps • Direct Reading R.F. VTVM scales via optional RF-10A High Freq. probe • Voltage Regulated bridge type circuit • Constant 13½ Megs input resistance to 600 V. 133½ Megs at 6000 V • Complete with test cables and manual • Matched heavy gauge steel cabinet 10½ x 12 x 6" **Net Price: \$97.20**

**SERIES 612**— Modern Free-point Cathode Conductance TUBE TESTER, and dynamic A-B-C Battery Tester.

Incorporates RTMA recommended circuit principles! 10 lever free-point element selection! Built-in roller chart! Dual short-check sensitivity! Noise, Ballast and Pilot Test! Free replacement tube test data chart! service! Complete, ready to operate! In matched heavy gauge steel cabinet 10½ x 12 x 6".

**Net Price: \$72.75**

**BUY PERFORMANCE— NOT SPECIFICATIONS!— BUY "PRECISION"**  
"PRECISION" PERFORMANCE, ACCURACY, WORKMANSHIP and VALUE have been setting a standard of comparison for over 15 years. . . . . DO NOT BE MISLED. . . . . It is not "PRECISION" test equipment unless it is manufactured by Precision Apparatus Co., Inc., Elmhurst, L. I., N. Y.

"Precision" Performance — Engineered Instruments are on display at leading radio parts and equipment distributors.



**PRECISION APPARATUS CO., INC.**

92-27 Horace Harding Boulevard, Elmhurst 14, New York

Export Division: 458 Broadway, New York, U.S.A. • Cables—Morhanex

In Canada: Atlas Radio Corp., Ltd., Toronto, Ontario

AM • FM • TV • AM • FM • TV

AM • FM • TV • AM • FM • TV

**OTHER MATCHED COMBINATIONS**

The instruments shown above illustrate one of many possible MATCHED COMBINATIONS of diversified "PRECISION" Test Equipment for TV-FM-AM. Each combination provides a selected and basic, modern, efficient Laboratory at moderate cost.

**SERIES TV-4**— Super-High Voltage Safety Test Probe.

Extends range of Series EV-10A (above) to 60 KV direct reading, with full safety to operator and equipment. Multiplier cartridges also available to match most VTVM's and 20,000 ohms/√v. test sets.

Series TV-4: — Complete, for use with EV-10A.

**Net Price: \$14.75**

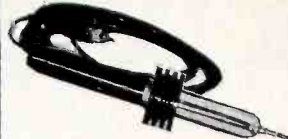

Convenient "Precision" Purchase Terms can be arranged with your favorite authorized Precision Distributor.

Please mention Successful Servicing when answering advertising.



# A 3rd and 4th "School of Thought" on Front-End Tuner Service

**RCA SERVICE CO., INC.**  
A RADIO CORPORATION  
OF AMERICA SUBSIDIARY  
CAMDEN 2, NEW JERSEY

October 17, 1952

Mr. John F. Rider  
John F. Rider Publisher, Inc.  
480 Canal Street  
New York 13, New York

Dear Mr. Rider:

I want to commend you on your very fine article on "Front End Tuner Service" which appeared in the September, 1952 issue of SUCCESSFUL SERVICING. The treatment you have given the "two schools of thought" on this important service is indeed thought provoking. However, I want to point out a third school of thought which I believe you will find interesting.

We—and perhaps others—have a tuner exchange arrangement which we believe is not only economical but permits rendering of complete tuner service with the least possible delay. This plan provides for stocking our distributors with RF tuners for ready use to replace defective tuners. Thus, a serviceman may exchange a tuner taken from a customer's set for a stock tuner. For this, he pays a nominal flat rate.

The outstanding merit of this plan, in addition to the moderate charge, is that it assures the serviceman a high standard of performance on tuners which have been overhauled in the field under factory controlled methods.

In our own repair activities of the tuner, we have established a standardization of the required jigs, tools, test equipment and replacement parts. This enables us to give each tuner a complete checkout under actual operating conditions as a final check and at a minimum cost.

Our service is truly invaluable to the average serviceman, who usually does not have the needed variety of jigs, parts and test facilities for the various types of tuners he may deal with.

We, therefore, feel that under this "third school of thought", the customer and the serviceman are best served with tuner repair centers on an exchange basis. This, of course, spells the best in all around service on this important component.

As has been our custom, we will continue to cover the RF tuner in our detailed service notes for those servicemen who wish to make the repairs themselves.

Very truly yours,  
C. M. Rigsbee, Manager  
Commercial Service Section

## RAYTHEON TELEVISION AND RADIO CORPORATION

A SUBSIDIARY OF RAYTHEON MANUFACTURING COMPANY  
5921 W. DICKENS AVE. CHICAGO 39, ILLINOIS

October 23, 1952  
Mr. John F. Rider  
480 Canal Street  
New York City 13, New York

Dear Mr. Rider:

It was with great interest that we at Raytheon read in "Curtain Time" your comments regarding tuner repairs. We believe that no specific remarks on tuner repairs in general can be made, but that on a particular type or make, a generalized answer is warranted.

The Raytheon tuner was devised with three main objects in mind, to be extremely sensitive electrically, to be exceptionally rugged mechanically and have ease of serviceability. This combination has resulted in a product which is, we believe, unsurpassed in its high efficiency and trouble-free service.

A tuner cannot be considered as a component in the same sense as a transformer or resistor. It is just another device with electronic components which form circuits with all the usual performance variations, and thus subject to all the usual non-performance tests.

A competent technician using factory replacement parts with the requisite equipment for RF alignment (equipment which a good service organization should have) and a little extra care in lead dress and component replacement are the only factors which control successfully, time and money saving repair on our tuners. By carrying in stock a small complement of replacement parts, he can, at low inventory cost be in a position to service successfully any of our VHF tuners.

The tuner can easily be serviced by removing the three (3) hex head nuts holding the bottom cover in place. Removing the bottom cover makes all the tuner components within easy reach and all parts can be serviced. It is suggested that after the bottom cover is removed, the tuner be inspected for burnt parts, solder splashes, and defective solder connections. When working inside the tuner do not move components a great distance as a change in distributed capacity will result and offset the alignment.

A majority of tuner troubles are often open or high resistant ground, coil or solder connections. These can easily be repaired by placing a hot soldering iron at the solder connection.

Since the tuner is small and compact, it is suggested that a long, small diameter tipped soldering iron be used to prevent damage to surrounding components. Do not over-heat trimmer condensers

(Continued on page 17)

# TELL-A-FAULT

is

## A BIG HELP

"to the serviceman, especially those of us who are new to TV servicing."

Harry J. McBride  
7125 Woodrow Ave.  
St. Louis 20, Mo.

"it is as essential as test equipment and tools."

Hugo Bonavita  
2330 Symmes Ave.  
Cincinnati, Ohio

"I can hardly wait for the succeeding issues."

Eugene L. Weidenbach  
408-16th St.  
Brooklyn 15, N. Y.

## NEED WE SAY MORE!

These comments are from servicemen just like yourself who are using TELL-A-FAULT in their everyday servicing work. They have found that TELL-A-FAULT does their troubleshooting for them. It can do the same for you!

This quadruple-threat service consists of:

- (1) time-saving pictorial, symptom and cure sheets
- (2) fault pinpointing circuit guides
- (3) servicing-techniques short cuts
- (4) how to use all sorts of test equipment

Save anywhere from 50 to 200 hours of troubleshooting time per year by using this practical service based on symptoms rather than circuitry. It completely removes the guesswork in locating receiver troubles by rapidly locating the faults and giving you the proper cures.

TELL-A-FAULT is only a few months old, but the idea has caught on with thousands of progressive service technicians throughout the country.

The entire service costs you less than twenty cents a week. You receive a full 12 month's TELL-A-FAULT for only \$10.00.

Start your subscription today! We'll send you your TELL-A-FAULT binder, subject separators and all the installments that have been released to date. For full information on the most unique SERVICE ever made available to TV and radio service technicians — write to Dept. TF 7.



**JOHN F. RIDER**

PUBLISHER, INC.  
480 Canal St., N. Y. 13, N. Y.





for greater speed and  
accuracy of TELEVISION INSTALLATIONS  
in any locality use the new

# Simpson

MODEL 488

## TV FIELD STRENGTH METER

In addition to location of maximum signal areas, the Simpson Model 488 Television Field Strength Meter is also ideal for antennae orientation, comparison of antennae systems, adjustment of TV signal boosters and checking antennae and lead-in installations to list but a few of the many functions available . . . THE 50 MICROVOLT FULL SCALE RANGE IS AN OUTSTANDING FEATURE FOR THOSE CONCERNED WITH FRINGE AREA INSTALLATIONS WHERE MAXIMUM EFFICIENCY MUST BE ATTAINED . . . The 500, 5,000 and 50,000 microvolt ranges extend the usefulness of the Simpson Model 488 into areas of higher signal strength. The large 4½-inch modernistic meter is easily read from a considerable distance and all controls and connections are arranged for greatest accessibility. Model 488 is housed in a beautiful gray hammerloid finished case for greater portability. LINE VOLTAGE: 105-125 volts, 50-60 cycles. SIZE: 8" x 11" x 8½".

WEIGHT: 11½ lbs. Shipping weight 15 lbs.  
DEALER'S NET PRICE, including operating instructions and shoulder strap . . . \$89.50

**SIMPSON ELECTRIC COMPANY**

5200 WEST KINZIE STREET, CHICAGO 44, ILLINOIS

Phone: COlumbus 1-1221

In Canada: Bach-Simpson, Ltd., London, Ontario



## Checking Electrolytic Capacitors

Experimentation shows that if the series resistance of the output section of the filter capacitor is as much as 6 ohms, the set will oscillate and produce a noticeable hiss. If the resistance is as much as 15 ohms, the receiver will squeal and motor-boat. Sometimes this trouble is not easily traced to the filter capacitors. The usual method for locating the trouble is to have the set playing on a station where the oscillation is present and bridge the filter condensers with another capacitor of the same value. All too often when this is done the shock of bridging the additional capacitor in the filter circuit will cause the oscillation to stop, and it may not reappear when the additional capacitor is removed from the circuit. A good way to avoid this is to use a two or three thousand ohm wire wound potentiometer in series with the test condenser. With the pot set in its maximum resistance position the test capacitor is connected across the suspected filter capacitor. Due to the high resistance of the pot the test capacitor charges slowly and the operation of the receiver is not disturbed. The resistance of the pot is slowly decreased until the test capacitor is connected directly across the suspected filter capacitor. This method has proved of considerable value in pinning down this type of filter trouble.

C. J. Overall

## A 3rd and 4th "School of Thought" on Front-End Tuner Service

(Continued from page 15)

as the insulation will melt. Avoid using excess solder, as solder splashes may result and cause damage to the tuner.

Tube sockets are extremely difficult to replace and therefore, it is not recommended. Broken tube socket pins can be easily replaced by carefully removing the broken pin parts, and inserting a new pin from the top of the socket. Loose tube socket pins may cause intermittent operation when the tube is jarred or moved. This condition can be remedied by carefully bending or squeezing the top of the pin contacts together with a sharp instrument. Rosin on the socket pins may also cause intermittent operation. This can be rectified by filing the tube pins which will leave a slight burr and insure good contact.

In conclusion, a factor we believe to be of utmost importance is the fact that our tuner has only four (4) movable contacts. These may be replaced in seven easy operations, taking under three minutes flat. We believe it to be automatic, that the smaller the number of contacts, the better the reception and the fewer the service problems.

Yours very truly,  
 RAYTHEON TELEVISION & RADIO CORPORATION  
 Frank Loasby  
 Sales Engineering Dept.

## Replacement Parts in TV Receivers

(Continued from page 8)

- single section
- multiple section
- Can type (etched foil or plain)
- twist lug
- single section
- multiple section
- screw-in
- single section
- multiple section
- Plug-in (etched foil and plain)
- single section
- multiple section

The branches of the capacitor family tree represent physical differences and electrical differences. We acknowledge that all features are of interest to the servicing industry, but a complete resume is impossible because of space limitations. Of greater concern are those details which relate to uses and replacements, hence pertinent constructional features will be discussed briefly in connection with the electrical characteristics.

The illustrations of the physical shapes of the different varieties of capacitors bear ranges of physical dimensions. No one brand is indicated by these sizes. As far as original equipment is concerned, that is, parts used

in receivers, the size selected by the set designer is one which is determined by two factors; supply, and the space available in the receiver. This tends to set a limit on the variety of sizes because the prime producers of these units manufacture items of like capacitance and voltage values in substantially the same physical dimensions, and also because the general dimensions of TV chassis are very much alike. Of course, when housing quarters are crowded, size is an important factor — but never losing sight of the electrical requirements.

### Constants of Capacitors

The constants of capacitors are numerous. An appreciation of their meaning by the servicing industry is important to successful operation. Not that service technicians have facilities for the determination of these constants, rather it means a better understanding of the entire replacement problem. Moreover, it gives more meaning to the specifications applicable to capacitors.

*This is the second in a series of articles on "Replacement Parts in TV Receivers." Will be continued next month.*

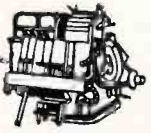

yours for the asking...

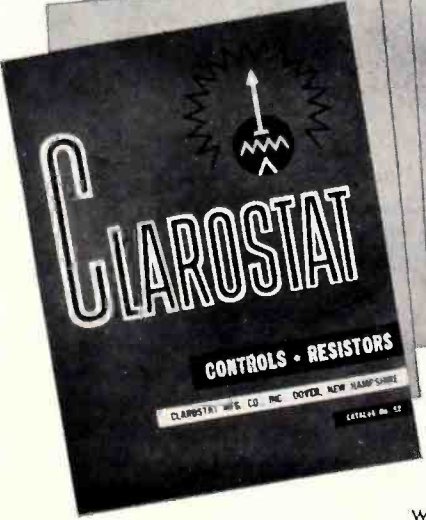

# NEW

## CLAROSTAT CATALOG

Hot off the press! Presents exceptional choice of resistors, controls and resistance devices.

Expanded listings. Carbon and wire-wound controls include Pick-A-Shaft types taking 12 different shafts, plus non-metallic shaft and high-voltage coupler.

Also aircraft-type metal-cased power rheostats, miniaturized carbon and wire-wound controls, sound system controls, power resistors, Glasohms, etc.

Ask your Clarostat distributor for your copy. Or write us.



## Controls and Resistors

CLAROSTAT MFG. CO., INC., DOVER, NEW HAMPSHIRE

In Canada: Canadian Marconi Co., Ltd., Toronto, Ontario



**★ Build Your Service-  
Sales Future on a Firm  
Foundation with . . . .**

**PRECISION  
TEST EQUIPMENT**

*Standard of Accuracy...*

**...These 5 Matched "Precision"  
Instruments provide a Complete  
MODERN SERVICE LABORATORY for  
TV-FM-AM at only moderate cost.**

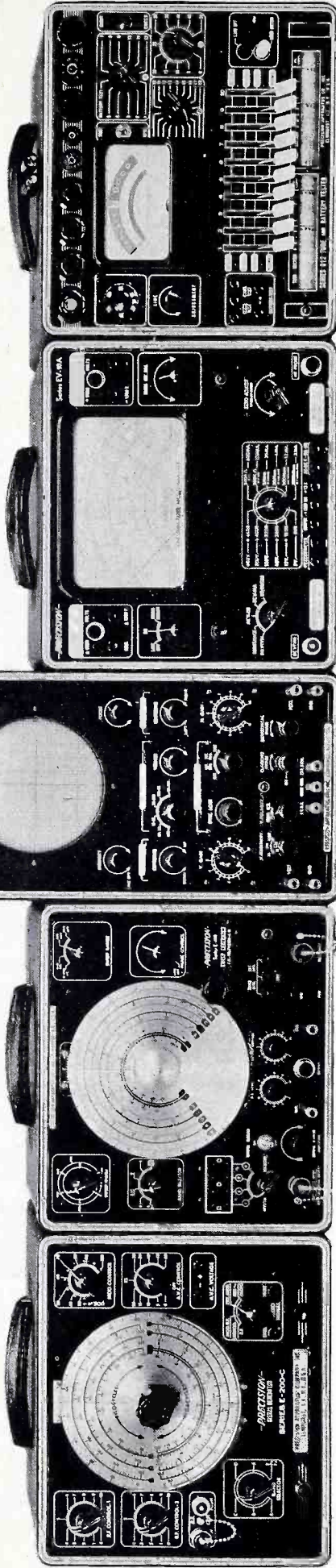

**SERIES E-200-C—Modern Multi-Band  
SIGNAL and MARKER GENERATOR  
for A.M., F.M., and TV alignment.**

Exceptional Accuracy and Stability! 1000 pt. vernier calibrating scale! 0-100% Modulation! A.V.C. — A.G.C. substitution-over-ride network! Direct reading 88KC to 120 MC! Complete with Coaxial output cable and technical manual! In matched, heavy gauge steel case 10 1/2 x 12 x 6".

**Net Price: \$73.25**

**SERIES E-400 — Wide Range H.F.  
SWEEP SIGNAL GENERATOR  
Direct Reading from 2 to 480 MC.**

Narrow and Wide Band Sweep for F.M. and TV, 0-1MC and 0-15MC • 1500 pt. vernier calibrating scale • Multiple Crystal Marker • 8 tubes including V.R. and rectifier • RG/62U Coaxial Terminated Output cable • Complete with 2 crystals • In matched copper-plated case 10 1/2 x 12 x 6".

**Net Price: \$135.75**

**SERIES ES-500A — 20 MV.  
High Sensitivity, Wide Range  
5" C.R. OSCILLOGRAPH.**

Push-Pull "V" and "H" amplifiers • 1 MC Band Width • High impedance, compensated "V" input Step Attenuator • Z axis modulation • 12 Tubes incl. V.R. and 2 rect. • Light Shield and Mask • Heavy Steel Case: 8 1/4 x 14 1/2 x 18".

**Net Price: \$173.70**

**SERIES EV-10A — High Sensitivity  
True Zero-Center VTVM—MEGOhmmETER  
— with large 7" meter.**

58 ranges to 6000 Volts, 2000 Megs,  $\pm 70\text{DB}$ , 12 Amps • Direct Reading R.F. VTVM scales via optional RF-10A High Freq. probe • Voltage Regulated bridge type circuit • Constant 13 1/2 Megs input resistance to 600 V. 133 1/2 Megs at 6000 V • Complete with test cables and manual • Matched heavy gauge steel cabinet 10 1/2 x 12 x 6"

**Net Price: \$97.20**

**SERIES 612 — Modern Free-point  
Cathode Conductance TUBE TESTER,  
and dynamic A-B-C Battery Tester.**

Incorporates RTMA recommended circuit principles! 10 lever free-point element selection! Built-in roller chart! Dual short-check sensitivity! Noise, Ballast and Pilot Test! Free replacement tube test data chart! serviced Complete, ready to operate! In matched heavy gauge steel cabinet 10 1/2 x 12 x 6".

**Net Price: \$72.75**

**BUY PERFORMANCE— NOT SPECIFICATIONS! — BUY "PRECISION"**  
"PRECISION" PERFORMANCE, ACCURACY, WORKMANSHIP and VALUE have been setting a standard of comparison for over 15 years. . . . DO NOT BE MISLED. . . . It is not "PRECISION" test equipment unless it is manufactured by Precision Apparatus Co., Inc., Elmhurst, L. I., N. Y.

"Precision" Performance — Engineered Instruments are on display at leading radio parts and equipment distributors.

AM • FM • TV • AM • FM • TV

**OTHER MATCHED COMBINATIONS**

The instruments shown above illustrate one of many possible MATCHED COMBINATIONS of diversified "PRECISION" Test Equipment for TV-FM-AM. Each combination provides a selected and basic, modern, efficient Laboratory at moderate cost.

**SERIES TV-4 — Super-High Voltage Safety Test Probe.**

Extends range of Series EV-10A (above) to 60 KV direct reading, with full safety to operator and equipment. Multiplier cartridges also available to match most VTVM's and 20,000 ohms/V. test sets.

Series TV-4: — Complete, for use with EV-10A.

**Net Price: \$14.75**

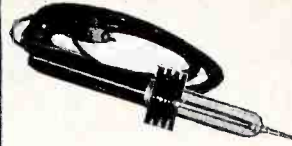

**PRECISION APPARATUS CO., INC.**

92-27 Horace Harding Boulevard, Elmhurst 14, New York

Export Division: 458 Broadway, New York, U.S.A. • Cables—Morhanex

In Canada: Atlas Radio Corp., Ltd., Toronto, Ontario

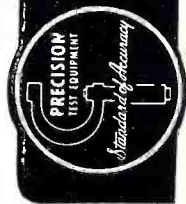

Please mention Successful Servicing when answering advertising.

Convenient "Precision" Purchase Terms can be arranged with your favorite authorized Precision Distributor.

AM • FM • TV • AM • FM • TV



# A 3rd and 4th "School of Thought" on Front-End Tuner Service

**RCA SERVICE CO., INC.**  
A RADIO CORPORATION  
OF AMERICA SUBSIDIARY  
CAMDEN 2, NEW JERSEY

October 17, 1952

Mr. John F. Rider  
John F. Rider Publisher, Inc.  
480 Canal Street  
New York 13, New York

Dear Mr. Rider:

I want to commend you on your very fine article on "Front End Tuner Service" which appeared in the September, 1952 issue of **SUCCESSFUL SERVICING**. The treatment you have given the "two schools of thought" on this important service is indeed thought provoking. However, I want to point out a third school of thought which I believe you will find interesting.

We—and perhaps others—have a tuner exchange arrangement which we believe is not only economical but permits rendering of complete tuner service with the least possible delay. This plan provides for stocking our distributors with RF tuners for ready use to replace defective tuners. Thus, a serviceman may exchange a tuner taken from a customer's set for a stock tuner. For this, he pays a nominal flat rate.

The outstanding merit of this plan, in addition to the moderate charge, is that it assures the serviceman a high standard of performance on tuners which have been overhauled in the field under factory controlled methods.

In our own repair activities of the tuner, we have established a standardization of the required jigs, tools, test equipment and replacement parts. This enables us to give each tuner a complete checkout under actual operating conditions as a final check and at a minimum cost.

Our service is truly invaluable to the average serviceman, who usually does not have the needed variety of jigs, parts and test facilities for the various types of tuners he may deal with.

We, therefore, feel that under this "third school of thought", the customer and the serviceman are best served with tuner repair centers on an exchange basis. This, of course, spells the best in all around service on this important component.

As has been our custom, we will continue to cover the RF tuner in our detailed service notes for those servicemen who wish to make the repairs themselves.

Very truly yours,  
C. M. Rigsbee, Manager  
Commercial Service Section

## RAYTHEON TELEVISION AND RADIO CORPORATION

A SUBSIDIARY OF RAYTHEON MANUFACTURING COMPANY  
5921 W. DICKENS AVE. CHICAGO 39, ILLINOIS

October 23, 1952  
Mr. John F. Rider  
480 Canal Street  
New York City 13, New York

Dear Mr. Rider:

It was with great interest that we at Raytheon read in "Curtain Time" your comments regarding tuner repairs. We believe that no specific remarks on tuner repairs in general can be made, but that on a particular type or make, a generalized answer is warranted.

The Raytheon tuner was devised with three main objects in mind, to be extremely sensitive electrically, to be exceptionally rugged mechanically and have ease of serviceability. This combination has resulted in a product which is, we believe, unsurpassed in its high efficiency and trouble-free service.

A tuner cannot be considered as a component in the same sense as a transformer or resistor. It is just another device with electronic components which form circuits with all the usual performance variations, and thus subject to all the usual non-performance tests.

A competent technician using factory replacement parts with the requisite equipment for RF alignment (equipment which a good service organization should have) and a little extra care in lead dress and component replacement are the only factors which control successfully, time and money saving repair on our tuners. By carrying in stock a small complement of replacement parts, he can, at low inventory cost be in a position to service successfully any of our VHF tuners.

The tuner can easily be serviced by removing the three (3) hex head nuts holding the bottom cover in place. Removing the bottom cover makes all the tuner components within easy reach and all parts can be serviced. It is suggested that after the bottom cover is removed, the tuner be inspected for burnt parts, solder splashes, and defective solder connections. When working inside the tuner do not move components a great distance as a change in distributed capacity will result and offset the alignment.

A majority of tuner troubles are often open or high resistant ground, coil or solder connections. These can easily be repaired by placing a hot soldering iron at the solder connection.

Since the tuner is small and compact, it is suggested that a long, small diameter tipped soldering iron be used to prevent damage to surrounding components. Do not over-heat trimmer condensers

(Continued on page 17)

# TELL-A-FAULT

is

## A BIG HELP

"to the serviceman, especially those of us who are new to TV servicing."

Harry J. McBride  
7125 Woodrow Ave.  
St. Louis 20, Mo.

"it is as essential as test equipment and tools."

Hugo Bonavita  
2330 Symmes Ave.  
Cincinnati, Ohio

"I can hardly wait for the succeeding issues."

Eugene L. Weidenbach  
408—16th St.  
Brooklyn 15, N. Y.

## NEED WE SAY MORE!

These comments are from servicemen just like yourself who are using TELL-A-FAULT in their everyday servicing work. They have found that TELL-A-FAULT does their troubleshooting for them. It can do the same for you!

This quadruple-threat service consists of:

- (1) time-saving pictorial, symptom and cure sheets
- (2) fault pinpointing circuit guides
- (3) servicing-techniques short cuts
- (4) how to use all sorts of test equipment

Save anywhere from 50 to 200 hours of troubleshooting time per year by using this practical service based on symptoms rather than circuitry. It completely removes the guesswork in locating receiver troubles by rapidly locating the faults and giving you the proper cures.

TELL-A-FAULT is only a few months old, but the idea has caught on with thousands of progressive service technicians throughout the country.

The entire service costs you less than twenty cents a week. You receive a full 12 month's TELL-A-FAULT for only \$10.00.

Start your subscription today! We'll send you your TELL-A-FAULT binder, subject separators and all the installments that have been released to date. For full information on the most unique SERVICE ever made available to TV and radio service technicians — write to Dept. TF 7.



**JOHN F. RIDER**  
PUBLISHER, INC.  
480 Canal St., N. Y. 13, N. Y.



**★ Build Your Service-  
Sales Future on a Firm  
Foundation with . . . .**

**PRECISION  
TEST EQUIPMENT**

*Standard of Accuracy...*

**...These 5 Matched "Precision"  
Instruments provide a Complete  
MODERN SERVICE LABORATORY for  
TV-FM-AM at only moderate cost.**



**SERIES E-200-C—Modern Multi-Band SIGNAL and MARKER GENERATOR for A.M., F.M., and TV alignment.**

Exceptional Accuracy and Stability! 1000 pt. vernier calibrating scale! 0-100% Modulation! A.V.C. — A.G.C. substitution-over-ride network! Direct reading 88KC to 120 MC! Complete with Coaxial output cable and technical manual! In matched, heavy gauge steel case 10½ x 12 x 6".

**Net Price: \$73.25**

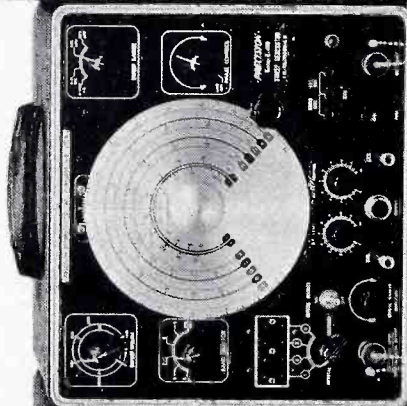

**SERIES E-400—Wide Range H.F. SWEEP SIGNAL GENERATOR Direct Reading from 2 to 480 MC.**

Narrow and Wide Band Sweep for F.M. and TV, 0-1MC and 0-15MC • 1500 pt. vernier calibrating scale • Multiple Crystal Marker • 8 tubes including V.R. and rectifier • RG/62U Coaxial Terminated Output cable • Complete with 2 crystals • In matched copper-plated case 10½ x 12 x 6".

**Net Price: \$135.75**

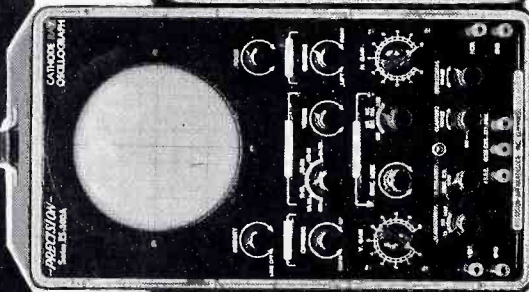

**SERIES ES-500A—20 MV. High Sensitivity, Wide Range 5" C.R. OSCILLOGRAPH.**

Push-Pull "v" and "h" amplifiers • 1 MC Band Width • High impedance, compensated "v" input Step Attenuator • Z axis modulation • 12 tubes incl. V.R. and 2 rect. • Light Shield and Mask • Heavy Steel Case: 8¼ x 14½ x 18".

**Net Price: \$173.70**

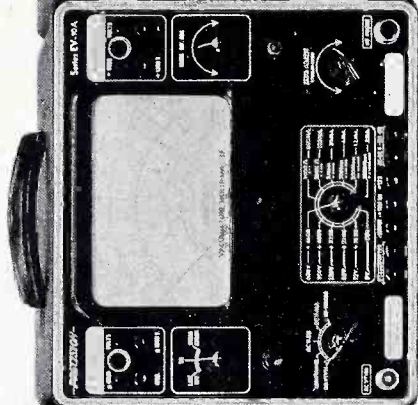

**SERIES EV-10A—High Sensitivity True Zero-Center VTVM—MEG OHMMETER — with large 7" meter.**

58 ranges to 6000 Volts, 2000 Megs, ±70DB, 12 Amps • Direct Reading R.F. VTVM scales via optional RF-10A High Freq. probe • Voltage Regulated bridge type circuit • Constant 13½ Megs input resistance to 600 V. 133½ Megs at 6000 V • Complete with test cables and manual • Matched heavy gauge steel cabinet 10½ x 12 x 6"

**Net Price: \$97.20**

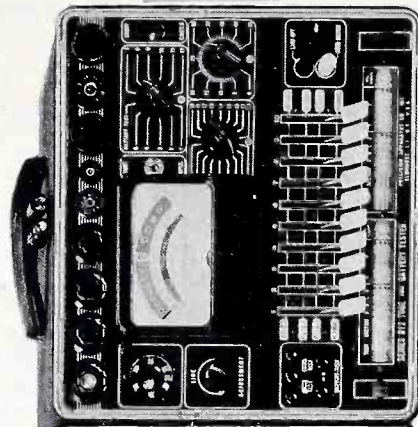

**SERIES 612—Modern Free-point Cathode Conductance TUBE TESTER, and dynamic A-B-C Battery Tester.**

Incorporates RTMA recommended circuit principles! 10 lever free-point element selection! Built-in roller chart! Dual short-check sensitivity! Noise, Ballast and Pilot Tests! Free replacement tube test data chart! service! Complete, ready to operate! In matched heavy gauge steel cabinet 10½ x 12 x 6".

**Net Price: \$72.75**

**BUY PERFORMANCE—NOT SPECIFICATIONS!—BUY "PRECISION"**  
"PRECISION" PERFORMANCE, ACCURACY, WORKMANSHIP and VALUE have been setting a standard of comparison for over 15 years. . . . . DO NOT BE MISLED . . . . . It is not "PRECISION" test equipment unless it is manufactured by Precision Apparatus Co., Inc., Elmhurst, L. I., N. Y.

"Precision" Performance—Engineered Instruments are on display at leading radio parts and equipment distributors.

AM • FM • TV • AM • FM • TV

**OTHER MATCHED COMBINATIONS**  
The instruments shown above illustrate one of many possible MATCHED COMBINATIONS of diversified "PRECISION" Test Equipment for TV-FM-AM. Each combination provides a selected and basic, modern, efficient Laboratory at moderate cost.

**SERIES TV-4—Super-High Voltage Safety Test Probe.**  
Extends range of Series EV-10A (above) to 60 KV direct reading, with full safety to operator and equipment! Multiplier cartridges also available to match most VTVM's and 20,000 ohms/v. test sets.  
Series TV-4:—Complete, for use with EV-10A.

**Net Price: \$14.75**

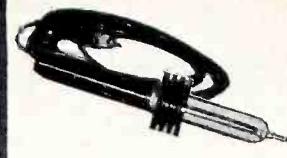

Convenient "Precision" Purchase Terms can be arranged with your favorite authorized Precision Distributor.

AM • FM • TV • AM • FM • TV

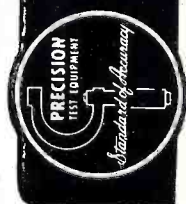

**PRECISION APPARATUS CO., INC.**  
92-27 Horace Harding Boulevard, Elmhurst 14, New York  
Export Division: 458 Broadway, New York, U.S.A. • Cables—Morhanex  
In Canada: Atlas Radio Corp., Ltd., Toronto, Ontario

Please mention Successful Servicing when answering advertising.



# A 3rd and 4th "School of Thought" on Front-End Tuner Service

**RCA SERVICE CO., INC.**  
A RADIO CORPORATION  
OF AMERICA SUBSIDIARY  
CAMDEN 2, NEW JERSEY

October 17, 1952

Mr. John F. Rider  
John F. Rider Publisher, Inc.  
480 Canal Street  
New York 13, New York

Dear Mr. Rider:

I want to commend you on your very fine article on "Front End Tuner Service" which appeared in the September, 1952 issue of **SUCCESSFUL SERVICING**. The treatment you have given the "two schools of thought" on this important service is indeed thought provoking. However, I want to point out a third school of thought which I believe you will find interesting.

We—and perhaps others—have a tuner exchange arrangement which we believe is not only economical but permits rendering of complete tuner service with the least possible delay. This plan provides for stocking our distributors with RF tuners for ready use to replace defective tuners. Thus, a serviceman may exchange a tuner taken from a customer's set for a stock tuner. For this, he pays a nominal flat rate.

The outstanding merit of this plan, in addition to the moderate charge, is that it assures the serviceman a high standard of performance on tuners which have been overhauled in the field under factory controlled methods.

In our own repair activities of the tuner, we have established a standardization of the required jigs, tools, test equipment and replacement parts. This enables us to give each tuner a complete checkout under actual operating conditions as a final check and at a minimum cost.

Our service is truly invaluable to the average serviceman, who usually does not have the needed variety of jigs, parts and test facilities for the various types of tuners he may deal with.

We, therefore, feel that under this "third school of thought", the customer and the serviceman are best served with tuner repair centers on an exchange basis. This, of course, spells the best in all around service on this important component.

As has been our custom, we will continue to cover the RF tuner in our detailed service notes for those servicemen who wish to make the repairs themselves.

Very truly yours,  
C. M. Rigsbee, Manager  
Commercial Service Section

## RAYTHEON TELEVISION AND RADIO CORPORATION

A SUBSIDIARY OF RAYTHEON MANUFACTURING COMPANY  
5921 W. DICKENS AVE. CHICAGO 39, ILLINOIS

October 23, 1952

Mr. John F. Rider  
480 Canal Street  
New York City 13, New York

Dear Mr. Rider:

It was with great interest that we at Raytheon read in "Curtain Time" your comments regarding tuner repairs. We believe that no specific remarks on tuner repairs in general can be made, but that on a particular type or make, a generalized answer is warranted.

The Raytheon tuner was devised with three main objects in mind, to be extremely sensitive electrically, to be exceptionally rugged mechanically and have ease of serviceability. This combination has resulted in a product which is, we believe, unsurpassed in its high efficiency and trouble-free service.

A tuner cannot be considered as a component in the same sense as a transformer or resistor. It is just another device with electronic components which form circuits with all the usual performance variations, and thus subject to all the usual non-performance tests.

A competent technician using factory replacement parts with the requisite equipment for RF alignment (equipment which a good service organization should have) and a little extra care in lead dress and component replacement are the only factors which control successfully, time and money saving repair on our tuners. By carrying in stock a small complement of replacement parts, he can, at low inventory cost be in a position to service successfully any of our VHF tuners.

The tuner can easily be serviced by removing the three (3) hex head nuts holding the bottom cover in place. Removing the bottom cover makes all the tuner components within easy reach and all parts can be serviced. It is suggested that after the bottom cover is removed, the tuner be inspected for burnt parts, solder splashes, and defective solder connections. When working inside the tuner do not move components a great distance as a change in distributed capacity will result and offset the alignment.

A majority of tuner troubles are often open or high resistant ground, coil or solder connections. These can easily be repaired by placing a hot soldering iron at the solder connection.

Since the tuner is small and compact, it is suggested that a long, small diameter tipped soldering iron be used to prevent damage to surrounding components. Do not over-heat trimmer condensers

(Continued on page 17)

# TELL-A-FAULT

is

## A BIG HELP

"to the serviceman, especially those of us who are new to TV servicing."

Harry J. McBride  
7125 Woodrow Ave.  
St. Louis 20, Mo.

"it is as essential as test equipment and tools."

Hugo Bonavita  
2330 Symmes Ave.  
Cincinnati, Ohio

"I can hardly wait for the succeeding issues."

Eugene L. Weidenbach  
408-16th St.  
Brooklyn 15, N. Y.

## NEED WE SAY MORE!

These comments are from servicemen just like yourself who are using **TELL-A-FAULT** in their everyday servicing work. They have found that **TELL-A-FAULT** does their troubleshooting for them. It can do the same for you!

This quadruple-threat service consists of:

- (1) time-saving pictorial, symptom and cure sheets
- (2) fault pinpointing circuit guides
- (3) servicing-techniques short cuts
- (4) how to use all sorts of test equipment

Save anywhere from 50 to 200 hours of troubleshooting time per year by using this practical service based on symptoms rather than circuitry. It completely removes the guesswork in locating receiver troubles by rapidly locating the faults and giving you the proper cures.

**TELL-A-FAULT** is only a few months old, but the idea has caught on with thousands of progressive service technicians throughout the country.

The entire service costs you less than twenty cents a week. You receive a full 12 month's **TELL-A-FAULT** for only \$10.00.

Start your subscription today! We'll send you your **TELL-A-FAULT** binder, subject separators and all the installments that have been released to date. For full information on the most unique **SERVICE** ever made available to TV and radio service technicians—write to Dept. TF 7.



**JOHN F. RIDER**  
PUBLISHER, INC.  
480 Canal St., N. Y. 13, N. Y.





for greater speed and  
accuracy of TELEVISION INSTALLATIONS  
in any locality use the new

# Simpson

MODEL 488

## TV FIELD STRENGTH METER

In addition to location of maximum signal areas, the Simpson Model 488 Television Field Strength Meter is also ideal for antennae orientation, comparison of antennae systems, adjustment of TV signal boosters and checking antennae and lead-in installations to list but a few of the many functions available . . . THE 50 MICROVOLT FULL SCALE RANGE IS AN OUTSTANDING FEATURE FOR THOSE CONCERNED WITH FRINGE AREA INSTALLATIONS WHERE MAXIMUM EFFICIENCY MUST BE ATTAINED . . . The 500, 5,000 and 50,000 microvolt ranges extend the usefulness of the Simpson Model 488 into areas of higher signal strength. The large 4½-inch modernistic meter is easily read from a considerable distance and all controls and connections are arranged for greatest accessibility. Model 488 is housed in a beautiful gray hammerloid finished case for greater portability. LINE VOLTAGE: 105-125 volts, 50-60 cycles. SIZE: 8" x 11" x 8½".

WEIGHT: 11½ lbs. Shipping weight 15 lbs.  
DEALER'S NET PRICE, including operating instructions and shoulder strap . . . \$89.50

### SIMPSON ELECTRIC COMPANY

5200 WEST KINZIE STREET, CHICAGO 44, ILLINOIS

Phone: COLUMBUS 1-1221

In Canada: Bach-Simpson, Ltd., London, Ontario



## Checking Electrolytic Capacitors

Experimentation shows that if the series resistance of the output section of the filter capacitor is as much as 6 ohms, the set will oscillate and produce a noticeable hiss. If the resistance is as much as 15 ohms, the receiver will squeal and motor-boat. Sometimes this trouble is not easily traced to the filter capacitors. The usual method for locating the trouble is to have the set playing on a station where the oscillation is present and bridge the filter condensers with another capacitor of the same value. All too often when this is done the shock of bridging the additional capacitor in the filter circuit will cause the oscillation to stop, and it may not reappear when the additional capacitor is removed from the circuit. A good way to avoid this is to use a two or three thousand ohm wire wound potentiometer in series with the test condenser. With the pot set in its maximum resistance position the test capacitor is connected across the suspected filter capacitor. Due to the high resistance of the pot the test capacitor charges slowly and the operation of the receiver is not disturbed. The resistance of the pot is slowly decreased until the test capacitor is connected directly across the suspected filter capacitor. This method has proved of considerable value in pinning down this type of filter trouble.

C. J. Overall

## A 3rd and 4th "School of Thought" on Front-End Tuner Service

(Continued from page 15)

as the insulation will melt. Avoid using excess solder, as solder splashes may result and cause damage to the tuner.

Tube sockets are extremely difficult to replace and therefore, it is not recommended. Broken tube socket pins can be easily replaced by carefully removing the broken pin parts, and inserting a new pin from the top of the socket. Loose tube socket pins may cause intermittent operation when the tube is jarred or moved. This condition can be remedied by carefully bending or squeezing the top of the pin contacts together with a sharp instrument. Rosin on the socket pins may also cause intermittent operation. This can be rectified by filing the tube pins which will leave a slight burr and insure good contact.

In conclusion, a factor we believe to be of utmost importance is the fact that our tuner has only four (4) movable contacts. These may be replaced in seven easy operations, taking under three minutes flat. We believe it to be automatic, that the smaller the number of contacts, the better the reception and the fewer the service problems.

Yours very truly,  
 RAYTHEON TELEVISION & RADIO CORPORATION  
 Frank Loasby  
 Sales Engineering Dept.

## Replacement Parts in TV Receivers

(Continued from page 8)

- single section
- multiple section
- Can type (etched foil or plain)
- twist lug
- single section
- multiple section
- screw-in
- single section
- multiple section
- Plug-in (etched foil and plain)
- single section
- multiple section

The branches of the capacitor family tree represent physical differences and electrical differences. We acknowledge that all features are of interest to the servicing industry, but a complete resume is impossible because of space limitations. Of greater concern are those details which relate to uses and replacements, hence pertinent constructional features will be discussed briefly in connection with the electrical characteristics.

The illustrations of the physical shapes of the different varieties of capacitors bear ranges of physical dimensions. No one brand is indicated by these sizes. As far as original equipment is concerned, that is, parts used

in receivers, the size selected by the set designer is one which is determined by two factors; supply, and the space available in the receiver. This tends to set a limit on the variety of sizes because the prime producers of these units manufacture items of like capacitance and voltage values in substantially the same physical dimensions, and also because the general dimensions of TV chassis are very much alike. Of course, when housing quarters are crowded, size is an important factor — but never losing sight of the electrical requirements.

### Constants of Capacitors

The constants of capacitors are numerous. An appreciation of their meaning by the servicing industry is important to successful operation. Not that service technicians have facilities for the determination of these constants, rather it means a better understanding of the entire replacement problem. Moreover, it gives more meaning to the specifications applicable to capacitors.

*This is the second in a series of articles on "Replacement Parts in TV Receivers." Will be continued next month.*



**yours for the asking...**

NEW

**CLAROSTAT CATALOG**

Hot off the press! Presents exceptional choice of resistors, controls and resistance devices.

Expanded listings. Carbon and wire-wound controls include Pick-A-Shaft types taking 12 different shafts, plus non-metallic shaft and high-voltage coupler.

Also aircraft-type metal-cased power rheostats, miniaturized carbon and wire-wound controls, sound system controls, power resistors, Glasohms, etc.

Ask your Clarostat distributor for your copy. Or write us.

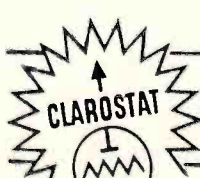

**Controls and Resistors**

CLAROSTAT MFG. CO., INC., DOVER, NEW HAMPSHIRE

In Canada: Canadian Marconi Co., Ltd., Toronto, Ontario





for greater speed and  
accuracy of TELEVISION INSTALLATIONS  
in any locality use the new

# Simpson

MODEL 488

## TV FIELD STRENGTH METER

In addition to location of maximum signal areas, the Simpson Model 488 Television Field Strength Meter is also ideal for antennae orientation, comparison of antennae systems, adjustment of TV signal boosters and checking antennae and lead-in installations to list but a few of the many functions available . . . THE 50 MICROVOLT FULL SCALE RANGE IS AN OUTSTANDING FEATURE FOR THOSE CONCERNED WITH FRINGE AREA INSTALLATIONS WHERE MAXIMUM EFFICIENCY MUST BE ATTAINED . . . The 500, 5,000 and 50,000 microvolt ranges extend the usefulness of the Simpson Model 488 into areas of higher signal strength. The large 4½-inch modernistic meter is easily read from a considerable distance and all controls and connections are arranged for greatest accessibility. Model 488 is housed in a beautiful gray hammerloid finished case for greater portability. LINE VOLTAGE: 105-125 volts, 50-60 cycles. SIZE: 8" x 11" x 8½".

WEIGHT: 11½ lbs. Shipping weight 15 lbs.  
DEALER'S NET PRICE, including operating instructions and shoulder strap . . . \$89.50

### SIMPSON ELECTRIC COMPANY

5200 WEST KINZIE STREET, CHICAGO 44, ILLINOIS

Phone: COlumbus 1-1221

In Canada: Bach-Simpson, Ltd., London, Ontario



## Checking Electrolytic Capacitors

Experimentation shows that if the series resistance of the output section of the filter capacitor is as much as 6 ohms, the set will oscillate and produce a noticeable hiss. If the resistance is as much as 15 ohms, the receiver will squeal and motor-boat. Sometimes this trouble is not easily traced to the filter capacitors. The usual method for locating the trouble is to have the set playing on a station where the oscillation is present and bridge the filter condensers with another capacitor of the same value. All too often when this is done the shock of bridging the additional capacitor in the filter circuit will cause the oscillation to stop, and it may not reappear when the additional capacitor is removed from the circuit. A good way to avoid this is to use a two or three thousand ohm wire wound potentiometer in series with the test condenser. With the pot set in its maximum resistance position the test capacitor is connected across the suspected filter capacitor. Due to the high resistance of the pot the test capacitor charges slowly and the operation of the receiver is not disturbed. The resistance of the pot is slowly decreased until the test capacitor is connected directly across the suspected filter capacitor. This method has proved of considerable value in pinning down this type of filter trouble.

C. J. Overall

## A 3rd and 4th "School of Thought" on Front-End Tuner Service

(Continued from page 15)

as the insulation will melt. Avoid using excess solder, as solder splashes may result and cause damage to the tuner.

Tube sockets are extremely difficult to replace and therefore, it is not recommended. Broken tube socket pins can be easily replaced by carefully removing the broken pin parts, and inserting a new pin from the top of the socket. Loose tube socket pins may cause intermittent operation when the tube is jarred or moved. This condition can be remedied by carefully bending or squeezing the top of the pin contacts together with a sharp instrument. Rosin on the socket pins may also cause intermittent operation. This can be rectified by filing the tube pins which will leave a slight burr and insure good contact.

In conclusion, a factor we believe to be of utmost importance is the fact that our tuner has only four (4) movable contacts. These may be replaced in seven easy operations, taking under three minutes flat. We believe it to be automatic, that the smaller the number of contacts, the better the reception and the fewer the service problems.

Yours very truly,  
 RAYTHEON TELEVISION & RADIO CORPORATION  
 Frank Loasby  
 Sales Engineering Dept.

## Replacement Parts in TV Receivers

(Continued from page 8)

- single section
- multiple section
- Can type (etched foil or plain)
- twist lug
- single section
- multiple section
- screw-in
- single section
- multiple section
- Plug-in (etched foil and plain)
- single section
- multiple section

The branches of the capacitor family tree represent physical differences and electrical differences. We acknowledge that all features are of interest to the servicing industry, but a complete resume is impossible because of space limitations. Of greater concern are those details which relate to uses and replacements, hence pertinent constructional features will be discussed briefly in connection with the electrical characteristics.

The illustrations of the physical shapes of the different varieties of capacitors bear ranges of physical dimensions. No one brand is indicated by these sizes. As far as original equipment is concerned, that is, parts used

in receivers, the size selected by the set designer is one which is determined by two factors; supply, and the space available in the receiver. This tends to set a limit on the variety of sizes because the prime producers of these units manufacture items of like capacitance and voltage values in substantially the same physical dimensions, and also because the general dimensions of TV chassis are very much alike. Of course, when housing quarters are crowded, size is an important factor — but never losing sight of the electrical requirements.

### Constants of Capacitors

The constants of capacitors are numerous. An appreciation of their meaning by the servicing industry is important to successful operation. Not that service technicians have facilities for the determination of these constants, rather it means a better understanding of the entire replacement problem. Moreover, it gives more meaning to the specifications applicable to capacitors.

*This is the second in a series of articles on "Replacement Parts in TV Receivers." Will be continued next month.*

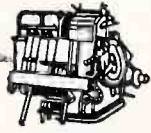

**yours for the asking...**



# NEW

## CLAROSTAT CATALOG

Hot off the press! Presents exceptional choice of resistors, controls and resistance devices.

Expanded listings. Carbon and wire-wound controls include Pick-A-Shaft types taking 12 different shafts, plus non-metallic shaft and high-voltage coupler.

Also aircraft-type metal-cased power rheostats, miniaturized carbon and wire-wound controls, sound system controls, power resistors, Glasohms, etc.

Ask your Clarostat distributor for your copy. Or write us.

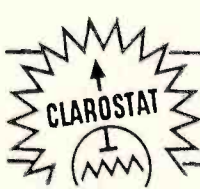

## Controls and Resistors

CLAROSTAT MFG. CO., INC., DOVER, NEW HAMPSHIRE

In Canada: Canadian Marconi Co., Ltd., Toronto, Ontario





Tung-Sol "Quality Control" recognizes but one standard. All Tung-Sol Tubes meet the highest original equipment requirements of leading radio and tv set manufacturers! Use Reliable Tung-Sol Tubes.

TUNG-SOL ELECTRIC INC.  
Newark 4, N. J.

Sales Offices: Atlanta • Chicago • Culver City  
Dallas • Denver • Detroit • Newark

**TUNG-SOL MAKES:**

All-Glass Sealed Beam Lamps, Miniature Lamps, Signal Flashers, Picture Tubes, Radio, TV and Special Purpose Electron Tubes.

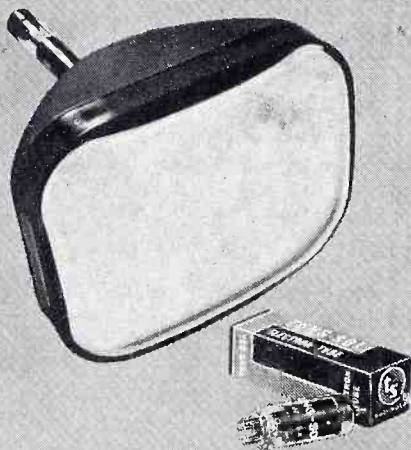

**TUNG-SOL®**

RADIO, TV TUBES, DIAL LAMPS



Here's a real lively "stopper" to attract attention to your place of business and emphasize the quality of your service. Colorful—bright red and two shades of blue. 15 inches high. Your jobber salesman will tell you how to get one.

**ATTENTION AUTHORS:**

We are soliciting articles concerning radio, television, and allied electronic maintenance. All aspects are of interest. Articles of 1,000 to 2,000 words are desired. Preference is given to subject matter which reflects practical work rather than theory. The presentation should be *direct, to the point, and amply illustrated.* Finished art work will be prepared by us from the roughs submitted. Photographs are welcome. The rate of payment is on a word basis — and, needless to say, good writing rates good pay!

Submit all articles and inquiries to  
Editor, *Successful Servicing.*

JOHN F. RIDER PUBLISHER, Inc.  
480 CANAL STREET  
New York 13, N. Y.

**There's a RIDER Book  
For Every Phase  
of  
Radio — Television**

TV Troubleshooting and Repair Guide Book 204 pages.....	\$3.90
UHF Practices and Principles 390 pages .....	\$6.60
Encyclopedia on Cathode-Ray Oscilloscopes and Their Uses 992 pages .....	\$9.00
Vacuum-Tube Voltmeters, 2nd Ed. 432 pages .....	\$4.50
TV and Other Receiving Antennas (Theory and Practice) 606 pages .....	\$6.90
TV Installation Techniques 336 pages .....	\$4.50
TV Master Antenna Systems 356 pages .....	\$5.00
Receiving Tube Substitution Guide Book, 1st Ed. 224 pages.....	\$3.00
First Supplement, Receiving Tube Substitution Guide Book 48 pages .....	\$.99
TV Picture Projection and Enlargement 192 pages .....	\$3.30
Television—How It Works 203 pages .....	\$2.70
FM Transmission and Reception, 2nd Ed. 460 pages .....	\$4.95
Radio Operator's License Q & A Manual, 3rd Ed. 734 pages.....	\$6.60
Broadcast Operator's Handbook, 2nd Ed. 440 pages .....	\$5.40
Radar—What It Is 60 pages.....	\$1.00
Understanding Vectors and Phase in Radio 160 pages .....	Cloth cover \$1.89 Paper cover \$ .99
Installation and Servicing of Low Power Pa Systems 208 pages.....	\$3.00
Servicing by Signal Tracing 360 pages .....	\$4.00
Inside the Vacuum Tube 424 pages .....	\$4.50
Servicing Superheterodynes 288 pages .....	\$2.00
Servicing Receivers by Means of Resistance Measurement 203 pages .....	\$2.00
The Business Helper 134 pages .....	\$2.00

**RIDER'S TV 10**

with  
**REPLACEMENT PARTS**  
listings

**Makes TV Servicing EASY!**



Circuit action descriptions!  
Unpacking and installation data!  
Signal waveforms for trouble shooting!  
Complete alignment data!  
Complete Parts Lists!

**ONLY \$24.00**

**Official, accurate factory-authorized data!**  
**All pages filed in place!**  
**All production runs and changes through September 1952!**  
**Big 12" x 15" size**  
**Cumulative index TV Volumes 1 through 10**  
**Over 2,000 pages (equivalent of 8½" x 11")**

**ORDER FROM YOUR JOBBER TODAY!**

WE GUARANTEE your satisfaction! Make these books PROVE their value to you. Examine them at your favorite jobber. If he does not have them — order from us.

**Order Your Copy Now!**

JOHN F. RIDER PUBLISHER, INC.  
480 Canal Street, New York 13, N. Y.



Greater than Ever!



THE RADIART  
*TV Booster*

with these added features:

- ★ Automatic On-Off Switch
- ★ Stand-By Position — eliminating "warm-up" time for booster
- ★ EXTRA 110 volt convenience outlet — plug in rotor or any appliance

and these too: High Signal-to-Noise Ratio ★ Wide Band Amplification ★ Complete Neutralization for Stable Operation ★ Mahogany Grained Polished Finish ★ Completely Enclosed for Dust-Free Operation ★ 15 Degree Tilt for Easier Visibility.

Accepted as outstanding... now with the ADDED features this BOOSTER leads the field. The automatic switch makes it possible to shut off the TV set by switching off the booster... the stand-by position keeps the booster in readiness for use... and the extra outlet adds versatility to the booster.

It's the Perfect Partner to the CDR ROTOR... the TV TWINS



SUBSIDIARY OF



THE RADIART CORPORATION CLEVELAND 13, OHIO

VIBRATORS • AUTO AERIALS • TV ANTENNAS • ROTORS • POWER SUPPLIES

Please mention Successful Servicing when answering advertising.



## SUCCESSFUL SERVICING

by John F. Rider



RAY RILING, Service Mgr.  
J. W. Scotchard & Co.  
Philadelphia, Penn.

## "I HAVEN'T HAD A SINGLE CALL BACK IN NINE MONTHS!"

### WHAT'S THE SECRET?

It's simple! The one thing that Rider gives you is *all the facts*. That's the one big difference between Rider Servicing Data and any other kind. Rider data is official, complete, factory-authorized data. Exactly as issued by the manufacturer who made the set... with *all* of his changes, and trouble cures organized into indexed, easy-to-follow style. This means that when you repair a set with Rider Servicing Data, you have *everything* in front of you. Everything that you must know to do a fast, accurate diagnosis and make a prestige-building, permanent repair. Rider Manuals make servicing easy!

### NEW FEATURE ADDED!

Now, in Rider's latest Servicing Data, beginning with TV Manual Vol. 10, you'll find a feature that can't be beat—a listing of *dependable* replacement parts. All listed parts check against the physical and electrical requirements of the original parts used in the receiver. This means reduced servicing time and faster repairs because of less changes on parts replaced.

### RIDER TV SERVICING DATA COMES IN TWO FORMS.



#### MANUALS

The TV Manual form has ten volumes covering more than 4,650 models of television receivers. Each volume has over 2,000 (8½ x 11") pages of servicing data with an index covering the contents of all volumes. Each volume is attractively bound in a permanent hard cover. The Manual form is ideal for shop use and as a permanent reference.



#### TEK-FILE

The Tek-File form now covers more than 2,200 models. Each Tek-File pack contains complete data for several of the most popular models... the ones you are called to work on every day. (Contents are clearly marked on the cover of each pack.) Get your free Tek-File indexes covering the contents of all packs at your jobber's. If he doesn't have them, write us.

For the complete servicing facts on radio get Rider Radio Manuals. In 22 volumes Rider Radio Manuals give you the complete, factory authorized, Official AM, FM radio servicing data for receivers manufactured over the past 22 years! Plus complete data on auto radios, record changers, tuners and recorders. *Everything is organized and indexed to make radio servicing easy.*

### DON'T BE SWITCHED.

Remember, Rider Manuals and Tek-Files are the only source, for complete factory-authorized servicing data. If your jobber doesn't have them, **DON'T BE SWITCHED!** If he doesn't have Rider Manuals, write to us... we'll tell you where to get them. If he doesn't have Rider Tek-Files, write to us... we'll fill your order directly. (Please include your jobber's name.) *Why not prove to yourself that Rider Servicing Data really makes servicing easy? Try one Rider TV Tek-File pack at our risk! Try a pack for the next receiver you repair... if you don't agree that it makes your servicing easier than anything you've ever used RETURN THE PACK TO US WITHIN SEVEN DAYS AND WE'LL SEND YOU A FULL REFUND! So act now... you have absolutely nothing to lose!*

### RIDER "HOW-TO-DO-IT" BOOKSHELF.

#### 1. TV Troubleshooting and Repair Guide Book.

Save time! Loaded with trouble-shooting charts and waveform pictures. 10 vital chapters. 204, 8½ x 11" pages. Paper cover \$3.90.

#### 2. Ency on CR'Scopes and Uses.

Most complete work on 'scopes! What they are, what they do, construction and capabilities. 992 pages 8½" x 11". 3,000 ill. Cloth cover \$9.00.

#### 3. Vacuum Tube Voltmeters.

All the facts! Design, construction, testing, maintenance, application, etc., of all types of VTVM's. 432 pages 5½" x 8½". 210 ill. Cloth cover \$4.50.

#### 4. Receiving Tube Substitution Guide Book.

Lists 2,500 radio, TV and electronic tube subs in numerical order. Gives ratings, wiring changes, tube base diagrams and characteristics chart. 224 pages. 8½" x 11". Paper cover \$3.00.

#### 4a. First Supplement to Original Guide.

Lists 750 completely new and different tube substitutions. 48 pages 8½" x 11". Paper cover \$1.99.

#### 5. UHF Practices and Principles.

The complete, up-to-the-minute story on UHF told in a clear, down-to-earth style. Covers practical, working applications and equipment including brand-name converters. 400 pages. 5½" x 8½". Cloth cover \$6.60.

### IT'S NEWS! TELL-A-FAULT

It's Rider's new monthly TV trouble-shooting service. Save countless hours of diagnosis time. Rider experts do your trouble-shooting for you... in pictures, charts, and symptom and cure sheets. Monthly bulletins. Send coupon for complete story—no obligation.

**BE SMART... MAIL THIS COUPON TODAY!**

JOHN F. RIDER, Publisher, Inc.  
480 Canal Street, New York 13, N. Y.

Please send me book(s) circled. I understand, if not satisfied, I may return them within 10 days for full refund.

1  2  3  4  4a  5  
 Send Free Data on Tell-A-Fault.

NAME \_\_\_\_\_

ADDRESS \_\_\_\_\_

CITY \_\_\_\_\_

ZONE \_\_\_\_\_ STATE \_\_\_\_\_ SS-12

(Please Print)





A monthly summary of product developments and price changes of radio, electronic, and television parts and equipment, supplied by United Catalog Publishers, Inc., New York City, publishers of RADIO'S MASTER.

These REPORTS will help you to buy and sell to best advantage. They will also help you to keep your inventory up to date. A complete description of most products will be found in the Official Buying Guide, RADIO'S MASTER available through local parts distributors.

**COMMENT:** There is an apparent trend toward increased prices by the leading TV tube manufacturers. While "change activity" continues to center around the introduction of new items, it is noticeable at this time that there is a decrease in the number of manufacturers involved.

**New Items**

- with N-1600A network at \$156 net and No. S-20, packaged public address system at \$275.00 net.
- AMERICAN PHENOLIC CORP.**—Added 500 and 1000 foot lines to their twin-lead transmission line series No. 14-023 and No. 14-079.
- A.R.R.L.**—Introduced new publication, "Gateway to Amateur Radio", sold as a 4-book unit containing: "How to Become a Radio Amateur"; "The Radio Amateur's License Manual"; "Learning the Radiotelegraph Code"; and "Operating an Amateur Radio Station", at \$1.25 net.
- ARCO ELECTRONICS**—Introduced ceramic disc capacitor series CCD and CCDN used primarily for coupling and by-pass in RF and higher frequency circuits; wax impregnated with low-loss phenolic coating; voltage rating 1500 VDC, 500 VDCW. Also feed thru capacitor series CCF designed for high frequency coupling with a minimum of inductive reactance through elimination of wire leads.
- BIRNBACH RADIO**—Introduced No. 6261 at \$1.41 net and No. 6263 at \$1.41 net. Both are bat handle center off switches of molded bakelite, rated at 3 amps, 250 volts.
- HALLDORSON TRANSFORMER** — Introduced No. DF604, deflection yoke at \$6.45 net . . . No. FB405, FB406, horizontal deflection, and H.V. flyback transformers at \$4.59 and \$4.71 net respectively.
- JACKSON ELECTRICAL INSTR.**—Added Model 710, selenium rectifier test set at \$29.50 net. This pocket size unit tests all selenium rectifiers rated from 20 to 650 ma and has a variable indicated voltage range from 25 to 300 volts ac. It is designed to operate on 110 to 125 volts ac and includes "line adjust" control to give more accurate readings.
- JERROLD ELECTRONICS**—Added three new high Q interference traps, No. TLB, TFM, THB, each at \$25.00 net.
- JONTZ MFG.**—Added Model E in their series of roof mounts, a package of 5 complete mounts and bolts at \$3.25 net.
- LITTELFUSE**—Added No. 30307.5, 7½ amp fuse in their 7AG fuse series.
- MERIT TRANSFORMER**—Added No. HVO-9 to their TV component series of horizontal output and hi-voltage transformers at \$6.00 net.

- PORCELAIN PRODUCTS**—Introduced a series of porcelain lead-in tubes for UHF TV cable. This set of lead-in tubes comes in 7 different lengths, and its snug fit prevents entry of rain or insects.
- R.C.A.**—Added TV component part No. 232T1, universal type horizontal deflection transformer (auto. trans. type) at \$6.00 net . . . receiving tubes 6BQ7A at \$3.05 list and 6U8 at \$2.90 list.
- RADIO MERCHANDISE SALES**—Introduced a number of economy V-type antennas, window antennas, and stacked 5 element Yagi antennas.
- RAYTHEON**—Introduced receiving tubes 6CL6, miniature version of type 6AG7, a 9-pin miniature pentode designed for use as a video amplifier in TV receivers at \$2.90 list . . . 12BZ7, a 9-pin miniature, high-mu dual triode designed for use as a sync separator in TV receivers at \$2.40 list and 20AV5G1, a beam pentode power amplifier designed for use as a horizontal deflection amplifier in TV receivers at \$2.90 list. Also introduced 17JF4, TV picture tube employing magnetic focus and deflection and designed to be used with an external ion trap magnet at \$26.00 net.
- RIDER, JOHN F.**—Added No. 142, "High Fidelity Simplified" at \$2.50 net.
- SCALA RADIO**—Added Model BZ-123, (a combination of Models BZ-1, BZ-2, BZ-3, containing a signal tracing probe, a low capacity probe, and a 100:1 voltage divider probe,) at \$27.50 net. Also introduced Model BZ-C, a spare or replacement low capacity calibrated coaxial cable for any of the above probes at \$1.00 net.

**Discontinued Items**

- AMER. TELEVISION & RADIO**—Discontinued several standard and heavy duty radio inverters and their series of standard and heavy duty industrial inverters.
- HALLICRAFTERS** — Discontinued Model S-80, supersensitive battery radio for remote areas.
- JOHNSON CO. E. F.**—Discontinued four radio frequency chokes, No's. 101-760, 102-750, 102-752, 102-754.
- NATIONAL CO.**—Discontinued Model HFS, VHF receiver and the six HFS plug-in coils that tuned the receiver to 6 bands.
- R.C.A.**—Discontinued receiving tubes 6AR5 and 6K8G.
- RADIO MERCHANDISE SALES**—Discontinued a number of 4 element Yagi antennas and several double driven 4 and 5 element Yagis.

- RECOTON**—Their series of juke box osmium phonorecords has been discontinued.
- TRIO MFG.**—Discontinued their controlled pattern antenna system series . . . their two-channel coverage Yagi antenna series and a number of models in their double dipole, five element Yagi series.

**Price Increases**

- AMERICAN PHENOLIC CORP.**—Increased price on No. 21-199 series of transmission line.
- G.E.**—Increased price on three 10", two 12", one 14", four 16", seven 17", three 20", three 21", one 24", and one 27" TV picture tubes.
- HALLICRAFTERS**—Increased price on a number of items including Model SA-62, all-wave listener receiver to \$299.50 amateur net price and Model S-76, double conversion receiver to \$179.50 amateur net price.
- R.C.A.**—Price increases on 5W4GT, radio receiving tube to \$1.75 list and No. WS-18A, rack-adaptor panel to \$11.50 net.
- RAULAND CORP.**—Increased price on two 10", two 12", two 14", seven 16", four 17", two 19", two 20", and two 21" TV picture tubes.
- RAYTHEON**—Price increases on two 10", three 12", two 14", five 16", three 17", three 20", one 21", and one 24" TV picture tubes.
- RIDER, JOHN F.**—No. 134, "TV and Other Receiving Antennas" increased to \$6.90 net.
- WESTINGHOUSE**—Increased TV picture tubes 16AP4-A to \$46.00 suggested list . . . 16GP4-B to \$46.00 suggested list . . . 17GP4 to \$42.00 suggested list and 19AP4-B to \$59.00 suggested list.

**Price Decreases**

- AMERICAN ELECTRICAL HEATER**—Decreased price on No. 3798, copper tip for very heavy operation soldering iron to \$1.689 net.
- AMERICAN PHENOLIC CORP.**—No. 82-843, RF connector decreased to \$5.40 net.
- CREST LABS.**—Decreased prices on cathode ray tube rejuvenators Model C, to \$2.40 net and Model D to \$2.79 net.
- JERROLD ELECTRONICS**—Decreased price on No. C-61, coaxial cable connector to \$.48 net.
- JONTZ MFG.**—Decreased price on 3 items in their Model 200 "super" kwick climb tower series. The 50 foot tower with foundation mountings reduced to \$82.50 net . . . 10 foot top section to \$18.50 net and 10 foot mid sections to \$16.00 net.

**UHF... and really HOT!**

**TITAN BOW TIE**

**FULL DETAILS AT YOUR DISTRIBUTOR**

**TECHNICAL APPLIANCE CORPORATION SHERBURNE, N. Y.**

**FREE**

Write today for "How to Service T. V. Receivers" with the HICKOK VIDEO GENERATOR.

**The Hickok Electrical Instrument Co.**

10820 Dupont Ave., Cleveland, Ohio



# ASTRON SERVES UP SATISFACTION

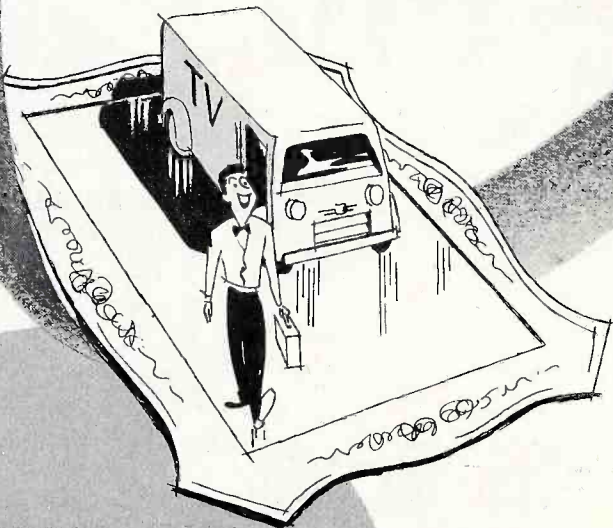
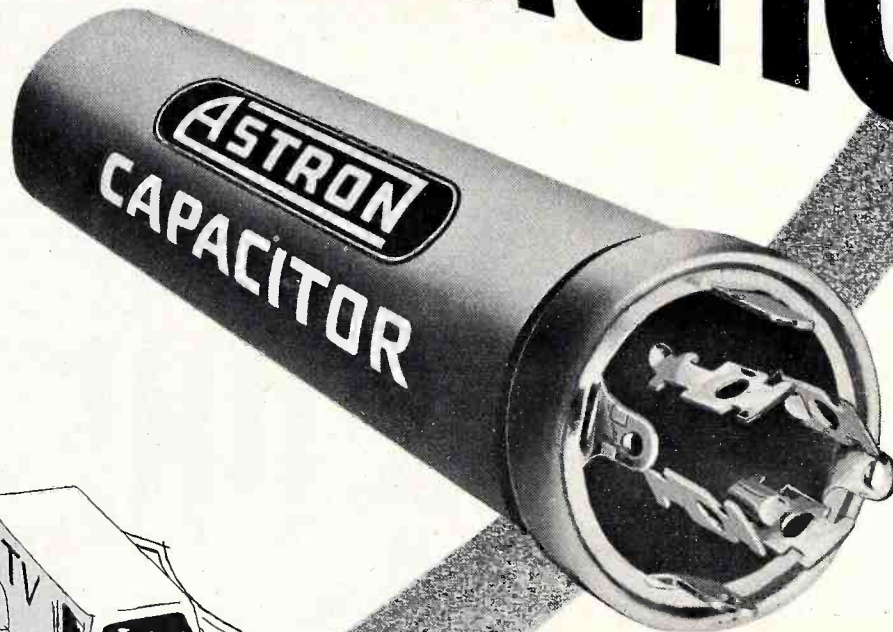

## on *Every* Service Call

When you replace with Astron Capacitors you are equaling or bettering original equipment—add to this:

- The service your customer expects
- The exact performance characteristics you demand
- Reduced call-backs everyone demands

And you have a few of the reasons why Astron Capacitors help "serve up satisfaction" to your customers. Alert jobbers are stocking Astron Capacitors—make sure you talk to your supplier today—or write to us for the name of the Astron Distributor nearest you. Send for catalog AC-3.



# ASTRON

C O R P O R A T I O N

255 Grant Avenue • E. Newark, N.J.

DEPEND ON . . . INSIST ON . . . **ASTRON**



# uhf converters

(Continued from page 13)

## Antenna Input Impedance

- UHF—Choice: 300 ohms balanced or 72 ohms unbalanced.
- VHF—300 ohms balanced.

## Tube Complement

Tube Used	Function
CK 710	Crystal Mixer
6BQ7	R-F Oscillator
6CB6	I-F Amplifier

The UHF Selector has been designed to operate from either of three types of antenna installations. It will operate from the VHF antenna, or from a separate UHF antenna with 300 ohm transmission line or from a separate UHF antenna with 72 ohm co-ax transmission line.

In all cases, the VHF antenna transmission line must be disconnected from the VHF receiver and reconnected to the selector VHF antenna terminals. A short length of 300 ohm line must then be connected between the VHF receiver antenna terminals and the selector terminals marked "Receiver."

**Model U70.** UHF Selector Model U70 permits the reception of any UHF television station within receiving range when employed with a VHF television receiver. The unit employs three tubes plus rectifier and a crystal mixer.

## Television R-F Frequency Range

All 70 UHF television channels.....470 mc. to 890 mc.

I-F Output Frequency .....Channel 5 or 6

Power Supply Rating.....115 volts, 60 cycles, 40 watts

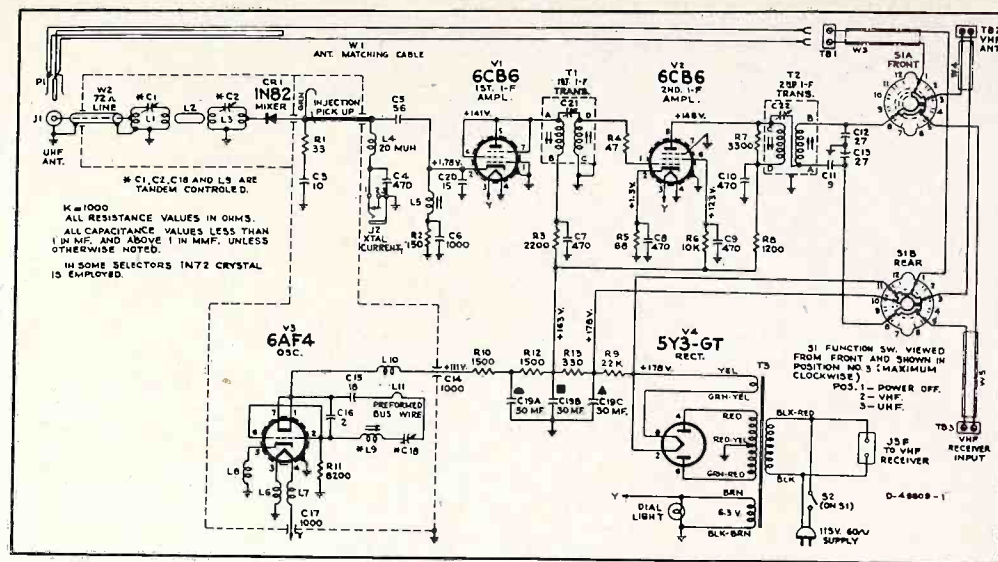

Fig. 4. Schematic of RCA U70 UHF Selector.

Courtesy RCA

## Weight and Dimensions

Net Weight	Shipping Weight	Width Inches	Height Inches	Depth Inches
10 lbs.	12 lbs.	11 1/8	8 1/4	9 3/4

## Antenna Input Impedance

- UHF—Choice: 300 ohms balanced or 72 ohms unbalanced.
- VHF—300 ohms balanced.

## Tube Complement

Tube Used	Function
6A4	R-F Oscillator
1N82	Crystal Mixer
6CB6	1st I-F Amplifier
6CB6	2nd I-F Amplifier
5Y3GT	Rectifier

The UHF Selector has been designed to operate from either of three types of antenna installations.

In all cases, the VHF antenna transmission line must be disconnected from the VHF receiver and reconnected to the selector VHF antenna terminals. A short length of 300 ohm line must then be connected between the VHF receiver antenna terminals and the selector terminals marked "Receiver."

## UTPI Sarkes Tazian Self-Powered UHF Translator.

Input Pre-set to any one UHF station —UTPIA (470-710) mc. — UTPIB (700-890) mc. Output into balanced 300 ohms, channel 2 to 6 inclusive.

This translator will provide satisfactory UHF reception in the many areas which will be served by a UHF station. It works in conjunction with a TV Receiver of any type, bringing a new station through one of the unused low channels.

In order to install this translator it is not necessary to get into the TV Receiver at all. It can be conveniently placed on the back of the set and need be connected only to the external antenna terminals of the receiver. As it is self powered it does not place added drain on the receiver power supply.

The receiver itself operates normally as when receiving a low channel. This makes it possible to take advantage of the full gain and performance of the VHF receiver when receiving UHF.

A switch button featured with this translator performs the following functions:

- It turns the translator on or off.
- It connects the translator output to the TV set or it disconnects it thus leaving the set undisturbed and capable of receiving the 12 VHF channels.
- It connects the presently used VHF antenna to the translator in case it is found to be satisfactory for UHF reception.

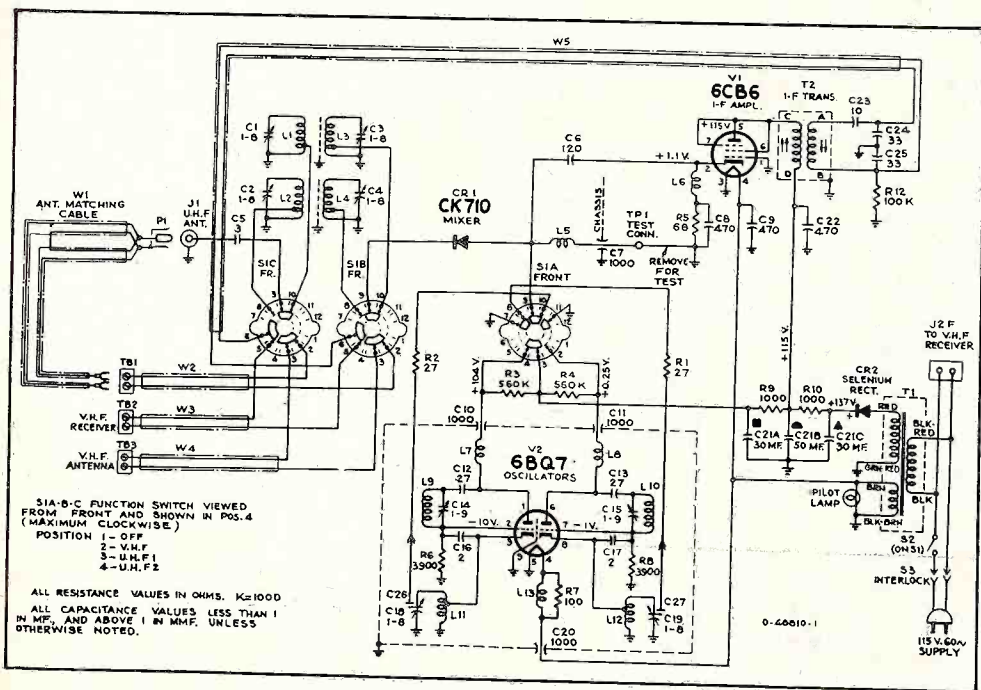

Fig. 3. Schematic of RCA U2 UHF Selector.

Courtesy RCA

(Continued on next page)



# uhf converters

(Continued from page 23)

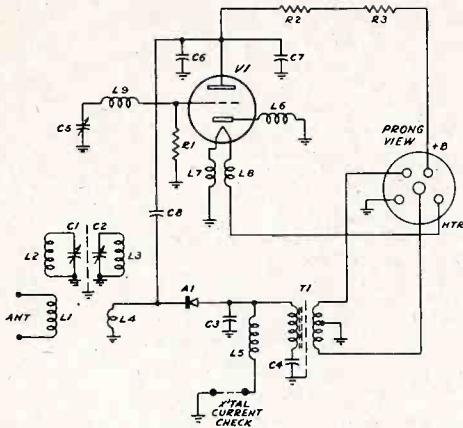

Courtesy Sarkes-Tarzian

Fig. 5. Schematic of the Sarkes-Tarzian UHF Translator.

It disconnects the VHF antenna and grounds it to prevent interference and, at the same time, it connects a UHF antenna to the translator, should a UHF antenna be found necessary.

The complete range of frequencies and antenna switching possibilities makes this translator completely universal in application.

## Crosley Service Hint

**Subject — SIMPLE "HI-POT" FOR BURNING OUT DIRT OR SCALE FROM VARIABLE CAPACITOR PLATES.**

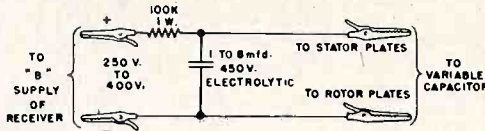

In many cases, when variable tuning capacitors have become noisy or their plates have shorted due to dirt and scale collecting between the plates, the capacitors can be repaired by applying high voltage to their plates. See schematic sketch.

## MAIL THIS COUPON TODAY

... if you wish to receive SUCCESSFUL SERVICING at your mailing address every month. Otherwise, you can still pick up your alternate copy of the magazine at your Rider distributor.

John F. Rider Publisher, Inc.,  
Dept. C9  
480 Canal Street  
New York 13, N. Y.

Gentlemen:

Rather than take the chance of missing the alternate copy of SUCCESSFUL SERVICING at my jobber's, I am enclosing one dollar (\$1.00) to cover the cost of direct-to-my-home mailing every month.

Name.....

Address.....

City..... Zone.....

State.....

Cash  Check  Money Order

## RIDER TV TEK-FILE

Packs 1-69

2571 Models

Now Available

At Your Jobber!

# What Every Hi Fi Enthusiast Should Know!

Just Off the Press

## HIGH FIDELITY SIMPLIFIED

by Harold D. Weiler

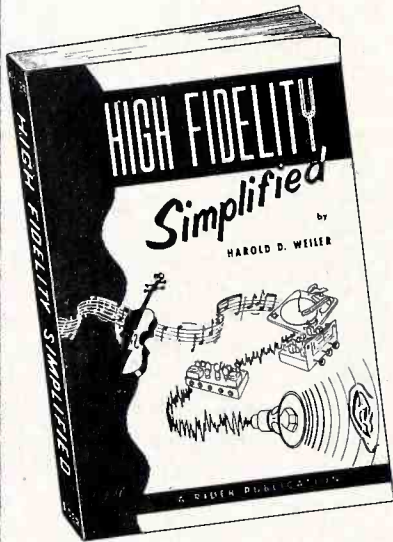

HIGH FIDELITY SIMPLIFIED is written for those who now own, intend to purchase or improve a high fidelity music system. It is the complete story of high fidelity from the point of origin, through the tuner, into the amplifier, and then into the loudspeaker. The author provides a thorough explanation of the characteristics required for high fidelity reproduction.

HIGH FIDELITY SIMPLIFIED has over 100 illustrations, blueprints and photographs of the latest equipment available.

HIGH FIDELITY SIMPLIFIED provides for the first time the minimum requirements for each component

and explains in simple language the terminology used by the manufacturers in their specifications.

The problems encountered in housing a high fidelity system are discussed in detail and many suggested installations are illustrated. The Nova Wall Units are described in detail with complete dimensional drawings. Audio hobbyists, record collectors, and all who enjoy lifelike reproduction will find this book authentic and practical.

HIGH FIDELITY SIMPLIFIED contains 204 pages in a handsome paper binding, provides information which will save its purchaser hundreds of dollars, in building and selecting a home music system.....\$2.50

John F. Rider Publisher, Inc., 480 Canal Street, New York

PERMIT NO. 9427  
NEW YORK, N. Y.  
**PAID**  
U. S. POSTAGE  
Sec. 3466, P. L. & R.

LANCASTER, PENN.  
437 NEVIN ST.  
JOHN L. GIGL

Forwarding and Return Postage Guaranteed  
480 CANAL ST., NEW YORK 13, N. Y.  
JOHN F. RIDER PUBLISHER, Inc.  
From



# SUCCESSFUL

# Servicing

JANUARY 1953

with **TECH-FILE INDEX**

THERE ARE TWO important ideas to keep in mind in dealing with the filament circuits of a television receiver. First of all, chokes may be used in series and capacitors in parallel with filaments in a television receiver to prevent coupling of signals between the several sections; secondly, series and parallel arrangements of the filaments may be found. In addition to these, manufacturers may not use the same filament circuits in their different models. Also, more taps may be used on the power transformer to supply the different filament voltages and to divide the load, as well as to prevent unwanted coupling between stages. Therefore, the serviceman cannot haphazardly pull out tubes which are not lighted and replace them thinking that the trouble has been fixed. The wiring diagram must always be checked.

A low-impedance path into the filament circuit from the cathode is thus presented to high-frequency signals. We are dealing with a very real circuit component even though it is not represented on the schematics of receivers. It would be simple for signals to be coupled through the filament of an r-f tube back to the common source, and then to the filaments and the cathodes of the picture and video tubes, thus causing interference in the picture.

It has been shown that these signals may be coupled into the circuits of other tubes. How can this be prevented? If another component were inserted in series, or in parallel, with the filament, blocking or bypassing of the signal is readily accomplished. For instance, with the 12AT7, the filament resistance for parallel operation is equal to the filament voltage divided by the current

will effectively block or drop most of the stray r.f. in the filament circuit and prevent it from entering any other circuit. At 60 cps the reactance of the choke is negligible, being much less than a small fraction of an ohm.

In addition to this, a capacitor may be placed directly across the filament. The action with a 5,000- $\mu\text{f}$  capacitor would be as follows. Its reactance at 25 mc is  $\frac{1}{2\pi fC}$   
 $= \frac{1}{1/6.28 \times 25 \times 10^6 \times 5,000 \times 10^{-12}}$  or a little over 1 ohm. Therefore, the r-f signal is effectively bypassed to ground, and does not pass to the other filament circuits of the set.

### Examples of Filament Isolation

In Fig. 2 the partial filament circuit for Admiral Chassis 20X1 is shown. One side of the circuit is grounded, the other being at

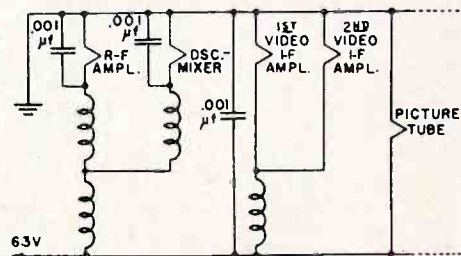

After Admiral

Fig. 2.—The schematic diagram of the Admiral Chassis 20X1 filament circuits with the use of r-f blocking chokes and bypass capacitors.

# TV Filament Circuits

### R-F Chokes and Bypass Capacitors

The eye is more sensitive to changes than is the ear. In the same way the video section of a television set is more sensitive to irregularities than is the audio portion. Since r-f signals are inaudible, the sound system does not usually have to be protected from any stray r-f signal. However, r.f. may easily be coupled through to the video stage causing interference in the picture if precautions are not taken.

Coupling in the filament stage occurs through the small but still significant capacitance between the cathode and filament of a tube (see Fig. 1). For instance the twin triode, the 12AT7, has a filament-to-cathode capacitance (for each unit) of 2.5  $\mu\text{f}$ . This might be thought small, but at the frequencies used in a television receiver, it becomes important. At a frequency of 80 mc the reactance of this 2.5- $\mu\text{f}$  capacitance is equal to

$= \frac{6.3 \text{ volts}}{0.3 \text{ amperes}}$  or 21 ohms. The effective r-f circuit is shown in Fig. 1B. Since the filament offers a low-impedance path to signals, an r-f choke is placed in series with it. The reactance of even a 1- $\mu\text{h}$  choke at a frequency of 80 mc is  $2\pi fL = 6.28 \times 80 \times 10^6 \times 1 \times 10^{-6}$  or about 500 ohms. This

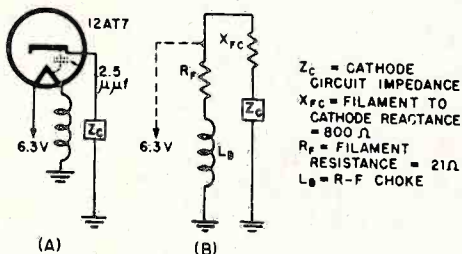

Fig. 1.—(A) shows a simplified tube circuit showing the filament-to-cathode capacitance. (B) is the equivalent r-f circuit showing the low filament-to-cathode reactance used for coupling the filament and cathode circuits of a tube.

$$\frac{1}{2\pi fC} = \frac{1}{6.28 \times 80 \times 10^6 \times 2.5 \times 10^{-12}} = 800 \text{ ohms.}$$

an a-c potential of 6.3 volts. The r-f amplifier and the oscillator-mixer are each in series with a choke, the two circuits being in parallel, and both are in series with another choke. The first and second video i-f amplifiers, in contrast, are directly in parallel with each other, the combination then being in series with a choke. The high-frequency stages are thus isolated from the rest of the circuits; the r-f tuning unit more so than the video i-f stages. The rest of the filaments are directly in parallel across the 6.3-volt supply.

The filament circuits of Capehart-Farnsworth Models 3001-B and 3001-M, 3002-B and 3002-M, and their Series A, are shown in Fig. 3. It is seen that the B- is connected to one side of one 6.3-volt winding. There is no ground involved in this source of filament voltage. However, there is another 6.3-volt source used, one end of which is grounded. This winding is used to supply the four video i-f amplifiers and the r-f tuning unit filaments. These stages are seen to

(Continued on page 36)



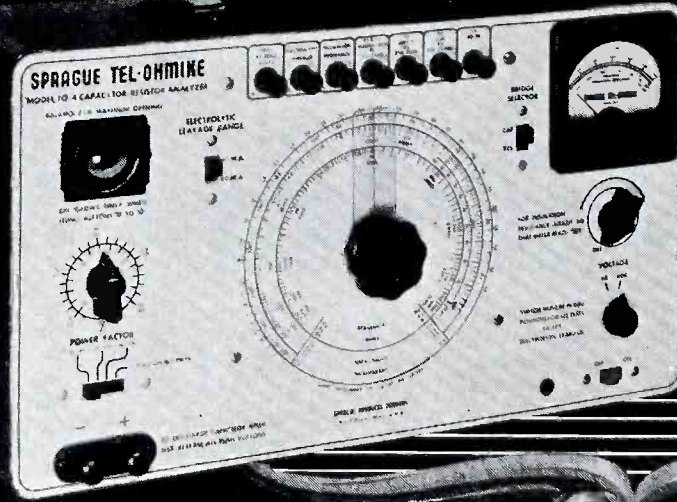

Here's The New

## Model TO-4 TEL-OHMIKE<sup>®</sup> CAPACITOR-RESISTOR ANALYZER

- You'll be proud to have this completely new instrument on your service bench!
- The result of a nationwide survey of radio and television technicians makes the new TO-4 Tel-Ohmike meet your capacitor test needs to a capital "T". Trim and trustworthy, it has instant push-button range selection, magic-eye bridge balancing, safety discharge feature, direct meter readings of leakage current and insulation resistance, and a continuously adjustable test voltage for checking electrolytics at exact rated voltages.
- Two especially valuable features are the provision of a special low capacitance circuit for checking small ceramics and "gimmick" capacitors down to 1 mmf (in addition to a top capacitance range of 2000 mf) and the simplified insulation resistance circuit with a top reading of 20,000 megohms.
- See a demonstration of this new instrument at your distributor without delay!
- And the price of this new improved Tel-Ohmike is still the same . . . . Only **\$73.50 NET.**

**SPRAGUE**

Write for full descriptive bulletin today  
**SPRAGUE PRODUCTS COMPANY**  
 (Distributors' Division of Sprague Electric Co.)  
 55 MARSHALL STREET, NORTH ADAMS, MASS.

ANOTHER NEW DEVELOPMENT BY THE WORLD'S LARGEST CAPACITOR MANUFACTURER



# USING AN A-M SIGNAL GENERATOR ...IN PLACE OF A CROSS-HATCH GENERATOR

*\*This material originally appeared in the General Electric Company's copyrighted publication Techni-talk.*

In some areas tv stations have either reduced "test-pattern time" to only a few minutes a day or the time is such, that when the test pattern is on, very few if any receivers can be installed and adjusted. Several manufacturers of test equipment are producing cross-hatch generators which can be conveniently used to adjust the height, width and linearity controls. These instruments should be used whenever available since they are designed for this particular application. Some service-technicians may not as yet have acquired one of these instruments or in a large service organization there may not be a sufficient number to go around. If a cross-hatch generator is not available an ordinary a-m signal generator can be used for the same purpose.

The vertical linearity and height controls can be checked and adjusted by setting the channel selector to some channel not used in your area. This should probably be one of the lower channels since most of the older signal generators do not cover the high tv channel frequencies. The r-f output cable of the signal generator should be connected to the antenna terminals of the receiver. The output of the signal generator must be modulated since it is the frequency of the modulation which is visible on the picture tube screen. Most signal generators have provision for 400-cycle modulation which produces a bar pattern similar to that shown in Fig. 1.

The output of some signal generators such as the General Electric YGS-3 can be modulated by a 60-cycle or 400-cycle fixed frequency, or by any frequency within the variable frequency range of 100 to 12,000 cycles. The 60-cycle modulation produces a pattern consisting of two horizontal bars as shown in Fig. 2. The positive half of the sine wave produces the bright bar, while the negative half produces the black bar. The 400-cycle modulation produces six bright bars and five dark bars as shown in Fig. 1. The number of black and white bars will vary depending on the frequency of the

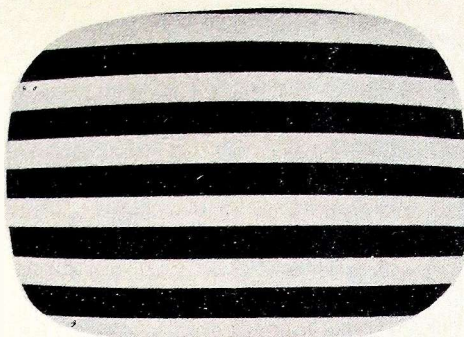

Fig. 1. Pattern produced by signal generator with 400-cycle modulation.

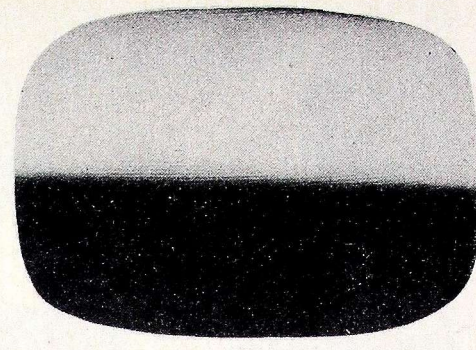

Fig. 2. Pattern produced by signal generator with 60-cycle modulation.



Fig. 3. Pattern produced by signal generator with 1500-cycle modulation.



Fig. 4. 400-cycle modulation with poor vertical linearity.



Fig. 5. 1500-cycle modulation with poor vertical linearity.

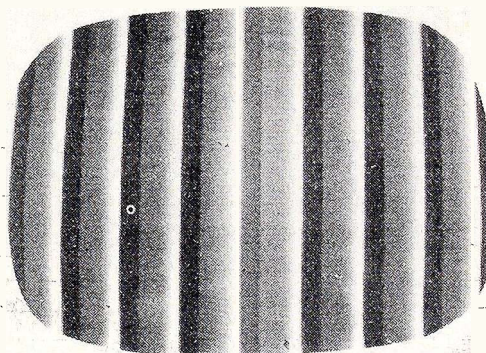

Fig. 6. Pattern produced by Signal generator with 157.5 K C unmodulated output.

audio modulation. If the frequency of the audio modulation is increased to 1,500 cycles, the number of black and white bars will increase to 25 as shown in Fig. 3. The number of bars which appear on the screen can also be varied somewhat by adjusting the vertical-hold control which changes the frequency of the vertical oscillator.

The vertical linearity and height controls can be adjusted with either 400-cycle modulation or some higher frequency such as 1,500 cycles. A squeezing at the top is shown with 400-cycle modulation in Fig. 4 and with 1,500-cycle modulation in Fig. 5. The controls should be adjusted until the spacing between each bar is the same, keeping in mind, of course, that the top and bottom should not extend more than one-half inch beyond either the top or bottom of the screen.

Reasonably good vertical adjustments can also be made without instruments by checking the scanning lines for crowding near the top or bottom of the screen. This type of adjustment can be made somewhat easier if the vertical-hold control is adjusted so that the vertical scan lines for each frame pair up or overlap. If a receiver has good interlace, this point may be very close to the position where the vertical loses sync.

Still another method which can be used is to adjust the vertical-hold control so that the vertical rolls slowly. The height of the blanking bar between frames can be observed as it moves from the top to the bottom of the screen. If the height of this bar changes either near the top or near the bottom of the screen, the picture will be affected in the same way at the same point.

(Continued on page 8)



# USE TUNG-SOL TUBES FOR TROUBLE-FREE SERVICE!

TUNG-SOL "QUALITY CONTROL" recognizes but one standard. All Tung-Sol Tubes meet the highest original equipment requirements of leading radio and tv set manufacturers.

TUNG-SOL ELECTRIC INC., Newark 4, N. J.  
Sales Offices: Atlanta · Chicago · Culver City · Dallas  
Denver · Detroit · Newark

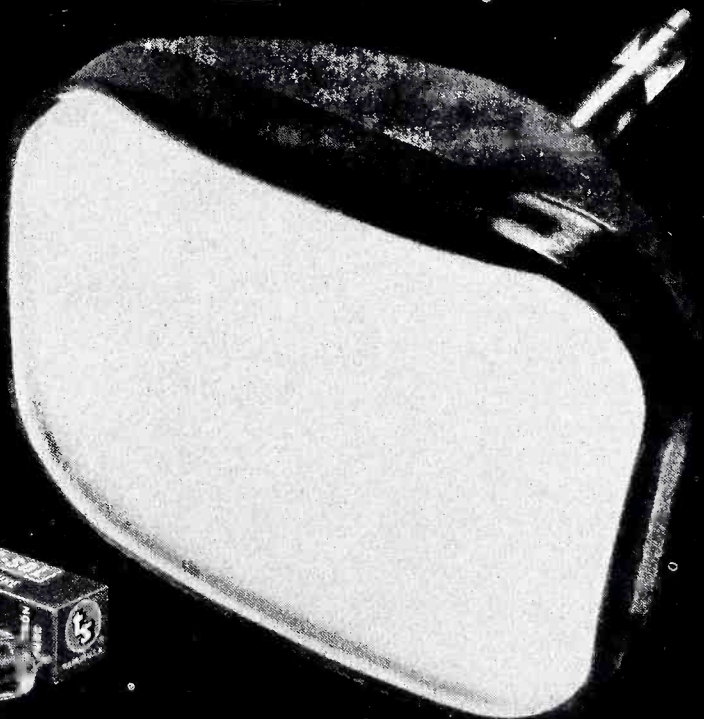

No Call-Backs for me, pal

Here's a real lively "stopper" to attract attention to your place of business and emphasize the quality of your service. Colorful—bright red and two shades of blue. 15 inches high. Your jobber salesman will tell you how to get one.

TUNG-SOL MAKES ALL-GLASS SEALED BEAM LAMPS, MINIATURE LAMPS, SIGNAL FLASHERS, PICTURE TUBES, RADIO, TV AND SPECIAL PURPOSE ELECTRON TUBES

Please mention *Successful Servicing* when answering advertising.