

*Most - Often - Needed*

1958

VOLUME TV-14

# Television

*Servicing Information*



Compiled by

M. N. BEITMAN

VOLUME TV-14

SUPREME PUBLICATIONS

PRICE **\$3**



*Most - Often - Needed*

1958

VOLUME TV-14

# Television

*Servicing Information*



Compiled by  
**M. N. BEITMAN**

*Supreme Publications*

Highland Park, Illinois

## RADIO DIAGRAM MANUALS

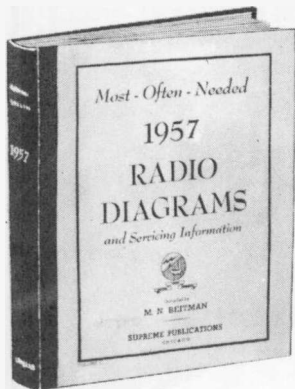

New 1957 VOLUME 17  
Price \$2.50

Repair quickly all new 1957 sets as well as older radios. This big volume contains clearly printed, large schematics, needed alignment data, replacement parts lists, voltage values, and information on stage gain, location of trimmers, and dial stringing, for all important new 1957 sets. Includes material on portables, clock radios, record changers, FM, and auto sets. A worthy companion to sixteen previous volumes used by over 143,000 shrewd radio servicemen. Large size: 8½ x 11 inches. Manual style binding. Postpaid, only ..... **\$250**

### RADIO DIAGRAMS FOR PREVIOUS YEARS

Speed up and simplify all radio repairs. Service radios faster, better, easier, save money and time, use these **SUPREME Most-Often-Needed** diagram manuals to get ahead. At the low cost (only \$2 for most volumes) you are assured of having for every job needed diagrams and other essential repair data on 4 out of 5 sets you will ever service. Clearly printed circuits, parts lists, alignment data, and helpful service hints are the facts you need. Average volume has 192 pages, large size 8½ x 11 inches. Manual style binding.

1956 Volume 16 \$2.50     1955 Volume 15 \$2.00     1954 Volume 14 \$2.50     1953 Volume 13 \$2.50     1952 Volume 12 \$2.50     1951 Volume 11 \$2.50

1950 Volume 10 \$2.50     1949 Volume 9 \$2.50     1948 Volume 8 \$2.00     1947 Volume 7 \$2.00     1946 Volume 6 \$2.00

1942 Volume 5 \$2.00     1941 Volume 4 \$2.00     1940 Volume 3 \$2.00     1939 Volume 2 \$2.00     1926-1938 Volume 1 \$2.50

INDEX for all Radio and TV Manuals ..... 25¢



### RADIO MATHEMATICS

Explains arithmetic and simple algebra in connection with units, color code, meter scales, Ohm's law, alternating currents, ohmmeter testing, wattage rating, series and parallel connections, capacity, inductance, mixed circuits, vacuum tubes, curves, the decibel, etc., and has numerous examples. Only ..... **25¢**

### Practical Radio & Electronics Course

Here is your complete home study course of 35 lessons designed to train any beginner to be an expert in radio and electronics. Covers every topic of radio, electronics, with lessons on test equipment, FM, TV, radio, etc. Giant 8½ x 11 inches, 3-in-1 volume, includes all lessons, instructor's notes, test questions. New edition. Only... **\$395**

ANSWER BOOK to the above course ..... 25¢

1957-1958 RCA Victor TV Manual **\$150**



### RADIO SERVICING COURSE

Here is your practical radio course of 22 easy-to-follow lessons. Review fundamentals, learn new servicing tricks. Just like a \$200.00 correspondence course. Everything in radio servicing. With self-testing questions. New edition. Price only ..... **\$250**

## SUPREME TELEVISION MANUALS

ADDITIONAL 1957 TV Manual, TV-13, **\$3**

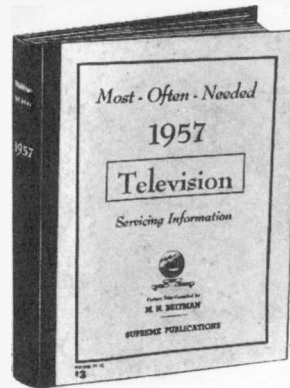

This new ADDITIONAL volume of television factory data will give you everything you need to repair and adjust all present-day TV sets. The **television series** manuals are amazing bargains and defy competition. The 1957 volume contains circuit explanations, 192 pages of alignment facts, test patterns, response curves, waveforms, voltage charts, hints, and dozens of mammoth double-page work-bench diagrams. Large size 8½ x 11 inches. Sturdy covers. Book binding opens flat. Amazing value. Price postpaid, only.... **\$3**

1957 TV Manual, TV-12

### EARLIER TV MANUALS FOR 1956 TO 1948

Supreme TV manuals cover all needed service material on every popular TV set of every important manufacturer. Here is helpful, practical, factory-prepared data that will really make TV servicing and adjustment easy for you. Supreme giant TV manuals have complete circuits, alignment facts, test patterns, response curves, service hints, recommended changes, voltage charts, waveforms, and many double-page diagram blueprints. Here is your TV service material to help you do more expert work quicker; and priced at only \$3. The **UHF Converters** manual at only \$1.50 has everything you need on UHF. Radio manuals described at left.

1956 TV Volume TV-11 \$3.00     1955 TV Additional, TV-10 \$3.00     1955 TV Early, Vol. TV-9 \$3.00     1954 TV Volume TV-8 \$3.00

1953 TV Volume TV-7 \$3.00     1952 TV Volume TV-6 \$3.00     1951 TV Volume TV 5 \$3.00     1950 TV Volume TV-4 \$3.00

1949 TV Volume TV-3 \$3.00     1948 TV Volume TV-2 \$3.00     UHF Converters Volume UHF-1, \$1.50

### TELEVISION SERVICING COURSE

Let this new course teach you TV servicing. Amazing bargain, complete only \$3, full price for all lessons. Giant in size, mammoth in scope, topics just like a \$200.00 correspondence course. Lessons on picture faults, circuits, adjustments, short-cuts, UHF, alignment hints, antenna problems, trouble-shooting, test equipment, picture analysis. Special, only ..... **\$3**

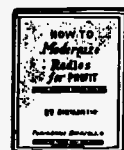

### How to Modernize Radios

Cash in by improving and modernizing all out of date radio sets and cabinets. Practical job-sheets with schematics and photographs make this work easy. Size 8½ x 11 inches. Your price only..... **\$1**

### Simplified Radio Servicing by COMPARISON Method

Revolutionary different **COMPARISON** technique permits you to do expert work on all radio sets. Most repairs can be made without test equipment or with only a volt-ohmmeter. Many simple, point-to-point, cross-reference, circuit suggestions locate the faults instantly. Plan copyrighted. Covers every radio set — new and old models. This new servicing technique presented in handy manual form, size 8½ x 11 inches, 92 pages. Over 1,000 practical service hints. 26 large, trouble-shooting blueprints. Charts for circuit analysis. 114 tests using a 5c resistor. Developed by M. N. Beitman. New edition. Price only..... **\$150**





## CONTENTS

### Admiral Corp.

Chassis 16G1, 16AG1, 16L1, 16AL1 . . . . .	5 to 7
(For list of models see page 5)	
Chassis 17J1 (and 4R2) used in Models LHR21F32, LHR21F33, and LHR21F34 . . . . .	8 to 11
Chassis 17L1, 17L1B, 17AL1, with Tuner 8H1A . .	12 to 15
(For complete list of models see page 14)	
Chassis 17K1, 17AK1, 17K1B (models listed page 16)	16 to 18

### Emerson Radio and Phonograph Corp.

Chassis 120369C, 120370G, 120377C, used in Models 1420, 1421, 1424, 1425, 1426, and 1428 . . .	19 to 22
Chassis 120380H, 120381M, 120388H, 120389M, used in Models 1282, 1283, 1284, 1285, 1286, 1287 .	23 to 28
Chassis 120382H, -HC, 120383M, -MC, 120386H, -HC, 120387M, -MC, 120390H, -HC, 120391M, -MC, Models 1276, 1277, 1288, 1289, 1290, 1291. .	29 to 32

### General Electric Co.

"Q" Line, Models 14T016, 14T017, 14T018, 14T020 .	33 to 40
"U2" Line, Models 21C1548, 21C1549, 21C1550, 21C1551, 21C1552, 21C1553, 21C1554, 21C1555, 21C1556, 21T1540, 21T1541, 21T1542, 21T1543, 21T1544, 21C1562, 24C1660, 24C1661, 24C1670, 24C1671	41 to 44
"U" Line, Models 21C137, 21C138, 21C143, 21C159 through 21C162, 21C172, 21T050, 21T054, through 21T057, 21T060, 21T061, 24C182, -C183	45 to 52

### Hotpoint Co.

"Q" Line, Models 14S201, 14S202, 14S203, 14S204 . .	33 to 40
"U" Line, (list of models on page 45). . . . .	45 to 52

### Motorola, Inc.

Chassis TS-423, TTS-423, WTS-423 (models listed) .	53 to 59
Chassis TS-425, -Y, WTS-425, -Y (models listed p. 60)	60 to 66
Chassis TS-426, -Y, TS-428, -Y (models listed p. 67)	67 to 76
Chassis TS-542, -Y (list of models on page 77) . .	77 to 82

### Montgomery Ward & Co.

Models WG-4042A, WG-4052A, WG-5042A, WG-5047A, and WG-5052A . . . . .	83 to 86
--------------------------------------------------------------------------	----------

(Continued on page 4)

Table of Contents, Continued

Packard-Bell Co.

Chassis 88S3, Models 21SC6, 21SC7, 21SC8, 21SK3,  
 21ST3, 21VT2, 24SC2, and 24VT1 . . . . . 87 to 90  
 Chassis 98D3, Models 21DC5, 21DC6, 21DC7, 24DC4 91 to 94

Philco Corp.

Chassis 8E11, 8E11U, and 8E13 . . . . . 95 to 100  
 Chassis 8L41, -U, 8L42, -U, 8L43, -U, 8P51, -A, -U 101 to 104  
 (For a cross reference of models see page 101)  
 Chassis 8L71, -U, 8L72, -U, 8L73, -U . . . . . 105 to 110  
 (Complete list of models given on page 105)  
 Chassis 8H25, 8H25U (list of models on page 111) 111 to 116

R. C. A. Victor

Models using Chassis KCS-107A through KCS-107D,  
 complete list of models on page 117 . . . . . 117 to 124  
 Models using Chassis KCS-108C through KCS-108F,  
 complete list of models given on page 125 . . . 125 to 130  
 Models using Chassis KCS-109A through KCS-109D,  
 for complete list of models see page 131 . . . 131 to 139  
 Models using Chassis KCS-111A through KCS-111F,  
 and KCS-111H; for list of models see page 140 140 to 142  
 Models using Chassis KCS-113A, B, E, F, H, K, P, R;  
 for complete list of models see page 143 . . . 143 to 152  
 Models 21D8281(U), 21D8282(U), 21D8305(U),  
 21D8306(U), 21D8307(U), 21D8628(U),  
 using Chassis KCS-116A through KCS-116D 153 to 160

Westinghouse Electric Corp.

Chassis V-2371, V-2381 (list of models on page 161) 161 to 170  
 Chassis V-2372, V-2382 (list of models on page 171) 171 to 174  
 Chassis V-2373, V-2383 (list of models on page 175) 175 to 180

Zenith Radio Corp.

Chassis 15A25, 17A20, -Q, 17A21Q, 19A20, 19A20Q 181 to 190  
 (Complete cross reference of models on page 181)

INDEX (by make and model or chassis number) . . . 191 and 192

This manual is made up of factory prepared service material. Editorial changes and selections were made to conform with the objectives of this manual. Our sincere thanks and appreciation is extended to every manufacturer whose products are covered by the material in this manual and who aided us in the preparation of this book.

*M. N. Beitman*, Chief Editor of the Engineering Staff, Supreme Publications.

# Admiral TELEVISION

CHASSIS 16G1, 16AG1, 16L1, and 16AL1  
(Models listed below; schematic for 16AG1, 16AL1 is on pages 6-7, schematic for 16G1, 16L1, is essentially the same without UHF.)

Chassis 16G1, used in Models T21E1, T21E2, T21E3,  
Chassis 16AG1, used in Models TA21E1, TA21E2, TA21E3,  
Chassis 16L1, used in Models C21E2, C21E3, C21E6, C21E7,  
Chassis 16AL1, used in Models CA21E2, CA21E3, CA21E6, CA21E7.

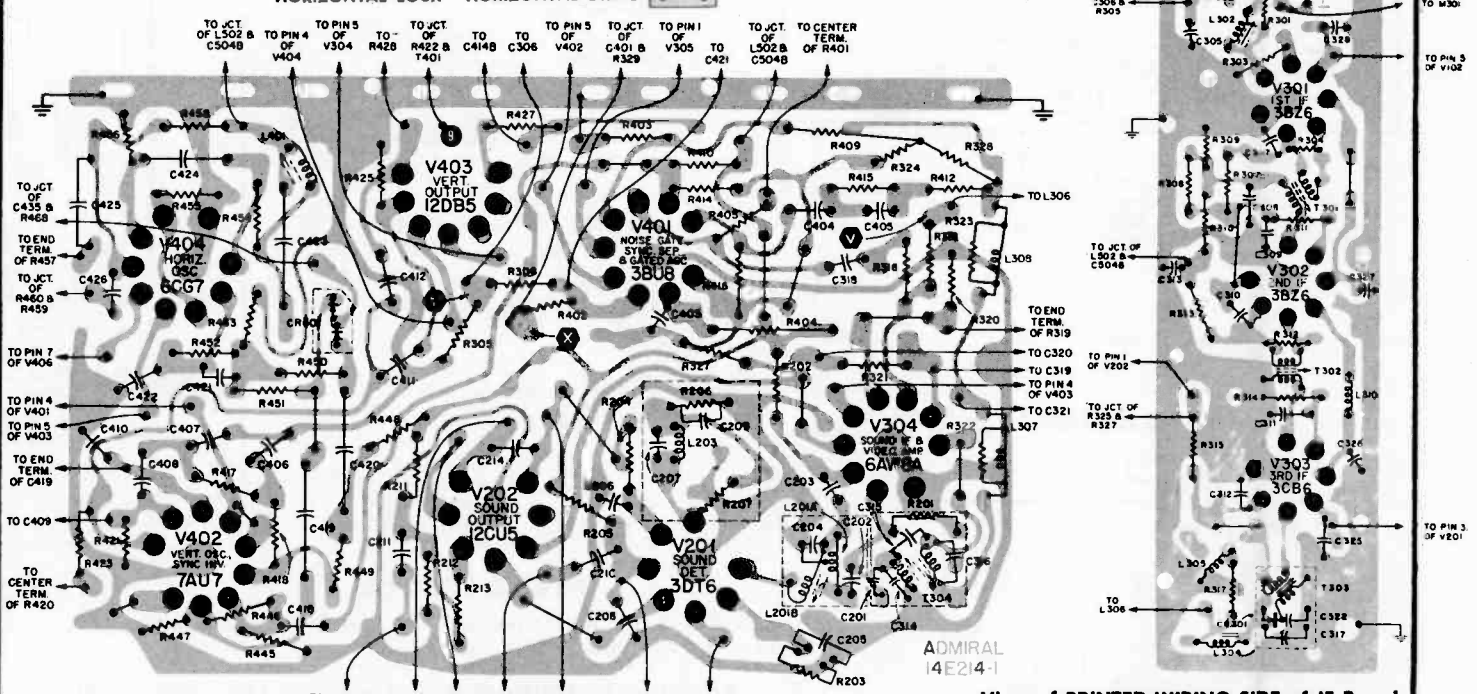
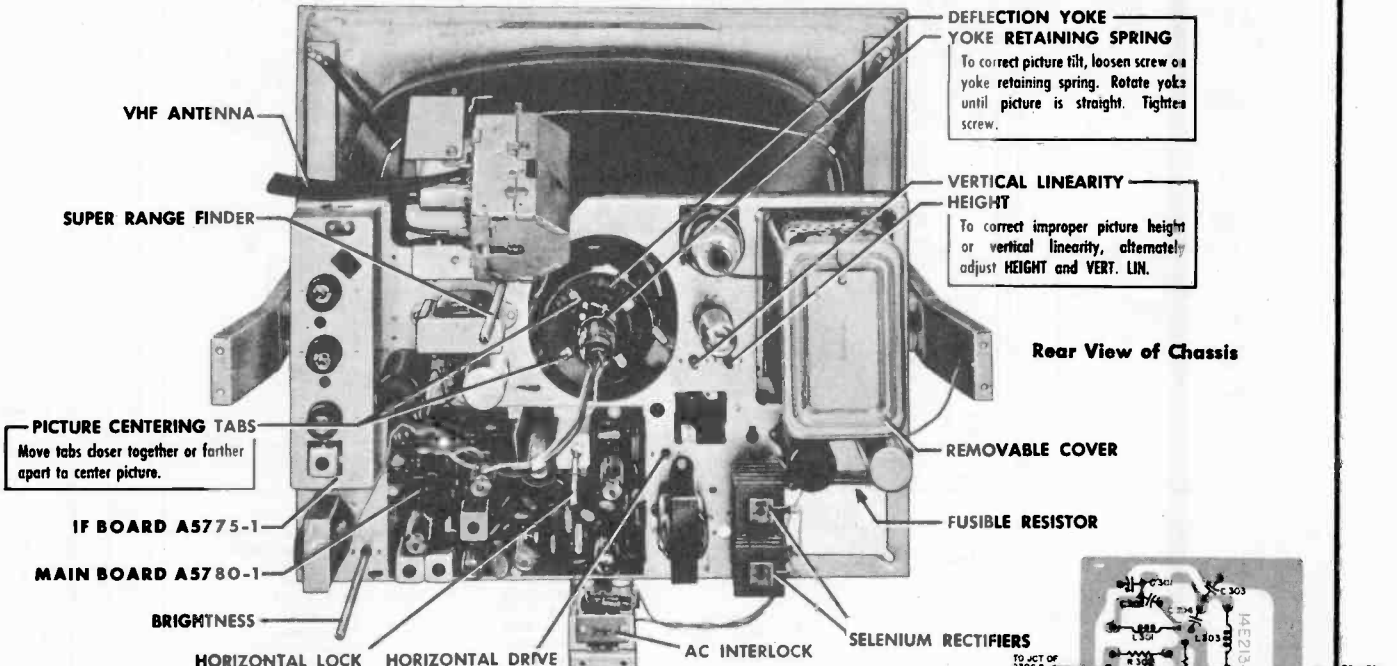

Admiral Schematic for 16AG1C and 16AL1C Television Chassis Stamped Run 24

VHF TUNERS 94E144-9, 20, 22, OR 27

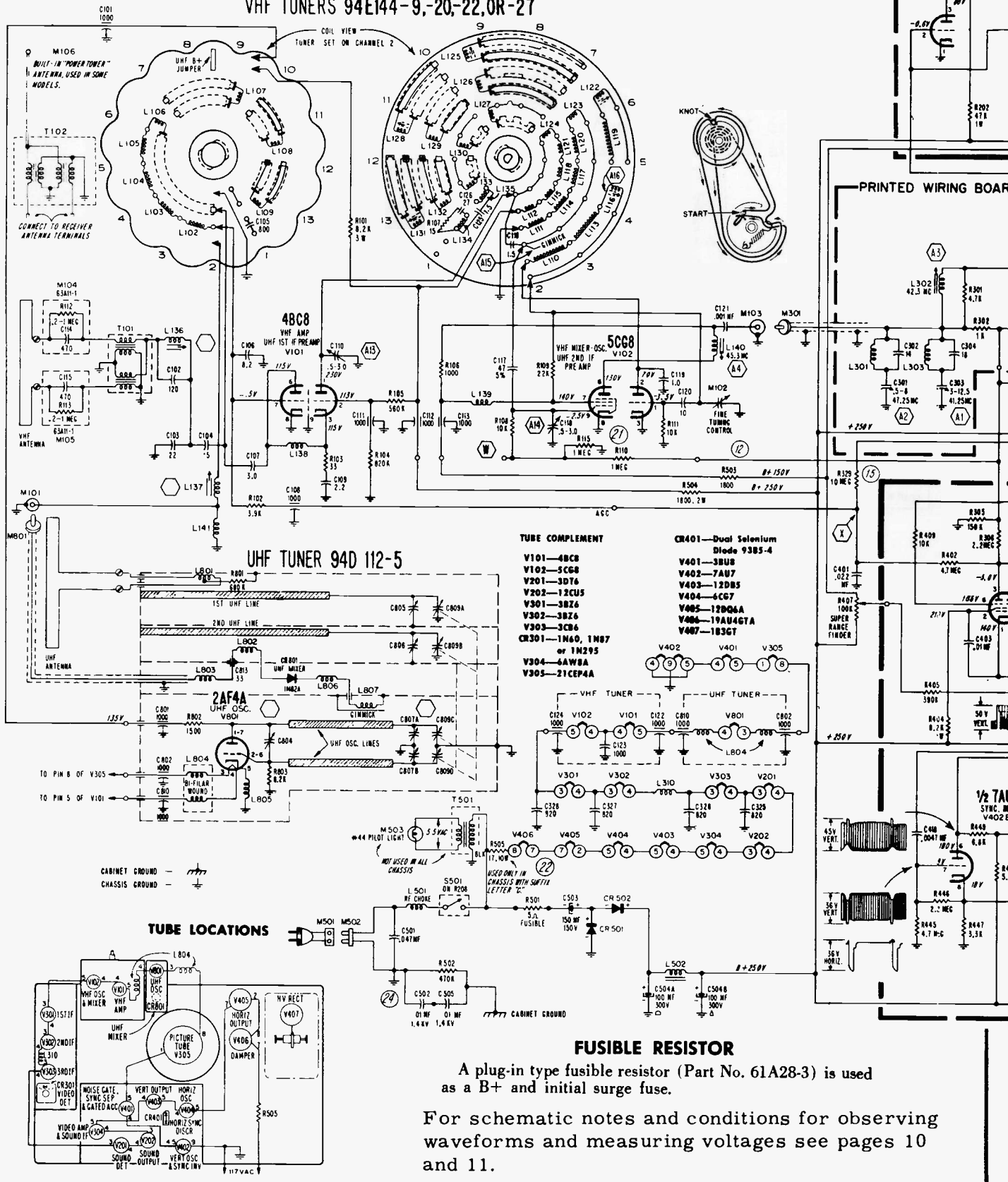

# VOLUME TV-14, MOST-OFTEN-NEEDED 1958 TELEVISION SERVICING INFORMATION

PRINTED WIRING BOARD A5780-1

CAUTION: ALWAYS CONNECT SPEAKER BEFORE TURNING VOLUME CONTROL. MAXIMUM.

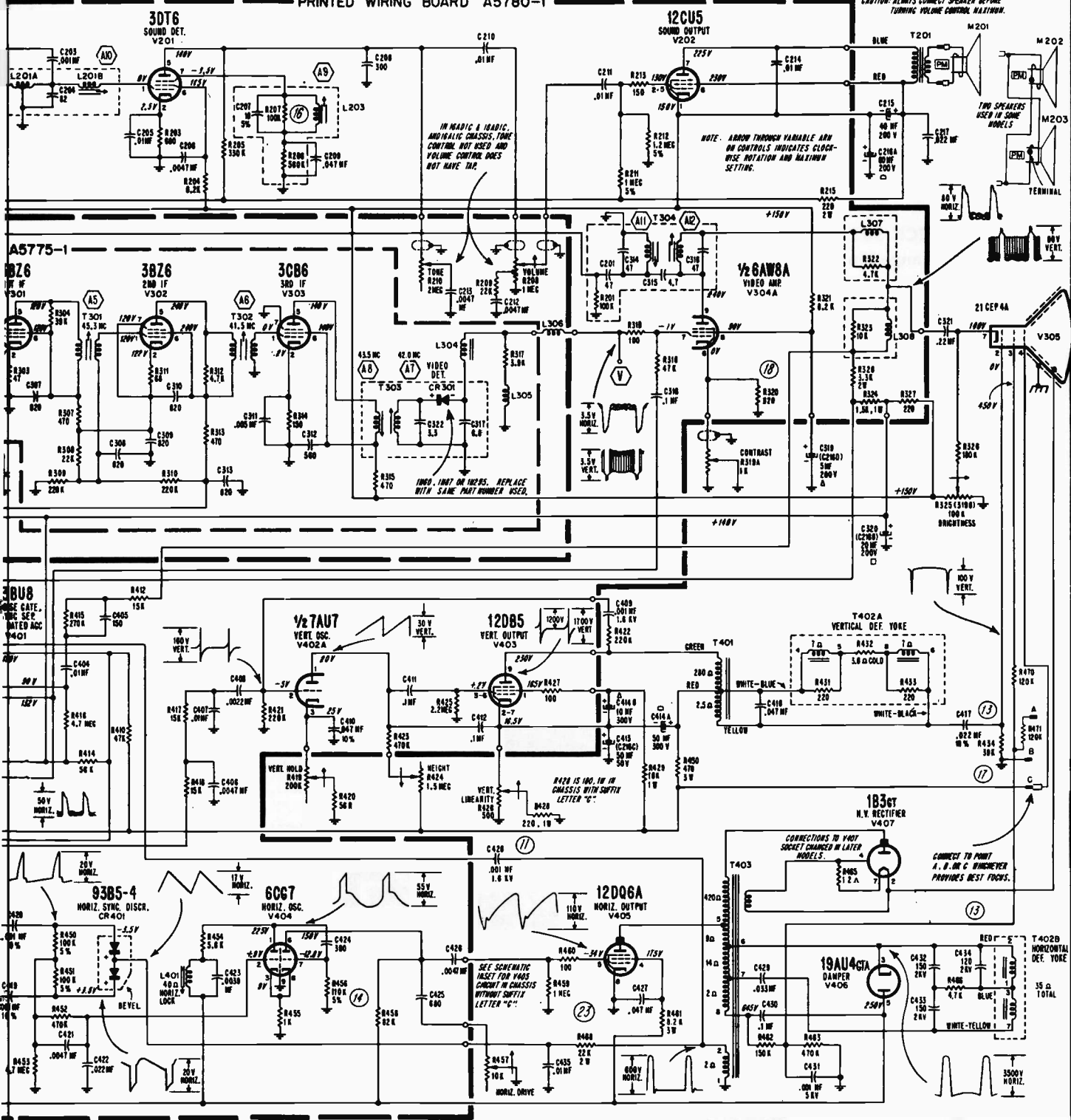

## RUN CHANGES

- (10) Start of production.
- (11) To improve AGC action, C428 was changed from 300mf to .001 mf, 1.6KV.
- (12) To reduce voltage to VHF oscillator, R503 was changed from 470 to 1800ohms.
- (13) To prevent possible breakdown of C431 due to arc over in V305, R470 was relocated from between junction of R462 and R463 and focus connection 'A' to opposite side of connection 'A'.
- (14) To improve operation of horizontal oscillator, R456 was changed from 120K to 110K, 5%.
- (15) To prevent AGC overload due to tube variation, R329 was changed from 7.5 to 10 megohms.
- (16) To prevent possible frequency drift with resulting sound distortion, R207 was changed from 220 K to 100 K.
- (17) R471 was added to prevent possible breakdown of C431 due to arc-over in V305.
- (18) To center usable range of contrast control, R320 was changed from 470 to 220 ohms.
- (19) (20) (21) No changes made.
- (22) To prevent possible damage to V405 due to arc-over in V406, heaters of V405 and V406 relocated in heater circuit.
- (23) Start of production chassis with suffix letter 'C'. New horizontal output circuit used.
- (24) C502 changed from .005mf to .01mf. C505 added in series with C502 for increased breakdown safety factor.

# Admiral TELEVISION

## TV-17J1 HI-FI AMPLIFIER - 4R2 CHASSIS STAMPED RUN 14 THROUGH RUN 20

Chassis 17J1, used in Models LHR21F32, LHR21F33, LHR21F34  
(Service material on pages 8 and 9, schematic on pages 10-11)

### CHECK SUPER RANGE FINDER

The **Super Range Finder** control is used to improve TV reception in fringe areas and in areas where there is interference. **This control should be set fully counterclockwise (to the left), if satisfactory pictures can be obtained by using the main operating controls.**

Where the TV signal strength is weak, the picture can often be improved by turning the Range Finder part way to the right.

White flashes across the picture, or "snow" in the picture, can sometimes be minimized by careful adjustment of the Range Finder. **CAUTION: If the Range Finder is turned too far to the right for a normal signal, the picture may have excessive contrast or may disappear completely.**

If the signal strength changes, it may be desirable to change the setting of the Range Finder, however, it is generally possible to set it at a compromise position which gives reasonable reception for different signal strengths.

Important: Keep the Super Range Finder setting as far to the left as possible consistent with satisfactory pictures.

### ADJUSTING REMOTE CHANNEL TUNING MECHANISM TO STOP ONLY ON OPERATING CHANNELS

To adjust Son-R controlled Power Tuning mechanism to stop only on TV channels operating in the area and skip non-operating channels, proceed as follows:

1. Turn receiver off and remove cabinet back.
2. Turn Channel Selector knob to a non-operating channel.
3. Locate recessed hole above tuning motor mounting plate. Turn adjustment screw (visible through hole) fully to the left (counterclockwise) until tight. Perform steps 2 and 3 for each non-operating channel.
4. Turn Channel Selector knob to an operating channel. Turn adjustment screw fully to the right (clockwise) until tight. Perform this step for each operating channel.
5. Install cabinet back. Turn receiver on; set Remote-Manual switch at rear of set to Remote position.
6. Check channel tuning with "Son-R" remote tuner. Each time tuner push button is pressed for channel selection, the channel tuner should advance and stop on an operating channel only.

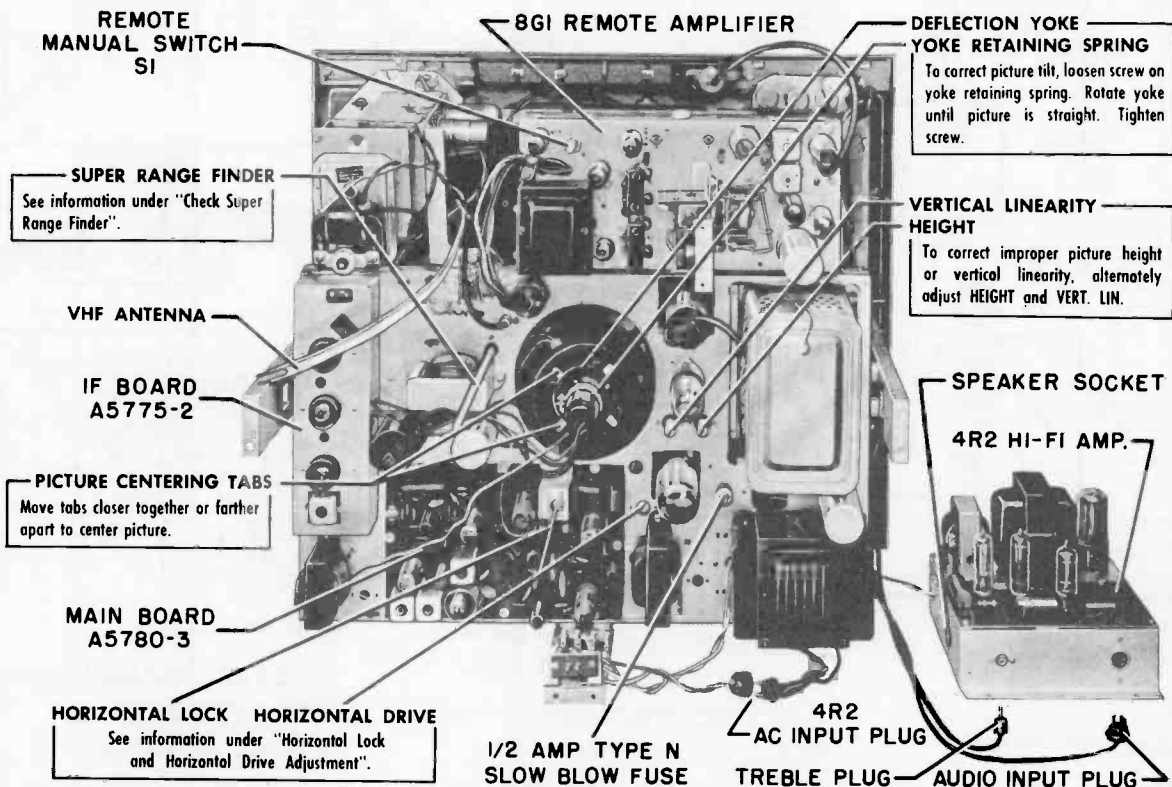

Rear View of Chassis Showing Adjustments.

ADMIRAL Chassis 17J1 Service Information, Continued

**HORIZONTAL LOCK AND DRIVE ADJUSTMENT**

A receiver which requires Horizontal Lock or Horizontal Drive adjustment can be corrected only by following in exact detail the procedure given here.

1. Allow receiver to warm up for a few minutes. Tune in a station, set the **Brightness** and **Contrast** controls for normal picture. **Important:** Before proceeding, be sure that the **Super Range Finder** control (AGC) is adjusted according to instructions given in this manual.
2. Turn **Horizontal Drive** control fully clockwise. At this point, picture compression and/or foldover will appear near the center of the picture.
3. Very slowly turn the Horizontal Drive adjustment counterclockwise, just to the point at which picture foldover and/or compression disappears. Note that maximum width and brightness is also produced at this setting. **Caution:** Turning the **Horizontal Drive** control too far counterclockwise will shorten life of the horizontal output tube.

**CHASSIS REMOVAL**

The chassis, picture tube and front escutcheon are removable as a unit. Remove chassis as follows:

1. At the rear of the cabinet, disconnect leads from the antenna terminals and remove cabinet back. Unplug the following cables for the 4R2 amplifier: (1) treble control plug, (2) AF input plug and, (3) AC input plug. Remove the screws which mount rear of chassis support channels to sides and bottom of cabinet.
2. Remove chassis, picture tube and front escutcheon as a unit through the **front** of the cabinet.
3. To reinstall chassis, insert chassis through **front** of cabinet.

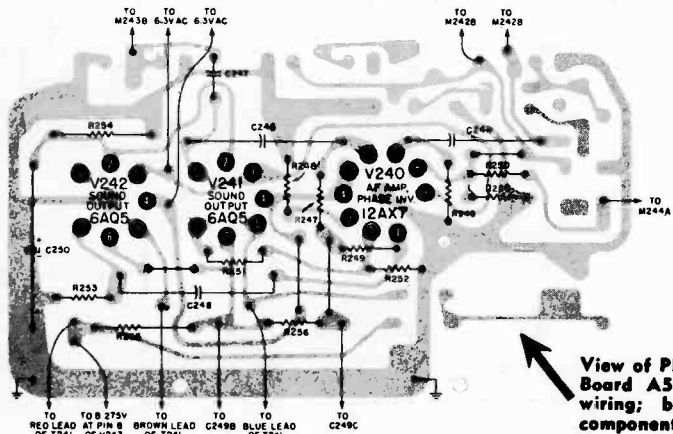

Rear View of Escutcheon with Picture Tube Mounted, Chassis Removed.

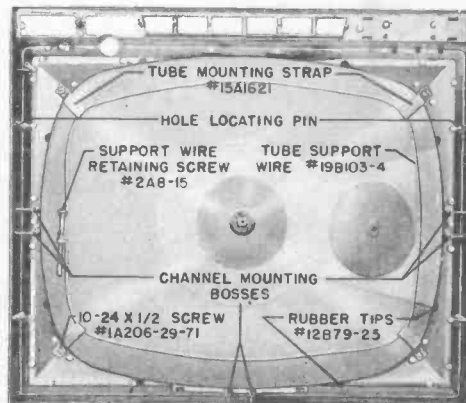

View of PRINTED WIRING SIDE OF 4R2 Hi-Fi Board A5975. Gray area represents printed wiring; black symbols and lines represent components and connections on opposite side.

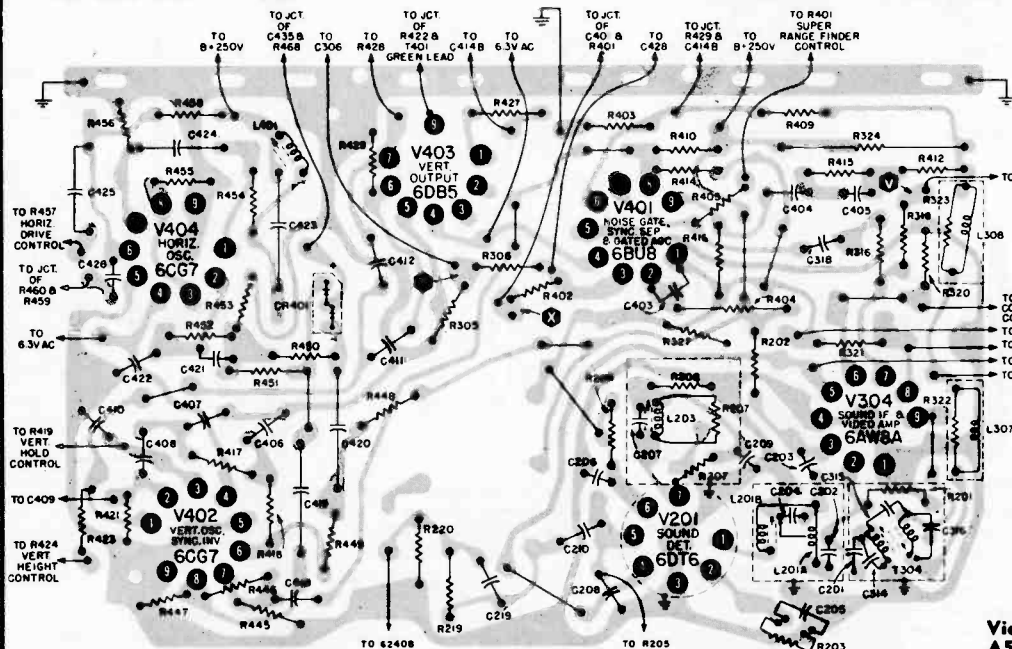

View of PRINTED WIRING SIDE of Main Board A5780-3. Gray area represents printed wiring; black symbols and lines represent components and connections on opposite side.

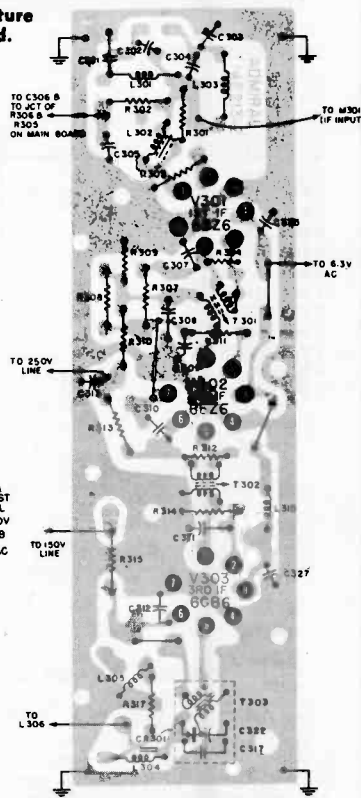

View of PRINTED WIRING SIDE of IF Board A5775-2. Gray area represents printed wiring; black symbols and lines represent components and connections on opposite side.



Schematic for 17J1 Television, 4R2 Hi-Fi Amplifier Chassis Stamped Run 14 Through Run 20

Admiral Corporation

PICTURE TUBE HANDLING PRECAUTION

**WARNING:** The newly developed picture tube used in these sets must be handled with much greater care because of its short, thin neck and wafer type base. ALWAYS lift picture tube by grasping firmly around face plate; NEVER LIFT TUBE BY ITS NECK. Use care when inserting socket to prevent bending pins. WHEN TUBE IS REMOVED, ALWAYS PLACE IT FACE DOWN.

TUBE LOCATIONS

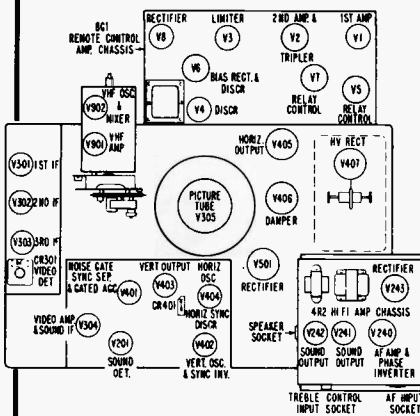

TUBE COMPLEMENT

- V1 -6AU6
- V2 -6AU8
- V3 -6BN6
- V4 -6AL5
- V5 -6CM7
- V6 -6BJ7
- V7 -6CM7
- V8 -6X4
- V201-6DT6
- V240-12AX7
- V241-6AQ5
- V242-6AQ5
- V243-SY3GT
- V301-6BZ6
- V302-6BZ6
- V303-6CB6
- V304-6AW8A

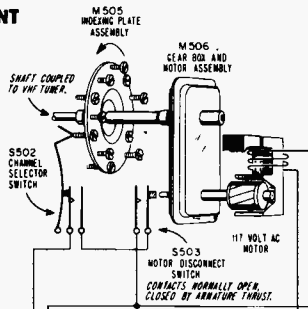

- V305-21CEP4A
- V401-6BU8
- V402-6CG7
- V403-6DB5
- V404-6CG7
- V405-6CD6GA
- V406-6AU4GT
- V407-1B3GT
- V501-SV3
- V901-6BN4
- V902-6CG8
- CR301-1N87 (crystal diode)
- CR401-93B5-4 Dual Selenium Diode

DUMMY PLUS REQUIRED FOR OPERATING SET WHEN REMOTE AMPLIFIER IS NOT PLUGGED IN.

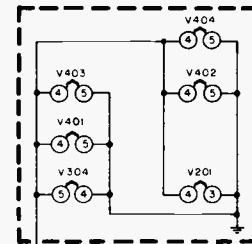

OSCILLATOR CIRCUIT USED IN 94DI51-4 TUNER

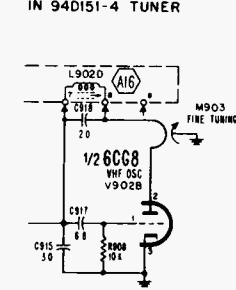

VHF TUNER 94DI51-12

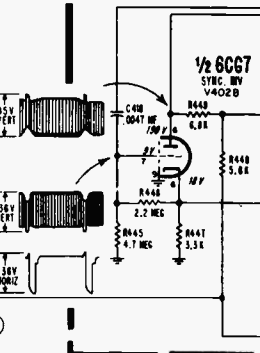
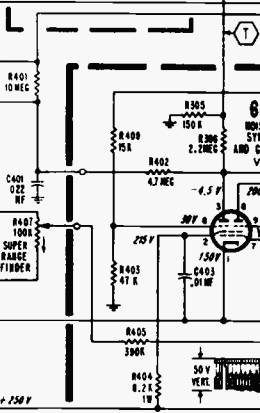
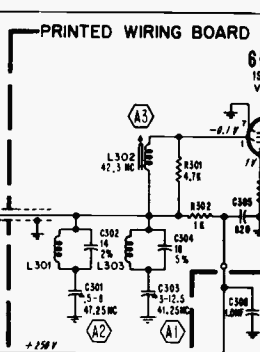
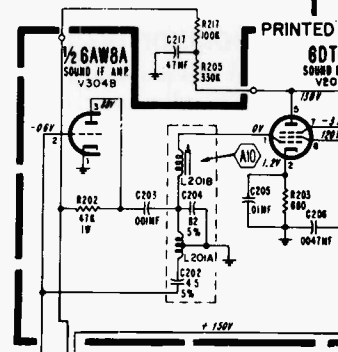
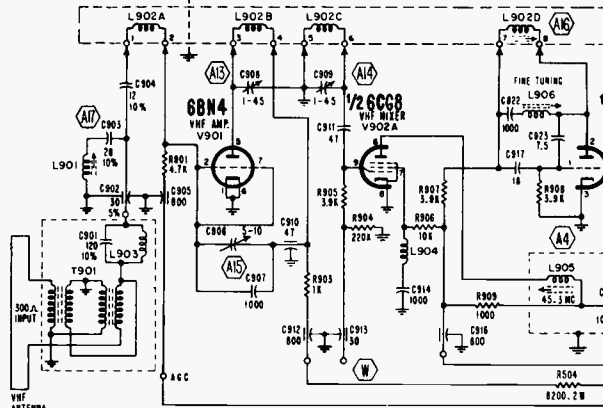

CONDITIONS FOR OBSERVING WAVEFORMS

**Warning:** Pulsed high voltages are present at the caps of V405 and V407, and at pin 3 of V406. Do not attempt to observe waveforms at these points unless suitable test equipment is used.

- Set all controls for normal picture. Set Super Range Finder control fully counterclockwise. After the receiver is set for a normal picture, turn the Contrast control fully clockwise.
- Oscilloscope sweep is set at 30 cycles for vertical waveforms and at 7.875 cycles for horizontal waveforms, to permit 2 complete cycles to be observed.
- Peak-to-Peak voltages will vary from those shown on the schematic

depending on the input signal strength, test equipment employed and chassis parts tolerance.

- Waveforms were taken with a comparatively strong transmitted signal input to the television chassis.

SCHEMATIC NOTES

Numbers and letters inside hexagons indicate alignment points. Fixed resistor values shown in ohms  $\pm 10\%$  tolerance,  $\frac{1}{2}$  watt; capacitor values shown in micromicrofarads  $\pm 20\%$  unless otherwise specified.

NOTE: K = x 1000, MEG = x 1,000,000, MF = microfarad.

# VOLUME TV-14, MOST-OFTEN-NEEDED 1958 TELEVISION SERVICING INFORMATION

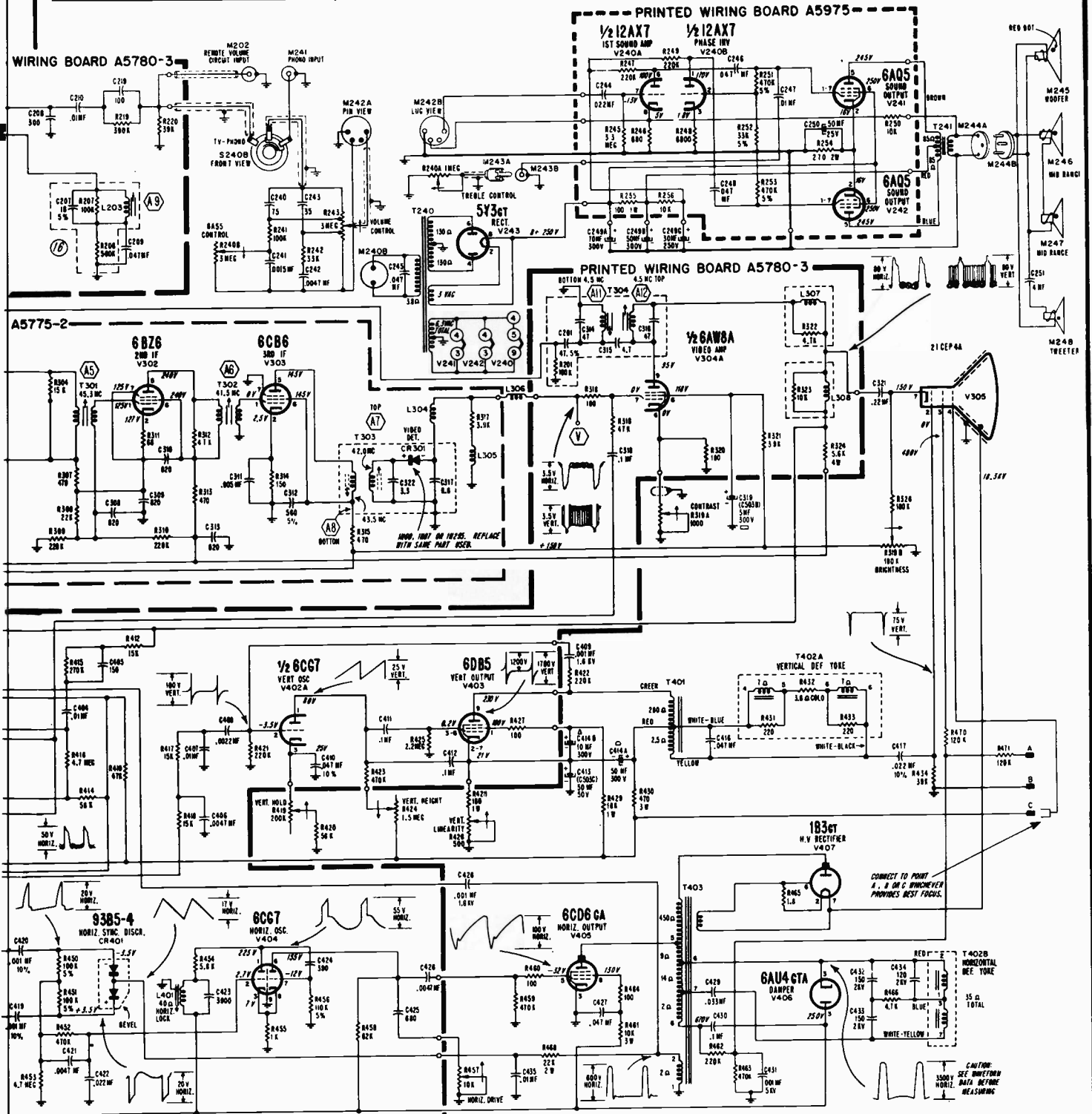

## CONDITIONS FOR MEASURING VOLTAGES

**Warning:** Pulsed high voltages are present at the caps of V405 and V407, and at pin 3 of V406. Do not attempt to measure voltage at these points without suitable test equipment. A VTVM with a high voltage probe should be used when measuring picture tube 2nd anode voltage.

- Set the Channel Selector on an unused channel. Contrast control fully clockwise. All other controls fully counterclockwise. Do not disturb Horiz. Lock and Horiz. Drive adjustments.
- Antenna disconnected and terminals shorted together.
- Line voltage: 117 volts AC.
- DC voltages measured with a VTVM between tube socket terminals and chassis, unless otherwise indicated.

## RUN CHANGES

- Start of production of 17L1.
- Bleeder, R507 (270K ohms 1W) added to power supply.
- To improve sound detector, R207 changed to 100K.
- R470 changed to 120K, R220 to reduce focus voltage to picture tube.
- No changes made on VHF chassis.
- R506 (5K 15W) deleted. New transformer added. (See Parts List for T501. R471(120K, 1/2W, 10%) added to reduce focus voltage)
- No changes made on VHF chassis.

# Admiral TELEVISION

CHASSIS 17L1, 17L1B, 17AL1, with Tuner 8H1A  
See page 14 for list of models using these chassis.  
Service material is on pages 12 through 15.

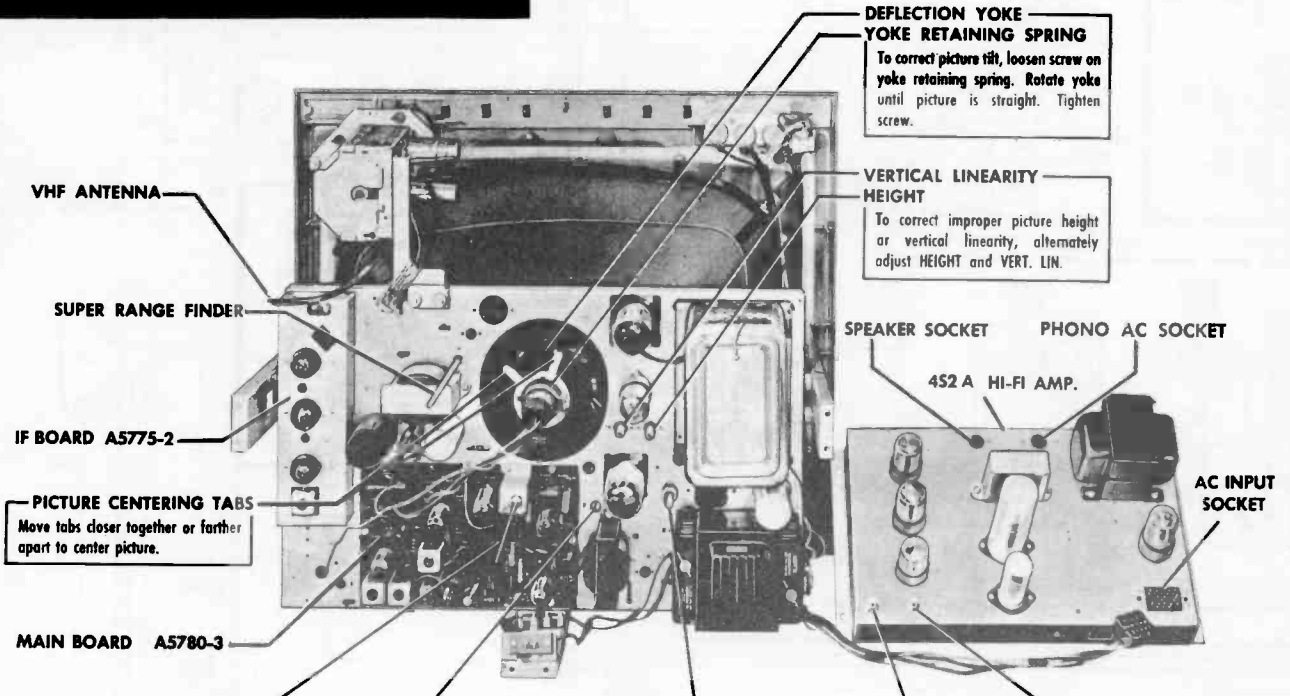

**HORIZONTAL LOCK HORIZONTAL DRIVE**  
Rear View of Chassis Showing Adjustments.

1/2 AMP. TYPE N SLOW BLOW FUSE

AUDIO INPUT TV

AUDIO INPUT FM-AM TUNER

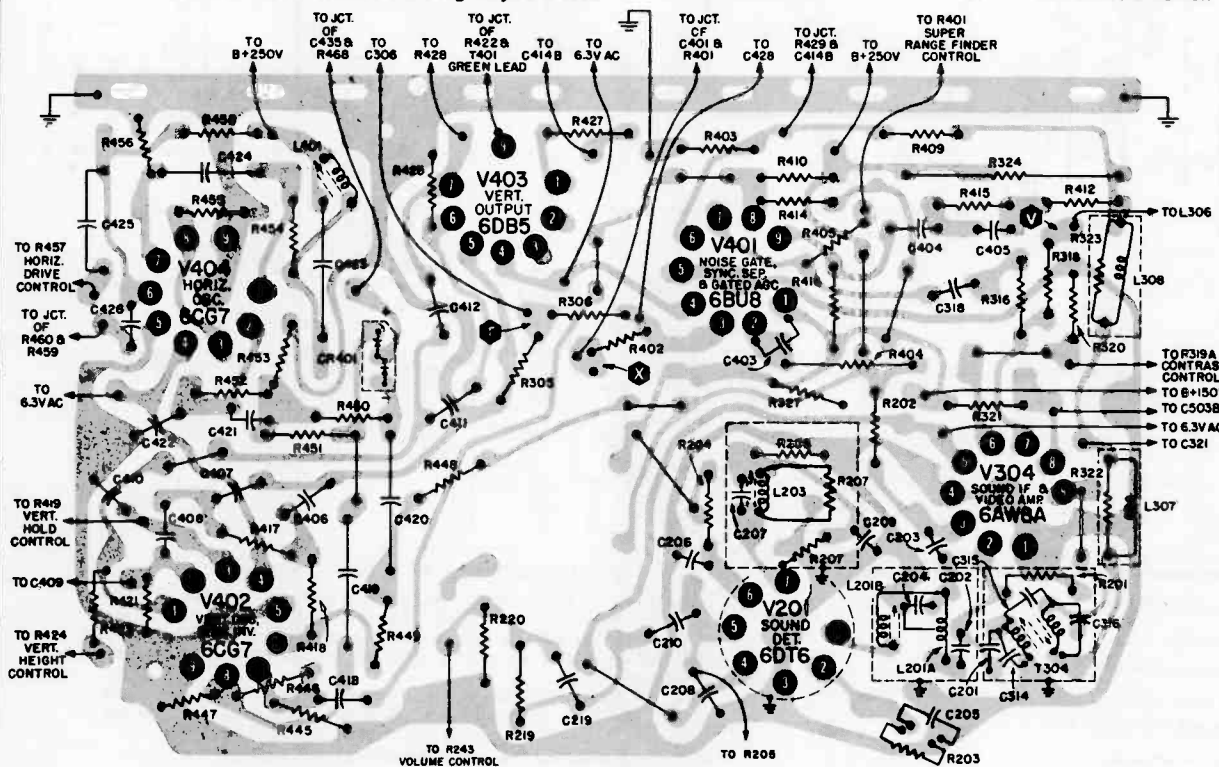

View of PRINTED WIRING SIDE of Main Board A5780-3. Gray area represents printed wiring; black symbols and lines represent components and connections on opposite side.

(For view of IF Board A5775-2 see illustration on page 18.)

**VOLUME TV-14, MOST-OFTEN-NEEDED**

**ADMIRAL Schematic for 8H1A Tuner**  
used with 17L1, 17L1B,  
and 17AL1 Chassis.

**Schematic for 8H1A FM-AM Tuner**

- TUBE COMPLEMENT**  
 V601-68Q7A  
 V602-6AU6  
 V603-6AU6  
 V604-6BA6  
 V605-6AL5
- V606-12AX7**  
**V607-6AV6**  
**V608-EM34**  
**Tuning Eye**

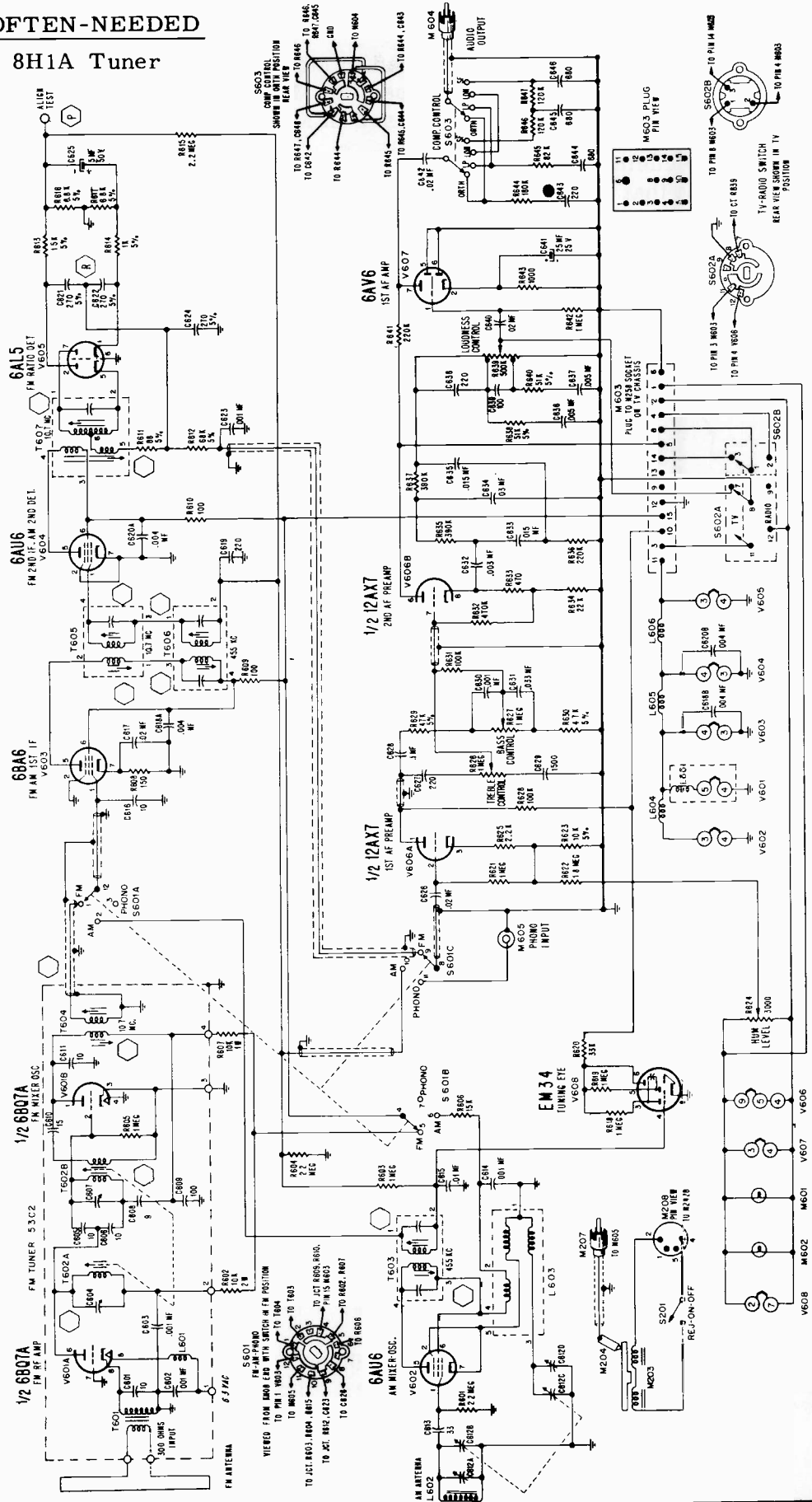
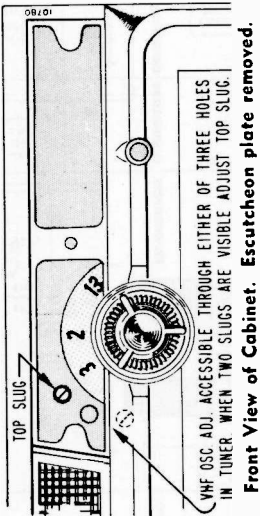
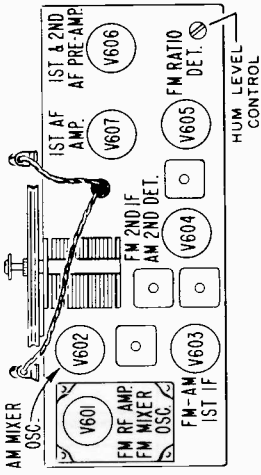



VOLUME TV-14, MOST-OFTEN-NEEDED 1958 TELEVISION SERVICING INFORMATION

**Admiral Schematic for 17L1 Television and 4S2A Hi-Fi Amp. Chassis Stamped Run 17**

BOARD A5780-3

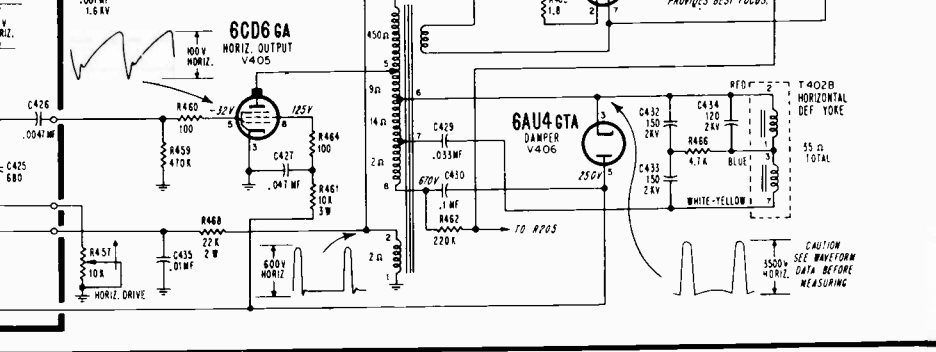
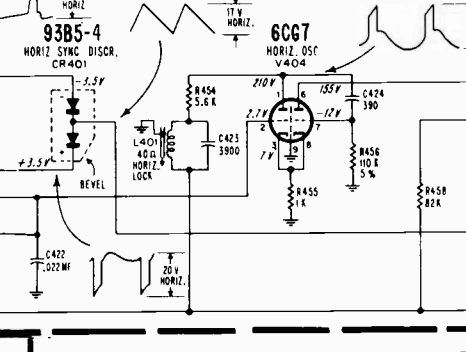
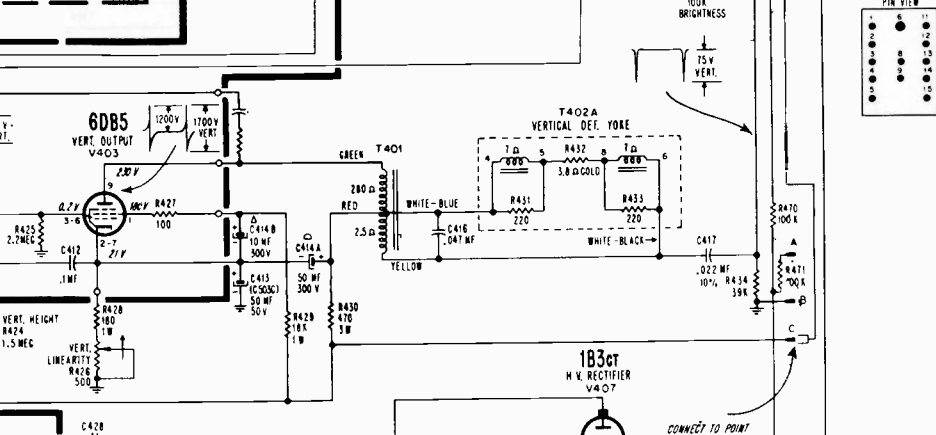
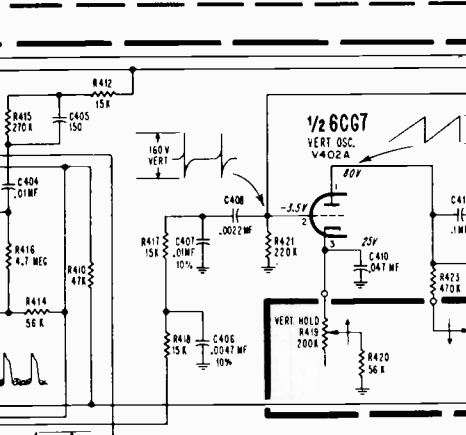
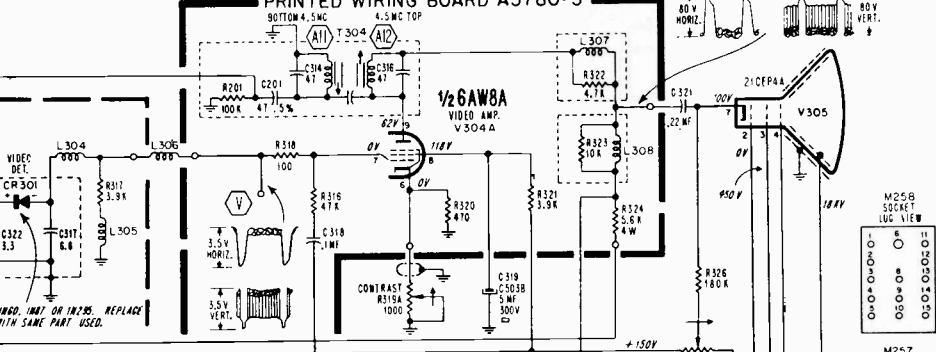
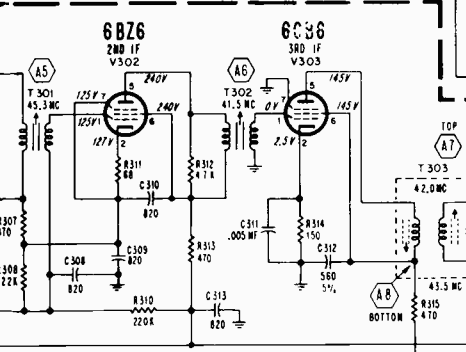
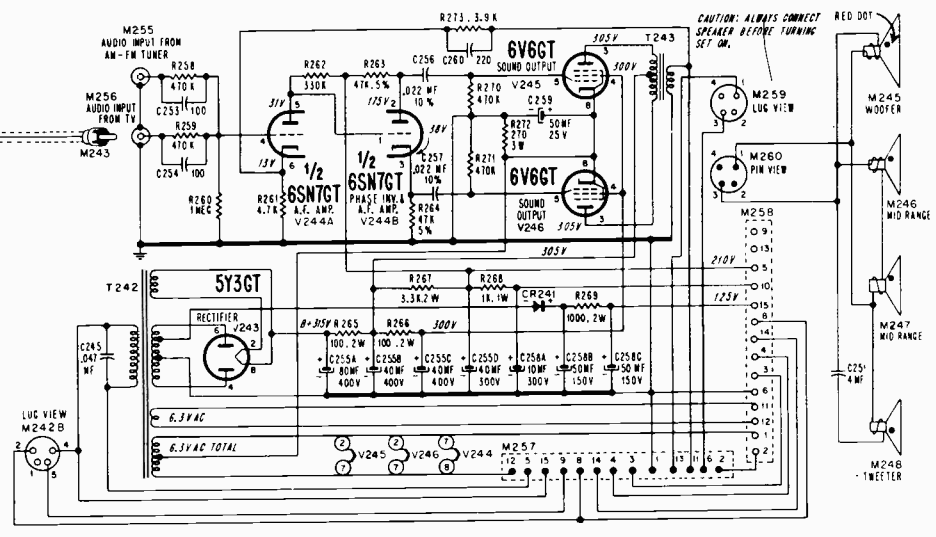
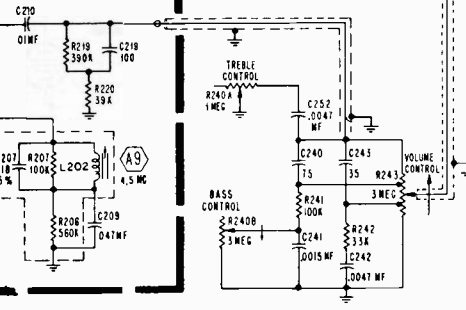

**VOLUME TV-14, MOST-OFTEN-NEEDED 1958 TELEVISION SERVICING INFORMATION**

**ADMIRAL Chassis 17K1, used in Models HF21F22, HF21F23,  
Chassis 17AK1, used in Models HFA21F22, HFA21F23,  
Chassis 17K1B, used in Models HF21F22B, HF21F23B.**

This schematic is exact for Chassis 17K1, Run 14. Chassis 17AK1 is identical except for the addition of a UHF tuner. Chassis 17K1B is a later version with minor modifications and a different VHF tuner. All chassis use 4R2 HI-FI amplifier. Additional material on page 18. Schematic notes are the same as given on pages 10 and 11.

**VHF TUNER 94E144-25**

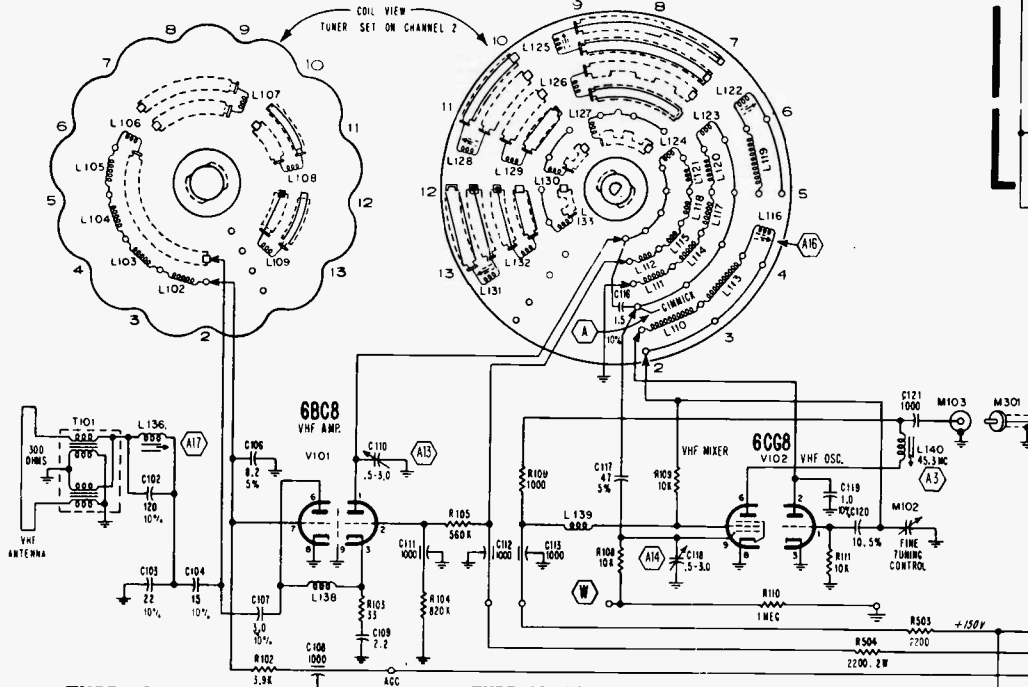

**TUBE LOCATIONS**

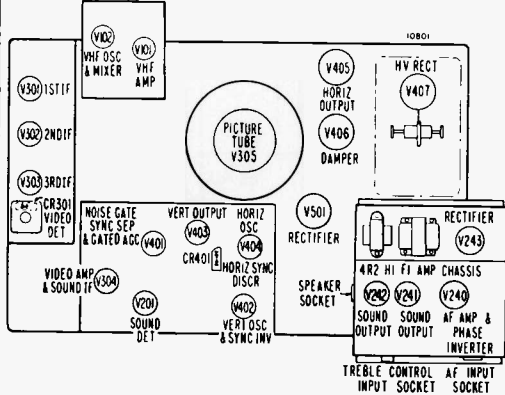

**TUBE COMPLEMENT**

- V101-6BC8
- V102-6CG8
- V201-6DT6
- V240-12AX7
- V241-6AQ5
- V242-6AQ5
- V243-5Y3GT
- V301-6BZ6
- V302-6BZ6
- V303-6CB6
- CR301-1N87 (Crystal Diode)
- V304-6AW8A
- V305-21CEP4A
- V401-6BU8
- CR401-93B5-4 (Dual Selenium Diode)
- V402-6CG7
- V403-6DB5
- V404-6CG7
- V405-6CD66A
- V406-6AU4GT
- V407-1B3GT
- V501-5V3

NOTE: ARROW THROUGH VARIABLE ARM OF CONTROLS INDICATES COUNTERCLOCKWISE ROTATION AND MAXIMUM SETTING.

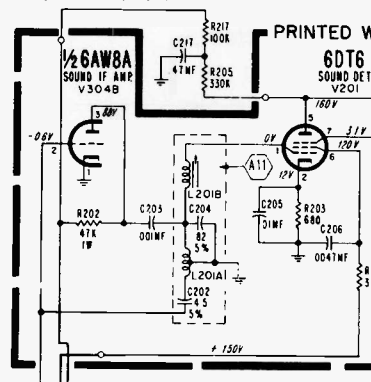
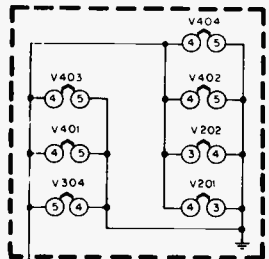

**PRINTED WIRING BOARD A5**

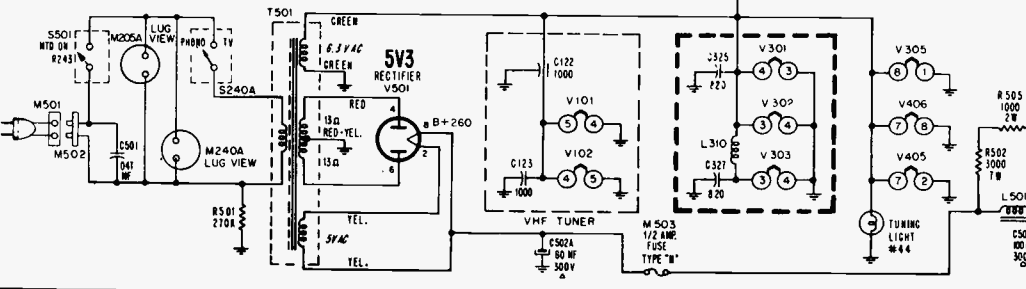
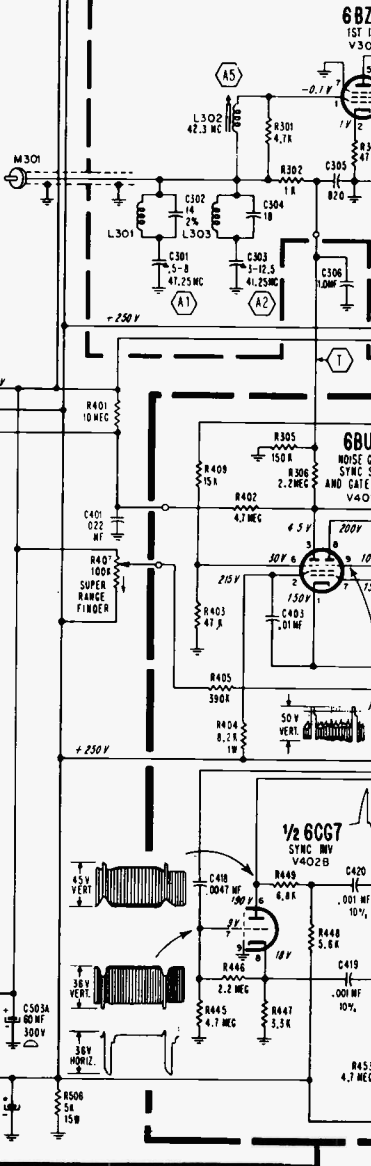



**Admiral Corporation**

**Schematic for 17K1 Television and 4R2 HI-FI Amp.  
Chassis Stamped Run 14**

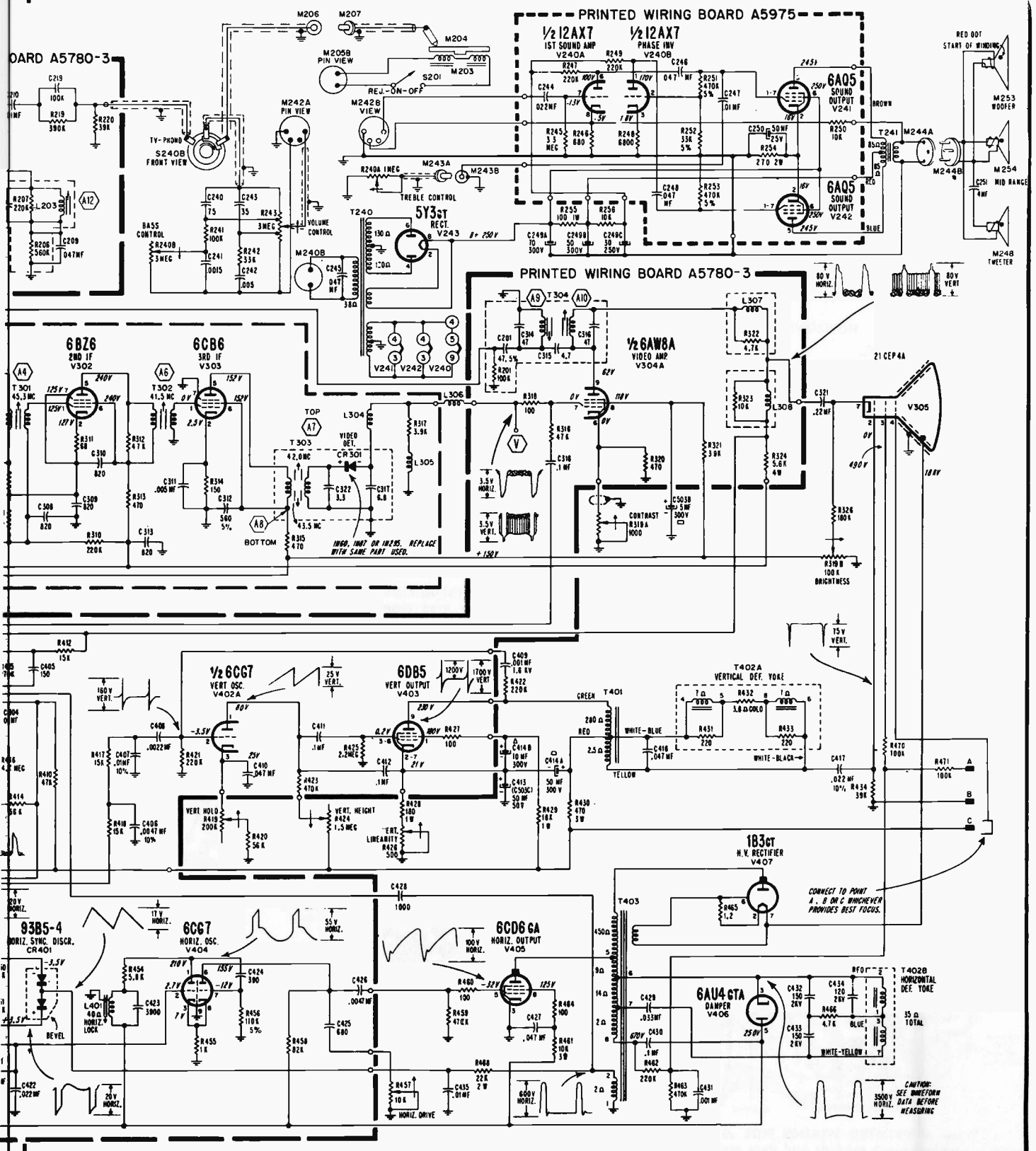





4, MOST-OFTEN-NEEDED 1958 TELEVISION SERVICING INFORMATION

ARSON Chassis 120369C, 120370G, 120377C, Schematic Diagram

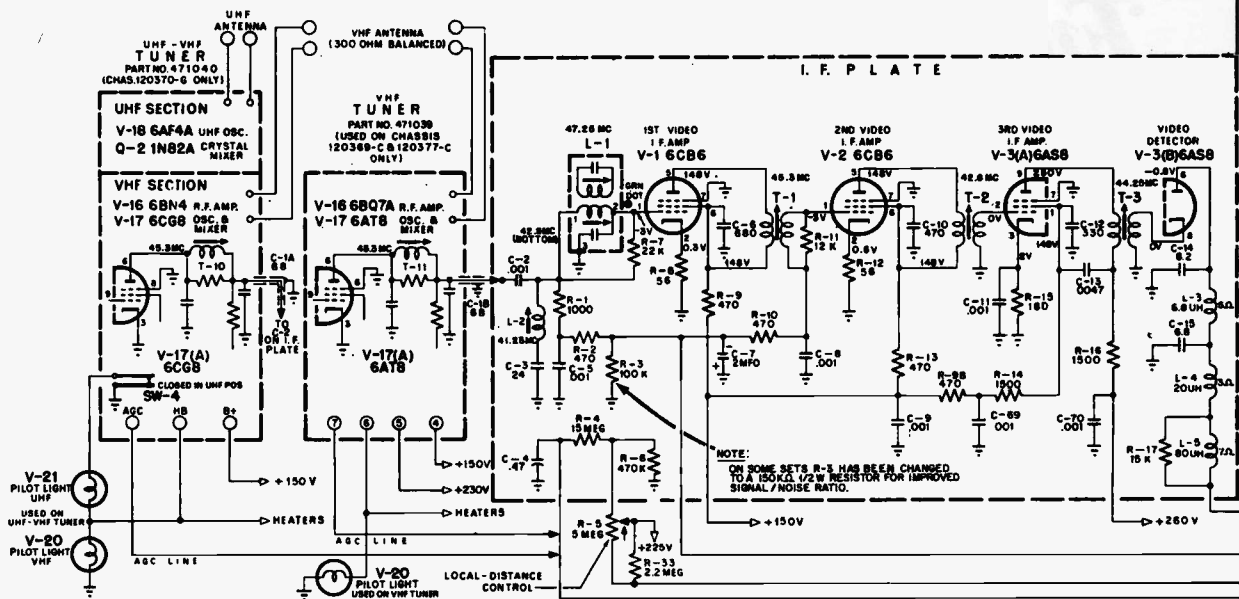

CONDITIONS FOR TAKING VOLTAGE AND RESISTANCE READINGS

The voltage and resistance measurements listed were taken on Chassis 120377C Δ.

Due to component variations, voltage and resistance readings may vary slightly from those given here. Slight variations may also be noticed if chassis is not coded as mentioned above.

The picture tube, deflection yoke and high voltage circuits were connected to take the following readings and waveshapes:

1. Antenna disconnected and antenna terminals shorted on tuner and connected to chassis (use short leads).
2. Line voltage 117 volts (Disconnect power for resistance readings).
3. 3 volt bias battery connected to A.G.C. circuit, positive terminal to chassis, negative terminal to junction of R-2, R-3. BIAS BATTERY USED FOR VOLTAGE READINGS ONLY. R-5 maximum ccw position - (local).
4. All controls in position for normal picture. (Varied when it directly affects reading).
5. All measurements taken with a vacuum tube voltmeter and ohmmeter.
6. All readings listed in tables were taken between points shown and chassis.
7. Resistance readings are given in ohms unless otherwise noted.
8. N.C. denotes no connection.

WAVE SHAPE ANALYSIS CHART

The waveshapes shown taken on chassis 120377C Δ.

Slight peak-to-peak voltage differences may be noticed on chassis of later triangle codes.

The peak-to-peak voltage given may also vary slightly depending on signal strength and component variations! To accurately observe the wave shapes, the relatively high input capacity of an oscilloscope must be reduced so as not to change the operating characteristics of the television set. Failure to do this will result in wrong wave shape readings.

1. Connect antenna and tune receiver to channel where best reception has been obtained in the past.
2. Low end of the probe is connected to CHASSIS and the contrast control is set for MAXIMUM UNDISTORTED CONTRAST.
3. The 30 and 7875 C.P.S. oscilloscope sweep settings are used so as to permit observation of two cycles of the wave shape.

NOTE: A wave shape seen on your oscilloscope may be upside down from same wave shape shown here.

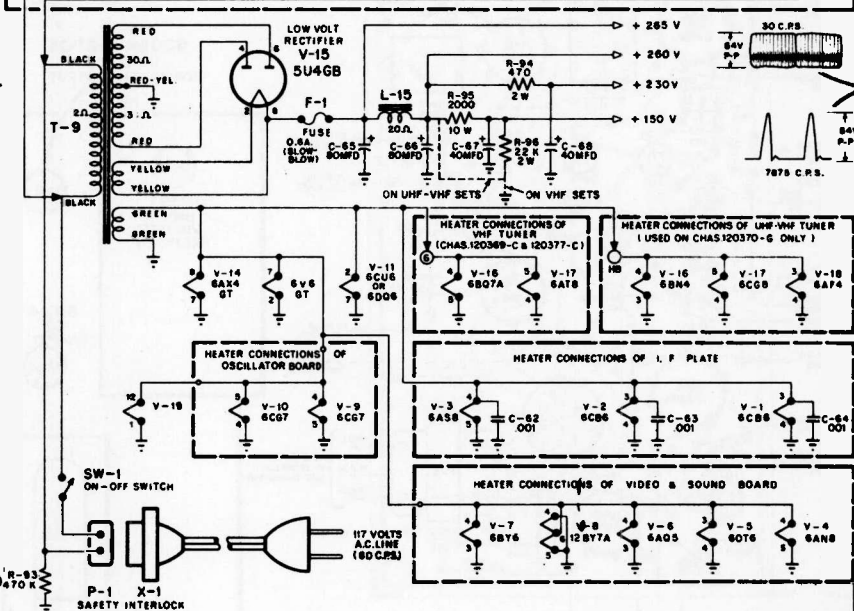
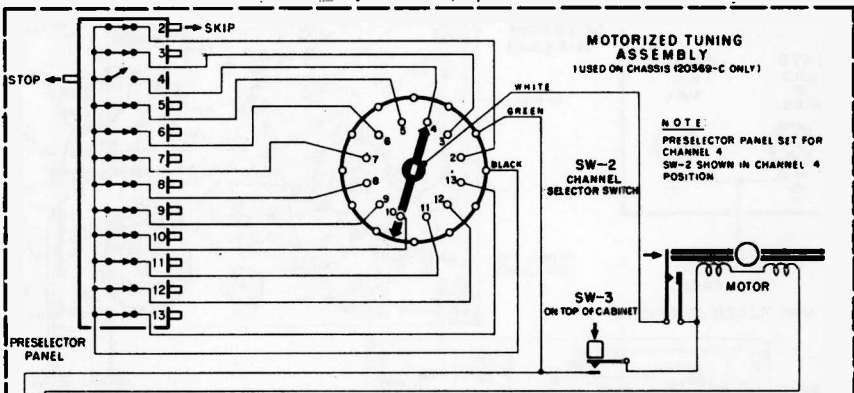

CHASSIS NOS. 120369-C, 120370-G & 120377-C

# VOLUME TV-14, MOST-OFTEN-NEEDED 1958 TELEVISION SERVICING INFORMATION

## EMERSON Chassis 120369C, 120370G, 120377C, Schematic Diagram

NOTE: TWO SPEAKERS CONNECTED IN SERIES MAY BE USED ON SOME SETS. CORRECT PHASING OF SPEAKERS MUST BE OBSERVED.

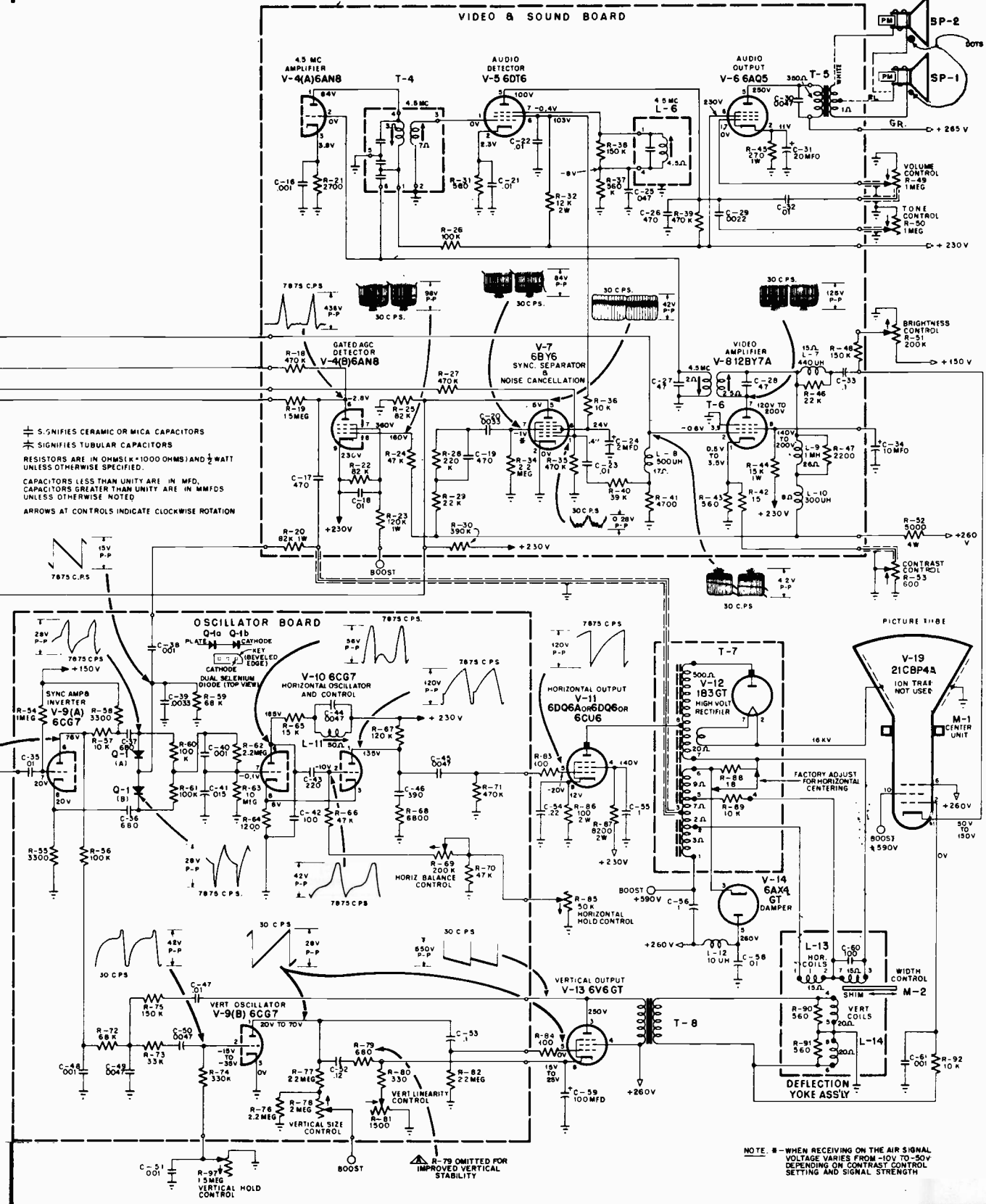

VIDEO I.F. ALIGNMENT (See Fig. No. 4) for EMERSON Chassis 120369C, 120370G, 120377C

1. Connect 3 volt bias to A.G.C. line. Negative terminal to junction R-3, C-7, positive terminal to chassis. (R-33 maximum ccw position).
2. Connect I.F. marker generator to floating shield of tuner mixer tube (See Note Below) and V.T.V.M. to junction of L-8, R-41.

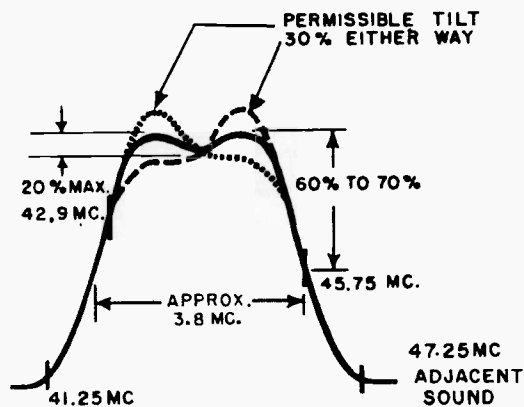

Figure 1. OVERALL I.F. RESPONSE CURVE

3. Adjust output of signal generator so that peaking of coils does not produce more than -2v D.C. on V.T.V.M.
4. Peak the following for maximum response: T-3, 44.25MC; T-2 42.6MC; T-1, 45.3MC; L-1 bottom 42.9MC and T-11 45.3MC.
5. Peak the following for minimum response increasing generator output if necessary: L-2, 41.25 MC and L-1 top, 47.25MC.
6. Re-adjust L-1 bottom (42.9MC) and T-11 (45.3MC) for maximum response.
7. Connect an oscilloscope through a 20,000 ohm isolation resistor in place of the V.T.V.M. and connect a sweep generator to floating shield of tuner mixer tube along with marker generator. Adjust output of sweep to produce about 2 volts peak to peak of oscilloscope and reduce marker signal so as not to upset the response curve.
8. The 45.75MC marker should appear between 60% and 70% down with respect to its related peak. If necessary, adjust T-3 slightly.
9. The 42.9MC marker (See Fig. No. 1) should not fall below 20% of its related peak. Limits of response curve are 30% tilt and 20% peak to valley ratio.

NOTE: Part of the procedure calls for use of a "floating" shield over the mixer tube of the tuner. The tube shields now used in the tuner cannot be removed from their mounts. Instead of a "floating" shield the following method is used.

Take a thin piece of copper or brass foil 1/2" by 2" and paste on to a thin piece of onion skin insulation. The insulation should extend about 1/8" beyond the two long sides and one short side while the foil should extend beyond the insulation on the other short side. The shim assembly is then slipped lengthwise to fit between the mixer tube and its shield with the metal foil facing the tube. The short side with the extended insulation is placed towards chassis while the side with the foil extending beyond the insulation is connected to the sweep generator. The shim may now be rotated for maximum coupling as observed on the oscilloscope.

4.5 MC VIDEO TRAP ALIGNMENT, T-6 Top (See Fig. 4)

Using a good signal, set the fine tuning control to the point where you begin to see 4.5 mc beat in the picture. Then adjust T-6 top for minimum 4.5 mc beat in the picture.

SOUND IF ALIGNMENT (See Fig. 4)

1. Using a strong signal, adjust T-6 bottom and T-4 top and bottom, for loudest sound.
2. Adjust L-6 for clearest and loudest sound. If two peaks are encountered use position with slug closest to chassis.
3. With antenna loosely coupled to set, adjust receiver to a weak signal channel and repeat step #1, tuning for maximum volume and minimum distortion.
4. If a V.T.V.M. is available, the measured voltage across R-37, 560KΩ should not vary more than 2 volts between strong and weak signals. Voltages should read between -4 and -9 volts.
5. Check sound on all channels and repeat entire procedure if necessary.

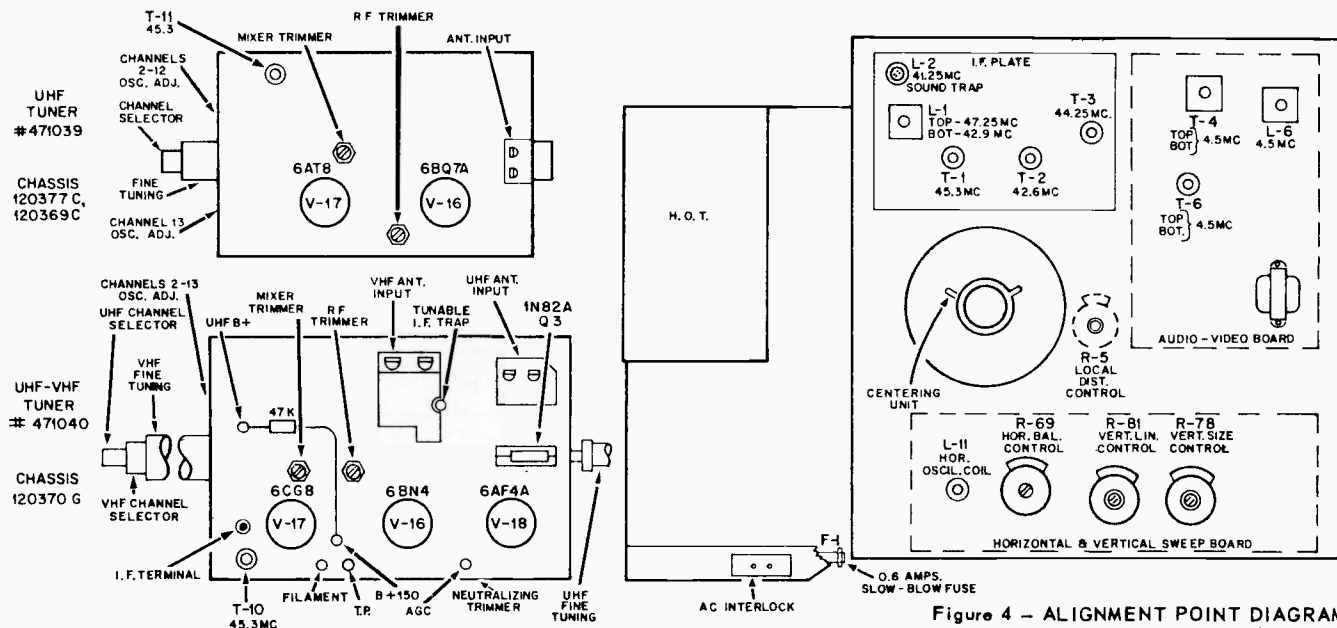

Figure 4 - ALIGNMENT POINT DIAGRAM



# Emerson Television

TYPE	MODEL NUMBER	TV CHASSIS	TUBE SIZE	TV TUNER
VHF RECEIVERS	1282, 1284	120380H	21DAP4	471055
	1286	120388H	21DAP4	471055
UHF-VHF RECEIVERS	1283, 1285	120381M	21DAP4	471056
	1287	120389M	21DAP4	471056

**MODELS  
USING CHASSIS:**

120380H, 381M  
120388H, 389M

(Service information on pages 23 through 28)

## GENERAL INFORMATION

These "Tru-Slim" 110° chassis are exceptionally easy to service due to: horizontally mounted chassis, two etched circuit boards, picture tube removable from the front of the set, easy access to all tubes, etc.

Some additional features of these chassis are: Fringe Compensator Control, Phono input jack with Phono-T.V. switch, and personal listening attachment jack which allows for the use of an external speaker, hearing aid attachment, or under-pillow speaker.

Portable VHF models come equipped with a built-in 4-section telescopic VHF antenna and a separate UHF loop antenna is provided on UHF-VHF portables.

Port-O-Rama models 1286 and 1287 include a radio which operates thru the audio system of the T.V. chassis.

**NOTE:** No ion trap is required with the 110° deflection picture tube used in these sets since they are straight gun tubes.

### Antennas

Portable VHF Models 1284 and 1286 are equipped with a telescopic dipole antenna. To operate, extend rods to maximum length and rotate for clearest reception. If an external VHF antenna is required disconnect telescopic antenna leads from VHF antenna terminals and connect the leads from the external VHF antenna.

Portable UHF-VHF Models 1285 and 1287 are equipped with a telescopic dipole antenna for VHF reception and a separate loop antenna for UHF reception. To operate UHF antenna, adjust loop in upward position for best UHF reception. Since these antennas are directional, positioning set also improves reception.

Should external antennas be required disconnect dipole and loop and connect external antennas to their respective terminals.

If a single all-channel (VHF-UHF) antenna is used a commercially available VHF-UHF crossover network is recommended.

On non-portable VHF Model 1282 a built-in VHF antenna is provided. UHF-VHF Table Model 1283 is provided with separate built-in VHF and UHF antennas.

The radio used in our Port-O-Rama Models 1286 and 1287 derives its signal from one side of whichever VHF antenna (Built-in or external) is connected to the set.

### Video I.F. Alignment

1. Connect 3 volt bias to A.G.C. line. Negative terminal to junction R-15, R-13 positive terminal to chassis.
2. Connect I.F. marker generator to floating shield of tuner mixer tube (see Note below) and V.T.V.M. to junction L-8, R-34.
3. Adjust C-T for maximum capacity.
4. Adjust marker to 45.5 MC and peak T-4 for maximum (keep signal generator output as low as possible).
5. Adjust marker to 43.25 MC and peak T-3, L-2 and T-8 (Tuner I.F.) for maximum (keep signal generator output as low as possible).
6. Connect an oscilloscope through a 20,000 ohm isolation resistor in place of the V.T.V.M. and connect a sweep generator to floating tube shield of mixer tube along with marker generator. Adjust output of sweep to produce about 2 volts peak to peak at oscilloscope and reduce marker signal so as not to upset the response curve.
7. Adjust marker to 45.75 MC. This marker should appear 60% down with respect to related peak of response curve. If not at 60% adjust C-T. Limits of response curve are 30% tilt and 20% peak to valley ratio.

**NOTE:** Part of the procedure calls for use of a "floating" shield over the mixer tube of the tuner. The tube shields now used in the tuner cannot be removed from their mounts. Instead of a "floating" shield the following method is used.

Take a thin piece of copper or brass foil 1/2" by 2" and paste on to a thin piece of onion skin insulation. The insulation should extend about 1/8" beyond the two long sides and one short side while the foil should extend beyond the insulation on the other short side.

The shim assembly is then slipped in lengthwise to fit between the mixer tube and its shield with the metal foil facing the tube. The short side with the extended insulation is placed towards chassis while the side with the foil extending beyond the insulation is connected to the sweep generator. The shim may now be rotated for maximum coupling as observed on the oscilloscope.

### Sound I.F. Alignment

1. With antenna loosely coupled to set adjust receiver to a weak signal channel.
2. Place a V.T.V.M. (negative scale) to junction L-1, R-1 and adjust T-9 and L-4 for maximum limiter voltage on V.T.V.M. Amount of input signal should be such that a sharp maximum reading can be obtained.
3. Connect V.T.V.M. to junction R-5, C-4 (negative scale) and detune discriminator (T-1) secondary to produce a maximum negative reading. (Looking at top of chassis secondary slug is closest to you.)
4. Adjust primary of T-1 for maximum negative reading.
5. Re-adjust secondary of discriminator T-1 towards original slug position for minimum reading on V.T.V.M. Check audio, if distorted. Repeat steps No. 1-5.



EMERSON Chassis 120380H, 120381M, 120388H, 120389M, Alignment, Continued

**Alignment of Miracle Picture Lock (Horizontal Oscillator and A.F.C.)**

This can be accomplished without removing chassis from cabinet as follows:

1. Turn picture stabilizer (R-31) fully clockwise (minimum resistance) and tune set to a known good channel.
2. Short phasing coil (L-9) by a jumper wire across C-32, .01 mfd capacitor.
3. Rotate horizontal hold control (R-57) fully clockwise (looking from front of set).
4. Starting with horizontal frequency slug (T-6) all the way "out" (towards you looking at back of chassis), rotate "in" until picture just locks into sync. Then, turn slug in about 1/2 turn more.
5. Remove short from phase coil and starting with slug all the way "out", adjust phase coil "in" until picture almost locks into sync (3-4 diagonal bars).
6. Turn horizontal hold (R-57) to counterclockwise position to lock picture "in", then turn horizontal hold back to full clockwise position. If picture falls out of sync, adjust frequency coil slug (T-6) slightly.
7. Check for horizontal hold while switching channels. If this is not obtained at extreme clockwise position of horizontal hold control, turn frequency slug T-6 "in" slightly until desired results are obtained. If excessive squedging (Christmas Tree effect) is experienced while switching channels, readjust phase coil slightly. Check to make sure no horizontal bending is introduced at top of picture.

\*NOTE: T-6 and L-9 must be adjusted with a hex head adjustment tool and not a screwdriver.

**Adjustment of Picture Stabilizer (R-31)**

For local signals, this control (R-31) should be set to its extreme clockwise position (minimum resistance).

If sync improvement is required in electrically noisy areas, the picture stabilizer control (R-31) is turned in a counterclockwise direction until the best sync stability is obtained. Be sure to check all channels for sync instability, since a compromise setting of R-31 might be necessary.

**Horizontal Size Adjustments**

These "Tru-Slim" 110° chassis have been designed to provide proper horizontal sweep under normally encountered line voltage variations.

Should you encounter insufficient horizontal sweep due to low line voltage, short out R-85 a 4700Ω, 1 watt resistor located on terminal strip near V-7 (vertical osc. tube). Should horizontal oversweep be present because of high line voltage, remove short from across R-85. The shorting or removal of short across R-85 can be made without removing chassis from cabinet. Simply remove masonite back and R-85 becomes accessible.

**Field Alignment of Tuners**

Ordinarily the only adjustments required in the field are those necessary to compensate for variations in oscillator tube replacements. This can usually be accomplished with the channel #13 oscillator adjustment. If individual channel adjustments are necessary, then proceed as follows: (Since this tuner is of the incremental inductance type, all oscillator adjustments should be made commencing with the higher channel and then proceeding to the lower channel.)

1. Set channel selector to channel #13. Set fine tuning control to electrical center of its range.
2. Adjust channel #13 oscillator adjustment, for best picture and sound. Use a non-metallic screwdriver.
3. Channels #2, #4 and #6 have slug adjustments and should always be adjusted starting with the higher channel. It is recommended that channels #13, #6, #4 and #2 slugs, only, be adjusted in the field in that order when necessary.
4. Channels #12 through #7 can be adjusted when required by bending the hairpin inductances through the hole provided.
5. Channels #3 and #5 split-coil windings should not have to be compressed or separated ordinarily.

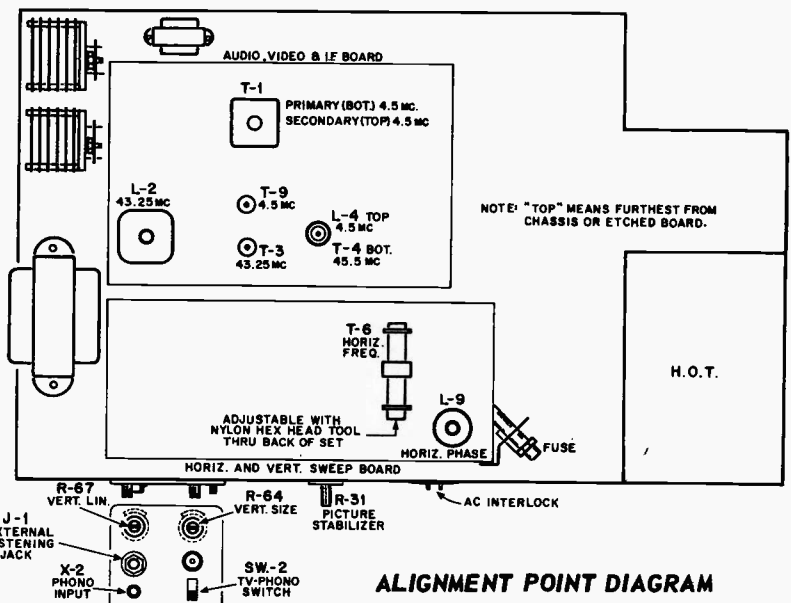
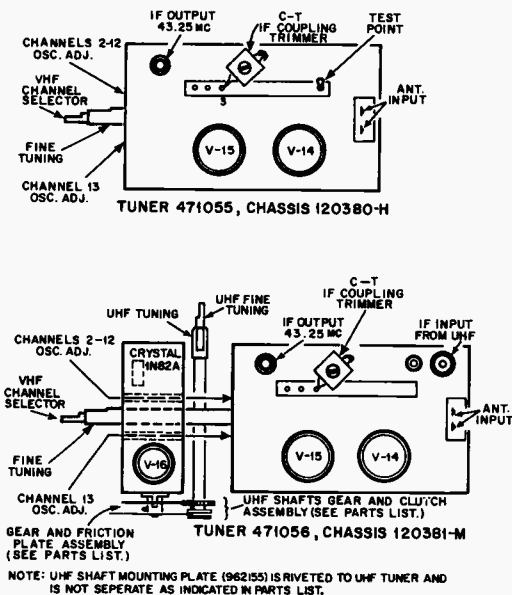



# VOLUME TV-14, MOST-OFTEN-NEEDED 1958 TELEVISION SERVICING INFORMATION

## EMERSON Chassis 120380H, 120381M Schematic Diagram

(See page following, over, for schematic details on Chassis 120388H, 120389M.)

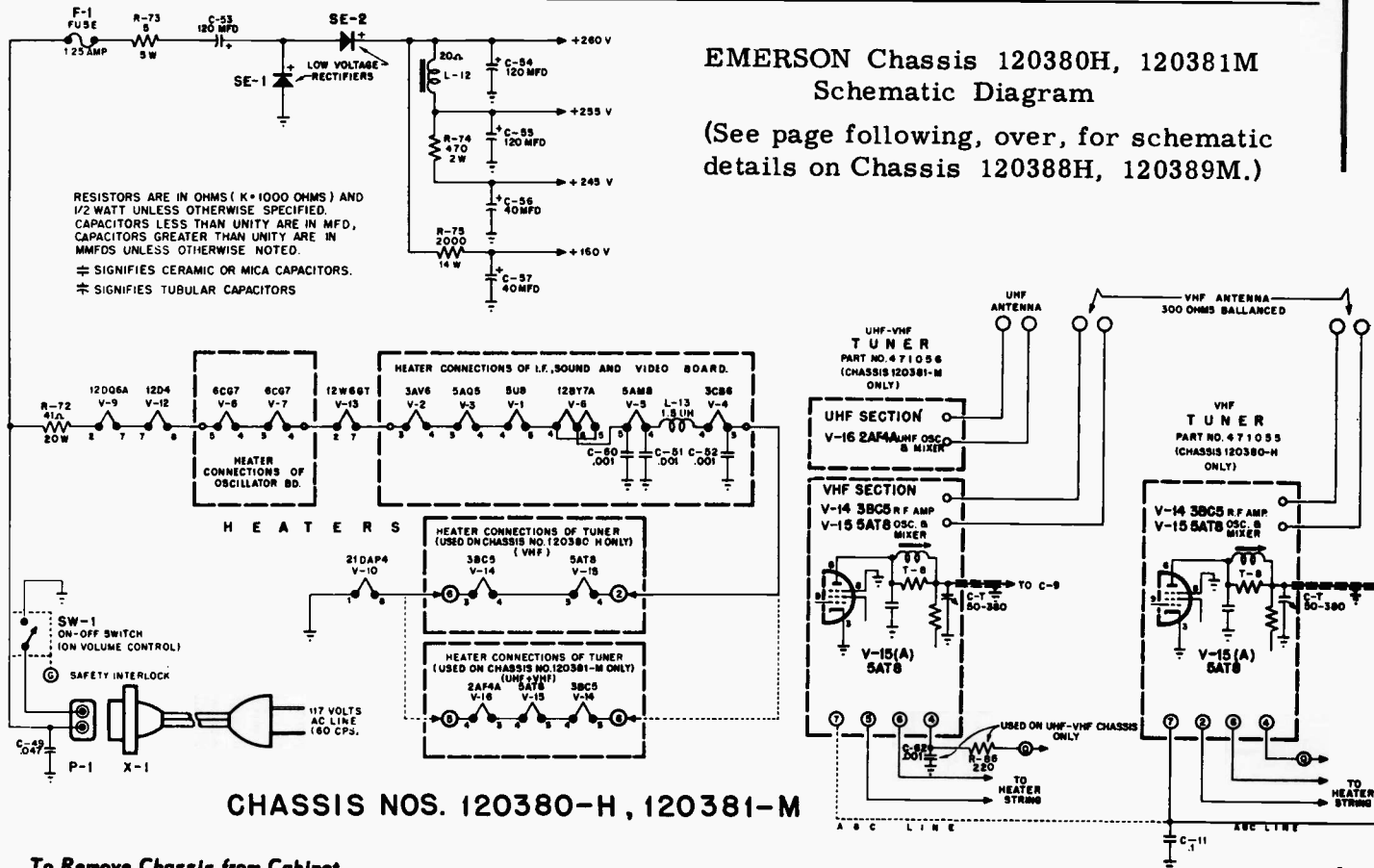

CHASSIS NOS. 120380-H, 120381-M

### To Remove Chassis from Cabinet

1. Remove all knobs and masonite back.
2. From the back of cabinet remove 2 screws which hold the dual contrast volume and on-off control to cabinet bracket.
3. Remove antenna terminal strip and disconnect speaker leads.
4. Remove two screws holding tuner support bracket to side of cabinet. The same two screws also support radio section on 120388H and 120389M chassis only.
5. Remove one screw holding rear tuner support brace to rear side of cabinet.
6. Remove two Phillips head screws that hold control escutcheon to side control ass'y.
7. Remove 5 screws which hold chassis to base of cabinet.
8. Remove picture tube socket, and high voltage lead. (Be sure to discharge high voltage.)
9. Loosen yoke clamp and pull chassis out towards rear of cabinet, being careful to guide and support deflection yoke as it slides off picture tube neck.

### CONDITIONS FOR TAKING VOLTAGE AND RESISTANCE READINGS

The voltage and resistance measurements listed were taken on Chassis 120380H (no triangle code).

Due to component variations, voltage and resistance readings may vary slightly from those given here. Slight variations may also be noticed if chassis is not coded as mentioned above.

The picture, tube, deflection yoke and high voltage circuits were connected to take the following readings and waveshapes. If picture tube is not connected to chassis insert test picture tube or short pins 1 to 8 in picture tube socket to complete filament circuit.

1. Antenna disconnected and antenna terminals shorted on tuner and connected to chassis (use short leads).
2. Line voltage 117 volts (Disconnect power for resistance readings).
3. 3-volt bias battery connected to A.G.C. circuit, positive terminal to chassis, negative terminal to junction of R-13, R-15.  
BIAS BATTERY USED FOR VOLTAGE READINGS ONLY.
4. All controls in position for normal picture. (Varied when it directly affects reading.)
5. All measurements taken with a vacuum tube voltmeter and ohmmeter.
6. All readings listed in tables were taken between points shown and chassis.
7. Resistance readings are given in ohms unless otherwise noted.
8. N.C. denotes no connection.

### WAVE SHAPE ANALYSIS CHART

To accurately observe the wave shapes, the relatively high input capacity of an oscilloscope must be reduced so as not to change the operating characteristics of the television set. Failure to do this will result in wrong wave shape readings. This is accomplished by using an Emerson low capacity probe as outlined previously in the service note for models 686L, 687L and 696L using chassis 120142-B which was issued at an earlier date.

1. Connect antenna and tune receiver to channel where best reception has been obtained in the past.
2. Low end of the probe is connected to CHASSIS and the contrast control is set for MAXIMUM UNDISTORTED CONTRAST.
3. The 30 and 7875 C.P.S. oscilloscope sweep settings are used so as to permit observation of two cycles of the wave shape.

NOTE: A wave shape seen on your oscilloscope may be upside down from same wave shape shown here. This will depend on the number of stages of amplification in the oscilloscope used.



VOLUME TV-14, MOST-OFTEN-NEEDED 1958 TELEVISION SERVICING INFORMATION

EMERSON Chassis 120388H, 120389M, etc.  
Service material continued.

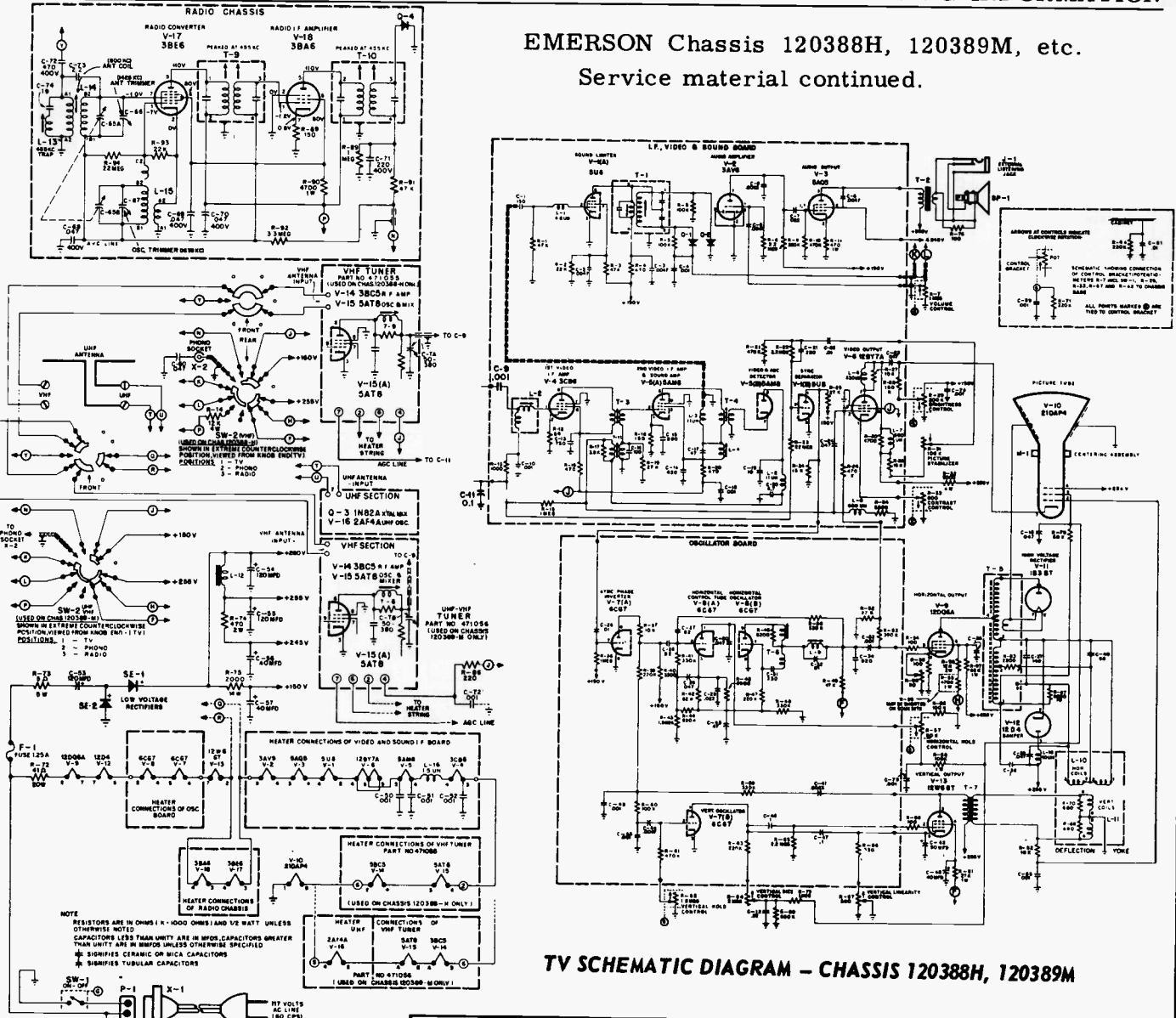

TV SCHEMATIC DIAGRAM - CHASSIS 120388H, 120389M

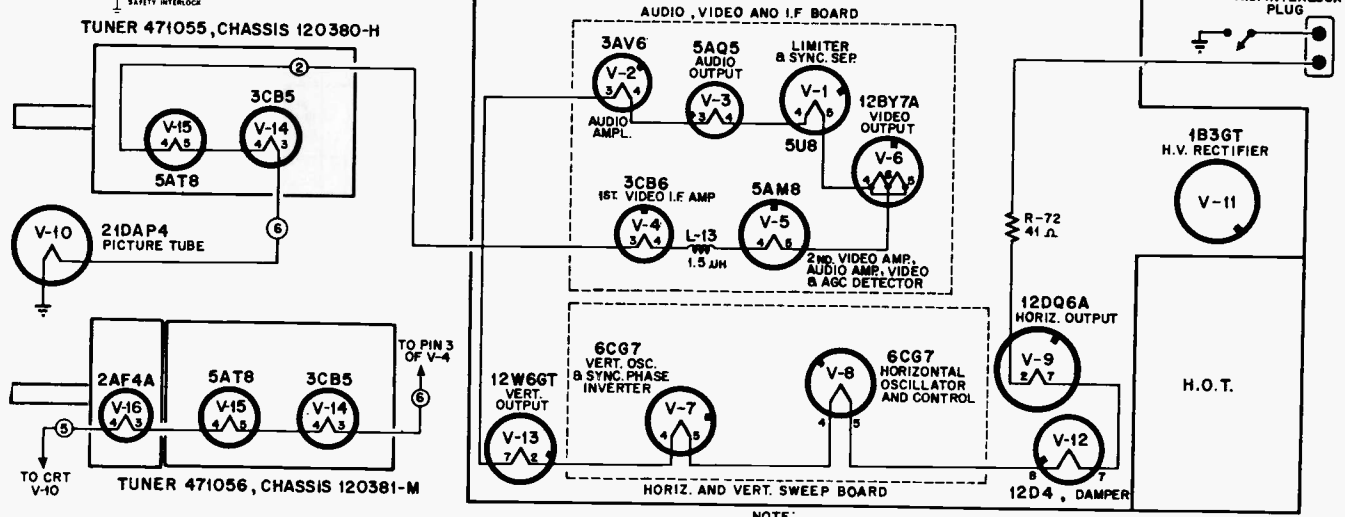

TUBE LOCATION DIAGRAM

NOTE: ■ INDICATES GAP BETWEEN PINS 1 & 7 (OR 9) ON MINIATURE SOCKETS OR KEYING FOR OCTAL SOCKETS.



EMERSON TELEVISION  
Chassis 120386HC, -H,  
120387MC, -M, 120390HC, -H,  
120391MC, -M, Diagram

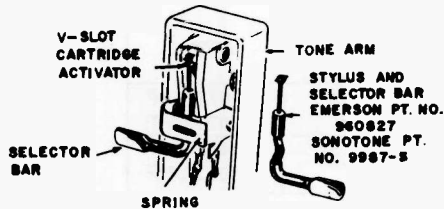

FIGURE 3 - STYLUS ASSEMBLY REMOVAL

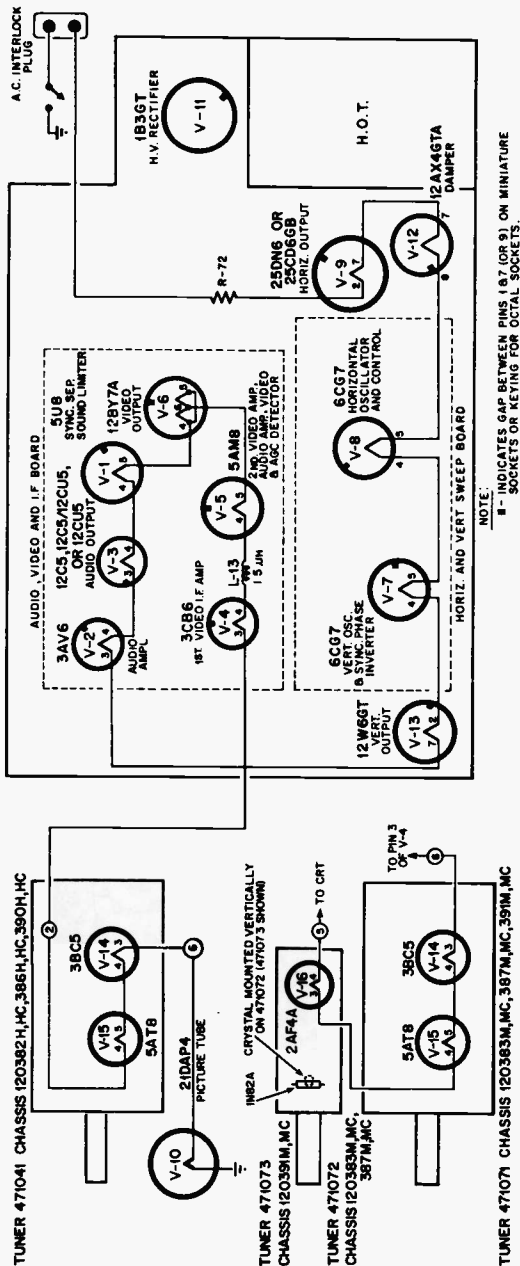
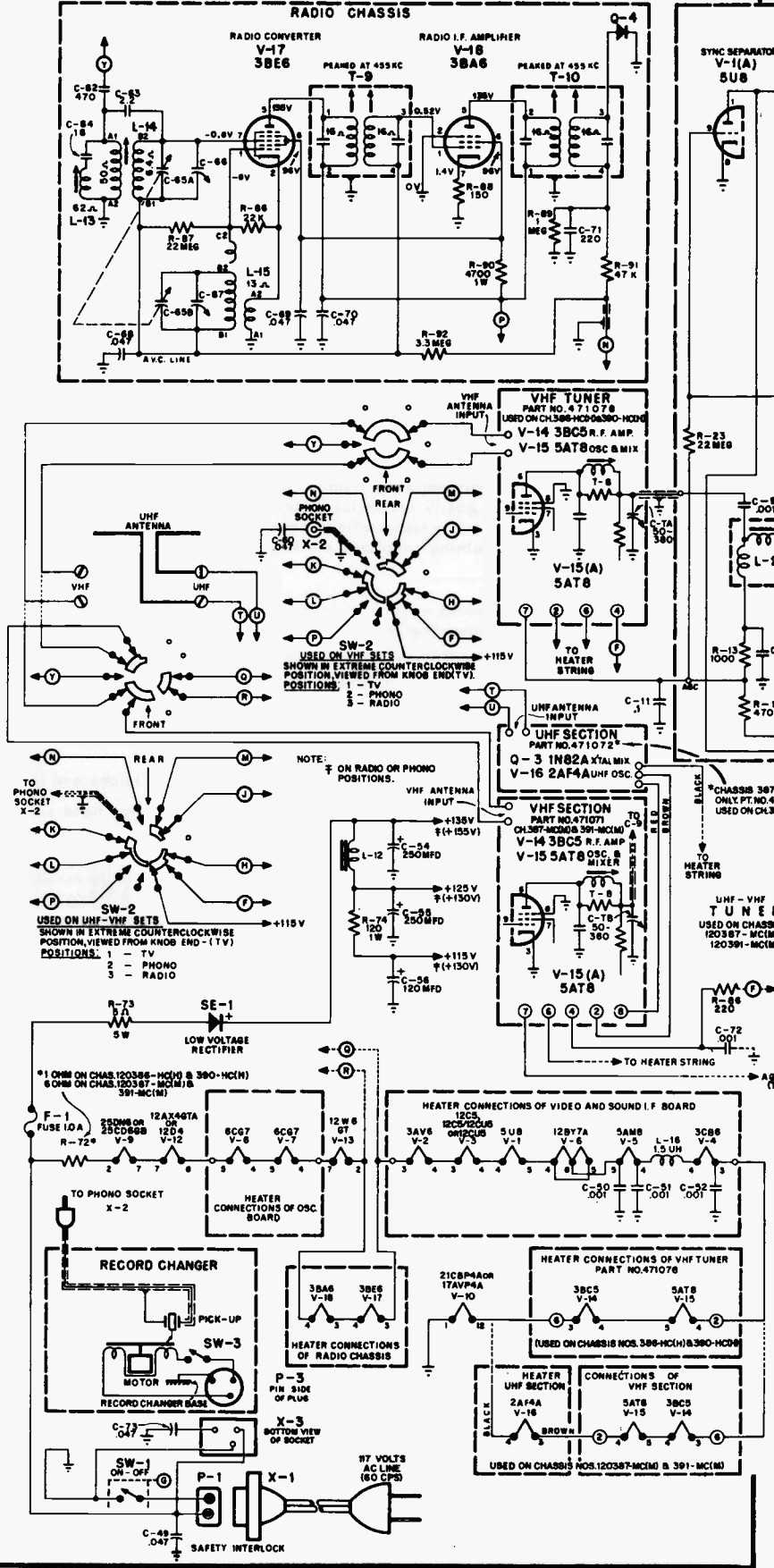

FIGURE 4 - TUBE LOCATION DIAGRAM





# VOLUME TV-14, MOST-OFTEN-NEEDED 1958 TELEVISION SERVICING INFORMATION

CHASSIS NOS 120386-HC,H,390-HC,H,387-MC,M,391-MC,M

## VIDEO I.F. & SOUND I.F. BOARD

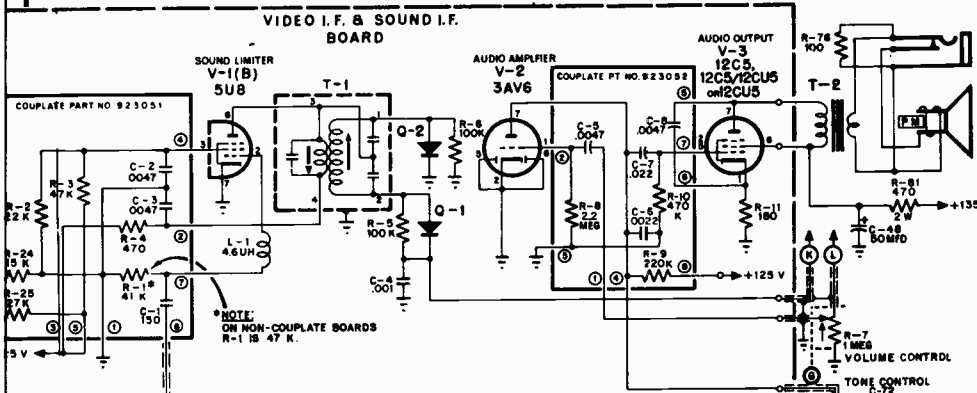

THE LETTER C INDICATES USE OF COUPLATES. ON NON-COUPLE BOARD INDIVIDUALLY MOUNTED COMPONENTS OF THE SAME VALUES ARE USED, UNLESS OTHERWISE NOTED.

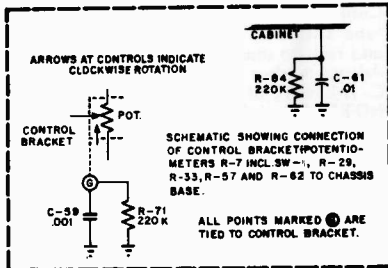

RESISTORS ARE IN OHMS (K=1000 OHMS) AND 1/2 WATT UNLESS OTHERWISE NOTED. CAPACITORS LESS THAN UNITY ARE IN MFDS, CAPACITORS GREATER THAN UNITY ARE IN MMFDS UNLESS OTHERWISE SPECIFIED. # SIGNIFIES CERAMIC OR MICA CAPACITORS. \* SIGNIFIES TUBULAR CAPACITORS.

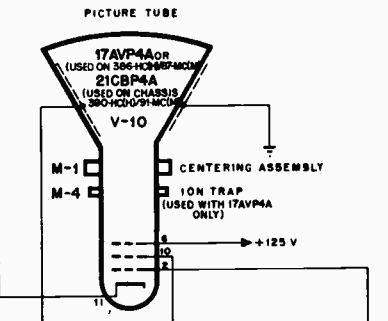
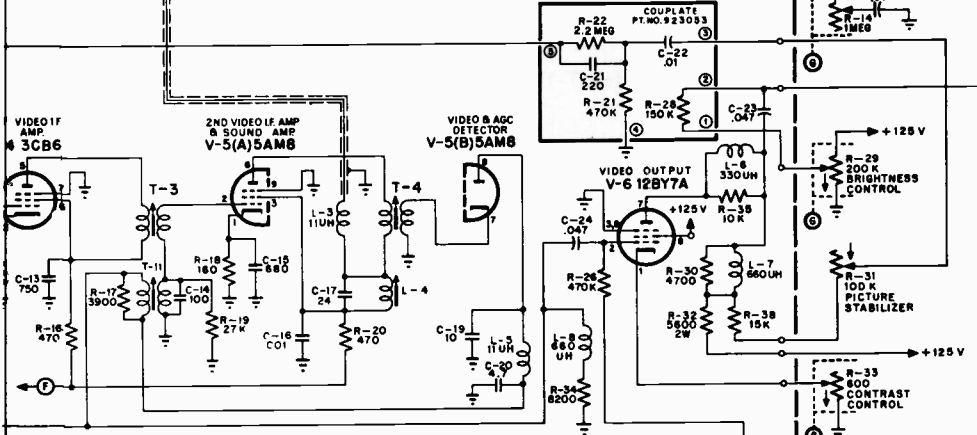

## OSCILLATOR BOARD

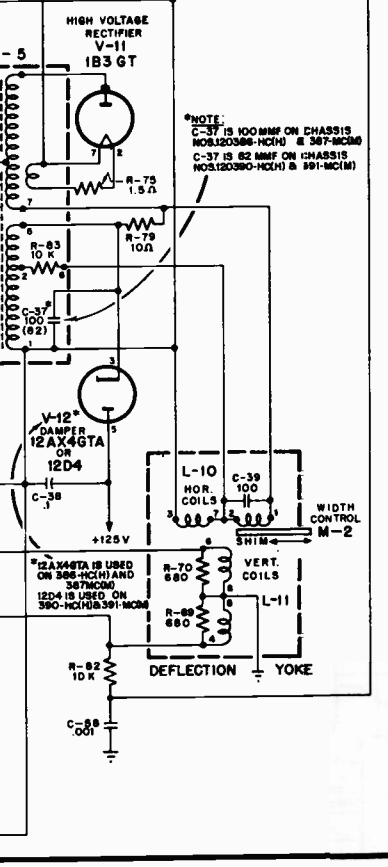
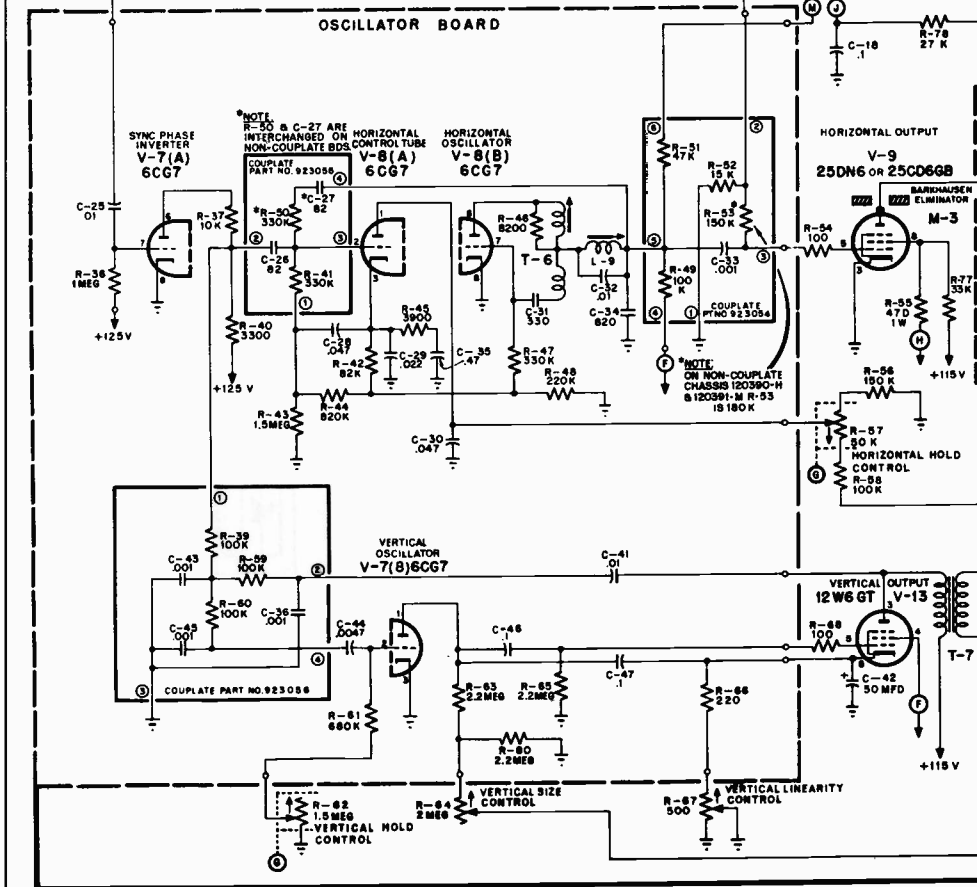

EMERSON Alignment Information, Chassis 120382HC, -H, 120383MC, -M, 120386HC, -H, etc

Video I. F. Alignment

1. Connect 3 volt bias to A.G.C. line. Negative terminal to junction R13, R15, C4, positive terminal to chassis.
2. Connect I.F. marker generator to floating shield of tuner mixer tube (see Note below) and V.T.V.M. to junction L8, R-34.
3. Adjust C-T for maximum capacity.
4. Adjust marker to 45.5 MC and peak T-4 for maximum (keep signal generator output as low as possible.)
5. Adjust marker to 43.25 MC and peak T-3, L-2 and T-8. (Tuner I.F.) for maximum (keep signal generator output as low as possible.)
6. Connect an oscilloscope through a 20,000 ohm isolation resistor in place of the V.T.V.M. and connect a sweep generator to floating tube shield of mixer tube along with marker generator. Adjust output of sweep to produce about 2 volts peak to peak at oscilloscope and reduce marker signal so as not to upset the response curve.
7. Adjust marker to 45.75 MC. This marker should appear 60% down with respect to related peak of response curve. If not at 60% adjust C-1. Limits of response curve are 30% tilt and 20% peak to valley ratio.

NOTE: Part of the procedure calls for use of a "floating" shield over the mixer tube of the tuner. The tube shields now used in the tuner cannot be removed from their mounts. Instead of a "floating" shield the following method is used.

Take a thin piece of copper or brass foil 1/2" by 2" and paste on to a thin piece of onion skin insulation. The insulation should extend about 1/8" beyond the two long sides and one short side while the foil should extend beyond the insulation on the other short side.

The shim assembly is then slipped in lengthwise to fit between the mixer tube and its shield with the metal foil facing the tube. The short side with the extended insulation is placed towards chassis while the side with the foil extending beyond the insulation is connected to the sweep generator. The shim may now be rotated for maximum coupling as observed on the oscilloscope.

Sound I.F. Alignment

1. With antenna loosely coupled to set adjust receiver to a weak signal channel.
2. Place a V.T.V.M. (negative scale) to junction L-1, R-1 and adjust T-9 and L-4 for maximum limiter voltage on V.T.V.M. Amount of input signal should be such that a sharp maximum reading can be obtained.
3. Connect V.T.V.M. to junction R-5, C-4 (negative scale) and detune discriminator (T-1) secondary to produce a maximum negative reading. (Looking at top of chassis secondary slug is closest to you.)
4. Adjust primary of T-5 for maximum negative reading.
5. Re-adjust secondary of discriminator T-1 towards original slug position for minimum reading on R.V.V.M. Check audio, if distorted. Repeat steps No. 1-5.

Alignment of Miracle Picture Lock (Horizontal Oscillator and A.F.C.)

This can be accomplished without removing chassis from cabinet as follows:

1. Turn picture stabilizer (R-31) fully clockwise (minimum resistance) and tune set to a known good channel.
  2. Short phasing coil (L-9) by a jumper wire across C-32, .01 mfd capacitor.
  3. Rotate horizontal hold control (R-57) fully clockwise (looking from front of set.)
  4. Starting with horizontal frequency slug (T-6) all the way "out" (towards you looking at back of chassis), rotate "in" until picture just locks into sync. Then, turn slug in about 1/2 turn more.
  5. Remove short from phase coil and starting with slug all the way "out", adjust "in" until picture almost locks into sync (3-4 diagonal bars).
  6. Turn horizontal hold (R-57) to counterclockwise position to lock picture "in", then turn horizontal hold back to full clockwise position. If picture falls out of sync, adjust frequency coil slug (T-6) slightly.
  7. Check for horizontal hold while switching channels. If this is not obtained at extreme clockwise position of horizontal hold control, turn frequency slug T-6 "in" slightly until desired results are obtained. If excessive squedging (Christmas Tree effect) is experienced while switching channels, readjust phase coil slightly. Check to make sure no horizontal bending is introduced at top of picture.
- \*NOTE: T-6 and L-9 must be adjusted with a hex head adjustment tool and not a screwdriver.

Adjustment of Picture Stabilizer (R-31)

For local signals, this control (R-28) should be set to its extreme clockwise position (minimum resistance).

If sync improvement is required in electrically noisy areas, the picture stabilizer control (R-31) is turned in a counterclockwise direction until the best sync stability is obtained. Be sure to check all channels for sync instability, since a compromise setting of R-31 might be necessary.

Horizontal Size Adjustment

Width is controlled by an aluminum shim inserted between the picture tube neck and the yoke. To reduce width the shim is placed further inside the yoke and vice-versa to increase width. Then recheck ion trap setting.

To Eliminate Barkhausen and/or Snivets

We have found that under certain conditions some 25CD6-GA, GB tubes cause "snivets" in the picture. To eliminate this possibility so that servicemen will not have to hand pick 25CD6-GA, GB tubes, we are using an ion type of trap around the top portion of the 25CD6-GA, tube. These are factory adjusted and should not usually require any further adjustment. This trap can be adjusted in the field if need be, simply by turning around tube until snivets and/or Barkhausen is eliminated. If necessary, turn the trap over and rotate once again. Make sure you check all channels received in that area.

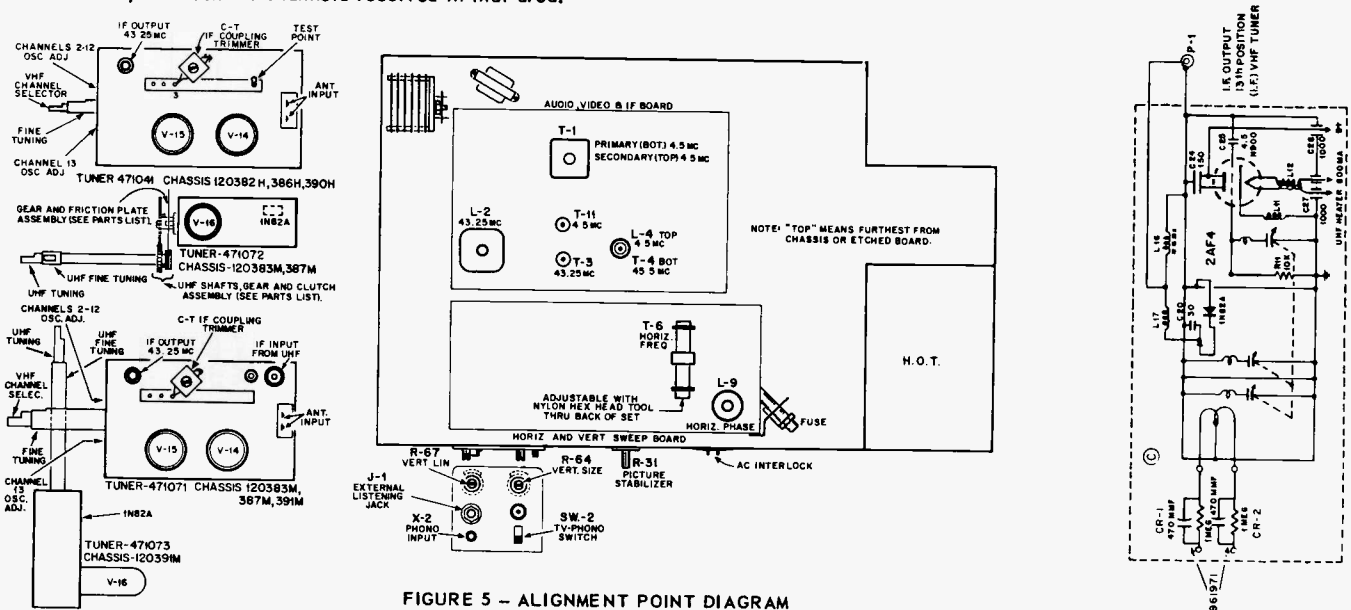

FIGURE 5 - ALIGNMENT POINT DIAGRAM

FIGURE 2 - UHF TUNER NO. 471073

# GENERAL ELECTRIC

"Q" Line Receivers, Models 14T016, 14T017, 14T018, 14T020 (and UHF)

Material on the next eight pages is exact for the above listed General Electric sets as well as the Hotpoint sets listed below.

## Hotpoint

"Q" Line Receivers, Models 14S201, 14S202, 14S203, 14S204 (and UHF)

### PICTURE TUBE ADJUSTMENTS

**YOKE POSITION**—Loosen the yoke clamp wing nut. Seat the yoke firmly against the bell of the picture tube and rotate the assembly to correct for any tilt of the picture, squaring the picture within the mask. Tighten the wing nut after adjustment is made.

**PICTURE CENTERING**—The levers and ring assembly for picture centering are located on the neck of the tube mounted directly on the rear of the yoke. Rotate the levers towards and away from each other to center the picture on the face.

**FOCUS**—On the back of the picture tube is a focus jumper connector. This is so designed as to connect pins 2 and 6 or 10 and 6 together. Best focus is usually found with pins 2 and 6 connected together (focus potential near ground). A check of focus quality may be made by changing this jumper.

**ION TRAP**—Power should not be changing the jumper for extended periods of time without proper adjustment of the ion trap. Rotate and slide the ion trap on the neck of the picture tube to obtain maximum picture brightness without neck shadow and consistent with good focus. Brightness should be kept moderate during the ion trap adjustment.

### TO REMOVE THE CHASSIS FROM THE CABINET

Remove any antenna connected to the antenna terminal board. Remove the screws securing the back to the cabinet and the screw holding the back to the chassis. Remove the back assembly.

Since there are no plugs on the speaker, if desired remove the nuts securing the speaker and remove the speaker or unsolder the lead connections to the speaker terminals.

Remove the knobs from the shafts on the side of the cabinet. Remove the picture tube socket, the ion trap, the centering lever assembly and the yoke clamp, the latter secured by a yoke clamp screw wing nut, from the picture tube. Remove the top screw and two bottom chassis screws. Tilt the chassis out from the right side, as viewed from the rear, at the same time pull the yoke back over the neck of the tube. Slide the chassis out over the neck of the tube. The anode should be discharged with a jumper, connected *first to the chassis*, and then disconnect the anode lead by squeezing the anode clip.

To install the chassis reverse the above procedure remembering: the speaker leads go under the tuner shaft and the picture tube socket is dressed through the center hole so that all leads should be at the rear of the chassis. Tilt the left edge in and slide the chassis into the cabinet to where the control shafts line up with the respective holes. Connect the H.V. anode lead. Slide the yoke over the neck of the tube and then move both the yoke and the chassis forward to position.

### A WORD OF CAUTION—

THE CAPTIVATION OF THE TUBE SHIELDS IS NECESSARY FOR THE CUSTOMER'S PROTECTION AGAINST SHOCK HAZARD. WHEN SERVICING THIS CHASSIS, BE SURE THAT THE TUBE SHIELDS ARE CAPTIVATED AND THAT THE CHASSIS IS NOT SHORTED TO THE METAL CABINET. BE SURE THAT THE BLACK SPEAKER LEAD IS CONNECTED TO THE PROPER SPEAKER TERMINAL. DISTORTED AUDIO MAY RESULT WHEN THE LEADS ARE REVERSED. THE BLACK LEAD BELONGS ON THE BOTTOM OR GROUNDED SPEAKER TERMINAL.

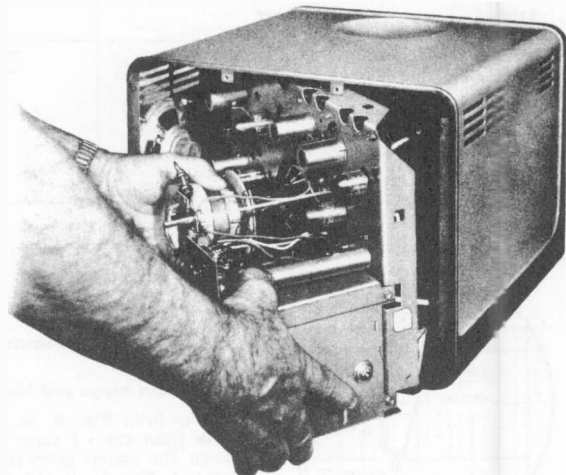

Fig. 2. Chassis Removal

In order to first remove the picture tube from the cabinet, it is necessary to remove the chassis from the cabinet as outlined.

The picture tube is secured by the clamping action of the cabinet projectors against the rim of the picture tube. Remove the two clamping screws from the top cabinet projection clamps while supporting the rear of the picture tube with one hand—slide the tube out through the front of the cabinet.

### HORIZONTAL AFC CONTROLS:

1. Tune receiver to a weak signal and adjust controls for normal operation.
2. Short test point IX to X.
3. Shunt L251 (horizontal stabilizer coil) with 1000 ohms.
4. Adjust horizontal hold potentiometer R267 so that the picture "floats" back and forth across the screen. Leave R267 set like this.
5. Remove 1000-ohm shunt across L251, and adjust L251 so that picture again "floats" back and forth across the screen. Leave L251 set like this.
6. Remove connection from test point IX and X.

GENERAL ELECTRIC "Q" Line, Models 14T016, 14T017, 14T018, 14T020

VIDEO I-F SYSTEM

GENERAL NOTES:

1. Allow receiver and alignment equipment at least 20 minutes of warm-up time before proceeding.
2. Turn the volume control to minimum sound output and contrast fully clockwise to maximum. Set channel selector to channel 11 or some other high band channel where oscillator influence is not noted as the fine tuning control is turned.
3. Connect sweep generator to converter stage using a test jig made up of an ungrounded tube shield terminated to ground as specified by the generator manufacturer. Users of General Electric test equipment need not terminate as the attenuator is terminated—see Fig. 10.
4. Connect a 3-volt bias battery to Test Point II with positive battery lead to chassis.
5. Connect -45V bias on pin 5 of V110 with positive lead going to ground.
6. Connect the scope through a 10,000-ohm resistor to Test Point III. Calibrate the vertical gain of the scope for 3 volts peak to peak to give 2 inches of deflection. When aligning, keep 2 inches as the 100% base line. Proceed as follows:

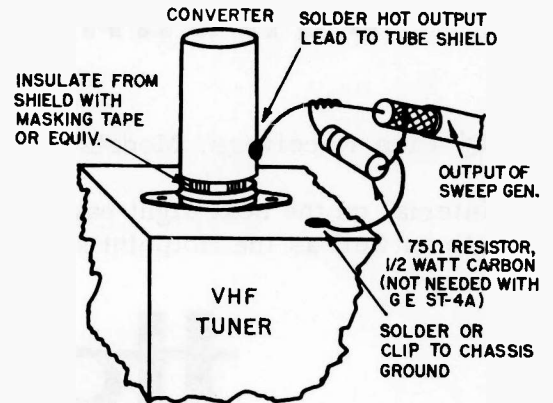

Fig. 10. I-F Sweep Jig

VIDEO I-F ALIGNMENT CHART

STEP	ADJUST	DESIRED RESPONSE	REMARKS
1	L151 to set 42.5 mc marker at 35-40%.		Adjust L135 simultaneously with L150. 41.25 mc marker is very critical and should be kept between limits of 7 to 9%. Peak of curve may fall between limits of 105% and 125% using 45 mc as the 100% reference.
2	T151 to set 45.75 mc marker at 50%.		
3	L135 and L150 for peak region symmetry.		

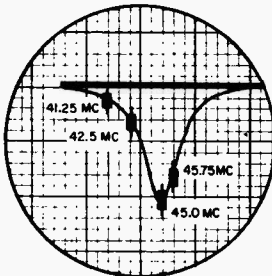

Fig. A

VIDEO I-F ALIGNMENT CURVES

The two curves shown are obtained from stage-by-stage alignment.

Connect scope and bias batteries as in steps 4, 5, and 6 above.

The first, Fig. A, is obtained by removing the shielded i-f link from the r-f tuner solder terminal and inserting a signal from the sweep generator into the interconnecting cable. The second, Fig. B, is obtained by shorting pins 5 and 6 of V103 and inserting a sweep signal into pin 1 of V104. Maximum gain of the scope may be necessary to obtain the response of the second curve.

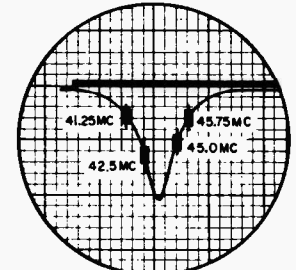

Fig. B

AUDIO I-F ALIGNMENT

NOTES:

1. Tune in a television signal. This will provide a 4.5 mc signal source for audio IF alignment. Keep the volume control turned down unless the speaker is connected.
2. Connect two 100,000-ohm resistors (in series) between pin No. 2 of V113 (5T8) and chassis.

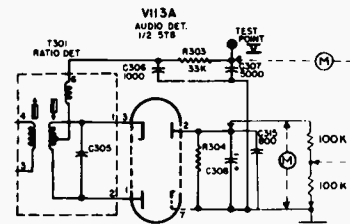

Fig. 11. Ratio Detector

AUDIO ALIGNMENT CHART

STEP	CONNECT VTVM OR 20,000 OHMS/VOLTMETER	ADJUST	METER INDICATION	REMARKS
1	Between Pin No. 2 of V113 and chassis.	L301	Adjust for maximum deflection.	Repeat steps 1, 2, and 3 to assure proper adjustments.
2		T301 primary (rear)	Adjust for maximum deflection.	
3	Between Test Point V and the center of the two 100,000-ohm resistors.	T301 secondary (front)	Adjust for zero volts d-c output.	

VOLUME TV-14, MOST-OFTEN-NEEDED 1958 TELEVISION SERVICING INFORMATION

GENERAL ELECTRIC "Q" Line, Trouble Shooting Chart, Continued

SYMPTOM	CHECK FOR
<b>DEFECTS OF THE SYNC SECTION</b>	
A. Weak or no horizontal sync; vertical sync, picture and sound satisfactory	<ol style="list-style-type: none"> <li>1. Defective phase detector, Y251-2</li> <li>2. Open capacitors, C251, C258</li> <li>3. Open resistor, R266</li> <li>4. Defective sweep components, R255, C253, C254, C256</li> <li>5. Defective coil, L251</li> </ol>
B. Weak or no composite sync, otherwise picture and sound normal	<ol style="list-style-type: none"> <li>1. Defective V105A</li> <li>2. Open R170</li> <li>3. Defective grid components, C159, C163, R165, R169</li> </ol>

<b>DEFECTS OF THE HORIZONTAL DEFLECTION CIRCUITS</b>	
A. Inadequate picture width	<ol style="list-style-type: none"> <li>1. Defective or weak, V109, V110, V112</li> <li>2. Correct waveshape of driving pulse on grid of V110</li> <li>3. Low B+ from power supply</li> <li>4. Defective output transformer, T251</li> <li>5. Leaky capacitor, C259</li> </ol>
B. Single vertical line in center, sound normal	<ol style="list-style-type: none"> <li>1. Open horizontal deflection coils, L252</li> </ol>
C. Poor horizontal linearity, bright vertical bars, inadequate width	<ol style="list-style-type: none"> <li>1. Defective yoke coils, L252</li> <li>2. Defective damper, V112</li> <li>3. Defective output transformer, T251</li> </ol>
D. Black "beady" vertical line or lines, receiver normal otherwise	<ol style="list-style-type: none"> <li>1. Defective output tube, V110</li> <li>2. Defective yoke coils, L252</li> <li>3. Defective output transformer, T251</li> </ol>

<b>DEFECTS OF THE VERTICAL DEFLECTION CIRCUIT</b>	
A. Poor vertical linearity, inadequate height, foldover at bottom	<ol style="list-style-type: none"> <li>1. Low emission of vertical output tube, V107</li> <li>2. Defective vertical output transformer, T201</li> <li>3. Low B+ from power supply</li> </ol>
B. Inadequate picture height	<ol style="list-style-type: none"> <li>1. Defective vertical tube, V107</li> <li>2. Low plate voltage on output tube, B+ boost low</li> <li>3. Change of value of R212</li> </ol>
C. No vertical deflection	<ol style="list-style-type: none"> <li>1. Defective vertical tube, V107</li> <li>2. Open vertical deflection coils, L201</li> <li>3. Open vertical output transformer, T201</li> </ol>
D. Vertical keystoneing	<ol style="list-style-type: none"> <li>1. Short in vertical deflection coils, L201</li> </ol>

**MISCELLANEOUS DEFECTS**

A. No raster, sound satisfactory	<ol style="list-style-type: none"> <li>1. Defective picture tube, V106</li> <li>2. No voltage on first anode of picture tube (B+ boost) pin 10</li> <li>3. No high voltage—V111. Check horizontal section</li> <li>4. High bias on cathode of picture tube</li> </ol>
B. Brightness control partially or completely inoperative	<ol style="list-style-type: none"> <li>1. Defective brightness control, R167 or associated components</li> <li>2. Leaky capacitor, C162</li> <li>3. Cathode to grid leak in picture tube, V106</li> </ol>
C. Intermittent streaks	<ol style="list-style-type: none"> <li>1. High voltage arcing or corona discharge</li> <li>2. Interference in video signal</li> </ol>
D. Herringbone or diagonal lines across picture	<ol style="list-style-type: none"> <li>1. FM disturbance or other i-f interference—may be eliminated with wave trap RLW-016</li> </ol>
E. Poor focus	<ol style="list-style-type: none"> <li>1. Focus potential on pin 6—jumper may be changed from pin 2 to 6 (ground potential) or pin 6 to 10 (B+ boost potential)</li> <li>2. Ion trap adjustment</li> </ol>
F. Low brilliance, sound satisfactory	<ol style="list-style-type: none"> <li>1. Low voltage at H.V. anode of picture tube, caused by defective rectifier, V111</li> <li>2. Improper adjustment of ion trap</li> <li>3. Defective brightness control circuit</li> <li>4. Low voltage at 1st anode of picture tube (pin 10)</li> <li>5. Defective picture tube</li> </ol>
G. Picture blooms	<ol style="list-style-type: none"> <li>1. Defective H.V. rectifier, V111</li> <li>2. Defective picture tube, V106</li> <li>3. Open or high value, R171</li> </ol>

GENERAL ELECTRIC "Q" Line, Models 14T016, 14T017, 14T018, 14T020, Continued

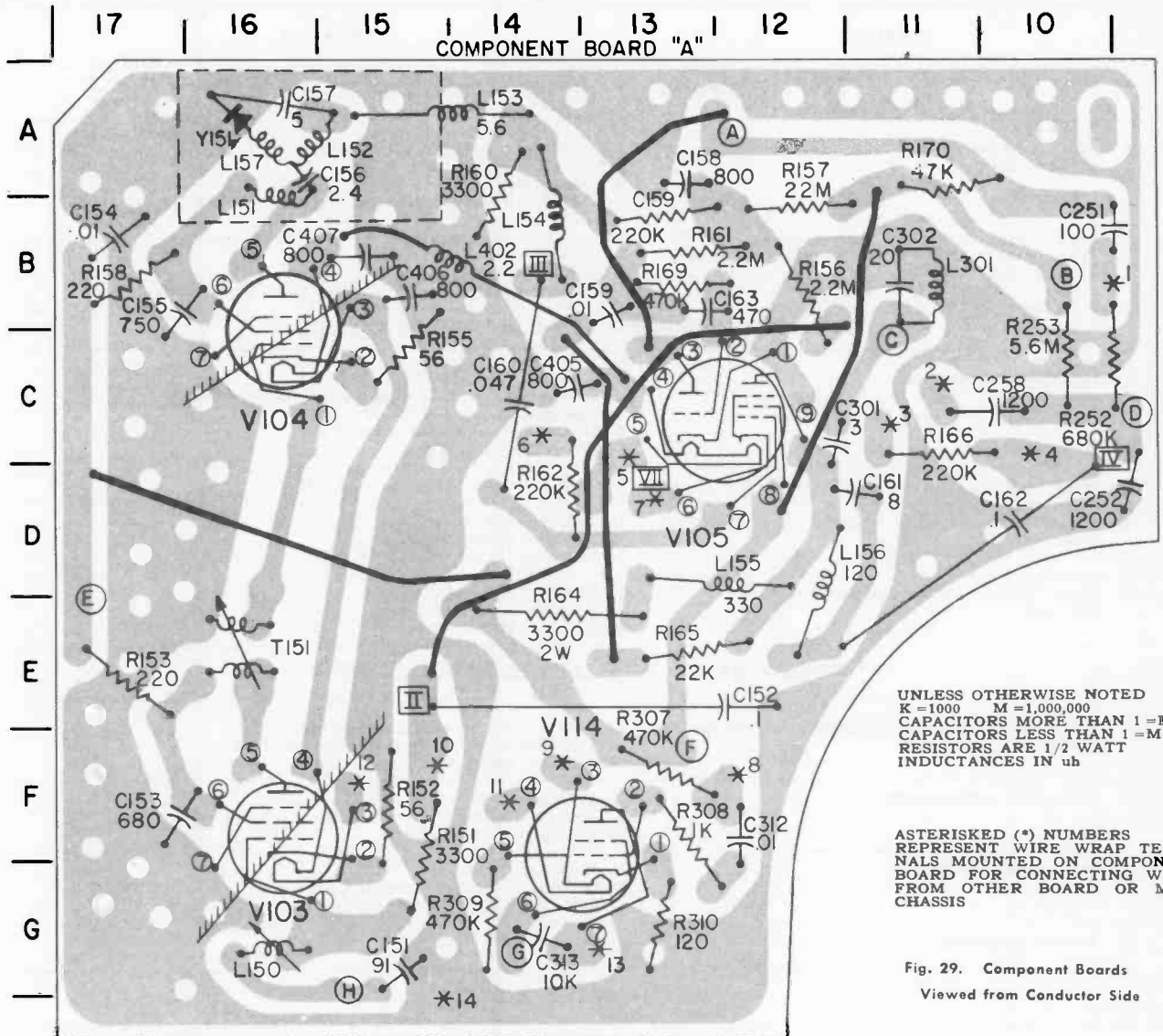

UNLESS OTHERWISE NOTED  
 K=1000 M=1,000,000  
 CAPACITORS MORE THAN 1=MMF  
 CAPACITORS LESS THAN 1=MF  
 RESISTORS ARE 1/2 WATT  
 INDUCTANCES IN  $\mu$ h

ASTERISKED (\*) NUMBERS  
 REPRESENT WIRE WRAP TERMINALS  
 MOUNTED ON COMPONENT  
 BOARD FOR CONNECTING WIRES  
 FROM OTHER BOARD OR MAIN  
 CHASSIS

Fig. 29. Component Boards  
 Viewed from Conductor Side

COMPONENT BOARD "A"

TEST POINTS

- II E15
- III B14
- IV D10
- V B5
- VII D13
- VIII C2
- IX C9
- X D8
- XI D4

CIRCLED (A) LETTERS

- A TO R203
- B TO R302
- C TO PIN 1 OF V108
- D TO C265, R254
- E TO R167 BRIGHTNESS
- F TO +135V
- G TO +120V
- H TO VHF TUNER-I-F OUT-PUT

ASTERISKED (\*) NUMBERS

- \* 1 FROM C265
- \* 2 FROM R266
- \* 3 FROM 167 BRIGHTNESS
- \* 4 FROM PIN 11 OF V106
- \* 5 FROM PIN 1 OF V106
- \* 6 FROM C262, R263, R264
- \* 7 FROM R163 CONTRAST
- \* 8 FROM PIN 9-V113
- \* 9 FROM PIN 9-V107
- \* 10 FROM VHF TUNER AGC
- \* 11 FROM PIN 7 OF V112
- \* 12 FROM PIN 5 OF V113
- \* 13 FROM T302
- \* 14 GND FOR I-F INPUT CABLE SHIELD

COMPONENT LOCATION BY CO-ORDINATES

A3-C207	A16-Y151	B14-L154	C12-C301	D12-L156	E17-R153
A3-R205	B1-L206	B14-L402	C13-V105	D13-L155	F3-R261
A3-R212	B2-C205	B15-C406	C14-C160	D14-R162	F5-R272
A4-C203	B2-R214	B15-C407	C14-C405	E1-C210	F12-C312
A4-C204	B3-R306	B16-L151	C15-R155	E1-R213	F13-R307
A5-R204	B4-C311	B17-C154	C16-V104	E1-R215	F13-R308
A5-C307	B5-C309	B17-R158	D2-C211	E2-C208	F15-R151
A5-C309	B6-T301	C2-V117	D2-R263	E3-C262	F15-R152
A6-R303	B7-C304	C3-R216	D3-C259	E3-R264	F16-V103
A6-C306	B8-V108	C3-R217	D3-C260	E4-R168	F17-C153
A7-R203	B9-R254	C5-V113	D3-R262	E4-R260	
A7-R302	B10-C251	C5-R304	D4-L251	E4-V109	G13-R310
A8-R301	B11-L301	C5-C315	D5-C256	E5-R269	G14-V114
A8-R303	B11-C302	C5-C404	D7-R271	E6-C254	G14-R309
A11-R170	B12-R156	C7-C308	D8-R251	E6-C267	G14-C313
A13-C158	B12-R157	C8-C265	D8-C253	E6-R270	G15-C151
A14-R160	B13-C159	C10-R252	D8-R255	E7-C266	G16-L150
A15-L153	B13-C163	C10-R253	D9-Y251	E13-C152	
A16-C156	B13-R159	C10-R253	D9-C252	E13-R165	
A16-C157	B13-R161	C10-C258	D11-C161	E14-R164	
A16-L152	B13-R169	C11-R166	D11-C162	E16-T151	
A16-L157					

GENERAL ELECTRIC "Q" Line, Models 14T016, 14T017, 14T018, 14T020, Continued

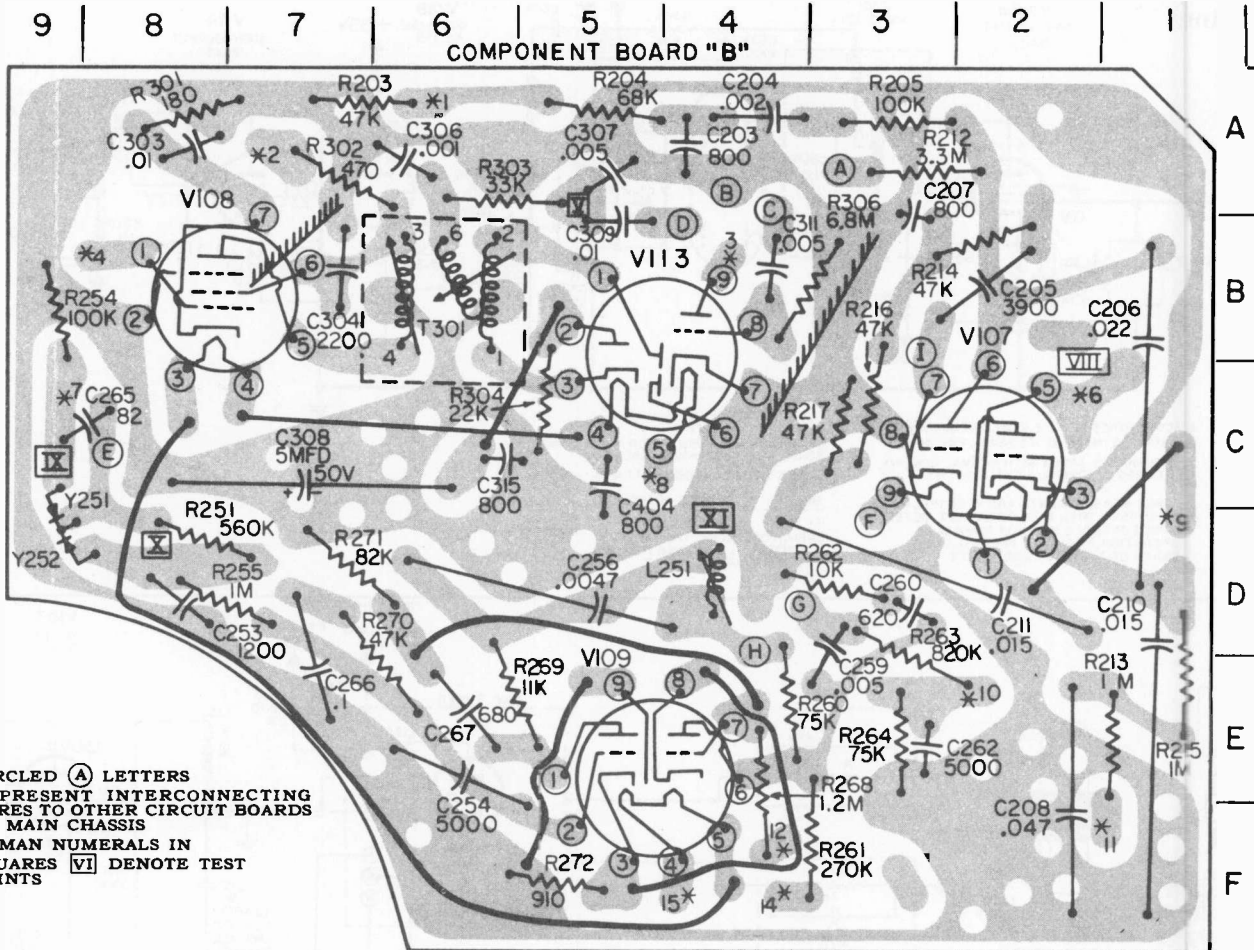

CIRCLED (A) LETTERS REPRESENT INTERCONNECTING WIRES TO OTHER CIRCUIT BOARDS OR MAIN CHASSIS  
 ROMAN NUMERALS IN SQUARES [VI] DENOTE TEST POINTS

COMPONENT BOARD "B"

CIRCLED (A) LETTERS

- A—TO R211—VERT. LIN. CONT.
- B—GND.—AUDIO CABLE SHIELD
- C—FROM R305—VOL. CONT.
- D—TO R305—VOL. CONT.
- E—TO C251, R252
- F—TO PIN 3 V114
- G—TO R265
- H—TO +135V
- I—TO R207 VERT. HOLD CONTROL

ASTERISKED (\*) NUMBERS

- \* 1—FROM C251, R170 and PIN 3 of V105
- \* 2—FROM R253
- \* 3—FROM C312, R307
- \* 4—FROM C302, L301
- \* 6—FROM PIN 12 OF V106
- \* 7—FROM R252, R253
- \* 8—FROM PIN 3 OF V103
- \* 9—FROM T201—BLUE
- \*10—FROM R162
- \*11—FROM R209 HEIGHT CON. TROL
- \*12—FROM R267 HORIZ. HOLD
- \*14—FROM B+ BOOST
- \*15—FROM R+F TUNER—FIL. TERM.

TEST POINTS

- II E15
- III B14
- IV D10
- V B5
- VII D13
- VIII C2
- IX C9
- X D8
- XI D4

COMPONENT LOCATION

BY SYMBOL

CAPACITORS

- C151—G15
- C152—E13
- C153—F17
- C154—B17
- C155—B17
- C156—A16
- C157—A16
- C158—A13
- C159—B13
- C160—C14
- C161—D11
- C162—D11
- C163—B13
- C203—A4
- C204—A4
- C205—B2
- C206—B1
- C207—A3
- C208—E2
- C210—E1
- C211—D2
- C251—B10
- C252—D9
- C253—D8
- C254—E6
- C256—D5
- C258—C10
- C259—D3
- C260—D3
- C262—E3
- C265—C8
- C266—E7
- C267—E6
- C301—C12
- C302—B11
- C303—A8
- C304—B7
- C306—A6
- C307—A5
- C308—C7
- C309—B5
- C311—B4
- C312—F12
- C313—G14
- C315—C5

RESISTORS

- R151—F15
- R152—F15
- R153—E17
- R155—C15
- R156—B12
- R157—B12
- R158—B17
- R159—B13
- R160—A14
- R161—B13
- R162—D14
- R164—E14
- R165—E13
- R166—C11
- R169—B13
- R170—A11
- R203—A7
- R204—A5
- R205—A3
- R212—A3
- R213—E1
- R214—B2
- R215—E1
- R216—C3
- R217—C3
- R251—C8
- R252—C10
- R253—C10
- R254—B9
- R255—D8
- R260—E4
- R261—F3
- R262—D3
- R263—D2
- R264—E3
- R268—E4
- R269—E5
- R270—E6
- R271—D7
- R272—F5
- R301—A8
- R302—A7
- R303—A6
- R304—C5
- R306—B3
- R307—F13
- R308—F13
- R309—G14
- R310—G13

TRANSFORMERS AND COILS

- T151—E16
- T301—B6
- L150—G16
- L151—B16
- L152—A16
- L153—A15
- L154—B14
- L155—D13

TUBES

- V103—F16
- V104—C16
- V105—C13
- V108—B8
- V109—E4
- V113—C5
- V114—G14
- V117—C2

MISCELLANEOUS

- Y151—A16
- Y251—D9



GENERAL ELECTRIC

"Q" Line

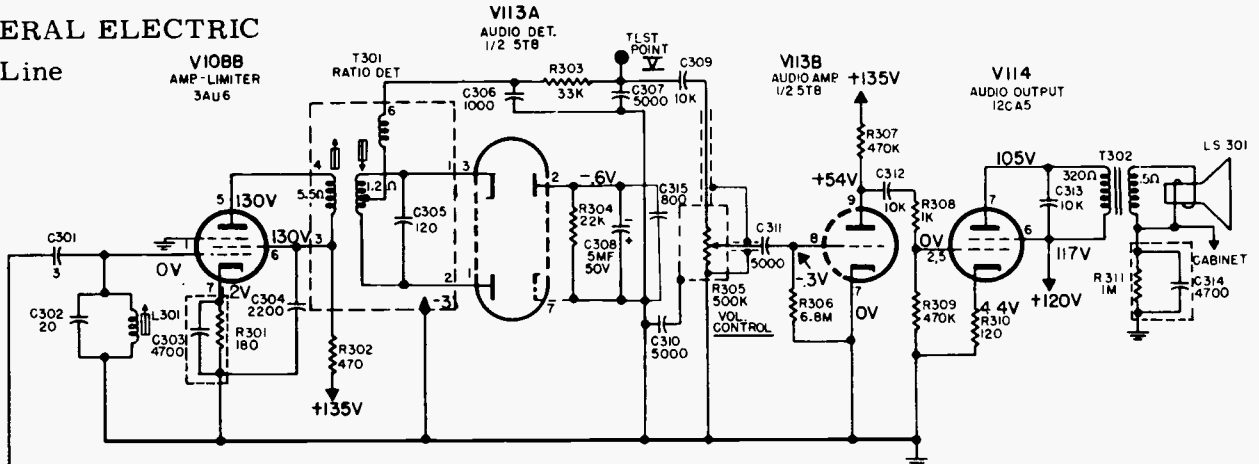

\* SCOPE SYNCED AT 1/2 VERT. FREQUENCY.  
 \*\* SCOPE SYNCED AT 1/2 HORIZ. FREQUENCY.  
 WAVE SHAPES TAKEN WITH NORMAL CONTROL SETTINGS & NORMAL SIGNAL APPLIED.

VOLTAGE MEASUREMENTS ARE IN RESPECT TO CHASSIS WITH A 20,000 VOLT METER, WITH CONTROLS SET FOR NORMAL OPERATION, NO SIGNAL APPLIED, USING 5AXP4 CR TUBE FOR CONTINUITY.

▲ MEASURED WITH VTVM. ENCIRCLED LETTERS REFER TO TERMINAL BOARDS OF TEST POINT DIAGRAM.  
 • VARIES WITH CONTROL SETTINGS.

UNLESS OTHERWISE NOTED  
 K = 1000 M = 1,000,000  
 CAPACITORS MORE THAN 1 MF  
 CAPACITORS LESS THAN 1 MF  
 RESISTORS ARE 1/2 WATT

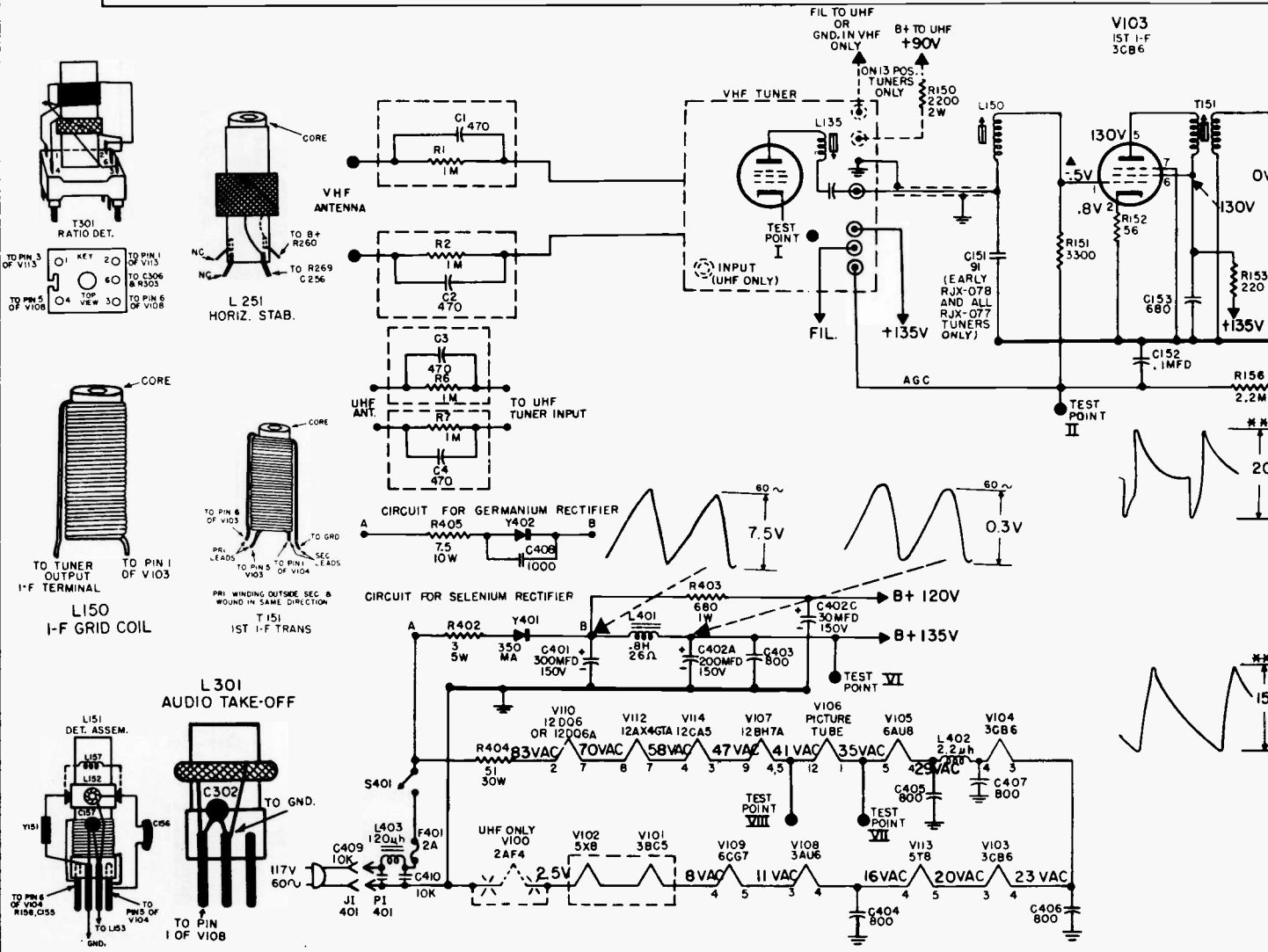

Fig. 30. Component Wiring

GENERAL ELECTRIC

"Q" Line  
Schematic

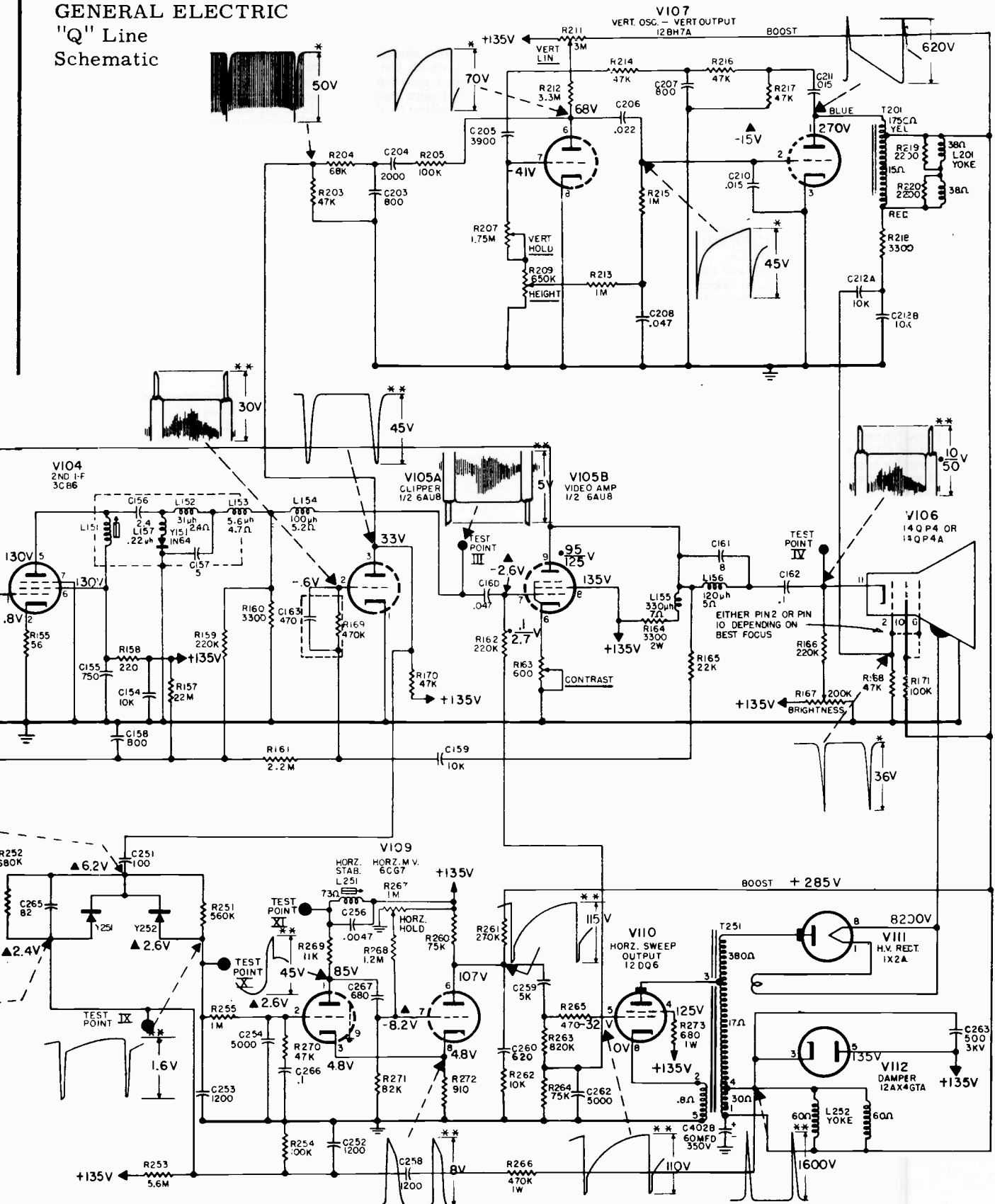
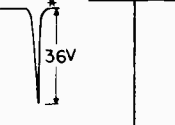
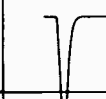

Fig. 39. Main Chassis Schematic with Voltages and Wave Shapes

GENERAL ELECTRIC "Q" Line, Models 14T016, 14T017, 14T018, 14T020, Continued

**PRODUCTION CHANGES**

The following changes were made in the "Q" Chassis during production.

1. C155 was 680 mmfd. and was changed to 750 mmfd.
2. R264 was 82K and was changed to 75K.
3. C259 was .0047 paper and was changed to .005 ceramic.
4. C263 was 260 mmfd. and was changed to 500 mmfd.
5. C264 240 mmfd. which was connected in parallel with C263 was deleted.
6. C152 was .2 mfd. and was changed to .1 mfd.
7. R170 was 150K and was changed to 47K ohms.

The following Resistors and Capacitors may be found as either single components or Resistor-Capacitor combinations: R169 and C163, R301 and C303, R311 and C314, R1 and C1, R2 and C2, R6 and C3, R7 and C4.

The local-distant range switch and network was eliminated on late production sets. However, in extremely strong signal areas where an attenuator is needed, the switch and network is available, Part Number REM-010.

On some receivers a 2 mmfd. capacitor catalog number RCW-003 was placed across the antenna input terminals to increase gain on the high VHF channels.

An alternate germanium power rectifier was used during production and is shown on the main schematic, pages 32 and 33.

The dual selenium horizontal phase detector diode was replaced by two separate germanium diodes which are direct replacements.

Those chassis which used Tuners RJX-095 or RJX-096, a capacitor C116 was included in these tuners which eliminated the need for capacitor C151 on the main chassis board. Capacitor C151 was, therefore, clipped in half but the leads were left in the board.

Late production receivers using late production tuner RJX-078 had a capacitor C121 included in the tuner which eliminated the need for capacitor C151 on the main chassis board, therefore, C151 was clipped in half, but the leads were left in the board.

A line radiation filter network was added to late production receivers to conform with F.C.C. requirements and consists of L403, C409, and C410. This filter network is shown on the main chassis schematic, pages 32 and 33.

During production, one lead of the 2-amp line fuse was removed from the dip soldered terminal board and connected to the "ON-OFF" switch. The tube location chart found on the inside of the

cabinet back shows only the fuse connection on early production sets. To check the fuse in late production sets with the back removed, a continuity check can be made from the top terminal of the 51-ohm resistor through the "ON-OFF" switch in the "ON" position to the high side of the interlock socket.

Those chassis stamped "21Q" on the upper right-hand corner have the later production vertical circuit. The early production vertical circuit is shown below and the following changes were made as may be seen by comparing the circuit with the latest circuit shown on the main schematic.

- R203 was 15K and was changed to 47K.
- R213 was 470K and was changed to 1 megohm.
- C202 was .15 mfd. and has been deleted.
- R210 was 180K and has been deleted.
- R208 was 470K and has been deleted.
- R206 was 220K. It was changed to 100K and later deleted.
- R209 was a 2-megohm separate control. It was changed to a 650K-ohm control with a stop at 150K and is combined with the vertical linearity control.

R170, the plate resistor of the clipper, V105A, was changed from 150K to 47K because of this vertical change.

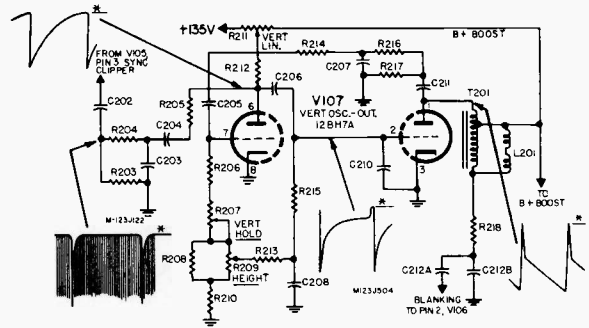

Early Production Vertical Circuit

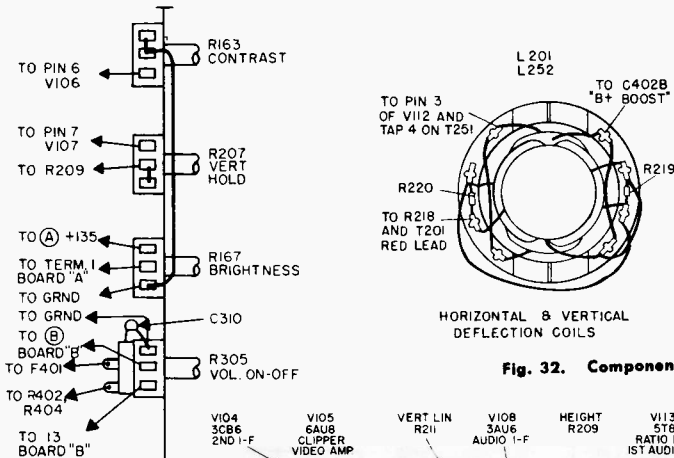

Fig. 32. Component Wiring

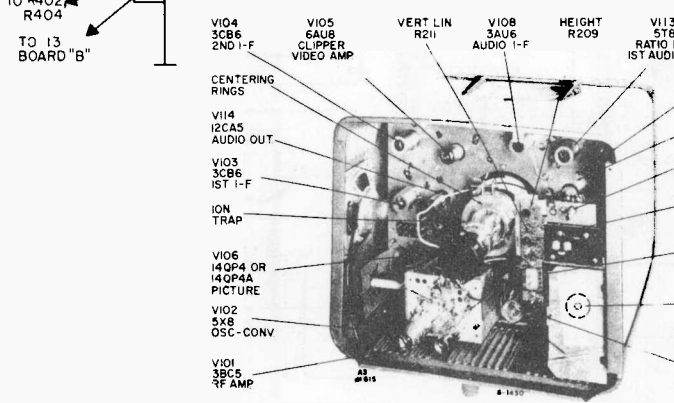
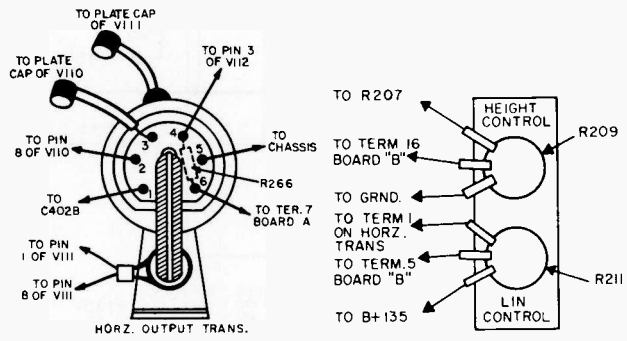
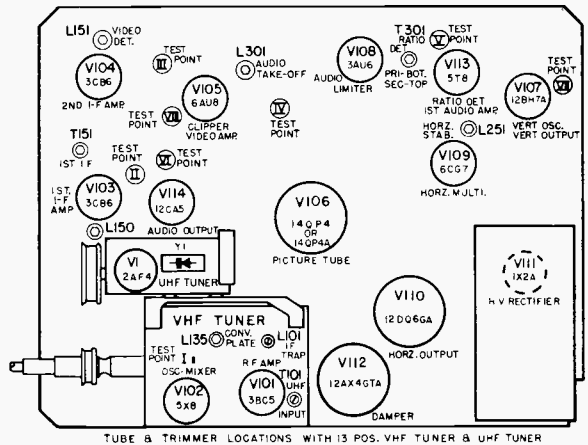

Fig. 34. Tube and Trimmer Location



TUBE & TRIMMER LOCATIONS WITH 13 POS. VHF TUNER & UHF TUNER

# GENERAL ELECTRIC

"U2" Line Receivers, used in Models 21C1548, 21C1549, 21C1550, 21C1551, 21C1552, 21C1553, 21C1554, 21C1555, 21C1556, 21T1540, 21T1541, 21T1542, 21T1543, 21T1544, 21C1562, 24C1660, 24C1661, 24C1670, 24C1671, and UHF.

This material includes the latest revised schematic used in U2 line, information on power tuning unit, and other service material. For additional service material and earlier schematic, see pages 85 through 92, in Volume TV-13, ADDITIONAL 1957 Television Servicing Information manual.

## SERVICING THE PUSH BUTTON POWER SELECTOR AND TUNING UNIT

Should there arise a necessity to disassemble the push button selector assembly, this step by step process should be followed. This procedure is set forth here with added notes pertaining to particular points to observe.

It is first necessary to remove the chassis and tube assembly from the cabinet as is required for normal service. The front escutcheon, Item Number 22 on the cutaway view, would be removed from the assembly in order to slide the chassis out of the cabinet either by pulling the ring from the front much the same as removing a large knob or by the pressure of the front knob escutcheon against the ring when pulling the chassis from the cabinet.

The power selector is then fully exposed for service. The whole assembly is secured to the main chassis by three self-tapping screws located on the frame, Item 19. To remove the assembly, disengage the fine tuning plate, Item 13, from the tuner fine tuning cam. Remove the three screws from the frame, Item 19, and pull the assembly forward from the tuner. The selector unit is coupled to the tuner much the same as a knob, with a keyed slot and compression ring, Item 27. The tuner is not secured at the front to the main chassis when the power selector is used but is allowed to "float" in order to provide flexibility in the coupling.

Where service to components of the power selector assembly only is required, it is advised not to remove the assembly from the main chassis. One, the wiring need not be disconnected; two, power is available in case operation of the unit is desired; three, the chassis becomes a solid mounting for the assembly making it easier to work on.

The nylon shoe, 18, at the top center to which the contact spring is riveted, is secured with two 1/4 inch hex head screws, 26. This shoe acts as the contact release on the push button contact springs, 6. The position of this shoe determines the time at which the contact is released and the pressure exerted on the selector spring to release it. Correct alignment may be made by loosening the holding screws, 26, and moving the shoe assembly to the desired position. The frame is knurled to securely hold the shoe when locked in place by the 2 screws.

At the front of the center drive shaft, Item 16, is the retaining screw, Item 1, which is removed with a 1/4 inch open end hex wrench. The removal of this screw allows the number disk, 3, to be removed as well as the support ring, Item 2. The support ring is keyed to the center shaft.

The retainer cup, 5, secures the spring contacts to the collector ring assembly, 7, and the center shaft, 16. This cup is forced over the spring contacts and has small splines which grip the center shaft. Pry the cup from the shaft to free the 13 selector spring contacts, 6. The collector ring assembly, 7, will also be free to be removed from the center shaft, 16. Behind this collector ring assembly lies the fine tuning screw support disk, 8. Each of the 12 VHF channels has a fine tuning screw, 9. The UHF position is marked by the absence of a screw and has a fixed locator pin. To maintain tension on the fine tuning screws, a wire spring is woven around the outside of the screws and is held in place by legs on the support disk.

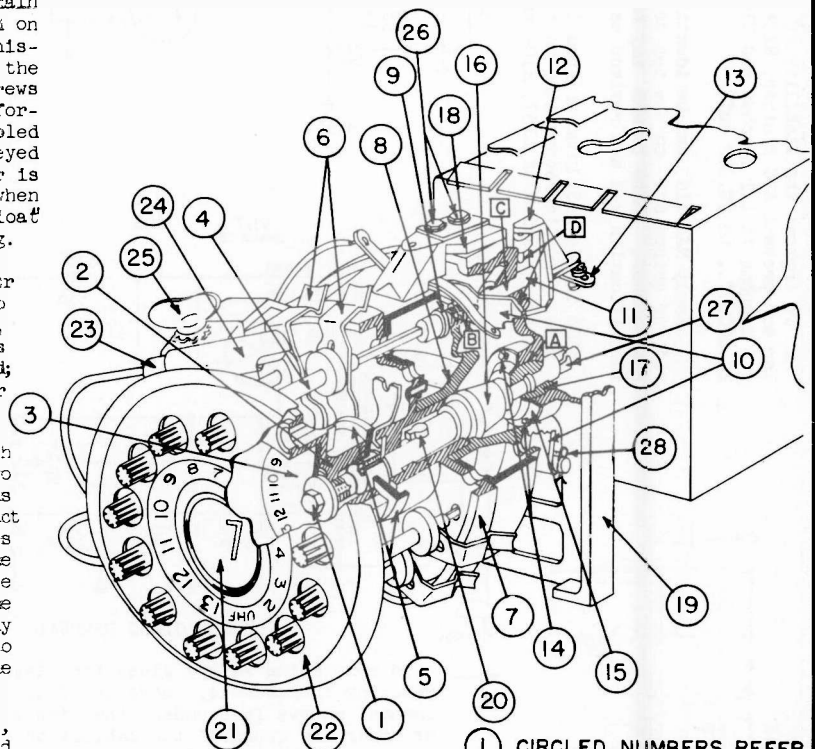

POWER SELECTOR ASSEMBLY CUTAWAY

① CIRCLED NUMBERS REFER TO ASSEMBLY CAT. NO'S.

ⓐ BOXED LETTERS REFER TO GREASING LOCATIONS

GENERAL ELECTRIC "U2" Line

In using the RUX-022 with early UHF tuners a 22 ohm resistor is connected from the +275V feed thru to the UHF B+ input feed thru (C112 to C110), R194 the 9500 ohm 7 watt dropping resistor is then connected between the UHF B+ output C111 to the B+ input point on the UHF tuner. With late version UHF tuners R194 is connected between C112 and C110 and a lead connects directly from C111 (B+ output) to the UHF B+ input point. No 22 ohm resistor is used with late version tuners.

To improve the stability of the noise canceler and prevent AGC flutter, R204 was changed from 1.5 megohms to 1.2 megohms and C169 changed from 10,000uuf., to 20,000 uuf.

Early RJX-110 can be identified by a brown, red, or orange dot on the top deck at the right rear corner. Late tuners may have other colors identification and are revised as follows:

R106 is changed in value from 1000 ohms to 470 ohms. R105 is reconnected to the +275V input at the junction of L137, R104 and C112.

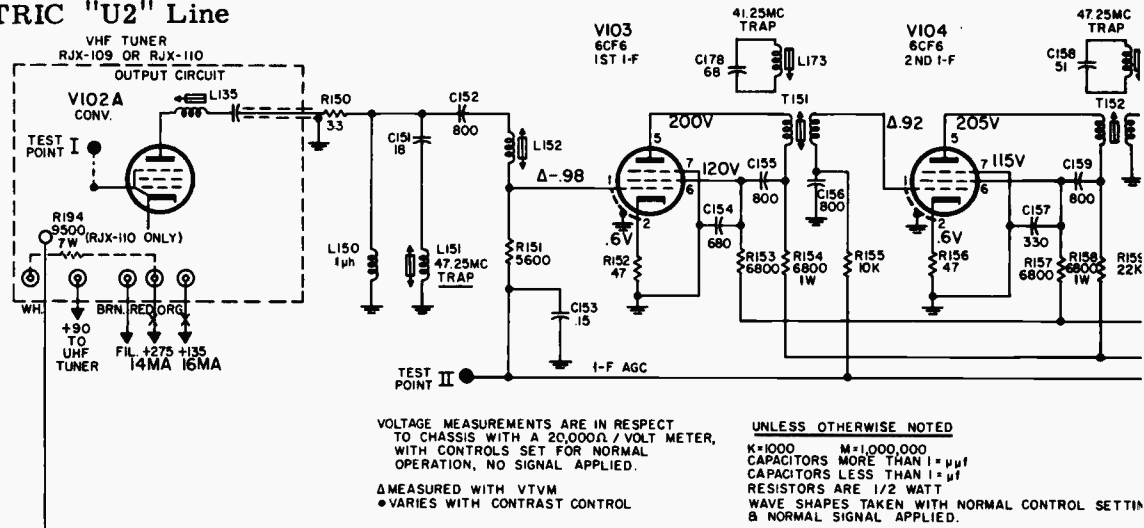

VOLTAGE MEASUREMENTS ARE IN RESPECT TO CHASSIS WITH A 20,000Ω / VOLT METER, WITH CONTROLS SET FOR NORMAL OPERATION, NO SIGNAL APPLIED.  
 Δ MEASURED WITH VTVM  
 • VARIES WITH CONTRAST CONTROL

UNLESS OTHERWISE NOTED  
 K=1000 M=1,000,000  
 CAPACITORS MORE THAN 1-μuf  
 CAPACITORS LESS THAN 1-μuf  
 RESISTORS ARE 1/2 WATT  
 WAVE SHAPES TAKEN WITH NORMAL CONTROL SETTING & NORMAL SIGNAL APPLIED.

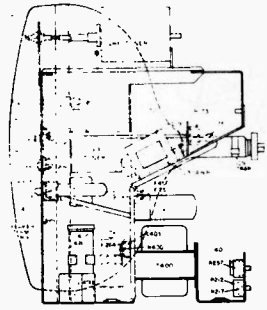
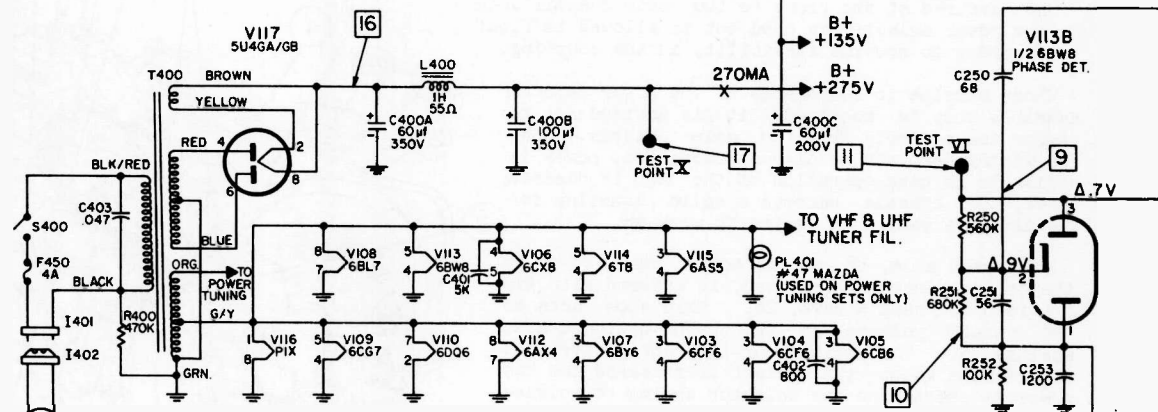
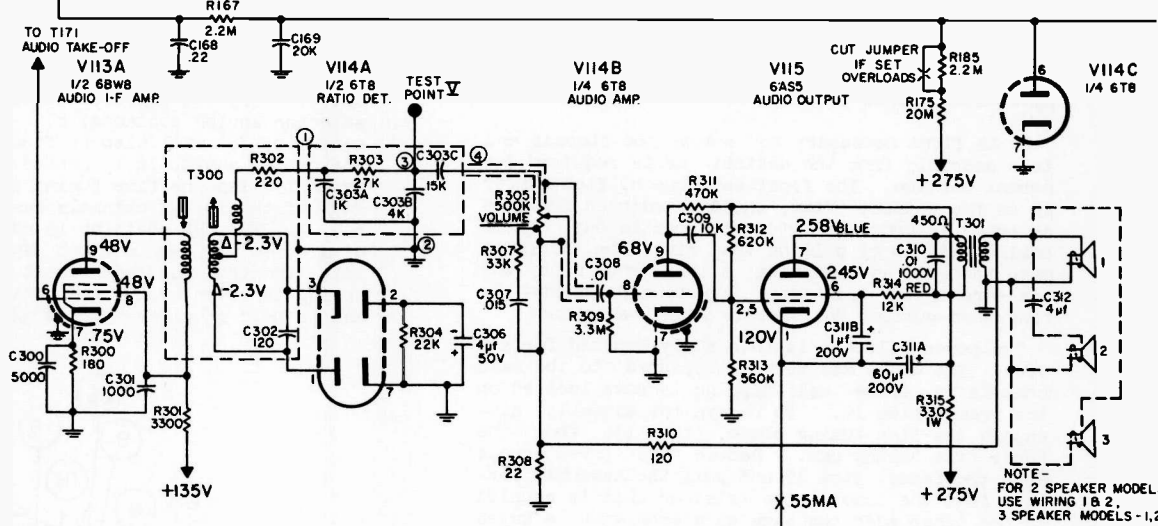

SIDE VIEW OF CHASSIS ASSEMBLY

SAFETY GLASS REMOVAL

To remove the safety glass for cleaning without removing the chassis, move the four bottom glass channel screws from under the front cabinet rail or under the front of the cabinet on table models. Slide the bottom glass channel out. Pull the safety window out at the bottom and drop away from the upper channel. For safety reasons, the mask is not removable from the front. Replace the glass in reverse order of disassembly.

GENERAL ELECTRIC "U2" Line

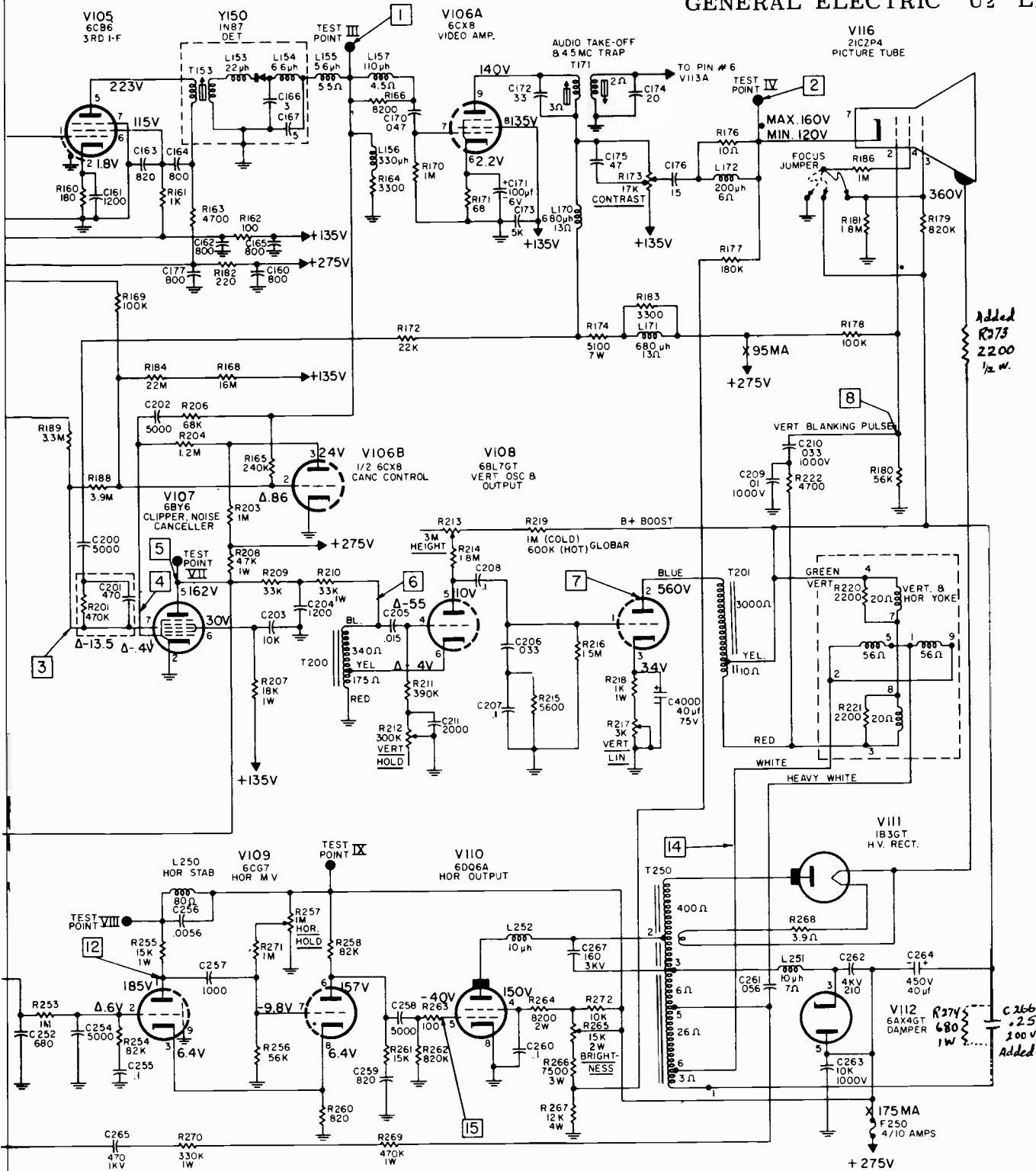

Revised schematic of "U2" Line Receivers. Numbers in squares refer to waveshapes shown on pages 87 and 88 in Volume TV-13, ADDITIONAL 1957 Television Servicing Information manual.

GENERAL ELECTRIC "U2" Line Receivers, Continued

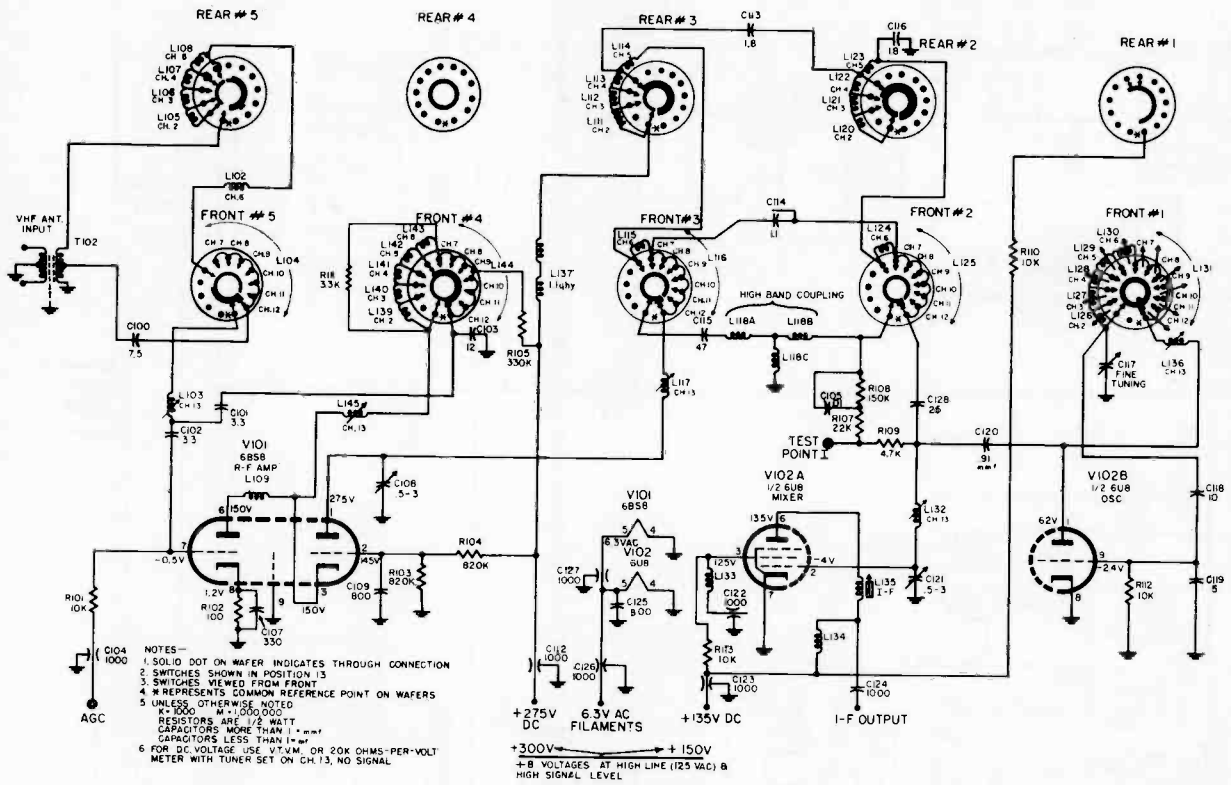

RJX-109 VHF TUNER SCHEMATIC

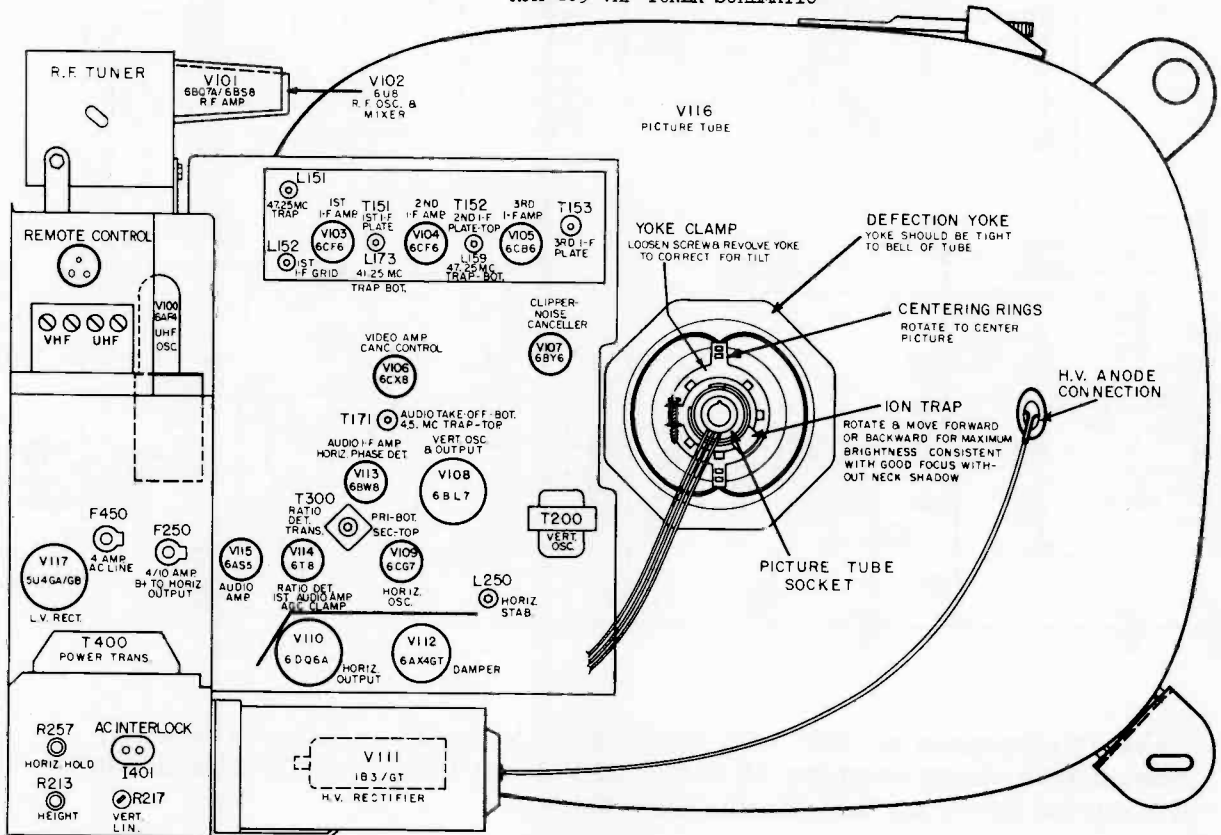



# GENERAL ELECTRIC

## "U" LINE TELEVISION RECEIVERS

UHF MODEL NUMBERS BEAR SUFFIX "UHF"

General Electric "U" Line receivers are used in models listed at right. This service material is presented on pages 45 through 52. The Hotpoint Co. "U" Line receivers, used in models listed below, are identical to sets covered by this material.

# Hotpoint Co.

MODELS	
With or without UHF	
21C137	
21C138	
21C143	
21C159	
21C160	
21C161	
21C162	
21C172	
21T050	
21T054	
21T055	
21T056	
21T057	
21T060	
21T061	
24C182	
24C183	

"U" Line Receivers, Models 21S401, 21S402, 21S403, 21S451, 21S452, 21S501, 21S502, 21S552, 21S553, 21S554, 24S801, 24S802.

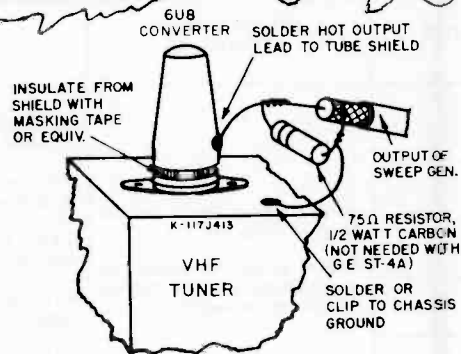
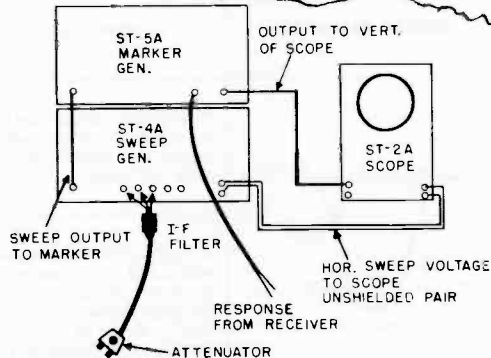
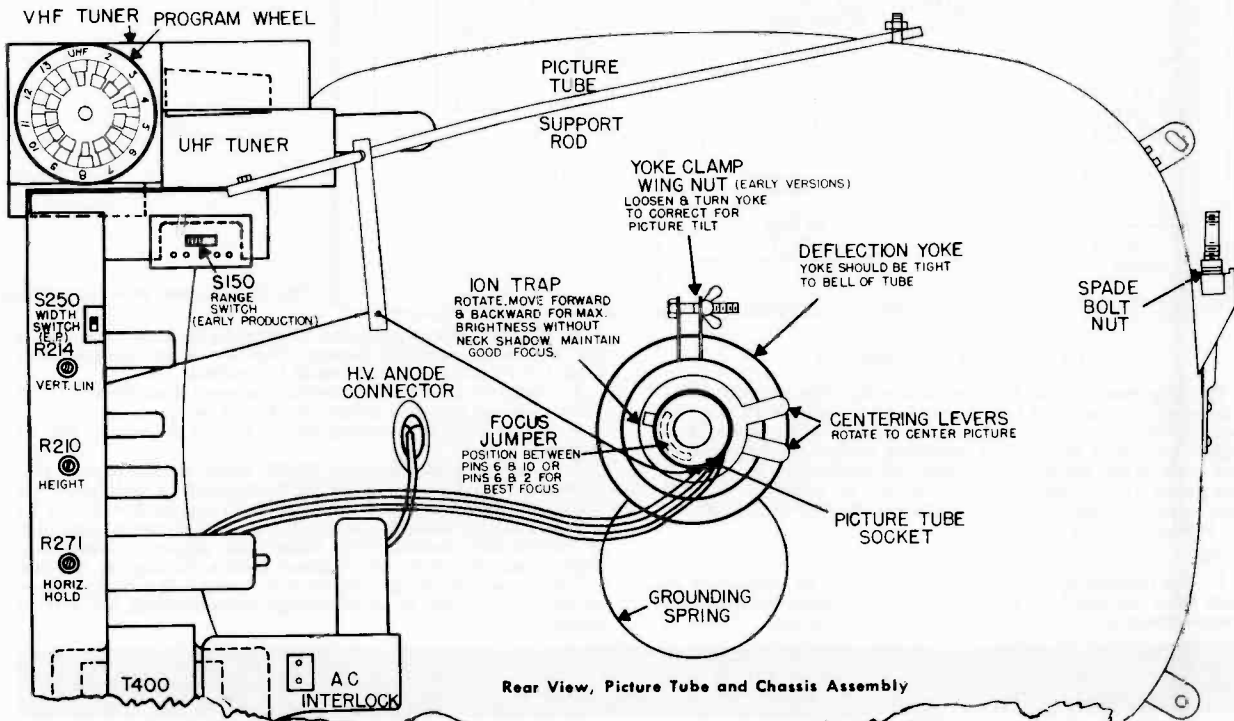

GE "U" Line

RECEIVER ALIGNMENT

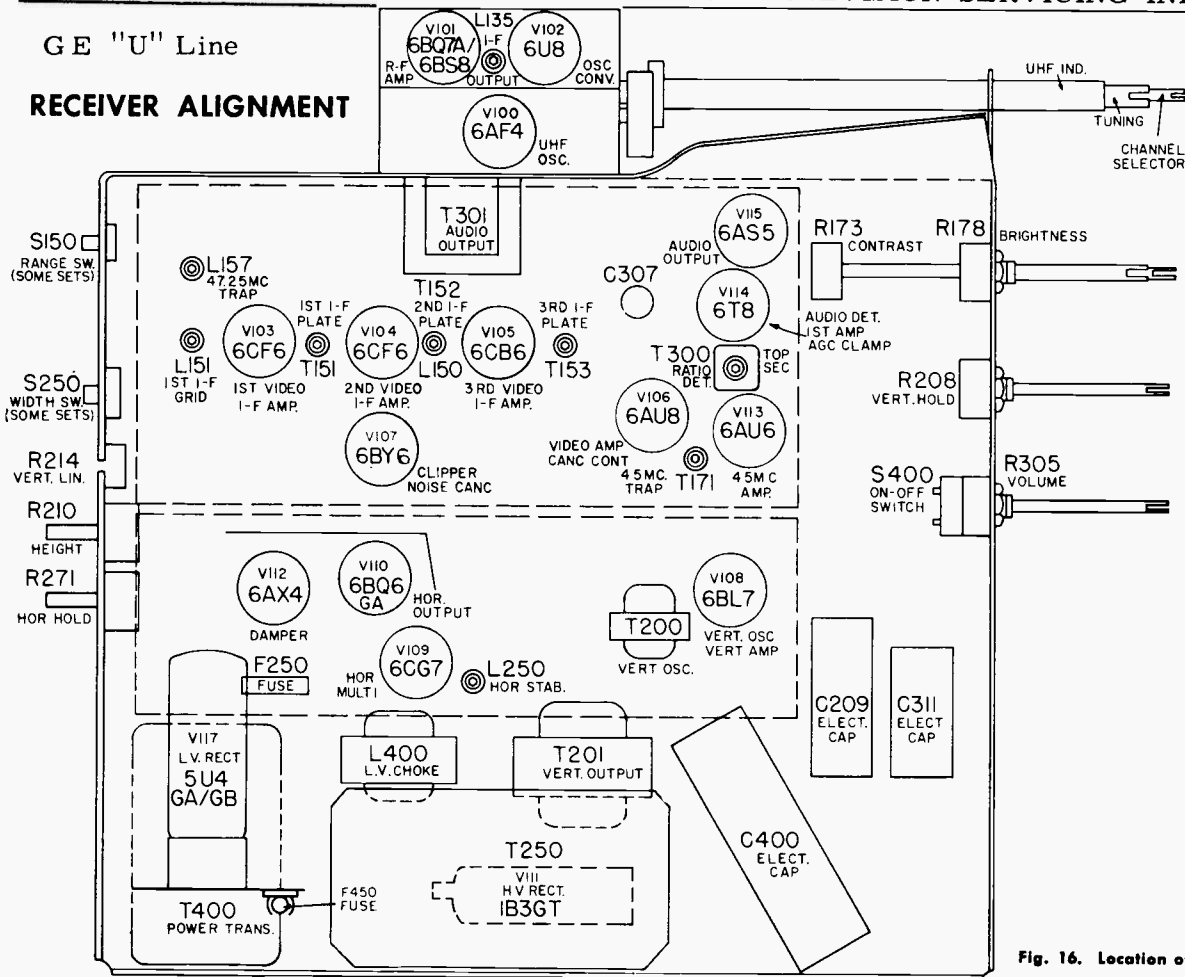

Fig. 16. Location of Tubes and Trimmers

I-F SYSTEM ALIGNMENT

The alignment of the I-F system involves the adjustment of 3 traps and 5 pass-band tank circuits. Allow at least 15 minutes warm-up for the receiver and test equipment before proceeding. Follow the usual precautions regarding equipment termination and cable dress. Some tuning cores will apparently go through two peaks. In all cases, the cores should be tuned to the first peak starting from the "out" position. Adjustment locations are indicated in Fig. 16.

NOTES:

1. Set channel selector and volume control to channel 11 or some other unused high channel. Turn fine tuning control fully counterclockwise. Set contrast control fully clockwise.

2. Connect sweep generator to capacity type jig as shown in the alignment chart. If General Electric sweep equipment is used, the indicated resistor should be omitted.

3. Connect a 3-volt bias battery between Test Point II and chassis ground (positive battery lead to chassis).

4. Place -45v bias voltage on pin 5 of V110 (positive side to ground).

5. Connect scope through 10,000 ohms to Test Point III. Calibrate vertical gain of scope for 5 volts peak to peak for 2-inch deflection. When aligning, base-line to 45 mc marker should be kept at 2 inches. Refer to pre-peaking chart if alignment difficulty is experienced. Immediately below the alignment chart are shown stage I-F response curves starting at the last I-F stage and working progressively toward the tuner. These curves may be used to an advantage when checking I-F system difficulties.

VIDEO I-F ALIGNMENT CHART

STEP	CONNECT SWEEP GENERATOR	ADJUST	DESIRED RESPONSE	REMARKS
1	Using sweep input jig as shown in Fig. 15.  Center sweep frequency to approximately 44 mc. Sweep width approximately 10 mc.	L150 & L157 for minimum at 47.25 mc.		<p>"Blow-up" scope pattern to see trap. After setting traps, set scope gain per note #5 above.</p> <p>Adjust L135 simultaneously with L151. 41.25 mc marker is very critical and should be kept between limits of ±5%. Peak of curve may fall between limits of 110% and 130% using 45 mc as the 100% reference.</p>
2		T151 to set 42.5 mc marker at 40-55%.		
3		T152 to set 45.75 mc marker at 40%.		
4		L135 to set width of peak region of curve.		
5		L151 & T153 for peak region symmetry.		

GENERAL ELECTRIC "U" Line Receivers, Alignment Continued

**PRE-PEAKING:** Should difficulty be experienced in obtaining the proper video I-F response curve, the tuning and gain of the individual stages may be checked.

If each coil is peaked at the indicated frequency in the chart at the right using an AM signal, an over-all i-f response curve which closely approximates the proper curve will be achieved. After this is done, the over-all sweep method should be used to permit proper final shaping of the curve. This peaking may be done by using an AM signal or the sweep method may be used by adjusting the coils for maximum amplitude at the desired marker points.

Since it may be possible to obtain two peaks through the coil adjustment range, make certain the coil is aligned for the first peak (slug starting from "out" position), except for L150.

As a further aid to response trouble shooting, the i-f system curves obtained by progressively inserting the sweep signal

stage by stage starting from the last i-f grid are indicated. When observing these responses, use the same equipment and bias battery connections as for the sweep alignment procedure above, except for the sweep generator output cable. Remember to reduce the sweep signal amplitude while progressing toward the 1st i-f stage.

**A-M PRE-PEAKING FREQUENCIES**

L135	44.5 mc
L150 TRAP	47.25 mc
L151	To set 42.5 at maximum from base line
T151	42.5 mc
T152	45.75 mc
T153	44.15 mc

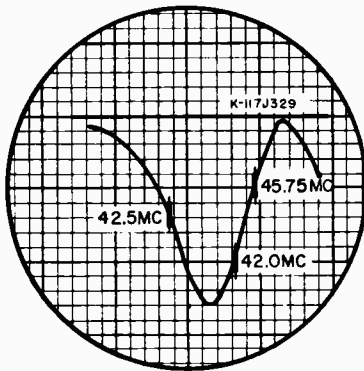

T153, T152, T151 Response  
(Sweep at grid of V103 through .001 MF)

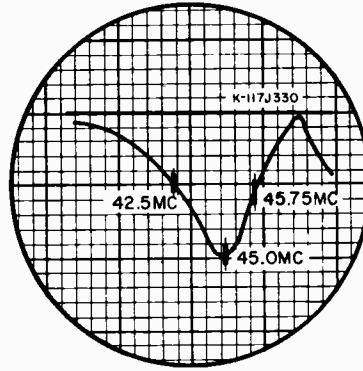

T153 & T152 Response  
(Sweep at grid of V104 through .001 MF)

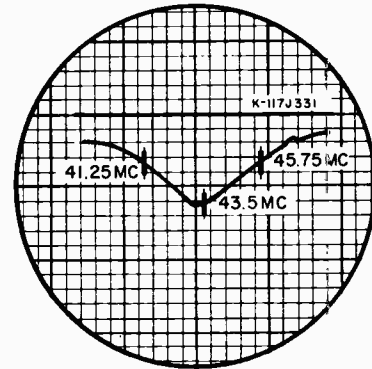

T153 Response  
(Sweep at grid of V105 through .001 MF)

Fig. 17. Progressive Alignment Curves

**AUDIO I-F ALIGNMENT**

1. Tune in a weak television signal. This will provide a 4.5 mc signal source for audio i-f alignment. Keep the volume control turned down unless the speaker is connected.
2. Connect two 100,000-ohm resistors (in series) between pin #2 of V114 (6T8) and chassis. These resistors should be chosen as accurately as possible for equal resistance.

**AUDIO ALIGNMENT CHART**

STEP	CONNECT VTVM OR 20,000 OHMS/VOLTMETER	ADJUST	METER INDICATION	REMARKS
1	Between Pin #2 of V114A and chassis.	T171 secondary (bottom)	Adjust for maximum deflection.	Repeat steps 1, 2, and 3 to assure proper alignment.
2		T300 primary (bottom)	Adjust for maximum deflection.	
3	Between Test Point V and the center of the two 100,000-ohm resistors.	T300 secondary (top)	Adjust for zero volts d-c output.	

**4.5 MC TRAP ALIGNMENT**

1. Turn contrast control fully clockwise.
2. Connect detector network (Fig. 18) to Test Point IV and set contrast to maximum. Connect oscilloscope to network.
3. Apply a 4.5 mc AM signal through .001 MF to Test Point III.
4. Tune the bottom core of T171 for minimum signal observed on oscilloscope.

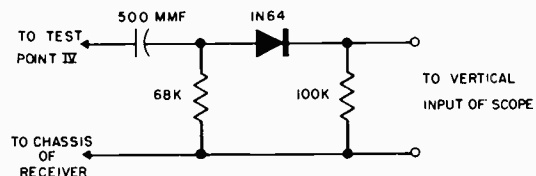
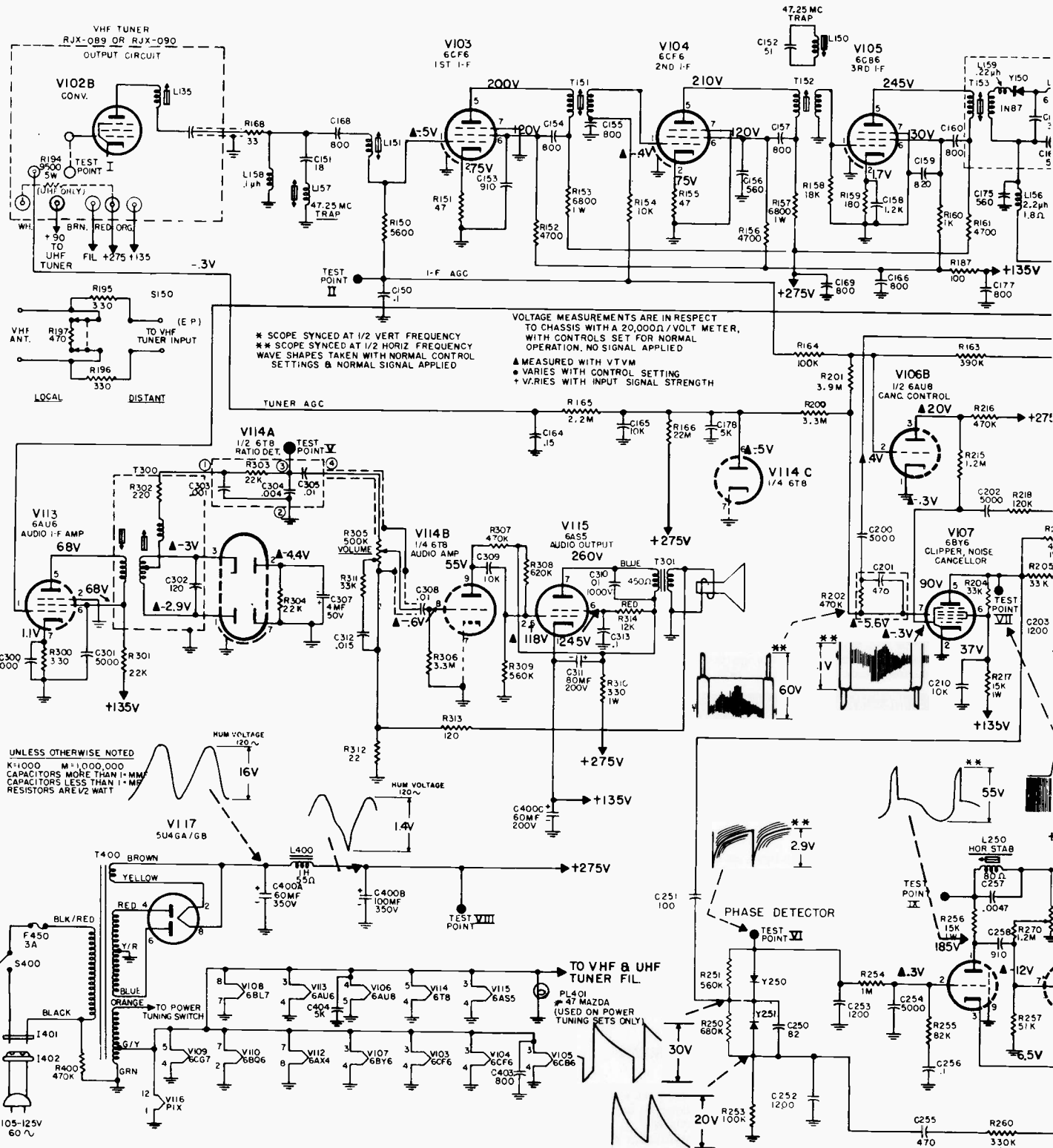

Fig. 18. Detector Network

GENERAL ELECTRIC "U" LINE Late Production Main Chassis Schematic



Main Chassis Schematic (Late Production) with Wave Shapes and Voltages

GENERAL ELECTRIC "U" Line Schematic Diagram and Production Changes

PRODUCTION CHANGES

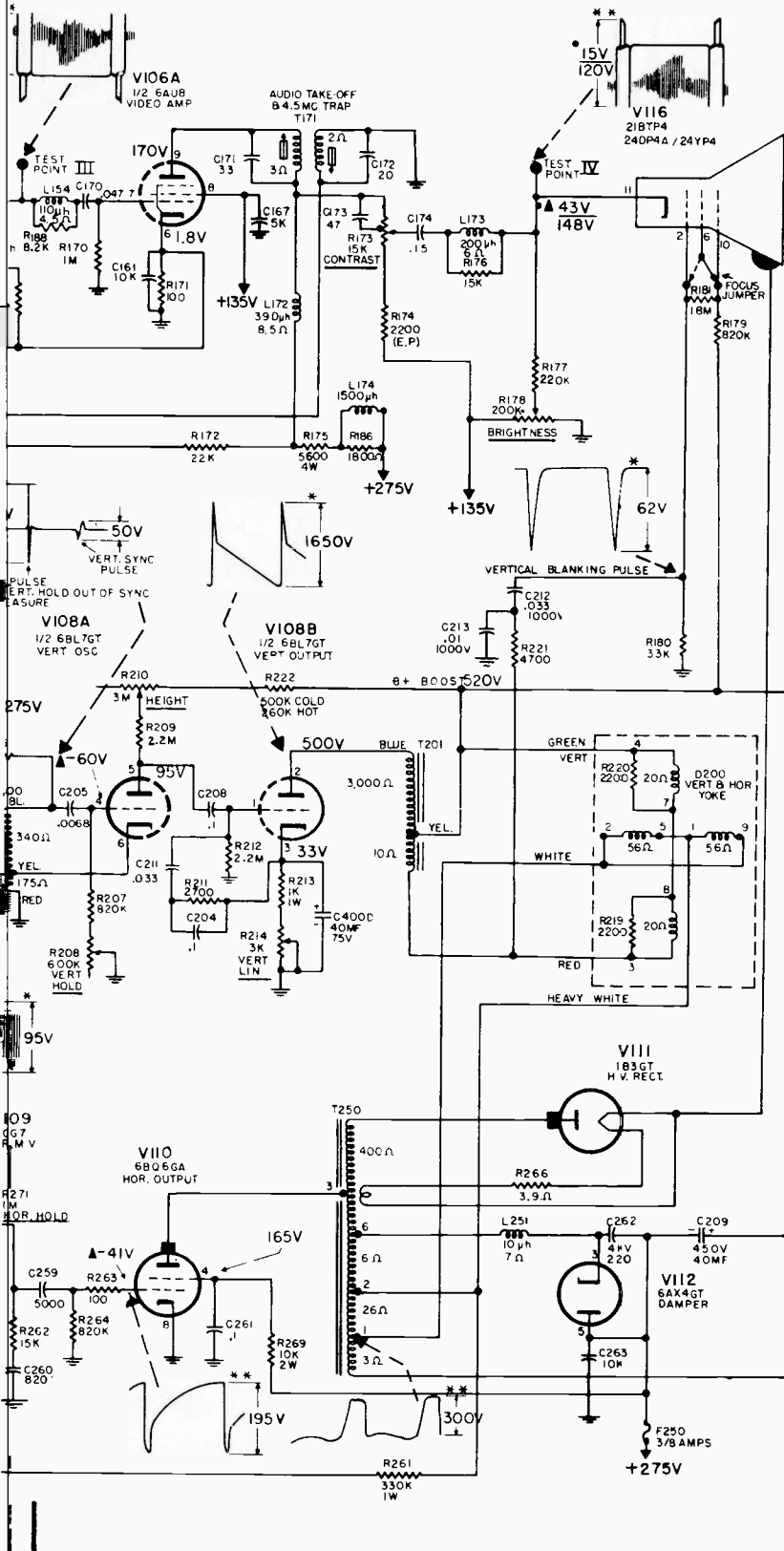

1. R-F Tuners

a. During production, two types of VHF tuners were employed. These types bear the same catalog number except for the use of a suffix "A." The two tuners differ only in the mechanical selector shaft. Therefore, either may be used, RJX-039 or RJX-089A for VHF-UHF combination tuners and the RJX-090 or RJX-090A for VHF only models.

b. The supply voltage to the R-F tuners was changed slightly during production. Early chassis employed a dropping resistor between the +275 volt supply and the high B+ input to the tuner. This resistor dropped the voltage to approximately +265 volts. In later chassis this resistor (R401) was removed and the +275 volts was supplied directly to the tuner.

2. Audio Output—Low Voltage Section

The bleeder resistor R402 was removed very early in production as the voltage divider formed by the audio output tube was found to be of sufficient regulation.

3. Width Control

The Width Switch S250 was removed in early production and a nominal size horizontal raster was established making adjustment unnecessary.

4. R-F Attenuator

The Antenna Attenuator Circuit and Switch was removed during late production. If, in your area, the set has a tendency to overload or attenuation is necessary to prevent cross modulation, an attenuator accessory kit is available. This kit bears the Catalog No. REM-010.

5. Phase Detector

A great improvement in phase detector stability was found in the use of germanium diodes in place of the dual selenium phase detector. These diodes should be used whenever phase detector diode replacement is necessary. The diodes are furnished individually and bear the Catalog No. RED-006. Receivers containing this change will be stamped #74 or higher on the chassis.

6. Fusing

An AC line Fuse (F401, 3 amp Slo-Blo, Catalog No. REF-028) has been added to later production models in series with the AC switch and the power transformer.

7. Vertical Oscillator

In order to prevent changes in the vertical size during warm-up or variations in line voltage, a temperature compensating resistor (R222) was added between the B+ Boost supply and the height control. This change also necessitates a change in value of C211 from .036 mfd to .033 mfd. The bottom end of R210 (Height Control) is no longer connected to low B+ 135 volts. For differences see the main chassis schematics.

8. Picture Tubes

a. Three 21-inch versions of picture tubes have been used in production. These are in order from early to late 21ALP4A, 21ATP4A and the 21BTP4. These tubes differ only in their aquadag coating and the latest version will always replace an earlier type. If it were necessary to replace a 21BTP4 with either of the other types, the filter capacitor and resistor C264 and R268 must be installed in the chassis. These components are incorporated with chassis having the early type tubes.

b. Two versions of 24-inch tubes were used. They are the 24YP4 and the 24DP4/24YP4. Here the latest version should be used for replacement. In any case, the replacement of a picture tube may always be made with the same type as found in the receiver.

9. Cabinet Backs

On console models only, two types of cabinet backs were used during production. Early models employed a back with metal louvers at the top and only the lower fibre board section is available, Catalog No. HAB-005 for 21 in. and HAB-004 for 24 in. Late production models used a full fibre board back and is available as Catalog No. HAB-007 for 21-in. models and HAB-008 for 24-in. sets.

GENERAL ELECTRIC "U" Line Component Boards Service Data (Continued)

COMPONENT BOARD "A"

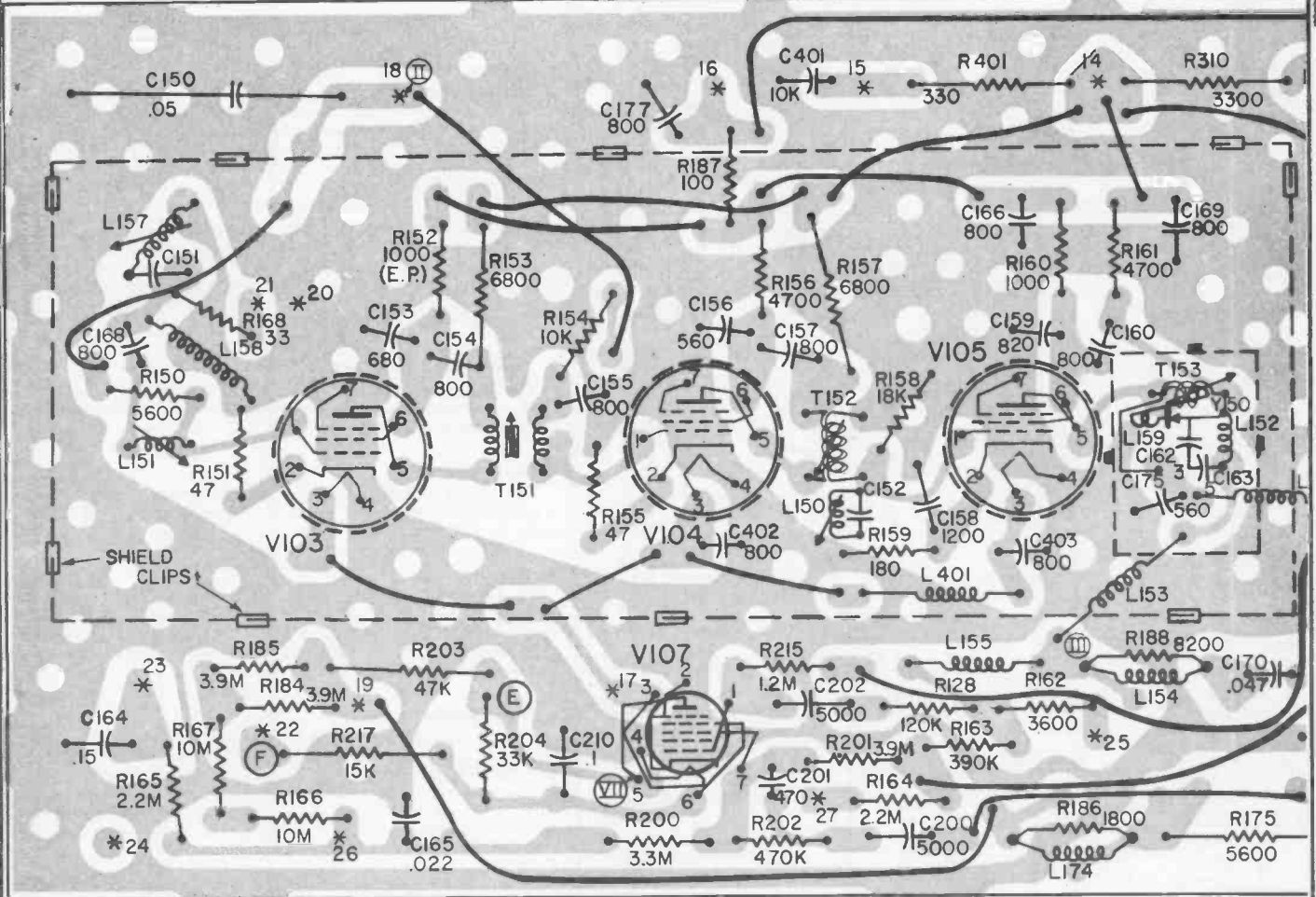

COMPONENT BOARD "B"

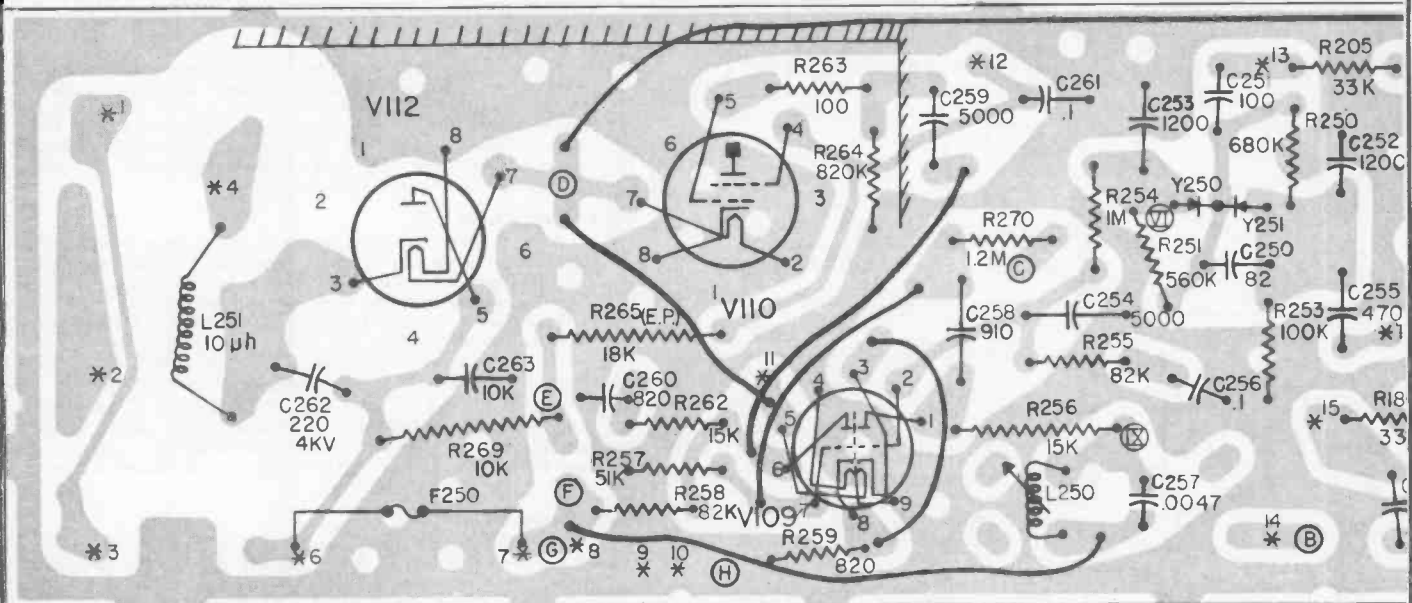

Component Location from Component Side of Solder Boards

This separation is made for printing convenience only

GENERAL ELECTRIC "U" Line Component Boards Service Data (Continued)

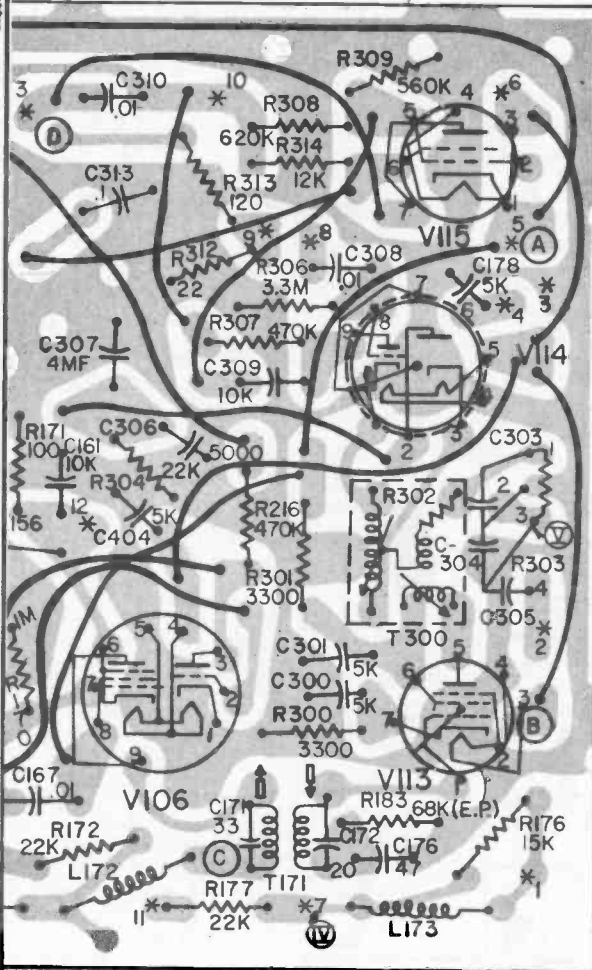

**BOARD "A"**

- \* 1 From C174
  - \* 2 From R305—volume control
  - \* 3 From chassis & lug of T301
  - \* 4 From \*25 C.B. A
  - \* 5 From C400C, +135V
  - \* 6 From VHF tuner 6.3 VAC
  - \* 7 From pin 11—V116, Crt. socket
  - \* 8 From center arm R305
  - \* 9 From bottom tab R305
  - \*10 From +C311 & T301 red
  - \*11 From R178 center (brightness)
  - \*12 From \*25 C.B. A
  - \*13 From T301 blue
  - \*14 From R173 tap
  - \*15 From \*19 C.B. A, VHF tuner +275V
  - \*16 From VHF tuner +135V
  - \*17 From pin 7 V110, C.B. B (D)
  - \*18 From \*27 C.B. A
  - \*19 From +275V C.B. B (F)
  - \*20 From VHF tuner I-F cable shield
  - \*21 From VHF tuner I-F cable center
  - \*22 From \*16 C.B. A
  - \*23 From VHF tuner—AGC
  - \*24 From T400 orange—24VAC for power tuning.
  - \*25 From \*12 C.B. A
  - \*26 From \*4 C.B. A
  - \*27 From \*18 C.B. A
- A to R178—brightness  
 B to pin 8—V108, C.B. B \*21  
 C to C173—contrast top  
 D to T301 green  
 E to C251 & R205, C.B. B \*13  
 F to R210, +135V

**ASTERISKED (\*) NUMBERS**

Represents wirewrap terminals mounted on component board for connecting wires from other board or main chassis.

**CIRCLED (A) LETTERS**

Circled letters represent interconnecting wires to other circuit board or main chassis.

■ Represents element of the tube that is attached to cap at top.

Ⓢ Circled roman numerals indicate test points.

Unless Otherwise Noted

K = 1000, M = 1,000,000  
 Capacitors more than 1 = MMF  
 Capacitors less than 1 = MF  
 Resistors are 1/2 watt  
 Inductances in  $\mu$ h

View shows components and wiring as mounted on component side of board.

**BOARD "B"**

- \* 1. From R210—Height cont. R179—Crt. socket
- \* 3. From yoke pin 4, \*14
- \* 4. From pin 6 of T250
- \* 6. From negative term. of C209 and fuse F250
- \* 7. From fuse F250
- \* 8. From L400—Choke, +275V
- \* 9. From T400—Green wire
- \*10. From T400—Y/R wire
- \*11. From T400—G/Y wire
- \*12. From S250—width switch
- \*13. From R203 & R204, C.B. A (E)
- \*14. From pin 4 of D200—Def. yoke & yellow ld of T201
- \*15. From pin 2—Crt socket
- \*16. From R260—8 on T250
- \*17. From pin 3 of D200—Def. yoke & red ld. of T201
- \*18. From R208—vert. hold cont.
- \*19. From C400D—pos. terminal
- \*20. From T201—blue ld.
- \*21. From pin 3—V113, C.B. A (B)
- \*22. From R210—height cont. C.T.

- A. To R214—vert. lin. contr.
- B. To C209—pos. terminal
- C. To R271—horiz. hold cont.
- D. To pin 3 of V107, C.B. A17
- E. To S250—width switch
- F. To +275V, C.B. A\*19
- G. To C400B—pos. terminal, +275V
- H. To R271—gd. side

**SERVICE HINTS**

There is little reason for removing the boards from the metal chassis. Occasionally, shorts occur between the component lead endings and the metal chassis. When checking a receiver suspected of intermittent shorts, it will save the technician time if first he inserts a screw driver through the holes and bends over those long leads that remain to where they do not come in contact with the metal chassis. Care should be taken not to bend the leads to where they contact other component leads or connections.

In cases where soldering to the component board appears difficult, it will be found that access can be improved by using a bent tip lightweight soldering iron. The 1/8-in. tip available for the General Electric low-wattage iron may be bent to 45° and will easily reach all points on the soldered boards through the holes. A number of solder irons appear on the market which may be equipped with a 45° tip (UNGAR is a good example). The edges of the holes can be used as a rest for the side of the iron which allows the technician to steady the tip while soldering. The smaller size tip and lower wattage of the iron allows heat to be applied to a connection for longer periods without damage to the plated board. Care should be observed not to scrape solder from the iron onto the side of the chassis holes for this will later come loose and fall between the chassis and plated boards and develop shorts. Parts which require removal for checking should have the lead connections heated alternately while applying pressure to the component until the leads become loosened from the solder boards. In most cases, loosening only one lead will be sufficient to make a component or circuit test. The use of a soldering aid tool is recommended, mostly to clean the component mounting holes after component removal.

The case where some difficulty has been found in component removal is the Audio Ratio Detector Transformer and with tube sockets. Here removal is hindered by the number of connections that must be loosened. With careful heating, the part can be removed for checking. In some cases, it is advisable to break-away the transformer base or plastic socket and remove each connection separately.

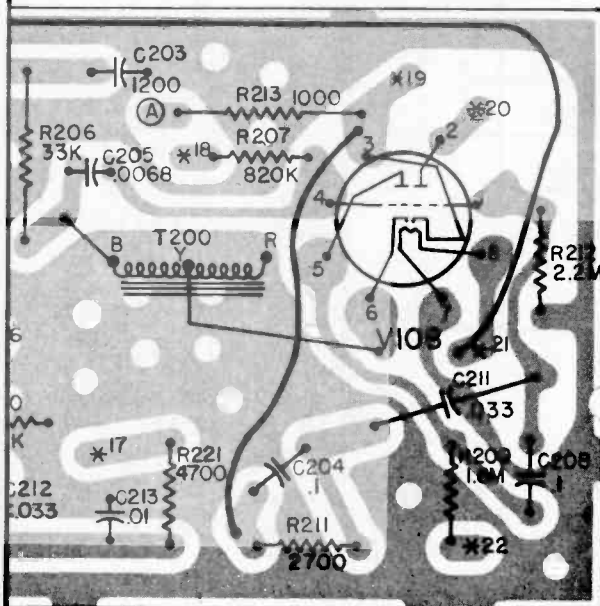



**MAIN SCHEMATIC  
EARLY PRODUCTION**

**GENERAL ELECTRIC "U" Line Early Production Main Schematic Diagram**

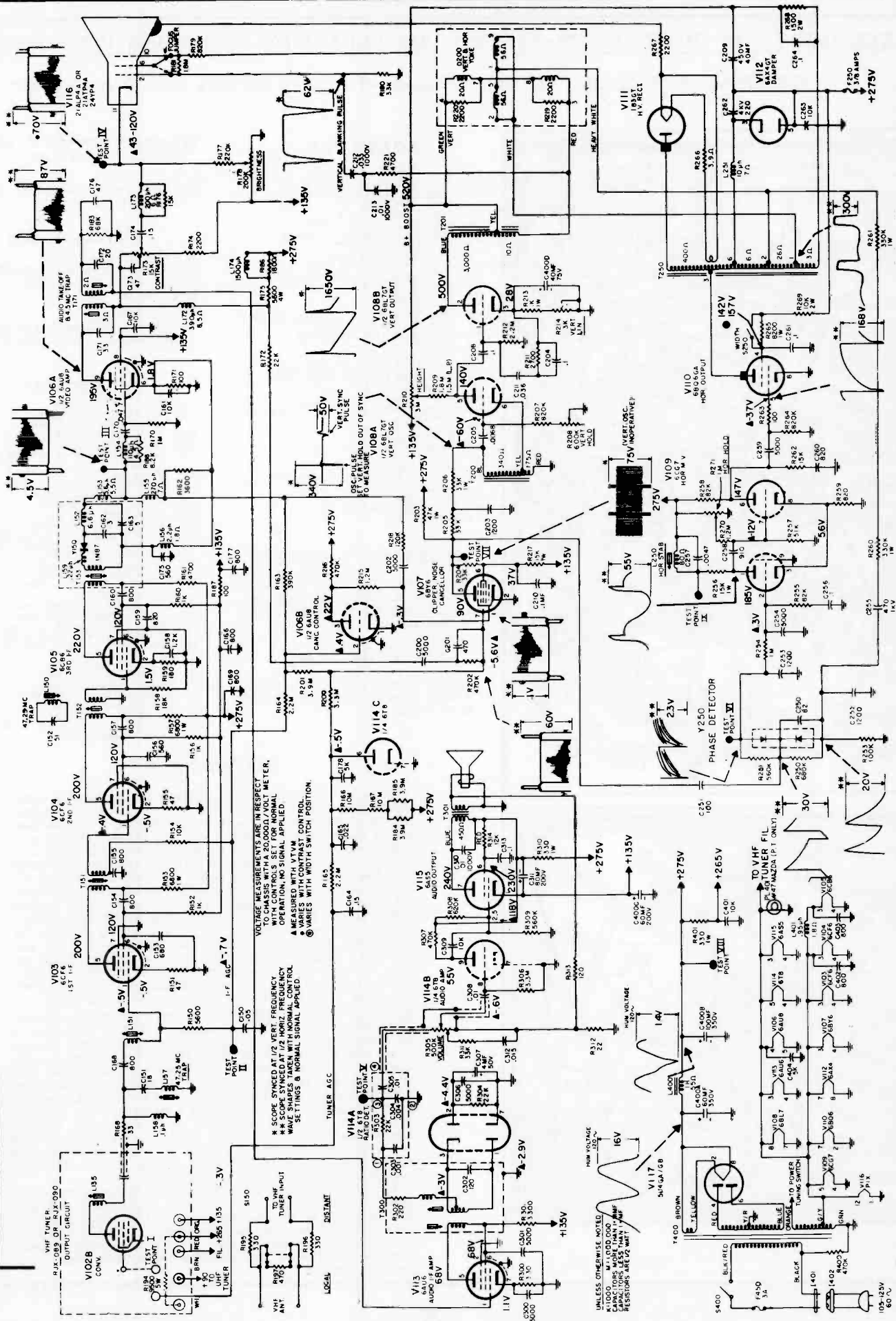

VOLTAGE MEASUREMENTS ARE IN RESPECT TO CHASSIS WITH A 20,000Ω/VOLT METER. OPERATION, NO SIGNAL APPLIED.  
 \* SCOPE SYNCHED AT 1/2 HORIZ. FREQUENCY  
 \*\* SCOPE SYNCHED AT 1/2 HORIZ. FREQUENCY WAVE SHAPES TAKEN WITH NORMAL CONTROL SETTINGS & NORMAL SIGNAL APPLIED  
 Ⓢ VARIES WITH CONTRAST CONTROL.  
 Ⓣ VARIES WITH WIDTH SWITCH POSITION.

UNLESS OTHERWISE NOTED:  
 R1000 Ω, R10000 Ω, R100000 Ω  
 CAPACITORS LESS THAN 100PF  
 RESISTORS ARE 2% TOL.

# MOTOROLA

## CHASSIS TS-423, TTS-423, WTS-423

This material is exact for TS-423, and this chassis schematic is on pages 58-59, with the Sound Section printed on page 57. Chassis WTS-423 differs only in the use of VTT-84Y Tuner with this schematic printed on page 57. Chassis TTS-423 is the same as TS-423 except for the use of a three stage I. F. and a tuner with a different shaft length. The circuit of this different Video I. F. Section is on page 56.

RECEIVER MODEL BREAKDOWN CHART

Model	Description	TV Chassis
14P3-1	Table, charcoal: steel	WTS-423
Y14P3-1	Table, charcoal: steel	WTS-423Y
14P3-2	Table, charcoal: steel	TS-423
Y14P3-2	Table, charcoal: steel	TS-423Y
14P4-1	Table, mocha & white: steel	TS-423
Y14P4-1	Table, mocha & white: steel	TS-423Y
14P5-1	Table, flame & white: aluminum	TS-423
Y14P5-1	Table, flame & white: aluminum	TS-423Y
14P5-2	Table, yellow & white: aluminum	TS-423
Y14P5-2	Table, yellow & white: aluminum	TS-423Y
14P5-3	Table, light blue & white: aluminum	TS-423
Y14P5-3	Table, light blue & white: aluminum	TS-423Y
14P6-1	Portable, mocha: steel	TTS-423
Y14P6-1	Portable, mocha: steel	TTS-423Y
14P7-1	Portable, antique white: steel	TTS-423
Y14P7-1	Portable, antique white: steel	TTS-423Y
14P7-2	Portable, flame & white: steel	TTS-423
Y14P7-2	Portable, flame & white: steel	TTS-423Y
14P8-1	Portable, saffron & white: aluminum	TTS-423
Y14P8-1	Portable, saffron & white: aluminum	TTS-423Y
14P8-2	Portable, cerulean blue & white: aluminum	TTS-423
Y14P8-2	Portable, cerulean blue & white: aluminum	TTS-423Y

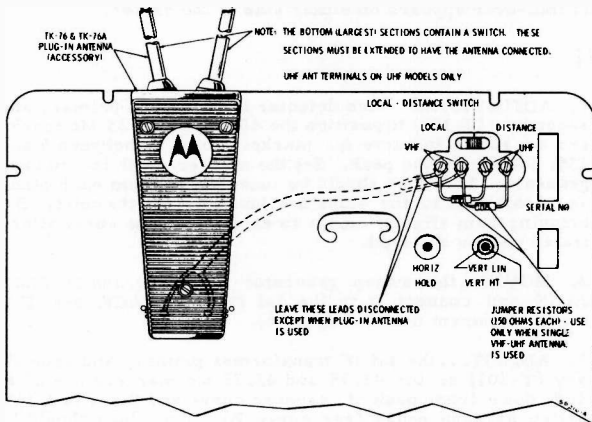
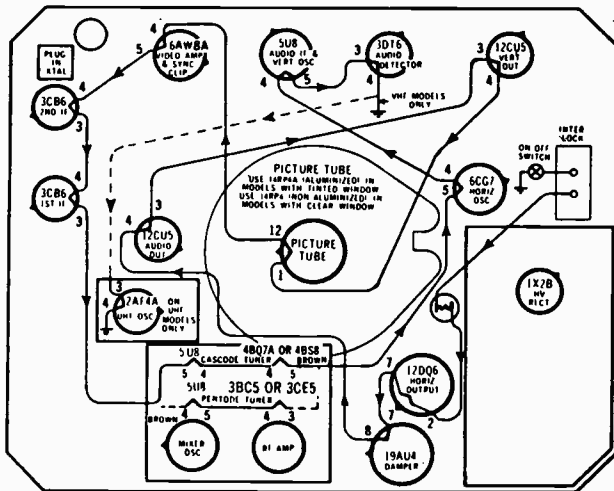

### TO REMOVE THE CHASSIS

1. Remove the back cover.
2. Remove the carrying handle by removing two screws in the handle. Remove the handle completely to eliminate scratching of the cabinet.
3. Remove all operating control knobs.
4. Using a protective pad, turn the receiver so the bottom screws are accessible. Remove the two screws holding the chassis to the cabinet (these screws are located midway between the front and rear of the cabinet).
5. Disconnect the yoke plug.
6. Disconnect the speaker leads.
7. Disconnect the picture tube socket.

8. Carefully slide the chassis toward the rear of the cabinet. When the chassis is near the end of the cabinet, it will be necessary to swing the right-hand side of the chassis (as viewed from the rear) outward and the left-hand side of the chassis inward to give sufficient room between the chassis and the cabinet for disconnection of the high voltage anode lead. After the high voltage lead is removed, the chassis may then be removed.

NOTE: It should not be necessary to remove the ion trap, centering device or deflection yoke to remove the chassis. However, care must be exercised when the chassis is being removed from the neck of the tube so as not to damage the yoke by cutting into the windings with a sharp edge of the chassis... also keep from bending the other neck components.

### TO REMOVE THE SAFETY GLASS FOR CLEANING

1. Remove two Phillips head screws (1 & 2) from handle (H) and remove the handle.
2. Position cabinet so the screws 3 and 4, underneath the cabinet front (CF) may be removed.

NOTE: Special holt head screws were used on some chassis. A special tool, Motorola Part No. 66T742501 will be required to remove these screws in order to remove the safety glass.

3. Pull lower portion of cabinet front (CF) outward, away from cabinet.
4. Lift cabinet front (CF) upward until it is released from the upper edge of the cabinet.
5. Clean the safety glass with water, mild soap, and a clean soft cloth. Dry the surface with a clean, damp chamois. Never try to clean the safety glass by hard rubbing with a dry cloth. This will only tend to scratch the surface and produces an electrostatic charge on the plastic which will attract more dust from the air.

MOTOROLA Chassis TS-423

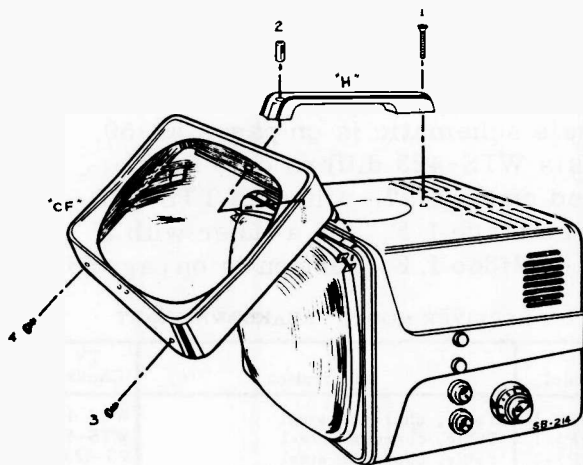

**SAFETY GLASS REMOVAL**

After the dust and grease film have been removed from the plastic, the safety screen may be waxed with a good grade of commercial wax (make certain the wax is not harmful to plastic surfaces). The wax will fill in minor scratches and help prevent further scratching. Apply the wax in a thin, even coat and bring to a high polish by rubbing lightly with a dry, soft cloth such as cotton or flannel.

**TO REPLACE SAFETY GLASS**

1. Carefully insert top edge of cabinet front (CF) into slots provided at top of cabinet.
2. Allow cabinet front to swing into place. Replace lower screws 3 and 4; Place handle into position and replace screws 1 and 2.

**IF AND MIXER ALIGNMENT**

1. REMOVE...the deflection yoke plug to eliminate RF interference and use a variac to maintain 117 volt line voltage.
2. APPLY...minus 3 volts to IF AGC, by connecting a 3 volt battery between the IF AGC test point and chassis ground. Positive side of the battery goes to ground (see IF alignment detail and use the appropriate test receptacle).
3. DISABLE TUNER OSCILLATOR...by grounding pin #9 of V-2 (5U8), and turn the channel selector to channel #13.
4. TUNE...the sweep generator center frequency to 44 Mc with a sweep width of 10 Mc, and do not change these settings. Adjust generator output below point of receiver limiting.
5. ADJUST...the receiver's contrast control to minimum (fully counterclockwise).
6. CONNECT...a .001 to .005 mf capacitor in series with the generator lead, and connect generator as given in the procedure. Terminate generator at end of cable with proper matching resistor.
7. REMOVE...the receiver's antenna and short out terminals, if required, to remove transmitted signals.
8. CONNECT THE OSCILLOSCOPE...with a 47k ohm resistor in series with the input lead to the VIDEO DETECTOR TEST JACK. This location will not change for the entire IF and mixer alignment.

**PROCEDURE**

With the sweep generator connected to the 2nd IF TEST JACK and the oscilloscope at the VIDEO DETECTOR TEST JACK:

**DEFLECTION YOKE ADJUSTMENT**

If the deflection yoke shifts, the picture will be tilted. To correct, loosen the clamp at the rear of the deflection yoke holding the rubber wedge against the yoke. Push the yoke as far forward as possible, then rotate until the picture is straight. Loosen rubber wedge clamp and push rubber wedge tight against rear of yoke. Release wedge clamp.

**HORIZONTAL OSCILLATOR ADJUSTMENT**

The HORIZONTAL HOLD control should have a sync range of approximately 30 degrees. If the control is too critical, adjust by the following procedure. It should be possible to adjust the horizontal oscillator coil with the receiver in the cabinet.

1. Set all controls for a normal picture.
2. Using a piece of wire, short the pin labeled "HORIZ AFC" to ground. Use the appropriate test receptacle and correct pin number as required by the particular chassis (for test receptacles and pin connections see Figure 5).
3. Connect a .1 mfd 400 volt capacitor in parallel with the HORIZONTAL OSCILLATOR COIL (L-501). These connections may be made externally to the chassis by using the pins labeled "HORIZ OSC COIL" and "GND". Use the appropriate test receptacle and correct pin numbers as required.
4. Adjust HORIZONTAL HOLD control, at rear of receiver, to the point where the picture almost remains stationary...as far as horizontal sync is concerned. Also, make sure that the picture is synced vertically.
5. Remove the .1 mfd capacitor shunting the HORIZ COIL and without turning the HORIZONTAL HOLD control, adjust the HORIZ COIL slug to the center of the range in which the picture almost remains in sync horizontally. Screw of the slug is located just behind the local-distance switch.
6. Remove the wire shorting the HORIZ AFC to ground and adjust the HORIZONTAL HOLD control (rear panel) so that no fold-over appears on either side of the raster.

**ALIGNMENT**

1. ADJUST...the video detector transformer primary and secondary (T-102) to position the 45.75 and 42.25 Mc markers as shown in curve A. Markers must be between 5 and 15% down from the peak. Set the markers with the marker generator. The slugs should be tuned as far from each other as possible...so the slugs are just entering the coils. By bringing them slightly closer to each other, the curve illustrated will be obtained.
2. MOVE...the sweep generator from the 2nd IF TEST JACK and connect it to the 1st IF TEST JACK (see IF & sound alignment detail -Figure 6).
3. ADJUST...the 1st IF transformer primary and secondary (T-101) so the 45.75 and 42.25 Mc markers are 25 to 40% down from peak of response curve and there is a 15% valley between peaks (see curve B). The slugs should be tuned as far from each other as possible...so the slugs are just entering the coils.
4. MOVE...the sweep generator from the 1st IF TEST JACK and connect it to the MIXER TEST RECEPTACLE (point F) located on the tuner.
5. ADJUST...the mixer plate coil on the tuner (L-11) and the 1st IF grid coil (L-102) to position the markers down 50% to 65% from the peak of the response curve (see curve C). The slugs should be tuned as far from each other as possible...so the slugs are just entering the coils.
6. EXAMINE THE RESPONSE CURVE...and note position of the 42.25 Mc marker. If it is less than 50% down from the peak of the curve, spread the turns of the mixer band-pass coil (L-101 located on the main chassis) so it is down 50% to 65%.
7. TOUCH-UP...the mixer plate coil (L-11) and the 1st IF grid coil (L-102) until the proper bandpass curve is obtained as shown in curve C. Observe slug position as given in step #5.

MOTOROLA Chassis TS-423, TTS-423, WTS-423, Alignment, Continued

SOUND ALIGNMENT (Station-signal method)

The sound system used in the TS-423 receiver consists of an audio IF amplifier stage, a quadrature grid detector and an output stage. Since this type of sound system is extremely sensitive, relatively small input signal voltage will cause grid current to flow in both the IF amplifier and the detector stages. Grid current through the tuned coils will load them down making the adjustment extremely broad and alignment impossible. For this reason, it is necessary to use a very weak signal when aligning the driver and the detector input coils. Actually, the signal should be well down into the noise level for proper tuning action.

PROCEDURE (For strong signal areas)

1. CONNECT...the negative prod of the VTVM to pin #2 of the quadrature coil (L-302); this test point is the junction of R-306 (560K) and pin #2 of the quadrature coil. Connect the positive meter lead to chassis ground.
2. CONNECT...the antenna and tune in a station.
3. SET...the CONTRAST control to maximum (fully clockwise).
4. SET...the VOLUME control for average usable sound amplification.
5. ADJUST...the quadrature coil (L-302) for maximum negative reading on the VTVM (tune slug as close to chassis as possible).

NOTE: There are two points of tuning for the quadrature coil...one of which is incorrect.

The correct tuning point will produce approximately 2-1/2 volts. The incorrect tuning point will produce approximately 1-1/2 volts. Severe misalignment of the driver and detector grid coils will reduce the value of this tuned

voltage. If this occurs, tune for maximum negative reading on the VTVM...later adjustment of the input coils will produce the 2-1/2 volts.

After the correct tuning point has been established, make the final adjustment of the quadrature coil based on minimum sound distortion. MAKE NO FURTHER ADJUSTMENTS OF THE QUADRATURE COIL DURING THE REMAINDER OF THE ALIGNMENT.

Proper adjustment of the quadrature coil is important to proper sound operation on all signal strength levels.

6. REDUCE...the signal input at the antenna (disconnect one or both leads and separate from the receptacle...or insert resistors) until the picture has been considerably weakened.
7. ADJUST...the primary and secondary of the audio interstage transformer (T-301) for best signal-to-noise ratio as determined by listening to the sound. If signal is too strong, exact tuning will be difficult. (Cores of transformer must be tuned as far from each other as possible...so that cores are just entering the coils.)
8. ADJUST...the audio take-off coil (L-301) for best signal-to-noise ratio as determined by listening to the sound output. If signal is too strong, exact tuning will be difficult. (Tune core as close to chassis metal as possible.)
9. READJUST...the interstage transformer (T-301) for best possible signal-to-noise condition.

10. If considerable alignment was required to complete the foregoing procedure, it would be advisable to recheck the tuning of the quadrature coil using a strong signal as in step #5. However, if the quadrature coil is realigned, it will be necessary to repeat steps 6, 7 and 8 for tuning of the audio take-off coil and interstage transformer using a weak signal.

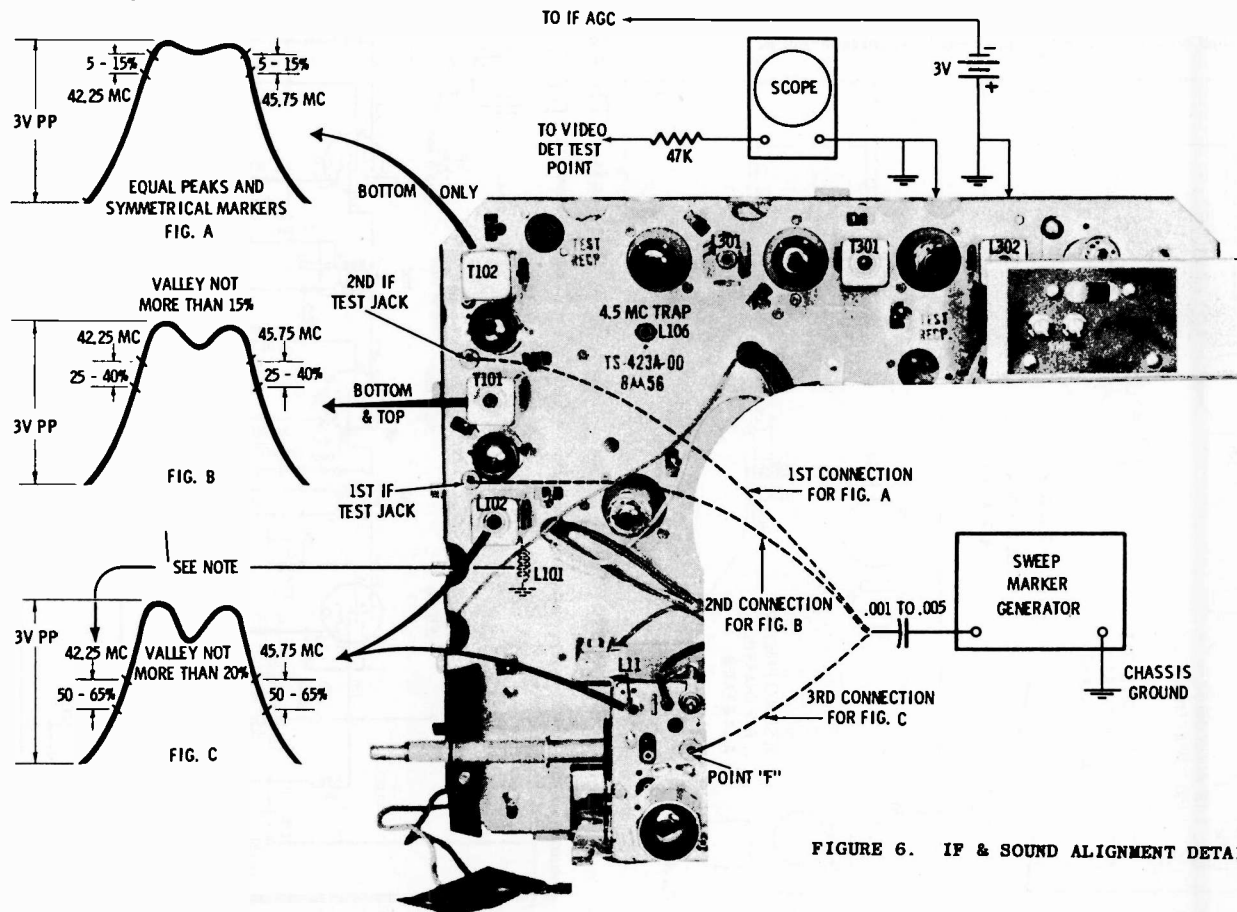

FIGURE 6. IF & SOUND ALIGNMENT DETAIL

MOTOROLA Chassis TS-423, TTS-423, WTS-423, Service Information, Continued

PROCEDURE (For weak signal areas)

1. CONNECT... the negative prod of the VTVM to pin #2 of the quadrature coil (L-302). Connect the positive meter lead to chassis ground. This test point is the junction of R-306 (560K) and pin #2 of the quadrature coil.
2. Using maximum available signal input, roughly align the primary and secondary of the interstage transformer (T-301), the take-off coil (L-301) and the quadrature coil (L-302) for maximum quadrature grid bias (meter reading) of 1-1/2 volts. (See note under Part 5 of the procedure for strong signal areas.)
3. Using maximum available signal, align the quadrature coil (L-302) for minimum sound distortion. (Tune slug as close to chassis metal as possible.)
4. Using the weakest signal possible, adjust the primary and secondary of the interstage transformer (T-301) for best signal-to-noise conditions. (Tune cores of transformer as far from each other as possible... so cores are just entering the coils.)
5. Using a weak signal, adjust the take-off coil (L-301) for best signal-to-noise ratio. (Tune core as close to chassis metal as possible.)
6. Repeat the procedure several times, if required, until the optimum adjustment is obtained. Keep in mind that the IF amplifier and detector input coils must always be re-adjusted on a weak signal if the quadrature coil setting is changed.

4.5 MC TRAP ADJUSTMENT

1. Carefully tune receiver to local station and advance contrast control. Turn "LOCAL-DISTANT" switch to distant position.
2. Adjust local oscillator (fine tuning) to bring 4.5 Mc interference dots into picture by tuning video carrier down side of response (toward sound break-up).
3. Adjust sound trap (L-106) to find the two points of adjustment at which sound is just noticeable on the picture tube screen. Rotate the core toward center of the two points. Use minimum amount of inductance (core out of coil) that will result in no apparent beat interference.

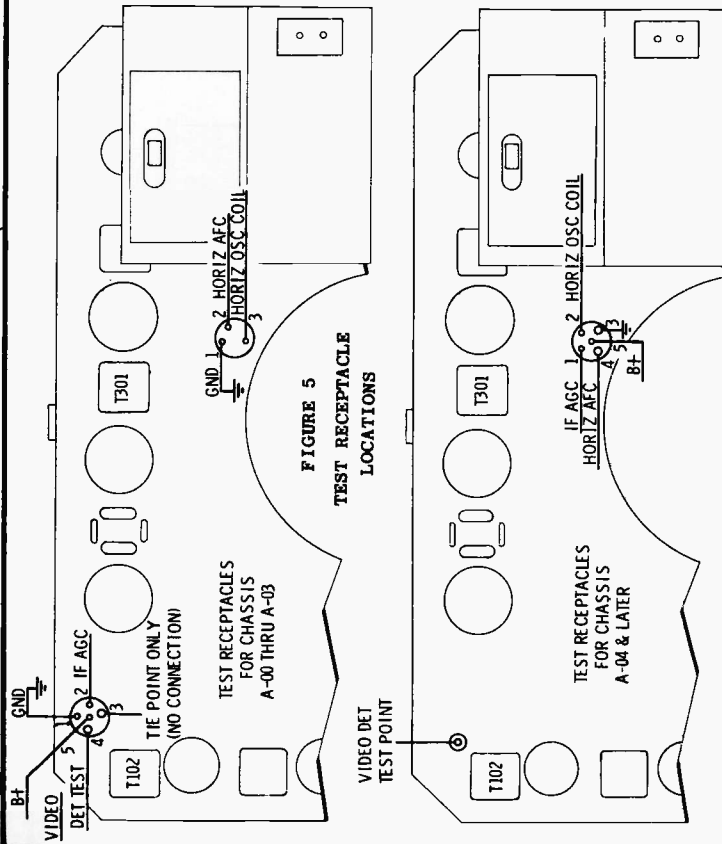

Video I. F. Section diagram of Chassis TTS-423, balance of circuit same as TS-423.

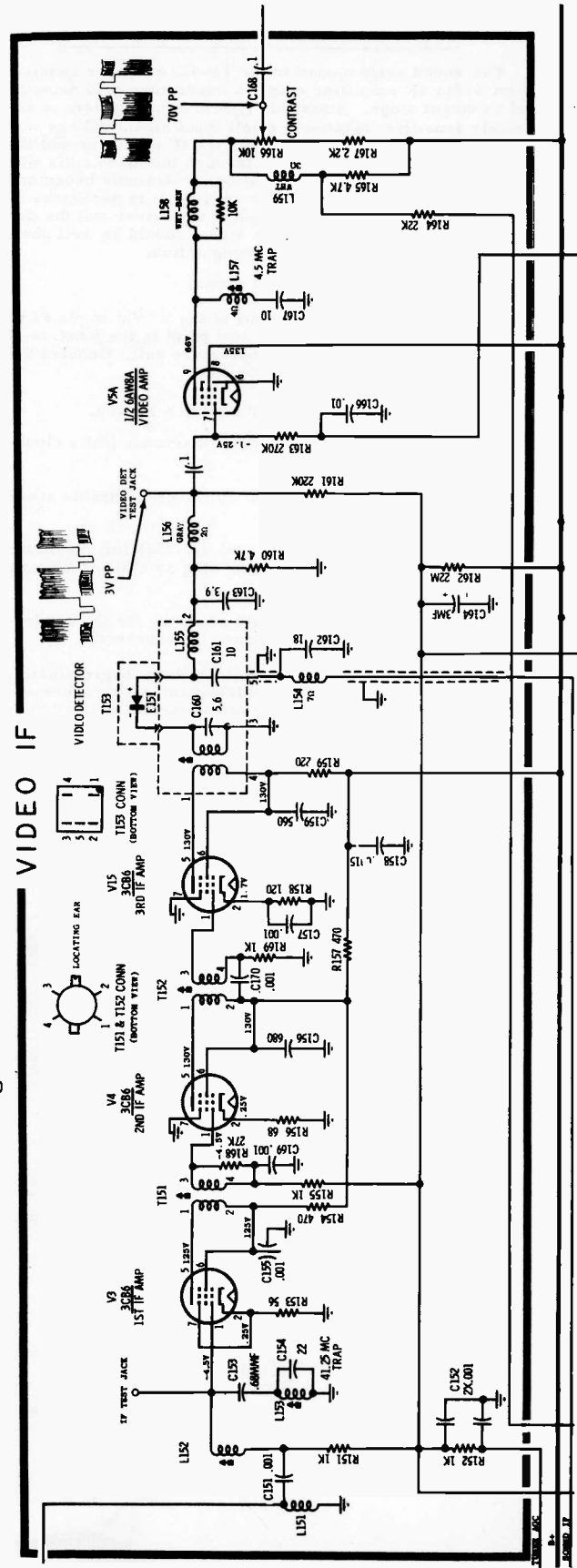

To improve vertical and horizontal sync, R-113 (10K) changed to 22K and one end of resistor is re-located from top end of L-108 to the low end; C-403 (56 mmf), E-601 (diode crystal) and C-612 (.02 mf) removed; C-602 (.15 mf) removed - plate of V-5B (6AW8A sync separator) connects to junction R-601, R-602 and R-603; R-601 (22K) changed to 47K; R-611 (100K) changed to 150K; C-608 (.02 mf) changed to .05 mf; C-613 (.01 mf) added between plate of V-6B (1/2 5U8) and ground.

MOTOROLA Chassis TS-423 (Continued)

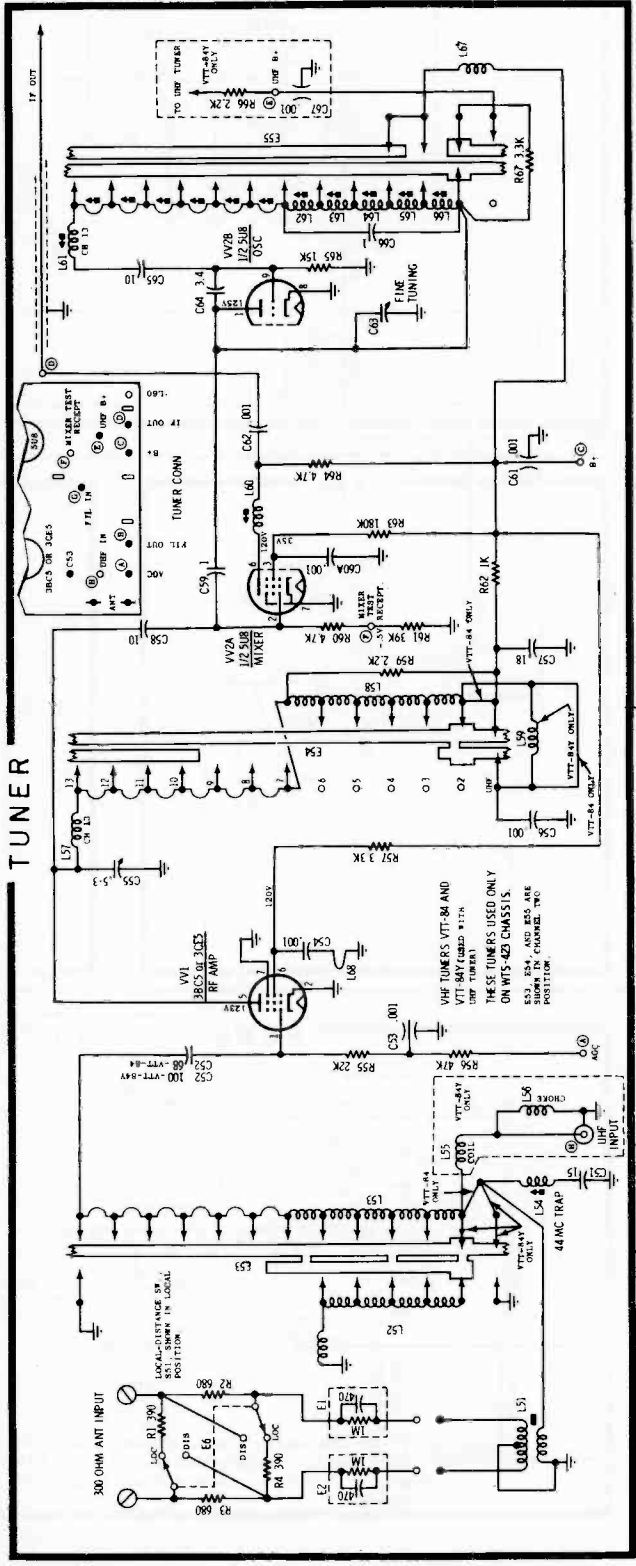

TUNER VTI-84Y USED IN WTS-423 CHASSIS

Sound Section of Chassis TS-423. Wire extensions connect to correspondingly marked wires of the main schematic printed for convenience on pages 58 and 59.

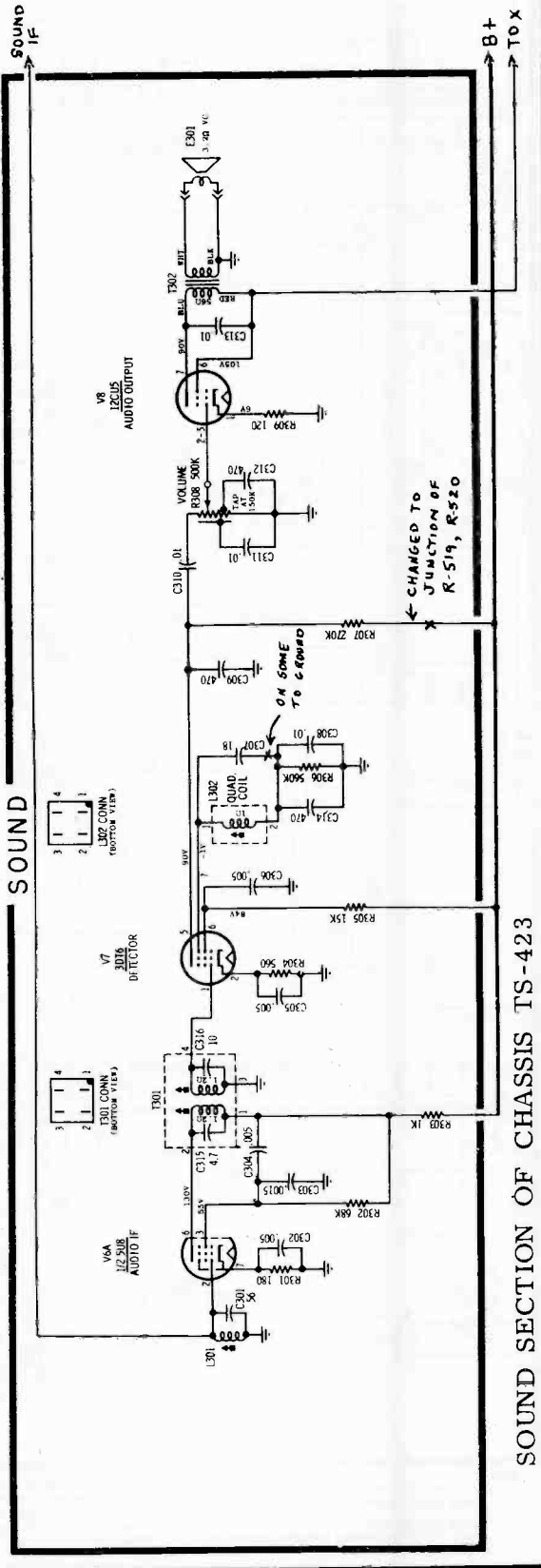

MOTOROLA Chassis TS-423

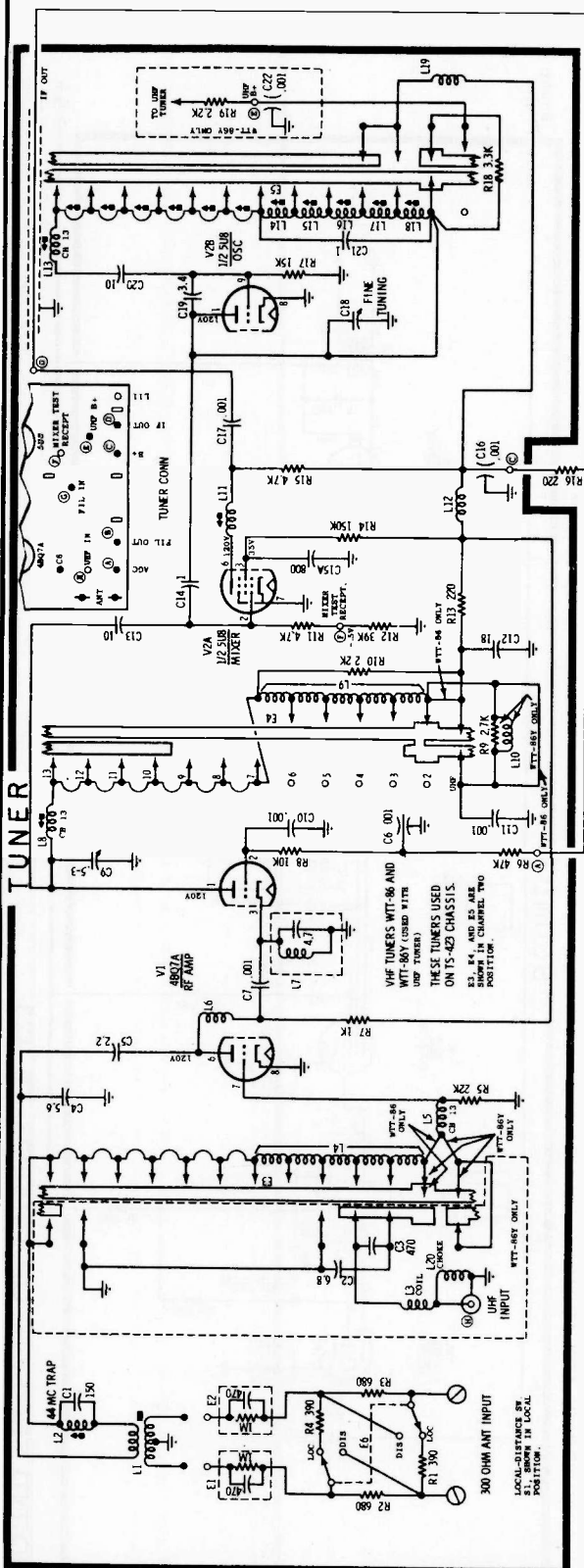

- NOTES:
- 1. CAPACITORS - Decimal values in MF, all others in MMF unless otherwise specified.
  - 2. VOLTAGE MEASUREMENTS
    - 1. Made with a VTVM from point indicated to common ground.
    - 2. Line voltage - 117 VAC (use Isolation Transformer).
  - 3. Antenna disconnected and input shorted across.
  - 4. Channel selector switch on channel which develops least noise at video deflector test receptacle.
  - 5. All controls in normal operating position.
  - 6. Voltages associated with variable-control circuitry will vary with control setting.

See page 57 for schematic of the Sound Section. Wire extensions connect to correspondingly marked wires of the Sound Section.

(See Sound Section circuit on page 57)

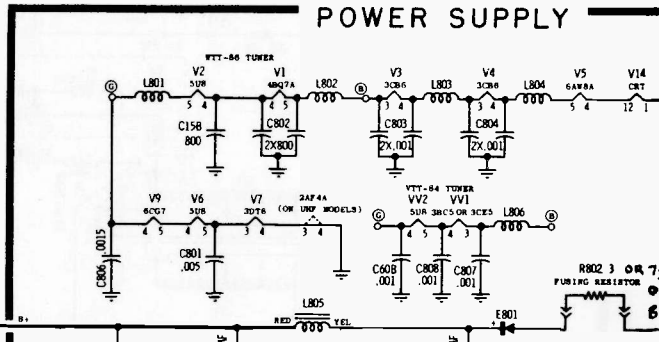
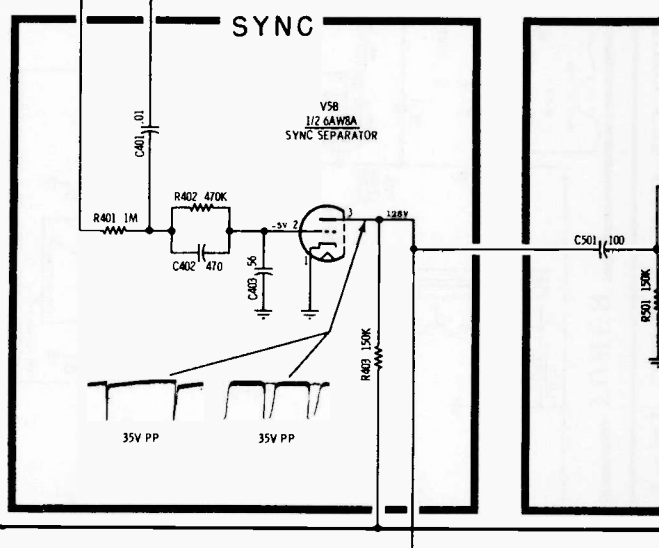
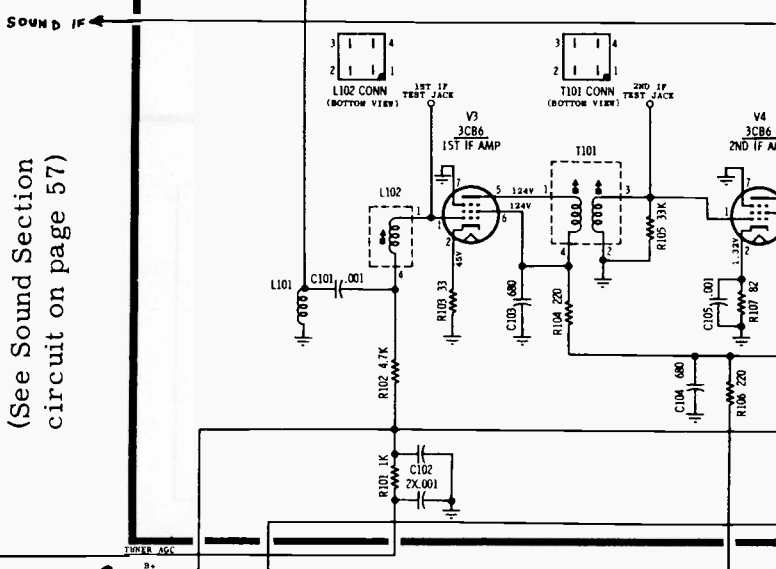

To decrease 4.5 Mc harmonic radiation, C-8 (470 mmf) added between pin #4 of V-7 (3DT6) a ground. This change affects only 'Y' vers chassis.



VOLUME TV-14, MOST-OFTEN-NEEDED 1958 TELEVISION SERVICING INFORMATION

MOTOROLA TELEVISION CHASSIS TS-423A-00

VIDEO IF

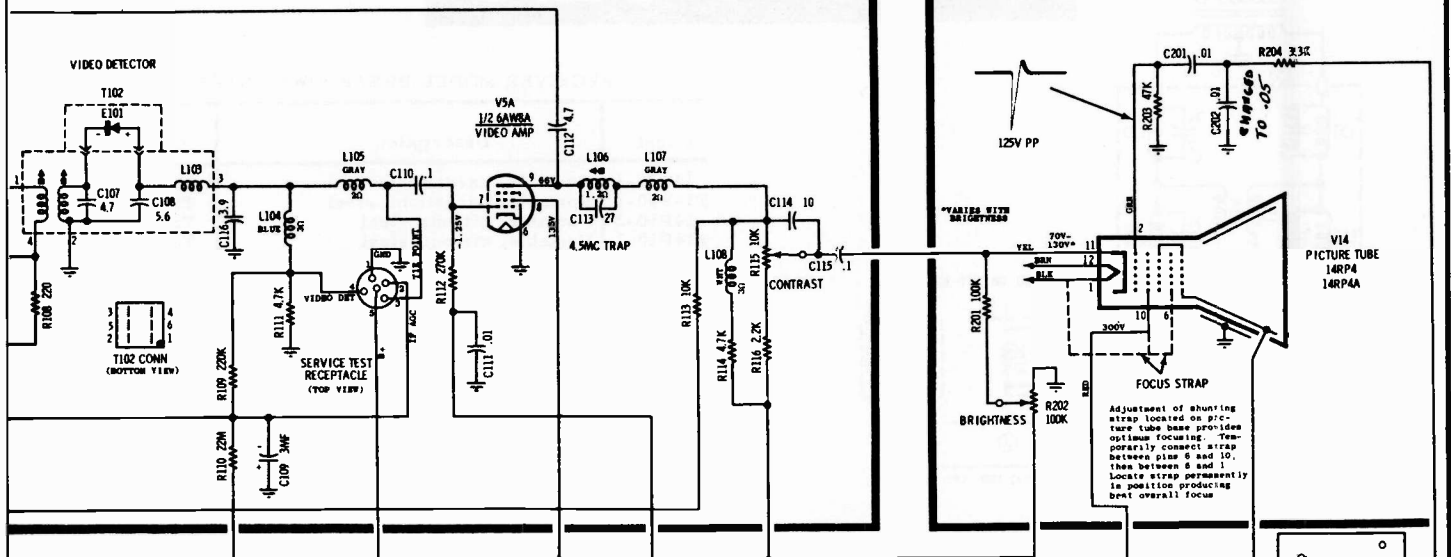

HORIZ SWEEP & H.V.

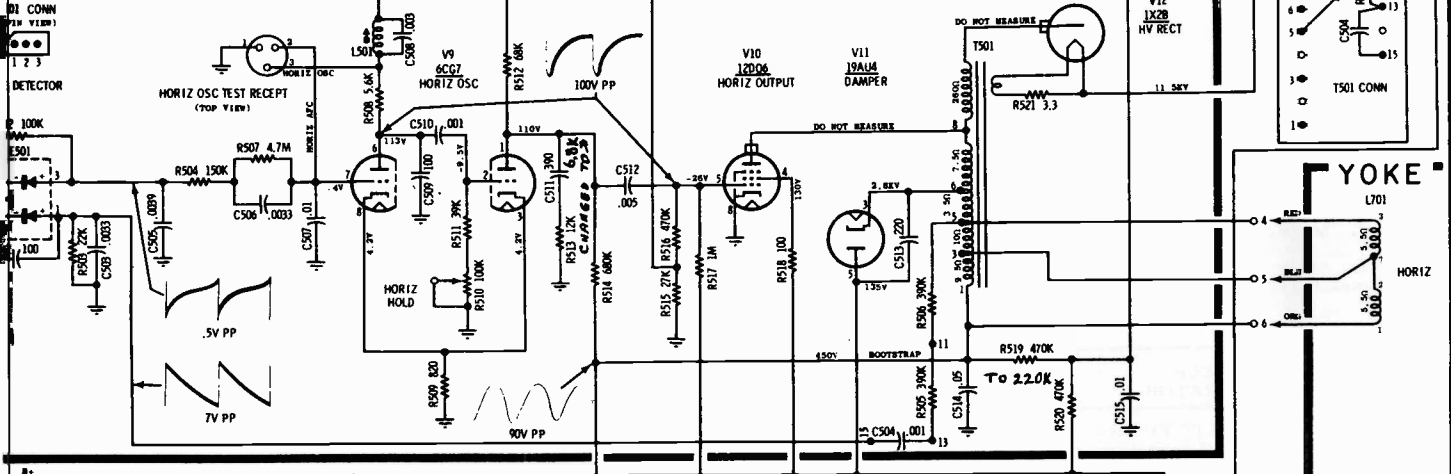

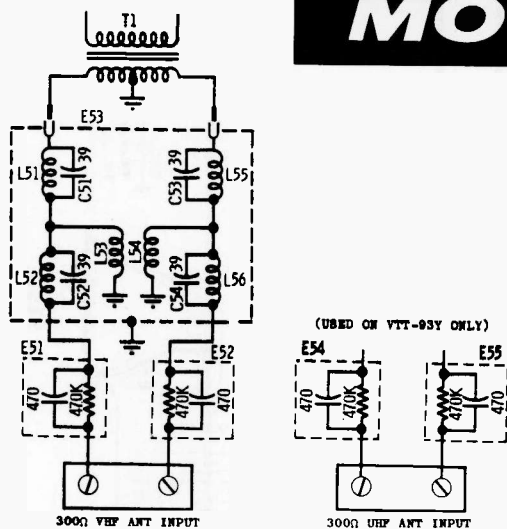

FIGURE 1. HI-PASS FILTER ASSEMBLY (VTT-93 & VTT-93Y)

RECEIVER MODEL BREAKDOWN CHART

Model	Description	TV Chassis
I4P10-1	Portable, carnation: steel	TS-425
Y14P10-1	Portable, carnation: steel	TS-425Y
I4P10-2	Portable, citron: steel	TS-425
Y14P10-2	Portable, citron: steel	TS-425Y
I4P11-1	Portable, antique white: aluminum	TS-425
Y14P11-1	Portable, antique white: aluminum	TS-425Y
I4P11-2	Portable, cerulean blue: aluminum	TS-425
Y14P11-2	Portable, cerulean blue: aluminum	TS-425Y
I4P10-1A	Portable, carnation: steel	WTS-425
Y14P10-1A	Portable, carnation: steel	WTS-425Y
I4P10-2A	Portable, citron: steel	WTS-425
Y14P10-2A	Portable, citron: steel	WTS-425Y
I4P11-1A	Portable, antique white: aluminum	WTS-425
Y14P11-1A	Portable, antique white: aluminum	WTS-425Y
I4P11-2A	Portable, cerulean blue: aluminum	WTS-425
Y14P11-2A	Portable, cerulean blue: aluminum	WTS-425Y

WTS-425 SERIES Same as TS-425 except for addition of a hi-pass filter to VHF tuner. Tuners change to VTT-93 & VTT-93Y. See Fig. 1.

(Continued below and on the next six pages)

ALIGNMENT

VIDEO IF & MIXER ALIGNMENT

Pre-Alignment Information

1. Remove the deflection yoke plug from its socket.
2. Maintain 120V line voltage with variac.
3. Apply minus 4.5V volt battery lead to pin #1, and remaining lead to pin #3 of the SERVICE TEST RECEPTACLE.

4. Disable tuner oscillator by shorting pin #9 of V-2 to chassis.
5. All coil slugs should be tuned away from the chassis (except 2nd IF slug and 3rd IF bottom slug tuned toward chassis).
6. Refer to Video IF Alignment Detail (Figure 5) for coil and test point locations.

VIDEO IF & MIXER ALIGNMENT PROCEDURE

STEP	SWEEP GENERATOR	INDICATOR	ADJUST	REMARKS
1.	To 3rd IF TP thru .001 mf capacitor at 44 Mc with 10 Mc sweep width	Scope thru 47K resistor to video det TP	T-103	Maximum gain and marker positions (see curve A). Both slugs may be reached from bottom side of T-103 "can".
2.	To 1st IF TP thru .001 mf capacitor at 44 Mc with 10 Mc sweep width	"	T-102	Maximum gain and 45.75 Mc marker position (see curve B).
3.	"	"	T-101	Maximum gain and 42.25 Mc marker position. If curve is tilted, readjust T-103 (see curve B).
4.	To mixer test receptacle thru .001 mf capacitor at 44 Mc with 10 Mc sweep width	"	L-101	Maximum gain and 45.75 Mc marker position (see curve C).
5.	"	"	L-102	Minimum output at 41.25 Mc marker position (see curve C).
NOTE: Temporary removal of bias may be necessary to make the trap dip more pronounced.				
6.	To mixer test receptacle thru .001 mf capacitor at 44 Mc with 10 Mc sweep width	Scope thru 47K resistor to video det TP	L-16	Adjust for flat response.
7.	Repeat steps 4, 5 and 6 as necessary, to obtain the overall curve C.			

MOTOROLA Chassis TS-425, -Y, WTS-425, -Y, Alignment Information, Continued

**SOUND ALIGNMENT**  
(Station Signal Method)

The sound system used in the TS-425 receiver consists of an audio IF amplifier stage, a quadrature grid detector and an output stage. Since this type of sound system is extremely sensitive, relatively small input signal voltage will cause grid current to flow in both the IF amplifier and the detector stages. Grid current through the tuned coils will load them down making the adjustment extremely broad and alignment impossible. For this reason, it is necessary to use a very weak signal when aligning the driver and the de-

tor input coils. Actually, the signal should be well down into the noise level for proper tuning action.

**Pre-Alignment Instructions**

1. Tune in a strong TV station.
2. Adjust all controls for normal operation. (Deflection yoke must be plugged into its socket.)
3. Refer to Video Alignment Detail for test point and coil locations (Figure 5).

**SOUND ALIGNMENT PROCEDURE**

STEP	SWEEP GENERATOR	INDICATOR	ADJUST	REMARKS
1.	Use station transmission (strong signal)	VTVM negative lead to pin #2 of L-302 and other lead to chassis.	L-302	Maximum negative deflection (coarse adjustment).
2.	"	Listening test.	"	Maximum sound with minimum distortion (fine adjustment).
3.	Use station transmission (weak signal*)	"	T-301 (double tuned)	Maximum sound (top slug) and minimum distortion (bottom slug). (Maintain hiss level.)
4.	"	"	L-301	Maximum sound signal with minimum distortion. (Maintain hiss level.)

If sound is not clear at this point, repeat the above procedure as necessary.

\*NOTE: The signal must be weakened considerably by disconnecting one side of the antenna lead, or connecting low value resistors across the antenna terminals until a pronounced hiss appears in the sound. This hiss level must be maintained during alignment.

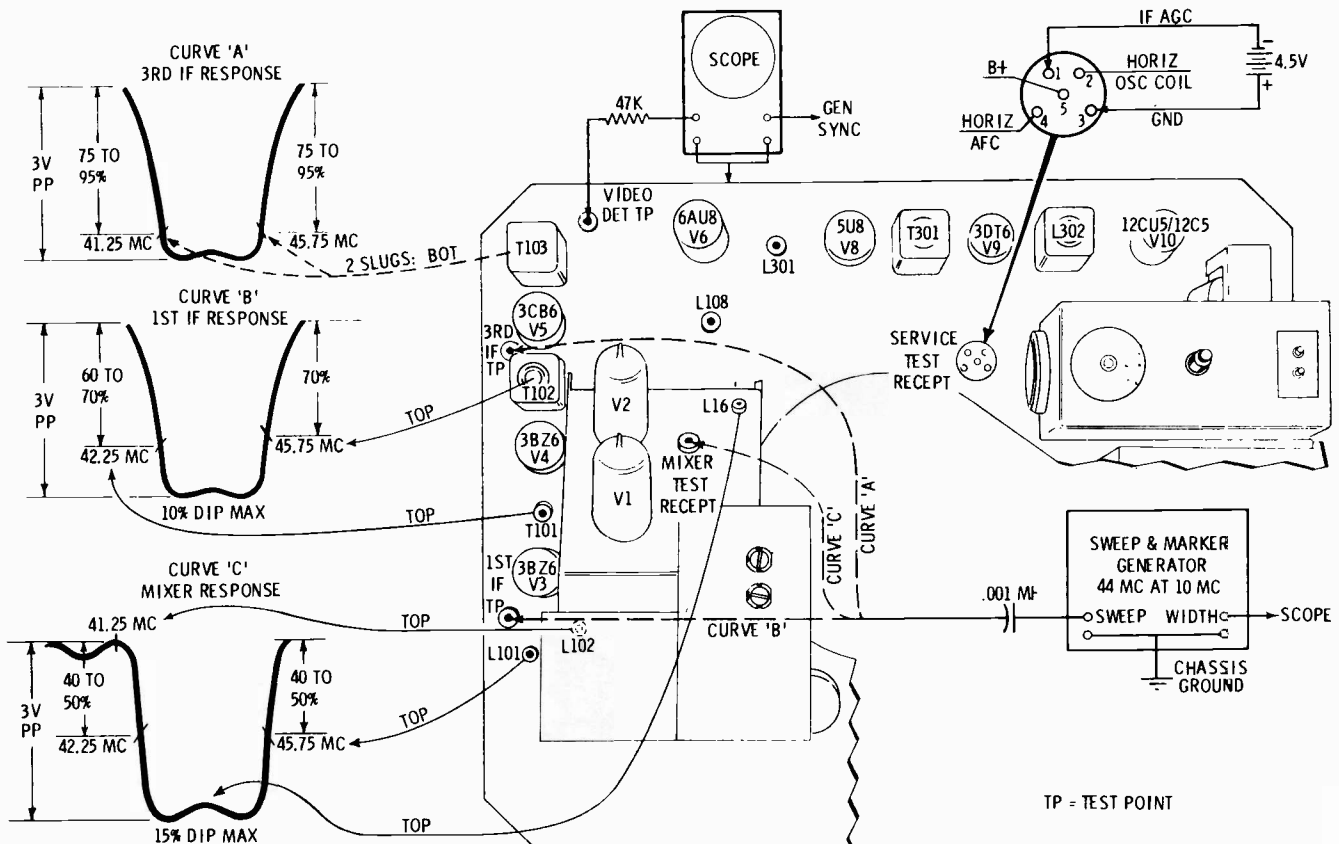
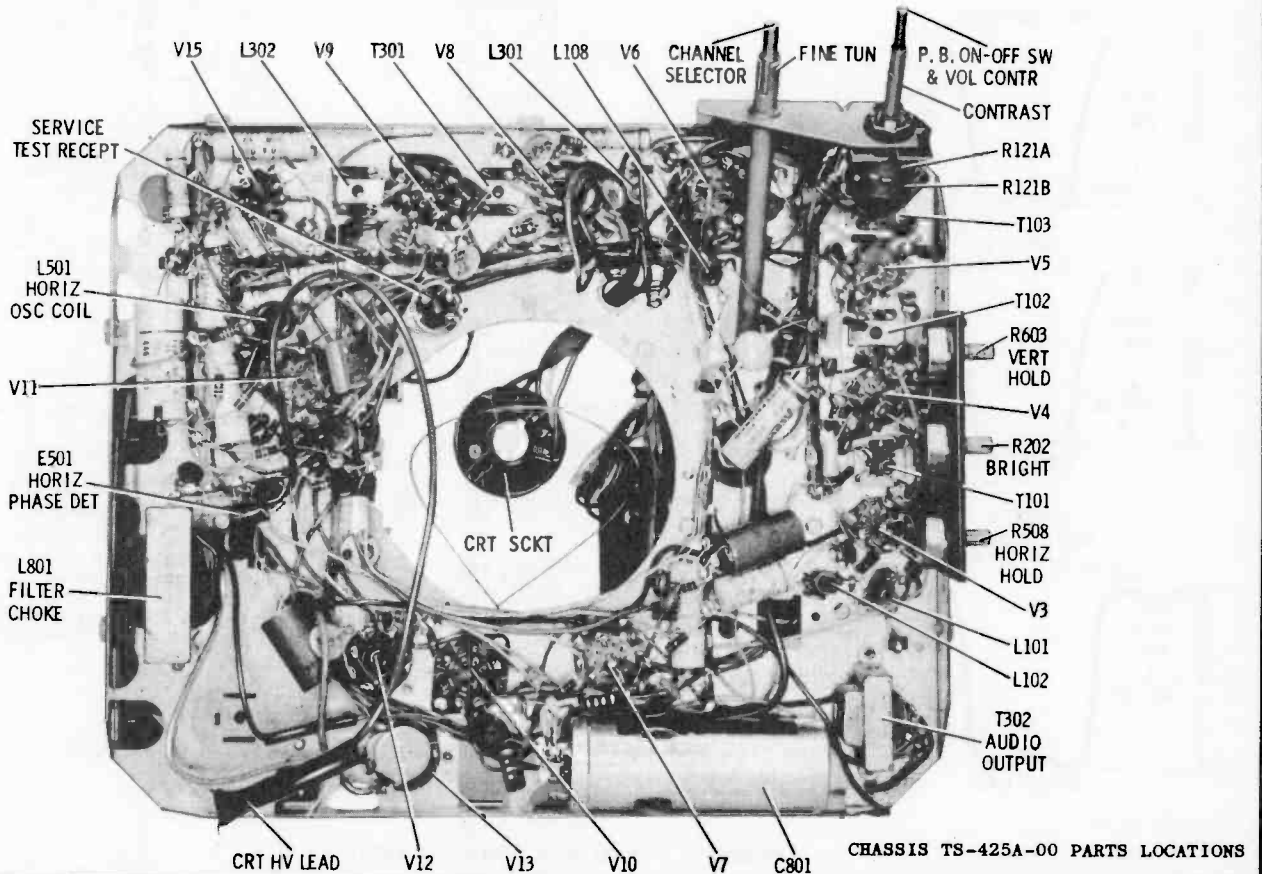
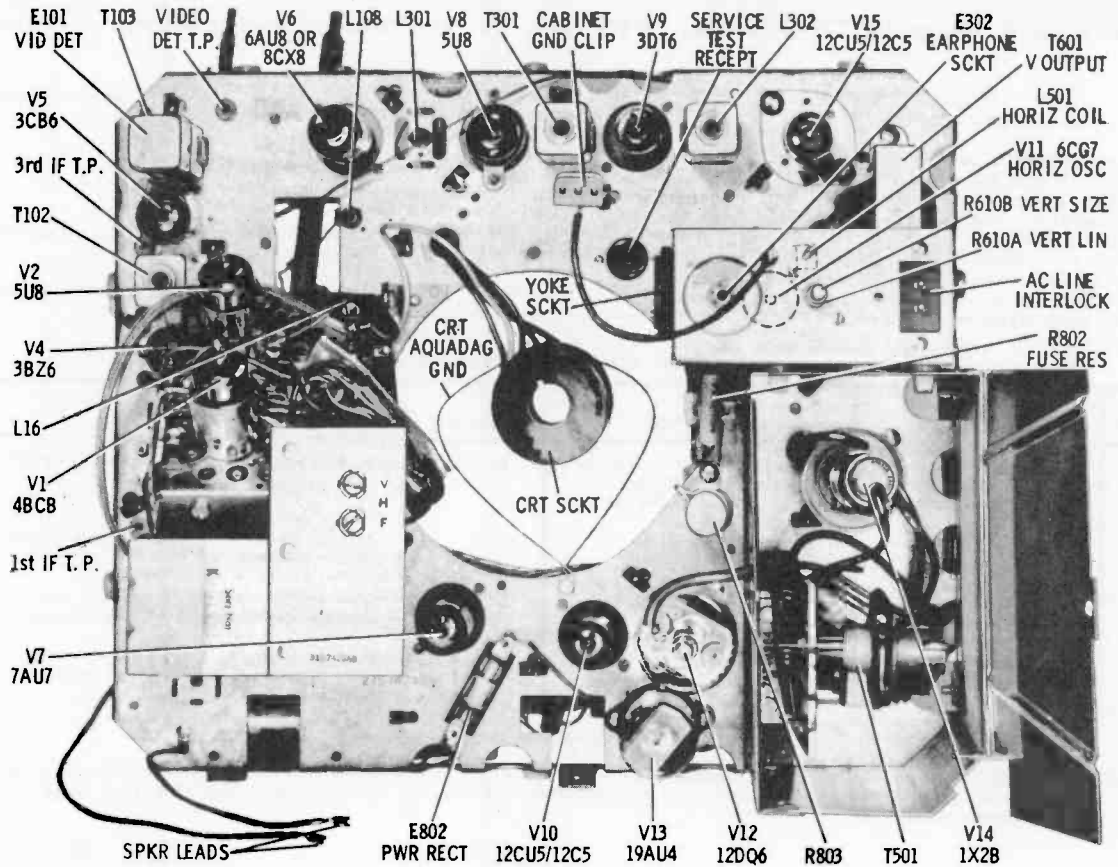

FIGURE 5. VIDEO IF & SOUND ALIGNMENT

VOLUME TV-14, MOST-OFTEN-NEEDED 1958 TELEVISION SERVICING INFORMATION



CHASSIS TS-425A-00 PARTS LOCATIONS

MOTOROLA Chassis TS-425, Part of Schematic Diagram, Continued

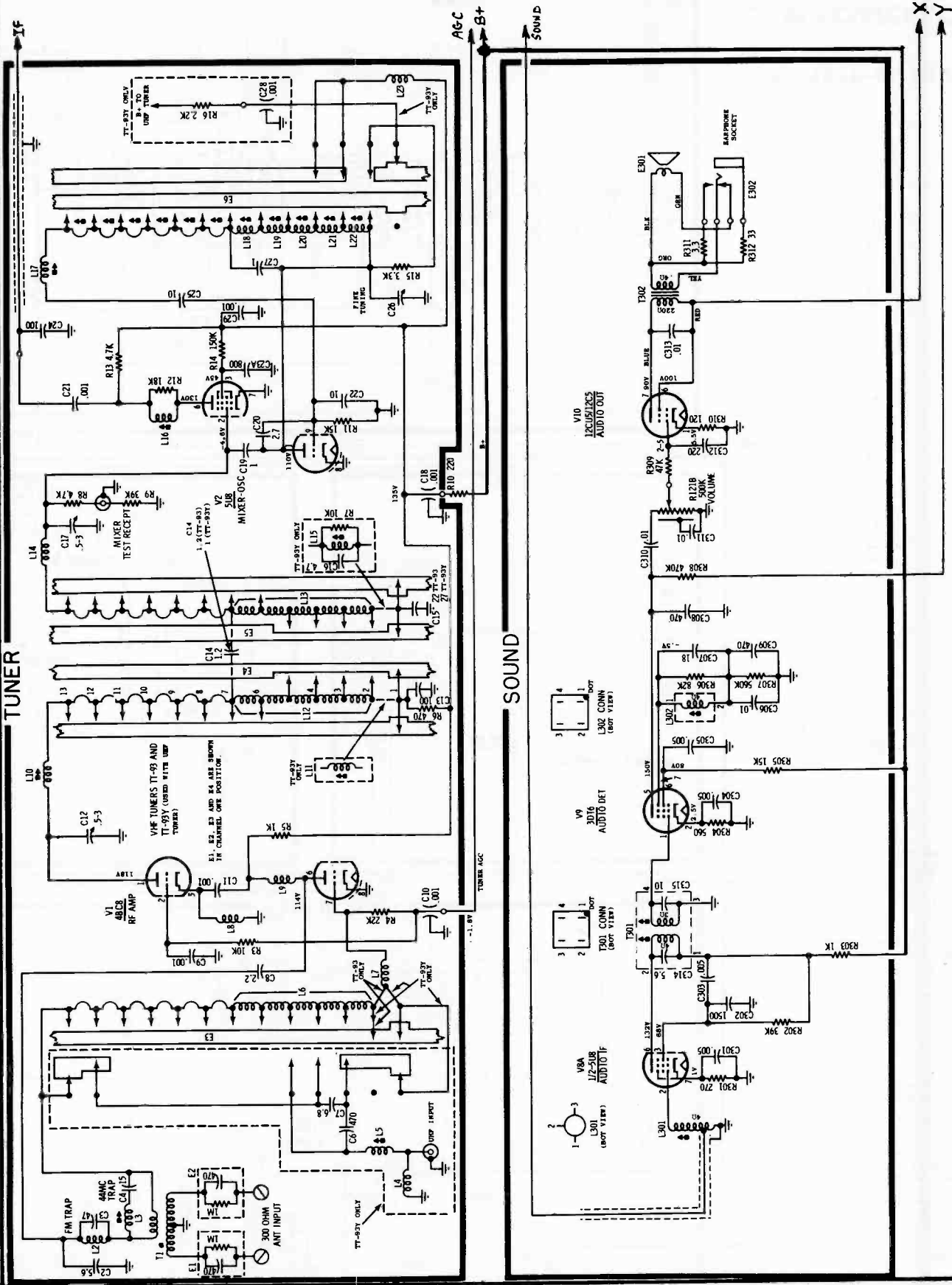

Wires ending and marked connect to corresponding wires of main diagram on next page.

**MOTOROLA**

**CHASSIS TS-425A-00**

Wires ending and marked connect to corresponding wires of Tuner and Sound sections printed on previous page. The separation is made for printing convenience.

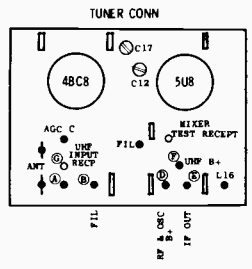
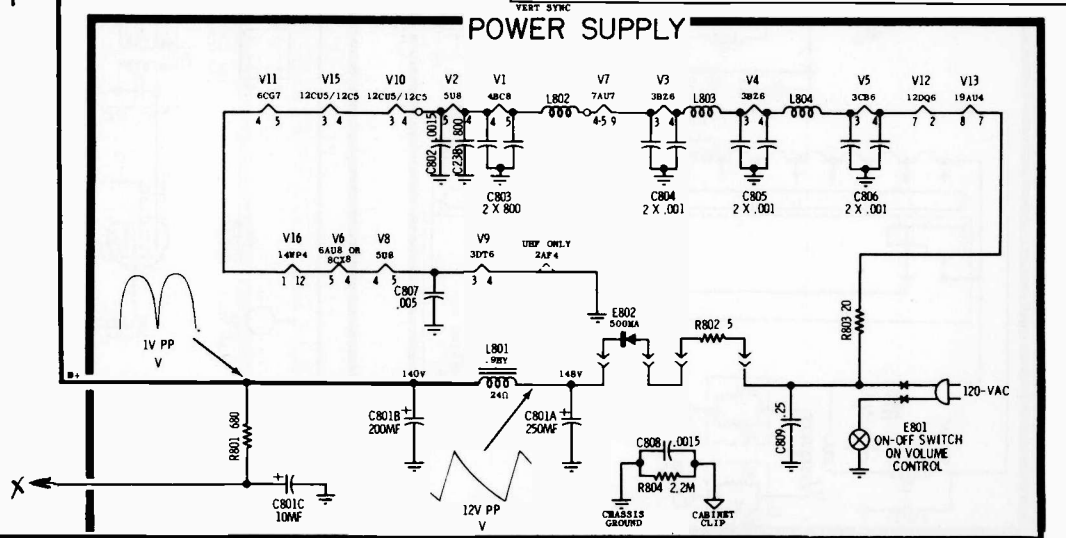
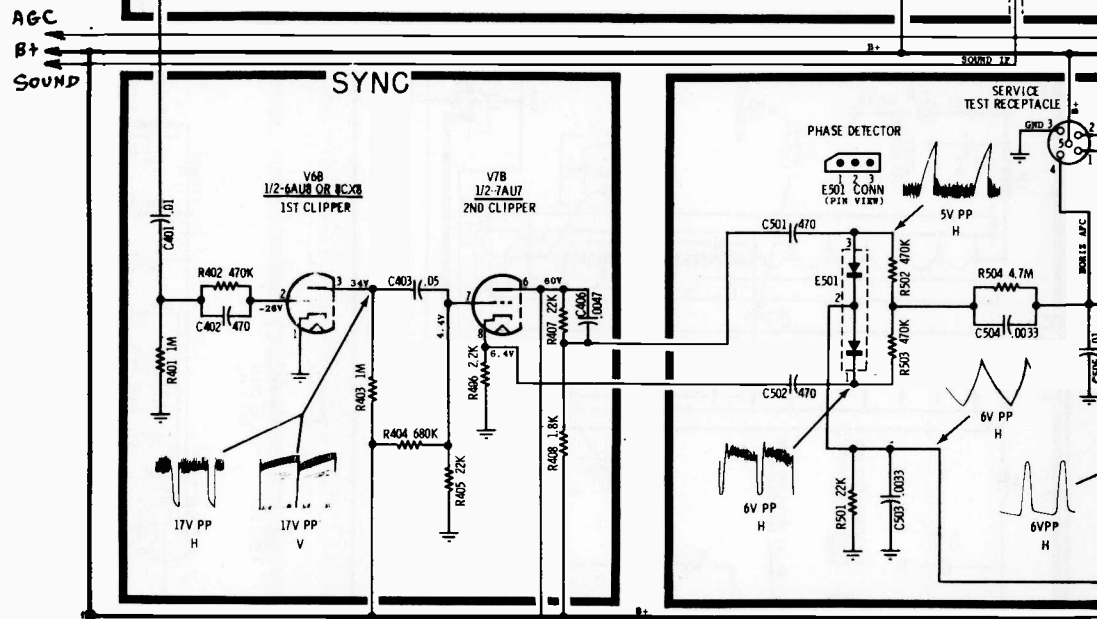
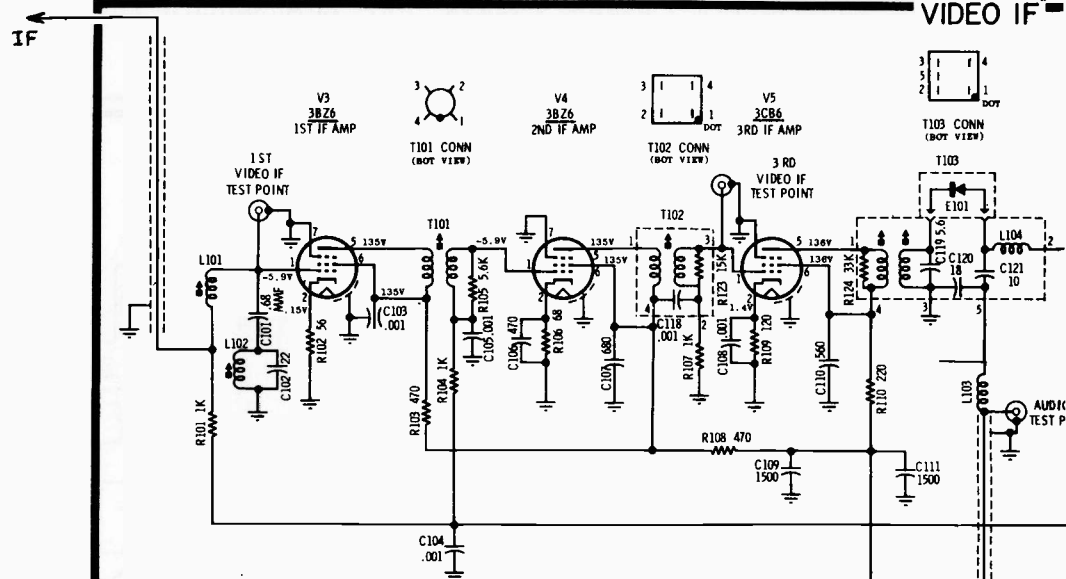

- NOTES:**
- CAPACITORS - Decimal values in MF, all others in MMF unless otherwise specified.
  - VOLTAGE MEASUREMENTS
    - Made with a VTVM from point indicated to common ground.
    - Line Voltage - 122 VAC (Use Isolation Transformer).
    - Voltages indicated by an asterisk (\*) will vary with associated control setting.
  - WAVEFORMS
    - Taken with wide-band oscilloscope.
    - Receiver in operating condition and showing a normal picture.
- V - VERTICAL  
H - HORIZONTAL

# VOLUME TV-14, MOST-OFTEN-NEEDED 1958 TELEVISION SERVICING INFORMATION

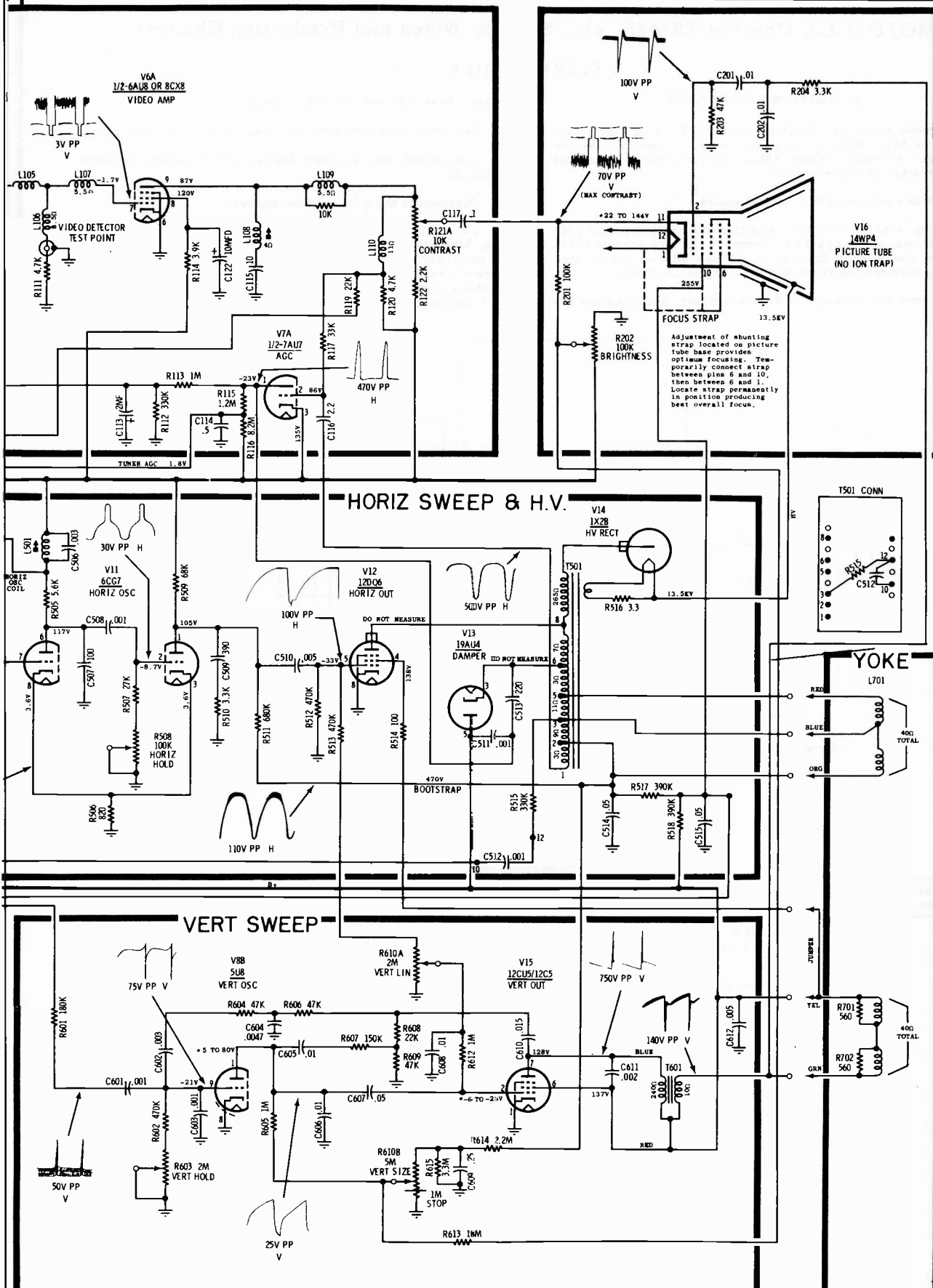

no resistor in series with the filament lead, but with a 27,000 ohm resistor in series with the second anode lead.

Only high voltage transformers designed for use with the 3A2 HV rectifier tube are furnished by Motorola for field replacement purposes. When using a replacement transformer, BE SURE TO USE A 3A2 HV RECTIFIER TUBE.

Two versions of the high voltage transformer assembly were used in the TS-425 chassis under Part No. 24C742676. Both versions have identical primary and secondary windings, but they differ in the high voltage rectifier tube and circuits used. One transformer used the 1X28 HV rectifier with a 3.3 ohm resistor in series with one of the filament leads; the second transformer used a 3A2 HV rectifier with



MOTOROLA Chassis TS-425, etc. Service Notes and Production Changes.

SERVICE NOTES

TO REMOVE THE CHASSIS

1. Remove receiver's back cover. NOTE: Lug that is secured to top retainer screws as a counterpoise for Monopole antenna. When replacing cover, make sure lead is again attached under screw.
2. Remove all operating control knobs.
3. Using a protective pad, position the cabinet so the bottom screws are accessible. Remove the two screws holding the chassis to the cabinet (these screws are located midway between the front and rear of the cabinet).
4. Remove the screw, inside the cabinet, securing the top

of the chassis to the cabinet bracket.

5. Disconnect the yoke plug and chassis clip lead to cabinet.
6. Disconnect the speaker leads. If necessary, remove speaker.
7. Disconnect the picture tube socket.
8. Carefully slide the chassis toward the rear of the cabinet. When the chassis is near the end of the cabinet, it will be necessary to swing the right-hand side of the chassis (as viewed from the rear) outward and the left-hand side of the chassis inward to give sufficient room between the chassis and the cabinet for disconnection of the high voltage anode

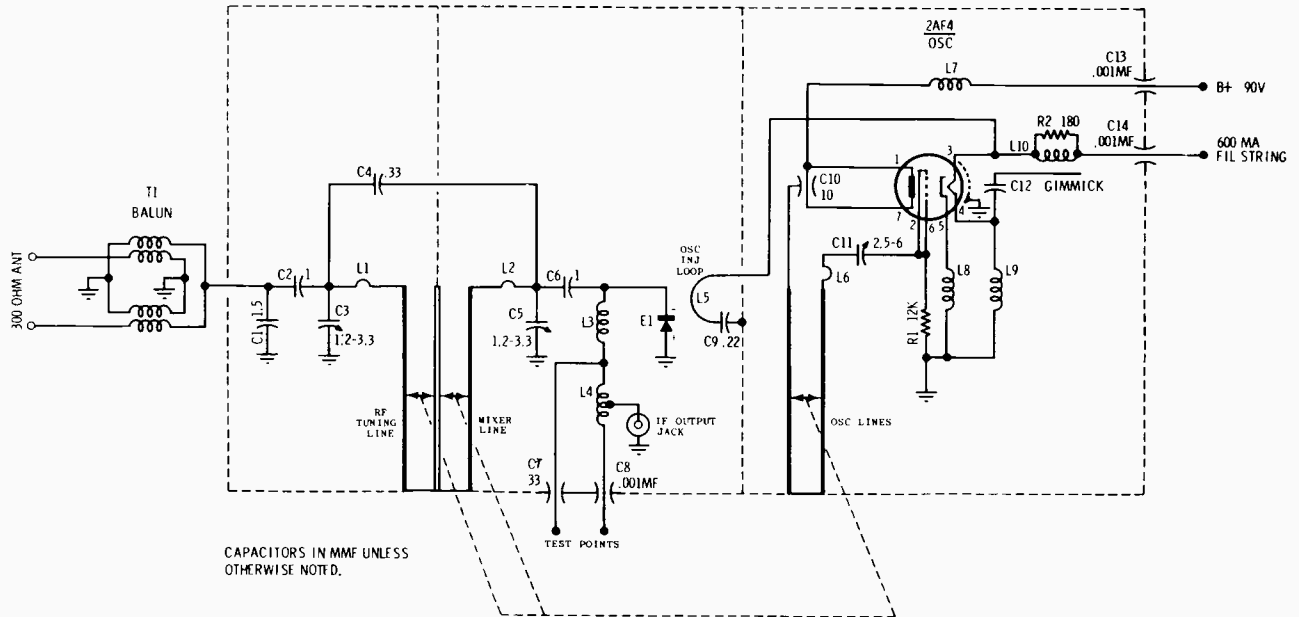

UHF TUNER SCHEMATIC DIAGRAM

PRODUCTION CHANGES

TS-425A-01 thru A-10

Chassis Coding	Changes	Chassis Coding	Changes
A-01	TO IMPROVE TUNER OSCILLATOR STABILITY: New cement is used to prevent movement of coils.	A-06	TO REDUCE NEED FOR QUADRATURE COIL ADJUSTMENT AFTER THE AUDIO IF (5U8) TUBE IS CHANGED: R-313 (220K) is added between pin #2 of Audio IF tube and ground; C-302 (.0015 mf) changed to .002 mf.
A-02	HIGH VOLTAGE RECTIFIER TUBE & CIRCUIT CHANGE: V-14 (1X2B) changed to 3A2; R-516 (3.3) removed (filament leads now connected to pins 2 and 9 of high voltage rectifier tube socket); R-519 (27K) added in series with second anode lead.		TO MINIMIZE CORONA DUE TO PROXIMITY OF FILTER CHOKE & SECOND ANODE LEAD: Vinyl plastic tape added to corner of choke nearest 2nd anode lead.
A-03	TO ELIMINATE HORIZONTAL RASTER DISTORTION: Physical location of L-801 (filter choke) and T-601 (vert output trans) are interchanged; connections on "tie points" (pins #1 and #3 of V-12--12DQ6) are interchanged. NOTE: There are no electrical circuit changes involved in the A-03 changes.	A-07	TO ELIMINATE A 60 CYCLE HORIZONTAL INTERFERENCE LINE: C-810 (.001 mf) is added across E-802 (silicon rectifier).
A-04	TO RAISE THE LINE VOLTAGE DESIGN CENTER TO 122VAC: R-803 (20) changed to 25 ohms.	A-08	ELECTROLYTIC CHANGE: C-801 (three-section) and C-122 (one-section) replaced by C-811 (4-section -Part No. 23B744100).
A-05	TO REDUCE CORONA SPRAY FROM THE SECOND ANODE CONNECTOR CLIP: New second anode clip & lead assembly (including rubber cup) is added to high voltage transformer.	A-09	TO IMPROVE VERTICAL STABILITY: C-618 (.0033 mf) added between ground and junction of C-601 (.001 mf) and R-601 (180K); R-616 (2.2 meg) added across Vertical Hold control (R-603).
		A-10	VOLTAGE RATING INCREASE: C-611 (.002 mf) voltage rating increased from 1,000V to 2,000V.

# MOTOROLA

The material on the next ten pages is exact for Chassis TS-426, used in Models 17P1-1, 17P1-2, 17P2-1, and Chassis TS-426Y, used in Models Y17P1-1A, Y17P1-2A, Y17P2-1A. In addition, Chassis TS-428, used in Models 17T30CH, 17T31GP, and Chassis TS-428Y, used in Models Y17T30CHA, Y17T31GPA, is very similar to TS-426, -Y. The "H" panel used incorporates changes in high voltage and sweep systems to operate 17BJP4 (90° deflection) picture tube. The last page of this section has a partial circuit diagram showing these changes. Tuner TT-101, used in TS-428, is identical to TT-95 used on the TS-426, except for shaft length.

### SAFETY PRECAUTIONS

1. Do not service this chassis on a metal plate, due to the possibility of a short circuit through the exposed leads and terminal plating.
2. Use caution when handling the chassis with power applied, since all leads (high voltage, power line, etc.) are

exposed. Always use an isolation transformer when servicing this receiver.

3. The outer edge of the chassis and various plated areas are at power line potential.

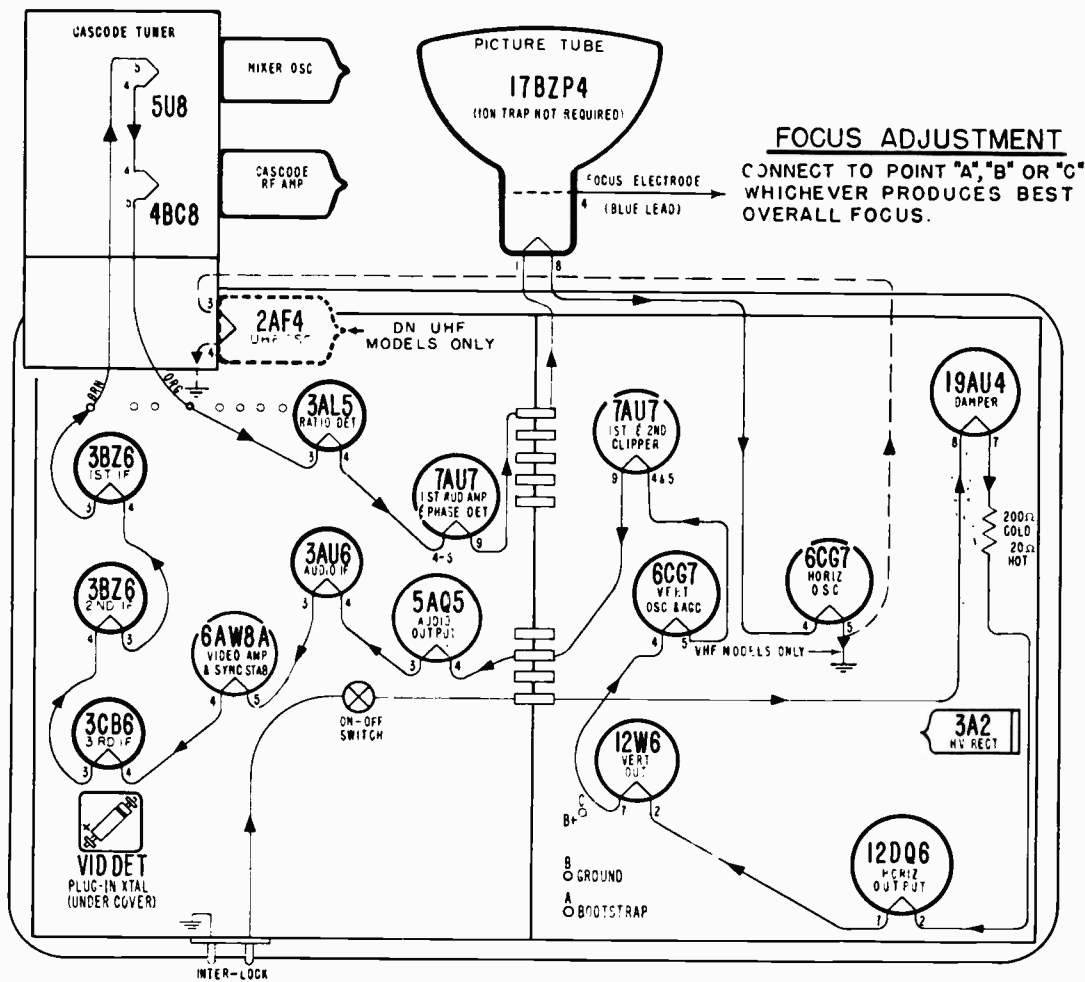

TUBE LOCATION AND FILAMENT WIRING

MOTOROLA Chassis TS-426, "I" Panel Parts Locations, Continued

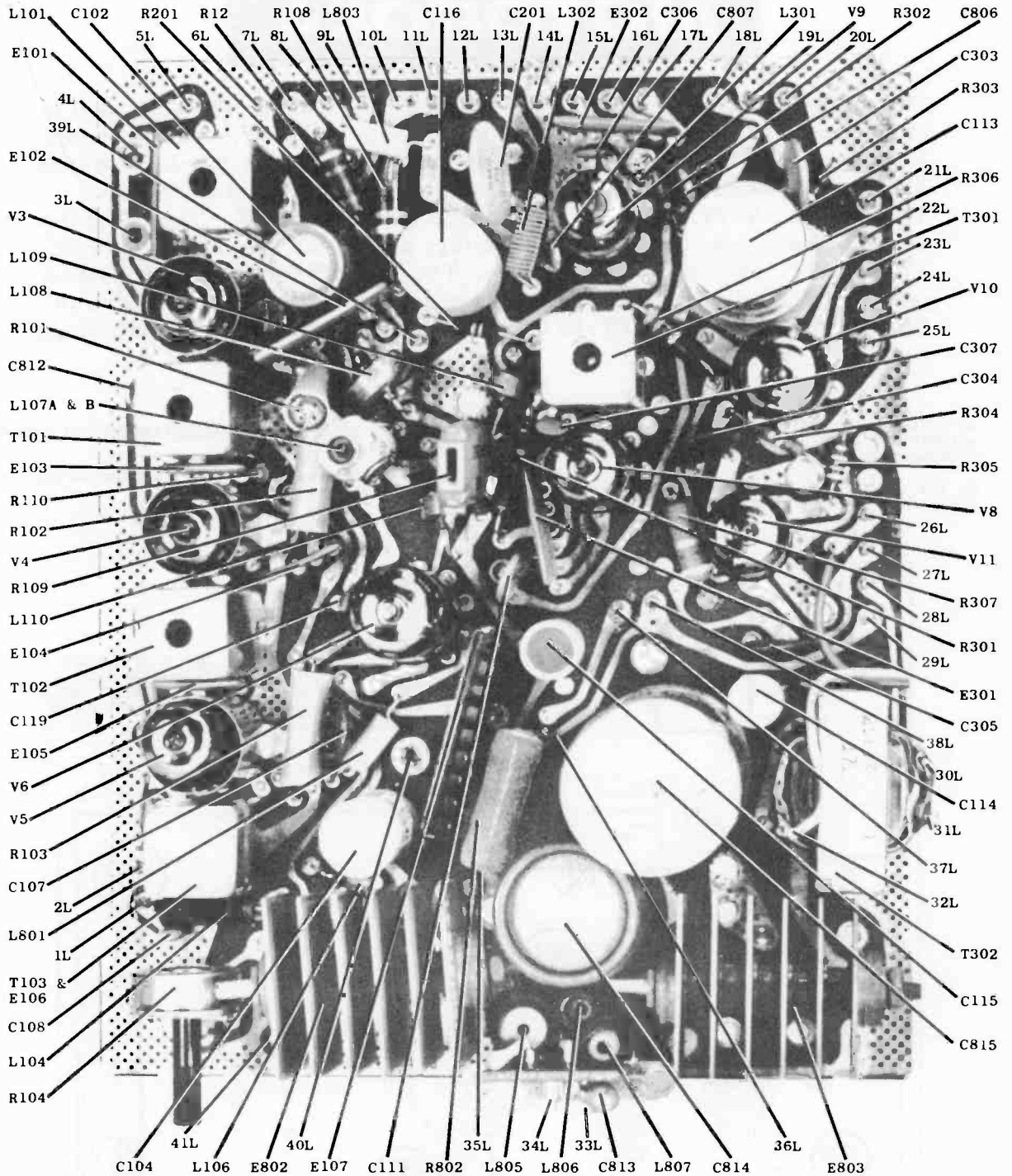

"I"-PANEL PARTS LOCATIONS

The Model TS-426 plated circuit chassis is composed of two, separate, plated panel boards. The left-hand panel board (viewed from rear of receiver) contains the IF, video amplifier and sound systems and is identified as the "I" panel. The right-hand panel contains the high voltage, sweep and sync systems and is identified as the "H" panel.

The "H" and "I" panel boards are interconnected by 9 small clip-type connectors between the panels. These connectors are visible from the top of the chassis and, due to ease of accessibility, provide excellent test points for trouble shooting.

The panel boards are secured to the metal chassis pan by means of self-tapping screws, chassis punch-out tabs arranged around the edges of the panels, and on the underside of the "I" panel, two grounding braids soldered between the panel and the chassis pan. These metal chassis tabs ground the plated-panels since the entire outer edges of the panels (checkerboard sections) are part of the ground system.

The panel boards are plated on both sides (top and bottom) and the circuitry is conventional in the respect that

MOTOROLA Chassis TS-426, "H" Panel Parts Locations, Continued

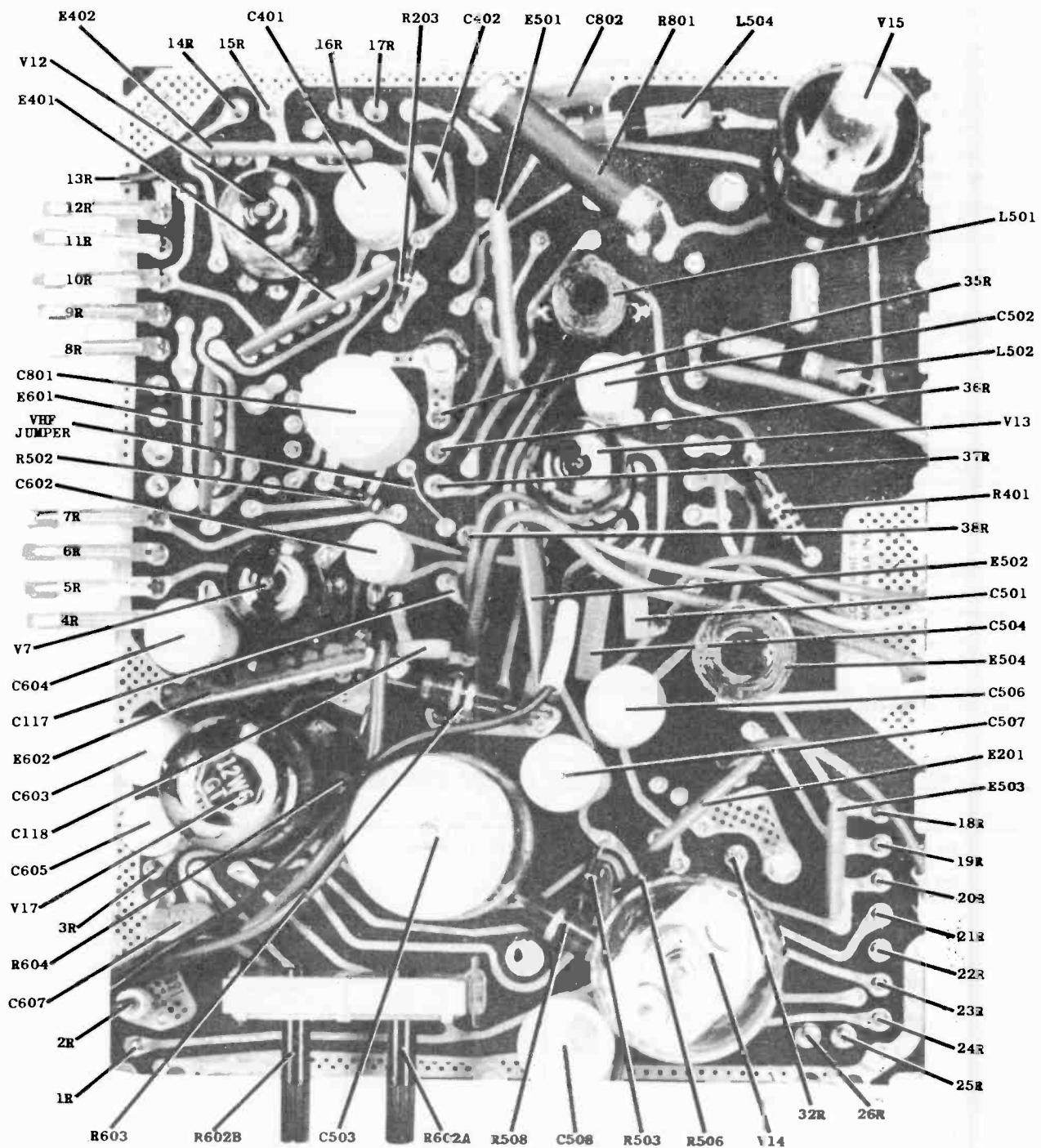

"H"-PANEL PARTS LOCATION

there are no built-in resistors or capacitors in the plating: The plating composes only the wire connections of the receiver. All component parts are mounted to the top side of the panels and with the exception of removal of components for replacement (by unsoldering), or the necessity of inspecting the underside of the panels for cracked or broken connections, there should be no need for removing the panels from the metal chassis.

The left-hand chassis board ("I" panel) has all exposed test points and wiring connector points identified by a num-

ber followed by the letter "L". The numbering starts with "1L" in the lower left-hand corner and progresses numerically around the outer edge of the board in a clockwise manner. The right-hand chassis board ("H" panel) uses an identical identification system except that all numbers have an "R" suffix. This system makes it possible to instantly locate any test point physically on either the left or right-hand chassis when transferring information from the schematic to the actual receiver.

MOTOROLA Chassis TS-426, Alignment Information, Continued

CHASSIS POSITION FOR EASE OF SERVICING

The chassis can be partially removed for general service work by removing: the rear cover, the side panel operating knobs, four bottom screws (screws underneath cabinet) and the ground braid connecting the tuner, chassis and control bracket. Slide the chassis out of the cabinet as far as the lead lengths will allow.

NOTE: Sliding the chassis out of the cabinet allows the aquadag coating of the picture tube to float... which might cause arcing and interference problems. Therefore, it is advisable to provide a ground from the coating to chassis by means of a wire taped to the coating and clipped to the receiver chassis.

To completely remove the chassis, add the following procedure to the foregoing information.

1. Unplug the tuner cable and volume control leads from the chassis.

2. Unplug the picture tube socket, high voltage anode lead, yoke leads, and tuner ground braid from the chassis.

3. Unplug the leads from the speaker terminal board.

4. Remove the chassis.

5. Loosen the two screws securing the tuner bracket assembly to the cabinet (located towards the front of the cabinet).

6. Remove the two screws (located at rear of cabinet) securing the tuner bracket assembly to the cabinet and remove tuner and volume control (front tuner screws may remain in cabinet).

7. Remove the two speaker retainer nuts and remove the speaker.

NOTE: To have the receiver operate a speaker during "bench" servicing (with the phone jack leads disconnected), connect a shorting wire between terminals 5S and 6S of the speaker terminal strip.

ALIGNMENT

SERVICING THE IF SECTION

Before alignment of the video IF section is attempted, it is advisable to thoroughly check the IF system. If alignment is started on an IF section in which a faulty component exists, successful alignment will probably be impossible and

the entire procedure will have to be repeated when the real cause of the trouble is corrected. Preliminary tests of the system should include voltage and resistance measurements, routine check for bad soldering connections, and visual inspection of the circuits for overheated components as well as for obvious wiring defects.

VIDEO IF & MIXER ALIGNMENT

Pre-Alignment Information

1. Remove the deflection yoke lead plugs from the chassis (remove the hex head screw first).
2. Apply negative lead of a 6 volt bias supply to the IF AGC test point (12L): remaining lead to chassis ground.
3. Connect a 2200 ohm 50 watt resistor between the B++ line (26L) and chassis ground.

4. Disable tuner oscillator by shorting point (N), on top of tuner near 5U8, to chassis.

5. Maintain line voltage at 120 by use of variac.

6. Tune all coil slugs TOWARD the chassis except the following which are tuned away from the chassis... T-102 top, T-101 top and L-101.

7. Refer to Figure 11, Video IF and Sound Alignment Detail, for coil and test point locations.

VIDEO IF & MIXER ALIGNMENT PROCEDURE

NOTE: The sweep generator output cable should be properly terminated. If not terminated, connect a resistor across the cable's output terminals equal in value to that of the generator output impedance.

STEP	SIGNAL GENERATOR	INDICATOR	ADJUST	ADJUST FOR AND/OR REMARKS
1.	To 1st IF TP (3L) thru a .01 mf capacitor. Set at 44 Mc with 10 Mc sweep width	Scope thru 47K resistor to video detector test point (1L)	T-101 (top slug)	Minimum response at 41.25 Mc. See step #6 in Pre-Alignment.
2.	"	"	T-102 (top slug)	Minimum response at 47.25 Mc. See step #6 in Pre-Alignment.
3.	"	"	T-101 (bot slug)	Maximum gain and 42.25 Mc marker position.
4.	"	"	T-102 (bot slug)	Maximum gain and 45.75 Mc marker position.
5.	"	"	T-103 (bot slug)	Best symmetry and flat response.
Repeat the above procedure until curve "A" is obtained.				
6.	To tuner's mixer test receptacle (F). Set at 44 Mc with 10 Mc sweep width	Scope thru 47K resistor to video detector test point (1L)	L-101 & L-15 simultaneously	Maximum gain and 45.75 Mc marker position. See curve "B" and step #6 in Pre-Alignment.

IF ALIGNMENT CHECKS

BANDWIDTH

Bandwidth may be determined by noting the marker frequencies at the 50% points on the curve. Mixer and IF bandwidth over 3.7 Mc may result in sound bars or burble in the picture; if less than 3 Mc, a loss of resolution will be noticed.

REGENERATION

Remove bias and decrease generator signal until there is a marked decrease in the oscilloscope waveform amplitude. Unwanted regeneration will be indicated by spikes on the overall response curve at about 43 Mc. Curve peaking up to 50% at approximately 45 Mc is normal. If regeneration is present, check IF circuit cathode resistors, bypass capacitors and lead dress.

MOTOROLA Chassis TS-426, Alignment Information, Continued

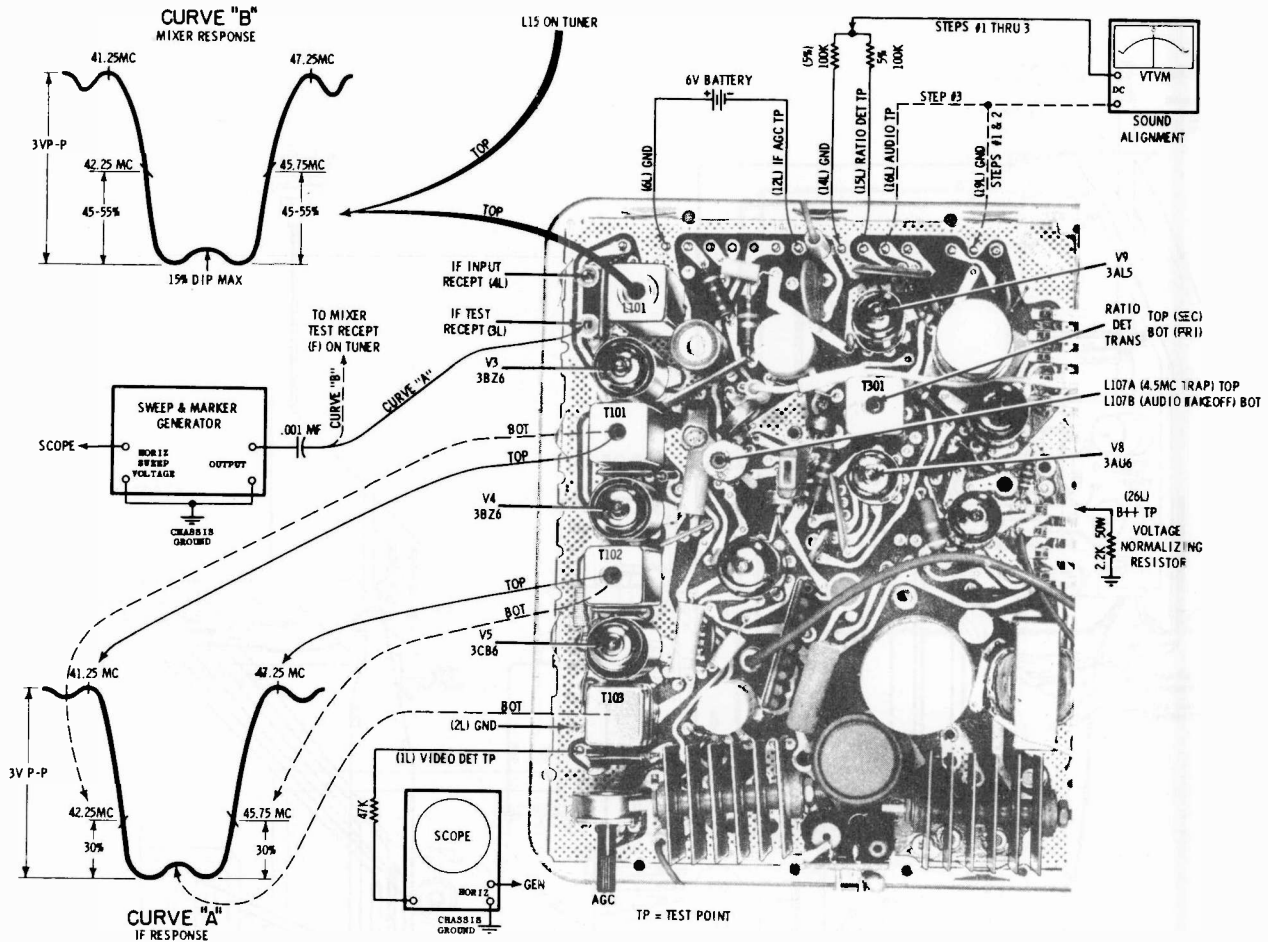

FIGURE 11. IF & SOUND ALIGNMENT DETAIL

SOUND ALIGNMENT

This alignment may be made by injecting an accurate 4.5 Mc signal into the VIDEO DETECTOR test point. A second practical method is the use of a station transmission after a preliminary alignment is made with a fairly accurate generator. The latter method will produce an accurate 4.5 Mc signal at the output of the video detector.

The alignment procedure will be the same whether the test signal originates from a crystal controlled generator or from a station.

Pre-Alignment Information

1. Set contrast control to maximum.
2. Maintain approximately 3 to 5 volts on the VTVM.
3. Correct point of tuning is with slugs tuned away from each other.
4. Refer to Video IF and Sound Alignment Detail (Figure 11) for coil and test point locations.

SOUND ALIGNMENT PROCEDURE

STEP	SIGNAL GENERATOR	INDICATOR	ADJUST	ADJUST FOR AND/OR REMARKS
1.	To video detector T. P. (1L) thru a .005 mf capacitor at 4.5 Mc	VTVM to center tap of two 100K (5%) resistors in series from T. P. (15L) to chassis ground (Fig. 11).	L-107B (bot slug)	Maximum deflection
2.	"	"	T-301 (bot slug)	" "
3.	"	VTVM between center tap of 100K ohm resistors and T. P. (16L).	T-301 (top slug)	Zero voltage reading.

4.5 MC TRAP ADJUSTMENT

1. Carefully tune receiver to local station and advance the contrast control.
2. Adjust tuner's local oscillator (with the fine tuning control) to bring the 4.5 Mc interference strongly into the picture.

3. ADJUST...4.5 Mc trap (L-107A) to find the two points of adjustment at which the sound beat is just noticeable on the picture tube screen. Rotate the core toward center of the two points. Use minimum amount of inductance (core out of coil) that will result in no apparent beat interference.

VOLUME TV-14, MOST-OFTEN-NEEDED 1958 TELEVISION SERVICING INFORMATION

MOTOROLA Chassis TS-426, Locations of Controls, Connections, Test Points

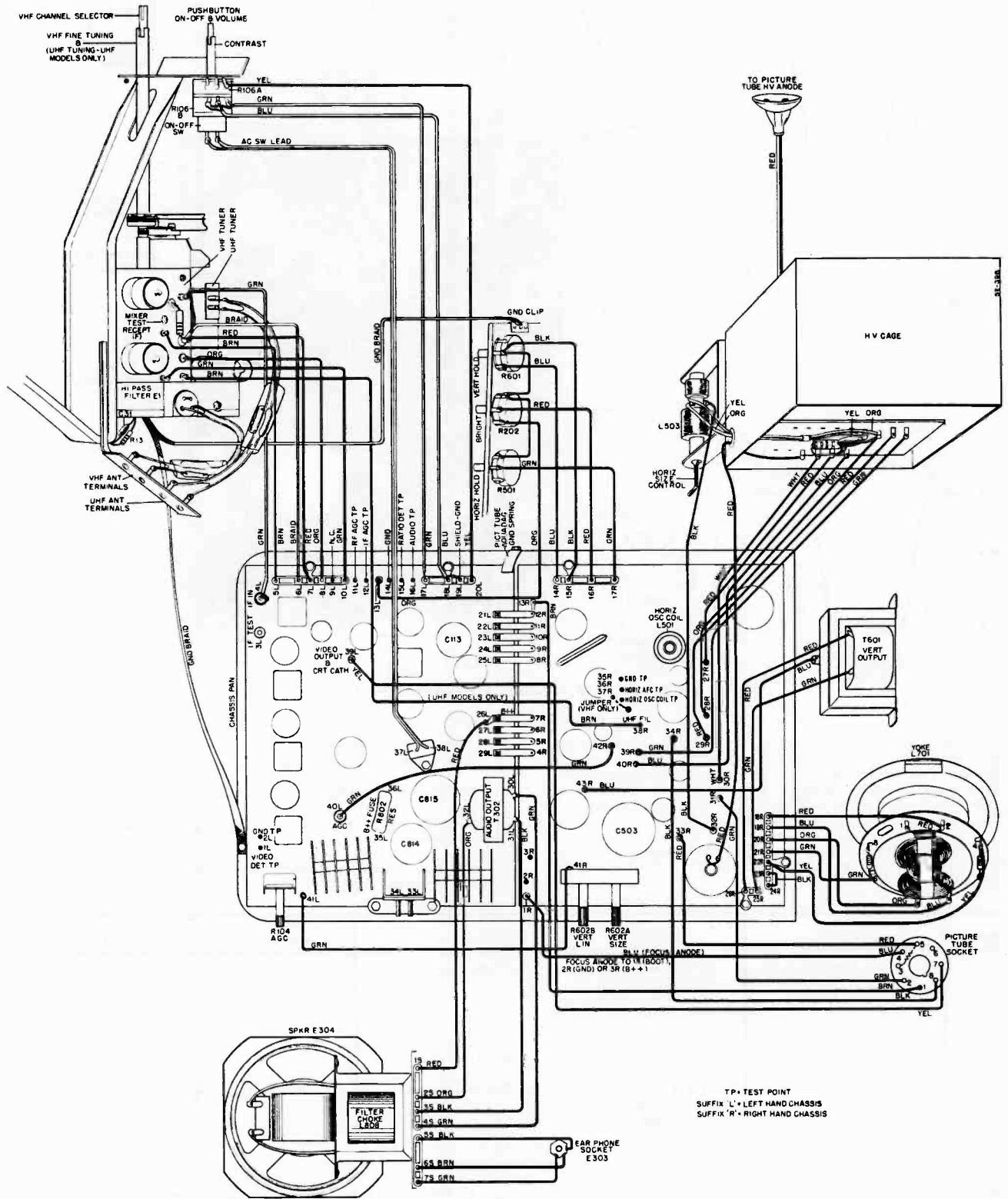

TP = TEST POINT  
 SUFFIX 'L' = LEFT HAND CHASSIS  
 SUFFIX 'R' = RIGHT HAND CHASSIS

CONTROLS, CONNECTIONS AND TEST POINT LOCATIONS



VOLUME TV-14, MOST-OFTEN-NEEDED 1958 TELEVISION SERVICING INFORMATION

MOTOROLA Chassis TS-426, Part of Schematic Diagram, Continued on next page.

(Wires ending and marked connect to corresponding wires of main diagram)

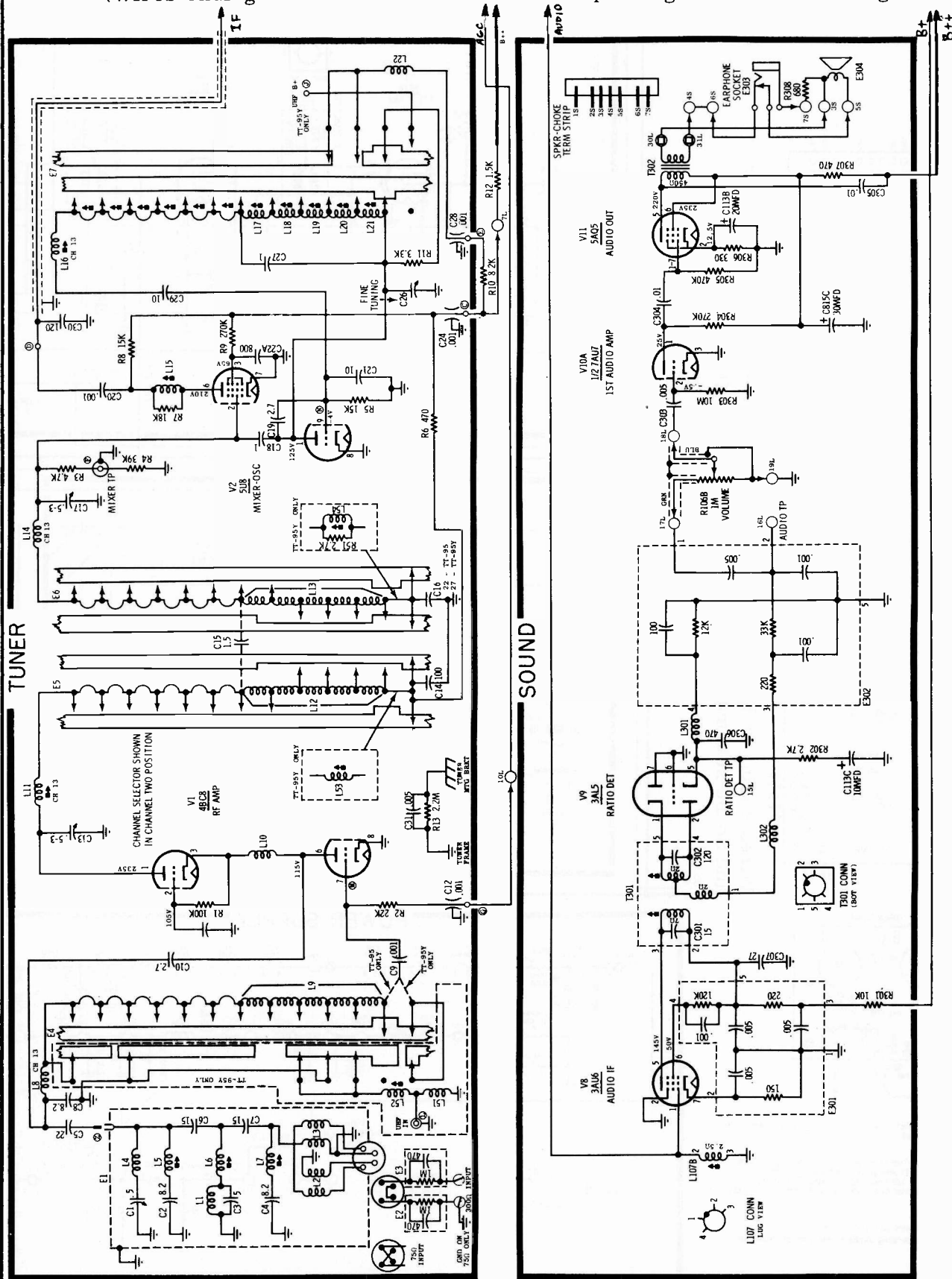

Part of schematic diagram. Wires ending and marked connect to corresponding wires of main schematic printed on the next two pages. This separation is made for printing convenience only.



VOLUME TV-14, MOST-OFTEN-NEEDED 1958 TELEVISION SERVICING INFORMATION

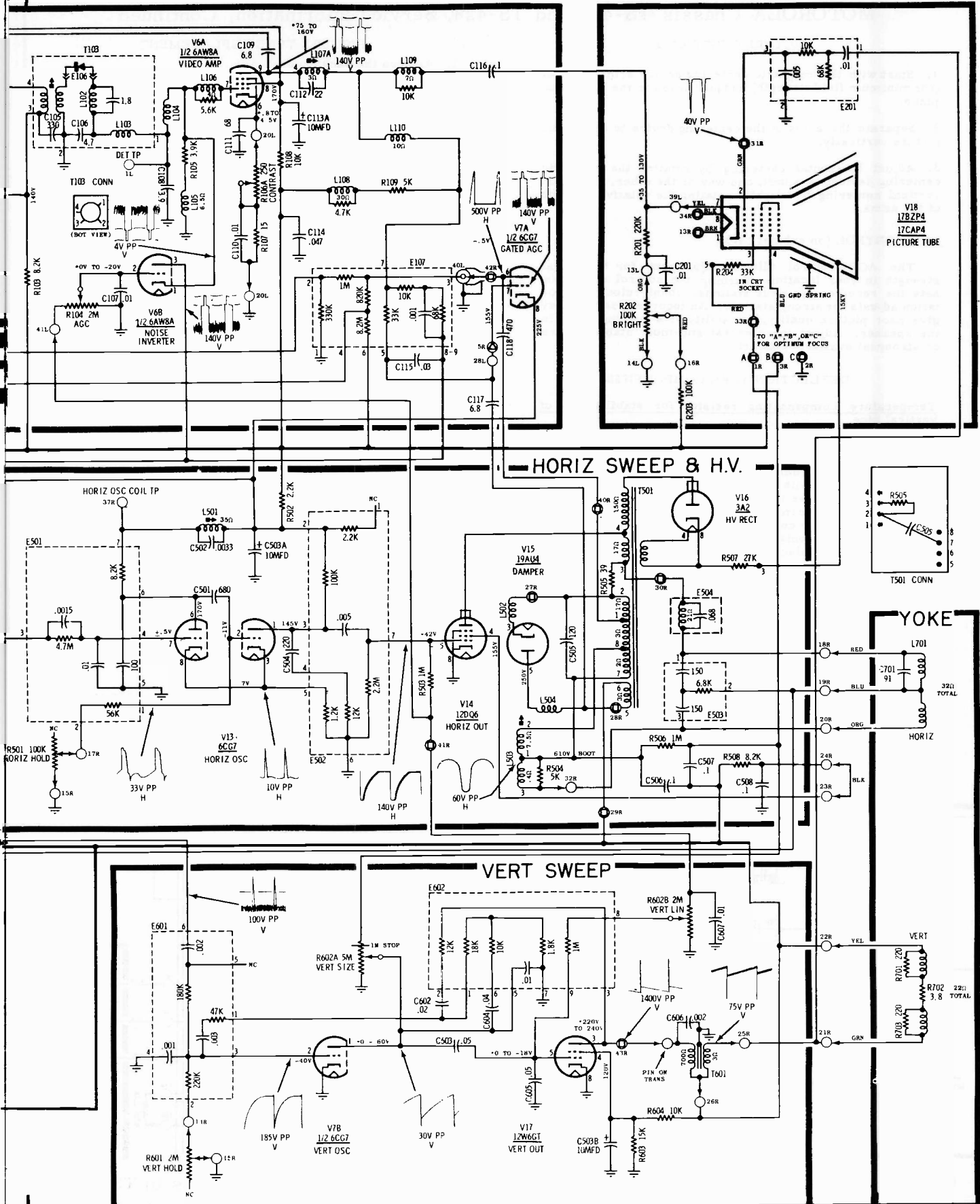

MOTOROLA Chassis TS-426 and TS-428, Service Information, Continued

PICTURE CENTERING

1. Start with the magnetic centering device arms together (for minimum field strength) and positioned in the horizontal plane.
2. Separate the arms of the centering device to center the picture vertically.
3. Adjust horizontal centering by rotating the magnetic centering device, as a unit, one way or the other. Readjust vertical centering by slightly rotating the relative position of the arms.

AGC CONTROL (on cabinet back)

The AGC control allows adjustment for the signal strength in your location. Turning the control clockwise sets the receiver for weak stations: counterclockwise rotation adjusts for strong stations. An incorrect setting may give poor picture quality, instability or a buzzing sound in the speaker. Adjust for clearest and most stable picture on strongest available channel.

DEFLECTION YOKE COMPONENTS

Temperature compensating resistor for stabilization of vertical size

To maintain constant vertical size, regardless of resistance changes occurring in the vertical deflection yoke winding, a temperature compensating resistor (R-702) is incorporated in series with the vertical winding. This resistor is located on the yoke itself and, depending on the receiver model, will either be imbedded in the yoke fibre and in close contact with the yoke core... or mounted to the periphery of the yoke and in contact with the yoke core by means of a metal strip held in place by the yoke core band. A defect in the temperature compensating resistor could result in loss of vertical sweep or reduction in vertical size of the raster and picture.

Pincushion magnets

Pincushion magnets, in both the vertical and horizontal planes, are provided as part of the yoke. These magnets are glued into pockets provided in the yoke flare and, under normal operating circumstances, require no service or adjustment.

The magnet polarity is indicated by a paint dot on one end. If it should be necessary to replace a magnet, polarize magnet with paint dot running in same direction as other three magnets.

PICTURE TUBE REPLACEMENT

1. Remove the back cover.
2. Remove the two screws underneath the cabinet, holding the front of the cabinet, and remove the front by swinging the bottom outward and then lifting over the top retainer projections.
3. Remove the picture tube socket, neck components and the high voltage anode lead.
4. Remove the two upper corner screws securing the picture tube to the cabinet and take the picture tube out of the front of the cabinet.
5. Replace black tape around tube mounting area and replace tube in reverse order to that given above.

PRODUCTION CHANGES TS-426A-01 thru A-03

Chassis Coding	Changes
A-01	TO DECREASE SYNC BUZZ: R-502 (2200) changed to 3900 thereby decreasing the voltages, at the cathode of V-7A (AGC) and at the plates of V-13 (Horiz Osc), by approximately 10 volts.
A-02	TO DECREASE RINGING: C-509 (470 mmf) and R-509 (820) were wired in series and then paralleled across R-504 (5K).
A-02-1	SAME AS A-03 CHANGE. NOTE: The high voltage transformer (T-501) was erroneously stamped 24C744406 but has a red dot as the distinguishing code. Order 24K745702 as a replacement for the red coded 24C744406.
A-03	TO INCREASE HIGH VOLTAGE & HORIZ SIZE: T-501 (high voltage transformer) changed: T-501 primary coil changed: C-505 (120 mmf) changed to 100 mmf: L-503 (Horiz Size Coil) changed: R-504 (5K) removed: R-508 (8200) changed to 5600.

Chassis coded A-02-1, A-03 and later, should use the 24K745702 high voltage transformer and a 24K745704 Horiz Size Coil.

Chassis coded A-00, A-01 & A-02, should use 24C744406 high voltage transformer and a 24C745936 Horiz Size Coil.

The two parts should not be indiscriminately interchanged as "ringing" could appear if the parts are not properly matched and the other circuit changes are not made.

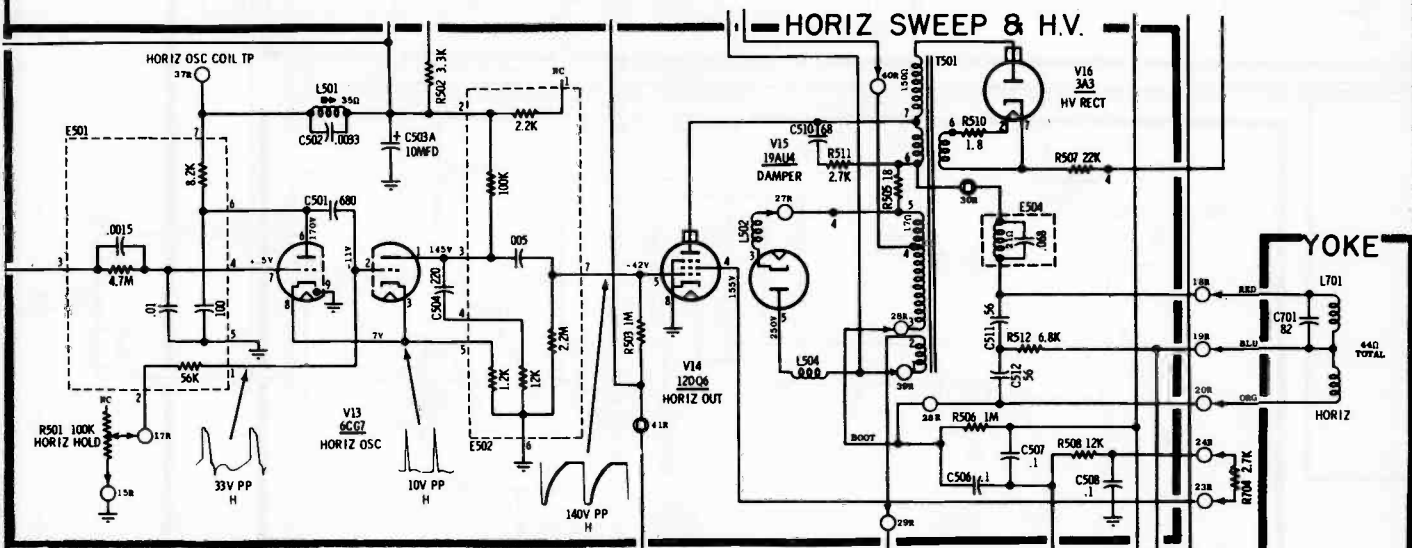

Circuit of Horizontal Sweep and H. V. as used in Chassis TS-428. (Balance as in TS-426)

# MOTOROLA

CHASSIS  
TS-542

MODELS  
21T37 & 21K70 Series

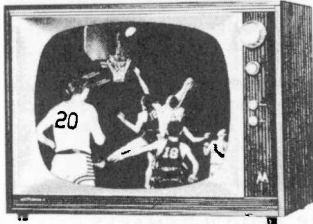

21T37

RECEIVER MODEL BREAKDOWN CHART

Model	Cabinet	TV Chassis	VHF Tuner	UHF Tuner
21K70B	Console, limed oak: masonite	TS-542	TT-96	-
Y21K70B	Console, limed oak: masonite	TS-542 Y	WTT-96	77K744280
21K70M	Console, sienna mahogany: masonite	TS-542	TT-96	-
Y21K70M	Console, sienna mahogany: masonite	TS-542 Y	WTT-96	77K744280
21T37B	Table, blonde oak: masonite	TS-542	TT-96	-
Y21T37B	Table, blonde oak: masonite	TS-542 Y	WTT-96Y	77K744280
21T37M	Table, sienna mahogany: masonite	TS-542	TT-96	-
Y21T37M	Table, sienna mahogany: masonite	TS-542 Y	WTT-96Y	77K744280

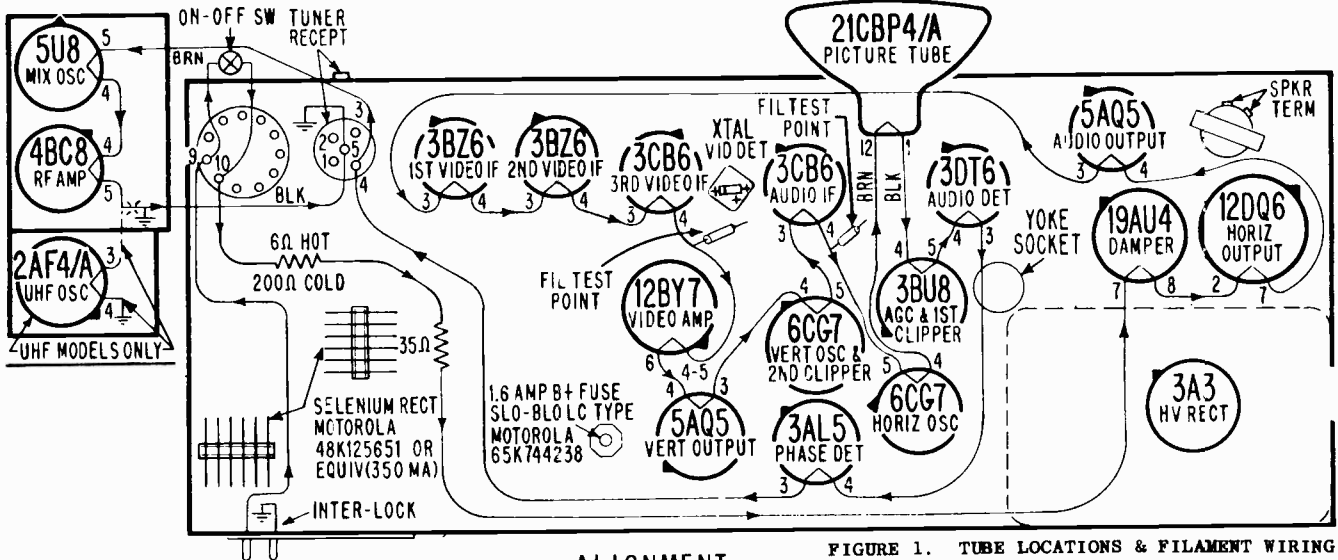

FIGURE 1. TUBE LOCATIONS & FILAMENT WIRING

ALIGNMENT

SERVICING THE IF SECTION

Before alignment of the video IF section is attempted, it is advisable to thoroughly check the system. If alignment is started on an IF section in which a faulty component exists, successful alignment will probably be impossible and the

entire procedure will have to be repeated when the real cause of the trouble is corrected. Preliminary tests of the system should include voltage and resistance measurements, routine checks for bad soldering connections, and visual inspection of the circuits for overheated components as well as for obvious wiring defects.

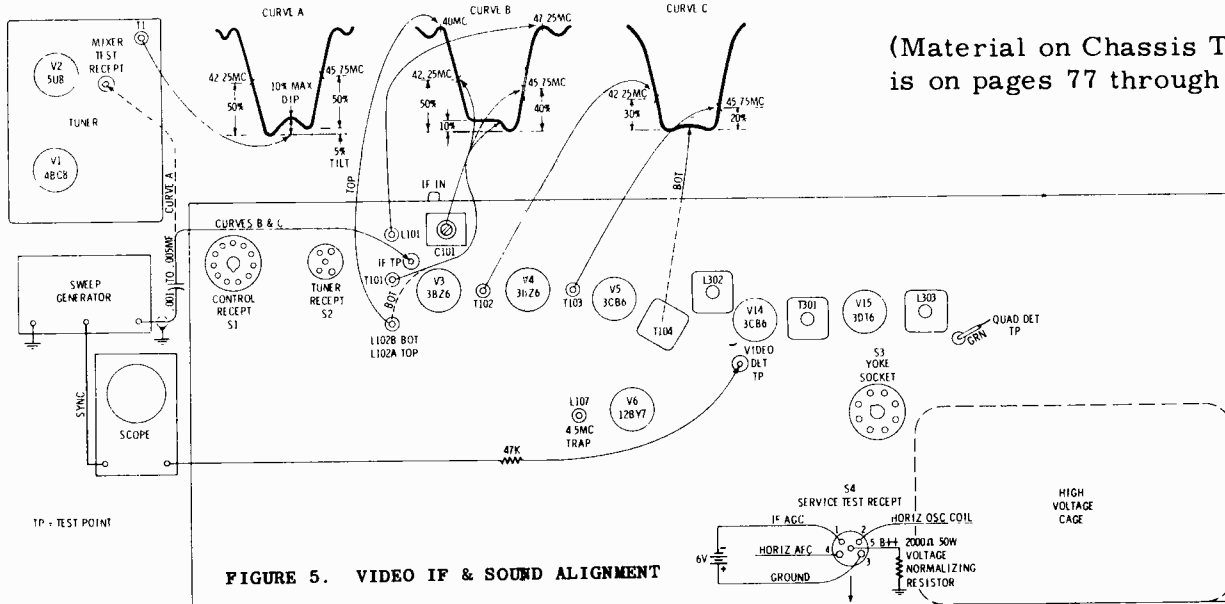

FIGURE 5. VIDEO IF & SOUND ALIGNMENT

(Material on Chassis TS-542 is on pages 77 through 82)

MOTOROLA Chassis TS-542, Alignment Information, Continued

VIDEO IF & MIXER ALIGNMENT

Pre-Alignment Steps

1. Maintain line voltage at 120 with variac.
2. Remove the deflection yoke plug to eliminate RF interference radiation.
3. Short pin #9 of oscillator tube (V-2) to chassis.
4. Apply...negative lead of a 6V bias supply to pin #1 of

the Service Test Receptacle and the positive lead to pin #3.

5. All coil slugs should be tuned away from the chassis except 3rd IF, mixer secondary coil and 40 Mc trap coil which are tuned toward chassis.

6. Refer to Video IF & Mixer Alignment Detail for component and test point location (Figure 5).

7. Set channel selector on channel #13 and connect a 2000 ohm 50W voltage normalizing resistor from B++ to chassis. (Use pins #5 and #3 of the Service Test Receptacle.)

VIDEO IF & MIXER ALIGNMENT PROCEDURE

STEP	SWEEP GENERATOR	INDICATOR	ADJUST	ADJUST FOR AND/OR REMARKS
1.	To IF TP thru .001 mf capacitor at 44 Mc. Set to 10 Mc sweep width	Scope thru 47K resistor to video det TP	T-102	Correct 42.25 Mc marker position as shown in curve C.
2.	"	"	T-103	Correct 45.75 Mc marker position (curve C).
3.	"	"	T-104	Flat response with minimum curve tilt (curve C).
4.	To MIXER TEST RECEPT thru .001 mf capacitor at 44 Mc. Set to 10 Mc sweep width	"	T-1	Adjust until its effect is out of the IF bandpass.
5.	"	"	L-101	47.25 Mc trap dip. See curve B.
6.	"	"	L-102A (top slug)	40 Mc trap dip. Temporary removal of bias may be necessary to make the trap dip more pronounced (curve B).
7.	"	"	C-101, T-101 & L-102B (bot slug)	Alternately adjust for correct curve and marker positions as shown in curve B.
8.	"	"	T-1	Flat response with 5% tilt as shown in curve A.

NOTE: Repeat any portion of the above procedure until the proper overall curve A is obtained.

SOUND ALIGNMENT  
(Station Signal Method)

The sound system used in the TS-542 receiver consists of an audio IF amplifier stage, a quadrature grid detector and an output stage. Since this type of sound system is extremely sensitive, relatively small input signal voltage will cause grid current to flow in both the IF amplifier and the detector stages. Grid current through the tuned coils will load them down making the adjustment extremely broad and alignment impossible. For this reason, it is necessary to use a very weak signal when aligning the driver and the de-

tor input coils. Actually, the signal should be well down into the noise level for proper tuning action.

Preliminary Steps

1. Tune in a strong TV station.
2. Adjust all controls for normal picture and sound.
3. Refer to Video IF & Mixer Alignment Detail for coil and test point locations (Figure 5).

SOUND ALIGNMENT PROCEDURE

STEP	STATION	INDICATOR	ADJUST	REMARKS
1.	Strong signal	VTVM to quad det test point (grn lead)	L-303	Maximum deflection (coarse adj.)
2.	"	Listening test	"	Maximum sound with minimum distortion (fine adj.)
3.	Weak signal*	"	T-301	Maximum sound with minimum distortion (maintain hiss level)
4.	"	"	L-302	"

If sound is not clear at this point, repeat the above procedure as necessary.

\*NOTE: The signal must be weakened considerably either by disconnecting one side of the antenna lead, or connecting low value resistors across the antenna terminals until a pronounced hiss appears in the sound. This hiss level must be maintained for proper alignment.

4.5 MC TRAP ADJUSTMENT

1. Carefully tune receiver to local station and advance contrast control.
2. Adjust local oscillator (with fine tuning control) to bring the 4.5 Mc interference strongly into the picture.

3. ADJUST...sound trap (L-107) to find the two points of adjustment at which the sound beat is just noticeable on the picture tube screen. Rotate the core toward center of the two points. Use minimum amount of inductance (core out of coil) that will result in no apparent beat interference.

VOLUME TV-14, MOST-OFTEN-NEEDED 1958 TELEVISION SERVICING INFORMATION

MOTOROLA Chassis TS-542, Part of Schematic,  
Corresponding wires connect to main schematic, page 80.

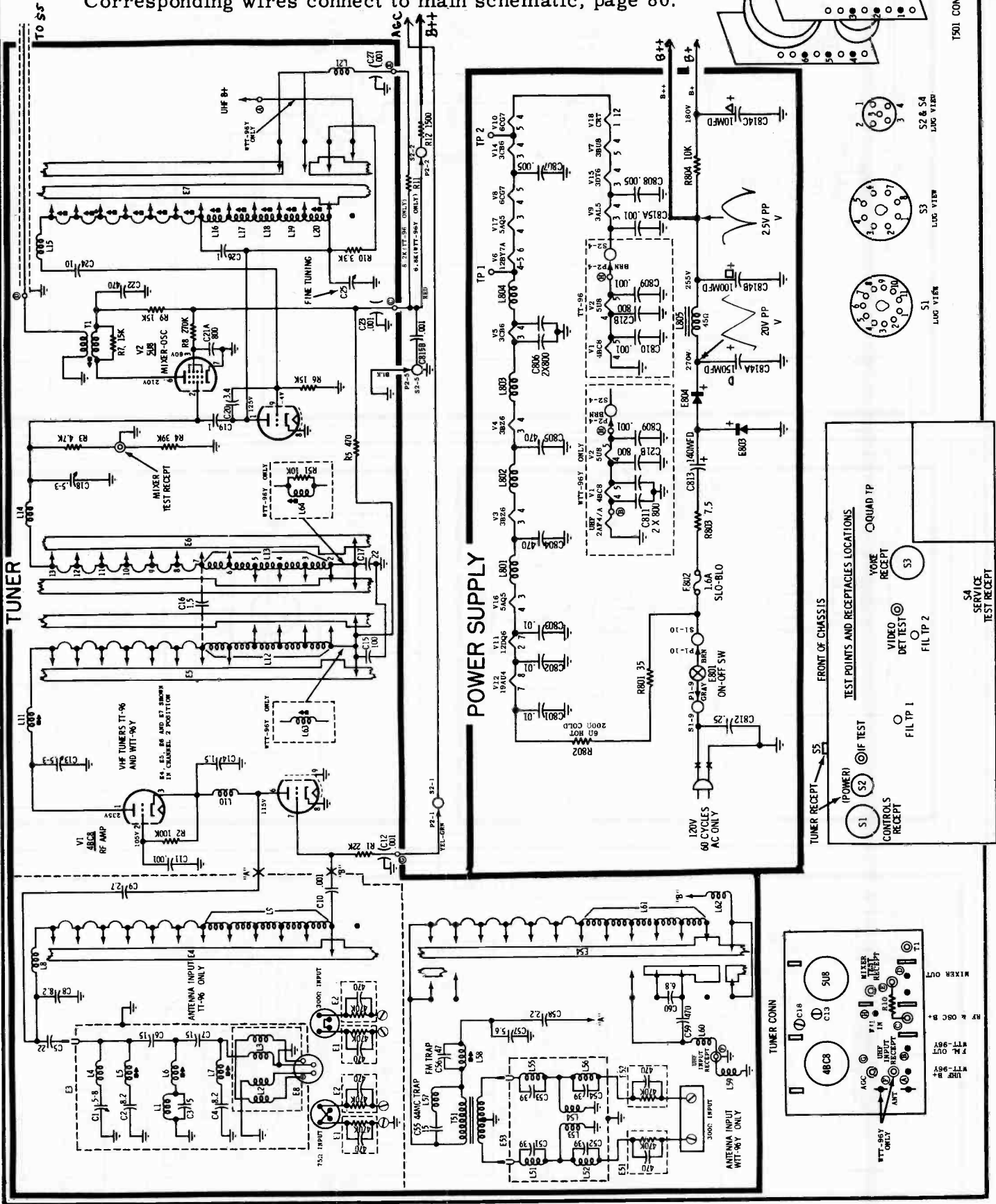



VOLUME TV-14, MOST-OFTEN-NEEDED 1958 TELEVISION SERVICING INFORMATION

VIDEO IF

These wires connect to balance of schematic printed on page 79.

MOTOROLA Chassis TS-542, Main Part of Schematic

CAPACITORS - Decimal values in MF, all others in MMF unless otherwise specified.

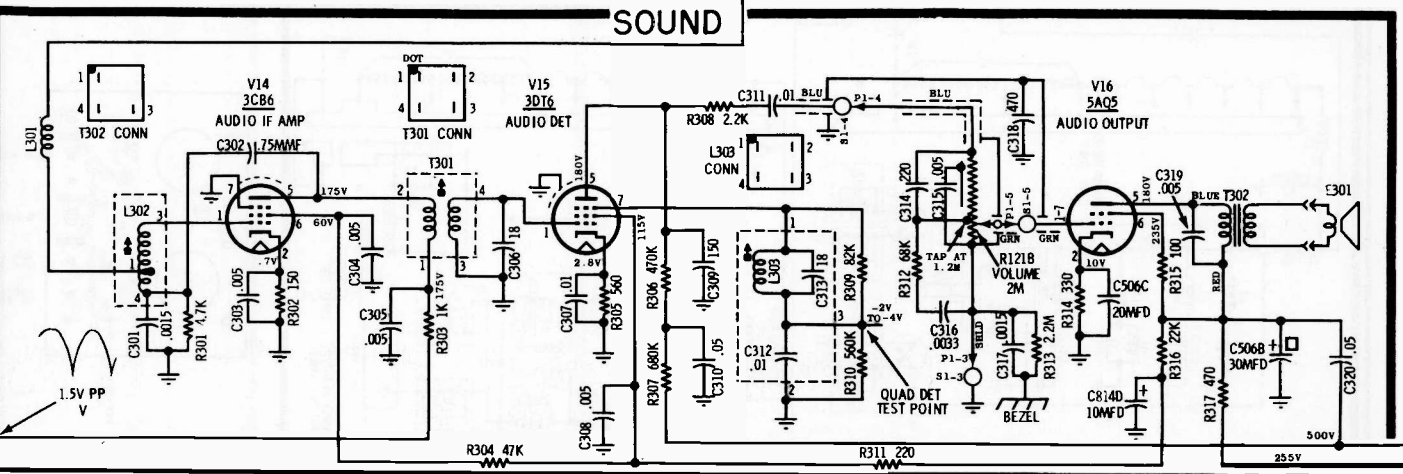
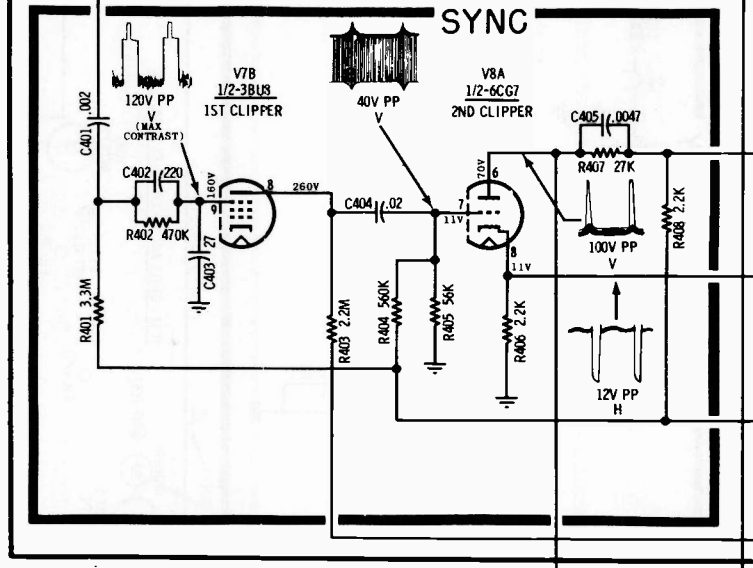
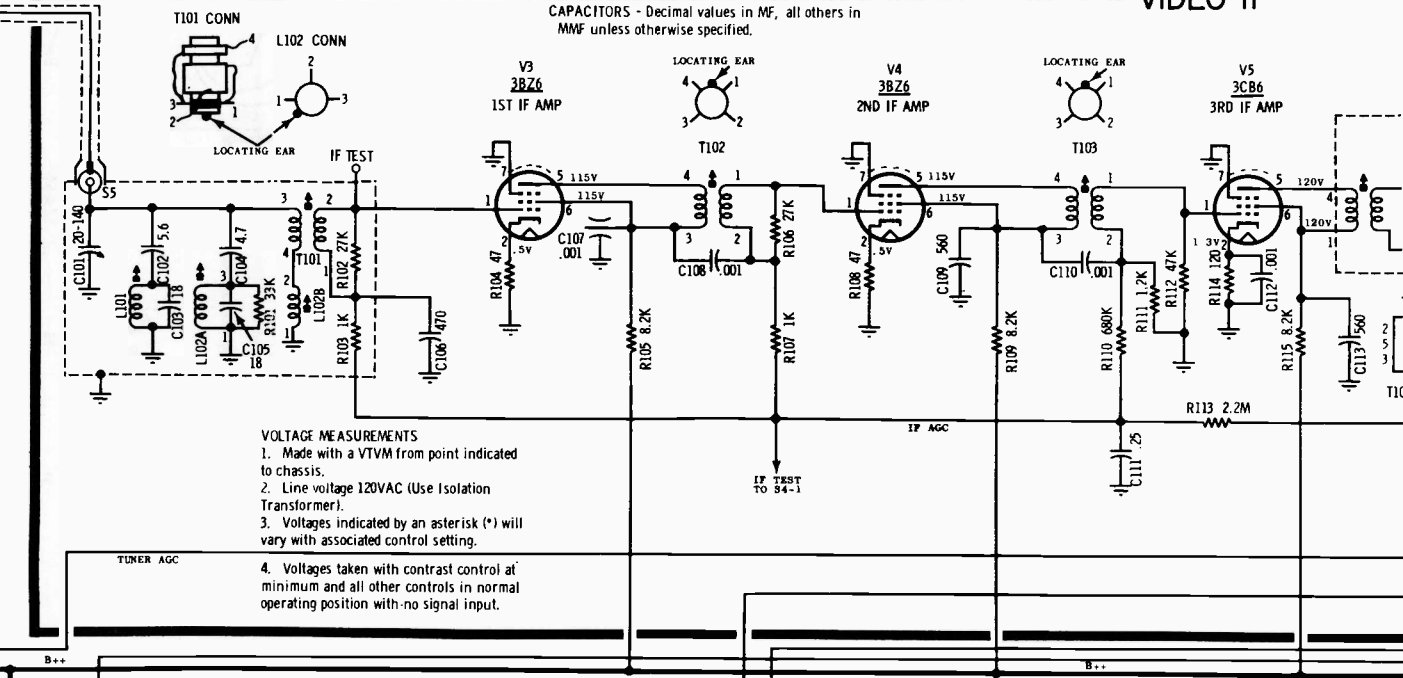

VOLUME TV-14, MOST-OFTEN-NEEDED 1958 TELEVISION SERVICING INFORMATION

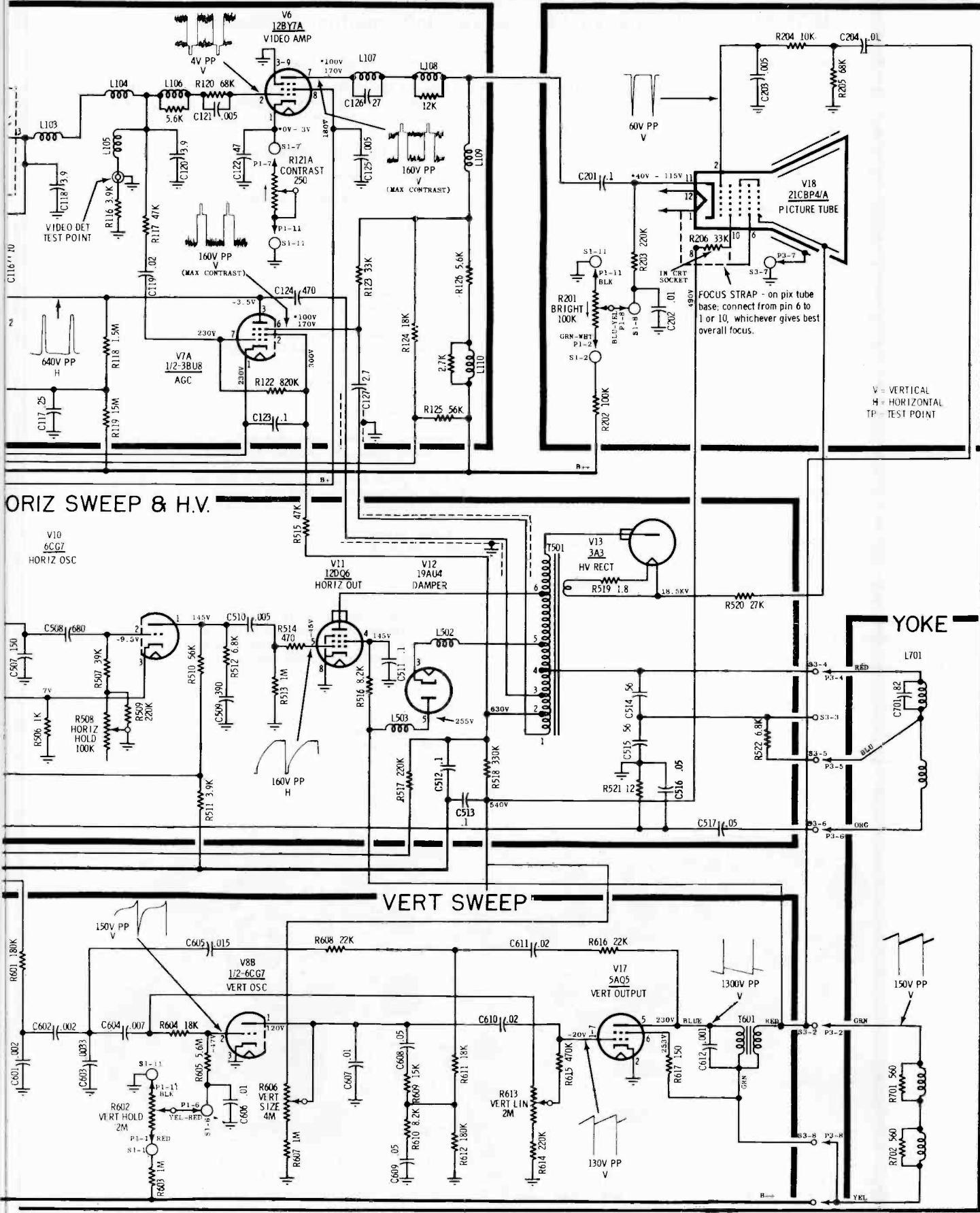

MOTOROLA Chassis TS-542, Service Information, Continued

REMOVING THE BACK COVER

1. Remove the back cover screws and the single interlock screw.
2. Unplug the tuner lead from the back cover antenna receptacles.
3. Remove the cover.

RECEIVER REMOVAL AS A UNIT (less control bracket)

1. Remove the back cover.
2. Remove channel selector and fine tuning knobs.
3. Unplug speaker lead from speaker receptacle.
4. Remove the four (4) bottom chassis retaining screws.
5. Remove the two (2) tuner bracket screws securing the bracket to the cabinet.
6. Unplug the operating control cable.
7. Remove chassis from the rear.

CHASSIS REMOVAL (less picture tube, speaker & control bracket)

1. Remove the rear cover.
2. Unplug speaker lead from speaker receptacle.
3. Remove the four (4) bottom screws securing the chassis to the cabinet.
4. Remove the four (4) chassis screws securing the chassis to the picture tube mounting assembly.
5. Unplug the tuner, operating control cable, picture tube socket, yoke and high voltage anode connector.
6. Remove chassis to rear.

OPERATING-CONTROL-BRACKET REMOVAL

1. Remove the back cover.
2. Remove the complete receiver (see receiver removal).

3. Remove front panel knobs.

4. Remove the four (4) screws securing the control bracket to the cabinet. When replacing controls, be sure to replace grounding bracket between control panel and bezel.

PICTURE TUBE REPLACEMENT

1. Remove back cover.
2. Remove the receiver as a unit.
3. Unplug the picture tube socket and yoke.
4. Remove the yoke and picture tube high voltage anode connector.
5. Loosen the two (2) picture tube retainer strap bolts sufficiently to enable removal of the tube from the rear.
6. Replace black tape around mounting area of new tube and install in reverse order to that given above.

SAFETY GLASS REMOVAL

1. Turn power off.
2. Remove the five (5) screws holding metal trim at the top of the safety glass and remove the metal trim.
3. Allow glass to move outward at the top: Grasp glass at left and right-hand sides and lift upward until glass is out of lower retaining channel. Place glass in a safe place.

When replacing glass, make sure rubber protective channel is on glass at top and bottom before installation.

FUSE REPLACEMENT

A special "limited current" bayonet type fuse is used in the B++ line. This fuse is a 1.6 amp "Slo-blo, LC" type and is accessible upon removal of the receiver back cover. To remove fuse, push down and rotate until fuse pops up. Replace fuse with exact rating only.

SERVICING THE VHF TUNER

The tuner has been provided with removable wafers for the tuning sections, to facilitate checking of the component parts as well as provide a simple method of replacement should one of the tuned sections be damaged.

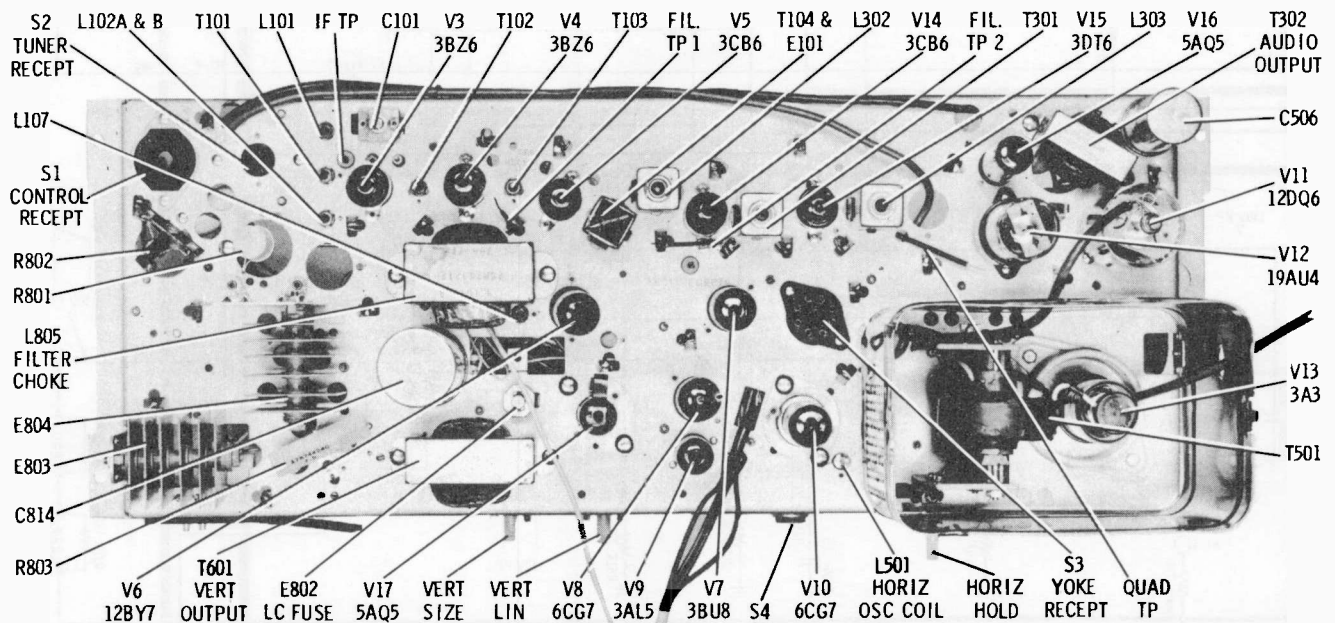

M O N T G O M E R Y W A R D

MODELS WG-4042A, WG-4052A, WG-5042A, WG-5047A, WG-5052A

(Circuit diagram on pages 84-85,  
Alignment information on page 86)

**CHASSIS ASSEMBLY REMOVAL**

1. Remove the knobs, the secondary control escutcheon and the secondary control knobs from the front of the cabinet.
2. Remove cabinet back.
3. Disconnect the antenna and speaker leads.
4. Remove screws holding chassis brackets to top of cabinet.
5. Remove only 4 screws (2 at each side) from the bottom side of the shelf.
6. Gently pull the chassis assembly out from the cabinet.

**CAUTION — DO NOT LOOSEN OR REMOVE ANY OTHER SHELF SCREWS INSIDE CHASSIS COMPARTMENT.**

7. Place entire assembly face down on a cushioned surface which should be thick enough to allow for clearance of control shaft. Disconnect the yoke plug, picture tube socket, anode lead and remove the beam aligner magnet and deflection yoke.

**MAGNET ADJUSTMENT**—The beam aligner magnet should be positioned close to the base of the tube. From this position adjust the magnet by moving it back and forth and at the same time rotating it slightly around the neck of the picture tube until the brightest raster and best focus is obtained on the picture screen. **MAXIMUM RASTER BRILLIANCE AND BEST FOCUS OCCUR AT THE SAME POINT.** Do not sacrifice brilliance for best focus. The magnet adjustment is a very critical one, especially with the electrostatic type zero focus picture tube. Consequently, great care should be taken to make sure that the magnet is correctly adjusted.

**DEFLECTION YOKE ADJUSTMENT**—The deflection yoke should be positioned as far forward on the neck of the tube as the bell will allow. Then, if the lines of the raster are not horizontal or squared with the picture mask, rotate the deflection yoke until this condition is obtained. Upon completion of this adjustment, tighten the clamp at the rear of the deflection yoke.

**CENTERING ADJUSTMENT** — If horizontal or vertical centering is required, adjust each ring in the centering device until proper centering is obtained. If a clamp type centering device is used, rotate the device to the left or right and turn the knob located at the top of the device until the picture is centered correctly.

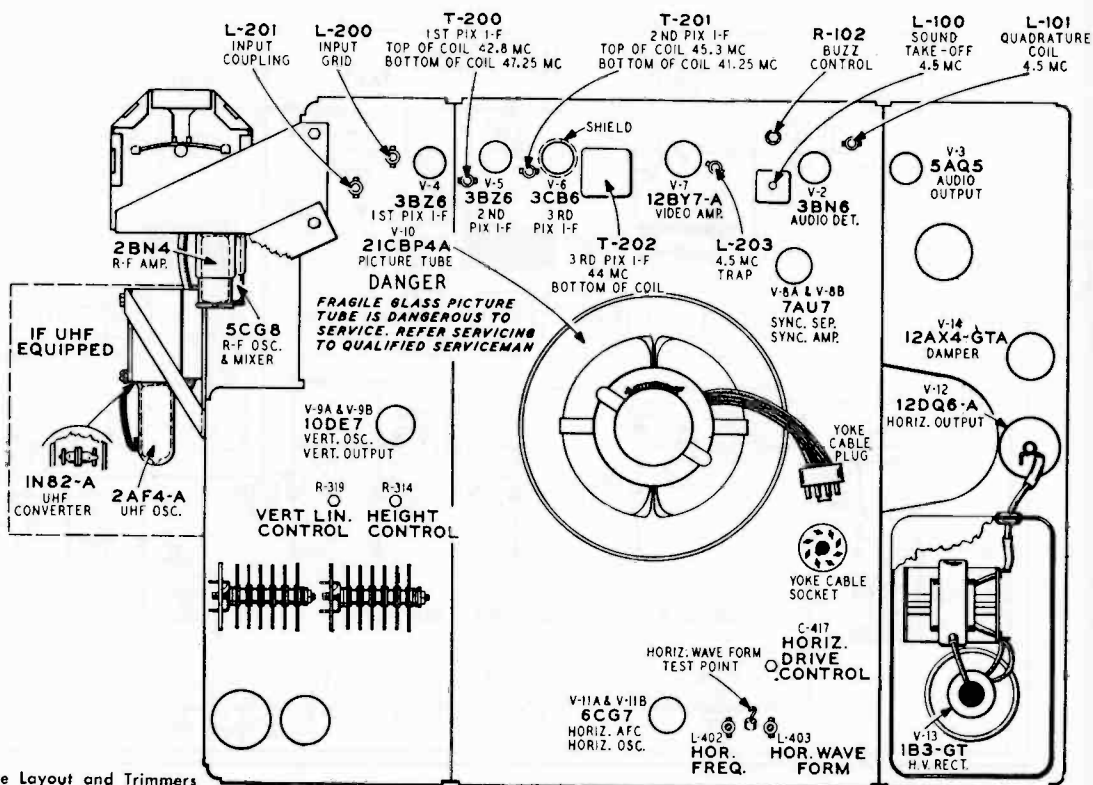

Fig. 1—Chassis Tube Layout and Trimmers

**SERVICE SUGGESTIONS**

**NO RASTER ON PICTURE TUBE**—If raster cannot be obtained, check below for the possible causes:

1. Magnet adjustment is incorrect.
2. No +B voltage. Check thermal cut-out. Reset if open. If thermal cut-out continually opens, check:
  - A. For short in +B.
  - B. Selenium rectifiers.
  - C. Check DC resistance of horizontal output transformer.
3. No high voltage. Check V-11, V-12, V-13 and V-14 tubes and circuits. If horizontal deflection circuits are operating as evidenced by the correct voltage (600V) measured on terminal num-

ber 1 of the horizontal output transformer, the trouble can be isolated to the high voltage rectifier circuit. Either the high voltage winding to the V-12 plate and the V-13 plate is open or pix tube elements shorted internally.

4. Defective picture tube Cathode return circuit open.

**SMALL RASTER**—This condition can be caused by:

1. Low +B or line voltage. Check selenium rectifiers.
2. Insufficient output from V-12. Replace tube.
3. Insufficient output from V-8 and V-9. Replace tubes.
4. Incorrect setting of horizontal drive control.
5. V-14 defective.

NOTE—In UHF receivers the filament voltages in the tuner and above the tuner in the heater string will be slightly greater because of the filament voltages of the tuner tubes. Console receivers use two five inch speakers connected in parallel. The voice coil impedance of these speakers is 6.4 ohms 400 cycles.

SCHEMATIC IS DIVIDED INTO FOUR SECTIONS WITH EACH SECTION HAVING ITS OWN SERIES OF REFERENCE NUMBERS.

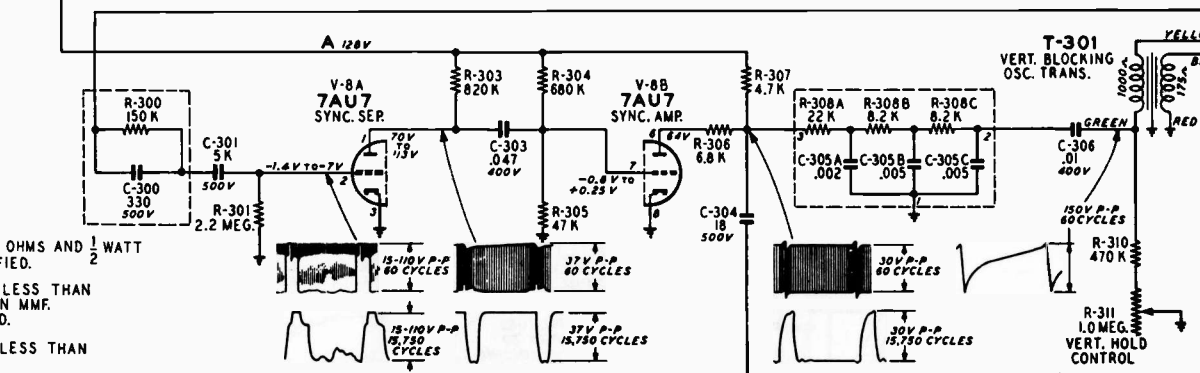
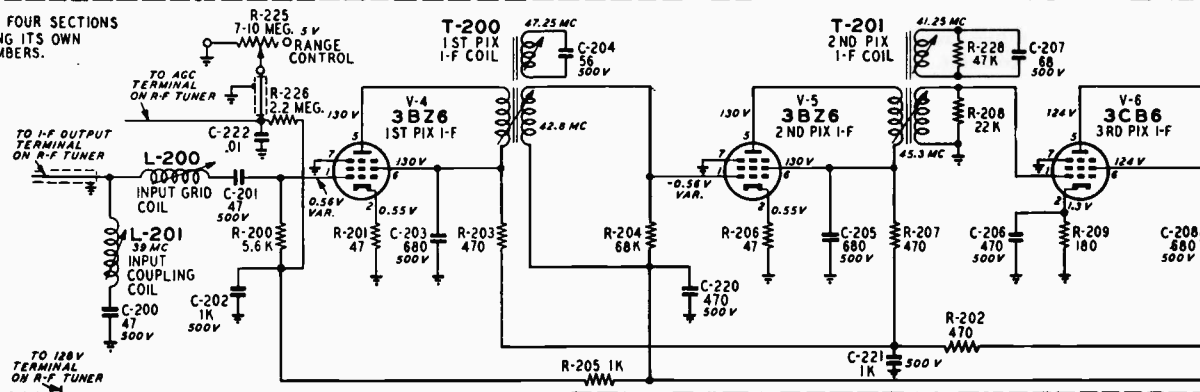

ALL RESISTANCE VALUES IN OHMS AND  $\frac{1}{2}$  WATT UNLESS OTHERWISE SPECIFIED.  
 ALL CAPACITANCE VALUES LESS THAN 1.0 IN MF. AND ABOVE 1.0 IN MMF. UNLESS OTHERWISE NOTED.  
 COIL RESISTANCE VALUES LESS THAN 1.0 OHM ARE NOT SHOWN.

K=1000

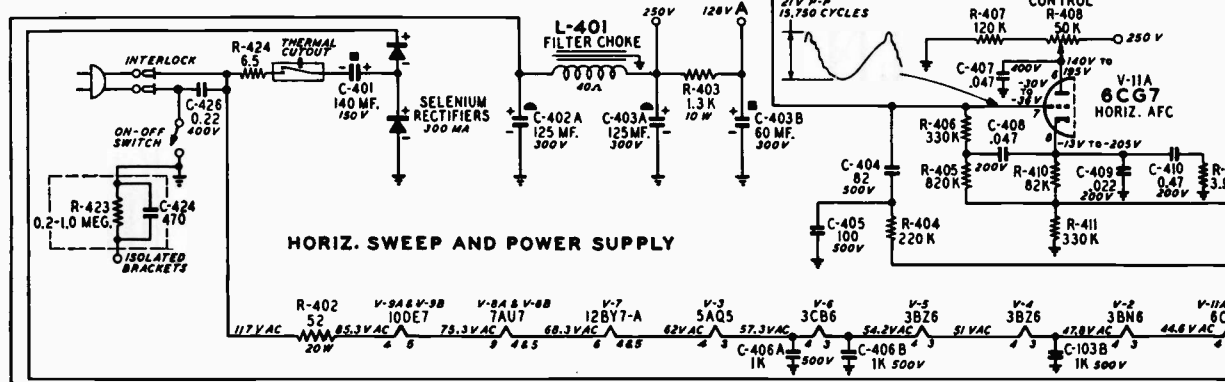

**OSCILLOSCOPE WAVEFORM PATTERNS**

The waveforms shown on the schematic diagram are as observed on a Tektronix type 524D wide band television oscilloscope with the receiver tuned to a reasonably strong signal and a normal picture. The voltages shown on each waveform are the approximate peak to peak amplitudes. The frequency accompanying each waveform indicates the repetition rate of the waveform not the sweep rate of the oscilloscope.

MONTGOMERY WARD  
Models WG-4042A,  
WG-4052A, WG-5042A,  
WG-5047A, WG-5052A.

**SOUND I-F AND AUDIO**

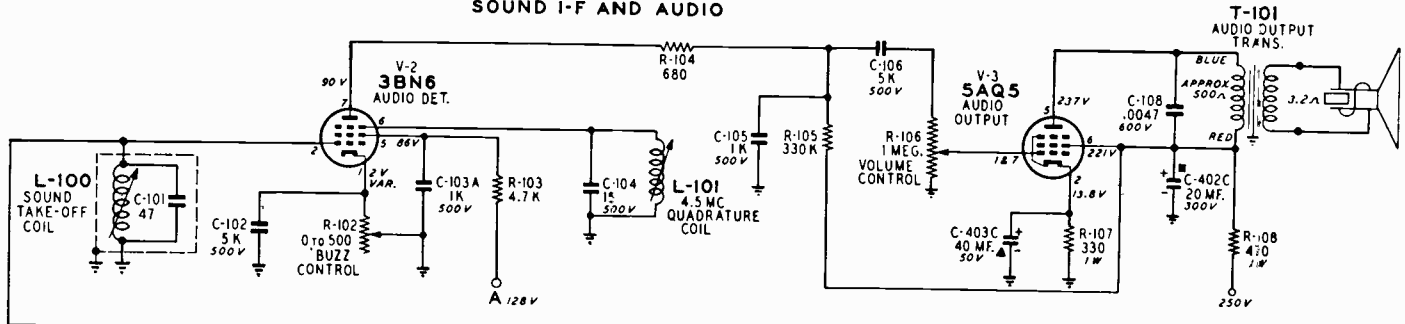

**VIDEO**

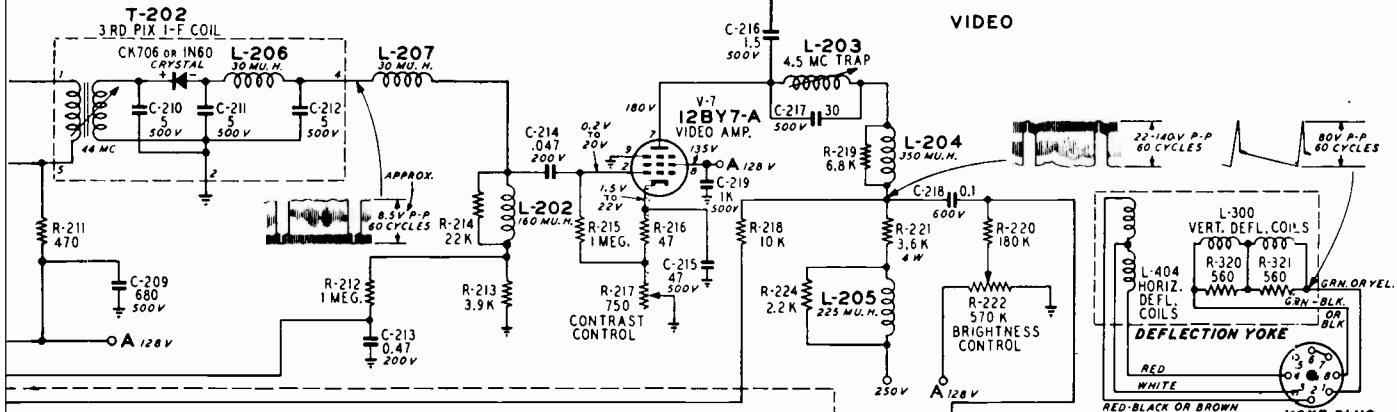

**VERTICAL SWEEP AND SYNC.**

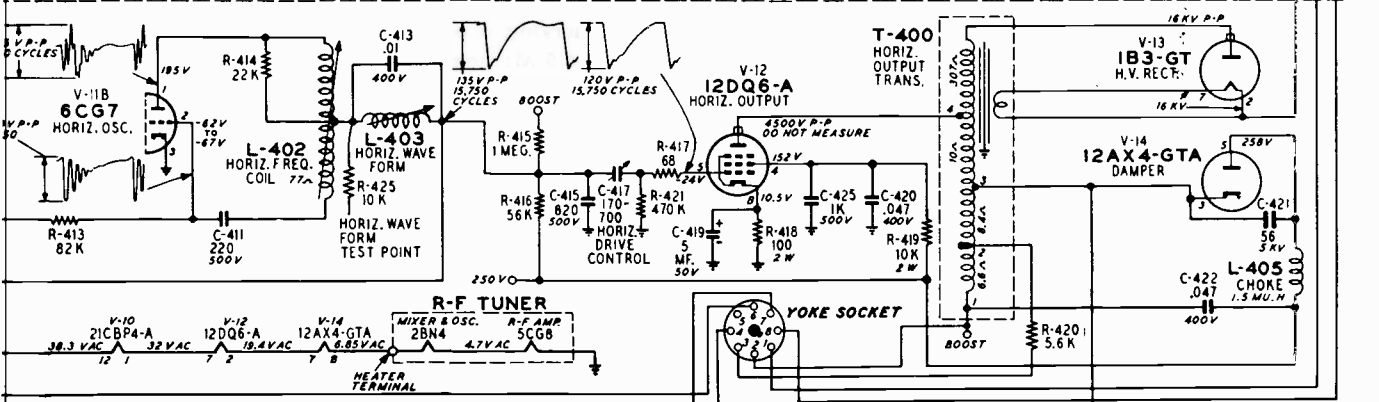
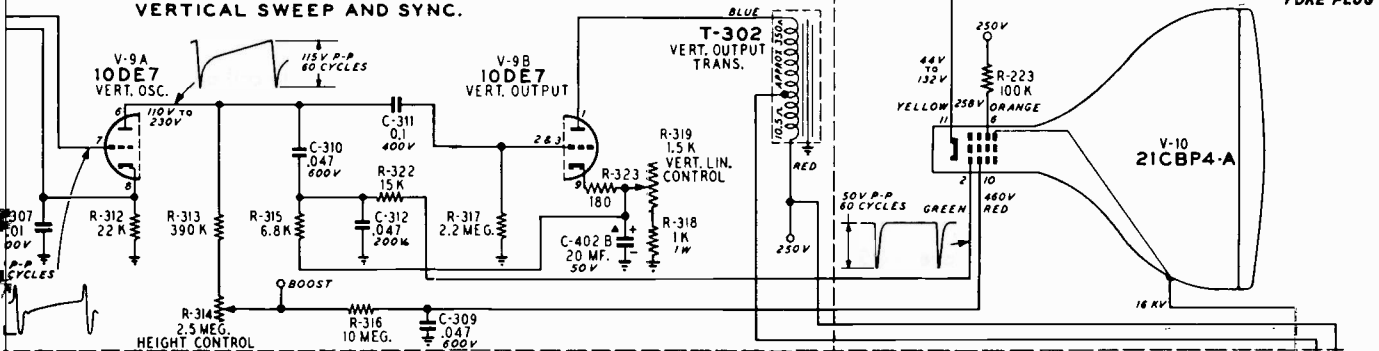

**ALIGNMENT PROCEDURE**

**40 Mc I-F ALIGNMENT**—Connect sweeper with very short leads through a 1 K mmf disc ceramic capacitor to mixer grid. (Lead of a 3.9 K resistor which is accessible through a hole located between the R-F Amplifier & Mixer tubes on the tuner. With short leads connect crystal diode detector (Fig. 5) to plate of 1st I-F tube. Connect -1.5V to A.G.C. line (Junction of C-220 & R-205). Connect oscilloscope to detector output. Adjust sweep output to give adequate deflection.

- | A. FREQUENCY | ADJUST                                                                                                                              |
|--------------|-------------------------------------------------------------------------------------------------------------------------------------|
| 1. 47.25 Mc  | 1st Pix I-F Coil (T-200 Bottom of Coil) to center notch over 47.25 Mc marker.                                                       |
| 2.           | Converter Plate Coil (Top of Tuner) Input Grid Coil (L-200) and Input Coupling Coil (L-201) to give the response shown in figure 6. |

The converter plate and input grid coils control the shape of the top. The input coupling coil controls the position of the 41.25 marker. This adjustment must be made accurately or the sound rejection will not be correct (41.25 Mc 31 to 36 db down from top of overall P.I.F. response). 45.75 Mc marker must be set exactly on peak or the position of the 44.5 Mc marker in the overall response curve will not be correct.

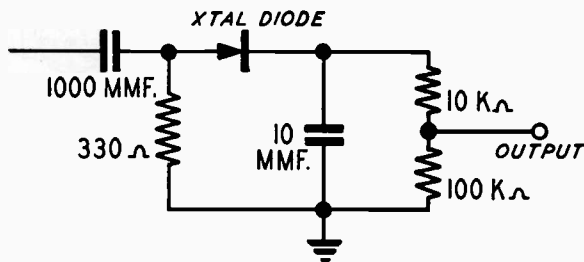

Fig. 5—Crystal Diode Detector

- B. When the input circuit is aligned place -4.5V bias on the AGC line. (Junction of C-220 & R-205). Remove the crystal detector and connect oscilloscope and VTVM to the 2nd pix detector load resistor R-213. Adjust sweep output to give 2.0 VDC at detector.

- | FREQUENCY   | ADJUST                                                                             |
|-------------|------------------------------------------------------------------------------------|
| 1. 42.8 Mc  | 1st Pix I-F Coil (T-200, Top of Coil) for maximum height of 42.8 Mc marker.        |
| 2. 41.25 Mc | 2nd Pix I-F Coil (T-201, Bottom of Coil) for minimum height of 41.25 Mc marker.    |
| 3. 45.3 Mc  | 2nd Pix I-F Coil (T-201, Top of Coil) for maximum height of 45.3 Mc marker.        |
| 4. 44.0 Mc  | 3rd Pix I-F Coil (T-202, Bottom of Coil) for maximum height of the 44.0 Mc marker. |

These adjustments may be made with a single frequency generator if it is more convenient to do so.

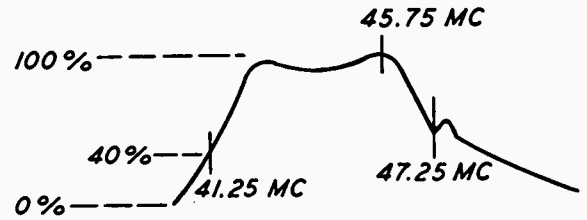

Fig. 6—Input Circuit Response

- C. After these adjustments have been made recheck the peak to peak output on the oscilloscope. If the shape of the curve is not as shown in figure 7, it will be necessary to retouch the adjustments. A small fraction of a turn is all that is necessary if the strip is operating correctly. The position of the 44.5 Mc marker is critical (98%). The 44.0 Mc transformer (3rd I-F) controls the symmetry of the top. The 45.3 Mc transformer (2nd I-F) controls the height of the 45.75 Mc marker. The 42.8 Mc transformer (1st I-F) controls the height of the 42.4 Mc marker. This adjustment will very seldom need retouching.

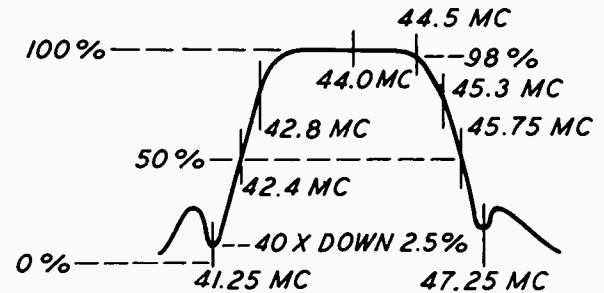

Fig. 7—Overall Response Curve

DO NOT RETOUCH the converter plate coil or the input grid coil. These coils MUST be adjusted correctly with the diode detector. Recheck position of 41.25 Mc and 47.25 Mc markers. Reset if necessary.

**VIDEO**

With 4.5 Mc unmodulated signal into grid of the video amplifier tube and VTVM on picture tube cathode, tune 4.5 Mc trap for minimum response. VTVM on 0-10 V AC scale. This adjustment can also be made while observing a picture from a station. Tune trap for least 4.5 Mc beat (grainy appearance) in picture.

**AUDIO**

1. Tune in a TV station and reduce signal strength at antenna terminals by use of an attenuator or similar device until a "hiss" accompanies the sound.
2. Adjust sound take-off coil (L-100), quadrature coil (L-101) and buzz control (R-102) for maximum undistorted sound and minimum buzz.
3. If "hiss" disappears during step 2, further reduce signal strength.



# Packard Bell

Chassis 88S3, Table Models 21ST3, 21VT2, 24VT1, Console Models 21SC6, 21SC7, 21SC8, and 24SC2. Combination Model 21SK3 is essentially similar to these models. (Service material on pages 87 through 90)

## CHASSIS REMOVAL:

1. Pull out AC plug and disconnect antenna.
2. Remove back, lift antenna terminal board out of slot, and pull speaker plug.
3. Removal of tuner and knobs requires more detailed instructions.

**SIDE CONTROLS:** Pull off knobs at side. Remove two hex nuts, one from the brightness control and one from the vertical hold control. Then, at the rear of the set, loosen one screw in slot of tuner mounting bracket and slide tuner away from cabinet.

**FRONT CONTROLS:** Pull off channel selector and fine tuning knobs at top and volume and contrast knobs at bottom. Plate over other two knobs is a force fit and may be pulled out. Brightness and vertical hold knobs may then be removed. Then, at the rear of the set, remove one screw at center of the three controls and unhook tuner by lifting and moving to rear. (Tuner bracket may now be fastened to chassis.)

4. Unfasten the bracket located at top rear center of cabinet.
5. Remove four chassis mounting screws from underneath.
6. Pull out chassis and picture tube on mounting plate.

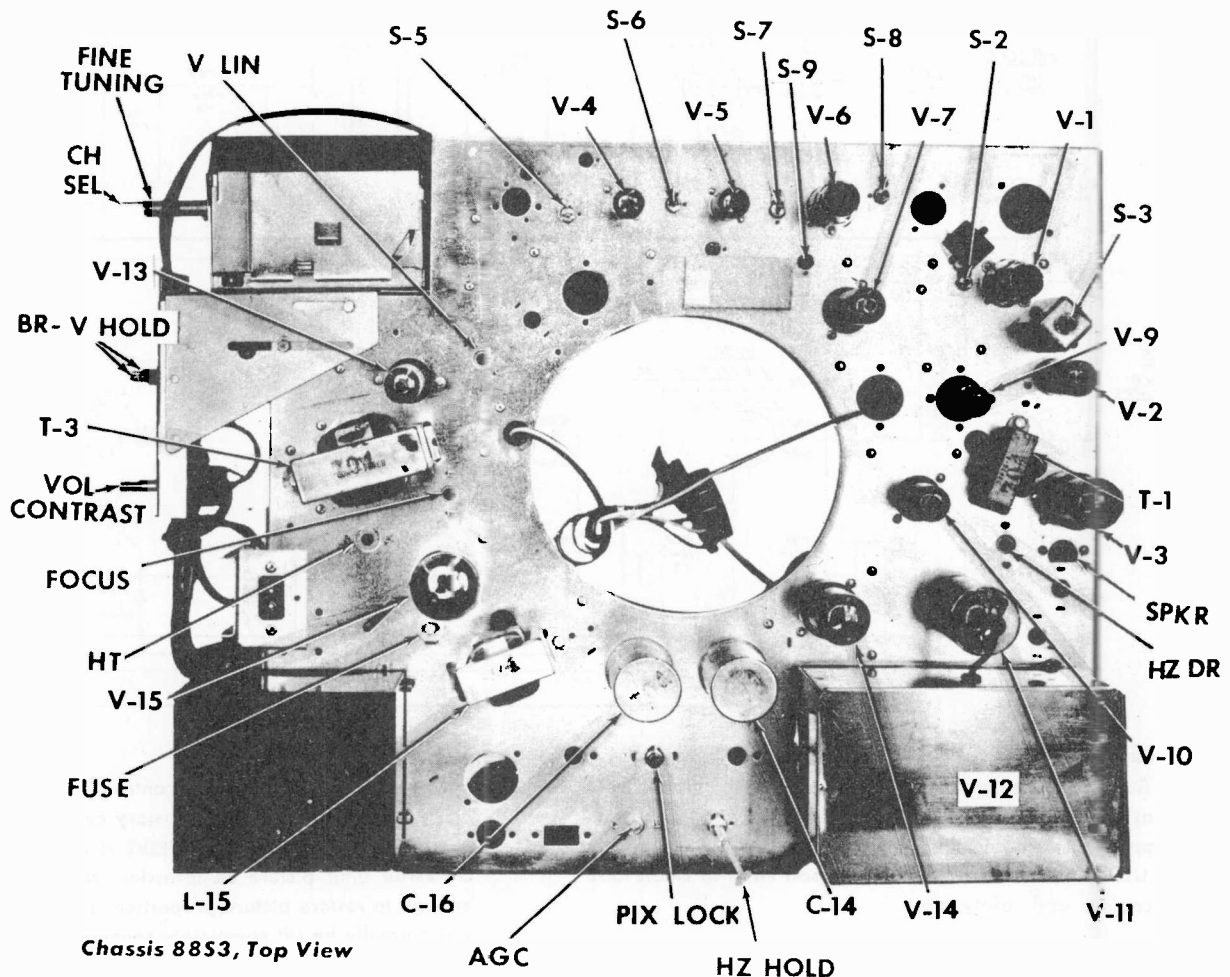

Chassis 88S3, Top View

# VOLUME TV-14, MOST-OFTEN-NEEDED 1958 TELEVISION SERVICING INFORMATION

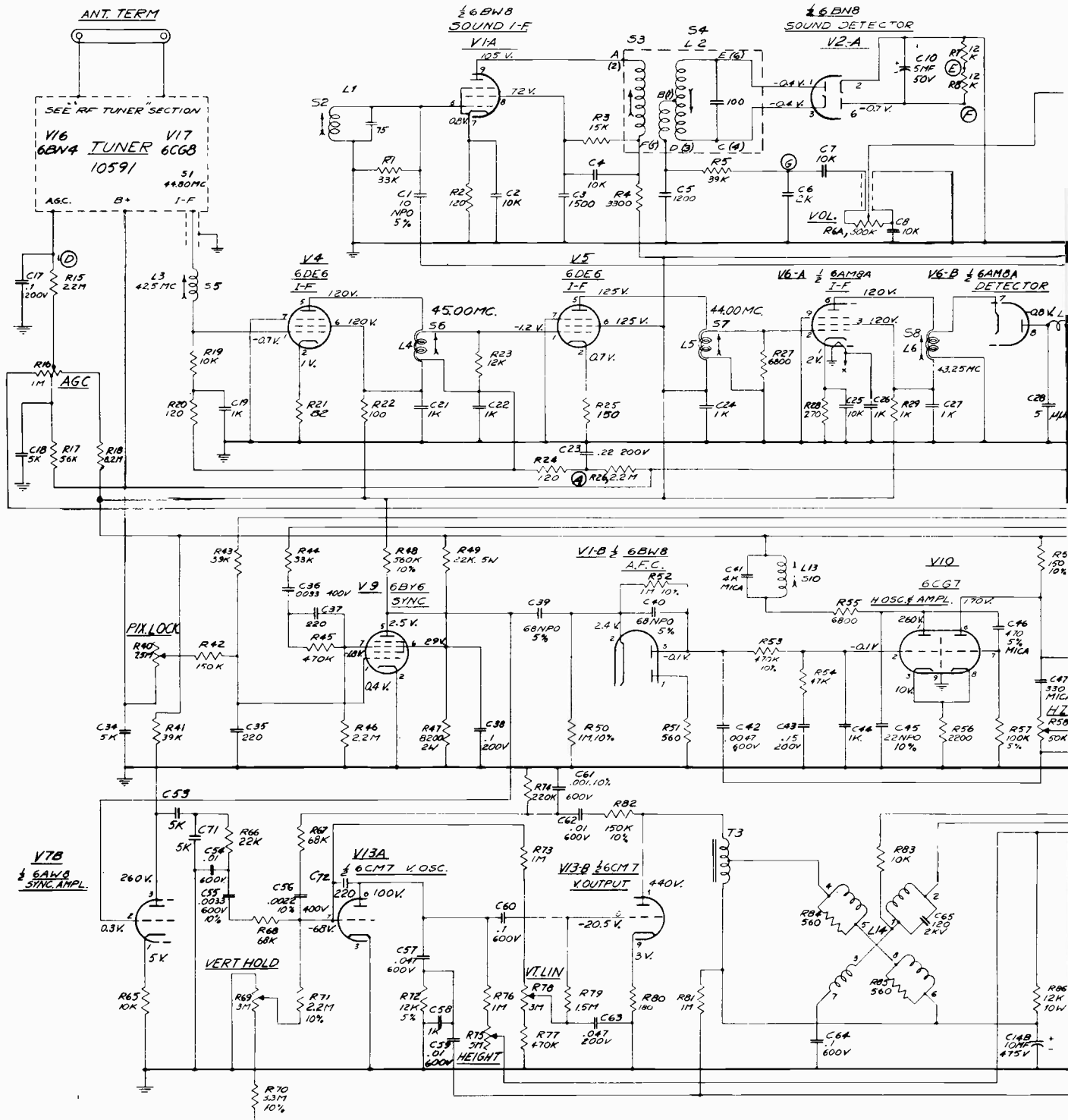

## CLEANING PICTURE TUBE FACE:

Safety glass is removed by first taking out the three screws that hold the top glass rail. Rail is now removed and glass slipped outward and up.

Use window cleaning fluid on a soft cloth to clean tube faceplate and safety glass.

## OPERATION:

Most of the non-operating controls are self-explanatory. The picture tube has the customary centering magnet and ion trap. The HORIZONTAL DRIVE is adjusted by rotating clockwise until picture compression, then backing up just enough to restore picture proportion. The PIX LOCK control will normally be set completely counter-clockwise.

# VOLUME TV-14, MOST-OFTEN-NEEDED 1958 TELEVISION SERVICING INFORMATION

PACKARD BELL Chassis 88S3,  
Models 21ST3, 21VT2, 24VT1,  
21SC6, 21SC7, 21SC8, 24SC2,  
Schematic Diagram.

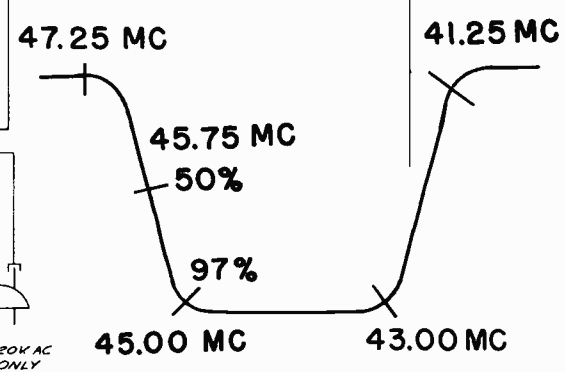
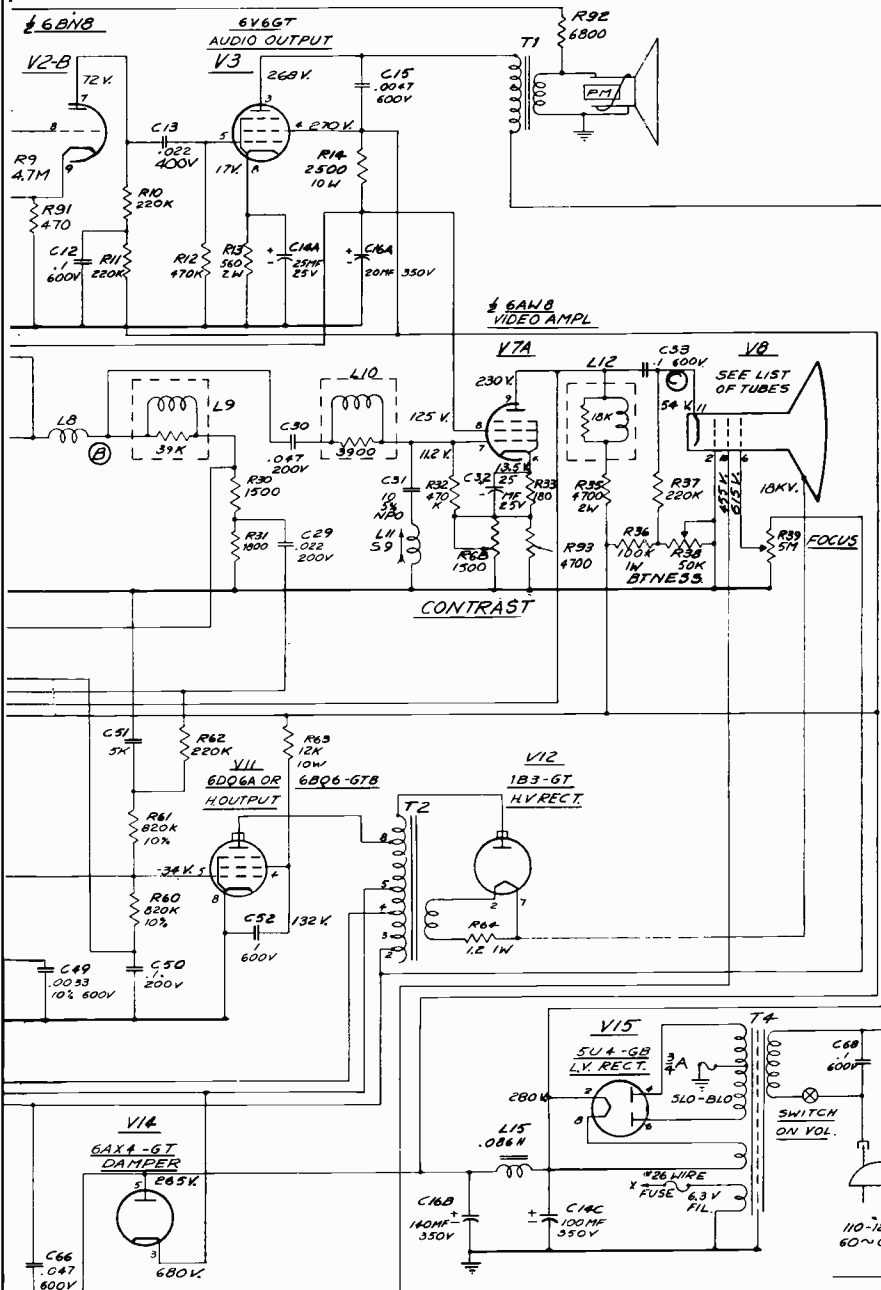

### PICTURE I-F ALIGNMENT:

1. Connect VTVM between point "B" and ground.
2. Connect signal generator to R-F tuner test point using a .001 mfd isolating capacitor.\*

\* In models using VHF-UHF tuner 10559, lift the 6AT8 tube shield and connect generator between shield and ground.

STEP	SIG. GEN. FREQUENCY	ADJUST	FOR
3.	44.80 mc	S-1 (mixer I-F in tuner)	MAXIMUM
4.	42.50 mc	S-5	MAXIMUM

5.	45.00 mc	S-6	MAXIMUM
6.	44.00 mc	S-7	MAXIMUM
7.	43.25 mc	S-8	MAXIMUM

### REPEAT STEPS 3 THROUGH 7

8. Connect scope to point "B" through a 22,000 ohm isolating resistor. Connect VTVM to point "A".
9. Connect sweep generator to antenna terminals through the impedance matching network. (Antenna terminals 300 ohms balanced.)
10. Rotate tuner to channel 3, and set sweep generator to center frequency of channel (63 mc). With a sweep width of 8 mc, adjust generator output to develop about 4 volts of AGC at point "A".

PACKARD BELL Chassis 88S3, Alignment Information, Continued

11. Adjust AGC control at rear of set so that voltages at points "A" and "D" are the same. Then, if necessary, readjust sweep generator output so that AGC voltage is again four volts.
12. Disconnect signal generator from tuner test point and connect between bottom of tuner shield and ground connection of tuner I-F output cable. Generator ground lead goes to tuner shield.
13. Adjust signal generator output to provide the markers shown on the illustrated response curve. Check position of markers one at a time. Some slight touching-up of the I-F adjustments may be needed to make the curve correspond to the illustration.
14. The adjustments have the following effects:  
 S-1 moves the 45.75 mc marker up or down the curve (should be 50%).  
 S-5 controls tilt, or flatness of response, and also affects the overall bandwidth.  
 S-6 controls the position of the 45.00 mc marker (should be at a maximum of 97% response).  
 S-7 affects tilt or flatness of response.  
 S-8 helps to establish band width on sound side of curve.

IMPORTANT: The 45.00 mc marker must not exceed 97% on channel three or picture may smear on higher channels.

**ALIGNMENT OF 4.5 MC TRAP:**

1. Connect signal generator between point "B" and ground.
2. Turn contrast control to maximum.
3. Connect RF probe of VTVM to point "C".
4. Set signal generator to 4.50 mc, with the output at one volt or more.
5. Adjust trap, S-9 for minimum VTVM reading.

NOTE: If generator is not capable of one volt output, trap may be adjusted by visual means while receiving a TV station signal. If no 4.5 mc beat is present, S-9 requires no adjustment. If a beat appears, detune signal to exaggerate the beat and then adjust S-9 for minimum beat.

**SOUND I-F AND RATIO DETECTOR ALIGNMENT:**

1. Connect signal generator between point "B" and ground.
2. Connect VTVM between point "F" and ground.
3. With generator frequency at 4.50 inc, adjust S-2 and S-3 for MAXIMUM VTVM reading.
4. Connect VTVM between points "E" and "G".
5. Adjust ratio detector secondary, S-4, for zero between positive and negative peaks.
6. Repeat steps 2 thru 5.

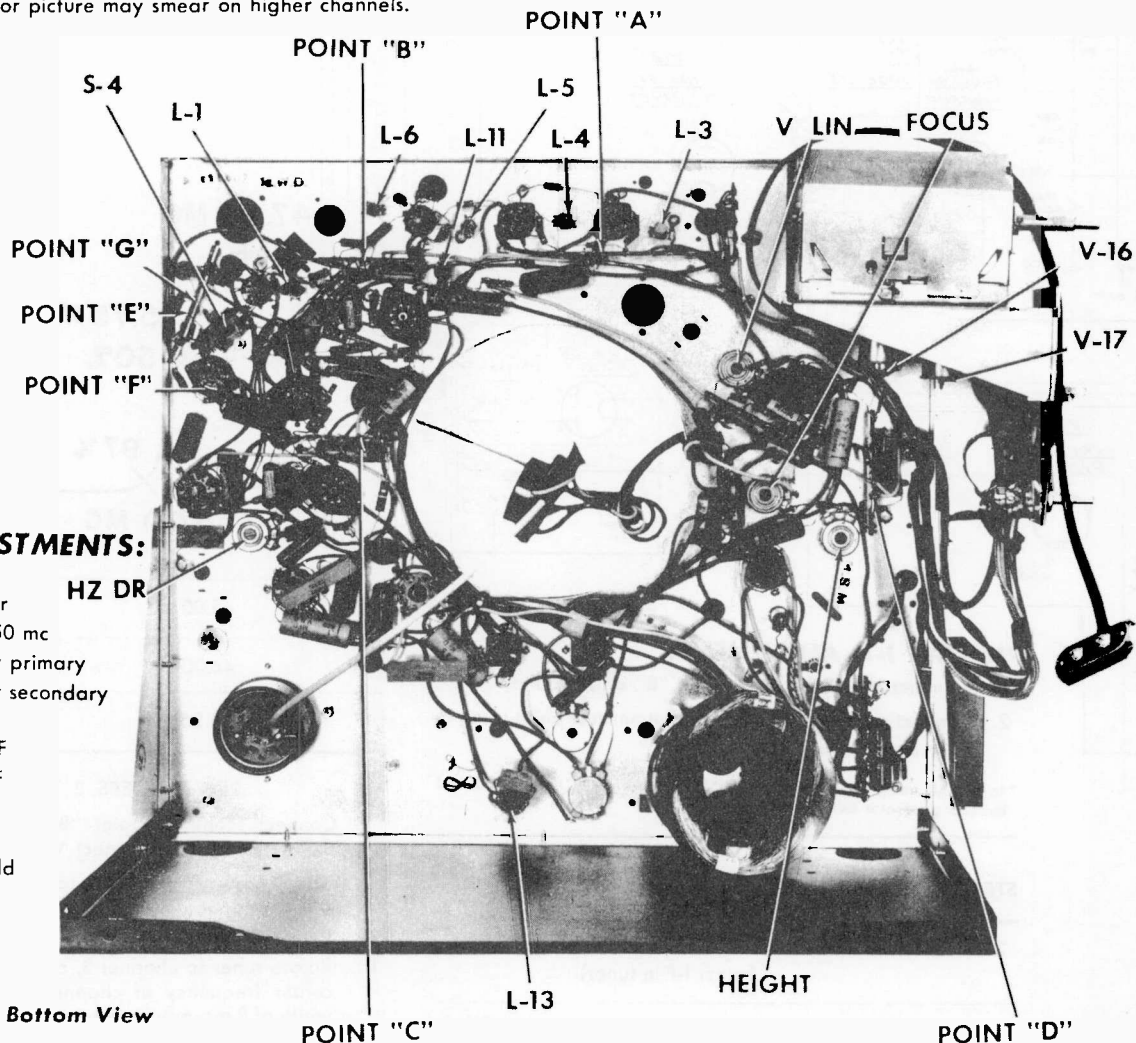

Chassis 88S3, Bottom View

**LIST OF ADJUSTMENTS:**

- S-1 I-F on RF tuner
- S-2 Sound I-F, 4.50 mc
- S-3 Ratio detector primary
- S-4 Ratio detector secondary
- S-5 1st picture I-F
- S-6 2nd picture I-F
- S-7 3rd picture I-F
- S-8 4th picture I-F
- S-9 Trap, 4.50 mc
- S-10 Horizontal hold

# Packard Bell

## MODELS 21DC5, 21DC6, 21DC7, & 24DC4 (CHASSIS 98D3)

(Alignment below and continued on page 94; circuit diagram on pages 92-93)

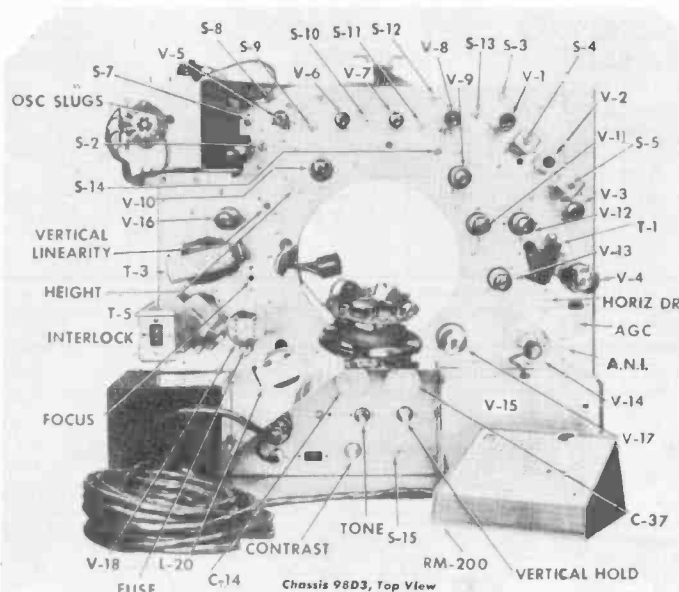

The ANI (automatic noise inverter) control must be adjusted at the location where the receiver is to be used. Moreover, it must be adjusted using the strongest signal that will be received. The steps are:

- a. Rotate ANI control to extreme right.
- b. Turn control to left till picture begins to distort.
- c. Return to the right slightly beyond the point where the distortion disappears.
- d. Check all channels for picture stability.

The HORIZONTAL DRIVE control is adjusted by rotating it clockwise until a bright vertical bar appears, causing picture compression. Then the control is rotated the other way until the compression just disappears.

The setting of the AGC control is covered in step 22 of the picture alignment.

### PICTURE I-F ALIGNMENT

1. Remove ANI tube 12AX7 (V-1).
2. Connect a 4½ volt battery between point "A" and ground, with the negative lead to point "A".
3. Connect a VTVM between point "B" and ground.
4. Connect signal generator to R-F tuner test point through the .001 mfd capacitor. This is right next to the tuner B-plus terminal, so care should be taken to avoid a short.
5. Set generator output at maximum.

STEP	SIG. GEN. FREQUENCY	ADJUST	FOR
6.	47.25 mc	S-7 & S-12	Minimum
7.	39.75 mc	S-8	Minimum
(Adjust generator output for 2½ to 3 volts VTVM reading for steps 8 through 13.)			
8.	43.30 mc	S-13	MAXIMUM
9.	45.75 mc	S-11	MAXIMUM
10.	42.50 mc	S-10	MAXIMUM
11.	44.50 mc	S-9	MAXIMUM
12.	42.50 mc	S-2	MAXIMUM
13.	45.00 mc	S-1 (tuner)	MAXIMUM
REPEAT STEPS 6 THROUGH 13			

14. Disconnect VTVM and connect it between point "D" and ground.
15. Also connect a 1.0 mfd capacitor between point "D" and ground.
16. Connect scope between point "B" and ground through the 22,000 ohm resistor.
17. Connect sweep generator to antenna terminals through the impedance matching network.
18. Rotate selector to channel 3 and set sweep generator to center frequency of channel (63 mc). With a sweep width of 8 mc, adjust generator output to develop approximately minus 4 volts of AGC as indicated by the VTVM.
19. Disconnect signal generator from tuner test point and connect hot lead to ground lead of I-F input cable. If this gives insufficient marker signal on the response curve, try connecting to other ground points in the vicinity of the 1st I-F stage.
20. Adjust signal generator output to provide the markers shown on the illustrated response curve. Check positions of the markers one at a time. Some slight touching-up of the I-F adjustments may be needed to make the curve correspond to the illustration.
21. Remove battery, marker generator, and capacitor; reduce sweep width to zero, but do not change sweep output.
22. Connect VTVM between point "A" and ground, and adjust AGC control for minus 5½ volts on meter at point "D". This will be the normal AGC setting. In cases of fringe reception or high signal, performance may be improved by readjustment of the AGC control to produce a minimum of noise or interference in the picture.
23. Replace ANI tube, 12AX7.

PACKARD BELL Chassis 98D3 Schematic Diagram

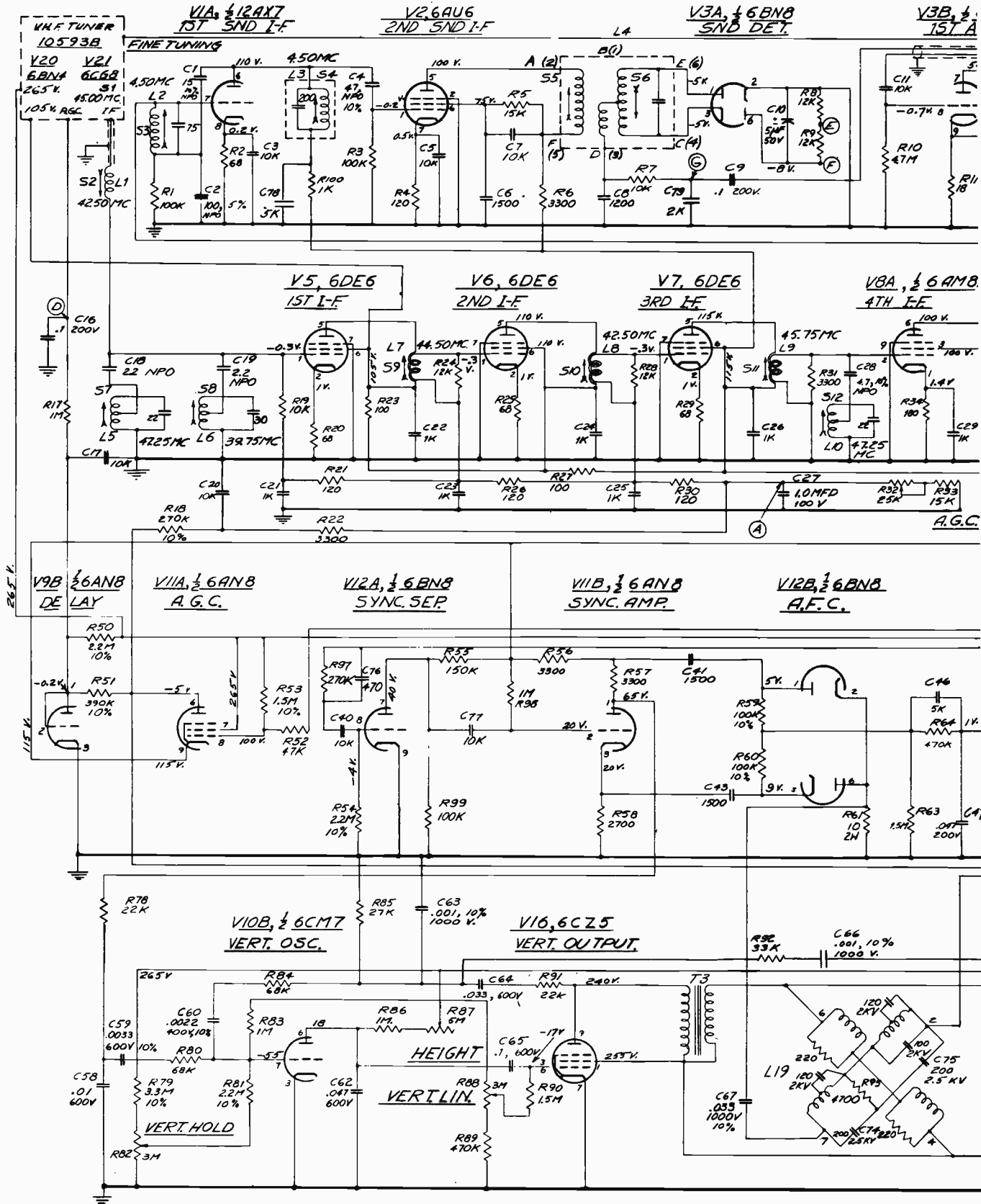

VOLUME TV-14, MOST-OFTEN-NEEDED 1958 TELEVISION SERVICING INFORMATION

PACKARD BELL Chassis 98D3 Schematic Diagram

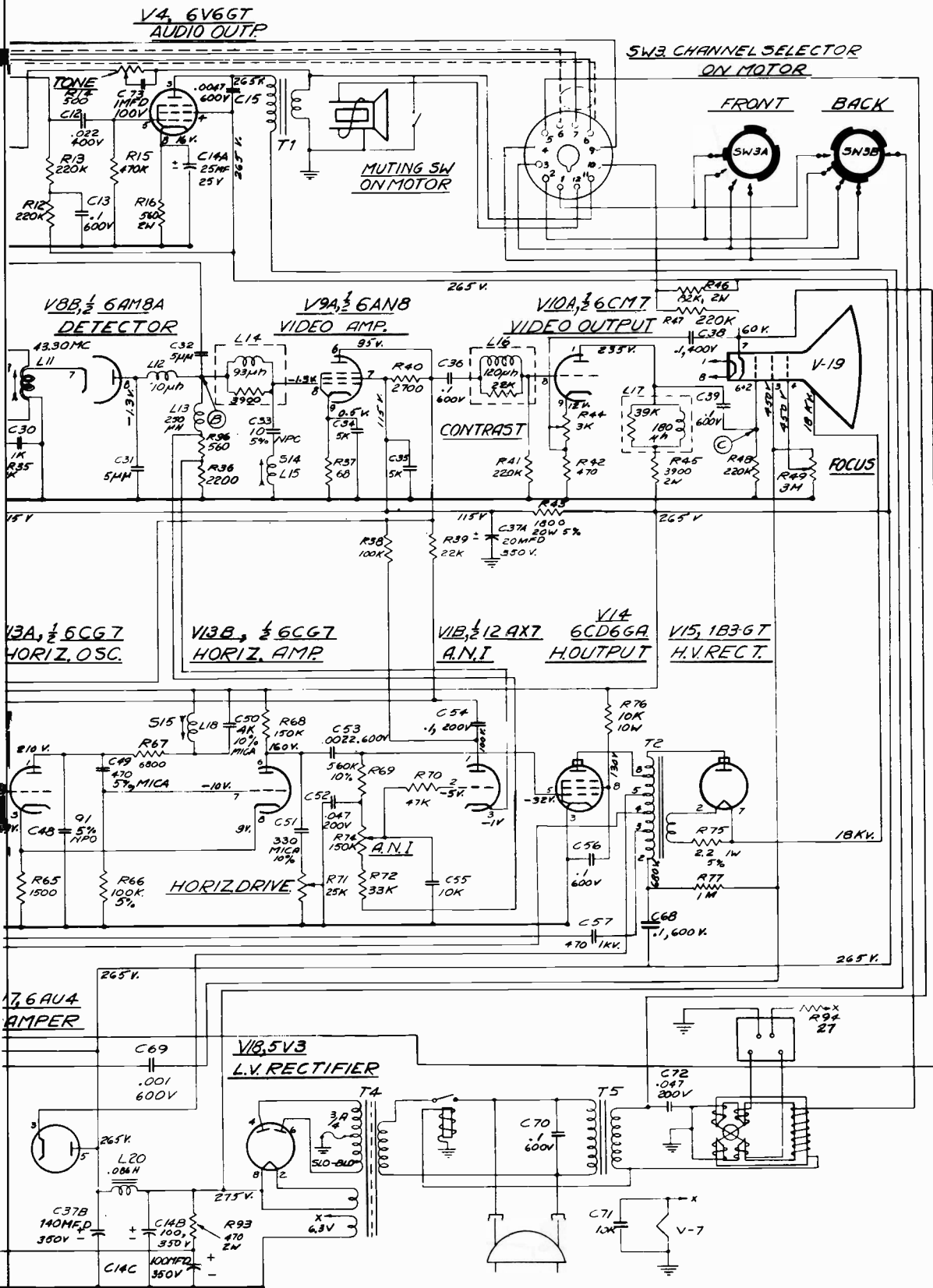



PACKARD BELL Chassis 98D3 Alignment Information, Continued

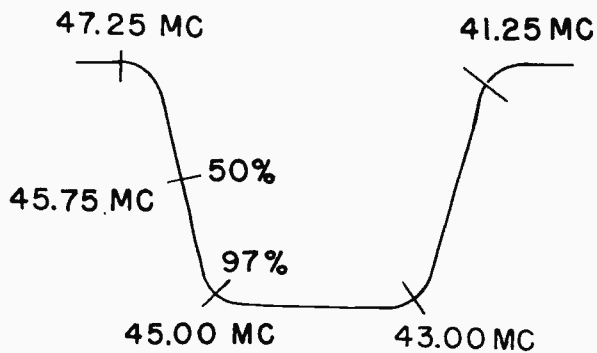

**ALIGNMENT OF 4.5 MC TRAP:**

1. Remove picture detector tube 6AM8A (V-8).
2. Connect signal generator between point "B" and ground.
3. Turn contrast control to maximum.
4. Connect RF probe of VTVM to point "C".
5. Set signal generator to 4.50 mc, with the output at one volt or more.

6. Adjust trap, S-14, for minimum VTVM reading.
7. Replace picture detector tube.

NOTE: If signal generator is not capable of one volt output, the trap may be adjusted by visual means. Observe the picture and detune the signal to accentuate the 4.5 mc beat. Then adjust S-14 for minimum beat in the picture.

**SOUND I-F AND RATIO DETECTOR ALIGNMENT:**

1. Connect signal generator between point "B" and ground through a .001 mfd isolating capacitor.
2. Connect VTVM between point "F" and ground.
3. With a generator frequency of 4.50 mc, adjust S-3, S-4, and S-5 for MAXIMUM.
4. Connect VTVM between points "E" and "G".
5. Adjust ratio detector secondary, S-6, for zero between positive and negative peaks.
6. Repeat steps 2 thru 5.

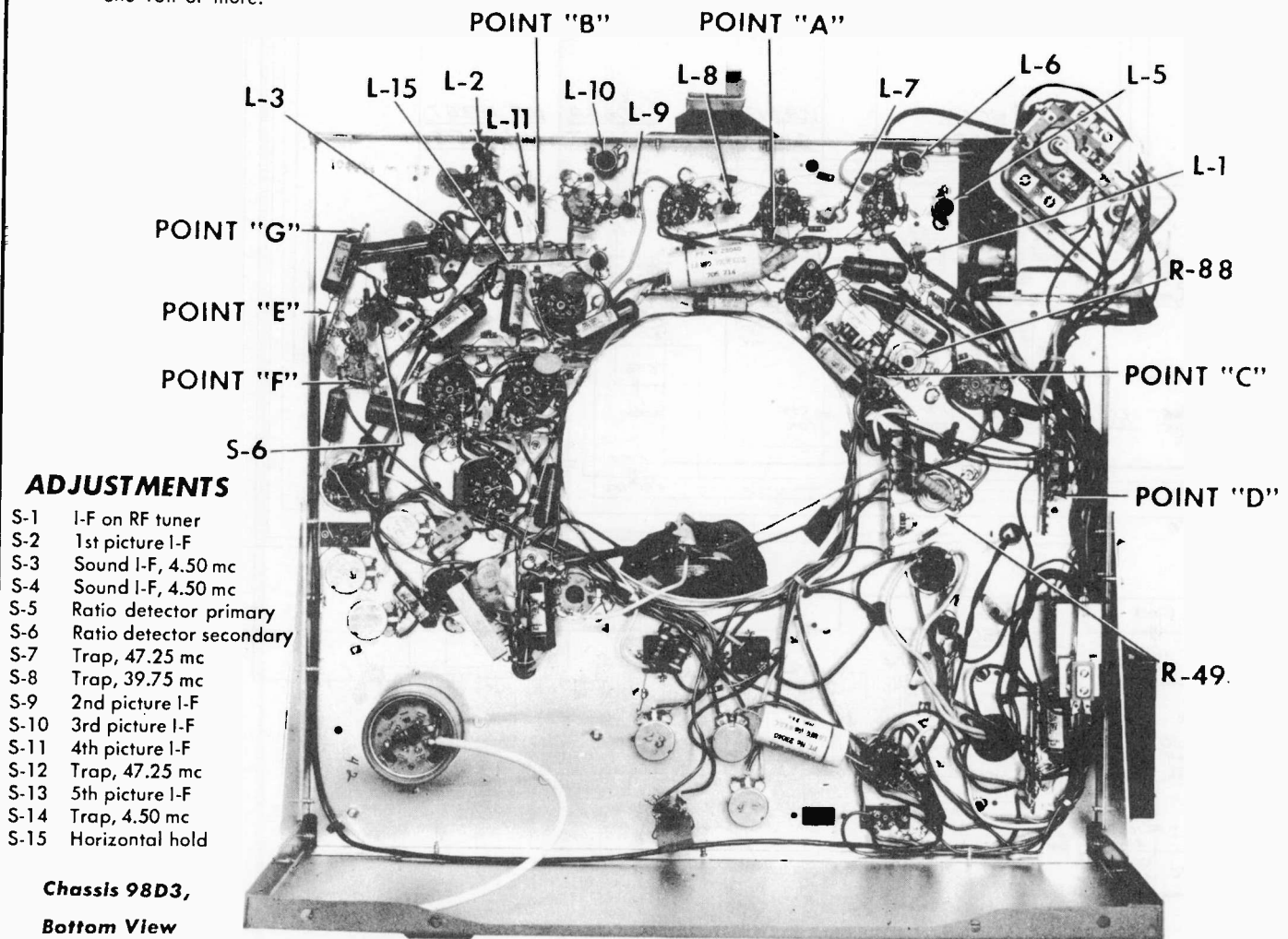

**ADJUSTMENTS**

- S-1 I-F on RF tuner
- S-2 1st picture I-F
- S-3 Sound I-F, 4.50 mc
- S-4 Sound I-F, 4.50 mc
- S-5 Ratio detector primary
- S-6 Ratio detector secondary
- S-7 Trap, 47.25 mc
- S-8 Trap, 39.75 mc
- S-9 2nd picture I-F
- S-10 3rd picture I-F
- S-11 4th picture I-F
- S-12 Trap, 47.25 mc
- S-13 5th picture I-F
- S-14 Trap, 4.50 mc
- S-15 Horizontal hold

Chassis 98D3,  
Bottom View

# PHILCO

## 8E11, 8E11U and 8E13 CHASSIS

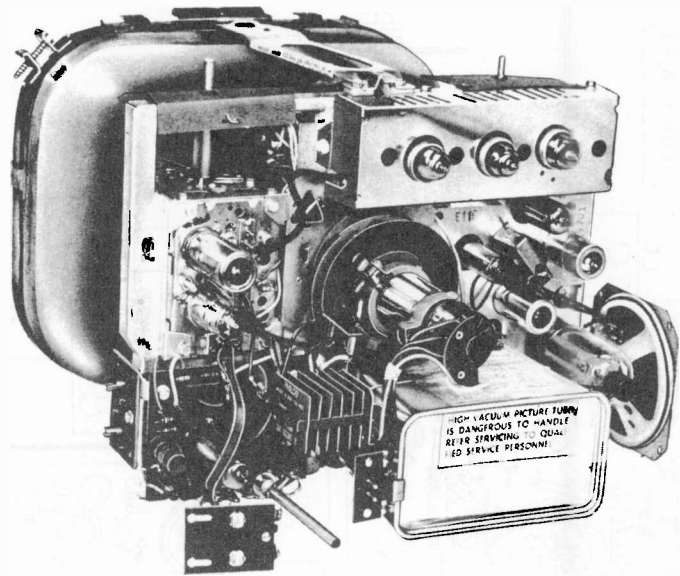

### VIDEO I-F ALIGNMENT

#### AM ALIGNMENT

BIAS: —3.5V applied to L11Y, the AGC line.

CHANNEL SELECTOR: Channel 4.

CONTRAST: Fully clockwise.

SCOPE: Connected through a 10,000 ohms resistor to L1U, the video detector output lug. Calibrate scope for 2 volts peak to peak.

AM GENERATOR: Connected to test lug #2 on tuner strip for T-70 and T-80-1; to tuner test lug on T-71.

INPUT LEVEL: Adjust input level to maintain scope level below 2 volts peak to peak.

Input Frequency	Adjust for Maximum
44.4 MC	T1U
43.5 MC	T2U
45.75 MC	T3U
45.0 MC	T1 (on tuner)
40.4 MC	T4U

#### SWEEP ALIGNMENT

SWEEP GENERATOR: Channel 4 sweep signal (69mc with 6mc sweep width) to antenna terminals through a 70 Ω/300 Ω matching network.

MARKERS: 67.25 MC marker fed into antenna. 45.75 MC marker fed into test lug #2 of tuner. Adjust fine tuning until the 67.25 MC marker becomes coincident with the 45.75 MC marker. **DO NOT disturb the fine tuning during balance of alignment.** Remove the 45.75 MC signal.

ADJUST: T1 (tuner) to position carrier (67.25 MC marker at 50%).

T1U to level curve if tilted.

T2U to position 42.5 MC slope (70.0 MC marker at 50%).

**DO NOT** adjust poles T3U or T4U from their original AM settings.

#### 4.5 MC TRAP ADJUSTMENT

- Connect a 4.5 MC detector to CRT cathode, video output lug, L2Y. (see circuit below, fig. 3). Preliminary padding of 4.5 MC detector:—Connect detector to an accurate source of 4.5 MC signal and pad core of transformer for maximum D.C. voltage.
- Connect a V.T.V.M. or 20,000 ohms/volt meter to the detector output.
- Detune fine tuning control slightly, in a CW direction, from the point of best picture.
- Adjust TC1Y (T4Y top core) of transformer (4.5 MC trap) for minimum output.

#### SOUND I-F ALIGNMENT USING STATION SIGNAL

- Connect a V.T.V.M. or 20,000 ohms/volt meter to top of volume control.
- Detune TC4Y (top core of transformer T5Y) to give a positive peak voltage.
- Detune the fine tuning control CCW, or reduce signal input to receiver, so as not to exceed .75 volts during alignment (this is to insure non-limiting action). In some areas it may be necessary to apply bias voltage to AGC, L11Y of the video panel, to maintain meter reading below .75 volts.
- Adjust TC2Y (bottom core of T4Y) and TC3Y (bottom core of T5Y) for maximum DC voltage.
- Adjust fine tuning for best picture (remove bias voltage if used) and adjust TC4Y for zero voltage (crossover).

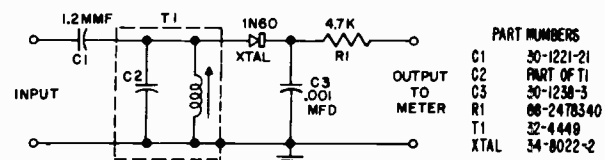

Figure 3. 4.5 MC Detector Probe

(Continued on the next five pages)

VOLUME TV-14, MOST-OFTEN-NEEDED 1958 TELEVISION SERVICING

PHILCO 8E11, -U, 8E13, Continued

OMITTED  
R6W, C7W, E1

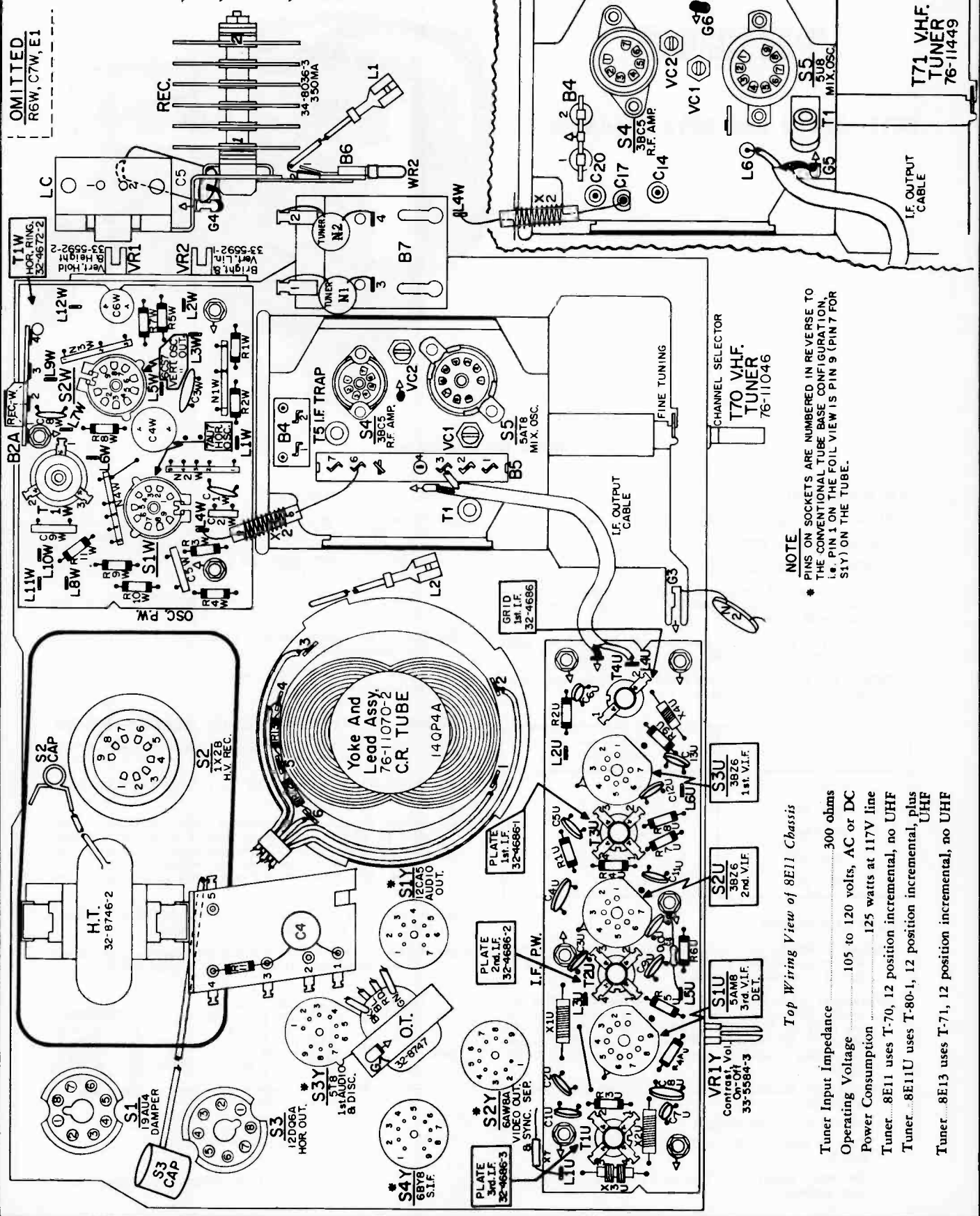

NOTE  
\* PINS ON SOCKETS ARE NUMBERED IN REVERSE TO THE CONVENTIONAL TUBE BASE CONFIGURATION, i.e. PIN 1 ON THE FOIL VIEW IS PIN 9 (PIN 7 FOR S1Y) ON THE TUBE.

Top Wiring View of 8E11 Chassis

- Tuner Input Impedance ..... 300 ohms
- Operating Voltage ..... 105 to 120 volts, AC or DC
- Power Consumption ..... 125 watts at 117V line
- Tuner ..... 8E11 uses T-70, 12 position incremental, no UHF
- Tuner ..... 8E11U uses T-80-1, 12 position incremental, plus UHF
- Tuner ..... 8E13 uses T-71, 12 position incremental, no UHF



PHILCO Chassis 8E11, 8E11U, and 8E13, Schematic Diagram

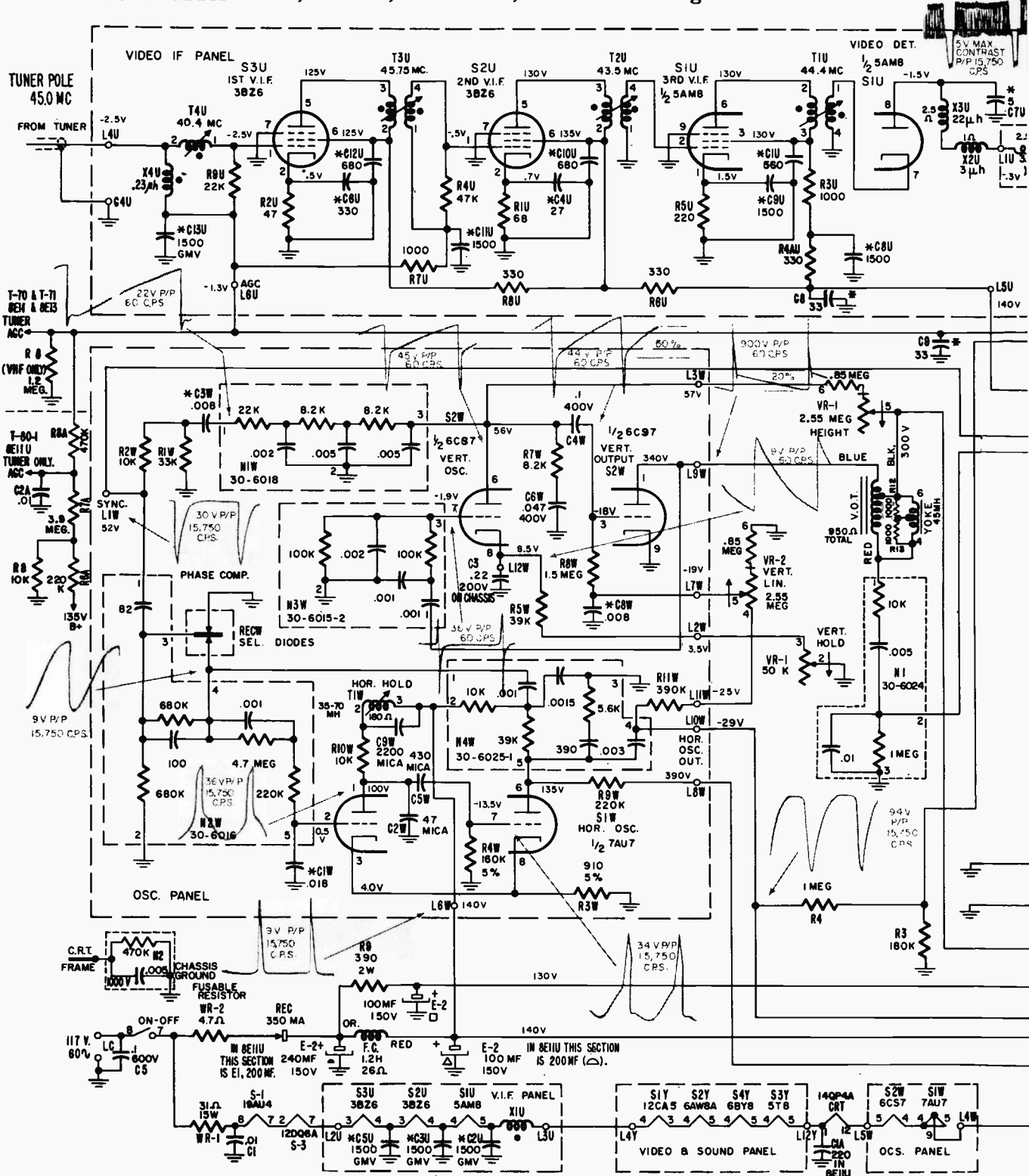

CHECKING THE PHASE COMPARER SELENIUM DIODE (REC.-W)

When servicing these portable television receivers where the dual selenium diode phase comparer is suspected, a fast and efficient method of checking them is this:—

A 20,000 ohm/volt meter is employed. On the 10k scale the forward resistance (meter connected in the same polarity as the diode) should be a maximum of 6000 ohms. The ratio of the

forward resistances of the two diodes should be less than 2 to 1. On the 100k scale the back resistance (meter connected in reverse polarity to the diode) should be a minimum of 2 megohms.

The center conductor of the phase comparer unit is the common negative.

# VOLUME TV-14, MOST-OFTEN-NEEDED 1958 TELEVISION SERVICING INFORMATION

## PHILCO Chassis 8E11, 8E11U, and 8E13, Schematic Diagram

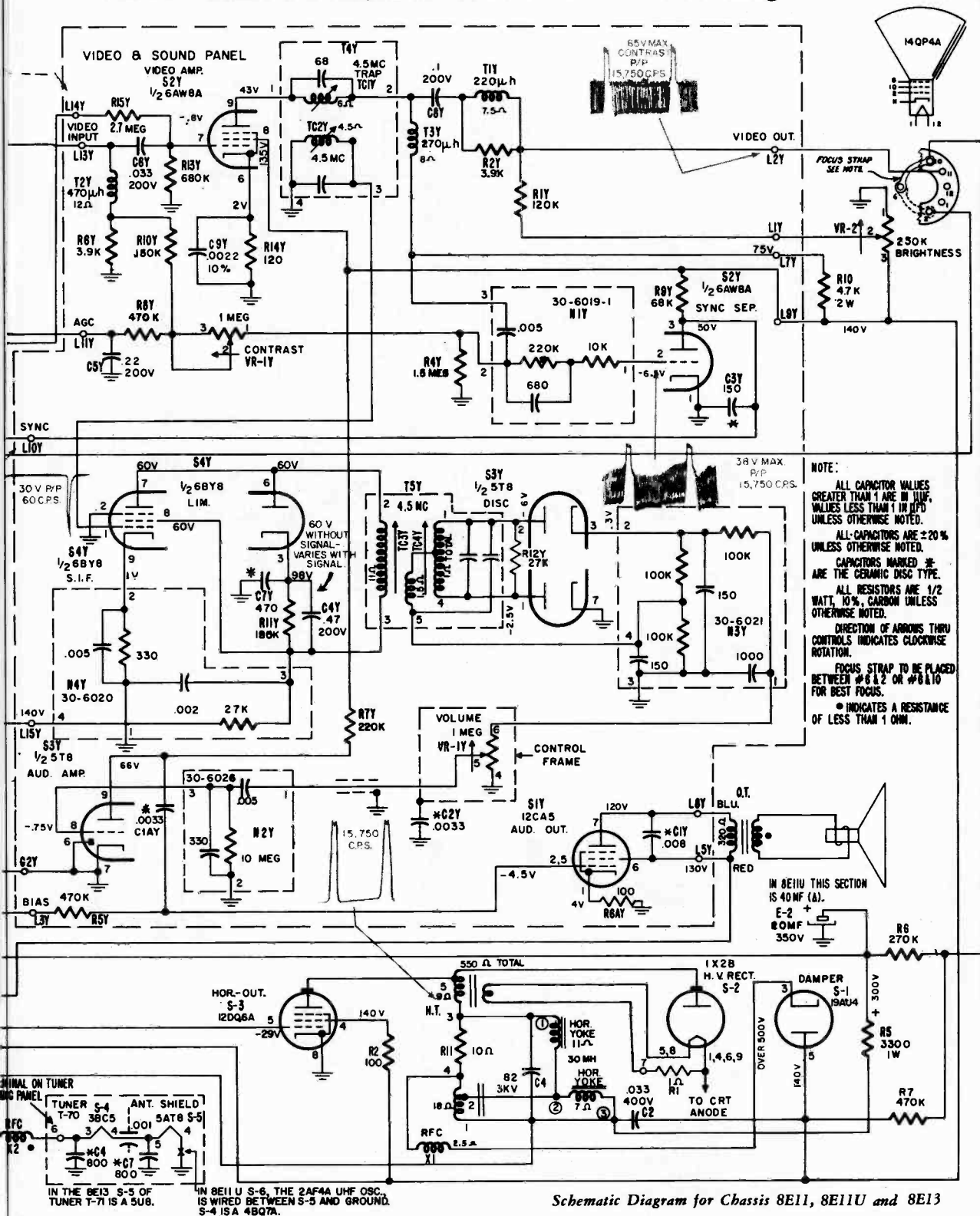

Schematic Diagram for Chassis 8E11, 8E11U and 8E13



PHILCO Chassis 8E11, 8E11U, and 8E13, Service Material, Continued

**CRITICAL LEAD DRESS INFORMATION**

- A. To Prevent Corona**  
 (1) The cap of S2, the 1X2B Hi-voltage rectifier (when connected to tube) must dress such that the open ends of the cap are facing directly toward the horizontal output transformer.  
 (2) All leads connected to S2 socket must be kept free of solder points and leads of R-1 (the filament resistor) must be kept as short as possible.
- B. To Prevent Hum**  
 (3) AC leads to the switch of VR1Y (lugs 7 and 8) must dress down close to panel and leave panel in the vicinity of L7Y.
- C. To Prevent Buzz**  
 (4) S3Y and T5Y (filament output) must dress between B3 and T5Y and must lay down to chassis and away from C1AY (audio coupling).  
 (5) Lead to L10Y (sync. output) must lay down close to panel and dress between B3 and E2 and under clamp CL6.  
 (6) CRT 2nd anode lead must have excess slack taped to lower side of CRT Bell.
- D. To Prevent Lead Burning**  
 (7) All leads must be dressed clear of WR-1, R-9 and R-10 by at least 1/2 inch.

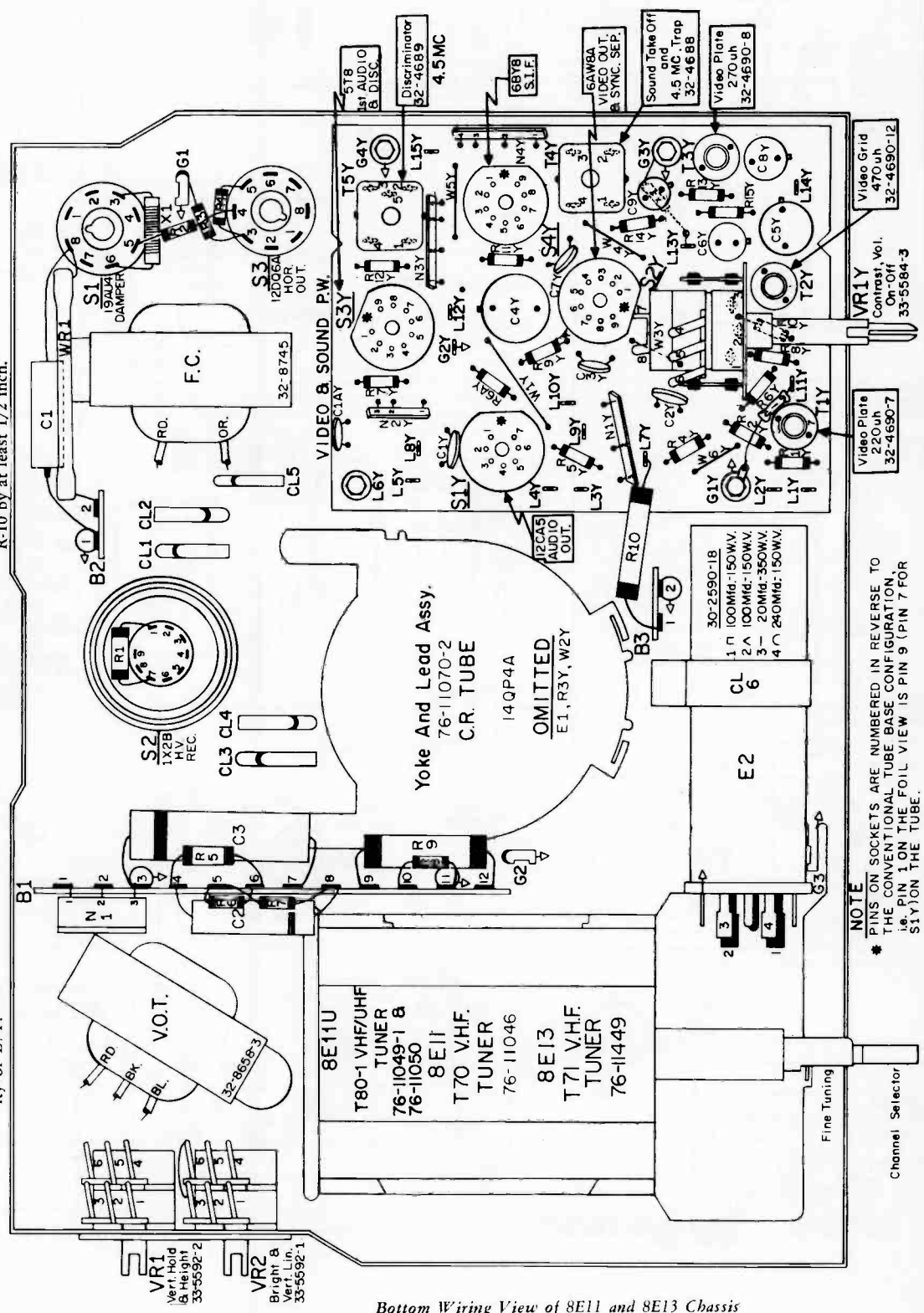

**NOTE**  
 \* PINS ON SOCKETS ARE NUMBERED IN REVERSE TO THE CONVENTIONAL TUBE BASE CONFIGURATION, i.e. PIN 1 ON THE FOIL VIEW IS PIN 9 (PIN 7 FOR S1) ON THE TUBE.

Bottom Wiring View of 8E11 and 8E13 Chassis



# PHILCO TELEVISION

## 8L41, 8L41U, 8L42, 8L42U, 8L43, 8L43U, 8P51, 8P51A and 8P51U CHASSIS

Model No.	Chassis	Tuner No.
F4210	8L41	(T-68B) 76-11450-2
UF4210	8L41U	(T-69A) 76-11547-1
F4210L	8L41	(T-68B) 76-11450-2
UF4201L	8L41U	(T-69A) 76-11547-1
F4210E	8L41	(T-68B) 76-11450-2
UF4210E	8L41U	(T-69A) 76-11547-1
F4212	8L41	(T-68B) 76-11450-2
UF4212	8L41	(T-69A) 76-11547-1
F4212L	8L41	(T-68B) 76-11450-2
UF4212L	8L41U	(T-69A) 76-11547-1
F4214STN	8L42	(T-68B) 76-11450-2
UF4214STN	8L42U	(T-69A) 76-11547-1
F4214STM	8L42	(T-68B) 76-11450-2
UF4214STM	8L42U	(T-69A) 76-11547-1
F4620SL	8L41	(T-68B) 76-11450-2
UF4620SL	8L41U	(T-69A) 76-11547-1
F4620SM	8L41	(T-68B) 76-11450-2
UF4620SM	8L41U	(T-69A) 76-11547-1
F4622	8L43	(T-68B) 76-11450-2
UF4622	8L43U	(T-69A) 76-11547-1
F4622L	8L43	(T-68B) 76-11450-2
UF4622L	8L43U	(T-69A) 76-11547-1
F4624	8L43	(T-68B) 76-11450-2
UF4624	8L43U	(T-69A) 76-11547-1
F4632	8L43	(T-68B) 76-11450-2
UF4632	8L43U	(T-69A) 76-11547-1
F6206SM	8P51A	(T-63) 76-11190
F6206SL	8P51A	(T-63) 76-11190
UF6206SM	8P51	(T-69A) 76-11547-1
F6206SL	8P51	(T-68B) 76-11450-2
UF6206SL	8P51U	(T-69A) 76-11547-1
F6620SM	8P51	(T-68B) 76-11450-2
UF6620SM	8P51U	(T-69A) 76-11547-1
F6620SL	8P51	(T-68B) 76-11450-2
UF6620SL	8P51U	(T-69A) 76-11547-1
F6620SL	8P51A	(T-63) 76-11190

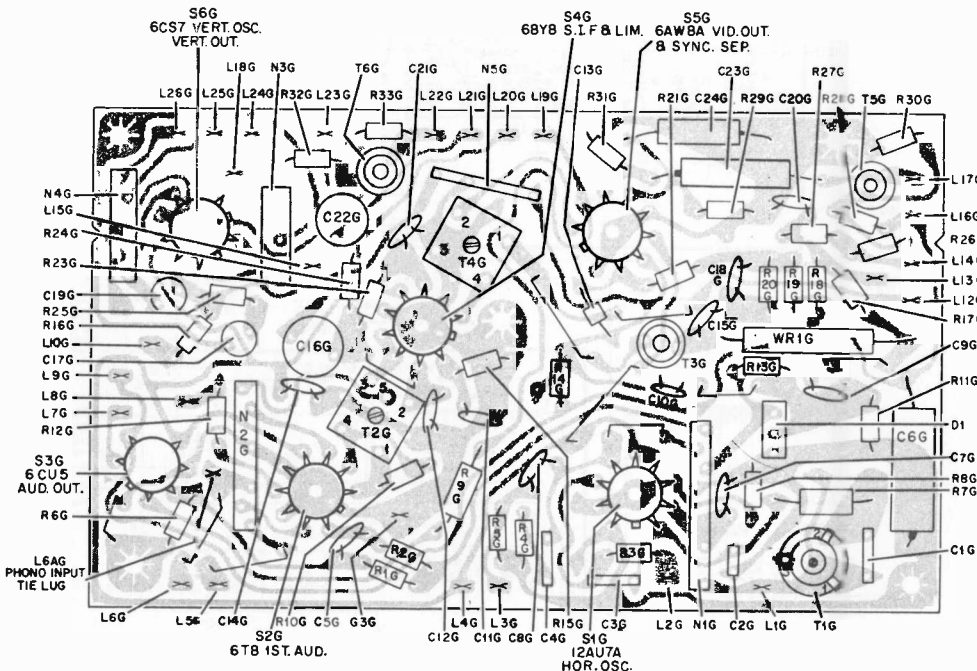

Video-Oscillator-Sound Printed Wiring Panel

### TERMINAL LUG IDENTIFICATION—V.O.S. PRINTED PANEL

- |                                                                                                                                                                                                                                                                                                                                                                                                                                                                                                                                                                                                                                                                                                                                                                                                                                                                                            |                                                                                                                                                                                                                                                                                                                                                                                                                                                                                                                                                                                                                                                                                                                                                                                                                              |
|--------------------------------------------------------------------------------------------------------------------------------------------------------------------------------------------------------------------------------------------------------------------------------------------------------------------------------------------------------------------------------------------------------------------------------------------------------------------------------------------------------------------------------------------------------------------------------------------------------------------------------------------------------------------------------------------------------------------------------------------------------------------------------------------------------------------------------------------------------------------------------------------|------------------------------------------------------------------------------------------------------------------------------------------------------------------------------------------------------------------------------------------------------------------------------------------------------------------------------------------------------------------------------------------------------------------------------------------------------------------------------------------------------------------------------------------------------------------------------------------------------------------------------------------------------------------------------------------------------------------------------------------------------------------------------------------------------------------------------|
| <p>L1G De-coupled B+.</p> <p>L2G To Aux. Hor. Hold control, VR5 (lug 4).</p> <p>L3G Hor. Osc. Output, to grid, pin 5, of 6DQ6A.</p> <p>L4G Filament input, 6.3 volts, A.C.</p> <p>L5G To arm of Volume Control, VR1.</p> <p>L6G To top of volume control, VR1.</p> <p>L6AG Phono Input, 8L43 and 8L43U only.</p> <p>L7G Audio Output plate, blue lead of audio output transformer and one side of C6.</p> <p>L8G Tuner AGC clamp, tied to L13G.</p> <p>L9G 270V B+, red lead of audio output transformer and one side of C6.</p> <p>L10G To arm of Height control, VR2 (lug 5).</p> <p>L11G Not used.</p> <p>L12G To top of contrast control, VR1 (lug 3).</p> <p>L13G Tuner AGC delay, tied to L8G.</p> <p>L14G Tuner AGC, to tuner and fringe switch, SW1 (3).</p> <p>L15G To vert. lin. control, VR2 (lug 3).</p> <p>L16G I.F. AGC, to I.F. panel (L5S) and Fringe Switch, SW1 (4).</p> | <p>L17G Video input from 2nd det., X1 choke.</p> <p>L18G Vert. output plate, blue lead from vert. output transformer.</p> <p>L18AG To SW1(5), Range Switch Panel Run #5 (green dot) —chassis Run 6</p> <p>L19G 150V B+, jumper to L20G. On automatic chassis, jumper is removed and lead goes to pin 7 of remote control socket.</p> <p>L20G Jumper to L19G. On automatic chassis, jumper is removed and lead goes to pin 8 of remote control socket.</p> <p>L21G To arm of contrast control VR1 (lug 2).</p> <p>L22G Video output, yellow lead to CRT cathode.</p> <p>L23G To vert. hold control, VR4 (lug 1).</p> <p>L24G To arm of brightness control, VR3 (lug 2).</p> <p>L25G Retrace suppression, green lead to grid of CRT.</p> <p>L26G Red lead from vertical output transformer and lead to yoke socket, pin 9.</p> |
|--------------------------------------------------------------------------------------------------------------------------------------------------------------------------------------------------------------------------------------------------------------------------------------------------------------------------------------------------------------------------------------------------------------------------------------------------------------------------------------------------------------------------------------------------------------------------------------------------------------------------------------------------------------------------------------------------------------------------------------------------------------------------------------------------------------------------------------------------------------------------------------------|------------------------------------------------------------------------------------------------------------------------------------------------------------------------------------------------------------------------------------------------------------------------------------------------------------------------------------------------------------------------------------------------------------------------------------------------------------------------------------------------------------------------------------------------------------------------------------------------------------------------------------------------------------------------------------------------------------------------------------------------------------------------------------------------------------------------------|

### VIDEO I-F ALIGNMENT

#### AM ALIGNMENT

**CHANNEL SELECTOR** — Set tuner to channel 4 position.

**SIGNAL INJECTION**—To mixer grid through T-L2.

**BIAS** — -5.0 volts to L16G. Connect 2:1 voltage divider from L16G to ground. Feed from divider -2.5 volts to L14G.

**SCOPE** — Connect to video detector output, L17G on V.O.S. panel.

**OUTPUT LEVEL** — Not greater than 2 volts peak to peak during pole and sweep alignment; not less than 0.2 volts peak to peak during trap alignment.

**WARM UP** — Allow equipment and chassis 15 minutes warm-up.

- 45.75 mc Adjust T1A (tuner) for maximum.
- 41.25 mc Adjust trap VC3S for minimum. Bias may be reduced as minimum is approached.
- 47.40 mc Adjust traps VC2S and VC4S for minimum. Bias may be reduced as minimum is approached. Repeat for accuracy.
- 42.7 mc Adjust VC1S and T2S for maximum.
- 45.0 mc Adjust T3S for maximum.
- 44.4 mc Adjust T1S for maximum.

(Service material continued on next 3 pages)

### SOUND I-F ALIGNMENT

- Connect 20,000 ohms/volt meter (10V range) to L6G.
- Inject a 4.5 MC AM signal into L17G or use station signal.
- Adjust T2G (sound discriminator) top core for zero voltage. It may be possible to obtain zero crossover at two positions of the tuning core. The correct one is the first crossover from the maximum CCW position of the core. Crossover point is that core setting where opposite polarity voltage is delivered for each direction of rotation from center.
- Connect the 20,000 ohms/volt meter (50V range) across the limiter diode load resistor (R23G).

**CAUTION:** Care should be exercised when placing meter lead connections as both ends of R23G are 50 volts or more above ground potential.

- Adjust T4G bottom core and T2G bottom core for maximum voltage. It may be possible to obtain two peaks while adjusting T2G. The correct one is the first peak from the maximum CW position of the core.
- Connect the 20,000 ohms/volt meter (10V range) to L6G and readjust T2G top core for zero voltage.

**NOTE:** During alignment it is necessary to maintain the voltage across R23G below 30 volts, in order to prevent limiter action. If using the station's signal, this may be accomplished by connecting a 330 mmf condenser from L1S (video det. output) on V.I.F. panel to ground and adjusting the fine tuning control toward the smear region.



# VOLUME TV-14, MOST-OFTEN-NEEDED 1958 TELEVISION SERVICING INFORMATION

## PHILCO 8L41, -U, 8L42, -U, 8L43, -U, 8P51, -A, -U, Diagram

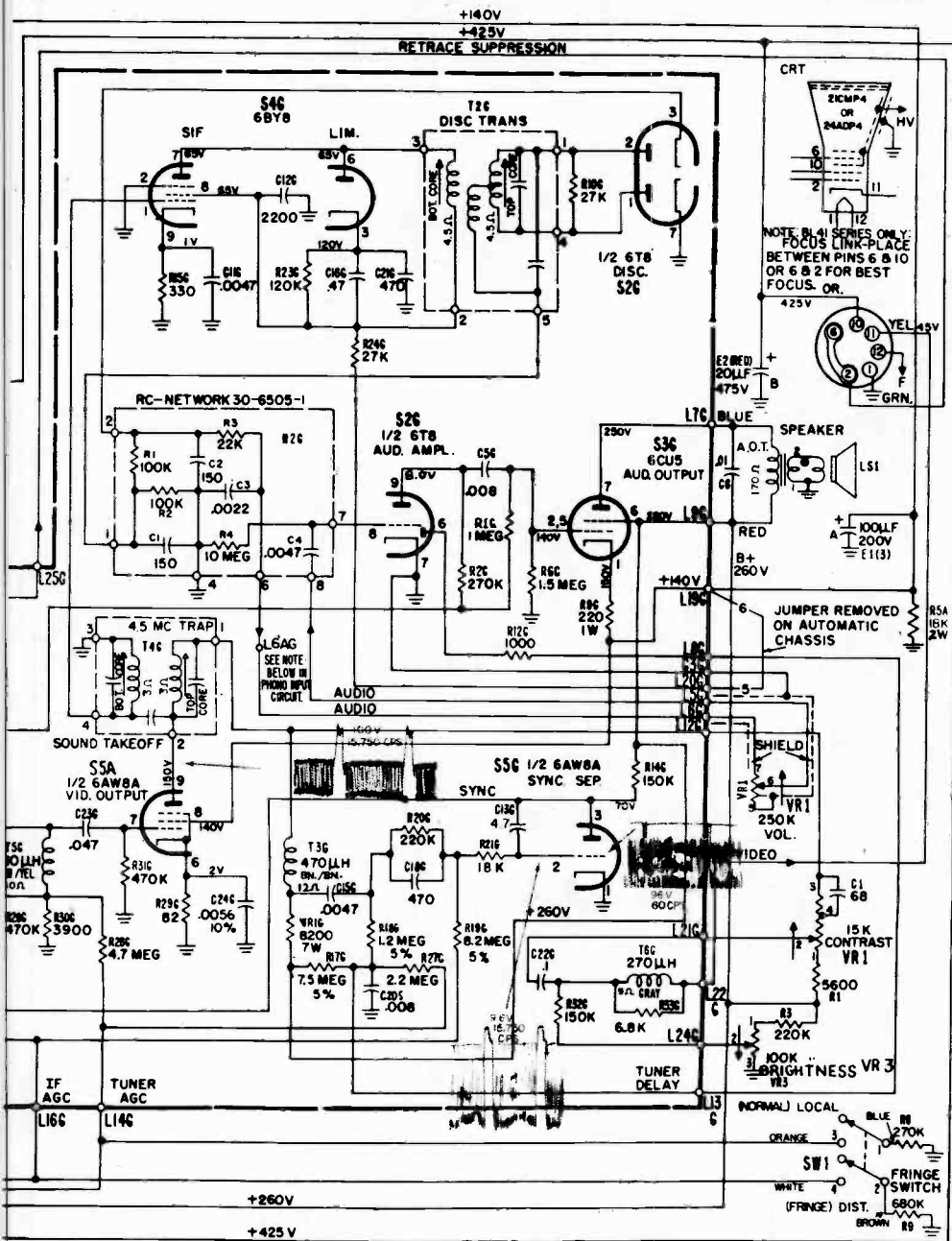

**V.O.S. Printed Wiring Panel Assy.**  
 Note: Identifying color dot appears on edge of V.O.S. panel.  
 Run 1—White dot, First production.  
 After 5000 assemblies, panel changes to 54-5278-1 with addition of wiring Lug L6AG. This new tie lug will be used as a phono connection in chassis 8L43 and 8L43U. In non-phono models a jumper is wired from L6G to L6AG.

Run 2—Red dot, N4G, retrace suppression R-C network, changed from 30-6507-2 to 30-6507-3. To improve retrace suppression.  
 Run 3—Orange Dot—same as run 2.  
 Run 4—Yellow dot  
 N3G, vertical feedback R-C network, changed from 30-6504-1 to 30-6504-2. R16G, vertical osc. plate resistor, changed from 1.0 megohm to 1.8 megohms part number 66-5188340.  
 R25C, vertical oscillator plate charging resistor, changed from 15,000 ohms to 13,000 ohms, 5%, part number 66-3138240.  
 C17C, vertical oscillator plate charging condenser, changed from .035 mfd to .022 mfd, part number 30-4688-4.  
 To improve interface characteristics.  
 Run 5—Green Dot. Added L18AG tie lug to 6AW8A (5S) video amp. cathode circuit. Modified foil in vicinity of C24G. Value of C24G changes to .001 mfd, part number 30-4650-52. Panel is 54-5278-1.

Run 6—Range switch, SW1, changes to a DPDT, part number 42-2075-4. Added a black wire from SW1-5 to L18AG (added tie lug) of new V.O.S. panel. Changed V.O.S. panel to run 5, green dot.  
 Added a condenser (C3A) between B2-2 (ground) and B3-3 (junction of R6 and blue lead from SW1-1). C3A is thus across R6. C3A in the part number 30-650-56. This circuit places R6 and C3A in the video cathode circuit in local (normal) position and adds filtering to AGC line in distant position.  
 Run 7—R4, vertical hold return resistor, changed to 27,000 ohms, 5%, part number 66-5278240. To center vertical hold control.  
**8L42 & 8L42U**  
 Run 1—First production, includes changes made in 8L41 up to and including run 4.  
 Run 2—Same as run 5 of 8L41.  
 Run 2Z—Same as run 5Z of 8L41.  
 Run 3—Same as Run 6 of 8L41.  
 Run 4—Same as run 7 of 8L41.  
**8P51, 8P51A & 8P51U Chassis**  
 Run 1—First production, starts with changes made in 8L41 up to and including Run 5.  
 Run 2—Same as run 6 of 8L41.  
 Run 2Z—Same as run 5Z of 8L41.  
 Run 3—Same as run 7 of 8L41.

### RUN CHANGE INFORMATION

**8L41, 8L41U, 8L43 & 8L43U Chassis**  
 Run 1—First Production of 8L41 and 8L41U.  
 Run 2—R4, vertical hold return resistor, changed from 15,000 ohms, 10% to 20,000 ohms, 5%, part number 66-3208240. To improve vert. hold stability and center control.  
 Run 3—VR-1, volume-contrast control, changed value of volume section from 250,000 ohms to 500,000 ohms, part number 33-5592-14. V.O.S. panel with L6AG, phono tie lug added. Run 1 after 5000 units of V.O.S. panel. To add phono input for 8L43 and 8L43U. This is first production of 8L43 and 8L43U but will be identified as Run 3 for these chassis. From here on 8L41 and 8L43 will have same run numbers.  
 Run 4—V.O.S. panel changed to run 2 or 3 (identical except for color dot—red or orange.) To improve retrace suppression.  
 Run 5—V.O.S. panel changed to run 4 (yellow dot) to improve interface.  
 Run 5Z—Yellow dot V.O.S. panel (run 4) with R4 change of chassis run 7.

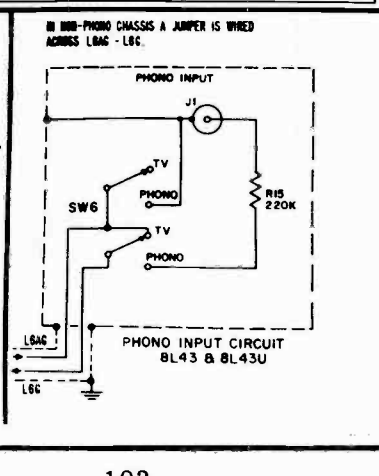
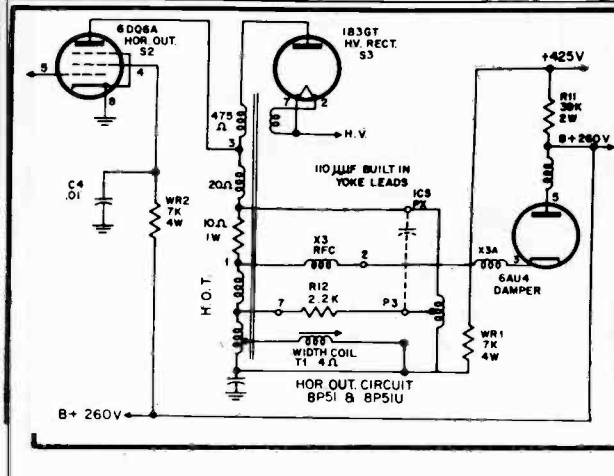

VOLUME TV-14, MOST-OFTEN-NEEDED 1958 TELEVISION SERVICING INFORMATION

PHILCO  
\* 8L41, etc.  
Continued

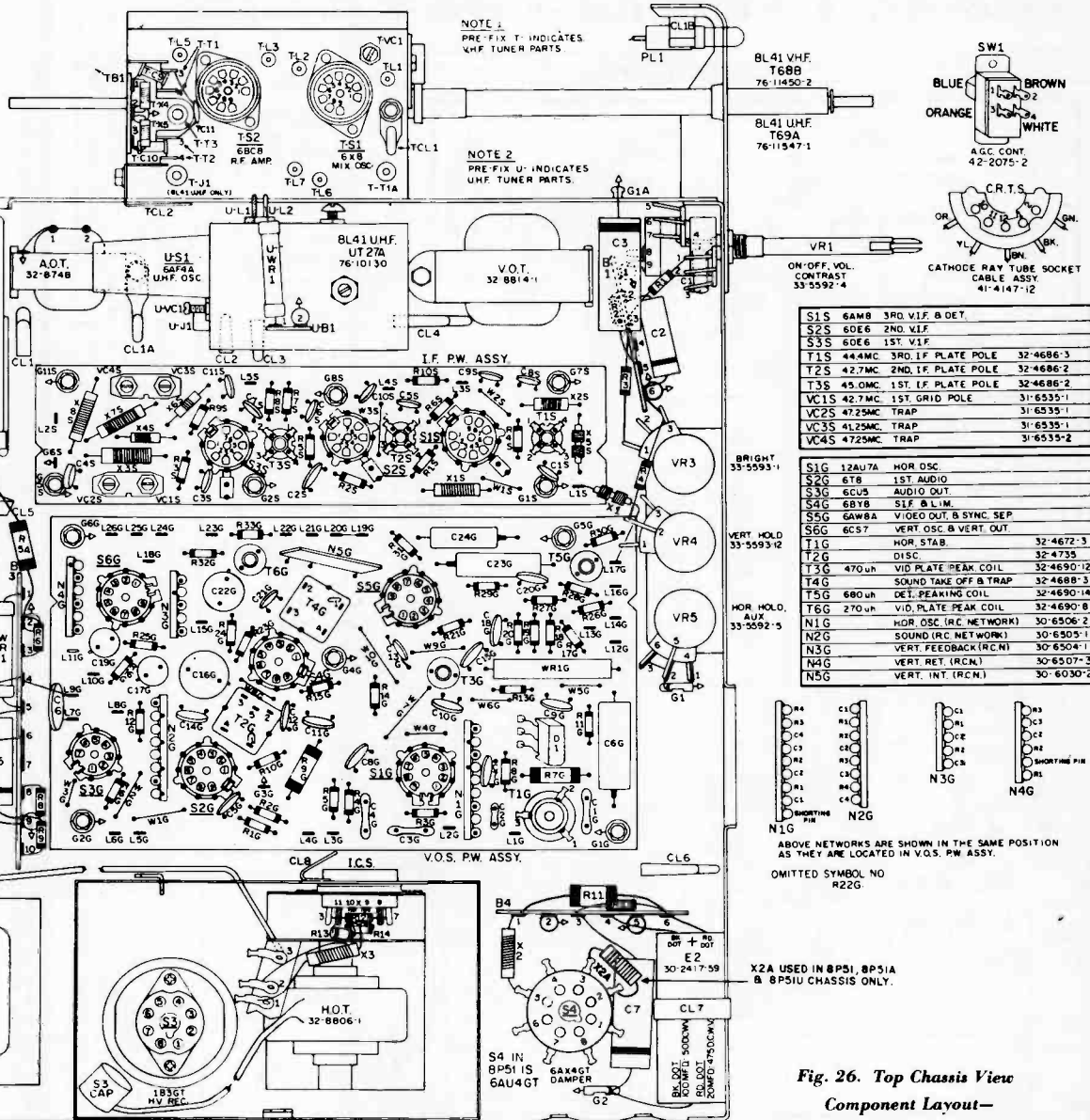
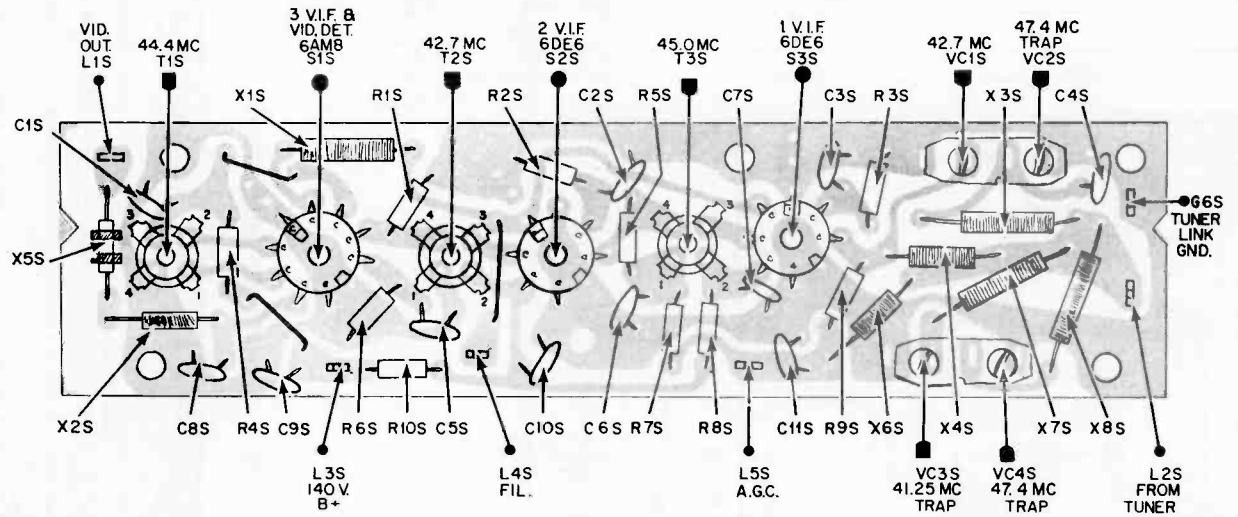
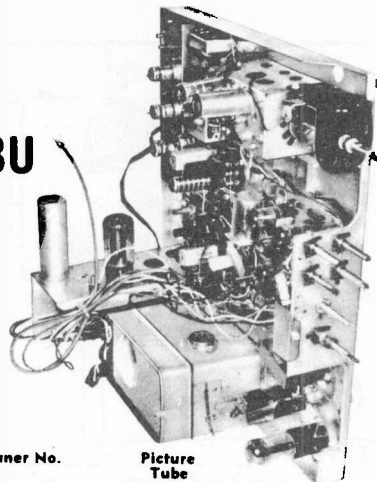

Fig. 26. Top Chassis View  
Component Layout—



# PHILCO TELEVISION

## 8L71, 8L71U, 8L72, 8L72U, 8L73 AND 8L73U CHASSIS



Model No.	Chassis	Tuner No.	Picture Tube
F4216	8L71	(T-67A) 76-10131-3	21BSP4
UF4216	8L71U	(T-65A) 76-10131-4	21BSP4
F4216L	8L71	(T-67A) 76-10131-3	21BSP4
UF4216L	8L71U	(T-65A) 76-10131-4	21BSP4
F4626	8L73	(T-67A) 76-10131-3	21BSP4
UF4626	8L73U	(T-65A) 76-10131-4	21BSP4
F4626L	8L73	(T-67A) 76-10131-3	21BSP4
UF4626L	8L73U	(T-65A) 76-10131-4	21BSP4
F6624T	8L72	(T-65B) 76-10131-2	24ADP4
UF6624T	8L72U	(T-65B) 76-10131-2	24ADP4
F6624TL	8L72	(T-65B) 76-10131-2	24ADP4
UF6624TL	8L72U	(T-65B) 76-10131-2	24ADP4

The i-f system comprises three stagger-tuned i-f amplifiers and the video detector. The first and second stages have individual pentode tubes while a diode-pentode tube serves as the third stage and video detector. AGC voltage is applied to the first and second i-f stages.

### VIDEO I-F ALIGNMENT

#### AM ALIGNMENT

CHANNEL SELECTOR: On VHF models (T-67A) set to channel 4; on UHF models (T-65A or B) set to UHF position.

SIGNAL INJECTION: VHF models (T-67A) to I-F output test point of tuner, TP-1. UHF models (T-65A or B) to UHF input jack on tuner, TP-1.

BIAS: -5.0 volts to I-F A.G.C., L16L (on video panel) and -2.5 volts to tuner A.G.C. L9L (on video panel).

SCOPE: Connect to L11L on video panel, video second detector output.

OUTPUT LEVEL: Not to exceed 2 volts peak to peak during pole and sweep alignment. Not less than .2 volts peak to peak as null, during trap alignment, is approached.

- 45.75 MC adjust tuner pole T1 for maximum.
  - 41.25 MC adjust VC-3S trap for minimum.
- NOTE: Bias may be reduced as trap minimum is approached.
- 47.4 MC adjust VC-2S and VC-4S traps for minimum.
  - Repeat steps two and three.
  - 42.7 MC adjust VC-1S and T2S for maximum.
  - 45.0 MC adjust T3S for maximum.
  - 44.4 MC adjust T1S for maximum.

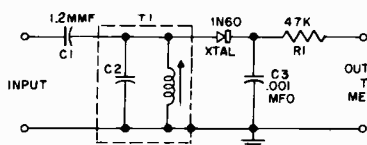

Fig. 1. 4.5 mc. Detector Tube

PART NUMBERS	
C1	30-121-21
C2	PART OF T1
C3	30-123B-3
R1	86-24783-0
T1	32-4449
XTAL	34-8022-2

### SWEEP ALIGNMENT

CHANNEL SELECTOR: Set to channel 4.

SIGNAL INJECTION: To antenna terminals through an antenna matching network (generator to 300 ohms).

BIAS, SCOPE and OUTPUT LEVEL: Same as above under AM Alignment.

- Inject 65.75 MC AM, 30% modulated, into antenna. Adjust fine tuning control for minimum output. Do Not Disturb fine tuning during balance of adjustments.
- Inject channel 4 sweep signal (69 MC with 6 MC sweep width) into antenna. If necessary, adjust the following cores to bring the curve within limits (see curve figure 2).
  - Adjust 67.25 MC to fall at the 50% point with tuner core T1.
  - Level curve with core T1S.
  - Position 70.5 MC at the 50% point with core T2S.

DO NOT DISTURB T3S AND VC-1S

### 4.5 MC TRAP ALIGNMENT

- Inject 4.5 MC AM signal into L11L or use station signal.
- Connect 4.5 MC detector (see circuit figure 1) to L13L (pin 2 of CRT).

NOTE: Preliminary padding of 4.5 MC test detector—Connect detector to an accurate source of 4.5 MC signal and pad core of transformer for maximum DC output voltage.

- Connect 20,000 ohms/volt meter, set to 2.5 volt range, to detector output.
- Turn contrast control fully clockwise (to maximum).
- Adjust 4.5 MC trap (top core of T3L) for minimum indication.

### SOUND I-F ALIGNMENT

NOTE: The sound I-F alignment is based upon a properly aligned video I-F strip.

- Connect a 20,000 ohms/volt meter (set to 10 volt range) to L7F on sound panel.
  - Inject a 4.5 mc AM signal into L11L or use a station signal.
  - Adjust T1F top core for zero voltage.
 

NOTE: It may be possible to obtain zero crossover at two positions of the tuning core. The correct one is the first crossover from the maximum CCW position of the core.
  - Connect a 20,000 ohms/volt meter (set to 50 volt range) across the limiter diode load resistor, R4F. CAUTION: Care should be exercised as both leads of volt meter are approximately 50 volts above ground potential.
  - Adjust T3L bottom core and T1F bottom core for maximum voltage. See note, step 3. Correct core position is first peak from maximum CW position.
  - Re-connect meter to L7F and readjust T1F top core for zero voltage.
- NOTE: During alignment it is necessary to maintain the voltage across R4F below 30 volts, in order to prevent limiting action. If using the station's signal, this may be accomplished by connecting a 330 mmf condenser from L1S (2nd video detector output) to ground and adjusting the fine tuning control toward the smear region. If using a signal generator, decrease the generator output.

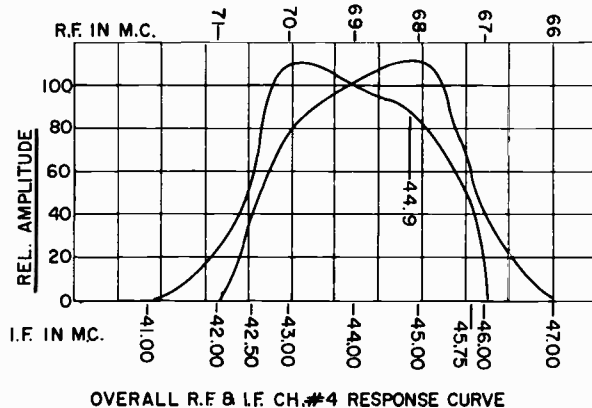
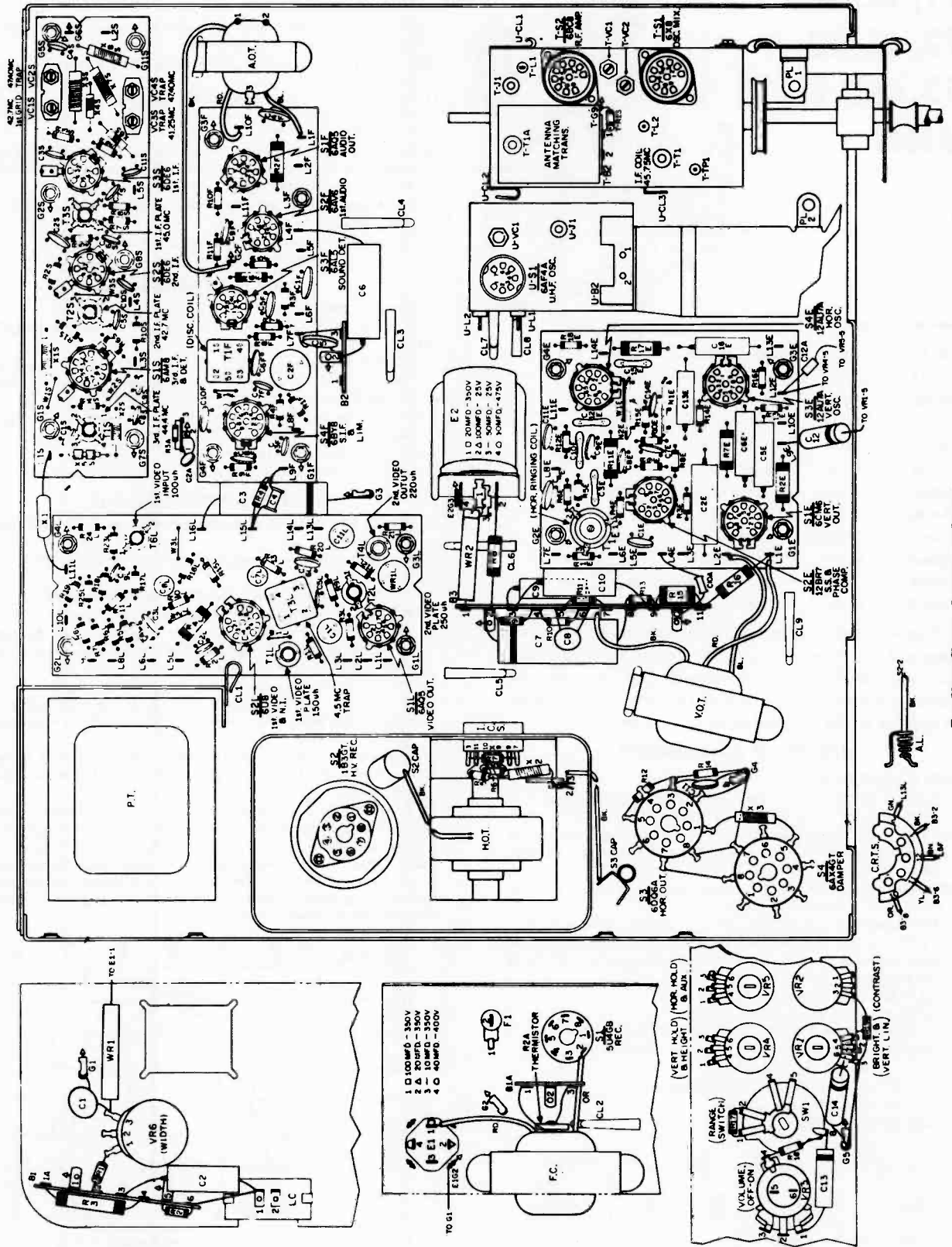

Fig. 2. Overall R-F I-F Response Curve.

PHILCO Chassis 8L71, -U, 8L72, -U, 8L73, -U, Top View, Continued



Top View Chassis Component Layout



PHILCO Chassis 8L71, -U, 8L72, -U, 8L73, -U, Service Data, Continued

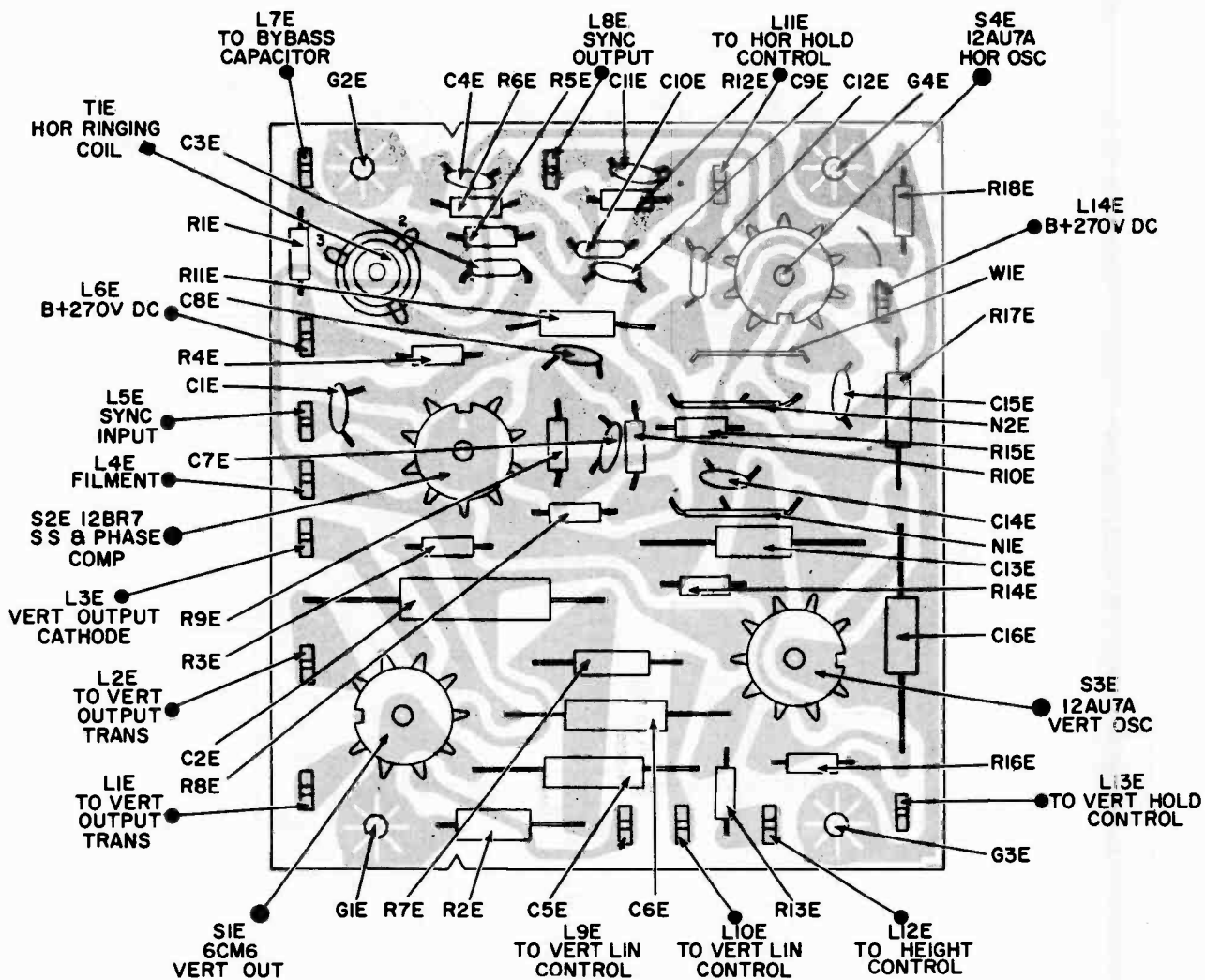

Oscillator Printed Wiring Panel

**OSCILLOSCOPE WAVEFORM PATTERNS**

These waveforms were taken with the receiver tuned to a local station, range switch in normal position and contrast at maximum. The voltages given are approximate peak to peak values and are based on approximately a 5.0 V. signal at the output of the 2nd detector. The frequencies shown are those of the waveform—not the sweep rate of the oscilloscope.



Sync separator grid, pin 2 of 12BR7 (S2E), 40 volts, 60 c.p.s.

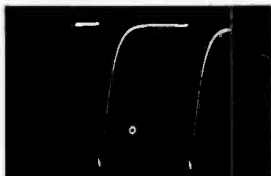

Sync separator plate, pin 1 of 12BR7 (S2E), 21 volts, 15,750 c.p.s.



Vertical oscillator plate, pin 6 of 12AU7A (S3E), 110 volts, 60 c.p.s.



Vertical oscillator plate, pin 1 of 12AU7A (S3E), 120 volts, 60 c.p.s.



Vertical oscillator cathode, pins 3 and 8 of 12AU7A (S3E), 23 volts, 60 c.p.s.

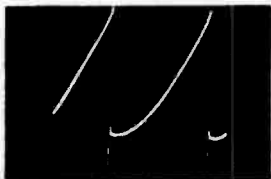

Vertical output grid, pin 3 of 6CM6 (S1E), 32 volts, 60 c.p.s.

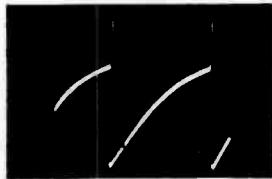

Top of vertical hold control (VR-4), 68 volts, 60 c.p.s.

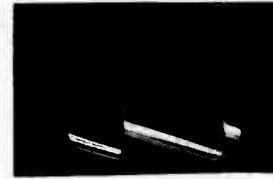

Vertical output plate, pin 9 of 6CM6 (S1E), 1250 volts, 60 c.p.s.





# VOLUME TV-14, MOST-OFTEN-NEEDED 1958 TELEVISION SERVICING INFORMATION

## PHILCO Chassis 8L71, -U, 8L72, -U, 8L73, -U, Schematic

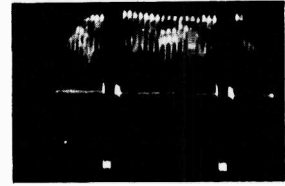
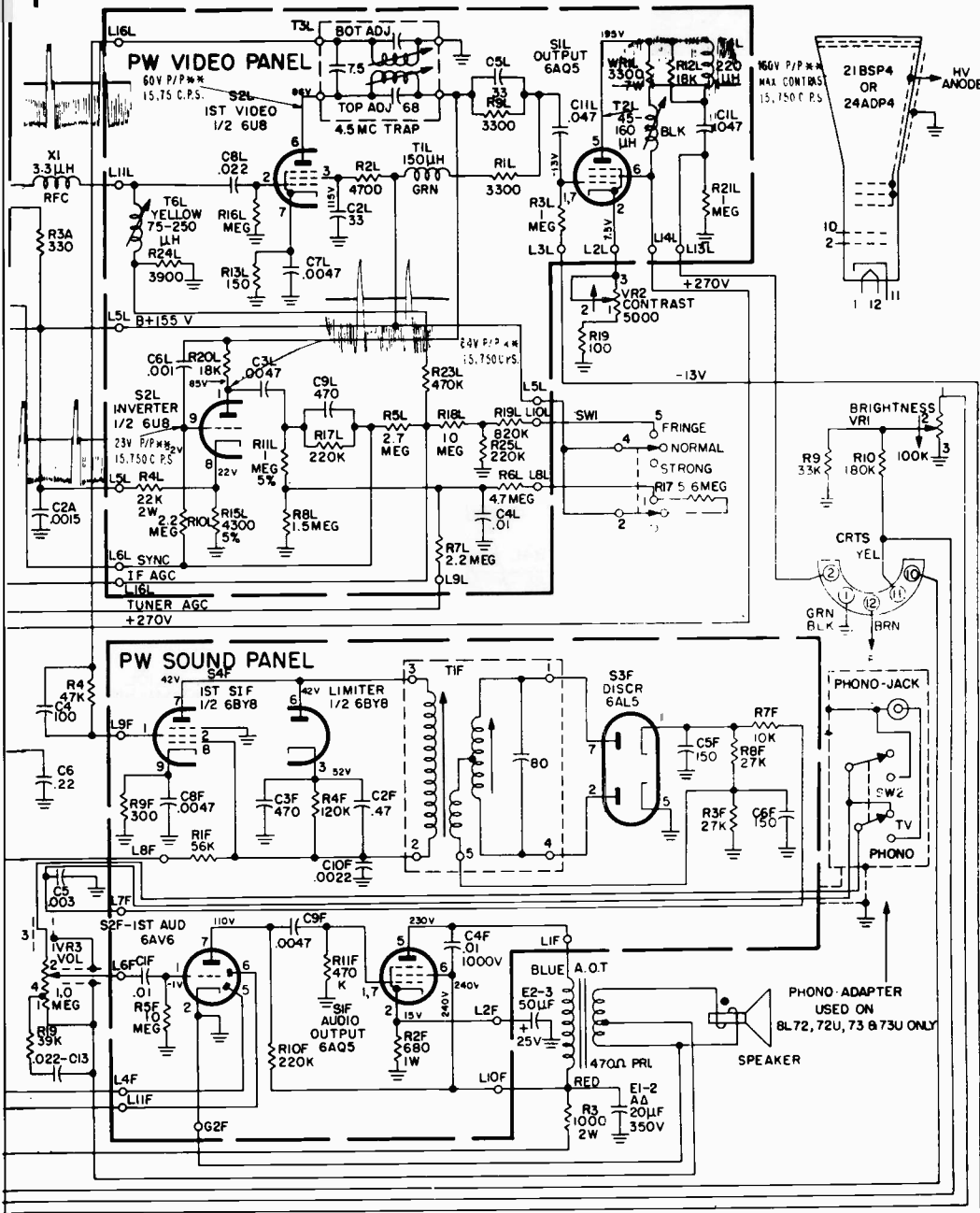

Composite video, 2nd detector output (L1S on I-F panel), 5.0 volts, 15,750 c.p.s.; composite video, video output, pin 5 of 6AQ5 (S1L), 160 volts, 15,750 c.p.s.

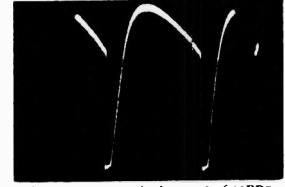

Phase comparator cathode, pin 8 of 12BR7 (S2E), 8 volts, 15,750 c.p.s.

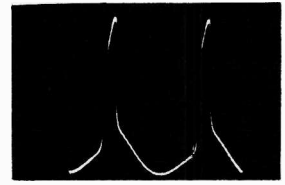

Horizontal oscillator plate, pin 1 of 12AU7A (S4E), 60 volts, 15,750 c.p.s.



Horizontal oscillator plate, pin 6 of 12AU7A (S4E), 165 volts, 15,750 c.p.s.

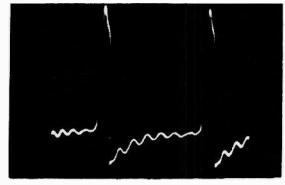

Horizontal output plate, loosely coupled to lead, 15,750 c.p.s.

### NOTES

- ALL CAPACITOR VALUES GREATER THAN 1 ARE IN MMF UNLESS OTHERWISE NOTED.
- ALL CAPACITOR VALUES LESS THAN 1 ARE IN MFD UNLESS OTHERWISE NOTED.
- ALL RESISTORS ARE 1/2 WATT 10% CARBON UNLESS OTHERWISE NOTED.
- ARROW THROUGH CONTROL INDICATES CW ROTATION.
- INDICATES A RESISTANCE OF LESS THAN 1 OHM.

## RUN CHANGE INFORMATION

### CHASSIS RUN 2

To reduce overloading and to eliminate sync buzz.  
R17, tuner A.G.C. delay (fringe switch) resistor, changes in value to 7.5 megohms, part number 66-5758340.

### CHASSIS RUN 3

To center Vertical Hold control and improve vertical hold circuit.  
VR4, the vertical hold control was changed from 3 megohms to 2 megohms, part number 33-5573-42.

### SWEEP OSCILLATOR PRINTED WIRING PANEL, RUN 2

To improve vertical oscillator hold circuit.

The following resistors were changed in value:

- R4E Resistor, sync. sep. plate, 120,000 ohms....66-4128340
- R8E Resistor, vert. sync. divider, 8200 ohms....66-2828340
- R16E Resistor, vert. os. grid, 2.2 megohms, 5%...66-5228240

## Schematic Diagram for Chassis 8L71, 8L71U, 8L72, 8L72U, 8L73, and 8L73U

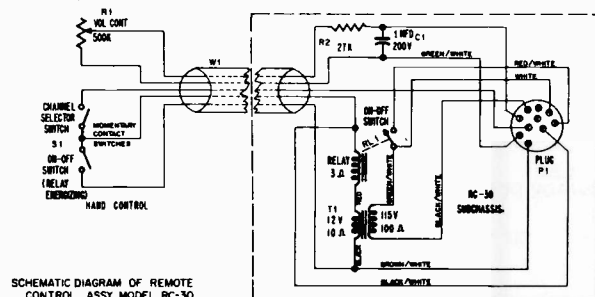

Schematic Diagram of Remote Control Assembly Model RC-30

PHILCO

Chassis 8L71, -U, 8L72, -U, 8L73, -U, Continued

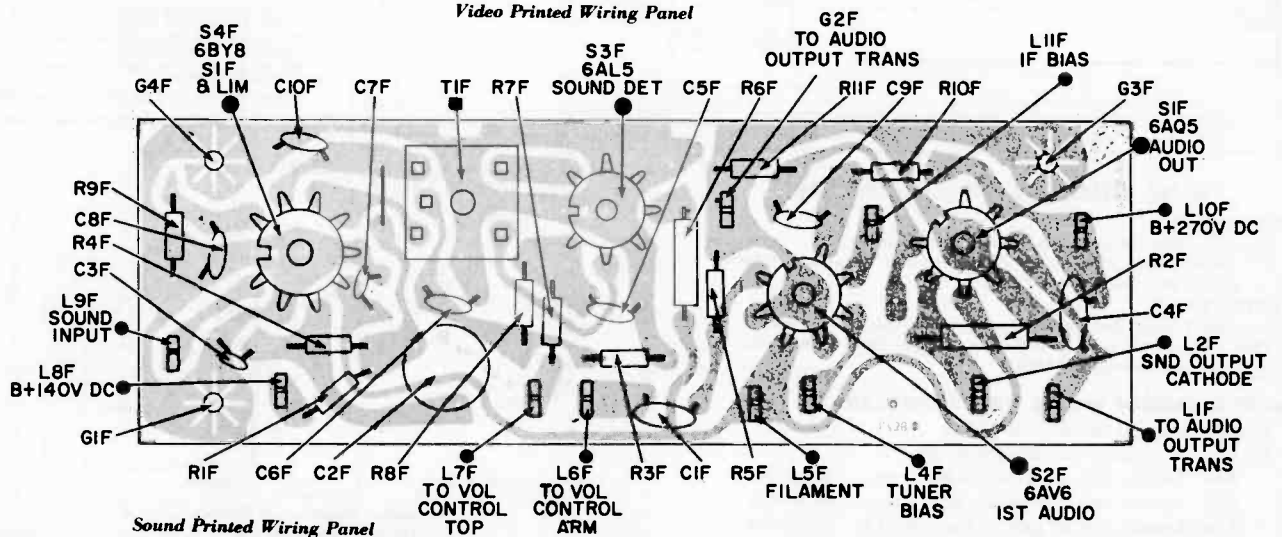
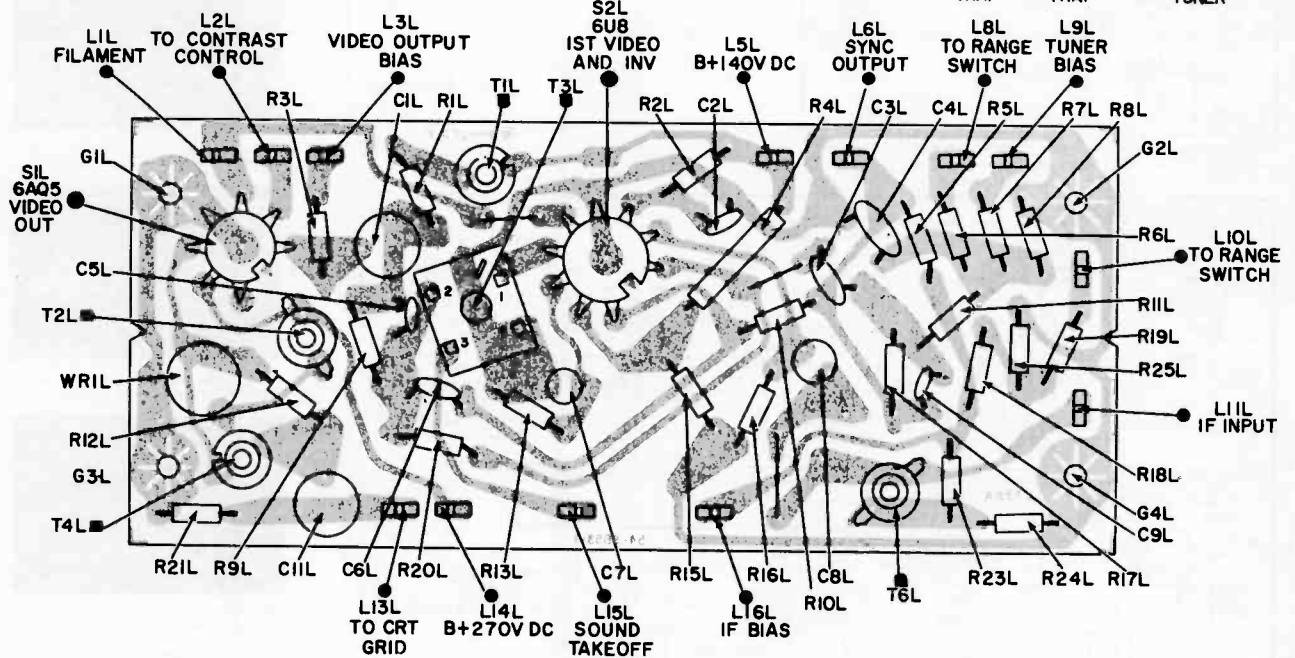
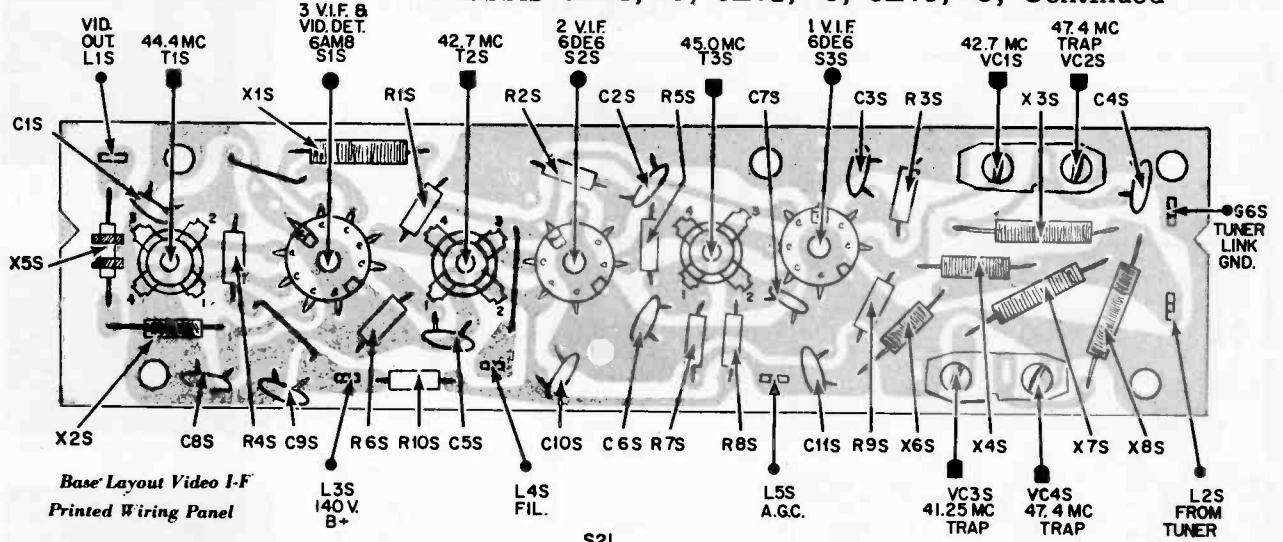

# PHILCO

## 8H25 and 8H25U CHASSIS

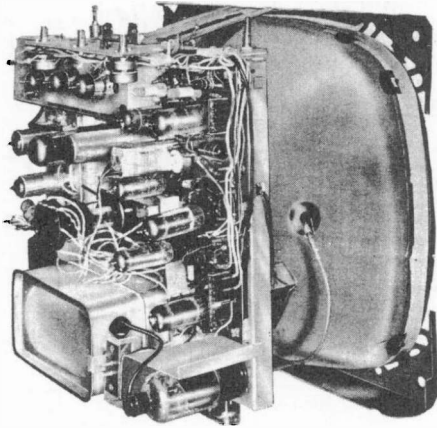

Model No.	Chassis	Tuner No.	Picture Tube
F3042G	8H25	(T-66A) 76-11548-1	17BWP4
UF3042G	8H25U	(T-69F) 76-11547-4	17BW <sup>2</sup> 4
F3042F	8H25	(T-66A) 76-11548-1	17BW <sup>2</sup> 4
UF3042F	8H25U	(T-69F) 76-11547-4	17BW <sup>2</sup> 4
F3044A	8H25	(T-66A) 76-11548-1	17BW <sup>2</sup> 4
UF3044A	8H25U	(T-69F) 76-11547-4	17BW <sup>2</sup> 4
F3202C	8H25	(T-66A) 76-11548-1	17BW <sup>2</sup> 4
UF3202C	8H25U	(T-69F) 76-11547-4	17BW <sup>2</sup> 4
F3204M	8H25	(T-66A) 76-11548-1	17BW <sup>2</sup> 4
UF3204M	8H25U	(T-69F) 76-11547-4	17BW <sup>2</sup> 4
F3204L	8H25	(T-66A) 76-11548-1	17BW <sup>2</sup> 4
UF3204L	8H25U	(T-69F) 76-11547-4	17BW <sup>2</sup> 4
F3204B	8H25	(T-66A) 76-11548-1	17BW <sup>2</sup> 4
UF3204B	8H25U	(T-69F) 76-11547-4	17BW <sup>2</sup> 4

(Material on pages 111 through 116)

### RECEIVER SET-UP CONTROL LOCATIONS

(Refer to Base View, figure 19)

1. Vertical Linearity — Adjust with a thin screwdriver through the hollow brightness shaft.
2. Height — Adjust with a thin screwdriver through the hollow vertical hold shaft.
3. Horizontal Hold Centering — Remove cabinet back (7 screws, 4 at top and 3 at bottom). Control is between vertical and horizontal hold controls.
4. Width — Remove back. Width switch is at lower right, just under the AC interlock.
5. Fusible B+ resistor — Remove back. Resistor is a plug-in at lower left corner of chassis.
6. Tubes — All tubes (except CRT) are accessible after removing back. 1G3GT high voltage rectifier is in cage.

### HORIZONTAL OSCILLATOR ADJUSTMENT

Allow set to warm up. Tune in a picture.

1. Short out the horizontal ringing coil, T5D, by placing a jumper across terminals 1 and 3.
2. Set the horizontal hold control, VR3, to the center of its range.
3. Adjust the horizontal hold centering control, VR4, to set the oscillator to the correct horizontal line frequency (to stop the picture; it will not be stable).
4. Remove the shorting jumper from across T5D and adjust the ringing coil core for stable picture sync.

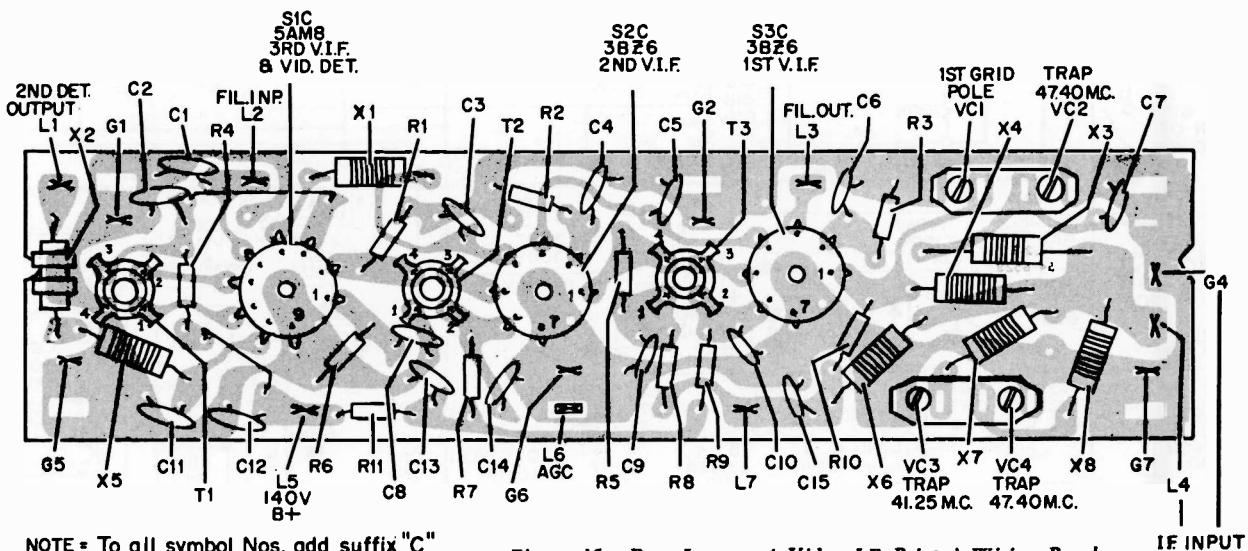

NOTE = To all symbol Nos. add suffix "C" (this panel only).

Figure 15. Base Layout of Video I-F Printed Wiring Panel

PHILCO Chassis 8H25 and 8H25U Schematic Diagram

Figure 20. Schematic Diagram for Chassis 8H25 and 8H25U

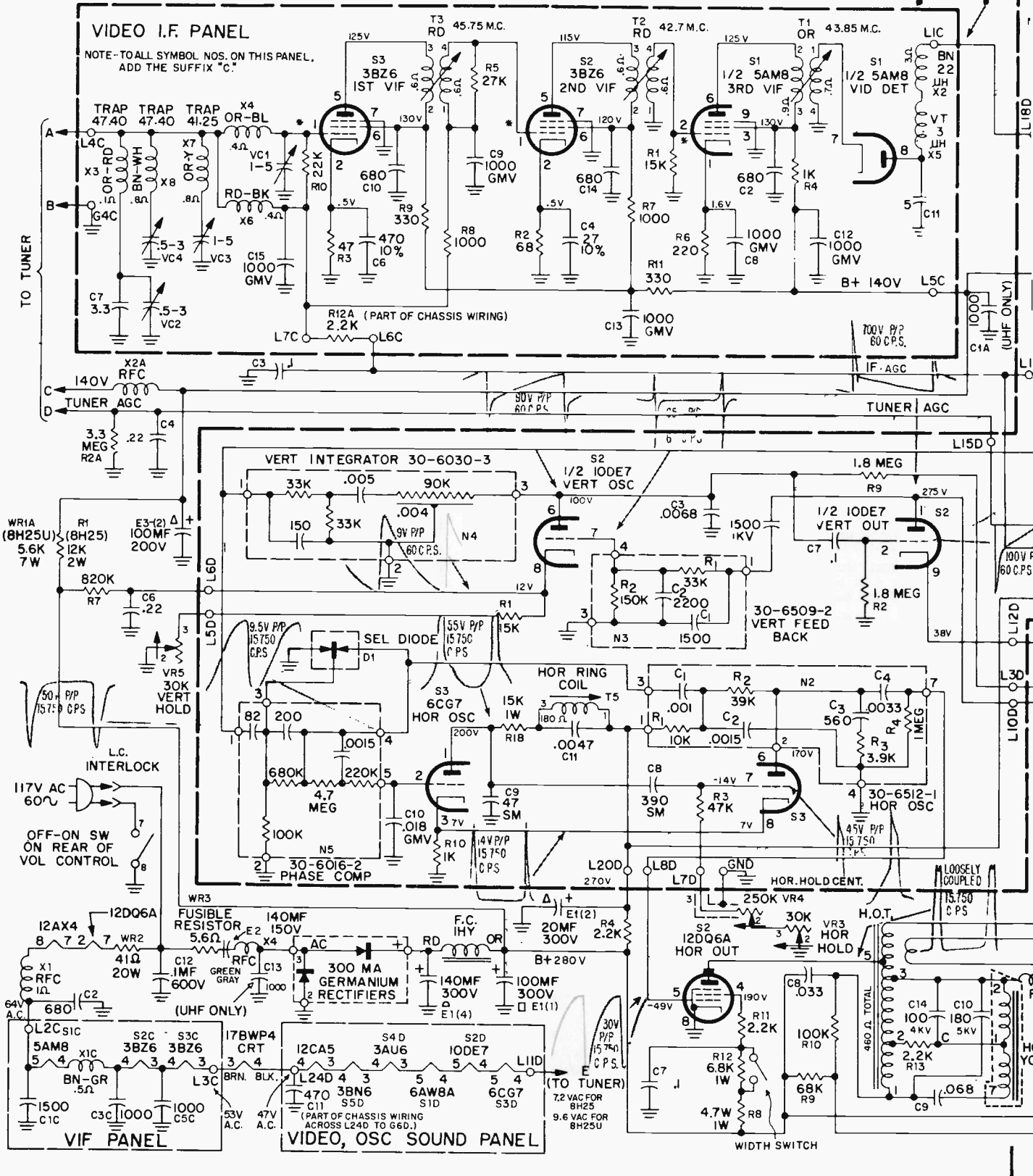

PHILCO Chassis 8H25 and 8H25U Schematic Diagram

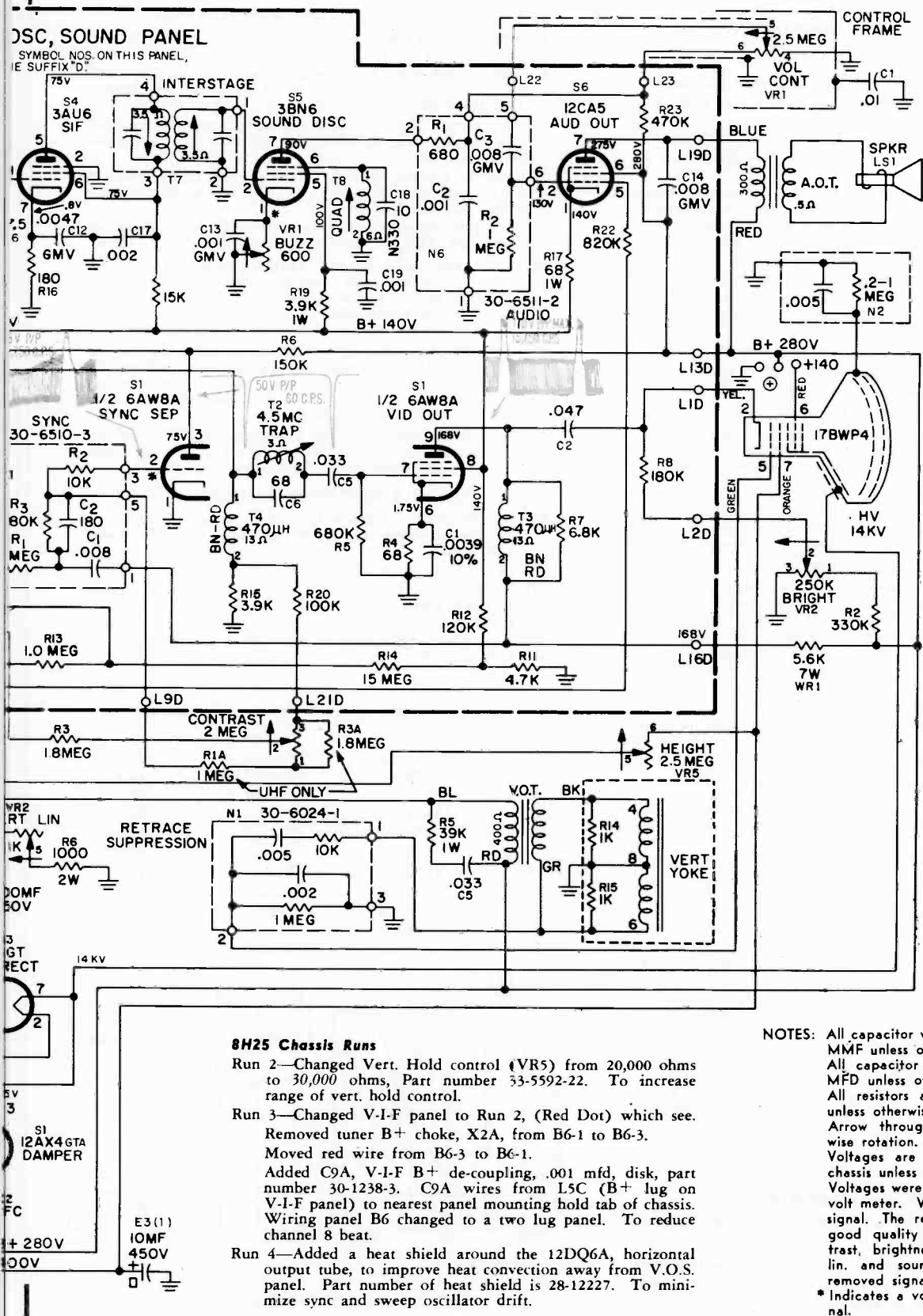

⊗ Focus voltage optional for best focus.

To provide additional focus voltage.

SERVICE NOTE: In cases where optimum focus would be obtained by a focus voltage between 0V and +275V, an additional voltage may be added to wiring panel B6. Add a wire from B1-5 to B6-3; this will put +140V at B6-3 for connection to focus anode.

**8H25 Chassis Runs**

- Run 2—Changed Vert. Hold control (VR5) from 20,000 ohms to 30,000 ohms, Part number 33-5592-22. To increase range of vert. hold control.
- Run 3—Changed V-I-F panel to Run 2, (Red Dot) which see. Removed tuner B+ choke, X2A, from B6-1 to B6-3. Moved red wire from B6-3 to B6-1. Added C9A, V-I-F B+ de-coupling, .001 mfd, disk, part number 30-1238-3. C9A wires from L5C (B+ lug on V-I-F panel) to nearest panel mounting hold tab of chassis. Wiring panel B6 changed to a two lug panel. To reduce channel 8 beat.
- Run 4—Added a heat shield around the 12DQ6A, horizontal output tube, to improve heat convection away from V.O.S. panel. Part number of heat shield is 28-12227. To minimize sync and sweep oscillator drift.

NOTES: All capacitor values greater than 1 are in MMF unless otherwise noted. All capacitor values less than 1 are in MFD unless otherwise noted. All resistors are 1/2 watt, 10%, carbon unless otherwise noted. Arrow through control indicates clockwise rotation. Voltages are DC from point shown to chassis unless otherwise noted. Voltages were read using a 20,000 ohms/volt meter. Voltages were taken with no signal. The receiver was adjusted for a good quality picture; i.e., normal contrast, brightness, width, height, vertical lin. and sound, picture in sync, then removed signal. \* Indicates a voltage dependent upon signal.

PHILCO Chassis 8H25 and 8H25U Service Information (Continued)

**VIDEO I-F ALIGNMENT**

**AM ALIGNMENT**

**CHANNEL SELECTOR:** Set tuner to channel 4 position.  
**SIGNAL INJECTION:** To tuner feed-thru, L2, in mixer grid circuit.

**BIAS:** —4.5 volts to I-F A-G-C, L17D, on V.O.S. panel.  
**SCOPE:** Connect to L18D on V.O.S. panel, video second detector output.

**OUTPUT LEVEL:** Not to exceed 2.0 volts peak-to-peak during pole and sweep alignment. Not less than .2 volts peak-to-peak as null, during trap alignment, is approached.

- (1) Adjust tuner pole, T1, for maximum at 47.4 MC. This is a temporary setting for trap alignment.
- (2) Adjust trap VC3C for minimum at 41.25 MC. \*
- (3) Adjust traps VC2C and VC4C for minimum at 47.4 MC. \*
- (4) Repeat steps 2 and 3. Bias may be reduced as trap minimum is approached.
- (5) Adjust tuner pole, T1, for maximum at 45.0 MC.
- (6) Adjust VC1C and T2C for maximum at 42.7 MC.
- (7) Adjust T3C for maximum at 45.75 MC.
- (8) Adjust T1S for maximum at 43.85 MC.

\* These traps are sharp. During adjustment, the generator output frequency may change with generator attenuator setting. This must be compensated for at the generator.

**SWEEP ALIGNMENT**

**SIGNAL INJECTION:** To antenna terminals through an antenna matching network (generator to 300 ohms.)

**CHANNEL SELECTOR, BIAS, SCOPE and OUTPUT LEVEL:** Same as above under AM alignment.

- (1) Inject 65.75 MC, AM, 30% modulated signal, into antenna. Adjust fine tuning control for minimum output. *Do Not Disturb* fine tuning during balance of I-F adjustments.
- (2) Inject channel 4 sweep signal (69 MC with 6 MC sweep width) into antenna. If necessary, adjust the following poles to bring the curve within limits (See curve, figure 2).
  - a. Tuner I-F pole, T1, to set carrier level.
  - b. T1C, 3rd V-I-F pole, to adjust curve tilt.
  - c. T2C, 2nd V-I-F pole, and VC1C, 1st grid pole, to adjust 42.7 MC (sound side) slope.
  - d. T3C, 1st V-I-F pole, to adjust carrier level.

**4.5 MC TRAP ALIGNMENT**

- (1) Inject 4.5 MC AM signal into L18D or use station signal.
- (2) Connect 4.5 MC detector (see circuit, figure 1) to L1D (pin 2 of CRT).

**NOTE:** Preliminary padding of 4.5 MC test detector — Connect detector to an accurate source of 4.5 MC signal and pad core of transformer for maximum DC output voltage.

**NOTE:** When using generator, calibrate by zero beating with sound I-F developed from station signal.

- (3) Connect 20,000 ohms/volt meter, set to 2.5 volt range, to detector output.
- (4) Turn contrast control fully clockwise (to maximum).
- (5) Adjust 4.5 MC trap. (T2D) for minimum indication.

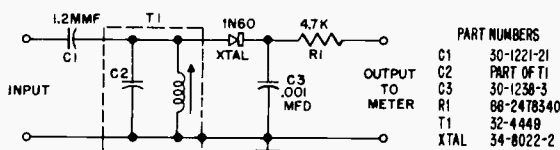

Figure 1. 4.5 mc. Detector Tube

**SOUND I-F ALIGNMENT**

**NOTE:** The sound I-F alignment is based upon a properly aligned video I-F strip.

1. With a weak station signal (antenna disconnected) tune receiver for best possible picture. Do not readjust fine tuning control during balance of procedure.

2. Set buzz control, VR1D, to the center of its range,
3. With a strong signal (antenna connected) adjust the quadrature coil, T8D, for maximum sound. See Note 1 below.
4. With a weak signal (antenna disconnected) adjust the sound take-off coil, T6D, and the sound interstage transformer, T7D (both pri. and sec. cores), for maximum sound.
5. With a weak signal, back off on the contrast control. Adjust the buzz control, VR1D, for minimum buzz and noise. See Note 2 below.
6. Reset the contrast control. With a weak signal, touch-up T6D (sound take-off) and T7D (sound interstage) for maximum. See Note 3 below.
7. With a strong signal (antenna connected) adjust the quadrature coil, T8D, for maximum sound. See Note 1 below.

**NOTE 1:** The quadrature coil, T8D, will peak at two points. The correct peak is the first peak reached as the core is backed out from the full in position. If this coil is misadjusted weak and distorted output will result and the other coils will not tune properly.

**NOTE 2:** The buzz control, VR1D, sets the operating point of the 3BN6 midway between saturation and cut-off. This enables the tube to provide proper limiting action. If this control is misadjusted, excessive buzz or noise will result.

**NOTE 3:** Misadjustment of the sound take-off, T6D, and the sound interstage, T7D, will cause either weak sound or an excessively high noise level, or both.

**TUNER OSCILLATOR ALIGNMENT**

**AM GENERATOR:** Connect to receiver antenna-input terminals (no matching network is required). Use 30% modulated signal.

**PRE-SET:** Fine tuning control to middle of its range.

**OSCILLOSCOPE:** Connect to L18D, video detector output, on V.O.S. panel.

**NOTE:** This procedure uses the traps of the video I-F channel. Proper oscillator adjustment is therefore dependent upon an accurately aligned I-F strip.

STEP	AM. GEN. FREQ.	TUNER POSITION	ADJUST FOR MIN.
1	209.75 mc	Channel 13	T5
2	203.75 mc	Channel 12	TC6
3	197.75 mc	Channel 11	TC5
4	191.75 mc	Channel 10	TC4
5	185.75 mc	Channel 9	TC3
6	179.75 mc	Channel 8	TC2
7	173.75 mc	Channel 7	TC1
8	81.75 mc	Channel 6	T10
9	75.75 mc	Channel 5	T9
10	65.75 mc	Channel 4	T8
11	59.75 mc	Channel 3	T7
12	53.75 mc	Channel 2	T6

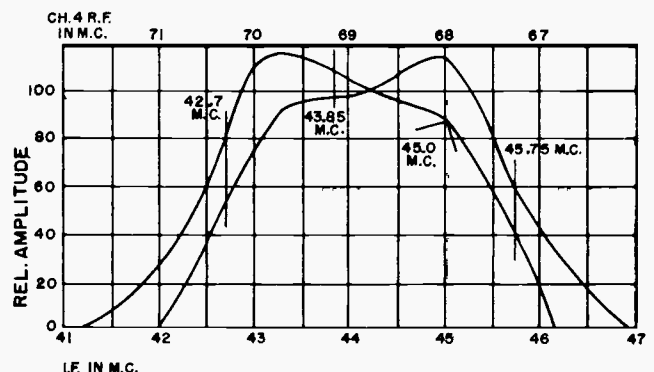
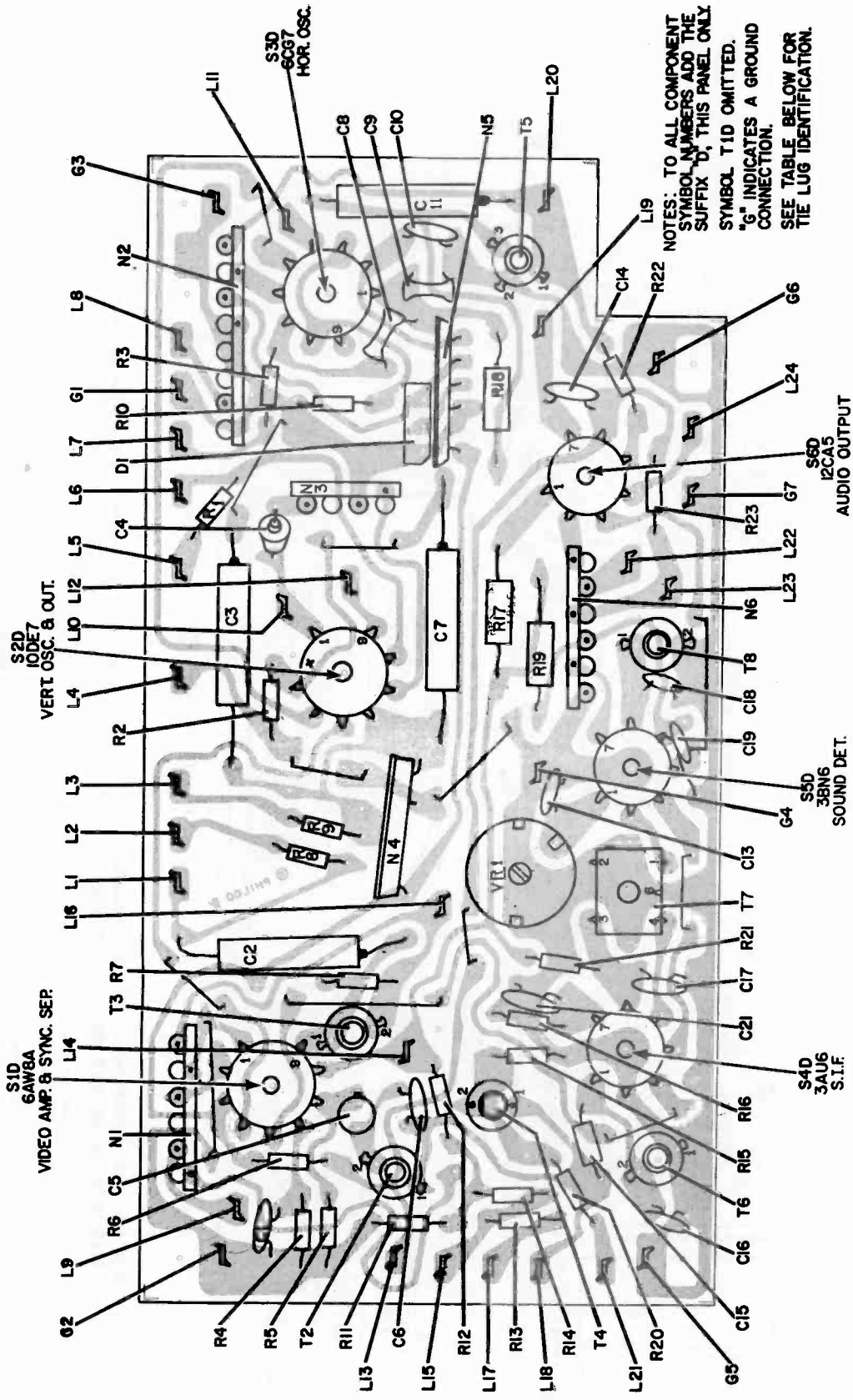

Figure 2. Overall R-F I-F Response Curve



PHILCO Chassis 8H25 and 8H25U Service Information (Continued)



NOTES: TO ALL COMPONENT SYMBOL NUMBERS ADD THE SUFFIX 'D', THIS PANEL ONLY. SYMBOL 'T' IS OMITTED. 'G' INDICATES A GROUND CONNECTION. SEE TABLE BELOW FOR THE LUG IDENTIFICATION.

TERMINAL LUG IDENTIFICATION - V.O.S. PANEL

- L1D Video output to CRT cathode, yellow lead.
- L2D Lead to arm of Brightness control, VR2-2.
- L3D Not used.
- L4D Lead to top of vert. hold control, VR5-3.
- L5D Lead to B4-5, vertical osc. cathode by-pass (C6) and fixed bias (R7).
- L6D Shielded lead to top of Hor. hold centering control, VR4-3.
- L7D Horizontal oscillator output to grid of 12DQ6A, pin 5 of S2.
- L9D Lead to bottom of contrast control, VR1-1, from sync network.
- L10D Vertical sweep output to blue lead of V.O.I.
- L11D Filament output to tuner.
- L12D Vertical output cathode to top of vert. lin. control, VR2-6, and cathode by-pass, E3(3).
- L13D 275V B+
- L14D 140V B+
- L15D Tuner A-G-C output.
- L16D To VR1, video amp. plate resistor, at B2-3.
- L17D I-F A-G-C and to R3 at B2-6.
- L18D Video output from I-F panel.
- L19D Audio output from I-F panel.
- L20D De-coupled B+ to hor. osc.
- L21D Lead to top of contrast control, VR1-3.
- L22D Lead from arm of volume control, VR1-5.
- L23D Lead to top of volume control, VR1-6.
- L24D Filament input and C11, filament by-pass.
- S4D 3AU6 S.I.F.
- S5D 3BN6 SOUND DET.
- S6D 12CA5 AUDIO OUTPUT
- S3D 6C97 HOR. OSC.
- S2D 6AW8A VIDEO AMP. & SYNC. SER.
- S1D 10DE7 VERT. OSC. & OUT.

Figure 14. Base Layout of Video-Oscillator-Sound Printed Wiring Panel

PHILCO Chassis 8H25 and 8H25U Service Information (Continued)

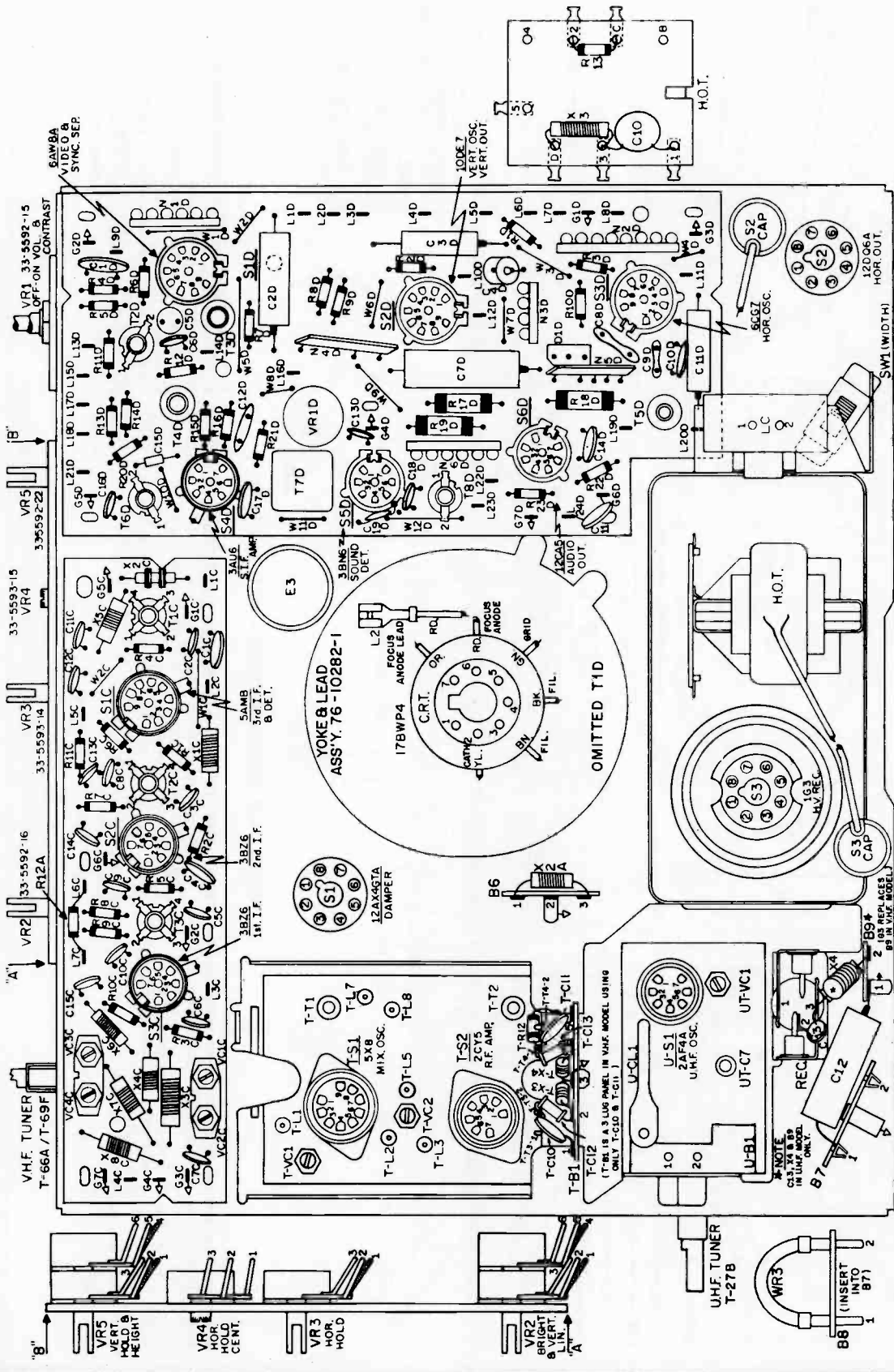

Figure 19. 8H25U — Top Wiring View

**CHECKING THE HORIZONTAL PHASE COMPARER SELENIUM DIODE (D1D ON V.O.S. PANEL)**

When servicing television receivers where the dual selenium diode phase comparer is suspected, a fast and efficient method of checking them is this:—

A 20,000 ohm/volt meter is employed. On the 10K scale the forward resistance (meter connected in the same polarity as the diode) should be

a maximum of 6000 ohms. The ratio of the forward resistances of the two diodes should be less than 2 to 1. On the 100K scale the back resistance (meter connected in reverse polarity to the diode) should be a minimum of 2 megohms.

The center conductor of the phase comparer unit is the common negative.



# RCA VICTOR

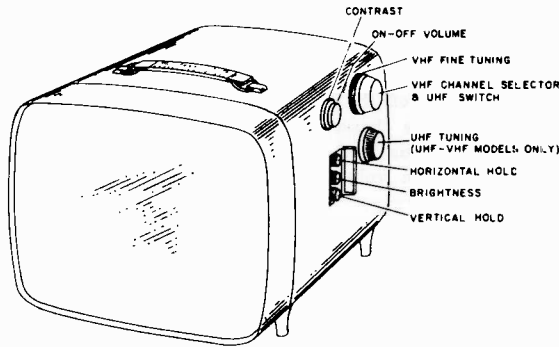

Figure 1—Operating Controls Portable and Table Models

## MODELS 21-PD-8115(U)

21-T-8221(U), 21-T-8222(U), 21-T-8225(U),

21-T-8226(U), 21-T-8227,

**21-T-8245(U), 21-T-8246(U)**

**21-T-8247(U), 21-T-8475(U)**

**21-T-8477(U), 21-T-8478(U)**

Chassis Nos. KCS107A, KCS107B, KCS107C  
or KCS107D

### CENTERING ADJUSTMENT

The electrostatic focus kinescope is provided with special centering magnets. These magnets are in the form of two discs mounted on the back of the deflection yoke. When the magnets are rotated on the tube so that the levers are together, maximum centering effect is produced. To shift the picture, rotate one of the magnets with respect to the other. To shift the picture in the desired direction rotate both magnets simultaneously in the same direction on the neck of the kinescope. By alternately rotating one magnet with respect to the other, then rotating both simultaneously around the neck of the tube, proper centering of the picture can be obtained.

### DEFLECTION YOKE ADJUSTMENT

If the lines of the raster are not horizontal or squared with the picture mask, rotate the deflection yoke until this condition is obtained. The yoke clamp must be loosened to allow the yoke to be rotated, see Figure 5. Make sure the yoke assembly is pushed forward against the kinescope bell.

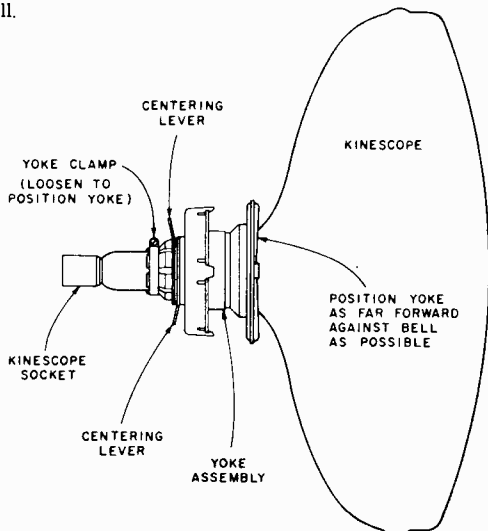

Figure 5—Yoke and Centering Magnet Adjustments

### FOCUS

An electrostatic focus type kinescope is employed in these receivers. The receivers operate with fixed focus, having a fixed voltage applied to the focusing electrode.

### VHF R-F OSCILLATOR ADJUSTMENTS

Tune in all available stations to insure the receiver r-f oscillator is properly adjusted on all channels. Correct adjustment will be indicated by the ability to tune the fine tuning control on each channel from a condition where sound bars appear at or near one extreme, through proper picture and sound to the other extreme where the picture will appear smeared with poor definition.

If adjustment is indicated on any channel, after the adjustment has been made all channels lower in frequency should be rechecked for proper oscillator range. Always proceed with adjustment from the highest frequency channel to the lowest.

Adjustments for channels 2 through 12 are available through the holes on the front of the tuner and are accessible on portable and table models when the channel selector and fine tuning knobs are removed.

Oscillator adjustments on the corner console models are accessible from inside the cabinet. A short, thin screwdriver must be used to make adjustments on some channels.

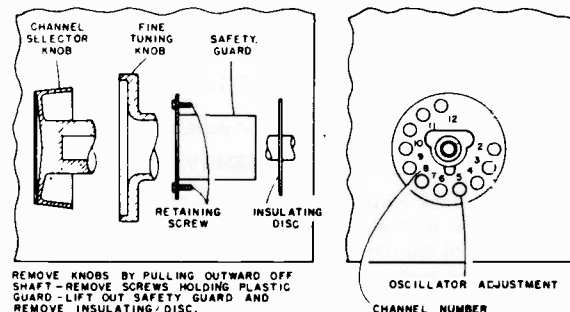

Figure 7—VHF Oscillator Adjustments

**RCA VICTOR**

**WIDTH ADJUSTMENT**

The width adjustment is located on the chassis rear.

The width of the picture should be adjusted to fill the mask with a line voltage of 105V. With normal voltage of 117V, the picture should overscan the tube at each side by approximately 3/4 inch. The adjustment should be made with the brightness control set at normal operating position.

**KINESCOPE AND SAFETY WINDOW CLEANING**

The front safety window may be removed to allow for cleaning of the kinescope faceplate and the safety window if required.

In portable and swivel table models, remove two screws from under the front edge of the cabinet. Pull out at the bottom and lift off the bezel. Refer to Figure 8. Take out six spring clips and remove safety window.

The kinescope faceplate and safety window should be cleaned with a soft cloth and water only.

Replace the window and bezel and replace the two bottom screws.

Models 21-T-8475(U), 21-T-8477(U) and 21-T-8478(U)—These models have a "U" shaped channel in front of the top edge of the safety glass and also at the bottom edge. Pry off the top and bottom channels starting at the extreme ends.

Insert the blade of a small screwdriver in one of the vertical slots in the middle of a retainer at the top of the safety glass. Slide the bar to the right to release the retainer. Refer to Figure 9.

The bottom retainers are removed in a similar manner except the slide bar is moved to the left.

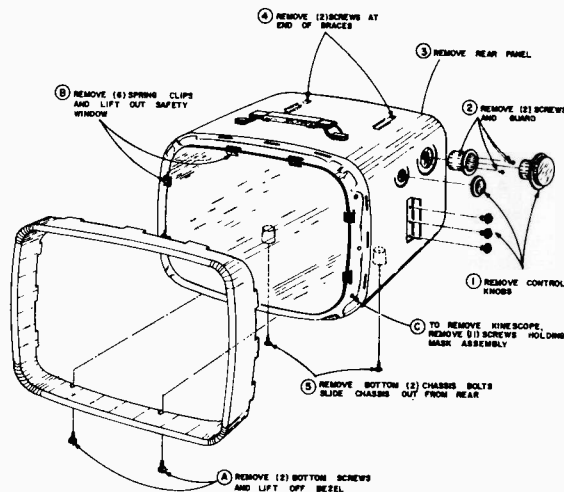

Figure 8—Safety Window and Chassis Removal

**CHASSIS REMOVAL**

PORTABLE AND TABLE MODELS—To remove the chassis from the cabinet, remove the cabinet back, the control knobs and the plastic guard. Unplug the antenna cable, the kinescope socket and the speaker cable. Loosen the yoke clamp. Remove two chassis screws on the bottom of the cabinet and the two screws at the rear edge of the cabinet. Refer to Figure 8. Disconnect the H.V. anode lead and remove the chassis together with the deflection yoke.

21-PD-8115(U)  
21-T-8245(U) to 21-T-8478(U) Incl.

**CHASSIS REMOVAL**

CORNER CONSOLE MODELS—To remove the chassis from the cabinet, remove the cabinet back and the control knobs. Unplug the antenna cable, the tuner power plug, the kinescope socket and the speaker cable. Loosen the yoke clamp. To remove the volume control assembly, remove one screw accessible through the side of the cabinet and lift off the assembly. Remove two screws at the bottom of the chassis and two nuts at the top. Disconnect the H.V. anode lead and remove the chassis together with the deflection yoke.

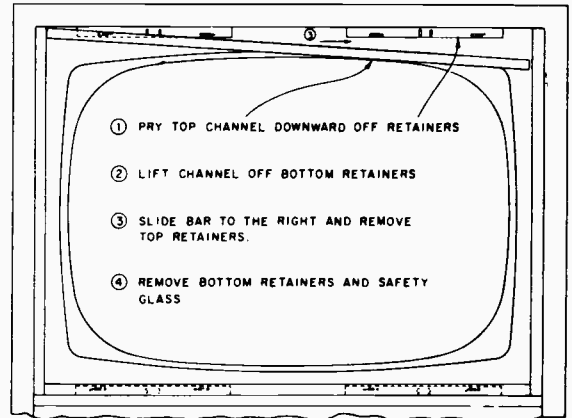

Figure 9—Safety Glass Removal

Horizontal Drive Adjustment.—Turn the horizontal hold control until the picture falls out of sync with the diagonal lines sloping down to the left. Slowly turn the horizontal control counter-clockwise and note the number of diagonal bars obtained just before the picture pulls into sync.

Pull-in should occur with one and one-half to three bars present.

Set the width control fully counter-clockwise.

With the horizontal control set at the pull-in point, adjust the horizontal drive trimmer C109 counter-clockwise for a bright vertical line in the center of the picture. Turn the trimmer clockwise until the line just disappears. If no line appears set the drive trimmer fully counter-clockwise.

Set the brightness control to normal and adjust the width control so the picture overscans the mask 3/4" at each side with normal line voltage (117V. AC). Readjust the horizontal drive trimmer as above.

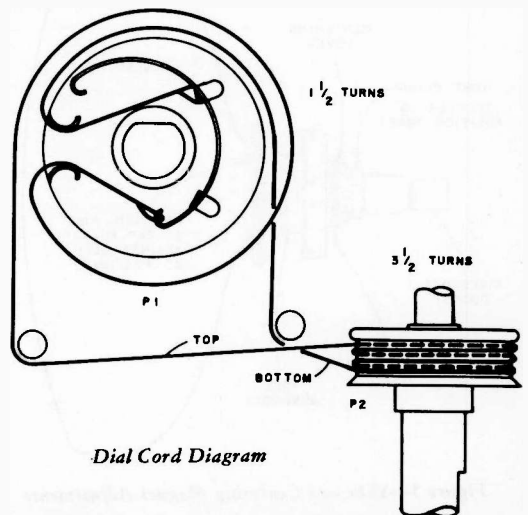

Dial Cord Diagram

RCA VICTOR

CHASSIS FRONT VIEW

21-PD-8115(U)  
21-T-8245(U) to 21-T-8478(U) Incl.

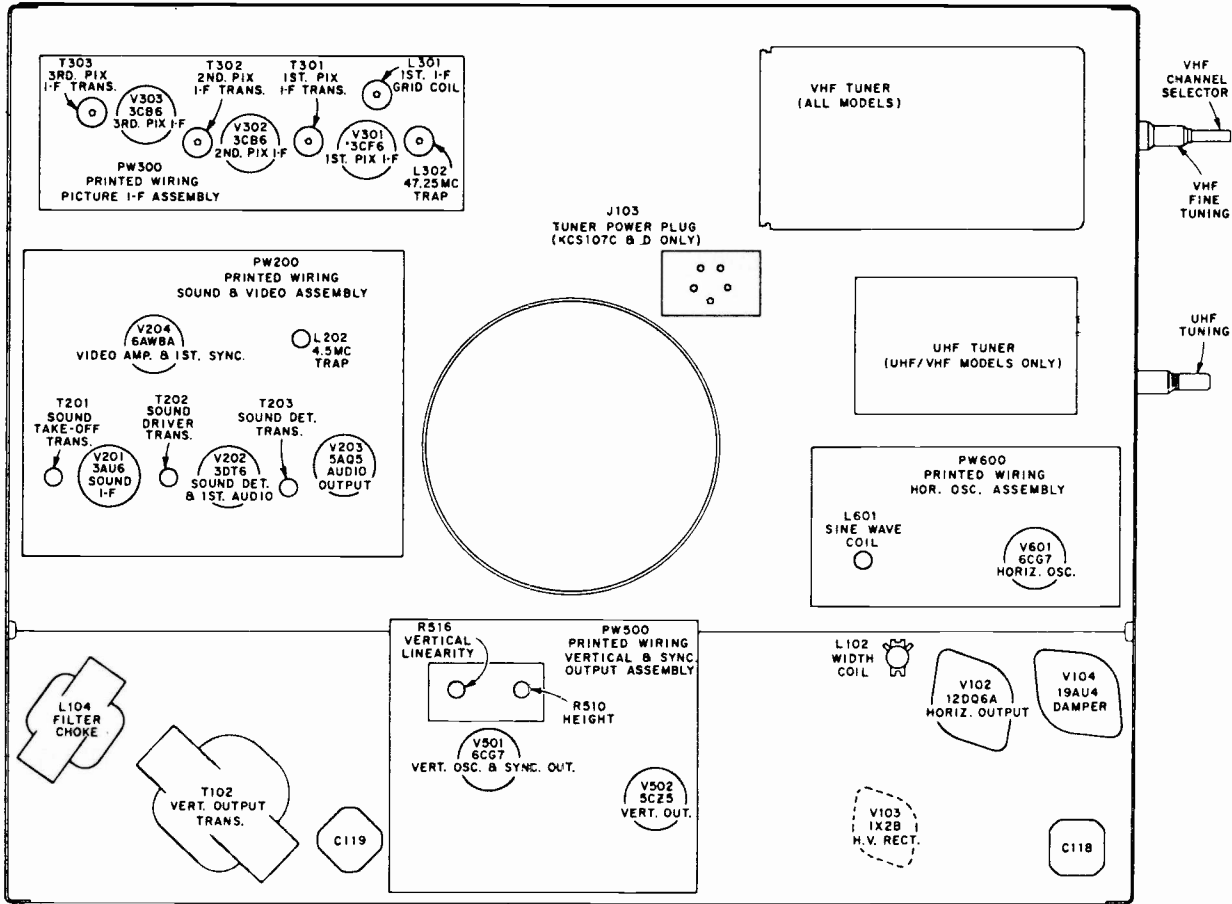

Chassis Front View

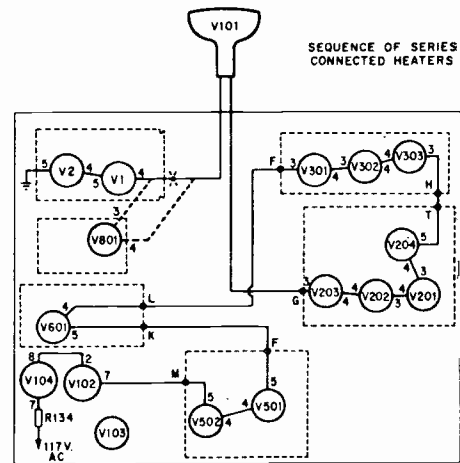
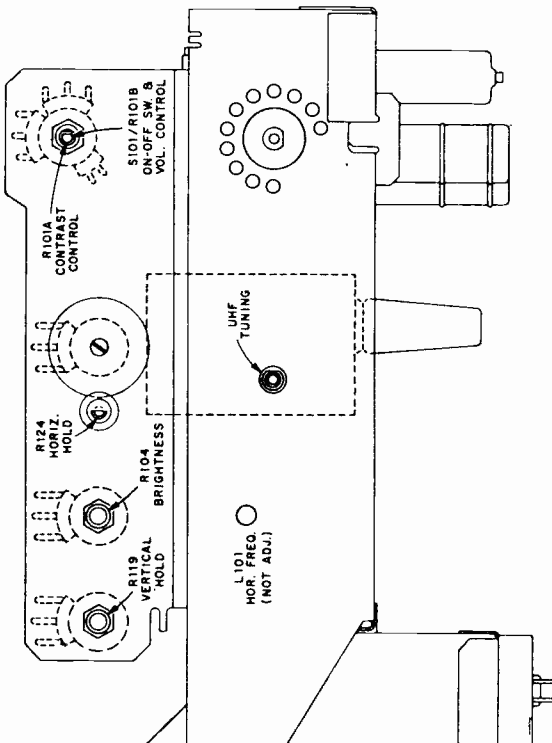

RCA VICTOR

ALIGNMENT PROCEDURE

21-PD-8115(U)  
21-T-8245(U) to 21-T-8478(U) Incl.

PICTURE I-F TRANSFORMER AND TRAP ADJUSTMENTS

TEST EQUIPMENT CONNECTIONS:

BIAS SUPPLY ..... Apply -4 volts to I-F AGC bus at terminal "J" of PW300. Ground positive lead to chassis.  
 SIGNAL GENERATOR ..... Connect to mixer grid or strap on S1B, in series with 1500 mmf. capacitor. (See below.)  
 VACUUM TUBE VOLTMETER. Connect to 2nd Detector output at terminal "Q" of PW200 using direct probe. Ground lead connected to chassis.

STEP	SIGNAL GENERATOR	ADJUST	REMARKS
1	44.5 mc.	T303	Peak T303, T302 and T301 on frequency for maximum output on meter. Adjust generator output for 3 volts on meter when finally peaked.
2	45.5 mc.	T302	
3	43.0 mc.	T301	
4	47.25 mc.	L302	Minimum output indication on meter

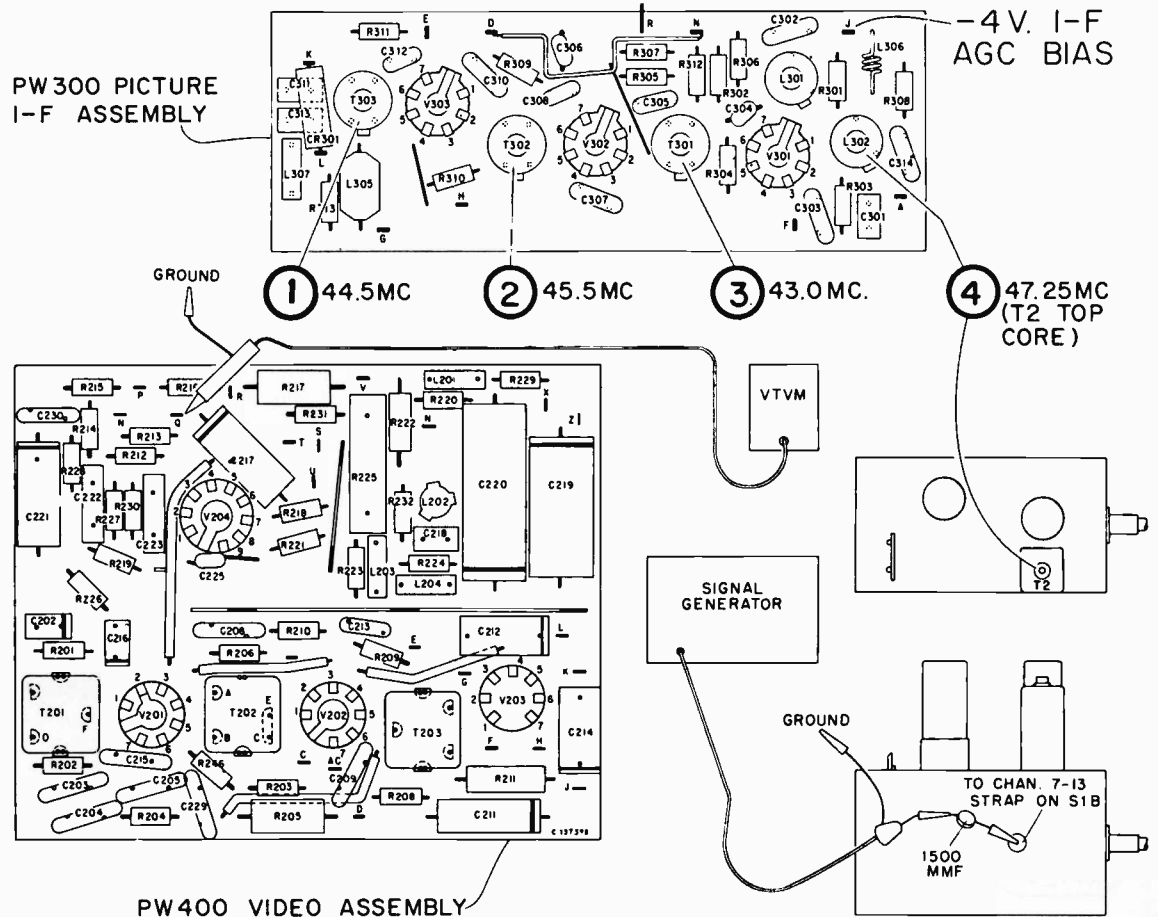

Figure 15—Picture I-F Transformer and Trap Adjustments

RCA VICTOR

ALIGNMENT PROCEDURE

21-PD-8115(U)  
21-T-8245(U) to 21-T-8478(U) Incl.

**SOUND I-F, SOUND DETECTOR AND 4.5 MC TRAP ALIGNMENT**

**TEST EQUIPMENT CONNECTIONS:**

- BIAS SUPPLY ..... Apply -10 volts to the I-F AGC bus at terminal "J" on PW300.
- OSCILLOSCOPE ..... Connect across speaker voice coil.
- SIGNAL GENERATOR ..... Connect to terminal "Q" on PW200.
- VACUUM TUBE VOLTMETER... Connect to output of diode detector shown below. Set meter for negative readings.
- MISCELLANEOUS ..... Connect test diode detector, as shown below, to terminal "AC" on PW200.

STEP	SIGNAL GENERATOR	ADJUST	REMARKS
Set contrast control maximum clockwise			
1	4.5 mc.	T202 (top & bottom)	Adjust T202 top & bottom for maximum negative DC on meter. Set generator for 1.0 to 1.5 volts on meter when finally peaked. Peak cores at open end of coils (maximum core separation).
2	4.5 mc.	T201	Adjust T201 for maximum negative DC on meter. Set generator for 1.0 to 1.5 volts on meter.
3	Disconnect the diode test detector. Turn off signal generator and tune in strongest signal in area adjusting volume control for normal volume (approx. 1/4 turn from c.c.w.). Turn T203 core flush with top of form.		
4	Observing oscilloscope and listening to audio output adjust T203 clockwise to a peak. Continue clockwise to a second louder peak and adjust T203 for maximum on this second peak.		
5	4.5 mc. A-M Mod. 400 Cycles	L202	Adjust for minimum 400 cycle indication on oscilloscope.
Alternate Method Using Generators with F-M Modulation Provided			
1	Same as step 1 above. Modulate 4.5 mc. signal with F-M 400 cycle signal with 7 1/2 kc. deviation.		
2	Same as step 2 above. Modulate 4.5 mc. signal with F-M 400 cycle signal with 7 1/2 kc. deviation.		
3	4.5 mc. 400 cycle F-M Mod. 7 1/2 kc. Dev.	T203	Adjust T203 for maximum 400 cycle output on scope using maximum amplitude peak. Adjust volume control for .70 v. p-p on scope when peaked. See response below.
4	4.5 mc. 400 cycle F-M 7 1/2 kc. Dev.	T201 & T202	Decrease input signal to minimum usable signal and retouch T201 & T202 for symmetrical breakout. Response below.
Move the oscilloscope to terminal "W" on PW200. Use the diode probe. Set the contrast control to maximum clockwise position.			
5	Same as step 5 above. Adjust for minimum 400 cycle indication on oscilloscope.		

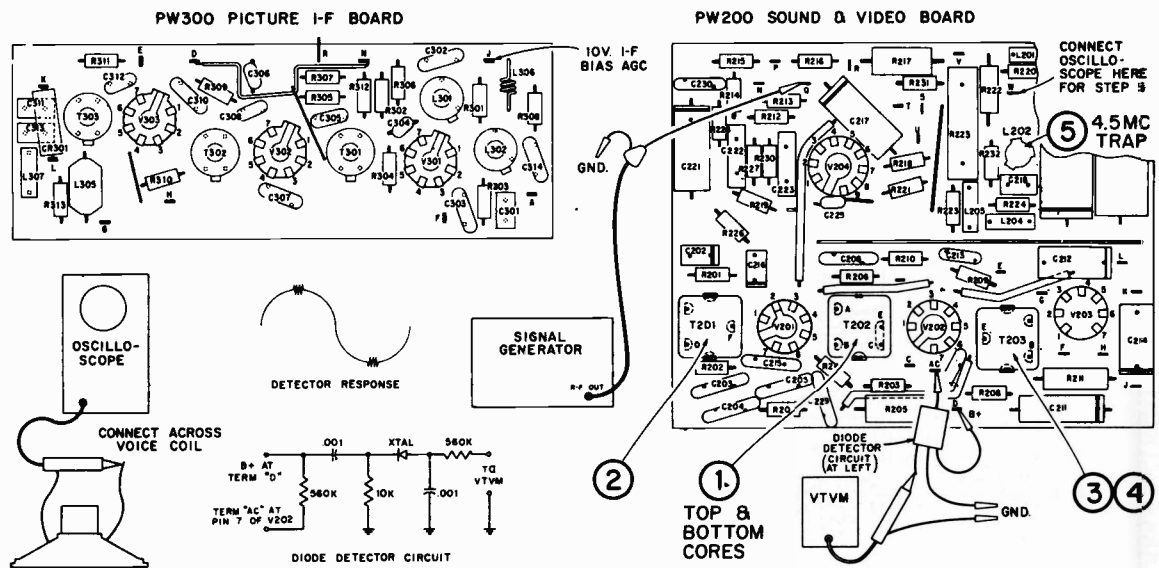

Figure 21—Sound I-F, Sound Detector and 4.5 mc. Trap Alignment







RCA VICTOR

21-PD-8115(U)  
21-T-8245(U) to 21-T-8478(U) Incl.

PRINTED WIRING ASSEMBLIES

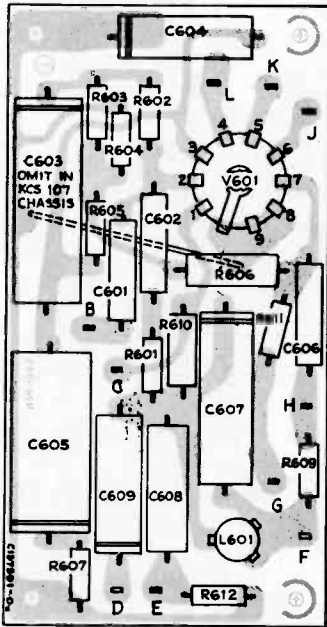

Figure 25—PW600—Horizontal Oscillator Assembly Layout

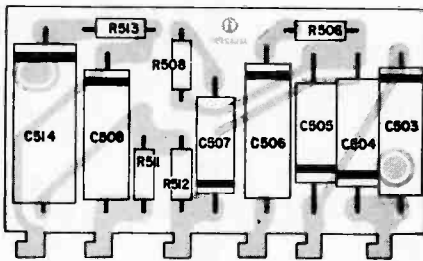

Figure 27—PW500A—Subassembly for PW500

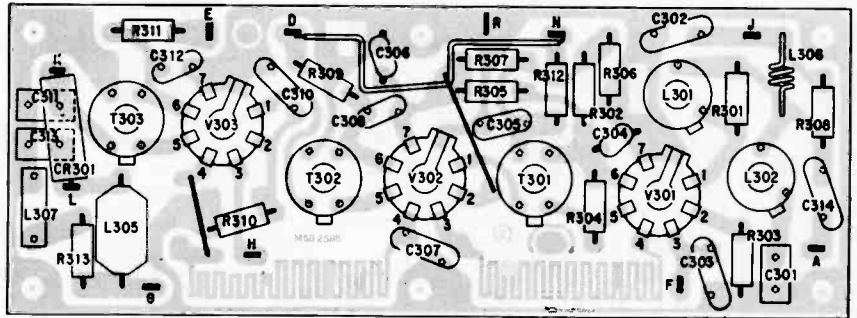

Figure 26—PW300—Picture I-F Assembly Layout

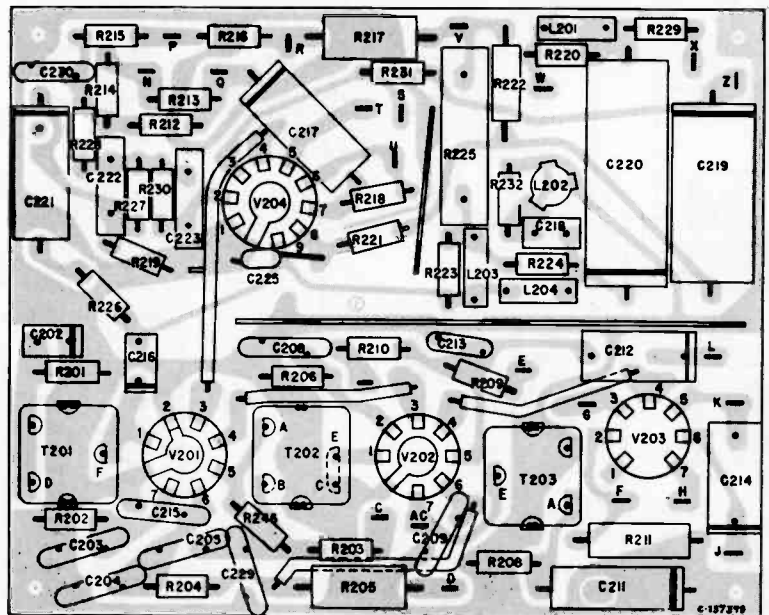

Figure 28—PW200—Sound, Video & 1st Sync Assembly Layout

The printed wiring, on the reverse side of the boards, is presented in "phantom" views superimposed on the layouts. This will enable circuit tracing without removing the assemblies from the chassis to see the printed wiring on the reverse side.

**HORIZONTAL OSCILLATOR AND OUTPUT ALIGNMENT—**

Place a jumper across the terminals of the sine wave coil L601 and adjust the horizontal hold control until the picture pulls into sync. Remove the short across the sine wave coil.

Connect the low capacity probe of an oscilloscope to terminal "F" of PW600. Turn the horizontal hold control clockwise until the picture falls out of sync, then counter-clockwise until the picture just pulls into sync. The pattern on the oscilloscope should be as shown in Figure 22c. Adjust the sine wave adjustment core L601 until the two peaks are at the same height. During this adjustment, the picture must be kept in sync by readjusting the horizontal (frequency) control if necessary.

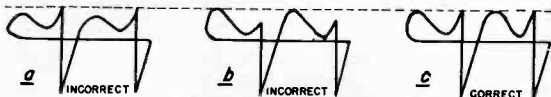

Figure 22—Horizontal Oscillator Waveforms

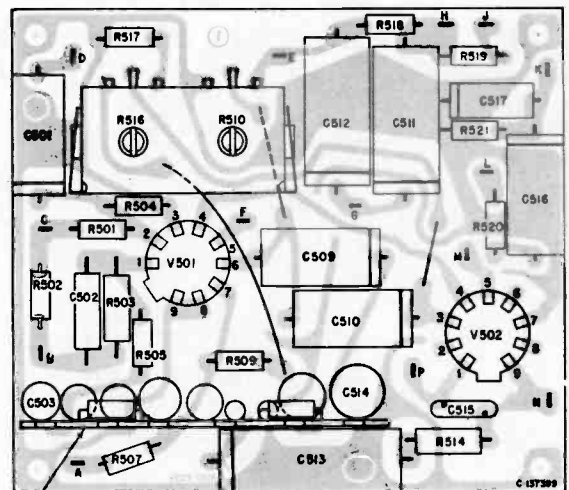
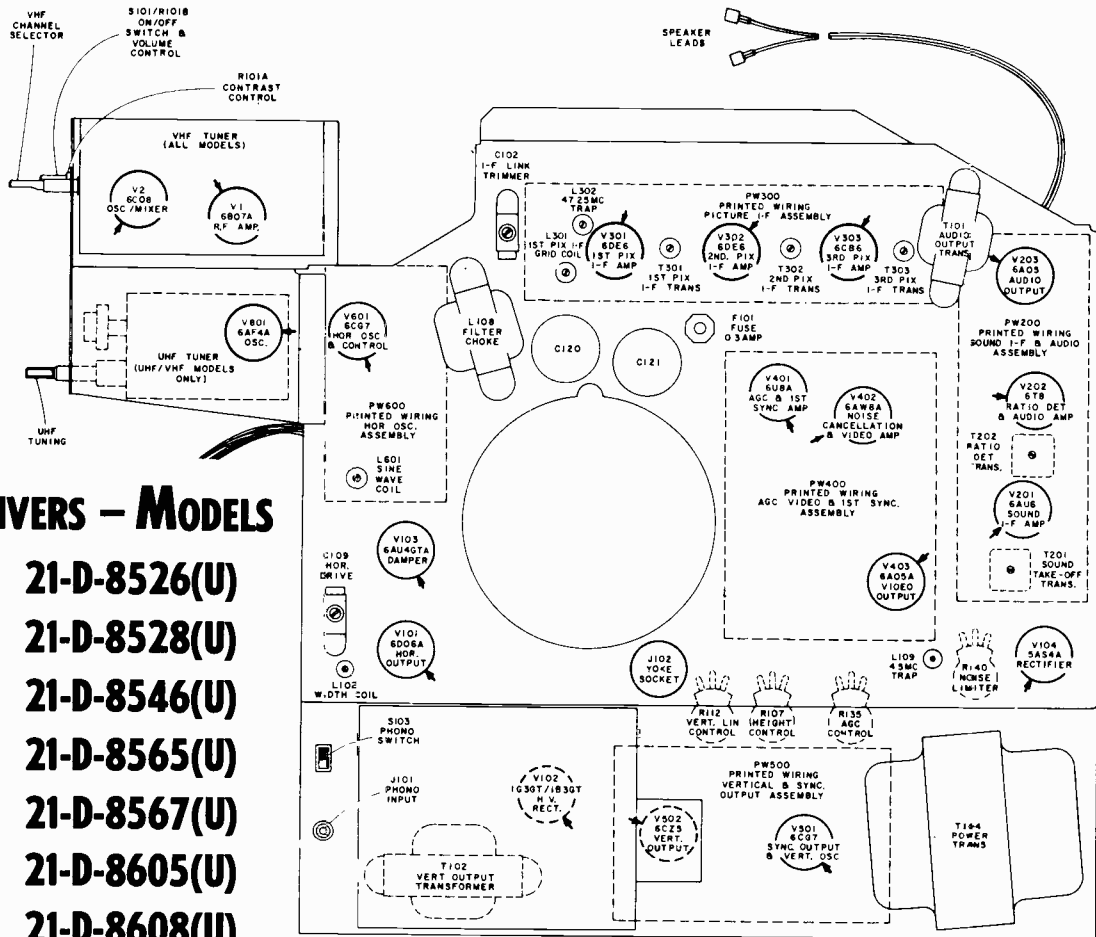

Figure 29—PW500—Vertical & Sync Output Assembly Layout



# RCA VICTOR



## TELEVISION RECEIVERS — MODELS

- 21-D-8525(U), 21-D-8526(U)
- 21-D-8527(U), 21-D-8528(U)
- 21-D-8545(U), 21-D-8546(U)
- 21-D-8547(U), 21-D-8565(U)
- 21-D-8566(U), 21-D-8567(U)
- 21-D-8588(U), 21-D-8605(U)
- 21-D-8607(U), 21-D-8608(U)

Chassis Nos. KCS108C, KCS108D, KCS108E, KCS108F

The additional models listed below use 24" picture tube but are essentially the same as the corresponding sets covered in this material.

## TELEVISION RECEIVERS — MODELS

- 24-D-8655, 24-D-8655U
- 24-D-8657, 24-D-8657U
- 24-D-8676, 24-D-8676U
- 24-D-8678, 24-D-8678U

Chassis Nos. — KCS108C, KCS108D, KCS108E, KCS108F

(Material continued on the next 5 pages)

### CHASSIS REMOVAL

To remove the chassis from the cabinet for repair, remove the cabinet back, unplug the speaker cable, the antenna cable, the pilot lamp, the kinescope socket, and the yoke. Remove the "on-off" volume and contrast control knobs and remove the two screws holding the "on-off"/volume/contrast control. The screws are located at the bottom of the control mounting bracket.

Remove the knobs from the controls in the control case and remove the two screws holding the control bracket to the control case. Unplug the I-F link cable and the tuner power plug.

Remove the two nuts at the top of the chassis and the two screws at the bottom. Move chassis out slightly to enable the H.V. lead to be disconnected from the kinescope. Clear all wires from lances and retaining springs. Remove chassis from cabinet.

If it is necessary to remove the tuner assembly, remove the three nuts holding the tuner mounting plate to the side of the cabinet. Also remove a screw holding a brace to the cabinet top. The tuner and control brackets may be fastened to the chassis for transporting.

### KINESCOPE REMOVAL

After removing the chassis, loosen the yoke clamp and slide the yoke off the neck of the kinescope. Remove the four nuts holding the kinescope assembly to the cabinet and remove the assembly.

Loosen the screw clamp sufficiently to remove the kinescope.

RCA VICTOR

ALIGNMENT PROCEDURE 21-D-8525(U) to 21-D-8608 (U) Incl.

PICTURE I-F TRANSFORMER AND TRAP ADJUSTMENTS

TEST EQUIPMENT CONNECTIONS:

- BIAS SUPPLY ..... Apply -6 volts to I-F AGC bus at terminal "J" of PW300. Ground positive lead to chassis.
- SIGNAL GENERATOR ..... Connect to mixer grid at strap on S1B, in series with 1500 mmf. capacitor. (See below.)
- VACUUM TUBE VOLTMETER ..... Connect to 2nd Detector output at terminal "K" of PW400 using direct probe. Ground lead connected to chassis.

STEP	SIGNAL GENERATOR	ADJUST	REMARKS
1	44.5 mc.	T303	Peak T303, T302 and T301 on frequency for maximum output on meter. Adjust generator output for 3 volts on meter when finally peaked.
2	45.5 mc.	T302	
3	43.0 mc.	T301	
4	47.25 mc.	L302 & T2 (top core)	Minimum output indication on meter

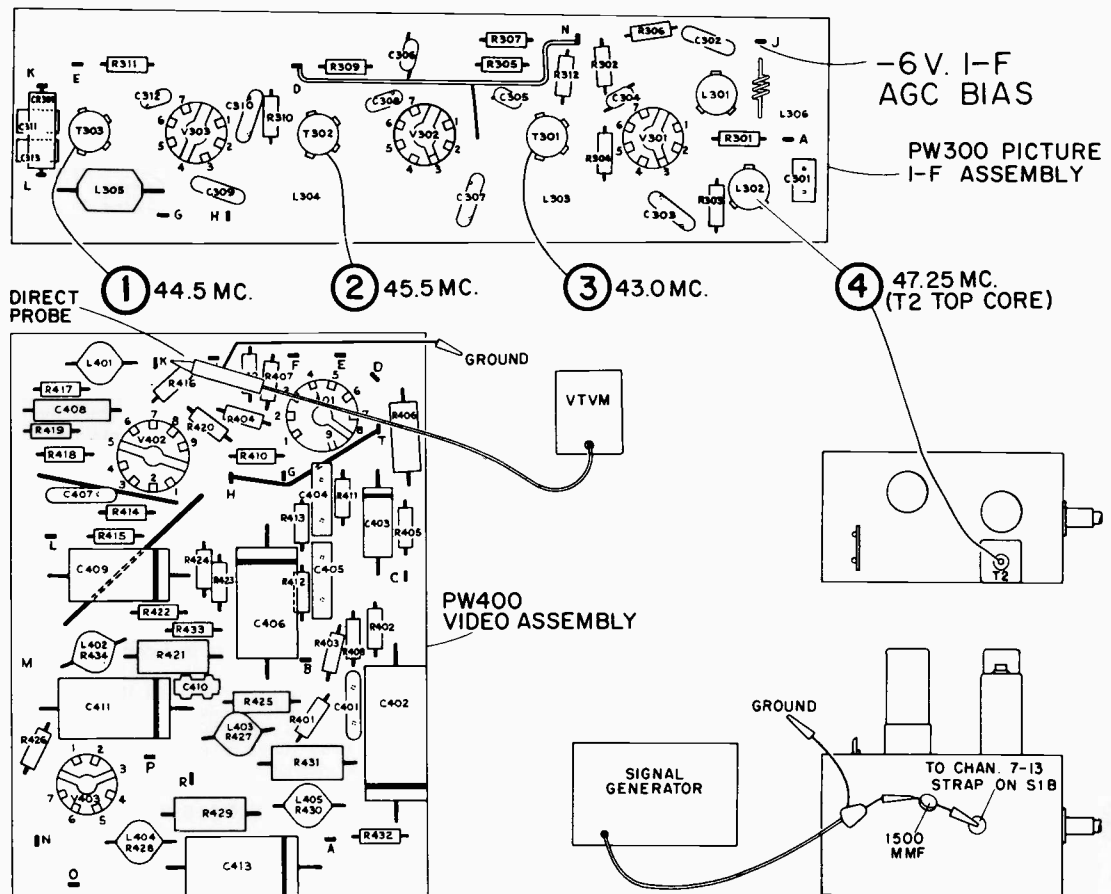

Picture I-F Transformer and Trap Adjustments

RCA VICTOR

ALIGNMENT PROCEDURE 21-D-8525(U) to 21-D-8608 (U) Incl.

SOUND I-F, RATIO DETECTOR AND 4.5 MC TRAP ALIGNMENT

TEST EQUIPMENT CONNECTIONS:

- BIAS SUPPLY ..... Apply -10 volts bias to I-F AGC, terminal "J" of PW300.
- OSCILLOSCOPE ..... Connect to terminal "A" on PW400 at the kinescope grid, using the diode probe.
- SIGNAL GENERATOR ..... Connect to Video Detector output at terminal "K" of PW400.
- VACUUM TUBE VOLTMETER ..... Connect to terminal "N" of PW200.
- MISCELLANEOUS ..... Connect a matched pair of 100,000 ohm resistors in series from terminal "N" of PW200 to ground.

STEP	SIGNAL GENERATOR	ADJUST	REMARKS
1	Adjust Ratio Detector Trans. & Sound Take-off	4.5 mc.	T202 (Top & bottom cores) & T201 for maximum reading on VTVM. Set generator for 10 to 12 volts on VTVM.
Move VTVM to terminal "D" of PW200, with ground lead to junction of 100,000 ohm resistors. (See illustration below.)			
2	Adjust Ratio Detector Trans. Secondary	4.5 mc.	T202 (Bottom core) for zero reading on VTVM.
Repeat steps 1 and 2 until proper results are obtained.			
*3	Adjust 4.5 mc. Trap	4.5 mc. (Modulate 30% with 400 cycles)	L109 for minimum 400 cycle output indication on the oscilloscope. Set contrast control full clockwise.
*Step 3 may be performed "on the air" using a transmitted signal if desired. Observe picture on kinescope for 4.5 mc beat, set fine tuning to exaggerate beat, then tune L109 for minimum beat pattern with contrast fully clockwise.			

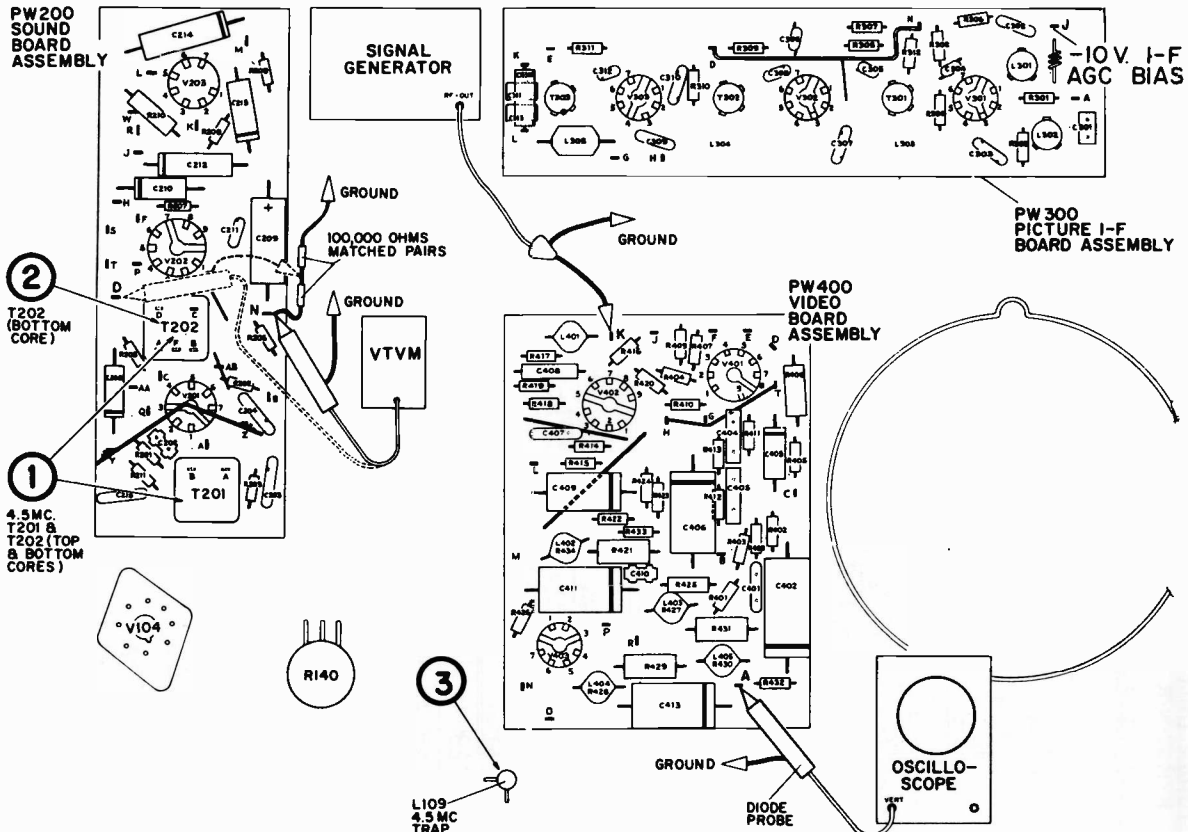

Sound I-F, Ratio Detector and 4.5 mc. Trap Alignment

RCA VICTOR

21-D-8525(U) to 21-D-8608(U) Incl.

**KRK62M or KRK62P TUNER CIRCUIT SCHEMATIC DIAGRAM**  
(Used in KCS108C or KCS108E Chassis)

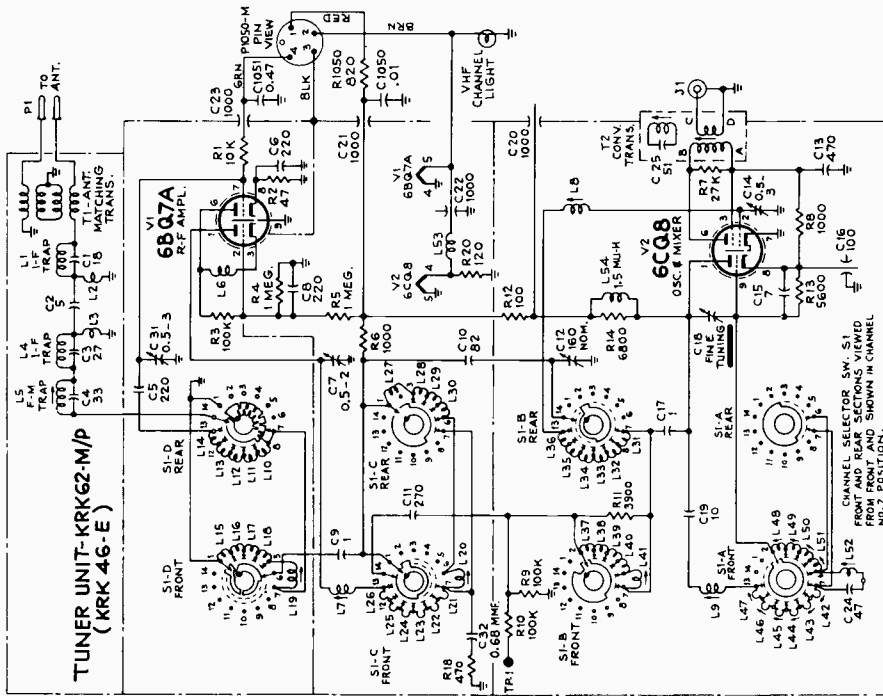

Figure 27—Tuner Circuit Schematic Diagram for KCS 108C or KCS108E Chassis VHF Models

The schematic is shown in the latest condition at the time of printing.  
All resistance value in ohms, K = 1000.  
All capacitance values less than 1 in MF and above 1 in MMF unless otherwise noted.  
Direction of arrows at controls indicates clockwise rotation.

**KRK62M or KRK62P TUNER CIRCUIT SCHEMATIC DIAGRAM**  
(Used in KCS108C or KCS108E Chassis)

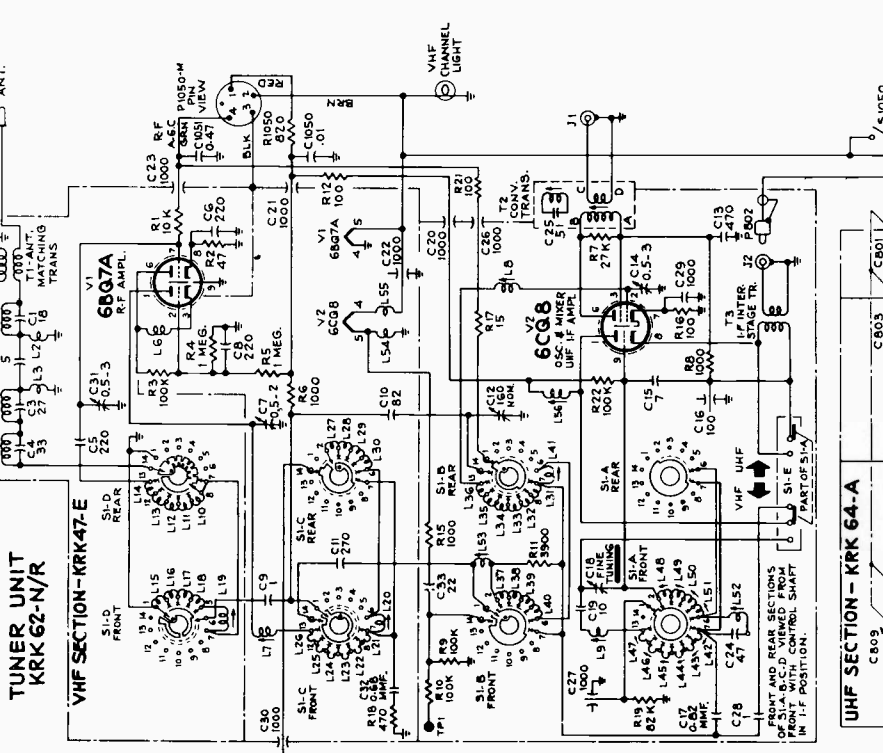

Figure 28—Tuner Circuit Schematic Diagram for KCS 108C or KCS108E Chassis UHF Models

**NOTE:** The KCS108C and KCS108E chassis listed above are identical to chassis KCS108D or KCS108F shown in the large schematic, except for the tuner which is a KRK62M or KRK62P, shown in smaller schematic above.

**CHASSIS CIRCUIT SCHEMATIC DIAGRAM KCS108D or KCS108F**





RCA VICTOR

PRINTED WIRING ASSEMBLIES

21-D-8525(U) to 21-D-8608(U) Incl.

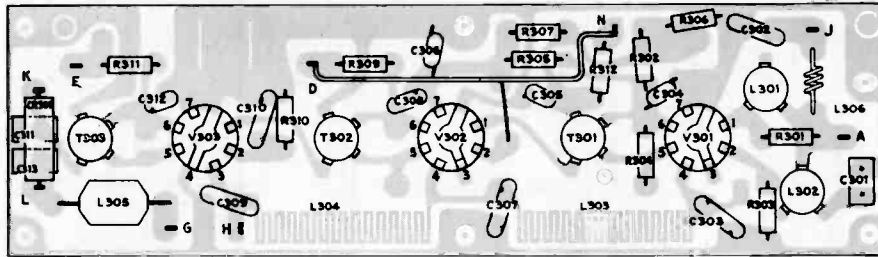

PW300 Picture I-F Assembly Layout

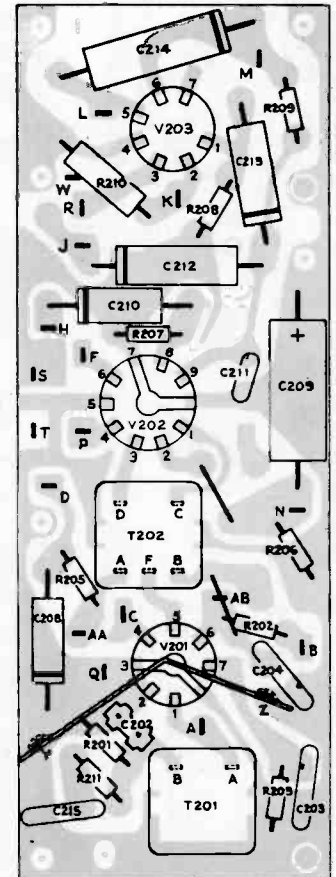

PW200 Sound I-F and Audio Assembly Layout

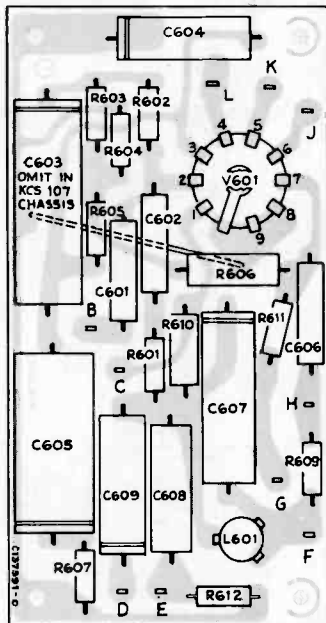

PW600 Horizontal Oscillator Assembly Layout

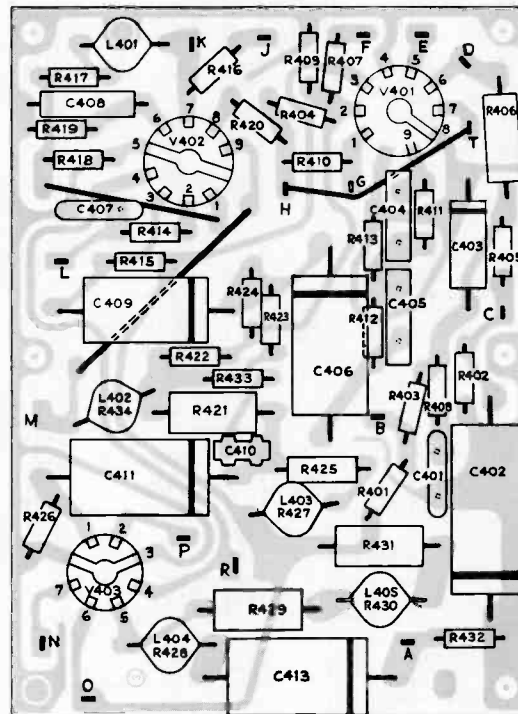

PW400 Video, 1st Sync and AGC Assembly Layout

The assemblies represented above are viewed from the component side of the boards and are oriented as they will usually be viewed on the chassis.

The printed wiring, on the reverse side of the boards, is presented in "phantom" views superimposed on the component layouts.

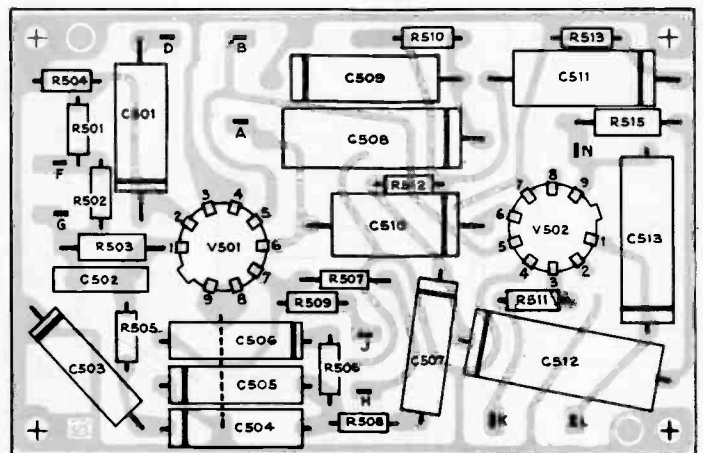
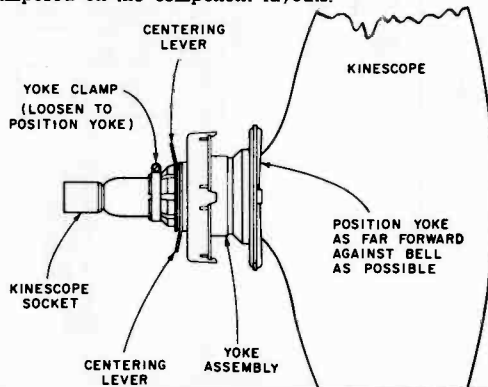

PW500 Vertical and Sync Output Assembly Layout



RCA VICTOR

TELEVISION RECEIVERS - MODELS

17-D-8185(U)

17-D-8186(U), 17-D-8187(U)

17-PD-8093(U), 17-PD-8094(U)

17-PD-8096(U), 17-PD-8099(U)

17-PT-8071(U), 17-PT-8072(U)

Chassis Nos. KCS109A, KCS109B, KCS109C and KCS109D

(Material on pages 131 through 139)

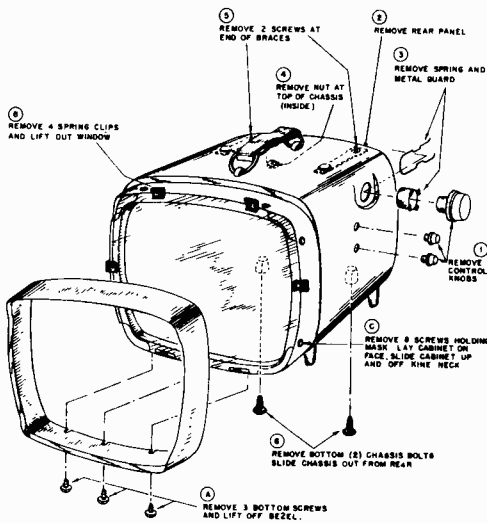

Chassis Removal and Safety Glass Cleaning

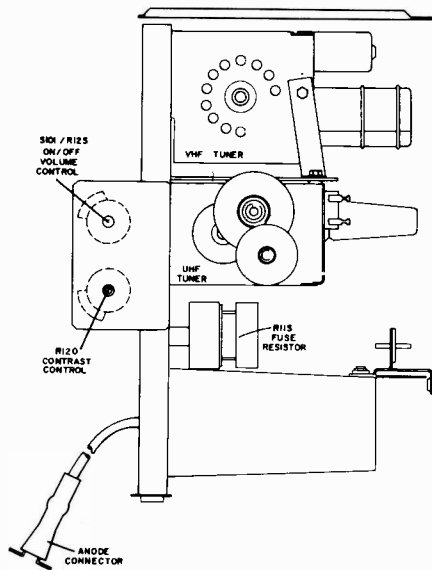

CHASSIS REAR VIEW

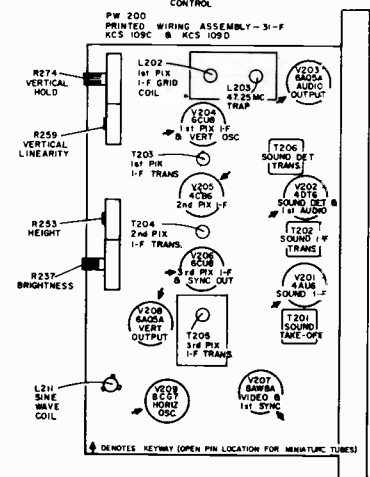
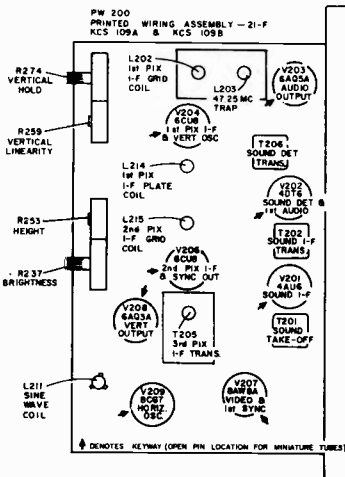
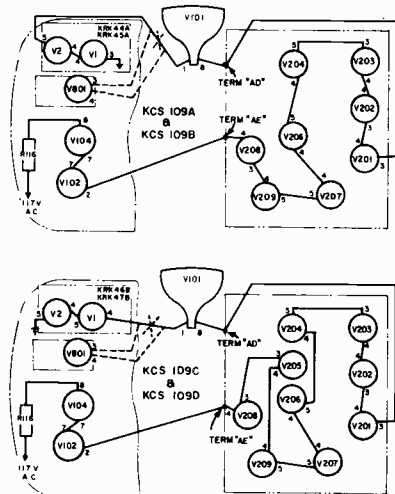
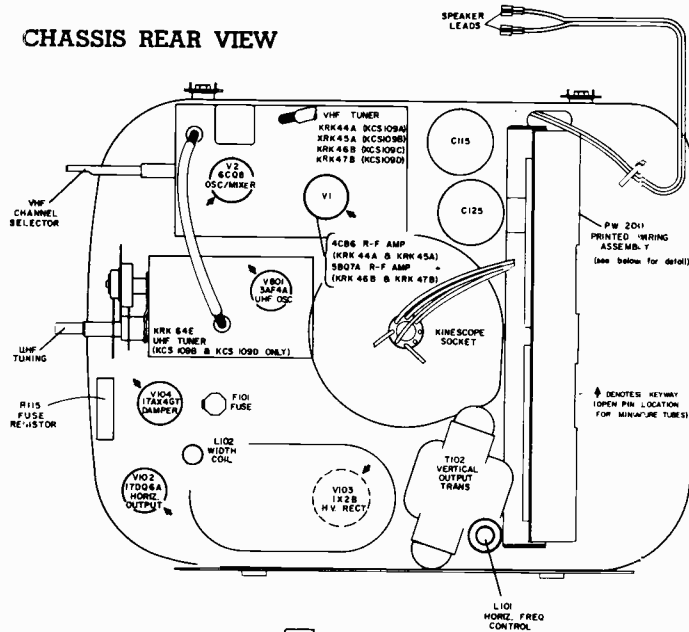

Chassis Rear View

RCA VICTOR

ALIGNMENT PROCEDURE

17-D-8185 to 17-PT-8072 Incl.  
17-D-8185U to 17-PT-8072U Incl.

**PICTURE I-F TRANSFORMER AND TRAP ADJUSTMENTS**

**TEST EQUIPMENT CONNECTIONS:**

- BIAS SUPPLY ..... Apply —4 volts to I-F AGC bus at terminal "P" of PW200. Positive lead to chassis.
- SIGNAL GENERATOR ..... Connect in series with 1500 mmf. to mixer grid at S1B as shown below.
- VACUUM TUBE VOLTMETER..... Connect to 2nd Detector output at terminal "TP". Use DC probe.

STEP		SIGNAL GENERATOR	ADJUST	REMARKS
KCS109A & KCS109B CHASSIS — (2 I-F)				
1	Peak 2nd pix. I-F transformer	44.5 mc.	T205	Peak T205, L215 and L214 on frequency 44.5 mc. for maximum on meter. Set generator output for 3 volts on meter when finally peaked.
2	Peak 2nd pix. I-F grid coil	44.5 mc.	L215	
3	Peak 1st pix. I-F plate coil	44.5 mc.	L214	
KCS109C & KCS109D CHASSIS — (3 I-F)				
1	Peak 3rd pix. I-F transformer	44.5 mc.	T205	Peak on specified frequencies for maximum indication on meter. Set generator output for 3 volts on meter when finally peaked.
2	Peak 2nd pix. I-F transformer	45.5 mc.	T204	
3	Peak 1st pix. I-F transformer	43.0 mc.	T203	
ALL CHASSIS				
4	Adjust 47.25 mc. trap	47.25 mc.	L203	Adjust for minimum voltage on meter

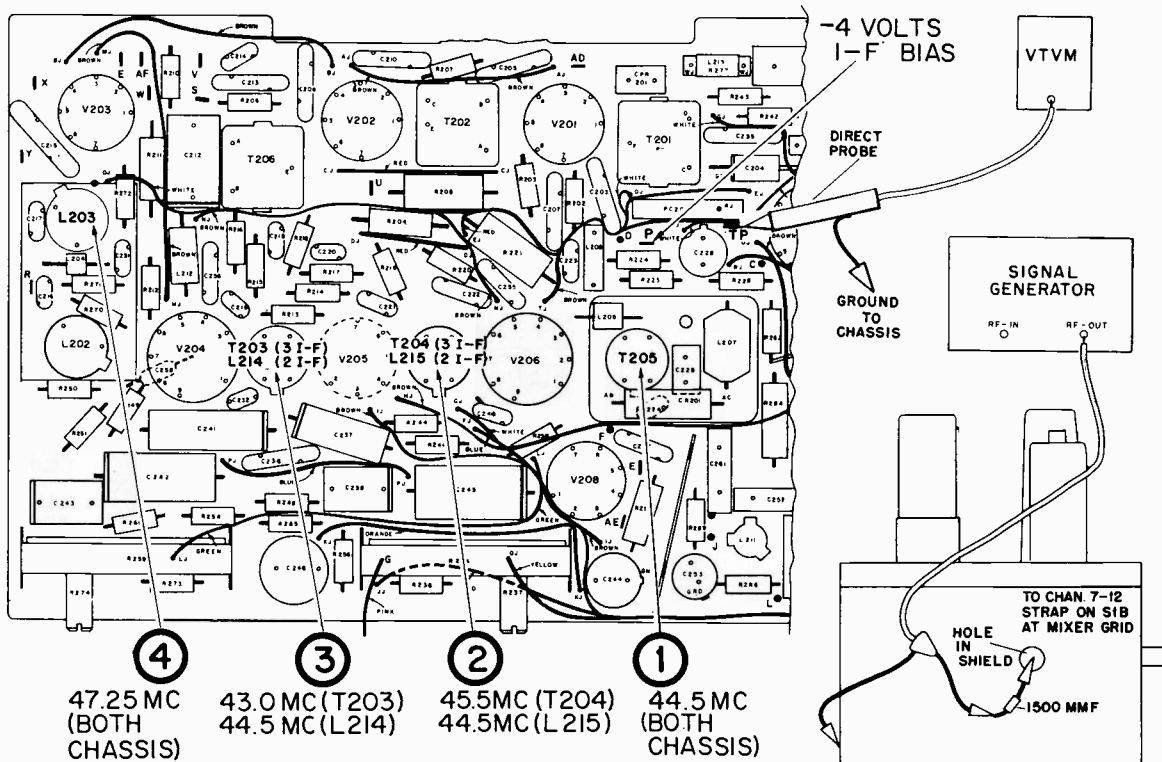

Picture I-F Transformer and Trap Adjustments

RCA VICTOR

ALIGNMENT PROCEDURE

17-D-8185 to 17-PT-8072 Incl.  
17-D-8185U to 17-PT-8072U Incl.

SOUND I-F AND SOUND DETECTOR ALIGNMENT

TEST EQUIPMENT CONNECTIONS:

- BIAS SUPPLY ..... Apply —10 volts to the I-F AGC bus at terminal "P" on PW200.
- OSCILLOSCOPE ..... Connect across speaker voice coil.
- SIGNAL GENERATOR ..... Connect to terminal TP on PW200.
- VACUUM TUBE VOLTMETER ..... Connect to output of diode detector shown below. Set meter for negative voltage readings.
- MISCELLANEOUS ..... Connect test diode detector as shown below.

STEP	SIGNAL GENERATOR	ADJUST	REMARKS
Set contrast control maximum clockwise.			
1	Adjust Driver Transformer Primary and Secondary 4.5 mc.	T202 (top & bottom)	Adjust T202 top & bottom for maximum negative DC on meter. Set generator for 1.0 to 1.5 volts on meter when finally peaked. Peak cores at open end of coils (maximum core separation).
2	Adjust Sound Take-Off Trans. 4.5 mc.	T201	Adjust T201 for maximum negative DC on meter. Set generator for 1.0 to 1.5 volts on meter when finally peaked.
3	Disconnect the diode test detector. Turn off signal generator and tune in strongest signal in area adjusting volume control for normal volume (approx. 1/4 turn from c.c.w.). Turn core of T206 flush with top of coil form.		
4	Adjust Sound Detector Trans.	Observing oscilloscope and listening to audio output adjust T206 clockwise to a peak. Continue clockwise to a second louder peak and adjust T206 for maximum on this second peak.	
Alternate Method Using Generators With F-M Modulation Provided			
1	Same as step 1 above. Modulate 4.5 mc. signal with F-M 400 cycle signal with 7 1/2 kc. deviation.		
2	Same as step 2 above. Modulate 4.5 mc. signal with F-M 400 cycle signal with 7 1/2 kc. deviation.		
3	Adjust Sound Detector Trans. 4.5 mc. 400 cycle F-M Mod. 7 1/2 kc. Dev.	T206	Adjust T206 for max. 400 cycle output on scope using max. amplitude peak. Adjust volume control for .70 v. p-p on scope when peaked. See response below.
4	Retouch Driver and Sound Take-Off Trans. for breakout 4.5 mc. 400 cycle F-M Mod. 7 1/2 kc. Dev.	T201 & T202	Decrease input signal to minimum usable signal and retouch T201 & T202 for symmetrical breakout. Response below.

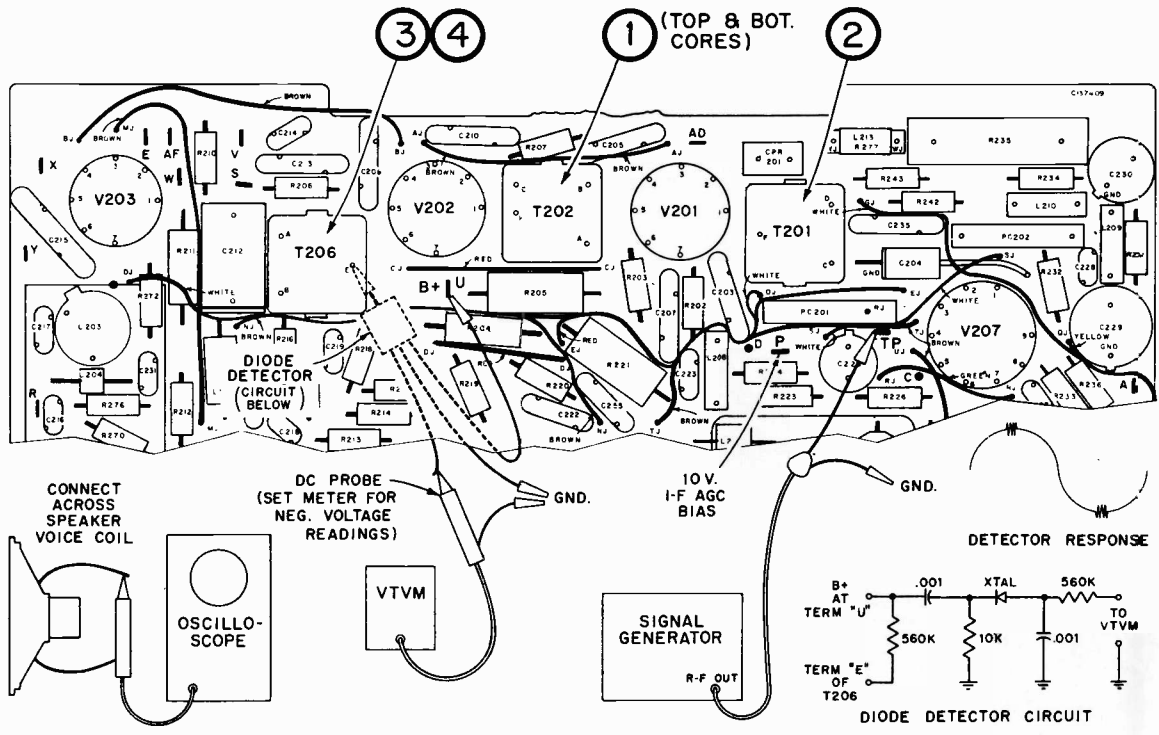

Sound I-F and Sound Detector Alignment

Figure 26—KCS109A & KCS109B Printed Wiring Assembly

CAUTION:—LEAD COLORS OF INTERCONNECTING WIRES IS CRITICAL—LEADS SHOULD BE DRESSED AS SHOWN

COMPONENT LOCATION GUIDE

C203	D2	R205
C204	E2	R206
C205	D1	R207
C207	D2	R210
C208	B1	R211
C210	C1	R212
C212	B1	R214
C213	B1	R220
C214	B1	R221
C215	A1	R222
C217	A2	R223
C218	B2	R224
C222	C2	R225
C223	D2	R226
C224	E3	R231
C225	E3	R232
C226	E2	R233
C227	F2	R234
C228	F2	R235
C229	F2	R236
C230	F1	R237
C231	A2	R238
C232	B3	R242
C235	E1	R243
C236	F3	R244
C237	C3	R245
C238	B3	R246
C239	C4	R247
C240	B4	R248
C241	B3	R249
C242	A4	R250
C243	A4	R251
C244	B4	R253
C246	B4	R254
C247	E3	R255
C248	D3	R256
C249	F2	R257
C250	F3	R258
C251	E4	R259
C252	E4	R260
C253	E4	R261
C254	E4	R262
C255	D2	R263
C256	B2	R264
C258	A3	R266
CPR201	E1	R267
CR201	E3	R268
L202	A3	R269
L203	A2	R270
L204	A2	R271
L205	D2	R272
L207	E3	R273
L208	D2	R274
L209	F1	R275
L210	F1	R276
L211	E4	R277
L212	B2	R278
L213	E1	T201
L214	B3	T202
L215	C3	T205
PC202	F1	T206
R202	D2	
R203	D2	
R204	C2	

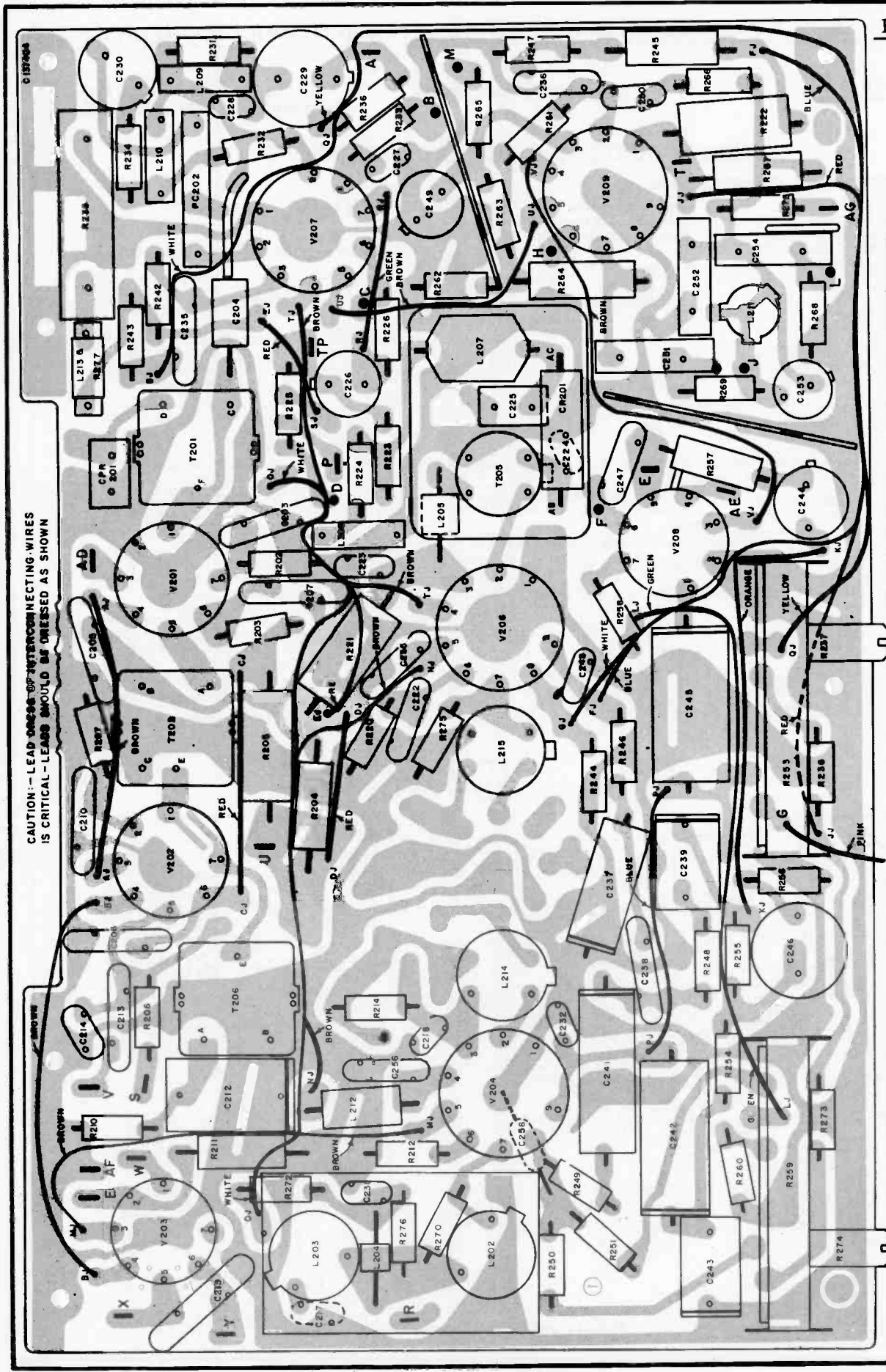



CAUTION— LEAD DRESS OF INTERCONNECTING WIRES IS CRITICAL— LEADS SHOULD BE DRESSED AS SHOWN.

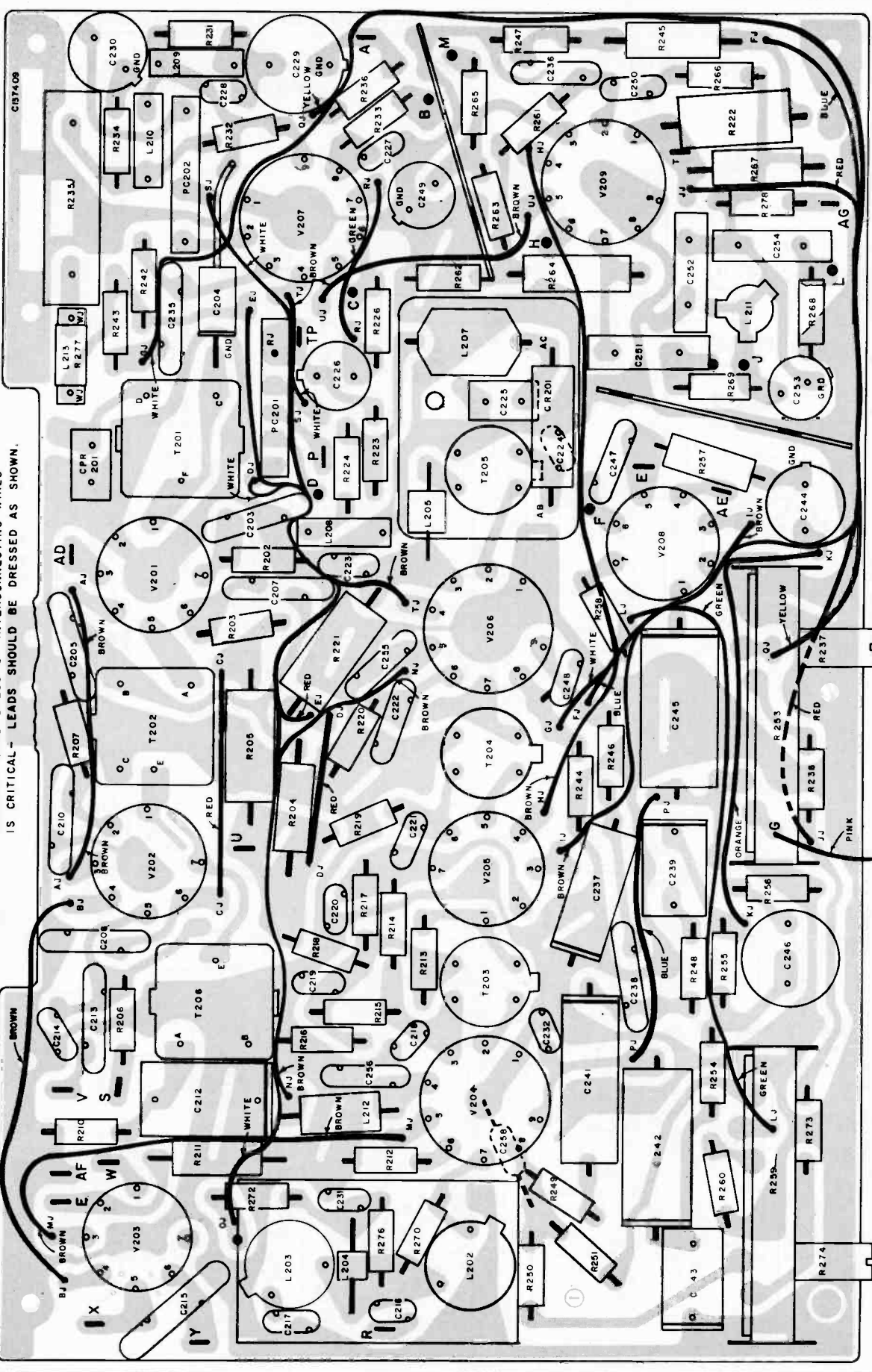

COMPONENT LOCATION GUIDE

C203	D2	R205	C2
C204	E2	R206	B1
C205	D1	R207	C1
C207	D2	R210	B1
C208	B1	R211	A1
C210	C1	R212	A2
C212	B1	R213	B2
C213	B1	R214	B2
C214	B1	R215	B2
C215	A1	R216	B2
C217	A2	R217	C2
C218	B2	R218	B2
C219	B2	R219	C2
C220	C2	R220	C2
C221	C2	R221	D2
C222	C2	R222	F4
C223	D2	R223	E2
C224	E3	R224	D2
C225	E3	R226	E2
C226	E2	R231	F1
C227	F2	R232	F2
C228	F2	R233	F2
C229	F2	R234	F1
C230	F1	R235	F1
C231	A2	R236	F2
C232	B3	R237	D4
C235	E1	R238	C4
C236	F3	R242	E1
C237	C3	R243	E1
C238	B3	R244	C3
C239	C4	R245	F4
C240	B4	R246	C3
C241	B3	R247	F3
C242	A4	R248	B4
C243	A4	R249	A3
C244	D4	R250	A3
C246	B4	R251	A3
C247	E3	R253	C4
C248	D3	R254	B4
C249	F2	R255	B4
C250	F3	R256	C4
C251	E4	R257	E4
C252	E4	R258	D3
C253	E4	R259	A4
C254	E4	R260	A4
C255	D2	R261	F3
C256	B2	R262	E3
C258	A3	R263	F3
CPR201	E1	R264	E3
CR201	E3	R265	F3
L202	A3	R266	F4
L203	A2	R267	F4
L204	A2	R268	E4
L205	D2	R269	E4
L207	E3	R270	A2
L208	D2	R272	A2
L209	F1	R273	B4
L210	F1	R274	A4
L211	E4	R276	A2
L212	B2	R277	E1
L213	E1	R278	F4
PC201	E2	T201	E1
PC202	F1	T202	C1
R202	D2	T203	B3
R203	D2	T204	C3
R204	C2	T205	D3
		T206	B2



RCA VICTOR 17-D-8185 to 17-PT-8072 Incl.  
17-D-8185U to 17-PT-8072U Incl.

**KRK44A VHF TUNER CIRCUIT SCHEMATIC DIAGRAM**  
(For KCS109A Chassis — VHF Models)

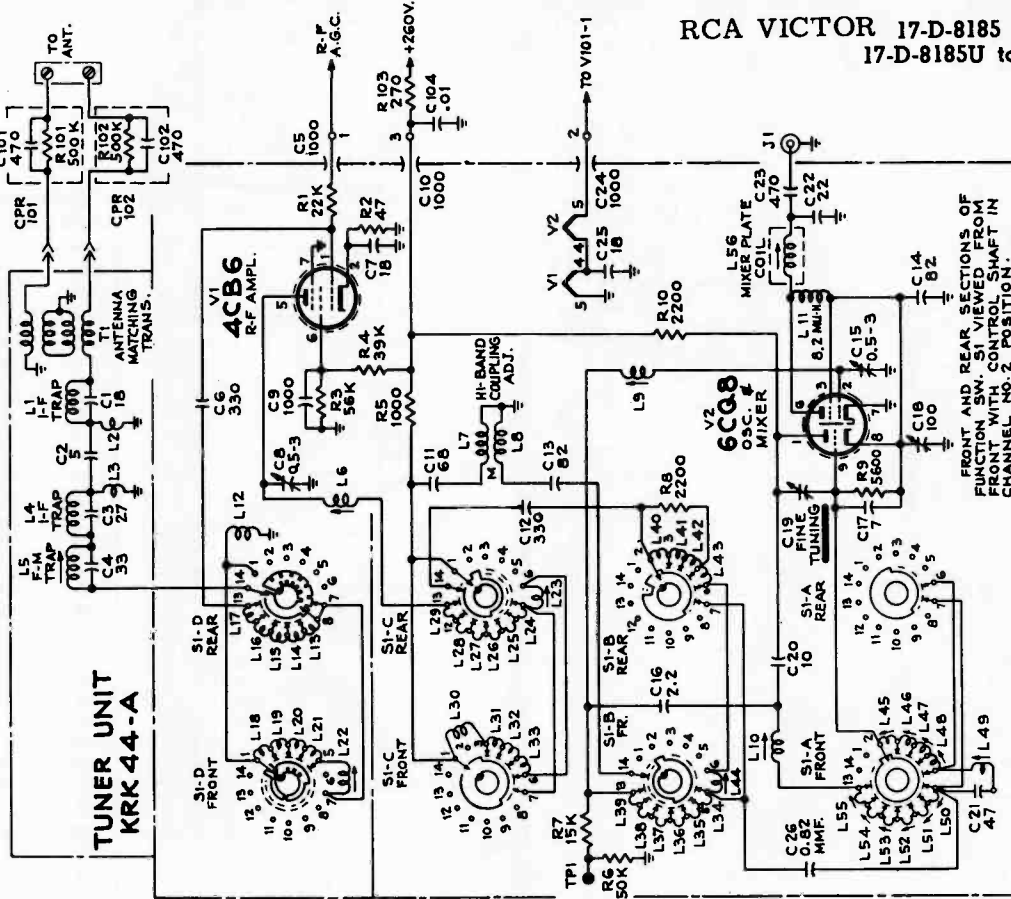
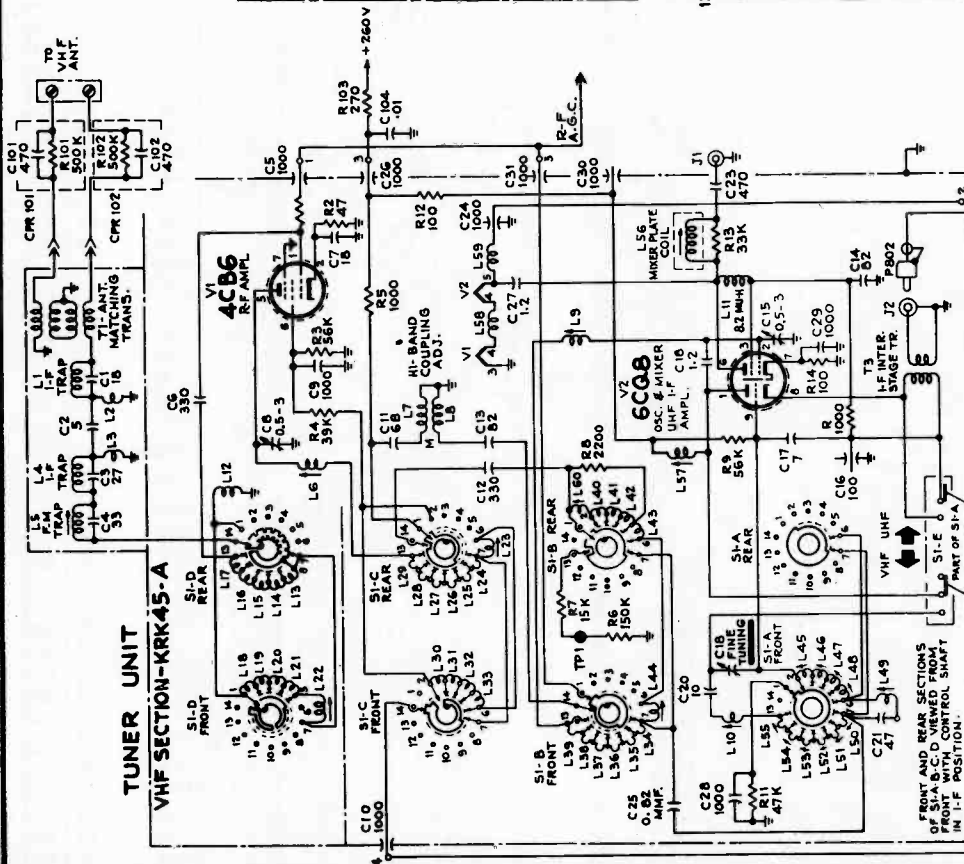

Figure 23—Tuner Circuit Schematic Diagram for KCS109A Chassis

**NOTE:** — The KCS109A chassis listed above is identical to that shown in the large schematic in Figure 27, except for the tuner shown in Figure 23 above.

The schematic is shown in the latest condition at the time of printing.  
All resistance values in ohms.  $K = 1000$ .  
All capacitance values less than 1 in MF and above 1 in MMF unless otherwise noted.  
Direction of arrows at controls indicates clockwise rotation.

**TUNER UNIT**  
VHF SECTION—KRK45-A



**UHF SECTION—KRK 64-E**

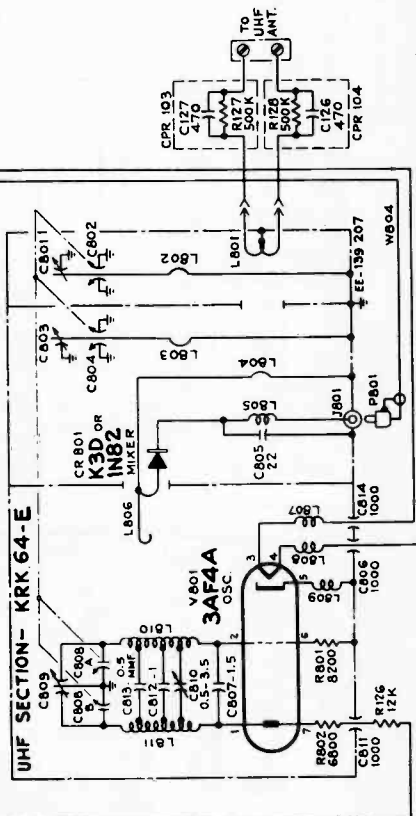



RCA VICTOR

17-D-8185 to 17-PT-8072 Incl.  
17-D-8185U to 17-PT-8072U Incl.

KRK46B VHF TUNER CIRCUIT SCHEMATIC DIAGRAM  
(For KCS109C Chassis — VHF Models)

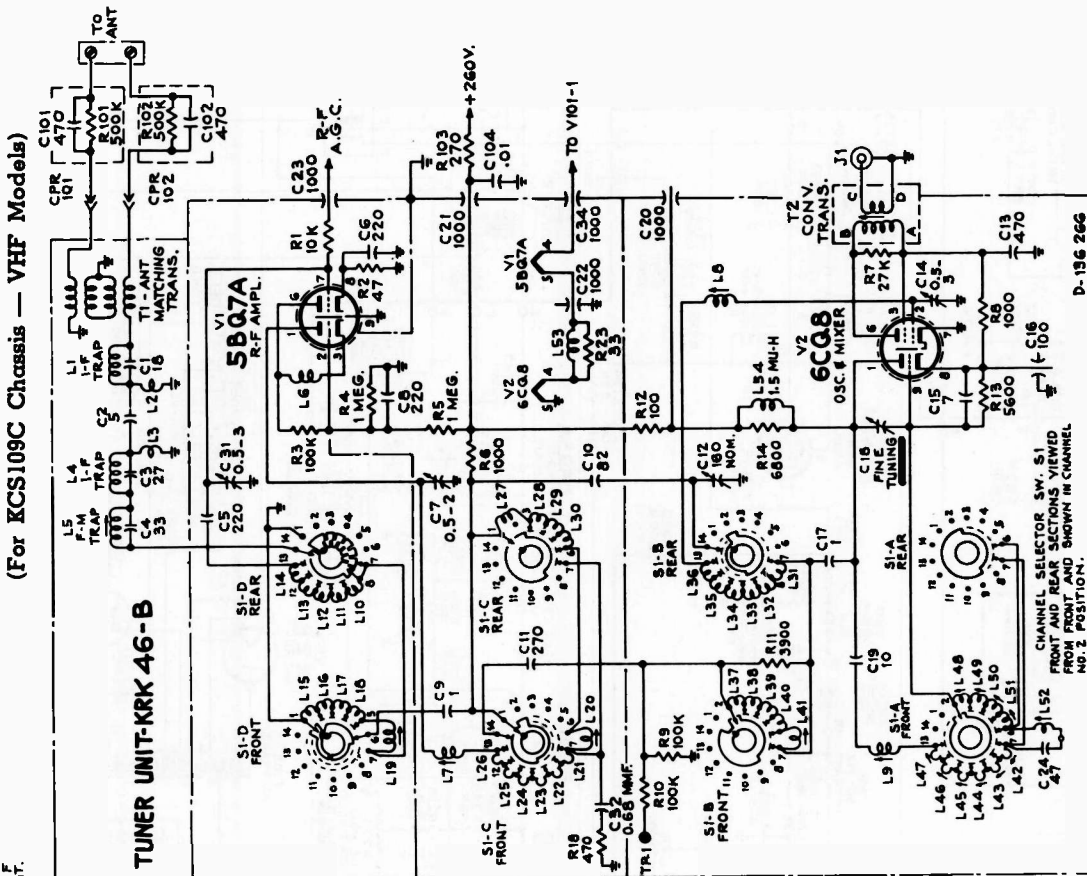
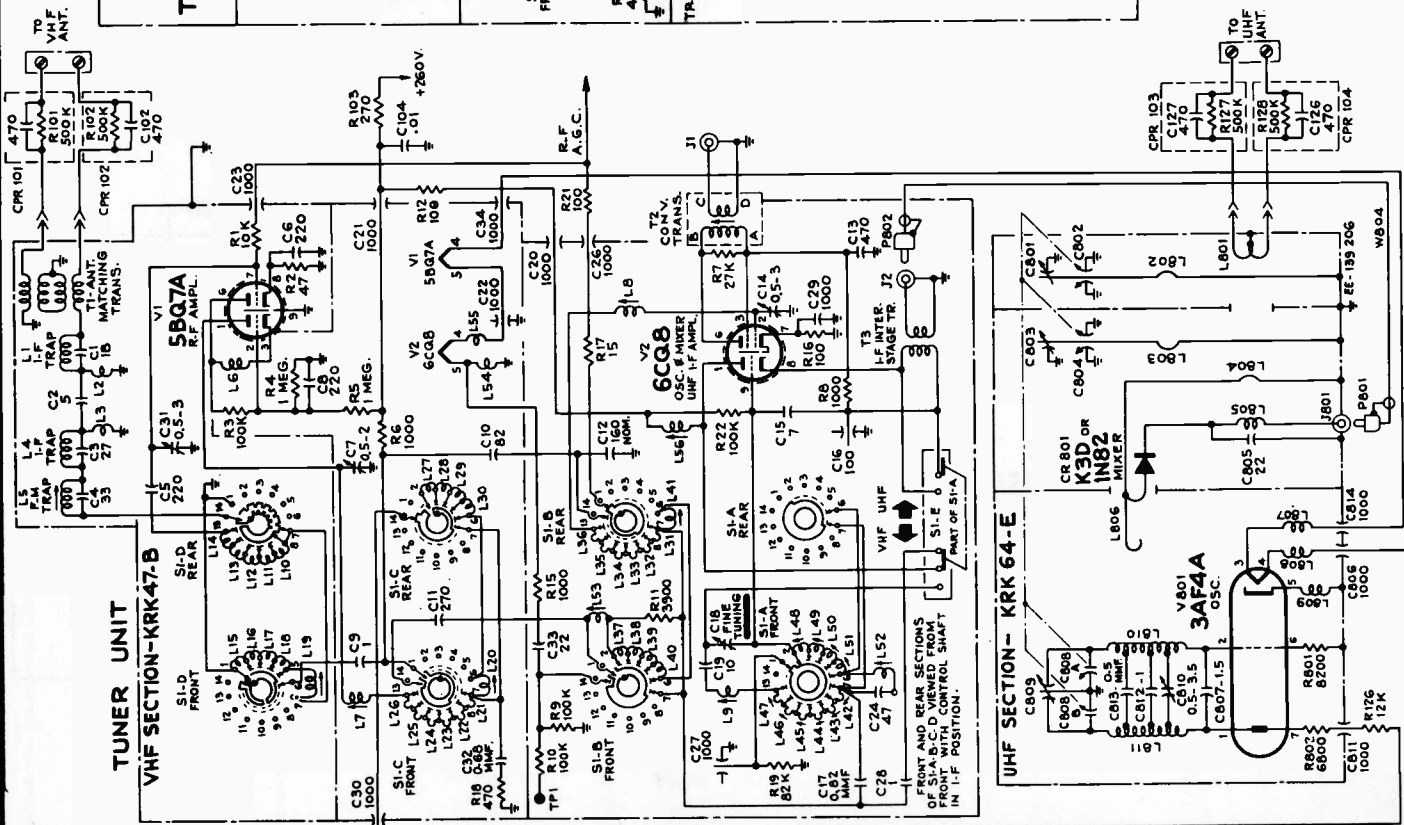

Figure 24—Tuner Circuit Schematic Diagram for KCS109C Chassis

NOTE: — The KCS109C chassis listed above is identical to that shown in the large schematic in Figure 28, except for the tuner shown in Figure 24 above.

The schematic is shown in the latest condition at the time of printing.  
All resistance value in ohms. K = 1000.  
All capacitance values less than 1 in MF and above 1 in MMF unless otherwise noted.

Direction of arrows at controls indicates clockwise rotation.



RCA VICTOR

17-D-8182U, 17-D-8184U 17-PD-8092U to 17-PD-8096U Incl.

CIRCUIT SCHEMATIC DIAGRAM KCS109D (See Figure 24 for KCS109U, 1100E/1)

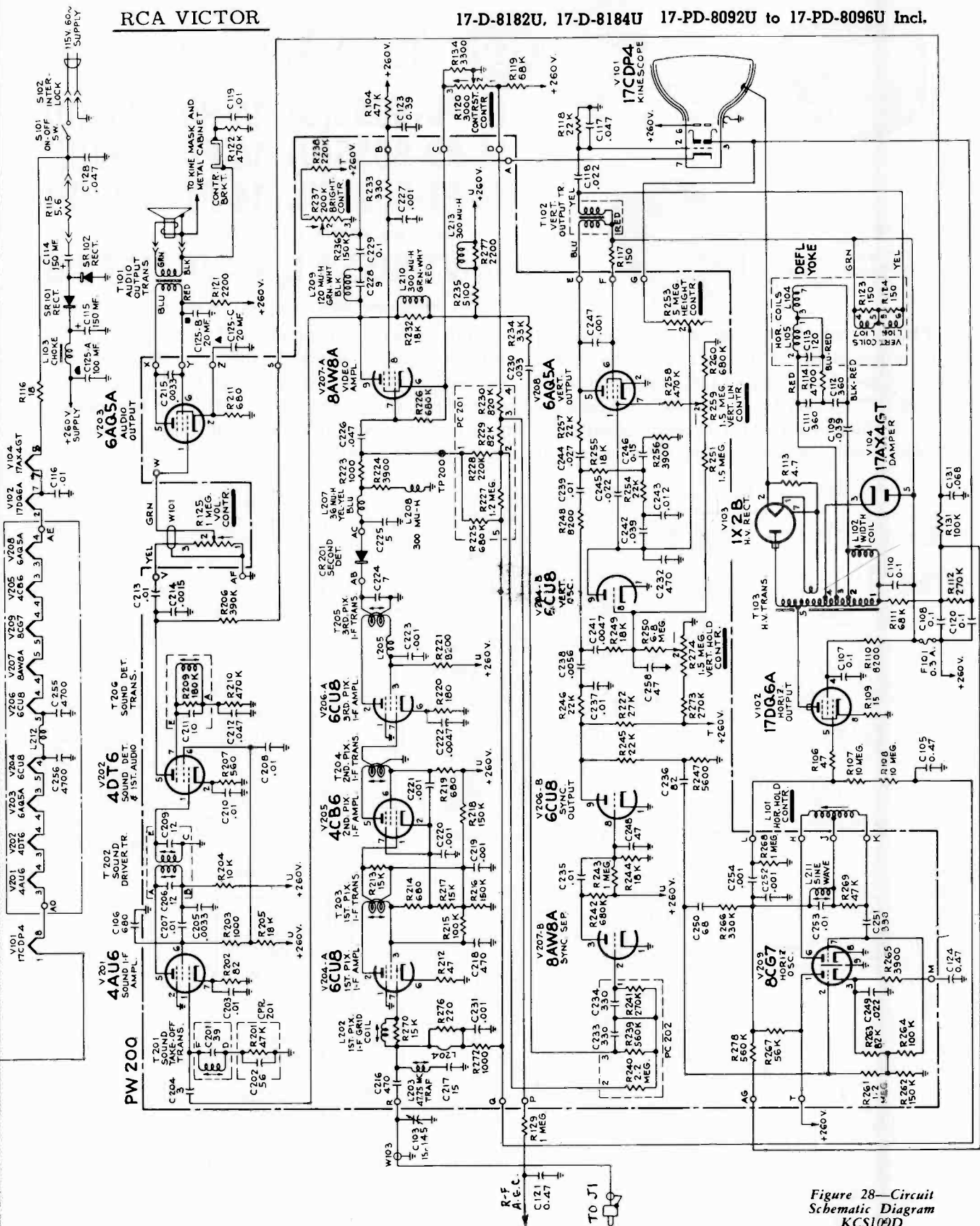
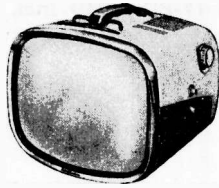

Figure 28—Circuit Schematic Diagram KCS109D



**"The GLADWIN"**  
Models  
14-PD-8053(U)—Garnet  
14-PD-8054(U)—Ivory  
14-PD-8055(U)—Charcoal/Gold  
14-PD-8057(U)—Gold/Ivory



**RCA VICTOR**

**14-PD-8053(U), 14-PD-8054(U)  
14-PD-8055(U), 14-PD-8057(U)  
14-PT-8021(U), 14-PT-8022(U)**

Chassis Nos. KCS111A, KCS111B, KCS111C and KCS111D

**14-VT-8155 & U, 14-VT-8157 & U**

Chassis Nos. KCS111F or KCS111H and KR523A

**"The NASSAU"**  
Models  
14-PT-8021(U)—Gray  
14-PT-8022(U)—Black



This group of sets is very similar to the group covered on pages 131 through 139. Chassis KCS-111A corresponds closely to KCS-109A of the prior group; KCS-111B to KCS-109B; KCS-111C and KCS-111F correspond to KCS-109C; and KCS-111D and KCS-111H to KCS-109D. The alignment for both groups is practically the same, while other material is very similar. Important service material on some of these additional chassis is included below and on pages 141 and 142.

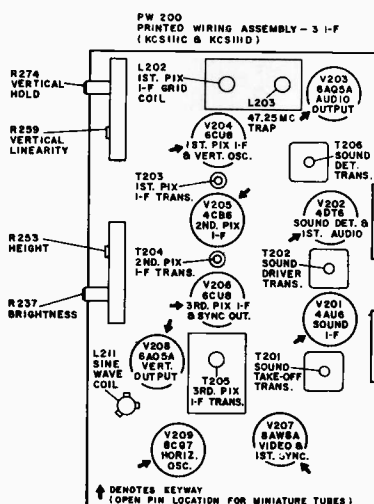
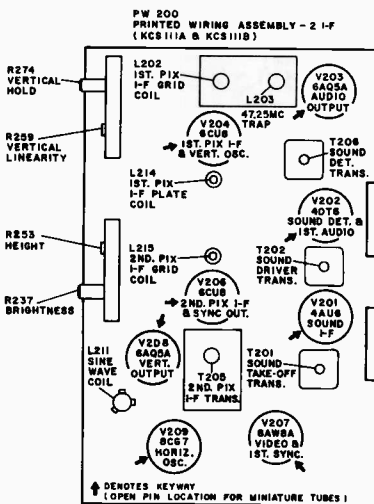

Chassis Rear View

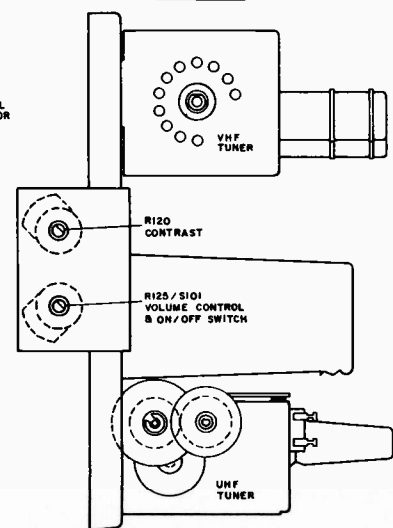
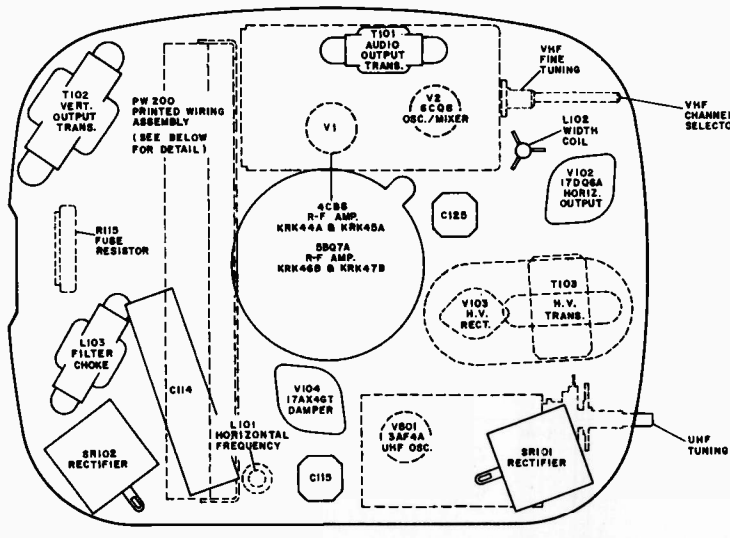
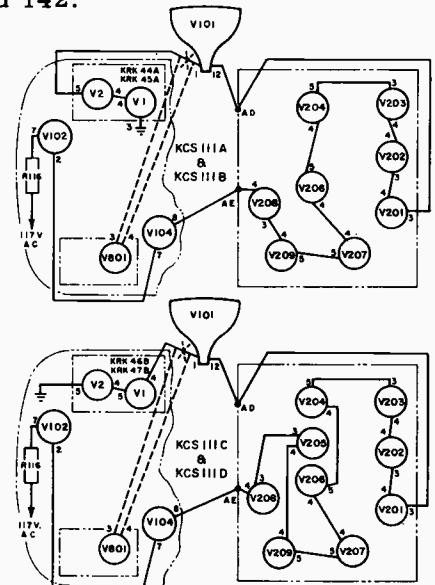

MAIN SCHEMATIC OF CHASSIS KCS111A AND KCS111B RCA VICTOR  
(See page 136 for schematic of tuners KRK44-A and KRK45-A)

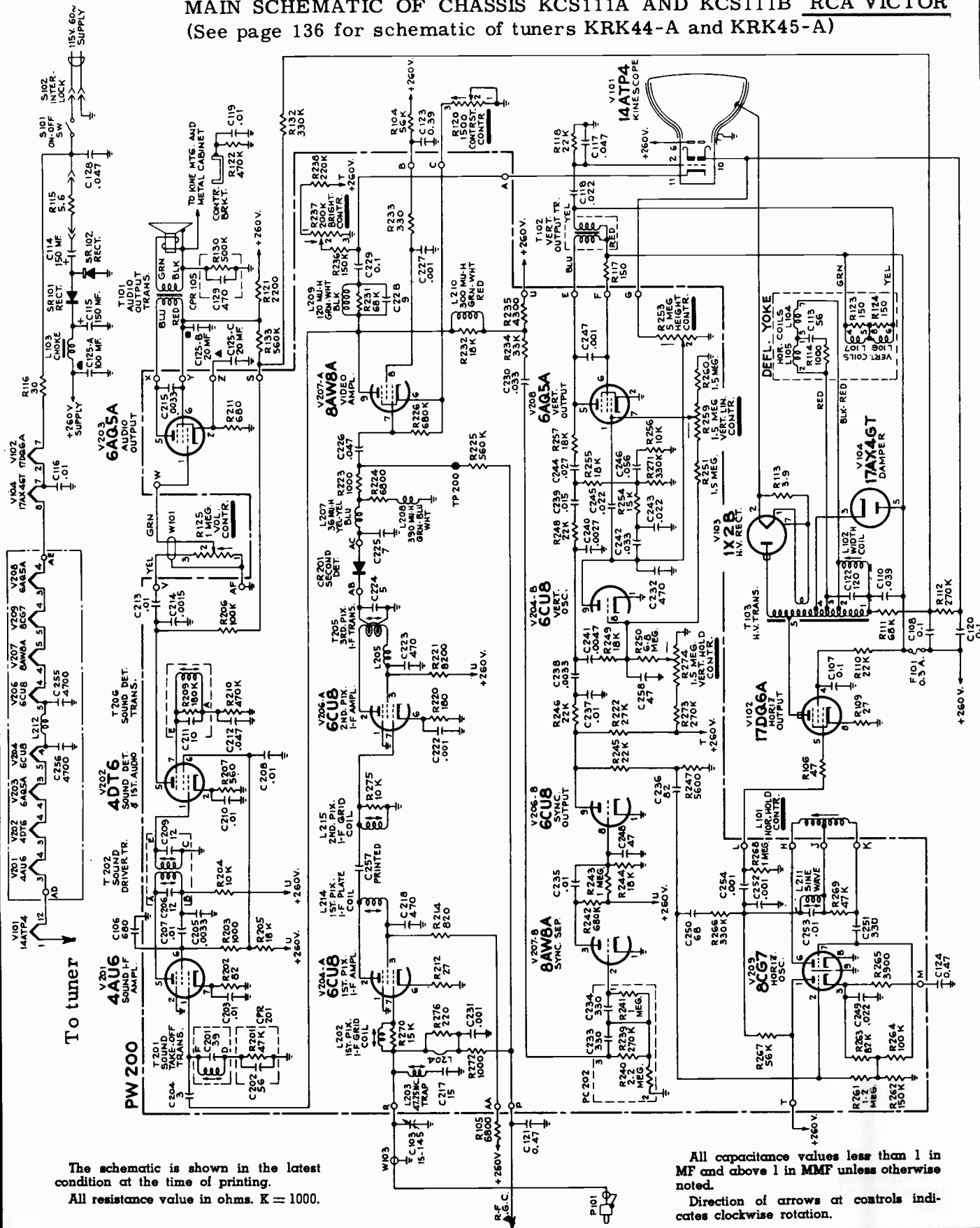

The schematic is shown in the latest condition at the time of printing.  
All resistance value in ohms. K = 1000.

All capacitance values less than 1 in MF and above 1 in MMF unless otherwise noted.  
Direction of arrows at controls indicates clockwise rotation.



MAIN SCHEMATIC OF CHASSIS KCS111-C AND KCS111-D RCA VICTOR  
 (See page 138 for schematic of tuners KRK46-B and KRK-47-B)

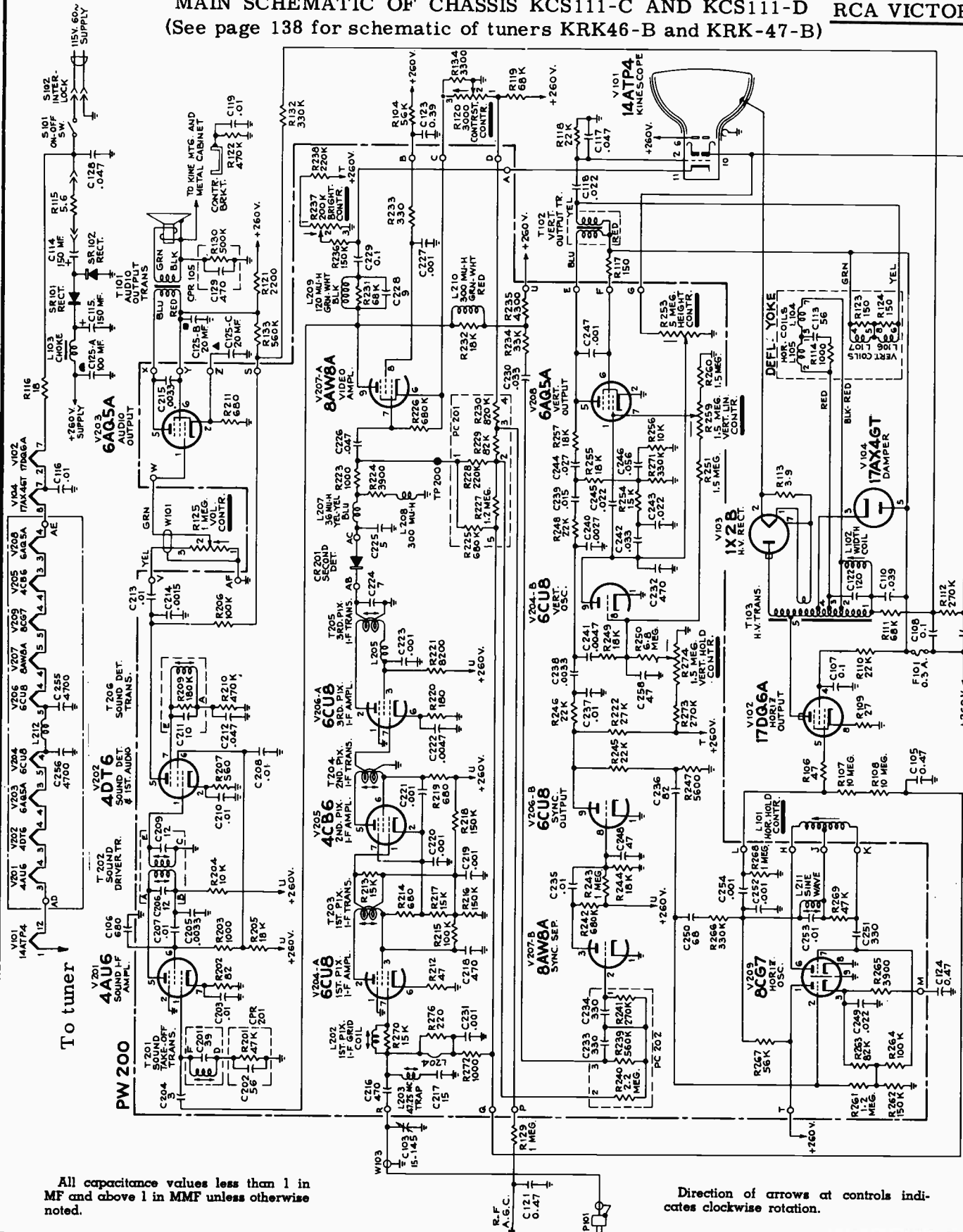

All capacitance values less than 1 in MF and above 1 in MMF unless otherwise noted.

Direction of arrows at controls indicates clockwise rotation.





# RCA VICTOR

**MODELS 21-RT-8202, 21-RT-8425**  
**21-T-8202-5-7 & U, 21-T-8265-7 & U**  
**21-T-8375-6-7 & U, 21-T-8395-7 & U**  
**21-T-8405-7 & U, 21-T-8425-6-7-8 & U**  
**21-T-8445-7-8 & U, 21-T-8465-6-7-8 & U**  
**21-T-8485-6-7 & U**

Chassis Nos. KCS113A, B, E, F, H, K, P, R

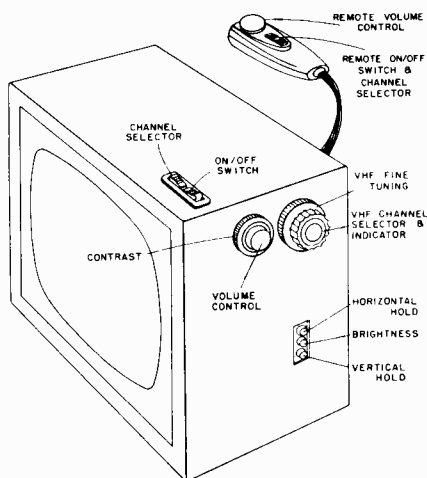

Figure 1—Receiver Operating Controls (Remote Control Models)

#### CHECK OF HORIZONTAL OSCILLATOR ADJUSTMENT

Turn the horizontal hold control to the extreme clockwise position. The picture should be out of sync, with approximately eight bars slanting downward to the left. Turn the control counter-clockwise slowly. The number of diagonal black bars will be gradually reduced and when only  $1\frac{1}{2}$  to 3 bars sloping downward to the left are obtained, the picture will pull into sync upon slight additional counter-clockwise rotation of the control. The picture should remain in sync for approximately one-quarter of a full turn of additional counter-clockwise rotation of the control. Continue counter-clockwise rotation until the picture falls out of sync. Rotation beyond fallout position should produce between 2 and 5 bars before interrupted oscillation (motorboat) occurs. Interrupted oscillation (motorboat) should be reached before full counter-clockwise rotation.

#### ADJUSTMENT OF HORIZONTAL OSCILLATOR

If in the above check the receiver failed to hold sync over approximately one-quarter of a full turn of counter-clockwise rotation of the control from the pull-in point, it will be necessary to make the following adjustments.

The width and drive adjustments should be properly set, as explained in paragraph below, before adjusting the sine wave coil.

Set the sine wave coil L601 fully counter-clockwise.

Adjustment of the horizontal frequency control in the counter-clockwise direction will show a multiple numbers of bars before "motorboat" occurs. Adjust the sine wave coil L601 until 3 or 4 bars are present before "motorboat" occurs, when the horizontal frequency control is rotated counter-clockwise from the fall out point.

#### CENTERING ADJUSTMENT

Centering is accomplished by means of two levers on the back of the yoke. By alternately rotating one magnet with respect to the other, then rotating both simultaneously around the neck of the tube, proper centering of the picture can be obtained.

#### HEIGHT AND VERTICAL LINEARITY ADJUSTMENTS

Adjust the height control (R107 on chassis rear) until the picture overscans approximately  $\frac{3}{8}$ " at both top and bottom. Adjust vertical linearity (R112 on chassis rear), until the test pattern is symmetrical from top to bottom.

The material on this page and the next nine pages is exact for the sets listed above. The 24" picture tube sets listed below are practically identical to these sets and this material is applicable.

### TELEVISION RECEIVERS — MODELS

**24-T-8325, 24-T-8325U**  
**24-T-8327, 24-T-8327U**  
**24-T-8335, 24-T-8335U**  
**24-T-8337, 24-T-8337U**

Chassis Nos. — KCS113M or KCS113N

#### WIDTH AND DRIVE ADJUSTMENTS

Set the horizontal control at the "pull-in" point. Set the width coil maximum counter-clockwise and adjust horizontal drive trimmer counter-clockwise until a bright vertical line appears in the middle of the picture then clockwise until the bright line just disappears. If no line appears set the drive trimmer at maximum counter-clockwise position.

At normal brightness adjust the width control L102 to obtain  $\frac{3}{4}$ " overscan at each side with normal line voltage.

Readjust the drive trimmer C109 as was done previously.

#### FM TRAP ADJUSTMENT

In some instances interference may be encountered from a strong FM station signal. A trap is provided to eliminate this type of interference. To adjust the trap tune in the station on which the interference is observed and adjust the FM trap for minimum interference in the picture. The trap is L5 and is located on the rear of the antenna matching unit.

**CAUTION.**—In some receivers, the FM trap L5 will tune down into channel 6 or even into channel 5. If channels 5 or 6 are to be received, check L5 to make sure that adjustment does not affect sensitivity on these two channels.

RCA VICTOR

21-RT-8202, 21-RT-8425

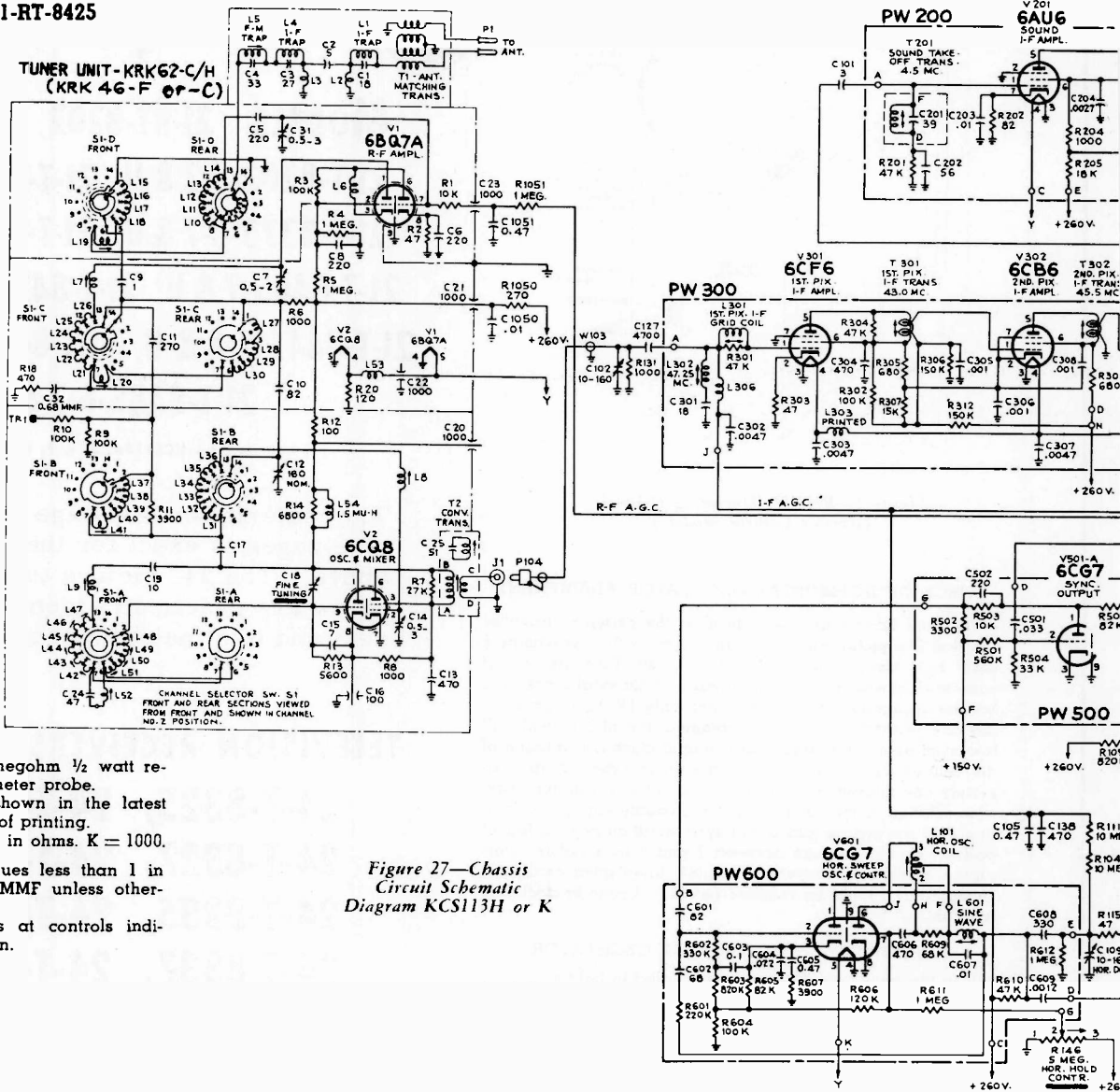

Figure 27—Chassis Circuit Schematic Diagram KCS113H or K

\*Measured with 1 megohm 1/2 watt resistor in series with meter probe.  
 The schematic is shown in the latest condition at the time of printing.  
 All resistance value in ohms. K = 1000.  
 All capacitance values less than 1 in MF and above 1 in MMF unless otherwise noted.  
 Direction of arrows at controls indicates clockwise rotation.

REPLACEMENT PARTS (Partial Listing)

SYMBOL NO.	STOCK NO.	DESCRIPTION	SYMBOL NO.	STOCK NO.	DESCRIPTION
<b>CHASSIS ASSEMBLIES</b> KCS113A, B, E, F, H, K, P & R					
C101	102415	Capacitor—Fixed, ceramic, 3 mmf., ±1 mmf., 1000 v. N-750	R101A, B	104922	Control—Volume and picture control. For KCS113K
C106	102416	Capacitor—Fixed, mica, 1000 mmf., ±10%, 300 v.	R101A, B	104923	Control—Volume and picture control. For KCS113H
C107	77293	Capacitor—Fixed, ceramic, 470 mmf., +100—0%, 500 v.	R102	104834	Resistor—Fixed, wire wound, 1800 ohms, ±10%, 4 w. For KCS113A, B, E, F, P, R
C114	76579	Capacitor—Fixed, mica, 270 mmf., ±20%, 1000 v.	R102	104926	Resistor—Fixed, wire wound, 1500 ohms, 4 w. For KCS113H, K
C117, C118	104179	Capacitor—Fixed, ceramic, 470 mmf., ±10%, 2000 v.	R106	104088	Control—Brightness
C127	73473	Capacitor—Fixed, ceramic, 4700 mmf., +100—0%, 500 v.	R107	100290	Control—Height
C138	77293	Same as C107	R110	104089	Control—Vertical hold
F101	104295	Resistor—Fuse type	R112	102408	Control—Vertical linearity
R101A, B	104092	Control—"On-Off" volume, picture control. Includes S101. For KCS113A, B	R116	104188	Resistor—Fixed, wire wound, 100 ohms, ±10%, 7 w.
R101A, B	104294	Control—"On-Off" volume, contrast control. Includes S101. For KCS113E, F, P, R	R120	104181	Resistor—Fixed, wire wound, 0.39 ohms, ±10%, 1/2 w.
			R126	104187	Resistor—Fixed, wire wound, 4700 ohms, ±10%, 7 w.
			R146	104090	Control—Horizontal hold
			T103	104236	Transformer—High voltage



SYMBOL NO.	STOCK NO.	DESCRIPTION
		<b>PW600—Printed Wiring Horizontal Assembly</b>
C601	76474	Capacitor—Fixed, mica, 82 mmf., ±5%, 1000 v.
C602	76475	Capacitor—Fixed, mica, 68 mmf., ±5%, 1000 v.
C606	104147	Capacitor—Fixed, mica, 470 mmf., ±5%, 1000 v.
C608	76476	Capacitor—Fixed, mica, 330 mmf., ±10%, 1000 v.
		<b>MISCELLANEOUS</b>
102581		Knob—Brightness, vertical hold and tone control—maroon
104400		Knob—Contrast control—maroon—for ebony Models 21RT8202 & 21T8202 & U
104386		Knob—Contrast control—wine—for mahogany grain Models 21RT8425, 21T8205 & U, 21T8265 & U, 21T8375 & U, 21T8395 & U, 21T8405 & U, 21T8425 & U, 21T8445 & U, 21T8465 & U, 21T8485 & U
104395		Knob—Contrast control—taupe—for walnut grain, oak grain Models 21T8207 & U, 21T8267 & U, 21T8376 & U, 21T8377 & U, 21T8397 & U, 21T8407 & U, 21T8426 & U, 21T8427 & U, 21T8447 & U, 21T8466 & U, 21T8467 & U, 21T8486 & U, 21T8487 & U
104396		Knob—Contrast control—mocha—for birch grain Models 21T8428 & U, 21T8448 & U, 21T8468 & U
100620B		Knob—"On-Off" volume—maroon—for ebony Models 21RT8202 & 21T8202 & U
101138B		Knob—"On-Off" volume—wine—for mahogany grain Models 21RT8425, 21T8205 & U, 21T8265 & U, 21T8375 & U, 21T8395 & U, 21T8405 & U, 21T8425 & U, 21T8445 & U, 21T8465 & U, 21T8485 & U
100621B		Knob—"On-Off" volume—taupe—for walnut grain, oak grain Models 21T8207 & U, 21T8267 & U, 21T8376 & U, 21T8377 & U, 21T8397 & U, 21T8407 & U, 21T8426 & U, 21T8427 & U, 21T8447 & U, 21T8466 & U, 21T8467 & U, 21T8486 & U, 21T8487 & U
101140B		Knob—"On-Off" volume—mocha—for birch grain Models 21T8428 & U, 21T8448 & U, 21T8468 & U
104076		Knob—UHF dial knob—maroon—for ebony Model 21T8202U for Tuner KRK64A
104522		Knob—UHF dial knob—maroon—for ebony Model 21T8202U for Tuner KRK64A-M1
104074		Knob—UHF dial knob—wine—for mahogany grain Models 21T8205U, 21T8265U, 21T8375U, 21T8395U, 21T8405U, 21T8425U, 21T8445U, 21T8465U, 21T8485U for Tuner KRK64A
104520		Knob—UHF dial knob—wine—for mahogany grain Models 21T8205U, 21T8265U, 21T8375U, 21T8395U, 21T8405U, 21T8425U, 21T8445U, 21T8465U, 21T8485U for Tuner KRK64A-M1
104075		Knob—UHF dial knob—gray—for walnut grain, oak grain, birch grain Models 21T8207U, 21T8267U, 21T8376U, 21T8377U, 21T8397U, 21T8407U, 21T8426U, 21T8427U, 21T8447U, 21T8448U, 21T8466U, 21T8467U, 21T8468U, 21T8486U, 21T8487U for Tuner KRK64A
104521		Knob—UHF dial knob—gray—for walnut grain, oak grain, birch grain Models 21T8207U, 21T8267U, 21T8376U, 21T8377U, 21T8397U, 21T8407U, 21T8426U, 21T8427U, 21T8447U, 21T8448U, 21T8466U, 21T8467U, 21T8468U, 21T8486U, 21T8487U for Tuner KRK64A-M1
104073		Knob—UHF tuning—maroon—for ebony Model 21T8202U
104071		Knob—UHF tuning—wine—for mahogany grain Models 21T8205U, 21T8265U, 21T8375U, 21T8395U, 21T8405U, 21T8425U, 21T8445U, 21T8465U, 21T8485U
104072		Knob—UHF tuning—taupe—for walnut grain, oak grain Models 21T8207U, 21T8267U, 21T8376U, 21T8377U, 21T8397U, 21T8407U, 21T8426U, 21T8427U, 21T8447U, 21T8448U, 21T8466U, 21T8467U, 21T8468U, 21T8486U, 21T8487U
104405		Knob—UHF tuning—mocha—for birch grain Models 21T8428U, 21T8448U, 21T8468U
104069		Knob—VHF channel selector—maroon—for ebony Models 21RT8202, 21T8202
104304		Knob—VHF channel selector—wine—for mahogany grain Models 21RT8425, 21T8205, 21T8265, 21T8375, 21T8395, 21T8405, 21T8425, 21T8445, 21T8465, 21T8485
104303		Knob—VHF channel selector—taupe—for walnut grain, oak grain Models 21T8207, 21T8267, 21T8376, 21T8377, 21T8397, 21T8407, 21T8426, 21T8427, 21T8447, 21T8466, 21T8467, 21T8486, 21T8487
104597		Knob—VHF channel selector—mocha—for birch grain Models 21T8428, 21T8448, 21T8468
104070		Knob—VHF/UHF channel selector—maroon—for ebony Model 21T8202U
104305		Knob—VHF/UHF channel selector—wine—for mahogany grain Models 21T8205U, 21T8265U, 21T8375U, 21T8395U, 21T8405U, 21T8425U, 21T8445U, 21T8465U, 21T8485U
104306		Knob—VHF/UHF channel selector—taupe—for walnut grain, oak grain Models 21T8207U, 21T8267U, 21T8376U, 21T8377U, 21T8397U, 21T8407U, 21T8426U, 21T8427U, 21T8447U, 21T8448U, 21T8466U, 21T8467U, 21T8486U, 21T8487U
104596		Knob—VHF/UHF channel selector—mocha—for birch grain Models 21T8428U, 21T8448U, 21T8468U
104401		Knob—VHF and UHF fine tuning—maroon—for ebony Models 21RT8202, 21T8202 & U
104397		Knob—VHF and UHF fine tuning—wine—for mahogany grain Models 21RT8425, 21T8205 & U, 21T8265 & U, 21T8375 & U, 21T8395 & U, 21T8405 & U, 21T8425 & U, 21T8445 & U, 21T8465 & U, 21T8485 & U

**RCA VICTOR**

**TUNER UNIT  
KRK 62-B/F/AA/U**

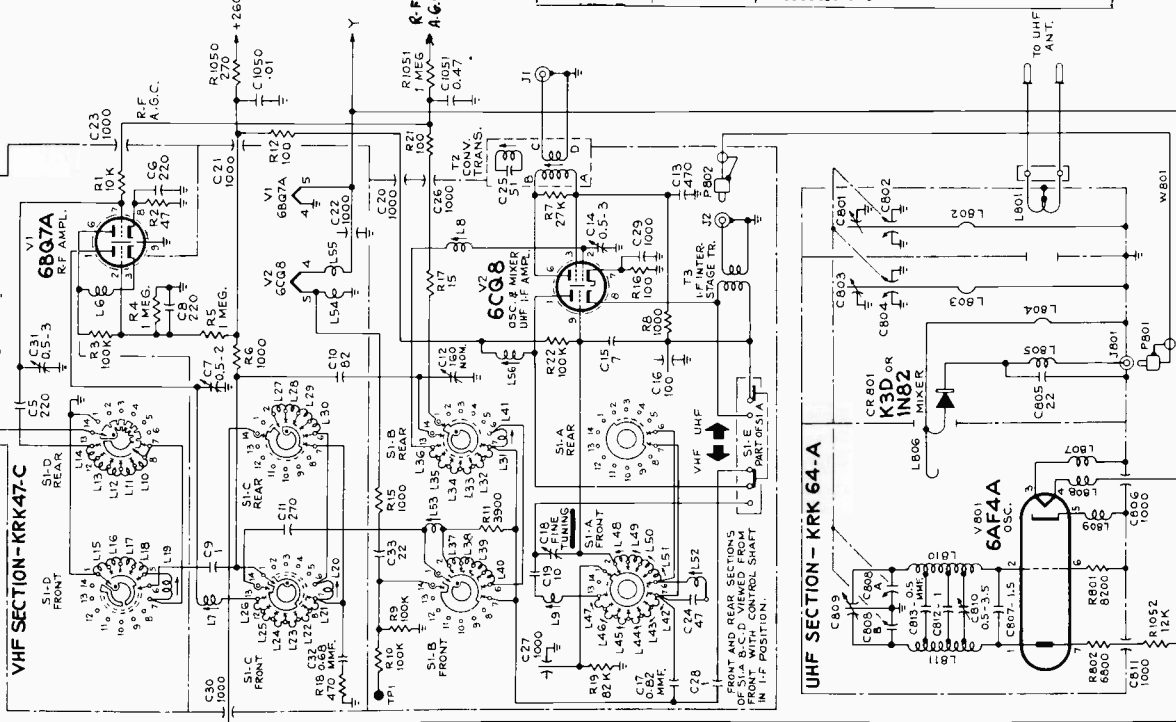



RCA VICTOR

CHASSIS REAR VIEW

21-RT-8202, 21-RT-8425  
21-T-8202(U) to 21-T-8487(U) Incl.

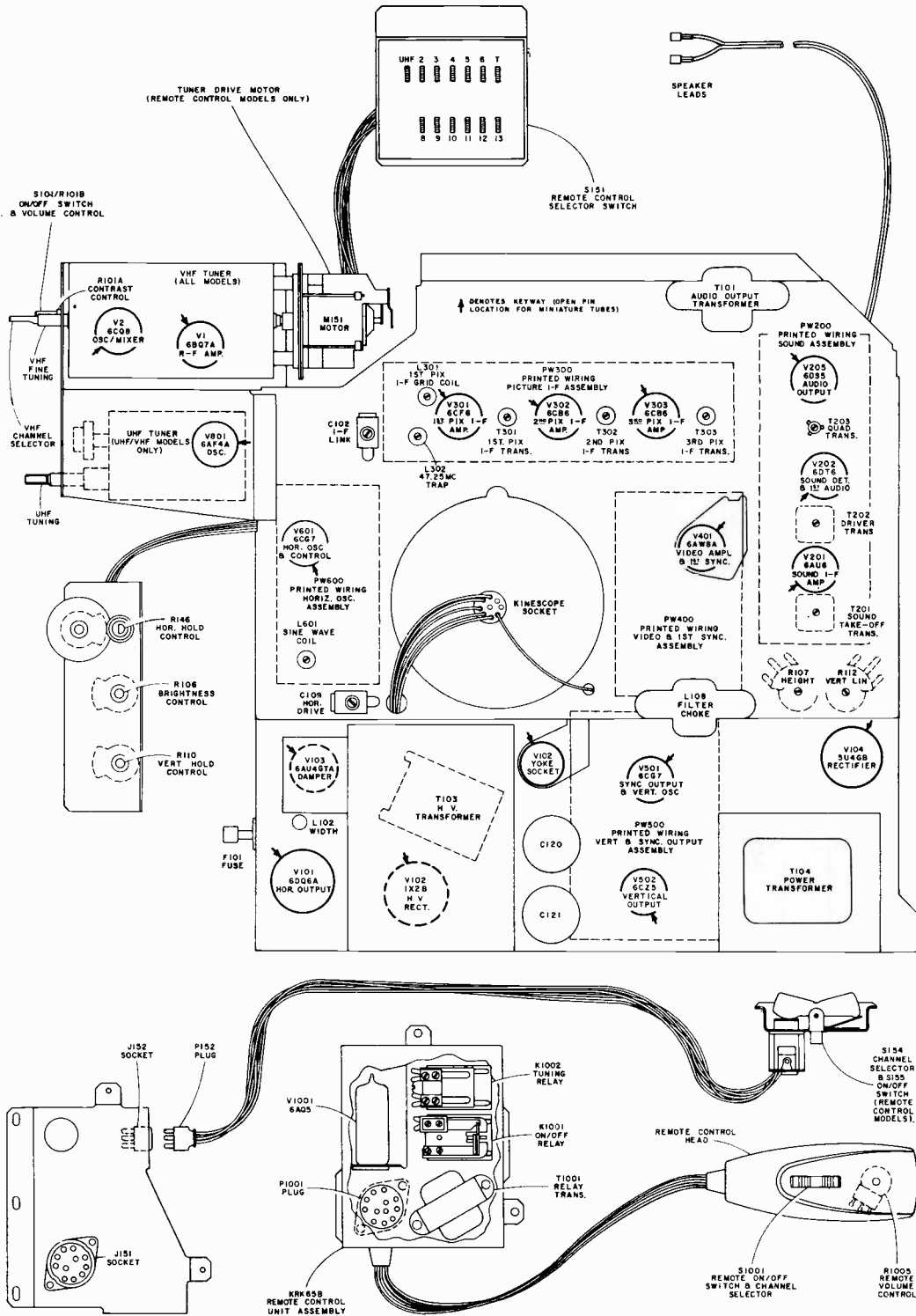

Figure 6—Chassis Rear View (Tube Side)

**RCA VICTOR**

21-RT-8202, 21-RT-8425  
21-T-8202(U) to 21-T-8487(U) Incl.

**KINESCOPE AND SAFETY GLASS CLEANING**

The front safety glass may be removed to allow for cleaning of the kinescope faceplate and the safety glass if required.

Table models have a "U" shaped channel under the front top edge of the cabinet, in front of the top of the safety glass. Take out the screws holding the channels and remove the channel and safety glass.

Console models have a "U" shaped channel in front of the top edge of the safety glass and also at the bottom edge. Pry off the top and bottom channels starting at the extreme ends.

Insert the blade of a small screwdriver in one of the vertical slots in the middle of a retainer at the top of the safety glass. Slide the bar to the right to release the retainer. Refer to Figure 5.

The bottom retainers are removed in a similar manner except the slide bar is moved to the left.

**CHASSIS REMOVAL**

To remove the chassis from the cabinet for repair or installation of a new kinescope, remove the control knobs, the cabinet back, unplug the speaker cable, the kinescope socket, the antenna cable, the yoke and high voltage cable. Take out the screws and nuts holding the chassis. Withdraw the chassis from the back of the cabinet.

**REMOTE CONTROL MODELS**

In addition to the above, it is necessary to unplug the remote control unit and the cable for the local "on-off"/channel selector switch. Remove the preselector slide switch assembly and the corner brace for the remote control unit.

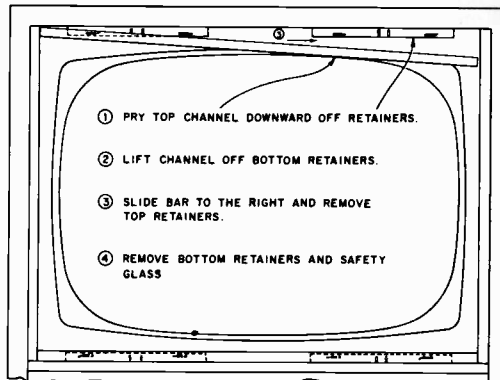

Figure 5—Safety Glass Removal

**REMOTE CONTROL FUNCTION**

**SELECTOR SWITCH OPERATION**

Models with remote control will automatically select channels when the channel selector switch is pressed. The channels selected are determined by the setting of the slide switches on the back of the receiver. Refer to Figure 19. To provide automatic selection of the channels in a particular location, slide the switches to uncover the numbers of the channels to be received. The numbers on all other switch positions should be covered.

The channel selector switch on top of the receiver or on the remote control unit should be pressed just long enough to start the channel selector motor. After the motor has been started it will continue to run until the next preselected channel is reached.

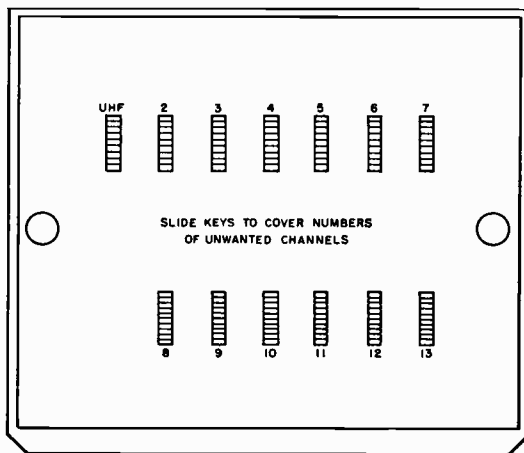

Figure 19—S151 Channel Preselector Switch Assembly

**KRK65B REMOTE CONTROL CHASSIS**

KRK65B is the designation assigned to the remote control chassis and includes the five-conductor cable and remote switch assembly. When KRK65B is plugged into the receptacle on the back of the receiver 115 volts AC is applied to the 12-volt transformer even with the receiver "turned off." Refer to Figure 27. This makes it possible to energize the 12-volt relays with the "on-off" or channel selector switch.

If necessary, the receiver may be operated with the remote unit unplugged. To do this, another plug (P151) similar to the

plug on the remote chassis is prepared with two jumpers as shown in Figure 27. When the plug is connected to receptacle J151 normal operation of the receiver is obtained.

**"ON-OFF" Function.**—When the "on-off" switch (local or remote) is pressed, the "on-off" relay is energized and closes the switch that applies AC to the primary of the power transformer in the main chassis. The "on-off" relay is of the mechanical latching type and the switch remains in the closed position although the relay is no longer energized. When the "on-off" button is again pressed the relay is energized again, the switch opens, and the receiver is turned off.

**CHANNEL SELECTOR FUNCTION.**—The function of the channel selector switch on the remote switch assembly or on top of the receiver is to apply 115 volts AC to the drive motor for the VHF tuner. The remote switch accomplishes this by momentarily closing the contacts of the channel selector relay. However, the contacts of the "on-off" relay must also be closed to complete the circuit for operation of the motor. Therefore, the receiver must be "on" before selection of channels can be made. It should also be noted that although the receiver may be "off" the selector relay can be made to "click" by closing the channel selector switch.

The tuner drive motor will continue to run after the contacts of the selector relay have opened due to the action of switch S153. The contacts of this switch will close when the motor is started and 115 volts AC will be applied to the motor through S153 instead of the contacts of the relays.

The motor will drive the shaft of the tuner and turn switch S152 until an open circuit on S151 is contacted. The motor then stops on the preselected channel.

**AUDIO REPEATER CIRCUIT**

The function of the 6AQ5 tube in the KRK65B remote control chassis is to provide a means for utilizing a conventional volume control at a remote location without hum pick-up.

The remote volume control is a part of a low impedance circuit that takes audio from the plate of the audio repeater tube and applies it to the grid of the audio output tube. The low impedance of this circuit prevents stray pick-up from the long cable of the remote unit.

The local volume control is located in the grid circuit of the audio repeater tube in a conventional circuit.

It is important to note that the full range of audio cannot be obtained from a volume control unless the unused control is first set to the maximum volume position.

A muting switch is provided on the channel selector relay to silence the speaker when the channel selector button is pressed.



RCA VICTOR

ALIGNMENT PROCEDURE

21-RT-8202, 21-RT-8425  
21-T-8202(U) to 21-T-8487(U) Incl.

PICTURE I-F TRANSFORMER AND TRAP ADJUSTMENTS

TEST EQUIPMENT CONNECTIONS:

- BIAS SUPPLY ..... Apply -4 volts to I-F AGC bus at terminal "J" of PW300. Ground positive lead to chassis.
- SIGNAL GENERATOR ..... Connect to mixer grid at strap on S1B, in series with 1500 mmf. capacitor (see below).
- VACUUM TUBE VOLTMETER..... Connect to 2nd Detector output at terminal "A" of PW400 using direct probe. Ground lead connected to chassis.

STEP	SIGNAL GENERATOR	ADJUST	REMARKS
1	44.5 mc.	T303	Peak T303, T302 & T301 on frequency for maximum output on meter. Adjust generator output for 3 volts on meter when finally peaked.
2	45.5 mc.	T302	
3	43.0 mc.	T301	
4	47.25 mc.	L302 & T2 (top core)	Minimum output indication on meter.

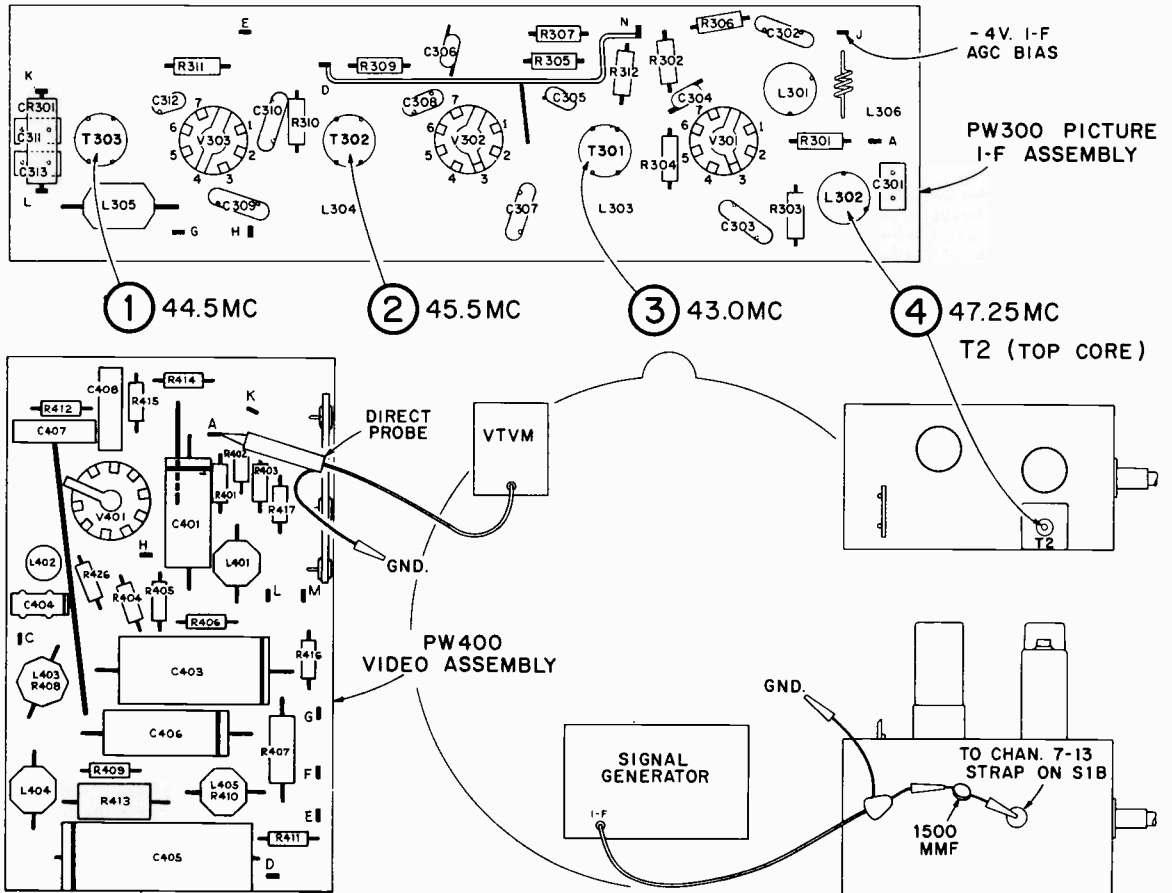

Figure 11—Picture I-F Transformer and Trap Adjustments

RCA VICTOR

ALIGNMENT PROCEDURE

21-RT-8202, 21-RT-8425  
21-T-8202(U) to 21-T-8487(U) Incl.

SOUND I-F, SOUND DETECTOR AND 4.5 MC TRAP ALIGNMENT

TEST EQUIPMENT CONNECTIONS:

- BIAS SUPPLY ..... Apply —10 volts to the I-F AGC bus at terminal "J" on PW300.
- OSCILLOSCOPE ..... Connect across speaker voice coil.
- SIGNAL GENERATOR ..... Connect to terminal "A" on PW400.
- VACUUM TUBE VOLTMETER ..... Connect to output of diode detector shown below. Set meter for negative voltage readings.
- MISCELLANEOUS ..... Connect test diode detector as shown below.

STEP	SIGNAL GENERATOR	ADJUST	REMARKS
Set contrast control maximum clockwise.			
1	Adjust Driver Transformer Primary and Secondary 4.5 mc.	T202 (top & bottom)	Adjust T202 top & bottom for maximum negative DC on meter. Set generator for 1.0 to 1.5 volts on meter when finally peaked. Peak cores at open end of coils (maximum core separation).
2	Adjust Sound Take-Off Trans. 4.5 mc.	T201	Adjust T201 for maximum negative DC on meter. Set generator for 1.0 to 1.5 volts on meter.
3	Disconnect the diode test detector. Turn off signal generator and tune in strongest signal in area adjusting volume control for normal volume (approx. 1/4 turn from c.c.w.). Turn core of T203 flush with top of coil form.		
4	Adjust Sound Detector Trans.	Observing oscilloscope and listening to audio output adjust T203 clockwise to a peak. Continue clockwise to a second louder peak and adjust T203 for maximum on this second peak.	
5	Adjust 4.5 mc. trap 4.5 mc., A-M Mod., 400 Cycles	L402	Adjust for minimum 400 cycle indication on oscilloscope.
Alternate Method Using Generators With F-M Modulation Provided.			
1	Same as step 1 above. Modulate 4.5 mc. signal with F-M 400 cycle signal with 7 1/2 kc. deviation.		
2	Same as step 2 above. Modulate 4.5 mc. signal with F-M 400 cycle signal with 7 1/2 kc. deviation.		
3	Adjust Sound Detector Trans. 4.5 mc., 400 cycle F-M Mod., 7 1/2 kc. Dev.	T203	Adjust T203 for max. 400 cycle output on scope using max. amplitude peak. Adjust volume control for .70 v. p-p on scope when peaked. See response below.
4	Retouch Driver and Sound Take-Off. Trans. for breakout 4.5 mc., 400 cycle F-M Mod., 7 1/2 kc. Dev.	T201 & T202	Decrease input signal to minimum usable signal and retouch T201 & T202 for symmetrical breakout. Response below.
Move the oscilloscope to terminal "D" on PW400. Use the diode probe. Set the contrast control to maximum clockwise position.			
5	Adjust 4.5 mc. trap	Same as step 5 above. Adjust for minimum 400 cycle indication on oscilloscope.	

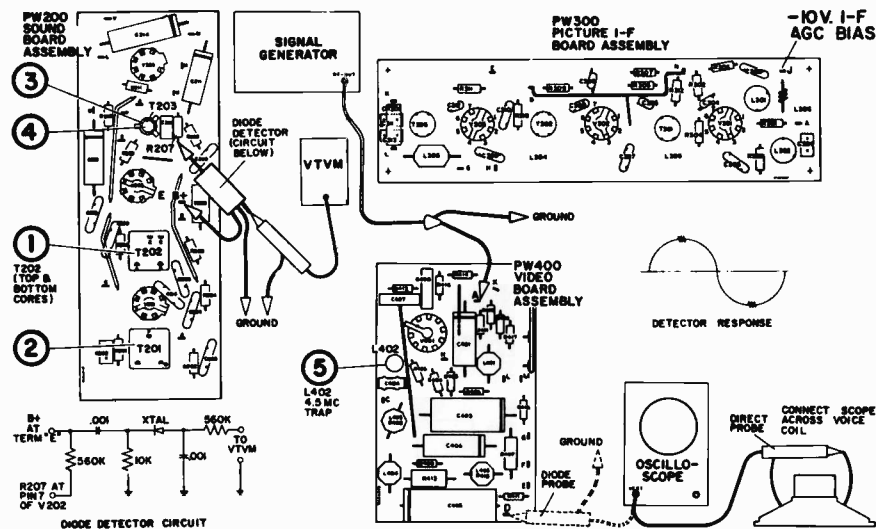

Figure 17—Sound I-F, Sound Detector and 4.5 mc. Trap Alignment

RCA VICTOR

PRINTED WIRING ASSEMBLIES

21-RT-8202, 21-RT-8425  
21-T-8202(U) to 21-T-8487(U) Incl.

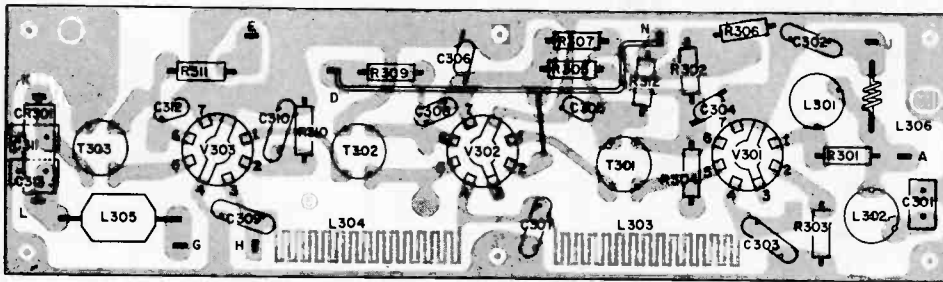

Figure 22—PW 300 Picture I-F Assembly Layout

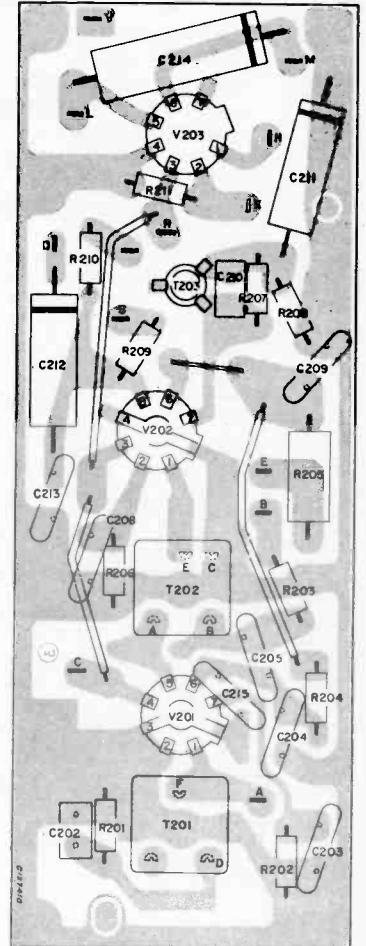

Figure 25—PW 200 Sound I-F & Audio Assembly Layout

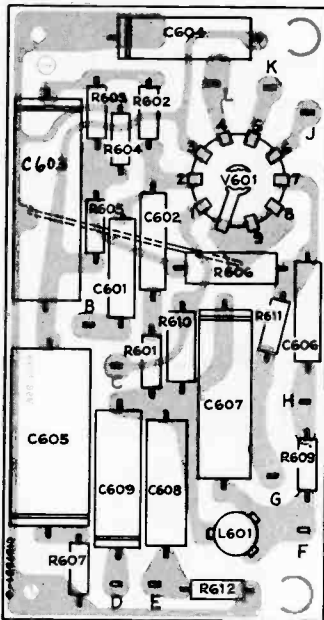

Figure 23—PW 600 Horizontal Oscillator Assembly Layout

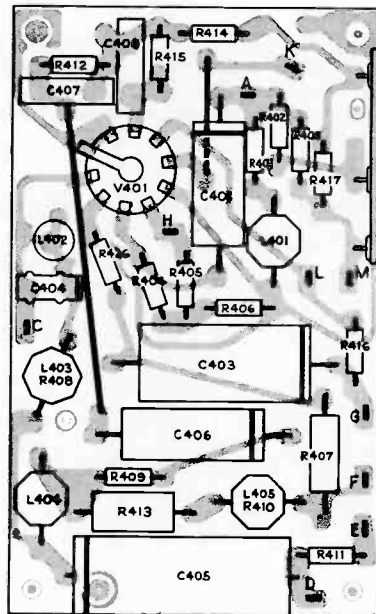

Figure 24—PW 400 Video & Sync Assembly Layout

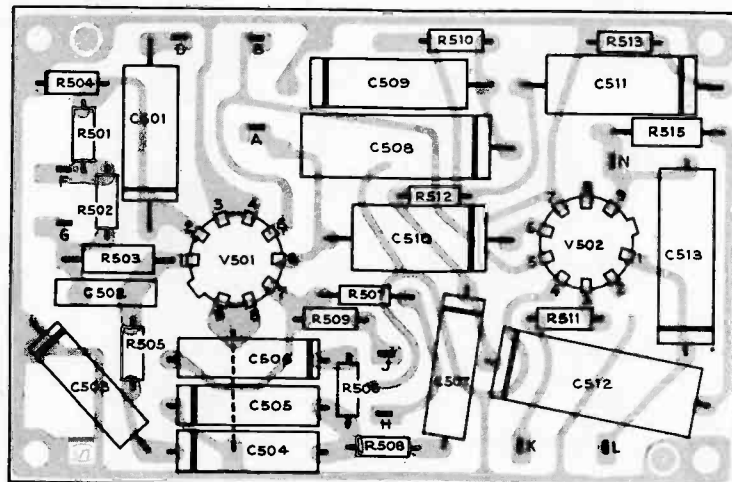

Figure 26—PW 500 Vertical & Sync Assembly Layout

The assemblies represented above are viewed from the component side of the boards and are oriented as they will usually be viewed on the chassis.

The printed wiring, on the reverse side of the boards, is presented in "phantom" views superimposed on the component layouts. This will enable circuit tracing without removing the assemblies from the chassis to see the printed wiring on the reverse side.

CHASSIS DESIGNATIONS

CHASSIS	TUNER ASSEMBLY	TUNER Sub-assemblies	MODELS
KCS116A	→	KRK46K	21-D-8281 21-D-8282 21-D-8305 21-D-8306 21-D-8307
KCS116B	→	KRK47K KRK64A	21-D-8281U 21-D-8282U 21-D-8305U 21-D-8306U 21-D-8307U
KCS116C	KRK67A	KRK46M	21-D-8628
KCS116D	KRK67B	KRK47M KRK64C	21-D-8628U

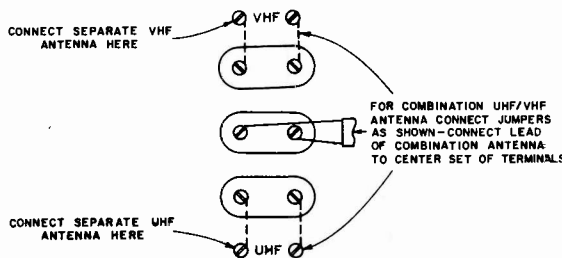

Figure 4—Crossover Network Antenna Connections

CHECK OF HORIZONTAL OSCILLATOR ADJUSTMENT

Turn the horizontal hold control to the extreme clockwise position. The picture should be out of sync, with a minimum of eight bars slanting downward to the left. Turn the control counter-clockwise slowly. The number of diagonal black bars will be gradually reduced and when only 1½ to 3 bars sloping downward to the left are obtained, the picture will pull into sync upon slight additional counter-clockwise rotation of the control. The picture should remain in sync for approximately one quarter of a full turn of additional counter-clockwise rotation of the control. Continue counter-clockwise rotation until the picture falls out of sync. Rotation beyond fall out position should produce a minimum of 2 bars before end of rotation or a minimum of 7 bars before interrupted oscillation "motorboat" occurs.

When the receiver passes the above checks and the picture is normal and stable, the horizontal oscillator is properly aligned. Skip "Adjustment of Horizontal Oscillator" and proceed with "Centering Adjustment."

ADJUSTMENT OF HORIZONTAL OSCILLATOR

If in the above check the receiver failed to hold sync for one-quarter of a turn of counter-clockwise rotation of the control from the pull-in point, it will be necessary to make the following adjustments.

The width and drive adjustments should be properly set, as explained in the paragraph below, before adjusting the sine wave coil.

Connect a short jumper across the terminals of the sine wave coil L601 through the opening in the chassis. Also short the grid of the sync output tube, pin 2 of V501, to ground with a small screwdriver or jumper.

Adjust the horizontal hold to obtain a picture with the sides vertical (picture may drift slowly sideways). Remove the jumper on the sine wave coil L601 and adjust L601 to again obtain a picture with the sides straight. When the sine wave coil is properly adjusted, alternate shorting and no short should not cause a change in frequency, only a slight sideways shift should occur.

Remove the short on the grid of the sync output. The horizontal hold should now perform as outlined above under "CHECK OF HORIZONTAL OSCILLATOR ADJUSTMENT."



MODELS

21-D-8281(U), 21-D-8282(U),  
21-D-8305(U), 21-D-8306(U),  
21-D-8307(U), 21-D-8628(U)

Chassis Nos. KCS116A, KCS116B, KCS116C  
or KCS116D

(Pages 153 through 160)

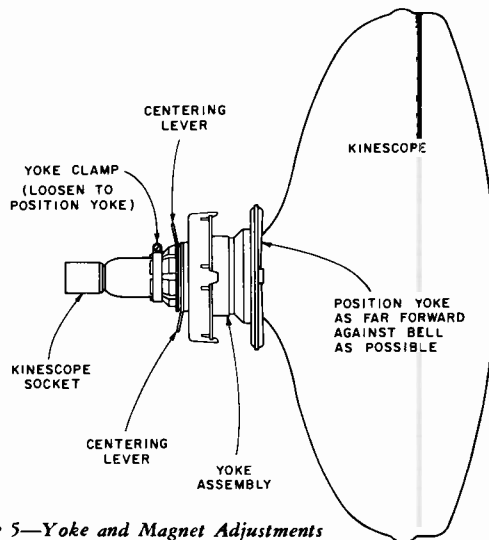

Figure 5—Yoke and Magnet Adjustments

CENTERING ADJUSTMENT

The electrostatic focus kinescope is provided with special centering magnets. These magnets are in the form of two discs mounted on the back of the deflection yoke. When the magnets are rotated so that the levers are together, maximum centering effect is produced. To shift the picture, rotate one of the magnets with respect to the other. To shift the picture in the desired direction rotate both magnets simultaneously in the same direction on the neck of the kinescope. By alternately rotating one magnet with respect to the other, then rotating both simultaneously around the neck of the tube, proper centering of the picture can be obtained.

WIDTH AND DRIVE ADJUSTMENTS

Set the horizontal control at the "pull-in" point. Adjustment of the horizontal drive control affects the high voltage applied to the kinescope. In order to obtain the highest possible voltage hence the brightest and best focused picture, set the width coil maximum counter-clockwise and adjust horizontal drive trimmer counter-clockwise until a bright vertical line appears in the middle of the picture, then clockwise until the bright line just disappears. If no line appears set the drive trimmer at maximum counter-clockwise position.

At normal brightness adjust the width coil L102 to obtain ¾" overscan at each side with normal line voltage. Readjust the drive trimmer C109 as was done previously.

**RCA VICTOR**

21-D-8281(U), 21-D-8282(U), 21-D-8305(U)  
21-D-8306(U), 21-D-8307(U), 21-D-8628(U)

**HEIGHT AND VERTICAL LINEARITY ADJUSTMENTS**

Adjust the height control (R510 on chassis rear) until the picture overscans approximately  $\frac{3}{8}$ " at both top and bottom with normal line voltage 117V. AC. Adjust vertical linearity (R516 on chassis rear) until the test pattern is symmetrical from top to bottom. Adjustment of either control will require a readjustment of the other. Adjust centering to align the picture with the mask.

**FOCUS**

An electrostatic focus type kinescope is employed in these receivers. The receivers operate with fixed focus, having a fixed voltage applied to the focusing electrode.

**AGC AND NOISE LIMITER CONTROLS**

The AGC and Noise Limiter controls should be checked for proper adjustment at the time of installation of the receiver.

To check the adjustment of these controls, tune in a strong signal and sync the picture. Momentarily remove the signal by switching off channel and then back. If the picture reappears immediately, the receiver is not overloading due to improper adjustment. If the picture bends at all, readjustment should be made.

Turn the Noise Limiter control R140 fully clockwise.

Adjust the AGC control slowly clockwise for a slight bend in the picture, then turn the control counter-clockwise approximately  $\frac{1}{4}$  turn (90°) from this point.

Adjust the fine tuning control until the 4.5 mc. beat is just perceptible in the picture. Readjust the AGC control for start of picture bend, then counter-clockwise 45° from this point.

Set the horizontal hold control as far counter-clockwise as possible (toward motorboat condition) without sync becoming unstable.

Turn the Noise Limiter control counter-clockwise until a horizontal bend or shift in position is visible in the picture, then clockwise about 30° past the point where the bend just disappears. In noisy locations set 15° from point of bend.

Return the horizontal hold control to the center of its holding range.

**DEFLECTION YOKE ADJUSTMENT**

If the lines of the raster are not horizontal or squared with the picture mask, rotate the deflection yoke until this condition is obtained. The yoke clamp must be loosened to allow the yoke to be rotated, see Figure 5. Make sure the yoke assembly is pushed forward against the kinescope bell.

**VHF R-F OSCILLATOR ADJUSTMENTS**

Tune in all available stations to insure the receiver r-f oscillator is properly adjusted on all channels. Correct adjustment will be indicated by the ability to tune the fine tuning control on each channel from a condition where sound bars appear at or near one extreme, through proper picture and sound to the other extreme where the picture will appear smeared with poor definition.

Adjustments for channels 2 through 12 are available through the holes on the front of the tuner and are accessible on portable and table models when the channel selector and fine tuning knobs are removed. Channel 13 adjustment is on top of the tuner.

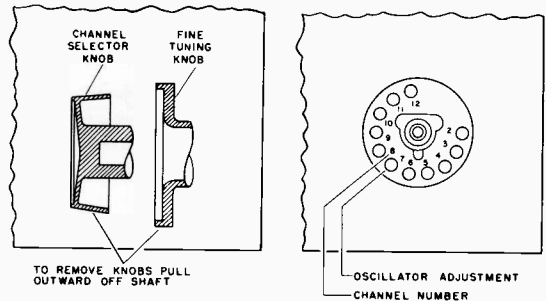

Figure 6—VHF Oscillator Adjustments

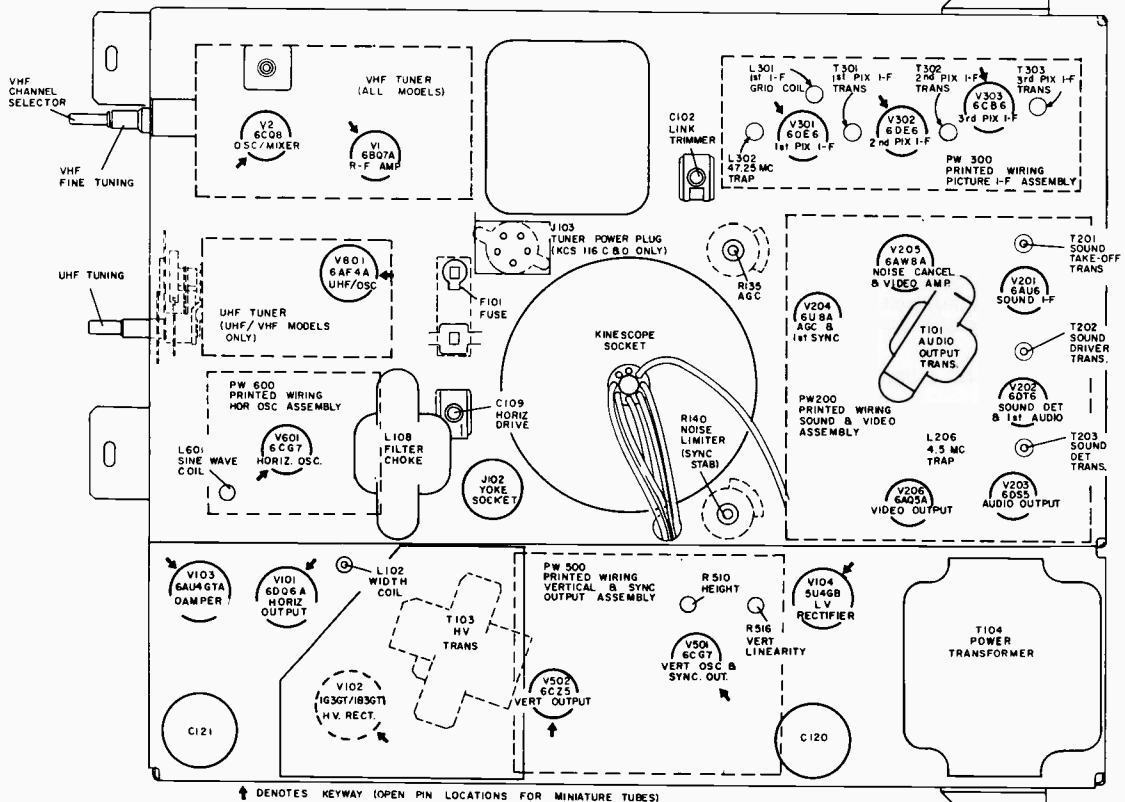

Figure 9—Chassis Rear View



**RCA VICTOR**

**ALIGNMENT  
PROCEDURE**

21-D-8281(U), 21-D-8282(U), 21-D-8305(U)  
21-D-8306(U), 21-D-8307(U), 21-D-8628(U)

**PICTURE I-F TRANSFORMER AND TRAP ADJUSTMENTS**

**TEST EQUIPMENT CONNECTIONS:**

- BIAS SUPPLY** ..... Apply -6 volts to I-F AGC bus at terminal "R" of PW200. Ground positive lead to chassis.
- SIGNAL GENERATOR** ..... Connect to mixer grid at strap on S1B, in series with 1500 mmf. capacitor (see below).
- VACUUM TUBE VOLTMETER** ..... Connect to 2nd Detector output at terminal "X" of PW200 using direct probe. Ground lead connected to chassis.
- MISCELLANEOUS** ..... Disable horizontal circuits (Horizontal Interference.)

STEP		SIGNAL GENERATOR	ADJUST	REMARKS
1	Peak 3rd pix. I-F transformer	44.5 mc.	T303	Peak T303, T302 & T301 on frequency for maximum output on meter. Adjust generator output for 3 volts on meter when finally peaked.
2	Peak 2nd pix. I-F transformer	45.5 mc.	T302	
3	Peak 1st pix. I-F transformer	43.0 mc.	T301	
4	Adjust 47.25 mc. trap	47.25 mc.	L302 & T2 (top core)	Minimum output indication on meter.

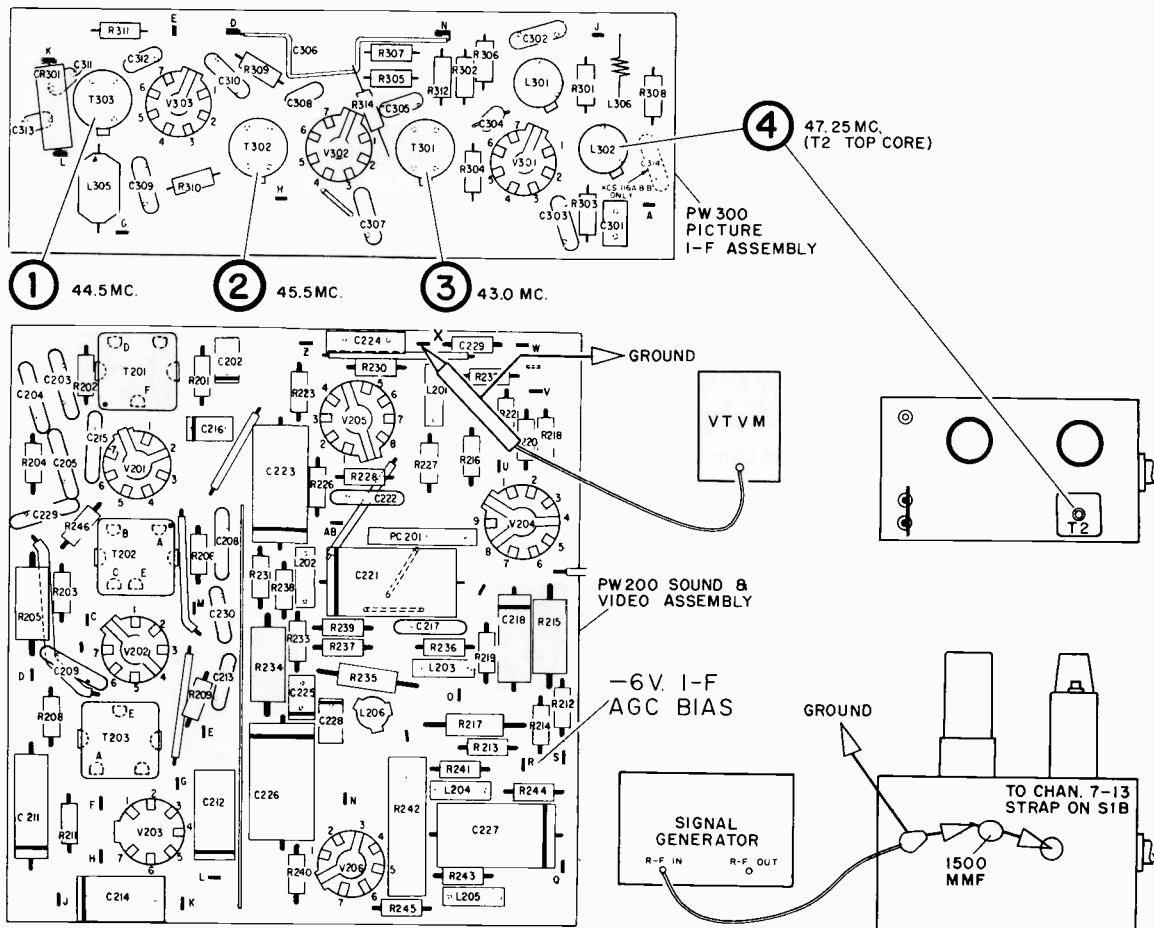

Figure 14—Picture I-F Transformer and Trap Adjustments



RCA VICTOR

ALIGNMENT  
PROCEDURE

21-D-8281(U), 21-D-8282(U), 21-D-8305(U)  
21-D-8306(U), 21-D-8307(U), 21-D-8628(U)

SOUND I-F, SOUND DETECTOR AND 4.5 MC TRAP ALIGNMENT

TEST EQUIPMENT CONNECTIONS:

- BIAS SUPPLY ..... Apply -10 volts to the I-F AGC bus at terminal "R" on PW200.
- OSCILLOSCOPE ..... Connect across speaker voice coil.
- SIGNAL GENERATOR ..... Connect to terminal "X" on PW200.
- VACUUM TUBE VOLTMETER ..... Connect to output of diode detector shown below. Set meter for negative readings.
- MISCELLANEOUS ..... Connect test diode detector, as shown below, to pin 7 of V202 (see below).

STEP	SIGNAL GENERATOR	ADJUST	REMARKS
Set contrast control maximum clockwise.			
1	Adjust Driver Transformer Primary and Secondary 4.5 mc.	T202 (top & bottom)	Adjust T202 top & bottom for maximum negative DC on meter. Set generator for 1.0 to 1.5 volts on meter when finally peaked. Peak cores at open end of coils (maximum core separation).
2	Adjust Sound Take-Off Trans. 4.5 mc.	T201	Adjust T201 for maximum negative DC on meter. Set generator for 1.0 to 1.5 volts on meter.
3	Disconnect the diode test detector. Turn off signal generator and tune in strongest signal in area adjusting volume control for normal volume (approx. 1/4 turn from c.c.w.). Turn core of T203 flush with top of coil form.		
4	Observing oscilloscope and listening to audio output adjust T203 clockwise to a peak. Continue clockwise to a second louder peak and adjust T203 for maximum on this second peak.		
Move the oscilloscope to terminal "Q" on PW200. Use the diode probe. Set the contrast control to maximum clockwise position.			
5	Adjust 4.5 mc. trap 4.5 mc., A-M Mod., 400 Cycles	L206	Adjust for minimum 400 cycle indication, generator output set to produce .2 to .5 volts on scope.
Alternate Method Using Generators With F-M Modulation Provided.			
1	Same as step 1 above. Modulate 4.5 mc. signal with F-M 400 cycle signal with 7 1/2 kc. deviation.		
2	Same as step 2 above. Modulate 4.5 mc. signal with F-M 400 cycle signal with 7 1/2 kc. deviation.		
3	Adjust Sound Detector Trans. 4.5 mc., 400 cycle F-M Mod., 7 1/2 kc. Dev.	T203	Adjust T203 for max. 400 cycle output on scope using max. amplitude peak. Adjust volume control for .70 v. p-p on scope when peaked. See response below.
4	Retouch Driver and Sound Take-Off Trans. for breakout 4.5 mc., 400 cycle F-M Mod., 7 1/2 kc. Dev.	T201 & T202	Decrease input signal to minimum usable signal and retouch T201 & T202 for symmetrical breakout. Response below.
Move the oscilloscope to terminal "Q" on PW200. Use the diode probe. Set the contrast control to maximum clockwise position.			
5	Adjust 4.5 mc. trap	Same as step 5 above. Adjust for minimum 400 cycle indication on oscilloscope.	

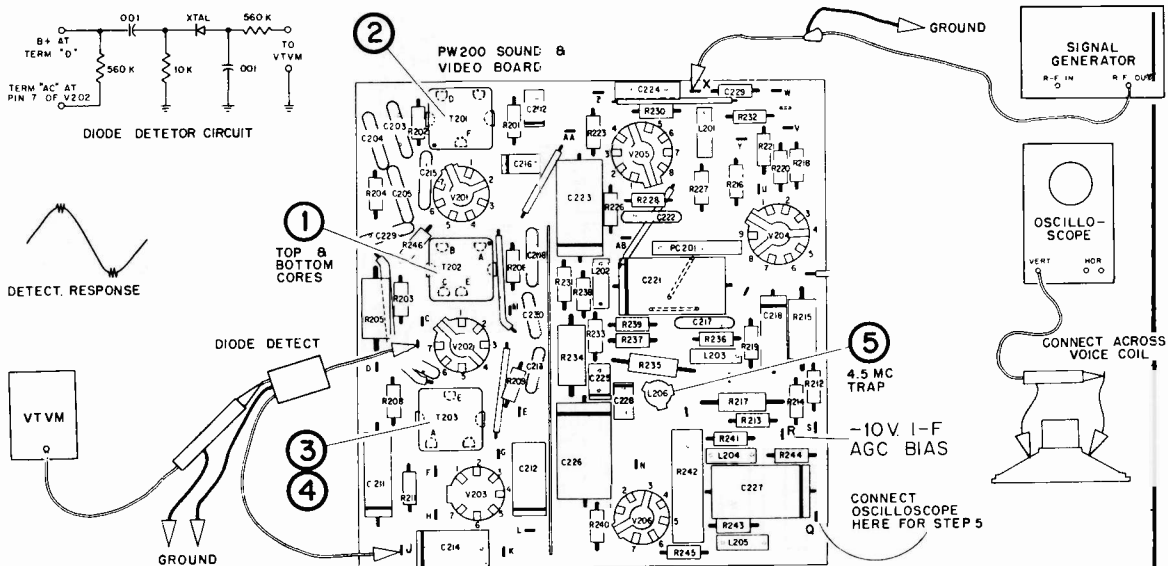
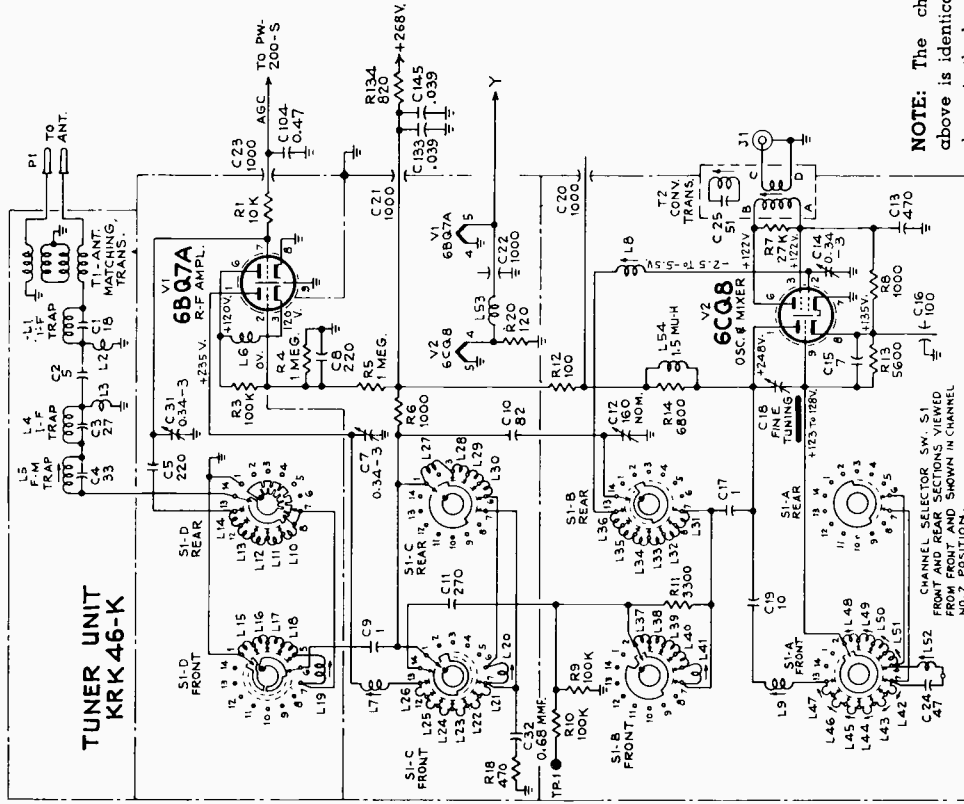

Figure 20—Sound I-F, Sound Detector and 4.5 mc. Trap Alignment

RCA VICTOR

21-D-8281(U), 21-D-8282(U), 21-D-8305(U)  
21-D-8306(U), 21-D-8307(U), 21-D-8628(U)

**KRK46K VHF TUNER CIRCUIT  
SCHEMATIC DIAGRAM**  
(Used in KCS116A Chassis)



**NOTE:** The chassis listed above is identical to chassis shown in the large schematic, except for the tuner which is a KRK46K shown in smaller schematic above.

Direction of arrows at controls indicates clockwise rotation.

All voltages measured with "VoltOhm-ys" and with no signal input. Voltages should hold within  $\pm 20\%$  with 117 v. a-c supply.

Figure 22—Tuner Circuit Schematic Diagram for KCS116A Chassis for VHF Table Models

The schematic is shown in the latest condition at the time of printing.  
All resistance value in ohms. X = 1000.

All capacitance values less than 1 in MF and above 1 in MMF unless otherwise noted.

**TUNER UNIT-VHF SECTION  
KRK 47-K**

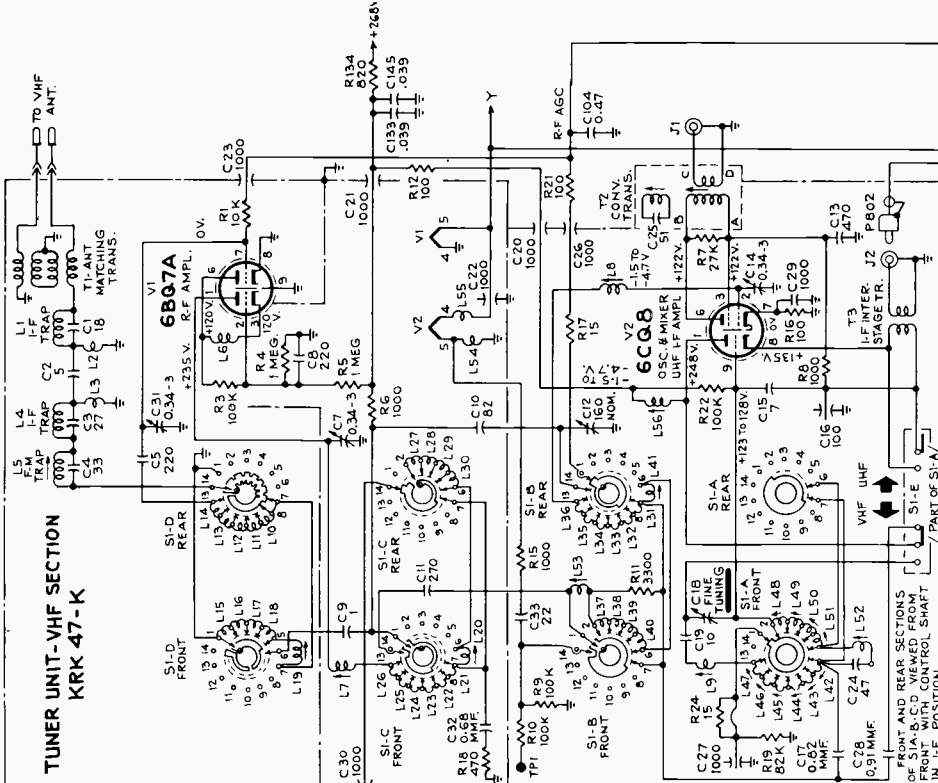

**UHF SECTION - KRK 64-A**

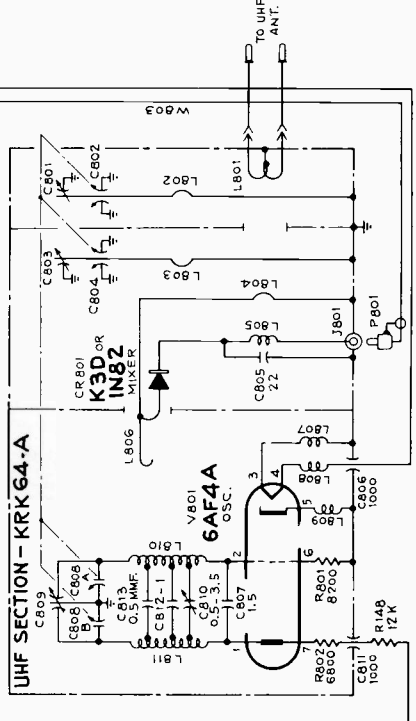

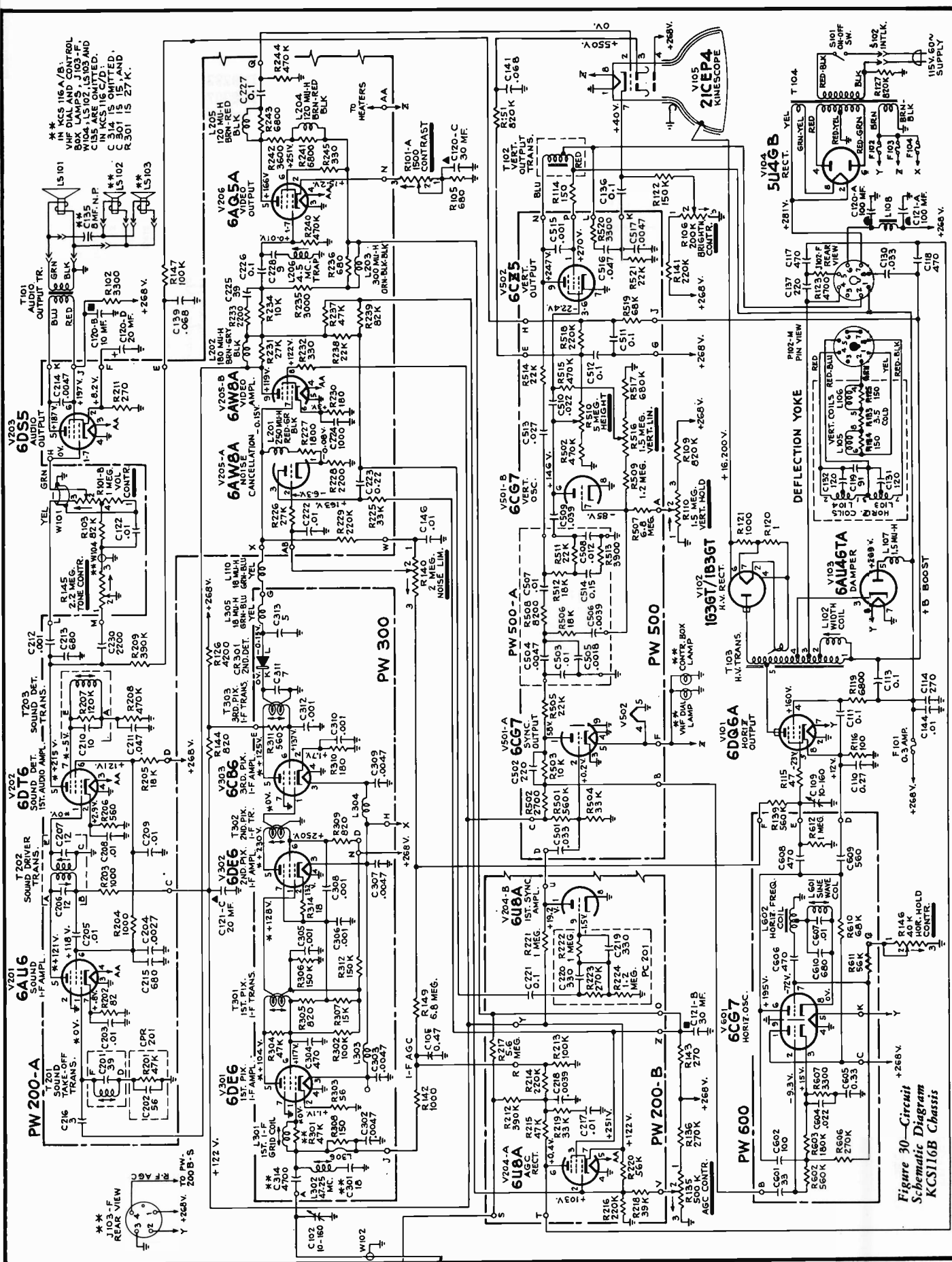

Figure 30—Circuit Schematic Diagram KC8116B Chassis

RCA VICTOR

21-D-8281(U), 21-D-8282(U), 21-D-8305(U)  
21-D-8306(U), 21-D-8307(U), 21-D-8628(U)

**KRK67A (KRK46M) VHF TUNER CIRCUIT  
SCHEMATIC DIAGRAM  
(Used with KCS116C Chassis)**

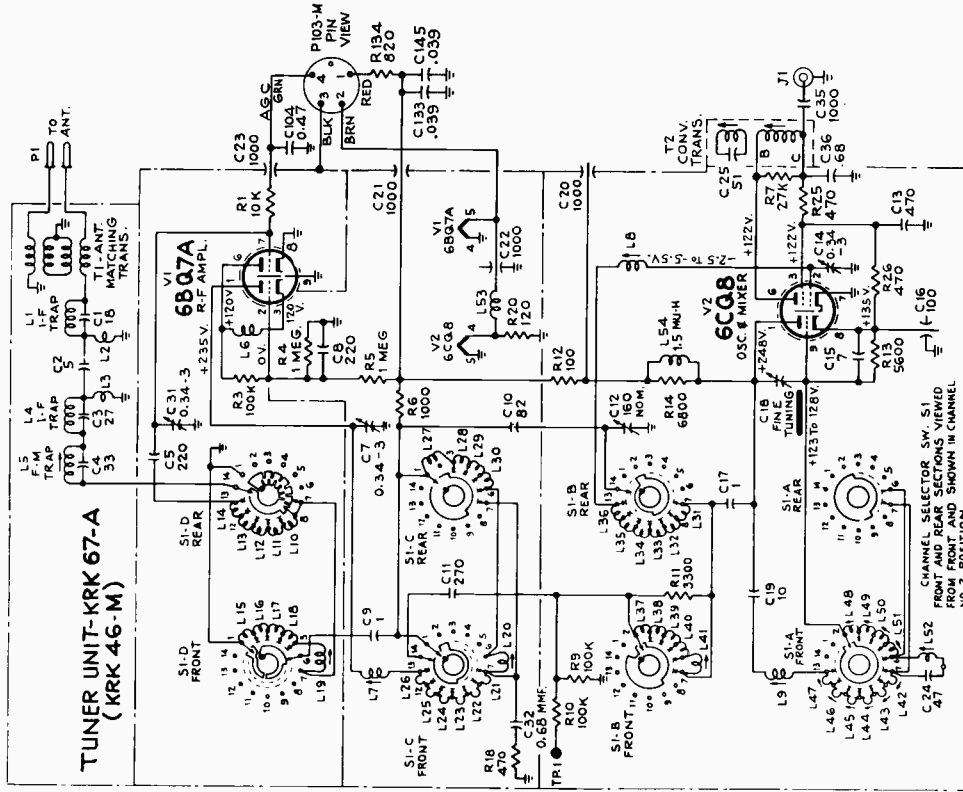
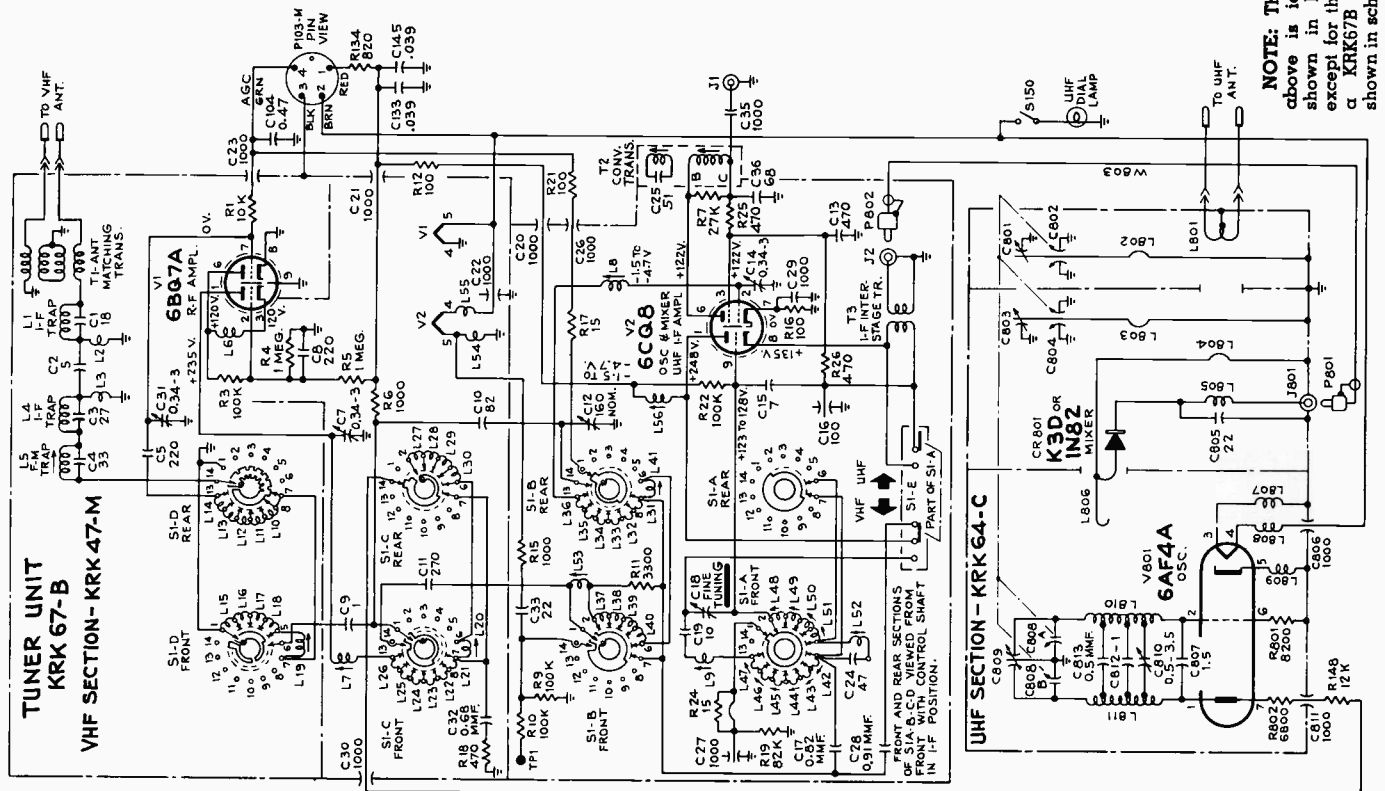

Figure 23—Tuner Circuit Schematic Diagram for KCS116C Chassis for VHF Corner Console Models

**NOTE:** The chassis listed above is identical to chassis shown in the large schematic, except for the tuner which is a KRK67A (KRK46M) shown in smaller schematic above.

**KRK67B (KRK47M/64C) UHF/VHF TUNER  
(Used in KCS116D Chassis)**



**NOTE:** The chassis listed above is identical to that shown in large schematic, except for the tuner which is a KRK67B (KRK47M/64C), shown in schematic above.

Figure 24—Tuner Circuit Schematic Diagram for VHF Corner Console Models

# Westinghouse

## CHASSIS ASSEMBLIES V-2371 and V-2381

Chassis assembly V-2371, is equipped with a VHF tuner. This chassis may be used in manual tuning and power tuning models. Chassis assembly V-2381 is the same as V-2371 except that it has both VHF and UHF tuners.

MODELS	CHASSIS	TUNER USED
H21T201B H21T202B H21K204B H21K205B	V-2371-22	VHF: 470V030H01 12 pos. 4BX8 RF amp 5AT8 Mix-Osc
H21T201 H21T202 H21K204 H21K205	V-2371-24	VHF: 470V029H01 13 pos. 2CY5 RF amp 5CL8 Mix-Osc
H21K212 H21K213 H21K214 H21K215 H21K216	V-2371-29	VHF: 470V042H03 13 pos. 2BN4 RF amp 5CG8 Mix-Osc
H21KU212 H21KU213 H21KU214 H21KU215 H21KU216	V-2381-202	VHF: 470V021H03 13 pos. 2CY5 RF amp 5AT8 Mix-Osc UHF: 472V024H01 2AF4A Osc.
H21TU201 H21TU202 H21KU204 H21KU205	V-2381-203	VHF: 470V024H01 13 pos. 2CY5 RF amp 5AT8 Mix-Osc UHF: 472V024H01 2AF4A Osc
H21KU212A H21KU213A H21KU214A H21KU215A H21KU216A	V-2381-204	VHF: 470V020H03 13 pos. 2CY5 RF amp 5CL8 Mix-Osc UHF: 472V020H01 2AF4A Osc.

## ADJUSTMENTS

### DEFLECTION YOKE ADJUSTMENT

The deflection yoke adjustments are made by loosening the 1/4" self-tapping screw on the deflection yoke cover clamp and rotating the yoke either clockwise or counterclockwise until the raster is level or square with respect to the mask, then fasten in place. When fastening the cover clamp in place, make sure that the yoke is well up against the CRT flare, or neck shadows will result.

### CENTERING

Centering is accomplished by rotating the centering magnet tabs clockwise or counterclockwise as required. The two adjusting rings are located on the back of the deflection yoke as shown. A tab projection on each of the rings serves to facilitate adjustment.

If difficulty is experienced in centering the picture or eliminating "neck shadows", make certain the yoke is tight against the flare of the CRT, and re-adjust the ion trap.

### ION TRAP MAGNET

*It is extremely important that the ion trap magnet be correctly adjusted immediately after the set is first turned on during installation.* This is true even though the set appears to be operating satisfactorily. When the magnet is not correctly oriented, the electron beam strikes the edge of the aperture gun structure instead of moving cleanly through the hole. The resultant heat may release gas which has a harmful effect on the tube. An excessively high setting of the brightness control will aggravate this condition. From this it is apparent that the brightness control should never be turned up to compensate for an incorrectly adjusted ion trap magnet. The tube can be ruined in a very short time under this condition.

To adjust the ion trap magnet, position the magnet near base of tube, then orient the magnet for the brightest raster.

If the brightness peaks at two positions of the magnet, the position nearer the base of the tube is the correct one. Never move the ion trap magnet to remove a shadow from the raster if the brightness is decreased by so doing. Shadows should be removed by adjusting the position of the deflection yoke. *The ion trap magnet must always be adjusted for maximum picture brightness.*

### HEIGHT AND VERTICAL LINEARITY

The height adjustment on the back of the chassis controls the overall height of the picture, and the vertical linearity adjustment controls the relationship between the vertical dimensions of the upper and lower sections of the picture. A balance between the two controls is necessary to make the picture symmetrical and fill the mask vertically.

### HORIZONTAL RINGING COIL

The horizontal ringing coil (L400) should be adjusted as follows:

- Short out the ringing coil with a short jumper wire. This can be done on top of the chassis.
- Set the horizontal hold control to the middle of its range, and leave it in this position during the steps that follow.
- Connect a VTVM to test point F (Figure 13) or to pin #7 of the horizontal multivibrator socket to measure the DC voltage between this point and B minus.
- With the receiver tuned to a TV station, adjust C421 for zero voltage on the meter. If zero voltage can be approached but not quite reached at one extreme of the C421 adjustment, it may be necessary to set the horizontal hold control slightly to one side of mid-position to obtain zero voltage.
- Remove the jumper from across the ringing coil.
- Adjust the ringing coil L400 for zero voltage on the meter, and check the adjustment by switching to another channel and then back again. The receiver should pull into horizontal synchronization on all channels.

### SPEAKER LOAD RESISTOR

When the chassis is removed from its cabinet for test or repair, and the speaker is disconnected, a load resistor (3.2 ohms, 2 watts) must be connected across the audio output transformer. Failure to do so may result in damage to the 12C5 audio output tube.

(Material continued on pages 162 through 170)

WESTINGHOUSE Chassis V-2371 and V-2381 Service Material, Continued

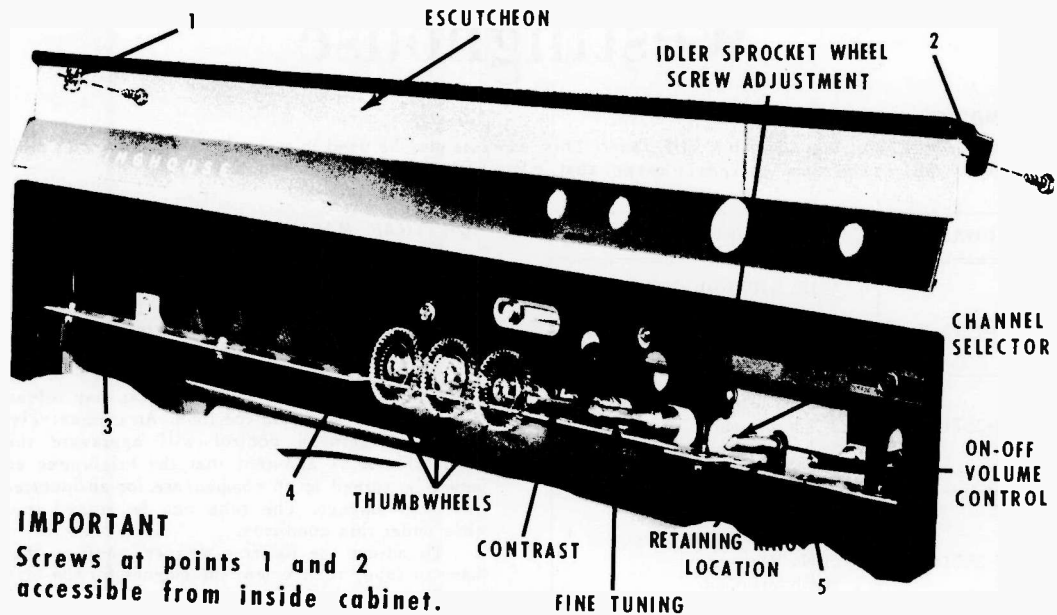

**IMPORTANT**  
Screws at points 1 and 2 accessible from inside cabinet.

Figure 1 - Manual Tuning Receiver, Escutcheon Removed

**CHASSIS REMOVAL**

1. Remove back cover.
2. See Figure 1. FROM INSIDE THE CABINET (behind the escutcheon) remove screws located at points 1 and 2. These screws secure the escutcheon to the cabinet.
3. Remove speaker leads.
4. Remove control knobs. (The thumbwheels cannot be removed at this time.) If the receiver is a UHF model, remove the tuning knobs at the right side of the cabinet.
5. (Figure 1.) Remove screws 3, 4, and 5. Remove escutcheon.
6. Remove thumbwheels.
7. Remove chassis bolts, accessible from the bottom of cabinet.
8. Remove chassis from the cabinet.

**VHF TUNER REMOVAL, MANUAL TUNING CHASSIS (V-2371-22)**

1. See Figure 1. Remove retaining ring from channel selector shaft.
2. See Figure 2. Loosen idler sprocket wheel nut.
3. (Figure 2). Lift idler sprocket wheel to slip bead chain off the other two sprocket wheels.
4. Disconnect all wires at the tuner.
5. Remove the tuner mounting screws, at the rear of the tuner.
6. Remove tuner.
7. (Figure 2). Remove the fine tuning shaft sprocket wheel.

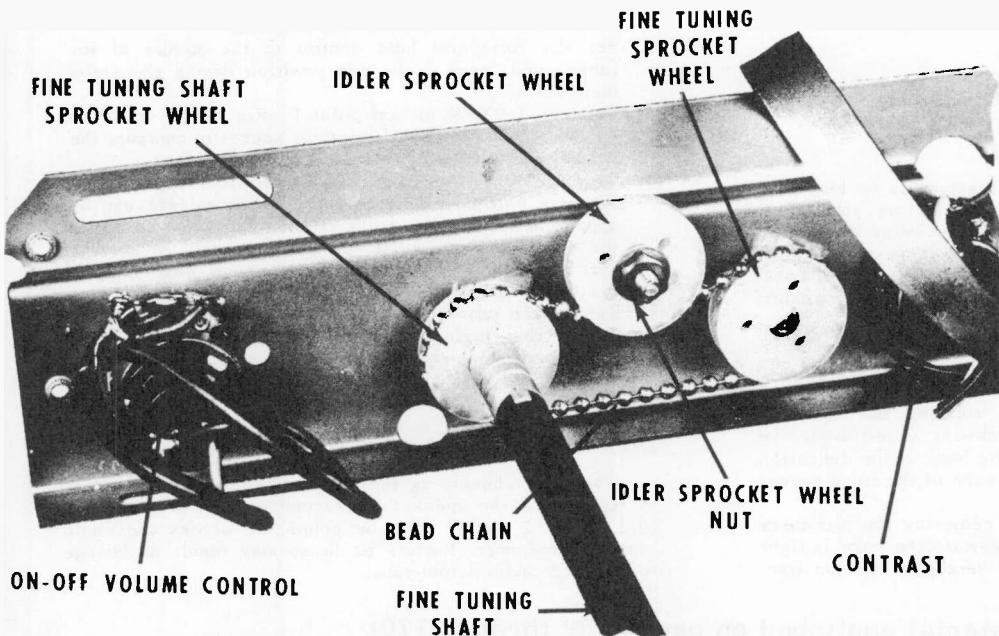

Figure 2 - Control Bracket, Manual Tuning Chassis, Rear View

**VHF TUNER INSTALLATION, MANUAL TUNING CHASSIS (V-2371-22)**

1. See Figure 2. Place sprocket wheel on fine tuning shaft of replacement tuner. Figure 2 shows sprocket wheel in place.
2. Slip bead chain over tuner shaft and sprocket wheel. Set tuner in place, with channel selector shaft through hole in control bracket.
3. Mount tuner with mounting screws.
4. Fasten retaining ring on channel selector shaft at the front of control bracket. Retaining ring location shown in Figure 1.
5. See Figure 2. Place bead chain under the idler sprocket wheel.
6. Adjust idler sprocket wheel for proper tension. Tighten idler sprocket wheel nut.
7. Connect wires to replacement tuner.

# VOLUME TV-14, MOST-OFTEN-NEEDED 1958 TELEVISION SERVICING INFORMATION

## TEST EQUIPMENT

Use an isolation transformer during all servicing and alignment operations.

1. RF sweep generator capable of producing a 10 mc sweep at center frequencies ranging from 10 to 90 mc and 170 to 216 mc.
2. A cathode ray oscilloscope and a low-capacitance input probe. The oscilloscope should have good low frequency response characteristics.
3. Marker generator capable of producing an accurate signal at all intermediate frequencies between 4.5

and 50 mc and all picture and sound RF frequencies. Keep the output of the signal generator adjusted to provide a constant 1 volt output on the VTVM during all alignment adjustments.

4. A vacuum tube voltmeter.
5. A special tool to adjust the slugs in the IF transformers T300, T301, T302, T303, & L300. This tool must fit into the 3/32 hex type hole in the slug. An incorrectly designed tool will cause chipping of the slug. A suitable tool is shown in Figure 7.
6. A negative 3 volt bias connected to test point A. (See Figure 13).

## VIDEO ALIGNMENT PROCEDURE CHART – Test points shown in Figure 13

Step	Test Equipment	Adjust	Indicator Output
1.	Sweep Generator: connected to pin #1, 3rd I.F. Grid, (3DK6 or 3CB6). Set to sweep 40-50mc. Terminate output lead in generator output impedance (see Figure 9) Marker Generator – loosely couple to sweep generator output cable. Set to 43.9 mc. Oscilloscope – connect vertical input to test point B using isolation network shown in Figure 10. Calibrate scope for 2 volts peak-to-peak.	T303	Adjust bottom slug to peak at 43.9mc and top slug to rock the curve about 43.9 mc when top slug is turned back and forth.
2.	Marker Generator – Connected to test point D. Use termination shown in Figure 9. VTVM – connected to test point B. Use isolation network, shown in Figure 10.	T302	Maximum at 43.1 mc. Generator output adjusted so VTVM reads -1.5V at max.
3.	Same as step 2 above.	L300	Minimum at 47.25 mc.
4.	Same as step 2 above.	T301	Maximum at 45.2 mc. VTVM as Step 2
5.	Sweep Generator – connected to test point D. Set to sweep 40 to 50 mc. Output lead should be terminated in generator output impedance. (Figure 9) Marker Generator – loosely couple to sweep generator output cable. Oscilloscope – same as in Step 1.	T300 & T301 if necessary	Adjust for response curve as shown in Figure 11: Amplitude of response curve should be 2 volts peak-to-peak.
6.	Marker Generator – connected to tuner test point (use termination shown in Figure 9). Set generator to 41.25 mc. VTVM – Same as in step 2 above.	T300 top slug (sound trap)	Minimum at 41.25 mc.
7.	Marker Generator – set to 215.75 mc and connect to antenna terminals. Use termination shown in Figure 8. Channel Selector – Set to channel 13. VTVM – same as in step 2 above.	Fine tuning control	Minimum at 215.75 mc.
8.	Sweep Generator – connect to antenna terminals with impedance matching network shown in Figure 8. Set to sweep channel 13. Marker Generator – same as in step 1 above. Set to 213 mc. Channel Selector – Set to channel 13. Oscilloscope – same as in step 1 above.	L103	Maximum amplitude of response curve.
9.	Same as in step 8 above.	T300 (bottom slug)	Adjust L103 to the position which will rock the overall response about the center frequency of 213 mc. when bottom slug of T300 is turned back and forth. Set bottom slug of T300 for symmetrical response.
10.	Signal Generator – connect to test point B. Set to 4.5 mc (crystal controlled if possible and strong enough to produce a proper null.) VTVM – connect to test point C (low side to B-)	L303 (4.5 mc trap)	Minimum at 4.5 mc.



Figure 7 – Alignment Tool

Z0	R1	R2
50 Ω	56 Ω	120 Ω
72 Ω	82 Ω	110 Ω

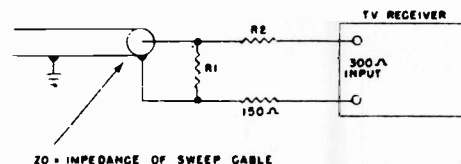

Z0 = IMPEDANCE OF SWEEP CABLE

Figure 8 – Impedance Matching Network



WESTINGHOUSE Chassis V-2371 and V-2381 Service Material, Continued

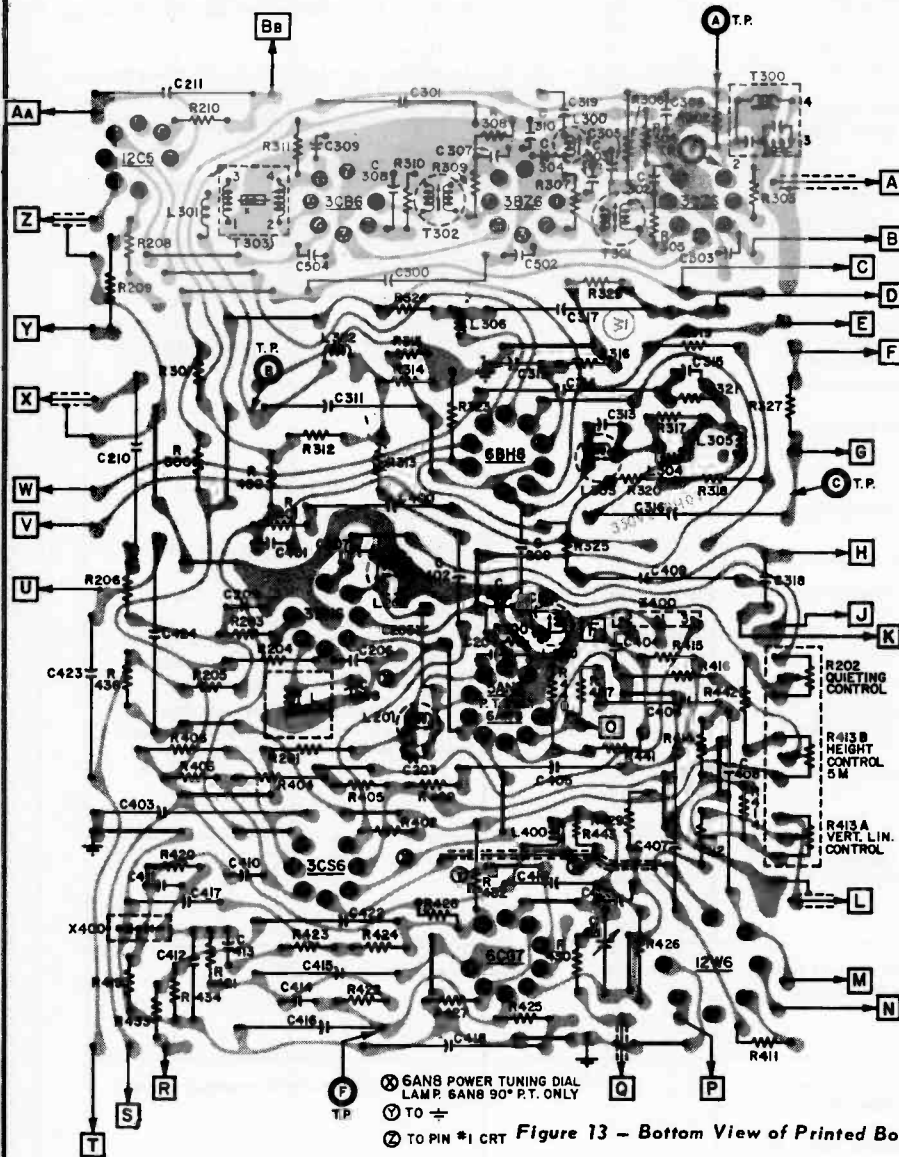

Circled letters designate test points discussed  
Other reference points are listed below.

- A - tuner IF output cable
- B - heater to tuner
- C - AGC to tuner
- D - CRT control grid, pin 2
- E - CRT focus, pin 6, B+ to tuner
- F - arm of brightness control
- G - CRT cathode, pin 11
- H - vertical output transformer vertical deflection yoke
- J - vertical deflection yoke ground
- K - CRT screen grid, pin 10
- L - shielded wire - from vertical hold control
- M - wire to vertical output transformer
- N - tap of vertical output transformer
- O - shielded wire to vertical hold control
- P - to pin 2 of 12DQ6
- Q - shielded wire to horizontal hold control
- R - pin 5 of 12DQ6
- S - low B + R503
- T - terminal 3, horizontal output transformer
- U - junction of R503 and L500
- V - arm of contrast control
- W - top of contrast control
- X - shielded wire to top of volume control
- Y - connection to bottom of audio output transformer feed-back secondary
- Z - shielded wire to arm of volume control
- AA - top of audio output transformer primary
- BB - bottom of audio output transformer primary and terminal of R504

⊗ GANB POWER TUNING DIAL LAMP GANB 90° P.T. ONLY  
⊙ TO ⊕  
⊙ TO PIN #1 CRT

Figure 13 - Bottom View of Printed Board Showing Top Components as Schematic Symbols

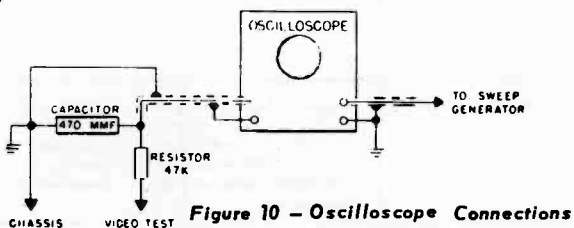

Figure 10 - Oscilloscope Connections

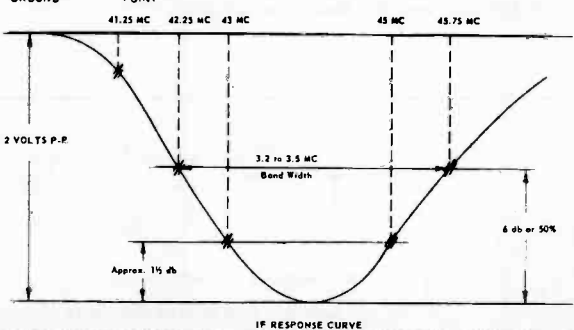
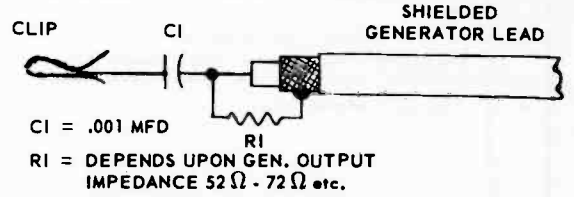

Figure 11 - IF Response Curve



C1 = .001 MFD  
R1 = DEPENDS UPON GEN. OUTPUT IMPEDANCE 52 Ω - 72 Ω etc.

Figure 9 - RF Generator Coupling

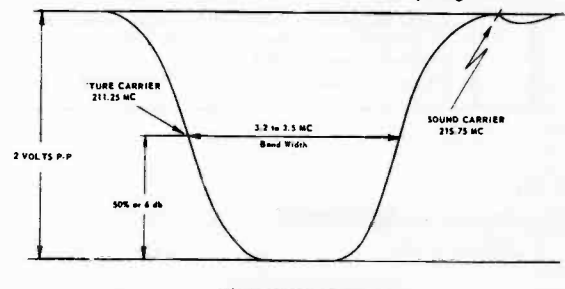
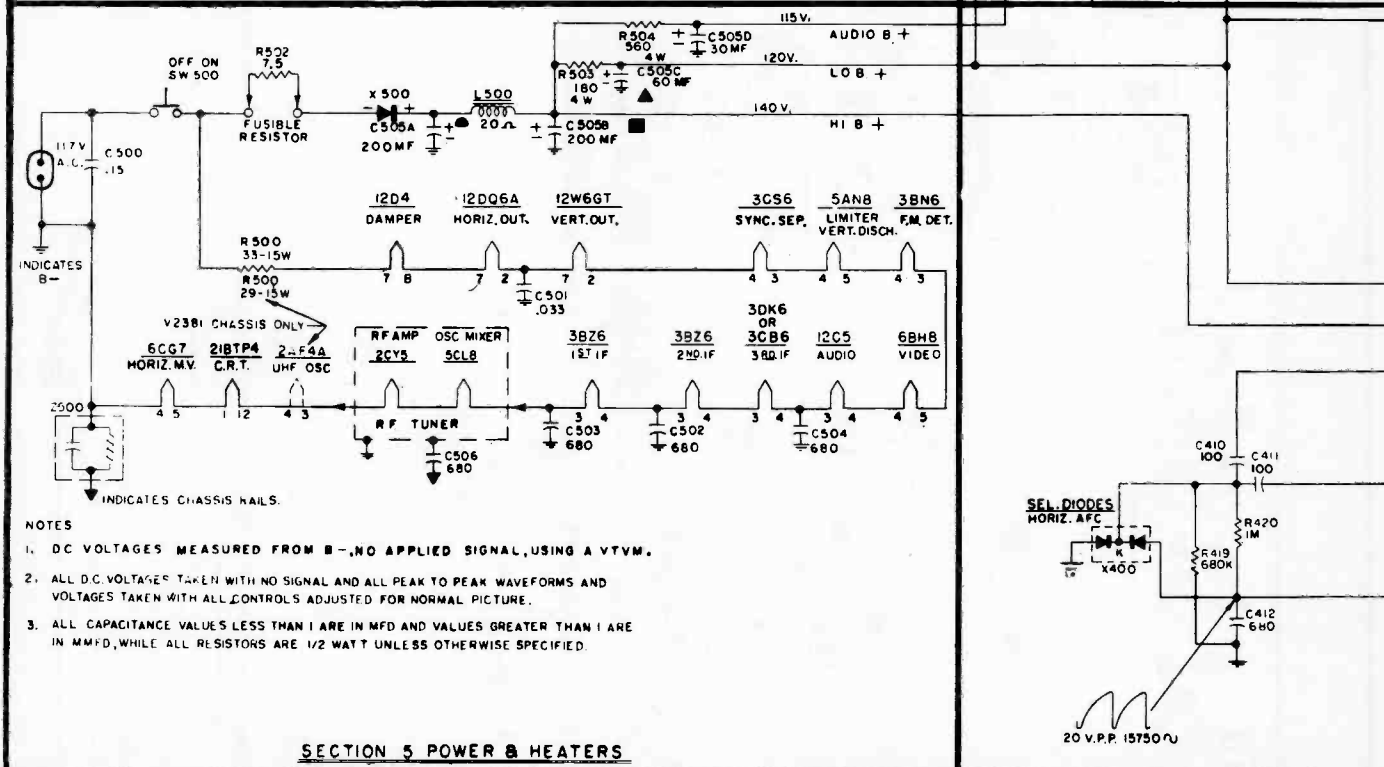
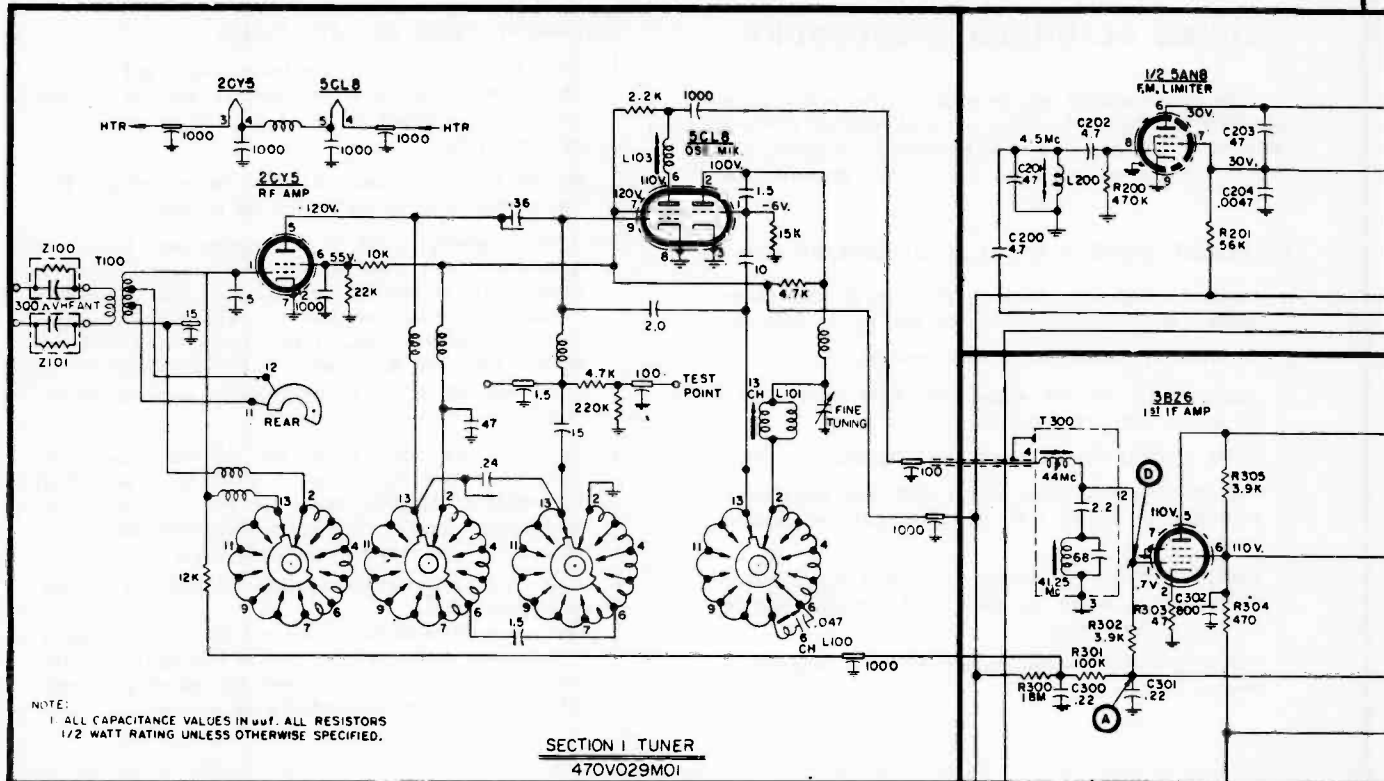

Figure 12 - Overall Response Curve



WESTINGHOUSE Manual Tuning Chassis V-2371 and V-2381 Schematic Diagram



**Caution**

When servicing or adjusting the receiver, connect the receiver AC power plug through an isolation transformer, to the AC outlet. This is necessary because one side of the receiver AC input is connected to the receiver chassis.

Do not confuse isolation transformers with autotransformers, Variacs, etc. Such transformers offer no isolation. Side-rails, customer controls, and metal cabinet are insulated to protect the user. After receiver repair, check for any possible short between the electrically hot chassis and normally insulated chassis and metallic parts.

VOLUME TV-14, MOST-OFTEN-NEEDED 1958 TELEVISION SERVICING INFORMATION

WESTINGHOUSE

Manual Tuning Chassis, V-2371 & V-2381, Schematic Diagram

SECTION 2 SOUND IF AND AUDIO

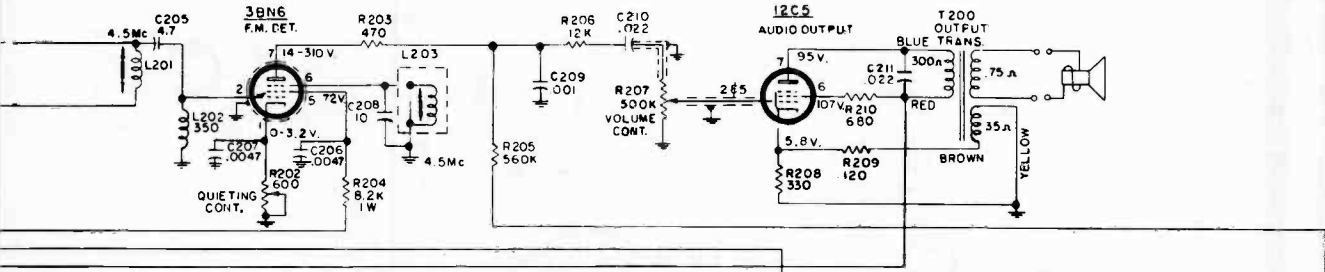

SECTION 3 VIDEO

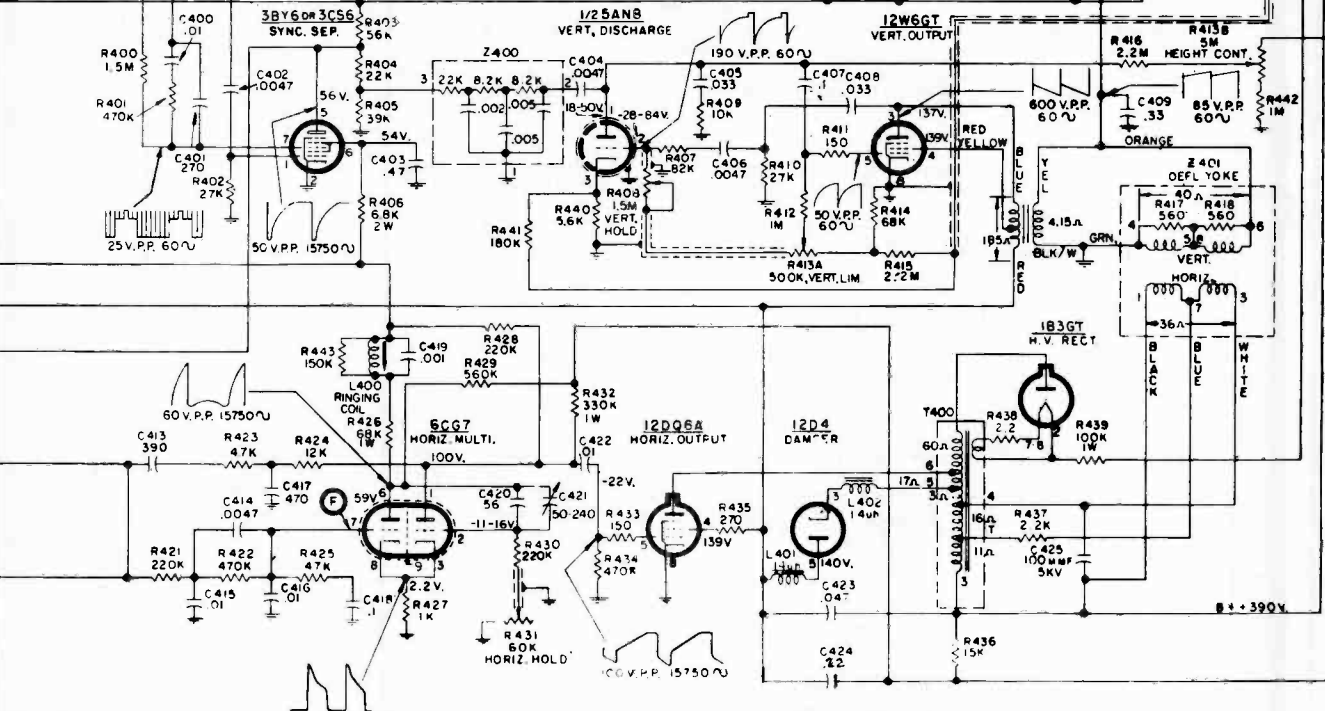
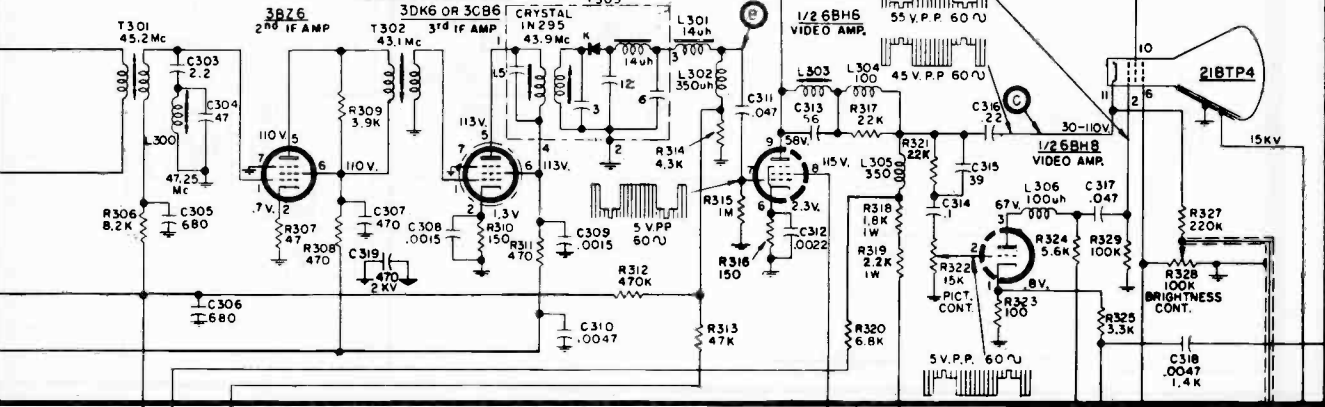

SECTION 4 SWEEP

WESTINGHOUSE Power Tuning Chassis V-2371 and V-2381 Schematic Diagram

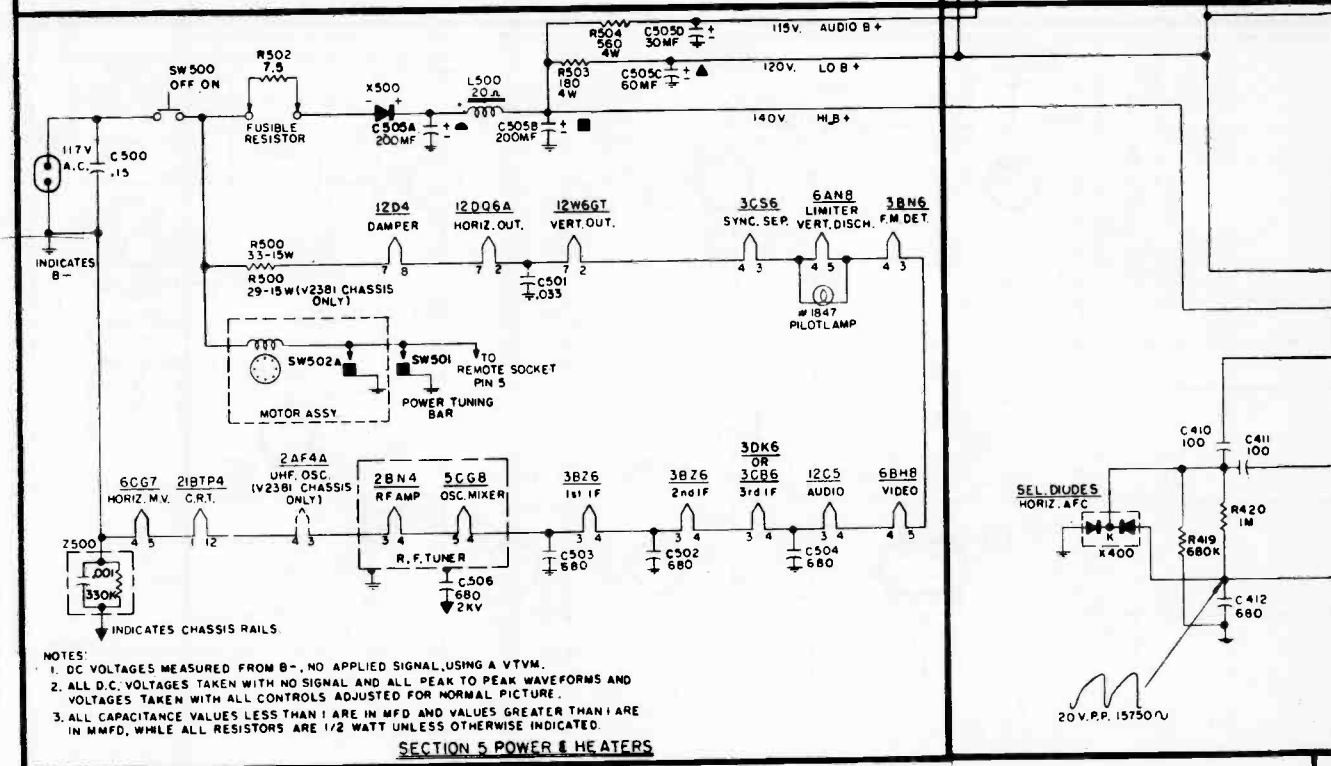
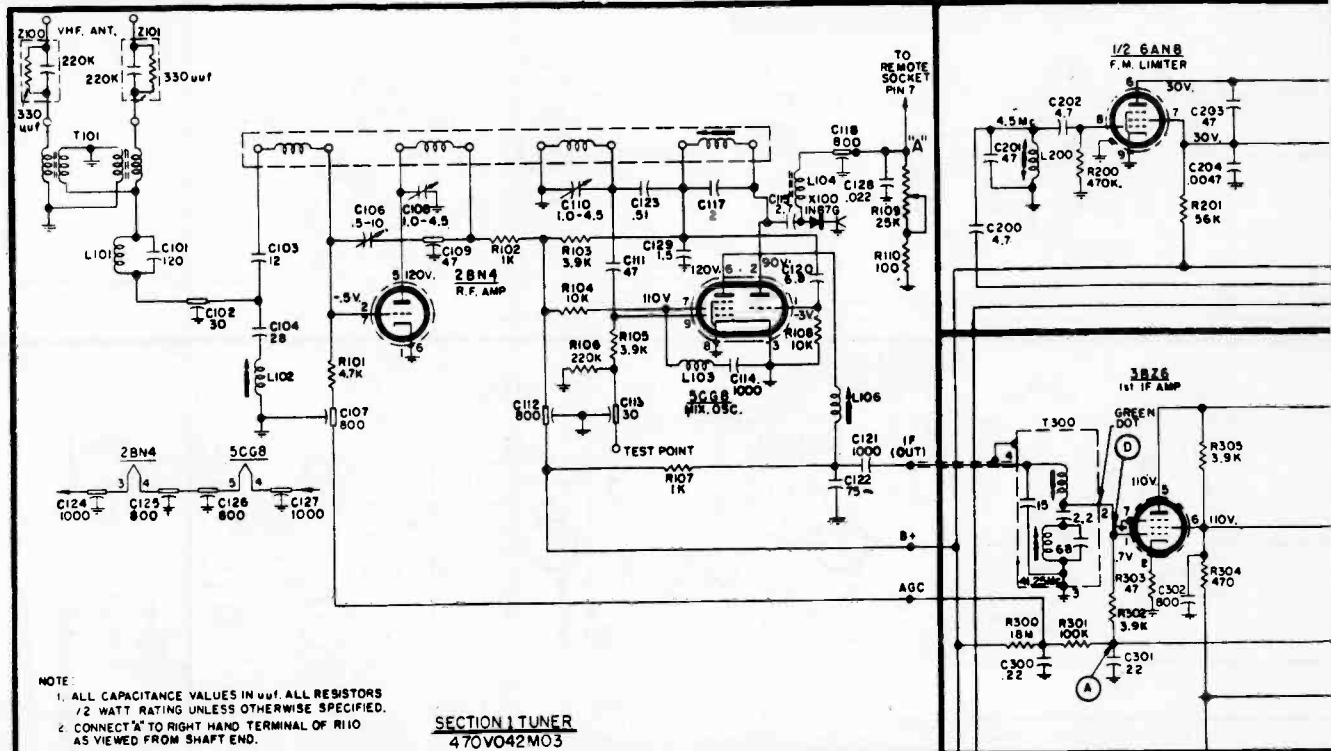



WESTINGHOUSE Chassis V-2371 Power Tuning Operation (Continued)

**POWER TUNING OPERATION (V-2371-29 CHASSIS)**

When the power tuning switch, SW501 (on the front panel of the receiver) is depressed momentarily, AC is momentarily applied to the motor. This causes the following:

- 1) An armature is pulled up to engage a clutch. (Clutch action is required for the transfer of mechanical energy).
- 2) Turning energy is transferred to a cam, through a gear train.

The cam also has a double function. 1) As the cam turns, it closes SW502. SW502A of this switch is in parallel with the front panel power tuning switch, SW501. When SW502A is closed by the cam, it provides an alternate AC circuit through the motor. Therefore, the motor continues to turn when the front panel switch is released. 2) A roller on the cam turns the programming wheel, in step fashion. The amount of turn is sufficient to advance the programming wheel from one channel to the next. The tuner detent snaps the channel selector into place.

The programming wheel has 13 nylon sliders. When a slider is pushed into the A position, (outermost position) it holds SW502A closed after the cam has completed its cycle. If several adjacent sliders are in the A position, each slider successively actuates SW502, and the motor keeps turning until a stop position is reached. The stop position, on the programming wheel, is one where a slider is in the C position. When a stop position is reached, SW502A is no longer held closed. Therefore, the AC line to the motor is opened; the tuner is at the desired channel.

When SW502 is actuated, other sections of the switch function as follows: SW502B shorts the secondary of the audio output transformer, to mute the sound during the change of channels. SW502C provides CRT blanking by feeding positive (cut-off) bias to the CRT cathode during the change of channels.

**TEST POINTS**

**Test point A** – AGC line

During video IF alignment, an external bias voltage is applied to this point. Also, an external bias voltage may be applied to this point when a substitute voltage is needed for test purposes.

**Test point B** – Video detector output

The scope input is connected to this point. With normal operation, (an air signal being received), a negative going composite video signal (approx. 5 volts P-P) is seen. The scope input is kept at this point during IF alignment. When the VTVM leads are placed between test point B and ground, a small negative voltage will be indicated.

**Test point C** – Cathode of CRT

Video waveform and bias voltage check point.

**Test point D** – Grid of first IF amplifier

The output of sweep and marker generators are fed to this point during IF alignment.

**Test point F** – Grid of controlled section of the horizontal multivibrator.

Under normal operating conditions, voltage is zero at this point. The VTVM is connected to this point when the horizontal multivibrator and ringing coil are adjusted.

**ELECTRICAL FINE TUNING**

Electrical fine tuning, used in power tuning receivers, enables the user to make fine tuning adjustments using the H-985 Chairside Remote Control Unit or the variable resistor on the front panel of the receiver. Fine tuning is accomplished by adjusting a variable resistor which determines how much effective capacity is placed across an oscillator coil. (The more capacity across the coil the lower the frequency, and vice versa.)

The circuit, which acts as a variable capacitor, consists (in part) of a capacitor in series with a crystal diode. This series circuit is connected across the oscillator coil. Connected across the crystal diode (in shunt with the diode) is a variable resistor. This resistor functions as a variable diode load. When the resistance is lowered, the diode is more heavily loaded. More current flows through the diode which acts as a lower resistance. Therefore, the capacitor has a greater effect on the oscillator circuit; the oscillator frequency is lowered. When the load resistance is increased, less of a load exists across the diode. Therefore, the effective resistance of the diode is increased and the capacitor has less effect on the oscillator circuit. Consequently, the oscillator frequency is raised. An RF choke isolates the RF circuit from the variable resistor. It should be noted that the variable resistor on the remote control unit is in parallel with the one on the receiver. For this reason, there is inter-action between both variable resistors. Both should be set, initially, to approximately mid-range for proper fine tuning control.

The variable resistor used for electrical fine tuning has a counter-clockwise 10% log taper. When a replacement variable resistor is required, the correct replacement part must be used and wired correctly.

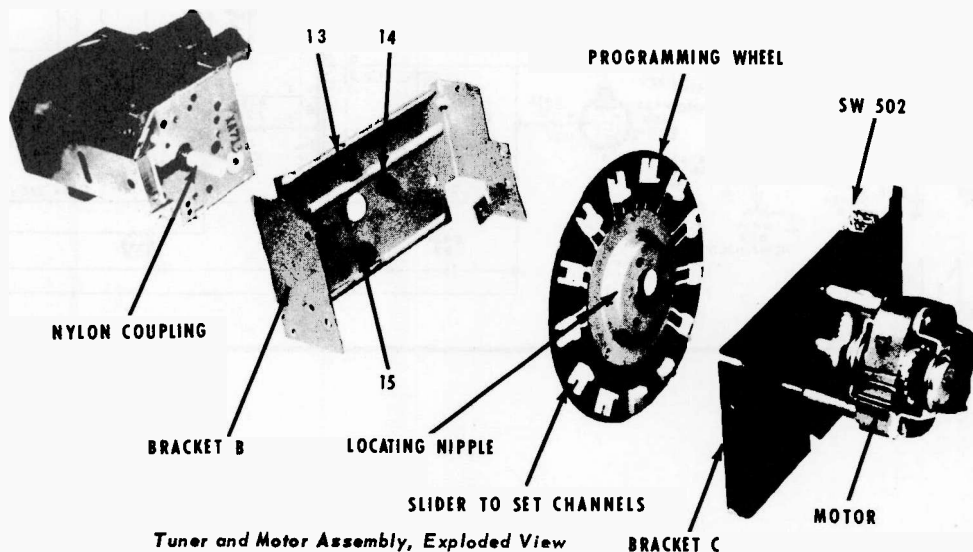

Tuner and Motor Assembly, Exploded View



# Westinghouse

MODELS		CHASSIS	
H21T218	H21K225	V-2372-27	
H21T219	H21K226		
H21T220	H21K227		
H21T221	H21K228		
H21T222	H21K229		
H21K223	H21K232		
H21K224	H21K233		
H21T218A	H21T221A		V-2372-67
H21T219A	H21T222A		
H21T220A			
H21TU218	H21KU225	V-2382-202	
H21TU219	H21KU226		
H21TU220	H21KU227		
H21TU221	H21KU228		
H21TU222	H21KU229		
H21KU223	H21KU232		
H21KU224	H21KU233		

MODELS		CHASSIS	
H21TU218A	H21KU225A	V-2382-204	
H21TU219A	H21KU226A		
H21TU220A	H21KU227A		
H21TU221A	H21KU228A		
H21TU222A	H21KU229A		
H21KU223A	H21KU232A		
H21KU224A	H21KU233A		
H21TU218B	H21TU221B		V-2382-602
H21TU219B	H21TU222B		
H21TU220B			
H21TU218C	H21TU221C	V-2382-604	
H21TU219C	H21TU222C		
H21TU220C			

## ALIGNMENT

1. OSCILLOSCOPE with appropriate decoupling network. (See figure 1). Calibrate oscilloscope for 2 volts peak to peak. Connect oscilloscope vertical input to test point B. (Marked "T.P.B." on schematic diagram, in output circuit of video detector.)
2. VTVM with appropriate decoupling network. (See figure 1). Set VTVM to read -1 V to -1½ V. Connect VTVM to T.P.B.
3. MARKER OR CW SIGNAL GENERATOR with adjustable output and accurately calibrated frequencies between 40 and 220 mc. Use proper output cable termination, as shown in figure 2.
4. SWEEP GENERATOR with adjustable output covering frequencies from 40 to 220 mc, with or without built in marker generator. Terminate sweep generator output in proper impedance, as shown in figure 2.
5. BIAS SUPPLY. (Source of substitute bias voltage). Voltages required: -12 volts to tuner and -4 volts to IF stages during IF alignment. For RF alignment, use -1 volt bias to tuner and -4 volts to IF stages. Battery bias supply shown in figure 5.
6. Gimmick coupling, shown in figure 6, to mixer grid.

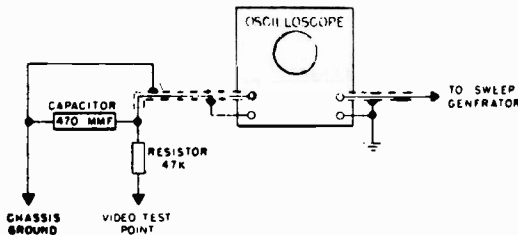

FIGURE 1; Oscilloscope Coupling Network

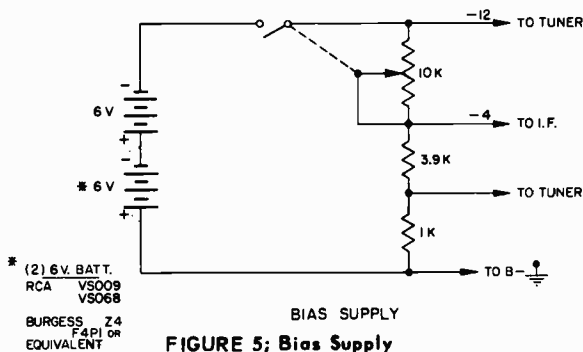

FIGURE 5; Bias Supply

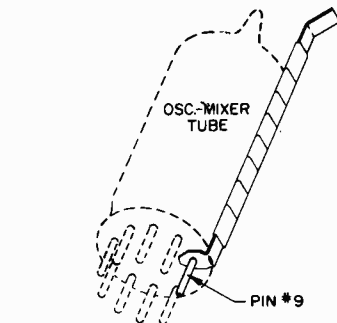
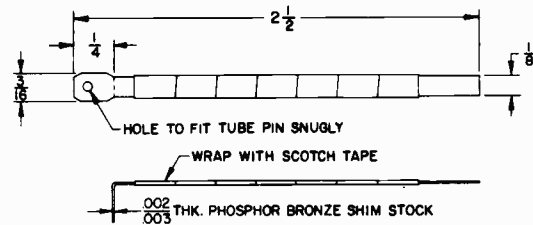

FIGURE 6; Gimmick Coupling Device

VOLUME TV-14, MOST-OFTEN-NEEDED 1958 TELEVISION SERVICING INFORMATION

WESTINGHOUSE Chassis V-2372 and V-2382 Schematic Diagram

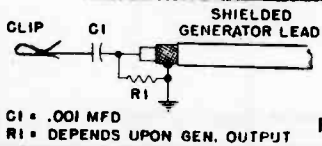
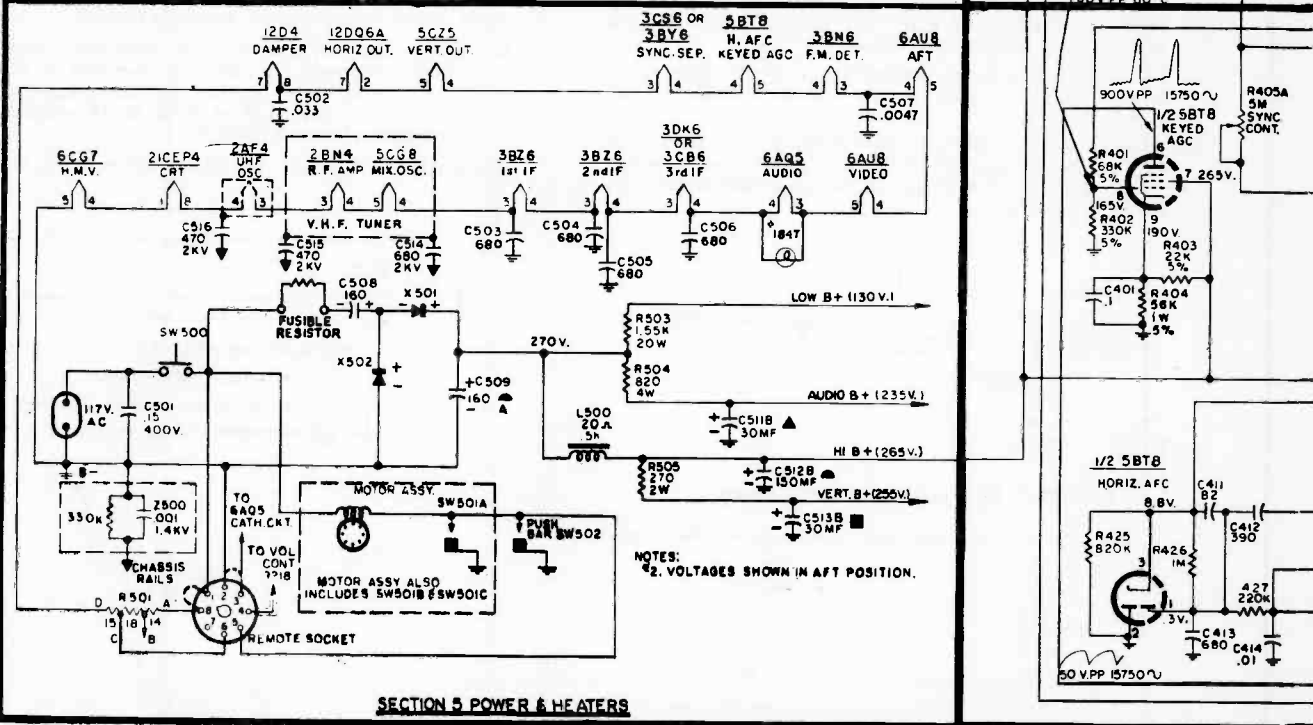
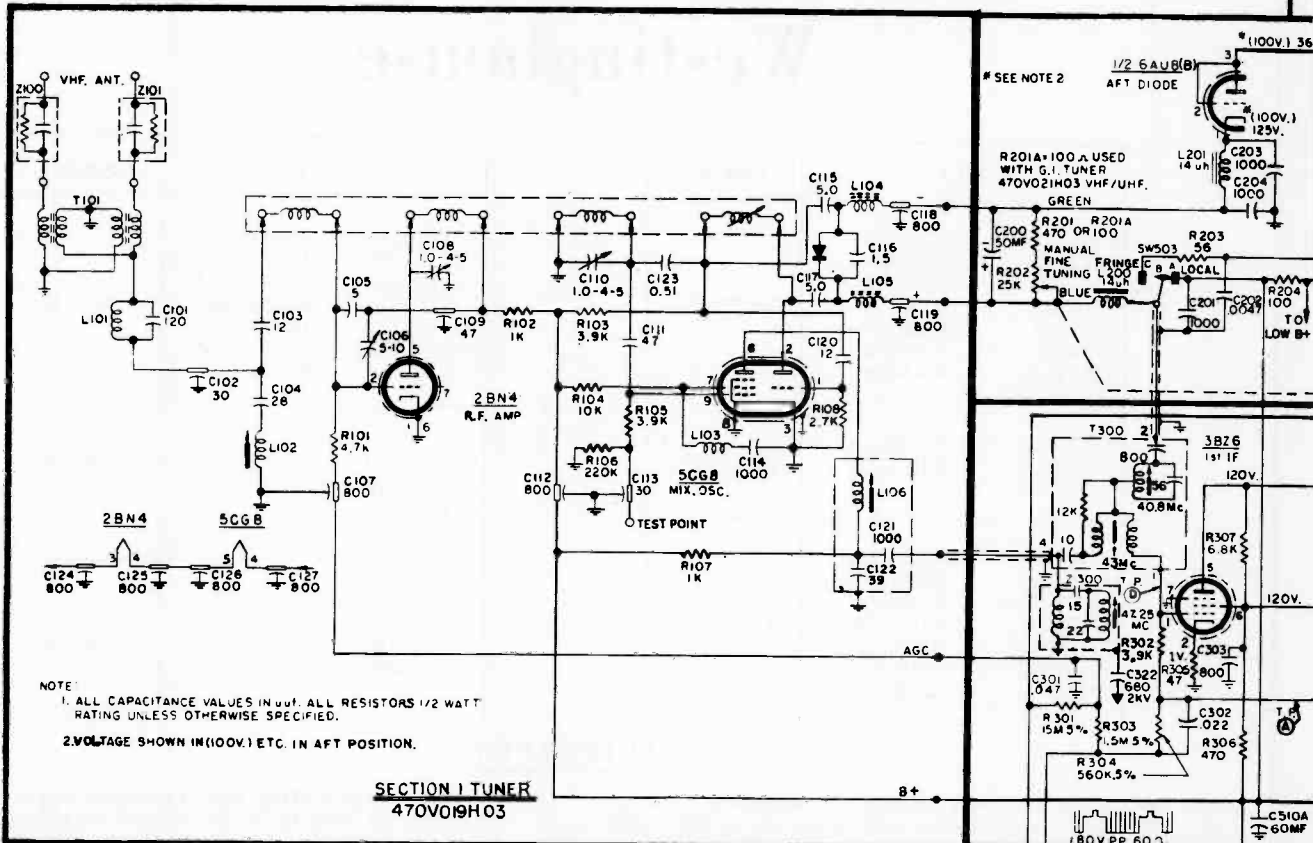

FIGURE 2; RF Generator Coupling



FIGURE 3; Alignment tool

# VOLUME TV-14, MOST-OFTEN-NEEDED 1958 TELEVISION SERVICING INFORMATION

## WESTINGHOUSE Chassis V-2372 and V-2382 Schematic Diagram

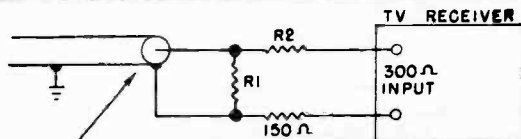
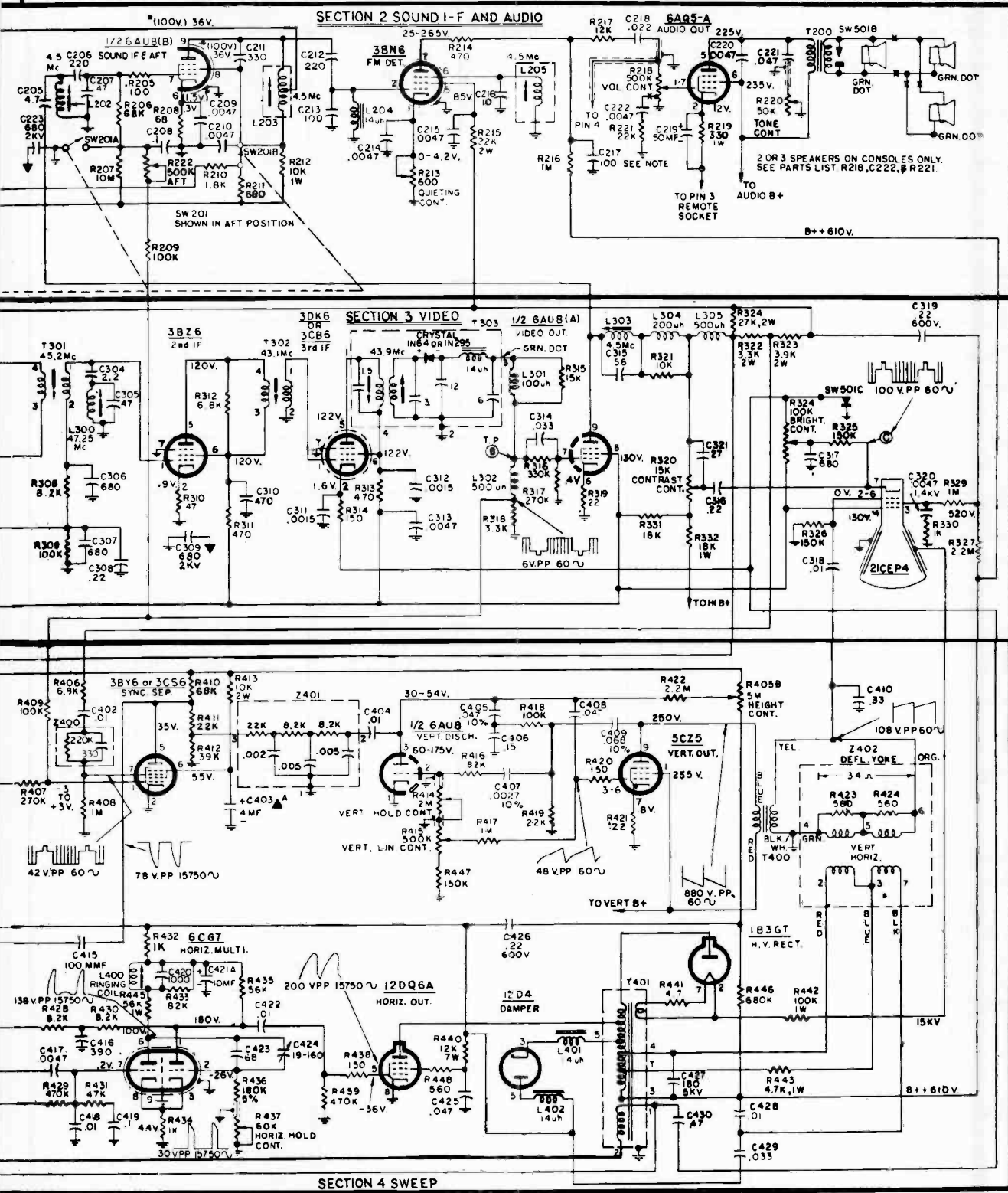

Z0	R1	R2
50 Ω	56 Ω	120 Ω
72 Ω	82 Ω	110 Ω

FIGURE 4; Impedance Matching Network

Z0 = IMPEDANCE OF SWEEP CABLE

VOLUME TV-14, MOST-OFTEN-NEEDED 1958 TELEVISION SERVICING INFORMATION

WESTINGHOUSE Chassis V-2372 and V-2382 Alignment Information (Continued)

STEP	GENERATOR	FREQ.	CONNECTION	CHAN. SELECTOR	INDICATOR	ADJUSTMENT
1	Sweep	43.9	Grid 3rd I.F.		Scope 2V. P-P at T.P.B	T303 Bottom slug for max. Top slug to rock Response at 43.9 MC.
2						Detune (counter-clockwise) L106 & T300
3	CW	43.1	T.P. D 1st I.F. Grid		VTVM keep below -1.5V	Max. T302
4	CW	47.25	"		"	Min. L300
5	CW	45.2	"		"	Max. T301
6	Sweep	44	"		Scope 2V. P-P	Touch up T301 & T302 to resemble response curve shown in Figure 7
7				Chan. No. 13 set to fringe position		Set to manual fine tuning
8	CW	50.0	Mixer grid pin No. 9 with gimmick (see Fig. 6)	"	VTVM keep below -1.5V	Min. Z300 (see note 1)
9	CW	44.1	"	"	"	Max. L106
10	CW	43.0	"	"	"	Max. Bottom slug T300
11				UHF set to local position		Set to manual fine tuning
12	CW	40.8	Mixer grid pin No. 9 with gimmick (see Fig. 6)	"	VTVM keep below -1.5V	Min Top adjustment T300 (see note 2)
13				Chan. No. 12 set to local position		Set to manual fine tuning
14	Sweep	44	Mixer grid pin No. 9 with gimmick (see Fig. 6)	"	Scope 2V. P.P.	Retouch L106 if neces- sary so that picture car- rier lies 50% or 6DB from peak and response curve resembles Fig. 8

NOTE 1: If an indication of resonance cannot be obtained on the VTVM, proceed as follows: Increase the 50 mc signal level and/or remove the (substitute) IF bias. If adjacent channel sound interference exists, tune Z300 to 47.25 mc.

NOTE 2: If an indication of resonance cannot be obtained on the VTVM, proceed as follows: Increase the 40.8 mc signal level and/or remove the (substitute) IF bias.

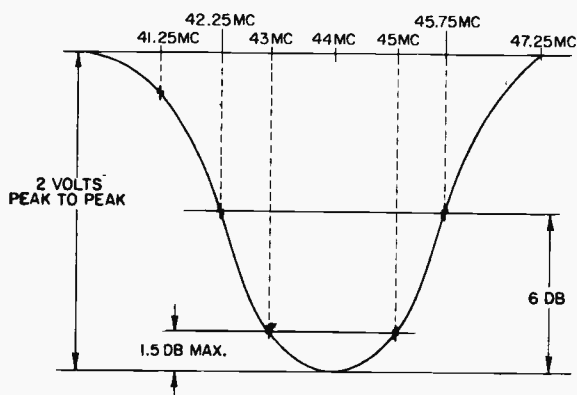

FIGURE 7; I.F. Response - 1st IF Grid to Video Detector

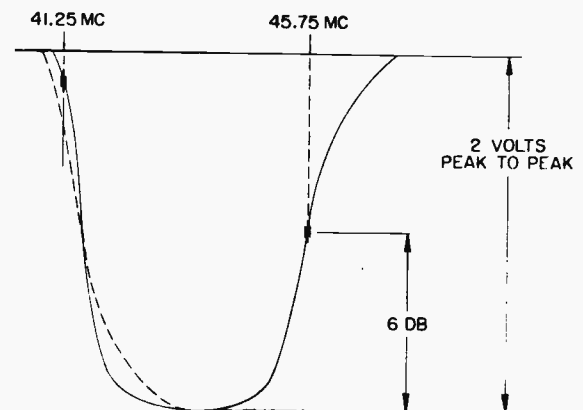

FIGURE 8; IF Overall Response - Mixer Grid to Video DETECTOR; Local-Fringe Switch Set to "Local".

# Westinghouse

## CHASSIS ASSEMBLY V-2373 & V-2383

(Service material on pages 175 through 180)

### MODEL AND CHASSIS CHART

MODELS	CHASSIS	TUNER	TUNER TUBES
17T241 17T242 17T243 17T244 17T245	V-2373-1	VHF: 470V040H01 code 305, channels 2-13	RF amp: 3BN4 Mix-osc: 6CG8A
17TU241 17TU242 17TU243 17TU244 17TU245	V-2383-1	VHF: 470V041H01, code 305, channels 2-13 plus a UHF position  UHF: 472V032H01	RF amp: 3BN4 Mix-osc: 6CG8A  UHF osc: 3AF4A Crystal mixer: IN82A

### CENTERING

To center the picture, turn the centering magnet tabs clockwise or counterclockwise, as required. The tabs are located on the back of the deflection yoke. If difficulty is experienced in making adjustments, or if neck shadows are troublesome, make sure the yoke is pushed forward, tight up against the flare of the CRT.

### HORIZONTAL RINGING COIL

- The horizontal ringing coil (L400) is adjusted as follows:
- Short out the ringing coil (accessible from the top of the chassis) with a short jumper wire.
  - Set the horizontal hold control (HORIZ.) to the middle of its range, and leave it in this position during the steps that follow.
  - Connect a VTVM to test point F (figure 13) or to pin 7 of the horizontal multivibrator socket to measure DC voltage between this point and B minus.
  - With the receiver tuned to a TV station, adjust C419 for zero voltage on the meter. If zero voltage can be approached but not quite reached at one extreme of the C416 adjustment, set the horizontal hold control slightly to one side of mid-position to obtain zero voltage.
  - Remove the jumper from the ringing coil.
  - Adjust the ringing coil (L400) for zero voltage on the meter. Check the adjustment by switching to another channel; then back again. The receiver should pull into horizontal synchronization on all channels.

### CHASSIS REMOVAL

Note: The CRT is NOT removed with the chassis.

- Remove back cover. (Figure 1.)
- Remove antenna-holding screw. This screw is located between the telescoping antenna rods, at the top of the cabinet. Loosen antenna terminal screws to remove antenna lead.
- Remove telescoping antenna.
- Remove speaker as follows: Disconnect speaker leads. Remove two speaker-mounting hex nuts. Use a stubby (short) hex wrench.
- Remove the following:  
CRT socket  
Yoke clamp and deflection yoke  
HV anode lead from CRT

Two trimount studs which hold antenna terminal board to cabinet.

Four screws accessible from the bottom of the receiver. Two screws. One is located to the left of filter capacitor C503A-C504A; the other located to the right.

- Slide chassis from cabinet.  
(When installing chassis, reverse above procedure.)

### CRT REMOVAL

Note: To remove CRT, it is advisable to first remove chassis.

- Remove screws 1 through 8. (Figure 2). Screws 5 and 6 are accessible from the bottom of the cabinet.
- Remove CRT support strap as follows:
  - Remove two hex head screws. One screw is at the upper left of the CRT support strap; the other at the upper right.
  - Remove two CRT support strap-holding nuts, accessible from the bottom of the cabinet.

Important: When installing CRT, insert rubber (bumper) pads at areas in direct contact with CRT glass.

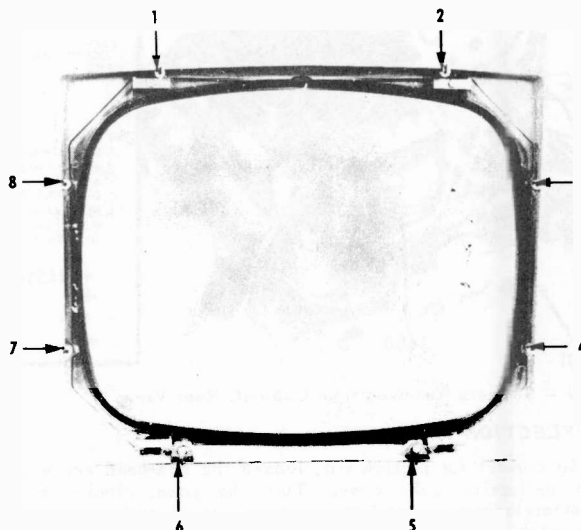

Figure 2 - Mask and Safety Shield Assembly

WESTINGHOUSE Chassis V-2373 and V-2383 Schematic Diagram

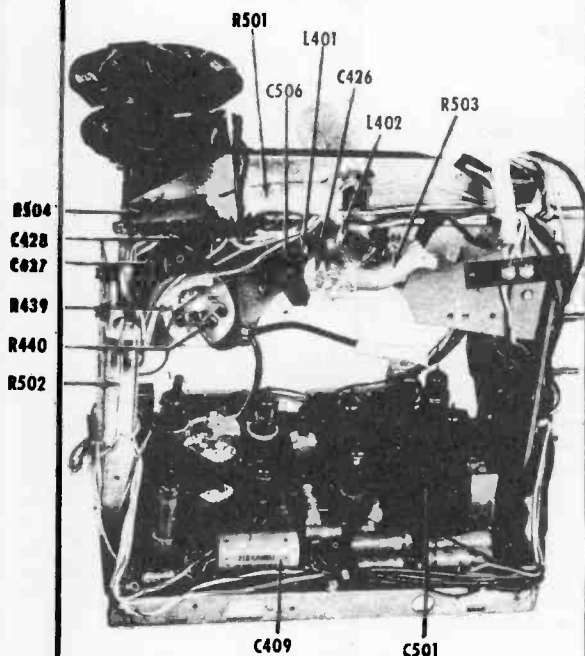
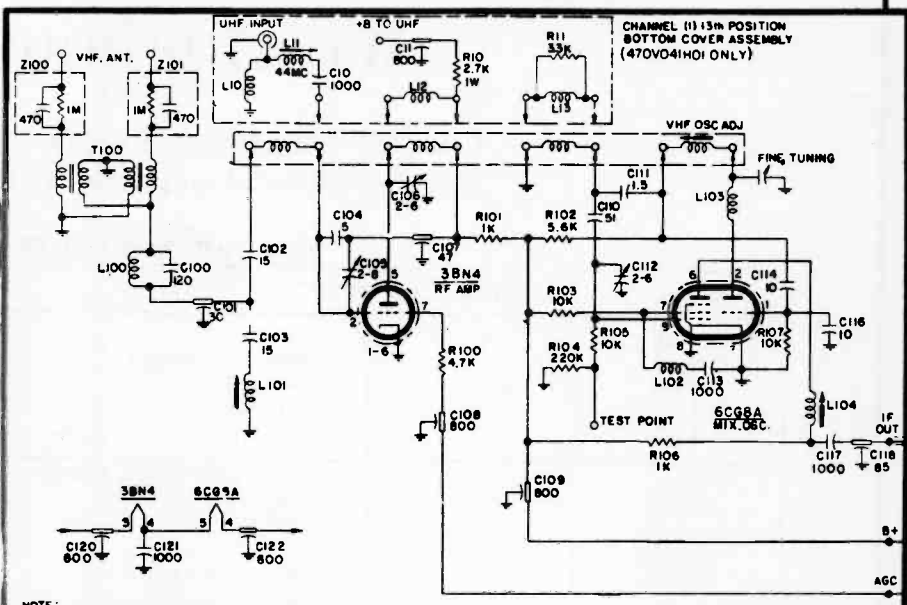

Figure 3 - Chassis Removed from Cabinet, Front



NOTE:  
1. ALL CAPACITANCE VALUES IN  $\mu$ F. ALL RESISTORS 1/2 WATT UNLESS OTHERWISE SPECIFIED.

SECTION 1 TUNER

470V040H01-VHF (CODE 305)  
470V041H01-VHF WITH CH. 1, 13 1/2 POS. (CODE 305)

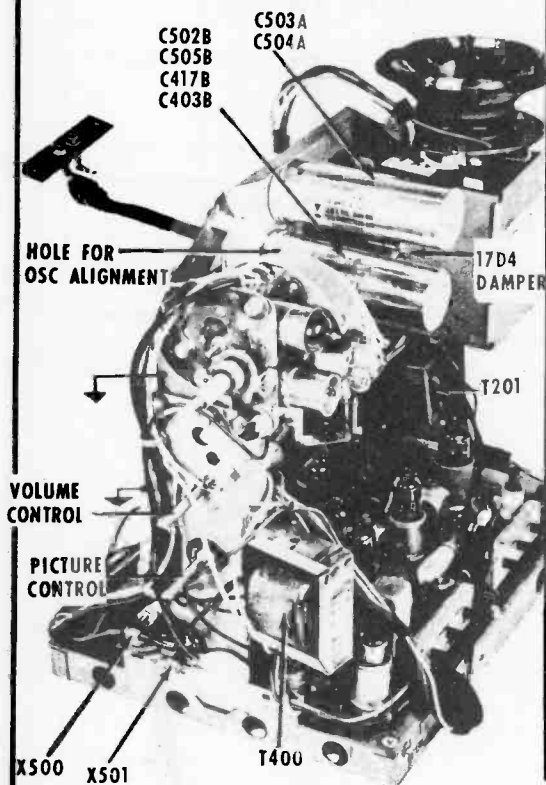
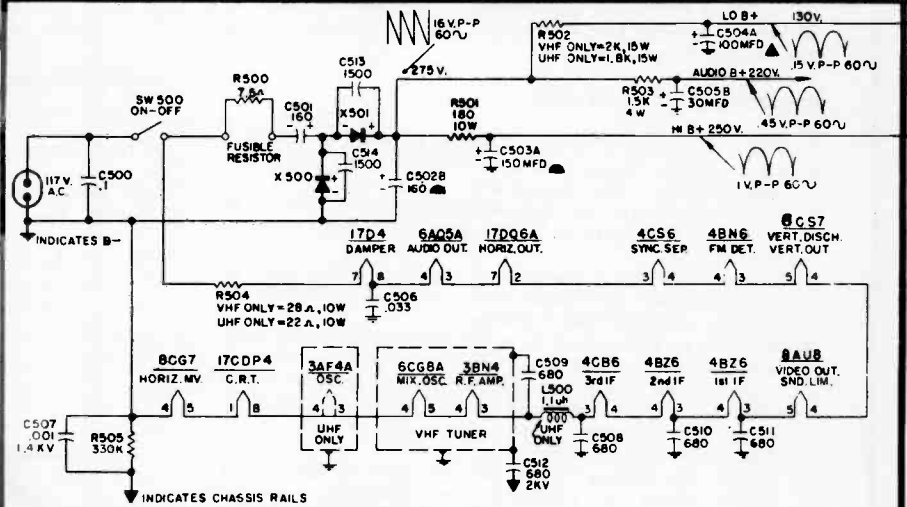

Figure 4 - Chassis Removed from Cabinet, Rear View

DEFLECTION YOKE

To correct for picture tilt, loosen the hex-head screw on the deflection yoke cover. Turn the yoke, clockwise or counterclockwise, until the raster is level with respect to the mask. Tighten the hex-head screw. Important: Make sure the yoke is pushed up against the CRT flare, as far forward as it will go. If this is not done, neck shadows result.



NOTES:  
1. DC VOLTAGES MEASURED FROM B- WITH NO APPLIED SIGNAL USING A VTVM.  
2. PEAK TO PEAK WAVEFORMS WERE TAKEN WITH PICTURE CONTROL SET FOR A 50 VOLT PEAK TO PEAK SIGNAL AT THE C.R.T. CATHODE, ALL OTHER CONTROLS SET FOR NORMAL PICTURE.  
3. ALL CAPACITANCE VALUES LESS THAN 1 ARE MFD AND GREATER THAN 1 ARE M.M.F., WHILE ALL RESISTANCE VALUES IN OHMS AND 1/2 WATT UNLESS OTHERWISE INDICATED.

CHASSIS RAIL

B-

SECTION 5 POWER & HEATERS

HEIGHT ADJUSTMENT AND VERTICAL LINEARITY ADJUSTMENT

Both controls are at the back of the chassis. The HEIGHT adjustment controls the height of the picture. The vertical linearity adjustment (V. LIN) controls the relationship between vertical dimensions of the upper and lower parts of the picture. A balance between the two controls is necessary to make the picture symmetrical and fill the mask vertically.

# VOLUME TV-14, MOST-OFTEN-NEEDED 1958 TELEVISION SERVICING INFORMATION

WESTINGHOUSE

V-2373 & V-2383 Chassis, Schematic Diagram

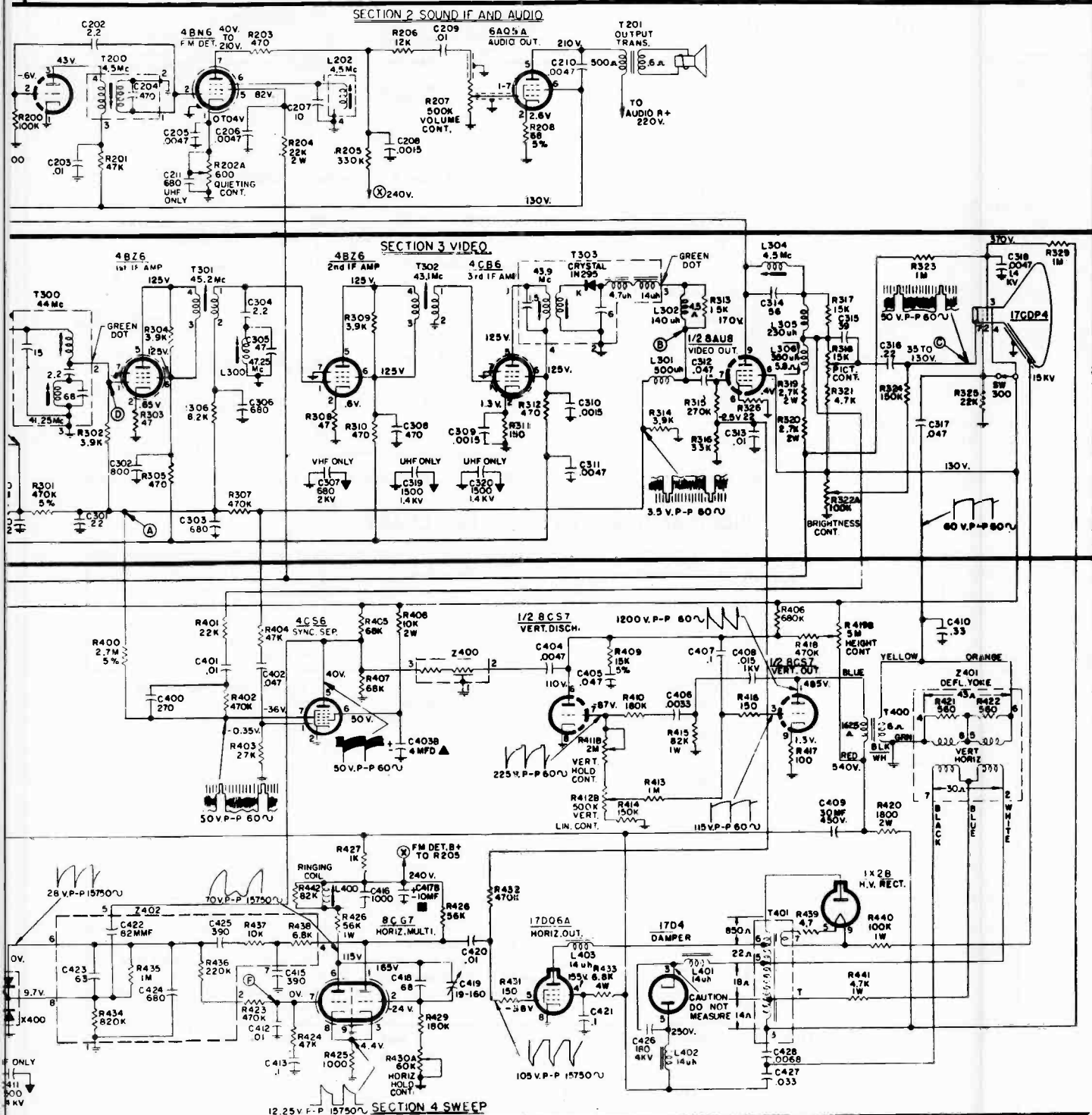

## QUIETING CONTROL

The quieting control is located on the back of the chassis. This control, which determines the AM rejection characteristics of the sound system, is normally adjusted during sound alignment and will not ordinarily require further adjustment. In weak signal areas, however, a reduction in noise or hiss of the sound may be obtained by slightly re-adjusting the control.

## SPEAKER LOAD RESISTOR

When the chassis is removed from its cabinet, with speaker disconnected, substitute a load resistor (3.2 ohms, 2 watts) for the speaker. Connect the resistor to the audio output transformer secondary. Failure to do so may result in damage to the audio output tube.



WESTINGHOUSE Chassis V-2373 and V-2383 Alignment Information (Continued)

VIDEO ALIGNMENT



Figure 5 - Alignment Tool

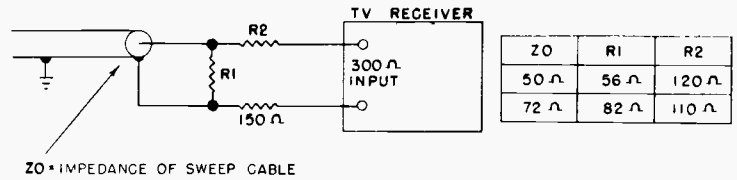

Figure 8 - Impedance Matching Network

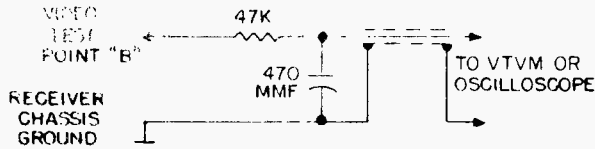
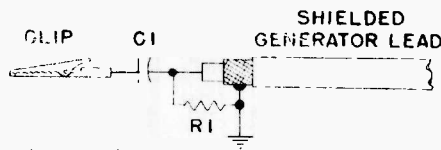

Figure 6 - Decoupling Network, Oscilloscope or VTVM Input



C1 = .001 MFD  
R1 = DEPENDS UPON GEN. OUTPUT IMPEDANCE 52 Ω, 72 Ω etc.

Figure 7 - Coupling Network, RF Generator

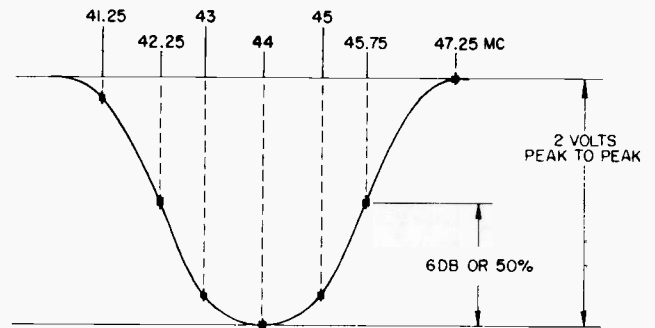
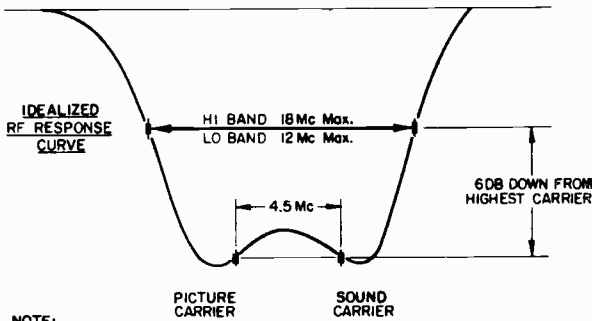

Figure 9 - Response Curve, First IF Grid to Test Point B

VIDEO ALIGNMENT PROCEDURE CHART

Step	Generator	Freq. (mc)	Connection	Indicator	Adjustment
1.					Connect -3V bias to test point A. Detune L104 by turning slug CCW, all the way out.
2.	IF sweep	43.9	Grid of 3rd IF amplifier (Pin 1) thru terminated cable. (Figure 7)	Scope, calibrated 2V P-P. Connect to test point B through decoupling network (Figure 6)	T303. Bottom slug for max. output - top slug to rock response at 43.9 mc
3.	CW	43.1	Test point D, thru terminated cable. (Figure 7)	VTVM. Connect to test point B through decoupling network. (Figure 6) Set VTVM below - 1.5V.	T302, max. output
4.	CW	47.25	" "	" "	L300. Min. output
5.	CW	45.2	" "	" "	T301. Max. output
6.	IF sweep	44	" "	Scope. Calibrated 2V P-P. Connect to test point B thru decoupling network (Figure 6)	Touch up T301, T302 and T303 so that curve resembles that shown in figure 9. Note: If excessive tilt is observed, adjust T303 to 44.5 mc.
7.	CW	41.25	Tuner test point through terminated cable. (Figure 7)	VTVM. Connect to test point B thru decoupling network. (Figure 6) Set VTVM below - 1.5V.	T300. Top slug for min.
8.	CW	59.75	Antenna terminals thru impedance matching network (Figure 8)	" "	Set fine tuning control for min. output.
9.	RF sweep	CH 2 54-60	Antenna terminals thru impedance matching network. (Figure 8)	Scope, calibrated 2V P-P. Connect to test point B through decoupling network. (Figure 6)	Tune L104 (on tuner) to max. output and T300 (bottom slug) to rock response at center of pass band. (57 mc) (Figure 11) Use alignment tool .080" on flats.

WESTINGHOUSE Chassis V-2373 and V-2383 Alignment Information (Continued)



NOTE:  
A -2DB TILT FROM THE HIGHEST CARRIER IS ACCEPTABLE ON EITHER SIDE.

Figure 10 - Response Curve, RF

SOUND ALIGNMENT PROCEDURE

ALIGNMENT USING A LOCALLY GENERATED SIGNAL

1. Connect a high impedance AC voltmeter or oscilloscope across the volume control for use as an indicator.
2. Set quieting control, R202A, to mid-range.
3. Apply a 4.5 mc FM signal (deviation approximately 7.5 kc) to video test point B. (Figure 13.)

4. Using a strong signal, adjust the quadrature coil, L202, for maximum output.
5. Reduce the signal to the lowest level that will produce an indication. Adjust L200 and T200 again for maximum output.
6. Apply a 4.5 mc AM signal (modulated approximately 30 percent) to video test point B. Adjust the generator output for strong signal level.
7. Adjust the quieting control for minimum AM response or output.

ALIGNMENT USING AN AIR SIGNAL

1. Tune the receiver to a television station. Connect an attenuator between the antenna lead-in and receiver so that signal strength may be varied from weak to strong.
2. Set the quieting control, R202A, to mid-range.
3. Apply a strong signal to the receiver. Adjust the quadrature coil, L202, for maximum program sound. If peaks occur at two widely separated positions, use the one that occurs with the slug farthest counterclockwise. If two peaks occur within a narrow range of adjustment, sufficient signal is not being applied to the receiver or the quieting control is not set at the correct position.
4. Apply a very weak signal that allows noise to be heard. Adjust the 4.5 mc IF slugs (L200 and T200) for maximum program sound. If peaks occur at two different positions of the slug, use the peak that occurs when the slug is farthest counterclockwise.
5. Apply a strong signal and readjust the quieting control for minimum hum. This control determines the AM rejection characteristics of the sound system. Its correct setting is normally about mid-position.

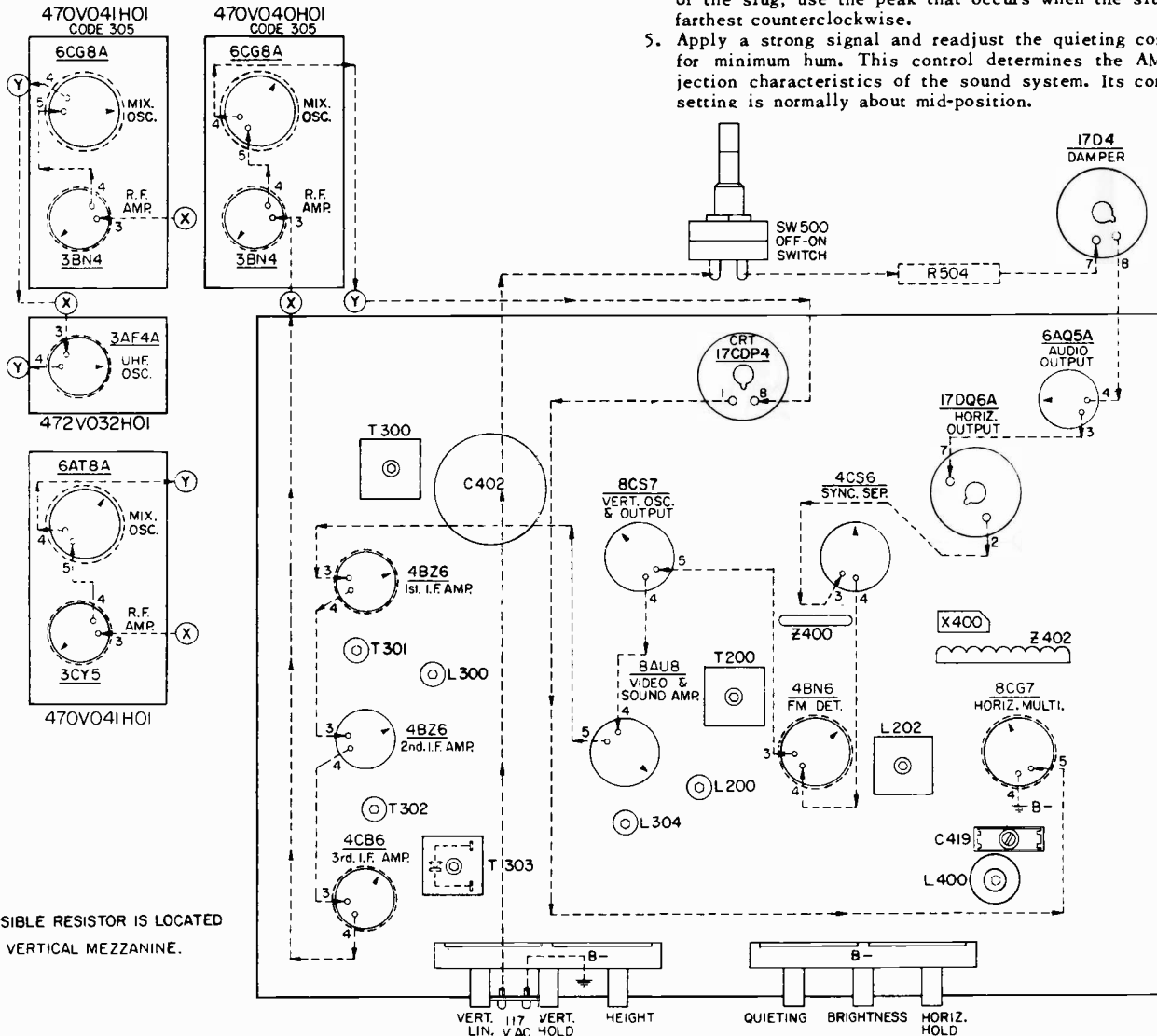

Figure 12 - Tube Location, Heater String and Adjustments

WESTINGHOUSE Chassis V-2373 and V-2383 Service Material, Continued

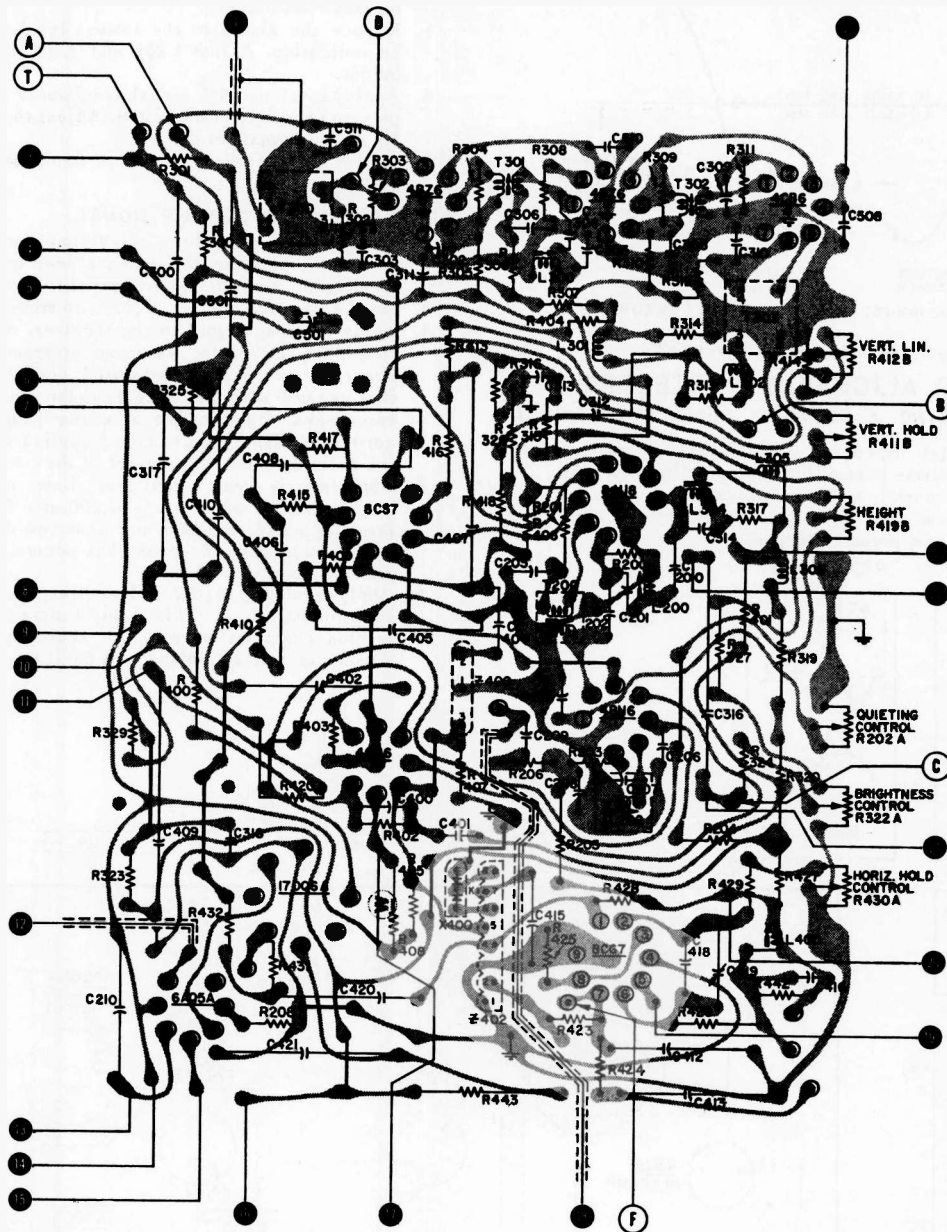

Figure 13 - Bottom View of Printed Board Showing Top Components as Schematic Symbols

KEY

- 1 - IF input from tuner
- 2 - Brown heater lead to tuner
- 3 - White AGC lead to tuner
- 4 - Grey & white lead to R500
- 5 - Grey & white lead to X500 & X501
- 6 - Green lead to CRT pin 2 & SW300
- 7 - Blue lead to T400
- 8 - Yellow lead to T400
- 9 - Red lead to CRT pin 3
- 10 - White & black lead to T401, term. 3
- 11 - Red lead to T400
- 12 - Shielded lead to R207
- 13 - Blue lead to T201
- 14 - Orange lead to R502 & C504A (lo B-)

- 15 - Brown lead to 17D4, pin 8
- 16 - Red & white lead to R501 & C503A (250V hi B-)
- 17 - Orange & white lead to C403B
- 18 - Shielded lead to R207
- 19 - Black lead to CRT heater pin 1
- 20 - Red & black lead to C417B
- 21 - Brown lead to CRT heater pin 7
- 22 - Green lead to R318
- 23 - Blue lead to R318
- A - AGC test point & external bias connection
- B - Video load test point
- C - CRT video drive test point
- D - Video alignment signal injection test point
- F - HMV correction voltage test point
- T - Tuner AGC test point & external bias connection



CHASSIS 15A25 - 17A20 - 17A20Q - 17A21Q - 19A20 - 19A20Q

(Service material on pages 181 through 190)

<u>MODEL</u>	<u>TYPE</u>	<u>CHASSIS</u>	<u>TUNER</u>	<u>PICTURE TUBE</u>
A1510L	Table	15A25	Bandswitch	14XP4A
A1511G	Table	15A25	Bandswitch	14XP4A
A1512J	Table	15A25	Bandswitch	14XP4A
A1515W	Table (Base)	15A25	Bandswitch	14XP4A
A2221J & Y	Table	17A20	Bandswitch	21CXP4
A2223E,H,R,Y	Table	17A20	Target Turret	21CXP4
A2245E & R	Console	17A20	Target Turret	21CXP4
A2250M & R	Console	17A20	Target Turret	21CXP4
A2251E & R	Console	17A20	Target Turret	21CXP4
A2282E & R	Console	17A20	Target Turret	21CXP4
A2329J	Table	19A20	Bulls Eye Turret	21CXP4
A2330E,H,R	Table	19A20	Bulls Eye Turret	21CXP4
A2358E & R	Console	19A20	Bulls Eye Turret	21CXP4
A2359E,H,R	Console	19A20	Bulls Eye Turret	21CXP4
A2362M & R	Console	19A20	Bulls Eye Turret	21CXP4
A2673E & R	Console	17A20	Target Turret	24AJP4
A3000E & R	Table	17A21Q	Target Turret	21CXP4
A3001E,H,R	Table	17A20Q	Target Turret	21CXP4
A3004, E,R	Console	17A21Q	Target Turret	21CXP4
A3006E,H,R	Console	17A20Q	Target Turret	21CXP4
A3008E & R	Console	17A20Q	Target Turret	21CXP4
A3010E,H,R	Console	19A20Q	Bulls Eye Turret	21CXP4
A3011, E,Y	Console	19A20Q	Bulls Eye Turret	21CXP4
A3012H & R	Console	19A20Q	Bulls Eye Turret	21CXP4
A3013H	Console	19A20Q	Bulls Eye Turret	21CXP4
A3014H & R	Console	19A20Q	Bulls Eye Turret	21CXP4
A4007E & R	Console	19A20Q	Bulls Eye Turret	24AJP4

Suffix "Q" following the chassis number identifies a receiver equipped with the Zenith Space Command remote control.

Suffix "U" is added to the chassis and model number when the receiver is factory equipped with the Zenith UHF continuous tuner.

### BULL'S EYE TUNER ADJUSTMENTS

To adjust the receiver for bull's eye tuning, set the fine tuning control to its approximate center position. Without further adjustment of the control insert an 68-31 alignment wrench through the hole provided at the rear of the tuner and adjust each operating channel to resonance. It will be noted that tuning to one side

of resonance results in a faded, washed-out picture with the spacings between the wedge lines fogged and tuning in the opposite direction causes the spaces between the lines to clear up. However, going beyond this point causes the picture to take on a "wormy" appearance from sound getting into the picture. Correct adjustment is obtained by tuning to the "wormy" picture and then backing the adjustment screw slightly until the picture clears up.

ZENITH Chassis 15A25, 17A20, -Q, 17A21Q, 19A20, -Q, Continued

### AGC ADJUSTMENT

To adjust the AGC, slowly turn the delay control until a point is reached where the picture distorts and buzz is heard in the sound. The control should then be backed down from this position and set at a point comfortably below the level of inter-carrier buzz, picture distortion and improper sync. This setting will correspond to approximately 3 V. peak to peak output from the video detector.

### FRINGE LOCK ADJUSTMENT 17A AND 19A CHASSIS

The fringe lock adjustment is made to obtain best possible synchronization under weak and noisy signal conditions. To make the adjustment, first check the AGC adjustment and proceed as follows.

1. Turn the fringe lock control fully clockwise and then back it off approximately 1/4 turn. Adjust the vertical and horizontal hold controls and check operation of the receiver to see that it syncs normally when the turret is switched from channel to channel.
2. If the picture jitters or shows evidence of delay, tearing, split phase, etc., back down the fringe lock control further, a few degrees at a time, each time re-adjusting the hold controls and switching from channel to channel until normal sync action is obtained. It will be found that under normal signal conditions, the correct adjustment will be near the counter-clockwise position of the control.
3. In fringe and noisy areas, the best adjustment will be found at or near the maximum clockwise position of the control; however, do not automatically turn the fringe lock fully clockwise in fringe areas. Follow the procedure outlined. In areas where both local and fringe signals are received, a compromise setting should be made for best overall performance.

### AFC ADJUSTMENT 15A25, 15Z30 AND 15Z31 CHASSIS

The horizontal oscillator ringing coil is adjusted as follows:

1. Connect a jumper from the grid end of diode X2 (see Fig. 31) to chassis. Connect a short jumper across the terminals of the oscillator coil. Set the horizontal fine control to the center of its range.
2. Tune in a TV station and adjust the horizontal coarse control until the picture is as nearly synchronized as possible.
3. Remove the jumper from the oscillator coil and adjust the core until the picture is again as nearly synchronized as possible.
4. Remove the jumper from the AFC diode and check operation. A slight readjustment of the coarse control may be necessary to insure positive synchronization with the fine control approximately in the center of its range.

### CENTERING ADJUSTMENT

The centering assembly is built into the yoke housing. This assembly is made of two magnetic rings which can be rotated by means of tabs.

### CORRECTOR MAGNET ADJUSTMENT 19A20 CHASSIS

Two corrector magnets are used to obtain straight, sharply focused sweep lines across the face of the picture tube. The magnets are mounted on the deflection coil mounting brackets and can be moved in and out or up and down by bending the flexible arms which support them. Adjustment has been made at the factory and should not require re-adjustment unless accidentally bent out of position. If this occurs, proceed as follows:

1. With the vertical and horizontal size controls, reduce the size of the picture to a point where the four corners and sides of the picture are visible. (In some receivers it may not be possible to reduce the picture size sufficiently to see all the sides and in this case it may be necessary to shift the picture with the centering control to view one side at a time).
2. Bend the corrector magnet arms until the corners become right angles and the top of the raster is parallel with the bottom and the left side is parallel with the right side. After adjustment, the picture should be restored to normal size.

## ALIGNMENT

A suitable VHF and UHF sweep generator in conjunction with an accurate marker must be used for alignment work. It is extremely important to terminate the sweep generator output cable properly and to check whether or not the attenuator is reactive. If the attenuator is reactive or if the output cable is improperly terminated, correct alignment cannot be made since the degree of attenuation then may change the shape as well as the amplitude of the response curve. The position of the attenuator should only vary the amplitude and not the shape of the response curve.

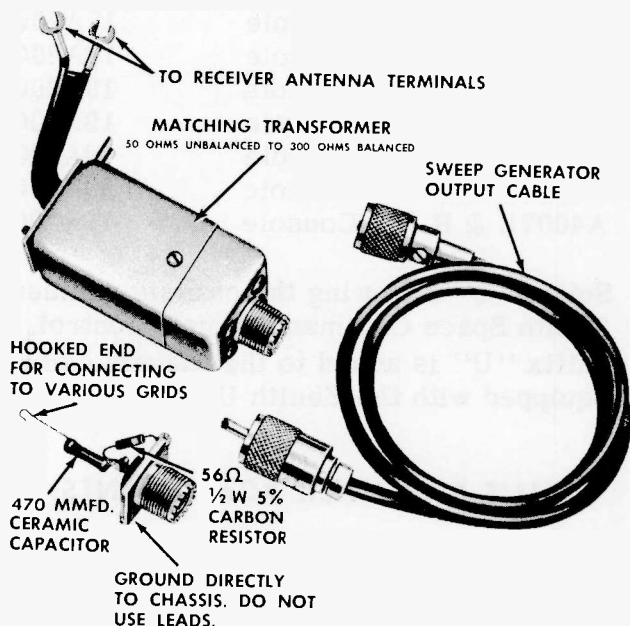

Fig. 5 IF-RF Alignment Fixtures.

ZENITH Alignment, Continued

**SOUND ALIGNMENT**

Proper alignment of the 4.5 Mc intercarrier sound channel can only be made if the signal to the receiver antenna terminals is reduced to a level below the limiting point of the 6BN6 Gated Beam Detector. This level can be easily identified by the "hiss" which then accompanies the sound.

Various methods may be used to reduce the signal level; however, a step attenuator is recommended for most satisfactory results.

1. Connect the step attenuator between the antenna and the receiver antenna terminals.
2. Tune in a tone modulated TV signal. Adjust the step attenuator until the signal is reduced to a level where a "hiss" is heard with the sound.
3. Adjust the sound take-off coil (top and bottom cores), intercarrier transformer, quadrature coil and buzz control for the best quality sound and minimum buzz. It must be remembered that any of these adjustments may cause the "hiss" to disappear and further reduction of the signal will be necessary to prevent the "hiss" from disappearing during alignment.

**VIDEO IF ALIGNMENT 15A AND 17Z SERIES RECEIVERS**

The video IF amplifier is stagger tuned, using one double tuned and four single tuned circuits. The converter plate coil tunes to 45.4 Mc, the first IF to 43.6 Mc, the second IF to 42.75 Mc, the third IF to 45 Mc, and the fourth IF (both cores) to 43.6 Mc. Two 47.25 Mc traps are used in the 15Z30 and 31 chassis (one in the 15A25). One is a part of the 1st IF transformer assembly and the other is wound on the same form as the 40.50 second IF cathode trap. Attenuation of the 41.25 Mc associated sound carrier is controlled by adjusting the band width. With the exception of the traps, a slight deviation from the above mentioned frequencies is permissible to obtain proper band pass; however, the order must be maintained. To align the IF, proceed as follows:

1. To prevent an erroneous IF response, disable the local oscillator by wrapping a short bare wire around the oscillator grid and grounding same. In "U" models it is only necessary to switch to the UHF position. Connect terminal "F" (Fig.31) to chassis.
2. In the 15A20 and 15Z30 chassis connect the negative lead of 6 V bias to "E" and the positive lead to chassis. In the 15Z31 chassis use 5 V bias, however, connect the positive lead to the junction of the 56 and 1500 ohm resistors in the cathode circuit of the 1st IF and the negative lead to "E".
3. Connect a calibrated oscilloscope through a 10K isolation resistor to terminal "C".
4. Connect the sweep generator through a terminating network (Fig. 5) to the grid (pin 1) of the third IF.
5. Adjust the sweep generator to obtain a pattern similar to Fig. 6 with a detector output of 3 volts peak to peak. Do not exceed this output during alignment.

6. Adjust the top and bottom cores of the fourth IF transformer to obtain a response similar to Fig. 6 . The 41.25 and 45.75 Mc markers should be adjusted for symmetry and should fall as close to the response curve humps as possible. If the correct response curve cannot be obtained, check the position of the two cores to see that they are not butted but are entering their respective windings from the opposite ends of the coils.
7. Connect the sweep generator to test point "A" (Fig. 1 or 2 depending on tuner used) and adjust attenuator to obtain 3 volts peak to peak output at the detector.
8. Adjust the first IF bottom core (44.Mc), second IF (42.75 Mc), third IF (45 Mc), and converter plate coil to obtain a response similar to Fig. 7.
9. Switch the oscilloscope to 10X gain used in the above steps to blow up the trap slots. Adjust the 47.25 Mc trap for maximum attenuation of 47.25 Mc marker. The 41.25 Mc marker should be in the approximate position shown in Fig.8 . On some receivers more oscilloscope gain, more signal input, or lower bias may be necessary to adjust the 47.25 Mc trap. (If the 41.25 Mc marker does not fall at the approximate position shown or nearer the base line, it may be necessary to make a slight re-adjustment of the 2nd IF. If this is done, check the overall response after adjustment).

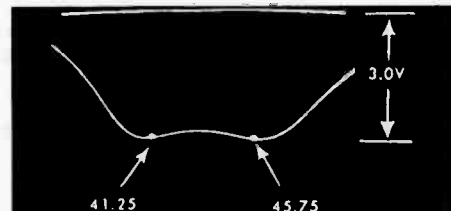

Fig. 6 4th IF Response.

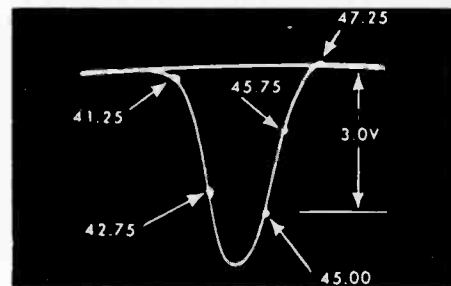

Fig. 7 Overall IF Response.

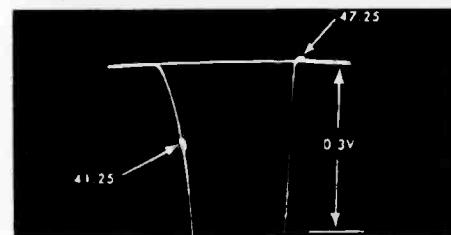

Fig. 8 Expanded View of Traps.

10. Switch oscilloscope to position used in Step 8. Remove the bias battery and ground the AGC. (In the 15Z31 chassis connect a jumper between "E" and the junction of the 56 and 1500 ohm resistors). Adjust signal generator to obtain a 3 volt peak to peak response similar to Fig.9 . Adjust the 2nd IF cathode trap for maximum displacement of the 40.50 Mc marker but not to exceed the displacement of the 41.25 Mc marker.

ZENITH Chassis 15A25, 17A20, -Q, 17A21Q, 19A20, -Q, Alignment, Continued

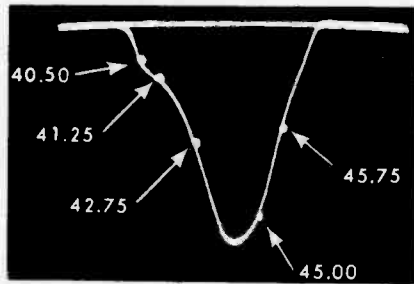

Fig. 9 Overall Response with Zero Bias for adjusting the 40.5 Mc Trap.

**VIDEO IF ALIGNMENT 17A AND 19A CHASSIS**

1. Slowly turn the channel selector until the turret is made to rest between two channels. This will prevent an erroneous response.
2. Connect an oscilloscope through a 10,000 ohm isolation resistor to terminal "C" (detector). Connect the ground lead to chassis.
3. Feed the sweep generator through the special termination network shown in Fig. 5 to point "G" (Pin 1 of 6BZ6, 3rd IF). Adjust generator to obtain a response similar to Fig. 10 with a detector output of 3 volts peak to peak. Do not exceed this level during any of the adjustments.
4. Set the marker generator to 45.75 Mc and alternately adjust the top and bottom cores of the 4th IF for maximum gain and symmetry with the 45.75 Mc marker positioned as shown in Fig. 10. The 39.75 Mc

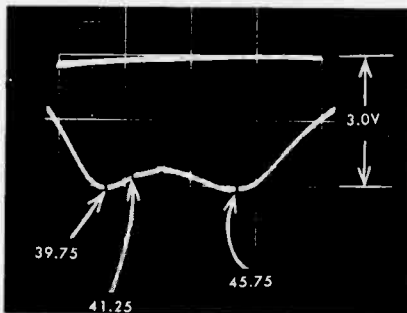

Fig. 10 4th IF Response.

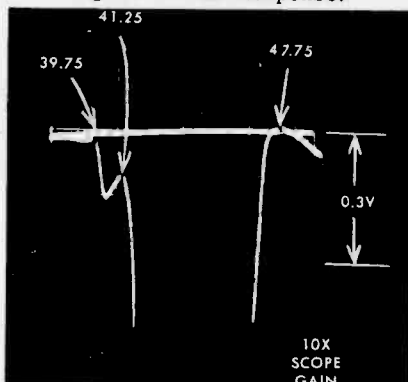

Fig. 11 Expanded View of Traps.

marker can fall within  $\pm 0.5$  Mc of the specified frequency. If the correct response cannot be obtained, check the position of the cores to see that they are not butted but are entering their respective windings from the opposite ends of the coils.

5. Connect the sweep generator to terminal "A" (Mixer grid, see Fig. 2). Connect terminal "F" to chassis and connect a jumper between terminal "E" and the junction of the 56 and 1500 ohm resistors in the cathode of the 1st IF. Adjust sweep to obtain a response similar to Fig. 13.

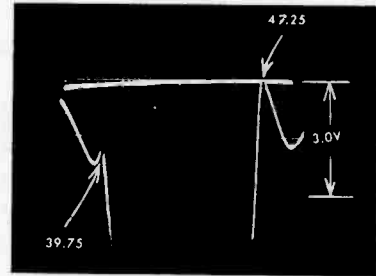

Fig. 12 Further Expansion of Fig. 11 for detail view of the 39.75 and 47.25 Mc Traps.

6. Refer to Fig. 11 and adjust the 39.75 Mc, 41.25 Mc, and the two 47.25 Mc traps for minimum marker amplitude as in Fig. 11. It can be seen that high

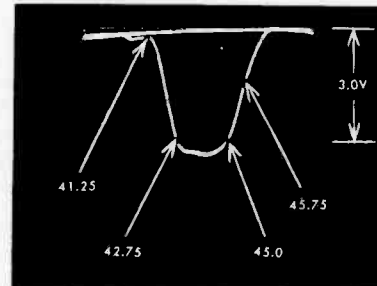

Fig. 13 Overall IF Response.

oscilloscope gain must be used to "run" the response off the screen in order to view a "blow up" of the traps.

7. Disconnect the jumper between "E" and the 56 and 1500 ohm cathode resistors. Connect this jumper between "E" and chassis. Adjust sweep generator for 3 volts peak to peak output. Alternately adjust the 2nd, 3rd, 1st IF and the converter plate coil until an overall response similar to Fig. 13 is obtained. It will be found that the 2nd IF affects the low side (42.75 Mc) and the 3rd IF the high side of the response. After alignment remove all jumpers and check operation.

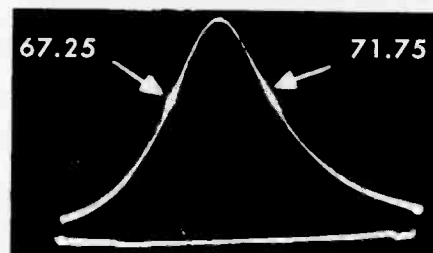

Fig. 14 Channel 4 RF Response. This is representative of other channels.



# VOLUME TV-14, MOST-OFTEN-NEEDED 1958 TELEVISION SERVICING INFORMATION

## ZENITH Chassis 15A25 Tube and Trimmer Layout, Continued

VHF BAND SWITCH TUNER S-40282

AS SHOWN BELOW

NOTE "U" MODEL INCORPORATE A UHF CONTINUOUS TUNER S-40504 AND A S-40283 VHF TUNER. REFER TO 17230U TUBE AND TRIMMER LAYOUT DRAWING (123-1598) FOR ADJUSTMENTS

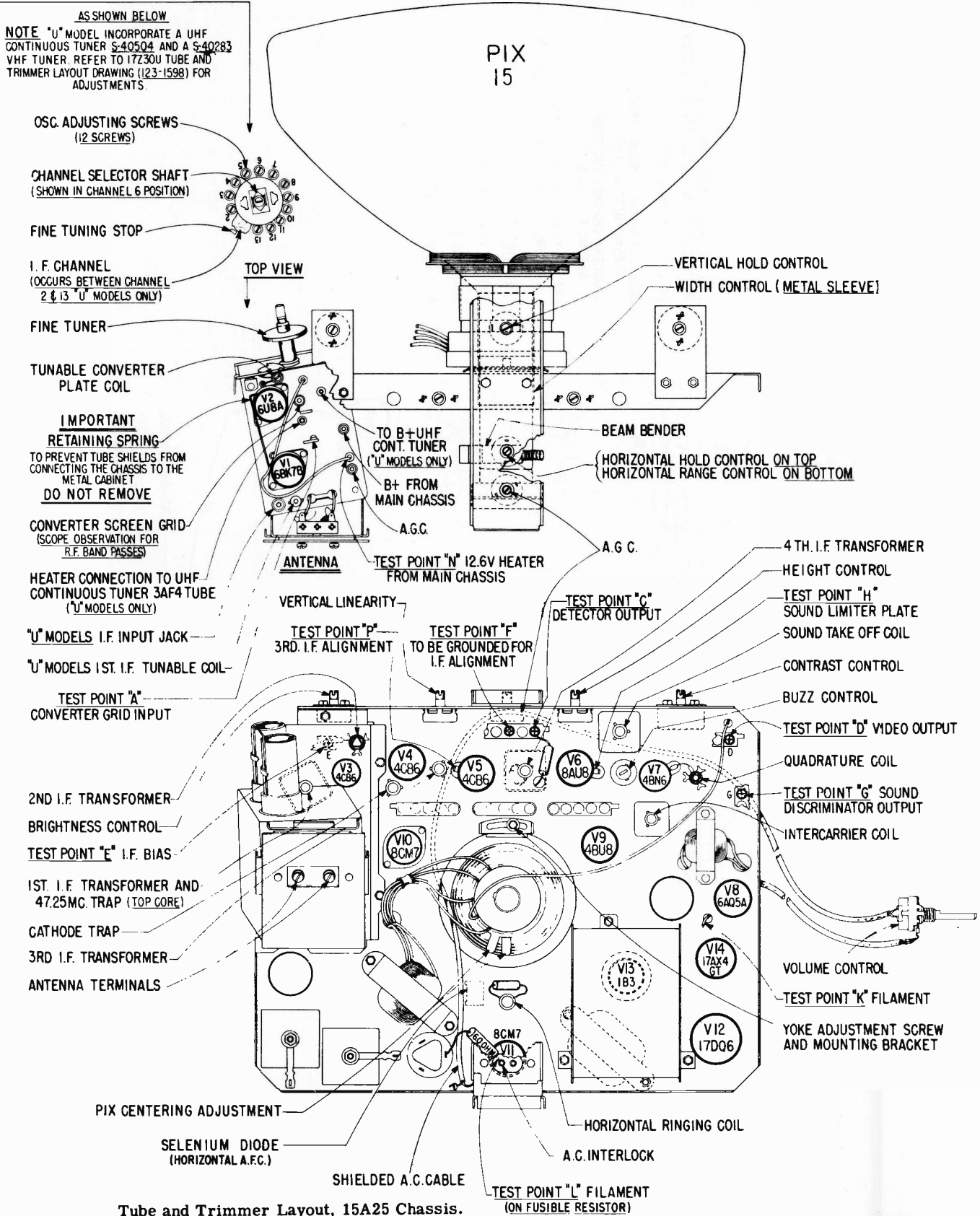

Tube and Trimmer Layout, 15A25 Chassis.

ZENITH Chassis 17A20 Tube and Trimmer Layout, Continued

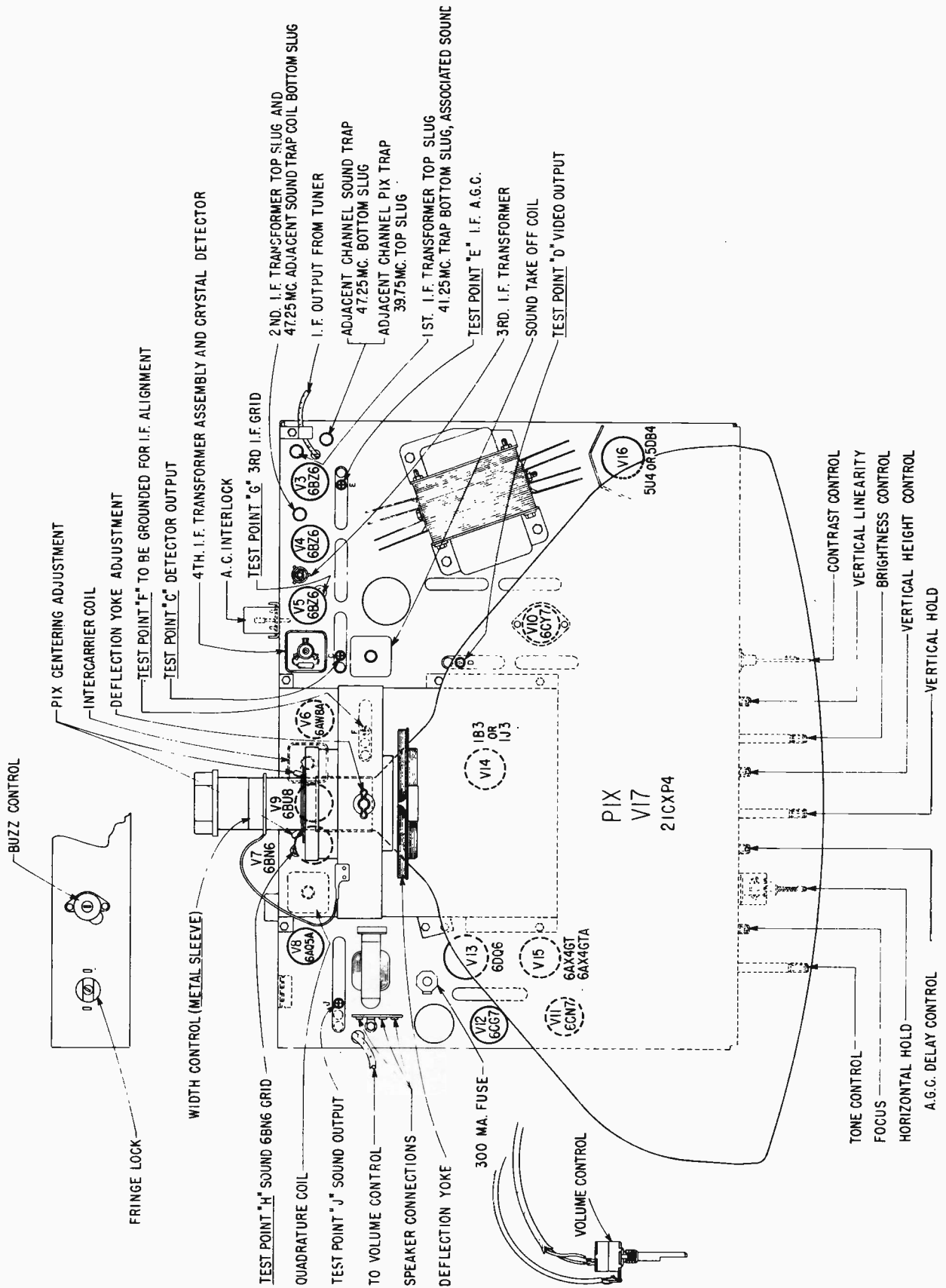

Tube and Trimmer Layout, 17A20 Chassis.





ZENITH Schematic Diagram  
Chassis 19A20 and 19A20Q

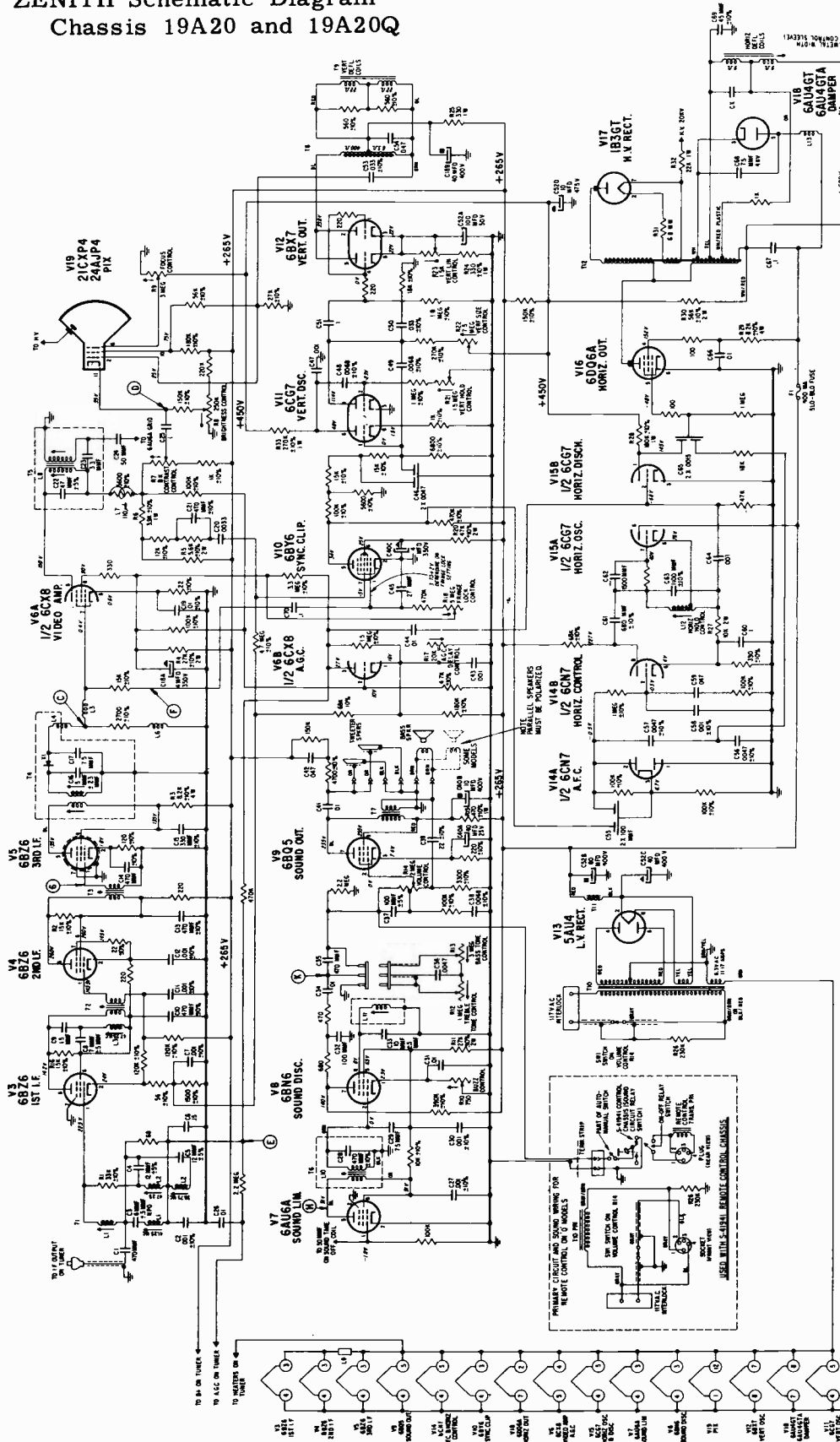

**NOTES**  
 ALL VOLTAGES MEASURED FROM CHASSIS TO POINTS INDICATED  
 ALL VOLTAGES ARE DC UNLESS OTHERWISE SPECIFIED.  
 ALL DC VOLTAGES TO BE MEASURED WITH AN OHM METER.  
 ALL VOLTAGE MEASUREMENTS TO BE MADE WITH NO SIGNAL  
 PRESENT. NORMAL SETTINGS OF CONTROLS AND CHANNEL  
 SELECTOR SET TO 2 UNLESS OTHERWISE SPECIFIED.  
 ALL CAPACITOR VALUES IN MICROFARADS UNLESS OTHERWISE  
 SPECIFIED. CAPACITANCE TOLERANCE ±20% UNLESS  
 OTHERWISE SPECIFIED.

**ALL RESISTORS ARE ±20% TOLERANCE, CARBON, 1/2 WATT  
 UNLESS OTHERWISE SPECIFIED.  
 RESISTANCE MEASUREMENTS SHOWN WITH COILS DISCONNECTED  
 COIL RESISTANCES NOT GIVEN ARE UNDER ONE OHM  
 CATHODE RAY TUBE 2ND ANODE VOLTAGE TO BE MEASURED WITH  
 ELECTROSTATIC OR 20K MIN OHM PER VOLT HIGH VOLTAGE  
 METER.  
 ARROWS ON POTENTIOMETERS INDICATE CLOCKWISE ROTATION  
 ALIGNMENT POINTS  
 CIRCLED LETTERS INDICATE ALIGNMENT AND TEST POINTS**

**TEST POINTS**  
 C- DETECTOR OUTPUT  
 D- VIDEO OUTPUT  
 E- I.F. A.G.C.  
 F- GROUND DURING I.F. ALIGNMENT  
 G- SOUND LAMPER PLATE  
 H- SOUND LAMPER PLATE  
 J- SOUND LAMPER PLATE  
 K- SOUND OUTPUT

Schematic Diagram, 19A20 and 19A20Q Chassis.

ZENITH Schematic Diagram of Chassis 15A25

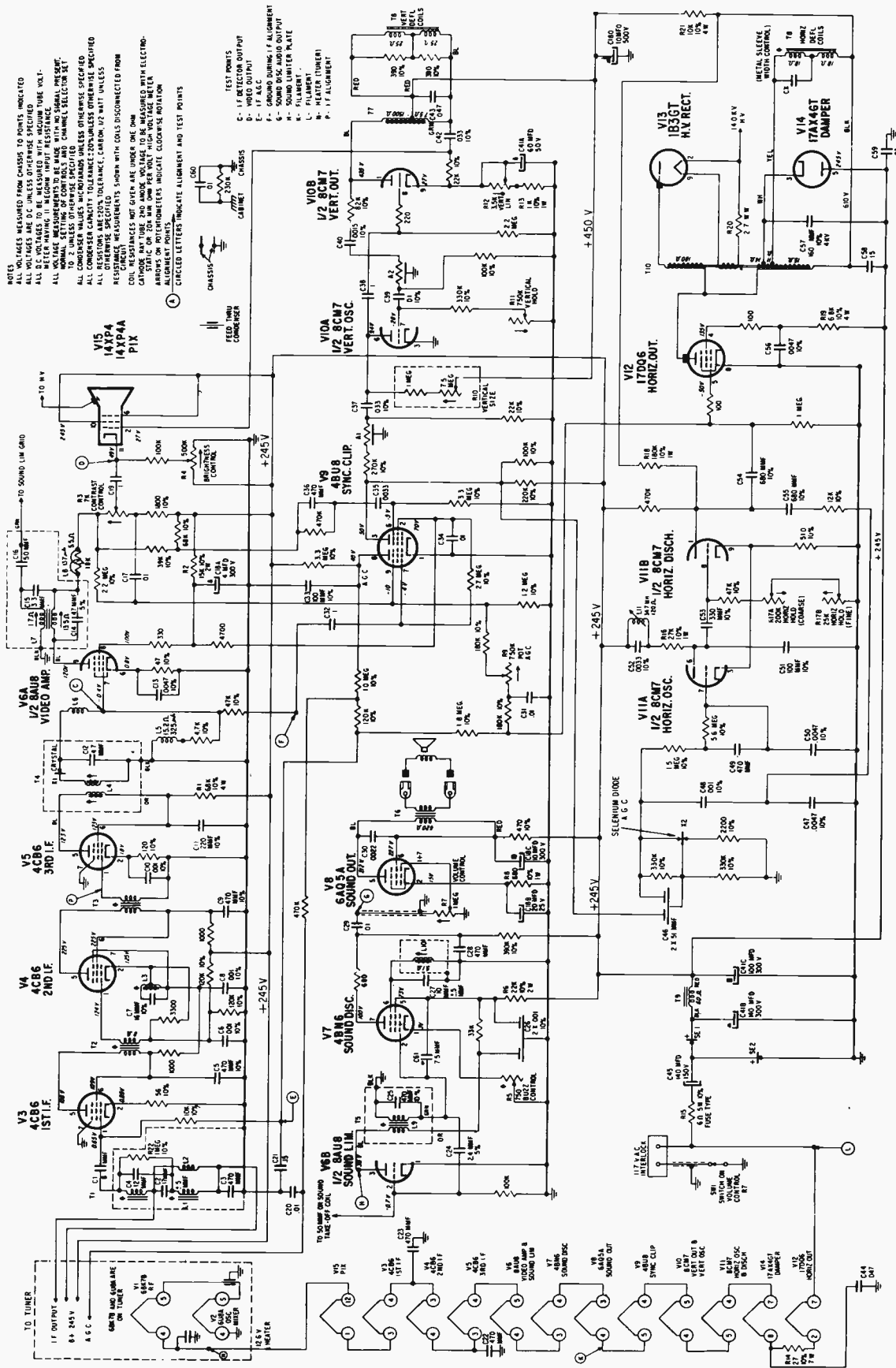

Fig. 31 Schematic Diagram, 15A25 Chassis.

# Index

Under each manufacturer's name are listed that make chassis and models in numerical order, at left. The corresponding page number at right of each listing refers to the first page of each section dealing with such material.

<u>Admiral Corp.</u>	<u>Emerson Radio</u>	<u>GE, Continued</u>	<u>Hotpoint, Cont.</u>	<u>Motorola, Cont.</u>
4S2A 14	1276 29	21C162 45	21S554 45	Y21T37B,M 77
8H1A 12	1277 29	21C172 45	24S801 45	TS-423,-Y 53
16AG1 5	1282 23	21C1548 41	24S802 45	TTS-423,Y 53
16AL1 5	1283,1284 23	21C1549 41		WTS-423,Y 53
16G1 5	1285 23	21C1550 41	<u>Montgomery</u>	TS-425,-Y 60
16L1 5	1286 23	21C1551 41	<u>Ward &amp; Co.</u>	WTS-425,Y 60
17AK1 16	1287 23	21C1552 41	WG-4042A 83	TS-426,-Y 67
17AL1 12	1288 29	21C1553 41	WG-4052A 83	TS-428,-Y 67
17J1 8	1289 29	21C1554 41	WG-5042A 83	TS-542,-Y 77
17K1 16	1290 29	21C1555 41	WG-5047A 83	
17K1B 16	1291 29	21C1556 41	WG-5052A 83	<u>Packard-Bell</u>
17L1 12	1420 19	21T050 45		21DC5 91
17L1B 12	1421 19	21T054 45	<u>Motorola</u>	21DC6 91
C21E2 5	1424 19	21T055 45	14P3-1,-2 53	21DC7 91
C21E3 5	1425 19	21T056 45	14P4-1 53	21SC6 87
C21E6 5	1426 19	21T057 45	14P5-1,-2 53	21SC7 87
C21E7 5	1428 19	21T060 45	14P5-3 53	21SC8 87
CA21E2 5	120369C 19	21T061 45	14P6-1 53	21SK3 87
CA21E3 5	120370G 19	21T1540 41	14P7-1,-2 53	21ST3 87
CA21E6 5	120377C 19	21T1541 41	14P8-1,-2 53	21VT2 87
CA21E7 5	120380H 23	21T1542 41	14P10-1,2 60	24DC4 91
HF21F22 16	120381M 23	21T1543 41	14P11-1,2 60	24SC2 87
HF21F22B 16	120382H,HC 29	21T1544 41	Y14P3-1,2 53	24VT1 87
HF21F23 16	120383M,MC 29	24C182 45	Y14P4-1 53	88S3 87
HF21F23B 16	120386H,HC 29	24C183 45	Y14P5-1,2 53	98D3 91
HF21F32 14	120387M,MC 29	24C1661 41	Y14P5-3 53	
HF21F32B 14	120388H 23	24C1670 41	Y14P6-1 53	<u>Philco Corp.</u>
HF21F33 14	120389M 23	24C1671 41	Y14P7-1,2 53	8E11 95
HF21F33B 14	120390H,HC 29		Y14P8-1,2 53	8E11U 95
HF21F34 14	120391M,MC 29	<u>Hotpoint Co.</u>	Y14P10-1 60	8E13 95
HF21F34B 14		<u>Q Line</u> 33	Y14P10-2 60	8H25 111
HFA21F22 16	<u>General Elect.</u>	<u>U Line</u> 45	Y14P11-1 60	8H25U 111
HFA21F23 16	<u>Q Line</u> 33	14S201 33	Y14P11-2 60	8L41,-U 101
HFA21F32 14	<u>U Line</u> 45	14S202 33	17P1-1,-2 67	8L42,-U 101
HFA21F33 14	<u>U2 Line</u> 41	14S203 33	17P2-1 67	8L43,-U 101
HFA21F34 14	14T016 33	14S204 33	17T30CH 67	8L71,-U 105
LHR21F32 8	14T017 33	21S401 45	17T31GP 67	8L72,-U 105
LHR21F33 8	14T018 33	21S402 45	Y17P1-1A 67	8L73,-U 105
LHR21F34 8	14T020 33	21S403 45	Y17P1-2A 67	8P51,-A 101
T21E1 5	21C137 45	21S451 45	Y17P2-1A 67	8P51U 101
T21E2 5	21C138 45	21S452 45	Y17T30CHA 67	F3042F 111
T21E3 5	21C143 45	21S501 45	Y17T31GPA 67	F3042G 111
TA21E1 5	21C159 45	21S502 45	21K70B,-M 77	UF3042F 111
TA21E2 5	21C160 45	21S552 45	21T37B,-M 77	UF3042G 111
TA21E3 5	21C161 45	21S553 45	Y21K70B,M 77	F3044A 111

(Index continued on page 192, over)



INDEX, Continued

Philco, Cont.	RCA, Continued	RCA, Continued	RCA, Continued	Westinghouse+
UF3044A 111	14VT8155 140	21T8375,U 143	KCS-113K 143	H21T201,B 161
F3202C 111	14VT8155U 140	21T8376,U 143	KCS-113M 143	H21TU201 161
UF3202C 111	14VT8157 140	21T8377,U 143	KCS-113N 143	H21T202,B 161
F3204B,-L 111	14VT8157U 140	21T8395,U 143	KCS-113P 143	H21TU202 161
UF3204B 111	17D8185,U 131	21T8397,U 143	KCS-113R 143	H21T218,A 171
F4210,-E 101	17D8186,U 131	21T8405,U 143	KCS-116A 153	H21TU218+ 171
UF4210,-E 101	17PD8093 131	21T8407,U 143	KCS-116B 153	H21T219,A 171
F4210L 101	17PD8093U 131	21T8425,U 143	KCS-116C 153	H21TU219+ 171
UF4210L 101	17PD8094 131	21T8426,U 143	KCS-116D 153	H21T220,A 171
F4212,-L 101	17PD8094U 131	21T8427,U 143		H21TU220+ 171
UF4212,-L 101	17PD8096 131	21T8428,U 143	Westinghouse	H21T221,A 171
F4214STM 101	17PD8096U 131	21T8445,U 143	17T241 175	H21TU221+ 171
F4214STN 101	17PT8071 131	21T8447,U 143	17TU241 175	H21T222,A 171
UF4214STM 101	17PT8071U 131	21T8448,U 143	17T242 175	H21TU222+ 171
UF4214STN 101	17PT8072 131	21T8465,U 143	17TU242 175	V-2371 161
F4216,-L 105	17PT8072U 131	21T8466,U 143	17T243 175	V-2372 171
UF4216,-L 105	21D8281,U 153	21T8467,U 143	17TU243 175	V-2373 175
F4620SL 101	21D8282,U 153	21T8468,U 143	17T244 175	V-2381 161
F4620SM 101	21D8305,U 153	21T8475,U 117	17TU244 175	V-2382 171
UF4620SL 101	21D8306,U 153	21T8477,U 117	17T245 175	V-2383 175
UF4620SM 101	21D8307,U 153	21T8478,U 117	17TU245 175	
F4622,-L 101	21D8525,U 125	21T8485,U 143	H21K204,B 161	Zenith Radio
UF4622,-L 101	21D8526,U 125	21T8486,U 143	H21KU204 161	15A25 181
F4624 101	21D8527,U 125	21T8487,U 143	H21K205,B 161	17A20,-Q 181
UF4624 101	21D8528,U 125	24D8655,U 125	H21KU205 161	17A21Q 181
F4626,-L 105	21D8545,U 125	24D8657,U 125	H21K212 161	19A20,-Q 181
UF4626,-L 105	21D8546,U 125	24D8676,U 125	H21KU212 161	A1510L 181
F4632 101	21D8547,U 125	24D8678,U 125	H21K213 161	A1511G 181
UF4632 101	21D8565,U 125	24T8325,U 143	H21KU213 161	A1512J 181
F6206SL 101	21D8566,U 125	24T8327,U 143	H21K214 161	A1515W 181
F6206SM 101	21D8567,U 125	24T8335,U 143	H21KU214 161	A2221J,Y 181
UF6206SL 101	21D8588,U 125	24T8337,U 143	H21K215 161	A2223+ 181
UF6206SM 101	21D8605,U 125	KCS-107A 117	H21KU215 161	A2245E,R 181
F6620SL 101	21D8607,U 125	KCS-107B 117	H21K216 161	A2250M,R 181
F6620SM 101	21D8608,U 125	KCS-107C 117	H21KU216 161	A2251E,R 181
UF6620SL 101	21D8628,U 153	KCS-107D 117	H21K223 171	A2282E,R 181
UF6620SM 101	21PD8115 117	KCS-108C 125	H21KU223 171	A2329J 181
F6624T 105	21RT8202 143	KCS-108D 125	H21K224 171	A2330+ 181
F6624TE 105	21RT8425 143	KCS-108F 125	H21KU224 171	A2358E,R 181
UF6624T 105	21T8202,U 143	KCS-109A 131	H21K225 171	A2359+ 181
UF6624TE 105	21T8205,U 143	KCS-109B 131	H21KU225 171	A2362M,R 181
	21T8207,U 143	KCS-109C 131	H21K226 171	A2673E,R 181
	21T8221,U 117	KCS-109D 131	H21KU226 171	A3000E,R 181
RCA Victor	21T8222,U 117	KCS-111A 140	H21K227 171	A3001+ 181
14PD8053,U	21T8225,U 117	KCS-111B 140	H21KU227 171	A3004,E,R 181
through	21T8226,U 117	KCS-111C 140	H21K228 171	A3006+ 181
14PD8055 140	21T8227,U 117	KCS-111D 140	H21KU228 171	A3008E,R 181
14PD8057 140	21T8245,U 117	KCS-111F 140	H21K229 171	A3010E,+ 181
14PD8057U 140	21T8246,U 117	KCS-111H 140	H21KU229 171	A3011,E,Y 181
14PT8021 140	21T8247,U 117	KCS-113A 143	H21K232 171	A3012H,R 181
14PT8021U 140	21T8265,U 143	KCS-113B 143	H21KU232 171	A3013H 181
14PT8022 140	21T8267,U 143	KCS-113E 143	H21K233 171	A3014H,R 181
14PT8022U 140		KCS-113H 143	H21KU233 171	A4007E,R 181

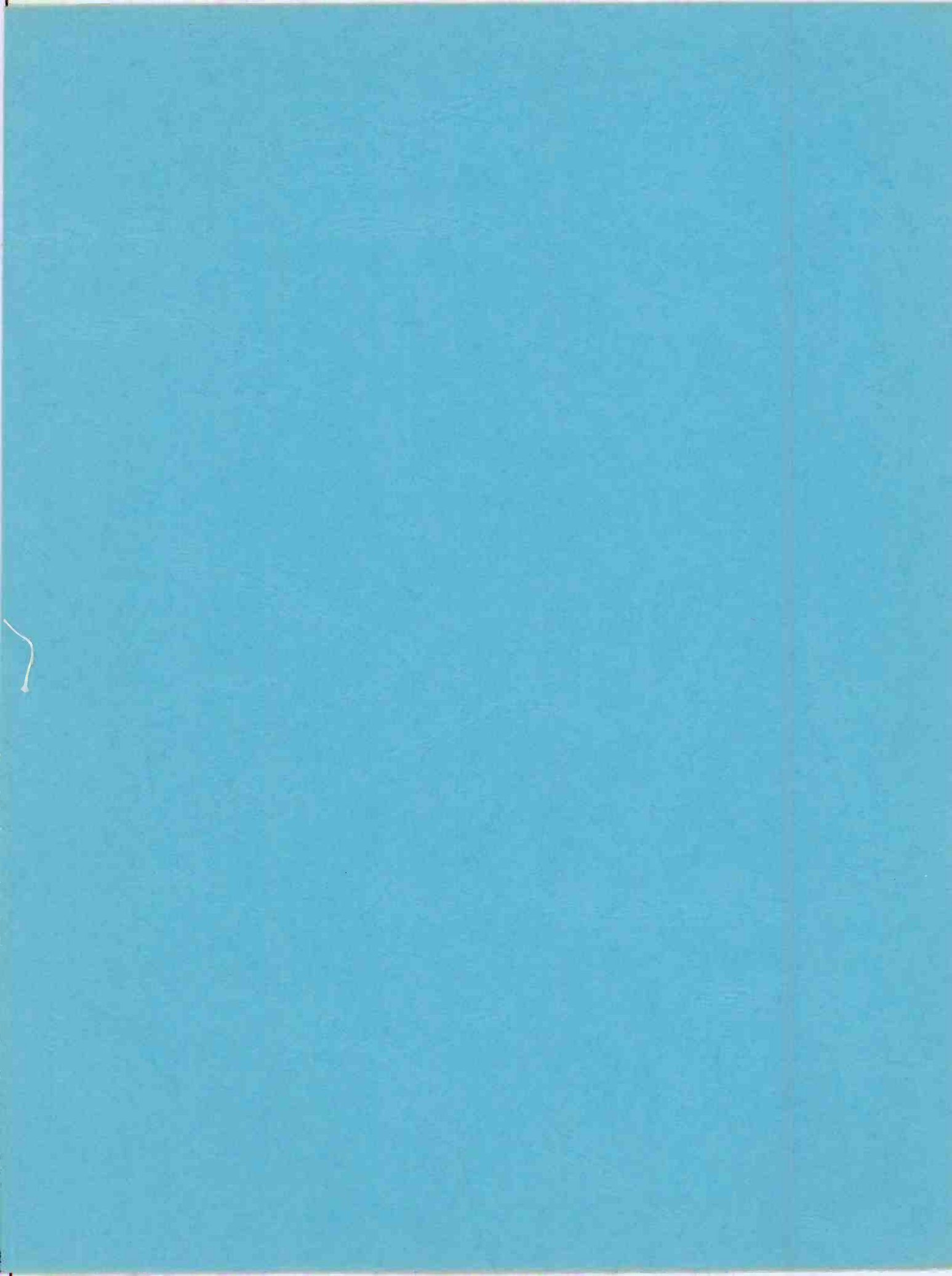

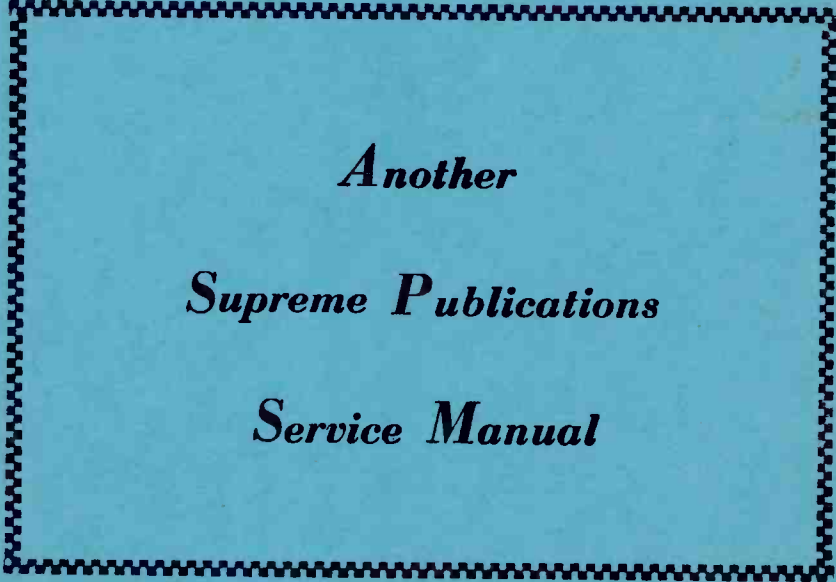

*Another*  
*Supreme Publications*  
*Service Manual*

**Supreme Publications are Available at All Leading Parts Jobbers**