

RADIO

JUNE, 1945

Design • Production • Operation



The Journal for Radio & Electronic Engineers



OWI uses **RAYTHEON** tubes IN UNIQUE MOBILE RECORDER

● This "traveling recording studio" of the Office of War Information has everything for making recorded pickups for broadcasting on international short wave. Such important equipment must be the finest that science can provide, so Raytheon High-Fidelity Tubes are used to assure the highest quality reception.

Wherever they are employed, Raytheon Tubes live up to their reputation for fine performance. That is why they are first choice among electronic engineers planning post-war products . . . and first choice among radio service-dealers who are building soundly for the future.

There's a real promise of greater profits and greater customer-satisfaction for service-dealers who feature Raytheon Tubes. And there's a revolutionary Raytheon merchandising program planned, too . . . to help you be more successful than ever before.

Switch to Raytheon Tubes now!

Increased turnover and profits, plus easier stock control, are benefits which you may enjoy as a result of the Raytheon standardized tube type program, which is part of our continued planning for the future.

Raytheon Manufacturing Company
RADIO RECEIVING TUBE DIVISION

Newton, Mass. • Los Angeles • New York • Chicago • Atlanta



Listen to
"MEET YOUR NAVY"
Every Saturday Night
AMERICAN BROADCASTING CO.
Coast to Coast
181 Stations



All Four Divisions Have Been Awarded
Army-Navy "E" With Stars

RAYTHEON

High Fidelity

ELECTRONIC AND RADIO TUBES



DEVOTED TO RESEARCH AND THE MANUFACTURE OF TUBES FOR THE NEW ERA OF ELECTRONICS

MYKROY
PERFECTED MICA CERAMIC INSULATION

**DOESN'T
CARBONIZE!**

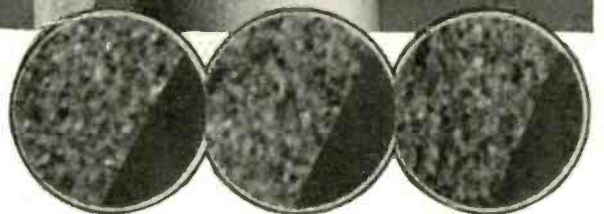
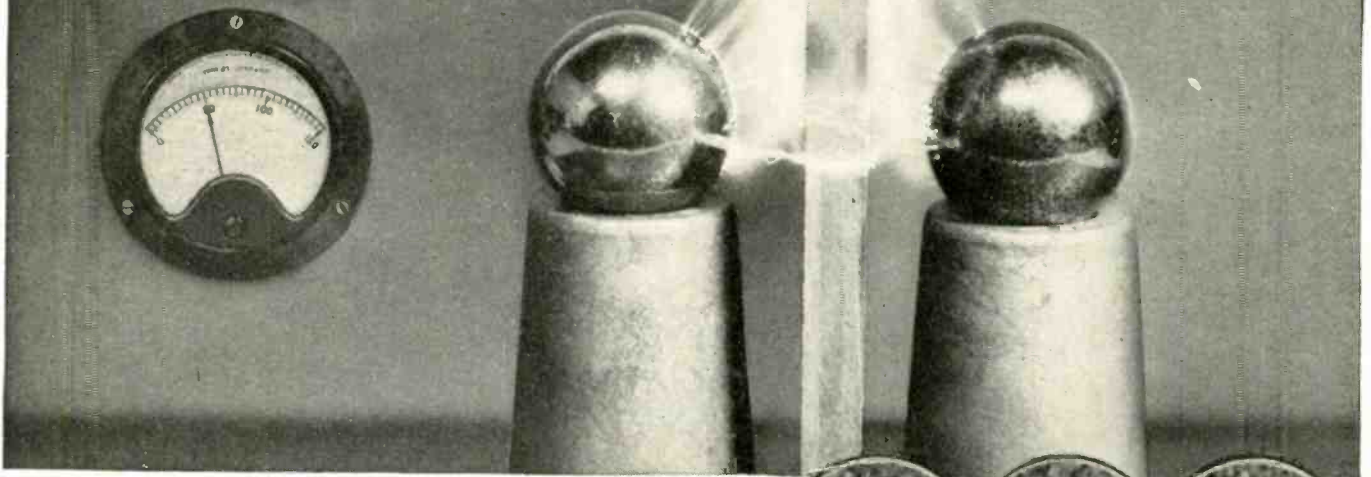

Cross sections of the test sheet made at the point of exposure to the 50,000 volt arc (magnified 10 times) show no trace of damage.

This high frequency insulation will not carbonize under arc, yet it possesses dielectric properties of the highest order. Made entirely of inorganic materials, Mykroy cannot char or turn to carbon even when exposed to continuous arcs and flashovers.

The sheet of Mykroy in the photo was exposed to a 50,000 volt arc after which it was sectioned and carefully examined for signs of damage. None were found . . . not even the slightest excoriations were present, hence no low resistance paths formed to support breakdown.

Engineers everywhere are turning more and more to Mykroy because the electrical characteristics of this perfected glass-bonded ceramic are of the highest order—and do not shift under any conditions short of actual destruction of the material itself. Furthermore Mykroy will not warp—holds its form permanently—molds to critical dimensions and is impervious to gas, oil and water. For more efficient insulation investigate Mykroy. Write for copies of the latest Mykroy Bulletins.

MECHANICAL PROPERTIES*

MODULUS OF RUPTURE.....18000-21000 psi
HARDNESS
Mohs Scale 3-4 BHN. BHN 500 K9 Load. 3-7
IMPACT STRENGTH.....ASTM Charpy .34-.41 Ft. lbs
COMPRESSION STRENGTH.....42000 psi
SPECIFIC GRAVITY.....2.75-3.0
THERMAL EXPANSION......000006 per Degree Fahr
APPEARANCE.....Brownish Grey to Light Tan

ELECTRICAL PROPERTIES*

DIELECTRIC CONSTANT.....6.5-7
DIELECTRIC STRENGTH (1/4").....630 Volts per Mil
POWER FACTOR......001-.002 (Meets AWS L-4)

***THESE VALUES COVER THE VARIOUS GRADES OF MYKROY**

GRADE 8 Best for low loss requirements.
GRADE 38. Best for low loss combined with high mechanical strength.
GRADE 51 Best for molding applications.

Special formulas compounded for special requirements.

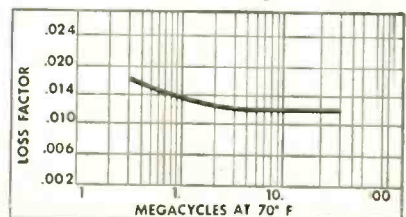

Based on Power Factor Measurements made by Boonton Radio Corp. on standard Mykroy stock.

MADE EXCLUSIVELY BY

ELECTRONIC MECHANICS
INC.

70 CLIFTON BLVD., CLIFTON, N. J.
CHICAGO 47; 1917 N. Springfield Ave., Tel. Albany 4310
EXPORT OFFICE: 89 Broad Street, New York 4, New York

MYKROY IS SUPPLIED IN SHEETS AND RODS — MACHINED OR MOLDED TO SPECIFICATIONS

RADIO

★ JUNE, 1945



Through full utilization of new war-time advancements in production methods, manufacturing facilities, and engineering techniques, Jefferson Electric is prepared to meet tomorrow's transformer needs with a product capable of maximum application to postwar technical developments.

The superiority of Jefferson Transformers will continue to be based on such vital and fundamental quality characteristics as: improved steel to reduce electrical losses; advanced methods of using carefully selected iron for laminations followed by Jefferson's own process of annealing; improved compounds, materials and impregnation methods to provide greater resistance to moisture, extreme heat and cold.

In addition to these features, full control over all methods of manufacture, assembly and inspection insures that every Jefferson Transformer is laboratory correct whether ordered in small lots or hundreds of thousands.

Consult now with Jefferson Electric transformer engineering specialists about your present and anticipated future needs and assure yourself of the ultimate in dependable, reliable transformer service. JEFFERSON ELECTRIC COMPANY, Bellwood (Suburb of Chicago), Illinois. *In Canada:* Canadian Jefferson Electric Co. Ltd., 384 Pape Avenue, Toronto, Ont.



TRANSFORMERS

RADIO

Published by RADIO MAGAZINES, INC.

JUNE 1945

Vol. 29, No. 6

John H. Potts Editor
Sanford R. Cowan Publisher

CONTENTS

COVER

Mount Assembly of voltage-amplifier and full-wave rectifier type vacuum tubes at the Western Electric Company's Vacuum Tube Shop

ARTICLES

Radio Insulating Materials— <i>Albert H. Postle</i>	29
<i>One of a series. This article deals with the characteristics and applications of phenolics in radio design</i>	
Variable Air-Dielectric Capacitors— <i>A. C. Matthews</i>	33
<i>Useful data for the receiver designer</i>	
Time Delay Relays— <i>Geoffrey Herbert</i>	37
<i>Design, construction, and operation of various types of time delay relays. Methods of testing and their application are described</i>	
Notes on Aligning and Testing Superheterodynes— <i>W. H. Anderson</i>	42
<i>Useful short-cuts in familiar operations</i>	
Optical Path Chart (Grazing Distance)	44
Final Frequency Allocations	45
<i>This FCC report covers assignments for the portion of the spectrum between 25 and 30,000 mc, with the exception of the 44 to 108 mc region, which is left unassigned pending further tests of FM transmission</i>	
Radio Design Worksheet, No. 37: Thévenin's Theorem; Note on Self-Excited Oscillator Circuits	48
Radio Bibliography: 17—Aircraft Radio, Part 10. 18: Velocity Modulation, Part 1— <i>F. X. Rettenmeyer</i>	50

MISCELLANEOUS

Transients	6
TECHNICANA	
The Clamp Circuit	10
Color Television Scanning Systems	16
Miniature Dual Triode, Type 6J6	20
Miniature Dual Triode, Type 6N4	22
New Products	53
This Month	54
Advertising Index	71

John H. Potts President
Sanford R. Cowan Sec'y-Treas.
Charles H. Farrell Adv. Manager
Elaine Wilson Adv. Production
Miriam Birnbaum Circ. Manager

PACIFIC COAST REPRESENTATIVE

H. W. Dickow
1387 40th Ave., San Francisco 22, Calif.

GREAT BRITAIN REPRESENTATIVE

Radio Society of Great Britain,
New Ruskin House, Little Russell St.,
London, W.C. 1, England

RADIO Magazine (title registered U. S. Pat. Off.) is published monthly at Boston Post Road, Orange, Connecticut, by Radio Magazines, Inc. Executive and Editorial Offices at 332 Madison Avenue, New York 17, N. Y. Subscription rates: United States and Possessions, \$3.00 for 1 year, \$5.00 for 2 years; elsewhere \$4.00 per year. Single copies 35c. Printed in U. S. A. All rights reserved, entire contents Copyright 1945 by Radio Magazines, Inc. Entered as Second Class Matter October 6, 1942, at the Post Office at East Stroudsburg, Pa., under the Act of March 3, 1879. Permit for Second Class entry pending at Orange, Connecticut.

From A F

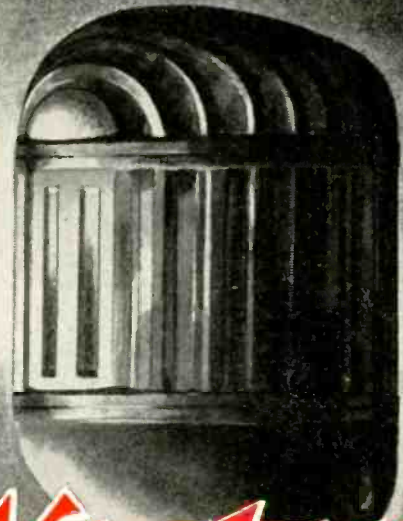

Western

Why Western Electric equipment leads the way!

1. Western Electric products are designed by Bell Telephone Laboratories—world's largest organization devoted exclusively to research and development in all phases of electrical communication.

2. Since 1869, Western Electric has been the leading maker of communications apparatus. Today this company is the nation's largest producer of electronic and communications equipment.

3. The outstanding quality of Western Electric equipment is being proved daily on land, at sea, in the air, under every extreme of climate. No other company has supplied so much equipment of so many different kinds for military communications.

As you probably know, many of the electronic marvels of this war have been made possible by the successful harnessing of Super High Frequencies. The scientists at Bell Telephone Laboratories have taken a leading part in this work with MICROWAVES.

The devices they have designed have been built in vast quantities by Western Electric. In this work, Western Electric has added greatly to its fund of spe-

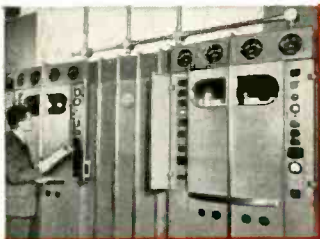

AM • BROADCASTING • FM



MARINE RADIO



AVIATION RADIO



MOBILE RADIO

Western Electric has specialized

to SHF

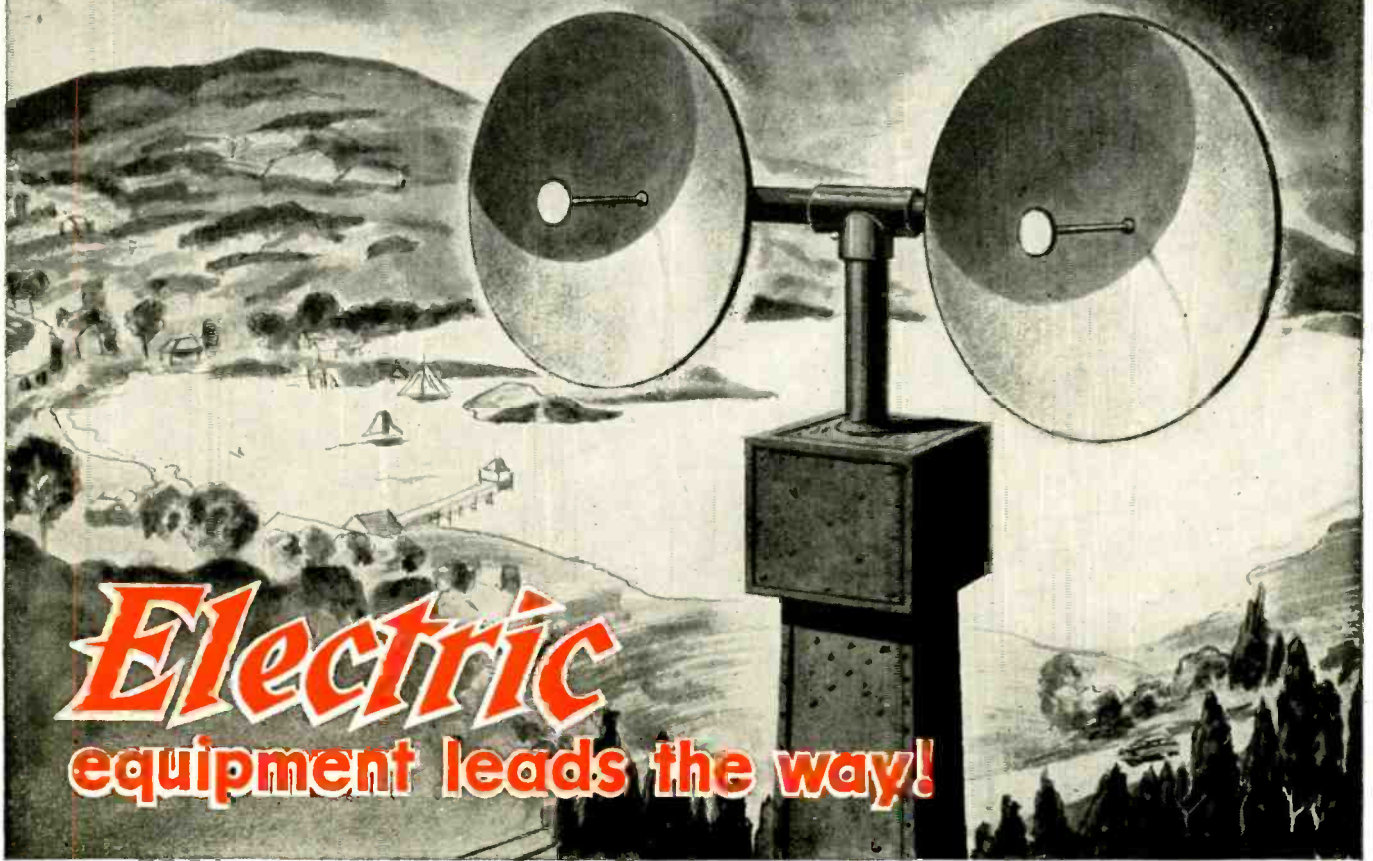

Electric equipment leads the way!

cialized knowledge and its manufacturing techniques.

These wartime microwave developments hold great promise for the future of communications and television transmissions.

From the audio band and extending through the many services in the radio frequency spectrum up to the frontiers of super high frequencies, count on Western Electric equipment to lead the way!



*During the 7th War Loan Drive,
buy bigger, extra War Bonds!*



SOUND SYSTEMS



TELEVISION



SOUND MOTION PICTURES

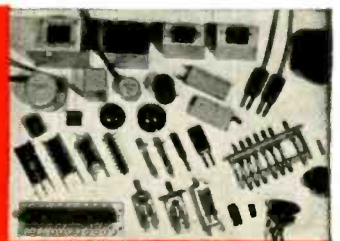

COMPONENT PARTS

knowledge in all of these fields

Transients

RADIO SURVEY

★ The Milwaukee Journal 1945 Consumer Analysis of the Greater Milwaukee market, recently released, contains information of considerable interest to manufacturers now planning radio production for the civilian market. This survey has been conducted annually since 1922 and the percentages derived are based on returns of about 3 per cent of all families in the Greater Milwaukee area. It is stated that experience has shown that additional coverage does not materially change results.

Returns show that 226,033 families, or 99.3 per cent, own radios. This degree of saturation is somewhat less appalling when we find that 27.7 per cent of these sets are in need of major repairs. Types of sets owned are:

Type	Per Cent
Cabinet or Console	63.2
Table	33.9
Console Radio-Record Player Combination...	14.2
Table " " " "	3.5

Of the features preferred in new sets, television comes first with 84.3 per cent. FM is second with 77.4 per cent. Regular broadcasting is preferred by 75.9 per cent, automatic record changers by 68.6, and short wave by 62.6 per cent. FM is 5 years old in Milwaukee and WMFM is a 50-kw station, on the air 12 hours a day. Yet 51 per cent of the families in the area have never listened to FM and only 5.9 per cent of the total number of receivers are FM types.

Types of main living room sets families will buy when available, according to the survey, are

Type	Per Cent
Combination Radio-Record Player, Console Type..	71.4
Straight Radio, Console or Cabinet	20.3
Straight Radio, Table Model	5.6
Combination Radio-Record Player, Table Type...	3.2

To many of us, the second tabulation represents a degree of wishful thinking. We don't believe that the percentage of console type, combination radio-record players sold will increase from the 14.2 per cent now

owned to 71.4 per cent, although there will undoubtedly be some increase.

FCC FREQUENCY ALLOCATIONS

★ Elsewhere in this issue the FCC's final frequency allocations are presented, for frequencies from 25 to 3,000 mc. The FCC has decided to postpone final allocation of the 44 to 108 mc region pending further tests, which depend upon the final band selected for FM. The three alternatives for FM are 50-68 mc, 68-86 mc, and 84-102 mc. This means that final designs for not only FM apparatus, but also television, amateur, and facsimile, operating within this region, must be delayed until a final decision is reached.

The Commission claims that the delay in making a final decision as to FM allocation will not hamper this service because the WPB has predicted that the radio industry will not resume production of new AM, FM and television transmitters and receivers in 1945 or even the first part of 1946, unless Japan capitulates.

It is vitally important to get these allocations settled as soon as soon as possible. The FCC doesn't seem to realize that a manufacturer cannot go into production overnight. It takes months of preparation to prepare designs, get materials and set up for production after the final allocations have been made, even under normal conditions. And now, with manpower shortages as they are, particularly in the engineering field, there is serious danger that the public will be deprived of the opportunity of purchasing apparatus for these services when interest and purchasing power are at their peak.

There has been a great deal of technical hair-splitting on both sides of the FM controversy. Eliminating this hogwash, it should be emphasized that it is possible to build and sell FM apparatus for the lowest frequency band at lower cost for equivalent performance than for the higher frequency bands. This is apparent from the articles on FM receiver design, published in the April and May issues of this magazine. This should be kept in mind in determining what is best for the public interest.

—J. H. P.

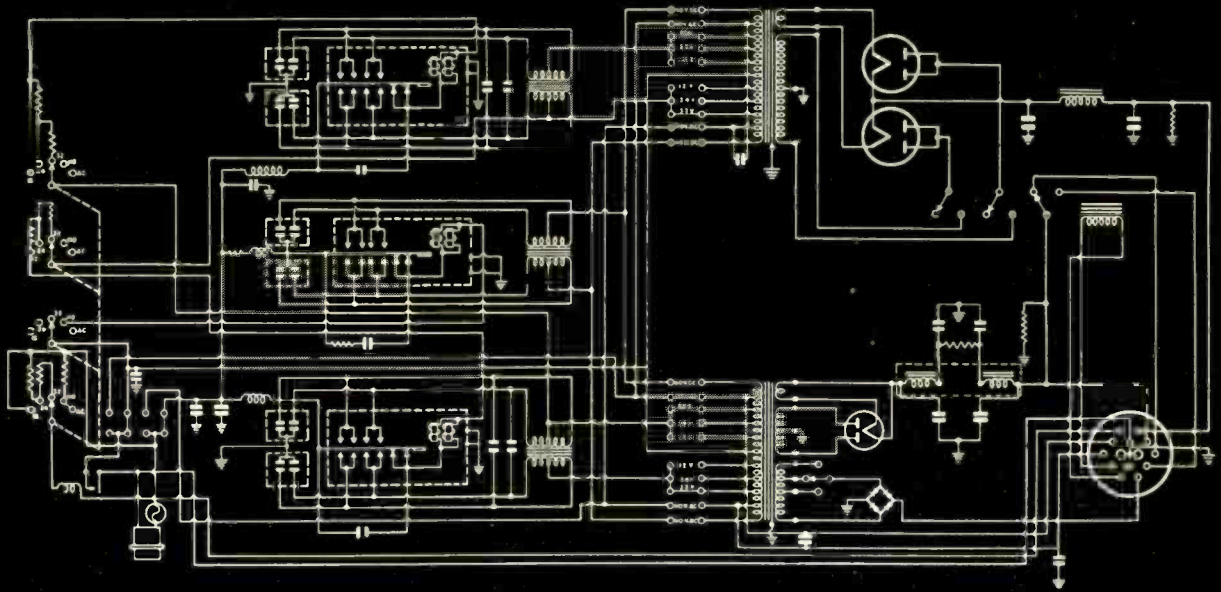

E-L DEVELOPMENTS PROVIDE MULTIPLE INPUTS AND OUTPUTS IN VIBRATOR POWER SUPPLIES

● Electronic Laboratories has greatly increased the flexibility of power supply design and versatility of power conversion circuits, through special new developments during the war period. One of these, resulting from intensified research to meet military needs, is vibrator power equipment capable of delivering various voltages, currents and frequencies from a variety of input voltages. This naturally has vastly broadened the field for vibrator power conversion equipment.

The typical circuit diagram shown above illustrates a multiple input and output system. This power unit is designed to be operated from either 12, 24, or 32 volts from storage batteries, or 110 volt DC or AC power lines. Various outputs are available to supply the high voltage plate current required for the grid, and the AC voltages suitable for operation of the filaments. In addition, a source of alternating current power for the operation of the automatic tuning system which is incorporated in this unit, has been provided. There is a current division system associated with the contacts of the vibrators and the circuit is so designed that the phase displacement provides equivalent performance of a two-phase rectifier system, assuring low

hum level with a minimum amount of filter.

During the war period, E-L has designed many other similar units having a multiplicity of input and output voltages. In addition to DC sources, in many cases, AC sources of any frequency between 18 and 180 cycles have been made available to meet specific engineering problems.

The requirements for power equipment reach into many fields as war born inventions are applied to postwar needs. E-L Vibrator Power Supplies will have wide application because they are the most economical, efficient and versatile means of solving the many power supply problems that will arise. Electronic engineers will soon be at your service to help meet the power requirements presented by postwar industry.

E-L STANDARD POWER SUPPLY MODEL 1200

This E-L unit is a typical Vibrator Power Supply with multiple inputs and outputs and was designed for transmitter and receiver use. Inputs: 12 volts DC, 24 volts DC, 32 volts DC, 110 volts DC and 110 volts AC, 50-60 cycles; Outputs: 600 volts DC at 150-250 MA; 300 volts DC at 75-150 MA; 6-8 or 10 volts DC at 1 amp.; and 110 volts AC (50-60 cycles) at 75 watts. Dimensions: 26-1/16" x 15" x 13-9/16". Weight: 160 pounds.



Electronic
LABORATORIES INC.
INDIANAPOLIS

VIBRATOR POWER SUPPLIES FOR LIGHTING, COMMUNICATIONS, ELECTRIC MOTOR OPERATION - ELECTRIC, ELECTRONIC AND OTHER EQUIPMENT

SYLVANIA NEWS

ELECTRONIC EQUIPMENT EDITION

JUNE

Published by SYLVANIA ELECTRIC PRODUCTS INC., Emporium, Pa.

1945

SYLVANIA ISSUES NEW BOOKLET ON PUBLIC'S POST-WAR WANTS IN RADIO AND TELEVISION



YOU LIKE YOUR RADIO!

Our question:
How do you consider the performance of your latest set?

The answer:

Good	75%	Fair	20%	Poor	5%
------	-----	------	-----	------	----

Prophecy: You'll like the new post-war radios even better!



Your latest set has short wave!

Our question:
Do you have short wave band on your latest set?

The answer:

YES!	52%	NO!	48%
------	-----	-----	-----

But--in spite of such wartime short wave broadcasting, our survey shows you hardly ever tune in on it!

... And here's what you like about it!

Our question:
What features do you like most about your present radio set?

The answer:

Tone quality	52.4%
Model	29.6%
Appearance	23.6%
Reception clarity	21.7%
Push button feature	19.1%
Record player	8.7%
Sensitivity-selectivity	8.2%
Range	7.7%
Volume	5.6%

Hint: Sylvania radio tubes go a long way to make any radio sound better.

12



You like to push a button when you tune-in!

Our question:
If your radio has push-button tuning, what do you think of it?

The answer:

Like it	78%	Could be improved	22%
---------	-----	-------------------	-----

Post-war radios will doubtless have quicker, easier push-button tuning.

13

Summarizing the results of a recent nationwide survey, a new booklet, "They Know What They Want," is now being widely distributed. This survey was conducted by one of America's leading market research organizations—at the request of Sylvania Electric's Sales Research Department.

CIRCULATION AMONG CONSUMERS

The booklet is being mailed to consumers in response to inquiries stimulated by questionnaire-type advertisements appearing in national magazines. Through these advertisements Sylvania Electric is continuing its study of public preferences in radio sets. Public distribution of the booklet is expected to be helpful in maintaining the popular interest in post-war radio sets which has been created by Sylvania's advertising.

VALUE TO INDUSTRY

In addition, "They Know What They Want" is being widely circulated among the electronic equipment manufacturing industry. Providing a convenient digest of the public's desires, the booklet should prove helpful to set manufacturers in planning post-war designs that will appeal to buyers' tastes.

Copies of the booklet are available on request to set manufacturers for distribution to their engineering departments and sales forces. A more complete and detailed presentation of the survey findings has also been prepared, and will be shown to interested manufacturers on request to the nearest Sylvania sales office.

Here is a typical two-page spread from the booklet "They Know What They Want," which summarizes the results of a nation-wide survey of public preferences in radio sets.

SYLVANIA ELECTRIC

MAKERS OF RADIO TUBES; CATHODE RAY TUBES; ELECTRONIC DEVICES; FLUORESCENT LAMPS, FIXTURES, ACCESSORIES; INCANDESCENT LAMPS



Save Valuable Man-Hours!

with AMPHENOL

COMPLETE CABLE ASSEMBLIES

With Amphenol COMPLETE Cable Assemblies you have only one source of supply . . . issue only one purchase order . . . cut your procurement cost . . . reduce your labor and tool cost . . . eliminate production and assembly worries . . . all of these add up to a substantial savings in valuable man-hours and manufacturing cost.

Tremendous volume production has necessitated the creation of countless jigs, fixtures and special equipment with resultant lower assembly cost, pre-

cision and quality workmanship, and dependability that characterizes all Amphenol products.

. . . Engineered to your specifications . . . Efficiently assembled . . . Exacting precision in testing—three additional reasons why you should specify Amphenol complete, quality Cable Assemblies.

Your inquiry will receive prompt, careful and confidential consideration.

Depend upon AMPHENOL Quality.



AMERICAN PHENOLIC CORPORATION

Chicago 50, Illinois

In Canada • Amphenol Limited • Toronto

U.H.F. Cables and Connectors • Conduit • Fittings • Connectors (A-N, U.H.F., British) • Cable Assemblies • Radio Parts • Plastics for Industry



OUT OF THE GROOVE

SOUND is captured and imprisoned upon a phonograph record. Its release for entertaining, educational and commercial use has for years been made possible by The Astatic Corporation through Astatic Phonograph Pickups. Long favorites with most leading manufacturers and jobbers of phonographs and phonograph equipment, Astatic Pickups have supplied the highest degree of quality and fidelity to record reproduction. For the days ahead, Astatic promises even greater true-to-life tonal realism, improvements in pickup design, construction and operating efficiency that will contribute immeasurably to the clarity and beauty of reproduction from the new, fine-grain, noise-free, Vinylite recordings of tomorrow. Conversion to peacetime production, when such permission is given, will be prompt and Astatic's greatly increased manufacturing facilities will be ready to serve its great host of manufacturing and jobber customers.

**"You'll HEAR MORE
from Astatic"**

ASTATIC Crystal Devices
manufactured under Brush
Development Co. patents.

THE
Astatic
ASTATIC CORPORATION
CONNEAUT, OHIO
IN CANADA, CANADIAN ASTATIC LTD., TORONTO, ONTARIO

TECHNICANA

THE CLAMP CIRCUIT

★ The term *clamp circuit* is applied to a circuit of the pulse-driven switch type which, when the wave to be reproduced contains a reference point, enables the elimination of the entire low-frequency section of the pass-band. The theory underlying this type of circuit as well as a practical circuit of this kind are discussed by C. L. Townsend in the February and March 1945 issues of the *Broadcast Engineers' Journal*.

Because clamp action controls frequencies that are well below the clamp frequency, the use of a clamp circuit

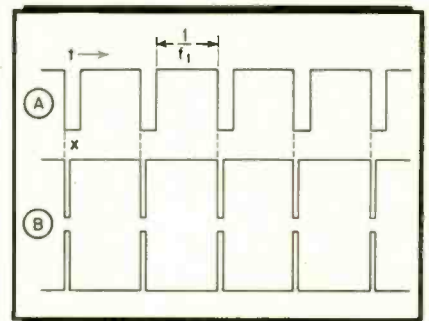

Figure 1

enables the reproduction of a good wave shape under adverse conditions that would otherwise seriously distort the wave. In consequence, the clamp circuit enables the elimination of switching surges, transients caused by movements of the gain control, power line variations, and ground current fluctuations.

Because of certain types of interference a wave may ordinarily undergo shifts in its a-c axis, but assuming that the wave has some sort of reference point the clamp circuit compels this reference point always to assume a constant potential, so that as a result of shifting the operating point of a vacuum tube, the level of amplification of the wave becomes independent of shifts of the a-c axis. Among its other uses the clamp circuit can be employed for the purpose of d-c restoration.

Consider the rectangular wave of Fig. 1A as containing no frequency components below f_1 in frequency. Fig. 2 shows this same wave to which has been added an interfering low frequency component f_2 , and it is the function of the clamp circuit to remove the interfering wave f_2 .

Suppose that the commencement of each cycle of f_1 (indicated by an *x* in

[Continued on page 12]

SPRAGUE HYPASS CAPACITORS

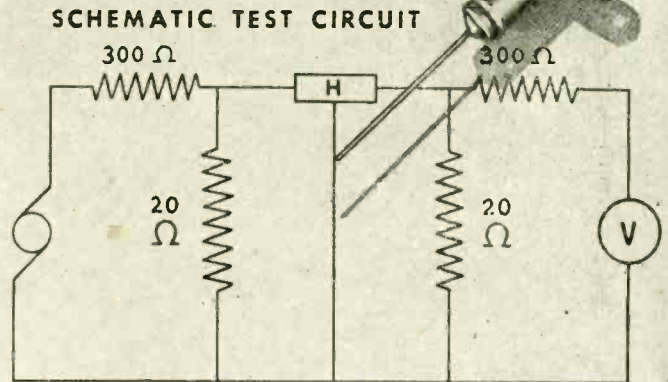
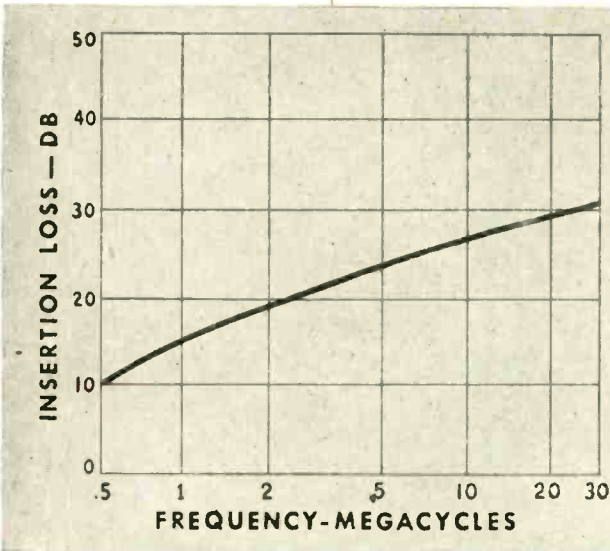
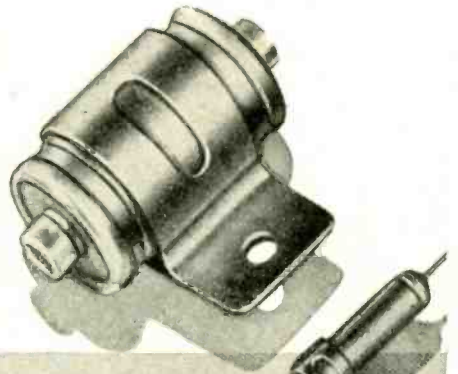

Curve showing insertion loss of a Sprague HYPASS Capacitor.

The Solution to "WHAT TO DO WITH ANTI-RESONANT FREQUENCIES?"

Conventional methods of getting rid of vibrator "hash" usually call for the use of a by-pass capacitor, shunted by a mica capacitor. This system, however, has at least one anti-resonant frequency. Of course the engineer juggles his constants so that this anti-resonant frequency comes where it causes the least trouble—BUT, in today's all-wave devices, there just isn't any such place!

The New Sprague Method is simply to utilize the Sprague HYPASS Capacitor. Technically, this is a 3-terminal network which, at low frequencies, "looks" like a capacitor in respect to its capacity, voltage rating, and size. At high frequencies—well, the above diagram tells the story. Although accurate measurements of their performance at the very high end of the spectrum are difficult to obtain as yet, qualitative indications show that HYPASS units do the job at 100 megacycles and more—so much so that, if you have a "hash" problem, we'd welcome an opportunity to stack them against it.

SPRAGUE ELECTRIC COMPANY, North Adams, Mass.
(Formerly Sprague Specialties Co.)

* T. M. REG. U. S. PAT. OFFICE

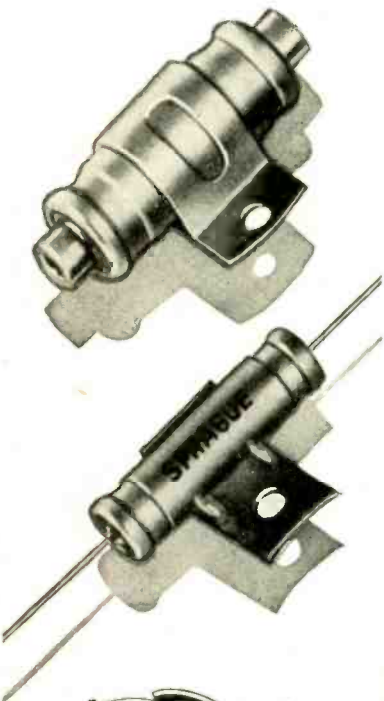

SPRAGUE

CAPACITORS — * KOOLOHM RESISTORS

ENGINEERS! DRAFTSMEN! ACCOUNTANTS! STUDENTS!

ORDER TODAY! Sensational NEW

MULTI Slide Rule

WITH **8** ADDITIONAL, EXCLUSIVE TABLES!
NOW FIGURE ANYTHING... WITH ONE RULE!

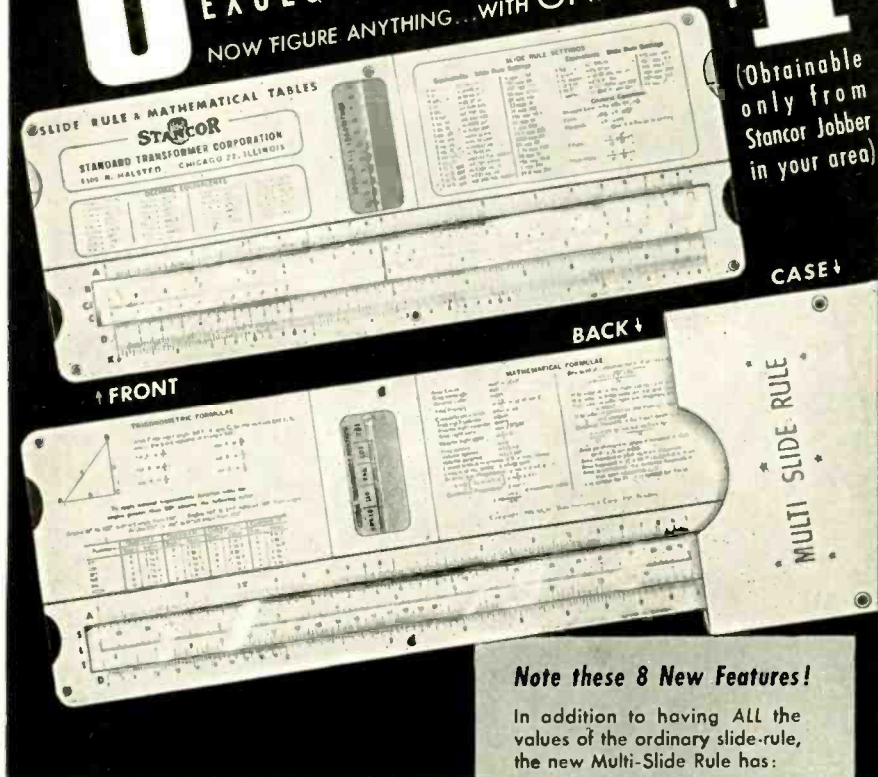

(Obtainable only from Stancor Jobber in your area)

Note these 8 New Features!

In addition to having ALL the values of the ordinary slide-rule, the new Multi-Slide Rule has:

- 1 Four-place LOGARITHM TABLE
- 2 SIGNS and LIMITS of VALUE assumed by trigonometric functions
- 3 Table of NATURAL TRIGONOMETRIC FUNCTIONS
- 4 Table of TRIGONOMETRIC FORMULAE
- 5 Table of SLIDE-RULE SETTINGS
- 6 Table of GENERAL EQUATIONS
- 7 Long list of common MATHEMATICAL FORMULAE
- 8 DECIMAL equivalents of a fraction

OFFERED AS A SERVICE TO THE TRADE BY

STANCOR

Clear, legible print... Tough, durable for long wear... Size 10" x 4"... Fits 3-ring binder... In case... Full instructions... TRANSPARENT PLASTIC INDICATOR...

STANCOR now offers the entire electronic industry the new Multi-Slide Rule. First developed for our own use, it is today made available to all... Greatly simplifies calculation of unlimited range of problems... A genuine professional rule—not a toy. This rule is obtainable ONLY THROUGH STANCOR JOBBERS. PLEASE DO NOT ORDER DIRECT. See your local directory for the name of the Stancor jobber in your city or, write for his name. Price of Stancor Multi-Slide Rule: One Dollar!—America's biggest slide-rule bargain—a service to the trade by Stancor.

STANDARD TRANSFORMER CORPORATION
1500 N. HALSTED ST. CHICAGO 22, ILL.

ORDER FROM YOUR JOBBER

TECHNICANA

[Continued from page 10]

Fig. 1A) is brought to some definite potential as a result of some restoring force, which is indicated symbolically by the arrows in Fig. 2A. When the

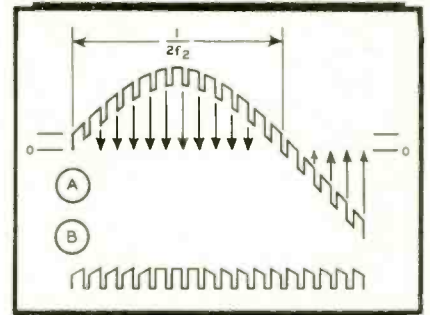

Figure 2

low-frequency wave f_2 is above its axis in a positive direction the x points of the wave of Fig. 1A are forced downward to the zero potential reference line, whereas when f_2 is below its axis in the negative direction the reference x points are forced upward towards this zero potential. As a result, when f_1 is considerably higher in frequency than f_2 , all that remains of the interfering effect of f_2 are those very small components of f_2 that occur during a single cycle of f_1 . Consequently, despite the interfering effect of wave f_2 , wave f_1 has been restored to its original shape.

Now consider the circuit shown in Fig. 3, and suppose that the desired

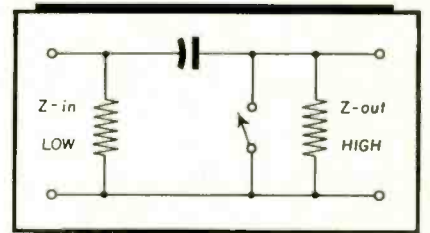

Figure 3

f_1 wave is impressed upon the input terminals. If the time constant of R and C are long compared to the period of a single cycle of f_1 , then at the output terminals there will appear a faithful reproduction of the original wave f_1 .

Let us now assume that wave f_2 is also impressed upon the input terminals at that same time as wave f_1 . Then, although it is assumed that the frequency of f_1 is considerably higher than f_2 , the time constant of R and C will still be such as to permit some part of f_2 to appear in the output of the circuit. However, if every time that point x of the wave of Fig. 1A

[Continued on page 14]

PLASTIC PARTS... *Post-Formed*



A New Production Technique

Recently developed methods of post-forming fully cured Formica laminated plastic sheets have adapted the material for very much wider use in a great many applications that were formerly thought impractical.

In this process the sheets are heated, and formed quickly with inexpensive wooden or Pregwood dies into many curved shapes.

Previously to secure such shapes it was thought necessary to mold the material in curing with the use of very elaborate and expensive steel molds—which were impractical for any but a few large volume applications.

This shaping method provides a very light (specific gravity 1.35) material, that is strong, stable in dimensions, inert chemically and therefore possessing a finish that is free from corrosion and long of life.

Formica engineers will be glad to tell you the story.



THE FORMICA INSULATION COMPANY, 4638 SPRING GROVE AVENUE, CINCINNATI 32, OHIO

RADIO

★ JUNE, 1945

13

CONCORD

Amplifiers Intercoms and Recorders

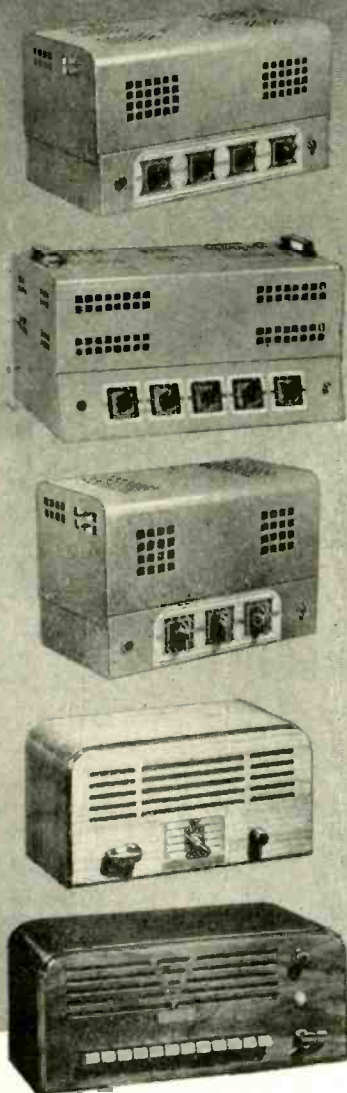

FOR EVERY PURPOSE

Concord's full line of Amplifiers range up to sizes covering 200,000 square feet indoors or 75,000 square feet outdoors. A complete line of speakers, microphones, and all essential equipment is also available.

Concord Intercom Units are carried in a variety of master and sub-station units permitting up to 100 stations.

Concord Recording Equipment—professional-type for microphone recording, radio recording, reproduction of transcriptions, public address system.

Mail the coupon below for special folders and literature which picture and describe the complete Concord line of Amplifiers, Intercoms and Recorders.

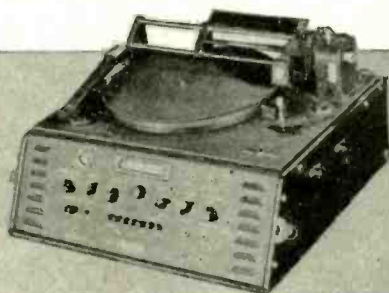

CONCORD RADIO CORPORATION
Lafayette Radio Corporation

CHICAGO 7, ILL. ATLANTA 3, GA.
901 W. Jackson Blvd. 285 Peachtree Street

Concord Radio Corporation
901 W. Jackson Blvd. Dept. F-C
Chicago 7, Illinois

Please send me at once, literature covering your line of Amplifiers, Intercoms and Recorders.

Name.....
Address.....
City..... State.....

TECHNICANA

[Continued from page 12]

appeared, the switch S were closed for a short period just long enough to discharge condenser C through Z -in, then point x and the short horizontal portion of the wave immediately following would be at zero potential. This is followed, as is seen in Fig. 1A, by an abrupt upward rise, a long horizontal portion, and then an abrupt drop to the x -point level. Now during the time that the switch is open the circuit is responsive only to changes in the voltages applied at the input terminals, and starts with no charge on condenser C , since the charge due to wave f_2 has been discharged as a result of the switch being closed for a short time. Since the switch is assumed to be closed each time that the initial point x of wave f_1 arrives, it is seen that the effect of wave f_2 has been eliminated from the output of the circuit, except for that negligible amount that acts during a cycle of f_1 . In consequence, the output wave, as seen in Fig. 2B, is a fairly good replica of the original wave f_1 .

This mechanical switching action can be electronically obtained by employment of the clamp circuit shown in Fig. 4. It will be observed that the

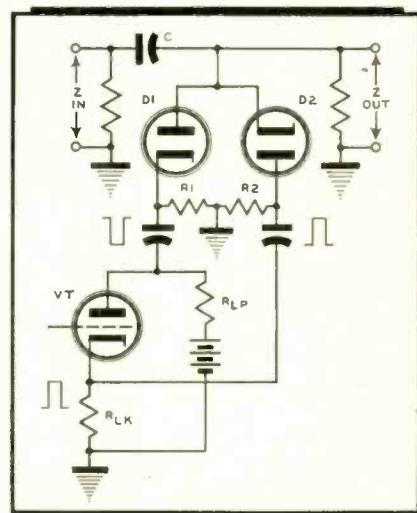
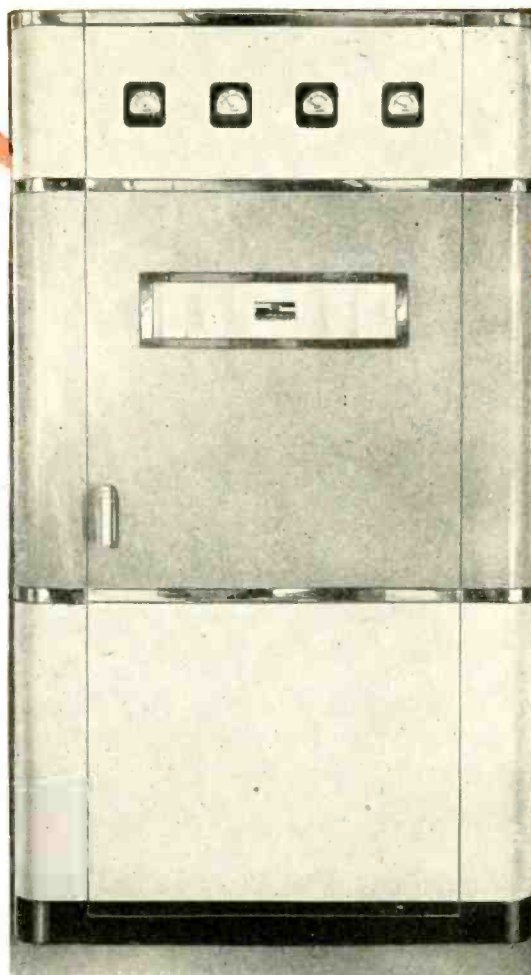
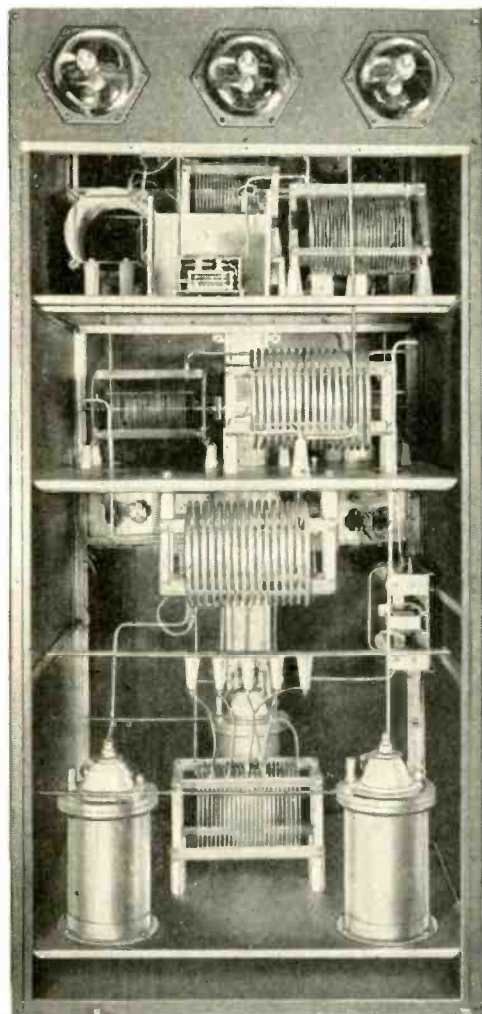

Figure 4

"back-to-back" connection of the two diodes $D1$ and $D2$ are so connected in relation with the phase inverter VT and its associated plate load R_{LP} and R_{LK} and B-supply voltage so as to produce a positive charge on the cathode of diode $D1$ and a negative charge on the plate of diode $D2$. Under these conditions diodes $D1$ and $D2$ do not conduct, since they are biased to produce this result. Under these circumstances any signal applied to the Z -in circuit will appear at the Z -out circuit unaffected

[Continued on page 16]

DIRECTIONAL ANTENNA EQUIPMENT



Johnson engineers have designed many highly successful installations of phasing and antenna coupling equipment to individual specifications. These units may be built to match any existing transmitter and thus become an integral part of your station. Let us help you and your consulting engineer plan your transmitting equipment for better market coverage. Orders received now will get first attention when priority restrictions are removed.

Here are two of the many installations of phasing equipment Johnson has furnished for Broadcast Stations, built to match existing equipment. Other items available from Johnson, made to individual specifications, are gas filled pressure condensers, coupling networks, tower lighting filters and special inductors.



JOHNSON

a famous name in Radio

E. F.
JOHNSON
COMPANY
WASECA, MINNESOTA

AMCON

AN AMERICAN SOLUTION TO YOUR CAPACITOR PROBLEMS

ALL TYPES • BY-PASS AND ELECTROLYTIC

DATA SHEETS ON REQUEST

AMERICAN CONDENSER CO.

4410 No. Ravenswood Ave. • Chicago 40, Ill.

Washers and Stampings

ALL KINDS - FOR ALL PURPOSES!

No matter what your requirements may be . . . washers of any size or shape, any material or finish, in any quantity . . . we can supply or make what you want. Over 22,000 sets of dies available for producing standard and special sizes.

Our facilities are at your service.



WROUGHT WASHER MFG CO.

WORLD'S LARGEST PRODUCER OF WASHERS

2203 SOUTH BAY STREET • MILWAUKEE 7, WISCONSIN

TECHNICANA

[Continued from page 14]

appear at the *Z-out* circuit unaffected by the combination diode and phase inverter circuit.

Suppose that a positive pulse is applied to the input of the phase inverter *VT*. A similar positive pulse will appear at the cathode of this tube and a similar pulse, but negative, will appear at the plate of this tube. If it is assumed that the input pulse to the phase inverter *VT* is timed to correspond to point *x* of *Figs. 1A* and *1B*, and that further, the pulse voltage is

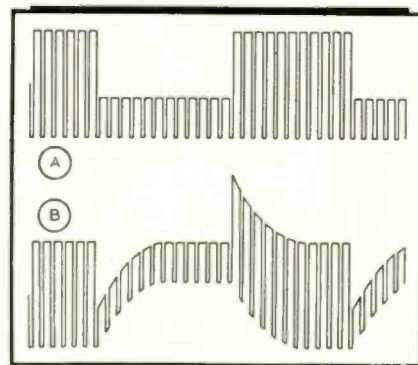

Figure 5

sufficiently great to overcome the bias on the two diodes, it is seen that the diodes will conduct, and will thus act in the same manner as the switch of *Fig. 3*. If the charge on condenser *C* is positive due to the signal applied to the *Z-in* circuit, then diode *D1* will conduct, while if the charge on condenser *C* is negative due to this signal then diode *D2* will conduct and thereby cause the rapid discharge of condenser *C*. This thereby brings all the negative peaks of the input signal down to the same reference level.

How the circuit of *Fig. 4* can be employed can be seen from an examination of *Fig. 5*. In *Fig. 5A* is shown the combined desired high-frequency and undesired low-frequency waves. In the absence of a clamp circuit, for reasons already discussed, the wave would be reproduced as that shown in *Fig. 5B*. By reason of the clamp action acting on the beginning of each of the most negative portions of the high frequency wave, all of these negative tips will be forced to the same potential, in consequence of which the output wave will be a faithful replica of *Fig. 5A*.

COLOR TELEVISION SCANNING SYSTEMS

★ Considerable interest has recently been displayed regarding the practicality of color television. One of the major factors involved in securing a

[Continued on page 18]



**"I HAVE AN IMPORTANT ANNOUNCEMENT.
ALBION CAN SHIP ALL THE COILS YOU NEED."**

SUPER-QUALITY COILS AT REASONABLE PRICES

More and more every day, the industry is turning to Albion for fast, quality and quantity production of coils, chokes, and transformers. That's because here you benefit from the unbeatable combination of management "know how," skilled workmanship, streamlined facilities, and central location. Your requirements will be given prompt and thoughtful attention.

**ALBION
COIL COMPANY**

ALBION, ILLINOIS

R. F. AND TRANSMITTING COILS AND CHOKES;
I. F. TRANSFORMERS

workable color television system is the scanning technique employed. This subject is analyzed under the title "Scanning Systems for Colour Television" in *Electronic Engineering* for April, 1945, by L. C. Jesty.

Workable systems of color reproduction fall into two main classifications: (1) those which break the original color into two complementary colors, and those which split the color to be reproduced into three primary colors. The complementary color system has been abandoned in color reproduction except for low-grade fidelity reproduction, and we may consider this process completely inadequate for color television.

In photographic processes, one major difficulty has been that of color fringes, due to an incomplete lack of proper registration. In cinematography, as a result of motion of the object between

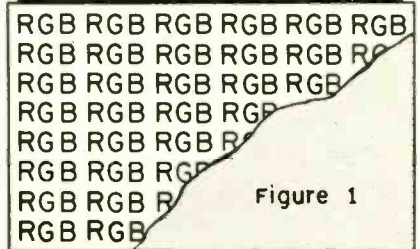

Figure 1

Method of color scanning

self-colored film, for this technique avoided color fringing. There are two basic types of self-colored film: (1) the color mosaic type, as used in the Finlay process, Dufaycolor, etc., and (2) the integral tri-pack type which utilizes special dye-coupler developers, and which are available as Kodachrome, Agfacolor, etc. Since there is no physical separation of the three colors, neither of the two types of color fringing are present in this system.

As matters stand at the present time, color television transmissions that are analogous to the self-colored picture do not seem feasible. Due to the time interval between the transmission of one color and another, it would appear that some color fringing would occur, unless some suitable scanning sequence is found. It has been proposed that three separate pickup tubes and three separate receiving cathode ray tubes be employed either in conjunction with successive frames of film, another type of color fringing was introduced. Both these types occur in color television, although the latter can be minimized

[Continued on page 20]



For Perfect Calibration
MONARCH
 MEASURING • TESTING • CALIBRATING
EQUIPMENT

For better war production • For finer civilian production

Throughout the war period, Monarch instruments have facilitated production of better equipment, giving more accurate results. As soon as conditions permit, these same dependable instruments will be used to insure finer results in products designed for civilian use.



Toroids..

by **DX**

Doughnut Coils for electronic and telephone purposes. High Permeability Cores are hydrogen annealed and heat treated by a special process developed by DX engineers. Send us your "specs" today—ample production facilities for immediate delivery.

DX RADIO PRODUCTS CO.
 GENERAL OFFICES 1200 N. CLAREMONT AVE., CHICAGO 22, ILL., U.S.A.

DX COILS
 "the heart of a good receiver"

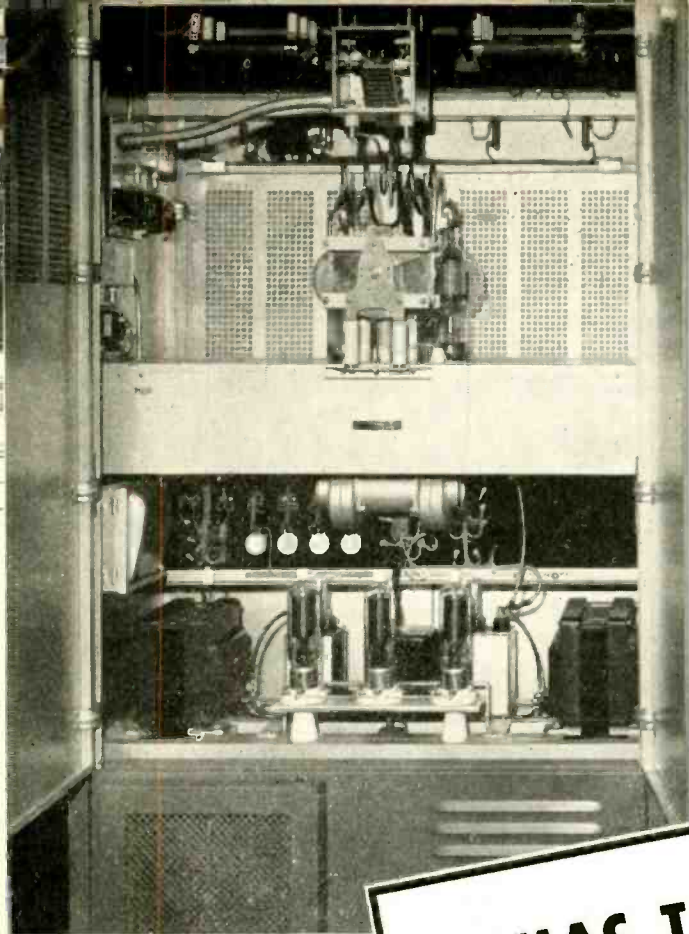

A pair of Eimac 1000-T's give 3 KW output in this Link-built FM transmitter for the emergency services.

Here's a 500 watt supersonic test generator for operation at 1 to 300 kc which uses Eimac 152-T tubes.

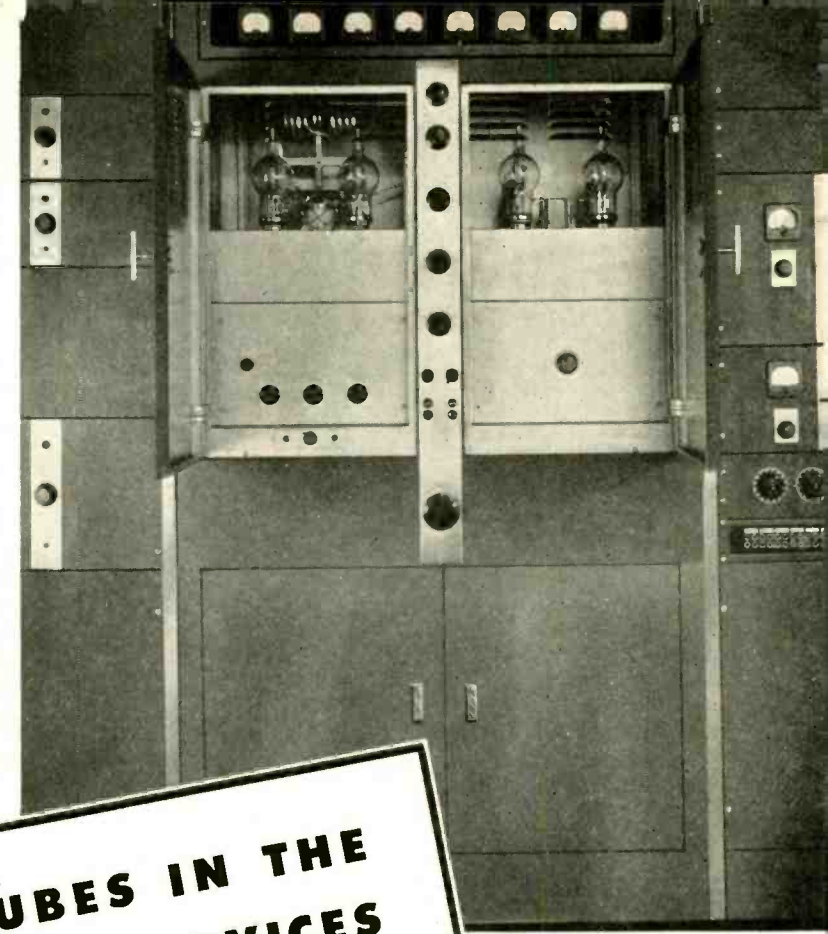

500 watt AM police transmitter for 30-40 Mc operation, built by Fred M. Link, using Eimac 250-TH tubes in the final.

**EIMAC TUBES IN THE
EMERGENCY SERVICES
WHERE DEPENDABLE
PERFORMANCE COUNTS!**

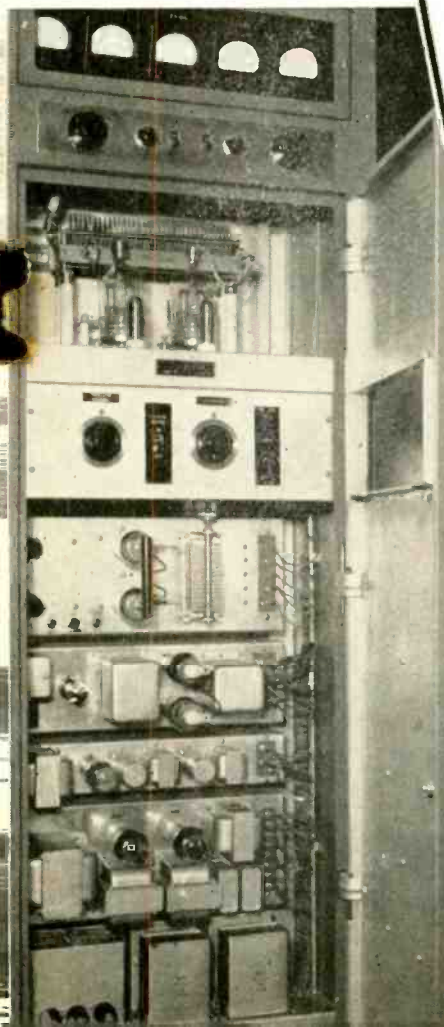

The transmitters shown on this page were developed and built for the emergency services — police, fire and transportation — by Link Radio Corporation of New York City. Recognition such as that enjoyed by the Link organization in this field is built upon sound engineering and the right choice of equipment components. That Eimac tubes occupy the important sockets in these vital transmitters is fitting acknowledgement of their inherently superior performance capabilities. That Fred M. Link specifies Eimac tubes is confirmation of the fact that Eimac tubes are first choice of leading electronic engineers throughout the world.

FOLLOW THE LEADERS TO

Get your copy of Electronic Telesis ... the sixty-four page booklet which gives the fundamentals of electronics. This little booklet will help electronic engineers explain the subject to laymen. It's yours for the asking ... no cost or obligation. Available in English and Spanish languages.



EITEL-McCULLOUGH, INC., 1033 San Mateo Ave., San Bruno, Calif.
Plants located at: San Bruno, California and Salt Lake City, Utah
Export Agents: Frazer & Hansen
301 Clay Street, San Francisco 11, California, U. S. A.

The End

RESULT



IS THE ONLY ONE
THAT COUNTS IN
SOUND

Regardless of high quality pick-up, amplification, radio broadcast or home reception, the end result is the only one that counts in quality sound reproduction. Perfect sound reproduction from 40 to 15,000 cycles plus is the end result of the Duplex Speaker. That's the end result that counts with top sound engineers and discriminating listeners.

SEND FOR BULLETINS

ALTEC

LANSING CORPORATION

1210 TAFT BLDG., HOLLYWOOD 28, CALIF.
250 WEST 57 STREET, NEW YORK 19, N. Y.
IN CANADA: NORTHERN ELECTRIC CO.

TECHNICANA

[Continued from page 18]

to a negligible extent by a sufficiently great scanning speed.

One method of improving the film quality came about through the use of

sively scanned in each of the primary colors, as shown in *Fig. 2*. Since storage in the mosaic has to occur over a number of lines in order to obtain adequate illumination, it would appear that this method, or a modification thereof, is the only feasible one of the three mentioned. Color fringing, also, is minimized with this system, although

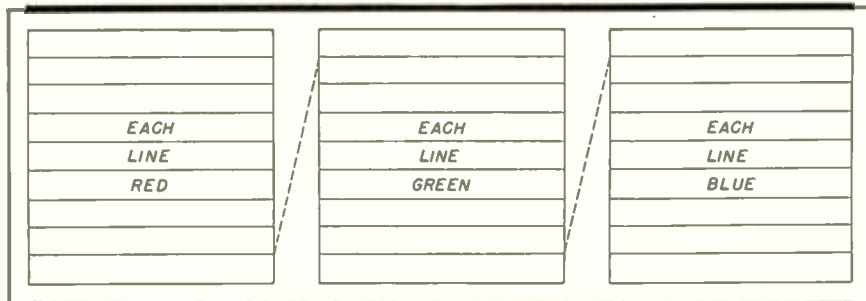

Figure 2

three separate channels or by employing sequential switching on a single channel. In either case color fringing is very likely to result because of the difficulty of accurate simultaneous registration of the three images.

A workable color television system would seem to necessitate a single camera tube, a single receiving CR tube, a straightforward scanning technique, in conjunction with fixed or

there will be some on fast moving objects.

This latter type seems to be quite satisfactory as employed by the Columbia Broadcasting System. As shown in *Fig. 3*, they found the combination of 120 color fields per second, 40 color frames per second, 60 frames per second, and 20 color pictures per second, interlaced 2 to 1, to be quite good in picture quality.

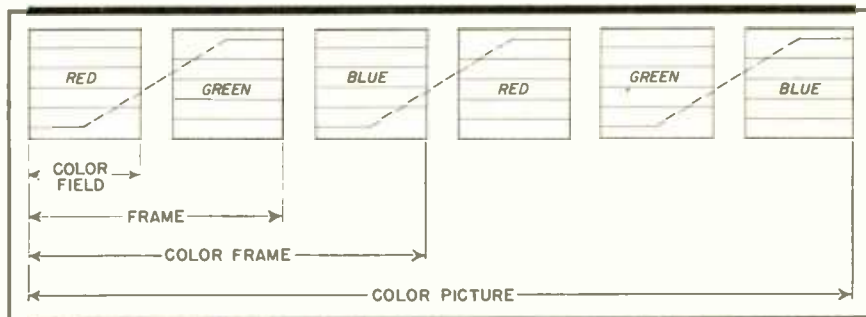

Figure 3

synchronously driven color filters. On this basis there are three alternative scanning systems:

(1) Each picture point may be successively scanned in each of the primary colors, as shown in *Fig. 1*. Because of the difficulty of registration of any mosaic on the fluorescent screen, this method does not seem feasible. In addition, this method suffers from "aperture distortion" since the moving spot of the electron beam is of the same order as the elements of the mosaic. Furthermore, light storage does not seem possible in this system.

(2) Each picture line can be successively scanned in each of the three primary colors. This method suffers from the same defects mentioned under (1) above.

(3) Each picture frame is succes-

6J6 — MINIATURE DUAL TRIODE

★ For a considerable time Raytheon has been assigned a major role in supplying the essential requirements for a versatile, miniature, dual triode tube called type 6J6.

The precise manufacturing techniques which must be maintained are obvious from a consideration of the physical structure of this tube. Two high transconductance triodes are obtained from a single relatively large flat cathode which also acts as a shield to prevent interaction between two separate half-grids. These are wound with extremely fine wire and accurately spaced a few thousandths of an inch on either side of the cathode. Two individual half-plates complete the tube.

The applications utilizing 6J6 tubes

[Continued on page 22]

More than **35** Years of Service

to the

RADIO INDUSTRY

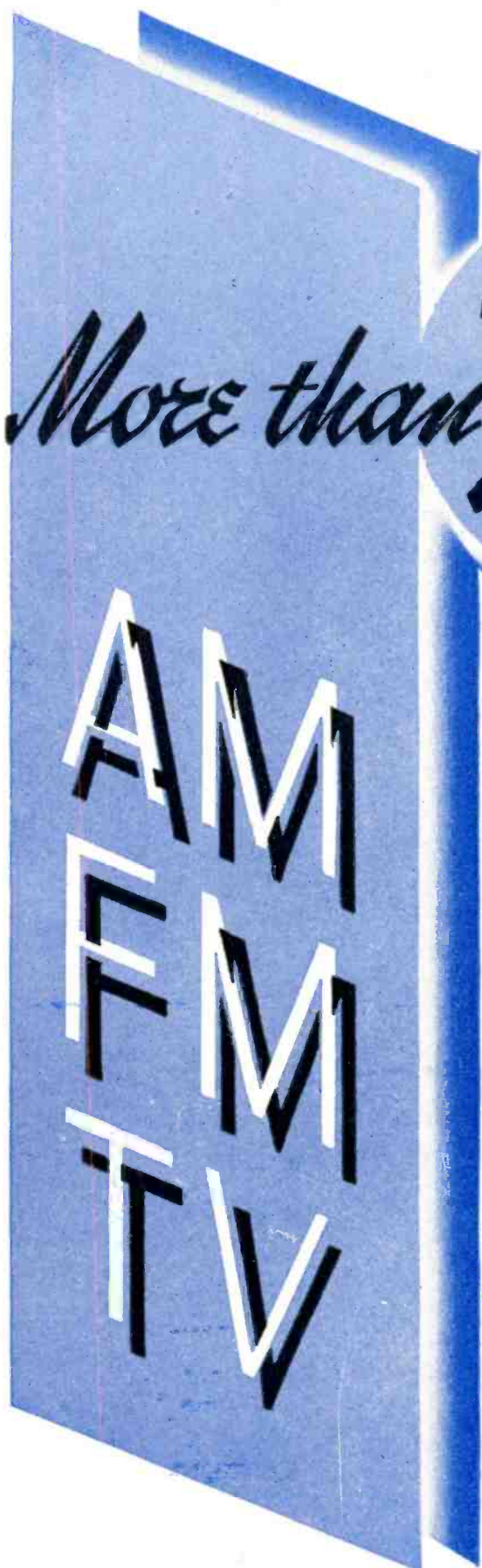

Whether Amplitude Modulation . . . Frequency Modulation . . . or Television — dependability is a *must* for all broadcast equipment.

Federal broadcast equipment has earned a reputation for that dependability because *it stands up*.

For more than thirty-five achievement-studded years . . . from the Poulsen Arc to the new CBS Television Station . . . Federal has served the broadcast industry with superior equipment.

Federal's background includes such milestones of electronic progress as the 1000 Kw Bordeaux Transmitter; Micro-ray, the forerunner of modern television technique; and the first UHF multi-channel telephone and telegraph circuits, part of a world-wide communications system . . .

All this, plus the war-sharpened techniques that are the result of ability *and* experience, combine to give you craftsmanship . . . the kind of craftsmanship that builds dependability into all Federal equipment.

In AM . . . FM . . . TV . . .

. . . your prime need in broadcast equipment is dependability — *look to Federal for it.*



Federal Telephone and Radio Corporation



Newark 1, N. J.

TECHNICANA

[Continued from page 20]

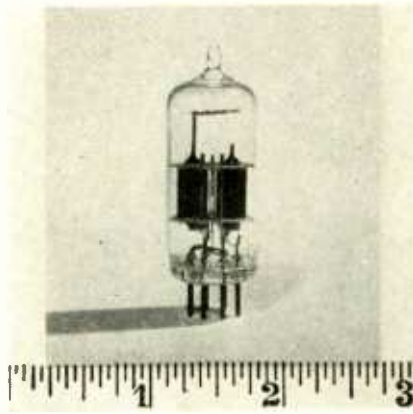

Type 6J6 miniature triode

are varied and numerous. Its unique construction lends itself to connection as a high permeance diode, a single very high transconductance triode or a dual triode with common cathode. Applications range from a diode detector to an ultra high frequency push-pull oscillator capable of producing useful energy at frequencies of several hundred megacycles. The 6J6 also lends itself to cathode follower service and high frequency mixer applications:

Following are the 6J6 characteristics:

Dimensions:		
Maximum Overall		
Length	2 $\frac{1}{8}$	inches
Maximum Seated Height	1 $\frac{7}{8}$	inches
Maximum Diameter	$\frac{3}{4}$	inches
Ratings:		
Heater Voltage	6.3	volts
Heater Current	0.45	amperes
Maximum Plate Voltage	300	volts
Maximum Plate Dissipation (per unit)	1.5	watts
Direct Interelectrode Capacitances (Approx. for each unit)—Unshielded		
Grid to Plate	1.6	μf
Input	2.2	μf
Output	0.4	μf
Class A₁ Characteristics (Each triode)		
Plate Voltage	100	volts
Cathode Bias Resistor—		
Both units operating	50	ohms
Plate Current	8.5	ma
Transconductance	5300	umhos
Amplification Factor	38	
Plate Resistance (Approx)	7100	ohms

6N4—MINIATURE U-H-F TRIODE

An important contribution by Raytheon tube design engineers towards the efficient generation of ultra high frequency power is a miniature triode designated as type 6N4.

This cathode type tube combines the desirable features of reduced interelectrode capacitances and lead inductances

with high transconductance. Thus, the inevitable internal losses are minimized making the 6N4 particularly adaptable as an amplifier, doubler or oscillator at frequencies extending to approximately 500 megacycles.

The foregoing characteristics can be used to advantage in many types of equipment which are still unmentioned. However, such innocuous but important functions as performed by the local oscillator in a u-h-f television or fm receiver are readily visualized possibilities. Then there is the exciting probability that the Citizens Radiocommunication band recently proposed by the Federal Communications Commission will be approved. The contemplated frequencies are 460-470 megacycles. There, private radio telephone equipment primarily portable in nature would very likely find considerable demand. Since the 6N4 has moderate heater power requirements and performs efficiently in this region of the spectrum, it would make an ideal tube for civilian "walkie-talkies".

Following are the physical and electrical specifications for the Raytheon type 6N4:

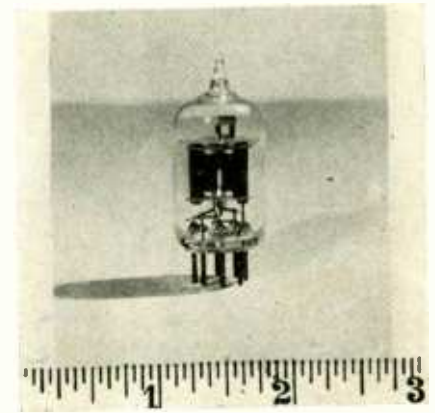

Type 6N4 miniature triode

Dimensions:		
Maximum Overall		
Length	1 $\frac{3}{4}$	inches
Maximum Seated Height	1 $\frac{1}{2}$	inches
Maximum Diameter	$\frac{3}{4}$	inches
Ratings:		
Heater Voltage	6.3	volts
Heater Current	0.2	amperes
Maximum Plate Voltage	180	volts
Maximum Plate Dissipation	3	watts
Direct Interelectrode Capacitances*:		
Grid to Plate	1.1	μf
Input	3.0	μf
Output	1.6	μf
Typical Class A Characteristics:		
Plate Voltage	180	volts
Grid Voltage	-3.5	volts
Plate Current	12	ma
Amplification Factor	32	
Transconductance	6000	umhos

*Approximate—with close fitting shield connected to cathode.

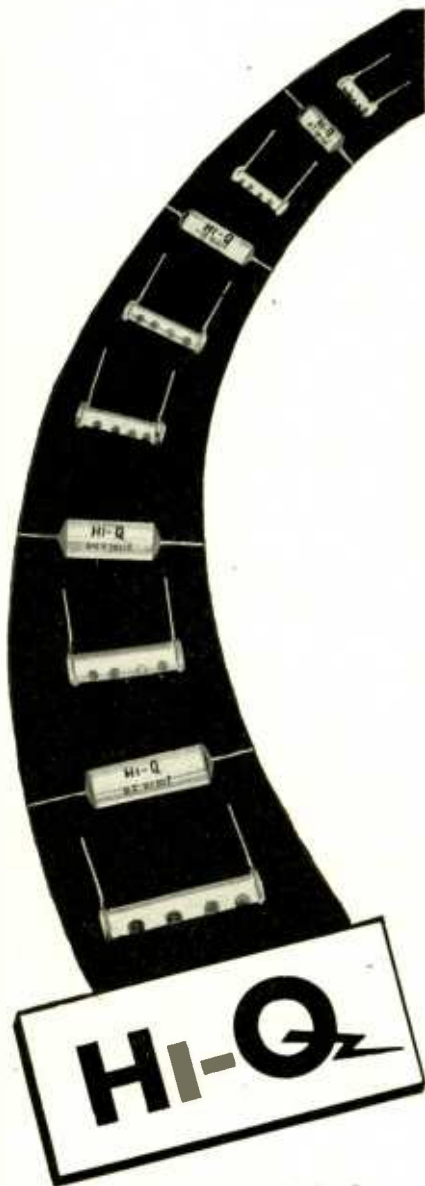

CERAMIC CAPACITORS

● Available in Temperature Compensating and Hi-K type. Dielectric factors 19 to over 1200. Solid Silver condenser plates, non-aging and non-corrosive, gauged to thousandths of an inch, fused for long life performance.

Hi-Dielectric Enamel Finish withstands mechanical and thermal shock.

Color coded for accuracy in identification.

ELECTRICAL REACTANCE CORPORATION
FRANKLINVILLE, N. Y.

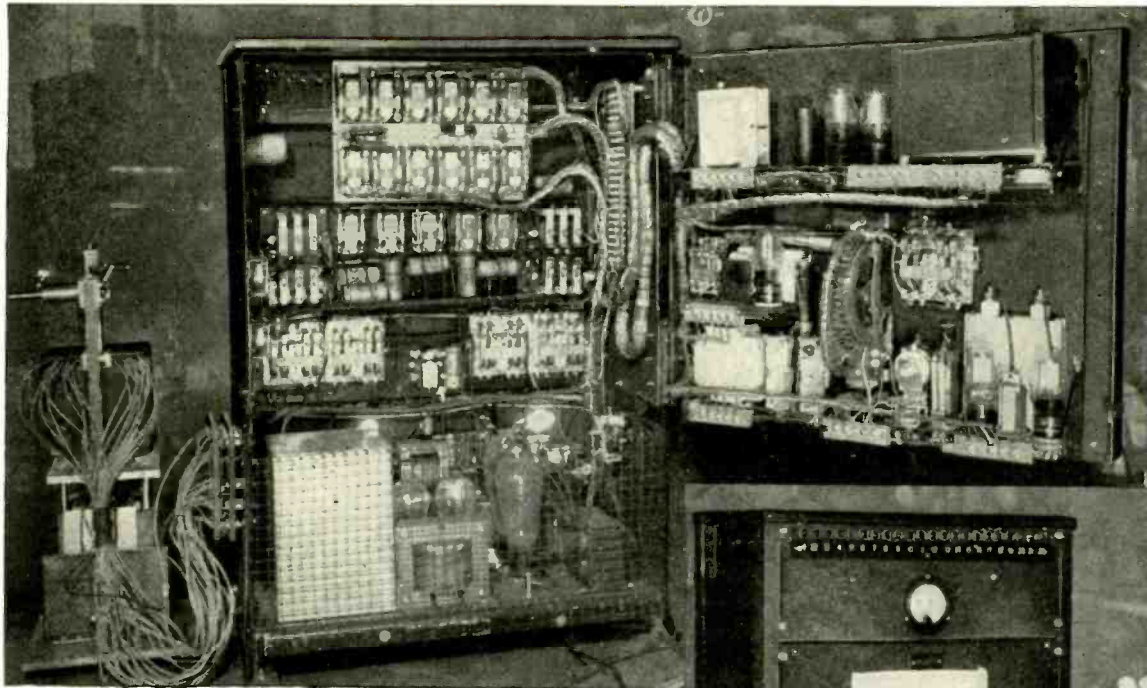

Rear view of new FOSTER "ROBOT" TESTING APPARATUS. Open panel reveals complex electrical units.

Front view of "ROBOT." Controls are few and easy to operate. High-precision readings visible at a glance.

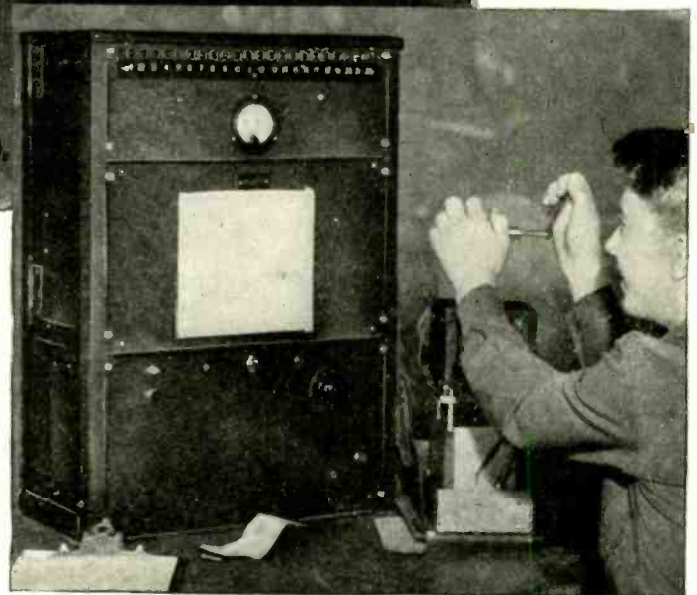

FOSTER AUTOMATIC "ROBOT" ELIMINATES HUMAN ELEMENT IN TRANSFORMER INSPECTION

This is the new Foster "Robot"—an ingenious Foster development designed to eliminate fallible human judgment in the final test and inspection of Foster transformers.

The "Robot" is never tired. Its judgment never fails. It has no memory, and no conscience—it accepts or rejects automatically. All in one operation this stern mechanism tests core loss, turns ratio, leakage resistance and winding resistance. All Foster transformers must meet the "Robot's" requirements, both for usual running conditions as well as a high specified safety margin. And the "Robot" does this vital work faster,

more accurately and more uniformly than was ever possible before.

Designed to meet the heavy demands of Foster's wartime commitments, the new Foster "Robot" will continue as an integral part of Foster testing equipment after the war. It is one more assurance that your peacetime Foster transformers will maintain the highest possible standard of performance. And, because it is a time-saver, the "Robot", together with Foster's other streamlined techniques, will actually save you money.

BOB REID
810 West 57th Street
Indianapolis 5, Ind.
Telephone Broadway 2725

BAUMAN AND BLUZAT
2753 West North Avenue
Chicago 47, Ill.
Telephone Humbolt 6809-10-11-12

THE A. P. FOSTER COMPANY
BARRETT BORDER
11 W. 42nd St., New York 18, N. Y.
Telephone PEnnsylvania 6-9133

SPECIALISTS IN BUILDING TRANSFORMERS SINCE 1938

A. P. FOSTER COMPANY

TRANSFORMER ENGINEERS & MANUFACTURERS
719 WYOMING AVENUE, LOCKLAND 15, OHIO

one step

Nearer...

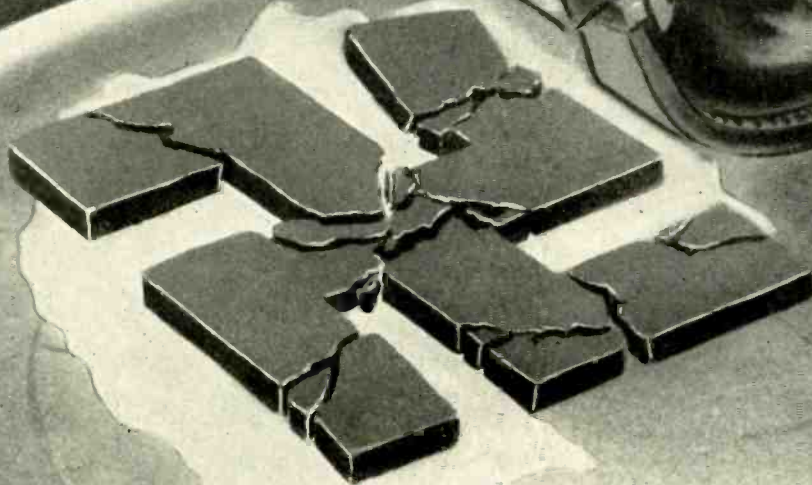

Smashing the Swastika does not mean total Victory. There is still the Rising Sun to be taken care of . . . But, the victory in Europe is *one step nearer* to conversion to peacetime pursuits.

Here at JENSEN total conversion will be merely a matter of continuing to produce outstanding, improved, high quality acoustic equipment. This is a continuing tradition at JENSEN . . . One example of advancement will be JENSEN Loud Speakers with *ALNICO 5*.

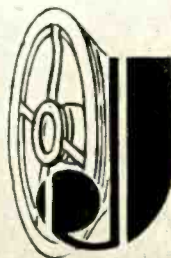

Jensen
SPEAKERS WITH

ALNICO 5

Specialists in Design and Manufacture of Acoustic Equipment

JENSEN RADIO MANUFACTURING COMPANY, 6601 SOUTH LARAMIE AVENUE, CHICAGO 38, ILLINOIS

You are cordially invited
to help write the "specs"
for this new
Gammatron Tube



Heintz and Kaufman Ltd.—first to design and produce such popular tube types as the 24, 24G, 54, and 257B—cordially invite you as a designer or manufacturer of electronic equipment to have a hand in the development of a new series of H & K "firsts." ☆ Our engineering staff welcomes your suggestions for additions to the Gammatron line. If you have a requirement not adequately met by existing tubes, please let us know so that our development program may be directed accordingly. ☆ It will be to our mutual benefit if you will take a few minutes now to set forth your suggestions, and thus participate in the designing of outstanding new Gammatrons.

HEINTZ AND KAUFMAN LTD.
SOUTH SAN FRANCISCO • CALIFORNIA

Gammatron Tubes

Export Agents: M. Simons & Son Co., Inc. 25 Warren Street, New York City, N. Y., U. S. A.

**BUY WAR
BONDS**

RADIO

★ JUNE, 1945

25



**"Can Bridgeport Handle
Volume Like Ours?"**

**"Sure thing . . . That's why they'll
have our postwar business."**

**Bridgeport Has
the Personnel and
the Capacity To Handle
Your Order, Too.**



The technicians who are meeting military specifications in the production of search coils and variometers will be available after the war to build equipment for you. The capacity that now enables Bridgeport to ship by the carload will be here, too.



You'll like the fast, trunk line service to any point that is a natural result of Bridgeport's central location. Write to Bridgeport today to insure early postwar delivery of R. F. Coils and Chokes, I. F. Transformers and Transmitting Coils and Chokes.

BRIDGEPORT

MANUFACTURING COMPANY
Bridgeport, Illinois

R. F. Coils • R. F. Chokes • I. F. Transformers
Transmitting Coils • Transmitting Chokes



HOW FUNGUS-PROOFING KEEPS FIELD TELEPHONES FIT FOR COMBAT

In the South Pacific the life of an ordinary field telephone might be measured in hours...were it not for fungus-proofing. Minute organisms, which thrive in the hot, humid islands of the Pacific, strip unprotected wires of their insulation...quickly corrode exposed metals and reduce untreated plastics to a moldy heap of uselessness.

To prevent this costly and dangerous destruction of precision instruments, the EE8-B field telephones we turn out for the U. S. Signal Corps are specially fungus-proofed during their manufacture. There

can be no margin for error in this vital process—because men's lives depend on sure-fire communications.

You may not need fungus protection in the telephone instruments, electrical equipment, or electronic devices you will one day install in your plant. But you *will* be looking for sound, progressive engineering... adaptability to your particular needs... uniform high quality. Ask the returning soldier who has used Connecticut Telephone & Electric Division equipment in the field what he thinks of it. We'll rest our case with him.

INSPECTION IN THE DARK

Fungus-resistant liquid is applied to Army field telephones in the form of an atomized spray. Tell-tale ingredient of the fungus-proofing is a fluorescent dye which glows under "black light" . . . Thus, by means of a final inspection in total darkness, the slightest defect in the continuity of the protective spray coating is instantly detected.

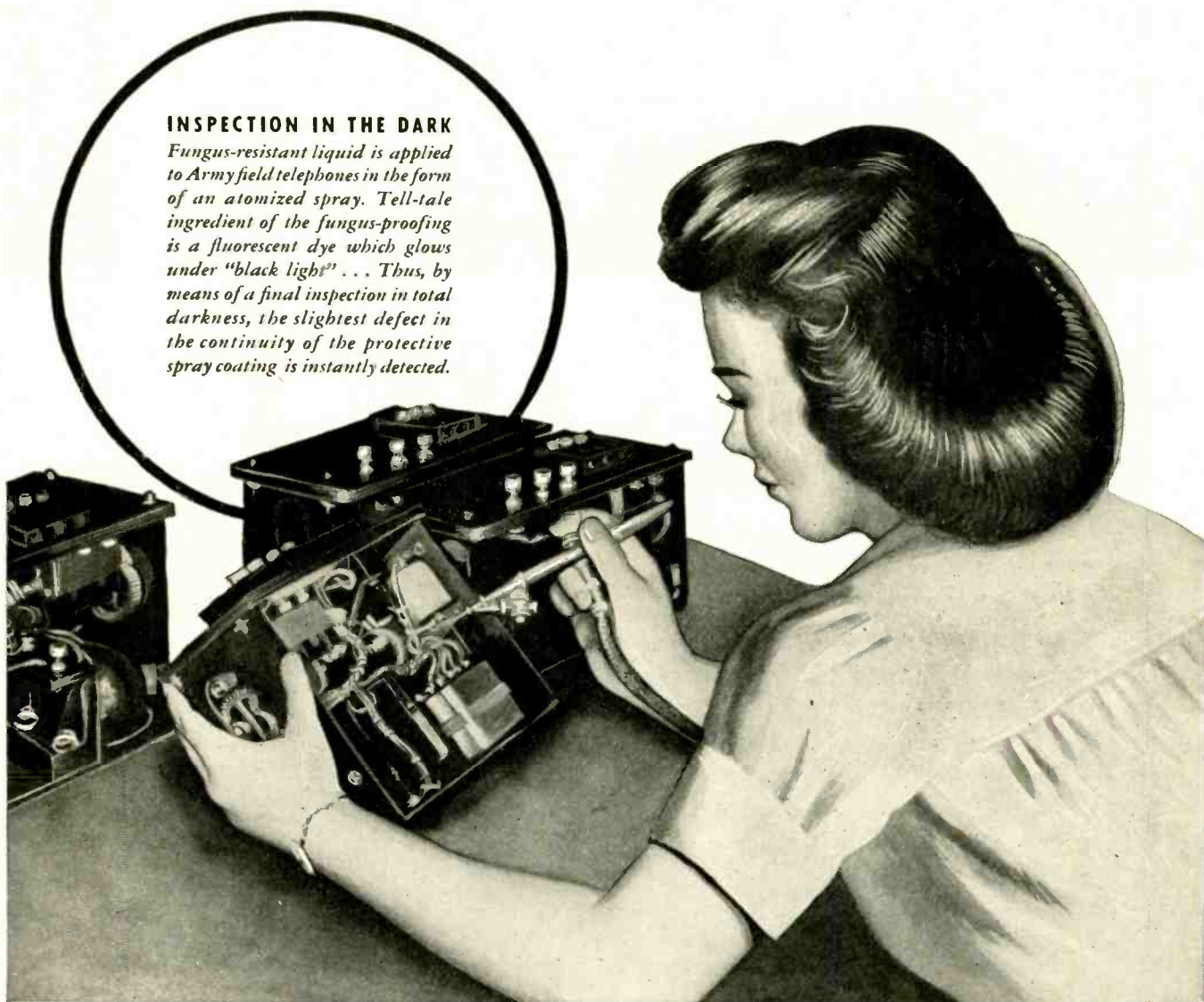

CONNECTICUT TELEPHONE & ELECTRIC DIVISION

GREAT AMERICAN INDUSTRIES, INC. • MERIDEN, CONNECTICUT

TELEPHONIC SYSTEMS • SIGNALLING EQUIPMENT • ELECTRICAL EQUIPMENT • HOSPITAL AND SCHOOL COMMUNICATIONS AND SIGNALLING SYSTEMS • IGNITION SYSTEMS

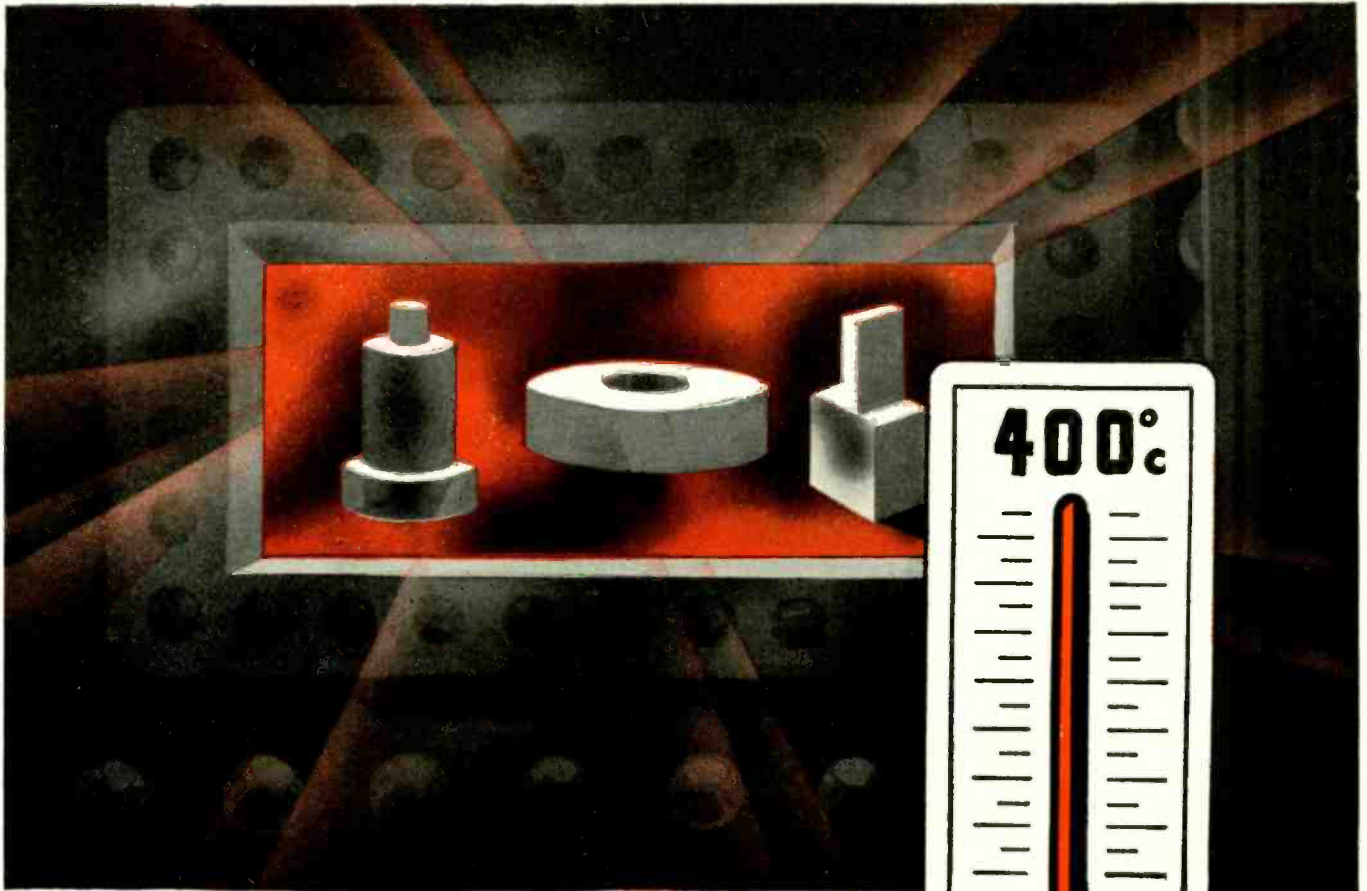

MYCALEX 400

WITHSTANDS HIGH TEMPERATURES

An outstanding characteristic of MYCALEX 400 is that it can withstand temperatures above 400° C. without softening or any permanent change in dimensions or properties.

Thus MYCALEX 400 has proved of great value as a low loss insulator in communications and other high frequency apparatus intended for use at elevated operating temperatures.

MYCALEX 400 is inorganic, free of carbonization... impervious to oil and water... not subject to cold flow. It meets all Army and Navy specifications as Grade L-4 material (JAN-I-10). It combines low loss factor with machinability to close tolerances. In sheets and rods. Fabricated to specifications.



OTHER MYCALEX CORPORATION PRODUCTS

MYCALEX K

A series of ceramic capacitor dielectrics, with dielectric constant selectable from 8 to 19. Low power factor, high dielectric strength. Meets Army and Navy requirements as Class H material (JAN-I-12). To specifications.

MOLDED MYCALEX

Low loss, high temperature injection molded insulation. Molded in union with metals in irregular shapes. High production rates result in economical prices.

MYCALEX K and MOLDED MYCALEX will also withstand 400° C.

MYCALEX CORPORATION OF AMERICA

"Owners of 'MYCALEX' Patents"

Plant and General Offices, CLIFTON, N. J.

Executive Offices, 30 ROCKEFELLER PLAZA, NEW YORK 20, N. Y.

Radio Insulating Materials

ALBERT H. POSTLE

Engineer, Sperry Gyroscope Company, Inc

A discussion of the types, uses, properties, and limitations of certain phenolic forms

OLDEST and most widely used plastic material in radio equipment, the phenolic plastic seems best suited for many applications because of a number of properties. Phenolics — or bakelites, as they are commonly termed — are available in a number of different forms for a multitude of applications. The extent of their use is limited only by the imagination of the designer and the willingness or ability of the laminator to supply the material in the desired form.

Because of such diversity, the author has felt it necessary to limit this discussion to conventional types and to indicate the general conclusions which can be observed. Also, to present a fuller picture of the phenolics, certain analogous forms such as the ureas, melamines, and anilines have been omitted from the discussion.

Outstanding Properties

The phenolics have been selected for many applications because of their low

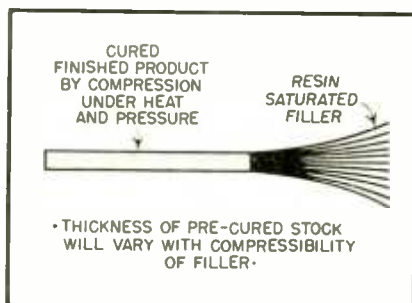

Fig. 1. A laminated phenolic

cost, electrical insulating properties, light weight, dimensional stability, and chemical inertness. They possess the additional properties of being readily machinable and punchable in most standard forms.

Outstanding limitations of the material include the deterioration of most grades under high temperatures or high humidities, limited resistance to strong alkalis, low arc resistance, cold creep and brittleness in certain grades.

All the above analyses are subject to qualification, depending on the grade

of material employed. These statements and the data which follow are not indicative of any specific proprietary grade of any manufacturer, but are representative of industry-wide accepted properties.

Before discussing the material's properties in detail, some attention must be given to the manufacture of the plastic. A laminated phenolic is simply a suitable filler impregnated with a phenol formaldehyde resin, cured under heat and pressure. Usually the filler is stacked in sheet form to build up to the required thickness when compressed.

The final product's properties and appearance will be based on the filler and resin employed and on the manufacturing methods. (See Fig. 1).

The basic filler materials include various grades of paper, linen, canvas, asbestos, and glass cloth or sheets. Individual binder and filler constituents of the common NEMA or JAN grades are summarized in Table 1.

The resin is composed of a compound of phenol and formaldehyde, both

TABLE 1

NEMA Type	JAN Type	Filler
X	LTS-M-1	Paper
P(XP)	LTS-E-1	Paper, punching stock
XX	LTS-E-2	Paper
XXP	LTS-E-3	Paper, punching stock
XXX	LTS-E-4	Paper
XXXP	LTS-E-5	Paper, punching stock
C	LTS-M-4	Canvas
CE	LTS-EM-1	Canvas
L	LTS-M-3	Linen
LE	LTS-EM-2	Linen
A	LTS-H-1	Asbestos paper
AA	LTS-MH-1	Asbestos fabrics

(NEMA types are described in "NEMA Laminated Phenolic Products Standards," JAN types are those listed in Joint Army-Navy Specification JAN-P-13, "Plastic Materials, Laminated Thermosetting Sheets and Plates.")

TABLE 2

NEMA Type	Dielectric Strength V/mil	Insulation Resistance (log ohms)	Dielectric Loss Factor (at 1 mc)
X	500	8.3	—
P	500	8.3	—
XX	500	8.3	.20
XXP	500	8.4	.20
XXX	470	8.3	.15
XXXP	470	—	.12
C	150	—	.70
CE	360	8.3	.22
L	150	—	—
LE	360	8.3	—
A	160	7.4	—
AA	50	7.3	—

(Dielectric strength and dielectric loss factor, NEMA averages; Insulation resistance, JAN average on one-inch spaced holes.)

coal tar derivatives. The phenols, similar to carbolic acid, are produced from the fractional distillate of benzine or by synthetic processes. In natural form, cresols and xylenols, compatible with the phenols, are retained. The formaldehyde is produced from coke or by synthetic means.

Mixed in the presence of a catalyst (to hasten the chemical process and to add hardness to the plastic), and under live steam, the phenolic plastic is formed. As a liquid impregnant it is applied to the filler material and allowed to cure in part before stacking. During this precuring operation, the excess solvent is removed by evaporation. A plasticizer is often added to give greater flexibility for certain manufacturing operations such as punching. Fig. 2 shows typical operations.

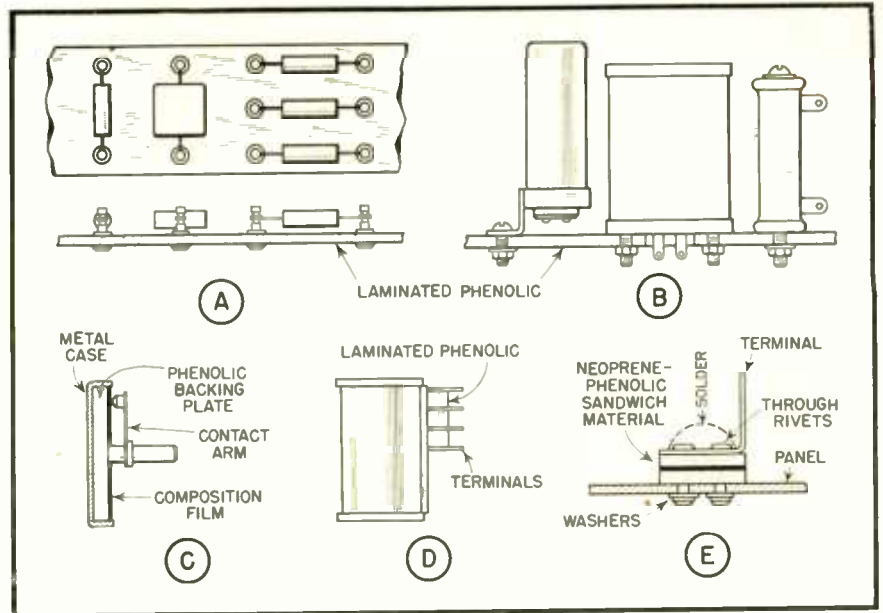

Fig. 4. Typical applications of laminated phenolics

Contents vs. Properties

It was stated previously that the final product's properties and appearance would be based on the type of filler and resin employed and on manufacturing methods. How then can this be done?

Consider first the manufacturing methods and how they affect the material's properties. Curing of the material is a function of time, temperature, and pressure. This will, of course, vary with the type of resin, filler, and shape. But proper curing is that process which allows an even, uniform flow of the resin throughout the filler during the curing operation. Improper cure can allow a soggy center section or cause a hard brittle surface. Proper cure will

insure a uniformly dense material, with good electrical properties and with the majority of the stresses removed.

The quantity of resin versus the solid content of filler determines the strength and overall humidity resistance of the plastic. The higher the resin content, as a general rule, the lower the mechanical strength of the plastic but the higher the material's imperviousness to moisture attack. This statement, however, is dependent upon the filler material employed. For example, a cellulose product will have a higher moisture absorption than a non-cellulose product, assuming equal resin saturation.

The resin, itself, can be variously

compounded for resiliency and strength or for electrical properties. Formaldehyde in the resin adds to the resiliency and strength, phenol to the electrical properties. (It must be admitted, however, that these statements have been generalized to the point that the existence of different substances, each known as phenol, has apparently been overlooked. This is mentioned lest the reader get the erroneous impression that each of these substances we are dealing with is a specific material rather than a group of materials).

Finally, the filler determines the overall performance of the plastic. Since between 35% and 65% of the solid content of most laminated phenolics is comprised of the filler, its effectiveness is a highly important consideration. The commonly employed fillers, mentioned above, each have varying properties:

Paper . . . good electrical properties, low moisture penetration, machinability in finished form, low cost.

Canvas . . . toughness, poor electrical and moisture properties, high impact strength, machinability in coarse forms.

Linen . . . toughness, poor electrical and moisture properties, high impact strength, machinability in fine forms.

Glass . . . toughness, heat resistance, low moisture penetration, good electrical properties, poor machinability, high cost.

Asbestos . . . toughness, high heat resistance, fair moisture resistance, poor electrical properties, high impact strength.

Electrical Grades

Judging by the available constituents, heavily saturated paper or glass based

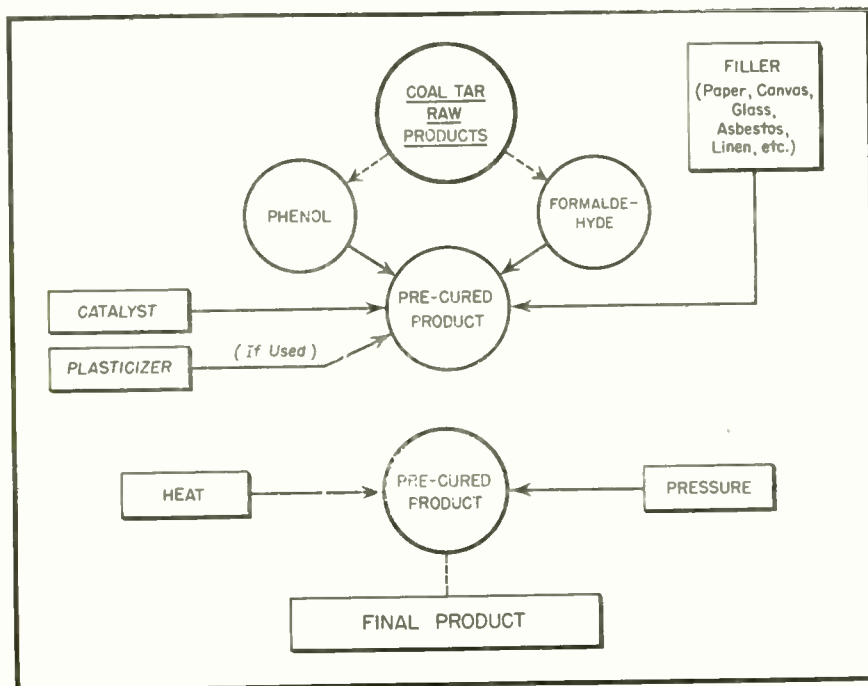

Fig. 2. Flow chart of manufacture of laminated phenolics

phenolics have the most usable electrical properties. Since in most commercial applications, the relative scarcity of glass today and the difficulty of machining are of prime consideration, most electrical work has been best served by paper-based phenolics.

Several grades of paper based phenolics have been standardized as desirable types. Broadly, these phenolics fall into two groups: punching stock, designated by a *P*, and stock not designed for punching with lower cold flow characteristics. Punching stock is constructed with a high surface resin content, suitably plasticized.

The grades available are *X*, *XP*, *XX*, *XXP*, *XXX*, and *XXXP*. The *X* and *XP* grades represent the lowest saturated materials (approximately 40-45% resin), while the *XXX* and *XXXP* represent the highest saturated materials (approximately 55-60% resin).

Three factors determine the electrical rating of a material: the dielectric strength (or maximum unit voltage stress the material will accept without electrical failure), the insulation resistance (a function of surface and volume resistivity), and dielectric loss factor (the product of the resistance-reactance ratio and the dielectric constant).

Table 2 and Fig. 3 summarize the electrical properties of the more conventional phenolics. It must again be pointed out that special formulations of material and proprietary products of

individual laminators will far exceed the values reported here.

Importance of Electrical Properties

No electrical designer needs to be reminded of the importance of high dielectric strength, high insulation resistance, and low loss factor when applied to electrical insulation; with the projection of radio and television receivers into higher r-f and i-f frequencies, the importance of these characteristics is magnified.

Cost, performance, and machinability—as well as the other properties to be discussed—should also be considered before the choice of material is made on the basis of electrical data alone.

Consider some average design problems—as shown in Fig. 4. Fig. 4a shows a typical assembly for intermediate or radio frequency work with resistors, capacitors, and r-f chokes soldered across the terminal board. Here, heat resistance, high strength, and machinability must be subjugated to the considerations of dielectric strength parallel to the laminations, stability of insulation resistance under extreme humidity conditions, moderate dielectric loss, punchability. If the frequency is projected even higher, loss must be kept to a minimum. Comparison of the various tables presenting data shows that a highly saturated paper stock is the desired material, such as *XXP* or *XXXP*. The final result will be a relatively stable material; further improvements can be made in the material if

the rough cut ends are impregnated or coated with an electrical varnish.

Another problem, shown in Fig. 4b, is the terminal board supporting the power supply of a typical receiver. Here the problems of low electrical loss are not of chief importance, but impact strength and general toughness are. Heat resistance and arc resistance are also desirable. Working only in the phenolic field, there is no standard material available that can truly fulfill all the requirements—hence, a compromise must be effected. Phenolics, on the whole, show poor arc resistance; asbestos-filled phenolics show good heat resistance but poor electrical properties, etc. The choice of manufacturing operations will indicate the final selection of material: it is readily apparent, however, that the lower saturated paper laminates will have the dielectric strength required, the punchability or the machinability, and higher impact strength rather than the more heavily saturated types. NEMA types *XP*, *XXP*, *X*, or *XX* are indicated. (The choice between *X* and *XX* will be determined by the humidity conditions affecting the equipment. *XX* will be more stable under higher humidities.)

The carbon potentiometer represents an entirely different problem. As shown in Fig. 4c, the resistance element consists of a composition film sprayed on a bakelite disc. Since the material is usually prepared in long strips and punched to size at assembly, the material must be punchable and must have a smooth uniform surface. Its dielectric

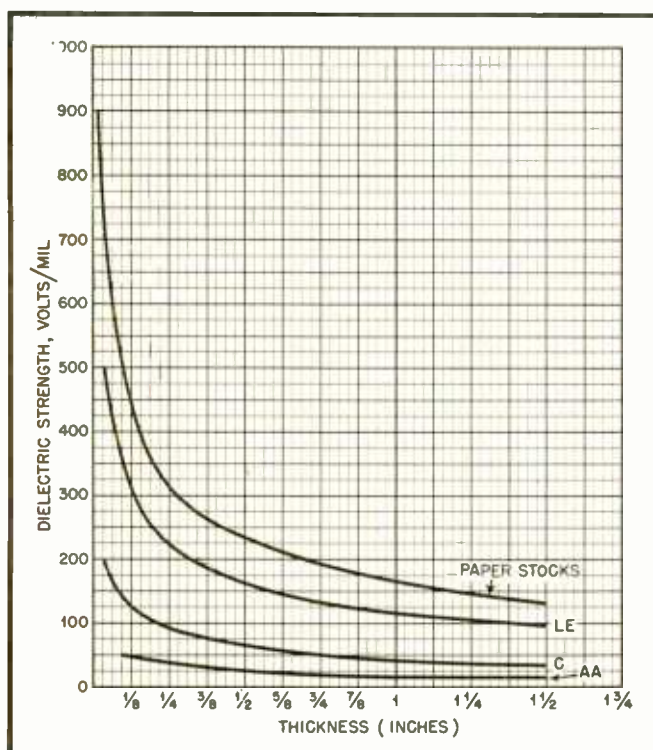

Fig. 3. Dielectric strength vs. thickness curves for typical phenolics

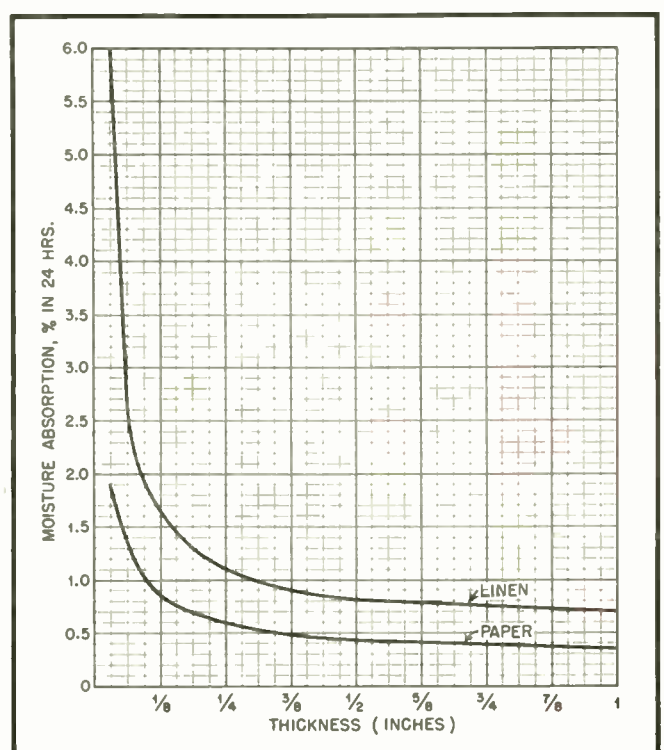

Fig. 5. Moisture absorption characteristics of linen and paper stock phenolics

strength requirements differ in that the strength must be perpendicular to the laminations, since the phenolic insulates the contact arm from the case. The material must be stable under high humidity conditions since any swelling of the disc will cause a separation of the carbonaceous granules, causing an increase in resistance. Again, it must be admitted that the standard phenolic grades represent a compromise, but that paper-based phenolics of special formulation have been the answer to this problem.

Relay spacers, shown in Fig. 4d, represent a problem similar to the composition potentiometer problem. Punching, compressibility, high insulation resistance and low swelling under high humidity conditions, and dielectric strength perpendicular to the laminations are the factors to be weighed. The relay industry has employed various materials such as linen or paper-based phenolics for this purpose, but each material employed represents a special formulation on the part of the laminating trade. Perhaps the most desirable material is a paper-based material because of its dimensional stability under high humidity, but certain special grades of linen—high compressed—have been employed. (See Fig. 5).

The last design problem, illustrated in Fig. 4e, is the choice of "sandwich material" for the capacitor bushing. Here, a hermetical seal is required, with good insulation resistance stability under high humidity. Punchability and close tolerances are of importance. Various materials of this sort are regularly compounded by several of the laminators. The sandwich material consists of a synthetic rubber (such as neoprene) on two sides with a thin wafer of phenolic in the center. The neoprene is glued to the bakelite on both sides. The materials regularly employed—and with merit—are paper-based punching stocks such as XXP or XXXP.

Mechanical Properties

General all-around toughness cannot be achieved with a paper stock because of the nature of the filler. Here the laminating trade has compounded standard grades of fabric-based stock, such as the linen or canvas stocks.

In general, these materials do not possess the moisture properties desired of phenolics because of their cellulose nature—but can be used for spacers, gears, and other mechanical applications where real toughness is required.

Of the two materials, linen and canvas, the choice must be based on the extent of precision machining required. Heavy duty gears, for example, where closeness of tolerance is not required employ a canvas stock. Fine tolerance, light duty gears are made of linen stock.

Heat-Resistant Types

Certain asbestos formulations are used for high temperature applications. Two types of asbestos have been standardized: asbestos paper filler, A; and asbestos fabric filler, AA. The fabric filler adds toughness to the material.

Both of these types are poor under high humidity conditions and cannot be used where swelling would affect the design.

As with all materials, a properly selected phenolic will do its job properly. Careful analysis of the material in design will make the difference between a well-functioning part and a non-functioning part.

Appended is a table of properties of the standard phenolic types. This data has been obtained from the NEMA and JAN standards and represents the

(Continued on page 71)

CHARACTERISTIC	SOURCE	GRADES OF PHENOLIC MATERIALS											
		A	AA	C	CE	L	LE	X	XP	XX	XXP	XXX	XXXP
COMPARATIVE PROPERTIES													
WATER ABSORPTION (%)	JAN	1.00	1.00	2.40	1.25	1.50	1.00	2.10	2.40	0.90	0.90	0.90	0.90
VOLUME RESISTIVITY (log ohms/cm)	JAN	10.1	9.2		10.1		10.1		10.1	10.1	10.0	10.1	10.0
DIELECTRIC CONSTANT (1mc)	NEMA			7.0	5.5	7.0	5.0			5.0	5.0	4.8	4.5
POWER FACTOR (1mc)	NEMA			0.10	.055	0.10	.045			.040	.040	.032	.027
DIELECTRIC LOSS FACTOR (1mc)	NEMA			0.70	0.30	0.70	0.22			0.20	0.20	0.15	0.12
DIELECTRIC STRENGTH (V/mil)	NEMA	160	50	150	360	150	360	500	500	500	500	470	470
TENSILE STRENGTH (psi)	NEMA		8000	7500	6500	7000	6500	9000	6000	6000	6000	5000	5000
FLEXURAL STRENGTH (psi)	NEMA		16000	16000	13,000	15,000	15,000	16,000	11,000	12,000	12,000	12,000	12,000
IMPACT STRENGTH, EDGEWISE (ft. lb in notch)	JAN	.80	3.00	2.00	1.50	1.20	1.00			0.40	0.40	0.35	0.35
COMPRESSIVE STRENGTH, EDGEWISE (psi)	JAN	16,500	18,000	23,600	22,400	21,000	21,500	18,000	9000	22,000		22,000	
F O R M S													
SHEET	NEMA	YES	YES	YES	YES	YES	YES	YES	YES	YES	YES	YES	YES
ROLLED TUBES	NEMA	YES	YES	YES	NO	NO	YES	YES	NO	YES	NO	NO	NO
MOLDED TUBES	NEMA	YES	YES	NO	YES	YES	YES	YES	NO	YES	NO	YES	NO
RODS	NEMA	YES	YES	YES	YES	YES	YES	NO	NO	YES	NO	YES	NO
SHEET THICKNESSES (in inches)													
MINIMUM	NEMA	3/64	1/16	1/32	1/32	.010	.015	.010	.010	.010	.015	.015	.015
MAXIMUM	NEMA	2	2	10	2	2	2	2	1/4	2	1/4	2	1/4
COLORS													
NATURAL	NEMA	YES	YES	YES	YES	YES	YES	YES	YES	YES	YES	YES	YES
BLACK	NEMA	YES	NO	YES	YES	YES	YES	YES	YES	YES	YES	YES	NO
BROWN	NEMA	NO	NO	NO	NO	NO	NO	NO	YES	NO	YES	NO	NO
FINISHES													
SEMI-GLOSS	NEMA	YES	YES	YES	YES	YES	YES	YES	YES	YES	YES	YES	YES
DULL	NEMA	NO	NO	NO	NO	NO	NO	NO	YES	NO	YES	NO	YES
POLISHED	NEMA	NO	NO	NO	YES	NO	YES	NO	NO	YES	NO	YES	NO

Variable Air-Dielectric Capacitors

A. C. MATTHEWS

Characteristics and applications of variable air-dielectric capacitors in radio design

VARIABLE AIR-DIELECTRIC capacitors are characterized by relatively low losses or high Q at radio frequencies. This may be attributed to the fact that air is a perfect dielectric medium, and since the major portion of the dielectric in a good variable capacitor is air, the losses are low. There are, however, other factors which contribute to the losses and these will be discussed with particular reference to their magnitude and variation with frequency.

In order to clarify the problem of variable capacitor design, let us examine the desired characteristics for radio receiver applications. For scale calibration purposes the capacity vs. angular rotation should follow, within reasonable tolerances, a prescribed curve shape, and also be capable of being reset to any desired point with accuracy. Because most receivers require that several circuits be tuned simultaneously and that the resonant frequency of the circuits "align" properly, it follows that the "matching" or "tracking" between sections must be quite accurate. Next, it is desirable that the capacitor have low losses (high Q) at the operating frequency. These three requirements, curve shape, tracking and low losses are basic; without them, it would be impossible to build production receivers.

In addition, there are other characteristics that must also be considered if a quality product is to result. Variations in capacity with changes in temperature and humidity must be minimized. Rotational torque should be relatively low (two to five inch-ounces) and smooth in action. The capacitor must be sturdy in construction and not subject to mechanical distortion when properly mounted. It should not be subject to vibration or microphonic effects

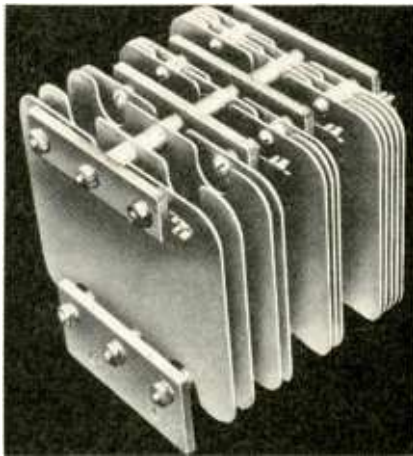

Gang capacitor
(Courtesy Technical Radio Co.)

and above all must be low in cost. This last item, incidentally, is probably the most difficult to obtain.

Now that the desired characteristics have been noted, it might be well to discuss briefly some of the factors influencing the design.

Capacity

The capacity of a parallel plate air-dielectric capacitor can be calculated from equation (1), where A is the effective area of one plate in square inches, d the spacing between adjacent plates in inches and N the total number of plates.

$$C = 0.2246 \frac{(N-1)A}{d} \mu\mu\text{f} \quad (1)$$

This equation holds for any plate shape so long as both rotor and stator plates are equivalent in size.

Several plate designs are commonly used which give straight-line capacity, straight-line frequency, straight-line wavelength or modifications thereof. These are illustrated in Fig. 1.

It should be pointed out at this time

that design equations for calculating the desired plate size to fit a certain curve shape serve only as a guide, or a first approximation. For instance, the actual capacity will exceed the calculated capacity due to so-called "fringe effect" which varies with the spacing between plates. After preliminary samples are completed, the judicious use of a file to correct small variations in the curve, is generally required. After one or more experimental corrections the curve shape is usually satisfactory and the plate design is then complete.

Figure of Merit (Q)

The figure of merit of a capacitor is commonly expressed as Q , and can be represented by the equation:

$$Q = \frac{1}{\omega CR} \quad (2)$$

It can also be represented by power factor:

$$P.F. = \frac{R}{1/\omega C} \times 100 \quad (3)$$

When the capacitor losses are low (the usual case) the Q factor is equivalent

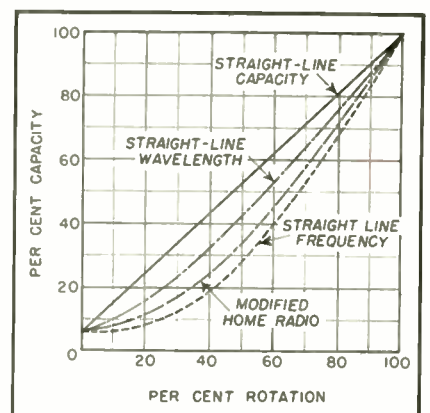

Fig. 1. Capacity vs. angular rotation

to the reciprocal of the power factor. This is a convenient fact to remember since either quantity can be measured and readily converted to the other with a minimum of effort.

Since the figure of merit "Q" is inversely proportional to the resistance, as shown in equation (2), it is obvious that the resistance or loss-determining quantity should be minimized for good design.

Residual Parameters

In the design of a variable capacitor there are two inherent residual electrical parameters which influence its operation over a range of frequencies. These are inductance and resistance, the latter being a combination of losses due to the metal parts and those due to the insulating supports, while the former is due to the magnetic field set up by conduction currents in the unit.

Residual Inductance

To understand the residual inductance, assume a charge is applied to the stator connection *A* in Fig. 2. This divides through the stator plate support and finally flows out through the stator plates and back to the rotor plates. Because the resulting current sets up a magnetic flux, an inductive reactance results. This is represented by L_1 and L_2 in Fig. 2, where L_1 is the inductance of the connection to the stator plates and L_2 the inductance through the rotor wipers and shaft to the rotor plates. The current in and between the plates contributes little to the inductance, since the area involved is relatively large. For this reason, it would appear that the residual inductance of a variable capacitor remains nearly constant for any angular degree of rotation. But as the capacity is changed (which in turn changes the frequency of the circuit being tuned), the residual inductance results in an increase in the effective capacity, according to the frequency and capacity involved. In other words, as the capacitive reactance decreases the inductive reactance increases, thus resulting in an increase in the apparent capacity.

Residual Resistance

Resistance losses in a variable capacitor can be divided into two parts: (1) eddy current loss in the metal parts, (2) hysteresis loss in the insulating material.

The eddy current loss occurs in the plates, plate staking at the rotor shaft, the shaft itself, its bearings, wipers and in any part of the metallic structure in which current flows. These losses are represented by R_m in Fig. 3. At medium and low radio frequencies R_m is ap-

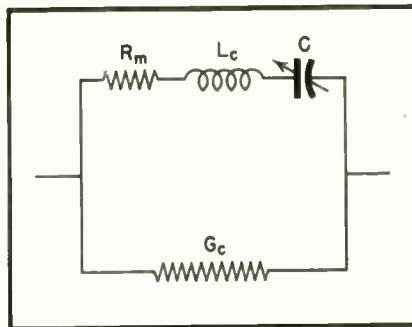

Fig. 3. Equivalent circuit of capacitor

proximately constant with angular rotation and is mainly due to contact resistance at the rotor wipers, and in the case of non-insulated rotors, the resistance through the bearings contribute their part. Current density is high at these points and because it is not appreciably changed by the position of the rotor the losses remain practically constant. At high frequencies, due to skin effect, the resistance increases approximately as the square root of the frequency. This can be minimized by silver-plating the metal parts and is standard practice in high-quality units.

Hysteresis loss in the insulating material (G_c in Fig. 3) is usually thought of as a conductance. This is particularly convenient when it is necessary to evaluate the effect of several components in circuit analysis studies. The insulation of a well-designed capacitor is located in an electric field which does not vary with the rotor setting; it can therefore be considered a constant at any given frequency. But, as the frequency is increased the conductance increases, depending upon the quality of insulation employed.

As an example of design desideratum, let us consider the condenser as shown in Fig. 4. This is a grounded rotor, bar-type frame construction. While it may

not represent the ultimate in high-grade capacitor design, it does represent a typical tuning capacitor as used in present day receivers. Insulated rotor capacitors are inherently costly and are seldom used except in high quality communication equipment.

Frame Structure

The overall construction must be sturdy, or when the driving mechanism is attached a twisting action will take place which will distort the frame. Off-hand this sounds improbable, but when the capacitor is held stationary in its mounting and pressure is applied to the tuning shaft either through a cable type drive or by the operator's hand, there is a tendency for the frame to bend. This is especially true where tie bars are not provided, as in the case of a "U" type bent frame. The tie-bars can be either round, square or flat stock but they must be securely staked to the end plates or frame. It is usually not necessary to braze or weld the joints, although this is sometimes done.

Another reason a sturdy frame is so necessary is that in some designs it is desirable to mount the unit at each end. If all mounting surfaces are not parallel or plane, due to possible variations in chassis construction, there will be a twisting action in either the capacitor or chassis or both when the unit is mounted. It is obvious that any twisting of the capacitor frame will change the plate alignment so this type of mounting is to be avoided if at all possible.

A recommended mounting which eliminates, to a large degree, distortion of the capacitor frame is shown in Fig. 5. Here we mount the capacitor on its bottom surface with three screws: two screws establishing the plane of the capacitor with respect to the chassis and locating the unit, the third screw is used only as a "tie-down", be-

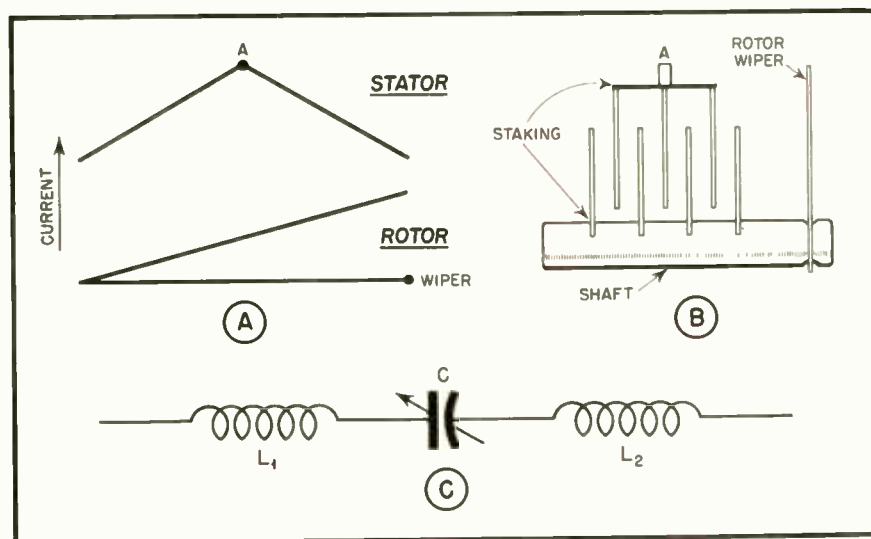

Fig. 2. In (A), current distribution, (B), mechanical details, (C), schematic equivalent showing residual inductance

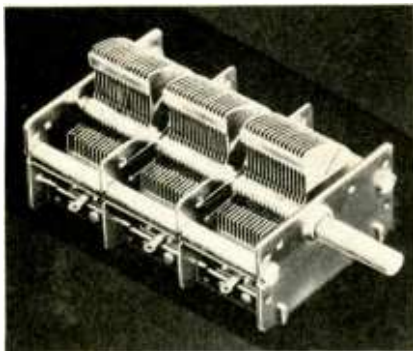

Fig. 4. Typical 3-gang capacitor
(Courtesy Radio Condenser Co.)

cause the chassis mounting hold is nearly surrounded by a circular cutout which provides sufficient flexibility to prevent possible distortion of the frame. Of course, when the capacitor is mounted on rubber grommets, frame distortion is minimized. Nevertheless, there are instances where it is advisable to have as much of the capacitor frame as possible in contact with the chassis (thereby reducing the current density in the ground connections), so that rubber mountings cannot be employed. In such cases, the bottom mounting will usually give the best results.

Of equal importance are the bearings for the rotor assembly. Usually the front bearing is of the ball type, while the rear is of the thrust type using a single ball which can be accurately adjusted to meet specified torque requirements. Because only straightforward bearing design is required for variable condenser applications due to the light load and low speed of operation, the subject will not be discussed further. A small amount of suitable lubricant is of course employed to maintain smooth action and prevent dirt and dust from interfering with the operation.

Plate Structure

Rotor and stator plate assemblies are generally soldered or staked depending upon the material employed. Where extreme accuracy is required a few types still employ precision metal spacers. Ordinarily sufficient accuracy can be obtained with the soldered or staked construction, because centering jigs are always used to hold the individual plates during the assembly operation. As an additional safety factor to ensure the capacitor meeting certain specifications, the outside plates on each rotor section are slotted in several places to about half their radius. This permits the final test operator to adjust the capacity curve at any particular point where it does not quite meet specifications. Plate bending is not desirable because of the additional time involved in testing and because strains are often set up which tend to gradually change the capacity

once it has been correctly adjusted. Mass production, however, necessitates such procedure as it would be impractical to gauge each plate for size and thickness to the accuracy required in order to maintain a uniform capacity curve between units.

Aluminum is nearly always employed as the plate material although copper, brass and steel have been used. The latter two materials are very susceptible to microphonic effects and therefore aluminum and copper, because of their "deadness", are extensively employed. The stator plate assembly is attached to the stator support by soldering while the unit is held firmly in a jig or centering fixture.

Stator Supports

Stator insulating supports are generally attached to the frame with rivets or screws and nuts as shown in Fig. 6.

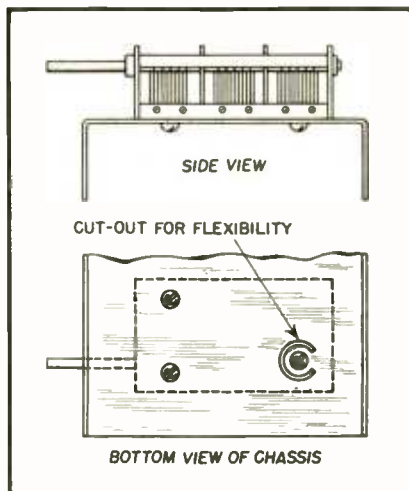

Fig. 5. Typical mounting to prevent frame distortion

Regardless of which method is used, it is imperative that the stator assembly be securely fastened and remain so under all operating conditions. Vibration tests will readily shown weaknesses in design as well as poor workmanship. Such tests however are not all-conclusive unless the effects of aging are taken into consideration. Aging is due mainly to repeated variations in temperature which gradually change the physical size of some insulating materials. Obviously a change in the physical dimensions of the insulator, whether

it is attached to the frame by rivets, bolts or staking will definitely have an effect on the tightness of the fastening. Accelerated life tests can be made by subjecting the unit to two-hour heat cycles from room temperature to 150° F. for five to seven days. Practice has shown this to be a sufficiently long test period.

Several factors should be considered when choosing the insulating material for a variable capacitor. The dielectric constant, power factor, mechanical stability with variations in temperature and humidity and physical strength are all significant. It is not always advisable to choose the lowest loss material available unless the material also has good mechanical properties. In other words the effective insulation of a variable capacitor cannot be judged solely by the electrical quality of the insulation. Some materials, although relatively poor electrically, but because of their good physical characteristics make excellent capacitor insulators. This apparent contradiction to all electrical design practice is due to the fact that the volume of the insulation required is smaller than if the higher electrical grade material was employed. The loss per unit of volume may be higher but since less material is required the total loss may actually be less. Mechanically strong insulation permits the use of designs having long leakage paths which result in low surface leakage.

The surface of the material used also has a direct bearing on its characteristics when subjected to high humidity. Porous materials not only absorb moisture but under certain conditions tend to wet easily. This obviously is an undesirable condition since the conductivity of even a thin film of moisture is appreciable. Even quartz, which has long been considered an excellent insulator, tends to wet easily in the presence of high humidity. The problem is to obtain a surface which will not wet. Polystyrene, wax and some of the silicone resins are excellent examples of surfaces that do not tend to wet. Here the water vapor collects in small discrete globules which do little harm. The application of moisture repellent substances is therefore advisable. Any leakage resulting from the use of poor

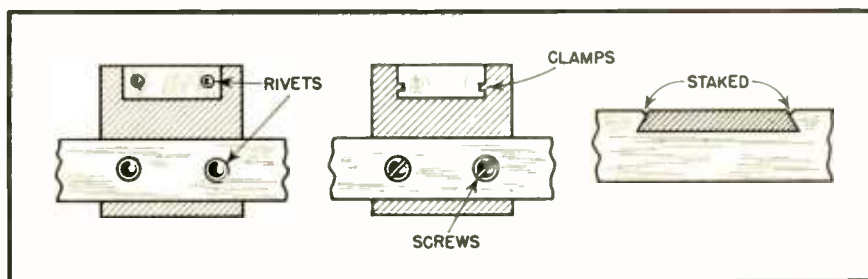

Fig. 6. Methods of anchoring stator insulators to frame

insulating material or inadequate design represents a loss when subjected to high frequency currents and consequently decreases the Q of the unit.

Rotor Wipers

Rotor wipers or connectors are generally made of spring brass although phosphor bronze or spring silver is sometimes employed. Standard practice is to include one wiper for each section in the capacitor, except in some of the low priced units where a "V" shaped wiper between sections is used. This type grounds the adjacent sections to the frame and provision is made for external wiring connections on the internal shield plates.

Where it is desirable to reduce the residual inductance of a capacitor, wipers are provided at each end of each rotor section. They should be as short in length as possible and preferably riveted and soldered to the frame. The use of a number of wipers reduces the inductance and variations in bearing resistance by distributing the current more uniformly from the rotor and acting like several inductances or connections in parallel between the rotor and frame. In spite of the use of several wipers a considerable amount of current will flow in the frame structure. The effect of this current can be minimized by mounting the unit on its bottom surface, thus providing extra contact area between the capacitor and the chassis as mentioned previously. Connections to the capacitor should, however, be made to the wipers just as if the frame were not grounded. Such practice is not necessary at broadcast and medium high frequencies and because it presents problems in isolating the unit from a microphonic standpoint, it is only used where troubles due to grounding are more important than microphonics.

Temperature Compensation

In general air-dielectric capacitors have a good temperature characteristic. That is, the change in capacity with changes in temperature are comparatively low as compared with other types of condensers.

Several factors influence the temperature characteristic, probably the chief cause being the choice of materials used in their construction. The coefficient of expansion or elongation of the materials used in the construction is of prime importance. It is sometimes desirable to construct the frame, rotor shaft and stator spacer from the same material. Thus, when the rotor shaft elongates (which will increase the rotor plate spacing), the frame and stator supports elongate and tend to keep the plates

centered. The increased plate spacing is counteracted by the increased size of the plates themselves. Of course all of these physical changes are very small in magnitude, otherwise an appreciable change in capacity would result.

Another source of capacity change which is apparent only when the plates are nearly unmeshed (minimum capacity) is due to the quality of the dielectric employed. Here the dielectric constant of the material and its stability with temperature are important factors, ceramics being favored in preference to the phenolic types of insulation.

No fixed rule exists, such as the specification of invar plates, whereby a capacitor may be designed for perfect stability with variations in temperature. Each specific design must be studied to determine the source of the trouble and corrective measures taken to eliminate or rather compensate for the deficiency.

Medium Transmitter Types

Since variable capacitors for low powered transmitting service are, in general, quite similar to their smaller

brothers just discussed, the few design exceptions should be pointed out.

Because of the higher operating voltages encountered the plate spacing must be increased considerably. It should be remembered that in some circuit applications (modulated service) the peak voltage may be as much as four times the normal d-c operating potential. Not only should the plate spacing be adequate for the higher voltages but the insulation must be capable of withstanding the surges without appreciable heating.

Precautions must also be taken to minimize the concentration of electrostatic flux at any one point which might result in corona. Plates should therefore be highly polished and all sharp corners should be eliminated since corona will cause ionization and result in high power losses. Consideration must also be given to voltage breakdown at high altitudes.

Characteristic Curves

Typical characteristic curves are shown in Fig. 7. These show the effect

[Continued on page 70]

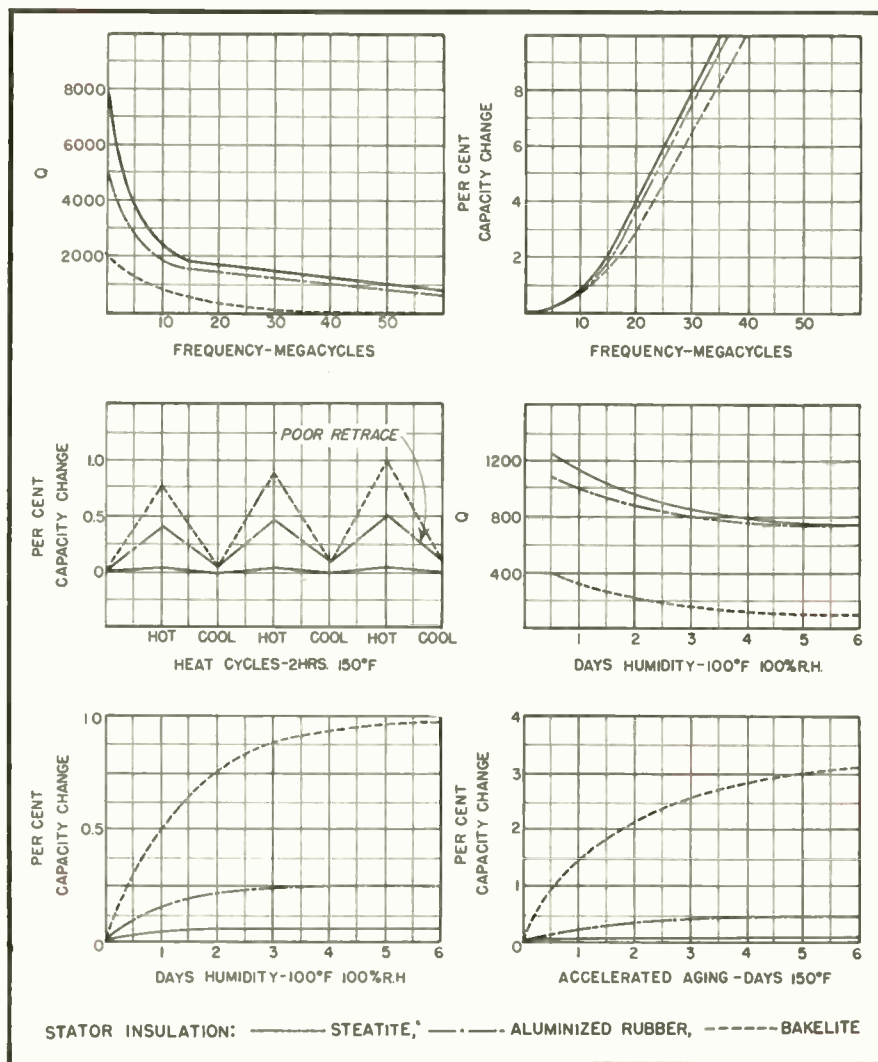
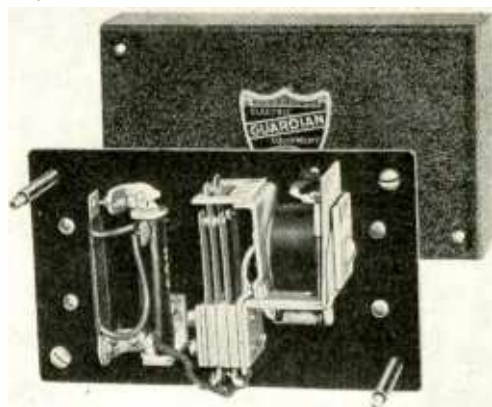

Fig. 7. Curves of variable capacitor characteristics

TIME DELAY RELAYS

GEOFFREY HERBERT



(Courtesy Guardian Electric Co.)

A comprehensive survey, describing the characteristics, general design, construction, and applications in radio design of various types of these relays

FOR STRAIGHTFORWARD control of power and remote switching between alternate circuits, it is desirable to complete the job as quickly as possible so that the next action can be started. Due to the inertia of armature and contact arms, a relay would have to be built with an extravagantly large magnetic circuit to supply enough attractive force to approach instantaneous operation. Another factor which operates to defeat any attempt to use large magnetic circuits is that all coils induce into their own windings a proportional counter-electromotive force which bucks the applied voltage and thereby prevents the field strength from rising rapidly. These are two factors which give every relay a definite operate-time and release-time. Ordinarily, the average light duty, small control relay has an operate-time and release-time of about .001 to .05 second, depending upon size and number of contacts.

Quick-Acting Relays and Time Measurements

The particular operate-time and release-time of a general purpose relay is

determined by the ratio of the mass actuated to the forces developed by the magnetic circuit and the return spring respectively. The general purpose relay is of the quick-acting family. Where its use in the equipment demands a fast action, a smaller, more compact relay will usually prove superior. The speed of operation can be checked with a cathode ray oscilloscope and a suitable a-f generator. The audio signal is sent through the relay contacts to the oscilloscope at the same moment that power is applied to the relay coil by means of a fast-acting double-pole toggle switch. The oscilloscope is then set to sweep at a suitable rate. The operate-time is determined from the number of complete and partial audio signal waves shown on the oscilloscope. The circuit is shown in Fig. 1.

If the sweep rate of the oscilloscope is known accurately enough, the audio signal generator can be eliminated and replaced by a small d-c potential from a dry cell. The operate-time is then determined from the ratio of the length of the horizontal line above the zero

axis to the length of the zero axis. The circuit for this arrangement is shown in Fig. 2.

In these two circuits the testing switch applies the signal voltage at the beginning of the time period and the normally closed relay contacts interrupt the signal voltage at the end of the time period. For a normally open relay contact a different type of circuit, similar to Fig. 3, must be used. The testing switch applies the signal voltage as before, but the closing of the relay contacts shorts the signal across the oscilloscope terminals to zero. The resistor is used to limit the short-circuit current in this circuit.

To measure the release-time of a relay, a circuit similar to Fig. 3 can be used except that the opening of the testing switch will remove the short against the signal voltage applied to the oscilloscope terminals and thus begin the timing period while the opening of the normally open relay contacts will interrupt the signal voltage and end the timing period.

Instead of the double-pole toggle switch, which might cause a slight time error because the contacts of each circuit do not close simultaneously, a three-circuit switch can be used. In this type of switch, the common circuit is switched to a pair of circuits, the contacts of which are isolated when on open circuit. These switches have only one moving contact bar, and the possibility of one contact tripping before the other is greatly reduced.

The cathode ray oscilloscope is not needed when the time interval to be measured is greater than .01 second.

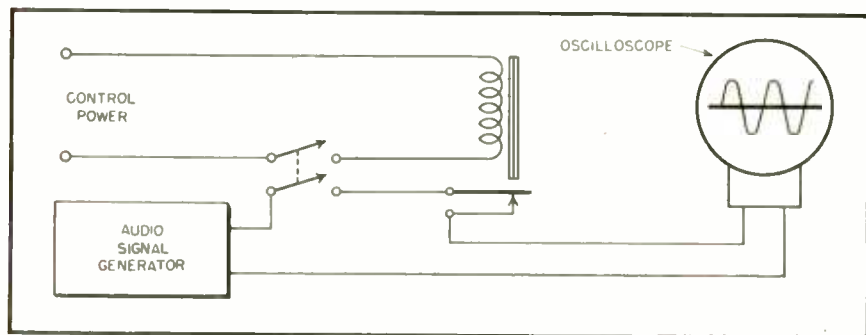

Fig. 1. Setup for measuring speed of operation of relay

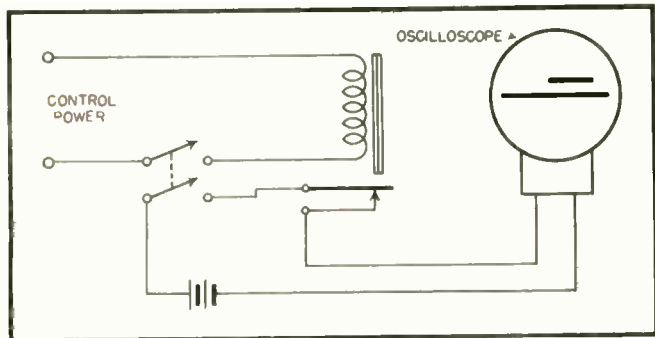

Fig. 2. Measuring operate-time with d-c potential

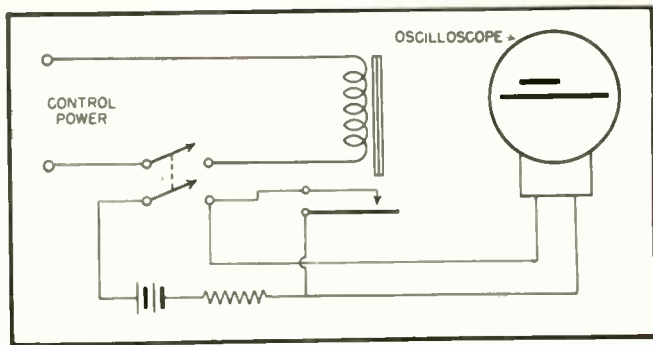

Fig. 3. Method of testing when relay contacts are normally open

Timers for measuring elapsed time intervals are available as standard items. They are driven by 60-cycle synchronous motors, but the motor is not run from the time signal. A small high-speed electromagnetic clutch is operated by the time signal and controls the starting and stopping of the hands. With a.c. applied to the clutch, an accuracy of within .01 second can be secured. A d-c clutch will permit an accuracy of .005 second. In Fig. 4 is shown a typical precision timer.

For some applications it will be found that a standard design, general purpose relay does not have a fast enough operate-time. Typical cases are cutoff mechanisms which must operate with a minimum of lost time and high speed repeater devices. A good part of the operate-time delay is due to the apparent low power factor of the magnetic coil, but the external circuit can be adjusted to partly correct this. This is done by winding the coil for a much lower resistance and heavier current, and adding a series resistor to the circuit. Although there will be a heavier power consumption by the coil, the operate-time can be easily halved.

Time Delay Relay-Telephone Type

The requirements for a time delay period range usually from .01 second to several minutes. It is not practical to use any one method for all periods. It has just been indicated above that the



Fig. 4. Typical precision timer. (Courtesy Standard Electric Timer Co.)

magnetic circuit is responsible for an inherent time delay in all relays. A method highly successful of increasing the natural time delay is to alter deliberately the magnetic circuit. This is popularly known as the copper-slug method.

Slow-Operating

In Fig. 5 is shown a typical telephone relay frame upon which a portion of the coil has been replaced by a copper collar at the armature end. The copper collar is of very low resistance and acts like a shorted turn. When the coil circuit is closed, the flux through the magnetic circuit links the copper slug. This results in an electromotive force and corresponding current in the copper slug which produces a magnetic flux opposing the main flux. This opposing flux gradually dies away, allowing the main flux to take full control. Since the copper slug is placed at the armature end, the opposing effect is localized at exactly the point where the flux attracts the armature and the maximum operate-time is thereby secured. Three standard lengths of copper slugs are usually employed— $11/16$ ", 1", and $1\frac{1}{2}$ ". The operate-time delay secured from these copper slugs varies from .010 to .100 second.

There is one sacrifice which must be made for this operate-time delay. The same copper slug which has created an opposing magnetic flux when current is applied to the coil, also creates a supporting magnetic flux when power is removed from the coil. This supporting flux retards the dying away of the magnetic field and causes a longer release-time delay. The release time which accompanies the above operate-time ranges from .020 to .250 second.

Slow-Releasing

By placing the copper slug at the heel-piece end of the core as shown in Fig. 6, the opposing flux is localized where it has little effect on that part of the core which attracts the armature. This permits the operate-time to be kept down to between .004 to .025 second. When the control voltage is removed,

the supporting magnetic flux generated by this copper slug is able to contribute effectively to the release time because a closed magnetic circuit then exists between armature and core. Depending upon the size of the copper slug and the adjustment of the residual gap between armature and core, the release time ranges from .020 to .350 second.

Slow-Acting

When both slow operating and slow releasing is desired, a copper sleeve can be placed directly over the full length of the core. This yields a range of operate-time of .010 to .050 second and release-time of .020 to .350 second. Whenever either type of time delay is desired, it is preferable to use the slow-acting construction. Because the coil winding is outside and extends the full length of the spool, the wattage rating does not have to be reduced.

Variations of the Copper-Slug Method

The application of telephone type relays with time delay characteristics is principally for automatic telephone exchanges. Dial systems use the time delay relay to distinguish between the short-time intervals of current pulses sent out by a single sweep of the dial and the longer time interval before the start of the next set of current pulses.

The longer time-delay periods, mentioned previously, are attained only when the relays are rigidly mounted and protected from vibration, as is custom-

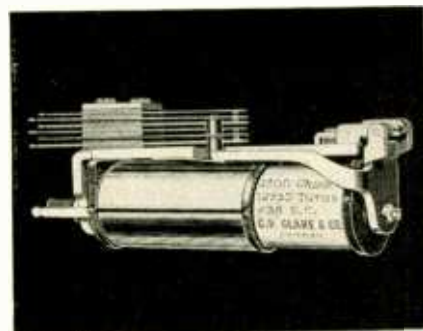

Fig. 5. Slow-operating relay. Copper collar at armature end furnishes delay action. (Courtesy C. P. Clare and Co.)

ary in telephone exchanges. When vibration is encountered, the spring and residual gap adjustments must be set for shorter time delays, if reliable, reproducible operation is necessary. Therefore, it is not advisable to expect more than .200 second release time from a slow-release relay and corresponding reductions in time delay for all other types.

The copper-slug method of securing time delay can be applied to any magnetic relay. In Fig. 7 is shown a general purpose remote control relay which has been equipped with four copper slugs. As shown, the copper slugs are at the armature end of the coil and the relay has a minimum delayed attract of .075 second. This relay will perform satisfactorily under all service conditions encountered in aircraft, such as the 10G acceleration test, vibration at an amplitude of .020 inch and 2500 cycles per minute for 3 hours, temperature range of -70°F to 200°F , and up to 50,000 feet altitude. For some applications, the operate-time delay can be increased to .200 second.

Some applications which require a slow-operate, will not permit the accompanying long release time. With the standard form of copper slug there is no way to avoid this. However, relays of the type shown in Figs. 5, 6 and 7 can be wound with a double coil. One of these windings is used as the control coil and is connected to the control circuit. The other winding is connected to an extra pair of normally closed contacts so that this coil is shortened by these contacts when the relay is not energized. This second winding then acts as a multi-turn copper slug. When the relay is energized, this slug winding is open-circuited by its contacts and cannot act to cause a long release time. The same method using normally open contacts for the slug winding will give a slow release without a long operate-time. The time delay will not be as long as with a solid copper slug due to the poorer space factor of the copper winding.

When a slightly longer time delay is

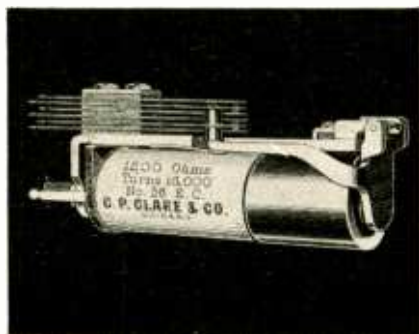

Fig. 6. Slow-releasing type. Copper collar is at heel piece.
(Courtesy C. P. Clare and Co.)



Fig. 7. Remote control relay with copper slug delay.
(Courtesy Guardian Electric Co.)

required, two or more time delay relays can be used in cascade. To accomplish this, the first time-delay relay actuates the control coil of the second relay and the second or last time-delay relay does the actual switching desired. The apparent time delay of the combination is the sum of the time delays of each relay. Where heavy loads or many contacts are to be controlled, the final relay can be a general purpose, quick-acting relay.

Capacitor Method of Time Delay

The copper-slug method of adding time delay characteristics to the basic relay puts to work the natural energy stored up in the magnetic field of the relay coil and core. Another method of utilizing the principle of energy storage to secure time delay is to use a circuit network consisting of relay coil, large capacitor and resistor. The basic principle in this form of circuit is a resistor used in series with a capacitor to limit the charging rate of the capacitor. A relay of the telephone type, or especially of the sensitive type, can be adjusted to pull in and drop out at precise coil voltages. This type of circuit is shown in Fig. 8.

The circuit shown in Fig. 8 approximates the performance of the slow-acting copper-slug relay. It can be made to give a slow-operate performance by adjusting the relay to pull in as the voltage across the capacitor nears its maximum. It will give a slow-release performance by adjusting the relay to pull in and drop out at a voltage which is only a small percentage of the circuit voltage. By using a low voltage, high capacitance electrolytic capacitor and a sensitive relay capable of a wide range of adjustment and having a low power coil consumption, the time delay can be varied over a wide range, up to several seconds. The fixed resistance shown in Fig. 8 can be replaced by a variable resistor which will permit easy manual adjustments for various applications.

Ballast Method of Time Delay

All the previous methods will function only when the operating coil is supplied by d.c. The following methods will operate on either a.c. or d.c.

Often it is desired to use a general purpose relay for time delay work in order to standardize on one relay for several purposes. As has been discussed before, no basic adjustments can be made to a quick-acting relay that will have much effect on its time delay. Therefore, only some method of delaying the application of full voltage to the relay will have any appreciable effect. The capacitor method has just such an effect but is far too bulky for a relay having an appreciable coil power consumption.

Incandescent filaments possess a combination of two properties which give them unique time-delay characteristics. Due to the rapid radiation of the energy by which they are being heated, they take an appreciable length of time to reach a steady operating temperature. Also they have a huge positive temperature coefficient of resistance. The ratio of resistance between hot and cold is about ten to one. When used in a circuit such as Fig. 9, time delays from a fraction of a second to several seconds can be obtained. When the actuating current is first applied, the filament acts as a low resistance by-pass across the relay coil and there is a considerable voltage drop across the fixed resistor. The current through the filament causes the filament resistance to rise; thus the decrease of current through the filament reduces the voltage drop across the fixed resistor and the relay operates. For the incandescent filament, an ordinary incandescent lamp of suitable wattage and filament voltage can frequently be used.

A device which has even better resistance change characteristics and consequently better time delay control is the ballast tube usually employed for voltage regulation. This tube consists of an iron wire hermetically sealed in a bulb containing hydrogen or helium. Both gases have high heat conductivity. The iron wire has a very high temperature coefficient of resistance. The rapid cooling of the filament by the hydrogen or helium lengthens the time delay char-

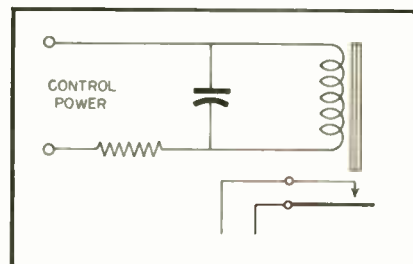

Fig. 8. Schematic of resistance-capacity delay method

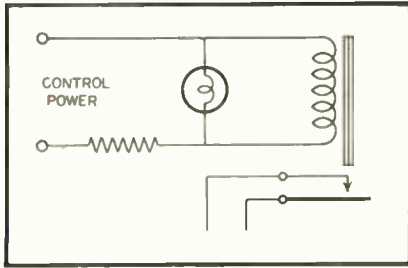

Fig. 9. Ballast time delay schematic

acteristic. A typical ballast tube is shown in Fig. 10.

Thermal Relay Time Delay Method

These are extremely simple devices and work on an entirely different principle from that of the magnetic relay. In the magnetic relay, the power supplied by the coil is transferred by the magnetic forces of the core into mechanical power to operate the contact springs. In the thermal relay, the control power is used to heat a small coil of resistance wire placed adjacent to a bimetallic strip or disc. The bimetallic strip is composed of two metals bonded together and having different thermal coefficients of expansion. The dissimilar expansion of the two metals causes the strip to bend in an arc and move a contact fastened to the free end of the strip. Thus the heat energy supplied from the resistance wire by the electrical power, has been converted into mechanical movement by the bimetal strip. Inherently, the thermal relay is a slow-acting relay and is naturally suited for time delays ranging from

several seconds to one minute. They are made by various manufacturers for ranges of 1 second to 2 minutes, but when the range of several seconds to one minute is exceeded in either direction, trouble can be expected.

The explanation for this troublesome operation is typical of the use of most products originally designed for operation indoors. The heat required to actuate the bimetal element cannot be made excessive or it will injure the metals of the element. In practice, it is found that with the maximum heat supplied to the bimetal element, the resulting time delay is about one second. This, however, leaves no safety margin for high ambient temperatures or over-voltage on the heater. Consequently for reliable operation, the minimum time delay should not be less than two or three seconds. The same type of reasoning applies to the use of thermal relays for long time delays. A typical curve for temperature vs. time of the heater for the bimetallic strip would show that the curve levels off with the time axis at slightly more than two minutes. This means that if the heater voltage is on the low side, a disastrous increase in time delay may occur. Provided thermal relays are used within conservative time ranges, the results will be excellent in spite of heater voltage variations of plus or minus ten per cent. The usual tolerance in original calibration at nominal heater voltage is $\pm 20\%$ for a strip type bimetal element.

In Figs. 11 and 12 are shown typical bimetal strip element actuated time delay relays which are hermetically sealed in glass and filled with an inert gas. It will be noted that there are two strip elements. Both carry contacts. The strip which is insulated with sheet mica and wound with resistance wire to form a heater is always made of bimetal. When the other strip is made of a bimetal element, the relay is known as an ambient temperature-compensated unit.

The two bimetal elements are of the same length and deflection behavior so that as one deflects toward the other due to a change of ambient temperature, the other strip will recede the same amount, thus keeping the contact gap constant. On a well made unit of the compensated type, the time delay will be virtually unaffected over the entire temperature range of -65°F. to 150°F. Where reliable timing is expected of a thermal relay over a wide temperature range, this is the only type of compensation that should be used.

Occasionally, for motor protection or where an entire equipment may over-heat, it may be preferred to make the relay also responsive to ambient temperature. This is easily done by replac-

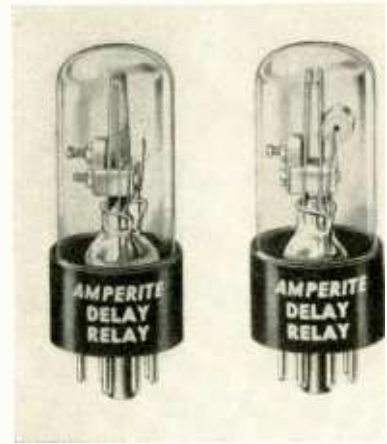

Fig. 11. Bimetal strip time delay relay. (Courtesy Amperite Co.)

ing the compensating bimetal strip with that of a single metal. This uncompensated form of construction should never be used unless the time delay response of the relay has been carefully checked at each of the various ambient temperatures that the equipment will be expected to perform.

Bimetal elements can also be made in a circular disc shape, dished at the center to form the familiar oil can action. This disc is held at the edges and the electrical resistance heater causes the center of the disc to snap from one side to the other due to the internal stresses set up between components of the bimetal. Small leaf spring contacts are actuated by an insulated rod attached to the center of the disc. This form of bimetal disc thermal relay is made in both uncompensated and compensated types. The compensation cannot be performed in the same manner as with the bimetal strip elements because the contacts on the disc type are switched when the heated disc pops and it is not like the case where the heated strip caught up with the unheated strip. Therefore, the compensation in the heated disc due to am-



Fig. 10. Typical ballast tube. (Courtesy Amperite Co.)



Fig. 12. Thermal relay. (Courtesy Thomas A. Edison Co.)

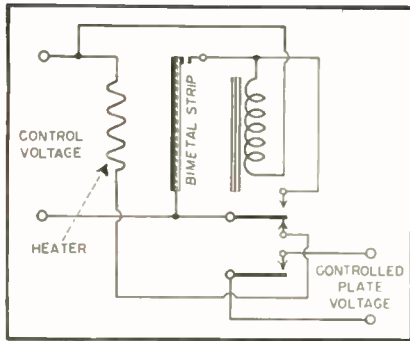

Fig. 13. Schematic of thermal element and quick-acting relay. A representative commercial model is shown on page 37

bient temperature change by another unheated bimetal disc whose direction of motion due to ambient temperature change opposes that of the heated disc. The stresses set up by this form of compensation are very complex and the resultant compensation is difficult to reproduce reliably at temperatures below -20°F , or above $+120^{\circ}\text{F}$.

All thermal relays have a considerable recycling time, which is equivalent to the release-time of magnetic relays. Thermal relays having a time delay between 10 and 70 seconds will usually recycle in about 10 seconds. This recycling time is frequently considered a disadvantage. Actually, for some work it will prove an advantage. In a typical application the contacts of the time delay relay energize the coil circuit of a power relay. A 500-ohm resistor is connected in series with the heating coil of the time delay relay when the power relay operates. This reduces the voltage to the heating coil and maintains the temperature of the bimetal strip just above the operating point. During a momentary power interruption, the thermal relay contacts do not open; however, during a longer power interruption, the time required to restore normal operation is proportional to the length of the power inter-

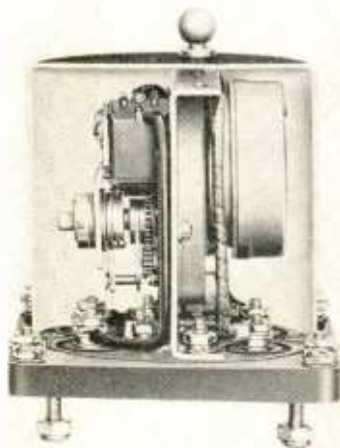

Fig. 14. Typical motor-driven time delay relay. (Courtesy R. W. Cramer Co., Inc.)

ruption. This is an advantage, since it is not necessary to recycle completely each time the supply is interrupted momentarily.

The contact arrangements available in the bimetal strip type are only single pole, single throw, normally open or normally closed. The maximum contact rating is 10 amperes, 115 volts a.c. Due to the slow rate of the contact break, a protective capacitor and resistor must be connected across the contacts when they are used on voltages above 50 v.d.c. The heater can be wound for voltages up to 115 v.a.c. or d.c. and any frequency.

Occasionally, time delay relays are used with normally closed contact arrangements for starting motors and lamp flashing. In typical designs the current carried by the contacts also passes through the bimetal strips. When these currents are light, their heating effect is not noticeable and is automatically compensated for. Inrush loads of large motors and incandescent filaments will cause an abnormal temperature rise in both strips. Since both the heated and unheated strips are then working at a temperature well above ambient, the temperature vs. time curve will begin to flatten off even more for the heated element. The result of this shift of temperature equilibrium by the current flow through the bimetal strips is to increase the time delay of a relay with normally closed contacts. Whenever heavy loads are anticipated, the time delay and recycling of a thermal relay should be checked under full load.

To overcome the limitations on contact arrangement and power rating, a simple thermal relay is combined with a quick acting power relay to form a flexible and versatile time delay relay. In Fig. 13 is shown a typical arrangement of parts and wiring schematic. To permit the relay immediately to recycle, the closing of the power relay contacts also shorts out the thermal relay. When the control power is removed from the time delay relay, it will be ready to cycle again.

Timing Motor Method of Time Delay

Practically all these motor-driven time delay relays are powered by small induction synchronous motors which have a built-in gear reduction. These motors are extremely small but possess a built-in magnetically operated counter balanced gear shift. This automatically engages and disengages the gear train when the motor field is energized and de-energized. The drive shaft is then free to be reset back to starting position by means of an external spring. In Fig. 15 is shown the cross section of a typical motor. Another feature which makes this motor espe-

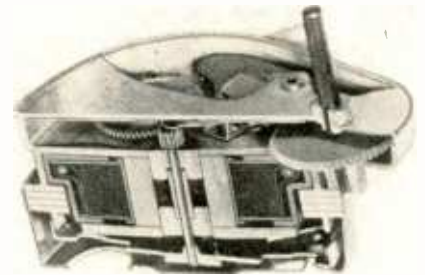

Fig. 15. Cross section of typical motor (Courtesy Haydon Mfg. Co., Inc.)

cially suited to this work is that it can be stalled across the line for indefinite periods of time. However, an auxiliary relay is usually used to lock itself across the line and release the timing motor. A one-way friction can also be incorporated into the motor gear train to absorb the sudden shock at the end of the spring-driven reset return travel.

These motors are usually made for operation on 60 cycles a.c. 115 volts. Recently, a line of d-c motors has been developed which have the same features. Consistent speed is obtained by the governor effect of an electrical eddy current drag built into the motor. The gear trains in these motors have sealed-in lubrication. It is extremely important to check in a cold-test chamber the type of lubrication that these motors have, since if they are not specially lubricated they will not pull into synchronism and time correctly at temperatures below minus 20°F .

These timing motors are mounted on a plate, and drive a shaft equipped with one or two cams and a small spiral spring. The spiral spring is wound with sufficient tension to reset the cams and gear train of the motor back to

[Continued on page 70]



Fig. 16. Electro-pneumatic relay (Courtesy American Gas Accumulator Co.)

Notes on ALIGNING and TESTING

THE PRIME REQUIREMENT of any communications receiver is that it have good selectivity. The general acceptance of the superhet as against the t-r-f set, for instance, can be traced to a number of its advantages, but generally speaking, greater selectivity is its outstanding virtue. It is not unreasonable, then, to attribute this superiority to the i-f amplifier unit. Unfortunately the proper functioning of this portion of the receiver is often taken for granted and the full capabilities of the receiver are not utilized, as a result of haphazard alignment methods.

Before actually aligning the i-f channel, a thorough check should be made of all socket voltages. In fact, the actual alignment should always be left until the last, so as not to be affected by changes in by-pass capacities, tube voltages, tube inter-electrode capacities, etc. It is surprising how a set will often work fairly well with a partially open screen grid resistor or a shorted cathode capacitor. Obviously even commercial receivers are not immune from such troubles, and should not be assumed to be normal, even though the receiver be new and of a reputable make. The vari-

ous measured voltages should agree with tube handbook data, or service notes, especially in regard to bias and maximum allowable potentials. The cathode voltage in self-bias arrangements is of particular interest, not only because it represents the operating bias, but low cathode voltage means improper tube performance and consequent low amplification.

Checking the A-V-C Line

Another extremely revealing test is to isolate the a-v-c line (see Fig. 1) and measure its resistance to ground on the highest scale on your ohmmeter. This test should be conducted *with normal filament and plate voltages*. As an ohmmeter invariably employs a battery, one way of connecting the leads will place the positive battery voltage on the grid, while reversing the test leads will place a negative potential on the grid. The leakage resistance should be of the order of 30 megohms with negative grid and very close to that figure with positive grid. As most ohmmeters use a battery voltage of 3 volts or less, consequently as the cathodes generally run about 3-5 volts above ground, the grid will at all times be negative with respect to the cathode, and no grid current will flow. However any combination of ohmmeter battery and cathode voltages that will make the grid positive with respect to the cathode will result in grid current, and the ohmmeter will indicate low resistance.

Many possible sources of trouble may be detected by this test. Should any of the a-v-c line by-pass capacitors have appreciable leakage, this leakage resistance will combine with R_1 (Fig. 1) to form a voltage divider across the output of the a-v-c rectifier with only a fraction of the a-v-c voltage being applied to the various tubes and resulting danger existing of overloading on high level signals.

Recently in checking a 6L7 mixer in this manner, a considerably lower resistance with positive test lead on grid was noted. This condition disappeared when the h-f oscillator was disabled. All voltages were apparently normal, at

W. H. ANDERSON

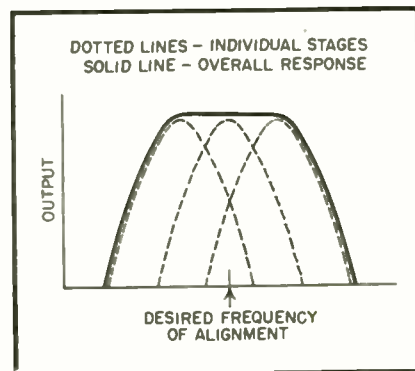

Fig. 2. Broad selectivity curve due to tuning i-f stages to different frequencies

least well within ratings. However, an increase of 25 volts on the 6L7 screen caused the a-v-c line resistance to be very high on both polarities of the test leads. Actually, this imperfect screen-grid action resulted from coupling existing between the control grid and the injector grid and was a potential source of oscillation and pulling between the mixer and h-f oscillator.

Alignment Procedures

The customary method of alignment using an output meter across either the primary or secondary of the output transformer, or simply by loudspeaker volume, will naturally require that a modulated test signal be used. The modulation frequency used is generally 400 cycles. Therefore, considering sidebands, the signal is actually 800 cycles wide. Accordingly each i-f tuned circuit could be tuned anywhere within this 800 cycles and the output meter indication would be unaffected, regardless also of whether all are tuned to the same frequency or not. For instance, one may be tuned to the desired frequency plus 400 cycles, another to desired frequency minus 400 cycles or any other intermediate values. Even in reception of phone signals, an i-f bandwidth of 800 cycles plus the unavoidable slope of the response on both sides, gives an overall

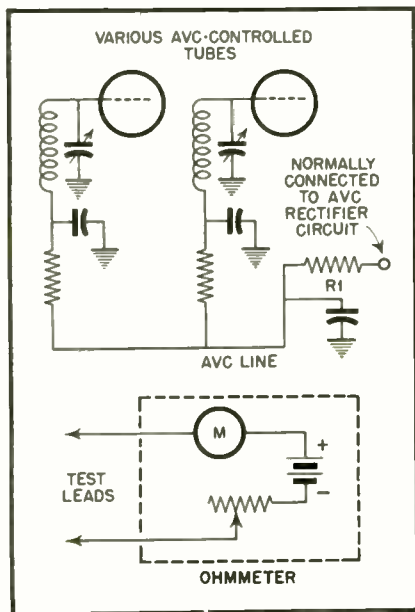

Fig. 1. Isolating and checking a-v-c line

SUPERHETERODYNES

Useful short-cuts in familiar operations

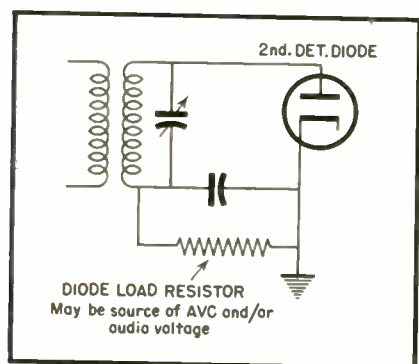

Fig. 3. Diode load resistor used for output measurements

response that has much too broad a "nose." (See Fig. 2). Similarly aligning by ear on atmospheric noise or with a magic eye or a vacuum-tube voltmeter on the a-v-c line is very misleading, as the breadth of the signal contributes to the indication. In the alignment procedure outlined below it will sometimes be noted that the meter will drop down, but the audio output will actually increase as an i-f trimmer is tuned, definitely indicating that the i-f stage has an increasing output by virtue of passing a broader band. It is evident, then, that the methods mentioned above cannot be relied upon to indicate when the i-f channel is in its most selective condition.

Unmodulated Signal Necessary

An unmodulated signal with its theoretically zero bandwidth must therefore be employed. The only place that a measurement may conveniently be made of such a signal is in the 2nd detector circuit. (See Fig. 3.) Output measurement may be made with a voltmeter across the diode load (preferably a vacuum-tube voltmeter to avoid altering the normal load on the diode due to the shunting effect of the meter) or a milliammeter may be used in series with the load resistor.

When the plate load of a tube changes,

its grid input characteristics change (this is known as "Miller effect"), it will be seen to be necessary to align from the 2nd detector "back" to the 1st detector. In order to get the most pronounced "swing" on the meter and a more definite and sharper peak reading, indicating proper adjustment of the trimmer, it is generally best to align with a.v.c. off. This assures that the set will be aligned in its most sensitive condition—i.e., when receiving cw signals, or phone signals too weak to actuate the a.v.c. The further precaution should be taken of cutting down the output of the signal generator occasionally to make sure this causes the meter to drop sharply, otherwise the stage or stages are being overloaded. In short, the signal generator output should be kept as low as possible and still provide a reading of suitable "swing" as the i-f trimmer is tuned through resonance.

In order to prevent interaction between stages, it is advisable to couple the generator to the grid of the last i-f tube and then align the 2nd detector grid and last i-f plate, then move to the grid of the next to last i-f tube and tune the last i-f grid and next-to-last i-f plate, and so forth to the 1st detector grid. Once a stage has been aligned, do not go over the following stages in an

endeavor to "trim" them up. Incidentally, the signal generator should always be well grounded to the set chassis.

Simple Signal Generators

The signal generator itself may be readily improvised, if necessary, from a b-f-o coil of proper frequency and a small oscillator tube such as a 6J7. (See Fig. 4.) Calibration may then be effected by beating a harmonic of such an oscillator against stations in the broadcast band—e.g., the second harmonic of 465 kc is 930 kc, a readily identified broadcast frequency. As has been emphasized before, it is not so important that all stages be aligned to a certain specified frequency, as it is that they be aligned to the *same* frequency.

Single Signal Receivers

If the set has a crystal filter, the crystal may be hooked into the oscillator (See Fig. 4) and alignment to the exact frequency effected. In such sets, when the alignment process has reached the point where the oscillator is coupled to the mixer grid, the vacant crystal socket in the receiver should be bridged out with a large capacitor (.1 μ f or so) and the phasing and selectivity controls set at approximately the most used positions. Alignment of the i-f grid and mixer plate circuit may then be done. A slight compromise is involved in this case as the variation of

[Continued on page 71]

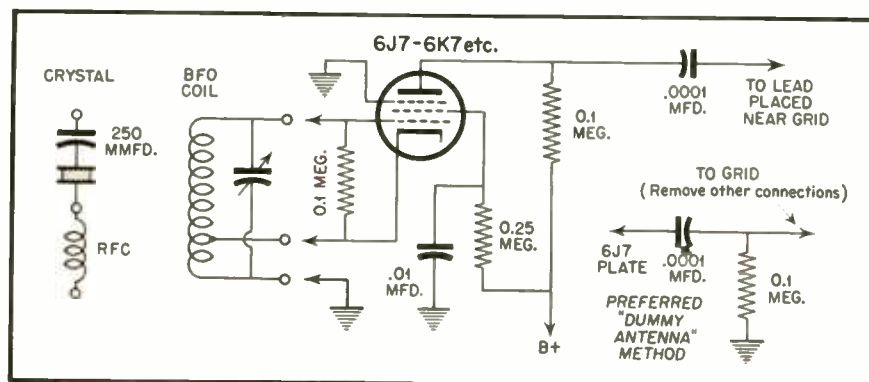
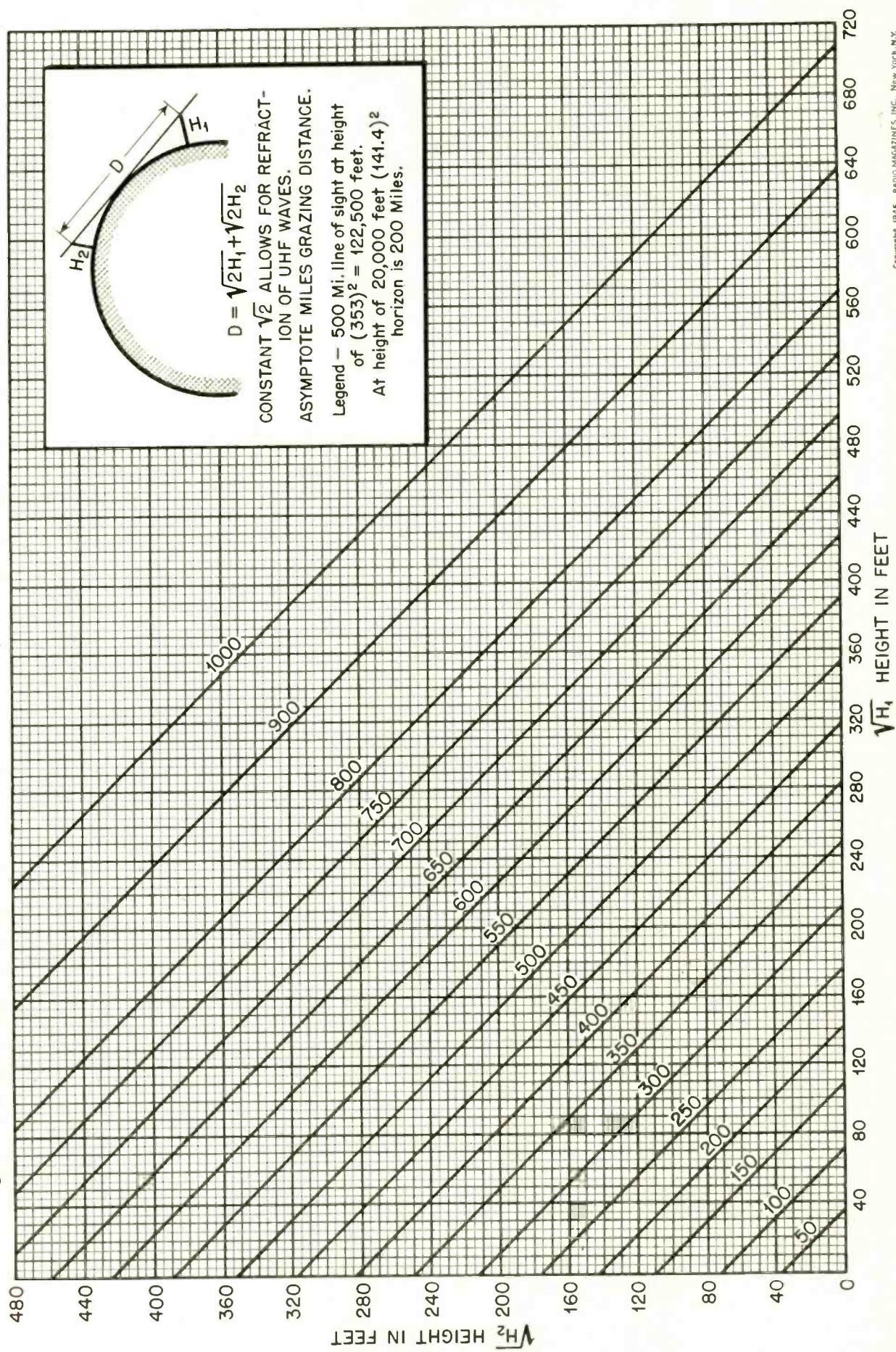

Fig. 4. Simple signal generator for i-f alignment

OPTICAL PATH CHART (GRAZING DISTANCE)



Copyright 1945, RADIO MAGAZINES, INC., NEW YORK, N.Y.

Final Frequency Allocations

This FCC Report, dated May 17, 1945, covers assignments for the portion of the spectrum between 25 and 30,000 mc, with the exception of the 44 to 108 mc region, which is left unassigned pending further tests of FM transmission

THE FEDERAL COMMUNICATIONS Commission has just announced its final frequency allocations to the non-governmental radio services in the portion of the spectrum between 25 and 30,000 megacycles with the exception of the 44 to 108 megacycle region of the spectrum, which is left unassigned at this time pending the outcome of measurements and tests of FM transmission during the coming summer.

This space will ultimately be allocated as follows: 36 megacycles to television, 18 megacycles to FM, 2 megacycles to facsimile, 4 megacycles to the amateurs and 4 megacycles to non-government fixed and mobile services. The precise allocation within this region to the above services remained undecided but the Commission indicated three possible alternative allocations for this region, which turn upon the exact location of FM. The three alternatives for FM are (1) 50-68 mc, (2) 68-86 mc, and (3) 84-102 mc. The Commission also announced that with the cooperation of the radio industry it is immediately planning to proceed with tests during the summer which are designed to determine the best of the three alternatives. A joint committee, under the chairmanship of the Commission's Chief Engineer and composed of engineers from the Commission and the radio industry, will conduct these tests.

The reason for not making a final decision at the time was that the Commission felt that further measurements were desirable before making a final allocation for FM. In this connection the Commission pointed out that its decision not to make a final allocation for FM at this time would not in any way hamper the future development of that service because the Commission has received advice from the War Production Board that the radio industry will not resume production of new AM,

COMPARISON OF CHANNEL ASSIGNMENTS BETWEEN 25 MC AND 162 MC TO SERVICES LISTED BELOW

Service	January 15, 1945 Proposed Report			Draft Final Report		
	Non-Sharing	Sharing*	Total	Non-Sharing	Sharing*	Total
Police	122	0	122	132	0	132
Fire	35	0	35	39	0	39
Provisional	0	26 ¹	26	0	36 ²	36
Power, Petroleum etc.	21	0	21	31	0	31
General Highway Mobile	24	0	24	40	0	40
Marine Mobile	0	16 ³	16	8	15 ⁴	23
Special Emergency	10	0	10	6	10 ⁵	16
Urban Transit	0	10 ^{6a}	10	0	17 ⁶	17
Urban Mobile	0	7 ⁷	7	24	0	24
Forestry & Conservation	23	37 ⁸	60	25	34 ⁹	59
Aeronautical (Flying School & Flight Test)	0	4 ¹⁰	4	7	0	7
Railroads	33	0	33	60	0	60
Geophysical	0	35 ¹¹	35	0	49 ¹²	49
Relay Press	0	26 ¹³	26	0	10 ¹⁴	10
Relay Broadcast	0	26 ¹⁵	26	0	36 ¹⁶	36
Motion Picture	0	26 ¹⁷	26	0	18 ¹⁸	18
General Experimental	30	4 ¹⁹	34	0	26 ²⁰	26
Rural Subscriber Telephone	0	0	0	0	24 ²¹	24
Total	298	217	515	372	275	647

*The television channels subject to sharing are not shown in this table.

¹Shared with Motion Picture, Relay Press, Relay Broadcast & Geophysical.

²21 shared with General Experimental, 10 shared with Special Emergency, and 5 shared with Urban Transit and General Experimental.

³9 shared with Geophysical, 7 shared with Forestry, Conservation and Urban Mobile.

⁴9 shared with Geophysical, 6 shared with Forestry and Conservation.

⁵Shared with Provisional.

⁶Shared with Forestry and Conservation.

^{6a}12 shared with Forestry and Conservation, and 5 shared with Provisional and Experimental.

⁷Shared with Forestry and Conservation and Marine Mobile.

⁸10 shared with Urban Transit, 20 shared on secondary basis with Fire, 7 shared with Marine Mobile and Urban Mobile.

⁹6 shared with Maritime Mobile, 12 shared with Urban Transit, 4 shared with Relay Press and Geophysical, and 12 shared with Relay Broadcast, Motion Picture and Geophysical.

¹⁰Shared with General Experimental on temporary basis.

¹¹26 shared with Provisional, Motion Picture, Relay Press and Relay Broadcast, 9 shared with Maritime Mobile.

¹²24 shared with Relay Broadcast, 9 shared with Maritime Mobile, 4 shared with Relay Press, Forestry and Conservation, 12 shared with Relay Broadcast, Motion Picture, Forestry and Conservation.

¹³Shared with Provisional, Motion Picture, Relay Broadcast and Geophysical.

¹⁴6 shared with Motion Picture, 4 shared with Forestry, Conservation and Geophysical.

¹⁵Shared with Provisional, Motion Picture, Relay Press and Geophysical.

¹⁶24 shared with Geophysical, 12 shared with Motion Picture, Geophysical, Forestry, and Conservation.

¹⁷Shared with Provisional, Relay Press, Relay Broadcast and Geophysical.

¹⁸6 shared with Relay Press, 12 shared with Relay Broadcast, Geophysical, Forestry and Conservation.

¹⁹4 to be used temporarily by Flying Schools.

²⁰21 shared with Provisional and 5 shared with Urban Transit and Provisional.

²¹Shared with Urban Mobile and short distance toll telephone circuits.

Freq. Band Mc.	Proposed International Allocation	United States Allocation	Remarks
25.015-27.185	Fixed and Mobile, except Aero. and Maritime	Gov. and Non-Gov. Fixed and Mobile. Note 1	Power to be limited internationally to 500 watts peak.
27.185-27.455	Scientific, Industrial and Medical	Scientific, Industrial and Medical	All equipment to be adjusted and maintained as closely as possible to 27.320 mc.
27.455-28	Fixed and Mobile except Maritime	Gov. and Non-Gov. Fixed and Mobile. Note 1	Power to be limited internationally to 500 watts peak.
28-29.700	Amateur	Amateur	
29.700-30	Fixed and Mobile except Maritime	Gov. and Non-Gov. Fixed and Mobile. Note 1	Power to be limited internationally to 500 watts peak.
30-30.5	Fixed and Mobile except Aero.	Government	Note 2
30.5-32	Fixed and Mobile except Aero.	Non-Gov. Fixed and Mobile	Notes 2 and 3
32-33	Fixed and Mobile except Aero.	Government	Note 2
33-34	Fixed and Mobile except Aero.	Non-Gov. Fixed and Mobile	Notes 2 and 3
34-35	Fixed and Mobile except Aero.	Government	Note 2
35-36	Fixed and Mobile except Aero.	Non-Gov. Fixed and Mobile	Notes 2 and 3
36-37	Fixed and Mobile except Aero.	Government	Note 2
37-38	Fixed and Mobile except Aero.	Non-Gov. Fixed and Mobile	Notes 2 and 3
38-39	Fixed and Mobile except Aero.	Government	Note 2
39-40	Fixed and Mobile except Aero.	Non-Gov. Fixed and Mobile	Notes 2 and 3
40-40.96	Fixed and Mobile except Aero.	Government	Note 2
40.96-41	Scientific, Industrial and Medical	Scientific, Industrial and Medical	
41-42	Fixed and Mobile except Aero.	Government	Note 2
42-44	Fixed and Mobile except Aero.	Non-Gov. Fixed and Mobile	Notes 2 and 4

44-108 MC — ALTERNATIVE NO. 1

44-48	Amateur	Amateur	
48-50	Broadcasting	Facsimile	
50-54	Broadcasting	Educational FM Broadcasting	
54-68	Broadcasting	Commercial FM Broadcasting	
68-74	Broadcasting, Fixed and Mobile	Television	
74-78	Fixed and Mobile except Aero.	Non-Gov. Fixed and Mobile	Notes 5A and 6
78-84	Broadcasting, Fixed and Mobile	Television, Fixed and Mobile	Note 5

FM and television transmitters or receivers "in 1945 or even in the first part of 1946 unless Japan capitulates. This is not to say that a small quantity of receivers and possibly a few transmitters may not be made available. However, this will have little or no effect on the future expansion of AM, FM and television services." The War Production Board has also advised the Commission that in the event there is any change in its prediction, it will give 90 days advance notice.

These allocations will probably be ordered into effect service by service, with the Commission taking into account such factors as the availability of manpower and materials, the results of the Inter-American Conference at Rio, and the preparation of the Commission's rules and standards. Of course, any allocations made by the Commission are subject to being changed to conform to the provisions of international agreements.

The Commission's report was made in the form of an allocation table, the full text of which is attached. This table will ultimately be included as Section 1, of Part I of the Commission's report on allocations above 25 megacycles, which will be released in the near future and which will give in detail the reasons for the Commission's decision. Since this report is lengthy and contains information which must be checked for security reasons prior to release, some time will necessarily elapse before it can be issued. The Commission felt that it was important that its final allocations be known as soon as possible and that announcement of the result should not be delayed until the text of the report is available. Moreover, the Commission decided that it was extremely important that the tests with respect to FM broadcasting should begin at once since the season of the year is approaching during which sporadic E transmissions are expected to be at their maximum.

The allocation table which was released disclosed three principal changes from the proposed report which was issued last January and which was subsequently the subject of oral argument.

(1) The band in the 27 mc region available for scientific, industrial and medical devices, including diathermy machines, was enlarged in accordance with the recommendation of the manufacturers of diathermy machines, from the 30 kilocycle channel width assigned in the proposed report to 270 kilocycles. The other allocations for the scientific, industrial and medical devices were left unchanged.

(2) Television has been assigned a thirteenth channel at 174 to 180 mc. In the proposed report this band had

originally been assigned to air navigation aids. In addition, two of the three alternative allocations suggested for the region from 44 to 108 mc would make possible the immediate use of all television channels. In the proposed report it was noted that the television channel from 72 to 78 mc would not be useable until the aviation markers centered on 75 mc were moved. Under alternatives 1 and 2 the band around 75 mc has been assigned to services other than television and television has been given assignments which will not have to wait until other services move out. This would make available 13 channels below 300 mc, all of which could be assigned to television immediately. Of course, there is also available to television a very substantial amount of space above 400 mc which will permit the development of color television and superior black and white television through the use of wider channels.

(3) In the proposed report 6 mc were left unassigned with the statement that they would ultimately be assigned to television, FM, facsimile or the safety services, upon a showing of need.

The allocation table released today makes the unassigned space available as follows: 2 mc are added contiguous to the FM band of 18 mc width wherever that band is finally placed. Initially these 2 mc will be available for stations rendering a facsimile service exclusively, but manufacturers of FM receivers should include these 2 mc in new FM receivers as eventually it is contemplated that facsimile may move above 400 mc, thus making these 2 mc available for FM. In the proposed report no separate assignment was made for facsimile below 400 mc, except insofar as it was stated that FM stations might be authorized to employ facsimile during hours when they were not rendering aural broadcast service—a provision which is retained in the final report.

The remaining 4 megacycles which were unassigned in the proposed report have been made available to the safety services. As a result of this, and also as a result of making some changes in channel widths, a total of 139 additional channels have been made available to the fixed and mobile services in excess of provisions made in the proposed report. The distribution of these channels to the various fixed and mobile services is as shown in the accompanying tables.

POLICE RADIO SERVICES

At the present time there are 31 medium frequencies allocated for use

[Continued on page 56]

Freq. Band Mc.	Proposed International Allocation	United States Allocation	Remarks
84-90	Broadcasting, Fixed and Mobile	Television, Fixed and Mobile	Note 5
90-96	Broadcasting, Fixed and Mobile	Television, Fixed and Mobile	Note 5
96-102	Broadcasting, Fixed and Mobile	Television, Fixed and Mobile	Note 5
102-108	Broadcasting, Fixed and Mobile	Television, Fixed and Mobile	Note 5
44-108 MC — ALTERNATIVE NO. 2			
44-50	Broadcasting, Fixed and Mobile	Television, Fixed and Mobile	Note 5
50-56	Broadcasting, Fixed and Mobile	Television, Fixed and Mobile	Note 5
56-60	Amateur	Amateur	
60-66	Broadcasting, Fixed and Mobile	Television, Fixed and Mobile	Note 5
66-68	Broadcasting	Facsimile	
68-72	Broadcasting	Educational FM Broadcasting	
72-86	Broadcasting	Commercial FM Broadcasting	Note 5A
86-92	Broadcasting, Fixed and Mobile	Television	
92-98	Broadcasting, Fixed and Mobile	Television, Fixed and Mobile	Note 5
98-104	Broadcasting, Fixed and Mobile	Television, Fixed and Mobile	Note 5
104-108	Fixed and Mobile, except Aero.	Non-Gov. Fixed and Mobile	Note 6
44-108 MC — ALTERNATIVE NO. 3			
44-50	Broadcasting, Fixed and Mobile	Television, Fixed and Mobile	Note 5
50-54	Amateur	Amateur	
54-60	Broadcasting, Fixed and Mobile	Television, Fixed and Mobile	Note 5
60-66	Broadcasting, Fixed and Mobile	Television, Fixed and Mobile	Note 5
66-72	Broadcasting, Fixed and Mobile	Television, Fixed and Mobile	Note 5
72-78	Broadcasting, Fixed and Mobile	Television, Fixed and Mobile	Notes 5 and 5A
78-84	Broadcasting, Fixed and Mobile	Television Broadcasting	
84-88	Broadcasting	Educational FM Broadcasting	
88-102	Broadcasting	Commercial FM Broadcasting	
102-104	Broadcasting	Facsimile	
104-108	Fixed and Mobile, except Aero.	Non-Gov. Fixed and Mobile	Note 6

RADIO DESIGN WORKSHEET

NO. 37 – THÉVENIN'S THEOREM; NOTE ON SELF-EXCITED OSCILLATOR CIRCUITS

THEVENIN'S THEOREM

Thévenin's Theorem for a network containing a single source of voltage may be stated as follows:

Any linear network with a load impedance connected across two terminals may be replaced, so far as the load impedance is concerned, by a voltage connected in series with an impedance. The new voltage is the one which would appear across the load terminals with the load removed. The new impedance is that looking into the load terminals of the network with the source of voltage short-circuited.

Consider the circuit of Fig. 1.

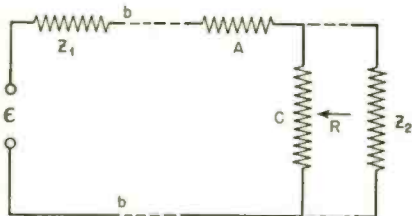

Figure 1

First remove Z_2 ; the voltage appearing across the load or output terminals is:

$$I_1 = \frac{E}{Z_1 + A + C}$$

$$E_1 = \frac{CE}{Z_1 + A + C} \quad (1)$$

When E is short-circuited the impedance R , looking into the output terminals is:

$$R = \frac{C(A + Z_1)}{C + A + Z_1}$$

Whence the equivalent circuit according to Thévenin's Theorem is shown in Fig. 2.

The current which would flow through load impedance Z_2 then is:

$$I_0 = \frac{E}{R + Z_2} = \frac{CE}{Z_1 + A + C}$$

$$\times \frac{Z_1 + A + C}{CA + CZ_1 + Z_2Z_1 + Z_2A + Z_2C}$$

$$= \frac{CE}{C(Z_1 + A) + Z_2(Z_1 + A + C)}$$

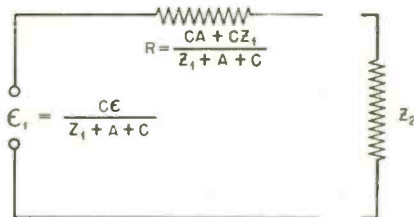

Figure 2

If Z_2 is a resistance, the power dissipated in the load will be:

$$P_o = I_o^2 Z_2 = \frac{Z_2 C^2 E^2}{[C(Z_1 + A) + Z_2(Z_1 + A + C)]^2}$$

If the network were removed and Z_2 connected directly to the generator; i.e. to terminals bb , then:

$$I_1 = \frac{E}{Z_1 + Z_2}$$

$$P_1 = I_1^2 Z_2 = \frac{Z_2 E^2}{(Z_1 + Z_2)^2}$$

The ratio of the power dissipated in Z with the network in circuit and with it removed is:

$$\frac{P_o}{P_1} = \frac{Z_2 C^2 E^2}{[C(Z_1 + A) + Z_2(Z_1 + A + C)]^2} \times \frac{(Z_1 + Z_2)^2}{Z_2 E^2} = \frac{C^2 (Z_1 + Z_2)^2}{[C(Z_1 + A) + Z_2(Z_1 + A + C)]^2} \quad (1)$$

In order to better visualize the use of these formulae we may assign some probable values to the circuit resistances. Thus let:

$$Z_1 = 100$$

$$A = 95$$

$$C = 10$$

$$Z_2 = 10$$

$$I = \frac{E}{100 + 95 + 5} = \frac{E}{200} \quad (\text{in Fig. 3})$$

Since the current will divide equally between C and Z_2 , then the current flowing in Z_2 in Fig. 3 will be:

$$I_o = \frac{I}{2} = \frac{E}{400}$$

$$P_o = I_o^2 Z_2 = \frac{10E^2}{160,000} = \frac{E^2}{16,000}$$

If the network were removed and the load connected to the generator:—

$$I_1 = \frac{E}{110} = \frac{E}{10E^2} = \frac{E^2}{1210}$$

$$P_1 = Z_2 I_1^2 = \frac{1210}{16,000} = \frac{E^2}{16,000}$$

$$\frac{P_o}{P_1} = \frac{E^2}{16,000} \times \frac{1210}{E^2} = \frac{1210}{16,000}$$

$$= .0755 = 11.1 \text{ db loss.}$$

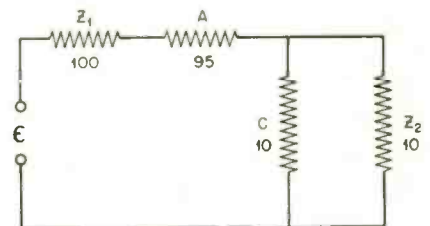

Figure 3

Substituting in equation (1) we have:

$$\frac{P_o}{P_1} = \frac{100(100 + 10)^2}{[10(95 + 100) + 10(10 + 95 + 100)]^2}$$

$$= \frac{100(110)^2}{4000^2} = \frac{1,210,000}{16,000,000}$$

$$= \frac{1210}{16,000} = .0755 = -11.1 \text{ db}$$

which checks the formula derived by Thévenin's Theorem.

In a later Radio Design Worksheet this Theorem will be applied to resistances and reactance combinations. It will be shown that even complicated ladder and lattice network yield to this Theorem. One application is to the computation of frequency characteristics of wave filters and equalizers.

NOTE ON SELF EXCITED OSCILLATOR CIRCUITS

Fig. 4 shows in schematic form the Meissner oscillator circuit omitting all elements except those circuits actually involved in producing oscillations. Most modern oscillator circuits used in radio receivers are derived from this fundamental circuit. Although many derivatives of this circuit are

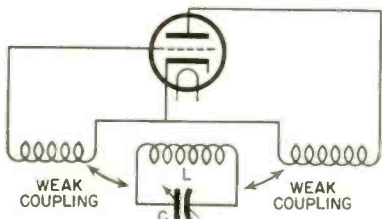

Figure 4

employed, that of Fig. 4 is seldom used as shown in radio receivers. The frequency of oscillation is determined by the constants of the tuned circuit LC. The electrical inertia of the tuned circuit tends to resist any change in frequency in much the same way that the mechanical inertia of a flywheel tends to resist the mechanical motion from its normal mode. It is on this fundamental principle that the gyroscope operates. Such an oscillator properly constructed is very stable. Fig. 5 shows a tuned plate oscillator circuit and Fig. 6 a tuned grid circuit oscillator.

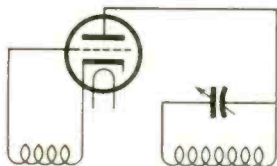

Figure 5

Both are very popular in radio receivers, since they are simple to build, stable over a wide range of supply voltages, and require a minimum of adjustment, none being critical.

Fig. 7 illustrates schematically the electron coupled oscillator. In this circuit, the grid, cathode, and screen are elements of the oscillator circuit. The plate of this converter tube acts as a collector of such electrons as pass

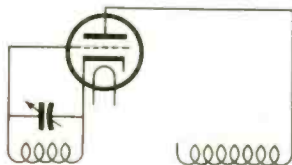

Figure 6

through the screen. The magnitude of this output can be adjusted by varying the plate potential of the converter tube. In some instances no plate voltage at all is used. One of the principal virtues of this circuit is its stability. This is in turn dependent to some extent on the weak coupling to the oscillator circuit. As a result, low plate voltage is a common occurrence.

Fig. 8 shows the Dow oscillator, which is a modification of the electron coupled oscillator. In this circuit the plate grid capacitance of the converter

tube is neutralized to reduce unwanted coupling to the load to a minimum. If this circuit is to be effective, complete shielding of oscillator circuit is required. The plate-grid capacitance of a typical 6A7 is of the order of .01 μf or less. Consequently other coupling of this order must likewise be reduced substantially if neutralization is to be effective.

Fig. 9 illustrates the Hartley oscillator, an old but still popular type and Fig. 10 illustrates the Colpitts oscillator. There are of course many variations

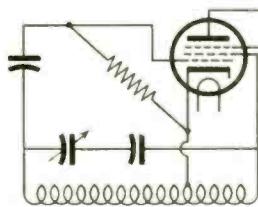

Figure 7

of the above circuits which are popular and convenient for certain applications.

If the oscillator frequency is very close to the signal frequency (say 3% to 4%) it is a relatively simple matter to effect oscillator tracking by bending the rotor plates of the variable tuning capacitor. If however, as is more often the case, the oscillator frequency differs from the signal frequency by 5% to 10% then either a specially shaped capacitor rotor plate (usually referred to as cut plates) is required for proper tracking or a padded circuit must be used. A common type of padded circuit is illustrated in Fig. 11.

This type of tank circuit is intended for use when the oscillator frequency is higher than the signal frequency. Adjustment is commonly made to the proper capacity value at the setting of the gang capacitor for highest signal frequency by means of trimmer C_3 and at the lowest signal frequency by C_2 . Other points in the band may likewise be chosen for tracking. Even so, a portion of the band will usually vary

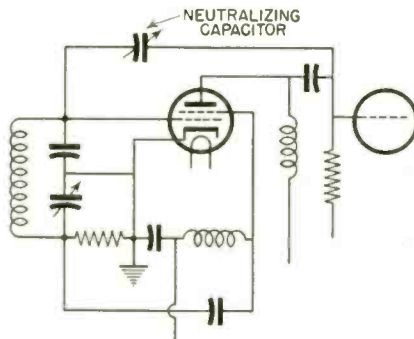

Figure 8

from the required value of capacity enough to materially reduce sensitivity.

As mentioned above, it is common

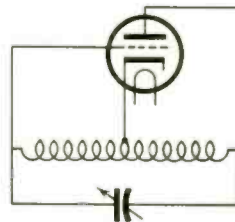

Figure 9

practice to tune the oscillator in receivers above the signal rather than below. This is of little importance except in variable tuning receivers covering a relatively wide band. To illustrate with a simple case, assume a receiver to cover the band of 550 Kc to 1500 Kc with an intermediate frequency of 385 Kc. If the oscillator is to be tracked below the signal frequency it must cover the range of $(550-385) = 165$

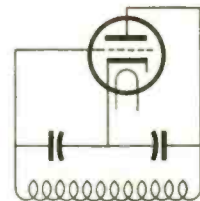

Figure 10

Kc to $(1500-385) = 1115$ Kc or 1050 Kc. If on the other hand the oscillator were tuned above signal frequency it must be tunable from $(550+385) = 935$ Kc to $(1500+385) = 1885$ Kc or a range of 950 Kc. Since

$$f = \frac{1}{2\pi\sqrt{LC}}$$

we may deduce that the capacity ratio for covering a specific tuning range

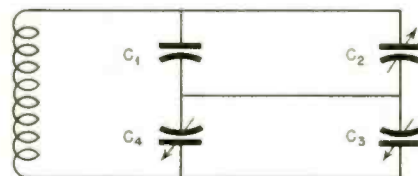

Figure 11

(i.e. maximum capacity to minimum capacity) will be proportional to the square of the tuning range. Thus we find:

Frequency Range	Frequency Ratio	Capacitance Ratio
1500-550 =	2.73	$(2.73)^2 = 7.45$
1115-165 =	6.8	$(6.8)^2 = 46.00$
1885-935 =	2.01	$(2.01)^2 = 4$

A capacitance ratio of more than about 8 is impractical.

RADIO BIBLIOGRAPHY

F. X. RETTENMEYER

RCA Victor Division, Radio Corporation of America

17-AIRCRAFT RADIO, PART 10

18-VELOCITY MODULATION, PART 1

AIRCRAFT RADIO

PART 10—CONCLUSION

- The Lower Ionosphere—S. K. Mitra, J. N. Bhar and S. P. Ghosh — *Indian Jour. Phys.*, Vol. 12, Pages 455-465, December 1938.
- Diurnal Variation of Absorption of Radio Waves—F. W. G. White and T. W. Straker—*Proc. Phys. Soc.*, (London), Vol. 51, Pages 865-875, September 1939.
- Further Investigations of Very Long Waves Reflected from the Ionosphere—K. G. Budden, J. A. Ratcliffe and M. V. Wilkes—*Proc. Roy. Soc.*, Ser. A, Vol. 171, Pages 188-214, May 1939.
- Solar Eruptions and Their Influence on the Propagation of Electromagnetic Waves—M. Waldmeier—*Helvetica Phys. Acta.*, Vol. 2, Pages 537-538; fasc. 7, (1938).
- Nature of Radio Fade-Out—L. V. Berkner—*Phys. Review*, Vol. 55, Pages 536-544, March 15, 1939.
- Ionosphere and Short-wave Fade-outs — R. Jouast—*Jour. de Phys. et le Radium*, Vol. 10, Pages 251-259, June 1939.
- Reinforcement of Long Waves at Time of Short-wave Fade-outs—R. Bureau—*Jour. de Phys. et le Radium*, Vol. 10, Pages 271-273, June 1939.
- Radio Fade-Outs and Solar Eruptions — R. V. Giovanelli and A. J. Higge—*Terr. Mag.*, Vol. 44, Pages 181-187, June 1939.
- Radiation from Solar Flares and Radio Fade-Outs—T. H. Johnson and S. A. Korff—*Terr. Mag.*, Vol. 44, Pages 23-27, March 1939.
- Solar Eruptions and Ionosphere Perturbations—L. d'Azambuja—*Jour. de Phys. et le Radium*—Vol. 10, Pages 274-281, June 1939.
- Fifth Report of the Commission on Solar and Terrestrial Relations—International Council of Scientific Unions. Presented, International Union of Geodesy and Geophysics, Washington, D. C., September 1939.
- Ionosphere Disturbances, 1937-1938—J. H. Dellinger — Presented I.R.E.—U.S.R.I. Meeting—Washington, D. C., April 29, 1939.
- The Experimental Verification of the Diffraction Analysis of the Relation Between Height and Gain for Radio Waves of Medium Lengths — T. L. Eckersley and G. Millington—*Proc. Phys. Soc.* (London), Vol. 51, Pages 805-809, 1939.
- Characteristics of the Ionosphere at Washington, D. C.—T. R. Gilliland, S. S. Kirby and N. Smith — Published each month, *Proc. IRE*.
- Application of Graphs of Maximum Usable Frequency to Communication Problems—N. Smith, S. S. Kirby and T. R. Gilliland—*Jour. Res. Nat. Bur. Stand.*, Vol. 22, Pages 81-92, January 1939.
- The Prediction of Ionosphere Characteristics and Maximum Usable Frequencies—N. Smith and A. S. Taylor—Presented I.R.E.—U.R.S.I. meeting, Washington, D. C., April 29, 1939.
- Trends of Characteristics of the Ionosphere for Half a Sunspot Cycle—N. Smith, T. R. Gilliland and S. S. Kirby—*Jour. Res. Nat. Bur. Stand.*, Vol. 21, Pages 835-845, December 1939.
- The Solar Cycle and the F2 Region of the Ionosphere—W. M. Goodall—*Proc. I.R.E.*, Vol. 27, Pages 701-704, November 1939.
- A Representation of the Sunspot Cycle—C. H. Anderson—*Bell Sys. Tech. Jour.*, Vol. 18, Pages 292-299, April 1939.
- Report of Commission II, Radio Wave Propagation, International Scientific Radio Union—J. H. Dellinger—*Proc. I.R.E.*, Vol. 27, Pages 645-649, October 1939.
- Averages of Critical Frequencies and Virtual Heights of the Ionosphere, Observed by the National Bureau of Standards at Washington, D. C. Published quarterly in *Terr. Mag.*
- The Ionosphere at Huancayo, Peru—H. W. Wells and H. E. Stanton—Published quarterly in *Terr. Mag.*
- The Ionosphere at Watheroo, Western Australia—W. C. Parkinson and L. S. Prior—Published quarterly in *Terr. Mag.*
- Ionospheric Observations—I. Ranzi—*La Ricerca Sci.*, Vol. 10, Pages 32-38, January-February 1939.
- Annual Variation of the Critical Frequencies of the Ionized Layers at Tromso during 1938—L. Harang—*Terr. Mag.*, Vol. 44, Pages 15-16, March 1939.
- Midday F2 Region Critical Frequencies for Deal, New Jersey—W. M. Goodall—*Terr. Mag.*, Vol. 44, Page 212, June 1939.
- Simultaneous Ionosphere Observations at Washington, D. C., and Deal, N. J.—J. P. Schafer and W. M. Goodall, *Terr. Mag.*, Vol. 44, Pages 205-208, June 1939.
- Deviations of Short Radio Waves from the London-New York Great-Circle Path—C. B. Feldman—*Proc. IRE*, Vol. 27, Pages 635-645, October 1939.
- Scattered Reflections of Radio Waves from Height of More than 1000 KM—L. Harang and W. Stoffregen—*Nature*, Vol. 142, Page 832, November 1938.
- Scattering of Radio Waves in the Ionosphere—T. L. Eckersley—*Nature*, Vol. 143, Pages 33-34, January 16, 1939.
- Scattering of Radio Waves in Polar Regions—E. V. Appleton and R. Naismith—*Nature*, Vol. 143, Pages 243-244, February 11, 1939.
- Scattered Reflections in the Ionosphere—B. Beckmann, W. Menzel and F. Vilbig—*Telegr.-und Funk-Techn.*, Vol. 28, Pages 130-135, April 1939.
- The Polarization Condition of Radio Waves by Reflection on Layers Which Are Formed by Magnetic Storms and Northern Lights—L. Harang and W. Stoffregen—*Hochfrequenztech. und Elektroakustik*, Vol. 53, Pages 181-187, June 1939.

RADIO BIBLIOGRAPHY

- Ionospheric Effects Associated with Magnetic Disturbances—L. V. Berkner, H. W. Wells and S. L. Seaton—*Terr. Mag.*, Vol. 44, Pages 283-311, September 1939.
- Incident Angle of Short Waves and High-Frequency Noise (Resembling "Grinders") During Dellinger Effects—M. Nakagami and K. Miya—*Elcc. Jour.* (Tokyo), Vol. 3, Page 216, September 1939.
- Some Principles in Aeronautical Ground-Radio-Station Design—P. C. Sandretto—*Proc. IRE*, Vol. 27, Pages 5-11, January 1939.
- A Cathode Ray Frequency Modulation Generator—R. E. Shelby—*Electronics*, Vol. 13, No. 2, February 1940, Page 14.
- Frequency Modulation—*Electronics*, Vol. 13, No. 1, January 1940, Page 10.
- Multi-Wire Antennas—J. D. Krans—*Electronics*, Vol. 13, No. 1, January 1940, Page 26.
- UHF—W. E. Jackson—*Aviation*, Vol. 39, No. 4, April 1940, Page 44.
- Notes on FM Transmitters—F. A. Gunther—*Communications*, Vol. 20, No. 4, April 1940, Page 11.
- Some Notes on Selenium Rectifiers—*Communications*—Vol. 20, No. 4, April 1940, Page 11.
- A High Efficiency R-F Amplifier—E. J. O'Brien and H. Kees—*Communications*—Vol. 20, No. 2, February 1940, Page 7.
- Charts for Transmission Line Measurements and Computations—P. S. Carter—*RCA Review*, Vol. 3, January 1939, Page 355.
- Recent Developments in Radio Transmitters—J. B. Coleman and V. E. Trounat—*RCA Review*, Vol. 3, January 1939, Page 316.
- Modulation Suppression—H. Roder—*Communications*, Vol. 18, No. 2, February 1938, Page 14.
- Selenium Rectifiers—*Communications*—Vol. 18, No. 3, March 1938, Page 7.
- High Frequency Triode Oscillator—G. Reber—*Communications*, Vol. 18, No. 3, March 1938, Page 13.
- A Receiver for Frequency Modulation—J. R. Day—*Electronics*, Vol. 13, No. 6, June 1939, Page 32.
- A Noise Suppressor Circuit for Heterodyne Receivers—A. Richardson—*Communications*, Vol. 18, No. 1, January 1939, Page 10.
- Private Flying Equipment and Facilities**
- Icing of Aircraft Antenna Wires—G. L. Haller—*Journal of the Aeronautical Sciences*, Vol. 6, No. 1, November 1938, Page 27.
- Developments in Aircraft Radio Area—*Electronics*, February 1938.
- Reduction of Night Error by Adcock Aerial—H. Busignies—*L'Onde Elec.*, March and April 1938, Page 195-210.
- Constants of Fixed Antennae on Aircraft—G. L. Haller—*Proceedings IRE*, April 1938.
- Improvements in the Marconi-Adcock Radiogoniometer—*Assoc. Suisse Elect. Bull.*, January 12, 1938.
- Model Measurements on Aircraft Fixed Aerials to Obtain Polar Diagrams in the Short-Wave Region—E. Harmening—*Hochfrequenztechnik und Elektroakustik*, February 1939.
- The Useful Radiation Power Beam Antennae—Y. Kato—*Nippon Elect. Comm. Eng.*, May 1939.
- Antenna Systems; Direction Finding—*Electrician*, September 9-16, 1938.
- Installation of Antennas for Direction Finding—J. C. Franklin, *Air Commerce Bulletin*—April 1938.
- Precipitation-Static Interference on Aircraft and at Ground Stations—H. M. Hucke—*Proceedings IRE*, 27:301-16, May 1939.
- Radio in Aviation; A General Survey with Special Reference to the Royal Air Force—N. F. S. Hecht—*I.E.E. Journal*—85:215-19, August 1939.
- Development of Aircraft Radio Antennas—R. McGuire—J. Demonte—*Communications*, Vol. 20, No. 3, March 1940, Page 5.
- Industry Trends**
- Further Note on the Propagation of Radio Waves Over a Finitely Conducting Spherical Earth—B. van der Pol and H. Bremmer—*Phil. Mag.*, Vol. 27, Pages 261-275, March 1939.
- The Diffraction of Wireless Waves Around the Earth—G. Millington—*Phil. Mag.*, Vol. 27, Pages 517-542, March 1939.
- The Propagation of Wireless Waves Around the Earth—B. van der Pol and H. Bremmer—*Philips Tech. Rev.*, Vol. 4, Pages 245-253, September 1939.
- Diffraction and Refraction of a Horizontally Polarized Electromagnetic Wave Over a Spherical Earth—M. C. Gray—*Phil. Mag.*, Vol. 27, Pages 421-436, April 1939.
- Oblique-Incidence Ionospheric Data and the Lorentz Polarization Term—N. Smith—*Trans. Amer. Geophys. Union of 1939*, Page 375, April 1939.
- Lorentz Polarization Correction in the Ionosphere—D. F. Martyn and G. H. Munro—*Terr. Mag.*, Vol. 44, Pages 1-6, March 1939.
- Effect of Lorentz Polarization Term in Ionospheric Calculations—J. A. Ratcliffe—*Proc. Phys. Soc. (London)*, Vol. 12, Pages 747-756, September 1939.
- Reflection of Electromagnetic Waves in the Ionosphere—R. C. Majumdar—*Trans. Bose Res. Inst. (Calcutta)*, Vol. 12, Pages 125-140, 1936-1937.
- An Ionospheric Investigation Concerning the Lorentz Polarization Correction—H. Booker and L. V. Berkner—*Terr. Mag.*, Vol. 43, Pages 427, 450, December 1938.
- Observations on Sky-Wave Transmission Frequencies Above 40 Megacycles—D. R. Goddard—*Proceedings IRE*, Vol. 27, Pages 12-15, January 1939; *RCA Review*, Vol. 3, Pages 309-315, January 1939.
- 40-CM Waves for Aviation—*Electronics*, Vol. 12, Pages 12-15, November 1939.
- Aircraft Radio Vibration—L. B. Hallman—*Communications*—Vol. 20, No. 5, May 1940, Page 5.
- Details of the Sikorsky Helicopter—*Acro Digest*, Vol. 36, No. 6, June 1940, Page 56.
- Into the Sub-Stratosphere—R. J. Minshall—*Aviation*, Vol. 39, No. 5, May 1940, Page 46.
- An Engineer's Closeup of the Curtiss-Wright Transport—G. Page—*Aviation*, Vol. 39, No. 3, March 1940, Page 46.
- Electrical Insulation for Aircraft—G. L. Moses—*Aviation*, Vol. 38, No. 9, September 1939, Page 28.
- AC for Aircraft—P. C. Sandretto—*Aviation*, Vol. 38, No. 6, June 1939, Page 30.
- Tests with Ultra-High Frequency Radio Transmitting and Receiving Equipment for Itinerant Aircraft Communication—*CAA Tech. Report No. 7*, July 1938.
- Some Theoretical Considerations on the Philips Ultra Short Wave Radio Beacon—*Philips Transmitting News*, Vol. 6, Nos. 3 and 4, December 1939.

[Bibliography on Velocity Modulation appears on following page]

VELOCITY MODULATION

PART 1

- A New Method of Producing Short Undamped Waves of Great Intensity—Arsenjew-Heil and Heil—*Zeit. für Phys.*, vol. 95, pp. 752-762; July 12, 1935.
- A High-Frequency Oscillator and Amplifier—R. H. Varian and S. F. Varian—*Jour. App. Phys.*, vol. 10, pp. 321-327; May, 1939.
- On the Resonant Frequency of Closed Concentric Lines—W. W. Hansen—*Jour. App. Phys.*, vol. 10, pp. 38-45; January, 1939.
- On Resonators Suitable for Klystron Oscillators—W. W. Hansen and R. D. Richtmyer—*Jour. App. Phys.*, vol. 10, pp. 189-199; March, 1939.
- Electromagnetic Natural Vibrations of Dielectric Spaces—F. Borgnis—*Ann. der Phys.*, vol. 35, pp. 359-384; June 11, 1939.
- Dielectric Resonators—R. D. Richtmyer—*Jour. App. Phys.*, vol. 10, pp. 391-398; June, 1939.
- On the Natural Electromagnetic Oscillations of a Cavity—M. Jouguet—*Compt. Rend.*, vol. 209, pp. 203-204; July 24, 1939.
- Theoretical Relationships of Dielectric Guides—A. G. Clavier—*Elec. Comm.*, vol. 17, pp. 276-290; January, 1939.
- Velocity-Modulated Tubes—W. C. Hahn and G. F. Metcalf—*Proc. I.R.E.*, vol. 27, pp. 106-116; February, 1939.
- Ultra-High-Frequency Power Amplifier of Novel Design—A. V. Haeff—*Electronics*, vol. 12, pp. 30-32; February, 1939.
- A Wide-Band Inductive-Output Amplifier—A. V. Haeff and L. S. Nergaard—*Proc. I.R.E.*, vol. 27, p. 610; September, 1939 (Abstract only) (See this issue).
- Wave Energy and Transconductance of Velocity-Modulated Electron Beams—W. C. Hahn—*Gen. Elec. Rev.*, vol. 42, pp. 497-502; November, 1939.
- The Electronic-Wave Theory of Velocity-Modulation Tubes—Simon Ramo—*Proc. I.R.E.*, vol. 27, pp. 757-763; December, 1939.
- Influence and Control of the Variable Density of Electron-Currents in Tubes and the Use of this Phenomenon for Generating Short-Wave Oscillations by the Impulse Methods—G. Jobst—*Telefunken Hausmitteilungen*, vol. 20, pp. 84-96; July, 1939.
- Small Signal Theory of Velocity-Modulated Electron Beams—W. C. Hahn—*Gen. Elec. Rev.*, vol. 42, pp. 258-270; June, 1939.
- Space Charge and Field Waves in an Electron Beam—Simon Ramo—*Phys. Rev.*, vol. 56, pp. 276-283; August 1, 1939.
- Cathode-Ray Bunching—D. L. Webster—*Jour. App. Phys.*, vol. 10, pp. 501-508; July, 1939.
- Theory of Klystron Oscillators—D. L. Webster—*Jour. App. Phys.*, vol. 10, pp. 864-872; December, 1939.
- Space-Charge Effects in Electron Beams—A. V. Haeff—*Proc. I. R. E.*, vol. 27, pp. 586-602; September, 1939.
- Limiting Current Densities in Electron Beams—J. R. Pierce—*Jour. App. Phys.*, vol. 10, pp. 715-724; October, 1939.
- The Inference of Space Charge in Planar Braking-Field Tubes—W. Kleinstaubler—*Hochfrequenz und Elektroakustik*, vol. 53, pp. 199-213; June, 1939.
- Production of Ultra-High-Frequency Oscillations by Means of Diodes—F. B. Llewellyn and A. E. Bowen—*Bell. Sys. Tech. Jour.*, vol. 18, pp. 280-291; April, 1939.
- Development of a 20-Kilowatt Ultra-High-Frequency Tetrode—A. V. Haeff, L. S. Nergaard, W. B. Wagener, P. D. Zottu, R. B. Ayer and H. E. Gihring—*Proc. I.R.E.*, vol. 27, pp. 610-611; September, 1939. (Summary only).
- Effect of Electron Transit Time on Efficiency of a Power Amplifier—A. V. Haeff—*RCA Rev.*, vol. 4, pp. 114-122; July, 1939.
- The Anode-Tank-Circuit Magnetron—E. C. Linder—*Proc. I.R.E.*, vol. 27, pp. 732-738; November, 1939.
- High-Efficiency Sentron—S. Uda, M. Isida, and S. Shoji—*Electrotech Jour.* (Tokyo), vol. 2, p. 291; December, 1938.
- A new Ultra-High-Frequency Amplifier of Unique Design—A. V. Haeff—*Electronics*—vol. 12, pp. 30-32; February, 1939.
- The Anode-Tank-Circuit Magnetron—E. G. Linder—*Proc. I.R.E.*, vol. 27, pp. 732-738; November, 1939.
- Velocity Modulation—R. Kompfner—*The Wireless Engineer*, vol. XVII, No. 206, pp. 478, November, 1940.
- On the Phase Focusing of Electrons Moving in Rapidly Changing Fields—E. Brueche & A. Recknagel—*Zeitschr. f. Physik*, vol. 108, pp. 459.
- Experimental Proof of Phase Focusing—L. Mayer—*Zeitschr. f. tech. Phys.*, p. 38, 1939.
- The Electron Lens with Transit Time Phenomena—A. Recknagel—*Jahrb. AEG Forsch.*, vol. 6, 1939, pp. 72.
- Electronic—Curve Theory of Velocity-Modulated Tubes—S. Ramo—*Proc. I.R.E.*, vol. 27, No. 9, p. 615; Sept., 1939.
- Beam Tubes as Ultra-High-Frequency Generators—R. King—*Journ. of Applied Phys.*, vol. 10, No. 9, pp. 638-647, Sept. 1939.
- On the Electronic Space Charge Between Plane Electrodes, Taking into Consideration the Initial Velocity and Velocity Distribution of the Electrons—M. J. O. Strutt & A. van der Ziel—*Physica*, vol. 6, No. 9, pp. 977-996, Oct., 1939.
- Wave Energy and Transconductance of Velocity-Modulated Electron Beams—W. C. Hahn—*Gen. Elec. Review*, vol. 42, No. 11, pp. 497-502; Nov., 1939.
- Corrections to "Small-Signal Theory of Velocity-Modulated Electron Beams." W. C. Hahn—*Gen. Elec. Review*, vol. 42, No. 11, pp. 497-502; Nov., 1939.
- Measurement and Calculation of the Oscillation Amplitude of a Retarding Field Generator—W. Schwarz—*Hochf. tech. u. Elek. akus.*, vol. 54, No. 1, pp. 11-19, July 1939.
- On the Theory of Retarding Back-Coupling—G. Gorelik—*Journ. of Tech. Phys.*, No. 5, vol. 9, pp. 450-454, 121-128, 1939.
- The Fundamental Electrical Oscillation of Cylindrical Cavities—F. Borgnis—*Hochf. tech. u. Elek. akus.*, vol. 54, No. 4, pp. 121-128, Oct., 1929.
- Short-Wave Valves: Advantages of Specialized Types—F. E. Henderson—*Wireless World*, vol. 46, No. 4, pp. 120-123, Feb. 1940.
- Ultra-Short Waves in Concentric Cables, and the "Hollow-Space" Resonators in the Form of a Cylinder with Perforated-Disc Ends—H. Buchholz—*Hochf. tech. u. Elek. akus.*, vol. 54, No. 5, pp. 161-173, Nov., 1939.
- The Electronic Valve with Velocity Modulation—J. Bethenod—*Comptes Rendus*, vol. 210, No. 3, pp. 103-104, 15th Jan. 1940.
- The Use of Ballistic Models for the Study of Energy Exchange Conditions in Velocity-Modulated & Other Devices—H. E. Hollmann—*Zeitschr. f. tech. Phys.*, No. 12, vol. 20, 1939.
- Velocity-Modulated Beams: The Electron Density Distribution—D. M. Tombs, *Wireless Engineer*, vol. 17, No. 197, pp. 54-60, Feb., 1940.

New Products



This new "submersion-proof" Western Electric lip microphone and headset combination was developed by Bell Laboratories. The microphone is fitted with a gland which will pass air but exclude water

200-KW H-F TUBE

The most powerful high frequency tube, with an output of 200 kilowatts, is being manufactured by Federal Telephone and Radio Corporation, associate of International Telephone and Telegraph Corporation, especially for use in high power, high frequency broadcasting, FM broadcasting and industrial heating applications.

The new tube will be used in short wave equipment built by Federal for the OWI to wrest command of the ether from the Japanese in the North and South Pacific. These newest OWI stations having a carrier power of 200 kw are located at Dixon and Delano, California, and will exert coverage over an area extending from Siberia to Australia and from Hawaii to India, where heretofore the only practical re-

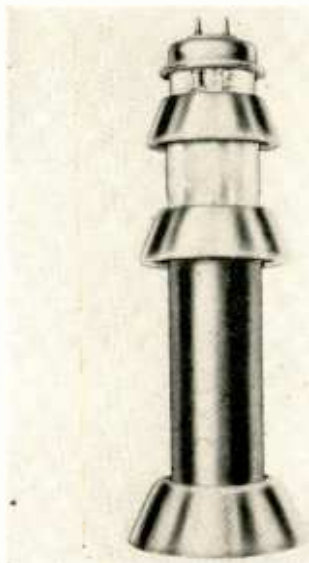

ception has been for the most part of Japanese-originated broadcasts.

Incorporating a low inductance grid lead, with very complete shielding between filament and plate, the new tube has three electrodes, and an available thermionic emission of 120 amperes.

Specifications for the tube set the power output at 200 kw per tube when operated as an oscillator or in Class C Telegraphy, with a plate voltage of 18 kilovolts and a plate dissipation of 150 kw. In operation as a Class C Plate Modulated Amplifier the carrier power output is set at 100 kw per tube with a plate voltage of 12.5 kilovolts, the peak instantaneous power output at full modulation being 400 kw per tube.

Cooling of the tube is accomplished by water, a steady flow of 40 gallons per minute being required for this purpose. Sixty pounds of copper are used in the construction of the anode block, and the completed tube weighs about 100 pounds.

MINIATURE ELECTRON TUBES

Miniature tubes designed for efficient use in battery-operated radio receivers, hearing



aids and many other electronic circuit applications where light weight and compactness are important considerations, are manufactured by Sylvania Electric Products Inc., Emporium, Pa.

The miniature tube types, now largely absorbed by the urgent needs of the armed forces, include a complete line of T-5½ sizes. Wartime developments, the trend toward the use of higher frequencies and physically smaller tubes will be extended to many postwar applications where miniature tubes will serve civilian purposes.

HERMETICALLY SEALED RESISTORS

Five new types of hermetically-sealed resistors are now available to meet exacting electronic and electrical requirements. Special features of construction assure absolute immunity to moisture, corrosive fumes and fungus with resultant freedom from circuit noise and premature breakdown due to leakage or electrolysis.

One important factor in their construction is the sealing-in process, consisting of a wax impregnation and oven dehydration which excludes all possibility of trap-



ped moisture or air. The resistor unit itself is enclosed in molded bakelite. The case is in two parts with telescope construction at the juncture. Ceramic spools are used. Mounting of any type is permissible—panel, bracket, center band, etc.

The five series now in production are "RX", "SX", "WX", "CX" and "BX". "BX" and "CX" units have 2" No. 18 copper axial leads while the others are equipped with 8-32 threaded studs capable of mounting several lugs, wires or mounting brackets. The two types of mountings—leads and studs—fill all requirements. Units are tropicalized for humid climates and are particularly desirable for airborne and mobile installations where light weight and dependable operation are primary factors.

These resistors provide a range to 1 megohm max. and 2 watts max. Standard tolerance 1%; closer tolerance at additional charge.

Products of Instrument Resistors Company, 25 Amity Street, Little Falls, New Jersey.

CERAMIC-DIELECTRIC CAPACITORS

Fixed ceramic-dielectric capacitors conforming to joint Army & Navy specification JAN-C-20 may now be had in production quantities from the Micamold Radio Corporation, 1087 Flushing Avenue, Brooklyn 6, N. Y.

Available in preferred temperature co-
[Continued on page 64]

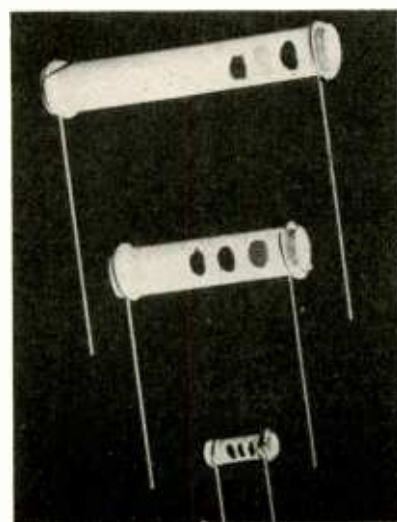

This Month



Ken Gardner, Chief Engineer of WHAM-W51R, checks up on the final amplifier in Rochester's 3-kw FM job, W51R. The circular peep-hole allows a safe look at the cherry-red plates of the 1500 Ts

RCA MULTIPLEX SYSTEM

Development of a system of word transmission by which eight channels can be employed simultaneously to carry messages thousands of miles over a single radio-telegraph transmitter was announced today by Lieut. Col. Thompson H. Mitchell, Vice President and General Manager of RCA Communications, Inc. The new system—regarded as a major advance in international communications—has been placed in operation between New York and London to increase communication capacity between the United States and Great Britain, and, with extension of channels to San Francisco, to expedite the flow of government and press traffic to and from the United Nations Conference.

By means of specially designed RCA equipment which employs what is known in the industry as "time division multiplex telegraph" principles, the equipment can handle 488 words per minute inward and outward simultaneously, corresponding to eight channels each way with an individual channel speed of 61 words per minute. The equipment also permits operation of four or two channels instead of eight channels, when desired.

All eight channels may be utilized for two-way communication with one distant station. Alternatively, they may be set up in such a way that four channels with a total capacity of 244 words per minute can be operated in both directions simultaneously between two different stations, with automatic re-transmission of one or more of the channels to a third station.

Moreover, printing mechanism incorporated in the new RCA multiplex system accomplishes the feat of making the circuit virtually error-proof, despite its high speed. Let any letter be mutilated or garbled in transmission and a warning bell rings

under the receiving printer. At the same instant, in lieu of the mutilated character, a maltese cross appears to mark the exact spot of the error and facilitate correction. In other words, no error can get through directly to the message blank.

GRENBY AND CARDWELL MERGE

The Grenby Mfg. Co. of Plainville, Conn. and the Allen D. Cardwell Corp. of Brooklyn, N. Y. have consolidated. Both companies will maintain their present corporate identities and will continue their present management.

This consolidation brings together complementary engineering, research and manufacturing facilities in both the electronic and mechanical fields.

PERSONAL MENTION

Murray G. Crosby

Murray G. Crosby has joined the firm of The Paul Godley Company, Consulting

Radio Engineers, Upper Montclair, New Jersey. He will specialize in radio communication systems including: frequency-modulation problems, development projects, point-to-point mobile and air-borne communications, multiplex operation, relay transmission, satellite stations, television and facsimile.

Mr. Crosby has been a research engineer for the Communications Division of RCA Laboratories for the past 20 years. In that position he specialized in frequency modulation and has over 100 patents, among them being the reactance-tube automatic-frequency-control type of frequency modulator used in frequency-modulation transmitters marketed by the Radio Corporation of America and the General Electric Company. He is author of a considerable number of basic technical articles on the subjects of frequency and phase modulation.

Born in Elroy, Wisconsin in 1903 he attended the University of Wisconsin receiv-

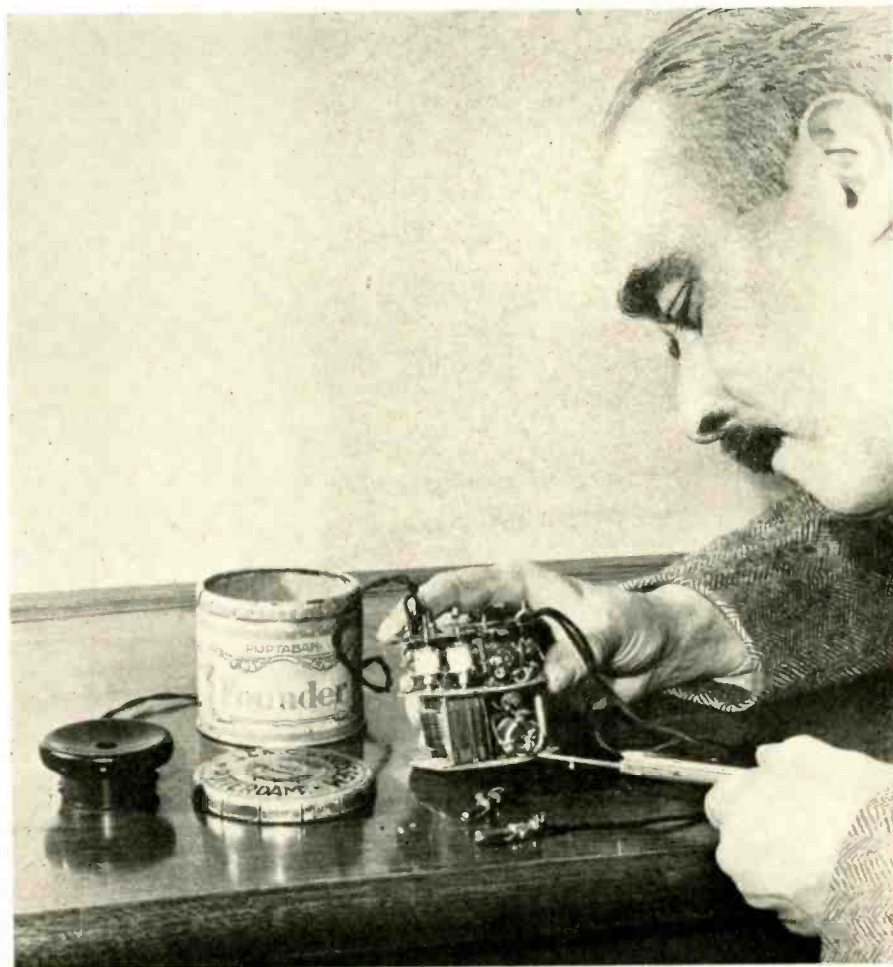

Herve Schwedersky calls attention to construction features of the tiny two-tube clandestine radio concealed in a tobacco tin, over which members of the Dutch underground listened to forbidden broadcasts during the German occupation. Mr. Schwedersky obtained the set while on a recent Navy mission to England, France, Belgium and Holland. This set uses a new type of selenium rectifier, to replace the usual rectifier tube, for a-c operation

ing the B.S. degree in 1927 and his professional E.E. degree in 1943.

In 1940 he received a Modern Pioneer Award from the National Association of Manufacturers for contributions which improved the American standard of living. In 1943 he was Vice Chairman of the New York Section of the Institute of Radio Engineers. He holds the Fellow grade in that body and is a member of the 1945 I.R.E. Papers Committee, the Papers Procurement Committee, the Admissions Committee and the Technical Committee on



Murray G. Crosby

frequency modulation. He is also a Fellow of the Radio Club of America and a Member of the American Institute of Electrical Engineers.

In 1943 and 1944 Mr. Crosby served as Expert Technical Consultant to the Secretary of War and received official commendations for his work.

John F. Rider

★ With a number of commendations from the Chief Signal Officer, Lieut. Col. John F. Rider recently completed three years of service in the U. S. Army Signal Corps. For the past seventeen months he has been stationed at Fort Monmouth attached to the Publications Agency of which he was Acting Director at the time of his assuming inactive status on May 30th.

Now returned to his desk as head of John F. Rider Publisher, Inc., he has already set in motion the plans for expanding the Rider Manual activities of the business to embrace television and when it becomes public, radar.

Key civilian technical personnel of the Rider organization who followed John Rider into his Army work have returned

to their former duties and an accelerated program of expanded operations in the Rider development laboratory is the result. Here material for future publications as well as new pieces of electronic equipment will be developed.

An activity to which John Rider is devoting much effort at the present time is that of the post-war problems of the servicing industry—problems not only of the industry, but of the individual and his adjustment to current and predictable conditions of the near future.

From this well rounded program will come many new and timely titles which will be added to the list of Rider Radio Books.

Timothy E. Shea

★ Timothy E. Shea, formerly chief engineer of the Electrical Research Products Division of Western Electric Company, has returned to the company following four years' service as director of research for Columbia University Division of War Research, which operates under the National Defense Research Committee. Mr. Shea has been appointed superintendent in charge of manufacturing engineering at the company's Vacuum Tube Shop in New York City, and will take over his new assignment this month.

During the past year and a half, Mr. Shea has been working chiefly with the submarine forces, a job that has required extensive travel to many points throughout



Timothy E. Shea

the world. Most important of the activities which he has directed has been the New London (Conn.) NDRC Laboratory which was specially organized for submarine and anti-submarine work in close cooperation with the Navy. Most of the projects Mr. Shea has supervised are still guarded by secrecy, but they have had a decided influence in the successful prosecution of the war.



This cathode ray tube apparatus, developed in the research laboratories of Sylvania Electric Products, Inc., enables characteristic curves of vacuum tubes to be determined quickly. The operator at the left places a tube in the circuit and the photographic record of the curves is taken directly from the cathode ray tube screen by the cameraman

Freq. Band Mc.	Proposed International Allocation	United States Allocation	Remarks
108-112	Air Navigation (Localizers)	Government	
112-118	Air Navigation (Ranges)	Government	
118-122	Aero Mobile (Airport Control)	Airport Control	
122-132	Aero Mobile	Aero Mobile (primarily Non-Gov.)	
132-144	Fixed & Aero Mobile	Government	



Now! Shop Measurements to One Millionth of an Inch With Simple Light Wave Setup!

The wave length of light is the basis for this amazing new optical measuring equipment—which measures millionths of an inch as easily as a micrometer measures tenths! All that is required, in addition to a simple setup, is average eyesight, intelligence and arithmetic.

As shown above, the work was placed under the Monochromatic Light, upon the work and gauge block—and covered by the optical flat. The light, reflected back to the operator, by the top and bottom surfaces of the optical flat, creates interference bands, representing height intervals of 11.6 millionths of an inch. So that from the center of one dark band to the center of the next, the level of the work has risen or fallen 11.6 millionths of an inch. The bands, simply, are a contour map of the surface. This fact, in a simple mathematical formula, is sufficient to explain all the shop uses of optical flats, and give the work measurement, quickly and accurately.

No longer, however, can your dealer give you Wrigley's Spearmint Gum. Today, under present conditions, this product cannot be manufactured up to Wrigley's quality standards. To protect consumer and dealer alike, the makers of Wrigley's Spearmint have decided to keep the quality Wrigley's Spearmint wrapper empty. Remember this wrapper, it means chewing gum of finest quality and flavor.

You can get complete information from
Acme Scientific Division of Acme Industrial Co.,
200 No. Laflin St., Chicago 7, Ill.

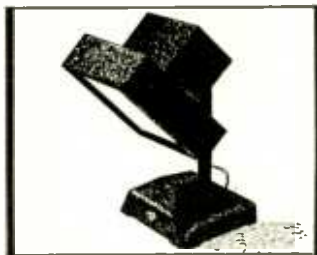

The Monochromatic Light.



Optical Flat. Surface of Work. Interpretation of bands on truly flat surfaces.

FREQUENCIES

[Continued from page 47]

by municipal and state police stations. These frequencies are assigned within the specified geographical areas to state and municipal police departments.

In addition, there are at present 3 medium frequencies and 6 high frequencies allocated for use by zone and inter-zone police stations. They are as follows:

2804 kc. calling, 5135 kc. working, 7480 kc. day only; 2808 kc. working, 5140 kc. working, 7805 kc. day only; 2812 kc. working, 5195 kc. calling, 7935 kc. day only.

At the hearing, RTPB Panel 13, Committee I, requested the allocation of the following frequencies for radio-telephone purposes for use by city, county and state police.

1610 kc.	1698 kc.	2422 kc.
1618 kc.	1706 kc.	2430 kc.
1626 kc.	1714 kc.	2442 kc.
1634 kc.	1722 kc.	2450 kc.
1642 kc.	1730 kc.	2458 kc.
1650 kc.	2326 kc.	2466 kc.
1658 kc.	2366 kc.	2474 kc.
1666 kc.	2382 kc.	2482 kc.
1674 kc.	2390 kc.	2490 kc.
1682 kc.	2406 kc.	
1690 kc.	2414 kc.	

In addition, the following police zone and inter-zone radio-telegraph channels were requested:

2036 kc.	2072 kc.	5140 kc.
2040 kc.	2076 kc.	5144 kc.
2044 kc.	2804 kc.	5148 kc.
2048 kc.	2808 kc.	5156 kc.
2052 kc.	2812 kc.	7917 kc.
2056 kc.	2816 kc.	7925 kc.
2060 kc.	2824 kc.	7930 kc.
2064 kc.	5135 kc.	7935 kc.
2068 kc.		

Because of existing international agreements and the necessity for negotiation of new agreements, it is not possible at this time to state exactly the particular frequencies which the Commission proposes to allocate for police use. However, it is possible to specify the region of the spectrum that the Commission proposes to set aside for police use.

The Commission recognizes the need for medium and high frequencies for land-mobile and fixed point-to-point police radio communications. Channels for this purpose will be designated for land-mobile use in the bands 1605-1800 Kc, 2350-2495 Kc, and for fixed point-to-point service in the bands 2250-2300 Kc, and 2700-2850 Kc. It is anticipated that additional frequencies in the bands designated for government and non-government fixed services between 4000 and 8200 Kc will be made available for

[Continued on page 58]

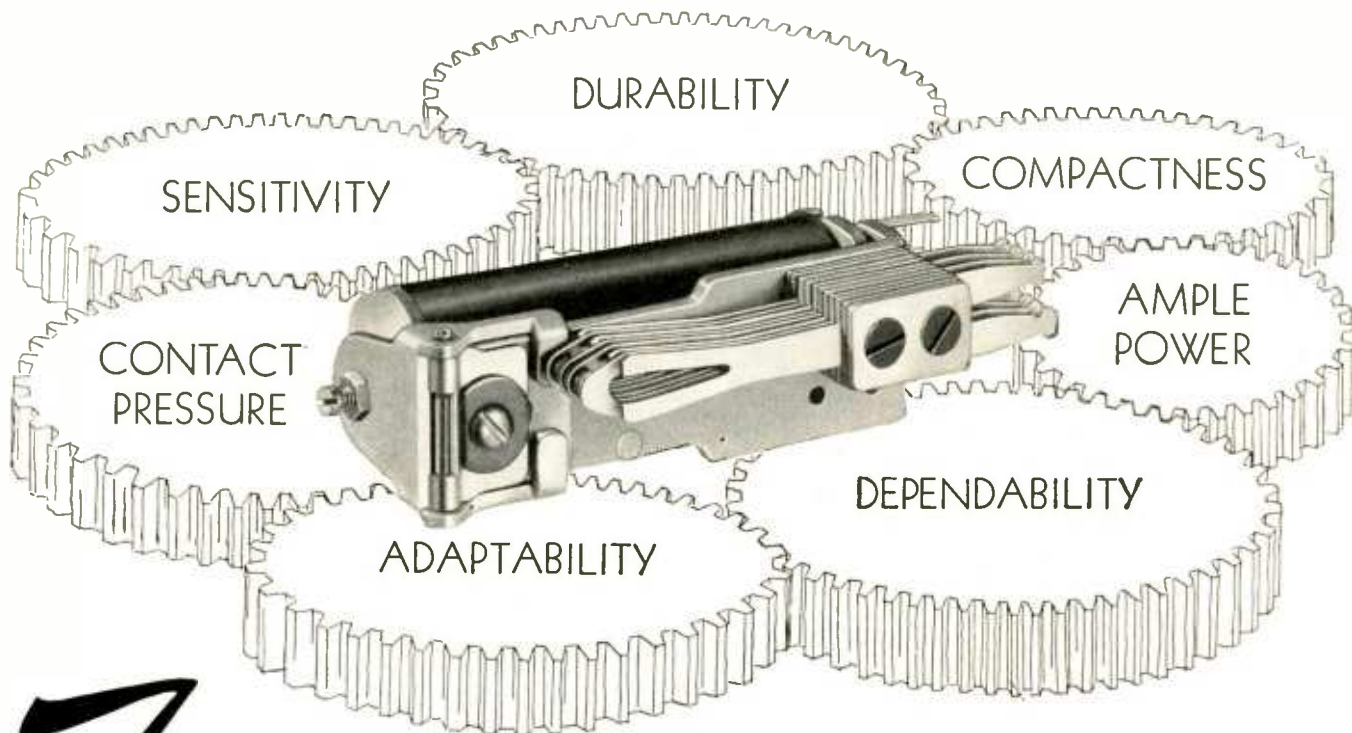

7 vital qualities **GEARED TOGETHER**

IN THE NEW AUTOMATIC ELECTRIC CLASS "B" RELAY

• Check over one by one the qualities you want most in any relay. Here, in this new relay, you will find them all—combined to give outstanding performance in any electrical control application.

Sensitive enough to operate on minute current, the Class "B" has also the high contact pressure needed for perfect closure—

Compact enough for multiple mounting in small space, yet with ample power for operating up to 28 contact springs—

With inbuilt quality needed for long service under tough conditions, and the dependability provided by dual circuit paths through independent twin contacts—

It will pay you to get the full story on this remarkable new relay. It is one of the forty basic types described in Automatic Electric's catalog 4071-D. Write today for your copy.

ONLY THE CLASS "B" RELAY HAS ALL THESE DESIGN FEATURES:

Twin Contacts—providing dual circuit paths for maximum reliability.

Efficient Magnetic Circuit—for sensitivity and high contact pressure.

Unique Armature Bearing—for long wear under severe service conditions.

Compact Design—for important savings in space and weight.

Versatility—Available for coil voltages to 300 volts d-c and 230 volts a-c, and with contact capacities up to 28 springs; also with magnetic shielding cover if desired.



AUTOMATIC ELECTRIC SALES CORPORATION
1033 West Van Buren Street • Chicago 7, Illinois

In Canada: Automatic Electric (Canada) Limited, Toronto

PARTS AND ASSEMBLIES FOR EVERY ELECTRICAL CONTROL NEED

RADIO ★ JUNE, 1945

Freq. Band Mc.	Proposed International Allocation	United States Allocation	Remarks
144-148	Amateur	Amateur	
148-152	Fixed & Aero Mobile	Government	
152-162	Fixed & Mobile except Aero.	Non-Gov. Fixed & Mobile	Note 7
162-174	Fixed & Mobile	Government	
174-180	Broadcasting, Fixed & Mobile	Television & Government	
180-186	Broadcasting, Fixed & Mobile	Television & Government	
186-192	Broadcasting, Fixed & Mobile	Television, Fixed & Mobile &	Note 5
192-198	Broadcasting, Fixed & Mobile	Television, Fixed & Mobile	Note 5
198-204	Broadcasting, Fixed & Mobile	Television, Fixed & Mobile	Note 5
204-210	Broadcasting, Fixed & Mobile	Television, Fixed & Mobile	Note 5
210-216	Broadcasting, Fixed & Mobile	Television, Fixed & Mobile	Note 5
216-220	Fixed & Mobile	Government	
220-225	Amateur	Amateur	

Services now operating between 156 and 162 mc. may continue temporarily on a non-interfering basis in the 152 to 162 mc. band.

FREQUENCIES

[Continued from page 56]

police zone and inter-zone communication.

Because of the demands for frequencies below 25000 Kc, the Commission expects that all police departments serving cities or municipalities having relatively small geographical area will operate on frequencies above 25000 Kc insofar as possible.

Note 1—On the basis of an average channel width of 25 kc. provisions will be made for the following services in the band 25 to 28 mc.:

Class of Station	No. of Channels
Relay Broadcast and Geophysical	24
Power, Petroleum, etc.*	12
Provisional and Experimental	10
Relay Press and Motion Picture	6
Aeronautical (Primarily Flight Test & Flying School)	7

Note 2—No change proposed in existing services between 30 and 44 mc. outside of the Continental United States.

Note 3—On the basis of an average channel width initially (see Sec. 2 of Part I) of 40 kc. provisions will be made for the following services in the band 30 to 40 mc.:

Class of Station	No. of Channels
Provisional and Experimental	2
General Highway Mobile**	20
Maritime Mobile and Geophysical	5
Forestry and Conservation (6 shared with Maritime Mobile and 6 shared with Urban Transit)	29
Special Emergency	6
Power, Petroleum, etc.*	7
Urban Transit, Provisional and Experimental	5
Fire	15
Police	36
Low Power Provisional and Experimental***	2

Note 4—On the basis of an average channel width initially (see Sec. 2 of Part I) of 40 kc provisions will be made for the following services in the band 42 to 44 mc.:

Class of Station	No. of Channels
Maritime Mobile and Geophysical	5
General Highway Mobile**	20
Police	24
Provisional and Experimental	1

[Continued on page 60]

Introducing the
NEW TRIPLETT LINE
of
HERMETICALLY SEALED INSTRUMENTS

All the features of standard instruments retained. Withstand submersion tests at 30 feet. Comply with thermal shock, pressure and vibration tests. Resistant to corrosion. Conform to S.C. No. 71-3159 and A.W.S. C-39.2-1944 specifications. 1 1/2", 2 1/2" and 3 1/2" metal cases with 1/16" thick walls, in standard ranges. D.C. moving coil, A.C. moving iron and thermocouple types. Write for circular.

Labels: NUT, CASE, GASKET, GLASS, TERMINAL, FLANGE, SCREW-ON BEZEL

Triplett

ELECTRICAL INSTRUMENT CO. BLUFFTON, OHIO

HOW hallicrafters EQUIPMENT COVERS THE SPECTRUM

MODEL SX-28A — from 550 kc to 42 Mc

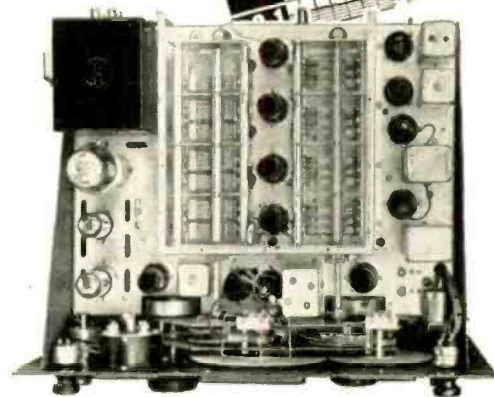

HALLICRAFTERS Super Sky rider, Model SX-28A, covers the busiest part of the radio spectrum — standard broadcast band, international short wave broadcast bands, long distance radio telegraph frequencies, and all the other vital services operating between 550 kilocycles and 42 megacycles. Designed primarily as a top flight communications receiver the SX-28A incorporates every feature which long experience has shown to be desirable in equipment of this type.

The traditional sensitivity and selectivity of the pre-war SX-28, ranking favorite with both amateur and professional operators, have been further improved in this new Super Sky rider by the use of "micro-set" permeability-tuned inductances in the RF section. The inductances, trimmer capacitors and associated components for each RF stage are mounted on small individual sub-chassis, easily removable for servicing.

Full temperature compensation and positive gear drive on both main and band-spread tuning dials make possible the accurate and permanent logging of stations. Circuit features include two RF stages, two IF stages, BFO, three stage Lamb-type noise limiter, etc. Six degrees of selectivity from BROAD IF (approximately 12 KC wide) for maximum fidelity to SHARP CRYSTAL for CW telegraphy are instantly available. Speaker terminals to match 500 or 5000 ohms are provided and the undistorted power output is 8 watts.



BUY A WAR BOND TODAY

hallicrafters RADIO

COPYRIGHT 1945 THE HALLICRAFTERS CO.

THE HALLICRAFTERS CO., CHICAGO 16, U.S.A., WORLD'S LARGEST EXCLUSIVE MANUFACTURERS OF SHORT WAVE RADIO COMMUNICATIONS EQUIPMENT

RADIO

★ JUNE, 1945

59

Freq. Band Mc.	International Allocation Proposed	United States Allocation	Remarks
225-328.6	Fixed & Mobile	Government (military) with adequate channels to be reserved for civil aviation	
328.6-335.4	Air Navigation Aids (Glide Path)	Air Navigation Aids (Glide Path)	
335.4-400	Fixed & Mobile	Government (military) with adequate channels to be reserved for civil aviation	
400-420	Fixed & Mobile (including Radio Sonde)	Government (including Radio Sonde)	
420-450	Air Navigation & Amateur	Amateur & Air Navigation	Note 8

All Non-Government services will be established in the bands above 450 mc on an experimental basis pending adequate showing as to need and requirements.

450-460	Air Navigation	Non-Gov. Fixed & Mobile	Note 9
460-470	Fixed & Mobile	Citizens' Radio	
470-480	Broadcasting	Facsimile Broadcasting	
480-920	Broadcasting	Television	
920-940	Broadcasting	Experimental Broadcast Services	

Look Here...



for Radio Parts

for specialized equipment



for Industrial and Professional Use

Transformers and other Audio Components.

Resistors, condensers and thousands of other hard-to-get

parts immediately available on priorities.



Phone, wire or write us your requirements.

Selections made and shipped same day your order is received.

RADIO WIRE TELEVISION INC.

World's Largest Radio Supply House • Known since 1922 as reliable jobbers, wholesalers and manufacturers of radio and electronic equipment

100 SIXTH AVENUE, Dept. Q-6, NEW YORK 13
BOSTON, MASS. • NEWARK, NEW JERSEY

ORIGINATORS AND PEACETIME MARKETERS OF THE CELEBRATED

Lafayette Radio

FREQUENCIES

[Continued from page 58]

Note 5—Provision may be made for the operation of non-governmental fixed and mobile services (such as, police control and relay circuits, point-to-point, marine control circuits, forestry fixed circuits, rural telephone, broadcast studio to transmitter links, railroad, terminal and yard operations) upon proper showing of need and that these channels may be shared on a mutually non-interfering basis.

Note 5.1—Aeronautical markers to remain on 75 Mc with adequate guard bands as long as required or until moved to another suitable frequency.

Note 6—On the basis of an average channel width of 50 kc provisions will be made for the following services in the band 104-108 mc:

Class of Station	No. of Channels
Provisional and Experimental	2
Forestry and Conservation	8
Power, Petroleum, etc.*	6
Urban Transit — Forestry and Conservation	6
Special Emergency (Including Highway Maintenance)	10
Provisional	
Fire	12
Police	36

Note 7—On the basis of an average channel width of 60 kc provisions will be made for the following services in the band 152 to 162 mc:

Class of Station	No. of Channels
Police	36
Fire	12
Provisional and Experimental	2
Relay Press	4
Forestry-Conservation, Geophysical	
Power, Petroleum, etc.*	6
Maritime Mobile	8
Urban Mobile**	24
Rural Subscriber Telephone	
Short Distance Toll Telephone	
Relay Broadcast	12
Motion Picture, Geophysical, Forestry-Conservation	
Provisional and Experimental	2
Railroads	60

Note 8—To be used temporarily for "Special" air navigation aids. Band to be exclusively Amateur when no longer required for "Special" air navigation aids; meanwhile Amateur peak power to be limited to 50 watts.

Note 9—To be temporarily used for "Special" air navigation aids and reserved for Non-Government services when no longer required for "Special" air navigation aids.

[Continued on page 62]

90-MILE LABORATORY for Telephone and Television

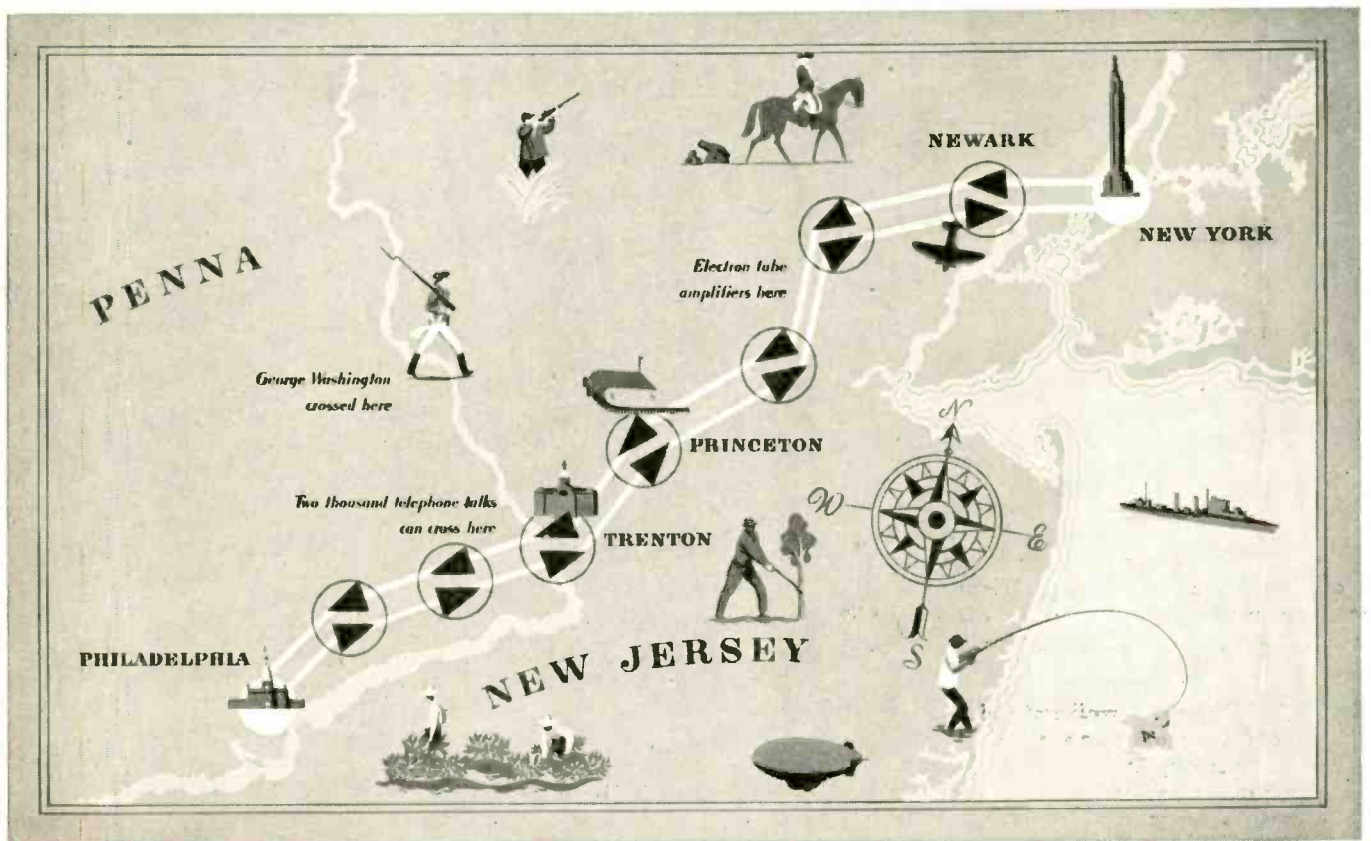

BETWEEN telephone offices in New York and Philadelphia once stretched a strange sort of laboratory. Most of the way it was underground; engineers made their measurements sometimes in manholes. It was a lead-sheathed cable containing two "coaxials" — each of them a wire supported in the center of a flexible copper tube the size of a lead pencil.

Theory had convinced engineers of Bell Laboratories that a coaxial could carry many more telephone talks than a full-sized voice frequency telephone cable; that it could carry adequately a television program. Experimental lengths were tested; terminal apparatus was designed and tried out. Finally, a full-sized trial was made with a system designed

for 480 conversations. It was successful; in one demonstration people talked over a 3800-mile circuit looped back and forth. Now the cable is carrying some of the wartime flood of telephone calls between these two big cities.

This cable made television history also: through it in 1940 were brought spot news pictures of a political convention in Philadelphia to be broadcast from New York. Bell System contributions to television, which began with transmission from Washington to New York in 1927, have been laid aside for war work. When peace returns, a notable expansion of coaxial circuits is planned for both telephone and television in our Bell System work.



BELL TELEPHONE LABORATORIES

Exploring and inventing, devising and perfecting for our Armed Forces at war and for continued improvements and economies in telephone service.

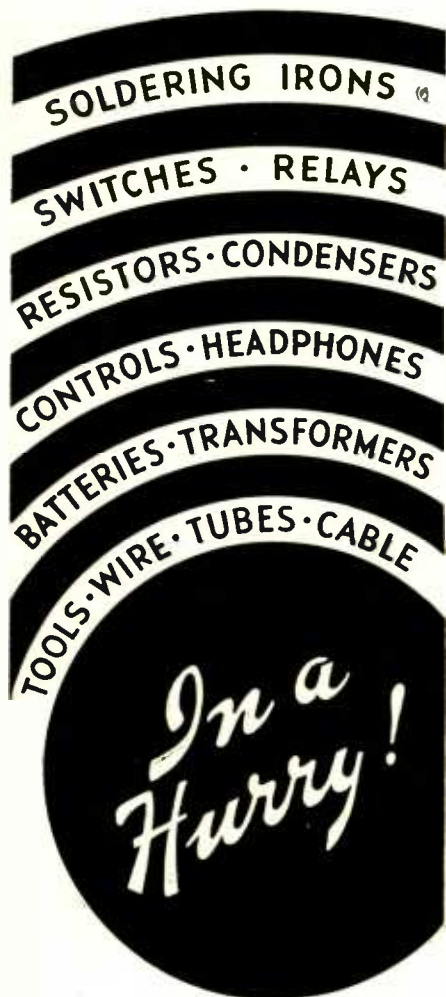

● Try DALIS "Know-How" to avoid those expediting headaches. Here's an outstanding stock of radio-electronic parts, materials, equipment —at your call!

And DALIS has the well-trained organization, long experience and exceptional factory connections that deliver hard-to-get items in a hurry. A dependable source of supply since 1925. An indispensable source, today.



● Write on your business letterhead for a copy of Dalis Catalog "RJ". And for those rush orders, try DALIS — just write, 'phone or wire.

H. L. DALIS

Wholesale Distributors
RADIO-ELECTRONIC SUPPLIES & PARTS
 17 Union Square
NEW YORK 3, N. Y.
 Phones: ALgonquin 4-8112-3-4-5-6-7

FREQUENCIES

[Continued from page 60]

Freq. Band Mc.	Proposed International Allocation	United States Allocation	Remarks
940-960	Fixed & Broadcasting	Fixed & Experimental Broadcasting	Note 10
960-1145	Navigation Aids	Navigation Aids	
1145-1245	Amateur	Amateur	
1245-1325	Fixed & Mobile except Aero.	Television Relay	
1325-1375	Fixed & Mobile	Non-Gov. Fixed & Mobile including Aero.	
1375-1600	Fixed & Mobile	Government	
1600-1700	Air Navigation Aids	Air Navigation Aids	
1700-1750	Meteorological	Meteorological	
1750-2100	Fixed & Mobile except Aero.	Non-Gov. Fixed & Mobile	
2100-2300	Fixed & Mobile	Government	
2300-2450	Amateur	Amateur	
2450-2700	Fixed & Mobile except Aero.	Non-Gov. Fixed & Mobile	
2700-2900	Meteorological & Air Navigation Aids	Meteorological & Air Navigation Aids	
2900-3700	Navigation Aids	Navigation Aids	
3700-3900	Air Navigation Aids	Air Navigation Aids	
3900-4400	Fixed & Mobile except Aero.	Non-Gov. Fixed & Mobile	
4400-5000	Fixed & Mobile	Government	
5000-5250	Air Navigation Aids (Instrument landing)	Air Navigation Aids (Instrument landing)	
5250-5650	Amateur	Amateur	
5650-7050	Fixed & Mobile except Aero.	Non-Gov. Fixed & Mobile	
7050-8500	Fixed & Mobile	Government	
8500-10000	Special Navigation Aids	Government	
10000-10500	Amateur	Amateur	
10500-13000	Fixed & Mobile except Aero.	Non-Gov. Fixed & Mobile	
13000-16000	Fixed & Mobile	Government	
16000-18000	Fixed & Mobile except Aero.	Non-Gov. Fixed & Mobile	
18000-21000	Fixed & Mobile	Government	
21000-22000	Amateur	Amateur	
22000-26000	Fixed & Mobile	Government	
26000-30000	Fixed & Mobile except Aero.	Non-Gov. Fixed & Mobile	
30000-Up	Experimental	Experimental	

[Continued on page 64]

There's **RACON** — the finest

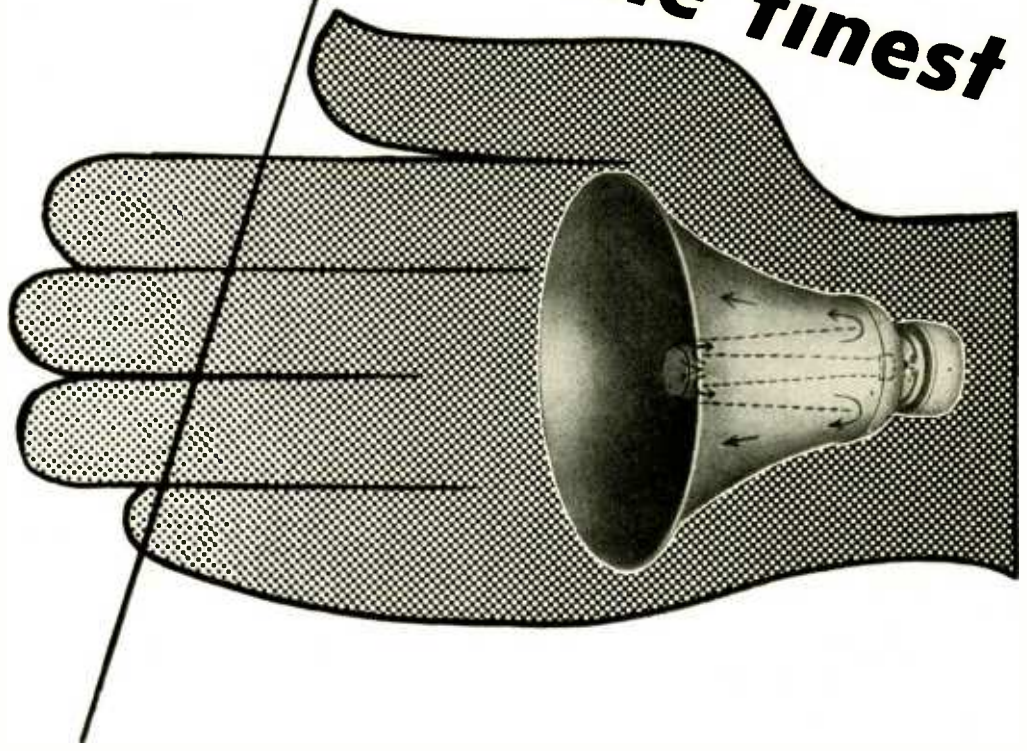

A properly planned sound installation is a good investment and soon pays for itself. Practically all industrial firms

use, or plan to buy, some type of P-A or paging installations.

The majority want RACON speakers and driving units because they have proven to be the finest that money can buy.

RACON receiver units are supplied with either metal or plastic diaphragms. RACONS outperform higher power-rated speakers of other manufacture, yet cost no more and afford peak efficient, dependable service over a longer period of time. Specify RACONS!

There's a speaker, horn or driving unit for every purpose. Literature will be sent upon request. Hand prospective P-A buyers our catalog — they'll "OK" RACONS.



RACON ELECTRIC CO. 52 EAST 19th ST. NEW YORK, N. Y.

FREQUENCIES

[Continued from page 62]

Note 10—May be used by low power fixed point-to-point stations for such services as studio-transmitter links, control circuits, police fixed facsimile circuits, etc.

*Other industries requiring similar radio service.

**May provide radio communication service to all types of mobile units such as marine, land vehicles, aircraft, etc. Pending final determination of the best method of operation of this service these channels will be assigned on an experimental basis—12 for development on a common carrier basis, 4 for trucks and 4 for buses, except in those cases where it is shown that a different distribution is more desirable.

***Antenna input power limited to 5 watts peak.

****In addition, 11 government channels are to be designated in this band.

NEW PRODUCTS

[Continued from page 53]

efficient for any capacity under designations CC20, CC25, CC30, CC35, CC40 and CC45. Samples and prices obtained by writing the manufacturer on your letter-head.

SMALL OPEN BLADE SWITCH

Designed for more compactness and long life, this small single pole open blade switch will solve many installation prob-

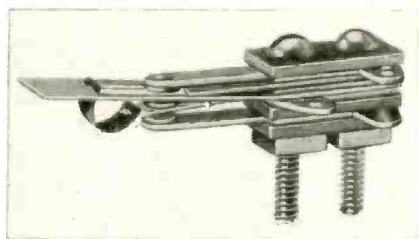

lems. It is smaller in size and requires less operating pressure. Engineered with the beryllium Rolling Spring, the overall dimensions are approximately 2 1/32" x 10/16" x 23/64".

Contact arrangements are for normally open, normally closed, or double throw circuits. Being an open blade switch, the means of actuation is provided by the user. Tests of these switches have shown a mechanical life expectancy of more than ten million operations. Standard operating pressure at the end of the blade is only 3 to 6 oz. Rated at 15 amp., 115 volts a.c.

Manufactured by the Acro Electric Company, 1423 Superior Avenue, Cleveland 14, Ohio.

TRANSPARENT FIBRON TAPE

A transparent, flexible thermo-plastic tape, greatly facilitating inspection and servicing of equipment on which it is used, has been introduced by the Irvington Var-nish and Insulator Company.

Useful not only as electrical insulation, Fibron Tape No. 3 also protects wiring.

[Continued on page 66]

Here is a Good Permanent Job FOR A COMMUNICATIONS EXPERT

You may be interested in this permanent position with a long established, progressive Radio school. The job is open right now — but we will hold it, for the right man, until he can be released from his war job.

To qualify for this position, you should be a college graduate with engineering and operating experience in Radio communications. Experience teaching Radio subjects will be an advantage — and experience in writing instruction manuals clearly, interestingly is essential.

Get in touch with us now. Let's see if we can come to a mutual understanding so you can start with us the day you are available.

Tell us all about yourself — your education and experience — your ambitions — your salary requirements. We will hold your letter in strict confidence.

Write Box 322,
RADIO MAGAZINE, INC.
342 Madison Ave., New York 17, N. Y.

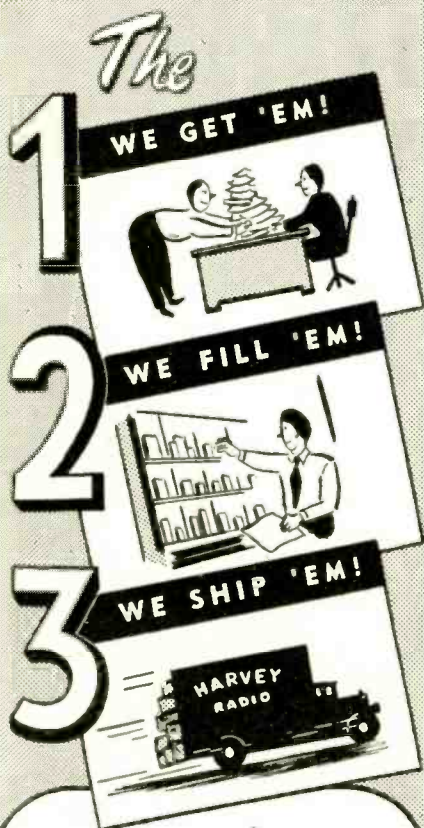

... of HARVEY ORDERS

Many of the radio and electronic components now on the critical list can be obtained without delay at HARVEY. In stock we have an unusually wide assortment of meters, resistors, capacitors, test equipment, transformers, etc. When a specific item is not on our shelves, our trained staff exerts every effort to procure it. Or, if not obtainable quickly, they may suggest an equally effective substitute. Eighteen years of experience have taught us how to handle orders efficiently, and assure prompt deliveries.

The proper priority must accompany each order. If you are uncertain as to your priority, we can supply the information you need.

Telephone orders to LOngacre 3-1800

HARVEY
RADIO COMPANY
HARVEY
103 WEST 43rd ST., NEW YORK 18, N. Y.

MADE BY
Engineers
FOR *Engineers*

it won't
be long
NOW

... and then we'll be able
to sell you these fine

WIRES

cornish
WIRE COMPANY, INC.

CORWICO

15 Park Row,
New York City

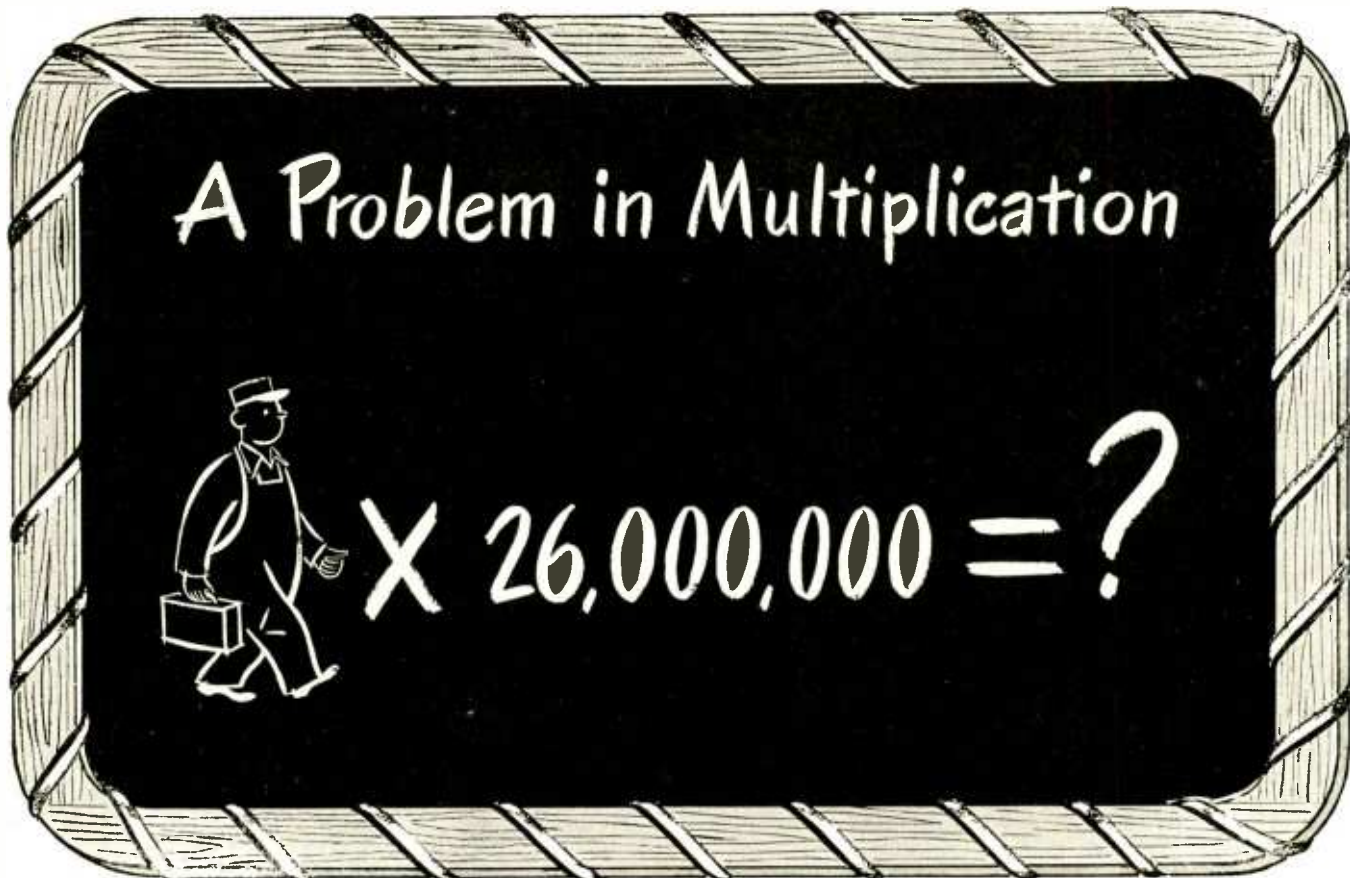

Take the case of John Smith, average American:

For over three years now, he's been buying War Bonds through the Payroll Savings Plan. He's been putting away a good chunk of his earnings regularly—week in, week out. Forgetting about it.

He's accumulating money—maybe for the first time in his life. He's building up a reserve. He's taking advantage of higher wages to put himself in a solid financial position.

Now suppose everybody in the Payroll Plan—everybody who's earning more than he or she needs to live on—does what John Smith is doing. In other words, suppose you multiply John Smith by 26 million.

What do you get?

Why—you get a whole country that's just like John Smith! A solid, strong, healthy, prosperous America where everybody can work and earn and live in peace and comfort when this war is done.

For a country *can't help* being, as a whole, just what its people are individually!

If enough John Smiths are sound—their country's got to be!

The kind of future that America will have—that you and your family will have—is in your hands.

Right now, you have a grip on a wonderful future. Don't let loose of it for a second.

Hang onto your War Bonds!

BUY ALL THE BONDS YOU CAN...
KEEP ALL THE BONDS YOU BUY

RADIO

This is an official U. S. Treasury advertisement—prepared under auspices of Treasury Department and War Advertising Council

RADIO

★ JUNE, 1945

65

NEW PRODUCTS

[Continued from page 64]

cables, and equipment against abrasion. The tape is heat sealing, flame resistant, flexible at low temperatures, and resists attack by acids, alkalis, moisture, oil, grease and corrosive fumes. With proper adhesives, it may be bonded to fabrics, metal, ceramics, wood, and other materials.

Fibron Tapes have been applied successfully as gasketing material; in the construction of automotive and aircraft lighting and ignition harnesses; and in the splicing of plastic insulated wire and cable. Complete information can be obtained from Irvington Varnish and Insulator Company, 6 Argyle Terrace, Irvington, New Jersey.

STANCOR SLIDE RULE

Mathematical demands upon electronic designers and technicians at Standard Transformer Corporation were so endless

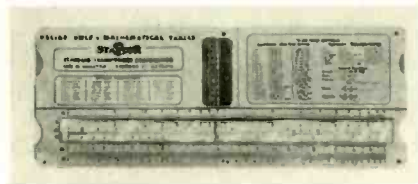

that extreme need dictated a new, compact compendium of tables all in one rule. Now we have all the values of the regular slide rule plus 8 mathematical tables, thus practically dispensing with all need for book reference. This should be welcome news to busy engineers, draftsmen, accountants, students, etc.

Stancor announces that as a service to the trade the Multi-Slide Rule will be placed with all Stancor jobbers throughout the country for distribution. Orders should not be sent to Stancor direct. The Stancor jobber in your locality is now stocked and ready to handle all requests.

MOBILE TRANSMITTER

A compact, eight channel, mobile service transmitter, which can be set for any frequency in the 100-156 megacycle band,

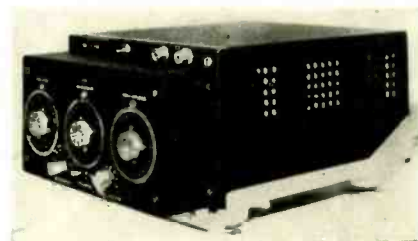

and uses but one crystal has been developed by the Bendix Radio division of Bendix Aviation Corporation.

In announcing development of the wide range, single crystal transmitter, W. L. Webb, chief engineer of Bendix Radio, stated that the new transmitter could be used in any type of mobile service and could be quickly converted from amplitude modulation to frequency modulation.

A new three dial, eight channel, automatic shifter used in the unit has many

SLIDE RULE

OR

SCREWDRIVER

... which for you?

It is up to you to decide if you will be a "screw-driver" mechanic or a real technician in a responsible engineering position. CREI home study courses provide you with up-to-date technical training, covering such important subjects as: U. H. F. circuits, cavity resonators, wave guides, Klystrons, Magnetrons and other tubes. U. H. F. as well as all other basic principles of modern, practical radio-electronics engineering are covered in CREI home study courses.

CREI can help you prepare by providing you with a proved program of home study training that will increase your technical ability and equip you to advance to the better-paying radio jobs that offer security and opportunity.

WRITE TODAY! If you are a professional or amateur radio man and want to make more money — let us prove to you we have something you need to qualify for the better job opportunities that can be yours. To help us intelligently answer your inquiry — please state briefly your education, radio experience and present position.



CAPITOL RADIO ENGINEERING INSTITUTE

Dept. RA-6, 3224 16th St. N.W., Washington 10, D.C.



● Just eight numbers — a mere handful — yet these selected capacitances in Aerovox wartime paper tubulars can take care of most of your service needs for the duration — or until other types are again available for civilian use. Keep these Aerovox Type "84" paper tubulars handy for your everyday work.

AEROVOX TYPE "84"

Non-inductive paper sections in sturdy tubular casing.

Extra-wax-sealed ends. Thoroughly wax-impregnated paper casing.

Bare pigtail terminals that won't work loose or pull out.

Colorful yellow-black-red label jacket stamped with working voltage and capacitance value.

Eight selected wartime or general-purpose values are: 600 v. D.C.W.: .001, .002, .005, .01, .02, .05, .1 and .25 mfd.

● Ask Our Jobber!

AEROVOX
Capacitors
INDIVIDUALLY TESTED

AEROVOX CORP., NEW BEDFORD, MASS., U. S. A.
In Canada: AEROVOX CANADA LTD., HAMILTON, ONT.
Export: 13 E. 40 St., NEW YORK 16, N. Y. Cable: 'ARLAB'

FREE TO YOU

COLOR CODE and OHMS LAW CALCULATOR

Great Time Saver

Burstein-Applebee of Kansas City offers you this great convenience FREE. Easy to work. Solves many problems in a jiffy. FREE to Radio men, electronic engineers and others in the business. Attach coupon to your letterhead.

MAIL COUPON NOW



BURSTEIN-APPLEBEE CO.
1012 MCGEE ST.
KANSAS CITY 6, MO.

Send me FREE Color Code and Ohms Law Calculator along with latest catalog.

I am _____
STATE CONNECTION IN INDUSTRY

NAME _____

ADDRESS _____

TOWN _____ STATE _____

possibilities in multi-channel applications. The number of dials could be varied on the basic design from one to ten, and as high as sixteen channels could ultimately be incorporated into design.

On any one of the eight channels, frequencies are accurately determined by dial calibration without the use of a crystal frequency indicator.

The new transmitter was designed by R. B. Edwards of the division's transmitter engineering department.

CAPACITOR MOUNTING CLIP

A new universal capacitor mounting clip which can be attached to the chassis instantaneously with one simple hand mo-

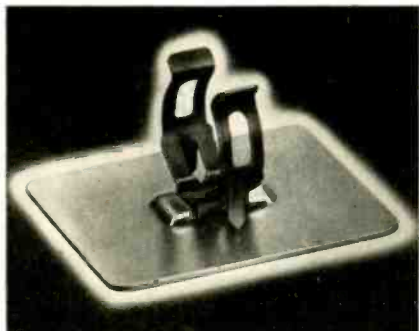

tion and without assembly tools of any kind, has been announced by the Prestole Division, Detroit Harvester Company, 4500 Detroit Avenue, Toledo, Ohio.

There are no nuts or bolts used to attach the clip to the chassis thereby eliminating this assembly operation. The pointed retaining tongues bite into the chassis firmly and prevent any loosening due to vibration. The clip is designed to give maximum engagement between capacitor and clip.

H-F TUBE SOCKETS

A series of new transmitting and receiving tube sockets molded of Mykroy—the perfected mica ceramic high frequency insulation has been developed by Electronic Mechanics, Inc., of Clifton, New Jersey.

Included in this series are: standard 4, 5, 6 and 7 prong type—Octal and Loctal sockets for multi-prong tubes—also 5 and



7 prong Acorn sockets—4 prong high voltage rectifiers sockets and improved heavy duty "50 Watters."

The sockets are produced by compression molding and are of one-piece construction featuring spring phosphor bronze contacts anchored to the sockets by a method which assures rigid non-turning position. Top surfaces are perfectly flat and smooth to permit unimpeded mounting beneath chassis. Patented spring action clips provide

ANOTHER PUBLICATION
BY THE
EDITORS OF
RADIO

CQ

The Radio Amateurs' Journal



If you are or intend to be a "ham" — or if your work entails radio communications — you'll like CQ. Subscribe now!

12 issues \$2.50
24 issues 4.00
36 issues 5.00

In U.S.A. & Possessions
Elsewhere \$3.50 per year

Tear Off
and Mail

(Not sold on newsstands for the duration).

CQ-RADIO MAGAZINES, INC.
342 MADISON AVE., NEW YORK 17, N. Y.

Sirs: Here is my check (or money order) for \$..... Send me..... issues of CQ.

Name

Address

City State

Occupation Call Letters

TOUGH!



Cinaudagraph Speakers are made to take the tough raps. This is the built-in result of better manufacturing experience. Look at the record of achievement and you'll put Cinaudagraph Speakers at the top of your list.

Watch Cinaudagraph
Speakers After Victory!

Cinaudagraph Speakers, Inc.

3911 S. Michigan Ave., Chicago
Export Div., 13 E. 40th St., New York 16, N. Y.



"No Finer Speaker in all the World"

RADIO

★ JUNE, 1945

67

CHIEF ENGINEER

Prominent, old and established Radio Manufacturer in the East seeks services of top Chief Engineer, able to take over entire department, thoroughly experienced in designing straightforward radio receivers in small, medium and large brackets; must be up-to-the-minute in knowledge of FM and Television. Salary commensurate with ability. Wonderful opportunity for right man.

Write Box 280

RADIO MAGAZINE

342 Madison Ave., N. Y. 17, N. Y.

OPENINGS FOR RADIO ENGINEERS ELECTRICAL ENGINEERS MECHANICAL ENGINEERS

In the development and production of all types of radio receiving and low-power transmitting tubes. Excellent post-war opportunities with an established company in a field having unlimited post-war possibilities.

Apply in person or in writing to:

Personnel Manager

**RAYTHEON
MANUFACTURING
CO.**

Radio Receiving Tube Div.
55 Chapel St., Newton, Mass.

firm, unvarying, highly conductive contact with tube terminals.

An eight-page bulletin containing complete information and fully illustrated with sockets, tube parts and accessories, dimension data and charts showing electrical, mechanical and physical properties is available free upon request. Write for Mykroy Bulletin #104, entitled, "Mykroy Parts and Accessories for Electronic, Radio and Radar Tubes." Electronic Mechanics, Inc., 76-82 Clifton Boulevard, Clifton, New Jersey.

UNIVERSAL HANDI-MIKE

Universal Microphone Co., Inglewood, Cal., in addition to its new microphone models, has announced a re-issue of several types that have been unavailable since the outbreak of the war.

The first of these is the 204-TA, dynamic handi-mike. It has been internally restyled and redesigned progressively to meet the need for a rugged, dependable, compact hand-held precision instrument.

The re-issue of this model will be marketed in both carbon and dynamic types with a variety of switches and circuits from which to choose, seven models in all.

Technically: impedance is 35-50 ohms;



frequency response 200 to 7,000 cps; output level into 50 ohm input; 44 db below 6 milliwatts for 100 bar signal. The shipping weight is two pounds and the assembly includes six feet of rubber jacketed cord, 2 conductors and shield.

Distribution will be through radio parts jobbers. The organization also maintains 15 factory representatives in various parts of the country.

NEW CALCULATOR

Allied Radio Corp., Chicago, has just released a new Parallel-Resistance and Series-Capacitance Calculator. This new calculator is essentially a slide-rule device, designed to provide a rapid and accurate means of determining the reciprocal of the sum of two reciprocals as expressed by the

formula $\frac{1}{x} = \frac{1}{a} + \frac{1}{b}$. A single setting

of the slide automatically aligns all pairs of a and b values which will satisfy the equation for any given value of x .

This calculator indicates in one setting the numerous pairs of resistances which may be connected in parallel, or capacitances in series, to provide any required

[Continued on page 70]

Ted McElroy
World's Largest Manufacturer of
Wireless Telegraphic Apparatus
COMPLETE CENTRAL OFFICE EQUIPMENT
McElroy Manufacturing Corp.
82 Brookline Avenue • Boston, Massachusetts

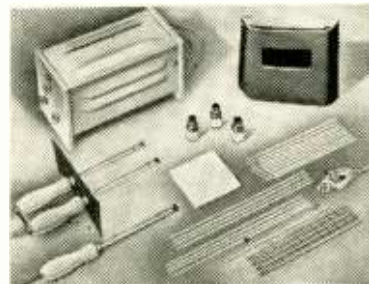

THE WELPROD

ELECTRIC WELDER

For Shop, Farm and Home Repairs

Welds, brazes, silver-solders, all metals. Anyone can operate it. Repairs steel, cast iron, aluminum, brass, copper, bronze, etc. Complete with power unit, flame and metallic arc attachments. (Really two welders in one). Carbons, fluxes, rods, mask included. Just plug it into electric outlet. 110 volts AC or DC. For hobbyist or professional.

Used by Defense Plants. Guaranteed for one year. Complete simple instructions with each set.

ONLY

19.95

WELDER PRODUCTS CO.

321 Broadway, Dept. RAD-1, New York, N.Y.

Wanted ENGINEERS

Radio

- * Electrical
- Electronic
- * Mechanical
- * Factory Planning
- Materials Handling
- Manufacturing Planning

Work in connection with the manufacture of a wide variety of new and advanced types of communications equipment and special electronic products.

Apply (or write), giving full qualifications, to:

R.L.D., EMPLOYMENT DEPT.,

Western Electric Co.

100 CENTRAL AV., KEARNY, N. J.

*Also: C. A. L.

Locust St.,

Haverhill, Mass.

Applicants must comply with WMC regulations

JUNE, 1945 ★

RADIO

RADIO

**GROUP SUBSCRIBERS
SAVE UP TO 50%***

and Here's Why:

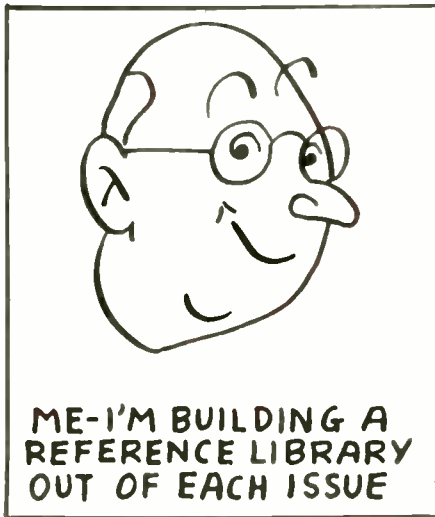

FORM YOUR GROUP TODAY-

Every month, RADIO'S exclusive articles acquaint you with newest developments — editorial "ear-to-the-ground" releases keep you abreast of trends, in fact, ahead of most coming events.

Everyone who joins a RADIO Group saves up to half the regular cost of a RADIO subscription. The more in a Group the more each saves, up to 50%*. Present subscribers may join a Group too. We'll extend their subscription from its expiration date.

*** THE GROUP PLAN**

Here's what Group Subscriptions cost:

One 1 yr. subscription \$3.00
Two 1 yr. subscriptions 2.50 each
Three 1 yr. subscriptions 2.00 "
Four 1 yr. subscriptions 1.75 "
Five 1 yr. subscriptions 1.60 "
Six or more 1 yr. subscriptions	1.50 "

Make a list giving each subscriber's name, address, employer's name and their respective positions.

RADIO MAGAZINES, INC.

342 MADISON AVENUE

NEW YORK 17, N. Y.

NEW PRODUCTS

[Continued from page 68]

resistance or capacitance value. Range: 1 ohm to 10 megohms; 10 $\mu\text{fd.}$ to 10 $\mu\text{fd.}$ However, the capacitance and resistance figures on the face of the rule can just as well serve to represent inductance,



impedance, reactance, or other units which can be handled in a similar manner. Thus, the calculator becomes equally valuable in solving problems involving inductance in parallel, coupled inductance, numerical magnitude of impedance, parallel reactance, etc.

An invaluable time-saving aid to students, technicians, engineers, and others in the radio and electronics field. Available from Allied Radio Corp., 833 West Jackson Blvd., Chicago 7, Illinois.

CORRECTION

In the center column, page 42, of the April issue the equation should read

$$P_1 = \frac{AE^2}{X^2(N+1)^2} = \frac{NE^2}{X(N+1)^2}$$

Therefore, the sixth equation becomes

$$\frac{P_2}{P_1} = \frac{(N+1)^2}{4}$$

We regret that these errors were not discovered in checking the text and wish to thank Raymond P. Ghelardi for bringing them to our attention.

VARIABLE CAPACITORS

[Continued from page 36]

of different insulating materials for the stator supports together with the Q factor over a range of frequencies. Since the curves are self-explanatory no further discussion will be required.

Specifications

Besides the usual mechanical specifications we have several electrical requirements to satisfy, such as capacity curve and tracking.

The capacity of home receiver capacitors is usually checked against a specified curve at 0, 25, 50, 75 and 95 or 100% rotation with a tolerance of $\pm (1 + 1\%) \mu\text{fd.}$ The curve having been established, the tracking of the other sections to the reference or standard section is usually maintained at $\pm (1 + \frac{1}{2}\%) \mu\text{fd.}$, this being checked at the same points as were originally chosen for the specified curve.

The reason for the greater tolerance on the reference section is that this affects the scale calibration only and is not as important as tracking between

sections which affects the overall operating performance.

Tests are usually required to indicate badly aligned plates or possible small metal burrs on the plates. Poor plate alignment is likely to result in serious microphonics and obviously should be avoided. A typical test consists of subjecting the capacitor to an a-c potential of 350 volts, 60 cycles, at 20°C, 50% relative humidity, and at an altitude of sea level without breakdown occurring at any point of angular rotation.

The specification of minimum Q at a given frequency is also desirable. This insures the maintenance of high quality insulating materials when such are necessary.

Specifications for maximum capacity change, both with temperature and humidity, as well as retrace capacity after repeated heat cycling, are sometimes desired, although these characteristics seldom vary once a satisfactory design has been made.

TIME DELAY RELAYS

[Continued from page 41]

the starting position. Mounted on the plate are one or two sensitive-action switches whose leaf-type actuators bear against the cams. The contour of the cams and the output speed of the motor gear train determine the operate and release times. The contour of the cams can be made so that one switch is actuated before the other, or so that one switch can be closed and opened several times before the motor reaches the cam stops and stalls indefinitely at the last position. Each switch can be had in single pole double throw arrangement and is rated at 10 a., 115 volts a.c. In Fig. 14 is shown a typical assembly. Motor and cam combinations can be arranged to provide timing periods from about 1 second to 1 hour without additional gearing.

Dash-Pot Method of Time Delay

The method of timing used here is very ancient. Essentially it consists of controlling the rate of motion of a plunger or diaphragm by the flow of air or liquid, which is trapped in the compartment, through an adjustable orifice. Their special advantage lies in the ease and range over which they may be adjusted. A typical unit shown in Fig. 16 may be adjusted from less than a second to several minutes. The plunger or diaphragm is driven by an a-c or d-c solenoid. The slow movement of the plunger actuates a small snap-action switch. It has two distinct limitations. It can be operated reliably in only those positions which do not deviate more than 45° from vertical. Its timing would become very short

Electrolytic Capacitor Engineer Wanted

to manage and supervise manufacturing

A top opening exists for a man with real knowledge of the manufacturing of electrolytic capacitors. He may now be in charge (or acting as a key assistant) of such work. He should have full engineering knowledge of electrolytics, as well as the ability to manage people, arrange factory facilities, etc.

To such a man we offer an unparalleled opportunity for good compensation and advancement. Our present capacitor plant (now greatly enlarged and modernized) is located about 200 miles from N.Y.C. in a fine community for pleasant living. Our sales organization is strong; our future bright. Our organization has been informed of this advertisement. Write us in complete confidence and detail. An early meeting will be arranged at our expense if you have the proper qualifications. **Box 1260** Radio Magazines, Inc., 342 Madison Ave., New York 17, N. Y.

at high altitudes because of the thinning of the air.

Mercury relays of the displacement type which have a movable iron plunger sealed into a glass or metal shell and actuated by an external solenoid coil can also be made into time delay relays of the dash-pot method. Since in the displacement type of mercury relay the mercury has to flow around the iron plunger, it is a simple matter to restrict this passage and convert the basic quick acting design into a time delay design of either slow operate or slow release. The 45° degree position limitation also applies to this type.

SUPERHETERODYNES

(Continued from page 431)

the selectivity control (See Fig. 5) will couple a varying load to the mixer plate circuit which will in turn reflect (Miller effect) a varying impedance into the mixer grid circuit. This slight

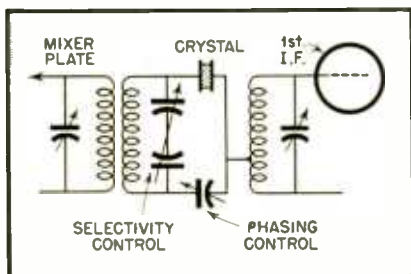

Fig. 5. Conventional crystal filter circuit

loss in selectivity is of course more than made up by the use of the crystal in the filter.

Front-End Alignment

Adjustment of the front end of a superhet for tracking, etc. varies widely between sets, and individual instructions are generally issued. While the adjustment of the grid circuit of the first tube in any set is very important as it determines largely the overall signal to noise ratio, it cannot be overstressed that proper and careful i-f alignment is absolutely necessary for good selectivity.

INSULATING MATERIALS

(Continued from page 321)

minimum acceptable limits which all laminators will meet.

The author has attempted to present simply the use of phenolics, and trusts that his own personal opinions have not prevailed too much in the selection of materials, etc. It certainly can be stated that when the less rigorous conditions of peacetime radio sets are considered, selection of moisture-resistant phenolics will not be as compelling—for industrial applications, however, these problems will still be of prime importance.

ADVERTISING INDEX

ADVERTISER	PRODUCT	PAGE
Aerovox Corporation	Capacitors	66
Albion Coil Company	Coils	17
Altec-Lansing Corporation	Loudspeakers	20
American Condenser Co.	Capacitors	16
American Phenolic Corporation	Plugs, Cables, Connectors, Sockets	9
Astatic Corporation, The	Plugs, Cables, Connectors	10
Automatic Electric Sales Corp.	Relays	57
Bell Telephone Labs.	Institutional	61
Bridgeport Mfg. Company	Coils	26
Burstein-Applebee Co.	Electronic Equipment	66
Capitol Radio Engineering Inst.	Educational	66
Cinaudagraph Speakers, Inc.	Speakers	67
Concord Radio Corporation	Electronic Equipment	14
Conn. Tel. & Elec. Div.	Electronic Equipment	27
Cornish Wire Co., Inc.	Wire & Cable	64
Dalis, Inc., H. L.	Electronic Equipment	62
D-X Radio Products Co.	Coils	18
Eitel-McCullough, Inc.	Tubes & Vacuum Pumps	19
Electrical Reactance Corp.	Capacitors	22
Electronic Laboratories, Inc.	Vibrator Power Supplies	7
Electronic Mechanics, Inc.	Insulation Materials	1
Federal Tel. & Radio Corp.	Cable, Wire	21
Formica Insulation Co., The	Laminated Plastics	13
Foster Co., A. P.	Transformers	23
Goodrich Co., The B. F.	Insulation Material	72
Hallierafters Co., The	Communications Equipment	59
Harvey Radio Co.	Radio & Electronic Equip.	64
Harvey Radio Labs., The	Electronic Instruments	Cover 3
Heintz & Kaufman Ltd.	Transmitting Tubes	25
Jefferson Electric Co.	Transformers	2
Jensen Radio Mfg. Co.	Acoustic Equipment	24
Johnson Co., E. F.	Transmitter Components	15
Klye Corp.	Transformers	Cover 4
McElroy Mfg. Co.	Wireless Tel. Apparatus	68
Monarch Manufacturing Co.	Test Equipment	18
Mycalex Corp. of America	Insulating Materials	28
Racon Electric Co.	Speakers	63
Radio Wire Television	Electronic Equipment	60
Raytheon Manufacturing Corp.	Tubes	Cover 2, 68
Sprague Electric Co.	Resistors	11
Standard Transformer Corp.	Transformers	12
Sylvania Electric Products Co.	Tubes	8
Triplett Elec. Instru. Co.	Portable Instruments	58
U. S. Treasury Dept.	War Bonds	65
Welder Products Co.	Welders	68
Western Electric Co.	Communications Equipment	4, 5, 68
Wrigley Jr., Co., Wm.	Institutional	56
Wrought Washer Manufacturing Co.	Washers & Stampings	16



From dam site to drawing room...

**with
wire insulation
made from
Geon**



WIRE insulation made from GEON polyvinyl raw materials will have almost universal application just as soon as restrictions on its use are lifted. A greatly expanded knowledge of compounding, derived from a research program accelerated by war needs, has resulted in a large group of special-purpose insulating materials which are being supplied to wire manufacturers for essential applications.

The pictures indicate the wide range of applications—from shot-firing wire to lamp cord. In between there is a long list of uses in industrial and domestic construction, communications, manufacturing of all kinds, transportation, public utilities and every other industry in America.

The list of properties of insulating material made from GEON is headed, of course, by outstanding electrical properties. Following is a long list of normally destructive factors which compounds made from GEON can be designed

to resist; oils and greases, water, air, aging, sun, abrasion, flame, chemicals and many others. GEON has certain limitations, of course. For example, being a thermoplastic material, insulation made from GEON cannot yet be used on wire for certain types of heating units such as toasters, roasters, irons or home heaters. But current research indicates that these applications may soon be included in the list.

Right now all the GEONS are subject to allocation by the War Production Board. Limited quantities may be had for experiment. And our development staff and laboratory facilities are available to help you work out any special problems in connection with essential applications.

For more complete information, write Department WW-6, B. F. Goodrich Chemical Company, Rose Building, East 9th and Prospect, Cleveland 15, O.



B. F. Goodrich Chemical Company A DIVISION OF THE B. F. GOODRICH COMPANY

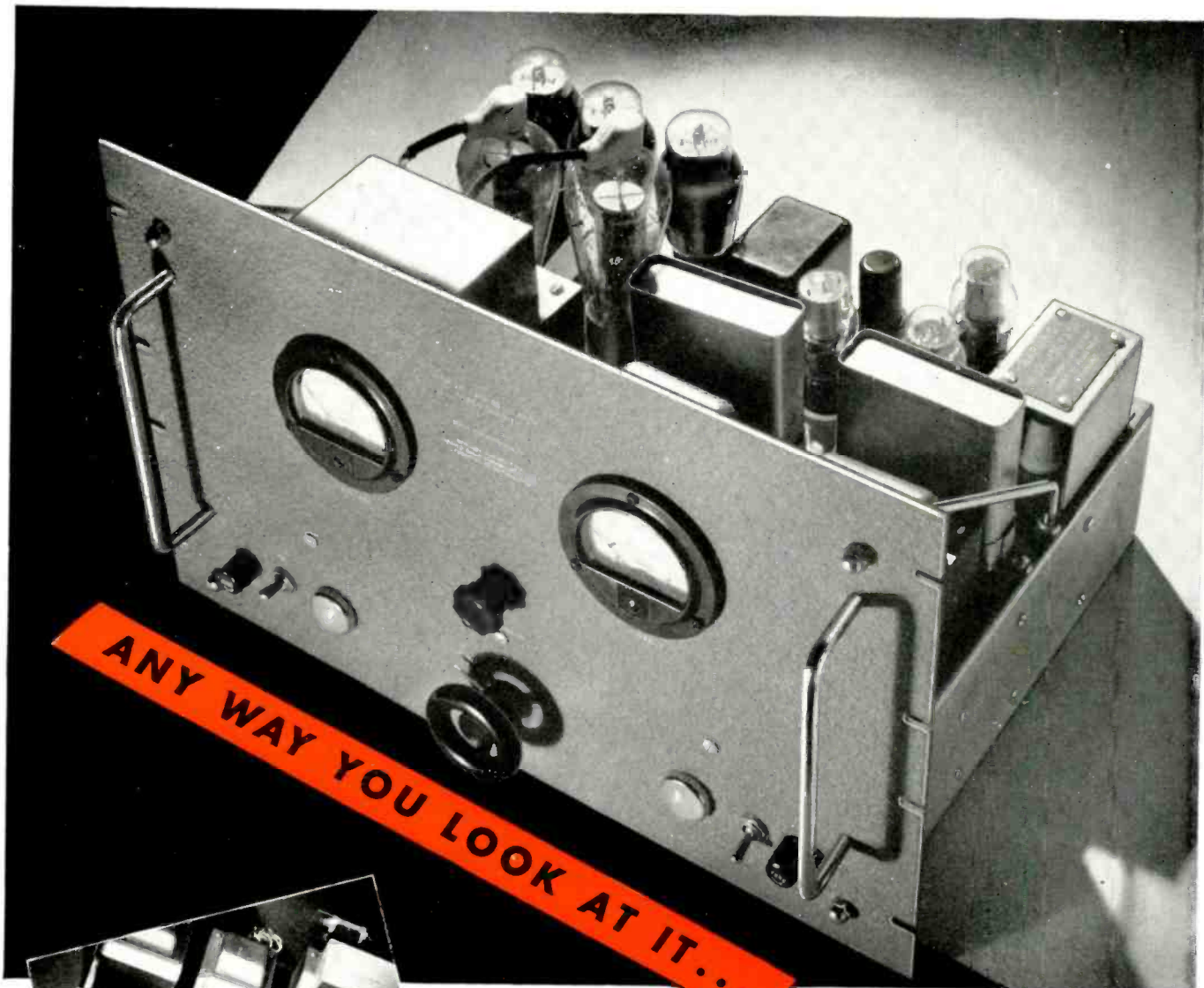

ANY WAY YOU LOOK AT IT...

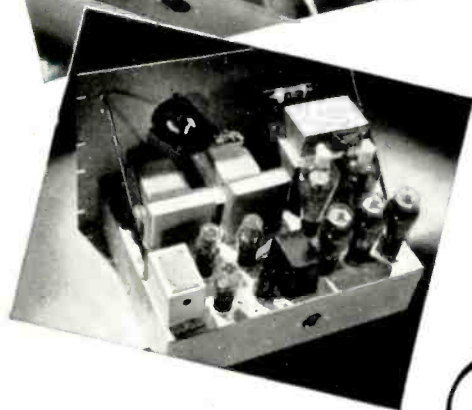
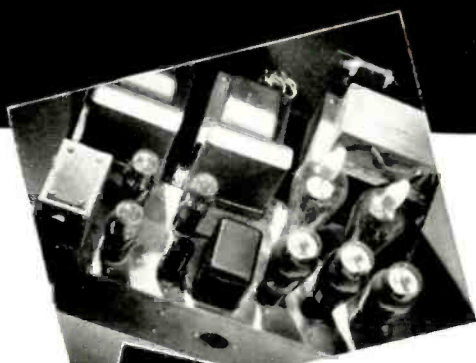

The HARVEY Regulated Power Supply 206 PA is your best source of laboratory D.C. power between ranges of 500 to 1000 volts. The HARVEY 206 PA operates in two ranges — 500-700 volts at $\frac{1}{4}$ amp., 700 to 1000 volts at $\frac{1}{5}$ amp. Regulation is 1% or better in both ranges and output remains constant even though line voltage varies between 95 and 130 volts . . . The HARVEY 206 PA is designed for safe and convenient operation. It has overload relay and interlocking relay protection at all voltages. Time delay for high voltage circuit applications and pilot lights to indicate unit in use. It is mounted on a standard relay rack panel and all components are easily accessible. Sturdy, precision-built, its dimensions are $12\frac{1}{4}$ " x 19" with a depth of 13". Weight but 72 pounds. . . . For complete information write

HARVEY

OF CAMBRIDGE

HARVEY RADIO LABORATORIES, INC.

454 CONCORD AVENUE • CAMBRIDGE 38, MASSACHUSETTS



KK

transformers
FOR RADIO-RADAR-ELECTRONIC CONTROLS

Call on Kyle Engineers . . . Trained experts are ready at all times to assist in the design of new transformers to meet your specifications. Write Kyle today.

● Kyle Transformers are the product of one of the leading manufacturers of electric power distribution equipment. ☞ Kyle's unusual facilities for the design and manufacture of precisely built, dependable small transformers have been thoroughly proven in the service of wartime radio communications, radar detection and electronic controls. ☞ Specializing in hermetically sealed equipment of highest quality, Kyle transformers function perfectly under the most extreme conditions of climate and altitude. ☞ Experienced Kyle engineers are anxious to work with you in the design of specific transformers to meet your postwar requirements.



KYLE  **CORPORATION**

SOUTH MILWAUKEE, WISCONSIN