

# RADIO

ESTABLISHED 1917



I.F. AMP DESIGN  
BAND  
PDS

## THIS MONTH:

- Antenna Directivity Fundamentals
- 
- Converting an SW-3 into a Superhet
- 
- Diversity Reception for Amateurs
- 
- Cascade Modulation
- 
- A Metal Tube "Super-Gainer"
- 
- A Compact 100-Watt Portable
- 
- High Efficiency Crystal Oscillators
- 
- Improved I.F. Amplifier Design

March, 1936 — No. 207

30c in U.S.A. and Canada

1/8 in the United Kingdom  
2/- in Australasia

# RCA ANNOUNCES TWO NEW TYPES

## RCA 834

The RCA 834 is designed primarily for use at ultra-high frequencies and can be operated with maximum rated input at frequencies up to 100 megacycles. With reduced input, this new RCA type may be operated at frequencies as high as 350 megacycles. Rated at 50 watts plate dissipation for Class C telegraph service, the RCA 834 is capable of real output in conventional circuits at ultra-high frequencies. Amateur's Net Price \$12.50.



## RCA 830-B

RCA 830-B is rated at 60 watts plate dissipation for Class C telegraph and Class B service. Maximum plate voltage is 1000 volts. This tube is particularly good as a Class B modulator: Two tubes will deliver 175 watts of audio power. The RCA 830-B is also useful as an r-f amplifier. Power output in Class C telegraph service is approximately 90 watts. Amateur's Net Price \$10.00.

The RCA 834 and RCA 830-B are available for immediate delivery from your supplier.

AMATEUR RADIO SECTION  
**RCA MANUFACTURING COMPANY, INC.**

Camden, New Jersey · A subsidiary of the Radio Corporation of America

# Clay Bailey, Chief Radio Operator Second Byrd Antarctic Expedition...

gives high praise to great performance of  
**MASTERPIECE** receivers  
at "bottom of the world"!

• Now, the story can be told of the really triumphant performance of the four MASTERPIECE II receivers selected for the Second Byrd Antarctic Expedition. And it comes direct from the man who knows—Clay Bailey, Chief Radio Operator of the expedition.

For a receiver to give satisfactory foreign reception under IDEAL conditions is ONE thing.

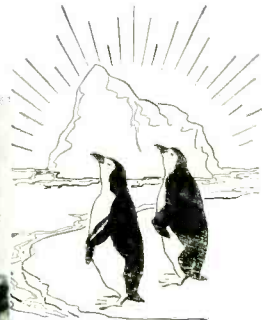

Chief Operator Bailey, in his furs at Little America.

Mr. McMurdo Silver,  
3354 North Paulina Street,  
Chicago, Illinois.

3961 Falcon Street,  
San Diego, California,  
November 13, 1935.

Dear Mr. Silver:

As Chief Operator of the Second Byrd Antarctic Expedition I feel that a word of praise and thanks is due you and your Corporation in regard to the satisfactory performance of the four MASTERPIECE II receivers which were the official all-wave receivers of the Expedition, one of which remained on the "Bear of Oakland" and one on the "Jacob Rupert", providing the entire expedition with regular home entertainment as well as a choice selection of foreign programs during their 30,000 or so miles voyage to and from the bottom of the world.

On the departure of our two vessels from the Bay of Whales for one long year, possibly two, contact with the outside world depended solely upon radio to that body of men who faced the cycle of Antarctic seasons. One can readily realize to what extent the broadcasts from home and the outside world contributed to the contentment and morale of the ice party. How comforting and consoling, snug in our little city, listening to the voices of our loved ones, thousands of miles away, as though separated only by a few feet.

The familiar clang of "Big Ben" from London, in addition to other choice programs from Europe, were regular morning features. From noon until early evening we were naturally more interested in broadcasts from home of which the volume and clarity was no question. For evening entertainment one's choice was of programs from South America, New Zealand, Australia, and Japan as well as other Asiatic countries.

The care and maintenance of these receivers was of little or no consequence. Little things like a few drops and rough handling by the transportation department and drifting snow on the trail between Little America and the ships are barely worth mentioning.

As these were the only all-wave broadcast receivers on the expedition I am sure the crews of both ships, while wintering in New Zealand, in addition to the ice party, join me in expressing appreciation to you and your Corporation for providing us with this means of world-wide broadcast entertainment.

Sincerely yours,

*Clay Bailey*  
Clay Bailey,  
Chief Radio Operator,  
Byrd's Second Antarctic  
Expedition.

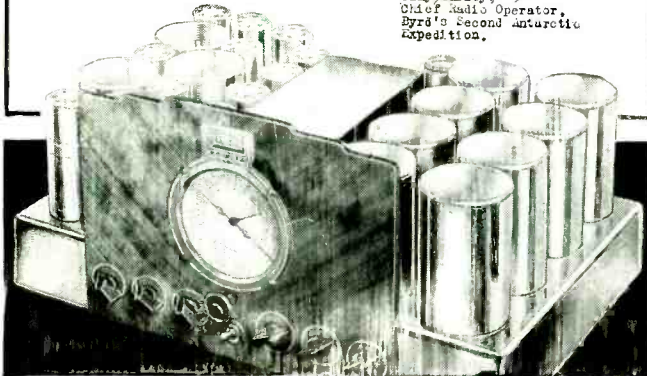

But to stand up and give consistently brilliant trouble-free performance under the MOST DIFFICULT CONDITIONS possible to imagine—with little opportunity for service or repairs—is an achievement which we believe is unequalled in the history of all-wave radio.

Mr. Bailey's letter is reproduced here, exactly as it came to us. Need we offer more convincing proof of MASTERPIECE quality and workmanship? . . . or more significant assurance of what you may expect of the even greater MASTERPIECE IVa of today?

The coupon will bring you a free copy of the 32-page "Blue Book", containing complete description of this "ace of professional receivers", with new low prices, easy payment plan, and 30-day home trial offer. Mail it today . . . there's no obligation.

*Custom Built*  
**SILVER**  
**MASTERPIECE IVa**

ALL-WAVE • WORLD-WIDE

McMURDO SILVER CORP., Div. of G.P.H. Inc.  
3352 N. Paulina St., Chicago, Ill.

Send Free "Blue Book" with complete details of MASTERPIECE IVa and 30-DAY TRIAL.  
 Send details of New Easy Payment Plan.

Name .....

Address .....

City.....State.....

3-RM

FOR BETTER RADIO

*Use*

# Hammarlund SOCKETS

- 1 MADE OF ISGLANTITE—  
LOWEST LOSSES
- 2 REINFORCED SIDE  
GRIPPING CONTACTS—  
RUST PROOFED
- 3 CONSTANT RESISTIVITY—  
MAXIMUM EFFICIENCY
- 4 UNAFFECTED BY  
TEMPERATURE OR  
HUMIDITY
- 5 SUB PANEL OR BASE  
MOUNTING—TUBE  
LOCATING GROOVE—
- 6 4, 5, 6, AND 7 PRONGS

WRITE DEPT. PR-3 FOR  
GENERAL CATALOG

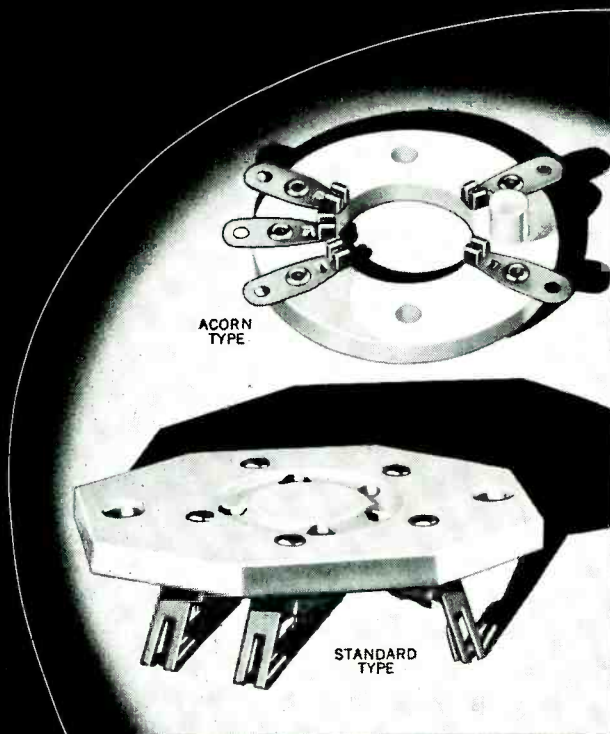

HAMMARLUND MANUFACTURING CO.

424-438 West 33rd Street, New York

CANADIAN OFFICE: 41 WEST AVENUE NORTH, HAMILTON, ONTARIO



*The publishers assume no responsibility for statements made herein by contributors and correspondents, nor does publication indicate approval thereof.*

CONTENTS

Cascade Modulation in a 210 Transmitter— <i>Martin A. Brown, W'6ABF</i>	9
"100 Watts with a Handle on It"— <i>Faust Gonssett, W'6VR</i>	12
Cascade Modulation— <i>J. N. A. Hawkins, W'6AAR</i>	17
Automatic Bandsread	19
Eastern Version of the "Simple Tower"— <i>Robert S. Kruse, W'1FG</i>	20
Open Forum	23
A Compact Transceiver That Really Performs— <i>Frank C. Jones, W'6AJF</i>	24
Making Antenna Lead-in Panels— <i>Robert S. Kruse, W'1FG</i>	26
A High-Efficiency Crystal Oscillator— <i>John L. Reinartz, W'1QP</i>	28
"QRG Meters" in Commercial Practice— <i>Rufus P. Turner, W'1AY</i>	30
How Big a Resistor?	32
A De luxe Amateur Radio Station	34
28 and 56 Megacycle Activity	37
Converting Your SW-3 into a Superheterodyne— <i>Fay W. Harwood, W'6BHO</i>	38
Antenna Directivity Fundamentals— <i>J. N. A. Hawkins, W'6AAR</i>	44
Metal Tubes in the "Super-Gainer"— <i>Frank C. Jones, W'6AJF</i>	50
Intermediate Amplifier Design— <i>Clayton F. Bane, W'6WB</i>	52
Calls Heard	56
Economical, High Quality Modulation— <i>Guy Forest</i>	58
Hams Across the Sea	60
DX Department	61
Sidebands and Modulation— <i>Guy Forest</i>	62
New Fire Underwriters Rules	65
"I Learned the Code in Ten Hours"— <i>R. H. Lampkin, Jr., W'8OGY</i>	66
Diversity Reception for Amateurs— <i>Carl Roland</i>	68
Transmitting Tube Charts	69

"RADIO" CONTRIBUTIONS

Contributions to our editorial pages are always welcome; though they will be handled with due care we assume no responsibility for those which are unsolicited; none will be returned unless accompanied by a stamped, addressed envelope. We do not suggest subjects on which to write; cover those you know best; upon request, we will comment on detailed outlines of proposed articles, but without committing ourselves to accept the finished manuscript.

Since we regard current "chiseling" policies as decidedly unfair, a small payment will be made, usually upon publication, for accepted material of a technical or constructional nature. Freehand, pencilled sketches will suffice. Good photographs add greatly to any article; they can easily be taken by the layman under proper instructions. For further details regarding the taking of photographs and the submission of contributions see "Radio" for January, 1936, or send stamp for a reprint.



Phone: WHitney 9615  
Published by Radio, Ltd.

# RADIO

7460 BEVERLY BOULEVARD  
LOS ANGELES

Cable address:  
Radiopubs, Los Angeles

Direct all correspondence to the home office at  
Los Angeles except as otherwise requested.

**Eastern Business Office:**  
500 Fifth Avenue, New York  
Phone: CHickering 4-6218

**Chicago Advertising Office:** New York Circulation Office:  
3618 No. Bernard St. 253 West 128th St.  
Tel. JUNiper 5575 Tel. MONument 2-2812

**Eastern Editorial Office:**  
and Laboratory: Great Hill Rd.  
Guilford, Connecticut

## Rates and Notices

### Single Copy Rates

#### On newsstands:

30c in U.S.A. and Canada  
1/8 in the United Kingdom  
2/- in Australia and New Zealand

#### By mail, postpaid from home office:

30c in U.S.A., Canada, and all countries  
which take the \$2.50 subscription  
rate; back copies, 5c extra.  
40c elsewhere; no extra charge for back  
copies when available.

(These rates do not apply to annual or other  
special issues)

### Subscription Rates

U.S.A.\* (and possessions), Canada, An-  
dorra, Argentina, Bolivia, Brazil,  
Chile, Columbia, Costa Rica, Cuba,  
Dominican Republic, Ecuador, Guate-  
mala, Haiti, Honduras, Mexico, New-  
foundland, Nicaragua, Panama, Para-  
guay, Peru, Salvador, Spain (and 1 Year 2 Years  
possessions), Uruguay, and Venezuela;  
duties, if any, not included..... \$2.50\* \$4.00\*

Elsewhere, duties, if any, not included 3.25 5.50

\*In California, add 3% sales tax.

### FREQUENCY

Published monthly under date as of the following  
month; ten issues yearly including special annual  
number; the August and September issues (which  
would normally appear in July and August) are om-  
itted. Short-term subscriptions are accepted pro-rata,  
but no special numbers will be included.

### Terms and Remittances

Terms, strictly cash or equivalent with order. All  
foreign and territorial remittances must be payable  
at par in U.S.A. or Canadian funds or at current ex-  
change in British funds. Cash, stamps, "bearer in-  
struments", etc., are at sender's risk. Gummed, un-  
used U. S. postage stamps accepted in small amounts;  
3c denomination preferred.

### Back Copies

Subscriptions cannot be started with back issues.  
Back copies, if available, will be supplied from the  
home office at single copy rates above.

### Changes of Address

Notice of change of address must reach us by the first  
of month preceding nominal date of issue with which  
it is to become effective. We will not supply back  
issues nor pay forwarding postage because of failure  
to receive such advance notice.

### Advertising

Advertising is accepted only at terms stated on our  
current Advertising Rate Card which will be sent on  
request to the Los Angeles or New York offices. For  
classified advertising, see classified section of any  
issue.

### PRINCIPAL FOREIGN AGENTS

**Canada:** John A. Holmes, 815 W. Hastings Street,  
Vancouver, B. C.  
**Europe:** N. E. Read, 37, Willow Street, Oswestry,  
Shropshire, England.  
**Australasia:** "The Bulletin," Box 2521BB, Sydney.

## The Staff

### Technical and Editorial Department

#### Editor

W. W. SMITH, W6BCX

#### Associate Editor

K. V. R. LANSINGH, W6QX

#### Engineering Editors

FRANK C. JONES, W6AJF

ROBERT S. KRUSE, W1FG

J. N. A. HAWKINS, W6AAR

#### Assistant Editors

HERBERT BECKER, W6QD

GEORGE D. WALKER, W4CTO

E. H. CONKLIN, W9FM

CHARLES A. HILL, W6BRO

RUFUS P. TURNER, W1AY

#### Technical Consultants

RALPH O. GORDON, W6CLH

JAMES M. SHARP, JR., W6DMY

CHARLES D. PERRINE, JR., W6CUH

#### Laboratorian

FAUST GONSETT, W6VR

#### Laboratory Assistants

RAYMOND DAWLEY, W6DHG

MARTIN A. BROWN, W6ABF

JACK HARWOOD, W6DJZ

LOUIS E. TOT, W1BNR

#### Technical Draftsmen

M. S. DAVIS

WILLIAM ROBERTS, W3BOI

#### Photographer

ROBERT NELSON

#### Editorial Secretary

D. O. WORTHINGTON

### Business Department

#### Publisher

K. V. R. LANSINGH

#### Managing Editor

M. Q. HAURET

#### Circulation Manager

B. L. HOVER

#### Eastern Manager

V. R. LANSINGH

### Correspondence and Manuscripts

Address all correspondence and manuscripts to the  
home office at Los Angeles except as follows:

1. Technical and constructional manuscripts and  
relevant correspondence from east of the Missis-  
sippi River which may be sent to R. S. Kruse<sup>1</sup>.
2. *Radiodivities*, *Strays*, and the like may be sent to  
Rufus P. Turner<sup>3</sup>.
3. Calls Heard may be sent to George Walker<sup>2</sup>;  
also dx news and station descriptions from east-  
ern America and from transatlantic countries.

Unusable, unsolicited manuscripts will be destroyed  
unless accompanied by a stamped, addressed envelope.

Copyright, 1936. All rights reserved.  
Reproduction without permission is forbidden; permission  
is usually granted amateur radio papers on request.

Printed in U.S.A. by  
GLENDALE PRINTERS, GLENDALE, CALIFORNIA

RADIO Laboratory, Great Hill Road, Guilford, Connecticut  
2Box 355, Winston-Salem, North Carolina.  
3159 W. Springfield Street, Boston, Massachusetts.  
4512 N. Main St., Wheaton, Illinois.



**MORE NEW EXCITER UNITS**  
**MORE NEW 10 METER JOBS**  
**MORE TECHNICAL FACTS**  
**MORE WORDS OF WISDOM**  
**MORE NEW ANTENNAS**  
**MORE NEW 5 METER RIGS**  
**MORE NEW, AUTHORITATIVE THEORY**  
**MORE NEW RECEIVERS**  
**MORE NEW TUBE DATA**  
**than ever before**

**THE 1936 EDITION**

*of*

# The "Radio" Handbook

You can't afford to be without one

Late As Usual—Better Than Usual—\$1.00, as Usual  
 (Foreign, \$1.15)

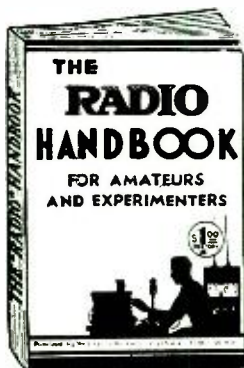

100,000 COPIES

RADIO Magazine,  
 7460 Beverly Blvd.,  
 Los Angeles, Calif.

Please send me postpaid a copy of the 1936 "RADIO" Handbook, published by the Pacific Radio Publishing Co., just as soon as they are off the press. I have enclosed \$1.00 and am expecting a lot for my money.

Name..... Call.....

Street and Number.....

City and State.....

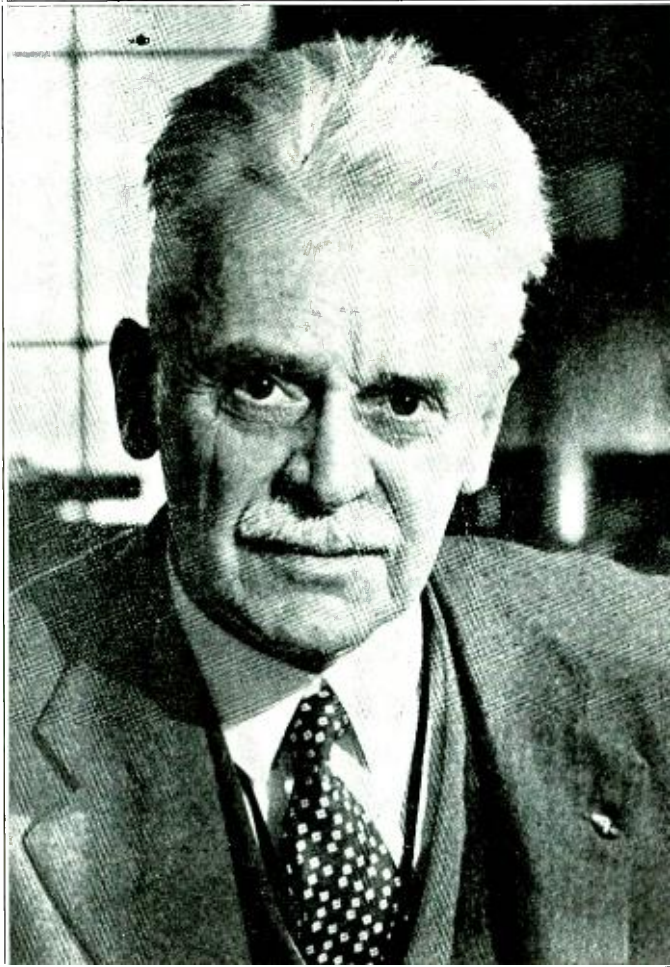

IN MEMORIAM  
HIRAM PERCY MAXIM, WIAW



# Cascade Modulation in a 210 Transmitter

By MARTIN A. BROWN, W6ABF

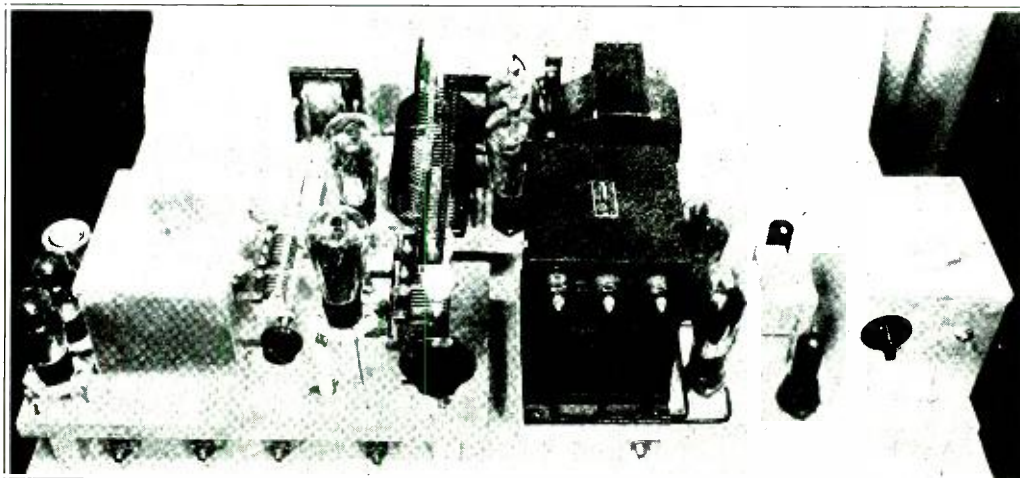

The complete 210 transmitter described in the story. The different units should preferably be spaced more than in the photograph; they were placed in this position merely to get them in one picture.

This transmitter gives a very good account of itself on 160, 75, and 20 meters; and is conservatively rated at 75 watts of carrier output. The fidelity and linearity are considerably better than average due to the use of somewhat oversized class B transformers and due to the use of cascade plate modulation, which allows 95% linear modulation capability to be more than just an idle dream.

The r.f. portion of the rig is straightforward and was completely described on page 27 of the January, 1936 issue of RADIO. The use of parallel 42's as the crystal oscillator allows high oscillator output and a good impedance match to the 210 buffer grid to be obtained without going to link coupling. The use of shielding around the buffer stage is highly desirable as it eliminates all signs of unwanted regeneration from the oscillator and buffer stages. The shield material is cadmium plated furniture steel. The buffer shield box and the preamplifier shield box are exactly the same and are available commercially. Care must be taken to see that the buffer plate tuning condenser and the neutralizing condenser can stand the peak modulation voltage. However, as the buffer is only modulated about 25% on peaks, this voltage is only 25% higher than the unmodulated voltage. The buffer and final amplifier must be very carefully neutralized if good results are

to be obtained as all the shielding in the world will not eliminate regenerative feedback through the tube itself.

## The Audio Channel

The audio channel is largely standard practice except for the use of the newer metal tubes. If it is desired to use glass tubes no changes in the circuit are necessary. Use a 75 as the first stage in place of the 6F5, a 76 in place of the 6C5, and 42's in place of the 6F6's. As crystal microphones are standard practice these days the audio channel was designed to handle all types of diaphragm type mikes. The total gain is approximately 112 db with the gain wide open and no signs of either audio or r.f. feedback have been experienced.

Note that the first stage uses fixed battery bias rather than cathode bias. This has been found desirable in order to minimize hum pick-up and also to minimize motorboating. The bias battery consists of one cell of a fountain pen type of flashlight battery mounted inside of the shield can. These cells sell for a nickel apiece and a cathode resistor and its large by-pass condenser are eliminated by use of one. This cell should last at least a year as there is normally no load on it. Note that the bias voltage appears across the crystal microphone. It has been found that about one and a half volts across a crystal microphone eliminates the peculiar

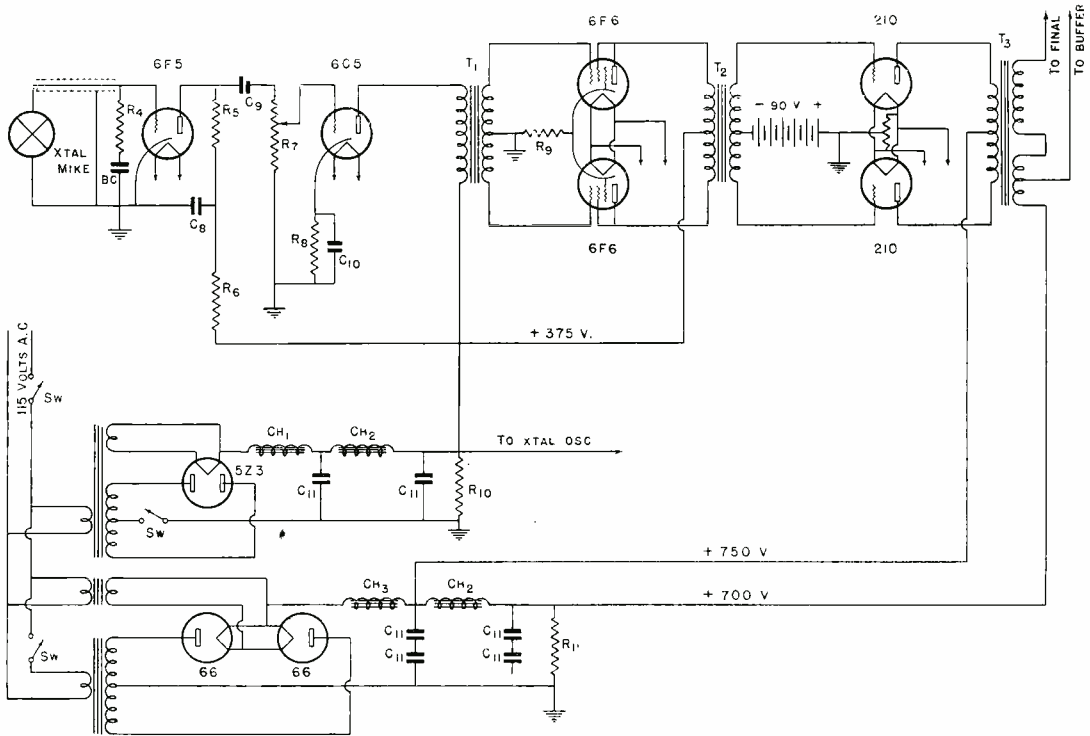

The Power Supplies and Audio System

C<sub>8</sub>—0.5 μfd. paper tubular  
 C<sub>9</sub>—0.006 μfd. mica  
 C<sub>10</sub>—10 μfd. 25 volt electrolytic  
 C<sub>11</sub>—8 μfd. 525 volt electrolytics  
 R<sub>1</sub>—5 megs., 1 watt  
 R<sub>2</sub>—250,000 ohms, 1 watt  
 R<sub>3</sub>—50,000 ohms, 1 watt  
 R<sub>4</sub>—1 meg. tapered potentiometer  
 R<sub>5</sub>—2500 ohms, 1 watt

R<sub>10</sub>—750 ohms, 10 watts  
 R<sub>11</sub>—40,000 ohms, 25 watts  
 R<sub>12</sub>—100,000 ohms, 25 watts  
 CH<sub>1</sub>—200 ma. swinging choke  
 CH<sub>2</sub>—250 ma. smoothing choke  
 CH<sub>3</sub>—350 ma. 5-25 hy. swinging choke  
 T<sub>1</sub>—2:1 push-pull input  
 T<sub>2</sub>—45's to Class B 210's  
 T<sub>3</sub>—Class B output for 800's, 830's, etc. (Must have

several taps and be designed to carry secondary current)  
 T<sub>4</sub>—400-0-400 volts, 5 volts, and 6.3 volts, b. c. l. transformer  
 T<sub>5</sub>—2.5 volt, 10 amps., 5000 volt insulation  
 T<sub>6</sub>—950-0-950 volts, 300 ma. Filament transformer for 10's —7.5 volts, 6.5 amps.

iar rushing background noise made by some makes of crystal microphones when subjected to a strong r.f. field.\* Note that the mike jack is of the shielded type.

The audio gain control is located in the grid of the second stage where it belongs in order to eliminate noise. The second stage uses a 6C5 with normal cathode bias and is transformer coupled to the push-pull driver stage which uses triode-connected 6F6's. This stage has more than enough output to drive the class B 210's to better than 60 watts of audio output.

It must be emphasized that class B input and output transformers are a poor place to economize in a phone transmitter. Both the class

B input and output are made for class B RK18's or 800 tubes. These transformers list for only a very few dollars more than the 210 types and the turns ratios are almost exactly the same. In this particular transmitter only \$2.50 net could have been saved by using the smaller class B transformers and the truly high quality of this rig was much more than worth the difference.

Battery bias was used on the 210 modulators because batteries are quite cheap now and a set will last from six months to a year in this transmitter. Four 46's or 59's could have been used for modulators but they require much more grid driving power and the author sincerely believes that they are actually not capable of as good quality as the 210's. Class AB 250's could have been used to give 60 watts from four tubes; but tube, transformer, and power

\*This practice is not recommended by the manufacturers, but does not seem to hurt the microphone. Higher voltage across it might damage it, but 1½ volts seem to do no apparent harm.

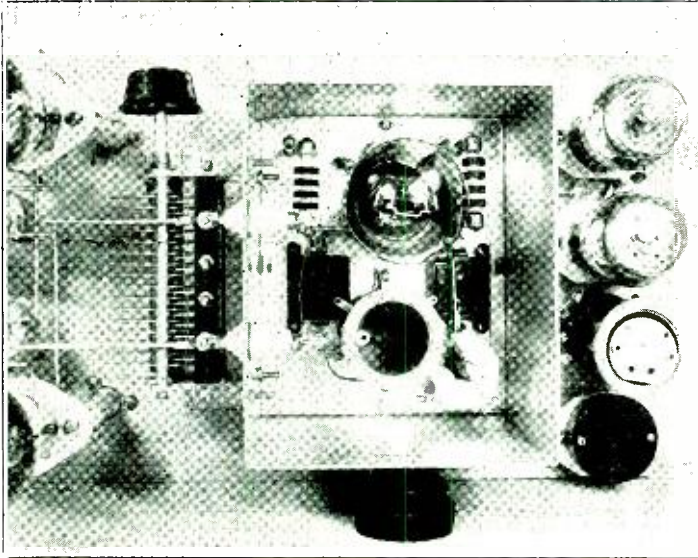

Many requests were received to show the interior of the buffer shield-can by amateurs building the r.f. portion from the article in January "RADIO". Here it is.

supply costs would have been considerably higher.

Note that the plate voltage supply to the 210 buffer stage is obtained from a tap on the class B output transformer secondary in order to apply cascade modulation. This tap is not critical in location. About 25% up (in turns) from the cold end of the class B secondary will be about right in most cases.

Only about 5% of the modulator output is dissipated in the buffer stage during 100% modulation of the final.

The power supply is standard practice. The 350 volt supply operates the speech channel and the crystal stage. The 750 volt supply operates the rest of the rig. A pair of 66's were used in place of some of the smaller rectifiers which have, on occasion, "gotten by" on 750 volts. However, 66's are now quite inexpensive; so there would be little saving in the use of smaller rectifiers. Also it pays to play it safe on rectifiers as a rectifier short usually means other blown equipment.

Note that the modulators take their plate voltage *ahead*

of the smoothing choke in the high voltage power supply. This improves voltage regulation and also reduces the amount of filtering necessary, which reduces the cost. Practically no carrier noise is added through this procedure as the modulators are in push-pull and thus require somewhat less filtering than a single-ended class A modulator for the same transmitter.

The total cost for the parts in this transmitter came to less than \$100, using the best available components. This included batteries, tubes, crystal, and microphone.

The breadboards are of the new RADIO standard type and are 17 inches wide by 8¾ inches deep. They fit nicely behind a relay rack and are easy to

work on, in addition to being inexpensive.

#### ◆ Breaking Glass

Make a small notch by means of a file on the edge of the glass, then heat the end of an iron rod red hot and apply the iron to the notch, drawing it slowly along the surface of the glass in any direction desired, and a crack will follow the direction.—W6DOB.

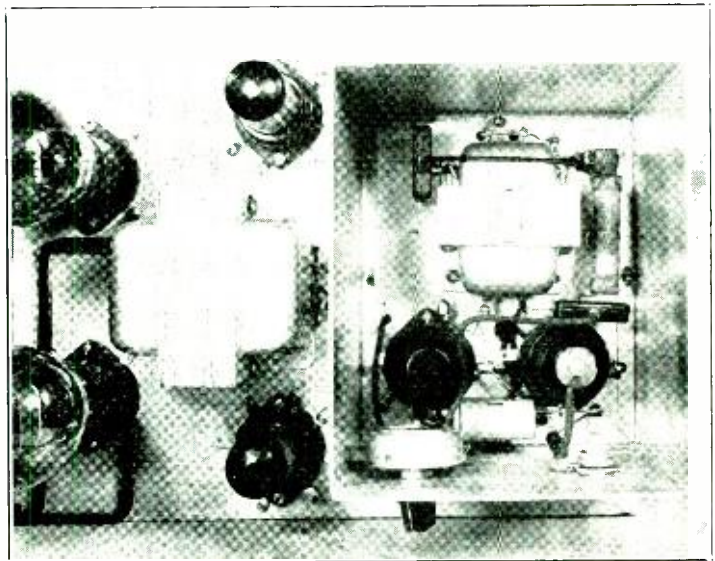

Looking down into the "front end" of the speech system.



## "100 Watts with a Handle on It"

By FAUST GONSETT, W6VR

Most of the portable rigs we have seen either have been flea-power affairs or else, in the case of

those giving a decent output, took two men to lift them and a trailer to haul them. There is no doubt about it; 100 watts in the antenna is just as desirable for portable operation as it is at home. Just because we are on a trip is no indication that extremely low power will push through the QRM any more than it will at home. So after deciding that at least 100 watts was desired in the antenna, we proceeded to determine just how compact and inexpensive we could make a transmitter that would turn out that much power. The transmitter to be described was the result.

A single 2A5 crystal oscillator, running at 500 volts, drives a pair of type 10's in parallel running at 900 volts. Because portable c.w. operation is usually confined to the 80 meter band (no frequency doubling being necessary) and because the 2A5 has sufficient output to drive the 10's to 100 watts output at good efficiency when high plate voltage is used on the 10's, no buffer stage was used. This omission of a buffer stage allows a more compact and economical arrangement, in addition to keeping the weight down. The weight, by the way, may be reduced appreciably by substituting a fiber or wood case for the metal one, the metal case accounting for approximately half of the 39 lbs. of the transmitter as shown in the photographs (including dust cover). However, the metal case provides much more rugged construction, and in addition provides very good shielding. For these reasons the metal case was chosen in preference to a wood one in spite of the additional 10 lbs. weight.

### "Henry's Are Heavy"

One method of holding the weight down that proved entirely practicable was the omission of filter chokes. Though at first it might seem that this would not give a sufficiently clean note, in actual practice it was found that 8  $\mu$ fds. on the oscillator and 4  $\mu$ fds. on the amplifier gives a very decent d.c. note. Every one of eleven stations worked with the transmitter one after-

*Right now is the time to build up a portable rig for those trips to the mountains or beach this spring and summer. Here is one that should interest every c.w. man; it puts 100 watts into most anything you might wish to use for an antenna, and weighs but 39 lbs. And you can get by hotel clerks with it by passing it off as a diathermy machine—provided you hide the key.*

noon reported "T9X". The note actually has less ripple in it than the majority of phone carriers on

the air. Even with no choke, 4  $\mu$ fds. provides a surprising amount of filtering when across a supply that furnishes high voltage at low current. Elimination of filter chokes in the two power supplies saves several pounds.

Just to see if it would be desirable to provide more excitation to the 10's, the grid coil for the amplifier was link coupled to the output of a small transmitter winding up in a pair of 46's at 550 volts. The 46's put over 3 times as much r.f. into the grids of the 10's as did the 2A5 oscillator, which had an output of about 10 watts at the voltage shown. The increase in efficiency of the 10 stage at the same input (900 volts at 150 ma.) was negligible, the output going up from approximately 100 watts to approximately 104 watts. Evidently 10 watts of excitation was enough; so the 2A5 was allowed to remain on the job.

A glance at the diagram shows all plate circuit tuning condensers to be grounded. This greatly simplifies construction, as it allows the condensers to be mounted directly on the metal panel. The neutralizing condenser, which is left alone when once adjusted, is mounted on the top shelf sub-panel and is insulated from the metal shelf with thick, fiber washers. This is not considered a tuning condenser, because it is set but once and then left alone. It is a good plan to bend with a pair of long-nosed pliers the spring tension-contact on the neutralizing condenser so that the rotor turns rather hard. This prevents it from being jarred out of adjustment. Be sure that the rotor of the neutralizing condenser goes to the grid coil, and that the stator goes to the plates of the 10's. If this arrangement is reversed, the insulating washers used to mount the condenser will probably break down; therefore be sure to connect the condenser as shown in the diagram, with the stator the "hot" side.

The grid tuning condenser for the 10's must be insulated from the metal panel with insulating washers. The voltages here are small and



100 watts output on 3.5 mc. c.w., entirely self-contained.  
39 pounds.

no elaborate insulated-mounting method is necessary. If a split-stator condenser were used at this point it could be mounted directly on the metal panel with no insulation, but such a condenser adds a bit to the expense and apparently nothing to the performance.

#### Antenna Considerations

With the output circuit shown, most any type of antenna may be used. A twisted pair doubler should be coupled by wrapping a couple of turns around the output coil. End-fed, single wire fed, Marconi, etc. antennas should be connected to the antenna post. Antenna adjustment will be described later in the article, along with the tuning of the transmitter.

The tank coil for the 10's "hangs from its heels" on the under side of the top shelf. This allows a more compact layout and provides the incidental advantage of shielding effectively the output tank from the grid tank and the oscillator tank. The amplifier stage neutralizes "stone cold" with no trouble whatsoever, and this shielding effect is probably a contributing factor. The plate tank is wound on a "giant" plug-in form with no. 14 enamelled wire.

All coils were made plug-in in the event that the transmitter should be used on 40 or 160

meters. No coils were wound for these bands, but there is no reason in the world why the transmitter should not work like a "million dollars" on these bands as well as on 80 meters. With a 20 meter crystal the transmitter could probably be used, with a little care, to work on 20 meters, though careful tuning and neutralizing would be necessary to guard against fracturing of the crystal from r.f. feedback. The oscillator will work well with a 20 meter "power" crystal and the crystal current will be within safe limits provided no feedback from the 10's is present. Because of the pentode connection of the oscillator and the low bias used, the crystal current is extremely low on 80 meters and will not rise to a dangerous value even with a 20 meter crystal. Because there will be less excitation, because of the parallel connection of the 10's, and because output has a habit of falling off on higher frequencies anyhow, the 20 meter output will probably be limited to around 75 watts if the plate dissipation of the 10's is to

be kept within reasonable limits. It seems to us that if one wants to work Asia or South Africa he should not wait till vacation time, but we mention the practicability of using the transmitter on bands other than the 80 meter band because there probably are a few amateurs that will want to try a little "mountain top dx-ing."

The crystal oscillator power supply is used for bias on the 10's by grounding the positive side instead of in the usual manner (negative to ground). Thus the 10's do not try to "run away" when the excitation either fails or is removed. Fixed bias is a great help in tuning the transmitter and has been known to save a good many 10's from an untimely end. The slider on the voltage divider  $R_3$  is adjusted (key down but  $SW_2$  open) to approximately 125 volts as measured between the slider and ground. This is just sufficient bias to cut off the plate current on the 10's and a little to spare. This sounds as though the bias would not be great enough for efficient operation, but with plate voltage on the 10's the grid current flowing through the voltage divider will raise the bias considerably, the exact amount depending upon the amount of excitation.

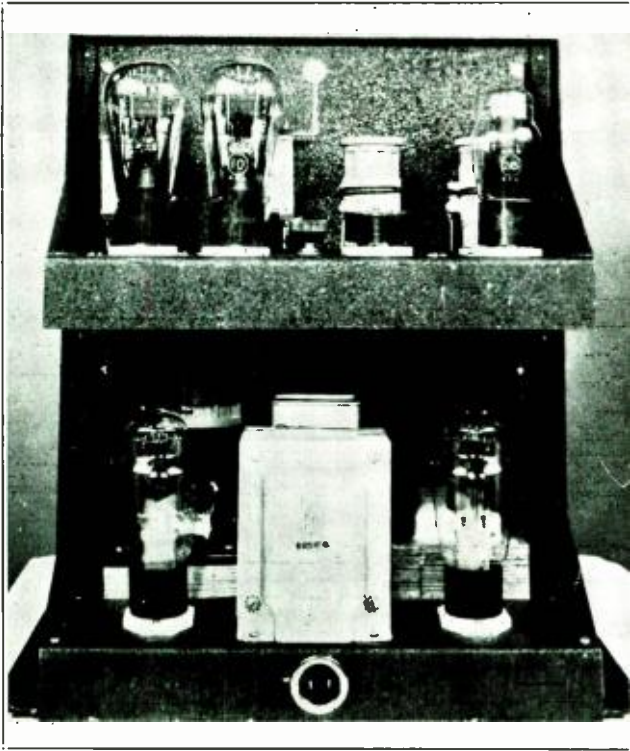

Back view of the transmitter with the dust cover removed. The tank coil for the 210's can be seen peeking between the power transformer and the left-hand rectifier tube.

### Keying

The method of obtaining bias used allows keying in the oscillator, highly desirable from the standpoint of key clicks and the working of break-in. With the key open there is no trace of filament hum in an adjacent receiver, nor is there heard any "mercury hash" from the 83 rectifier.

The filter condenser for the 900 volt supply is mounted between the power transformer and the front panel. It is mounted inverted with the grounded terminal being screwed directly to the metal subpanel, and the other terminal protruding through an insulating grommet in the subpanel, connection being made from underneath. This condenser, being of the oil impregnated type, is small in size even though rated at 4  $\mu\text{f}$ . and 1000 working volts.

The oscillator power supply should use either an 80 or a 5Z3 for rectifier. The high voltage on the oscillator supply comes on with the filaments, and if an 83 is used the tube will invariably flash inside when first turned on, due to the simultaneous application of high voltage and filament voltage.

The use of an 83 in the 900 volt power supply for the 10's may look to some like an invitation for trouble. For the benefit of several skeptical spectators, the 83 was removed and a half dozen others of various and sundry makes were tried. None flashed over or showed other signs of failure. The important thing seems to be to let the filament of the 83 run for at least 30 seconds before applying high voltage. The power transformer is rated at 700 volts r.m.s. each side of center and delivers approximately 725 volts at no load. The d.c. output voltage of the filter at no load measured 1010 volts, and dropped to 900 volts at 150 ma.

After the transmitter is once turned on, it is left on until you are through transmitting for the time being. To transmit, merely punch the key; no throwing of switches is necessary. To turn on the rig, turn on SW<sub>1</sub>; wait 30 seconds (the receiver can be warming up; no time wasted); throw SW<sub>2</sub>; punch the key at your leisure, without throwing any switches until ready to leave the air. What could be simpler?

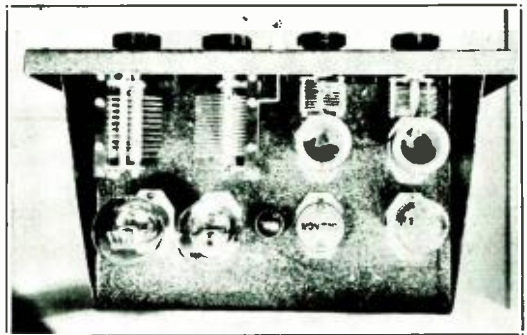

Looking down on the top shelf. The small knob to the right of the crystal holder tunes the neutralizing condenser.

Only one meter is provided, the milliammeter in the plate circuit of the 10's. The oscillator is not tuned by plate current, but rather for maximum stable output. For that reason no means was provided for measuring the oscillator plate current. The bias, plate voltage, and screen voltage are such that it is impossible to tune for maximum output and have excessive plate current, as the oscillator will refuse to os-

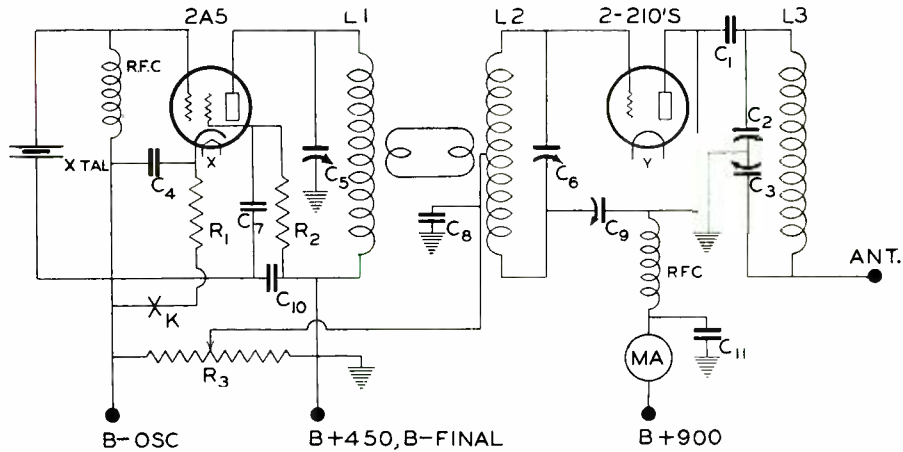

**The Radio Frequency Portion**

- |   |   |   |
|---|---|---|
| C <sub>1</sub> —2500 volt mica, .002<br>μfd.    | spaced midget   | close wound on 1½"<br>form (80 meters)  |
| C <sub>2</sub> —100 μμfd., 3000 volt<br>spacing | C <sub>10</sub> —0.006 μfd. mica, 1000<br>volt          | L <sub>2</sub> —27 turns same, tapped<br>at center (80 meters)  |
| C <sub>3</sub> —365 μμfd., 1000 volt<br>spacing | C <sub>11</sub> —0.001 μfd. mica, 2500<br>volt          | L <sub>3</sub> —24 turns no. 14 en-<br>amelled, wound on<br>2¼" form, spaced<br>slightly less than di-<br>ameter of wire (80<br>meters) |
| C <sub>4</sub> —0.006 μfd. mica, 1000<br>volt   | R <sub>1</sub> —400 ohms, 10 watts                      | Note—C <sub>6</sub> , C <sub>9</sub> , and K (key-<br>ing jack) must be in-<br>sulated from chassis<br>with insulating wash-<br>ers.    |
| C <sub>5</sub> —50 μμfd. midget                 | R <sub>2</sub> —50,000 ohms, 3 watts                    |   |
| C <sub>6</sub> —100 μμfd. midget                | R <sub>3</sub> —30,000 ohms, 50 watt,<br>adjustable tap |   |
| C <sub>7</sub> —0.006 μfd. mica, 1000<br>volt   | RFC—8 mh., pie wound<br>transmitting type r.f.<br>choke |   |
| C <sub>8</sub> —0.006 μfd. mica, 1000<br>volt   | MA—0-200 or 0-250 ma.<br>d.c.                           |   |
| C <sub>9</sub> —35 μμfd. double                 | L <sub>1</sub> —44 turns no. 22 d.c.c.                  |   |

cillate if the loading is so excessive that the tube would draw enough plate current to damage it. Likewise, for the sake of portability, no grid meter is provided. We don't have to worry about damaging the 10's with too much grid current, and as for tuning for maximum grid current we can do just as well with a flashlamp around the grid coil. What matter if we don't know the exact grid current so long as we know it is all we can get and that it can't possibly be enough to do any damage? So we wind up with but the one meter. Others would be handy, but we can get along without them.

**Tuning**

To tune up, leave SW<sub>2</sub> open, close SW<sub>1</sub>, and, having made the bias adjustment already described, tune C<sub>5</sub> and C<sub>6</sub> for the maximum amount of grid current into the 10's. This will be indicated by maximum brilliancy of a flashlamp coupled with a one-turn pickup coil to L<sub>2</sub>. C<sub>6</sub> should always be tuned to resonance, if the loading on the oscillator is too tight at resonance and the oscillator either does not want to key or goes out of oscillation, reduce the coupling between L<sub>1</sub> and L<sub>2</sub> by either adjusting the positions of the links or by reducing the links to a single turn. The idea is to have C<sub>6</sub> on

the "peak" and have as much r.f. in L<sub>2</sub> as it is possible to get without the oscillator becoming unstable.

The indicator lamp is then coupled to the final tank coil, L<sub>3</sub>, and the neutralizing condenser adjusted until you find a position where moving it either way will give an indication of r.f. in L<sub>3</sub> (plate voltage still off) when C<sub>2</sub> is tuned through resonance. Now go back and touch up C<sub>6</sub>; adjusting the neutralizing condenser will affect it slightly. When the stage is once neutralized you need not change the position of the neutralizing condenser except possibly when changing bands, and ordinarily it will be close enough even then that no reneutralizing is necessary. It is quite easy to tell when the stage is not neutralized properly; when it is not, the plate current will not drop to zero when the key is up, indicating self-oscillation of the 10's.

If you wish to use several frequencies in one band, it would be wise to mount the crystal holder on the front panel, so that changing of crystals would be possible without removing the dust cover. Two insulated tip jacks on the front panel, properly spaced, would do the trick.







# Cascade Modulation

By J. N. A. HAWKINS, W6AAR

Oscilloscope tests on a wide variety of phone transmitters show that very few class C modulated amplifiers are anywhere near linear above about 75% modulation. It is known that a truly linear class C stage develops an instantaneous peak power output of four times the carrier power output on the positive peaks at 100% modulation. It was found that most amateur transmitters were incapable of swinging the carrier power up to four times the unmodulated value on the 100% positive peaks. It was found that, in general, the r.f. grid excitation to the class C stage had to be increased out of all reason to get the stage to really settle down. This effect was particularly noticeable when only fixed battery or pack grid bias was used on the class C stage. In cases where grid leak bias only was used the peak power could be made to rise to *more* than four times the unmodulated value on the positive peaks of 100% modulation. Thus with fixed bias the linearity curve takes a dip at the upper end, while with pure grid leak bias the curve peaks upward. In both cases the result is undesirable, as non-linearity produces distortion and carrier shift; also, excessive grid driving power is necessary.

In an attempt to straighten out the linearity curve various combinations of battery-plus-grid leak bias were tried with quite good success. However, it is almost impossible to forecast just what proportions of grid leak and battery bias will give linear results in any given class C stage. Determination by cut and try methods requires the careful use of a sine wave audio oscillator in conjunction with a cathode ray oscilloscope.

In an attempt to do something about this situation and also to allow smaller and more economical r.f. driver tubes to be used to drive the modulated amplifier, several tests were made with cascade plate modulation of the last buffer as well as the final class C amplifier.

It was found that if the final amplifier obtains cut-off bias from a fixed source, such as batteries, etc., and the rest from a grid leak resistor, truly linear modulation is very easy to obtain when the plate of the buffer stage is modulated about one quarter as much as the final stage. In other words, when the final stage is modulated 100%, the buffer plate

is being modulated 25%. A great deal of flexibility is allowed in the excitation and bias on the buffer and final amplifier before serious non-linearity of the modulation characteristic occurs, so that there is nothing critical in the adjustment of a cascade-modulated transmitter.

Figure 1 shows a simplified diagram of an r.f. driver and final amplifier cascade modulated by a class B stage. Note that the total bias on the final amplifier is slightly less than twice cut-off. As part of the bias is supplied by the drop through a grid leak, when the grid excitation is increased due to modulation of the buffer, the grid current and grid bias both increase. This brings the peak bias up to slightly beyond twice cut-off, where it belongs on peaks, yet materially reduces the *average* amount of grid driving power necessary to make the stage operate properly.

Figure 1 shows a 50T buffer driving two 150T's in the final stage. This tube was used as a buffer due to the fact that it will stand just as much plate voltage as the 150T. However, it operated at very low plate current (40 ma.) as very little grid drive was required on the final stage.

A pair of 210's would have done just as well, as about 30 to 40 watts of average grid driving power sufficed to excite fully the final stage when the buffer was modulated. Without cascade modulation over 125 watts of grid drive were necessary to straighten out the modulation characteristic of the final amplifier.

On another transmitter using push-pull parallel 354's in the final amplifier, push-pull 860's working hard were formerly necessary to excite fully the final amplifier in order to get a good oscilloscope picture. When cascade modulation was applied to the final stage and the 860's both, it was found that a better picture could be obtained on the 'scope with only about one quarter the plate input to the 860's formerly required. A pair of 210's could easily have replaced the 860's.

Note the 210 transmitter described by Martin Brown in this issue for another good example of cascade modulation.

It might be thought that cascade modulation wastes considerable audio power in the buffer stage. This is not the case. If the buffer rep-

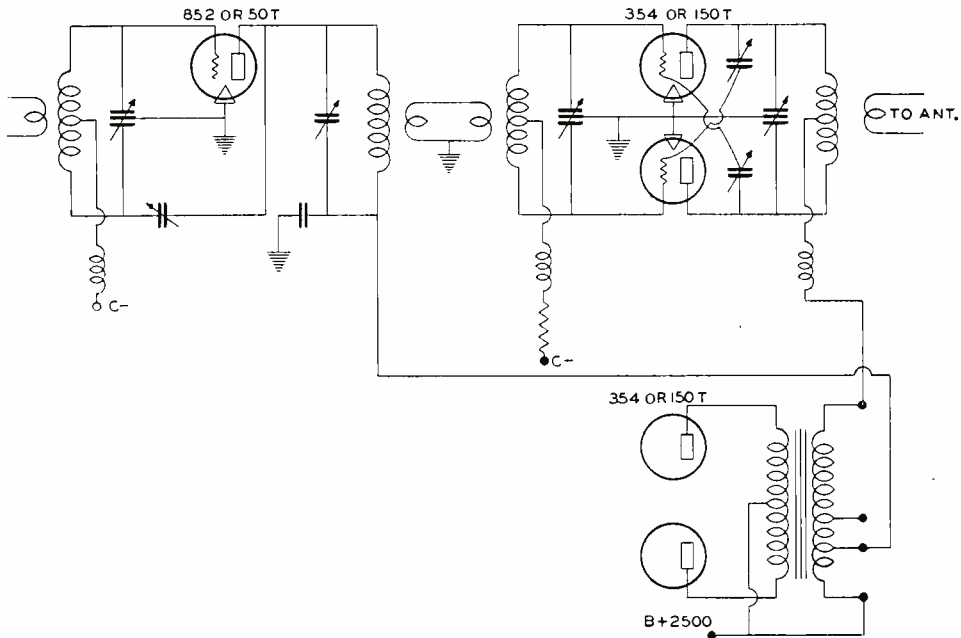

Figure 1

Showing an example of cascade modulation whereby a saving in driving power and better linearity is obtained. The bias on the driver stage should be approximately 1.5 times cut-off. This makes for ease of excitation. The bias on the push-pull stage is approximately 1.75 times cut-off, cut off bias being provided from batteries and the rest being developed across the grid leak. This amount of bias would be insufficient for good linearity were cascade modulation not used, but is plenty when the buffer is modulated as described in text.

resented the same load on the modulator as the final amplifier, 25% modulation of the buffer would mean that about 6% as much audio power as on the final would have to be applied to the buffer. However, the buffer rarely operates with more than 10% of the plate input applied to the final stage; thus only about 10% of the 6% would be applied to the buffer. Thus only about 1% of the total modulator output is dissipated in the buffer stage. Even under the worst conditions not more than 5% of the modulator output need be "wasted" on the buffer.

Note that it is not necessary for the modulated buffer to operate at the same plate voltage as the final amplifier. If the buffer operates at a lower plate voltage than the final stage, a series dropping-resistor and shunt audio-by-pass condenser can be used to drop the high voltage from the final stage.

In other cases the buffer can be modulated from the audio driver stage which drives the class B modulators. For example: one transmitter used a pair of 250's as audio drivers for the modulators, operating at 650 volts plate voltage. As the r.f. buffer consisted of a pair

of 210's the 25% modulation was easily produced by tying the B plus lead from the 210 stage directly to one of the 250 plates.

The close coupling in the primary of the transformer prevented much distortion from being produced from unequal loading on the 250's. Any distortion developed in the r.f. buffer stage due to non-linearity, etc. is unimportant, as the audio power applied at that point is not radiated.



### 'Just Around the Corner'?

"Television has a long way to go before it will be ready for general home service, and any report that R.C.A. is about to market television receivers is absolutely without foundation," said R. R. Beal, acting chairman of the Radio Corporation's committee on television today. Mr. Beal's statement was made in reply to numerous inquiries resulting from a published report that R.C.A. was preparing to market television sets.

"When R.C.A. announced its three point development program last spring," he said, "it was estimated that it would require twelve to fifteen months to build a television transmitter and a number of experimental receivers necessary to carry out the field tests. We are still engaged in that preliminary phase of the project, and obviously cannot be in a position to contemplate commercial service in the near future."

# Automatic Bandspread

Excellent bandspread tuning can be obtained by the old dodge of placing another condenser in series with the tuning condenser. The difficulty is that the bands are not of equal width so that the condenser must be re-set for each band, though it need not be adjusted again while one stays in that particular band.

A neat escape from this situation, as well as a scheme for getting numerous tuning ranges from only two untapped coils has been devised by Paul Weisz and was described by him in the October issue of *CQ-MB*. Fundamentally this idea is merely to connect *mechanically* the band-spread condenser  $C_1$  and the range-switches  $S_1$  and  $S_2$  so that one knob adjusts them all at once. A simplified form of the arrangement, adapted to American switches, is shown in the diagram.

The switches are shown in the 80 meter bandspread position. The coil  $L_2$  is not in use and for the moment  $S_1$  is also idle. The band-spread condenser  $C_1$  is short-circuited by  $S_2$  which has also shunted a padding condenser  $C_3$  across  $C_2$ . Thus our tuning system consists of  $L_1$  shunted by both the variable condenser  $C_2$  and the fixed condenser  $C_3$ .

If the switch is rotated to point 2 we find  $C_3$  disconnected and  $C_1$  cut into circuit at nearly maximum capacitance, the tuning range being a *non* spread one of about 39-58 meters. Points 3, 4 and 5 give similar ranges, each a little narrower and for somewhat shorter wavelengths as  $C_1$  continues to become smaller until on point 6 we find the 40 meter band well spread out on the dial of  $C_2$ . For transmitting amateur use points 2, 3, 4, and 5 are accordingly unimportant as shown by their blackness. We only need point 6 as a guide-point. Nothing is connected to it but its location must be about 110 degrees from point 1, the condenser  $C_1$  being maximum at point 1.

The 20 meter band clearly calls for different treatment. As we turn switches to points 7 we find  $S_1$  going into action and connecting the small coil  $L_2$  across  $L_1$ , giving a total induc-

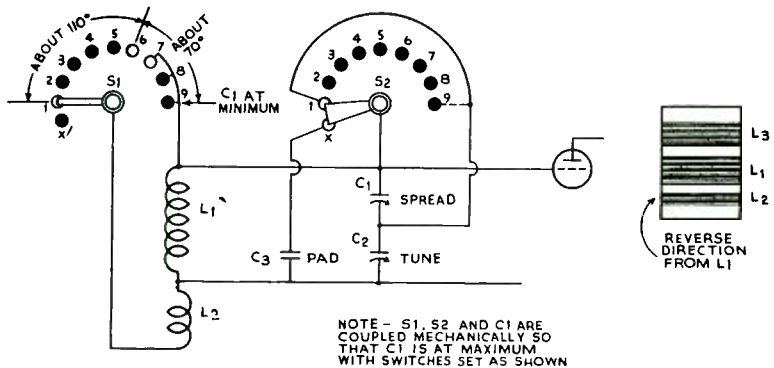

NOTE -  $S_1$ ,  $S_2$  AND  $C_1$  ARE COUPLED MECHANICALLY SO THAT  $C_1$  IS AT MAXIMUM WITH SWITCHES SET AS SHOWN

tance a little less than that of  $L_2$  alone. The 20 meter band appears obligingly spread on the dial of  $C_2$ . Point 7 should be about 20 degrees from point 6, that is, about 130 degrees from point 1. Again an exact location is not vital.

Points 8 and 9 are of no particular importance to a transmitting amateur. Point 9, of course, is not spread-tuning as  $C_1$  is again short-circuited. In fact this point gives practically the whole 19-28 meter range.

Summarizing, the ranges are as follows.

Switch Position	Amateur Bandspread	General Purpose
1	80 meter	.....
2	.....	39-58 meters
3	.....	.....
4	.....	.....
5	.....	.....
6	40 meter	.....
7	20 meter	.....
8	.....	19 meter b.c.
9	.....	19-28 meters

If only the amateur-band ranges are wanted,  $C_1$  may be half as large and the 40 meter point placed at a position near the 80 m. point.

## Constants

Assuming a coil-form about  $1\frac{1}{8}$ " in diameter and a wire of a size near no. 28, the coil  $L_1$  will have about 14 to 17 turns, the actual number being chosen so as to place the 40 meter band correctly when the switches are on point 6. The coil  $L_2$  used as a 20 meter shunt is wound in the *reverse* direction. Both its position and its number of turns may need adjustment to place the 20 meter band properly. 7 to 9 turns is about right. The coil  $L_3$  is shown simply because someone may wish to use a tickler.



# Eastern Version of the "Simple Tower"

By ROBERT S. KRUSE, W1FG

But the other 1/3 of the United States, which lies east of St. Louis, can't build the "Simple Tower for Simple Folks" which Tom Whiteman described in our January issue. There are several good reasons, all having to do with

*The "Simple Tower for Simple Folk" described in the January issue loses its simplicity when the lumber specified is not available and post holes must be blasted with dynamite. "The Mayor" described a tower for Pacific Coast amateurs; here Mr. Kruse gives the eastern version of a simple, low-cost tower.*

Oregon 6" x 8" stuff, we to pay for the wood at prices a trifle below that of ma-

hogony, and then to pay for the millwork at the rate of \$3.50 per man-hour.

Furthermore, nobody around here ever heard

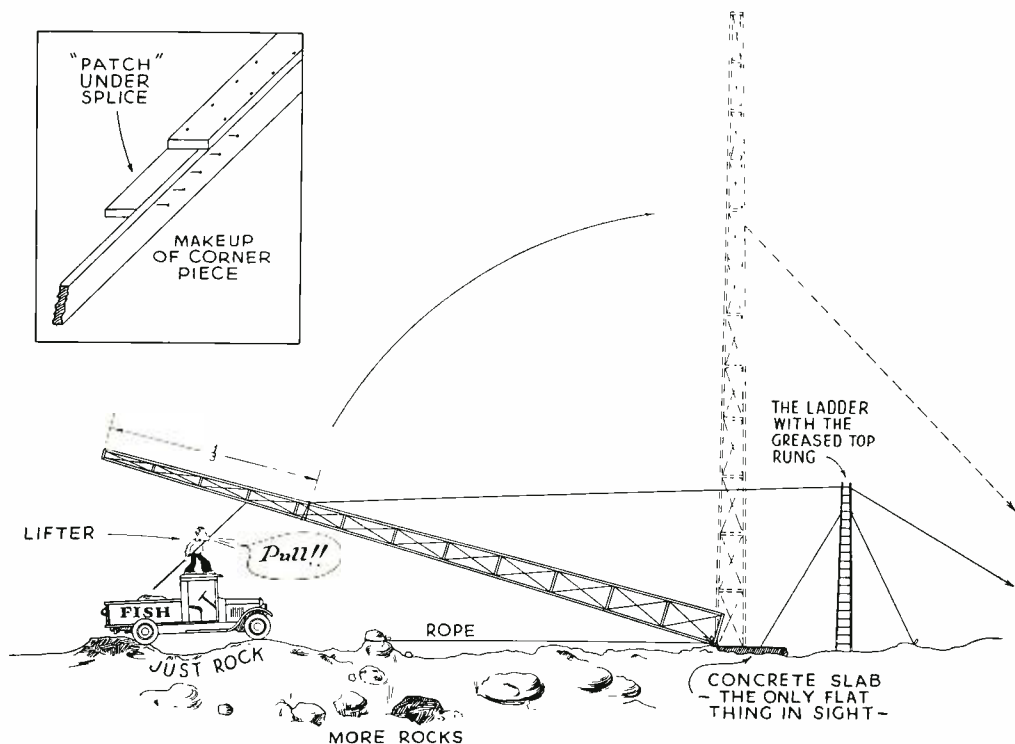

The rocks in the picture are New England rocks and are not supposed to represent the whole eastern seaboard.

the materials Tom calls for.

To start with, try and get redwood railroad ties around here. The very lumberyards hardly know what redwood is, and few indeed have it. A few will offer you another sort of redwood—the pungent red cedar, but the price has no resemblance whatever to 10c per post.

Also, just try to buy clear 20 foot lengths of 1" x 3" or 2" x 2" in these parts. Go right ahead and try. After combing through 9 yards in 3 cities of 100,000 or more we came no nearer than an offer to cut up for us some

of "car strips", any more than a Californian knows what "tobacco lath" is.

In so far as the hilly places around here are concerned, there is another difficulty: the post holes need to be blasted at a cost of about \$22, per tower.

One just naturally has to be still cheaper somehow. One way out is to make the 4 legs of the tower (all the way up) out of shorter stuff so used that the no-good places will not weaken the tower too much. This is done by using no. 2 lumber in 1" x 2" size, instead of

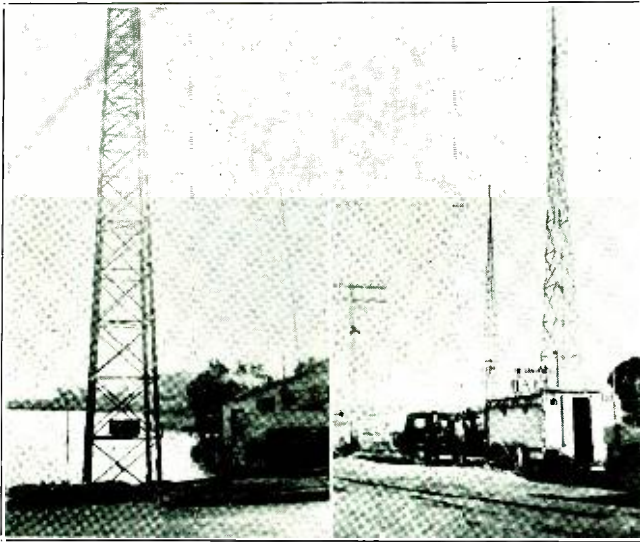

### The "Mayor's" Skyhook

We have been asked by the score why no pictures were shown of the "Mayor's" tower in the January issue. The reason is that when the weather is foggy it is impossible to get a good picture, and when the weather is sunny it is too nice a day in Moss Landing to stay home and take pictures, especially when the fish are biting. Anyhow, we show herewith the two towers of the Mayor, both of them. The tower in the left picture is the far tower in the right hand picture, and believe it or not, that water you see is part of the Pacific Ocean. The antenna runs directly over the water, which, being salt, also makes an excellent ground connection for Tom's 160 meter Marconi. This picture explains why his 30 watts of carrier persists in making many 1 kw. phones sound rather humble.

2" x 2" or 1" x 3" (clear). The lengths will almost surely not average over 10 feet which means lots of splices. The strips will be unstraight, have crooked grain and some knots. Used singly they are useless, but nailed together in an "L" shape they are surprisingly decent. If the tower is to be 80 feet high this means that the first job is to make 4 such "L" shaped pieces, each 80 feet long. Use 6d. nails, galvanized, not only for this part of the job, but also to nail "patches" over the joints. Driven through and clinched, these nails hold better and much longer than screws in the sort of stuff we've had to use.

#### "Tobacco Lath"

Since "car strips" are not available in the east, we instead use "tobacco lath" where it is available—otherwise, plaster lath. Where tobacco is grown the tobacco lath is to be preferred as it is tougher and cheaper. With this the cross and diagonal bracing is put on as shown in the Whiteman story, but for the rather flimsy plaster lath it is better to brace both ways so as to produce a complete "X" for each panel, instead of one diagonal only.

Do *not* try to climb the resultant product a la Whiteman, because when you come to the bum plaster lath it goes "pop", you hit the next one a little harder and the result is B-r-r-r-r-r-r-r-r-r-r Bump! Alternative methods are suggested later.

#### Hoisting

This is a pretty flimsy structure to be sure. One side of it, tried alone, is about as stiff as a wet rope, but when the four sides are all to-

gether it is suddenly stiff and hoistable. However it still shows one sort of weave; it tries to change its cross-sectional shape. In plainer language, it refuses to stay square. To cure this, brace diagonally through the tower at a few places from the no. 1 leg to the no. 3 and from no. 2 to no. 4. About 4 sets of braces in 80 feet are enough.

Well—there the thing lies. Can we get it up? The "derrick" pole suggested by Mr. Whiteman for lifting the hoisting rope would be fine if we had it, but the thing would cost around \$5 here and be a dead loss afterward. Instead we hunt up a house-painter or tinner who has an extension ladder, brace it up with no. 14 fence wire for guys, grease the top rung liberally with cheap cup grease, and carry the rope over that. The painter will be real irked unless the grease is taken off with kerosene.

Our berry-crate will probably not stand being hinged at the ground level; hence we tie the butt back with whatever rope is available and start hoisting, steering the tip with two guy wires fastened 2/3 of the way up the tower, and lifting hard from below it with anything that is long enough—poles, ladder, in one case a motortruck with two men and a vaulting pole on the cab roof—the thing eventually starts heavily upwards, wobbles, weaves, and stands up.

The guy wires are *not* removed. Their absorption factor is just as bad here as in California or Kansas, but we have no buried post-leg foundations and have to put up with guys. Accordingly the antenna is planned so



as to keep away from the tower's lower parts as far as possible. Once upon a time we did put up such a tower with a hoisting rope hooked on near the top and then tried to remove it by shooting it off. We were not very good shots; the wind wiggled the rope, and we sprayed the river-bottom with .22 long-rifle bullets for an hour before the thing was finally cut.

When it comes to paint, asphaltum is cheap too, and with fairly spongy, rough, wood it does a good enough job for most cases. Tom didn't let you in on the whole truth as to that painting job. In an 80 foot tower like the one described here, there are approximately 3,000 flat surfaces to be painted—figure it up for yourself. That is about the only drawback this sort of a sky-hook has.

### ◆ Transpacific Signal Reporting

By G. MERRIMAN, VS6AH

If after RADIO has designed you a decent rig and that code magician McElroy has shown you how to bat out forty per, you still go on the air and clutter it up with pedantic legends like

"Hr ur sigs T9 QSA5 R7"

it is pretty nigh time some energetic feller like your humble writer pointed out the need for snappier reporting. S'alright, I'm not going to try to sell you another of these newfangled RST, things where you have to try and memorize yet one more table of strengths. Nunno, I'm just suggesting that we lop some of the unnecessary deadwood from the above reporting method. In a few months the transpacific air is going to be filled again with everyone trying to see how many Asian and Australasian stations he can bag. Over here we, too, are going to enter the race mostly for the fun of fast and furious operating, for it is evident we don't enter these contests with the object of chewing the rag.

The writer has entered every contest available ever since a well-meaning California Ham visiting Hongkong gave him a Bug so he could retaliate somewhat. This year of grace 1935 I have worked close on a thousand stations, most of them across the Pacific, and many of them of course in the various contests. In each one of them I have longed to hear that report "Ur sigs T9, QSA5, R7" clipped to "Urs 957". It's no use anyone telling me that the RST system is any better than that. Out of those

thousand stations worked this year only one of them ever gave me an RST report. Why? Because as long as the old system is satisfactory to our needs, and it certainly is, it will be used by the majority. People are no longer fooled into doing things just because it is new. They demand to know, and rightly too, wherein lies the improvement before they uproot old customs and practices.

There is nothing wrong with our old T, QSA, R system and no amount of ballyhoo and advertising will push a rival system into its time-honored place. But we can certainly improve the old system itself by abbreviating the above report to "URS 957". Every ham knows that the first thing he is going to get from a station reporting him is the old phrase "Ur Sigs" so "URS" will replace that piece quite well. Then, too, out of those thousand stations worked this year over three quarters of them commenced with the Tone report followed by the QSA and the R strength in that order. We nearly all do it. In this system there is no need to uproot old ideas and memorize new audibility tables. No sir, you just use the old system but clip it down to its essentials. When I think of the thousands of technical brain-waves that have been tried out over the Pacific Ocean I have no qualms in suggesting that if the West Coast gang will get together in this method of reporting they will start something good and lasting. In any contest time means valuable points. "URS 957" will save time. And, in case we meet—Transpacific—may my report be "URS 959". Hi!

### ◆ Etching Solution

Add three parts nitric acid to one part muriatic acid. Cover the piece to be etched with beeswax. This can be done by heating the piece in a gas or alcohol flame and rubbing the wax over the surface. Use a sharp steel point or hard lead pencil point as a stylus. A pointed glass dropper can be used to put the solution at the place needed. After the solution foams for two or three minutes, remove with blotting paper and put oil in the piece and then heat and remove the wax.—W6DOB.

◆  
WSB and W4SB are in the same town. . . . Sometime ago we stated that there is only one Ohm in the Call Book. It also has low current (thanks to John Wilkinson, Washington, D. C.). There are only three "Mils" present — W8MIL, W9MIL, and W6MIL.

\*Box 414, Hong Kong.



  
**THE OPEN FORUM**

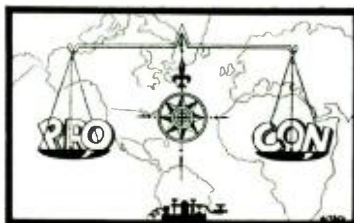

Capitola, California

Sirs:

The other day hiz oner the Mayer of Moss Landing was rakin' urs trooly over the coles fer wailing about my ailings, affictions, the hard times, and etc. and so forth. Well, it started me to thinkin', which ain't any too good fer the asthma, and this morning way early while most hams are trying to work New Zealand, I borned an idee. The old timers will remember years ago back when 201-A's cost six dollars and a half, the broadcast stations used to lay off the air fer a while every evening or once a week or something to give the listeners a chance to hear eastern stations. Well what's that got to do with me gettin' an idee you ask? Why just this:

If all the hams that use Pacific time would lay off the air say every Tuesday evening during the winter between 8 and 10:30 and all the Mountain time hams lay off Wednesday evening, and the Central Timers pipe down fer a while Friday eve., etc., and just listen and see how much dx they could log, I'll bet it would be plenty. A contest could be sponsored to see who could hear the most miles or most dx stations.

Someone will now say, "Why don't you buy a good receiver and you will hear them anyhow, and why don't you put on more power and you will be heard anyway." But when there isn't cnuf kilocycles to go around there will always be the "underneath boys" even if the average power goes up to 5 kw., and the 10 kw. boys will be covering up the 1 kw. fellers.

I say we need a change; we low power birds\* that constitute the noise level are gettin' plum tired of settin' around twiddling our thumbs waitin' fer some bird with a kw. to QRT so we can work our sked with some one four or five miles away. I fer one am in favor of giving the high-powered stations a channel, the medium-power stations a channel, and the low-power stations (30 watts down) a channel or

\*W6CCJ at Capitola, using a grid-modulated 26 (just one tube, which acts as the entire r.f. and speech system—truly a "one tube" transmitter) puts a readable signal into Los Angeles, 400 miles away, on 160 meter phone most any winter night after the "QRM has gone to bed".

maybe rule 'em off the air altogether, like they want to rule the slow drivers off the highways.

The low-power ham with a home-made receiver is not gettin' a break the way things are now and it's a gettin' worser every night. Xmas night while a few coast hams were polishing off the turkey bones I heard a W5 in Shreveport, La., on my PR-3 ("PR" meaning *plain regenerative*). That was on 160 meter phone, and of course that is the place where every one tries to test his lung power, his old phonograf records, his new circuits, tell all the dirty stories he knows, brag about what he's doin' on 10 meters, see how long his y.l. can yell CQ—where everything goes and everybody is happy.

There will now be a brief pause for station identification: This is W6CCJ at Capitola-By-the-Sea and W6CCJ is now leaving the air. Thank you.

WM. A. SLOCOMB.



Chicago, Ill.

Sirs:

I don't begrudge anyone a kilowatt; if a fellow can afford an r.f. power house, why more power to him! But why not put all these high power stations—say 200 watts and over—in a designated part of each band. In other words, if a fellow has more money than I have, I don't mind his putting on lots of power to get out further and louder than I; but if the extra power is merely a means of blasting out a clear channel at the expense of the low power fellows, then I want to register a good strong "gripe". I feel that just because a fellow happens to be better off financially than I is no reason for his having any more right than I to immunity to QRM troubles. If these high power birds were made to stay in one certain part of the band, they would have a taste of what the low power fellows have to contend with. No they wouldn't either; they would need a few 20 kw. stations in their territory to give them an idea of what fun it is to try to push 50 watts through a kilowatt of QRM!

CARL JOHNSON



After English (or should we say, *American?*) Japanese was the next language to be transmitted over the telephone.

# A Compact Transceiver That Really Performs

By FRANK C. JONES

This five meter transceiver is small, but powerful. A 6A6 tube performs several functions, acting as a super-regenerative detector and audio amplifier, a transmitting oscillator and speech amplifier. The 42 tube acts as mod-

*Here is a new transceiver which, though having several innovations, is not the least bit tricky in adjustment or operation. It is inexpensive and simple to build, and works surprisingly well both on "send" and "receive". It may be used with either phones or a speaker, and will make the latter really "talk".*

two-plate tuning condenser terminals. Probably the same circuit would work on

2½ meters if a smaller coil were employed, since the leads are very short and the 6A6 is a very good ultra-short-wave tube.

A four-pole double-throw switch with an "off" position in the center of its three positions connects the circuits either as a transmitter or receiver. When transmitting, this switch connects the 6A6 audio triode to the microphone transformer and disconnects it from the receiver volume control. It also disconnects the loudspeaker and connects the 6A6 oscillator to the 42 modulator.

When receiving, the 6A6 detector is connected to the 6A6 audio amplifier section, and the 42 then becomes an audio output tube working into the loudspeaker. The oscillator section becomes a super-regenerative detector by switching in more grid leak, causing blocking-grid-type of super-regeneration. A half-megohm grid leak returned to plus B causes super-regeneration. In transmit position this resistor is

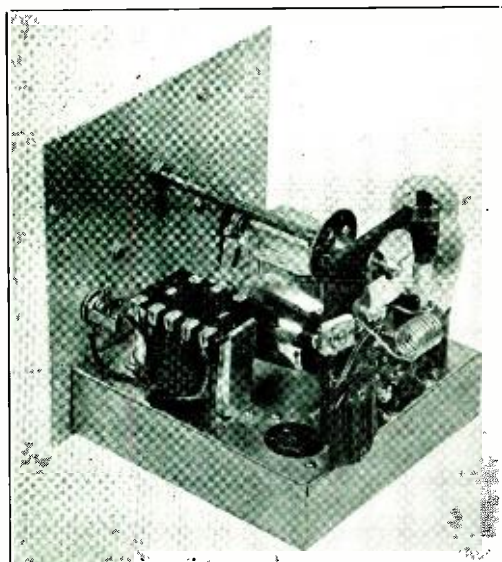

Showing mechanical construction of the 6A6-42 transceiver

ulator for plate modulation when transmitting, and as a second stage of audio amplification for reception on a loudspeaker. A headset can be substituted for the loudspeaker, since a volume control allows any degree of audio output. No d.c. plate current flows through the headset or loudspeaker.

One triode section of the 6A6 tube connects by very short leads to the five meter tuned circuit; the other section is used for audio amplification. It was found that better sensitivity was obtained when there was no plate r.f. choke. The .006 µfd. by-pass condenser has to be connected to the approximate nodal point on the coil, which turned out to be three turns from the grid end of an 8 turn coil. This coil was wound with no. 14 wire, ½ inch in diameter, with less than 1/16 inch spacing between turns. The coil was soldered directly across the

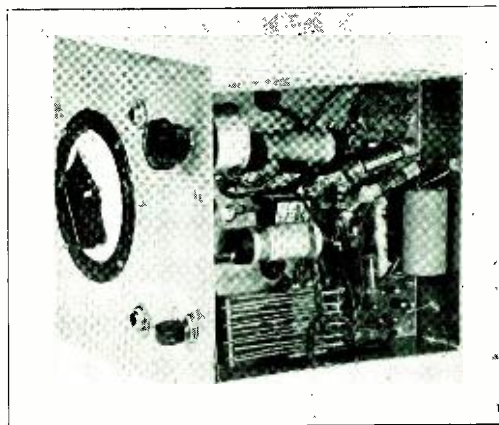

Sub-chassis View

grounded and the 5000 ohm resistor acts as the oscillator grid leak. Because of the relatively low value of resistance, an r.f. choke is connected in series with it. The design of this choke is not at all critical; any of the usual five-meter r.f. chokes is satisfactory.



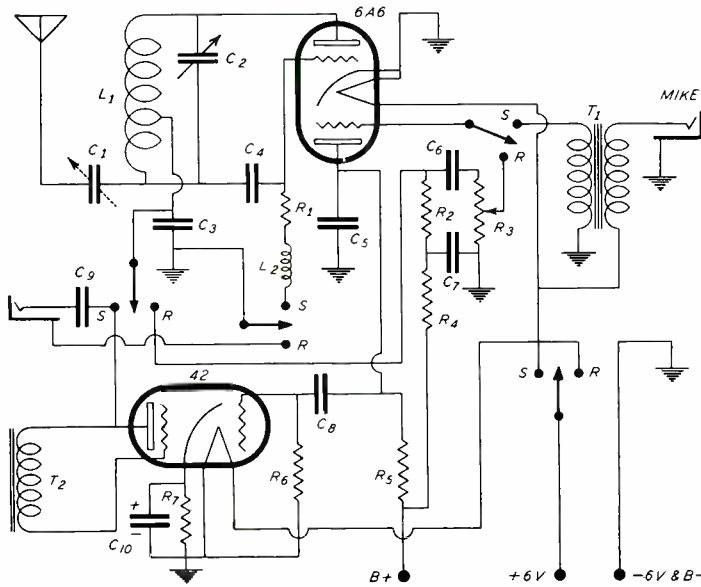

### Wiring Diagram

- L<sub>1</sub>—8 t. no. 14, 1/2" dia., tapped at 3 t. from grid end.
  - L<sub>2</sub>—R.f.c., 75 t. no. 34 d.s.c., 3/8" dia.
  - T<sub>1</sub>—Mike to grid transformer.
  - T<sub>2</sub>—20 or 30 hy., 100 ma.
  - C<sub>1</sub>—3-30 μfd. trimmer.
  - C<sub>2</sub>—2 plate midget.
  - C<sub>3</sub>—.006 μfd., 600 v.
  - C<sub>4</sub>—.00025 μfd. mica.
  - C<sub>5</sub>—.01 μfd., 600 v.
  - C<sub>6</sub>—.01 μfd., 600 v.
  - C<sub>7</sub>—.025 μfd., 400 v.
  - C<sub>8</sub>—.01 μfd., 600 v.
  - C<sub>9</sub>—.025 μfd., 400 v.
  - C<sub>10</sub>—10 μfd., 25 v.
  - R<sub>1</sub>—5000 ohms, 1 watt.
  - R<sub>2</sub>—10,000 ohms, 1 watt.
  - R<sub>3</sub>—1/2 meg. tapered pot.
  - R<sub>4</sub>—10,000 ohms, 1 watt.
  - R<sub>5</sub>—30,000 ohms, 1 watt.
  - R<sub>6</sub>—1/2 meg., 1 watt.
  - R<sub>7</sub>—400 ohms, 2 watts.
- Send-Rec. Switch—4 pole 2 throw (three position with center "off").
- Note: Bottom end of T<sub>2</sub> should connect to B+. This is not shown in the diagram.

The resistance network in the detector plate circuit prevents motorboating. The 10,000 ohm resistor connected from plus B to the detector plate resistor can be higher in value. Better sensitivity and less receiver radiation will take place if the actual plate voltage on the detector is just high enough to allow super-regeneration with the particular antenna in use. A 50,000 ohm variable resistor controlled by a knob on the front panel would be a worthwhile addition in place of this 10,000 ohm resistor connecting to plus B supply.

An .01 μfd. condenser was connected from the audio plate to chassis ground as an r.f. and i.f. by-pass. The hiss level is high enough to overload the 42 tube unless a large by-pass capacitance is connected as shown. The r.f. by-passing effect is necessary because this triode plate is close to the r.f. plate inside of the 6A6 glass envelope.

When a transceiver of this type is operated from an automobile car battery, a microphone filter is generally needed. A 25 or 50 μfd. 25 volt electrolytic condenser should be connected from the microphone transformer primary to chassis ground on the battery side and a 100 ohm 1 watt resistor connected in series with the A battery lead to this transformer. Polarity of this condenser will depend upon the polarity of battery connections in the car, and in all cases the plus side of the battery should be connected to the plus side of the electrolytic condenser.

From 90 to 250 volts plate supply is satisfactory with this transceiver. The power output is of course much higher at high values of plate voltage. The percentage modulation is quite satisfactory at any value of plate voltage within the above limits. Good voice quality is obtained, and a 6.3 volt pilot lamp, link coupled to the coil, will indicate upward values of modulation when speaking into the mike. The latter can be any type of single-button microphone.

The antenna coupling condenser is set to as much capacity with a screwdriver (for a given antenna or antenna feeder system) as will still allow super-regenerative hiss without dead spots over the tuning range on receive position. This coupling is sufficient for both transmitting and receiving.

The chassis, 6" x 6" x 1 1/2", is of plated 22 ga. steel. The front panel is 7" x 7" of no. 12 ga. aluminum, large enough so the whole unit can be slipped into a metal can 7" high, 7" wide and 7 1/2" or 8" deep. The bakelite panel is 4" x 2 1/2" and supports the 6A6 tube (horizontally) and the tuning condenser and coil. The tuning condenser has an insulated shaft extension to the dial on the front panel. Horizontal mounting of the 6A6 tube allows very short grid and plate leads in the r.f. circuit. Connection to the power supplies is by means of a wafer socket, plug, and battery cable. The six volt battery switch is part of the main send-receive switch since it has an off position.



# Making Antenna Lead-in Panels

By ROBERT S. KRUSE

If you own the place or the landlord is friendly, one of the nicest of all antenna lead-ins is possible. A window pane is removed and in its place is secured a "pane" of sheet insulation which isn't as brittle as glass. The lead-in insulators are put through that.

Do you think of bakelite? So did I until I happened to remember the price of a sheet of a size for our window, which happens to take four panes, each 12" x 24". That was clearly out. Beaver board does not stand the weather and even when soaked in paraffine it bulges into wild shapes in the summertime. Now it happened that last summer there was a tercentenary celebration for Connecticut. That isn't an "ad", because it is over. The neatest signs I happened to see were at Guilford (that's an ad all right), and were made of "Masonite", painted. They stayed in perfect shape all summer, and we have rain. There are two sorts of "Masonite". One is a thick fuzzy sheet used for sound-absorption and heat-insulation. The other kind is a thin hard sheet of a light brown color, with one smooth face and one face having a "waffled" (sometimes) or a cloth (other times) surface. It is about 3/16" thick, firm, saws easily, and is cheap. The panel shown in the photo was made of this second sort of Masonite. Incidentally a lot of those "snorty" photographs showing apparatus sitting on a piece of coarse "cloth" are made with a Masonite background.

The Masonite sheet was cut to approximate size, the putty and the triangular zinc "points" removed and the glass lifted out of the sash. It did not get broken—then. The Masonite was given a final trimming with a plane having a sharp blade and set for a light cut. When it fitted nicely it was secured with glazier's points just as glass would be—they cost 5c a package—and then puttied into place. Here's a tip: *don't* under any circumstances use the sort of putty that comes in a tin can and is made of oil and "whiting" only. Go to a shop that does window work it has to back up and get a half pound of "white lead putty". It refuses to keep in a can and has to be made up every day or two, but once you get it on a window and painted over, it is there for years

and years. The whiting-and-oil stuff falls out in 6 months.

Having "set" the Masonite we melted the block of wax you see near the brace, turned the smooth side of the Masonite up, and with the paintbrush at the left painted on a good thick layer. It "jelled" immediately; so an ordinary 600 watt "sunbowl" electric stove was used to melt it into the weather face of the panel. The wax was not paraffin but one of the harder waxes; we got it from a telephone man who called it "cerasin", but ordinary hard candles do rather well, being made of another hard wax called "stearine". This order of procedure was possible because we had the window out; that is, the sash had been taken from the casing and laid on the floor. In most windows this is easily done after prying the side mouldings loose, but watch out for the window weights and don't let them escape you before a good knot is made to keep the rope from being pulled into the casing, where it takes surgery to recover it.

If the window frame cannot be taken out, the Masonite panel must be weatherproofed before being puttied in. In that case begin by painting a 1/2" strip all around the panel's edge with white outside paint, let it dry and then wax the Masonite, taking some care to scrape off the wax which gets on the paint. This is to give the putty something to stick to.

The actual lead-ins may be anything you like. Here a 1/4" hole was cut with the brace and circle-cutter seen in the photo and a 4 1/2" Johnson standoff insulator placed on either side, being secured by four 2" x 3/16" cadmium-plated machine screws passing through the insulator bases and the Masonite together—that is, with the Masonite sandwiched between and the joint made reasonably tight by more hard wax. One pair can be seen in place at the center of the panel while below is another single standoff, a pair of the 3/16" screws used to secure the standoffs, and one of the 12" x 1/4" brass rods which pass through the standoffs and serve as the actual leading-in conductor. These are simply threaded on each end for about 2", using a 1/4"-20 thread so that standard hex. brass nuts can be used. Yes, brass nuts come with a 1/4"-20 thread all right, even at small-

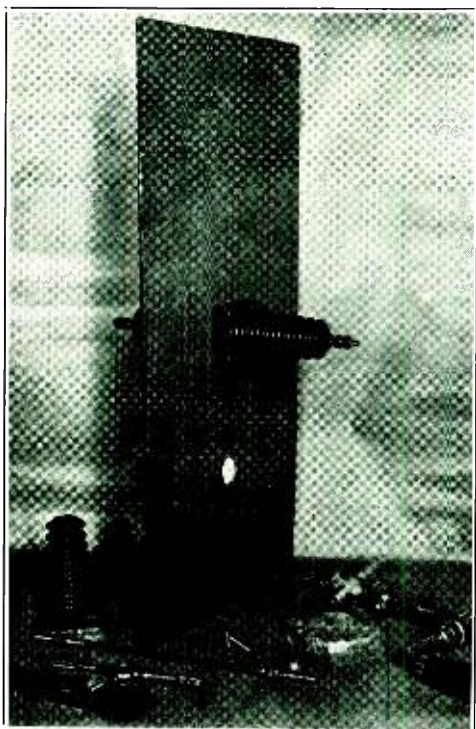

Not transparent, but weatherproof

town hardware stores. To prevent the through-  
rods from splintering the porcelain, a lead  
washer was placed under the brass washer and  
nut, but that isn't really essential.

By the way, in cutting circular holes of any  
size in either metal or insulating sheets, please  
do not struggle with a flimsy circle-cutter (also  
called fly-cutter) but hunt around until you  
find a sturdy one like that shown in the photo-  
graph. The pilot of this is a  $\frac{1}{4}$ " twist drill  
secured by a stout setscrew. The arm is a  $\frac{1}{2}$ "  
rod with a flat side to permit a  $\frac{5}{16}$ " setscrew  
to hold it fast, and the cutter is an honest-to-  
goodness lathe tool held by another substantial  
setscrew. Bob Hertzberg put me "wise" to this  
tool and it has been a joy. It cuts 1" to  $5\frac{1}{2}$ ",  
is known as "Pawood no. 5".

Meantime the panel has stood up under  
wind, snow, rain, zero temperature and one  
mechanical test consisting of jerking the an-  
tenna wire in two. It was a no. 12 copperclad  
wire but the panel did not suffer. Did you  
want to know how that wire was pulled in two?  
It was done by a 5 ton Federal truck. The test  
was not planned.

◆  
A billion-ohm resistance is termed a *begohm*.

## HAM HINTS

By JAYENAY

### Cheap Relays

The newer mechanical vibrators used in auto-  
mobile broadcast receivers make fine keying and  
control relays for amateur use. These replace-  
ment vibrators are quite cheap and most mount  
in a four or five pin tube socket. There are  
many different contact and solenoid combina-  
tions available. Even double pole double throw  
vibrators can be purchased for around a dollar.  
There are countless applications for a good re-  
lay in a ham station. They are essential for  
keying high power stages. A little thought will  
show applications where improved remote con-  
trol or break-in operation can be effected. One  
good application of a relay is to cut off the plate  
voltage to the final stage if anything happens to  
the bias supply. A small relay investment at  
such a point can easily save 25 times the cost  
of the relay if a tube failure is thereby pre-  
vented.

### Key Clicks and the Oscilloscope

The problem of key clicks has always been  
with us and probably always will be with us as  
long as current changes continue to affect in-  
ductance and capacity in accordance with the  
laws of Mr. Henry and Mr. Farad. However,  
key clicks and thumps can best be minimized  
by visualizing the effect of changes in circuit  
inductance, capacity, and resistance on those  
clicks. The newer cathode ray oscilloscopes  
provide a fine means of looking at the clicks as  
they occur. The linear sweep circuit should be  
adjusted to a very low frequency, perhaps two  
or three cycles per second, and the r.f. from the  
transmitter should be applied to the vertical  
deflection plates. Send a series of dots on a  
bug and the clicks appear as sharp, needle-like  
points shooting up at the beginning and end of  
each impulse. Thumps show up as a relatively  
broad hump or peak at the start of each im-  
pulse. By watching the clicks as the click filter  
is adjusted the point of least click and also the  
least "tail" on the dots can be determined.

◆  
The Cunningham Radio Service Co. of  
Houston, Texas, has telephones listed on three  
different exchanges, yet each number is 7777.  
The auto registration tag on the company's de-  
livery truck is also numbered 7777.

◆  
The ground connection, immediately recog-  
nized by radio and communication men, is now  
close to a hundred years old.

# A High-Efficiency Crystal Oscillator

By JOHN L. REINARTZ,\* 1QP

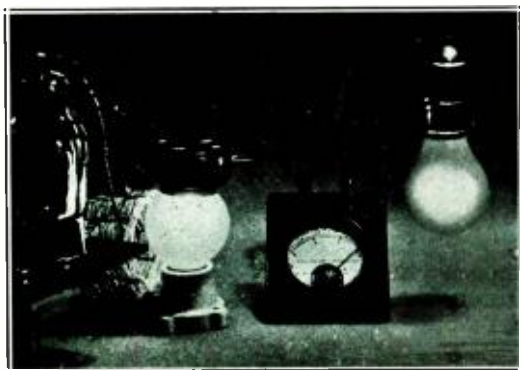

**Figure 1**  
The portable 802 Reinartz crystal oscillator at the RADIO laboratory turning out more than 25 r.f. watts. The lamp at the right is a 25 watt, 115 volt lamp on a 60 cycle 125 volt line. The identical lamp at the left is lighted by the oscillator. It is brighter; also the r.f. wattmeter is off the end of its 25 watt scale.

Large output from a crystal-controlled oscillator is always a goal the amateur is seeking. The desirable features of a crystal-controlled oscillator are low crystal current and little (if any) reaction on the crystal's functioning when the plate circuit is tuned through resonance. The tube that becomes most desirable is one in which the screening is quite perfect and the power gain quite high.

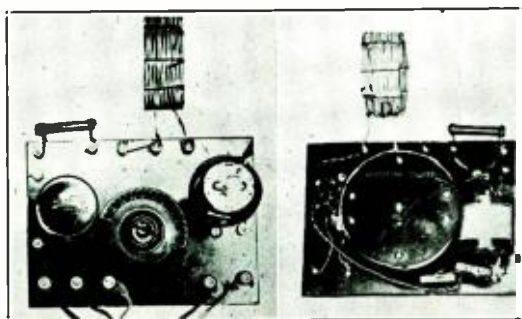
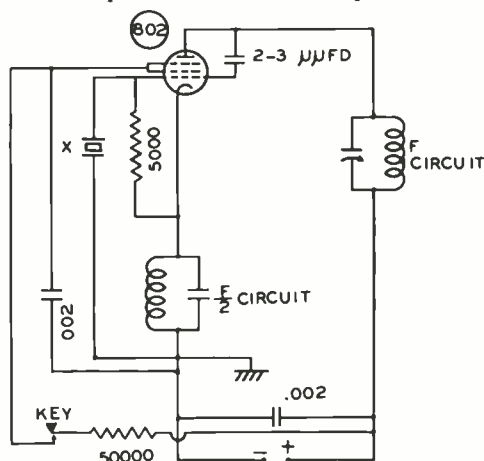

**Figure 2**  
Front and rear views of the portable demonstration rig, showing basket-weave plate coil tuned by the ancient "Sexton" air condenser alongside of which (bottom view) is the F/2 coil.

There are many ways in which the crystal operation can be aided to overcome the load normally placed on the crystal where the crystal current is found to be too high, or where it is

hard to get the crystal to function properly. However all these aids are focal points of trouble when adjustments are not carefully made.

A crystal-controlled circuit which meets the requirements of paragraph 1, and which does not have undesirable features such as a tendency to go off frequency, or to hesitate in beginning operations when the power is turned on, and which has performed well in a regular amateur



**Figure 3**  
The circuit for an 802 used as a tetrode.

setup, is offered for the consideration of the amateur. It is a form of crystal-controlled oscillator which can be expected to work at once, without the usual weeding out of kinks.<sup>1</sup>

As we see in the circuit diagrams, the cathode circuit contains a tuned circuit (marked as F/2) which, however, is not critical and allows operation over any complete amateur band with no change other than the crystal, nor does the plate coil (marked "F") have to be changed for any one amateur band. The tuning range is quite sufficient to cover any amateur band completely.

For high power output we tie two grids of an 802, numbers 2 and 3, together at the socket and supply these grids with a positive voltage of about 150, either through a tap on the power supply or else through a resistor (R in figure

<sup>1</sup>This circuit has been used for a long time at W1QP and was first printed publicly in the transmitter description of W1QP on pages 19-22 of R/9 for April, 1935.

\*Manchester, Connecticut.

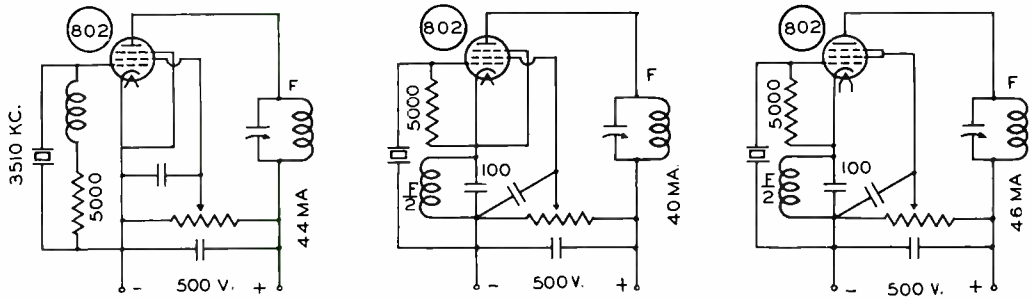

Figure 4  
Comparison of various 802 oscillator circuits

Conventional Pentode Oscillator	
Watts in	22.0
Watts out	7.3
Efficiency	33.0%

Reinartz Pentode Oscillator	
Watts in	20.0
Watts out	11.2
Efficiency	56.0%

Reinartz Tetrode Oscillator	
Watts in	23.0
Watts out	14.0
Efficiency	61.0%

3). The value of this resistance is not critical, and can be from 40,000 to 50,000 ohms and of about 25 watts rating. The shield inside the tube is connected to the cathode at the socket.

If we wish to use this circuit as a complete c.w. transmitter it will be found that it can be keyed in the *screen* grid circuit (figures 1 and 3). When so keyed the plate current goes to zero when the key is open. The circuit allows fast keying without fail and with no noticeable chirp in the note.

A plate-circuit efficiency of 50% and greater can be expected from this crystal-controlled circuit, and it almost equals the plate efficiency of a non-crystal circuit. (See figure 2 for typical results.) Full output (for the 802) can be expected when normal voltages are applied to the plate and the two grids, and but 10 or 12 ma. of r.f. grid current will be found at the crystal.

When the circuit is used to drive an r.f. amplifier, link coupling or inductive coupling is recommended in place of capacity coupling (to the next tube).

#### Construction

At W1QP a construction is used which makes the oscillator a unit that can be removed from the panel at will by merely dismounting the plate-tuning condenser and disconnecting 5 wires; that is, two heater leads and three high voltage wires. Let us take an 11-plate, double-spaced Cardwell variable condenser and so mount it on the panel that the back of the condenser is upward—that is, so that the rotating plates move downward and out of the way of anything we wish to mount on the condenser. The two cars that hold the stud to which the front and back endplates are fastened is removed; the condenser is still sturdy enough. On four small metal angle-pieces, secured by

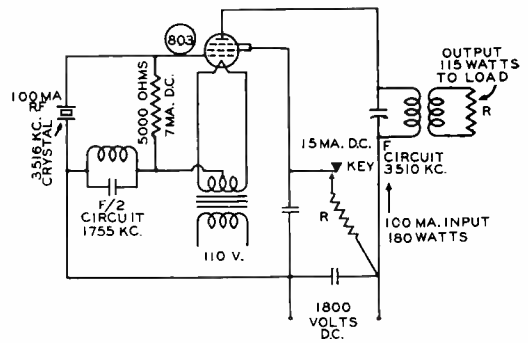

Figure 5  
100 watt crystal oscillator using an 803. This is in use at a number of amateur stations with results about as indicated by the figures.

the same screws which hold the stator assembly to the endplates, we mount two sockets of the wafer type. A 7-prong socket, to hold the 802 tube, is mounted to the rear of the condenser; a 5-prong socket to hold the crystal-holder is mounted at the front of the condenser. To the backplate of the condenser is mounted the tuned cathode (F/2) coil and its fixed tuning condenser, and also the bypassing condenser and the series resistor for the screen when no voltage tap on the power supply is available for that purpose. Between the two sockets go the crystal connections and also the 5000 ohm wire-wound gridleak connecting the control grid and the cathode of the 802. This is not the construction shown in the photographs, which show a portable demonstration-rig employing an 802.

When out of insulating washers and needing some in a hurry, they may be cut (sliced) from a small cartridge fuse. The material is strong and a good insulator.—W8NLZ

# "QRG Meters" in Commercial Practice

By RUFUS P. TURNER, WIAY

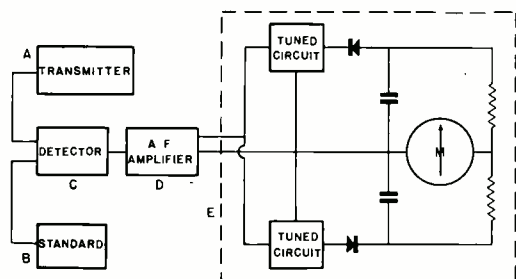

Figure 1

Amateur frequency checking at present does not embrace a great deal more than observing the approximate operating position of a transmitter within a band several hundred kilocycles wide. The average ham does not worry too much about *exact* frequency; and when he does attempt actual frequency measurement, the accumulated error is of a large order of magnitude, and a quarter of one percent is considered mighty good accuracy.

Other radio services, on the other hand, are assigned definite transmitting frequencies, not relatively wide bands in which to drift back and forth, and these frequencies must be maintained within the narrow limits specified for the particular services. Some study of the problems encountered in these services and of the schemes employed in frequency monitoring should incite a larger degree of frequency-consciousness in amateur ranks.

At the outset, it should be recognized that the commercial and experimental services invest more money than do amateurs in their crystals and go to considerable pains to secure precision temperature control of quartz plates ground to *exact* frequencies. And the same degree of exactitude carries over into the design or selection of frequency monitoring or measuring devices which are required by the Commission to be separate from the transmitter stabilizing equipment. Those fellows do not lie down in the realization that the crystal is steering the transmitter down the right road.

## Tolerances in Other Services

Broadcast stations operating in the 550-1500 kc. band are required to maintain their assigned frequencies within *fifty cycles* per second plus or minus. In the case of the lowest standard

broadcast frequency, such a tolerance amounts to a little better than one-hundredth of one percent; and at the highest frequency, three-thousandths of one percent. The frequency tolerances for services other than broadcast (except amateur) vary from one-hundredth to one-half of one percent, depending upon the nature of the service.

## Systems Employed

In some cases, such as the lower frequency short wave experimental stations, where the tolerance amounts to a kilocycle or more, systems might be used which check the transmitter frequency against that of a crystal, or other acceptable precision oscillator operating on the exact assigned frequency. A frequency difference between the two would give rise to a beat note in a detector-amplifier which might be referred to a calibrated audio-frequency oscillator to determine the cycles deviation from the assigned frequency. Such a system does not, however, indicate the direction of the deviation. An equal deviation above or below the assigned frequency gives rise to a beat note of the same audible frequency. A second objectionable feature of this scheme is that a second standard, the audio oscillator, is introduced, and this may be subject to variations which increase the error of indications.

Another system in use at several of the general experimental stations makes use of an electron-coupled oscillator which is set to zero beat with some standard signal, such as the 5,000 kc. transmission from WWV. Usually, it is some odd harmonic of this oscillator that coincides with some odd harmonic of the standard frequency signal. The instrument is designed for use only in conjunction with the assigned frequency specified, and its dial is marked in cycles deviation from that frequency. After calibration from the standard frequency signal, the instrument may be used as a monitor in the usual fashion. The transmitter is tuned in to zero beat at a point on the dial which corresponds to the deviation from the assigned frequency.

Broadcast stations, being required to maintain the plus or minus fifty cycles tolerance must employ devices capable of indicating only a few cycles variation. The *deviation meters* or mon-

itors in use make use of a beat-note system, with the standard operating higher or lower than the assigned frequency. Visual frequency meters indicate the deviation in cycles; and since such meters cover only a narrow frequency

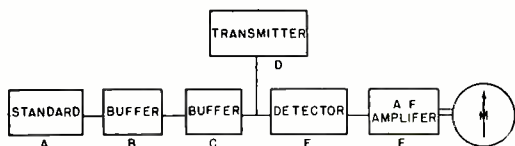

Figure 2

band with accuracy, the monitor standard operates at such a frequency that the value corresponding to zero deviation is moved to a point in the audio range where 50-cycle deviations on either side represent smaller audio percentage changes.

#### Practical Broadcast Monitors

Figure 1 shows the General Radio frequency monitor equipment in block diagram. "B" is the standard, which comprises a crystal oscillator operating at a frequency 1,000 cycles per second higher than that of the transmitter, "A". Due to this difference in frequency, a beat note results and the resulting e.m.f. is impressed across the input of the detector, "C". The audio-frequency output of this detector is amplified at "D" and fed into the deviation meter shown within the dotted block at "E". The deviation meter consists of two tuned circuits, two rectifiers, and the meter, "M". The latter is a zero-center d.c. microammeter which deflects 100 microamperes on either side of center, and has been provided with a scale reading a maximum of 100 cycles either side of zero-center. In operation, it is actuated by the difference in currents delivered by the two rectifiers.

When the transmitter is operating on its exact frequency, the beat note fed into the detector is of the order of 1,000 cycles, corresponding to the zero position of the meter. Deviations either above or below the assigned frequency are indicated as such by the meter, which will show a one-cycle change.

A block diagram of the Doolittle-Falknor frequency monitor is shown in Figure 2. In this system, the crystal standard operates at a frequency 500 cycles lower than the assigned frequency, and its output is fed through two buffer stages, "B" and "C", into a detector "E". An e.m.f. picked up from the transmitter is introduced in series with the output of the second buffer, and on being rectified these two voltages combine to produce a beat note

of 500 cycles when the transmitter is operating on the assigned frequency. The frequency meter, "M", driven in the output circuit of the audio-frequency amplifier, "F", is a standard meter designed to indicate frequencies between 450 and 550 cycles per second, with 500 cycles at the center. Instead of the regular 450-550 scale, there is provided one which reads 50 cycles at each extreme and zero at the center. Thus, a beat note of 500 cycles, indicating that the transmitter is operating on its assigned frequency, corresponds to zero on the meter. Variations above or below the assigned frequency cause corresponding changes in the beat-note frequency and are indicated as such in cycles per second by the meter.

#### Data Sources

Articles will appear subsequently on these pages describing better amateur frequency measuring equipment. The amateur interested in this subject is referred particularly to the Bureau of Standards circular, *Uses of Transmissions of Standard Radio Frequencies*, which may be obtained for the asking by addressing the Bureau of Standards, Washington, D.C.

#### Mailing Photographs

We continue to receive from our contributors photos and snapshots that have been permanently marred by paper clips.

When attaching photos to a manuscript with paper clips for mailing, be sure that the photo is *facing* the paper to which it is clipped. In this way the metal of the clip does not come in contact with the finished surface of the photo. These clips have a very damaging effect on the surface of a photo; the marks can be removed (or rather covered) only by retouching the photograph. Better yet, don't use paper clips at all; mark the photo with a *soft* pencil on the *back* indicating to which part of the manuscript the photo refers. Then wrap the photo in tissue and mail it the way it is—with a piece of stiff cardboard in the envelope if the photo is very large.

No state in the Union is now without a broadcasting station. California and New York lead the Country with forty-three stations each. Delaware, Nevada, New Hampshire, and Wyoming each have only two.

Not only was amateur radio called "citizen radio" a little over ten years ago, but we have evidence that amateurs were referred to as *radio citizens*.



## How Big a Resistor?

An *approximate* idea of the wattage which may reasonably be wasted in a resistor of the usual cylindrical shape may be obtained from the accompanying chart.

This chart shows three ratings for each resistor. The "A" or top rating is about the most that can be endured by a good enamel-coated resistor when it has ample room and excellent ventilation. "Ample" means *a foot of clearance all around*. Even so it will run at about 450 degrees Fahrenheit, which is hot enough to scorch many things, including the insulation of the wires connected to it. These wires should therefore be bare, or insulated by asbestos, or by beads strung on the wire.

The "B" or  $\frac{1}{2}$  rating is about right for most uses and as its name indicates, this rating allows just half as many watts as the A rating.

For cramped unventilated places, such as the interiors of receivers, amplifiers, enclosed powerpacks and the like, it is much better to drop down to the "C" or  $\frac{1}{4}$  rating.

### Interpreting the Curves

The curves do not go to the left of the 1" line because a very short resistor gets rid of much of its heat into the connecting wires. If these are thick they may add considerably to the safe wattage. As an example, notice how the filament of an electric lamp runs cooler near the supporting leads. This is most easily seen when the lamp is not too bright. For this reason the curves are not reliable on a short resistor; in fact, they had better not be trusted very much below 2" lengths. For similar reasons very thin resistors do not agree at all well with each other. One type might agree with the dashed curve, another would not.

For that matter there is a considerable difference between resistors of different construction. The "A" ratings of the chart are about right for resistors with the wire completely embedded in baked-on enamel.

A resistor is not "poor" just because it is not intended for such hot operation; most exposed-wire resistors are made for convenience of tapping and not to run smoking hot. Of course no precision or semi-precision resistor should ever run anywhere near such temperatures; even the "C" rating is too much. For such units stay within the special rating of the manufacturer.

### Tapped Resistors

Where a resistor is tapped the current is not usually the same through all sections of the winding and the hottest section is the one to worry about.

As an example, suppose we are putting together an amplifier which uses a 400 volt plate supply and has an output stage drawing about 60 ma. We guess that a 50,000 ohm bleeder will be o.k. and since 50,000 ohms at 40 volts passes but 8 ma. we figure that the bleeder wattage is:

$400 \text{ volts} \times .008 \text{ amp.} = 3.2 \text{ watts}$   
and accordingly decide we'll "get by" with a 5 watt resistor.

Now that is a bad guess for several reasons. In the first place the resistor is to be in cramped quarters with no ventilation to speak of, and in the second place we need a tap to supply the lower-power stages, so that there will be additional load on the resistor between the tap and the positive end.

Suppose that we find the "earlier" stages of the amplifier are all to work at 25 volts, and that they take 12 ma. This means that the "top" section of the resistor must carry both the 8 ma. "bleed" and the 12 ma. load of the smaller tubes. This is 20 ma. instead of 8, that is, the current has been increased  $2\frac{1}{2}$  times; therefore the heating is increased  $6\frac{1}{4}$  times! No wonder the top section warms up.

Now let us see what the top section should be. In it we must drop from 400 volts to 250 volts, which is a drop of 150 volts. Thus the voltage across the section is 150 volts and as it carries 20 ma. the resistance must be:

$150 \text{ volts} \times .020 \text{ amp.} = 7,500 \text{ ohms}$   
and the power to be gotten rid of in heat is:

$150 \text{ volts} \times .020 \text{ amp.} = 3 \text{ watts}$

The rest of the bleeder is of course the rest of our original 50,000 ohms, which is to say  $50,000 - 7,500 = 42,500$  ohms and as it carries only 8 ma. it needs to get rid of only:

$250 \text{ volts} \times .008 \text{ amp.} = 2 \text{ watts}$

### Picking the Resistors

Now we can choose the resistors. The "A" rating is not useful because we cannot stand 450 degrees in an amplifier chassis. We could crawl by with the B rating, and this is done in receivers, but C is safer and better, especially if there are electrolytic condensers nearby. Accordingly we had better figure that the "top"



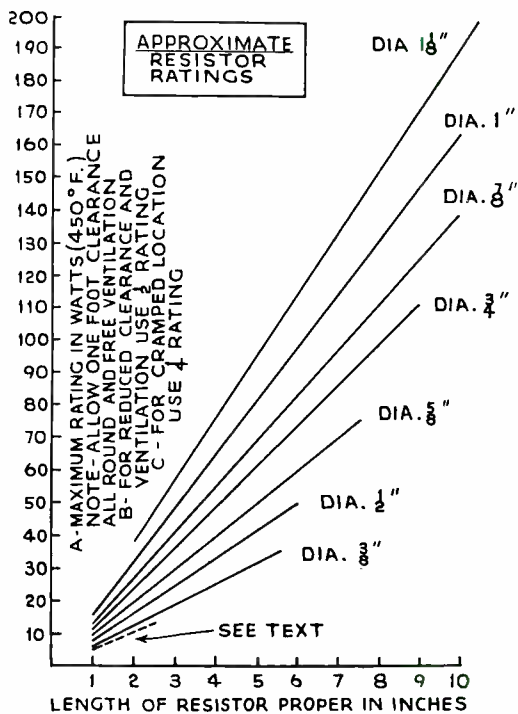

section is to get rid of  $3 \times 4 = 12$  watts. If we use a single resistor unit with a tap it must be chosen to fit the first of these figures, remembering that the 3 watts are to be used up in the *first seventh* of the resistor—not the entire resistor. Since we are using the C rating we must allow for 12 watts in each 1/7 of the resistor, or 84 watts total, though of course the lower 6/7 will run cooler. We therefore choose either a 75 watt or a 100 watt resistor of 50,000 ohms. It will be better to use the 100 watt size because it will have larger wire, less easily cut by the slider.

Another way of working it is to use two resistors of different size. The "top" section is now a simple 7,500 ohm unit to dissipate 12 watts, but since there is no standard 12 watt size we choose a 25 watt 7500 ohm resistor. The "bottom" section is to dissipate 8 watts in 42,500 ohms, and since we need a slider to "hit" this trick ohmage we go into the 25 watt size again, use a 50,000 ohm unit and set at about 42,500 ohms.

There is little choice in cost between the two arrangements but one may fit into the chassis better than the other.

#### Uneven Windings

Some tapped resistors have different sizes of wire in the different sections. These are usually

"exact replacement" resistors intended for one particular job with certain drains at each tap. If put on another job the heating is naturally distributed differently, so one must not be surprised if one section starts to smoke and crackle. It isn't the manufacturer's fault. In fact very few of the things that happen to resistors are the fault of the manufacturer.

◆ Philadelphia, Pa.

Sirs:

The editorial in the September issue of *QST* seems to land a good idea quite close to home.

To a certain degree most of us are guilty of using the wrong bands for the type and distance of communication we have in mind. In many cases this is unavoidable, but if only 10% of us were to use the appropriate band for the time of day and distance involved there would result considerable saving in unnecessary interference.

Would it not be reasonable to plan a table of bands, times, and distances and perhaps power? Naturally, such a table could not be more than a general tenet, but there are quite a few instances where definite rules could apply; for instance, working locally on 20-meter ground waves should be *out*; working distances under 5 and perhaps 10 miles use 5 meters exclusively or even shorter waves; under 100 miles, 160 meters, or 80 if necessary, and, as a rule, no local work on 40, 20 and 10 meters (under 50 miles).

Such a plan would probably require the reconstruction of at least 80% of our transmitters, and while this would be a boon to the "junk" manufacturers, it would nevertheless entail an outlay of cash beyond the point of reason for most of us.

What is the answer? One cannot very well dictate to another what hours he shall operate for the one band in which he happens to operate. It is, however, the obligation of each operator to know the distance possibilities of the band he is using at the time he is working it, and to operate his station in a manner liable to cause the least interference at other points more distant than the one he is interested in working, and this means, especially, *tune up with a dummy antenna, use standard short procedure, and break-in.*

JOHN BUCK MORGAN, W3QP

◆ A difference of potential exists between certain parts of the human body.



## A De luxe Amateur Radio Station

Having decided to expand from the old transmitter composed of five standard relay racks (see RADIO,

June, 1935), D. Reginald Tibbetts, W6ITH, figured that he would have to build a new house. The basement at the old location was not quite large enough, and being but an unfinished cellar, gave an appearance that was not any too pleasing. The only solution seemed to erect a special building just to house the equipment, with room left over for a shop and of course a place to prepare something to eat. As a final thought, a nice comfortable bedroom was included, since amateurs do sometimes break the "all-night of operating" habit.

Many sites in and near Berkeley, California were considered. A chart was drawn up with all the factors. Each factor that would be considered was given a certain maximum number of points and each site given its score. Many things had to be taken into account: height above sea level, the surrounding territory, accessibility, improvements, availability of electric power, nearness to other dwellings and traveled roads, etc. Many other factors were considered, including cost, police and fire protection, taxes, and the expected water charges. After the general points were carefully weighed and the sites were narrowed down to but a few, the radio tests were carried out. These consisted mainly of extensive listening tests with study of the noise level and the general strength of signals received from all directions.

The site that was finally selected and the one that stood head and shoulders above all others is just north of the city limits of Berkeley, over in the unincorporated territory of Contra Costa County. Two choice lots were found on the very top of the ridge and on the highest point north of Berkeley. A clear sweep in nearly all directions is assured. To the west is San Francisco Bay and the Golden Gate, and a clear view also is secured to the north and east. All the property to the north and east is owned by the local water district and as such will never be available for private development or building, thus giving the maximum privacy without being too far off the beaten track.

*The de luxe amateur station of W6ITH is one of the most elaborate in existence, and as such is of interest to every amateur. "Reg" is admired by his fellow amateurs because, although he is blessed with the necessary "wherewithal" to purchase factory-built transmitters, he chooses to construct his own equipment.*

The ceiling and upper half of the walls of the radio room are finished with Insulite, a very heavy sheet

insulation material. The lower half of these walls is finished with thick ply-wood fastened with wood screws in order to be removable for wiring. The floor is completed with heavy inlaid tile linoleum and then covered with medium size rugs.

Five separate transmitters compose the equipment. Each transmitter is complete within itself and any or all can go on the air at the same time. All the transmitters are of different power, and, within certain limitations, the plug-in coils allow the use of any transmitter on several bands. However, under normal conditions the transmitters are not switched from one band to another.

### The 10 Meter Transmitter

By inspecting the photograph, the equipment can more easily be described. From left to right, facing the racks, the first rack contains the ten meter transmitter. The final stage is in the top unit with the monitor and frequency meter in the next unit. The oscillator, doubler, and amplifier are on the next shelf. The protective cover houses twenty of the flat-type telephone relays; which are used on the remote control switching, for the telephone switchboard, and for the transmitters. The remainder of this rack is used to mount the modulator, the power supplies, and the bias supply.

This medium-power ten meter transmitter utilizes an 802 crystal oscillator with the crystal oscillating on 20 meters. The frequency doubler is a single 53, with the elements in a push-push circuit. The doubler is followed by a single 10 amplifier and the final class C modulated amplifier consists of a pair of 10's in push-pull. This transmitter is modulated by a pair of 46's in Class B. The driver for the modulator is a single 46 in Class A. Two power supplies, each with 83v's, furnish plate potentials. The normal input to the final stage is 75 watts. The antenna used is a half-wave vertical rod fed by a two-wire matched impedance transmission line of 600 ohms impedance.

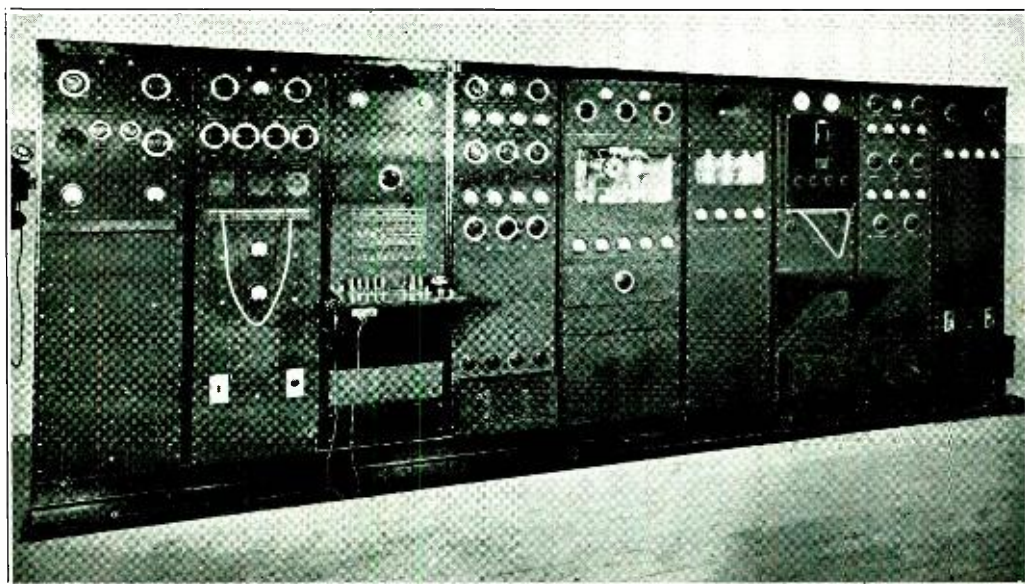

An amateur layout that makes many commercial rigs look like "small potatoes"

### 2½ Meters

The next rack, or the second from the left end, contains the 2½ meter transmitter together with four overlapping ultra-high frequency receivers. The four receivers have, together, continuous bandspread from two to eleven meters. Combined volume and regeneration controls are located below each receiver dial. The modulated oscillator and the audio system are on the top deck, the receivers and their speakers below. The next two-unit strip contains the master jack-switching panel. All lines either from the outside or in the building pass through this panel. The jacks are used in vertical pairs, exactly as is done in telephone practice. A line normally feeds through and can be opened in either direction by the use of a patch cord, each end of which terminates on a double plug. The outside exchange telephones and several leased circuits together with all terminating equipment pass through here. The rest of this rack is filled with power supplies, line balancing coils, equalizers, and various other equipment. The tube line-up of the 2½ meter transmitter is very simple, in as much as a single 6A6 in a push-pull "TNT" oscillator circuit is modulated by another 6A6 used in Class B. The modulator is driven by a third 6A6, triode connected in Class A. The power input to the modulated oscillator is 30 watts. The antenna used is another half-wave vertical rod fed by a two-wire matched im-

pedance line with a characteristic impedance of 600 ohms.

The third rack, besides containing the telephone switchboard, also mounts a standby receiver and several speech and bridging amplifiers, power supplies, and other equipment associated with the switchboard. After the lines pass through the master jack panel on the second rack, they go to the switchboard and are there switched in the usual manner. All lines as well as amplifiers, speakers and repeater circuits appear on the board.

### The 'Ham's Dream'

The next three racks to the right, including the 24" rack in the center, contain the large transmitter which is used on both twenty and seventy-five meters. All racks except the center rack are standard 19" relay racks. All the racks were constructed in the adjacent shop, using only a small mail-order house drill press, a vise, a hand tap and lots of elbow grease. An article will appear in RADIO giving complete constructional details and kinks for building a home rack that will in every respect be as good as a purchased unit and will cost only a few dollars.

The fourth rack contains the 47 crystal oscillator, 865 buffer or doubler, 50T first amplifier, and a pair of Eimac 50T's in the second amplifier, together with their power supplies and protective equipment. The bias supplies for these stages can also be found in this rack.



Each stage is metered in its plate circuit, grid circuit when necessary; and all filament supplies are metered. It will be noted the rectifiers are enclosed in housings at the bottom of this and several other racks. When using 866's, this type of housing is found to be the utmost desirable in as much as the tubes are well shielded, in plain sight of the operator, the cover is quickly removable, and full protection is assured against accidental contact. Just above the housing on this fourth rack is the "Variac" voltage control panel. All filament transformers on all the racks are adjusted from this point for exact filament voltage regardless of line or load conditions.

The center rack holds a pair of 500T's in the final class C plate modulated amplifier. The design of this stage is characterized by symmetry and short leads. The tank coil can be seen directly between the tubes. The tank condenser is right above with its dial in the center of the upper panel. To either side of the tank condenser are the variable condensers for the low pass  $\pi$  section network which couples the final stage to the antenna. The  $\pi$  net coils are on top and the very upper portion of one can be seen back of the left hand antenna lead in. The two meters in the top panel are the

[Continued on Page 74]

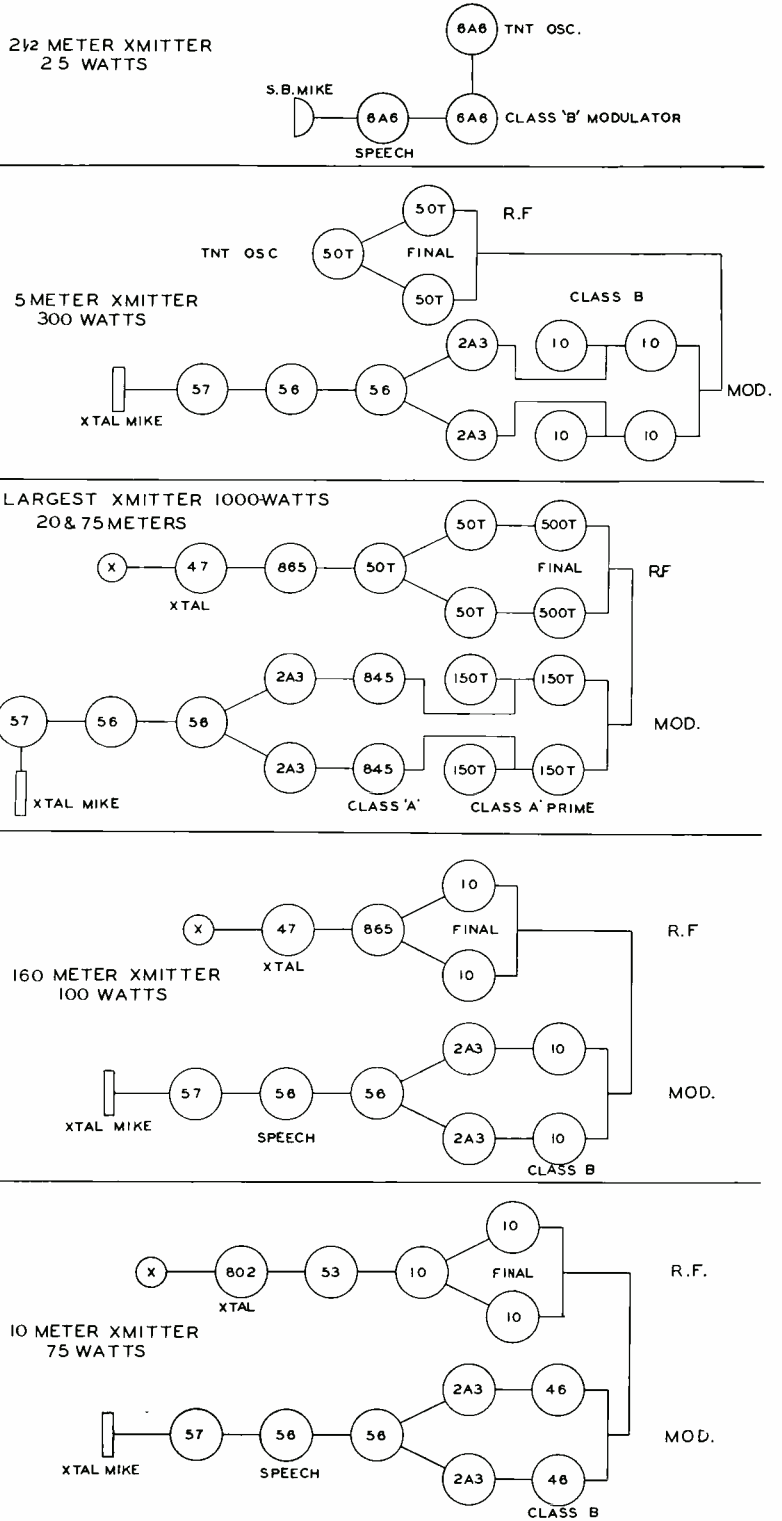



## 28 and 56 Megacycle Activity

[Reports and other material referring to the 28 and 56 mc. bands should be sent to E. H. Conklin, W9FM, Assistant Editor of RADIO, 512 No. Main St., Wheaton, Illinois, who will correlate and assemble the data for publication. Reports should reach him by the 22d of each month.]

### 28 Megacycle Conditions

W1DZE says: "The band has been open here every day this month (January). The Europeans are being heard here R9 at times; G6DH is the most consistent English station right now, and D4ARR is very consistent. The boys are getting in fast, including some rare ones. CN8MQ reported that he has heard every W district, and SX3A in Athens, Greece, has heard many; the former is transmitting on 'ten,' and the latter is going to be, soon. CP1AC (Bolivia) is now on ten, and was worked. ZS2A has a fine signal and is heard quite often. No Asians now. VK3YP comes through now and then."

And from W6DOB: "The past month has been fair for U.S.A. On Sundays the phone QRM is fierce. For the past week, EA4AO has been R7 daily for about 45 minutes; I have burned up more juice on him than on VP5PZ! Guess those guys never listen for a weak signal. I QSO VK3YP regularly. No J's here. ZS2A was R2 last Sunday; guess he can't hear much from the sound of the fellows calling him."

W5EHM is moving, but hears a few signals when he listens. W9KJW-W9BUK have found no dead days, always a half dozen or more west coast stations to work; they report a dip in signal strength in mid-afternoon, with a recovery to normal levels in late afternoon.

Another report of West Coast conditions on "ten" was received from W6EWC. Wayne Cooper says that no Europeans were heard in December, but on January 1 F8CT, F8OL and EA4AO were in for an hour with fair strength; on January 5 G5BY, F8CT and EA4AO were heard; EA4AO was again heard on the 10th. J2LU was the only Asian heard in December, who was worked on the 14th at 4 p.m. Pacific time. The VK's never fail to show up on week-ends, with VK3BD and VK3YP the outstanding stations. South America was heard in mornings and late afternoons during early December and in January. (If 28 mc. shows two peaks daily on South American signals as on 14 mc.,

it may be an indication that the *best* frequency for mid-day is still higher. We wonder who will be the first to work South America on 56 mc.). The W7's have not been coming through much. VK5PZ is the best dx station, with his signals an average R8 all day when he is on.

Elmer Bond, W8MAH, says that not much has been going on there. Europe comes through fine on "ten" and can be worked easily; regular contacts have been held including 2S2A, CP1AC and ZL2KK. CP1AC said that he is using about 350 watts to an 860 on 28 mc., the band being open from 7 a.m. to 10 p.m. Eastern time. CP1AC has heard a "slew" of W's and has made some nice dx contacts. ZS2A explains the week-end break in his 28 mc. schedules: 1400 to 1800 G.m.t. daily except week-ends. His y1 lives in another town; so how can he be on the air week-ends?

### 58 Megacycles

Herb Wareing, W9NY in Milwaukee, requests that 56 mc. c.w. and tone-modulated code stations attempting long-distance QSO's (see "5 Meters on Parade" in R/9 for October and the detailed report of last summer's dx work in the September issue) stay within the first few hundred kilocycles starting at 56 mc. to reduce the band that must be tuned by the listener. This should not be difficult, due to the harmonic relationship of the band and the frequencies of our crystals. The further request is made of 5 meter phones that they "lay off" the frequencies from 56 to 56.5 mc. to give weak dx code signals a chance.

The crystal controlled transmitter on five meters at W9NY uses this lineup: 6A6, 6A6, 802, pair of 801's. The problem of getting a sensitive, stable c.w. receiver has stumped most of the gang; Wareing plans to use an u.h.f. converter in front of his HRO, as a double i.f. super. This will permit tuning the HRO (1st i.f.) rather than the first oscillator, and should be easy to handle. Good front-end gain may be necessary to over-ride tube hiss.

Because dx on 56 mc. may be only occasional, pioneers may find the band as lonely as 28 mc. was a year or two ago. Herb has promises from a number of foreign stations to get on five meter c.w. and wants schedules with U.S.A. stations beyond 500 miles. As W3AIR says, it

[Continued on Page 73]

# Converting Your SW-3 into a Superheterodyne

By FAY W. HARWOOD, W6BHO

When located out in the country, 17 miles from the closest amateur, we took delight in hearing on our "old faithful"

SW3 everything the rest of the boys heard and sometimes more too. But upon moving to a temporary location in metropolitan Los Angeles

*The SW3, long-time favorite, all-time example of fine craftsmanship, and still preferred by many of the dx men in isolated locations, is a rather sorry performer when called upon to work through heavy local QRM in the present crowded bands, and does not show up so well in comparison with present-day supers in that respect. All right,—then why not convert one into a super? It is not a difficult undertaking, and costs but \$5 to \$13, depending upon how many of the parts you have to buy.*

—if you want it. Adjustable regeneration in the i.f. stage allows a wide degree of selectivity. To get enough gain and

selectivity in the limited space allowed, the use of iron-core i.f. transformers and regeneration was practically a necessity.

A glance at the diagram shows a 57 acting as a regenerative 1st detector. This is in the left front shield, where the r.f. stage was formerly located. A 57 electron-coupled high-frequency oscillator now occupies the space that was occupied by the SW3 detector. As seen in the photographs, the 58 i.f. stage, the 53 second detector and b.f.o., and the 2A5 power tube have all been tucked snugly away in the rear of the chassis with plenty of room to spare.

The second detector and b.f.o. are the only things that are not strictly conventional. After going over the 2½ volt tube family, the 53 was selected to do the job, as it was imperative for reasons of space restrictions that the two jobs

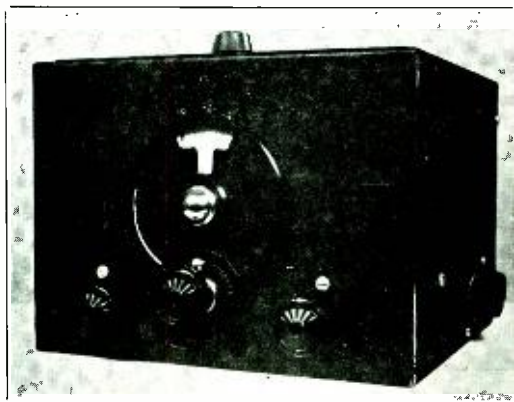

From outside, the receiver looks the same as before the operation, except for an extra couple of knobs (one in back and one on the right hand side).

we soon discovered that the only place for the SW3 was on the shelf. The dense local QRM made the amateur bands nothing but bedlam, and our fine dx-inhaler was rendered useless by the terrific local interference.

After one or two unsuccessful attempts to accomplish an appreciable increase in selectivity by circuit juggling, it was decided that the only thing that would get through the mess of locals and bring in anything in the way of dx was a superheterodyne of some sort. Then the idea occurred to convert the SW3 into a superheterodyne. It has a nifty cabinet, lots of good components that would fit into a super, and a dial with an action as smooth as silk. The resulting receiver appears in the photographs. It will drag in dozens of dx signals that would be lost in the QRM when using a regular SW3.

The sensitivity and compactness of the SW3 have largely been retained, while the selectivity has been brought up to practically single-signal

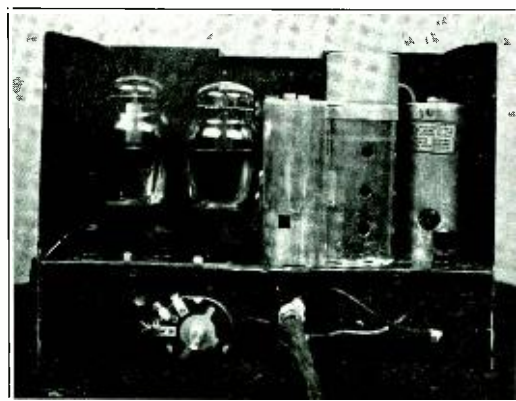

Back view with case removed, showing how the extra tubes and i.f. transformers are "squeezed in". The potentiometer is the a.i. volume control.

be combined in one envelope. One element is used as a straight power detector and the other element as a shunt-fed Hartley oscillator. The latter supplies the beat note necessary for c.w. reception.

If you have decided that there is too much QRM in your locality and that your SW3 "as

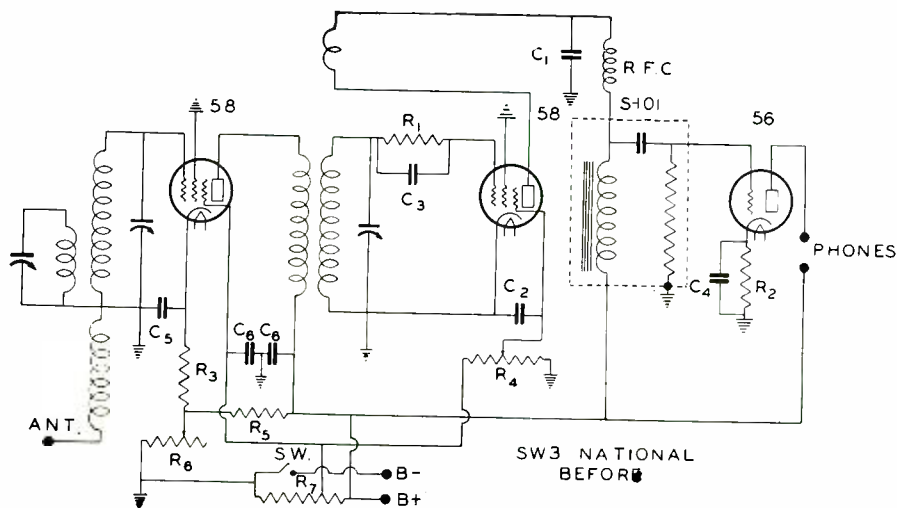

#### SW3 Before the Major Operation

R <sub>1</sub> —5 megohms	R <sub>5</sub> —100,000 ohms	C <sub>2</sub> —0.5 μfd.
R <sub>2</sub> —2500 ohms	R <sub>6</sub> —15,000 ohms	C <sub>3</sub> —0.0001 μfd.
R <sub>3</sub> —300 ohms	R <sub>7</sub> —25,000 ohms	C <sub>4</sub> —0.5 μfd.
R <sub>4</sub> —50,000 ohms	C <sub>1</sub> —0.01 μfd.	C <sub>5</sub> —0.01 μfd.

is" won't cut the mustard, probably the best way to start converting your set over into a super is to turn to the end of this article where a list of all parts necessary for the job are listed, and to take inventory. The chances are that you already have some or a good portion of the parts. After procuring those that you don't have on hand, you are ready to administer the anesthetic.

The way the SW3 is constructed makes the changeover comparatively easy. First, take off the knobs of the trimmer condenser and regeneration control—also the nuts that hold them in place. Loosen the set screw on the condenser shaft at the dial, remove the screws from the front, sides, and back (12 in number) and then take the back off. The shelf, or chassis, is then slipped down enough to clear the shields and out the back. Next, remove the audio transformer and all accessories, including wiring, by-pass condensers, resistors, etc. Rather than try to "save" any of the wiring, it is actually easier to start from scratch and replace all the old wiring with new.

If the SW3 is one of the later ones, the two front sockets will already be of the six-prong type, and will not need changing. Now examine the photos carefully and get the layout fixed clearly in mind, as considerable care is necessary to get the two i.f. transformers and the two extra tubes in the space allotted them. With a scribe mark the holes to be used in

mounting the i.f. transformers and sockets. It will be found that some of the original screw holes fall where they can now be used for other purposes. The others must be drilled.

Now we can mount the i.f. transformers and the sockets. From left to right (looking down on the top of the receiver) we put first the 1st stage i.f. transformer; then a six prong socket, with heater pins to the front; then the second stage i.f. transformer; and next a seven prong socket with the heater pins to the left. A six prong socket for the 2A5 is mounted in the hole originally used for the 56 audio tube. The heater prongs for this tube are placed to the front. With this arrangement of these components, the leads to them can be made very short and direct. Mount the voltage divider as in the photograph.

The tuning trimmer condenser is moved over to the left side, making for shorter leads. The i.f. gain-regeneration control is put on the right, and the thumb control in the center is used for first detector regeneration. Next, the chassis is put back in the case and the holes for the b.f.o. transformer and switch are located. Note that the knob for adjusting the pitch of the beat note is on the outside of the case, making it unnecessary to raise the lid of the receiver to make this adjustment.

The shunt-fed Hartley circuit is used for the beat oscillator. A small Miller type 312 b.f.o. transformer was used because of its compact

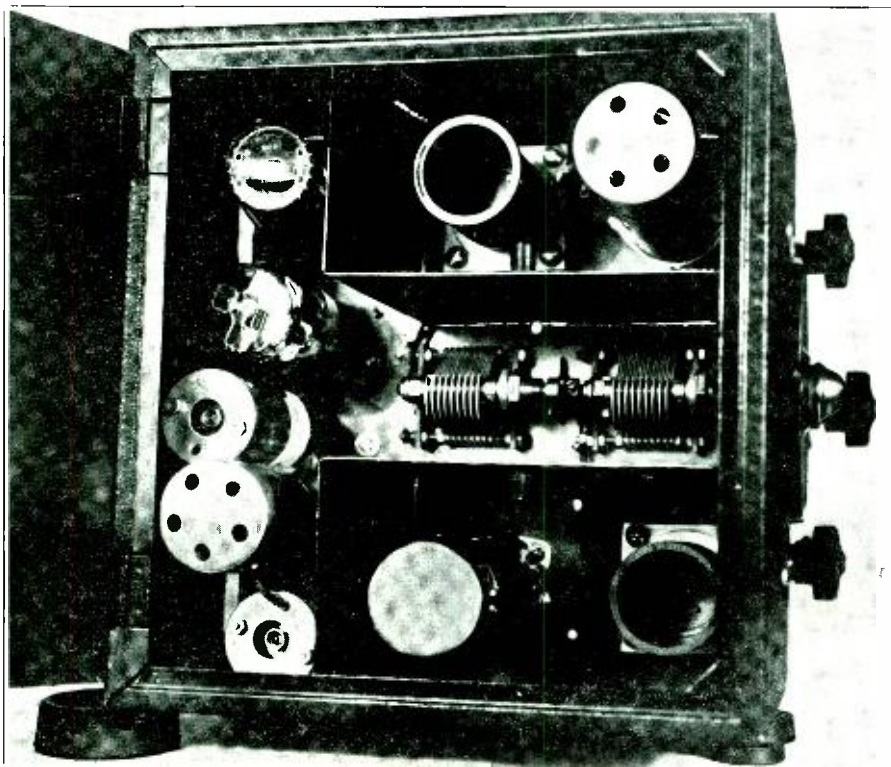

Looking into the Converted Receiver

ness. In the circuit used here, the leads will be different from the conventional electron-coupled arrangement. If you use this transformer just follow the color code in the wiring diagram given here. When you finish the receiver, if you find the beat note too strong it can be cut down by increasing the 1 megohm resistor in the B plus to about 2 megohms. No coupling device is necessary, as the proximity of the pairs of elements in the 53 provides adequate coupling. Make sure when you wire the b.f.o. that the tap on the b.f.o. coil goes to *cathode* and not to ground.

Now locate and drill the hole in which to mount the audio volume control. It is placed on the back of the case directly below the 2A5, making the grid lead to the 2A5 very short. The audio output transformer should then be mounted under the chassis, just in front of the b.f.o. transformer. This coupling transformer must be of the midget type if it is to fit in the cramped quarters, and while these transformers are not very high fidelity they give sufficiently good quality for amateur work. With this transformer, either phones or a magnetic speak-

er may be used by merely plugging in one or the other, and no d.c. will flow through them.

The h.f.o. coupling condenser is now put in place. It is a 35  $\mu\text{fd}$ . compression-type padding condenser, and is mounted to the stator side of the trimmer condenser of the 1st detector, which is the same as making connection to the grid lead of the tube. The coupling condenser seems to give best coupling when adjusted to between 5 and 8  $\mu\text{fd}$ . Plug in the soldering iron and start looking for your diagonals; the set is ready to be wired.

First, wire up the heaters, and then you can proceed in your pet method, whatever it may be. The leads on the coil sockets are changed as shown in the diagram. This makes it unnecessary to make any changes in the coils themselves.

Now, if everything is wired properly, you can test and adjust voltages. The tap on the voltage divider for the screen voltage on the first detector should be adjusted to about 35 volts and the h.f.o. screen to about 65 volts. Next, the i.f. transformers are aligned, a phone signal and your ear doing duty if more elab-



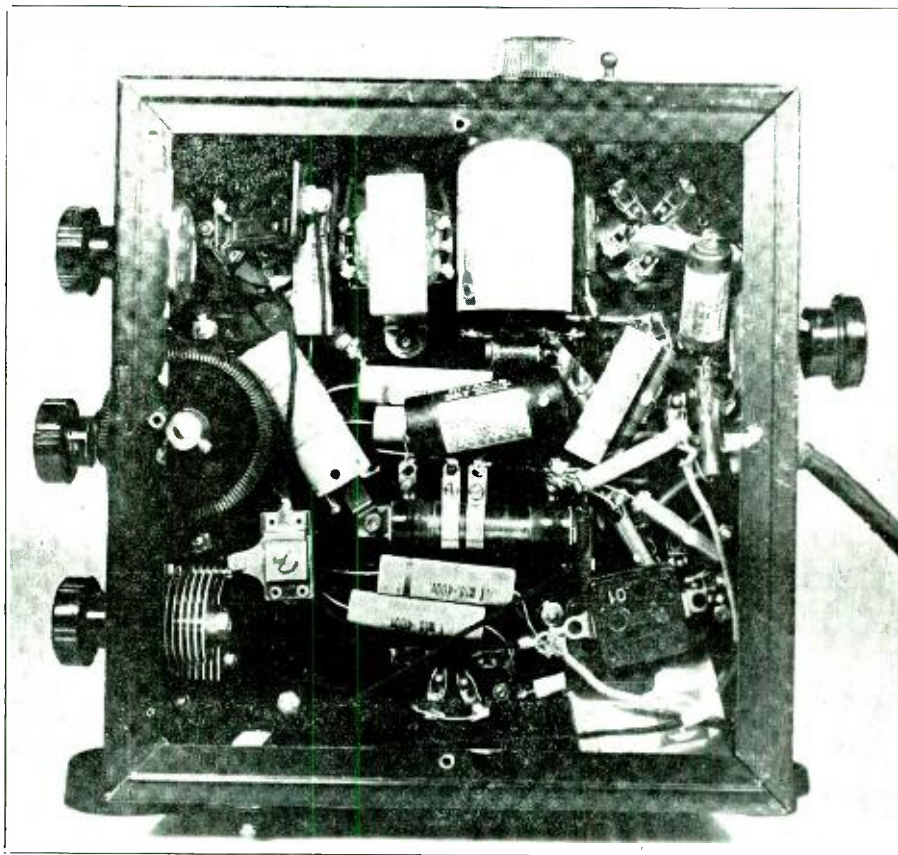

Underneath View of the Converted Receiver

orate aligning equipment is not available. Because there are but two i.f. transformers alignment is not particularly difficult. Adjust the h.f.o. coupling to where signals sound best on an average signal. The 58 in the i.f. stage should go into oscillation quite smoothly when the gain control is advanced to nearly full on. If it goes into oscillation before this point, the little b.c.l. coil that is across the potentiometer has too many turns. If it will not oscillate with the control turned clear on, the little coil does not have enough turns. This is not critical, but the stage should be capable of oscillation, as the point of maximum selectivity is just below the oscillation point. When the i.f. regeneration is peaked up to maximum, the selectivity approaches that obtainable with a crystal filter.

Most any type of antenna coupling may be used. It will be found that quite loose coupling will suffice, and aids in cutting down cross talk, image interference, etc. One turn of stiff hook-up wire around the coil of the first detec-

tor does the job well with an antenna of average length.

A preselector may be used with the set by bringing out the primary leads on the 1st detector coil for coupling. However, the image interference is not at all bad even on the higher frequencies when the regeneration on the first detector is peaked up, and very good operation is had with no preselector.

Many variations of the arrangement described will occur to the advanced amateur. A dynamic speaker may be used if field supply is available and the output coupling transformer need no longer be incorporated in the receiver. Or, a permanent magnet dynamic could be used. If one wishes to go into six volt tubes, the 6L7 offers possibilities as the mixer tube, and the 6F7 as the combined second-detector-beat-oscillator. Or, you can use metal tubes throughout if you wish to spend more money.

The amateur bands will be found at a lower setting on the tuning condenser dial than be-

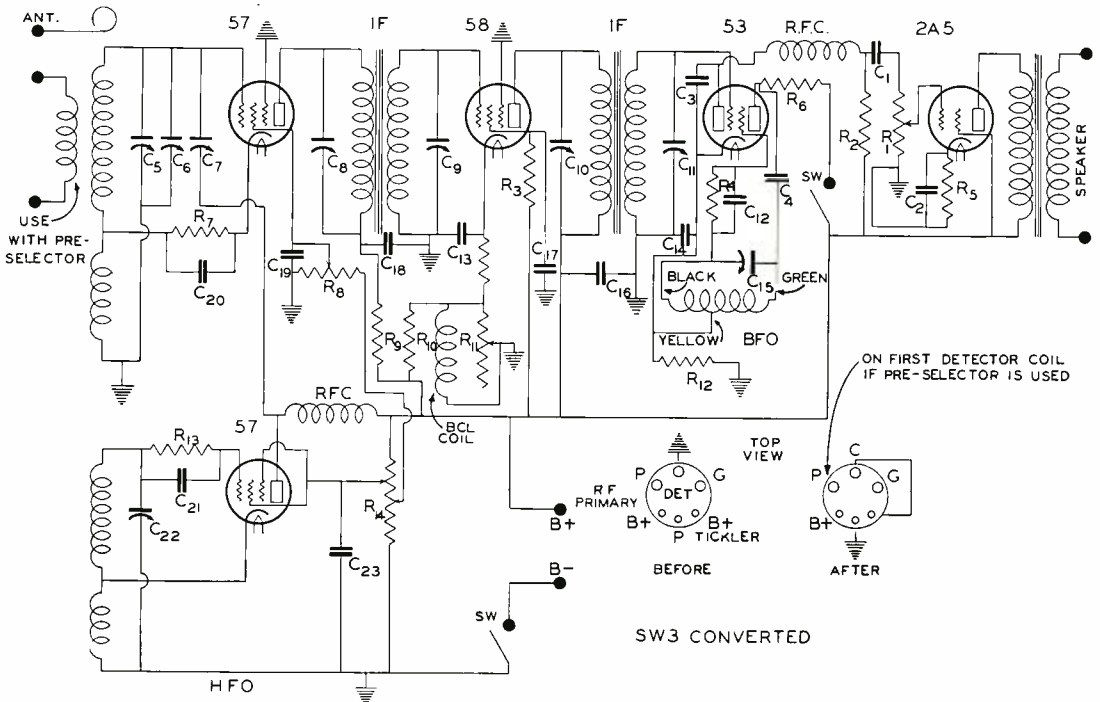

The Converted Receiver

- R<sub>1</sub>—500,000 ohm potentiometer
- R<sub>2</sub>—100,000 ohms, 1 watt
- R<sub>3</sub>—75,000 ohms, 1 watt
- R<sub>4</sub>—50,000 ohms, 1 watt
- R<sub>5</sub>—425 ohms, 5 watts
- R<sub>6</sub>—1 megohm, 1 watt
- R<sub>7</sub>—1500 ohms, 1 watt
- R<sub>8</sub>—50,000 ohm potentiometer
- R<sub>9</sub>—15,000 ohms, 1 watt
- R<sub>10</sub>—100,000 ohms, 1 watt
- R<sub>11</sub>—15,000 ohm potentiometer

- R<sub>12</sub>—50,000 ohms, 1 watt
- R<sub>13</sub>—50,000 ohms, 1 watt
- R<sub>14</sub>—25,000 ohms, 25 watts, with 2 sliders
- C<sub>1</sub>—.01 µfd. mica
- C<sub>2</sub>—25 µfd. 50 volt electrolytic
- C<sub>3</sub>—.001 µfd. mica
- C<sub>4</sub>—.01 µfd.
- C<sub>5</sub>—Section of regular gang condenser (original)
- C<sub>6</sub>—Original tuning trim-

- mer
- C<sub>7</sub>—35 µfd. compression type
- C<sub>8</sub>, C<sub>9</sub>, C<sub>10</sub>, C<sub>11</sub>—I.f. transformer trimmers
- C<sub>12</sub>—.0001 µfd. mica
- C<sub>13</sub>—0.1 µfd.
- C<sub>14</sub>—0.1 µfd.
- C<sub>15</sub>—Trimmer on b.i.o. coil
- C<sub>16</sub>—0.1 µfd.
- C<sub>17</sub>—0.1 µfd.
- C<sub>18</sub>—0.1 µfd.

- C<sub>19</sub>—0.1 µfd.
- C<sub>20</sub>—0.1 µfd.
- C<sub>21</sub>—.0001 µfd.
- C<sub>22</sub>—Section of gang condenser
- C<sub>23</sub>—.01 µfd.
- Output transformer—Pentode to magnetic speaker, midget type
- One side of heaters should be grounded through 0.1 µfd. condenser

fore, as the oscillator is tuned 456 kc. removed from the incoming signal. Only general coverage coils were on hand when tests were made; it may be that some changes would be required with band-spread coils to get them to track within "trimmer distance". All general coverage coils track satisfactorily from 15 to 200 meters, meaning that the trimmer can always be made to "peak". Because of the great selectivity, bandspread coils are highly desirable on 20 and 40 meters. However, due to the excellent vernier movement of the tuning dial, operation in these bands with the general coverage coils is entirely practicable.

Those willing to fuss with the coils may realize a slight improvement by using a cathode tap instead of a tickler winding on the detector coil. The tickler is either removed or used as an antenna coil, and the cathode tap put on the

coils as follows: 10 meters, 3/4 turn from ground end; 20 meters, 2 1/4 turns; 40 meters, 4 turns; 80 meters, 6 turns; 160 meters, zero turns from ground end. Before tapping the coils, it is advisable to remove turns as follows: 10 meters, 7/8 turn; 20 meters, 1 turn; 40 meters, 2 1/2 turns; 80 meters, 5 turns off; 160 meters, none removed. This will put the h.f. oscillator on the low side, somewhat of an advantage though not of great importance.

A cathode tap instead of a tickler may be used also in the h.f. oscillator circuit. The coils should be tapped as follows: 10 meters, 1 turn from ground end; 20 meters, 2 1/4 turns; 40 meters, 6 turns; 80 meters, 11 turns; 160 meters, 20 turns.

It should be realized that these coil changes are unnecessary refinements, listed merely for the benefit of those who like to count turns



and wind wire. The receiver works very well with the coils intact when wired as in the diagram, and you need make no hard work for yourself unless you wish to.

**List of Parts Necessary to Convert an SW3 into the Superheterodyne Described**

*Sockets:*

- 2—6 prong wafer (4 if set uses 5 prong sockets)
- 1—7 prong large wafer for 53

*Transformers:*

- 1—Aladdin no. 100, 456 kc.
- 1—Same, no. 200
- 1—Midget output transformer, pentode to magnetic speaker
- 1—Miller no. 312 b.f.o.
- 1—Sub-midget b.c.l. coil for i.f. regeneration

*Resistors:*

- 1—15,000 ohm potentiometer, i.f. gain control
- 1—500,000 ohm potentiometer, a.f. gain control
- 1—25,000 ohm adjustable (two sliders) 25 watt resistor
- 1—425 ohm, 5 watt resistor

*One watt fixed resistors:*

- 1—500 ohms
- 2—15,000
- 1—50,000
- 1—75,000
- 2—100,000
- 1—500,000
- 1—1 meg.

*Condensers:*

- 1—35  $\mu$ fd. compression trimmer
- 1—100  $\mu$ fd. mica fixed
- 2—.01  $\mu$ fd. mica
- 6—0.1  $\mu$ fd. paper
- 1—25  $\mu$ fd. 50 volt electrolytic

*Switches:*

- 2—Single pole single throw toggle

*Tubes:*

See diagram

◆  
"INVISIBLE LIGHT" ICONOSCOPE

Drs. Zworykin and Morton, of the R.C.A. television research laboratory, recently demonstrated a very interesting development of the Zworykin Iconoscope, which is the television camera used in the R.C.A. high-definition cathode ray television system. The newest Television camera is so constructed that invisible light on both sides of the visible spectrum (infra-red and ultra-violet) releases the electron flow through the external circuit which, when amplified and focussed on the screen of a suitable cathode ray tube, reproduces in visible light an image equivalent to the invisible light image applied to the camera, or iconoscope. Thus visible light filters placed in front of the television camera reduced the brightness of the received image only slightly.

This means that it may no longer be necessary to use the excessively strong illumination on television subjects that is necessary now for direct pick up. The subject can be illuminated by invisible light rays which should cause considerably less physical discomfort to the subject being televised.

The sensitivity of the new iconoscope to the ultra-violet and infra-red ranges of the light spectrum also opens the field of television to uses in magnification of small or distant objects which can only imperfectly be studied by means of strictly optical magnification of visible light.

Another suggested use for the new television camera is to see through haze and fog. It is known that ordinary haze and fog offer relatively little obstruction to the infra-red waves. Thus, as the infra-red images are exactly similar to those produced by visible light, the use of the new television system to change the invisible rays into visible rays would allow a ship's navigator, for example, to see effectively right through the fog and haze nearly as well as if the fog and haze were not there.

◆  
Drilling Glass

This is done very readily with a common drill by using a mixture of turpentine and camphor. When the point of the drill has come through it should be taken out and the hole worked through with the point of a three cornered file, having the edges ground sharp. Use the corners of the file, scraping the glass rather than using the file as a reamer. Great care must be taken not to crack the glass or flake off parts of it in finishing the hole after the point of the drill has come through. Use the mixture freely during the drilling and scraping. The above mixture will be found very useful in drilling hard cast iron.—*W6DOB.*

◆  
Inverted Tubes

Surprisingly few amateurs have thought of the possibility and desirability of mounting tubes upside down in their ultra-high frequency rigs. An inverted tube may not look as well but in most cases shorter leads are the result. A solid mounting can be had by fastening the tube socket face downward on two pieces of  $\frac{3}{8}$ " wooden dowling. By having the tube socket at the same level as the tuning condenser and the tank inductance, much shorter leads can be obtained.

# Antenna Directivity Fundamentals

By J. N. A. HAWKINS, W6AAR

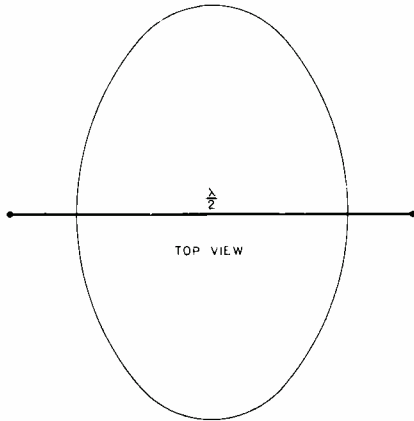

Figure 1

There are two kinds of antenna directivity: horizontal plane and vertical plane directivity. Directivity in the vertical plane affects the angle of radiation with respect to the horizon and affects the skip distance for any frequency. It has been pretty well determined that low angle radiation (7 to 20 degrees) is most useful for working locally and for very long distances, such as 4,000 miles or more. Higher angle radiation (20 to 50 degrees) is more useful for working out from 500 to 4,000 miles. The best angle for a given distance varies with the frequency, time of day, season of the year, and the sunspot cycle.

Until such time as we have a simple and effective method of *varying* the vertical directivity, as proposed by Reinartz, most amateurs will be wise to forget about vertical directivity and concentrate on getting maximum horizontal directivity.

If amateur stations were uniformly scattered around the horizon, horizontal directivity would be undesirable for the amateur who wishes to be able to work everyone else. However, a short study of an Azimuth projection of the world (wherein all great circle courses from a given point are straight lines) will show that the vast majority of amateurs in the world are concentrated in from four to six great circle courses from a given point. Here in California two bi-directional antennas will effectively cover all continents but Europe, as North America and Africa are directly opposite Australia while

South America is directly opposite the Orient. Europe is a little East of North from here and in the opposite direction the great circle course travels about halfway between Tasmania and Little America, which means that an antenna directive on Europe would not be particularly useful in the opposite direction.

## Antenna Radiation Characteristics

All antenna discussions start with the half-wave or dipole radiator. A half-wave doublet, zepp., single wire fed, matched impedance, or Johnson "Q" antenna all have practically the same radiation pattern, when properly built and adjusted. They are all dipoles, and the feeder system *should* have *no* effect on the radiation pattern.

The radiation pattern from a dipole can best be conceived as a fat doughnut with the antenna wire passing through the center of the hole. See figure 1. Thus if the wire is vertical, the doughnut of radiation extends outward in all directions in the horizontal plane. When the dipole is horizontal, radiation in the horizontal plane is least off the ends of the wire and greatest in a direction at right angles, or broadside to the wire. However, as the "doughnut" around a simple half-wave antenna is quite fat the actual difference between the power radiated broadside and the end fire power radiated is not very great. Nearby objects also minimize the

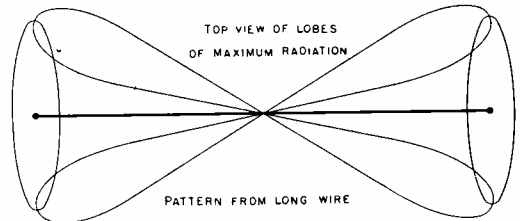

Figure 2

directivity of a dipole radiator so that it hardly seems worth while to go to the trouble to rotate a simple half-wave dipole in an attempt to improve transmission and reception in any direction.

## Long Wire Antennas

The first and simplest step toward increased directivity is to use a long wire, which may be up to fifteen or twenty wavelengths long. The long wire antenna has several advantages and

also several disadvantages but for certain purposes its use is desirable.

As the length of the radiator is increased, in even multiples of a quarter wave-length, the doughnut of radiation around the simple dipole changes into two cones located apex to apex. In other words, there is a cone of radiation around each end of the wire. See figure 2. The angle that the cone makes with the wire gets smaller as the length of the wire is increased so that as the length of an antenna is increased the antenna changes from a broadside radiator into an end fire radiator. As all long wire antennas are necessarily horizontal, or parallel with the horizon, the portion of the radiating cones that shoot radiation upward into the sky and downward into the earth are useless and only those portions of the cones that shoot radiation outward more or less parallel to the surface of the earth are useful. It will be seen that a small part of each side of each cone usefully radiates so that a long wire antenna radiates best in four directions. The longer the wire the smaller is the angle between the lobes of maximum radiation and the wire itself. If the wire had an infinite length and had no r.f. resistance the lobes of maximum radiation would shoot exactly off the ends of the antenna. I think it unnecessary to point out, however, that an infinite antenna would have no ends, and if we could put up wires of infinite length we wouldn't bother with radio for communication anyway.

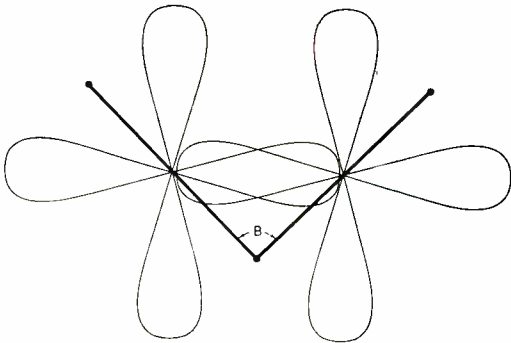

Figure 3

Note that if two long-wire antennas are built in a form of a "vee", it is possible to make two of the maximum lobes of one leg shoot in the same direction as two of the maximum lobes of the other leg of the vee. See figure 3. It is also possible to make the other two lobes of each leg of the vee neutralize and cancel each other. Thus a properly built vee

antenna is bi-directional; in other words it radiates maximum power in two exactly opposite directions. A typical vee antenna can be six and three-quarters wavelengths on each leg. The angle between the two legs (which de-

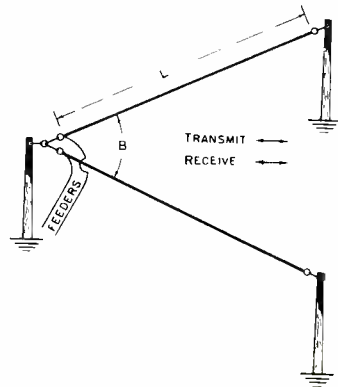

Figure 4

creases as the length of each leg increases) should be approximately 40 degrees. Another useful vee antenna, though much less directional than the preceding one, is one and a half wavelengths long on each leg, in which case the angle between the legs is exactly 90 degrees or a right angle.

The antenna can have each leg either an even or an odd number of wavelengths long. If an even number of quarter waves long the antenna must be voltage fed at the apex of the vee, while if an odd number of quarter waves long current feed can be used. Figure 4 shows a typical vee antenna and figure 5 gives a table showing the relationship between the length of each leg and the angle included between the two legs.

Building a reflector vee similar to the radiator, an odd number of quarter waves behind or in front of the antenna, concentrates all the radiation in one direction. Building a similar vee above or below the vee, and fed in phase, gives some vertical directivity and concentrates the radiation at a low angle with respect to the horizon. See figure 6.

The directivity of a long wire does not increase very much as the length is increased beyond about fifteen wavelengths. In fact the directivity does not go up in proportion to the additional cost of the long wire after about 8 wavelengths are used. This is due to the fact that all long wire antennas are adversely affected by the resistance of the wire. This resistance also affects the "Q" or selectivity of the long

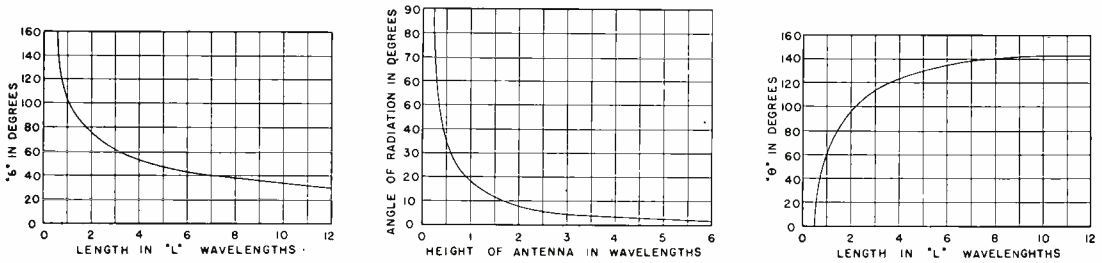

Figure 5

wire and as the length is increased the tuning of the antenna becomes quite broad. In fact, a long wire about 15 waves long is practically aperiodic and works almost equally well over a wide range of frequencies.

Terminating the far end of a long wire antenna in its characteristic impedance makes it even more aperiodic and, at the same time, tends to make it unidirectional. See figure 7. In other words it radiates only away from the transmitter out over the terminating resistance. The power that otherwise would be radiated out back in the opposite direction from the resistance-terminated end is dissipated in the resistance.

ity. The other half, or the vee portion terminated in the resistor, merely serves to absorb and dissipate the backward radiation. It serves to make the antenna aperiodic and also allows

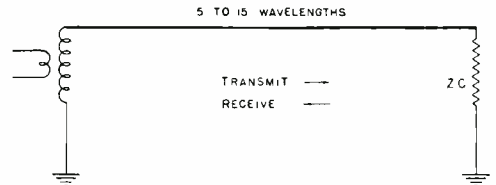

Figure 7

the angle of radiation in the vertical plane to be satisfactory over a wide range of frequencies.

The diamond antenna is very desirable for commercial use where unidirectional transmission and reception is essential to reduce QRM and QRN. The ability of the diamond to work well on all frequencies over a range of two to one is also desirable for commercial use, as commercial stations must change frequency three to four times a day and their frequencies are not harmonically related. However, note that the unidirectional characteristic of the diamond is *not* obtained by reflecting the radiation in the undesired direction back into the desired direction. Instead it merely absorbs and dissipates the undesired radiation in a big resistor. Thus half of the r.f. power applied to the diamond is dissipated in heat. See figure 5 for angle  $\theta$  for the diamond.

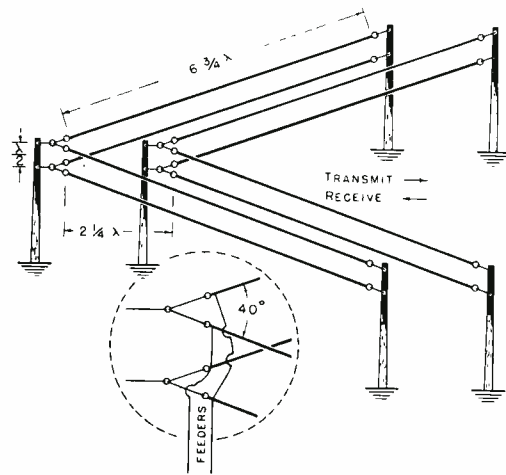

Figure 6

This leads us to the diamond, or horizontal Rhombic type of antenna. The diamond antenna is simply a vee antenna with another vee backed up against the first one. See figure 8. A properly built diamond antenna is always unidirectional. R.f. power is fed into one apex of the two vees and the apex of the other vee is terminated in its characteristic impedance with a resistor. The horizontal directivity of the diamond is not particularly high as only half the antenna actually contributes to the directiv-

Therefore it seems more desirable, for amateur use, to utilize the stacked dipole type of antenna array instead of the long wire type, as no power is wasted in this type of array. The fact that this type of array is resonant rather than aperiodic is no disadvantage as amateur operation is concentrated in narrow bands of frequencies that are harmonically related.

#### Stacked Dipole Antennas

Earlier in this article the characteristics of a half-wave dipole were described. It will be remembered that maximum radiation from a

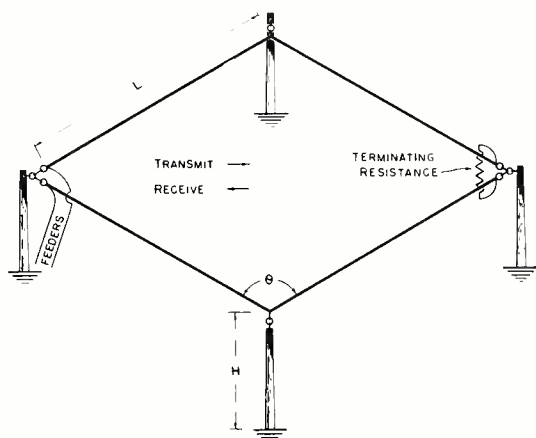

Figure 8

simple dipole occurs in a plane perpendicular to the axis of the dipole. The electromagnetic field around the dipole extends out and induces energy in any object placed within its field, such as a distant receiving antenna. Every object in the field of the dipole absorbs some energy but the absorption is quite small even only 20 wavelengths away. Up to one wavelength away the absorption in a nearby object can be quite large, but if the nearby object is capable of reradiating the energy absorbed, there will be no waste of energy, though there will be a definite change in the shape of the field pattern.

If the nearby object that causes the interference with the radiated wave consists of another dipole tuned to a slightly lower frequency than the radiator, and is a quarter wave away and parallel with the radiating dipole, an interesting phenomenon occurs. As electromagnetic waves travel with the speed of light through space, the radiated wave arrives at the interfering dipole a quarter of a cycle after it leaves the radiator, as they are spaced a quarter wave apart. A current is induced in the interfering dipole which lags by a half-cycle the electromagnetic flux which produces it. (By Lenz' law.) Thus the current in the interfering dipole lags the current in the radiating dipole by three quarters of a cycle, or 270 electrical degrees. The current flowing in the interfering dipole causes radiation from that dipole and this radiated wave arrives back at the radiating dipole after another quarter cycle, or 90 degrees, so that the wave from the interfering dipole arrives at the radiating dipole just 360 degrees after the originating wave started from the radiating dipole. Thus the wave from the interfer-

ing dipole arrives at the primary radiator just as the next wave starts from the primary radiator. The two waves are in phase so they combine into a wave twice as strong in a direction away from the interfering or reflecting dipole. Also note that as we move back to the reflecting dipole one wave gains 90 degrees while the other wave loses 90 degrees so that the two waves are 180 degrees out of phase in that direction and consequently neutralize each other. Thus the radiation in the direction of the reflector is canceled out. See figure 9.

Therefore, a dipole tuned to a frequency slightly below that of the primary radiator and spaced a quarter wave from the radiator acts as a reflector and the lobe of maximum radiation is in line with the two dipoles.

If the interfering dipole is slightly shorter than the radiator (tuned to a slightly higher frequency) it has the opposite effect, and acts as a director. the lobe of maximum radiation pointing toward the interfering dipole.

Whether the interfering dipole acts as a director or reflector depends on the phase of the interfering radiation relative to the phase of the original wave. When the interfering dipole offers an inductive reactance (dipole longer than half wave) to the voltage induced in it by the primary wave the phase of the secondary or interfering wave is such that the interfering dipole acts as a reflector. When the reactance

### FREQUENCY-LENGTH CHART For Half-Wave Dipoles

Kc.	Length	Kc.	Length
3500	133' 3"	14.000	33' 5"
3550	131' 10"	14.050	33' 3"
3600	130'	14.100	33' 2"
3650	128' 2"	14.150	33' 1"
3700	126' 5"	14.200	32' 11"
3750	124' 9"	14.250	32' 10"
3800	123' 1"	14.300	32' 9"
3850	122'	14.350	32' 7"
3900	120' 5"	14.400	32' 6"
3950	118' 5"		
4000	117'	28.000	16' 8½"
		28.250	16' 6¾"
7000	66' 10"	28.500	16' 5"
7050	66' 4"	28.750	16' 3¾"
7100	65' 11"	29.000	16' 1½"
7150	65' 5"	29.250	16'
7200	65'	29.500	15' 10½"
7250	64' 6"	29.750	15' 8¾"
7300	64' 1"	30.000	15' 7½"

This table is quite accurate for wire sizes between no. 8 and no. 14. If the dipole is less than a quarter wave above ground the length may have to be reduced as much as 3%.

No table for frequencies above 30,000 kc. can be very accurate, as wire size, surrounding objects, and insulator characteristics have a marked effect on resonant length. However, the small size of the higher frequency dipoles makes experimental determination simple.

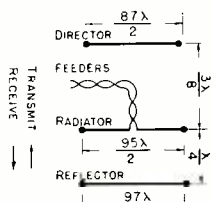

Figure 9

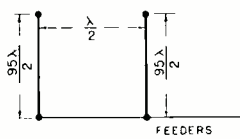

Figure 10

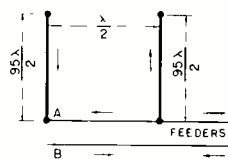

Figure 11

is capacitive to the induced voltage (dipole less than a half wave) the interfering dipole acts as a director. See figure 9 and also figure 18. This is the simplest form of an end fire array using stacked dipoles.

If the two dipoles are spaced a *half wavelength* apart the current flowing in the parasitically-excited, interfering dipole will be 360 degrees, or a full wave behind the current in the radiator, and the two dipoles are said to be *in phase*. When this happens the two waves from the two dipoles meet at a point half way between the two (a quarter wave from each) and they are 180 degrees *out of phase* and thereby cancel. Thus there is minimum radiation in line, or end fire, but the radiation broadside is maximum. This is the simplest form of broadside array using stacked dipoles. See figure 10.

If the interfering dipole in the simple broadside array (dipoles half wave apart) were fed by a transmission line instead of parasitically by radiation from the other dipole, the result would be the same, as long as both dipoles were excited *in phase*. See figures 12 and 13. If the second dipole is fed either 90 or 270 degrees *out of phase* the array becomes end fire. See figure 11.

Note the difference between figure 12 and figure 13. They both give exactly the same results but notice that in figure 12 the resonant half-wave line that couples the two radiators together is transposed once in order to provide proper phase shift, while in figure 13 the

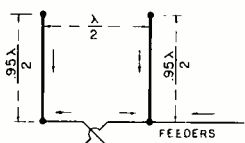

Figure 12

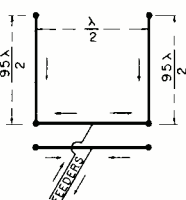

Figure 13

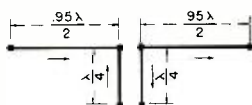

Figure 14

coupling line is *not* transposed. In fact, at first glance the coupling between the two broadside radiators of figure 13 looks exactly like the out-of-phase coupling for the two end fire radiators of figure 11. The difference lies in the fact that the feed line from the transmitter is connected to the center of the phasing line in figure 13 while it connects to one extremity of the line in figure 11. The presence of the resonant feeders makes the difference and causes the proper phase shift. The phase shift of the coupling lines in all the stacked dipole arrays is indicated by the small arrows adjacent to each resonant half-wave section. These arrows indicate the direction of current flow *at any given instant*. Note that current flows in opposite directions in any two half-wave sections that are connected together. These current-flow arrows enable any complex directive array to be analyzed quickly to determine whether it is a broadside or end-fire array. If the arrows in two parallel half-wave radiators point in the same direction at any instant the array radiates broadside to the plane of the radiators. If the arrows point in opposite directions the array is either end fire or else unworakble.

Note that the arrays of figure 17 depend on the same unusual feeder and coupling line connection of figure 13. The arrays of figure 12 and figure 13 give about the same results, the difference being that the array of figure 12 is fed at a high voltage point while the array of figure 13 is fed at a high current point. Figure 13 gives better balance. Note that a rather simple switching arrangement can be used to change the end-fire array of figure 11 into the broadside array of figure 12. A single-pole double-throw switch is used to connect the lower end of the left hand radiator of figure 11

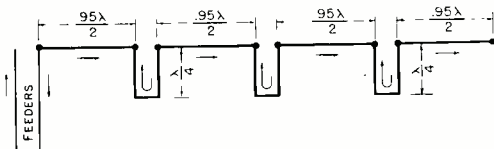

Figure 15

to either side of the phasing line at points A or B. When the radiator connects to feeder A the array is end fire. With the radiator connected to B the array becomes broadside. In either connection the array is bi-directional.

Another common type of bi-directional broadside antenna uses two half-waves in phase along a common axis, as shown in figure 14. This antenna is merely the old center-fed zepp.



worked on its second harmonic. In other words if each half of the flat top is 66 feet, the fundamental wavelength of the antenna is 80 meters, where it radiates as a simple half-wave dipole. However, on 40 meters the two half-waves in phase provide materially more broadside directivity than the antenna gives on 80. The use of more than two half waves in phase to get still greater broadside directivity is shown in figures 15, 16 and 17. The array of figure 15 is fed at a high voltage point at one end. This is bad because the current that flows to the dipole radiator farthest away from the feeders has to flow through the loss and radiation resistance of all the other half-wave phasing and radiating sections. This causes a progressive phase shift which cannot be tuned out by adjusting the phasing sections and also causes an uneven current distribution which makes the realized directivity less than it should be.

The arrangement of figure 16 is a big improvement over figure 15 as the feeders are connected to a high current point at the center of the array. However, a certain amount of phase shift and current unbalance still reduce the directivity.

The arrangements shown in figure 17 are much to be preferred although there is half as much horizontal directivity (theoretically) and twice as much vertical directivity as with the arrays of figures 15 and 16. Tests with both types indicate that the arrays of figure 17 have almost as much horizontal directivity as those of figures 15 and 16 and the added vertical directivity is usually quite welcome for long-distance high-frequency work. The arrays of figure 17 require only half as much distance between the supporting poles but the poles should be somewhat higher.

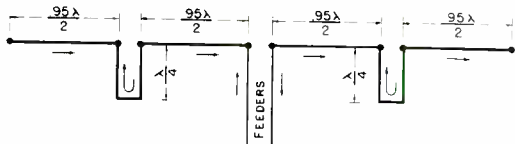

Figure 16

their center at least a full wave above ground for best results.

The best commercial arrays using stacked dipole radiators usually group the radiators into groups of four as in figure 17; then additional groups of four are added, each fed from a separate feed line so that all quads get exactly the same current. The difficulty in this method arises when they try to get current to all quads

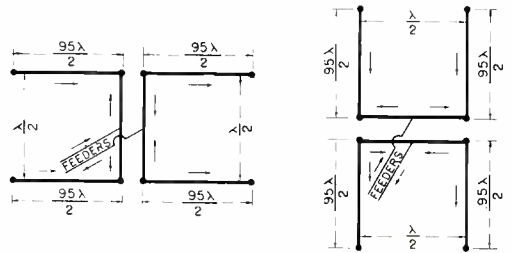

Figure 17

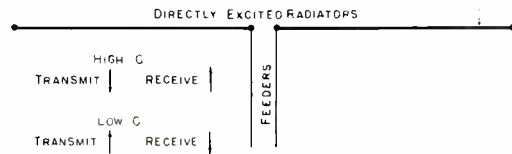
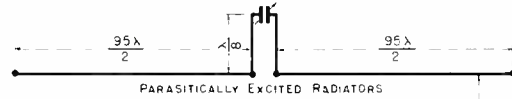

Figure 18

in exactly the same phase. As most amateurs lack the expensive measuring equipment necessary to balance up more than one resonant feed line, it is suggested that if more directivity is desired than given by the array of figure 17 some form of long-wire array be used.

The first step toward increasing the directivity of a broadside array is to hang a curtain of parasitically excited reflectors and directors a quarter wave behind and in front of the antenna proper.

The writer offers the antenna shown in figure 18 as a simple and rather effective unidirectional array, whose direction can be quickly reversed. As was pointed out above, the only difference between a reflector and a director lies in whether the parasitically excited interfering dipole is longer or shorter (electrically) than a half wave at the frequency of operation. If longer, it acts as a reflector; if shorter it acts as a director. In the arrangement of figure 18 the directly excited portion of the array consists of two half waves in phase, and they can either be horizontal or vertical, depending on whether horizontal or vertical directivity is desired. A quarter wave away and in the same plane, are mounted two more half waves connected to a phasing stub, each leg of which is approximately one-eighth wavelength. As the total electrical length of the phasing stub in the parasitically excited array must approximate a

[Continued on Page 76]



# Metal Tubes in the "Super-Gainer"

By FRANK C. JONES

The circuit consists of a 6L7 regenerative first detector, 6C5 h.f. oscillator, 6F5 regenerative second detector, and a 6C5 audio amplifier. The 6L7 is a special tube designed with an additional grid for connection to the h.f. oscillator. There is practically no interlock between the two circuits with this tube when used with sufficient shielding. The plate impedance and conversion gain are high with a 6L7 tube; so a small iron-cored i.f. unit in a copper can works satisfactorily.

This i.f. unit together with second detector regeneration is the real source of selectivity in

*The glass tube version of the super-gainer receiver has met with widespread popularity due to its high selectivity and sensitivity for such a simple and inexpensive superheterodyne. A metal tube version of this receiver is described here. Its sensitivity seems to be a little greater than the glass tube receiver previously described in "RADIO".*

this receiver. The regeneration gives good sensitivity, and for c.w. operation provides beat note reception

by letting the 6F5 tube oscillate. Regeneration is controlled by a 5000 ohm tapered variable resistor shunted across the 6F5 cathode coil  $L_1$ . This coil is 100 turns of no. 26 or 28 d.s.c. wire jumble wound on a piece of  $\frac{5}{8}$ " diameter dowel rod. There is no magnetic coupling between this coil and the i.f. tuned coils. Cathode feed-back is used in all circuits of this receiver for regeneration or oscillation.

Grid leak detection is shown through cathode

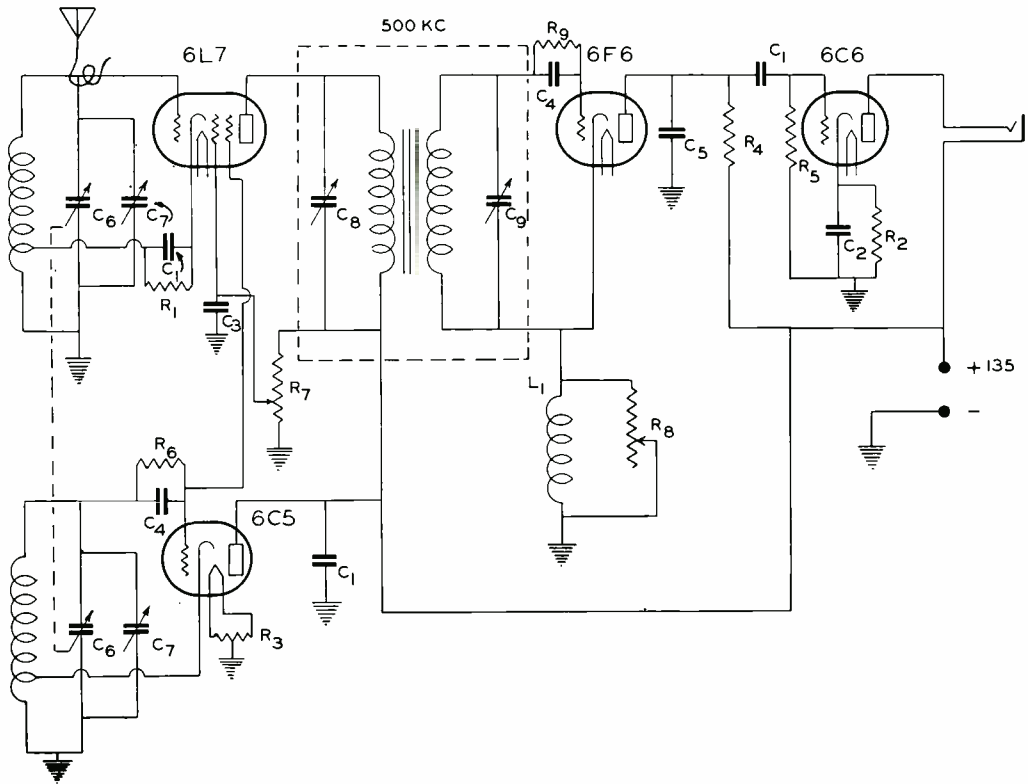

Wiring Diagram of the Metal Tube Version of the Super-Gainer

- |                                       |   |                             |   |
|---------------------------------------|---|-----------------------------|---|
| $C_1$ —0.1 $\mu$ d. paper tubular     | $C_4$ —20 $\mu$ d. per section            | $R_1$ —500 ohms, 1 watt     | $R_6$ —50,000 ohms, 1 watt              |
| $C_2$ —10 $\mu$ d. 25 v. electrolytic | $C_7$ —.0001 $\mu$ d. variable            | $R_2$ —1000 ohms, 1 watt    | $R_7$ —50,000 ohm tapered potentiometer |
| $C_3$ —0.1 $\mu$ d. tubular           | $C_8$ —I. f. trimmer (integral with unit) | $R_3$ —50 ohm c.t. resistor | $R_8$ —5000 ohm var. resistor           |
| $C_4$ —.0001 $\mu$ d. mica            | $C_9$ —I. f. trimmer                      | $R_4$ —10,000 ohms, 1 watt  | $R_9$ —2 megohms, 1 watt                |
| $C_5$ —.004 $\mu$ d. mica             |   | $R_5$ —100,000 ohms, 1 watt |   |

bias detection works as well and sometimes allows smoother regeneration in this second detector. The output of the 6F5 tube is resistance coupled to a 6C5 audio amplifier for headset operation. The 6F5 plate by-pass condenser can be any value from .002 to .006  $\mu$ fd., its function being to allow regeneration by grounding the plate circuit to the i.f. frequency.

The i.f. transformer is tuned for maximum sensitivity on a weak signal using the second detector regeneration control while setting the i.f. condensers. At resonance, there is a tendency to pull out of oscillation; this effect is dependent upon the coupling between the i.f. coils.

A 6F5 high  $\mu$  tube was decided upon for the second detector though a 6C5 tube would be nearly as good with grid leak detection. Other resistor values might be satisfactory in the audio coupling circuit.

The chassis is 7" x 7" x 1 $\frac{3}{4}$ ", of no. 20 gauge plated steel. The front panel is 7" x 8" x 12 gauge aluminum so that a metal cabinet 8" long x 7" high x 7 $\frac{1}{8}$ " deep could be fitted onto

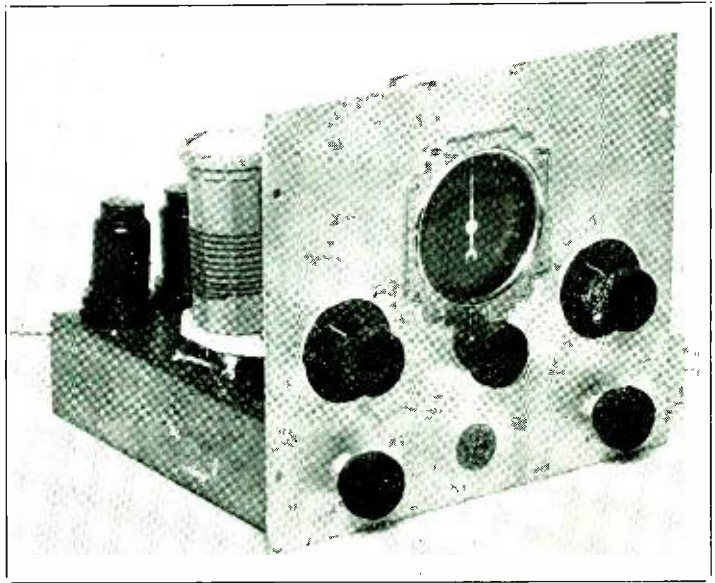

The metal tube Super-Gainer looks neat from the front. Here is a view of the completed job

the receiver. A hinged top would be necessary for changing plug-in coils. The tuning condenser is a two-gang double-spaced midget condenser with four stator plates per section. A shield fits between these two sections and also serves as a baffle between the two plug-in coils. This shield is necessary to prevent "pulling" or interlock on 10 and 20 meters.

The vernier dial is isolated from the tuning condenser shaft so as to prevent noise while tuning. The dial mechanism would form an additional varying ground lead from the rotor, resulting in noise and instability. Often tuning noise in 5 meter sets can be traced to this effect. The 100  $\mu$ fd. front-panel-controlled condensers are for band setting. The first detector has to be tuned exactly when using regeneration to any extent. The 6L7 should never be allowed actually to oscillate, as that is a function of the 6C5 h.f. oscillator. The latter oscillates at about 500 kc. higher frequency than that to which the detector is tuned. The signal is heterodyned to 500 kc. for further amplification in the regenerative

[Continued on Page 80]

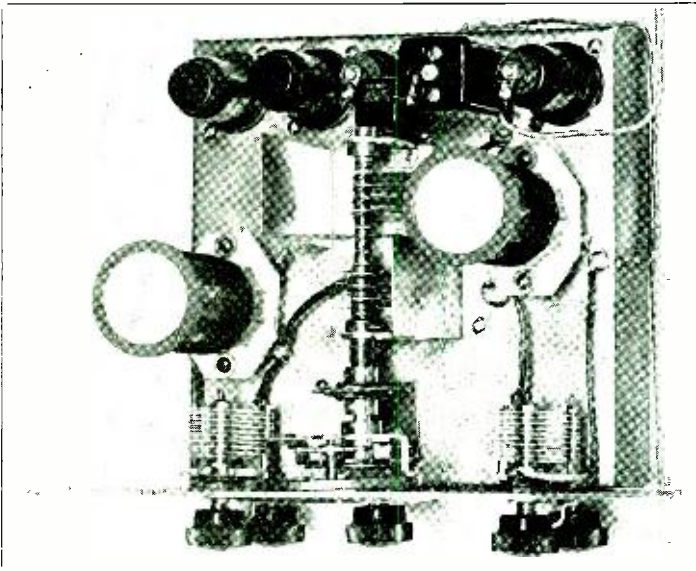

Top view of the metal tube Super-Gainer. Note the "Z"-shaped shield which separates the two condenser sections and the two coils.

# Intermediate Amplifier Design

By CLAYTON F. BANE, W6WB

It is fairly safe to state that there are but very few superheterodynes on the market today that are working up to their full capabilities. Realizing of course, that this is a broad statement, let us qualify it by saying that the noise introduced by the i.f. stages alone can, by de-

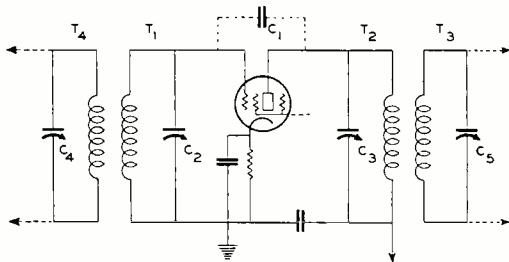

Figure 1

creasing the signal-to-noise ratio, make the entire receiver only about fifty percent effective. Arbitrarily take any receiver and short out the front end so as to make certain that no signal or noise is getting into the i.f., and turn the gain full on; then turn off the b.f.o. and see what you hear. Actually, with a good two-stage i.f. amplifier you should hear nothing; and at worst, but a very faint suggestion of hiss far in the background. If (as we suspect) you are greeted with a loud hiss, if not a downright roar, the following considerations will help you to clear the trouble and increase many times the effectiveness of your receiver.

Excessive noise in the i.f. stages is oftentimes traceable to regeneration in one or more stages. Regeneration definitely has its place but *not* in the intermediate stages except where economy is a prime factor. Consider that these stages are always working at frequencies where the gain from the pentodes used is considerable; that further, the "Q" of the coils in the i.f. transformers is high, which makes for considerable amplification. This by way of saying that the realizable gain from a well-designed two-stage amplifier is more than sufficient for ordinary purposes without the addition of regeneration. Here let it be stated that gain and noise are not necessarily synonymous; that while they can, and frequently do appear at the same time, the gain can still be of a high value without amplifying noises inherent in the tubes to more than a limited extent. Bear in mind that we

are now considering the i.f. amplifier as being totally free of any signal input,—that we are discussing spurious noise originating in the i.f. stages themselves.

If the causes of regeneration and oscillation are clearly understood, the problem of eliminating both will be made considerably more simple. In the first place, a moment's reflection will show that an ordinary i.f. stage is capable of being an excellent, tuned-grid, tuned-plate oscillator. Consider figure 1. Forgetting for the moment T4 and T3 (input and output tuned circuits) it can be seen that the circuit differs in no manner from the t.p.-t.g. circuit previously mentioned. The only reason it does *not* oscillate is that there is insufficient capacity between grid and plate to feed back enough energy to maintain oscillation. This low grid-to-plate capacity is an inherent property of the 57—58 variety of pentode and is due to the interjection of the screen and suppressor grids as well as to the wide interelement spacings. There is no reason however, why energy cannot be fed back from grid to plate by other means than the grid-plate capacity of the tube. This feedback seldom if ever occurs directly from the grid lead to the plate lead due to the fact that the spacing between these leads is generally great. It can happen in just this manner however if the grid and plate leads are not widely separated.

Most generally, feedback occurs either through common coupling, perhaps from some resistor common to two or more stages, or from the grid circuit of one stage back to the grid circuit of the preceding stage. This can be made more clear by again referring to figure 1. If circuit T3 is coupled back in some manner to circuit T4, (perhaps due to close proximity of leads) energy can be transferred from circuit T2 to T1 just as effectively as though it were being fed back through the tube. The remedy is to isolate as far as possible all circuits by paying careful attention to the placement of the leads out of the transformers. Also avoid coupling between by-pass condensers, particularly watching that the outside foil on the paper tubular type goes to ground. Coupling of T3 and T4 back through a common B plus or volt-

age divider lead can be avoided by the judicious use of by-pass condensers and isolating resistors.

A suggested circuit for a two-stage i.f. amplifier is shown in figure 2. It will be seen that all circuits are thoroughly isolated by resistors

fastens to its terminating lug. (See figure 3-c.)

If the design precautions as previously outlined are followed closely, the i.f. stages should be totally free from any noise due to regeneration. There will always be however, (with the

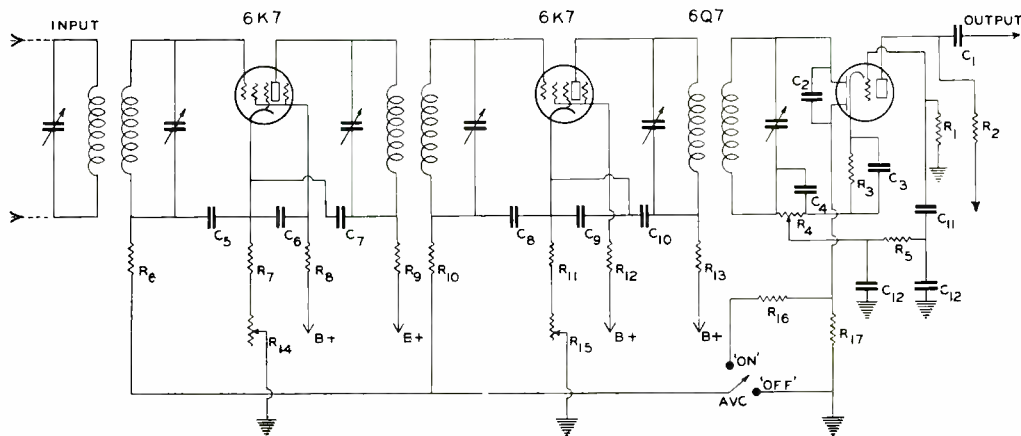

Figure 2

- |   |                           |                     |                        |
|---|---------------------------|---------------------|------------------------|
| $C_1$ —0.05 $\mu$ d. paper              | $C_7$ —0.5 $\mu$ d.       | $R_2$ —100,000 ohms | $R_9$ —10,000 ohms     |
| $C_2$ —0.0001 $\mu$ d. mica             | $C_8$ —0.1 $\mu$ d.       | $R_3$ —2200 ohms    | $R_{10}$ —250,000 ohms |
| $C_3$ —10 $\mu$ d. 25 volt electrolytic | $C_9$ —0.1 $\mu$ d.       | $R_4$ —500,000 ohms | $R_{11}$ —400 ohms     |
| $C_4$ —0.0005 $\mu$ d.                  | $C_{10}$ —0.5 $\mu$ d.    | $R_5$ —2000 ohms    | $R_{12}$ —50,000 ohms  |
| $C_5$ —0.1 $\mu$ d.                     | $C_{11}$ —0.05 $\mu$ d.   | $R_6$ —250,000 ohms | $R_{13}$ —10,000 ohms  |
| $C_6$ —0.1 $\mu$ d.                     | $C_{12}$ —0.0025 $\mu$ d. | $R_7$ —400 ohms     | $R_{14}$ —20,000 ohms  |
|   | $R_1$ —500,000 ohms       | $R_8$ —50,000 ohms  | $R_{15}$ —20,000 ohms  |

and by-pass condensers and further that no reliance is placed upon radio frequency chokes in the plate leads, due to possible resonance effects. The use of resistors in the plate leads is advisable even though some slight drop in plate voltage results. A further variance from more or less standard practice is the use of individual variable resistors in the cathode leads of the i.f. tubes. This resistance is of course used to control volume and it functions to reduce the gain of the tubes by increasing the bias as more resistance is cut into the circuit. The 400 ohm fixed resistors are merely a precaution that some bias will always be applied even though the variable control is at zero resistance setting. Dual potentiometers are readily available (b.c.l. replacements) and their use is strongly advocated to avoid the possibility of common coupling through cathode circuits.

It hardly seems necessary to mention that all grid leads from the tubes to the transformers should be shielded; this is particularly so when the stages are very close together. It is also an excellent idea to shield the plate leads from the i.f. transformers to the tubes. This shielding should start *inside* of the transformer, right at the point where the lead from the i.f. coil

present day tubes) some noise due to shot effect. This effect is caused by the fact that the electrons as emitted from the cathode do not all travel with a constant velocity to the plate; the electron flow is not a continuous stream but rather a series of irregular particles. This effect causes slight irregularities in the plate current, which variation is passed on to succeeding stages as noise. While a complete cure is not possible the effect may be cut to a minimum by creating a heavy space charge in the tube so that there is, in effect, a reservoir of electrons held in reserve which tends to reduce the irregularities of the plate current. This space charge can be achieved by running the screen voltage up to the maximum permissible value and by running the heater voltage to the same limits. It can be seen by this last statement that the heater voltage must always be at least up to rating and possibly a wee bit higher. It is astonishing how many receivers there are with the heaters running below normal rating. Don't take the label on the transformer as your criterion. Use number 14 wire to hook up the heaters and *measure* the voltage at the tube terminals!

Since, as we have said, some of this shot effect noise will persist even with the suggested

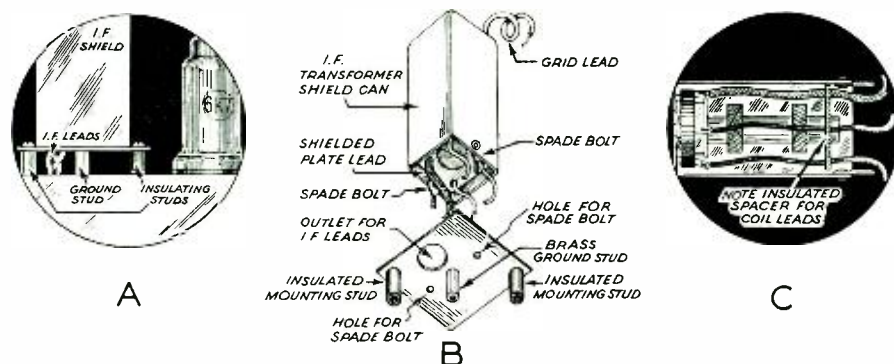

Figure 3

- A—Showing method of mounting i.f. transformers on chassis that prevents intercoupling of transformers due to induced currents set up in the chassis, particularly applicable when iron-cored transformers are used.
- B—Showing mounting detail of bottom shield plate; note that it is grounded to the chassis at but one point.
- C—Interior of i.f. transformer housing, showing how the shielding on the plate lead starts directly at the trimmer inside the can. Note how the coil leads are separated by a fiber spacing-plate to hold them away from one another.

precautions, a question arises that should be given careful consideration: namely, "What is the practical limit to the number of i.f. stages that can be used?" The writer believes two stages are a practicable maximum and has a decided leaning toward a single stage. In face of the present-day trend toward three stages some explanation of this stand is perhaps in order. The only possible justification for the use of three stages would be in the added selectivity so obtained. The gain is certainly not needed and the total noise has been increased by the addition of the extra tube. The problem of intercoupling has been increased tremendously with the net result that an extremely careful design must be used if oscillation is to be avoided. What will probably happen is that the design will not be so perfect and oscillation will be prevented by the use of higher grid bias to cut the gain of the stages down to a point where things do not break into oscillation. Result: little more if any gain over a two-stage job and more noise.

So much for the gain aspect, but how about the added selectivity which most certainly is desirable? The answer is very simple: leave the tube out entirely but retain the additional tuned circuit. The tuned circuits add the selectivity, not the tube. It is well known that the amount of noise admitted to the i.f. stages from the high frequency portion of a superheterodyne is a function of the width of the selectivity curve of the i.f. amplifiers. In general, three factors govern the shape of this curve, these being: The

"Q" (factor of merit) of the i.f. transformer coils; the co-efficient of coupling of the transformers; and the number of tuned circuits in use.

One might conceivably reason that this being so, if a sufficient number of tuned circuits could be added, the selectivity might eventually approach that obtained with a crystal filter. Such reasoning is erroneous due to the fact that each tuned circuit has some amount of resistance and consequently, each circuit would expend some of the signal energy until there would be little left to impress on the grid of the detector. Parenthetically, it would also take a corps of seven engineers from the Bell Laboratories to get the system in line!! The addition of another transformer between the two i.f. stages will help the selectivity considerably, the effect of this being noted by a narrowing of the *base* of the selectivity curve. It requires a good crystal filter to sharpen up the peak of the curve, but even such a filter is working at a disadvantage if there is not considerable selectivity in the i.f. stages.

All quartz resonators have more than a single resonant peak; some, in fact, have several. Obviously, the degree to which the i.f. stages respond to these spurious peaks (as the signal is tuned two or three thousand cycles past resonance) depends upon the base width of the selectivity curve. Putting this another way, let us say that a signal occurring at three kilocycles off resonance might drop to a value of 40 decibels below the level of the same signal at



resonance. Now let this signal be five kilocycles off resonance and the response drops to minus 60 decibels. However, moving over to seven kilocycles the response drops perhaps only another 10 db. From which we can see that the near-resonance selectivity is excellent but the off-resonance selectivity not so good. This off-resonance selectivity interests us greatly in that it dictates the strength of the spurious resonator peaks. Elimination of this "skirt" is highly desirable. Additional tuned circuits help to give us the desired effect.\*

Certainly no discussion of intermediate frequency amplifiers would be complete without some mention of the iron-core transformers recently put on the market by several manufacturers. The outstanding advantage of such transformers lies in the fact that they have a much higher "Q" than the old, air-core types. This higher "Q" is possibly due to the fact that the individual transformer coils have considerably less wire than an air-core equivalent, and consequently the copper loss or resistance is much lower. The effect of this increased "Q" is to increase both the sensitivity and selectivity of the circuit using such transformers.

It would seem then that, having these distinct advantages, iron-cored coils would be the thing to use. However, the higher the "Q" of a circuit, the easier it is for that circuit to oscillate. This is perhaps easier to understand when we state that high "Q" means low resistance. Resistance is always the enemy of oscillation; in fact, if all resistance could be removed from a resonant circuit, that circuit (upon being supplied with a "kick" of energy) would oscillate practically indefinitely. The opposite holds true of course; large amounts of resistance in a circuit will damp out oscillation. One well-designed stage of intermediate frequency amplification using iron-cored transformers can give practically the same gain as a two-stage affair using air transformers. In a two-stage job extreme care must be taken in the design or the troubles from oscillation stated earlier in this paper are certain to result. The earlier stated precautions will certainly apply two-fold.

From the standpoint of sensitivity there is practically nothing to choose between the use of metal or glass tubes. Metal tubes do have an advantage in that they permit a better mechanical layout and invariably make for shorter grid and plate leads. The fact that

they require no external shield is an obvious advantage. It is due to this latter point that we have brought these tubes into the dissertation, a word of caution being advisable. We have noted in a number of cases that the ground connection from the ground pin to the shell is not making good contact and consequently the metal shell is "floating". This inevitably gives rise to i.f. oscillation. Until the manufacturers clear up this trouble, it is wise to make contact to the shell externally.

In conclusion the writer would like to state that the data presented in this paper is all practical; most of it has been uncovered in the laboratory while working out the design of commercial and amateur superheterodyne receivers in regular service at the present time.

◆  
It is evident that Bostonians reporting annoyance from radios stimulate the literary efforts of the Bean Town police. Says the *Boston Traveler*, "When Lt. Buccigrosse of the Matapan station writes a report he writes a report, and here's one, item no. 5 on the police journal, set down following a report to him. . . . 'A man named Leroy Hodges . . . complained that the terrific tintanabulatory staccatos, the reverberating crescendoes and the dismal diapasons that diurnally and nocturnally assail his auditory tympanums have ultimately exhausted his patience so that he feels impelled by the lash of necessity to seek succor. Mr. Murray Fine upon being apprised of the gravity of the situation, engaged most cordially to eschew the obnoxious arts of his radio concerts in the future so that Mr. Hodges may be free to pursue esoteric cogitations without let or hindrance.'"

◆  
Most people in the early days of electricity visualized electricity as a sort of fluid; but Benjamin Franklin, far ahead of the times, thought of it in the modern electronic sense as "particles extremely subtle."

### Hiram Percy Maxim

With sorrow in our hearts we have the unpleasant task of recording the death of Hiram Percy Maxim, W1AW, president of the A.R.R.L. and the I.A.R.U., in La Junta, Colorado, on February 17th.

\*See "The Super Phone Super", page 73 of January, 1936 RADIO.

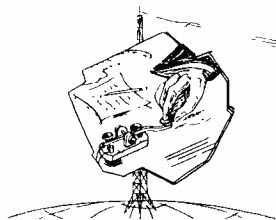

# CALLS HEARD AND DX DEPARTMENTS

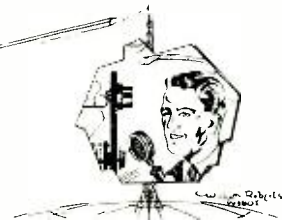

Numeral suffix indicates "R" strength. Send Calls Heard to Calls Heard Editor\*, not to Los Angeles.

*Petr. Jastrzembkas, LY1J, Hipodromo 14,  
Kaunas 1, Lithuania  
July 5 to December 6, 1935*

(3.5 mc.)

DJHPG-7; G6LG-5; LA3F-5; LA4H-7; OH1NI-5; OH2DSA-5;  
OH2PW-4; OK1LZ-6; OZ7MP-7; SM2TF-4; SM7SF-6.

(7 mc.)

W 1GKJ-4; 2DFV-4; 2FHS-5; 2HHF-4; 210H-4; 21ZG-4;  
2JB0-5; 3DCR-3; 8KR6-4. — CR7MB-4; CSLZ-5; CT02J-5;  
CT2BD-5; D2BD-5; D4GRF-6; EA3EV-5; EA3OP-6; EA7AV-4;  
EA8AN-4; FT4AG-8; G2JD-7; G2K0-7; G2SD-6; G5LG-4;  
G6GT-5; G6PQ-5; HB9BG-6; K6GKB-5; LA4J-6; LX1A0-4;  
OH2DSA-5; OH8NA-6; OH8NE-4; OK2AR-5; OK2RR-5;  
OK3R1X-5; OM2RZ-5; ON4MC-4; PA0LB-5; SM5SJ-5; SM7SF-3;  
SM7UR-5; SP1EF-5; SX3A-4; U1AN-5; U2A0-5; U3DM-6;  
U5AK-5; UK3AH-6; VK2PY-5; VK6FO-3; VO2HW-4; XOHIT-5;  
XU3ST-3; YL5H-4; Y17RR-3; YL2CG-6; YR5AR-6; YR5CRX-7;  
YU7EF-6; ZC6CN-5; ZL1GX-4; ZL3BJ-4; ZL3JA-3; ZL4CK-3.

(14 mc.)

W 1AEH-5; 1AFU-5; 1BHM-4; 1BRB-4; 1BXC-6; 1CGN-4;  
1DHC-4; 1DLD-6; 1DMD-4; 1EBO-4; 1ENE-6; 1EYP-4; 1FGL-4;  
1HM-5; 1IG-3; 1IGU-3; 1TS-5; 1TW-5; 1UD-4; 2ADP-6;  
2AGU-6; 2AWF-6; 2BJ-6; 2CBW-4; 2CZV-7; 2DPA-5; 2DTB-5;  
2DZE-3; 2ECW-4; 2ESO-5; 2EYZ-5; 2GLG-4; 2GLZ-5; 2GKR-5;  
2GOM-6; 2GTZ-5; 2GVZ-6; 2HLW-5; 3ATL-4; 3BES-4; 3CEK-5;  
3ENX-4; 3FGB-4; 3JA-6; 3QM-6; 4CEN-4; 5COU-4; 5CX-6;  
6CGQ-3; 6CNX-4; 6DRE-5; 6ENX-5; 6GML-4; 6GRX-3; 6KJ0-3;  
6LYM-4; 6QD-4; 7AMX-4; 7GCR-4; 8APD-4; 8HCL-6; 8JAN-5;  
8WQ-3; 9AEH-4; 9CIU-4; 9CYT-4; 9POV. — CM2AF-4; CT1BG-5;  
CT1JS-5; CT1JU-4; CT1LC-4; CT10I-5; CT2BC-5; CT3AN-3;  
F3AJ-3; F8JJ-6; G2VD-4; G5T0-8; G6GH-5; G6JQ-5; G6PF-5;  
G6WO-5; HJ3AJH-5; J2CN-3; J2HJ-4; J2LU-5; J8CD-6; K5AC-4;  
K5AF-5; K5AM-4; KA1CM-4; LU1CA-3; LU4BQ-3; LUBEN-4;  
LX1A0-5; MX2B-5; OA4Q-5; ON4HC-7; ON4KD-5; ON4XU-6;  
OZ1NW-4; PX1B-5; PY1AW-3; PY2AE-3; TI2TA0-5; U9AD-3;  
VE1HK-3; VE2DC-5; VE2FG-3; VE2IY-4. — VK 2AF-3; 2HS-5;  
2HF-3; 2YW-4; 3CP-5; 3HK-4; 3IK-4; 3KX-4; 4BB-4;  
4GK-4; 5EE-6; 5FM-4; 5KL-4; 5RT-5; 5SU-5; 6FO-4. —  
VQ4CR0-5; VR5BC-6; ZC6CN-5; ZL1DV-6; ZL1GX-4; ZL2GN-4;  
ZL4CK-4; ZU6B-4.

*Wayne Cooper, W6EWC, Box 59, RR no. 1,  
Santa Barbara, California  
October 15 to December 1, 1935*

(28 mc.)

W 1AEP-7; 1AHI-4; 1AKD-4; 1AKR-4; 1ATD-4; 1AVV-4; 1AYG-4;  
1AZE-4; 1BNN-4; 1BNN-3; 1BPX-4; 1BVL-4; 1BX-4; 1BXC-4;  
1CAA-4; 1CFD-4; 1DBE-4; 1DF-4; 1DHE-4; 1DZE-4; 1FJN-4;  
1FRK-4; 1GBE-4; 1GSH-4; 1HBD-4; 1HDV-4; 1INC-4; 1SZ-4;  
1WV-4; 1ZB-4; 2AEP-4; 2AOL-4; 2BCR-4; 2BQK-4; 2DLO-4; 2DTB-4; 2EUG-4;  
2FAB-4; 2FDL-4; 2FHI-4; 2FWK-4; 2GQ-4; 2HHG-4; 2HQB-4;  
2TP-4; 3AWH-4; 3BIA-4; 3BPH-4; 3BWB-4; 3BYF-4; 3CHH-4; 3DBX-4;  
3DLB-4; 3EVF-4; 3FAR-4; 3FEU-4; 3JM-4. — CX1CG-4; EA4A0-4; F8CT-4;  
F8KJ-4; F8CR-4; J2HJ-4; J2IS-4; J2JK-4; J2LK-4; J2LU-4; J3DF-4;  
J3FJ-4; K6BFI-4; K6ECN-4; K6KSI-4; K5AC-4; LU2EQ-4; LU3DH-4; LU7AX-4;  
LU7AZ-4; LU9AX-4; LU9BV-4; OA4J-4; T15MR-4; VE1CO-4; VE1EA-4; VE3DU-4;  
VE3WA-4; VE4AC-4; VE4EI-4; VE4OB-4; VE4QY-4; VE4QZ-4; VE4R0-4;  
VE4SH-4; VE4GJ-4; VE4TR-4; VK2HF-4; VK2LZ-4; VK3BD-4; VK3BQ-4;  
VK3KX-4; VK3MR-4; VK3YP-4; VK4BB-4; VK5HG-4; VK5WJ-4; VK7JB-4;  
VK7KV-4; VP5AC-4; VP5PZ-4; X1AA-4; X1AG-4; X1AM-4; X1AX-4; X1AY-4;  
X1G-4; X1XDA-4; X2C-4; X2CM-4; ZL1AR-4; ZL1CD-4; ZL1DA-4; ZL2GQ-4;  
ZL2KI-4; ZL2KK-4; ZL3DJ-4; ZS1H-4; ZU6P-4.

*James Alexander, 2AXX, 63 Tennyson Road,  
Birmingham, England  
September 11 to November 12, 1935*

(14 mc. phone)

W 1AJZ-7; 1CCZ-9; 1CJV-9; 1CMD-7; 1JJ-7; 2BSD-9; 2CTK-7;  
2JDW-8; 3BDI-6; 3DLQ-8; 3EOZ-7; 4CRF-6; 4ZF-8; 8CYJ-6. —

\*George Walker, Assistant Editor of RADIO, Box 355, Winston-Salem, N. C., U. S. A.

K4DDH-6; VE1CR-7; VE2FQ-8; VE2HK-7.

(7 mc.)

W 1CH-4; 1FGX-4; 1FNP-4; 1NA-4; 1PC-2; 2BUJ-4; 2HBC-4; 3EYF-4;  
4DJE-4; 9ELL-4.

(14 mc.)

W 1BPX-4; 1CGB-4; 1CZ-4; 1DBE-4; 1ECK-4; 1H10-4; 1H1D-4;  
1VZ-4; 2AH-4; 2ADQ-4; 2AYS-4; 2BEB-4; 2CCZ-4; 2DTB-4; 2DUS-4;  
2GQ-4; 2ICJ-4; 2MG-4; 3AFC-4; 3BRK-4; 3BSH-4; 3DAV-4; 3DCG-4; 3DPC-4;  
3E0F-4; 3FFP-4; 3FQG-4; 3KU-4; 3PT-4; 4BBR-4; 4CRE-4; 4EF-4; 4TR-4;  
6CXW-4; 7AMX-4; 8AVB-4; 8AZD-4; 8BKC-4; 8CHO-4; 8EEN-4; 8HDC-4; 8HWE-4;  
8KKG-4; 8KTW-4; 8LEZ-4; 8LKC-4; 8MWY-4; 9BW-4. — K4RJ-4; K4SA-4;  
K5AA-4; K5AF-4. — VE 1BV-4; 1CE-4; 1EA-4; 1ED-4; 1EK-4; 1FV-4; 1HQ-4;  
1SG-4; 2CA-4; 2DM-4; 2GE-4; 2KA-4; 3AB-4; 3AC-4; 3AD-4; 3WA-4; 4RO-4.

*F. C. Whitmore, ZT6AZP, ZE1JJ, Box 591,  
Umtentweni, nr Durban Union of South Africa  
November 1st to November 23, 1935*

(14 mc.)

W 1LZ-3; 1WE-4; 4JBA-3; 6BCV-4; 6BNX-3; 6BSE-3; 6CNX-5;  
6CXW-4; 6DCV-4; 7IX-3; 6KRI-6; 6PR-3; 6QB-4; 7GA-3. —  
D2CU-3; D4A00-4; D4ARR-3; D4BMH-3; D4BQM-3; D4CSA-3;  
D4DIC-3; D4GRF-3; D4MNL-3; EA1BC-4; EA3EA-3; EA4A0-3;  
EA4AW-4; F8BS-4; F8E0-5; F8LVY-3; F8PA-3; F8AB-5;  
F8BC-5; G2NN-3; G2ZQ-3; G5CV-3; G5J0-4; G6KU-5; G6QX-4;  
G6UP-4; HAF3BZ-4; LY1J-4; LY1JK-4; OE3FL-3; OK1BC-3;  
OK3YA-3; ON4DS-3; OZ7LP-3. — PA OAZ-3; OBC-3; ODC-3;  
OFA-3; OFK-2; OIW-3; ONP-3; OSD-3; OTB-4; OUN-4. —  
PK1CM-3; PK1PK-3; PK1RI-6; PK2MP-5; PK3BM-3; SU1PG-3;  
SU5NK-5; VE3J-3; VK2EB-3; VK2TI-3; VK3BX-3; VK3CS-4;  
VK3XU-3; VK5MD-5; VK5SD-3; VK6F0-4; VK6SA-4; VQ2RS-4;  
VQ4CRE-3; VQ8AC-4; VQ8AF-5; VU2CQ-5; VU2EJ-6; XZ2NC-5;  
Y7TAQ-4; ZB1E-5; ZB1H-4; ZB1TS-3; ZE1JM-6; ZE1JN-7;  
ZE1JR-7; ZE1JS-5; ZE1JT-4; ZE1JU-5; ZL2BZ-3.

*T. V. Magnusson, SM7YG, Skogstorpsgatan 14,  
Helsingborg, Sweden  
April 30 to June 28, 1935*

(7 mc.)

OZ9W-7; SM1ZR-8; XOZ7KG-8.

(14 mc.)

W 1AEP-7; 1AFB-8; 1AJZ-8; 1BEQ-8; 1BFK-4; 1CBT-7;  
1CMX-8; 1CNU-8; 1CQR-8; 1CUN-8; 1DBU-7; 1DGC-8; 1DMA-8;  
1DSX-8; 1DYA-8; 1EDC-8; 1EZ-6; 1FLH-9; 1GF-8; 1GLF-7;  
1HCM-8; 1HU0-7; 1IBD-8; 1IUS-8; 2AIF-8; 2ARY-7; 2AWF-8;  
2BEF-8; 2BST-8; 2CBG-7; 2CQX-8; 2CZV-8; 2DFN-8; 2DNG-7;  
2EUC-8; 2EIE-8; 2FKD-7; 2GAF-8; 2GBA-6; 2GDU-8; 2GVZ-5;  
2HSP-7; 2IFZ-8; 3AMP-8; 3ANS-7; 3BSB-7; 3COP-8; 3CZ0-7;  
3EAQ-7; 3EBK-6; 3ENX-5; 3EVW-8; 3HN-8; 4BKS-7; 6AVB-8;  
6CUH-6; 6FQY-7; 8AZD-8; 8BFG-8; 8CNT-6; 8CTE-6;  
8DJW-8; 8EEN-7; 8GAM-8; 8HYC-7; 8ITS-8; 8LDA-8; 8LEA-7;  
8MAH-7; 8PQ-7; 8ZY-8; 9IU-7. — EA7A0-7; F8LU-8; HJ3AJH-8;  
TF5C-7. — VE 1AE-5; 1AQ-6; 1ED-6; 1EZ-6; 1GL-8; 2BD-8;  
2FQ-8; 3AM-7; 3JE-8; 3TA-4.

(3.5 mc.)

D4HPG-9; LA4U-7; OH2PQ-6; OK1BM-6; SM5RH-9; SM6UA-9;  
SM7JA-9; SM7XF-9; SM7VE-9; XOZ7KG-9.

*E. Valentin Granqvist, OH3NP, Rabankatu 9,  
Hameenlinna, Finland*

(14 mc.)

W 1APL-4; 1BAU-4; 1BUX-7; 1CC-6; 1CNU-7; 1GOU-4;  
1GPF-4; 1HQK-6; 1HTP-5; 1IAS-6; 1TS-6; 1WE-6; 2AH-6;  
2AMP-7; 2A0A-5; 2BEM-4; 2BVJ-5; 2CQX-6; 2CZV-6; 2DNG-7;  
2DTB-6; 2FKD-6; 2GDQ-4; 2GOX-6; 2GRG-5; 2GTZ-5; 2GW-6;  
2HLW-6; 2IFZ-4; 3ANS-6; 3BUC-6; 3CYQ-6; 3DSY-4; 3HN-6;  
3JM-6; 4AGP-6; 4AUV-6; 4BKS-6; 4CEN-5; 4CC-6; 4FT-8;  
5EGA-4; 5QL-7; 6AHZ-6; 6AWA-6; 6AWT-6; 6BAM-5;  
6CXW-7; 6CYY-5; 6DRE-4; 6EA-6; 6CEM-6; 6CGP-6; 6CIS-4;  
6BGW-6; 6BYU-6; 6BZU-6; 6CDK-6; 6EGH-6; 6ENV-6; 6EVL-5;





6EXG-6; 6FMP-5; 6FT-5; 6FZY-8; 6GAL-5; 6GNZ-6; 6GPB-6; 6GRL-7; 6GRX-6; 6GWW-6; 6HX-6; 6INP-5; 6IRA-6; 6JBO-6; 6JU-6; 6KEW-4; 6KIP-6; 6LFL-6; 6QD-6; 6RIP-5; 6TJ-5; 7ADU-6; 7ADN-3; 7AMX-6; 7BAC-6; 7BD-6; 7BNK-6; 6BPJ-1; 7CGR-6; 7DL-6; 7DZL-7; 7EGR-5; 7EJD-6; 7FH-5; 7IF-5; 7KF-5; 7QC-5; 7VQ-5; 8AZD-6; 8BAS-5; 8CNT-5; 8CRA-6; 8DHC-5; 8DJW-6; 8EEN-4; 8GTN-5; 8JMP-5; 8MAH-6; 8NBM-6; 8ZV-5; 9ABE-6; 9ARL-7; 9BMX-5; 9BPU-6; 9BTW-6; 9DHM-5; 9DKU-4; 9DWU-4; 9ELA-5; 9EVU-6; 9FQG-6; 9FQC-5; 9FSO-5; 9GHN-6; 9HAQ-5; 9HPE-4; 9IFD-5; 9IWE-5; 9JMB-6; 9KA-6; 9KG-4; 9KZJ-4; 9LBB-5; 9NBM-6; 9NFA-5; 9NKZ-5; 9NNZ-6; 9NV0-5; 9RMA-5; 9SHE-6; 9TGN-5; 9TH-5; — FB8C-4; HC2M0-4; J2CB-3; J5CE-6; K5AA-5; K5AC-5; K5AM-4; K6AJA-5; K6JPD-4; LU5AP-4; LU6DG-5; LU7EF-5; LU8EN-5; 0A4J-5; 0A4M-5; PK2K0-3; PY1DM-5; PY2AE-5; — VE 1BV-4; 1EP-6; 2BE-4; 3SV-3; 4BF-6; 4EA-3; 4HG-4; 4RO-6; 5BI-6; 5E0-4; 5FH-3; 5HC-6; 5KC-4; 5KZ-6; 50A-4; — VK2BQ-5; VK2EO-5; VK2QAN-4; VK3BW-5; VK3MR-4; VK3PG-4; VK3Y0-5; VK3YP-4; VK5RT-4; VS1AJ-4; VS6AG-6; VQ8A-4; VU2JP-4; XU6F-6; ZL3JA-4.

F. C. Smith, W3AIR, 2 Nassau Street,  
Princeton, N.J.  
To December 10

(28 mc. dx only)

C02KC; C060M; DBARR; D4BLN; D4GWF; D4JMDV; D4ORT; D4QET; EA1AH; EA4AV; EA1A0; E15F; E18B; FA8CR; F8CT; F8KJ; F80L; F8RJ; F8V5; F8WK; G2VF; G2HG; G2HX; G2IO; G2PL; G2MV; G2YL; G5BY; G5FV; G5IS; G5LA; G5ML; G5OJ; G5OY; G5WP; G5VU; G6CJ; G6DH; G6JW; G6LK; G6NF; G6QB; G6RB; G6RH; G6TT; G6WN; G6WY; LU1EP; LU7AZ; LU9AX; LU9BV; HAF8C; HB9J; OE1ER; OE1FH; OK1BC; ON1AC; PA0AZ; PA0FX; PA0Q0; PA0UN; PA0ZK; PA0ZM; VK2JN; VK2LZ; VK3BD; VK3KX; VK3YP; VP5PZ; XE1AA; XE1AG; XE1AY; XE2C; YM4AA; ZSLH; ZU6P.

Al. Parham, W4MR, 1711 W. Lee St.,  
Greensboro, N. Car.  
December 25 to January 5

(28 mc. only)

D4GWF; EA1A0; E18B; F8CT; F8JJ; F80L; F8RJ; F8WK; G20L; G2PL; G5BY; G5VU; G6DH; G6LK; G6NF; G6QB; G6RH; G6VP; G6WY; HB9J; LU9AX; OK1BC; ON1LX; ON4MY; ON4NC; PA0AZ; VE4HU; VE4IG; VE4NI; VE4QY; VE4UM; VP5PZ; XE1AA; XE1AY; XE1CM; XE2C; XE2CG.

R. J. Painter, W4BBP, 736 Lillian Avenue,  
Atlanta, Georgia

January 3, 1936 on 28 mc.

CP1AC; D4ARR; D4AUU; D4GWF; D4KJP; F8KJ; G5JW; G5ML; G6CJ; G6SR; G6WN; HJ3AJH; K5AC; K6KSI; OH7ND; OK1BC; ON1AC; PA0XD; PA0XR; PY2M0; SM6WL; VE1CO; VE1DC; VK3KX; VK7KV; ZP2AC.

January 12, 1936 on 28 mc.

D4GWF; D4QET; D4QEX; D4QEZ; D4SAX; EA1A0; E18B; F8CT; F8RJ; F8WK; G2NH; G5FV; G6DH; G6NF; G6RH; HB9J; HJ3AJH; OK1BC; ON4LX; OK4NC; SU1JT; VE1CO; VE1DC; VE2DC; VE4TV; VE4UM; VP5AC; VP5PZ; ZS2A.  
(21 COUNTRIES, 5 CONTINENTS)

Jack Pinard, W9PTF, 1505 Flett Ave., Racine, Wis.  
July, 1935 to January, 1936

(14 mc.)

CP1AC; CT1CB; CT1JU; CT1KR; CX2AK; CX1CX; CX1CH; D4CSA; D4FND; EA1BC; EA2AD; EA3AV; EA3AN; EA3EG; EA4AV; EA4A0; E14AV; E15F; E18B; E18G; F8WK; F8FC; F8HU; F8EF; F8RR; F8UM; F8AI; F8EO; F8EB; F8DR; F8BC; F8BA; F8BA; F8BA; F8M8; G2DV; G2TM; G2DZ; G2PN; G2NM; G2HX; G2KX; G2BK; G2PL; G2JH; G2BY; G2ZQ; G2GQ; G2GI; G5CH; G5YH; G5GQ; G5GM; G5WT; G5QA; G5KT; G5WI; G5KG; G5XA; G5J0; G5FA; G5T0; G5BJ; G5LA; G5NI; G6NQ; G6RV; G6GF; G6NJ; G6NB; G6VP; G6QN; G6GS; G6LK; G6WY; G6ZS; G6VU; G6JQ; G6OS; G6RY; G6XS; G6IR; HAF4H; HH9AQ; HH5PA; HH2X; H17G; H15X; HPIA; HJ1AA; HJ3AJH; J2GJ; J2HJ; J2LU; J5CC; K4RJ; K4SC; K4SA; NY2AC; NY2AD; NY2AB; K5AC; K5AG; K5AF; K5AQ; K5AM; K5AA; K5AN; K5AH; K5AL; K6KPD; K6LHK; K6GCL; K6LJV; K6MTE; K6CMC; K6JLV; K6AUQ; K6DDN; K6HHL; K6LTZ; K6BUX; K6EQW; K6LKN; K6IBW; K6GQF; K7BC;

KA1CM; LU1EP; LU4BQ; LU5AN; LU6AP; LU6AX; LU7BH; LU7EF; LU7AZ; 0A4Z; 0A4M; 0A1J; 0A1N; 0H3NP; 0H8NF; 0K1LN; 0K1FK; 0K3ID; 0N4NC; 0N4SV; 0N4HC; 0N4AU; 0N4GW; 0N4RX; 0N4DX; 0N4JU; 0Z3G; 0Z7LZ; 0Z9WB; PA0TI; PA0XG; PA0RN; PA0QL; PA0JV; PA0UN; PA0SD; PA0ZK; PA0XF; PF2DB; PY1AW; PY1DJ; PY1CR; PY1DI; PY2AE; PY2BX; PY4AD; PY5AG; PY5AF; PY9AH; PY9HC; TI2RC; TI2TA0; TI2EA; TI3AV; TI3WD; TI5MR; U3VC; VK2FY; VK2PX; VK2HP; VK2LZ; VK2HL; VK2IC; VK2ZX; VK2EG; VK2PW; VK2EL; VK2EO; VK2AP; VK2XU; VK2CY; VK2JZ; VK2AS; VK2RM; VK2OJ; VK2FM; VK2EP; VK3OC; VK3MR; VK3CX; VK3GQ; VK3KX; VK3YP; VK3RJ; VK3KG; VK3NW; VK3CP; VK3JU; VK3RX; VK3ZU; VK3GC; VK3XQ; VK3HK; VK3ES; VK3BW; VK3JK; VK3ML; VK4BB; VK4RG; VK4DO; VK4KA; VK5FM; VK5WK; VK5SU; VK5JC; VK5ZY; VK5ZX; VK5GW; VK5WR; VK5MY; VK5AI; VK6F0; VK7BJ; VK7RC; V01I; V01N; V03F; VPIJR; VP2AM; VP5PZ; VP5AD; VP5AC; VP5JB; VP6NW; VP7NB; VP9R; VU2CQ; X1Q; X1G; X1AA; X1AG; X1AM; X1CZ; X1AY; X1CC; X1FY; X1DA; X1R; X1BA; X1FQ; X1CM; X2N; X2CG; X2R; YN1AA; YN10P; Z08A; ZE1JR; ZL1FE; ZL1HY; ZL1DV; ZL1GX; ZL2KX; ZL2M0; ZL2GN; ZL2OF; ZL2FA; ZL2CI; ZL2JA; ZL2BZ; ZL3DJ; ZL3ID; ZL3BJ; ZL4BQ; ZL4GW; ZL4A0; ZL4CK; ZAG6T; ZS6AL; ZS6AF; ZS1AH; ZS1AL; ZULT; ZT5AC; ZT1Z; ZZZA.

(28 mc. heard during January, 1936)

CM2FA; CM60M; D4LTN; EA1A0; E18B; F80Z; F8CT; F8BG; G6QB; G6TT; HB9J; HJ3AJH; K5AF; LU9AX; 0A4B; OE1FH; OK1BC; PA0AZ; TI3WD; VK3YP; V01N; V04Y; VP5PZ; XE1AA; XE1CZ; XE1CM; XE1AY.

Al Parham, W4MR, 1711 West Lee Street,  
Greensboro, North Carolina  
January 1 to January 14, 1936

(28 mc.)

EA1A0; E18B; F8CT; F8JJ; F80L; F8WK; G20A; G2PL; G5BY; G5ML; G5VU; G6DH; G6LK; G6NF; G6QB; G6RH; G6VP; G6WY; HB9J; LU9AX; OK1BC; ON4LX; ON4MY; ON4NC; VE4IG; VE4NI; VE4QY; VE4UM; VE4UY; XE1AY; XE1CM; XE2C.

Donald W. Morgan, B.R.S. 1338, 15 Grange Road,  
Kenton, Middlesex, England  
September 1 to December 1, 1935

(14 mc. phone)

W 2BSD-9; 4BCR-7; 4BQZ-7; 4BDC-8; 4DLA-6; 4PW-8; 4UT-7; 4WV-7; 4WZ-7; 7FL-7; 8KLL-7; 8LP1-7; 9NN0-7; C05RY-8; EA2BH-8; EA3ER-7; HB9AQ-7; HB9B-7; HB9T-7; HH2W-8; H15X-7; H160-7; H17G-7; K4DDK-6; K4SA-7; LA1G-8; LA1V-8; LA2Y-7; LA2Z-8; LA4N-7; LA5G-8; LU7AZ-8; LY1AG-7; OH2NE-6; OH5NG-7; OK2AK-7; OK3VA-8; OZ11-7; PY2BA-8; SM5TA-7; SM5TC-8; SM5WK-8; SU1CH-7; SU1RK-7; SU1R0-7; VE2HK-7; V01I-7; VP2CD-7; VP9R-6.

Alice R. Bourke, W9DXX, 2560 East Seventy-  
Second Place, Chicago, Illinois  
December 10, 1935 to January 10, 1936

(14 mc. phone)

VP6YD-8; VP7NB-6; X1PS-7; YN10P-8.

(7 mc.)

E48AC-7; H55PA-6; K6KVX-6; LU3DX-6; VE2CJ-6; VE2J0-7; VE4BF-6; XE2DQ-7.

(14 mc.)

CM6AB-6; CM6DW-8; D4CSA-5; K4BU-6; K5AC-6; K5AF-6; K5AI-6; LU4BTX-7; VE1GE-6; VE2DG-6; VE2HS-7; VE2IT-6; VE2JK-6; VE2LR-7; VE3AER-8; VE3AGL-6; VE3AGW-6; VE3AH-5; VE4GW-6; VE4OX-6; VK2MY-5; X1CM-6.

E. H. Swain, G2HG, 31 Woodbastwick Rd.,  
Sydenham S.E. 26, London, England  
November 17, 1935 to January 12, 1936

(28 mc.)

CN8MQ; FT4AF; HJ3AJH; LU9BV; SU1JT; SU1R0; SU1SG; VE1CO; VE2EE; VE2AC; VE2JB; VE3DU; VE3MJ; VE3WA; VK2LZ; VK3BD; VK3BQ; VK3NM; VK3YP; VK4BQ; VK4EI; VK5HG; VK5WJ; VK6SA; VP5PZ; VU2BV; UL3AJ; ZL4BK; ZS1H; ZT6K;

[Continued on Page 84]



# Economical, High Quality Modulation

By GUY FOREST

Many amateurs have never tried radiotelephony because of the idea that high-quality phone transmitters are expensive. As a matter of fact a phone rig can be made to cost about as much or as little as one wants. If the rig

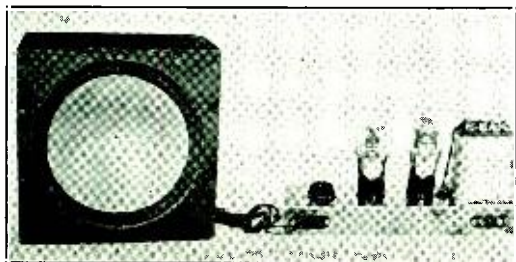

A rather large microphone, but a very inexpensive and effective one, capable of quite good quality.

takes in cathode ray oscilloscopes, condenser microphones, high-power plate-modulators, and so on, it is way out of the class of most amateur pocketbooks. However, a high-quality phone signal which will compare with the best can be put out with little or no cash outlay, depending chiefly on the condition of the surplus stock. Even more engineering ingenuity and experience may be involved in the application of "economy specials" than is needed in the better equipped outfits.

The usual bottle neck through which quality has to squeeze is the microphone. Microphones of the better kinds begin to run into money, but the way to get around that is to use a loudspeaker for the microphone. In general a loudspeaker used as a sound pickup will have about the same sort of fidelity as when used as a sound source. The output level of the average loudspeaker mike is greater than that of the double-button microphone used for broadcasting, so that tremendously high gains in a speech amplifier are not involved. Of course there is no carbon hiss, and speech picked up by a "fair-to-middling" loudspeaker will have all the naturalness and crispness that could be desired.

The magnetic speakers are most convenient to use, and in view of their general obsolescence probably would be more easily found on the stock shelf (euphemism for "junk box"). The electro-dynamic type speaker of course will func-

tion equally well in the role of sound pickup, but often is less convenient to use because of the necessary field supply. A headphone, also, can be used as a microphone and has the advantage of compactness, which might be desirable in some close-talking or semi-portable applications. However, neither the fidelity nor the output level of the headphone mikes approaches that of the loudspeaker pickups. The first step, then, towards economical modulation is to round up a fairly good magnetic speaker—one whose quality of voice reproduction sounds good to you.

For the speech amplifier and modulator unit, the tube combination and circuit diagram of figure 1 offers about the maximum in gain, fidelity, and power output for the least outlay. The resistance coupling combination in the 53 tube produces a gain per triode of around 27, with practically no frequency discrimination or distortion—and resistors and condensers cost less than good audio transformers. The pentode output transformer should be rated for a 2A5 or 42 into a 10,000-ohm load.

The "speaker" microphone must be fitted with a shielded cord; a single wire lead with metallic braid covering will do. One side of the speaker winding, and the frame, are operated at ground potential connected to the grounded shielding, to minimize hum. The 3-volt C-bias battery on the 53 greatly simplifies motorboating and feedback troubles, although for the benefit of those so inclined it might be added that with more work and more filtering it is quite possible to use self-bias. The rest of the hookup is more or less conventional, and details may be gleaned from the legend and the photo. After the wiring is completed and has been checked over, close the gain control and connect a pair of phones to the secondary on the output transformer. After testing for hum level and quality of operation, the unit is ready to be hooked to the transmitter.

The overall voltage gain measured from the input grid of the 53 to the plate of the 2A5 was 9,000, when using a 300-volt plate supply. This figures around 79 db, and is more than ample to load the 2A5 to capacity from any magnetic speaker. No input transformer of any

sort is required, it being sufficient simply to bridge the loudspeaker terminals directly across the input potentiometer.

Although primarily intended for control-grid or suppressor modulation, the unit will handle plate modulation on tubes whose d.c. plate input runs up to 8 or 10 watts. The small ultra-high-frequency transmitters are about the only ones that come within this rating; the load resistance presented by the modulated tube, i.e., plate volts divided by plate amperes, at least *approximately* should approach the 10,000-ohm value.

When the unit is used for control-grid or suppressor modulation on the transmitter, a 15,000 ohm, 5-watt resistor should be placed across the secondary of the 2A5 output transformer, so as to present a definite load to the tube. No grid leaks or high resistance elim-

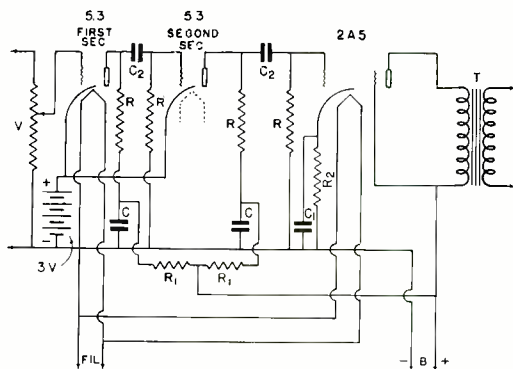

Figure 1

- V—100,000 ohm tapered potentiometer
- R—250,000 ohm, 1 watt carbon resistor
- R<sub>1</sub>—50,000 ohms, 1 watt
- R<sub>2</sub>—450 ohms, 2 watts
- C—1 μfd. 400 volt condenser
- C<sub>1</sub>—10 μfd. 50 volt electrolytic
- C<sub>2</sub>—0.1 μfd. paper
- T—Pentode output transformer, 2A5 to 10,000 ohms.

inators can be used to furnish the bias for the modulated radio-frequency tube. Either batteries or an eliminator with a bleeder of some 5,000 ohms or less must be provided.

With just a little bit of time and material this modulation outfit can be put together, and high-quality radiophone up to two hundred watts can be accomplished with grid modulation.

It is good practice in wiring ultra-high-frequency equipment on metal bases to mount fixed *coupling* (not by-pass) condensers on edge to reduce the effect of capacity between the condenser and ground.

## RADIODDITIES

*Electrical Taste* was observed in 1752.

Think television is remarkable? John Hays Hammond, Jr., has patented a system for transmitting and receiving the entire shape (length, width, and thickness) of any object. Picture, if you can, the radioing of statues from the leading galleries! . . . A large number of patents have been taken out on radio-controlled clocks . . . In 1831, Joseph Henry, with his newly-invented electromagnet, attracted the clapper of a small bell, producing the first sound by a bell in response to electromagnetism. On December 17, 1923, almost a century later, the New York State Museum allowed this same bell to be sounded in a Henry memorial program over a broadcast network . . . For many years, Edison was a confirmed hater of radio. Alexander Graham Bell, father of the telephone, on the other hand, found his own invention a nuisance and had it moved out of his room in favor of a radio . . . W1BLV at Woonsocket, R. I. was QSO with Red Hill, Pa., while using only *five* volts on the plates of two type '10 tubes in parallel . . . When the A.R.R.L. gang saw Paul Godley off prior to the latter's establishment of a listening post in Scotland, they sent messages from the dock to Paul on board the liner by opening and closing their hands, held far above the heads of the roaring crowd, to form Morse characters . . . A ham in New Zealand saved another in Alaska, 7,000 miles distant, from death by carbon monoxide . . . The Radio Society of Great Britain staged a one-watt week in 1931, during which time participating hams reduced their transmitter powers to a single watt.

◆  
W2CO's initials are W.A.C. . . . Though Goyne Reinhart's call is AC (W3AC) his note is most decidedly DC, since he uses "B" battery plate supply . . . W8OLD (thanks to W8KNP-W8KTF) is assigned to the youngest ham in Pontiac, Mich. . . . W4BWY is named *L. A. Valier*.

◆  
W8IHJ reports that Dr. Lyon's tooth powder is what the doctor ordered for removing India ink marks from crystals or crystal holders. His directions are to wet a finger-tip, dip it into the powder, and rub over the crystal until the blemish is removed.

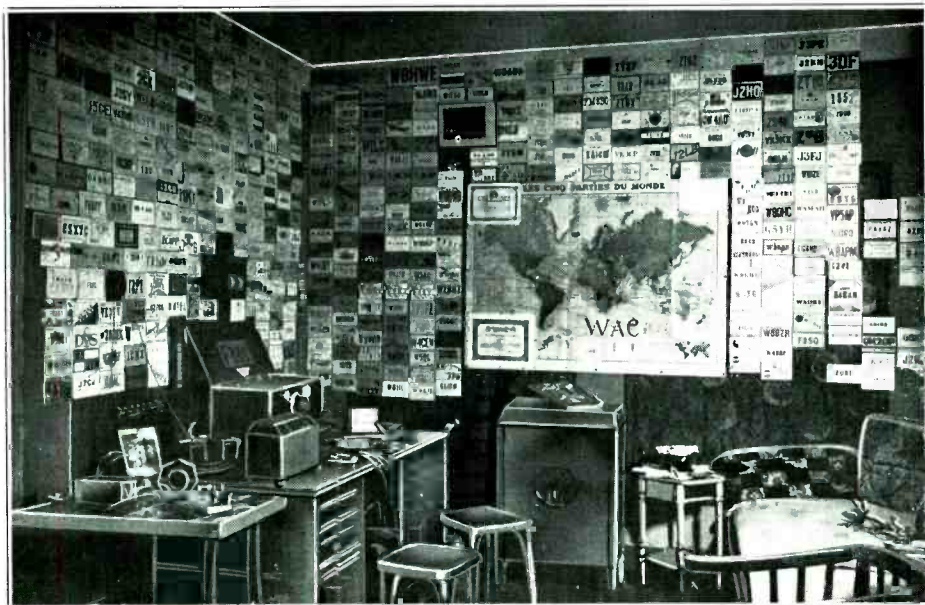

FB8AB, ex-FB8C



FB8AB and his "junior op"

Here is the station for which we have all been waiting . . . FB8AB, ex-FB8C, owned by J. Paul Bour, and located in Tananarive on the island of Madagascar. When that low gurgly signal of Paul's started to break through it almost set off a miniature revolution among the dx men the world over. At last here was a station in Madagascar actually on the air, and this meant another country. FB8AB at first was



Some of the Madagascar gang. Left to right: FB8AA, FB8AB (ex-FB8C), FB8AE, FB8AF, FB8AG, FB8AD. Madagascar isn't the elusive country it once was from the standpoint of working dx,—not with this bunch of fellows stirring up the ether down there.

using some German made tubes, RS-241's, at 350 volts, the input being close to 20 watts. Later he changed to the TC 04/10 type and a little more power input. Paul has built a 3 stage crystal rig and is operating temporarily on 14,200 kc. with a peach of a signal.

A look at the picture of FB8AB's station will give a good idea of the dx he hauls in. Although a comparatively new station, he has

made WAC 15 times, once in 4 hours and another in 7 hours; and this is quite an achievement, because WAC in that part of the world is not as easy as in other sections. The antenna in use at present is a vertical Lynch type, the best of any tried. This is also used for receiving, as he claims a reduction in QRN.

Paul is in the radio business, having his own shop in Tananarive, and at present is working to supply the local government with small c.w. stations to be used in the commercial bands. Due to frequent cyclones and thunder storms the cost of maintaining telephone lines is very high, and it is with this in mind that FB8AB is going to come in handy to the government.

Please notice in the photograph of Paul and his "junior op" that the latter really has a grip on that key like a veteran. I can see right now that he has his eye on the future—probably going to run shifts and keep the station on day and night. Not a bad idea at that.

FB8AB takes great pride in the collection of QSL cards and a glance at the photo will show that nearly all of the 87 countries worked by him are represented by a card on the wall. As for himself: he always QSL's.

## DX NEWS

The day that you receive this issue of RADIO everyone will be right in the midst of denying that he is going into the coming dx contest which starts March 13th. It's a funny thing how all the boys are trying to pull the wool over the other fellow's eyes by saying, "Naw, I'm not going to get in this contest to make any score; I might get on to work some new stations, or countries, or something, but that's all." Humph! You just wait; every one of these buzzards will be in there batting away, and with that satisfied feeling that he has put a good one over on the rest of 'em. Oh well, fun's fun.

In a letter from Art Simons, G5BD, he outlines



By HERB. BECKER, W6QD

Readers are invited to send monthly contributions for publication in these columns direct to Mr. Becker, 1117 West 45th Street, Los Angeles, California.

a few facts regarding dx conditions in England. He says one of the most surprising things of this winter period is the fact that the W6's are coming through very consistently day after day around 1500 to 1600 g.m.t. The most frequently heard W6's at this time are CNX, GRX, KRI; followed closely by FZY, BYU, QD, TJ, CXW, GAL, GRI and FKC. Of W7's the best are AMX, BPJ and QC. Very rarely do South Americans break through but when they do it is usually between 1830 and 2000 g.m.t. W5's are scarce and are seldom heard at this time of year. On January 8th, K7UA was heard R4 on 14100 kc., and this is a very rare incident in England. From 0900 to 1200 g.m.t. the VK's and ZL's pop through, although VK6FO is usually a bit later, around 1500 g.m.t. One thing which struck me as odd is that according to G5BD, when the W6's are working VU2CQ (here's this fellow again) he is also being copied at G5BD's Q4/5. The same applies to FB8AB and VS1AJ. The above has all been on the 14 mc. Art reports that on 7 mc. some W6's are being contacted between 0630 and 0730 g.m.t. VK and ZL also are worked at this time. On 3.5 mc., W1, W2, W3, and W8 are heard at fair strength just after midnight g.m.t., with W4 and W9 coming in about two hours later. VK2LZ and VK4EI are in

[Continued on Page 86]

## DX TIME CHART FOR EASTERN U. S. A.

Compiled by W3SI

(ALL TIMES ARE E.S.T.)

	28 mc.	14 mc.	7 mc.	3.5 mc.
Europe.....	9 a.m. to 12 a.m.	7 a.m. to 3 p.m.	4 p.m. to 11 p.m.	12 p.m. to 2 a.m.
South America.....	10 a.m. to 12 m.	5 p.m. to 10 p.m.	9 a.m. to 3 a.m.	10 p.m. to 3 a.m.
Africa				
Algeria, Morocco,				
Egypt, etc.....	10 a.m. to 11 a.m.	8 a.m. to 11 a.m.	4 p.m. to 12 p.m.	8 p.m. to 12 p.m.
S. Africa, Rhodesia,				
Madagascar, etc.....	10 a.m. to 12 m.	2 p.m. to 4 p.m.	8 p.m. to 11 p.m.	.....
		10 p.m. to 12 p.m.		
Oceania.....	6 p.m. to 8 p.m.	6 a.m. to 9 a.m.	2 a.m. to 8 a.m.	4 a.m. to 6 a.m.
		11 p.m. to 1 a.m.		
Asia.....	7 p.m. to 8 p.m.	9 a.m. to 10 a.m.	4 p.m. to 5 p.m.	.....
		5 p.m. to 6 p.m.	5 a.m. to 6 a.m.	
North America,				
Alaska.....	.....	7 p.m. to 10 p.m.	11 p.m. to 3 a.m.	1 a.m. to 3 a.m.
Central America.....	11 a.m. to 2 p.m.	6 a.m. to 12 m.	6 p.m. to 7 a.m.	10 p.m. to 5 a.m.



# Sidebands and Modulation

By GUY FORREST

It is informative to review the field of radiotelephone transmission methods, and to look into practical circuit designs for producing the transmissions. This is particularly true in view of the recent interest in the subject. Some of the less common forms would bring distinct advantages if applied to the present-day conditions of amateur or commercial radiotelephony, but they are not applied or attempted, generally, because of the complications surrounding their use. Nevertheless, if a grasp is had of the physical and electrical aspects of the various emissions a pretty fair foundation will result on which to build future developments.

The most common method, by far, of radiotelephone transmission is that in which the carrier and both sidebands are radiated. The original Heising modulation, the more modern high-level plate modulation, control-grid modulation, suppressor modulation—all create a carrier-plus-sidebands output. The first figure in the illustrative table shows the schematic circuit, a conventional plate-modulated class C r.f. amplifier, for producing the emission. The second figure shows graphically the current amplitudes in the audio and radio frequency stages. An arbitrary distribution of currents in the audio range is assumed, roughly similar to the components present in the human voice. When applied to a carrier frequency of, say, 2,000 kilocycles, an upper sideband ranging from approximately 2,000,020 to 2,005,000 cycles, and a lower sideband from 1,999,980 to 1,995,000 cycles, appears around the carrier—in the well known manner. So much for the frequency spectrum, except to note that the band width required in the radio ranges is twice the highest modulating frequency.

The form of the antenna current is drawn in the next figure. Instead of a band of voice frequency voltages, for the sake of simplicity a single audio tone is now assumed as modulating the transmitter. Under the condition of no modulation the carrier is a steady alternating current, with maximum value of  $I$ . The envelope of the antenna current swings about this maximum in the shape of the modulating signal, and the conditions are drawn for both 50% and 100% modulation. Below the curve the average r.f. power contained in the signal, for

each condition, is expressed, and to the right is given the peak power of the wave at maximum amplitude of 100% modulation. These data on the power are included so as to facilitate comparisons with the other systems on down the line.

## Controlled Carrier

The first step from the well-known carrier-plus-sidebands method leads to the controlled-carrier systems, or zero-carrier as they have sometimes been called. They are similar in fundamental principle to the constant-carrier schemes, but aim at the reduction of the carrier to a value no larger than needed at any instant of modulation. The bugaboo of the ordinary transmission is the continuous carrier wave, eating up two-thirds of the power capacity in the transmitter, steadily heterodyning all other signals within beat-note range, and performing no useful purpose except in the detector of the receiver. There it heterodynes the sidebands to yield audio beat notes which are replicas of the original modulating signals.

In the controlled-carrier circuit, starting the second line of the table, the d.c. plate voltage to the modulated class C r.f. amplifier is controlled by the audio signal. A saturation reactor is put in series with the 60-cycle line feeding the class C plate supply unit. The reactor, under static conditions, drops the a.c. supply voltage so that little plate voltage is applied to the r.f. amplifier. When the class B modulators draw appreciable plate current, under the influence of a modulating signal, this plate current passes through the reactor and saturates the iron core, decreases the inductance and thereby the voltage drop on the a.c. side, and so raises the plate voltage on the amplifier. Ideally, there is no carrier radiation when there is no modulation signal; and, in the presence of the latter, just sufficient carrier is passed to encompass the modulation. Another way of putting it is to say that the modulation is 100% for any audio signal level.

A saving in the average r.f. power is at once apparent on inspection of the antenna current curves. There is none of the heavy drag of a continuous carrier—the controlled carrier systems allow in r.f. amplifiers pretty much what class B does in an audio amplifier.

	CIRCUIT DIAGRAM	FREQUENCY SPECTRUM	ANTENNA CURRENT	PEAK POWER
CARRIER AND SIDEBANDS				$2(I^2R)$
CONTROLLED CARRIER OR ZERO CARRIER				$2(I^2R)$
DOUBLE SIDEBAND ELIMINATED CARRIER				$\frac{1}{2}(I^2R)$
SINGLE SIDEBAND ELIMINATED CARRIER				$\frac{1}{2}(I^2R)$

The peak-power capability of the transmitter must be the same as for the constant-carrier system, however, because at peak output the current touches 2I just as it did before. Of course the percentage designations as used for the first type of transmission now have little meaning. However, these and the following antenna-current curves have been so drawn that, at maximum output, each creates an equal audio signal in the output of a receiving detector.

Some practical considerations regarding controlled-carrier have to do with heterodyning between stations, with automatic volume control at the receiver, with reception on a square-law detector, and with duplex phone operation. Since there is no steady carrier there can be no steady heterodyne between a wanted controlled-carrier station and an unwanted constant-carrier transmitter. Although there is a heterodyne varying in level with speech on the controlled-carrier signal, the improvement in reception is noticeable since the speech always matches in level the interfering beat. Maximum improvement, of course, would be had if the carriers of both the conflicting stations were controlled.

A receiver equipped with automatic volume control will do its best to make a constant-carrier signal out of a controlled carrier—that is the nature of the device. On speech the effect is not so noticeable as it would be on music modulation. Usually a running line of talk is made which holds the level of the carrier above zero. During a lull, or period of very low modulation, the a.v.c. effect will become apparent, as the general noise level and any crosstalk come up. On music where slower and wider excursions in the modulation take place, a.v.c. action on a receiver becomes obvious.

A somewhat similar difference between speech and music, on a controlled-carrier signal, takes effect when a square-law detector operates in the receiver. There is an exaggerated volume spread as the carrier level slides the detector operating point up and down the parabolic detector characteristic. At low levels of modulation the detector efficiency is low and the rectified signal is unduly lessened. At high levels the converse is true. The effect on amateur phone is not overimportant, and in any case could be corrected by a linear detector.

In the strictly zero-carrier systems, where there is a complete absence of radiation without modulation, the operation of duplex phone

near, or even on, the transmitting frequency is facilitated. This is true for any of the carrierless modes of emission, since the radiation is automatically cut off and the blanketing effect removed from the receiver.

#### Eliminated Carrier

In coming to the true eliminated-carrier modes of transmission, fundamentally different characteristics are encountered. The term "eliminated carrier" is rigorously descriptive; no currents are radiated which have the frequency of the carrier. A simple but effective circuit\* for creating a double-sideband eliminated-carrier output is shown in the table. Carrier input drives two tubes in parallel and their outputs are received in push-pull—or, vice versa. The tubes have no steady plate voltage, but are supplied directly with audio a.c. voltages, in the manner of a self-rectified stage. One tube operates on one-half cycle of modulation potential, when its plate is positive, and the other tube functions on the succeeding half cycle. The point to be noticed is that, due to the r.f. input and output arrangement, the phase of the antenna current is reversed on alternate half-cycles of modulation. The envelope of the antenna current is the audio voltage, varying above and below the zero line as an axis.

The frequency spectrum for the DSB-EC radiation is similar in extent to the two previously-pictured modes. A band width of twice the audio range is required. However, the spectrum now contains no heavy center line denoting a carrier. At the receiver a local carrier must be resupplied, in order to beat in the detector with the received sidebands. To get a physical picture of the action, the resupplied carrier should be thought of as an alternating current exactly equal, not only in frequency, but also in phase, to the original carrier. It may be seen that on the first audio half cycle the received signal currents add precisely to the local currents and give an envelope peak of amplitude I above normal. On the next half cycle they subtract precisely to give the valley. The net result applied to the detector is an envelope form exactly similar to that received in its entirety from constant-carrier radiation.

Because the DSB-EC transmitter has to handle no carrier radiation, a distinct advantage in average power requirement results.

*[Continued on Page 90]*

\*E. H. Robnson, *Exp. Wireless and Wireless Eng.*, Dec., 1927.





## New Fire Underwriters Rules

On November 1, 1935, new rules and regulations of the National Board of Fire Underwriters, covering radio receiving and transmitting equipment, went into effect.

These regulations are designed to cover the specific details of radio installations, and, as stated are in addition to the general requirements of the Code, which treats radio equipment generally as electrical apparatus, subject to the detailed requirements pertaining to the individual apparatus, equipment, device or installation.

The importance of these Code requirements cannot be overemphasized, and unfortunately many amateur stations are far from being able to comply with them. Probably ignorance or indifference is chiefly the cause of this condition, but the alert progressive amateur will see to it that he modernizes his station as far as possible to make it comply with the Code.

The Code is of far greater importance than is usually realized, even to the individual amateur, both from a standpoint of personal safety and as far as the safety and even the lives of his friends and relatives are concerned. Many, not knowing, consider it a set of "fool rules" gotten up by insurance people for their own selfish advantage, but nothing is farther from the truth. The fundamental idea behind the entire National Electrical Code is to make electricity safe—so safe that it will never cause damage either to persons or property.

The carelessness and ignorance on the part of many amateur constructors with reference to the danger of instant death from the high voltages in plate supply and transmitter circuits is a shame and disgrace. Few realize that close contact, say between their two hands, if wet, may cause their death on the common "110" circuits. When it comes to "fooling around" with thousands of volts, the only wonder is that there have been as few casualties as there have been. Fellows, it is *your own lives* that you are fooling with, when you take these chances!

The National Electrical Code is enforced as law in many localities; in others it is enforced by the power companies, or electric companies. In many of the larger cities, the electrical inspection and fire departments, both working co-operatively, enforce the Code. Often the Code, as written, is made the subject of local

laws or ordinances. Sometimes, local rules go even further than the Code, and prohibit certain practices that are approved by the Code, where conditions have shown the Code provisions to be too lenient, or inapplicable. Often severe fines and imprisonment are provided for persons who wilfully and deliberately violate the provisions of the Code. In other jurisdictions, the right to obtain electrical service may be refused if the equipment is not in conformity to the Code requirements.

In case of a fire, if there is any "reasonable doubt" as to whether or not the electrical equipment which may have caused the fire was not strictly in accordance with the Code, the insurance company may very well refuse to pay the loss, with every prospect that they will be upheld in court, if suit is filed. It is even quite possible that the owner of the property where a serious fire started might be held liable for the damage to his neighbors, if it could be shown that he had maintained radio equipment and apparatus which was not in conformity to the requirements of the National Code. It may seem that some of the provisions of the Code are rather strict. In all probability, it was intended that they should be, as most of the amateur stations, at least those we have seen (with a few notable exceptions) are such messes of haywire "junk", most of which carries from 1000 to 5000 volts, that if an electrical inspector ever saw the "shack" he would throw up his hands in horror. On the other hand, the enforcing authority (inspection department) has plenty of latitude as far as both enforcement and acceptance of reasonable conditions are concerned; plenty of good advice and technical assistance can usually be obtained if the inspector is approached with the idea that he is not a demon, but a reasonable, decent fellow, especially if the amateur really intends to put things in ship-shape condition.

Don't forget, also, that even if you don't value your own life, station, or property at more than 10c, it may be that there are others in your immediate family or household who would be interested in saving their own lives, which might otherwise be risked, or even lost in the event of a fire caused by some careless or improper wiring in your radio "shack" or transmitter.

[Continued on Page 80]



## "I Learned the Code in Ten Hours"

By R. H. LAMPKIN, JR., W8OGY

When the radio examiner came to town on his last visit I appeared before him and passed the code test for an amateur radio license. Apparently there is nothing in that statement to crow about, for in that same session some fifty or sixty other fellows also satisfied the examiner that they could receive correctly at least 50 successive characters transmitted in the Continental code at a speed of 50 characters per minute. But there is something back of the statement that does make it interesting. For the code part of the examination, my preparation totaled exactly ten hours!

The job of learning the code well enough to pass the government examination for an amateur radio operator's license is not so difficult as many people consider it to be—provided that it is tackled in a systematic fashion. If you've come up for the examination and flunked, or if you've simply been loath to begin what looked like an arduous task, you may be interested in how I did it.

Probably the most important factor in my passing the test was my very real desire to pass it. If I tell you why I wanted to, it's not because I consider it so important that you know my reasons. It's because you should know that I had reasons which were important to me; and that you should examine your reasons to make sure that your reasons are important to you. If they are, you can go ahead with the virtual assurance that you too can pass the code test.

My first reason for wanting an amateur license was the help it would give me in doing my work better. I'm a teacher of the physical sciences in the high schools. And not only did I think that some practical knowledge of radio would help my teaching in the classroom—I was suddenly saddled with the supervision of the school radio club and I had to learn some radio in a hurry. Another reason was that my brother, ex-W8ALK, had moved to Florida. Radio seemed to offer a good way of keeping in touch with each other.

With these reasons to spur me on I attacked the problem of learning the code. It seemed to me that it could be divided into two large parts: first, learning the various combinations of long and short sounds which represent the

characters; and second, making the dots and dashes of the proper lengths relatively, and phrasing them into letters and into words.

In order to learn the groups of dots and dashes representing the letters I adopted the plan of learning whole words at a time. I selected eight words which contained nineteen of the twenty-six letters in the alphabet, and made up two more combinations which contained the other seven letters. These words are given in figure 1, together with their equivalents in dots and dashes. It is rather important to notice that I made no use of a code alphabet other than in the derivation of this table.

In learning these first words I did not use a key or buzzer. It seemed to me that the relatively minor problems connected with the use of a key would distract my attention from the major problem of fixing the rhythmic patterns of these words in my mind. I wanted some way of producing a monotone which could be interrupted to form dots and dashes. I could have adopted singing or whistling, but, because it requires less effort and is capable of precise manipulation, I adopted the device of *tahing*—a method quite commonly used in music schools for helping the pupils to learn difficult rhythms. *Tahing* is the performing of a rhythmic pattern by initiating each pulse in the pattern with the somewhat explosive expulsion of the breath that is inevitable in pronouncing the word "tah", and continuing the pulse simply by exhaling the breath or by a monotone on any convenient pitch.

*Tahing* permits the learner to practise without a key, at least for a while. In fact, the first four hours of my practise was done on the street car, while I was riding to and from my school. In carrying out my plan I taked the first word, *the* until I felt sure that I knew it. Then I taked *and* until I thought I knew it. Then I reviewed by taking *the* and *and* alternately until any difficulties encountered in doing them that way were overcome. Then I added the third word, *from*, taked it until I knew it, and then practised all three words together. I continued this procedure until finally I taked *qxz*, added it to the first nine, and taked all ten combinations together.



There is good psychology behind the practise of taping, insofar as taping means the representation of a dot by a monotone of a certain duration, and of a dash by a monotone of the same pitch but of greater duration. This is exactly what is heard in the headphones and the transition from taping to receiving code offers little difficulty. Various studies made on

THE	(---) (---) (---)
AND	(---) (---) (---)
FROM	(---) (---) (---) (---) (---) (---)
BUT	(---) (---) (---) (---)
VERY	(---) (---) (---) (---) (---) (---)
WILL	(---) (---) (---) (---) (---) (---)
GO	(---) (---) (---)
UP	(---) (---) (---) (---)
WACK	(---) (---) (---) (---) (---) (---)
QXZ	(---) (---) (---) (---) (---) (---)

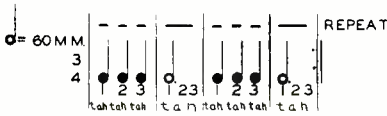

Figure 1

the transfer of training indicate the superiority of taping over such methods of learning the code as the *dabdit* method, and various attempts to visualize the patterns of dots and dashes. The same studies should point out the advantages of learning letters as parts of words over learning letters in isolation. Lest some may fear that the letters learned in these words would not be recognized in other contexts it may be stated that no such difficulty was experienced. Further, at no time was any confusion experienced between such letters as *a* and *n*, or *f* and *l*, which are in a sense opposites of each other.

After this excursion I can return to the second major problem, that of the proper spacing of the character groups. In my case the spacing problem occurred simultaneously with that of learning the combinations and the two had continually to be analyzed. However, there are many licensed operators who have already learned their combinations but have seriously neglected this second important phase of good sending. These "hams" run letters together so that *be* sounds like a *6*, and run words together so that their sending must be copied solid and broken into words later. Such operators, as well as beginners, might well put some hard work on improving their sending in this respect, whether or not they follow this analysis.

The rule for the relative lengths of the dots and dashes is that a dash occupies the time of

three dots. The rule is quite simple, but there is some difficulty in its application. For example, no sooner does the learner try to *tah* the word *the* than he runs into trouble. How fast are those dots in the *b* to go in order for them to be in keeping with the dash of the *t*? The rule sounds good, but how is it to be applied? The means lies within the experience of anyone who has ever waltzed, listened to waltzes, or played music in 3/4 rhythm. In figure 1 are given two different expressions of the same thing. In the first line there are three dots followed by a dash, once repeated. The first two measures might be considered as a *v* or the second and third measures as a *b*. In the second line the same thing is expressed in musical notation. The notes with solid heads are quarter notes. The notes with open heads followed by dots are dotted half notes, and each of them is equivalent to three of the quarter notes. Below each measure of the musical notation the figures, "1, 2, 3" are repeated to make it clear that each measure consists of three pulses. Below these figures *tah*'s are written with the *t* of each *tah* indicating the beginning of a pulse and with remaining letters somewhat spread out in order to indicate roughly the duration of the *tah*.

The illustration of figure 1 shows that the code may be expressed in musical notation, for most letters. This makes it possible for anyone with a musical background quickly to assimilate the fundamental relations of the code. People without such a background may get this fundamental relation with just a little bit of work. If one counts repeatedly at an even rate of speed *one, two, three, one, two, three* and taps with a pencil on a desk in unison with the counting, lightly for the *two*'s and *three*'s and heavily for the *one*'s, he will soon find that the counting and tapping assume a swing which will carry them along in spite of him. Probably he will find that the process goes just as smoothly if he continues to count *one, two, three* but taps only for the *one*'s. From this stage it is only a small step to taping the rhythm represented in figure 1, which has alternate groups of *three*'s tied together. If this illustration is *tahed* repeatedly it will serve as an excellent exercise for drilling one in the fundamental spacing relation of the code, viz., one dash equals three dots.

This rhythmic relation holds for the spacing of the individual parts of most of the letters. It does not hold, however, for the spacing be-

[Continued on Page 85]



# Diversity Reception for Amateurs

By CARL ROLAND

"Diversity" reception is old. It has a good record. It is a practical answer to some kinds of fading.

Fading is supposed to travel across the country. Antennas at different places often show fade-down at different times. Reception would be better if they could be averaged. Reception would be still better if the receiver kept choosing the antenna with the best signal. That is diversity reception.

One method is to place an operator and a receiver at each antenna. They are connected by telephone lines to one listening place. This is expensive. Sometimes one operator goes to sleep. This is irritating.

Another way is to bring r.f. transmission lines from the antennas to one receiver. The receiver works on the average signal from all the antennas. It cannot pick the best antenna. Maybe this is better than one antenna.

A third way is to bring the r.f. lines to one place, but to use one receiver for each antenna. The receivers feed the same loudspeaker *and their automatic-volume-controls are tied together*. If one receiver gets a good signal its a.v.c. voltage goes up and blocks off the other receivers, so they cannot contribute noise. One uses only the best antenna. After a while another antenna is best. The receivers use it.

It sounds good; it *is* good.

## An Amateur Adaption

The answer to "who has two identical superhets" is "two nearby broadcast listeners." We used broadcast supers. They had diode 2d detectors working into resistance-coupled audio tubes. The d.c. voltage drop across the resistor was fed through a 1 megohm resistor (to filter out audio and i.f.) to the grids of the tubes which took a.v.c. From one end of this resistor to chassis was a small filter condenser. This was the end of the resistor farthest from the diode. We hunted up this condenser in both receivers. It was hard to find, but we finally found it. After connecting the two condensers of the two receivers in parallel through 3 feet of lampcord, the one receiver yelled; the other receiver mumbled. We decided the connections were crossed; so we straightened them out. When we connected an antenna to one it worked; when we connected the antenna to the other one it worked and the first one was

silent. It all looked very easy. Then we tried it on weak signals, and found that it did not work at all. Nothing but silly noises came out, caused by the two oscillators interfering with each other, due to lack of shielding. We shielded them, and then re-trimmed them, thus ending the second day. No diversity reception so far.

## Antennas

Having available three antennas and two receivers, we picked the two antennas farthest apart. One was right where we were; the other was 600 feet away. A 2-wire line spaced for 600 ohms on glass and porcelain insulators was used. There were 7 kinds of insulators before we had gone 600 feet. The last were porcelain cleats. They are not good but cheap. At the antenna end was an r.f. transformer with 50 turns of no. 24 d.s.c. on a 2" tube. This was probably wrong. Many pieces of tinfoil were laid lengthwise on this winding, with oiled paper strips under each one to keep them apart. One end of each tinfoil strip was connected to a common connector, and to the ground, and to the center of the secondary winding (which was the line winding). It had 25 turns. This was probably wrong too, but the signals struggled through and came out at the receiving-station end of the line. At the receiving end of the line we used a coil just like the first one, but turned around. This was probably wrong, but it worked too. Maybe it did not work well. Maybe that is why signals from the distant antenna were weaker than those from the nearby antenna. We should have improved the transformers, but did not know how. So we made the distant antenna 20 feet longer, and the "home" antenna 20 feet shorter. We stopped the a.v.c. on one set from working and shut the other set off. Now both antennas gave about the same signal.

## Combining Audio Outputs

We turned on both sets. One was on the "home" antenna; the other was on the "distant" antenna. We tuned them to the same signal and let each one use its own loudspeaker. As far as we could see this was good enough.

The system sounded all right. The oscillators still interfered a little on very weak signals, but it did not matter. In some commercial sta-

*[Continued on Page 92]*

## TRANSMITTING TUBES

### Static Characteristics

Type	Max. Continuous Plate Loss In Watts	Cathode		Max. Plate Voltage	Max. Continuous D.C. Plate Current Ma.	Amp. Factor	Inter-Electrode Capacities			Base	Purpose
		Voltage	Current (Amps.)				Grid to Plate $\mu\text{fds.}$	Grid to Fil. $\mu\text{fds.}$	Plate to Fil. $\mu\text{fds.}$		
45	10	2.5	1.5	300	40	3.5	8	5	3	M4	Low $\mu$ General Purpose Triode. Class A Audio, Self-Excited Oscillator, etc.
46	10	2.5	1.75	300	45	30				M5	High $\mu$ Dual Grid Triode. Class B Audio and Doubler-Buffer.
59	10	2.5	2	300	45	30				M7	General Purpose Pentode. Class B and A Audio, Crystal Oscillator and Doubler.
47	10	2.5	1.75	300	45	150	1.25	8.7	13.2	M5	General Purpose Pentode. Class A Audio, and Crystal Oscillator
6B5	10	6.3	.8	400		.....	.....	.....	.....		Audio Amplifier and Crystal Oscillator
RK15	10	2.5	1.75	400	.....	.....	7.5	2.7	5	M4C	Class B Modulator and R. F. Doubler
RK16	10	2.5	2	400	.....	6	7.5	3.8	6	M5	Class B Driver or R. F. Amplifier
RK17	10	2.5	2	400	.....	220	1	7.5	16	M5G	Crystal Oscillator and Doubler
53 6A6	10	2.5 6.3	2 8	300	40	27				M7	Dual High $\mu$ Triodes. Class B Audio and Crystal Oscillator-Doubler.
RK34	10	6.3	.8	300	40	27	2.7	4.2	2.1	M7AA	Similar to 53-6A6, except Plate leads out of top of envelope
RK23 RK25	12	2.5 6.3	2 .8	500 500	50 50	* *	.02 .02	10 10	10 10	M7A M7A	Shielded R. F. Pentode. For Crystal Osc., Doubler and Suppressor Mod. Amp.
802	15	6.3	.....	500	50	*	.....	.....		M7A	Somewhat similar to RK 23.
WE307A	15	5.5	1	500	50	*	55	15	12	M5A	Similar to RK 23, but has filament instead of heater
2A3 6A3	15	2.5 6.3	2.5 1	300	60	4.2	13	9	4	MA	Low $\mu$ General Purpose Triode. Class A Audio, Self-Excited Osc., etc.
210	15	7.5	1.25	600	75	8	8	5	4	M4	General Purpose Triode. Medium $\mu$ . Class B & C Primarily.
841	15	7.5	1.25	600	75	30	8	5	3	M4	General Purpose High $\mu$ Triode. Class B & C Primarily.
865	15	7.5	2	750	75	*	.05	10	7.5	M4A	R. F. Tetrode. Mainly useful as Buffer-Doubler below 10 Megacycles.

# TRANSMITTING TUBES

## Static Characteristics

Type	Max. Continuous Plate Loss In Watts	Cathode		Max. Plate Voltage	Max. Continuous D.C. Plate Current Ma.	Amp. Factor	Inter-Electrode Capacities			Base	Purpose
		Voltage	Current (Amps.)				Grid to Plate $\mu$ fds.	Grid to Fil. $\mu$ fds.	Plate to Fil. $\mu$ fds.		
801	20	7.5	1.25	750	75	8	6	4.5	1.5	M4	General Purpose Medium $\mu$ Triode. Carbon Plate. Similar to 210
250	25	7.5	1.25	550	60	3.8	9	5	3	M4	Low $\mu$ Triode for Class A and Class AB Audio
WE254B	25	7.5	3.25	900	90	*	.085	11.2	5.4	M4A	R. F. Tetrode similar to 863, but larger
800	35	7.5	3.25	1,250	100	15	2.5	2.75	1	M4AC	General Purpose Medium $\mu$ High Frequency Triode. Useful to 200 Mc.
RK20	35	7.5	3	1,250	85	*	.012	11	10	M4A	R.E. Pentode. Used as Crystal Osc., Buffer-Doubler, Suppressor Mod. Amp.
RK18	40	7.5	3	1,250	85	18	4.8	4.6	2.9	M4A	General Purpose Medium $\mu$ Triode. Useful up to approx. 50 Mc.
RK30	40	7.5	3.25	1,250	90	14	2.5	2.75	2.75	M4AC	General Purpose Medium $\mu$ High Frequency Triode. Similar to 800.
RK31	40	7.5	3	1,250	85	27	...	...	...	M4	Zero Bias High $\mu$ Triode. Mainly for Class B Audio
RK32	40	7.5	3.25	1,250	90	14	3	2	1	M4AC	Ultra-High Frequency Triode
830	40	10	2	800	75	8	9.9	4.9	2.2	M4	General Purpose Medium $\mu$ Triode. Somewhat similar to 801
830B 841A	50	10	2	1,250	100	30	10	6	2	M4A	High $\mu$ Triode. Class B Audio and Class C Amplifier below 15 Megacycles
WE304A RCA834	50	7.5	3.25	1,500	90	11	2.5	2	.67	M4AC	Ultra High Frequency Triode. Useful up to about 250 Megacycles
WE282A	70	10	3	1,500	125	*	.2	12.2	6.8	M4A	R.F. Tetrode. Buffer Doubler useful below 15 Megacycles
50T	75	5	6	3,000	125	12	2	2	.2	M4AD	General Purpose Medium $\mu$ Low C Triode. Useful up to 250 Mc.
WE242A	100	10	3.25	1,250	175	12	13	6.5	4	J4	General Purpose Medium $\mu$ High C Triode. Class A, B & C up to 10 Mc.
WE261A	100	10	3.25	1,250	175	12	9	6.5	4	J4	Similar to 211-242A
WE276A	100	10	3	1,250	160	12	9	6	4	J4	Similar to 211-242A

# TRANSMITTING TUBES

## Static Characteristics

Type	Max. Continuous Plate Loss In Watts	Cathode		Max. Plate Voltage	Max. Continuous D.C. Plate Current Ma.	Amp. Factor	Inter-Electrode Capacities			Base	Purpose
		Voltage	Current (Amps.)				Grid to Plate $\mu\text{fids.}$	Grid to Fil. $\mu\text{fids.}$	Plate to Fil. $\mu\text{fids.}$		
<b>211</b>	100	10	3.25	1,250	175	12	15	8	7	J4	Similar to WE-242A
<b>203A</b>	100	10	3.25	1,250	175	25	15	8	7	J4	General Purpose Triode, High $\mu$ . Class B & C. Useful up to 10 Mc.
<b>838</b>	100	10	3.25	1,250	175	27	8	6.5	5	J4	High $\mu$ , High C Triode. Zero Bias Class B; Class C, up to 15 Mc.
<b>845</b>	100	10	3.25	1,250	175	5	15	8	7	J4	Low $\mu$ , High C Triode. Class A and AB Audio. Also Self Excited Osc.
<b>850</b>	100	10	3.25	1,250	165	*	.2	17	26	J4C	R.F. Tetrode. Buffer-Doubler. Useful below 5 Megacycles.
<b>RK28</b>	100	10	5	2,000	160	.....	.02	15.5	5.5	J5A	R.E. Pentode. Similar to 803.
<b>WE284A</b>	100	10	3.25	1,250	160	4.7	8.2	7	7.8	M4A	Low $\mu$ Triode. Similar to 845.
<b>852</b>	100	10	3.25	3,000	125	12	3	2	1	M4BC	Medium $\mu$ Triode. Mainly for High and Ultra-High Frequencies.
<b>860</b>	100	10	3.25	3,000	125	*	.05	8.5	9	M4BC	R.F. Tetrode Doubler-Buffer. Useful below 15 Megacycles.
<b>211H</b>	120	10	3.25	1,500	175	12	8	5.5	2	J4A	General Purpose High Frequency Triode. Useful also for Ultra-High Frequencies.
<b>803</b>	125	10	3.25	2,000	160	*	.15	15.5	28.5	J5A	R.E. Pentode. Used as Buffer-Doubler and Suppressor Modulated Amplifier.
<b>HF200</b>	150	10.5	3.4	2,000	200	18	5.8	5.2	1.2	J4AD	Medium $\mu$ Low C Triode. Class B and Class C to 60 Megacycles.
<b>HK354</b>	150	5	10	3,000	200	12	3.7	9	.5	J4A	General Purpose Medium $\mu$ Low C Triode. Class B & C up to 250 Mc.
<b>150T</b>	150	5	10	3,000	200	12	3.2	3	1	J4AD	General Purpose Medium $\mu$ Low C Triode. Class B & C up to 250 Mc.
<b>F108A</b>	175	10	11	3,000	175	12	7	3	2	J4BC	Tungsten Filament General Purpose Triode. Class C up to 100 Mc.
<b>HF300</b>	200	11.5	4	2,500	250	23	6.5	6	1.4	J4AD	Medium High $\mu$ , Low C Triode. Class B & C up to 60 Megacycles.

## TRANSMITTING TUBES

### Static Characteristics

Type	Max. Continuous Plate Loss In Watts	Cathode		Max. Plate Voltage	Max. Continuous D.C. Plate Current Ma.	Amp. Factor	Inter-Electrode Capacities			Base	Purpose
		Voltage	Current (Amps.)				Grid to Plate $\mu$ fds.	Grid to Fil. $\mu$ fds.	Plate to Fil. $\mu$ fds.		
WE212D	200	14	6	1,500	250	16	19	19	12	Spec.	W.E. 4 Pin Base, Gen. Purpose Medium $\mu$ , High C Triode. Not useful above 2 Mc.
204A	250	11	3.85	2,500	250	24	17	8	3	J3A	High $\mu$ , High C Triode. Class B & C up to about 10 Mc.
300T	300	7.5	11	4,000	300	16	4	3.5	1.5	J4AD	General Purpose Medium $\mu$ , Low C Triode. Class B & C, up to 250 Mc.
WE270A	300	10	9.75	2,500	300	16	21	18	2	WE2BC	General Purpose Triode. Class B & C up to 10 Megacycles.
849	350	11	5	2,500	300	19	33.5	17	3	J3A	General Purpose Triode. Class B & C up to 5 Megacycles.
831	400	11	10	3,000	300	14.5	4	3.8	1.5	J3BC	Medium $\mu$ , Low C Triode. Class C up to 100 Mc.
861	400	11	10	3,000	300	*	1	17	13	J3BC	R.F. Tetrode. Buffer-Doubler up to 10 Mc.
500T	500	7.5	20	4,000	500	14	4.5	4	1.5	Spec. † 4AD	General Purpose Medium $\mu$ , Low C Triode. Class A, B, or C up to 150 Mc.
F100A	500	11	25	4,000	300	14	10	4	2	J3BC	Tungsten Filament Triode. Low C, and useful Class C up to 100 Megacycles.
851	750	11	15.5	2,000	500	20	55	30	7	J3A	High $\mu$ , High C Triode. Class A, B & C, up to 2 Megacycles.
WE251A	750	10	16	3,000	500	10.5	8	10	6	WE2BC	Medium $\mu$ , Triode. Useful Class B & C below 15 Megacycles.
WE279A	1000	10	21	3,000	650	10	18	15	8	WE2BC	Similar Triode to WE-251A, but larger

A—Plate Lead Brought Out of Top of Envelope.

B—Plate Lead Brought Out of Side of Envelope.

C—Grid Lead Brought Out of Top of Envelope.

D—Grid Lead Brought Out of Side of Envelope.

M-4, 5, 6, 7:—Medium Receiving Type Socket.

J3—R.C.A. 250-Watt Socket.

J4—R.C.A. 50-Watt Socket.

WE2—Western Electric 2-Pin Socket.

†Special Eimac 4-Pin Base.

\*The  $\mu$  of all tetrodes and pentodes varies with screen voltage. The amplification factor is lowered as the screen voltage is raised, but the transconductance is increased.

Limits of plate loss, plate voltage and plate current, given in the above table, are all independent limits and should not be exceeded. Rarely will the circuit efficiency permit the above values of plate voltage and plate current to be used at the same time. These limiting values are not to be considered the actual operating conditions. In general, as the frequency of operation is raised the limits must be reduced in order to keep the radio-frequency grid and plate currents from heating the tube seals. See Manufacturers' Application Notes for limits of grid and plate r.f. current.





## 28 and 56 Mc.

[Continued from Page 37]

takes two to make a QSO!

Tentatively, we suggest that listening and transmitting both on 56 mc. and 28 mc. be concentrated when the bands seem dead. The most important period to be at the set could be the first five minutes of each hour, the next in importance being the five minutes following every half hour, and lastly the five minute periods beginning at the quarter hours. Select *any* two minutes in the five minute period for transmitting, and listen during the other three—thus reducing the chance that both stations will be transmitting at the same time. Before agreeing to this plan, let's hear from those interested in this work so that other suggestions can be considered also.

W7CHT has a confirmed report of his 56 mc. signals in Illinois. W9EWH in Rock Island, using a Peake five meter super, was at the receiving end. Who says "five" isn't a dx band?

W6CNE has been transmitting on 56 mc. Sundays while using the 14 mc. phone rig.

W9FM received a pleasant surprise in the form of a certificate for seventh place in the recent R.S.G.B. 28 mc. contest.

XE1AY will transmit daily from noon to 3 p.m. Central time on 56.1 mc. with a 100 watt short line controlled oscillator, this schedule to continue until the International dx contest in March. Experience on 28 mc. suggests that the path from XE1AY in Mexico City to the U.S.A. is a good one for u.h.f. work.

Bare wire of the heavy bus bar variety is f.b. for ultra-high-frequency wiring. Not only is its d.c. resistance low, but it is rigid and lack of insulation makes for lower capacity with neighboring parts and removes unwanted dielectric from r.f. fields. No. 12 enamelled (untinned) is better yet, but not as easy to work with.

## See for yourself . . . Data on H & K 354 Gammatron

### PHYSICAL DATA

Plate . . . . .	Cylindrical Tantalum
Grid . . . . .	Braced Vertical Bar Tantalum
Filament . . . . .	Thoriated Tungsten
Blank . . . . .	Nonex Glass
Base . . . . .	Standard Fifty Watt
Base Insulator . . . . .	Ceramic
Net Weight . . . . .	6½ Ounces
Shipping Weight . . . . .	4 Pounds
Maximum Height . . . . .	8¼ Inches
Maximum Diameter . . . . .	3 Inches

### ELECTRICAL DATA

Filament Voltage . . . . .	5.0 Volts
Filament Current . . . . .	10 Amps.
Normal Plate Dissipation . . . . .	150 Watts
Max. Av. Plate Current . . . . .	0.3 Amps
Max. Av. Grid Current . . . . .	0.05 Amps
Average Plate Impedance . . . . .	2800 Ohms
Average Amplification Constant . . . . .	14.

### Inter-Electrode Capacities

Grid-Plate . . . . .	4. mmfd.
Grid-Filament . . . . .	9. mmfd.
Plate-Filament . . . . .	0.2 mmfd.



YOU DON'T HAVE TO KEEP YOUR FINGER CONTINUOUSLY ON THE PULSE OF YOUR TRANSMITTER IF ITS HEART IS A

# GAMMATRON

WRITE FOR BULLETIN 354-B



SOUTH  
SAN FRANCISCO

CALIFORNIA  
U. S. A.

## \$24<sup>50</sup>—NET

F.O.B. SOUTH SAN FRANCISCO



## CALLING all Servicemen!

When "Squad-car" Centralab is at the wheel things happen. He stands for no foolin'. Out goes that noisy control on its ear . . . and a smooth, efficient CENTRALAB RADIOHM preserves the peace.

The best pacifier for noisy receivers, servicemen agree, is a Centralab Radiohm . . . and . . . a mere handful will service practically any set ever made . . . and make it work "better than ever before."

*Centralab smoothness results from the action of the non-rubbing contact whereby a strip of polished metal rocks on the resistor . . . and the only rubbing action is between an oilless wood bearing and the polished metal.*



Every Radio Service Man should be a member of the Fraternity of Radio Service Men

# Centralab

Milwaukee, Wisconsin  
**RADIOHMS  
 SUPPRESSORS  
 FIXED RESISTORS  
 WAVE CHANGE SWITCHES**

thermo-couple meters in each feeder. The antenna used is a half-wave horizontal type, one-quarter wave above ground and fed with the usual two-wire matched impedance transmission line. One of the two neutralizing condensers can be seen behind and to the left of the right-hand tube. These condensers are three plate affairs mounted on large stand-off insulators. The spacing between the rotor and either of the stator plates is three-fourths of an inch. One of the blocking condensers can be seen on top of the center of the glass window. There are two of these condensers, one in each feeder, blocking the plate voltage from the antenna. These condensers are 0.002  $\mu$ f., 7500 volt mica. The grid tuning of this stage is right below the meter panel and the power supply is on the bottom. The power supply consists of a pair of 872A's followed by a double-section filter network. The strip of five meters holds the plate voltage and plate current meters for this stage as well as the grid current and filament voltage meters. The right hand meter reads the plate current for the modulators in the next rack. These modulators can be seen behind the plate glass window. The tubes are four Eimac 150T's in Class AB push-pull parallel. The remainder of this rack contains the bias supplies and the protective circuits. The large speaker mounted in the top of the sixth rack is used for various monitoring purposes.

The seventh rack, or the third from the right, contains speech and control equipment. The two electric clocks on the top panel show Pacific standard time and Greenwich mean time. The large second panel is the rather new Western Electric 10A high-fidelity broadcast receiver. This receiver is used for broadcast entertainment, the testing of amplifiers, and for recording off the air. Directly under the receiver another patching panel can be seen. This panel mounts the tie circuits to the equipment in the right hand end of the racks and the circuits to the other switching positions. The high-fidelity speech amplifier is next below and is used as the main speech amplifier for all circuits. The overall gain of this amplifier is 132 db and it will deliver a full twelve watts output from a crystal microphone. The shelf below is used when operating equipment from this position. Under the shelf are found the power supplies for the tuner, together with the high level speech equipment for the large transmitter, a pair of 845's in push-pull class A. The power supply for the 845's is on the bottom.

For Local Rag Chews

The next rack, or the second from the right hand end, contains a complete 160 meter transmitter. This transmitter uses a pair of 10's

in push-pull in the final stage, driven by an 865 buffer which in turn is excited from a 47 crystal oscillator. The final stage is modulated by a pair of 10's in Class B. The antenna tuning is on the top unit, then the meter panel for the final stage and the modulator, followed by the output stage and the meter panel for the lower stages. The two-dial unit tunes the crystal oscillator and the buffer stage. The remainder of the rack is taken up with the modulator, bias supplies, and power supplies. The antenna used at present with this transmitter is a half-wave hertz, fed by a single wire line.

The last rack on the far right contains the complete five-meter transmitter. This transmitter uses three Eimac 50T's, one as a t.p.t.g. oscillator and the remaining pair as a push-pull amplifier. The input to the amplifier is 300 watts and this stage works at very high efficiency. The top unit contains the complete radio frequency portion of the transmitter. The next unit right below is another of the many meter panels, measuring filament voltage, plate current of both the oscillator and amplifier as well as the grid current to the amplifier.

Following down one finds the power supply for the modulators, the modulators, and the bias supplies. The modulator consists of four 10's in class B push-pull parallel and their power supply. The remainder of this rack holds the switching and protective panel and the power supply for the radio frequency portion. The antenna used on 56 mc. is another half-wave vertical matched-impedance type, fed by a two wire 600 ohm line.

The antenna systems center around a large 75 foot telephone pole set at the lower street corner of the property. This pole is a standard pole, set in six feet of concrete. There are three ropes on the pole supporting the 160, 75 and 20 meter antennas. The 2 1/2 meter antenna is cleated to the top of the pole, with the ten meter antenna rod right below. The remaining antenna, the five meter rod, is located on top of the building. The ten, five and two and one-half meter antennas are all vertical rods giving a desirable low angle of radiation. The twenty meter antenna is a Johnson "Q".

All transmitters are turned on and off from the control panel on the operating desk, which is located four feet out from the center rack, but was moved aside for the photographer. Placed either side of the control panel are the receiver and the oscilloscope. The receiver in use at present is a National HRO and the 'scope was also made by National. Each new receiver placed on the market is tested under actual operation at W6ITH, and therefore the actual receiver in use at any given time will vary. The oscilloscope gives a continuous check on the radiated signal. To watch the modulation



## These Splendid Books...FREE!

Think of it! 2 books full of invaluable information, to be had for just the mailing costs! One with 20 *complete transmitter designs* including 12 tested transmitter RF section designs and 8 modulator and speech amplifier designs. Circuits, complete parts specifications, inductances, etc., all included. Outputs ranging from a little fellow all the way up to the big ones comparable to the best broadcasters.

*Ten complete designs for public address amplifiers* in the other book. It includes one for every purpose, from 3 Watts to 30 Watts output, tried and tested designs that you can build, with complete parts list for each.

These books should be in every amateur's technical library. They are invaluable for reference purposes. Just 22 cents in stamps, to cover postage, brings them both to you, or get them from any Standard Distributor. Send for your copies today.

## STANDARD TRANSFORMER CORPORATION

850 BLACKHAWK ST., CHICAGO, ILL.

**MAIL THIS COUPON!**

STANDARD TRANSFORMER CORP.,  
Dept. B, 850 Blackhawk St., Chicago

- I am enclosing 12c for Transmitter Manual.  
 I am enclosing 10c for Amplifier Manual.

Name.....

Address.....

City..... State.....



percentage, besides the 'scope a power level db meter is in operation on the control panel. This meter is calibrated in percentage modulation for each transmitter. To prevent over-modulation, an 879 high voltage rectifier is connected as a reverse current rectifier. No current will flow through this rectifier, the plate of which is grounded, when the percentage modulation is below 100%. Just as soon as the modulation goes over this percentage, the plate voltage is negative with respect to the ground and current will flow. This current flows through a relay which operates and inserts a 10 db loss attenuator in the speech amplifier. This relay is of the slow release type and as such will hold all overmodulation peaks. Thus, excitable y.l.'s who desire to yell "Hello, Toots," haven't a chance of overmodulating.

Though primarily a phone station, c.w. is occasionally used, teletypewriters being utilized to send machine-code up to 60 w.p.m.

Pressures are exerted by electromagnetic waves on surfaces of an opaque nature. For example: light rays, such as bright sunlight, press upon a opaque black surface to the extent of four-tenths of a milligram for each square meter of surface.

**Gosh! It's a DANDY!**



**"OF COURSE I USED ALLIED PARTS"**

What pep!  
What power!  
Take a tip, fellow Hams  
—you can't beat ALLIED matched kits when you're "building your own." I never knew it would be so easy to build this set. Every part fits right; all I did was follow the diagram and presto—here it is! Say, if ALLIED can make radio building this easy—I'm going to build more rigs. ALLIED says they can supply FREE parts lists for any circuit; I'm going to take 'em up on it. They've got what I need and they save me money. I'm darned glad I've got an ALLIED Catalog handy—it certainly pays!

WRITE FOR CATALOG. DEPT. J



**ALLIED RADIO**  
833 W. JACKSON BLVD.  
CHICAGO, ILLINOIS

## Directive Antennas

[Continued from Page 49]

quarter wave the other missing two eighth-waves are folded up in the tuning condenser. The adjustment of the tuning condenser effectively changes *both* of the parasitically excited dipoles at the same time and a very small change in the capacity of the tuning condenser C effects the desired 180 degree shift in the directivity of the whole array. Incidentally, when tuning up the antenna, do not tune C for either maximum current in the reflector-director circuit or maximum loading of the transmitter. It will be necessary to adjust C while in contact with a station more than 500 miles away as field strength tests at closer distances are often badly affected by the ground wave. Once the two points have been determined, some permanent stops can be mounted on the frame of the tuning condenser C which will enable rapid and accurate change-over of the array.

One user of this array uses a relay to cut in a small locked variable condenser across the main locked variable condenser in order to change direction; his shack is several hundred feet away from the antenna.

Incidentally note that the stub can be practically any convenient length, just so it can be resonated with a suitable condenser "C" so that there is high voltage at the points where the stub connects to the two dipole reflector-directors. A line several full-waves long may be used to bring the condenser C right into the shack, but remember that resistance losses in the line detract from the directivity of the array.

### Feeding Directional Arrays

Note that practically all directional arrays utilize resonance of a multiplicity of half-wave sections, excepting of course, the aperiodic arrays such as the terminated long wire types which few amateurs use, as approximately half of the power supplied to the array is wasted in the terminating resistor.

Thus some form of resonant matching line is necessary to connect a non-resonant transmission line to the resonant arrays. As all non-resonant lines usually have a characteristic surge-impedance between 60 and 600 ohms, a

[Continued on Next Page]

## 100 WATT PORTABLE

### DESCRIBED IN THIS ISSUE

—was built in an R. H. Lynch 14B rack. Price complete with leather handle **\$6.85**. Ship. wt. 19 lbs. R. H. Lynch Mfg. Co., 970 Camulos St., Los Angeles, Calif. See our classified ads.

# Announcing the ALL-STAR BUILD-IT-YOURSELF TRANSMITTER

**A**T LAST! A transmitter you can build yourself! All you need is the foundation unit consisting of drilled and finished panels and bases and the necessary STANDARD parts. A screw driver, pliers and soldering iron—a few hours' time—and the job's done! With clear instructions as a step-by-step guide, the unit is easy to assemble. When completed, it looks and operates like a professional, ready-built job. Designed for standard rack and panel mounting.

## From 40 to 500 Watts Nothing Discarded

Efficient performance is assured if you use the STANDARD parts recommended by the seven prominent manufacturers listed. These parts have been built into a completed unit that has withstood repeated tests for proved performance. You start with the smallest unit of 40 watts, either C.W. or phone, and expand to a 500-watt C.W. transmitter or a 400-watt plate modulated phone. *No units are discarded in increasing power or going to phone operation.*

## Various Combinations

For C.W. operation, start with a 40-watt unit and low voltage power supply. The addition of speech amplifier and power supply makes a 40-watt phone station with simultaneous screen and plate modulation, giving a peak power of 160 watts. To increase power, add high-power R.F. amplifier and high-voltage power supply. This gives the 500-watt C.W. transmitter. The same high-powered R.F. amplifier and high-voltage power

supply, with the addition of the 200-watt modulator, gives a 400-watt plate modulated phone, with peak power of 1600 watts.

## 40-Watt Transmitter

Input, 40 watts to final stage. No neutralization required. Operates on 20, 40, 80 and 160-meter bands. Same 40-watt unit also acts as exciter for amplifier having input of 500 watts. Tubes for 40-watt unit—47 crystal oscillator, 802 buffer-doubler, push-pull 802's in amplifier. Two crystals will give operation on all four bands. Switching arrangement connects meter in plate circuit of any of three stages.

*Seven Leading Manufacturers Make  
Standard Parts for  
ALL-STAR TRANSMITTERS*

- THORDARSON ELEC. MFG. CO., 500 W. Huron St., Chicago, Ill.
- HAMMARLUND MFG. CO., 424 W. 33d St., New York.
- CORNELL-DUBILIER CORP., 4377 Bronx Blvd., New York.
- TRIPLETT ELECTRICAL INSTRUMENT CO., Bluffton, Ohio.
- OHMITE MFG. CO., 4829 West Flourney St., Chicago, Ill.
- E. F. JOHNSON CO., Waseca, Minn.
- CROWE NAME PLATE MFG. CO., 1749 Grace St., Chicago, Ill.

*Unit at top and inset,  
40-watt All-Star Transmitter.  
Panel, 400-watt  
phone transmitter  
complete.*

• • •

★ BUILD YOUR OWN ★  
**ALL-STAR**  
TRANSMITTER

## See Your Jobber

for STANDARD parts for ALL-STAR Transmitters,

or write

any of the sponsor-manufacturers listed, or write direct to ALL-STAR HEADQUARTERS, 222 W. Adams St. Chicago.



# WHY

## They Stand Up

**1.** They are all treated with Pyranol — a new General Electric synthetic material that assures permanence of their high dielectric strength and operating characteristics

**2.** Every unit must pass a high-voltage test of double rated voltage + 1000. You can operate them continuously at 10 per cent above rated voltage.

**3.** They are hermetically sealed and leak-tested under vacuum.

G-E transmitter capacitors are very small in size, and fireproof. You can mount them in any position. Get them from your dealer. Bulletin GEA-2021 on request. Radio Dept., General Electric, Schenectady, N. Y.

**GENERAL  ELECTRIC**

[Continued from Last Text Page]

quarter-wave section will be necessary when feeding a high voltage point in the array in order to allow the non-resonant transmission line to connect to a high current (low impedance) load. If the array is fed at a high current point it will usually be necessary to provide a half-wave matching section. It should be noted that a quarter-wave matching line means a quarter wave *in each leg*. Thus the total length is really a half wave. Similarly, a half-wave matching line has a half-wave *in each leg*, making a total electrical loop of a full wave.

In some cases it is possible to tap a low-impedance line directly on the array at a low-impedance point. However, for practical reasons, it is usually best to isolate the transmission line so that resonances in the line will not unbalance the array.

All directional arrays should be tuned up with the transmission line disconnected. The antenna can be excited from a nearby half-wave antenna fed from a small transmitter. Tune each element separately for maximum current and then start tying the elements together. If all the radiating and phasing sections are the proper length there should be no trouble in tying them together. However, remember that reflecting and directing dipoles must be tuned *off resonance* so that they can wait until the directly excited portion of the array is operating before they are adjusted. In fact, it is a good idea to detune completely all reflectors and directors while adjusting the primary radiators for length and resonance.

Note that the exact length of a reflector or director is quite hard to calculate, as quite small variations from quarter-wave spacing of primary and secondary dipoles causes a noticeable change in the length of the parasitically excited secondary radiators. Thus reflectors and directors are best adjusted by means of distant field strength reports.

### DIRECTIVE ANTENNA CHART

#### RADIATORS

The dipole radiators in a broadside array should be exactly a half-wave apart. All primary, or directly excited radiators should be 95% of a half-wave long.

#### REFLECTORS

A dipole reflector should be 97% of a half-wave long and should be mounted exactly a quarter-wave behind the antenna.

#### DIRECTORS

A dipole director should be 87% of a half-wave long and should be mounted 75% of a half-wave in front of the antenna.

The fine-reading mechanical scale was invented by a man named *Vernier*, hence the name. Slow-moving radio dials and knobs, however, receive the name vernier incorrectly.

### Free Handbooks!

Each month we will pick at random from the latest callbook several amateur calls and list them somewhere on the "Marketplace" page among the classified ads. If the holders of the calls listed will drop a postcard to RADIO to the effect that they have noticed their call, they will be mailed free a copy of the 1936 "Radio" Handbook. The card must be postmarked before the 15th of the month on the cover of the issue in which the call appears.

Early KDKA engineers had found a tent atop a roof to be an ideal summer studio. Good acoustic properties were noted; and when a high wind took the tent sailing across town, they erected another in a room downstairs. There followed immediately the tent-like draped studios common so long in broadcasting. The first WJZ studio was an abandoned cloakroom.

The letters, *O. H. M. S.*, printed across the tops of envelopes used by the Canadian Radio Service do not refer, as it might seem, to the familiar resistance unit, but stand for, "On His Majesty's Service."

To Color Brass a Steel Blue  
Dissolve three drams antimony sulphite and four ounces calcined soda in one and one-half pints water. To this add five and one-half drams Kermes. Filter and mix this solution with five and one-half drams tartar, eleven drams sodium hyposulphate, and one and one-half pints water. Polished sheet brass placed in the warm mixture will assume a steel blue color.—*W'6DOB.*

All the hams in the world could stand in a space of less than one sixty-fourth of a square mile.

### Record Hamfest

More than 2,300 radio amateurs and short-wave fans jammed the grand ballroom of the Hotel Pennsylvania, New York, on Monday evening, February 3d, to attend the second "hamfest" sponsored by Wholesale Radio Service Co. This is said to be the largest individual turnout of radio amateurs on record in the metropolitan area.

Exhibits of new apparatus by five manufacturers and a series of interesting talks by well-known technical speakers kept the crowd occupied from 6 p.m. until midnight. The featured talker of the evening was Robert S. Kruse, engineering editor of RADIO, who gave an illustrated lecture on radio frequency amplifier design and operation.

## Only One Cardwell Quality, 'THE FINEST!'



### ★ TYPE MT-100-GD ★

**FOR USE IN BUFFER STAGES, 700 TO 1000 VOLTS,  
USING 211 - 50T - 150T - 354 - 203A TUBES**

- ★ **Plate Edges Rounded and Buffed**
- ★ **Mycalex Insulation**
- ★ **100 mmf. Per Section**

**AMATEURS:** Note the number of times that CARDWELL Condensers are specified in circuit diagrams published for your use. Ask the leading Amateurs in your district and learn that they, too, prefer CARDWELLS.

**ENGINEERS:** In leading Laboratories throughout the world, CARDWELL Condensers are invariably used for circuit designing, resulting in the use of CARDWELLS in Land Stations, Marine Stations, Airplanes, Medical Therapy and wherever variable condensers are used.

The Allen D. Cardwell Mfg. Corp., 81 Prospect Street, Brooklyn, N. Y.

# CARDWELL ★ CONDENSERS

# TRIPLETT Instruments

## ●● ARE DISTINCTIVE

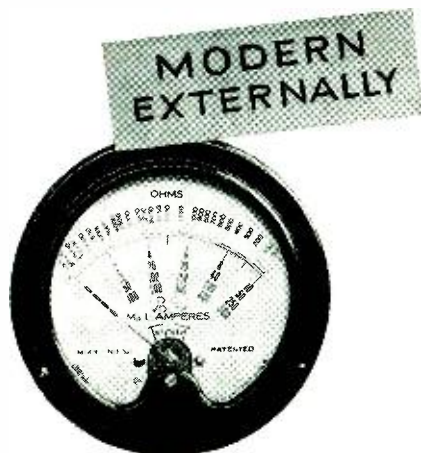

**Model 321 0-1 D.C. Milliammeter**  
Accuracy Within 2%

Model 321 is installed in a Bakelite Case, 3 1/2" in Diameter overall. This is the flush mounting model. Available also in projection mounting. Triplett offers a complete line of 2", 3", 4" and 5" instruments.

Appearance and Accuracy of Triplett Instruments make them particularly desirable for dressing up panels either in the laboratory or on standard equipment items. You will be amazed at the moderate, volume-production prices.

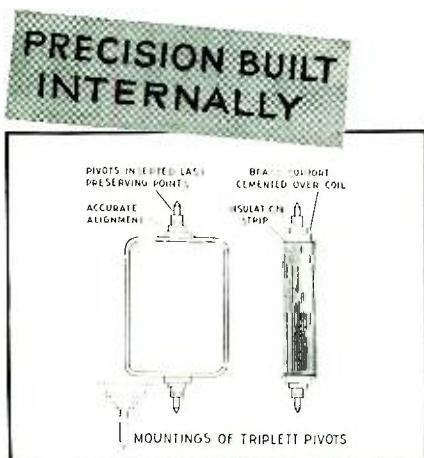

### Why Accuracy Can Be Guaranteed Within 2%

Triplett's Method as illustrated insures true alignment of moving element without strain and with maximum insulation against breakdowns. The pivot points are protected perfectly by the method of assembly—attaching them just before inserting in their sapphire jewel bearings.

**Triplett Instruments Represent**  
Precision Without Extravagance

### Triplett Manufactures

a complete line of electrical instruments for radio, electrical and general industrial purposes—both standard and custom built. Write for catalogue. See them at your jobbers. Prices on application.



## The Metal Tube Gainer

*[Continued from Page 51]*

second detector and audio amplifier. Coil data are given in the following table:

Wave-length	Detector Coil	Oscillator Coil
160 meters	1 3/4" of no. 24 e. close-wound tap at 1 1/4 turns.	1 1/4" of no. 24 e. close-wound. Tap at 1/3 total turns.
80	38 t. no. 22 d.s.c. 1 3/4" long. Tap at 3/4 turn.	32 t. no. 22 d.s.c. 1 3/4" long. Tap at 10 turns.
40	12 t. no. 22 d.s.c. 1 1/2" long. Tap at 1/2 turn.	11 t. no. 22 d.s.c. 1 1/4" long. Tap at 3 1/2 turns.
20	6 t. no. 22 d.s.c. 1" long. Tap at 1/4 turn.	6 t. no. 22 d.s.c. 1" long. Tap at 1 1/2 turns.
10	3 1/2 t. no. 22 d.s.c. 1" long. Tap at 1/4 turn.	3 1/2 t. no. 22 d.s.c. 1" long. Tap at 1 turn.

*All Forms 1 1/2 in. diameter*

## Fire Underwriters Rules

*[Continued from Page 65]*

Naturally, there are many cases during experimenting and transmitter building where it may be necessary to do some things not entirely approved in the Code, but there is certainly little excuse for a completed transmitter, operating regularly, which still looks and is fixed up like a Rube Goldberg cartoon, with high voltage running around loose on cotton-covered bell wire.

Broadcast stations are handy for calibrating amateur freqmeters, test oscillators, and the like, since broadcasters must maintain their assigned frequencies within plus or minus 50 cycles, and are usually much closer. 1,000 kc. stations are particularly useful for the purpose. A test oscillator with its fundamentals including 1,000 kc. and providing harmonics galore can be calibrated from any of the following 1,000 kc. stations: KFVD, WHO, WOC, and WORK.

Another useful broadcast frequency for this purpose is 1500 kc., and the stations on this frequency are: KDB, KGFI, KGFK, KGKB, KGKY, KNOW, WDNC, WGAL, WHEF, WJBK, WKBB, WKBV, WKBZ, WKEU, WMBQ, WMEX, WNBF, WOPI, WPEN, WRDW, WRGA, WSYB, WWRL, WWSW.

### MAIL THIS COUPON TODAY!

Triplett Electrical Instrument Co.,  
353 Harmon Drive, Bluffton, Ohio.

Please send me your new 1936 catalogue.

Name.....

Address.....

City..... State.....





### To Cement Brass to Glass

To make home-made standoff insulators, towel rod antenna insulators, etc., where brass or copper is used to stick to glass, mix a paste of two parts litharge, one part white lead, three parts linseed oil, and one part gum copal; use immediately. If desired, one may roughen the glass with coarse sandpaper or emery.—*W6DOB.*

A large number of reputable authorities stood-by for possible signals from Mars when the planet passed near the Earth in 1924. The U. S. Signal Corps stationed a crack operator at an Army listening post; C. Francis Jenkins, television pioneer, rigged up signal-recording equipment for the purpose; and in England Messrs. Dowding and Rogers built a 24-tube receiver for the Martian signals. These were only a few of the experimenters.

The practice of recording the serial numbers of radio receivers on the part of service men is to be commended. It is not unusual these days for police authorities to inquire at repair shops for information relating to stolen radios.

### HANDBOOK ORDERS

Copies of the "Radio Handbook" for those whose orders are on hand at this office will be shipped by the printer as soon as they are off the press. The Handbook is published by a concern with whom we have no connection, and we therefore cannot guarantee any certain publication date.

*Daily and Weekly* are Sixth District hams. . . . *Call and Work* are W6HMM and W6HDI.

*C. W. Double* is W8GZF, *R. F. Popp* is W6GSY, *A. C. Trapp* lives in Chicago . . . K6GOM's first name is *Ab* . . . W6KHD's initials are *I. O. U.* . . . *Joy* and *Jolley* operate W6HSH and W6HSI, neighbors in the Call Book . . . W6HUM, HUN, HUO, and HUP are all owned by *Smiths.*

Between the earth and the upper conducting layer of the atmosphere there is an electric current of approximately one-thousand amperes.

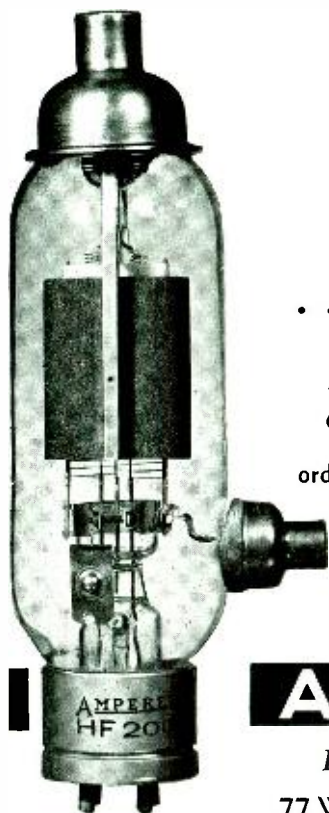

Price, \$24.50



LEE De FOREST SAYS " . . . We have had nothing but most satisfactory results, and frankly have found Amperex tubes superior for our work to those of other manufacturers which we have tried. "We are highly pleased with the results obtained. We feel that manufacturers of radio transmitters are fortunate to have available oscillator tubes possessing this degree of reliability."

*. . . advanced in design  
amazing in performance . . .*

**THE TUBE WITH THE HIGHEST RATIO OF TRANSDUCTANCE TO INTERELECTRODE CAPACITANCE**

A design characteristic which is mainly responsible for the extraordinary performance of these tubes at ultra high frequencies. Plate power outputs as high as 400 watts have been obtained from a single tube at five meters.

There are many other brilliant engineering refinements and radical design developments incorporated in the structure of these tubes as well as the entire line of Amperex Carbon Anode Tubes.

# AMPEREX

*Electronic Products, Inc.*

77 Washington St. Brooklyn, N. Y.

What Results Have You Experienced with Amperex Tubes?

We know what the leading engineers and manufacturers say about our products . . . they have written and told us. We would like to hear from you. Send us your comment with photograph and call signal.

If you haven't as yet tried Amperex tubes . . . write for FREE descriptive literature.

## "40,000 Times \$.50"

Red tape is a funny thing. Funny when considered in the abstract, for purposes of amusement, and a pain in a highly localized portion of one's anatomy when necessary to wade through it. Granting that a goodly percentage of it is an essential evil if this formidable bugaboo "chaos" is to be prevented, it might as well also be granted that the customary net result is a fine kettle of parboiled goldfish.

Concerning the above in the field of radio, we have in mind the contemplation of two things: The F.C.C.'s notorious lack of suitable appropriations; and that peculiar breed of parasite, the Notary Public. Of course we all understand why the F.C.C. doesn't get more dough when Uncle is divying up the loot—there are too many more accomplished fingers in the pie. But what we can't understand is why all the hard-earned money paid in by all the enterprising radio operators and station licensees should fall into the underserving hands of these legal Shylocks.

To our un-legal mind, there is neither rhyme nor reason for the existence of the animals, but that is beside the point. What isn't beside the point is this: There have been numerous suggestions and scares that can be classed under the general head of "Prospective Radio Taxation". Needless to state, having our own little hatchets to hone, none of us have ever smiled on such thoughts. It must be admitted, however, that monies thusly accrued placed at the disposal of F.C.C. wouldn't be such a bad thought, were it not for the fact that we've already been soaked by our highbinding pals, the N. P.'s. Suppose now, for the good old sake of

argument, that it were possible to climb around the legal angles to the point where instead of paying four-hits to one of these parasites for an o.k. on the Oath of Secrecy, you paid it to the examining officer at the Radio Supervisor's office, and it went into the coffers of the Commission. *Not* as a tax, you understand, but just as you pay it to the N. P. You could even make it more realistic by actually taking the oath. You'd probably be at least as secretive about things as you are now. Think of it. Think of all the little four-bitties you have dropped in the assorted laps of those habitués of the Custom House. Notaries Public scattered throughout small towns aren't so bad, because they merely snag onto what drifts their way, but these predatory niche-dwellers and Exploiters of Juicy Fields . . . Yoicks!

For example, those of you who recall having your licenses notarized in the San Francisco Custom House, turn them over and see how many of you find the same signature affixed thereto. Is that a soft graft, or is it just gravy? How'd you like to have the boys line up every morning and contribute fifty cents apiece for your autograph? Too bad you haven't got all your applications that were notarized, too. It must have been an awful shock to \_\_\_\_\_ and her pals when the F.C.C. started putting out those combined station and operator licenses for amateurs. They used to get us coming and going, but now they have to be content with the application.

However, back to the story: As far as the legality of the situation goes, we'll have to leave that for some more competent mind to arrange, but you'll have to admit that 45,000 Amateurs, plus all the Commercials, both operators and stations, kicking in about a buck apiece every few years to the F.C.C. would at least be just that much more than they have now. And we'll also venture that the amateurs, at least, would shell out gladly, feeling that it was going toward the advancement and protection of their chosen art. As for the Commercials, well, at least the F.C.C. would get four-bits out of R.C.A. for every frequency channel they hold.

But I suppose then that we would have to watch to see to it that our dear lawmakers didn't take advantage of the situation, raise the ante a couple of bucks, and harpoon us properly. They'd do it if they thought for a minute they could get away with it.

That's the way it goes. Try and be a Samaritan and you're liable to get hung for it. Oh, well, it was a good idea, anyway.—*QSA5*.

# 5 RELAYS

both economical and hardy...

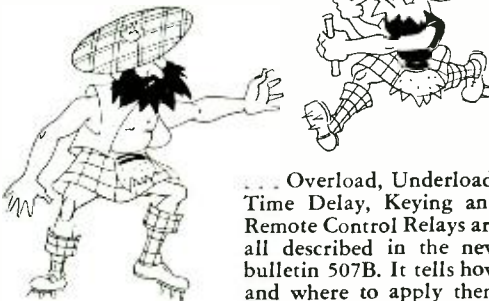

Overload, Underload, Time Delay, Keying and Remote Control Relays are all described in the new bulletin 507B. It tells how and where to apply them in your transmitter. Send for your FREE copy...now.

WARD LEONARD ELECTRIC CO.  
South Street, Mount Vernon, N. Y.  
Please send me a FREE copy of 507B.

Name.....  
Street.....  
City and State.....  
Call Signal.....

RR9

## Hi-Power for Sound Equipment



The Carter Genemotor supplies the most Reliable and Economical "B" power for Class A or B Amplifiers from a 6 or 12 volt battery. Output up to 500 volts. Sturdy—Compact—Quiet in operation—Requires no oiling—Guaranteed.

Write for Bulletin showing complete line of Genemotors for every purpose or specify your requirements.

CARTER MOTOR CO.

365 W. SUPERIOR ST.

CHICAGO

## WHAT'S NEW

### Brush Spherical Microphone

A new spherical microphone recently introduced by The Brush Development Company, Cleveland, Ohio, meets the demand for a good, all-round, low-priced,



general purpose microphone for station announcement, "PA", police, commercial interstation and amateur transmission work. The microphone cases resemble those introduced more than a year ago and still used on the company's laboratory microphones. These are of wire mesh construction — finished attractively in dull chromium.

#### Non-Directional

The microphones like all other Brush microphones produced during the last 3 years are non-directional. Sound waves emanating from any direction can pass through the mesh to the

internal members without interference. There is no distortion from close speaking.

Brush spherical, or BR2S microphones, as they are called, require no input transformers. They operate directly into the grid of the first amplifier tube. The microphones are assembled integrally with a three-prong locking type plug, and are furnished with sockets for either suspension or stand mounting. Size  $2\frac{1}{8}$  inches in diameter. Output level minus 66 D.B.

#### Concentric Line

Doolittle and Falknor, Inc., are marketing three sizes of concentric transmission line. The sizes are  $\frac{3}{8}$ ", 1", and 2" in diameter. The  $\frac{3}{8}$ " size looks ideal for high power ham rigs as the insulation and spacing will withstand 1000 watts of carrier 130% modulated. This corresponds to a peak voltage of approximately 600 volts. The characteristic surge impedance of this line is 75 ohms; it may be used to connect directly to the center of a dipole radiator.

Due to the small amount of dielectric in the field of the line the losses, even at 100 megacycles, are exceptionally low. The rated loss at 1000 kc. is

.8 db per thousand feet of line. This line may be bent and generally handled like aluminum tubing but the radius of any bend must not be less than 8 inches. It comes in standard lengths of 50 feet although standard lengths may be purchased factory-connected up to 500 feet. Fittings are available which allow the line to be kept filled with dry nitrogen in order to prevent moisture from entering, when the line is used outdoors in a humid climate.

As the outer conductor can be grounded in most circuits no special supporting insulators are necessary.

#### New Oil Condensers

Something new in an ultra-compact high voltage condenser for use in the filter and audio coupling circuits of transmitters and public address systems has been placed on the market by Tobe Deutschmann.

Use is made of an oil termed Micranol in the manufacturing process. These condensers are said to withstand peak surges of thousands of volts and give long faithful service under hard-working conditions. They are sealed against moisture absorption. Housed in round aluminum containers with porcelain insulator supported terminals, they mount very easily by means of ring clamps.

The condensers have a working voltage of 2000 volts d.c., and are tested at 6000 volts d.c.

It is stated that the big feature of these new condensers is their extremely low cost to the amateur or experimenter.



### TRANSFORMERS and CHOKES

Send for complete Reference Guide of Better Transformers and Chokes for all Receiver and Transmitter Purposes.

**UTAH RADIO PRODUCTS CO.**  
Orleans St., Chicago

## BIG 1936 WHOLESALE CATALOG FREE!

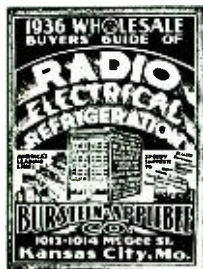

164 pages — Radio, Electrical and Refrigeration Equipment at lowest net prices. A catalog of great value to every dealer, service man and amateur. Complete sets, parts, amateur and commercial apparatus. Write today.

**BURSTEIN - APPLEBEE CO.**  
1012-14 McGee Street  
Kansas City, Mo.



### Calls Heard

(Continued from Page 57)

ZU6P. — W 1AEP; 1AFB; 1AVV; 1BGY; 1BNM; 1BUX; 1CBZ; 1CMX; 1DBE; 1DF; 1DQD; 1DZE; 1ELR; 1FJN; 1HXW; 1KH; 1SZ; 1VW; 1ZB; 1ZE; 1ZW; 2ACY; 2AIW; 2AJX; 2AOG; 2A00; 2AWF; 2BCR; 2CDL; 2CJM; 2CPA; 2DTB; 2EMV; 2FBA; 2FDL; 2FF; 2GJK; 2HIJ; 2HZ; 2JN; 2SZ; 2TP; 3AIR; 3AWH; 3AXK; 3DBX; 3BIW; 3BPH; 3BYP; 3EBC; 3EDP; 3ENX; 3EPR; 3EVT; 3FAR; 3FED; 3HC; 3PC; 3SI; 4AGP; 4AJY; 4BBG; 4BBP; 4FT; 4MR; 5EEX; 5EHM; 5QL; 5WG; 6DIO; 6FLZ; 6KIP; 8AGU; 8ANN; 8ANQ; 8CRA; 8CXC; 8DJJ; 8DSU; 8DYK; 8FYC; 8ID; 8KTW; 8LEA; 8MAH; 8MMH; 8MWL; 8PK; 9ARK; 9ARN; 9BPU; 9BQM; 9CYT; 9DCB; 9DRD; 9GHN; 9HPB; 9HUV; 9JGS; 9KPD; 9MKZ; 9NY; 9SPB; 9TQW.

*H. F. Wareing, W9NY, 4547 N. 21st Street,  
Milwaukee, Wisconsin  
December 10, 1935 to January 10, 1936*

(28 mc.)

CM2FA; C060M; D4ARR; D4LTN; D4QET; EA4A0; E15F; E18B; F8CT; F8JJ; F80Z; G2HG; G2HX; G2IO; G2MG; G2PL; G5B0; G5BY; G5FV; G5ML; G5QY; G5VU; G5WP; G6AY; G6CJ; G6CL; G6DH; G6GS; G6NF; G6QB; G6RB; G6VP; G6WN; G6ZV; HB9J; HJ3AJH; LU9AX; OE1FH; OK1AW; OK1BC; OK3ID; ON4NC; PA0AZ; PA0FLX; PA0QQ; PA0XD; VE1BL; VE1DC; VE1JE; VE2EE; VE3WA; VE4HA; VE5BE; VE5FU; VE5HC; VE5IQ; VE5KC; VK3BD; VP5AC; VP5PZ; XE1AM; XE1AY; ZL3AJ; ZS2A. — W 1AEP; 1AV; 1AVJ; 1CAR; 1FJN; 1HUD; 1RA; 1SZ; 1ZE; 2AER; 2BHM; 2DTB; 3BWB; 3ENX; 3SVT; 4AEJ; 4AGP; 4AGR; 4BBR; 4CCR; 4CQD; 4CYU; 4EF; 4MR; 5A0T; 5BB; 5BBR; 5BDB; 5BYG; 5EHM; 5EIV; 5ELL/6; 5EUK; 6AAA; 6AEF; 6BAM; 6BPD; 6BVC; 6CIS; 6CKR; 6CNX; 6CXW; 6CYP; 6DCV; 6DGP; 6DLY; 6DOB; 6EPP; 6EQO; 6ETX; 6EWC; 6FEX; 6FMY; 6FOL; 6FOW; 6FQY; 6FWM; 6FXA; 6FZY; 6GAL; 6GCX; 6GGZ; 6GNZ; 6GRL; 6GVT; 6HCE; 6HDY; 6HG0; 6HUV; 6IDO; 6IDW; 6IRX; 6IXJ; 6JS;

6JJU; 6JN; 6JNR; 6JYH; 6KB; 6KBB; 6KBD; 6KFQ; 6KGW; 6KJG; 6KNF; 6KPR; 6LAH; 6LDF; 6LXY; 6MBN; 6MJU; 6MKL; 6MTU; 6NFA; 6QD; 6RH; 6SC; 6SN; 6TJ; 6VC; 6ZH; 7AMX; 7AYQ; 7AVV; 7BAA; 7BGH; 7BPJ; 7BYW; 7CHT; 7CQT; 7DDU; 7DNP; 7DOX; 7DSZ; 7DWQ; 7EFB; 7ESN; 7FH; 7IF; 8ANO; 8ANQ; 8BCT; 8BOS; 8CGI; 8CRA; 8CTE; 8DCK; 8DSU; 8EBS; 8ID; 8IL; 8IXM; 8JLQ; 8LAC; 8LEA; 8MWL; 9AEH; 9ARK; 9ARN; 9BHT; 9BPU; 9BQM; 9BVI; 9CYT; 9GYK; 9HAQ; 9HUV; 9ICO; 9IWK; 9LF; 9LQ; 9MIN; 9PST; 9PTC; 9SPB; 9TQ.

*John J. Michaels, W3FAR, North Wales, Pa.  
December 19, 1935 to January 7, 1936*

(28 mc. dx worked)

DJARR; D4GWF; D4LTN; DJMDN; EA4A0; F8JJ; G2NH; G2YL; G5BY; G5DH; G5ML; G5VU; G6NF; G6RH; HB9J; OE1ER; OE1FH; OK1BC; OK1AW; ON4NC; PA0XD; PA0AZ; VK3BD; VK4EI; VP5PZ; YM4AA; ZS1H; ZS2A.

*Dr. J. P. Jones, W8ASI, Buckhannon, West Va.  
To December 23, 1935*

(28 mc.)

F8CT; F8WK; G2PL; G5BY; G5FV; G6DH; G6QB; G6ZV; HM9J; LU9AX; VE1DR; VE4IG; VE4QB; VE4QZ; XE1AY; ZBIX. — W 1AEP; 1AHA; 1AV; 1AVV; 1DSX; 1EER; 1ELR; 1LZ; 1ZZG; 2GSD; 2TP; 4AGP; 4AJY; 4BBR; 4C00; 4FK; 4TZ; 5AHK; 5BT; 5CQV; 5EME; 5JV; 5WG; 6ATW; 6CTH; 6CXW; 6DZ; 6DIO; 6DOB; 6DOK; 6EPZ; 6ERT; 6JUU; 6ZH; 7AMX; XAYQ; 7FLU; 8CRA; 8MAH; 9ABP; 9AEH; 9EKU; 9DZG; 9EGE; 9FFQ; 9FV; 9FYY; 9HJA; 9IWE; 9IWX; 9JGS; 9LF; 9MCD; 9NRO; 9NY; 90GG; 9TR.

*Leonard Holmes, W9JGS, Wheaton, Illinois  
December 8 to January 12*

(28 mc. dx only)

CM2FA; CM8AI; C02TC; C060M; D4ARR; D4GET; EA4A0; EA4AV; E18B; F8CT; F8HS; F8WK; G5BY; G5FV; G5LA; G5OJ; G5UD; G6DH; G6LK; G6RH; G6WY; G6ZV; HB9J; HJ3AJH; LU6AX; LU5AN; LU9AX; OE1FH; OK1BC; ON4LK; PA0QQ; VK3YP; VK3BQ; VK5JC; V04Y; VP5PZ; VE1AM; VE1AY; VE1CA; VE2C; ZL2KK; ZS2A.

*Henry J. Houlding, BRSY20, 21 Talbot Avenue,  
Kingswood, Bristol, England*

*November 30 to December 29, 1935*

(14 mc. phone)

W 2BSD-7; 2EUG-6; 2FWK-7; 2IXY-7; 3AER-7. — HB9T-8; LA1G-7; LA1V-9; LA2Z-8; V011-8.

(3.5 mc.)

W 1BEQ-6; 1GU0-6; 1IJV-6; 1TA-6; 2DYF-6; 2HMA-5; 3AS0-7; 8HFN-5; 8IMD-6; 8NEZ-6; 9CEO-6. — VE11R-6.

(7 mc.)

W3CYN-6; W3EXI-6; W4DJA-6; CM2WW-6; FB8AA-6; VK3GW-4; VK3ZW-5; VP5AD-6.

(14 mc.)

W 1AK-6; 1AKA-7; 1AKR-6; 1ALB-6; 1AQT-7; 1ARH-6; 1BFT-6; 1BGY-6; 1BL0-7; 1BUX-7; 1CMX-6; 1CO-5; 1DE0-6;

# TIME



\* SX 9 \*  
Super Sky rider

Buy your new receiver the easy way on our really "Low Payment" Plan. Small down payment and easy monthly payments. Write at once for data.

### HINDS & EDGARTON

(Est. 1914 W9APY-W9WR Management)  
19 S Wells Street, Chicago, Illinois

# PAYMENTS

## MORE IS EXPECTED OF . . .

## TRIMM Featherweight HEADSETS

There is a definite reason why most discriminating amateurs prefer them. Write for information.

### TRIMM

Radio Manufacturing Co.  
1770 W. Berteau Avenue  
Chicago, Illinois

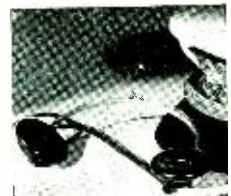



1DGC-6; 1DHE-7; 1DKU-6; 1DKZ-6; 1DUJ-7; 1DUK-7;  
 1EWD-6; 1EZW-5; 1FAX-6; 1FFK-6; 1FFM-7; 1FUO-7; 1FPP-6;  
 1GF-6; 1GGI-5; 1GH-6; 1GU-6; 1GPE-8; 1GXY-6; 1HEQ-6;  
 1HI0-7; 1HM-6; 1HTZ-6; 1HWY-7; 1IGA-6; 1ICY-6; 1IED-6;  
 1IGD-6; 1IHX-4; 1IKT-6; 1ILY-7; 1IOE-4; 1ILZ-7; 1IRA-6;  
 1TS-7; 1WV-6; 1ZB-6; 2AGY-6; 2AFU-6; 2AIW-6; 2BHM-6;  
 2BIC-6; 2BJ-6; 2BPH-6; 2BYJ-6; 2C1Q-6; 2CJM-7; 2CJX-6;  
 2CMR-6; 2CTC-6; 2CTO-6; 2CTX-6; 2CZV-6; 2DNG-6; 2DDE-5;  
 2DYF-5; 2EYZ-5; 2FAR-6; 2FBS-6; 2FF-5; 2FSK-6; 2GAH-6;  
 2GFH-6; 2GIA-6; 2GNT-6; 2GOM-6; 2GQU-4; 2GTZ-7; 2GVZ-6;  
 2GWE-6; 2HHF-6; 2HMJ-6; 2HOJ-6; 2HQG-6; 2HSP-6; 2HTO-6;  
 2HWF-6; 2HXB-6; 2IC0-6; 2IFZ-6; 2IKZ-6; 2MJ-6; 2RS-6;  
 2SZ-6; 3ATR-6; 3AYU-5; 3BES-6; 3BET-6; 3BSB-5; 3CHG-7;  
 3COG-6; 3CUB-7; 3CWG-6; 3DJF-6; 3DKG-6; 3DMQ-7; 3DUE-6;  
 3EAO-7; 3EAO-6; 3EJ0-6; 3EML-6; 3ENX-7; 3EUC-6; 3FIA-6;  
 3FX-5; 3JM-6; 3KT-7; 3RT-7; 3SI-6; 3UR-6; 3ZD-6; 4AU-6;  
 4BCR-6; 4CFD-6; 4CBC-6; 4DRD-5; 4DYN-7; 4OC-6; 4TJ-6;  
 4TR-6; 4ZH-7; 5FT-6; 6GAL-5; 6GRL-5; 6TJ-5; 7AMX-6;  
 7FH-5; 8AIE-6; 8AKX-6; 8AOR-6; 8BKH-7; 8CFF-6; 8CRA-6;  
 8CX-5; 8DOD-6; 8DWV-6; 8FXN-6; 8FSA-5; 8GKF-6; 8GRX-6;  
 8GWZ-7; 8HUW-6; 8HWE-6; 8IIL-6; 8JAN-6; 8JIN-5; 8JJY-6;  
 8KCA-6; 8LAP-5; 8LEA-6; 8LGO-6; 8LHC-6; 8NBM-5; 8ONR-5;  
 8PO-6; 8SGO-6; 9SM-5; 9TIZ-4; CX1G-6; F40L-5; SUSNK-6;  
 VE1DT-6; VE1DZ-7; VE1EP-6; VE1HG-6; VE2EE-7; VE2HG-6;  
 VE2HS-6; VE2KF-5; VE3QI-6; VE3UF-6; VE5G1-6; VK2E0-4;  
 VK2TF-4; VK4BB-4; VK4JU-4; VK5LB-4; VK5MD-6; VP5GM-5;  
 VU2JM-5; YR5IG-6; ZB1E-7; ZB1H-7; ZL1AK-4; ZL1GX-5;  
 ZL2FA-5; ZL20Q-6; ZL3AZ-5; ZL4CK-6; ZS1AL-5; ZU6M-6.

### Code in 10 Hours

[Continued from Page 67]

tween letters. I was able to find no simple rule for regulating this inter-letter spacing. The best method I found was to make a definite break in rhythm between each letter. By emphasizing the space between each character the unity of the individual groups was brought out. Then as my proficiency increased I cut down the inter-letter space, but never to such a point that the individual letters became confused. The same plan may be followed for determining the proper spacing between words.

If the foregoing material is practised at the speed indicated by the metronome mark in figure 1 (three quarter-notes per second) the learner will find when he begins the use of a

key and buzzer that he has a quite respectable speed of six or seven words per minute. It is not very difficult to bring this speed up to the required ten words per minute. One very good method is for two or three friends to work together, alternately sending and receiving. This method offers the distinct advantage of mutual criticism of "fists", and, with people who can take criticism as well as give it, brings rapid improvement. I had to work by myself. It is very helpful to listen in and find somebody going just a bit faster than is comfortable to receive, and copy as much as possible. You'll be pleasantly surprised to see how fast your speed picks up.

At the outbreak of the World War, Charles E. Aggar, a New Jersey amateur, made phonograph records of signals from an unneutral German-owned station on Long Island. These records, which furnished the Government with evidence of great value, are now preserved in the N.B.C. radio museum at Radio City.

## The Outstanding Microphone Buy of the Year

Now only  
**\$45.00**  
 List



Microphone Brush B25

Here it is . . . the new low price Brush Sound Cell Microphone for public address, amateur phone, remote pickup, sound car and dance band work. Typical Brush Sound Cell construction insures long life and satisfactory performance. Not affected by wind or severe changes in atmospheric conditions. Operates directly into high-gain amplifier. No input transformer. No distortion from close speaking. Fully guaranteed. Weight 3 ozs. —overall height 4¼ inches. Illustrated folder free on request. Send for a copy. *If your dealer cannot supply you with this big new value write*



## NEW from RESISTOR HEADQUARTERS

LAST year's popular AMATEUR HANDBOOK has been enlarged to 24 pages. A whole new section has been added on Band-Switching, with diagrams for most basic circuits. The new 2nd Edition also contains data on Modulators from 4 to 100 watts, and a world of other useful information.

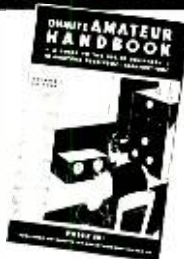

Last year's ingenious tables and charts have been revised and supplemented. They eliminate formulas and do away with difficult calculations in selecting voltage dividers, bleeder resistors, filament rheostats, etc., for transmitters and receivers. You'll get a lot more fun out of operating with this handy manual to help you. Order direct, enclosing 10c, or see your dealer.



**OHMITE**  
 MANUFACTURING COMPANY  
 4837 FLOURNOY ST., CHICAGO, I.L.

**DX News**

*[Continued from Page 61]*

there once in a while between 1830 and 1930 g.m.t.

W3AYS heard ET1TT (T9) calling CQ U.S.A. at 1:30 p.m. e.s.t. on 14,360 kc. Says he used 36 1/2c worth of "juice" calling the guy but that all he got out of it was a little code practice. For the benefit of some of you uninitiated dx owls, I might add that this station is supposed to be in Abyssinia . . . anyway, in Ethiopia, which is the same place. AYS also hooked VQ3MSN in Tanganyika, 14,400 kc., T8. South Africa is coming in regularly at Charlie's station around 2:30 p.m. e.s.t., the best being ZS6AF, ZS1AH, ZU'6B and ZE1JS.

Have you heard of F7CFV in New Caledonia? Well, W6DLN has, and not only that but he went so far as to work him. It was a most unusual QSO, as the 14 mc. band had apparently folded for the night when Dick steps in there and digs out this fellow at 11 p.m. p.s.t.

F8FC is building a new transmitter. He says now he is very QRP as he is only running 350 watts into a 203. His new rig will be a 59 Tritet, 802, 210, 203 and into push-pull 852's. Hopes to run 800 to

1000 watts and has a 3-phase power supply available. This rig will be used on 20 and 40; on 10 he will have a final of two 800's in p.p. F8FC has been on the air since 1924 and has held the calls: F8TK, F8XO, and F8YRT.

W8HWE kicks through with some antenna "info" which will probably be of interest to many hams. Bob wanted to have a good antenna for 7 mc. So after working this out right on the nose he passes the result of his experiments along. The flat top is two wavelengths long, 270 feet, running east-west. The west end is 75 feet high while the other end is 40 feet. It is fed in the center of the first half wave with a pair of quarter-wave bars of one-half inch aluminum tubing 33 feet long and spaced 2 1/8 inches from center to center. The radiation resistance of a two-wave antenna at the center of any half wave is about 110 ohms and the quarter-wave bars very effectively match this impedance to the 600 ohm line running to his transmitter. Dx reports on this antenna jumped 2 "R's" for Bob. Of course the main disadvantage with a skywire of this type is that it is for one-band operation, and therefore another would be necessary for 14 mc. Some "stuff" coming through at W8HWE includes: ES5C, 7140; YM4AF, 7130; 111T, 7140; OH3OE, 7100; OZ5K, 7150; OZ7FD, 7100; HAF2G, 7130; HAF8C, 7110; YR5AS, 7100; LA6B, 7090; LA4P, 7100; LA2B, 7100; SM7XZ, 7050; UK6AA, 7000; YU7AB, 7000; TF3Z, 7140; OK1CS, 7135. Bob has worked 69 countries, 62 on 40 and 7 on 20. One of his biggest thrills was working J2JJ at 4:45 p.m. e.s.t. in December. Remember, this was on 7 mc. He uses separate rigs for 20 and 40, each with two HK-354's in p.p. for final amplifiers. Both transmitters are link coupled through-out. The receiver is an HRO.

K6CGK gives us an insight on the dx situation over Honolulu way. VQ2WAB 7010 T9; VQ8AB 7120 T7; VQ8AC; FB8AA 7220; FB8AD 7190; ZE1JU 7210; ZE1JY 7200 (fone); VU2CQ 7150 (fone); YJ1RV 6990 T9; CR7AU 7060; CR7AC 7158; CR7MB 7100; CR7GC 7200. Others on 7 mc. include ZS2X, ZT2Q, ZS4E, ZS5U, ZT5Z, ZU5AC, ZU5AF, ZU6AB, ZU6AM, ZU6AL, ZT6AK, ZT6AM and ZT6N. Not much is doing on 14 mc. this time of year in Hawaii other than some South American stations.

W5EZA, in Redwood, Miss, sure handed me a surprise while QSO him last month. Had given him R9 and the jolt came when he said he was using 8 watts. I told him he had left off a couple of zeros, but he says "nix". The rig is a 36 e.c. osc.

**WANTED** —Fully experienced Radio Service Expert. "Screw driver mechanics" need not apply. Must be fast, accurate and thoroughly familiar with all types of modern radio work. A real opportunity for the right man. State qualifications in detail. Box 101, c/o Bulletin.

**Could You Fill This Service Job?**

Under improved business conditions, dozens of good-paying opportunities will soon be popping up in radio. Your future depends on whether or not you are qualified to grasp them. Will they go to other fellows—or will you MAKE them come to you!

Sprayberry Training is designed NOT for beginners but for men already in the service business who recognize the need for keeping up-to-date. It is for men who know that, to get better-than-average jobs, they have to be better-than-average workmen. It is sound, practical business and technical training at a price within the reach of all. Investigate!

**LET ME HELP YOU BUILD FOR REAL SUCCESS IN SERVICING**



**F. L. Sprayberry,** 2548 University Pl., N. W., Washington, D. C.

Without obligation, send me details on your advanced Service training.

Name.....  
Street.....  
City..... R1/36

**SPRAYBERRY'S PRACTICAL MECHANICS OF RADIO SERVICE**

**YOU**

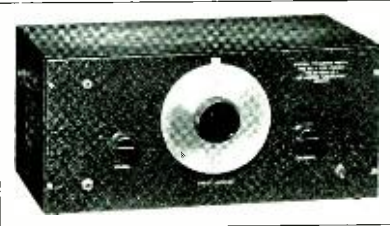

can check frequency on a police or fixed-channel transmitter -- with the Type 102 STATION FREQUENCY METER! No calculations—the dial reads cycles deviation. Readings readily made to ± 0.001%. Write for data.

**LAMPKIN LABORATORIES**  
BRADENTON, FLORIDA



link coupled to 12A in the final. 360 volts of B batteries feeding it 20 ma. Receiver is an SW3. Antenna is a Johnson "Q" 50 feet high, and the station is on a high hill. Has worked all continents but Asia, and for an unusual incident EZA worked 6 VK's in a row on 14 mc. between 1 and 3 a.m. c.s.t. He has contacted stations in 22 countries and 17 zones. This is certainly exceptional work, especially for a ham in the U.S.A. Nice going. Dan Blake . . . go get that Asian!

FT4AF, according to W2BJ, is getting all primed for the contest. I shouldn't tell you, but his freq. is 7080 kc. and x.d.c. Ray also says that EA3AN wants W6 and W7 QSO's. European stations complain of fone QRM around 7060 kc. from CT and EA; so any of you birds who have trouble working Europe near that frequency . . . well, you better just QSY, thasall, 'cause you know these fones.

The troubles of W3CHG are few. Heard some guy tossing out a CQ and when he started to sign he said "de W2???" then changed to NX2V. He should be in Greenland, but in view of the above facts your guess is better than mine. New ones for Gabe are: FM8D ex-F3MTD 14.303 T9X; HJ3AJH 14.410 T9X; HJD2 in Colombia 14.360 RAC; U9RK Siberia 14.315 T7; FR8VK 14.460 (Ahem?) T7; and CP1AC whose QRA for QSL cards is, Radio CP1AC, Yacuiba, Bolivia. Yes, he sends 'em, too. He is ex-W2CDA. Gabe keeps a sked with ZD8A on Ascension Island, who is still on 14.317 T9X.

W9KG, "Keat" Crockett, of good old Kansas City, works a new one. FB8AG is the station, and comes in at 14.325 kc. about 9 p.m. c.s.t. Keat was his first "W" QSO. So that we will all be better acquainted with W9KG I'm going to sneak up on him and give a little inside information. Up to last summer "Keat" had never been much for dx, and had never been on 20 meters. W9ARL got him interested and in five months he worked 67 countries. His rig uses two 276A's in the final with about 400 watts input.

Charlie Myers, W3SI, worked SX3A in Greece on 7 mc. QRA is: Direction Services Radiotelegraphiques, De La Marine, Athens, Greece. New stations for Charlie are FB8AG, VQ8AF, ZD8A, VU2CQ, ZE1JN, ZE1JS and ZE1JJ. And, as he says, "And about a million ZS, ZT and ZU." 3SI is in a huddle with his boss . . . the idea being to get time off for the dx contest. Here's one guy who stands on two feet and says he's going after all he can get. Chas. has completed a time chart for hams in the Eastern section of U.S.A. The data has been collected during

the past five years. You know, good ol' Charlie was high scorer in '34 and '35.

Here and There

From Atlanta . . . W4DHZ and W4CBY have combined for the contest. W4CDE, BBR and BBP are all doing good work on 20 and 40 . . . altho 4BBR wants to know if I think the only two guys in Atlanta are DHZ-CBY, W8BCT, 'Ossie' Presnell.

[Continued on Next Page]

## RALPH O. GORDON CONSULTING ENGINEER

High Frequency Radio  
and  
Sound Equipment

5708 Keniston Ave.  
Los Angeles, Calif.  
Phone University 7570

## QUALITY VERNIER DIALS



**TYPE 2210** is a 2 1/4" direct drive egg-shell, black bakelite dial. Easily illuminated, if desired, it rotates clockwise 0-100 through 180 degrees. For 1/4" shaft . . . . . List **\$ .75**

**TYPE 2212**—similar to 2211 minus two windows and is finished in smart antique. 9 to 1 ratio for 1/4" shaft. . . . . List **\$1.50**



Other dials and quality parts for the "ham" serviceman and radio industry available. Also complete facilities to meet your every requirement, large or small in drilling and engraving of panels on all insulating materials and metals. Available at all ICA distributors. For complete catalog send 10¢ in postage or coin to cover cost of handling and mailing.

**INSULINE**  
CORP. OF AMERICA  
75 PARK PLACE • NEW YORK • N.Y.

## DON'T WAKE UP THE WHOLE HOUSE

Just because you are intent on getting some distant foreign station late at night. . . . Use

### Cannonball Headsets

and you will receive better results and the family will not be disturbed.

Order from your dealer. If he cannot supply you, we will.

WRITE FOR ILLUSTRATED CIRCULAR L-3  
**C. F. CANNON COMPANY**  
SPRINGWATER, N. Y.

[Continued from Preceding Page]

works PZ1PA in Surinam . . . 7080 kc. W6GK works the same guy which is "VFB" dx for W6 . . . W8BCT also hooked PF2BF in that unknown country. W9ARL works gobs of LU and Africans . . . W9CCT, TOQ and LBB are all quite active on 20 . . . 9KG snagged VU2BG on 14,400 at 9 p.m. e.s.t. . . . W3EYS plans on doing heavy work in the contest . . . W8CRA's poles took the count in last storm; he now uses his maw's clothesline. W7AMX works Europeans every day on 20 and a few in the

p.m. on 40 . . . W3EVW and 3EOI work ZZ2A, the Greek ship, but can't squeeze a QRA for mailing outa him (they're not alone) . . . W9KA in Chicago works KA1MD on 7010 kc. and that, my friends, is good dx for Chi . . . W6CXW hears and QSO's PZ1AA, 14,000, T9X; VQ4SNB, 14,235, T9X, 2200 g.m.t.; ON4CSL, 14,425, 1600-2000 g.m.t. FB8AB has a new rig going . . . xtal on 14,200 . . . FO8AA in Tahiti, 14,340, T9X, 0400 g.m.t. YM4ZAA, 14,350, QSO's W6CXW. W6CXW says he's going to rebuild his rig during the tests . . . Oh yeah? . . . W8ZY hooked up with VU7FY for his 35th zone and 96th country . . . W8DVS, the 210 kid, QSOed CR7AD and CR7GC in 30 minutes, and K7UA made him country no. 88 . . . Ol' Ed Stevens, W7BB, is blazing away again after a stretch of inactivity . . . W2GWE and W2GIZ, both with a "resonant-filter note" are heard nightly going after the elusive ones . . . W6GRX still using his diamond beam for Europe on 20 and 40 with great success . . . W8CRA says he thinks he might get married . . . Better wait, Frank, there's still dx to be had.

F8EO sends through a few items of interest: On 14 mc., for the past six months the most consistent signals were from W6KRI and W6CNX. On 7 mc. W6GRX has contacted F8EX quite a few times. The 80 meter tests didn't turn out so well. F8OG and F8EX were the only F stations to QSO the U.S.A., and they were hams on the East Coast. A few W9's were heard on 80 but none from the Pacific Coast. F8EO has noticed that the number of stations in the W6 and W7 districts are not as numerous as in previous months and lays it to 10 meter activity . . . most of them being down there. He thinks QRM too great on 40 for very many really good QSO's.

Chas. Perrine, W6CUH, has just finished a new transmitter. It has three Eimac 150T's in parallel in the final. He doubles to 14 mc. in the final, facilitating QSY. The new rig has many new features, the most radical departure being that the operator is able to QSY to four different frequencies by turning a switch on the operating desk. The trick is done with relays. Band changing is done in a similar manner. Next thing I expect from Charlie is some stunt whereby he won't even have to get up to work dx . . . just set the alarm, that in turn firing up the receiver and transmitter . . . and all he will have to do will be to get up a few hours later and find his log full of dx QSO's. Anyway the rig works fine; first I hear him on 7000 kc. and when I tune down the band I find he has done a quick QSY and is on 7200 kc. working some bird.

#### VK-ZL Contest

VK3EG, Ivan Miller, won the recent VK-ZL contest. Details are lacking but he had over 14,000 points with 52 countries. We had hoped to have complete results of this contest by press time but they will not be known for some days yet.

I hate to record this but it seems that my very close friend, John Hawkins, W6AAR, of RADIO has pulled a couple of fast ones. Without wasting much time in bringing this out I will list them in the order of their importance . . . that is, to me. Of course, John would probably reverse the order, but that's his affair.

No. 1) John, being a rather dyed-in-the-wool phone man, gave some of the c.w. gang high blood pressure when he hooked up with a G on 75 meter phone. I understand that he became so awed at this achievement he fell into a trance. He better snap

[Continued on Next Text Page]

## Typically AEROVOX



### • Mica

#### CONDENSERS

An exceptionally varied line to choose from. • Thirteen types, ranging from popular "postage stamp" bakelite molded unit and other small units, to metal-cased 7000-volt unit • All commonly used capacities and voltage ratings.

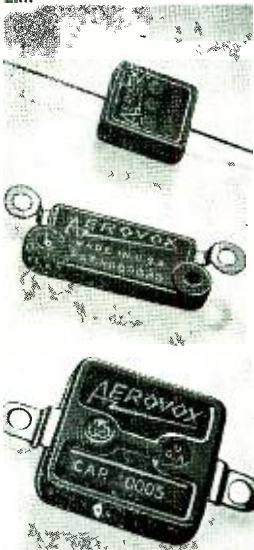

### • Uncased

#### PAPER SECTIONS

Handy, inexpensive, non-inductively wound sections, uncased, for new assemblies or as replacements • In short, medium and long sizes • 200, 400, 600 and 1000 volt ratings. 1 to 4 mfd • Low in price. You save container cost. Most paper capacity for least money.

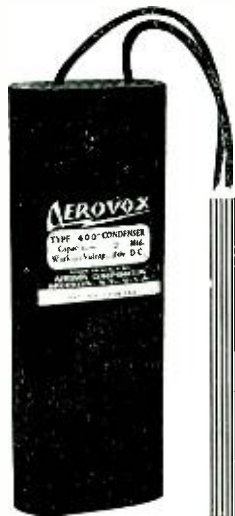

**DATA** Send for 1936 Catalog covering complete line of condensers and resistors. Also sample copy of monthly Research Worker. Meanwhile, meet the local AEROVOX supplier.

# AEROVOX

CORPORATION

84 Washington Street

Brooklyn, New York



# Q S Z

# RACKS PANELS BASES

Just in case you  
didn't see the  
last "RADIO"

## RELAY RACKS



Our Relay Racks are built to stand up under the heavy loads of modern transmitter construction. Uprights are made of 3/16" stock, 1 3/4" wide. Welded angle supports, cross braces and sturdy cross bars insure extreme rigidity. LEEDS Racks

unlike some units on the market, are drilled for panel mounting according to Bureau of Standards specifications.

**Table Rack type RAD** 3 3/4" panel space high, 20 1/2" wide, 12" deep, with a complete set of drilled and tapped panel mounting holes **\$5.75**

Shipping weight 30 lbs.

**Type RBD rack** 6 1/4" panel space high, 20 1/2" wide, 12" deep, with a complete set of panel mounting holes **\$7.45**

Shipping weight 50 lbs.

**Brackets**—4" high, 5 3/8" deep, 1/2" bend for mounting; pair 25c; 7 1/2" high, 9 1/2" deep, 1/2" bend for mounting, pair 35c

## Rack Panels



By LEEDS are furnished with black shrivel finish in the standard 19" length, 3/8" thick. Mounting slots are spaced according to Bureau of Standards specifications, insuring freedom from all trouble in mounting or interchanging panels.

Steel	Price	Width	Aluminum	Price
PS-1.....	\$.52	1 3/4"	PA-1.....	\$.74
PS-2.....	.57	3 1/4"	PA-2.....	1.03
PS-3.....	.68	5 1/4"	PA-3.....	1.30
PS-4.....	.71	7 "	PA-4.....	1.55
PS-5.....	.95	8 3/4"	PA-5.....	1.90
PS-6.....	1.15	10 1/4"	PA-6.....	2.45
PS-7.....	1.30	12 1/4"	PA-7.....	2.90
PS-8.....	1.50	14 "	PA-8.....	3.35
PS-9.....	1.70	15 3/4"	PA-9.....	3.70
PS-10.....	1.90	17 1/2"	PA-10.....	3.95
PS-11.....	2.05	19 1/4"	PA-11.....	4.45
PS-12.....	2.30	21 "	PA-12.....	5.20

Brass panel mounting screws 1/2" long 10/24 thread. 15c per dozen.

## BASES and DEMI- BASES



By LEEDS for use with rack panels are now available in a greatly increased variety at lowest prices. Crystalline finished units of 20 gauge steel; each base is finished with a bottom cover plate, so that apparatus underneath the chassis may be kept free from dust and at the same time electro statically and electro magnetically shielded.

8 1/2 x 8 x 2.....	.65	10 x 17 x 2.....	1.10
8 1/2 x 10 x 2.....	.70	10 x 17 x 3.....	1.30
8 x 17 x 2.....	.95	12 x 17 x 2.....	1.30
8 x 17 x 3.....	1.15	12 x 17 x 3.....	1.40
4 x 17 x 2.....	.70		

## COMMUNICATION PRODUCTS

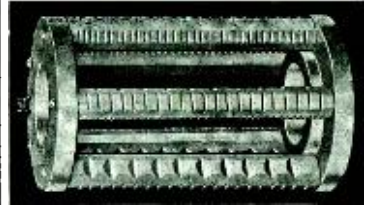

**VITROLEX Universal Coil Form;** diameter 4", length 6 1/4"; grooved for 10-20 and 33 turns. Just rotate the spacing bars a quarter turn and you have a new form. Ideal for use **\$1.50** on all ham bands. Price.....  
Bars separately 25c each.

Use **VICTRON "G"** for high frequency insulation. Lowest losses of any dielectric on the market. Easily machined or drilled.

	6"x12"	6"x6"	1"x12"
1/16" thick	\$1.40	\$.75	\$.25
1/8" thick	2.50	1.35	.45
3/16" thick	3.60	2.00	.75

### TOBE KITS IN STOCK

The finest low cost communication receiver on the market. **\$41.40**  
Complete kit.....  
Wright DeCoster 8" speaker in metal cabinet.....**\$4.90**  
Receiver cabinet.....**\$4.80**  
Complete kit RCA tubes.....**\$3.32**  
Wiring and testing for lazy hams, including single signal reception with regenerative I.F.....**6.50**

## BLOWING OUR HORN!

In addition to our regular "over the counter trade" from the four corners of the earth, we are particularly proud of our REPEAT mail order business. With nearly 500 dealers in the field, LEEDS regularly furnishes supplies to 5% of the world's 60,000 radio amateurs located in this and 70 other countries.

## No 'Random Frequencies' at LEEDS

Our crystals provide the greatest accuracy at the lowest cost. All LEEDS crystals are 7/8" square with a guaranteed accuracy of plus, minus 1 kc. on 1.7 mc. and 3.5 mc. minus 2 kc. on 7.0 mc. Two days delivery on any desired frequency.

X cut 1.7 mc. and 3.5 mc.....	\$2.25
X cut 7.0 mc.....	\$3.25
AT cut 1.7 and 3.5 mc.....	\$5.00
Leeds crystal holder for UY socket mounting.....	\$1.00
Hill all metal adjustable holder	\$1.65

## Leeds Transmitting Tubes

provide the greatest power output at the lowest cost. Backed by our usual 90 day guarantee against all defects except filament and envelope breakage.

*203-A.....	\$8.45	†830-B.....	\$7.25
†210-11F.....	1.75	*838.....	11.75
866.....	1.50	†841.....	2.95
*211.....	8.45	845.....	11.50
†800.....	7.25	*852.....	11.50
†801.....	2.95	866-A.....	3.95

\*Graphite Anode Tubes

†Isolantite Base

Tubes Shipped by Express Only

## A THIN DIME

Now that the 1936 bulletins are available, we are renewing our offer of last year. A thin dime brings to you post paid the latest bulletins of 25 manufacturers of short wave equipment, together with our own B-73 bulletin. Far more information on the latest and best short wave equipment is contained in this assortment than can be found in any mail order catalog. Write for yours today.

## LEEDS Cased Oil Im- mersed Filter Condensers

Thousands of microfarads in use without a single case of failure.

	1000 V.	1500 V.	2000 V.
1 mid.	\$1.10	\$1.45	\$1.75
2 mid.	1.50	2.00	2.45

## LEEDS Type 1-B Freqmonitor

is now in use in hundreds of amateur stations. A complete description of this two purpose instrument may be found in the April 1934 issue of "QST". "Ask the man who owns one." Complete with **\$19.75** tubes and calibration chart....  
Our type 1-E Power Supply is ideal for use with the 1-B **\$6.50**  
priced at .....



**LEADS THE FIELD**  
World Wide Service to Amateurs

43 Vesey Street  
New York City

Telephone Cortlandt 7-2612  
Cable Address: "RADLEEDS"

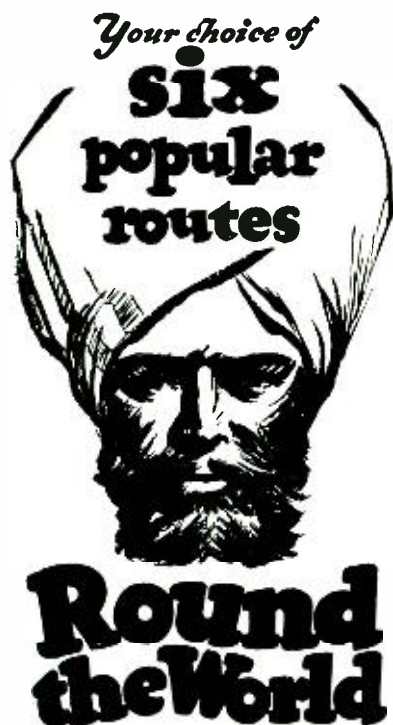

"ALL  
EXPENSE"  
TOURS  
ALSO  
AVAILABLE

◆ **CRUISE** around the world on a tour of your own planning—a cruise personally conducted by no one but yourself. Go where you please, stay in any land that suits your fancy. And your ticket is good for two years. Roam the seven seas—on either

side of the equator. New thrills await you . . . the mysteries of Asia . . . enchanting Bali . . . the spell of India . . . the drums of Africa . . . the Holy Land . . . Europe, New Zealand, Australia. Where do you want to go? Come in and discuss your plans with us. Over 200 itineraries from which to choose. Special round the world service.

### Send for Descriptive Booklet

Information regarding the various routes, fares and sailings are included in our new booklet, "Independent Round the World Tours". Ask your local agent or the Canadian Pacific: New York, Chicago, Los Angeles, San Francisco, Montreal and 32 other cities in the U.S. and Canada.



[Continued from Last Text Page]

out of it because . . .

No. 2) On February 29, 1936 this same Hawkins, now of dx fame, will be standing at the altar looking up that long, long aisle at his bride-to-be. Yes, 'tis true, fellows. But there is a little ray of hope at that, because she is Miss Retha Gompertz, the sister of W6DDO in San Francisco, and quite familiar with amateur radio.

W8BCT just snagged PK1BO, who was on 7130 kc. The QSO was about 6 p.m. e.s.t. PK is really a tuff one for the eastern U.S.A. Nice going, Ossie.

No, that is not a new commercial "V" wheel on the high frequency end of the 20 meter band . . . just the Sultan of Cannonsburg, W8CRA, and his new bug; or at least he claims it is a bug. Incidentally, Frank has a new QSL card, a real hot weather card, showing Miss September Morn. Pse QSL, OM!

### 80 Meter Dx

ZL2GN in a recent QSO with W8CNC informed him that the ZL's and VK's are going to make an effort to make the 3.5 mc. band a good dx band during March. Magee reports that most of the ZL-VK gang will be found between 3500 and 3650 kc. The best time to QSO them during March appears to be from 2:30 a.m. to 4:30 a.m., e.s.t. W8EUY, W8DCI, and W9AUT are doing fine 80 meter ZL-VK work right now.

Who . . . me? In the dx contest? Why, er—that is, ah, well if I, that is, I mean, naw, I'm just going to get on to work a couple of nines. Remember now, fellows, don't overload those 210's.

By the way, gang, all "dx" copy for the April issue of RADIO must be at my QRA by March 3d at the latest, preferably sooner.

### Sidebands and Modulation

[Continued from Page 64]

Further, although the voltage at the detector is equal and similar to that from the previously described systems, the peak antenna current is only I, and the peak power capability demanded of the tubes is only one-fourth. It is in this field of power saving, in the laying down of a tremendous phone signal with only small tubes, that the DSB-EC has its promise. The system will tend to eliminate heterodyning between adjacent stations, and, of course, will lend very well to duplex operation.

The DSB-EC system is not in general use because present-day development does not show a way to replace the carrier to the requisite accuracy. The resupplied current must, as suggested in the analysis of reception, maintain both zero beat and zero phase as compared with the suppressed carrier. If this condition is not met, there is a flutter, or waxing and waning, that effectively precludes good voice reception. An illustrative effect can be accomplished by beating a stable frequency meter against a phone carrier, and trying to hold the zero phase. Attainment of such is impossible for any length

of time, but the reception will hardly be tolerable, otherwise.

The single-sideband eliminated-carrier is created from a DSB-EC, usually by accepting only one sideband through a band-pass filter. A schematic circuit is depicted in the table, wherein a balanced modulator yields a DSB-EC output. The carrier frequency is applied in parallel to the grids of the tubes, and so balances out in the push-pull plate tank. In order to permit construction of a filter that will have the required sharpness of cutoff, it is necessary to produce the sidebands in the region of 50 to 150 k.c. If the SSB-EC must be on a still higher frequency, then it is usual to modulate the higher frequency by the first produced SSB. The separation of the new sidebands then is sufficient for a second band-pass filter to cut between. The spectrum of the single sideband is a duplicate of the audio modulating spectrum, but moved bodily out into the radio frequencies. Obviously, this is the first of the described systems which effects a saving in the band width.

The antenna current from a tone-modulated SSB-EC transmitter is a simple alternating current whose frequency is the sum of the tone frequency and the carrier frequency. To receive intelligibly the transmission it again is necessary to resupply a carrier at the receiver. The signal current for full modulation adds to the local carrier in the conventional heterodyne fashion, yielding a peak at the detector equivalent to 2I, and a dip equivalent to zero.

In practice, there is no such stringent tolerance in replacement of the carrier as is true for the DSB-EC wave. Entirely acceptable quality results if the carrier for the SSB-EC signal is resupplied to within 20 cycles or so. The maintenance of such stability for the duration of amateur conversations is perfectly feasible. If the new carrier is too close to the sideband the pitch of the voice is lowered; for instance, a tenor might be changed to a bass voice, and vice versa if the carrier were too far removed. The outstanding advantage of the SSB-EC method is the reduction in mutual interference between stations, due to the smaller band width required.

The first two modes of transmission described have been rather well exploited. The second two modes would have outstanding advantages if they were utilized in radio-telephone practice. The DSB-EC transmission is fairly easy to produce, but before general application can be made, apparently a method of accurately replacing or controlling the carrier must be devised. The reception of the SSB-EC transmission can well be done with conventional receivers and oscillators, but the method of creation must be vastly simplified before common usage occurs. Neither problem is easy—but—a problem well stated is half solved.

## THE DECKER COIL AND LINK

A LOW-LOSS WIRE COIL THAT TAKES A KILOWATT AND LIKES IT!

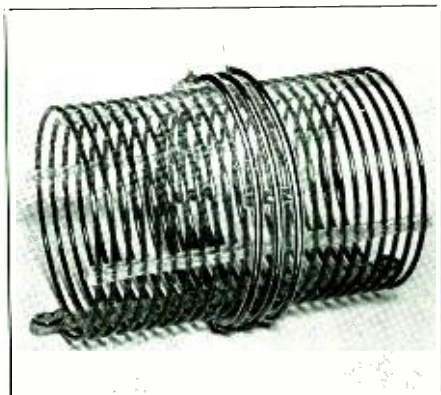

The final important improvement in "wound-on-air" wire coils has been achieved. The unavoidable mechanical weakness of copper wire has been overcome.

The new series "B" Decker Coil is made of a special high carbon steel-core wire. The Series "B" not only "Takes a kilowatt and likes it", but also smiles at mechanical abuse.

The electrical efficiency remains the same and the strength is increased enormously by the steel core.

Band	Coil	Series "A"	Series "B"
160	Final	\$4.15	\$6.25
80	Final	3.30	5.00
40	Final	2.90	4.40
20	Final	2.50	3.75
10	Final	2.10	3.00
All Bands	Link	1.50	2.50

Above prices are list  
40% discount extended licensed amateurs

When ordering, send us a diagram of the circuit for which you want the coil. Be sure to note the capacity of the condenser with which you intend to tune. We have a large selection of inductances in each band. WE SEND YOU THE CORRECT COIL TO RESONATE IN YOUR CIRCUIT.

The supporting material is fire-resistant and cannot be ignited from a soldering iron. This makes tapping easy, or, if requested, we do your tapping for you.

If your dealer cannot supply you order direct.

◆  
**DECKER MFG. CO.**  
SOUTH PASADENA, CALIF.



## Diversity Reception

[Continued from Page 68]

tions one oscillator is used for several receivers.

Whenever one set was turned off the fading was as bad or worse than with both. The noise was worse. The combination got all signals. We could hear well with either receiver, and some we could not get with either receiver alone. It made some signals sound better.

We did not find out which way fading travels. There seems to be no rule about it. If the broadcast listeners had not wanted their receivers back we would have kept on using diversity reception.

The Victor Talking Machine Co. was radio-minded long before the days of Victor radios or the merger with R.C.A. In 1918, this company produced and sold, in collaboration with the Marconi Institute, a series of code-practice phonograph records, including the very novel recording, *press with static*.

## NEW TRANSMITTING TUBES

The 834

R.C.A. has released to amateurs a new, general-purpose "low-C" tube that is especially adapted to u.h.f. work. The grid and plate are supported from the top of the glass bulb by individual leads which are brought out of the tube through separate seals. This construction insures low interelectrode capacities and minimum lead inductance. This new tube carries the type number 834, and may be operated at maximum rating at frequencies as high as 100 mc., and at reduced input up to 350 mc.

This new tube has a thoriated tungsten filament drawing 3.25 amperes at 7½ volts, and a 50 watt plate dissipation. Performance at lower frequencies may be taken as approximately the same as that of the well-known 800 type; at frequencies above 50 mc. an improvement will be noticed, due to the shorter internal leads and elimination of supporting material.

New High Mu, Low C, 35 Watter

One of our engineers, after gaining admission (or maybe he just sneaked in) to the *sanctum sanctorum* of the laboratory of one of the well-known transmitting tube manufacturers, returned with a story of a new high  $\mu$ , low C, 35 watter that is soon to be released. In fact he very nearly got away with one of the experimental models, but was unfortunate in not having an overcoat on at the time. However, we hope to have samples to "play with" by the time this appears in print, and next month we will have all the dope and perhaps a transmitter using the new tube. The tube has a  $\mu$  of 27; approximate transconductance of 2750  $\mu\text{mhos}$ ; 35 watt plate dissipation; and interelectrode capacities of less than one  $\mu\text{fd}$ . between any two elements. The plate lead is brought out the top of the envelope and the grid lead out the isolantite base. The nominal power output in class C is 90 watts at 1250 volts. The class B audio output (pair) at the same plate voltage is 130 watts. The filament is thoriated tungsten and draws 4 amps. at 5 volts.

W9DUM is a college station.



# COILS

... for ...

## R. M. Jones-Silver

5 TO 500 WATT

# TRANSMITTER

as described in December RADIO

No. 99—160 Meter Oscillator Coil.....List	\$1.50
No. 95— 80 Meter Oscillator Coil.....List	1.50
No. 98—160 Meter Doubler Coil.....List	1.50
No. 94— 80 Meter Doubler Coil.....List	1.50
No. 91— 40 Meter Doubler Coil.....List	1.50
No. 88— 20 Meter Doubler Coil.....List	1.50
No. 96—160 Meter Buffer Coil.....List	3.00
No. 92— 80 Meter Buffer Coil.....List	3.00
No. 89— 40 Meter Buffer Coil.....List	3.00
No. 86— 20 Meter Buffer Coil.....List	3.00
No. 85— 10 Meter Buffer Coil.....List	3.00
No. 97—160 Meter Grid Coil.....List	1.50
No. 93— 80 Meter Grid Coil.....List	1.50
No. 90— 40 Meter Grid Coil.....List	1.50
No. 87— 20 Meter Grid Coil.....List	1.50

40% Discount to Amateurs

## BUD RADIO, INC.

1937 E. 55th St.

Cleveland, Ohio



### TRADE IN YOUR RECEIVER

- HAMMARLUNDS-NATIONALS-RME 69
- MCMURDO-SILVER-PATTERSON. ETC.

### SCHWARZ RADIO SERVICE

15 LAWRENCE AVE. DUMONT, N. J.

## Contest

"Radio" is convinced that there are dozens of capable authors in the amateur ranks who have insisted upon "hiding their light under a bushel basket" and, as potential authors, need particular coaxing or incentive to rouse them to the extent of "taking pen in hand". We are therefore sponsoring a contest for the express benefit of these shy, retiring amateurs.

The rules of this article contest are as follows:

- 1) The contest is open to anyone who has had no feature-length article published in R/9 or Radio since July 1, 1934.
- 2) The article must be technical in scope to qualify; constructional articles will be given more "points" than non-constructional articles of the same merit. Photos count 25%.
- 3) Manuscript must be postmarked by March 30th.
- 4) All articles accepted for publication will be paid for at regular rates without regard to the contest.
- 5) The author of the article that is chosen as best of all entries submitted will receive, in addition to payment for the article at regular rates, a bonus of \$50.00.
- 6) No rejected manuscripts returned unless accompanied by a stamped, addressed envelope.
- 7) The members of the Radio technical staff will act as judges.
- 8) The story must be original and must not have appeared in other periodicals.
- 9) We reserve the right to declare "no contest" should not more than two entries suitable for publication be received and accepted at regular rates.

USE A

## Modulation Monitor

to Comply with FCC Rule 381



★ This modulation monitor reads directly percentage modulation on either positive or negative peaks and indicates carrier shift during modulation. May be used on frequencies from 500 to 30,000 kc.

*A simplified version of the type of required by the FCC in all broadcast stations by November 1, 1936. Requires no changes in your "rig".*

Net Price \$20.00

**DOOLITTLE & FALKNOR, Inc.**  
7421 SOUTH LOOMIS BLVD.  
CHICAGO, ILL.

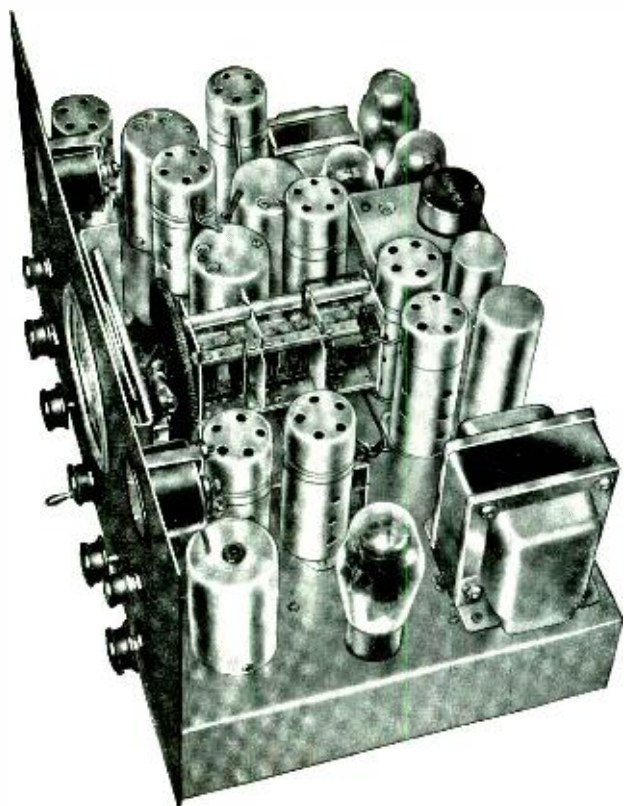

THE...

## BRETING 12

• An outstanding receiver especially adapted to amateur requirements, designed by Ray Gudie, generally conceded the most competent and successful designer of short wave radio today. We invite comparison, band for band, with any receiver on the market today, regardless of price or the number of tubes used. Your verdict will be the same as that of hundreds of amateurs who are Breting owners.

•  
Frequency coverage—550 to 32,000 kc.

Audio Output—Flat from 30 to 11,000 cycles, 18 watts at 5% distortion.

Meters—Two, one for carrier strength and one for percentage modulation.

Communication switch—Allows use of receiver as speech amplifier or modulator.

Price—\$93.00 net, complete with 12" speaker, crystal, and tubes, F.O.B. Los Angeles. Weight packed for shipment, 63 lbs.

•  
See your local jobber or write

**BRETING RADIO MFG. CO.**  
2117 Venice Blvd. Los Angeles, U.S.A.



Osockme, Japan.  
September 23, 1935.

Yours Truly Dear Sir  
Editor of RADIO,  
Dear Ed:—

Scratchi are asked what are his professions and to wits I reply that I build amateur equipment for sail, I repair defunct receiving sets, I are owner of a radio store, I are an insulting radio engineer for large radio corporation, and my wife support my family.

I were quite despondent of late, Hon. Editor, because I are in need of additional attractive offer for occupations to help boost up my present revenue which are nil. My wife make ravings and she say I do not live up to President Roosevelt's wish that every people over in United Shakes have two garages for each chicken on pot and three windows to throw such out from. She harp and drum on me musically with treacherous language until I decide to go down

by railroad tracks and wait for train to come by and make less of me.

While I are laying at correct phase angle across railroad tracks along come police copper who pick me up by neck and trot me to close-by jail house. He stand me up before Justice of the Pieces and third degree commence on me for fourth time. Hon. Judge ask me to give reasons why I are found on railroad tracks with one-way ticket to heaven in my coat pocket. I tell him it are all because of the great strain under which I labor. Long hours, many occupation, which begin at sunrise when I make open doors of radio store and play musical tune on cash register to make passing by prospect believe business are booming inside. I stay in store for four hours and then I go to repair shop and mop up drippings from grid leaks from cheap radio sets. Next four hour are spent at afternoon school where I teach student how to make shorter dots and fewer CQ callings. It are then 8 p.m. and I are then engaged for next four hour at Amalgamated Sophisticated Associated International Industrial Manufacturing Corporation for Radio Equipment of Japanese Empire, Ink. It are there where real hard work begin. Engineering problem in such factory are numerous and many, which include taking weights out of the Heaviseide Layer. Another problem which stump manufacturers over here are scarcity of air-ships to sell to amateur trade for Zeppelin antenna operation. It were later found advisable to ignore use of Zeppelin ships for such purpose and amateurs have all receive circular letter in mails which advise them to tie their antenna to a pole instead. Forthwith come back answers to such letters that immigration bureau find that no Poles have arrive in Japan in last nine years, and Scratchi are forced to start engineering problem all over again.

When such work are completed it are midnight on the dot, and next four hours are spent by Scratchi for purpose of scientific research. Long range guns for shooting crooners 3,000 miles away are in process of perfection by Scratchi and method are being devise to stop 5-meter bootlegging by simple process of suspending all amateur licenses for ninety days so that bootlegger will have nobody to talk to and few million investigators can then easily find locations where 5-meter bootleggers hide in the open.

So you see do you not, Hon. Ed., that Scratchi work 24 hours in each 24 hour day. I tell such woe-ful story to Judge at jail house and he take grate pity on me. He say, "I are sorry for you, Scratchi you lid, but please tell me how long have you been



**CHICAGO MORRISON HOTEL**  
In the Heart of the Loop  
SINGLE ROOM \$2.50 UP  
\$4.00 Double  
Each, with Bath, Servidor  
and Circulating Ice-Water  
**LEONARD HICKS**  
Managing Director

### Special Radio Services by Robert S. Kruse, E.E.

- For the Professional:  
Apparatus and station designs and improvements.  
Construction of special apparatus.  
Problems involving cathode ray equipment.
- For the Amateur:  
High-grade discontinued commercial transmitting equipment.  
"The Answer Factory," a low-cost information service on operating and constructional problems.  
Quotations on request.

**ROBERT S. KRUSE**  
GUILFORD, CONNECTICUT  
(Near New Haven)

working at such jobs?" To which I reply to Hon. Judge that I are supposed to start such heavy labors on following day and that are why I were found laying on railroad tracks. Hon. Judge then turn me over to Custodian of the Jug, where I again peacefully repose, waiting for you to bale me out once more again, Hon. Editor, for fear that Scratchi will be sent to Insane Asylums if you do not do so quickly.

Your destitoot subscriber,  
HASHAFISTI SCRATCHI.

### Portable Power Plants

D. W. Onan and Sons, Minneapolis, have just announced for 1936 a new, light weight, 110 volt, 60 cycle alternating current plant. Ideal for cottages, camps, summer homes and places where the user must

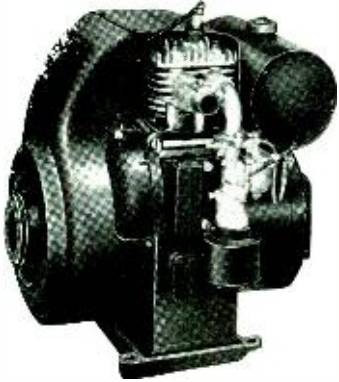

provide his own electricity, they are made in a standard and a light weight type for portable use. The latter are particularly adapted for operating sound car, public address, amateur, and radio communication purposes where no a.c. is available.

The 350 watt size is fully enclosed, streamline in design, has a 1 h.p., four cycle engine that turns over at 1800 r.p.m. Other sizes up to 3 kw. are available for heavier service.

## NEON OSCILLOSCOPE KIT

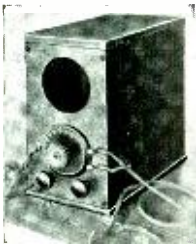

THE FINISHED JOB!

Radio amateurs—Experimenters will want this for viewing and demonstrating wave form, for making resonance and r.f. indicators and audio oscillators. Many other uses too. Neon oscilloscope tube is brilliant and has long life. *Complete kit only \$2.00 includes tube, clips, mirror and motor shaft adapter.*



OSCILLOSCOPE KIT

Write for folder or see at your jobber or order now from

**\$2.00 Net**

Prepaid with Tube, Clips, Mirror and Motor Adapter

**SUNDT ENGINEERING CO.**  
4236 LINCOLN AVE. CHICAGO, ILL.

(Affiliate of Littlefuse Labs. Makers of Instrument Fuses—Radio and Auto Fuses—High Voltage Fuses—Aircraft Fuses—Fuse Mountings.)

## IT'S TRUE!

It is to your advantage to buy from me. Your inquiry about any amateur apparatus will prove that to you.

I give you specialized personal service of genuine value that is not available from other jobbers.

I take in trade used apparatus. I sell on time payments.

I stock at wholesale prices all amateur apparatus. I am jobber for Collins, RCA, RME, Marine transmitters. Trade in your transmitter. Buy on time. Write for information.

I have in stock the new All Star transmitter kits. Supplied assembled at nominal cost. Also Radio-Silver transmitters.

I ship all receivers on ten-day trial. You need send but \$5.00 with order.

**FLASH—W9ARA can supply rotary beam antennas for 20, 10, and 5 meters.**

### TRADE IN YOUR TRANSMITTER OR RECEIVER

PR-16s complete prepaid.....	\$ 95.70
National HRO Jrs.....	99.00
Super Pros complete (At Last).....	194.04
RME-69s.....	118.83
National HROs.....	167.70
Bretting 12s complete prepaid.....	93.00
Super Skyriders complete.....	79.50
Silver 5Ds complete prepaid.....	109.80
RCA ACR-136s complete.....	62.50

Every inquiry and order is personally attended to by Robert Henry, W9ARA; an active amateur for eleven years; graduate E.E. from M.I.T.; and owner of Henry Radio Shop selling amateur apparatus for seven years. You can reach me by letter, telegram, or phone call 24 hours a day, 365 days a year. When in a hurry order from W9ARA. Write for any information.

## HENRY RADIO SHOP

211-215 North Main Street

Butler, Missouri

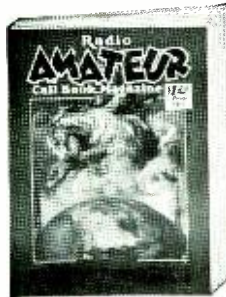

## The Most Complete Callbook Ever Published

Your QRA is listed in the latest edition

The only radio callbook published that lists all radio amateur stations throughout the entire World.

Also a complete list of high frequency commercial stations, International abbreviations and amateur prefixes, "Q, R, & T," systems for reporting signals, new US inspection districts and high frequency time, press and weather schedules.

Each copy contains a double post card addressed to the CALLBOOK for use in reporting your new QRA. We are extremely anxious to publish a callbook that will be 100% correct and want you to help us by checking your QRA at once in the latest edition and advise us of any errors.

**PUBLISHED QUARTERLY MARCH, JUNE, SEPTEMBER AND DECEMBER**

Single Copies \$1.25 Annual Subscription USA, \$4.00

Order your copy today from your local radio jobber or direct from:

**RADIO AMATEUR CALL BOOK, Inc.**  
606 South Dearborn Street, Chicago, Illinois



# BUYER'S GUIDE

Where to Buy It

## CALIFORNIA—Fresno

Ports Manufacturing Co.  
3265 E. Belmont Ave. Radio W6AVV  
National FB7-SW3 and Parts; Hammarlund, Cardwell, Blile; Crystals; Johnson Insulators Distributors RCA-DeForest Transmitting Tubes  
Established 1914 Send for Wholesale Catalog

## CALIFORNIA—Los Angeles

Radio Supply Company  
912 So. Broadway  
THE AMATEURS' HEADQUARTERS OF  
THE WEST

All Nationally Advertised Parts for Receiving and Transmitting Carried in Stock at All Times. 9 Licensed Amateurs on Our Staff.

## CALIFORNIA—Oakland

Radio Supply Company  
2085 BROADWAY  
Hammarlund, Yaxley, Carter, National, Johnson, IRC, Cardwell, Miller, Morrill, Flechtheim, Triplett, Haigis Transceivers.  
W6GFY

## CALIFORNIA—San Francisco



1452 Market Street  
"The House of a Million Radio Parts"  
Hammarlund and National sets and parts  
RCA and EIMAC Tubes.  
Arcturus Receiving Tubes.  
Trimm Phones, all types.  
Johnson Antenna Feeders, Insulators,  
Transposition Blocks.

## ILLINOIS—Chicago

CHICAGO RADIO  
APPARATUS CO., Inc.  
Established 1921  
415 SOUTH DEARBORN STREET  
(Near Van Buren Street)

ALL SUPPLIES FOR THE SHORT  
WAVE FAN AND RADIO AMATEUR  
QUOTATIONS FREELY GIVEN ON  
ANY KIT OR LAYOUT

Short Wave Receivers Taken in Trade  
Get our low prices

## PARTS REQUIRED FOR BUILDING EQUIPMENT SHOWN IN THIS ISSUE

The parts listed are the components of the models built by the author or by "Radio's" Laboratory staff. Other parts of equal merit and equivalent electrical characteristics may usually be substituted without materially affecting the performance of the unit.

### Jones 6A6-42 Transceiver

C<sub>1</sub>—Hammarlund type MEX  
C<sub>2</sub>—Hammarlund Star SM-15  
Switch—Yaxley type 762  
Transformers—U. T. C. light-weight series

### Brown 210 Modulator

Transformers—All Inca as follows:

CH<sub>1</sub>—Type D3  
CH<sub>2</sub>—Type D5  
CH<sub>3</sub>—Type D42  
T<sub>1</sub>—Type G16  
T<sub>2</sub>—Type L28  
T<sub>3</sub>—Type N12  
T<sub>4</sub>—Type C66  
T<sub>5</sub>—Type J5  
T<sub>6</sub>—Type B27

Microphone—Shure type 70-S  
C<sub>11</sub>—Standard Duco Electrolytics

### Gonsett 100 Watt Portable

C<sub>2</sub>—Cardwell MT-100-GS  
C<sub>3</sub>—Cardwell MR-365-BS  
C<sub>5</sub>—Hammarlund SM-50  
C<sub>6</sub>—Hammarlund SM-100  
C<sub>9</sub>—Hammarlund SM-35X  
MA—Triplett type 223  
RFC—National 100 (grid);  
Hammarlund CH-8 (plate)  
C<sub>13</sub>—Cornell-Dubilier Type  
T-D  
T<sub>1</sub>—Inca type C5  
T<sub>2</sub>—Inca type J31  
T<sub>3</sub>—Inca type B-15

## ILLINOIS—Chicago

NEWARK ELECTRIC CO.  
226 WEST MADISON STREET

The Best at Lowest Prices—Write for  
Complete Catalog

## MASSACHUSETTS—Boston

"Ben's"—Tremont Electric  
Supply Co.  
10 BOYLSON STREET

Up-to-date and complete line of short and long wave receiving and transmitting equipment.

## NEW MEXICO—Albuquerque

WM. H. ALLEN CO.  
BOX 641  
DISTRIBUTORS OF NATIONALLY  
ADVERTISED RADIO

## NEW YORK, N. Y. 227 FULTON ST.



Complete Stock of Amateur Radio Supplies  
at Wholesale Discounts

## PENNSYLVANIA—Philadelphia

M & H Sporting Goods  
Company  
512 Market Street

## PENNSYLVANIA—Pittsburgh

CAMERADIO COMPANY  
603 GRANT STREET

## WASHINGTON—Spokane

Spokane Radio Co., Inc.  
611 First Avenue



## The Marketplace

(a) Commercial rate: 10c per word, cash with order; minimum, \$1.00. Capitals: 13c per word. For consecutive advertising, 15% discount for 3rd, 4th, and 5th insertions; 25% thereafter. Break in continuity restores full rate. Copy may be changed often as desired.

(b) Non-commercial rate: 5c per word, cash with order; minimum, 50c. Available only to licensed amateurs not trading for profit; our judgment as to character of advertisement must be accepted as final.

(c) Closing date (for classified forms only): 25th of month; e.g., forms for March issue, published in February, close January 25th.

(d) No display permitted except capitals.

(e) Used, reclaimed, defective, surplus, and like material must be so described.

(f) Ads not relating to radio or radiomen are acceptable but will be grouped separately.

(g) No commissions nor further discounts allowed. No proofs, free copies, nor reprints sent.

(h) Send all Marketplace ads direct to Los Angeles accompanied by remittance in full payable to the order of Radio, Ltd.

(i) We reserve the right to reject part or all of any ad without assigning reasons therefore. Rates and conditions are subject to change without notice.

LARGE STOCK new and used equipment for sale by Southern Ohio's only amateur owned amateur business—Jos. N. Davies, Box 602, R.R. 9, North Bend Rd., Mt. Airy, Cincinnati, Ohio.

W9PCH may write for a free Handbook

SARGENT RECEIVERS \$59.50—W8ANT.

VIBROPLEXES, rebuilt \$5-\$7, guaranteed. New large base bugs \$9. Lydeard, 28 circuit, Roxbury, Mass.

BREITING RECEIVERS—in stock—W8ANT.

W9ECS may write for a free Handbook

NEON TUBES, four inches, for RF testing, Oscilloscopes, special lengths made to order. Postpaid (U. S., Canada) \$3.00. W8AXB, GLOMU SPECIALTIES, 3411 Harrison Avenue, Cheviot, Ohio, Dept. B.

QSL's, SWL's-Cards. Finest quality stock. Very attractive. Photo type. Different. Very reasonable. Samples? (Stamps). RADIO-PRESS-W8ESN, 1827 Cone St., Toledo, Ohio.

USED TUBES—852's, 860's, 800's, 42A's—W8ANT.

SELL: 852's, 1 Kw. Transformer, Crystals, Holders, Old UV202's, 50 watter, Generator, 300 miscellaneous parts. Illustrated list. Lane Jackson, Independence, Missouri.

JANUARY "RADIO", limited number of copies, 30c in U.S.A. Edward Byrne, 253 W. 128th St., New York.

A free Handbook to W1HBI

RELAY RACKS—cheap—W8ANT.

TRANSFORMERS REWOUND and built to specifications. Very best quality materials and workmanship. Ecoff Transformer Co., 1929 Forest Ave., St. Louis.

ONE Handbook free to W8EQN

"100 WATTS WITH A HANDLE ON IT", portable transmitter described in this issue, laboratory model to be sold for approximate cost of parts, \$47.50 F.O.B. Los Angeles, less key, relay, tubes, and crystal, 80 meter coils included. RADIO, 7460 Beverley Blvd., Los Angeles. Include tax if in California.

GUARANTEED TRANSFORMERS and chokes. Power supplies, modulation equipment, microphones, amplifiers, preamplifiers, etc. Universal class B transformers, 100 watts, pair \$8.00. Racks and panels, all sizes. Ampere tubes. Langrick Radio Engineering Service, W6PT, 626 Maltman Avenue, Los Angeles.

PYREX 3" stand-offs—35c—W8ANT.

A free Handbook to W4AGW

WANTED: Old radio sets or parts for ham antique collection. All letters answered. W6LM.

FOR SALE: 6A6-42 5 meter transceiver described in this issue. Price \$15 less tubes. Frank C. Jones, 2037 Durant Ave., Berkeley, Calif.

SHIELD CANS, 7 x 10 x 6 1/4". Steel, crackle finished. Removable panel and deck. Hinged lid. \$2.20. Six pounds. R. H. Lynch, 970 Camulos, Los Angeles, Calif.

DANGER! High voltage card (red and blue), 10c; CALL-BOOKS, \$1.25. Biley 14 mc. crystal, \$7.50. W8DED, Holland, Mich.

CRYSTALS: SATISFACTION OR MONEY BACK. 160-80 meters within 10 kilocycles Y-cut \$1. X-cut \$1.35. Wright Laboratory, 5859 Glenwood, Chicago, Ill.

FOR SALE: One Westinghouse 500 volt d.c. motor generator set in good condition, \$18.00. Motor is 110 volts a.c. W9CDE.

QSL SWL Cards, neat, attractive, reasonable. Samples free. Miller, Printer, Ambler, Pa.

METERS: New and used Weston, Jewell meters at bargain prices. All types, perfect condition, individually checked. Free bulletin. W2EDW, Far Rockaway, New York.

WHEN you don't know what to build it in, see R. H. Lynch, 970 Camulos, Los Angeles. Steel cabinets and racks, aluminum cans, panels. Special sizes to order. Send for circulars.

TRANSFORMERS, chokes, all types. Reasonable. Guaranteed. Special universal class B inputs and outputs 100 watts audio—pair \$8.00. California Radio Labs., W6CYQ, 2523 South Hill Street, Los Angeles.

WANTED: Edison storage "A" batteries, UX852s. Grote Reber, Wheaton, Illinois.

NEW EIMAC 300T—\$60.00—W8ANT.

FINE QSL's! SWL's! Samples. W9UHI Press, 2009 Fremont Street, Chicago.

QSL's, 300 one-color cards \$1.00. Samples. 2143 Indiana Avenue, Columbus, Ohio.

SELLOUT. Complete station comprising 500 watt remote controlled transmitter, rack mounted, 345 final; frequency-meter-monitor; modified FBX with regenerative preselector; EO-1 cable; insulated guys; boxes of spare C's, R's, etc. \$345 f.o.b. Honolulu. Capt. R. E. Pirtle, Wheeler Field, Oahu, T.H.

CASCADE MODULATED 210 TRANSMITTER described in this issue by Martin Brown. Sell for approximate net cost of parts, \$80 F.O.B. Los Angeles. Price includes 80 meter coils but less microphone, tubes, meter, and crystal. This includes power supply unit, modulator and speech unit, and radio frequency unit. RADIO, 7460 Beverley Blvd., Los Angeles.

COMPLETE 1935 volume "RADIO", January to December. Several on hand. \$3.00, postpaid. Pacific Radio Pub. Co., 422 Pacific Bldg., San Francisco, Calif.

ONE Handbook free to W6CYO

AIR-WOUND coils—W8ANT.

GENERAL ELECTRIC dynamotors 24/750 volts, 200 mills., \$25.00. Two for 1500 volts \$40.00. Westinghouse 27/350 \$10.00. 500 Watt, 500 cycles, \$10.00. List. Harry Kienzle, 215 Hart Blvd., Staten Island, New York.

75-160 DE LUXE PHONE TRANSMITTER, complete. Uses 2A5 into 210 into two Sylvania carbon plate 210's, 75 watts input. Continental two-button mike with desk stand. Speech: 56, 56, 2A3's, 46's class B. Factory built metal racks (two) complete with dust covers; 14 inches wide, 19 high. National dials, 4 Triplet meters. Complete, ready to operate including 75-160 coils, 160 crystal, all tubes and mike. Parts alone cost \$175 net. Will sell \$125 F.O.B. Has very good quality and delivers a good "sock". W6VR, 902 So. Cloverdale, Los Angeles.

WE have our PR-16 and can make deliveries. Used sets and parts. List Free. W9OC, Spencer, Iowa.

SUPER-SIGNAL, the new crystal supreme, \$5.00. Information on request. Also V, AT, and X at popular prices. W1BD.

SELL or trade Esco 2000 volt motor-generator. Want big bottles, big filter chokes and condensers, meters. W5KD.

# 7000 Kc XTALS

Thick C & S cut—Highly Active—  
Low Drift—Single Freq.—Cleaner  
Note—Close to Freq. Guaranteed \$2.25

80M-160M—C & S cut as above.....\$2.00 pp.  
80-160M—Thinner Cut Low Drift.....\$1.35 pp.

**C&S XTALS**

836 E. WEBER AVE.

STOCKTON, CALIF.

# EIMAC Tubes for Greater DX

Practially all DX work is done on frequencies higher than that on which the majority of transmitting tubes were ever designed to operate. It is logical that maximum results will be obtained from equipment designed to give maximum performance at these frequencies.

## EIMAC TUBES ARE SPECIFICALLY DESIGNED TO GIVE MAXIMUM PERFORMANCE ON FREQUENCIES UP TO 100 MEGACYCLES

The "dyed in the wool" DX man will appreciate at once these obvious advantages of EIMAC tubes.

### RELIABILITY—

- (1) Conservatively rated.
- (2) Tantalum electrodes assures complete freedom from gas failures.
- (3) Complete freedom of internal insulator failures.
- (4) Large, rugged, thoriated tungsten cathode.
- (5) Time tested dependability.

### EFFICIENCY—

- (1) Lowest interelectrode capacities of any tubes with equal power ratings or capabilities.
  - (a) Neutralizing easy and effective on the highest frequencies.
  - (b) Eliminates spurious sidebands caused by faulty neutralization of high capacity tubes.
- (2) Ease of excitation caused by the low values of grid current necessary for optimum performance.
  - (a) EIMAC tubes have exceptionally high power gain eliminating cumbersome buffer stages; greatly facilitating rapid band changing.
- (3) High efficiency and output at any plate voltage makes EIMAC tubes the logical choice for ALL transmitters.
- (4) Ample filament emmission permits highest possible power output to input ratio.
- (5) Adequate grid and plate insulation minimize losses of r.f. power at these points.

## RELIABILITY AND HIGHEST EFFICIENCIES ARE ESSENTIAL FOR GREATEST DX



### AN EIMAC TUBE FOR EVERY PURSE AND PURPOSE

TYPE	PLATE DISSIPATION	CLASS "C" OUTPUT	PRICE
EIMAC 50T.....	75 watts	250 watts	\$13.50
EIMAC 150T.....	150 watts	450 watts	24.50
EIMAC 300T.....	300 watts	800 watts	60.00
EIMAC 500T.....	500 watts	1350 watts	175.00

EIMAC tubes at all leading dealers.

## EITEL-McCULLOUGH, INC.

SAN BRUNO, CALIFORNIA  
U. S. A.

CABLE "EIMAC"

**NEW CROSLY  
SAVAMAID  
FOOT-CONTROL IRONER**  
(Model 60)

Handles every thing from laciest frills to heaviest garments in a minimum of time. No personal instructions needed, it's so simple. As effective as most expensive ironer. Just *guide* the garment through . . . it comes out with perfect satiny sheen. A marvel to demonstrate.



**\$49.95**

With Pump \$59.95

**THE CROSLY SAVAMAID**  
(Model 61)

A high-grade washing machine, standard in design and features. Heavy pressed-steel chassis, tub vitreous-porcelain-enameled inside and out. Mounted on rubber. Latest type Lovell wringer. Oilless bearings, enclosed transmission. Smart two-tone appearance.



**\$49.95**



**\$99.95**

**THE CROSLY  
SAVAMAID  
SPE-DRY**  
(Model 64)

Improved spinne-type washer. You can wash, blue, rinse, dry right in the washer itself. Possible, even, to do a complete washing without wetting the hands. More than a washing machine . . . a complete new *method* and routine for washing that enables the housewife to cut the thirteen tiresome things she now does when washing clothes to five simple things. Highest quality, handsome appearance. A crowd collector when demonstrating.

**CROSLY**

**FIRST in Radio Value  
FIRST in Refrigerator Value**

**Now FIRST In Home Laundry  
Equipment Value!**

More than a million and a half washing machines will be sold during 1936. Home laundry equipment is a tremendous business, one that has suffered less from unfavorable conditions than any other home utility. Crosley now enters this field with a sensational line of washing machines and ironers, containing features that lift them clear out of competition...priced to meet all comers: styled for today. Models to meet every purse and viewpoint.

This decision gives to Crosley dealers a new contact with their market, a new opportunity for

year-round profit, a new point of interest to bring people to the store, a new possibility for increased sales of Crosley radios and Shelvadors, as well as home laundry equipment, a new kind of crowd-collecting store demonstration.

Match washing machines or ironer against anything, and you will realize that, from now on, your customers need not pay high prices for the best laundry equipment that can be made.

Savamaid Models 61, 62, 63 equipped with gas engine assembly at additional cost.



**\$69.95**

WITH PUMP \$78.95

**\$79.95**

Standard  
(Model 62)  
De Luxe  
(Model 63)

WITH PUMP \$89.95

**THE CROSLY SAVAMAID**  
(Models 62 and 63)

Featuring the sensational Crosley VELVETOUCH wringer that insures full wringing action even when clothes are bunched. No careful feeding necessary. So resilient you can run a long chain through it; so safe it won't break a glass eye-dropper; so positive in action that it leaves no saturated spots. The most interesting demonstration imaginable. Washer has special Mid-zone agitation. Highest quality throughout.

**The Crosley Radio Corporation**

POWEL CROSLY, Jr., President

CINCINNATI

(Prices slightly higher in South and West)



Most Complete Transformer  
Line in the World

**QUALITY · RELIABILITY**

Now Available

**NEW** HIGH POWER  
CLASS B INPUTS AND  
OUTPUTS for the 150T, HF300,  
HK354, 849, 204A, 838 tubes

UTC class B audio and power components are available for every type of transmitter. Thorough research, expert engineering design and exacting laboratory checkups are responsible for the enviable reputation of UTC products.



The output transformer illustrated, designed either for 204A's or 849's in class B, has a linear response from 30 to 12,000 cycles. The unit is oil immersed and shielded in a heavy gauge high permeability casting. All leads are terminated in high tension ceramic bushings. The transformer is insulated for 20,000 volts and will handle 1000 watts audio power.

**INPUT TRANSFORMERS**

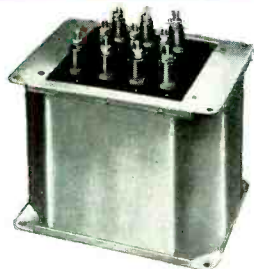

	<u>LIST</u>	<u>NET</u>
<b>PA-238</b> Push pull parallel 2A3, 45, 50 plates to four 838 or 203 Class B grids	17.50	<b>10.50</b>
<b>PA-239</b> Four 2A3, 45, 50 or two 211, 845 plates to Class B 204, HF 300 or 849 grids	17.50	<b>10.50</b>
<b>PA-501T</b> Four 2A3, 45, 50 or two 50T, 211, 845 plates to Class B or 150T grids	17.50	<b>10.50</b>
<b>PA-512</b> 500, 200 or 50 ohm line to two 150T, 204, HF 300 or 849 grids	20.00	<b>12.00</b>

**OUTPUT TRANSFORMERS**



	<u>LIST</u>	<u>NET</u>
<b>PA-601</b> Primary arranged to match 838 or 203 Class B plates to 6500, 5000 to 3500 ohm RF load	32.50	<b>19.50</b>
<b>PA-438</b> Primary arranged to match push pull parallel 838 or 203 Class B plates to 6000, 4000 or 3000 ohm RF load	50.00	<b>30.00</b>
<b>PA-489</b> Primary arranged to match 204A, HF 300 or 849 Class B plates to 6500, 5000 or 3400 ohm RF load	125.00	<b>75.00</b>
<b>PA-150T</b> Primary arranged to match Class B 150 T's or HK 354's in A prime or Class B at various plate voltages. Specify primary plate voltage and secondary RF load when ordering	125.00	<b>75.00</b>

Write to Mr. Mills for our FREE new 44 page technical bulletin on Transformers and Amplifier Circuits.

WIN A TRANSMITTER · Write for details or watch this page in the next issue.

**UNITED TRANSFORMER CORP.**

72 SPRING STREET

NEW YORK, N. Y.

EXPORT DIVISION - 15 LAIGHT STREET, NEW YORK, N. Y.