

NOVEMBER, 1929

RADIO

REG. U.S. PAT. OFF.

25 CENTS



NEWER than Screen Grid

A year ahead of the field: the new Grebe. The trade has known it since June when it made its bow at the National Radio Show. Now the public knows it too. While the trade talks and the public reacts to the Grebe advertising, franchise-holders are reaping profits. It will pay you to take on the Grebe franchise for your district.

Grebe radio

SUPER-SYNCHROPHASE  

A. H. GREBE & CO., Inc., Richmond Hill, N. Y.
WESTERN BRANCH, 443 So. San Pedro St., Los Angeles, Calif.

3450

SCREEN GRID CHASSIS

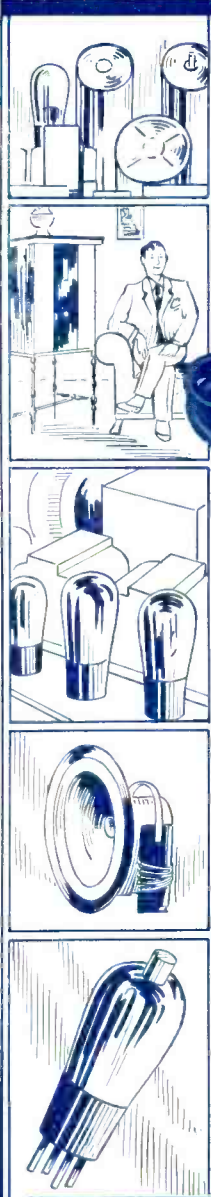

FREE
Radio Catalog



A POWERFUL super-sensitive A. C. receiver that answers today's demand for the ultra-modern in a high-grade screen grid receiver. It offers everything you look for that is modern in radio. Nothing has been overlooked to secure outstanding quality—advanced engineering features—or efficient performance.

It is establishing a new standard of perfection in radio design. Incorporating such advanced features as screen grid R. F., power detector, "245" push-pull power audio, dynamic tone quality plus practical scientifically shielded construction, it is blazing a new trail in perfection of circuit design. Its super power assures unusual distance range—its ultra-selectivity adapts it for use in the most congested broadcasting districts. Its remarkable tone quality and tremendous volume win for it the instant admiration of the radio purchaser.

Write Today for this new 196-page catalog full of all the latest in radio showing the new, humless, Screen Grid A. C. all-electric and battery operated sets. Beautiful consoles, dynamic speakers, accessories, parts, kits; in fact, everything in radio and all at rock-bottom wholesale prices. Hundreds of real radio bargains from a Radio House backed by over \$3,000,000 in resources. This book will save you money. Send for it now before you buy anything more in radio supplies!

Use the Coupon

ALLIED RADIO CORPORATION
711 W. Lake St. Dept. E-2 Chicago, Ill.

Allied Radio Corporation,
Dept. B-3
711 W. Lake Street, Chicago, Ill.

Please send me your new 1930—196-page radio catalog—which we understand is to be absolutely free.

Name.....
Address.....
City..... State.....

Guaranteed QUALITY...!
...that reduces service calls!..!



HOW often the service calls that follow a sale overbalance the money you've made on it! TRIAD quality stops this dangerous leak in your profits. When you sell a TRIAD Tube, you're sure of the satisfaction it will give. You're sure also that it will still be giving the same trouble-free performance long months afterward. TRIAD quality is *insured!* A printed certificate, accompanying each tube, *guarantees* a minimum of six months' perfect service—or a satisfactory adjustment will be made. *Cut your service calls to a minimum*—stock TRIAD trouble-free tubes! They sell faster and easier, they assure customer satisfaction and dealer protection. They represent your greatest profit opportunity!

TRIAD MANUFACTURING CO., INC.
PAWTUCKET, R. I.

Call your jobber or write us direct for complete TRIAD information.

▼
West Coast Representatives
W. J. NOEL
508 Eddy St., San Francisco, Calif.
R. C. JAMES
Pioneer Bldg., Seattle, Wash.

TRIAD
INSURED
RADIO TUBES

T O

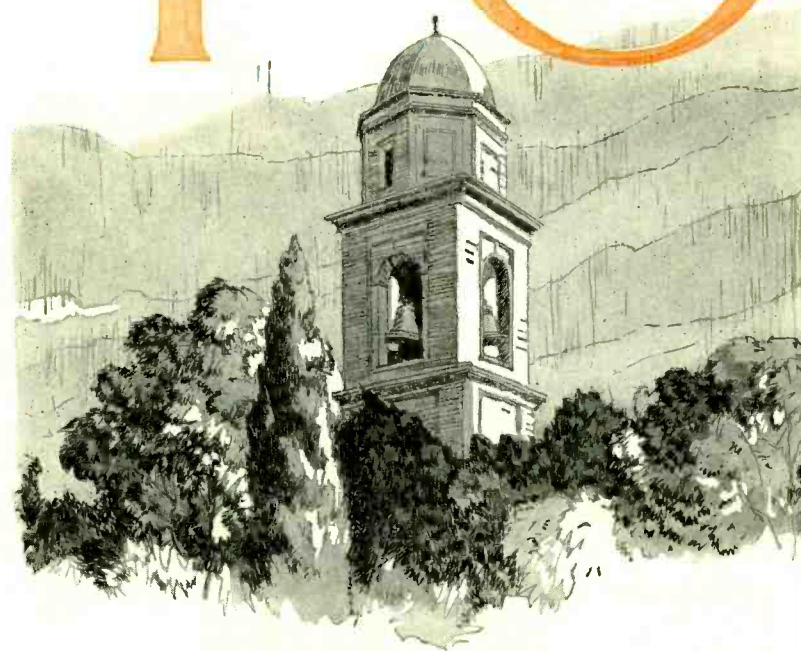
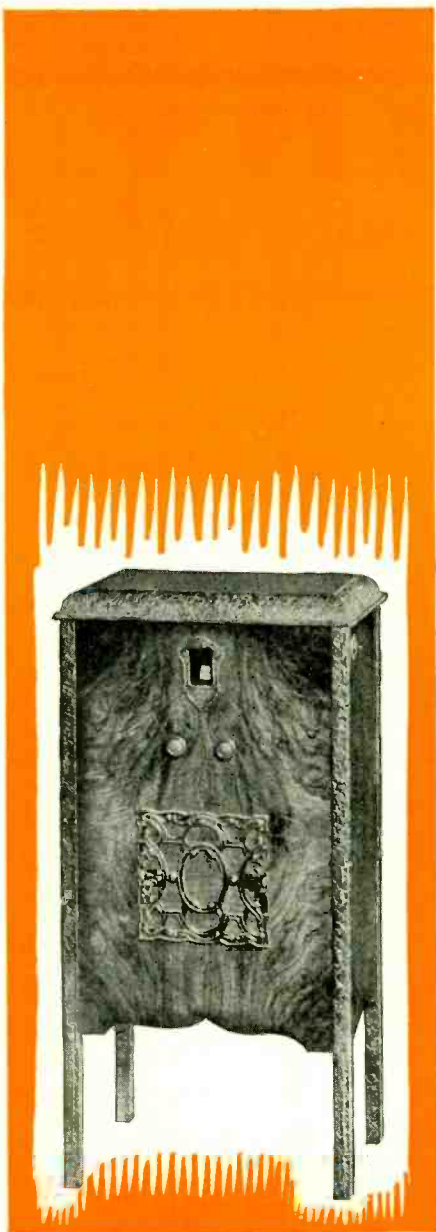

The Troubadour

The Ideal set for small homes or apartments. 3 screen grid tubes—perfect for long range reception. Less tubes. \$129.50

THE FINEST performing set ever made—and the best looking. All the latest mechanical improvements unite to give the Sterling Concertone its magnificent Tone. Sensitive and selective beyond anything else so far developed Screen-grid, push-pull amplification, all stages shielded, electro-dynamic speaker In handsome cabinets (three models) that sell themselves Give your prospects the "ear test"—let them hear the Sterling Concertone, and they'll never be satisfied with anything else A few choice districts are still open to reputable merchants Inquire by mail today, or ask your jobber Sterling of Cleveland, for more than 23 years one of America's leading manufacturers of delicate electrical instruments and radio appliances.

THE STERLING MANUFACTURING COMPANY · Cleveland, Ohio

NEW



Imperial

Beautiful Walnut high-boy; 3 screen grid tubes, with each stage completely shielded. \$187.50
Less tubes.



The Serenader

A handsome, medium sized Walnut low-boy, 3 screen grid tubes afford perfect long range tuning. \$149.50
Less tubes.

Sterling
CONCERTONE
RADIO
MADE BY STERLING OF CLEVELAND

Prices slightly higher in far West

Tell them you saw it in RADIO

The Big 3 for Quick Sales

Performance—

Good Looks—

Low Price

ALL three are well represented in the New 1930 Browning-Drake, plus many other points, which make for easy, profitable selling. For example, *construction*. Backed by a reputation for quality over many years, Browning-Drake construction assures maintenance of performance and so keeps customers satisfied.

Browning-Drake tone, selectivity, distance-getting—all are unsurpassed by sets selling at twice the price.

Do not overlook this good "buy." Some good territories still open.

Send for full information

Browning-Drake Corp.
224 Calvary Street
WALTHAM, MASS.

Builders of quality radio for five years

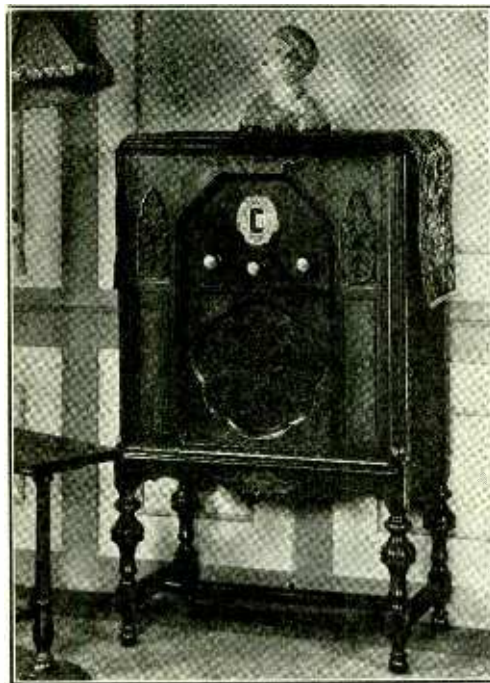

MODEL 56

Screen-Grid, Small Console, 42x25x15, \$154.50
less tubes

MODEL 66

Heater Type, Small Console, 42x25x15, \$149.50
less tubes

Prices the same throughout the country

Some Details You'll Want to Know

1. Semi-automatic tuning, both kilocycles and call letters on dial.
2. Five tuned circuits—nine tubes.
3. Tuned antenna.
4. Push-pull audio (245 power tubes).
5. Power detection (plate rectification) optional.
6. Hum eliminator.
7. Band-pass filter effect (10 kc selectivity).
8. Mershon trouble-proof condenser.
9. Voltage regulation adjustment (manual).
10. Power unit integral part of chassis.
11. Large size dynamic speaker.
12. Phonograph, short-wave and television connections.
13. Selected walnut and American gum wood cabinet.
14. Hand-rubbed satin Duco finish.

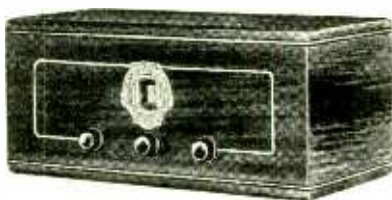

MODEL 53

Table Model, Screen-Grid Type, list, \$102.50
less tubes

MODEL 63

Table Model, Heater Type, list, \$98.00
less tubes

Prices slightly higher West of Rockies

Browning-Drake

RADIO

Eight models, table and console, heater and screen-grid types

Nearly 1,500,000 People Are Using Browning-Drake Sets



An
INDUSTRY
measures its
PROGRESS

Tone quality is the yardstick



CONSTANTLY the objective of the radio industry has been better *tone quality*. For successive years all known features of the radio set have been improved and exploited, but today *tone quality* definitely measures the success of any radio receiver. The industry's success now rests on *tone quality* and its future promise of progress rests on *tone quality*.

Many of the industry's leading manufacturers depend for their superiority on the tone quality of Jensen Electro-Dynamic Speakers.

In each case the laboratories of these manufacturers, in collaboration with Peter L. Jensen, adapted these speakers to their specific needs. Dealers who sell these sets pin their faith in making the sale on the superior tone quality and shrewd dealers insist on sets equipped with Jensen Electro-Dynamic Speakers.

Write us for the names of Jensen equipped sets and for information regarding the Jensen Auditorium, Concert and Standard Electro-Dynamic Speakers.

Prices from \$25 to \$100 (including both units and cabinet models). Attractive trade discounts.



JENSEN RADIO MANUFACTURING CO. · 6601 S. Laramie Ave., Chicago, Ill. · 212 Ninth St., Oakland, Cal.

Tell them you saw it in RADIO

...and here's

Kylectron

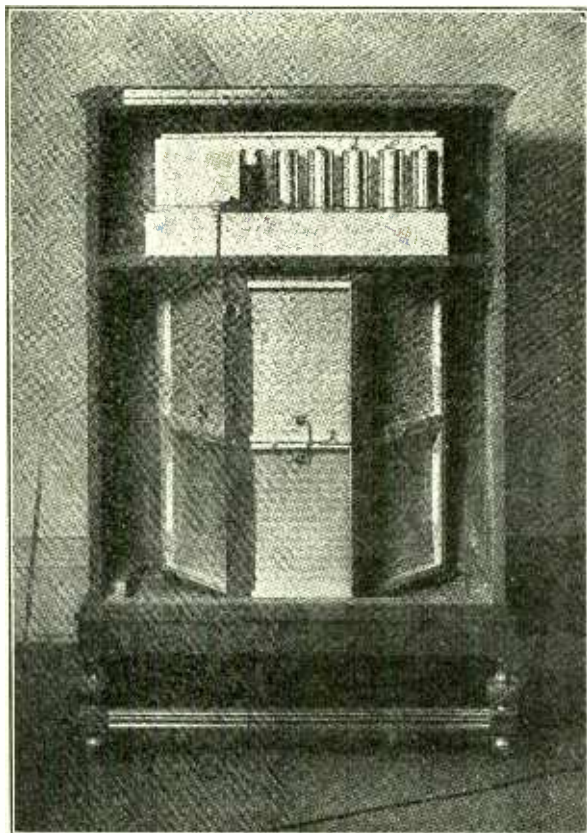

Here's Kylectron—the *only exclusive selling feature of any radio today*. It's not an attachment—not just an improvement. It's an *entirely new method of sound reproduction*. The results it brings to radio are truly amazing.

Radio engineers have pronounced Kylectron the “most direct method of sound transmission.” To the radio listener that means *true* radio. It means reproduction without distortion, without over-accents of treble or bass. It means perfect response over the entire broadcast range.

When you know *all* about Kylectron—what it is and how it works—you'll realize *why* it is the “biggest development in radio since the first tube set.” And you'll realize why the three words “equipped with Kylectron,” followed by a demonstration of Kylectron *tone*, are worth more than hours of selling talk about the ordinary radio.

Offered only on...

COURIER *and*
PEERLESS *Radios*

***"It isn't radio . . .
it's the human voice"***



... the new method of Reproduction!



At the Chicago Show

Kylectron was first introduced at the Chicago Show in May. Experts were amazed. All Chicago stampeded the Boston Store to see and hear the new radio sensation.

—at the New York Show

At New York again, Kylectron was the sensation of the show. Dealers' shops were filled with people who wanted to know more about the development that was revolutionizing radio.

—and everywhere else

The same enthusiasm greets Kylectron every place it is shown. People read about Kylectron in the newspapers. They visit the dealer who offers Peerless and Courier Radios. They see—hear—marvel. And they buy. They're buying these radios so fast it's keeping four factories busy filling orders.

NO wonder Peerless and Courier Radios, equipped with Kylectron, are causing a sensation wherever they are shown. It would be a wonder if they didn't!

Other radios have improvements—refinements—attachments of one kind and another that improve reception or sharpen selectivity. Certainly, Courier and Peerless sets have all these improvements too. Screen grid—power detection—single dial tuning—single light socket operation and all.

But—and here's the big point—only Peerless and Courier Radios have Kylectron. And Kylectron is *more* than an attachment—*more* than just an improvement—*more* than a refinement. Kylectron is an entirely *new method of sound reproduction*. It's new as the first vacuum tube was new. And it offers a dealer the same opportunity for profit that an exclusive franchise for tube sets would have offered a few years ago.

Don't ever look back on 1929 as the year you overlooked a big bet. Grab this chance. Kylectron is going over big now. But compared to what it's *going* to do, its present sensation is less than nothing.

If you don't already handle Peerless and Courier Radios, write, wire or phone your distributor at once. Get your share of business from the swarms of people already interested in Kylectron—already *wanting* to hear it—and all ready to *buy* the radio that has it. Get the details now—*today!*

UNITED REPRODUCERS CORPORATION
Springfield, Ohio

Tell them you saw it in RADIO

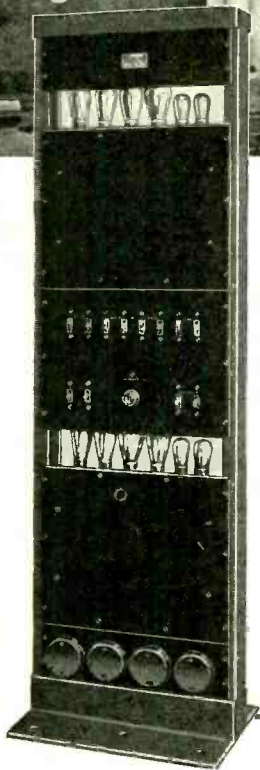
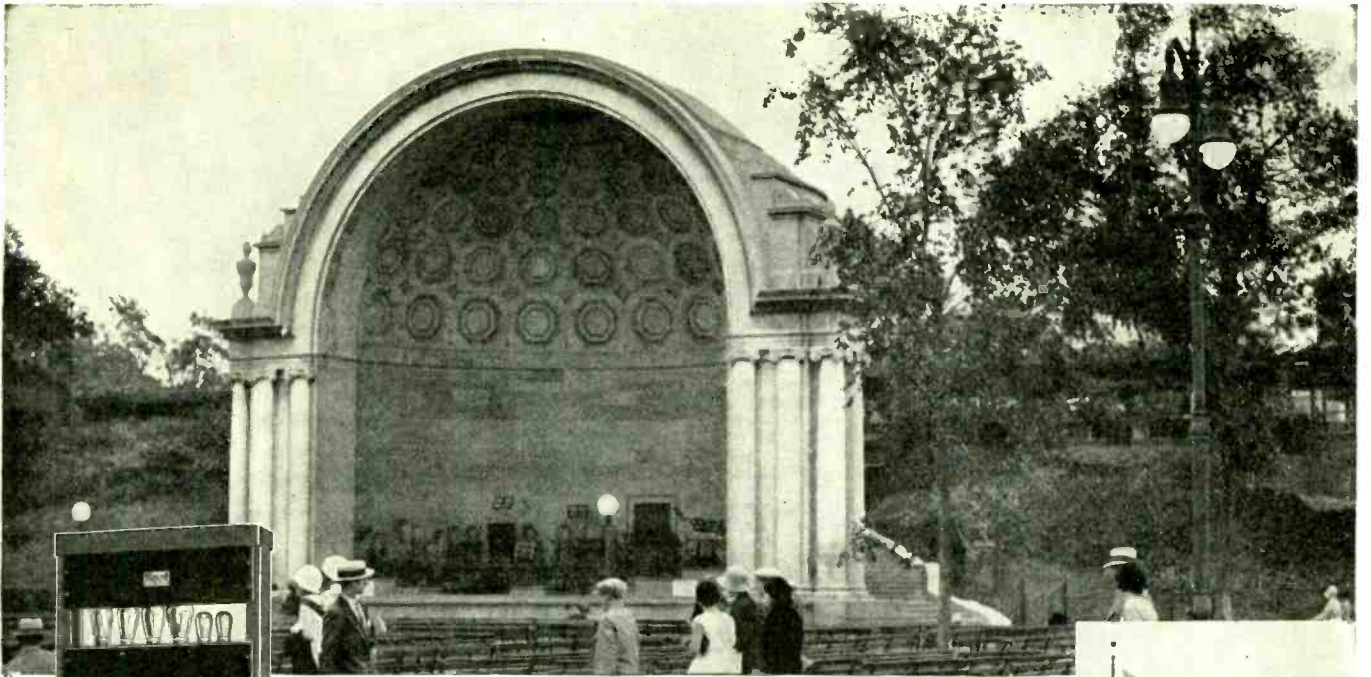

2-V PAM 19

New York Parks are PAM Equipped

IN CENTRAL PARK, NEW YORK, programmes such as Goldman's Band, speeches originating in the bandstand, etc., are picked up and amplified by a PAM amplifier similar to that illustrated at the left and fed over wires to twenty-five municipal parks in other sections of the city.



One of New York's Parks

In each of these other parks is installed a 2V PAM-19 shown above which supplies reproducers located at proper points, thus permitting simultaneous quality reproduction at widely separated points.

The parks in your city are logical prospects for a similar type of equipment.

Have you seen your park authorities?

A new 16-page bulletin giving mechanical and electrical characteristics, representative installations and many new PAM amplifiers will be sent upon receipt of 10 cents in stamps to cover postage. When writing ask for bulletin No. R-13.

Main Office:
Canton, Mass.



Factories: Canton and
Watertown, Mass.

Manufacturers Since 1882

PACIFIC COAST OFFICES:

327 Tilden Sales Bldg.
SAN FRANCISCO, CALIF.

324 North San Pedro Street
LOS ANGELES, CALIF.

2607-11 Second Avenue
SEATTLE, WASH.

637 East Broadway
PORTLAND, ORE.



EVEREADY RAYTHEON

4-PILLAR TUBES

BRING OUT THE BEST THAT'S
IN ANY RADIO RECEIVER

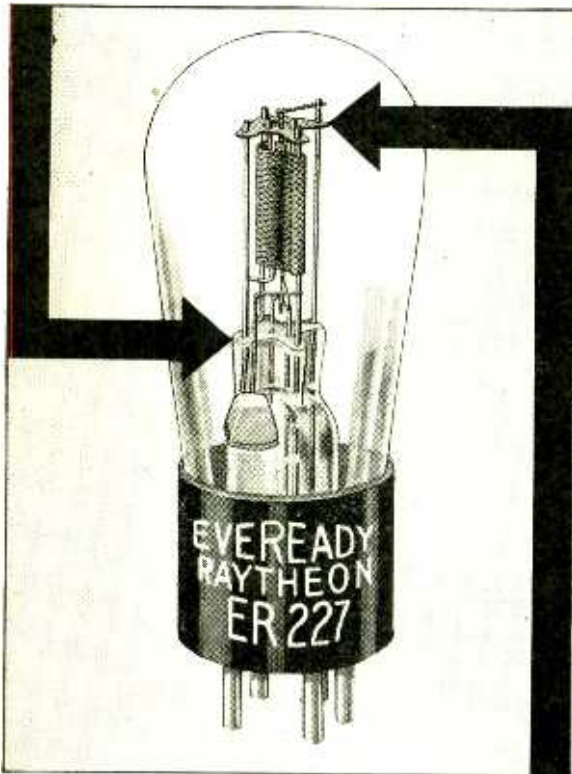

Trade-marks

THE GREATLY superior performance of new Eveready Raytheon Tubes means the very best reception a radio receiver can give. People in all parts of the country report amazing results from their own receivers since installing these marvelous new tubes. Greater distance, more power, improved tone, quicker action!

Put a new Eveready Raytheon Tube in each socket of a receiver—and note the vast improvement. Then examine one of these tubes. Observe the solid, four-cornered glass stem at the base of the elements, supporting the four rigid pillars which hold the elements. Notice how the elements are anchored at both sides as well as at the ends. Note how this 4-Pillar construction is braced still further by a stiff mica plate at the top.

The jolts and jars all tubes receive in shipment cannot distort the elements in an Eveready Raytheon. Handling these tubes and installing them cannot impair their performance. For the elements are permanently held in their correct and accurate positions by the patented Eveready Raytheon 4-Pillar construction.

No other tube can give you all the advantages of this 4-Pillar construction, for it is patented and exclusive with Eveready Raytheon. These fine tubes come to you in the same perfect condition as when they leave our laboratory test room... all their superlative performance intact.

NATIONAL CARBON CO., INC.

General Offices: New York, N. Y.

Branches: Chicago Kansas City
New York San Francisco

Unit of Union Carbide  and Carbon Corporation

Check these money-making Values *against* any radio cabinets in America!

The reasons why the WOOD CABINET CORPORATION has become one of the greatest factors in the Radio Cabinet Business are illustrated and described in "GENERAL" Radio Cabinets shown in this advertisement.

Check each one of these models. Check its construction and prices. Analyze its VALUE and let your own experience and knowledge of radio cabinets be your guide.

The phenomenal values presented in this great line are entirely due to the fact that this nation-wide organization sells only direct from factory to dealer. All middleman profits, shipping, handling and selling expenses are eliminated. Prices are NET to you.

Cabinets to fit all standard make sets, including Atwater Kent and the new Crosley Screen-grid receiver. Speaker brackets supplied with all models for Atwater Kent chassis.

Order direct from factory-to-dealer headquarters — or write for descriptive literature describing and illustrating the complete "GENERAL" line.

10% discount when purchased in quantities consisting of any assortment of models shown in our general catalog.

*Cabinet designs by Hammarstrom
Salesmen—Valuable Territory Still Available*

**All prices
are net
You decide
your own
profit.**



WOOD CABINET

T. J. Molloy, Pres.
194 Lexington Avenue, New York.

**Factory-to-dealer
saves shipping
costs and middle
man profits..**

**YOU GET
ALL THE**

Profit!

Model No. 103

Dimensions, 43-in. H. x 25 1/2-in. W. x 15 1/2-in. D. Set Compartment, 10 3/4-in. x 24-in. x 12 1/4-in. Space for dials 12 1/2-in.

\$20.50
Net F.O.B.
York, Pa.



\$16.50
Net F.O.B.
Hanover, Pa.

Model No. 101 (Right)

Dimensions, 42-in. H. x 25 1/2-in. W. x 15 1/2-in. D. Set Compartment, 10 3/4-in. x 24-in. x 14-in. Space for dials 11 1/2-in.



Model No. 301 (Below)
Dimensions, 46 1/4-in. H. x 27 1/2-in. W. x 15 1/2-in. D. Set compartment, 11-in. x 24 1/2-in. x 14-in. Space for dials 12 1/2-in.

\$16.50
Net F.O.B.
York, Pa.



\$13.50
Net F.O.B.
Phila. Pa.



Model No. 801 (Left)

Dimensions, 40-in. H. x 25 1/2-in. W. x 14 3/4-in. D. Set Compartment, 9 3/4-in. x 22-in. x 13-in. Space for dials 10 2/3-in.

Model No. 401 (Right)

Dimensions, 44-in. H. x 25 1/2-in. W. x 15-in. D. Set Compartment, 11 1/2-in. x 24-in. x 13 1/2-in. Space for dials 9-in.

\$16.75
Net F.O.B.
Jamestown, N.Y.



CORPORATION

T. J. Molloy, Pres.
194 Lexington Avenue, New York

Tell them you saw it in RADIO

Now....

you can get into the **BIG MONEY!**

*Bigger sales units and bigger profits per unit . . .
Sell \$350 to \$1000 and MORE... Easy-to-handle
installations all over your neighborhood*

BIG BUSINESS! And it's easy for you to capture! Just imagine . . . every theater and dance hall, every hospital and apartment house in your district is a logical user of broadcasting entertainment. By simply stretching out your hands for it, you can secure your share of this big-unit, big-profit business. Get into Power Amplification! Sell the equipment . . . make the installations . . . get bigger advertising value . . . and keep your organization busy making real money for you all the year around!

Show the business men in your area how a modern system of A-C Power amplification will draw big crowds and make big money for them. We make the heart of the system, **POWERIZER** Amplifiers employing the new UX-245—UX-250 Tubes. Our new Control Panels and Amplifier Racks afford ideal flexibility in arranging audio-distribution to suit local conditions. Capitalize our years of experience. Consult us freely!

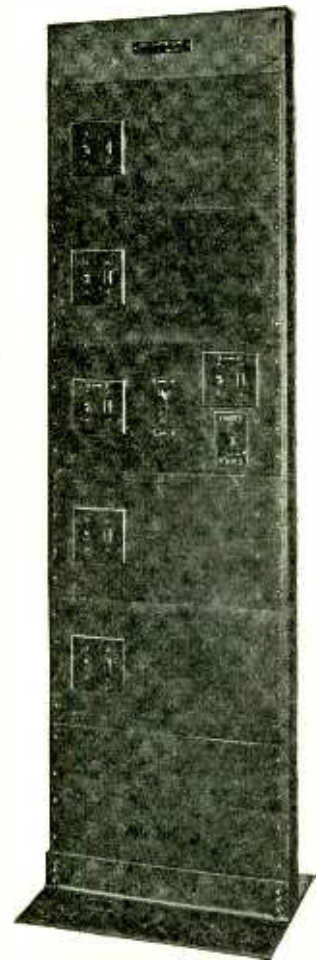

Send for Bulletin No. PR 1028

POWERIZER

Power and Super Power

AMPLIFIERS

Licensed by Radio Corporation of America and Associated Companies

RADIO RECEPTOR COMPANY, Inc.

106 Seventh Ave.

New York, N. Y.

Service agencies in important cities.

**POWERIZER 2-channel
amplifier panel, ideal for**

Amusement Parks	Dance Halls	Riding Academies
Aviation Fields	Factories	Sanatoriums
Band Stands	Gymnasiums	Skating Rinks
Baseball Parks	Hospitals	Sporting Arenas
Camps	Hotels	Stadiums
Churches	Playgrounds	Steamships
Circuses	Public Parks	Swimming Pools
Civic Centers	Race Tracks	Theaters
Convention Halls	Railroad Depots	Yacht Clubs
	Restaurants	

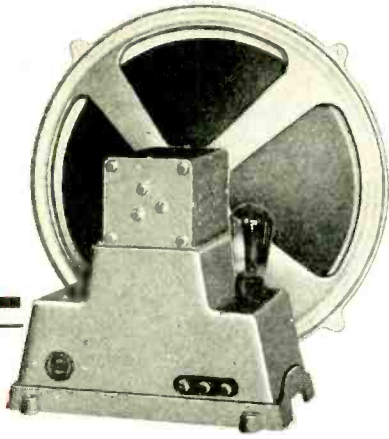

Not "Just Another"
Electro-Dynamic—

VICTORY SPEAKERS

—are Entirely **NEW**—
amazingly **DIFFERENT**
and **FAR SUPERIOR!**

ADVERTISING space for the announcement of a new electro-dynamic of *only ordinarily good attributes* would be valueless—but—the VICTORY GIANT *commands attention justifiably!*

Here is a speaker—the largest—the most rigidly constructed and most efficient ever developed. Its remarkable frequency curve, reproduced below, is the marvel of engineers. The Victory Giant cone has *twice* the area of any other and sets *twice* the air in motion, the cone angle spreading the sound waves, rather than making them entirely directional.

An exclusive feature concentrates energy of the field and intensifies magnetic flux at four hot points on the heavy top plate, giving more sensitive and more powerful drive to the movable coil, and the heavy top plate assures a more uniform cone drive.

This combination of new, exclusive features assures the unusually full, rich tone quality, clarity, and enormous volume of the Victory Giant, developed to a point unapproached in other speakers.



Neutralizing coils and filters are not used on
Victory Speakers.



SPECIFICATIONS

16" cone (inside)—(19" outside).
1/2" top plate.
2" movable coil—1/2" wide.
1—280 rectifying tube for field excitation.
Net weight complete with input and rectifying transformers 38 lbs.
LIST PRICE, \$95.00 (Less Rectifier Tube)

Victory manufactures a complete line of electro-dynamic speakers, ranging in price from \$22.50 to \$25.00 for DC models and from \$35.00 to \$95.00 for AC models. Special theatre models with 90-volt field for use with generators.

JOBBERS—AGENTS

Attractive Franchises for desirable territory are still available. Complete information upon request to responsible concerns.

VICTORY SPEAKERS

INC.

OAKLAND CALIFORNIA
7131 East Fourteenth Street

The "VICTORY" Curve

Here is the Frequency response curve of the Victory Electro-Dynamic Speaker, plotted by Frank C. Jones, eminent radio engineer. Note that the lower register—or BASS—frequency range is as near perfect as is humanly possible in any mechanical sound reproducing device. Note how evenly the frequency curve follows the scale, even at high frequency register. There are not many "high's." No shrill, piercing frequency hump. The Victory speaker curve proves that this speaker combines ALL of the good qualities of sound reproduction. Life-like, faithful, it is amazing. We guarantee each Victory Giant speaker follows this frequency curve.

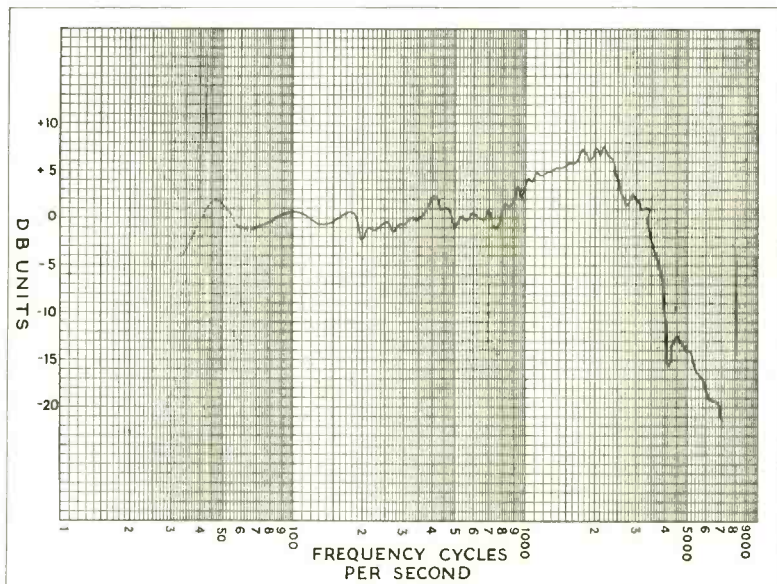

THE WARE ELECTRIC COMBINES

THE SELLING POINTS

· · · OF MANY

FINE SETS · · ·



The Ware is a fine radio to own . . . *and to sell.* It is built by Paul Ware for faithful reproduction. Vreeland Band Selector tuning—receiving the whole broad channel of frequencies broadcast—gives marked tonal excellence. With this go well-controlled power, clean selectivity, ample sensitivity.

The Ware may now be had in a complete selection of cabinets developed along modern decorative lines. Prices range from \$135* to whatever your customer wants to spend. At any price, he gets handsome furniture.

And, Throughout the Line, the Allowance Which Has Been Made for the Dealer's Profit Sets a New Record. Ask About It. Ware Manufacturing Corporation, 480 Lexington Avenue, New York, N. Y.

*Prices slightly higher west of the Rockies.

By PAUL WARE: With Vreeland Band Selector Tuning, Screen-Grid and 245 Output Tubes, Built-in Dynamic Speaker, Custom Cabinets if desired.

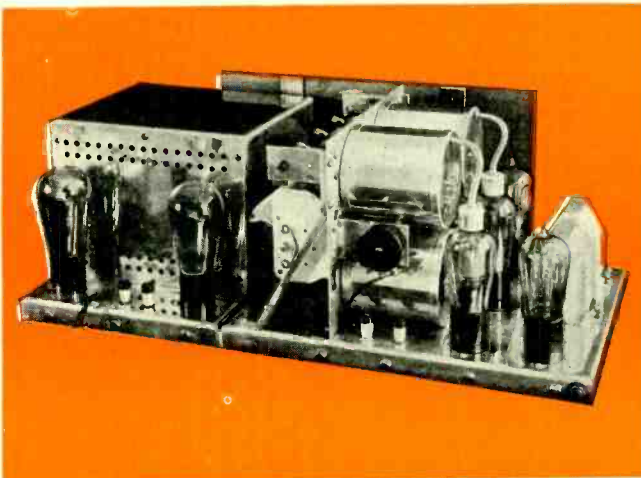

WARE
Electric
RADIO

THE FAMOUS

Super Phonovox

... now even better
than before



List Price
\$15.25

*Slightly higher west
of the Rockies*

ALERT DEALERS may anticipate even greater sales of the Super Phonovox . . . the fastest selling pick-up made . . . and the finest, too, regardless of price. For Pacent has developed wonderful new improvements for this famous pick-up.

Combination Switch and Volume Control and Phonotrol Adapter

The Phonotrol is a new combination switch and volume control. The first turn of the knob switches instantly from radio to records . . .

without disturbing any connections. Further turning increases phonograph volume.

With this is the Phonotrol Adapter . . . for use with screen grid tube sets such as Atwater Kent, Crosley and others. These devices, together with the regular Adapter, are furnished with the Super Phonovox *at no extra cost.*

LOW IMPEDANCE MODELS

Two new low Impedance Models 106-VA, 106-VB, especially designed for the new Victor Radio Sets and broadcasting stations.

List Price \$12.00 and \$15.00



List Price **\$26.50** *West of the Rockies \$26.50*

Complete with 12-inch turntable

Electric Phonograph Motor

In simplicity of design and construction, in power and in the smoothness and silence of its operation, the Pacent Induction-Type Motor has no rival. Completely insulated against noise. Dynamically balanced rotor makes it vibrationless. Operates on 110 Volts, 50 or 60 Cycles A. C.

*Dealers . . . get your orders in now . . .
see your jobber or write us direct.*

PACENT ELECTRIC CO., 91 Seventh Ave., N. Y.

Pioneers in Radio and Electric Reproduction for Over 20 Years

Manufacturing Licensee for Great Britain and Ireland: Igranic Electric Co., Ltd., Bedford, England—Licensee for Canada: White Radio Limited, Hamilton, Ont.

Your Radio

can only be as good
as its Speaker

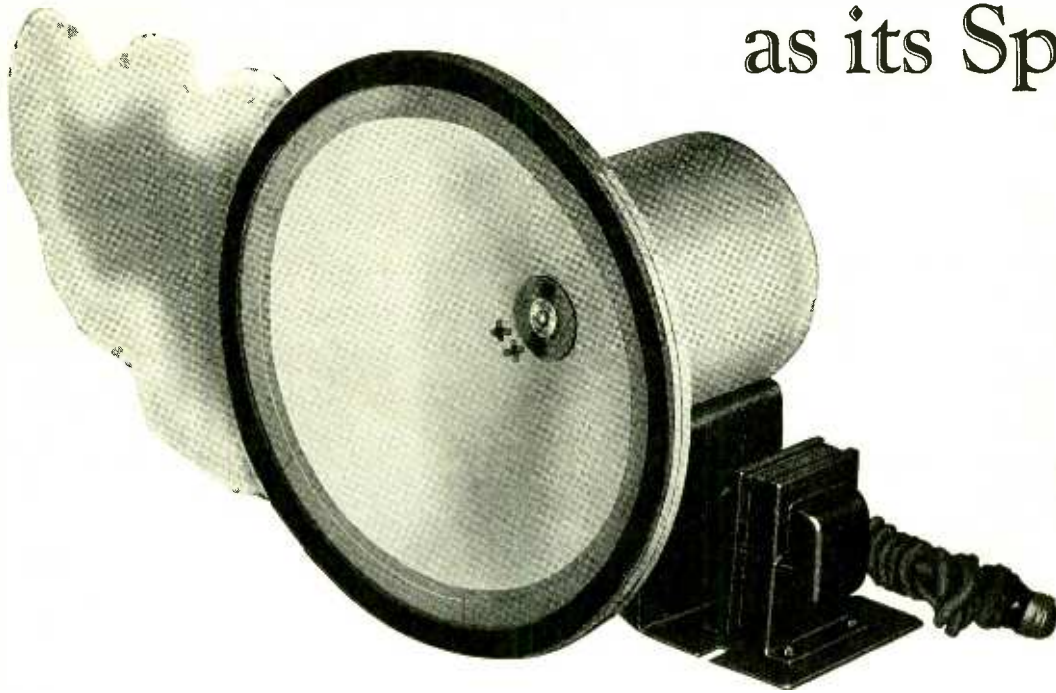

"The Speaker of the Year"

Wright-DeCoster Reproducer

Write Department "D"
for Descriptive Folder
of Chassis and Different
Cabinet Models

WRIGHT-DECOSTER, INC.
ST. PAUL, MINNESOTA

You Control Your Profit With the Acme Plan

TOO many retailers are operating on an inadequate margin. The mark-up, fixed by the set builder, is not enough to give a proper return and allow for the demanded servicing.

The Acme Plan is helping thousands of dealers and set builders to greater profit.

The three cardinal points are:

An up-to-the-minute screen-grid chassis at rock bottom price;
Consoles of your own choosing from any manufacturer you prefer;
You make your own mark-up to fit your costs.

You get three big benefits:

You can build up a set exactly fitted to the desires of your trade;
You build a personal trade and reputation;
You make a satisfactory profit, fixed by yourself.

Surely, these are desirable advantages; you want to know the facts and judge for yourself whether this plan of sales is to your greater profit.

Write us today for details of the Acme chassis and the Acme Plan.

The Acme Electric & Manufacturing Co.

CLEVELAND, OHIO

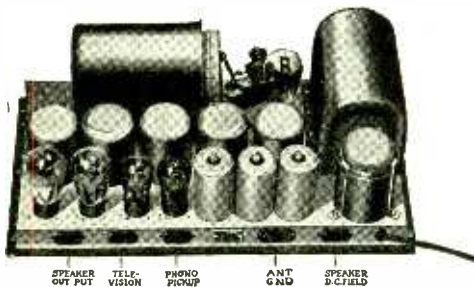

Acme 88 SG—Screen-Grid Chassis

Eight Tubes—
3—224 2—227
2—245 1—280

Four Stages Tuned
A. C. Screen-Grid

Push-Pull Power Tubes
Complete Shielding
Wired for Phonograph
Pick-up and Television
Apartment Antenna
Built-in

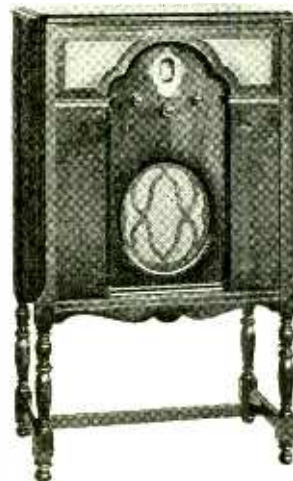

One of the very popular styles of console which can be sold at a low price at a good profit.

SELLING

YOU CAN LEARN ALL OF THE
AT RETAIL BY READING
★ ★ ★ BY HECKERT
MERCHANDISING

THIS SERIES STARTS

Do You Know ~

- how to organize a “sales talk” or canvass
- how and when to close a sale
- successful inside and outside selling methods
- how to secure live “leads” to prospects
- about licenses, contracts, warranties
- how to handle repossessions and trade-ins
- how much a radio salesman should be paid ?

A complete and practical exposition

of successful methods for selling radio sets starts in the December issue of “RADIO.” No salesman should miss it. Mr. Parker, the author of this practical series of articles, has sold radio for years and has taught hundreds of others how to sell it. He has been manager of a prominent Radio Trade Association, sales manager for the Magnavox Company, in charge of sales promotion for the Leo J. Meyberg Company, and now gives the results of this experience, as well as several years as an electrical salesman, in the form of a complete series of articles to be published in “RADIO” during the next year.

You can learn all these things and all of the other fine points of selling radio at retail by reading this monthly series of articles by Heckert L. Parker, Merchandising Editor of “RADIO.”

ASK YOUR DEALER FRIENDS TO SUBSCRIBE

RADIO

FINE POINTS OF SELLING RADIO

« « « « « "SELLING RADIO" »

L. PARKER ★ ★ ★

EDITOR OF "RADIO"

NEXT MONTH IN "RADIO"

Here Are Some of the Subjects That He Discusses

The Profession of Salesmanship.
Selling Yourself to Yourself.

Enthusiasm. Motives Impelling Purchase.
Steps in a Sale. Favorable Attention, Interest, Appreciation of Value, Desire for Possession, Decision to Possess, Action, Satisfaction, Confidence.

Organizing a "Sales Talk" or Canvass.
Testing and finding weak points of a canvass. How and when to close the sale.

Inside Selling.

Outside Selling.

Advertising Directly Affecting Selling.

Time Payment Sales.

Legal Points—

License to sell—when—where.

Agency contracts.

Salesmen's contracts with employers.

Warranties, misstatements, etc.

Better Business Bureau.

Receiving Set Manufacturers.

License Group Patent.

Radio Broadcast Apparatus Manufacturing.

Receiver parts, kits, custom built sets.

Receiver patent groups.

Tube manufacturing and patent licensing.

Reproducer (loudspeaker) manufacturing and patent licensing.

Manufacturers' Trade Custom Warranties.

Receivers, speakers, tubes, furniture.

National Production of Sets, Speakers, Tubes, Furniture.

Future Development of Sets, Speakers and Tubes.

"Wired Radio" Possibilities.

National Market.

For Home Entertainment Merchandise.

Saturation Figures.

Receivers, phonographs, electrical appliances.

Wired Homes With and Without Radio.
Rural Markets.

Television. Home Talkies and Movies.
Tape Records.

Auto Radios. Public Address Systems.
Air Ship Radio.

The Chain of Distribution of Merchandise.
Manufacturer, wholesaler, retailer.

Types of Radio Retailers.

Time Payment Finance Methods.

Kinds and costs of contracts.

Reporters.

Service Methods, Costs and Results.

Good installation method.

Trade-Ins. How to Handle.

Retail Advertising of Radio.

How the dealers' salesman can make use of it.

Newspaper, magazine, billboard, broadcast, direct mailing.

Ways to secure mailing lists.

How Retail Salesmen Are Paid.

How to Secure "Leads."

Knowledge Required by Salesman of Broadcasting and How to Use It in Selling Merchandise.

Who pays for broadcast programs?

How talent is secured and programs arranged.

Chain programs. Independent stations.

Effect of radio laws on retail selling.

Foreign radio programs.

Speech and music over radio.

What to know about both.

How to use feature programs to get live prospects and close them.

Inside Store Selling Methods.

Outside Selling, Cold Turkey and Planned Canvassing.

Demonstration methods.

Simple Explanation of the Fundamentals of Radio.

Laws and Regulations for Broadcasting.

The R-F Tuner and Amplifier.

The Super-Heterodyne Tuner.

Types of Detectors and A-F Amplifiers.

The Differences in Audio Reproducers.

Modern Vacuum Tubes.

Power Supply for Radio Receivers.

Radio Furniture.

Combination Radio and Phonographs.

NO SALESMAN SHOULD MISS THIS MONTHLY COURSE OF INSTRUCTION THAT STARTS IN THE NEXT ISSUE OF "RADIO." HERE, ALSO, IS A GOLDEN OPPORTUNITY FOR THE SERVICE MAN WHO WANTS TO LEARN HOW TO SELL RADIO.

TO "RADIO"..... \$ 2.00 PER YEAR

All Around the World!

ANTARCTICA

HOLLAND

JAVA

JAPAN

MELBOURNE

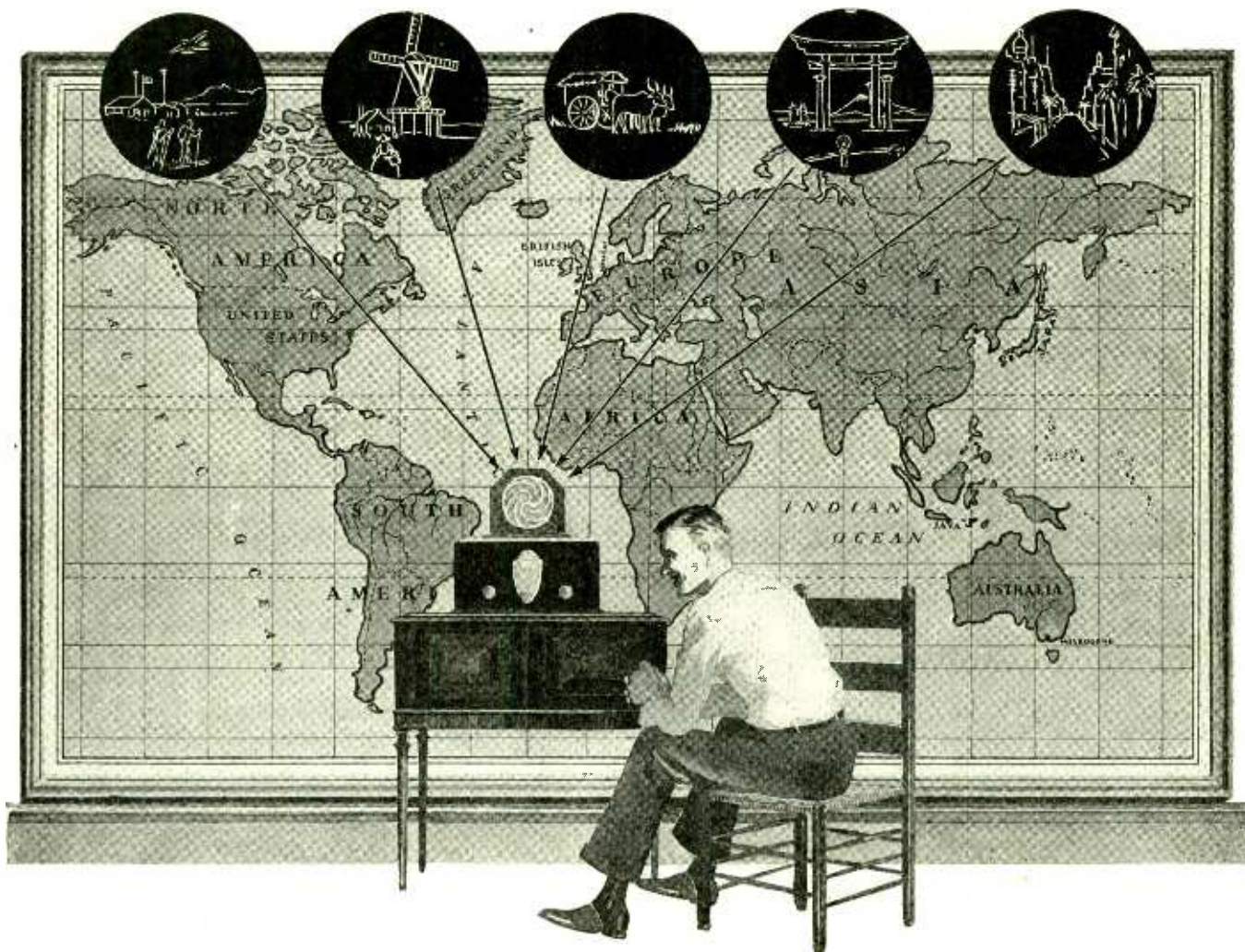

YOU can hear words and music from Java, Australia, England, France—from all around the world,—with the NATIONAL Screen-Grid SW-4 THRILL BOX.

Already many famous broadcasting stations abroad and in this country are putting their regular programs on the short waves, too. More and more stations are doing this. These broadcasts may be received anywhere else in the world, in cities, in the country, at the frozen poles, in the jungles and the deserts, with the NATIONAL THRILL BOX.

This simple Four-Tube Screen-Grid THRILL BOX is a trim, neat receiver with single dial tuning and smooth sensitivity-control. It is free from annoying radiation and the design eliminates "tuning holes," formerly a troublesome short-wave difficulty. The special audio system with 171-A Power Tube gives excellent loudspeaker operation, and the plate

supply may be taken from the lighting circuit, through the NATIONAL Velvet-B,—a feature not usually found in short-wave receivers. The interchangeable tuning transformers are kept in special storage sockets *inside* the cabinet, protected from dust and damage, and always ready for use.

The cabinet itself is more than just a box. It is of simple and very attractive design and finish, which harmonizes with the most tasteful surroundings.

Write us for full information and prices today.

NATIONAL COMPANY, INC.
ENGINEERS & MANUFACTURERS
61 SHERMAN ST., MALDEN, MASS.

Est. 1914 . . . W. A. Ready, Pres.



NATIONAL THRILL BOX

SCREEN-GRID SW-4

Dealers *Listen!*

THE SET YOUR CUSTOMER WANTS - THE SET THAT MEANS QUICK SALES

Tom Thumb

SCREEN GRID PORTABLE RADIO

Speaks in the tone
of PROFITS

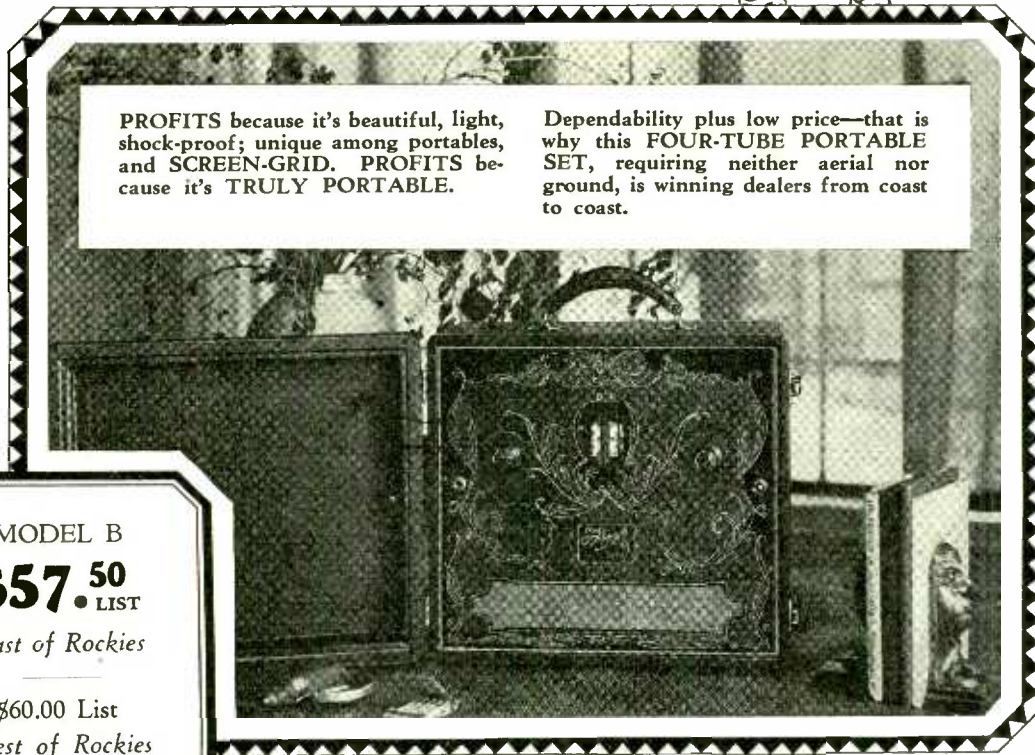

PROFITS because it's beautiful, light, shock-proof; unique among portables, and SCREEN-GRID. PROFITS because it's TRULY PORTABLE.

Dependability plus low price—that is why this FOUR-TUBE PORTABLE SET, requiring neither aerial nor ground, is winning dealers from coast to coast.

It Will Pay
You to
SEND
for
Dealer's
Proposition
Now!
Wire or Write

MODEL B
\$57.50 LIST
East of Rockies

\$60.00 List
West of Rockies
Less Tubes and
Batteries

ALL-ELECTRIC PORTABLES

Just Plug Into the Light Socket—and Tune In!

A-C PORTABLE ALL ELECTRIC, SCREEN GRID, 110 Volts, 60 Cycles, complete with special cone speaker in front cover—large output—QUALITY REPRODUCTION.
DE LUXE BATTERY MODEL, complete with special cone speaker in front cover and uses power tube. The prince of portables.

\$95.00	LIST	\$99.00
Less Tubes		West of Rockies
\$65.00	LIST	\$67.50
Less Equipment		West of Rockies

AUTOMATIC RADIO MANUFACTURING COMPANY, INC.

332 "A" STREET, BOSTON, MASS.

Northern California Distributors

OFFENBACH ELECTRIC CO., 1452 Market Street SAN FRANCISCO, CALIF.

Tell them you saw it in RADIO

Service Plus!

It's the *plus* that counts!

Like the "it" in personality, the knockout blow in boxing, or the crashing ace in tennis, it's the punch that counts!

The SUPREME DIAGNOMETER is full of *extra punch!*

Would you patronize a plumber who couldn't stop a leak?

A doctor who couldn't cure a cold?

Then why use servicing equipment that doesn't fill your every need?

That doesn't provide for every test?

That doesn't do justice to your skill?

That doesn't enable you to give service *plus?*

Your customers expect and appreciate SUPREME LEAGUE SERVICE which is the Service *Plus* in radio. You can give SUPREME LEAGUE SERVICE with the SUPREME DIAGNOMETER.



"Set Testers" prove only 29% to 40% efficient in comparison with the SUPREME DIAGNOMETER

Thorough and complete, yet surprisingly simple. The SUPREME RADIO MANUAL gives full instruction and much valuable radio information.

Portable Radio Testing Laboratory

No other radio testing device can anywhere near approach the range, completeness and flexibility of the SUPREME DIAGNOMETER. Make any test you like. Send for ours, which is confidently called "A Test that Challenges Attention." Some of the outstanding features of the SUPREME are:

All tubes tested under actual operating conditions.

Screen grid socket analysis without oscillation.

750 Volt 4 scale A.C. and D.C. meters, 3 scale milliammeter.

Self-contained power plant.

Modulated radiator for testing, synchronizing, neutralizing.

External connections to all apparatus.

Tests both plates '80 type rectifiers.

All continuity tests without batteries.

Universal analyzer plugs.

and a request for complete specifications will reveal numerous other superiorities.

Handy carrying case providing compartments and space for all tools and spare tubes.

750/150/16/4 A.C. Meter.

750/250/100/10 D.C. Meter.

2/12 Ampere-125-25 Milliammeter.

Thermo couple meter for measuring output of a set.

Measures resistances.

Measures capacity of condenser 5 to 9 M.F.D.

Makes all analysis readings.

Supreme Service League



To Radio Owners: Look for this emblem in your radio shop, on the lapel button or card of your service man. It is your guarantee of dependable radio service. Cash in on the prestige the SUPREME SERVICE LEAGUE is building.

Order NOW

Present production permits immediate deliveries but the momentum of sales is such that buyers are cautioned to place their orders now. Reservations will be made against all orders placed for future delivery on specified dates. Make use of this plan to avoid disappointments.



Most good distributors carry the SUPREME DIAGNOMETER in stock. If yours cannot supply you, send order direct on form to right.

SUPREME

Radio Diagonometer

Makes every ^{conceivable} test on any Radio Set-

Supreme Instruments Corp.
344 Supreme Bldg.
Greenwood, Miss.

Please ship SUPREME DIAGNOMETER Model 400-B on basis checked below.

- Net cash \$139.50.
- Time payment plan—\$33.50 cash and 8 monthly payments of \$15.00 each.

All prices are F.O.B. Greenwood, Miss. No dealer's discount.

Date shipment desired

Signed

Firm Name

Street Address

.....

City

State

.....

.....

.....

.....

.....

.....

.....

.....

.....

.....

.....

.....

Please give three or more bank or trade references and names of distributors from whom most purchases are made.

LIKE TWO VISES



This Jobber says:—

“ . . . and Perryman is the only brand of tube we have ever carried on which we did not have a loss. We have found that Perryman gives much better satisfaction, fewer service calls, resulting in more satisfied dealers, and naturally more satisfaction to us.”

The double Perryman Bridge grips the elements in Perryman Tubes, top and bottom. It holds the grid, plate and filament in permanent parallel alignment. This absolutely assures uniform operation of every Perryman Tube.

With this sturdy bridge construction Perryman Tubes defy all necessary

contraction of the filament due to temperature changes.

Both these features mean fewer replacements—greater net profits to you.

handling in shipment, in your store and in your customers' sets.

The Tension-Spring, another exclusive Perryman feature, allows for the uniform expansion and

Point out the double Perryman Bridge and Tension-Spring to your customers

THE PERRYMAN ELECTRIC CO., INC., 4901 Hudson Blvd., North Bergen, N. J.

PERRYMAN

RADIO  TUBES



TOBE By-Pass Filter Condenser



TOBE 400 Line Short Path Condensers



TOBE 600 Line Condensers for Power Pack Work



TOBE 1300 Line Hi-Voltage Surg-proof



TOBE Transmitting Condensers



TOBE Majestic Eliminator Replacement Block, Price \$10.00

SINCE 1923 Tobe apparatus has been standard with Newark Electric Company. During years of examination and test, we have found the apparatus to be rugged, carefully designed and above all faithfully guaranteed. We know of no better line of Condensers to meet the current needs.



New TOBE A SUPPLY
Price \$24.75

NEWARK ELECTRIC COMPANY realizing the importance of radio interference suppression has prepared to extend quick delivery on Filterettes and answer any requests for information on radio interference.



TOBE By-Pass and Filter Condensers



TOBE Junior Filterette
Price \$3.50



TOBE Senior Filterette
Price \$7.50



TOBE Filterette No. 110
Price \$12.50

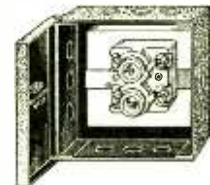

TOBE Filterette No. 11
Price \$10.00



TOBE Filterette No. 110
Price \$15.00



TOBE DA Filterette
Price \$5.00

Write for Complete TOBE Catalog and Discounts

NEWARK ELECTRIC CO.

"Nothing But Radio"

226 West Madison Street

Chicago, Ill.

Tell them you saw it in RADIO



SERVICE MEN!

Uncased Surge-Proof Condensers For General Repair and Power-Pack Work

We are prepared to furnish immediate delivery on Surge-proof Condensers without metal casings, for general service and repair work.

These Condensers are of Surge-proof type, all unconditionally guaranteed to operate for a period of one year without breakdown, when used according to directions. These Condensers are not to be used on A. C., but for pulsating D. C. or straight D. C. work. They are self-healing, in that should a surge take place, the condenser will not fail to operate.

The Condensers are constructed in 1 and 2 microfarad units with the following ratings:—

Type No.	Capacity	Voltage	Size	Price
331	1 Mfd.	300 v.	4x1½ x ¾ inches	\$.75
332	2 Mfd.	300 v.	4x2 x ½ inches	1.45
441	1 Mfd.	400 v.	4x1¾ x ½ inches	1.10
442	2 Mfd.	400 v.	4x2¼ x ¾ inches	2.15
661	1 Mfd.	600 v.	4x2 x ¾ inches	1.45
1101	1 Mfd.	1000 v.	4x2 x ¾ inches	1.75
1331	1 Mfd.	1300 v.	4x2 x 1½ inches	2.25

Service men, set builders and general repair shops will find these Surge-proof Condensers ideal. They WILL NOT break down.

MAJESTIC B BLOCK REPLACEMENT UNIT

the size of which is 5¼"x2½"x4" and composed of 4-4-2-1-1-1-1-1-1 microfarads.

This Block can be used in either the Master or the Super Majestic B Eliminator.

Type MB Price \$10.00



MAJESTIC A ELIMINATOR REPLACEMENT UNIT

Size: 7½"x3"x4 1/16"

A dry high-capacity condenser fully guaranteed for one year.

Type MA Price \$10.00



REPLACEMENT CONDENSERS

For "A-B-C" power packs using 171 and 280 tubes. Designed for use in Majestic, Mohawk, Sonora, Zenith electric sets. Outside dimensions, 4⅞"x1¾"x6¾". Mounted in heavy cardboard container suitable for insertion in standard metal container used in the above sets. Condensers are of "Surge-proof" type with the usual "Tobe" guarantee—for one year.

Type MZSM Price \$12.00

High capacity Dry condensers, 4000 mfd. effective capacity for replacement in "A" Eliminator units. Outside dimensions 4¼"x5"x1¼". Two of these condensers are generally required in a standard "A" Eliminator.

Type TA Price \$5.00



We are now ready to make delivery and should you require any condensers for work on hand, please send us your order at once. Service men, Set Builders, and General Repair Shops discount 40%. Write for discount schedule on quantity orders.

Tobe Deutschmann Corporation

CANTON, MASSACHUSETTS

Tell them you saw it in RADIO

COMMAND

the ENTIRE WORLD
with Pilot's Double Duty
SUPER-WASP

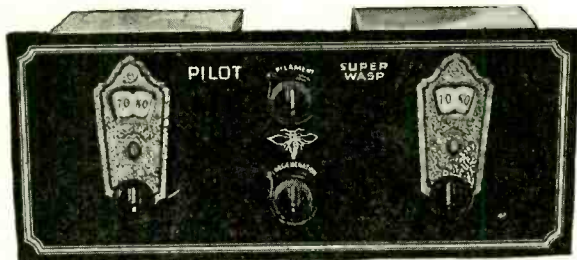

CUSTOM SET-BUILDER'S PRICE

A combination short wave and broadcast receiver covering all wave lengths from 14 to 500 meters. Price of kit includes two sets of five interchangeable plug-in coils, full-sized blueprint, and complete assembly data.

\$29⁵⁰

Slightly higher west of the Rockies

Why miss half the joy of radio? The Pilot Double-Duty Super-Wasp, designed by Robert S. Kruse internationally famous short-wave authority, will give you radio's greatest thrill for a few dollars and a single evening's "work" with screwdriver and pliers. Uses only four tubes—including the super-sensitive screen grid! Enthusiastic radio fans report nightly reception of Chelmsford, (England), PCJ Eindhoven (Holland), Costa Rica, Central and South America, Canada, Cuba, South Africa and Australia! Exceptional results because exceptionally engineered, and priced right because produced in the world's largest radio parts plant! Hear the Super-Wasp at any authorized Pilot Agency.

PILOT Now Makes RADIO TUBES!

Pilotron tubes "Built for Professionals" are especially designed and constructed for the professional radio engineer, custom set-builder and amateur—an audience which is super critical—and has a right to be! Moreover Pilotron tubes are available many months before you can obtain them from the usual sources. This gives custom set-builders an opportunity to use new tubes long before they are available in manufactured receivers. You would think that because of this, Pilot tubes would cost more—but they don't! Pilot's self-contained manufacturing provides definitely superior tubes at the usual prices! Stocked by all Pilot authorized agencies.



BUILT for PROFESSIONALS

TRADE MARK



REGISTERED

DEALER'S OPPORTUNITY! The Pilot policy of encouraging individual experimentation and custom set-building is the greatest single factor in stabilizing and maintaining the parts and kit business. Technically qualified and financially responsible dealers are invited to write for details of our agency plan.

HOW TO KEEP STEP WITH NEW DEVELOPMENTS. Send 50c for four quarterly issues "Radio Design" and membership in the Radio International Guild, a world-wide organization of radio engineers, experimenters, and custom set-builders. Radio Design, Dept. Z, 103 Broadway, Brooklyn, N. Y.

PILOT RADIO & TUBE CORP.

WORLD'S LARGEST RADIO PARTS PLANT
323 BERRY STREET
BROOKLYN NEW YORK
U. S. A.

THE OLDEST TUBE MANUFACTURER IN NEW ENGLAND



HYTRON TUBES!

THE Hytron Tube Corporation of Salem, Mass., is the oldest manufacturer of radio tubes in New England. The prestige of Hytron's years of experience, plus unexcelled manufacturing and technical resources, is the best possible assurance to the purchaser that every Hytron Tube will fully equal his expectations for the purpose for which it was designed.

The Hytron Line gives the trade the utmost possibilities for profit. It comprises a tube for every purpose; guaranteed quality unsurpassed; the stability of an old established Company; attractive prices; big profit margin.

DISTRIBUTORS: Write for discounts and other information. Valuable territory still open. Hytron production assures a complete supply for your requirements.

KEELER, WHITE CO.
211 So. San Pedro St.
Los Angeles, Calif.

1149 Howard St.
San Francisco, Calif.

406 Occidental Ave.
Seattle, Wash.

THE BARSOOK CO.
202 S. State St.
Chicago, Ill.

HOUSTON CRANE
817 Norris Bldg.
Atlanta, Ga.

GRAY SALES CO.
611 Widener Bldg.
Philadelphia, Pa.

L. E. JAQUES
1248 Augusta Ave.
University City, Mo.

WM. P. JOHNSON
ELECTRIC CO.
43 South Third St.
Minneapolis, Minn.

E. D. LILLY
SALES CO.
Urban Building
Louisville, Ky.

H. C. POMMERENK
412 Arthur Bldg.
Omaha, Neb.

HYTRON



CORP.

KEELER, WHITE CO., Los Angeles—San Francisco—Seattle
SALEM, MASSACHUSETTS

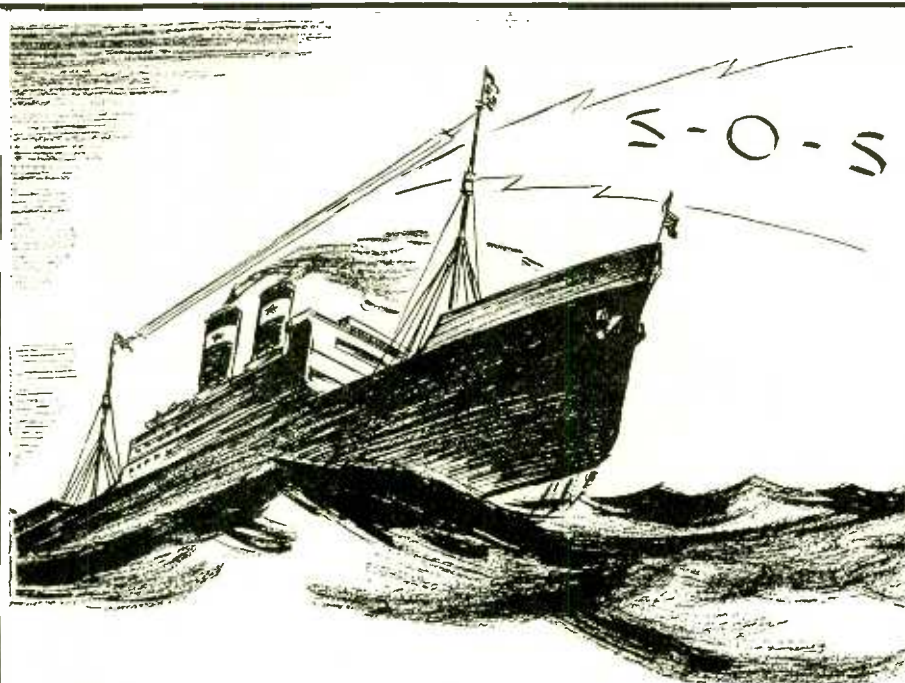

LIKE A SHIP without A RUDDER

the "control" is gone . . . not powerless . . . but rudderless . . . no longer does she respond to the helmsman.

Your radio without a good resistance device like the CENTRALAB resistance, doesn't respond to the slightest touch of the "helmsman."

You steer your way through the ether by fits and starts . . . augmenting the "static storms" by internal "self-inflicted" noises. Better be sure that your radio is "Centralab" equipped.

"Volume Control, Voltage Controls and Their Uses," is the title of an interesting pamphlet that is yours for the asking.



This shows the exclusive rocking disc construction of Centralab volume control. "R" is the resistance. Contact disc "D" has only a rocking action on the resistance. Pressure arm "P" together with shaft and bushing is fully insulated.

The tailor uses the same principle as Centralab. He does not want to ruin the garment by placing the iron on it so he places a cloth in between. Centralab controls cannot ruin the resistance because the rocking disc is in between the pressure arm and the resistance.

The action of the usual wire wound control after it has been in use for some time is like dragging a stick over a cobblestone pavement.

Centralab

CENTRAL RADIO  LABORATORIES

20 Keefe Ave.

Milwaukee, Wis.

Jensen

ELECTRO-DYNAMIC SPEAKER

TO MEET EVERY NEED

JENSEN Standard Speaker

Has eight inch cone. Extremely fine tone quality and excellent volume. Used extensively for modernizing earlier model radio receivers. Unit, AC, \$32.50; DC, \$25.00. In Jensen Model 6 Cabinet with AC Unit, \$50.00, DC Unit, \$42.50.



JENSEN Concert Speaker



Used by many of America's leading set manufacturers in their 1930 console model receivers. The standard of comparison for all reproducers. Ten inch cone. Unit, AC, \$35.00; DC, \$27.50.

JENSEN Auditorium Speaker

Unequaled where tremendous volume is required. Used extensively for public address systems, talking movies, and in auditoriums and large halls. Twelve inch cone. Unit, AC, \$70.00 (less tube); DC, \$55.00.



The IMPERIAL



Acclaimed, upon its introduction, as America's finest and most beautiful reproducer. Equipped with either the Concert or Auditorium Units. Prices, with Auditorium AC Unit, \$100.00 (less tube); with DC Unit, \$90.00; with Concert AC Unit, \$80.00; DC Unit, \$72.50.

Jensen Electro-Dynamic Speakers are made in types to meet every present day need. Write for technical data and attractive trade discounts

JENSEN RADIO MFG. CO.
6601 S. Laramie Ave. 212 Ninth Street
Chicago, Ill. Oakland, Calif.
LICENSED UNDER LEKTOPHONE PATENTS

These six new Frost-Radio Volume Controls are representative of the service rendered by Herbert H. Frost, Inc., in meeting the demands of the manufacturers of receiving sets of today and tomorrow. Tandem units such as these operate smoothly, noiselessly and with



No. 280-280. Combination metal shell wire wound and composition elements. Wire wound up to 15,000 ohms. Composition, 5,000 to 1 megohm. Rheostat or potentiometer type in either unit. Units insulated from each other. Diameter, 1 11/16 in. Depth of shell, 1 3/8 in.

an almost total absence of wear. They are non-inductive, unaffected by temperature or humidity changes. They may be obtained in any desired curve.

Wire wound or carbon element type. Clockwise or counter-clockwise knob rotation. Shaft and thimble length to suit your needs.

As the world's largest manufacturers of high grade variable resistors, we are singularly well equipped to supply your requirements, no matter what



No. 890. Double depth metal shell unit in rheostat or potentiometer type. Rotors in same electrical connection. Composition elements, 5,000 ohms to 1 megohm in each unit. Diameter, 1 7/8 in. Depth of shell, 1 3/16 in.

they may be.

Write us in detail regarding your variable resistor problems, and have us submit samples to meet your specifications.



No. 1880-1880. Same as 280-280 except all bakelite.

No. 200-200. Metal shell type wire wound resistors with resistances from 5 ohms to 10,000 ohms. Split windings. Rheostat or potentiometer types. Units insulated. Diameter, 1 7/16 in. Depth of shell, 1 1/2 in.



No. 2880-2880. Bakelite shell composition element only. Resistance range from 5,000 ohms to 1 megohm. All curves. Potentiometer or rheostat types. Units insulated from each other. Diameter, 1 1/2 in. Depth of shell, 1 1/8 in.

No. 590-590. Metal shell, composition element only. Resistances from 5,000 ohms to megohm. All curves. Potentiometer or rheostat types. Units insulated from each other. Diameter, 1 5/16 in. Depth of shell, 1 1/8 in.



HERBERT H. FROST, Inc.
Main Offices and Factory
ELKHART, IND.
160 North La Salle St., Chicago

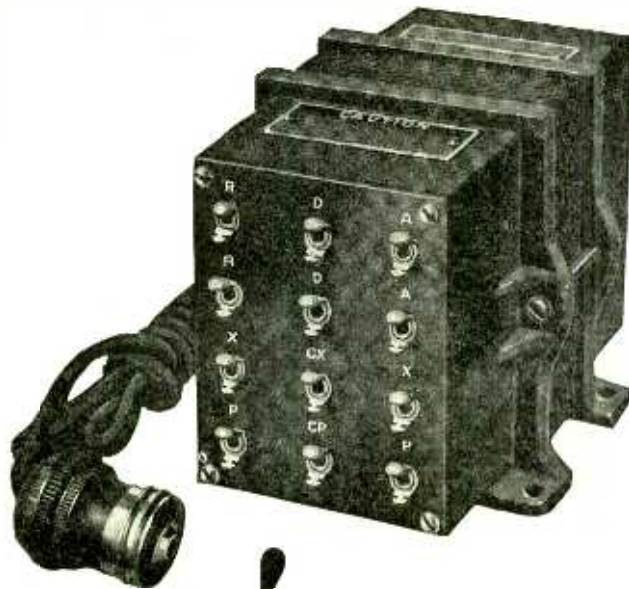

New!

the PF 245 A

AmerTran Power Transformer

Continuing its progress in the development of power transformers for all radio receiving sets the American Transformer Company announces the perfection of the new type PF 245 A. This new power transformer operates a radio receiver equipped with 2 1/2 volt heater for heater type A. C. tubes and 2 1/2 volt filament for a power tube (UX245 or CX345) which closely approaches the 210 in undistorted watts output.

The AmerTran Power Transformer Type PF 245 A is designed for a 60 cycle 115 volt line source, and has a continuous rating of 100 VA. with primary taps for 100—108—115—120 volts. A four point radial switch regulates the operation for different primary voltages. There are five secondary windings. Because of its lower maximum voltages, all secondary connections terminate in solder lugs attached to a bakelite terminal board.

This new, heavy duty power transformer is compact, sturdy, beautifully machined and mounted in cast iron end clamps provided with mounting feet. Like all AmerTran Transformers the PF 245 A is built to deliver sufficient excess voltage for maximum requirements.

Fill out and mail the coupon for AmerTran Bulletin No. 1088 giving complete description of the PF 245 A Power Transformer.

AMERTRAN

TRADE MARK REG. U.S. PAT. OFF.

AMERICAN TRANSFORMER CO.

Builders of transformers for over 29 years
178 Emmet St., Newark, N. J.



List Price \$22
East of the Rocky Mountains

AMERICAN TRANSFORMER CO., 178 Emmet St., Newark, N. J.

Please send me complete information on the new PF 245 A Power Transformer.

Name.....

Address.....

R-11-9

BUILDINGS COMPLETED THIS YEAR

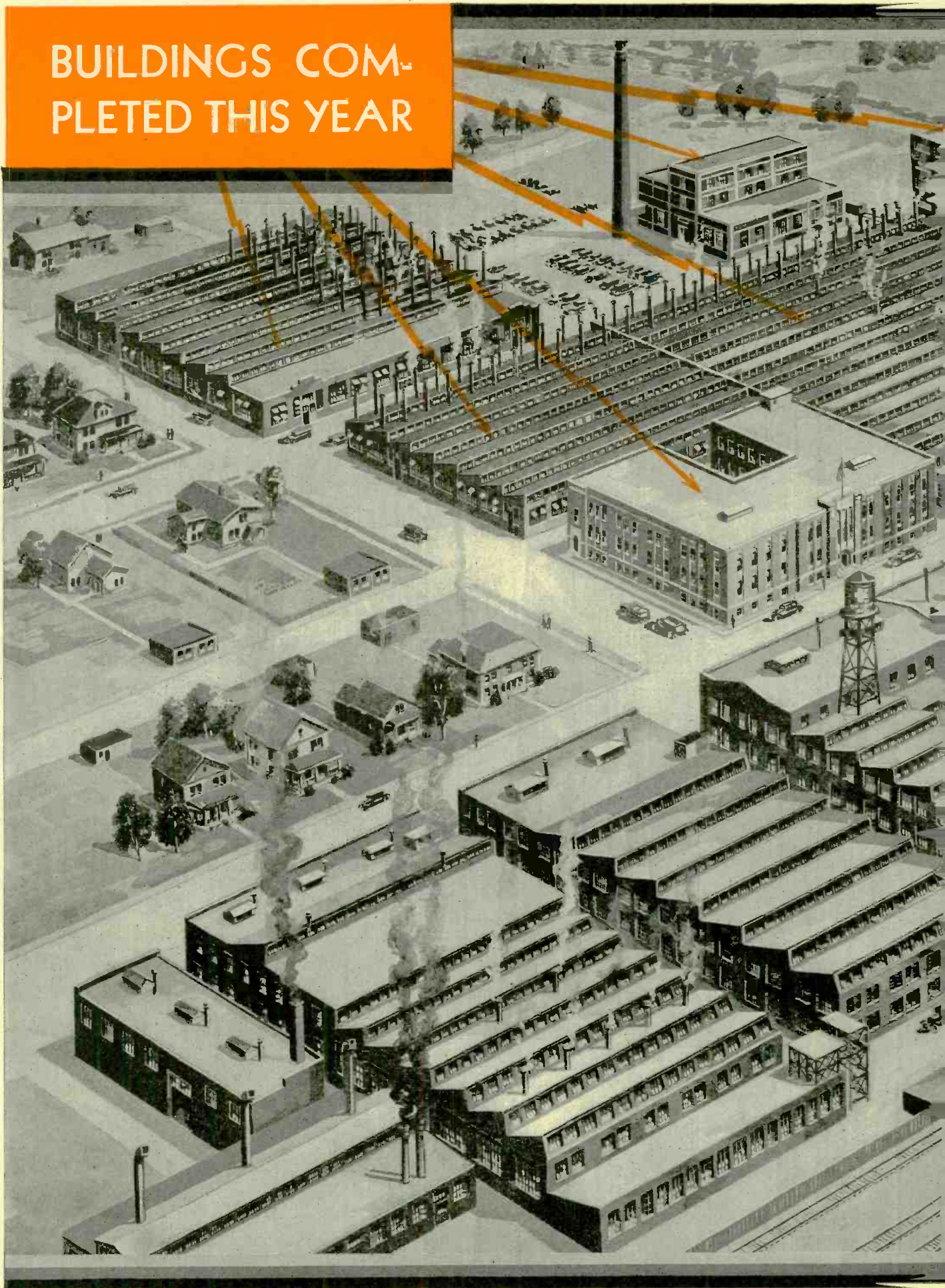

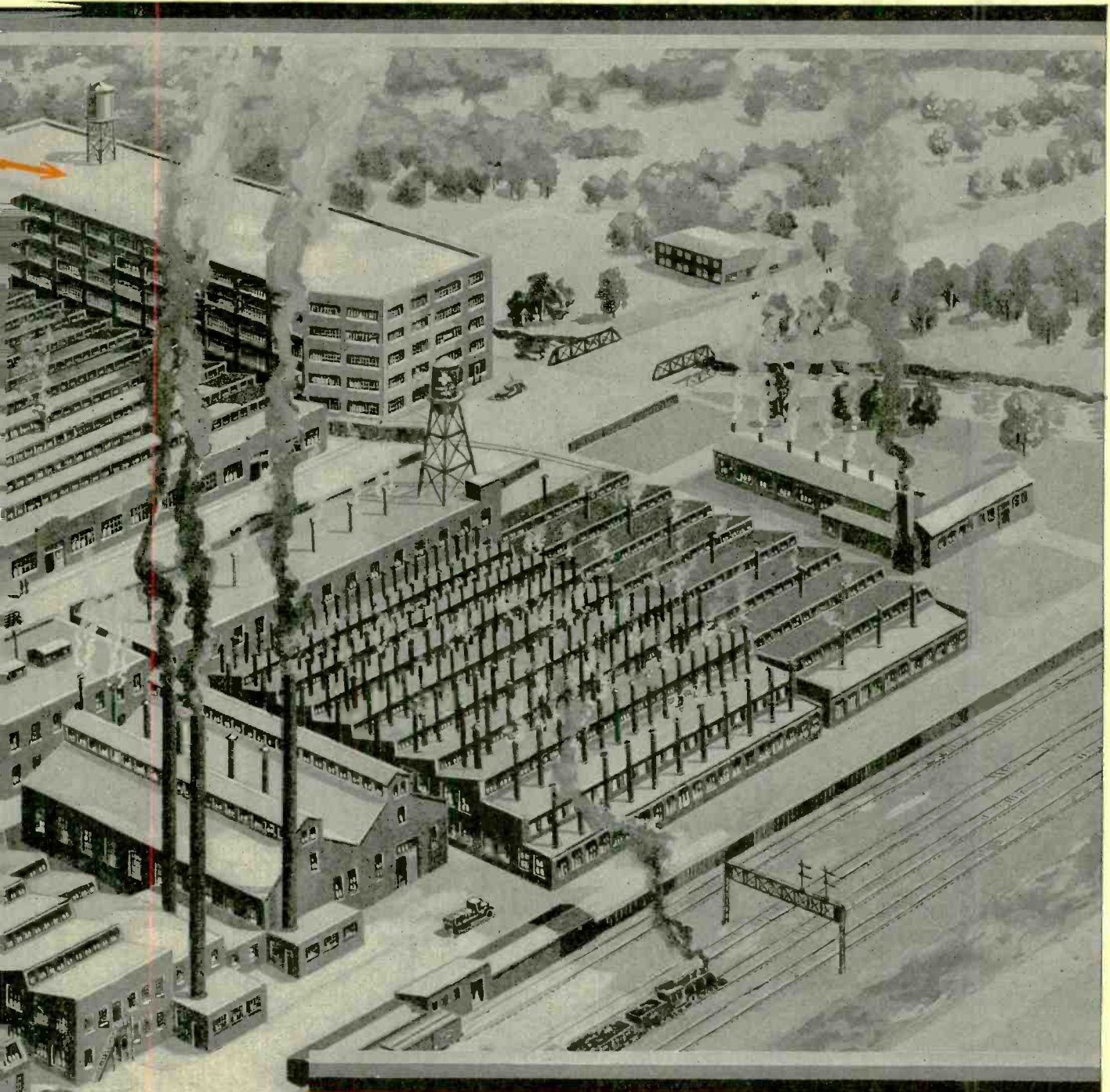

• THESE completed buildings, and the acres of equipment now being installed, are eloquent testimony of Dudlo's faith in radio. « » The coming season will find Dudlo fitted as never before to assume its responsibility—the industry's preferred source of supply for wire and coils.

DUDLO MANUFACTURING COMPANY, FORT WAYNE, IND.

Division of General Cable Corporation

Tell them you saw it in RADIO

SHORTWAVES

The World at Your Fingertips With a *Baird* Shortwave Converter

This converter, together with all other apparatus shown on this page, is the development of years of intensive expert work by our chief engineer, Hollis Semple Baird, B.Sc., Fellow of the Television Society of Great Britain, Member of the Television Society of America and Associate Member of the I. R. E. In offering our new models and additions to the public we honestly believe that we have done everything humanly possible to build the finest and most efficient apparatus ever offered. Get the thrill of tuning in foreign stations in the daytime. We have authentic and verified reports of customers who tune in G5SW, Chelmsford, England, PCJ Holland, etc., with consistent loud speaker volume. (These letters are on file for public inspection at any time.) To operate simply remove the detector tube from your receiver, plug the converter in its place, put a detector tube in the converter, connect your aerial to the converter and you are ready to tune in by simply operating the dial on the converter and not tuning your receiver at all. The *Baird* shortwave converter is an improvement in many ways over any other converter which has so far been offered to the public. Some of its advantages are: .00015 SLF *Baird* special variable tuning condenser, which spreads your signals over the whole dial range. *Baird* special antenna tuning condenser allows for efficient use with any type of aerial. Special volume control to prevent the usual awful squealings when tuning in a station. Cushion socket to eliminate microphonic troubles. A four-foot flexible lead for the plug in allowing ample working space. By special patent applied for method A. C. hum is entirely eliminated from A. C. models. Compact, size being only 9 1/2" x 5 1/2" x 4". 100 to 1 ratio vernier dial. Equipped with complete set of 4 OCTOCOILS, the finest and most efficient coils on the market, with a wavelength range of 16 to 225 meters.

Judge Fabyan of Brighton, Mass., logs G5SW and KGO practically every night. John Tee of Denver listens to Europe and South America. Ronald W. Brown of Stoneham, Mass., rets Australia occasionally. We do not guarantee that you will get consistent reception over five or ten thousand miles, but we do claim that with patience and careful tuning greater *Baird* distances can be obtained with the shortwave converter than ever can be had with the ordinary broadcast receiver. If you have not the patience to tune carefully, systematically and patiently, do not buy this converter, as you will be disappointed. An 8-page instruction booklet, together with the latest revised list of shortwave stations all over the world, furnished with each converter.

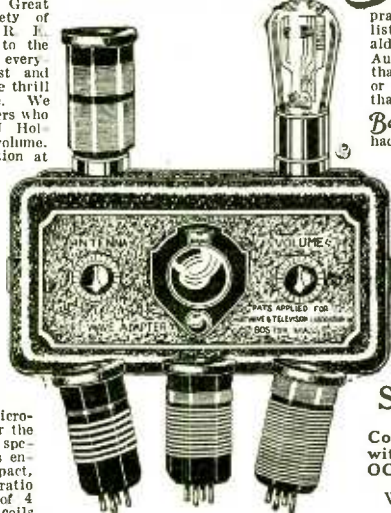

The No. 1-T Kit is a complete assembly of parts for the construction of a one-tube shortwave receiver. Can be assembled in 30 minutes. The chassis is all aluminum and the finest parts obtainable are included in this assembly. One complete set of 4 OCTOCOILS furnished with each kit.

Baird Shortwave Converter

Complete with Four OCTOCOILS \$25.

Wavelength Range 16 to 225 Meters

OCTOCOILS are unquestionably the finest, most rugged and most efficient shortwave coils ever designed and have been built to a standard of efficiency and appearance seldom if ever attained in commercial production. The actual size of these coils is 3 3/4" high and 1 1/4" in diameter. With OCTOCOILS and the proper receiver or converter, distance means nothing in tuning your stations. Everything worth while has been logged, even Byrd in the Antarctic (from Schenectady, New York). We furnish diagrams gratis for one-tube shortwave receiver and converter and two-tube shortwave receiver and converter with screen grid radio frequency, simply for the asking. The circuit is ideally simple for the fan who wishes to build his own shortwave receiver or converter. Within an hour he can be ready to tune in anything anywhere. OCTOCOILS are made in four distinctive colors, green, brown, blue and red, on genuine bakelite moulded forms and wound with Nos. 12, 14, 16 and 25 enameled wire. Will plug into the ordinary tube socket and has a rugged rim to grasp coils so that they will not break. If you are not satisfied with their appearance and performance, we will gladly refund your money. Packed in individual boxes of the same color as the OCTOCOILS with wavelengths printed on each box. The entire set is in a special attractive container. Broadcast coil also furnished, list price \$1.25 each. These coils will also cover the 10 to 80-meter amateur bands if used with our special No. 5 condenser, list price \$1.25.

Baird Shortwave Kit No. 1-T. Complete with 4 Coils. 2950



The No. 2-T Kit is a tuned antenna circuit, making it extremely desirable and simple to operate, it being only single-dial control. Will tune unbelievable distances and pull in stations one can never hope to get with the regular broadcast receiver. Remember that the stations you can get actually give you the same quality and type of entertainment as you can get on the long waves, with the difference that you might be listening to England or Holland or even further. This kit is composed of an all-metal chassis and panel and all the component parts are of the highest quality and fully guaranteed against defects. Simple to construct and can be built in one hour. Two complete sets of ten OCTOCOILS furnished with each kit.

Baird Shortwave Kit No. 2-T. Complete with 10 Coils, 3950 16 to 550 Meters.

Baird International Shortwave Kit No. 4-T

The *Baird* International No. 4-T Kit is composed of a detector, one stage of tuned screen grid radio frequency and two stages of audio amplification, using either 112 or 171 in the last stage. Will operate satisfactorily with loud speaker volume on practically any signal that can be pulled in. Get the thrill of hearing the chimes of Big Ben in your home every evening. All necessary parts for complete construction are included in this kit. Can be built in less than two hours. This kit is of all-metal construction. Two complete sets of ten OCTOCOILS furnished with each kit.

Baird International Shortwave Kit No. 4-T. Complete with 10 OCTOCOILS, 16 to 5950 550 Meters.

OCTOCOILS

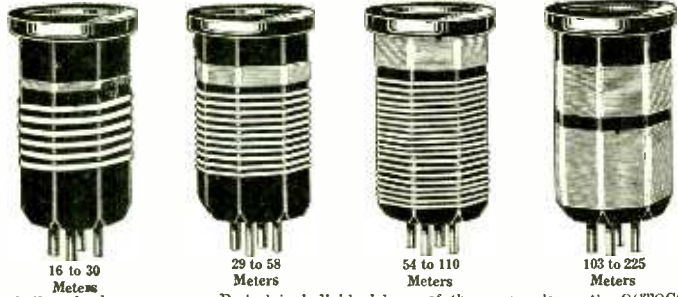

gladly refund your money. Packed in individual boxes of the same color as the OCTOCOILS with wavelengths printed on each box. The entire set is in a special attractive container. Broadcast coil also furnished, list price \$1.25 each. These coils will also cover the 10 to 80-meter amateur bands if used with our special No. 5 condenser, list price \$1.25.

Set of Four OCTOCOILS Wavelength Range 16 to 225 Meters \$5 Per Set of Four
For those who desire the ultimate in a shortwave receiver we offer our No. 20 Super, which is composed of one stage of screen grid tuned radio frequency with power amplification for either battery or A. C. operation. This is a complete unit in itself, is built into a beautiful metal cabinet finished in green and gold and is equipped with National illuminated vernier drum dial. Not only will this receiver work on the aerial which you now are using for your broadcast set, but it will work at the same time on the same aerial without any interference. This is a single-dial control receiver and uses the screen grid tuned antenna circuit, which is accepted by leading engineers as the method of giving the greatest possible amplification of a signal. For those who want loud speaker reception on shortwave signals with wonderful quality and simple tuning, we sincerely recommend the *Baird* No. 20 Super Shortwave Receiver.

A UNIVERSAL RECEIVER

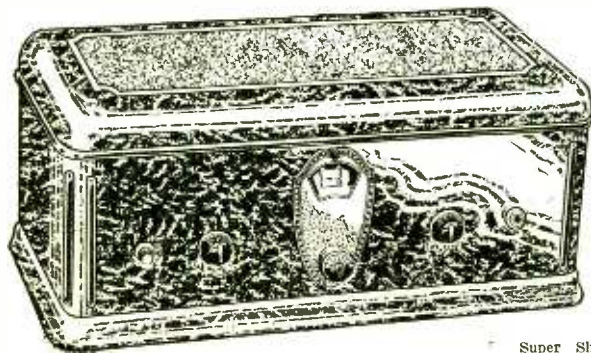

Baird Super Shortwave Receiver Battery Model, Less Equipment \$88.
Baird Super Shortwave Receiver A. C. Model, Less Tubes \$135.

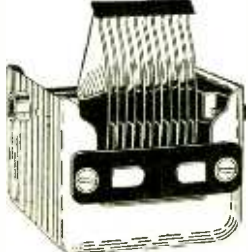

The BT-15 SLF Tuning Condenser is the bath-tub type, rigidly built and especially adapted and constructed for shortwave work.
BT-15—.00015 SLF Variable Tuning Condenser. 275

TELEVISION Wavelength Range 16 to 550 Meters
WATCH FOR OUR ANNOUNCEMENT IN A FORTHCOMING ISSUE OF OUR NEW TELEVISION RECEIVER—THE ONLY COMMERCIAL PRACTICAL UNIVERSAL TELEVISION RECEIVER EVER OFFERED THE PUBLIC. For further information, write.

Mfd. by **SHORTWAVE & TELEVISION LAB., Inc.**
18,000 Sq. Feet Devoted to the Manufacture of Shortwave and Television Apparatus
70 Brookline Avenue, Dept. 11
Boston, Massachusetts

Shortwave & Television Laboratory, Inc.
70 Brookline Ave., Dept. R-11, Boston, Mass.

Please send me

for which I enclose \$.....

as 25% deposit or \$..... which is in full payment for merchandise selected.

Name.....

St. & No..... City..... State.....

TELEVISION

Tell them you saw it in RADIO

FADA PRESENTS

THE NEW SERIES 35 ULTRA-SELECTIVE VIBRA-CONTROL RECEIVERS FOR CONGESTED AREAS

THE NEW FADAS ARE HERE. THEY WERE DESIGNED TO GIVE RAZOR-EDGE SELECTIVITY FOR CUTTING THROUGH THE POWERFUL BROADCAST BANDS IN HIGHLY CONGESTED CITIES SUCH AS LOS ANGELES AND CHICAGO. AN ENGINEERING TRIUMPH.

THE NEW SERIES 35 **FADA** Radio

VIBRA-CONTROL

Competition Blasted by Revolutionary Improvement in Radio Reception

LIGHT socket sets . . . dynamic speakers . . . screen grid tubes . . . and now Vibra-Control.

. . . One of the most revolutionary improvements since radio was first invented.

Vibra-Control has taken the country by storm. Overnight America has found a new sensation, as Fada dealers strip their stocks to meet the unprecedented landslide of public interest that followed the first announcement of Vibra-Control.

And no wonder: for Vibra-Control makes obsolete old-fashioned uncontrolled radio reception, and the public knew it instantly.

For when Fada finally solved radio's greatest problem it freed music from mechanical slavery and at last reproduced programs exactly as broadcast . . .

Today, Vibra-Control is smashing all national sales records . . . Even the duller ears quickly appreciate the difference.

Eventually others must follow: but only Fada dealers today can present a series of instruments with complete Vibra-Control.

F. A. D. ANDREA, INC., Long Island City, N. Y.



VIBRA-CONTROL FADA 35-B AND 35-C HIGHBOY

Uses screen-grid tubes, new 245 power tubes in push-pull amplification, with Fada Pre-Selector for sharpest selectivity. Fada full-power dynamic speaker, equipped for phonograph attachment.

35-C \$220.00
(\$227.00 West of Rockies)
35-B \$255.00
(\$265.00 West of Rockies)

Reputable dealers who are interested in getting first profits should communicate immediately with us for information regarding the selective Fada franchise.



VIBRA-CONTROL FADA 25 HIGHBOY

Uses screen-grid tubes, new 245 power tubes in push-pull amplification. Fada full power dynamic speaker, single illuminated dial—equipped for phonograph attachment.

Model 25 \$165.00
(\$172.00 West of Rockies)

FADA ON THE AIR

Hear the Fada Orchestra conducted by David Mendoza, broadcast over the Columbia chain every Tuesday night at 10 P. M., Eastern Standard Time.

FADA Radio

THE CHOICE OF THE EXPERTS

Tell them you saw it in RADIO

TRIPLE SCREEN-GRID

AMRAD



The ARIA

What tremendous value is represented in this leading model of the Amrad Bel Canto Series!

Within the exquisitely beautiful, tastefully proportioned console cabinet, richly veneered in butt walnut and African walnut, is the Amrad standard Screen-Grid Chassis, using eight tubes, including THREE Screen-Grid tubes and two 245 tubes in push-pull.

The interior panel is handsomely designed in Gothic inspiration—with illuminated dial calibrated in both meters and kilocycles. Has phonograph pickup attachment, built-in antenna, Mershon condenser and full nine-inch electric power speaker mounted on a baffle board.

Price at \$198
(Less Tubes)

Prices slightly higher West of the Rockies

A HAIR-RAISING FIVE HUNDRED PER CENT increase in business in 1929 over 1928 makes us stop to think — and check up.

Why is Amrad selling FIVE TIMES as many sets in 1929 as in the preceding year? It isn't enough just to say the retail dealers are moving the goods. We know that. But WHY? Possibly the answer lies in the critical analysis of all radio lines in comparison to Amrad which shows that the Amrad triple screen-grid chassis is unexcelled in sensitivity, selectivity or ease of operation; that Amrad has a chassis of extremely heavy, foolproof construction; that reports of trouble of any kind are practically non-existent; that Amrad cabinets constitute indisputably the finest furniture in the industry—and that due to a magnificent audio system, the world's best electric power speakers, and special adjustments, Amrad has the finest tone in radio!

The Amrad franchise is valuable—let us send you the name of your nearest Amrad distributor—he can prove it.

THE AMRAD CORPORATION

Medford Hillside, Mass.

J. E. HAHN
President

POWEL CROSLY, JR.
Chairman of the Board

The FINEST TONE in RADIO..



Attention Dealers

Cunningham Tube News

Vol. 1, No. 1 NEW YORK

NOVEMBER, 1929

Published Monthly

BEST OF RADIO NOW AVAILABLE TO ALL

Moderate Wage Earner Enjoys Latest Set Improvements

A new Elysium, where all men are equal, is being created by modern industry, declares George K. Throckmorton, vice-president and general manager, E. T. Cunningham, Inc.

The moderate wage earner, thanks to present day methods of intensified production and distribution, may share with the millionaire in enjoying the best of the entertainment means provided by science, is his opinion.

"Nowhere is this more true than in the radio field, where mass production, standardized manufacturing methods, world-wide distribution and greater economy in retailing have placed the finest of radio sets within the means of the working man of limited income," he states. "Just as the income of the individual may no longer be judged by the type of automobile which he is driving, so is radio quality no longer limited by price.

"The same standard of performance is achieved by the set in the lowly cottage as by that one within the castle on the hill. In truth, it likely is the same identical type of set with the same maximum of tonal quality.

"The 1929 radio, including all of the most modern type of improvements, such as screen grid tubes, single dial control, improved means of power amplification and electrification and other new mechanical features, is not a luxury for the few but a pleasure-bringing product for the millions."

C-327 AS AMPLIFIER

The C-327 radio tube is usually known as a general purpose A. C. type, according to a report of E. T. Cunningham, Inc.

Originally used as a detector in conjunction with the CX-326 type in the remaining sockets of the A. C. set, its characteristics adapt it also for service as an amplifier. Many receivers now on the market use this tube for this purpose.

Tube Quality Has Placed Radio On All Year Basis

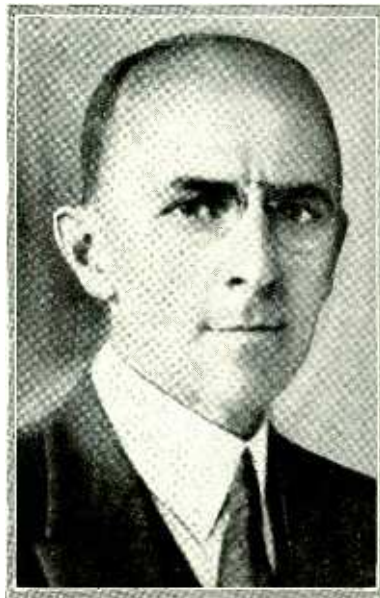

George K. Throckmorton, Executive Vice President, E. T. Cunningham, Inc.—"Radio, due to its rapid advances, has now the same universal appeal and demand which have made the American automobile a family institution."

Aviation Industry Uses Screen-Grid

The screen grid tube, latest development of the radio industry, already has been successfully adapted to the aviation field, it is reported by an official of E. T. Cunningham, Inc., radio tube company.

In the most workable type of receiving sets now being installed in aircraft for radio communication with ground stations, the circuit includes four heater type of tubes, three of which are possessed of screened grids. Through the screen-grid, the extreme sensitivity necessary to tune-in specific ground stations is achieved with remarkable success, it is reported.

Modern Day Set Makes Summer Broadcasting As Popular As During Other Months

The high quality of radio programs during the past summer has been one of the most substantial factors in placing radio popularity on a year-round basis, declares M. F. Burns, Vice-President and General Sales Manager of E. T. Cunningham, Inc.

"Radio sets are now capable of the same high degree of reception performance during summer as in winter and broadcasting stations are showing they are aware of this by continuing their best features upon a twelve months basis. Program sponsors also have noted this fact and a survey shows that the number of the sponsors was practically as high during the past summer months as during the cold months," he stated.

Public Response

"Definite proof of the modern day set to overcome the former handicaps of summer broadcasting has been carried directly to broadcasting sources by public response," he advises. Progressive stations that were the first to boldly continue offering the best of artists and the finest program that could be produced without abatement received enthusiastic approval from the listening public, it is reported to Mr. Burns.

"Program sponsors know that by maintaining the high standard of programs during the past summer, it has created an unusual stability in the sales volume of their products. Manufacturers accustomed to a seasonal let-down during this period assert that the success of radio broadcasting has, in many instances, accelerated and stimulated sales volume to a new high record."

Tube Efficiency

It is the increased efficiency of the present day radio tube that has placed set reception on a par with the quality of broadcasting transmission, Mr. Burns declares. It is through the radio tube that greater selectivity and more accurate tonal qualities have been achieved, he believes.

VISUALIZING CONSTRUCTION OF RADIO TUBES

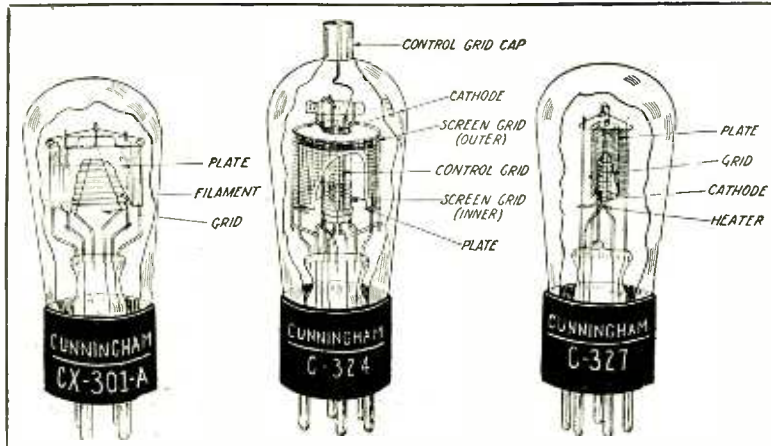

Showing in particular how construction of direct and indirect heater elements, as employed in modern radio tubes, differs. At the left is pictured the CX-301-A radio frequency detector tube, employed for battery operated sets, with its direct electron emitting filament. In the center is shown the most recent development of radio frequency amplifier—the C-234 screen grid tube—which utilizes the indirect heater cathode. On the right is the C-327 tube, a popular type of radio frequency amplifier, which also employs the indirect heater element. It sometimes is called the cathode type of tube, and is designed primarily for A. C. operation.

METALS RARE FOR YOUR RADIO TUBE!

The radio vacuum tube is one of the most complex products of the modern scientific age in the make-up of its chemical and physical properties, it is stated by research engineers of E. T. Cunningham, Inc., radio tube company.

These every-day tubes, as used in radio receivers, comprise no less than forty-three elements, together with fourteen rare earths, the Cunningham engineers report. Among the better known metals incorporated in their composition are: silver, copper, aluminum, mercury, tin, lead, iron, nickel and tantalum. Among the gases employed are hydrogen, argon, helium, nitrogen and chlorine.

BILLION ANNUALLY PREDICTED VOLUME

A billion dollars a year is likely to be the business volume of the radio industry before the close of the next decade, declares George K. Throckmorton, Executive Vice-President and General Manager of E. T. Cunningham, Inc.

"In the ten years since radio was first introduced," he points out, "it has grown with unbelievable rapidity to where it is now showing a business volume of more than six hundred million dollars annually. With each succeeding year showing a remarkable percentage of increase, every third home in the country contains a radio set," he advises.

"FADE OUT" CAUSES

If the tone volume of a set has a tendency to alternately "fade out" and then come back in "blaring" tones, don't always blame it upon fluctuations of the power current supply, it is advised by engineers of E. T. Cunningham, Inc.

In distant reception, it often is the fault of the signals which have a natural tendency to fade according to atmospheric interferences. If an outside aerial is being used swinging aerial wires, or contact with ground leads and aerials connected with other sets, also may be the cause.

TUBES REQUIRE EXACTING DESIGN

The simple appearance of the radio tube of best quality belies the highly scientific development which has entered into its final completed state, advises L. Hyams of the engineering department, E. T. Cunningham, Inc., radio tube company.

The requirements of a well-designed tube are very exacting and complex, it is pointed out. The best efforts of many highly-trained engineers with the most complete laboratory facilities are involved.

In order that each tube may embody a definite combination of all the essential characteristics so that it may perform a definite function, various changes may be made in the grid, in the plate and in the filament construction. As an example, the larger the filament, the greater the plate current due to increase of emission from the larger filament surface.

Large Plate

At the same time, he advises, a large plate will reduce plate resistance, but in turn, will increase the grid-plate capacity, thus causing greater feedback through the tube. The spacing of the grid wire, the number of wires per inch and the diameter or gauge size of the grid wire are all of importance in their effect on the amplification factor.

Even the distance between the elements is of vital importance, for if the grid is moved away from the plate, there will be a decrease in plate resistance and a loss in amplification factor. When the grid is closer to the plate, there is an increase in amplification and an increase in plate resistance. Which of these results is most desirable depends on the use to which the tube will be put.

These few instances are cited to give a partial insight into the many engineering problems confronting the designer of the tube. The science of designing a good radio tube, capable of maintaining maximum performance in the duties for which it is intended, must meet hundreds of similar laboratory tests before success is finally attained.



Write for free dealer slide information



Strange Elements in Tubes

Is "Yttrium" a member of the solar system, or the secret pass-word of a fraternal lodge?

It is neither according to an engineer of E. T. Cunningham, Inc., who defines it as one of the rare elements that are contained in the tiny everyday radio tube—in fact, one of the many strange sounding elements that must all be adjusted to their proper place in the intricate make-up of the tube.

Only in the research laboratories, for instance, does the weird name of "Zirconium" bring a glow of recognition, or does "Molybdenum" mean more than just another word for the cross-word puzzle.

DECREASING VOLTAGE

Set owners using "B" eliminators may often be bothered by varying voltage power as the rectifying tubes become old, according to F. H. Larabee of E. T. Cunningham, Inc.

As this voltage is reduced, he advises, the "C" battery voltage also should be decreased. As he explains it, a tube normally requiring 40.5 volts negative on the grid when the plate voltage is 180, may be reduced to 35 volts on the "C" bias, when this plate voltage decreases to 160.

Efficiency of a tube should not be determined by measuring the plate current, but by measuring the emission.

Short tube life is often caused by poor line voltage control.

An aerial placed too near another may cause interference.

**Give your
radio
a fair chance**

USE

**Cunningham
RADIO TUBES**

They Rhyme

"Cadmium," "Rubidium," "Caesium" and "Titanium" may have a pleasant cadence to the layman's ear, but who would know that they are hidden in the prosaic interior of each radio tube within his set?

And if these were not enough to make the radio owner amazed at the unseen elements lurking within the tube, the Cunningham engineer lists "Strontium," "Boron," "Thorium," "Iridium," "Argon" and "Mischmetal," as a few more of the approximately fifty elements which every well built radio tube should have.

"Antimony," it is explained, also is one of this strange group.

VOLUME TROUBLE

Causes of Weak Reception Explained by Radio Engineer

If a set is troubled with weak reception or low volume in a battery-operated set, don't always place the blame upon the tubes or batteries, advises an engineer of E. T. Cunningham, Inc., radio tube company.

Often, he explains, such lack of sound volume may be due to a variety of other causes. Among the most common ones, he lists, are:

1. Poorly constructed aerial; 2. Poor location of aerial; 3. No ground, or a ground hook-up that does not work; 4. Poor contact between tubes and sockets.

Other common sources of power decrease in battery-operated sets, as tabulated, include:

1. Low battery voltages; 2. Defective detector grid condenser or leak; 3. Shorted radio frequency transformer; 4. Loose wiring and connections; 5. Incorrect grid bias; 6. Incorrect wiring.

RUSH TUBE SHIPMENT TO BYRD EXPEDITION

A tube shortage in the shadow of the South Pole has been averted by a special shipment of thirty Cunningham tubes, of three different series, to the Byrd Antarctic Expedition.

The tubes are duplicates of Cunningham tubes that have been used by the Expedition since its arrival at the "Little America" base in the Antarctic and were forwarded after a request by wireless from Mal-

colm Hanson, Chief Radio Engineer of the Byrd organization.

The tubes sent were one dozen CX-301A tubes, one-half dozen CX-112A, and one dozen CX-322.

These were speeded to Norfolk, Va., where they were placed aboard a Norwegian whaler, which will transfer them to a communicating ship as it approaches the Antarctic boundaries of the Pacific Ocean. Imperative haste was called for as radio communication is the only means by which the Expedition may contact with the outside world.

Other types of Cunningham tubes being used in the receiving sets at the "Little America" base include the CX-310 series; CX 371-A and CX-299.

What Home Owners Prefer in Radio

Cunningham Tube Expert Declares Distance Not Prime Essential

What constitutes the average radio receiver set in use today?

Answered by C. R. King, assistant general manager of E. T. Cunningham, Inc., radio tube company, he states that the average set now in use has from six to seven tubes, either battery or power-line operated.

Its average daily use is four hours, or approximately 1,450 hours a year, he declares.

And what about distant reception? Is the average radio owner interested in getting stations located, say, over 1,000 miles from point of reception?

Mr. King answers decisively—No.

Recent surveys, he states, have demonstrated clearly that Mr. Average Radio Owner tunes in regularly on two or three favorite stations of his selection and within a comparatively short radius of his own locale. The uniformly fine programs available in all sections of the country today, combined with national hook-ups, have eliminated much of the need for such distant reception.

And, lastly, is use of the radio seasonal?

In the early days of radio, Mr. King answers—Yes. Today—No.

He adds that present-day radio owners, due to the increasing diversity of radio programs, and high standards of reception, now use their radios practically as much in summer as in winter, many of them even taking their radios with them during vacation time.

HINTS FOR MAXIMUM SERVICE OF CX-345 TYPE OF AMPLIFIER

For maximum service of the CX-345 loud speaker power amplifier tube, it is recommended that set owners check plate voltage and see that it does not exceed the maximum recommended value of 250 volts.

When the power obtained from one tube is insufficient for volume requirements, it is further advised that two tubes can be used in the conventional push-pull circuit. Operating a push-pull amplifier with the maximum voltage of 250 volts, the power output obtainable is 3200 milliwatts, which is equivalent to the output obtained from one CX-350 operated at 400 volts.

MAJOR FACTORS FOR QUALITY IN SET RECEPTION

Radio Performance Depends Upon Four Important Component Phases

Radio performance depends upon the efficiency of four major factors in the operation of every set, according to engineers of E. T. Cunningham, Inc., radio tube company. Failure of any one of these important component parts will lessen tonal quality, no matter how maximum perfect is the performance of the other three, it is declared.

These four factors are enumerated as follows:

1. The fidelity and efficiency of the loud speaker;
2. The circuit design of the receiver, which requires proper tone frequency characteristics of the audio circuits, and correct circuit constants for the particular tubes for which the receiver was designed;
3. The correct tubes for which the circuit was designed;
4. The use of correct voltages for most efficient operation of the tubes and circuit.

Indifferent selection of tubes not adapted to the set is a frequent cause of poor radio reception, the Cunningham engineers report. "Radio tubes must be chosen with great care, with due regard to the manner in which they are to be used," it is declared.

Radio Tubes Have Cat's "Nine Lives"

Radio tubes may be delicate in appearance but, in reality, are more difficult to "kill" than a cat with the proverbial nine lives, it was proven in a recent fire and explosion in a New Orleans home.

During the blaze, a terrific blast of ignited gas blew the home radio set through a room wall of solid brick and plaster, burying it in the debris. Two weeks later, it was uncovered from the ruins and was discovered to be giving unimpaired reception.

The six Cunningham tubes in the thoroughly battered set were removed and tested and showed such perfect performance that they now are being used in another receiver, according to the owner, Charles J. Justice, President of the Lighting Fixture and Supply Company, of that city.

The New Super-Buoyant Circuit

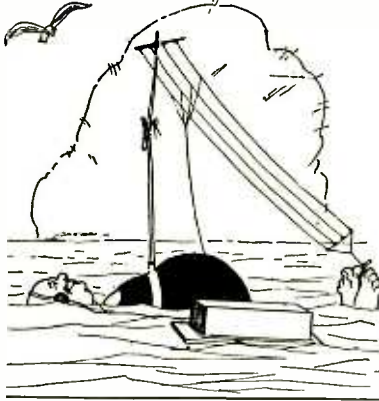

Humor in the Mauve Decade. This 14-year-old cartoon is said to be the first ever to have appeared referring to the new wonder of that day, the radio. It was published in 1915 in a house organ of E. T. Cunningham, Inc.

In explaining the cartoon the unknown creator predicted: "Music while you float or an imitation of 99.44% purity, will be popular at the beach resorts next summer thanks to this new and improved nautical hook-up."

APPOINT NEW MANAGERS

Important changes in management of their district offices located at San Francisco and Chicago are announced by E. T. Cunningham, Inc.

The new appointments transfer E. Lloyd Sutton, formerly district sales manager of the Chicago territory, to the district managership at San Francisco; F. E. Harding, formerly in charge of the Cleveland office, to Chicago.

NEW RATING BASIS FOR CX-380 VALVE

Sufficient Voltage and Current for Sets Using Two CX-345 Tubes

A new rating basis for their CX-380 rectifier tube, just announced in a bulletin of E. T. Cunningham, Inc., places the maximum R. M. S. voltage input at 400 volts per anode with a rectified current not exceeding 110 milliamperes. Under the old rating the maximum R. M. S. voltage input was 350 volts per anode, with a rectified current up to 125 milliamperes.

This new method of rating will allow a CX-380 tube to supply sufficient voltage and current for sets employing two CX-345 tubes, and using the rectified output for dynamic speaker field excitation.

Old Rating

Under the old rating the maximum input voltage rating was based on tube operation at the maximum current rating. As the rectified current through the rectifier is reduced, the wattage dissipation is reduced to such a point that it was believed the input rating could be increased. After exhaustive live tests, it was found that after the tubes were operated at reduced current rating, the voltage rating could be increased.

For example, if the current output is 110 m. a., or less, the voltage input may be increased to 400 volts R. M. S. per anode. According to the Cunningham bulletin, it is noted that with 110 m. a. rectified output the voltage is approximately 390 volts, while at the current output of 100 m. a., it is approximately 400 volts.

STANDARD SINCE 1915

Cunningham
RADIO TUBES

MILLIONS IN USE

The Fastest Horse Is Always the Best Bet

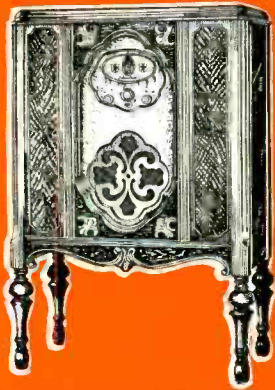

THE CONCERT GRAND, illustrated, is of beautiful and unusually substantial construction. Four-way matched butt walnut, carefully selected oriental walnut panels, the right amount of birds-eye maple, all contribute to make it an outstanding cabinet. Priced absolutely complete, less only tubes . . . \$173. Other models \$160 and \$195. All prices slightly higher west of the Rockies.

WHY is it that out of hundreds of radio sets on the market,

ONLY ONE bases its campaign on direct comparative tests that can be made anywhere, by anyone, without laboratory instruments — definite tests that really mean something — and gives away through dealers millions of circulars telling plainly how to make these tests on any radio?

ADJECTIVES help to sell goods, without a doubt. We know some good ones, too. And we have plenty of celebrity endorsements — not baseball celebrities, but famous musical authorities. And there's a heavier advertising appropriation with every SILVER RADIO than with any other make we know. And yet, for all that, we say and believe—

"In the hard-fought radio market of 1929-30, the safest investment on any dealer's floor is a receiver that will consistently outperform all competitive makes irrespective of price."

Your SILVER RADIO distributor stands squarely back of the claim here implied. Make him prove it!

SILVER-MARSHALL, Inc., 6441 W. 65th St., Chicago

SILVER
Radio



SILVER · ON · RADIO · LIKE · STERLING · ON · SILVER

There Is No Substitute For QUALITY

Insist on ELECTRAD Voltage Controls
and Be Sure of the Best

BACK of every ELECTRAD product is a world-wide reputation gained through superior workmanship and service, plus right prices. The strongest endorsement of ELECTRAD Resistances and Voltage Controls comes from radio engineers, manufacturers, and custom set builders who *compare* before they buy.

No better proof of ELECTRAD supremacy could be found than the willingness of these men to stake the reputation of *their* products upon ELECTRAD performance.

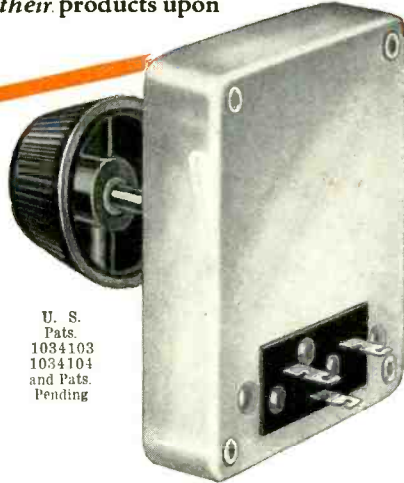

The SUPER

The ELECTRAD heavy duty volume control which has set new standards of efficiency and long life.

Easily dissipates 5 watts without breaking down or varying in resistance. The resistance element is fused at high temperature to an enameled metal plate. The pure silver floating contact of new de-

U. S. Pats. 1034103 1034104 and Pats. Pending

TONATROL

sign has an astonishingly smooth and positive action which *improves* with use. Laboratory tests approximating 10 years' average use amply prove its stamina. Metal cover, firmly riveted, aids rapid heat dissipation. Bakelite insulation.

Seven types for every volume control purpose, including output from electrical phonograph pickups. \$2.40 to \$3.50.



U. S. Pat. 1676869 & Pats. Pend.

TRUVOLT

All-Wire Resistances

The **SAFE** resistance for eliminator and power pack use owing to its unusually stable value, generous margin of safety and durability.

Patented open construction assures cooler operation. Nichrome resistance wire is first wound around an asbestos covered copper core. This is then wound on the fire-clay base. The sliding clip, an *exclusive TRUVOLT feature*, enables quick adjustment of resistance values. All usual sizes.

TRUVOLT VARIABLES have same distinctive construction plus variable knob control. Metal shield protects resistance and aids heat dissipation. Less wear owing to endwise travel of contact. 22 stock sizes, \$2.50.

ROYALTY

Variable High Resistances

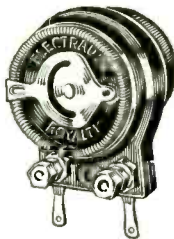

Licensed by Technidyne Corp. U. S. Pats. 1593658 1034103 1034104

A quality-built voltage control with many distinctive features, widely used in circuits requiring variable resistors with low self-inductance.

Variable contact is made *indirectly* with the resistance element, resulting in a more positive control and absolute freedom from variations due to wear.

Entire resistance range covered with one turn of the knob. 11 types with all usual ranges and ratings. Potentiometer, \$2.00. Other types, \$1.50.

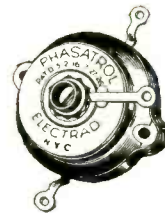

U. S. Pats. 5/2/16 7/27/26 and Pats. Pending

PHASATROL

The Universal Radio-Frequency Balancer

A PHASATROL to each stage of R-F amplification effectively controls oscillations and greatly simplifies balancing any radio frequency circuit, tuned or untuned. Completely eliminates R-F distortion.

Can be quickly installed without experience. Handsome enclosed Bakelite case. Easily mounted anywhere on panel or sub-panel. Instructions for installing in different circuits packed with each PHASATROL. Price, \$2.00 each.

175 Varick Street

New York, N. Y.

ELECTRAD

INC.

Western Representatives: UNIVERSAL AGENCIES, 905 Mission Street, San Francisco, Calif.

ELECTRAD, INC., Dept. PR11, 175 Varick Street, New York, N. Y.

Please send data on the following products: SUPER-TONATROL, TRUVOLTS, ROYALTY, PHASATROL, All Products.

Name _____

Address _____ City and State _____

RADIO

for the profession

VOL. XI

NOVEMBER, 1929

No. 11

Divorcing Service from Sales

By P. S. LUCAS

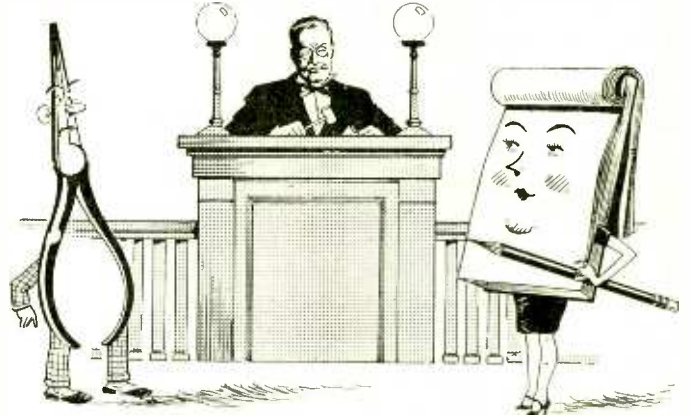

SERVICING is still a necessary evil in the sale of radio. Even the most highly perfected a-c set is liable to develop some little trouble which calls for the attention of a service man. Anticipating such trouble, the dealer generally gives free service for a limited time after purchase and installation. Thereby he insures satisfaction to the customer.

But this free service costs money and cuts into profits. In extreme cases all the profit on a sale may be lost in the subsequent cost of service. Furthermore the regular fees which are charged for service work on older sets are frequently

insufficient to show a reasonable margin of profit.

Of course there are exceptions where a well-managed service department makes as much or more profit than does its associated sales department. In such cases the owner is generally a good service man himself. For servicing is just as highly a specialized business as selling, and one man is seldom equally good in all both branches of the business.

The average dealer is far more interested in making sales than in doing service work. He regards his service department as a white elephant and would welcome a nice easy way of getting it

out of his establishment without creating ill will among his customers. Yet he realizes his obligation to keep the set in satisfactory order after it is sold and he values the contact and opportunity for future business which is offered by good service work.

In such a dilemma he is like the man who grabbed the cow's tail; he's afraid to let go and afraid to hold on. What shall he do? Of the many solutions which have been offered for this problem, two are outstanding successes, and an account of how two dealers solved the question in different ways may be of in-

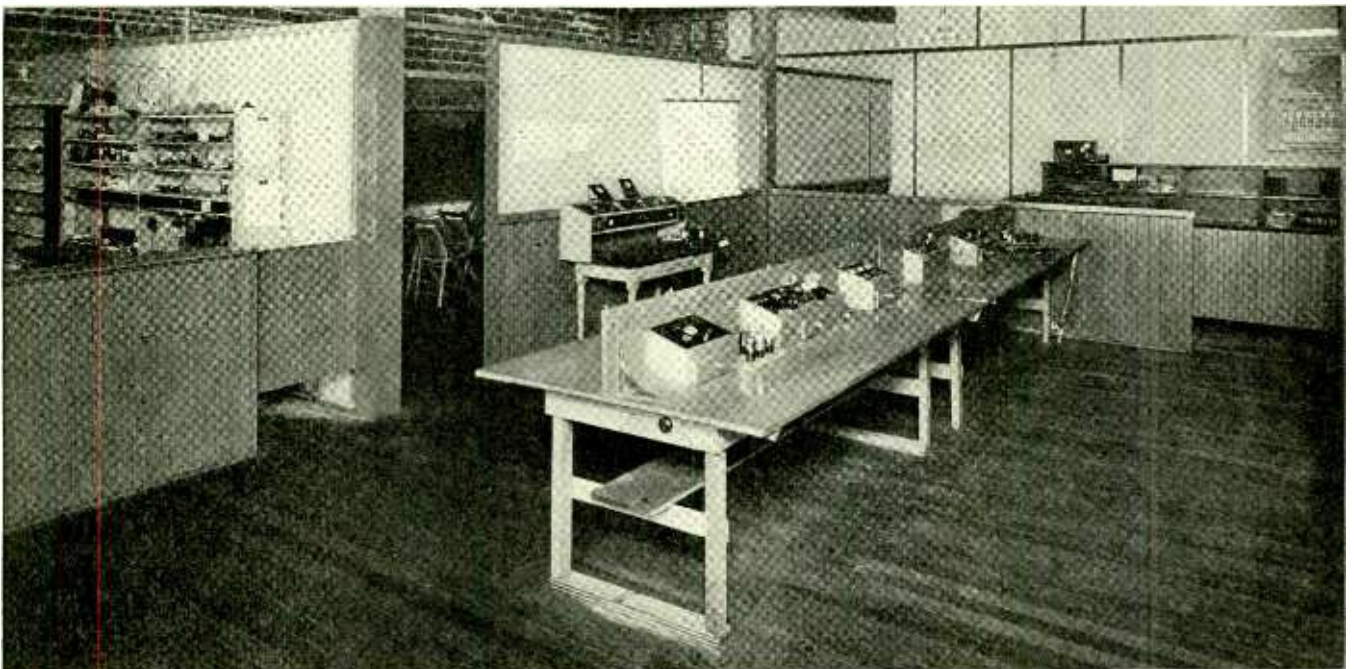

Testing Room of East Bay Radio Service Co.

terest and value to other dealers who are confronted by the same question.

One method is that adopted by the Guy Radio Company at Petaluma, a typical small town in California. Mr. Guy is a pioneer radio dealer. His business was large enough to employ several service men and several salesmen. Yet he found that the maintenance of his repair shop and service car constituted a goodly part of the overhead, even when the shop was not charged for its due proportion of the regular overhead. Furthermore many service accounts were uncollectible because the customers felt entitled to unlimited free service.

As the shop was thus a liability when associated with the salesroom, Mr. Guy decided to divorce them by selling the service equipment, car and stock of repair parts to the service men. He took their note for the purchase price, payable in monthly installments. He gave them the use of the shop premises without rent, paid them a certain amount per set for the sixty-day free service on each receiver he sold, and turned over all the service business to them. It was also agreed that he would pay them for hauling consoles to and from demonstrations, run a line for them in each of his advertisements, and allow them all the battery and tube sales made on the job. In any case of question as to price or quality

of work on the part of the customer Mr. Guy was to be the judge.

The advantages of this plan proved themselves instantly. The sales force devoted itself to sales; the service men demanded cash on the job and got it; and other dealers, knowing that they were not dealing with a competitor, made use of the increased service facilities of this organization to the material gain of both. The service men, being far sighted, have realized the importance of turning in any prospect for a new radio set to the dealer for whom they were servicing, keeping faith both with Mr. Guy and with the other dealers from whom they received calls. So the dealer and the service man made money and the public was better served.

ANOTHER solution to the problem is offered by the service man who takes the initiative in contracting to do the servicing for a number of dealers exclusively. The dealer contacts with the customer and telephones the service order to the wholesale service man who services the set and sends his bill to the dealer for collection, charging a flat rate for labor and allowing a discount from the list price of material. The dealer collects from the customer after adding a legitimate profit and then pays the service man.

This is the method which is being

successfully employed by the East Bay Radio Service Co. of Oakland, Calif., which maintains a well-equipped shop and employs a staff of service men who carry portable testing kits in whose use they are given a complete course of instruction. This instruction includes a method of making preliminary tests for opens and shorts on any a-c or d-c receiver in three minutes without reference to a circuit diagram.

The dealer who uses this service can offer a customer 90-day free service, which is supplied by the service company at a cost of three dollars to the dealer who merely relays the service calls from his customer to the service company. For other calls the dealer is offered flat rates on labor and material and may charge the customer as he sees fit. The service company guarantees that its men will act as the dealer's representative when calling on customers and that the good will accruing from a well-performed job will go to the dealer.

Either one or both of these methods may be adapted for use elsewhere. They relieve the dealer of his responsibility without loss of good will and assure the customer of expert service. The service department no longer appears on the wrong side of the profit and loss statement and the service man can make an honest living.

Wiring a Radio *Installation*

By N. A. ROLLAH

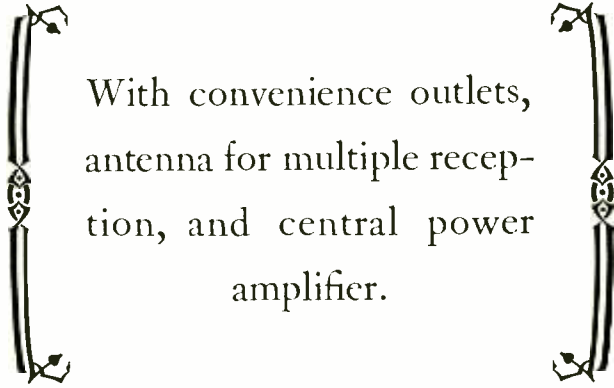

With convenience outlets,
antenna for multiple recep-
tion, and central power
amplifier.

THE advent of convenience outlets specifically designed for radio, gives the electrical contractor an opportunity to install a workmanlike job instead of the unsightly makeshifts which have characterized radio installations in the past. Radio has become an accepted and expected feature not only in homes but also in apartments, clubs, hospitals, schools, and even office buildings. While the installation is best planned when the architect is preparing the plans, yet the running of wires and the placing of outlets in old buildings is much simpler than it is to provide for electric, gas, water or refrigeration service.

Special outlets are now available for practically every radio wiring need. In size and general appearance they are sim-

ilar to the standard electrical convenience outlets and can be attached to the standard electrical outlet boxes. A radio outlet consists of two parts: The wall plate and the device which it covers, whether a jack, selector switch, volume control, or other accessory. The wall plate and accessory are separable, the latter usually being mounted on a supporting strap by which it may be attached to the switch or outlet box or fastened directly to the laths or studding by means of two wood screws. The wall plate is lined up and fastened to the supporting strap with screws.

Outlets are made for aerial and ground connections, loudspeaker connections, multiple cable battery or power-pack connections, volume control, and

a-c power supply. These are available either in single plate outlets or in various gang combinations. They are made by a number of manufacturers who will supply data regarding their use upon request. The information that follows was supplied by the Yaxley Manufacturing Company, with their own equipment in mind, but is, in general, applicable to the devices made by other firms.

For a combination aerial and ground outlet an opening is made in the wall just large enough to receive the switch-box or receptacle and at a point convenient to the position of the receiver. The lead-in wire is brought from the aerial behind the wall to the opening, pulling through enough wire so that it can be worked conveniently. The ground

wire is run to the nearest good ground. The ends of the antenna lead-in wire and the ground wire are easily attached to the jack by terminal screws.

The excess wire is neatly coiled and pushed into the outlet box or opening, the supporting strap fastened to the box or lath, the wall plate lined up and fas-

tened to the supporting strap. The usual procedure for long or short lead-ins, such as shielding and the like, should be followed. A good rubber covered, solid conductor is preferable.

Connection to the receiver is made with a flexible conductor and phone tip plugs which are furnished with the aerial and ground convenience outlet. Solid No. 14 wire can be used, but the other method of connecting is much better looking and therefore desirable. Aerial and ground wires should never be run parallel for any considerable distance, nor should they be run too close to the speaker extension circuit.

For loudspeaker outlets for service in various rooms for a single receiver, the most convenient locations are selected and the wall openings made as already described. From the original outlet near the receiver the wires are pulled through back of the plaster. In a home or small apartment the connections to the proper terminals on the jacks may then be made either for series or parallel connection as shown in Fig. 1. Any approved twisted insulated wire

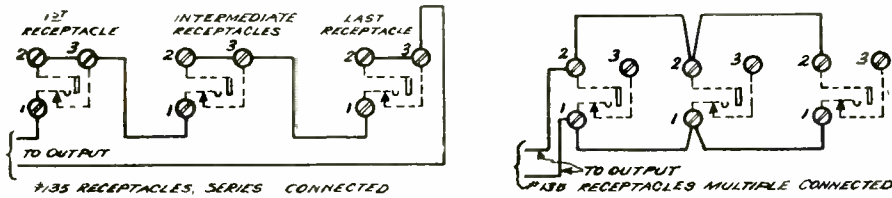

Fig. 1. Series and Parallel Connections of Speaker Outlets in Small Installation

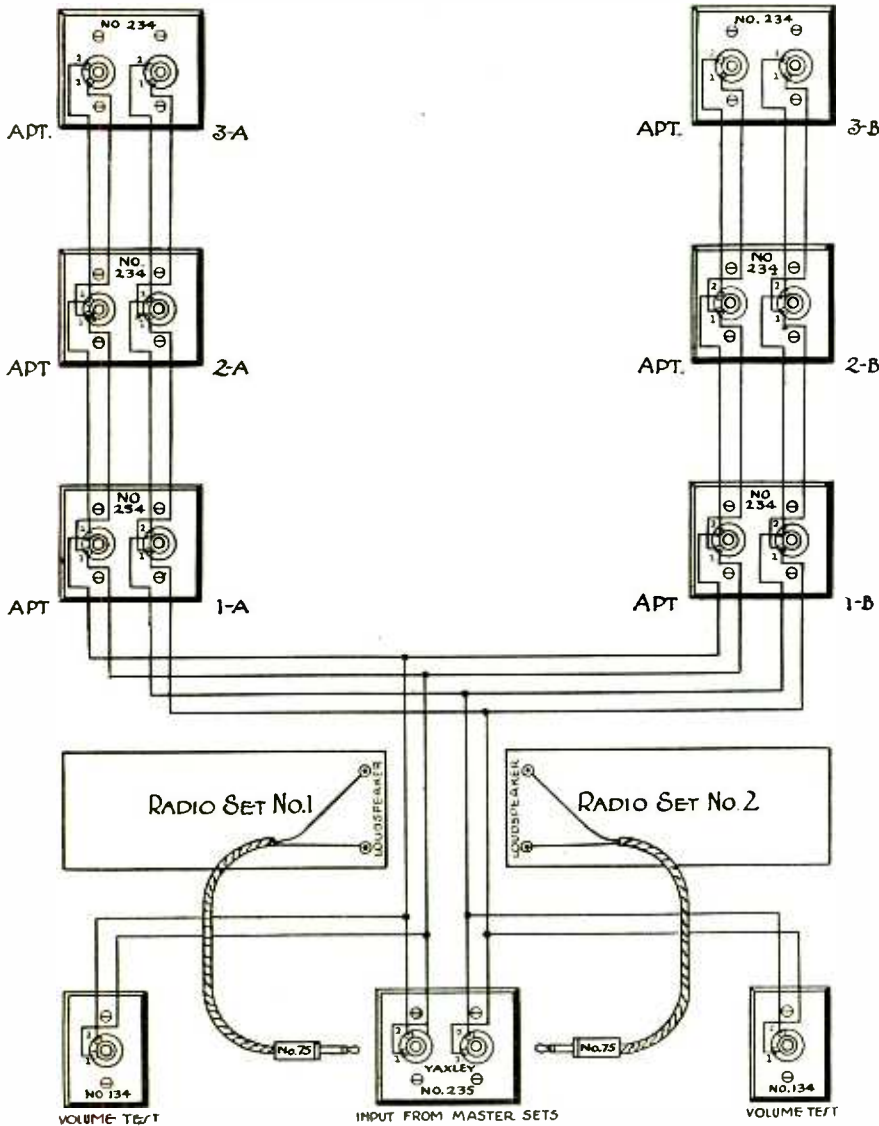

Fig. 3. Connections for Choice of Programs

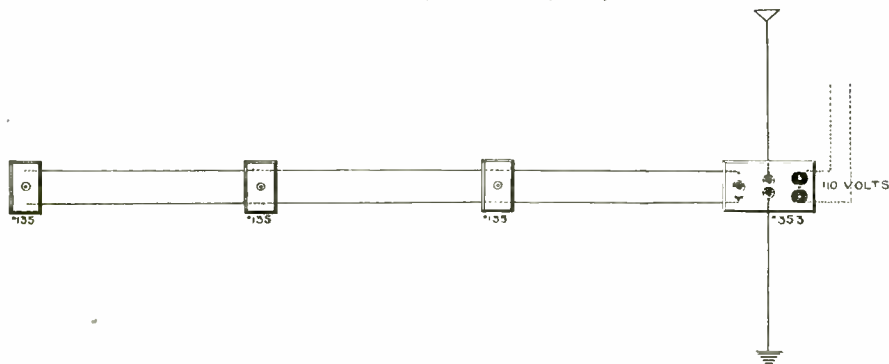

Fig. 4. Loudspeaker, Aerial-Ground and A-C Connections

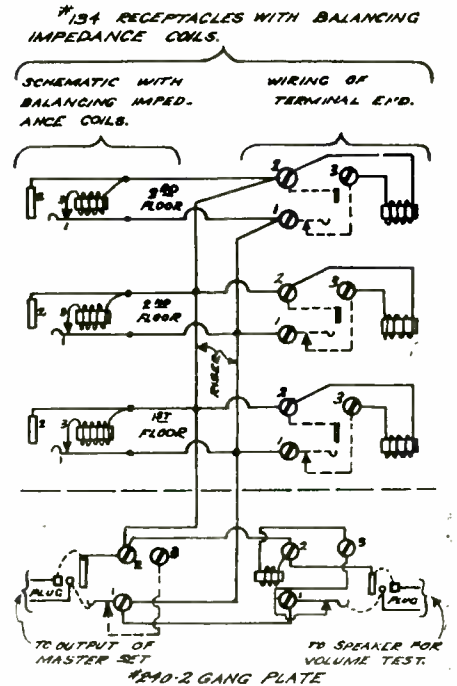

Fig. 2. Parallel Connection of Coil-Equipped Outlet for Large Installation

may be used, No. 19 telephone wire being entirely satisfactory, especially if it is lead-covered with grounded sheathing.

In larger installations where quite a number of loudspeakers or head sets are to be used at the same time, it is necessary to use an outlet with a jack which is equipped with a coil whose impedance is about the same as that of the loudspeaker unit. When the loudspeaker is plugged in it cuts out the coil. When the speaker plug is removed, the coil is cut in. Thus equal volume may always be had from one or several loudspeakers.

The receptacles are wired in parallel as shown in Fig. 2. The two-gang plate at the receiver provides an outlet for testing the volume.

Where a choice of two programs is desired in connection with two radio sets, the outlets may be connected as shown in Fig. 3. Either program may be heard by plugging the loudspeaker plug into the appropriate outlet, which should be equipped with balancing coil.

Fig. 4 shows the wiring for a combination outlet which gives connections for aerial and ground, several loudspeakers and a-c supply. Fig. 5 shows a more ambitious layout which also provides for remote control in any room in which the loudspeaker may be installed. The set or speaker may be switched on or off from any room, thus preventing energy supply to a dynamic speaker when the set is not in use.

More complicated installations with power amplifiers, volume controls, and other intermediates, should not be made without competent advice unless the installer is well experienced himself.

Among such somewhat complicated installations are those furnished by the Radio-Victor Corporation of America for utilizing either a single antenna to supply a large number of radio sets or a single set to supply a large number of loudspeakers. The former is known as the RCA antenna system for multiple receivers and the latter as the RCA centralized radio equipment. By the former as many as 80 different receivers can be operated simultaneously from one antenna without interaction or mutual interference. By the latter as many as 200 loudspeakers or 3000 headsets may be operated from one receiver and amplifier unit.

In the antenna system a single UX-226 tube untuned r-f amplifier is used to couple a single antenna to a transmission line which serves ten similar coupling units, each of which is connected to a radio convenience outlet containing an antenna and ground terminal, an a-c power plug and power switch. The switch controls the power supply to the coupling unit and to the receiver, so that the extension coupling unit is in operation only when the receiver is being used. A single antenna can thus be coupled to eight transmission lines, each of which feeds ten receivers.

The antenna lead-in is connected to one of the antenna coupling boxes through a grounded resistance and capacitance unit as shown in the schematic diagram of the antenna coupling box. The box contains, in addition to the r-f amplifier and line-coupling transformer, a filament transformer and a plate supply unit with 280 rectifier, the latter also supplying plate voltage for ten extension coupling units.

All signals brought in by the antenna are equally amplified and passed on to

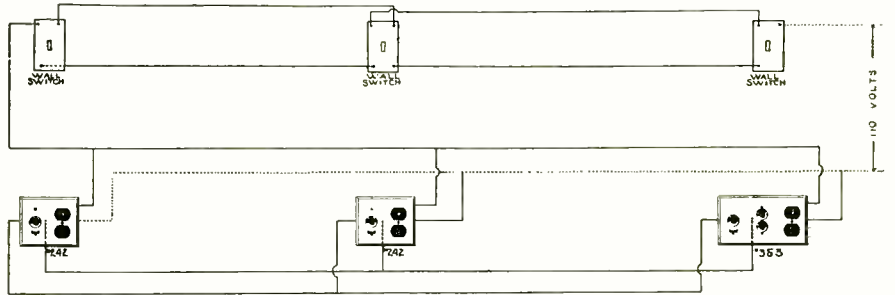

Fig. 5. Circuit for Remote Control Installation

the transmission line which is loaded with inductance coils so placed as to balance the distributed capacity of the three-conductor cable and to cut off all frequencies greater than 1500 kc. This limits reception to frequencies within the broadcast band.

The various extension units couple the individual receivers to the transmission line through separate untuned r-f amplifiers whose grid signal and plate voltages are carried by the line. Each extension coupling unit contains a filament transformer whose a-c power is controlled by the power switch in the convenience outlet. The r-f output of this amplifier is fed to the antenna and ground pin-jack terminals on the con-

venience outlet through an r-f transformer whose secondary is in series with a condenser. The last unit on each transmission line is terminated with a mid-tapped resistor and fixed condenser which matches the impedance of the line to that of the antenna coupling tube which supplies the line. Fig. 6 gives circuit details.

The RCA centralized radio equipment consists of a radio receiver for the reception of broadcast programs, a power amplifier, and an audio distribution system to supply reproducers placed throughout a large building or ship. The receiver has three r-f, detector, and one a-f stage. A unit amplifier uses two 250 tubes in push-pull, capable of de-

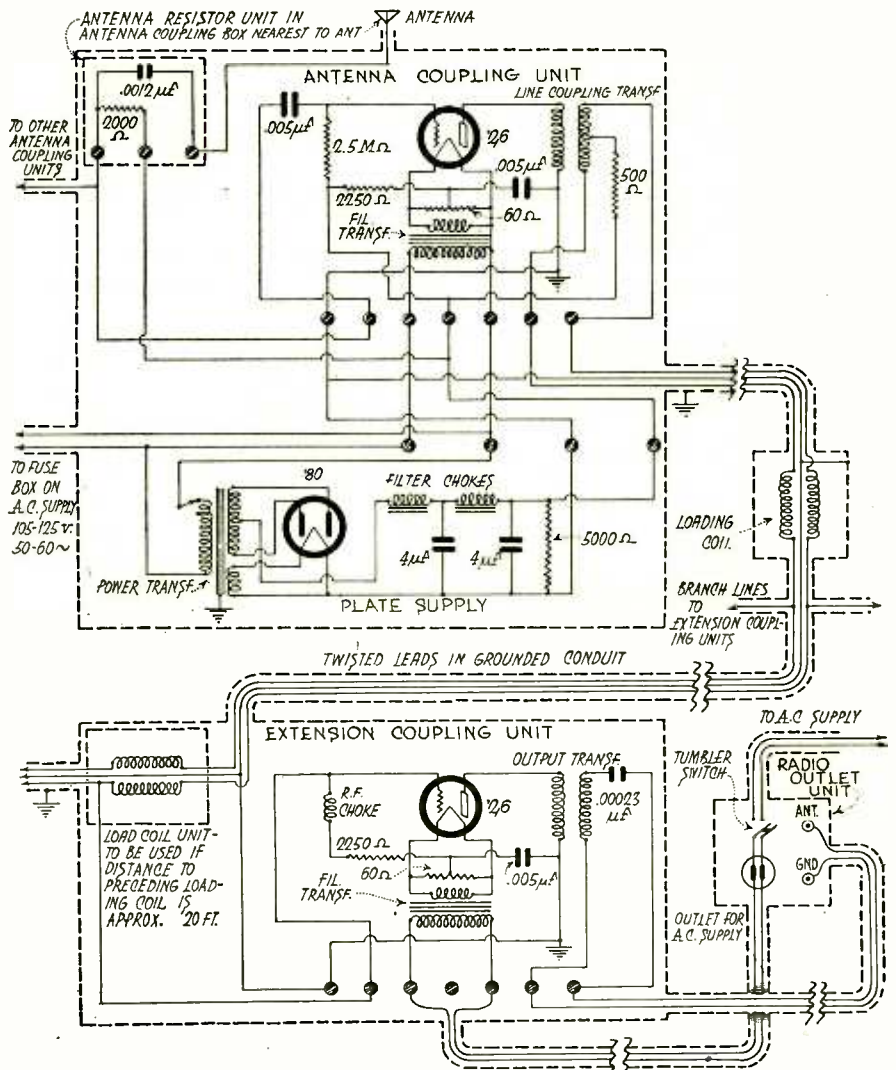

Fig. 6. Circuit of RCA Antenna System for Multiple Receivers

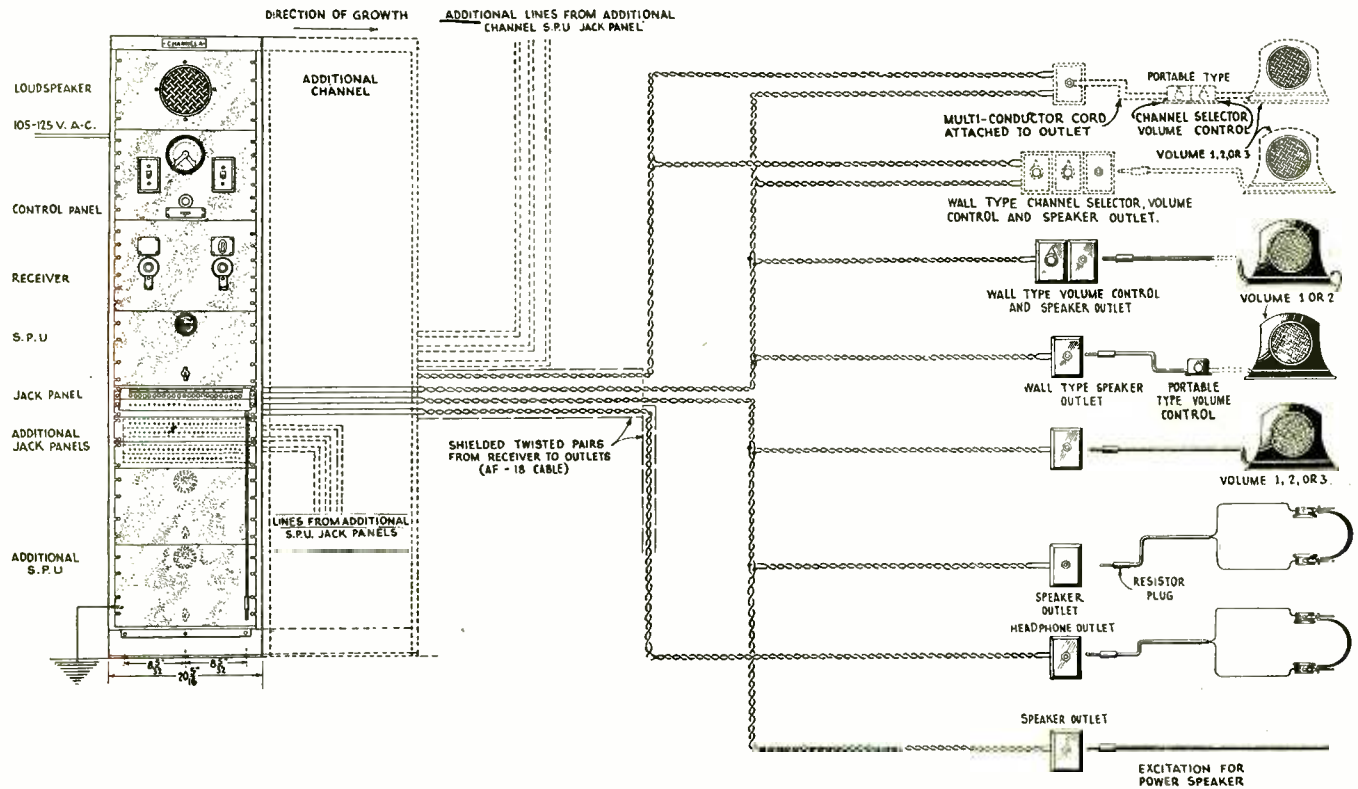

Fig. 7. Layout of RCA Centralized Radio Equipment

livering 10 watts which is deemed sufficient for 200 private hotel rooms or 2000 headphones. The amplifier panel also supplies filament, grid and plate power to the receiver. From one to three amplifiers may be installed on each panel.

The general layout of the equipment is shown in Fig. 7. The top panel in the rack contains a loudspeaker to be used in monitoring any circuit through the jack panel. The control panel has a manually operated and an automatic time switch for throwing on and off the power supply through a current tap, as well as a pilot lamp, fuse cut-out, and a key which cuts in either radio or

phonograph. The receiver panel is equipped with tuning and volume controls which may be locked in place. The power amplifier or SPU panel has an operating switch and a distortion indicator.

The receiver is conventional except that its audio tube contains two UX-226 tubes in push-pull. Fig. 8 is the circuit diagram of the power amplifier unit. The general idea as to wiring may be obtained from Fig. 7. A complete line of extension equipment is supplied with this system. This includes jack outlets for loudspeaker or phone connection, and channel selectors where more than one power amplifier is used, volume con-

rol, and loudspeakers. These are available either in wall or portable types.

IMPROVING AUDIO CIRCUITS

By WALTER DOYLE

MANY service men have failed to notice any improvement when they have substituted up-to-date a-f transformers for the small ones of older design. Unless care is taken to use bypass condensers and resistors, the advantage that can be gained by using the large transformers with high impedance and large core is lost. One of the most common difficulties in the use of high-grade transformers is feed-back from the power tube into the grid circuit of the first audio stage.

In using the large type of transformers, a resistor of from 8000 to 60,000 ohms should be connected between the *F* terminal of the transformer and *C* negative. A $1 \mu\text{f}$ bypass condenser should then be connected from *F* on the transformer to one side of the filament—either side will do—or in the case where the filament current is supplied by transformer connections should be made to the center tap.

For the first audio stage 60,000 ohms resistance is best suited and in the power stages incorporating '71-A or 112-A tubes 25,000 ohms should be used. A resistance of 15,000 ohms should be used for the '10 type tube and 10,000 for the '45 type. The '50 tube works very well with 7500 ohms, although 8007 is correct.

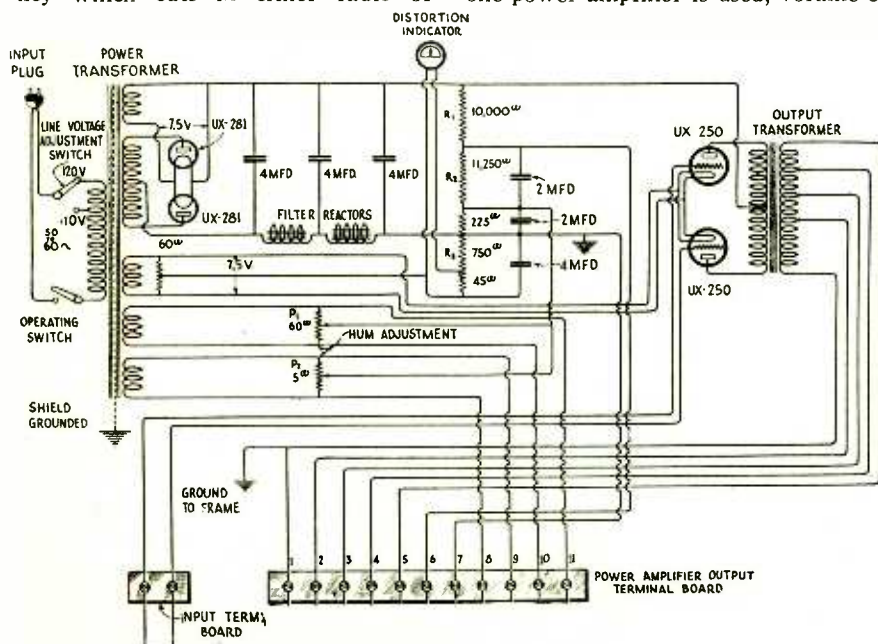

Fig. 8. Circuit Diagram of Power Amplifier in RCA Centralized Radio Equipment

Let's Play Bridge

By KEITH LA BAR

Directions for making and using an inductance and capacity bridge and a tube checker.

THOSE who go in for filters and equalizers and general test work need a bridge to measure inductance and capacity to within 5 or 10 per cent. After the theory of its operation is understood any service man can readily make such a bridge at low cost.

In the conventional bridge, whose circuit appears in Fig. 1, the purpose is to balance the resistance arms so that no current flows through the galvanometer *G*. This is accomplished when the ratio

of *A* to *B* is the same as that of *X* to *S*, *X* being the unknown resistance whose value is to be found, and *S* a standard. In the slide wire bridge, which consists of a slider and a length of resistance wire strung along a meter stick, *A* and *B* being combined.

If an unknown inductance L_x is inserted in the *X* arm and a standard inductance L_s in the *S* arm, after the bridge is balanced, and the battery is replaced with a source of a-c, and the gal-

vanometer by a pair of headphones, as in Fig. 2, there is no current in the phones only when $X/S=A/B=L_x/L_s$. This means that both sides must be at the same potential at the same time. Since the insertion of an inductance involves a phase shift, we must see that the phase angle, the ratio of inductance to resistance, is the same in the two circuits. Thus if the standard inductance is twice the unknown, it would seem proper for it to have twice the resistance in that arm of the circuit. Thus the potentials balance at both sides of the phones.

We see then the need of varying *A* and *B* to get the ratio of the inductances and also varying the resistance *X* or *S* to get the same ratio. In usual practice we disregard the value of *X*, because *X* contains the resistance of the unknown, and it may be too much bother to measure it. *X* also includes the effective resistance, which may run up into several hundred ohms with a choke containing poor iron.

After trying various slide wires and associated junk we came to the arrangement shown in Figs. 3 and 4. The resistances *X* and *S* are combined into a 10,000-ohm midget Carter potentiometer. This has an arrow to show the approximate location, but no dial. Resist-

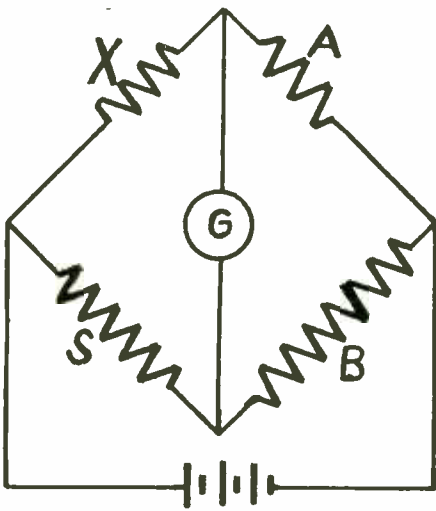

Fig. 1. Circuit of Simple Resistance Bridge

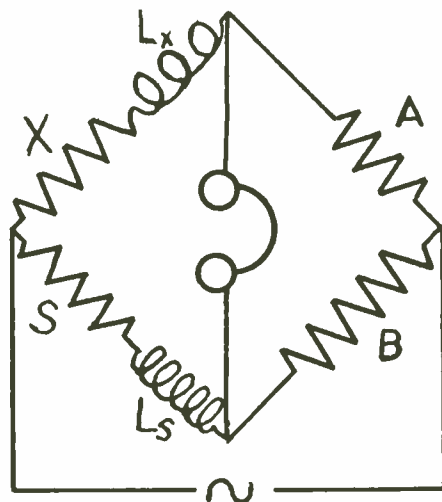

Fig. 2. Circuit of Simple Inductance Bridge

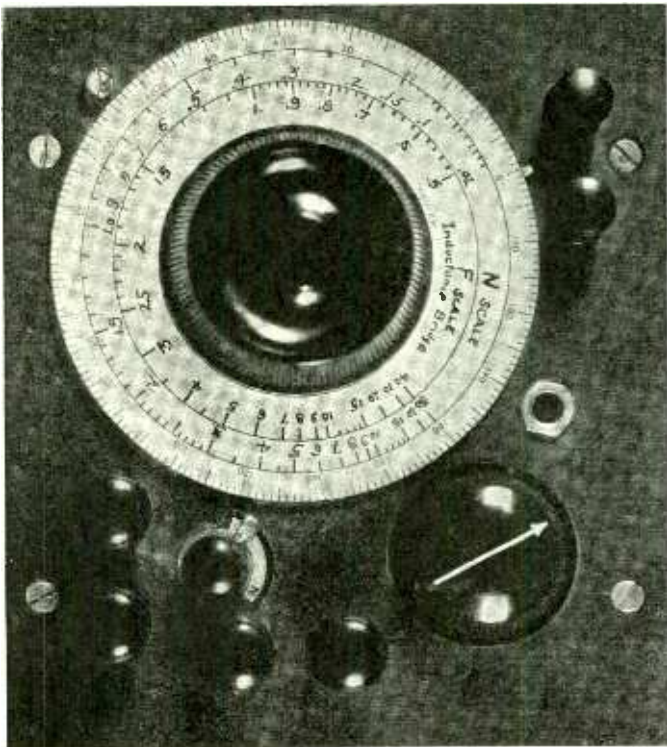

Fig. 3. The Bridge Itself

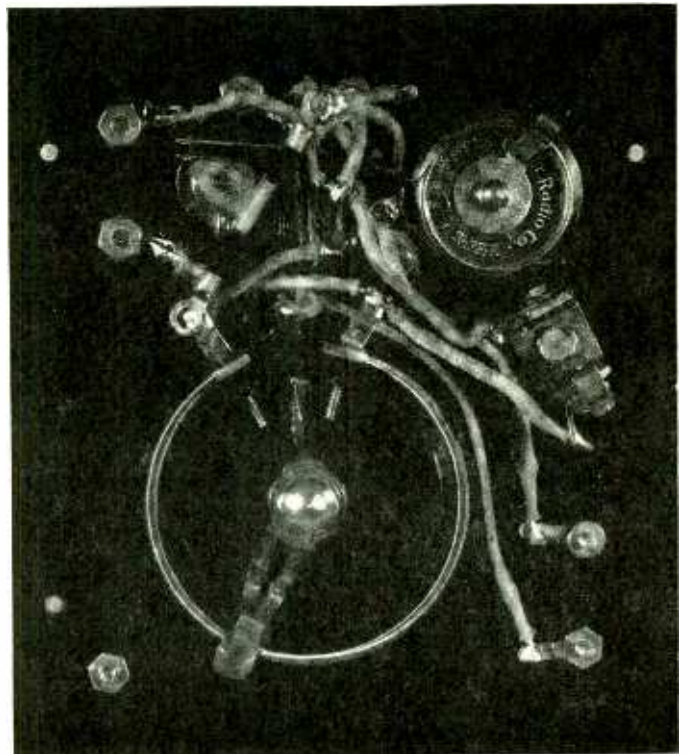

Fig. 4. The Innards of the Bridge

ances *A* and *B* are combined into a 2000-ohm DeJur potentiometer with a Remler dial. The dial shows the ratio of the resistances on each side of the slider arm. Fig. 5 shows the arrangement. Theoretically the ratio goes from 0/2000 to 2000/0 (zero to infinity), which is quite a range. In practice, since there is always a little wire in the circuit the dial runs from .02 to 30 times the standard. An additional 1000-ohm resistance is inserted in the *B* arm, with a shorting switch. With the 1000 ohms in, the lowest reading is then 1000/2000,

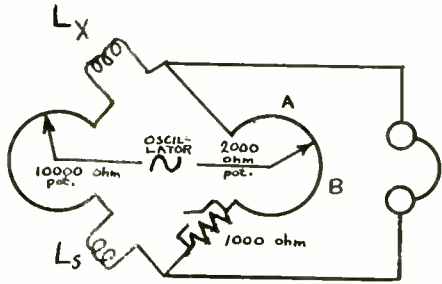

Fig. 5. Diagram of Bridge Shown in Pictures

or .5. The highest reading happens to be 40. One thousand ohms added to each side of the rheostat would run the scale from $\frac{1}{3}$ to 3, which might be desirable when a number of inductances of about the same size are to be measured.

The ratios are obtained by finding the d-c resistance of the two sides of the potentiometer at 5 degree steps around the dial. This was done with a Leeds and Northup ohmmeter. It might be done equally as well with a home-made slide wire bridge. A curve is then plotted, enabling one to catch errors and then even points such as 1, 1.1, etc., and mark the dial.

In practice an oscillator is attached, the phones plugged in, and with the oscillator yowling at the resonant frequency of the phones if possible, to make them more sensitive, the two dials are turned together until the sound disappears. If the small potentiometer is left alone and the dial rotated we may get a minimum say at .8. This may not be absolute zero. By budging the small potentiometer a trifle, we may get a minimum at .75 with less sound than before. By more budging of the small potentiometer we get absolute silence at say .72, which is then the correct value. This is of course multiplied by the standard you have to give the inductance of the unknown. It is seen that it is important to use a potentiometer with many turns of wire at both places. The 10,000-ohm midget shown is difficult to use, for a single turn of wire may make quite a difference. A larger sized one is thus recommended. It may be you have an additional large 2000 and not a ten. In that case fixed resistors on each side capable of being cut in will be entirely satisfactory.

It is easier to obtain an accurate balance with a high pitched source of a-c, such as a thousand cycles, than with 60 cycles. This is because one can hear the higher note better and also because the reactance of the inductance is higher to the thousand cycles and the accuracy thus much better. For this reason it might be well to construct a small oscillator, consisting of an amplifying transformer feeding back into the grid in the manner shown in the diagram. This must be used with an additional tube between it and the bridge because the inductance and resistance of the bridge may cause the oscillations to reach inaudible values or to slide up and down the scale, a most annoying thing when trying to get a balance.

The bridge may be used for measuring capacity. In this case the position of the standard and unknown are reversed. This is because what we really measure is reactance, and with more capacity the reactance goes down instead of up.

age of 1 volt across the grid, the voltage between the plate and the filament will be this multiplied by the amplification factor of the tube. This must be balanced by having the two resistances in the same relation, when the dial will give the amplification factor directly. In the instrument shown, a 1000-ohm resistance is on one side of the 2000-ohm potentiometer and a 300-ohm resistance on the other side.

Honeycomb coils are probably the most convenient standards for small values of inductance. The inductance values for typical sizes are:

INDUCTANCE OF HONEYCOMB COILS

Turns	Inductance in Millihenrys	Turns	Inductance in Millihenrys
25	.04	300	5.4
35	.07	400	9.6
50	.15	500	15.5
75	.325	600	21.5
100	.550	750	34.0
150	1.3	1000	62.0
200	2.3	1250	103.0
250	3.7	1500	155.0

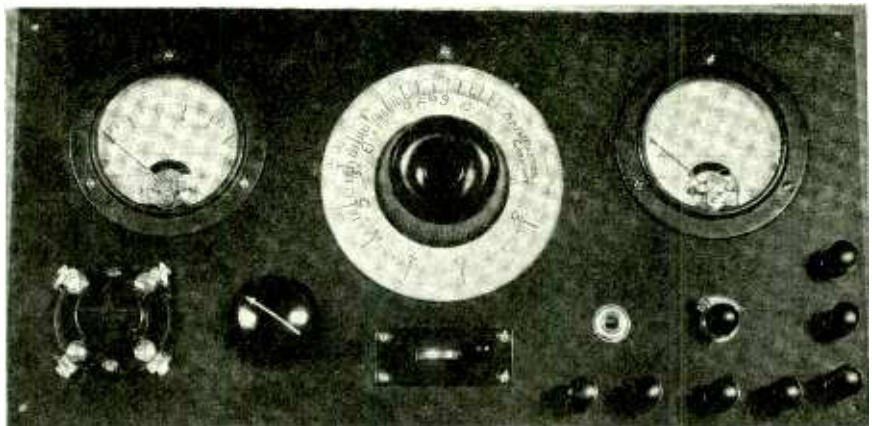

Fig. 6. Tube Checker

Another use for the bridge is for measuring the amplification constant of a tube. The tube checker shown in Fig. 6 was constructed for checking UX864 tubes, a non-microphonic small tube used with condenser microphones. The small switch is merely for introducing *C* bias and noting the change in plate current, a rough way of checking the amount of hop a tube will give. With the telephone key switch to the right the circuit is as shown in Fig. 7. If there is an a-c volt-

WHY METALS ARE CONDUCTORS

The electrical conductivity of metals, according to Dr. W. W. Houston of the California Institute of Technology, is due to free electrons which can move about inside the metal, but which cannot escape through the surface of the metal because of the relatively heavy electrical forces present there. On this basis quantitative expressions may be derived for the emission of electrons by hot bodies, for the electrical resistance as a function of the temperature, for the thermoelectric forces, and for other phenomena. According to Dr. Houston, studies involved in the development of radio tubes have done much to expedite the development of the present theory. In emphasizing the importance of further study along these lines, he states that a certain percentage of the noise emanating from radio loudspeakers is due to the erratic motion of electrons and molecules within the conductors connecting the various parts of the set.

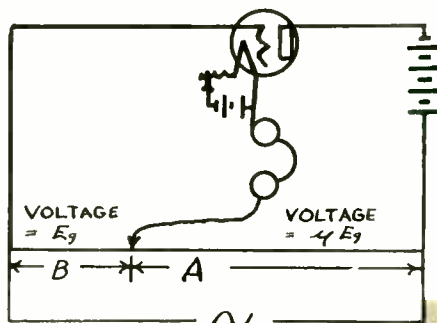

Fig. 7. Diagram of Tube Checker

European Circuits for Screen-Grid Tubes as R-F Amplifiers

By R. RAVEN-HART

Some interesting suggestions for the experimenter who is interested in getting greater amplification from a single stage.

WHILE European experimenters generally follow American practice in the use of the screen-grid tube as an r-f amplifier, there are certain striking variations that have found enthusiastic support. The purpose of these changes is to secure the great amplification of which this tube is capable, without sacrificing stability and selectivity. There seems to be a tendency to abandon tuned-plate and auto-transformer coupling in favor of an r-f transformer coupling which causes less a-c hum if batteries are not used.

In England Sowerby has shown that the greatest amplification is obtained when the r-f transformer primary is as large or larger than the secondary. In the case of the auto-transformer this gives simple tuned-plate coupling. But as this upsets the stability and lessens the selectivity, either the number of primary turns must be reduced, with corresponding reduction of amplification, or the loss must be increased in one of the circuits, either the grid or the plate. Since the typical European set employs only one r-f stage the latter method can readily be adopted by damping the grid circuit, which is already loaded by the antenna, and by keeping the plate circuit losses at a minimum by means of good construction and the use of regeneration. A theoretical discussion of this method was given by Butterworth in *Experimental Wireless* for June, 1929.

Two variations which are so well known in America as to require no diagrams are the use of a "grid suppressor" series resistance in the grid lead and the use of a moving coil feed-back, rotating through 180 degrees so that reversed feed-back can be employed on the shorter waves. The latter, in conjunction with a tuned-plate circuit with *B* battery feed, either direct or in parallel through a choke, gives a simple construction and a flexible receiver that is unusually pleasant to handle.

Another alternative is the use of neutralization as shown in Fig. 1, this method being described by Sowerby in *Wireless World* of April 24 and May 1, 1929. This complication is unnecessary unless the construction of the two

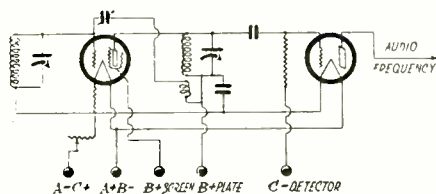

Fig. 1. Neutralized Screen-Grid Tube

circuits is so good that oscillations are set up without the use of feed-back; it will be noted that a plate detector is shown, rather than the standard grid detector, to reduce the loading on the tuned-plate circuit. The same idea is applicable to transformer coupling. It is necessary to use a step-down transformer in order that the neutralizing condenser may be of the normal type; two or three turns closely coupled to the low-tension end of the tuned coil will suffice. If an attempt were made to use the usual neutrodyne circuit, the condenser would have to be made extremely small, and its adjustment would be

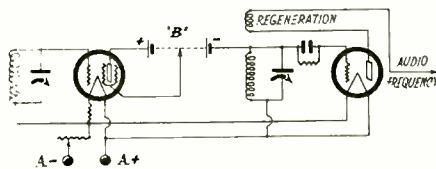

Fig. 2. Screen-Grid Tube with Battery Coupling

almost impossible. Theoretically, enormous gains should be obtainable by this method; but practically it is doubtful whether the average amateur can arrive at such results.

Fig. 2 shows a complete departure from standard practice, and a return to the oldest of all couplings, "battery couplings." This is quite a practical method, since the drain on the one dry

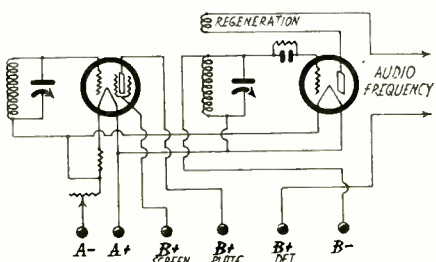

Fig. 3. Screen-Grid Tube with Battery Coupling Common to the Detector

battery used is very small, the remaining tubes being fed from some *B* power device. It should be noted that, though swinging-coil regeneration is shown (for reasons already stated), any type can be used.

A variant of this coupling is that shown in Fig. 3; this is, I believe, originally due to Prof. Borchardt of Berlin. Here it will be noted that the detector tube is fed from part of this same battery. The undesirable feature here is the tendency for the a-f component to be fed back to the screen-grid tube, and so to the detector. However, the circuit works reasonably well, especially if heavy filter condensers and resistances are used (not shown in the figure). Here again a conventional regeneration coil is shown, any type being usable.

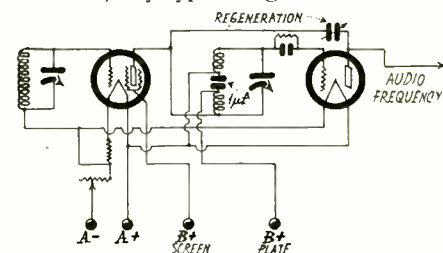

Fig. 4. Screen-Grid Tube with Split Tuned Coil

Fig. 4 shows another circuit, also hailing from Berlin, and using an auto-transformer. There does not appear to be much advantage in thus splitting the tuned coil and tying its center to ground through the $1 \mu\text{f}$ condenser from the low-tension end of this coil to ground (as in Fig. 1), except that the reaction arrangements are simplified.

Fig. 5 shows a circuit hailing from Austria (*Radioamateur* June, 1928, Dr. Lachner). There are two interesting points here: one is that the value of the coupling condenser is somewhat critical, depending largely on the value of the choke (2 mh in the diagram) and that for this reason it is made variable and rather large. The second is the use of another screen-grid tube as anode-bend ("power") detector. The fact should be noted that the tuning condenser is across part of the coil only. No regeneration is shown by the author in this case, though, unless the coil un-

(Continued on Page 94)

Inside FACTORY BUILT RECEIVERS . . .

By "RADIO" LABORATORY STAFF

Victor *Micro-Synchronous* Radio

Models R-32, RE-45 and R-52

THIS receiver contains many unusual features, most novel of which are the mechanical tuning equalizer from which the term micro-synchronous evolves, the volume control system, the first audio transformer with separate primaries for phonograph and radio output, and the harmonic modulator or tone control. UX-226 tubes are used in the antenna coupler, the four tuned r-f stages and the first a-f stage; a 227 serves as a detector while two 245s are employed in the push-pull power stage. The rectifier is a 280 full wave type.

Before taking up the circuit analysis a few of the mechanical features should be discussed. The four tuning condensers are placed around the circumference of a large disc and are coupled to the latter by rollers. A tuning arm on the panel just below the selector scale is moved from left to right to the frequency desired. This arm is connected to the disc by an eccentric, its movement causing the disc to turn, and in doing so, to revolve the tuning condensers.

Inside the disc are four sets of five adjusting screws; one set for each condenser. As each screw is tightened or

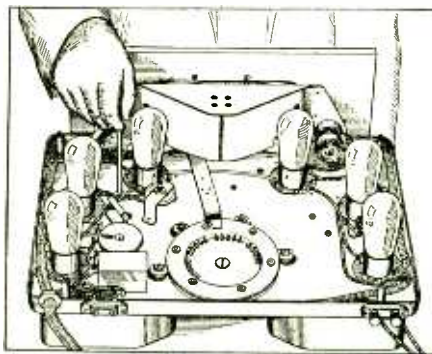

General Arrangement of Victor Chassis

loosened it pushes the condenser out or lets it in as the case may be, varying the capacity of that particular condenser at that particular frequency only. The result of this system is that the four condensers may be aligned at five different frequencies, no one alignment affecting the alignment at any other frequency. In other words, when the four condensers are aligned for loudest signals at 1500 kc then at 1200 kc, or whatever the next chosen point may be, a different set of adjusting screws is used and the capacity of the condensers at 1500 kc is affected

not in the least by the second set. This is the first system yet popularized that overcomes that original evil of single control receivers, their inability to maintain their alignment at all frequencies.

Another mechanical feature of the Victor receiver is the ease with which the three separate units, namely, the radio unit, the power amplifier and the electro-dynamic speaker, may be removed. The terminal block shown in the circuit diagram between the radio unit and the power amplifier is a heavily insulated socket with 16 terminals. Into this are fitted two plugs; one with prongs for terminals 1 to 12, the other with the four speaker connections, 13 to 16. In order to completely disconnect the three units from each other it is necessary merely to pull out these two plugs and the a-c line voltage plug.

A third mechanical feature is the construction of the electro-dynamic speaker. Around the field coil of this speaker is constructed a flat "horse-shoe" magnet, in reality a continuation of the iron core of the field coil. This is designed to concentrate the external lines of force in the magnetic field and is based upon the

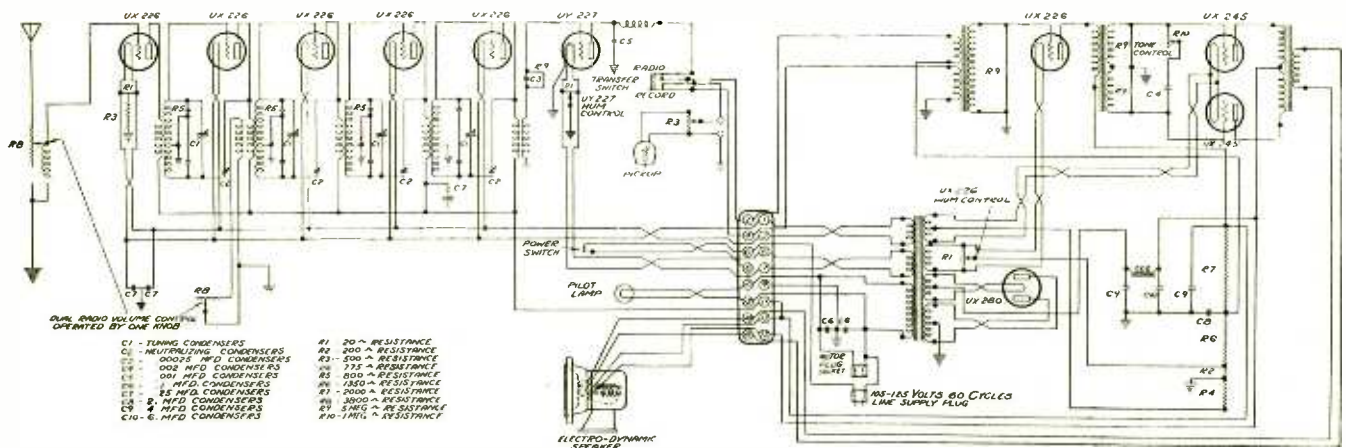

Fig. 1. Circuit Diagram of Victor Models R-32, RE-45 and R-52

principle that iron will carry more magnetic lines of force per square millimeter than will air.

Turning now to the circuit diagram we find that the first r-f stage is untuned, acting as an antenna coupler and protecting the resonance of the tuned circuits from changes in antenna capacity. A variable resistor, one section of the dual volume control, is connected between the antenna and ground. Across the center tap of this resistor and the ground end is shunted an r-f choke, one end of which leads to the grid of the

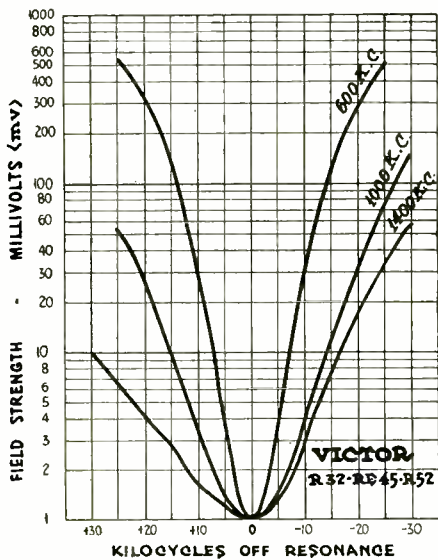

Fig. 2. Victor Selectivity Curves

The Selectivity curves of the Victor receiver are uniform, showing slight attenuation of sidebands, even at 600 kc, and a selectivity at all frequencies rather above the average.

first tube. A center-tapped resistor is shunted across the filament of this tube and a 500-ohm resistor is connected across the center tap of the former and ground, supplying the grid bias for all r-f tubes.

Inductive coupling is used between this stage and that following. The secondary of the r-f transformer is divided into two parts, the smaller section being a part of the neutralization circuit. In series with this section of the winding and the plate of the following tube is a small semi-variable neutralizing condenser. Across the complete secondary winding is connected the tuning condenser which is shunted with two small fixed condensers in series with each other. These two condensers and the 800-ohm resistor that is connected from their junction to the tap between sections of the secondary coil, or ground, constitute an r-f stabilizing system, and are not intended to affect the resonance of the tuned circuit.

The following three r-f circuits are identical to the first, with the exception of an independent winding on the second transformer across which is a variable

3800-ohm resistor. This resistor forms the second section of the dual volume control, acting as an absorption circuit in the r-f field. One side is grounded. A .25 μ f bypass condenser is connected from the high potential end of the fourth stage primary to ground for filtering.

The transformer coupling the last r-f tube to the detector input is designed for gain only, sufficient selectivity being accomplished in the four r-f amplifier circuits. A high inductance coil comprises the secondary so that the voltage step-up should be fairly high. Small signal grid

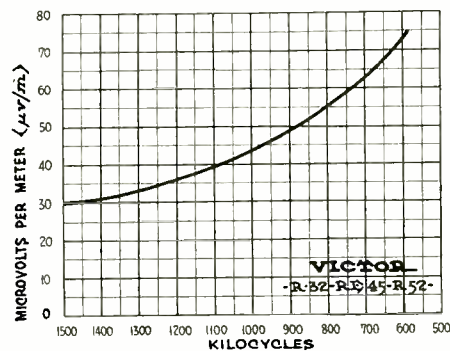

Fig. 3. Sensitivity Curve Taken on Victor Stock Model

This curve shows that the Victor receiver is more sensitive at the high frequencies than at the lows. The field strength required of a broadcast station on 1400 kc to produce a receiver output of 50 milliwatts is 33 microvolts per meter, while a 600 kc station would have to have a 75 microvolt per meter field strength to produce the same result.

detection is used, the grid condenser and leak being standard. The grid return, after passing through the secondary, is grounded, as is the cathode of the detector. A semi-variable 20-ohm resistor is connected across the detector heater terminals, the variable tap being grounded, so that any residual hum may be balanced out of the detector circuit. An r-f filter in the detector output circuit serves to eliminate the r-f component in this circuit.

The phonograph pickup for which these receivers are provided is connected into the circuit by means of a knob switch on the panel. When this switch is turned to the phonograph side it disconnects the detector plate from its power supply and connects the output of the pickup into the a-f amplifier. The first a-f transformer is constructed with two separate primaries; one for the detector output and the other for the output of the phonograph, thus eliminating the necessity of tapping the one in order to provide the correct impedance.

The first audio stage is conventional with the exception of the fact that the grid bias is supplied from a section of the voltage divider. And this section is

on the positive side of the ground, serving to apply a positive potential, with respect to the grid or ground, to the center tap of the resistor which shunts the filament. This resistor is variable so that it may serve as a hum balancer.

Across the two secondary sections of the second a-f transformer is shunted a variable 1-megohm resistor in series with which is a .002 μ f fixed condenser. This constitutes the harmonic modulator or tone control, making it possible to lower the upper limit of the cut-off frequency. This is of advantage in reducing static

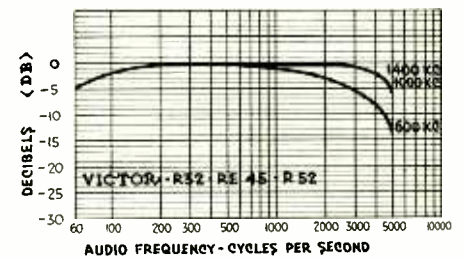

Fig. 4. Representing the Overall Fidelity of the Victor

Fidelity seems to be the Victor's strong suit. The 1000 and 1400 kc curves coincided exactly, falling, at 5000 cycles, but a little over 6 decibels. Even the drop of 13 db in the 600 kc curve is so far above the average that it should not cause alarm. The bass notes are also reproduced with excellent fidelity.

or needle scratch, both of which occur at frequencies above or at the top of the usual 5000-cycle range. The system is also of value to the listener who prefers music with a slight accentuation of the bass.

The power transformer is equipped with secondaries for the r-f tube filaments, the detector heater, the first a-f tube filament, the power tube filaments, that of the rectifier tube and the high voltage supply. The filter system consists of two π sections, a 4 μ f condenser, choke and 6 μ f condenser forming the first section; the same 6 μ f condenser, the speaker field winding and another 4 μ f condenser forming the second. A tap is taken off at the junction between the choke and the speaker field winding, from which a voltage of 230 is supplied to the plates of the two power tubes. The plates of the r-f and first a-f tubes are supplied with 105 volts from the low potential end of the speaker field winding which, at this point, is connected to the positive end of the voltage divider. The first tap in the latter provides the detector plate with 40 volts, the second is the one which puts 9 volts negative on the grid of the first a-f tube. The grid bias for the power tubes is furnished by a 775-ohm resistor on the extreme end of the voltage divider.

The Edison *Light-O-Matic*

Receivers R-4, R-5 and C-4

THESE receivers employ the same type of chassis whose circuit has several interesting features, including high and low r-f primaries, resistance-capacitance filters, dual volume control and grid bias equalization in the push-pull circuit. The chassis has three tuned and neutralized r-f stages, grid rectification detector, and two transformer-coupled audio stages, the last of which is in push-pull; '27 tubes are employed in all but the power stage in which two '45s are used. The power unit utilizes an '80 rectifier.

The r-f amplifying circuit is a form of "constant gain" circuit, wherein two primaries are used in each r-f transformer, one resonated below and one above the broadcast frequency spectrum. The four r-f transformers are identical and their secondaries are tuned by identical tuning condenser sections. In the circuit diagram L_1, L_2, L_3 and L_4 are low frequency primaries, resonated to approximately 450 kc by means of the condensers C_5, C_6, C_7 and C_8 which are shunted across them.

Stabilization of the r-f amplifier is accomplished by the neutralizing condensers, C_{10}, C_{11} and C_{12} . These condensers are connected from the plate of each r-f tube to the high frequency primaries of the circuits preceding.

Substantial resonance of the first r-f input circuit to the resonant frequency of the second and third r-f and detector input circuits is maintained by holding

the effective antenna-ground capacity to a value less than 100 μmf . Antennas of less than this capacity should be connected to the binding post marked "Antenna," while antenna of greater than 100 μmf are to be connected to the "Long Ant." post. The latter connection places the condenser C_9 in series with the antenna-ground capacity, reducing the effective value of the latter to less than 100 μmf for antennae of capacities up to 500 μmf .

Grid bias of the first r-f tube is secured by the use of the resistor R_1 , bypassed by C_{20} . The r-f component of the plate current of this tube is isolated by means of the resistor R_2 and the condenser C_{10} . The bias for the second and third r-f tubes in common is effected by the resistor R_3 and section *A* of the volume control, both being bypassed by the condenser C_{20} . Isolation of the r-f components of the plate currents of these two tubes is accomplished by the use of R_5 and C_{22} .

A turn of the volume control simultaneously increases the resistance *A*, hence the grid bias on the second and third r-f tubes, as it decreases the resistance *B*, which is shunted across the antenna and ground. R_4 , connected between the common cathode lead and the common plate lead limits the necessary amount of resistance in section *A* of the volume control by increasing the current at minimum volume setting from a fraction of 1 ma to between 3 and 4 ma.

When minimum volume setting of the control has been reached a further slight turn of the control throws the radio-phonograph switch S_1 from the radio to the phonograph position, thus eliminating the necessity for a separate switch.

C_{13} and R_7 are the grid condenser and leak, respectively, while C_{14} and L_{13} constitute an r-f filter designed to prevent the passage of the r-f component of the output of the detector tube. The detector plate supply is obtained from the plate supply for the r-f and first a-f amplifying tubes through a resistance-capacitance filter consisting of R_9, C_{25}, R_8 and C_{24} . This filter serves a triple purpose; it effects the necessary reduction of plate voltage, the isolation of the a-f currents in the detector plate circuit and a reduction of ripple in the detector plate supply. A positive bias is placed on the heater of the detector tube with respect to its cathode by the connection of the variable contact of the hum adjuster R_6 to the cathode of the first r-f tube.

A high frequency cut-off is provided by the condenser C_{15} which shunts the secondary of the first a-f transformer. Bias is supplied the grid of the first audio tube by resistor R_{11} which is bypassed by C_{26} . Another resistance-capacitance filter, composed of R_{10} and C_{21} connected in series between the first a-f tube cathode and its plate lead is designed to be 9 (the *mu* of the tube) times the impedance of the parallel circuit $R_{10}-C_{26}$.

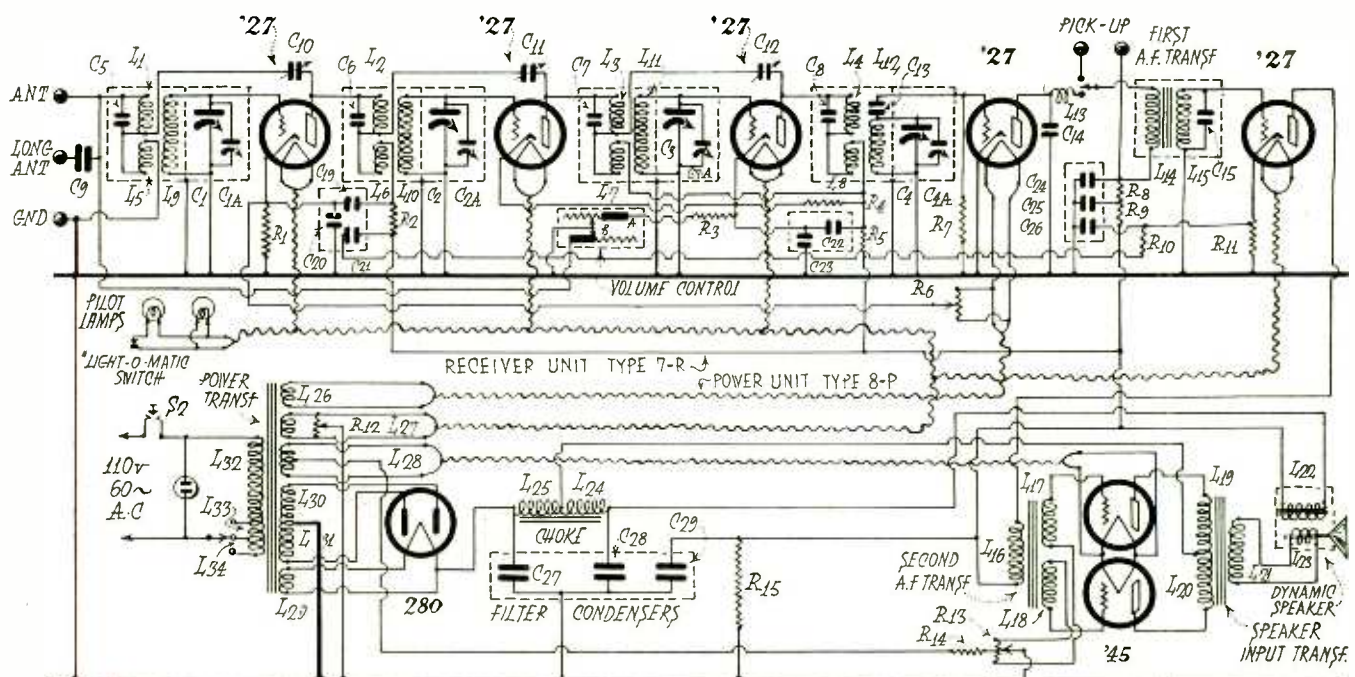

Fig. 1. Circuit Diagram of Edison R-4, R-5 and C-4 Receivers

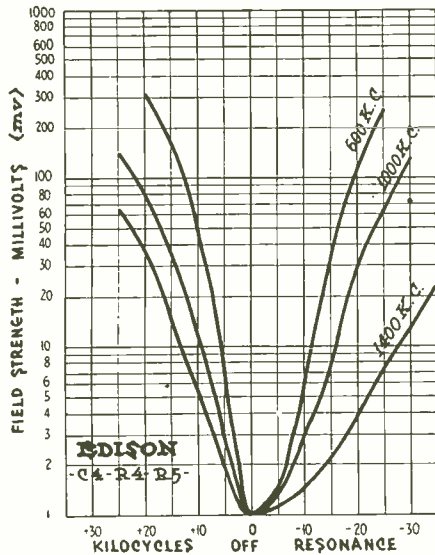

Fig. 2. Selectivity Curves of Edison Receivers

The Edison receiver is not as selective on 600 kc as other receivers that have been tested by RADIO's laboratory staff, but thereby the danger of cutting sidebands is reduced. (It has been pointed out that the usual extreme selectivity on this frequency is conducive to this fault.) The close similarity of the three curves in this set indicate that, with the exception of the 1400 kc curve on the negative side only, there is less variation in selectivity over the entire tuning scale than usual.

This system is intended to balance out the residual 120-cycle hum in the plate supply of the first a-f tube.

The two sections of the second a-f transformer are separated by a resistor

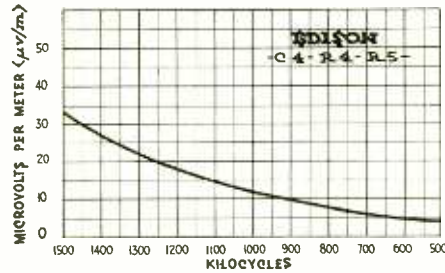

Fig. 3. Sensitivity Curve of the Edison

The sensitivity of this receiver is unusually high, and very uniform over the whole tuning scale. At 1400 kc a field strength of but 27 microvolts per meter is required to produce an output of 50 milliwatts while at 600 kc a mere value of $4\frac{1}{2}$ microvolts per meter is required. Sensitivity above these values would be of little or no use as static and other electrical disturbances are constantly present with a much higher field strength.

R_{13} which has a fixed center tap and a variable contact. Between the filament center tap and the fixed center tap of the resistor another resistor, R_{14} , supplies the grids of the two '45 tubes with the necessary bias. The variable contact is connected to the negative of the plate supply, its function being to permit equalization of the bias on the two power tubes. This results in a substantially exact a-f balance, which is a condition that must be obtained for most efficient utilization of push-pull amplification.

The primary of the power transformer is fitted with three taps for voltage variations. Besides the high voltage

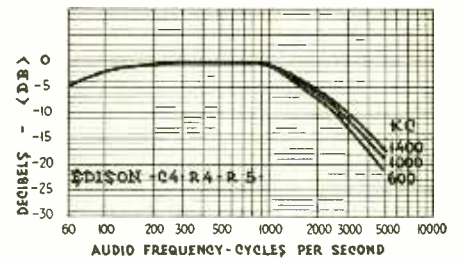

Fig. 4. Edison Fidelity Curves

Due to the fact that the sidebands are not seriously cut by the r-f stages in the Edison receiver it is evident that the attenuation shown in the above curves is due to the audio amplifier. The bass frequencies hold up very well and although the upper notes begin to decline in strength rather early the drop does not become extremely serious until the 5000 cycle notes are reached.

secondary there are four low-voltage windings—one for the rectifier tube, one for the two '45s, one for the detector alone and the fourth for the three r-f and first a-f tubes. The last mentioned is shunted by a variable hum adjuster. A tapped choke is used in the positive high-voltage lead, the tap feeding the plates of the power tubes. A filter condenser is shunted across the rectified output at each end of this choke, while a third filter condenser shunts the circuit at the low potential end of the speaker field winding which serves as the second choke.

R_{15} is a stabilizing resistor connected across the plate supply for all the '27 tubes.

Bremer-Tully Models 81 and 82 and Brunswick Models 14, 21, 31

The work of the service man is simplified by the fact that all of the above models employ the same circuit as shown in the accompanying diagrams except that in the Brunswick 31 the pickup jack is replaced by a radio-record switch cable and input transformer. The chassis consists of two units which are bolted to a single laminated mounting board. One unit consists of the r-f and detector stages. The other unit consists of the two a-f stages and power plant. As the field of the electrodynamic speaker is an integral part of the circuit the chassis should not be operated unless the field or an equivalent 600-ohm resistor of 100 ma current-carrying capacity is connected across the field coil terminals.

The chassis incorporates three tuned r-f stages in which '27 tubes are used, a '27 detector and first a-f stage, and a power stage employing two '45 tubes in push-pull. The r-f stages are neutralized and each transformer is enclosed in a separate shield.

Provision is made for a long or a short antenna by tapping into the antenna coil or primary of the first r-f transformer. A trimmer across the secondary of this transformer is labeled the antenna compensator

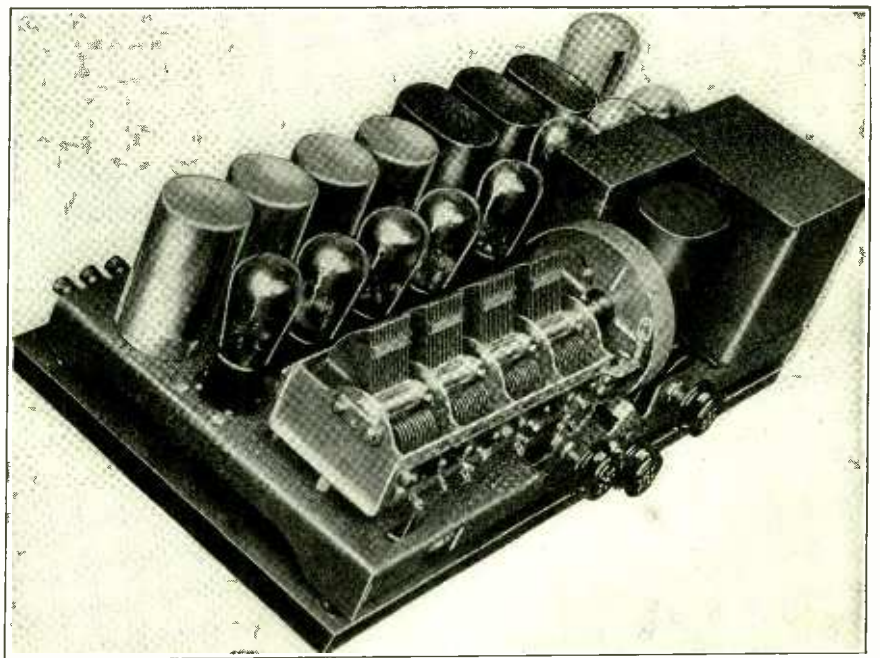

Chassis of Brunswick Models 14 and 21

although it obviously does not affect the tuning of the antenna circuit. Its actual effect is to restore the resonance of the input circuit of the first tube to that of the following tubes, leaving the antenna circuit and secondary circuit as far off resonance as they might happen to fall.

Inductive coupling is used in the following three transformers and a tap is provided in the secondary of each for neutralization. The four tuning condensers are mechanically coupled for synchronous operation. The cathodes of the three r-f tubes are led through a fixed 800 ohm resistor which supplies the minimum bias necessary for the grids of these tubes, then through a variable 25,000 ohm resistor to ground. This resistor is the volume control, and is equipped with a switch which opens or closes the a-c circuit in the power pack.

A 35,000 ohm resistor is connected across the common r-f cathode lead and the plate voltage lead for the purpose of stabilization. The cathode lead is bypassed to ground through a .2 μ f condenser and again to the plate lead through a .02 μ f condenser. The plate lead is bypassed to ground through a .2 μ f condenser.

Small signal grid detection is used, the grid-leak being connected across grid and ground. The cathode is grounded. A .002 μ f condenser connected between the plate and the cathode of the detector provides a path for the remaining r-f component.

The r-f detector unit is connected to the power supply and a-f unit by means of a

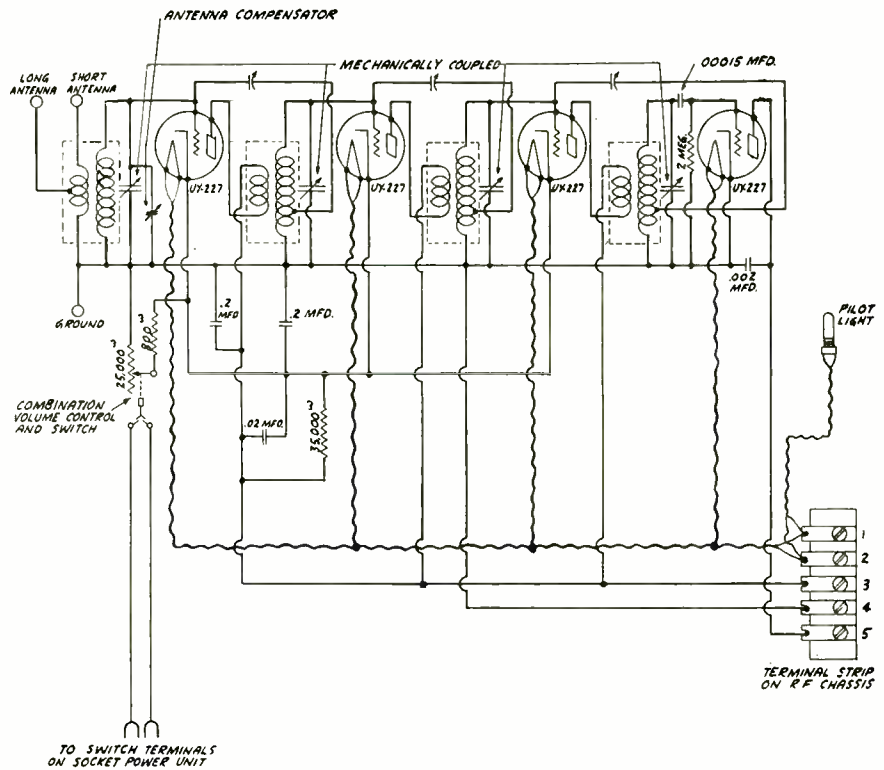

Fig. 1. Circuit Diagram of Bremer-Tully R-F Detector Unit

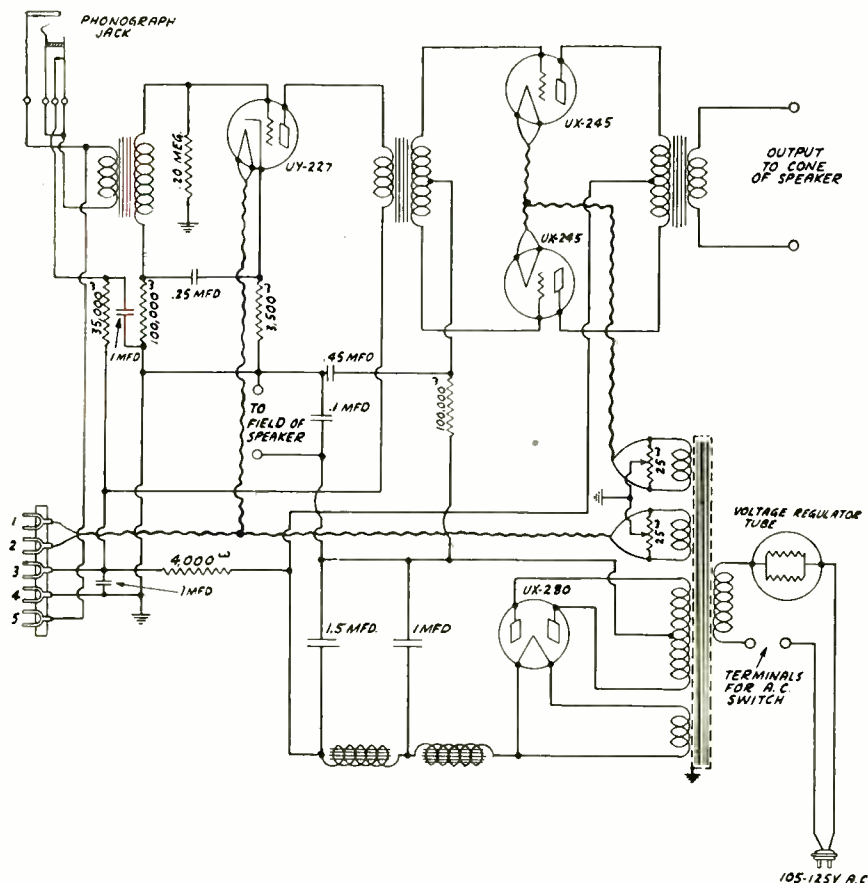

Fig. 2. Bremer-Tully Model 81, 82 A-F and Power Supply Circuit

five-tap terminal strip. A phonograph jack in the a-f unit opens the plate circuit of the detector, shunting the phonograph pickup across the input of the first a-f transformer. The detector plate receives its voltage from the positive side of the line, through a 4,000 ohm resistor and again through a 35,000 ohm resistor. A 1 μ f condenser at the junc-

tion of the two resistors and another between the large resistor and the transformer primary serve to bypass this lead.

A .2 megohm resistor, shunting the secondary of the first audio transformer, tends to build up the low end of the audio frequency scale. A rather elaborate resistance-capacitance filter circuit is included in the

grid return lead of each stage. The plate of the first a-f tube is supplied with 145 volts from the positive potential through the 4,000 ohm resistor; those of the last stage being fed directly from the maximum line voltage. The grids of the power tubes receive the required drop from the resistance of the speaker field which is connected between the negative high voltage lead and ground; the filament center tap is grounded.

The low capacity used in the filter circuit is made possible by the use of the resistance-capacitance filter circuit mentioned above.

BAROMETRIC SIGNS

By H. G. PEARCE, KUDL

Any operator who, upon copying weather, would like to have an understanding of what his barometer readings foretell will find the following estimations of great interest and some practical value. They are usually relied upon by navigators.

Rapid fall—stormy weather. If accompanied by westerly wind—storm from north. If accompanied by northerly wind—rain or storm in summer or snow in winter.

Fall with moisture in air and increasing heat—rain and wind from south. Fall with dry air and cold—snow. Fall after calm with warm weather—bad weather with rain and squalls.

Rises for northerly winds, including those from northwest by north to eastward—dry weather and less wind may be expected, except in a few cases where rain, hail and snow come from the north accompanied by very stormy weather.

Rising rapidly—unsettled weather. Rising gradually—settled weather. A rise with dry air and increasing cold in summer—wind from north and drier weather. A rise with moist air and low temperature—wind and rain from north. A rise with an easterly wind—fine weather.

Barometer still with dry air—continued fine weather.

Radiotorial Comment

By the Editor

THE battery-operated set is staging a big comeback. Manufacturers who neglected it while perfecting a-c sets realize that there are millions of homes which are not served with alternating current

The Battery Set Comes Back

and that there are great opportunities for promoting the sales of improved battery models. The agricultural field is particularly fertile in this respect. Then also there is the growing craze for equipping automobiles with radio. The d-c screen-grid tube, which has never really come into its own, appears to have a chance at last.

This comeback presages a revival in the demand for batteries. The dealer and service men who are new in the game should brush up on the idiosyncrasies of dry and storage batteries. Sufficient stocks should be carried to meet the demand that can be measured by the sale of the newer models that are now being announced.

One out of six cases of radio interference can be traced to defective power lines and one out of four to domestic electrical devices.

VACUUM tube manufacturers hesitate to introduce the pentode into the 1930 market for fear that it will cause an upset like that introduced by the a-c and screen-grid tubes. The pentode, be it known,

How Soon Pentode?

is a five-element tube, consisting of a filament, plate, and three grids, as contrasted to the single grid in the three-element tube and the two grids in the four-element or screen-grid tube. The third grid is intended to neutralize the "space-charge" effect and enables greater amplification from a single tube. This tube has been used by European experimenters for some time, a number of good circuits having been developed to utilize its capabilities. Notwithstanding the hesitation of some of the tube makers, it will probably be available for experimental purposes in America during the next year.

An ounce of prevention at the source of radio interference is worth a pound of cure at the receiver.

WHEN an economist studies the high cost of distributing radio products he is likely to conclude that it can be reduced by eliminating the middleman.

Is the Jobber Needed?

Yet there is hardly an industry whose products are not distributed in greater volume through the jobber than directly from manufacturer to the dealer. Why does the jobber persist when the theorist can prove that he is an economic superfluity? This answer is, of course, that the jobber performs certain necessary functions more economically than any other agency.

Take the function of warehousing, for instance. The manufacturer refuses to undertake to carry reserve stocks at strategic points. The dealer who attempts to carry sufficient stock to meet all probable demands between factory shipments usually goes bankrupt. Any dealer who does so with his own capital ought to have his head examined by the sanity commission. Yet these reserves are necessary and the jobber tries to maintain them.

Then again there is the matter of an adequate selling force. The jobber's salesman can regularly call on hundreds of dealers in his territory while representing a score or more manufacturers. To secure corresponding individual representation each manufacturer is put to prohibitive expense. Likewise in the credit department and in the many other services which the jobber maintains for the benefit of the dealer, neither the individual manufacturer nor the individual dealer can afford to maintain an equivalent service.

These services, such as the testing of returned sets, are essential. The dealer can't perform all of them himself. He doesn't care who else may perform them, whether manufacturer or jobber, but he must have them. So the jobber is generally the one who will assume the responsibility until some other equally effective agency is found.

Recently there have been signs of such an agency in mutualization. This is being tried out in the drug industry on a big scale. Thousands of independent retailers have agreed to buy most of their stock from one company and to push the sale of its products and those of its associated manufacturers. In return, the stores are given newspaper and radio advertising, window displays, and other merchandising helps de-

signed to enable them to compete with the chain stores. Furthermore they may buy a limited stock interest in the company whose products they are handling.

This plan may also be tried in the radio industry as one result of the mergers that are being made between manufacturers. But it can survive only if it can better perform the essential functions that are now served by the jobber.

SINCE the advent of the a-c receiver with built-in reproducer, radio accessories, such as batteries, chargers, A and B eliminators, and loudspeakers, no longer constitute an appreciable part of a dealers' sales. The accessories market is almost as dead as the parts market when compared with the sales of complete sets. Consequently any new accessory which may be used to stimulate sales is welcome. There is now good reason to believe that such an addition to a radio set will soon be available to utilize a new service from the broadcast station.

A New Radio Accessory

It is understood that the National Broadcasting Company is making arrangements with the Associated and United Press for late news flashes which are to be transmitted by the facsimile process so as to give a type record on a type machine installed at the receiver. The equipment is somewhat like the Doud tape-recorder and is connected in place of the loudspeaker while this special form of transmission is taking place.

RADIO parallels the automobile industry in finding one of its most difficult problems in the pricing and handling of second-hand equipment which is turned in as part payment on new equipment. The

One Solution of the Trade-in Problem

problem starts with the customer who shops around in search of the dealer who will give him the best allowance on his old set, and it is not solved until the old set has been sold to a new purchaser. How can the dealer protect himself against the trade-in shopping? What should be the basis upon which old sets are priced? Where can the old sets be marketed?

These several questions bring to mind the successive standards of a man's worth in a business. The man who merely knows how is generally paid less than the man who knows why, while the man who knows what and when to do is better paid than both. But the biggest salary goes to the man who knows whether.

The "whether" question as regards radio trade-ins has been definitely answered. They must be taken if the dealer is to get sufficient turn-over to pay his overhead. Likewise they must be taken when offered, or

else some other dealer will get the business. So the problem logically reduces itself first to what price trade-ins.

This question has numerous answers. Some concerns have a standard rule to offer for an old set five per cent of the purchase price of a new set. This virtually amounts to a five per cent reduction in profit, for it seldom carries with it any plan for disposal of the old set at a price commensurate with its cost.

Other concerns figure that an old set loses half its value by being second-hand. Then as the old tubes will probably have to be replaced, the cost of new tubes is deducted from half the list price of a new set of that model. This figure may be said to represent the selling price of the old set after it has been reconditioned. The cost of such reconditioning, together with the usual overhead charges and selling costs, as well as a reasonable profit, again cut this selling price in half when the buying price is figured.

This is a safe and conservative method, like the old rule for buying stocks and bonds when they are cheap and selling when they are dear. But how many dealers have the intestinal fortitude to apply it, especially when they know that their competitors do not?

Here is the crux of the situation—the other fellow. Unless there is a general understanding among all the dealers in a given territory that they will follow such a formula, the dealer who does follow it is likely to be the loser. But such general understandings are regarded as being in restraint of trade and consequently illegal. The Department of Justice has ruled that no association can fix prices, either for buying or selling.

However, there is a practical and legal method for accomplishing this purpose. There is nothing to prevent an individual from establishing a bureau which will advise its subscribers as to a proper price to be offered on any trade-in and will also give the name and address of any party who is known to be shopping. As these prices are likely to vary from week to week, especially as list prices are changed by the manufacturer, the subscriber can be assured a valuable service which he could himself duplicate only at prohibitive cost.

Such a bureau could also advise regarding parties who make a habit of having a constant stream of demonstration sets delivered to their homes so that they have the benefits of radio without paying for them. And finally it can arrange for outlet channels which will pay the dealer the price that he pays for a trade-in, thus relieving him of the burden of selling second-hand merchandise.

The details of just such a plan have actually been worked out by an experienced retailer, and the opportunity to subscribe to it is being offered to the dealers in several western cities. A similar plan might well be adopted in other localities. It is believed to be the best solution to the trade-in problem which has yet been offered. It certainly answers the questions of how, what, and where.

Consider *IKE*--the Service Man

By GRID BIAS

THE august representative of the Eastern manufacturer leaned over the table impressively. Ringed about him were a score or more of his Western agents.

"Gentlemen," he said, "I cannot too emphatically stress the value of service in the marketing of our products. The service man is the backbone of public satisfaction. See to it that your service man sustains this faith and meets public need."

This sounded intensely important. So we put it up to Ike. We always put radio problems up to Ike because he is a service man. His card says so. Ike borrowed a cigar, found a match, and combined the two in smoke.

"He's dead right," he said. "A service man is the works. There ain't a kid ever went to school that he wasn't serviced by his mother. Same with radio. Somebody has to connect the set, doesn't he? Well, then!"

Ike is short and fat and wheezes when he walks up hill. Sometimes when he bends over, his shirt-tail flies out from under his belt. But he is likable and good natured. There are scores like him.

"Does a service man have to have a technical education?" we asked.

"For radio?" Ike seemed surprised. "Sure not. All he needs is a screw driver and a pair of pliers. The rest is hooley."

HOOEY—the motive power of American commercial success, as some of our satirical writers have it. There must, however, be something else to the service thing. We looked Ike over—technically. Ike, frankly, knew nothing at all about a radio set. He could fasten *G* on the set to the water pipe if he had a clamp, and *A* to antenna, if there was an antenna. If there wasn't, it was Ike's business to put one up. Ike's antennas were, in a sense, famous.

Stand anywhere. Cock your eye along the roof line of the nearest buildings. Sooner or later you will see a completely insane jumble of wires. That will be one of Ike's antennas. Ike works on the theory that if you give the public a simple wire for an antenna, it will feel that it is being cheated. So Ike hangs wires on everything.

"What's a little wire alongside of good will?" he demands.

What indeed? Ike, ignorant of fundamentals, resonance points, directional effects, and whatnot, strings his cobwebs to anything handy. When Ike finishes an antenna, it resembles a pole for a Western Union transcontinental network, where there are no cable ordinances. It points in all directions at once. It is looped forward and backward. It

is half insulated and half not insulated. Ike throws in insulators where they look artistic and not where they are needed.

And the strange part is—the antennas, for the most part, receive broadcast signals. Just as a wire mattress or a dressmaker's dummy hoisted to the roof would receive them. Ike makes a point of keeping his antennas all different.

"No two alike on any house I've ever worked," he says proudly.

He maintains that this is an item where you have customers to satisfy. In fact he will sell this idea to nine out of ten women.

"How'd you like a different antenna?" he asks. "Something nobody on the street has anything like?"

What woman, who has fought and won the battle of millinery, can resist that bait. Equipped with her full permission, Ike strings and restrings his aerial harp until even the most particular is satisfied. Finished, folks for blocks around come to look at it. Ike never knew that a magazine once ran a picture of one of his antennas as the worst it had been able to find. To Ike, an antenna is a symbol of a satisfied customer.

"Nobody ever kicked because I didn't give 'em enough wire," he says with pride.

IKE has a dumb partner, Joe, who is learning the business. Joe is Ike's helper. At the rate Joe is learning, he will be as good a radio man as Ike by the fall of 1968. Joe's job is to hand Ike this and that. The rest of the time he spends trying to solve the mystery of a monkey wrench. He has never been able to figure out why it opens and shuts its jaws when the little dinkus in the middle is revolved.

Ike is a bear-cat on static. Any noise in the set is static. All static, Ike has found, comes from a garage. There is always a garage within a few blocks of every home. Ike blames everything on the garage.

"It's their rectifiers," Ike tells the customer. "There's an ordinance about it. I'd complain if I was you."

Of course the customer never complains, but he privately curses the garage and probably takes his machine elsewhere to be stabled. We asked Ike just what a city ordinance was.

"Oh," said Ike, "an ordinance tells 'em to cut it out."

WHEN Ike installs a set, there is no limit to distance. "Chicago? Say, lady, that is backyard stuff for this set. But don't expect to get it right away. It's like learning to drive a machine. You've got to learn the fine points. In

a month or so, just practicin' a little evenin's, you'll roll Chicago in like a baby carriage."

Ike is in his element when servicing a set his company didn't sell to the owner. He'll pluck out a tube, hold it up to the light and shake his head.

"It's a dirty shame what some stores will sell people," he'll remark.

Then, taking the same identical kind of a tube out of his grip, Ike will substitute it for the one he has removed.

"What do you do with the old tube?" we asked him once.

"Oh, use that in the next set. I just keep 'em revolv'in' round, so to speak. I ain't had to put in any new tubes for a couple of years."

If a woman complained that one of Ike's sets was not working, had a bad tube, Ike would pluck out a tube and hold it up to the light.

"See that glass? See how smoky it is? That's free carbon, lady, stuck on the glass. It's just like carbon in your cylinders. You know what that does."

The woman is always completely knocked over. No woman is going to admit to a strange service man that she doesn't know the effect of carbon in her cylinders. Ike would put in one of his "new" tubes, with the remark: "Now don't turn 'em so high the next time."

"How do you know she turns 'em up?" we asked Ike.

"Sure she does. Everybody does. That's a good safe crack."

IKE's crowning achievement was the night he connected up a new set and struck a network program. A soprano was singing "O Sole Mio" at KPO. Ike turned the dial. In came KGO—and "O Sole Mio." Ike tried again. KFI—and "O Sole Mio." Once more he twisted. KGW—and "O Sole Mio." Ike took a last shot—KOA. He got "O Sole Mio." His face clouded.

"You got a neighbor with a set?" he asked.

"Why, yes," said the new owner. "In the upstairs apartment."

Ike spread his hands.

"That's the answer," he said. "She's heterodyning. I've got to get you another kind of a set entirely. You should have told me about this."

Ike took the set back and got a more expensive one and the owner paid for it without a whimper—and cursed the neighbor upstairs.

IKE is a service man. Here's to him. He doesn't know the difference between a kilowatt and an input transformer. His antennas violate every known city regulation, and every law of

(Continued on Page 90)

New Sets & Accessories Announced in October. Changes in Models, Prices, Etc.

<p>High Lights of the Month</p> <p>New Fada 35 Series. Ultra selective receivers for congested areas.</p> <p>New Awater Kent chassis with '50 tubes.</p> <p>New PHILCO "Screen-Grid Plus" line.</p> <p>New Gulbransen Radio-Phonograph Combination.</p> <p>New Victor Console, Model R-52. Kennedy prices reduced.</p> <p>Entry into radio set manufacturing by Mills Novelty Company.</p> <p>Reduction in prices of WARE receivers.</p> <p>New Ware Trianon chassis.</p> <p>Centro-Matic tuning device on Earl receivers.</p> <p>New Kolster K-33 and K-34. Lower priced.</p>	<p>FADA</p> <p>Knowing that a receiver sufficiently selective and sensitive for the broadcast congestion in Southern California will meet with enthusiastic response elsewhere in the United States, FADA engineers have perfected an entirely new screen-grid receiver. These new receivers are the result of actual extensive research in the Southern California market where, it is known, congestion of high powered broadcast stations is more serious than in any other sector of the country.</p> <p>Principal among the new FADA receivers is the Model 25, with the new 7MA chassis combination, a one screen-grid tube receiver with one '24 tube, four '27 tubes, two '45's and one '80.</p> <p>The list price of this receiver is East\$165.00 West\$172.00</p> <p>The new circuit offers increased regeneration, resulting in greater selectivity. A higher voltage power pack and controlled regeneration introduced into the R-F Amplifier, together with the FADA 7-C speaker, has greatly increased the undistorted output of this receiver.</p>	<p>FADA</p> <p>Model 35-B—Three screen-grid tube r-f circuit, with controlled regeneration, resulting in increased sensitivity and selectivity. Uses three '24 tubes; two '27 tubes; two '45 tubes; one '81 rectifier tube. Cabinet same as standard Model 35. Eastern list price\$225.00 Western list price.....\$265.00</p> <p>The above additions to the FADA line complete the new "Series 35 Receivers," catalogued as follows:</p> <p>FADA-35 available in one screen-grid chassis (list Fada 35-C) \$220.00</p> <p>FADA-35, available in two screen-grid chassis (list Fada 35) \$245.00</p> <p>FADA 35, available in three screen-grid chassis (list Fada 35-B) \$255.00</p> <p>Western list prices, above, \$227.00; \$255.00; \$265.00, respectively.</p> <p>Kennedy Prices Reduced</p> <p>Model 210 reduced to.....\$152.00 Former price, \$159.00</p> <p>Model 310 reduced to.....\$182.00 Former price, \$197.00</p> <p>Model 320 reduced to.....\$189.00 Former price, \$197.00</p> <p>Western prices same as Eastern prices.</p>	<p>PHILCO</p> <p>Screen-Grid Plus</p> <p>Announced October 15</p> <p>De Luxe screen-grid receiver using numerous new features. Four tuned and one untuned circuits; nine tubes, including rectifier; three '24 tubes; three '27 tubes; two '45 tubes; one '80 rectifier. Has double tuned input circuit, giving greater selectivity. Reduction of background noises. An important change in detector circuit is made. Two '27 type tubes are used in this circuit, one as a detector and the other as a detector-amplifier. Audio system consists of resistance coupled '27 tube, first audio stage, and transformer coupled second audio stage, using two '45 tubes in push-pull. Audio transformer has high impedance primary winding. Automatic volume control regulates detector and radio frequency amplifier.</p> <p>PRICES—Screen-Grid Plus line:</p> <p>Lowboy, East\$149.50 Highboy, East\$169.50 De Luxe Highboy, East.....\$225.00</p> <p>Western prices \$10.00 higher on all models.</p>
<p>FIRST NATIONAL RECEIVER</p> <p>First National Radio Corporation, 254 West 54th St., New York. A table model, screen-grid receiver, with one screen-grid tube as a detector. All other tubes are of the heater type and '45 for power audio stage. Receiver made by the Balkeitt Radio Company of Chicago for First National. Table model, list price at\$75.00</p>			

New Sets & Accessories Announced in October. Changes in Models, Prices, Etc.

<p>The Following Sets Are Priced the Same East and West</p> <p>RCA MAJESTIC GRAYBAR KENNEDY WARE COLUMBIA BRUNSWICK BREMER-TULLY VICTOR EARL FREED</p> <p>Console Models of BROWNING-DRAKE</p> <p>All SONORA models except A-36 and A-34. One EVEREADY model No. 31 (table).</p>	<p>WARE</p> <p>Model 10 reduced to.....\$235.00 Former price, \$280.00</p> <p>Table Model reduced to.....\$135.00 Former price, \$195.00</p> <p>New Trianon Chassis, six tubes—at\$135.00</p> <p>"Bryon" Model, six tubes...\$400.00</p> <p>New Metropolitan—Five-tube receiver, including rectifier, list price at\$150.00</p> <p>Prices are same East and West.</p> <p>The new Ware receivers use the Vreeland Band Selector system of tuning.</p>	<p>EARL</p> <p>New Centro-Matic Tone Finder. A combined visual station selector and "tone finder." Finder locates true center of broadcast band. Adjustable for ten different stations.</p> <p>Model 33 with Centro-Matic Tone Finder, (East and West).....\$179.00</p> <p>Eight-tube neutrodyne. Inductor Dynamic Speaker. Phonograph pick-up connection.</p>	<p>KOLSTER</p> <p>1930 Kolster Models K-43 and K-44, with selector tuning, equi-poised-dynamic reproducer. Screen-grid tubes.</p> <p>K-43—Seven tubes and rectifier, push-pull '45 audio system. Eastern list price\$175.00 Western list price.....\$188.00</p> <p>K-44—Seven tubes and two rectifier tubes. Push-pull '45 audio. Eastern list price.....\$260.00 Western list price.....\$275.00</p>
<p>TEMPLE D-C SETS</p> <p>Same cabinets, same prices as A-C sets. 14-inch Temple electro-dynamic speaker used.</p>	<p>VICTOR</p> <p>Victor-Radio R-5 2—Console. Same chassis as R-32. List price, without tubes\$215.00</p> <p>Priced same East and West.</p>	<p>GULBRANSEN</p> <p>Phono-Radio Combination</p> <p>Announced October 15</p> <p>Model 200—"Nine-in-Line" screen-grid, phono-radio combination. Uses five '26 tubes; one '24 tube; two '45 tubes; one '80 rectifier. Eastern list price.....\$235.00 Western list price.....\$245.00</p>	<p>ATWATER KENT</p> <p>Model 66—Chassis only. Eastern list price\$135.00 Western list price.....\$140.00</p> <p>A 7-tube chassis. Uses '24 tubes and '27 tubes. This chassis uses two '50 power tubes in the last audio stage.</p>
<p>SPARTON D-C SETS</p> <p>Models 931 and 301 available with D-C chassis. Prices are same as corresponding models with A-C chassis.</p>	<p>FADA</p> <p>Model 35-C—Chassis combination identical to above but installed in standard Model 35 Cabinet. Eastern list price\$220.00 Western list price.....\$227.00</p>	<p>OXFORD AUDITORIUM SPEAKERS</p> <p>11¾-inch cone speakers of the electro-dynamic type. Metalized one piece cloth diaphragm.</p>	<p>STROMBERG-CARLSON</p> <p>846 screen-grid chassis now available in De Luxe cabinets of oriental design. Price\$795.00</p> <p>Italian Renaissance cabinet...\$745.00</p> <p>English Linenfold cabinet...\$695.00</p>

EASTERN LIST PRICES OF HEATER & FILAMENT TUBE SETS

NOTE: RECTIFIER TUBES ARE NOT COUNTED IN LISTINGS BELOW.

Table with columns: MAKE, No. of Tubes, LIST PRICE. Rows include manufacturers like A-C DAYTON, ACME, ALL AMER "LYRIC", APEX, AUDIOLA, BALKEIT, BRANDES, BREMER TULLY, BROWNING DRAKE, BRUNSWICK, BUSH & LANE, COLUMBIA, CONTINENTAL, CROSLEY, DAYFAN, EARL, EDISON, EVEREADY, FADA, FREED, GRAYBAR, HOWARD, KENNEDY, MAJESTIC, MANDEL, PHILCO, PREMIER, RCA, STEWART WARNER, SPARTON, STEINITE, TEMPLE, and VICTOR.

*Denotes this manufacturer also builds screen-grid models.

WESTERN LIST PRICES OF HEATER & FILAMENT TUBE SETS

NOTE: RECTIFIER TUBES ARE NOT COUNTED IN LISTINGS BELOW.

Table with columns: MAKE, No. of Tubes, LIST PRICE. Rows include manufacturers like A-C DAYTON, ACME, ALL AMERICAN "LYRIC", APEX, AUDIOLA, BALKEIT, BRANDES, BREMER TULLY, BROWNING DRAKE, BRUNSWICK, COLUMBIA, CONTINENTAL, CROSLEY, DAYFAN, EARL, EDISON, EVEREADY, FADA, FREED, GRAYBAR, HOWARD, KENNEDY, MAJESTIC, MANDEL, PHILCO, PREMIER, RCA, STEWART WARNER, SPARTON, STEINITE, TEMPLE, and VICTOR.

*Denotes this manufacturer also builds screen-grid models.

EASTERN LIST PRICES OF SCREEN-GRID SETS

NOTE: RECTIFIER TUBES ARE NOT COUNTED IN LISTINGS BELOW.

Table with 15 columns: MAKE, No. of Tubes, LIST PRICE. Rows include manufacturers like ACME, ALL AMERICAN LYRIC, AMERICAN BOSCH, AMRAD, ANDREA FADA, APEX, ATWATER KENT, ARCO, AUDIOLA, BALDWIN, BROWNING DRAKE, COLONIAL, CROSLEY, EARL, ERLA 'TROPHY', EVEREADY, FIRST NATIONAL, GRAYBAR, GREBE, KOLSTER, KENNEDY, MANDEL, PEERLESS, PHILCO, PREMIER, RCA, SILVER, STEWART WARNER, STEINITE, STERLING, STROMBERG CARLSON, SONORA, TEMPLE, TRAV-LER, WARE, and ZENITH.

*Denotes this manufacturer also builds non-screen-grid models.

WESTERN LIST PRICES OF SCREEN-GRID SETS

NOTE: RECTIFIER TUBES ARE NOT COUNTED IN LISTINGS BELOW.

Table with 15 columns: MAKE, No. of Tubes, LIST PRICE. Rows include manufacturers like ACME, ALL AMER 'LYRIC', AMERICAN BOSCH, AMRAD, ANDREA-FADA, APEX, ATWATER KENT, ARCO, AUDIOLA, BALDWIN, BROWNING DRAKE, COLONIAL, CROSLEY, EARL, ERLA 'TROPHY', EVEREADY, GILFILLAN, GRAYBAR, GREBE, HOWARD, KELLOGG, KENNEDY, KOLSTER, PEERLESS, PHILCO, PREMIER, RCA, SILVER, STEWART WARNER, STEINITE, STROMBERG CARLSON, SONORA, TEMPLE, TRAVELER (Portables) Add Frt., WARE, and ZENITH.

*Denotes this manufacturer also builds non-screen-grid models.

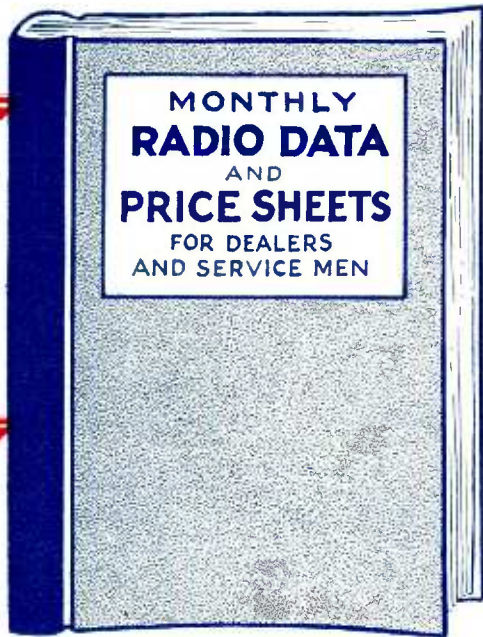

LOOSE LEAF BINDER

for "RADIO'S" PRICE SHEETS

FREE WITH YOUR SUBSCRIPTION TO "RADIO" FOR ONE YEAR

Here Is What We Give You for **\$2⁰⁰**

- 1** A SUBSCRIPTION to "RADIO" for one full year. The magazine will be mailed to you on the first of each month, starting December first.
- 2** A ONE year subscription service to the loose leaf monthly price and data sheets. These sheets are mailed to you separately each month for one year. Holes are punched in proper places for inserting these sheets into the loose leaf binder.
- 3** A HEAVY, durable loose leaf binder in green and gold, made especially for these price sheets. This binder is sent to you by parcel post, prepaid, upon receipt of your subscription to "RADIO."

. ALL THIS FOR ONLY \$2.00. Positively no further payments of any kind to be made.

THE REASON FOR MAKING THIS SENSATIONAL OFFER

THIS offer sounds almost too good to be true. The low price for the subscription to the magazine, loose leaf data sheet service and the loose leaf binder, is made for the purpose of increasing the net paid dealer and service man's circulation of "RADIO" to 50,000 copies, thereby giving "RADIO" a net paid circulation almost 100% greater than any other radio trade magazine.

SPECIAL COMBINATION OFFER FOR TWO SUBSCRIPTIONS

TWO people can subscribe to "RADIO" for only \$3.00, a saving of still another dollar. The dealer and his service man can subscribe jointly. Each will receive the entire service—and the magazine—for one year. Each will receive a loose leaf binder. Or one individual can

subscribe for two years for only \$3.00. Or two dealers can subscribe for one year for \$3.00 for BOTH subscriptions. Tell your dealer and service men friends about this offer and ask them to subscribe at this special rate.

SAVE 50% BY Mailing the ! Coupons Now.

"RADIO,"
428 Pacific Building,
San Francisco, California.

Here is \$_____ in FULL PAYMENT for a one-year subscription to "RADIO," the monthly loose leaf price and data sheet service and a loose leaf binder.

(Note: Subscription rate, one year, \$2.00. Two years, \$3.00. If two subscriptions are sent at same time, the rate is only \$1.50 per year per subscriber.)

Name _____
Street and No. _____
City _____
State _____

"RADIO,"
428 Pacific Building,
San Francisco, California.

Here is \$_____ in FULL PAYMENT for a one-year subscription to "RADIO," the monthly loose leaf price and data sheet service and a loose leaf binder.

(Note: Use this coupon only if two subscriptions are sent at one time. Use other coupon if only one subscription is being sent.)

Name _____
Street and No. _____
City _____
State _____

SOME of the NEW RECEIVERS

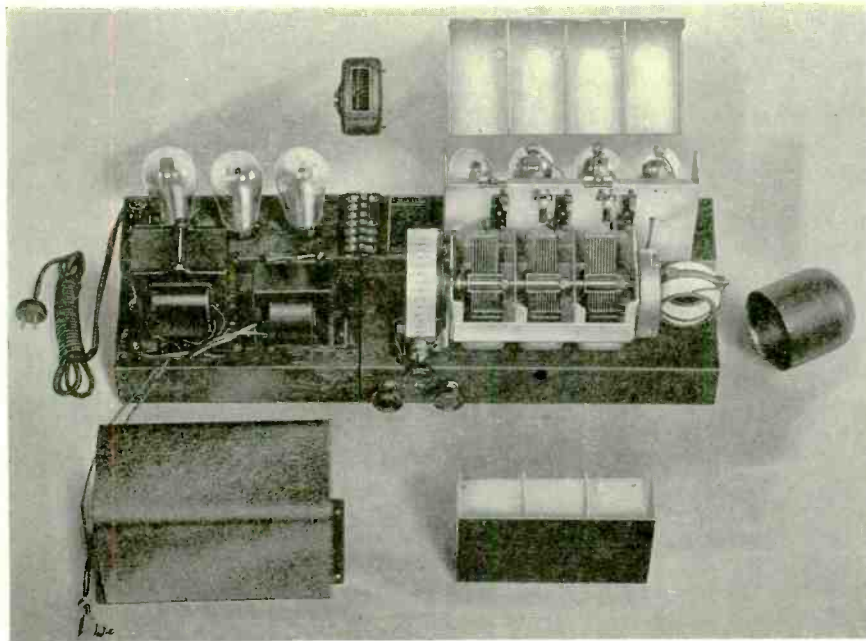

Chassis of the New Screen-Grid Bosch Receiver

The shielding is shown lifted away, screen-grid tubes and condensers being completely isolated. Three '24 tubes are used as r-f amplifiers, one '27 as power detector, and two '45 tubes in push-pull in the single audio stage, the rectifier being an '80 tube.



Zenith Model 52

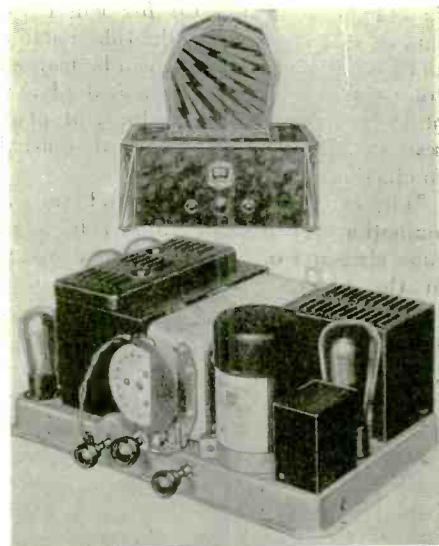

The Crosley Monotrad

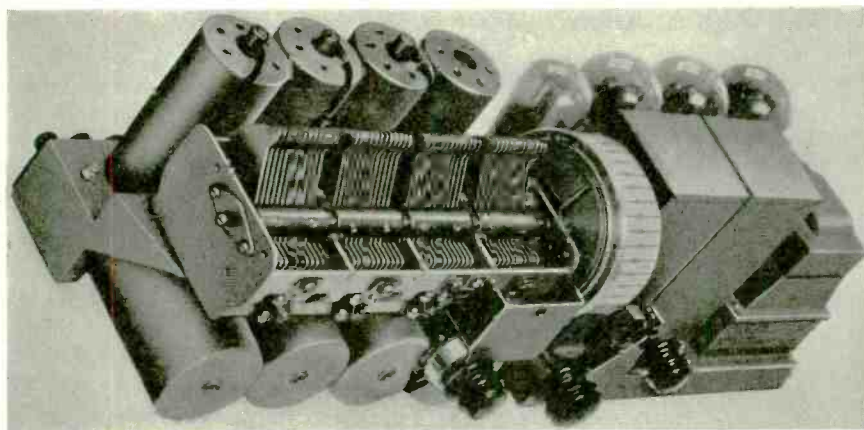

Chassis Used in Courier Sets by United Reproducers Corporation

Model 65 chassis uses three screen-grid tubes as r-f amplifiers with low-loss uniform gain transformers, '27 tubes for power detector and first resistance-coupled audio, and two '45 tubes in push-pull for second transformer-coupled audio, together with an '80 rectifier. The chassis is fully shielded and tuned with a single illuminated dial marked in kilocycles.



Model 653 Courier

This 46-in. console is equipped with Model 65 Chassis and Kylectron speaker.

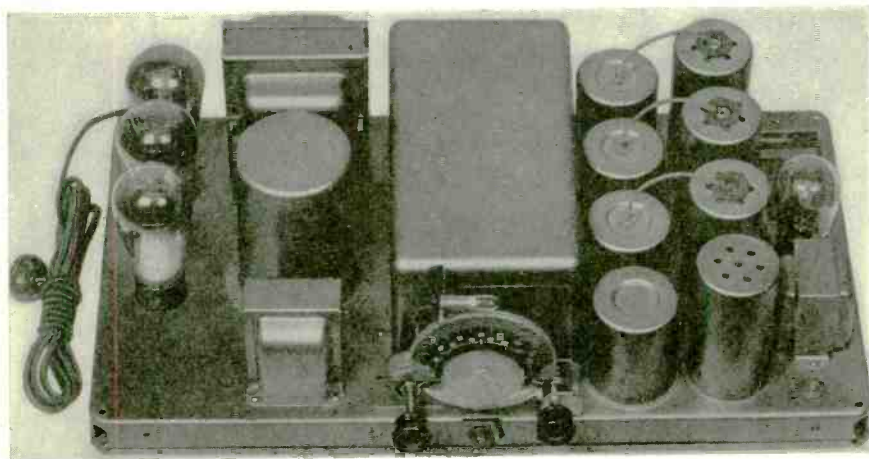

Kennedy Model 20 With Three R-F Screen-Grid Tubes, '27 Power Detector, Resistance-Coupled First A-F Stage, and Two '45 Tubes in Push-Pull in Last A-F Stage

What Happens When You Press the Button of a Tube Tester?

The "reason why" of emission and mutual conductance tests and the standards which tubes should reach.

By ARTHUR HOBART

WHILE a service man may readily test vacuum tubes in a routine manner without regard to the reasons for the various tests, he can do a better job and be better satisfied with himself if he knows why certain connections are made and what the readings really indicate. Even such a simple and common test as that for filament emission teaches much about the tube's action and condition. Still more can be learned from tests for gas, measurement of amplification factor, and readings of plate resistance and current and of mutual conductance.

The usual service tests include an examination for possible contact between tube elements or a possible open circuit in the filament. The circuit connections for indicating an open filament or a short circuit between the filament and grid, between the filament and plate, or between the grid and the plate, are so obvious as to require no explanation.

The next routine test is for filament emission. Electrons are emitted from a heated filament much as steam is evaporated or emitted from heated water. These electrons are attracted from the filament to the plate because the *B* or plate voltage keeps the plate positive with reference to the filament. The ensuing flow of electrons constitutes what is called the plate current. When measured by a milliammeter it indicates the emitting ability of the filament, this being a good index of a tube's condition.

A filament gradually loses its emission when a tube is used in a radio set, most of the free electrons being "boiled" away. In the case of oxide-coated filaments, such as are used in the '24, '26, '27 and '45 types, as well as in the —11, 12, 112, '00, '80 and '81 tubes, this loss is permanent and the tube should be discarded if the emission is not up to standard. Thoriated tungsten filaments, such as used in the '99, 112A, '01A, '00A, 220, '40, '71A, '10 and '50, may be paralyzed by overload because of lack of surface thorium, but this lack can often be supplied by re-activating the filament, with a slight filament over-voltage without plate or grid voltage, the tubes then being suitable for use.

Any one of three general methods may be used in making emission tests. In one, the tube is pronounced OK if the plate current reading on a milliammeter reaches a certain minimum value when a specified voltage is applied to the junction of plate and grid, which are tied together, and a specified voltage is applied to the filament. In the second method the tube is considered all right if the filament voltage does not exceed a specified minimum in order to cause a specified grid current. In the third method the filament emission is assumed to be sufficient if a reversal of the grid connections causes a difference in the reading of the plate current.

The first method is recommended by the Institute of Radio Engineers for plotting a curve of filament emission. The minimum m-a readings for plate current, as well as the specified filament and plate voltages, are indicated in the following table for various tubes:

Type of Tube	Filament Voltage	Voltage to Plate & Grid Junction	Plate Current
11-12	1.1	50	6. ma
'99	3.3	50	5.5 ma
120	3.3	50	13. ma
'01A	5.	50	20. ma
'00A	5	50	14. ma
'40	5	50	14. ma
112	5	50	45. ma
'71-A	5	50	40. ma
'26	1.5	50	35. ma
'27	2.5	50	35. ma
'10	6	100	85. ma
'13	4	100	40. ma
'16B	6	125	85. ma
'80	5	80	100. ma
'81	7.5	150	200. ma

Such readings cannot be taken on a 112A tube.

The second method requires a voltmeter in the filament circuit and a milliammeter in the grid circuit, with —3 volts on the plate. The filament rheostat is adjusted until the milliammeter indicates either 3 or 5 ma, depending upon the type of tube. The voltmeter reading should not be greater than that indicated in the following table:

Type of Tube	11-12	'99	'20	'01A	'40	112A	'71
Grid Current.....	3	3	3	5	5	5	5
Max. Fil. Volt.....	1	2.9	2.8	3.9	3.9	3.5	3.7

The third method is that ordinarily employed in commercial tube checkers.

It requires a voltmeter and rheostat in the filament circuit so that the voltage can be adjusted to the rating specified for the tube. Readings of the plate current are taken from a milliammeter first when the grid connections are normal, and second when they are reversed. If the two readings are different they indicate that emission is occurring. The magnitude of the difference measures the mutual conductance of the tube, of which more will be said later.

The third method also gives an indication of gas in the tube, its presence being indicated by a reversed grid current when the grid is negative. Another test for the presence of gas is the performance of the tube after an excessive plate voltage has been applied; if the plate current is normal there is not too much gas; if the plate current is too great and a "blue-glow" is seen in the tube, gas is present and the grid voltage cannot be effective in controlling the plate current. Still another indication of excessive gas is a plate current change of more than 0.1 ma when a high resistance is inserted in the grid circuit.

These routine service tests, while useful in determining whether a tube is in good working condition, are not sufficient to determine the best conditions under which it should be operated, nor how it will actually perform. So the better grades of tube testers also make provision for finding other characteristics of a tube. Different tubes are designed to work to the best advantage with different plate and grid voltages and with different plate current drains. Tube manufacturers publish this information in the form of tables which show the average characteristics under standard conditions of plate and grid voltage.

But in the design of power units it is not always possible to supply either the exact plate or the exact grid voltage specified, especially for power amplifiers, and the question frequently arises as to what is the plate current drain or what should be the *C* bias when a non-standard *B* voltage is used. Consequently the accompanying chart of recommended plate and grid voltages with

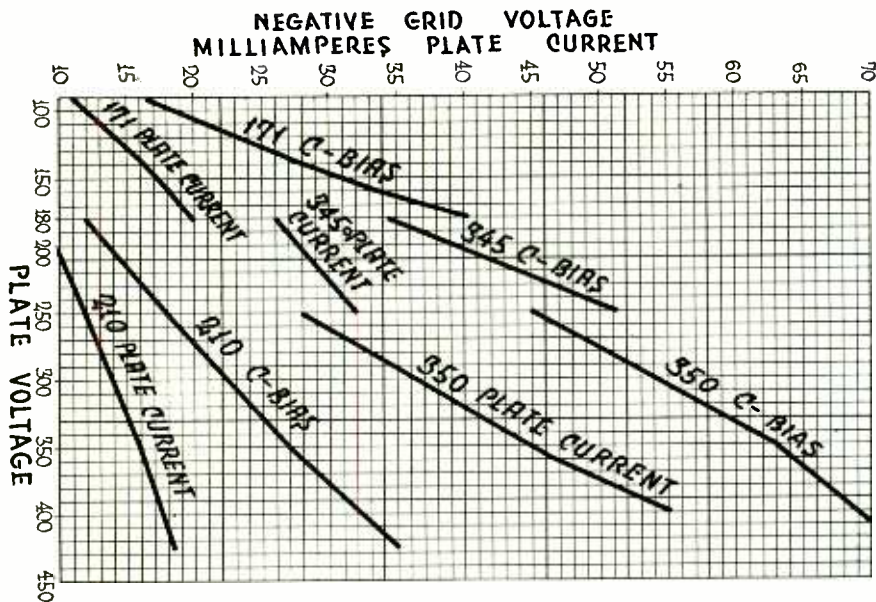

Power Tube Grid Voltages and Plate Currents for Different Plate Voltages

their corresponding plate current drains will be found to be a handy addition to the service man's note book. This chart shows two sets of facts: First, the proper grid bias to be used with various power tubes at different plate voltages intermediate to the recommended extremes. Then it shows the approximate plate current drain for these tubes when used at these different plate voltages, together with the corresponding proper grid voltage.

Actual measurements of the plate current of any tube will show how closely the individual tube approximates to the average. The plate current of any tube is inversely proportional to the a-c resistance between the filament and plate. This is known as the plate resistance of the tube and has values ranging from 1950 to 10,000 ohms in various tubes in common use, although it amounts to 400,000 ohms in the screen-grid tube. It varies slightly as the plate and grid voltages are changed. Its value may be roughly estimated as being equal to one-half the plate voltage reading divided by the corresponding plate current reading in amperes, since the a-c resistance is about one-half the d-c resistance. It may also be read directly by means of some of the more elaborate tube testers.

Knowledge of the plate resistance of the tube has two practical applications: First, in providing an equal impedance or resistance in the load supplied by the tube so as to give the greatest efficiency in amplification, and second in computing the mutual conductance, which is the best index of a tube's merit, as will be explained later.

When a vacuum tube is used as an amplifier with constant plate current, any change in the input grid voltage causes a corresponding change in the output plate voltage. The ratio of these changes is known as the amplification factor of the tube. It is usually design-

ated by the Greek letter μ , *mu*. It is a constant which depends upon the structure of the tube and is practically independent of the operating voltage. The tubes in common use have a *mu* of from 3 to 9, although the screen-grid tube has a *mu* of 420, or an actual *mu* of from 40 to 50 in the best of the present r-f amplifiers. It is numerically equal to the change in plate voltage which is caused by a 1-volt change in grid potential while the plate current is maintained at a constant value.

The *mu* of a tube is equal to the maximum possible voltage amplification which the tube is capable of producing. Under ideal conditions it equals the voltage delivered to the load divided by the voltage applied to the grid, thus being similar to the turns ratio of an ideal transformer which steps up a small grid voltage to a large plate voltage. But in practice the actual voltage amplification is from 50 to 90 per cent of the theoretical maximum since the resistance of the load must also be taken

into consideration. The accepted formula is

$$\text{Voltage Amplification} = \frac{\text{Amplification Factor} \times \text{External Impedance}}{\text{Plate Resistance} + \text{External Impedance}}$$

From this formula it is evident that the greatest voltage amplification can be obtained from a tube which has a high amplification factor and a low plate resistance. Consequently the ratio between these two quantities gives an excellent index as to a tube's performance.

This ratio is called the mutual conductance of the tube. For different types of tubes it has values of from 200 to 2100 as given in the tables of tube characteristics, the higher the value the better the performance of the tube, it being understood that the tubes under comparison are designed for the same purpose and are of the same type. Since conductance is the reciprocal of resistance, this ratio is expressed in mhos, or rather in micromhos, millionths of a mho.

Mutual conductance is also a measure of a tube's ability to give a large change in plate current for a small change in grid voltage while the plate voltage is held steady and there is no load in the plate circuit. Its value can therefore be measured directly instead of being merely calculated. This is particularly useful in testing screen-grid tubes, which have a very high plate resistance.

The circuit used in a typical mutual conductance meter, General Radio Type 443, is shown in Fig. 1. It may be seen to consist essentially of an oscillator and bridge circuit. The output of the oscillator is impressed across the arms R_1 (250 ohms variable) and R_3 (1000 ohms), R_1 being adjusted until the voltage drops across R_1 and R_3 are the same, as indicated by a minimum signal in the headphones. The ratio of plate current to grid voltage, which is the mutual conductance, is then equal to $R_1/R_2 R_3$ if the resistance of R_3 is negligible as compared to that of the plate resistance. By

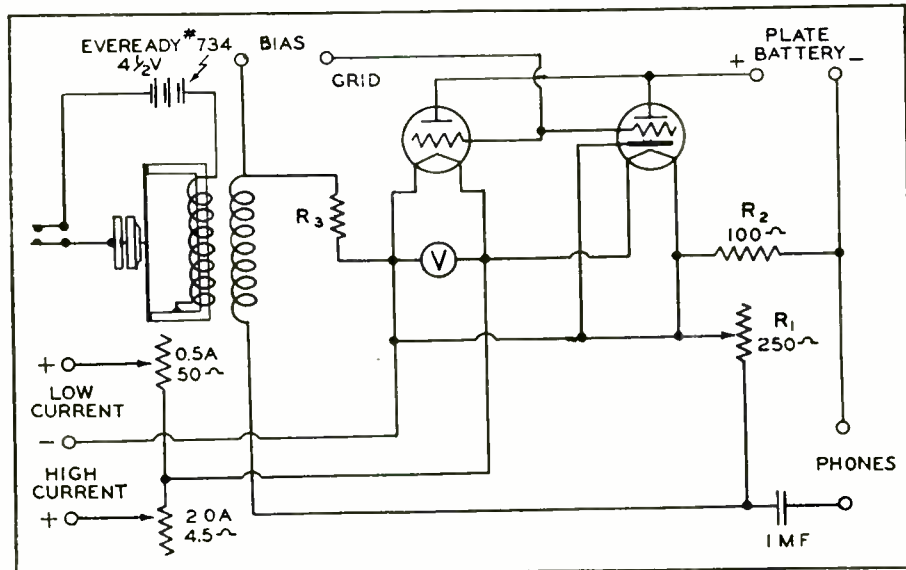

Fig. 1. Circuit Diagram of Mutual Conductance Meter

calibrating the dial control of R_1 in micromhos it is possible to get a direct reading with an accuracy of within 5 per cent.

The accompanying chart gives the mutual conductance of different standard tubes, as well as their corresponding power output for the plate voltages indicated in parenthesis except in the case of those whose output is less than 50 milliwatts. It shows that a '50 tube has the highest mutual conductance and the greatest power output, a '45 tube being second best. A 112A tube has a higher mutual conductance, but a lower power output than either a '10 or a '71A.

Once it is understood, the mutual conductance oscillation test is the quickest and most informative. It is the only simple method for testing screen-grid tubes and it gives full indication of a tube's performance as a power amplifier, detector, modulator, or oscillator. If the elements are improperly spaced or the emission is insufficient the mutual conductance will be too low. The one precaution in its use is to test for shorted elements before testing for mutual conductance, as otherwise a plate current may burn out the resistor R_2 .

Muzzling Stray Impulses

How to install an aerial and receiver so as to prevent interference from radiation and magnetic induction

Copyright by EARL BORCH

RADIO interference is caused either by an arc, spark or heterodyne effect. An arc or spark caused by a break in an electrical circuit causes an r-f oscillating current, part of which is radiated into surrounding space and part of which travels along the circuit wires. Such circuit breaks occur when an electric light or appliance is turned off, a door bell is rung, a commutator motor is running, an a-c motor is stopped, or a battery is being charged. These actions may be heard as clicks from a loudspeaker if the radiations reach its aerial or its unshielded parts. Such stray impulses often ruin the reception of a broadcast program.

Yet they can be obviated if proper precautions are taken in installing the

aerial and receiver, it being remembered that any wire, pipe or metal in a building is a possible absorber and radiator. In many cases of interference from stray impulses the reception may be improved by moving the aerial lead-in or receiver to another location, even a movement of 1 ft. often being effective.

If the following precautions are remembered when the installation is made, very little interference should be encountered from stray impulses. They are here given in the order of their importance:

1. Before an installation is attempted check the vicinity to determine if any causes for stray impulse interference are present.

2. After determining the room where the receiver is to be located, check the wiring of the building as much as is possible, so as to be able to locate the aerial lead-in and ground wires farthest away from them.

3. After receiver location is determined inspect the roof of the building and lay out the location for the flat top portion of the aerial in such a manner that it will be farthest away from all power wires and metallic objects, and is also placed at a right angle to any high-tension wires.

4. Choose the location of the lead-in and ground with great care, as it is in these wires that the greatest amount of stray impulse pick-up is had.

The above discussion has considered only the interference caused by the arc. The problems encountered from the spark are similar in nature to those from the arc, mainly because after a spark has started between two points an arc is started across them. The current flowing in the circuit may be too small to keep the arc alive, but, due to the high potential across the points, the resultant spark will act so as to keep the arc alive. Examples of such conditions are automatic oil heaters, any kind of spark coil, electro-therapeutical devices such as diathermy, X-ray, violet ray, etc., or power leaks on high-tension lines.

Any disturbance caused by any of these devices will set up stationary waves along the power lines and will be radiated into adjacent metallic bodies to be again re-radiated and so will act like the impulses set up by arcs. Generally speaking, the greater the current flowing across the arc, the greater will be the

(Continued on Page 92)

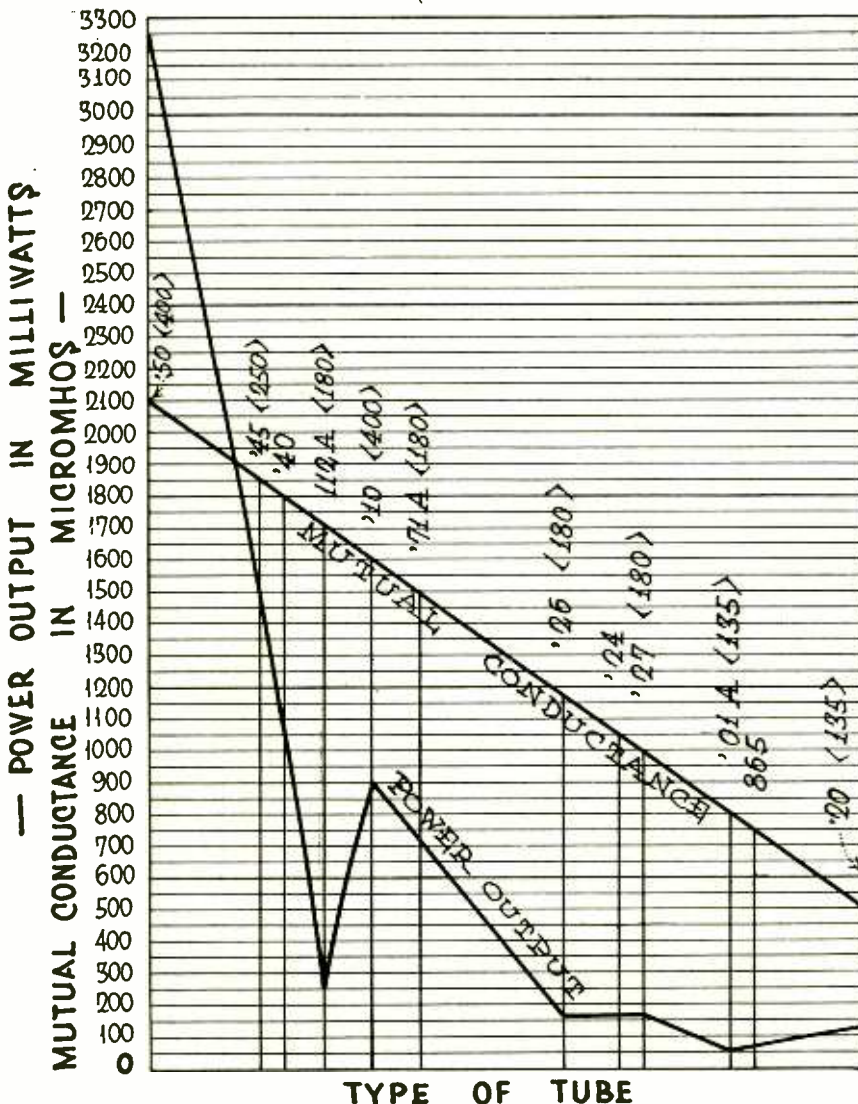

Mutual Conductances and Power Outputs of Tubes

As The Trade Thinketh...



POWEL CROSLY, JR.:
President, Crosley Radio Corp.

"You cannot sell any more of a given product than there are people to buy it."

"When the screen-grid tube was invented it was so sensitive and its amplification powers were so great that no circuit known at the time could control it. It was like a rookie baseball pitcher with plenty of 'stuff' but no control. Just as a young pitcher is sent back to the minors for further seasoning, the screen-grid tube was sent to the laboratories of radio engineers, who concentrated on designing a circuit in which the tube could be successfully used."

H. M. AYLESWORTH:
President, National Broadcasting Company.

"The most important development in radio, although not the most sensational, in the coming year will be organized promotion of musical appreciation."

C. A. EARL:
President, Earl Radio Corp.

"The next great step in radio development will be the elimination of man-made static. It is a crime that the results of years of intensive scientific and engineering radio research has been ruined by the carelessness of engineers in other fields."

DR. LEE DE FOREST

"There is no more excuse or justification for a one-tube radio set than there is for a one-cylinder automobile."

WILLIAM S. PALEY:
President, Columbia Broadcasting System, Inc.

"The formation and adoption of a concrete plan or curriculum for a broad scheme of education by radio will, in my estimation, be radio's greatest achievement of the 1929-1930 broadcasting season."

OSCAR GETZ:
Vice-President, Steinite Radio Company.

"The time is coming when radio receiving sets will be considered as an essential part of the equipment of airplanes as they are of ocean liners. Their use as a means of entertainment for passengers, and more especially for the receiving of weather reports and flying conditions, is gradually becoming imperative, and the market for a set suitable for such purposes is growing by leaps and bounds."

DR. FULTON CUTTING:
President, Colonial Radio Corporation.

"The beautiful appearance of a radio console is now taken for granted and the public is buying 'from the inside out.' Where are the mechanisms that produce the greatest acoustical perfections? Where is the rugged chassis and integral construction that guarantee long and satisfactory service? These are some of the points upon which buyers must be satisfied before matters of appearance become important."

JAMES W. GARSIDE:
President, DeForest Radio Company.

"The quality of vacuum tubes is largely a matter of good equipment, capable personnel, and, above all, a clear conscience. Irrespective of equipment and personnel, it is impossible to turn out every tube alike and every tube perfect. Hence the severity of tests and inspections, which may impose at times a serious shrinkage in the percentage of tubes available for shipment, must always be the gauge of vacuum tube quality."

H. M. LIGHT:
Service Manager, Williams Hardware Co.,
Streator, Ill.

"Dealers and their service men must acquaint the customer with the limitations of radio reception, what to expect and what not to expect. If you do this you will have fewer calls from new set owners. When a service man goes into a customer's home he goes there as a representative of some commercial establishment, and it is absolutely necessary that he be polite, courteous and considerate. The service man must answer all questions, regardless of how stupid they may seem to him. You must make the customer enjoy your visit. If you can do that, you will make a good service man."

Simple *Equipment* for Suppressing *Line Interference*

By D. A. BROWN

Directions for winding coils and installing filters to cut out static from domestic electric appliances.

THE electrical appliances ordinarily used around the home are so innocent looking that the average person, whose knowledge of electricity is limited, would never suspect them of being the cause of many of the noises heard in their radio receiver, which to them is "static." Electric sweepers, washers, ironers, hair clippers, oil burners, refrigerators and water pumps are only a few of the appliances that cause interference. For those who would like to suppress such interference, the writer

will describe the construction and placing of devices which should give good results.

The first place to start for noise elimination is at the meter board. As shown in Fig. 1, two pieces of $\frac{1}{2}$ -in. black conduit 6 in. long are slipped over the power line wires between the meter and the distributing fuse block. These are connected together and run to a good ground, preferably water pipe. This forms a choke to filter the impulses in the line.

The rest of the equipment is mounted at the appliance power outlet, this being a choke coil and condenser unit. In the installation for homes, the writer would mount the choke coil on a wooden form and mounted the condensers on the side of the form. This makes a compact filter unit and can be fastened on a washer or refrigerator without detracting from their appearance. The coil form is shown

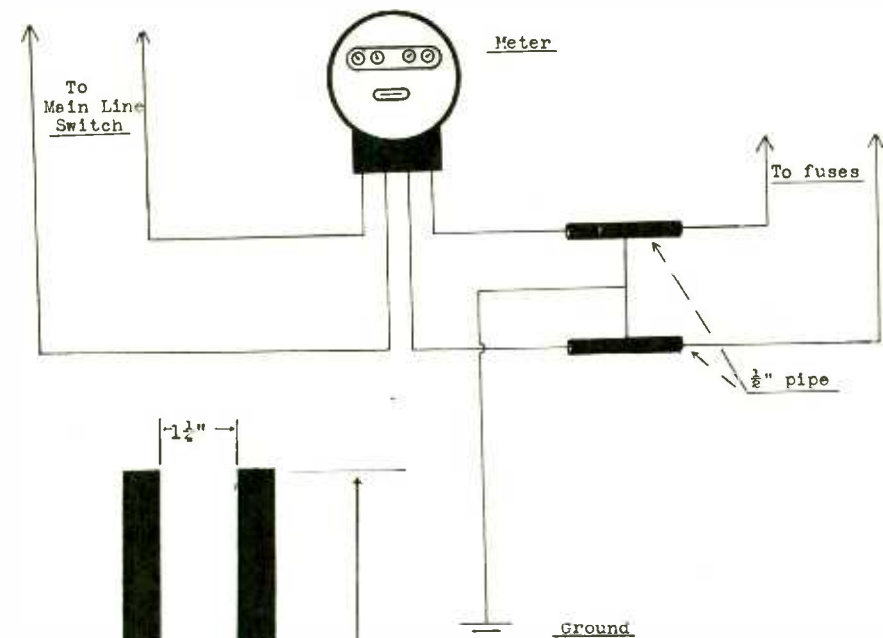

Fig. 1. Simple Interference Checks at the Meter

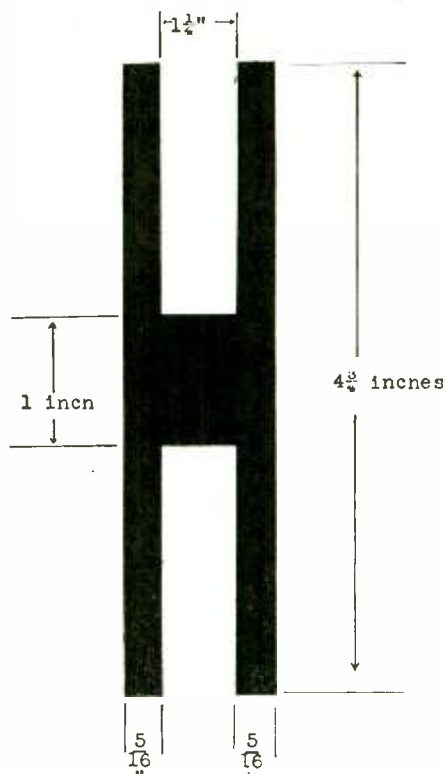

Fig. 2. Side View of Coil Form

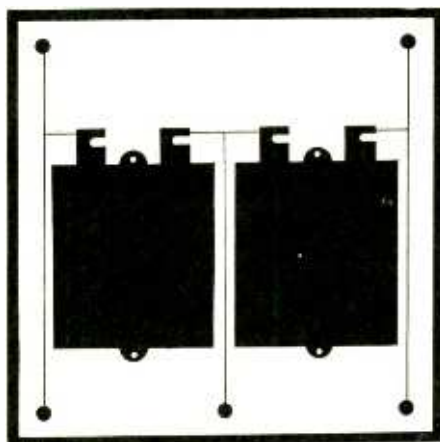

Fig. 3. Layout of Coil Form With Condensers Mounted on Side

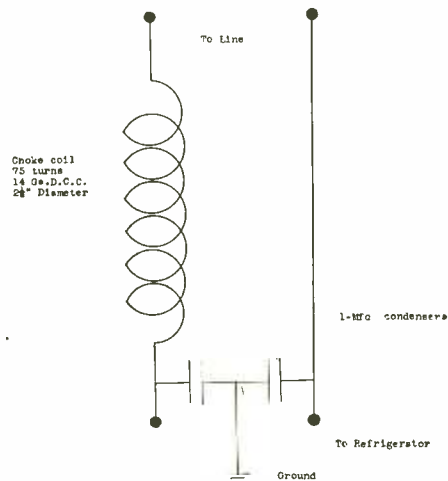

Fig. 4. Suppressor for Washer or Refrigerator

in Fig. 2, with dimensions and the layout of the condensers in Fig. 3. The method of connection appears in Fig. 4. The same kind of unit is also applicable to sign flashers, ironers, oil burners, water pumps and flasher buttons.

For appliances taking not over 350 watts this coil form will handle the case nicely if wound with No. 14 copper
(Continued on Page 95)

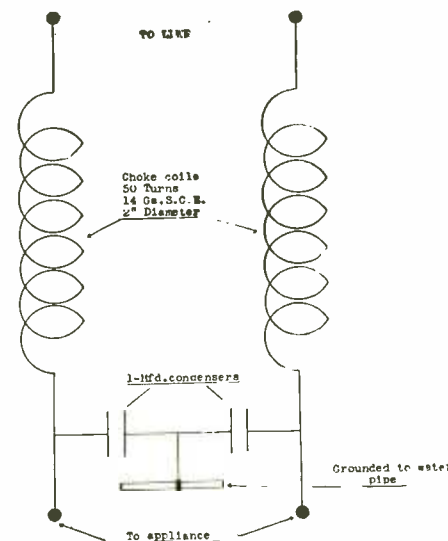

Fig. 5. Suppressor for Commutator Type Motors

Radio Pickups

Items of trade interest from here, there, and everywhere, concentrated for the hurried reader.

The De Forest Radio Company has filed a damage suit for \$3,000,000 against the Radio Corporation of America because of restraint in trade resulting from the requirement that only RCA tubes be used in sets made by RCA licensees.

The Radio Corporation of America has bought the Loftin-White patents on tuned r-f amplification and on the "non-reactive plate circuit" method of preventing r-f oscillation, and has optional rights on the Loftin-White "constant-coupling" system. This eliminates the possibility of infringement suits against it and its licensees.

The Theremin is a new musical instrument invented by Professor Leon Theremin, whose patents have been acquired by the Radio-Victor Corporation of America. Its sounds orig-



inate from two oscillating circuits which produce a heterodyne beat note which is varied and controlled by the position of the player's hands in relation to a vertical antenna with which it is equipped. A second horizontal antenna controls the volume of sound, also by the relative positions of the player's hands. The pitch becomes higher as the hand approaches the vertical antenna and the volume

becomes greater as the hand is withdrawn from the horizontal antenna. For tubes it employs one UX-224, three UY-327, one UX-120, two UX-171A, and one UX-280, whereby the sounds are created, amplified and reproduced in a loudspeaker. The first public showing of the new instrument was at the Radio World's Fair in New York City.

Shortwave and Television Laboratory, 70 Brooklyn Ave., Boston, Mass., plans to install a 500-watt television transmitter for operation on the 2100-2200 kc band and to sell television receivers.

Kolster Radio Corp. and Earl Radio Corp. have been consolidated with Rudolph Spreckels as chairman of the consolidated company, Ellery W. Stone as chairman of the executive committee, and Clarence A. Earl as president. Kolster, Brandes, Earl and Freed-Eisemann sets will be marketed as distinct brands without disturbing jobber and dealer contracts. The union of the two companies combines the strong patent position of Kolster with the successful production methods of Earl.

The Oxford Radio Corporation has increased its production of Oxford electrodynamic speakers to 4000 per day to meet the demand from such customers as Zenith Radio Corp., Wells-Gardner Co., Wextark and Montgomery Ward & Co.

Through the installation of a novel group address system, New York baseball enthusiasts can follow every play, without bothering to look at the score board. Every decision of the umpire can be heard clearly and distinctly throughout the stands and at the farthest point in the bleachers. In order to accomplish this, an Amplion microphone is installed in the mask of the umpire. The wires run down his trouser legs to two contact plates on which he stands. An Amplion input amplifier feeds the energy to a high-power a-f system, which delivers an audio power of 45 watts to ten Amplion Giant units, of the new AA-102 type. These are connected to ten six-foot trumpet horns, located at the proper acoustic points, under the roof of the grandstand and in the bleachers. The response of the baseball fans to this innovation has been so favorable that it is now only a matter of time, before similar group address systems will be installed in the big league stadiums throughout the country.

R. C. A. Institutes, Inc., is a subsidiary of the Radio Corporation of America whose purpose is to establish radio schools in various

cities so as to meet the demand for trained radio men. In addition to its existing schools in New York, Boston and Philadelphia, new schools are first to be started in Newark and Baltimore, and then in other cities throughout the country. Instruction is to be given in regular classes and by correspondence.

Atlantic City has been chosen as the site for the 1930 convention and trade show of the Radio Manufacturers' Association. The date, probably around June 1, will be fixed later.

The intermediate-frequency amplifiers in this year's RCA superheterodynes are tuned to 175 kc; last year's models operated at 180 kc.

C. R. Leutz, Inc., of Altoona, Pa., are building a laboratory designed especially to give favorable results for long-distance reception. It is located at an elevation of 3000 feet and miles away from any power lines.

A heavy schedule of hearings this Fall and early Winter faces the Federal Radio Commission. More than 400 cases have been docketed to be heard before December 31st, when the present term will expire. About one-half are applications for new stations. Most of the remainder are petitions for kilocycle changes and increase in power. There are now 609 broadcasting stations. When the Commission was created there were 732.

All carrier pigeon activities of the United States Navy were abolished on October 1st, and the Navy will send all its messages by radio, it has been announced by the Navy Department. Four hundred birds will be kept at the Lakehurst, N. J., naval air station, and the naval station at Guam, but will not be used in regular message service. The Anacostia, D. C., naval air station lofts now have the greatest number of prize winning birds. "Jolly Tar," the station's star pigeon, won both the 500-mile and the 600-mile race. The station has furnished eight winners this year.

The new battery-operated Templetone receiver has four '22 screen-grid tubes in the r-f amplifier, '01A detector and first audio, and two 112A tubes in push-pull in the second audio with transformer coupling. It has a sensitivity of from 4 to 10 micro-volts per meter and a plate current drain of from 27 to 28 ma.

The Delco-Remy automobile radio receiver, with which the new Cadillac and LaSalle cars are equipped, employs two stages of screen-grid r-f amplification, detector and two resistance-coupled audio stages. Type '24 heater type screen-grid tubes are used in the r-f stages, a '27 in the first audio stage and a type 112-A in the detector and last a-f stage. The heaters of the two '24s and the '27 are connected in series, two volts being delivered to each. The two 112-A tube filaments are also in series, each operating on 3 volts. 180 volts are used on the plates of the r-f tubes and the power tube, the detector operating on 45 and the first a-f tube receiving 135 volts. Plate voltage is supplied from B batteries and grid bias from separate C batteries, the batteries being carried in a special box. Filament current is supplied from the storage battery in the car.

The tuner unit consists of three variometers ganged together on a single shaft, each

In order to avoid ignition noises it is necessary to shunt a 25000-ohm resistor across each spark plug and coil contact, and to connect a condenser across the battery side of the charging generator and the starting switch. The two little gadgets shown at the right of the tuning unit in the illustration are a pair of resistors supplied with the receiver for shunting the spark plugs and coils.

The Delco-Remy automobile radio costs \$165 complete and installed on the Cadillac or LaSalle and \$185 on any other type of car. It promises to open up a new field for the radio dealer who is willing to go after some of the business, and for the radio service man wherever he may be.

Stimulation of new and improved broadcasting features for the radio public, including measures to insure public reception of national events, such as sports which some

was to the effect that the Rola Company did not infringe the patents of the Lektophone Corporation in the design and construction of their speaker. In the lower court the Lektophone Corporation of New Jersey sued Rola for infringement on Hopkins' patents No. 127-1527 (claims 29 and 30) and No. 1271529 (claims 1 to 8). In affirming this decision the Circuit Court of Appeals, while not actually declaring the above patents invalid, have interpreted the above claims to be of such limited scope both with respect to dimensions and materials used as to render them of only secondary importance in the art.

A \$10,000,000 corporation has been formed by General Motors Corp., with 51 per cent of the stock, and Radio Corporation of America, with 49 per cent of the stock. While this corporation is interested in the radio equipment of automobiles it may also be used to provide an outlet for radio sales through General Motors distributors and dealers, a number of whom have recently started radio departments. Definite information is lacking as to what radio sets will be handled. General Motors recently bought the Dayfan plant at Dayton, Ohio. The Delco-Remy receiver is being sold for installation in Cadillac and LaSalle cars. New RCA models for battery operation will soon be available. But under any circumstances it is evident that radio sets are to be sold through General Motors.

Sylvania Products Company recommend that the control grid negative bias of the SY-224 tube be from 1½ volts to 2½ volts, while the screen-grid voltage should be raised from 75 volts to 90 volts.

Lynch Manufacturing Company, Inc., has succeeded Arthur H. Lynch, Inc., as manufacturers of a complete line of resistors at Cranford, N. J., and Malden, Mass. L. R. Beardslee is president in place of Arthur H. Lynch, who is now associated in an advisory capacity. The line consists of Dynomhic resistors, Veritas resistors which formerly were manufactured by Tobe-Deutschmann Company, leakproof mountings, single or double, resistance-coupled audio amplifier kit, the Lynch deck, Lynch equalizers and the Lynch tubadapta.

The Court of Appeals of the Third Circuit has sustained the decision of the lower court that the Langmuir high-vacuum patent is invalid. The suit had been brought by the General Electric Company against the De Forest Radio Company, which thereby obtains the right to use a high vacuum in the manufacture of radio tubes.

A remote control tuning device which has been invented by A. E. Ellinger, chief engineer of the Ellmar Radio and Television Division of Markel Electric Products, Inc., Buffalo, N. Y., utilizes an electric motor, several solenoid-operated levers, a group of eight selector fingers, a revolving shaft, and a cam. The cam is connected to the gang condenser shaft. The device is connected by a control cord to a small control box with an indicating knob that can be moved to any one of eight positions, corresponding to as many stations.

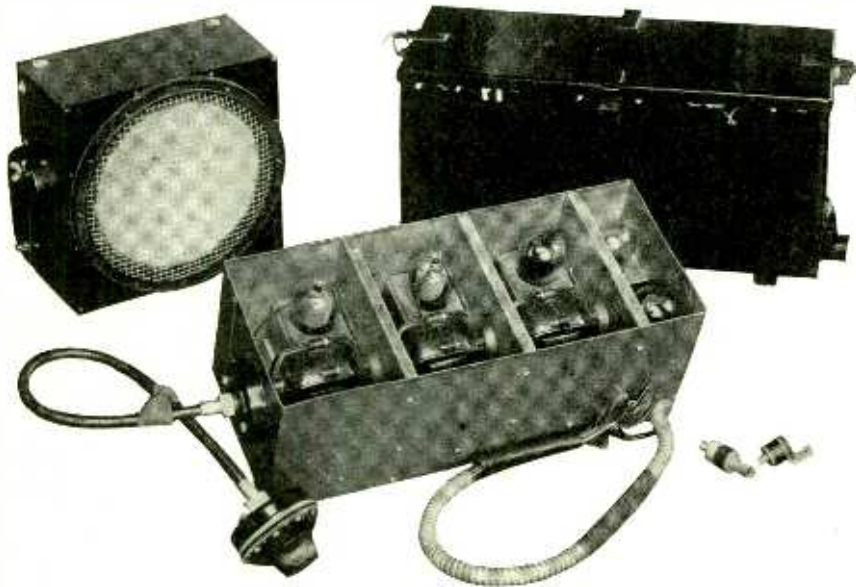

The Delco-Remy Automobile Receiver; Tuning Unit With Lid Off, Loudspeaker and Battery Box. Notice the Two Small Resistors for Shunting Spark Plugs and Coil.

trimmed with a low capacity condenser. R-f chokes in the plate and screen-grid leads and the usual by-pass condensers serve to isolate the r-f currents from the battery leads. Each r-f stage and the detector are separately shielded by heavy copper walls and all tubes are mounted in a felt-lined container which protects them from vibration.

The tuner unit is mounted in back of the instrument board (called dashboard before the advent of the airplane) and connected to the battery box, which is mounted on the chassis below the body, by means of an armored cable. The speaker, which is of the magnetic cone type, is built into a wooden frame and protected by a heavy screen. It is usually mounted on the bulkhead just forward of the floor boards. A vernier dial is mounted on the instrument board and connected to the variometer shaft at the end of the tuning unit by means of a flexible steel cable similar to those used in speedometers. On the instrument board, also, is mounted a potentiometer which is connected across the A battery for volume control and a lock switch designed to match the ignition lock.

The ground lead serves as one A battery connection, the other being made to the terminals in the rear of the instrument board. The body of the car is used as a ground and a few turns of wire around the top, with the far end left open, form the antenna.

private promoters are reluctant to have broadcast, is planned by the Radio Manufacturers' Association. Convinced that broadcasting of baseball, boxing contests, and other sports actually increases paid attendance at such events, and are desired by the radio public, the leaders of the industry are considering steps to prevent possible loss of any such outstanding events to the radio public.

Except for the probable continuation of the Federal Radio Commission for another year, comparatively little important radio legislation is expected during the present session of Congress, according to reports to the RMA board by C. C. Colby of Boston, Chairman of the Legislative Committee, and Frank D. Scott of Washington, Legislative Counsel. Changes in the law improving procedure of business before the Federal Radio Commission are probable which will give relief to the broadcasting interests appearing before the Commission.

The Circuit Court of Appeals for the Ninth Circuit has affirmed the decision of the United States District Court for the Northern District of California, southern division, which

Kit Reviews

HAMMARLUND HIQ-30

THIS kit is designed for the custom set builder, and may be purchased as a complete kit or in separate units. It employs three '24 a-c screen-grid tubes as r-f amplifiers, '27s in the detector and first a-f stage and two '45s in the power stage. An '80 rectifier tube is used, as well as a voltage regulator tube.

Preceding the first r-f amplifier circuit is a three-stage pre-selector or tuned band filter. This unit is built up into four individual shields; one for each transformer and one for the gang condenser that tunes the latter. The secondary of the first transformer is inductively coupled to the antenna coil and is in series with its tuning condenser and the primary of the succeeding transformer, the junction between the latter two being their connections to ground. The secondary of the third transformer in the pre-selector is across the grid and cathode of the first tube, a resistor in series with the cathode and ground furnishing the necessary grid bias to this tube.

Each screen-grid tube is shielded in an individual case and the cathode of each is bypassed to the plate, the screen grid and to ground in a condenser block which has one common set of plates. This results in bypassing the plate and screen grid to ground as well as to the cathode, via their own sections of the condenser block and that of the cathode. Each transformer is shielded also and each of the shields used for this purpose contains the r-f plate choke which is separately shielded from the transformer in an aluminum case of its own. Another three-gang condenser with trimmers is used to tune the three secondary circuits of the r-f amplifier.

Separate cathode resistors supply the r-f

grids with the bias voltage; the plates are fed from the voltage divider; the screen-grids from the variable tap in a potentiometer between the detector plate voltage terminal in the voltage divider and ground. A resistor is included in each of these leads for filtering purposes.

The detector grid circuit varies a bit from the customary idea in that the secondary is tapped for the grid connection, the remaining portion passing through the tuning condenser to ground. In other words the condenser tunes the whole secondary while only a portion of the latter is across the grid and cathode. The usual leak and condenser is in the grid lead and is contained in the transformer shield. The detector plate voltage is obtained from a tap in the voltage divider, through the primary of the first a-f transformer and another shielded r-f choke.

Transformer coupling is used in the audio amplifier, grid bias for the first tube being supplied by the drop in a resistor between cathode and ground or grid, that for the '45s from the extreme negative end of the voltage divider.

Voltage regulation for the power supply is obtained by use of a regulator tube for small changes and a tap in the primary of the transformer for greater variations. Besides the rectifier filament secondary and the high voltage winding there are but two secondaries; one for the filaments of the '45s and one for the heaters of the '27s and '24s. The transformer and two chokes are enclosed in a single shield while another shield encloses all the filter condensers. The high voltage for the plates of the '45 tubes is taken from the junction between the two chokes.

The complete set is built on a strong metal chassis with no visible wiring. The sub-panel wiring, "unit" construction, and factory assembly, wiring and testing of the filter

and amplifier units make the construction a simple operation requiring but two or three hours. The standard size chassis (7" x 12 $\frac{3}{4}$ " x 24") allows an unrestricted choice of cabinets. The walnut panel and control knobs with the statuary bronze dial escutcheon and switch make the panel arrangement exceptionally pleasing and compact. The radio-phono switch is mounted on the front panel for convenience of operation.

The set operates on either an inside or outside antenna. A copper screen tacked on to the rear of the cabinet suffices for local reception. The "HIQ-30 Manual" which lists at 25c contains complete information on both the a-c and battery operated model of "HIQ-30" receivers and tuners.

NEW RADIO CATALOGS

Yaxley Mfg. Co. has issued a booklet which illustrates and describes its Radio Convenience Outlets and their use in wiring residences, hospitals, schools, hotels, apartments, etc., for radio service.

As an integral part of its 1929-1930 catalog Aerovox Wireless Corporation of Brooklyn, N. Y., presents a helpful manual on the proper use of radio condensers and resistors with special reference to their use in power supply units.

Catalog No. 140 from the Insuline Corp. of America, New York City, is fundamentally concerned with insulating materials for radio use, such as panels, tubing, rods, and insulated wire. In addition it illustrates and describes some radio specialties, including a screen gridifier, selectuner, and lightning arrester, as well as a complete line of television parts and kits.

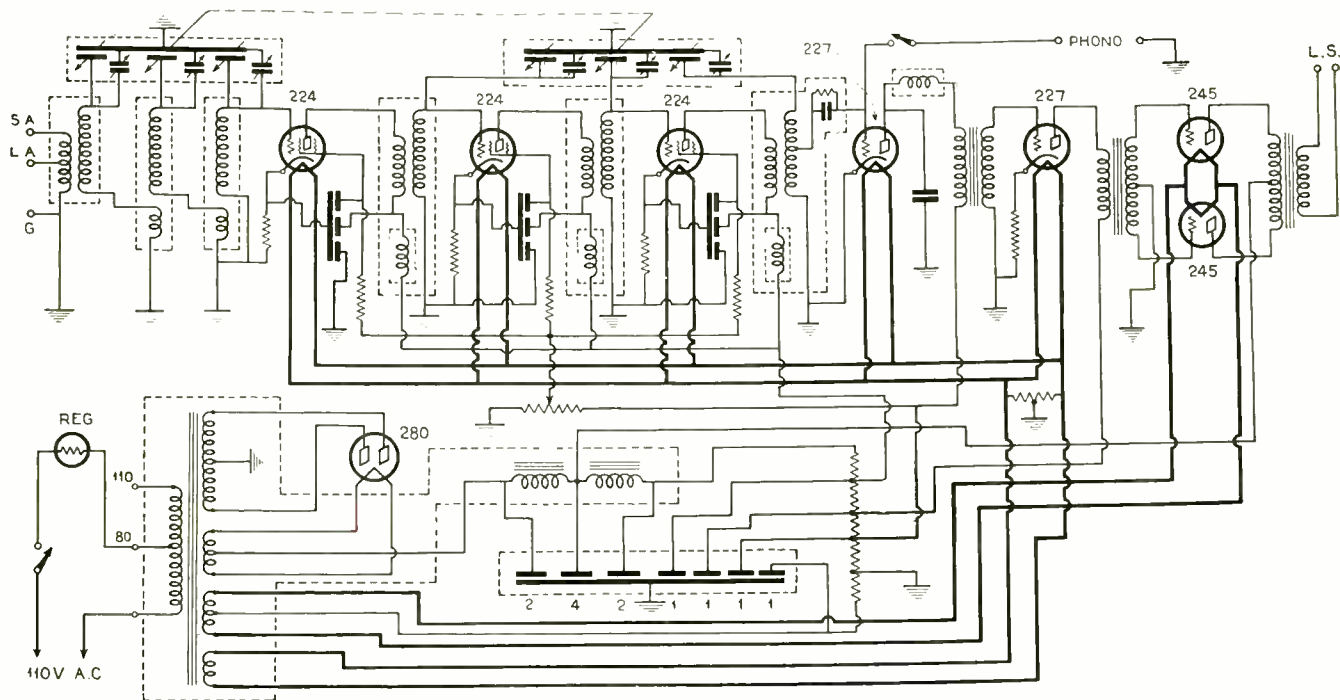

Fig. 1. Circuit Diagram of Hammarlund HIQ-30

What *Constitutes* Good *Tone* From *A Radio*

By J. EDWARD JONES

An analysis of the effect of radio design upon the reproduction of tone, with special reference to baffle size.

BEAUTY is in the eye of the beholder. Music is in the ear of the listener. However true this may be, masterful interpretation and faithful reproduction have kept alive the famous works of the old masters. Arias and symphonies may be jazzed and parodied, but these variations die in their own generation. Only the true original work is handed down through the ages.

So only true reproduction by radio can live—or, rather, only the radio receiver that reproduces truly can live. When an art is young we suffer imperfections, but behind the scenes men are striving—some to give the public what it thinks it wants, a whim of the moment—others to give perfection, a lasting monument.

Faithful reproduction equals perfect radio receiver. A simple formula, but in the term “faithful reproduction” there are many factors. The one to be discussed here is frequency range.

The sensation of hearing is caused by sound waves which enter the ear, impinge on the membrane or drum, and set up vibrations which register in the brain. Different frequencies affect different parts of the membrane, creating the sense of tone, noise, harmony, speech—all depending on frequency, although differences in structure or sensitiveness in different human ears cause two persons to give different interpretations to the same sound. The range of frequencies that the human ear can detect is approximately from 16,000 to 20,000 cycles per second.

Music and speech consist of a fundamental frequency and various harmonics or overtones. The character of the music, the type of instrument, different words, letters, etc., depend upon the harmonics, but the pitch depends upon the fundamental frequency. Musical instruments and voices have definite fundamental range. The male voice fundamental frequency averages around 120 cycles per second, while the female fundamental voice frequency is about 240 cycles, an octave higher. However, overtones exist in some speech sounds up to 8000 per second, for while female speech has less overtones than male, they extend up to 8000 and the richest overtone area of the male voice is between 3000 and 5000 cycles per second.

It is these differences in the number and combinations of harmonics and over-

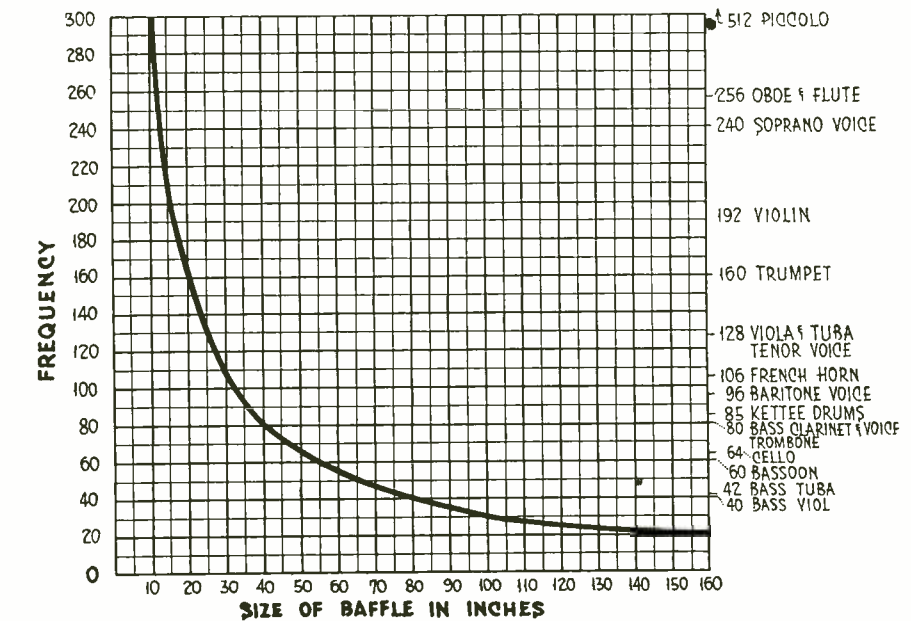

Fig. 1. Limiting Effect of Baffle Size Upon Reproduction of Low Notes

tones that enable the human ear to distinguish between different persons' voices. Likewise, it is these different harmonic combinations that enable the human ear to distinguish between a violin, clarinet, French horn, piano, etc., when each instrument sounds or plays the same note on the chromatic scale of music. A 'cello solo may sound on some sets over some stations as a natural violin or saxophone would sound to the same human ear.

Many obsolete and present-day inferior receiving sets (transmitting sets as well) cut off the higher frequencies. Cutting to 6000 eliminates the characterizing features of the unvoiced sounds such as s, f, sh, th, z., etc., especially in the upper reaches of the female voices. This, of course, accounts for the disapproval of worthy soprano voices over earlier limited receiving sets.

In cutting off the low frequencies, tone color or timbre is lost. Timbre is very important in music, as it is one of the factors that define the various instruments. The fundamental and the first three or four overtones are the distinguishing features. On the other hand, if too many higher overtones are lost, “brilliance” and “definition” disappear.

Drums have fairly low fundamental, but are particularly rich in higher har-

monics; cutting these high overtones renders their reception dull and dead. The organ, harp and piano have a fundamental range from 16 to 4000 cycles, and, as the chief characterization of all these is a strong first octave, frequencies up to 8000 should be unimpeded for good definition. (See Table I for ranges of voices and instruments.)

There are many limiting factors in radio, some of which can be overcome. Some sets emphasize bass by sacrificing harmonics. There is really no more bass; the apparent tone is merely lowered. There are many extraneous noises which are caused by poorly constructed parts. On many sets the higher overtones down to 5000 and in a few cases even down to 4000 are cut off deliberately at the speaker. The untrained ear enjoys this overpronounced depth—for a little while. Other manufacturers use no limitative devices on the speaker, and are constantly striving to extend the frequency range up and down, relying on the increasing demand of a public rapidly becoming educated to perfect reproduction, which we have found among other things equals reception of all frequencies from the fundamental even unto the third and fourth harmonic.

Clarity seems to be a stock selling ar-

(Continued on Page 96)

New Equipment From the Radio Manufacturers

Contributions to This Department Are Invited

The Flewelling Ohmmeter is a direct reading instrument for determining the value of resistors used in radio work. The



indicating meter is a sensitive galvanometer which is assembled on a Formica panel and installed in a bakelite case 7 x 5½ x 3½ in.

The new Aero a-f transformers comprise a complete line designed to give nearly uniform amplification from 60 to 5000 cycles when used with a-c tubes. The AE-300 has a 1 to 3 ratio for use in the first audio stage;



its primary has a d-c resistance of 2250 ohms and an inductance of 65 henrys; its secondary has a d-c resistance of 8600 ohms and an inductance of 585 henrys. The AE-400 is for use in the second audio stage; its primary has a d-c resistance of 1900 ohms and an inductance of 50 henrys; its secondary has a d-c resistance of 9400 ohms and an inductance of 800 henrys. The AE-2408, with its 1 to 1 ratio or the AE-2922 with its 1 to 2 ratio, is designed to couple a single stage of a-f into a stage of push-pull with two power tubes. The primary of the former has a d-c resistance of 2000 ohms and an inductance of 50 henrys; its secondary has a d-c resistance of 9500 ohms and an inductance of 800 henrys. The primary of the latter has a d-c resistance of 1300 ohms and an inductance of 45 henrys; its secondary has a d-c resistance of 13,000 ohms and an inductance of 720 henrys, using two individual secondaries with opposed windings to insure balance with the grid return at the electrical center. The AE-2973 is an inter-stage push-pull transformer for use in a public address system. The d-c resistances of the primary and secondary are 4200 and 10,400 ohms, respectively, and the inductances 370 and 1480 henrys.

The Erla Model 62 pick-up is mounted on a balanced arm to give even pressure on the record. It uses cobalt steel magnets and



a rubber-cushioned armature. All parts are hermetically sealed to exclude dirt. A volume control is mounted on the base.

The Hammarlund RF-3 is a completed, wired and assembled three-stage screen-grid r-f amplifier designed especially for use with a three-stage band-pass filter pre-selector tun-

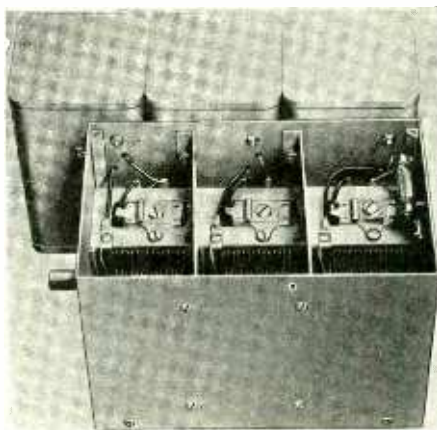

ing unit, BS-3. The RF-3 contains a matched .0005 μ f three-gang condenser enclosed in an aluminum can with partition shielding and three matched r-f coils in separate copper cans, each can also containing a shielded r-f choke which has no external field. The r-f unit which feeds into the detector also contains a metallized grid leak and mica condenser. The BS-3 contains a matched .0005 μ f three-gang condenser housed in an aluminum shield, and a set of three r-f filter coils, each enclosed in a copper can. The latter unit gives flat-top tuning. Both units are tested and sealed before they leave the factory.

The I. C. A. Screen-Gridifier is designed to allow the use of '24 tubes as r-f amplifiers in place of '01A, '26 or '27 tubes in any receiver where it can be mechanically inserted,



when 110-volt a-c is available to supply the filament transformer, and where a plate tap supply of 135-220 volts is obtainable. The device consists essentially of a high-impedance coupler for use in the plate circuit, a self-adjusting shield grid bias unit, complete shielding, and a two-outlet filament transformer, the latter not being necessary for sets using '27 tubes. One transformer suffices for two or more r-f tubes. The 180-degree adjustable revolving base fits a standard four or five-prong socket.

The Aero Overseas Four is an a-c short-wave receiver which uses a '24 tube as r-f amplifier, '27 tubes as detector and first audio, '12A tube as second audio, and an '80 tube as rectifier. By means of five plug-in coils it covers the wave band from 15 to 550 meters. On the front panel is an "off-on" switch, a single tuning-knob which operates a two-gang condenser, and a regeneration control. While this set is primarily designed for the reception of short-wave broadcasts, it is also suitable for code reception.

Hammarlund new a-f apparatus includes straight, push-pull, and output transformers, and a complete power unit. The AF-2 first stage transformer has a 1½:1 ratio and the AF-4 a 2:1 ratio on each side, both having large primaries and cores designed to give uniform amplification from 46 to 4800 cycles.

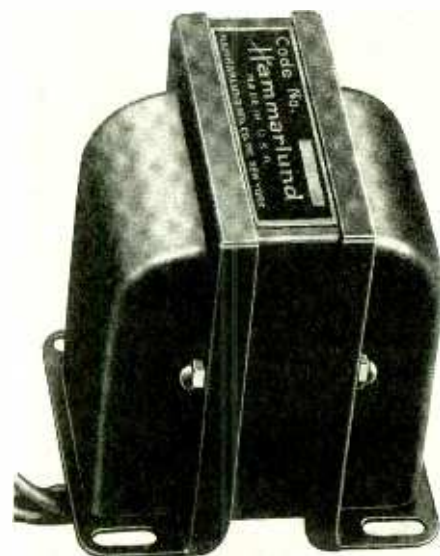

The AF-M is an output transformer whose impedance matches 45 tubes to a magnetic speaker and the AF-D likewise matches the moving coil of a dynamic speaker.

The power supply unit, PS-45, consists of a pair of 30-henry chokes and of a high voltage transformer, with a 110-volt primary, tapped at 80 volts for use with a voltage regulator. The high voltage secondary has an output of 750 volts, is rated at 100 mills, and is center tapped. There is also a 5 volt, 2 ampere center tapped winding for supplying filament voltage to a 280 tube; a 2-½ volt, 3 ampere center tapped

(Continued on Page 90)

Who Makes It

Classified Index of Radio Equipment and Its Manufacturers Corrected Monthly

Key to Letters and Numbers

- A-1 The Abox Co., 215 N. Michigan Avenue, Chicago, Ill.
 A-2 The A-C Dayton Co., 300 E. First St., Dayton, Ohio.
 A-3 Accusti-Cone Laboratories, 1 N. Seventh, Philadelphia, Pa.
 A-4 Acme Apparatus Corp., 37 Osborn St., Cambridge, Mass.
 A-5 The Acme Elec. & Mfg. Co., 1444 Hamilton Ave., Cleveland, Ohio.
 A-6 Acme Products Co., 22 Elkins St., South Boston, Mass.
 A-7 The Acme Wire Co., New Haven, Conn.
 A-8 The Actron Corp., 123 N. Sangamon St., Chicago, Ill.
 A-9 Adler Mfg. Co., 29th and Chestnut Sts., Louisville, Ky.
 A-10 Adrola Corp., Fort Jefferson, N. Y.
 A-11 Advance Electric Co., 1260 W. 2nd St., Los Angeles, Calif.
 A-12 Aerial Insulator Co., Inc., 429 N. Washington St., Green Bay, Wis.
 A-13 Aero Products, Inc., 4611 E. Ravenswood Ave., Chicago, Ill.
 A-14 Aerovox Wireless Corp., 70 Washington St., Brooklyn, N. Y.
 A-15 Ajax Electric Specialty Co., 1926 Chestnut, St. Louis, Mo.
 A-16 Akron Porcelain Co., Akron, Ohio.
 A-17 Alden Mfg. Co., Brockton, Mass.
 A-18 Aladdin Mfg. Co., 602 E. 18th St., Muncie, Ind.
 A-19 All-American Mohawk Corp., 4201 Belmont Ave., Chicago, Ill.
 A-20 Allan Mfg. Co., 102 N. Fifth St., Harrison, N. J.
 A-21 Allen-Bradley Co., 494 Reed St., Milwaukee, Wis.
 A-22 Allen-Hough-Carryola Co., 279 Walker St., Milwaukee, Wis.
 A-23 Aluminum Co. of America, 2400 Oliver Bldg., Pittsburgh, Pa.
 A-24 American Bosch Magneto Corp., Springfield, Mass.
 A-25 American Electric Co., 64th and State St., Chicago, Ill.
 A-26 American Hard Rubber Co., 11 Mercer St., New York City.
 A-27 American Lava Corp., 29 William St., Chattanooga, Tenn.
 A-28 American Mechanical Labs., 281 N. Sixth St., Brooklyn, N. Y.
 A-29 American Porcelain Co., Akron, Ohio.
 A-30 American Radio Hardware Co., 135 Grand, New York City.
 A-31 American Reproducer Corp., 1200 Summit St., Jersey City, N. J.
 A-32 American Transformer Co., 178 Emmet St., Newark, N. J.
 A-33 Amoroso Mfg. Co., 60 India St., Boston, Mass.
 A-34 Amplex Instrument Labs., 132 W. 21st St., New York City.
 A-35 Amplion Corp. of America, 133 W 21st St., New York City.
 A-36 The Amrad Corp., 205 College Ave., Medford, Mass.
 A-37 Anaconda Wire & Cable Co., 111 W. Washington St., Chicago, Ill.
 A-38 F. A. D. Andrea, Inc., Jackson, Orchard and Queen Sts., Long Island City, New York.
 A-39 Anylite Electric Co., Fort Wayne, Ind.
 A-40 Arc-Aerial Inc., Green Bay, Wis.
 A-41 Arco Electrical Corp., 207 E. Columbia St., Fort Wayne, Ind.
 A-42 Arcturus Radio Tube Co., 255 Sherman Ave., Newark, N. J.
 A-43 Argon Tube Corp., 102 Livingston, Newark, New Jersey.
 A-44 Argus Radio Corp., 257 W. 17th St., N. Y. C.
 A-45 Armstrong Electric Co., 187 Sylvan Ave., Newark, N. J.
 A-46 Armstrong & White, 9th and Liberty Ave., Pittsburgh, Pa.
 A-47 Arnold Electric Co., Racine, Wis.
 A-48 Aston Cabinet Mfrs., 1223 W. Lake St., Chicago, Ill.
 A-49 Atlantic Electric Lamp Co., Salem, Mass.
 A-50 Atlas Radio Corp., Peabody, Mass.
 A-51 Atwater Kent Mfg. Co., 4700 Wissahickon Ave., Philadelphia, Pa.
 A-52 Auburn Button Wks., Inc., Auburn, N. Y.
 A-53 Audak Co., 565 Fifth Ave., New York City.
 A-54 Audiola Radio Corp., 430 S. Green, Chicago, Ill.
 A-55 The D. L. Auld Co., 5th Ave. and 5th St., Columbus, Ohio.
 A-56 Automatic Radio Corp., 1014 Chamber of Commerce Bldg., Cincinnati, Ohio.

- A-57 Automobile Radio Corp., 1475 E. Grand Blvd., Detroit, Mich.
 A-58 American Battery Corp., 2053 N. Racine Ave., Chicago, Ill.
 A-60 American Apparatus Co., Richmond, Ind.
 A-61 American Storage Battery Co., 128 Dartmouth, Boston, Mass.
 A-62 American Piezo Supply Co., 1101 Huron Bldg., Kansas City, Mo.
 A-63 Amperite Corp., 561 Broadway, New York City.
 B-1 Bailey-Cole Electrical Co., 1341 Flatbush Ave., Brooklyn, N. Y.
 B-2 Baldor Radio Corp., 80 4th Ave., N. Y. C.
 B-3 Nathaniel Baldwin, Inc., 3474 S. 23rd St., E., Salt Lake City, Utah.
 B-4 Balkeite Radio Co., North Chicago, Ill.
 B-5 Barkelew Electric Mfg. Co., Middletown, Ohio.
 B-6 The Wallace Barnes Co., Box 506, Bristol, Conn.
 B-7 Bassett Metal Goods Co., Derby, Conn.
 B-8 Bastian Bros. Co., 1600 Clinton Ave. N., Rochester, N. Y.
 B-9 Batteryless Radio Corp., 116 W. 65th St., New York City.
 B-10 Beaver Manufacturing Co., 625 N. 3rd St., Newark, N. J.
 B-11 Belden Mfg. Co., 2300 S. Western Ave., Chicago, Ill.
 B-12 Benjamin Electric Mfg. Co., 128 S. Sangamon St., Chicago, Ill.
 B-13 Benwood-Linze Co., 19th and Washington Ave., St. Louis, Mo.
 B-14 Best Mfg. Co., 1200 Grove St., Irvington, N. J.
 B-15 Birnbach Radio Co., 254 W. 31st St., N. Y. C.
 B-16 Bisby Mfg. Co., 59 Warren, New York City.
 B-17 Bodine Electric Co., 2254 W. Ohio St., Chicago, Ill.
 B-18 Bond Electric Corp., Jersey City, N. J.
 B-19 Bosworth Electric Mfg. Co., Main and Lexington Ave., Norwood, Cincinnati, Ohio.
 B-20 L. S. Brach Mfg. Corp., 127 Sussex Ave., Newark, N. J.
 B-21 The Brandes Corp., 200 Mt. Pleasant Ave., Newark, N. J.
 B-22 Braun Co., W. C., 551 Randolph, Chicago, Ill.
 B-23 Bremer-Tully Mfg. Co., 656 Washington Blvd., Chicago, Ill.
 B-24 Brooklyn Metal Stamping Corp., 718 Atlantic Ave., Brooklyn, N. Y.
 B-25 Brook Electrical Supply Co., 213 S. Peoria, Chicago, Ill.
 B-26 Browne & Caine, Inc., 2317 Calumet Ave., Chicago, Ill.
 B-27 Browning-Drake Corp., 110 Brockline St., Cambridge, Mass.
 B-28 Bruno Radio Co., 40 Paynter Ave., Long Island City, N. Y.
 B-29 Brunswick-Balke-Collender Co., 623 S. Wabash Ave., Chicago, Ill.
 B-30 Buckeye Electric Mfrs., Gladwin, Mich.
 B-31 The Buckingham Radio Corp., 440 W. Superior St., Chicago, Ill.
 B-32 Bud Radio, Inc., 2744 No. Cedar, Cleveland, O.
 B-34 Burgess Battery Co., Harris Trust Bldg., Chicago, Ill.
 B-35 Bush & Lane Piano Co., Holland, Mich.
 B-36 Boudette Mfg. Co., 67 Crescent Ave., Chelsea, Mass.
 B-37 Bright Star Battery Co., Hoboken, N. J.
 B-38 Borden Electric Co., 480 Broad, Newark, N. J.
 B-39 Bernard Electrical Mfg. Co., 36 Flatbush Ave., Brooklyn, N. Y.
 B-40 Broadcaster's Service Bureau, San Jose, Cal.
 B-41 Baritone Mfg. Co., 844 W. Jackson, Chicago.
 C-1 Cable Radio Tube Corp., 84 N. Ninth St., Brooklyn, N. Y.
 C-2 Candy & Co., Inc., 2515 W. 35th St., Chicago.
 C-3 Cannon & Miller Co., Inc., Springwater, N. Y.
 C-4 Capehart Automatic Phonograph Corp., Fort Wayne, Ind.
 C-5 Carborundum Co., Niagara Falls, N. Y.
 C-6 Cardwell Mfg. Corp., 81 Prospect St., Brooklyn, New York.
 C-7 Carter Radio Co., 407 S. Aberdeen St., Chicago, Ill.
 C-8 The Caswell-Runyan Co., Huntington, Ind.
 C-9 CeCo Mfg. Co., Inc., 702 Eddy St., Providence, Rhode Island.
 C-10 Central Radio Corp., Beloit, Wis.
 C-11 Central Radio Labs., 16 Keefe Ave., Milwaukee, Wis.
 C-12 Champion Radio Works, Inc., 140 Pine St., Danvers, Mass.

Items

- ADAPTERS, Tube**
 A-17, C-7, C-33, F-21, G-9, I-1, I-4, L-10, P-1, R-11, R-17, S-22, W-25.
- AERIAL EQUIPMENT, Leads, Lightning Arresters, Loops, Mastarms, Plugs, Poles**
 A-15, A-28, A-30, A-33, A-40, A-46, B-7, B-11, B-16, B-17, B-20, B-32, C-7, C-15, C-16, C-30, D-8, E-1, E-20, F-11, F-14, G-1, G-9, G-21, G-25, H-7, H-13, H-24, I-4, K-12, L-9, M-5, M-14, M-17, N-5, R-12, R-21, R-23, S-11, S-14, S-28, S-42, T-9, T-17, T-18, U-6, W-13, W-19, Y-1.
- AERIAL INSULATORS**
 A-12, A-15, A-16, A-27, A-29, B-5, B-20, C-27, C-29, D-14, F-13, F-15, G-9, H-6, H-13, I-1, I-3, I-4, J-3, J-6, K-13, L-9, M-8, M-10, P-8, P-18, P-23, S-27, S-42, T-15, U-4 U-5, W-5.
- ALUMINUM, Sheet, rod & tube**
 A-23.
- AMPLIFIERS, Audio**
 A-1, A-41, B-21, C-19, F-2, G-7, G-19, H-18, K-2, L-10, M-4, M-15, O-4, P-1, P-20, R-3, S-1, S-5, S-16, S-21, S-31, T-7, W-8.
- BATTERIES, Dry**
 B-1, B-18, B-34, B-37, D-7, F-18, G-4, N-2, S-44.
- BATTERIES, Storage**
 A-58, B-30, E-12, G-18, G-27, P-7, S-44, U-15, W-15.
- BATTERY CHARGERS**
 A-19, A-41, A-42, A-58, C-19, D-16, E-11, E-12, E-15, E-24, G-6, G-13, G-15, K-15, K-19, K-21, N-3, P-7, S-17, S-45, S-47, T-12, U-16, W-24.
- BATTERY CHARGING RELAYS**
 A-19, A-41, B-20, C-7, C-37, C-40, E-12, E-25, G-1, H-6, H-13, L-11, R-26, T-5, U-5, W-8, Y-2.
- BATTERY ELIMINATORS (For Plate Current Supply)**
 A-19, A-40, A-60, A-61, B-13, B-18, B-21, B-39, C-33, C-39, D-5, E-10, E-12, E-15, E-25, F-2, F-16, F-23, G-7, G-22, K-15, K-16, K-19, K-20, K-21, M-19, N-3, P-1, P-7, P-20, P-22, P-29, R-12, S-1, S-8, S-15, S-17, S-35, S-47, T-9, T-13, W-2, W-7, W-15.
- BATTERY POWER UNITS, Combination**
 A-38, A-41, A-61, C-41, D-13, D-16, E-11, E-12, G-7, G-13, G-18, G-23, H-7, K-10, K-19, P-7, R-8, S-15, S-17, S-46, S-47, T-10, V-6, W-15, W-24.
- BINDING POSTS**
 A-3, A-15, A-23, A-52, B-6, B-20, B-28, C-16, E-4, E-10, F-1, F-7, G-9, I-4, P-13, R-14, S-22, W-5, X-1.
- BRACKETS, Sub Panel**
 A-13, B-12, E-10, F-21, I-4, K-2, S-15, S-22.
- BROADCASTING EQUIPMENT**
 B-40, F-21, G-6, G-9, G-20, K-3, R-13, S-1, T-7.
- CABINETS**
 A-9, A-48, A-55, B-21, B-29, B-31, B-35, C-8, C-14, C-21, D-17, E-3, E-17, E-21, E-22, F-5, F-9, H-2, H-20, K-14, L-6, L-7, G-24, M-9, P-12, P-15, P-17, R-5, R-6, R-10, R-18, S-13, S-19, S-26, S-28, S-30, S-33, S-34, S-38, U-1, U-9, W-4, W-6, W-23.

CABLE, CABLES AND CONNECTING WIRE

A-7, A-37, B-11, B-15, C-19, C-30, C-31, G-17, H-17, I-4, K-3, N-9, P-2, R-25, S-15, Y-2.

CLAMPS, Ground

A-59, B-6, B-11, B-20, B-38, C-37, C-38, E-1, E-7, F-1, F-21, F-22, G-28, H-6, H-13, I-4, M-14, M-17, R-23, T-22.

CLIPS

A-15, A-17, B-6, F-1, K-15, L-10, M-14, M-17, P-8, W-5, W-8.

COILS, A-F Choke

A-4, A-7, A-41, B-20, C-7, C-13, D-11, D-15, E-2, E-15, F-4, F-6, G-3, G-5, G-7, G-9, G-10, G-19, H-1, I-2, K-9, M-17, N-3, P-13, P-16, P-22, P-24, R-3, R-19, R-20, S-1, S-4, S-15, S-17, T-13, W-8.

COILS, R-F Choke

A-4, A-13, C-6, E-10, G-9, G-19, H-3, H-5, K-2, M-17, N-3, P-24, R-3, R-20, S-1, S-15, S-22, T-24.

COILS, R-F

A-4, A-5, A-6, A-13, B-12, B-15, B-17, B-23, B-28, B-30, C-10, C-19, D-1, D-15, E-10, G-3, G-5, G-9, G-19, H-3, H-4, H-5, K-2, K-9, M-4, N-3, P-1, P-13, P-21, P-24, R-14, R-19, R-20, S-1, S-5, S-15, S-22, T-21, T-24, V-2, V-5, W-8.

COIL WINDING MACHINES

B-11, H-1, M-14.

CONDENSERS, Fixed Mica

A-14, A-34, C-7, C-33, D-14, E-8, E-10, F-21, K-2, M-17, P-13, P-16, P-19, S-2, W-17, X-1.

CONDENSERS, Fixed Paper

A-7, A-14, B-26, C-7, C-28, C-30, D-1, D-14, E-8, F-3, F-6, F-12, G-9, I-2, K-3, K-15, L-10, M-17, N-3, P-13, P-16, P-19, P-20, R-4, S-2, S-15, S-23, W-17.

CONDENSERS, Electrolytic

A-14, A-36, C-33, D-14, E-15, P-13, P-19, P-22, S-17.

CONDENSERS, Variable

A-13, A-17, C-6, C-33, D-4, E-10, G-1, G-3, G-7, G-9, G-19, H-3, K-2, M-17, N-3, P-1, P-8, P-13, P-21, P-24, R-7, R-14, S-1, S-15, S-28, U-11.

CONDENSER SHAFTS AND COUPLINGS

H-3, P-21.

CRYSTALS, PIEZOELECTRIC

A-62, R-28.

DIALS

A-17, A-26, A-52, B-24, B-28, C-33, C-34, D-4, E-10, G-9, G-19, H-3, I-1, I-4, K-2, K-17, M-5, N-3, N-13, P-1, P-8, P-13, P-14, P-21, P-24, R-2, R-14, S-15, S-22, T-21, W-5, Y-2.

DIAL LIGHTS

B-10, M-5, N-2, P-24, Y-2.

FIBRE, Vulcanized sheet, rod & tube

C-24, I-4, N-6, S-21.

FILAMENT BALLASTS

A-6, B-20, D-1, L-10, M-17, P-13, P-16, R-2.

GRID LEAKS, Fixed

A-14, A-21, C-5, C-16, E-8, I-5, L-10, M-10, M-17, P-1, P-8, P-16, S-48.

GRID LEAKS, Variable

A-21, A-34, C-11, C-16, C-36, E-8, M-17, R-9.

GRID LEAK HOLDERS (See MOUNTINGS, Resistor)**HEADSETS**

A-15, A-31, B-3, B-21, C-3, C-16, F-21, G-20, P-1, P-8, T-12.

INSULATION, Composition

A-7, A-17, B-31, C-2, C-24, F-15, G-8, I-4, K-17, L-9, M-11, N-6, P-14, S-7, S-22.

INSULATORS (See AERIAL INSULATORS)

C-13 Chicago Transformer Corp., 4541 Ravenswood Ave., Chicago, Ill.
 C-14 Chillicothe Furniture Co., 1 Cherry St., Chillicothe, Mo.
 C-15 Circle F. Mfg. Co., Trenton, N. J.
 C-16 Clarostat Mfg. Co., Inc., 285 N. Sixth St., Brooklyn, N. Y.
 C-17 Colonial Radio Corp., 25 Wilbur Ave., Long Island City, N. Y.
 C-18 Columbia Phonograph Co., Inc., 1819 Broadway, New York City.
 C-19 Columbia Radio Corp., 711 W. Lake St., Chicago, Ill.
 C-21 The Conner Furniture Co., 5th and Oak St., New Albany, Ind.
 C-22 Consolidated Elec. Lamp Co., 88 Holten, Danvers, Mass.
 C-23 Consolidated Vacuum Tube Corp., 222 Washington, Hoboken, N. J.
 C-24 Continental-Diamond Fibre Co., 1150 W. 3rd St., Cleveland, Ohio.
 C-25 Continental Electric and Mfg. Co., 1890 East Fortieth, Cleveland, Ohio.
 C-26 Continental Radio Corp., Fort Wayne, Ind.
 C-27 Cook Porcelain Ins. Corp., Cambridge, Ohio.
 C-28 Cornell Elec. Mfg. Co., Rawson St. and Anable Ave., Long Island City, N. Y.
 C-29 Corning Glass Wks., Corning, N. Y.
 C-30 Cornish Wire Co., Inc., 30 Church St., N. Y. C.
 C-31 Crescent Braid Co., Providence, R. I.
 C-32 Cresradio Corp., 166 Jamaica Ave., Jamaica, New York.
 C-33 Crosley Radio Corp., 3401 Colerain Ave., Cincinnati, Ohio.
 C-34 Crowe Name Plate & Mfg. Co., 1749 Grace St., Chicago, Ill.
 C-35 E. T. Cunningham, Inc., 370 Seventh Ave., New York City.
 C-36 The Cutler-Hammer Mfg. Co., 12th and St. Paul Ave., Milwaukee, Wis.
 C-37 Connecticut Electric Mfg. Co., Bridgeport, Conn.
 C-38 Crouse-Hind Co., Syracuse, N. Y.
 C-39 Cole Sales Co., 36 Pearl, Hartford, Conn.
 C-40 Connecticut Telephone & Electric Co., Meriden, Conn.
 C-41 Cooper Corp., 8th and Main Sts., Cincinnati, O.
 D-1 Daven Corp., 158 Summit St., Newark, N. J.
 D-2 Day-Fan Electric Co., 1320 Wisconsin Blvd., Dayton, Ohio.
 D-3 De Forest Radio Co., Central and Franklin Sts., Jersey City, N. J.
 D-4 Dejour-Amsco Corp., 418 Broome St., N. Y. C.
 D-5 Demco Products Co., 1521 Market St., Wheeling, W. Va.
 D-6 Diamond Appliance Co., South Bend, Ind.
 D-7 Diamond Electric Corp., 780 Frelinghuysen Ave., Newark, N. J.
 D-9 Diamond Vacuum Products Co., 4049 Diversey Ave., Chicago, Ill.
 D-10 Diehl Mfg. Co., Elizabethport, N. J.
 D-11 Dongan Electric Mfg. Co., 3001 Franklin St., Detroit, Mich.
 D-12 Donle-Bristol Corp., Meriden, Conn.
 D-13 Dooley Rectifier Co., Wheeling, W. Va.
 D-14 Dubilier Condenser Corp., 10 E. 43rd St., N.Y.C.
 D-15 Dudlo Mfg. Co., Fort Wayne, Ind.
 D-16 D. A. Radio Co., 30 Hollister St., Buffalo, N. Y.
 D-17 Davis Industries, Inc., 314 W. 43rd St., Chicago, Ill.
 D-18 Duovac Radio Tube Corp., 360 Furman, Brooklyn, N. Y.
 E-1 Eagle Electric Mfg. Co., 59 Hall St., Brooklyn, N. Y.
 E-2 Easton Coil Co., P. O. Box 237, Easton, Pa.
 E-3 Ebert Furniture Co., Red Lion, Pa.
 E-4 The H. H. Eby Mfg. Co., Inc., 4710 Stenton Ave., Philadelphia, Pa.
 E-5 Thomas A. Edison, Inc., West Orange, N. J.
 E-7 The Ekko Co., 111 W. Monroe St., Chicago, Ill.
 E-8 Electrad, Inc., 175 Varick St., New York City.
 E-9 Electrical Products Mfg. Co., Providence, R. I.
 E-10 Electrical Research Labs., Inc., 1731 W. 22nd St., Chicago, Ill.
 E-11 Electric Autolite Co., Toledo, Ohio.
 E-12 Electric Storage Battery Co., Philadelphia, Pa.
 E-13 Electron Relay Co., 83 Fourth Ave., N. Y. C.
 E-14 Elgin Cabinet Corp., Union and W. Chicago Sts., Elgin, Ill.
 E-15 Elkon, Inc., 200 Fox Island Road, Port Chester, New York.
 E-16 Emerson Radio & Phonograph Corp., 635 Sixth Ave., New York City.
 E-17 The Empire, Ltd., 11th and Harrison, Rockford, Ill.
 E-18 Empire Steel Corp., Mansfield, Ohio.
 E-20 Essenebe Radio Devices Co., 2016 W. Lake St., Chicago, Ill.
 E-21 Eureka Talking Machine Corp., 5939 S. Lowe Ave., Chicago, Ill.
 E-22 Excello Products Corp., 4820 W. 16th St., Cicero, Ill.
 E-23 Electrical Specialty Co., 25 South St., Stamford, Conn.
 E-24 Electric Heat Control Co., 5902 Carnegie Ave., Cleveland, Ohio.
 E-25 C. A. Earl, 122 E. 42nd St., New York City.

F-1 Fahnstock Electric Co., East Ave. and 8th St., Long Island City, N. Y.
 F-2 Farrand Mfg. Co., Inc., Metropolitan Bldg., Long Island City, N. Y.
 F-3 John E. Fast & Co., 3982 Barry Ave., Chicago, Ill.
 F-4 Federal Radio Corp., 1738 Elmwood Ave., Buffalo, N. Y.
 F-5 Federal Wood Products Corp., 206 Lexington Ave., New York City.
 F-6 Ferranti, Inc., 130 W. 42nd St., New York City.
 F-7 Fibroc Insulation Co., Valparaiso, Ind.
 F-8 Fidelity Radio Corp., Walker Bank Bldg., Salt Lake City, Utah.
 F-9 Robert Findlay Mfg. Co., Inc., 1027 Metropolitan Ave., Brooklyn, N. Y.
 F-10 Fisch Radio Co., 1283 Hoe Ave., New York City.
 F-11 Fishwick Radio Co., 133 Central Parkway West, Cincinnati, Ohio.
 F-12 A. M. Flechtheim & Co., Inc., 136 Liberty St., New York City.
 F-13 M. M. Fleron & Son, Trenton, N. J.
 F-14 Foote-Pierson & Co., 75 Hudson, Newark, N. J.
 F-15 The Formica Insulation Co., Cincinnati, Ohio.
 F-16 Freed-Eisemann Radio Corp., Junius St. and Liberty Ave., Brooklyn, N. Y.
 F-17 French & Sons Piano Co., Jesse, New Castle, Ind.
 F-18 French Battery Co., Madison, Wis.
 F-20 S. Freshman Co., 225 N. Michigan Ave., Chicago, Ill.
 F-21 Herbert H. Frost, Inc., 1124 W. Beardsley Ave., Elkhart, Ind.
 F-22 Fairmount Electric & Mfg. Co., 59th and Woodland Ave., Philadelphia, Pa.
 F-23 France Mfg. Co., 10325 Berea Rd., Cleveland, Ohio.
 F-24 Fansteel Radio Co., No. Chicago, Ill.
 G-1 Gardiner & Hepburn, Philadelphia, Pa.
 G-2 Gardner Electric Mfg. Co., Oakland, Calif.
 G-3 Gearhart Radio Co., Fresno, Calif.
 G-4 General Dry Batteries, Inc., 13100 Athens Ave., Cleveland, Ohio.
 G-5 General Coil Co., Weymouth, Mass.
 G-6 General Electric Co., Schenectady, N. Y.
 G-7 General Instrument Corp., 225 Varick St., New York City.
 G-8 General Plastics, Inc., Walck Road, North Tonawanda, N. Y.
 G-9 General Radio Co., 30 State St., Cambridge, Mass.
 G-10 General Transformer Corp., 910 W. Jackson Blvd., Chicago, Ill.
 G-11 Gilby Wire Co., 150 Riverside Ave., Newark, New Jersey.
 G-12 Gilfillan Radio Corp., 1815 Venice Blvd., Los Angeles, Calif.
 G-13 Globe Electric Co., 14 Keefe Ave., Milwaukee, Wisconsin.
 G-14 Globe Technoleon Corp., Reading, Mass.
 G-15 Gold Seal Electrical Co., Inc., 250 Park Ave., New York City.
 G-16 The L. S. Gordon Co., 1800 Montrose Ave., Chicago, Ill.
 G-17 Gossard Radio & Wire Co., Belvidere, Ill.
 G-18 Gould Storage Battery Co., 250 Park Ave., New York City.
 G-19 Gray & Danielson Mfg. Co., 260 First St., San Francisco, Calif.
 G-20 Graybar Electric Co., Lexington Ave. and 43rd St., New York City.
 G-21 Gray Products, Inc., Poughkeepsie, N. Y.
 G-22 A. H. Grebe & Co., Inc., 109 W. 57th St., New York City.
 G-23 Grigsby-Grunow Co., 5891 W. Dickens Ave., Chicago, Ill.
 G-24 Gulbransen Co., 3232 W. Chicago Ave., Chicago, Ill.
 G-25 Gustin-Baker Mfg. Co., Kansas City, Mo.
 G-26 Guthrie Co., Elyria, Ohio.
 G-27 General Lead Battery Co., 1 Lister Ave., Newark, N. J.
 G-28 Gillette-Vibber Co., New London, Conn.
 H-1 Halldorson Co., 4500 Ravenswood Ave., Chicago, Ill.
 H-2 Hamilton Mfg. Co., Two Rivers, Wis.
 H-3 Hammarlund Mfg. Co., Inc., 424 W. 33rd St., New York City.
 H-4 Hardwick Hindle, Inc., 215 Emmet St., Newark, N. J.
 H-5 Kenneth Harkness, Inc., 72 Cortlandt, New York City.
 H-6 Hart & Hegemann, Hartford, Conn.
 H-7 Hartford Battery Mfg. Co., 47 W. 63rd St., New York City.
 H-8 Hartford Metal Products Co., Hartford, Conn.
 H-9 Hartman Electrical Mfg. Co., 31 E. 5th St., Mansfield, Ohio.
 H-10 Harvey Hubbell Co., Bridgeport, Conn.
 H-12 Herald Electric Co., 35 East End Ave., New York City.
 H-13 Heinemann Electric Co., Trenton, N. J.
 H-14 Heintz & Kaufman, 219 Natoma St., San Francisco, Calif.
 H-15 Hickok Electrical Instrument Co., 10514 Dupont, Cleveland, Ohio.
 H-16 High Frequency Labs., 28 N. Sheldon St., Chicago, Ill.
 H-17 The Holyoke Co., Inc., 621 Broadway, N. Y. C.
 H-18 Howard Radio Co., South Haven, Mich.
 H-19 Hoyt Electrical Instrument Works, 857 Boylston St., Boston, Mass.

- H-20 H. L. Hubbell, 59 Market Ave., N. W., Grand Rapids, Mich.
- H-21 Hyatt Electric Corp., 836 N. Wells St., Chicago, Ill.
- H-22 Hygrade Lamp Co., 60 Boston, Salem, Mass.
- H-23 Hytron Corp, Salem, Mass.
- H-24 Hope Webbing Co., Providence, R. I.
- I-1 Imperial Molded Products Corp., 2925 W. Harrison St., Chicago, Ill.
- I-2 Igrad Condenser & Mfg. Co., 4322 Lake Ave., Rochester, N. Y.
- I-3 Insulation Mfg. Co., Herkimer & N. Y. Aves., Brooklyn, N. Y.
- I-4 Insuline Corp. of America, 78 Cortlandt St., New York City.
- I-5 International Resistance Co., 2006 Chestnut St., Philadelphia, Pa.
- J-1 Jaeger Research Labs., 280 Park Ave., Weehawken, N. J.
- J-2 Jefferson Electric Co., 1500 S. Laffin St., Chicago, Ill.
- J-3 Jenkins Glass Co., Kokomo, Ind.
- J-4 Jenkins Television Corp., 346 Claremont Ave., Jersey City, N. Y.
- J-5 Jensen Radio Mfg. Co., 6601 S. Laramie Ave., Chicago, Ill.
- J-6 Jewell Electrical Instrument Co., 1640 Walnut St., Chicago, Ill.
- J-7 Howard B. Jones, 2300 Wabansia Ave., Chicago, Ill.
- J-8 Jones-Motrola Sales Co., 370 Gerard Ave., New York City.
- K-1 F. Kallus Mfg. Co., 104 Court St., Hoboken, N. J.
- K-2 Karas Electric Co., 4040 N. Rockwell St., Chicago, Ill.
- K-3 Kellogg Switchboard & Supply Co., 1066 W. Adams St., Chicago, Ill.
- K-4 Kendrick & Davis Co., Lebanon, N. H.
- K-5 Colin B. Kennedy Corp., 212 W. Ewing Ave., South Bend, Ind.
- K-6 The Ken-Rad Corp., Owensboro, Ky.
- K-7 Kersten Radio Equipment, Inc., 1415 Fulford St., Kalamazoo, Mich.
- K-8 Kester Solder Co., 4201 Wrightwood Ave., Chicago, Ill.
- K-9 Keystone Radio Labs., Inc., 129 N. Jefferson St., Chicago, Ill.
- K-10 Kimley Electric Co., 2665 Main St., Buffalo, N. Y.
- K-11 King Mfg. Corp., 254 Rano St., Buffalo, N. Y.
- K-12 Kirkman Engineering Corp., 1 Dominick, New York City.
- K-13 Knox Porcelain Corp., Knoxville, Tenn.
- K-14 The Knoxville Table & Chair Co., P. O. Box 1087, Knoxville, Tenn.
- K-15 The Kodel Electric & Mfg. Co., 507 E. Pearl St., Cincinnati, Ohio.
- K-16 Kolster Radio Corp., 200 Mt. Pleasant Ave., Newark, N. J.
- K-17 The Kurz Kasch Co., 1415 S. Broadway, Dayton, Ohio
- K-18 Kwik Test Radio Labs., 4464 Cass Ave., Detroit, Mich.
- K-19 Kato Co., 727 So. Front, Mankato, Minn.
- K-20 Knapp Electric, Inc., Port Chester, N. Y.
- K-21 King Electric Mfg. Co., 1681 Filmore Ave., Buffalo, N. Y.
- K-22 K. & H. Electric Corp., 68 Springfield Ave., Newark, N. J.
- L-1 Langbein-Kaufman Radio Co., 62 Franklin, New Haven, Conn.
- L-2 La Salle Radio Corp., 143 W. Austin Ave., Chicago, Ill.
- L-3 C. R. Leutz, Inc., 195 Park Place, Long Island City, N. Y.
- L-4 Liberty Electric Corp., of New York, 342 Madison Ave., New York City.
- L-5 Liberty Radio Corp., 123 N. Sangamon, Chicago, Ill.
- L-6 The Logan Mfg. Co., 338 E. Front St., Logan, Ohio.
- L-7 I. A. Lund Corp., 1018 S. Wabash Ave., Chicago, Ill.
- L-8 Lundquist Tool & Mfg. Co., Worcester, Mass.
- L-9 Luzerne Rubber Co., Muirhead Ave., Trenton, New Jersey.
- L-10 Lynch Mfg. Co., Inc., 1775 Broadway, New York City.
- L-11 Liberty Bell Mfg. Co., Minerva, Ohio
- L-12 Lincoln Radio Corp., 329 So. Wood St., Chicago, Ill.
- M-1 Magnatron Corp., 406 Jefferson, Hoboken, N. J.
- M-2 The Magnavox Co., 1315 S. Michigan Ave., Chicago, Ill.
- M-3 Markel Electric Products, Inc., 145 E. Seneca St., Buffalo, N. Y.
- M-4 Radio Corp., 18th and Springdale Ave., East Orange, N. J.
- M-5 Martin-Copeland Co., Providence, R. I.
- M-6 Marvin Radio Tube Corp., Irvington, N. J.
- M-7 Master Engineering Co., 122 So. Michigan Ave., Chicago, Ill.
- M-8 McKee Glass Co., Jeannette, Pa.
- M-9 McMillan Radio Corp., 1421 S. Michigan Ave., Chicago, Ill.
- M-10 Micamold Radio Corp., 1087 Flushing Ave., Brooklyn N. Y.
- M-11 Micarta Fabricators, Ind., 500 S. Peoria St., Chicago, Ill.
- M-12 Midwest Radio Corp., 410 E. 8th St., Cincinnati, Ohio.
- M-13 Minerva Radio Co., 154 E. Erie St., Chicago, Ill.
- M-14 Morris Register Co., Council Bluffs, Iowa.
- M-15 C. E. Mountford, 105 Sixth Ave., N. Y. C.
- M-16 Munder Electrical Co., 97 Orleans, Springfield, Mass.
- M-17 Leslie F. Muter Co., 8440 S. Chicago Ave., Chicago, Ill.
- M-18 Mutual Phone Parts Mfg. Corp., 610 Broadway, New York City.
- M-19 Modern Electric Mfg. Co., 312 Mulberry, Toledo, Ohio.
- M-20 Murdock, Wm. J., Chelsea, Mass.
- N-1 Nassau Radio Co., 60 Court St., Brooklyn, N. Y.
- N-2 National Carbon Co., Inc., 30 E. 42nd St., New York City.
- N-3 National Co., Inc., 61 Sherman St., Malden, Mass.
- N-4 National Electrical Products Co., 10 E. Kinzie St., Chicago, Ill.
- N-5 National Electric Specialty Co., 314 N. St. Clair, Toledo, Ohio.
- N-6 National Vulcanized Fibre Co., Maryland Ave. and Beech St., Wilmington, Del.
- N-7 Neonlite Corp. of America, 500 Chancellor Ave., Irvington, N. J.
- N-8 Neutrowound Radio Mfg. Co., 3409 W. Madison St., Chicago, Ill.
- N-9 New England Electrical Works, Lisbon, N. H.
- N-11 Northern Mfg. Co., 371 Ogden St., Newark, N. J.
- N-12 The Northwestern Cooperage & Lbr. Co., Gladstone, Mich.
- N-13 Norton Labs., Lockport, N. Y.
- N-14 National Radio Tube Co., 3420 18th St., San Francisco, Calif.
- O-1 Old Masters Paper & Pulp Corp., 154 Nassau St., New York City.
- O-2 O'Neil Mfg. Corp., 715 Palisade Ave., West New York, N. J.
- O-3 Operadio Mfg. Co., St. Charles, Ill.
- O-4 Oxford Radio Corp., 3200 Carroll Ave., Chicago, Ill.
- P-1 Pacent Electric Co., Inc., 91 7th Ave., N. Y. C.
- P-2 Packard Electric Co., Warren, Ohio.
- P-4 R. M. Feffer, Harrisburg, Pa.
- P-5 Perryman Electric Co., 33 W. 60th St., N. Y. C.
- P-6 Pfanstiehl Radio Co., 10 E. Kinzie, Chicago, Ill.
- P-7 Philadelphia Storage Battery Co., Ontario and C Sts., Philadelphia, Pa.
- P-8 Philmore Mfg. Co., 106 7th Ave., N. Y. C.
- P-9 Phono-Link Co., 490 Broome, N. Y. C.
- P-10 Phonomotor Co., 121 West Ave., Rochester, N. Y.
- P-11 Pierce-Airo, Inc., 119 Fourth Ave., N. Y. C.
- P-12 The Pierson Co., Cedar and Pleasant Sts., Rockford, Ill.
- P-13 Pilot Electric Mfg. Co., 323 Berry St., Brooklyn, N. Y.
- P-14 Pioneer Radio Corp., Plano, Ill.
- P-15 Platter Cabinet Co., Madison Ave., North Vernon, Ind.
- P-16 Polymet Mfg. Corp., 829 E. 134th St., N. Y. C.
- P-17 The Pooley Co., 1600 Indiana Ave., Philadelphia, Pa.
- P-18 Porcelain Products., Inc., Findlay, Ohio.
- P-19 The Potter Co., 1950 Sheridan Rd., North Chicago, Ill.
- P-20 Powrad, Inc., 121 Ingraham Ave., Brooklyn, N. Y.
- P-21 Precise Products, Inc., 254 Mill St., Rochester, N. Y.
- P-22 Precision Mfg. Co., 1020 Santa Fe Ave., Los Angeles, Calif.
- P-23 Premax Products, Inc., Niagara Falls, N. Y.
- P-24 Premier Electric Co., Grace and Ravenswood Aves., Chicago, Ill.
- P-25 Premier Radio Corp., Defiance, Ohio.
- P-26 Presto Machine Products Co., Inc., 70 Washington St., Brooklyn, N. Y.
- P-27 Prime Mfg. Co., 653 Clinton, Milwaukee, Wis.
- P-28 M. Propp Co., 524 Broadway, New York City
- P-29 Harold J. Power, 5 High St., Medford Hillside, Mass.
- Q-1 QRS-DeVry Corp., 1111 Center St., Chicago, Ill.
- Q-2 Quam Radio Products Co., 9705 Cottage Grove Ave., Chicago, Ill.
- Q-3 Quinn Tube, 1890 E. 40th, Cleveland, Ohio.
- R-1 Racon Electric Co., Inc., 18 Washington Place, New York City.
- R-2 Radiall Co., 50 Franklin St., N. Y. C.
- R-3 Radiart Labs., Inc., 13229 Shaw Ave., East Cleveland, Ohio.
- R-4 Radio Appliance Corp., Springfield, Mass.
- R-5 Radio Cabinet Co., 818 Butterworth St., Grand Rapids, Mich.
- R-6 Radio Cabinet Co., Seminary St., Rockford, Ill.
- R-7 Radio Condenser Co., Thorne and Copewood Sts., Camden, N. J.
- R-8 Radio Corp. of America, 233 Broadway, New York City.
- R-9 Radio Foundation, Inc., 1 Park Place, New York City.
- R-10 Radio Master Corp., Bay City, Mich.
- R-11 The Radio Products Co., Fifth and Norwood Sts., Dayton, Ohio.
- R-12 Radio Receptor Co., 106 7th Ave., N. Y. C.
- INTERFERENCE ELIMINATORS**
A-14.
- JACKS**
A-3, A-17, B-6, B-24, B-32, C-7, D-4, E-4, E-8, F-21, G-9, K-3, P-1, P-8, P-24, S-22, Y-2.
- KEYS, SOUNDERS AND BUZZERS**
K-3, S-14, S-22, T-23, V-7.
- LOUDSPEAKERS**
A-3, A-15, A-18, A-19, A-24, A-31, A-35, A-38, A-39, A-51, A-55, B-3, B-14, B-21, B-23, B-29, B-30, B-36, B-41, C-3, C-27, C-33, E-15, F-2, F-4, F-8, F-16, G-20, G-23, H-12, I-5, K-5, K-7, M-2, M-17, N-2, O-2, O-3, O-4, P-1, P-7, P-15, P-17, P-26, Q-2, R-1, R-8, R-9, R-13, R-22, S-16, S-19, S-24, S-29, S-31, S-32, S-35, T-4, T-12, T-19, U-3, U-9, U-10, U-12, U-14, V-2, W-14, W-21, W-23.
- LUGS, Soldering**
A-17, B-5, H-14, K-3, L-5, W-5.
- MARKERS, Metal Cable**
C-34, W-5, Y-2.
- METERS, Ammeters & Voltmeters**
D-11, G-6, H-15, H-19, J-6, R-11, R-17, S-29, S-40, W-11, W-12.
- MOTORS, Phonograph**
A-22, A-47, B-17, B-29, D-10, G-6, G-16, J-8, K-4, L-4, P-1, P-10, P-27, S-14, S-19, S-31, S-36, U-7.
- MOUNTINGS, Resistor**
A-14, C-16, D-4, K-3, L-10, M-15, M-17, P-16.
- OUTLETS, Convenience Wall**
B-10, B-32, C-7, F-21, H-10, Y-2.
- PANELS, Composition**
A-26, F-7, F-13, F-15, F-21, I-4, L-9, N-10, P-15, P-22, R-14, W-11.
- PANELS, Metal**
A-23, A-55, B-8, B-30, C-10, C-24, C-33, C-34, P-13, R-14, S-29, U-5, V-3.
- PICK-UPS, Phonograph**
A-17, A-22, A-24, A-25, A-35, A-36, A-51, A-53, B-21, B-31, C-3, C-20, C-33, E-9, E-10, G-14, M-18, P-1, P-9, R-3, S-14, S-31, S-35, S-36, S-41, T-11, T-19, U-2, U-7, W-8.
- PLATES, Name**
A-15, A-55, B-6, C-7, C-34.
- PLUGS, Phone & Multiple Connector**
B-10, B-20, B-36, C-7, D-4, G-9, F-21, H-10, M-5, M-17, P-16, S-22, W-12, Y-2.
- REACTIVATORS, Tube**
A-42, I-5, J-2, S-29.
- RECTIFIER UNITS**
A-1, A-41, A-42, B-4, D-5, E-15, F-2, G-7, G-23, K-15, K-16, K-20, N-2, P-7, S-8, S-15, S-16, T-12, W-8.
- RECEIVING SETS**
A-2, A-5, A-11, A-19, A-24, A-34, A-36, A-38, A-51, A-54, A-56, A-57, B-2, B-4, B-9, B-19, B-21, B-23, B-25, B-27, B-29, B-30, B-31, B-35, C-17, C-18, C-19, C-26, C-33, D-2, D-5, D-17, E-5, E-9, E-10, E-16, E-25, F-4, F-16, F-17, F-24, G-12, G-19, G-20, G-22, G-23, G-24, G-26, H-5, H-9, H-18, K-3, K-5, K-9, K-11, K-16, L-1, L-3, L-5, M-4, M-9, M-12, M-13, M-17, M-20, N-1, N-2, N-3, N-4, N-8, O-3, P-1, P-7, P-8, P-11, P-12, P-13, P-14, P-24, P-25, Q-1, R-8, R-11, R-13, R-24, S-8, S-9, S-10, S-11, S-12, S-13, S-14, S-15, S-16, S-19, S-20, S-26, S-28, S-29, S-32, S-34, S-35, T-4, F-6, T-8, T-14, T-20, U-9, U-11, U-12, V-1, W-1, W-3, W-4, W-9, W-14, W-20, W-22, W-25, Z-1.
- RECEIVING SET KITS OR CHASSIS**
A-13, B-27, G-19, G-22, H-3, H-5, H-16, K-2, L-3, L-12, N-3, P-13, P-24, R-20, S-9, S-15, S-49, T-21, V-5.

- R-13 Radio-Victor Corp. of America, 233 Broadway, New York City.
- R-14 Ranger Coil Co., W. Davenport, N. Y.
- R-16 R. B. M. Mfg. Co., Logansport, Ind.
- R-17 Readrite Meter Works, 15 College Ave., Bluffton, Ohio.
- R-18 Red Lion Cabinet Co., Red Lion, Pa.
- R-19 A. E. Rittenhouse Co., Honeyoe Falls, N. Y.
- R-20 Robertson-Davis Co., 361 W. Superior St., Chicago, Ill.
- R-21 Rodale Mfg. Co., 200 Hudson, N. Y. C.
- R-22 The Roila Co., 4250 Hollis St., Oakland, Calif.
- R-23 Rosenbeck & Sons, Torrington, Conn.
- R-24 Roth-Downs Mfg. Co., 2512 University Ave., St. Paul, Minn.
- R-25 Runzel-Lenz Electric Mfg. Co., 1751 N. Weston Ave., Chicago, Ill.
- R-26 Reliable Parts Mfg. Co., Wellington, Ohio.
- R-27 Rival Radio & Battery Co., 180 E. 123rd St., New York City.
- R-28 J. T. Rooney, 4 Calumet Bldg., Buffalo, N. Y.
- R-29 Radio Engineering Labs., 100 Wilbur Ave., Long Island City, N. Y.
- S-1 Samson Electric Co., 227 Washington St., Canton, Mass.
- S-2 Sangamo Electric Co., Springfield, Ill.
- S-3 Saturn Mfg. & Sales Co., 48 Beekman St., New York City.
- S-4 Scanlon Electric Mfg. Co., 1113 N. Franklin St., Chicago, Ill.
- S-5 Scott Transformer Co., 7620 E. Lake Terrace, Chicago, Ill.
- S-6 Scovill Mfg. Co., 99 Mill St., Waterbury, Conn.
- S-7 Scranton Button Co., Scranton, Pa.
- S-8 Sentinel Mfg. Co., 9705 Cottage Grove Ave., Chicago, Ill.
- S-9 Shamrock Mfg. Co., 196 Waverly Ave., Newark, N. J.
- S-10 Shelby Co., 10 Prince, Trenton, N. J.
- S-11 Shinn Mfg. Co., N. Racine Ave., Chicago, Ill.
- S-12 Shortwave & Television Lab., 104 Brooklyn Ave., Boston, Mass.
- S-13 Showers Brothers Co., 10th and Morton Sts., Bloomington, Ind.
- S-14 Signal Electric Mfg. Co., Menominee, Mich.
- S-15 Silver-Marshall, Inc., 6401 W. 65th St., Chicago, Ill.
- S-16 Simplex Radio Co., Sandusky, Ohio.
- S-17 B. H. Smith, Danbury, Conn.
- S-18 Sonatron Tube Co., 108 W. Lake St., Chicago, Ill.
- S-19 Sonora Phonograph Co., Inc., 50 West 57th St., New York City.
- S-20 The Sparks-Withington Co., Jackson, Mich.
- S-21 Spaulding Fibre Co., Inc., 484 Broome St., New York City.
- S-22 Specialty Insulation Mfg. Co., Hoosick Falls, N. Y.
- S-23 Sprague Specialties Co., 1511 Hancock St., Quincy, Mass.
- S-24 Standard Radio Corp., 41 Jackson St., Worcester, Mass.
- S-25 Standard Transformer Co., Warren, Ohio.
- S-26 The Starr Piano Co., S. 1st and A, B, C and D Sts., Richmond, Ind.
- S-27 Starr Porcelain Co., Trenton, N. J.
- S-28 Steinite Radio Co., 506 S. Wabash Ave., Chicago, Ill.
- S-29 The Sterling Mfg. Co., 2831 Prospect Ave., Cleveland, Ohio.
- S-30 Stettner Phonograph Corp., 310 E. 75th St., New York City.
- S-31 Stevens Mfg. Corp., 46 Spring St., Newark, N. J.
- S-32 Stewart-Warner Speedometer Corp., 1826 Diversey Parkway, Chicago, Ill.
- S-33 St. Johns Table Co., Cadillac, Mich.
- S-34 Story & Clark Piano Co., 173 No. Michigan Ave., Chicago, Ill.
- S-35 Stromberg-Carlson Tel. Mfg. Co., Rochester, N. Y.
- S-36 Studner Bros., 67 W. 44th St., N. Y. C.
- S-37 Sunlight Lamp Co., 76 Coit, Irvington, N. J.
- S-38 Superior Cabinet Corp., 206 Broadway, N. Y. C.
- S-39 Supertron Mfg. Co., Hoboken, N. J.
- S-40 Supreme Instruments Corp., Bright Bldg., Greenwood, Miss.
- S-41 Swaboda Co., Maritime Bldg., Seattle, Wash.
- S-42 Swan-Haverstick, Inc., Trenton, N. J.
- S-43 Sylvania Products Co., Emporium, Pa.
- S-44 Sturges Multiple Battery Corp., Jamaica, N. Y.
- S-45 Sarras Electric Co., 67 Park Place, N. Y. C.
- S-46 See Jay Battery Co., 915 Brook Ave., N. Y. C.
- S-47 A. R. Spartana, 806 N. Gay, Baltimore, Md.
- S-48 Shallcross Mfg. Co., 700 Parker Ave., Collingdale, Pa.
- S-49 Scott Transformer Co., 4450 Ravenswood Ave., Chicago.
- T-1 Taylor Electric Co., Madison, Wis.
- T-2 Tectron Radio Corp., 1270 Broadway, N. Y. C.
- T-3 Televocal Corp., 588 12th St., West New York, N. J.
- T-4 Temple Corp., 5253 W. 65th St., Chicago, Ill.
- T-5 Therm-A-Trol Mfg. Co., 52 Willow, Springfield, Mass.
- T-6 Thompson Radio Co., 25 Church, N. Y. C.
- T-7 Thorndarson Electric Mfg. Co., 500 W. Huron St., Chicago, Ill.
- T-8 Tilman Radio Corp., Lagro, Ind.
- T-9 Tobe Deutschmann Co., 136 Liberty St., New York City.
- T-10 Todd Electric Co., 42 Vesey, N. Y. C.
- T-11 Toman & Co., 2621 W. 21st St., Chicago, Ill.
- T-12 Tower Mfg. Corp., 124 Brookline Ave., Boston, Mass.
- T-13 Transformer Corp. of America, 2301 S. Keeler Ave., Chicago, Ill.
- T-14 Trav-Ler Mfg. Corp., 1818 Washington Ave., St. Louis, Mo.
- T-15 Trenle Porcelain Co., East Liverpool, Ohio.
- T-16 Triad Mfg. Co., Inc., Fountain and Blackstone Sts., Pawtucket, R. I.
- T-17 Tri-Boro Radio Mfg. Corp., 62 W. 21st St., New York City.
- T-18 Trico Products Corp., 817 Washington, Buffalo, N. Y.
- T-19 Trimm Radio Mfg. Co., 847 W. Harrison, Chicago, Ill.
- T-20 Trutone Radio Sales Co., 114 Worth, N. Y. C.
- T-21 Tyrman Electric Corp., 314 W. Superior St., Chicago, Ill.
- T-22 Thomas & Betts Co., 15 Park Place, N. Y. C.
- T-23 Teleplex Co., 76 Cortlandt, N. Y. C.
- T-24 Teleradio Engineering Corp., 484 Broome St., New York City.
- U-1 The Udell Works, 1202 W. 28th St., Indianapolis, Ind.
- U-2 Ultraphonic Products Corp., 270 Lafayette, New York City.
- U-3 Ultratone Mfg. Co., 1046 W. Van Buren St., Chicago, Ill.
- U-4 Union Electric Porcelain Works, Muirhead Ave., Trenton, N. J.
- U-5 Union Insulating Co., 296 Broadway, N. Y. C.
- U-6 Union Metal Products Co., 2938 Pillsbury Ave., Minneapolis, Minn.
- U-7 United Air Cleaner Co., 9701 Cottage Grove Ave., Chicago, Ill.
- U-8 United Radio & Electric Corp., 500 Chancellor Ave., Irvington, N. J.
- U-9 United Reproducers Corp., Springfield, Ohio.
- U-10 United Research Labs., Inc., 864 W. North Ave., Chicago, Ill.
- U-11 United Scientific Lab., Inc., 113 Fourth Ave., New York City.
- U-12 U. S. Radio & Television Corp., Marion, Ind.
- U-13 Universal Electric Lamp Co., Newark, N. J.
- U-14 The Utah Radio Products Co., 1737 S. Michigan Ave., Chicago, Ill.
- U-15 Universal Battery Co., 3410 S. La Salle, Chicago, Ill.
- U-16 Universal Electro Chemical Corp., 30 W. 15th St., New York City.
- V-1 Vaga Mfg. Co., 720 Atlantic Ave., Brooklyn, N. Y.
- V-2 Valley Appliances, Inc., 634 Lexington Ave., Rochester, N. Y.
- V-3 Van Doorn Co., 160 N. La Salle St., Chicago, Ill.
- V-4 Van Horne Tube Co., 280 Center St., S. Franklin, Ohio.
- V-5 Victoreen Radio Co., 2825 Chester Ave., Cleveland, Ohio.
- V-6 Valley Electric Co., 4221 Forest Park Blvd., St. Louis, Mo.
- V-7 Vibroplex Co., 825 Broadway, N. Y. C.
- W-1 Walbert Radio Corp., 1000 Fullerton Ave., Chicago, Ill.
- W-2 Ward Leonard Electric Co., Mt. Vernon, N. Y.
- W-3 Ware Mfg. Corp., Broad St. Bank Bldg., Trenton, N. J.
- W-4 Wasmuth-Goodrich Co., Peru, Ind.
- W-5 Waterbury Button Co., Waterbury, Conn.
- W-6 Watsontown Table & Furniture Co., Watsontown, Pa.
- W-7 The Webster Co., 850 Blackhawk St., Chicago, Ill.
- W-8 Webster Electric Co., Racine, Wis.
- W-9 Wells Gardner & Co., 1720 N. Damen Ave., Chicago, Ill.
- W-10 Western Felt Works, 4029 Ogden Ave., Chicago, Ill.
- W-11 Westinghouse Electric & Mfg. Co., Pittsburgh, Pa.
- W-12 Weston Electrical Instrument Corp., 614 Frelighuysen Ave., Newark, N. J.
- W-13 T. C. Wheaton Co., Millville, N. J.
- W-14 Wilcox Labs., Charlotte, Mich.
- W-15 Willard Storage Battery Co., 346 E. 131st St., Cleveland, Ohio.
- W-16 Wireless Corp. of America, 1744 N. Robey, Chicago, Ill.
- W-17 Wireless Specialty Appliance Co., 76 Ather-ton St., Jamaica Plain, Mass.
- W-18 Wise-McClung Corp., New Philadelphia, Ohio.
- W-19 Wirt Co., 5221 Greene (Germantown), Philadelphia, Pa.
- W-20 Wiz Mfg. Co., 225 Sixth Ave., N. Y. C.
- W-21 J. W. & W. L. Woolf, 133 W. 21st St., N. Y. C.
- W-22 World Electric Co., San Dimas, Calif.
- W-23 Wright-DeCoster, Inc., 2233 University Ave., St. Paul, Minn.
- W-24 Wubco Battery Corp., Swissvale Sta., Pittsburgh, Pa.
- W-25 Workrite Radio Corp., 1838 E. 30th St., Cleveland, Ohio.
- X-1 X-L Radio Labs., 1224 Belmont Ave., Chicago, Ill.
- Y-1 Yahr-Lang, Inc., 215 E. Water, Milwaukee, Wis.
- Y-2 Yaxley Mfg. Co., 1103 W. Monroe St., Chicago, Ill.
- Z-1 Zenith Radio Corp., 3620 Iron St., Chicago, Ill.
- Z-2 Zetka Labs., Inc., 67 Winthrop, Newark, N. J.
- RESISTORS, Fixed Carbon**
A-21, C-7, C-11, C-16, E-1, E-8, H-10, M-15, P-13, P-16.
- RESISTORS, Fixed Processed**
A-14, C-5, C-7, C-16, C-32, D-14, D-15, E-8, I-5, L-10, M-15, P-13, P-16, R-2, T-9.
- RESISTORS, Fixed Wire Wound**
A-14, A-17, A-32, C-7, C-16, C-32, D-1, D-4, E-1, E-8, E-10, F-21, G-5, G-9, H-10, K-18, M-10, M-15, M-17, P-1, P-13, P-16, R-17, R-20, S-48, W-2, Y-2.
- RESISTORS, Variable Carbon**
A-21, B-24, C-7, C-16, E-1, F-21, K-3, M-15, P-13, P-16.
- RESISTORS, Variable Wire Wound**
A-17, C-7, C-6, C-36, D-4, E-8, E-10, F-4, F-21, G-7, G-9, H-10, K-18, M-5, M-15, M-17, P-1, P-8, P-13, P-16, R-14, U-11, V-5, W-2, W-8, Y-2.
- SHIELDS**
A-23, C-7, C-10, C-33, G-19.
- SOCKETS, Tube**
A-17, A-26, A-52, B-12, C-10, C-16, C-36, D-4, E-4, E-10, F-4, F-11, G-9, G-19, I-4, K-3, K-5, K-18, N-13, P-1, P-8, P-13, P-14, P-24, R-14, S-3, S-9, S-15, S-22, U-5, W-5.
- SOLDER, Self-Fluxing**
K-8.
- SWITCHES & SWITCH CONTACTS**
A-15, B-5, B-10, B-20, B-24, B-28, C-7, C-11, C-36, E-4, E-8, E-10, F-1, F-21, G-1, G-9, H-13, H-16, K-3, K-19, M-5, M-17, P-1, P-8, P-13, P-21, R-14, S-3, S-22, S-42, U-5, W-17, Y-2.
- TESTING EQUIPMENT, Tube and Set**
E-24, F-10, G-9, H-15, H-19, J-2, J-6, K-18, L-8, P-4, P-28, R-11, R-17, S-14, S-29, S-40, T-1, T-19, W-12.
- TRANSFORMERS, Audio**
A-4, A-13, A-17, A-32, A-34, C-6, C-7, C-13, C-19, E-1, E-8, F-3, F-4, F-13, G-2, G-3, G-5, G-7, G-9, G-10, G-17, G-19, G-21, H-1, H-3, H-5, I-5, J-2, K-2, K-3, L-5, M-15, M-17, N-13, P-1, P-20, P-21, P-24, R-7, R-14, R-19, R-20, S-1, S-2, S-3, S-4, S-5, S-15, S-23, S-25, T-7, T-9, T-13, V-3, W-5, W-2, W-5, W-8.
- TRANSFORMERS, Power**
A-4, A-6, A-13, A-32, A-41, B-19, B-20, B-24, C-6, C-7, C-13, D-11, E-4, E-15, E-24, F-1, F-7, G-3, G-7, G-9, G-10, G-17, G-19, G-21, H-1, K-2, K-3, K-9, K-10, K-15, K-18, M-17, N-3, N-9, P-15, R-2, R-3, R-9, S-1, S-2, S-5, S-9, S-17, S-22, S-25, T-7, T-9, T-21, U-5, V-5, W-2, W-7, W-17.
- TRANSFORMERS, R-F (See COILS, R-F)**
- TRANSMITTING APPARATUS**
A-4, A-13, A-62, C-6, E-23, F-21, G-9, K-3, N-3, N-14, R-13, R-29, S-2, T-7.
- TUBING, Spaghetti**
A-7, A-15, I-4, P-8.
- UNITS, Loudspeaker & Phonograph**
A-3, A-13, A-22, A-51, B-3, B-14, B-41, C-18, E-7, E-10, E-15, F-4, F-8, H-16, M-17, P-8, R-1, R-22, S-19, S-31, T-12.
- VACUUM TUBES**
A-8, A-20, A-24, A-42, A-43, A-45, A-49, A-50, B-18, B-22, C-1, C-9, C-12, C-22, C-23, C-25, C-35, D-1, D-3, D-7, D-9, D-12, D-18, E-13, E-16, E-19, G-15, G-23, H-22, H-23, J-1, K-3, K-6, K-22, L-2, M-1, M-6, M-10, M-16, N-2, N-7, N-11, P-5, O-3, R-13, S-9, S-18, S-37, S-39, S-43, T-2, T-3, T-16, U-8, U-13, V-4, W-11, W-16, Z-2.
- VARIOMETERS & VARIO-COUPERS (See COILS, R-F)**
- VOLTAGE REGULATORS**
A-4, A-63, C-16, I-4, M-7, R-17.
- WIRE (See CABLE)**

RECEPTION OF SUPER HIGH FREQUENCIES

By THOS. A. MARSHALL

FROM observations made over a period of eleven months it appears that 28,000 kilocycles should be excellent for transcontinental work as well as to South America, Europe and elsewhere. The possibilities are certainly bright for certain hours of the day. 28,000 kilocycles should be used for transcontinental work after 10:00 a. m., E. S. T., and may be used up to 6:30 p. m., E. S. T. 30,000 kilocycles may also be used for this work between the hours of 10:30 a. m. and 5:30 p. m., E. S. T.

While at Panama, it was possible to receive from 12,000 to 40,000 kilocycles. 38,910 kilocycles gave very good results, while 40,000 kilocycles were not received with very good signal strength, due to the skip distance effect. Reception at 40,000 kilocycles (7.5 meters) is the record for the lowest wave at a great distance.

During the cruise, other observations were made on the second harmonic values of stations transmitting between 13,000 and 18,000 kilocycles. While in southern waters, WLL could be heard with very good signal strength on 35,800 kilocycles. At Los Angeles, California, NKF, on 28,000 kilocycles, using a 150 watt transmitter, could be heard with excellent signal strength from 10:30 a. m. to 4:30 p. m., E. S. T.

BOOK REVIEWS

"How to Pass U. S. Government Radio License Examinations," by Rudolph L. Duncan and Charles E. Drew. Paper; 6 $\frac{3}{4}$ x9 $\frac{3}{4}$ in.; 169 pp.; 92 figures. Published by John Wiley & Sons, Inc. Price \$2.

For the beginner who wishes to become a radio operator, the experienced radio man who wishes to become familiar with commercial apparatus, or the Army or Navy radio operator who intends to engage in the commercial operating profession, this book will prove valuable. Thorough study of it will not only prepare the student for the questions put to him by the government but will crystallize his other reading on the subject, linking the theoretical with the practical. The treatment gives answers to actual questions.

The first chapter is devoted to the regulations which govern radio operators' licenses. The second is a thorough treatise on commercial and broadcast transmitters, including the arc and spark. Although the latter are generally considered obsolete they are nevertheless ever present at sea. Instructions in tuning and operating the latest broadcast transmitters, and the care of various types of transmitting tubes and carbon and condenser microphones are also given, as are descriptions of the different kinds of transmitting antennas.

The third chapter deals with the theory of receiving sets, the operation of the usual low frequency receiver found on shipboard, and the construction and operation of radio compasses. Motor generators, starting panels and overload relays come in for treatment in the fourth chapter, while the fifth explains the theory, care and upkeep of storage batteries.

The sixth chapter contains the more important radio laws and regulations, while the last or appendix consists of some very handy formulae and tables and a list of international abbreviations. This book is not intended as a complete technical treatise pertaining to radio theory and practice but as a supplement to the standard radio textbook. It enables the prospective radio operator to gain some familiarity with the equipment he will have to operate.

"Radio Traffic Manual and Operating Regulations," by Rudolph L. Duncan and Charles E. Drew. Paper; 6x9 in.; 187 pp. Published by John Wiley & Sons, Inc., New York. Price \$2.

Outside of a short chapter on acquiring the code and the use of the abbreviations, this manual is a compilation of the Operating Rules and Regulations of the Radiomarine Corporation of America, the International Radiotelegraph Convention, the U. S. Radio Act of 1927, the Ship Act of July 23, 1912, and the Regulations Governing the Issuance of Radio Operators' Licenses. It makes a good reference volume for the radio station, and operators of the Radiomarine Corp. of America as well as those of other companies who will not take offense at the assumption of their non-existence will find it occasionally handy. It might be said that the only serious weakness of the three books by these authors is the omission of practically everything that does not bear the stamp of the R. C. A. This is a matter over which the authors evidently have no say.

"General Contract Purchase Catalog of Radio Receivers and Loudspeakers," 106 pp.; 4 $\frac{3}{4}$ x6 $\frac{1}{2}$ in.; paper bound. Published by General Contract Purchase Corporation of America, Graybar Bldg., New York City. Price \$2.

This booklet presents in handy form the names and addresses of manufacturers of

(Continued on Page 95)

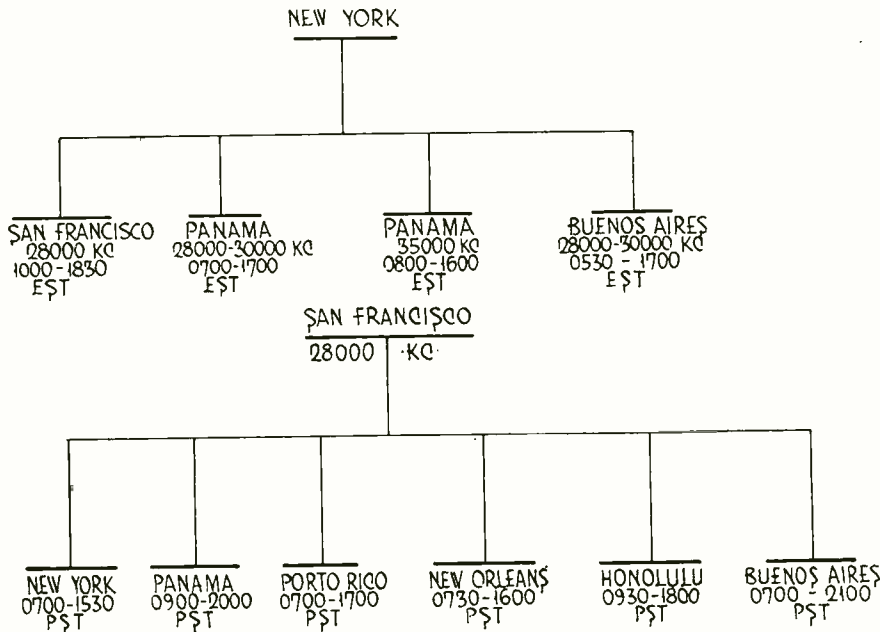

Fig. 1. Frequencies, Hours and Locations for Reliable Communication

Fig. 1 shows graphically the frequencies, hours, and locations for reliable communications between certain points. The hours and frequencies given are for results accomplished during winter months. Theoretically, the daylight period of reception for these frequencies should be increased during summer months. It may be possible to receive at shorter distances due to the increased height of the layer.

The writer used his own receiver (described in May, 1929, RADIO) in taking observations during a cruise from Seattle, Washington, to Panama and return, lasting approximately eleven months. During this time daily tests for periods of one week were conducted with Naval Research Laboratory at Bellevue, D. C., using frequencies from 20,000 to 40,000 kilocycles.

Since the absorption of these super high frequencies is negligible in the Kennelly-Heaviside layer, and the primary skip distance is very long, strong signals should be received at a great distance. The primary skip distance depends entirely on the radiation angle and the height of the Kennelly-Heaviside layer. Fig. 2C illustrates a possible condition for 28,000 kilocycles. We cannot change the height of the layer, but it should be possible to concentrate the angle of radiation by employing a reflector system. For long distance work, say from America to Europe or Australia, the angle of radiation should be made parallel to the earth at the transmitting station, as shown in Fig. 2D, thus making possible a long primary skip distance, reaching the receiving station through space.

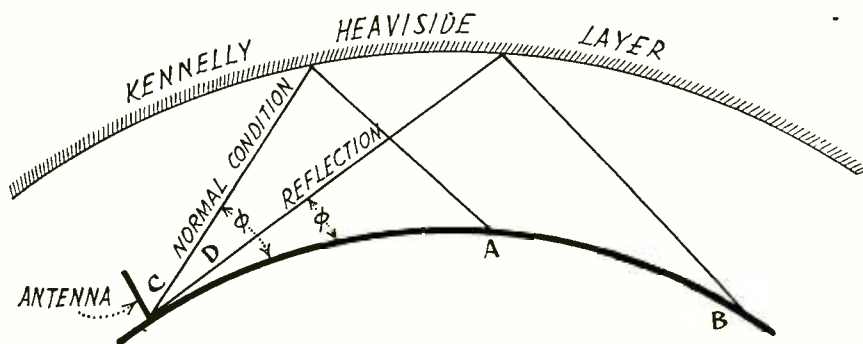

Fig. 2. Effect of Radiation Angle Upon Primary Skip Distances

TOBE

Filterette

COPYRIGHT 1929 by Tobe Deutschmann Corporation. Excerpts may be used if credit is given.

VOL. 1, NO. 6

NOVEMBER, 1929

CANTON, MASS.

CITY OF PITTSBURGH SPECIFICATIONS INCLUDE FILTERETTES

Traffic Control Systems Must Not Interfere With Radio

RADIO INTERFERENCE is revolutionizing an entire industry. To those who have watched skeptically the development of public interest in this field, the recent action of the city of Pittsburgh must come as decisive proof that man-made static as a public issue has come to stay. The city of Pittsburgh in advertising for bids on a traffic control system specifically demands that the contractor shall furnish and install all necessary radio interference prevention devices. But the most significant recognition of the preëminence of the Tobe Deutschmann Corporation in this field comes in Section 23D which reads:

"Interference Eliminated"

"In the removal of radio, telephonic or telegraphic interference, as provided for in Section 11C, if a filter is to be used, it shall be a Tobe Deutschmann Company (Canton, Mass.) filter, or satisfactory equivalent filter, approved by the director in writing."

The import of this provision is clear. Not traffic blinker manufacturers alone, but all manufacturers of radio interfering electrical apparatus will ultimately be asked to furnish products which are free from this nuisance. The manufacturer who apprehends this fact now, and gets the jump on his less foresighted brethren, is the one who is going to reap the profits in the next few years, for what chance has the manufacturer of an interfering blinker nowadays, in Pittsburgh or anywhere else?

Will your product be next? Don't be caught napping when it costs nothing to get particulars on radio interference elimination.



W. F. "Billy" Murray

RADIO ATTRACTING FOOTBALL MEN

Among the latest of football men who have followed the example of Jess Hawley, former Dartmouth coach, in entering the field of radio is William J. Murray, former Harvard football captain, who has joined Tobe Deutschmann Corporation in an executive capacity.

Mr. Murray will be remembered as the leader of the last undefeated Harvard team—the one which, in 1919, made the trip to the coast and defeated the champion Oregon team at the Tournament of Roses at Pasadena, California, a feat which no other eastern team had been able to accomplish in years previous.

Mr. Murray's interest was aroused early this fall in the possibilities of the Tobe Deutschmann Corporation to such an extent that he turned down a very attractive coaching proposition in order to enter upon his new duties immediately.

SENDS 212 DIFFERENT INTERFERENCE PROBLEMS

Power Company Plans Wholesale War on Interference

AN ARRAY of interference problems, many of which had stumped the filter experts of the department, were sent to the Tobe Deutschmann Corporation recently for solution, by a prominent New York state power company.

"While we have succeeded in solving many of these problems ourselves," they wrote, "we believe that time will be saved all around if they are submitted to a specialist. We have wasted too much time in experimenting on problems of this nature and we believe it will be far more economical in the long run to have you handle this work for us, than to attempt the costly progress of assigning to its solution, engineers whose time cannot readily be spared from their present duties."

A Bridgeport, Conn., wire manufacturer, and a Boston Eveready Radio distributor who had experienced trouble from interference, both apparently came to the same conclusion. The machines of the former radiated interference for some six miles. A converter used by the latter for demonstrating a-c sets in a d-c district made it impossible to hear anything but an ear-splitting roar. Both reported complete satisfaction when Filterettes had been properly installed, although previous attempts at filtering had failed completely.

The Tobe Deutschmann Corporation, with its well equipped laboratories and its specializing engineers, takes pride in its success in quelling interference where others have failed. Our business is to eliminate interference by means of a thorough study of the cause and an intelligent application of the remedy.

Flashing Sign *Interference*

Radio Interference Created by Flashing Signs Due to Both Conductive and Inductive Coupling

By RESEARCH LABORATORIES
Tobe Deutschmann Corporation

IT HAS long been thought that the interference created by flashing signs of all descriptions is due only to the direct connection of the sign flasher to the power lines. While this condition is doubtless responsible for considerable disturbance, it is not by any means the only factor which must be considered in a discussion of sign flasher interference. The reason for this statement will readily be understood by comparison of a sign flashing circuit to that of a simple transmitter as shown in Fig. 1. In any

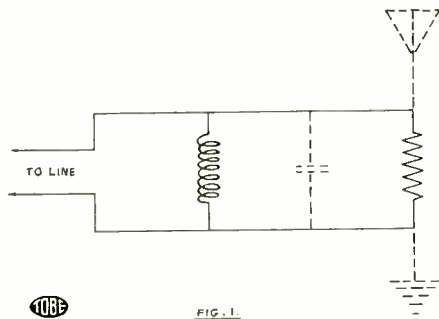

Fig. 1. Simple Transmitter Circuit

sign flasher the switch mechanism may be considered as the spark gap, and the supply lines as the close-coupled antenna system.

Cause of Interference

FROM this analogy, it will be seen that the interference created by flashing signs is due to the opening and closing of the switches which control the load circuits. This applies regardless of the type of switching mechanism employed. The switching action sets up oscillations both in the supply lines to the flasher mechanism and in the connecting lines between the flasher mechanism and the sign.

Such interference as is conductively impressed on the supply lines may generally be reduced so as not to be noticeable by installing an inductive-capacitive filter in the main supply leads. The interference due to the oscillations in the leads between the flasher mechanism and the sign, however, requires that an entirely different type of interference suppressing filter be used, as the interference created by this part of the circuit is usually due to direct radiation which may be picked up by the antenna system of any receiver within several hundred feet of the sign.

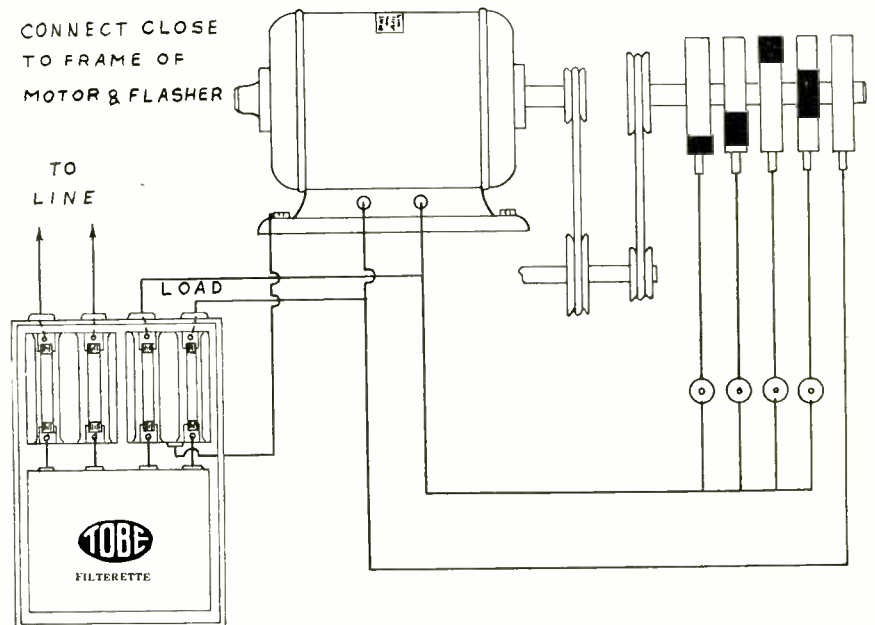

Fig. 2. Installation of Inductive-Capacitive Filter for Suppressing Primary Interference

In order to differentiate between these two types of interference, we have designated that caused by conductive coupling between the flasher mechanism and the power supply lines as primary interference, and that caused by radiation from the load leads as secondary interference.

Types of Filterettes

FIG. 2 shows the installation of an inductive-capacitive filter* for suppressing primary interference. This arrangement is often satisfactory when the receiver is located at a considerable dis-

* TOBE Filterette Nos. 131-2-3-4-5.

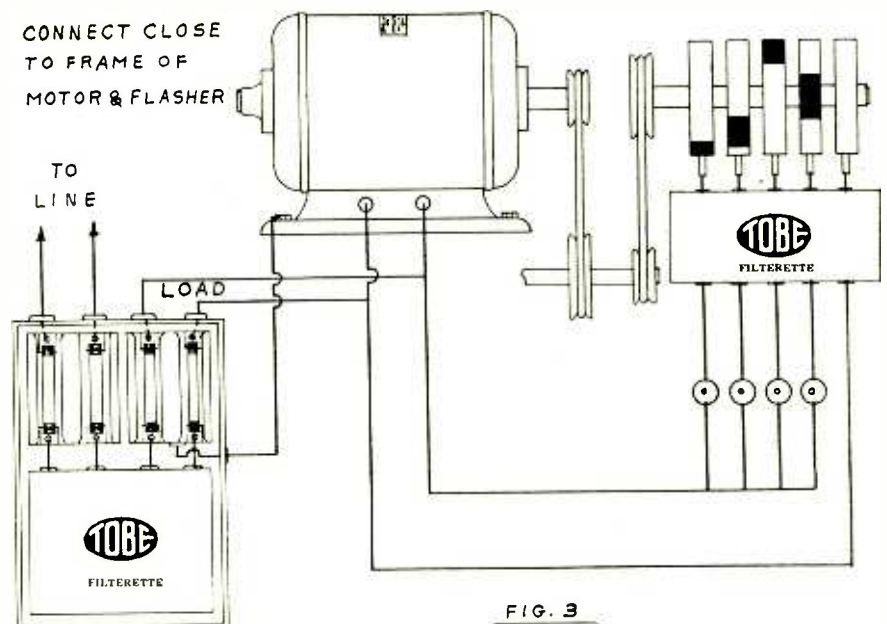

Filters for Suppressing Primary and Secondary Interference

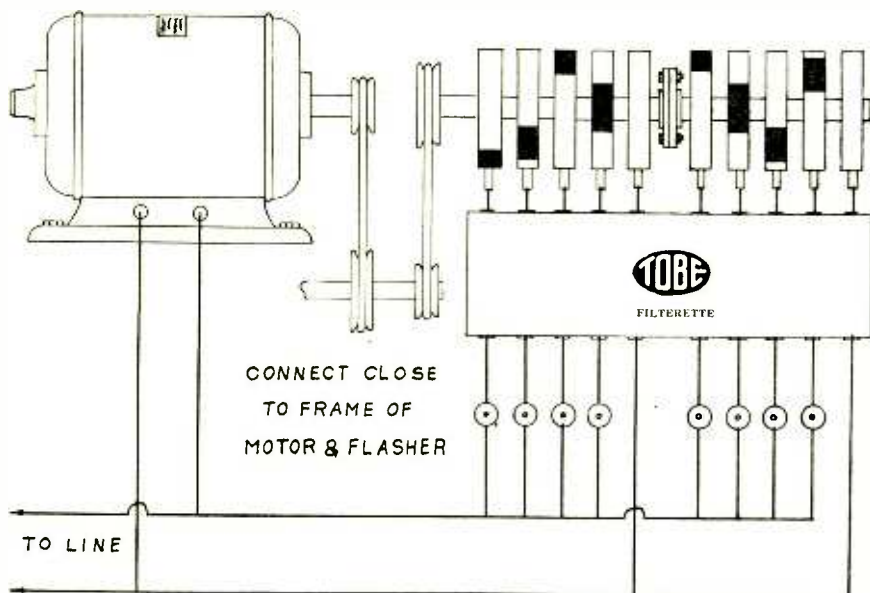

Fig. 4. Improved Type of Filter for Suppressing Primary and Secondary Interference

tance from the sign flasher installation, or when the leads between the flasher mechanism and the sign are very short or carried in conduit. If the receiver is to be operated in close proximity to the flasher mechanism or the sign, both primary and secondary interference will have to be considered.

Fig. 3 shows the application of filters for suppressing both types of interference. While this method is generally satisfactory, space limitations frequently make the installation of two types of filters extremely difficult. Furthermore, due to the fact that the amount of copper required in a filter for suppressing primary interference increases with the increase of total load, it can readily be appreciated that the cost of a filter of this type for application to a large flashing sign would be entirely out of proportion to its value. Also, the space required for the installation of a primary and secondary filter has an important bearing on the ease of installation and the effective arrangement of the two filters.

This, of course, means that a single multiple filter should be constructed for suppressing both primary and secondary interference. The construction of such a filter, however, presents quite a difficult problem, due to the number of circuits used in the average sign flasher, and to the heavy loads commonly handled. Flashing signs drawing as much as 10 kilowatts and having from 25 to 50 switches are very common. With such signs it has been found that if complete elimination of both primary and secondary interference is to be obtained, a filter must be connected in each flashing circuit. If, for example, in a flasher installation having 20 switches, a single circuit is left unfiltered, the effect of the remaining filters may be materially reduced, if not nullified. The installation of an improved type of filter for sup-

pressing both primary and secondary interference is shown in Fig. 4.

Design of Filter

IN SOME cases the practice commonly followed in suppressing primary interference has been applied to the suppression of secondary interference without due consideration being given the factors governing the transmission of such interference. Such indiscriminate use of inductance and capacity in many cases not only provides no decrease in interference, but often intensifies the interference. This is due to the fact that the addition of inductances and capacity to a circuit containing a spark generator directly coupled to a long antenna causes a tuning effect which, in many cases, peaks the interference on some portion of the broadcast band. In order to avoid this resonant condition, considerable care must be taken in the design of filters for suppressing secondary interference. The antenna effect of the leads between the flasher mechanism and the sign is also often increased by the effect of capacitive coupling provided by the frame of the switching mechanism in installations in which the frame is not placed at a common potential to all of the switching circuits. This does not mean that the frame of the mechanism should be grounded, as the potential to which we are referring is the radio frequency or interference potential, rather than the 60-cycle power supply potential. Suitable filter design will take this factor into consideration so that it seldom need be considered after secondary filters are used.

Effect of Grounding

IN SOME cases it may be found that grounding the frame of the mechanism will apparently nullify the effect of such interference suppressing devices as may have been applied. This is due to the fact that there are, of course, always

interference currents of some magnitude present in the circuit, regardless of the type of filter used. The grounding of the switch mechanism frame causes an increase in the length of the effective antenna for the radiation of such disturbances, and in this way may materially reduce the effect of filters. In cases where a primary filter only is used, it may seem ineffective until the ground connection is removed from the flasher frame. This is due to the increase in effective antenna length previously noted. In most cases it may be considered advisable to remove all ground connections from the switching mechanism frame in order to obtain complete elimination of interference. Although this may, in some cases, conflict with local wiring regulations, it is probable that the installation of flasher and filters within a metal cabinet which may be grounded will overcome this difficulty.

The question of coupling has a most important bearing on the design and installation of all interference filters, and particularly that of secondary filters. It has been found that best results are obtained if the individual sections of a multiple secondary filter are shielded, in order that coupling between circuits may be reduced to a minimum.

In some cases where filters have been installed, the interference is not entirely suppressed or returns faintly at irregular intervals instead of ceasing altogether. By observing this effect, one might suppose that some poor connection existed which caused the filter to be effective part of the time and ineffective at other times. On the contrary, this phenomenon is due to incorrect filters for the particular situation. What really happens is that the switching action may take place at different parts of the power cycle. If this action occurs when the voltage wave is passing through the zero position, interference will be at a minimum, but if it occurs at other portions of the cycle, interference will be more noticeable. To overcome this difficulty, the filter must, in most cases, especially if it is of the multiple circuit secondary type, be designed for the particular sign from which interference is to be suppressed.

Solenoid Operated Flashers

DUE to the presence of inductance in the circuit of a solenoid operated flasher, the interference created by this type of mechanism is usually more difficult to suppress than that created by a flasher employing rotary switches. For suppressing interference from a solenoid operated flasher, the filter must be designed with particular attention to the effect of the inductance in the circuit, in order that the creation of a resonant condition intensifying the interference on the broadcast band may be avoided.

It is a common belief that Neon signs

are likely to be responsible for radio interference, due to the fact that they are operated from high-tension transformers. This, however, is not the case, as a steady burning Neon sign in good electrical and mechanical condition will seldom cause any radio interference. If interference is traced to a Neon sign, the sign should be thoroughly overhauled before any interference filters are applied. By cleaning the sign and perhaps rebushing the electrodes, the interference may usually be overcome. If this procedure does not completely eliminate the interference, an inductive-capacitive type filter* should be connected at the primary side of the transformer used for supplying the high-tension current for operation of the sign. If the sign consists of a number of sections operated from a sign flasher, the procedure previously described for suppressing both primary and secondary interference must be followed.

Interference Characteristics

INTERFERENCE created by sign flashers is usually noticeable in one of two forms. If the sign is of the type in which various sections flash on and off, the interference will be in the form of a steady clicking, noticeable whenever a section of the sign is illuminated or cut off. Although interference from this type of sign is extremely annoying, it is not so objectionable as that created by signs having a running border, or what is known as bursts. Interference from this type of sign is usually in the form of a steady rattling like machine gun fire. These running borders or bursts are controlled by high-speed rotary switches, and it is this type of flasher which was re-

ferred to in the statement in an earlier paragraph that on some occasions the omission of a filter from one switching circuit will minimize the effect of the entire filter.

In general, it may be said that all flashing signs are creators of radio interference. The area covered by this disturbance will be governed by the manner in which the sign and flasher are installed, the current and voltage at which the apparatus is operated and the proximity of power or other wiring to the flasher mechanism and load leads. While primary interference may be independent of secondary interference and may thus be suppressed by a separate filter, it is usually advisable to provide for the suppression of both primary and secondary interference with a single filter of suitable design. While primary interference may be distributed over a relatively wide area, due to the fact that it is conductively impressed on the power lines, secondary interference is usually objectionable only when within a few hundred feet of the sign, and is noticed principally in the same building or in adjoining buildings, although when this interference is inductively transferred to the power lines, it may be distributed in the same manner and over the same area as the primary interference.

The exact location of the source of the interference may usually readily be determined by comparison of the interference signals with the visible flashing of the sign under suspicion. When the sign has been located and proved to be responsible for the interference, the number of circuits, the total load per circuit and the length of lead between the flasher mechanism and the sign should be taken into consideration in the design of suitable filters. With this information, a properly designed filter may be constructed which will satisfactorily suppress the interference.

The Tobe Deutschmann Corporation, Filterette Division, welcomes all inquiries and will gladly correspond with those interested in this work.

It is planned in future articles to discuss openly each problem without regard for possible patent disclosures. For although many patent claims have been filed, we are not waiting for any action by the authorities at Washington, but will disclose our findings as soon as each problem is solved.

FILTERETTES FEATURE OF RADIO SHOWS

WHILE the interest manifested in Los Angeles, Minneapolis and New York furnished indisputable evidence of how public attention is focused on the elimination of extraneous radio noises, it must be admitted that the interest manifested in the Tobe Deutschmann exhibit at the Los Angeles Radio Show decisively exceeded all previous demonstrations.



Tobe Filterette Booth at Los Angeles Radio Show

The Minneapolis show, when Mr. C. W. Metcalf addressed the Northwest Radio Trade Association on the subject, "The Advance of Radio Interference Suppression," was an unquestioned success, and as a consequence of this talk being broadcast, dealers reported a direct rise in public interest during the following week. People had learned that radio noises could be stopped, and they were demanding Filterettes.

At the time this article was written complete reports from the New York show were not yet available, but it is estimated that the engineers in charge of the booth will answer something like 23,465,936 questions, a goodly percentage of which will be foolish. Inquiries for direction ("It's out of order, the plumbers are working there now") are not included.

Those familiar with the dignified policy of the home office of the corporation at Canton, Mass., will readily appreciate the stir created when a photograph of the Los Angeles "exhibit" arrived by telephoto—or was it by plane? Gray-haired executives discussed hotly the pros and cons of such a policy, and at last report the directors were reported deadlocked—half for bringing the young lady to Canton, and the other half for moving the plant to Los Angeles.





- We Will Do This For You—**
1. Tell the recipients that YOU have subscribed to "RADIO" for them as a Christmas gift.
 2. Send a card, like the one shown above, mailing it so as to arrive on December 24th.
 3. We will also send them our monthly loose leaf price and data sheet service and a binder for holding the sheets.
 4. We will start the subscriptions with our December (Christmas) issue, in which the first article on "SELLING RADIO" will be published.

A Christmas Suggestion For Dealers and Jobbers

Somebody in your organization will remember this gift for an entire year

DEALERS—Send subscriptions to "RADIO" for your salesmen and service men as Christmas gifts. Nothing makes a more acceptable—more educational—more interesting gift than a subscription to "RADIO."

Because each issue, for the next year, will have a feature story on "SELLING RADIO." The series starts in our next issue, the big Christmas Number.

JOBBERS—Send subscriptions to "RADIO" for YOUR salesmen—YOUR dealers—YOUR service men. We will send a Christmas Card to the persons for whom you subscribe, telling them that "RADIO" is being sent to them as a holiday gift with your compliments. They will think of you each time the magazine reaches them. The rate is \$2.00 per subscriber per year. Send the magazine to two people for \$4.00 . . . to three people for \$6.00.

RATES / / /

For One Subscription TWO DOLLARS

For Two Subscriptions FOUR DOLLARS

For Three Subscriptions SIX DOLLARS

Publishers of "RADIO" . . .

428 Pacific Building San Francisco, Calif.	415 Lexington Avenue New York City, N. Y.
86 St. Botolph St. Boston, Mass.	307 N. Michigan Ave. Chicago, Ill.

[Send your Subscription to the Office of "RADIO" Nearest You.]

Name _____

Street and Number _____

City and State _____

Send "RADIO" for one year to the names listed:

Name _____

Street and Number _____

City and State _____

Name _____

Street and Number _____

City and State _____

Donor's Name _____ Address _____

(WRITE OR PRINT PLAINLY IN PENCIL OR TYPEWRITER. INK WILL BLUR ON THIS PAPER.)

CIRCUIT DIAGRAM OF STEINITE 40-50-102 RECEIVERS

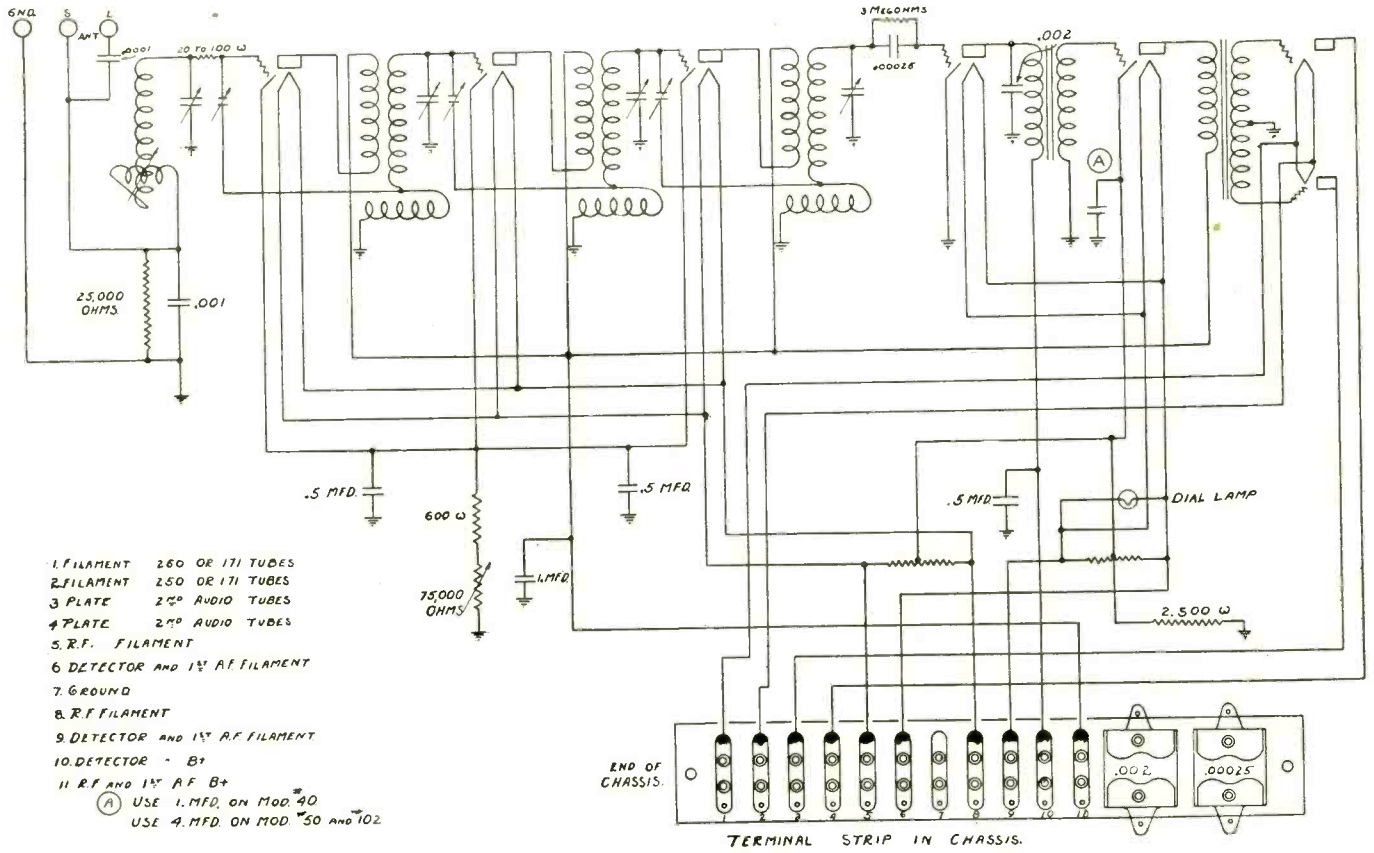

CIRCUIT DIAGRAM OF STEINITE 50 POWER UNIT

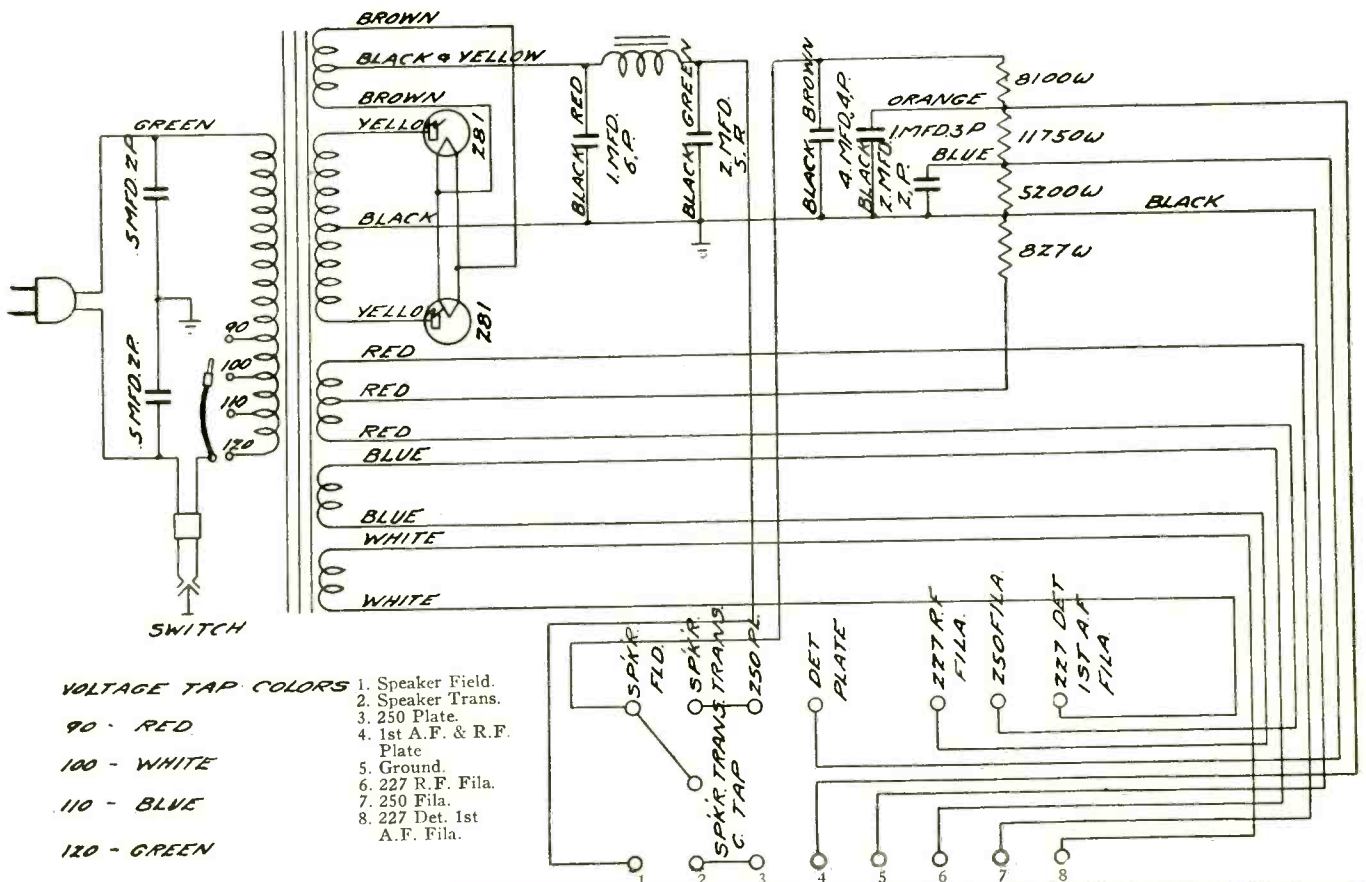

CIRCUIT DIAGRAM OF EARL MODEL 32 A-C RECEIVER

a. ARCTURUS-127
b. ARCTURUS-145

c. ARCTURUS-180

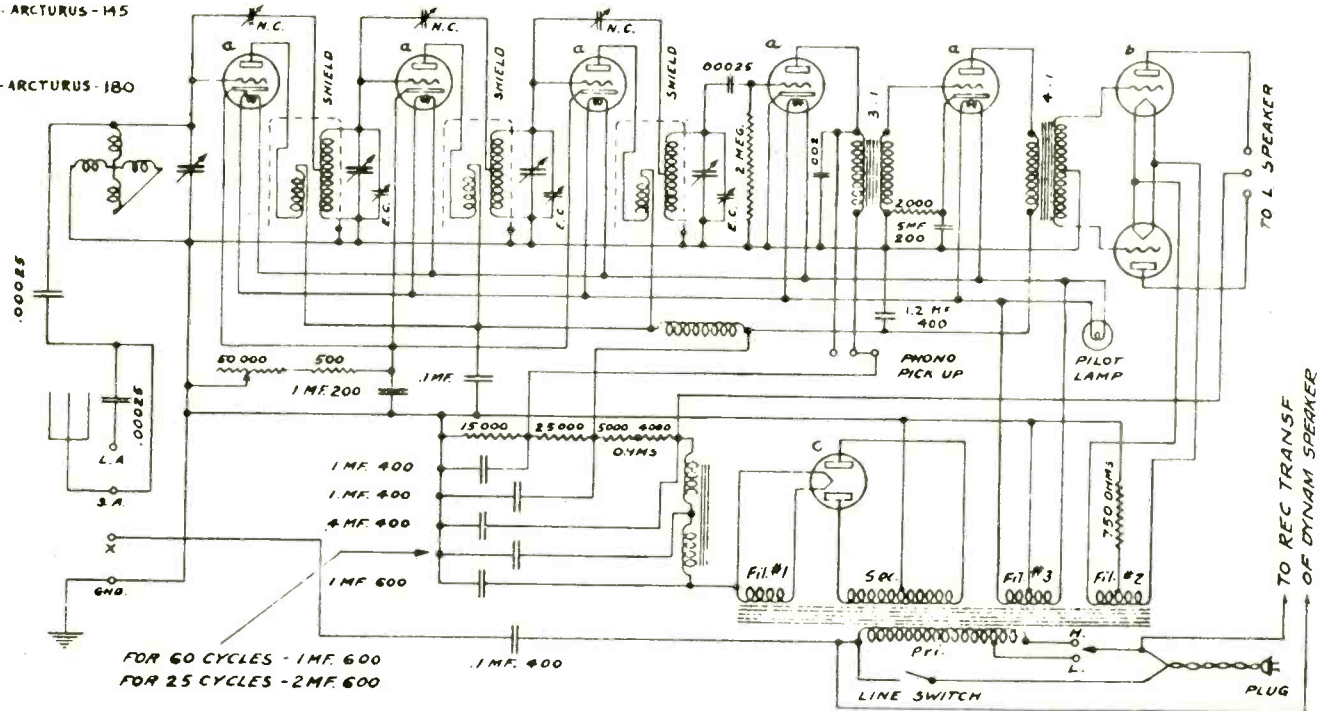

CIRCUIT DIAGRAM OF EARL MODEL 41 RECEIVER

a. ARCTURUS TYPE 127
b. ARCTURUS TYPE 145
c. ARCTURUS TYPE 180

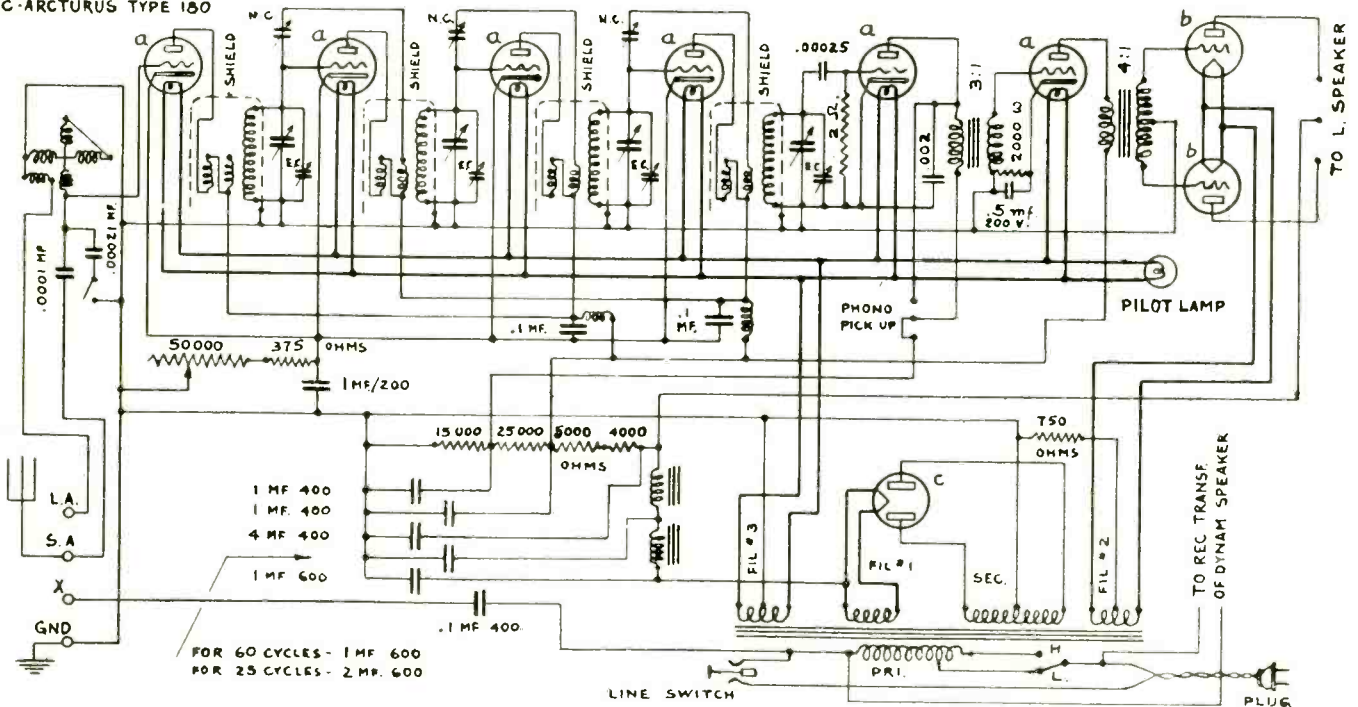

CIRCUIT DIAGRAM OF RADIOLA 66 RECEIVER

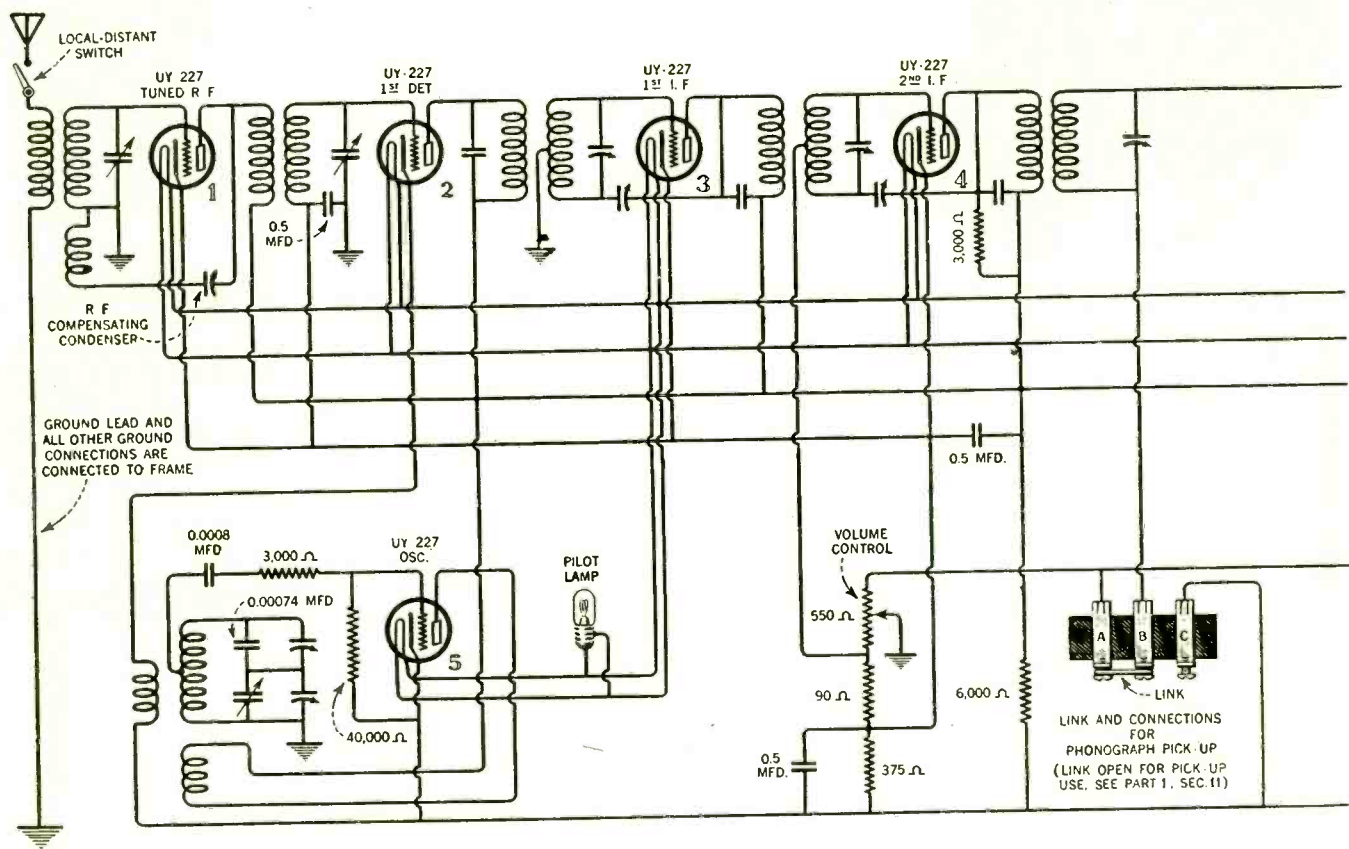

CIRCUIT DIAGRAM OF RADIOLA 66 POWER UNIT

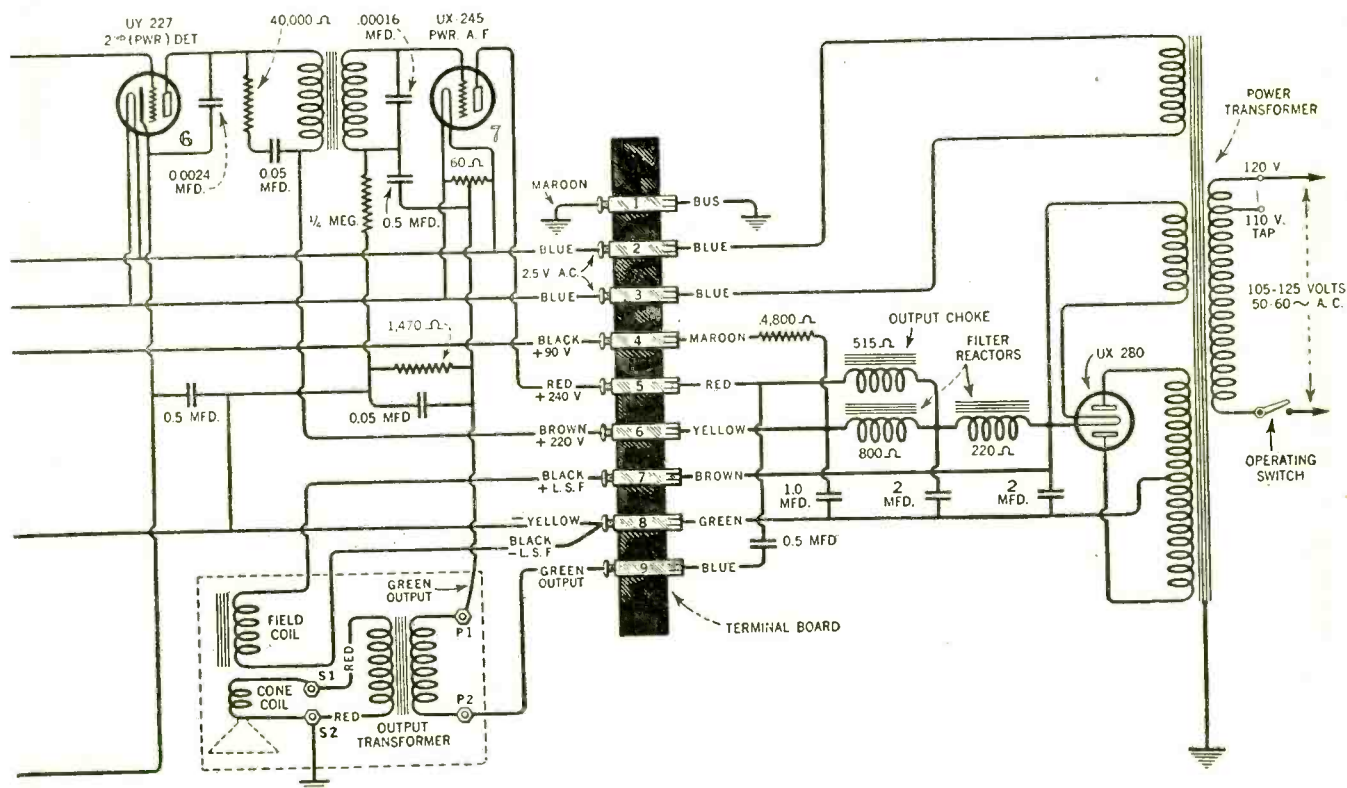

SM

"Can't Beat the S-M 720?" Just Try this All-A. C. 722--And at \$74.75!

Have you heard the whisperings among the fans this fall—how Silver Marshall has brought out an all-electric custom receiver design which sells, completely wired at the factory, for only \$74.75 net—and yet which combines perfect convenience of operation with such extreme performance as has seldom been seen in the most complicated sets? Three screen-grid tubes, with band selector tuning—four tuned circuits in all—with screen-grid power detection—these, built up to the highest S-M standard of engineering, mean, of course, distance range right up among the top notchers. And if you think for one moment that selectivity has been sacrificed to full single-dial control—one test of a 722 on the most powerful local in your town will give you an entirely new conception of what S-M precision in coil manufacture can accomplish!

All-A. C. Operation

These receivers are *absolutely all electric*—even the 735 short-wave set, the first of its kind ever offered on the market. Power supplies are built into the receivers—not separate. (Power supply for the 712 is built into the 677 Amplifier.) The full advantages of the new a.c. screen-grid tubes are secured. The characteristic superior S-M tone quality, distance-range, and selectivity are in these receivers as never before, due not alone to band-selector tuning but also to still greater refinements of design and accuracy of manufacture.

Starting in perfection of tone quality, the 677 Clough-system Amplifier (right) is ideal either for powerful record amplification, or with the 712. Tubes required: 1—'27, 2—'45, 1—'80. \$58.50, less tubes. Component parts total \$43.40 net.

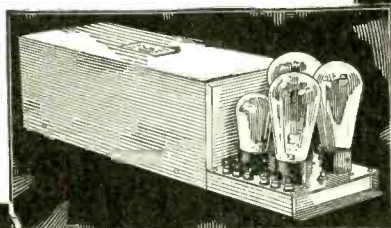

735 Short-Wave Receiver

(Left)—a screen-grid r. f. stage, new plug-in coils covering the bands from 17 to 204 meters, regenerative detector, typical S-M audio amplifier all help to make this first a. c. short-wave set first also in performance. Price, wired complete with built-in power unit, less cabinet and tubes, only \$64.90. Component parts total \$44.90. Tubes required: 1—'24, 2—'27, 2—'45, 1—'80. Two extra coils, 131P and 131Q, cover the broadcast band at an extra cost of \$1.65.

Adapted for battery use (735DC) price, \$44.80, less cabinet and tubes. Component parts total \$26.80. Tubes required: 1—'22, 4—'12A.

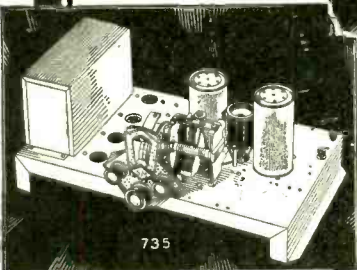

New!—

S-M 233U Universal Output Transformer

With a characteristic curve flat (to within 1.7 DB.) from 30 to 10000 cycles, this transformer has the further advantage of extreme flexibility. Three windings, with a total of 12 lugs, enable it to be used to match almost any impedances. As an output transformer it will work out of '71, '45 or '50 tubes singly or in push-pull. It will work into 12 different impedances from 9 to 200 ohms to feed directly into the voice coils of 1, 2, 3, 4 or 8 dynamic speakers. It will also match with 1000, 2000, 4000 or 8000 ohm circuits; may be used as a line output transformer as well. Open mounted, size: 3' long, 3 3/4' high, 3 3/8' wide. Price, \$9.00.

The RADIOBUILDER for October contains a full description of the 712 Tuner, 677 amplifier, and the new 233 Output Transformer, as well as an interesting article on Television Amplification. If you haven't seen it—use the coupon.

If you build professionally—write us about the authorized S-M Service Station franchise—it pays!

SILVER-MARSHALL, Inc.

6441 West 65th St., Chicago, U. S. A.

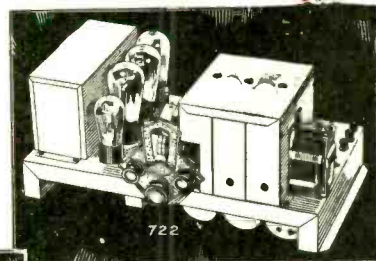

(Above)—three screen-grid tubes (including detector), band-filter, 245 push-pull stage—these help make the 722 the outstanding buy of the year at \$74.75 net, completely wired, less tubes and cabinet. Component parts total \$52.90. Tubes required: 3—'24, 1—'27, 2—'45, 1—'80.

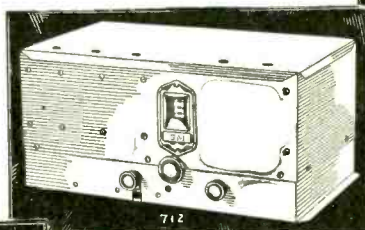

The New "Boss of the Air"—S-M 712

(Above)—A worthy successor to the famous Sargent-Rayment 710 of last season is the splendid new 712 tuner. Even if you have experienced the uncanny 10-kc. sharpness of the famous 5-vernier Sargent-Rayment—a new thrill comes with the 712. Here again are the five tuned circuits—two of them now joined in an ultra-modern band filter—and again the perfect shielding and the special shielded coils, whose tremendous accuracy makes possible the straight single dial tuning of the 712—without verniers, yet with performance far beyond competition regardless of price. Feeds perfectly into any audio amplifier; the S-M 677 is ideal, furnishing also all necessary ABC power. Tubes required: 3—'24, 1—'27. Price, only \$64.90, less tubes, in shielding cabinet. Component parts total \$40.90. Ideally suited for rack panel installations.

Beautiful Cabinets

The handsome new 707 table model shielding cabinet, finished in rich crystalline brown and gold, suitable for 722, 735, or 735DC, is only \$7.75. Special arrangements have been made whereby these receivers may be housed in magnificent consoles especially adapted to them. Be sure to send for the new Fall S-M General Parts Catalog, for details of these cabinets.

Silver-Marshall, Inc.
6441 West 65th Street, Chicago, U. S. A.

... Please send me, free, the new Fall S-M Catalog; also sample copy of The Radiobuilder.

For enclosed..... in stamps, send me the following:

.... 50c Next 12 issues of The Radiobuilder
.... \$1.00 Next 25 issues of The Radiobuilder

S-M DATA SHEETS as follows, at 2c each:

- No. 3. 730, 731, 732 Short-Wave Sets
- No. 4. 255, 256, etc. Audio Transformers
- No. 5. 720 Screen Grid Six Receiver
- No. 6. 740 "Coast-to-Coast" Screen Grid Four
- No. 7. 675ABC High-Voltage Power Supply
- No. 8. 710 Sargent-Rayment Seven
- No. 9. 678PD Phonograph-Radio Amplifier
- No. 12. 669 Power Unit (for 720AC)
- No. 14. 722 Band-Selector Seven
- No. 15. 735 Round-the-World Six
- No. 16. 712 Tuner (Development from the Sargent-Rayment)
- No. 17. 677 Power Amplifier for use with 712

Name.....
Address.....



TYPE 360 TEST OSCILLATOR

ONE of the new test oscillators for the radio service laboratory is now ready. It will deliver a modulated radio-frequency voltage at any point in the broadcast band (500 to 1500 kilocycles) and at 175 and 180 kilocycles. The tuning control is calibrated with an accuracy of 2 per cent.

The Type 360 Test Oscillator is intended to be used for neutralizing, ganging, and tuning of the radio-frequency stages in a receiver, and it is fitted with an output voltmeter for indicating the best adjustment.

Price \$110.00

GENERAL RADIO CO.

30 State Street Cambridge, Massachusetts

FREE RADIO GUIDE

SEND FOR IT

This book tells about newest startling developments. How to take advantage of the new wrinkles in radio, television, short wave, etc. Pictures and descriptions of thousands of new ideas. Shows new A-C Screen Grid tube and other sets, kits, parts, accessories and supplies at wholesale prices. Shows you how to save money on these and many home necessities besides. New edition now ready. Send for it today—NOW!



BARAWIK CO. 189-B Canal Sta., Chicago, U. S. A.

Mail me free Radio Guide as advertised.

Name

Address

City State

A RADIO PARTS GUIDE

The New

YAXLEY

Catalog



Send for it today for complete listings of Radio Convenience Outlets, Connector Plugs, Rheostats, Fixed and Grid Resistances, Jacks, Jack Switches, Phone Plugs, etc.

YAXLEY MFG. CO.

Dept. A, 1528 W. Adams St., Chicago, Ill.

DeJUR-AMSCO

Condensers Meet All Modern Radio Requirements



This is our shielded multiple condenser for screen-grid work. It can be had in all combinations with or without dial assembly. It is exceedingly low loss.

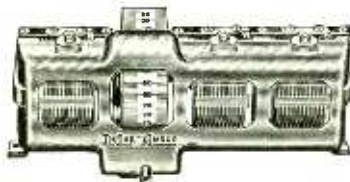

Shown above is the DeJur Amsco Standard Multiple Condenser available in all combinations with or without dial assembly.

Write for Engineering Data and Working Drawings. Send us your specifications and let us quote. Samples on request.

DeJUR-AMSCO CORPORATION

BROOME AND LAFAYETTE STREETS

NEW YORK CITY

SEND FOR SHORT WAVE BOOK—IT'S FREE!

Shows how to make new design short-wave receivers and short-wave adapters. How to use the new screen-grid tube in D-C and A-C circuits. How to make short waves get long distance. Latest information on all new radio developments. It's free. Send for copy today.

AERO PRODUCTS, Inc., Dept. 599B

4611 E. Ravenswood Ave., Chicago, Ill.

Name

St. and No.

City and State

"RADIO" Is No Longer Sold on Newsstands

Subscribe now to insure yourself against missing a single issue

SPECIAL RATES TO DEALERS: \$2.00 PER YEAR

"RADIO"

Send your subscription to the office nearest you

415 Lexington Ave.
New York City, N. Y.

307 No. Michigan Ave.
Chicago, Ill.

86 St. Botolph St.
Boston, Mass.

428 Pacific Bldg.
San Francisco, Calif.

Great New Book On

Power Amplifiers



FROM the Diagrams and Instructions in this new FERRANTI book you can build 10 different wonderful Power Amplifiers using new U X 171, U X 250, and even the very new U X 245 tubes. Follow the FERRANTI instructions and your Power Amplifiers will have high gain, flat response level, natural tone, tremendous power. Endorsed by engineers and reproduction experts. Sent postpaid for 15¢ coin. Write for YOUR copy today.

FERRANTI, Inc.
230 W. 42 St. Dept. 18
New York N. Y.

An 'A' To Meet The Trade's Demands

\$24.75



AN "A" Power Unit to meet this season's trade demands required a radical departure in construction.

The unit had to be exceptionally good and so designed that it could be produced economically.

The new Tobe "A" Power is de-

signed to meet these requirements. Our greatly increased production facilities make it possible for us to construct this unit at an unheard-of low price, extend the customary trade discounts and leave a legitimate margin of profit for the manufacturer.



Tobe's 14 Points

1. Dry rectifier (steady and quiet).
2. Variable transformer.
3. High inductance chokes.
4. Three Tobe "A" Condensers, 12,000 mfd.
5. Dial for regulating voltage.
6. Receptacle for "B" Supply.
7. Pendant switch controlling "A" and "B" Supply.
8. Most compact of all "A" units.
9. Simplified construction, will not get out of order.
10. Absolute elimination of hum or crackling.
11. Rigid construction, will withstand shipping.
12. Constructed with louvres, will not heat up.
13. Priced for quick turn-over.
14. Dull black finish on heavy metal, a beautiful unit.

Order your sample today, remove the cover and see a marked advance in "A" Eliminator construction.

Tobe Deutschmann Corporation

CANTON, MASS.

Tell them you saw it in RADIO

SERVICE MEN

To Do the Job Right

Always Use
FLECHTHEIM
 SUPERIOR CONDENSERS

A COMPLETE LINE OF BYPASS, FILTER, HIGH VOLTAGE AND TRANSMITTING CONDENSERS, FOR EVERY PURPOSE. HIGHEST QUALITY OF MATERIALS AND WORKMANSHIP, REPRESENTING GREATEST VALUES FOR YOUR MONEY.



Flechtheim Superior Condensers are used by an increasing number of radio service men, for all kinds of work—New constructional jobs, such as Power Packs, Power Amplifiers, and Receiving Sets. Also, for numberless types of repairs—"B" Eliminators, line filters, etc.

We make special dipped-in-pitch filter condensers that are rated at 450 volts D-C and are small in size and dependable. Then again, we have our famed Midget Condensers in a capacity range from .0001 to .05 mfd. at very reasonable prices. You will most certainly need and use them, once you see them.

Condenser Blocks for all types of amplifier tubes, Types F14 and F14A, for the 171; Type RM-14 for the 280-171; FA10, for the 210; and TC-244 our latest, non-inductive filter for the 250 push-pull, at considerable money saving prices.



For your transmitter: Type T, 1500-volt D-C, 750 A-C; TH, 2000-volt D-C, 1600 A-C; HP, 3000-volt D-C, 2200 A-C; VM, 5000-volt D-C, 3300 A-C. All obtainable in 1, 2 and 4 mfd. capacities. Plate blocking condensers and others, too.



Absolutely Indispensable Are These Flechtheim Superior Voltmeters

For testing line circuits, "B" batteries, eliminators and power jobs, we have three important, portable meters that will repay you for their cost on your first job. 0-300 D-C; 0-500 D-C and 0-600 A-C and D-C. All equipped with flexible, well insulated leads, and polarity colored cord tips. Really indispensable, for all repair and service work.

Write for catalogs now and name of nearest supplier

A. M. FLECHTHEIM & CO.
 Inc.
 136 Liberty Street, New York City

More Radio Pickups

The National Union Radio Corporation of 400 Madison Avenue, New York City, now owns the Sonatron, Televocal, Magnatron and Marathon vacuum tube plants in West New York, Hoboken, Chicago and Newark, with an aggregate capacity of 100,000 tubes a day.

during the same month. Five questions each are asked regarding installation, tubes, power supply, batteries, speakers, fundamentals and diagrams, each subject counting for ten points in the final grading; fifteen questions are asked regarding service, which counts for thirty points.

Electrical interference with radio reception in the downtown section of Bristol, Tennessee, has been solved by the installation of a Fada set in the home of Mr. Wilson of the Wilson Radiophone Service Company and the running of a telephone line to various hotels and stores who pay for the service on a monthly rental basis. Each store installation consists of a Fada speaker with local volume control.

Estimates as to the number of receiving sets that will be manufactured during 1929 vary from three and a half to eight million, while actual sales are estimated at from two and a half to four millions, this being slightly higher than estimates of 1928 sales. To secure accurate figures, the Radio Manufacturers' Association will make a survey of production and sales of radio receivers for the past two years.

Major Herbert H. Frost has resigned as vice-president of the merchandising division of Kolster Radio Corporation in order to become president of a new company which represents a consolidation of Utah Radio Products Company, Carter Radio Company and the H. H. Eby Manufacturing Company. L. T. Breck, formerly sales manager with Kolster, has taken Major Frost's position.

The Radio Receptor Company of New York City announces a new line of microphones for public address and sound reproduction purposes. These microphones have been designed primarily for use in conjunction with Powerizer sound amplifying systems. They include a 3½-inch, a six-inch, and a hand microphone for portable use. The construction includes a special alloy diaphragm that has no fundamental period. There is also a "non-packing" carbon button.

McMurdo Silver, president of Silver-Marshall, Inc., manufacturers of Silver radios, who was injured in an automobile accident, has been pronounced definitely out of danger by the attending physicians. At his request, his executive duties are being handled during his month's absence by a committee of three, consisting of G. A. Norton, H. C. Bodman and W. J. Frisbee.

The total value of the radio set installations in the world is estimated at \$1,843,750,000 by the Electrical Equipment Division of the Department of Commerce. The value of broadcasting stations in operation is placed at \$22,682,222. The report states there are 21,629,107 receiving sets in the world; the United States having 10,250,000. Europe, aside from Russia and Turkey, has 9,139,824 sets. The figures indicate there is one receiving set for every 12½ persons in the United States, one for every fifty-three in Europe, and one for every eighty-eight in the world.

The Radio Service Managers' Association of 1400 Broadway, New York City, gives examinations and certifications as to the proficiency of service men who apply in person. New sets of questions are used each month and no applicant can be examined twice

PHONOGRAPH RECORDS ANALYZED —A NEW DEPARTMENT IN "RADIO"

—TELLING YOU HOW TO SELECT RECORDS
 FOR PROPERLY DEMONSTRATING RADIO SETS

The frequency range of phonograph records will be analyzed in each issue of "RADIO," starting next month.

made by the large phonograph manufacturers will be selected by actual frequency tests made in our laboratory. Then we will tell you what records to select so that you can use those which are best adapted to the radio set you are demonstrating.

"RADIO" will give you the high-lights on the best bets of the month. Records

See December "RADIO" . . . Out on December 1st

LEUTZ

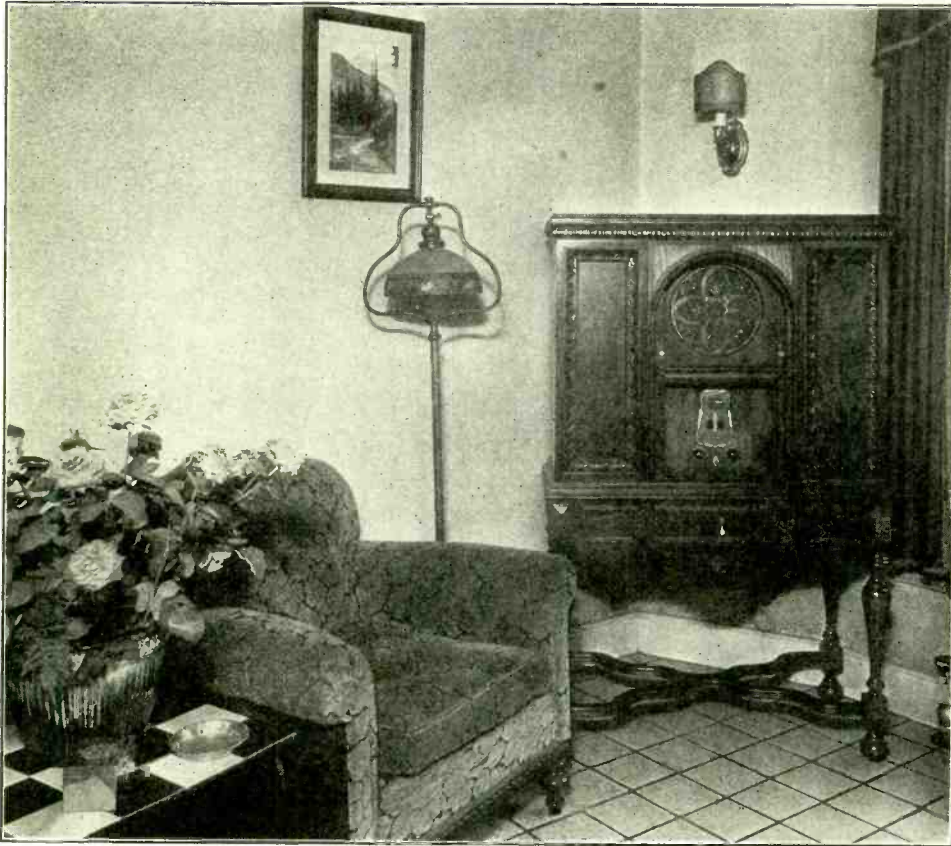

Above: Leutz "Seven Seas" Radio Phonograph Combination

Write, Wire or Cable Today

C. R. LEUTZ, Inc.

ALTOONA, PA., U. S. A.

Cables Experinfo, Altoona, Pa.

WEST COAST
B. J. HOWDERSHELL
 Detwiler Building
 412 West Sixth St.
 LOS ANGELES, CALIF.

NEW YORK
 Suite 628
 112 West 42nd St.
 NEW YORK CITY

FRANCE
BALDWIN M. BALDWIN
 1 Boulevard Haussmann
 PARIS, FRANCE
 Cables Experinfo Paris



Close-up of Phonograph

Three Screen-Grid Tubes
 12-in. Dynamic Speaker
 Electric Phonograph
 Adjustable Selectivity
 Push-Pull 2-250 Tubes
 Single (Split) Dial
 Panel Illumination
 Unit Construction
All LEUTZ QUALITY

SEVEN SEAS

Tell them you saw it in RADIO

(Continued from Page 71)

winding for the filaments of a pair of 245 tubes, and a 2-1/2 volt, 9 ampere winding for the heaters of five '24 or '27 tubes. The voltage-divider, RHQ-30, consists of a 9525-ohm treated enameled wire wound resistor conservatively rated at 30 watts. It is wound on a 3/4-in. diameter vitreous tube, 5 in. long, and is accurately tapped at 850, 3000, 2160 and 2375 ohms. The filter condenser block, CHQ-30, has seven condenser sections consisting of a 2 μf condenser rated at 600 volts, a 4 μf condenser rated at 500 volts, a 2 μf condenser rated at 400 volts, a 1 μf condenser rated at 300 volts, a 1 μf condenser rated at 400 volts and a pair of 1 μf condensers, each rated at 200 volts. Pig-tail leads are provided for sub-base connections.

The Jefferson replacement audio transformer, No. 371, is a low-priced unit which may be used to replace an old transformer in an a-c or d-c set so as to give full amplifica-

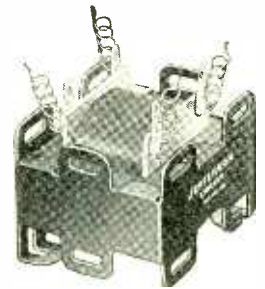

tion without distortion. It is 1 3/4 by 2 3/8 by 2 in. and can be mounted vertically or horizontally. It has brackets on six sides and uses either lugs or flexible leads for connection.

IKE, THE SERVICE MAN

(Continued from Page 56)

electricity. But from Chilcoot to Tiajuana, Ike leaves satisfied customers. We put the question up to him and he gave the answer cryptically.

"I give 'em what they want, don't I? Well—what the hell?"

We ventured one more question.

"How about Joe—will he be any good, do you think?"

Ike lowered his voice.

"Between me and you," he said, confidentially, "he won't. He ain't got no technical experience."

LOOSE LEAF BINDER

FREE 6 x 9-in. loose leaf binder for data sheets given free with one year subscription to "Radio." SUBSCRIBE NOW!

ANNOUNCING ~

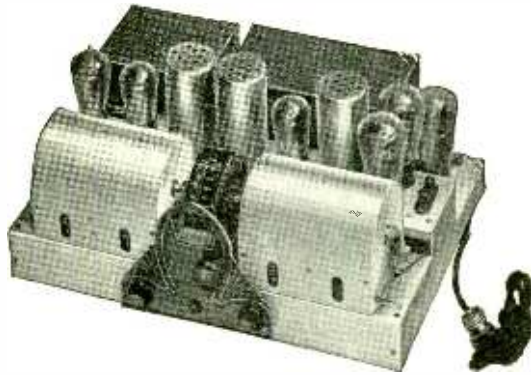

Antenna-less

MANDEL Screen Grid Chassis

THE first radio that satisfactorily receives distant stations *without an aerial, loop, or ground.* In the Mandel Screen-Grid Chassis atmospheric static is greatly reduced, and distortion is totally absent. No other radio possesses these outstanding qualities. Those who recognize fine construction in radio, will turn to the MANDEL.

Built for those who wish to increase their profits by marketing a fine radio under their own name.



MANDEL Electro-Dynamic Speaker

Made to match the fine quality of the MANDEL Chassis. Wired for 90 to 125 volts, 50 to 60 cycles, alternating current, or for direct current operation in connection with the MANDEL Chassis. Also made to operate from a 6-volt storage battery.

The MANDEL Electric Co.

2159 No. California Avenue Chicago, Ill.
Makers of Fine Radio Apparatus Since 1920

West Coast Representative
WM. G. LANDES
905 Mission Street, San Francisco, Calif.

For Exact Radio Tube Voltage

With micrometer accuracy, AMPERITE automatically controls each tube. Lengthens tube life. A type for every tube. \$1.10 with mounting (in U. S. A.).

AMPERITE Corporation
661 BROADWAY, NEW YORK
FREE—"Amperite Vest Pocket Tube Chart."
Write Dept. PR11

AMPERITE
REG. U. S. PAT. OFF.
The "SELF-ADJUSTING" Rheostat

This symbol in a radio diagram means—

Choice of 1200 Newest RADIO VALUES

SEND for our wholesale 1930 catalog. Filled with amazing values in screen grid radios, 245 push pull audio, radio consoles, kits, parts. Guaranteed merchandise at wholesale prices.

FREE

WESTERN RADIO MFG. CO.
130 W. LAKE ST. CHICAGO ILL.

FROST-RADIO

wants you to have a copy of its valuable 16-page Parts Catalog **FREE**

We want every reader of RADIO who has not yet received his copy to send for our big 16-page Parts Catalog containing a vast amount of useful information, in addition to illustrating and describing the complete line of Frost-Radio Parts and accessories. It describes our big special offer to radio set builders. It tells about special hook-ups, short cuts, "how to do things better." Get your copy of this book today. Remember, it's FREE for the asking. So just mail the coupon NOW and get your copy by return mail.



FROST-RADIO WIRE-WOUND RESISTORS

Made in four different sizes, all metal shell, with resistances ranging from fractional to 10,000 ohms, and with or without D. C. Battery Switches . . . Frost-Radio Carbon Element Resistors are made in several types, Bakelite or metal shell cases; distinguished by low hop-off, in fractional ohms if desired; also may be combined with A. C. switch.

HERBERT H. FROST, Inc.

Main Office and Factory

ELKHART, INDIANA

FREE

TO OBTAIN OUR CATALOG JUST FILL OUT AND MAIL THIS COUPON

HERBERT H. FROST, Inc.
160 N. La Salle Street, Chicago

Send me your 16-page Parts Catalog by return mail. I understand it will be sent to me FREE and postpaid.

Name.....

Address.....

City.....State.....

Longer life
High Vacuum
23 Years of engineering leadership
minimizes service costs
No hum
No buzz
No crackle

1906 1929

de Forest
AUDIONS

DE FOREST RADIO COMPANY
JERSEY CITY, N. J.

Branch Offices located in

Boston	Chicago	Los Angeles
New York	Minneapolis	Seattle
Philadelphia	St. Louis	Detroit
Atlanta	Kansas City	Dallas
Pittsburgh	Denver	Cleveland

BE A RADIO DOCTOR



Radio servicing offers the biggest opportunity for the man interested in radio. About 10,000,000 receivers need service some time or other, many are naturally inefficient and can be improved on.

The Radio Doctors, Inc., is the only institution teaching exclusively radio repairs, having specialized on this phase of radio for a number of years.

\$3,000 to \$5,000 per year

The professional "Radio Doctor" receives \$2.00 or \$3.00 per visit and is welcomed in the best of homes—may I tell you more about this new, fascinating and extremely profitable business? Write now for free booklet, "Why the Radio Doctor?" (Early inquiries will receive a blueprint of a recent well-known manufactured superheterodyne.)



E. W. PARKER, Pres. RADIO DOCTORS, INC.

Dept. R-1, 131 Essex Street

Salem, Mass.

Tell them you saw it in RADIO



Pyrohm Resistors

Accurate — Unchanging

REDUCED sensitivity, low volume, distortion and poor tone quality are the inevitable results of using inaccurate resistors which do not maintain their proper resistance values.

To be assured of satisfactory operation in power supply units and power amplifiers, be sure to specify and use—Aerovox Pyrohm resistors of the proper resistance values and current carrying capacities.

These units are made of the best grade of resistance wire wound on a refractory tube, and protected by a porcelain enamel against moisture, oxidation and mechanical injury.

Send for Catalog

Complete specifications of all Aerovox Pyrohm resistors are contained in a complete catalog which will be sent free of charge on request.

The Research Worker

contains, each month, valuable information on radio design. It will be sent free on request.



"Condensers to be CARDWELL or equivalent"

appears quite frequently in specifications for receivers and transmitters intended for real service.

WHY?

Because maximum performance is demanded and, insofar as condensers are concerned, the designers are insuring it by specifying the best.



Transmitting Condensers for powers up to 50 K. W.
Receiving Condensers in all Standard capacities.

Send for Literature
Write for Literature

The
**ALLEN D. CARDWELL
MFG. CORPN.**

81 Prospect Street, Brooklyn, N. Y.



G E A R S

In stock—immediate delivery
Gears, speed reducers, sprockets, thrust bearings, flexible couplings, pulleys, etc. A complete line is carried in our Chicago stock. Can also quote on special gears of any kind. Send us your blue-prints and inquiries.
Write for Catalog No. 100
Chicago Stock Gear Works
769-773 W. Jackson Blvd. Chicago, Ill.

MUZZLING STRAY IMPULSES

(Continued from Page 64)

radius within which the resultant interference is heard in radio receivers.

In the electrically controlled automatic burners the current density is comparatively small and the interference is usually confined to the building in which the burner is located. But in exceptional cases it will be telegraphed along the power wires into two or three adjacent buildings. The current consumption of such devices as X-ray and diathermy is much greater than that of a burner and will therefore spread out over a much greater territory, sometimes as much as two or three square blocks. On the power lines, if the arc is carrying the total current flowing in the circuits, the territory interfered with will vary according to the amount of current flowing; in other words, will increase with peak load in the evening and will be a minimum during the daylight hours.

The treatment for this type of interference is the same as that given for stray impulses, with the exceptions that filters may be installed on such devices so as to prevent the interference from being radiated at broadcast frequencies.

The preceding discussion has considered only the radiated component of the stray impulses. While this is by far the most prevalent, as also the most objectionable source, it must be remembered, that wherever an electric current is flowing, a corresponding magnetic field surrounds the circuit. This magnetic field varies in intensity in direct proportion to the variations in the current value, and hence, if a radio receiver is placed close to a device producing fluctuating magnetic fields, interference will be set up by magnetic induction. An r-f amplifier tube will amplify an audio frequency current to some extent, and so, if induction is taking place between the source and the aerial lead-in or ground wire, the resultant disturbance will be amplified through the receiver to the loud-speaker. Examples of this condition are:

1. Receiver located inside the magnetic field of any device which makes and breaks the electric circuit periodically, such as motors, or electro-therapy devices.

2. Where the receiver is placed close to an a-c or d-c circuit in which the current flowing is varying rapidly and at a great rate.

A noticeable difference in the intensity of the interference is seen when the receiver is moved from the proximity of the branch wires carrying the total current load of the interfering device to the main service wires of the building. The current flowing in circuit leading to the device varies periodically from zero to maximum, while, beyond the point

Thordarson Transformers and Chokes

For Use With

"245" Type Power Tubes

and "224" Screen Grid Power Detectors

Input Couplings

Single "245" tube, from any radio amplifying tube, use any one of three transformers	{ R-260 \$5.00 R-300 8.00 R-400 9.00
(R-400 especially suited to "226" and "227" tubes)	
Push-Pull "245" tube, from any audio amplifying tube. Use 1-to-1 ratio input transformer	T-2408 \$8.00
Use 2-to-1 ratio input transformer	T-2922 12.00
Screen grid power detector "224" to any single power tube, use "Autoformer" for choke-resistance type of standard circuit	R-190 \$5.00
Screen grid power detector "224" to any push-pull power tubes use R-190 Autoformer for parallel feed to detector plate and 2-to-1 coupling transformer	T-2922 \$12.00

Speaker Couplings

Single "245" tube to dynamic speaker with built-in transformer to cone speaker, or to magnetic speaker—Use either one of two transformers	{ T-2876 \$6.00 T-2901 12.00
Use choke condenser coupling, employing one choke	R-196 5.00
Single "245" tube to moving coil of dynamic speaker—Use transformer	T-2902 \$12.00
Push-pull "245" tubes to dynamic speaker with built-in transformer, to cone speaker, or to magnetic speaker—Use coupling transformer	T-2880 \$12.00
Use choke coupling, employing double choke	T-2420 8.00
Push-pull "245" tubes to moving coil of dynamic speaker—Use either one of two transformers	{ T-2629 \$10.00 T-2903 12.00

Filament Supplies

For six "224" screen-grid tubes or six "227" tubes—Use filament transformer (10.5 amps at 2.5 volts)	T-3660 \$9.00
For two "224" tubes or two "227" tubes and one or two "226" tubes use double voltage transformer	T-3081 \$6.00

Power Compacts

For filament current, plate current and bias on "245" push-pull power stage, also plate current for set. Contains filter chokes. Uses one 280 rectifier tube	R-245 \$24.00
For filament current, plate current and grid bias on single "245" power tube and one "226" audio tube, also plate current for set. (Requires extra T-3081 filament transformer.) Contains filter chokes	R-480 \$17.00

THORDARSON

RADIO TRANSFORMERS

Thordarson Electric Manufacturing Co.
Transformer Specialists Since 1895

WORLD'S OLDEST AND LARGEST EXCLUSIVE TRANSFORMER MAKERS

Huron and Kingsbury Streets, Chicago, Ill., U. S. A.

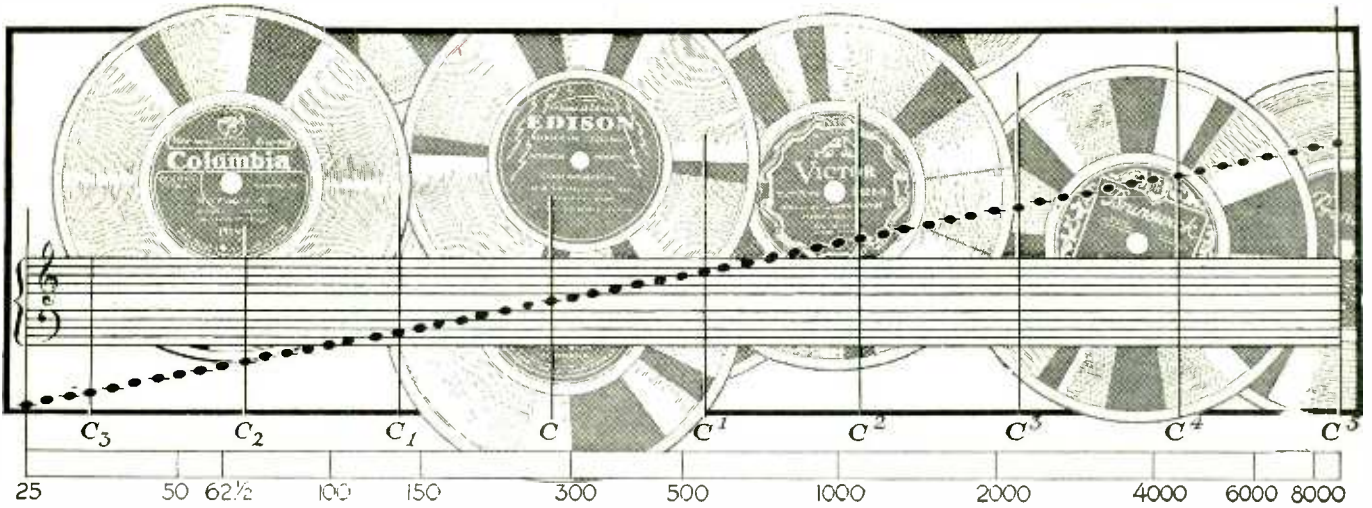

SELLING RADIO BY RECORDED MUSIC

....TELLING YOU HOW TO SELECT
THE PROPER RECORDS FOR THE
BETTER DEMONSTRATION OF RADIO
SETS, PHONO-RADIO COMBINATIONS
AND SOUND AMPLIFYING DEVICES.

A NEW department in "RADIO" . . . starting in the December issue . . . out on December first. In this department you will find our monthly recommendations for selecting the proper records to use in demonstrating radio sets, phonographs and amplifiers. Each month "RADIO" will analyze the best bets released by well known makers of phonograph records.

An acoustical engineer will give you the frequency ranges of these records. A musician will tell you a bit about the artist who composed the selection. A well known sales writer will tell you how to sell more radio sets by using "RADIO'S" recommended list of phonograph records . . . how to demonstrate these records . . . how to sell them!

[FOLLOW THIS MONTHLY
DEPARTMENT IN "RADIO."
TELL YOUR SALESMEN ABOUT IT.
ASK THEM TO SUBSCRIBE TO "RADIO."]

Publishers of

RADIO

ESTABLISHED 1917

NEW YORK . 415 Lexington Ave. 'Phone: Murray Hill 5992
CHICAGO . . 307 North Michigan Ave. 'Phone State 6079

SAN FRANCISCO, Pacific Building. 'Phone: DOuglas 0136
BOSTON, MASS 86 St. Botolph Street

Over 200 Radio Specials

in the **Federated Purchaser** "Radio Bargain News" to boost your Sales!

New Edition just mailed. If you did not get your FREE COPY, write us immediately. The items listed on this page are only a few of the many fine sales boosters, listed in our "RADIO BARGAIN NEWS."

We also have listed in our BULLETIN complete line of Aerial Equipment, Electrical Necessities, such as triple outlets, plugs, sockets, etc. In other words merchandise that sells, that you want, and that we have.

For the Dealers We Have SETS:

ERLA PEARSON 5-tube battery console set \$18.50

SPEAKERS

NEWCOMB-HAWLEY Magnetic Table Model \$7.50
 NEWCOMB-HAWLEY Dynamic mounted in Console Table to fit any set \$23.50
 FADA Table Model Dynamic Speaker No. 14 \$19.00

FEDERAL 7-tube one dial control, fully shielded battery operated loop set, Model F-10

\$27.50

HUNTINGTON 8-tube electric set, R.C.A. Licensed in beautiful console with Dynamic Speaker

\$59.50

Federated Purchaser

Serving Over Ten Thousand Retail Radio Merchants

Vol. 11, No. 10. November, 1929

MONEY SAVERS and SALES BOOSTERS

ELIMINATORS AND CHARGERS:

ATWATER KENT "B" Eliminator 135-150 volt \$13.50
 BALKITE Trickle Chargers, Model "J" \$6.50
 WEBSTER Bone Dry Charger, less cartridge \$1.50

TUBES:

R.C.A. and SONATRON, complete line, at *Unusual Discounts*.

MISCELLANEOUS:

BALDWIN Units \$1.50
 TIMMONS Phones 1.12
 BRACH Automatic Relay90
 PRIME Electric Turntables 10.50

FADA Dynamic Chassis Model No. 15 \$13.50

CROSLY Musicone \$2.75

B. B. L. Table Model Speakers \$6.50

UTAH Speaker in Chest Cabinet \$2.95

FOR THE SERVICE MAN:

TRANSFORMERS: CONDENSERBLOCKS:

Complete EAGLE Line		DUBILIER Super B and Master B, PL-1223	\$4.80
Federal 65A	\$1.45	DUBILIER Special Master B, PL-1737	6.60
ATWATER KENT Replacements	1.50		
FREED-EISEMANN Transformers	1.45		
ERLA Transformers	1.10		

FOR MAJESTIC ELIMINATORS:

DUBILIER PY-1778 \$5.40
 A complete line of replacement blocks for MAJESTIC SETS in Stock.

FOR ATWATER KENT SETS:

"Hylvoltage" Atwater Kent replacement blocks for Model 37 sets \$7.50

FOR ZENITH SETS WE HAVE:

"Hylvoltage" Zenith block for all Zenith sets using 280 rectifier tube \$5.50

OUR TERMS are 20% cash with order and Balance C. O. D.

Send in your Business Card or Letter-head and we will put you on our mailing list at once.

Federated Purchaser

22 Hudson Street, New York, N. Y.

Phone: Barclay 7584

**CAPS MADE OF LEAD ONLY
METAL USED FOR X-RAY AND
RADIUM SHIELDS**



Type 224

**Screen-Grid Tube
Shield
With Shielded
Lead**

List Price 60c
Net. Wt. about 4 ozs.



Type 227

**Shield Type
No-Phonic Tube
Cap**

List Price 35c
Net Wt. 5 ozs.



Type 200

**Plain Type
No-Phonic Tube
Cap**

List Price 25c
Net Wt. 5 ozs.



Type 199

**No-Phonic Tube
Cap for 199 Tubes**

List Price 25c
Net Wt. 2½ ozs.



"SADDLE"
Approved
Ground Clamp
1", 2" and 3"
sizes

MERTZ SPEC. CO.
1308 Stockton St. Wilmington, Del.

**Copper, Brass,
Phosphor Bronze,
Nickel Silver**

Hot Tinned or Plain

We specialize in the manufacture of rolled metals .001 thick and thicker, 1/16" wide and wider, either hot tinned or plain.

The BALTIMORE BRASS CO.
1206 Wicomico Street
Baltimore, Maryland

where this circuit is connected to the building mains, the fluctuations are imposed upon the total current flow of the mains, and will cause slight ripples in this current, but will not again vary from zero to maximum. Therefore, the interference near the main circuits of the building is only a proportion of that near the branch line to the interfering device. In order to reduce the magnetic induction interference to a minimum, the same precautions as those for radiated interference must be taken.

A certain amount of the energy contained in stray impulses, both static and magnetic, will be transmitted directly into the receiver by means of the power wires to the receiver, and these wires, running close to potential leads of the chassis, will react on all such leads so as to produce interference (by potential leads is meant all wires in the receiver not at ground potential). In the modern chassis most of the potential leads are shielded inside the chassis, but some of them, such as loudspeaker, ground and aerial leads, must be outside the shielding cans, and are possible pick-up aeriels for stray impulses carried in over the power leads. The same is true if the condenser plates are not shielded or if the tubes are not inclosed in metal cans. If all stray impulse pick-up has been eliminated from the aerial, lead-in and ground wire, the component carried into the receiver over the power leads may be efficiently eliminated by a filter consisting of 2 condensers of .5 µf capacity connected in series across the power leads and with the center tap connected to a cold water pipe (not to ground binding post on receiver).

Very often, when filters are connected across the power input to the receiver, little if any difference in the interference is noticeable. This is due to the fact that most of the interference is picked up by the aerial, lead-in and the ground wire. Therefore, before attempting to filter the line, the above precautions pertaining to aerial lead-in and ground wire pick-up must be taken.

The aerial lead-in and the ground wire should only be considered as a medium for transmitting radio signals from the flat top portion of the aerial, and not as a part of the aerial.

To prevent stray impulse pick-up on the aerial flat top, it must be erected as far away from power wires and metallic objects as is possible.

Most stray impulse pick-up takes place in the lead-in and ground wire.

A filter is of no use whatever if pick-up is had on the lead-in and ground wire.

A common ground carrier, such as water pipe used by power lines and telephones, should never be used for a ground connection, unless the connection from the receiver is made near where the water pipe enters the earth.

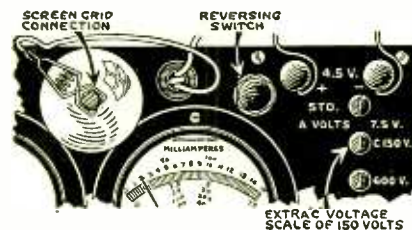

**Your Old Jewell 199
SET ANALYZER
CHANGED OVER**

For Screen-Grid Operation **\$13.50**

Changeover includes all parts, labor, accessories and complete instructions for operating the remodeled Set Analyzer. Why send to the factory, pay \$22.50 and wait for 60 days when we'll hustle your Set Analyzer.

Back in 10 Days or Sooner and save you money. Above illustration shows finished job. Send us yours today **\$13.50**

NEW JEWELL MODEL 409
A 4-Instrument Set Analyzer
for Expert Service Men
\$93.38 F. O. B. Spokane, Wash.

SPOKANE RADIO CO., INC.
528 First Avenue Spokane, Wash.
Complete Mail Order Service for Dealers

**Something
NEW**



**An Accurate
Resistor**

5 OHMS TO 5,000,000 OHMS

THE Super Akra-Ohm Resistor, wire wound, has been designed with the primary thought of commercial acceptability. In order to insure an accuracy of 1% and permanency of calibration it is manufactured by a special process, (patent pending).

BULLETIN NO. 62

which fully describes the use of the Super Akra-Ohm Resistor as a Voltage Multiplier, also contains the first complete chart for the employment of accurate resistors with microammeters and milliammeters. The Super Akra-Ohm Resistor is also especially recommended for use as Laboratory Standards, High Voltage Regulators, Telephone Equipment and Television Amplifiers, and Grid and Plate Resistors, etc.

Send now for your copy of this useful Bulletin, and a reprint of the article, "Multiplying the Usefulness of a Single Meter by Means of Resistors," which appeared in September "RADIO."

Shalleross Mfg. Company
ELECTRICAL SPECIALTIES
700 PARKER AVENUE
Collingdale, Pa.
Accurate
NON INDUCTIVE
WIRE WOUND
RESISTORS

**USE THE CLASSIFIED ADS
IN "RADIO"**

**They Bring Results
Mail Your "Ad" Now**

Tell them you saw it in RADIO



Carton of four Eveready Raytheon B-H Tubes

SELL NEW B-H RECTIFYING TUBES TO YOUR CUSTOMERS FOR THEIR "B" ELIMINATORS

EVEREADY RAYTHEON B-H

MILLIONS of "B" eliminators have been sold in the past few years. The majority are especially designed and built for the B-H tube . . . the original gaseous rectifying tube. When tube replacements are necessary, a new Eveready Raytheon B-H is the tube to use. Tell your customers what a great difference in reception a new rectifying tube will make. The replacement market for B-H tubes is enormous!

Eveready Raytheon B-H Tubes come in handy cartons of four tubes each. Always keep at least one full carton out where customers can see it.

NATIONAL CARBON CO., Inc.
 General Offices: New York, N. Y.
 Branches: Chicago Kansas City
 New York San Francisco
 Unit of Union Carbide and Carbon Corporation



Trade-marks

EUROPEAN SCREEN-GRID CIRCUITS

(Continued from Page 48)

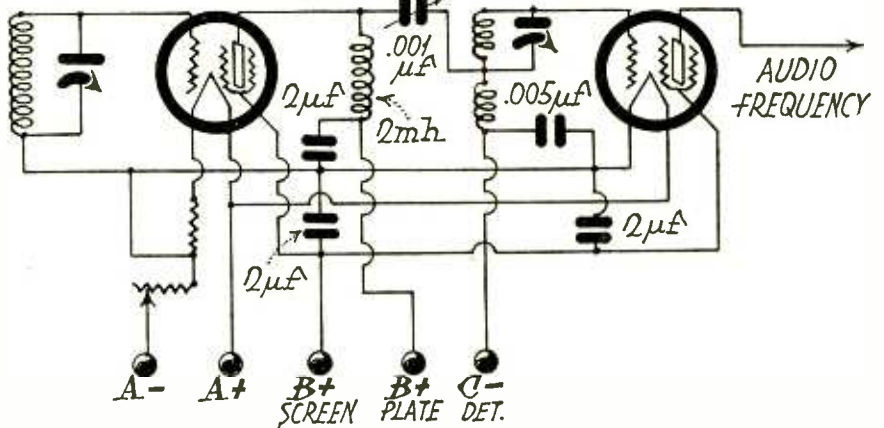

Fig. 5. A Recommended Austrian Circuit with Screen-Grid Tubes in R-F Amplifier and Detector

struction is really first class, I have found it desirable to add it.

At least one circuit using resistance coupling has been widely used, that of Fig. 6. This I have found to be greatly improved by heavy filtering, not specified in the original. It should not be forgotten that it is necessary to make "B+" plate" higher than usual to make up for the drop (of about 30 volts) in the

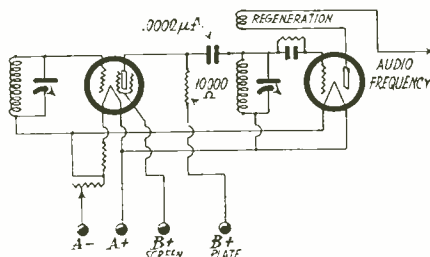

Fig. 6. Screen-Grid Tube with Resistance Coupling

coupling resistance, or alternatively to reduce the screen-grid voltage.

Finally, an elaborate idea, due to Hasenberg (Funk, Berlin, May 31, 1929) is that given in Fig. 7. The author's specifications for the components marked (all others being standard) are: R_1 and R_2 , 50,000 ohms; R_3 and R_4 , 20,000 ohms; C_1 and C_2 , $\frac{1}{2}$ μ f; C_3 and C_4 , .0005 μ f; C_5 and C_6 , .00025 μ f; C_7 , .0005 μ f.

To simplify this figure, the positive A lead has been omitted. Regeneration is obtained by the combined action of

C_5 , C_6 and C_7 , the two former being set once for all to approximately equal values, and the latter used for control. Personally, I should add bypass condensers from outside R_3 and R_4 to negative filament, of say 1 μ f each, and also chokes in series between these resistances and their common lead to B+.

In fact, in all these circuits, filtering is desirable; in some cases it has been specified by the authors but omitted from the figures in order to simplify them. The general form is of course standard—bypass condensers of at least $\frac{1}{2}$ μ f from the low-tension end of the coupling device (whether this be a tuned circuit, primary, auto-transformer, or resistance) to ground (or, more constructionally speaking, to the negative filament terminal of the tube in question rather than to the bus-bar); and, be-

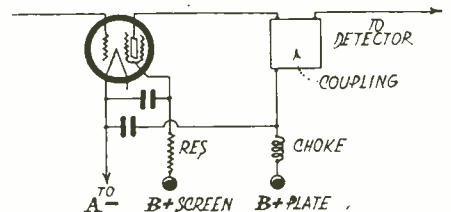

Fig. 8. Filter Circuit

tween these and the B battery, either large resistances, of 20,000 ohms at least, or, where the drop in voltage across such would be excessive, r-f chokes. Fig. 8 gives the general idea.

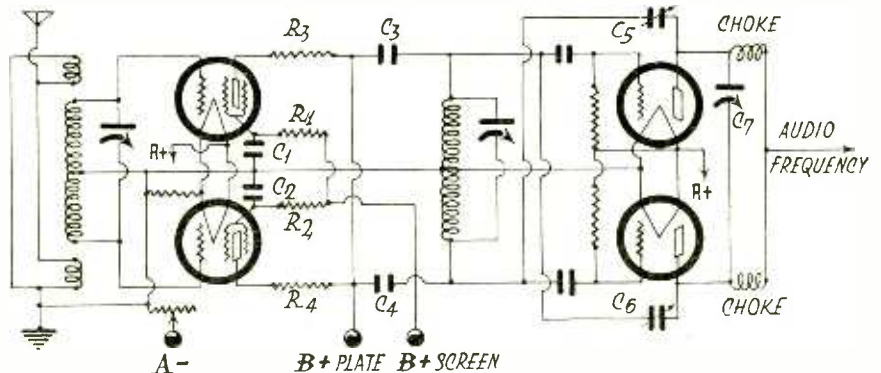

Fig. 7. An Elaborate German Circuit

SUPPRESSING LINE INTERFERENCE

(Continued from Page 66)

wire. Over this the size of the wire will have to be increased in proportion to the load to be carried. After the coil form is made it should be lined, in the winding space, with sheet asbestos, leaving about an inch stick over the edge to lap over the completed coil; 75 turns of No. 14 d.c.c. are wound in the slot, the ends being taken out to binding posts on the side where the condensers will be mounted.

For commutator type motors two coils will have to be used, one in each side of the line. The forms are the same

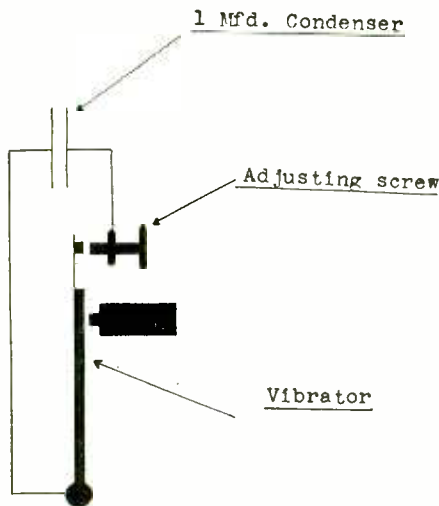

Fig. 6. Suppressor for Vibrator Type of Battery Charger

size and the winding on each coil is 50 turns No. 14 s.c.e. wire connected as shown in Fig. 4. This filter for sweepers and such is connected across the power outlet from which the appliance is used and becomes a permanent installation. It is suitable for use with elec-

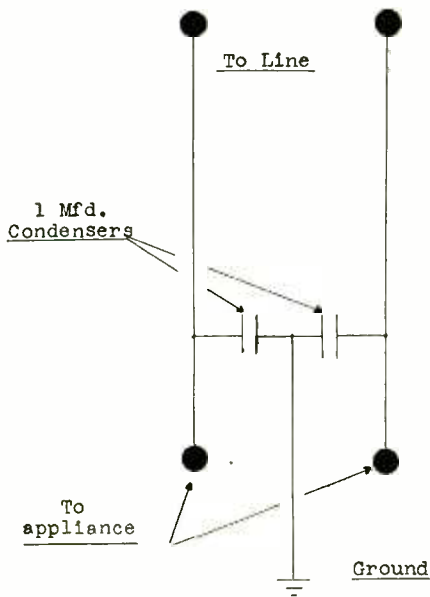

Fig. 7. Suppressor for Small Installation

tric vibrators, hair clippers, drink mixers, serving machine motors, fans, and drills.

For a vibrator type battery charger, a 1 μ f condenser connected across the contact points, as shown in Fig. 6, will eliminate one of the most common sources of radio interference. Two 1 μ f condensers across the contacts as in Fig. 7 will generally suffice for farm lighting plants, motor-generator sets, d-c generators and small motors.

BOOK REVIEWS

(Continued from Page 76)

radio sets and loudspeakers as well as of their officials and branch managers, together with brief specifications as to their products and list prices. Information is also given as to association membership and patent owners whose licenses are used in the sets and speakers. Sets are listed as to their trade name, model number or name, style of cabinet, type of speaker, kind of power, tubes, price and power consumption. Speakers are listed as to name, type, style of cabinet, type of rectifier, power requirements and price.

"A B C of Television," by Raymond Francis Yates; 210 pp.; 5 $\frac{3}{4}$ x8 $\frac{3}{8}$ in. Published by The Norman W. Henley Publishing Co., New York City. Price \$3.

This is a practical and popular explanation of the how and why of television and telephotography. After a general description of the various methods which have been employed, it discusses the principles and action of photoelectric cells, resistance-coupled amplification, the neon lamp, scanning discs and synchronizing methods. Much of the material presented is compiled from publications of the Bell Telephone Laboratories. The concluding chapter gives directions for building a television receiver which consists of a short-wave tuner, resistance-coupled amplifier, scanning disc, and neon lamp. The book in its entirety presents a comprehensive picture of the present crude stage of the art.

SAVE MONEY!

"Radio Engineering" and
"RADIO"—Both for a full year
\$3.00

"Radio News" and "RADIO"—
Both for a full year
\$3.00

TWO MAGAZINES FOR A LITTLE
MORE THAN THE PRICE OF ONE

SUBSCRIBE NOW!

"RADIO"

Pacific Building San Francisco

SALESMEN WANTED!

Men to call on radio dealers, jobbers and service men to sell "RADIO'S" Price and Data Sheet Service and loose leaf binder for same. Liberal commissions. Large territory. Write at once for complete details.

PUBLISHERS OF "RADIO"
Pacific Bldg., San Francisco

Tune in on This



New Radio Course

IT PROVIDES an easy way to prepare for a good position in radio work. It furnishes a broad knowledge of radio that applies to the job at hand, whether that job be the simple act of removing a tube or figuring on the most modern installation. It explains the technicalities of radio in clear, understandable language, first laying a fine mathematical background.

There is no better way for you to succeed in radio than to study this new course of the International Correspondence Schools. Every day new students are finding out its many advantages. The course is endorsed by leading radio experts and radio manufacturers.

Mark and mail the coupon today and let us tell you what the new Radio Course can do for you.

Mail the coupon for FREE booklet

International Correspondence Schools
Box 8263-E, Scranton, Penna.

Without cost or obligation, please tell me all about the
NEW RADIO COURSE

Name _____
Street Address _____
City _____ State _____

Tell them you saw it in RADIO

A NEW SELLER!

CORWICO
VULCAN

LIGHTNING ARRESTER

\$1



It also dissipates accumulated static charges—an exclusive feature you can talk about and sell.

If your jobber cannot supply you with Corwico Vulcan Lightning Arresters, order a sample carton of six direct.

CORNISH WIRE COMPANY
26 Church Street, New York City

MAKERS OF
CORWICO BRAIDITE HOOK UP WIRE

Potter Condensers

Replacement Blocks and Bypass Units

Now Available for
"B" Eliminators
and
Power Supply Units
for
Service and Repair Men

Potter Filter Blocks

RR-245	Condenser Block for single and push-pull 245 type tube amplifiers	\$19.75
T-2900	Condenser Block for the single 250 type tube amplifier....	\$20.00
T-0295	Condenser for the push-pull 250 type tube amplifier....	\$22.50
T-2098	Condenser Block for single 210 type tube amplifier....	\$20.00
T-280-171	Condenser Block for power pack with 280 type tube rectifier	\$18.00

The Potter Co.

North Chicago, Illinois
A National Organization at Your Service

Remember—CLAROSTAT for Every Purpose

Not merely a product; nor again an entire line of products; nor still again a resistance for every purpose. More than all that, it is the name of a service dedicated to

AIDS TO BETTER RADIO
ranging from improved wave interception to detector action, radio and audio amplification, volume control, tone quality and all manner of new and experimental applications.

Write for data on Clarostat line or ask your dealer about it.
CLAROSTAT MFG. CO., Inc., 287 N. 6th St., BROOKLYN, N. Y.

GOOD TONE

(Continued from Page 70)

gument, and of course clearness is desirable. It is, however, merely a result of proper design. Many obsolete sets gave forth "clear" sounds. Clarity without frequency range is not good music. A policeman's whistle can sound clear, but give a very poor rendition of Lohengrin.

We have one very obvious limitation of low frequencies, namely, the speaker baffle in a cone type speaker and the projector of a horn type speaker. A baffle is any partition separating the sound waves produced by the front of the speaker cone from those produced by the rear surface of the cone.

Table 1—Fundamental Ranges

Instrument Voice	Lowest Fundamental	Highest Fundamental
Organ	16	4000
Piano	26	4096
Bass viol	40	240
Bass tuba	42	342
Bassoon	60	480
'Cello	64	682
Bass clarinet	78	480
Trombone	78	480
Bass voice	80	342
Kettle drums	84	170
Baritone voice	96	384
French horn	106	860
Tenor voice	128	480
Viola	128	1152
Trumpet	160	960
Clarinet	160	1536
Alto voice	170	682
Violin	192	3072
Soprano voice	240	1152
Oboe	256	1536
Flute	256	2304
Piccolo	512	4608

The lowest possible note that a speaker can radiate is, roughly, one whose quarter wavelength is equal to the distance from the front center of the cone around the baffle to the rear center of the cone. Wavelength equals velocity divided by frequency, where velocity equals 1100 feet per second. Therefore a hundred-cycle note has a wavelength of 11 ft.; $\frac{1}{4}$ wavelength equaling $2\frac{3}{4}$ ft., which would be the size of baffle required to produce such a note. (See Curve I.)

The design of a horn projector follows a logarithmic law for increasing diameter with length. Granting transmission and reception possibilities are ideal, still for perfect reproduction the volume should be the same as originally played, for it is a phenomenon of the human ear that as volume increases the lower tones produce a blanketing effect which renders the higher frequencies inaudible.

In speech the frequency change is very rapid, but in music the notes are more sustained, and may call for considerable reserve power expenditure from the last tube. However, be it understood that the average power used in a speaker for good home reception is between 100 and 200 milliwatts, and that a single '71-A tube and a single '45 tube are capable of delivering 700 and 1600 milliwatts respectively to the loudspeaker.

Today's Radio Demand Thoroughly Trained Service Men and Reliable Testing Equipment



WESTON Model 547 Set Tester meets every requirement of radio's demands. Its use is proof of conscientious servicing and high professional standing, assuring manufacturer and dealer of prime set performance wherever it is periodically employed.

ance wherever it is periodically employed.

With the Model 547, the operator can quickly and positively check up any receiver made—locate and correct troubles without loss of time and add materially to his profits.

It is a triumph of constructional perfection and electrical completeness—a marvel of simplicity, its operation can be quickly mastered. Enclosed in a durable, abrasion-proof case of black bakelite with all external fittings of the same material, it offers a handsome appearance which will retain its newness in spite of hard usage.

A unique instruction book including individual data for most receivers on the market accompanies each outfit. Before purchasing any testing equipment carefully investigate the unusual merits of this tester. A fair and impartial comparison will convince you of its superior qualifications for service. Write for free copy of "Testing Instructions for Service Men."

WESTON ELECTRICAL INSTRUMENT CORPORATION
600 Frelinghuysen Ave., Newark, N. J.

Pacific Coast Representatives

GRAYBAR ELECTRIC COMPANY, Inc.
84 Marion Street
Seattle, Wash.

J. H. SOUTHARD
San Francisco, Calif.

A. A. BARBERA
Los Angeles, Calif.
REPAIR SERVICE LABORATORY
682 Mission Street
San Francisco, Calif.

Weston
PIONEERS SINCE 1888
INSTRUMENTS

Everything in RADIO! at Lowest WHOLESALE PRICES

Get this... CATALOG



This big book of 148-pages—rich from cover to cover with radio bargains—is yours for the asking. It contains all the latest radio devices and improvements—sets, accessories, parts and kits—profusely illustrated. No radio need is overlooked. Everything in this big book is available at wholesale prices, and many items are spotlighted as Specials at truly astounding reductions. To be without this book is to miss your greatest buying opportunity in radio. Every page points the way to money-saving. Never before have such startling values been offered—made possible by our tremendous buying power and low cost of operation. Quick deliveries and expert cooperation assured to all our clients. A trial order will make you a regular customer, just as it has thousands of our pleased customers.

Clip the Catalog Coupon, and mail it today!

New SCREEN-GRID Models

Marvelous offerings in new, Humless, Screen Grid A. C. all-electric and battery operated sets; a wide range of beautiful consoles, from the small table model types to the most ornate and artistic of radio furniture; dynamic speakers of tremendous volume and richest tone; accessories, parts and kits in wide variety—in fact, everything that is standard, as well as everything that is new, in Radio. Get this book today!

Price-Saving COUPON

Chicago Salvage Stock Store
Dept. 127
509 So. State St., Chicago, Ill.

Kindly send me (free of charge and postpaid)
your new 148-page Book of Radio Bargains.

Name.....

Address.....

City..... State.....

CHICAGO SALVAGE STOCK STORE
World's Largest Radio Store
509 So. State St. Dept. 132 Chicago, Ill.

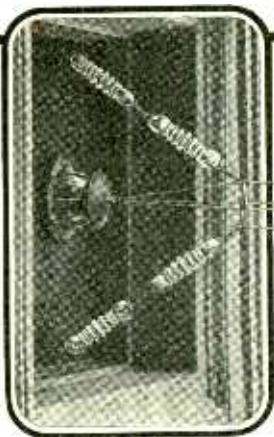

The right insulating equipment to avoid radio energy loss at a close-coupled horizontal lead-in

THIS antenna insulator installation has helped Broadcasting Station WQAM, owned by Miami Broadcasting Co., Miami, Fla., to send its fine programs far into the south-western, central and northeastern portions of the country without loss of clarity and with the moderate power of 1000 watts.

The PYREX Navy Type Entering Bowl coupled direct to the end of the antenna carries the lead-in squarely through the center of an opening in the wall, and two PYREX Strain Insulators in series on each anchorage and tension line keep the radio energy *in* and the disturbing stray secondary currents *out* of the antenna. Semi-tropical rains and moist salty atmosphere do not impair the protection because PYREX Insulators have a dense impervious surface that sheds water and collects no deposits. Likewise in dust and smoke-laden atmosphere, particles that settle on PYREX Insulators are blown off by wind and washed off by rain. In any location, there is no deterioration in insulating value. The mechanical strength of PYREX Insulators is equally permanent, so that once placed, they assure continuous operation. In a number of instances, storms that wrecked wiring and towers did not break the PYREX Insulators.

Suitable types and sizes of PYREX Insulators for every antenna, lead-in, stand-off, base support, and bus-bar purpose are illustrated and described in the PYREX Radio Insulator Booklet, which will be sent on request.



Write to us for the booklet and buy PYREX Insulators from your nearest supply house.

CORNING GLASS WORKS, Dept. 65
Industrial and Laboratory Division: CORNING, N. Y.



SILVER THE KING

Gosilco Super Aerial Wire
Gold over Silver on Copper

Amazing DX Reception. 50% Improvement in Volume and Selectivity—Superb Tone—Non-Corrosive. Endorsed by Sparton Engineers, Gerald M. Best. The Peer of all aerial wire or devices. No. 14, 100 ft., \$4.00; 75, \$3.25; 50, \$2.50. Patented. If dealer cannot supply you, write us. Over 50,000 GOSILCO Aerials in use—There's a Reason.

Eastern Jobbers Write. Exclusive Territory
GOSILCO RADIO PRODUCTS CO.
6420 Marbrisa Ave. Huntington Park, Calif.

Northern California Customers Order Your GOSILCO SUPER AERIAL WIRE from
Radio Dealers Supply Service
Wholesale Division of **OFFENBACH** ELECTRIC COMPANY 1452 Market Street San Francisco, California

How many turns will it make this year?

Your profits in tubes depend on your turnover. And your turnover depends upon the number of lines you carry.

A. B. C. stuff? Yes. But it is surprising to find that some radio dealers are carrying 20, 25 and 30 different brands of tubes.

Actual figures

You can easily prove the value of increased turnover in terms of profit. Take the following case: Sales \$30,000, margin of profit 30%, operating expense \$7,500, average inventory at selling price \$5,000. Here is a turnover of 6 times a year and a yearly profit of \$1,500. With 7 turnovers—annual profit doubles—\$3,000. With 8 turnovers profit is \$4,500—and so on.

The lines you concentrate on must be well-known brands of the highest quality

When a dealer decreases his number of brands, he must be sure that each line he carries has these two features:—

1. Must be of the highest quality.
2. Must be nationally accepted merchandise.

The quality of CeCo tubes is beyond question.

Two foremost manufacturers and two large tube distributors, by actual laboratory tests, proved that CeCo tubes have 30% to 50% longer life—and ordered, in aggregate, over 5,000,000 tubes.

CeCo is nationally known

CeCo tubes are sold from coast to coast. The CeCo Couriers broadcast every Monday night over the Columbia chain.

We are embarking on an extensive national advertising program. If you stock and display the CeCo line a good share of this business resulting from this campaign is bound to come to you.

This book shows you how to increase your tube sales

Send for this book. Following are only a few of the many helpful suggestions for building up tube sales that it contains:

- 1—The size and development of the radio market.
- 2—The percentage of profit in tubes.
- 3—The growing replacement market for tubes.
- 4—How quality tubes cut losses on set sales and service.



The AC 224 Screen Grid Tube was developed and perfected by CeCo over a year and a half ago.

Licensed under patents and applications of the Radio Corporation of America, the General Electric Company, and the Westinghouse Electric and Manufacturing Company.

Ce Co Manufacturing Company, Inc. PROVIDENCE, R. I.

CeCo Manufacturing Company, Inc., Dept. 810, 1200 Eddy St., Providence, R. I. Send me a copy of the dealer book "Tomorrow in the Tube Industry."

Name _____
Company _____
Address _____

The New
HAMMARLUND



Shielded
Polarized

R-F
CHOKE
COIL

A RADIO frequency choke specially developed for modern high-gain shield-grid receivers.

Shielded in an aluminum shell and polarized.

Minimum external field. No undesired coupling to cause circuit instability or feed-back. High inductance—low distributed capacity.

Efficient. Compact. Convenient.

Write Dept. PR11 for Details

HAMMARLUND MFG. CO.

424-438 West 33rd Street, New York

For Better Radio
Hammarlund
PRECISION
PRODUCTS



ON THE OCEAN FRONT

The
Breakers
ATLANTIC CITY N.J.

Preferred—

In all seasons by those who know and wish the best upon either the American or European Plan.

Sensible Rates Withal!

HILLMAN MANAGEMENT

SALESMEN WANTED
To take subscriptions to "RADIO"
Write Today

SCORE 1 2½ miles of wire — primary inductance of 175 henries with 1 mill D. C.

SCORE 2 for
FERRANTI

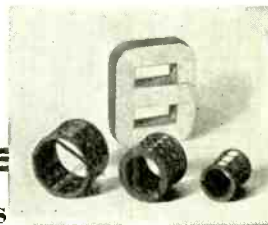

Flat Curve—25 to 8000 cycles
no pronounced resonant peaks at any frequency

FERRANTI Coil Design is different from that used in any other audio transformers. Ferranti Audio Transformers are built differently, as well. So Magnetic Leakage, and self and mutual capacity are reduced to an absolute minimum... no compound is used.

Ask any unbiased, really informed engineer. He will tell you that Ferranti Audio transformers are used whenever the finest attainable reproduction is demanded.

A. F. 5 Audio Transformer \$14
Ferranti O. P. M. C series Output Transformers \$16

There are 27 different Ferranti Transformers for every audio need. Write for correct type for your requirements

Of course you want such transformers. Then insist on FERRANTI from your dealer. Write us if he will not supply you.



Inc.

130 W. 42nd St. Desk 111
New York, N. Y.

SAVE MONEY ON RADIO!

LARGE DISCOUNTS

On Lafayette All-Electric, Screen-Grid Radio Receivers

The 1930 Lafayette Screen-Grid Radio Set is the sensation of the field. We offer you an opportunity to sell this tremendously popular receiver to people who want the finest in radio. Most liberal discounts to dealers and agents. Because of the tremendous demand for the Lafayette it sells at a price amazingly low.

30-DAY FREE TRIAL!

The 1930 Lafayette has every new feature of radio construction.

Screen-Grid Volume
All Electric Selectivity
245-Push-Pull Amplification
Illuminated Single Dial Control
Clearest Reception of Any Set on the Market!

30 Different Cabinet Models. Finest Custom-built work. AND—a 30-Day Free Trial on Every Lafayette Set. Unconditionally Guaranteed!

WE OFFER GREATEST BARGAINS ON NATIONALLY KNOWN PRODUCTS

WHOLESALE PRICES on nationally-known merchandise! Biggest discounts on standard equipment. TREMENDOUS SAVINGS. Everything shown in our newest 1930 Catalog—just out! Nothing to compare with it! Immediate personal service on all your orders.

MAIL COUPON FOR BIG CATALOG—ABSOLUTELY FREE

DEALERS—AGENTS—Mail the coupon below AT ONCE for your FREE copy of the new 1930 Wholesale Radio Service Catalog. See our money-saving bargains—beautifully reproduced in color. Over 200 pages of big specials. You buy under our "Satisfaction or money back guarantee." Get your copy today. Rush coupon!

TEAR HERE. FILL OUT AND MAIL

WHOLESALE RADIO SERVICE COMPANY
36 Vesey Street Dept. A-12 New York City

Name
Street
Town State

NEWEST 1930 CATALOG

RADIO Questions and Answers

By NILSON & HORNUNG

AT LAST, a book covering practically every conceivable radio problem and question has been published! This book, just off the press, is crammed full of highly important new radio information. It will be invaluable to those who wish to take examinations for their Commercial, Broad-

cast, Radiotelephone or Amateur License. For this book is intended especially for students and operators who are about to take the government examination for a radio operator's license. It gives over four hundred actual examination questions and shows how they should be answered.

\$2.00 PER COPY
POSTPAID

RADIO

PACIFIC BUILDING
SAN FRANCISCO

Tell them you saw it in RADIO

tone quality

An Outstanding Feature of All General Amplifiers

THE manufacturer and the purchaser of "Sound Projection" equipment realize the important relationship of the power amplifier to the satisfactory performance of the complete assembly. The rapidly increasing demand of the general public for finer tone quality necessitates improved design in all associated equipment. This demand has been successfully met in General Amplifiers.

Created by an engineering staff whose sole aim has been to give the public the best in power amplification. Built by men thoroughly experienced in their construction and operation. A product of merit is the result.

Sound engineering and inbuilt quality together with the incorporation of many distinctly unusual features have made possible this line of power amplifiers of unrivalled performance and tone quality. From the faintest whisper to tremendous volume absolute faithfulness in reproduction is maintained. Volume, tone fidelity, stability and service are assured with General Amplifiers.

Our engineering staff, specialists in the design and manufacture of power amplifiers to meet specific requirements, are always pleased to cooperate with you in your problems of audio amplification.

These and other models, not illustrated, are fully described in our Bulletin R3, which will be sent on request.

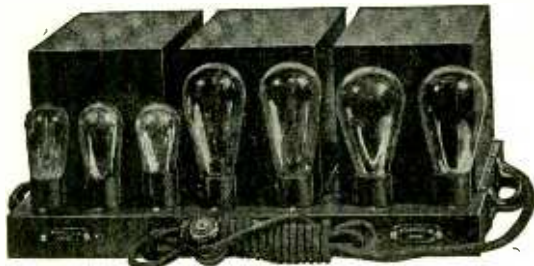

MODEL GA-20

A three-stage power amplifier incorporating dual push-pull. The tubes required are one 227, two 226s, two 250 power tubes and two 281 rectifiers. Will deliver approximately 14 watts of undistorted energy to the reproducers. Suitable for apartment house, theatre or other service requiring extreme volume reserve.

Price (less tubes)\$225.00



MODEL GA-15

A two-stage power amplifier employing one 227, two 245 power tubes in push-pull and one 280 rectifier. Will deliver approximately 4.5 watts of undistorted energy to the reproducer. Suitable for the home or other moderate sized installations.

Price (less tubes)\$85.00

GENERAL AMPLIFIER COMPANY

27 Commercial Avenue, Cambridge, Mass.

MAKERS OF HIGH-GRADE POWER AMPLIFIERS

Buy Direct From Manufacturer at Jobbers' Prices!

De Luxe Model **CHELSEA** Electric Radio

STANDARD MODEL

\$35.00

Uses four 226, one 227, one 280,
one 245 tubes

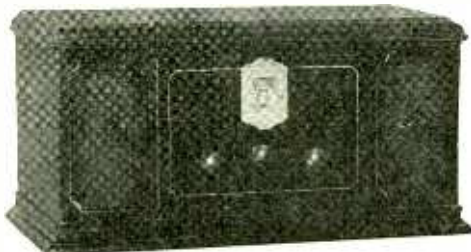

24 3/4-in. long, 12 3/4 in. wide, 12 3/4 in. deep

SCREEN-GRID MODEL

\$37.50

Uses four 226, one 224, one 245,
one 280 tubes

Operating Features:

Uses 245 power tube at full voltage.
Automatic pickup jack.
Built-in socket antenna.
Illuminated drum dial
Receptacle for A-C dynamic.
Provision for long or short antenna.
RCA licensed power pack.
Copper finished chassis.

CONSOLE MODEL

With

Electro-Dynamic Speaker

STANDARD MODEL\$53.50

SCREEN-GRID MODEL\$56.00

Technical Features:

Litz wound binocular coils
Speaker output choke
General Radio Transformer
C. R. L. volume control.
R-F choke in each stage.
Adjustable hum control.
Rotary power switch.
Four tuned circuits.

CABINET Made of selected woods with genuine Maple Burl panels, overlaid on four-way matched veneer. Hand-rubbed in dark brown Mahogany with glass-like lacquer finish. Massive and extremely beautiful, a true product of the cabinet maker's art. Size 24 3/4-in. x 12 3/4-in. x 12 3/4-in. TERMS: 25% with order, balance C.O.D. 2% discount full cash remittance.

BARTY RADIO COMPANY

11-42 31st Avenue, Long Island City, N. Y.

Quantity Manufacturers of Radio Receivers under private brands

Established 1920

Cable Address—BARTYRAD

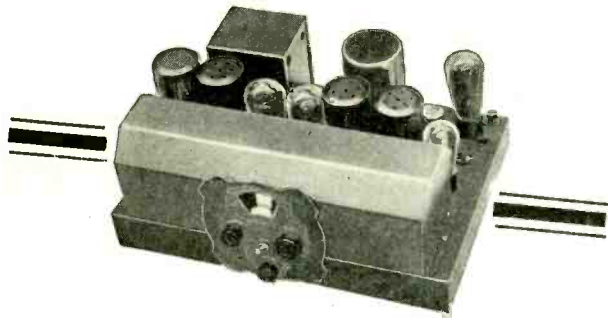

LOOK! Screen-Grid plus Power Detection — Under Your Own Brand

Cash in big this season by offering radio's newest and most modern development—using your own brand name. You set your own resale price to meet every market condition—you banish the bugaboo of one-sided contracts and restricted territories, and by *purchasing direct from factory*, you get every possible price concession. Most important, you preserve your greatest asset—your trade identity and good will.

This Premier Has Every Needed Feature

The new Premier screen-grid chassis, Model 724, 7 tubes (8 with rectifier), is illustrated. A great performer. Full tone, volume, pleasing eye value. Many features—power detection, 100% shielded, all metal, D.C. dynamic speaker terminals, phonograph pickup, safety fuse and latest tube combination using four 224's, one 227, two 245's in push-pull and one 280 rectifier. Chassis is 18 inches wide, 12 deep, and 7½ high.

WRITE FOR FULL DETAILS

PREMIER ELECTRIC COMPANY

1821 Grace Street, CHICAGO

Established 1905

MAJESTIC REPLACEMENT CONDENSER BLOCKS

By the foremost manufacturer of radio-condensers



List
Price

PL-1223

For Majestic B Eliminators, Super B and Master B Models...\$8.00

PL-1737

For Majestic B Eliminators, Special Master B Model...\$11.00

PL-1309

For the Power Unit of the 1928 Majestic Set\$10.00

Without exception, these are the best ever made.

They are condensers of superlative excellence—built on the wealth of manufacturing experience and practice which have made Dubilier condensers the standard of the industry.

They are designed and tested to give ten years, or more, of service. This testimony is typical:—"Get these in at earliest date—we have had perfect service from all of the Dubilier that we have used, which is more than can be said of some other makes."

WARNING! Replace with Dubiliers!

"You can forget the condensers, if they are Dubiliers"

Dubilier

CONDENSER CORPORATION

342 Madison Avenue

New York City

YOU WILL GET

GREATER PERFORMANCE from MILES

Electro-Dynamic Speakers for Talking Pictures, Public Address Systems
and All Types of Amplifiers

Not An Experiment!

THE RESULT OF YEARS OF
EXPERIENCE

M 9 Combination Unit and 9-ft. Horn.....	List \$230.00
M 10 Combination Unit and 10-ft. Horn.....	List \$275.00
M 12 Combination Unit and 9-ft. Junior Horn.....	List \$185.00
M 3½ Combination Unit and 3½-ft. Trumpet.....	List \$170.00

NOW READY—New Miles M 1000—Junior
Electro-dynamic Air Column Unit.
Send today for Catalogue.

MILES MANUFACTURING CORP.

"Builders of Acoustical Reproducers Since 1923"

31 West Twenty-first Street, New York City
Cable Address: "Milesman" N. Y.

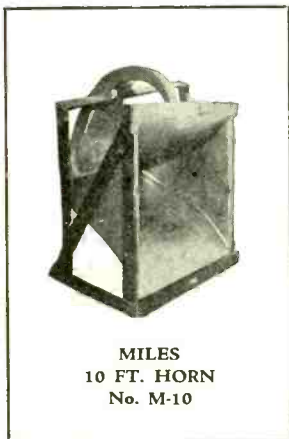

MILES
10 FT. HORN
No. M-10

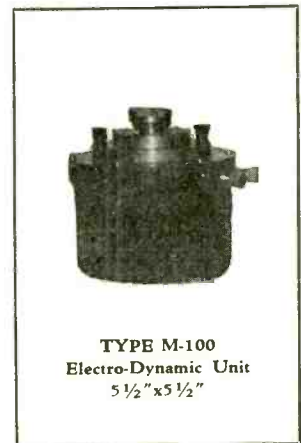

TYPE M-100
Electro-Dynamic Unit
5 1/2" x 5 1/2"

Has U. S. Standardization Gone Too Far?

By R. RAVEN-HART, M. I. R. E.

LOOKERS-ON are said to see most of the game; perhaps a European on-looker may be excused for putting the query that forms the title of this article. Standardization is a blessing; one would give a great deal to find it extending among European manufacturers. Nevertheless, it *can* be carried too far, and perhaps in American tube manufacture it *has* been carried too far.

The accompanying diagram needs a few words of explanation. It represents a novel method of showing tube characteristics at a glance, and will illustrate my point better than yards of tables would do. The plate resistance and amplification factor form the two main axes (laid off logarithmically). Any tube can thus be represented by a point on the figure, and the interesting feature is that tubes having the same mutual conductance will lie along one of a series of straight lines inclined at forty-five degrees to each axis. Furthermore lines at right angles to these lines of mutual conductance represent values of the *product* of amplification factor and plate resistance.

The device is due to Decaux, *L'Onde Electrique*, Paris, January, 1929; it was copied, for British tubes, by Beatty, *Wireless World*, London, July 17, 1929. Both of these authors take the point of view that tubes can be classified according to their purposes by means of this last-mentioned constant, the product of amplification factor and plate resistance; and this is generally accepted. As the limiting values between one purpose and another Beatty takes the "frontiers" shown in the figure; those used by Decaux are slightly different, but not sufficiently so to change the argument.

On this figure, French tubes are shown by dots, British ones by crosses, and American by circles. The 240 type tube is shown, although it should be borne in mind that practically speaking this is unusable in the vast majority of present day sets, being a battery tube.

Now, before going further, please note that the British author showed only a *selection* of British tubes on his diagram, and the French author only a *selection* of French ones; and, to keep the present figure reasonably simple, only a selection of these selections has been shown. Nor are any of the "freak" tubes shown (double grid, triple grid, double plate, etc. . . .); nor any of the German, Austrian, Czech and other European tubes.

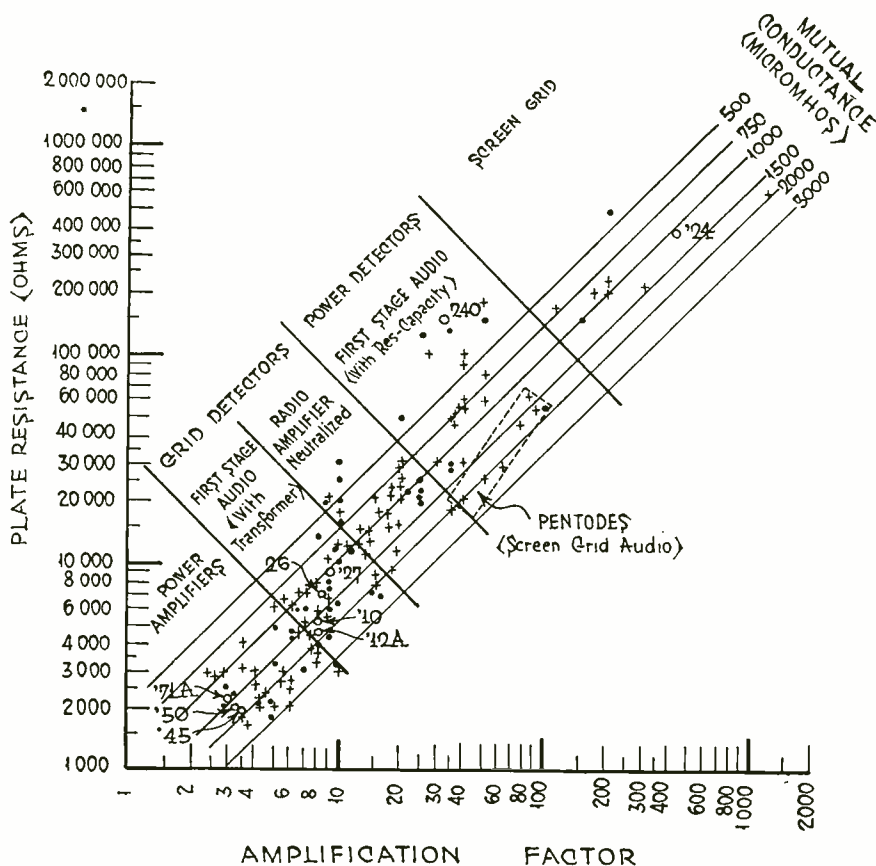

Characteristics of French, British and American Tubes

With this in mind, hunt up the nine circles that represent the American tubes; and then stop to think. . . .

According to the British point of view, no American tube suitable for neutralized radio-frequency amplification exists; none for audio-frequency amplification with resistance-capacity coupling (except the unusable 240); none for power detection (except again the 240); and there is of course no example of the very interesting screen-grid audio-frequency amplifier group contained in the dotted rectangle. Even if all the old battery tubes are included, the argument is unchanged.

Perhaps we no longer need any neutralized radio-frequency amplifiers now that we have the screen-grid tubes? Perhaps not.

Again, the American amateur might reply that there is no need for resistance-capacity audio amplification "now-a-days," with the excellent audio transformers available. Again, perhaps not, though there would be a shriek of protest from the British and German users at such a statement.

But what about the power detector? and what about the pentode?

And, perhaps most important of all, what about the serious experimenter who needs a tube for some new application, which may of course lead to a complete revolution in receiver construction? In Europe he has a regular "procession" of tubes, ranging from the screen-grid to the power amplifier; in America he has an excellent group of standardized tubes at one end of the scale, and then (except for the 240) a hopeless blank between amplification factors of 9 and 400, plate resistances of 10,000 and 400,000 ohms.

Heaven forbid that the American amateur should be exposed to the European tube chaos; but—is there nothing between these extremes of 9 tubes on the one hand and 180 tubes (approximately) on the other?

To us it looks as if all American tube manufacturers were content to wait until one of the biggest among them brings out a new tube, and then to copy it with a similar type number.

Is American radio progress best served thus?

RADIOADS

A CLASSIFIED ADVERTISING SECTION
READ BY BETTER BUYERS

Discontinued Merchandise and Job Lot Advertising Must Be Plainly Indicated as Such

REMITTANCE MUST
ACCOMPANY ALL ADS

RATES: 8 CENTS PER WORD

✓ \$6.00 PER DISPLAY INCH

RADIOADS FOR THE DECEMBER ISSUE SHOULD REACH US BY NOVEMBER TWENTIETH

"RADIO THEORY AND OPERATING"—4th edition revised, by Mary Texanna Loomis, President of Loomis Radio College, member Institute of Radio Engineers. The leading radio text and reference book of the day. Used by more than 300 radio schools, universities, high schools and technical colleges, and by all the Government radio schools. The book contains 992 pages, 800 illustrations, is right up to date, and is really a whole library on radio. Among the many subjects covered are marine radio operating, radio compass work, land radio operating, television, broadcasting, radio construction, repairing and servicing, airways communications, radio accounting, message forms, junior engineering, and the 1929 radio laws. For sale by bookdealers throughout United States and many foreign countries. Price \$3.50, postage paid. Buy of your bookdealer, or send check or money order to Loomis Publishing Company, Dept. 12, Washington, D. C.

AMATEURS-EXPERIMENTERS-BUILDERS—We serve over 4000 IRE, ARRL, etc., experimenters and "nuts." Full discounts. \$50,000.00 stock approved parts—no sets. Over four pounds, catalog, circuits, data, prepaid, 50c. Weekly bulletins (new items, results of experiments, etc.) 20 weeks, \$1.00. Sample experiments "Over the Soldering Iron" magazine, 25c. Transmitting data, price list, etc., 25c. Kladag Radio Laboratories, established 1920, Kent, Ohio.

450 REVIEW QUESTIONS—Supplement to the textbook "Radio Theory and Operating." Just off press. Designed for the home study work of persons preparing for Government examinations. Valuable assistance to instructors and students. Price 25 cents in coin or postage. Loomis Publishing Company, Dept. 25, Washington, D. C.

JEWELL RADIO SERVICE SET PATTERN 117, Weston A-C Voltmeter Model 528, Sterling R408 Tube and Set Tester, Jewell Radio Set Analyzer Pattern 199. Mello Heald eleven receiver in cabinet. G. R. Ewalt, Herington, Kansas.

LAST CHANCE! This is the last time that we can offer you a copy of Professor Hermann Schnitzel's humorous book of radio lectures—"Und Comes It Now." Only a handful of copies left. Get a copy free with a subscription to "RADIO" for 4 months. Full price for the book and the subscription to "RADIO," only one dollar. "RADIO," Pacific Bldg., San Francisco, Calif.

RADIO MEN WANTED—Positions wanted—Agencies wanted—Merchandise wanted and for sale—All of these matters can be brought to the attention of readers of "RADIO" with an advertisement in this RADIOAD Section. The rate is eight cents per word. One ad will convince you. More and more advertisers are using these columns. They pay! Mail your ad now for the next issue. "RADIO," San Francisco.

SALESMEN ATTENTION!—Chance to make extra money selling our complete radio index log to dealers. Write for sample and information. Shield Press, P. O. Box 1634, Indianapolis, Ind.

SALESMEN WANTED—Screw-holding screw driver. Amazing brand new patented invention! Retail \$1.50. Factories, garages, electricians, auto, radio owners buy on sight! Exclusive state territory. Genuine opportunity, earn big money. Free trial offer. Jiffy 1027, Winthrop Bldg., Boston.

MAIL ORDER RADIO

MAIL ORDER RADIO. Complete line of radio parts, kits, at same low prices of Eastern Mail Order Houses. Every part guaranteed. Cash refund on any unsatisfactory merchandise. PILOT 3 Gang Condenser, \$4.00. Screen-Grid and 255 TUBES each \$2.00. 280 Tubes, \$1.50. PILOT SUPER WASP KITS, \$29.50. Metal Cabinets, \$2.50. Send for our prices. MAIL ORDER RADIO, Box 1110, Portland, Oregon.

HELP WANTED

WANTED—Men to work with National Radio Service organization. No selling scheme. Radio Doctors, Inc., Dept. R, Essex St., Salem, Mass.

WANTED—Radio men to demonstrate MONARCH screen grid radio receivers. Easy work and big profits. Write for full information, also data for large buildings. The MONARCH Radio, 205 W. Wacker Drive, Chicago, Ill.

BIG OPPORTUNITIES for full and part time men to make big money demonstrating the new CLARK SCREEN-GRID RADIO RECEIVER, designed by J. H. Clark, radio engineer. Amazes all who hear it. Long distance, extra selective, dynamic speaker, beautiful tone and handsome cabinet. Moderate price and big discounts. Exclusive territory to men who make good. Write or telegraph for full information. CLARK RADIO CO., 205 West Wacker Drive, end floor, CHICAGO, ILL.

SITUATION WANTED

RADIO Broadcast Engineer, now employed, wants work in California. Plenty of experience.—Composite and Western Electric. Write care "RADIO," Pacific Building, San Francisco.

POWER-PACK SERVICE

WHOLESALE POWER-PACK AND AMPLIFIER SERVICE. Best equipped shop on the Coast. Lowest prices. Biggest dealers' discounts. Quick service. Write for price list. Dorival & Dorival, 129 W. Washington Blvd., Los Angeles, Calif.

FOR SALE—MISCELLANEOUS

NAVY SURPLUS—800 radio generators and battery dynamotors, D-C and 500 cycles. List. Harry Kienzle, 501 East 84th Street, New York.

BACK ISSUES WANTED

WANT one copy "RADIO," September, 1926 issue. Will pay reasonable price for same. C. P. Hering, 2415 29th Avenue, San Francisco, Calif.

An Advertisement
This Size

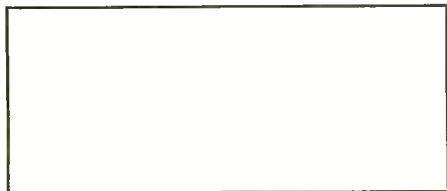

Will Cost Only \$6.00
in the "RADIOAD"
Section of "RADIO"

HERE is an opportunity for "job lot" advertising . . . advertisements for salesmen wanted . . . factory representatives . . . apparatus for sale and to buy and general advertising copy for QUICK ACTION RESULTS. These small advertisements will be published on this page in each issue of "RADIO" hereafter. At \$6.00 per inch you can bring your message to the attention of the great majority of radio dealers in the United States. The advertising department of "RADIO" will be glad to offer suggestions and prepare the copy for you. One advertisement will convince you of the pulling power of "RADIO."

Send Your Copy Now for the
Big Christmas Issue

It Can Be Accepted as Late
as November 20th.

The Bargain of Bargains!

Either of these KOLSTER items at less than one-fifth of the original list price



Model K-5
Height 42", width 25½",
depth 19"

Buy As You Sell

To give every dealer the opportunity of selling these KOLSTER items with the least investment and the most profit we make this

SPECIAL OFFER

Buy either item as needed at the top price but—if you order a total of 5 or more of one or the other within a period of 30 days from date of your first order, we will allow you the 5-lot price on all purchased.

GOING FAST

Wide-awake dealers are reducing the limited stock we have remaining every day. Repeat orders show how fast these items move. Start your first order on the SPECIAL OFFER today.

Licensed Under Patents of the Radio Corp. of America and
Lektophone Corp.



Model 6-H
Height 53", width
27", depth 18½"

K O L S T E R

ELECTRO-DYNAMIC REPRODUCER

Combined with 210 Power Amplifier
and "B" Supply Unit

Features

1. Electro-Dynamic Reproducer (10¼ in. dia.)
2. 210 Power Amplifier. Fine tone quality.
3. Supplies "B" voltage, if desired.
4. Can be used with any electric or battery set.
5. Complete A-C Electric Operation.
6. Beautiful pencil-striped walnut cabinet.

This finely matched, rugged unit comprises a complete heavy duty Electro-Dynamic Reproducer, including a 210 Power Amplifier with "B" supply unit, all self-contained in a steel frame. It weighs 45 pounds, without the cabinet. The cabinet itself is of pencil-striped walnut, beautifully designed with Cathedral grille. It is equipped with switch for control of house current to Reproducer, power unit and amplifier. A pilot light indicates when the Reproducer is in operation.

If desired, the 210 Power Amplifier will also supply 22, 67 and 90 volts "B" current, sufficient for any set using up to 8 tubes. An automatic voltage regulator tube, UX-874, maintains the "B" voltage silent and steady.

This Electro-Dynamic Reproducer

can be used with any battery or A-C set, replacing the last audio stage or be used with all tubes of the set. Wherever used, it will bring out every shading and range of tone; every note is reproduced with utmost faithfulness, pure and undistorted. It will modernize any radio receiver.

The following tubes are required for its operation: 2—UX-281 (for full-wave rectification); 1—UX-210 (for super power amplification); 1—UX-874 (for voltage regulation). For use with phonograph pickup, one additional audio stage is recommended between the pickup and this Reproducer.

A 20-ft. cable is included with each instrument. Operates direct from 50-60 cycle, 110-120 volt A-C current.

List Price, \$175.00 (less tubes)

Going at **\$33.50!**

Lots of 5 or more \$29.50 ea.

K O L S T E R

SIX-TUBE CONSOLE RECEIVER

With Built-in Kolster
Electro-Dynamic Reproducer

Features

1. Beautiful highboy console of burled walnut with maple overlay.
2. Kolster K-5, Electro-Dynamic Reproducer with built-in 210 Power Amplifier included for fine tone quality (see opposite page).
3. Famous Kolster 6-tube T. R. F. circuit.
4. Hairline selectivity. Distance Reception.
5. Single dial control—simple to operate.

The entire set can be operated direct from the A-C light socket, 50-60 cycle, 110-120-v., by simply adding any "A" supply unit and a small 4½-volt "C" Battery. The built-in Electro-Dynamic Power Reproducer furnishes the "B" supply current to the set. A switch snaps the receiver in or out of operation and a pilot light tells instantly when set is in operation. The single dial control makes this the simplest of receivers to operate.

This Receiver Employs the Famous Kolster T.R.F. Circuit

It operates on either indoor or outdoor antenna using three stages of R-F detector and two stages of A-F. The three point tap switch aerial adjuster operated from panel gives hairline selectivity. A loose coupled coil in conjunction with tap switch increases the distance getting value of the receiver. In addition, the 210 power amplifier built into the model K-5 Dynamic Reproducer, achieves remarkable tone quality. In this receiver is embodied everything looked for in modern radio.

The combination Kolster Set and Electro-Dynamic Reproducer is housed in a beautiful console of burled walnut with maple overlay. Full swinging doors found only in the finest cabinets add to its beauty. The receiver uses 6—UX-201A tubes and the Electro-Dynamic Reproducer uses 2—UX-281, 1—UX-210, and 1—UX-874 tubes.

List Price, \$295.00 (less tubes)

Going at **\$48.50!**

Lots of 5 or more \$44.50 ea.

TERMS: 20% cash with order, balance C.O.D. f.o.b., New York. (2% Discount for Full Remittance with

AMERICAN SALES COMPANY

The New Gould Kathanode



List Price \$39.50

Unipower

GOULD PRODUCT

(With Built-in Relay)

Automatic
Radio "A" Power
From Light Socket

Model A-C—6 K (Six Volt)
Furnishes rich, smooth, unfailing "A" current, without any trace of hum. No rewiring necessary in your set. Equipped with a new noiseless Balkite Charging Unit which has four graduated charging rates and in addition one booster rate (1½ amperes) for an emergency charge, which enables it to properly take care of all sizes of sets and conditions of operation. Operates on 110-120 V., 50-60 cycle A-C current. Complete with extra fuse.

Special \$9.75

Lots of three—\$8.50 ea.
Lots of six—\$7.50 ea.



Size 6"x5"x3 1/2"

Capacity	Rated D-C Working Voltage
2.0 mfd.	1000 V
1.0 "	800 V
1.0 "	800 V
3.0 "	400 V

AEROVOX or Dubilier

High Voltage Filter Condenser Blocks

Finest non-inductive High Voltage Filter Block. Made to be used with UX-250 Power Tubes but can be used safely in filter circuits of eliminators or high power Amplifiers in any combination of capacities desired.

Each Unit is equipped with long, heavy, flexible insulated leads, convenient for easy wiring, and also has mounting brackets. Latest design.

The insulation resistance of these Condenser Blocks is in excess of R.M.A. and N.E.M.A. standard requirements.

Due to the request of the manufacturers of these Condenser Blocks we cannot divulge the high list price of same.

Special \$2.50 Per Block

FREED-EISEMANN

SIX TUBE RECEIVER



(For Battery Operation)

Features:

Completely Shielded
3 Stages R-F, 1 Detector
2 Audios (1 Power Tube)

Stippled Panel
Genuine Mahogany Cabinet—
Cable Attachment

An excellent number for customers preferring an inexpensive set. This Freed-Eisemann Set is ideal for portable use.

Built of the finest of parts.
Uses 5—UX-201A tubes and 1—UX-171A tube.
Wired for "C" Battery.

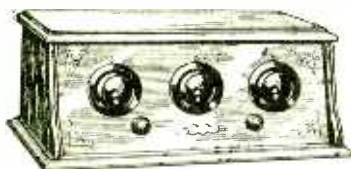

Model No. 130

List Price \$80.00
(less tubes)

Size
18 3/4" x 10 1/2" x 9 3/4"

Special \$9.50

Lots of 5 or more **\$9.00 each**

The New

Algonquin



Cone Speaker

Will stand powerful or weak volume equally well and reproduce with wonderful tone quality and volume. Has a full-floating large 18-inch Cone brought to the highest point of perfection. Made of a special impregnated fabric (not paper) which is absolutely unaffected by moisture or atmospheric conditions. Equipped with an extremely sensitive electro-magnetic Cone unit with direct drive to Cone and is exact to highest degree.

A beautifully designed Speaker with art metal scroll. Ship model. Finished in polychrome gold stipple.

List Price \$30.00 Ea.

Reduced to \$15.00

Special \$3.70

Lots of 5 or more \$3.25 ea.

Genuine RCA UX200

Radio Tubes



List Price \$1.75 ea.

Bakelite UX face detector tube drawing one ampere.

Due to the extreme low prices of these tubes, we cannot allow replacements. However, every tube is brand new and packed in the original factory sealed carton, we having purchased them direct from the Radio Corporation of America.

Special 13c ea.

\$6.50 Per Carton
Sold only in Carton Lots of 50

Manufacturers! and Jobbers!

We are prepared to offer cash for surplus stocks of Radio Merchandise. This means, of course, stock in first class condition and in such volume that insures a good value to our many established buyers. Send details of your offerings for quick action.

order.) All units offered are BRAND NEW, packed in original factory sealed carton and fully guaranteed.

19-21 WARREN ST., NEW YORK

HOTELS FOR RADIO TRAVELERS

Now Open
in New York
The HOTEL
GOVERNOR CLINTON

Opposite Penn. R. R. Station
New York's new hotel truly expressive of
the greatest city. 1200 pleasant rooms
each with Servidor, bath, circulating
ice water and radio provisions.

ROOMS
from
\$3.00

E. G. KILL
General Mgr.



31ST STREET **7TH AVENUE**

LAT. INC.

HOTEL MONTCLAIR

Room and Bath Tub and Shower \$3 to \$5 per day For 2 persons \$4 to \$6 per day Suites \$8 to \$12 per day Special Monthly and Yearly Rates	49th to 50th Sts. Lexington Ave. NEW YORK CITY 800 Rooms Each with Tub and Shower Radio in Every Room
--	---

3 minutes' walk from Grand Central. Times Square, Fifth Avenue Shops important commercial centers, leading shops and theatres nearby. 10 minutes to Penn. Station.

Grand Central Palace only 2 short blocks away



S. Gregory Taylor
President
Oscar W. Richards
Manager

HOTEL PLANTERS

19 N. Clark St.
Just North of Madison St
CHICAGO



Location: At the very center of the downtown business, shopping and theatre district, and within easiest reach of railroad stations.

Rates: \$2.00 per day minimum. Charges are much lower than at most hotels of this superior type.

Service and Equipment of the most modern character. Fireproof throughout; tastefully furnished and appointed. Beautiful serve-self restaurant.

Under the personal direction of GEORGE W. YOUST,
President and Manager. Write or wire for reservations.



**CINCINNATI'S
FINEST**

*ONE of the Nation's out-
standing hotels embodying
every modern convenience
that so attracts travelers
throughout the world.*

Rates: \$2.50 and Up

JOHN L. HORGAN
Managing
Director

Hotel Sinton
CINCINNATI

ARTHUR H. HALLORAN - - - Editor
 HECKERT L. PARKER - - - - -
 - - - - - Merchandising Editor
 P. S. LUCAS - - - Associate Editor
 H. W. DICKOW - Business Manager
 A. I. RIVETT - - - - Draughtsman
 FRANK C. JONES - Technical Adviser

RADIO

Established 1917 Published Monthly

Address all communications to
 "RADIO"
 Pacific Building, San Francisco, California

NEW YORK - 415 Lexington Avenue
 Phone: Murray Hill 5992
 CHICAGO - 307 North Michigan Avenue
 Phone: State 6079
 SAN FRANCISCO - Pacific Building
 Phone: DOuglas 0136
 BOSTON, MASS. - 86 St. Botolph Street
 Phone: Commonwealth 4873

Subscription Price, \$2.50 per year in
 U. S. and Canada
 \$3.00 in Foreign Countries

VOL. XI

NOVEMBER, 1929

No. 11

CONTENTS

Divorcing Service from Sales..... 41	What Happens When You Press the Button of a Tube-Tester 62
<i>By P. S. Lucas</i>	<i>By Arthur Hobart</i>
Wiring a Radio Installation..... 42	Muzzling Stray Impulses 64
<i>By N. A. Rollah</i>	<i>By Earl Borch</i>
Improving Audio Circuits..... 45	As the Trade Thinketh..... 65
Let's Play Bridge..... 46	Simple Equipment for Suppressing Line Interference.. 66
<i>By Keith La Bar</i>	<i>By D. A. Brown</i>
European Circuits for Screen-Grid Tubes as R-F Amplifiers 48	Radio Pick-Ups..... 67
<i>By R. Raven-Hart</i>	Kit Receivers..... 69
Victor Micro-Synchronous Radio..... 49	What Constitutes Good Tone from a Radio Set..... 70
Edison "Light-O-Matic" 51	<i>By J. Edward Jones</i>
Bremer-Tully Models 81-82 and Brunswick Models 21-31 52	New Equipment from the Radio Manufacturers..... 71
Radiatorial Comment..... 54	Who Makes It..... 72
Consider Ike, the Service Man..... 56	Reception of Super-High Frequencies..... 76
<i>By Grid Bias</i>	<i>By Thos. A. Marshall</i>
Some of the New Receivers..... 61	Book Reviews..... 76
	New Sets and Accessories..... 77
	List Prices of Sets..... 78
	Circuits 80

INDEX TO ADVERTISEMENTS

IN THIS ISSUE

Acme Electric & Mfg. Co..... 17	Herbert H. Frost, Inc..... 29
Aero Products, Inc..... 86	Hytron Corp..... 27
Aerovox Wireless Corp..... 92	International Correspondence Schools..... 95
Allied Radio Corp..... Inside front cover	Jensen Radio Mfg. Co..... 5
American Sales Co..... 104-105	C. R. Leutz..... 89
American Transformer Co..... 29	Mandel Electric Co..... 90
Amrad Corp., The..... 29	Mertz Specialty Co..... 93
Andrea, F. A. D., Inc..... 33	Miles Mfg. Co..... 101
Arcturus Radio Tube Co..... Outside back cover	National Carbon Co., Inc. (Eveready Raytheon)..... 9-94
Automatic Radio Mfg. Co..... 21	Newark Electric Co..... 24
Baltimore Brass Co..... 93	Norden Hauck, Inc..... 108
Barawik Co..... 86	Pacent Electric Co..... 15
Barty Radio Co..... 100	Perryman Electric Co..... 22
Browning Drake Corp..... 4	Premier Electric Co..... 101
Cardwell 92	Potter Co., The..... 96
Chicago Gear Works..... 92	Radiall Co..... 90
Central Radio Laboratories..... 28	Radio Doctors..... 91
Chicago Salvage Stock Store..... 97	Radio Receptor Co..... 12
Clarostat Manufacturing Co..... 96	Samson Electric Co..... 8
Classified Ads..... 103	Shallcross Mfg. Co..... 93
Corning Glass Works..... 98	Short Wave and Television Labs..... 32
Cornish Wire Co..... 96	Silver-Marshall, Inc..... 39-85
Crosley Radio Corp..... Inside back cover	Spokane Radio Co..... 93
Cunningham, E. T., Inc..... 35-36-37-38	Sterling, Mfg. Co..... 2-3
De-Jur-Amsco 86	Supreme Instruments Corp..... 21
DeForest Radio Co..... 91	Thordarson Elec. Mfg. Co..... 92
Dubilier 101	Tobe Deutschmann Corp..... 25
Dudlo Mfg. Co..... 30-31	Triad Manufacturing Co., Inc..... 1
Electrad, Inc..... 40	United Reproducers' Corp..... 6-7
Ferranti, Inc..... 99	Victory Speakers, Inc..... 13
First National Radio Co..... 26	Ware Mfg. Corp..... 14
Flechtheim, A. M. Co..... 88	Western Radio Mfg. Co..... 90
General Radio Co..... 86	Weston Electric Inst. Co..... 96
Gosilco Radio Products Co..... 98	Wood Cabinet Corp..... 10-11
Grebe, A. H., Inc..... Front cover	Wright DeCoster, Inc..... 16
Hammarlund Manufacturing Co..... 99	Yaxley Manufacturing Co..... 86

HERE IS THE PERFECT BROADCAST RECEIVER



The New Admiralty Super-10 is the very apex of Modern Research Engineering.

It is a brand new receiver for the radio connoisseur which we believe represents final superiority over any broadcast receiver now being manufactured or contemplated.

Strictly custom-built, this new model meets the requirements of those that want the best. It is, in fact, the Highest Class Receiver in the World.

SUPER FEATURES

10 Radio Tubes—Super Power—Complete self-contained electric operation—Exceedingly compact—Simplified controls—Full Vision Tuning Indicators—Uses Heater type A.C. Screen Grid and Power Tubes—Super Selective—Band Pass Filter Effect—Hum Eliminator—Line Voltage regulation—Scientifically correct shielding—Great range with sensitivity control—Minimum antenna requirements—Improved push-pull audio system—Perfect reproduction with great volume—Arranged for Electro-Dynamic Loudspeaker—Adaptable for short-wave television work—Universal wave-length range for use in any part of the

world—Phonograph pickup connection—Special Weston Meters for voltage and tuning resonance—Protected against moisture for tropical and marine installation—Built strictly according to U. S. Navy Standards—Cabinets of finest selected Mahogany and Walnut—Exquisite console combinations available—Entirely custom built—Thorough air test by receiving engineers on all classes of reception for range and quality of reproduction—Sold direct from factory and through selected franchise dealers in the principal cities of the United States and foreign countries—Unconditionally guaranteed against defects.

**THE
NEW**

Attractive illustrated descriptive literature on request

ADMIRALTY SUPER-10



Write, telegraph or cable today!

NORDEN-HAUCK, INC., *Engineers*

1 to 9 South Street

Cable: NORHAUCK

Philadelphia, Pa., U. S. A.

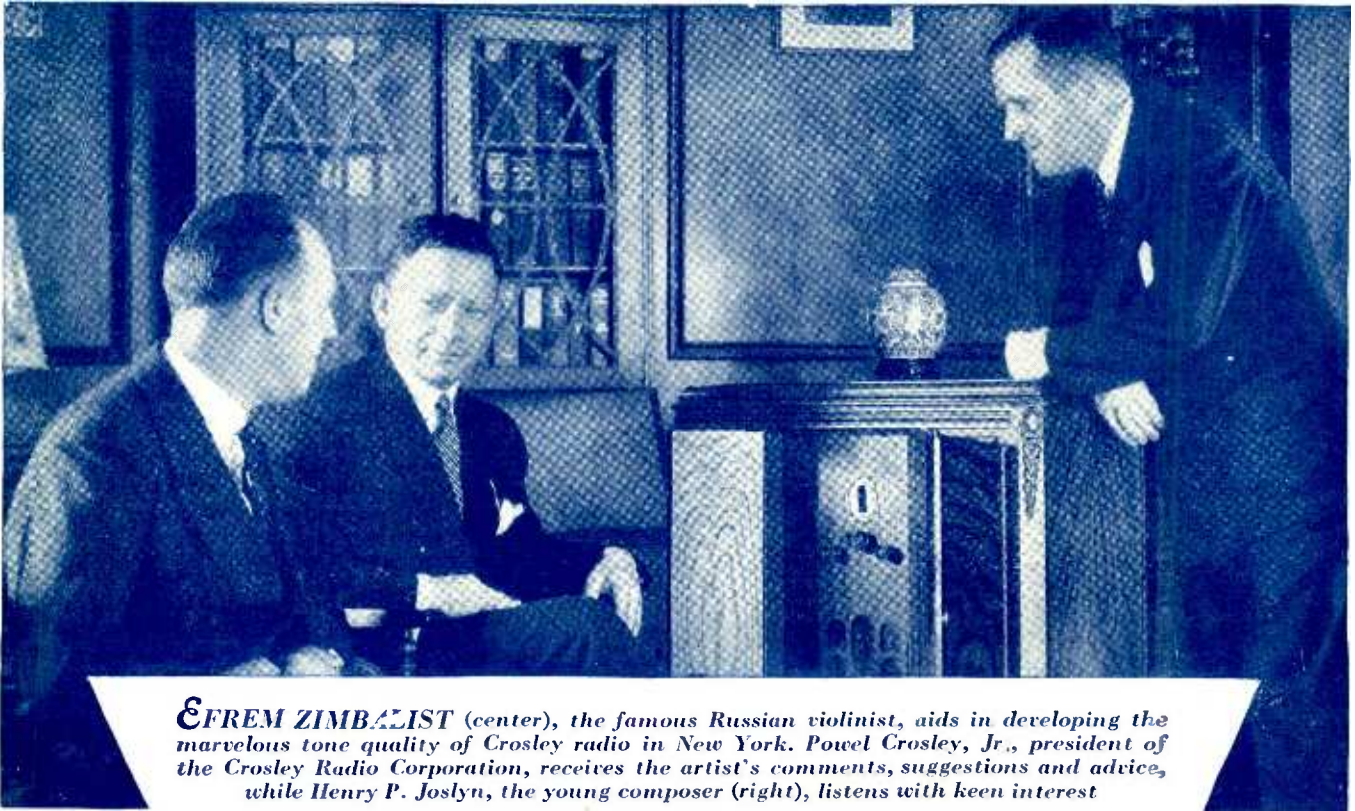

EFREM ZIMBALIST (center), the famous Russian violinist, aids in developing the marvelous tone quality of Crosley radio in New York. Powel Crosley, Jr., president of the Crosley Radio Corporation, receives the artist's comments, suggestions and advice, while Henry P. Joslyn, the young composer (right), listens with keen interest

TONE QUALITY NOW TESTED by AMERICA'S foremost musical artists

POWEL CROSLY, Jr., in his search for finer tone quality, has gone a step beyond the laboratory—a step further than radio has ever gone before!

And in doing so, he has provided you with a sales idea unique in the industry. It will place Crosley radio above and apart from all other sets—it will make Crosley advertising read as no other radio advertising is read today.

Briefly, the idea is this. Crosley has actually engaged the nation's leading musical artists to give Crosley engineers the invaluable benefit of their experience. They listen to Crosley sets, comment, advise . . . Under their guidance is achieved a mar-

velous tone quality that mechanical tests alone could never attain.

Naturally, this idea is being given the publicity it deserves—full pages in the leading national magazines and farm papers. And it is being backed by sets that embody every modern feature: Screen Grid, Neutrodyne circuits, Power Detection, etc.—*at the lowest prices in radio history*. Your distributor will gladly arrange to have you prove this to your own satisfaction.

THE CROSLY RADIO CORPORATION
Powel Crosley, Jr., Pres.
Cincinnati, Ohio
Home of WLW

*You're there
with a*

CROSLY

**THESE INTERESTING TUBE TESTS ARE FEATURED
IN ARCTURUS SATURDAY EVENING POST ADVERTISING**



There's no question about Arcturus' 7-second action when your customer holds the watch.



A two-minute demonstration of Arcturus' clear, humless tone is more convincing than a twenty-minute sales talk.



Arcturus Tubes hold the world's record for long life because they withstand the line surge that burns out other tubes. *Show* your customers that Arcturus Tubes easily withstand 75% more current than they are designed for.

A NEW IDEA IN SELLING TUBES

**THAT MEANS MORE
PROFITS FOR EVERY
ARCTURUS DEALER**

**137
FACTORY
INSPECTIONS
GUARD
ARCTURUS
QUALITY**

THE more Arcturus Tubes you sell, the better for your business.

And the best way to sell these superior tubes is to *demonstrate* their many good points.

Our National Advertising Campaign, beginning with a half page in the October 26th Saturday Evening Post, tells radio set owners to *make sure* of tube performance *before* they buy tubes. We tell them what points to check, and how to check them. And Arcturus Dealers will be glad to make these tests, because Arcturus performance measures up to the highest standards at every point.

These photographs, reproduced from our Saturday Evening Post advertising, illustrate three easy tube tests that clinch sales. *Show* your customers what Arcturus Blue Tubes can do, and watch your tube sales jump.

When your Arcturus sales go up your customers get better reception and your service overhead goes down.

Try selling Arcturus *Blue* A-C Tubes this way, and see what happens to your tube and set sales.

ARCTURUS RADIO TUBE COMPANY
Newark, N. J.

ARCTURUS
BLUE **A-C** **LONG-LIFE** **TUBES**