

MAY, 1926

25 CENTS

# RADIO

(REG. U. S. PATENT OFF.)



# Cunningham RADIO TUBES

## On Guard

An Invisible Integrity---  
ever present, never seen---  
is on guard tonight, and  
every night, in millions of  
American homes. Cease-  
lessly alert, it insures the  
performance of every Cun-  
ningham Radio Tube under  
the tremendously exacting  
conditions of 1926 radio re-  
ception.

Ten years of concentrated  
effort on a single product  
has brought such uniform  
perfection that confidence  
in these tubes and in the  
name they bear is almost  
universal among radio en-  
thusiasts. The vigilance  
that has won for Cunning-  
ham Radio Tubes such  
nation-wide confidence is  
not and shall not be re-  
laxed. Our reputation is  
by far our most valuable  
asset.

*All Types*

**C- and CX-**

*In the Orange and Blue Carton*

*E. J. Cunningham Inc.*

New York Chicago San Francisco



*Manufactured and sold under rights, patents and inventions  
owned and/or controlled by Radio Corporation of America.*

The dawn of a new day  
in Radio Speakers

# The Tower CONE

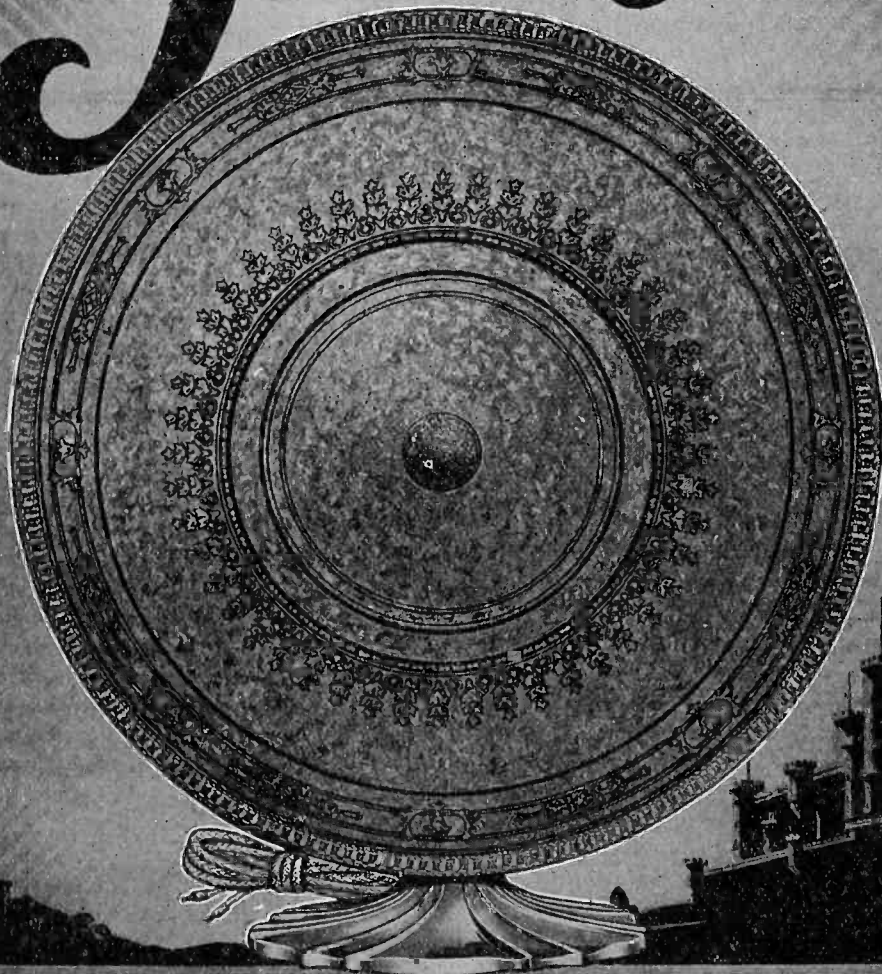

**T**HE most beautiful Cone in America! With those mechanical niceties that insure finer tone and volume, this Tower Speaker virtually revolutionizes present day conceptions. The double-drive unit, the acoustically perfect non-warping Cone, the eight connections from unit to Cone, the free-edge construction — these basic features establish Tower Supremacy.

Price  
**\$9.50**

*On Sale by Good Dealers from Coast to Coast.*

TOWER MFG. CORP.

BOSTON, MASS.

Tell them that you saw it in RADIO

# RADIO

With Which Is Incorporated "Radio Journal"  
Established 1917

Published Monthly by the Pacific Radio Publishing Co.

ARTHUR H. HALLORAN

Editor

GERALD M. BEST,  
Technical Editor

H. W. DICKOW,  
Advertising Manager

#### Branch Offices:

New York City, 17 W. 42nd St.  
Chicago, 307 N. Michigan Ave.  
Boston, 52 Irving St.  
Kansas City, Mo., Davies & Dil-  
lon, 707 Land Bank Bldg.

#### Rates:

Issued Monthly, 25c a copy.  
Subscription price, \$2.50 per year  
in the U. S., \$3.00 per year else-  
where.

#### Correct Addresses:

Instructions for change of ad-  
dress should be sent to the pub-  
lisher two weeks before the date  
they are to go into effect. Both  
old and new addresses must al-  
ways be given.

#### Advertising:

Advertising Forms Close on the  
First of the Month Preceding  
Date of Issue.

Member Radio Magazine Publishers' Association  
Entered as second-class matter at Post Office at San Francisco, Calif.  
Copyright 1926 by the Pacific Radio Publishing Co.

Address all communications to

**Pacific Radio Publishing Company**

Pacific Building, San Francisco, California

VOLUME VIII

MAY, 1926

NUMBER 5

## CONTENTS

RADIOTORIAL COMMENT .....	7
BREAKING INTO THE RADIO GAME.....	8
<i>By Howard S. Pyle</i>	
SOMETHING HERTZ .....	10
<i>By Keith La Bar</i>	
DATA ON VACUUM TUBES.....	12
<i>By S. C. Miller</i>	
THE HALF-WAVE "A B C" ELIMINATOR.....	13
<i>By G. M. Best</i>	
A TEN-TUBE SUPERHETERODYNE RECEIVER.....	15
<i>By Edwin E. Turner</i>	
WHAT CONSTITUTES A GOOD VARIABLE CONDENSER.....	18
<i>By H. Melchior Bishop</i>	
ELECTROLYTIC AND MERCURY ARC RECTIFIERS.....	19
<i>By Jennings B. Dow</i>	
IMPROVING 40-METER FOREIGN RECEPTION.....	21
<i>By Don C. Wallace</i>	
SWEETHEART, THE CRAZY.....	23
<i>By Jan Dirk</i>	
A SUPERHETERODYNE BAND FILTER.....	25
<i>By Raymond B. Thorpe</i>	
GETTING FOUR TUBES OUT OF THREE.....	28
<i>By L. W. Hatry</i>	
THE ARITHMETIC OF RADIO.....	31
<i>By E. M. Sargent</i>	
SARGENT CIRCUIT NO. 4.....	32
<i>By E. M. Sargent</i>	
SHORT WAVE RECEIVER DESIGN.....	33
<i>By F. J. Marco</i>	
A 15-WATT TUBE TRANSMITTER.....	35
<i>By D. B. McGown</i>	
QUERIES AND REPLIES.....	37
THE COMMERCIAL BRASS POUNDER.....	39
JAPANESE WEATHER CODES.....	40
<i>By L. O. Doran</i>	
STANDARD FREQUENCY TRANSMISSIONS.....	41
PARALLEL OPERATION OF TUBES.....	42
<i>By G. F. Lampkin</i>	
SHORT WAVE RECEIVER AT 6XAO.....	44
<i>By G. M. Best</i>	
CALLS HEARD .....	45

## Forecast of Contributions for June Issue

John J. O'Neill presents the results of many observations of the "Bending of Radio Waves by Storms" wherefrom he deduces some interesting conclusions regarding many so-called freak conditions in radio reception.

In "Modern Marine Radio Equipment" Howard S. Pyle describes an up-to-date type of commercial tube transmitter which may be used as a basis for passing the Federal examination for commercial license.

"What's What in Radio Inconsistencies" is the title under which Kirk B. Morcross explains many facts little known to the average radiocast listener.

"Adventures of a Ham" by Glenn Ellsworth Deamer is a thrilling narrative for light summer reading.

G. M. Best sums up the improvements and modifications that may be made in the several superheterodyne circuits that he has described in these columns during the past two years. He describes the construction of a one-stage tuned radio frequency unit that may be put ahead of any three-tap loop set for antenna connection, thus increasing its range and eliminating any radiation.

Clinton Osborne discusses resistance and impedance coupled amplifiers and simple remedies for obviating troubles that might occur.

Raymond B. Thorpe continues his article on "A Superheterodyne Band Filter" with design and constructional details for additional intermediate frequencies.

In response to many requests regular publication of the "Radio Notebook" pages is resumed.

An unusually simple and easily understandable explanation of how a vacuum tube operates as a detector, amplifier or generator is given by Arthur Hobart. A six-year-old boy can grasp its full meaning.

Paul Oard, whose writings have delighted many in the past, starts the first of a new series with an article on "Radio Construction Pointers."

"Red Dawn" by Earl Ennis is a worth while fiction feature.

In a paper on "Interference from Power Lines," Philip S. Donnell gives a complete list of electric power apparatus known to cause such trouble, together with an account of how it has been curbed in each case.

C. H. Reberger recounts some interesting facts about "Radio in the Chinese Empire."

# Four New Radios

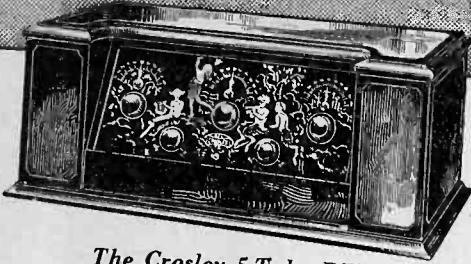

## The Crosley 5-Tube RFL-75

Absolutely balanced radio frequency amplification. Non-oscillating under any handling. Exquisite two-tone mahogany cabinet—satin finish. Decorated panel with rose-gold metal fittings. Cabinet holds necessary dry cells. Price without accessories . . . \$75



## The Crosley 5-Tube RFL-60

Same as RFL-75 but in compact cabinet only 17½ inches long. Truly marvelous selectivity, sensitivity and purity of tone. Art panel—solid mahogany cabinet—rose gold fittings. Price without accessories . . . \$60

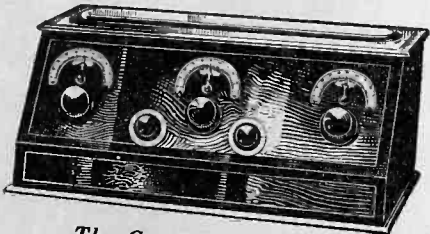

## The Crosley 5-Tube 5-38

All the volume, selectivity, sensitivity and fine tone in the best 5-tube set you've heard—plus the CRESCENDON. Two toned mahogany finished cabinet—daintily striped in gold. Price without accessories . . . \$38

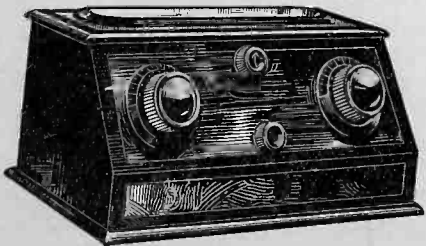

## The Crosley 4-Tube 4-29

A beautifully designed set—both to ear and eye. Crescendon equivalent to one or more additional tubes of radio frequency amplification. Two toned mahogany finished cabinet. Price without accessories . . . \$29

West of the Rockies add 10% to all prices

**“If inexperienced in radio, be sure your first set is a Crosley”**

It takes neither practice nor mechanical skill to tune in stations all over the country. Children and old people operate Crosley radios easily. They are fool proof.

They are inexpensive. They don't tie up a lot of money.

They have proven their efficiency over a period of years. Thousands of letters report remarkable demonstrations. Hundreds of thousands of sets sold substantiate all claims to excellence.

They are made by a reliable, well known and financially strong concern, that guarantees them absolutely.

The easy operation, tone and volume of these four new Crosley sets delight, not only the expectant beginner; they arouse the most confirmed radio lover to realization that Powel Crosley, Jr., has again made a revolutionary improvement in radio. And the RFL sets possess true cascade amplification. For Crosley has utilized an entirely new patented circuit which achieves cumulative amplification, actually approaching the theoretical maximum efficiency per tube.

## The Crescendon

In the 4-29 and the 5-38, the introduction of the Crescendon enables these two highly efficient radios to give almost unbelievable results and has lifted them away and beyond all competition.

The Crescendon is an exclusive Crosley device for increasing the weak signals of distant stations to full volume tones without distortion. Yet with these sets, loud nearby stations can always be softened practically to whispers. Their striking beauty will please your eye, and your ear will introduce to you new qualities in radio, which you are sure to pronounce a revelation.

See the new Crosley sets at your dealers or write Dept. 19 for literature. Crosley manufactures radio receiving sets which are licensed under Armstrong U. S. Patent No. 1,113,149 or under patent applications of Radio Frequency Laboratories, Inc.

**THE CROSLLEY RADIO CORPORATION**  
Powel Crosley, Jr., President  
CINCINNATI, OHIO

Owning and Operating WLW, first remote control super-power broadcasting station in America

# CROSLLEY RADIO

BETTER—COSTS LESS

FOR THE ENTERTAINMENT CORNER

Tell them that you saw it in RADIO

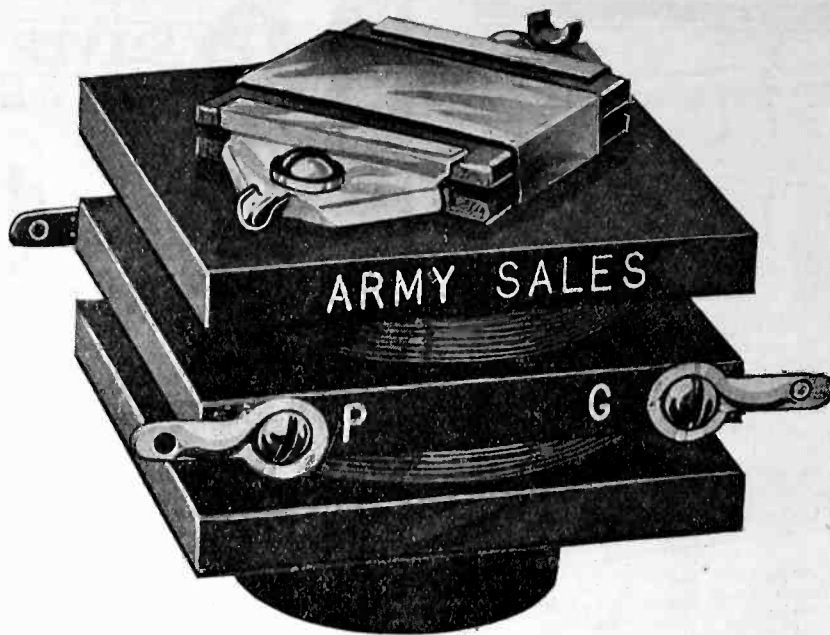

# Best Filter Transformer

A Filter Transformer of Guaranteed Accuracy. Furnished with Matched Tuning Condenser. The first device of its kind obtainable which combines great selectivity with high step-up ratio. Adaptable to any circuit requiring filters tuned from 25 to 80 kilocycles. An improved arrangement of coil windings makes it possible to tune this transformer to any frequency between 25 and

80 kilocycles. Sets having poor selectivity—inefficient sets using improperly tuned filter transformers—improper matching of tuning condensers—can be greatly improved by the installation of the new Filter Transformer. Experiments are costly. Install one of these new Filters and note the difference. Each Filter Transformer is guaranteed fully—on a money-back basis.

## *Five Dollars, Postpaid*

When ordering, please state type and frequency of the transformers already installed in your set. For new installations we will ship you the filter best adapted to the type of transformers you desire to use. Select the frequency best adapted to your particular locality. For extremely congested districts a pair of these Filter Transformers, matched to the same frequency, will enable you to cut out all local stations and bring in distance with remarkable ease.

### Order by Mail

Send \$5.00 and your Filter Transformer and matched condenser go by mail same day your order reaches us.

### Dealers

Our trade proposition will interest you. Write at once for complete information. Meet the demand for this device.

---

# ARMY SALES COMPANY

1650 Jackson Street

San Francisco, Cal.

---

SM

# S-C KIT

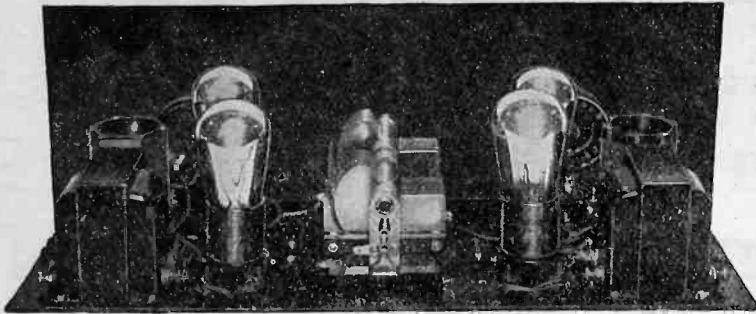

The famous S-C Receiver is now offered exclusively by Silver-Marshall, Inc., as a complete, Armstrong licensed kit, including every single part necessary to build this remarkable set in a few hours' time.

Behind the S-C Receiver is the reputation of "Popular Radio"—Laurence Cockaday—McMurdo Silver. And behind each and every part stands the pick of radio manufacturers—Belden Mfg. Co.—Central Radio Labs.—Polymet Mfg. Co.—Poster & Co.—Silver-Marshall, Inc.—Thordarson Elec. Mfg. Co.—Yaxley Mfg. Co. and the S-C Merchandising Co. What better guarantee could be demanded—or offered?

### SET BUILDERS SAY:

- "Our S-C certainly is a wonder for volume and clarity."
- "It's impossible to hook the S-C up wrong."
- "My S-C develops volume equal to 6 and 7-tube sets."
- "Bring Chicago into Newark, N. J., with plenty of volume."
- "Battery cord is certainly remarkable piece of work."
- "Never saw such simplicity and compactness."

**PRICE S-C KIT \$59.00**  
NO. 620

Licensed under Armstrong U. S. Patent No. 11113149. Manufactured by Tresco.  
Exclusive Distributing Agents: Silver-Marshall, Inc.

## SENSITIVITY MEASUREMENT!

The Silver-Marshall Laboratories have perfected a new and radical method of transformer measuring that insures an unbelievable degree of selectivity and sensitivity to weak signals. All 210 long wave interstage and 211 tuned transformers are now measured by this remarkable system. Price singly or in matched groups, \$6.00 each.

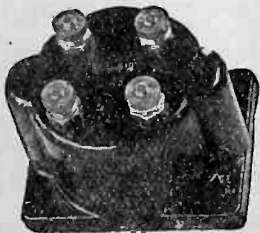

For those experimenters desiring to avail themselves of this special service, S-M transformers will be measured and matched at 50c each. All other makes at \$1.00 each, when returned accompanied by remittance.

*See S-M Parts  
at your dealers*

# Silver-Marshall, Inc.

852 W. Jackson Blvd.  
CHICAGO

The **SC** **SILVER COCKADAY**  
"All Wave Receiver"

Send for this  
New Hookup

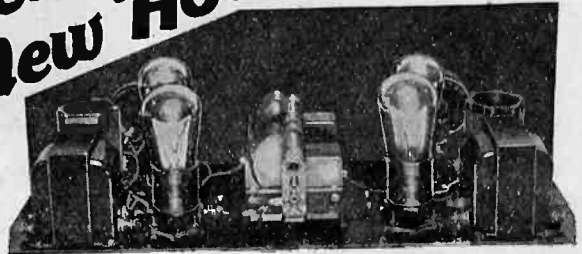

## Single Control 4-Tube Receiver

Designed by Silver, Cockaday and the engineering staffs of the seven manufacturers listed below . . . Sponsored by Popular Radio Magazine . . . Endorsed and Described by Radio News, Radio Magazine, Radio Age, On the Air, Popular Science Monthly, Radio Engineering, Christian Science Monitor and Newspapers throughout the country . . . The new S-C Receiver is presented to the Set-Builder with an astounding introduction that is his best assurance of a performance that will live up to promise . . . An Introduction that compels attention and appreciation . . . that speaks volumes of praise . . . that has been accorded only to the S-C Receiver.

### New S-C Features

Perfected Single Control — Unlimited Wavelength Range—Extraordinary Volume that equals that of many 6-tube receivers—Quality unsurpassed—Hair-line Selectivity that brought KFI through a blanket of powerful locals into New York City with ample loud-speaker volume. The S-C is adapted to any standard cabinet, tubes, batteries or eliminators, and to practically all installation conditions.

### Assembled Easily

S-C assembly is a marvel of simplicity. A special, multi-color, wiring harness eliminates soldering, unless desired, and prevents error. With only a screw driver and a pair of pliers even an absolute novice can assemble the S-C Receiver perfectly in a few hours.

The parts made by the following reputable concerns are recommended for the Silver-Cockaday, by the designers, and can be obtained in a complete kit from any Radio Dealer.

- Belden Mfg. Co.—S-C Wiring Harness.
- Central Radio Laboratories—Centralab Resistance
- Polymet Mfg. Corporation—Fixed Condensers, Leak and Leak Clips.
- Poster & Co.—Drilled and Processed Front Panel and Drilled Sub-Panel.
- Silver-Marshall, Inc.—Variable Condensers, Coil Sockets, Coils, Tube Sockets, Vernier Dial, Mounting Brackets.
- Thordarson Elec. Mfg. Co.—R200 Power Transformers.
- Yaxley Mfg. Co.—Rheostat, Jacks, Switch.

## S-C Merchandising Co., Inc.

285 S. Peoria St., Cor. Jackson Blvd, Chicago

GET

The S-C Book  
from your dealer  
or use this coupon today.

S-C MERCHANDISING CO.,  
285 S. Peoria St., Cor. Jackson Blvd., Chicago.

Herewith please find 25 cents for which send me the S-C Complete Assembly Booklet.

NAME.....

ADDRESS.....

# Breaking Into the Radio Game

Suggestions for Getting a Job in This Half Billion Dollar Industry

By *Howard S. Pyle*

**A** YOUNG man came into my office the other day and confided to me that he simply must find some entry through which he could find a place in the radio field. He was intensely interested in the art and determined to pursue it as a life work but he had not the vaguest idea of how to go about it. I queried him as to which particular branch of radio he was most interested in and with a surprised air he replied, "Branch? I'm not quite sure that I fully understand you. Just radio is what I want."

It will perhaps surprise some to know that radio isn't just "radio," that the industry, fast becoming stabilized, is divided into various branches in each of which some special development or use of radio plays the leading role. Operation of a high powered wireless telegraph station in some remote tropical country bears little relation to the design of a suitable amplifying transformer to increase the volume of musical notes without distortion, yet both are radio.

This indicates that the first thing an aspirant to entry into the radio industry must determine for himself, is just what particular branch of radio attracts him most. Like other fields, it may be necessary for him actually to try his hand in the game before he can determine where the greatest attraction lies, but many already have at least a vague idea of what particular application of radio holds for them the most fascination. For purposes of assisting those who are utterly undetermined, we may divide the radio industry into three main branches: manufacturing, selling and operating.

## Manufacturing

**F**OR any radio purpose, delicate and often intricate apparatus is required. Much apparatus can be made by the home builder, but there will remain a number of the really vital parts that are beyond the scope of the home workshop. Vacuum tubes, transformers and headphones are a few of the common articles thus classed. These must be made by skilled workers and on complicated machinery almost human in its activity. So also should be built the other radio parts which must be electrically and mechanically perfect. A number of factories may be engaged entirely in the design and manufacture of apparatus for radiocast reception; another factory may turn out apparatus for radio telegraphic purposes on ships at sea; still another may be building the equipment for high power, trans-oceanic work. If any one

of these holds more attraction for the embryo radio man than the others, that, then, should be his choice. And now, how will he do it?

Our applicant should present himself armed with experience. If he is far from a sea-coast or other large body of water sailed by radio equipped vessels, he is handicapped, for operating experience will be most difficult of attainment. He can then but enter the service of his employers in the capacity of an apprentice to radio, though the fact that he is a good machinist or mechanic will help. The main thing is to obtain employment somehow where the actual equipment is being manufactured. This serves as his entering wedge and places him in contact not only with the building up of the equipment, but with the men who design, build, install, and operate it. He cannot help but absorb knowledge from their discussions and conversation and if he is observant in addition to his natural attraction for the work, he will find ways and means of advancing himself in his chosen field.

Does the prospect live near a port where radio equipped ships can be found, he has a valuable opportunity which should not be lost sight of. It should be his endeavor to meet and become friends with the radio operators of these ships and he will find that this association will net him a very great deal more than he will expect and from close contact with these men he can prepare himself to

make application at his chosen factory armed with the equivalent of several months of experience—a basic understanding of the apparatus he wants to build and the ability to talk intelligently on the technical phases of the equipment. He should not lose the opportunity for home study from books as well, and it should be one of his aims to prepare himself for a commercial radio operator license, even though it be not required in the manufacture of apparatus. He may wish to become an inspector or tester of equipment at some future date and a knowledge of the code and a license to operate will then be a necessity.

We have discussed manufacturing, the construction of marine radio equipment. The procedure would be identical did the aspirant prefer to become associated with the manufacture of radiocast receivers. He could obtain in this branch, the equivalent to the marine man's association with ship operators, by frequent contact with local radio dealers, the building of a number of receiving sets and such odd jobs as he may feel competent to tackle in installing or repairing the radio sets of friends and neighbors. If possible, employment in the repair shop of a dealer would serve him excellently as a basic foundation for entry into the manufacturing field and would be the equivalent of experience. It follows then, that for entry into ANY branch of the radio manufacturing in-

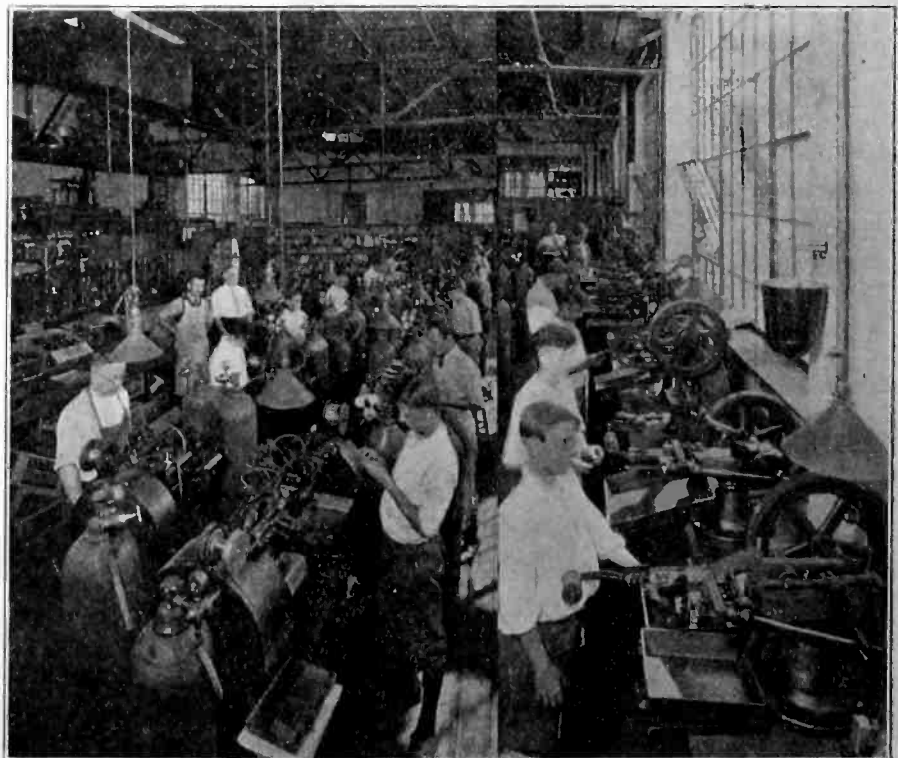

*Scene in a Vacuum Tube Factory.*



dustry the surest and best route is through the shops of an actual manufacturer, as an apprentice if need be, but an employe of the shop somehow. The rest is up to the man.

### Selling

**T**HE selling side of radio is not unlike salesmanship in any other line. It consists in presenting the good points of the product offered in such a way as to result in a sale without belittling the product of a competitor. The product cannot be successfully sold unless the salesman is himself sold on it and honestly believes that his product is actually a better buy than any other on the market.

Radio selling may be divided into sub-branches. There may be city salesmen and traveling salesmen representing jobbing houses and dealing only with the retail dealers, retail salesmen calling on the consumer directly, and counter salesmen serving the purchaser who enters the store to buy. A young man must then first decide which appeals to him most. Once that is settled, he can proceed with some definite object in view.

If you are successful in selling something foreign to radio, either on the road or to local dealers, you can be reasonably sure that you will be successful with radio, more particularly if it appeals to you more than the line you have been handling. On the other hand, if you couldn't put your firm's soap across and are discouraged and disheartened with your selling ability, stay away from radio. At any rate, if you do choose to try your hand at radio salesmanship in this way, ally yourself with a jobber handling a good outfit or you are bound to meet with grief. This is where a knowledge of radio sets either from home use, book knowledge or school-work, will assist you—you will know whether the product you are asked to

sell is a quality outfit or one of questionable make and performance.

If you desire to come in actual contact with the public, the ultimate purchaser, you will find it reasonably simple to obtain connection with a suitable dealer who will be glad to have you represent him on a commission basis. If you show results, you can demand a substantial drawing account or straight salary. The dealer has nothing to lose by taking you on on a commission basis provided he is satisfied with you otherwise, and it is your opportunity to prove both to yourself and the dealer that you can deliver the goods. It will be wise for you to familiarize yourself with the apparatus which your dealer handles before presenting yourself to him with a request for employment. Talk to him familiarly of the apparatus which he will expect you to sell, and you will impress him favorably. Be sure however, that you think the equipment which he offers to be an excellent piece of apparatus and an honest value at the prices asked.

You will find in this direct dealing with the public that you are going to require tact and adaptability to the nth degree. One evening you may be engaged in demonstrating apparatus in a cheap, loud pool-room while the next day may find you accepting the hospitality of a leading banker in the refined atmosphere of his home life. You must appear to good advantage in either extreme.

You will find your patience stretched to the snapping point very frequently. If you sell a person an outfit, they will naturally turn to you as their personal contact with the dealer in the event any little difficulty develops. It may be a cold, blustery night and your pipe and slippers mighty attractive around the home fire-place, but if Mr. X.— has set his heart on hearing Professor Umtydyke in a rendition of, "Where Do Bull

Frogs Go in Winter" from station BLAH, and his set just won't do a thing but howl, you're going to have to spend some time with him before you discover that little Willie has dropped tinfoil in the detector tube socket and succeeded in making a perfect short between the grid and plate contacts. Mr. X.— could have found it in a minute if he had looked, but you sold him the set, what more natural than that he call on you if it doesn't act just right? And he is going to do it—not once but often. And you can only look pleasant, assure him that your visit wasn't a bit of trouble and that you were glad to help him out. And your tone had best sound sincere if you want to sell Mr. X.—'s friends!

Counter salesmanship, while not requiring a great deal of actual ability as a salesman, is harder to break into than the home selling proposition. Few dealers place any of their counter salesmen on a commission basis, for sales are not dependent entirely on their efforts but a sale is considered half made when a prospect walks into a store. On the other hand, the outside salesman has first to work his prospect up to the desire to buy, and then sell him. So, counter salesmen are generally straight salaried men, and not too high salaried at that. It should be considered as a stepping stone to better things rather than as a permanent occupation. By reason of this fixed salary, the dealer is reluctant to take you on unless an actual vacancy exists.

Your greatest asset in counter salesmanship will be a thorough knowledge of the latest circuits, necessary parts, their prices and the names and prices of all the popular accessories, as well as an ability to talk well to any class of person and to think quickly. Many think it necessary to develop an ability at quick falsehood so that they may appear to have a superior knowledge of circuits when they actually are more ignorant of some particular obscure hook-up than the customer. That is extremely bad business, for if you suggest a wrong part to impress him with your superior knowledge, he will discover it sooner or later and it will mean a lost customer.

You must develop an ability to entirely satisfy your customer and fraternize with him to the extent of discussing his pet theory or hook-up, but in such a way that while talking you've sold him something, made out the ticket and by the time the package is wrapped and ready you can hand it to him with a pleasant "Good-bye" and turn to the next man without making the first customer feel slighted. The radio fan has a peculiar habit of believing that anyone associated with radio in the least way will be intensely interested in his latest method of growing grids in vacuum tubes and

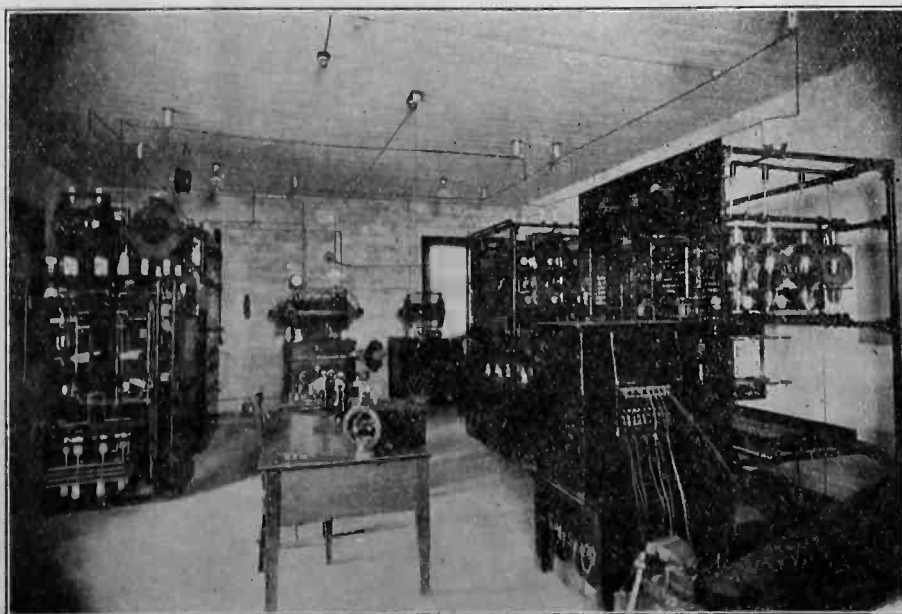

New 5-Kw. Radiocast Station at 3LO, Melbourne, Australia.

(Continued on Page 46)

# Something Hertz

By Keith LaBar

Illustrated by Louis McManus

IT WAS nine o'clock in the evening. The Seven Sap Sisters, after having poured themselves out of one small horn at frequent intervals in the past hour, retired in favor of the guest announcer, Sam Smith, builder of fine pants.

"An' folks, remember we always stand for a square deal an' —"

Sam expired naturally as the Business Man lovingly hunted among the figures on the dials for distant stations. The dials, knowing from long experience that evasion would be useless, obligingly arranged themselves to allow a more or less accurate rendition of the Anvil Chorus as given by energetic employees of Snirk's Haberdashery—"Snirk's for Shirts"—to spread around the room.

"Isn't radio wonderful," commented the Business Man to his friend, the Engineer. "Here we sit and listen to

ing without wires took the form of what is now known as ground telegraphy, used somewhat in the war. In 1838 the discovery was made that the ground was a good conductor of electricity. In 1842 Samuel F. B. Morse got the idea that it might be possible to make the earth serve the purpose of both sides of a telegraph circuit. He wanted to telegraph across a river and boats had an annoying habit of breaking his wires or cables. So he laid two parallel wires, one on each side of the bank, the four ends be-

current they are about the equal of the telephone, but the imagination has more of a chance to produce signals in a phone than from a galvanometer. Why, even you have heard Chicago with no tubes lit."

The Business Man subsided at this reference to a short lived triumph and the Engineer went on.

"Concurrent with the invention of the telephone came the discovery that signals from one telegraph line were causing signals to be received on a wire paral-

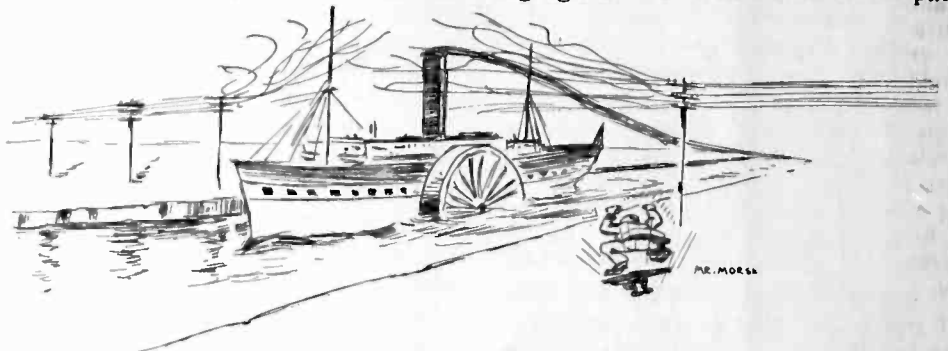

"Boats Had an Annoying Habit of Breaking Wires."

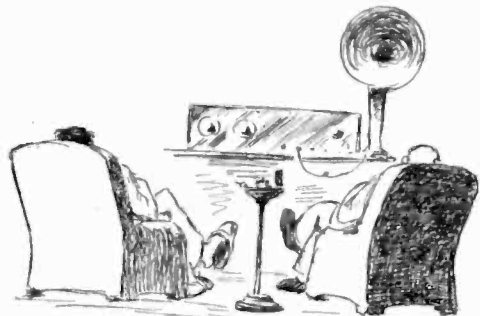

The Engineer. The Business Man.

music from across the continent. And to think how new the industry is. The sales of radio equipment are used with those of steel and grain to feel the business pulse of the nation."

"Trade reports? New?" The Engineer looked up from searching among the Sweet Young Thing's chocolates for one that looked as if it might contain a cherry. "Why, radio is as old as you are."

The Business Man opened his mouth to reply to this rather dubious compliment but thought better of it and again busied himself with his beloved dials. Finally he spoke.

"Funny I never heard about it. If you know so much let's hear about it."

The Engineer began. "Radio as you know it, broadcasting, is comparatively recent. Radio telephony from station to station extends a step behind that. Telegraph signaling came before telephony. Before that it was merely a laboratory plaything—but not for long. Too many bright minds even in those days for that.

"The earliest experiments in signal-

ing grounded. A galvanometer was put in the receiving wire and indicated signals by the deflection of a needle. Batteries and a key were in the circuit of the transmitting wire.

"Morse reasoned that part of the current flowing through the earth from one end of the wire to the other would cross the river and flow through the circuit at the other bank, the second wire offering a lower resistance to the current than the earth. Signals were successfully transmitted, and Morse reasoned he was correct in his theory.

"Many experimenters followed Morse, all working on the same plan. Lindsay, in the period from 1853 to 1860 succeeded in telegraphing across rivers a mile wide. Having got this far, imagination began to work and he announced to the popular press that it was only a question of time before the Atlantic was spanned. Having imparted this good news, he died, and left the work to other experimenters, who, having more money, more batteries and wire, got slightly better results.

"The invention of the telephone came along just then and it furnished a more sensitive device for the reception of signals."

"Are not some galvanometers as sensitive as a telephone receiver?" asked the Business Man, remembering past experiments in physics.

"Yes," answered the Engineer with a slight smile, "for the single surge of

labeled to the first wire but having no electrical connection. And then they found that the effect was more noticeable with a coil of wire. Sending a current through one coil would cause a current to be induced in a second coil some distance away.

"Once more popular imagination was excited. It was proposed to equip ships with enormous loops of wire, making it possible to carry on communication for short distances. Another wild idea was a wire from Maine to Florida."

"Wild idea — Florida —" murmured the Business Man.

"The magnetic field from this loop,"

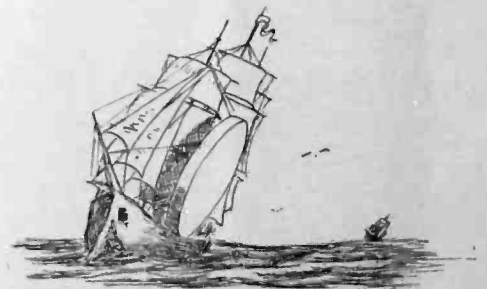

Electromagnetic Communication (?).

continued the Engineer, ignoring the interruption, "was to have been intercepted by a long wire extending across France. Both of these ideas fell rather heavily by the wayside."

"They needed a good promoter and an appropriation for advertising," remarked the Business Man, professional instincts calling.

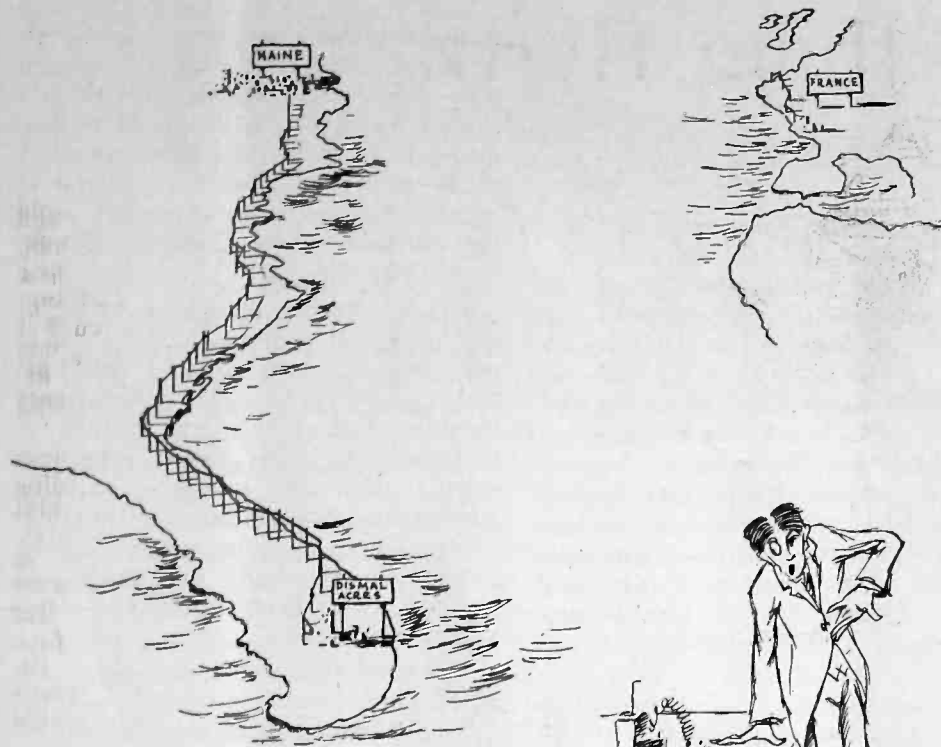

"A Wire from Maine to Florida was Proposed."

But the Engineer, not to be dissuaded from his purpose, went monotonously on.

"In 1885 Edison, working with other experimenters, developed a plan for telegraphing between moving trains and the stations by the use of induction. The plan was patented and upon trial worked successfully, but failed as a commercial success, due to the small number of messages sent.

"Employing the use of induction, it is no wonder the experimenters of those days had a hard time of it. Indeed, it is rather surprising that they managed to get results, as they did, of five miles or more. It is a good thing that in those days they had few electric motors, telephones, street cars, Fords, and 60 cycle house wires or they would have been surprised by the variety and intensity of unexpected signals received.

"In the year 1886 Hertz made his discovery of the waves that bear his name. Heinrich Hertz was a professor, and so failed to see the practical value of what he had discovered. The dis-

covery came about like this. In using a pair of coils for an experiment he found that the discharge of a small condenser through one of the coils and a gap resulted in setting up an induced current in the other. The current rushed back and forth across the gap in the first coil and set up waves, which set up very rapid alternating current in

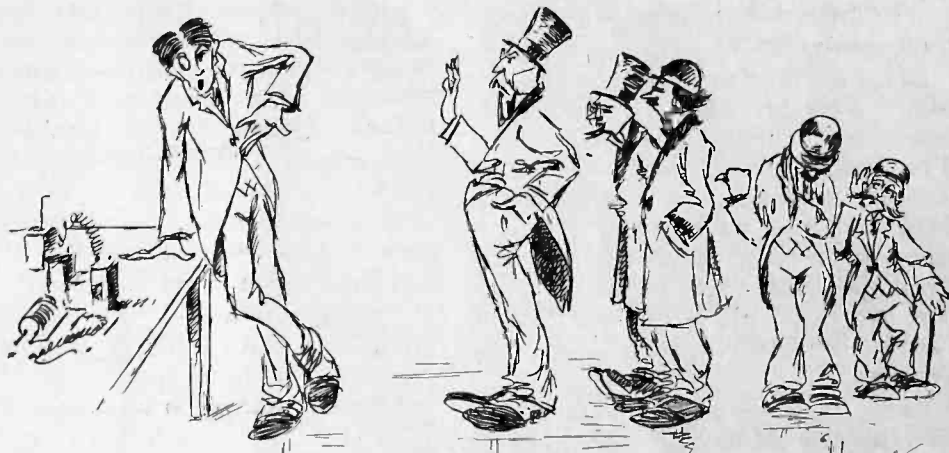

Hughes and Members of the Royal Society of London.

the second coil, enough to cause a small spark in the gap of the second coil. This was not caused by pure induction, for the currents did not act like induced currents, causing no galvanometer deflection, and what is more, the receiving end could be tuned.

"To prove this he set up a spark gap and a coil. A short distance away he placed the loop of wire and gap and variable condenser. By varying the capacity of the condenser a point was reached that gave maximum sparking in the receiving end."

"And all they needed to know all about it was a present-day ten-year-old boy," remarked the Business Man to the ceiling.

"These were the waves that were prophesied twenty years before by Pro-

plate. This was the forerunner of the present day crystal detector.

"Hughes called in some members of the Royal Society of London to show them his stuff. They, after seeing it work successfully in a number of experiments, were still unconvinced, and said that it was merely electromagnetic induction resurrected again and refused to believe in any new-fangled wave business. This discouraged Hughes, who was unable to say 'I told you so' for six or eight years."

"And so Hughes really was the discoverer?" queried the Business Man.

"Some admit his claim, and others believe he was antedated by experimenters who did not know what they had when they had it," absently answered the Engineer with a glance at the clock.

"The distance they could transmit was decidedly limited with apparatus modeled after Hertz's laboratory experiment, with a microscopic spark as the evidence of reception. In 1892 Branley brought forth the coherer, an adaptation of some earlier discoveries of Hughes.

"The coherer consists of a glass tube, filled with metal filings, with electrodes at the ends. The antenna was connected to one end, the ground to the other. The coherer was also part of a circuit with a battery and relay. Radio frequency currents would cause the filings to jump together, enormously lessening the resistance. The local battery would then flop the relay, which would work the

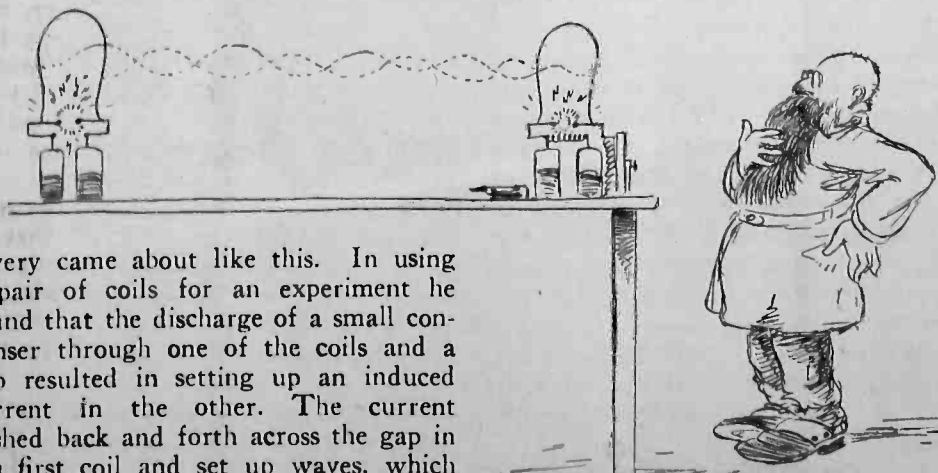

Heinrich Hertz and His Waves.

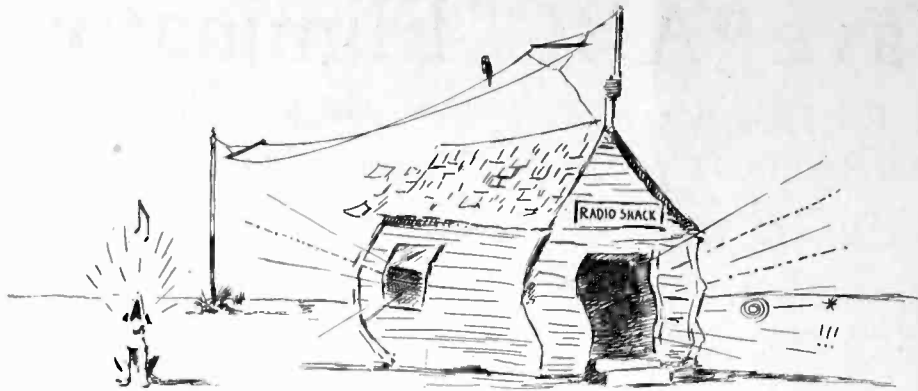

*A Coherer in Action.*

tape recorder and a tapper to knock the filings apart, ready for another signal.

"They made quite a spectacular receiver," said the Engineer reminiscently. "One could operate a fog horn or other wild piece of machinery quite easily. I remember—but let's get back to the story.

"Early experiments were conducted on short waves with parabolic reflectors, and if they did not try to transmit very far the experiments were usually a success. In the fifteen years between 1885 and 1900 experiment followed experiment so fast that it lost its value as first page stuff and had to be content with less publicity.

"In those days, if a trial did not succeed they merely added to the height of the antenna. The mathematicians were busy on the job, and made great calculations as to the distance possible to transmit with an antenna of given height. The transmitters and receivers were usually untuned, and when Marconi began to sell equipment to different ships there was much interference and squawks from operators whose tape recorders picked up everything going.

"Marconi was the first to realize that Hertzian waves could be used for telegraphing without wires and he obtained a number of patents and was a great factor in the speedy development of the art.

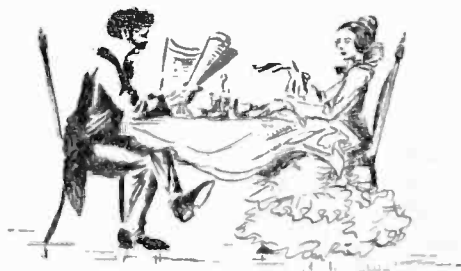

*The News of Successful Transmission Across the Atlantic.*

"Development went on quietly until 1901, when a really good first page story broke. On December 12, 1901, Marconi succeeded in telegraphing across the ocean from Poldhu, England, to Newfoundland, a distance of 1800 miles. The signal was merely the letter "S" but it was proof that it could be done and the public got highly excited.

"From that date on it is really a separate story," said the Engineer with a

yawn. "Radio was established on a more practical basis and it was merely a race to see who could get to the patent office first. Dr. John Stone held the record between 1901 and 1904 with seventy to his credit. The next highest was forty.

"Do not think, however, that the radio game was then any bed of roses. It still was an easy path to the poorhouse."

"The history of the art is quite interesting," said the Business Man, as he helped the Engineer find his hat. "You must come over again soon."

After the Engineer had left the Business Man cautiously turned on the set again.

"—just like a subdivision in Heaven. All is yours with each view lot. Invest now. Send for free booklet showing proposed sidewalks, proposed streets, proposed clubhouse, proposed—"

"A great industry," murmured the Business Man and went to bed.

### SOME INTERESTING DATA ON VACUUM TUBES

By S. C. MILLER

**W**HAT factors should be considered in the design of a vacuum tube for use in the modern set today? As practically all tubes manufactured today are made universal, that is, they can be used, either as radio frequency amplifiers, detectors, or audio frequency amplifiers, it is interesting to know how the tube manufacturer designs the tube to meet all of these conditions.

One of the most important factors to be considered is the type of receiving set in which the tube will be used. A few years ago, the receiving set in most general use was of the regenerative type. The vacuum tube therefore had to be designed to operate most satisfactorily as a regenerative detector, and audio frequency amplifier. However, receiver design has gradually changed from the regenerative type to that of the tuned radio frequency types, which are practically the standard receivers in this country today.

The tuned radio frequency receivers consist of three separate circuits: a radio

frequency circuit, a detector circuit, and an audio frequency circuit. The vacuum tube must operate well in either of these three circuits, yet there should be kept in mind, which of these three circuits is to be given the greatest consideration, because it is well nigh impossible to design one tube to give maximum efficiency in all three circuits.

From a recent survey of conditions throughout the country by a leading manufacturer, it was found that most makes of tubes with reasonable characteristics, gave satisfactory results in those sections where the stations were located near the receiving set. But when a station was located at least four or five hundred miles away from the listener, it was found that the results obtained with different makes of vacuum tubes varied greatly.

It seemed from this survey that great stress must be laid on the design of tubes as radio frequency amplifiers. This means, that more consideration must be given to the tube as a radio frequency amplifier than its use either as a detector or audio frequency amplifier. In order to make the standard tube a good radio frequency amplifier, a number of factors must be satisfied. First, the internal capacity between plate and grid should be as low as possible in order to prevent any by-passing of the signal at the lower wave lengths where this apparently small capacity becomes effective. Second, the vacuum tube at radiocast wave-lengths should have an impedance approximately equal to the impedance of the circuit to which it is coupled. Third, it should have an amplification constant as high as possible at this impedance. This tube would produce a high voltage amplification necessary for a good radio frequency amplifier. It is understood that a tube coupled to a radio frequency circuit operates as a voltage amplifying device instead of a power amplifying device.

Of course, the ideal arrangement of vacuum tubes would be the use of separate tubes for each of the different circuits. That is, a separate radio frequency amplifier, a separate detector, a separate audio frequency amplifier, each being especially designed for that type of circuit. Although this would involve the use of many different types of tubes in a set, yet it would be warranted for those who want both distance and quality.

As for the vacuum tube on the market today, I wish to make clear that the mutual conductance is not the only factor involved in the merits of a tube, but that in the majority of cases, more stress should be laid on the value of the tube as a radio frequency amplifier. Of course, this may not meet with the approval of those who live in the cities, and are very close to stations, and are interested in local reception only.

# The Half-Wave "ABC" Eliminator

For Supplying Rectified and Filtered Alternating Current for the Operation of Any Set Using Dry Battery Tubes

By G. M. Best

**N**CESSITY is the mother of invention, and necessity has hastened the development of the half wave battery eliminator described herein. In December 1925 RADIO, a description of how to build a complete full wave battery eliminator, capable of supplying 60 milliamperes of pure d. c. at 150 volts or more, was published, together with details for the modification of several popular types of receiving sets, so that the eliminator could be attached.

The full wave eliminator was designed to employ either a UX-213-CX-313 full wave rectifier tube, or the Raytheon rectifier, and required a power transformer with 110 volt primary, and two 250 volt secondaries connected in series. The General Radio Co. furnished the first sample of this type of transformer, with the 250 volt secondaries, and a successful ABC battery eliminator was constructed, for operation with either of the rectifier tubes mentioned.

It was assumed in good faith on our part that the transformer would be placed in commercial production with the 250 volt secondaries, but a few weeks later the Board of Fire Underwriters

ruled otherwise, for it seems that if the secondary voltage of power transformers exceeds 220 volts above the ground potential at any point, special wiring and transformer construction must be employed. Consequently before the transformer was put on the market, the secondary voltages were reduced to 200 per winding.

Hence, a number of our readers have assembled the ABC eliminator and have purchased the ready-made transformer instead of winding their own, with the result that in order to obtain 60 milliamperes from the rectifier circuit, the load resistance had to be materially reduced, particularly in the case of the Raytheon tube, which requires a slightly higher plate voltage than the filament type of rectifier tube when used in the ABC eliminator circuit. With the lower load resistance, the total available voltage for the plate circuits of the tubes was too low for most circuits, and in order that those who have already purchased the transformer with 200 volt secondaries may not be inconvenienced by the difficulty, the half wave rectifier system shown in Fig. 1 may be adopted with very little change in the circuit,

and with no change in the power transformer.

The rectifier consists of the power transformer, which is fortunately equipped with a 7.5 volt filament lighting secondary, a half wave rectifier tube, type UX-216-B, CX-316-B, and a filter system. The secondary of the transformer consists of the two 200 volt windings in series, making a total of 400 volts, one side of the secondary being connected to the plate of the rectifier tube, and the other to ground.

The filter used in the full wave eliminator consisted of two 20 henry chokes in series, with 4 mfd. across the d. c. line on each side of the chokes, and a 2 mfd. condenser at the mid-point between the two chokes. This filter is adequate where the full wave rectifier tube is used, and when connected to a receiving set, operates the filaments and provides plate voltage with absolutely no noise. With the half-wave rectifier, however, the filter does not have enough inductance for perfect filtering action, and a small amount of the fundamental 60 cycle a. c. is heard in the loud speaker, although this is not objectionable with most horn type speakers. With a cone speaker,

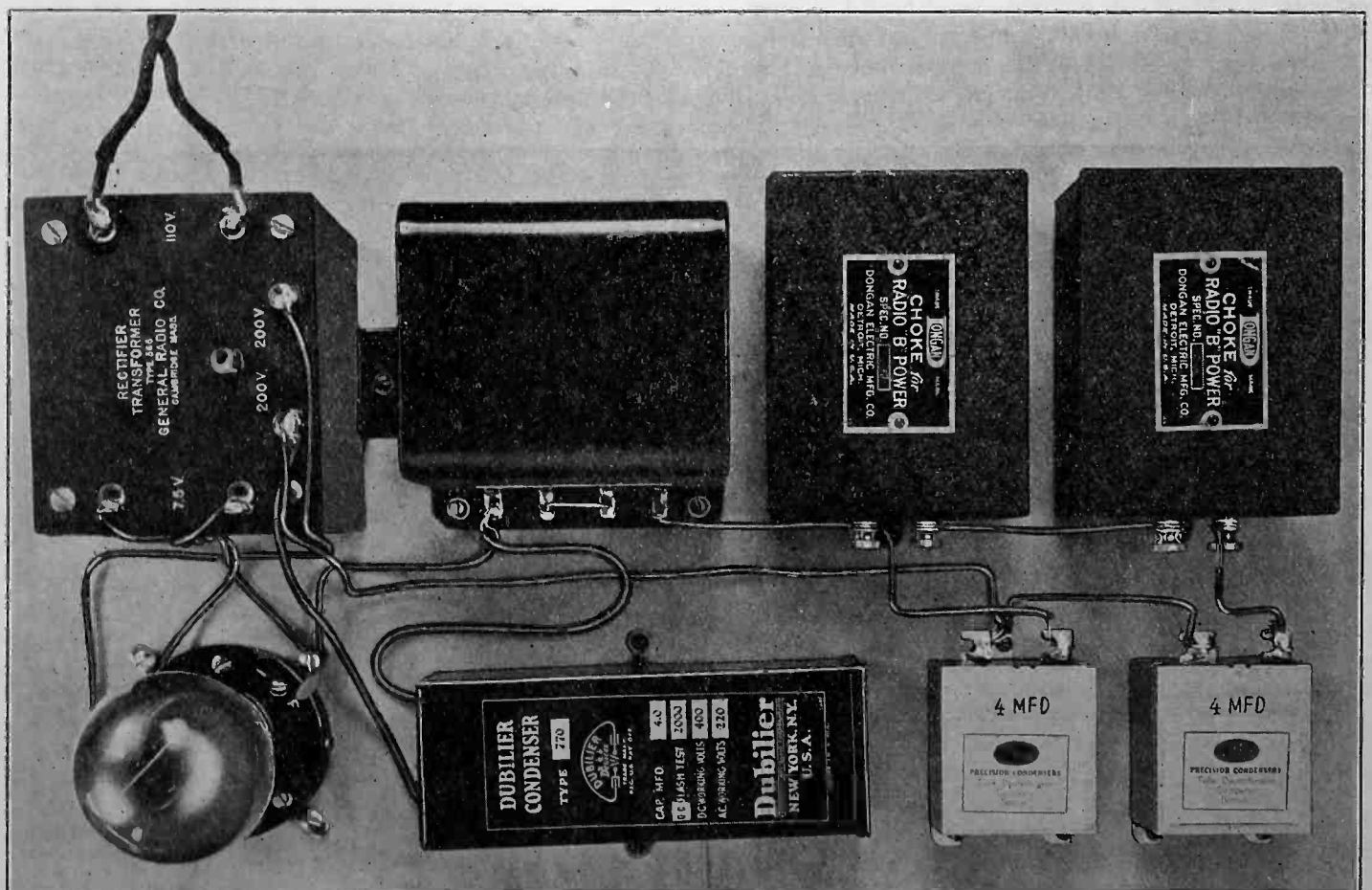

Baseboard Model of Half Wave ABC Eliminator.

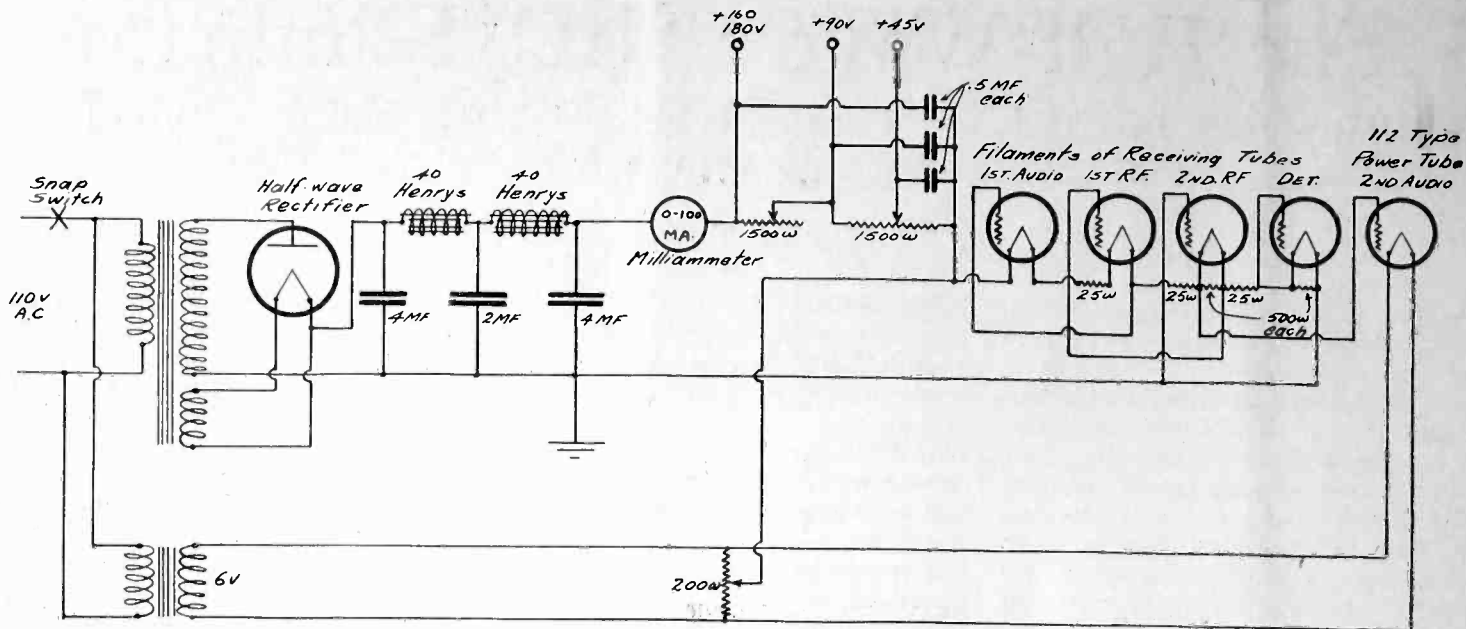

Fig. 1. Circuit Diagram of Half Wave ABC Eliminator.

which is very efficient at 60 cycles, it can be plainly heard, and hence at least one additional 20 henry choke is necessary, and preferably two, as is shown in Fig. 1, if the noise in the loud speaker is to be completely eliminated. Chokes having inductances as high as 100 henrys are now available, and are capable of carrying 60 milliamperes without heating, so that as long as at least 80 henrys inductance is placed in the positive rectifier lead, the d. c. output will be practically free from annoying pulsations.

The filter condensers should be capable of withstanding a continuous d. c. voltage of 200 and at least 400 volts a. c. With the CX-316-B rectifier in the circuit, the filter output, with two 40 henry chokes, will be 60 milliamperes at 190 volts, into a 2500 ohm load, so that ordinary by-pass condensers will not be satisfactory for use in the filter.

The load circuit is similar to that described in December 1925 RADIO. It consists of the filaments of the various tubes in the receiving set, which are wired in series, and a load resistance

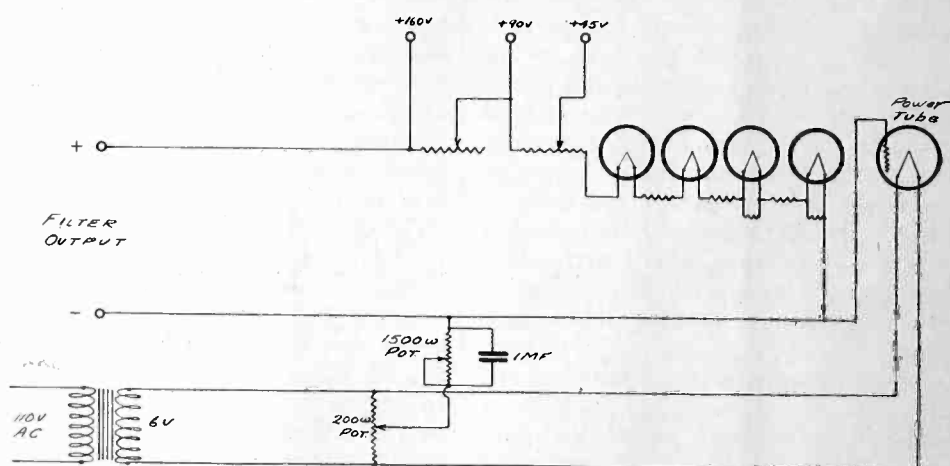

Fig. 2. Arrangement of Grid Return of Power Tube.

which can be varied. Two Federal No. 25 potentiometers placed in series will be the correct size for the half-wave rectifier, and the sliders of the two potentiometers can be used to tap the resistance at any point desired. Plate voltage for the various tubes is obtained from the voltage drop through the load resistance. Assuming that the set has four type 99 tubes in series, and a power tube whose

filament operates from a separate filament lighting transformer, the voltage across the load resistance will be approximately 180 volts. Setting the slider of the potentiometer nearest the filaments at the half way mark will provide 45 volts for the detector tube, and 90 volts can be had at the junction between the two potentiometers. The voltage

(Continued on Page 58)

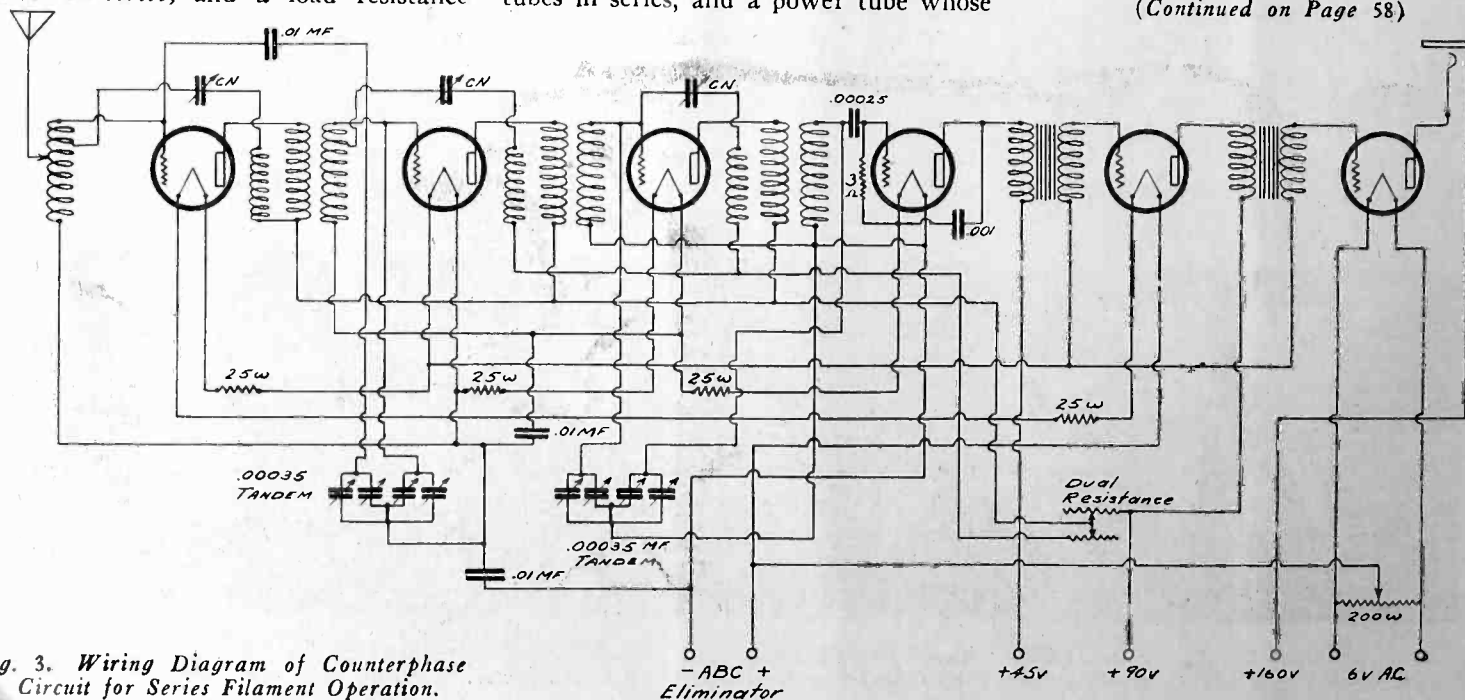

Fig. 3. Wiring Diagram of Counterphase Circuit for Series Filament Operation.

# A Ten-tube Superheterodyne Receiver

Permitting The Use of Five Tubes For Local Reception and Incorporating Partial Shielding and Controllable Selectivity

By Edwin E. Turner

THE most practical means for combining the selectivity and sensitivity essential for long distance work with the undistorted tone quality desirable in local reception is to employ a very sensitive and sharply tuned superheterodyne whose intermediate amplifiers, detector and oscillator may be easily cut out when only local stations are wanted.

The receiver described herewith was designed with this point in mind. It consists of a stage of tuned neutralized radio frequency, a regenerative first detector, a local oscillator, three stages of intermediate amplification, a second detector, one stage of transformer and two stages of impedance coupled audio. By the throwing of three small switches within the cabinet, the three intermediate amplifiers, the second detector and the oscillator filaments are extinguished and the receiver becomes a five tube set using the radio stage, the regenerative detector and the audio amplifier. The greater economy and ease of operation on nearby stations using the five tubes is patent. The quality is distinctly better. Depending upon the prevailing noise level conditions, a super-sensitive receiver of great selectivity or the ordinary five tube receiver may be selected at will.

Since the intermediate amplifier is to be used only to secure the great sensitivity and selectivity necessary for the reception of weak impulses through powerful local radiocasting, and since the quality of reproduction of these signals is of secondary importance, the intermediate amplifier is sharpened to the point at which actual cutting of the sidebands begins. This is accomplished by means of a tuned output impedance which couples the plate of the last intermediate amplifier with the grid of the second detector. The sharpness of the

LIST OF PARTS	
Panel	7x28x $\frac{1}{4}$ in.
Wooden Baseboard	27x14 $\frac{1}{4}$ x $\frac{3}{4}$ in.
Copper base plate (No. 18 gauge hard drawn copper plate)	20 $\frac{1}{2}$ x14 in.
3	Dials.
A-B	Voltmeter
4	Variable Condensers S. L. F., .00035 mfd. Max.
	Antenna coupler, solenoid as specified.
	Tuned transformers, solenoid as specified.
	Oscillator coupler, solenoid as specified.
10	Sockets.
3	Intermediate transformers.
1	Neutralizing condenser, 1 to 30 m.m.f.
2	R.F. chokes.
2	Filament switches.
2	Tap switches.
1	200 ohm potentiometer.
1	Audio transformer, 2-1.
2	Impedances.
3	Variable grid leaks, $\frac{1}{2}$ to 10 meg-ohms.
2	.0005 fixed condensers.
1	.00025 fixed condenser.
1	.004 fixed condenser.
1	.005 fixed condenser.
14	1 mfd. condensers.
1	Gridleak and Mount, $\frac{1}{4}$ meg.
1	500,000 ohm modulator.
1	0 to 50,000 ohm resistance.
3	$\frac{1}{4}$ ampere filament resistors, with mounts.
1	1 ampere filament resistor, with mount.
1	0.5 megohm grid leak, with mount.
1	Oscillator shield.
1	Intermediate amplifier shield.
1	Binding post strip.
14	Posts.
(Parts made by any reputable manufacturer may be used. The names of those actually used by the author will be supplied upon request to the publishers of RADIO if accompanied by stamped and addressed envelope.)	

resonance curve of the entire intermediate amplifier may be varied between wide limits by the selection of the proper ratio of inductance to capacity in this circuit. Keeping always at the peak frequency of the intermediate frequency transformers, the sharpness of resonance will be increased by an increase in capacity and a corresponding decrease in inductance. The use of tuned impedance output coupling makes it a relatively simple matter to select the peak fre-

quency of the intermediate transformers and to control the selectivity of the intermediate train as a whole. The author has found that a great deal of the trouble in the average superheterodyne may be traced to the tuned input or output transformer. Tuned choke output coupling is not a panacea for all superheterodyne troubles but properly applied it is a very effective tonic for general superheterodyne debility.

This receiver can get down to the noise level easily, with five tubes if the noise level be high, and with ten tubes if it be low. Interstage coupling has been reduced to a low value by partial shielding and the use of more than the usual number of large by-pass condensers. Toroid inductances are used more to prevent increase of resistance of the radio frequency circuits through eddy current losses in the metal shielding than as a means of securing the confined field. Although a certain amount of magnetic leakage exists in them, properly designed toroids undoubtedly do cut down the stray field linkages sufficiently to justify their use. For the builder who wishes to construct his own inductances equivalent solenoids are described.

The receiver employs complete shielding of the intermediate amplifier and of the local oscillator. The straight radio frequency circuits are not completely shielded, but electrostatic and conductive interstage coupling is reduced to a low value. A certain amount of feedback here is not objectionable. Electrostatically the receiver is shielded by the use of a heavy copper base plate to which one side of nearly every piece of apparatus in the entire assembly is directly connected. The high potential ends of these components are kept in the air by means of small pillars on which each piece is raised  $\frac{1}{2}$  in. above the base board. Leads connecting points of high potential are run

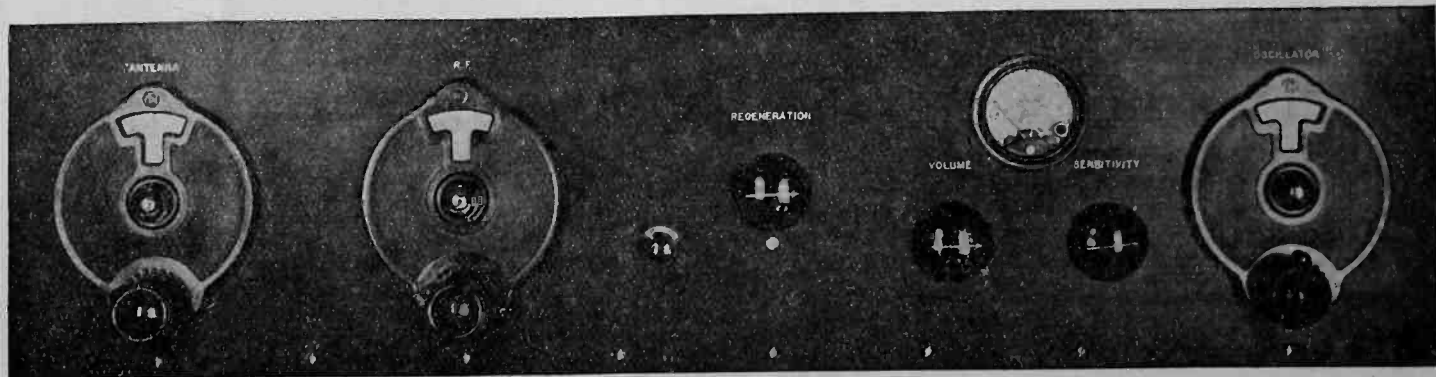

Front Panel View of Completed Receiver.

in air at some distance above the board. The importance of this "plane of zero potential," to which all apparatus connects, cannot be overestimated. The effects of electrostatic interstage coupling are greatly reduced by this means.

Conductive coupling between stages through the *A* and *B* battery commons is prevented by the liberal use of large by-pass condensers which short circuit the various radio and audio potentials at their source. Thus every filament in the radio frequency end of the receiver is connected directly to the copper base plate on one side and through a 1 mfd. by-pass condenser on the other side. Every plate return is similarly by-passed. In this way the currents flowing in the *A* and *B* battery leads are pure d. c. and their length becomes immaterial.

Energy is admitted from the completely shielded oscillator to the grid of the first detector through a suitable high resistance and capacity. By varying the value of resistance the exact amount of oscillator coupling may be selected for the optimum heterodyning of weak signals. A variable gridleak from  $\frac{1}{2}$  to 10 megohms has been found excellent for the purpose. If desired this leak may be controlled from the panel, but this is hardly necessary. Particular care was taken to prevent energy from the oscillator from being picked up except through the controlling resistance. Too tight coupling between the oscillator and the rest of the circuit is responsible for broad tuning and multiple dial settings on a great many superheterodynes. It is surprising what an increase in selectivity results from proper isolation of the local oscillator.

The potentiometer controlling the intermediate amplifiers is contained within the shield which encloses the amplifier and is not placed on the panel. The tendency of the intermediate train to oscillate is controlled by setting the potentiometer near the spillover point and

by varying the voltage applied to the plates of the tubes by means of a suitable variable resistance in the plate return. This resistance is controlled from the panel by means of the knob marked "Sensitivity" in the panel front picture. The gain of the audio amplifier is nicely adjusted by the 500,000 ohm modulator controlled by the knob marked "Volume." Overloading up to and including the first audio amplifier is prevented by suitable adjustments of the controls marked "Regeneration" and "Sensitivity" and beyond this point by the control marked "Volume."

The layout of the various components will be appreciated by examining the picture of the inside of the receiver. The intermediate amplifier and second detector assembly is grouped at the back left hand corner as the receiver is viewed from in front and above. Sufficient space should be left on all four sides, so that the shield may be placed over the whole. The shield should be fastened to the copper baseboard by a flange extending all

Flexible Celatsite was employed in wiring the receiver, being more convenient than bus-bar. The plate coil and the neutralizing coil should be connected in series aiding to form the tickler. If the oscillator fails to function one or both of these coils may have to be reversed. The terminals of the plate coil are marked *P* and *B* and those of the neutralizing coil *M* and *R*. To connect the coils in series aiding terminals *R* and *B* should be connected together. *M* should be connected to the plate of the oscillator and *P* to the positive side of the *B* battery.

For the home constructor the following equivalent solenoids are described. If a solenoid is used at *L*<sub>1</sub> in the wiring diagram the neutralizing condenser should be connected directly to the grid of the r. f. tube instead of to the tap *T* as shown. All coils are to be wound with No. 28 d. s. c. wire on forms having an external diameter of 2 in. Thin walled hard rubber tubing is to be preferred. Coil *L*<sub>1</sub> should be wound on a

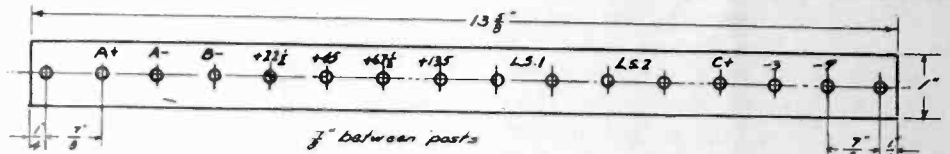

Fig. 2. Details of Binding Post Strip.

the way around the box and integral with it. Wood screws are passed through flange and baseplate and tightened until good contact is assured between the box shield and baseplate. The same procedure should be followed in the case of the oscillator which is at the extreme right of the panel and extends back the full width of the baseboard. The cases of the audio transformers, audio impedances and by-pass condensers should be grounded directly to the baseplate. All other parts should be raised  $\frac{1}{2}$  in. by suitable insulating spacers as above described.

form 2 in. long and should consist of 70 turns tapped at 3, 5, 10 and 15 turns for the antenna. *L*<sub>3</sub>, the oscillator coil requires a form 3 in. long. The grid coil consists of 70 turns. A space of  $\frac{1}{4}$  in. is left and the tickler consisting of 35 turns wound in the same direction. Coil *L*<sub>3</sub> consists of primary, secondary and tickler. The secondary and tickler are wound exactly as described for the oscillator coil. The primary consists of 40 turns wound on a tube just large enough to slip into the inside of the secondary. This coil is tapped in the middle. It is inserted in the filament end of the

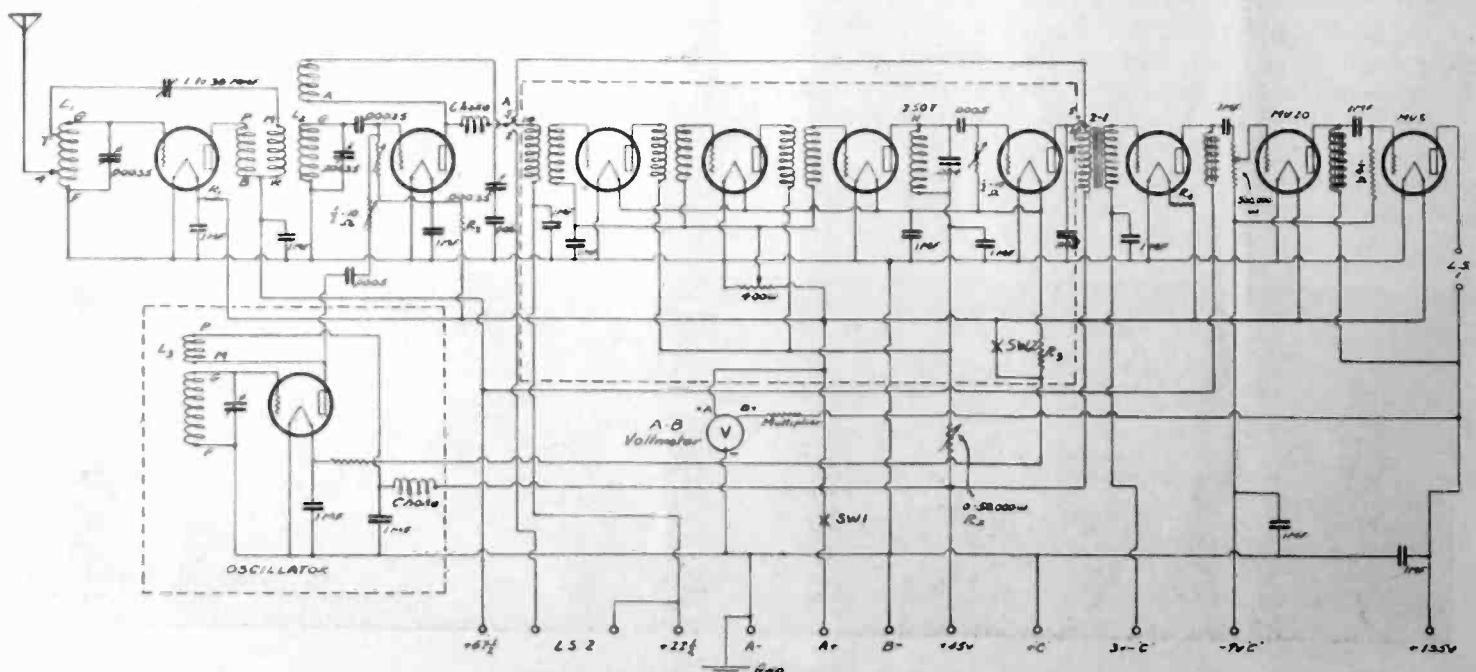

Fig. 1. Schematic Wiring Diagram.



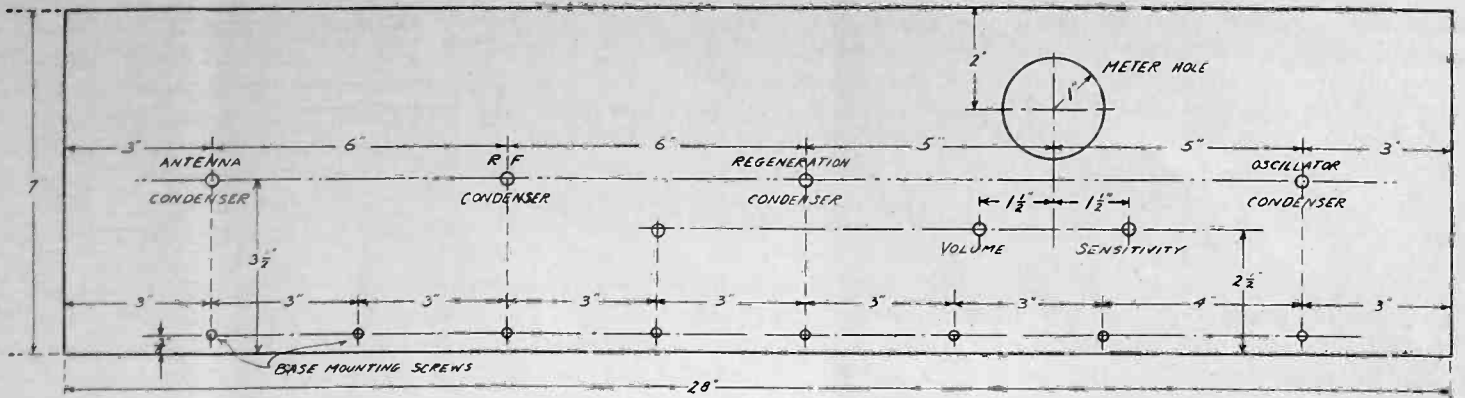

Fig. 3. Panel Drilling Template.

grid coil just far enough so that the center turn comes opposite the first turn of the secondary. The primary should be wound in the same direction as the secondary. The bottom turn should be connected to the plate of the r. f. amplifier, the center turn should go to the positive side of the *B* battery and the upper turn should connect to the neutralizing condenser. The oscillator coil should be placed in the center of its shielded compartment in an upright position. The antenna and tuned transformer solenoids should be opposite their respective tuning condensers which are six inches apart, should be on a line with each other and at right angles. The two chokes are composed of 500 turns of No. 36 d. s. c. wire on thread spools. The particular intermediate transformers used by the author peaked at 5100 meters.

Those who wish to construct their own transformers can use the data given here, which is taken from the article on the Best 5 tube Superheterodyne.

The construction of the intermediate frequency transformers is simple or difficult, depending upon the supply of core iron. It is out of the question for the

average home set constructor, without calibration apparatus, to build air core intermediate transformers which will be tuned within 5% of each other, but iron core coils can be made to work satisfactorily with a reasonable amount of care, and the filter coil to go with the intermediates is not hard to build. Have two spools of the dimensions shown in Fig. 5 turned out of hardwood or hard

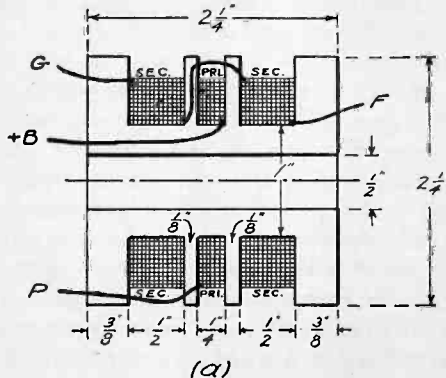

Fig. 5. Details of Intermediate Frequency Transformers.

rubber, a 1/2 in. hole being drilled through the center of the spool. In the center slot wind the primary, which consists of 500 turns of No. 32 single silk enameled wire, wound in a haphazard

fashion. In each of the two outside slots wind 1000 turns of No. 36 single silk wire, connecting the two secondaries in series aiding, the inside terminal of one coil being connected to the outside terminal of the other. The outside terminal of the primary goes to the plate of the intermediate amplifier tube, the inside primary to the positive *B* battery, and the outside terminal of the secondary coil whose inside terminal is connected to the opposite secondary coil is connected to the grid of the next i. f. tube, the remaining terminal being connected to the filament of the latter tube, through the *C* battery.

In the hole drilled through the center of the spool, crowd as much No. 36 soft iron or silicon steel wire as is possible, preferably bunching the wires together and wrapping with fine silk thread before placing in the spool, to insure solidity of the core. If very thin strips of silicon steel can be obtained, so much the better, the strips being crammed into the hole as tightly as possible.

A combination in the tuned output coupling consisting of a 250 turn honeycomb coil and a .004 mfd. shunt con-

(Continued on Page 60)

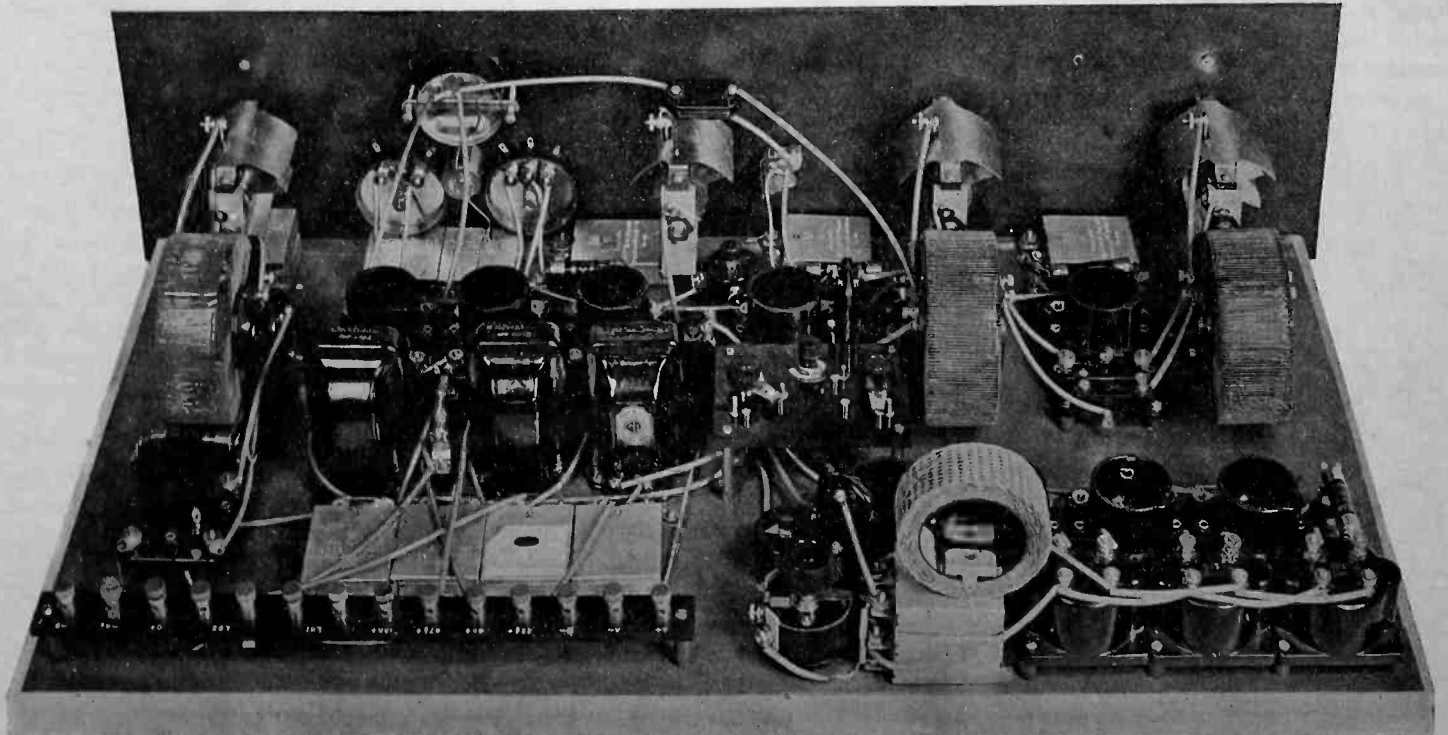

Rear View, Showing Shielded Amplifier.

# What Constitutes a Good Variable Condenser and Why

By *H. Melchior Bishop*

**T**HERE are on the market many different makes and designs of variable condensers, almost all of which lay claim to be positively the last word in all respects. That some of these claims must be unfounded goes without saying, since no two things, let alone dozens, may each be better in all respects than any of the others. There are, however, many good variable condensers on the American market, and it is the purpose of this article to tell what features to look for when buying one, and why these features should be looked for.

The prime requisites of a good variable condenser are sixfold, namely: (1) low high-frequency resistance, (2) adequate insulation, (3) ruggedness, (4) adjustability, (5) compactness, and (6) smoothness of operation. There are many, many condensers possessing some of these characteristics, but comparatively few having all of them.

The first consideration, which is a low value of resistance at the high frequencies used in radiocast work, is obtained by close attention to (1) low resistance of the various joints used in the construction of the condenser, (2) low absorption losses in the insulating material, and (3) low eddy current losses in the conducting parts of the condenser. It is of little note whether brass or aluminum is used, as both are low in resistance, especially when there is so much conducting surface. Condensers in which both brass and aluminum are used should be avoided for use in portable sets, however, as moisture may cause electrolytic action between the dissimilar metals at their joints, and thus give rise to crackling noises in, and faulty operation of, the set.

Neither is the silver plating of the plates and other conducting parts of the condenser as important as might be supposed, due to the plentiful conducting surface. It is true that silver oxide is practically as good a conductor as is silver itself, while most other metallic oxides are dielectrics, but as very little oxide is formed in any case, and as the surface is so great, the practical difference in conductivity is negligible.

Low resistance in joints may be secured in many ways. Some makers of the better type condensers die cast the plates into the supports; some mill the supports and plates out of a solid block of metal; some use brass plates and supports, soldered together; and some clamp the plates tightly with a through-bolt, spacing the plates by means of washers.

All of these methods are good, if carried out in the proper manner.

If the plates of the condenser are die cast into the supports, see that the joints between plates and supports are practically invisible, otherwise they are apt to be faulty. The milled type of plates and supports leaves no chance for faulty workmanship, but the condenser may be prohibitive in price, as this construction is expensive. Fortunately, it is possible to make the other efficient types, so that this drain on the pocketbook may be avoided. The soldered type is good, but it is well to see that no excess of soldering flux has been left on the joints, for this would ultimately cause them to corrode, thus producing all manner of annoying noises in the set, in addition to greatly increasing the resistance of the condenser. The other type, using washer spaced plates, is perhaps the most common, and is very good if the washers are of the milled type, or are punched from a sheet of accurate thickness, since the only fault likely to occur here is improper spacing. This can be detected by looking at the condenser edgewise as the plates are turned, when any irregularities will quickly show up. It is also well to see that the method of clamping the plates is a strong one.

The second factor, low absorption loss in the insulating material, is the reason for the metal end plate craze. It has been found that large masses of insulating material, placed parallel and close to the plates of a condenser, have the peculiar property of increasing the resistance of a variable condenser at radio frequencies. This phenomenon is explained by the fact that the insulating material so placed, be it bakelite, hard rubber, or "moulded mud," has the property of absorbing a certain amount of the energy expended upon the condenser, which then acts against the normal flow of current.

To avoid this, the modern condenser uses thin strips of insulation, sometimes grooved to more strongly resist surface leakage, and placed at right angles to the plates. Furthermore, it is generally placed at the points of the plates where their cross-section is smallest, as this serves to keep it as far as possible from the electrostatic field of the condenser, or rather, removed to the weakest possible part of this field.

The third factor, low eddy current loss in the metal parts of the condenser, is secured by making these as small and thin as is consistent with strength and durability. With proper attention to

the other two factors, this one may be at least partially disregarded, as it is the least important of the three, some condensers with very low losses employing thick plates. As a general rule however, it is best to choose a condenser in which the end plates are of a skeleton, or cut-away type, or else well removed from the active plates, as it is in the thick, strong end plates that the greatest eddy-current losses occur. To prevent body capacity effects, the end plates are connected to the rotor, preferably by either a pig tail or a strong spring, which is then grounded to the negative of the filament battery.

The second requisite of a good condenser, adequate insulation, is attained by close attention to the quality of the insulating material. It is here that many otherwise good condensers fall down, since the modern condenser uses so little insulating material, and the insulating surface is so short, that the use of insulation of the very highest quality is imperative. Particular care should be taken to see that no insulating material of the "moulded mud" class is used. This applies to all cheap moulded insulating materials whether made and shaped by the hot or the cold process, but not to moulded hard rubber or bakelite. They will generally leave a smudge or mark if rubbed forcibly on paper. The insulating materials most suitable for the purpose are both mechanically and electrically strong, and are as follows: hard rubber, bakelite, micarta, formica, porcelain, isolantite, and pyrex. Ordinary glass should not be used, as it generally contains lead, which, though almost infinitesimal in quantity, is capable of causing serious leakages of the precious, weak currents with which the radio set, whatever its type, must deal.

The third factor, ruggedness, is purely a matter of mechanical design and construction. It must be attained, however, without loss in electrical efficiency, otherwise it is more than worthless. For instance, the thicker the plates are made, the more rugged the condenser becomes. But, if they are made too thick, eddy currents set up within them seriously affect the efficiency of the condenser. One method of getting around this difficulty, which is being employed by a large number of reputable manufacturers, is to use brass or aluminum plates of a moderate thickness, which are then cold stamped under tremendous hydraulic pressure. This has the effect of making the plates permanently flat, as the pres-

*(Continued on Page 56)*

# Electrolytic and Mercury Arc Rectifiers

Their Design, Construction and Operating Characteristics

By Jennings B. Dow

**T**HE electrolytic rectifier consists essentially of a lead and an aluminum plate immersed in either a saturated solution of borax or in a neutralized solution of phosphoric acid. The latter may be made by adding one part of phosphoric acid to five parts of distilled water and then adding ammonia until the resulting solution is slightly alkaline, as indicated by a piece of litmus paper changing from red to blue.

The simplest form of circuit is shown in Fig. 1 which shows one cell consist-

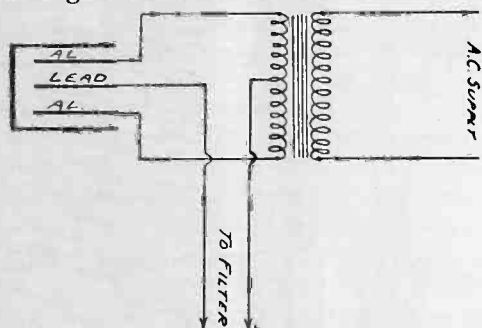

Fig. 1. Electrolytic Rectifier Circuit.

ing of two aluminum plates and one of lead immersed in a saturated solution of borax. As high as 40 or 50 volts may then be efficiently rectified by one such cell, greater voltages being secured by

adding more cells in series, as shown in Fig. 2.

The efficiency decreases as the current to be rectified increases, especially when such current causes an appreciable rise of temperature in the solution. The maximum efficiency is about 60 per cent.

Before an electrolytic rectifier will function properly the plates must be formed, i. e., the rectifying film must be deposited upon the aluminum plates. This is best accomplished by connecting all cells in parallel across a source of direct current and regulating the current flow to not over 100 milliamperes per sq. in. of aluminum plate surface. During the forming process, the posi-

tive side of the line should be connected to the aluminum plates.

An alternative method consists in the use of alternating current, in which case polarity need not be considered. The time required for the forming process depends very much upon the type of solution used, and the ultimate voltage drop across the cells. The less the allowed voltage drop per cell, the less will be the time required for depositing the one-way conducting film.

Assuming that the ultimate hook-up of the cells will be such that the voltage drop across one cell will not exceed 50 volts and that a forming current of 100 milliamperes per sq. in. of aluminum plate surface is maintained during the forming period, the film is adequately deposited when a phosphorescent glow is faintly visible over the submerged surface of the aluminum. This should require not over one-half hour when the solution is sodium borate and not over fifteen minutes when a phosphoric acid solution is used. It is important to watch the plates carefully during the forming process, for, if one cell fails to form, it will automatically take all of the forming current. Such a plate will be dark in contrast with the light grey

of the others, and should be removed, thoroughly cleaned and polished before further use.

It frequently happens that certain grades of aluminum do not function properly for this class of work, and investigation generally discloses that such grades are, for the most part, alloys of aluminum. It is not necessary to use chemically pure aluminum but a good grade is essential. Before constructing a large number of cells, the reader is urged to make a single cell and thus test the suitability of the material by actually forming a plate at the voltage per cell and current density to be used. A single cell formed on a 110 volt alter-

nating current source with a 25 watt lamp in series, will yield much information.

The following approximate cell dimensions are recommended for rectifying plate currents for transmitting vacuum tubes. It should be understood that for other purposes, higher current densities and a greater voltage drop per cell are often tolerated with satisfactory results. The plate dimensions here designated are based upon an operating current density of not more than 50 milliamperes per square inch of submerged aluminum surface and an allowance of 50 volts per cell. One lead and one aluminum plate of equal dimensions should be used, per cell. The number of cells is based upon the circuit of Fig. 2. This will result in a pulsating rectifier output wave having a frequency of 120 and may be more effectively filtered than other rectifier outputs having a 60 cycle fundamental.

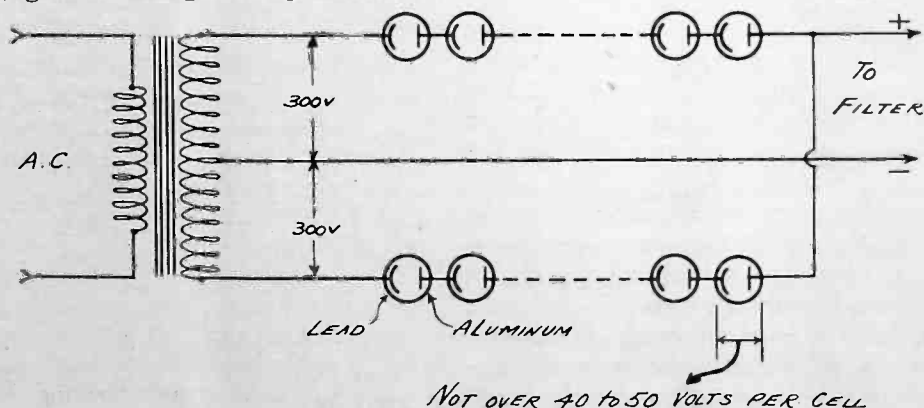

Fig. 2. High Voltage Rectifier Circuit.

adding more cells in series, as shown in Fig. 2.

The efficiency decreases as the current to be rectified increases, especially when such current causes an appreciable rise of temperature in the solution. The maximum efficiency is about 60 per cent.

Before an electrolytic rectifier will function properly the plates must be formed, i. e., the rectifying film must be deposited upon the aluminum plates. This is best accomplished by connecting all cells in parallel across a source of direct current and regulating the current flow to not over 100 milliamperes per sq. in. of aluminum plate surface. During the forming process, the posi-

of the others, and should be removed, thoroughly cleaned and polished before further use.

It frequently happens that certain grades of aluminum do not function properly for this class of work, and investigation generally discloses that such grades are, for the most part, alloys of aluminum. It is not necessary to use chemically pure aluminum but a good grade is essential. Before constructing a large number of cells, the reader is urged to make a single cell and thus test the suitability of the material by actually forming a plate at the voltage per cell and current density to be used. A single cell formed on a 110 volt alter-

nating current source with a 25 watt lamp in series, will yield much information.

The following approximate cell dimensions are recommended for rectifying plate currents for transmitting vacuum tubes. It should be understood that for other purposes, higher current densities and a greater voltage drop per cell are often tolerated with satisfactory results. The plate dimensions here designated are based upon an operating current density of not more than 50 milliamperes per square inch of submerged aluminum surface and an allowance of 50 volts per cell. One lead and one aluminum plate of equal dimensions should be used, per cell. The number of cells is based upon the circuit of Fig. 2. This will result in a pulsating rectifier output wave having a frequency of 120 and may be more effectively filtered than other rectifier outputs having a 60 cycle fundamental.

Type of Tube	Number of Tubes	A. C. Input Volts	D. C. Output Volts (with load)	Plate Dimensions (inches)	Number of Cells for Each Side of Transformer
5 watt	1	500	350	0.5 by 2	10
5 watt	2	500	350	0.5 by 3	10
50 watt	1	1000	700	0.7 by 3	20
50 watt	2	1500	1050	0.7 by 4	30
250 watt	1	2000	1400	0.7 by 4	40
250 watt	2	2500	1750	1.0 by 5	50

method of protecting the plates at this point is to paint with paraffin, asphaltum or sealing wax; in some cases, this has been found to appreciably prolong the life of the cells.

The thermionic rectifier, consisting of a specially constructed vacuum tube without a grid element, is making such strides in power rectification as to rival other types for all purposes. Rectifier tubes are now made in sizes from 20 watts to 1000 k.w. and are readily obtainable in the capacities ordinarily required for experimental and commercial radio work. Operating data for these have been printed so often in these columns as to make further comment unnecessary.

The mercury arc rectifier, while not in general use for the rectification of alternating current for the plate circuits of vacuum tubes, is readily available in capacities suitable for this use. Various possible hookups of this type of rectifier are shown in Fig. 3.

The simplest form of mercury arc rectifier circuit is shown in Fig. 3a. Near the top of the figure is the alternating current transformer which steps up the voltage to the desired value. The extreme ends of the secondary winding terminate at the anodes of the valve, while the mid tap forms the negative lead of the direct current output circuit. The positive pole or negative electrode of the valve is at *C*, and the rectified current flows from this terminal through the sustaining coil, *A*, to the direct current power consuming device, which, in the case under consideration, is the vacuum tube transmitter.

The resistance, *R*, and the auxiliary electrode, *B*, comprise the starter for the arc. To start, the tube is tipped to one side, causing the mercury to close the circuit *CB* through the disconnect *S*. The arc thus formed volatilizes some of the mercury, which lowers the resistance of the conducting path between the anodes and the cathode and this breaks down, forming the necessary arc. During half of the cycle current flows from one anode to the cathode and during the remaining half it flows from the other. Were it not for the inductance, *A*, which must be of the order of several henries, the arc would have to be restarted by means of the auxiliary circuit after each half cycle. Upon the collapse of the magnetic field around this inductance, following an extinction of the arc when the alternating wave reaches zero in value, an *emf* is impressed across the anode and cathode sufficiently great to re-ignite the arc, and the other half cycle is rectified in the same manner.

When the output of a transmitter is controlled by a telegraph key, various expedients are often resorted to in order to maintain the mercury arc during the period when the key is up. For this purpose a secondary load is sometimes

put on the rectifier output circuit by means of a back contact on the key. Frequently, a high voltage alternating current is maintained across the keep-alive terminals of the rectifier during the entire transmission period.

Regular radio telephone communication has been maintained between station KYB at Honolulu and KRQ at Lanai, an island sixty miles away, for over a year. While the installation is used primarily for the transaction of the business of the Hawaiian Pineapple Company it is also used for other inter-island communication. KYB operates on 238 meters and KRQ on 288 meters. The entire operation, including bell-ringing at either station is entirely automatic. The system was devised by M. A. Mulroney, radio engineer with the navy at Pearl Harbor.

Linoleum makes a good covering for the top of the radio table or desk. It is cleaned easily and will withstand scratches which would ruin a varnished surface.

Celluloid makes a handy insulator, readily worked. If some collodion, or acetone is also kept on hand, this may be used as a cement.

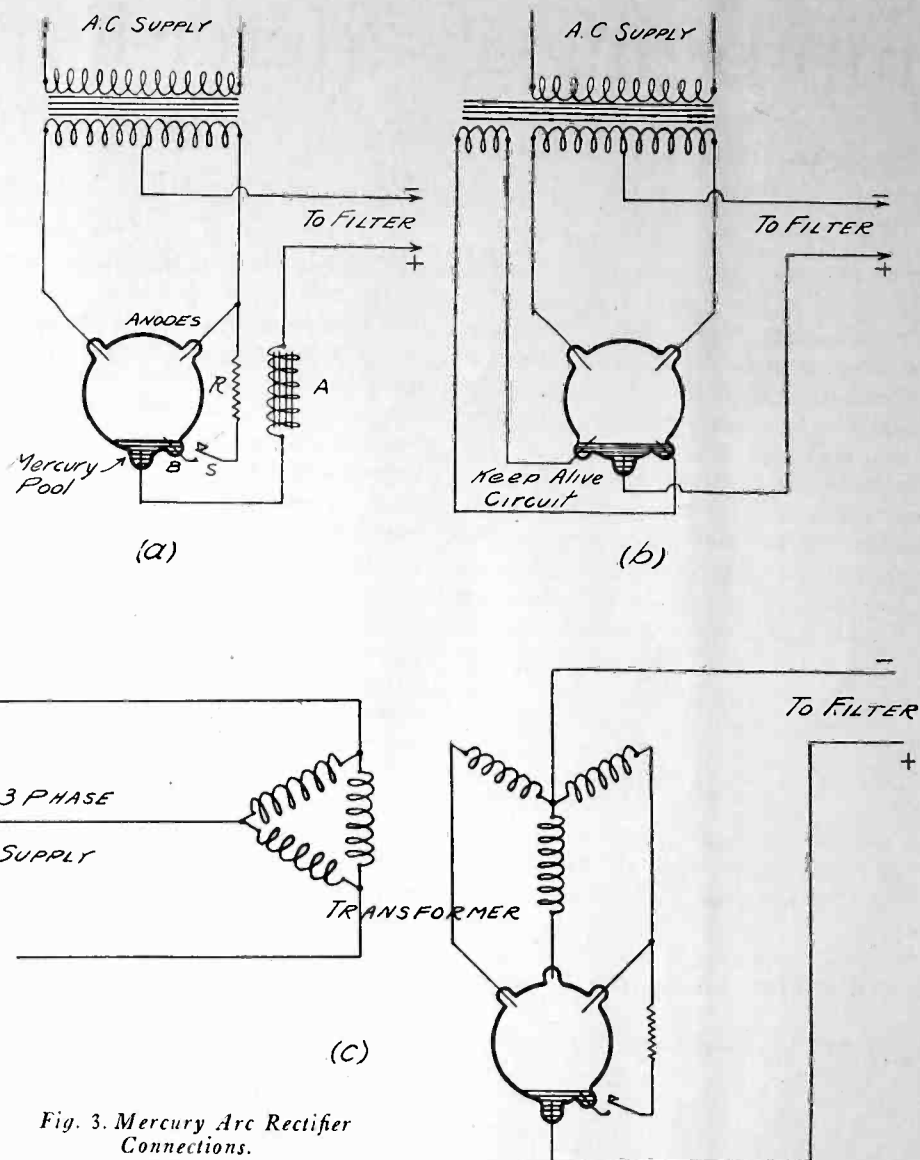

Fig. 3. Mercury Arc Rectifier Connections.

## EUROPEAN RADIO NOTES

From H. DE A. DONISTHORPE

Over one million receiving licenses have been granted to German listeners, half of them residing in Berlin.

EAJ.1, a new medium power station has been erected on Tibidabo, Barcelona, Spain, operating on 325 meters.

As a result of recent tests the Radio Bureau at Geneva has recommended a revision of wavelengths by a number of European stations so as to minimize interference.

The British Broadcasting Company has planned an extensive summer program, especially with the view of bringing music from the various beach resorts to the listeners in towns.

The British government is fitting an automobile to be used to locate radiating receivers and when found engineers will make them non-radiating.

If the diaphragms of telephone receivers become bent or dented, they may be turned over, so as to give better results until new ones can be purchased.

Frayed cord tips on flexible tinsel cords may be repaired by winding the tinsel ends with fine copper wire, and then flowing solder over them with a rather cool soldering iron.

# Improving 40-Meter Foreign Reception

Suggestions for Shielding Against Interference and as to Antenna Length  
Applicable to Radiocast as Well as Amateur Short Wave Work

By Don C. Wallace, 9XT-9XAX

FEW amateurs realize that the problems of reception, transmission, and communication should be taken up separately. Numerous articles have appeared from time to time concerning circuits and ideas on transmission, but few constructive articles on amateur reception have appeared recently.

This has probably been due to the general acceptance, on the part of those most interested in short wave telegraphy, of the fact that any well constructed receiving set works quite satisfactorily on short wavelengths. The design of amateur receiving sets has not changed materially during the past two years although the results obtained from the same style of receiving sets have increased materially. Most amateurs have found that the limiting factor in radio reception is not "how sensitive is my receiving set," but "how much extraneous noise must my set contend with?"

The problem of extraneous noises, therefore, must be met fairly and squarely before we can hope to improve our reception. Power leak noises are prevalent in most large communities. There is almost always a violent undercurrent of noises which prevents the use of really sensitive receiving sets, and prevents the use of additional audio frequency amplification which would automatically enable the weaker signals to be read. About three years ago the writer came to the rather conclusive belief that no remarkable reception could be expected at his location unless power leak noises were reduced to a minimum.

With this in mind a loop set was carried around the neighborhood, with the result that no definite source of trouble could be located. Noises appeared to be about evenly distributed throughout the entire locality, with only slight variations which appeared while passing through vacant lots. Apparently the noise was reduced noticeably as soon as the city wiring, telephone lines, or other wiring was left 50 to 100 feet away. These trips about the neighborhood were repeated at frequent intervals, in an attempt to locate a very violent, almost perpetual buzz which generally made its appearance about 10 or 11 p. m. and continued throughout the rest of the night.

Later on a set was placed in an automobile which was driven about, making trips into different sections of the city. It was found that Bryn Mawr, the writ-

er's location in Minneapolis, was as noisy, and apparently noisier, than any other section of the city. Two 110,000 volt high power lines pass through Bryn Mawr and join together. The writer's house is in the center of this gigantic V, with the power lines from two to three blocks in three directions.

These power lines naturally were the first to be suspected and very careful check-ups were made for several miles along the lines with no particular conclusion being drawn. Gradually, however, certain definite rules began to make themselves evident. The first of these was that the inductive noises were loudest on a 13,000 volt line rather than on the 110,000 volt lines. The same inductive noises were still louder on the 220 volt lines passing at the rear of the lot on which the house stood. By carefully checking and re-checking this it was found that in reality the high power lines had just as much noise on them as the 220 volt lines did at the same distance from the lines. The increased heights of the power lines made them considerably farther from the receiving set and thus they appeared to be slightly weaker. The first rule was, therefore, that all wiring had inductive noises on it regardless of the voltage.

About this time the telephone company took down two blocks of telephone line in front of the house and ran a telephone cable down the alley, this gave further basis for experimentation. It was found that a breadboard receiving set only had about half of the inductive noises in the front of the house that it had in the back of the house, and even less in the attic. Accordingly, the receiving set was installed in the attic as far away from the alley as possible, a short antenna run out of the front window, and reception increased several fold. To operate the transmitter it was

necessary to run downstairs to transmit, then run upstairs and receive. After several days this practice was, of course, discontinued as it was very hard on both the operator and the stairs.

This gave thought to some possible radical changes in amateur design, "Why not run the receiving aerial at some point where there was no wiring and thus allow the antenna to pick up a better proportion of signal vs. inductive noises?" A 250 ft. receiving antenna was accordingly strung across the street and New Zealand and Australian stations immediately came in daily in sufficient strength to definitely establish the fact that considerably better reception was being had.

The receiver, in the meantime, had been moved back to the rear of the house near the transmitter and considerable noise still persisted. This noise continued even with the antenna discontinued, showing that the set itself picked up a great deal of inductive noise due to the nearness of the alley wiring approximately 100 feet away. The house wiring was all in conduit. The fact that the receiver picked up a great deal of inductive noise and did not pick up as many distant stations as the antenna did, naturally caused the belief that if the receiver itself could be properly shielded so that nothing whatsoever would be received by the receiver except that which came from the antenna, a better ratio would exist. Accordingly a copper box was made, 4 ft. long, 12 in. deep, and 10 in. high. The entire receiving set was then brought into the box, the lid fitted over the box very snugly, and metal backed dials were used, so that the only hole in the entire set was the small 4 in. hole through which the antenna lead came, shown in Fig. 1 at A. This antenna lead does not take the trouble to go through a binding post and consists

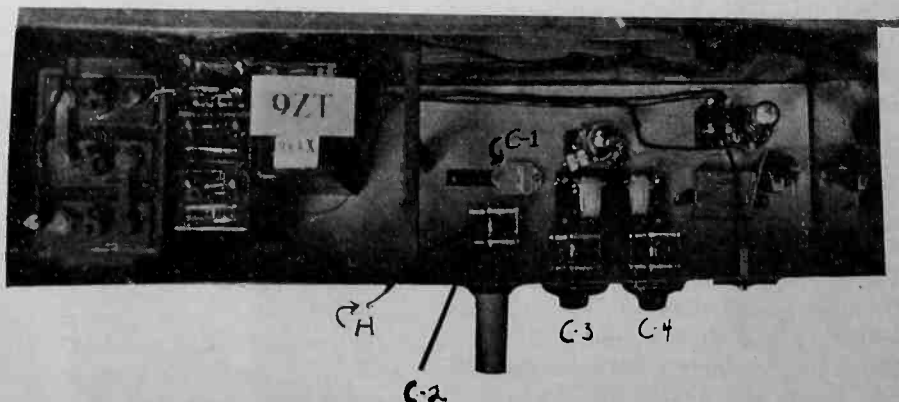

Fig. 1. View of Interior of Receiver.

merely of a piece of number 14 single braid rubber-covered wire.

Fig. 2 shows the diagram of the re-

strength and no noticeable increase in inductive noise, bearing out the first deduction. Now that we found inductive

each night. Reception from the following countries has also occurred since this larger antenna was put up: Switzerland, England, France, Panama, Haiti, South Africa, Java, Italy, Chile, Brazil, Argentina, Mexico, Canada, United States, Hawaiian Islands, Samoa, Australia, New Zealand, Tasmania, Porto Rico, Cuba, Bermuda, Society Islands, Holland, Sweden, Denmark, Finland.

A total of twenty-five countries has been worked to date and without a doubt the operation of the receiver has made this possible. As yet, reception of European stations from 4 o'clock on has seldom failed when tried. English stations are heard as late as 5 a. m. central standard time (almost noon in England); Philippine Islands, Australia and New Zealand are heard on some nights as early as 9:30 p. m. central standard time and as late as 9:30 a. m. in the morning. (CST).

A great deal of the above reception of course can be done and is done by other stations, but we must consider the fact that, in spite of what receiver was put in this station, power leak noises prevented any but the loudest of foreign stations from coming in. Now, even receiving tubes operated as transmitters are audible in many of these countries and this of course is the reason why they can be communicated with so readily. The high power foreign stations are quite hard to raise because so many U. S. stations are calling them at all times. Consequently they are very busy. The smaller stations on the other hand are quite easy to raise as very few U. S. stations ever call them. Many of the stations worked in Europe have stated that they have never before worked a 8th District U. S. amateur and the same has been true with some of the smaller

(Continued on Page 61)

ceiver, which is similar to the one used by Fred Schnell on his trip with the fleet to Australia and New Zealand aboard NRRL. The extra condenser in the antenna makes an excellent vernier. By the use of this vernier the tone changes of a distant transmitting set may be readily followed. This condenser has been found very useful in the maintenance of communication. The small fixed condenser, C-1, consists of two plates about 1½ in. square, ⅜ in. apart. The coils are 2¼ in. in diameter and were wound on celluloid strips spaced with string, the turns secured in place by collodion. The number of turns on the coils as used for 40 meter work is as follows: 11 for the secondary, 9 for the regeneration coil. The wavelength range of the set with these coils is from 30 to 48 meters and successfully receives amateurs from all over the globe.

The audio transformer used has a peak at 1700 cycles and materially aids in reducing the power leak noise that does come down the antenna. If a peak transformer is used (several are on the market at the present time) it is very important that the vernier condenser (C-2) be used, as only by keeping the tone consistently near 1700 cycles can the volume of the station be maintained. Vernier dials are used throughout as they have been found very important. A rigid cardboard tube was slipped over the dial of condenser C-2 as a slight trace of body capacity could be found in this condenser in spite of the insulated shaft, although no trace of body capacity is found on the other two condensers. No part of the receiving set is now grounded; neither is the cabinet, as this would definitely increase the ratio of inductive noises to signal with the antenna in the open as outlined above.

About this time the writer began to suspect that if an antenna 250 feet long were good, one 400 feet long might be better. One was accordingly run across the street at a little different angle, securing a very definite increase in signal

noises followed along wiring and did not exist where there was no wiring, a short 75 ft. single wire antenna was put up on the lot to prove that the larger antenna was really receiving in better ratio than the short one. There could be no doubt about this whatsoever, and as high as ten to thirteen different countries could be heard in a single evening with the new arrangement, whereas the best possible results before were from five to eight countries heard. Comparatively few stations were heard in each country.

About this time a desire for an even larger antenna caused the aerial to be extended another 350 ft., so that now the total length is 750 ft. During the month of November, 1925, the station was in operation sixteen nights. European stations were communicated with on each of these sixteen nights and in all a total of seven European countries was worked. For example, the first eleven nights on, England was worked

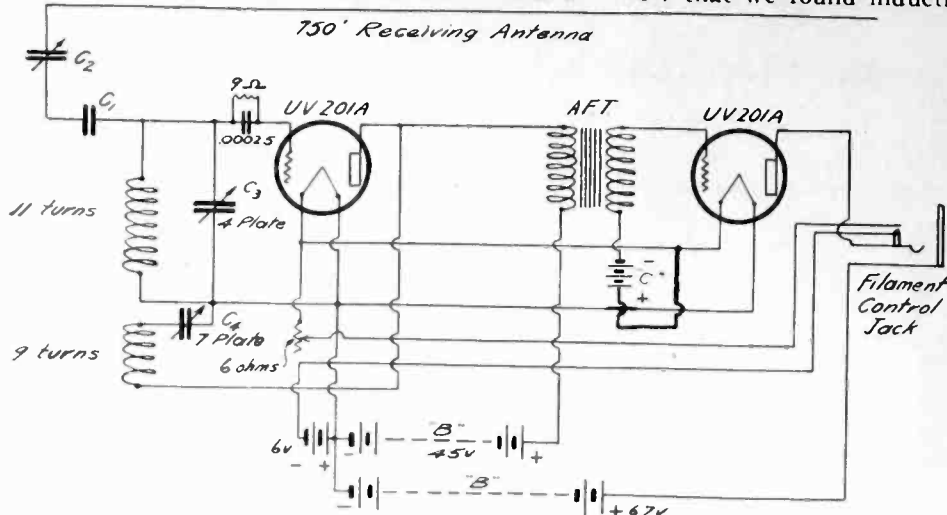

Fig. 2. Schematic Wiring Diagram of Receiver.

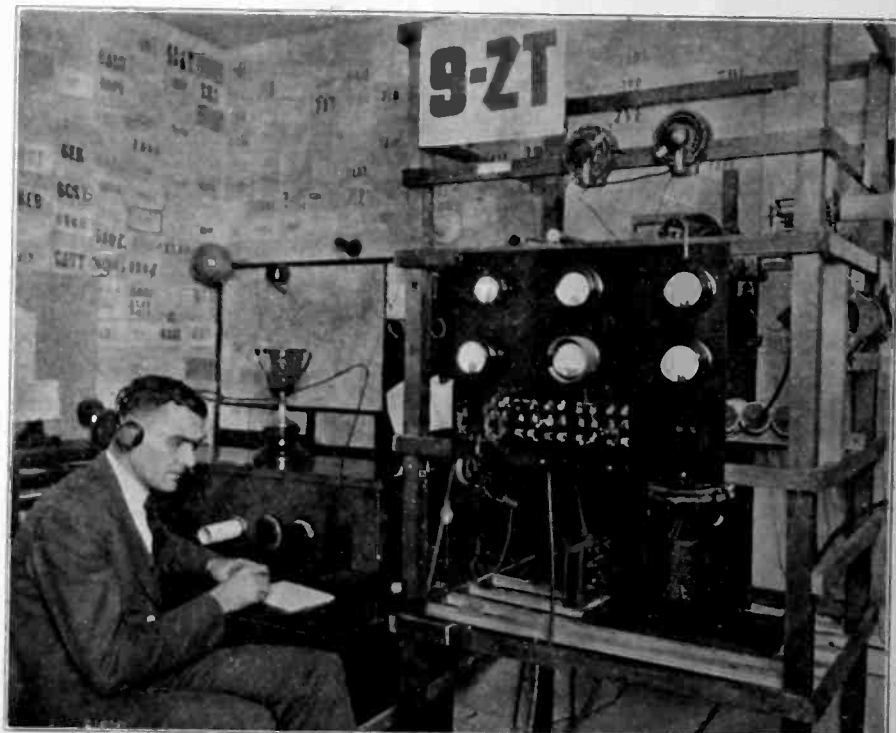

Fig. 3. Receiving and Transmitting Equipment at Station 9ZT.

# Sweetheart, the Crazy

By Jan Dirk

**N**OWADAYS with radios in the telephone booths to amuse you while Central goes through her repertoire of wrong numbers, and in the taxis to keep your mind off the meter—taxi, not wave—the whole world is crazy. Absolutely nutty. At least that's the way that it seems to a hard-boiled old ship op like me. I can't seem to get used to the idea of using the once pure an' far-famed ether for carrying music. All the saw-mill sopranos sing "The End of a Perfect Day," anyway. Oh, I know you'll call me a crabby old dead-head that isn't keeping up with Progress. I admit I'm no lily. Nobody ever crowned me for being the brightest light in the third grade—which was as far as I got.

The teacher crowned me with a book, so I left just to spite her. The book she crowned me with must've left an impression, though, because I've remembered its name, Hunt's "Modern Geography," it was. I've been butting my head against geography ever since, but

she's been the real kind. Not the kind where pink and green pictures have lines drawn across and up-and-down 'em.

I said something about the world being crazy, if I remember correctly. Don't take me too seriously. I thought that Sweetheart was crazy as a loon, for a while. And now I catch myself wondering every now and then if perhaps I didn't dream most of the whole thing, so I'm beginning to think I'm crazy myself. I'd hate to admit that I was. No one ever does; and all the crazy people in this world aren't running up bills in asylums, either. The world'll keep on broadcasting what passes for music whether I like it or not, for that matter. So—

I'll tell you about once when I did hear some real music in the old Baldwins. Sweetheart said that it was the music of the spears. He said that after I'd decided he wasn't crazy, so I s'pose it means something, but I'm not sure that I see what.

**H**E CAME aboard just as we—I was lone op on the *Cowalla*, a tramp freighter—was leavin' for Africa. We were going down there for wool or Shetland ponies or something, I forgot what. It was only a few years ago, but I've got a memory poorer than a Scotchman who has just been asked to contribute to a Whiskey fund for the starving Armenians. Up the gangplank came this big boy, six feet two and weighing 220 if he weighed an ounce. From the way he swung easily up the bouncing plank I knew that he had shipped out before, and his arms were swinging his two heavy suitcases, that were about the size of small steamer trunks, around like they were candy boxes.

He came over to me, me being the closest, and asked where was the Skipper. I looked at his face. His was the sweetest, sulky-babiest face I've ever seen. Honest! He had yellow hair and blue eyes, and kept his lips slightly pouted, like a bad little boy four years old, and he had the original skin you

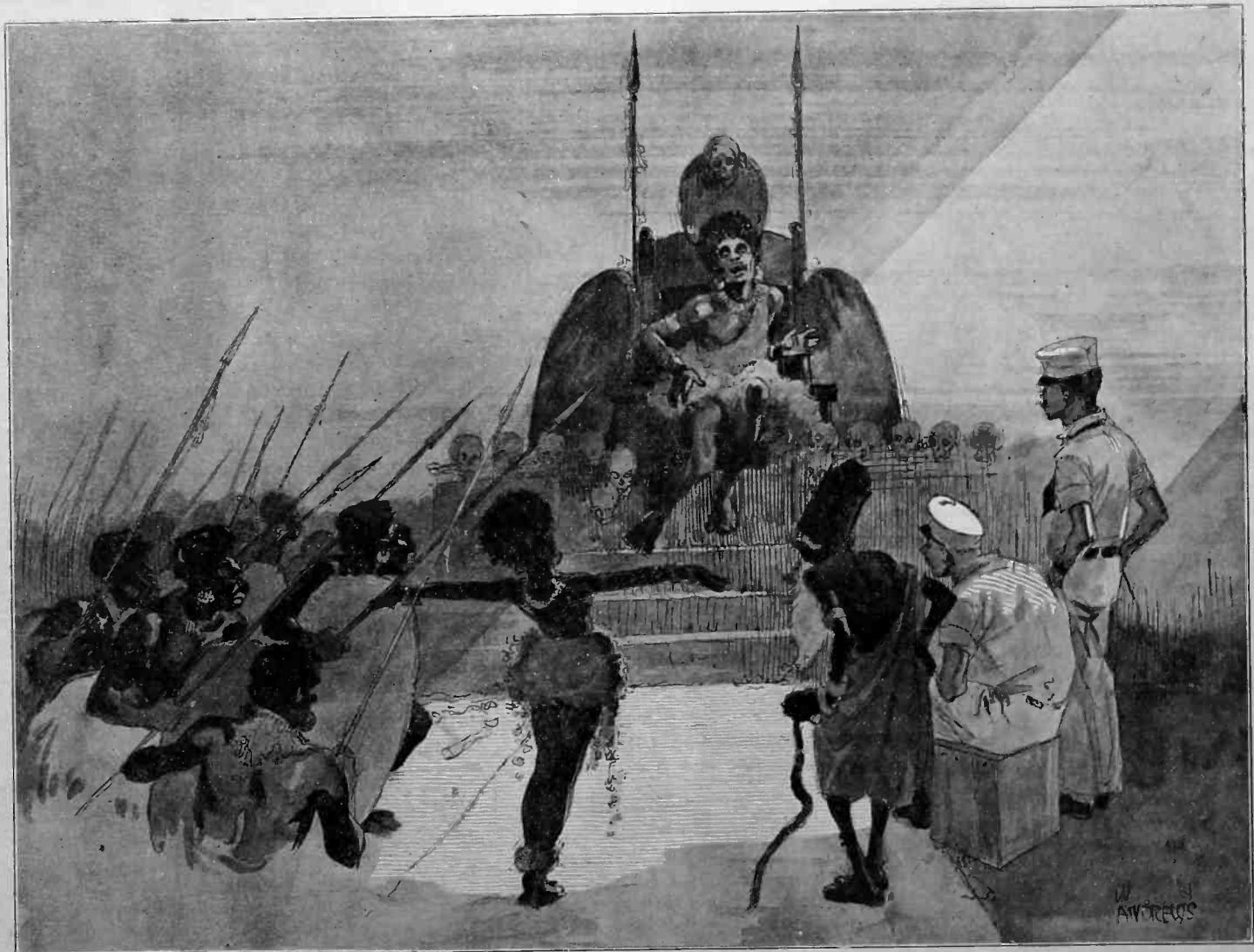

"Ndonga screamed shrilly."

love to touch. He had a sober, sweet expression, as if mama had just kissed him, after she had whipped him for promising to be a good boy ever afterward. And all this with a body that had the bulky muscles of Bull Montana and the beauty of Apple o' Belvedere, or whatever that guy's name was that all the women went crazy about.

I introduced myself as the radio op, noticin' at the time that his face lit up like a thousand-watt mazda at the mention of radio, and then I asked him his name.

"———," he said.

I can't spell it now any more than I could spell it then. I couldn't even pronounce it.

"Perhaps we'd better try again," I suggested politely. "What did your mother call you?"

"Sweetheart."

For some darn reason I blushed. I started to snicker, but I got a squint at the size of those fists and shoulders just in time. "I mean your regular first name," I explained. "O course, your mother's pet name for you is awfully nice, but I don't think it would be just the thing for this ship."

"Sweetheart is my regular first name," he says. "The sailors won't mind after they get used to it. I'm the new quartermaster." Seeing the curiosity in my face, I guess, he went on to explain that his father had been Welsh or something, which explained the unpronounceable name. His mother had called him Sweetheart as a baby, and as he had grown he had remained such a pretty child that she kept calling him by his baby name. His home town was so small that everyone knew what name he was called by, and came naturally to think of him always by it. No one saw anything funny in calling him Sweetheart, when they'd known him by that name since babyhood.

After he had told me, I nodded to show that I thought it was reasonable. It wasn't an uncommon thing, I knew.

If you've shipped on a freighter you know that the crew does nothing most of the time but play cards. This voyage was different. Radio was in its first flush of popularity, and the craze hit the sailors on the *Cowalla* strong. They all started building radio sets, mostly with parts they had bought ashore before leaving—but I missed lots of wire from the shack. And when they weren't on watch they hung around me like flies, till the Old Man told them to leave me alone and keep to the fo'c's'le. In the fo'c's'le the darn fools kept on building crystal sets instead of p'aying stud poker, as respectable sailors should.

Sweetheart turned out to be as bad as the rest of them. Worse, even. As quartermaster he was entitled to a few privileges, so I let him hang around. To

tell the truth, I liked the big dumbbell. Everyone did.

And then he confessed to me that his hobby was Martian communication.

"Don't waste your time, big boy," I advised. "Men that know a lot more about radio than we ever will have spent years listening on high waves, for Mars, and they've never heard anything."

"High waves! How do they know where to listen? Maybe the Martians are using extra low ones."

That remark wouldn't sound so foolish today, perhaps. But when Sweetheart made it—"You're crazy!" I told him.

He hunched forward in his chair as if he were going to start a long argument.

"There are only a few reasonable ways in which the people on Mars can reach us," he says. "We've got to receive all communication through our five senses! We only have five! Seeing, hearing, feeling, tasting, smelling! The last three are eliminated immediately. That leaves seeing—and hearing."

"Yeah," I said, bored. At the same time I was getting a big surprise out of the language the bozo was using. It didn't sound like that used by the common or ocean variety of sailor, the A. B. which you find after a sailor's name meaning not Bachelor of Arts, but Ab'e Bodied.

"We could see a blinding light on Mars, perhaps. Or they could change the surface of a part of one of their continents so our telescopes would pick up the change. Unless we regard the so-called canals in this light, no such thing has ever been observed, which would go to show that the Martians are trying to communicate with us not visually, but audibly."

"Are trying? Huh?" I gasped. "No soap, Sweetheart. You're going too fast."

"Ordinary sound wouldn't carry through the ether, and would be an improbable method to say the least, wouldn't it?"

"I s'pose so," I said weakly, not knowing what else to say.

"Then we're down to radio. Radio is what they're using. Radio is a form of sound."

"It is not."

"You hear the signals in a headset, don't you?"

"But—"

"That's what I meant!" he said, with an air of finality. He was the original dead-sure baby, I'll tell the halitosis-laden world! "If they aren't using radio as we know it, then they're using some form of magnetic flux, reaching from Mars to the earth."

I caught him up, there. "Flux?" I asked. "No ordinary dumbdora quartermaster knows that word. Where have you been studying this sort of junk?"

He blushed so hard that I thought

he was on fire, and hung his head, which made him look even more like a little baby. "Oh—I—I've read a bit," he said, ashamed-like.

He got over it after a second or so, and stood up and pounded on the table. "Radio! I'll bet they're sending dots and dashes, perhaps in some form we'd be sure to recognize! And I'm going to find out about it!"

He stalked out of the shack. When he was gone, I did something that I've been ashamed of since. I planned a practical joke on this infant. It came to me all of a sudden that here was a boob that was ripe for a good joke. He wanted to hear dots and dashes from Mars, did he? Well—

The only excuse I can offer is that, for two weeks, monotony had been driving everyone on the ship—including yours Sparkily—darn near crazy. For two thousand miles I hadn't been able to raise a ship. You think that's impossible, but I'm telling you it isn't; the ocean is no mud-puddle. The *Cowalla* was clanking along at a racing good pace about equal to that of a badly wounded tortoise. The sky was white and the sea was greasy green and as smooth as an automobile salesman. The *Cowalla* was originally named *Cow Wallow*, I think. She must have been, if there is Justice. We were doing nothing in the midst of nothingness, and the strain was enough to drive a man mad. Having a little joke in my mind, plotting and planning how I would go about it, day by day, gave me something to do.

I juggled the capacity in the tube receiving set so that, with a small fixed condenser added and rigged so that it could be cut off or on with a key, it could be made to imitate a freakish-sounding continuous wave when I pressed the key. I hid the key under the rug and put a stiff spring on it so I could work it with my foot. Then I sat back and waited for Sweetheart to pay one of his habitual calls on me. He did, very shortly. The rest was simple. Listening in, I faked surprize, and called him to take one of the headphones. He bit like the original fish.

With my foot, none too gracefully, I sent the four letters: M—A—R—S, again and again. That was about the rawest thing I could have done, but Sweetheart sat there with his eyes popping.

It wasn't until the next day, when he'd had time to sleep on it, that he came around with a sheepish grin on his face and we had a good laugh out of it. "Any fool would have known they couldn't send an English word. You won't fool me again."

After this one little interlude, the monotony settled down again. The sailors, beginning to fret, picked on Sweetheart. They developed a set of

(Continued on Page 49)



# A Superheterodyne Band Filter

A Practical Design for Improving Selectivity Without Impairment of Tone Quality

By Raymond B. Thorpe

THE problem of getting selectivity without distorting the audio frequencies between 60 and 5000 cycles can be solved only by a compromise. As the set is made more and more selective, say for 600,000 cycles, it tends to cut off the side bands at 605,000 and 595,000 cycles, so that the extreme audio frequencies on either side are either cut off or reduced in volume as compared with the lower audio frequencies. This fact is illustrated in Fig. 1 where the solid line indi-

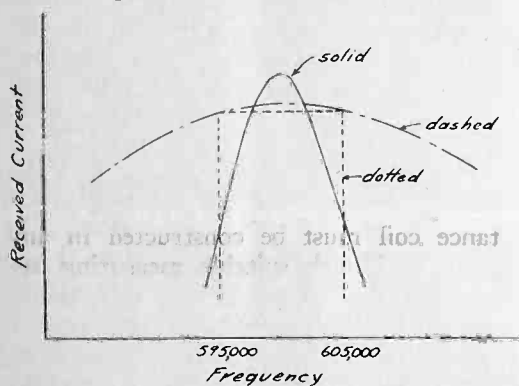

Fig. 1. Distortion Due to Sharp Tuning.

cates a very sharp receiver characteristic, while the dotted line shows the ideal characteristic. The dashed line shows how a broadly tuned receiver almost eliminates this type of distortion.

By using a superheterodyne receiver it is possible to amplify at a fundamental frequency of say 50,000 cycles with sidebands at 45,000 and 55,000 cycles for the extremes, i. e., the carrier frequency plus or minus 5000 cycles. So whereas the 10,000 cycle band was 1.6 per cent of the width of the 600,000 cycle band, it is now 20 per cent of the width of the 50,000 cycle band, thus greatly intensifying the distortion introduced by a sharply-tuned transformer.

The most obvious compromise between the broad tuning necessary to prevent distortion and the sharp tuning necessary to give selectivity is to apply the electric wave filter developed by George A. Campbell to freely transmit all frequencies within a certain predetermined band and to greatly reduce all other frequencies.

An electric wave filter consists, as shown in Fig 2, of a succession of exactly similar sections made up of series and shunt impedances. In the general form there are two series elements per section, consisting of an inductance  $L_1$  and a capacity  $C_1$  and two shunt impedances  $L_2$  and  $C_2$  as shown in Fig. 2a.

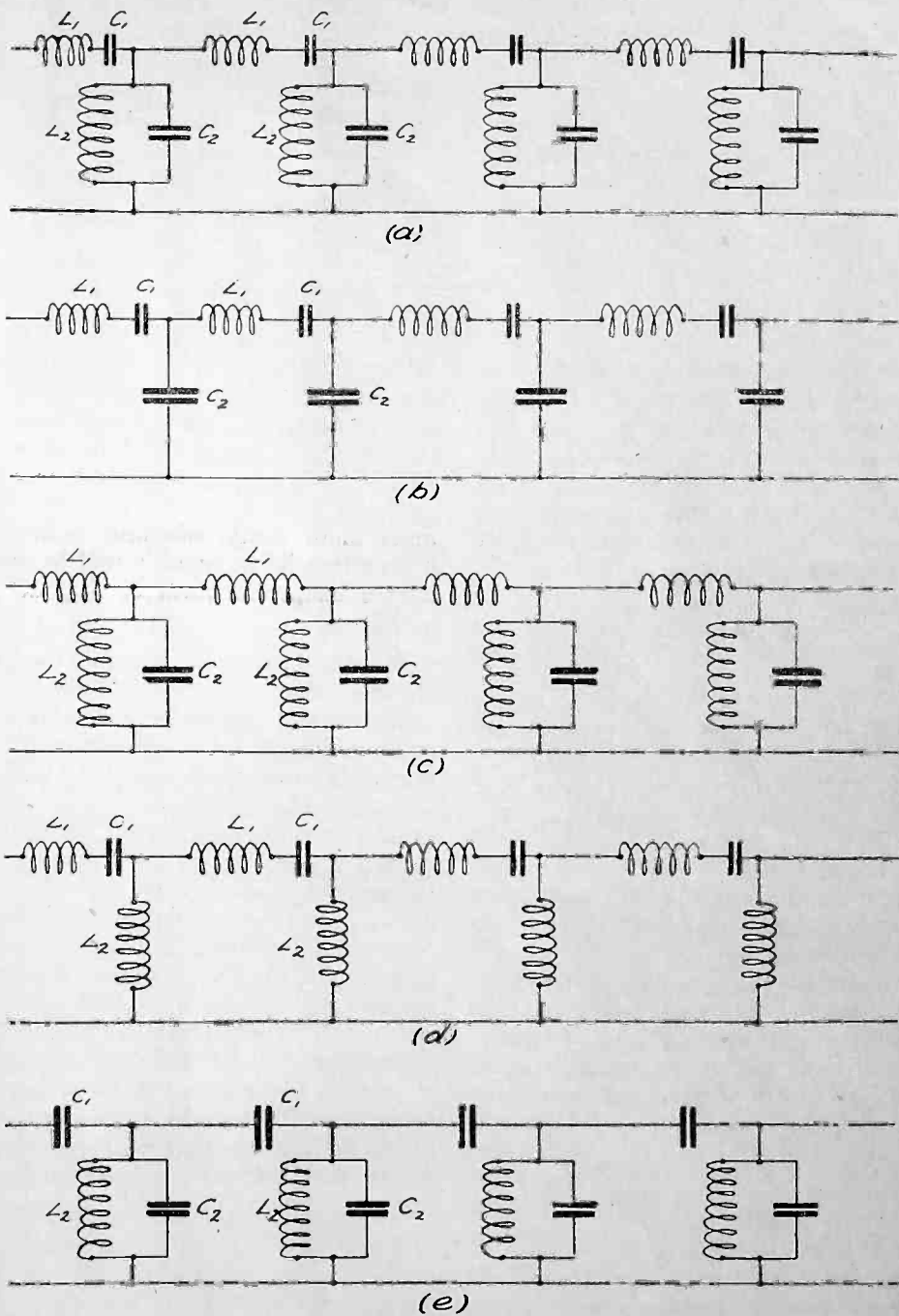

Fig. 2. Electric Wave Filters.

This type of filter provides two freely transmitted bands of frequencies.

A filter which will pass a single band of frequencies may consist of any combination derived from Fig. 2a by omitting one of the four elements. The four resulting arrangements are shown in Figs. 2 b, c, d and e. While any one of these filters has slightly different characteristics they are all alike in that they transmit freely a certain pre-assigned band of frequencies which may, by properly selecting the values of inductance and capacity, be made to lie between any two frequencies as limits

and will attenuate currents of all other frequencies. Any one of these four arrangements may be made to transmit freely the frequencies between 45,000 and 55,000 cycles and to present at the same time an impedance which will closely match that of the circuits to which it is connected.

In arriving at the practical design of a wave filter for use in a superheterodyne it will first be necessary to choose a good location in the circuit for the filter. Obviously it will have to be a part of the intermediate frequency amplifier and will ordinarily be introduced

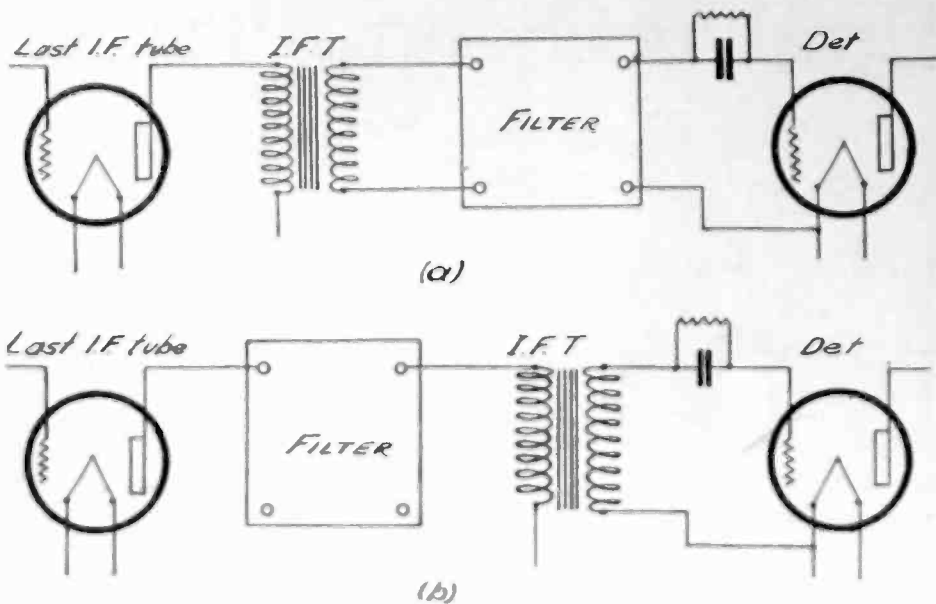

Fig. 3. Alternative Methods of Filter Connection.

between the last amplifier tube and the detector as is customary for tuned stages. It may be connected either on the grid side of the transformer as in Fig. 3a or on the plate side as in Fig. 3b. If the amplifying transformer has a step-up ratio then the filter must be designed for a higher impedance if used on the grid side than when used on the plate side. This means smaller capacity and larger inductances and it will be shown later that the most readily available condensers and inductances favor the lower impedance design. Our filter will, therefore, be located between the last amplifying tube and the input of the last transformer of the intermediate frequency amplifier.

Returning to Fig. 2, we must now choose the type of filter structure which will best meet our needs. If toroidal coils of suitable inductance values were readily available any one of these filters would be satisfactory. It is necessary, however, to eliminate mutual inductance between the several inductance elements of this simple type of filter and with the ordinary type of coil we are, therefore, limited to three ordinary inductances placed mutually at right angles.

On the other hand it is desirable to have as many sections in our filter as possible since the attenuation of one section is multiplied by that of each succeeding section so that several sections will be much better than one, giving a much sharper cut-off at the two limiting frequencies. For this reason the arrangements shown in Figs. 2c and 2d will not be satisfactory since they require two inductances per section of the filter. Figs. 2b and 2e, however, offer the possibility of constructing a three-section filter with a total of only three inductances. At first glance there appears to be no choice between these two arrangements but upon investigating to determine the values of inductance and capacity required it is found that a filter

of form 2b will require inductances on the order of 1 henry if it is to match the impedances of the vacuum tube circuits while a filter of the form shown in Fig. 2e will require inductances on the order of .005 henry. The latter is a much more easily obtained value and other things being equal it will be desirable to adopt the form of Fig. 2e for our filter.

Having decided the form of the filter we must now select the location of the band in the frequency spectrum, the band width, and the impedance of the filter. The sharpest selectivity will be obtainable if the frequency band is located at the lowest possible point. It is necessary, however, to avoid getting into the audio-frequency range and it is also desirable to choose some range for which commercial intermediate frequency transformers are already available. For these reasons we will take 30,000 cycles as the middle of our frequency band. The difficulties in design preclude the use of a perfect filter for 45,000 cycles, although constants will subsequently be given for a filter that will give better results than are otherwise obtainable.

The width of the band will be determined by the relative importance of quality versus selectivity. We will assume for the sake of obtaining high grade quality that the band width will be 10,000 cycles. The impedance which the filter is to present at the frequency of the transmitted band must be reasonably near to that of the vacuum tube and the transformer with which it

is to be associated. The filter will probably be used with vacuum tubes having impedances of from 12,000 to 20,000 ohms.

It will be noticed from Fig. 4, however, that the filter itself provides no means of applying the B battery voltage to the plate of the vacuum tube and it will be necessary to place either a choke coil or a resistance across the input of the filter for this purpose. A choke coil would be undesirable since it should have no mutual inductance with respect to the other filter coils and we would, consequently, be limited to a two-section filter.

The best arrangement will, therefore, be to connect a 12,000 to 20,000 ohm resistance across the filter input. This will reduce the resistance facing the filter to somewhat less than the impedance of the vacuum tube. As a suitable compromise value which will fit fairly well any combination of vacuum tubes and resistances we may take the filter impedance as 10,000 ohms. The resulting values for the capacities and inductances are as follows:  $C_1 = .000545$  mfd.;  $C_2 = .00227$  mfd.; and  $L_2 = .0091$  henry.

To obtain the exact value of  $L_2$  is not a very difficult problem since the inductance coil must be constructed in any event and with suitable measuring apparatus this value of 9.1 millihenries should be easily obtained. However, it would be rather difficult in practice to obtain the exact values for  $C_1$  and  $C_2$  unless the condensers were especially made. It would be much better if we could use some available standard values such as .0005 and .0025 mfd. respectively. It may be readily shown that the upper cut-off frequency (35,000 cycles in this case) is determined by the product  $L_2 C_2$  so that if we are to increase the value of  $C_2$  we will correspondingly decrease the value of  $L_2$ . This gives  $L_2$  equal to 8.25 millihenries, for  $C_2 = .0025$  mfd.

The lower cut-off frequency for a filter made up of .0005 mfd. series capacities and .0025 mfd. shunt capacities and 8.25 millihenry inductances may be shown to be 26,000 cycles, the upper cut-off remaining at 35,000 cycles and the corresponding impedance is 10,600 ohms. This is a sufficiently close approximation to the filter which we set out to design.

It should not be inferred, however, that no great care is necessary in the selection of these capacities. The ordi-

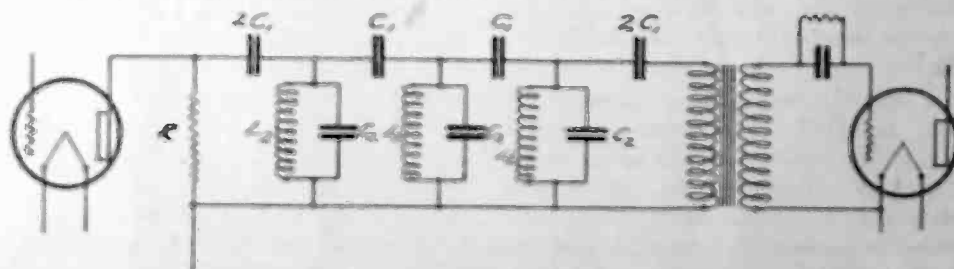

Fig. 4. Circuit Diagram for Wave Band Filter.

nary manufacturers' ratings cannot be relied upon to be sufficiently accurate for such a filter. If the cut-off at each side of the band is to be sharp it will be necessary for each section of the filter to be exactly like every other section, within 1 per cent, for each element. Small sized condensers as ordinarily available vary as much as 25% from the ratings and it is probable that the product of no one manufacturer could be relied upon within less than 5%. It is necessary, therefore, to select the condensers for this filter with great care, using some very accurate method. One such method will be described later in this article.

Referring again to Fig. 4 it will be noticed that the first and last of the series condensers are shown to have a capacity of twice the normal value, that is, in the case we have just computed these condensers should be .001 mfd. This is known as terminating the filter at mid-series section, a condition which may be shown to be necessary if the filter is to offer the normal impedance at its terminals. The only alternative would be to terminate it at mid-shunt section which, in this case, would be a much more complicated arrangement.

In Fig. 4 the filter is terminated by the last intermediate frequency transformer before the detector. This transformer should not be a tuned stage transformer but one of the type as used in preceding stages. The tuned stage as ordinarily used is entirely replaced by this band filter stage in this circuit.

The filter computed above will not satisfy all conditions, particularly the case where the vacuum tube impedance and the resistance across the filter input are rather low. If, for example, the tube impedance and the resistance are each 12,000 ohms the filter impedance should be on the order of 6,000 ohms. The values of  $C_1$ ,  $C_2$ , and  $L_2$  required for such a filter, designed to pass all frequencies between 25,000 and 35,000 cycles are as follows:  $C_1=.00089$  mfd.  $C_2=.00378$  mfd.  $L_2=5.45$  millihenries.

Not every one, of course, will be interested in such good quality as these filters make possible if by slightly narrowing the band they could obtain even greater selectivity. In fact, it should be pointed out that a band width of only 5,000 cycles would permit of nearly as good quality as is ordinarily expected of the 10,000 cycle band provided that the receiver is carefully tuned so that the intermediate frequency carrier lies at one of the cut-off frequencies. This permits one of the side bands to be amplified without distortion while the other is cut off entirely. Due to the loss of this second side band there will be some reduction in volume but to some persons the difference in selectivity may be more than worth it. The constants for a fil-

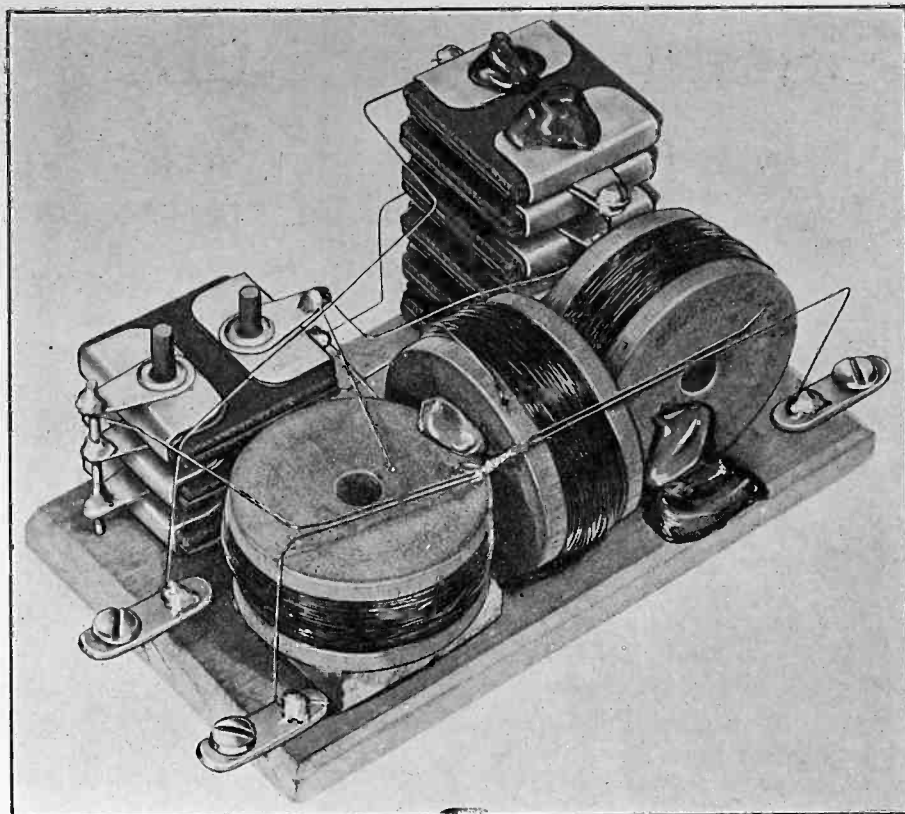

Completed Wave Band Filter.

ter of 10,000 ohm impedance designed to pass all frequencies between 27,000 and 33,000 cycles, that is, having a band width of 6,000 cycles with its center at 30,000 cycles are as follows:  $C_1=.000535$  mfd.;  $L_2=5.35$  millihenries; and  $C_2=.0041$  mfd. As a more readily realized set of values a filter having  $C_1=.0005$ ,  $C_2=.004$ , and  $L_2=5.42$  millihenries will have cut-off frequencies of 26,900 and 33,000 cycles and an impedance of 10,300. If a 6000 ohm filter for the band between 27,000 and 33,000 cycles is desired the constants will be  $C_1=.00089$  mfd.,  $C_2=.00667$  mfd. and  $L_2=3.25$  millihenries.

Since the coil is to have an inductance of from 5 to 10 millihenries, according to the filter chosen, it must be a form of multi-layer coil. This will not prove serious, however, since the distributed capacity of such a coil will probably not exceed 50 micro-microfarads so that, as compared to the condenser connected in parallel with this coil (.002 mfd. or larger), this distributed capacity is negligible. It will be possible then to make this coil as small as is consistent

with a good ratio of inductance to resistance.

It might be well to point out at this juncture the effect of resistance in this coil on the transmission characteristics of the filter. In Fig. 5 is shown in solid lines the theoretical response curve for the first filter designed above, assuming that there is no effective resistance in any of the elements. In dotted lines is shown at *A* the result of a small increase in the effective resistances and at *B* the result of a larger effective resistance. It is obvious that as the resistance increases the sharpness of the filter is rapidly lost and in addition the quality is impaired near the middle frequency of the band. Practically all of this resistance is introduced by the inductance coil since the condensers will ordinarily have mica dielectric and correspondingly low losses. Fortunately it is possible to construct inductances having low enough resistance to realize the curve *A* of Fig. 5.

The dimensions of suitable winding

(Continued on Page 54)

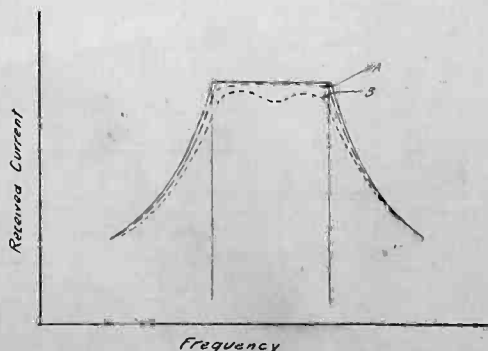
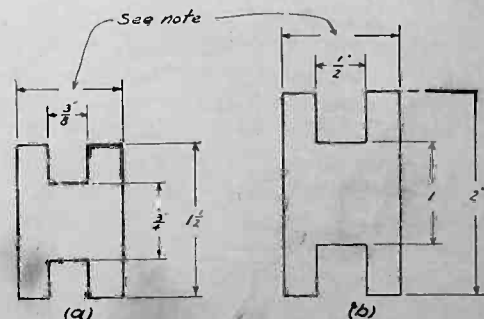

Fig. 5. Effect of Coil Resistance on Response Curve.



Note This dimension may be anything sufficient to give mechanical strength if it is made equal to the diameter it will simplify mounting

Fig. 6. Dimensions of Inductance Winding Forms.

# Getting Four Tubes Out of Three

## A Reflex Circuit Without Feedback Through the Audio Transformer, Thus Improving Tone and Selectivity

By L. W. Hatry

THE most popular circuits today seem to consist fundamentally of a stage of r.f. amplification, regenerative detector and two stages of audio amplification. It has been known under dozens of names and has been written up a thousand times. Nearly as well known is the reflexed version of the same circuit. This gives the effect mentioned in the first sentence, but with three tubes: one, the reflexed one, giving a stage both of r.f. and audio amplification. The normal circuit for this purpose is

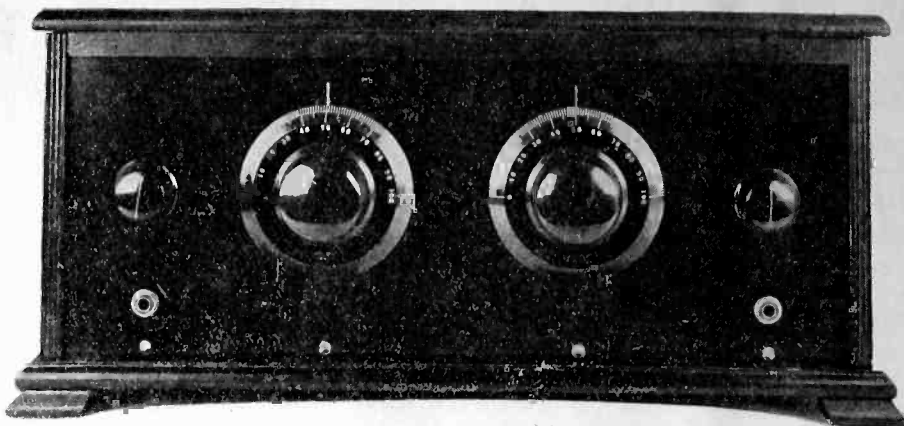

Panel View of Three-Tube Reflex.

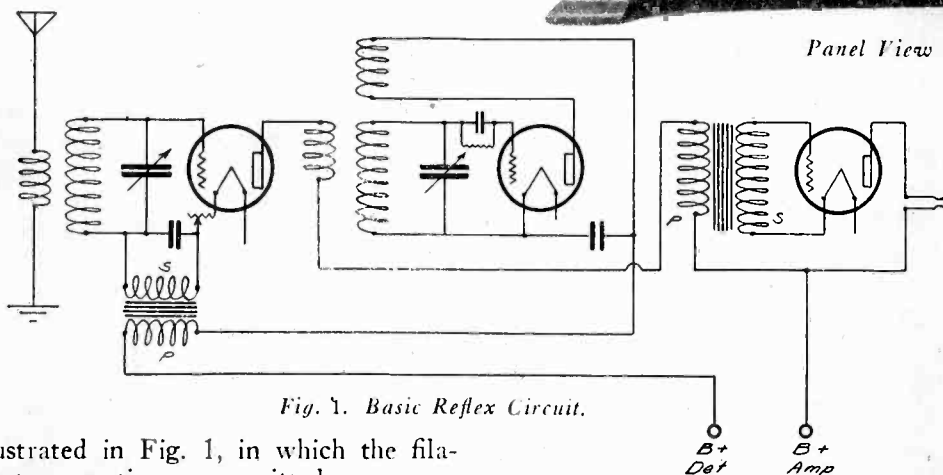

Fig. 1. Basic Reflex Circuit.

illustrated in Fig. 1, in which the filament connections are omitted.

However, the circuit of Fig. 1, while giving satisfactory performance to many hundreds of fans, has been criticized because it permits unnecessary feedbacks through the audio transformer, which in turn result in instability, neutralization difficulty and a reduction in selectivity

reflexing mode that has been called the "Times Reflex Circuit." This worked out very nicely for the reduction of instability and the simplification of neutralization by the elimination, mainly, of the feedback through the audio trans-

former. Once the circuit arrangement was used the selectivity trouble was also in part overcome, and the question of good audio quality was merely a question of proper choice of by-pass condenser capacities and a good grade of audio amplifying transformer. The essentials of the Times' circuit are shown in Fig. 2,

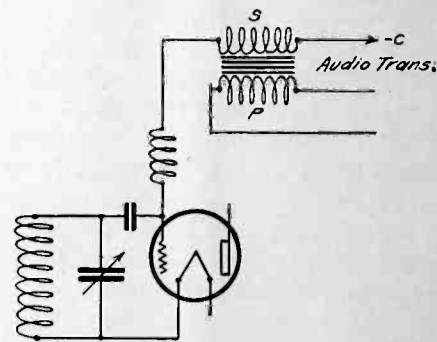

Fig. 2. Method of Eliminating Feedback Through Audio Transformer.

for it consists entirely in feeding the audio energy to the tube in a shunt circuit blocked on the r.f. side by a choke and on the audio side by a small condenser, C. The immediate desirability of

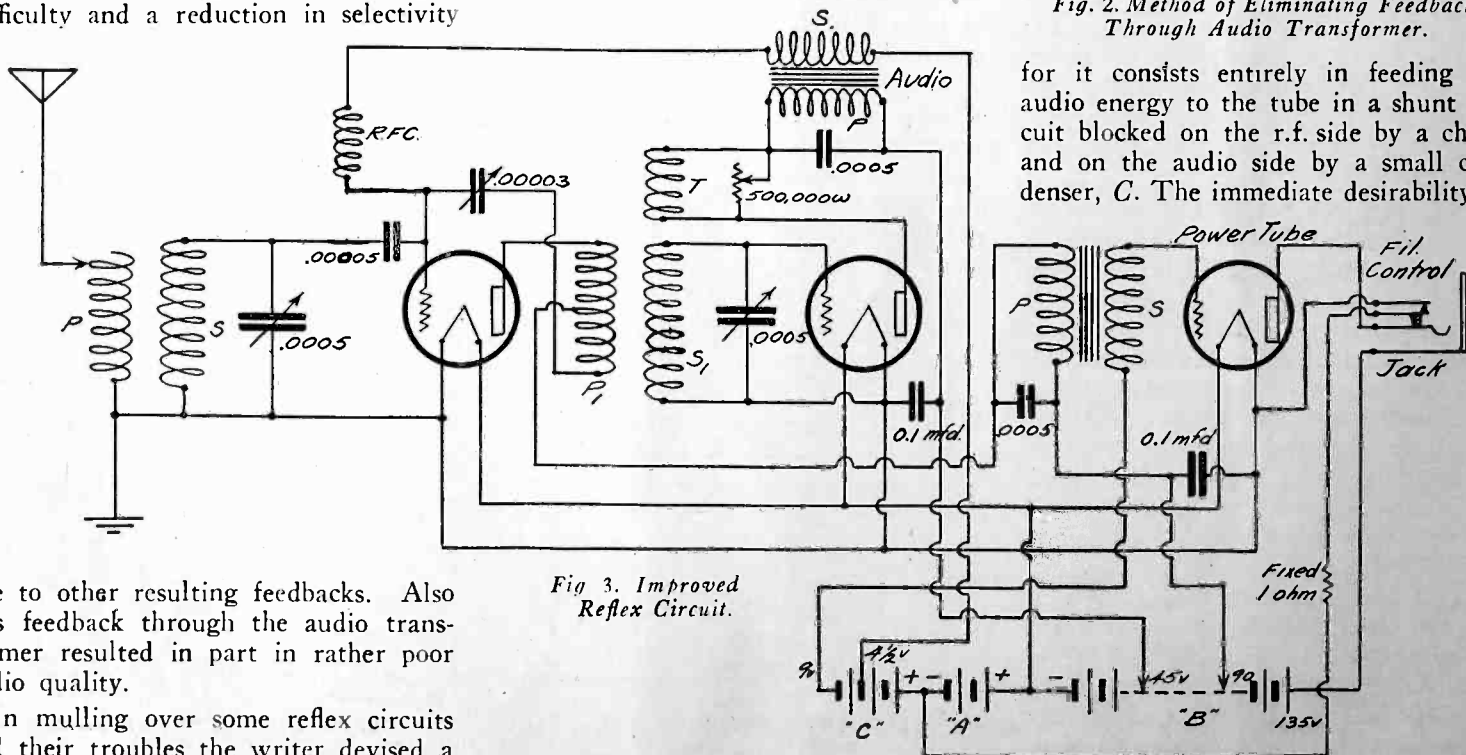
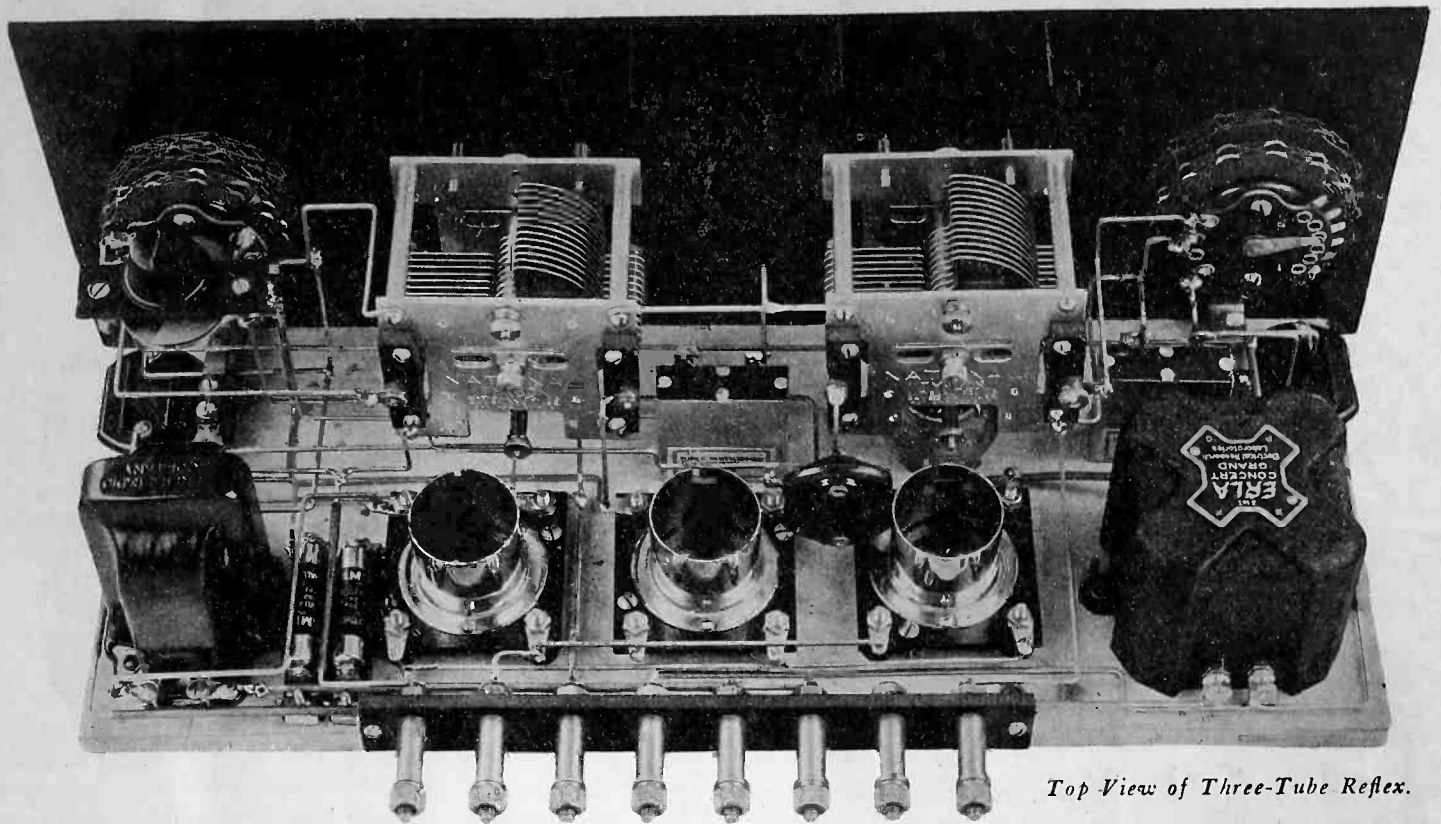

Fig. 3. Improved Reflex Circuit.

due to other resulting feedbacks. Also this feedback through the audio transformer resulted in part in rather poor audio quality.

In mulling over some reflex circuits and their troubles the writer devised a



Top View of Three-Tube Reflex.

putting this reflex arrangement into use in the circuit of Fig. 1 is obvious. This is shown in Fig. 3.

A word here should be said for the man that knows enough to arrange things to suit himself. The Browning-Drake, LC Circuit and others of a similar stripe can be revised safely into three-tube outfits by reflexing the first tube provided it is not a 199 (although it can be a 120 type). Therein is the chief merit of this scheme of reflexing, it does not interlock the audio and r.f. functions materially.

The detector tube is used without a grid-condenser; thus being less likely to distort than the method using the grid-condenser and leak. Regeneration is con-

trolled by a variable resistance. So the antenna circuit is tapped for coarse tuning. The pictured circuit arrangement is shown in Fig. 4.

The construction of the detector-coupler r.f. transformer will be of interest to any fan or tinkerer. It consists of spider-web tuning coils pressed slightly from the circular to fit the shape of the resistor housing. The general arrangement is detailed in Fig. 5.

The tickler is constructed as a separate unit of small diameter so as to fit between the metal plate in the front of the resistor housing, through which the screw compression adjustor feeds in a threaded hole, and the metal edge of the

resistance unit proper, which is a carbon grain device. The tickler is wound with enameled wire tied at either end of the form around the edges so that this tie wire, bared, makes contact with the metal plate at one end and the resistance back at the other, thus shunting the tickler with the resistance. The scheme is neat, mysterious to the uninitiated, and effective. However, all of the metal in the field of the primary and secondary increases the resistance through eddy-current losses. It is better to separate the coils from the resistor proper somewhat. Be careful to choose a smooth-running and mechanically strong variable resistor.

If a mechanically variable tickler is preferred and the maker desires to use spider-webs, a simple way is to purchase a  $\frac{1}{4}$  in. twist drill and a knob to fit the shank of it—a round drill. The tickler

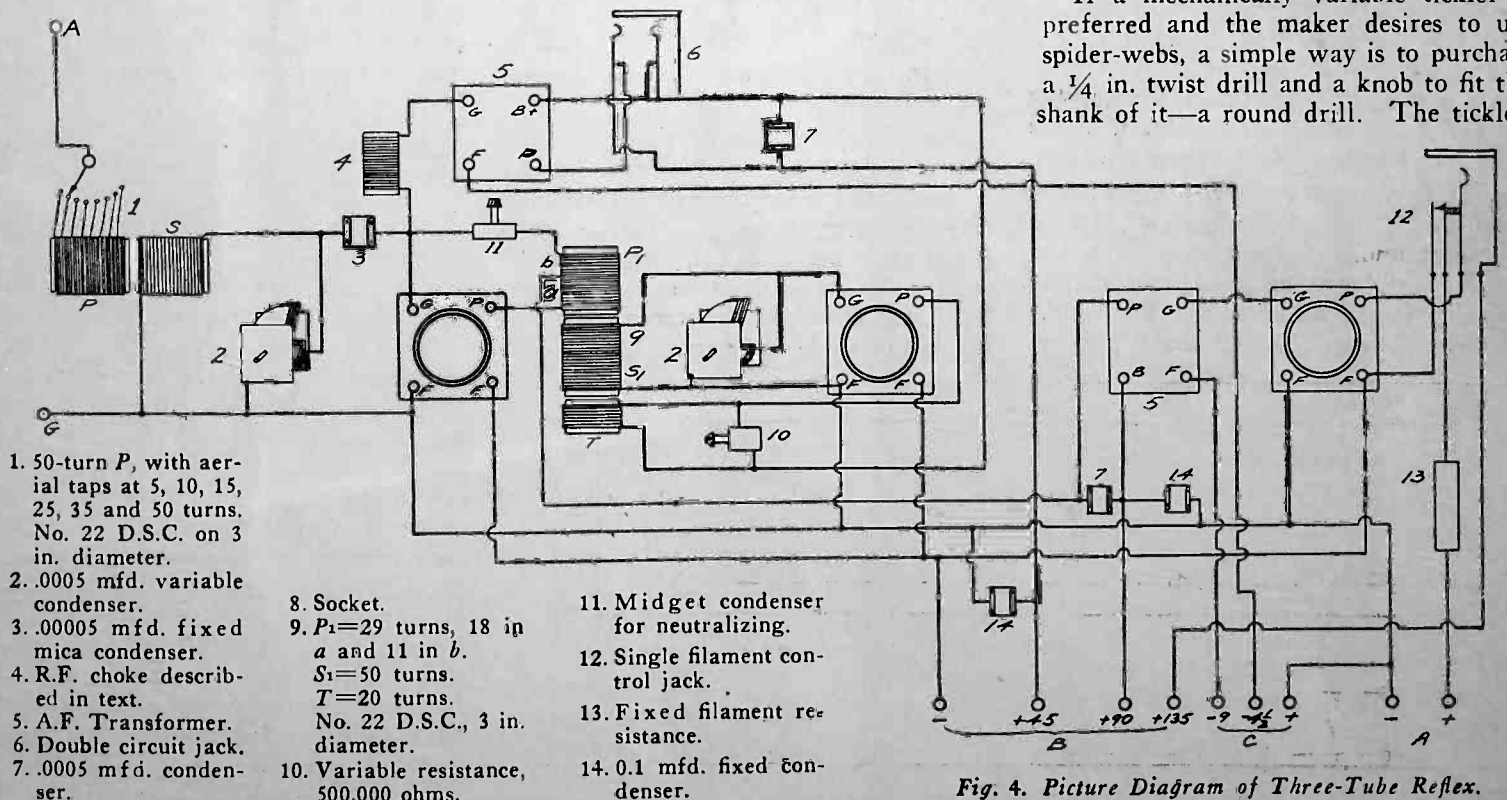

Fig. 4. Picture Diagram of Three-Tube Reflex.

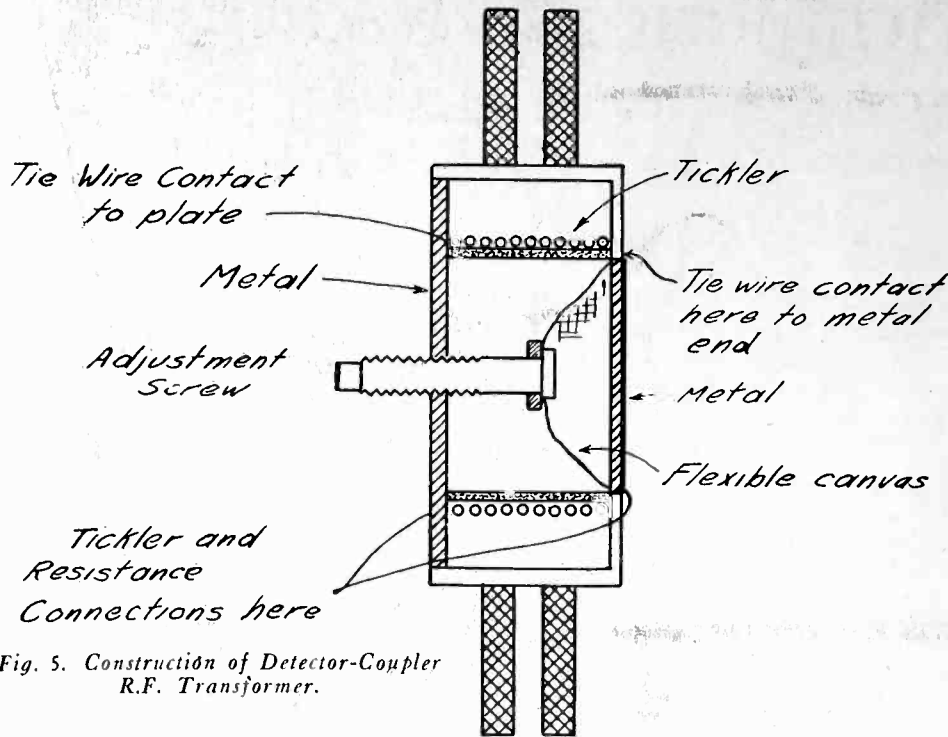

Fig. 5. Construction of Detector-Coupler R.F. Transformer.

is then thrust from the secondary by the twist portion of the drill which fits into a specially shaped hole in the tickler form as in Fig. 6. The tickler should

long and  $\frac{1}{4}$  in. diameter serves very well as a dummy to light the filaments when the left hand, or headphone, jack is used. This latter-named jack, by the

tube is wanted in the last audio stage two  $\frac{1}{2}$  ampere units can be clipped into the resistor mountings so that the 1 ampere at 5 volts will be available to the filaments. Since the resistor units clip in and out as desired, any tubes can be accommodated, from WD11's to UX210's. It is a convenient and certainly flexible arrangement.

The circuit is arranged with separate B battery connections to the three tubes. While this is not strictly necessary it fits in with the general flexibility of the set. The arrangement permits the use of 90 volts on the reflexed tube with a C battery return to  $4\frac{1}{2}$  volts negative. The detector works satisfactorily with 22 or 45 volts, as best determined by experiment, without any C battery unless more B is used. Ninety volts can be used as the detector B if  $4\frac{1}{2}$  negative C is used to bias the tube. If 90 volts B were used C battery voltages should be tried up to 9—to find the best. The chances are that the detector will oscillate with unsatisfactory control at that voltage but the trouble can usually overcome by finding the right tube for the job. With the C and B battery termi-

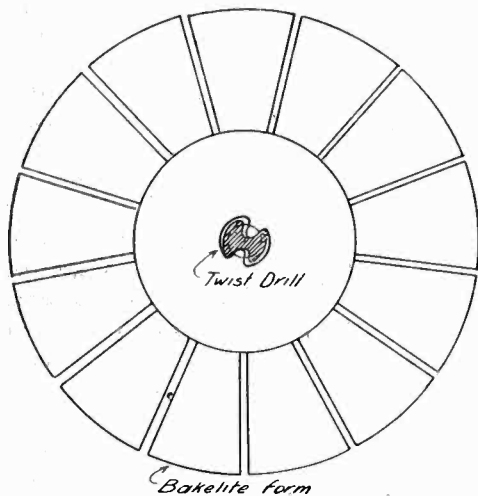

Fig. 6. Mechanically Variable Tickler.

be wound on thin bakelite or other strong material. The Crosley Mfg. Co. can provide a ready-made device of this sort.

The layout of the panel is shown in Fig. 7. The filament control jack in the last amplifier output controls the entire set without the need of a switch, which would spoil the symmetry of the panel. A wood dowel about  $2\frac{1}{2}$  in.

way, cuts in on only the r.f. amplifier and detector. An "open" plug can be used in the right-hand jack as a dummy too, of course.

Also, for the sake of simplicity and symmetry, no variable filament rheostat is used, fixed filament resistors sufficing. For the three tubes, if 201a type, two of the units are provided, one to pass  $\frac{1}{2}$  ampere for five-volt tubes, such as the 112, and the other  $\frac{1}{4}$  ampere, totalling the required  $\frac{3}{4}$  amperes. If a power

nals properly arranged, as in the case of this circuit, there is nothing to cause poor tone quality unless poor audio transformers are used.

The baseboard layout is shown in Fig. 8. The dimensions given do not have to be adhered to, although they produce a neat set if carefully wired. Don't hesitate to use a deeper baseboard, a larger panel or a different arrangement of sockets and transformers.

The r.f. choke in the set is a highly important little unit. Improperly designed, it will waste current, allowing the r.f. to leak away into the audio transformer and from there to filament. Properly designed it will prevent either the particular loss of r.f. or trouble of feedback through the audio transformer. If the r.f. choke is too small (too low in inductance) the higher end of the wavelength band will drop off in amplification. If too large it is possible that the distributed capacity will allow some of the shorter wavelengths to suffer through waste of current.

(Continued on Page 48)

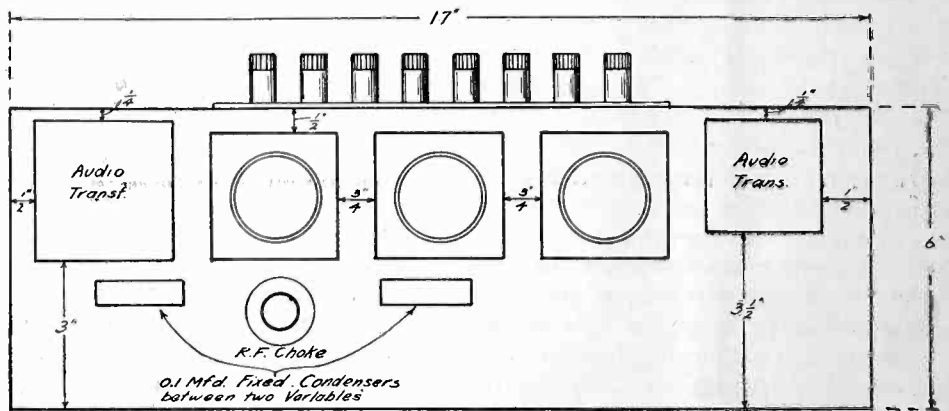

Fig. 8. Baseboard Layout for Three-Tube Reflex.

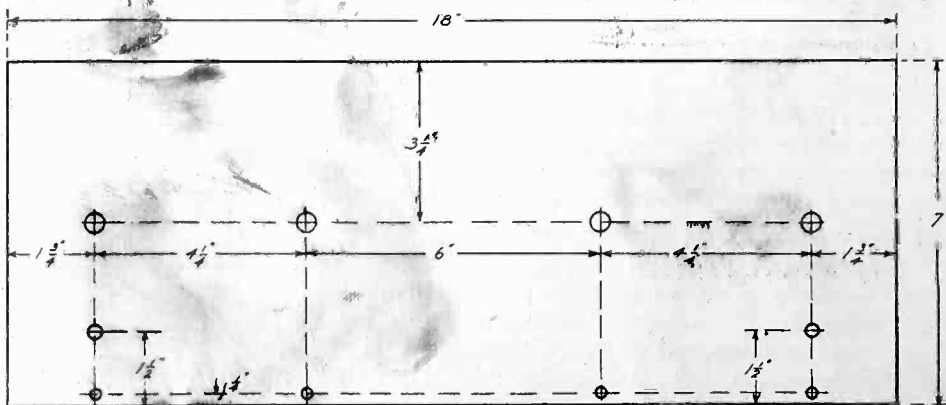

Fig. 7. Panel Layout for Three-Tube Reflex.

# The Arithmetic of Radio

A Convenient Compilation of the Simple Formulas Used to Compute the Various Constants of a Radio Receiving Set

By E. M. Sargent

THE purpose of this article is to illustrate the application of several radio formulas in computing the various constants of radio circuits. In order to do this, a fundamental circuit as shown in Fig. 1 has been chosen for analysis. The reader may make similar

furnaces, and other metallic objects. However, it gives an approximation which is valuable. The formula is applicable only to the flat top type of antenna and is as follows:

$$I_r = \frac{.01085 h_s h_r I_s}{R \lambda d}$$

in which

$h_s$  is the height of the sending antenna in feet,

$h_r$  is the height of the receiving antenna in feet,

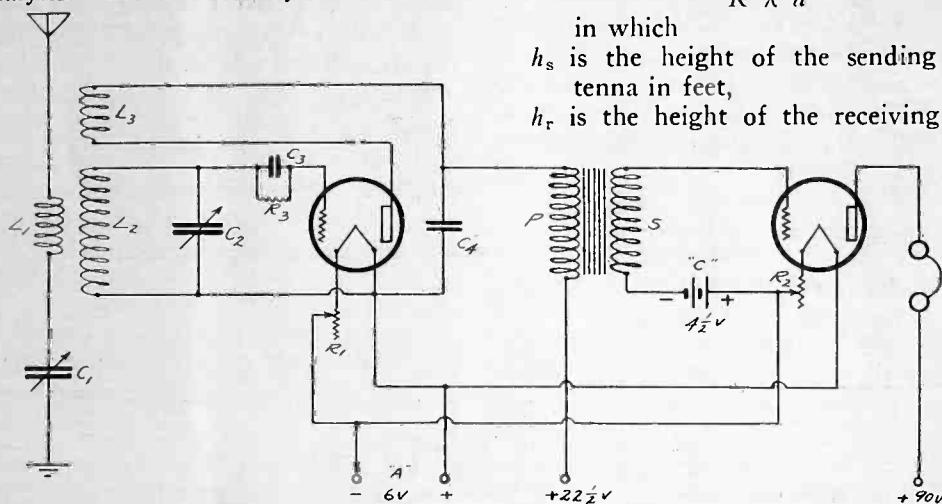

Fig. 1. Fundamental Circuit Analyzed.

analyses of other circuits after this one is thoroughly understood. It is not the idea of the article to go into the derivation of the various formulas that are used. It is assumed that they have been sufficiently well established to be accepted and it is the purpose here to show their practical application. After studying this article, the reader should be able to answer such questions as:

What size rheostat should I use to operate a 199 tube from a 6 volt storage battery?

What size by-pass condenser should be used across the primary of an audio transformer?

All of the formulas used have been arranged so that the units are the same throughout. Unless otherwise specified in a special case, these units are as follows:

Symbol	Unit of	Measured in
$R$	resistance	ohms
$L$	self inductance	microhenries
$M$	mutual inductance	microhenries
$C$	capacity	microfarads
$f$	frequency	cycles per sec.
$E$	potential	volts
$I$	current	amperes
$\lambda$	wavelength	meters

We might as well start at the beginning. It will therefore be interesting to know about what input we are receiving from a distant radiocast station. This formula is, naturally, subject to great variation from local causes, such as interfering power lines, house wiring,

tenna in feet,

$I_s$  is the number of amperes in the transmitting antenna.

$R$  is the resistance of the receiving antenna, and

$\lambda$  is the wavelength in meters,

$d$  is the distance between the stations in miles,

$I_r$  is the current that will flow in the receiving antenna.

The ohmic resistance of the antenna for direct current is equal to the number of feet of wire times the resistance per foot. This may be found from any standard wire table. For No. 14 copper wire the resistance per foot is .0025 ohms. As we are dealing with radio frequency and not with direct current, the d.c. resistance must be multiplied by a conversion factor which takes into account the skin effect at high frequencies. This factor is  $[2.54 r \sqrt{.0058f}]$  where  $r$  is the radius of the wire in inches. For No. 14 wire  $r$  equals .032 inches.

The natural wavelength of the antenna of the single wire inverted L type is approximately 1.2 times the total length from the extreme end of the antenna to the point where the ground lead enters the ground. Measuring this wire length in feet and multiplying by 1.2 will give the wavelength in meters.

The capacity of an antenna is not a practicable thing to calculate. Sufficient to say that the average antenna used for radiocast reception has a capacity of about .0007 mfd. Inasmuch as the ca-

capacity varies with the wavelength, and an average figure has to be decided upon in making computations, .0007 will serve as well as any.

A series condenser in the antenna circuit tunes to a lower wavelength with a given inductance than when the coil is inserted directly in series between the antenna and ground. To figure the waveband over which a given coil will respond, it is first necessary to find the maximum and minimum capacity values of the antenna with the condenser in series; that is, to find the capacity with the condenser set at 100 degrees and with the condenser set at 10 degrees, which is as low as it is practicable to go. This can be found from the formula

$$\frac{1}{C} = \frac{1}{C_1} + \frac{1}{C_a}$$

where

$C_1$  is the capacity of the series condenser,

$C_a$  is the antenna capacity of .0007,

$C$  is the resultant capacity of the two in series.

If the inductance is unknown, it may be calculated from any suitable inductance formula. The method described by the writer in RADIO for April 1925 is particularly recommended. The waveband may then be determined by multiplying the inductance by the minimum capacity and referring to an LC table to find the resulting wavelength, which will be the lower one of the band;—multiplying the inductance by the maximum capacity to find the higher wavelength.

The coefficient of coupling between Coils  $L_1$  and  $L_2$  is denoted by  $K$ , and is given by the formula:

$$K = \frac{M}{\sqrt{L_1 L_2}}$$

$L_1$  and  $L_2$  are easily calculated, while  $M$  must be measured.  $M$  may be found by connecting both coils in series and measuring their total inductance; call this  $L'$ . Then again connect the coils in series with the leads of one coil reversed so as to oppose the mutual reaction of their fields and measure the total inductance again. Call this  $L''$ . Subtract  $L''$  from  $L'$ , or if  $L''$  is larger, subtract  $L'$  from  $L''$  and divide by 4. The result will be  $M$ . The formula for  $M$  is

$$M = \frac{L' - L''}{4}$$

The most efficient coupling, that is, the value at which the most energy will be

transferred from the antenna circuit to the secondary circuit is reached when  $M = \sqrt{R_a R_b}$  where  $R_a$  and  $R_b$  are the respective circuit resistances of the antenna and secondary circuits.

The induced voltage into the secondary is given by  $E_s = 6.28 f M I_a$  where  $I_a$  is the antenna current.

The wavelength of the secondary circuit  $L_2 C_2$  may be found from an LC table or, if desired, may be computed from the formula:  $\lambda = 1884 \sqrt{L C}$ .

The current flowing in secondary circuit may be computed from Ohm's Law when the secondary circuit is tuned to the same wavelength as the antenna and both in turn are tuned to resonance with the incoming signal. This is the case with which we are usually concerned and under these conditions the computation is very easy,  $I = E/R$  where  $E$  is the voltage induced into the secondary and  $R$  is the resistance of the circuit  $L_2 C_2$ . When not in resonance with the incoming wave, the formula

$$I = \frac{E}{\sqrt{R^2 + (2\pi f L - 1/2\pi f C)^2}}$$

must be used. This is of value in computing the current that is received from an interfering station that is on a different wavelength than that which it is desired to receive.

The voltage built up across the secondary should not be confused with the voltage which is induced into the secondary coil  $L_2$ , as the voltage that is built up across the coil is many times greater than that which is induced. This is found by  $E = 6.28 f L i$ , where  $i$  is the current flowing thru the coil. Inasmuch as there is no appreciable voltage drop thru the grid condenser  $C_3$  and grid leak  $R_3$  this may be considered as the voltage that is applied between the grid and filament of the detector tube.

The Filament Circuit is computed by Ohms Law. We will assume that the tube is a CX-301A. From the manufacturer's specifications we find that this tube requires a filament current of  $1/4$  ampere and that there will be a drop of 5 volts across the filament. A 6 volt storage battery will be used. Suppose it is desired to find out what size rheostat will be required to cut down battery voltage to the 5 volts that the tube requires. As 5 volts will be the drop across the tube filament, the drop thru the rheostat must be 1 volt. Therefore,

$$R = E/I = 1/.25 = 4 \text{ ohms.}$$

If a CX-299 tube, which has a filament current of .06 amperes and a 3-volt filament is used and it is to be supplied from a 6-volt storage battery, the rheostat will have to be of 50 ohms capacity, as shown by the same formula.

In Fig. 1, the grid return is shown as going to the positive filament. This puts the grid at the potential of that point

less a small drop thru the leak. If the grid return is brought to the negative filament, there is no drop thru the leak and the potential is exactly the same as the point to which the wire is attached. If the grid return is brought to the negative A battery, the grid is one volt negative with respect to the filament on account of the drop thru the rheostat.

In the plate circuit the size of the tickler coil  $L_3$  depends upon the closeness of coupling. It should usually have from  $1/3$  to  $1/2$  the inductance value of the secondary  $L_2$ . Most audio transformers have a primary resistance of about 2000 ohms and a distributed capacity of about .00005 mfd. Suppose that the incoming signal is on 600 meters. The inductance of the audio transformer is so high as to make passage of this frequency impossible. The only radio frequency path, therefore, is thru the capacity of the primary windings. The reactance of this

$$\text{path may be found by } Z = \frac{159154}{f c}$$

which shows a capacity of .00005 to have a reactance of 6366 ohms to a 600 meter signal. This is usually too high to permit the tube to oscillate and, therefore, a by-pass condenser  $C_4$  is connected from the end of the tickler coil to the filament. If this by-pass condenser is .001 mfd., the reactance is reduced to 318.3 ohms for the same signal.

The impedance of the transformer primary at one thousand cycles, which is the average voice frequency, is about 30,000 ohms. The reactance of the by-pass condenser  $C_4$  to a frequency of 1,000 cycles, is 159,154 ohms. Thus the reactance of the by-pass condenser to the audio frequency is more than five times the impedance of the primary of the transformer and the by-pass condenser will not materially cut down the volume of the signal. If, however, a large by-pass, such as .006 mfd., is used, the reactance to 1000 cycles will be only 24,858 ohms, or less than that of the primary. Over half the signal will, therefore, be shunted back to the filament and lost with such

(Continued on Page 61)

## SARGENT CIRCUIT NO. 4

By E. M. SARGENT

Circuit No. 4 is exactly the same as Circuit No. 3, as described in March RADIO, except for an added stage of audio frequency amplification. Fig. 1 shows the wiring diagram. On the panel an extra jack is added 1 in. above the jack on the No. 3 panel (1 in. between centers); otherwise the panel is exactly as before. This added stage of audio frequency is controlled by the same rheostat that controls the first stage. The parts necessary to convert a No. 3 set into a No. 4 are: A Daven No. 42 resisto-coupler, a .05 megohm Daven resistor for the plate leak, a Daven 1 meg grid leak, a VT socket, a single closed circuit jack and a tube.

The circuit is now equipped with two jacks, one after the first stage of audio and one in the output circuit of the second stage. In order to make the proper connections, it will be necessary to take out the single open jack that was used in the No. 3 set and connect in its place the closed circuit jack specified in the above list. Fig. 1 shows the wiring for this jack. The open circuit jack is thus transferred to the output of the second stage.

The addition of another stage of audio frequency amplification to Circuit No. 3 adds quite a bit to the volume and makes loud speaker operation possible on several distant stations that come in weak on the No. 3 set. The addition of the fourth tube will not in any way affect the selectivity and will have very little effect in increasing distance. Its main purpose is to bring in louder and clearer that which is already received on the three tube set. Resistance coupled amplification has been chosen for this second stage because of its remarkable clarity of reproduction. A plate voltage of 90 on both stages is plenty.

Either the regular CX 301A tube or the CX 112 power tube may be used in this second stage. The set will operate the Western Electric Cone speaker if the power tube is used in the last stage.

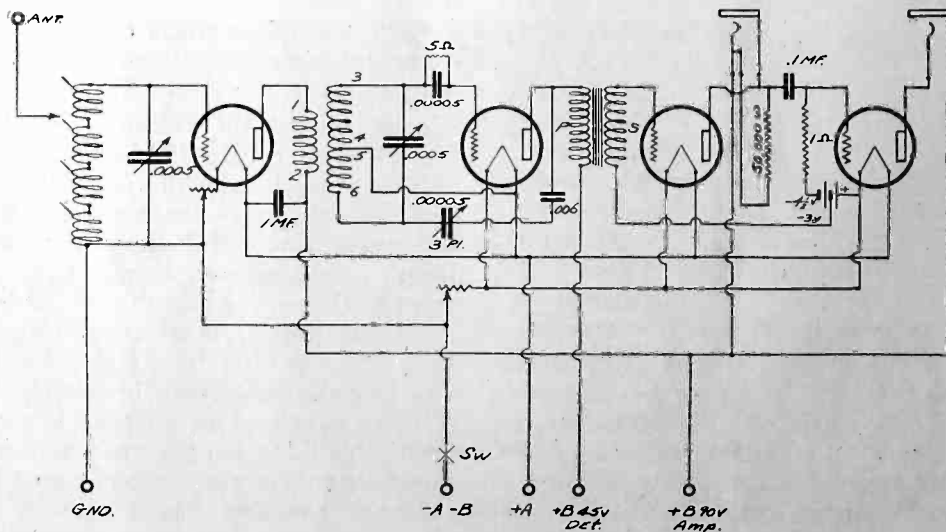

Fig. 1. Diagram for Sargent No. 4 Circuit.



# Short-wave Receiver Design

With Directions for Building a 17 to 550 Meter Capacity Controlled Regenerative Set Using Plug-in Coils

By F. J. Marco, 9ZA

THE design of radio receivers capable of handling the extreme frequencies encountered in waves below 100 meters calls for greater care than in lower frequency work. Many effects which are but slightly troublesome in the radiocast band are tremendously magnified as we approach the shorter waves. Some of these, such as parasitic capacities, become so important that in the ordinary system it is usually impossible to realize the amplification advantages of a greater number of receiving tubes.

Roughly, short wave receivers may be cast into three classes. First, the simple regenerative receiver, next the superheterodyne, and then the high-frequency amplifier. With the simple regenerator we are all familiar. The superheterodyne, as adapted to extreme high-frequency reception, has not been popular, probably because its cost and complication are usually not compensated by the increase in effectiveness. The high-frequency amplifier has demonstrated its possibilities, but seldom gives noticeable gain over the ordinary regenerator at 40 meters.

The requirements of a short-wave receiver depend to some extent upon the class of work for which it is intended. Low cost, simplicity of control, reliability, constancy of frequency calibration and sensitivity are always necessary. In addition, the radio relay man wants flexibility, selectivity through local high-powered stations, and constancy of regeneration with frequency. The short wave radiocast listener must also have smoothness of regenerative amplification

and good quality of reproduction. In order to include the frequencies of interest to the amateur and also those of the radiocast listener, wavelengths between 17 and 550 meters must be covered. Practically all of these quali-

ties may be had by a single regenerative tube, used with one or two stages of audio-frequency amplification.

From the standpoint of response only, one regenerative circuit is as good as another. Whether we use tuned-plate,

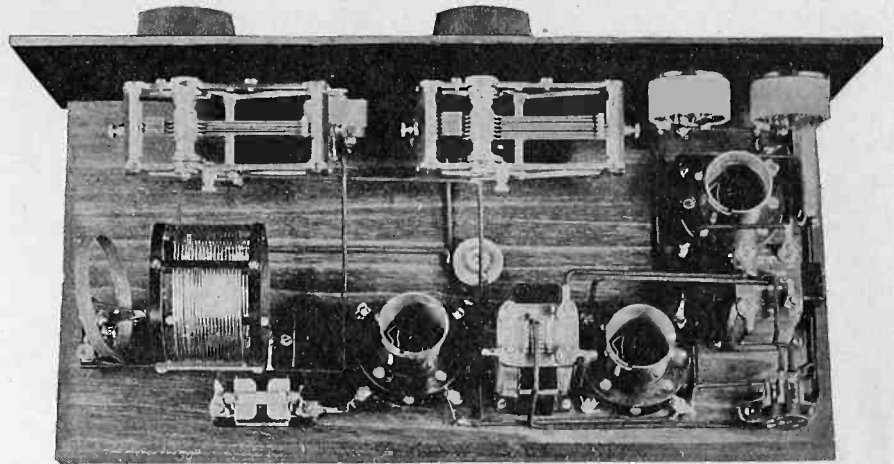

Top View of Short Wave Receiver.

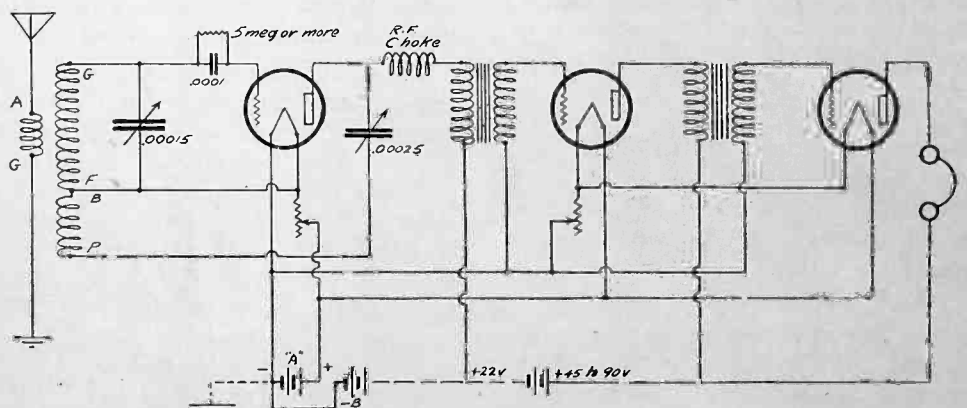
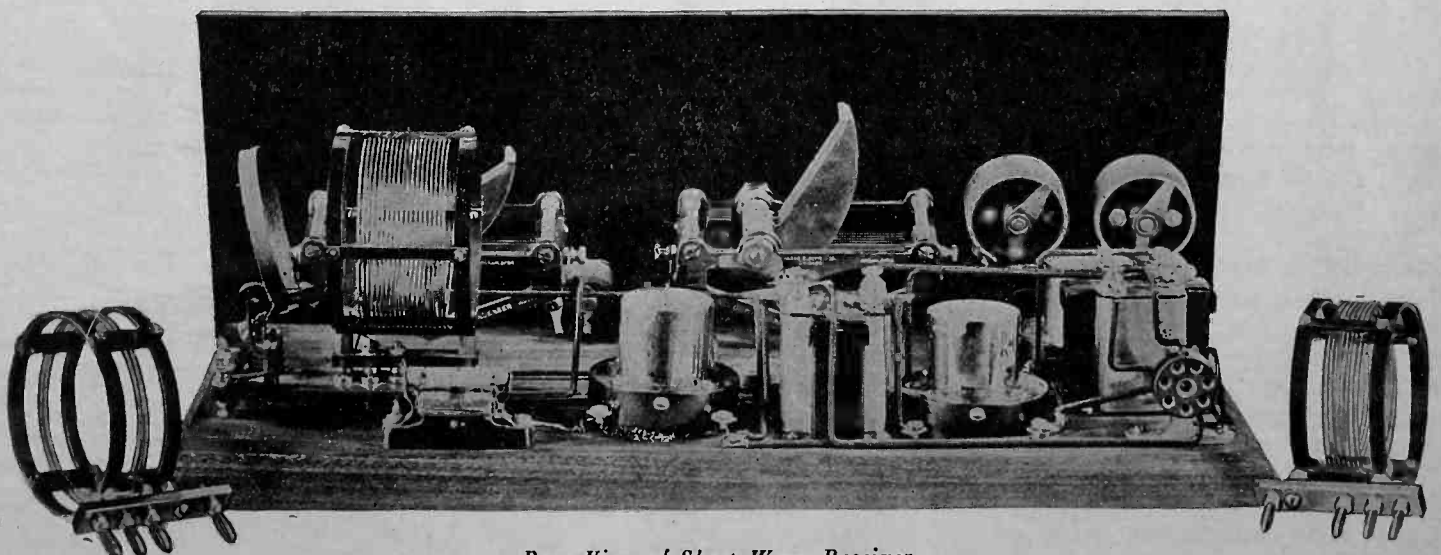

Fig. 1, Circuit Diagram for Short Wave Receiver.



Rear View of Short Wave Receiver.

tickler-feedback, inductive-capacity-feedback, throttle-control, or any other conceivable system, the signal strength of a distant station will be the same. However, it is always desirable to use the simplest and most stable circuit. Since both tuned-plate and rotating-tickler feedback circuits greatly affect the tuning as the regeneration is changed, the circuit shown in Fig. 1 has been chosen.

This is immediately recognized as being similar to the ordinary form of capacity controlled regenerative circuit and differs only in a slight rearrangement of parts. It is possible, with this system and proper proportioning of constants, to obtain a condition wherein the regeneration control varies only slightly with frequency, thus allowing a single setting of the feedback control to cover a fairly wide band of frequencies. This makes the receiver practically single control and keeps one hand free for copying and logging.

In Fig. 1, *A-G* is the antenna delivery coil, coupled to *G-F*, which, with its tuning condenser, constitutes the tuned grid circuit. The filament and grid of the detector tube, through its condenser and leak are connected across the main inductance. Closely coupled to the grid coil is the plate feedback inductance, *B-P*. This is located at the filament circuit through the 250 picofarad variable condenser, which acts as a regeneration control. This constitutes the radio-frequency portion of the circuit.

However, it is necessary to provide a direct-current path for the plate current through the B battery and it is therefore necessary to feed the output circuit (audio transformer or phones) through the radio-frequency choke coil to some point of the plate circuit. It is more desirable to connect the high potential end of the choke to the point shown rather than directly to the plate since the choke coil is acting merely as a very small capacity (equal to its dynamic distributed capacity when operating below its fundamental wavelength), and if connected directly to the plate it would have a greater effect on the operation of the r. f. circuit. The audio-frequency end of the circuit is essentially standard.

Since at the most, we are concerning ourselves with three tubes, only one of which is useful in actually rectifying the signal, the others merely serving to make it louder, it is extremely important that the losses in the radio-frequency input circuit be kept as low as possible. It has been stated that—"As long as a regenerative system can be made to oscillate (self-generate) its losses are of no consequence," and "Low loss apparatus is unnecessary in an oscillating circuit." Fortunately, it has been mathematically and experimentally proven that this opinion is erroneous, (Reference, "An Analysis of Regenerative Amplification," Landon

& Jarvis, Proc. I. R. E. Dec. 1925) and while "low-loss" design may not exactly serve to effectively move the transmitter next door to the receiver it represents a gain that is distinctly worth having.

Accordingly, the grid coils should be space-wound, solenoid fashion, on a skeleton structure having the minimum of solid dielectric within the coil's field. Since a very wide band of wavelengths is to be covered (17 to 550 meters) it is necessary to provide some system of interchanging inductances, such as is found in Aero coils. The plug-in mounting and base arrangement are purely mechanical in nature and can be easily understood from the picture. The single isolated plug at one end is the grid terminal, so placed that its capacity to the others, and therefore, the losses through the dielectric material of the base, are at a minimum. The increases in losses due to the plug-in arrangement have been found to be only about 1 percent at the worst condition. This is practically negligible.

The Aero coils are so proportioned as to cover the wave band in five steps, each overlapping the other slightly. 17 to 36 meters, 33 to 68 meters, 65 to 130 meters, 125 to 250 meters and 230 to 550 meters are covered with a 140 picofarad variable condenser when used with a 201A tube. The capacity of the grid condenser and tube inter-element capacity may slightly vary the lower limit of wavelength.

Bare No. 18 wire is used in the three smaller coils and the two larger (long wave) are wound with a smaller sized wire, covered but spaced. An extremely heavy size of wire was deliberately ignored because of the excessive losses incurred when such a coil must be put into a set where there is not enough room for wide spacing and large turns. There is a best size of wire for each frequency and geometrical construction of coil.

The plate coils are made of slightly smaller diameter and wound with a small size of cotton covered wire and slipped inside the main inductance and glued in place at the filament end. We are not concerned with the losses in the plate circuit and therefore it is desirable to use a fine wire so that the capacity to the grid coil will be small. The polarity of the windings of course must be correct so that the feedback is in the right direction.

In order to make the tuning sensitivity equal all over the dial, the straight frequency line plate was chosen for the grid tuning condenser, as shown in the pictures. This allows us to use the lower limit of the capacity-inductance ratio (in the tuned circuit) for the important frequencies and thereby obtain greater efficiency without critical tuning on these frequencies.

The primary coil is wound of 10 turns of No. 24 D. C. C. wire and mounted on the plug-in base at the filament end of the grid coil. This can be seen clearly in the pictures. It can be adjusted at an angle which gives the correct degree of coupling for the particular antenna used. Inasmuch as a lesser degree of coupling is desirable at higher frequencies, the coils are mounted so that the smaller sizes are automatically placed farther away from the primary as they are plugged in, thereby making it practically unnecessary to change the primary coil position when changing coils. The primary is sufficiently loosely coupled so that its effect upon the calibration of the receiver is negligible.

As most transmitting amateurs have the transmitter on the right, key and changeover switch in the center, and receiver on the left, the set is built so that the antenna enters from the right, thus making the shortest leads. This is optional, of course, and the receiver can be assembled in either fashion. Two stages of audio are used, primarily to allow loud-speaker reception of foreign amateurs and broadcast stations, although this too, is optional to the builder.

The feedback control condenser may be of any shape of plate, either S. F. L., S. W. L. or S. C. L., so long as its maximum capacity is about 200 to 250 picofarads.

Whatever type of tube is used, a good deal of time and patience must be spent in obtaining the best value of grid-condenser, grid-leak, and grid return. In order to make such adjustment feasible, the condenser and leak mounting are of the plug-in type so the different values may be tried. The smallest capacity possible on the highest resistance leak should be used, provided howling can be avoided. The writer has used 20 picofarads and 12 megohms to good advantage with an ordinary 201A tube, but such values usually cause the tube to snap into oscillation with a long-drawn howl and are therefore difficult to handle. The correct adjustment is one which allows the tube to slide into oscillation with a soft "swish" not a "click," and still betrays a slight tendency to roar or howl. While these adjustments are being made, the grid-return should be varied from positive to negative A battery, in order to get the best condition. You will usually end up with a positive grid return, about 100 to 200 picofarad grid condenser and 7 to 10 megohm leak, although much depends upon the characteristics of the detector tube in use. A good deal of patience and juggling will be rewarded by much peppier signals than are usual from a short-wave receiver.

# A 15-Watt Tube Transmitter

By D. B. McGown

WITH the advent of the type UX-210 CX-310 vacuum tubes, which are rated as 7.5 watt oscillators the transmitting amateur has available a tube which is of the same general characteristics as the old UV-202 vacuum tube, but with improvements resulting from the substitution of the thoriated, or "XL" tungsten filament for the plain tungsten. The tube is also better mechanically built as far as the internal elements are concerned. It is practically identical with the type UV-210 tubes of this rating, which have been used for a considerable time in the radiocasting stations of the General Electric Co., and in some branches of the Government service, with quite marked success. The electrical constants of the UX-210-CX-310 tube as an oscillator are as follows:

- Filament volts, 7.5.
- Filament Amperes, 1.25.
- Plate volts, 350.
- Plate Current, 60 milliamperes.
- Normal output, 7.5 watts.
- Plate dissipation 15.0 watts.  
(Maximum safe value).

Internally the plate is supported by a rigid metal band which is clamped over the glass base tube containing the leading-in wires, and all danger from breakdown in the base is eliminated by bringing in the plate terminal through the glass well below the leads for the grid and filament, much in the same manner as is done with the 50 watt tubes. A strong glass support is arranged at the top of the plate, which supports rigidly the filament tension springs, as well as the grid of the tube. The tube is exhausted through the base, giving the modern "tipless" effect, which is also a great improvement. The metal (Molybdenum) of the plate itself is sand-blasted, which tends to increase the heat radiation from this portion of the tube, and which still further aids in its operation.

The base used is the new UX, -CX type, which has the two large and two small pins, but which at the same time will fit the standard, or old type socket, for which the usual pin is provided on the side of the base. The latter is of bakelite, and while probably satisfactory on the longer waves, and for voice frequency currents, this may cause some question, when used in a high frequency tube transmitter. Tests have not shown any trouble from this source, however, and it is problematical whether this introduces serious losses, or not.

The Hartley circuit was selected as the most convenient one to use on the wavelength bands of 20 and 40 meters,

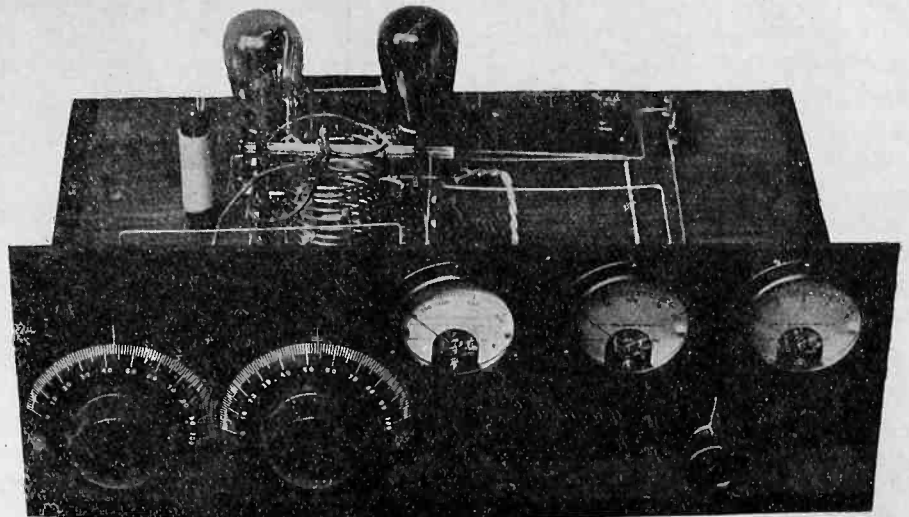

Panel View, Showing Tuning Controls.

as it is simple and easy to adjust, as well as being quite familiar to the amateur fraternity generally. The oscillator is coupled to the antenna circuit by a small inductance, making the circuit strictly in compliance with the Department of Commerce rules. The circuit diagram of the transmitter is shown in Fig. 1, the Hartley circuit being used in the conventional manner, except for the connection between the filament and mid-tap in the inductance, and in the keying system.

The keying system used pre-supposes the use of a direct current plate supply. Across the 350 volt plate circuit, a 100,000 ohm resistor is connected. This resistor was actually made up of several resistance sheets taken from a discarded high range voltmeter, but may be higher or lower than 100,000 ohms, provided that a convenient tap can be taken off about a fifth or a quarter of the way from one end.

The action of this keying system depends on the voltage drop across a resistance, and this potential drop is so used that a high negative bias potential is impressed on the grids of the tubes,

which blocks the plate current, and stops oscillation. This is purely a d.c. component, and hence does not require a large or heavy key, and close to the negative side of the plate supply does not result in any high potentials being set up across the key, which eliminates the unpleasantness of the operator receiving shocks from the live portions of the key. When the key is in the open position, as shown in Fig. 1, the filaments of the tubes are entirely insulated from the grid circuit, as far as any flow of direct current is concerned, except through the resistance directly across the plate supply. The filaments are placed at about 70 volts positive, as compared with the grids, assuming 350 volts plate supply and a 100,000 ohm total resistance bias resistor, which reduces the plate current to practically zero, and stops oscillation. When the key is closed, the potential of the grids is changed to the same as that of the filament, and the oscillations take place as usual, flowing through condenser  $C_2$ , while they are kept out of the keying and direct current circuits by the two chokes  $CH$ . Trouble due to "key clicks," which so often annoy nearby

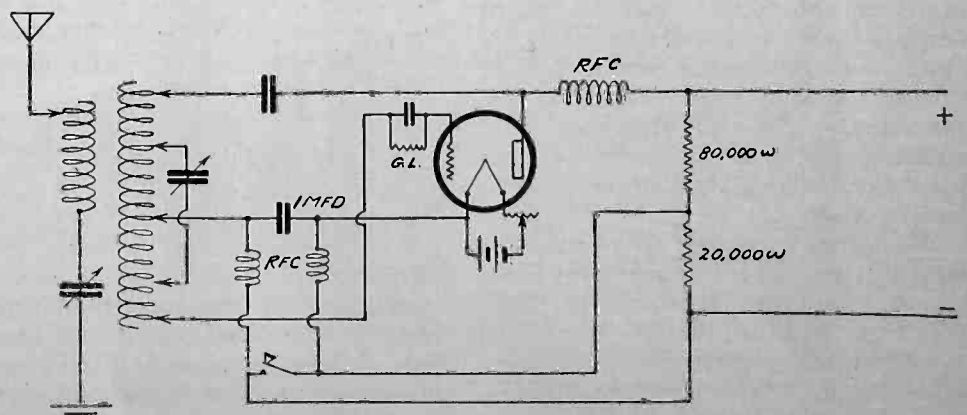

Fig. 1. Circuit Diagram of Transmitter.

listeners on other wavelengths, is absent with this method.

Resistors for the keying system should be capable of carrying a current of 10 milliamperes or more, without heating dangerously. In lieu of the resistances from an old meter, as used in the experimental model, a number of "lavite" resistances could be used in their place. These come in 48,000 ohm units, and 5 connected in series will reduce the current to such a low value that there is no danger of burning them out.

In this transmitter, it was found that the value of the grid leak was quite a bit more critical than is usually expected in amateur equipment. The value of the grid leak determines the potential of the grid in operation, and thus the plate current. While variation of the grid feed also affects this to a large extent, a high value of grid leak, with the resultant high grid potential gave much more stable operation and easier control than did a low resistance value. In the set here illustrated the grid leak was found to give best results with a resistance of about 7,000 ohms. It was made up by connecting two Ward-Leonard resistance tubes in series, which was found to be a cheap, efficient and easy way to solve the problem. 12,000 ohm lavite resistances might also be used here, but the d. c. grid current is usually so high that there is danger of burning them out.

The accompanying pictures show the layout of the complete equipment, as built by the writer. The whole equipment is mounted on a baseboard and rubber front panel. To the left the two tuning condensers appear, with their respective dials on the front, and from left to right the meters for measuring the various current values. As the power output was small, a thermo-ammeter of 0-500 milliamperes range was found to serve quite well, and even this was rather large, when working on the 20 meter band. An 0-200 m.a. ammeter was provided to measure the plate current, and an 0-8 volt range voltmeter was connected permanently in shunt to the tube filaments. Direct current was used to light the latter, from a 4 cell storage battery.

To cover the 20 and 40 meter wavelength bands, a 12 turn copper wire inductance was made by winding No. 10 hard drawn copper wire on a mandrel, and then allowing it to spring out to size. This resulted in an inductor about 2½ in. in diameter, and supported by Pyrex glass tubing tied to the inductor at intervals, with waxed string. The whole unit was supported from the base by cementing the glass into small brass fittings provided with screw holes and then screwing the unit to the baseboard. The coupling coil was made in similar manner, but is composed of but three turns, and is supported by a single piece

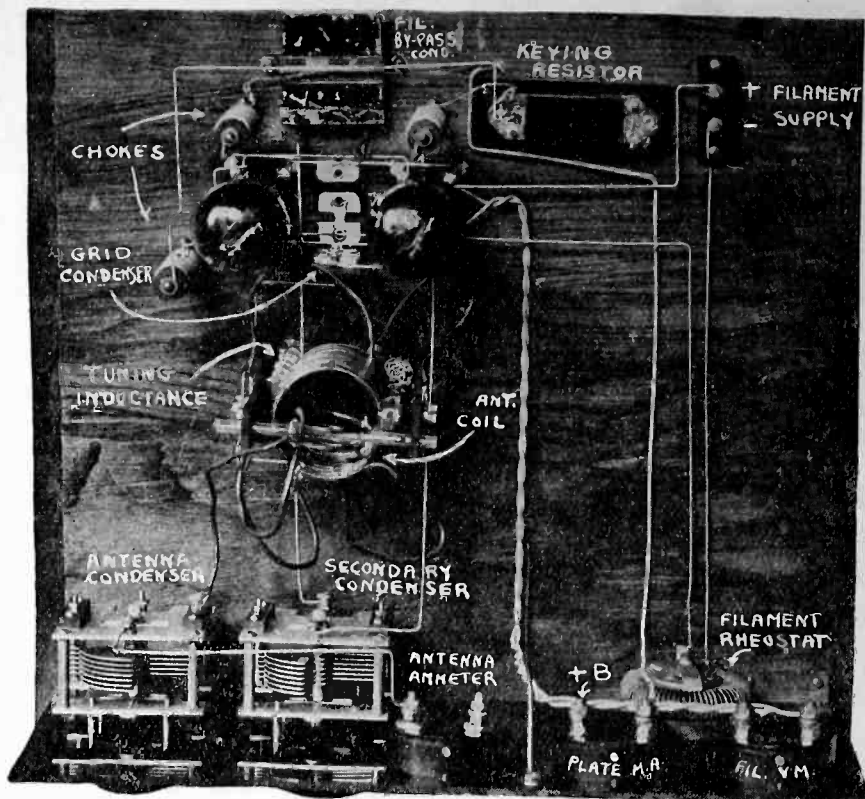

View of Apparatus Layout.

of glass tubing. Rubber supports are provided on each side of the inductors to hold the coupling coil, and these strips serve incidentally as terminal blocks where the flexible leads are attached for varying the inductance. The coupling coil may be rotated at will, to increase or decrease the coupling.

The tuning of the closed circuit is taken care of by the portion of the inductance shunted by the condenser  $C_4$ . As considerable power is to be handled here, a good condenser should be used, and as the adjustment for exact wavelengths is quite critical, vernier dials are desirable. These two-fold conditions were satisfied by using National condensers of .00025 mfd. maximum capacity, of the ordinary variety offered for use in receiving sets. Although these condensers were intended only for receiving circuits, they were found to stand up very well in this transmitter, handling anywhere from 15 to 40 watts of radio frequency energy. As all the power radiated from the set is impressed on the shunt condenser, care should be taken to use a good one, which will not waste any of this energy, it being rather poor policy to change the direct current into radio frequency, and then waste the latter in heating up the insulation of a poor condenser. If desired, the builder could use standard .00025 mfd., transmitting condensers, but it is hardly worth while when the smaller ones will suffice.

For the fixed condensers in the grid and plate circuits,  $C_1$  and  $C_3$ , ordinary fixed receiving condensers were used, which gave good satisfaction. A single .001 mfd. condenser was used as a grid feed condenser, while two .004 mfd. con-

densers in series were used in the plate system. The latter combination has a capacity of .002 mfd. but will withstand double the normal voltage of a single condenser which is desirable, as the plate condenser must stand the entire potential of the plate supply, and a breakdown in this unit might cause serious damage to the motor-generator or rectifier supplying the plate power.

The antenna circuit is tuned by the left hand air-condensers, which are visible in the view showing the set from above. It may not be convenient to do all the tuning with this, so an additional loading coil can be included to load the antenna circuit. No details are given for this coil, as the sizes and dimensions of the various antennas are liable to differ greatly in different stations. Also many amateurs wish to work on the harmonics of their antennae, which again precludes the setting down of any fast rule for sizes and dimensions. Occasionally the antenna tuning condenser may be dispensed with, which still further simplifies the operation and construction of the set.

The extreme simplicity, and ease with which it may be made up should appeal to many who have desired to make up a sending equipment, but who fear that their knowledge and skill is not equal to the task. This 15 watt set can be easily built up by anyone who knows how to use a soldering iron and screwdriver, so this need not deter the prospective builder, if he has the skill to use these simple tools.

The range of the transmitter is rather problematical, as is the case with all radio equipment of small power. The

(Continued on Page 62)



# QUERIES and REPLIES



Questions of general interest are published in this department. Questions should be brief, typewritten, or in ink, written on one side of the paper, and should state whether the answer is to be published or personally acknowledged. Where personal answer is desired, a fee of 25c per question, including diagrams, should be sent. If questions require special work, or diagrams, particularly those of factory-built receivers, an extra charge will be made, and correspondents will be notified of the amount of this charge before answer is made.

Please publish a method for testing and adjusting the intermediate stages of a superheterodyne to a pre-determined frequency.—H. W., East Chicago, Indiana.

A diagram showing how to build an oscillator and vacuum tube volt-meter is shown in Fig. 1. The oscillator coil for ordinary

set. The variable resistance should be shunted with a 1 mfd. paper condenser, or better still the condenser should be shunted between the 22 volt binding post on the radio set and the negative A battery lead.

Please give me the circuit of the Penetrola which I desire to use ahead of my

What advantage is there in using copper or brass for shielding a set, as compared with tin plate? Is one metal as satisfactory as the other? If a common tin can with the top removed were used to shield a solenoid coil, would the iron content of the can have any detrimental effect on the operation of the set? Is so-called "tin plate" of the same composition as the metal used in manufacturing the common tin can?—T. D. H., Oakland, California.

Copper has the lowest ohmic resistance and hence makes the best shielding. Brass is less expensive, however, and is the most economical to use. A tin can placed over a solenoid coil is the same as a short-circuited turn of wire and will greatly reduce the efficiency of the coil. It is better to place a copper or brass plate between the coil and other inductances in the set, leaving the shield floating and not connected to ground. A shield such as is placed on the inside of the cabinet to prevent pick-up from nearby local stations may be common tin plate if desired, although brass or copper is better, if cost is no object. Ordinary tin plate is sheet steel or iron, coated with tin. It is the same as is used in manufacturing tin cans.

Please tell me how the B battery eliminator described by Clinton Osborne in March RADIO may be applied to 25 cycle current operation.—C. E., Buffalo, New York.

It will be necessary to use 25 cycle bell ringing transformers to light the filaments of the rectifier tubes. The size of the filter will probably have to be increased by adding an additional 40 henry choke coil and an extra 4 mfd. condenser, making a two-section filter. No other changes would need to be made in the circuit.

I have a five tube neutrodyne and cannot get loud speaker volume on distant stations. Would an extra audio stage help matters?—R. G. S., Vancouver, B. C.

A stage of audio frequency amplification will not increase the distance over which

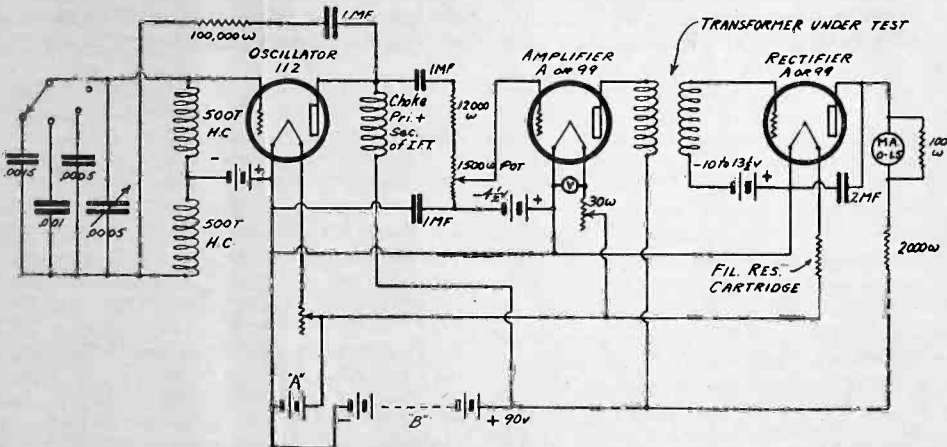

Fig. 1. Circuit for Measuring Superheterodyne Transformers.

intermediate transformers having a range from 25 to 80 kilocycles should consist of two 500 turn honeycomb coils placed in close inductive relation to each other. The galvanometer shown in the plate circuit of the rectifier tube should be a milliammeter having a range of 0 to 1.5 milliamperes. The stabilized oscillator shown is necessary in order to prevent harmonics from making the readings on the galvanometer inaccurate. In measuring intermediate transformers, it is important to use the tube which you intend to use in the actual operation of the superheterodyne in both the input and output circuits. Hence a filament rheostat and voltmeter to control the tube in the input circuit is advisable, as several types of tubes may be used.

Please describe how to connect a "B" battery eliminator to the superheterodyne described in September, 1925 RADIO.—F. D., St. Louis, Mo.

No changes are necessary in the circuit of this particular superheterodyne, for use with the "B" battery eliminator. Practically all "B" eliminators now on the market are equipped with adjustable voltages so that the 22, 45, 90 and 135 volt supply for the set can be obtained from the proper terminals of the "B" eliminator. In case the eliminator is equipped with only three output voltages such as 45, 90 and 135, the necessary 22 volts for the frequency changer tube can be obtained by placing a Bradley-ohm of 10,000 to 25,000 ohms range in series between the 45 volt tap of the eliminator and the 22 volt binding post on the radio

five tube neutrodyne.—R. S. K., Little Rock, Arkansas.

The circuit of the Penetrola is given in Fig. 2. If you wish to construct an amplifier of this type it is important that it be completely shielded. The output coil may be a variocoupler such as the oscillator coupler used in superheterodynes. The input coil may be another coupler of similar nature. It is important that the .5 mfd. bypass condenser be used, as otherwise trouble will surely be had from oscillation.

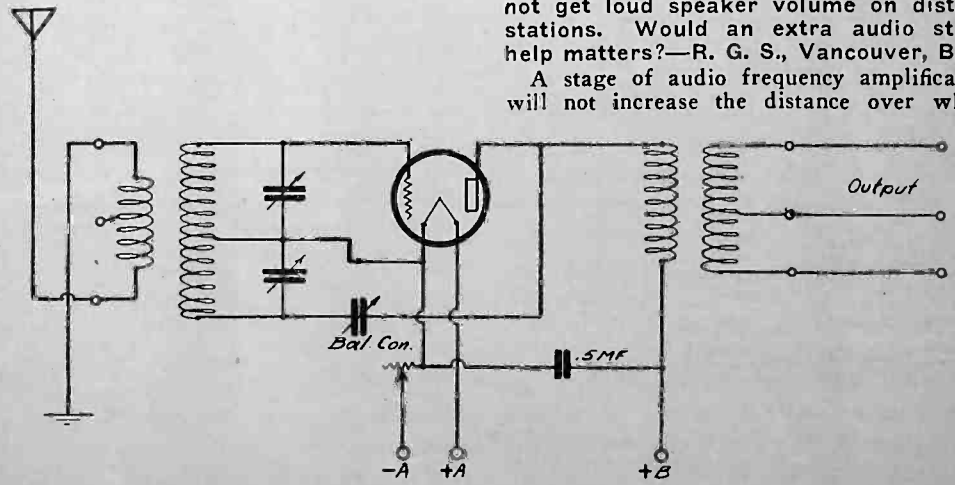

Fig. 2. Wiring Diagram of Penetrola Amplifier.

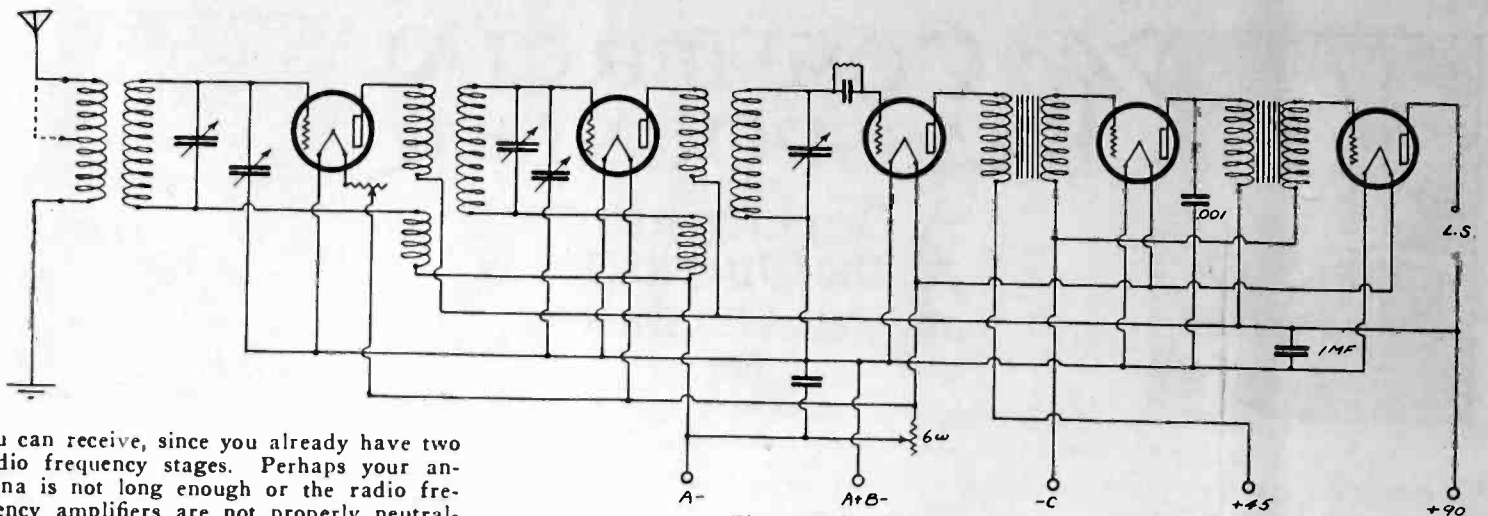

Fig. 3. Circuit of Crosley Type R.F.L. Receiver.

you can receive, since you already have two audio frequency stages. Perhaps your antenna is not long enough or the radio frequency amplifiers are not properly neutralized. Occasionally the range of a neutrodyne can be increased by tuning the antenna circuit. Place a .0005 mfd. variable condenser and a 200 turn honeycomb coil in series between the antenna and the antenna binding post on the set. Tune the antenna condenser until the distant station is heard at a maximum and you may find that the sensitivity of the set has been greatly increased.

What is the circuit of the Crosley R. F. L. receiver?—H. R. C., Cleveland, Ohio.

The circuit of the new Crosley R. F. L. set is shown in Fig. 3.

I have a Raven kit of parts for a superheterodyne and would like to know if I can use this kit in the construction of an Ultradyne.—E. H. G., Milwaukee, Wisconsin.

I see no reason why you cannot use the parts in the Ultradyne circuit. A wiring diagram of the Ultradyne receiver is shown in Fig. 4. This assumes that type "A" tubes are used throughout.

Please tell me how to make the oscillating circuit in my Best eight tube superheterodyne tune properly. How can I use a set of straight line frequency condensers without getting body capacity on the dials.—E. L. H., Tulsa, Okla.

Perhaps the coupling between the grid coupling coil and the oscillator coils is too close. Try rotating the coupling coil to a point near minimum coupling. Your filter transformer may not be sufficiently selective. Perhaps the condenser used to tune it is of the wrong capacity. Try reversing the connections to the condenser as you may have the rotor connected to the grid circuit.

Have built a Best superheterodyne from directions given in September, 1925 RADIO and have not been getting satisfactory distance. Would you recommend shielding or other changes in the circuit?—W. H. P., San Diego, Calif.

As previously explained in these columns an improved volume control for this particular model is now available. Substitute a 50,000 ohm potentiometer such as the Bremer-Tully, Centralab or Royalty in place of the 2000 ohm potentiometer specified in the original article. This will give smoother control of volume particularly on distant stations. Increase the capacity of the grid condenser in the frequency changer tube to .00015 mfd. If a Type "A" tube is used in the frequency changer circuit the grid leak should be not higher than 2 megohms. Shielding the inside of the cabinet will aid in preventing local interference but this should not be necessary in your location.

Would like to add a two-step amplifier to my present 5-tube tuned r.f. receiver. Please show a diagram of how this may be accomplished. When listening in, my set will suddenly break into oscillation, and the rheostat has to be turned back before the oscillations will stop, making the signals too weak. What is the cause of this?—S.Z., Oceanside, Calif.

It would be impracticable to add a two stage r. f. amplifier to your present set, and if the two audio stages already installed in the set are functioning properly, you should obtain ample volume to supply a loud speaker. If you are not satisfied with the volume obtainable at present, the addition of a power tube in the last audio stage will increase the output obtainable, without changes in the set other than to increase the

B and C voltages to 150 and 10½ respectively, when using the UX-CX-112 tube.

Sudden oscillation in a set which normally does not have this trouble may be caused by dirty contacts on the vacuum tube socket springs. A sudden change in resistance in the filament leads, due to corroded contacts, may change the filament current sufficiently to cause the set to oscillate. Sandpaper the prongs of the vacuum tube bases, and the springs of the sockets, to insure perfect contact.

With reference to my 3-tube Roberts circuit, there is a continuous crackling or frying noise. What is the cause of this noise and how may it be eliminated?—J.M.W., Long Beach, Calif.

The answer is the same as for the previous question. It may also be in the battery leads, at the batteries, or at the binding posts on the set, and a general house cleaning of contacts and terminals may entirely eliminate the trouble. There is nothing inherent in the Roberts circuit which would cause such trouble.

I have a motor-driven 8-volt d.c. generator which I use to recharge my radio storage batteries. Is there any system I can employ to recharge storage "B" batteries with this generator set, which charges at from 6 to 20 amperes—F.R.S., Akron, O.

While your generator is rated at 8 volts, it will actually deliver a voltage of much higher value at small loads, as the third brush, which is used for voltage regulation, becomes inoperative as the load falls off, and the voltage of the generator rises. You can safely charge the B battery in 24 volt sections, through a suitable resistance, keeping the current below ½ ampere.

(Continued on Page 41)

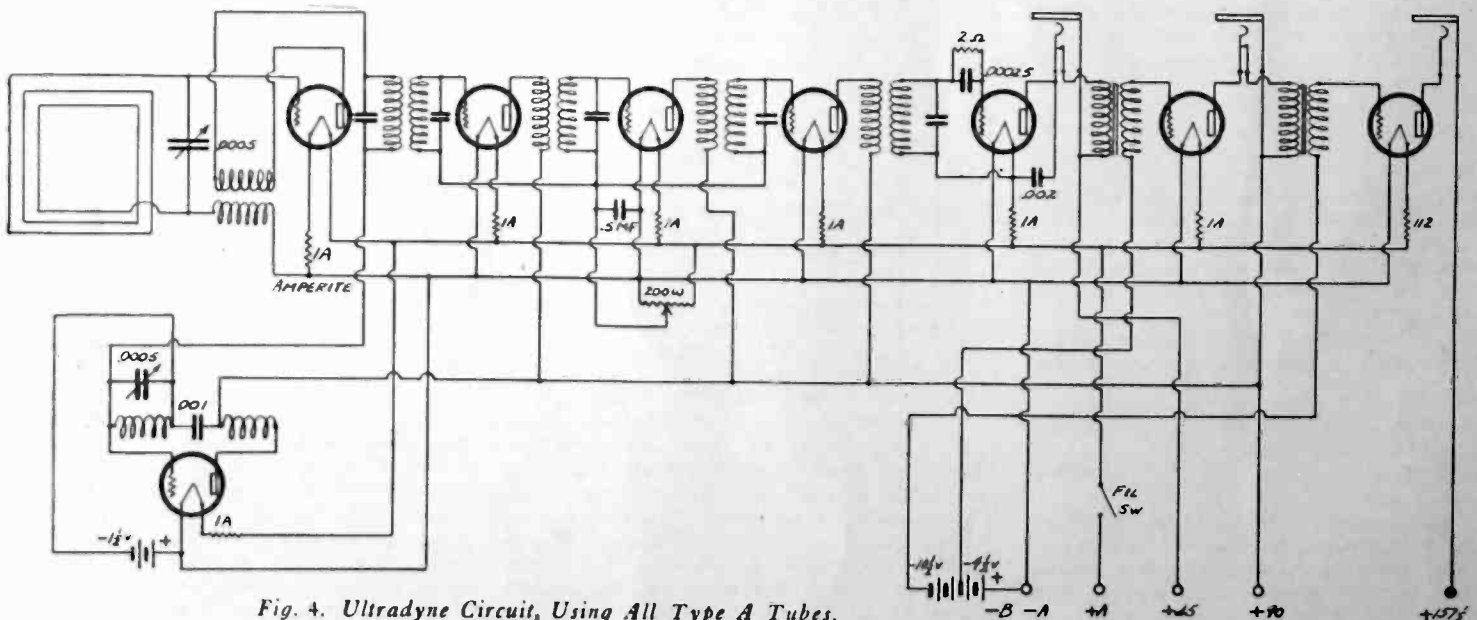
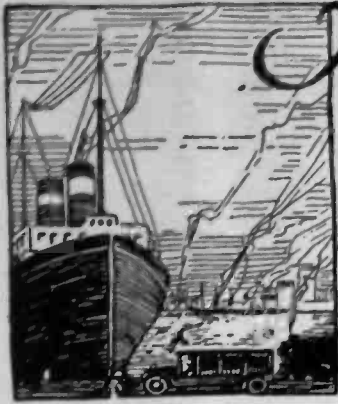
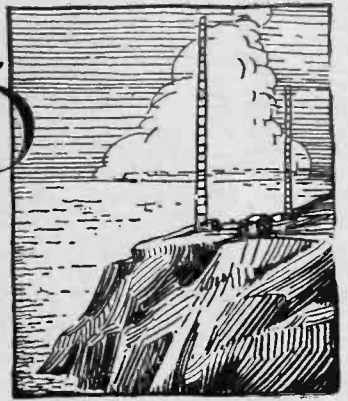

Fig. 4. Ultradyne Circuit, Using All Type A Tubes.



# The COMMERCIAL BRASSPOUNDER

## A Department for the Operator at Sea and Ashore



Edited by P. S. LUCAS

### OM, IT'S UP TO YOU

By R. O. KOCH, Chief, WMW.

**N**O DOUBT, many of you ops noticed that RADIO has decided to give this department a chance to make good, following the purchase of the "Radio Journal." If it does, it will be a permanent feature. If it doesn't— Oh well, we shall be in the same old rut that we have been for years gone by. Right here we have the root of the very thing we have been barking about since the birth of commercial brass-pounding. Here is our golden opportunity. It is up to us to show RADIO that we are going to make it work! If the ops won't support this now, they certainly have nothing to kick about in the future. The weakest point in commercial operating always has been that the operators have nothing in common. Each works and thinks as an individual and hence no one gets anywhere to speak of. One needs only to look at the amateurs to see what beautiful progress they have made as a body, which has only been made possible through the columns of a magazine. Here we have a good magazine with a large circulation that is offering us the same chance to make good. Brass pounding means more to us than pastime,—It is our bread and butter.

While it is true that commercial ops are comparatively poor, I am sure that 'most any one can scrape up the price of a subscription to this worth-while movement through the channels of this magazine. What's more, I am sure that we shall make it go! There are enough of us to put it over big if everyone will help. Unless I miss my guess, the Ed. will sit up and take notice shortly after navigation opens this year on the Great Lakes.

Of course, the first and most important thing is that you subscribe. Don't put it off, do it now! And tell the other ops about this department that may not know about it. Don't forget to send in anything that might be of interest to the gang whether it be stories, pictures, jokes, cartoons, description of new apparatus, circuits, comments, or any similar material. If you are glad to see this department and want to help it, write RADIO a few lines and tell them so. No doubt this department will encourage new advertising of many things that are especially attractive to the commercial op. When they appear, patronize the companies in back of them and tell them you saw the ad in RADIO. No magazine can succeed without advertising.

Now friends of the ether, how about it? Are you going to pass this up? Of course not!!!

Visitor at WMW (BCL): "Gracious, the static is bad this morning."

Operator: "No, that's just WFG calling Chicago."

We are told that WMW, Manitowoc, Wisconsin, is located on the roof of a brewery. Judging from the watch these men stand, it seems that an occasional eye-opener does the trick! No, there are no vacancies.

R. O. KOCH, *Great Lakes Correspondent*

### WEATHER AND QRM

*Any operator who has ever been on a coastwise run, and with a skipper who depended a lot on weather reports for his peace of mind, knows that the writer of this article on operating conditions on the Pacific Coast is right. Improvement in this line is in our own hands, so let's make use of it.*

BY A DESPAIRING COASTWISE OPERATOR

**T**HE other day when time was rather heavy on my hands I dropped into the Static Room of one of the Radio Schools where the prospective operators were allowed to gather and talk with a few of the Old Timers that gather around and had a look, see and listen, to what a few of them had to say. I will tell you boys I got an earfull.

The whole talk seemed to center around weather and unnecessary QRM. There were several Old Timers ashore and they all seemed to have about the same complaint: that there is too much unnecessary QRM going on during the weather periods. There are some points I would like to bring to light and see if conditions cannot be improved.

After listening to a few of the remarks that passed back and forth for an afternoon I hiked me back to my job and made a trip up the coast just to see how bad conditions were. I heard plenty in the Static Room and I heard plenty more when I was on the air again.

First it was the weather. Did you ever stop to think that WWBU weather can be copied very readily any time of the day or night from south of San Francisco if the rest of the gang would only keep quiet. KZZZ is very much more QSA off Point Arguello and will just blow it all to pieces if he happens to get a bright idea to call KOK or KSE, QTC Nil. If he would only wait a few minutes then he wouldn't interfere with any one but,— The air will become still a few minutes before 12 or 4 P. M. and, "Now is my chance, I can raise that guy now," and bang, in he comes, calls two or three times between 2 minutes to 12 and 5 minutes after, raises his party and all he has to say is QTC? Nil. Then every one on the coast has to have the weather relayed to him from Blunts Reef to Point Arguello. About 10 minutes later you will hear this same bird come on again and ask for the weather he has broken up and have to have it relayed to him. Things like this are uncalled for. There is no necessity for it. In the first place there isn't any need of that QTC?—Nil business any way. Listen in and you will get all that is coming your way. I have kept track of some operators and heard them clear two different stations every two hours all day and part of the night. They think they are good. They are.

Returning to the weather again. Blunts Reef can be readily copied from San Francisco and all light ships can be copied from Blunts Reef. The operator there once said

he could hear all the other light ships and I thought he was kidding until I overhauled my receiver and found it was no trick at all if the air was reasonably clear.

San Francisco light vessel WWBV can be heard and copied north of Cape Blanco or rather at Cape Blanco at noon. I have done it. I don't carry a super-het with me, either.

November 15, 1924, by special order of the Lighthouse Department Blunts Reef and San Francisco light vessels stopped the 4 P. M. QST. Then followed month after month of QRM from operators who were either dead from the neck up or restless for something to do. Asking for those two weather reports. Tell them that they were discontinued and they would ask you for them again the next day. Blunts Reef started giving the 4 P. M. report again August 1st last year. Eight months of QRM and bone-headedness.

Now about TRs. Have you orders from your Radio Company to clear through every station on the coast or just one station? I think just one station, if you will look it up. All coastal stations give their TRs to the Marine Exchange. Seattle has a land wire connection for that purpose, KEK sends his down on an arc or did because I have copied them, KOK and KSE forward also to San Francisco and then they are redistributed again so that all newspapers have them if they care to print them. Therefore, what is the use of sending them to three different stations?

Another guy I would like to hand the business end of 20,000 volts to is the fellow that comes in with the station call he wants to work and sends it twenty times, then about 10 V's, signs off with his own call 16 times and without stopping to listen to see if he has raised his man repeats the mixture. Three good minutes all gone to waste. Listen in some time and hear him. Calling KPH. And in the meantime KPH has tuned him out and gone merrily on about his business. But you can't. Your receiver isn't built that way.

That way of calling may be all right on an arc trying to work San Francisco from South Africa but it has no place on the air on a 600 meter spark set 200 miles from a land station and half a mile from some other ship that has a receiver that he can hear things with.

I was coming up the coast with a fellow of that style about ten miles astern of me the whole way. In the evening (we were about 200 miles from Portland), he called and sent his TR into Portland about 6 P. M. When it got dark he could hear KPH working so he started calling KPH. After about 45 minutes he got the Ga signal and sent the same TR into San Francisco. A little before 8 P. M. KOK commenced to come through and he starts off again, calling anywhere from ten to twenty times, sending V about ten times and signing off with an even dozen. He sent his TR into KOK. KEK couldn't shut him up and neither could I. When he started in on Seattle, KPE, I

told him to break and get off the air but ND.

With KPE, KFT and VAE still to work I shut down and went to bed. If I had listened a little longer I might have jumped overboard and I didn't want to take any unnecessary chances with my health and sanity. Don't be a Ham on the air. In looking through last month's reports I find that my TR was cleared every night within 3 minutes of the same time. And that was without any pre-arranged schedule. I cleared the nearest coastal station as quickly as possible. You can do the same. You don't send a paid message to but one station so why load the Marine Exchange down with paying for the same TR three times. The other night I was close to Seattle and heard him OK a string of TRs. Three of them were from ships bound into Seattle who were between San Francisco and San Pedro. Three others were from ships bound between San Pedro and San Francisco. One of these was like this: "SS So and So San Francisco for San Pedro 27 miles from San Pedro." OKed at Seattle. What is the matter? Were both KOK and KSE out of commission? I think hardly, or even busy. I will bet that that whole string of TRs were OK at KSE or KOK, KPH or KFS and maybe both of those places before KPE ever heard the station sending them.

Some of the American amateurs listen in on 600 meters and when you start to talk to one of them they will tell you plenty. Let's take our jobs a bit more seriously and quit being the kid aboard ship. You won't have near so much trouble and will be better respected by every one from the Old Man down.

Just a word to the Coastal Station operator. At 8 P. M., lay off a few minutes. A ship may be 1000 miles from you and only 100 miles from the station sending weather but you will be a lot more QSA in his receivers than what he is trying to copy. Give him a chance. You are on 706 but he hasn't a receiver that will cut very fine. Also don't start some bird with about 15 messages to send at 5 minutes to eight. You can't break him and he doesn't give a hang for weather when he is 500 miles off shore and getting farther every minute. His two kilowatts make the half kilowatt on the light ship sound like a buzzer.

The weather QRM can be cleared up and should be. If we don't clear it up they may take it away from us altogether or get operators that will keep the air clean.

## WHO'S WHO AND WHERE

The operator on the Lighthouse Tender Hyacinth is now Peter Reiss, ex-KFEI. Boy, he sure fixed up the note on WWDK!

Our old friend Rourke, who was formerly on WWDK is now at Chicago attending an electrical school.

George D. Fell has just taken the S.S. *Olinda*, of the Union Oil Company of Canada, to Vancouver where a regularly licensed Canadian operator relieved him on her trip to Alaskan and Canadian waters.

The S.S. *Coalinga* is just completing blow-down operations. She will soon resume her regular run to Anafagasta, Tal-Tal and other South American ports. She will be manned by Alex Kempfert.

F. L. Dewey, the man who puts 'em on the Federal boats around Los Angeles, has been spending his time working some real DX on 40 meters. He was worked Australia, South America and all of them, and claims his 7½ watts has KOK backed off the map.

## ORIENTAL RADIO NOTES

*This month we are running the second part of L. O. Doran's Oriental Schedules. These ought to be kept together, for no operator knows how soon he may find them valuable. If you didn't get a copy of the April Issue of RADIO, better write for one now, while they are still available.*

*And by the way, if YOU have any skeds jotted down on the bulkhead, why not follow Doran's example and let the rest of us get the benefit of them?*

### JAPANESE WEATHER CODES—Part II. By L. O. DORAN

DAILY weather reports are made from the ships to the coast stations at 6 a.m., noon and 6 p.m. 19 figures are sent without a break and are preceded by the prefix "MS" and the preamble in the Japanese code. To translate, the figures are separated into 10 groups as follows:

"08 18 127 31 2947 03 8 3 6 3"

#### Groups—

- 1st. Date, 08-8th, 16-16th, etc.
- 2nd. Hour, 06-6AM., etc.
- 3rd. Longitude, East.
- 4th. Latitude, North.
- 5th. Barometer in inches.

6th	7th	8th
Wind Direction	Wind Force	State of Weather
00 Calm	Beaufort Scale,	0 Clear.
01 NNE. 09 SSW.		1 Fine.
02 NE. 10 SW.	0 to 9	2 Cloudy.
03 ENE. 11 WSW.	Figure 9	3 Rain.
04 E. 12 W.	used for any	4 Snow.
05 ESE. 13 WNW.	force above	5 Fog.
06 SE. 14 NW.	that.	6 Thunder-Storm.
07 SSE. 15 NNW.		7 Haze.
08 S. 16 N.		

9th	10th
State of the Sea	Direction of Swell
0 Smooth as glass.	0 No swell.
1 Calm.	1 NE.
2 Small sea.	2 E.
3 Slightly disturbed.	3 SE.
4 Moderately rough.	4 S.
5 Rough.	5 SW.
6 Very high.	6 W.
7 Violent.	7 NW.
	8 N.

Example of Japanese ship weather report and translation:

08 18 127 31 2947 03 8 3 6 3  
"8th, 6PM, Longitude 127 East, Latitude 31 North, Barometer 29.47, Wind ENE force 8, Rain, Very high sea, SE swell."

### WARNINGS GIVEN BY JAPANESE COAST STATIONS

Form "A", Typhoon and Depression Warning.

Sixteen figures are sent without a break. The figures are divided into seven groups which translate as follows:

2 18 12 135 32 2945 14

#### Groups:

- 1st.—Depression.
- 2.—Typhoon.
- 2nd. Date.
- 3rd. Hour.
- 4th. Longitude, East.
- 5th. Latitude, North.
- 6th. Depth in inches.
- 7th. Direction of motion.

The figures of Group 7 translate according to the code given in the Ship Reports for Wind Direction except that in these Warnings, the figures 00 mean "Direction unknown."

The example above would translate as follows: "Typhoon, 18th, Noon, Long. 135 E, Lat. 32N, depth 29.45, moving Northwest." Form "B", Weather Warnings.

Three figures are sent which translate according to the tables below. Several of these three figure groups may be combined and sent as a single group without a break.

1st Figure.	Location of Disturbance.
1	Yellow Sea.
2	Eastern Sea.
3	Japan Sea.

- 4 North Japan Sea.
- 5 Eastern Sea of Japan.
- 6 Southern Sea of Japan.
- 7 Southeast of Japan.
- 8 Near Formosa.
- 9 North coast of China.
- 0 South coast of China.

#### 2nd Figure.

Nature of Disturbance.

- 1 Strong NE wind will blow.
- 2 Strong E wind will blow.
- 3 Strong SE wind will blow.
- 4 Strong S wind will blow.
- 5 Strong SW wind will blow.
- 6 Strong W wind will blow.
- 7 Strong NW wind will blow.
- 8 Strong N wind will blow.
- 9 It threatens to form a storm.
- 0 It threatens to form a heavy snow-storm.

#### 3rd Figure. Remarks.

- 0 No remarks.
- 1 Will rage.
- 2 Wind expected to slack tomorrow.
- 3 Wind will continue to blow tomorrow.
- 4 Strong winds but fine weather expected.

## INDO CHINA WEATHER REPORTS.

### No. 1.

This report is sent in French and gives average weather conditions for the past 24 hours at various points on the coast between Hong Kong and Cape St. James. The data are compiled by the Phulien Observatory, near Haiphong, Tonking, with filing time 4 PM and is made up as follows:

1st. Barometer readings. Given in figures for Hong Kong, Phulien and Cape St. James, and whether rising, falling or stationary at other reporting stations.

2nd. Wind direction and force.

3rd. State of the weather.

4th. Temperature. Centigrade scale.

5th. State of the sea.

The data are sent in this order for each reporting station, a list of these stations being given in the translation tables.

### No. 2.

This report gives observations taken at 6 AM. It is composed of four groups of figures, seven figures in each group except the last. Each group represents observations taken at stations as follows:

#### Groups:

- 1st. Phulien, near Haiphong, Tonking.
- 2nd. Cape Tientcha, mouth of Tourane harbor.
- 3rd. Cape St. James, entrance to Saigon river.
- 4th. Fort Bayard, Kwang Chow Wan.

The first three figures of each group represent barometer readings, expressed in tens, units and tenths millimeters. The figure for hundreds is 7 in all cases and is omitted; thus, 547 equals 754.7 millimeters.

The fourth and fifth figures indicate wind direction and the 6th figure, wind force, Beaufort scale 0 to 9.

The seventh figure indicates the state of the sea and is omitted from the last group.

When the observations of any particular station are missing, the entire group for that station is replaced by zeros.

## INDO CHINA WEATHER REPORT TRANSLATION TABLES

Barometer readings in millimeters. To convert to inches, multiply the reading in millimeters by .03937.

Temperature in Centigrade Scale. To convert to Fahrenheit Scale, multiply the Centigrade reading by 9, divide by 5 and add 32.

Stations in No. 1.	Wind Directions.
Hong Kong.	00 Calm.
Fort Bayard.	02 NNE. 18 SSW.
Phulien.	04 NE. 20 SW.
North Gulf Tonkin.	06 ENE. 22 WSW.



South Gulf Tonkin.	08 E.	24 W.
Cape Tientcha-	10 ESE.	26 WNW.
Tourane.	12 SE.	28 NW.
Cape Varella.	14 SSE.	30 NNW.
Cape Padaran.	16 S.	32 N.
Cape St. James.		

State of the Sea.	
0 Calm.	5 Rough.
1 Very smooth.	6 Very rough.
2 Smooth.	7 High.
3 Slightly disturbed.	8 Very high.
4 Moderate.	9 Violent.

Words Commonly Used in Report No. 1,	
Agite—disturbed.	Forte—strong.
Assez—rather, generally.	Grosse—large, great.
Baisse—fall.	Hausse—rise.
Beau—fine, fair.	Houleuse—swell.
Belle—calm.	Inconnu—unknown.
Brouillard—fog, mist.	Legere—slight.
Brunier—drizzle.	Nord—North.
Brumeux—fog, haze.	Nuageux—cloudy.
Cap—Cape.	Ouest—West.
Couvert—overcast.	Peu—little, small.
Est—East.	Pluie—rain.
Faible—weak, faint.	Sud—South.
	Tres—very.

### INDO CHINA TYPHOON WARNING CODE

Example: "Obs de Phulien le 4 a 17 h 45 typhon signalez 1521246."

The date is indicated by "le," the hour by "a" and the minutes by "h". The first two figures of the code group indicate Latitude North; the third and fourth figures indicate Longitude East with the first figure, which is always "1" omitted; thus, 21 equals 121. The fifth and sixth figures indicate Direction or Condition according to Tables 1 or 2. The seventh figure indicates the radius of a circle within which the center of the typhoon may be and also indicates the Intensity according to Table 3.

Table 1. Direction.	Table 2. Condition.
Same as code	51 Forming.
given for Wind	52 Two centers.
Direction	53 Direction unknown.
on preceding	54 Stationary or very
page.	slow.
	56 Recurring.
	58 Filling up.

Table 3. Radius and Intensity.

Radius of circle in miles—	Code.	Intensity.
120.....	1	Unknown.
120.....	2	Severe.
60.....	3	Unknown.
60.....	4	Severe.
	5	Deepening.
30.....	6	Unknown.
30.....	7	Severe.
	8	Exceptional Velocity.
	9	Continental depression.
	0	Position Uncertain.

Translation of example: "4th 5:45 PM, Typhoon of unknown intensity within 30 miles of Latitude 15 North, Longitude 121 East, moving West."

(The Third and last installment of 'Oriental Radio Notes' will appear in the June issue of RADIO.)

George Evans is now chief of the S.S. *Yale* vice F. W. Bevitt, who is getting his feet dry for a change.

Hamlet Loftfield is taking Alex Kempfert's place as second on the *Yale*.

Leo Shapiro, after holding down a berth on the S.S. *Los Angeles* for almost a year, is now being heard on the *La Brea*, the ship that holds the record of working KFS from the English Channel, or a distance of 6817 miles. And now they've gone and given her a new generator, and a lot of new equipment.

## SPECIAL RADIO SIGNAL TRANSMISSIONS OF STANDARD FREQUENCY

The Bureau of Standards transmits, twice a month, radio signals of definitely announced frequencies, for use by the public in standardizing frequency meters (wave-meters) and transmitting and receiving apparatus. The signals are transmitted from the Bureau Station WWV, Washington, D. C., and from station 6XBM, Stanford University, California.

The transmissions are by continuous-wave radio telegraphy. The signals have a slight modulation of high pitch which aids in their identification. A complete frequency transmission includes a "general call," a "standard frequency signal," and "announcements." The "general call" is given at the beginning of the 8-minute period and continues for about 2 minutes. This includes a statement of the frequency. The "standard frequency signal" is a series of very long dashes with the call letter (WWV or 6XBM) intervening. This signal continues for about 4 minutes. The "announcements" are on the same frequency as the "Standard frequency signal" just transmitted and contain a statement of the frequency. An announcement of the next frequency to be transmitted is then given. There is then a 4-minute interval while the transmitting set is adjusted for the next frequency.

The signals can be heard and utilized by stations equipped for continuous-wave reception at distance within about 500 to 1,000 miles from the transmitting stations. Information on how to receive and utilize the signals is given in Bureau of Standards Letter Circular No. 171, which may be obtained on application from the Bureau of Standards, Washington, D. C. Even though only a few points are received, persons can obtain as complete a frequency meter calibration as desired by the method of generator harmonics, information on which is given in the Letter Circular.

The schedule of standard frequency signals from both the Bureau of Standards and Stanford University, is as follows:

	Schedule of Frequencies in Kilocycles					
	(Approximate wavelengths in meters in parentheses)					
*Time	April 5	April 20	May 5	May 20	June 5	June 21
10:00 to	3000	125	300	550	1500	3000
10:08 p.m.	(100)	(2400)	(1000)	(545)	(200)	(100)
10:12 to	3300	133	315	630	1650	3300
10:20 p.m.	(91)	(2254)	(952)	(476)	(182)	(91)
10:24 to	3600	143	345	730	1800	3600
10:32 p.m.	(83)	(2097)	(869)	(411)	(167)	(83)
10:36 to	4000	155	375	850	2000	4000
10:44 p.m.	(75)	(1934)	(800)	(353)	(150)	(75)
10:48 to	4400	166.5	425	980	2200	4400
10:56 p.m.	(68)	(1800)	(705)	(306)	(136)	(68)
11:00 to	4900	205	500	1130	2450	4900
11:08 p.m.	(61)	(1463)	(600)	(265)	(122)	(61)
11:12 to	5400	260	600	1300	2700	5400
11:20 p.m.	(55)	(1153)	(500)	(231)	(111)	(55)
11:24 to	6000	315	666	1500	3000	6000
11:32 p.m.	(50)	(952)	(450)	(200)	(100)	(50)

\*Eastern standard time for WWV, Washington, D. C.; Pacific standard time for 6XBM, California.

Doyle C. Tandy, formerly chief operator at the Edison Station at Big Creek, is out on the *Washtenaw*, a tanker recently purchased from the Union Oil Co. by the California Petroleum.

## QUERIES AND REPLIES

(Continued from Page 38)

Kindly show me the equation necessary for figuring the resistance required to drop the voltage of a "B" eliminator from 250 to 18 volts. The circuit is to carry 60 milliamperes.—R. J. H., San Francisco, Calif.

The formula necessary is the familiar Ohm's Law in which  $E$  equals  $IR$ , where  $E$  is the voltage,  $I$  is the current and  $R$  is the resistance. Subtract 18 from 250 and you have the voltage drop which the resistance is required to produce, or 232 volts. Substituting in the formula,  $232$  equals  $.06R$ . Divide .06 into 232 and the answer is 3866 ohms.

I have been having considerable trouble from noise due to a small electric lighting plant located in a building quite close to my antenna. The lighting plant generates 110 volt d. c. and supplies several neighboring farm houses with electricity. How can this buzzing sound be eliminated?—E. C. S., Daytonville, California.

A diagram showing a suggested filter to be placed next to the motor generator is shown in Fig. 5. The filter should be placed in the direct current supply leads coming from the generator and the choke coil should be connected in the positive wire. The choke should contain at least 200 turns wound on a 4 in. tube and wound with wire heavy enough to carry the current. As a suggestion No. 6 or 8 B&S ought to be about the right size. This will make a rather large inductance but it is necessary due to the large amount of current probably being carried by the line. The paper condensers should be connected in series with a 1 or 2 ohm filament rheostat in order to prevent the formation of a welding spark on the commutator of the generator due to the condenser action. It is important to remember that unless the filter is placed directly at the output of the generator it will be of no use in eliminating the interference.

I have built a short-wave regenerative receiver and am having a great deal of trouble due to howling when tuning down to the silent point just prior to the cessation of oscillation. What can I do to cure this trouble.—A. H. B., Berkeley, Calif.

This sort of trouble is usually caused by interference by the oscillating detector tube with the audio frequency circuit. A 75 turn honeycomb coil or other similar type of radio frequency choke placed in the plate circuit of the detector between the B battery side of the tickler and the primary of the audio transformer ought to cure this trouble. One side of the tuning condenser in the plate circuit should be connected between the choke coil and the tickler coil, the other side going to the positive filament.

It is preferable to connect the rotor of the condenser to the filament, in order to eliminate body capacity effects. With condensers having metal-faced vernier dials this is particularly important. Condensers equipped with insulated shafts and a double rotor do not come under this rule.

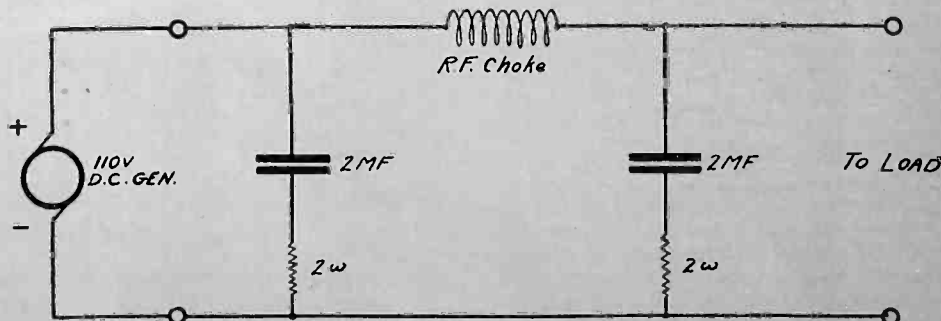

Fig. 5. Filter for Reducing Interference From D. C. Generator.

# Parallel Operation of Tubes

By G. F. Lampkin, 8ALK, "FO"-8CAU

**A**N ARTICLE on parallel operation of power tubes was published in QST some time ago, which gave data and explanation to show that the output, at radio frequencies, of paralleled power tubes was not the same per tube as for a single tube. That is, tubes operating in parallel did not give outputs proportional to the number of tubes. These results were obtained with a conductively-coupled Hartley circuit. This writing, backed by experimental work, is intended to show that, under certain conditions, outputs from paralleled tubes, proportional to the number of tubes, can very easily be obtained. With the output, or load circuit, coupled to the oscillator, this result is the rule rather than the exception.

In Fig. 1 is the circuit used in obtaining the experimental data; the ever-useful Hartley, with coupled load circuit. The electrical and physical dimensions of the circuit are given in order that comparisons or explanations may be made if desired. The

The coupled load circuit comprised a helix, exactly similar to that of the oscillator, a condenser, thermo-couple meter, and resistance. The resistance was nichrome wire, 3.5 ohms per foot, stretched into the three sides of a loop approximately  $2 \times 3\frac{1}{2}$  feet. The total radio-frequency resistance of the load circuit was 40 ohms. The coupling between the load and oscillator circuits was the same for all runs, at 3 in. This coupling was adjusted at the start to a point where the oscillator was perfectly stable, with the circuits in resonance.

Perhaps the most important feature in parallel operation of the tubes was the placement of the sockets, which determined the lengths of the various grid and plate leads. All grid leads should have exactly the same length, as should all plate leads. This was accomplished by symmetrical arrangement of the sockets in a circle, with plate and grid terminals on the inside. Each terminal was connected to the one diametrically opposite;

the grid jumpers going horizontally across, the plate jumpers going up, over, and down, to clear the grid wires. Thus, there were two sets of jumpers, each set bunching at the center of the circle, where the respective grid and plate leads were taken off. This arrangement automatically takes care of the length of leads. Six 5-watt tubes, using this arrangement, have been worked together in parallel, perfectly, at 80 meters; as have four 50-watt tubes at 40 meters. There was no unbalancing of loads, as judged by the relative temperatures of the tube plates.

With the circuit set up as described, the first step was to determine the adjustments for maximum output, with any given number of tubes. Only two factors were considered in making these adjustments for maximum output—grid excitation, and grid-leak resistance. Runs were also taken with varying plate voltage, but the object in these was to determine how the output power varied with plate voltage, rather than to find the optimum value of plate voltage. For all tests, the tube filament voltage was kept constant at 7.5 volts, and for the adjustment tests the plate voltage was 500. At each reading, the filament and plate voltages, and the wavelength, were checked, and plate current and radio-frequency load current were read. Output power was figured as the square of the radio-frequency current times 40, the load circuit resistance; input power was plate voltage times plate current; and efficiency was output divided by input.

In the grid excitation tests, the filament clip was moved toward the grid clip, until the circuit refused to oscillate. Then it was moved back, one turn at a time, with readings at each point, until the plate current reached a maximum safe value. In a

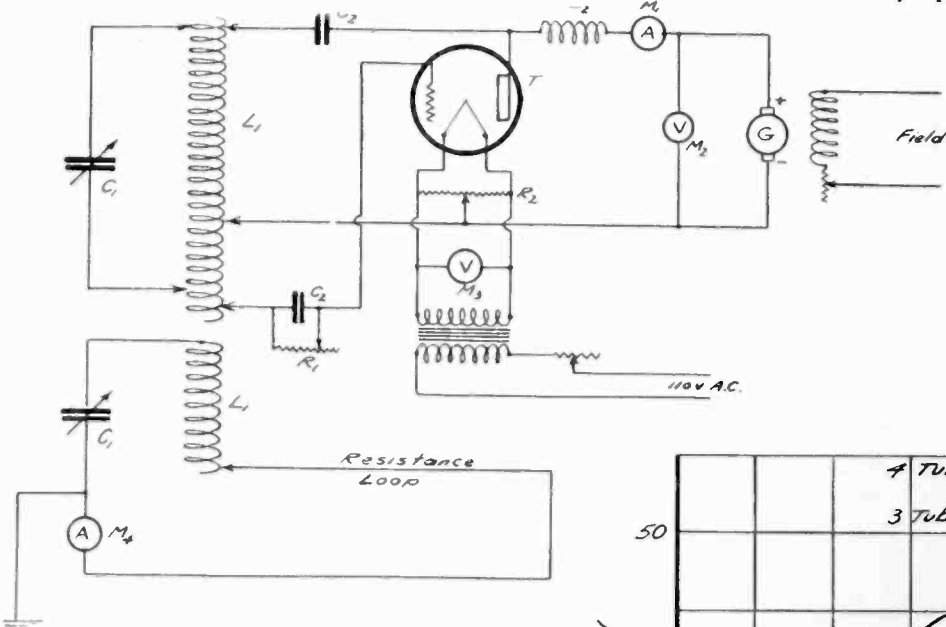

Fig. 1. Experimental Hartley Set-up.

- $C_1$ —.0005 mf. Cardwell.
- $L_1$ —10 turns  $\frac{1}{8}$ " Copper tubing, 4" dia. x 7".
- $C_2$ —.002 mf. Mica blocking.
- $L_2$ —150 turns No. 24 DCC on  $2\frac{1}{2}$ " tube.
- $R_1$ —Five 5000 ohm Ward-Leonard resistors.
- $R_2$ —40 ohm center-tap resistor.
- $M_1$ —Keystone 0-500 mil ammeter.
- $M_2$ —Jewell 0-750 DC voltmeter.
- $M_3$ —Jewell 0-15 AC voltmeter.
- $M_4$ —Jewell 0-1.5 RF ammeter.
- T—One to four Roice 202 tubes.
- G—800-volt DC generator.

tubes used were Roice 202 five-watters, rated at 7.5 volts filament and 350 plate voltage. Each tube was tested individually in the oscillating circuit, to make certain that each gave approximately equal radio-frequency outputs. The primary condenser clips were placed on the same turns as the plate and grid clips from the tubes; these clips included the total ten turns of the helix. The tests were all run at a wavelength of 80 meters (3750 kc.). The primary condenser setting for this wavelength was approximately 40. It varied slightly with the position of the filament clip, and, of course, with the number of tubes being used. The grid leak was made of five 5000-ohm resistors, taped into a bundle, with the taps available to vary the resistance, by means of a clip.

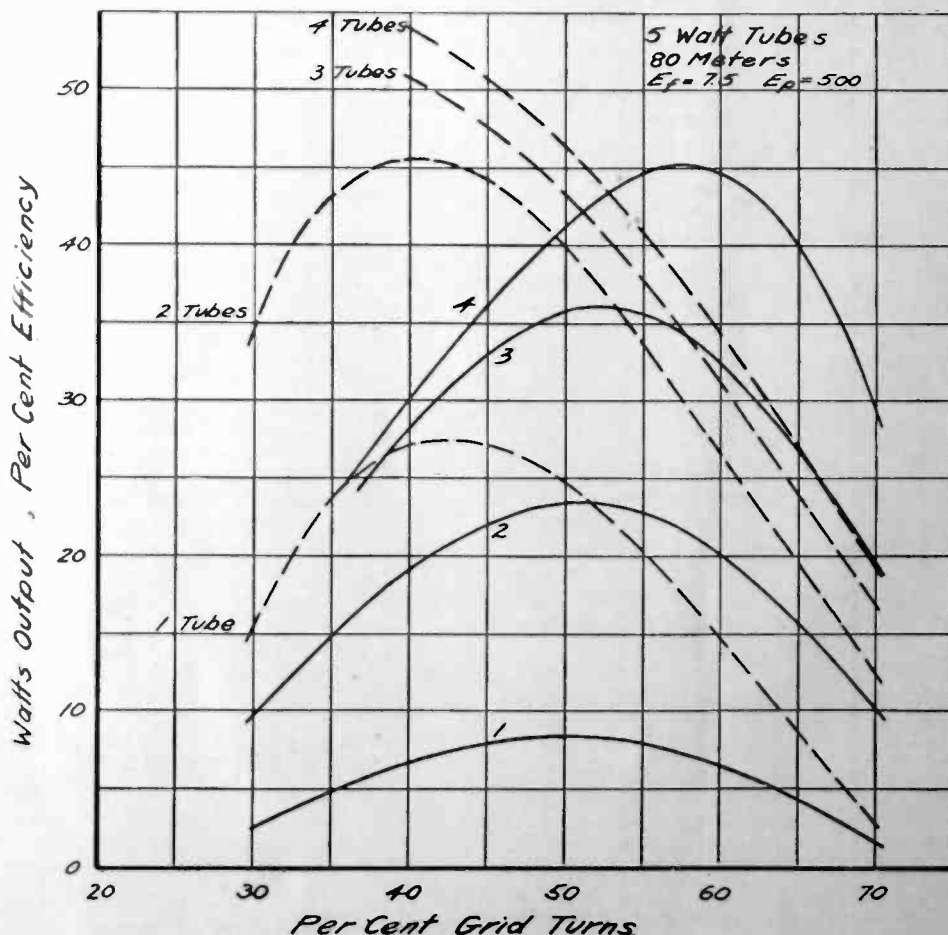

Fig. 2. Adjustments of Grid Excitation for Maximum Output.

Hartley circuit, other adjustments remaining the same, the plate current increases steadily as the filament clip is moved toward the plate clip. The readings were made with one tube, and with two, three, and four tubes in parallel. The grid leak was adjusted to 15,000 ohms for one tube, 10,000 ohms for two tubes, and 5,000 ohms for three and four tubes. The outputs and efficiencies were calculated, and plotted against the per cent grid turns of the total helix turns. Per cent grid turns were used to make the curves general for any helix. The curves are shown in Fig. 2. For one tube, maximum output is obtained with the grid turns, from grid clip to filament clip, equal to 50% of the total helix turns. This value changes gradually, with the number of tubes in parallel, until, with four tubes, maximum output is had with 58% grid turns. The adjustment becomes more critical with increasing number of tubes, but at no point is it overly so. The output curves are drawn solid, in the figure.

The dotted curves of the figure picture how the overall efficiency varies with the grid excitation, and with the number of tubes in parallel. The highest efficiencies are had with less grid turns than are necessary for the highest outputs. The efficiency of a transmitter does not matter much to an amateur, and naturally so. What is desired is maximum, steady, output, and as long as tube plates do not melt, and the electric bill does not go too high, the efficiency is unimportant.

Again, in the curves of Fig. 3—outputs and efficiencies against grid-leak resistance, the efficiencies are unimportant. The outputs increase with decreasing values of grid leak, and its best value would seem to be zero. However, there is a lower limit to the resistance value, which is set by the maximum safe plate current. Decreasing the value below this limit would overload the tube. So for any given set of conditions—plate voltage, filament voltage, filament-clip setting, etc.—the grid-leak, if adjustable, should be varied until the desired plate cur-

rent is drawn. Otherwise, approximate values of leak resistances are 15,000 ohms for one tube, 10,000 for two, and 5,000 for three and four five-watt tubes.

From the curves of Fig. 2 were plotted those of Fig. 4. These latter curves tell the tale about operation of tubes in parallel. If the output of paralleled tubes were exactly proportional to the number of tubes, the output curve would follow the light dotted

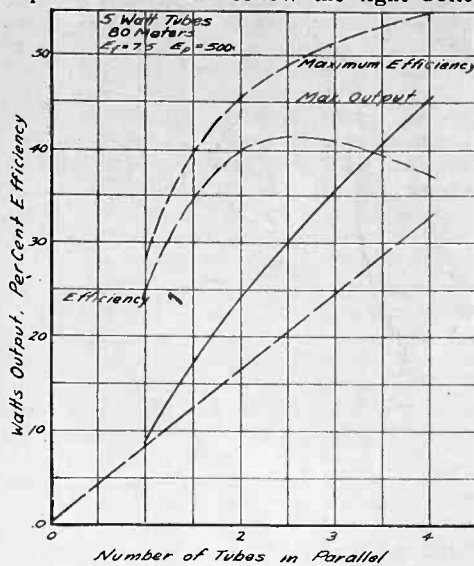

Fig. 4. Relation of Output to Number of Tubes in Parallel.

line through the origin. If less than proportional, the curve would fall below; and if more than proportional it would come above—as it does. For one tube, the maximum output was 8.1 watts. If proportional outputs were secured, four tubes should have given  $4 \times 8.1$ , or 32.4 watts, where they actually gave 45.3 watts. The reason lies in the increased efficiency obtained with more than one tube. With the circuit, and the conditions of the test, the efficiency was greater with four tubes than with one. It would no doubt be so for other circuits and conditions. The efficiencies spoken of are those

which resulted at adjustments for maximum output, and are shown by the heavy dotted curve; so that a final limit would be had, above which it would not be advisable to go. As noted before, maximum efficiency is not had at the adjustment for maximum output. The light dotted curve of maximum efficiency shows that efficiency can be made to increase with increasing number of tubes, if such were the thing desired.

The graphical data of Fig. 5 shows that it is best, with any number of tubes, to work

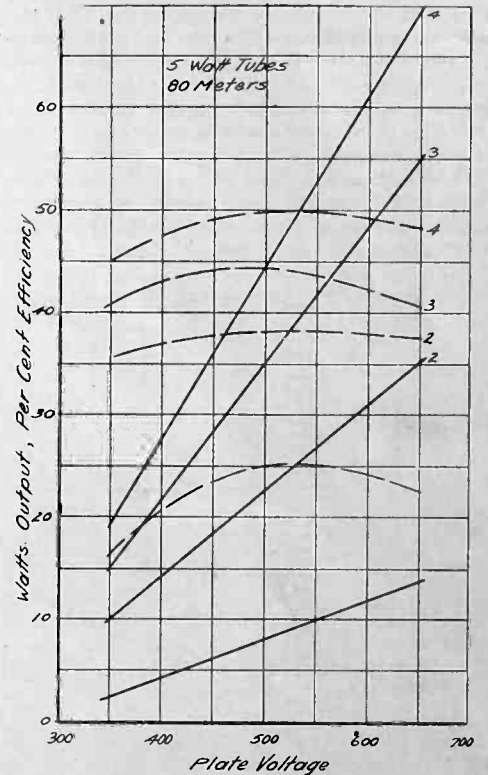

Fig. 5. Relation of Plate Voltage to Output.

at as high a plate voltage as possible, the limitations, of course, being the insulation of the tube, and the maximum safe plate current. The output, with other factors constant, increases linearly with plate voltage, and faster than proportional. Thus, with two tubes, an output of approximately 10 watts is had at 350 volts. This output doubles, not at 700 volts, but at 470 volts. At 700 volts the output is 35 watts. The efficiency is, as usual, unimportant; and even more so, in this case, for it is practically constant at all values of plate voltage.

In a conductively-coupled Hartley circuit, the capacities of the tubes are in parallel with the load, or antenna, capacity. The circuit is represented schematically in Fig. 6. It may be noted that the grid-plate capacity of the tube is directly in parallel

(Continued on Page 63)

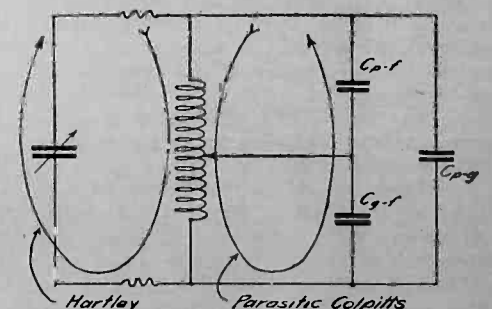

Fig. 6. Capacity Relations in Circuit.

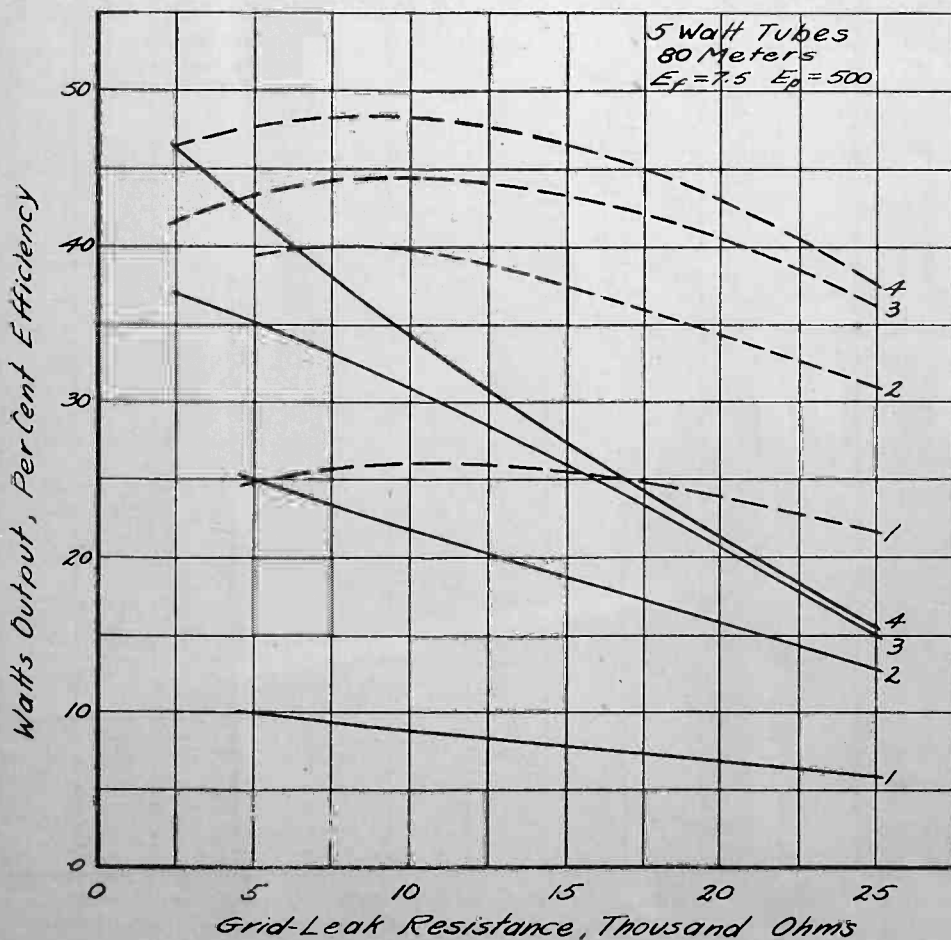

Fig. 3. Grid Leak Adjustments for Maximum Output.

# Short Wave Receiver at 6XAO

By G. M. Best

THE receiver used in conjunction with the transmitter at 6XAO, as described in March RADIO is a simplified form of the regenerative circuit with one stage of a.f. amplification. The tuner, two sockets, audio transformer and miscellaneous resistances and terminals are mounted on a bakelite shelf supported by bracket attached to the panel. The panel supports the two variable condensers, detector filament rheostat, filament switch and output jack. As is shown in Fig. 1, the detector is connected to a tuned circuit consisting of a fixed primary, which may be loosely coupled to the secondary, but not varied in inductance, a plug-in type secondary coil, and a fixed tickler, which is wound on the same form with the secondary, and is automatically connected in the circuit when the connections for the secondary are made.

A set of the newest Bremer-Tully inductances were used, with a mounting plate which supports both the secondary-tickler coil, and the fixed primary, so that the receiver has a wavelength range of from 10 to 200 meters, with four coils. The following table gives the number of turns for the secondary and tickler coils, which are all wound on a 3-in. diameter form,  $1\frac{3}{4}$  in. long.

Wavelength Range	Secondary Turns	Tickler Turns
10-30	3	2
25-50	6	3
45-100	15	6
75-200	30	9

The secondary coils are wound with No. 18 bare copper wire, except the 75-200 meter coil, which is wound with No. 26 silk covered wire. The tickler coils are all No. 28 silk covered wire, and are placed at the filament end of each secondary, with a separation of about  $\frac{1}{4}$  in.

The antenna coil is wound on a  $2\frac{1}{2}$  in. form,  $\frac{3}{4}$  in. wide, and has 10 turns of No. 26 silk covered wire. It can be varied with respect to the secondary, and has pig-tail connections to the mounting plate. The detector and audio amplifier tubes are mounted on the shelf adjacent to the tuner, and the audio transformer is mounted directly between the tubes, underneath the shelf, so that the leads will be short and the wiring job easy. The panel is of  $\frac{3}{16}$ -in. bakelite or formica,  $8 \times 14$  in., and the shelf is  $3\frac{1}{2} \times 12\frac{1}{2}$  in., of  $\frac{1}{4}$ -in. material. Automatic filament resistance cartridges are used to control the filament current, except that an

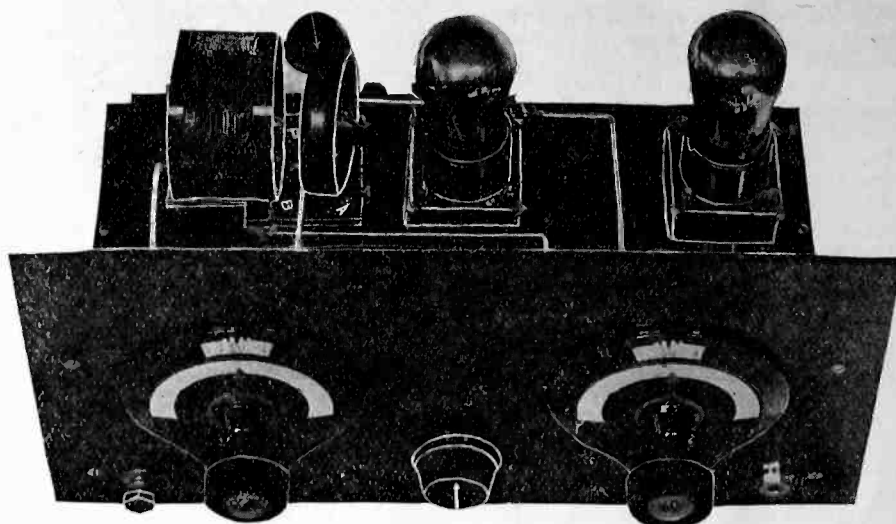

Panel and Shelf Arrangement, Showing Plug-In Inductance Coils.

additional rheostat is placed in the detector filament circuit to furnish additional control of regeneration. A r.f. choke consisting of either a 50 turn honeycomb coil or 100 turns on a  $1\frac{1}{2}$ -in. tube may be necessary, as shown in Fig. 1, although the use of the choke depends largely upon the amount of distributed capacity in the audio transformer, and is best determined by experiment.

A 5-plate, .00015 mfd. condenser is used to tune the secondary, and a 13 plate .00025 mfd. condenser controls regeneration, being connected from the battery side of the tickler to the positive filament of the detector tube. The circuit may be changed to the Reinartz if desired, with equally good results, no additional coils or condensers being necessary.

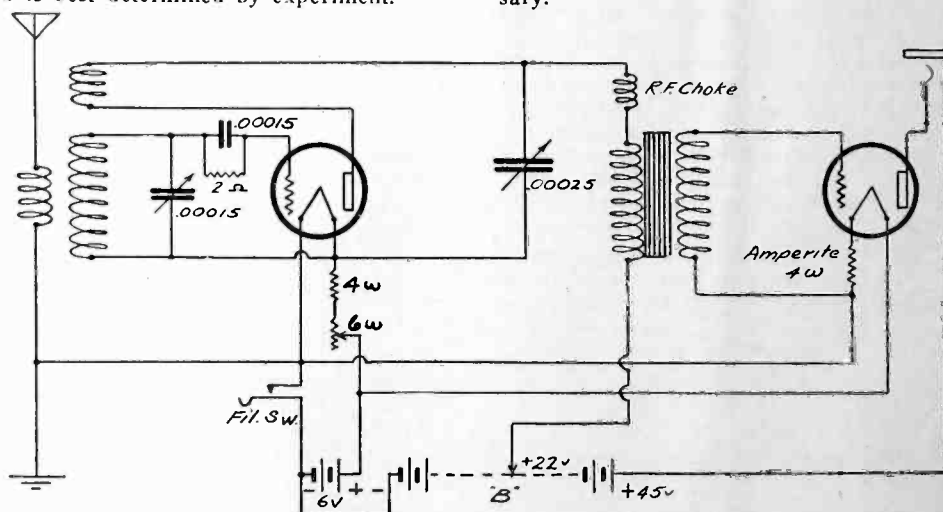
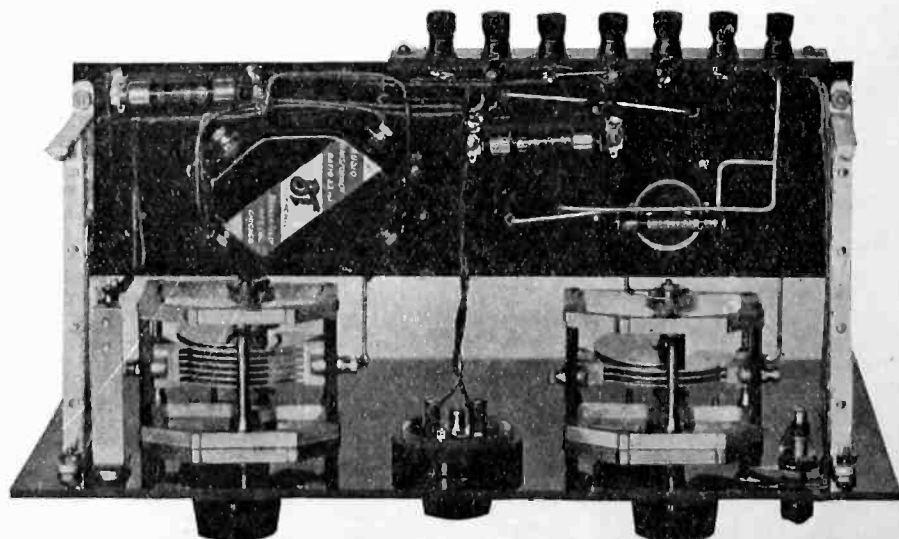

Fig. 1. Schematic Wiring Diagram of Short Wave Receiver.



View of Under Part of Shelf, With Details of Panel Apparatus.

## NEWS OF THE AMATEUR OPERATORS

6CCR, Arthur Arrizoni is now at 242A Hartford St., San Francisco,  $7\frac{1}{2}$  watts; all cards qsl'd.

6EB, L. F. Seefred, 343 So. Vermont Ave., Los Angeles, Calif., has worked all U. S. districts except 2nd and 3rd in daytime on 20 meters with a 50-watt tube. So why stay up all night?

2AVP, ex-2AHI, is now at 607 West Beech St., Long Beach, Long Island, N. Y.

A medal for conspicuous service by any non-professional radio listener or transmitter bringing aid by radio in time of trouble is to be awarded by *Popular Radio* of New York City. The award will be made upon the basis of the recommendation of a committee of representative men.

The trade-mark "S-L-F" for variable condenser has been issued to A. H. Grebe & Co. of New York, who state that they are prepared to take action against any firm infringing it.

# CALLS HEARD



**By 9APY, 3337 Oak Park Ave., Berwyn, Ill.**  
 1aae, 1ahb, 1ajp, (1ane), 1chl, 1ckm, (2adk), 2aiz, 2cjj, 2cyh, 2dx, 2wc, 3clo, 3ol, (4aa), 4cu, (4dt), 4fl, 4it, 4wg, 5abl, 5agu, 5ajm, 5akl, (5app), 5atv, 5aua, 5awf, 5hn, 5jd, 5qj, 5qk, 5yb, 6aa0, 6abg, 6aij, 6bil, 6cho, 6crz, 6ct, 6ctn, (6cuw), 6dbl, 6ka, 6lr, 6dd, 7fj, 7fl, 7jf, 8dhx, 8dkn, (8el), 8eu, 8uf, 8ut, Canadian: 3oh. Miscellaneous: wiz, (wyf). Card for card fellows.

**By R. W. Mintrom, 62 Barton St., Woolston, Ch. Ch., N. Z.**

U. S. A.: 1aa0, 1aff, 1amf, 1alr, 1ary, 1aof, 1ail, 1ads, 1are, 1apz, 1axa, 1bdi, 1bgw, 1bhs, 1ch, 1cmx, 1caw, 1cak, 1cln, 1cu, 1dl, 1ga, 1ka, 1np, 1pe, 1pl, 1qm, 1sl, 1te, 1yb, 1yd, 1za, 2aim, 2ahk, 2ate, 2ale, 2aes, 2auh, 2ag, 2aof, 2adk, 2agt, 2ahm, 2bm, 2bn, 2brb, 2beo, 2cft, 2cbg, 2cns, 2clg, 2cxl, 2cqz, 2ctg, 2clz, 2cp, 2gx, 2j, 2kg, 2ks, 2lu, 2nf, 2nz, 2tp, 2uk, 2xaf, 2zb, 3awh, 3auv, 3aib, 3afw, 3ade, 3alx, 3bmz, 3bwt, 3bta, 3cdk, 3cah, 3chg, 3dh, 3hg, 3id, 3lr, 3tr, 3ue, 3vi, 3wb, 4aah, 4ask, 4bu, 4fa, 4fl, 4gy, 4io, 4ja, 4km, 4ll, 4oa, 4rm, 4rr, 4tn, 4uz, 5afd, 5aid, 5agu, 5aec, 5agn, 5ade, 5aua, 5ail, 5ado, 5amk, 5ame, 5ahp, 5aky, 5atv, 5ain, 5aaq, 5aut, 5ce, 5co, 5ew, 5eh, 5fc, 5if, 5lg, 5nj, 5nw, 5oc, 5ox, 5qs, 5rg, 5se, 5sd, 5uk, 5va, 5xau, 5yd, 5za, 6alv, 6akx, 6aum, 6awt, 6adw, 6abg, 6aak, 6awl, 6asd, 6afs, 6ann, 6apq, 6amm, 6aiv, 6ay, 6apw, 6asm, 6ajt, 6aos, 6akt, 6aed, 6bbv, 6bau, 6bgb, 6bde, 6bt, 6bq, 6bk, 6bav, 6bjd, 6bvs, 6bqr, 6bts, 6bh, 6bkh, 6bjv, 6bis, 6bpg, 6cgw, 6csw, 6cmq, 6cls, 6cej, 6css, 6cdy, 6cto, 6cah, 6crf, 6ccl, 6cqa, 6cmd, 6cae, 6cet, 6ct, 6chl, 6cak, 6cbp, 6cqv, 6cgv, 6ccu, 6csx, 6cqt, 6chy, 6cev, 6cfe, 6cis, 6ckv, 6cux, 6dh, 6dam, 6dam, 6dbe, 6dax, 6dah, 6dau, 6dal, 6dag, 6daj, 6fj, 6fh, 6hj, 6ha, 6hv, 6hm, 6jp, 6js, 6jj, 6jq, 6jb, 6gk, 6kb, 6nw, 6oi, 6pr, 6qg, 6ro, 6rm, 6ts, 6uf, 6ur, 6vc, 6vz, 6za, 6zh, 6zk, 6zr, 7afo, 7ajb, 7abf, 7aft, 7aek, 7aaj, 7alk, 7ay, 7aly, 7bj, 7cs, 7df, 7dm, 7ef, 7ek, 7g, 7hb, 7it, 7jf, 7ku, 7ls, 7ly, 7nl, 7no, 7nh, 7oz, 7pu, 7rl, 7sl, 7tj, 7uj, 7vq, 7wu, 7wj, 7wq, 8av, 8aly, 8alf, 8aul, 8ac, 8acy, 8ayy, 8abm, 8abs, 8bch, 8bt, 8buk, 8bic, 8bww, 8bau, 8bit, 8bfq, 8cyl, 8cpj, 8ces, 8cud, 8ccm, 8chk, 8djp, 8dia, 8daa, 8dme, 8eg, 8er, 8eq, 8es, 8gz, 8gk, 8ji, 8kc, 8kw, 8pl, 8pk, 8ry, 8rt, 8se, 8sf, 8xe, 8ze, 8zk, 9alt, 9atq, 9adk, 9atg, 9aob, 9ato, 9aim, 9bvh, 9bhi, 9bme, 9bzl, 9bmt, 9bmd, 9bal, 9ba, 9bug, 9buz, 9bxj, 9bna, 9baq, 9bbf, 9bvw, 9bwb, 9bfg, 9bez, 9bn, 9bby, 9bey, 9cwn, 9ctr, 9cju, 9cwn, 9ckm, 9che, 9cxc, 9caa, 9ctg, 9cn, 9ccq, 9cdv, 9caj, 9cip, 9cid, 9dmz, 9dkq, 9dte, 9dde, 9doq, 9dpx, 9dol, 9dng, 9dqu, 9ddm, 9dez, 9dtk, 9dmj, 9ded, 9dww, 9dac, 9dex, 9eak, 9ecc, 9eli, 9eez, 9egh, 9eel, 9ebj, 9eky, 9ebx, 9nk, 9nm, 9nl, 9lf, 9og, 9pn, 9se, 9uq, 9xi, 9xax, 9yav, 9za, 9zt, 9zk, B, b2, y2, 4ra, 4rs, 4yz, b7, 9b, BE, ber, BZ, lab, lac, 2sp, C, lak, lar, 3aa, 3kp, 4dq, 4gt, 5go, 5gt, CH, leg, 2ar, 2ld, 2rm, 9tc, CS, ok-1, Canal Zone: 99x, D, 7zm, E, ar2, F, 3ca, 8aix, 8az, 8cs, 8co, 8ct, 8ca, 8ee, 8eu, 8fd, 8go, 8gm, 8hm, 8hu, 8jd, 8jn, 8jc, 8ix, 8sd, 8sz, 8tk, 8tok, 8ww, 8wag, 8xb, 8yr, G, 2ao, 2cc, 2dx, 2bz, 2kf, 2kz, 2lz, 2nb, 2nm, 2od, 2qm, 2sz, 2wj, 2xv, 2xy, 5lf, 5nn, 6lj, 6nf, 6ox, 6rm, 6td, 6tm, H, 9ad, HU, 6aff, 6aje, 6ajl, 6asr, 6buc, 6clj, 6cse, 6cst, 6dbl, 6dl, 6xl, 6cn, I, las, lau, lay, lco, ler, lgw, 1gt, 1mt, 1no, 1rg, 1rm, Ireland: 5nj, J, laa, 1pp, K, 2hr, 18, M, laa, laf, lax, lb, lk, lj, lx, 5c, 9a, xda, N, oba, obq, osv, pb7, pa9, PR, 4sa, PI, 1hr, R, bal, afl, ab2, db2, ga2, fa3, fb5, a8, aa8, cb8, S, smyy, smtn, smzs, Finland: 2co, French Indo-China: 8gq, 8lt, Russia: rdw, Palestine: 6zk, China: neqg, Java: ane, Samoa: 6zac, Tahiti: bam, Others: crp, gas, lxl, neqq, rrp, Will QSL all crds.

**By SDIA, P. S. Van Deusen, Kent, Ohio**  
 4al, 4av, 4bl, 4bu, 4bw, 4ch, 4cu, 4cy, 4dk, 4dm, 4du, 4dw, 4et, 4fa, 4fg, 4fl, 4fp, 4fs, 4fw, 4gy, 4it, 4iu, 4iz, 4jk, 4jn, 4jv, 4kl, 4lt, 4ml, 4my, 4ny, 4ok, 4oy, 4pf, 4pz, 4rm, 4rq, 4rr, 4ry, 4sl, 4sk, 4tv, 4ux, 4uz, 4vq, 4vs, 4we, 5aa, 5aa0, 5aaq, 5aau, 5aav, 5acl, 5acv, 5acy, 5ada, 5adz, 5agn, 5ags, 5ahc, 5ahg, 5ahp, 5ahr, 5ain, 5aja, 5ajg, 5aka, 5akn, 5alj, 5alz, 5amw, 5aph, 5aru, 5asd, 5asv, 5atf, 5atl, 5att, 5atu, 5atv,

5atx, 5aua, 5auz, 5awf, 5ax, 5ayq, 5bm, 5ce, 5dq, 5eh, 5fc, 5fs, 5gj, 5gk, 5gy, 5he, 5hn, 5hs, 5hy, 5jd, 5jf, 5kp, 5lc, 5lh, 5nw, 5oq, 5ov, 5pl, 5qj, 5qk, 5qw, 5rg, 5rn, 5se, 5sh, 5sp, 5to, 5uc, 5uk, 5ux, 5vl, 5vm, 5wi, 5xau, 5yb, 5zai, 6aak, 6aa0, 6abs, 6aec, 6aed, 6aeg, 6afg, 6afs, 6akm, 6akt, 6amm, 6ann, 6anp, 6anr, 6anw, 6aop, 6aou, 6api, 6apq, 6apw, 6aqg, 6aqp, 6aqr, 6asb, 6asd, 6ase, 6asm, 6atu, 6aul, 6avj, 6awt, 6ay, 6bcu, 6bge, 6bgn, 6bgo, 6bh, 6bhj, 6bhz, 6bil, 6bjd, 6bjv, 6bo, 6bon, 6bpg, 6bq, 6bts, 6bur, 6cae, 6cah, 6cbg, 6cbp, 6cck, 6cco, 6ccv, 6cev, 6cfe, 6cgw, 6chl, 6chx, 6chy, 6ckv, 6clu, 6cnd, 6cpq, 6crs, 6csw, 6csx, 6ctd, 6cur, 6cuw, 6dad, 6dag, 6dao, 6ea, 6eb, 6fa, 6fh, 6hm, 6hu, 6ih, 6ji, 6jp, 6jq, 6kb, 6lr, 6ml, 6nw, 6oi, 6qi, 6rm, 6rn, 6ts, 6wt, 7aek, 7aip, 7ajb, 7aky, 7ay, 7bf, 7bur, 7cs, 7df, 7ek, 7fy, 7hb, 7hi, 7ho, 7if, 7js, 7ki, 7lu, 7nf, 7ok, 7oz, 7pu, 7rl, 7ru, 7sl, 7uq, 7uz, 7vo, 7wu, Australia: 2cx, 2cs, 2kb, 2yl, 3bd, 3ef, 3gs, 3qh, (3co), bg, Brazil: lab, lac, 2sp, Canada: lam, lar, 2ao, 2ax, 2be, 4ah, 4cc, 4de, 4dw, 4lc, g2kf, Hawaii: 6aff, 6ceu, 6buc, 6dbl, 6oa, Italy: ret, 1rm, Mexico: laa, lj, lk, 5c, 9a, P. R. 4ky, q2jt, q2mk, rfh4, Samoa: 6jo, s2c, s5qa, ssmyy, z2ac, z2xa, Misc.: narl, nba, ncg, nism, nkf, noem, npb, npg, npl, nrm, npu, osnt, why, wiz, wqo, wyh, xa, 99x.

**By U5AC, 960 Marine Street, Mobile, Ala.**  
 Australia: a2bk, a2ds, a3wm, a5da, New Zealand: z1ao, z1ax, z2ac, z4ac, z4al, Brazil: bzlab, bziba, bzlac, bz2ab, bz2af, bz2ab, bzsnl, bzsql, African: oa3b, oa3e, oa4l, oa4v, oa4l, Chile: ch2ld, ch9tc, ch3ag, Hawaiian: 6clj, wyi, 37c, English: g2iz, g2cc, g2wj, g5hs, g6nf, Italian: iler, ilgw, ilrm, Argentina: r1af, r1ba, rbal, r5dh, r2cg, Mexican: 1k, laa, laf, 5c, Panama: 99x, Miscellaneous: afe, ntt, gdvb, nqg, sgc, nar-1, xda, o-1mf, All cards gladly answered. Look for my 50 watts of CW on 39.5 meters.

**By U2BUY, Bradley Park, N. J.**  
 6aak, 6abg, 6aed, 6ahp, 6akm, 6ann, 6ano, (6anp), 6app, 6bav, (6bha), 6bis, 6bt, 6bvw, 6cae, 6cah, 6ccn, 6cej, 6cig, 6cix, 6cqa, (6crs), 6csw, 6cur, 6dal, 6dan, 6ddx, 6ay, 6dh, 6jn, 6rn, Hawaii: 6aff, 6buc, 6cst, (6dbl), 6dcl, (fx1), 7ap, 7ay, (7aa), 7adq, (7ek), 7gw, 7ip, 7ki, 7nf, (7nh), (7ou), (7sw), 7ul, 7vu, Canada: 1ar, 1dd, 2bh, (2cb), 3gy, (3he), (3jf), 3ye, 3zd, 4aj, (5bz), 8ar, Porto Rico: 4ur, 4sa, France: 8arl???, (8bf), 8dk, 8eu, 8fn??, 8gl, (8jn), 8ln, (ocng), 8tk, (8xp), (8yor), Algiers: (8ip), Holland: pb7, pcll, Belgium: b2, o2, p2, s4, (u3), 4yz, South Africa: oa4v, Japan: j1aa, Spain: ear2, ear 2o, Uruguay: y-jcp, Argentina: r-bdv2, r-fa3, Italy: las, (lay), lbd, lbs, lgw, (lno), 1rm, Portugal: 3gb, 3co, Mexico: (1k), 9a, New Zealand: lax, 2ac, 2xa, 4ac, 4ar, 4as, Australia: 3ad, 3kb, 5da, England: 2fk, 2fm, 2kf, 2lz, 2nb, 2nm, 2qb, (2rf), 2xy, 5lb, 5rz, 5sz, 5yi, 6mx, 6nf, 6ry, Brazil: 1ia, 2af, lac, lab, 5ab, Chile: 3ij, Miscellaneous: ics, irf, nao, ntt, (at Italy), kfuh, (gdvb) QRA given as Fiji Isles, pt, lpt, pt2pt, pt5pt (anyone else hear 'em??) QRH below the bz's! QRA? Will appreciate all reports on my sigs (2BUY) 39 meters es 100 watts input. Plenty cards hr es wl answer all QSL's!

**By 1AKZ, A Hurnanen, 62 A Street, Gardner, Mass.**  
 England: 2cc, (2it), 2kf, 2lz, 2nb, 2nm, 2qb, (2qm), 2sz, (2xy), (5ma), 5nn, 5pm, 5yi, 6al, (6lv), (6og), 6ox, 6tm, France: 8aix, 8bf, 8cs, 8ct, 8dk, 8dd, 8ee, 8gi, 8ip, 8jn, (8rh), (8rbp), 8xp, 8yor, 8zm, Italy: 1ay, lbd, lbw, ler, lgw, lno, 1rm, Holland: 2pz, pc2, pb3, 19k, 1ljw, Germany: kd4, Spain: ear9, ear-24, Palestine: 6zk, Sweden: sgc, Australia: 2cg, 2cm, 2cs, 2ds, 2lo, 2rj, (2tm), 2yh, 2yi, 2zn, (3ad), (3bd), 3bm, 3hl, 3jk, (3jr), 3kb, (3qh), (3ot), 3wm, (3xo), 3yx, 4an, 5ay, 5bg, 5da, 5ip, 7jp, 7bq, New Zealand: lao, lax, 2ac, 2xa, 4ac, 4af, 4ak, 4al, 4ar, 4as, 4av, Brazil: lab, lac, lae, laf, lib, 5ab, Argentina: cb8, rf4h, Chile: 2ld, South Africa: o-a4z, o-a6n, Hawaii: 6aff, (6ajl), (6buc), fx1.

**By 8CQH, 8SV, 8IT, Huntington, West Virginia.**  
 U. S.—6aak, 6aed, 6aev, 6afg, 6alj, 6air, 6akm, 6ank, 6ann, 6apq, 6aps, 6aqp, 6aqw, 6awt, 6bcs, 6bgo, 6bha, 6bh, 6bil, 6bis, 6bjd, 6bls, 6bol, 6bpg, 6bsh, 6bur, 6bys, 6cax, 6cbb, 6cdn, 6cej, 6cev, 6cli, 6cjl, 6clp, 6clt, 6cqa, 6cqw, 6crz, 6css, 6csu, 6csw, 6cto, 6cur, 6cuw, 6cvp, 6daa, 6dah, 6dal, 6dat, 6bq, 6hf, 6ih, 6jl, 6jp, 6js, 6sx, 6lh, 6nx, 6ol, 6sz, 6ts, 6vq, 7ag, 7ay, 7adf, 7adm, 7cf, 7cs, 7ft, 7hi, 7ij, 7im, 7lq, 7nf, 7pj, 7sf, 7uj, 7uw, 7vq, Canada: lak, 3ft, 4ah, 4ez, 4gt, France: 8dk, England: 2od, 2gb, 2gw, 2nq, 2vq, Hawaii: 6aef, 6dbl, 6buc, 6aje, Mexico: laa, 5c, 9a, jj, South Africa: oa3b, oa3e, oa6n, Chile:

3ij, P. R.: 4je, 4sa, 4ur, Cuba: 2jj, 2mk, Brazil: lab, lac, lae, laf, lai, 2af, 2bd, 2lz, 2sp, 4ac, 5ab, Argentine: cb8, Italy: 1ar, Miscellaneous: 99x, fw, nar, narl, nba, npg, nkf, nosn, npm, wir, wiz, wva, wvy, fatx (qra?)

**By 9AFX, 106 N. Fair St., Champaign, Ill.**  
 1aa0, 1acx, lafo, laff, lacl, ladi, laiu, lajo, lamz, lanz, lapz, larj, lasu, lawb, laof, lave, laxa, laxn, layg, laye, lbal, lbay, lbg, lbdh, lbs, lbkc, lbnl, lbqa, lbsd, lbyx, lbzp, lbxh, lbzc, lca0, lcaw, lch, lci, lck, lcmx, lcu, ldl, lga, lhn, lja, llj, lor, lqb, lqm, lsw, lsz, lte, lyd, 2agq, 2akp, 2alw, 2amj, 2aof, 2apt, 2asb, 2auh, 2acs, 2bir, 2bm, 2bql, 2bum, 2bwa, 2bx, 2bsl, 2ccl, 2bse, 2cgb, 2cth, 2cty, 2cvi, 2cvs, 2cvu, 2cxl, 2ds, 2fo, 2gv, 2ha, 2hh, 2hs, 2jz, 2kg, 2ku, 2lu, 2mk, 2od, 2op, 2wr, 3abj, 2adb, 3agf, 3ahp, 3ahr, 3bhv, 3bqz, 3cdv, 3ckg, 3cki, 3ju, 3py, 3io, 3lw, 3nj, 3mv, 4aj, 4ah, 4bu, 4ch, 4cu, 4eh, 4fg, 4fl, 4io, 4iv, 4jj, 4js, 4jk, 4kj, 4kw, 4lt, 4pl, 4sh, 4si, 4uk, 4xe, 5aab, 5acl, 5adz, 5af, 5afd, 5agn, 5aiu, 5ak, 5ako, 5akz, 5aph, 5aqs, 5asv, 5atk, 5atx, 5atp, 5aua, 5aut, 5eh, 5he, 5hi, 5kk, 5nq, 5ph, 5pi, 5qj, 5qk, 5se, 5sp, 5uk, 6abg, 6akm, 6ank, 6ano, 6apw, 6ase, 6ajj, 6ato, 6bcu, 6bcu, 6bgo, 6bm, 6bls, 6bnp, 6bqr, 6bq, 6bsf, 6bur, 6cbb, 6cbj, 6cco, 6cfi, 6chl, 6cqa, 6css, 6csw, 6ctd, 6cuw, 6daa, 6dah, 6dam, 6dan, 6dat, 6dck, 6don, 6hu, 6oi, 6rm, 6rn, 6ue, 6vav, 6vr, 6vc, 6zaf, 7adm, 7df, 7dd, 7ek, 7fq, 7gr, 7hb, 7jf, 7pj, 7sf, 7sp, 7tm, 7uj, 7vq, 7ya, New Zealand: 2ac, 4as, Australian: 3kb, 3tm, 3bk, 2ss, (3ot), 3yx, 6ag, Brazilian: lab, lac, laf, lap, lbd, 2ab, Argentine: rbal, Canadian: 2au, 3kp, 3ni, 4aa, 4gt, etc, Cuban: 2jt, 2mk, Mexican: laa, lg, 9a, Porto Rican: 4bj, 4kt, South African: a6n, a6a, Panama Canal: 99x, Chile: 2ld, Miscellaneous: naw, nba, nlsq, nkf, npl, wir, wiz, wqo, fw, etc.

**By Z-2BG, J. G. Tinney, 74 Kainui Rd., New Zealand.**

U. S. A.: lbg, lch, ldl, lga, lka, lpl, lqm, lrd, lsa, lsl, lto, lxu, lyb, lza, laao, lacl, laff, lahg, lahl, laos, laze, lawe, laxa, laxn, lazd, lazi, lbad, lbu, lbzp, lbzs, lcal, lcmx, lcoj, 2ag, 2cv, 2ff, 2gy, 2hs, 2jx, 2ku, 2kx, 2mu, 2nb, 2nz, 2sz, 2wr, 2zb, 2aes, 2ahg, 2ahm, 2aim, 2ais, 2brb, 2cpa, 2cqz, 2ctm, 2cvu, 2cxl, 2cyw, 2zaf, 3cc, 4dh, 3ld, 3hg, 3ui, 3wn, 3ade, 3afq, 3aha, 3bit, 3buv, 3chg, 4cu, 4fl, 4gm, 4iv, 4jn, 4js, 4km, 4kn, 4ku, 4kw, 4ok, 4rm, 4rr, 4sb, 4si, 4tv, 4va, 4vl, 4vo, 4xe, 4aa, 5ac, 5ak, 5ew, 5ft, 5gx, 5hy, 5jd, 5jf, 5lg, 5ls, 5mq, 5nj, 5nw, 5og, 5pb, 5qz, 5xk, 5ux, 5va, 5agn, 5ahg, 5ahp, 5aid, 5akl, 5akn, 5aky, 5akz, 5ame, 5amf, 5amk, 5aph, 5asv, 5atv, 5aua, 5zai, 6bq, 6cg, 6cz, 6db, 6dt, 6ec, 6fa, 6fd, 6fj, 6gr, 6gu, 6hm, 6hu, 6hv, 6ij, 6jp, 6kg, 6lh, 6lj, 6ml, 6nw, 6oa, 6oi, 6rn, 6rw, 6sb, 6si, 6sk, 6tj, 6tq, 6tx, 6tz, 6ua, 6ue, 6uf, 6vc, 6vr, 6vt, 6vz, 6wt, 6zb, 6zd, 6zh, 6zr, 6zs, 6adw, 6aff, 6afh, 6agk, 6aiv, 6aje, 6ajj, 6ajl, 6ake, 6akm, 6akx, 6amm, 6ase, 6ast, 6auf, 6aum, 6aqp, 6bav, 6bbv, 6bek, 6bgb, 6bh, 6blm, 6bis, 6bjd, 6bjx, 6bkh, 6bls, 6bpg, 6bttm, 6bub, 6buc, 6bvs, 6bvy, 6bwu, 6cah, 6ccu, 6ccv, 6cev, 6che, 6chz, 6cin, 6cix, 6cju, 6cmh, 6cms, 6cmu, 6cnc, 6cpg, 6cqa, 6crs, 6css, 6cst, 6csw, 6csc, 6ctd, 6cuw, 6cvz, 6dad, 6dag, 6dah, 6dai, 6dam, 6dan, 6dat, 6dax, 6dbe, 6dbl, 6eck, 6xad, 6zac, 7ao, 7ay, 7cs, 7df, 7ek, 7hb, 7hi, 7it, 7lq, 7pk, 7rl, 7ru, 7sl, 7uj, 7uz, 7wu, 7aaj, 7aek, 8ay, 8bg, 8bt, 8eb, 8er, 8es, 8ex, 8gz, 8kw, 8pl, 8rv, 8vt, 8xe, 8zg, 8adg, 8ajn, 8ago, 8agq, 8alo, 8aly, 8bce, 8bdc, 8bgn, 8bnh, 8bpl, 8bpq, 8bsc, 8buk, 8bwb, 8bwr, 8byn, 8cau, 8ced, 8chk, 8cla, 8dfv, 8dsd, 9cj, 9cn, 9cp, 9dn, 9ee, 9ei, 9ek, 9hp, 9fi, 9lc, 9nl, 9pn, 9sd, 9ua, 9uq, 9wi, 9xi, 9xn, 9za, 9zd, 9zt, 9adk, 9ado, 9aey, 9ajj, 9akf, 9alt, 9aod, 9a0j, 9bbq, 9bdw, 9bez, 9bfp, 9bjk, 9bjn, 9bkk, 9bmd, 9bna, 9bol, 9bit, 9btt, 9bwt, 9bwo, 9bzl, 9bzw, 9ccv, 9cfy, 9che, 9cip, 9civ, 9ckm, 9cld, 9ctr, 9cwn, 9cwr, 9cwn, 9cxc, 9cxx, 9czz, 9dac, 9dbh, 9dez, 9dge, 9djp, 9dkh, 9dlv, 9dmj, 9dms, 9dmz, 9dng, 9dol, 9dpx, 9dqu, 9drd, 9dte, 9dvi, 9dvl, 9ebj, 9ees, 9efs, 9eji, 9eky, 9eli, 9elt, 9kky, England: 2cc, 2dx, 2kz, 2lz, 2nm, 2od, 2sz, 5lf, 5nj, 5nn, 5qv, 6nn, 6qr, 6rm, 6tm, Holland: o-ba, o-bq, o-sv, pcll, Belgium: b2, 4y2, Cuba: 2mk, Java: ane, Mexico: laf, lb, lj, lk, lx, 9a, Swiss: 7de, 9ad, Philippines: lcw, lfn, lhr, 2fn, neqq, nqgl, nuqg, Italy: las, lau, lco, ler, lgw, lmt, lno, lrt, lrm, Porto Rico: 4rl, 4sa, Canada: 2fo, 3aa, 3nf, 4gt, Japan: laa, lpp, (phone), Brazil: lab, lac, lad, lgw, 2sp, Sweden: smyy, smzs, Argentina: aa8, afl, ah2, bal, bg8, cbl, cb8, db2, de3, dd7, dh5, fa3, fb5, ff9, fg4, ga2, France: 3ca, 8az, 8bf, 8co, 8ct, 8dk, 8eu, 8ee, 8es, 8fg, 8gm, 8nu, 8jn, 8ww, 8xp, 8jbl, 8tok, 8wag, Morocco: maroc, Algiers: 8alg, French Indo-China: 8gq, South Victoria: aqe, Misc: kfuh, bam, sgc, ftj, ocdj, gdl, I keep log and plenty QSL cards. Z-2BG QRK?

(Continued on Page 52)

## NEW MODEL "T" CABINET



Sizes in stock. Have piano hinge, and are full 8" and 10" deep inside.

Mahogany Mahogany			Mahogany Mahogany		
Size	Finish	or Walnut	Size	Finish	or Walnut
7x18-8	\$8.55	\$9.50	7x18-10	\$10.20	\$11.55
7x21-8	9.30	11.50	7x21-10	10.90	13.25
7x24-8	10.10	12.60	7x24-10	11.70	14.65
7x26-8	10.70	13.35	7x26-10	12.65	15.80
7x28-8	11.80	14.70	7x28-10	13.00	16.20
7x30-8	12.75	15.85	7x30-10	13.30	16.65

## BEST'S SUPERHETERODYNE

A Specially Designed and Constructed Cabinet—Takes 10x20 Panel. Has Piano Hinge and Sloping Panel (1½" Slope) for Added Beauty.

Mahogany .....\$12.00  
Mahogany or Walnut Finish..... 14.00

"CORBETT'S CABINETS" have been preferred for several years by quality set builders and are unquestionably superior in design and finish. They are backed by our guarantee to please you. Carefully hand-rubbed piano finish. Well packed for shipment.

WRITE FOR CATALOG showing attractive models for all sizes of radio cabinets, consoles and tables.

Jobbers and Dealers, write for discounts  
Express Charges Prepaid in U. S. A. and Canada

**Corbett Cabinet Manufacturing Company**  
ST. MARY'S, PENNSYLVANIA

## JUDGED BY RESULTS

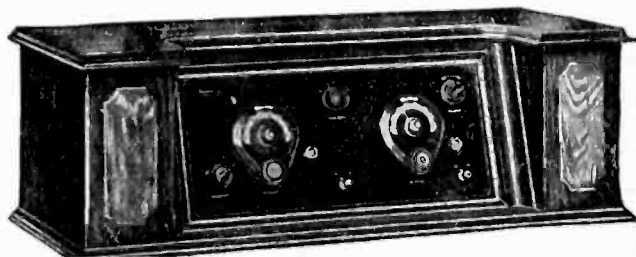

Counterphase  
Six  
Factory-built  
Receiver

**\$165.00**

\$175.00 West of  
the Rockies

By the RESULTS it delivers—that's the Public's way of judging a radio receiver. Advertising claims mean nothing after the test.

The season's leader, The COUNTERPHASE SIX still maintains the paramount position. It has been judged by RESULTS.

Send for Circulars

**BREMER-TULLY MFG. CO.** 532 SO. CANAL STREET  
CHICAGO, ILL.

### IDEAL FOR "DEAD SPOTS"

Lancaster, Calif., March 18, 1926.  
We are building a third 220,000 volt line from Los Angeles to Big Creek, approximately 230 miles, and I am using the COUNTERPHASE RECEIVER along the line. We are now in the Antelope Valley on the Mojave Desert, and I am getting very good results.

S. L. S.

### CONSISTENT DISTANT RECEPTION

Kindred, N. D., February 16, 1926.  
... At the recent International test, I got Lima, Peru, 6KW, Cuba, and CZE, Mexico City, all on loud speaker.

C. S.

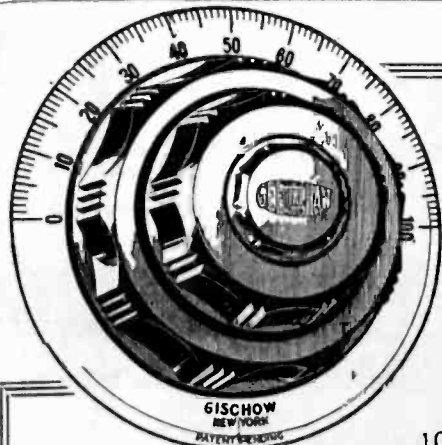

## GEE-HAW Micrometer TUNING DIAL

Ratio 100 to 1  
A New Mechanical Principle  
Absolutely No Backlash

Manufactured by  
OTTO R. GISCHOW CO., Inc.  
New York

For Sample Write to Pacific Coast Agents:

**American Commercial Co.**  
1067 Market Street, San Francisco, Calif.

## BREAKING INTO THE RADIO GAME

(Continued from Page 9)

though he may be rebuffed dozens of times by fellow fans, will fondly believe that the long suffering radio clerk will hang on his words. This the clerk must appear to do, but in justice to his employer, the discussion should be so manipulated that it comes to a close simultaneously with the delivery of the package.

### Operating

ALL transmitting radio stations are required by law to employ licensed radio operators. These licenses are issued only after an applicant has successfully passed a rigid technical, theoretical and code examination. Various grades of licenses are issued, authorizing the holder to operate in various classes of stations and thus we have different classes of operators in the different sub-branches of operating. These are, radiocast station operators, operators in private point-to-point commercial service, public service stations both for communication with other points and with ships at sea, and operators aboard such ships, aeroplanes and submarines.

Radiocast station operators are not required to have an extensive knowledge of the Continental radio telegraphic code. Their work does not involve radio telegraphy in any way, but they must be capable of recognizing distress signals sent in this code, so that in the event that their station is interfering with aid to a vessel in distress, they may be so informed by the vessel and must then cease operation. A speed capable of recognizing such distress calls is accepted as twelve words per minute, which is really slow and must be met by all applicants for a radiocast station operator's license. In addition they are required to be familiar with circuits, apparatus, adjustment, and repair of standard equipment. An aspirant to this branch of operating should become acquainted with the operators of such stations as are near him, where he can gain sufficient preliminary knowledge to allow him to study intelligently for his license examination. Information as to requirements can also be obtained from a radio school or the U. S. Supervisor of Radio at the point nearest him. Upon receipt of this information, he may then devote himself to study and when he feels competent, present himself for examination. Once he has successfully obtained his license, he is eligible to employment by any radiocast station and should endeavor to file application with all within a reasonable distance from him. When he does succeed in getting added to the staff of such station, his education will rise in direct proportion to his natural aptitude and observance. Operators at private stations engaged in radio telegraphic communication only in connection with the business of the

company employing them, are required to hold a license similar to that of a radiocast station operator, a speed of twelve words per minute in the code being required. Actually, the operators of these stations usually work at high speeds of from 30 to 35 words per minute and accordingly it is unusual for a new man to obtain employment with them. These positions are generally filled by men who have had long service as operators on sea-going vessels or at important public service shore stations. A young man with such a station as his aim, had best devote himself to preparation for some service at sea first, with the private service as his ultimate object.

The same applies to the operation of the high-powered trans-oceanic services. In some instances, the same license with a twelve word speed will serve in the event that employment is offered, but in most stations the law specifies that commercial first grade operators be used. This means a code speed of twenty words per minute and a more comprehensive knowledge of the apparatus. These operators are men of even greater code ability than the private service men and work at from 30 to 40 words per minute frequently. Long experience at sea and on other shore stations is a big asset here and the beginner had best strike off his desire to make one of these stations at the outset of his career and follow the course of the man preparing for a private shore station assignment.

The marine radio operating field offers perhaps the most diversified and interesting of the many sub-branches of radio operating. Operators on board ship are rated as junior officers and fed and quartered as such. They travel to all civilized ports of the world and get paid for so doing. Their education is comprehensive and their viewpoints broadened. The writer considers the marine radio operators berth as the most ideal start for entry into any branch of the radio industry. It is a foundation in radio training that cannot be equalled.

Entry into this field is simple and perhaps, aside from obtaining the license, the easiest of all. A first class commercial license is required in practically all cases, which means a code speed of twenty words per minute and a thorough technical and theoretical knowledge of marine equipment. From five to nine months is generally required in a good radio school and upwards of a year by constant effort at home study. If possible, the aspirant to a license should build himself a small amateur transmitting station at home, get an amateur operator and station license (a comparatively easy examination—a few months preparation will make you competent) and he will find it of great assistance in increasing his code speed.

When he has successfully obtained his commercial license, he need only present

# American Transformer Company

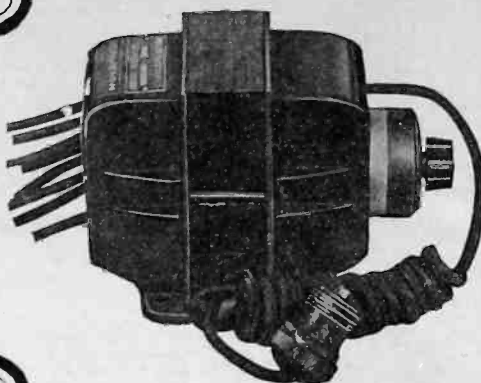

AmerTran Power Transformer  
Type PF-52

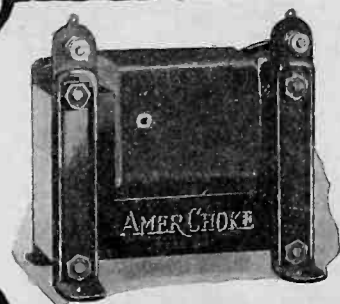

AmerChoke. Type 854.

**A** REPUTATION for fine transformers that has been maintained for over a quarter-century! Today this high standard of manufacture is more apparent than ever—for radio has adopted each of the advanced, dependable AmerTran Products as the leader of its field.

The new AmerTran DeLuxe Audio Transformer actually puts the development of the "audio side" ahead of existing acoustical devices. Faithful amplification with natural quality over the entire audible range is consistently obtained with this audio transformer. The new tubes, cone speakers, and clear signals from the detector tube bring the most satisfactory results in combination with the AmerTran DeLuxe.

It is significant that in 1926 the AmerTran DeLuxe is an essential unit in the finest set designs. One of these is the *Best 5 tube Super*. Before building this Receiver write us for complete information.

As the receiving set of the future is destined to be power operated the American Transformer Company is now offering two units of the finest type—especially adapted to the use of the new

7½ volt power tubes in the last audio stage. These are the AmerTran Power Transformer and the AmerChoke which are strictly up to standard, and may be depended on in the type of audio amplifier required. The Power Transformer, also has filament supply windings for the power tube in the last stage and for the rectifying tube, and supplies sufficient plate current, after rectification, for the operation of the set.

AmerTran DeLuxe 1st Stage . . .	\$10.00
AmerTran DeLuxe 2d Stage . . .	10.00
AmerTran AF-7 (3½-1) . . .	5.00
AmerTran AF-6 (5-1) . . .	5.00
AmerTran Power Trans. PF-45 . . .	15.00
AmerTran Power Trans. PF-52 . . .	18.00
AmerChoke Type 854 . . . . .	6.00

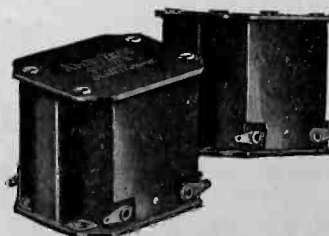

AmerTran DeLuxe  
two types for first and second stages.

Whether or not you are actually building a set, our booklet "Improving the Audio Amplifier" will prove decidedly interesting. It costs nothing and includes the most advanced information made practical for your use by our engineering staff.

California Representative for  
AmerTran Products

W. I. OTIS  
303 Rialto Building  
San Francisco

**HOW TO BUILD Gerald M. Best's 5 TUBE SUPER 5c**  
Complete Instructions with Additional Working Data. Reprinted from: April 1926 RADIO  
AMERICAN TRANSFORMER CO., 178 Emmet St., NEWARK, N. J.

## Transformer Builders for Over Twenty-Five Years

ARE YOU A SUBSCRIBER?

Tell them that you saw it in RADIO

# Why THE METALLIZED RESISTOR

?

METAL long has been recognized as the best of electrical conductors. The metallized resistor gives conductive resistance and absolutely silent operation.

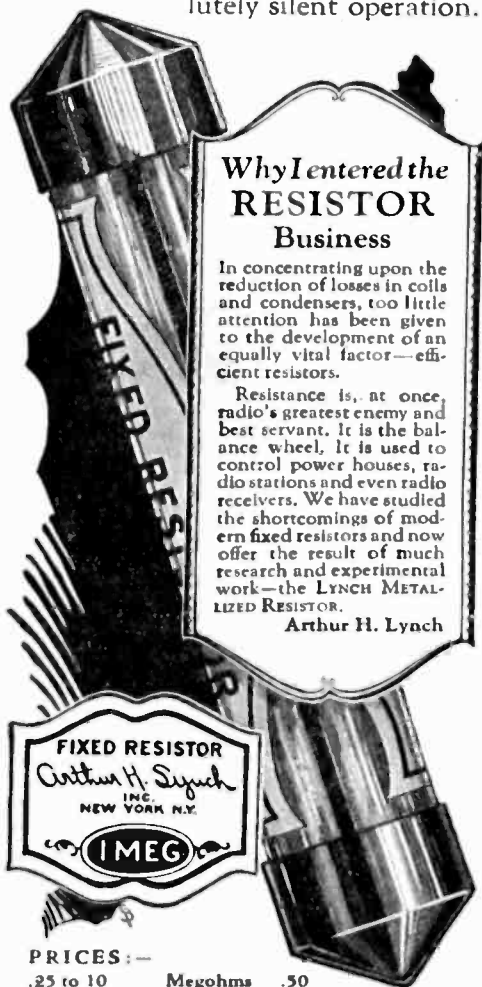

## Why I entered the RESISTOR Business

In concentrating upon the reduction of losses in coils and condensers, too little attention has been given to the development of an equally vital factor—efficient resistors.

Resistance is, at once, radio's greatest enemy and best servant. It is the balance wheel. It is used to control power houses, radio stations and even radio receivers. We have studied the shortcomings of modern fixed resistors and now offer the result of much research and experimental work—the LYNCH METALLIZED RESISTOR.

Arthur H. Lynch

FIXED RESISTOR  
Arthur H. Lynch  
INC.  
NEW YORK N.Y.

IMEG

PRICES:—  
.25 to 10 Megohms .50  
above .01 to .24 " .75  
.001 to .01 " \$1.00

The LYNCH METALLIZED FIXED RESISTOR comprises a concentrated coating of metal one-thousandth of an inch thick upon a glass core and sealed within a glass tube. Each Resistor is warranted noiseless, impervious to moisture, and of permanent resistance value.

The LYNCH label is your guarantee of accuracy, dependability and satisfaction. If your dealer cannot supply you, order direct and we will ship postpaid.

**ARTHUR H. LYNCH, Inc.**  
Manufacturers of Radio Devices  
Fisk Bldg., Broadway & 57th Street  
New York, N.Y.

DEALERS—write us!

## Headquarters for

C-10 and C-7 Parts  
Golden-Leutz Plios  
Pliodynes and Super Pliodynes  
General Radio Apparatus  
E. I. S. Apparatus  
Dubilier Condensers  
Weston Meters  
Formica Panels  
Premier Jacks  
Cunningham Tubes  
General Electric Tungars  
Mahogany Cabinets  
Special Engraving  
Special Condensers, Coils,  
Shielding, etc.

No General Catalog  
Issued

Write for quotation on any Radio  
Apparatus or material required

**NORDEN-HAUCK, Inc.**  
ENGINEERS  
1617 CHESTNUT STREET  
PHILADELPHIA, PA.

### JUST A FEW LEFT

The 112-page Book of Lively, Humorous  
Radio Stories by Mathison  
The Radiobuster  
**\$1.00 POSTPAID IN  
THE U. S.**  
Better Order Your Copy Right Now!  
"RADIO"  
Pacific Building  
San Francisco, California

### NEW

## HAYNES DE LUXE 9-TUBE SUPER

For Sale Cheap

Complete with matched tubes, in handsome mahogany cabinet, \$100. Has stage of r. f. amplification ahead of 1st detector, operates with small outdoor antenna, and has impedance coupled audio amplification. Parts alone worth more than price asked.

**G. M. BEST**  
1460 Grand Ave.  
Piedmont, California

himself at the office of one of the operating companies located at all important seaports, and he will find that it will not be long before he is assigned as junior operator to some vessel. From then on, his career lies in his own hands. If capable, conscientious and willing to work, he may advance to chief operator at sea, junior operator on a shore station, second trick man, chief, manager and so on, depending almost entirely upon himself.

### GETTING FOUR TUBES OUT OF THREE

(Continued from Page 30)

The compromise that gives proper operation is not critical in number of turns. The one in this set barely shows because it is mounted beneath the variable condenser to the left in the panel view. The choke consists of 1500 turns of No. 34 s.s.c., paraffined on the original spool

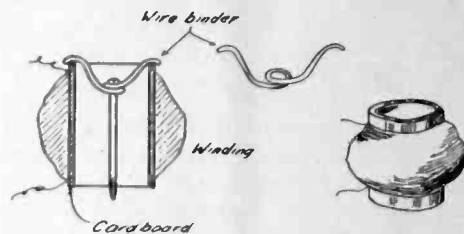

Fig. 9. R.F. Choke Coil.

and then wound into the choke, jumbled on 1 in. diameter tubing. The whole business looks in cross-section and in fact like Fig. 9. It will be noticed that the method of mount is simple and effective. A short length of cardboard, bakelite or wood, tubing or rod, of 1 in. diameter suffices for the form of the r.f. choke. There is no criticalness as to number of turns: between 1000 and 200 turns of No. 32 to 40 d.s.c. or s.s.c. or s.c.c. magnet wire on the size form mentioned will prove quite satisfactory.

As a "tube rejuvenator," a common B battery, if tapped, may be used in an emergency. Flash the 199 type tubes on about 7 volts (5 cells) and then let them burn for 10 to 20 minutes with the plate current OFF, on about 5 volts (4 cells). For the 201 type tubes the same process should be followed, except that voltages of about 14 and 10 should be used.

In moist soil a good ground connection can be made by burying a copper strip as deep as possible, and then piling all the worn-out dry cells on top and underneath, prior to filling in the earth. The cardboard cases should be removed, and if the cells are split down with a hatchet they will work better, owing to the larger surface exposed.

Common pulleys, such as are used for clothes lines, when equipped with porcelain rollers, make fine insulators for receiving aeriels.



## SWEETHEART, THE CRAZY

(Continued from Page 24)

falsetto voices yelling, "Yoo-hoo, Sweetheart," whenever they wanted him for something or other, but Sweetheart didn't think it was unusual, or even funny, which they were trying to be, so after a while they quit. Then they began hunting around for something else to do. They stopped building crystal sets—I don't know how they expected them to work, when my tube set hadn't been able to pick up a thing for two weeks—to take up stud poker, dropped that, and ended up picking fights with each other for amusement's sake.

All in all, I could see that it took a load off the Old Man's mind when we dropped anchor off a fairly good-sized island some fifty miles from the main continent to do a bit of trading and see what we could see. Sweetheart and I went ashore with all the crew who were off watch, the Skipper figuring that it would be good for the men and relieve the tension which had been collecting.

The village was a collection of palm huts, with the usual collection of naked black babies, flea-carrying dogs—or dog-carrying fleas—and reeking garbage. The natives stood around with their mouths open. Sweetheart and I broke away from the bunch and went straight up from the beach to prowl around between the palm huts and see if we couldn't buy some souvenirs.

Wherever we two went, I heard whispered exclamations. It got on my nerves, the first few times, and I had visions of roasted radio-operator steak, until I recollected that these people were farmers and iron-workers. Then I began to decide that it was simply that these natives had never seen a good looking white man before—having noticed several black fingers pointed in my direction. Just then we passed the largest hut on the women's side of the oval shape in which the village, like most African villages, was built, and I saw a dusky wench inside start and look at Sweetheart queerly, as we came opposite the doorway, through which the yellow sunlight poured, after first glancing off Sweetheart's yellow hair. If ever there was love at first sight, I saw it in the look that black girl gave the white boy beside me.

So it was Sweetheart they were all looking at, not me! I swallowed this heartbreak, and suddenly, by golly, had a thought! No wonder these blacks were looking at Sweetheart. Why, they had hardly seen a blonde all their lives. Even among our own men. Sweetheart had the only hair that was really yellow. Yellow hair or not, though, the look that black wench had given him had not been one of casual interest. I gulped and pulled him to the end of the

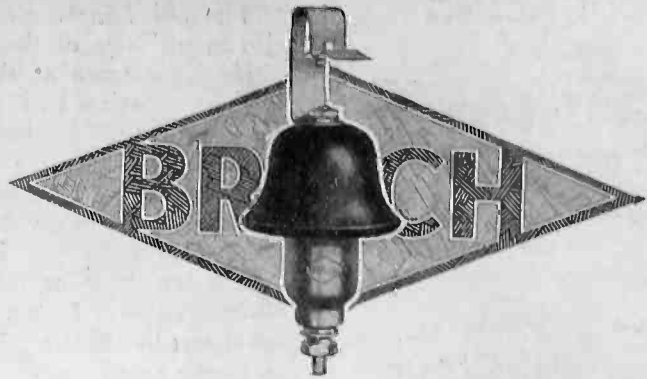

## Brach Radio Lightning Arresters Now Carry With Them \$100.00 Insurance

Against Damage to Any Standard Radio Set

The high efficiency of Brach Lightning Arresters enables us to attach to every Brach Arrester a \$100 guarantee against damage by lightning. This insurance covers only electrical parts in Radio Sets of Standard Make and does not apply to tubes or cabinets.

### L. S. Brach Mfg. Co., Newark, N. J.

Makers of Electrical Protective Devices for Over 20 Years.

## Silence the Thunder of the Near-by Station

Filtrola

NO LONGER need your radio set, if it is fairly selective, remain at the mercy of some near-by station whose signals are audible at all points on the dials. The Filtrola will "drop out" for you the station to which it is tuned, leaving the air as clear as though the near-by station had signed off.

Price \$15

**All-American Radio Corp.**  
*Pioneers in the Industry*  
Belmont, Tripp and Kenosha Aves., Chicago

EASY TO INSTALL

The Filtrola has four binding posts: Connect two of them to your antenna and ground leads, and the other two to the antenna and ground posts on your set. There are no tubes and no battery connections to be made.

EASY TO OPERATE

First tune in the interfering station on your own set. Then tune it out with the two dials of the Filtrola. Then tune in any station you want with the set—you need not touch the Filtrola again.

OWNING AND OPERATING STATION WENR—266 METERS

# ALL-AMERICAN

Radio Built for the Years to Come

Tell them that you saw it in RADIO

ANNOUNCING  
The New  
**FROST-RADIO  
GEM-JAC**  
The Jewel of all Radio Jacks

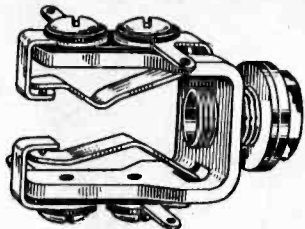

List:  
50c

**FROST-RADIO**

No. 951 Double Circuit Gem-Jac

**THE NEW FROST-RADIO GEM-JAC** is ready! It is the smallest and most compact radio jack made. An entirely new principle in spring design. The GEM-JAC projects only 1 inch back of panel. Has extremely low capacity effect, self-cleaning contacts, Bakelite insulation, sterling silver contacts, nickel plated brass frame. **FROST-RADIO GEM-JAC** gives you more room in your set for other parts. Order from your dealer now

No. 953 Open Circuit type, 40c  
No. 954 Closed Circuit type, 45c  
No. 951 Double Circuit type, 50c

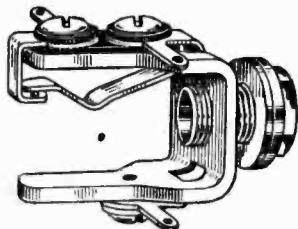

**FROST-RADIO**  
No. 954  
Closed  
Circuit  
Gem-Jac  
List:  
45c

**FROST-RADIO**  
No. 953  
Open  
Circuit  
Gem-Jac  
List:  
40c

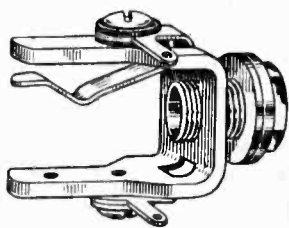

**HERBERT H. FROST, Inc.**  
314-324 WEST SUPERIOR ST., CHICAGO  
New York City Cleveland Kansas City  
Los Angeles  
Export Office: 314 W. Superior St., Chicago

**IN-A-CAP HYDROMETER**

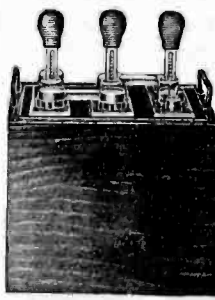

Stays permanently in your battery. Always ready and drip proof. No fuss or muss. No burned rugs or clothes, no stained floors or wet battery tops. Set of three \$2; single, 75c. At dealers or by mail post-paid.

Fits any cabinet by adjusting height of bolt.

**IN-A-CAP HYDROMETER CO.**  
1343 W. 14th Pl., Chicago



oval on the far side, where the men from the ship were gathered in a bunch.

"What's doin'?" I asked.

"The old King's coming out to say hello to us," one of the men explained.

"He lives down at the other end in that house that's a little bigger than this one, doesn't he?" I asked, doubtful. "I saw a woman in there as we went by that was good looking enough to be one of the King's private servants."

"Must've been the Princess. That house is for the King's daughter."

"Omigawd!" I gasps, grabbing Sweetheart by the arm. "C'mon; lets go out to the ship."

Sweetheart tells me that he is enjoying himself and don't want to go to the ship and what in hell is the matter with me, anyway. But—a love affair with a Princess. Gosh! One break for our team—he didn't see her look at him. That's something.

The sailor who told me where the Princess lived suddenly turned around. "Here he comes. Remember not to touch him, or we'll get speared. The King is taboo."

Out come the King. He was a pitiful little beggar, old and all twisted, with a long, dirty white beard that hung down over his body, that was like a skeleton for all the bones that showed. He looked up at us out of sad black eyes set deep in his small, old black face. He was so old that he cried all the time. Coming out, he said a few words which I suppose were to welcome us, and then we lined up to file past him and pay our respects. We were going back to the ship.

I was next to last in the line. Sweetheart was last. I got to the King and made my little bow, and turned around to watch Sweetheart. He started to bow, and then what did the darn fool do next but say, "You poor, lonely ole cuss," and put both his big hands on the King's bony old shoulders and give them a squeeze. The King's Congress—the blacks gathered around him—gasped, and I didn't blame them. I reached back and grabbed Sweetheart, cussing a blue streak at him, but he shook me off as if he knew it was all right. And the next thing I knew the King had his arms around that big yellow-headed baby and was calling him one of the few words I knew in the dialect. "Son," he was saying.

Every step we took till we reached the beach and the *Cowalla's* boats, I expected to feel an iron-shod spear sink into me with a dull, thudding sound. I don't think I breathed till we were aboard, and then I took a long breath and bawled Sweetheart out for fair. "Well, you prize lunatic," I roared, "of all the bow-legged, knock-kneed, cock-eyed—" I stopped. He wasn't listening to me. "Well," I smiled sarcastically, changing the line of talk—"I sup-

pose you want to tell me that he reminded you of your poor old grandfather. Go on. Tell me that, you—"

"Aw, shucks," Sweetheart moaned. "He—he looked so lonely. The poor old devil! All those guys around him are two-faced." He was silent for a moment. "Nope, he don't look like my grandpa," he said seriously. "He—his beard was just like my old billy-goat's that I used to play with, though."

We had one more day to stay in the place. Sweetheart went ashore the first thing in the morning; I never knew he was gone, until he came tearing back just before noon and busted into the radio shack, gulping for air.

"The guy that's most powerful, after the King, is going to rob the old King of his throne today," he busts out. "He figures now is a good time, when the people are all excited about our being here. If the King is dethroned he'll be killed. Loan me a spark coil an' some dry cells an' some wire, and come along. I'm going to crab Ndonga's dirty work."

"Ndonga? How do you know his name?" I asked, and then suddenly, getting interested, "Say! Who told you all this?"

"The Princess speaks a little English. She—"

"Ow!" I dived for the half-inch spark coil on the emergency set and yanked it free with one swipe. "Grab that wire, Sweetheart. Let's go."

**T**HE long palm house that was palace and Hall of Justice combined was jammed and packed. Sweetheart and I stood toward the rear, trying to conceal our anxiety as we looked at the palm walls to see if our wiring was hidden well enough. Sweetheart sat on the box holding the dry cells, and I had the switch in my pocket.

The blacks began to make speeches—the powerful men of the court. Ndonga stood over to one side, and from the sneering grin on his face he was satisfied with the way things were running. The blacks liked the old King, but they were afraid of Ndonga. A blind man could see that. There was some tom-foolery with a witch-doctor brought from his ghost house on the outskirts of the village, but he fawned and smirked at Ndonga.

"You can tell who's paying *his* salary," Sweetheart whispered.

"Yeh," I whispered back. Things were getting hot. It would happen any minute now. And it did. Ndonga, after some preliminaries, stalked to the center of the room, close to the old chair that was the throne—the throne he wanted—and came right out with it, publicly demanding to be King.

The sweating blacks went mad with suppressed excitement. The place was stifling with the heat of their bodies. In the silence their breaths sounded like

Tell them that you saw it in RADIO

slowly beaten drums. This was the moment for which we had coached the Princess, while she helped us with our wiring.

Splendid in her gracefulness, she stepped forward till she stood opposite Ndonga, who scowled. As we had coached her, she told her people that this grave matter was nothing to be decided by humans. She called on the gods to help her. She raised her arms above her head. She began to speak rapidly. There was no use in mere mortals trying to decide who should be King; let the gods decide. The gods would decide. The gods would never let the wrong man sit on the throne. Let the two who would be King advance and subject themselves to the will of the gods.

That knocked the people off their feet. Lazy, they were glad to have the gods, instead of themselves, take the responsibility. The Princess took care that no time was lost, lest the spell wear off. She spoke quickly to her father and asked him to take the throne. Blinking his watering old eyes, the little man obeyed, not knowing what it was all about. The blacks fell silent as death. Nothing happened.

"Now," shouted the Princess, her eyes flashing, "Ndonga will take the throne!"

Pleased as Puck, smirking knowingly at his followers, Ndonga took the throne. Sweetheart sighed mournfully, and I closed the switch that sent 6000 high-frequency volts into a certain portion of Ndonga's anatomy. Ndonga screamed shrilly. He leapt high into the air, his legs and arms stiffly outstretched, his eyes bulging. His shiny black face turned gray while he was in the air.

When the blacks, their courage reinforced by the gods' decision, had taken Ndonga and his gang outside to have a bit of African fun with them, the Princess brought her old father over to us. We four were all alone in the quiet, dusty, palm house.

"He—old," she said, having a hard time with her English. "Thanks—thanks." Suddenly she threw her arms around Sweetheart's neck and began to cry. He took her arms away, but shook hands with her. "Glad to have helped," he said, as though he were saying it to the finest society woman in New York. "Good bye."

On the ship he said, "My, she was awfully cut up about her father nearly losing his throne, wasn't she?"

"You damn blind fool," I exploded. "She's in love with you!"

"I'm sorry," he said, his voice getting sad. "I hope I didn't hurt her, not knowing. Say—say, Sparks! Look over there. The island is moving!"

I looked instantly at the flag pole forward. It was moving along horizontally across the panorama of the island,

## with Benjamin Radio Parts

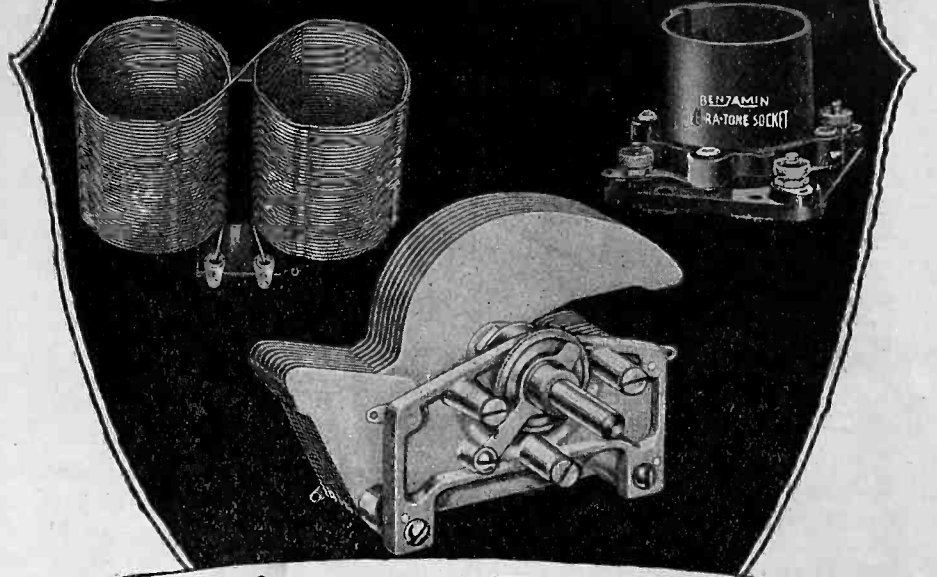

# Enjoy Radio all Year 'Round

With the right perspective and the use of the right radio parts, radio is an all year 'round source of entertainment. On the porch, in the garden, in camp and at the resort your radio may be a source of inspiration and amusement at all times. The longer days of Spring and Summer give us more time to plan and work. Our vacation periods are relatively short. For many of us it's just the time to do a lot of experimenting. The broadcast programs are just as fine. Except for distance, in extreme cases, reception on the average, is just as good.

Try it out. See what the right kind of radio parts mean in making radio good the year 'round.

Benjamin Radio Products increase sensitivity, aid selectivity and build up volume. Your radio dealer will show you.

If you haven't seen our latest 3-tube hookup, send for free instruction folder. And there's other literature for the asking to help radio 'round the year.

### Benjamin Electric Mfg. Co.

120-128 So. Sangamon St., Chicago

New York: 247 W. 17th St. San Francisco: 448 Bryant St.

Manufactured in Canada by Benjamin Electric Mfg. Co. of Canada, Ltd., Toronto, Ontario

# BENJAMIN

TRADE MARK

Tell them that you saw it in RADIO

**"A Better Condenser"**



The TOBE B BLOCK, No. 760, contains one 8 Mfd., two 2 Mfd., and two 1 Mfd. TOBE high voltage filter-condensers. It is ideal for construction of any B-Eliminator Unit, and is officially approved by the Raytheon Mfg. Co. for use with its famous Raytheon Tube.

Saves \$2.50 in cost of parts,—saves space,—saves wiring. Price, \$11.00.

AT YOUR DEALERS

In the silver case and silver carton. Send for free diagrams of B-Eliminators.

**TOBE DEUTSCHMANN CO.**  
Cornhill, Boston, Mass.

**Hoyt**  
**Radio Rotary Meter**



Price  
**\$24.00**

This is a unique 5-range precision moving coil voltmeter, made specially for the Radio Service Man, Dealer and Owner. It will make all tests necessary on Radio Receiving Sets, tubes, batteries and battery eliminators. It is rugged and will last a lifetime, yet will retain its extreme accuracy. Operation is simple and accident-proof.

**BURTON-ROGERS CO.**

26 BRIGHTON AVENUE, BOSTON, MASS.

National Distributors

HOYT makes a complete line of Radio Meters. Send for booklet, "HOYT Meters for Radio."

**Filter**  
**Condensers**  
for "B" Supply Unit

All sizes—All specifications—Meet all requirements—Made in three voltage ranges. Full specifications and details at your dealer's or direct. POTTER MANUFACTURING CO., North Chicago, Ill.

**Potter**  
By-Pass and Filter  
**Condensers**  
(An American-Made Product)

all right. "One of our anchors is loose; don't get excited," I hollered at the top of my voice. "The bow's drifting a bit, that's all." Just the same, I ran forward with Sweetheart to hang over and look at the anchor chains. So far as we could see, both anchors were holding fast.

"Come below! This is the moment I've waited for all my life. They're signalling us!"

He reached the set first, and got the tubes going while I split the headset so both of us could listen. Quiet! Then out of the stillness slowly came, one after the other—the eight notes of the harmonic scale! Eight long dashes, sent from something that had a tone like neither a spark nor a broadcasting set, soft and clear.

They didn't come second time. As soon as he dared, Sweetheart shouted, "Music! Why didn't I think of that before! The one medium we'd be sure to understand!"

I'll admit he had me believing everything. "Did the island really move?" I asked.

"They moved it to signal us to listen in. This must be the only place on earth where they can reach us, where conditions are right. Maybe they've been waiting for centuries. Perhaps the island is magnetized and floating, so they can turn it with a magnetic flux and signal anyone who is watching. I have been watching all my life." He thought a moment. "The island must be made of iron ore," he insisted. "Where else would these natives get their iron for spears? Some of those spears were made before any traders ever touched here; I noticed 'em particularly."

"I think we're both going crazy," I groaned, weakly.

Sweetheart stood like a soldier at attention, with a distant look in his eyes. "I'm coming back, some day," he said. "I've got to go back home with the ship; I owe it to the Old Man. But I'll come back."

**THAT'S** the end of the story. Maybe he did go back. I never saw him again. I can't explain things. They happened. Maybe he was playing a practical joke on me to get even with me for the one I played on him. I'd like to believe that, but somehow I don't—

Maybe he did go back. And maybe one of those long iron spears got him. I wonder if that was the music of the spears that he was talking about? Dam-mittall, anyway . . .

Worn files of various shapes make first class tools, such as knives, chisels, scribers, etc., when carefully ground to suitable edges, or points. Be careful not to burn the steel and draw the temper, however, if you grind them on an emery wheel.

**CALLS HEARD**

(Continued from Page 45)

From Dec. 16 to Jan. 5th, on 40 Meters at Lourenco Marques, Portuguese E. Africa—by Ioquim da Rocha Saraival  
1tcl, 1ah, 1air, 1aiu, 1amd, 1an, 1aof, 1bgd, 1bql, 1bsd, 1bst, 1by, 1cak, 1caw, 1cmp, 1gx, 1jr, 1my, 1si, 2agb, 2aim, 2ain, 2aky, 2ais, 2amj, 2aul, 2bse, 2cey, 2cft, 2orb, 2ds, 2gw, 2mk, 2mu, 2op, 2um, 2wh, 2xt, 3agg, 3umz, 3bwj, 3de, 3ng, 3pb, 3pf, 3po, 3pz, 3wb, 3xt, 4aa, 4aah, 4ac, 4av, 4cu, 4dk, 4eg, 4er, 4fr, 4iu, 4iz, 4je, 4jk, 4jn, 4js, 4nw, 4pl, 4pz, 4se, 4xe, 5aa, 5acl, 5adz, 5akl, 5am, 5ard, 5atp, 5fc, 5ni, 5jf, 5mi, 5qs, 5sd, 5se, 5ux, 5zai, 5zi, 6aak, 6abi, 6ael, 6aje, 6an, 6ana, 6ano, 6aps, 6aq, 6ase, 6at, 6au, 6asp, 6beo, 6bis, 6bpg, 6bql, 6btd, 6cav, 6cbb, 6cug, 6cco, 6cex, 6clx, 6cnn, 6cpl, 6cqa, 6cqw, 6ct, 6ctd, 6cuw, 6dab, 6dag, 6dam, 6eb, 6fe, 6ha, 6hu, 6ih, 6ji, 6kg, 6oa, 6oi, 6tq, 6ut, 6sz, 7am, 7wu, 8ada, 8am, 8ame, 8atv, 8av, 8avl, 8avo, 8awa, 8bau, 8bds, 8ben, 8bf, 8bnn, 8bq, 8bst, 8bt, 8vw, 8caw, 8cbr, 8ccq, 8cgo, 8eyl, 8da, 8dan, 8dem, 8dgl, 8djr, 8dm, 8dqz, 8dw, 8dzm, 8eb, 8edq, 8eq, 8kc, 8mc, 8nx, 8si, 8sj, 8uk, 8za, 8zk, 8az, 9acy, 9aig, 9alj, 9aim, 9aiv, 9aki, 9alf, 9amo, 9avj, 9axx, 9bnt, 9bme, 9bmm, 9bpb, 9bwe, 9cca, 9ccl, 9cpl, 9ctg, 9cvn, 9cyl, 9dct, 9dp, 9dpl, 9dud, 9ece, 9ep, 9mx, 9nv, 9og, 9oo, 9po, 9sw, 9wk, 9vo, 9wo, 9xi, 9xn, 9zd. 20 meters band 1el, 1rd, 2xi, 6yg. Can.: 3xi. Philippine islands 1in. South Africa: a4l, a5z, aya, a6n. Brazil: 6qa. Hawaii: wyi, 37c. U. S. N. air station, 1xl, 6buc. Palestine: 6zk.

By 3ABH, Clarence Wolf, Jr., 1521 No. 10th Street, Philadelphia, Pa.

1abz, 1acd, 1ajm, 1ajx, 1ane, 1aqi, 1axz, 1azj, 1bbk, 1bcr, 1bdm, 1bdr, 1bez, 1brz, 1chl, 1dgy, 1pe, 1pi, 1qb, 1qc, 1si, 1uc, 2aak, 2aav, 2abt, 2adc, 2adn, 2adw, 2atv, 2agl, 2aha, 2aib, 2aig, 2aij, 2aje, 2akj, 2amb, 2amq, 2aop, 2apc, 2apt, 2aux, 2bse, 2sj, 2cep, 2cgb, 2crp, 2ctn, 2cxi, 2ah, 2cp, 2jq, 2mt, 2pb, 4bk, 4cu, 4fg, 4ge, 4il, 4oa, 4sc, 4tf, 4wg, 5and, 5aps, 5onr, 5fs, 5to, 5vm, 6btz, 6cuc, 6hj, 6tr, 7ko, 7va, 8abs, 8amx, 8aw, 8ate, 8aul, 8axx, 8ayp, 8bdp, 8bin, 8blb, 8bzc, 8cag, 8ccr, 8cep, 8cgr, 8civ, 8ckp, 8cex, 8cor, 8cqs, 8cta, 8ctl, 8cyp, 8cwg, 8dax, 8ddb, 8dgv, 8dhu, 8dol, 8dpv, 8dqg, 8dqh, 8bg, 8dq, 8eu, 8kf, 8uf, 8uj, 8uz, 8wp, 8yv, 8zi, 9adw, 9afo, 9ahq, 9aiz, 9ajq, 9akj, 9apy, 9axx, 9atq, 9aup, 9awd, 9awe, 9axf, 9bbf, 9bca, 9bey, 9bfb, 9bfg, 9bge, 9bik, 9bjk, 9bli, 9bmy, 9btr, 9btz, 9bvq, 9bzi, 9caa, 9caj, 9cft, 9ckg, 9cvo, 9dco, 9dea, 9dgv, 9dkq, 9djh, 9dvt, 9ebv, 9efe, 9efj, 9eld, 9be, 9ei, 9ev, 9fp, 9jz, 9mi, 9pt, 9rt, 9rk, 9vh, 9vj, 9wn, 9xm. Canadian: 2am, 3dh, 3qs, nao, wiz, wir. QRTX mi 30 watts cw? A card goes out for every one that comes in.

By 2ASB, Frank R. Day, 30 Verandah Pl., Brooklyn, N. Y.

6aaf, 6aak, 6aec, 6ael, 6afs, 6ahp, 6ajj, 6ajm, 6akw, 6akx, 6ala, 6aoj, 6aou, 6api, 6apw, 6aq, 6as, 6avb, 6awt, 6ay, 6bam, 6bcq, 6bcu, 6bdw, 6bek, 6bgo, 6bgv, 6bhl, 6bnz, 6bil, 6boa, 6bol, 6bpb, 6bq, 6bqr, 6bsc, 6buc, 6bac, 6cah, 6caz, 6cbj, 6ccn, 6cco, 6ccv, 6cdy, 6cgk, 6cgv, 6cls, 6cja, 6cqv, 6ckv, 6clf, 6cnd, 6cpq, 6cqa, 6cqt, 6csw, 6ct, 6ctd, 6cuc, 6cur, 6cvq, 6daa, 6dab, 6dag, 6dah, 6dal, 6dam, 6dbe, 6dbi, 6ddh, 6eb, 6ec, 6ew, 6gn, 6ha, 6hf, 6hv, 6ih, 6ji, 6jk, 6js, 6kb, 6la, 6li, 6lr, 6ob, 6oi, 6pz, 6qg, 6rg, 6rn, 6sb, 6tq, 6ts, 6ul, 6us, 6vc, 6xl, 7aa, 7aek, 7aft, 7agq, 7alf, 7alo, 7au, 7ay, 7cs, 7dc, 7ds, 7df, 7ek, 7fl, 7gr, 7hb, 7jt, 7mz, 7ok, 7ps, 7rl, 7ru, 7sd, 7tm, 7uz, 7ya. Australia: 2am, 2bb, 2bk, 2cs, 2ds, 2gq, 2ij, 2jw, 2rj, 2tm, 2yi, 3ad, 3ak, 3bd, 3bm, 3cg, 3ef, 3hl, 3jm, 3jr, 3kb, 3qh, 3rc, 3wg, 3yn, 3yx, 4an, 5ay, 5bg, 5da. New Zealand: 1ao, 1fq, 2ac, 2ae, 3ad, 3af, 4ac, 4ag, 4al, 4ar, 4as, 4av. Philippines: 1hr. Japan: jrf. Brazil: 1ac, 1an, 5ab. Mexico: 1aa. Italy: 1gw, 1rm. Holland: pb3. Africa: oa4z, oa3b. Chile: 2ld. Argentine: afl. QRK 2asb? 10-20 watts input. All cards QSL'd.

By 6ALR-6CKW, Rt. F, Box 525 Fresno, Calif.

1ax, 1pl, 1te, 1so, 1aac, 1aao, 1xc, 1hh, 1cuv, 1kc, 1wa, 1abf, 1jr, 1oa, 1pl, 1air, 1aqo, 1anq, 1bcc, 1cmp, 1zt, 2ha, 2brb, 2iu, 2aay, 2wb, 2buc, 2bgl, 2cub, 2bjp, 2bmn, 3apv, 3ava, 3mf, 3mu, 3chh, 3kz, 3ll, 3qt, 3yo, 3zo, 2tp, 4gw, 4au, 4bq, 4cu, 4er, 4uk, 4sa, 4je, 4xe, 4sl, 5he, 5aci, 5qk, 5wy, 5uk, 5wo, 5ox, 5lg, 5amw, 5aom, 5sz, 6cev, 6ajm, 6nw, 6ase, 6mf, 6v, 6vl, 6uv, 6cl, 6ap, 6bsx, 6mm, 6zt, 6ear, 6cuo, 6dng, 6dxe, 6uq, 6cyr, 6nm, 6wv, 6bh, 6ge, 6dwx. Foreign: a-3lm, a-2ml, z-4ag, z-2ac, z3lb, z-2xa, m-1aa, m-bx, j-1aa, f-8ab.

Tell them that you saw it in RADIO

# Smallest Uniform Frequency Condenser

Easily Fits Into Present Sets

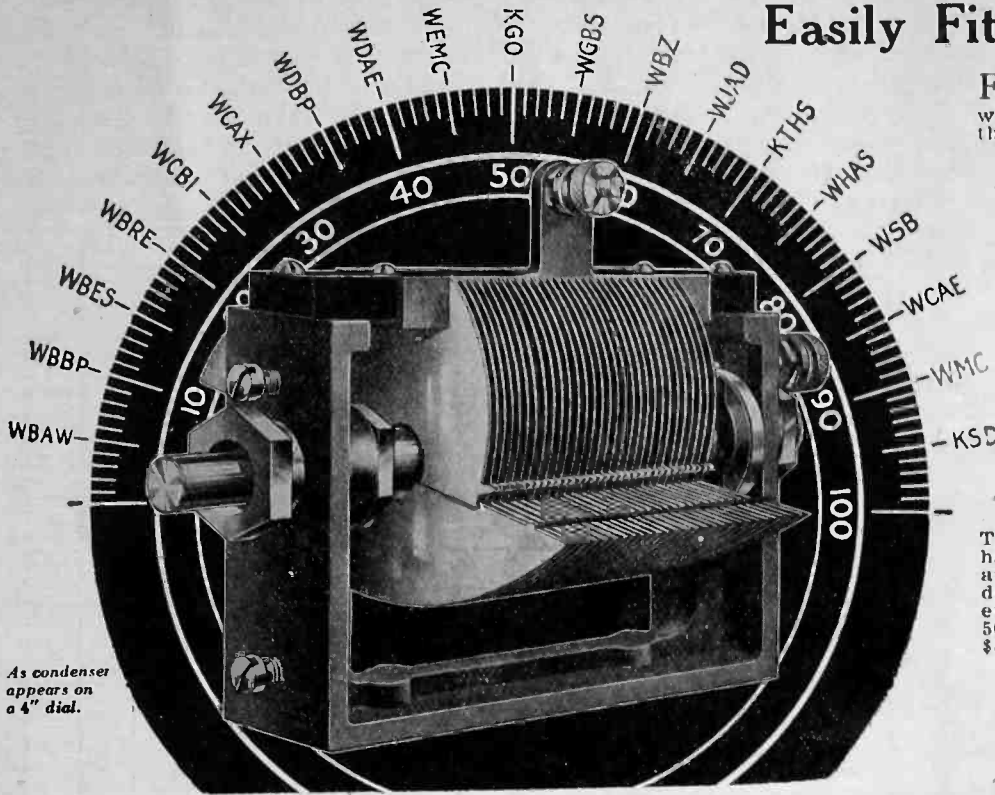

As condenser appears on a 4" dial.

FULL size illustration at left shows Samson Condensers are but  $\frac{3}{4}$ " diameter with plates fully extended—half to a third the size of others.

You can easily increase the selectivity of your present receiving set having ordinary condensers, and do away with the crowding of station readings—where 85 out of 100 come in below 50 on dial—by using

## Samson Uniform Frequency Condensers

Samson Uniform Frequency Condensers are built to a tolerance of 1/1000 inch, silver plated all over for high surface conductivity, and—in addition—have gold plated rotor and stator plates to prevent oxidization.

These grounded rotor type instruments have losses lower than the average laboratory standards. This condenser, due to its design, does not have the defects caused by either solid metal or dielectric end plates. 500 mmf., \$9.00; 350 mmf. \$8.75; 250 mmf. \$8.50.

### Samson Electric Company

Manufacturers Since 1882  
Canton, Mass.

Sales Representatives in Thirty Leading American Cities

Western Representatives: A. S. Lindstrom Co., Los Angeles, San Francisco, Portland, Seattle, and Salt Lake City; Radio Sales Service, Ltd., Vancouver, B. C.



This group covers wave bands 15-35 and 30-65 and 60-133.

Price **\$12.50**

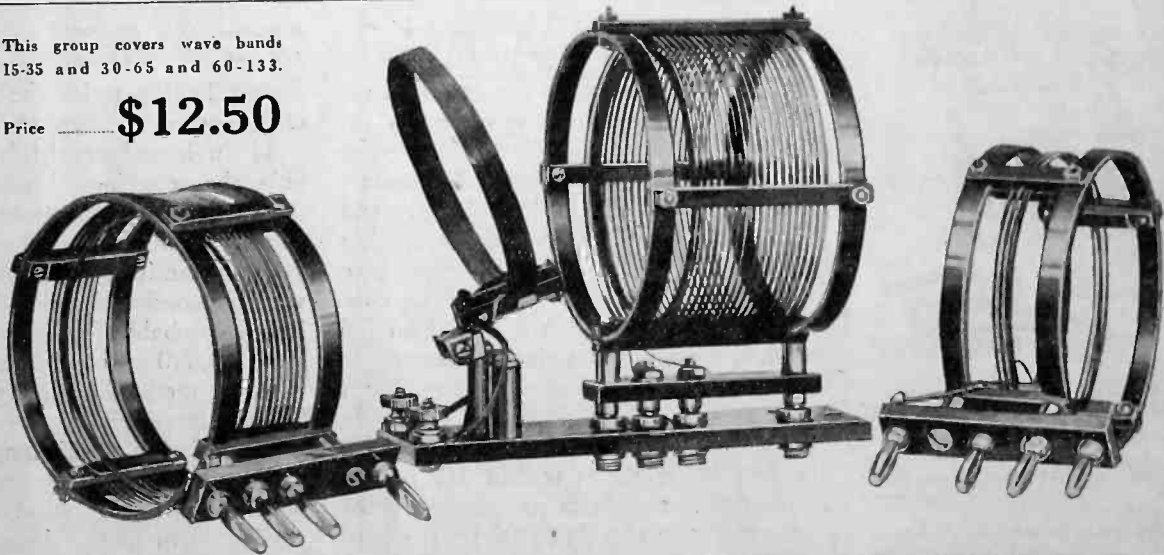

## 15 to 550 METERS WITH THIS KIT

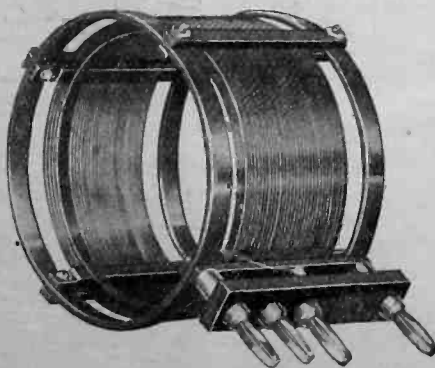

Aero Coil No. 4 for wave band 125-250 meters. Price \$4.00. (Fits mounting base in kit.)

Reception of amateurs from distances as far as 5000 to 7500 miles is nightly being accomplished with the new Aero Plug-In Coils. Amazingly efficient because of the patented Aero Coil construction. If your dealer is not stocked, order direct.

AERO PRODUCTS, INC.  
1768-1772 Wilson Avenue  
Dept. 18, Chicago

## AERO PLUG IN COILS

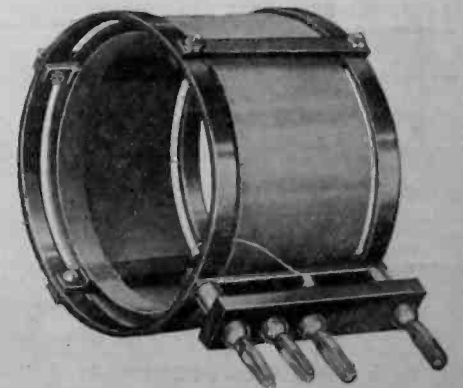

Aero Coil No. 5 for wave band 235-550 meters. Price \$4.00. (Fits mounting base in kit.)

Tell them that you saw it in RADIO

"He didn't need new tubes!"

# SANGAMO

## Accurate Condensers

(Solidly molded in impervious Bakelite)



saved  
\$15

FOR several weeks his receiving set had been disappointing. Previously, it had been a constant delight, but now programs came in so weak his family had to use headsets — they couldn't hear the loud-speaker clearly. Nothing but local stations. Friends said he needed new tubes, new batteries, new aerial, new this-and-that; all with a fine friendly disregard for the cost.

Then a real radio expert gave him good advice. "Trouble may be in your fixed condensers. Moisture creeps in at exposed edges and changes their capacity. This upsets the electrical balance; there is resistance where there ought to be exact capacity, and your reception is spoiled, both in quality and volume.

"Try Sangamo Mica Condensers. Their accuracy is guaranteed, and the solid, seamless bakelite jacket prevents the capacity from ever being affected by moisture, fumes, soldering heat, or any other cause of condenser troubles."

Putting in these accurate Sangamo Condensers increased volume, cleared up reception, brought in DX and saved a waste of money for new accessories. Such a little, inexpensive part — but tremendously important! Any real expert will tell you so.

APPROVED BY ALL NATIONALLY  
RECOGNIZED RADIO LABORATORIES

Sangamo By-pass Condensers are also accurate — and surges will not break them down. They last longer.



## Sangamo Electric Company

633 L-1 Springfield, Illinois

RADIO DIVISION, 50 Church Street, New York

SALES OFFICES—PRINCIPAL CITIES

For Canada—Sangamo Electric Co. of Canada, Ltd., Toronto.  
For Europe—British Sangamo Co., Ponders End, Middlesex, Eng.  
For Far East—Ashida Engineering Co., Osaka, Japan

LATEST "COAST TO COAST" FULLY GUARANTEED

**RADIO'S-10 DAYS FREE TRIAL**  
SAVE 1/3 TO 1/2

Users everywhere report Miraco Radios get programs coast to coast on loud speaker; outperform sets three times as costly. Many hear foreign countries. Radio's most amazing values in unconditionally guaranteed, factory-built long distance sets—let testimony of users convince you.

**MIRACO  
RADIO  
GETS 'EM  
COAST TO  
COAST**

Powerful New Multi-tube Miraco gets long distance on loud speaker. Set, ONLY \$27.35 retail

FREE! Literature on latest improved 1 to 5 tube models, new low prices, testimony of users and SPECIAL OFFERS. Write:

**MIDWEST RADIO CORP'N**  
Pioneer Builders of Sets  
414 W. E. 8th St. Cincinnati, O.



AGENT  
USERS  
WANTED  
Write for  
discounts.

ARE YOU A SUBSCRIBER?  
SEND FOR TRIAL SUBSCRIPTION  
\$1.00 FOR SIX MONTHS

## SUPERHETERODYNE BAND FILTER

(Continued from Page 27)

forms for such inductances are given in Figs. 6a and b. For inductances of 3 to 5 millihenries use the form shown in Fig. 6a, and for inductances of 5 to 10 millihenries use that of Fig. 6b. The wire should be No. 26 enamel insulated and the approximate number of turns required for any inductance is given in the curves of Fig. 7 for each form.

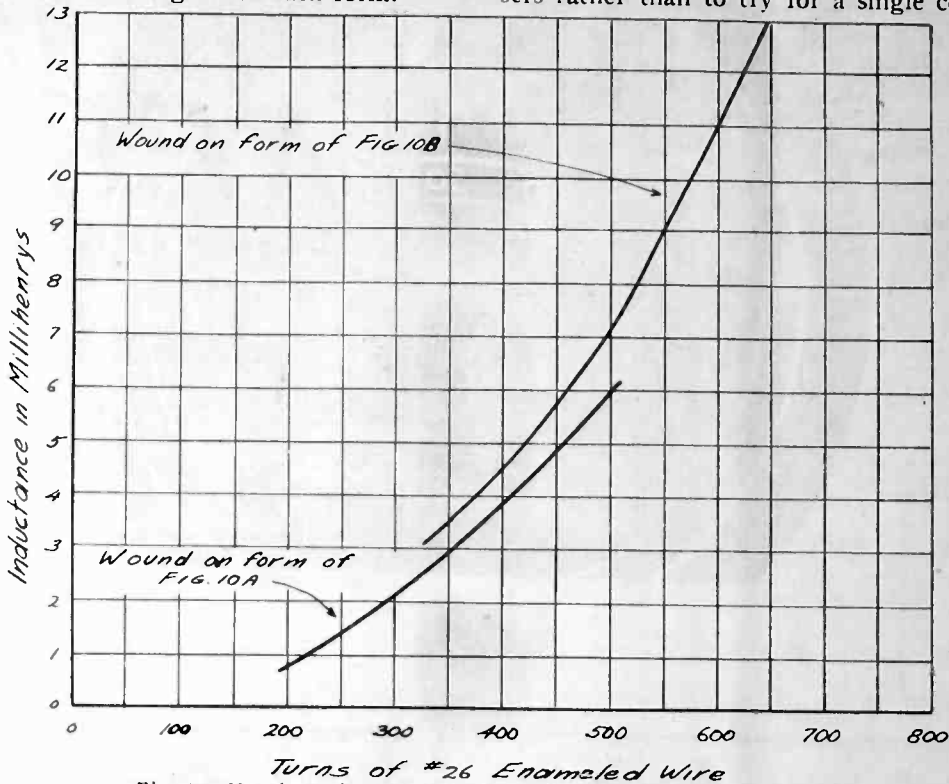

Fig. 7. Number of Turns Required for Given Inductances.

Methods of selecting the required capacities and measuring the necessary inductance are not available to the average constructor and he should, if possible, obtain carefully matched condensers and inductances from some reliable testing laboratory. However, if an impedance bridge, or a capacity bridge for the condensers, is available the selection of matched elements is a simple matter. It will probably be necessary to obtain about 20 condensers of each of the three values required in order to get a matched set which is within 1% of the required values. It is not necessary, of course, to have exactly .0005 mfd. where

this has been specified since, as may be seen from the cases worked out, a small variation from the specified value for a given set of elements will not seriously affect the cut-off frequencies nor the impedance provided that each similar element is exactly like its mates to the prescribed limit of 1%. Some time and trouble in testing may be eliminated by making up the terminating condensers from two of the regular series condensers rather than to try for a single con-

denser having twice the capacity of the chosen series condensers.

If an impedance bridge is not available the selection of capacities and inductances is rather more difficult. The capacity can, however, be quite accurately determined in terms of a calibrated variable condenser by building two oscillators probably having frequencies of from 30,000 to 100,000 cycles and using the beat method to determine resonance. Such methods have been described in previous issues of this magazine.

For the inductances, however, it will be necessary to wind an accurately turned form of the dimensions given in

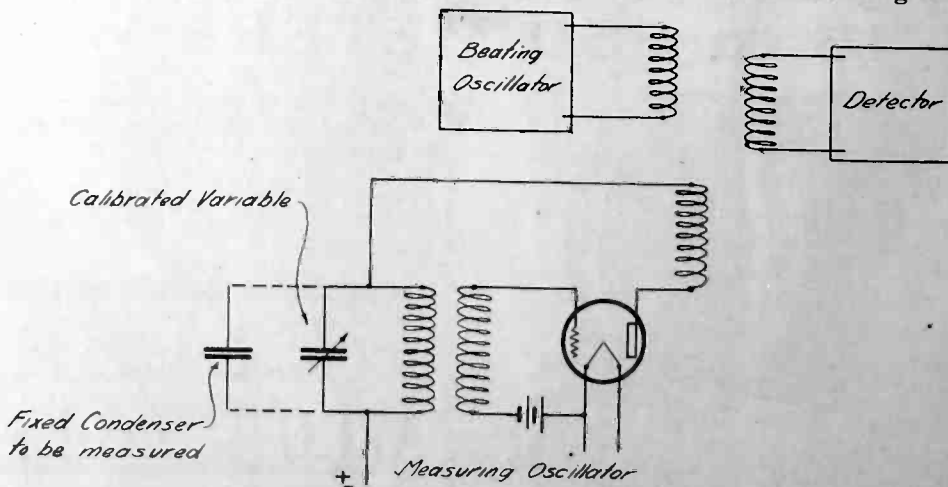

Fig. 9. Method of Matching Coils.

Fig. 6 with the number of turns shown by the curves in Fig. 7 to obtain the inductance required so that its value may be assumed instead of measured. The beating oscillators used above may then be used to adjust the three coils to have exactly the same inductance. This is accomplished by placing each coil in turn in series with the capacity of the oscillator as shown in Fig. 9 so as to determine which of the three requires the largest capacity setting for resonance as indicated by zero beat. This coil will have the least inductance and the other two may be adjusted to the same value by unwinding turns until the same value of capacity brings them to resonance.

Having selected the condensers and inductances the filter may now be assembled in some such form as that shown in the illustration of the completed fil-

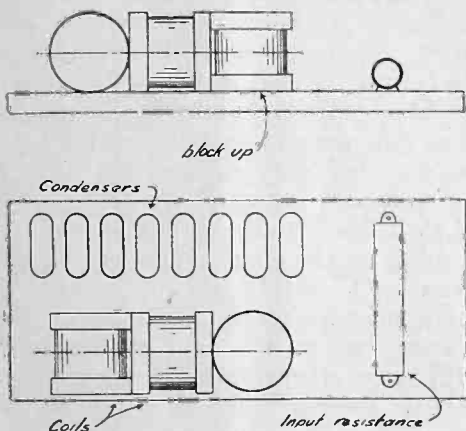
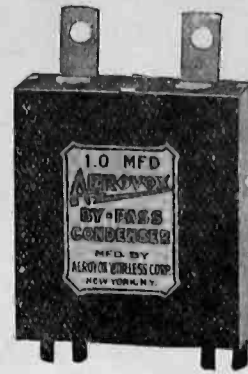

Fig. 10. Sketch of Completed Filter.

ter and indicated in the sketch of Fig. 10. Almost any physical arrangement for the condensers will be satisfactory provided that they are wired as shown in Fig. 4. The one important matter is to be sure that the three inductances have no mutual inductance. This is accomplished by placing them mutually at right angles as shown. It is not necessary to separate them widely in space and that the entire filter may consequently be made very compact. The one in the illustration has over-all dimensions of 4x6x3 inches.

There can be little doubt but that the superheterodyne offers the best possibility for perfection of design of any radio receiving circuit now known and it is equally true that it offers the greatest problems. The remarkable improvement which can be effected by the use of a well designed band pass filter has probably not been attempted in the past because of the lack of thorough knowledge of filter design as hinted in Campbell's remark that "any one skilled in the art may construct the electric wave filter." It is hoped that this article will have dispelled a little of the darkness hitherto surrounding Campbell's epochal invention and will have opened the way for a new advance in radio receiving.

Tested and approved by  
M. I. T., Yale, Radio  
News, Popular Radio  
and Popular Science.



Used by Over 200 of  
America's Leading Set  
Manufacturers.

# AEROVOX

By-Pass and Filter Condensers  
"Built Better"

AEROVOX WIRELESS CORP.

489, 491, 493 Broome St., New York City

Chicago, Ill., 53 W. Jackson Blvd.

Branch Offices:

Boston, Mass., 104 Portland St.

Los Angeles, Calif., 324 N. San Pedro St.

# BUILD THAT SET ON KELBRAKETS

## BUILD ON KELBRAKETS AND WIN TEN DOLLARS!

We'll pay \$10.00 for every photograph we accept showing Kelbraket-Built sets. Build that new set on Kelbrakets, or bring your old receiver up-to-the minute with new parts and Kelbrakets. Neater, sturdier, lighter, more compact, efficient and easier to wire. Model 7 specified in BEST'S 5-TUBE SUPER and in RADIO DIGEST "FOUR-FILTER SUPER." Ask your Dealer, or send for FREE Kelbraket Booklet, which shows actual size and many uses.

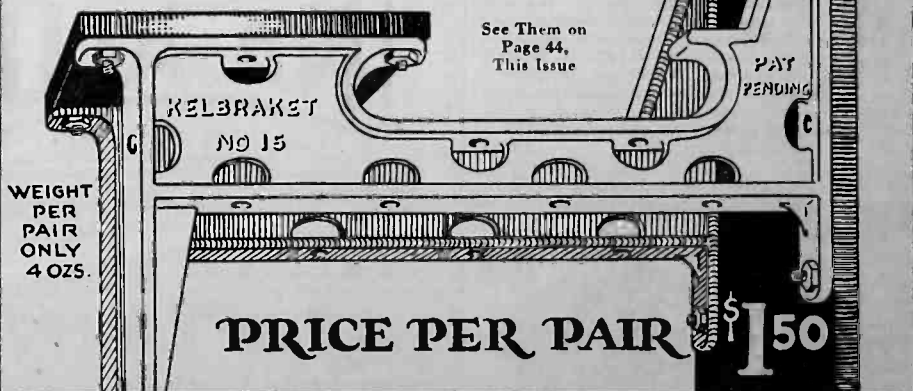

**KELLERADIO Inc.**  
821 MARKET ST. SAN FRANCISCO, CALIF.  
MADE IN THE U.S.A.

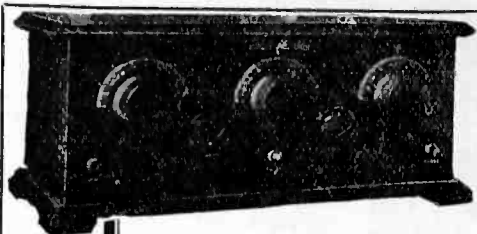

In  
7x18"  
Cabinet

# It's a 5-Tube

Gold Medal  
Tuned  
Radio Frequency  
Receiver

Was \$60  
without accessories

# NOW \$25

without accessories

Agents write for proposition

Satisfaction Guaranteed

Delivered free anywhere  
in the United States

Gold Medal Radio  
1048 Longwood Avenue  
New York City



NA-ALD de Luxe Socket No. 400

Specified for the  
10-Tube  
Superheterodyne Set  
featured in this issue

CLEAR reception is the chief reason why the Na-Ald de Luxe socket has been specified for this set. The contact is perfect. Equipped with the unique Na-Ald side scraping contact, a twist of the tube in the socket scrapes the corrosion from the tube terminals and the contact grips firmly the cleanly scraped portion. *It is the contact that counts.* Low loss and low capacity are assured by the Alden Processed Bakelite from which the socket is made.

The Na-Ald line of sockets is standard. Na-Ald sockets are specified in the Hammarlund-Roberts, the Diamond of the Air, and other well known sets. The Na-Ald sockets, adapters and connectorallds will fit any tube to any set. But there probably will never be a more efficient socket than the standard Na-Ald de Luxe No. 400 with its unique side scraping contact. Send for full information on the Na-Ald line of sockets and dials.

Alden Manufacturing Co.  
Dept. G-13, Springfield, Mass.

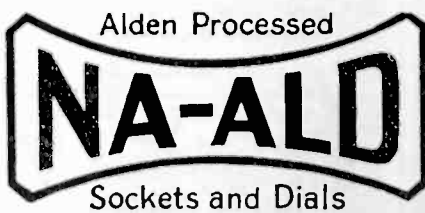

## A GOOD VARIABLE CONDENSER

(Continued from Page 18)

sure is so great as to actually thin out the plate and at the same time harden it by causing its molecular structure to become denser, just as a blacksmith causes a piece of metal to become more dense by rapidly and vigorously hammering it in a cold state.

The end plates of the condenser, while they should be heavy and rigid, should, if possible, be of a skeleton or cut-away pattern, or else very small and well removed from the active plates, as it is in the end plates that the greatest eddy current loss is prone to occur, due to their thickness.

The bearings of the condenser should be generously proportioned, adjustable for wear and for alignment of the rotary plates with respect to the stationary ones, and should preferably involve contact between dissimilar metals. The latter provision is especially important if the bearing is used as the contact member also, (this is *not* the best practice), as in this case no lubrication of the bearing may be employed, and the wear is apt to be very great. A far better method than this is to use a rigid spring, fastened to the end plate and bearing against some solid part of the rotor, say the shaft, to make contact, thus leaving the bearing free to act as a bearing only. Still better than this, is the pig-tail connection, the best forms of which are the so-called clock spring type, made of a thin, flexible strip of bronze or spring brass coiled up in this form; and the braided type, which is formed of fifty or sixty very thin bare wires, such as are used in loop wire, plaited together and looped loosely between the end of the rotor shaft and the outside of the end plate.

Another thing which affects the ruggedness of the condenser is the method of holding it together. The effectiveness of the method used may be tested most easily by gently twisting the condenser with the hands, to see if it be easily sprung out of alignment. If it be fairly resistant, no further attention need be paid to this feature, as twisting strains will not occur if the condenser is properly applied to its mounting.

The question of one or four hole mounting comes up here, although it has no direct bearing on the ruggedness of the condenser. The three point mounting type of condenser has the disadvantage of being more troublesome to mount, not only due to the necessity of drilling four holes, but also to the fact that very few panels are perfectly flat, which brings the necessity of shimming up one or more of the mounting supports to avoid springing the condenser out of alignment when the mounting screws are drawn up tight. It has the very definite advantage, however, that once



### NO MORE LOOSE CONNECTIONS X-L PUSH POSTS

A binding post that really does excel, looks, action, service, and convenience. Push it down—insert wire—cannot jar loose from vibration. No screwing or danger of shearing off wires. Furnished attractively plated with soldering lug and necessary markings. Price, Each 15c.  
X-L RADIO LABORATORIES  
2428 Lincoln Avenue Chicago



## GENUINE



### Kenotron Rectifying Tubes Model UV-216

Filament voltage 7½ volts, rated Input Voltage 550 A. C., but will safely rectify voltages up to 750 volts A. C. These rectifying tubes will pass plenty of current and voltage in your "B" ELIMINATOR, or for your TRANSMITTER. Standard base. Every tube brand new and packed in original cartons.

List Price \$7.50

Extra Special **\$1.85**  
ca.

AMERICAN SALES CO., 21 WARREN Street, N. Y. C.



mounted, it is forever in the same perfectly aligned position. The one hole mounting type, on the other hand, while easy to mount accurately, is somewhat harder to maintain in its original position, due to the unfortunate propensity of clamping nuts to gradually become loose. The balance of favor should rest, I feel, with the three point suspension type.

The fourth requirement, adjustability, refers to the bearings of the condenser, and has been fully discussed in the above paragraph.

The fifth feature, compactness, is attained by close attention to the details of design. Remember this: of two condensers of the same capacity, the smaller of the two is usually the better constructed condenser. Again, in the small condenser, it is easier to secure low minimum capacity, which insures accurate tuning on the low wavelengths. In a good condenser of 0.0005 microfarad capacity, the ratio of maximum to minimum capacity should be about fifty; in other words, if the maximum capacity is 0.0005 microfarads, the minimum capacity should be one fiftieth of this, or 0.00001 microfarads. A higher ratio than this is unnecessary for radiocast work, and tends to increase the resistance of the condenser. In pursuing the elusive phantom of compactness, however, one should not err on the side of purchasing a condenser so small that its construction is flimsy, for lack of ruggedness spells trouble,—trouble with a big "T."

The sixth and last requisite, smoothness of operation, is the direct outgrowth of accuracy in construction, and is quite a reliable barometer of the care with which the condenser has been designed and constructed. The shaft should turn easily and smoothly, yet should not be so loose that the plates tend to drift from their position when once set. The bearing, in its adjustable feature, should provide some means, usually a split tapered collar and clamping nut in the form of a collet chuck, to obtain just the right tension on the shaft. The use of a counterbalance is undesirable from two points, those of the bulkiness and unsightly appearance which it causes, and of the great eddy current losses which are bound to occur when so heavy a piece of metal is placed so close to the active current carrying parts of a variable condenser. It also makes low minimum capacity hard to obtain.

I have purposely failed to discuss the much mooted question of straight line capacity versus straight line wavelength versus straight line frequency, as these different types of capacity variation have no bearing on the general electrical and mechanical worth of a variable condenser, but merely deal with the ease of tuning.



## Pioneers— Now Leaders

Since B-Eliminators first attracted the eager experimenters Dongan has pioneered in the building of transformers and chokes. Our 15 years' experience in the production of transformers gave us a big impetus. Our forward-looking engineers told us B-Eliminators would predominate eventually.

Dongan has worked with Raytheon in the perfection of Raytheon B-Eliminators. Dongan B-Power Units are one of the most important factors in the operation and performance of Raytheon B-Eliminators.

Today we are supplying the leading manufacturers of Eliminators with Dongan B-Power Units. No matter what type you build, we can supply you—mounted or unmounted types.



Manufactured for 25, 40, 50 and 60 cycles  
 509 Full Wave For Raytheon Tubes  
 537 Full Wave For R. C. A. UX-213 Tubes  
 537 Full Wave For Cunningham CX-313 Tubes  
 538 Half Wave For R. C. A. UX-216B Tubes  
 538 Half Wave For Cunningham CX-316B Tubes  
 561 For R. C. A. UX-216B Tubes  
 561 For Cunningham CX-316 Tubes  
 (To be used with Power Amplifier Units)  
 (List \$7.00)

### CHOKES

514 20 Henry  
 \$5.00 List



Our Specification of 539 Output Choke is adapted for bridging across loud speaker.

RAYTHEON  
 TUBES  
 \$6.00 List

### FANS:

Build your own B-Eliminators. You can do it easily with Dongan B-Power Units—simply constructed and inexpensive. You'll be happily surprised at the wonderful results you'll get with your set.

*If Your Dealer Cannot Supply You,  
 Send Money Order Direct*

## Dongan Electric Manufacturing Co.

2981-3001 Franklin St., Detroit, Mich.

*Pacific Coast Representatives:*

San Francisco—  
 Industrial Sales Co., 471 Second St.  
 Los Angeles, Calif.—  
 Sierra Electric Co., 212 Calo Bldg.  
 Portland, Ore.—  
 C. E. Gay, 166 Lowndale Street  
 Seattle, Wash.—  
 E. P. Denham, 2476 45th Avenue S. W.



## World's Finest Loud Speaker

A three-foot cone speaker-unit developed by the inventor of the Tropadync. Can be assembled in fifteen minutes, saving 80% of the cost. Complete Kone Kit with blue prints sold on rigid money-back guarantee—shipped prepaid—\$10.

Engineers' Service Company  
 Suite 203, 15 Park Row, New York

ARE YOU A SUBSCRIBER?  
 SEND FOR TRIAL SUBSCRIPTION  
 \$1.00 FOR SIX MONTHS

# Amateurs--- Attention!

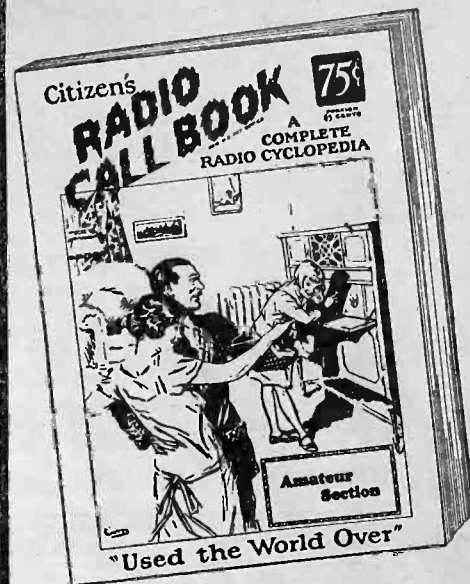

## The Most Complete Call Book Ever Published

Contains

An up to date list of all the amateur stations in the United States and Canada.

An accurate list of the amateur stations from over 30 different foreign countries.

The official ARRL traffic routes of the United States and Canada.

A corrected list of all the Commercial Land and Ship Stations in the United States.

All of the high powered land stations from every country in the World.

Compiled From Official Sources

### Only 75c

Write for this wonderful book today. Cash or money order.

## Citizens Radio Service Bureau

508 South Dearborn Street  
 Chicago, Illinois

## How to pass U.S. Govt. Radio Examination



310  
 Actual questions  
 answered  
 by E.E. Bucher

PASS the U. S. Government Commercial or Amateur Radio License examination! This book will help you do it! Send sixty cents in stamps or coin for your copy—postage prepaid to any point in the U. S., Canada or Mexico

For a Short  
 Time Only **60c**

RADIO INSTITUTE OF AMERICA  
 322 Broadway, New York City

Tell them that you saw it in RADIO

57



No guessing, less wiring and—no grief—with AMPERITE. Eliminates hand rheostats. AMPERITE is the only perfect filament control. Specified in all popular construction sets. Price \$1.10.

**Radiall Company**

Dept. R-5, 50 Franklin Street, New York City



Write for  
**FREE**  
Hook-ups

**AMPERITE**  
REG. U.S. PAT. OFF.

The "SELF-ADJUSTING" Rheostat

**AMPLION**

Product of nearly 40 years' Experience



For  
Better Radio  
Reproduction

Hear this creation of the originators and oldest makers of loud speaking devices, Alfred Graham & Co., England. Clear, life-like tone, supreme sensitivity and broad musical range explain its world-wide leadership in popularity. Six models, including phonograph units, with cords and panel plugs, at \$12 up. Write for "Amplion Pedigree."

**THE AMPLION CORPORATION,  
OF AMERICA**

Suite O, 280 Madison Avenue, New York  
Chicago Branch: 27-29 North Morgan St.  
Burndep't of Canada, Ltd., Toronto

**MURDOCK**

You Get Perfect Tone  
Quality With MUR-  
DOCK Headphones.

WM. J. MURDOCK CO.

211 South San Pe-  
dro St., Los Angeles;  
509 Mission St., San  
Francisco; 406 Occi-  
dental St., Seattle,  
Wash.

MURDOCK RADIO

**New Radio Log Book**

and

AIR LINE DISTANCE MAP

50c Money Refunded if you  
are not satisfied.

"RADIO," San Francisco

**DeJUR**  
AMPLIFIER

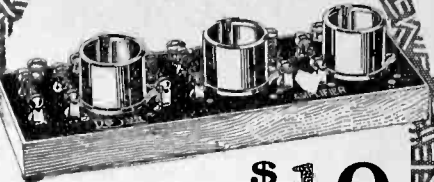

\$10

**Distortionless  
Amplification**

Equip your set with a DeJur Amplifier and enjoy REAL radio. Get tone, clarity and volume you never thought possible. Fits in the audio side of any set.

Equipped With DeJur Parts

Sockets of Genuine Bakelite and take standard or new UX tubes. Built with .01 Bakelite Impregnated Mica Condensers and DeJur Resistors. No bus bar in wiring. All metal strip connections are riveted. No screws, nuts or bolts to work loose.

Sold by all dealers  
Get the Genuine

Write for Catalog of  
DeJur Parts

**De JUR PRODUCTS Co**

The World's Largest Manufacturers of Rheostats  
173 LAFAYETTE ST. NEW YORK CITY

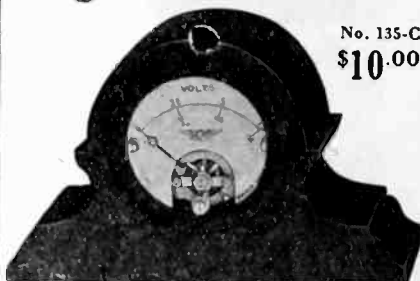

No. 135-C  
\$10.00

**WATCH Your Tubes  
and Batteries**

Send for Jewell Circular No. 739, which describes this Double Reading Portable Voltmeter with cords and phone tips for plugging into jacks of New Radiola, Victor and Brunswick sets. (7.5 and 150-volt scales.)

**Jewell Electrical Instrument Co.**

1650 Walnut St., Chicago

Twenty-six Years Making Good  
Instruments



**HALF WAVE "A B C"  
ELIMINATOR**

(Continued from Page 14)

drop across the entire load resistance provides adequate plate voltage for the power tube.

C voltages for the type 99 tubes are obtained by means of the voltage drop across the filaments of the various tubes, together with the drop across additional 25 ohm resistances placed between the tubes, as is shown in Fig. 1. It has been stated that if the C voltage for the power tube is obtained from voltage drop across the filaments of the type 99 tubes, distortion will result. While theoretically this may be true, this distortion is not evident if the power tube is not overloaded, and the arrangement shown in Fig. 1 is perfectly satisfactory. However, for those who would like an independent adjustment of the C voltage for the power tube, the arrangement shown in Fig. 2 may be used, as was described by E. E. Turner in March RADIO.

The actual wiring of the filaments of the tubes is best illustrated in Fig. 3, which shows the method of revising the circuit of the Bremer-Tully Counterphase. Wiring details for the Browning-Drake and superheterodyne circuits were given in the original ABC eliminator article, but for those who did not see these circuits, the Counterphase diagram will show the changes to be made for series operation of the tubes, and how to obtain the C voltages required.

It will be noted that several .01 mfd. fixed mica condensers which are not specified for use in the Counterphase circuit, will be required with the series arrangement, due to the .00035 mfd. tandem air condensers which tune the two pairs of r. f. transformers. The C voltage for the first r. f. tube is obtained through the voltage drop across the 2nd r. f. tube filament plus the drop through a 25 ohm resistance. The C voltage for the 2nd r. f. tube is had from the drop across the 3rd r. f. tube and a 25 ohm resistance, so that the grid returns of the first two r. f. tubes are made at different points in the filament circuit, and the resistance of the filament of the 3rd r. f. tube would disturb the adjustment of one side of the first tandem condenser. Hence, a .01 mfd. fixed condenser is shunted across the 3rd r. f. tube filament, and another .01 mfd. condenser is placed in series with the lead from the 1st r. f. tube grid to the tandem condenser. Neither of these fixed condensers have any appreciable effect on the tuning, and enable a balance to be obtained. The adjustment of the second pair of tuning condensers is easy, as their common return is to the same point, the positive filament of the detector tube. Another .01 mfd. fixed condenser is used for a ground return from the ground side of the antenna coil to the grounded negative of the ABC eliminator supply.

It is important that the filament of the detector tube be near ground potential, and that the grids of the r. f. tubes be as near to ground as possible, to avoid a. c. hum.

The assembly of the rectifier is optional with the builder. Some prefer to mount the apparatus in a box where it will be hidden from view, and others like panel mounted outfits, but the baseboard layout shown in the picture will serve as a guide, and will indicate the size of the assembled rectifier. An excellent idea is to place a thin sheet of brass, or tin plate, over the baseboard, and thoroughly ground all apparatus to the plate, which in turn is connected to a good water pipe ground. In this way, any trouble in the receiver due to ungrounded power apparatus will be eliminated, and wiring will be much easier, since the plate becomes the negative d. c. lead. No resistance or other voltage reducing device is needed in the filament circuit of the rectifier tube, as it requires  $7\frac{1}{2}$  volts. In the case of the full wave rectifier, the filament voltage is 5, and a rheostat is necessary to reduce the voltage.

A snap switch in the 110 volt primary circuit should be used for turning the radio receiver on and off. If the switch is placed in the high voltage d. c. lead, the stored energy in the filter circuit will burn the filaments out when the circuit is closed. The milliammeter shown in the positive d. c. lead is necessary when adjusting the current to the proper value, and once the constants of the circuit have been determined, it can be cut out of the circuit. For a circuit employing four 99 tubes, the total current should be adjusted to 63 milliamperes, so that the tube nearest to the load resistance will have a current in excess of 55 milliamperes. For five 99 tubes the current should be 65 milliamperes, and in this case, the two tubes nearest to the negative d. c. terminal of the filter should have shunt resistances of such value that the current in excess of 60 milliamperes is by-passed around the filaments. A 500 ohm tube protective resistance across the filament of each of these tubes will serve the purpose.

If the rectifier does not deliver enough current when all adjustments are made, and the apparatus appears to be O. K., it is well to check the line voltage. Several complaints of non-operation of the ABC eliminator have been traced to low line voltage, in one case the voltage being around 95 in the daytime and 100 at night, where it should have been at least 105 volts minimum. The only possible cure for this sort of trouble, if the power company cannot improve the service, is to take the power transformer out of its case and remove a few turns from the primary winding. It will be a cut and try method at best and should be done by someone who understands transformers.

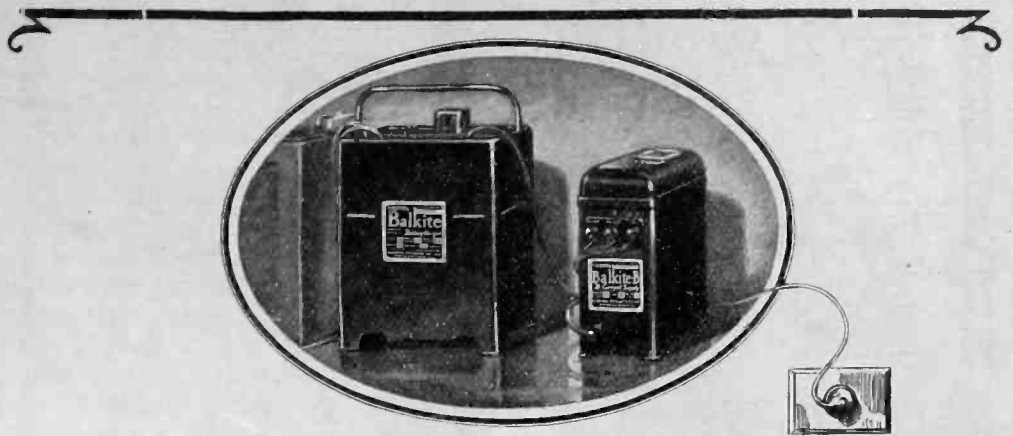

## Noiseless, full radio power from the light socket with Balkite "B" and the Balkite Battery Charger

Balkite Battery Charger, \$20. Balkite "B," \$35. At your dealer's.

Manufactured by FANSTEEL PRODUCTS COMPANY, Inc., North Chicago, Illinois

## A & B Battery Charger ONLY \$2

Satisfaction Guaranteed



Charges any type of storage A or B battery, using a few cents worth of ordinary house current. Tested and approved by Radio News Laboratories. Works perfectly on either alternating or direct current. Cannot injure battery. May be used as a trickle charger. Complete directions enclosed—anyone can operate. No expensive "Extras" to buy.

Why pay \$10.00 to \$18.00 for a charger when you can get this splendid GUARANTEED R. B. Charger by mailing us two dollars (bills, money-order, check or stamps), plus ten cents in stamps or coin, to pay mailing costs. Charger will be sent postpaid. If you are not satisfied, return within five days and we will refund your money. Order at once—TODAY.

**R. B. Specialty Co.**  
Dept. 340, 308 East Third Street  
Cincinnati, Ohio



**DON'T WAIT!**

### Pep Up That Set Now With **X-L VARIO DENSERS**

Install them in your receiver and hear them speak for themselves

SPECIFIED BY

**GERALD M. BEST**

Endorsed and Used by the Foremost  
Radio Engineers

SPECIAL FOR MODIFIED 45,000 CYCLE SUPERHETERODYNE  
CAP. RANGE .00002 to .0001 M. F., \$1.50

MODEL N—Capacity range 1.8 to 20 micro-microfarads for balance in Roberts two tube, Browning-Drake, McMurdo Silver's Knockout, Neutrodyne and tuned radio frequency circuits. Price, \$1.00.

MODEL G—Two capacity ranges, .00016 to .00055 and .0003 to .001 Microfarads, for the Cockaday circuit, filter and intermediate frequency tuning in superheterodyne and positive grid bias in all sets. Price, \$1.50.

**X-L RADIO LABORATORIES**  
2426 Lincoln Avenue CHICAGO

You Can Get

Greater Reflex or Crystal  
Set Reception if you  
use the

**BROWNLIE**

Vernier Detector

\$2.00 at Your Dealer or Direct

**ROLAND BROWNLIE & CO.,**  
22 Saunders St. Medford, Mass.



## RADIO from Factory to YOU

Get our list price on Parts also  
Knocked Down 1 and 3 Tube Sets  
Compare List Price with others then  
Deduct 20 to 50 per Cent Your Price  
**A. C. HAYDEN CO., Brockton, Mass.**

## Control Volume with this Modulator Plug

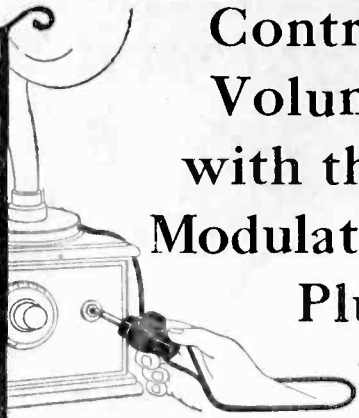

WITH your radio set operating under full power, you can now regulate tone and volume to suit your mood, by simply turning the knob on this *Centralab Modulator Plug*! Replaces ordinary loud-speaker plug. Provides perfect control of volume from a whisper to maximum, without touching the tuning dials or rheostat. *Cuts down static interference, smooths out powerful local stations, and brings through programs sweet and clear—improves spring and summer reception wonderfully!*

\$2.50 at your radio dealer's— or sent direct if he cannot supply you. Write for literature describing this and other Centralab controls.

**CENTRAL RADIO  
LABORATORIES, ]**  
14 Keefe Avenue  
Milwaukee, Wisconsin

*Manufacturers of variable resistances for  
all radio circuits.*

# Centralab

Make any Good Receiver  
**BETTER**

**CC  
TUBES**

C.E. MFG. CO.  
Providence  
R.I.



A SUBSCRIPTION TO  
"RADIO"  
INSURES REGULAR  
RECEIPT OF COPY

## TEN-TUBE SUPERHETERO- DYNE

(Continued from Page 17)

denser gave the best selectivity and sensitivity. The proper ratio of inductance to capacity in this circuit is best selected by trial. After the peak frequency of the intermediate transformers has been determined a combination of honeycomb coil and condenser should be selected which tunes roughly to this wavelength and subsequent adjustment made by trial and error. If the size of the inductance is increased the capacity must be correspondingly decreased with a consequent broadening of the circuit. If the peak

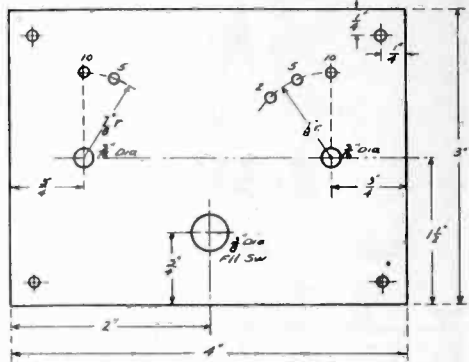

Fig. 4. Layout for Sub-Panel Switch Mounting.

of the intermediate transformers is sufficiently broad the selectivity may be varied considerably by a simple change in capacity using fixed inductance without detuning.

Audio frequency amplifiers of types other than transformer coupled should be used immediately following the second detector only with caution. Straight resistance or impedance coupling tends to pass radio frequency through the audio stages resulting in overloading and distortion. Some sort of filter must be interposed between the second detector and first audio tube with these types.

The two small switches controlling the number of tubes used and the filament switch for the intermediate stages and second detector are mounted on a small panel within the cabinet between the first detector and audio amplifier. Details are given in Fig. 4. The switches should be well separated and switchpoints well spaced because it is at this terminal board that the input and output terminals of the intermediate amplifier come closest together and feedback is most liable to occur. With switches *A* and *B* on points 10 the entire ten tubes are in use if filament switch *SW2* is on. With switches *A* and *B* at 5 and filament switch *SW2* off only five tubes are in use. With switch *A* on tap 2 the first two tubes only may be connected by means of the posts *LS2* to any external amplifier such as the RCA Type 104.

The particular arrangement described allows of progressive manipulation of the various circuits. For instance with the phones connected to posts *LS2* the

radio frequency stage and regenerative detector only are in use and may be adjusted to maximum efficiency. With the antenna condenser at approximately half scale the detector is caused to oscillate by advancing the regeneration control. The r. f. condenser is adjusted for maximum intensity of squeal and the antenna condenser slowly rotated through maximum. If the neutralizing condenser is properly adjusted the antenna condenser will have no effect upon the pitch of the squeal but will vary only its intensity.

After the first detector and radio amplifier have been adjusted so that distant stations are heard well the intermediate tubes and oscillator may be added by setting the two switches *A* and *B* at 10 and turning on filament switch *SW2*. With the variable resistance *R-x* set at  $\frac{3}{4}$  scale and before placing the shield on the intermediate amplifier adjust the potentiometer to near the spill over point. Place the shield in position. If the tuned output choke is properly adjusted fine control of oscillation should be had from the panel by means of *R-x*. Test the oscillator to see that it is operating by temporarily connecting a pair of telephones in series with its plate return. The moistened finger should be placed on the grid of the oscillator tube. If the tube is oscillating a click will be heard when the finger is touched to the post and another when it is removed. If the oscillator refuses to go, reverse the tickler connections. The oscillator coupling resistance to the grid of the first detector should be adjusted for maximum signal strength on a weak signal. In general the adjustment of this resistance which gives maximum results on strong signals is not the same as that for weak signals. In connecting up the *A* and *B* voltmeter do not forget to connect the multiplier in the *B* lead.

Due to its great sensitivity the receiver may be used with a small inside antenna. If desired the receiver may be used on an outdoor antenna because it radiates only to a very slight degree. However the necessity for a large antenna with a receiver of this kind is prima facie evidence that something is wrong.

In the panel layout only the center holes of the various instruments are shown so that substitution of equally efficient parts may be made if desired. One caution with regard to the straight line frequency condenser may not be amiss. In selecting your S. L. F. condenser be sure that it has a sufficiently high minimum capacity. If it does not, the combination of coil and condenser will not give you straight line frequency tuning. With a properly designed S. L. F. condenser the number of turns on the inductance will have to be adjusted so that with the condenser set at maximum 550 meters will be just reached at 100 on the dial.

## IMPROVING 40-METER RECEPTION

(Continued from Page 22)

Australian and New Zealand stations worked.

The transmitter sometimes uses one, and sometimes two, quarter kilowatt tubes. The output ranges between 300 and 700 watts with apparently very little difference in results.

Fig. 3 shows the transmitter and receiver set up and ready for action. Due to the fact that no ground is used on the receiver it has been found desirable to suspend the headphone cord by means of a long rubber band as shown in the picture.

Visiting amateurs without exception have been surprised at the signal strength and number of foreign stations available on any night they have been here, and some of them have gone home and put up a larger receiving antenna and have shielded their set, with correspondingly improved results. No exceptions to this rule have been found as yet, so we believe an increase in the size of the receiving aerial, and the shielding of the set, will better the signal strength as compared to inductive noises and bring about better communication. Incidentally, communication with stations in our own country is materially improved in the same proportion.

Those who are interested in short wave broadcast reception will find this set very satisfactory. In this case a regular broadcast type audio transformer should be used. The receiver here described has enabled voice to be heard from Chile and Mexico, and both music and voice from England and Australia.

## THE ARITHMETIC OF RADIO

(Continued from Page 32)

a large by-pass to say nothing of the distortion which would result.

The tube impedance may be found from Ohm's Law. With  $22\frac{1}{2}$  volts supplied to the plate and a plate current of 1 milliamp (.001 amperes), the tube d. c. resistance figures 22,500 ohms, and the impedance is 11,250 ohms or  $\frac{1}{2}$  the d. c. resistance.

The C battery voltage (usually  $4\frac{1}{2}$  volts) is impressed directly between the grid and filament thru the secondary of the audio transformer. Inasmuch as the negative C battery goes to the grid, no current flows in this circuit and there is no voltage dropped thru the secondary. In the plate circuit of the second tube there is no necessity for a by-pass condenser across the headphones or output, because there is no radio frequency current in this tube.

Thin strips of tinfoil (provided it is of real tin) may be used as a solder for small work, using the usual fluxes.

## Thordarson Equipped!

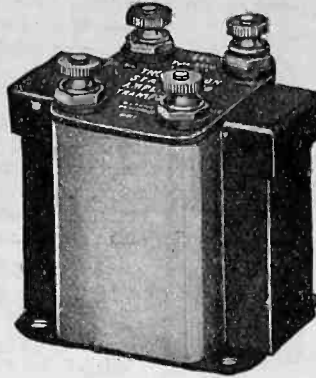

2 :1 ratio ... \$5.00  
3½ :1 ratio ... 4.00  
6 :1 ratio ... 4.50

**ZENITH**  
**KENNEDY**  
**Radiodyne**  
**Planstiehl**  
**Howard**  
**Thermiodyne**  
**OZARKA**  
**Deresnadyne**  
**ADLER-ROYAL**  
**MURDOCK**  
**MU-RAD**  
**Valleytone**  
**LEICH**  
**Silver-Marshall**  
**GLOBE**  
**John-crowk**  
**Newport**  
**BUCKINGHAM**  
**NUNN-LANDON**  
**KUSTOMBILT** and  
*many others*  
use Thordarsons

Month after month, season after season, these leading receiving set makers continue to specify Thordarson Amplifying Transformers.

They have learned that Thordarsons will "stand the gaff"—that in tone quality they satisfy even the most fastidious—that even in hardest service they will not break down—that they are designed right, built right, and sound right.

Build or replace with Thordarsons.

Write for descriptive circulars

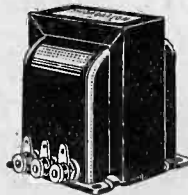

**AUTOFORMER**  
All frequency amplifier. Best bass note reproducer made. Price, each, \$5.00.

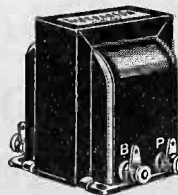

**R-200 AMPLIFYING TRANSFORMER**  
Super sized. Gives good musical reproduction. Price, each, \$8.00.

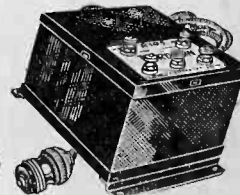

**B-ELIMINATOR TRANSFORMERS**  
For Raytheon Eliminator. Large capacity. Price, each, \$7.00.

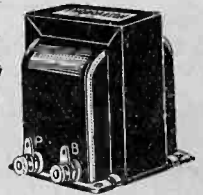

**B-ELIMINATOR CHOKES**  
30 henries. Completely shielded. Capacity, 60 milliamperes. Price, each, \$5.00.

# THORDARSON

## ELECTRIC MFG. CO.

Transformer Specialists Since 1895  
World's Oldest and Largest Exclusive Transformer Makers  
CHICAGO, U. S. A.

## CARTER "IMP" Loop Aerial

\$7.50



Compact, 16" dia.  
Light, weight 1 pound  
Attractive—Efficient  
Write for complete illustrated folder  
RMA

**Carter Radio Co.**  
300 S. PULASKI AVENUE  
CHICAGO, ILL., U.S.A.

ADDITIONAL COPIES

—of—

THIS ISSUE  
OF "RADIO" CAN BE PURCHASED FOR 25c FROM THE PUBLISHER.

For perfect control of tone and volume, use the Electrad 500,000-ohm compensator. For free hook-up write 428 Broadway, New York City.



**ELECTRAD** Inc.

# It's Easy to Build a Powerful Set

## Using the New and Improved FRESHMAN "TRF" Low Loss Kit



**Straight Line Wave Length Condensers With Low Loss Self Balanced Coils . . .**

These are the identical units which have made the **FRESHMAN MASTERPIECE** factory built Receivers the World's Greatest Radio Sets.

**\$9.50**

Complete instructions for building this powerful five tube receiver, written in plain everyday English, together with actual size schematic wiring diagram, are furnished with every FRESHMAN "TRF" Kit.

*Sold by Authorized Freshman Dealers Only!*

**CHAS. FRESHMAN CO., Inc.**  
Freshman Building, New York  
2626 W. Washington Blvd., Chicago



## RADIO PANELS

Bakelite, first quality,  $\frac{3}{8}$ " thick, 2 cents per square inch;  $\frac{1}{2}$ " thick, 1 1/2 cents per square inch, perfectly cut to any size. Engraving: letters, 4 cents; markers, arrows, etc., 15 cents. Dials, 50 cents up; borders, 35 cents up. Accurate drilling, 8 cents per hole; meter-holes, 50 cents. Mail orders solicited.

**Volney G. Mathison & Co.**  
660 Twelfth Street, Oakland, Calif.

## Stop Shifting Tubes

**N**O TUBE will do equally well all the things that must be done to give perfect reception. Special characteristics are essential for Detectors, Radio Frequency Amplifiers, Audio Frequency Amplifiers, Hi-Mu Amplifiers and Oscillators.

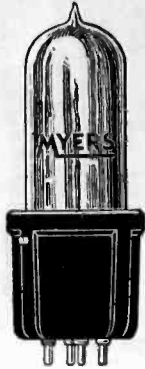

Myers Tubes are made and marked specifically for the function they are to perform, therefore they increase distance, improve quality and enlarge the volume.

**Don't Guess—Don't Match**

**Order the Exact Tubes You Want.**

*Made by Pioneer Designers and Builders of Radio Tubes*

**Type 01-A \$2.00**  
**Type 99 - 2.25**

*At your dealers, or we will ship, postpaid*

**Myers**

**Radio Tube Corporation**  
Cleveland, Ohio



# MYERS

*The Reason*  
THE TUBE WITH A SENSIBLE GUARANTEE

**Quality!**  
**Performance**  
**Dependability**

*are the factors which made Supertron the foremost Independent Tube in America !!!*

Supertron promises the Radio public and the Radio trade—a revelation in the art of making tubes—a New re-enforced interior construction that will positively cure the present tube ailments. Non-microphonic—uniform—better and a complete line, all types.

**All Types \$2.00**  
Canada, \$2.75

Try Supertron and Be Glad.  
At Good Dealers.

*Branch offices in principal cities throughout the United States*  
*Write for complete details.*

**SUPERTRON MFG. CO., INC.**  
Hoboken, N. J.

**SUPERTRON**  
A SERIAL NUMBER GUARANTEE

## New Radio Log Book

and

**AIR LINE DISTANCE MAP**

**50c** Money Refunded if you are not satisfied.

"RADIO," San Francisco

## 15-WATT TUBE TRANS-MITTER

*(Continued from Page 36)*

probable normal daylight range on 40 meters will not exceed two or three hundred miles, while the night range may be several thousand. The writer has succeeded in carrying on communication with this set from San Francisco to Hawaii, a distance of some 2100 miles. This cannot, however, be depended upon, as being within the normal range expectation, although it is no unusual feat. Communication with Australian stations, under good conditions should by no means prove impossible.

In order to note the effect, the tubes were operated at their normal plate voltage and current, and then when a distant amateur station was worked, the plate potential was raised, and the distant station asked to advise if any great difference was noted. The potential was allowed to go up to as high as 650 volts, and the reports were that the signals were a trifle louder, but not much—not enough to make it worth while to punish the tubes by operating them at an overload. The antenna current was greater, but this again proves that the antenna current reading is not all that is to be considered in the range of a station.

The life of tubes is a factor that should not be entirely neglected, and it is believed that if the tubes are operated somewhere near their normal rating, that the increased life as contrasted to the results of using them in an overloaded condition will make it unnecessary to try for great ranges out of the little set by overloading the tubes. Probably the highest voltage at which the tubes should be operated is from 425 to 475 volts, if any useful life expectation is to be obtained.

The writer used direct current for the plate supply, obtained from a motor-generator. Any of the other common methods would serve as well, such as S tube electrolytic and other rectifiers, the choice of the suitable type depending on the individual taste and pocketbook of the builder. If it is desired to use the set as a self rectified equipment, one tube can be used on either side of the power cycle, in the usual manner. It must be borne in mind, however, that if anything but a direct current supply is used, the bias-resistance system of keying will have to be abandoned, and some more conventional type substituted, such as breaking the plate supply lead, or keying in the transformer mid-tap point, etc. The filaments may also be operated on a. c., with the usual mid-tap in the secondary of the filament transformer. As the tubes draw only relatively a small amount of filament current, the load will not be found very serious for the average size of filament battery in use, and may prove to be simpler and easier.

## PARALLEL OPERATION OF TUBES

(Continued from Page 43)

with the antenna capacity; the grid-filament, and plate-filament capacities are in series, across the antenna capacity. But the last two tube capacities also form a miniature Colpitts oscillating circuit. Thus there are two distinct oscillating circuits—the desired Hartley, and the undesired, parasitic Colpitts. If the antenna circuit, and correspondingly, the Hartley, has a relatively high resistance, the main oscillation will take place at the parasitic frequency of the Colpitts circuit. This is exactly what happened when the conductively coupled circuit was set up, with the 40 ohms in the condenser leads to simulate antenna resistance. This resistance had to be cut to 2 or 3 ohms before any appreciable 80 meter currents were generated. Then, when finally oscillating at 80 meters, the tube capacities bypassed part of the current from the antenna circuit; which naturally showed up as a power loss, when the output power was figured as the square of the antenna current times the antenna resistance. As the number of tubes were increased the by-passing capacity was increased, so that more and more current was shunted from the load circuit, and more and more power lost. With a coupled circuit, this shunting of current from the primary capacity is not detrimental. The total oscillating current must flow through the primary helix. As the load helix is coupled to it, the full effect of the oscillating current is had, and no power lost. Also, with a coupled load circuit, the primary condenser circuit has a comparatively low resistance, so that the greater part of the radio-frequency power is developed at the desired high wave, and not at the parasitic wave.

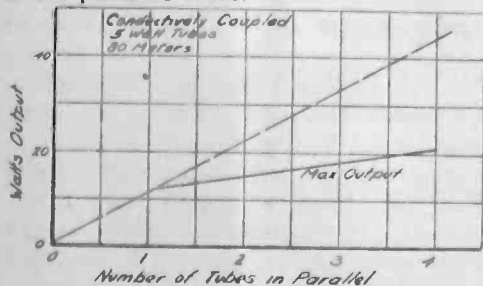

Fig. 7. Relation of Power Output to Number of Tubes.

Curves similar to those of Fig. 2 were run on the conductively-coupled Hartley circuit. The radio-frequency currents flowing through both the antenna and tube capacities were measured. The radio-frequency resistance of the antenna circuit was not measured; but for purposes of illustration it is allowable to assume a value of 2 ohms. Plotting the power in the antenna circuit gives the curve of Fig. 7. It is seen at once that the output power is far from proportional to the number of tubes used.

Which bans the conductively-coupled circuit on one more count.

### HANDY HINTS

By D. B. McGOWN

If an emergency tap is needed for brass, a common iron screw may be used, provided it is filed or ground to a three cornered effect. When dull or worn out it can be thrown away, and a new one made. Similarly, a crude die may be made by filing a slot in each side of the threads of an iron nut.

Small sized glass tubing makes a fine insulator for short lengths of wire, where there is danger of short-circuit. This can be used the same as the varnished cambric sleeving.

## RADIOADS

A Classified Advertising Section Read by Better Buyers.

The rate per word is eight cents net. Remittance must accompany all advertisements. Include name and address when counting words.

Ads for the June Issue Must Reach Us by May Fifth

SELL MARVELOUS NEW RADIO INVENTION THAT IMPROVES summer reception 100%. Effarsee marvel inside antenna gives better tone, greater selectivity. Write today. Sell to every radio owner for only \$4.00. Write today. Fishwick Radio Co., 135 W. Central Parkway, Cincinnati, Ohio.

AERODYNE 5-Tube Radio Sets, \$34.80, without accessories. 10% off on Sets and Parts. 20% of the amount must accompany your order. Balance, C.O.D. The Radio Specialty Shop, 525 Park Avenue, Kent, Ohio.

COMPLETE PARTS, including tube Rex Magnatron "B" Eliminator 150 volt. Little used. \$9.00. C.O.D. for \$1.00. James B. Hays, 309 B. C. National Bank Bldg., Boise, Idaho.

SONG POEM WRITERS. Write Song Poems? Write Y. Gillespie, Box 801, Cincinnati, Ohio.

A LIFETIME EDISON will solve your "B" battery troubles. Good, live, large size elements connected with pure nickel wire, electrically welded, 7c pair. All parts for sale. Sample cell and "dope" sheet, 10c. It will pay you to investigate. Paul Mills, Woodburn, Oregon.

GOOD AS NEW, Grebe CR-12 Receiver. New tubes, adapters. Was \$175.00, take \$75.00. W. L. Snyder, Clarksville, Virginia. 3A1J.

SCIENTIFIC SHORTHAND: 1926—the most applicable, syllabic system ever invented. Price, \$1.00 prepaid. Elmer Kinsey, Kirkland, Wash.

BUILDERS OF RECEIVERS, transmitters and eliminators. We have a list of parts that will be of value to you. Write Radio Parts Sales Co., Box 24, Orange, N. J.

\$16.50 BUYS A \$35.00 SOLOPHONE LOUD SPEAKER with Burns unit. Artistic design! Wonderful tone! Circular sent on request. T. Gelb, distributor, 710 S. Sacramento, Chicago.

NO MORE BATTERIES. You can eliminate all batteries and operate your set on light current, AC or DC—no hum—any kind of set—and type of tubes. Complete blue prints and instructions, guaranteed, \$2. Engineers' Service Company, Suite 203, 15 Park Row, New York.

FOR SALE: Owing to installation of more powerful apparatus, I have an Ecco motor-generator for someone who wants a guaranteed perfect machine. Type L-24—delivering 1600 volts at .99 amps. RPM, 1450. Price, \$225.00, F.O.B. Avalon, Catalina Island, California. 50-60 cycle drives it. With this power plant KFWO has been heard in every State and Canadian province. Major Lawrence Mott, Avalon, Catalina Island, Calif.

BE A DETECTIVE—Earn Big Money; fine work; great demand; cities, towns, traveling; we show you; particulars free; write Captain Wagner, 188 East 79th Street, New York. (31)

TESTED SET OF HAYNES GRIFFIN Super Transformers \$12.00. Tube Deutschmann Loop \$9.00. L. H. Hueter, 840 Van Ness Ave., San Francisco, Calif.

YOUR RADIO QUESTIONS ANSWERED FREE.—Gerald M. Best, technical editor of "RADIO," will answer ten radio questions for you if you subscribe to "RADIO" for only one year at \$2.50. Get this wonderful technical service, together with a good, practical radio magazine. "RADIO," Pacific Bldg., San Francisco.

WANTED—More readers of "RADIO" to advertise their used equipment in these columns. RADIOADS bring quick and profitable sales. Turn your excess apparatus into profit. Some of our readers want just what you have to offer. Try the RADIOADS. You, too, will then be convinced that they PAY. Mail your copy now for the next issue.

KEEP station records in THE RADIO LOG BOOK, a handy pamphlet for recording stations heard, dial settings and other data. The price is only 10 cents per copy. For sale by Pacific Radio Pub. Co., Pacific Building, San Francisco.

# WEEKLY CALL BOOK

and Station Program

**AT LAST** a Call Book corrected weekly, to take care of the many weekly changes made by broadcasters in wavelength, location and operating hours. Only a weekly book can keep you fully posted on the many changes. It also gives you a list of new stations as they "come on the air." As many as fifty changes a week are made in this new book to keep up-to-date station listings and as many as 300 changes in schedules are made every week. As a radio listener, you know what this means to you. The book is published by the publishers of "RADIO." It is known as "RADIOCAST WEEKLY."

**IMPORTANT INFORMATION** Every week in this 64-page book you get the "AROUND THE DIAL" station log, distance chart, spaces for dial recordings, wavelength, power, location and owner of station.

The popularity of this book has made it necessary for us to issue 53,000 copies weekly. It is sold by news dealers in 2500 cities and towns on the Pacific Coast. Now you can also get this magazine by subscription, 52 issues mailed to your home (one copy a week for a full year) cost but \$3.00. It's worth a lot more.

**GREAT OFFER** Send us \$3.00 today for the next 52 issues. If you don't like the book you get your money back without question.

# 10c

64 Pages a week mailed right to your home for 52 weeks for only \$3.

### Ten Radio Points for 10c

- 1—The list of important radio stations of the U. S.—corrected weekly and kept up-to-date. This is a "CALL BOOK" in itself.
- 2—The location of stations, their power and wavelength. This tells you, at a glance, just what reception you may expect.
- 3—The distance of important stations from various important centers along the Pacific Coast. This tells you how far you are receiving.
- 4—The operating hours of the stations within audible radius of Coast listeners. A speedy and accurate method for "what's on the air."
- 5—The listing of stations by wavelength, starting with the minimum operating wave and ending with the maximum. Use this for dial settings.
- 6—Logging spaces for "stations heard." Space is provided for three

dial readings, enabling you to quickly locate a station when you want to.

7—Listing of Canadian and Mexican stations. This is worth a lot to the listener who can "reach out." These listings are up-to-date.

8—VERY IMPORTANT is the weekly correction feature of the above high lights. Accuracy and reliability are responsible for the success of this magazine.

9—The listing of station programs by the day. Large headings in black type enable you to quickly locate the station you are after.

10—And—last of all—you get this data every week in "RadioCast Weekly," the reliable guide to WHAT'S ON THE AIR. The simplest form of schedules and the handiest reference book of its kind on the market. It costs 10 cents.

## "RADIOCAST WEEKLY"

—Published Weekly by—

Pacific Radio Pub. Co.

PACIFIC BLDG.  
SAN FRANCISCO  
CALIFORNIA

1411-F ALTA VISTA  
BOULEVARD  
HOLLYWOOD, CALIF.

Sample Copy for 10 Cents

# Electric Soldering Iron

*given to you*  
**FREE!**

**G**ET a dandy 110-120 volt electric soldering iron free with only a one year subscription to "RADIO." We have received a quantity of CHAPMAN Electric Irons, with large renewable copper tip, wire stand, paste and solder—all complete. These irons have been given a thorough test by us and we know that they will give good service. Everybody can use an electric iron. Simply send us \$2.50, the coupon at the foot of this page—and you will receive the iron on the same day your order reaches us. We will also mail "RADIO" to your address every month for a full year.

**The Supply Is Limited.  
Only One to Each Subscriber.  
Don't Delay!**

## OTHER FREE PREMIUMS

If you do not want the electric iron with your subscription, you can have your choice of one of the following:

Pair of 2000 ohm Headphones, (Big 3 Radio Co., Mfgs.)

Induction Filter for cutting down AC noises and power line hums, etc. Very effective. Made especially for "RADIO." Thousands have been given away.

Phonograph unit, made by Union Fabric Company.

"ELEMENTS OF RADIO COMMUNICATION," by Lieut E. W. Stone. A real good radio book. Sells for \$2.50.

Remember—you get one of the above premiums FREE with only one subscription to "RADIO" for one year. Full price, \$2.50. You get double value for your money.

**Use the Coupon and Mail It Now!**

## IMMEDIATE DELIVERY

The premium goes forward to you on the same day your order reaches us. We pay the forwarding charges. All that you pay is \$2.50 for the subscription to "RADIO." Nothing "suspicious" about this offer. We want to increase our subscription list.

"RADIO,"  
Pacific Building,  
San Francisco, Calif.

Here is \$2.50 in full payment for a one year subscription to "RADIO" and the following premium—

Ship premium prepaid today and start my subscription to "RADIO" with the issue of.....

Name.....

Address.....

City and State.....

## GUARANTEE

The publishers of "RADIO" guarantee this merchandise to be new, standard and fully covered against defects. We will cheerfully refund your money if you do not think that you have received double value for your money. This great offer good for only 30 days. No orders for premiums accepted after June 1, 1926.



# The UNIVERSAL

## Standards of Quality



Type 277-D

Coupling Coil  
Price \$1.50

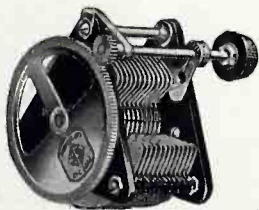

Type 247-H

Geared Condenser  
Price \$5.00



Type 368

Micro-Condenser  
Price \$1.25

In building a radio receiver, remember that its performance depends primarily upon two things: an efficient circuit, and the use of good parts.

Wherever you find a popular circuit you will invariably find General Radio parts.

The General Radio Company has contributed more in scientific apparatus for laboratory use than any other one Company in the history of radio. The same outstanding craftsmanship and materials are embodied in General Radio parts for use in the construction of broadcast receivers.

Through the merits of design, performance, and price, the General Radio instruments for the scientist or set-builder are universally recognized as the Standards of Quality.

Every instrument made by the General Radio Company is thoroughly guaranteed.

*The General Radio Company has endeavored to make it possible for the experimenter to obtain its products with a minimum of effort. A careful selection of distributors and dealers has been made. They are best fitted to serve you. If, however, you are unable to obtain our products in your particular locality they will be delivered to you, postpaid, direct from the factory upon receipt of list price.*

Write for Our Latest Parts  
Catalog 924-C

**GENERAL RADIO Co**

CAMBRIDGE 39, MASS.



Type 285

Audio Transformer  
6 to 1 and 2 to 1  
Price \$6.00 Each



Type 301

Rheostat  
12 Ohm and 25 Ohm  
Price \$1.25



Type 349

UX-Tube Socket  
Price 50c

# GENERAL RADIO

## INSTRUMENTS

*“Behind the Panels of Better Built Sets”*

# Cardwell

## Acclaimed!

By Every prominent engineer who has seen them, Taper Plate Type E Condensers represent the foremost step in condenser design since the original low-loss metal endplate, first made by Cardwell five years ago.

CLAYTON—Cockaday—Lynch—Best—Wing—Neely—the list of those who specify Taper Plate Cardwells reads like a roster of the greatest Technical Editors of Radio.

The Taper Plate Type E Receiving Condenser is designed to be practical rather than theoretically perfect. Its tuning characteristic is straight frequency over the lower part of the scale; tapering to approach straight wave-length at the top. Full size plates, far heavier than ever used before, assure positively permanent calibration.

The Type C approaches straight frequency on the very low portion of the scale only, changing to a modified straight wave-length as capacity is increased.

Type "C"	Type "E"	Capacity (Mmfd.)	Price
168-C	167-E	150	\$4.00
170-C	168-E	250	4.25
171-C	169-E	350	4.75
172-C	192-E	500	5.00

The Allen D. Cardwell Mfg. Corp.  
81 PROSPECT STREET, BROOKLYN, N. Y.

5c. in stamps brings this booklet on the Best Super Heterodyne.

If your dealer can't supply you, order direct. Write for illustrated catalogue and handbook.

Under a revised distribution system, some territory is now available for jobbers, and inquiries from responsible firms will be welcomed.

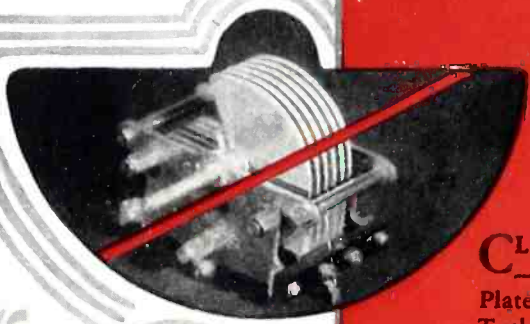

The Taper Plate Type "E" with straight frequency tuning characteristics

The Type "C" has a modified straight wave length tuning curve

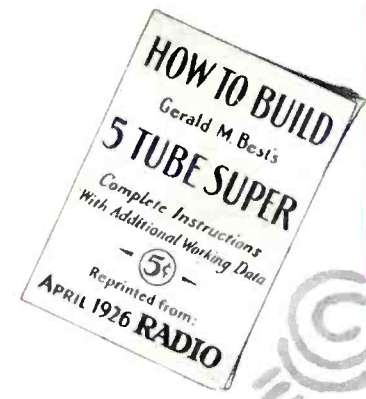

# Condensers

"THE STANDARD OF COMPARISON"

Printed by the Leighton Press, San Francisco