

SEPTEMBER, 1925

25 CENTS

RADIO

(Reg. U. S. Patent Off.)

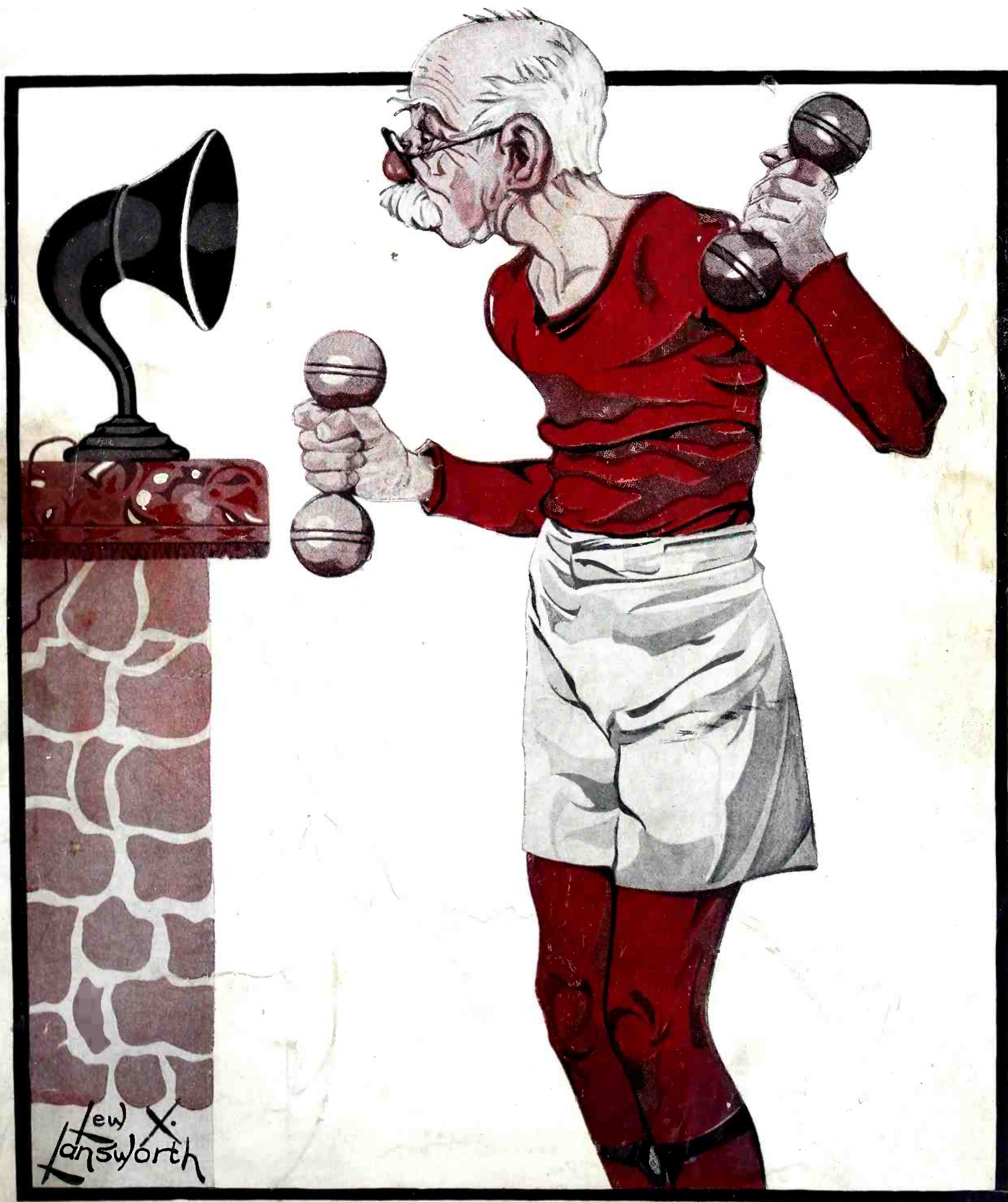

MacMillan demands Cunningham RADIO TUBES

*for Life
and Death
Service*

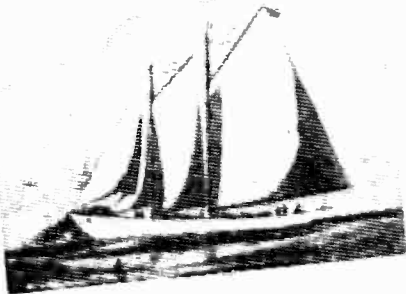

THE MACMILLAN ARCTIC ASSOCIATION

HERBERT L. BRIDGMAN,
PRESIDENT

M. J. LOOK,
VICE-PRESIDENT

EDWIN W. SPARRS,
VICE-PRESIDENT

GEORGE F. CARY,
TREASURER

EDWARD N. GODING,
SECRETARY

DONALD B. MACMILLAN,
MANAGING DIRECTOR

626 TREMONT BUILDING, BOSTON, MASS.

April 19th, 1925

Mr. E. F. McDonald, Jr.,
332 S. Michigan Avenue,
Chicago, Illinois.

My dear Gene:

I have had so much success and long life with the Cunningham tubes in my set, and I have heard such favorable reports during my lecture tour throughout the United States, that I have decided that we should equip the Expedition with Cunningham receiving tubes exclusively.

You will therefore please arrange to purchase these tubes, per the attached order, and have it shipped to the Bowdoin in time for the tests before the sailing at Wiscasset.

Sincerely yours,

Donald B. MacMillan

E. J. Cunningham Inc.

Since 1915—
Standard for all sets

Types C-301A : C-299
C-300 : C-11 : C-12

In the Orange and Blue Carton

In that white and silent Northland with its glistening ice, driving blizzards and endless, relentless cold Cunningham Radio Tubes deliver the same efficient, well-rounded service that makes them valued so highly in the shelter of the American home.

MacMillan's
choice may well
be yours

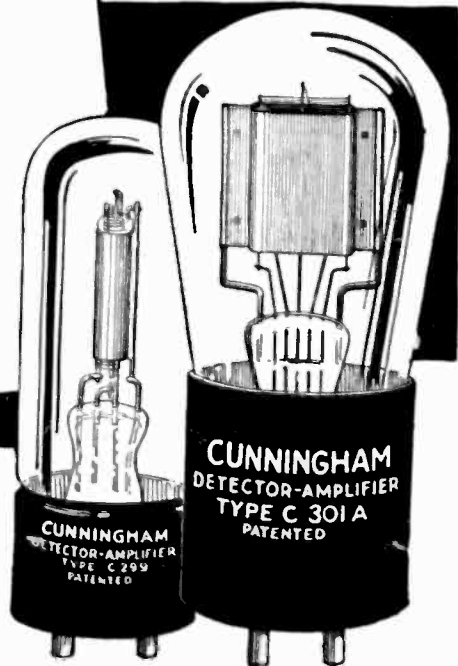

Home Office, 182 Second Street
SAN FRANCISCO

CHICAGO
NEW YORK

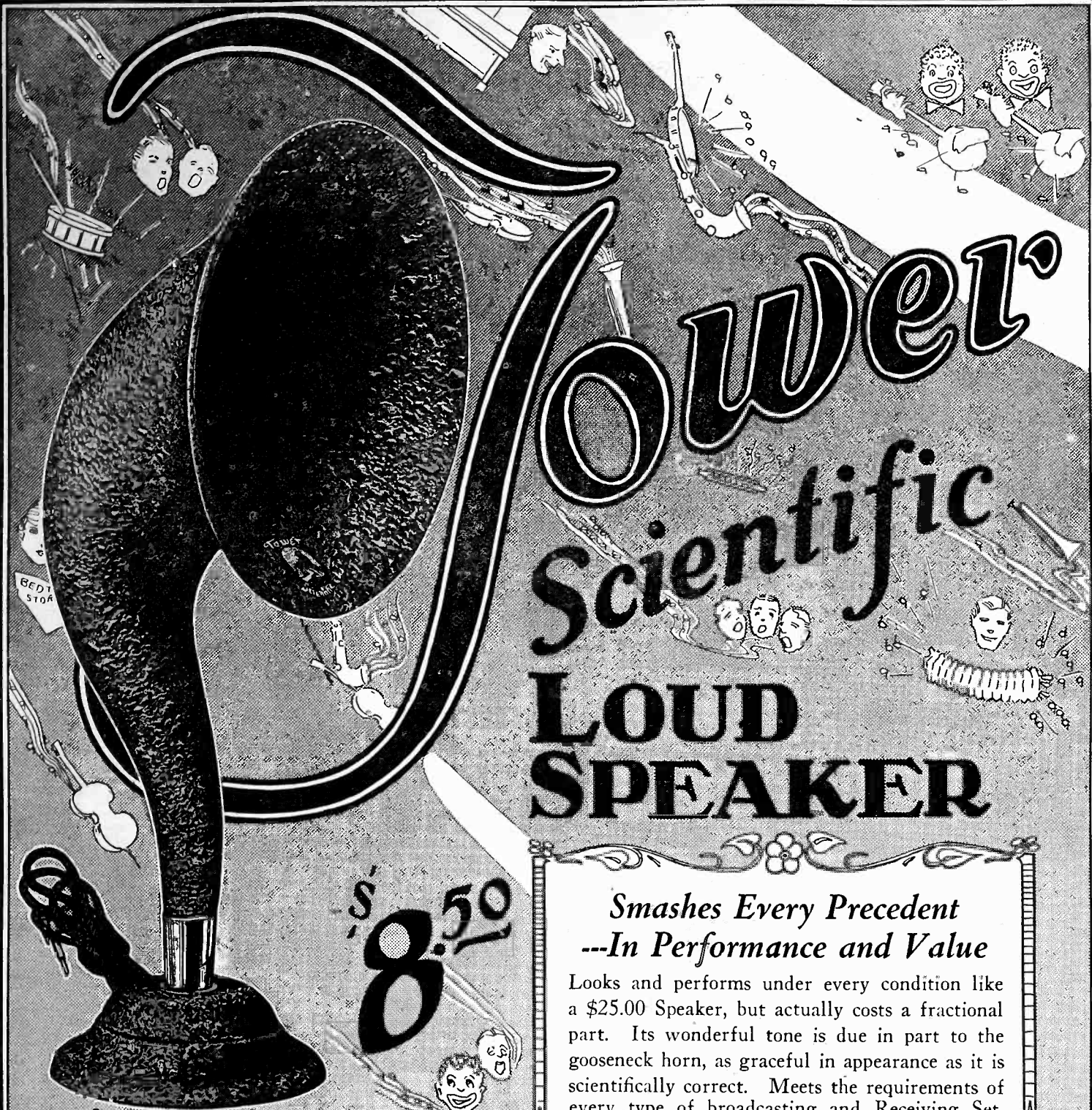

Tower

Scientific

LOUD SPEAKER

\$ 8.50

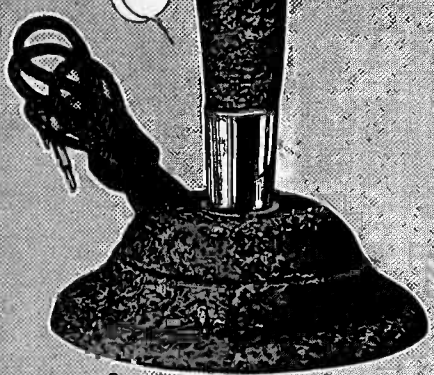

All Tower loudspeakers equipped with adjustable units

*Smashes Every Precedent
--In Performance and Value*

Looks and performs under every condition like a \$25.00 Speaker, but actually costs a fractional part. Its wonderful tone is due in part to the gooseneck horn, as graceful in appearance as it is scientifically correct. Meets the requirements of every type of broadcasting and Receiving Set.

Wherever there are ears that hear there is a Tower Quality Product to Fit your Taste and Pocketbook.
SOLD BY GOOD RADIO DEALERS EVERYWHERE

TOWER MFG. CORPORATION
98 BROOKLINE AVE. BOSTON MASS.



\$4.95

Little Spiffing Loudspeaker

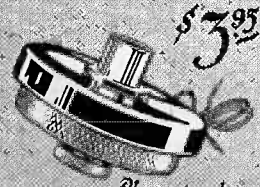

\$3.95

Phonograph Attachment



\$15.00

The Metstinger Speaker

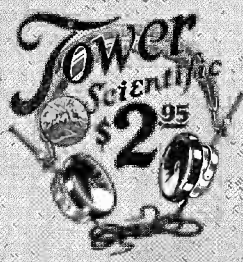

Tower Scientific \$2.95

WORLD'S GREATEST LOUDSPEAKER VALUES

Tell them that you saw it in RADIO

RADIO

Established 1917

Published Monthly by the Pacific Radio Publishing Co.

ARTHUR H. HALLORAN,
Editor

LAURENCE MOTT,
Associate Editor

GERALD M. BEST,
Technical Editor

H. W. DICKOW,
Advertising Manager

Branch Offices:

New York City—17 W. 42nd St.
Chicago—157 E. Ontario St.
Boston—52 Irving St.
Kansas City, Mo.—1102 Republic Bldg.

Correct Addresses:

Instructions for change of address should be sent to the publisher two weeks before the date they are to go into effect. Both old and new addresses must always be given.

Rates:

Issued Monthly, 25c a copy.
Subscription price \$2.50 per year in the U. S., \$3.00 per year elsewhere.

Advertising:

Advertising Forms Close on the First of the Month Preceding Date of Issue.

Member—Radio Magazine Publishers Association
Entered as second-class matter at Post Office at San Francisco, Calif.
Copyright 1925, by the Pacific Radio Publishing Co.

Address all communications to

Pacific Radio Publishing Company

Pacific Building, San Francisco, California

VOLUME VII

SEPTEMBER, 1925

NUMBER 9

CONTENTS

	PAGE
RADIO'S PART IN THE GREATEST OCEAN YACHT RACE.....	10
<i>By D. B. McGown</i>	
THE MODIFIED BEST SUPERHETERODYNE.....	12
<i>By G. M. Best</i>	
FUTURE DEVELOPMENTS IN AUDIO FREQUENCY AMPLIFIERS.....	19
<i>By G. M. Best</i>	
THE FACTS ABOUT LOW-LOSS RADIO APPARATUS.....	20
<i>By Glenn S. Browning</i>	
LOUD SPEAKER TESTING METHODS.....	22
<i>By John P. Minton</i>	
RESCUING UNCLE MARMADUKE.....	23
<i>By John Eugene Hasty</i>	
ELECTRICAL INSTRUMENTS FOR RADIO SETS.....	25
<i>By M. T. Rogers</i>	
WAVEMETERS.....	27
<i>By G. F. Lampkin</i>	
FOR THE RADIO NOTE BOOK.....	29
(Resistance Calculations, High Frequency Resistance).	
INTERESTING DATA ON RECEPTION.....	31
<i>By E. T. Jones</i>	
HANDY HINTS.....	31
TRANSMITTER TUNING WITHOUT METERS.....	32
<i>By L. W. Hatry</i>	
AN INEXPENSIVE CHEMICAL RECTIFIER.....	33
<i>By C. A. Weidenhammer</i>	
PUSH-PULL RADIO FREQUENCY OSCILLATOR.....	35
<i>By D. B. McGown</i>	
QUERIES AND REPLIES.....	37
SHORT-WAVE EXPERIMENTS WITH THE FLEET.....	38
<i>By F. L. Ulrich</i>	
WITH THE AMATEUR OPERATORS.....	39
CALLS HEARD.....	41
FROM THE RADIO MANUFACTURERS.....	42

Forecast of Contributions for October Issue

G. M. Best describes the construction of a new four-tube receiver having remarkable selectivity, sensitivity and tone quality. In another article he also tells how radio is used to help in detecting earthquakes.

Volney G. Mathison has written the real story of the radio compass under the title of "Piercing Neptune's Shroud." He not only explains how and why it works but he also brings realization of its wonderful value.

Every antenna owner will be greatly helped by reading Kirk B. Morcross' article "Check Up Your Antenna from Its Characteristics" wherein he shows the effect of resistance, inductance and capacity on radio reception.

R. Lewis Rockett has a good constructional article about an improved loop receiver using five tubes, three of which are radio frequency amplifiers and capable of being tuned below 200 meters as well as covering the radiocast band.

E. E. Griffin has built a detecting, oscillating and modulating radiocast wavemeter which may also be used as an efficient receiver. His account of its construction will enable others to do likewise.

M. K. Lock writes about "A Universal Meter for the Home Laboratory" and details the method whereby one meter can be used for many purposes.

D. B. McGown presents the practical data for the home construction of a quartz oscillator.

L. W. Hatry suggests the use of a loading coil as a means to de-tune an antenna and thus to reduce interference.

The fiction feature is "The Girl with the Madonna Voice," by H. P. Bridges, Jr.

Transmitting amateurs will be especially interested in "Heising and Grid Modulation Systems" by L. D. Grignon and F. C. Jones. The results of this clear-cut analysis show that grid modulation has many advantages over plate modulation of the carrier frequency. There will also be illustrated descriptions of several noteworthy amateur installations.

Dr. Maurice Buchbinder discusses various methods of eliminating oscillation in radio frequency amplifiers, pointing out the advantages and disadvantages of each method described.

Dr. John P. Minton follows up his article on the methods of loud speaker testing with a discussion of the limitations of commercial loud speakers of the small horn variety.

Carlos S. Mundt contributes a novel idea regarding a simple mast with a low center of gravity.

G. F. Lampkin tells "How Radio Circuits Work," analyzing the results shown by reactance diagrams.

NEW! *Radically different!*

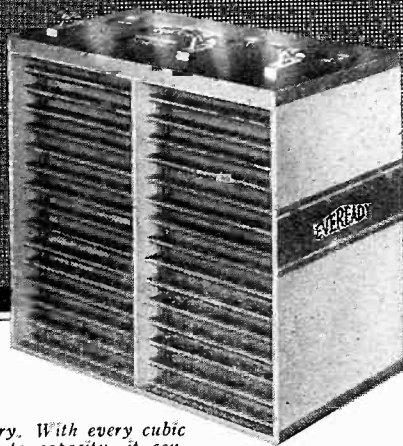

No. 486 Eveready Layerbilt "B" Battery. 45 volts. Length, 8 3/16 inches. Width, 4 7/16 inches. Height, 7 3/16 inches. Weight, 14 1/4 pounds. Price, \$5.50.

It's all battery. With every cubic inch packed to capacity, it contains about 30 per cent more electricity-producing material. All chance of loose or broken connections avoided by contact of full area of carbon plate against zinc plate. The scientifically correct construction.

The greatest improvement ever made in "B" Batteries

ABSOLUTELY new in construction—perfected through years of research, the new Eveready Layerbilt "B" Battery is as superior to the old type "B" Battery as a tube set is to a crystal.

Heretofore, all dry "B" Batteries have been made up of cylindrical cells—no one knew how to make them any other way. The new Eveready Layerbilt is made of *flat* layers of current-producing elements compressed one against another, so that every cubic inch inside the battery case is completely filled with electricity-producing material. Layer-building heightens efficiency by increasing the area of zinc plate and the quantity of active chemicals to which the plate is exposed.

After the most rigid laboratory tests, more than 30,000 of these new Eveready Layerbilt "B" Batteries were manufactured and tested by use under actual home-receiving conditions. These tests proved that this new battery is far superior to the famous Eveready Heavy-duty Battery No. 770, which up to now we have ranked as the longest lived "B" Battery obtainable.

On 4-tube sets, 16 mil drain, it lasts 35% longer.
On 5-tube sets, 20 mil drain, it lasts 38% longer.
On 6-tube sets, 24 mil drain, it lasts 41% longer.
On 8-tube sets, 30 mil drain, it lasts 52% longer.

The new Layerbilt principle is such an enormous stride forward in radio battery economy that we will bring out new sizes and numbers in this Layerbilt form as fast as new machinery is installed. For the present, only the extra-large 45-volt size will be available.

Buy this new Eveready Layerbilt No. 486 for heavy drain service. It far exceeds the performance for which Eveready Radio Batteries always have been famous and is, we believe, by far the most economical source of "B" current obtainable.

Manufactured and guaranteed by
NATIONAL CARBON CO., INC.
New York San Francisco
Canadian National Carbon Co., Limited, Toronto, Ontario

EVEREADY HOUR EVERY TUESDAY at 8 P.M.
Eastern Standard Time
Beginning Sept. 29th, 9 P. M. Eastern Standard Time
For real radio enjoyment, tune in the "Eveready Group." Broadcast through stations—
WEAF New York WGR Buffalo WWJ Detroit
WJAR Providence WCAE Pittsburgh WCCO Minneapolis
WEEI Boston WEAR Cleveland St. Paul
WFI Philadelphia WSAI Cincinnati WOC Davenport

EVEREADY

Radio Batteries

-they last longer

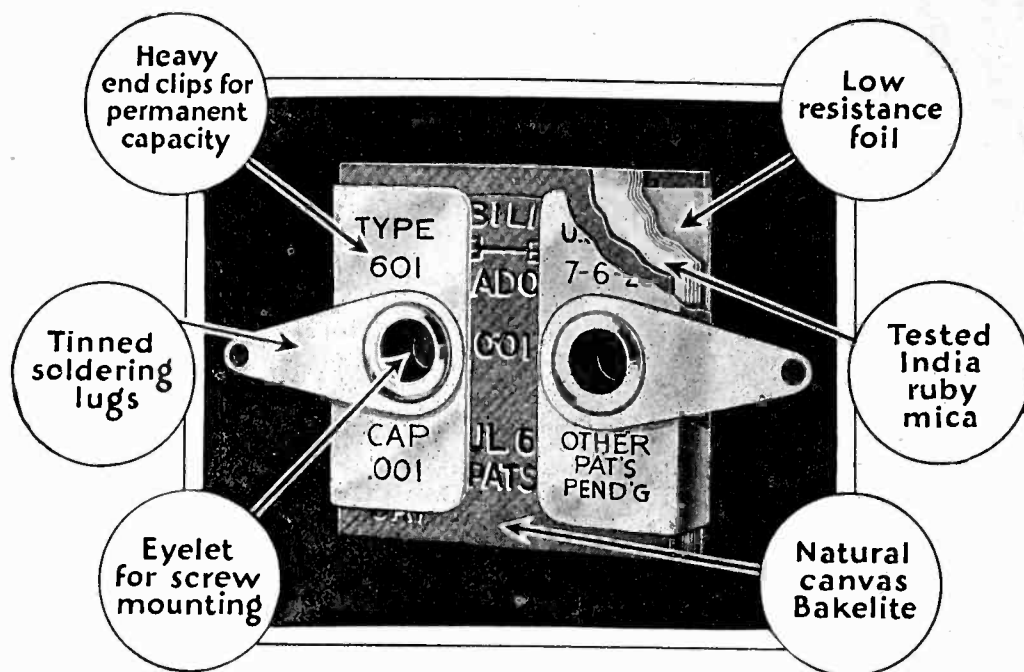

What makes for efficiency in fixed condensers?

This diagram indicates the efficient details of construction that have made Micadons the standard* fixed condensers of radio.

Dubilier engineers have developed these standard condensers of accurate and permanent capacity. Micadons are known the world over---and are used in 90% of all radio sets.

**Standard—anything recognized as correct by common consent . . . of a high degree of excellence.—Webster*

Dubilier

CONDENSER AND RADIO CORPORATION

Again They said
it couldn't be done!

Here it is

New and Improved
**FRESHMAN
MASTERPIECE**

But now . . .

Complete with built-in loud speaker of great volume and superb tone quality.

Encased in . . .

As fine a heavy genuine solid mahogany cabinet as ever graced any radio set.

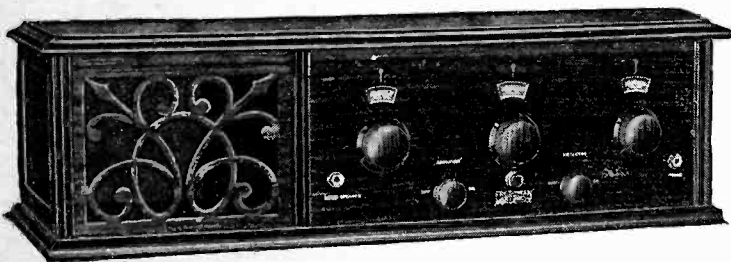

Model
5-F-5

At sixty dollars . . .

Not only complete with built-in loud speaker and massive mahogany cabinet, but this wonder circuit has been scientifically perfected and each and every single part strengthened and co-ordinated.

For example . . .

The new Freshman Masterpiece straightline wave length condenser with vernier attachment which assures hair-line selectivity—permitting you to tune in the station you want without interference over the entire wave length range. This is merely one exclusive feature of the

World's Greatest Radio Receiver

For sale at AUTHORIZED FRESHMAN dealers only

Chas. Freshman Co. Inc.
Radio Receivers and Parts
FRESHMAN BUILDING
240-248 WEST 40TH ST.—NEW YORK, N.Y.
CHICAGO OFFICE — 327 S. LA SALLE ST.

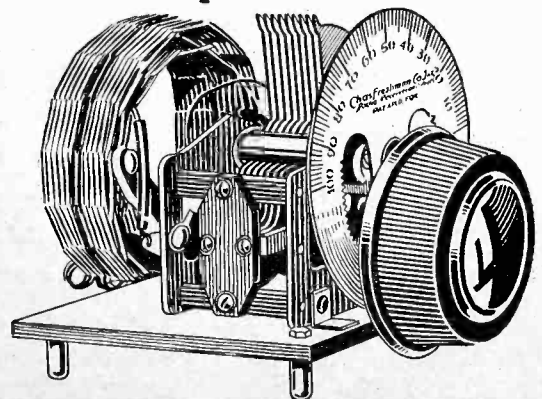

\$60

*And
how!*



ZENITH
TRADE MARK REG
→LONG DISTANCE←
TRADE MARK REG
RADIO

MacMillan Knew—

When Commander MacMillan chose Zenith radio for his latest North Polar Expedition, he knew from personal experience what Zenith would do—

MacMillan knew that Zenith—even one of the earlier models—would enable him to tune in stations all over the United States and Europe—even far-off Honolulu.

MacMillan knew that no other radio equipment would give him such extraordinary performance, such unfailing service.

When Arctic explorers of MacMillan's calibre stake their lives—repeatedly—on Zenith performance, one reason only can explain their choice—*Zenith has proved to be the best obtainable, at any price.*

Ask your nearest Zenith dealer for a demonstration.

Costs More—but Does More!

ZENITH RADIO CORPORATION
Straus Building, Chicago

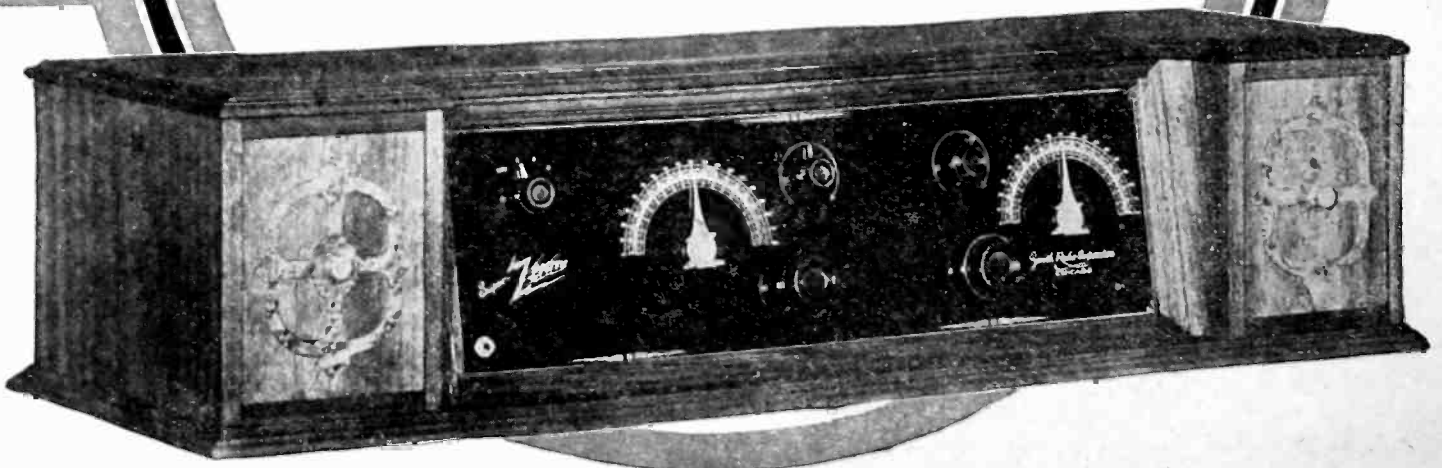

Tell them that you saw it in RADIO

Prest-O-Lite



There are many improvements in the new Prest-O-Lite Battery

IN THIS new battery you'll find all the good points and high quality that have made Prest-O-Lite an unfailing aid to better radio. And in addition there are many important refinements and improvements that make it the most attractive, most convenient battery you can buy.

This new battery has a beautiful stippled finish hard rubber case that blends with any furnishings. The case is molded in one piece, giving sturdy, leak-proof strength.

To make the battery convenient to carry, the handle has been given a comfortable rubber grip.

The oversize terminal nuts on the binding posts are easy to turn and insure perfect contacts.

Novel rubber insulators completely cover the tops and sides of the cell connectors, preserving the original

fine finished appearance at all times and giving protection against accidental short circuits.

No effort has been spared to make this a battery you will be proud to own. Yet, like the rest of the Prest-O-Lite line, it is priced to offer you the biggest value of the day. Ask your dealer to show you this battery and the Prest-O-Lite Chart that helps you select the right battery for your set. Or write Indianapolis for a copy of our interesting handbook on radio storage batteries and how to charge them.

THE PREST-O-LITE CO., INC.
INDIANAPOLIS, IND.

New York

San Francisco

In Canada: Prest-O-Lite Company of Canada, Limited, Toronto, Ontario

KARAS HARMONIK

AUDIO FREQUENCY



AMPLIFYING TRANSFORMER

These are the Audio Frequency Transformers used by Mr. Best in his wonderful, new hook-up published in this issue of Radio and recommended by him in his construction specifications.

The Triumph of a Masterpiece!

—A Marvel of Transformers that Brought Real Musical Quality to Radio Reception

JUST one year ago the Karas Harmonik Audio Frequency Transformer took the radio world by storm.

Nothing like it had ever been known before. For the first time, scientific study had been devoted to perfecting an audio transformer for the reception of broadcast music. The problem of amplifying high, low and medium frequencies to equal degree was finally solved. Bass notes were poured from the speaker in full strength and rich tone quality. The vital harmonics in rich overtones, formerly lost, were brought out in their full beauty by this marvel of audio transformers.

Music critics, who had always condemned radio music as false and distorted, approved the results of Karas Harmonik amplification with great enthusiasm. Prominent radio engineers subjected Karas Harmoniks to exhaustive laboratory tests—and pronounced it a technical masterpiece. Technical editors who promoted the season's most successful hook-ups specified Karas Harmoniks in their circuits. The triumph of the Karas Harmonik was complete!

But, for all of this, the enjoyment of Karas Harmonik amplification was too greatly confined to one class of radio enthusiasts. Home set builders bought Karas Harmoniks by the tens of thousands. They were free to pick and choose. *They* were most exacting in their demands for the newest and best developments.

It was the owners of factory-built sets who missed the

delightful pleasure of real, true radio music in their homes. Set manufacturers were prevented by price from adopting Karas Harmoniks for their sets. So the ready-made set-buyer, unless he undertook to switch transformers, had to do without Karas Harmoniks.

Today there are in use, hundreds of thousands of sets—good sets—which could be vastly improved in musical quality by the simple operation of replacing the old transformers with Karas Harmoniks. Perhaps *you* own one of these sets. It may be all you desire from the standpoint of selectivity, of range, and other tuning qualities. But, if it is not equipped

with Karas Harmonik Audio Frequency Transformers, you are NOT getting *nearly* the musical quality you can just as well enjoy. Are you going to be content with anything short of the best?

You can install Karas Harmoniks yourself. It's a short, easy job. Or, any radio repair man can do it for you. Make up your mind to do it now—at once. Get a pair of Karas Harmoniks TODAY!

In large cities, most good dealers carry Karas Harmoniks—and in many small towns. If your dealer is out of them, order direct from us. Send no money. Just use the coupon below!

Karas Electric Co.,
4057 N. Rockwell St.,
Chicago, Ill.

The Distinctive Qualities that Elevate Karas Harmonik Transformers to the Highest Pinnacle of Success in the Radio World.

1. Many thousands of turns of wire
2. Low ratio of turns
3. Extra large quantity of special formula iron in core
4. Controlled air gap
5. No core saturation
6. Minimum of Reluctance
7. Least Hysteresis and Eddy Current Loss
8. Low Distributed Capacity
9. Scientifically circular shielding preventing intercoupling of electrostatic and electromagnetic fields
10. Very High Primary Impedance
11. Extremely High Inductance
12. High and even Amplification of all Audio Frequencies.

Karas Electric Co.,
4057 N. Rockwell St., Chicago, Ill.

Please send me _____ pairs of Karas Harmonik Audio Frequency Transformers. I will pay the postman \$7 apiece, plus postage, on delivery. It is understood that I am privileged to return the transformers any time within 30 days if they do not prove entirely satisfactory to me, and my money will be refunded at once.

Name _____

Address _____

RADIO

VOLUME VII

SEPTEMBER, 1925

No.

Radiatorial Comment

WITH the probability of another radio conference to be called by Secretary Hoover at the end of the static season, there arise repeated rumors of radical changes in wavelength allocations. One of the most persistent of these rumors is that the amateurs are again to be crowded out of their upper band so as to make more room for the radiocasters. While no one can now accurately forecast the recommendations of the large group of radio men who may constitute the conference, there are certain fundamental facts which are significant of the improbability of this change being made this year.

In the first place, all except the "outs" are pretty well agreed that there are already enough stations on the air. Rather than increasing the number, the demand is for increasing the quality. Would it not be better to set certain standards to be met in return for the privilege of using a specified wavelength? Then when a station fails to meet the standards, another could be given its place if sufficient assurance is given that the newcomer will live up to them.

Although there is room for more stations between 150 and 200 meters than between 200 and 285, the present limit for Class A stations, there is every indication that the demand for this new space would as greatly exceed the supply as does the demand for the present wavelengths. Department of Commerce officials believe that a new rush of applications would follow the opening up of such a reservation and that within a short time the problem would be as bad as it now is with the more restricted band.

Finally, the matter of simple justice to the amateur requires that he not be deprived of this space. Like the Indian he has been continually crowded off his reservation, albeit making good use of what is left to him among the lower wavelengths.

But should these several considerations not suffice to prevent the opening up of a new band for radiocasting, there still need be no cause for alarm among the owners of the present types of receivers that will not tune to the lower wavelengths. In many cases the addition of a .0001 mfd. fixed condenser in series with the variable antenna condenser is all that is necessary. In other cases the coils may be tapped or enough turns removed to get down to 150 meters. So the radiocast listener, at least, need have no concern.

THE rapid growth of radio during the past four years has led many unthinking people to imagine that this modern miracle is revolutionary, both in its sudden growth and in its effects on our social life. But nothing can be further from the fact. Radio, like any other permanent advance, grew slowly for many years before it burst into bloom as nation-wide radiocasting, and its lasting effect upon our social habits and customs will be just as gradual. It is the result of evolution and not of revolution.

The main difference between evolution and revolution is a matter of time. Revolution attempts in a moment what evolution accomplishes in a generation or more.

For instance, the several stages in the development of the vacuum tube, the heart of the present day receiving and transmitting set, have been patiently accomplished during the past thirty years. The tube was practically perfected in its present form before there was any thought of radiocasting. And prior to that were years of endeavor in the development of the other electrical apparatus which makes radio possible today. In its entire history there has been no single spectacular invention that has suddenly upset the theory and practice of radio. Nor is there likely to be in the future.

Many people have been waiting for some revolutionary change in radio that will render all existing sets obsolete. But they are waiting in vain. Each year sees certain improvements, just as there are changes in automobiles, but the set of today will still be giving good service five years from now.

This tendency to wait for the revolution which will never materialize has been unwittingly fostered by the extravagant claims of some advertisers. The ideal which they set up, while impossible in the present state of the art, is accepted as the criterion in judging the performance of any set. But there is still many an improvement to be made before the perfect set will be even approximated. There will always be better sets coming, just as there will be better programs to be heard. But the present ones are well-worth while as an investment in the enjoyment of family life in the home.

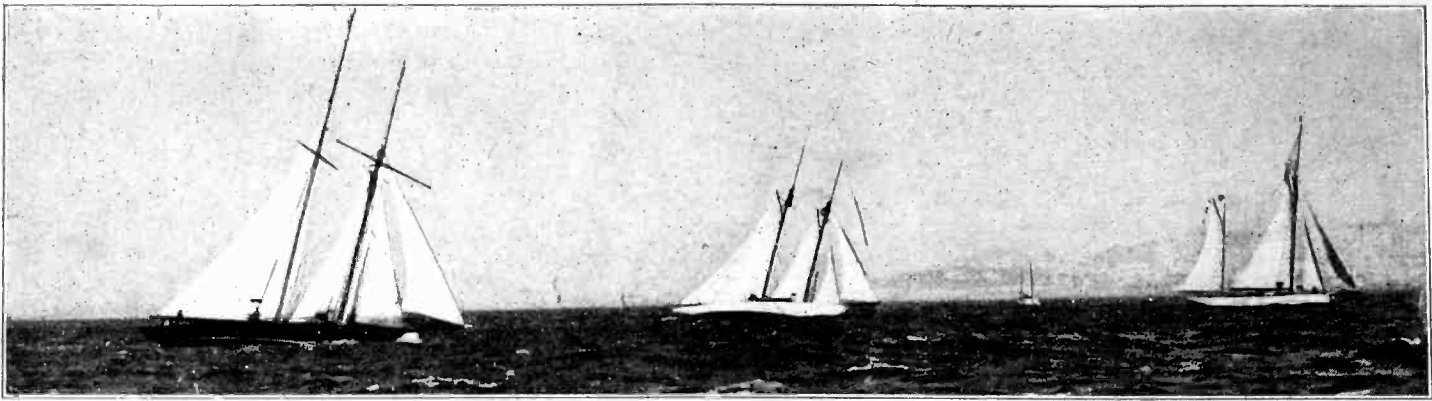

Start of race at the Golden Gate, San Francisco.

Radio's Part in the Greatest Ocean Yacht Race

A Description of the Transmitting and Receiving Equipment
Aboard the Yachts in the Tahiti Run

By D. B. McGown

ON June 10, 1925 there set sail from San Francisco four intrepid yachts, competing in the longest yacht race in history. These craft sailed, with the wind as their only motive power, for the port of Papeete, on the island of Tahiti, 3660 nautical miles from San Francisco. When it is remembered that the distance from New York to Liverpool is about 3000 nautical miles, it can be seen that this was a cruise of considerable magnitude, surpassing the feat of Columbus when he sailed from Spain to Watling's Island, these yachts being far smaller vessels than those of Columbus.

The yachts which entered the race were the IDALIA, ELOISE, MARINER and SHAWNEE, the race being won by the MARINER, which arrived at Papeete on July 1st, covering the distance in 20 days, 12 hours. The prize was a huge silver trophy offered by Sir

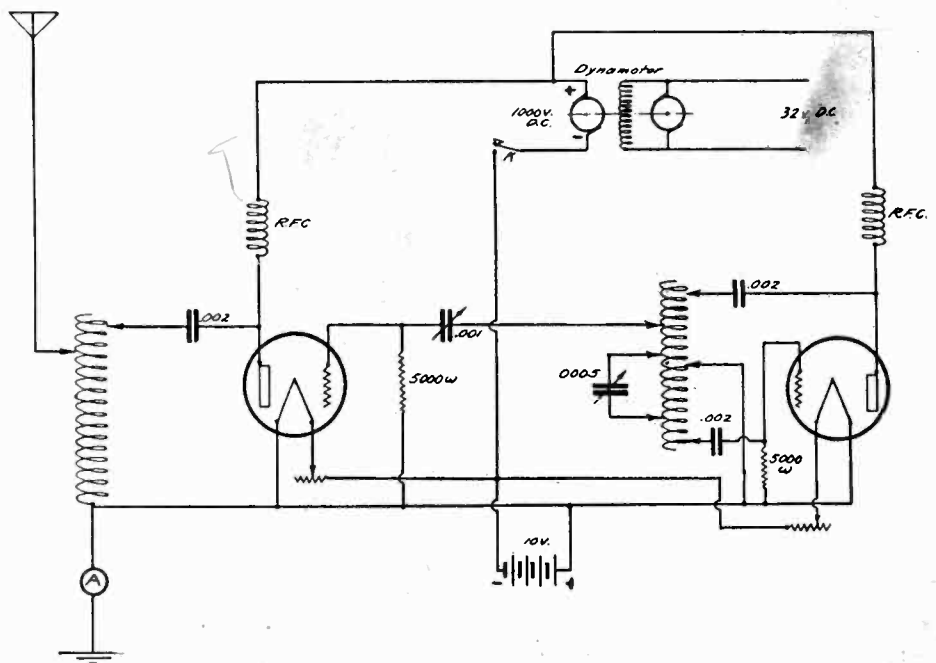
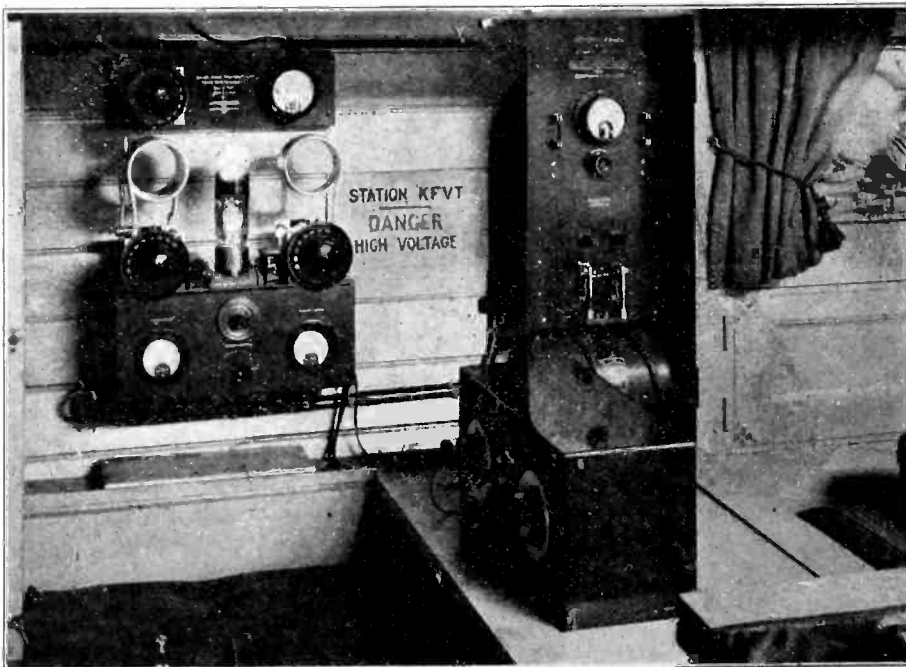

Fig. 1. Transmitter circuit for "IDALIA."



Radio equipment on the "ELOISE."

Thomas Lipton. The venturesome spirit of those entering the race can best be appreciated by remembering that these ships were none of them over 60 feet long, or over 10 feet beam. To a landsman it would seem that such small craft would be unseaworthy in heavy weather, but as a matter of fact they are as safe as a large ocean liner and in many cases are more comfortable sea-boats, to anyone who is really a sailor.

The IDALIA and ELOISE carried complete radio equipments on the trip, and since the use of radio on such boats is an innovation, the radio fraternity has been watching the race with more than usual interest. Space is at an extreme premium on such small vessels, both above and below decks, for every possible assistance is given to the spread of sails and consequent speed, and anything that would tend to interfere in the slightest with the speed of the vessel was forbid-

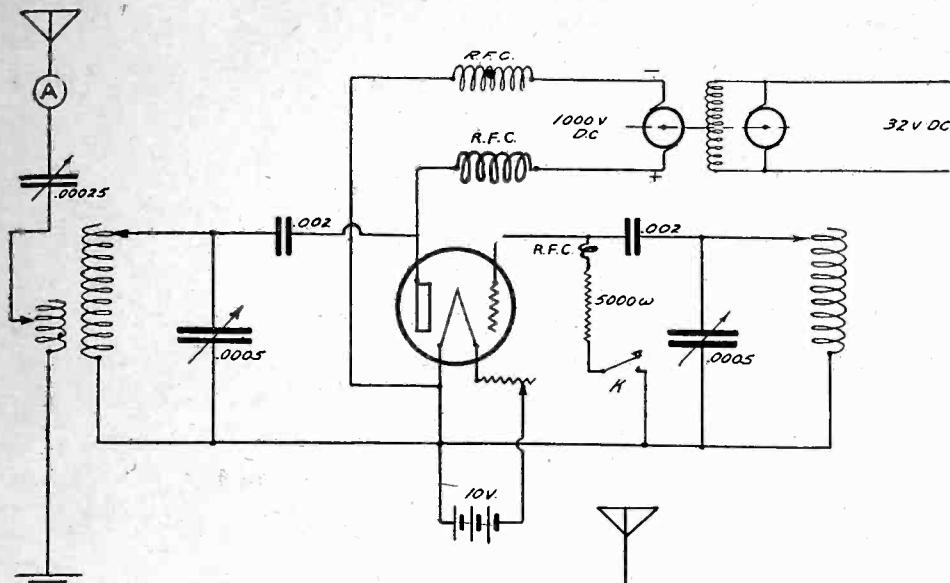

Fig. 2. Circuit of transmitter of "ELOISE."

den. Thus the construction of an elaborate antenna system was impossible and conditions necessitated crowding the apparatus into a tiny space below decks.

The accompanying pictures show the radio equipment on the IDALIA and the ELOISE and give a good idea of how compact it had to be, and the necessity for careful design. On the ELOISE, the apparatus is mounted in the main cabin, in a compartment built in the wall, and is so arranged that the entire apparatus may be concealed by folding up the panels, thus providing more room when the radio equipment is not in use. The receiving set and transmitting key are mounted on the hinged door, the transmitter being permanently mounted inside the cabinet. On the IDALIA, a slightly greater space was available and hence the apparatus could be mounted conveniently in a more accessible position.

The transmitter on the IDALIA, call KFVM, was designed and built by the ship's operator, Mr. Ray Newby, of San Jose, Calif. Mr. Newby is one of the oldest radio men on the Pacific Coast, having been employed in the radio business since 1907. The transmitter is of the "master oscillator-power amplifier" type, consisting of a 50 watt UV-203-A vacuum tube connected in a Hartley circuit, which energizes the grids of three similar type tubes which are connected in parallel. A schematic circuit diagram of the transmitter is shown in Fig. 1. As this equipment is to be used far away at sea, where no interference will be caused to nearby listeners, direct coupling was used, but it should be borne in mind that this circuit cannot be used for amateur work ashore, with the radio regulations as they are at the present time, as the latter require inductive coupling. The transmitter is mounted behind a plate glass panel, which affords good insulation and permits inspection of the apparatus at all times.

The power installation which is also used for lighting and auxiliary power,

hour capacity. A motor generator set operated from 32 volts d. c. provides 1000 volts d. c. for the plates of the tubes, the starting rheostat consisting of a number of heavy, cast resistance grids mounted behind the panel, and large enough to permit the full load current to pass through them without excessive heating. The rheostat switch is mounted on a leg of the table, and permits a voltage control from 500 to 1100 volts. The tube filaments are lighted from a separate 10 volt lead storage battery, the key being placed between the negative filament lead and the negative plate supply terminal. The receivers are mounted on the table to the right of the transmitter, one being a honeycomb coil regenerative set arranged to cover the waves from 150

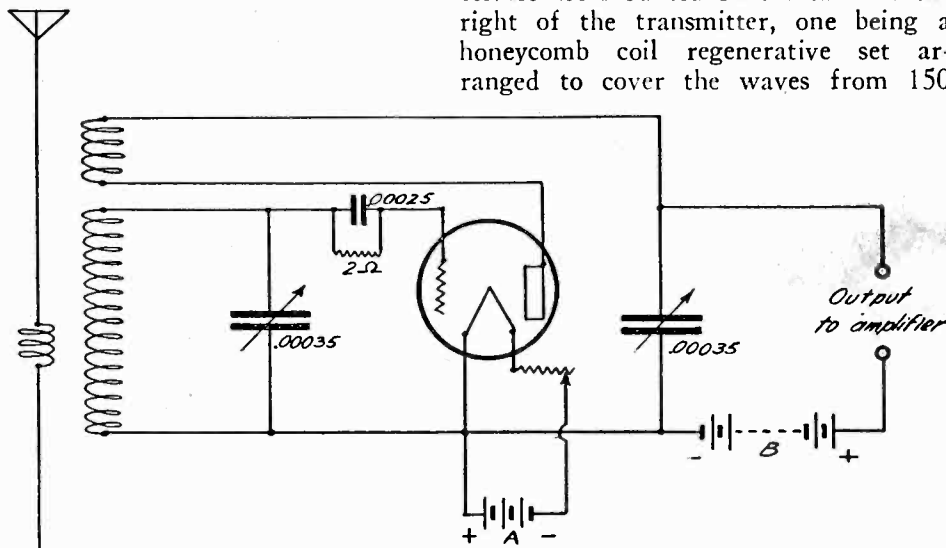

Fig. 3. Short wave receiver used on "IDALIA" and "ELOISE."

is identical on both vessels, consisting of a gasoline engine driving a 32 volt d. c. generator, which charges a set of lead storage batteries of 150 ampere

meters up, and the other a special short wave receiver.

Besides the short wave tube transmitter

(Continued on Page 68)

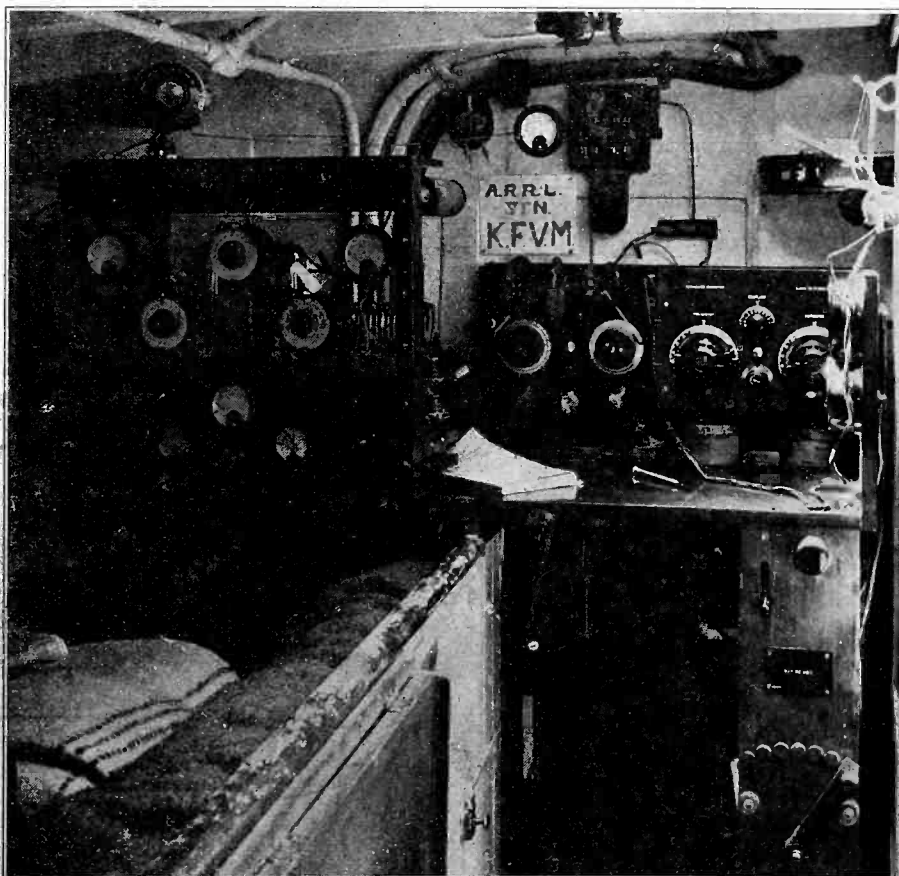

Installation aboard the "IDALIA."

The Modified Best Superheterodyne

Part II--Baseboard Model

Complete Constructional Details for a New Eight-Tube Loop Model Covering the Range from 50 to 600 Meters

By Gerald M. Best

DUE to the greater ease of assembly and wiring, a baseboard model superheterodyne is more popular than the shielded, panel-mounted set described in August RADIO. The important modifications,—the improved oscillator system and the grid condenser and leak specified for the frequency changer—are incorporated in the new design, so that it is possible either to make these changes in sets constructed in accordance with previous directions, or build an entirely new set, as the reader prefers.

This is intended primarily as a loop receiver, although a separate antenna adapter may be added if desired. It requires only two tuning controls and with its two stages of audio frequency amplification, can be connected directly to the loud speaker.

The set has been designed to employ eight tubes, five of the C-301-A or UV-201-A type and three of the UV-199 or C-299 type, the latter being the most satisfactory intermediate fre-

quency amplifiers where elaborate shielding is not used. Rheostats are minimized by the use of automatic filament cartridges. If it is desired to use large tubes throughout, it is better to use two intermediate stages, which will permit the omission of the voltmeter and 30 ohm filament rheostat necessary for the proper control of the small tubes.

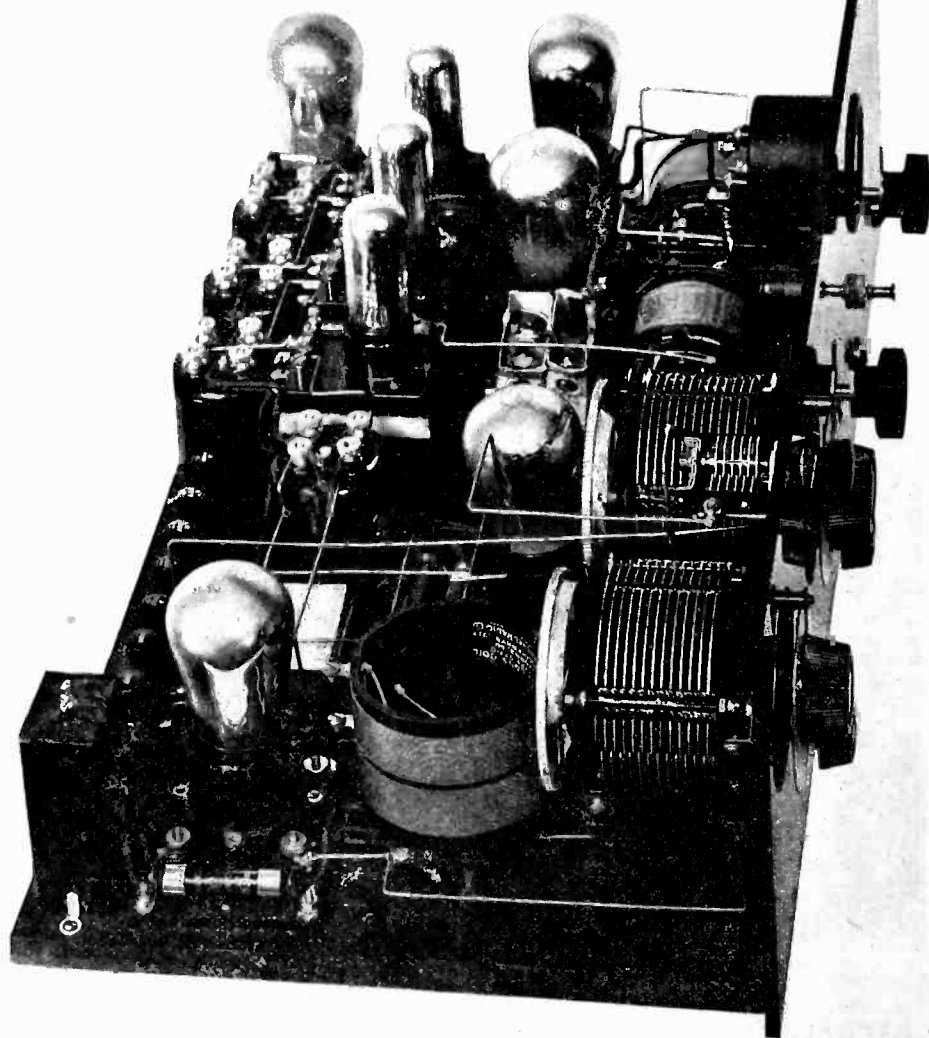

End View of Receiver, Showing Oscillator System.

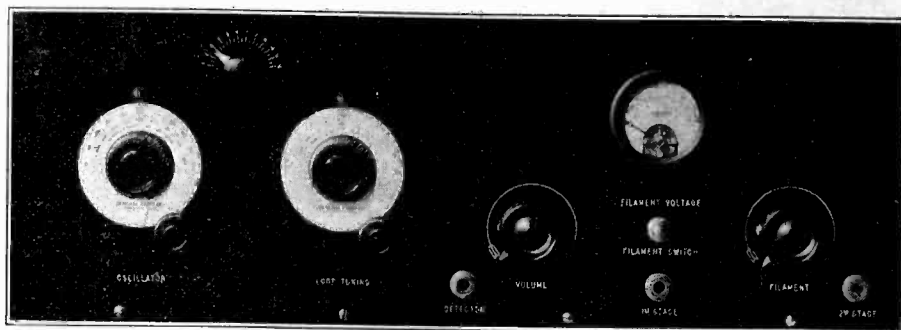

Fig. 1. View of Panel Front.

The general appearance of the panel is shown in Fig. 1, the oscillator and loop tuning condensers being at the left end with the feedback condenser mounted above them. To the right of the tuning controls are the volume control, filament rheostat and voltmeter, with the three output jacks arranged symmetrically below the rheostats, and the filament switch below the voltmeter.

Fig. 2 shows the drilling template for the panel. Many of the holes designated are for specific makes of apparatus, so that when the panel is ready for drilling, the templates generally furnished with each piece of apparatus should be used so as to make sure that the holes will be drilled in the right positions.

The illustrations show the appearance of the completed set, and will be of assistance in properly arranging the apparatus. The side view shows the method of mounting the oscillator coil, and the position of the frequency changer tube in back of the loop tuning condenser. In order to shorten the leads where possible, and simplify the work of wiring, the oscillator and frequency changer are mounted on the baseboard back of their respective panel controls, and while this does not lend to symmetry in the arrangement of the tubes, the increase in efficiency from shorter leads is obvious.

The shelf for the intermediate frequency tubes is made only large enough for three 199-type sockets, the detector tube being mounted on the baseboard. If intermediate frequency transformers of a type other than those shown are used, where the terminals are near the base of the transformer, it may be possible to omit the shelf and yet retain short grid and plate leads. This can best be determined when the parts are purchased.

FIG. 3 shows the schematic wiring diagram, which does not differ materially from that described last month. The oscillator tube is at the left, and is

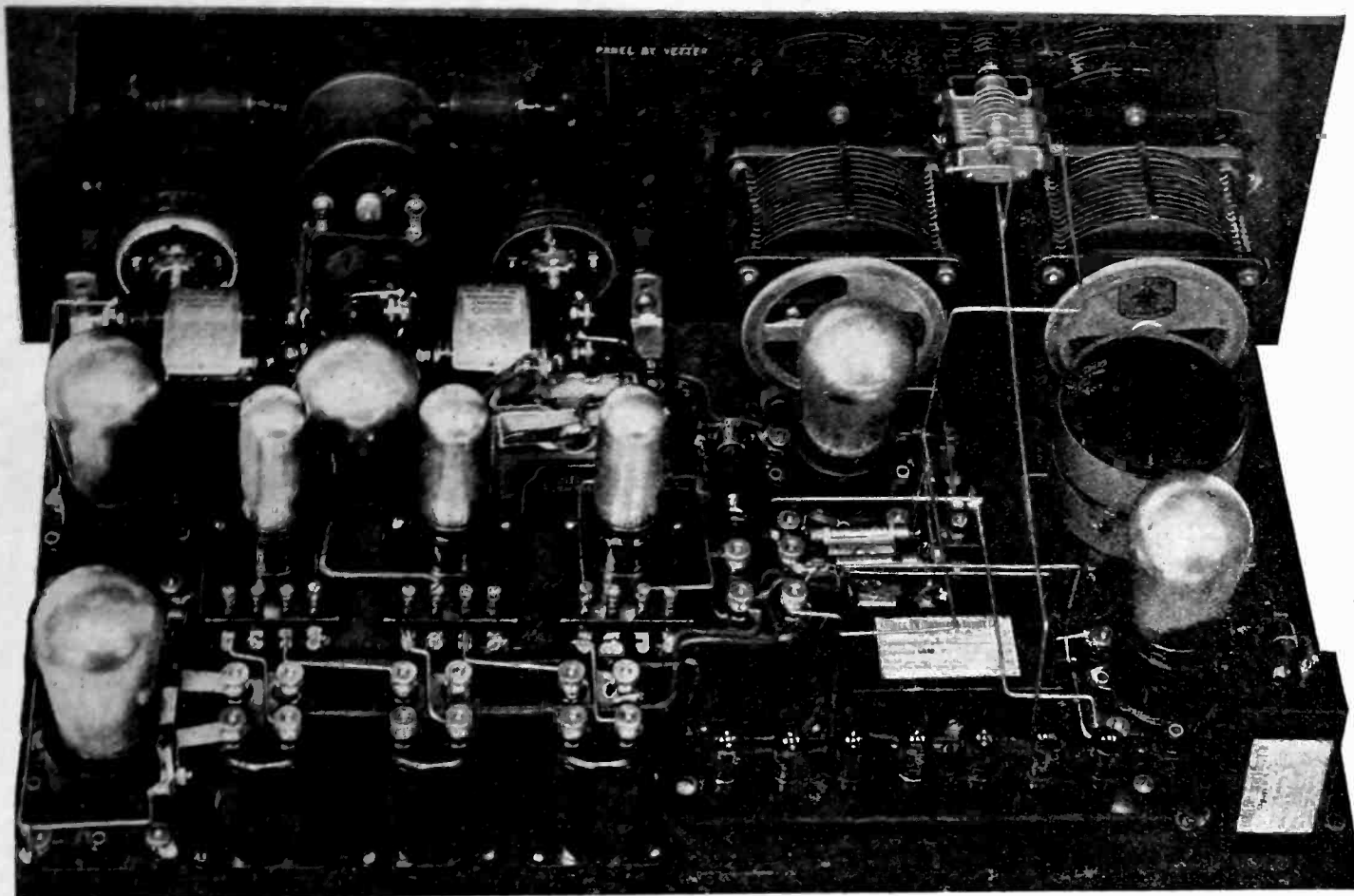

Rear View of Baseboard Model.

controlled by variable condenser C_2 , .0005 mfd., in series with protecting condenser C_4 , .006 mfd., the latter preventing the vacuum tubes being burned out in case the air condenser plates become shorted. Energy from the oscillator is fed into the frequency changer by means of a .1 megohm resistance R_3 in series with a fixed condenser C_5 , which is made large enough so that it will not affect the total resistance of the circuit between the grids of the oscillator and frequency changer.

The loop antenna is tuned by condenser C_1 , which is the same size as C_2 , the grid condenser C_3 being a variable of not over 50 micromicrofarads (.00005 mfd.) maximum and the grid leak R_2 from 2 to 3 megohms, depending on the tube. A center tap loop is employed, energy being fed from the plate of the frequency changer through a small air condenser C_{10} having a maximum capacity of .00005 mfd., to one side of the loop antenna. The center tap of the loop is connected directly to the positive filament of the frequency changer.

The three intermediate frequency stages are transformer coupled, using transformers either of the shielded type or open core non-shielded, as desired. The tuned stage should be of the proper design to match the intermediate stages, and the tuning condenser C_7 should be of the value specified by the manufacturer, the value shown on the diagram being for the particular transformer used in the experimental layout.

The volume control is obtained by

means of a 2000 ohm potentiometer shunted across the second intermediate stage, the potentiometer being arranged so that the circuit is open when the slider reaches its maximum position.

The three intermediate tubes are of the dry cell type and are controlled by a 30 ohm rheostat R_1 . The detector tube is of the storage battery type, the filament current being controlled by an Amperite in the same manner as for the oscillator and frequency changer. The grid condenser C_8 should be .00025 mfd. and is shunted by a grid leak R_4 of 3 megohms. In the plate circuit of the detector tube is the radio frequency by-pass condenser C_9 , which is shunted across both the primary of the audio frequency transformer, and the 45 volt B battery, so that the high frequency component in the detector plate circuit is localized within the set.

The two audio stages are connected in the conventional manner using shielded transformers such as the Karas Harmonik or other recently developed high quality makes and the tubes being storage battery type, supplied with either 90 or 135 volts plate, depending upon the volume required. Where normal room volume with a horn type speaker is required, 90 volts plate and $4\frac{1}{2}$ volts C battery is ample, but for large rooms and where a cone type loud speaker is used, the additional plate voltage and 9 volt C battery should be supplied for best results. The new UX-112 tube recently announced will increase the output of the set if used in the last

audio stage and requires a .5 amp. Type 112 Amperite in place of the .25 ampere size.

The by-pass condensers C_6 and C_{11} are shunted across the plate battery supply to the frequency changer and oscillator tubes respectively. If trouble due to high resistance in the B battery circuit is experienced, with resultant howling in the audio frequency stages, a small by-pass condenser of .006 mfd. or more may be connected from the positive B battery bus at the transformers, to the negative filament leads to the audio frequency tubes. This will also be necessary in case a protective resistance is placed in the B battery circuit, as was done in the shielded model.

Many of our readers find it difficult to wire up receivers from schematic diagrams, and so we have prepared a pictorial diagram, Fig. 4 in vertical perspective, showing the actual wiring for each piece of apparatus, each part being plainly marked with respect to the schematic diagram in Fig. 3. The picture is distorted in places to permit all the connections to be shown clearly.

IN assembling the set, the panel apparatus should be mounted first, and the connections to the jacks soldered before the panel is mounted on the baseboard, as some of the jack connections will be difficult to reach unless the wires are soldered first. Flexible wire is handy for these connections, and should be well insulated.

The tube shelf is made of wood, the dimensions being $2\frac{1}{4} \times 7 \times \frac{1}{4}$ in., and is

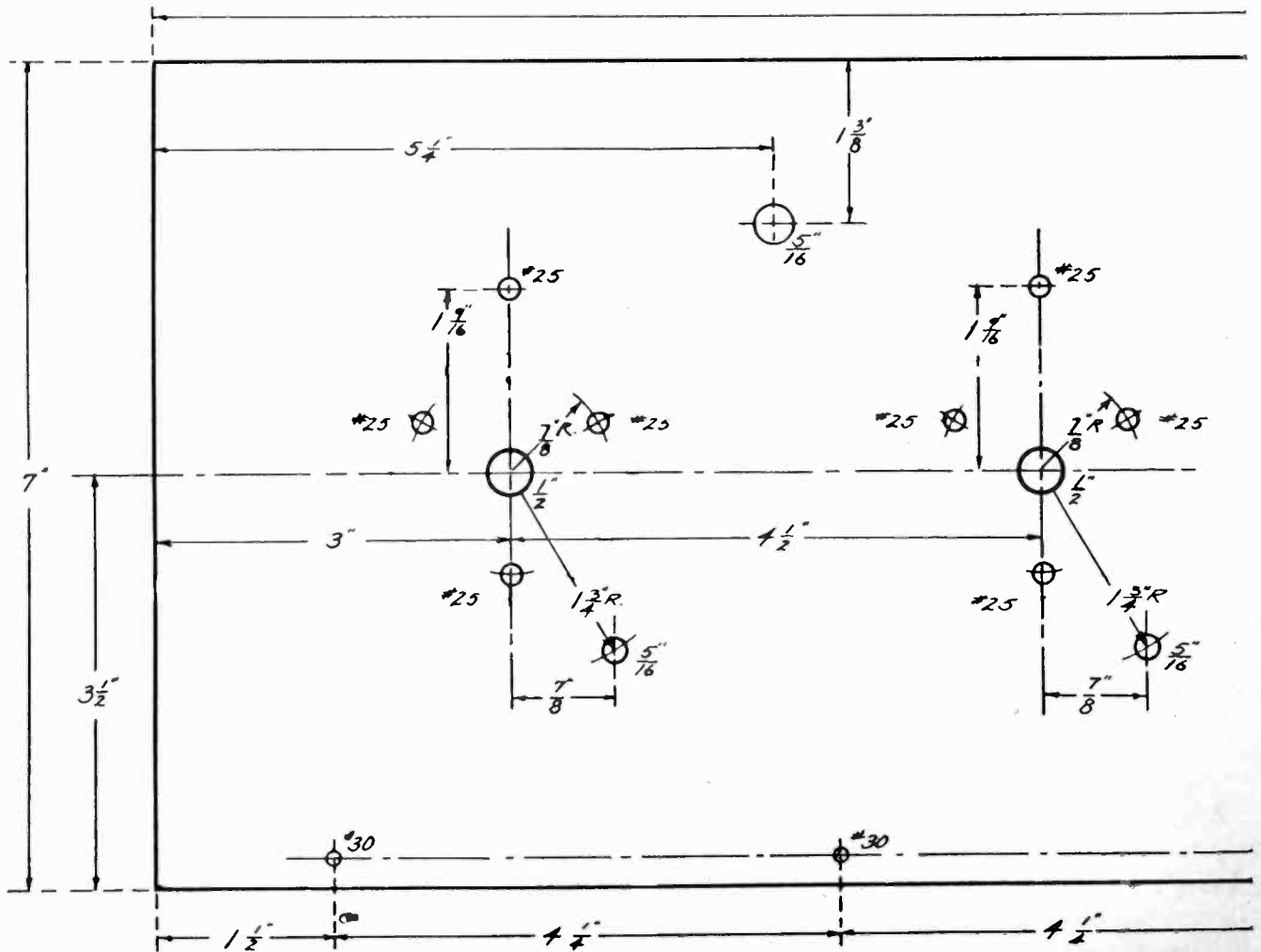
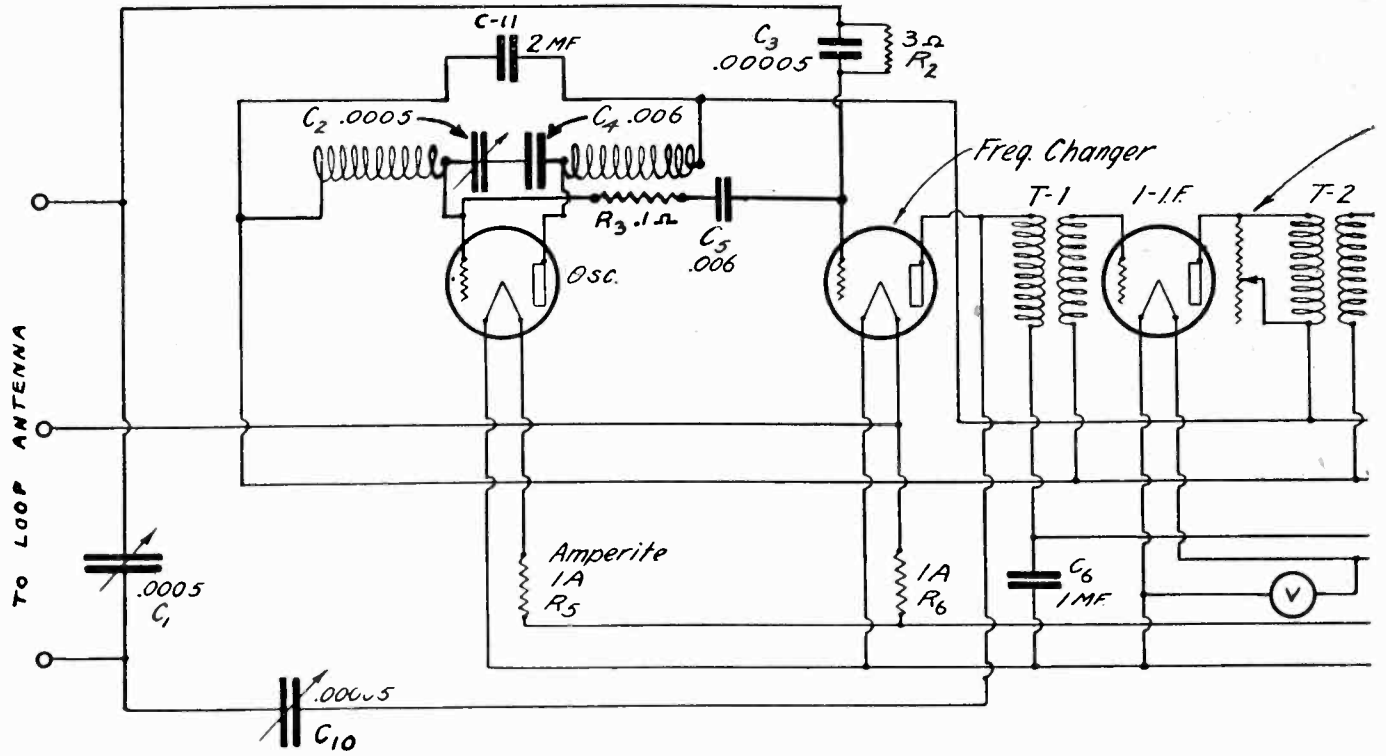

#25 Federal Potentiometer
2000 ω R-10

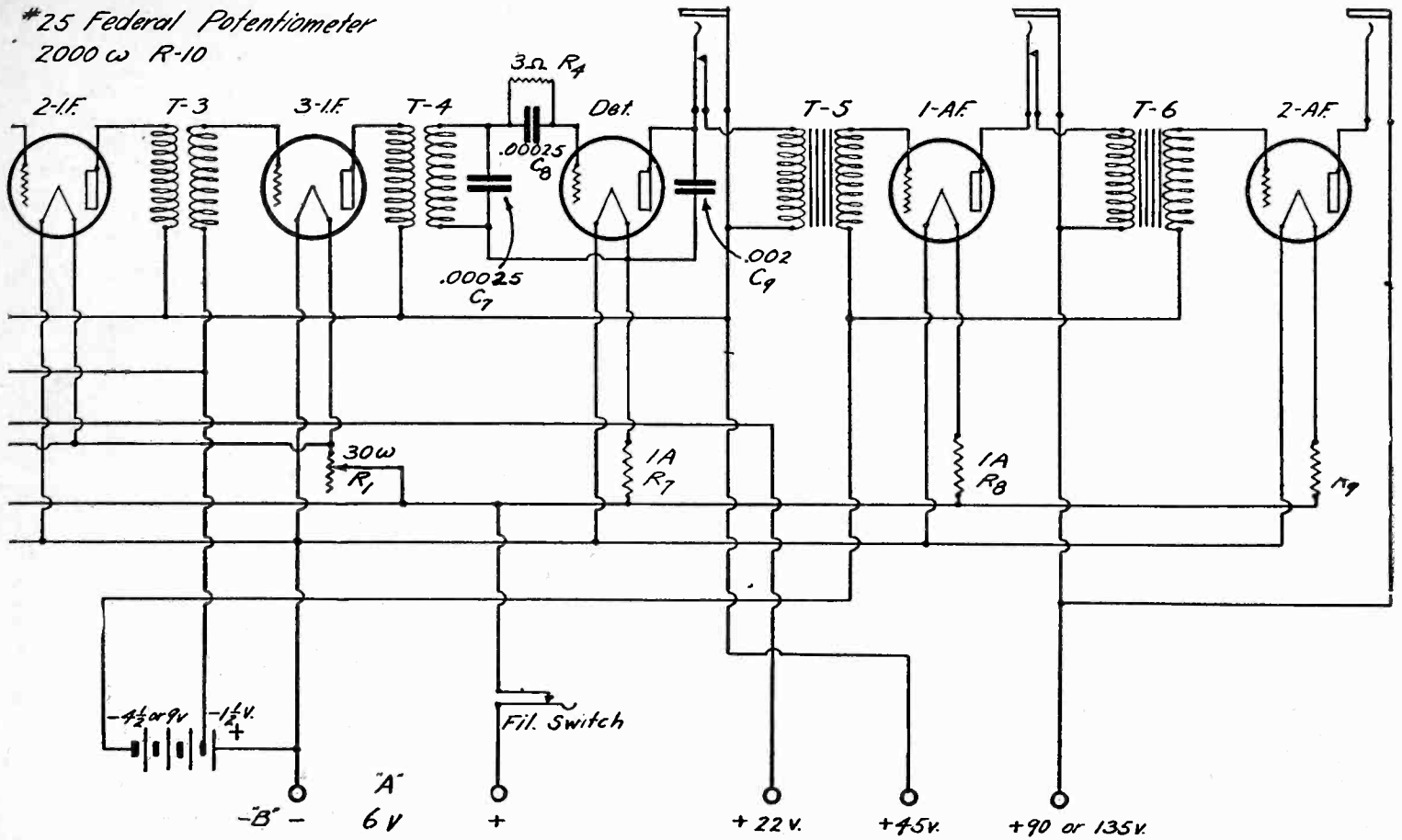

Fig. 3. Schematic Wiring Diagram.

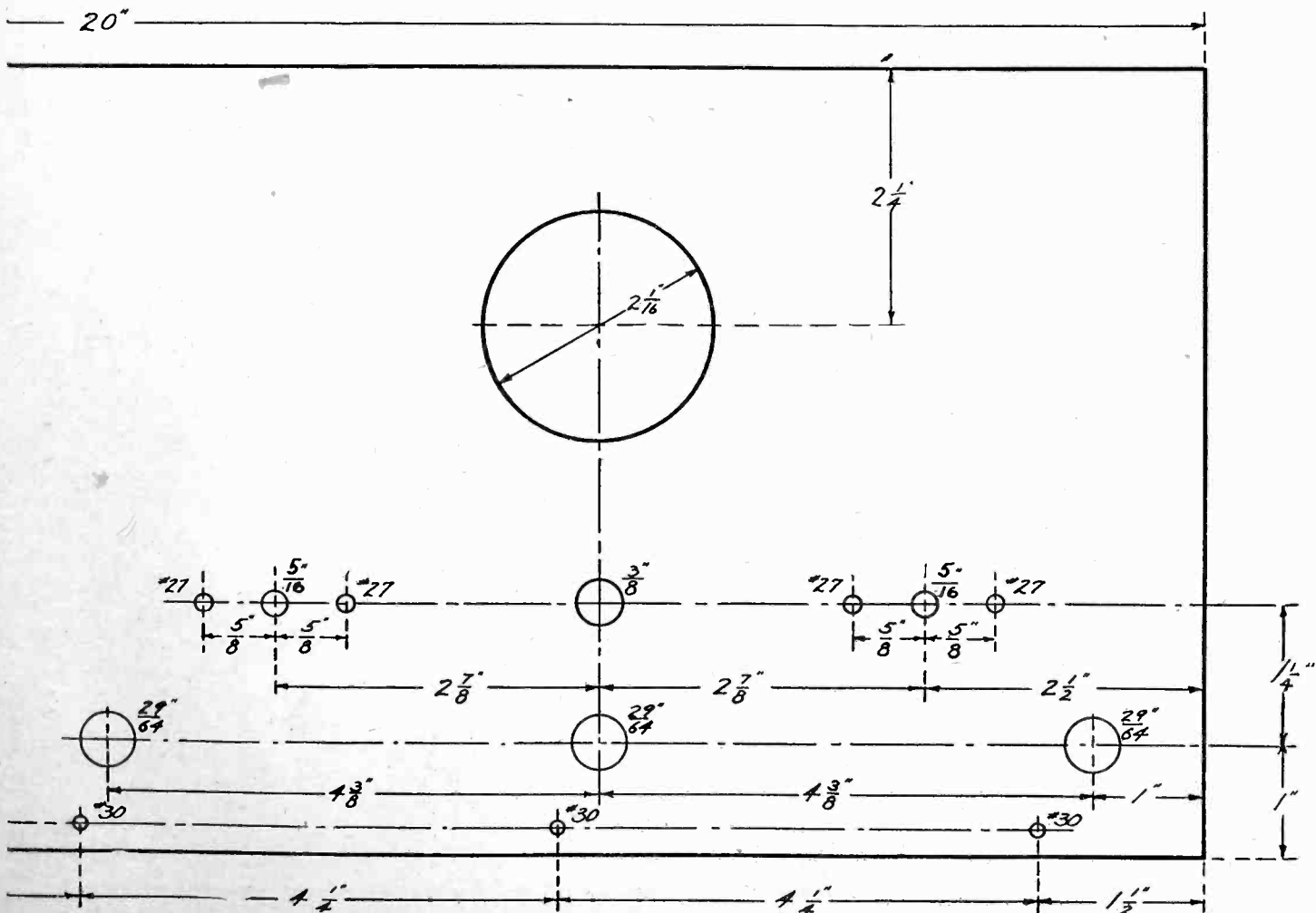

Fig. 2. Template for Drilling Panel.

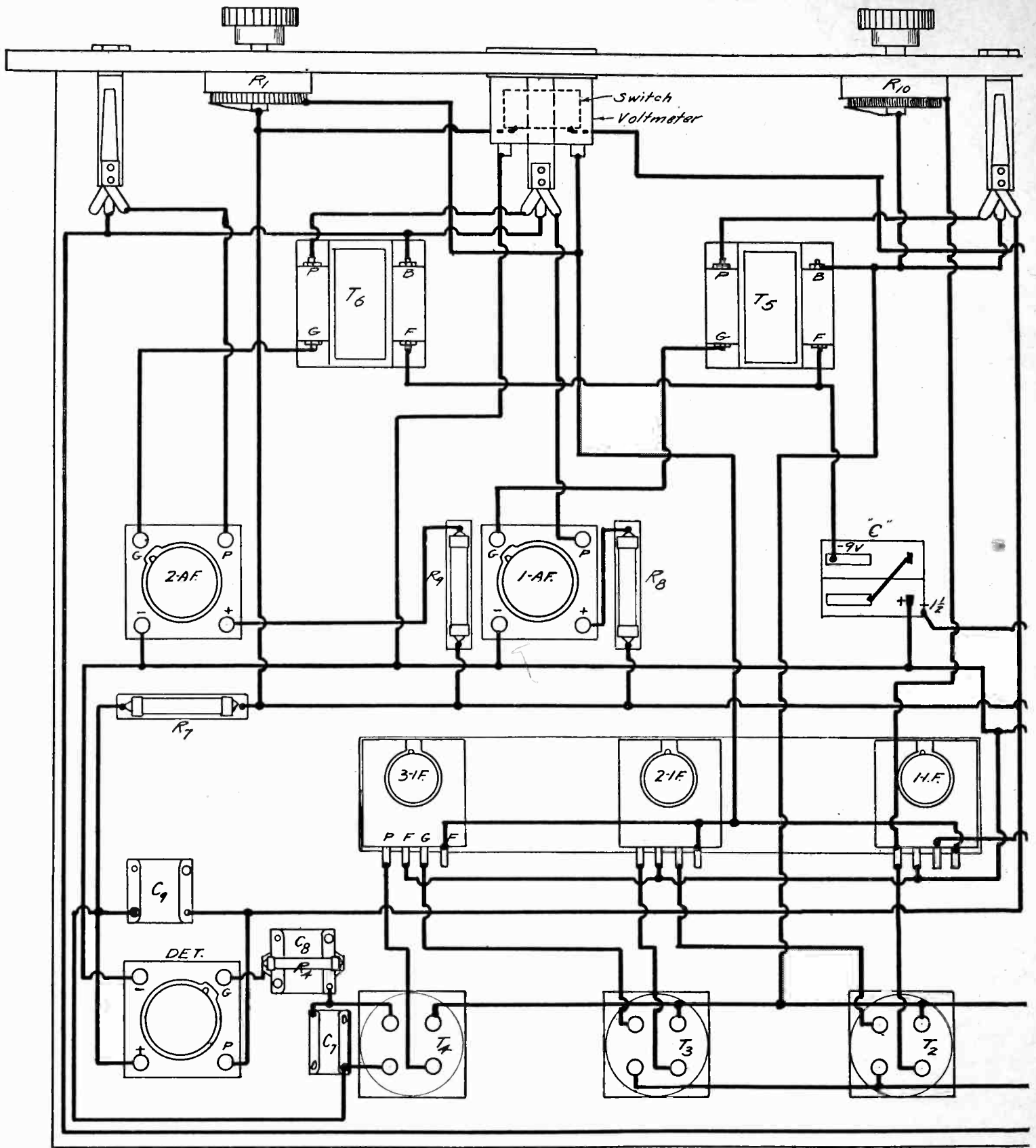

Fig. 4. Pictorial Wiring Diagram, Showing

supported by two brass brackets, the details of which are given in Fig. 5. In mounting the binding posts at the rear of the baseboard, a convenient strip of 7 posts equipped with supports and mounting screws was used, thus obviating the necessity for special parts.

The connections to the grid and plate of each intermediate frequency tube and to the detector should be made with bare wire, but the filament wiring may be bunched together, as can the grid and plate battery bus wires. On account of their small size, a pair of $4\frac{1}{2}$ volt flash-

light batteries were used for furnishing C voltage, the $1\frac{1}{2}$ volt tap being obtained by scraping away a small amount of the cardboard covering of one of the batteries, at the end next the positive terminal, and soldering the connection to the zinc case of the battery,

The apparatus on the baseboard should be mounted as shown on the pictorial diagram, the shelf going in place after the wiring of the audio frequency transformers and associated tube sockets is completed. Make the connections for the oscillator and frequency changer in

bare wire, using spaghetti only where it is necessary to prevent wires from touching each other. After the oscillator and frequency changer wiring is complete, make as many of the connections as possible to the intermediate frequency transformers and detector circuit, and then mount the tube shelf in place behind the intermediate transformers. The list of parts given on page 18 will enable the selection of apparatus suitable for the circuit. No specific recommendation of any of the parts listed is implied, and the set will function satisfactorily with any of the parts named in the list.

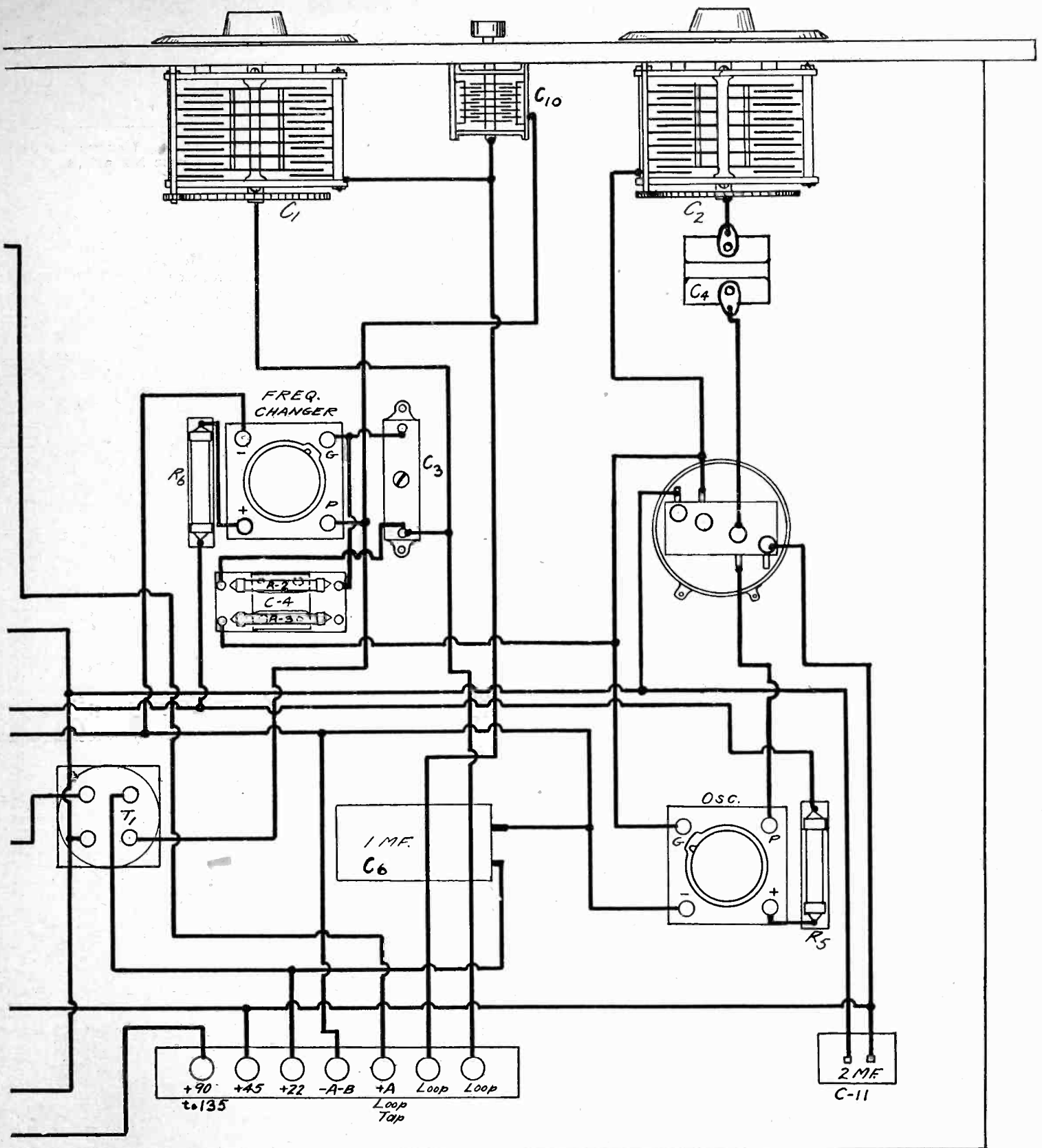

Actual Arrangement of Parts.

As soon as the wiring is completed, the *A* battery should be connected, and the tubes placed in their sockets. The automatic filament cartridges should be of the .25 ampere type, with the exception of a .5 ampere size in the last audio stage, and each one should be checked by shorting it out of the circuit temporarily. If the filament of the tube associated with the cartridge becomes brighter, the cartridge is O. K. The filament rheostat *R*₁ should be capable of reducing the voltage of the three 199-type tubes below 3 volts, with the *A* battery fully charged, and if this cannot

be accomplished, a rheostat of higher resistance should be substituted.

After the filament circuit is found to be correct, connect the positive *A* battery to the 22 volt binding post, and see that the filaments of the tubes do not light, for if any of the tubes should light, there is a short circuit in the set and it should be located before connecting the *B* battery. Connect the positive *A* battery to the 45 volt and 90-135 volt terminals and repeat the above test, and if no trouble develops it is safe to connect the *B* battery, and the loop antenna.

After placing the tubes in their sockets, turn on the filament switch and ad-

just the intermediate frequency tubes to 3 volts. Plug in the headphones in the first audio jack, and set the volume control at a point about one-third between zero and maximum. Tune in a local station to maximum, with the oscillator and loop controls, and reduce the volume to a point where it will be comfortable with the headphones.

Move the oscillator condenser back and forth slightly to observe the degree of selectivity of the oscillator system, and if the two points where the station can be tuned in on the oscillator condenser appear to be broad, too much oscillator energy is being fed into the fre-

PARTS FOR THE MODIFIED BEST SUPERHETERODYNE, BASEBOARD MODEL

quency changer, and it will be necessary to change the resistance R_3 to some higher value than .1 megohm. Grid leaks of .25 and .5 megohms are easily obtainable and one of these values will be sure to provide the correct resistance for the oscillator circuit. If the volume control is set at too high a point, the

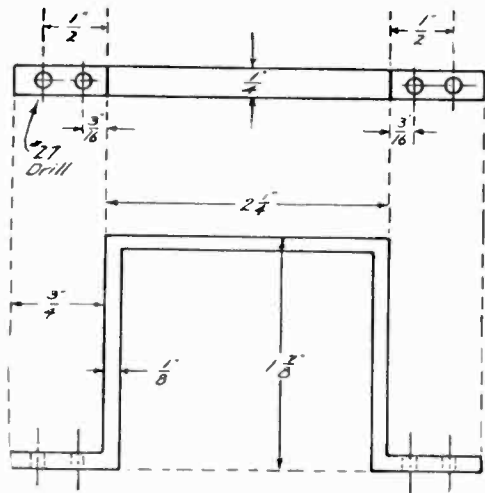

Fig. 5. Details of Brackets for Shelf.

tuning will be broad under any circumstances, so it is better to have the volume low when making this adjustment.

As has been explained many times, with the superheterodyne receiver a station can be tuned in at two places on the oscillator condenser dial, one setting being 45,000 cycles above the incoming frequency and the other 45,000 cycles below this frequency, when the intermediate amplifier is tuned to 45,000 cycles. Signals should be received at about the same degree of intensity at either point on the dial, and if it is found that this is not the case, grid condenser C_3 may be more than .00005

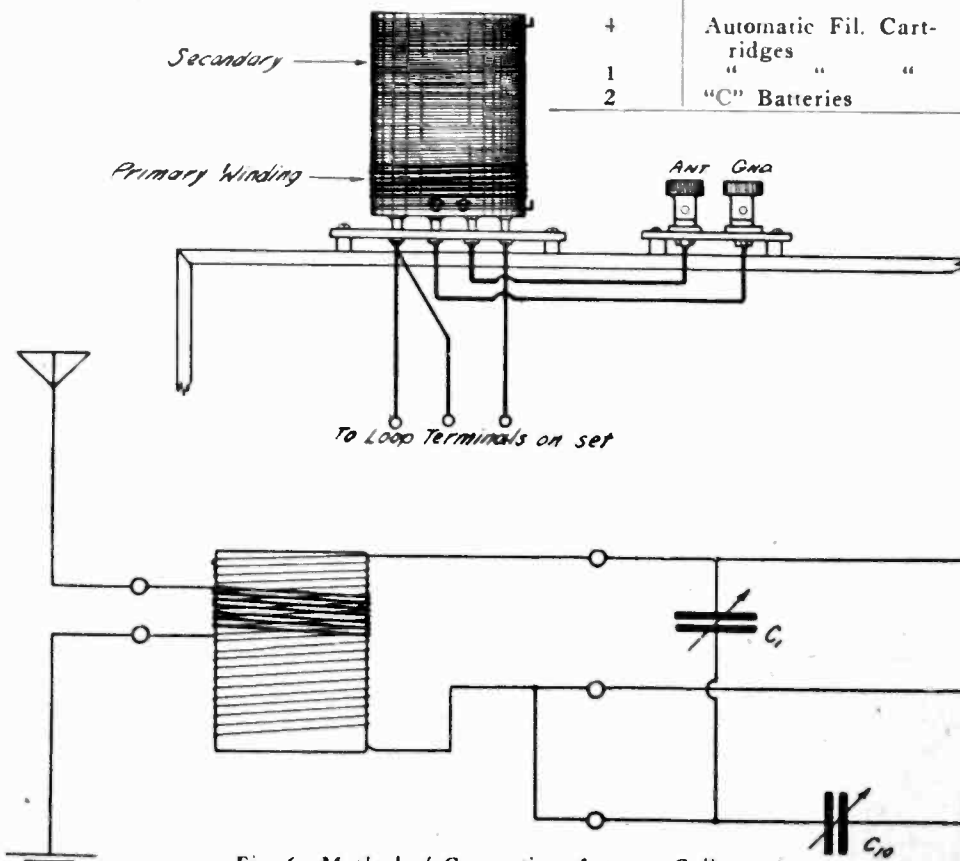

Fig. 6. Method of Connecting Antenna Coils.

No. Required	Part	Circuit Designation	Makes That May Be Used
3	I. F. Transformer	T_1, T_2, T_3	Baldwin-Pacific, General Radio No. 271, Jefferson No. 150, Remler, Silver 60 KC.
1	Tuned Transformer	T_4	See Text
2	Audio Freq. Transf.	T_5, T_6	All-American, Dongan, General Radio, Jefferson, Karas Harmonik, Pacent, Premier, Rauland Lyric, Stromberg-Carlson, Supertran, Thordarson 2:1.
3	Jack		Carter, Erla, Federal, Frost, Marco, Pacent.
3	Oscillator Coils		General Radio No. 277-A, B and C
1	Oscillator Coil Mtg.		General Radio No. 274-B
1	Rheostat	R_1	Amsco, Bradleystat, Carter, Federal, Frost, General Instrument, General Radio, Pacent.
2	Variable Condensers	C_1, C_2	Acme, Bremer-Tully, Camfield, Cardwell, Ensign, General Instrument, General Radio, Karas, Marco, National, N. Y. Coil, Phoenix, Remler, Signal, Silver-Marshall, U. S. Tool.
3	Tube Sockets, Plain Type 199		Amsco, Benjamin, Erla, Frost, General Radio, Kellogg, Marco, Remler, Silver-Marshall.
5	Tube Sockets, Cushioned Voltmeter		Benjamin, Frost
1	2 mfd. Fixed Cond.	C_{11}	Hoyt Model 17, Jewell Pattern 135, Weston Model 506 or 301.
1	1 mfd. Fixed Cond.	C_6	Dubilier, Kellogg, N. Y. Coil
1	.00025 mfd. Fixed Cond.	C_7	Dubilier, Electrad, Kellogg, N. Y. Coil, Federal.
2	.006 mfd. Fixed Cond.	C_4, C_5	Dubilier, Electrad, Federal, Hilco, Kellogg, N. Y. Coil.
1	.002 mfd. Fixed Cond.	C_8	Dubilier, Electrad, Federal, Hilco, Kellogg, N. Y. Coil.
1	.00025 mfd. Fixed Cond. with G-L mtg.	C_9	Dubilier, Electrad, Federal, Hilco, Kellogg, N. Y. Coil, XL.
2	.00005 mfd. Var. Cond.	C_3, C_{10}	Amplex, Continental, XL Model G, Chelton.
2	Grid Leak-3 megohm	R_2, R_4	Aerovox, Amsco, Daven, Durham, Electrad, Filko, Freshman, Rogers.
1	Grid Leak-.1 megohm with mounting	R_3	Aerovox, Amsco, Daven, Durham, Electrad, Filko, Freshman, Rogers.
1	Potentiometer, 2000 ohms	R_{10}	Centralab, Federal
7	Binding Posts		Amsco, Eby, General Insulate, General Radio.
4	Automatic Fil. Cartidges	R_5, R_6, R_7	Amperite No. 1A.
1	" " "	R_8	
2	"C" Batteries	R_9	Amperite No. 112. Eveready No. 751.

mfd., and should be adjusted to a lower value of capacity.

The adjustment of condenser C_{10} may be made from time to time, while tuning distant stations, or can be left in a permanent position, as desired. If the latter is preferable, adjust the set to the lowest wavelength at which the set is to be operated, with any given oscillator coil, and turn the feedback condenser until the set breaks into oscillation. Then back off the capacity slightly and you have the proper adjustment for the longer waves. If the set oscillates continuously at all times, this condenser may be defective and should be temporarily cut out of the circuit to see if the oscillations will cease. If the oscillator tube does not oscillate, and no stations are heard at any setting of the oscillator condenser, the trouble may be due to a defective tube, or incorrect wiring of the oscillator coil. Try reversing the con-

(Continued on Page 70)

Future Developments in Audio Frequency Amplifiers

A Forecast of the Probable Trend in Transformer and Tube Developments, Together with an Account of Test Methods Used

By G. M. Best

IN the preceding chapters of this series, the various forms of audio frequency amplification possible with existing apparatus have been discussed in detail, and the reader has no doubt formed his opinion as to the merits of each method, both from the discussion and from his own experience.

While the future cannot be forecast in great detail, it is safe to predict that the next few years will see long steps in advance toward perfection of audio frequency amplifying devices. Two main avenues of approach are open; one by way of vacuum tube development and the other by improvement of audio frequency intertube coupling devices.

At present the obvious advantages of resistance and impedance coupling are available only at the price of low amplification per stage, since such coupling devices cannot step up the voltage under normal conditions and therefore limit the gain to the amplification constant of the tube. It is apparent from the curves shown in the last chapter, for various types of impedance coupling, that if tubes having amplification constants as high as 30 or 40 were available to the radio constructor, impedance or resistance coupling could compare well with transformer coupling in amplification per stage and at the same time retain superior frequency characteristics. It is an open question, however, whether vacuum tube manufacturers will undertake to place such a tube on the market at the present time, since the price would have to be fairly low to compete with the standard tubes of low amplification constant.

Present day transformers, though still far from perfect, are a far cry from the inefficient, poorly designed products of

several years ago. The future may be expected to bring still greater improvements, as manufacturers begin to recognize the principles of design and the problems to be met. Too many transformers in the past were built to sell and not to amplify. Many were unintelligent copies of some transformer already on the market and others, if tested at all, were tested at some single frequency, with no thought for what might happen at other frequencies.

But today we find a number of transformer manufacturers giving thought to means of improving their products and undertaking extensive tests to determine their degree of success. The new high power radiocast stations have a practically perfect frequency characteristic from 30 to 5000 cycles, and the new cone type loud speakers will force the development of the audio amplifier as has no other means. Of what avail is a high class radiocast station and a fine reproducer, if the medium in the form of the audio amplifier cuts out the upper and lower extremes of the musical scale, as do 75 per cent of the present amplifiers in general use?

The impedance relations set forth earlier in this series show that good transformer design requires the highest possible primary impedance consistent with other factors. Present grades of core iron make possible higher primary impedances only by increasing the number of turns of wire or the size of the core or both. In this direction, however, there is the serious limitation of distributed capacity in the secondary wind-

ing, and the primary also if it is very large. Curves shown in previous chapters demonstrated the disastrous effect of too great an effective capacity across the secondary winding. There is, therefore, a limit to the number of turns which can be successfully employed in the secondary, which limits the primary winding to as few turns as possible consistent with a good step-up ratio and yet have sufficient turns to keep its impedance high. The interwinding capacity effect offers the possibility of some advance in this connection, for by choosing some moderate ratio, the primary and secondary turns may both be increased proportionately beyond the point where falling off at high frequencies begins, thus improving the low frequency characteristic. Then, by the cut and try method, the windings may be so proportioned that the inter-winding capacity will bring up the high frequency characteristic to its proper flatness. Some of the transformers on the market already embody this feature to a great degree.

Progress in the direction of larger cores or better proportioning of coils can be small at best. The real hope of the future is that some core material having far greater permeability, such as Permalloy, will be used. Because the inductive component of the impedance of any coil having a magnetic core is directly proportional to the permeability of the core, if we had a kind of iron whose permeability was say 100 times that of the silicon steel now in use, it would be possible

(Continued on Page 74)

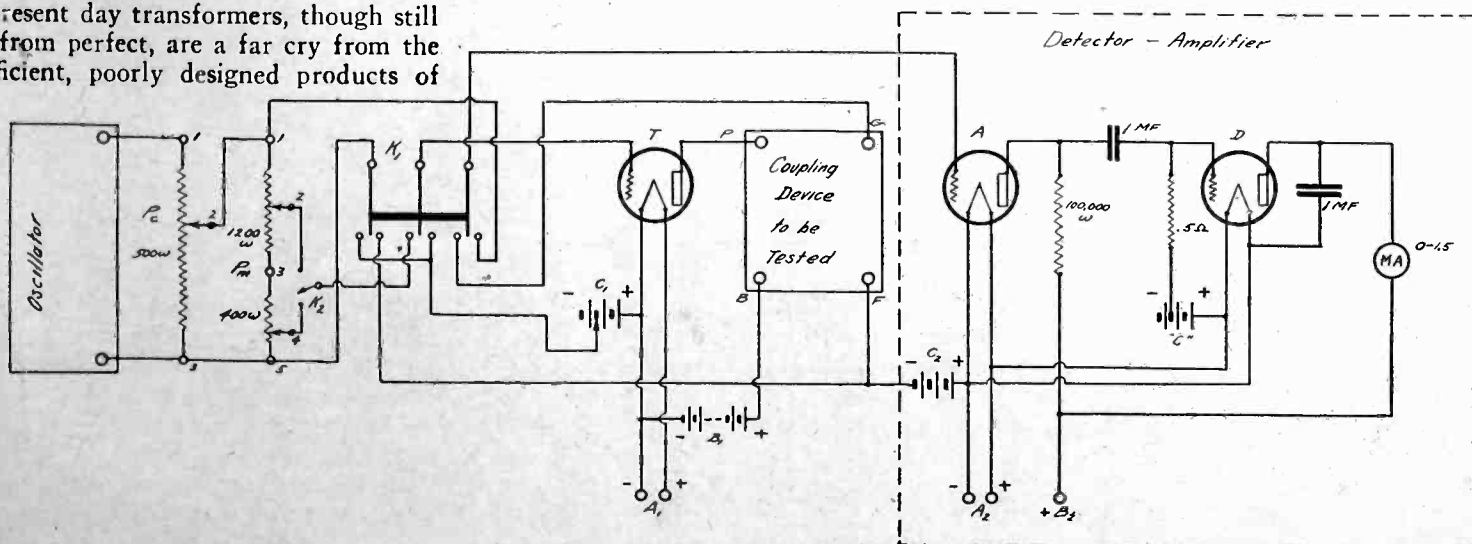

Fig. 1. Circuit Used in Audio Frequency Tests.

The Facts About "LOW LOSS" Radio Apparatus

A Consideration of the Effects of a Coil's Power Factor on
Its Performance in a Receiver

By Glenn H. Browning

At the present time there seems to be a maddening rush for so-called low-loss coils. Manufacturers have sensed this demand, and have put on the market spider web, honey comb, basket weave, and a host of other kinds of trick coils with and without a dielectric support, in order to cater to a popular demand. This movement towards reducing losses in various pieces of radio apparatus has been in good faith, both on the part of the purchaser, and the manufacturer, and will have a lasting effect on the radio industry. However, as will be pointed out, not every coil that looks efficient proves so when subjected to laboratory tests.

The worth of a coil depends upon its resistance. This resistance must be measured, not at a thousand cycles per second or ten thousand cycles per second, but at the frequencies at which it is to be used. If it is a tuning coil, or a radio frequency transformer to be used in the reception of radiocast signals, the resistance should be known at one million cycles (300 meters) and also at intervals down to five hundred thousand cycles (600 meters).

Besides the value of the radio frequency resistance of the coil, the inductance must also be known. This will be easily understood when you consider that a coil having six turns of wire on a 3 in. tube might have 3 ohms resistance at a million cycles a second, while another coil, having 12 turns around the same size tube would have 12 ohms re-

sistance at a million cycles. The first coil would be no better than the second for radio work, for the second has approximately four times as much inductance, as well as four times the resistance.

Thus three things must be specified when determining the worth of a coil; first the resistance; second the inductance, and third the frequency at which the resistance was taken. It turns out that these three quantities may be combined conveniently into a fourth quantity, which we will call n , which varies

little over the radiocast band of frequencies. Thus n will be defined as $n = R \div 2\pi fL$ where R is the resistance of the coil, whose inductance is L at the frequency f and π is the ratio of the circumference of a circle to its diameter. British engineers call this term the "power factor" of the coil and are thoroughly alive to the importance of the term.

Fig. 1 shows the radio frequency resistance of a number of coils where resistance is plotted against wavelength,

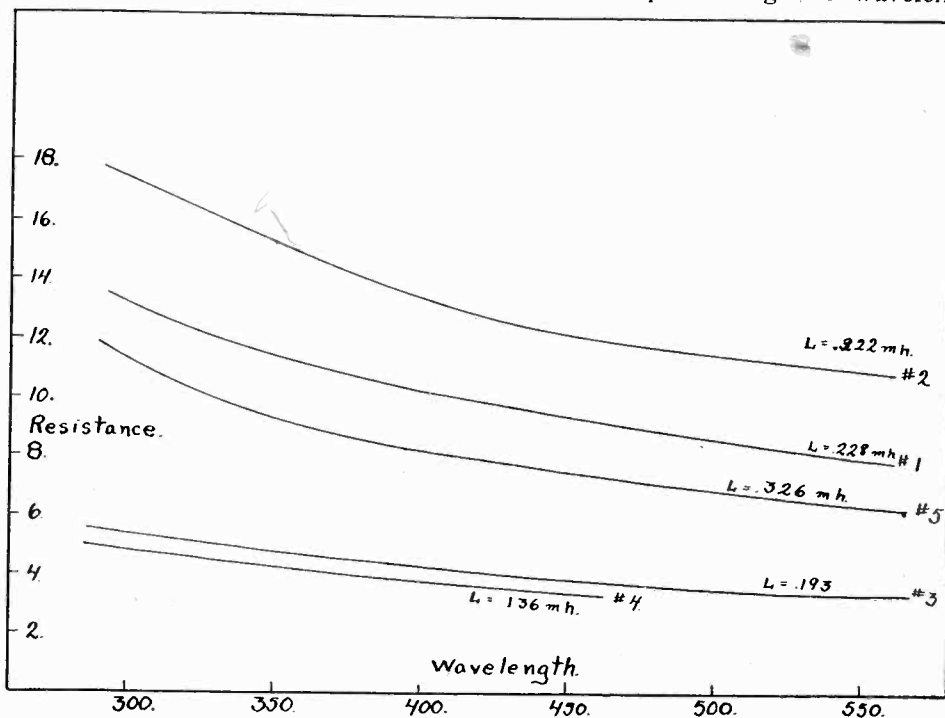

Fig. 1. Variation of Radio Frequency Resistance with Wavelength for Five Coils.

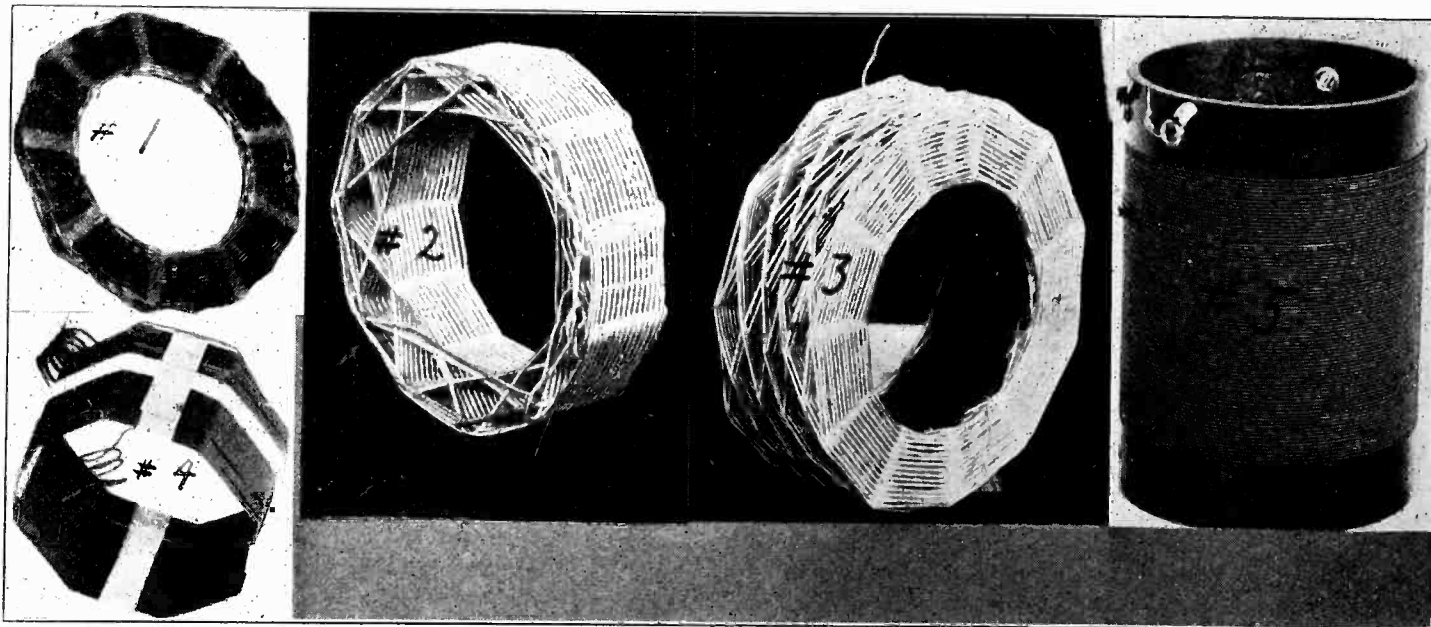

Fig. 2. The Five Coils Tested.

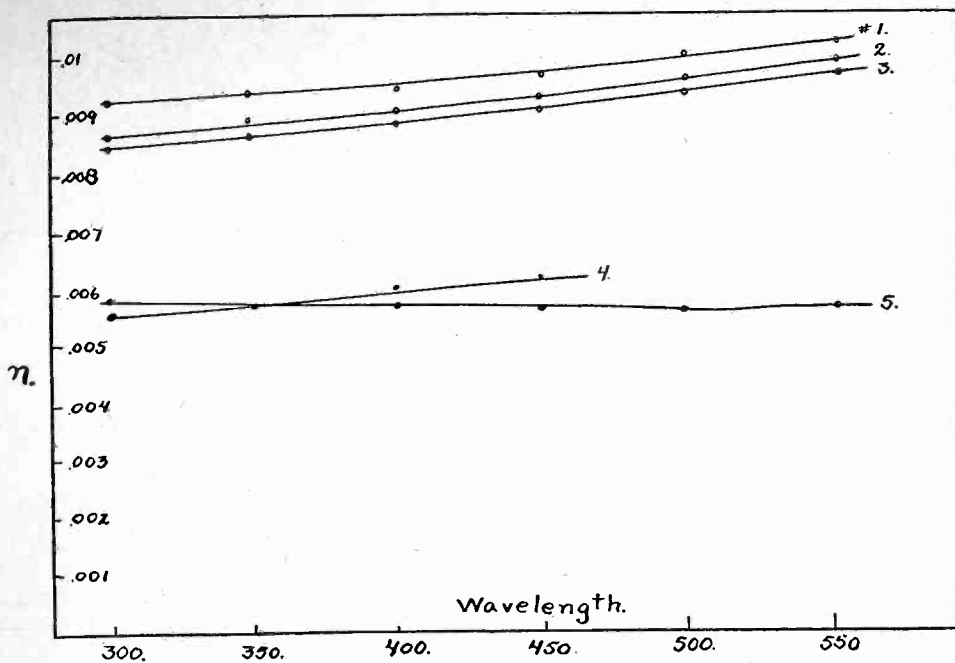

Fig. 3. Variation of "n" with Wavelength.

the inductance of each coil being also given on the chart. Fig. 2 shows each of the coils tested. Fig. 3 shows the quantity n plotted against wavelength, and gives an idea of the value of a coil when used in a radio circuit. The smaller the value of n , the lower the loss in the coil, and the better it is for use in the reception of radio signals. When the value is small, such an n equals .005 or .006, the tuning of the system shown in Fig. 4 would be very sharp. This means that stations say ten meters apart could be easily tuned out. However, if n was as large as .01 or greater, a marked loss in selectivity would be noticed.

From these charts, it is easily seen how a person might be confused by simply observing the high frequency resistance of a coil without considering its inductance. Notice that coil No. 3 has a resistance of only 5.8 ohms at 300 meters, but its inductance is only .193 millihenrys, so that when n is computed, it becomes .0085, which is large and indicates that the coil is not nearly as suitable for a radio circuit as coil No. 4 or 5.

Before showing how n affects the efficiency of a circuit, it will be necessary to say a few words about losses in good condensers: The "low loss" movement did the radio industry a real service here, for the condensers of a year ago, with bushed rotors and bakelite end plates did have losses which, in some cases, amounted to 100 ohms at 300 meters. Such condensers cut down the efficiency of a circuit much more than the coil did. Today, however, good condensers have an equivalent resistance of less than 1 ohm at 300 meters wavelength. When such a condenser is used in an oscillatory circuit, its loss is negligible in comparison to the coil, so that in the calculations which follow, we shall assume a perfect condenser which is almost realized in practice. Consider the circuit shown in Fig. 4.

We have an untuned antenna circuit coupled loosely to circuit LC . As the signal strength received with such a tuning system will be proportional to the voltage (e_g) on the grid-filament of the detector, we wish to determine upon what quantities e_g depend. (This voltage is the difference of the electrical pressure between top and bottom of the coil L .)

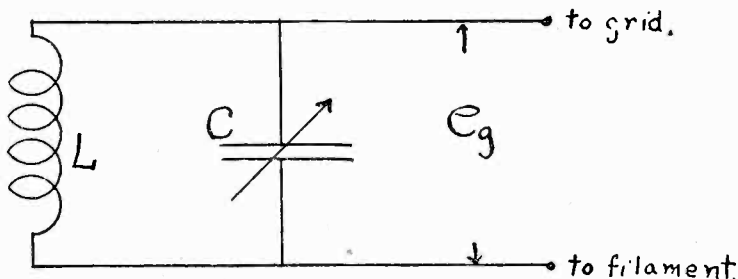
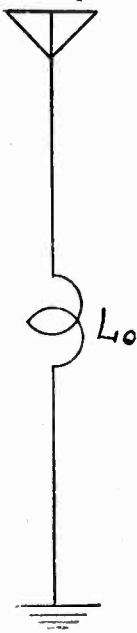

Fig. 4. Typical Tuned Circuit.

Now $e_g = iL2\pi f$ where i is the current in the oscillatory circuit LC , L is the inductance of the coil and f is the incoming frequency.

The current i depends upon whether the condenser C has tuned inductance L to resonance. When C is tuned for maximum signal strength, $i = E \div R$, where E is the induced emf, and R is the resistance in circuit LC , which in this case is the resistance of the coil L . The E , or induced emf, is that set up in coil L , due to an incoming signal through coil L_0 . (This equation assumes that the coupling between L_0 and L is loose.) Substituting the value of i given above in the equation for e_g we have:

$$e_g = \frac{2\pi f L E}{R}$$

If we introduce the value of n into the above equation we have:

$$e_g = \frac{E}{n}$$

This equation shows very plainly that

we should keep n as small as possible if we want e_g to be large. It also shows that it makes little difference whether we use large condensers and small coils, or large coils and small condensers, so long as n for the coil is the same.

It is also true that for the band of wavelengths used in radiocasting, that it makes little difference whether a coil has a dielectric support or not. For example, coil 5 is wound on a bakelite tube, while coil 4 is built so as to be self-supporting. As will be noticed by Fig. 3, coil 4 is slightly better at 300 meters while coil 5 is better from 350 to 550 meters.

The conclusions to be drawn from the data presented are that not all so-called "low-loss" coils are efficient when actually measured. Of all the coils shown, the single layered solenoid has smallest n and consequently is best suited for use in a radio receiver. The high frequency resistance per unit inductance at a given wavelength is the best way to determine a truly efficient coil. The lower the value of n the sharper the tuning and the lower the loss in the circuit. It is hoped that those buying apparatus will be inquisitive enough to demand such data from a manufacturer, as this would not only encourage good products, but would give the preference to the manufacturers who are scientific enough to have obtained exact data on their products

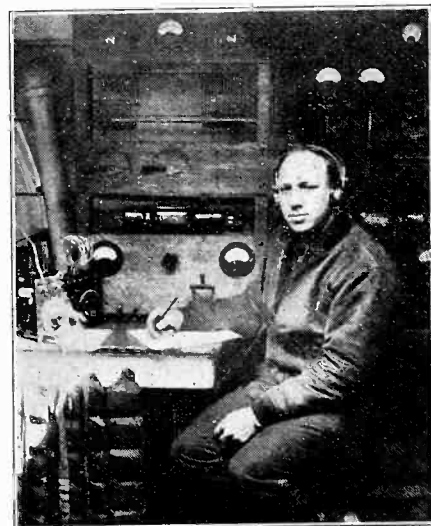

John L. Reinartz, first operator of the Mac-Millan Arctic Expedition on board the arctic schooner "Bowdoin" sitting at his Zenith-Reinartz short wave transmitter now in the Arctic. It is from this radio room and by this man and his associate operator, John McGee, on board the "S. S. Peary" that the public is receiving its messages from the Arctic.

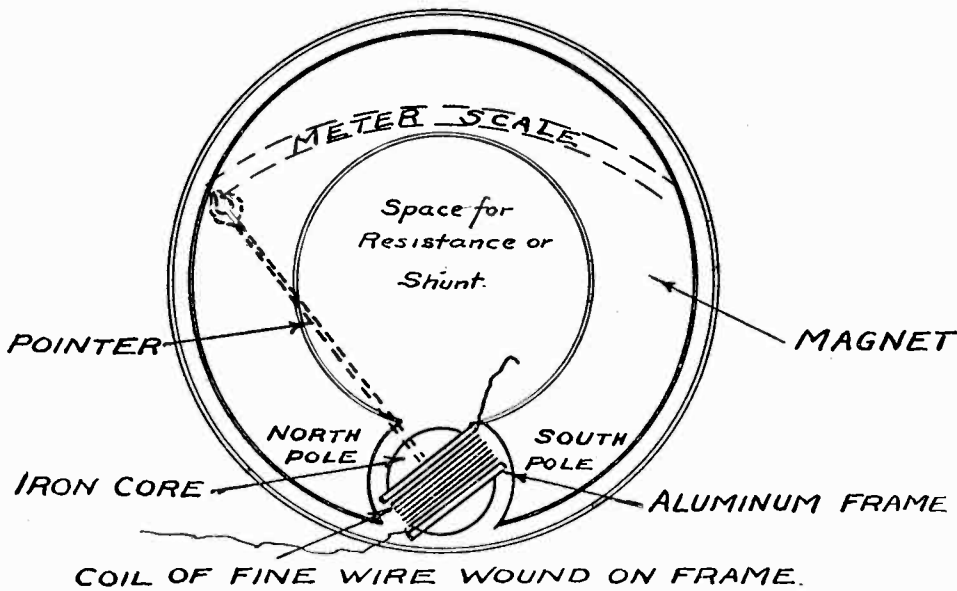

Fig. 3. Moving Coil Type of Meter.

freely. On this frame is wound a coil of very fine wire, through which a certain percentage of the current to be measured passes. As this current passes through the coil, the latter becomes an electro magnet, with north and south poles, which are immediately affected by the north and south poles of the permanent magnet. As the magnetic law is that "unlike poles attract—like poles repel," the north end of the electro-magnet is drawn toward the south pole of the permanent magnet and vice versa—which means that the aluminum frame is swung around and the pointer, attached to the frame, travels across the scale. Every meter of this type is in reality a millivoltmeter, as the coil is built in such a way that a small current flow through it causes the action described. External to the coil, but within the meter case where possible, is a shunt, if the instrument is an ammeter, or a resistance or multiplier, if it is a voltmeter. An example will describe how this is handled.

Ohm's law, the law governing the flow of electric current, is

$$I \text{ (current in amp.)} = \frac{E \text{ (voltage)}}{R \text{ (resistance in ohm)}}$$

If there are 10 ft. of fine wire on the aluminum frame having a resistance of 1 ohm per foot, the total resistance is 10 ohms. The frame is then set in position and it is found that .10 volts (100 milvolts) are necessary to send the pointer across the scale (that is, the frame moves through 90 degrees because of the magnetic pull exerted.) Then

$$I = \frac{.100}{10} = .010 \text{ amperes which is the}$$

current used, under .100 volts pressure to cause full scale deflection.

For an ammeter capable of measuring 5 amperes we permit the current to flow through a shunt and simply draw off enough current to cause full scale deflection,—in the case being considered—.01 amperes. The shunt is made to carry exactly 4.99 amperes while the .01 amperes are drawn through the

meter. See Fig. 4. For a voltmeter capable of measuring 6 volts, the following specifications are required: A voltmeter is placed "across the line," from positive to negative, and as it measures pressure, like a steam gauge, it must re-

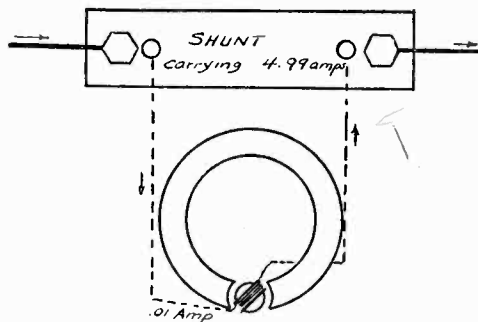

Fig. 4. Ammeter Shunt.

sist the flow of current. The meter itself requires .100 volts to cause full deflection and the balance must be used up in resistance. That is $\frac{6-.1}{6}$ or $\frac{59}{60}$ of the current is stopped while 1/60 flows through the meter. See Fig. 5.

Then it is seen that electrically, the construction of a meter is simple—the difficulties are mostly mechanical. It is easy to supply a piece of metal that will carry all the current except that needed for operating the moving system, but it is difficult to get that metal into a small

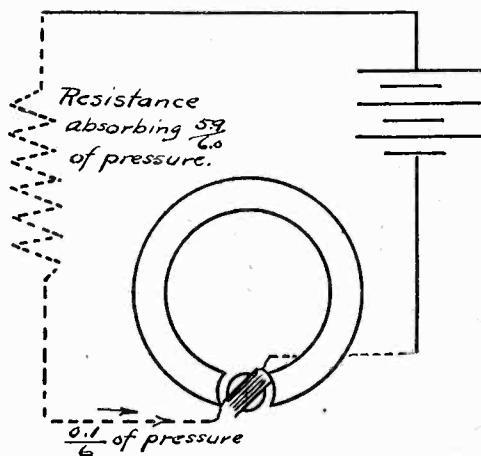

Fig. 5. Voltmeter Shunt.

place where it won't affect other things. It is easy to build an aluminum frame but hard to mount it, if it is too small to handle readily, so that it will swing freely between pole faces and core. The difficulty of getting the necessary resistance for a higher range meter in a small case is mechanical rather than electrical; it is a matter of clean design and careful workmanship.

Generally speaking, any meter manufacturer would prefer to build large meters for he has more space for shunts and resistances, his coil is easier to assemble and he can get better balance. But the radio industry demands small meters, which are in keeping with the rest of the set; instruments that add to rather than detract from the appearance. They want "wrist watch" construction with an accuracy equivalent to the best of the larger watches, and the meter manufacturers are striving to please. One company produced a moving coil meter two inches in diameter in December, 1924, and their whole production for three months was taken by two set manufacturers. This year will undoubtedly see other 2 in. or possibly smaller D'Arsonval meters offered to the trade, although it seems at this writing, as though this was the smallest size really practicable. And it is possible that some other type of meter may be developed that will offer enough electrical resistance to make it satisfactory for radio sets, for high resistance is a characteristic that every successful meter must have. If the resistance is low, too much current is drawn by the meter to permit its use for measuring currents such as are drawn by radio tubes or for obtaining the voltage readings on batteries.

AUSTRALIAN DOINGS

Work is progressing on the Australian beam stations for communication with England and Canada, the sites have been selected and are being prepared for the erection of the apparatus, which is at present in course of manufacture, and the personnel for operating these stations is being trained. The wavelengths have not yet been disclosed but will probably fall between 30 and 50 meters. The scheme calls for the erection of two stations for working duplex, one with England and the other one with Canada, together with six feeder stations situated in the various State Capitols to handle traffic originating at or destined for those cities. The main stations are being erected near Melbourne and remotely controlled from that city. Provision will be made for the expansion of the service to other countries later. The charges are to be one third lower than the existing cable rates, and it is expected that the time occupied in transmission will be less on account of the elimination of relay-points, and the use of high-speed automatic transmission.

Wavemeters

A Description of Various Types Best Adapted to Different Kinds of Receivers

By G. F. Lampkin, 8ALK

THE experimenter who in radio has found his heart's desire, and has come on up to receiving sets of the superheterodyne type, is never satisfied. That is why his set is now a super, instead of the original crystal layout; it is why he is ever on the lookout for information of one kind or another in his field; and is why he, himself, is able to contribute to that field. In the broadening of his knowledge beyond that of mere set construction, into the realms of why, and how, he more than likely will run into an instrument called the wavemeter — for it is the fundamental radio measuring device.

A wavemeter, as the name indicates, measures wavelength, or more truly, frequency. It consists merely of a coil and condenser, connected as in Fig. 1, with

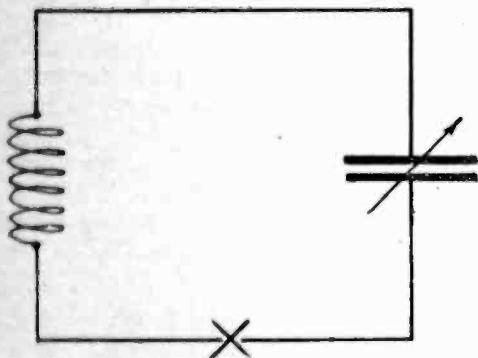

Fig. 1. Simple Wavemeter Circuit.

a device of some sort to show when the meter is in tune. The user of a receiving set knows his set is in tune with a station when he hears their signals, and if the set is up to date, he can mark the condenser setting and return to the station at will. Similarly, on a wavemeter, the condenser settings are marked; but instead of being put down as stations, the markings are made as wavelengths. More often a graph is drawn, which gives a wavelength for each point on the dial.

The wavelength to be measured may be that of a local transmitter, of a distant transmitter, or the wave to which a receiving circuit is tuned. The type of device used to show when the wavemeter is in tune, or resonance, depends on to which of these uses the wavemeter is to be put. If it is desired to measure the wave of a local transmitter, from which appreciable energy can be picked up, a current-indicating device is used; such as a milliammeter, a thermo-galvanometer, or a flashlight lamp. These are inserted in series with the wavemeter circuit at X,

and the meter placed near the transmitter. When the condenser is tuned to give maximum deflection on the meter, or maximum brilliancy of the lamp, the circuits are in resonance; and the wavelength of the transmitter may be read from the wavemeter condenser setting. A neon tube may also be used for this type of measurement. This is the little tube that is used in an automobile ignition tester; and which glows red when touched to a spark plug on which there is voltage. The tube is removed from the tester, and is connected across the wavemeter condenser. At resonance there is a maximum voltage across the condenser, which will cause the neon tube to give the brightest light. However, these types of resonance indicators are not in common use, as too much energy is required to give the indication.

In all wavemeter measurements the distance between the meter and the circuit should be as great as possible; in other words, the coupling should be loose. If a station is too close to a receiving set, it can be heard at more than one point on the dial, and marking the setting for the station will not mean a thing.

In the same way, if the wavemeter coupling is too close, the readings will not be accurate—resonance may be obtained at more than one point. It is best to get just enough of an indication to see easily, and use this for adjustment.

For the experimenter who uses regeneration, the most accurate instrument is the heterodyne wavemeter; which is nothing more than a one-tube regenerative receiver with a few precautions taken to make sure the readings of the condenser will always be accurate. The

circuit diagram is shown in Fig. 2. A tickler is used, but it is not movable; the number of turns necessary to make the set oscillate is found by the cut and try method, and then left fixed. The .005 mfd by-pass condenser is used in the plate circuit to destroy any tuning effect of the B battery and phones; a grid condenser and leak take care that changes in the filament setting cause no change in the tuning; and the whole outfit is shielded, with only a one-turn pickup coil outside the shielding. These precautions are simple, and if followed, the meter will be fairly accurate. A UV-199 tube with a 4.5 volt C battery used for an A battery, and another C used on the plate, will make a compact unit. The tube will oscillate readily with only the 4.5 volts on the plate, and will be steadier than if a higher voltage is used.

The heterodyne wavemeter is placed within two or three feet of an oscillating receiver, and tuned until a beat note is heard in the phones. The phones may be either in the receiving set or in the wavemeter. When the beat note goes to zero the circuits are exactly in tune, and the reading may be taken. The accuracy of the method will be seen when it is remembered how sharp the tuning of a regenerative receiver is on the carrier wave of a distant station. With the wavemeter set up near the receiver, any station within range which is transmitting, may be found at will. The wavelength of the station is looked up in the newspaper, log chart, or call book, and the wavemeter set to this wave. Then the receiver is tuned to zero beat with the meter, the meter is turned off, and a little more adjustment brings in the station. It was in this manner that amateurs first

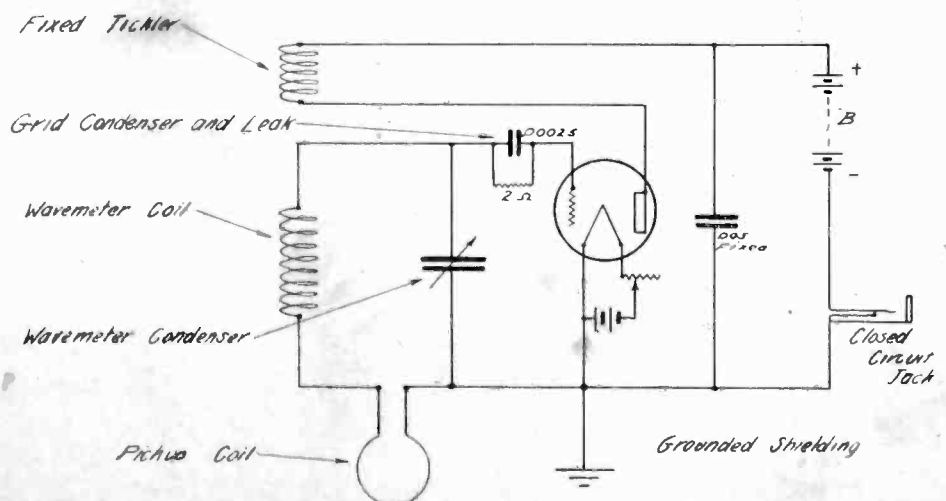

Fig. 2. Heterodyne Wavemeter Circuit.

Loud Speaker Testing Methods

Suggestions Applicable to Home as Well as Shop
Tests for Quality of Reproduction

By John P. Minton

THE editor of one of the technical magazines recently said that the quality of the sound from his radio set seemed to be poor. He had tried all the ideas he could think of to improve it, but had not succeeded in obtaining satisfactory results. He had concluded that the loud speaker was the source of his trouble, and with this particular part of his set he was not able to attempt an improvement. He could tinker, so to speak, with coils, tubes, batteries, wires, etc., but he was at a loss as to how to tinker with the loud speaker itself.

This is true—none of the fans know how to tinker with a loud speaker. Certain types of loud speakers are well nigh hopeless for the amateur to apply his innate desire for "tinkering," and for this reason, care in the selection of a loud speaker at the beginning should be exercised. The present short discussion of the testing of the commercial loud speakers of today will, without doubt, be helpful to many in suggesting methods for doing their own testing.

The usual method employed is the listening test with actual radio signals. This is a good test and an important one, but the experimenter cannot make use of it satisfactorily unless he has at least a half a dozen loud speakers to compare with one another. The speakers must be tried on various sets and comparisons made with speech and music from a number of different stations at various times. Logical conclusions of a comparative nature can then be drawn with considerable degree of certainty by a person who has been well trained to make just such tests. Fig. 1 illustrates this method of test.

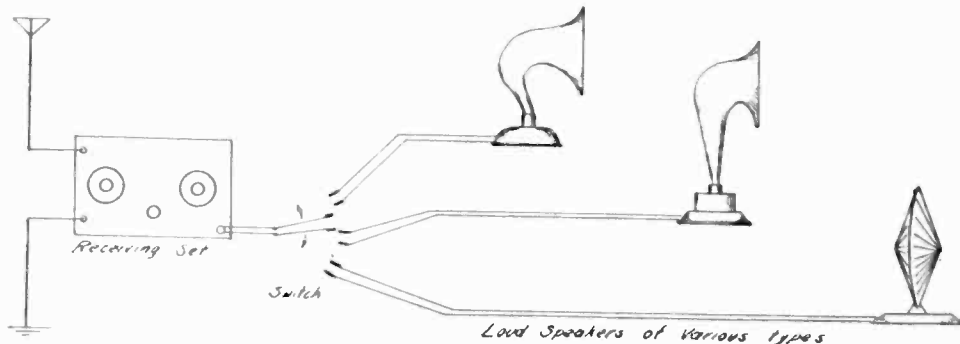

Fig. 1. Comparing Loud Speakers by Means of a Receiving Set.

Another method utilizes the voices of various people as they speak into a high quality microphone or, better still, the high quality condenser transmitter. The voice current generated by either one of these instruments is fed into a resistance

coupled amplifier which is as free from distortion as is possible to make it. From this amplifier the speech current is led to the loud speakers to be tested. This scheme of testing loud speakers, as illustrated in Fig. 2, gives very valuable results. Any distortion due to a receiving set or to the radiocast station is eliminated. The final result, then, will be characteristic of the loud speaker itself in direct comparison with the speaker's voice at the microphone.

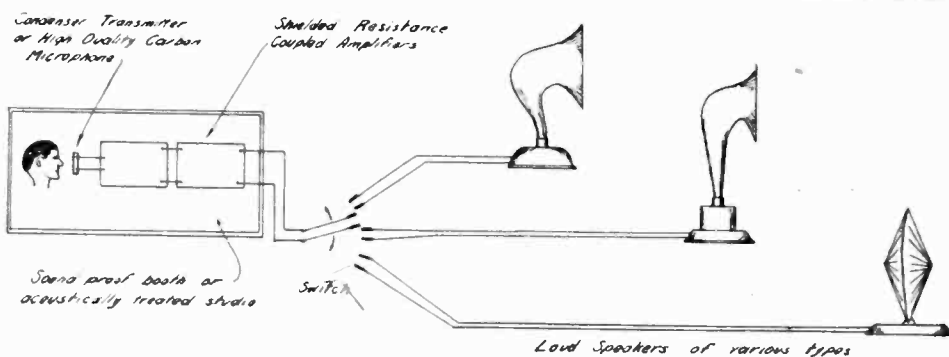

Fig. 2. Comparing Loud Speakers by Means of Actual Voice.

Usually the speaker is in a sound-proof booth and the listener is just outside. At any moment the doors can be opened as the speaker continues to talk without change in his voice or position, and we are then able to listen to his voice directly and thus are able to make the comparison between the original and the reproduction. A piano or other instrument may also be placed in the booth. In the Technical and Test Laboratory of the Radio Corporation of America is a studio whose acoustic characteristics are similar to those of their radiocast studios. Studio conditions can thus be obtained any time.

A third method used in loud speaker testing is electric phonograph reproduction. In place of the usual sound box into which the phonograph needle is placed, an electric sound box, as it may be called, is adapted so that the needle,

actuated by the record, is connected to a loud speaker unit of either the usual bipolar or balanced armature type. The needle's motion in the groove of the record causes corresponding vibration in the unit, and these in turn make possible the generation of corresponding electric currents. These currents are fed through a suitable amplifier for amplification and then led to the loud speaker. In this scheme of testing we have perfect control over the testing conditions, but it

has the disadvantage that any distortion which is in the records is reproduced in the loud speaker.

These three methods all employ the ear for observation. The ear can judge with great accuracy the human speech. We can tell instantly if a voice sounds natural, evenly balanced and whether or not it can be understood with perfect clearness. Such cannot be said so positively regarding music. Music will stand for a lot of abuse and distortion as far as the average listener is concerned; he will not be so conscious of these defects, particularly while listening to music over the loud speaker. Therefore, the second method is the most useful, the others being used for preliminary tests.

But the most important factor in making these tests is some permanent record of loud speaker performance as the basis for precise comparison and also as a legal means to substantiate claims. Fig. 3 shows the set-up employed, a loud speaker replacing the personal voice at the sending end and a highly sensitive current measuring system replacing the loud speaker at the receiving end.

By means of a vacuum tube oscillator electric currents can be produced whose frequencies cover a range from 10 cycles to as high as we desire to go—say 20,000 cycles. The human ear will perhaps include a range of frequency from 20 to 16,000 cycles. Above and below these

(Continued on Page 66)

Rescuing Uncle Marmaduke

By John Eugene Hasty

YOU know, I rather think there might be something in what these philosopher gents say about the darkest hour coming before the dawn. Of course, I imagine that dawn has been following the darkest hour for so many years that it's quite a habit with it by this time; but what I mean to say is that when a fellow gets in a bad jam and then up pops some friend to rally around him in the time of need, it sort of brings home the truth. Here I was facing the disagreeable experience of starving to death—or what is worse, having to go to work—when Bill Curtiss drifts into the picture, and But maybe I had better start at the beginning.

Curtiss is one of these amateur radio sharks, you know. We'd always been more or less chummy, having both been turned out of the same school—Curtiss with a diploma and I with a reprimand from the dean; so when I decided to become one of the great audience of radiocast listeners, he volunteered to run down to the old homestead and give me some top hole advice as to whether I ought to get a superiodine or a degenerative set. Then this other affair broke loose; and for the time being I forgot all about him.



"All of a sudden there came from it three distinct raps."

I was in my room at the club, restoring old tissues with a bit of the pure and unadulterated dreamless, when the telephone rang. Feeling more or less of a blank, I jerked myself out of the downy couch and groped through the cold, gray dawn to the phone. It was my sister Ruth calling. Just what she was doing in the city at that ghastly hour, I couldn't quite fathom; but finally it began to percolate through the old bean that she was all upset about something and wanted me to meet her at breakfast at the St. Francis. One thing about Ruth: when she makes up her mind about a thing, you might just as well give up the struggle. I mean to say that she's firm. Adamantine. The old rock of Gibraltar and that sort of thing. So an hour later, I was sitting across the table from her, waiting for the news. It wasn't long in coming.

"Reggie," she said, after the waiter had taken our order and had toddled out

to the kitchen for a game of checkers with the cook, "Reggie, what would you call a man who hid behind a woman's skirt?"

"In view of the present styles," I peeped, "I'd call him a magician. But if you've got any more riddles, save 'em until later in the day. Right now I'm a bit thick."

"Perhaps you're not too thick to get this:" she came back. "You and I are just about to lose every cent we possess. Uncle Marmaduke"

"What!" I shouted. "You don't mean to say he's mixed up with another chorus girl?"

"Worse than that. This time it's a medium."

"Medium?" I repeated, "Referring to a steak?"

"Don't be an ass, Reggie, I'm talking about a spiritualist medium—Mrs. Hoagworth, the new housekeeper. Of course, you know about *her*."

"I don't," I breathed, all aquiver, "tell me."

She did, to considerable length. It seemed that this estimable Mrs. Hoagworth is a spook sister; one of these ladies who pals around with ghosts, and goes in for table rapping, slate writing and messages from the great beyond. According to Ruth, she's jolly well succeeded in getting Uncle Marmaduke all wrapped up in the subject, and has put in a direct leased wire to the spirit world in order to give him all the advance tips.

"It's positively outrageous the way he follows that woman's advice," Ruth went on, "Absolutely hides himself behind her skirts; won't do anything or say anything without first asking Mrs. Hoagworth what the spirits have to say about it. And lately, mind you, she's been teaching him how to receive spirit messages on his own hook."

"Oh, well, it could be worse," I said, champing on a piece of toast which the

waiter had just brought in, "It's certain that any communications he might have with the spirits won't turn up as Exhibit A for the plaintiff in a breach-of-promise suit. If the old boy gets any fun out of it, let him proceed. I'd say it was all quite harmless."

"Harmless!" Ruth snapped, "Harmless! Do you know what the spirits have been advising him to do? Why, to turn over the entire Rockford-Peebles estate to the spiritualist cause, which means to Mrs. Hoagworth. If that woman succeeds with her plot, you and I will be left without a penny. We'll be paupers. And yet you can sit there calmly eating your breakfast, and say it's harmless."

Of course, that was a horse with a different face—as the expression goes. I mean to say that after having been raised in the lap of luxury so to speak, it's a bit muggy to be informed that you appear to be a winning candidate for the bread line.

"But—but what am I going to do about it?" I stammered, gulping down the toast.

"You're going home with me," Ruth said, "and you're going to stay there until you've rescued Uncle Marmaduke from that old dragon's clutches. The car is waiting for us outside. Here, waiter, let us have the check; never mind the coffee. Come on, Reggie."

That's the kind of a girl Ruth is. I mean to say firm. Righto!

BEING a light hearted and care-free chap who loves to revel among the bright lights, I usually find our country place a bit depressing. On this particular day, it seemed even more so. The lawn was overgrown with rank grass, the hedges needed trimming, and there was a sort of a run-down, gloomy air about the place which reminded me of the old mansion in the book where they break in and find the body of the eccentric millionaire who had been struck over the head with a blunt instrument by parties unknown.

"What, Ho!" I said to Ruth, "The home of my happy boyhood days has a lean and hungry look. What's wrong—gardeners on a strike?"

"Uncle Marmaduke has discharged all the servants, excepting the cook," she informed me, "It was the will of the spirits."

Inside of the house, things were just as bad: dust over everything, the blinds drawn, and the place so deucedly quiet that it gave a chap an uncomfortable, creepy feeling between the shoulder blades. When I heard a step on the upper landing, I leaped like a frightened young gazelle. Looking up, I saw a large, solid female coming down the stairs. I judged it was Mrs. Hoagworth. I can't say there was anything spiritual about her. Rather beefy, in fact. The sort of a woman who looked

as if she might be dangerous to the chap who would try to thwart her. She didn't say anything; but before she disappeared into the library, she shot me a grim, forbidding glance. It made me feel as if I were something the dog had dug up and brought into the parlor. I mean to say it seemed that she resented my being there; and was just biding her time to slip a slug of poison into my coffee.

The whole business was getting on my nerves. Somehow I caught myself tiptoeing about as if there had been a death in the family. If there had been anyone about to talk to, I would have probably spoken in a whisper. But there wasn't. Ruth had gone to her room; Uncle Marmaduke was taking his afternoon nap; and the Hoagworth woman had vanished somewhere in the rear of the house. Finally, the afternoon dragged itself out; and Ruth came down to dinner. Uncle Marmaduke had a tray sent up to his room; so Ruth and I ate by ourselves—by candle light. The electric current had been shut off—another idea which had been passed on to Uncle Marmaduke from the spirit world.

Right after dinner, I decided that if there were any rescuing to be done, it

had better be done with dispatch; so I toddled up the stairs and knocked at Uncle Marmaduke's door. For a minute or so, there was nothing but silence; then I heard him tell me to come in—in one of those sad, faint voices that sound like the bleat of a far-off sheep. I opened the door and oozed in. Even in the candlelight, I could see that the poor old chap was pretty far gone. He was huddled up in an arm chair by the fireplace, looking pale and wan, as the poets say.

"Cheerio, Unc," I said, in my sprightliest manner, "What's wrong? The old liver out of joint? What!"

He gave me a cold, fish-like hand, and wearily waived me to a seat before replying.

"I'm afraid I'm not long for this world, Reggie."

"Oh, nonsense," I retorted, "You're quite long enough. Five feet, nine inches, if I remember correctly; or is it five feet, ten?"

But the wise crack didn't register with him at all. He continued to stare off into space and to speak in a solemn, crushed voice.

"I've been a wicked man in my day, Reggie, a very wicked man. I must

(Continued on Page 50)

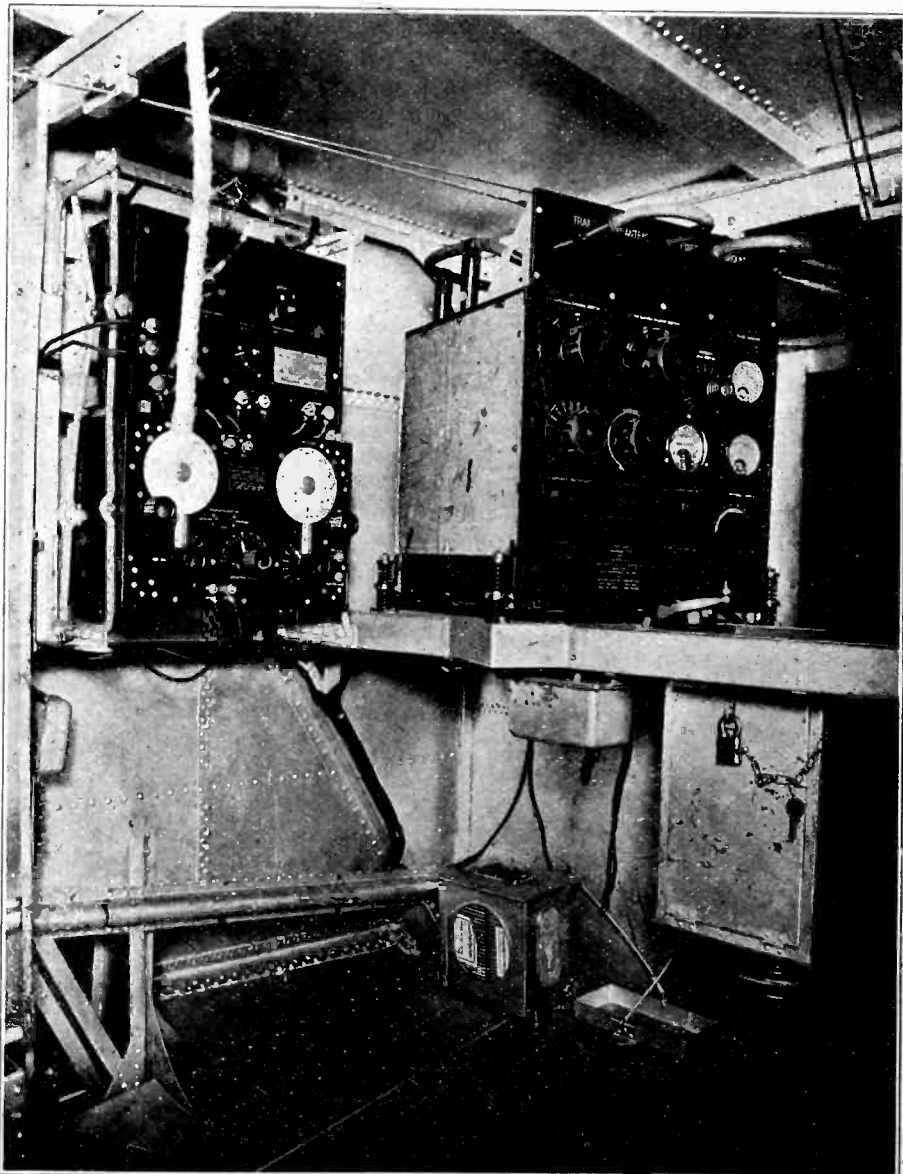

Transmitter and Receiver for Use on Seaplane Making the Flight From San Francisco to Honolulu in September.

Electrical Instruments for Radio Sets

An Account of the Theory and Construction of Different Types of Ammeters and Voltmeters

By M. T. Rogers

THERE are four general types of meters used for measuring current flow (in amperes or milliamperes) and battery potential (in volts), but three of the four have very decided limitations. The simplest and cheapest to build is the "solenoid type" of meter. It can be used for measuring current flow and battery voltage, but because of its construction requires a large amount of current to operate the moving system and so is the least desirable of all types. Such meters are usually built for testing dry cells and *B* batteries and if left across the terminals of a battery for any length of time, will not only draw down the battery, but the readings on the scale will vary several per cent because of the heat developed. Up to the present time, meters of this type have been supplied as pocket meters only.

type of meter has been used for many years by different manufacturers and one in particular claims to have accomplished considerable in the way of supplying high resistance and an accurate scale at all points. Generally speaking, however, meters of this type draw too much current for satisfactory use and they cannot be left in the circuit indefinitely, as they would subject the battery to too large a load.

A third principle is the "repulsion type." This meter is generally used for measuring alternating current but can be calibrated to work on direct if desired. Perhaps its greatest claim to recognition in the radio field is the fact that it can be supplied in small cases. Because of the principle on which it is constructed, it too, draws considerable current and cannot be left in the cir-

cuit indefinitely. It must be used with a switch when mounted on the panel. Fig. 2 shows the construction. A coil of wire is mounted on a spool, and through this coil the current to be measured flows. Fixed within the spool is one piece of soft iron and attached to the pivot of the meter is another, the pointer also being attached to the pivot. As the current flows through the coil, the latter becomes an electro magnet and immediately has an effect on the two pieces of iron, giving them the same polarity. As the magnetic law is that "unlike poles attract, like poles repel," the two pieces of iron repel each other, and as one is fixed, it follows that the other must move, and being attached to the pointer, through the pivot, it travels as shown in the sketch and the pointer moves across the scale.

The greatest objection to this type of meter is that it must draw considerable current in order to have power enough to make the pointer travel across the scale. It has the great advantage, however, of being built without a magnet and so can be placed in a very small case.

By far the most satisfactory instrument built for receiving sets is the "moving coil" type pictured in Fig. 3. It can be used for measuring the smallest currents common to radio reception, and when built as a voltmeter, can be left in the circuit without damage to itself or to the battery. It is a "high resistance" meter.

The moving coil principle was developed by a French scientist named D'Arsonval and is spoken of as the D'Arsonval movement. Between the pole faces of a permanent magnet is placed an iron core, allowing a gap between it and the pole faces large enough to permit an aluminum frame to swing

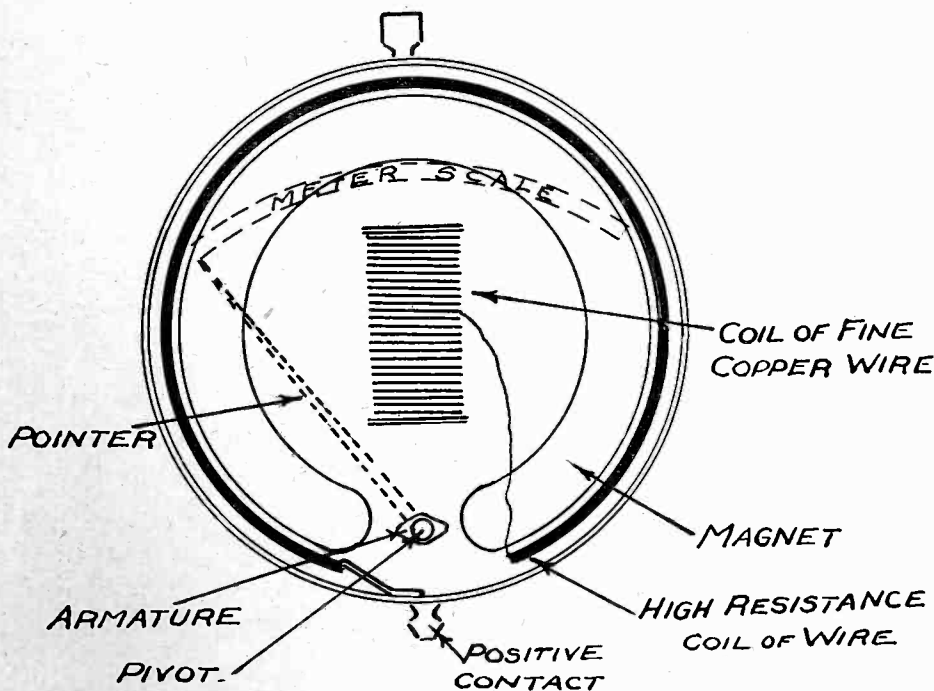

Fig. 1. Polarized Vane Type of Meter.

A step in advance of the solenoid is the "polarized vane" type, of which Fig. 1 is a diagrammatic sketch. This type is equipped with a magnet which, by the natural force of its magnetism, holds in a certain position an armature of soft iron, which is attached to the pivot. The current flows through the contact, a coil of high resistance wire and thence to the spool of fine wire, which becomes an electro magnet that tends to have an action on the armature. As the pull of the electro magnet opposes the pull of the permanent magnet, the armature turns and the pointer, attached to the same pivot, travels across the scale. This

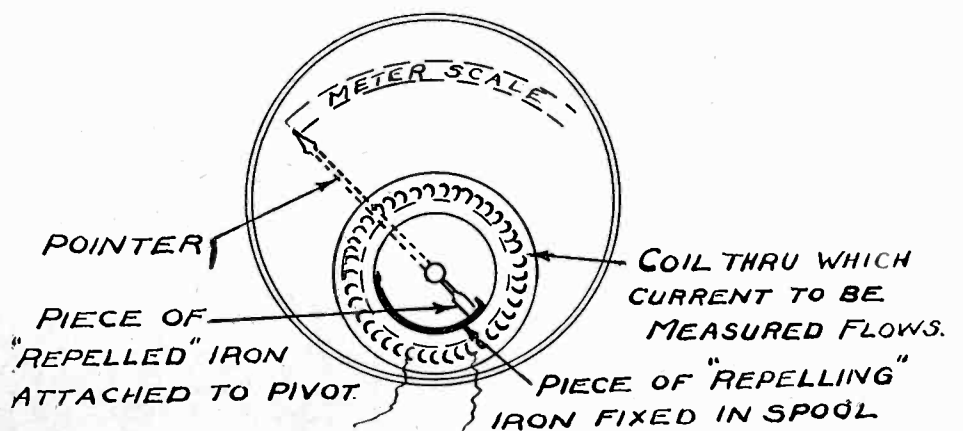
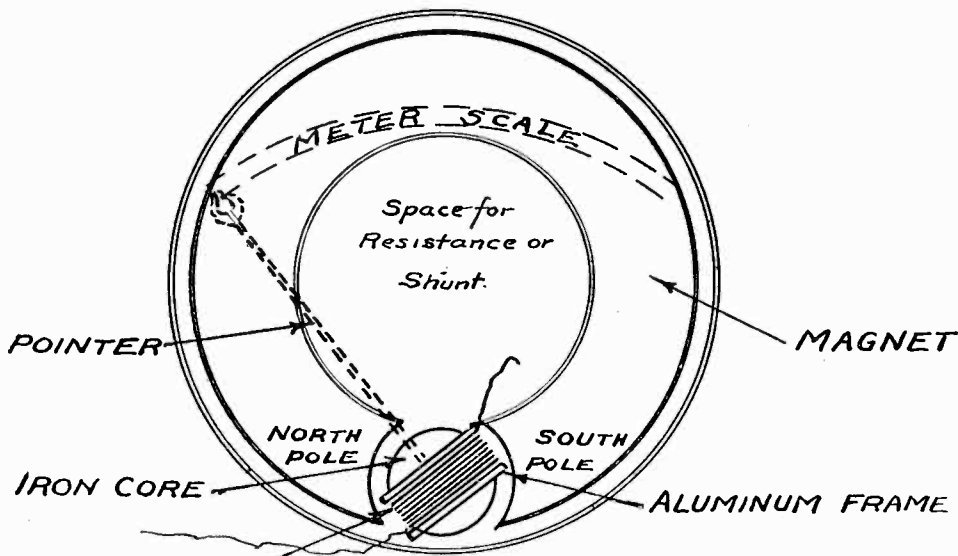

Fig. 2. Repulsion Type of Meter.



COIL OF FINE WIRE WOUND ON FRAME.

Fig. 3. Moving Coil Type of Meter.

freely. On this frame is wound a coil of very fine wire, through which a certain percentage of the current to be measured passes. As this current passes through the coil, the latter becomes an electro magnet, with north and south poles, which are immediately affected by the north and south poles of the permanent magnet. As the magnetic law is that "unlike poles attract—like poles repel," the north end of the electro-magnet is drawn toward the south pole of the permanent magnet and vice versa—which means that the aluminum frame is swung around and the pointer, attached to the frame, travels across the scale. Every meter of this type is in reality a millivoltmeter, as the coil is built in such a way that a small current flow through it causes the action described. External to the coil, but within the meter case where possible, is a shunt, if the instrument is an ammeter, or a resistance or multiplier, if it is a voltmeter. An example will describe how this is handled.

Ohm's law, the law governing the flow of electric current, is

$$I \text{ (current in amp.)} = \frac{E \text{ (voltage)}}{R \text{ (resistance in ohm)}}$$

If there are 10 ft. of fine wire on the aluminum frame having a resistance of 1 ohm per foot, the total resistance is 10 ohms. The frame is then set in position and it is found that .10 volts (100 milvolts) are necessary to send the pointer across the scale (that is, the frame moves through 90 degrees because of the magnetic pull exerted.) Then $I = \frac{.100}{10} = .010$ amperes which is the current used, under .100 volts pressure to cause full scale deflection.

For an ammeter capable of measuring 5 amperes we permit the current to flow through a shunt and simply draw off enough current to cause full scale deflection,—in the case being considered—.01 amperes. The shunt is made to carry exactly 4.99 amperes while the .01 amperes are drawn through the

meter. See Fig. 4. For a voltmeter capable of measuring 6 volts, the following specifications are required: A voltmeter is placed "across the line," from positive to negative, and as it measures pressure, like a steam gauge, it must re-

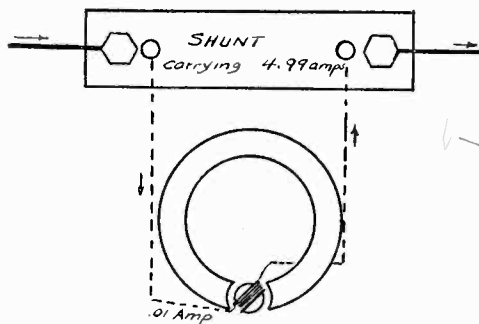

Fig. 4. Ammeter Shunt.

sist the flow of current. The meter itself requires .100 volts to cause full deflection and the balance must be used up in resistance. That is $\frac{6-.1}{6}$ or $\frac{59}{60}$ of the current is stopped while 1/60 flows through the meter. See Fig. 5.

Then it is seen that electrically, the construction of a meter is simple—the difficulties are mostly mechanical. It is easy to supply a piece of metal that will carry all the current except that needed for operating the moving system, but it is difficult to get that metal into a small

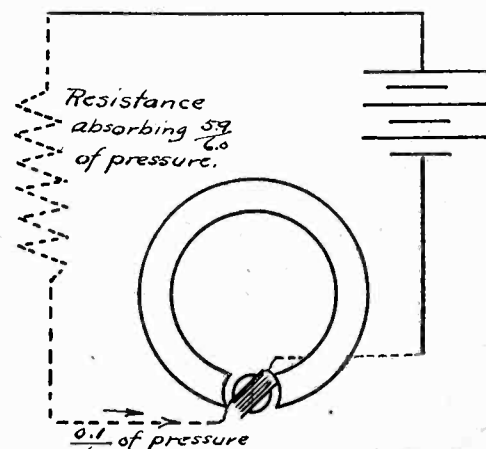

Fig. 5. Voltmeter Shunt.

place where it won't affect other things. It is easy to build an aluminum frame but hard to mount it, if it is too small to handle readily, so that it will swing freely between pole faces and core. The difficulty of getting the necessary resistance for a higher range meter in a small case is mechanical rather than electrical; it is a matter of clean design and careful workmanship.

Generally speaking, any meter manufacturer would prefer to build large meters for he has more space for shunts and resistances, his coil is easier to assemble and he can get better balance. But the radio industry demands small meters, which are in keeping with the rest of the set; instruments that add to rather than detract from the appearance. They want "wrist watch" construction with an accuracy equivalent to the best of the larger watches, and the meter manufacturers are striving to please. One company produced a moving coil meter two inches in diameter in December, 1924, and their whole production for three months was taken by two set manufacturers. This year will undoubtedly see other 2 in. or possibly smaller D'Arsonval meters offered to the trade, although it seems at this writing, as though this was the smallest size really practicable. And it is possible that some other type of meter may be developed that will offer enough electrical resistance to make it satisfactory for radio sets, for high resistance is a characteristic that every successful meter must have. If the resistance is low, too much current is drawn by the meter to permit its use for measuring currents such as are drawn by radio tubes or for obtaining the voltage readings on batteries.

AUSTRALIAN DOINGS

Work is progressing on the Australian beam stations for communication with England and Canada, the sites have been selected and are being prepared for the erection of the apparatus, which is at present in course of manufacture, and the personnel for operating these stations is being trained. The wavelengths have not yet been disclosed but will probably fall between 30 and 50 meters. The scheme calls for the erection of two stations for working duplex, one with England and the other one with Canada, together with six feeder stations situated in the various State Capitols to handle traffic originating at or destined for those cities. The main stations are being erected near Melbourne and remotely controlled from that city. Provision will be made for the expansion of the service to other countries later. The charges are to be one third lower than the existing cable rates, and it is expected that the time occupied in transmission will be less on account of the elimination of relay-points, and the use of high-speed automatic transmission.

Wavemeters

A Description of Various Types Best Adapted to Different Kinds of Receivers

By G. F. Lampkin, 8ALK

THE experimenter who in radio has found his heart's desire, and has come on up to receiving sets of the superheterodyne type, is never satisfied. That is why his set is now a super, instead of the original crystal layout; it is why he is ever on the lookout for information of one kind or another in his field; and is why he, himself, is able to contribute to that field. In the broadening of his knowledge beyond that of mere set construction, into the realms of why, and how, he more than likely will run into an instrument called the wavemeter — for it is the fundamental radio measuring device.

A wavemeter, as the name indicates, measures wavelength, or more truly, frequency. It consists merely of a coil and condenser, connected as in Fig. 1, with

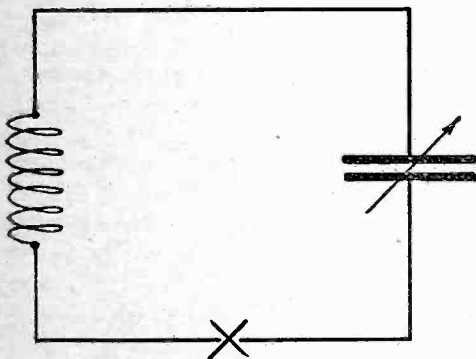

Fig. 1. Simple Wavemeter Circuit.

a device of some sort to show when the meter is in tune. The user of a receiving set knows his set is in tune with a station when he hears their signals, and if the set is up to date, he can mark the condenser setting and return to the station at will. Similarly, on a wavemeter, the condenser settings are marked; but instead of being put down as stations, the markings are made as wavelengths. More often a graph is drawn, which gives a wavelength for each point on the dial.

The wavelength to be measured may be that of a local transmitter, of a distant transmitter, or the wave to which a receiving circuit is tuned. The type of device used to show when the wavemeter is in tune, or resonance, depends on to which of these uses the wavemeter is to be put. If it is desired to measure the wave of a local transmitter, from which appreciable energy can be picked up, a current-indicating device is used; such as a milliammeter, a thermo-galvanometer, or a flashlight lamp. These are inserted in series with the wavemeter circuit at X,

and the meter placed near the transmitter. When the condenser is tuned to give maximum deflection on the meter, or maximum brilliancy of the lamp, the circuits are in resonance; and the wavelength of the transmitter may be read from the wavemeter condenser setting. A neon tube may also be used for this type of measurement. This is the little tube that is used in an automobile ignition tester; and which glows red when touched to a spark plug on which there is voltage. The tube is removed from the tester, and is connected across the wavemeter condenser. At resonance there is a maximum voltage across the condenser, which will cause the neon tube to give the brightest light. However, these types of resonance indicators are not in common use, as too much energy is required to give the indication.

In all wavemeter measurements the distance between the meter and the circuit should be as great as possible; in other words, the coupling should be loose. If a station is too close to a receiving set, it can be heard at more than one point on the dial, and marking the setting for the station will not mean a thing.

In the same way, if the wavemeter coupling is too close, the readings will not be accurate—resonance may be obtained at more than one point. It is best to get just enough of an indication to see easily, and use this for adjustment.

For the experimenter who uses regeneration, the most accurate instrument is the heterodyne wavemeter; which is nothing more than a one-tube regenerative receiver with a few precautions taken to make sure the readings of the condenser will always be accurate. The

circuit diagram is shown in Fig. 2. A tickler is used, but it is not movable; the number of turns necessary to make the set oscillate is found by the cut and try method, and then left fixed. The .005 mfd by-pass condenser is used in the plate circuit to destroy any tuning effect of the B battery and phones; a grid condenser and leak take care that changes in the filament setting cause no change in the tuning; and the whole outfit is shielded, with only a one-turn pickup coil outside the shielding. These precautions are simple, and if followed, the meter will be fairly accurate. A UV-199 tube with a 4.5 volt C battery used for an A battery, and another C used on the plate, will make a compact unit. The tube will oscillate readily with only the 4.5 volts on the plate, and will be steadier than if a higher voltage is used.

The heterodyne wavemeter is placed within two or three feet of an oscillating receiver, and tuned until a beat note is heard in the phones. The phones may be either in the receiving set or in the wavemeter. When the beat note goes to zero the circuits are exactly in tune, and the reading may be taken. The accuracy of the method will be seen when it is remembered how sharp the tuning of a regenerative receiver is on the carrier wave of a distant station. With the wavemeter set up near the receiver, any station within range which is transmitting, may be found at will. The wavelength of the station is looked up in the newspaper, log chart, or call book, and the wavemeter set to this wave. Then the receiver is tuned to zero beat with the meter, the meter is turned off, and a little more adjustment brings in the station. It was in this manner that amateurs first

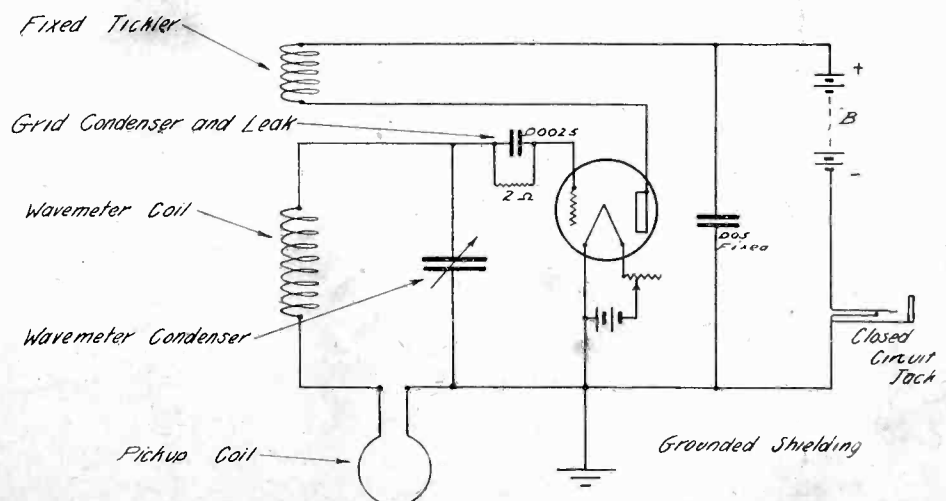

Fig. 2. Heterodyne Wavemeter Circuit.

established contact across the Atlantic. If a station is already tuned in, it is but a second's work to turn on the wavemeter, adjust to zero beat, and read the wavelength.

Another accurate method which may be used with a regenerative receiver is called the resonance click method. If a finger is touched to the grid of the oscillating set, a click will be heard as the oscillations stop. Similarly, if the simple wavemeter circuit of Fig. 1, without even the indicator at *X*, be coupled to the oscillating receiver and run through the wave, a click will be heard. This is because the wavemeter, when in tune, absorbs enough energy from the receiver to stop it oscillating, and the click results. This point on the wavemeter dial may be found very closely; if the coupling is too tight, two clicks will be heard, and the wavemeter must be moved away until only one comes through.

When it is desired to use a wavemeter with a non-oscillating receiver, such as a neutrodyne, the heterodyne and resonance click methods are useless. For there can be no beat note, nor resonance click, when there are no oscillations present. The remedy is to cause the wavemeter to generate a modulated

note or *b* of Fig. 4. The note is more likely to be ragged and broad than in the case of the audio oscillator. The buzzer is started working, and causes the wavemeter circuit to give off a signal whose wavelength is the same as that to which the meter is tuned. Of course, the coupling of the buzzer to the wavemeter circuit must not be too close, or the signal will be very broad, and will not be exactly the same wavelength as that which the dial reading shows. To measure the wavelength of a weak signal the phones and crystal detector may be connected, as in circuits *c* or *d* of Fig. 4. Neither of these connections will affect the accuracy of the circuit greatly.

The buzzer, and the crystal detector with phones, are the old standbys of pre-radiocasting days. They are used chiefly on damped waves, and have the inherent broad-tuning qualities of a damped wave so that the heterodyne wavemeter is the most convenient and the most accurate for the experimenter. Certain precautions must be observed in construction so that when the dial settings are once recorded they will always remain the same. All connecting wires on a meter should be run short and rigid and the condenser must be me-

chanically good, with bearings that will not wear and give play. The losses in the condenser are not overly important, though most condensers today which are good mechanically are also good electrically. The dial on the condenser shaft must be tight, for if it slips the readings will be worse than useless. It is best to spot a hole in the side of the shaft in which to drive the dial set screw. The wavemeter coil must of course be a permanent job. As cardboard forms for the coil are liable to shrink, wood or fibre should be used when possible. It is common to make several coils of different sizes for the wavemeter, to be used with the same condenser and indicator. A graph is drawn for each coil, and in this way the whole range of wavelengths is covered.

The wave range in which the experimenter is most interested is usually the radiocast band; the wavemeter to cover this range would use approximately the same size condenser and coils as are used in a radiocast receiver. The same is true for any other band.

After the wavemeter is built it must be calibrated, the dial settings being marked in terms of wavelength. The most convenient way is to tune the receiving set to one of stations KDKA, WBZ, WGY, WSB, WRC, WCAP, WEA, or WWJ. Other stations of course may be used, but the wavelengths of these stations have been checked many times by the Bureau of Standards, and have been found to be always the same, within .1 or .2 of a per cent. With the station tuned in as closely as possible, the wavemeter is tuned to the receiver, and the setting recorded. The wavelength of the station can be found in most newspapers, or in a call book. With six or seven points over the meter scale recorded, a graph may be drawn, and then the wave for any point on the dial may be read off. If the condenser has semi-circular plates, the curve should look like that shown in Fig. 5; but of

(Continued on Page 76)

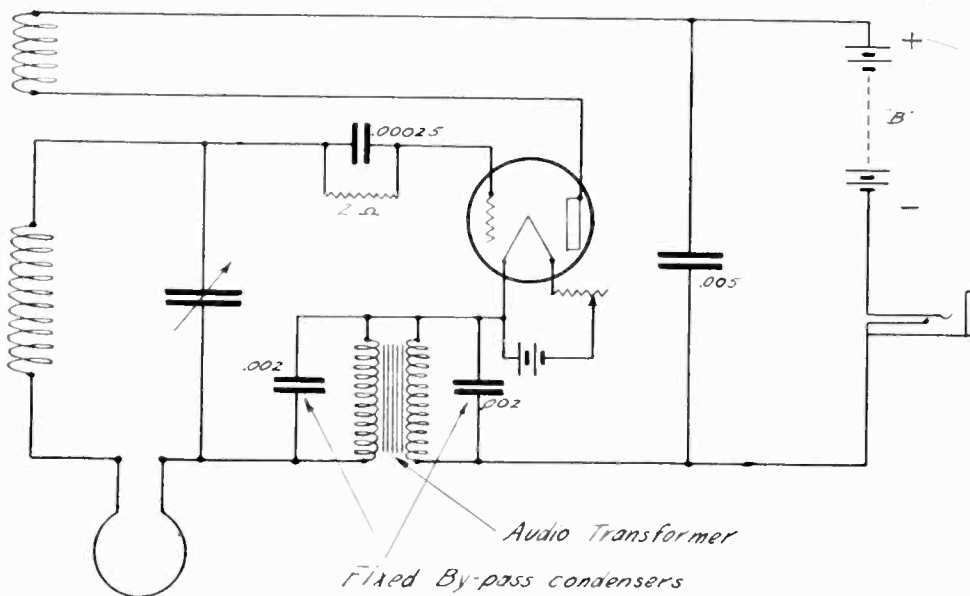

Fig. 3. Modulated Heterodyne Wavemeter.

wave. This can be done with the heterodyne wavemeter by connecting in an audio transformer as shown in Fig. 3. This makes the circuit oscillate at an audio frequency—i. e., howl. The howl will be sent out on the wave to which the wavemeter is tuned and may be picked up by a non-oscillating receiver. The connections to the transformer must be reversed if the circuit does not howl. The by-pass condensers on the transformer may have their capacities adjusted to give any desired musical note. Often a grid leak, connected promiscuously between transformer terminals, will cause a pleasing note.

The simpler way to give off a modulated wave from the wavemeter is to connect a buzzer in one of the circuits

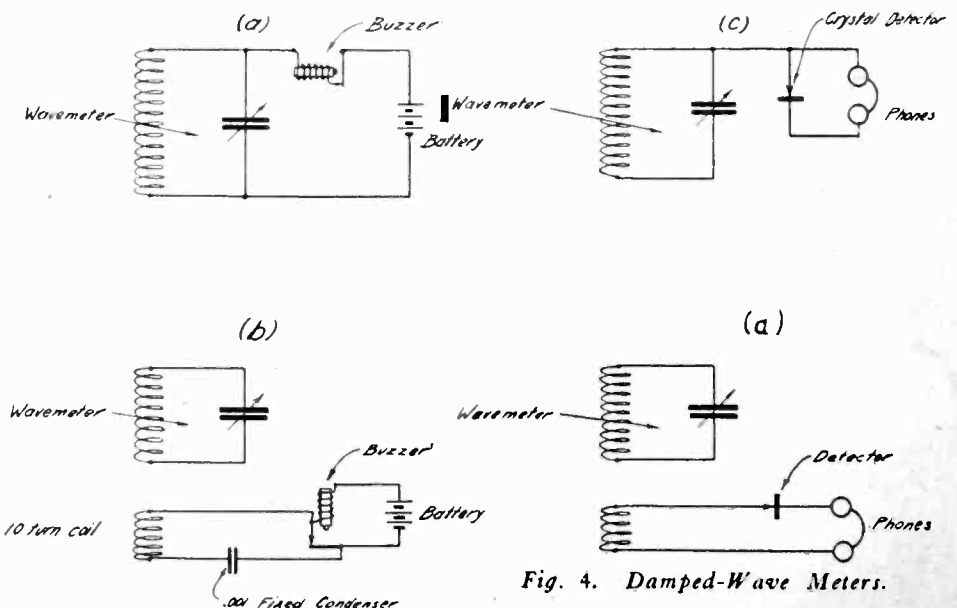
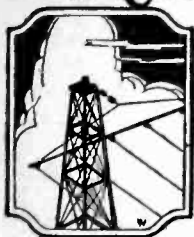

Fig. 4. Damped-Wave Meters.

For The RADIO NOTE BOOK



Useful Facts and Theory

Classified According to Dewey Decimal System.

Tear out page, cut along black lines, punch holes with pencil where indicated, and file numerically in standard notebook in accordance with Index Sheets Nos. 1 and 2.



music which would make you feel like
ning the set. Probably the fault lay
the operator of the receiving set, and
in the set itself. In his over-zealous
empt to bring it in loud enough for
a great number of distracting noises
e also brought in with the music and
you were not too absorbed in the
stery of the thing, you would have
mediately condemned the performance
secretly resolved never to listen to
t particular orchestra again.

There is a limit to the amount of am-
ication that should be employed and
limit is reached when the quality
the music is being impaired to pro-
e quantity. But you insist on quality,
which you are entitled to, when you pay
eral hundred dollars for a radio re-
er, and happily the design of modern
pment is towards that end. It is
ll to bear in mind that the slightest
ise in the radio receiver distracts from
e beauty and quality of the music.
You know quite well that if a phono-
graph dealer were to let you hear a popu-
lar record and you heard one scratch in
the entire selection, you would say that
you were pleased with the selection but
ld like a new record from stock.
at is how keen your ear is for good
ic when you are paying for it. There-
why inject any more noise into the
o receiver than is picked up from ex-
al sources.

The proper procedure in the operation
radio set, for loud speaker reception,
o adjust the volume to a point where
noise is in the background, and at no
becomes sufficiently severe to im-
the quality of the music or speech.
en the volume is increased beyond
point, the noise will increase in pro-
ion, and will have a greater interfer-
effect as it becomes more audible.
moral is, adjust your receiver to the
t where acceptable music is to be
no matter how much volume you
obtain and are holding in reserve.
e neighbors all know that you have a
dio set, and it is not necessary to in-
ease your volume until they have to
lose their windows due to the noise.
The word volume is strictly a synonym
of noise in radio reception and further-
more an antonym of quality.

creased, and from 500 to 1,000 miles is
a consistent range. If you happen to
hear such a station at a greater distance,
then you may consider yourself lucky,
for the station has exceeded its guaran-
teed range by many miles. If you fail
to hear the station tomorrow night,
don't throw up your hands and wish
you had bought a phonograph, for your
set is not to blame. Bear in mind that
nearly all the stations you listen to at
night are 500 watts output, or less, and
that if the sun failed to set one evening,
you would not hear any of the stations
you were accustomed to hear after sun-
down.

If you are located 100 miles or less
from a 500-watt station, you should
have consistent communication 365 days
in the year. At night the same station
should be heard at a greater distance,
and it has been found that this range
varies from night to night, so that no
guarantee can be given by the dealer as
to the exact maximum possible distance
obtainable, due to the variation in receiv-
ing conditions from night to night. If
you read a published statement that such
and such a station was received over a
distance of 1,000 miles in the day time,
you can bank on the fact that the recep-
tion took place after sunset, and that one
of the two locations was probably in
total darkness at the time. To obtain
reliable service over distances up to
1,000 miles would require at least 100
times the power now in use, so beware
of the receiver that has performed coast-
to-coast reception in "broad daylight,"
for the "dark man in the woodpile" was
probably the broad stretch of night that
covered 90 per cent of the space between
the two points.

The Australian Broadcasting Com-
pany's station (3LO) at Melbourne has
altered its wavelength from 1,620 meters
to 371 meters. This station had the
longest wave of any broadcasting sta-
tion in Australia. One Sydney station,
2BL, has altered its wavelength from
350 to 353 meters and has increased its
plate input to 1,500 watts. The other
station, 2FC, has intimated that changes
are being considered, but no official an-
nouncement has been made:

storage
battery will charge at a rate times than
to let it run down, and then give it
a long charge.

When laying up a lead storage battery
for a while, the simplest way is to give
it a good charge and then continue
this into an overcharge of about 10 or
12 hours at a reduced rate. Then re-
place the electrolyte with distilled water,
and again charge it at a low rate. All
that is necessary to lay up an Edison
alkaline battery is to put it away, pro-
vided there is enough electrolyte to
cover the plates. The state of charge
does not matter with this type battery.

Electrolysis in water pipes under some
conditions may set up enough trouble to
cause sparks and thus interfere with
radio reception.

One of the handiest tools around the
radio shop bench can be made up by
making a heavy chisel-like knife from an
old file. This can be used to scrape
wires, cut wood, or do any of a hun-
dred things you'd not care to use a
good tool on, and when its broken or
worn out, a new one can be ground up
again on any emery wheel.

Files can be resharpened, after the
loose dirt has been removed with a stiff
brush, by first boiling them for an hour
in a solution consisting of $\frac{1}{4}$ lb. of sal-
eratus to a quart of water so as to re-
move the grease. They are then washed
in clear water and dried preparatory
to being completely immersed, standing
on end, in a solution of $\frac{1}{4}$ lb of sul-
phuric acid to a quart of water, where
they should be left for 12 hours. They
should again be washed and dried.

Copper may be cleaned and brightened
in nitric acid, even if it is old and green.
This often is much easier than scraping
or sandpapering. Remove all traces of
acid, before leaving the job, however, or
things will corrode worse than they were
before.

In working around lead storage bat-
teries, celluloid sheeting can be used
to protect the table or floor, and will
prove to be as resistant to acid as the
usual lead or rubber, also being cheaper
and easier to handle.

A few sheets of blotting paper should
always be kept in or near the storage
battery cabinet to absorb any acid that
may be spilled.

for The RADIO NOTE BOOK



Useful Facts and Theory

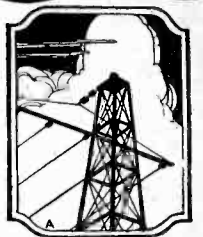

Classified According to Dewey Decimal System

Tear out page, cut along black lines, punch holes with pencil where indicated, and file numerically in standard notebook in accordance with Index Sheets Nos. 1 and 2.

the ,
becau
absolutenough energy from the receiver
to stop it oscillating, and the click results. This point on the wavemeter dial may be found very closely; if the coupling is too tight, two clicks will be heard, and the wavemeter must be moved away until only one comes through.

When it is desired to use a wavemeter with a non-oscillating receiver, such as a neutrodyne, the heterodyne and resonance click methods are useless. For there can be no beat note, nor resonance click, when there are no oscillations present. The remedy is to cause the wavemeter to generate a modulated

the accuracy or the circuit greatly.

The buzzer, and the crystal detector with phones, are the old standbys of pre-radiocasting days. They are used chiefly on damped waves, and have the inherent broad-tuning qualities of a damped wave so that the heterodyne wavemeter is the most convenient and the most accurate for the experimenter. Certain precautions must be observed in construction so that when the dial settings are once recorded they will always remain the same. All connecting wires on a meter should be run short and rigid and the condenser must be me-

wavemeter, to be used with the condenser and indicator. A graph drawn for each coil, and in this way whole range of wavelengths is covered.

The wave range in which the experimenter is most interested is usually radiocast band; the wavemeter to this range would use approximately same size condenser and coils as are in a radiocast receiver. The same is true for any other band.

After the wavemeter is built it must be calibrated, the dial settings marked in terms of wavelength. The most convenient way is to tune the receiving set to one of stations KIWBZ, WGY, WSB, WRC, WEA, WEAF, or WWJ. Other station course may be used, but the wavelengths of these stations have been checked many times by the Bureau of Standards and have been found to be always the same, within .1 or .2 of a per cent. the station tuned in as closely as possible, the wavemeter is tuned to the wavelength of the station and the setting recorded. With six or seven points over the meter scale recorded, a graph may be drawn and then the wave for any point on dial may be read off. If the condenser has semi-circular plates, the curve will look like that shown in Fig. 5; b

(Continued on Page 76)

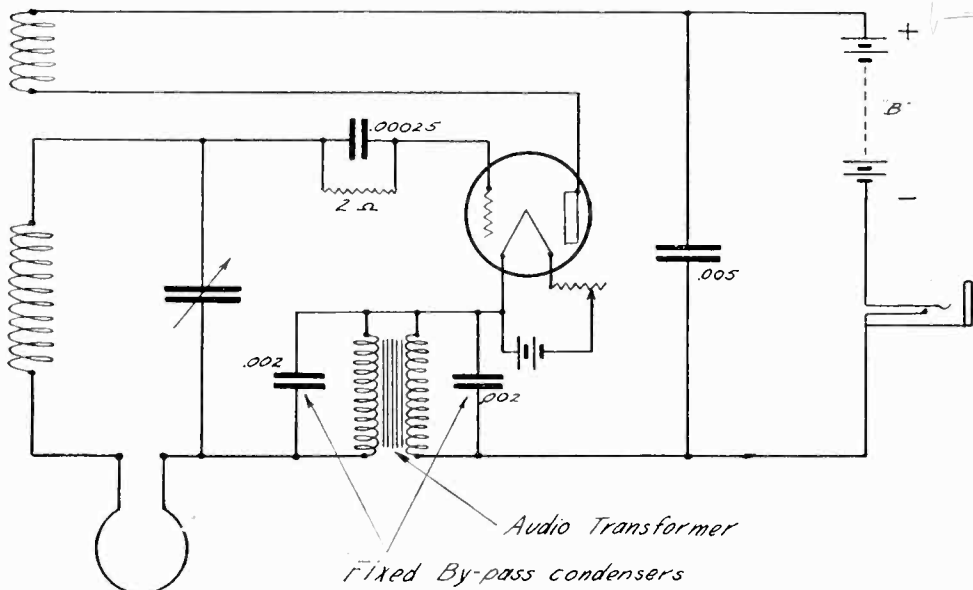

Fig. 3. Modulated Heterodyne Wavemeter.

wave. This can be done with the heterodyne wavemeter by connecting in an audio transformer as shown in Fig. 3. This makes the circuit oscillate at an audio frequency—i. e., howl. The howl will be sent out on the wave to which the wavemeter is tuned and may be picked up by a non-oscillating receiver. The connections to the transformer must be reversed if the circuit does not howl. The by-pass condensers on the transformer may have their capacities adjusted to give any desired musical note. Often a grid leak, connected promiscuously between transformer terminals, will cause a pleasing note.

The simpler way to give off a modulated wave from the wavemeter is to connect a buzzer in one of the circuits

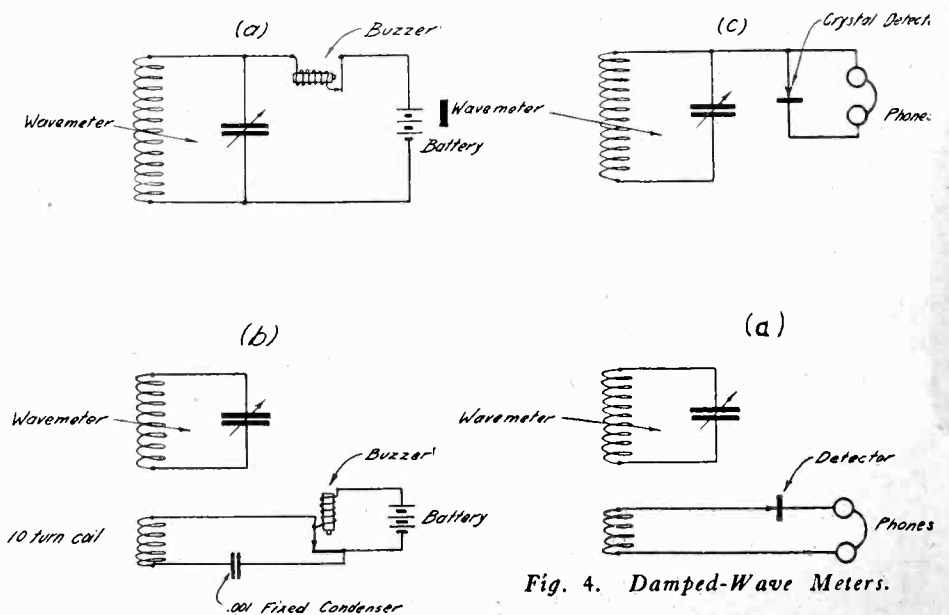

Fig. 4. Damped-Wave Meters.

Interesting Data on Reception

By E. T. Jones

YOUR first impression of radio was probably good, provided that you heard the announcer say that you had just listened to Vincent Lopez and his Pennsylvania orchestra, or some other notable organization. You hardly stopped a moment to recall whether you heard "music" or not, you were so bewildered and fascinated. The truth of the matter was that you may not have heard any real music, that is, the kind of music which would make you feel like owning the set. Probably the fault lay in the operator of the receiving set, and not in the set itself. In his over-zealous attempt to bring it in loud enough for you, a great number of distracting noises were also brought in with the music and if you were not too absorbed in the mystery of the thing, you would have immediately condemned the performance and secretly resolved never to listen to that particular orchestra again.

There is a limit to the amount of amplification that should be employed and this limit is reached when the quality of the music is being impaired to produce quantity. But you insist on quality, to which you are entitled, when you pay several hundred dollars for a radio receiver, and happily the design of modern equipment is towards that end. It is well to bear in mind that the slightest noise in the radio receiver distracts from the beauty and quality of the music. You know quite well that if a phonograph dealer were to let you hear a popular record and you heard one scratch in the entire selection, you would say that you were pleased with the selection but would like a new record from stock. That is how keen your ear is for good music when you are paying for it. Therefore, why inject any more noise into the radio receiver than is picked up from external sources.

The proper procedure in the operation of a radio set, for loud speaker reception, is to adjust the volume to a point where the noise is in the background, and at no time becomes sufficiently severe to impair the quality of the music or speech. When the volume is increased beyond that point, the noise will increase in proportion, and will have a greater interfering effect as it becomes more audible. The moral is, adjust your receiver to the point where acceptable music is to be had, no matter how much volume you can obtain and are holding in reserve. The neighbors all know that you have a radio set, and it is not necessary to increase your volume until they have to close their windows due to the noise. The word volume is strictly a synonym of noise in radio reception and furthermore an antonym of quality.

Then there is the question of distance, a subject which is the cause of continuous argument between customer and dealer. The manufacturers of most of the 500-watt radiocasting stations will not guarantee more than 100 miles daylight communication. This bears out the fact that you ought not to hear the numerous 500 watters if you are more than 100 miles distant. At night the range of such stations is greatly increased, and from 500 to 1,000 miles is a consistent range. If you happen to hear such a station at a greater distance, then you may consider yourself lucky, for the station has exceeded its guaranteed range by many miles. If you fail to hear the station tomorrow night, don't throw up your hands and wish you had bought a phonograph, for your set is not to blame. Bear in mind that nearly all the stations you listen to at night are 500 watts output, or less, and that if the sun failed to set one evening, you would not hear any of the stations you were accustomed to hear after sundown.

If you are located 100 miles or less from a 500-watt station, you should have consistent communication 365 days in the year. At night the same station should be heard at a greater distance, and it has been found that this range varies from night to night, so that no guarantee can be given by the dealer as to the exact maximum possible distance obtainable, due to the variation in receiving conditions from night to night. If you read a published statement that such and such a station was received over a distance of 1,000 miles in the day time, you can bank on the fact that the reception took place after sunset, and that one of the two locations was probably in total darkness at the time. To obtain reliable service over distances up to 1,000 miles would require at least 100 times the power now in use, so beware of the receiver that has performed coast-to-coast reception in "broad daylight," for the "dark man in the woodpile" was probably the broad stretch of night that covered 90 per cent of the space between the two points.

The Australian Broadcasting Company's station (3L0) at Melbourne has altered its wavelength from 1,620 meters to 371 meters. This station had the longest wave of any broadcasting station in Australia. One Sydney station, 2BL, has altered its wavelength from 350 to 353 meters and has increased its plate input to 1,500 watts. The other station, 2FC, has intimated that changes are being considered, but no official announcement has been made.

HANDY HINTS

A good portable ground connection can often be made to a piece of wire netting, laid on the ground. This serves only as a counterpoise, unless laid on very wet soil.

The substance sold by druggists as "new-skin" makes a good binder for holding inductance coils together.

It is much better to keep a storage battery well charged at all times than to let it run down, and then give it a long charge.

When laying up a lead storage battery for a while, the simplest way is to give it a good charge and then continue this into an overcharge of about 10 or 12 hours at a reduced rate. Then replace the electrolyte with distilled water, and again charge it at a low rate. All that is necessary to lay up an Edison alkaline battery is to put it away, provided there is enough electrolyte to cover the plates. The state of charge does not matter with this type battery.

Electrolysis in water pipes under some conditions may set up enough trouble to cause sparks and thus interfere with radio reception.

One of the handiest tools around the radio shop bench can be made up by making a heavy chisel-like knife from an old file. This can be used to scrape wires, cut wood, or do any of a hundred things you'd not care to use a good tool on, and when its broken or worn out, a new one can be ground up again on any emery wheel.

Files can be resharpened, after the loose dirt has been removed with a stiff brush, by first boiling them for an hour in a solution consisting of $\frac{1}{4}$ lb. of saleratus to a quart of water so as to remove the grease. They are then washed in clear water and dried preparatory to being completely immersed, standing on end, in a solution of $\frac{1}{4}$ lb. of sulphuric acid to a quart of water, where they should be left for 12 hours. They should again be washed and dried.

Copper may be cleaned and brightened in nitric acid, even if it is old and green. This often is much easier than scraping or sandpapering. Remove all traces of acid, before leaving the job, however, or things will corrode worse than they were before.

In working around lead storage batteries, celluloid sheeting can be used to protect the table or floor, and will prove to be as resistant to acid as the usual lead or rubber, also being cheaper and easier to handle.

A few sheets of blotting paper should always be kept in or near the storage battery cabinet to absorb any acid that may be spilled.

Transmitter Tuning Without Meters

Practical Directions for Using a Receiver as a Wavemeter to Calibrate a Transmitter

By L. W. Hatry

A TRANSMITTER can be adjusted to resonance without the use of a meter, by means of a receiver. When the antenna circuit of the receiving set is tuned to resonance with the secondary circuit, with the tube oscillating, oscillation will be stopped if the coupling between the coils is sufficiently close. This fact is utilized in the well-known click method of operating a wavemeter, for if there is an oscillating circuit near the wavemeter and this nearby circuit can be tuned to the wavelength of the active one, it will rob the latter of energy and stop oscillation. Let's make use of this fact in tuning the transmitter.

The first concern is wavelength. How can we tune the transmitter to the proper wavelength, particularly without a wavemeter? It is not very difficult; neither is it very exact unless extraordinary care is used and the whole procedure repeated several times. If one is listening regularly he knows what wavelength bands he can hear, especially since there are the so-called OWL stations (Official Wavelength Stations), that always sign off with the number indicating their correct wavelength; e. g., 1PPP 79 k. With your receiver, locate one of these whose wavelength is within the amateur wavelength band in which it is intended to operate, and if this can't be done, find the upper and lower limits of audible stations within this band and set the receiver tuning to the middle. This will locate the wavelength to which the receiver is tuned within the zone of

safety. For instance, amateurs on the 75-85 meter wavelength band tune in at readings on the secondary condenser scale of 50 to 95. 72, then, is the reading that should be used as the receiver setting to go by in tuning the transmitter according to the method to be described.

Notice Fig. 1, which shows the Hartley circuit, which will work on any wavelength in practical use with satisfactory results, and as it is in use at such a large majority of amateur stations, no other circuit will be considered.

Bring the receiver near the transmitter, or vice versa, and tune the primary of the transmitter to the point that stops oscillation in the receiver. Increase the distance between the two sets until the point at which oscillation stops in the receiver is narrowed to very nearly a click because the stopping and starting places of oscillation have moved close to each other and do not register for a greater dial reading than a single division. This done, the primary of the transmitter is now tuned to the same wavelength as that of the receiver. If the receiver is tuned to the intended operating wavelength, the primary circuit, then, is properly set. The only remain-

ing adjustment immediately necessary is to tune the antenna circuit to resonance with the primary.

The tune of the transmitter can first be obtained for any setting of the adjustments, provided it is within the range of wavelengths to which the receiver will tune, and then gradually shifted until it hits the reading that was chosen as that of the operating wave to be.

If it is inconvenient to move either of the sets near to the other, Fig. 2 shows two methods of doing the trick, the more accurate of the two being B which uses the coupling link. With A there is a slight tuning effect of one circuit upon the other and it is often impossible to narrow the oscillation stoppage space because the coupling is conductive, not variable and possibly too close. With the link method, the coupling can be varied by moving either of the link coils and the absorption space can be brought to a sharp and definite indication. Another method that works well is to have the transmitter working with but 22½ volts of B battery as the plate supply. By searching for the usual whistle with the receiver the tune of the primary of the transmitter can be found.

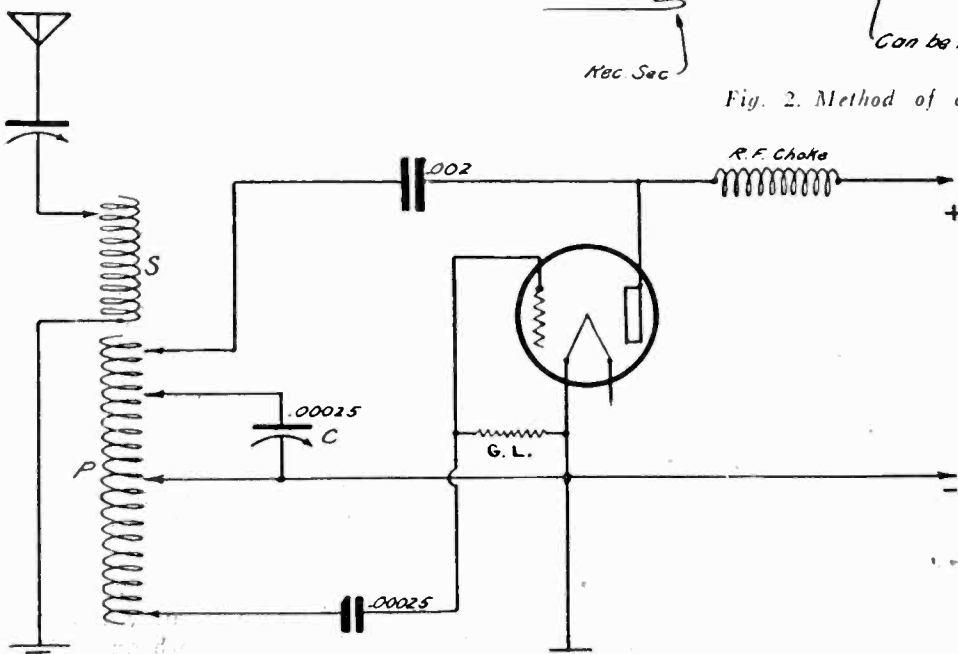

Fig. 1 Hartley circuit arranged for transmitting.

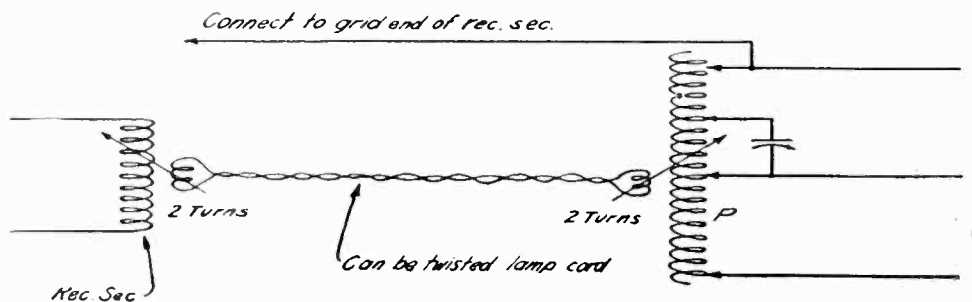

Fig. 2. Method of coupling transmitter to receiver.

Having tuned the primary circuit properly by one of the above methods, the antenna circuit is next, and with an antenna series variable condenser, the adjustment is easy, for usually the receiver is sufficiently close to the transmitter. Have the transmitter primary open-circuited so that it can have no effect and tune the receiver to the setting to which the primary of the transmitter has been adjusted. Adjust the receiver so that it is barely in the oscillating state. Then the least absorption will stop oscillation and it ought to be possible, the aerial being connected to the transmitter and not the receiver, to vary the series antenna variable condenser carefully and

(Continued on Page 72)

An Inexpensive Chemical Rectifier

Constructional Details of an Outfit That Will Supply 550-600 Volts for an Amateur Transmitter

By C. A. Weidenhammer, 1 ZL

IN these days of ultra-short waves and resulting poor notes it is unusual to hear a "ham" who sports a note which has no A. C. component. Of course, if a good note becomes unsteady, it is as exasperating as the hoarse squawk of an unfiltered synchronous rectifier or "pure" A. C., but barring unsteadiness, nine times out of ten the owner of such a note will tell you he has accomplished a lot more DX and consistent work just through its readability and cleanness.

The average amateur, on starting in the power game, turns to chemically rectified A. C. as the solution of his plate supply problem. In the first place he shuns A. C. from sheer fear of ostracism from the rest of the gang. Secondly, motor generators are beyond the reach of the average pocketbook. Then, too, "sink" rectifiers are rather beyond construction by the amateur who hasn't mechanical ability to a pronounced degree. Thus, in utter desperation, he turns to electrolytic rectification as the only way out of the difficulty.

In a great many cases, the builder of a chemical rectifier obtains a lot of jars, throws in aluminum and lead strips that are not too pure and clean, mixes a solution with suspiciously pure water, and then wonders why good rectification doesn't occur. He would have spared himself no end of trouble and disappointment if he had built his rectifier according to a set standard of construction. The rectifier to be described was built by the writer from universally accepted electrical data on rectifying apparatus and partly from wrinkles encountered in past experience. At any rate this particular combination has worked exceptionally well, indeed better than the average, and that seems enough justification for its description.

The builder will need a list of material that can be purchased for the most part at very nominal cost, the only expensive items being the lead and aluminum. The list follows:

16 Blue Ribbon mayonnaise jars (half-pint size).

(Any other jars of this type will do).

16 pieces of the purest aluminum obtainable, 1½ by 5 in.

16 pieces of sheet lead, 1½ by 5 in, (⅛ in. thick in both cases).

16 round head, brass machine screws, 8/32, 3/8 in. long, with nuts.

A pound of sodium phosphate.

A pint of medium grade transil oil.

A half-gallon of distilled water.

Lye for cleaning the elements.

A wooden tray for the rectifier.

The position of the rectifier in the sta-

tion will best determine the size of the tray and the arrangement of the jars. There are a few dealers at present who are selling aluminum and lead strips already bored. Although a little more expensive this way, the elements are bound to be truer and are really to be preferred to those cut by the builder from sheet aluminum and lead. There is a lot less work in store for the "ham" if he buys these, but if the sheet metal is decided upon, it is best to use a pair of tinner's shears for cutting up the lead and a hacksaw for the aluminum.

The drilling of the elements is a rather tedious job, but should be done carefully, nevertheless. An 8/32 hole is drilled in the center of each aluminum and lead strip, 5/8 in. from the end. Any metal drill of that size will do the job. Be careful not to wrap the lead pieces around the bit, a situation that will result if the strips aren't held firmly in the process of boring.

The elements now being ready for cleaning, it is absolutely necessary that they be rid of dirt and grime if the rectifier is to work. Foreign matter on the surface of the electrodes forms an efficient barrier against electrolytic action. A hot lye solution will solve the cleaning problem. Dissolve six or seven tablespoons of lye in a gallon of boiling water, in a pot or pail you have no use for. Do this in the open air, for lye is strong stuff and not especially recommended for inhalation. Stir the solution with an old stick and *don't* get any of the solution on the hands. Hooking a piece of wire in the hole at the end of each aluminum strip, suspend each one in the solution until the metal hisses and froths. As soon as this frothing has started, remove each strip from the solution and wash it in cold water. Don't

let the strips lie around, for they will become streaked where the excess lye on the surface eats in. Wash them immediately. If the aluminum is streaked with black lines and covered with dark splotches, it should not be used in the rectifier, for this is the sign of impurity. Pure aluminum should present a silvery appearance upon cleansing and there lies one secret of efficiency in rectifier operation.

The lead strips are given the same treatment and if the solution has lost its power, make a new one. The lead will not froth like the aluminum, but should be given a reasonably long immersion. Keep the aluminum strips away from the lead when you take the latter from the solution, for if any of the solution left on the lead strips splashes on the aluminum, black spots will result that won't come off. Clean and dry the aluminum first; then tackle the lead strips.

This operation completed and the elements dried, the strips can be bolted together and bent to fit the jars, allowing for separation between jars and a half-inch at the bottom of each jar. Four single pieces will be left for the end connections.

The writer has found sodium phosphate to be a much better solution than borax. In the first place it does not eat up the aluminum strips as borax does and secondly, it is not so messy to work with and on the whole it's general performance is much superior. A pound of the sodium phosphate will be needed for the solution, and it may be bought at any drug store for a very small sum. Fill a stone crock with enough distilled water to fill the jars to within a half-inch of their mouths, heat the water slightly and pour in the phosphate, stirring the solution slowly. Keep adding the powder until

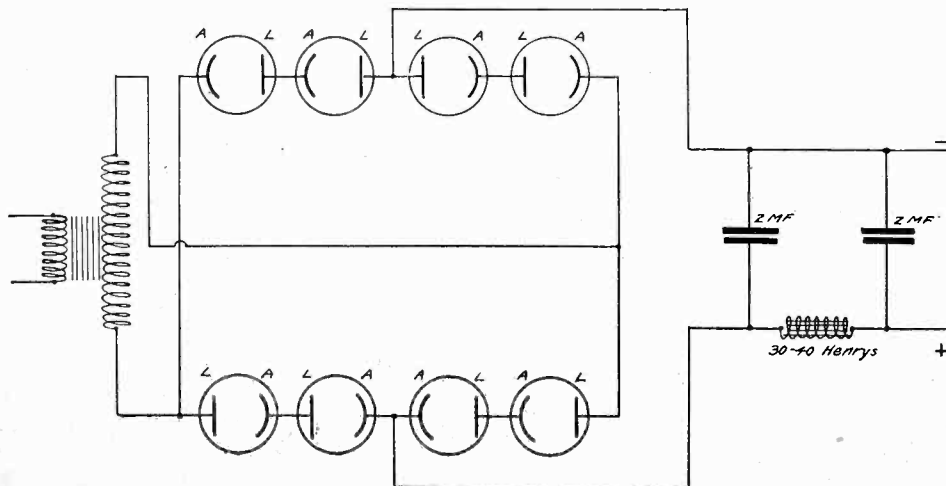

Fig. 1. Bridge Method of Connecting Rectifier Jars.

the solution has become saturated; that is, until the water will dissolve no more of the chemical. Let the mixture stand for a day or so until it has settled. The sediment will take crystal form in the bottom of the crock. The clear solution must be poured off and care should be taken not to pour any of the sediment along with it, for if this is done, the rectifier jars will be graced with a quantity of sediment after they have been standing a short time. Pour the solution into the jars and immerse the elements in their proper sequence, as shown in Fig. 1. Take care not to splash any of the solution on the aluminum and lead crosspieces and sides of the jars, for crystallization will result almost immediately and the rectifier will not be the thing of beauty that it should be with the proper precautions.

Placing a quarter-inch of medium grade transil oil, or medium auto lubricant if you haven't the other, in the top of each jar completes the job. This oil film is of real importance for not only does it prevent the solution from evaporating and creeping, but it also prevents arcing between the aluminum elements and the solution, a valuable feature in itself. It may seem superfluous to some, but it is worth its weight in gold in the end.

The rectifier is now ready for operation. The strips are connected according to Fig. 2 for a center tap connection, but

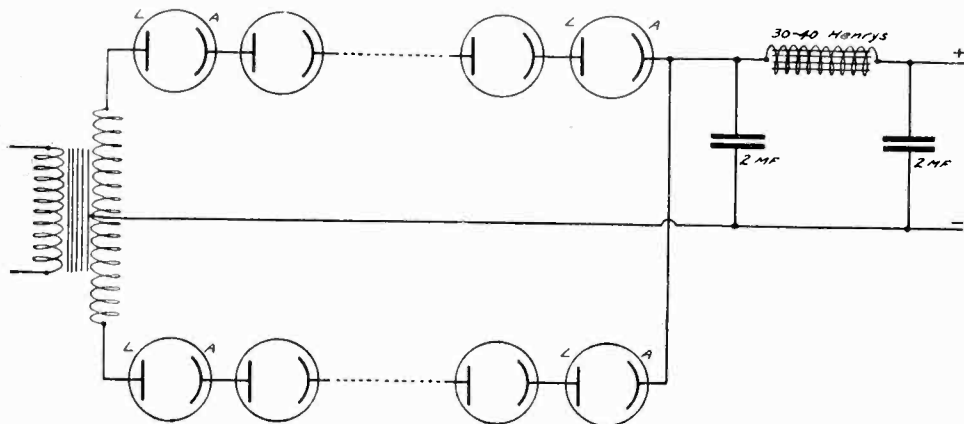

Fig. 2. Center Tap Method of Rectification.

a bridge connection can also be used as shown in Fig. 1, although it will require more jars which the builder can add as he sees fit. As soon as the connections have been made, throw on the juice and the aluminum will form almost immediately if pure, but the lead will take quite a little longer to coat. When the coating has been completed, a process that can be accomplished either by leaving the rectifier connected to the transformer for a few hours or by gradual formation through operation in conjunction with the transmitter, the aluminum will present a grayish appearance with little evidence of any great deposit on its surface, while the lead will be a chocolate brown. If the rectifier is working properly, all the aluminum strips will glow in the dark with a phosphorescent light without any pyrotechnic display. Fireworks, large arcs occurring on the

surface of the aluminum, are a sure sign of overloading and too few jars. There will be star-like lights all over the surface of the aluminum during the forming process, but these are negligible and are to be expected. It is the arcs of greater magnitude that bode evil. Those jars that do not glow at all are "duds" and should be replaced. The rectifier at the writer's station has been in commission for six months and is still working merrily with the original solution and elements. Every aluminum strip glows without any evidence of excess current.

The rectifier that has been described was designed primarily for 550 to 600 volts. If the builder intends to use a higher voltage, it will be necessary to place more jars in the rectifier system. There is a simple formula regarding the number of jars to be used with a certain applied voltage that has often been quoted, but which will always stand re-quotting. It is:

Volts to be applied
 $\frac{\quad}{40}$ = number of jars to be used.

There must be a jar for every 40 volts input if efficient rectification is to result, and the rule if incorporated in the design of your rectifier, will keep your electric bill down low enough to insure domestic tranquility.

The filter for this combination can best be the well known "brute force" type, made up of a 30 or 40 henry

choke in the plus lead with 2 mfd. shunted across the supply on each side. The writer uses only a 1 mfd. condenser across his supply for a filter, the small value being necessary because the set is keyed in the primary of the plate transformer. There is no key thump to speak of and all report the note "D. C.," erroneously, of course.

There is one "kink" that has become very popular of late that improves the note greatly and that is the combination of filament by-pass condensers and a large rheostat in the primary of the filament transformer. A rheostat in the tube filament circuit proper throws the center tap off, thus throwing the circuit out of balance and giving the station a poorer note than would result if the center tap were unaffected. The filament by-pass condensers explain themselves.

In closing it should be noted that

cleaning a rectifier frequently is a good plan for through continued use the lead strips become coated with a milky white substance that is better removed. Sediment in the bottoms of the jars should be poured out and distilled water added as evaporation takes place. With a little care the rectifier described will give the utmost satisfaction and should be a distinct asset to the station.

NEW TUBES AND BASES

Vacuum tube manufacturers have adopted a new form of standard base which may be used interchangeably in the present form of Navy socket or in a new type of push socket. In the case of the Radio Corporation of America these will be known as the "UX" tubes and in the case of Cunningham they will be "CX," in each case using the present series of numbers to designate various types of storage and dry battery tubes.

The new base has longer contact pins and the filament pins are larger than the grid and plate pins so as to insure correct placement in the socket. The "push" type of socket gives better contact and takes less space and will be made in two diameters to receive the large and small tubes. The present dry cell tubes with their original bases will be continued in production as long as the demand exists.

Three new types of receiving tubes will be announced at an early date. The "112" is an audio amplifier for use in the last stage; it requires 135 volt B battery and storage A. The "120" is similar except that it may be used with dry cell A. The "210" takes 6 volts A and up to 350 volts B. They are all low impedance tubes which provide improved quality of loud speaker reproduction. Two new types of rectifier tubes for B battery eliminators are also to be introduced for either half wave or full wave rectification.

Two Japanese news agencies, Toho and Teikoko, are using a 2000 watt radio station to send out news daily to Europe, America and the Far East.

The U. S. Forest service requests the co-operation of radiocast and amateur operators in sending out slogans and warnings about the prevention of forest fires.

Permalloy, the new magnetic material used in loading submarine cables so as to greatly increase their traffic carrying capacity, has great possibilities for improving the characteristics of the audio frequency transformers used in radio receivers. It is an alloy consisting primarily of nickel and iron and has a permeability about twenty times that of soft iron wire. For an alloy consisting of 78½ per cent nickel and 21½ per cent iron the permeability is about 2300 as compared with 115 for the best soft iron. Various other elements may be added to impart other desirable properties, chromium thus being added to secure high resistivity.

The Push-Pull Radio Frequency Oscillator

Constructional Details for an Easily Made Short Wave Transmitter Having no Harmonics

By D. B. McGown

THE General Electric Company has recently developed a circuit for use in their high powered short wave transmitters, which is deserving of consideration by all amateurs interested in transmission. This system uses two or more tubes, in groups of two, in such a way that each tube operates in "push-pull" fashion similar to the performance of the audio frequency amplifier system of the same name. The transmitters employed by the General Electric Co. are of comparatively high power, but the principle of the circuit is the same for any type of tube, and for the amateur with two tubes of identical type, provided they are not in excess of the power restrictions placed on the amateur, this circuit possesses many interesting features.

The chief advantage of the circuit is that it eliminates radiation of harmonics, which is ordinarily the most troublesome and objectionable cause of interference with reception of stations on other wavelengths, and is the cause of difficulties in the transmitting set such as heating of the small wires inside the vacuum tubes leading to the grid and plate elements. These currents are of extremely high frequency and have high power contents, so that in many cases the small connecting wires melt and open the circuit, thus ruining the tube. Inserting small chokes in series with the grid or plate leads where heating appears does no good, as these oscillations are apparently due to other causes than inter-tube coupling.

The "push-pull" transmitter also allows very easy control of the tubes at waves as low as 20 meters, thus being a good all around system for amateur use. In Fig. 1 is shown a schematic diagram of connections for the circuit, from which it is noted that the antenna circuit is coupled to the plate circuits of the respective tubes by coupling inductances L_1 and L_2 respectively. The antenna circuit may be the same as that used for any ordinary oscillating system and may be tuned to the fundamental wavelength to be used, or to one of its harmonics, whichever is desired.

The plate circuit is made up of two symmetrical coils of exactly equal size, indicated in the diagram by L_3 and L_4 . These coils are connected together at one end as shown and the plate supply fed through the mid point X . These coils should not be placed in inductive relation to each other, their normal po-

sition being about a foot apart and with their axes parallel.

The closed oscillatory circuit is formed by these inductances, L_3 and L_4 and the two variable condensers C_1 and C_2 , which are connected in series. The latter are of the double spaced, low loss type, of .00025 mfd. each. L_3 and L_4 were made up of 4 turns of 1/16 in. by 1/4 in. edgewise wound copper strip on a 4 in. diameter, with clips provided for any variation that might be needed. Condensers C_1 and C_2 were connected in series to give symmetry to the circuit and the grid of each tube was connected to the plate circuit inductance of the opposite tube through condensers C_3 and C_4 , which are similar to C_1 and C_2 . The grids were kept at the proper potential by the gridleaks marked GL , the proper value depending upon the size of tube used. For the UV-203-A 50 watt tube the leaks should be around 5000 ohms, and for lower powered tubes this value will be considerably higher. Inductively wound leaks were used, so that they choked back the radio frequency currents impressed upon them. If non-inductive type leaks are used, small radio frequency choke coils will be required in series with the leaks.

The filaments were supplied with low voltage a. c. from a step-down transformer, the actual balance between the

tube filaments being obtained by variation of the rheostats in series with the transformer secondary. No mid-tap is shown in the diagram, but it is possible that slightly better tube life might be obtained should one be provided. The plate current is fed through the tuned choke L_5 , C_5 , which is augmented by a larger untuned choke, L_6 . The antenna coupling coils were made of 3 turns each of 1/16 in. x 1/4 in. edgewise wound copper strip on a 3 in. diameter and were so arranged that they could be moved right into the plate inductances L_3 and L_4 , or coupled as loosely to them as was desired. Clips are provided to allow a variation of the inductance.

Standard vacuum tube sockets were employed, since the ultra-high frequencies were not to be used. The preliminary adjustments and set-up of this circuit are not critical, provided that reasonable care is given to symmetry. The adjustment and operation of the circuit depends entirely upon this symmetry and without it, the usual circuits might just as well be used.

In setting up the apparatus, it is a good plan to cut all the connecting wires in pairs, first having arranged the two tubes and their respective inductances and condensers in such a manner that they are symmetrically placed. A suggested set-up is shown in Fig. 2, which

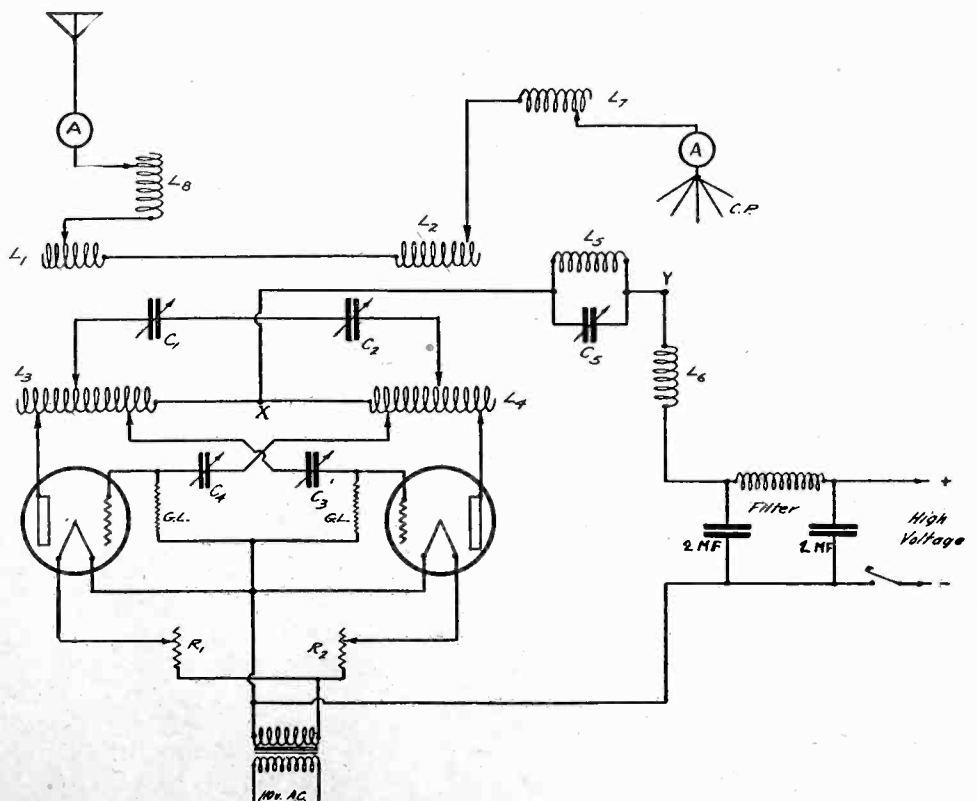

Fig. 1. Schematic Diagram of Push-Pull Radio Frequency Oscillator.

shows the layout of the various parts mentioned in Fig. 1. The grid taps of coils L_3 and L_4 should be set so as to include the same amount of inductance in each coil, and the plate taps should be likewise adjusted to symmetrical positions. The variable condensers and closed circuit taps should be adjusted to symmetry as far as can be observed with the eye, the coupling condensers in the grid circuits being set to about half their maximum capacity.

between L_1 and L_3 , and between L_2 and L_4 will be found to be very critical, so that resonance is often passed over if the wavelength variations are not made slowly and carefully.

With the circuit adjusted to its best operating condition, the plate choke should now be adjusted by varying condenser C_5 and inductance L_5 until the plate current drops slightly and the antenna ammeters indicate slight increases. This will indicate resonance and shows

moved, but generally this is not advisable, as if anything happens to throw the circuit off resonance, there will be a feedback of high frequency to the plate supply with resultant trouble. L_5 may be made up of 25 turns of No. 22 D. C. C. wire wound on a 3 in. tube, and L_6 may be a 50 turn coil of the same dimensions.

Keying is accomplished in the usual way, in the negative plate lead to the mid-tap of the transformer, on the supply side of the filter. Another method of keying could be employed by inserting the key between the two grid leaks and the point where they are connected to the filament circuit and in many cases may provide better control than breaking the negative plate supply lead.

While the adjustments are somewhat critical, especially the coupling coils, the circuit will be found to be very satisfactory over a band of wavelengths from 10 meters up, the oscillations being very uniform and easily controlled, without overheating of the vacuum tubes. In the transmitter constructed by the writer, a band of waves from 20 to 50 meters was ordinarily employed, and it was found that the steadiest note was obtained by adjusting the coupling between the antenna and oscillatory circuits to a point a trifle below maximum radiation, as at maximum there is likelihood of a shifting of energy due to mutual coupling.

An interesting feature of the circuit is the ease with which the load may be shifted from one tube to the other, for the increase in capacity of either C_3 or C_4 by a small amount beyond the condition of symmetry will unbalance the system so that the entire load will be shifted to one tube, with resultant heating of the plate of whichever tube is carrying the full load.

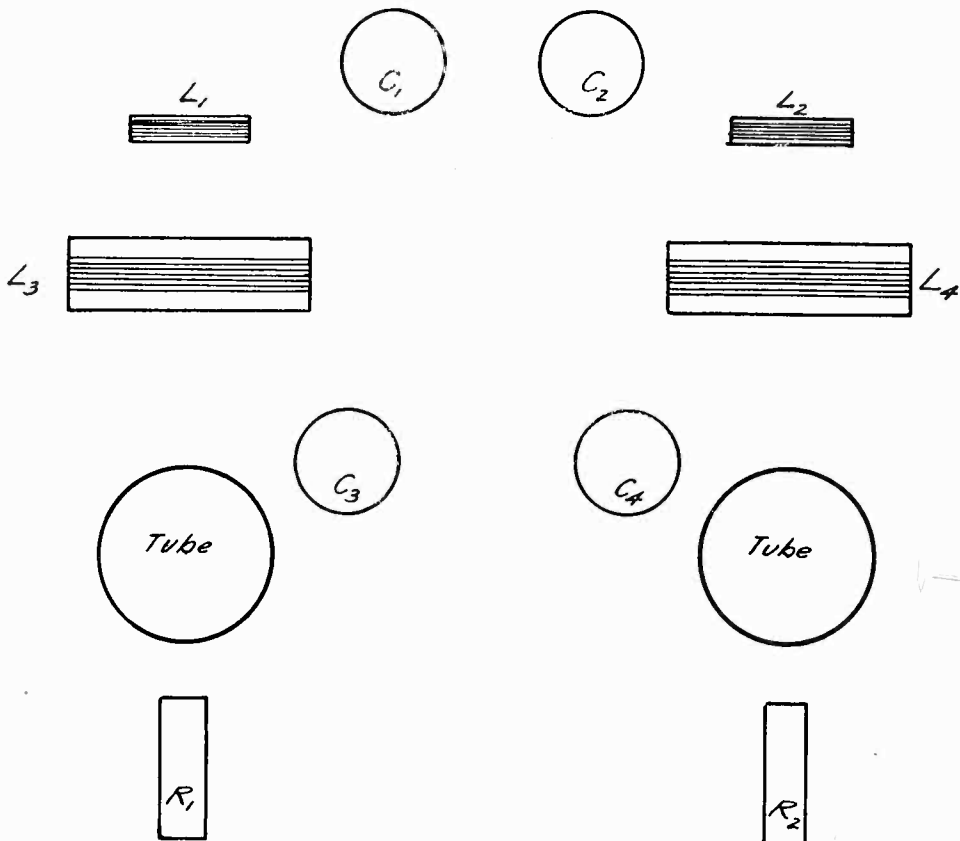

Fig. 2. Suggested Set-up of Apparatus.

The antenna circuit should either be loosely coupled, or else entirely disconnected during the preliminary tests. Next light the filaments of the tubes and apply a low plate voltage, so that if the adjustments have been made properly, oscillation should take place at once and with sufficient power to be detected with a wavemeter. If the wavelength is too high, reduce condensers C_1 and C_2 , or if it is way too high, reduce the amount of inductance in L_3 and L_4 as well as the capacity of the condensers in shunt. Now couple the antenna circuit to the oscillator and tune to resonance. This may be done either by varying inductance L_7 or by the use of a series air condenser, if the inductance is not desired. It has been found good practice to provide two inductances, L_7 and L_8 , one in the antenna and the other in the counterpoise lead, two radiation ammeters being used to obtain the optimum adjustment. A slight re-tuning of condensers C_1 and C_2 may be necessary to obtain maximum resonance, and it will probably be found desirable to vary the two grid condensers C_3 and C_4 , as well as their inductance taps. The coupling

that the tuned choke system is effectually rejecting any energy that reaches it. The untuned choke L_6 may then be re-

ELECTRIFIED HISTORY [No. 11]

When Rome Burned

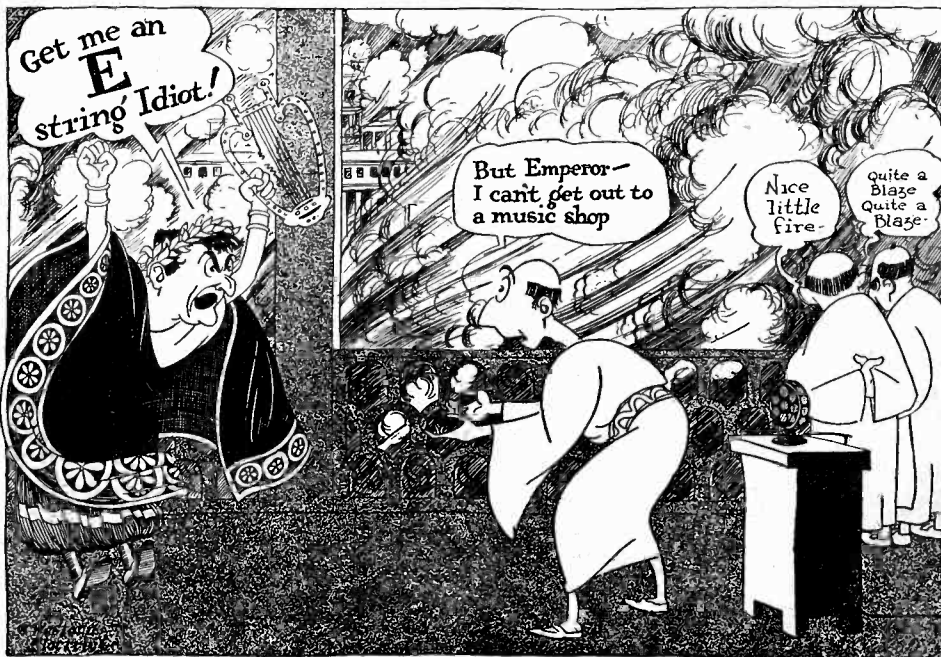



QUERIES *and* REPLIES



Questions submitted for answer in this department should be typewritten or in ink, written on one side of the paper. All answers of general interest will be published. Readers are invited to use this service without charge, except that 25c per question should be forwarded when personal answer by mail is wanted.

In the February issue of RADIO a combination transmitting and receiving set was described. Please publish the circuit showing the transmitting tube only, without receiving attachment.

—T. McD., Hamilton, Ohio.

In Fig. 1 is shown the circuit for the receiving tube when used as a transmitter. A separate antenna inductance is shown, to permit looser coupling. With a C-301-A tube or its equivalent, the plate voltage can be as high as 150, when used for C. W. telegraph only. The spark coil shown in the original circuit can be used if desired, but the arrangement shown in the sketch will produce a better unmodulated wave.

What is the simplest form of superheterodyne I can build, for portable purposes? I have in mind using crystal detectors in place of vacuum tubes and reflexing one or more of the intermediate frequency stages.

—P. W. D., Erie, Pa.

A satisfactory superheterodyne embodying the features you mention can be constructed according to the diagram shown in Fig. 2. The set consists essentially of an oscillator tube, crystal frequency changer, two intermediate frequency stages, crystal detector, one stage of reflexed audio frequency and a second stage of non-reflexed audio frequency amplification. This requires a total of four tubes, which is the minimum permissible number for best results. The oscillator coil is a standard coupler such as is used in

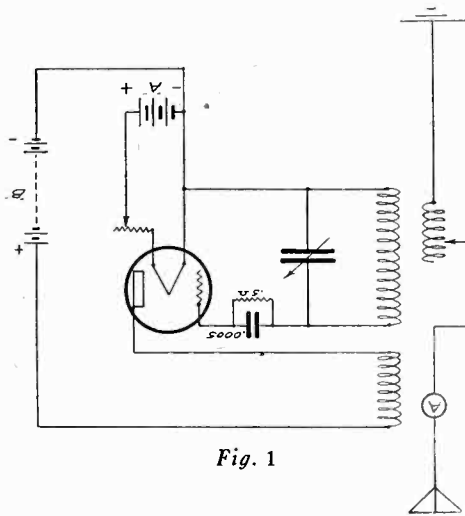

Fig. 1

many superheterodynes described in RADIO, with the grid coupling coil connected to the crystal frequency changer, D_1 . The two intermediate frequency transformers T_1 and T_2 are of the standard high ratio shielded type, using an intermediate frequency above 50,000 cycles if possible. Tuned transformer T_3 should be selected to match the intermediate frequency transformers, and the tuning condenser marked .00025 mfd. in the diagram should be of the value specified by the manufacturer. The output of the crystal detector D_2 is fed through a low ratio shielded audio frequency transformer, T_4 , and into the 1st intermediate frequency

amplifier tube, the output of which is connected to the primaries of transformers T_5 and T_6 in series, the latter being similar to T_1 . The by-pass condensers in the grid and plate circuits of the 1st intermediate frequency tube are very necessary and should not be omitted under any circumstances. It would be better, theoretically, to have them of larger size, but this cannot be permitted due to the fact that the audio frequency transformers would be tuned to some audio frequency well within the voice range and would destroy the quality of output into the loud speaker. Crystal detectors of the adjustable variety are preferable, as considerable experimenting may be necessary before finding the proper adjustment of each crystal. The oscillator requires only $22\frac{1}{2}$ volts plate, and the grid is connected directly to the filament, thus simplifying the wiring. It would be a good idea to shield the intermediate frequency stages from the rest of the circuit, with partitions of sheet brass or copper, connecting the shields to the negative A battery. Using a loop antenna at least 15 in. square, having 18 turns of wire, this set will receive stations with loud speaker volume over a distance of at least 750 miles at night, in the favorable months of the year.

Kindly publish information on nickel plating by means of the the electroplating method.

—G. T. G., Superior, Wis.

A complete story on the electroplating process, by D. B. McGown was published in (Continued on Page 46)

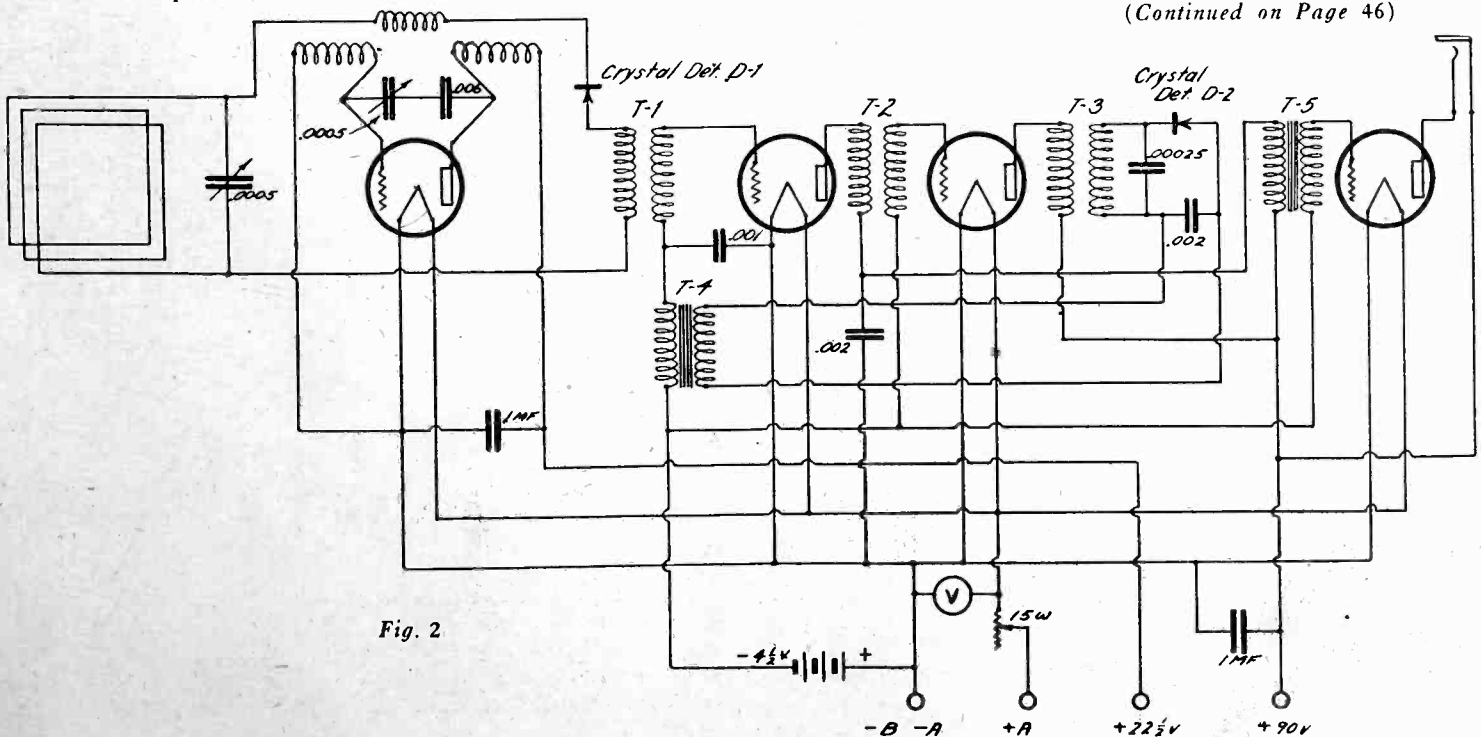

Fig. 2

Short Wave Experiments While With the Fleet

By F. L. Ulrich

FOR several months prior to the departure of the Pacific Fleet for the war maneuvers off Hawaii, experiments with short wave reception were conducted at station 6DBC, San Diego, Calif., and were continued aboard the U. S. S. *Langley*, Naval Aircraft Carrier, enroute to the islands. The experiments conducted on the vessel are of particular interest due to the excellent results obtained under difficult conditions of reception.

The short wave receiver with which these experiments were conducted was constructed from a tuning coil of the conventional low loss, three circuit type, which was stripped of its windings, leaving a substantial frame of the right size for the work. The coil frame was rewound with No. 12 copper wire, the primary consisting of 5 turns on a 4 in. diameter, the secondary 12 turns, and the tickler was wound with 20 turns of No. 20 D. C. wire, on the rotor, which was 2 1/2 in. diameter.

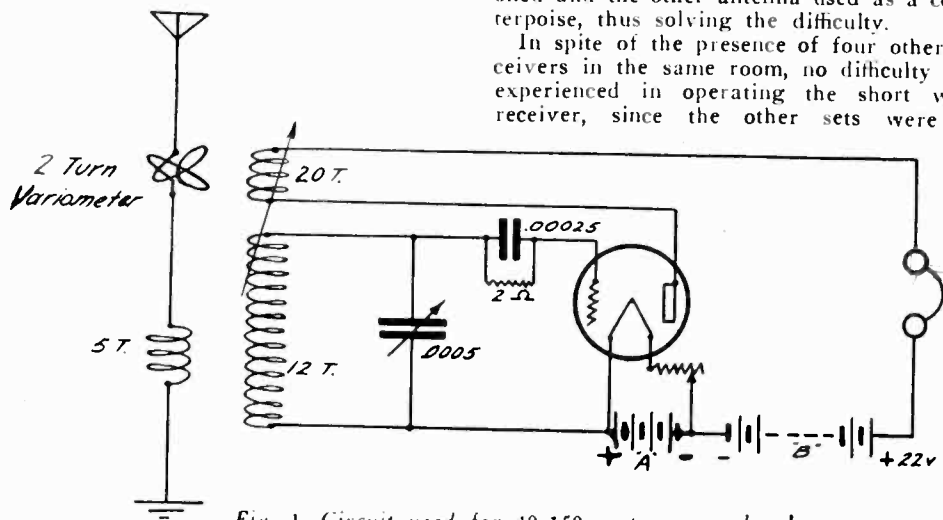

Fig. 1. Circuit used for 40-150 meter wave band.

As shown in Fig. 1, the secondary was tuned with a high grade condenser of .0005 mfd., the primary being aperiodic. The usual two step audio frequency amplifier was added, and the entire assembly can be

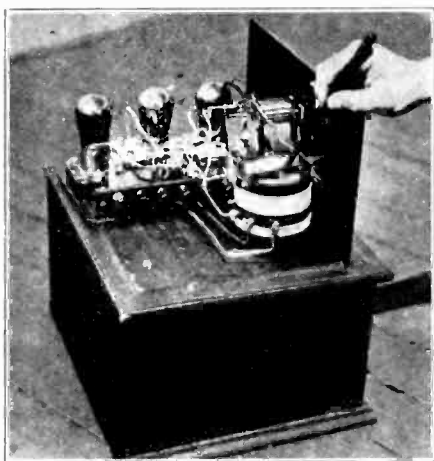

Fig. 2. Internal construction of 40-150 meter receiver.

seen in Fig. 2, particular attention being called to the fact that the tickler winding is split in the center, a total of 10 turns being wound on each side of the shaft which turns the coil. Any good low-loss coil form may be used for the coil mounting, an Uncle Sam tuning coil being used in the set illustrated. Before sailing, the receiver was calibrated according to the different frequencies transmitted from NKF, Bellevue Radio Laboratory at Washington, D. C., in

order to have a reliable check on the various wavelengths.

The conditions for installing antennas on the *Langley* were difficult, since everything on the flying deck which covers most of the superstructure must be kept clear, so as not to interfere with the landing of planes. Two small cage type antennas were erected, being extended out on 15 ft. booms in a horizontal position, at the most forward position of the ship's bow, one antenna being on the starboard side and the other on the port side. The antennas consisted of 5 wires on a 6 in. hoop, with a total length of 25 ft. each, plus a 25 ft. lead-in made from a copper tube 1/4 in. thick. At first one of the antennas was used with the regular ship's ground, but it was found that most of the energy was absorbed by the large masses of iron girders, stacks, winches, guys, etc., with which the ship was plentifully equipped. So the ground was abandoned and the other antenna used as a counterpoise, thus solving the difficulty.

In spite of the presence of four other receivers in the same room, no difficulty was experienced in operating the short wave receiver, since the other sets were all

Great trouble from induction was caused by the ventilating motors, aircraft engines and the like, so that coupling with antenna system was made as loose as possible. This sharpened the tuning to such an extent that a two turn variometer made of No. 12 cotton covered wire was necessary in series with the antenna, for vernier control. This variometer is shown in Fig. 1, in the antenna circuit.

While at sea we learned that experimental transmission from station NXN at Chicago was to be conducted on waves from 20 to 40 meters, so another receiver for these waves was constructed and is pictured in Fig. 3. An inductance consisting of 12 turns of No. 14 D. C. copper wire was wound,

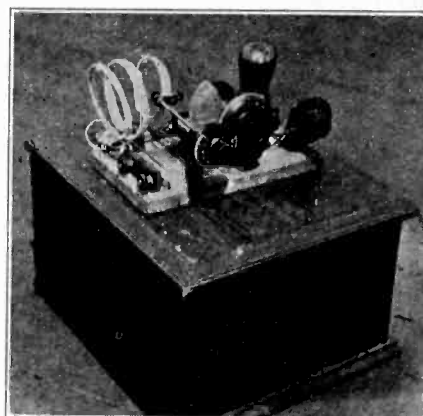

Fig. 3. Receiver for 20-50 meter wavelengths.

with a tap at the 9th turn, the nine turns being the secondary coil and the other three turns the tickler winding, which was coupled to the former. The antenna was coupled to the grid lead with four turns of heavy wire, thus acting as a condenser, as can be seen from the diagram in Fig. 4. A small choke made of 280 turns of No. 28 insulated wire was placed in the plate lead as shown, and the feedback from the plate was through a .00025 mfd. fixed condenser, making the circuit a more or less standard Reinartz.

With this receiver, especially between 4 and 9 A. M. Pacific time, signals from NXN were easily copied, although they were unsteady at times and subject to bad fading. Among the many stations copied at Honolulu were Z+AA, Canadian 3AP, 3XI, 9BM, 5GO, Porto Rico 4SA, Mexican 1XBX and hams from every U. S. district were too numerous to mention. Suffice it to say that our labor was well repaid in the results obtained, and as soon as a shore license in Hawaii can be obtained, the work will be continued.

coupled to one antenna by means of the Taylor coupling system. Schedules had been arranged with 6CGC at San Diego, before sailing, so we were able to copy him on 80.1 meters regularly every night on the way to Honolulu. During the voyage we passed through a dead spot during which the long wave receivers experienced violent fading of signals from San Francisco, the fading lasting over a period of two hours, during which time no fading was noticed on the very short waves. This dead spot is a familiar one to operators and is probably due to large deposits of ore at the bottom of the sea.

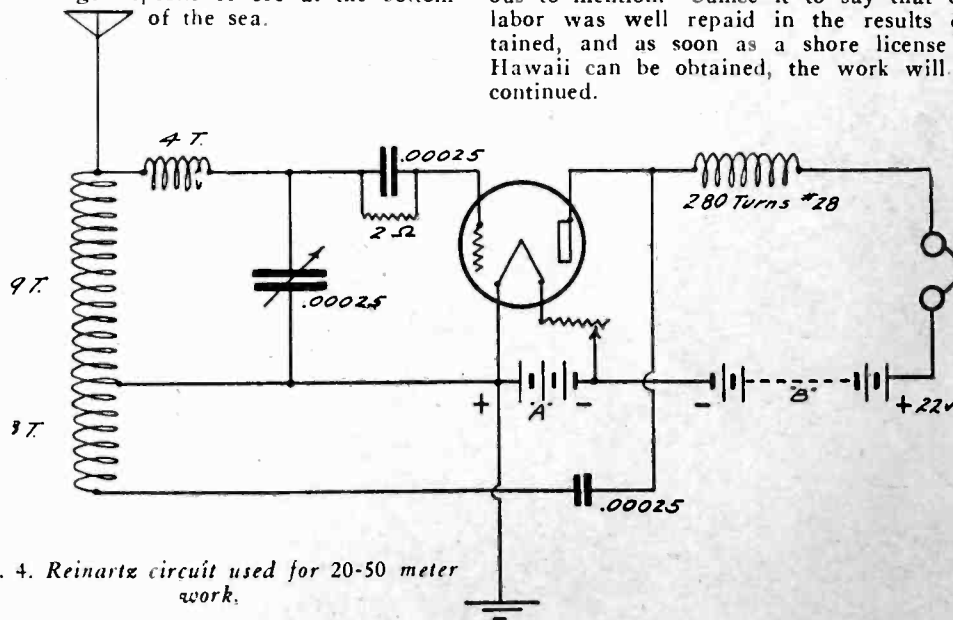

Fig. 4. Reinartz circuit used for 20-50 meter work.

With the Amateur Operators

SHORT WAVE TRANSMITTER AT 6XAD

Major Lawrence Mott, owner of Station 6XAD-6ZW, at Avalon, Catalina Island, California, is the proud possessor of a new short wave transmitter, which contains so many interesting features, and involves so great an amount of unusual short wave theory that a detailed description of the set will undoubtedly be of interest to all amateurs.

At the time of this writing the set has been in operation only two weeks and during that time, Major Mott has worked four European countries, the Antipodes, China, WNP at Labrador, and U. S. districts too numerous to mention, all on a wavelength of 40 meters. This success is principally due to the extraordinarily steady wave transmitted, together with the fine antenna ground system which has been designed especially for the new transmitter.

In the picture can be seen the transmitter proper, at the extreme left, in the center the 5 to 100 meter Townsend receiver and at the right the power panel. The transmitter is similar in principle to the one installed on the yacht ELOISE, a description of which is given elsewhere in this issue, except that two 250 watt tubes operated from 60 cycle a. c. supply are used instead of one 50 watt tube.

Referring to the circuit diagram in Fig. 1, the two Western Electric tubes are coupled in a reversed feedback circuit, to an antenna-ground system, the tuned circuit being mounted on the wall above the transmitter. The filaments are excited by a separate filament lighting transformer, which supplies 13 volts A. C. to the two filaments in parallel. The plate supply is obtained from a standard 4000 volt pole transformer, which is center tapped.

The grid and plate inductances, as well as the antenna inductance, are made of heavy copper tubing, silver plated, and arranged so that coils of different values of inductance can be substituted if desired. The antenna is tuned with two General Radio lab standard air condensers, and radiation meters are placed in both the antenna and ground leads.

The arrangement of the oscillator system is somewhat different from that ordinarily used, a theoretical diagram being shown in Fig. 2. Steadiness of frequency is of extreme importance in transmission, and for this reason, Mr. Ralph Heintz, who designed and built the station, made the inductances

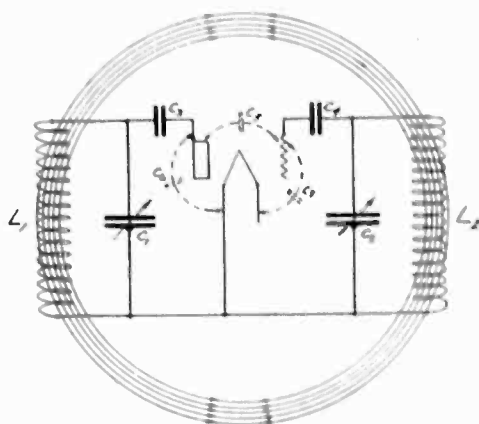

Fig. 2. Theoretical Circuit of Oscillation.

relatively small and the capacities correspondingly large, so that parasitic capacities have practically no effect on the closed circuits.

For instance, circuit L_1C_1 practically determines the frequency at which the set will oscillate and is hardly affected by the grid

or antenna circuits. Likewise, the grid circuit L_2C_2 is not appreciably affected by the plate circuit so that the former becomes a controlling factor as regards the output of the set, depending upon its approach to resonance with L_2C_2 . This is contrary to what takes place when the same circuit is used on long waves, in which case the grid circuit becomes more of a factor as regards frequency and the plate circuit as regards output.

This is easily explained when it is considered that in this circuit, or its modifications, the internal capacity of the tube itself becomes the medium for transferring energy from the plate circuit to the grid circuit, to effect grid excitation in the right proportion for efficient oscillation. This internal capacity is fixed and when used on the lower frequencies is not capable of transferring as much energy as when used on the higher frequency now used by amateurs. As a matter of fact, at these high frequencies, the feedback through the tube is too great and must be partially neutralized, accomplished by coupling L_1 with L_2 so that the fields are opposing and the inductive feedback is in the reverse direction, as shown in Fig. 2.

Now as we are concerned with a fairly narrow band of frequencies corresponding

(Continued on Page 64)

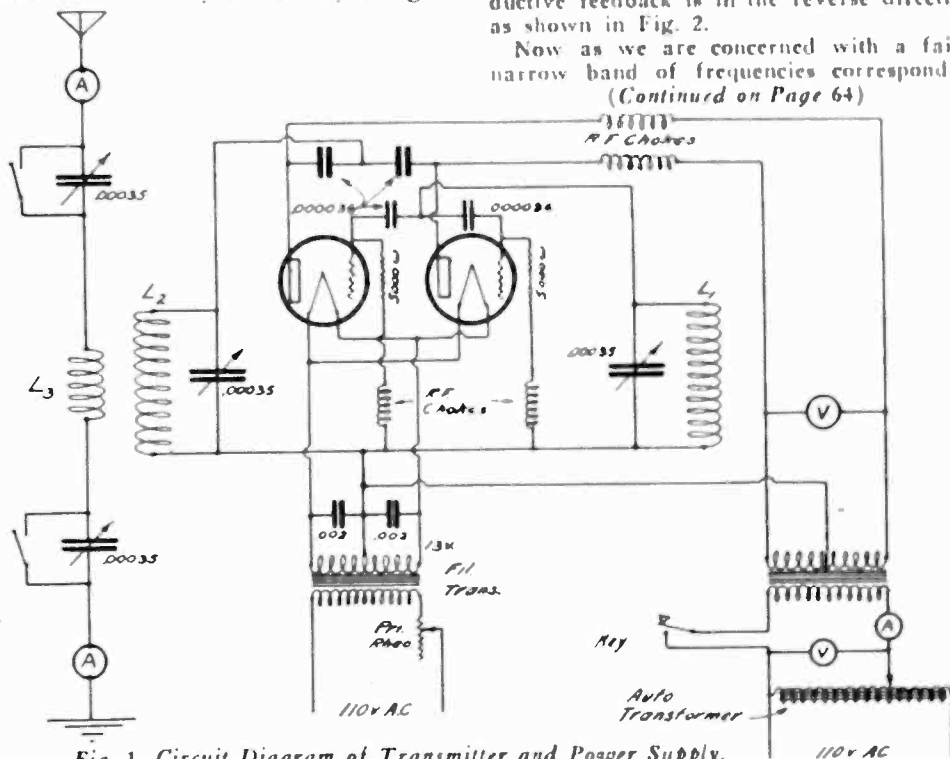

Fig. 1. Circuit Diagram of Transmitter and Power Supply.



New 500 watt, 5-80 meter Installation at 6XAD-6ZW

STATION 8ASE, 8AXG, ELM GROVE, W. VA.

This station was designed and constructed by S. Edward Pence, and from the picture it can be seen that an elaborate layout of apparatus is employed. Two transmitters are now in operation and a third will soon be added, the transmitter shown in the upper right hand corner of the picture operating on 155 meters, the antenna current being $6\frac{1}{2}$ amperes. The 500 watt tube operates on a wave of 79 meters, and is of Telefunken manufacture. Both transmitters use the loose coupled Hartley circuit, the plate voltage being supplied from either a kentrion rectifier system or a motor generator set.

Four receiving sets of various makes furnish efficient reception on all wavelengths, a Hartley circuit receiver being used for the waves from 40 to 100, and a 1BGF tuner being employed on the waves from 80 to 200 meters. By means of a wavemeter, which is shown at the right end of the table, a careful check of the transmitter wave is to be had.

The antenna is a three wire fan, with a four wire fan type counterpoise placed directly underneath the antenna. The fundamental wavelength is 155 meters. This station has been heard in many foreign countries and it can be seen from the cards that all American districts have been worked. Any foreign amateurs desiring an 8x10 photo of this station, for wall paper, can have same by sending a report of the stations signals.

RADIO STATION 9EGU

Station 9EGU is owned and operated by Cy L. Barker at Henning, Minnesota. The transmitter uses one UV203-A, 50 watt tube, operating on the lower wave bands of 20, 40 and 80 meters. The well-known inductively coupled Hartley circuit is used and performs very efficiently at this station. A borax chemical rectifier of 50 jars is used to furnish power to the plate of the tube, in connection with a 50 henry-4 mike "brute force" filter which gives a fine pure d. c. note when desired.

The tuner is built on the order of Schnell's set, and uses -2 tubes—detector and 1 step a. f. All U. S. States have been worked, and all Districts in the U. S. and Canada. Signals from this station have been copied in Cook Inlet, Alaska, and such points as Mexico City, Mexico; San Jose, Costa Rica;

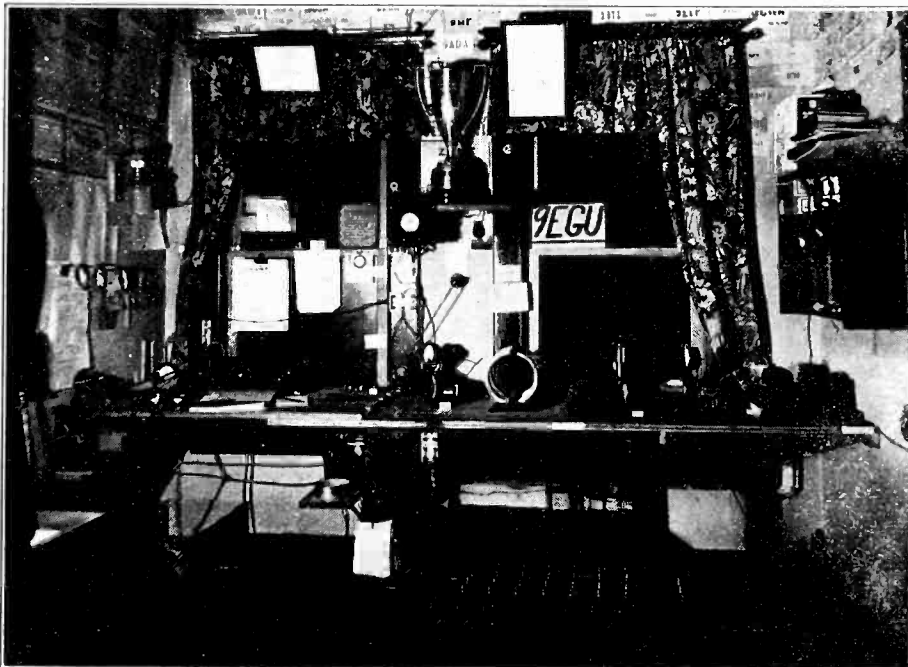

Radio Station 9EGU

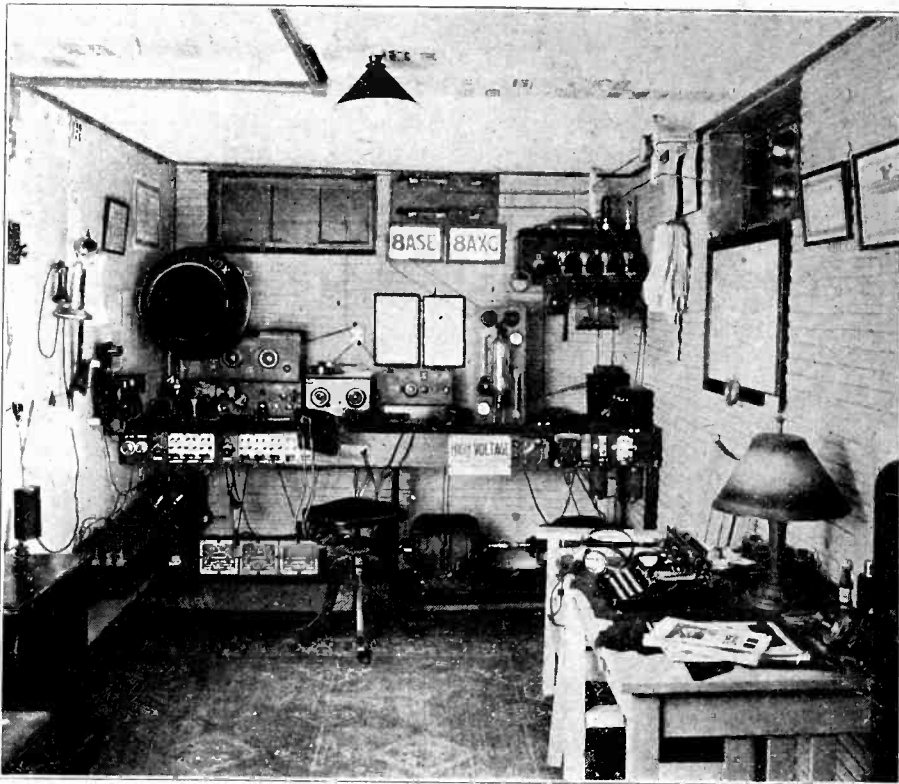

Radio Station 8ASE, 8AXG

and Sydney, Australia have been communicated with.

9EGU holds appointments as official relay station, broadcast station, railroad emergency station, official wavelength station and city correspondent, as well as being a member of the ARRL Experimenter's Section. This station is now the office of assistant division manager for Minnesota, of the Dakota Division, ARRL. 9EGU's main working wave is 38 meters, and he will be found on that wave the greatest part of the time.

NEWS OF THE AMATEUR OPERATORS

Call 6BWS has been re-issued to Russ Shortman, 1617 E. Van Buren St., Phoenix, Ariz.

7DE, Leo H. Machlin, Cordova, Alaska, will handle Alaskan traffic. Glad QSO anybody any time on 40 and 80 meters.

6 BUR, 340 No. Painter Ave., Whittier, Calif., will QSR traffic to pi 1 HR in the Philippines. He recently worked NUQG on 40 meters off Shanghai.

2AHK, Nelson Parker, has moved from Poughkeepsie, N. Y., to 554 So. Clinton St., East Orange, N. J., using 50 watt on 40 and 80 meters; all cards QSL'd.

D. Cordray, 1st operator at 8ATX will be on the job early in September after visiting many stations around Los Angeles. A 50 watt on 20 and 40 meters is contemplated.

3PY has been re-assigned to Francis Richardson, 507 South Orange Street, Media, Pa., who will appreciate reports of his signals on 175 and 41 meters.

U-6EA, H. C. Seefred, 343 South Fremont Avenue, Los Angeles, Calif., has been reported on 40 meters by 0-A4M, S. C. Pleass of Johannesburg, South Africa while U-6EA was working A-3BD of Melbourne, Australia. His signals were heard in Africa at 3:53 p. m. while he was working from 5:20 to 6:25 PST in California. Going west, the distance is 14,130 miles from Los Angeles to Johannesburg, most of the intervening space being in darkness. Going east, the distance is 9,010 miles, with daylight at both ends. During the same period 6EA was also heard by J. Watson of Perth, West Australia.

NEW RADIO CATALOGS

Burgess Battery Co. has published two new engineering circulars. No. 6, by W. B. Schulte, discuss the use of dry cell batteries for plate voltage of radio transmitting sets. No. 7, by V. H. Hoffman, illustrates and describes the No. III short wave radio receiver of 9XH-9EK.

Marshall-Gerken Co. have discontinued the manufacture of "Read 'em" binding posts because of the recognized validity of the patent recently granted the H. H. Eby Mfg. Co., who will hereafter take care of their orders.

CALLS HEARD



Pittsburgh, Penna

"8JQ," 2711 Espy Avenue, Dormont,
 6aak, 6aam, 6aao, 6ab, 6abe, 6abs, 6ac, (6adt), (6afa), (6afg), 6age, (6agk), 6agw, 6ahp, 6ahq, 6aib, 6aji, 6ajq, (6ajr), 6akw, (6alf), 6alw, 6ame, 6amf, 6amm, 6amo, (6ano), (6anq), 6aoe, (6apw), 6aqg, 6ary, 6ase, 6asv, 6atn, (6auf), 6aut, 6avj, (6awt), 6bab, 6bas, (6bbq), 6bcn, (6bcs), 6bdv, 6bez, (6bfw), (6bge), (6bgi), (6bgv), (6bh), 6bho, (6bhj), (6bik), 6bil, (6bir), (6bis), (6bjd), (6bjj), 6bjx, 6blw, (6bmo), 6bmw, 6bnu, (6bol), 6bpf, 6bql, 6br, (6bsn), (6btl), (6btm), (6btx), (6bui), 6bur, 6buw, 6bve, 6bwy, (6cae), (6caq), (6cct), (6ccv), 6ccy, (6cdg), 6cdn, 6cdy, 6cej, 6cfe, (6cgc), 6cgo, 6cgv, 6cgw, 6chl, (6chs), 6chx, 6chz, 6cig, 6cix, 6cjj, (6cka), 6cku, 6ckw, 6clp, (6clv), (6cmd), (6cmg), 6cmq, 6cms, 6cmf, (6cmu), 6cnc, (6cnk), (6cnl), 6cnm, 6cnn, 6cnp, 6cqd, (6cqe), (6crr), 6crs, 6crx, 6csi, 6cso, (6css), 6cte, 6ctn, (6cto), 6ctx, (6cty), (6cub), 6cuc, 6cuq, 6cvf, (6cvk), 6cvm, 6cwi, (6dah), 6dal, 6dan, 6dao, 6dax, (6dbh), 6cv, 6cw, 6dh, 6ea, 6eb, (6ew), 6ex, 6fa, (6fh), 6fy, 6gg, (6gt), 6hm, 6ih, 6il, 6im, 6ir, (6iv), 6ja, 6ji, 6jp, 6jy, 6kb, 6kr, 6lj, 6lv, 6mg, 6mw, 6no, 6now, 6oe, 6pl, 6py, 6qd, (6qi), 6rf, (6rn), 6rv, 6sb, 6ti, (6ts), 6ua, 6uc, 6uf, 6uo, (6ut), 6vs, (6vd), 6vf, 6vt, (6vw), 6wp, (6ws), 6xad), 6xg, 6xo, 6yb, 6zap, 6zbn, 6zh.

(7abb), 7adm, (7afo), 7agi, 7agz, 7ahs, (7aib), 7aif, 7aip, 7aiv, (7ao), 7ay, 7bj, (7cy), 7dd, 7df, 7dj, 7dx, (7ec), 7fj, 7fq, 7fr, (7fv), (7gb), (7gi), (7gm), (7ih), 7ij, 7jh, 7ku, (7lh), (7lr), (7ls), 7mf, (7mi), (7mp), 7mx, 7nh, (7nq), 7nt, 7nx, (7ob), 7qd, 7qu, 7rl, 7sb, (7si), 7sl, 7sy, (7uj), 7uq, (7uz), 7vn, 7wm, (7wu), 7ya, 7zz).

Mexico—1a, 1aa, 1af, (1b), 1j, 1k, 1n, 1x, (bx), 9a. British—2cc, 2dx, 2fu, (2jf), 2kf, 2kz, 2nb, (2nm), 2od, 2rb, 2sz, 2wj, 5dh, 5lf, 5nn, 5ma, (5pu), 5rz, 5uq, 5xn, (6lj), 6nf, 6td, (6tm). French—8ab, 8ba, 8bo, 8cp, 8dl, (8go), 8gp, 8fq, 8gm, 8sm, 8ssc, 8tk. Holland—Pc-1, o-nl, o-bq, o-ba, o-ll. Denmark—7bn, 7ec. Spain—E-ar6, e-ar2. South America—Cb8, wjs. Belgian—3ad. Australia—2ay, 2bk, 2cm, 2ds, 2ij, 2yg. New Zealand—(2ac), 2cp, 2xa, 4ak, (4ar).

At 2BRB, Brooklyn, N. Y., during June on 40 meters

U. S. A.—4cu, (4km), 4pz, (4rl), 4sa, (5ac), 5afd, 5agl, 5apu, 5ati, 5atv, 5ce, 5dx, 5er (5hy), 5lg, 5ov, 5sa, 5wi, 5zai, 5zas, 5sv. (6afg), (6agk), 6ahp, (6ajm), (6av), (6bgz), 6bhg, 6bji, 6bny, (6bqr), 6cc, 6cej, 6cgo, (6cgw), 6chh, 6cig, 6cmu, 6cpf, 6cto, (6css), 6cub, 6eb, 6dah, 6dat, 6fa, 6hu, (6jp), 6lj, (6qi), 6ts, 6vc, 6xg, 9adr, 9ajo, 9apm, (9bca), 9bek, (9beq), 9bhl, 9bnd, (9bpb), 9bu), (9bzg), (9chu), 9cuo, 9exc, 9dbz, 9dfj, 9diq, 9dng, 9duq, 9egg, 9fj, 9hn, 9hp, 9ka, 9kb, 9mm, 9nm, 9oo, (9zk). Australian—(2ay), (2bb), (2bk), 2cm, (2ds), (2ij), 2rj, (2yl), 3bd, 3bq, Bermuda—ber. Canada—2au, (3fc), (3tv), 4gt. French—(8qq). Mexican—1aa, 1b, 9a. New Zealand—(2ac), 2ae, (2xa), 3ad, 4ag, 4ak. Porto Rico—(4rl), 4sa. Others—nrri.

By 6CWP-BUX, 1485 E. Fifth Ave., Pomona, California, for June 40 meters

1asf, 1yb, 1xz, 2bbx, 2brb, 2cnk, 2qs, 3jw, 4cu, 4gy, 5ac, 5amb, 5afd, 5aee, 5ail, 5apu, (5ame), 5atk, 5alu, (5lg), (5vl), 5nj, 5amw, 6zac, 7cw, (7pz), (7ya), 7uz, 7fb, 7dd, 7uj, 7ku, (7yk), (7nx), (7nt), 7pp, 7wu, (8jj), 8do, 8bu, 8pl, 8nx, 8chc, 8buk, 8apw, 8dtr, 8xc, 8eq, 8qz, 8eb, 9dfh, 9cxx, 9ell, 9dbz, 9mm, 9hml, 9oo, 9bdr, 9apm, 9eak, 9dcg, 9ek, 9cft, 9bkr, 9dfj, (9cld), 9arf, 9bht, 9wo, 9duc, 9ayp, 9baf, 9adr, 9caa, 9dac, 9bkb, 9bsz. C5eu, c9ck, mlaa, nkf, (nrri). 20 meters 1pl, 7sf, 9ape, nrri, (6bil). Qrk my 5 watter.

By H. C. C. McCabe, 71 Holloway Rd, Wellington, New Zealand, May 1-31st, 1925

1yb, 1xu, 1xav, 1cmp, 1pl, 1oj, 1aa, 1zn, 2ov, 1cxw, 2agw, 2wc, 2rm, 3il, 5ag, 5ox, 5aah, 6baq, 6cms, 6dah, 6bsn, 6cls, 6cqe, 6oni, 6hm, 6zac, 6bmw, 6awt, 6chl, 6avj, 6vw, 6cmu, 6ql, 6cig, 6cto, 6bjj, 6cix, 6agk,

6ji, 6bbv, 6dh, 6rn, 6ur, 6cqx, 6cc, 6aol, 6cgo, 6bgo, 6zbn, 6bsc, 6ac, 6xh, 6vc, 6aws, 6clp, 6cub, 6cej, 6ahp, 6ea, 6csw, 6aji, 6ts, 6km, 6com, 6wd, 6xg, 6age, 6cst, 6alf, 6uf, 6no, 6xag, 6bh, 6cgw, 6bh, 6opu, 6qd, 6cvm, 6buc, 6chz, 6css, 6bur, 7df, 7ym, 7dc, 7kk, 7rl, 7ay, 7gj, 7pz, 7gb, 7ya, 7nh, 7ku, 7adm, 8aly, 8gu, 8bwb, 8bf, 8jj, 8bu, 8brc, 8er, 8rv, 8gdp, 8zu, 8avl, 8nx, 9og, 9bvh, 9eas, 9dum, 9cld, 9ig, 9ado, 9dps, 9edb, 9bdu, 9cfl, 9dqu, 9xi, 9bht, 9dct, 9dat, 9clj, 9bkr, 9sr, 9ded, 9cdw, 9oo, 9cul, 9dge, 9abc, 9dps. Canadian—5ba. Argentine—Cb8. Others—Nrri, nkf. Will gladly confirm by card any of above.

By 6CIX, 317 N. Friends Ave. Whittier, Calif.

1aao, 1ahl, 1cmx, 1fx, (1ka), 1wr, (1yb), 2bbx, 2brb, 2cdu, 1cty, 4cu, (4fw), 4mw, 4sa, (4ux), (8ahm), 8afs, 8ayy, 8bau, 8biq, 8chk, (8cyl), (8do), (8djf), (8dsc), (8eq), 8gz, 8uk, 8ze, 6asr, 6cst, (6dcf), ytg, (6zac), nrri. Argentine—ah2. Australia—2bc, (2bk), 2cm, 2ds, 2ij, 2rj, 2tm, 2yi. Japan—(1aa). Mexico—1b, 9a. New Zealand—(1ao), 2ac, 2ae, 2ak, 2xa, 3dt, 4ak. Miscellaneous—1hvt, zhc.

By Albert E. Searlett, Jr., 23 Cooley Place, Mount Vernon, New York

U. S.—6aak, 6afg, 6agk, 6ahp, 6aji, 6ajq, 6alf, 6awt, 6bmw, 6bur, 6ccv, 6cjj, 6cgw, 6chs, 6cls, 6cpl, 6cto, 6cub, 6dah, 6gi, 6mc, 6no, 6qi, 6rw, 6ts, 6ut, 6vc, 6xag, 6xg, 7ay, 7gb, 7uz, kel, npq. Mexico—1af, 1k. Cuba—2lc. England—2kf. Italy—1ev. France—8do. Bermuda—ber. Brazil—1ab, 2sp. Off Newfoundland—wnp. Hawaii—nrri. Porto Rico—4je, 4kt, 4rl, 4sa. Samoa—6zac. New Zealand—2ac, 2ae, 2xa, 4ar. Australia—2 bk, 2cm, 2ds, 2yg, 3bd. All heard on 1 audio and 80-foot indoor antenna.

At SATX, Canton, Ohio

(6chl), 6cmu, 6cix, 6crx, (6xad), 6xat, (6zz)?, 6zh? Seventh District—7abb, 7afo, 7afp, (7df), 7fq, 7gr, (7cu), (7ls), 7qr, 7gj, 7mf, 7zu, 7zo. English—(2cc), 2kf, 2kz, 2mk, (2od), (5gf), 5nn, 5xx, 6gh, 6nf, (6lj). French—8df, (8dq), 8soc? Canadian 1dd, 1dr, (2ju), 2bn, (2ku), (3gl), (3gg), (3ka), (3xx), (3acf), (3fs), (3nm), (4hh), (4xx), (5ba), (5gi). Australian—3bq, 2yi, 2ay, 2bk. New Zealand—1ao, *4aa, *4ak. Spanish—(ear 2), ear6. Italy—(1ler), acd. S. A. wjs, ch-8-ch9tc. Cuban—ber, 2mk. Special—Nrri, qsa, vy, wnp, nkf, wgh, wir, wiz, kdka, nat. For cards qsl to Donald Cordray ex-8atx, box 1226, station C, Los Angeles, Calif., these stations wkd and hrd fm Canton, Ohio, where 8atx was located—73's.

By 2-BUY, Bradley Park, N. J.

(4af), 4ask, 4bl, 4cu, 4du, 4jr, 4oa, 4pz, 4rm, 4rr, 4sh, 4tv, 4ua, (5ac), 5amw, 5aom, 5atx, (5hi), 5lg, (5nq), (5ph), 5sz, 5ty, (5wi), 6agk, 6bmw, 6chz, 6crs, 6csa, (6css), 6li, 6lj, 6xg, 7uj, (8adm), (8aub), (8bbl), (8bhj), (8bkm), (8ccw), (8dal), (8qj), (8rv), 9ado, 9ajj, 9aud, 9bdw, 9bht, 9bmx, (9buj), 9bxq, 9caa, 9cdv, 9crr, 9cxx, 9deg, 9dka, (9dwz), 9eas, (9db), 9es, 9ff, (9ra), 9di, (9sn), 9uq, (9wo). Canada (1am), (1ar), 2be, (3ae), (3en), 3tf, 3tv, p, r, 4kt, (4oi), 4rl, 4sa. Bermuda—B. e. r. Mexico—1ag. Brit.—5dh???. Misc.—Fox, wnp, (nkf), npg, qra? Would appreciate cards from station worked es station hearing my sigs on 39 meters. All cards answered!!!!

By 6EB, Lyndon F. Seefred, 343 So. Fremont Ave., Los Angeles, Calif. 70 to 100 meters

1aao, 1abf, 1ach, 1ad, 1af, 1ajx, 1all, 1ary, 1ban, (1bbe), 1bei, (1bes), 1bhv, 1bhb, 1bv, (1cab), 1cmp, 1cpc, 1er, (1fb), 1fd, 1gs, (1hn), 1id, 1kc, 1ow, 1qm, 1rd, 1se, 2aay, (2adk), (2ag), 2agh, 2agi, (2ana), 2azy, 2bck, 2bkr, 2bqa, 2br, (2brb), (2bse), 2by, 2cee, 2cg, (2cgl), 2clg, (2con), (2cpa), 2cpd, 2cqz, 2cty, 2cvw, 2cxw, 2exy, 2czr, 2dd, 2gk, 2ke, 2kf, 2kx, 2le, 2mu, 2pd, 2rk, 2wd, 2wl, 2wr, 3ab, 3ach, 3aew, 3aky, 3ash, 3bdo, 3bg, (3bnu), (3bpb), 3bta, 3btq, (3bva), (3bwj), 3cc, (3che), 3chg, 3cjn, 3cjt, 3dh, 3gb, 3hg, 3hh, 3hj, 3kg, 3kq, 3lg, 3ll, 3lw, 3nf, 3oe, 3sf, (3te), 3ue, 3ws, 4bq, 4dm, 4do, (4dv), 4eb, 4eh, 4fg, 4fm, 4fz, 4gw, (4io), 4jr, 4ku, 4my, 4oa, 4pn, 4sb, 4tj, 4ua, (5aaq), (5ab), 5acl, 5acz, 5ado, 5adz, 5aec, 5aex, 5afd, 5afn, 5afu, 5agq, 5ahd, 5ahw, 5ajj, 5ail, 5aiu, 5aja, 5ajb, 5ajh, 5ajj, 5akf, 5akn, 5akw, (5aky), 5akz, 5am, 5ame, 5amh, 5amu, 5amw, 5aph, 5apm, 5apt, 5aqw, 5aqy, 5as, 5asv, 5asz, 5atp, 5atu, 5atx, 5aul, 5aur, 5ayw, 5bg, 5bp, 5bx, 5bz, 5ca, 5ce, (5ck), 5cn, 5cp, 5cv, 5dm, 5dw, 5ew, 5gk, 5hd, 5hl, 5hl, 5hp, 5hs, 5im, 5in, 5jf, 5ka, 5kc, 5kk, 5kq, 5lg, 5lh, 5ll, 5lj, 5lr, 5ks, 5lu, 5mf, 5mi, 5mp, 5nj, 5nw, 5oq, 5ot, (5ov), (5ox), 5ph, 5py, 5qs, 5qw, 5qx, 5qy, 5rg, 5sd, 5se, 5ty, 5uj,

5uk, 5un, 5wg, 5wo, 5wy, (7abb), 7ac, 7acm, (7acy), 7adf, (7adm), (7afn), 7afo, 7aji, 7ajy, 7agn, 7agz, (7aif), 7aip, 7ajl, 7ajv, 7ajy, 7akk, 7ald, 7all, (7ao), 7av, 7bj, 7bm, 7cw, 7dc, 7dd, (7df), 7di, (7dj), 7dx, 7ec, 7eo, 7ex, 7fd, 7fj, 7fm, 7fq, (7fr), 7gb, 7gc, 7gj, 7gq, (7gr), 7gs, 7gv, 7gy, 7ij, 7iu, 7jm, 7jq, 7js, 7iv, 7jw, 7kc, 7kf, 7kq, 7kr, 7ku, 7lh, 7lj, 7lq, (7lr), 7ls, 7ly, 7mf, 7nh, 7nx, 7ok, 7ot, 7oy, (7pm), 7qc, (7qd), 7rh, 7rl, 7ry, 7sb, 7se, 7sf, (7sp), 7sv, 7to, 7ub, 7uj, 7un, (7uq), 7us, 7vg, 7vn, 7vu, 7vw, (7wuj), 7wm, 7zw, 8aa, 8abm, 8abs, 8aci, (8acm), 8acy, (8ada), (8aes), 8agp, 8ah, 8aly, 8ame, 8apr, 8aro, 8aub, 8avd, 8avl, (8awa), 8ban, (8bau), 8bbf, 8bch, 8ben, 8bf, (8bit), (8bk), 8bkh, 8blr, 8bnh, 8bpa, 8bpm, 8bpr, 8bqa, 8btl, 8bxh, 8byf, 8byn, 8cbp, 8cc, 8cdt, (8ced), 8cei, 8cjp, (8cko), 8coy, 8cp, 8cpy, (8ced), 8cva, 8cwu, 8cyl, 8czy, 8dae, 8dal, (8cud), 8cva, 8cwu, 8cyl, 8czy, 8dae, 8dal, 8dgo, (8dgp), 8dgv, 8do, 8doo, 8dpq, 8dse, 8dvw, 8dzz, 8eb, (8gz), 8jj, 8kc, 8ln, 8pl, 8qy, 8rv, 8ry, 8tc, 8uf, 8up, 8vc, 8wa, 9aaw, 9abf, 9aby, 9ach, 9aca, 9adg, 9ado, 9adq, 9afr, 9afz, 9agil, 9aim, (9aki), 9alt, 9amb, 9amj, 9amm, 9amq, 9amx, 9and, 9aob, (9aod), 9aol, 9ape, 9apm, 9asw, 9ato, 9auy, (9avv), 9awa, 9axs, 9axx, 9ays, 9azp, 9bbw, 9bcd, 9bch, 9bcj, 9bcy, 9bdf, 9bdh, 9bdu, 9bdw, 9beo, 9beu, 9bf, 9bfi, 9bfp, 9bfr, 9bfx, 9bgh, 9bhb, 9bht, 9bhy, 9bib, 9bjl, 9bjk, 9bjl, 9bkb, 9bkk, 9blk, 9blz, 9bm, 9bmk, 9bml, 9bmv, 9bmx, 9bnk, 9bnt, 9bov, 9bol, 9bpy, 9bsz, 9btz, 9buo, 9buo, 9bvy, 9bw, 9bwb, 9byg, 9byv, 9bz, 9ca, 9cbf, 9ccm, 9cdo, 9cdq, 9cdv, (9cea), 9ced, 9cee, 9cfc, 9cfj, 9cfs, 9cfy, 9cga, 9cgh, 9che, 9cii, (9cip), 9cjc, 9cju, 9ck, 9clb, 9eld, 9clq, 9co, 9coc, 9cou, 9cov, 9cpm, (9csg), 9ctd, 9ctr, 9cur, 9cuv, 9cyl, 9cvo, 9cvs, 9cy, 9dac, 9dbf, 9dbz, 9ddp, 9ded, 9deo, 9dev, 9dfh, 9dfz, 9dga, 9dgv, 9dhh, 9dhq, 9dhs, 9dkv, 9dme, (9dmj), 9dmz, 9dng, 9dps, 9dpx, 9dqu, 9dtk, 9dtl, 9dun, 9dvi, 9dvw, 9dwx, 9dxn, (9dxy), 9dyi, 9eae, 9eam, 9eas, 9ee, 9eeb, 9eep, 9efh, 9efy, 9efz, 9egh, 9eht, 9ei, 9eib, 9eih, 9eky, 9elb, 9eli, 9ell, 9em, 9en, (9er), 9es, 9ea, 9hn, 9hp, 9ig, 9ih, 9iw, 9iz, 9mi, 9mm, 9na, 9nm, 9on, 9pb, 9qy, 9rt, 9sb, 9sr, 9vc, 9vd; (1xam), 1xj, 1xm, 1xz, 1yb, 1zt, (2xbf), 2xq, 2za, 2zb, 3xm, 3yo, 4xe, 5xa, 5xau, (5za), (5zai), 5zas, 5zav, 5zh, 7zf, 7zn, 7zq, 7zz, 8xaf, 8xe, 8xv, 8yj, (8ze), 8zz, 9xbg, 9xpb, 9xe, 9xi, 9xt, 9za, 9zak, 9zb, 9zd, 9zk, (9zt), 9zy.—Canadian: (3ni), 3acu, (4cr), 4io, (4dq), 4fn, (4gt), 4eo, 4fv, 5go, (5an), 5bz, 5ba, (5gf), 5ef, 5ct, (5ak), 5hs, 5bo, (5hc), 5hh, 5af, 5bl. United States—2xd, wgh, nkf, (nqg), nfv, (npg), ket, kgi, kel, nek-1. Mexico—1b, (bx), 9a, (1aa). Porto Rico—4sa. French-Indo-China—hva. New Zealand—4ag. France—uft (2 step and loud speaker on lamp cord antenna). Brazil—ux8, (wjs). 2 step and loudspeaker on lamp cord antenna.

All of the above, except the last two, were copied on a low loss tuner with 1 or 2 steps of amplification and a cage antenna hanging from a 101 ft. pole, and no ground. Have printed cards for any of the calls mentioned if they will write and give me their correct address.

By J. G. Tinney, 74, Kainni Rd., Hataitai, N. Z.

U. S.: 1ax, 1pl, 1te, 1aao, 1anq, 1bcc, 1cki, 1cmp, 1xua, 1alw, 2ha, 2lu, 2qh, 2rm, 2zv, 2bee, 2brb, 2xaf, 3hg, 3il, 3bva, 3dek, 4dm, 4tv, 5iw, 5mi, 5nj, 5oq, 5ov, 5uk, 5acl, 5ajh, 5apu, 5atv, 6cc, 6eb, 6fa, 6ji, 6jp, 6km, 6nb, 6ns, 6nx, 6ts, 6xg, 6no, 6ahq, 6aji, 6aol, 6awt, 6bhl, 6bh, 6bjx, 6blz, 6bmw, 6buc, 6bur, 6eck, 6ccy, 6cgw, 6chs, 6cnc, 6cso, 6ess, 6cto, 6cvm, 6dcf, 6xad, 6zac, 7gb, 7gi, 7mf, 7ya, 7nt, 8do, 8eb, 8gz, 8lp, 8pl, 8ry, 8zf, 8apw, 8bfw, 8ced, 8chk, 8cht, 9ek, 9og, 9uq, 9wo, 9xw, 9zt, 9aao, 9akf, 9apm, 9baj, 9bht, 9crr, 9ddf, 9dct, 9ded, 9dfh, 9fw, 9dpx. Argentina: cb8. Canada: 5ba, 5gt. England: 2lz, 2nm, 2od. France: 8bv, 8co, 8ct, 8qq, 8yor. Italy: 1er, 1rg. Mexico: 1aa, 1b, 9a, xda. Sweden: smyy. Porto Rico: 4sa. Brazil: wjs. Hawaii: fxl, 3ze, 6asr. Misc: 1ab, (bz), 2sp, (bz), 1pz, nkf, nrm, nrri, wiz. Australia: 2at, 2bb, 2cm, 2bd, 2bk, 2ds, 2hm, 2hs, 2ij, 2me, 2rj, 2js, 2yi, 2zn, 1an, 3bm, 3bp, 3bq, 3ef, 3fm, 3lp, 3ze, 4an, 4wb, 5bd, 5kc, 5wj, 7aa, 7cs, 7gd, 7om, 7pf, 7rb.

By R. W. Mintrom, 62 Barton Street, Woolston, Ch. Ch, New Zealand.

1aao, 1py, 1te, 1xz, 1yb, 2brb, 2cgl, 2cxw, 2xaf, 3il, 3oc, 4cu, 5ew, 5nj, 5ov, 5uk, 5wi, 5zal, 6ahy, 6ahp, 6awt, 6age, 6agk, 6ajm, 6afg, 6ac, 6bh, 6buc, 6bmw, 6cet, 6cmu, 6cej, 6cgw, 6ccy, 6ccw, 6cst, 6chs, 6cub, 6cso, 6eb, 6ew, 6jp, 6ji, 6km, 6no, 6rw, 6ts, 6xg, 6zbn, 7gj, 7ls, 7ya, 8apw, 8ayy, 9afu, 9aey, 9bpb, 9ocs, 9eky, 9eli. Canada: 1ar, 4gt. Mexico: 1aa. England: 2lz, 2nm, 2kf, 2od. France: 8bv, 8ct, 8fq, 8qq. Italy: 1er, 1rg. Chile: 9tc. Brazil: wjs. Argentina: 1pz, Tutuila, Samoa: npu, 6zac. Special: nkf, nrri, wgh, wiz, kel, kio, kdka (music), lox (eritrea). All crds Q.S. led.

(Continued on Page 48)

FROM THE RADIO MANUFACTURERS

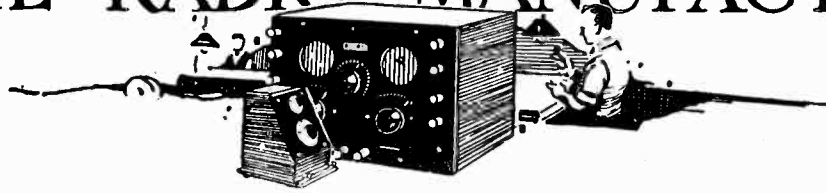

The B. M. S. verni-juster dial is a new unit which can be attached to any standard condenser or other tuning shaft without the

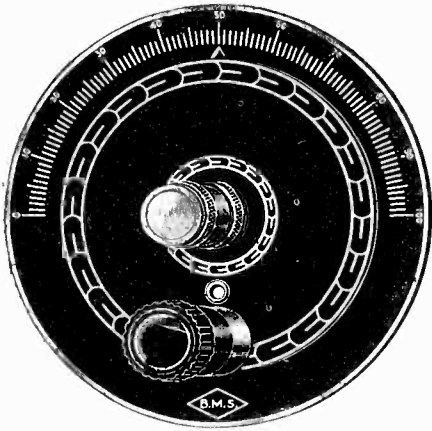

use of tools. It is merely necessary to unscrew and fasten a knurled cap. The entire device is of metal, insulated from the shaft by ingenious bushings.

The Camfield condenser is a low-loss instrument of the straight-line-wavelength type. It is distinguished by an ingenious and effective plate movement, a very low minimum capacity, and a gear ratio sufficient to permit its use in any radio circuit with-

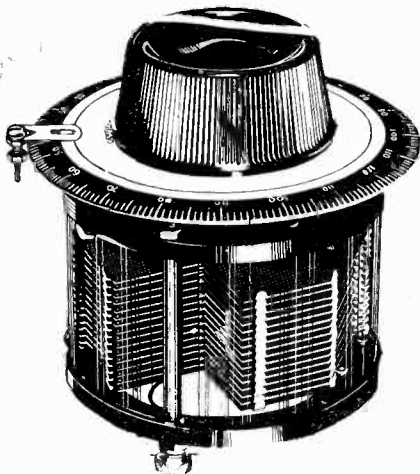

out the necessity of a vernier. It has a 360-degree dial and is enclosed in a transparent dust-proof cover. Extra paper logging dials are provided with each instrument.

The No-Dial Receiver is a compact set which is tuned by turning the cover of the instrument, its surface sufficing as a station register. The several variable con-

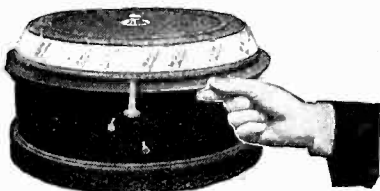

densers are adjusted by one shaft, all other adjustments either being automatic or made once for all at the factory. It is made in a five tube and in a four tube model.

The Tower Meistersinger speaker is one model of a new line of low priced loud-speakers giving an excellent quality of reproduction. It has a cast-iron base and a duraluminum horn with a goose-neck, standing 20½ inches high. Another type has a straight fibre horn with 10 in. bell, another has a 17 in. straight horn with 8½ in. and



a fourth midget model has a 5½ in. celluloid horn. All models employ an adjustable phone unit which is claimed to give great volume without distortion, this unit also being available as a phonograph attachment.

The Aalco collapsible loop is made of litz wire wound on hard rubber insulation. The wires are taut when collapsed as well

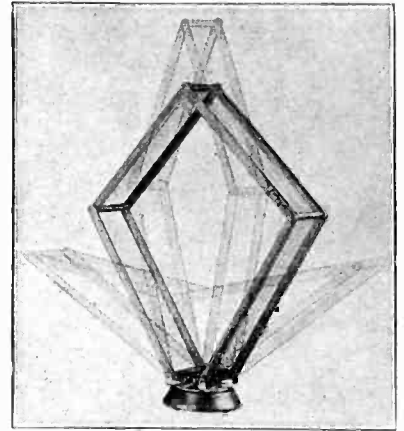

as when extended. It has three taps and a revolving base. The frame is of walnut and all metal parts are nickel-plated.

The Aerovox Grid Condenser is made in the convenient size of .00025 mfd. with spring clips for the grid leak and handy



terminals for mounting the condenser in the set. The best grade of mica is used for the dielectric and the condenser has a low internal resistance.

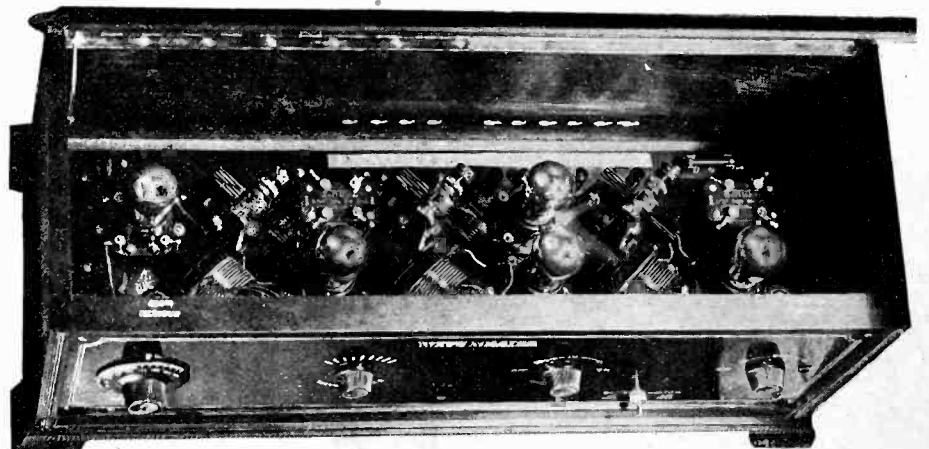

The Kellogg Wave Master is a five tube tuned radio frequency receiver with but one selector dial. This simplicity in tuning is secured without impairment of selectivity by using tapped stators for the two radio frequency transformers and the detector tuner, all the tap switches being controlled by a single knob, which selects any one of the nine 40-meter zones. The fine tuning for any station within a desired zone

is done with a single dial which operates three rotors within the above stators. All condenser settings are made at the factory and like the detector and audio rheostats need not be changed after once adjusted. The volume is controlled by the first rheostat and the oscillations by the second. Every technical effort has been made to reduce losses and to give maximum operating ability. It is designed to give best results with about an 80 ft. aerial.

Radio's Greatest Achievement

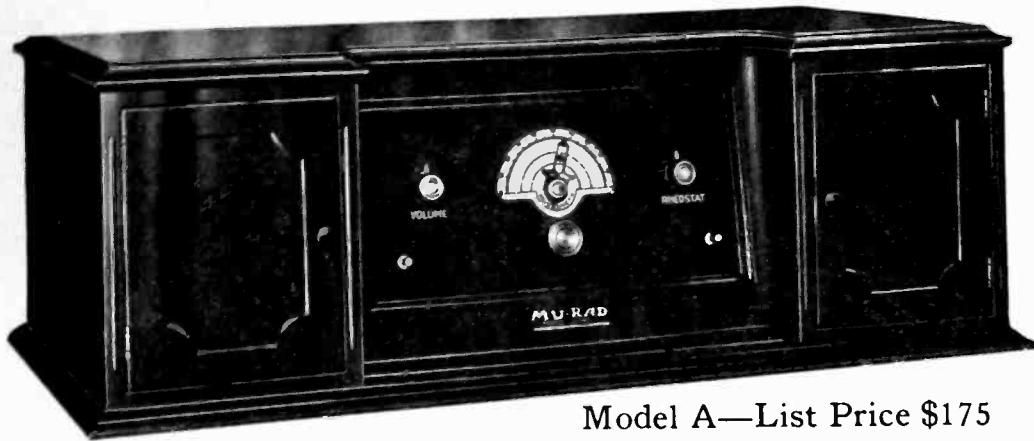

Model A—List Price \$175

THOSE persons who have delayed buying a Radio Receiver in the belief that "something newer and better" would appear, as well as those who have Radios but are not satisfied with results hitherto obtainable, will find the New Mu-Rad a revelation in the art of radio reception.

This remarkable receiver is the culmination of 8 years of study and laboratory experimentation of the Mu-Rad engineers, plus the knowledge gained by the mistakes and the progress of the entire radio industry.

The Mu-Rad Transcontinental Receiver

is a distinct advance in radio—a year or two ahead of the times. Its ideal circuit embodies two stages of tuned Radio Frequency, a Detector and two stages of Audio Frequency.

Great progress has been made by Mu-Rad engineers in eliminating lost energy in the circuit and in balancing the circuit so as to secure a degree of selectivity hitherto unknown in a Radio Receiver.

Coast-to-Coast reception all year round is made possible with this receiver and the quality of reception is extraordinary.

Ask Your Nearest Dealer for Demonstration

MU-RAD RADIO CORPORATION

Sales Office:
Newark, N. J.

Factory:
Asbury Park, N. J.

ONE DIAL CONTROL

A revolutionary feature of the New Mu-Rad is its one dial control. There is only one dial to tune. A slight movement of this beautiful Gold Finish Dial brings in one station after another—clear across the continent—without interference from local stations. The dial can be accurately "logged." Stations will always come in at the same dial setting. It's as simple as turning a doorknob.

A Child Can
Operate It

make the new

CAMFIELD STRAIGHT LINE LOW LOSS CONDENSER

"In the transparent dust-proof case"

*one of the most important
radio developments of the year!*

Here is a condenser that combines all the most advanced and proven principles of condenser construction with exclusive features of its own—such as the transparent dust-proof case, which keeps dust and dirt from the plates and makes the low-loss feature permanent.

The Camfield Condenser will add to the performance of your set and improve its looks. Ask your radio store to show you the Camfield Condenser, or write to us for name of nearest dealer.

CAMFIELD RADIO MFG. CO.
807 Harrison St. Oakland, Calif.

\$6.00
Complete
WITH DIAL
Sub-Dial and Marker

See Our Exhibits at San Francisco and Los Angeles RADIO SHOWS

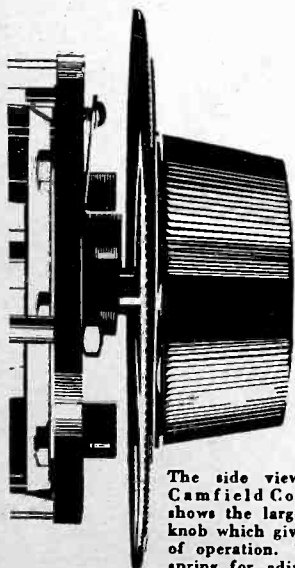

The side view of the Camfield Condenser shows the large bakelite knob which gives it ease of operation. The shaft spring for adjusting the dial tension is shown at the upper side of the condenser end plate.



dealers

Dealers: This Camfield display on your counter and the Camfield box on your shelf will identify you as a dealer in only the highest quality radio parts.

This remarkable condenser will be backed by an aggressive merchandising and advertising campaign. You will find it profitable. See your jobber about it immediately.

*West Coast
Representative:*

**A. S. LINDSTROM
COMPANY**

San Francisco, Los Angeles, Portland,
Seattle, Salt Lake City

Tell them that you saw it in RADIO

AEROVOX

is accurate because

The AEROVOX process insures electrical contact with the entire surface of end plates. This prevents leakage. Other makes depend on eyelet contact only. Convince yourself by trying it.

IMPREGNATION with our secret formula (patent pending) pre-termines and controls capacities. Result capacities are exact.

Endorsed by *Radio News*, *Popular Radio*, *Popular Science*, and Professor Wheeler of Yale. Approved and used by over 100 set manufacturers.

Made in all capacities. Write for particulars of complete line including Resistors, Rheostats, and Grid Leaks.

Chicago Office:
53 W. JACKSON BOULEVARD
Western Representatives
RICK-HITT COMPANY
San Francisco Los Angeles
AEROVOX WIRELESS CORP.
489 Broome St., New York City

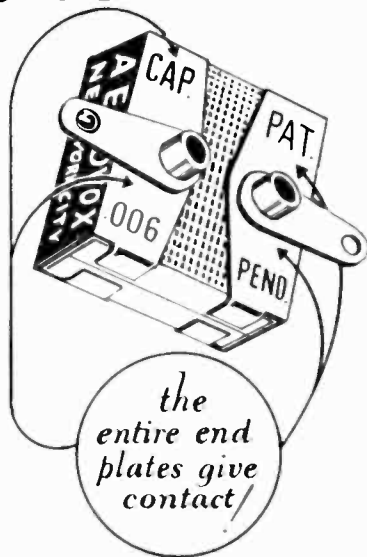

QUERIES AND REPLIES

(Continued from Page 37)

March, 1924 RADIO. A few of the interesting points in Mr. McGown's article are given here for your information. Polish the articles to be plated on a buffing wheel or other suitable polishing medium. Clean first in gasoline and then immerse in a bath of boiling lye, removing quickly and washing in running water until all trace of lye is gone. Fasten the article to a small copper wire and suspend in the plating bath, which is made up as follows; mix in a stone or glass jar 12 oz. nickel-ammonium sulphate with 1 gallon of distilled water, adding about .125 oz. benzoic acid. If a larger amount of solution is desired, increase the ingredients in proportion. Obtain several nickel anodes, or solid nickel bars, which may be obtained from any large chemical supply house. Suspend these anodes in the solution on one side of the tank or jar, used to hold the solution and the work to be plated at the other side. The current supply for small work may be a 6 volt storage battery, the amount of current required being about .1 ampere per sq. in. surface of the article to be plated. Connect the positive of the battery to the nickel anode and the negative to the apparatus to be plated, and allow the current to flow for from 10 to 20 minutes, depending upon the amount of plating desired. The current can be controlled by a series rheostat and ammeter without difficulty. After the plating is complete, wash the article in running water and dry in sawdust or warm air blast. For small work, the crock in which the solution is mixed will be O. K., but where a large amount of work is to be handled, the tank had best be made of wood. If articles made of metal other than copper or brass are to be plated, it will be necessary to copper plate them first, using a separate solution. Copies of the March 1924 issue of RADIO are available if a detailed description of electroplating is desired.

Strips of thin leather make very fair supports for the sockets of vacuum tubes, and help reduce the shocks and jars to which tubes are subject.

Thumb tacks of some varieties make very fair substitutes for switch points, provided they are used on thin panels.

The B-T Torostyle Transformer

A well known principle
now applied to radio

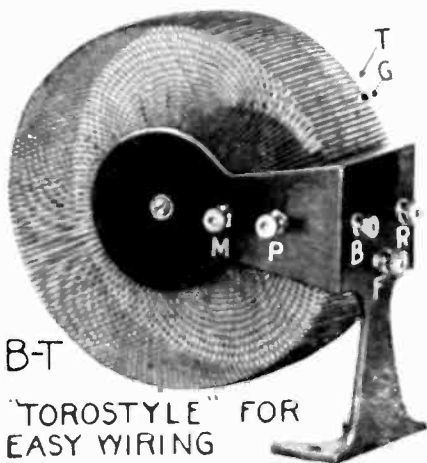

B-T

"TOROSTYLE" FOR
EASY WIRING

We will be pleased to send
descriptive circulars.

For years telephone engineers have known that "closed" or "toroid style" coils could be used to eliminate "cross talk" between trunk lines.

The most intensive research work this organization has ever done has been to adapt this type of coil to the high frequencies employed in Radio.

Our ambition has been realized. We now offer the B-T Torostyle Transformer with the assurance that its three great characteristics:

Reduction of inter-magnetic-coupling.
Nullification of "strong feed-back effects."
Elimination of signal pick-up have been obtained without the usual broad tuning and difficult oscillation control.

BREMER-TULLY MFG. CO.

532 South Canal Street

Chicago, Illinois

Carter New "IMP" Rheostat

(Pat. Pend.)

\$1.00 Smallest Rheostat made. Diameter only 1 3/8 in. Projects only 3/8 in. back of panel. One hole mounting. Complete with pointer knob. New, exclusive Carter method of contact. Positive, smooth, silent. Same high Carter quality. See one at your dealer's today. Write for information on other Carter original Radio products.

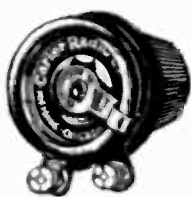

Half Size
6 ohms and 25 ohms

Coast Distributors:
A. S. LINDSTROM & CO.
274 Brannan St.,
San Francisco, Calif.

Branch Offices at:
Los Angeles
Portland
Seattle
Salt Lake City

Any dealer can supply

In Canada: Carter Radio Co., Ltd., Toronto

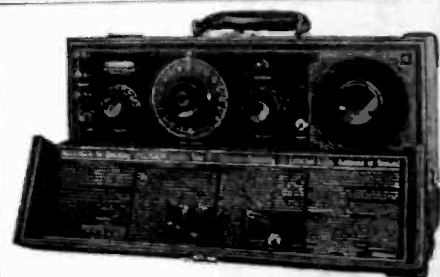

The Famous Truly Portable
TELMACO P-1 Receiver
Four Tubes Do the Work of Seven

The peer of portables in size, weight, ease of tuning, selectivity, distance, volume, workmanship and price. Aerial, loud speaker and batteries self contained. Complete with tubes and batteries. \$125.00 \$143.50. Receiver only

P-1 Kit Saves You Money!

Our offer of the Telmaco P-1 Receiver in kit form has met with enthusiastic reception. This contains all parts, as built by us, including case, drilled and engraved panel, and illustrated instructions. \$80.00 Complete kit

Ask your dealer or write us. Descriptive folder free.

Radio Division:

Telephone Maintenance Co.
20 So. Wells St. Dept. A Chicago, Ill.



Quality Radio Exclusively Established 1918

It's mahogany to the eye- but in fact it's Bakelite

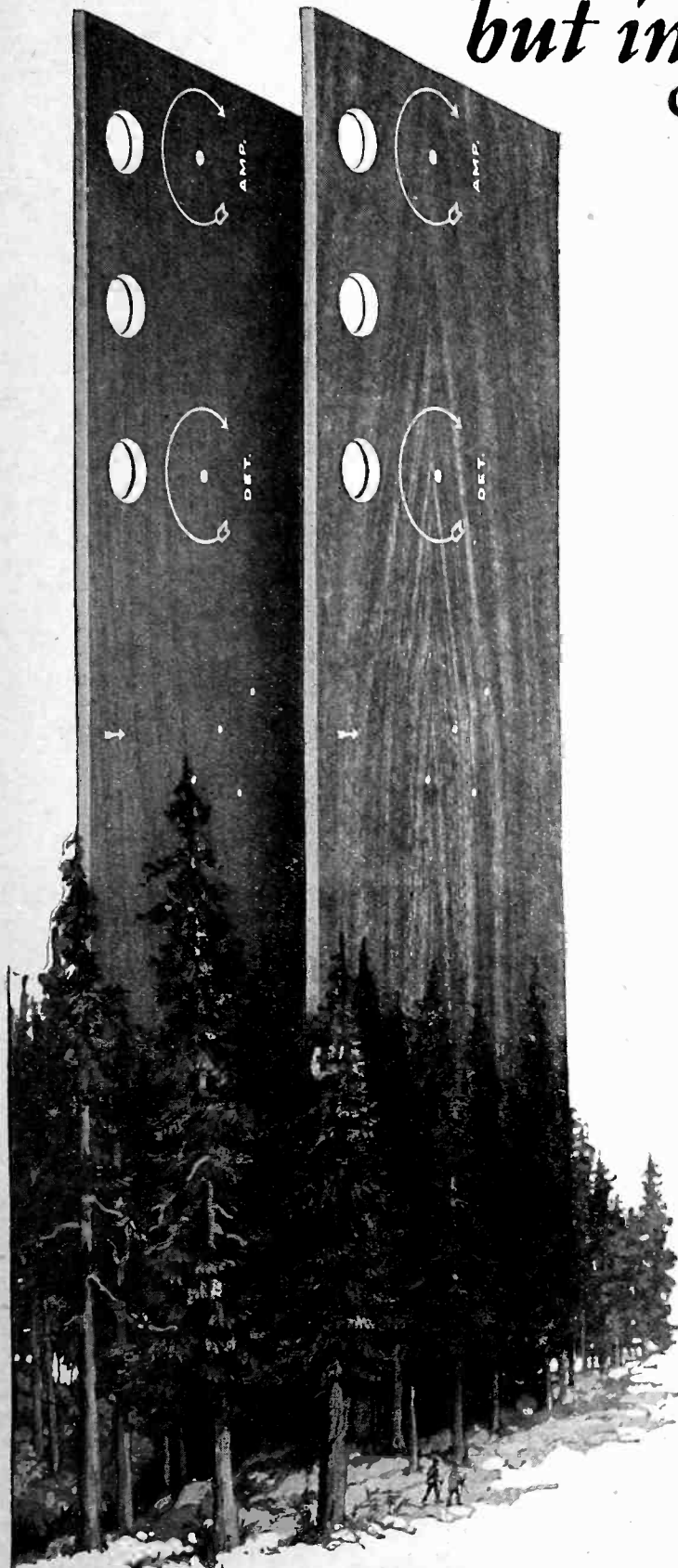

So perfectly is the grain and color of mahogany and walnut reproduced in these Bakelite Radio Panels, that the eye cannot distinguish them from the natural woods.

By using a Bakelite Panel that matches the wood in the cabinet, your finished set will be far more handsome than if a plain panel is used.

Rigid and strong, Bakelite Panels support the weight of heavy instruments without sagging. They will not compress, or cold-flow, under pressure of binding screws. Because of their resistance to extremes of heat, cold and moisture, they will not warp nor split. These properties and their insulation value, color and finish are permanent.

Be sure to ask your dealer to show you these wood finish Bakelite Panels—obtainable under any of the following trade-names:

FORMICA
Laminated Plastic

CELORON

Dilecto

Spaulding

Fibroc

Micarta

A Bakelite Panel on a set is an indication that the manufacturer has used the best.

Write for Booklet 30

BAKELITE CORPORATION

247 Park Avenue, New York, N. Y.
Chicago Office: 636 West 22nd St.
Visit Our Booth at the Chicago and New York Radio Shows.

Bakelite is an exclusive trade mark and can be used only on products made from materials manufactured by the Bakelite Corporation. It is the only material which may bear this famous mark of excellence.

BAKELITE

REG. U.S. PAT. OFF.



BAKELITE
is the registered trade mark for the phenol resin product manufactured under patents owned by the Bakelite Corporation.

THE MATERIAL OF A THOUSAND USES

Tell them that you saw it in RADIO

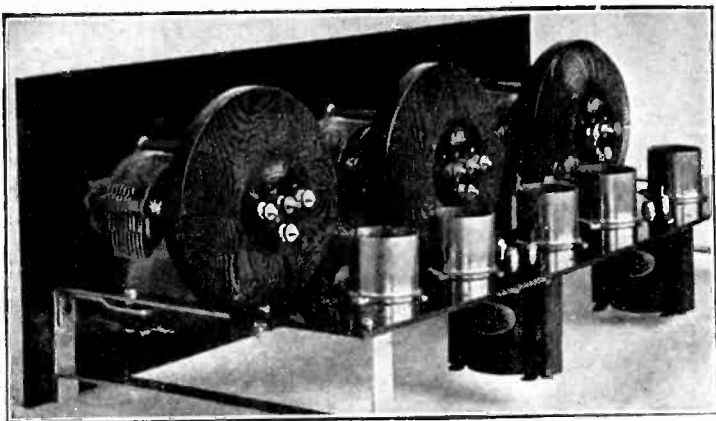

Amazing new receiver

NOW anyone can build it in an amazingly short time this new easy way. Experts assemble it at factory. You simply wire. Note revolutionary new principle it contains.

NO excuse now for not having a fine radio. At a surprisingly low cost, too. For a remarkable plan is showing thousands a new way to build their own. It is so easy that anyone can do it in an hour's time. So fascinating that many continue to build them for others. No wire bending or soldering. Merely attach a few ready-cut, flexible eyeletted leads, and the job is done.

And in addition to the fun and pride of building your own, the finished receiver actually contains a phenomenal feature not yet found in the most expensive sets; that brings results otherwise impossible.

This feature follows the discovery of a new inductance principle that overcomes many vital weaknesses of present day sets. It is based on an entirely new type coil—the Erla *Balloon *Circloid.

Circloids are the backbone of the Erla kit and are largely responsible for the striking improvements this kit alone offers. Note these four advantages in particular:

1. **Greater distance.** Circloids have no measurable external field to affect adjacent coils or wiring circuits. This makes possible higher amplification in each stage, with increased sensitivity and greater range.

2. **More volume.** Higher r. f. amplification enables Circloids to bring in distant stations scarcely audible in

ordinary sets with volume enough on the loud speaker to fill an auditorium.

3. **Increased selectivity.** Circloids have absolutely no pick-up qualities of their own. Only signals flowing in the antenna circuit are built up.

4. **Finer tone quality.** The self-enclosed field positively prevents stray feed-backs between coils. Hence no blurring or distortion. Tones are crystal clear.

Circloids are sold singly and in sets of three; also in kits containing three Circloids and three .00035 condensers.

Write for free information on kit—also book

See how a few minutes of fun will give you the newest and most nearly perfected set known to radio science. Examine it at any Erla dealer's, or send the coupon for full information, illustrations and diagrams contained in the remarkable new book, "Better Radio Reception," describing the sensational new Circloid principle. Enclose 10c for mailing and postage on book.

*Trade Mark Registered.

Electrical Research
Laboratories,
2500 Cottage Grove Ave.,
Dept. 19, Chicago, U. S. A.



Send me free information on kit. Enclose 10c for postage for book. "Better Radio Reception." This sign identifies authorized Erla distributors. All are equipped to give complete radio service.

Name.....

Address.....

City..... State.....

Dealers—Exclusive franchises are available to high class dealers in localities still open. Write or wire immediately.

The "Windham" Variable Condenser

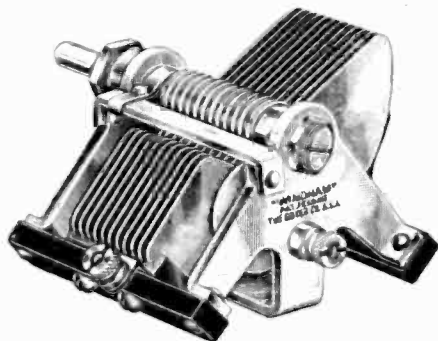

A durable, rigid instrument with correct electrical characteristics and made by skilled mechanics. It is provided with adjustable bronze cone bearings, the brake is independent of the bearings and adjustable. The plates are straight line.

It occupies small space, single hole mounting.
The price is right.
Desirable territory open.

The Goyer Company, Willimantic, Conn., U. S. A.

CALLS HEARD

(Continued from Page 41)

By GEB, Lyndon F. Seefred,
343 S. Fremont Ave.,
Los Angeles, Cal.
(40 meters)

(1ow), 1xav, 1pm, 1yb, 1cmx, 1za, 1pl, 1gu, 1gv, (1aao), 1anq, (2aay worked on 5 watts), 2brb, 2bg1, 2ctq, 2gk, 2agw, 2rm, (2bbx), 2buy, 3hg, (4bl), (4sl), (4eo), (5aec), (5atv), (5asv), 6cst (Hawaii), (7gp), (7dc), (7ya), 8byn, 8dal, (8gz), 8bac, 8cbp, 8do, (8chk), 8apw, 8cyl, 8bgq, (8pl), 8hgn, 8deb, (9dat), (9bht), Canadian: c1by, c4gt, c4cr, c1dq, c4oa, 45bf, (c5ba), c5ef. Porto Rico: 4sa. kfu, kfvt, wiz, kel, npg, napg, nps, nve, naj, nqw, nfv, (nr1), (nkf), (nrm), (fx1). Mexico: (m9a), (mlb), mbx, m1aa, mlk, mln, mlx. New Zealand: (z1ao), z4ag. Australia: a2yi, (a3yx), (a3bd), a2bk, a2yg. Japan: j1aa. Philippine Islands: (pilhr). Buenos Aires, Argentina: (raf2).

One 50 watt tube (uv2o3a) on 38.7, 39.8, 40, 41.9 meters, respectively, with 1000-1500 v. ac and 400 milliamperes on plate, 8.5-10 v. filament, was used. The old 80 meter antenna 97 feet long, 4 wire cage, old corroded stranded wire was used for 40 meters with no counterpoise. Antenna current was .7 to 1.3 T.C. amperes.

Am on 19.9 meters now with .8-.9 T.C. amperes antenna current, using 15 ft. single wire counterpoise in basement of house and single wire antenna 35 ft. long and 30 ft. high. All wire is No. 12 enamel and glass insulators. All reports of 6eb answered.

By 7pz, W. R. Farquharson,
1115 James Street
Chehalis, Wash.

1cmp, 1cmx, 1ow, 1pl, 1te, (1xu), 1yb, 2agw, 2bee, 2br, 2cv, 2ll, 2te, 2wb, 3apv, 3oe, (4rm), 4sa, (5aj), 5al, 5fv, (5ox), 8aa, 8aks, 8aly, 8avl, 8bcv, 8bro, (8buk), 8chk, 8cjp, 8cyl, 8eq, 8er, 8ex, 8gz, 8jj, 8jp, 8nx, 8ry, (8xaf), 9amq, 9ad, 9bbv, 9bdu, 9bdw, 9beq, 9bht, 9bht, 9bjp, 9bkr, 9caa, 9cap, 9ccs, 9cfi, 9cd, (9cpm), 9cpo, 9cul, 9bdz, 9dez, 9dpx, 9dxr, 9ee, 9efy, 9eib, 9fj, 9hk, 9oo, 9sr, 9wn. Canadian: 2bg, 4cr, 4ed, (9al). Australian: 2cm, 2ay, 2yl. New Zealand: 4aa. NKF, NPG, (NRRL). Would appreciate any reports on my signals. Glad to answer all qsl's.

6clz-6cow, 1045 Peralta Avenue,
Berkeley, California

U. S.: 1aac, 1abf, 1aci, 1aff, 1aid, 1ajg, 1ajt, 1ajx, 1alw, 1amd, 1azc, 1aqm, 1are, 1ary, 1asy, 1aur, 1avf, 1awe, 1axa, 1axn, 1axz, 1bbe, 1ban, 1bcc, 1bdx, 1bep, 1bkq, 1bpb, 1ckp, 1cln, 1cmp, 1cmx, 1af, 1by, 1er, 1gk, 1gt, 1gv, 1hn, 1ll, 1ka, 1kx, 1oj, 1ow, 1pl, 1pm, 1py, 1ql, 1rd, 1rr, 1sl, 1te, 1vd, 1ve, 1wy, 1xai, 1xam, 1xao, 1xay, 1xu, 1xz, 1yb, 1yd, 1za, 2aa, 2aan, 2aay, 2abt, 2acp, 2adk, 2adm, 2aey, 2agw, 2ahk, 2aim, 2ale, 2als, 2ana, 2ann, 2avg, 2axf, 2bck, 2bee, 2bgi, 2bjj, 2blm, 2bmi, 2bqa, 2brb, 2bsc, 2cee, 1cgl, 2chk, 2cla, 2lg, 2cnk, 2cpd, 2cpo, 1ctf, 2ctq, 2cty, 2cub, 2cvf, 2cwj, 2cxw, 2cyx, 2ag, 2bm, 2bo, 2br, 2bw, 2by, 2cm, 2cv, 2fb, 2gk, 2gx, 2ke, 2le, 2mm, 2mu, 2pd, 2ph, 2qh, 2rk, 2rm, 2wb, 2wi, 2xaf, 2xam, 2xbf, 2xi, 2zu, 2zv, 3adp, 3aec, 3ajd, 3apv, 3ash, 3ava, 3bfe, 3bjp, 3bmn, 3bnu, 3bpm, 3bss, 3bta, 3buy, 3bva, 3bwj, 3ccv, 3cdv, 3chg, 3chh, 3cjin, 3ab, 3bx, 3ck, 3cs, 3hg, 3hj, 3jw, 3kz, 3lg, 3ll, 3mf, 3mu, 3qt, 3tp, 3xan, 3yo, 3zo, 4au, 4bl, 4bq, 4cu, 4du, 4dv, 4er, 4gw, 4gy, 4jh, 4jr, 4ku, 4ll, 4pu, 3rm, 4te, 4tj, 4tv, 4tw, 4uc, 4uk, 4xe. Australia: 2bc, 2bk, 2cm, 2ds, 2lj, 2yl, 3bd, 3bq. Brazil: 3ad. Canada: 1ar, 1ei, 2az, 2cg, 2fo, 3co, 3gb, 3kq, 3mv, 3ni, 3ws, 3xi, 3xx, 9al. Hawaii: 6asr, 6cst, 6xo. Holland: orz. Mexico: 1aa, 1af, 1b, 1j, 1k, 1n, 9a. New Zealand: 2ac, 2ae, 2xa, 4aa, 4ak. Porto Rico: 4sa. Samoa: 6zac. qra???, 86a, (hp). All crds promptly and gladly answered. qrk, 6clz-6cow on 20 and 40 meters?

At 8ze-8gx, E. W. Thatcher,
Oberlin College, Ohio
(On 40 meters)

U. S.: 6age, 6agk, 6ahq, 6alj, (6aji), 6ahp, 6awt, (6bhz), 6blk, (6bkx), 6bjd, 6bmu, (6bsc), 6buj, 6bur, 6cgo, (6cgw), 6cej, 6chz, (6cig), (6cix), (6clr), 6clp, 6cnc, 6cpl, 6css, 6csw, 6cto, 6dah, 6cc, (6ji), (6im), (6hw), (6lj), 6kb, (6km), (6no), (6oi), 6ul, (6ur), (6ut), (6ts), (6vc), 6xag, 6xap, 7abb, 7ay, (7gb), (7nx), 7mf, 7pz, 7ya. Foreign and special: a2bk, (a2ds), (a2cm), a2ay, a2lj, a2yl, a3bg, c4gt, c5gt, g2kf, g6ym, P. R. (4sa), (4je), (m1-k), m1aa, z2ac, (z2xa), z4aa, z4ag, z4ak, z4ar. Hawaii: (nr1), 6zac, 6xap. Naval: (nr1), 75gos, (qra?).

8ze-8gx is maintaining a relay transmitter which is at present located on 14.5 meters. Tests are being conducted on the lower wave bands, particularly on five meters. Communications from men interested in taking part in these tests and reports on the character of the signals will be greatly appreciated. All cards will be answered.

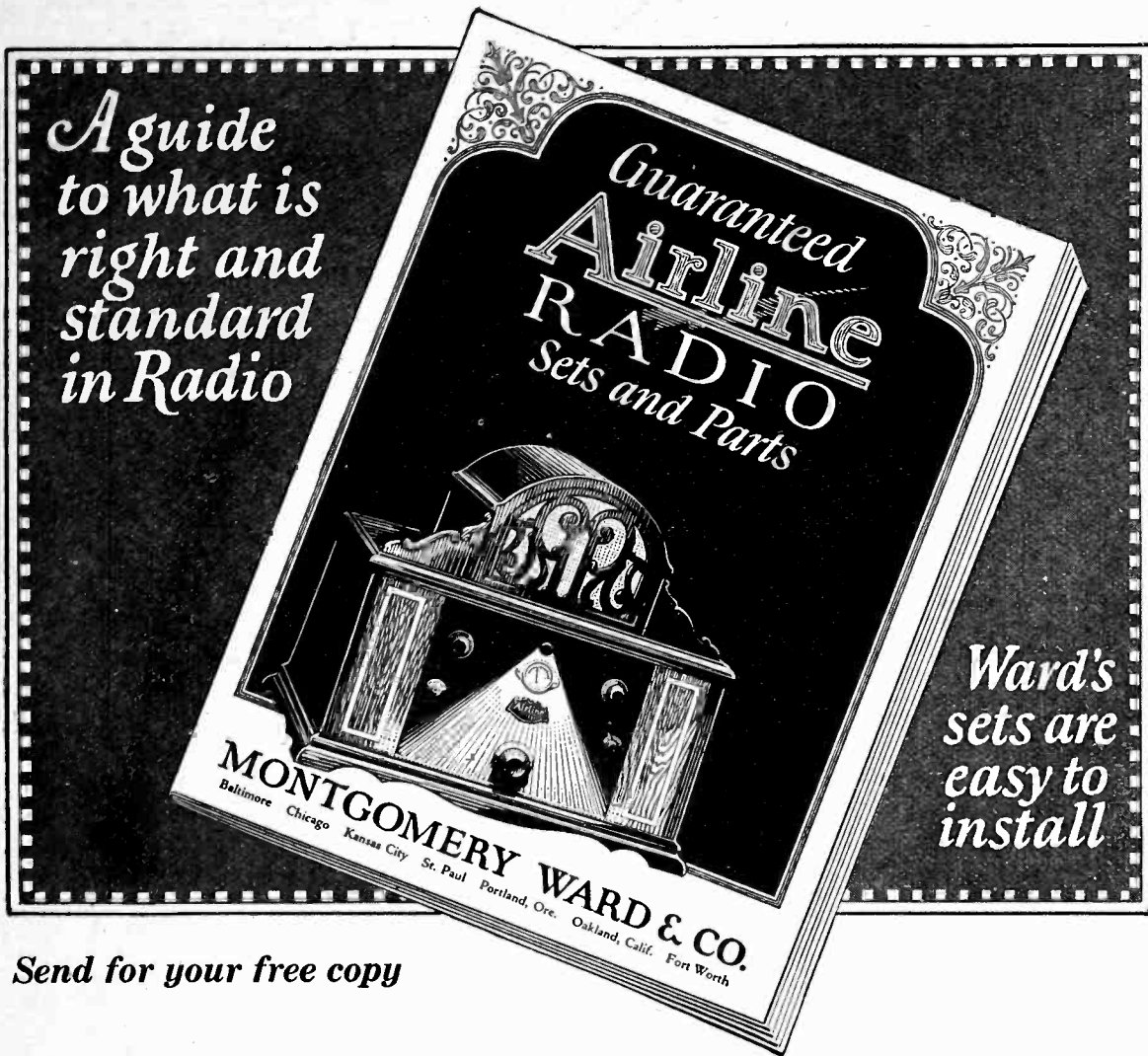

Send for your free copy

Ward's New Radio Catalogue

The best radio experts made this catalogue. It is one of the very best and most complete books on Radio ever published.

Its 52 fully illustrated pages are simply invaluable to everyone interested in radio. And one copy is to be yours Free—merely for the asking!

It shows guaranteed Radio sets, one tube sets that give remarkable results, and sets of every variety up to Ward's new five-tube one-dial control. Think of tuning in one station after another by turning a single dial!

It shows guaranteed, tested parts, bat-

teries, cabinets, contains a list of stations, a radio log for recording stations. It is a complete radio manual—sent entirely free!

Ward's is Headquarters for Radio

And best of all, the catalogue offers you everything new in Radio at a big saving in price.

At Ward's, everything for Radio is sold without the usual "Radio Profits." Thousands of pleased customers write us of their constant delight with Ward's Radio products.

Our 53 year old Policy

For 53 years we have sold only quality merchandise under a Golden Rule Policy. You can rely absolutely upon the quality of everything shown in this Radio Catalogue.

.....
 To Montgomery Ward & Co., Dept. 39-R
 Baltimore Chicago Kansas City St. Paul
 Portland, Ore. Oakland, Calif. Fort Worth
 (Mail this coupon to our house nearest you.)
 Please mail my free copy of Montgomery
 Ward's New Radio Catalogue.
 Name
 Local address
 Post office
 State

ESTABLISHED 1872 Montgomery Ward & Co.

The Oldest Mail Order House is Today the Most Progressive

Baltimore Chicago Kansas City St. Paul Portland, Ore. Oakland, Calif. Ft. Worth

AMSCO ANNOUNCES A SPACE - SAVING S.L.F. CONDENSER

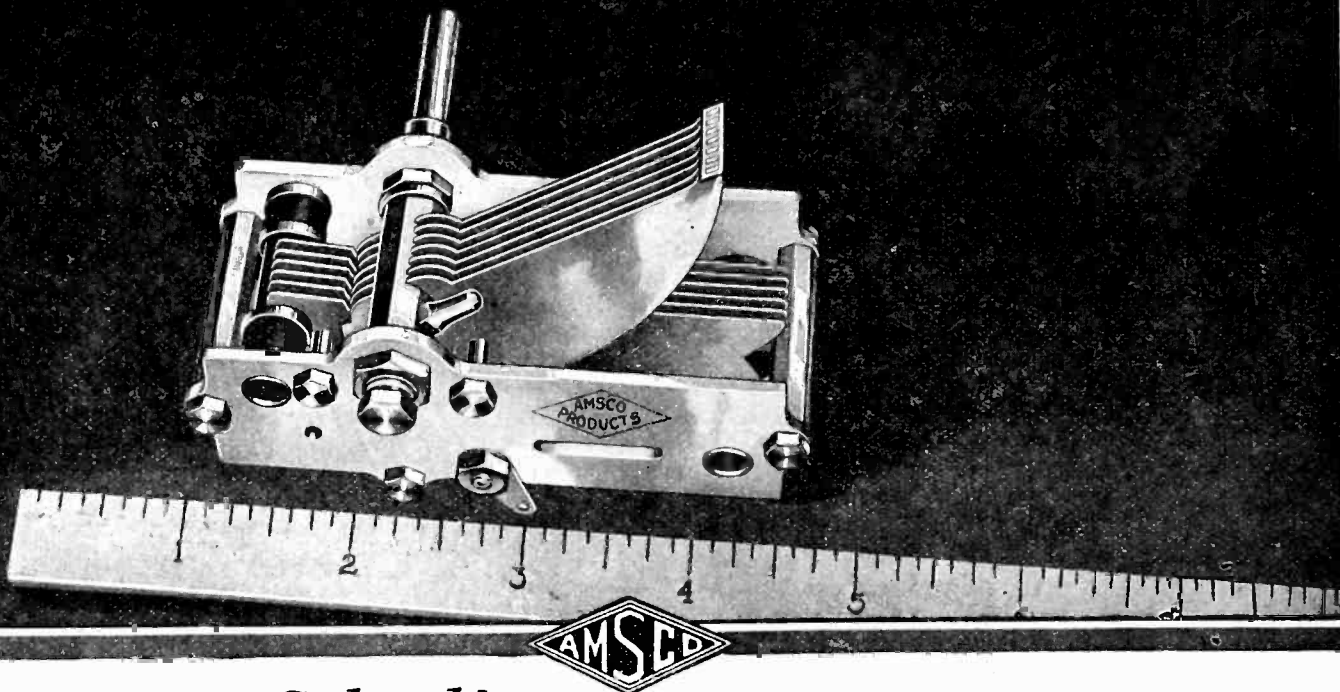

Solved! The space problem of the straight-line frequency condenser. The new AMSCO Allocating Condenser is ingeniously designed to save room in the cabinet—yet spreads the stations evenly around the dial, according to frequency. Greatly improves the selectivity of the set—and simplifies tuning. Three sizes—Single or Siamese.

Ask your dealer—or write Dept. I

AMSCO PRODUCTS, INC.
Broome and Lafayette Streets, New York City
MAKERS OF MELCO SUPREME RADIO RECEIVERS

Half a Heart
—is the secret.

Half a Heart
—is the shape of
the rotor plates.

Half a Heart
—is the new sym-
bol for efficient
S. L. F. variable
condensers.

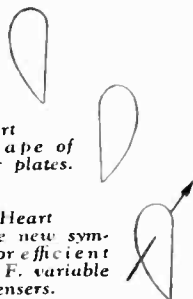

AMSCO
PRODUCTS
 ARE SPECIFIED BY
 STROMBERG-CARLSON FREED-
 EISEMANN PRIESS RADIO *SR*

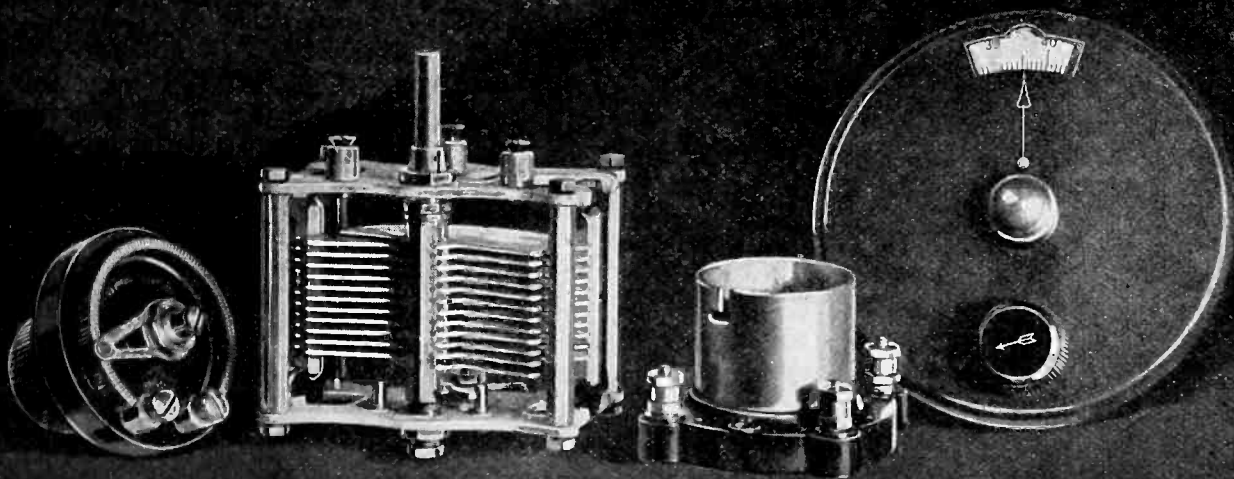

Set builders who strive for electrical and mechanical perfection inevitably come to AMSCO. Look behind the panel of the finest sets, and you will find the AMSCO trademark, the sign of *engineered* radio parts. Standardize on AMSCO Condensers, Vernier Dials, Rheostats, Potentiometers, Sockets and Binding Posts—each the best that can be made, and made to match each other.

Ask your dealer—or write Dept. I

AMSCO PRODUCTS, INC.
 Broome and Lafayette Streets, New York City
 MAKERS OF MELCO SUPREME RADIO RECEIVERS

NEW—The Amsco Vernier Dial—at a popular price. The right ratio for precision tuning.

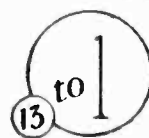

A Foe to Old Man Static

THIS demon tormentor with his rattles and hammers — This tiresome soloist with his monotonous concerts — This outlaw of the ether, — will be a stranger in your home when you use the "Electrad" Lamp Socket Antenna.

Just plug-in on any electric light line, no need of outdoor or indoor aerials. Reduces "canary bird" re-radiations from nearby oscillating sets. A distance getter. The complete, efficient and economical aerial.

Price 75c

At Most Good Dealers together with other handy "Electrad" Guaranteed Radio Essentials—Variohms, Audiohms, Lead-ins and Lightning Arresters. If your dealer can't supply you, write us.

"ELECTRAD" CERTIFIED GRID LEAKS
Price 50c

Made of high resistance material — unaffected by climate. Quiet, smooth and continuous operation. $\frac{1}{4}$ to 10 megohms.

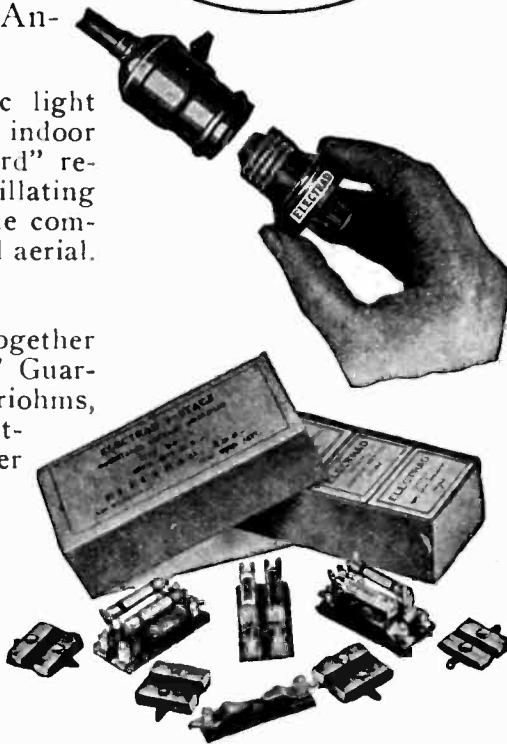

"ELECTRAD" 3-STEP RESISTANCE COUPLED AMPLIFIER KIT No. 1-C—A big \$6.75 value. Contains the necessary Resistor Couplers, Certified Mica Condensers, Condenser mountings, Certified Grid Leaks, and Resistors. Nothing else needed except sockets, rheostat and busbar.

ELECTRAD

The Six Point Pressure Condenser

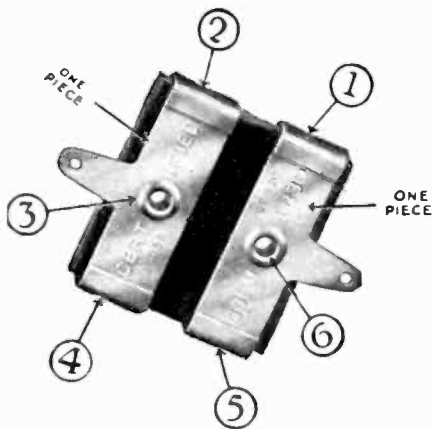

"The Six Point Pressure Condenser"

The "Electrad" Certified Fixed Mica Condenser is a revelation in accuracy and design. Ingenious, rigid binding and firm riveting fastens parts securely at six different points insuring positive electrical contact. Impervious to temperature and climatic variations. Exerts even pressure upon the largest possible surface—can't work loose. Binding strap and soldering lug in one piece. Value guaranteed to remain within 10% of calibration. Standard qualities, 3 types. Licensed under Pat. No. 1,181,623, May 2, 1916 and applications pending. Price 30c to 75c in sealed dust and moisture proof packages.

Also Type G. S.—with grid leak brackets and especially designed arms for direct connection with socket.

ELECTRAD, INC.

428 Broadway,
New York City

RESCUING UNCLE MARMADUKE

(Continued from page 24)

make amends before I pass on; and the time of my passing is not far off—no, it is not far off."

"Oh, you haven't been so bad," I said, comfortingly, "Of course, that affair you had with the chorus girl was a bit of a mess; but by and large, I'd say you would stack up just about par. There's been lots of chaps much worse than you: Jessie James or Gyp the Blood, for instance. Besides, who has been giving you all the inside dope about your passing?"

"The spirits!" He said it with a soft, sliding sound, biting the word off quickly at the end; and then continuing with a hollow-voiced, sing-song effect. "The spirits, Reggie. They come to me in the quiet of the night. Rapping—rapping—gently rapping. Revealing what is to be. Guiding and advising me. And always—always they say, 'Purify yourself of all wealth. Remove the taint of earthly gain. The time of your passing approaches.' They say it over and over again—over and over again."

I say, you know, that sort of thing in a dimly lighted room is likely to make a chap's nerves crawl; but I managed to keep myself bucked up.

"Rot! You've got a plain case of heebie-jeebies. Get out the old golf clubs, play eighteen holes with me tomorrow, and you'll feel better. This spirit business is the . . ."

I was about to say, "the bunk." But just then something happened that positively made my spine curl. In the center of the room stood a small table. All of a sudden, there came from it three distinct raps. For a moment, I just sat there with my mouth open, and the little shivers frolicking up and down my back.

"The spirits," Uncle Marmaduke whispered, "The spirits, signaling a message."

It was all quiet for an interval, so quiet that I could hear Uncle Marmaduke breathing through his nose like an acrobat getting ready to do a stiff trick. Then the table began rapping again, very slowly—rat-tat tat-tat-tat. I saw Uncle Marmaduke writing something in a notebook which he took out of his dressing robe pocket. The table kept up the rapping for a minute or two; then stopped.

"The spirit message," Uncle Marmaduke said, handing me his note book. He had written on one of the pages:—"Beware of evil influences. Free yourself from the taint of earthly gain. The time of your passing cometh soon."

I've read that chaps, whom Fate has given the old K.O., have a habit of picking themselves up and piecing themselves together again, so to speak. There's a lot to it. I know, because that's just what I did—or, at least, tried to do.

(Continued on page 54)

THOMPSON

Announces Same Good Policy for Fall Business

No less than 116 different types of Thompson Radio instruments preceded the creation of Thompson Radio Broadcast Receivers in that long climb through the past of wireless and radio development which culminated in the perfection of broadcasting and reception. In the history of radio development for ships, airplanes, submarines and the other forms of radio communication, the Thompson organization has contributed an unusually high percentage of the better equipments.

Armies and navies of the world use its apparatus and this organization now puts into its broadcast receivers all the experience and skill so gained by years of working with radio communication problems. Where the many newcomers have to guess, the Thompson organization knows by experience. Therein lies the greatest factor of safety for the dealer and distributor.

Today there are in use millions of radio receivers sponsored by manufacturers or assem-

blers who are as new to this difficult industry as broadcasting itself. Many of these sets will be unsponsored when inexperience has taken its toll. Between theory and practice there is a vast gap that no manufacturer can cross save over the bridge of experience.

So, we say to those dealers who have not yet made up their minds as to the line on which they expect to gain and keep their customers' confidence:

"The permanent profit value to you of Thompson Receivers and Speakers can best be judged by your own comparison of the Thompson *radio* ability, the company's background of *radio* success, the product itself, and the company's distributing policies."

The platform on which we will join with you in doing a profitable business this Fall is in your distributor's hands. It is known, it is definite---it is fair. We believe you can build a permanent radio business on it.

THOMPSON RADIO NEUTRODYNE

R. E. THOMPSON MFG. CO., 30 CHURCH ST., NEW YORK-CITY

Everywhere An Amazing Success!

The NATIONAL ANTENNA COIL and The NATIONAL REGENAFORMER

*Two units that are unexcelled
for wave filter, wave meter
or tuned radio frequency*

THE National Regenaformer designed by Browning and Drake of Harvard Research Laboratories is a tuned radio frequency transformer of highest efficiency. Combined with the National Condenser and the National Velvet Vernier Dial, the result is a well-balanced unit that gives *radio satisfaction*.

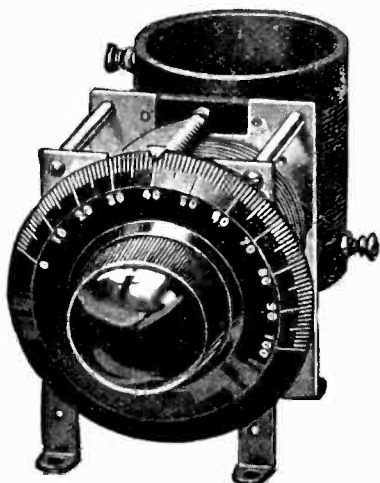

NATIONAL ANTENNA COIL

With National Velvet Vernier Dial and Condenser

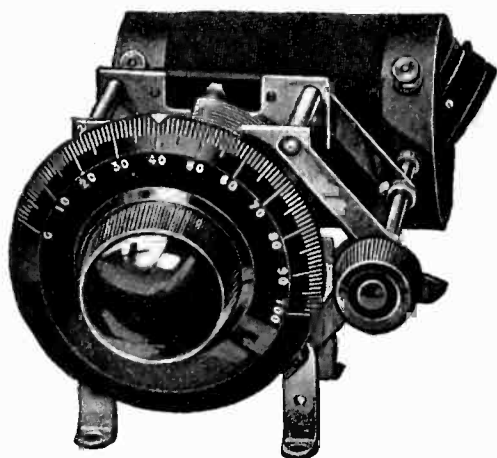

NATIONAL REGENAFORMER

With National Velvet Vernier Dial and Condenser

NATIONAL COMPANY, Inc.
110 Brookline St., Cambridge, Mass.

*Sole Licensees for the Manufacture of the
Genuine and Justly Famous Browning-Drake
Transformer. Patents Pending.*

ANNOUNCING

The Wilson "B" Radiopower Unit

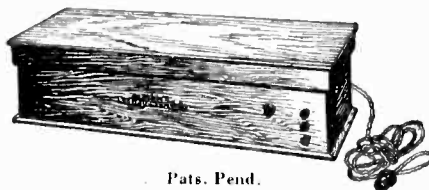

Pats. Pend.

This new unit will eliminate all "B" battery troubles. *It is guaranteed not to set up the slightest hum.*

Supplies uniform voltage at all times, insuring better reception. Nothing to adjust. No moving part to get out of order. No acid to spill. Will not affect your neighbor's set. Requires no attention whatever, except to switch it on and off as you want to use your receiver. In handsomely finished solid walnut case. Price, \$35.00.

The Andrews Paddlewheel Coil

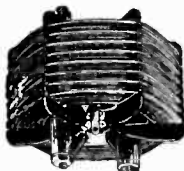

Pats. Pend.

The coil of ideal characteristics. *Has exceptionally high ratio of inductance to resistance.* Losses are negligible. Gives maximum range and volume with entire freedom from distortion. Increases selectivity and greatly improves tone quality. This coil is employed in such well-known receivers as the Andrews DERESNADYNE and the BUCKINGHAM, and can be used in all standard hook-ups where a high grade transformer-inductance is required. Provided with nickel plated bracket for mounting. Price, \$3.00.

Our Technical Dept. will answer questions relative to the Paddlewheel Coil and its use in any hook-up. Get blue-prints of well known receivers and circuits from your dealer, or write direct.

Duo-Spiral Folding Loop

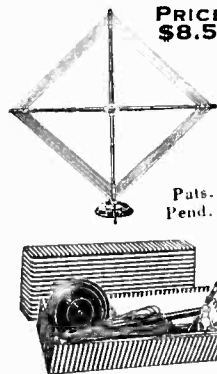

PRICE
\$8.50

Pats.
Pend.

Handsomely finished in silver and mahogany. Neat and compact. An ornament to your set—not an eyesore. Folds readily and can be used anywhere. Ideal for portable sets. Has silvered dial graduated in degrees. Helps to reduce static and cut out undesired stations. A special model for every circuit.

See these standard products at Booth No. 90 during the San Francisco Radio Exposition, or at Booth No. 3 during Los Angeles Exposition.

Radio Units Inc.

1303 First Avenue Maywood, Ill.

FREDERIC L. TOMLINSON COMPANY
443 S. Pedro St. 447 Pacific Building
Los Angeles San Francisco

(Continued from page 52)

After the seance in Uncle Marmaduke's room, I felt pretty shaky. I mean to say that the full horror of the thing rolled over me. A fellow can put up a scrap against another fellow; but I ask you, what can he do against a ghost? Absolutely nothing. Right!

But the next morning with the merry sunshine pouring through the windows, I began to feel different about it, sort of got myself together. Here, says I, is a chance to exercise the old bean. Solve the mystery of the rapping table, and win a fortune. It was worth trying.

So when I heard Uncle Marmaduke go down to breakfast, I gum shod into his room for a bit of sleuthing. Naturally, my first hunch was that the knocking was produced by strings or wires attached to the table. But there weren't any. I studied the table, moved it about, went over every inch of it with an eagle eye for clues. All minus. The table looked just about like maybe a million other tables I had seen. The thing had me fairly stymied.

Worse than that, it meant I was doomed to be thrust out into the cruel world without even a crust upon which to rest my weary head. I mean to say that the future looked pretty black for the younger generation of the Rockford-Peebles family. No question that Uncle Marmaduke was thoroughly sold on the spirit messages; and it was only a matter of time until he re-vamped his will as per the spirits' directions. I could close my eyes and see Mrs. Hoagworth, grim and cruel, clutching the deed to the property in one hand while she ordered Ruth and I out of the house with the other.

Feeling pretty low, I dragged myself downstairs, and went out in the garden to puzzle the thing out. There was a Ford car parked in front of the house; and coming up the walk was Bill Curtiss. He looked as fresh and fit as a dew-covered violet. Somehow, the very sight of him seemed to steady the old nerve centers, gave me new born confidence, as it were.

"I say, Bill," I shouted, rushing at him pell mell and grasping his hand like a drowning man grasps the well known straw, "how in blazes did you happen to drop in?"

"Why," he said, looking a bit ruffled, "I seem to have the impression that you invited me down for the week-end to give you some advice on radio sets."

"So I did! So I did!" I chortled, dragging him up to the porch, "But sit down; I've got something else on my mind. What do you know about these people who put you in touch with spirits?"

"You mean bootleggers?"

"No, no; spiritualists, medium.s."

"Not very much; why?"

(Continued on page 56)

SELECTIVITY

THE OBEDIENT SLAVE TO YOUR DESIRES

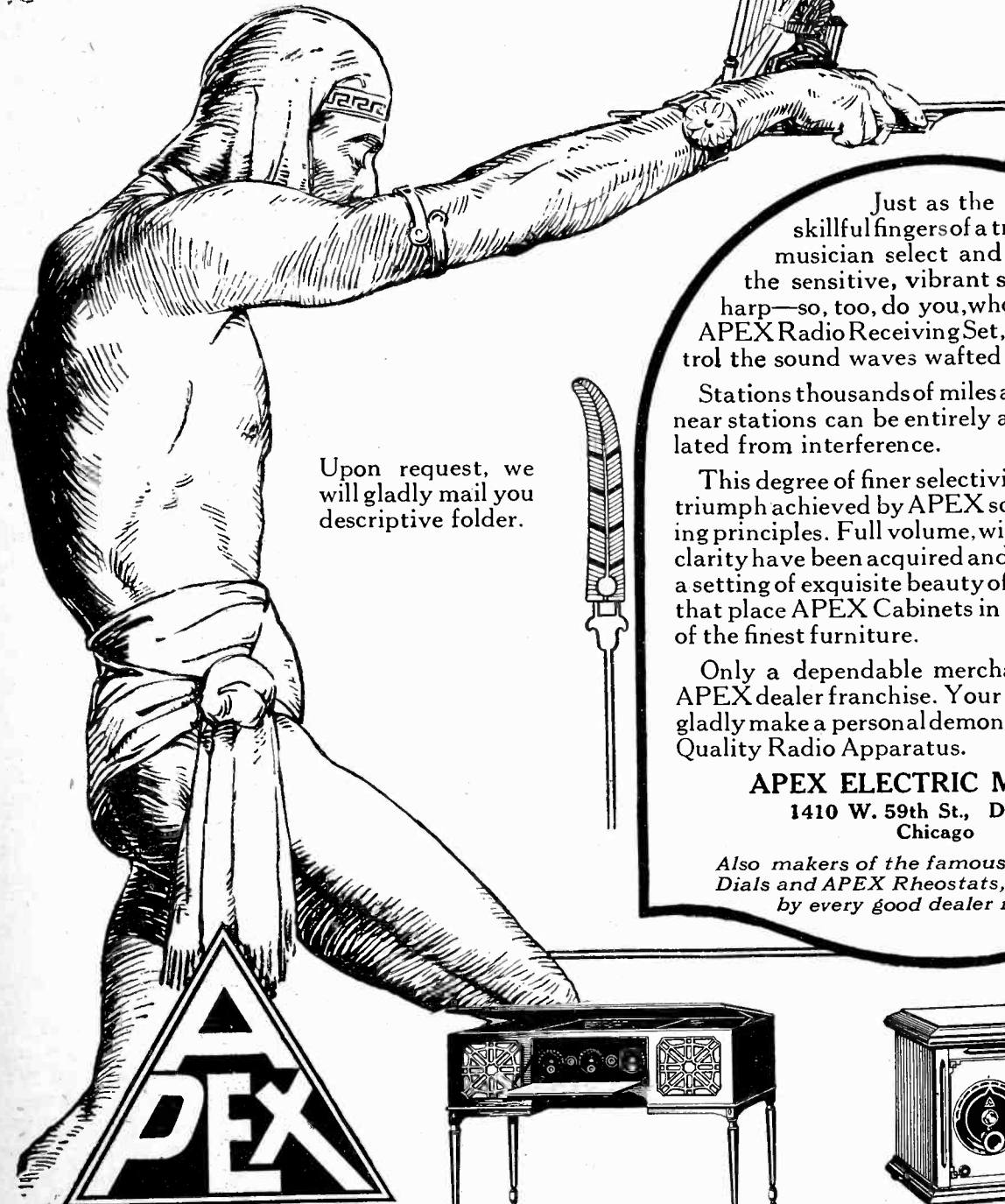

Upon request, we will gladly mail you descriptive folder.

Just as the skillful fingers of a trained musician select and control the sensitive, vibrant strings of a harp—so, too, do you, who operate an APEX Radio Receiving Set, select and control the sound waves wafted through the air.

Stations thousands of miles away, or powerful near stations can be entirely and instantly isolated from interference.

This degree of finer selectivity is not the only triumph achieved by APEX scientific engineering principles. Full volume, wider range, greater clarity have been acquired and are enthroned in a setting of exquisite beauty of design and finish that place APEX Cabinets in the highest ranks of the finest furniture.

Only a dependable merchant is given the APEX dealer franchise. Your APEX dealer will gladly make a personal demonstration of APEX Quality Radio Apparatus.

APEX ELECTRIC MFG. CO.
1410 W. 59th St., Dept. 910
Chicago

Also makers of the famous APEX Vernier Dials and APEX Rheostats, which are sold by every good dealer in Radio.

APEX
Quality Radio Apparatus

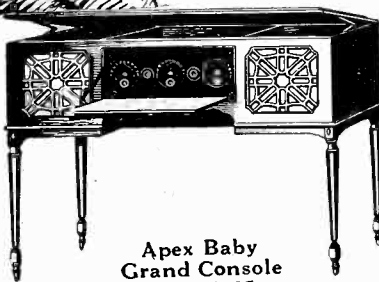

Apex Baby Grand Console
Price \$225

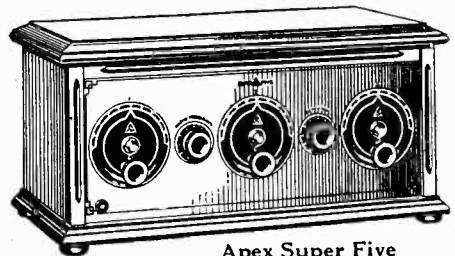

Apex Super Five
Price \$95
without accessories

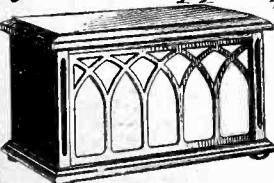

Apex Console Entertainer
Price \$27.50

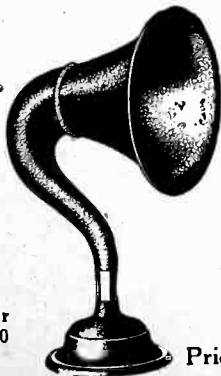

Apex Entertainer
Price \$22.50

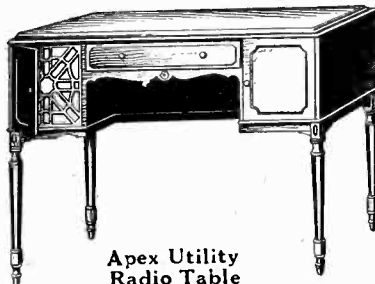

Apex Utility Radio Table
Price \$75

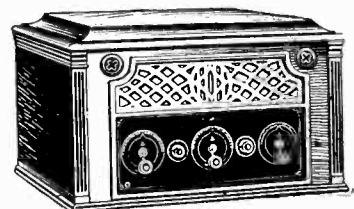

Apex DeLuxe
Price \$135

Prices West of Rockies slightly higher. Canadian prices approximately 40% higher.

Western Representative: A. S. LINDSTROM CO., San Francisco, California

Branch Offices: Seattle, Portland, Los Angeles and Salt Lake City.

Northern California Distributor: UNITED RADIO SUPPLIES CO., San Francisco, California

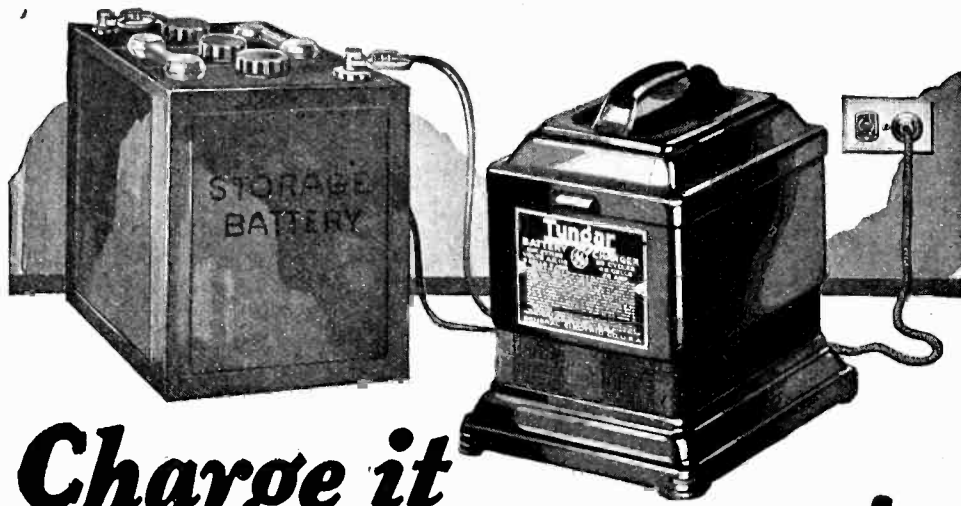

Charge it while you sleep!

Last thing at night—concert over—time to lock up. Radio battery low? Just clip on the Tungar, and plug it in. Or if you connect up the Tungar permanently, *just throw a switch*. Charge the battery while you sleep.

The Tungar is simple—makes no disturbing noise. And the low cost of Tungar recharging cuts battery upkeep to next to nothing. It means top notch performance—clear, full-volumed reception—*all the time!*



The Tungar is a G-E product developed in the great Research Laboratories of General Electric.

The new Tungar charges radio "A" and "B" batteries, and auto batteries.

Two ampere size (East of the Rockies) . . . \$18.00

60 cycles—110 volts

Tungar

REG. U. S. PAT. OFF.

BATTERY CHARGER

Tungar—a registered trademark—is found only on the genuine. Look for it on the name plate.

Merchandise Division
General Electric Company, Bridgeport, Conn.

GENERAL ELECTRIC

38-7

The "Windham" Wire Former

A Handy Tool for

Electricians, Radio Fans and Mechanics

This rugged little tool not only makes accurate loops or eyes for No. 4, 6, 8 and 10 screws but will make either sharp or easy radius right angle bends and the sharp cutter will cut the toughest wire as well.

It is drop forged of the very best steel and carefully tempered in oil.

Retails for \$1.25

Dealers and Jobbers send for full information. Desirable territory still open.

THE GOYER COMPANY
Willimantic, Conn., U. S. A.



(Continued from page 54)

I told him, unburdened my bruised and bleeding soul to him, so to speak. He listened attentively until I had finished the whole harrowing tale.

"Is your uncle's housekeeper present when these spirit manifestations take place?" he asked.

"No. I mean she wasn't around last night, anyway. Not a sign of her."

"You say you examined the table carefully?"

"Righto! It's just an ordinary table; been in the family for years."

"Does your uncle, when he is communicating with the spirits, ask questions which the table answers?"

"No, the table seems to do all the talking. I mean to say it raps out messages like—like . . ."

"Like a telegraph instrument?"

"Yes, by Jove, that's it exactly; just like a telegraph instrument. Unc takes the messages down in a little book."

"H'm, I wonder if there's any chance of my sitting in on a seance; I'd like to see the table perform. Perhaps you can palm me off as being somewhat of a medium myself."

"What, Ho! There's a brainy thought," I said, jumping up, "we can't get ruled out for trying, anyway. Come along, I'll speak to the old boy about it."

"Wait a minute," he answered, "I want to get something out of my bag. And by the way, Reggie, you wear a wrist watch; let me borrow it for a while."

"What for?" I asked, unstrapping the watch and handing it to him.

"Never mind; tell you later."

He ran out to his car, fussed around for a moment getting something out of his bag, and was back on the porch in a jiffy.

"All right, Reggie, my boy, lead the way."

We found Uncle Marmaduke in the library with Mrs. Hoagworth. She was talking to him in low tones, but cut her conversation off sharply as we entered.

"Here's good news, Unc," I said, "Meet Professor Bill Curtiss, world-famous medium, the man whose remarkable psychic powers have baffled the scientists of two continents."

Uncle Marmaduke smiled weakly and bowed; but the Hoagworth woman sat bolt upright in her chair and gave me another hard look. I pretended not to notice it, however, and babbled on. "I was just telling the prof about your table rapping stunt, and he says that's kindergarten stuff. He can make it do a song and dance. Eh, professor?"

"I'm afraid your nephew overestimates my ability," Curtiss said, smiling, "I'm merely a student of the occult, and would appreciate attending one of your seances."

(Continued on page 58)

NO-DIAL (Patented)

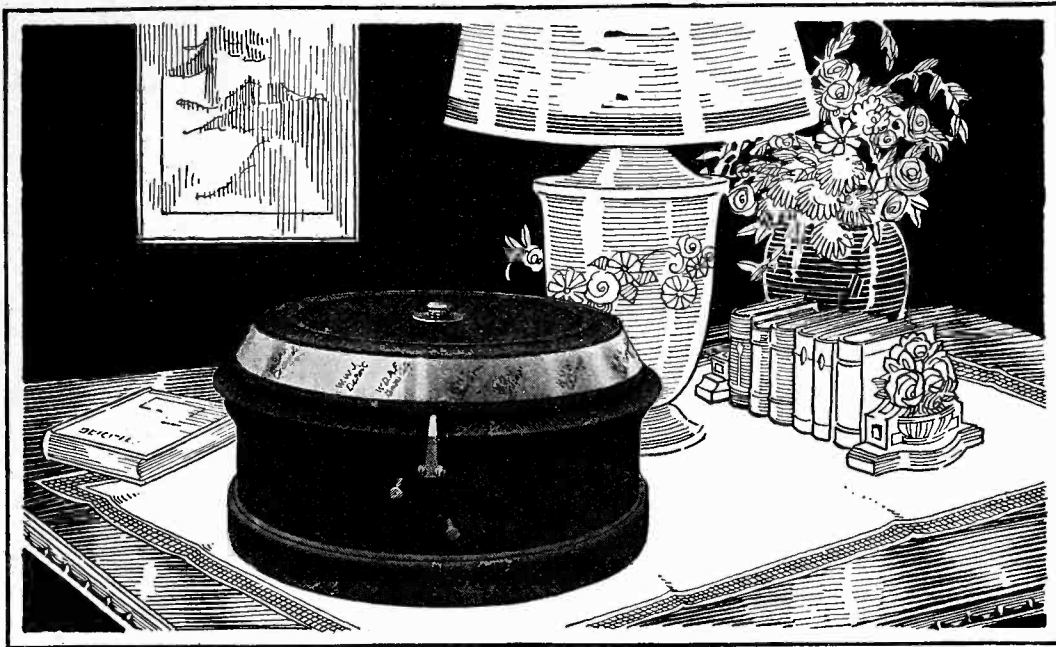

Licensed under Blackmore's Patents and Patents Pending, Hogan Patent No. 1014002

Revolutionizing Radio Operation

The "NO-DIAL" so simple in operation, so positive in performance, is just what you want

Dials are gone forever! Old-fashioned—obsolete! They served their purpose in the "radio pioneer days." Now up-to-date fans refer to them as primitive—pre-historic—"old-as-the-hills!"

Away with trouble, complicated tuning and puzzling operations! Scrap your log book! Forget your past disappointments.

For radio is SIMPLICITY itself now! Just what you predicted and everybody expected. You, who have waited for the "grief-less," and "worry-less" radio receiver, can buy NO-DIAL safely.

VISIBLE STATION RECORD

The NO-DIAL brings in stations far and near by merely rotating the cover. Each station comes in at a certain point. As stations are received they are recorded right on the cover (fig. 1) and thereafter they will always come in at the same point. Thus you have a *permanent* and *visible* station record which is positive and unailing.



*Permanent Visible Station Record.
A touch of the finger brings 'em in.*

Loud and Clear as a Bell

The tonal qualities of the NO-DIAL will please everyone, due to the fact that they are directly caused by our latest combination in resistance coupled amplification. The tonal qualities are so sweet, so clear, so mellow! Harshness and interfering noises are absorbed and never reach the ear. Volume is regulated with a control lever. Far distant stations come in almost as distinctly as local. Results are positive and instantaneous.

IT'S BEAUTIFUL

The NO-DIAL represents a complete departure in radio set design. It is housed in a compact, circular case finished in popular brown crystalline, a perfect match for most high grade loud speakers. Nothing to spot, scratch or mar. Easily cleaned with a damp cloth. Finally, it's trouble-proof and GUARANTEED.

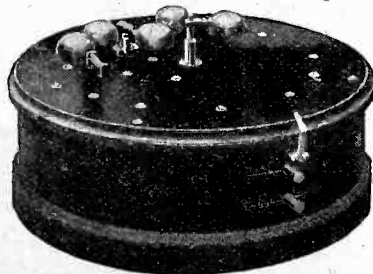

NO-DIAL with cover removed.

Tube for tube, the NO-DIAL recognizes no superior, and on test it has out-performed many higher priced receivers. The NO-DIAL will do everything any other single control set will do, and more, as regards fine volume, long range and clarity of tone.

See your dealer TODAY and ask for a demonstration. You'll be amazed.

As this is an advance announcement your dealer may not yet have NO-DIAL in stock. Write us for literature, sending dealer's name and address.

The Ohio Stamping and Engineering Company Dayton, Ohio, U. S. A.

*Super
Radio
Parts
for Better
Radio
Sets*

Benjamin Tuned Radio Frequency Transformers

Low Resistance—Low Distributed Capacity

Wires are space wound, adjacent coils are parallel, air insulated and so separated that while capacity is reduced to a minimum, inductance is maintained at a high point of efficiency.

Greater Tuning Range—Greater Selectivity

These coils are very uniform, both in inductance and distributed capacity, so that if desired they may be geared for single control of the three tuned stages. A minimum amount of material is used in the field of the coil, and an anti-capacity cement is used only where the wires cross. Coils are coupled so as to reduce capacity coupling to a minimum. Green double silk covering provides high insulation and gives a fine appearance to the coil.

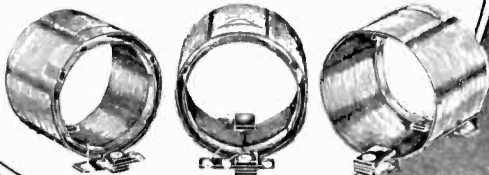

Benjamin Low Loss-Long Range Condensers

Straight line type. Definite and positive control of minute changes in condenser capacity, adapting it to both the higher and lower frequencies. Aids sharp tuning and increases selectivity.

No rear end plate. Minimum insulation. Leakage must go through long paths outside of strongest field. Unpolished silver plate finish. Small size of condenser makes it adaptable to any set, regardless of crowding of apparatus on sub-panel. Friction disc on rotor shaft adjusts tuning tension without throwing rotor plates out of alignment. Drilling template furnished with each condenser. Made in three sizes.

13 plate for .00025 Mfd.
17 plate for .00035 " "
25 plate for .0005 " "

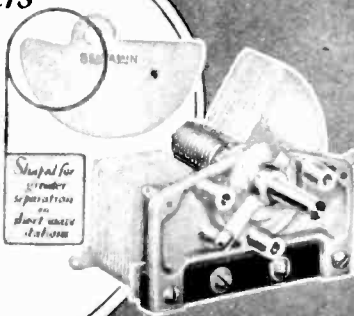

Benjamin Cle-Ra-Tone Sockets

Benjamin Cle-Ra-Tone Sockets prevent the transmission of outside vibrations into microphonic disturbances. Four delicately adjusted springs support the socket—"float" it above the base—and absorb all jars and shocks. An absolute necessity in portable sets. Used by leading manufacturers and recommended by radio engineers in their most popular hookups. There are no rubber parts to deteriorate. Bakelite is used wherever possible to insure sturdiness, long life and high insulation. Handy lugs make soldering easy. Still bus wiring does not affect the flexibility of the Cle-Ra-Tone springs.

Made also in gang sockets, mounted on Bakelite shelf, with binding posts and markers, leaving plenty of space for the mounting of accessory equipment.

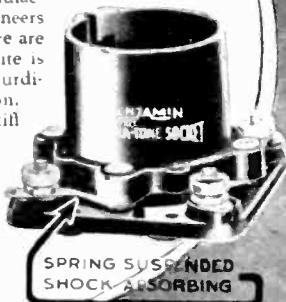

SPRING SUSPENDED
SHOCK ABSORBING

Any one of these important elements will improve, in its particular functioning, the quality of reception. In combination they mean all that is humanly available today in eliminating disturbance and distortion, in reducing radio losses, in increasing tuning range, in providing greater selectivity, and in improving the appearance of a set. Just take their individual advantages and add them up—the answer is "Better Radio."

For further information address the nearest office

Benjamin Electric Mfg. Co.
120-128 S. Sangamon St., Chicago
147 W. 17th St. 448 Bryant St.
New York San Francisco
Manufactured in Canada by the Benjamin Electric
Mfg. Co. of Canada, Ltd., Toronto, Ontario

(Continued from page 56)

"He doesn't hold seances," the Hoagworth woman interrupted.

"Oh, I beg your pardon," Curtiss said smoothly, "No doubt, I misunderstood the facts. If Reggie, here, were simply boasting, why . . ."

Sunken into the depths as he was, Uncle Marmaduke had still retained a few drops of the old Rockford-Peebles sporting blood. I mean to say that what Curtiss said rather cut him. His face went red, and he completely disregarded the warning glance which Mrs. Hoagworth shot at him.

"I make no claim at being a medium," he said testily, "but if the spirits see fit to communicate with me, I see no reason why you shouldn't witness the phenomenon."

I started to shout, "bravo"; but changed it into a cough when I caught the expression on Mrs. Hoagworth's face. I've seen the same look on some of the wild animals at the zoo; a sort of oh-if-I-could-only-get-at-you-for-about-a-minute effect.

"The spirits seldom manifest themselves at this time of day," she said.

"Indeed?" Curtiss replied, giving it the rising inflection, "Then perhaps we'd better not disturb them. Frankly, I had my doubts regarding the matter, anyway."

This was too much for Uncle Marmaduke.

"See here, young man," he fumed, "I'll have you to understand that my nephew told you the truth. Come up to my room; and I'll prove it." He turned to Mrs. Hoagworth, and went on in a wheedling voice. "There can't be any harm in it. Why don't you join us?"

"I'll have nothing to do with it," she said frostily.

She arose, swept out of the library and up the stairs, with the rest of us following along behind to Uncle Marmaduke's room. In the light of day, it wasn't so dashed spooky. In fact, I was beginning to get quite a kick out of the affair. We waited for about five minutes, and then the table signalled a message. Rat-tat-tat. It was followed by a pause, and, at length, a prolonged rapping. When the knocking finally stopped, Curtiss roused himself from his seat near the table.

"A remarkable psychic demonstration," he said, "Did I understand you to say that you had no control over these spirit manifestations?"

Uncle Marmaduke nodded. "I haven't anything to do with it. Whenever the spirits have a message for me, they knock on the table. Mrs. Hoagworth taught me how to translate the rappings. You see, the various knocks stand for different letters of the alphabet. For instance, one short knock followed by one long one stand for the letter A."

(Continued on page 60)

The Five Tube
Set which
startled
the World!

**FRESHMAN
MASTERPIECE**

The Greatest Value
Ever Offered in A
Radio Receiving Set

At Authorized Freshman
Dealers Only

The MOLLIFORMER "B" UNIT REPLACES "B" BATTERIES

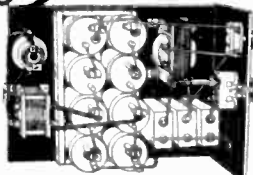

BUILD IT YOURSELF

You can assemble this powerful B Unit in an hour, at a great saving, and use the current from the light socket. Excellent for Supers and all TRF Sets—Noiseless—no Tubes or acid—Utilizes full wave rectification. Guarantees greater Clarity, DX and Volume at cost of 1/10c per hour. Completely eliminates "B" Battery, and is sold with a positive GUARANTEE of satisfaction or money refunded. Write for descriptive circular.

PRICE

Complete Kit—	\$22.50
60 Cycle Unit	
Complete Kit—	24.50
25 Cycle Unit	

Kits include Rectifiers.

Parts sold separately if desired.

DEALERS—Write for our proposition.

C. E. JACOBS, Sole Manfr.

2808 N. Kedzie Avenue

CHICAGO

Based on proved Kellogg principles, this new "loud speaker" allows the reproduction of the entire auditory range successfully. To appreciate it, is to hear it.

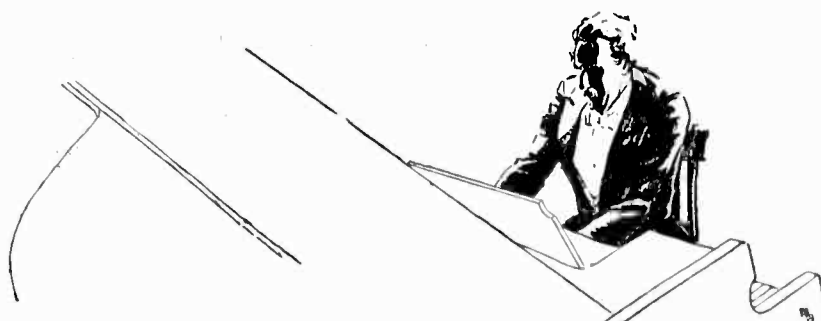

A Revelation in Tone—Volume—Clarity



"That Old Quartette"
*Every Note Clear~
Perfect Harmony!*

At all good dealers

"Not Merely a Loud Speaker"

Here is a "loud speaker" that brings the artists into your very room, so realistic is its reproduction.

Piano music, the most difficult to reproduce, sounds so natural that you are carried away by its beauty.

Vocal selections retain all of the colorings of the artist.

Orchestra music is a treat, every instrument can be heard, clear and full.

Magnetic diaphragm control—used exclusively in the Kellogg Unit—is the

new principle that performs these wonders in radio reception.

No excess vibration, no chattering, every tone true.

The Kellogg Unit is available for use with a phonograph, and will reproduce voice or music with a full, sweet, clear tone.

A popular instrument. The Kellogg Symphony Reproducer is a revelation in Tone - Volume - Clarity.

At your dealers for \$20.00—Hear one today.

KELLOGG SWITCHBOARD & SUPPLY COMPANY, Chicago, Illinois

Kellogg Symphony Reproducer

With every Kellogg Radio part, Use—Is The Test

OUT SEPTEMBER 10th

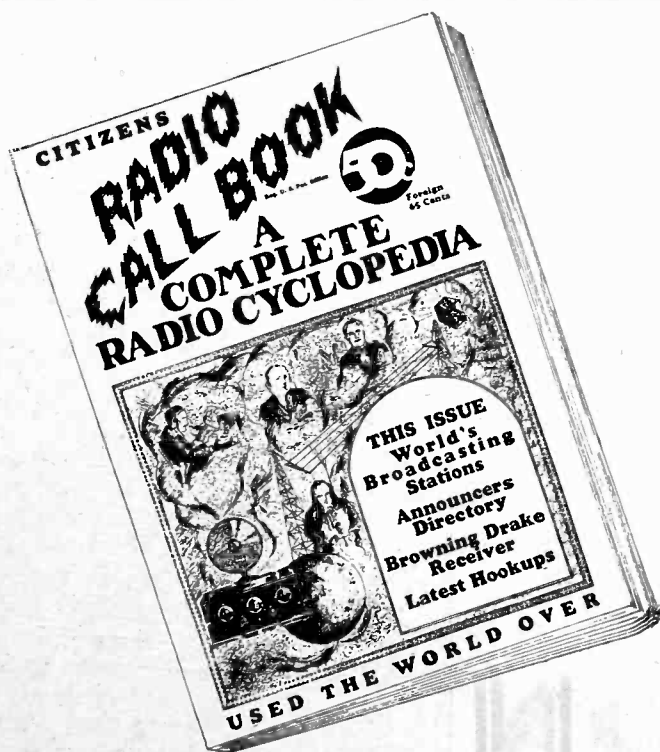

The Fall issue of the **CITIZENS RADIO CALL BOOK** will be ready about the tenth of September.

BIGGER AND BETTER THAN EVER
It will contain many new features in the form of articles showing how to build a 45 kilocycle Superheterodyne, Browning-Drake, 6 Tube Tuned Radio Frequency Receiver, Counterflex 8 Tube Superheterodyne, Roberts and many others.

Also a very complete directory showing pictures of radio announcers and artists. Calls and schedules of Broadcasting stations all over the world, maps, log sheets, etc. Price 50 cents.

**ATTENTION AMATEURS:
COMPLETE REVISED AMATEUR
SECTION**

OUT SAME DATE

BE SURE TO WAIT FOR IT

(Continued from page 58)

"Yes, I understand that," Curtiss answered, "In fact, I was able to translate the message. It was, 'Put not your faith in false prophets; for they shall vanish away!' I've had considerable experience with these kind of spirit messages myself."

"You don't tell me?" he said, perking up in his chair.

"Yes, indeed," Curtiss went on, "and what's more, I can usually control the spirits, make them give me messages whenever I'm in the mood. If you'll excuse me for a moment while I run down to my car, I'll be glad to conduct a seance right now."

By this time, Uncle Marmaduke was so tickled that he was twisting about like an electric fan.

"Oh, by all means! I would be delighted, positively delighted. And so will Mrs. Hoagworth, I'm sure. I'll send for her."

But he didn't have to send. Curtiss had hardly left the room when in popped Mrs. Hoagworth, her face the color of a bottle of ketchup.

"See here," she shouted, "What's the idea of letting this bum put on a seance? Let this bunk artist pull any of his tricks around here, and I warn you, you'll regret it."

"I can't see why the seance should have any serious consequences. What is there to warn me about?"

"There's this," she hissed, "The minute this smart Alec starts his tomfoolery in this room, it means that the hour of your passing is at hand. Just think that over."

With that, she turned and bounced out of the room, slamming the door behind her.

Uncle Marmaduke turned a bit pale; but there's no denying that the old boy was game. He didn't even flicker an eyelash when Curtiss returned, bringing with him a couple of dry cells, a coil of wire, a push button and a little oblong box, all of which he placed on the bureau.

"Before we start the seance," he began, "I want to explain my interest in this table of yours. It is the only spirit table I know of which transmits messages in Morse code. When Reggie told me about it, I was so fascinated that I decided to try a little experiment. I borrowed Reggie's wrist strap, took out the watch, and inserted a compass in its place." He took off the wrist strap, handed it to Uncle Marmaduke, and went on, "Ordinarily, the hand of the compass points north and south. But when the compass is brought into an electro-magnetic field, the hand points in the direction of the electro-magnet. I noticed that it did that very thing during the time you were receiving the spirit message; that is, instead of pointing north and south, it pointed toward the table."

(Continued on page 62)

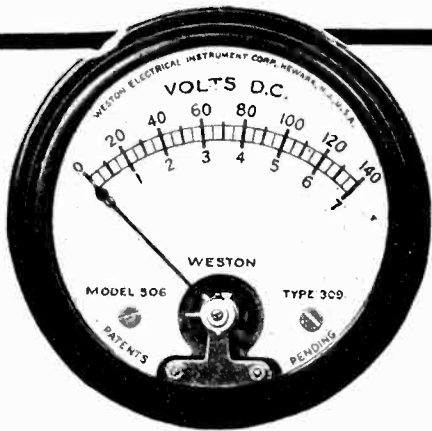

A New Two-Inch Radio Panel Voltmeter of Weston Standard Quality

THESE Model 506 instruments fill a longfelt need for small Panel Voltmeters for radio receiving sets. They have all the precision, craftsmanship of assembly and ruggedness of the famous Weston line. Made in single and double ranges for measuring filament and battery voltages, they have an exceptionally high internal resistance—125 ohms per volt. Regularly made with a black finish and narrow flange type of case; fastened to the panel with a special type of clamp supplied with each instrument.

For further information address Pacific Coast Representatives

WESTERN ELECTRIC COMPANY
Seattle, Wash.

J. H. SOUTHARD
San Francisco, Calif.

A. A. BARBERA
Los Angeles, Calif.

REPAIR SERVICE LABORATORY
682 Mission Street
San Francisco, Calif.

WESTON ELECTRICAL INSTRUMENT CORPORATION
156 Weston Avenue, Newark, N. J.



STANDARD THE WORLD OVER
WESTON
Pioneers since 1888



ARE YOU A SUBSCRIBER?

Send \$1.00 for a trial subscription to "RADIO" for 6 months.....

A NEW HI-MU TUBE THE HI-CONSTRON TUBE

Model 101A

A Cleartron Product

For resistance coupled amplifiers, also intermediate steps super-heterodyne and in Radio Frequency receivers.

GREATER VOLUME BETTER QUALITY

The Hi-Constron is a Hi-Mu tube with an amplification constant of 20 that has been especially designed for resistance coupled amplifiers. The Hi-Constron was the first Hi-Mu tube offered for sale to the general public and is the result of years of research work. Others may imitate the Hi-Constron in appearance, but none surpass its quality.

CLEARTRON VACUUM TUBE CO.

28 WEST FORTY-FOURTH STREET, NEW YORK, N. Y.

Factory: West New York, N. J.

We also manufacture:

C-T 201A

C-T 400 Rectron Tubes for B Battery Eliminators

C-T 199 Standard Base

C-T 199 Small Base

Above Types \$2.50

(Except the HI-CONSTRON, Which Sells for \$3.00)

CLEARTRON

GUARANTEED RADIO TUBES

Pacific Coast Distributors:

HOLBROOK, MERRILL & STETSON
665 Sixth St., San Francisco, Calif.



FADA Radio

If it's in the air
Fada gets it

PUT Fada *into* your home today.

It will prove its right to *stay* there.

Simply ask your dealer to install a Fada Neutrola-Grand, let him set the dials for you, and then leave the operation in your hands.

Simple to operate—Clear, perfect speech—
Music just as it is sung or played—Distant
stations without a jumbled program—No
screeching or whistling—And—cabinets
that harmonize with beautiful interiors.

Ask the dealer who specializes on Fada to ar-
range for a real test in your own home—tonight.

*There is a Fada Radio model for every purse—
all 5-tube Neutrodyne sets for dry cell or storage
battery tubes, from \$85 to Art Cabinet models up
to \$400.00.*

F. A. D. ANDREA, INC.

Chicago New York San Francisco

Fada Radio, Ltd.—Toronto

Fada Radio, Ltd.—London

*Manufacturers of TUNED RADIO FREQUENCY receivers using
the highly efficient NEUTRODYNE principle.*

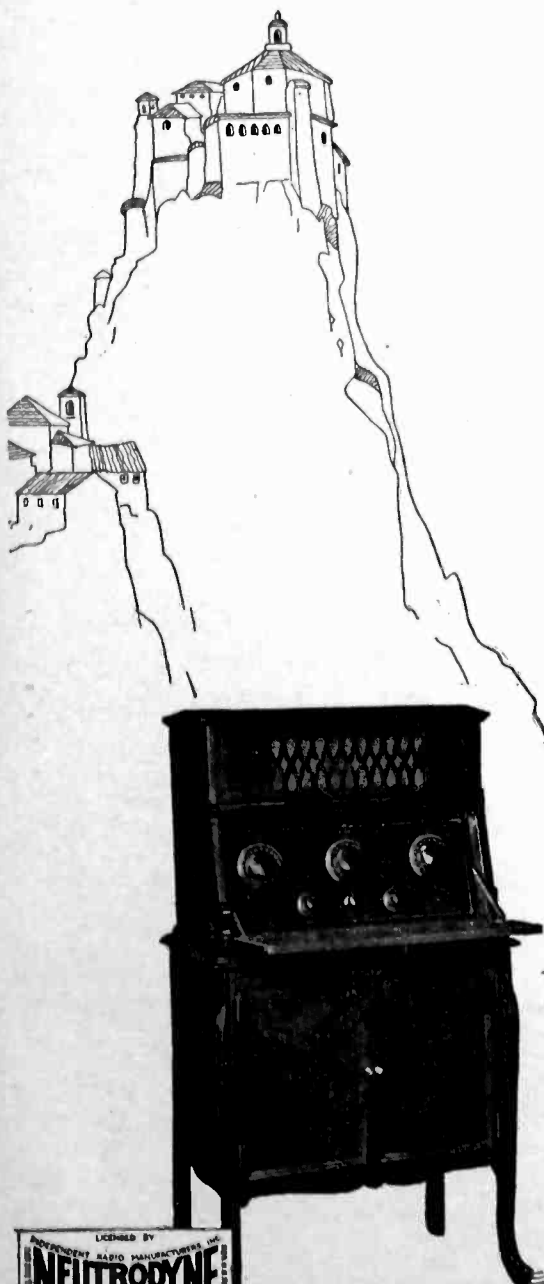

Fada Neutrola-Grand
\$225. Adapted for dry
cell or storage battery

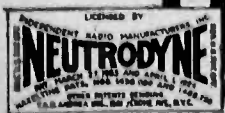

Tell them that you saw it in RADIO

(Continued from page 60)

"But—but what has all that to do with the spirits?" Uncle Marmaduke inquired, fidgeting about like a small boy waiting for dessert.

"I'm coming to that," Curtiss resumed, "just have patience. Now there's another little device which is also affected by electro-magnetic waves. It is called a coherer; and it consists of a glass tube filled with particles of iron between two solid electrodes. These particles of iron offer resistance to an electric current under normal conditions. but when they are brought into the presence of electro-magnetic waves, they cohere, and allow the current to pass through. The result is that you can transmit signals between two points without the aid of connecting wires. In fact, the coherer is one of the earliest radio receiving devices. To demonstrate . . ."

He had been hooking up the dry cells to the oblong box as he spoke. Now he did something to the push button. There was a series of shrill buzzes and the snapping of electric sparks. But what bowled me over, so to speak, was that the table was rapping with every buzz coming from the oblong box. Uncle Marmaduke fairly bounded from his chair.

"What's that?" he gargled, "What does this mean, sir?"

"It means," Curtiss said calmly, "that if you search Mrs. Hoagworth's room, you'll probably find just about the same equipment which I have here—a spark coil, a battery, and a push button or telegraph key. Moreover, if you'll remove the top of the table, you'll find a coherer arranged so that the hammer of the bell strikes against a hollow wooden block. I'll pay for the table just for the satisfaction of proving that I'm right."

He snatched up a poker which stood by the fireplace, and whacked it across the table, splitting the top. Sure enough, concealed in a little partition just underneath the broken top, was a couple of dry cells and the apparatus he had described.

"Why, sir," Uncle Marmaduke roared, "Mrs. Hoagworth has been sending me all these messages herself! I see it all now! It's a fake! I've been deceived!"

"It's a fake, all right," Curtiss said with a grin, "but you haven't exactly been deceived. I'd say that the table gave you some rather reliable advice. Didn't it warn you against false prophets, and didn't it tell you they would vanish away? Well, if you'll just glance out of the window, you'll see Mrs. Hoagworth vanishing down the road."

Deucedly clever chap, this fellow Curtiss. What!

At Last You Can Tell What Your Tubes Can Do



Superadio Dynometer illustrated above is entirely different from conventional meters. It tells if tube is underaged, gassy, etc. Enables tubes to be matched and tests 3 per minute. It's easy to operate—no complicated calculations or curves are necessary.

SUPERADIO SUPERHETERODYNE KIT only \$17.50

Here is the ideal kit to build the new Superheterodyne. Marvelous results. Contains 1 Antenna Coupler, 1 Oscillator Coupler, 1 Special Variable Condenser, 1 Tuned Filter Transformer, 3 Matched In-

SUPERADIO VACUUM TUBE DYNAMOMETER

This revolutionary Meter measures easily, with positive accuracy, the power of any vacuum tube on the market. No more do you have to buy a "pig in the poke." Now, you can get that "best" audio or radio frequency amplifier or that "right" detector tube. And you can always duplicate your tubes when it comes to renewal. Insist on having your tubes tested before you take them home.

The Superadio Dynometer is equipped with telephone headset, cord and plug, together with complete simplified instructions.

Every Set or Tube Manufacturer, every Jobber or Dealer will want this necessary Meter.

Reliable Representatives wanted in larger cities. Write for details.



termediate Transformers and all necessary hardware with diagrams, layouts and complete Superheterodyne Treatise by Louis C. Billotte. Write today for information.

DeWITT - LaFRANCE CO., Inc.

54 Washburn Avenue

Cambridge, Mass.

Boston Representative:

Martin, Hartley & Dewitt Sales Company

99 Bedford Street

Chicago Representative:

William A. Welty & Company

36 South State Street

Send \$1.00 for a trial subscription to "RADIO" for 6 months



The 100% Self Shielded Transformer

has made a big hit with both set makers and set manufacturers because of its small size, its amazing volume, and most of all, because of its pure, undistorted tone. It is half the size of other transformers, but its results are unsurpassed. Absolutely new and scientific design and construction. Ratios 1 to 3, 1 to 4, 1 to 5, \$3.50; Ratio 1 to 10, \$4.50. SEND FOR BULLETIN No. 94. Read all the exclusive features of this and other Premier parts. Tells how to get free hook-up diagrams beautifully printed in two colors.

Premier Electric Co., 3813 Ravenswood Ave., Chicago

PREMIER Quality Radio Parts

"B" BATTERIES

AN EVEREADY PRODUCT

At Standard Prices

43V. Batteries, tapped
22½ V. Batteries, Navy Type
22½ V. Batteries, Commercial Type

Latter two types especially adapted to Cunningham and Radiotron Tubes.

Postage Prepaid Anywhere in U. S.

ETS-HOKIN & GALVIN

Wireless Engineers

10 Mission Street San Francisco

Tell them that you saw it in RADIO

YANKEE TUBES

Types 201-A and 199

"A Yankee Yields To None"



Trade Mark
Registered

THE Manufacturers of Yankee Tubes have only one aim—to make the best tubes it is possible to build. To judge by the enthusiasm with which dealers and set manufacturers have received the latest types, this is to be a Yankee year.

In order to make sure of your quota of Yankees for the rapidly approaching season, write today for our special proposition to dealers.

Baldwin-Pacific & Co.

Pacific Coast Representatives

Pacific Building

San Francisco, California

"Simplify Radio" says Daven



Daven Engineers Blaze Another Trail



THE biggest of all the little things in radio is the grid leak. The Daven Grid Leak is known the world over as the grid leak of permanent, constant value. It is standard.

Almost as important is the condenser. But grid condensers change with temperature and humidity. The mica in condensers lacks uniformity or is impure. The tin foil plates melt or change their capacity.

In their constant efforts always to simplify and to improve, Daven engineers have made a remarkably effective combination of grid leak and condenser. Two-in-one!

The New Daven Tube

Type MU-20 increases the amplification of the Daven Super-Amplifier to equal or exceed that obtainable with transformer coupling. A one-purpose, three-element tube, 6 volt, 1/2 ampere—\$4.00 each. Daven Power Tube Type MU-6 is recommended for last or output stage—\$5.00.

THE DAVEN LEAKANDENSER

IT is so simple, so effective and so sturdy that you will wonder why it was not thought of before.

Similar in size to the Daven Grid Leak, it takes the place of the usual grid condenser which has shunted around it the usual grid leak. Made with five different values of grid leak resistance, 2, 3, 4, 5 and 7 megohms. The grid condenser capacity is fixed and correct for all makes of detector tubes.

With every Leakandenser a pair of new snap fastener clips that do not permit it to shake out. Precision-Built. Price \$1.00 each.

Manufacturers are invited to send for a sample.

THE HANDBOOK OF RESISTANCE COUPLED AMPLIFICATION

The authority on this important subject is THE RESISTOR MANUAL. At your dealer's 25c. By mail postpaid 35c.

DAVEN PRODUCTS ARE SOLD ONLY BY GOOD DEALERS

"The Sine of Merit"

DAVEN RADIO CORPORATION

Resistor Specialists

Newark

Reg. U. S. Pat. Off.

New Jersey

USE THIS FREE COUPON

A-9-25

DAVEN RADIO CORPORATION
158-160 Summit Street, Newark, New Jersey

Please send me the following on Resistance Coupled Amplification:—

- Resistor Manual. 25c is enclosed.
 Complete catalog (free). Check one.

Name.....

Address.....

For Dealers: Send your letterhead or card, or this coupon and we will have our nearest distributor communicate with you.

THE BIG LITTLE THINGS OF RADIO

SUPERTRAN

AUDIO TRANSFORMER

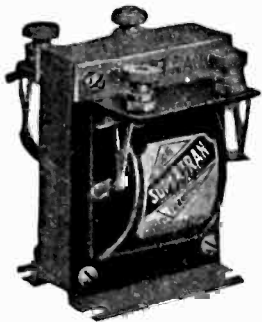

Leads
Them
All In
Quality
Value
and
Service

Distributed By

- L. W. Cleveland Co., Portland, Me.
- Waite Auto Supply Co., Providence, R. I.
- Gray Sales Co., Philadelphia, Pa.
- Rice Hitt Co., San Francisco, Calif.
- E. B. Denham, Seattle, Wash.
- S. B. Darmstadter, Chicago, Ill.
- Whiting Radio Co., Bridgeport, Conn.
- Paterson Radio Co., Paterson, N. J.
- Buffalo Radiophone Co., Inc., Buffalo, N. Y.
- The Jack L. Hirsch Co., Denver, Colo.

FORD RADIO & MICA CORP.
111 Bleeker St. New York



The TOWN CRIER
Radio's Most Beautiful Speaker

Send for illustrated description, in colors, of the Green and Golden Polychrome Models. Ask Your Dealer to Show You a Town Crier.

\$17.50 List Price.
\$18.50 West of the Rockies.

Representative: S. A. WINSOR
1221 Venice Boulevard Los Angeles, Calif.
GALE RADIO LABORATORIES
2511 Irving Park Boulevard CHICAGO

TRANSMITTER OF 6XAD

(Continued from page 39)

to waves between 10 and 80 meters, we can so proportion the set that the inductive coupling can also be fixed, so that as the frequency is increased, and the coupling effect of the tube increases with it, this coupling becomes more of a controlling factor and the inductive coupling between L_1 and L_2 becomes more of an erasing factor, keeping the capacity coupling in a more or less constant excess.

In this manner the circuit is not easily affected by changes in the antenna circuit, and most of the feedback energy is effected within the tube, thereby relieving the grid lead-in wire and the grid itself of practically all strain.

Circuit L_1C_1 should be coupled as loosely to the plate as possible, and yet transfer the necessary amount of energy, so that the coupling condenser C_3 need only be slightly greater than the plate-filament capacity of the tube. This condenser functions not only as a plate blocking condenser but as a grid coupling condenser, for it is clear from the diagram that the grid circuit receives its energy from L_1C_1 by virtue of three capacities in series (C_3, C_4, C_5). If C_3 and C_4 are small, the possible effect of L_2 on L_1 is very slight, and the effect of L_1C_1 on L_2C_2 is limited by the weak capacity coupling through C_3, C_4 and C_5 . The series capacities C_3 and C_4 are parasitic capacities in parallel with C_1 but are so small that where they changed in value, the effect on the constancy of frequency of L_1C_1 would be very slight. The same is true of the two series capacities C_4 and C_5 and their consequent effect on L_2C_2 .

The circuit, therefore, is very stable and can be relied upon to deliver oscillations of a steadiness rivalling that of the master oscillator-power amplifier system controlled by an oscillating crystal, such as is used at NKF.

The antenna used with this transmitter is a single wire 75 ft. high and is worked on the 3rd harmonic of 120 meters, being connected to a buried ground system which covers nearly 1/4 acre. The special house in which the transmitter is placed is entirely encased in chicken wire, which is bonded and grounded at various points.

Best's Super-Heterodyne

DESCRIBED IN LAST MONTH'S ISSUE

25c per copy

A Few Copies of August "RADIO" Are on Hand. Get Your Copy Now!

"RADIO," Pacific Building, San Francisco

INSURE YOUR TUBES

BY CONSISTENT USE OF

BURTON & ROGERS TUBE FLASHER

\$7.50

BRINGS BACK BAD TUBES

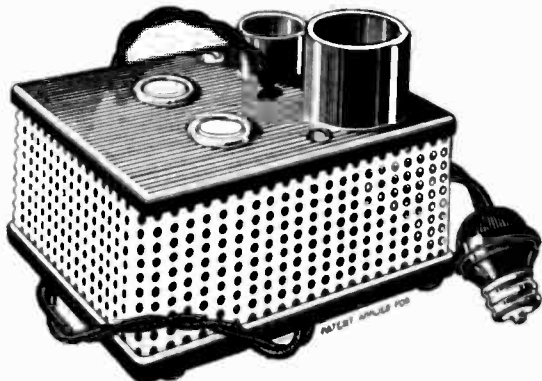

Developed by an organization skilled in the manufacture of electrical instruments and sensitive electrical apparatus.

Correct Engineering—Utmost Simplicity of Operation—One Model for D.C. or A.C.—Any Number of Cycles.

Filament does not cool for an instant during flashing.

Results will exceed your expectations.

Cannot be burned out—Fully guaranteed.

For tubes with thoriated filaments—types 201-A and 199 only.

Send for pamphlet "SAVE A LIFE"

BURTON & ROGERS MANUFACTURING CO.
755 Boylston St., Boston, Mass.

RADIO

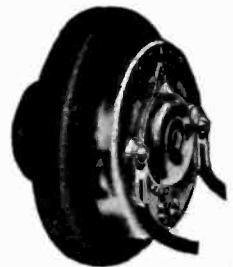

Type B

Price \$6

The success or failure of your radio apparatus for 1925-6 season (the greatest in radio history) will depend more on the loud-speaker unit than any other single component.

May we tell you why, also why our products will bring you all the results you are hoping for?

THE MOZART-GRAND CO.
MANUFACTURING FINE RADIO APPARATUS
At 235-49 ELIZABETH AVE.
NEWARK N.J. U.S.A.

Get One of These PREMIUMS FREE with your subscrip- tion to "Radio"

Take your choice. Select one of the premiums listed in this advertisement. Send us only \$2.50 in full payment for a full year's subscription to "RADIO" and the premium.

Electric Soldering Iron

A dandy 110-volt electric soldering iron (MARVEL). Get this iron free with only one subscription to "RADIO" for one year.

Phonograph Unit

The Union Fabric radio phonograph unit given free with one subscription to "RADIO" for one year. Full price, \$2.50.

Variable Condenser

The Kelford 21-plate lowloss variable condenser free this month with one subscription to "RADIO."

Lefax Radio Handbook

The seventh edition, bound form, Lefax Radio Handbook, free with only one subscription. Full price, \$2.50.

2000 Ohm Headphones

The Big Three Radio Corporation's 2000 ohm headphones given free this month with one subscription to "RADIO" for only one year.

ORDER NOW. This Offer Will Be Withdrawn Shortly

----- COUPON -----

"RADIO," Pacific Building,
San Francisco, California.

Here is \$2.50. Send me "RADIO" for one full year and the following premium:

Name

Address

City and State.....

13

New Models \$36⁵⁰ to \$130

MARWOL

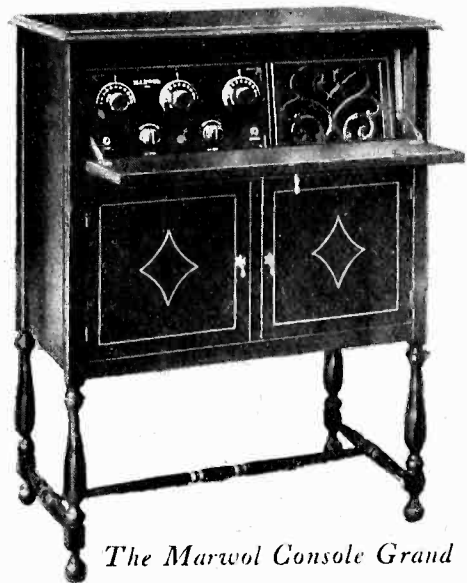

The Marwol Console Grand

Viewed from every standpoint—quality, beauty or results—every receiver in the MARWOL Line this year offers the greatest dollar for dollar value in radio. The Line includes 13 numbers—cabinet type receivers, console type receivers, receivers with enclosed loud speakers, phonograph panels, knock-down sets, and loud speakers.

MARWOL dealers and jobbers know from experience that MARWOL'S sound business policy is not merely talk but an actuality. MARWOL stands solidly behind its ironclad guarantee, price maintenance, and delivery agreements.

A new factory with more than 25,000 square feet has been added to the MARWOL Plant. There will be no disappointments or delayed shipments for dealers handling MARWOL.

Added Co-operation will be given MARWOL dealers this year with a dominating advertising campaign to consumers in The Saturday Evening Post, other magazines and newspapers. Generous trade helps are also free to dealers.

Write today for catalog of the complete line and full information. This is YOUR big opportunity! Don't miss it!

MARWOL RADIO CORPORATION
546 Broadway, New York City

Represented by

In California:
MARSHANK SALES CO.
926 Insurance Exchange Bldg.
Los Angeles, Calif.

In Oregon, Washington, Idaho:
C. E. GAY
166 Lowndale, Street
Portland, Oregon

Startling! Revolutionary! These



Crosley is the world's largest builder of radio sets and has built up a tremendous volume by offering the highest quality receiving sets at the lowest prices. More than a million satisfied users is the strongest testimonial of Crosley quality, simplicity, durability and value.

\$1000

Grand Prize!

Pedigreed Puppies and Larger Crosley Radios as Monthly Awards.

Who will send Crosley the best verified report of reception with a one-tube radio between September 1st and March 1st of next year?

Who will send the best report each month?

\$1000 prize for the best report for the entire period. A real live pedigreed puppy each month as first monthly prize and larger Crosley radio sets as other prizes. Contest open to all, except Crosley employees, no matter where you are or what set you own or use, factory or home built. Reports of reception must be verified. Judges may ask for affidavits.

Full details of the contest and entry cards are packed with each Crosley Pup or may be obtained from any Crosley dealer or upon application to The Crosley Radio Corporation, Cincinnati, Ohio. Try for the prizes as many times and as often as you like. Remember! The Crosley "Pup" is offered as a real selective, long range receiving set. It requires one dry cell, one B battery block, one WD 12 tube, a pair of head phones and antenna. Other similar one-tube Crosley receivers bring in stations from coast to coast, with frequent reports of trans-Atlantic reception in the United States.

The CROSLLEY Pup

A Genuine Armstrong Regenerative double circuit receiver



Radio, with all its romance, knows no more magic name than Crosley.

From the time that Powel Crosley, Jr., first enabled millions to build their own sets by offering parts at a fraction of existing prices—down to the present day, radio progress and Crosley achievements have gone hand in hand. Now Crosley announces not only vital improvements in radio performance—but in the Crosley "PUP" offers this finer performance at the lowest price in radio history.

This compact, efficient receiver is a development of the famous Crosley one tube set, with which Leonard Weeks, of Minot, N. D., heard the MacMillan Polar expedition while the rest of America listened in vain.

The employment of the double circuit not only reduces radiation to a minimum, but radically improves selectivity. It can be tuned through local stations more readily.

Under average conditions, its radius, with head phones, is 1500 miles or more.

You can use the "PUP" to check the performance of your larger set; to entertain the youngster whose curious fingers cannot resist the lure of dials and switches; to install in the maid's room, or even in your office—for the air is full each day. You can take it on canoe trips, picnics, outings, and on your business journeys—for it's only half the size of a shoe box. Engineered and built to the strictest standards of Crosley Quality, this genuine long distance set can be offered at the phenomenal price of \$9.75 only because of its simplicity and Crosley's tremendous manufacturing facilities.

\$9.75
WITHOUT ACCESSORIES

ADD 10% TO ALL PRICES WEST OF ROCKY MOUNTAINS

Crosley manufactures receiving sets which are licensed under Armstrong U. S. Patent No. 1,113,149 and priced from \$9.75 to \$60.00 without accessories.

Crosley owns and operates WLW, first remote control super-power broadcasting station.

CROSLLEY

**THE CROSLLEY RADIO CORPORATION
CINCINNATI**

Tell them that you saw it in RADIO

new developments of Powel Crosley, Jr.

3 Tubes Do the Work of 5 in These New SUPER-TRIRDYNS!

You have not heard the perfection of radio reception until you have listened to these two new Super-Trirdyns. There is no radiation. Distant stations come in clear and sharp on the loud speaker and can be accurately logged. Solid mahogany cabinets of exquisite beauty and design.

DE LUXE COMBINATION

At the extreme right sketched in outline is the new Super-Trirdyn Special De Luxe Combination. It consists of a handsome solid mahogany table, the Super-Trirdyn Special (batteries self contained) and the Musicone De Luxe. Sold separately if desired. Table \$25. Musicone \$27.50. Combination \$112.50.

Other CROSLLEY RADIOS for Every Pocketbook

In the Crosley one tube sets, one tube does the work of three, making possible the enjoyment of real long distance reception with dry batteries. Model 50, without accessories, \$14.50. Model 50 Portable, without accessories, \$16.00.

More than 150,000 Crosley two tubes 51's have been made and SOLD in less than two years. Local and nearby stations on loud speaker always and distance up

to 1500 miles under average conditions. Model 51, without accessories, \$18.50. Model 51 Portable, without accessories, \$23.50.

The Crosley three tube sets embody the Armstrong regenerative circuit and two stages of audio frequency amplification. Distant stations come in on the Musicone with exceptional clearness and volume. Model 52, without accessories, \$27.50. Model 52 Portable, without accessories, \$32.50.

BETTER PERFORMANCE—BIGGER VALUES!

The new low-priced models shown below represent radical improvements in selectivity, performance, appearance and value. More selective control and improved receptivity have been achieved by the use of the new worm type tickler, the new Crosley Vernier plate

condenser and the double circuit. Radiation is thus reduced to a minimum. Both are genuine Armstrong regenerative circuits, the 51 with one stage of audio frequency amplification; the 52 with two.

SUPER TRIRDYN REGULAR
\$50

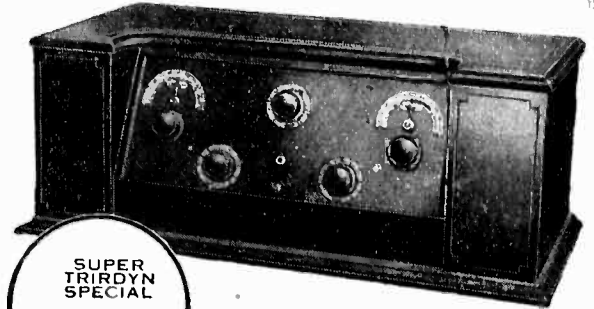
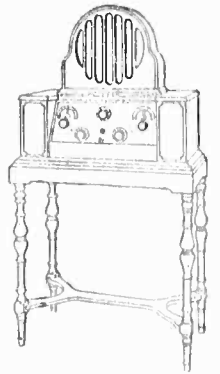
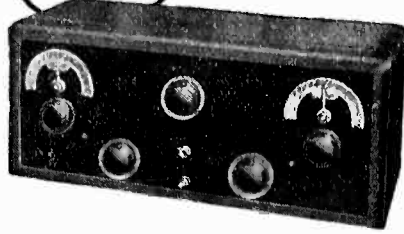

SUPER TRIRDYN SPECIAL
\$60

Crosley Musicones
Rapidly Replacing Other Types of Loud Speakers

The Crosley Musicone reproduces the full tonal range of the human voice and music without distortion, over tones, or chattering. It requires no adjustments nor additional batteries. Listen to the Crosley Musicone once—and you will never be satisfied with the best loud speaker you have ever heard. Covered by basic patents

\$17.50

THE MUSICONE DE LUXE
The Musicone has been artistically combined with a clock case of beautiful mahogany with a grilled screen. Price of **\$27.50**
Musicone De Luxe

\$23.50

\$32.50

New 2-Tube 51
Special De Luxe

Beautifully finished mahogany cabinet—sloping panel, new style controls—engraved metal dials—cabinet will hold all necessary dry cell batteries. Priced without accessories.

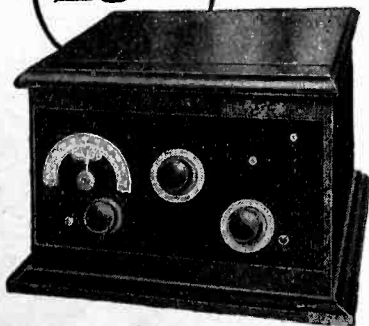

New 3-Tube 52
Special De Luxe

Exquisitely finished mahogany cabinet of latest design. Popular sloping panel, new style controls and art metal dials. Cabinet will hold all necessary dry cell batteries. Priced without accessories.

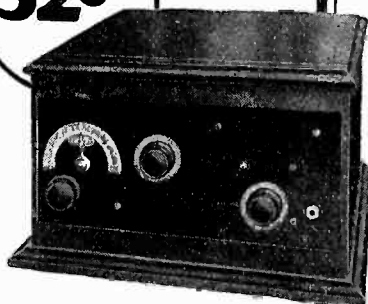

RADIO

THE CROSLLEY RADIO CORPORATION
CINCINNATI

See the Crosley line at your dealer's or write for full descriptive catalog.

Tell them that you saw it in RADIO

EVERY PRECISE INSTRUMENT IS A LABORATORY PRODUCT

Announcing Two New Precise Instruments The Syncrodenser

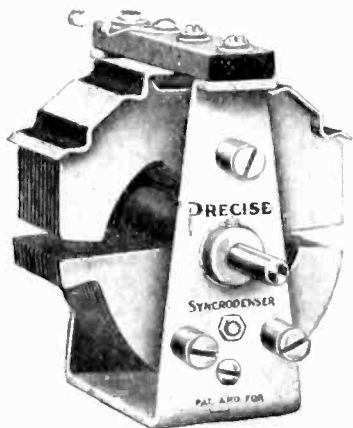

PRICES:
.00035 Cap. \$4.00
.0005 Cap. \$4.50

No. 480 Super-size Audio Transformer

The need for faithful reproduction of all forms of broadcasting caused this Precise super-size audio transformer to be designed. It reproduces with absolute fidelity the true richness of the original creation as broadcasted, with magnificent amplification. The core and windings are unusually large and designed to withstand great overload. Compactly housed to permit subpanel mounting.

The other audio transformers in the complete Precise line are the original No. 285 (4½ to 1) at \$5. Eclipse (2½ to 1) at \$4. Comet (3½ to 1) \$3.25. Push Pull No. 800-801 \$11 per pair. The Precise Super-Multiformer is four matched radio frequency transformers in one unit, \$20. Precise Filtoformer radio frequency choke coil and bypass condenser with inductance of 200 millihenries and .006 m.f.d. is \$4.50.

PRECISE MANUFACTURING CORPORATION
ROCHESTER, N. Y.

Like a pure straight-line frequency condenser, the Syncrodenser spaces the lower wavelength stations evenly over the first half of the dial from 0 to 50. It does not, however, start at that point to crowd the higher wavelength stations together over the last half of the dial, from 50 to 100.

This is because the Syncrodenser is a scientific combination of straight-line frequency, where it is vital, with straight-line capacity where that is superior.

The practical manner in which the Syncrodenser actually separates stations over this entire broadcast waveband marks a new era in condenser design.

Unusual design and great strength permit the Syncrodenser to be mounted on panel or subpanel in any conceivable position.

Made in two styles. The 750 type has extremely high minimum to maximum capacity ratio for use where a great frequency range is desired. The 750L is designed to cover the same frequency range as the average condenser of approximate capacity using the same coil.

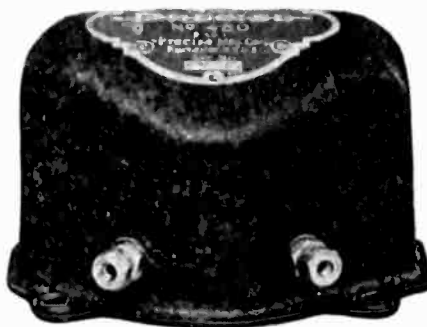

Made in two ratios, 5 to 1 and 2½ to 1.
Price for either ratio, \$7.50.

BRANCHES:

105 Park Ave., East Orange, N. J.
53 W. Jackson Blvd., Chicago, Ill.
821 Market St., San Francisco, Calif.
454 Builder's Exchange,
Minneapolis, Minn.

CANADIAN DISTRIBUTORS:

Perkins Electric, Ltd.
Toronto, Montreal, Winnipeg

JEWELL

No. 84
"B"
Battery
Voltmeter

Price
\$2.75

Test Your Batteries

Run-down batteries cause a lot of radio grief that you can avoid by using a Jewell No. 84.

Order from Dealer

Jewell Electrical Instrument Co.
1650 Walnut St., Chicago

"Use Empire-Trons for Perfect Radio Reception"

EMPIRE-TRONS

RADIO TUBES

Not an experiment — built to exact and rigid requirements and passing the most exhaustive tests.

Each tube a model of perfection.

Finest mechanical construction, and Bakelite bases. Tested in Our Factory. Made in U. S. A.

Every Tube Sold With a Positive Guarantee. Some Choice Territory Still Open.

A Superior Quality, Sold at a Price to Meet Competition, But Giving Larger Profits to Dealers.

Write for Particulars. Also for Our Line of "EMPIRE" Speakers.

AMERICAN-INTERNATIONAL TRADING COMPANY
59-61 PEARL STREET, NEW YORK
Cable Address "STANMARKS"

"Use Empire-Trons and Hear the Difference"

Copies of August, 1925, issue of "RADIO" are still available

25c
Per copy

Get a copy of last month's number containing Best's Superheterodyne article. The supply is limited.

ORDER YOUR COPY NOW!

Pacific Bldg. "RADIO" San Francisco

RADIOCAST WEEKLY

48 Pages of

Programs, Photos, Humor,
Musical Reviews, Schedules,
Tables, Editorials, Etc.

5c Per Radiocast Weekly
Copy 433 Pacific Bldg.,

SAN FRANCISCO

BRIGHTSON TRUE BLUE TUBES

QUALITY Not Price Sells Them

Those desiring the best always consider quality before price. Brightson True Blue Radio Tubes were designed to meet the needs of those seeking the best in radio.

No other tubes are comparable to True Blue Radio Tubes. You do not have to switch True Blue Tubes to get the best results. They are absolutely uniform and interchangeable. Every True Blue Tube is as good as every other True Blue Tube. Equipped with silver contact points and non-conductive bakelite bases to avoid electrical losses and disturbing tube noises. True Blue Tubes are also the clearest toned

because of their rigid non-microphonic construction and high degree of vacuum. Their special filament material lasts two or three times longer than the standard.

Brightson True Blue Radio Tubes are sold with a 60-day written guarantee against defects. "The Squarrest Selling Policy in Radio" permits users to return True Blue Tubes in 10 days if they don't think they are the best money can buy.

True Blue Tubes are 6 volt $\frac{1}{4}$ amp. storage battery tubes, made with standard base and small base. Ask your dealer to show them to you.

BRIGHTSON LABORATORIES. INC.

Northwest Corner Waldorf-Astoria Hotel
16 WEST 34th STREET, NEW YORK, N. Y.



The Finest Radio Tube in the World!

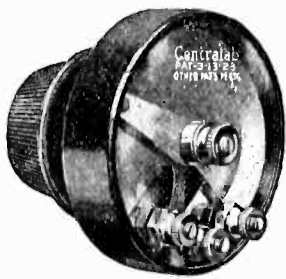

Perfect Control from a Whisper to Maximum!

The Centralab Modulator, used in audio circuits in connection with any ordinary transformer or with the new "Thordarson Autoformer," will give you perfect control of tone and volume, from a whisper to maximum volume! No need for inter-stage jacks, and eliminates the danger of transformer burn-outs. Has a total resistance of 500,000 ohms, smoothly variable from zero. Endorsed by Thordarson Electric Mfg. Co.

\$2.00 at your dealer's,
or mailed direct.

Write for literature and
circuits describing this and
other Centralab patented
controls.

Central Radio Laboratories

14 KEEFE AVE., MILWAUKEE, WIS.

Centralab

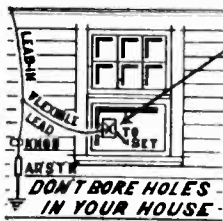

The Window-pane Lead-in Connector

Sticks to glass
without holes.
On or off instantly
\$2.00 At your dealer
or post paid
D. S. DU BOIS
1065 Tibbitts St.
Portland, Oregon

Authorized Cockaday Coil - \$5.50
Precision Autodyne Coupler - \$3.50

PRECISION COIL CO., Inc.
209 CENTRE ST., NEW YORK CITY

Specialists in the manufacture of all types
of radio coils

LOUD SPEAKER TESTING METHODS

(Continued from page 22)

limits the tones will be inaudible. The currents from this vacuum tube oscillator are fed into the loud speaker to produce a single constant intensity tone whose frequency or pitch can be varied at will.

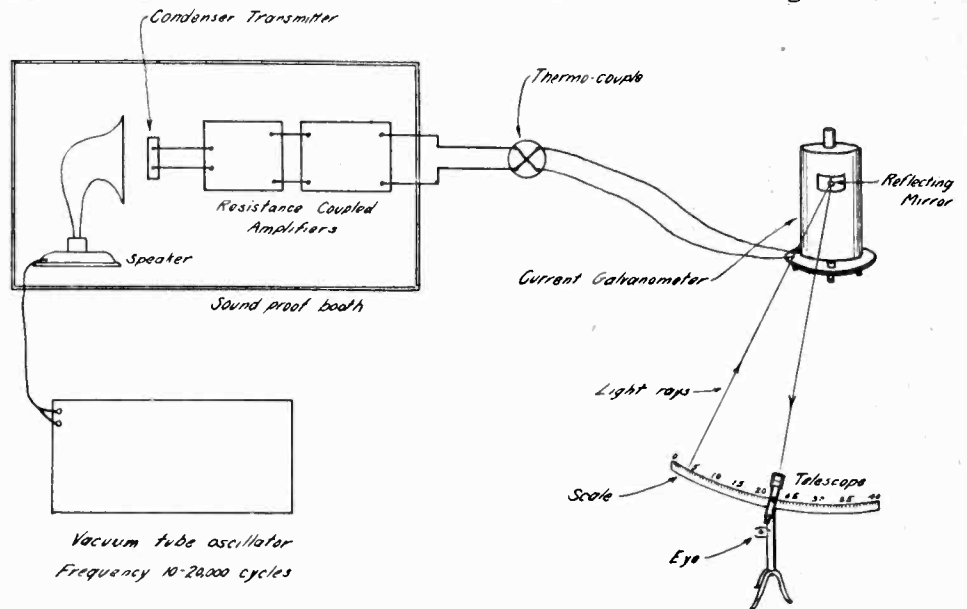

Fig. 3. Method Employed for Permanent Record.

These tones are air pressure variations due to a corresponding frequency. They are referred to as sound pressure and correspond to the pressure variations produced in speech and music. The condenser transmitter responds to these changes in pressure just as it does to the voice and musical sounds and these pressures are very small, being in the neighborhood of one-five hundred thousandth of a pound.

By means of elaborate tests the whole testing system, including the condenser transmitter and the amplifier, has been calibrated in such a way as to enable us to determine the sound pressure merely by observing the current output from the amplifier as measured by the sensitive

current-measuring device. Readings or observations are made at definite frequencies in order to cover the whole pitch range that a loud speaker is called upon to cover. The results are recorded in a note book for a permanent record.

From these data we plot a curve such as that illustrated in Fig. 4. This curve

shows the intensity or magnitude of the sound pressure given or produced by the loud speaker at the various frequencies in which we are interested for both speech and musical sounds. The height of the curve at the various frequencies indicates the intensity with which the tones of these various frequencies will be reproduced. The average height indicates in a general way the efficiency or loudness of the loud speaker when used on radio sets. This is true because the intensity of the tones as indicated by the sound pressure at the various frequencies is related directly with loudness, which is a psychological effect or phenomenon. We thus have a means of telling precisely what the performance of a loud speaker will be on radio signals, and furthermore we shall have a permanent record for reference at any time. In a succeeding article we shall give a number of curves and show how these curves tell us the story of what the loud speaker does to the radio signals.

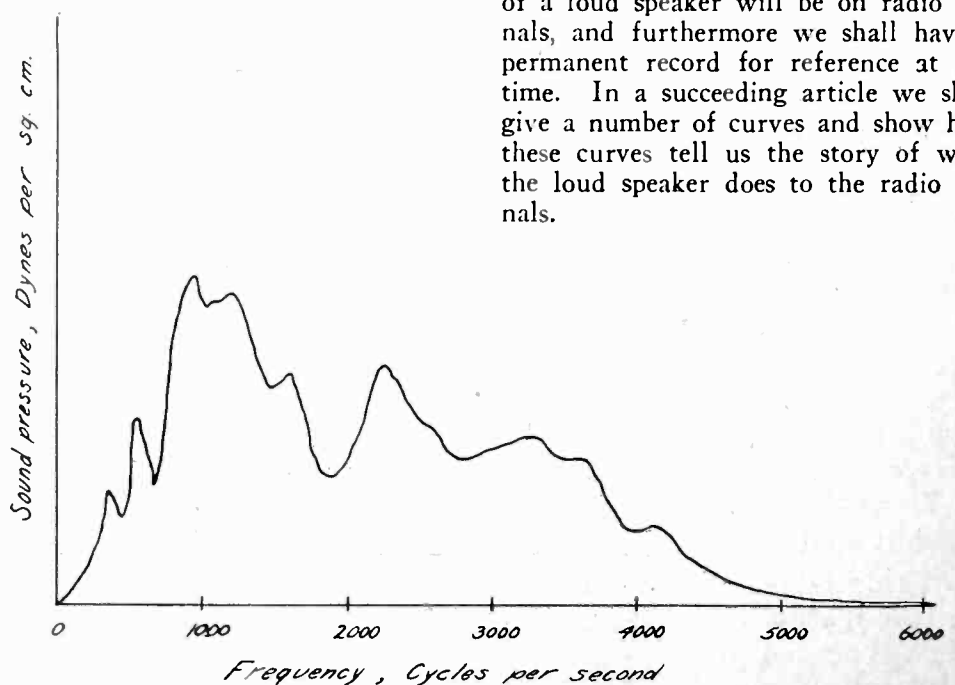
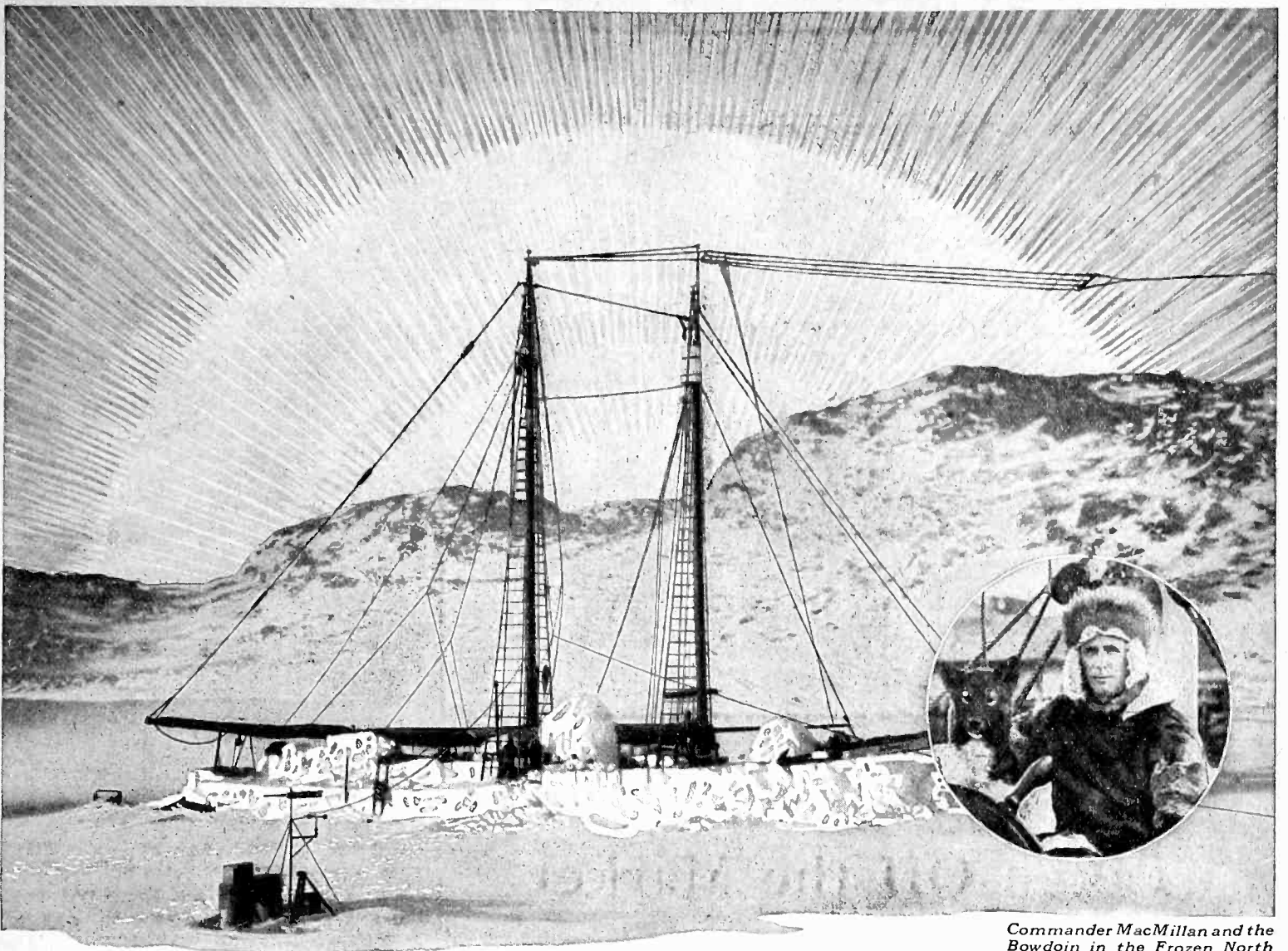

Fig. 4. Curve Showing Variation of Sound Intensity with Frequency.



Commander MacMillan and the Bowdoin in the Frozen North

With MACMILLAN in the ARCTIC

ONCE again that intrepid explorer, Donald MacMillan, has gone into the Frozen North. And once again—for the fourth time—he relied on Exide Batteries to serve him, without flinching, through the extreme rigors of the Polar region.

Each item of equipment on such an expedition is chosen with utmost care, for life or death hangs in the balance. On previous voyages to the Arctic with MacMillan, Exide Batteries have been through shipwreck, blizzard and incredible cold and never once have failed.

On this latest adventure all the storage batteries are

Exide—for radio sending and receiving, for electric light aboard ship and on shore, for operating the sensitive scientific instruments. The three U. S. Navy airplanes that accompanied MacMillan's two vessels are equipped with Exide Batteries.

Wherever radio must not fail, you will almost always find Exide Batteries have been installed—in government and commercial plants—on the giant ship Leviathan, on the Navy dirigible Shenandoah, on the new British airship R33; on every continent and the seven seas speeding up communication throughout the modern world.



Exide 6-volt "A" battery in one-piece case

There are also Exide "A" batteries for 2-volt and 4-volt tubes and "B" batteries, 24 and 48 volts, of 6000 milliampere capacity. The Exide line includes a most economical "B" battery rectifier.

The same qualities that make Exide the choice where lives are at stake are built into the Exide Batteries that you can have with your own receiving set. Staunch and dependable, the Exide gives uniform current through a long period of discharge and assures the clearest reception of which your set is capable. There is a type for every tube and a size for every set, obtainable at radio dealers and all Exide dealers.

THE ELECTRIC STORAGE BATTERY COMPANY

Philadelphia

In Canada, Exide Batteries of Canada, Limited
153 Dufferin Street, Toronto

Exide

RADIO BATTERIES

FOR BETTER RADIO RECEPTION USE STORAGE BATTERIES

Tell them that you saw it in RADIO

HOYT METERS INSURE RELIABLE RADIO RECEPTION

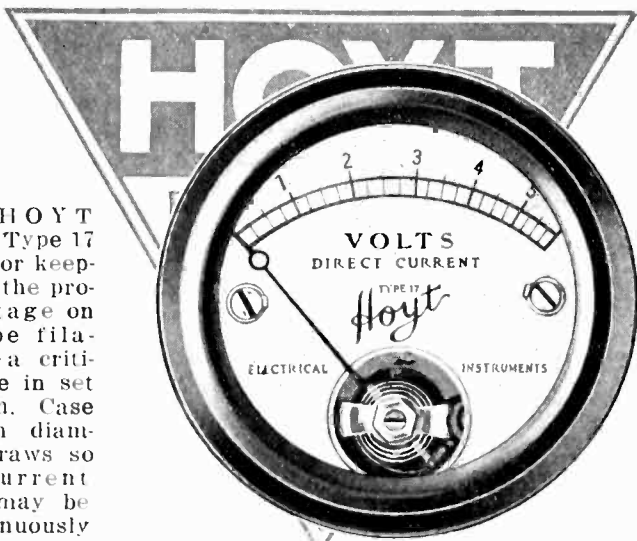

This is HOYT METER Type 17—Used for keeping just the proper voltage on the tube filaments—a critical value in set operation. Case 2 in. in diameter. Draws so little current that it may be left continuously in circuit.

HOYT builds a complete line of Radio meters of all sizes and types. Send for our book, HOYT METERS FOR RADIO.

BURTON-ROGERS CO.

26 Brighton Ave., Boston, Mass.
National Distributors

Read 'em Binding Posts Taken Off the Market

Our patent attorneys have advised us that Read 'em posts infringe on many of the broad claims in patents controlled by The H. H. Eby Manufacturing Company.

Recognizing the validity of these patents, we have decided to immediately discontinue the manufacture and sale of Read 'em posts and are going out of the Binding Post business entirely.

Our customers are referred to The H. H. Eby Manufacturing Company of Philadelphia, with whom we have arranged for the completion of our unfilled orders.

We take this opportunity to thank our friends for their many courtesies.

The Marshall-Gerken Co. Toledo, Ohio



FROST-RADIO

FROST-RADIO PAN-TAB JACKS ARE BEST for YOUR RADIO SET

The finest radio jacks made, for either panelhung assembly or usual installation. At your dealer's, 70c to \$1.00 list.

HERBERT H. FROST, Inc. Chicago
314-324 West Superior Street

Yours-free!



WRS 80-PAGE RADIO GUIDE BOOK

Profusely illustrated, 'chockful' of data for the radio fan:

Trouble Shooting Chart. Complete, New List of Broadcasting Stations. Log Chart

— and details of newest apparatus and hundreds of **Exceptional Radio Values** on offer

WHOLESALE RADIO SERVICE CO.

6-R CHURCH ST NEW YORK CITY

RADIO IN YACHT RACE

(Continued from page 11)

ter, the IDALIA is also equipped with a Telefunken spark set, tuned to 600, 706 and 800 meters, for communication with other ships and commercial shore stations. It consists of a 32 volt spark coil connected to an inductively coupled quenched spark equipment, and is controlled from the same operating table used for the tube set.

The equipment on the ELOISE, call KFVT, is not as elaborate as that of the IDALIA, as it consists of only one 50 watt tube, UV 203-A with associated apparatus. The transmitter was built by Heintz & Kohlmoos, of San Francisco, and employs the "tuned grid and plate" circuit as shown in Fig. 2, which resolves itself into the old reliable Armstrong circuit, where the plate and grid are tuned to resonance with each other and are fed through the inter-electrode capacities when resonance is reached.

Power is taken from the plate circuit by coupling the antenna and plate coils together, the coils being shown in the picture at the extreme ends of the set. Tuning condensers are mounted below these inductances, and the filament and plate meters on the panel below the condensers, adjacent to the rheostat and filament switch. The antenna condenser and ammeter are shown above the transmitter proper and the power panel and dynamotor are shown at the right, near the porthole. This circuit is of the coupled type and hence can be used ashore if desired.

For working amateurs, the transmitter of the ELOISE is tuned to 40 meters, but a special wave of 110 meters is also used, as is provided for small craft when necessary. The short wave receivers used on both ships are practically identical, and were built specially by Heintz & Kohlmoos from a design by Mr. P. J. Townsend.

The circuit is shown in Fig. 3, the antenna being connected to the small fixed coupling coil, which is permanently adjusted with respect to the secondary. The latter circuit is tuned with a shunt condenser, with fixed tickler coil coupled to allow the necessary feedback. Regeneration and oscillation are controlled by the variable shunt condenser across the output, which is in turn connected to an audio frequency amplifier. The wavelength range normally covered by the receiver is from 15 to 125 meters, and oscillation is obtained over the entire range. Slow motion dials were used to permit a small variation of the tuning controls.

The antenna system on both vessels is identical, consisting of a single vertical wire from one of the "yards" on the mast, to a lead-in insulator on the deck. The total length of the wire is 40 feet, and has a natural period, when grounded, of 50 meters. Connection is made to

the metal sheathing of the hull, which is connected to the keel, deep down in the water, thus providing a practically perfect ground. For operation above 80 meters, the antenna system is loaded with inductance, and on wavelengths of 40 or 20 meters, the antenna system oscillates on one of its harmonics. Ordinarily the antenna of each vessel is worked on the 2nd harmonic, which, although theoretically not as desirable as one of the odd harmonics, gives satisfactory results. The radiation at the antenna lead is but a few tenths of an ampere, but this does not indicate the carrying ability of the signals emitted.

The operator of the ELOISE is F. E. Clark of San Francisco, and both he and Mr. Newby are keeping watch on the amateur wavelengths, especially on 40 meters. During the voyage to Pa-peete, both ships were in steady communication with various amateurs throughout the U. S., and the only limitation to the number of stations worked was the necessity of conserving gasoline, and the requirement that all hands must take their turn at the wheel every 24 hours. As it will be several months before the yachts return to San Francisco, ample opportunity will be afforded many amateurs to work these vessels, and the results obtained will no doubt be of lasting benefit to short wave communication.

**NO STATIC
NO DANGER
OF LIGHTNING**

THE Antennaphone
REFLECTS THE AERIAL

IMPROVES RECEPTION
Gives wonderful results with any radio set. Not attached to, but merely placed under the telephone. Price One Dollar. Complete with insulated wire and simple instructions. At Your Dealer or Mailed C.O.D. on 3 days approval.
Antennaphone Co., 90 West St., N. Y. C.



Obsolete

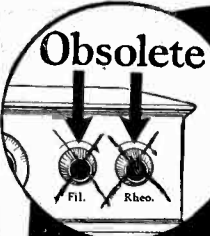

**The HEART
of the Circuit
is
AMPERITE**
The "Self-Adjusting"
Rheostat

AMPERITE controls the flow of current through the tubes automatically just as the heart controls the flow of blood through the body. Does away with hand rheostats and filament meters. Eliminates guessing and all tube worry. Prolongs tube life. Lowers set cost. Proved and adopted by more than 50 set manufacturers. For perfect filament control you must use AMPERITE. \$1.10 everywhere.

RADIALL COMPANY

Dept. R-14, 50 Franklin Street, New York, N. Y.

Write for
FREE
Hook-ups



AMPERITE
REG. U.S. PAT. OFF.

The "SELF-ADJUSTING" Rheostat

ARE YOU A SUBSCRIBER?
SEND FOR TRIAL SUBSCRIPTION
\$1.00 FOR SIX MONTHS

You Can Get
Greater Reflex or Crystal
Set Reception if you use
the
BROWNLIE
Vernier Detector

\$2.00 at Your Dealer or Direct
ROLAND BROWNLIE & CO.
22 Saunders St. Medford, Mass.

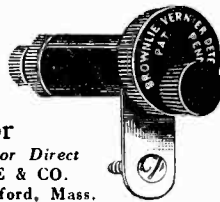

MUSICAL QUALITY

DX RECEPTION, SELECTIVITY and NOISE ELIMINATION is improved to an unusual degree by the use of NEW YORK COIL COMPANY'S PRECISION MICA FIXED CONDENSERS.

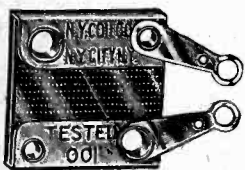

Used by the leading set manufacturers

Our "Selector" Variable Condensers, Mounted and Un-mounted Audio Transformers and B. Battery Eliminator Condensers, are leaders.

New York Coil Company

338 Pearl Street

New York City

Pacific Coast: MARSHANK SALES COMPANY

926 Insurance Exchange Building, Los Angeles, Calif.

BURGESS RADIO BATTERIES



Radio Engineer Extraordinary!

Old folks can take a tip from the family radio expert, for he and his gang constitute the last word in the choice of receiving set parts.

And when boys get together and talk Radio "A," "B" and "C" batteries there's only one brand that they're strong for—BURGESS—because Burgess Batteries are quiet, serve longer, and they do everything a battery should do—better.

"Ask YOUR Boy"

BURGESS BATTERY COMPANY
Engineers DRY BATTERIES Manufacturers
Flashlight - Radio - Ignition - Telephone
General Sales Office: Harris Trust Bldg., Chicago
Laboratories and Works:
Madison, Wis.
In Canada:
Niagara Falls and Winnipeg



Tell them that you saw it in RADIO

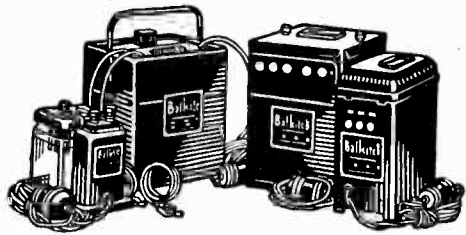

Equip your set with

FANSTEEL

Balkite

Radio Power Units

Balkite Battery Charger

Balkite Trickle Charger

Balkite "B"

Balkite "B" II

the ideal radio power supply

The Balkite Battery Charger for charging "A" batteries. The Balkite Trickle Charger for continuous charging. Balkite "B" replaces "B" batteries—for sets of 5 tubes or less. Balkite "B" II—for sets of 6 tubes or more.

FANSTEEL PRODUCTS CO., Inc.
North Chicago, Illinois

PACIFIC COAST DISTRIBUTORS:
Seattle, George H. Maire, 95 Connecticut St.
San Francisco, A. S. Lindstrom Co., 274 Brannan St.
Los Angeles, Lombard J. Smith, 324 N. San Pedro St.
Portland, H. A. Killam, 146½ N. 10th St.
Salt Lake City, Jennings-McCollom Co., 407 Dooly Bldg.
Denver, Jack L. Hirsch Co., 1641 Stout St.

FANSTEEL

Balkite *Radio Power Units*

BALKITE BATTERY CHARGER • BALKITE "B"
BALKITE TRICKLE CHARGER • BALKITE "B" II

SHARPEST TUNING

When You Use a
LOPEZ

Low Loss Tuner

Price \$10.00

At your dealer's or sent postpaid.

A. C. LOPEZ & CO.

334 Fifth Avenue, Dept. R-4
New York City

ULTRA-LOWLOSS
CONDENSER

SPECIAL CUTLASS PLATES DISTRIBUTE THE STATIONS EVENLY OVER THE DIAL SIMPLIFIES TUNING CAPACITY .0005 MFD

\$5.00

PHENIX RADIO CORP., 116 F East 25 St., N.Y.C.

MODIFIED BEST SUPER

(Continued from page 18)

nections to one of the windings of the coil, in case this trouble develops.

For covering the entire wavelength band from 50 to 600 meters, three oscillator coils are necessary, instructions for winding being given in August RADIO. They may also be purchased ready wound, if it is not desired to make them.

For the wavelengths between 50 and 200 meters, it is often a good idea to employ an outdoor antenna in place of the loop, as the loop would require taps for the short waves, and is not particularly efficient when used in that fashion. Hence, a simple antenna tuned circuit may be mounted on the back of the cabinet as shown in Fig. 6, and flexible connections may be brought inside the cabinet to the loop terminals on the binding post strip. The antenna coil for 50 to 125 meters should consist of 15 turns of No. 22 wire wound on a 2¾ in. tube, connected in place of the loop antenna, with a small aperiodic primary made up of 4 turns of No. 22 wire wound over the secondary at one end of the coil. For 100 to 300 meters, the antenna coil should be 30 turns of No. 22 wire on a 2¾ in. tube, with a primary of 8 turns, and for 200 to 600 meters the secondary should be 60 turns and the primary 10 turns. In using the antenna adapter for the radiocast range from 200 to 600 meters, employ a small indoor antenna, for the aperiodic primary is not sufficiently selective for use with a large outdoor antenna at these waves, and the loop antenna is preferable, or an arrangement having a tuned primary such as was described for the shielded model. When the antenna coils are in use, it should be noted that condenser C₁₀ is not used, as no particular advantage is to be gained by regeneration and the coil connections will be too complicated for ease in mounting on the back of the cabinet.

A number of well made loop antennas are now available on the market,

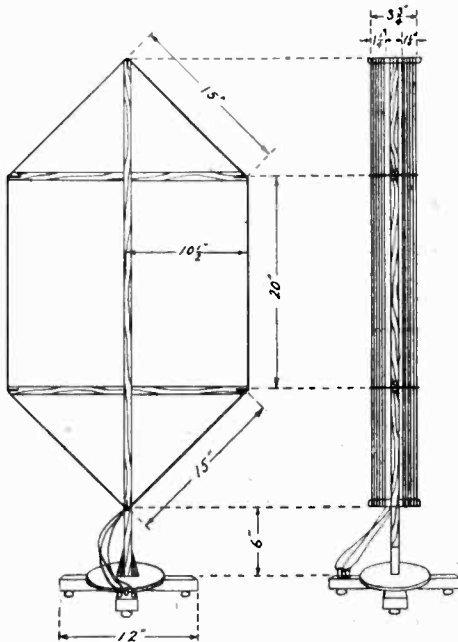
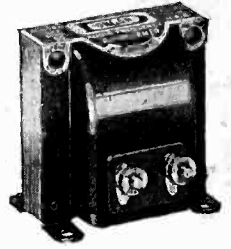

Fig. 7. Center Tap Loop Antenna.

DONGAN

Build Your Set
with
Quality Parts

For Fine Reception
Choose This
Transformer
Audio



Type S
Handsome Mountings
Ratio 2-1, list \$4; 3½-1,
list \$3; 6-1, list \$3.75.

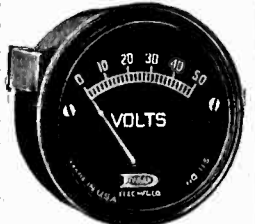

Type N
Panel Mountings
Nickel Finish, Black
Bezel Clamp Mounting
Range 0-7 volts, list
\$1.75; 0-50 volts, list
\$1.75; 0-100 volts, list
\$2.00.

Here is one of Dongan's most popular Audio Transformers. Sturdy, perfectly balanced and assuring the greatest possible amplification with practically no distortion, this handsome Type S Audio will get the best performance from your set. Suited to all hook-ups and designed particularly for low wave reception.

We build 35 types of Audio Transformers. Thousands are in use today as we supply 38 set manufacturers with transformers.

Voltmeters
That Are Accurate

Leading Set Manufacturers are equipping their sets with panel-mounted voltmeters for they know that efficient reception depends on correct tube and B Battery voltage. By all means, equip your set with a Dongan Voltmeter and keep performance up to par all the time.

Dongan builds 5 types of Voltmeters—each one is accurate over the entire range of scale. You get definite readings from these precision instruments.

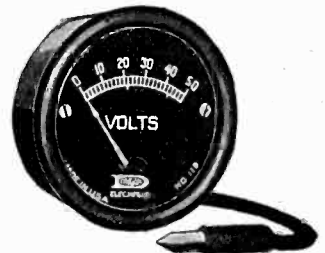

Type F—Portable

Handsome Black Finish
Range 0-7 volts, list \$1.50; 0-50
volts, list \$1.50; 0-100 volts, list
\$1.75.

Type B—A. C. Tube Transformer

Designed for Cockaday's Popular Radio A. C. Receiver and now the standard step-down A. C. Transformer used everywhere. (Distinctly not a toy transformer). Simply plug into your light socket—does away with A Batteries.

Ask your dealer or write to us direct for details. Money-orders filled same day as received.

Dealers: If you aren't acquainted with the Dongan sales plan, ask your jobber or write us.

DONGAN ELECTRIC MFG. COMPANY

2981 Franklin St., Detroit, Michigan

Distributors for Western Coast:

SIERRA ELECTRIC COMPANY

515 Market Street, San Francisco, Calif.

443 S. San Pedro Street, Los Angeles, Calif.

222 Hinckley Bldg., Seattle, Wash.

ROBINSON SALES COMPANY

53 Fourth Street, Portland, Oregon

Transformers of Merit for Fifteen Years

Tell them that you saw it in RADIO

A Pleasant Surprise Awaits the User of
The A. C. H. Sharp Turner Dials

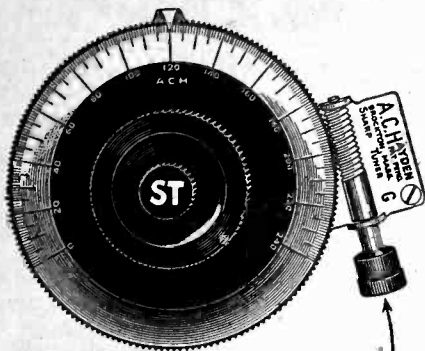

Why the A.C.H. is different

3 in. DIAL → ACH → (356-T0-1)
4 in. DIAL → ACH → (215-T0-1)

Will improve any receiving set,
making difficult tuning easy

MONEY BACK GUARANTEE

Price 3-inch size...\$2.50 Price 4-inch size...\$5.00
Regular fitting 5/16 shaft 1/4 and 3/16 .50 ea. extra

Extra Advantage of the A. C. H.

1. Can be attached or removed from any instrument.
2. Rough tuning same as any dial.
3. Movement so fine that the eye cannot detect but the ear can.
4. Automatically locks instrument so no jar can disturb it.
5. Dial grounded reducing the body capacity to a minimum.
6. Special dial 2 graduations where ordinarily one.

Mall Orders sent Prepaid in U. S. A.

A. C. HAYDEN COMPANY
Brockton, Mass., U. S. A.

Make \$100 Weekly— I Will Show You How!



J. Matheson Bell
Pres., Ozarka Inc.

YOU can do it in your spare time—evenings. Lay the foundation for a permanent, profitable business of your own. Give it all your time when you've proven the big opportunities it holds for you. Sell what the public wants—

Sell Radio In Spare Time!

Demonstrate the Ozarka in your own home or in your prospect's home. Sales experience not necessary—we teach you! Ozarka instruments priced right, with sales helps, national and local advertising, make your selling easy.

12 Selling Lessons FREE!

The Ozarka plan of selling radio is entirely different. Most practical—easier to explain. Sales are made quicker and easier. Knowledge of radio not necessary—we teach you every detail without charge! Our success with 8,100 men proves the merit of our teaching.

3,100 Men Are Doing It!

The Ozarka organization today consists of 3,100 men. In territory not now covered the right man is wanted. \$100 weekly in spare time is not unusual. Many Ozarka men are making far more—some have been with us for three years.

FREE Book Tells How—

Write me personally—tell me about yourself, and I'll see that my 64 page book, Ozarka Plan No. 100, is sent you without cost. Please mention the name of your county. To be sure of my personal attention, attach coupon below, to your letter.

J. Matheson Bell, Pres.

OZARKA
120 Austin Avenue L,



INCORPORATED
Chicago, Illinois

Gentlemen:

9-25-120L

I am greatly interested in the FREE BOOK "The Ozarka Plan" whereby I can sell your radio instruments.

Name.....

Address..... City.....

County..... State.....

and most of them are equipped with a center tap. The purpose of the center tap is to provide a means for reducing the resistance of the loop, by the use of capacitive feedback from the frequency changer tube. Energy from the plate circuit of the frequency changer is fed through the variable condenser C_{10} to one side of the loop, which is divided into two sections by the center tap. The feedback reduces the high frequency resistance of the loop practically to zero when adjusted properly, and enables reception over much greater distances than would otherwise be possible. Those wishing to construct their own loop will find the dimensions shown in Fig. 7 useful, the loop being wound with 12 turns of No. 18 single fixture wire, or other stranded wire of equivalent size, the total amount required being about 105 feet, including flexible leads. The center tap should be taken off at the end of the 6th turn, at the bottom of the loop.

If the receiver is to be used for amateur C. W. reception on the shorter waves, a separate beating oscillator should be mounted adjacent to the set and operated from the same A and B batteries. This oscillator should be arranged to work at approximately the same frequency as that used for the intermediate frequency amplifier, and should have an adjustable range at least 3000 cycles above and below the critical frequency, so that an audible beat note can be produced. In order to prevent too much of the beating oscillator energy from entering the intermediate circuit, a by-pass condenser of 2 mfd. should be shunted across the B battery terminals at the beating oscillator, and another condenser of like value should be bridged across the filament leads at the same point.

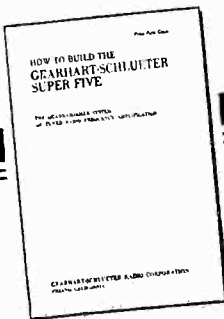

"a new 5-Tube Set with all the power and none of the grief of the Supers" — so wrote Henry M. Neely, Editor of Radio in the Home, Philadelphia.

How to Build the SUPER-FIVE

Write today for the QUADRAFORMER BOOK. It will bring you a new radio experience. Profusely illustrated with photographs, drawings. It takes you step-by-step through the making of the SUPER-FIVE, an exceptional 5-Tube Receiver developed by engineers of the Gearhart-Schlueter Radio Corporation.

Inclose 25c and you'll have it by return mail.

Gearhart-Schlueter Radio Corp'n.
710 Voorman St., Fresno, California

Tell them that you saw it in RADIO

Takes the mystery out of Radio

JUST OUT—514 PAGES

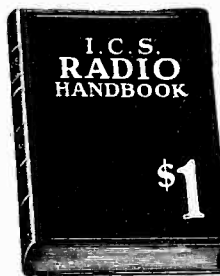

Compiled by
HARRY F. DART, E.E.
Formerly with the Western
Electric Co., and U. S. Army
Instructor of Radio.
Technically edited by
F. H. Doane

\$1
NO MORE need you turn from book to book, hoping to find what you want. It is all here, in 514 pages crammed full of every possible radio detail. Written in plain language, by engineers for laymen. 100,000 sold.

IT EXPLAINS: Electrical terms and circuits, antennas, batteries, generators and motors, electron (vacuum) tubes, many receiving hook-ups, radio and audio frequency amplification, broadcast and commercial transmitters and receivers, super-regeneration, codes, etc.

Send \$1 today and get this 514-page I. C. S. Radio Handbook—the biggest value in radio today.

International Correspondence Schools
Box 8260-D, Scranton, Penna.

I enclose One Dollar. Please send me—post-paid—the 514-page I. C. S. Radio Handbook. It is understood that if I am not entirely satisfied I may return this book within five days and you will refund my money.

Name.....

Address.....

Check here and enclose \$1.50 if you wish the edition bound in Leatheroid.

EBY PATENTED BINDING POSTS

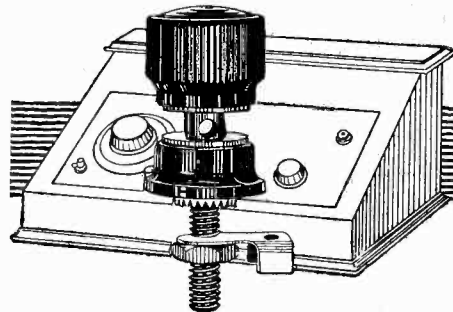

Standard Equipment On 150 Manufacturers' Sets

Unvarying, built-in superiority made them select EBY posts. They are your logical choice, too.

Furnished either plain or engraved in twenty-five different markings and the base of every post is clearly marked EBY.

The Tops Don't Come Off

15c—At All Dealers—15c

The H. H. EBY MFG. CO., Phila., Pa.

Electric Soldering IRON--- FREE

Subscribe to "RADIO" for one year—\$2.50—and get a 110-volt MARVEL Soldering Iron FREE

"RADIO," San Francisco



Nocturne

Miracle of science—this flight of music through the air! Into your home it comes, from hundreds of miles away. It speaks a universal language, straight to your heart. And not less a miracle is that magic building up of tonal power—still preserving every mood of the artist—until the room is filled. This is the supreme achievement of Rauland-Lyric.

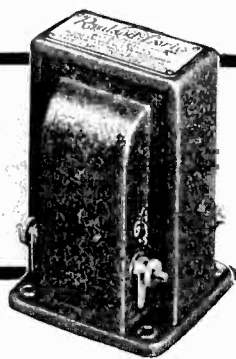

Rauland-Lyric is a laboratory-grade audio transformer designed especially for music lovers. The price is nine dollars. Descriptive circular with amplification curve will be mailed on request. All-American Radio Corporation, 4201 Belmont Ave., Chicago.

Rauland-Lyric
AN
ALL-AMERICAN
TRADE MARK
TRANSFORMER

The Choice of Noted Music Critics

Cut out leakage and bring in distance!

Get the most out of your set! Change to insulators that prevent energy leaks! PYREX is the ideal insulating material. Diamond hard, water-proof, self-cleaning, PYREX Antenna Insulators eliminate losses of wave energy. They cost so little and they are so easy to attach that it certainly is worthwhile to change to PYREX. 45c each at good dealers.

PYREX Insulators are used by the United States Government for the most exacting service.

PYREX

INSULATORS

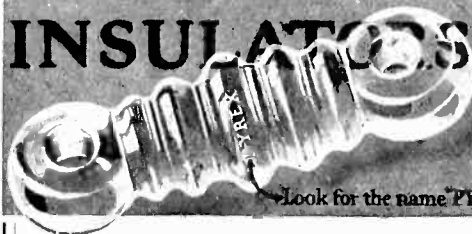

Look for the name PYREX

Industrial and Equipment Division
CORNING GLASS WORKS
CORNING, NEW YORK

World's Largest Makers of Technical Glassware

B. M. S. PLUG

THE new B. M. S. PLUG is absolutely shock-proof. The tips are held and released automatically, the tips being totally concealed when inserted. Moulded of bakelite in a beautiful keystone design.

Brooklyn Metal Stamping Corp.
718 Atlantic Avenue, Brooklyn, N. Y.

Western Representative:

F. L. Tomlinson & Co.
443 So. San Pedro Street, Los Angeles, Calif.
152 Security Building, Portland, Oregon

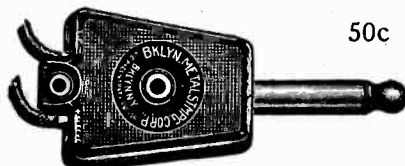

50c

TRANSMITTER TUNING

(Continued from page 32)

find a point where oscillation is stopped within the receiver. This stopping point ought to be fairly sharp, unless the transmitter and receiver are too close to each other. Once the dead-spot is located it ought to be sharp enough so that the starting and stopping points are within a scale division on the series condenser dial. If this is not true the receiver and transmitter must be separated farther from each other and one of the coupling methods of Fig. 2 used if necessary, to get the proper adjustments.

After the above adjustments have been completed, the two transmitting circuits, primary and secondary, should then be in tune with each other, this because they were adjusted to the same tune on the receiving set. The only thing remaining to be done is to couple the transmitting helices together and start the set going.

Listen on the receiver as the key is worked and go through the alphabet once or twice to see if any break in the note of the transmitter can be noticed on any of the letters. Make certain that the break is not due to your receiver tube being overloaded, by inserting an extra low resistance grid-leak temporarily. After making sure that such a change in the note can not be due to the receiver you are ready to go ahead. If the note break occurs anyhow, then the coupling between the primary and secondary of the transmitter is too close and the separation between the two helices should be increased. Loosening of the coupling should be continued until the note is definitely constant and no change or "missing" is noticed on any of the letters of the alphabet. It is better to have plenty of coupling and be certain than to have tight coupling and be uncertain of a smoothly operating transmitting set. A coupling of less than 1½ or 2 in. between the coils should be avoided, for to have closer coupling will very likely mean that only parts of the characters sent will get on the air, because the transmitter will be "missing fire." That will result in your signals being unreadable although everything is apparently O.K., and thus it will be impossible to raise a soul.

The one remaining adjustment is the tuning of the antenna circuit with inductance and series condenser until the antenna ammeter reads maximum.

If the transmitter is a five watter, or of similar low power output, the ideal ammeter to use is one of agile needle and nearly full scale deflection, with the current obtained, because often the meter used does not deflect sufficiently nor move rapidly enough. A good ammeter for a low-power set is one with a ½ ampere full-scale reading. It can be of the hot-wire type although they are supposed to hold their accuracy more by luck than attention. We have long got-

ten past the delusion that we need accurate readings of antenna current, and we only require something that will indicate the fact that we are getting antenna current, so that resonance can be found by the maximum indication. Values of current mean little regarding the actual power the transmitter will radiate and probably we will have meters some day with arbitrarily divided scales, with no attempt at accuracy so far as current readings are concerned. Our antenna meters will be rated instead as being capable of carrying so many amperes and from that we will know which one to purchase for a given transmitter. Furthermore, since accuracy is unimportant, when the meter won't stand the load but runs off the scale, a handy length of wire can be used to shunt it, and hold it down.

If a d.c. milliammeter is available, it can be used to tune the transmitter instead of employing the antenna ammeter. Follow the directions previously given for tuning the primary transmitting circuit to the desired wave, using the receiver. Then tune the antenna circuit and when it comes to resonance with the primary the plate milliammeter will jump either up or down, the direction depending upon the way in which the set is adjusted. That it jumps at all is sufficient indication of resonance.

The shunt condenser in the primary transmitting circuit is not mandatory. It is merely a convenience for it simplifies tuning adjustments. If the primary inductance alone is too small to reach the wavelength desired a condenser so connected across all or part of it often solves the difficulty. If the primary helix is large enough it will tune to the wave desired just as effectively alone. If the helix is too large, the wave will be over-reached and the unused portion will very likely absorb otherwise useful energy. If there is necessarily an unused portion of one or both of the transmitting helices that is as great as the used portion it is best to play safe and amputate it.

If the transmitting tube overheats, movement of the inductance centertap toward the grid end of the primary, which increases the number of turns included by the plate circuit, will result in a reduction of the power going into the tube and will help, therefore, to keep it cool. Movement of the centertap toward the plate end will decrease the number of plate turns and increase the input to the tube. If the tube is running too cool and could in your opinion, stand a greater amount of heating, it is only necessary to move the centertap plateward to increase the input to it and therefore the heating. This is partly limited by the plate-voltage. If it is very low it may be impossible to make the tube heat although poor adjustment, such as movement of the centertap to the inductance excessively in either direction, will stop oscillation.

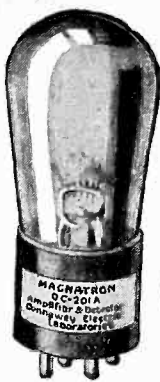

Your dealer sells Magnatrons in the type 201-A, 199 and 199 large base.

\$2.50
all types

"A Good Tube for a Good Set"

A GLASS, a base and some hunks of wire--- Kipling would have said about vacuum tubes. And so they are. But what a difference the method of assembly and manufacture makes! MAGNATRONS are built with the precision of a fine watch, and tested just as carefully before they leave the factory. You can *always* count on MAGNATRONS to get the most and the best out of your set.

Connevey Electric Laboratories,
Magnatron Building, Hoboken, N. J.



MAGNATRONS



It is significant that the Amplion is standard on the finest sets built in England, Belgium, France, Switzerland and other countries as well as on an increasing number of the highest type American sets.

Against any other loud speakers

test it for "selectivity!"

Hear the Amplion *in comparison*: let your ears tell you why this creation of the actual originators and oldest makers of loud speakers leads in sales throughout the world. Not only is The Amplion supreme for clarity, realistic tone and long distance volume. It also has "selectivity"—the ability to separate distinctly the different instruments in an orchestra, or the various voices in a quartet, instead of jumbling them together. Interesting Amplion literature will explain why. Write for it and dealer's name.

AMPLION
The World's Standard Loud Speaker

THE AMPLION CORPORATION OF AMERICA
Executive Offices: Suite A, 280 Madison Ave., New York City
Canadian Distributors: Bwmdept of Canada, Ltd., Toronto

An adjustment at the rear of every Amplion unit permits "tuning" it to the individual characteristics of each set. Alfred Graham & Co., London, England—patentees of the Amplion.

Send \$1.00 for a trial subscription to "RADIO" for 6 months.....

CARDWELL TORO-TRAN

The ideal inductance

Allen D. Cardwell Mfg. Corp.
81 Prospect Street
Brooklyn, N. Y.

Exide

RADIO BATTERIES

Tell them that you saw it in RADIO

Unconditionally Guaranteed

THORDARSON

Super TRANSFORMERS

Standard on majority of quality sets

The Nation's Leading Set Makers Endorse Thordarsons as Best

ONE reason that leading builders of fine sets use more Thordarsons than all competitive transformers combined is because Thordarsons run *absolutely uniform*; always "match up" perfectly; always amplify evenly.

And why shouldn't they? Aren't they made and unconditionally guaranteed by the world's oldest and largest exclusive transformer makers—transformer specialists for 30 years.

For the finest amplification to be had at any cost, follow the lead of the leaders—build or replace with Thordarsons.

TYPES AND PRICES!

Audio Frequency: 2-1, \$5; 3½-1, \$4; 6-1, \$4.50. Power Amplifying, per pair, \$13. Interstage Power Amplifying, each \$8. Autoformer All Frequency Amplifiers, each \$5. Write for latest hook-up bulletins—free. Dealers everywhere.

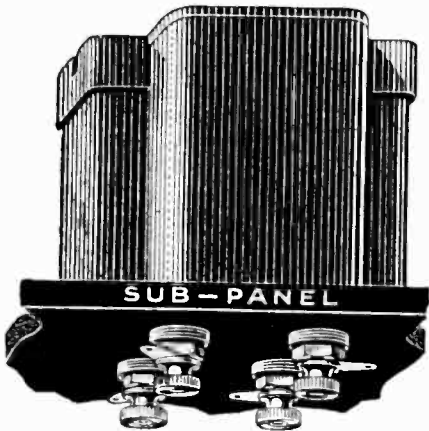

SUB-PANEL

THORDARSON ELECTRIC MANUFACTURING CO.
Transformer specialists since 1895
WORLD'S OLDEST AND LARGEST EXCLUSIVE TRANSFORMER MAKERS
Chicago, U.S.A.

ZENITH
KENNEDY
Radiodyne
Planstiehl
Howard
Thermodyne
GLOBE
Deresnadyne
ADLER-ROYAL
MURDOCK
MU-RAD
Valley
Silver-Marshall
OZARKA
ULTRADYNE
Newport
LEICH
NUNN-LANDON
KUSTOMBILT and
many others

Sub-Panel Mounting Type Thordarsons
Now On Sale.

They permit a neater assembly, the shortening of leads and the concealing of wiring—as in factory built sets. Same ratios—same prices—as standard type Thordarsons. If dealer cannot supply, order from us.

AUDIO FREQUENCY

(Continued from page 19)

sible to have 100 times the present primary impedance with the present number of turns. The frequency characteristic would therefore be almost perfect except as affected by winding capacities, or we might obtain 100 times the present voltage ratio with the present primary impedance by reducing the number of primary turns to 1/100th of the present value. Better still, the number of turns on both primary and secondary could be so chosen that one stage of amplification would not only do the work of two present day stages but do a better job of it as well.

Going back to present day transformers, there are at present some very good ones on the market along with many almost worthless ones. For those who purchase transformers in the future, the data given in this series will be of assistance. For those already in possession of poor transformers but who wish to improve their sets, three avenues are open. They may purchase improved transformers; re-arrange the circuit using the poor transformers as choke coils in an impedance coupled amplifier; or they may correct to some degree the resonant humps by means of shunt resistances and the rising frequency characteristic by means of secondary series resistances, as already described. If the extra vacuum tubes and battery drain are no object, then resistance coupled amplifiers are available, and the old transformers can be junked.

MANY of our readers have expressed interest in the methods of testing the various transformers and other coupling devices, and while detailed directions cannot be given here, a description of the apparatus and methods employed will serve to show the care necessary to obtain reliable measurements even at audio frequencies. In undertaking the problem of measuring audio frequency amplification, great care was taken to design the measuring equipment so that no errors localized in the equipment would be introduced, and yet the apparatus would be rapidly adjusted and flexible, permitting the measurement of amplification under all the conditions of actual operation.

The two equipments used consisted of a vacuum tube oscillator having a range of 90 to 5000 cycles, with an output control which would not affect the frequency of the oscillator and giving an output relatively free from harmonics, and a gain set. The latter consists essentially of a switching device by means of which the apparatus to be measured may be cut in or out of the circuit, a vacuum tube amplifier, and a vacuum tube voltmeter, or detector, sometimes called a Moullin Voltmeter.

The circuit used is shown in Fig. 1, the output of the oscillator being con-

The Andrews Deresnadyne

RADIO RECEIVING SET

Combines Tone Quality and Selectivity With Distance.
Price \$165 Without Accessories.

ANDREWS RADIO CO., Tribune Tower, Chicago.

F. L. TOMLINSON CO., Los Angeles and San Francisco

ROBINSON SALES CO., Seattle

ARE YOU A SUBSCRIBER?

Send for Trial Subscription

\$1.00 for Six Months

MARWOL

Five-Tube Radio Receiver Offers the Greatest Dollar for Dollar Value in Radio.

MARWOL RADIO CORPORATION

Represented by

MARSHANK SALES CO.

326 Insurance Exchange Bldg. Los Angeles, Calif.

nected to the calibrating potentiometer P_c , so that voltages appearing between terminals 2 and 3 of P_c are applied to the double measuring potentiometer P_m . This potentiometer consists of a high resistance section 1-3 (1800 ohms) and a low resistance section 3-5 (400 ohms), each wound uniformly and similarly with relatively few turns of high resistance wire, with a sliding contact. The 3 pole double throw key K_1 serves to switch the circuit from the calibrating to the measuring condition. When thrown to the right it connects the total drop across P_m to the grid circuit of the 1st amplifier-detector tube A . At the same time it connects the grid of the tube T under test direct to its own C battery to keep its plate current normal and to prevent any disturbance through this tube and the coupling circuit under test connected as shown. When thrown to the left K_1 connects the drop across the portion of P_m selected by K_2 and the sliding contacts, into the grid circuit of the tube under test. It also connects the output of the coupling device to the grid circuit of the first amplifier detector tube A . Thus when the switch is thrown to the right the total voltage across P_m reaches tube A direct and when thrown to the left some definite fraction of this voltage is applied to tube A after first being amplified in the tube and coupling device whose amplification-frequency characteristic we wish to determine. The second tube D of the amplifier-detector is made a rectifier by the use of a large negative C potential. A milliammeter M , having a range of 0-1.5 milliamperes, in the rectifier plate circuit then indicates the relative amounts of A. C. voltage applied to its grid.

The testing method is then as follows: The coupling device to be tested is connected in the circuit as indicated and after adjusting the potentials of the batteries B_1 and C_1 and the filament current of the test vacuum tube to the desired values, K_1 is thrown to the right and P_c is adjusted until a convenient scale reading on the milliammeter M is obtained. K_1 is then operated to the left and P_m is adjusted until the same reading is again obtained on M . Since a single frequency sine wave current is used, the equality of the readings on M means equal input voltages on tube A . That is, the total voltage across P_m is equal to the voltage across a fraction of P_m multiplied by the amplification through the test circuit. Since the grid currents drawn are zero or negligible while P_m is of low resistance, the ratio of the total voltage to the fraction selected is the ratio of the total resistance of P_m to the resistance between the sliding contact and terminal 5. Making use of this fact, a scale of ratios was laid off under each potentiometer pointer by adjusting to the appropriate resistances.

What Is Quality in Radio Reception?

Answer: Absence of the Sense of Transmission

When you feel as if the singer is beside you; when it seems as if the orchestra is playing in the same room with you; when you hear programs with a *natural* volume; when the deep, low tones and the high-pitched notes come in with the same clarity as the middle register—in short, when you do not sense the fact that the program is being transmitted, then you are getting **QUALITY** in radio reception. Samson Radio Parts help you realize the true meaning of Quality in Radio Reception.



Samson Radio Frequency Choke Coil: Clarifies reception; balances circuits of the neutrodyne type; keeps radio frequency currents out of audio side of the set. Price, \$1.50.

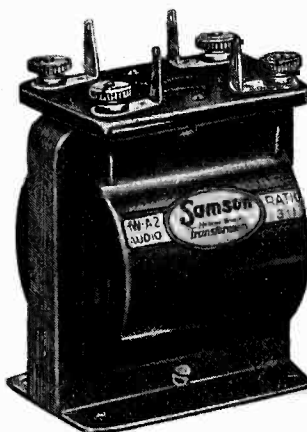
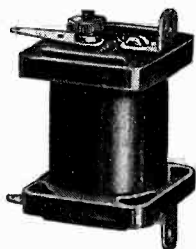

Samson H. W. Audio Transformer: "The Standard for Comparison." Only transformer with Helical Wound Coils faithfully reproducing singing, speaking and the playing of musical instruments. Proved by scientific and practical tests to be unequalled for audio frequency amplification. Ratios: 3 to 1 and 6 to 1. Price, \$5.00.

Samson Neutralizing Condenser.—Neutralizes any tube in a few moments; minimum capacity, .000025; maximum capacity, .000285 mfd.



Samson Radio Products

The Standard for Comparison.

In addition to the above are Double Rotor Coupler, \$7.50; Samson Long Wave Frequency Transformers for building the Cotton Super, \$4.50; Samson T-C Assembly, \$65.00, and the Samson-Transcript Kit, \$14.75. Send for Data Sheet 15. All Samson Radio Parts are guaranteed.

SAMSON ELECTRIC CO.

Manufacturers Since 1882

CANTON, MASS.

Western Sales Representatives: A. S. Lindstrom Co., 274 Brannan St., San Francisco, Calif.; 324 North San Pedro St., Los Angeles, Calif.; 146½ North Tenth St., Portland, Oregon; 95 Connecticut St., Seattle, Wash.; 407 Dooly Bldg., Salt Lake City, Utah.

HEATH

RADIANT CONDENSERS

For Real Radio Reception

HEATH RADIO AND ELECTRIC MFG. CO.,

208 First Street, Newark, N. J.

NA-ALD

Na-ald DeLuxe Sockets are the only ones with these 3 exclusive features—lowest loss, lowest capacity and positive side-scraping contact. Send for booklet and laboratory test. Alden Mfg. Co., Dept. G7, Springfield, Mass.

Get a Phonograph Unit FREE

With only one subscription to "RADIO" for one year—\$2.50. Unit is made by The Union Fabric Company.

SUBSCRIBE NOW

"RADIO"

Pacific Building, San Francisco

SUPER-HET KIT

\$93.57

Build the new Best-circuit super! Kit consisting of every unit specified by G. M. Best on Page 11 of August "RADIO" (except our own make oscillator coils), together with drilled and engraved panel, all necessary screws, bus-wire, sheet aluminum, bakelite shelving and brackets, and two Lyric audio transformers..... \$93.57
Assembled, wired and crated..... 140.00

Kit, as above, but with two Thordarson or All-American audio transformers..... \$85.57
Assembled, wired and crated..... 131.50

All units comprising this kit in stock and may be ordered separately at standard list prices, postpaid. Oscillator coils, complete set..... \$2.50
Drilled and engraved panel..... 4.95

(One-fourth cash with order. No wholesale discounts, except on oscillator-coils, panels, shelving and brackets.)

SUPER-HET CABINET, \$14.50—For above receiver, best solid mahogany, hand polished, large bottom battery compartment.

MATCHED TUBES—Precision-matched Cunningham or Radiotron tubes for supers and all sets, each, postpaid..... \$3.00

MATHISON-GLORIA TUBES — Matched, guaranteed, a superior product, each, postpaid, (201-A and 199)..... \$2.00

Radio Owners' Service Co., 660 Twelfth Street, Oakland, California
We sell engraving machines, \$525.00 and up

BAKELITE PANELS and ENGRAVING

Finest bakelite, black or mahogany, cut into panels of any size, to order. Price: 1/8 in. thick, 1 1/2 cents per square inch; 3/16 in. thick, 2 1/3 cents per square inch; 1/4 in. thick, 3 cents per square inch.

(To get cost of panel, multiply width and length multiply this answer by price per square inch; thus a 3/16 in. panel 7x20=140 sq. in. x 2 1/3=\$3.26.)

DRILLING—Holes up to 5/8 in., each 8 cents; 5/8 in. to 1 in., each 16 cents; 1 in. to 4 in., each 50 cents. Paper drilling pattern must be furnished.

ENGRAVING—Superfine work on costly imported machines, per letter, 5 cents; arrows and dial-markers, each 6 cents.

Attractive wholesale discounts to set-builders on panels, drilling and engraving.

B-BATTERIES — Eveready standard 45-volt, upright or flat, postpaid, each..... \$3.75

FREE TUBES! 201-A and 199—To introduce the new Mathison-Gloria tube, we will send one free with each order for two Eveready B-Batteries at \$3.75 each, postpaid.

DIAMOND WEAVE COILS—Complete set, Browning-Drake type, \$6.25; Roberts, \$6.75; double wound neodyne, tuned frequency and reflex, each..... \$1.25

(Discounts to builders.)

WAVEMETERS

(Continued from page 28)

course this particular curve will be of no use whatsoever on any other wavemeter.

There are other ways in which the wavemeter may be calibrated; one of which is to compare it with another wavemeter which has already been calibrated. A receiver is set to a given wave by the calibrated meter, the calibrated

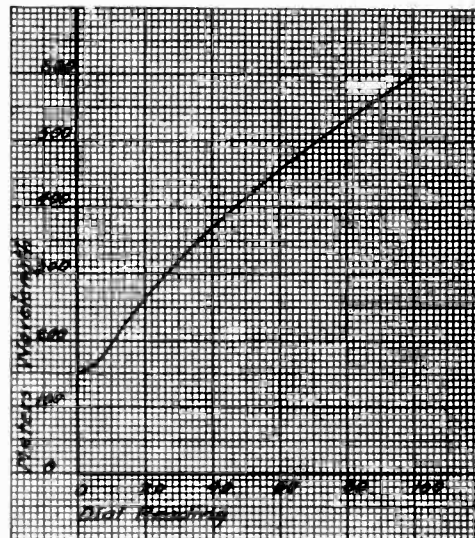

Fig. 5. Typical Calibration Curve of Wavemeter.

meter is taken away, the new meter is tuned to the receiver, and the setting read; so on until enough points are had with which to draw the curve.

WWV, the station of the Bureau of Standards, sends out standard wavelengths twice a month, on definite schedules. One wave band is covered at some ten points, at each schedule, the procedure being that one wavelength is sent for about ten minutes, then another after a few minutes intermission, and so on till the band is covered, the schedule lasting about two hours and a half. The transmissions and announcements are made by telegraph.

Another of the several advantages of the heterodyne wavemeter is that it can be used to measure wavelengths other than those for which it was calibrated. Any vacuum tube oscillator—which includes transmitters, regenerative sets, and the heterodyne wavemeter—sends out what are known as harmonics. These are waves whose lengths are 1/2, 1/3, 1/4, etc., that of the main wave, and which are known as the 2nd, 3rd, 4th, etc., harmonics. They are usually weak compared to the main wave, but may be used in measurements. Suppose a regenerative receiver to be oscillating at 250 meters. The beat note with the heterodyne wavemeter can be obtained at 250 meters; and if the wavemeter be turned up to 500 meters, another fainter beat will be heard. This is the 2nd harmonic of the meter beating with the receiver. Using this method, the range of the wavemeter can be extended to several times that which shows on the dial.

"Ask the man who was there last year"
Space Now
Selling! for the
5th Annual
**BOSTON RADIO
EXPOSITION**

OCT. 12-17 '25
Mechanics Bldg. Boston

Largest Exposition of its kind in the Country
5 Great Halls - 120,000 Sq. Feet of Space

Write, wire or phone **SHELDON FAIRBANKS Director**
209 Mass. Ave., Boston, Mass.

New!



THE
PROUDFOOT
100 to 1
VERNIER DIAL

At last, a 100 to 1, 4 in. genuine bakelite vernier dial that matches up with all standard dials on the market. Entire mechanism fitted into a small metal case in the knob. Nothing complicated about it, but extremely fine readings can be obtained.

The Proudfoot 100 to 1 Vernier Dial fits all condensers—both screw and locknut mounting types. Easily attached. See one at your dealer's. If he cannot supply you, write us. **\$3.00** Complete.



PROUDFOOT

Straight Line
Wave Length
Low Loss
Condenser

Theoretically and practically perfect. Most compact unit built. Write us for complete literature. Four capacities. At your dealer's.

Cruver Manufacturing Co.

2456 W. Jackson Blvd. Chicago, Ill.

Western Distributor:

DON E. CAMPBELL

2216 Hearst Bldg., San Francisco, Calif.

THE TUBE WITH A SENSIBLE GUARANTEE

RECLUSE OF
SUPERTRON
A GOOD TUBE



All for You

SAY Supertron to your dealer and watch him smile—notice how different he will serve you. So confident. He will make sure that the number on the tube corresponds with the number on the guarantee certificate. — Ah! If he does not smile—If he is not confident, or says "try this, it's just as good," then you must insist on Supertron—your dealer is obligated to you in consideration of your patronage.



Distributors:

Fireside Radio Set Co.	Chicago
Yahr & Lange Drug Co.	Milwaukee
The Roycraft Co.	Minneapolis
Sorenson Lamp Co.	Des Moines
Hippee-States Auto Sup.	Des Moines
Orr Bros.	Cedar Rapids
Radio Dealers Sup. Co.	San Francisco
Western Light and Fix. Co.	Los Angeles
Franklin Elec. Sup. Co.	Philadelphia
Keystone Radio Dist. Co.	Philadelphia
Allentown Radio Dist. Co.	Allentown
Goodlin Auto Sup. Co.	South Bend
Fort Wayne Iron Store	Ft. Wayne
Swanson Electric Co.	Evansville
M. Baker & Son	Syracuse
M. H. Johnson Electric Co.	Utica
Hinsdill Electric Co.	Troy
American Phonograph Co.	Albany
Rosen Talking Machine Co.	Boston
Balt. Hub Wheel & Mfg. Co.	Baltimore
Cycle Auto Supply Co.	Buffalo
H. D. Taylor Co.	Buffalo
Hamburg Bros.	Pittsburg
Reynolds Radio Co.	Denver
Burr Fowler	Syracuse
Ed. J. Goetz Co.	Cincinnati
Elgin Radio Corp.	Elgin

Genuine Supertrons are serial numbered for your protection

AT ALL GOOD DEALERS

Pacific Coast

GLOBE COM. CO.,
905 Mission St.,
San Francisco, Calif.

SUPERTRON MFG. CO.

222-228 Washington Street
Hoboken, N. J.
Export Division, 220 Broadway, N. Y. City

Exhibiting at
**NATIONAL RADIO
EXPOSITION**
Grand Central Palace,
New York
September 12-19



SUPERTRON

A SERIAL NUMBER GUARANTEE

Notice to our Readers

We have a few copies of the August, 1925 issue of "RADIO" on hand. This issue contains Best's Super-Heterodyne feature.

Send 25c for a Copy

Pacific Building "RADIO" San Francisco

Send for Trial Subscription
\$1.00 for Six Months

Potter
BY-PASS
CONDENSERS

- Prevent "B" voltage fluctuation
- Allow undistorted amplification
- Make possible full bass tones
- Improve reception with "B" Supply Units.

Made in $\frac{1}{10}$, $\frac{1}{5}$, $\frac{1}{2}$, 1, 2, 3 and 4 Microfarad sizes

At Your Dealer's
POTTER MANUFACTURING COMPANY
North Chicago, Illinois

Extraordinary Summer Offer

TWO-FOR-PRICE-OF-ONE

For New "RADIO WORLD" Subscribers

Ordering Now

RADIO WORLD is the great weekly radio authority. Profusely illustrated. Every issue contains many hookups. Latest developments in the art, science and entertainment of radio. Special features by Herman Bernard, J. A. Anderson, Thos. W. Benson, Lewis Winner, Herbert Hayden, and other authorities. Seven days of programs. List of stations. A great Question and Answer Dept. 15c copy. \$6.00 a year (52 numbers). \$3.00 six months. \$1.50 three months.

Radio World Has Made Arrangements

—To offer a year's subscription for any one of the following publications.

—with one year's subscription for RADIO WORLD

- RADIO NEWS or
- POPULAR RADIO or
- RADIO BROADCAST or
- RADIO DEALER or
- RADIO JOURNAL or
- RADIO (San Francisco) or
- BOYS' LIFE

This Is the Way to Get Two Publications

- for the price of one:
- Send \$6.00 today for RADIO WORLD
- for one year (regular price
- for 52 numbers)
- and select any one of the other
- seven publications for twelve months.
- Add \$1.00 a year extra for
- Canadian or Foreign postage.
- Present RADIO WORLD subscribers
- can take advantage of this offer by
- extending subscriptions one year
- if they send renewals NOW.

RADIO WORLD'S Special Two-for-Price-of-One Subscription Blank

RADIO WORLD, 1493 Broadway, New York City:

Enclosed find \$6.00, for which send me RADIO WORLD for twelve months (52 numbers), beginning....., and also without additional cost, Radio News, or Popular Radio, or Radio Broadcast, or Radio Dealer, or San Francisco "RADIO," or Radio Journal, or \$10.00 for two yearly subscriptions.

Offer Good Name
 Until Street Address
 Sept. 25, 1925 City and State.....

The New CHELSEA

SUPER-FIVE

West of Rocky Mountains.....\$55.00
 East of Rocky Mountains.....\$60.00

Chelsea Radio Co., Chelsea, Mass.

A Laboratory Product



CRESCENT LAMPE RESISTANCES

for Distortionless Amplification
 12,000, 48,000, 50,000, 100,000 Ohms. List \$1.50 each. Special Sizes to Order \$2.50 each. Dealers write for discounts. When Better Resistances are made they will be Crescents.

CRESCENT RADIO SUPPLY CO.
 8 Liberty Street Jamaica, N. Y.

ARE YOU A SUBSCRIBER?
 Send for Trial Subscription ..
 \$1.00 for Six Months

Best's New Super

25¢ Copies of August "Radio" —last issue are available. "RADIO," San Francisco.

"THE RADIOBUSTER"

Written by the author of
 "On the Trail of the
 Tube Sharks."

This wonderful book sells
 for only \$1.00.

PACIFIC RADIO PUB. CO.,
 San Francisco

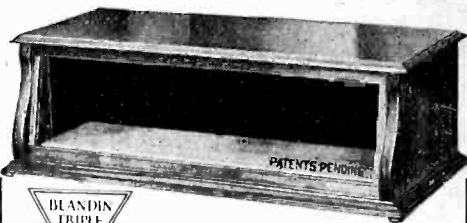

You'll Like This Duplex

One cabinet—

Any panel size, 7x26, 7x24, 7x21 or 7x18".
 Depth, 11".

Either straight or sloping panel—grooves, no screws.

Built of solid Honduras mahogany. Lacquer hand-rubbed piano finish. Entire lid raises. Full length piano hinge. Folding lid supports. Felt covered feet. Extra mounting board.

Write for Duplex price list.
 Dealers, write your jobber.

PACIFIC COAST DISTRIBUTORS:

L. D. Read & Staff, 518 Grant Bldg., Los Angeles, and 222 Chronicle Bldg., San Francisco.

Blandin
 Radio Cabinets

Built by
 Blandin
 1900 16th St.
 Racine,
 Wis.

with the \$100 Guarantee



Absolutely warranted to protect your set from lightning, with a guarantee to pay you \$100 or repair your set, should it be damaged through any fault of the

FIL-KO-ARRESTER

Listed as standard under the re-examination service of National Board of Fire Underwriters.

If your dealer has none, send his name with remittance to Dept. R-925

D-X INSTRUMENT CO.
 Harrisburg, Pa.

DX Instrument Co.
 Harrisburg, Pa.

FIL-KO LIGHTNING ARRESTER
 TRADE MARK REGISTERED

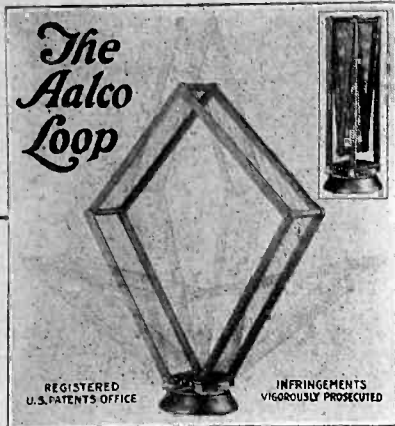

Adjustable to Any Position Wiring Always Taut

You will find that this exceptional loop adds greatly to the performance of your set, particularly in DX work—By changing the shape of the Aalco Loop you can bring in three stations on one dial adjustment—Eliminates all interference.

List Price, \$15.00

Jobbers write for discounts

REPRESENTATIVE:

A. M. MURTON & CO.

214 Chronicle Building San Francisco, Calif.

AALCO RADIO LABS.

6340 Cottage Grove Avenue CHICAGO

WITH better and more powerful broadcasting—

and with a sensitive, responsive Telemonic III receiver—the fascination of radio continues this year, regardless of the calendar.

Write to Danziger-Jones, Inc. Dept. R, 25 Waverly Place, New York, for Booklet, "The KIT of a Thousand Possibilities."

TELOS RADIO

**New LeFAX RADIO
HANDBOOK—\$2.00**
(Seventh Edition)

in bound form. For sale by
"RADIO," San Francisco

RADIOADS

A Classified Advertising Section Read by Better Buyers

The rate per word is eight cents net. Remittance must accompany all advertisements. Include name and address when counting words.

ADS FOR THE OCTOBER ISSUE MUST REACH US BY SEPTEMBER FIFTH

ARC & SPARK SYSTEMS
Send for Descriptive Circular QRD.

Interesting and Instructive
Pacific Radio School 433 Call Bldg., San Francisco

2650 MILES DISTANCE with one tube. Any novice understands our Simplified Instructions including Panel Layout, picture diagrams, etc. Write for **BIG FREE BOOKLET**. **VESCO RADIO CO., BOX 117-RC, OAKLAND, CAL. (TC)**

AGENTS—Signs for stores and offices. Entirely new. \$50 week easily made. **World Signs, 116 W. Washington, Chicago. (TC)**

RADIO HOSPITAL—Specialists in Neodyne and Superheterodyne, Dept. 3, Abilene, Kansas. (T.C.)

TESTED GALENA CRYSTALS 50c pound, bulk. Buskett, Metallurgist, Joplin, Mo. (3TO).

THE NEW square plate Ensign Variable Condensers. **JUST OUT!** Brass plates. Efficient on low waves. Get one of these condensers without cost in return for your subscription to "RADIO" for only two years. Five dollars brings you the condenser and the magazine. Send your check now. There are only a few of these condensers in our stock. "RADIO," Pacific Building, San Francisco.

THE LEFAX RADIO HANDBOOK, 7th Edition. In bound form. Contains a wealth of useful radio data. Very convenient size for carrying in your pocket. This \$2.50 book is given to you free of cost if you subscribe to "RADIO" for one year. \$2.50 covers the entire cost of this big offer. "RADIO," Pacific Building, San Francisco.

PHONOGRAPH UNITS FREE. The new Union Fabric Unit with soft rubber attachment. One subscription to "RADIO" for one year at \$2.50 brings you the unit as a premium. Get one now. Only a few on hand. "RADIO," Pacific Building, San Francisco.

KEEP station records in **THE RADIO LOG BOOK**, a handy pamphlet for recording stations heard, dial settings and other data. The price is only 10 cents per copy. For sale by Pacific Radio Pub. Co., Pacific Bldg., San Francisco.

FUNNY RADIO STORIES. 12 of 'em in the "RADIOBUSTER," Volney G. Mathison's humorous thriller. 112 pages in bound form. Mathison knows how to write. You will enjoy his stories. Send \$1.00 today for a copy of the "RADIOBUSTER," or get it free with your subscription to "RADIO" for one year (\$2.50). Pacific Radio Publishing Co., Pacific Bldg., San Francisco.

YOUR RADIO QUESTIONS ANSWERED FREE.—Gerald M. Best, technical editor of "RADIO," will answer ten radio questions for you if you subscribe to "RADIO" for only one year at \$2.50. Get this wonderful technical service, together with a good, practical radio magazine. "RADIO," Pacific Bldg., San Francisco.

BARGAINS: Crystalstat lowloss Receiving Sets, \$1.25. Crystalstat detectors, panel mounting, wonderful for reflex, 95c. Crystalstat mounted crystals, 20c. Lowloss variocoupler, \$1.25. All prepaid. Breckenridge Electric, 1923 Lysander, Detroit, Mich.

FOR "SCHOLARSHIPS" (Mail Courses), write Carnegie College, Rogers, Ohio.

6AGE SELLING OUT. Transmitting and receiving parts, Best Super in cabinet. S. T. Runyon, Walnut Grove, Calif.

HAVE TWO Western Electric 518-W Horn type loud speakers. Suitable for power amplifier. First reasonable offer takes them. G. M. Best, 433 Pacific Bldg., San Francisco, Calif.

FOR SALE—Set of 4 General Radio intermediate frequency transformers, \$12.00. Remier oscillator coupler, \$1.50. General Radio oscillator coupler, 75c. All American tuned superhet transformer, \$2.50. Guaranteed. Windsor Cutting, Campbell, Calif.

BLUEBIRD 5 watters, \$3.00; all types receiving tubes, \$2.00. Postage 15c extra. C. O. D. orders accepted. L. E. Fry, 6CLP, Empire, Calif.

LEYDEN JARS, .002 Mfd. Capacity, Pyrex Glass large size jars, rated at 12,500 volts. All brand new and in original packages, made by John Firth, \$2.00 each, while they last. D. B. McGown, 1247 Forty-seventh Avenue, San Francisco, California.

FOR SALE—Make your loudspeaker set be heard three blocks easy. My Western Electric three stage power amplifier complete with three "116-A" tubes used but little. Special at \$45.00. Elvyn J. Beall, Box 246, Newman, California.

AMRAD "S" TUBES, Type 4000-1, \$8.00 each. Immediate shipment. Dealers supplied. George Voigt Radio Supply Co., Dept. R, Maspeth, N. Y.

500 CYCLE BARGAINS. Great stuff for the plates of the tubes. Rectified and filtered makes most wonderful DC. Generators from 1/4 to 2 KW. Priced right. Details for the asking. For example—a 1/2 KW. Crocker-Wheeler motor-generator, 110 V DC. to 200 V 500 cycles AC, with shaft extended for external drive, for \$90.00, list at about \$425.00. D. B. McGown, 1247 Forty-seventh Avenue, San Francisco, Calif.

NEW WONDERFUL SELLER. Cost 10c, profit \$1.40, monogramming autos. Experience unnecessary. Free samples. Worcester Monograms, B-130, Worcester, Mass.

YES, SIR: I am proud of my **ELECTRICALLY WELDED EDISON** elements. I believe they make the best "B" battery in the world. I use only good live elements and **WELD** them in pairs with pure nickel wire. This welded connection keeps the battery from becoming noisy. My prices are only 7 1/2 cents per pair, postpaid; with hard rubber separators, perforated, at 1/2 cent each. Sample and "dope" sheet, 10 cents. Chas. Snively, Woodburn, Oregon. 7UV.

1500 VOLTS FOR \$45.00!!! Brand New Generators, General Electric make, 24 volt 31 amps., input, 233 MA rated output, full ball bearing. F. O. B. San Francisco, \$45.00. These may also be had with shafts extended for driving by an external motor, for \$3.00 extra. Made for the U. S. Naval Air-service, and all passed strict U. S. Gov't. inspection and test. Shipping weight about 40 lbs. Have 750 volt tap for lower voltage or may be run slower or on lower voltage, and lower output voltages obtained. D. B. McGown, 1247 Forty-seventh Avenue, San Francisco, Calif.

MAKE \$100 WEEKLY in spare time. Sell what the public wants—long distance radio receiving sets. Two sales weekly pays \$100 profit. No big investment, no canvassing. Sharpe of Colorado made \$955 in one month. Representatives wanted at once. This plan is

sweeping the country—write today before your county is gone. **OZARKA, INC.**, 126 West Austin Avenue, E, Chicago.

SUPERSENSITIVE GALENA CRYSTALS, pound, \$1.00, prepaid. **ALKEMITE** Allsensitive Crystals, 50c. Buskett, Metallurgist, Joplin, Mo. (T.C.)

RADIOCAST WEEKLY

48 Pages of Programs, Photos,
Humor, Musical Reviews,
Schedules, Tables,
Editorials, Etc.

5c Per Radiocast Weekly
Copy 433 Pacific Bldg.

SAN FRANCISCO

This Year —
Better, But Crowding Still Troublesome

Last Year —
Bad Crowding of Shorter-Wave Stations

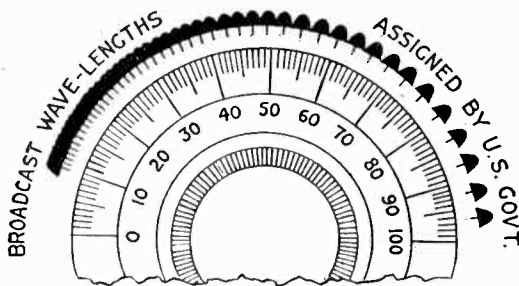
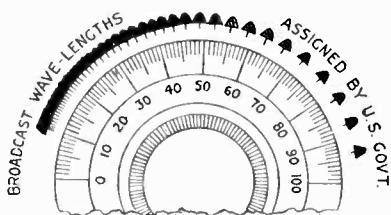

Next Year —
No Crowding!

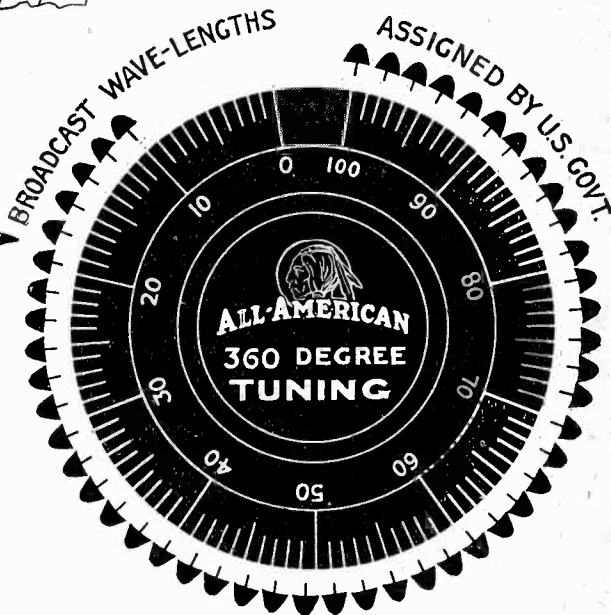

Straight-Line-Frequency Means —

That the distance on your dials from one station to the next adjacent one is uniform — throughout the short-wave stations, as well as the longer waves.

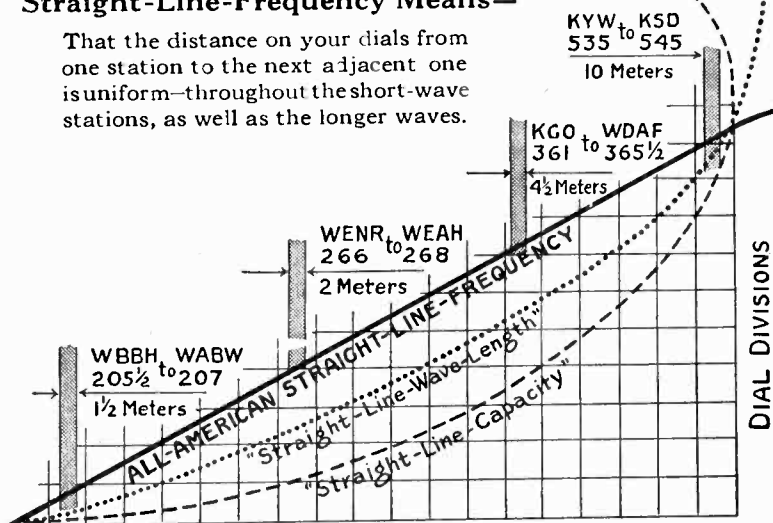

20-KILOCYCLE INTERVALS ARE SHOWN.
ALTERNATE CHANNELS OMITTED
FOR CLEARNESS

ALL-AMERICAN STRAIGHT-LINE-FREQUENCY TUNING

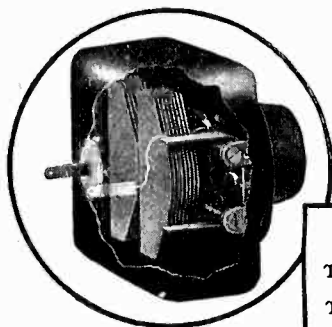

All-American Straight-Line-Frequency Condensers
Type C-35 Max. 350 micromicrofarads (Min. 10.5 mmf.) \$4.50
Type C-50 Max. 500 micromicrofarads (Min. 11.8 mmf.) 5.00

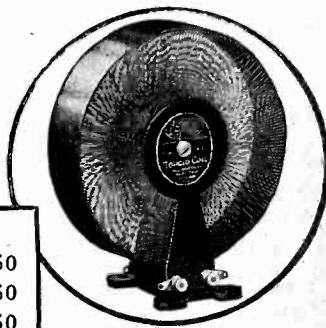

All-American Toroid Coils
Type T-1 Antenna Coupler \$3.50
Type T-2 R.F. Transformer 3.50
Set of 3 Coils complete . . 10.50

Ease and certainty in tuning — no more crowding of short-wave stations — no need to buy vernier dials — no gears or other back-lash makers — body capacity absolutely *not distinguishable* — electrical efficiency unsurpassed — on one-half the panel space: that is the ALL-AMERICAN Straight-Line-Frequency Condensers.

New power for distance reception through close coupling — tuning of arrow-like sharpness — elimination of all oscillation worries through the self-enclosed endless magnetic field — non-radiating reception: that is ALL-AMERICAN Toroid Coils — Antenna Coupler and Radio Frequency Transformers. See them at your dealer's.

A new edition of the famous RADIO KEY BOOK, together with complete information about the new ALL-AMERICAN Straight-Line-Frequency TUNING, is yours for 10 cents, coin or stamps. Send for it today sure!

ALL-AMERICAN RADIO CORPORATION, E. N. Rauland, *President*, 4209 Belmont Ave., CHICAGO

OWNING AND OPERATING STATION WENR—266 METERS

ALL-AMERICAN

Pioneers in the Radio Industry

Tell them that you saw it in RADIO

GENERAL RADIO

Condensers

are BALANCED



*Electrically
and
Mechanically
for Perfect Performance
in Radio Reception*

**GENERAL RADIO Condensers
Have Good Interplate Con-
ductivity and Low Losses.**

Total condenser losses at radio frequencies are the sum of conductivity losses, eddy current losses, and dielectric losses.

Conductivity losses most seriously affect the efficiency of a condenser under working conditions. They arise from poor contacts between plates and from poor bearing contacts. Soldered plates and positive spring bearings reduce these losses to a minimum.

Eddy Current losses occur in metal end plates and condenser plates themselves. The use of hard rubber end plates eliminates entirely eddy current losses introduced by metal end plates.

Dielectric losses are due to absorption of energy by the insulating material. When a good dielectric such as hard rubber is used in the end plates they have less effect upon the efficiency of a condenser at radio frequencies than any other set of losses.

For use at broadcast wavelengths General Radio Type 247 condensers represent the best balance between low conductivity, eddy current, and dielectric losses that is consistent with efficient design and popular price.

The plates of the rotor and stator groups are individually straightened before assembly and firmly soldered in a jig while they are in perfect alignment. The use of high-grade hard rubber in the end plates eliminates entirely eddy current losses from the end plates.

Specially shaped plates assure a uniform wavelength variation.

Positive contact spring bearings provide a good connection with the rotor group and eliminate the disadvantages of a pig tail connection. Mechanically as well as electrically General Radio condensers are the standards of excellence.

Rotor plates are counterbalanced to permit smooth operation and accurate dial settings.

Lower losses and lower prices make General Radio condensers the outstanding values for popular use.

Type 247-H 500 MMF Vernier	\$5.00
" 247-F 500 MMF Plain	4.00
" 247-M 250 MMF Vernier	4.50
" 247-K 250 MMF Plain	3.50

Write for descriptive folder, "Quality Condensers" and our latest Catalog 921-C.



GENERAL RADIO CO.
Cambridge, Mass.



It's a *genuine* UV-201-A
 only when it bears
 the name Radiotron
and the RCA mark



WD-11, WD-12, UV-199, UV-200, and
 UV-201-A are the type names of Radiotrons.
 They belong to Radiotrons only. To be sure
 you are buying the genuine, look for the name
 Radiotron and the RCA mark on the base.
 Then you are sure of quality.

Radio Corporation of America
 Chicago New York San Francisco

Radiotron

REG. U.S. PAT. OFF.

AN RCA PRODUCT